

Steam Schooner  
**WAPAMA**  
 HISTORIC STRUCTURE REPORT  
 1986

ON MUSEUM

PLEASE RETURN TO:  
TECHNICAL INFORMATION CENTER  
DENVER SERVICE CENTER  
NATIONAL PARK SERVICE

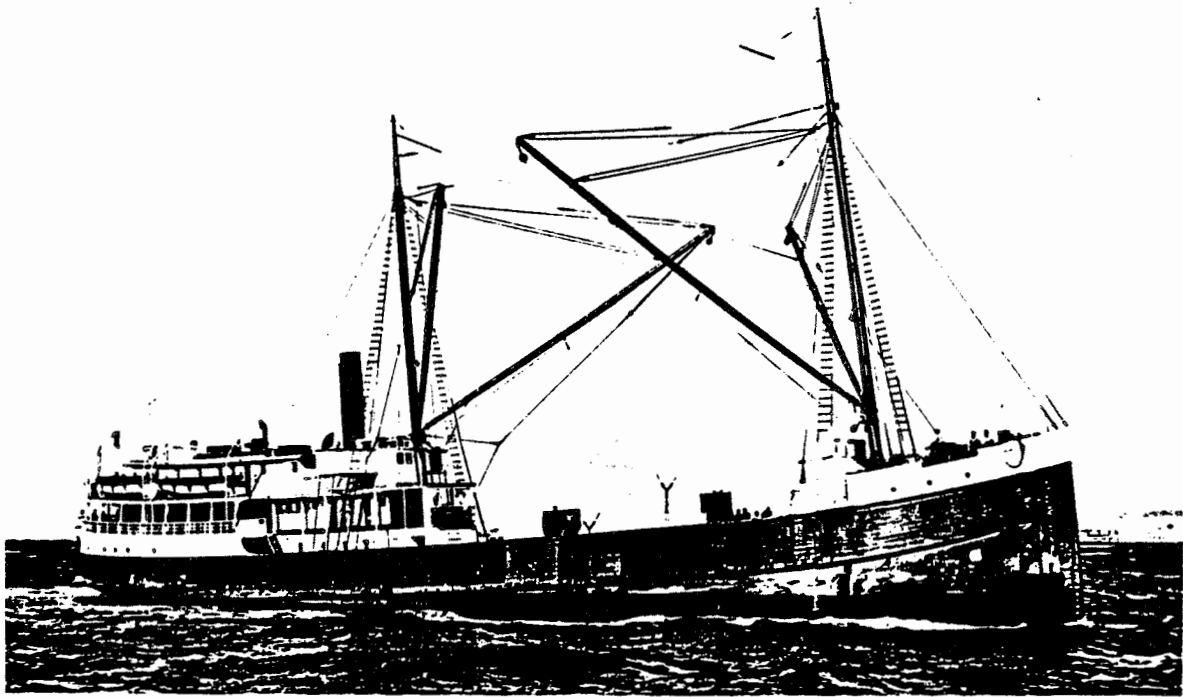

WAPAMA, near the mid-point of her working career, steams light across San Francisco Bay. Photo by John W. Proctor ca.1932-1937. Courtesy The National Maritime Museum at San Francisco

D-71

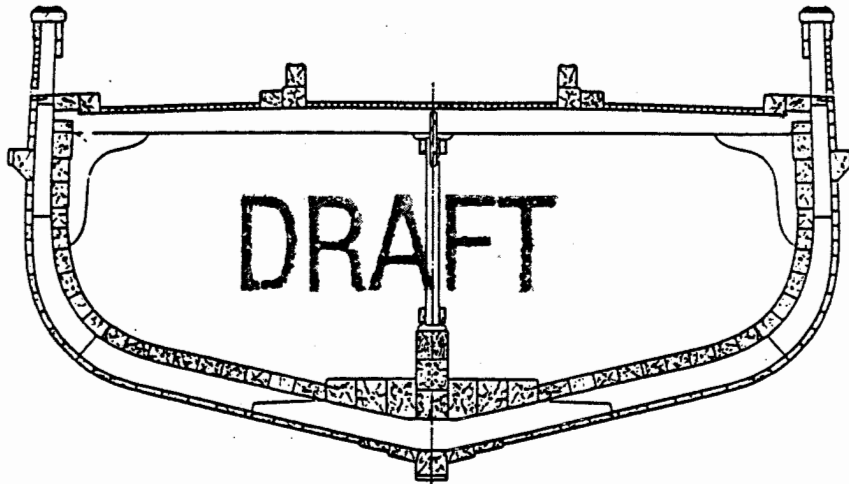

Steam Schooner  
**WAPAMA**  
HISTORIC STRUCTURE REPORT

1986

Prepared for

**The National Maritime Museum at San Francisco  
The National Park Service,  
Golden Gate National Recreation Area  
Fort Mason, Building 201  
San Francisco, California, 94123**

Prepared by

**Tri-Coastal Marine, Inc.  
(White Elephant Management)  
2104 Strand, Galveston, Texas, 77550**

1  
2  
3  
4  
5  
6  
7  
8  
9  
10  
11  
12  
13  
14  
15  
16  
17  
18  
19  
20  
21  
22  
23  
24  
25  
26  
27  
28  
29  
30  
31  
32  
33  
34  
35  
36  
37  
38  
39  
40  
41  
42  
43  
44  
45  
46  
47  
48  
49  
50  
51  
52  
53  
54  
55  
56  
57  
58  
59  
60  
61  
62  
63  
64  
65  
66  
67  
68  
69  
70  
71  
72  
73  
74  
75  
76  
77  
78  
79  
80  
81  
82  
83  
84  
85  
86  
87  
88  
89  
90  
91  
92  
93  
94  
95  
96  
97  
98  
99  
100

## Table of Contents

|  |           |
|--|-----------|
| Table of Contents .....                    | pg:<br>i. |
| List of Illustrations and Photographs..... | vii.      |
| Preface .....                              | x.        |
| Management Synopsis .....                  | xi.       |
| Acknowledgements .....                     | xii.      |

### **Section 1: Administrative Data**

|   |          |
|---|----------|
| <b>I. Project Identification.....</b>   | <b>1</b> |
| <b>II. Proposed Use of Structure.....</b>   | <b>1</b> |
| <b>III. Justification for Such Use.....</b>   | <b>1</b> |
| <b>IV. Recommendations for Preservation of the<br/>Work Products of this Study.....</b> | <b>1</b> |

### **Section 2: Physical History and Analysis**

|  |           |
|--|-----------|
| <b>I. Historical Significance .....</b>              | <b>2</b>  |
| A. Statement of Historical Significance .....        | 2         |
| B. WAPAMA's Chronology .....                         | 4         |
| <b>II. General Physical Description .....</b>        | <b>5</b>  |
| <b>III. Description of Existing Conditions .....</b> | <b>16</b> |
| A. Summary of Existing Condition .....               | 16        |
| B. Survey Background and Procedures .....            | 16        |
| 1. Previous Surveys and Studies.....                 | 16        |
| 2. Focus of Existing Condition Survey .....          | 17        |
| 3. Survey Methodology .....                          | 18        |
| 4. Organization of Report .....                      | 18        |
| 5. List of Terms .....                               | 18        |

|   |    |
|---|----|
| (III.) C. Existing Condition Survey ..... | 20 |
| 1. Forecastle Head .....                  | 20 |
| 2. Forecastle .....                       | 22 |
| 3. Main Deck .....                        | 24 |
| 4. Bulwarks .....                         | 27 |
| 5. Main Deck House .....                  | 29 |
| 6. Aft Compartments .....                 | 32 |
| 7. Forepeak .....                         | 36 |
| 8. Cargo Hold .....                       | 37 |
| 9. Engine Room .....                      | 41 |
| 10. Afterpeak .....                       | 45 |
| 11. Cabin Deck .....                      | 47 |
| 12. Boat Deck .....                       | 51 |
| 13. Hull Exterior .....                   | 55 |
| 14. Rig .....                             | 60 |
| 15. Machinery and Tankage .....           | 62 |
| 16. Electrical System .....               | 69 |
| 17. Piping .....                          | 70 |
| D. Load Bearing Limits of Structure.....  | 72 |

**IV. Measured Drawings .....**

|                                  |    |
|----------------------------------|----|
| A. Explanation of Drawings ..... | 76 |
|----------------------------------|----|

|                       |   |
|-----------------------|---|
| Sheet: 1. Cover Sheet | 7. Plan of Cabin Deck                     |
| 2. Profile View       | 8. Plan of Boat Deck                      |
| 3. Outboard Profile   | 9. Plan of Forecastle<br>and 'Tween Decks |
| 4. Inboard Profile    | 10. Midships Section                      |
| 5. Plan of Hold       | 11. Cross Sections                        |
| 6. Plan of Main Deck  | 12. Rigging Plan                          |

|   |    |
|---|----|
| <b>V. Evaluation of Treatment Alternatives;</b> |    |
| <b>Three Basic Alternatives</b> .....           | 78 |
| A. Restoration as a Floating Museum Ship .....  | 78 |
| 1. The 1984 Restoration Plan .....,.....        | 79 |
| 2. A Total Rebuild .....,.....                  | 80 |
| B. Stabilization, No Public Access .....        | 82 |
| C. Preservation with Interpretation .....       | 82 |
| <b>VI. Factors Affecting Preservation</b> ..... | 84 |
| A. Wood Preservation .....                      | 84 |
| 1. Factors Affecting Wood Structure .....       | 84 |
| 2. Nature and Cause of Fungus Decay.....        | 85 |
| 3. Rot Treatment Options.....                   | 86 |
| a. Renewal of Decayed Structure.....            | 86 |
| b. Reducing Moisture Content.....               | 86 |
| c. Chemical Treatment.....                      | 88 |
| 4. Other Wood Preservation Concerns.....        | 91 |
| 5. Coatings.....                                | 92 |
| 6. Recommended Wood Preservation Treatment..... | 93 |
| B. Metal Preservation.....                      | 94 |
| 1. The Major Factor: Corrosion.....             | 94 |
| 2. Recommended Treatment.....                   | 94 |
| a. Main Engine.....                             | 94 |
| b. Auxiliary Machinery.....                     | 94 |
| c. Boilers and Stack.....                       | 95 |
| d. Tankage.....                                 | 95 |
| e. Piping.....                                  | 95 |
| f. Deck Gear.....                               | 95 |



|           |  |     |
|-----------|--|-----|
| (VI.B.2.) | g. Fastenings.....                                     | 95  |
|           | h. Wire Rigging.....                                   | 96  |
|           | 3. Recommended Metal Coatings.....                     | 96  |
|           | 4. Metal Preservation Recommendations; Estimates...    | 97  |
| C.        | Weather Protection .....                               | 98  |
|           | 1. Extended Non-Permanent Covers.....                  | 98  |
|           | 2. Removable Fabric Awnings.....                       | 99  |
|           | 3. Encompassing Structure .....                        | 101 |
|           | 4. Renewal of Exposed Surfaces .....                   | 102 |
| D.        | Structural Integrity and Support .....                 | 104 |
|           | 1. Continued Deterioration and Effects of Drying...104 |     |
|           | 2. Bow Support .....                                   | 104 |
|           | 3. Additional Exterior and Interior Shoring .....      | 104 |
|           | 4. Long Term Support System .....                      | 105 |
|           | 5. Fabric and Equipment Removals .....                 | 106 |
|           | 6. Structural Renewals .....                           | 107 |
| E.        | Barge 214 .....  | 110 |
|           | 1. Particulars .....                                   | 110 |
|           | 2. Background .....                                    | 110 |
|           | 3. Conclusions .....                                   | 110 |
|           | 4. Cost Estimates .....                                | 112 |
| F.        | Location .....   | 114 |
|           | 1. The Bay Model Site .....                            | 114 |
|           | 2. Other Government Sites Considered.....115           |     |
|           | a. East Fort Baker .....                               | 115 |
|           | b. Hyde Street Pier .....                              | 116 |
|           | 3. Availability of Non-Government Sites.....117        |     |

|              |  |            |
|--------------|--|------------|
| G.           | Interpretation .....                                       | 120        |
| 1.           | Virtues in Necessity .....                                 | 120        |
| 2.           | Interpretation in the Near-Term .....                      | 121        |
| 3.           | Public Access .....  | 121        |
| 4.           | Circulation .....  | 123        |
| 5.           | Interpretive Aspects of Structural Support<br>Systems..... | 124        |
| 6.           | Weather Protection and Interpretation .....                | 124        |
| H.           | Safety .....   | 127        |
| 1.           | Immediate Safety Concerns .....                            | 127        |
| 2.           | Public Access and Egress .....                             | 127        |
| 3.           | Structural Deficiencies .....                              | 127        |
| 4.           | Electrical System Deficiencies.....                        | 128        |
| 5.           | Fire Safety .....  | 128        |
| 6.           | Asbestos .....   | 128        |
| <b>VII.</b>  | <b>Recommended Treatment .....</b>                         | <b>130</b> |
| A.           | Justification.....   | 130        |
| B.           | Preservation Plan .....                                    | 131        |
| 1.           | What Has Been Done to Date .....                           | 131        |
| 2.           | Further Stabilization Work .....                           | 131        |
| 3.           | Further Studies .....                                      | 134        |
| <b>VIII.</b> | <b>Impact of Proposed Treatment.....</b>                   | <b>140</b> |
| A.           | Historic Fabric .....                                      | 140        |
| B.           | Appearance .....   | 140        |
| C.           | Long-Term Preservation .....                               | 141        |
| <b>IX.</b>   | <b>Credits and References.....</b>                         | <b>142</b> |

### **Section 3: Appendices**

#### **A. Record of Fabric Analysis**

##### **1. Wood Test Boring Results**

##### **2. Wood Moisture Reading**

#### **B. Stability Calculations**

#### **C. Replication vs. Restoration; Jack Ehrhorn**

## LIST of PHOTOGRAPHS AND ILLUSTRATIONS

|  |              |
|--|--------------|
| WAPAMA underway, 1930s.....                            | frontispiece |
| fig. 1. WAPAMA at sea; Lyle Galloway.....              | Page 2       |
| 2. WAPAMA at launching.....                            | 4            |
| 3. WAPAMA docked in San Francisco, 1931.....           | 5            |
| 4. WAPAMA on exhibit at Hyde Street, 1963.....         | 5            |
| 5. WAPAMA on Barge 214, 1985.....                      | 10           |
| 6. Unidentified Steam Schooner in frame; deck.....     | 13           |
| 7. Unidentified Steam Schooner in frame; sides.....    | 14           |
| 8. WAPAMA on Barge 214 at Pacific Drydock, 1985.....   | 15           |
| 9. WAPAMA 1985; Roof on maindeck under construction... | 19           |
| 10. View of forecastle head deck.....                  | 21           |
| 11. View of main deck.....                             | 23           |
| 12. View of main deck, port side.....                  | 26           |
| 13. Deteriorated bulwark stanchions.....               | 28           |
| 14. Main deck engine flat, looking fwd.....            | 30           |
| 15. Main deck engine flat, looking aft.....            | 30           |
| 16. Dining saloon.....                                 | 31           |
| 17. Galley.....  | 34           |
| 18. Pantry.....  | 34           |
| 19. Hold, looking to port.....                         | 38           |
| 20. Hold, looking up.....                              | 40           |
| 21. Engine room, looking fwd.....                      | 42           |
| 22. Engine room, looking aft.....                      | 44           |
| 23. Afterpeak.....                                     | 46           |
| 24. Cabin Deck.....                                    | 48           |
| 25. Social Hall.....                                   | 48           |
| 26. Stairway from Social Hall.....                     | 50           |

|     |                                       |               |
|-----|---------------------------------------|---------------|
| 27. | View of Boat Deck, port side.....     | 52            |
| 28. | Transom Stern Launch, ashore.....     | 52            |
| 29. | Stack.....                            | 54            |
| 30. | Steel Double-ENDER, in place.....     | 54            |
| 31. | Fidley Trunk.....                     | 54            |
| 32. | Bottom, starboard side.....           | 56            |
| 33. | Section of Bottom Removed.....        | 57            |
| 34. | View of Starboard Quarter.....        | 59            |
| 35. | Topsides at Midships.....             | 59            |
| 36. | Winch Pit, mainmast.....              | 60            |
| 37. | Hand Forged Clevis.....               | 60            |
| 38. | Main Engine Bed and Crankshaft.....   | 61            |
| 39. | Boilers.....                          | 62            |
| 40. | Steam Windlass.....                   | 66            |
| 41. | Steam Winch.....                      | 66            |
| 42. | WAPAMA on Barge 214.....              | 71            |
| 43. | Rotten Trunnel.....                   | 71            |
| 44. | Existing Hull Distortions (1985)..... | 73            |
| 45. | View of Bottom.....                   | 73            |
|     | MEASURED DRAWINGS, 12 Sheets          | After page 76 |
| 46. | Brown Rot.....                        | 84            |
| 47. | Corroded Iron Spike.....              | 97            |
| 48. | Temporary Covers.....                 | 98            |
| 49. | Present Cover Over Main Deck.....     | 100           |
| 50. | View From Cabin Deck.....             | 100           |
| 51. | Proposed Preservation Shed.....       | 102           |
| 52. | Proposed Shed Structure.....          | 103           |
| 53. | Proposed Structural Support.....      | 106           |

|     |   |     |
|-----|---|-----|
| 54. | WAPAMA in the 1950s.....                          | 118 |
| 55. | WAPAMA in the 1960s.....                          | 119 |
| 56. | Proposed Hold and Main Deck Access (Section)..... | 122 |
| 57. | Proposed Hold and Main Deck Access (Profile)..... | 122 |
| 58. | Proposed Shed (Dry Season).....                   | 125 |
| 59. | St. Helens Shipbuilding Co.....                   | 125 |
| 60. | Proposed Shed (Rainy Season).....                 | 126 |
| 61. | Options for Additional Fixed Covers.....          | 135 |

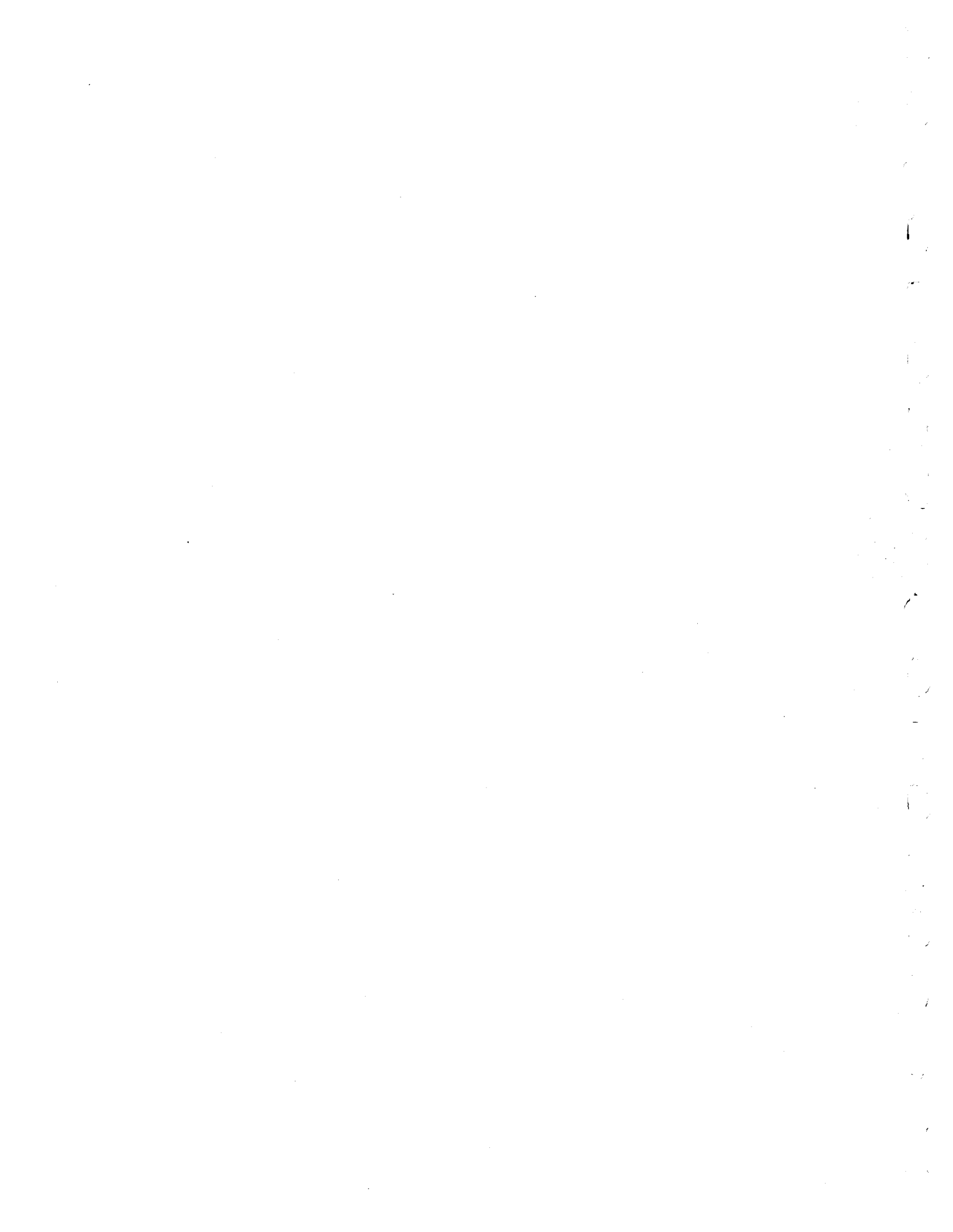

## **PREFACE**

Since her launching in 1915, the steam schooner WAPAMA has had a long and productive life. She has served well, both in plying cargo and passengers along the stormy West Coast from Mexico to Alaska, and in helping to transmit the heritage of West Coast seafaring to generations born long after her sisters had disappeared forever.

By 1979, her 64th year, the particular rigors of both kinds of duty had brought her to a crisis point, a crisis which has deepened in the years of lay-up since. By 1985, when she was listed as a National Historic Landmark, her continued survival had been rendered extremely problematic.

To guide its efforts in addressing WAPAMA's preservation problems, the National Maritime Museum at San Francisco, an entity within the National Park Service, initiated this Historic Structures Report. Since 1977 the NPS has been steward of WAPAMA and the other ships of an historic fleet which was first assembled by the State of California. The report was undertaken in the fall of 1985 by Tri-Coastal Marine Inc., a consulting group with experience in the restoration and management of historic vessels. The report includes a detailed survey of WAPAMA's present condition, a set of measured drawings, a discussion of factors affecting the vessel's preservation, an evaluation of alternative treatments, and a recommended treatment alternative.

This study initially investigated a broad range of options for treatment of the WAPAMA. As work progressed, it became evident that the range of actual treatment alternatives was limited. Within this range are decisions which must be made and numerous interdependent variables which complicate them.

The preservation of WAPAMA for museum interpretation, as opposed to her "restoration" as a floating vessel, stands out as the most realistic option for end use. WAPAMA has deteriorated to the point where true restoration would require an almost total rebuilding. Philosophical questions aside, the financial commitment this would demand appears beyond any level attainable in the foreseeable future. Were funding available on this scale, it might be better spent insuring that the other wooden vessels in the NPS fleet do not suffer a fate similar to WAPAMA's.

The less ambitious goal of preserving WAPAMA as an artifact will, in itself, require a major effort. Arresting decay, supporting weak structure and devising long-term weather protection will need to be achieved on a large scale.

It is hoped that this document will serve as a planning tool in WAPAMA's preservation and a guide for approaching similar problems in the NPS historic fleet.



0  
1  
2  
3  
4  
5  
6  
7  
8  
9  
10  
11  
12  
13  
14  
15  
16  
17  
18  
19  
20  
21  
22  
23  
24  
25  
26  
27  
28  
29  
30  
31  
32  
33  
34  
35  
36  
37  
38  
39  
40  
41  
42  
43  
44  
45  
46  
47  
48  
49  
50  
51  
52  
53  
54  
55  
56  
57  
58  
59  
60  
61  
62  
63  
64  
65  
66  
67  
68  
69  
70  
71  
72  
73  
74  
75  
76  
77  
78  
79  
80  
81  
82  
83  
84  
85  
86  
87  
88  
89  
90  
91  
92  
93  
94  
95  
96  
97  
98  
99

## MANAGEMENT SYNOPSIS

The steam schooner WAPAMA is presently in a state of advanced deterioration for which there is no easy or quick cure. Out of the water and unable to be refloated in her present condition, WAPAMA continues to deteriorate. This report explores the feasibility of three treatment alternatives:

1. Rebuilding as a floating museum ship
2. Stabilization and storage
3. Preservation for interpretation ashore

Restoration would require a level of funding beyond the resources of the NPS at this time. The recommended treatment is preservation as a shore based exhibit; stabilization is considered a prerequisite. A comprehensive program, coupled with a long term commitment, will be necessary to achieve this. The needs of the other ships in the historic fleet, and the availability of funding were considered in selecting this option.

The following is a projection of costs for stabilization and preservation. For comparison, a rough cost projection of a four-year rebuilding program is given.

It must be realized that there is a certain minimum level of commitment below which the goal of long term preservation becomes unrealistic.

|              | <b>Stabilization/Preservation</b> | <b>Rebuilding*</b>  |
|--------------|-----------------------------------|---------------------|
| FY 87        | \$ 211,000                        | \$ 1,500,000        |
| FY 88        | \$ 354,000                        | \$ 2,000,000        |
| FY 89        | \$ 457,000 - 667,000              | \$ 2,300,000        |
| FY 90        | \$ 350,000 - 550,000              | \$ 2,300,000        |
| <b>Total</b> | <b>\$ 1,372,000 - 1,782,000</b>   | <b>\$ 8,100,000</b> |

\* Rebuild estimate based on 250,000 man hours @ \$25 per hour, materials @ 30% of labor.



## **ACKNOWLEDGEMENTS**

The search for solutions to WAPAMA's dilemma has required the involvement of many individuals from various backgrounds. Their interest and willingness to assist reaffirms the importance of this worthy vessel, and represents a true resource working for her survival.

**Wood Sciences:** From the Forest Products Lab at Richmond, CA.: Dr. Wayne Wilcox (who has spread the word of WAPAMA in lectures from coast to coast), and Dr. Bill Dost for their invaluable assistance in the field of wood decay. Mr. Jeffery J. Morrell from Oregon State University, and Mr. Guy G. Helsing from the National Wood Treating Co. for their advice on the use of fumigants and other wood treatments. From U.S.BORAX: Mr. John Yannacakis, Mr. Bronson Schafer, and Dr. Robert Bianchini for their continued interest in solving WAPAMA's rot problem. Mr. Alex Barbour of Parks Canada, and Dr. David W. Grattan of Conservation Processes Research, Ottawa, Ontario for their advice on wood structures preservation. From the U.S. Forest Products Lab at Madison, WI.: Dr. William Fiest for his extensive information on wood coatings.

**Ship Construction and Support:** Shipwrights Mr. Jack Ehrhorn and Mr. William Elliott for advice and estimates on repair and rebuilding. Naval architects Mr. David J. Seymour, for his ideas on support and weather protection for the vessel, and Mr. Zachary Reynolds for sharing his reports, drawings and ideas.

**Patience and Guidance:** Mrs. Glennie Wall, Unit Manager, Maritime Unit, Golden Gate National Recreation Area, National Park Service, and Mr. H. Thomas McGrath, Assistant Unit Manager, Maritime Unit, GGNRA, NPS, for their continued support and assistance.

**Moral Support:** Jessie Brady for her unflagging enthusiasm for "an old steam schooner".

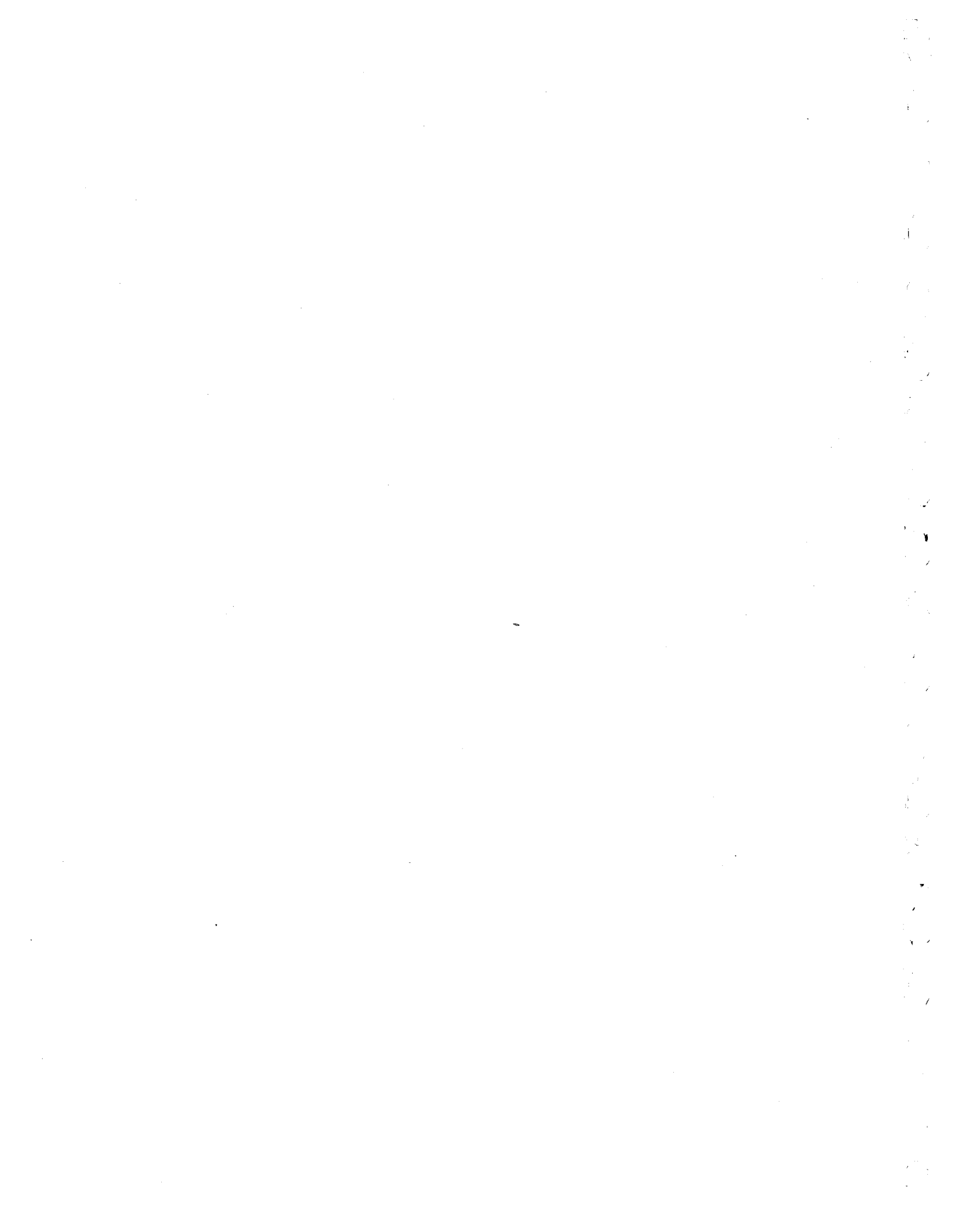

Section 1  
ADMINISTRATIVE DATA

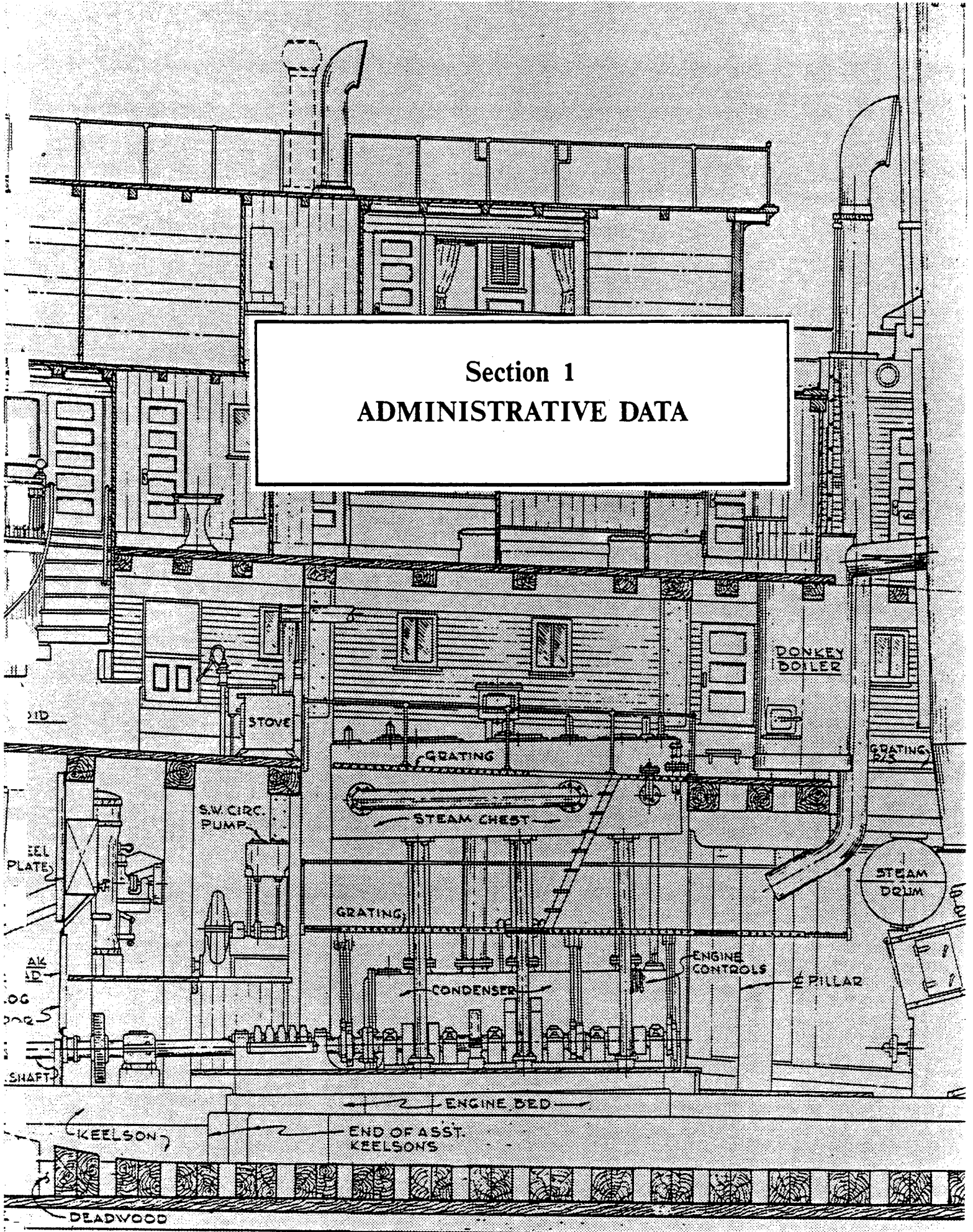

DONKEY BOILER

GRATING

STEAM CHEST

GRATING

CONDENSER

ENGINE CONTROLS

PILLAR

STEAM DRUM

ENGINE BED

END OF ASST. KEELSONS

KEELSON

DEADWOOD

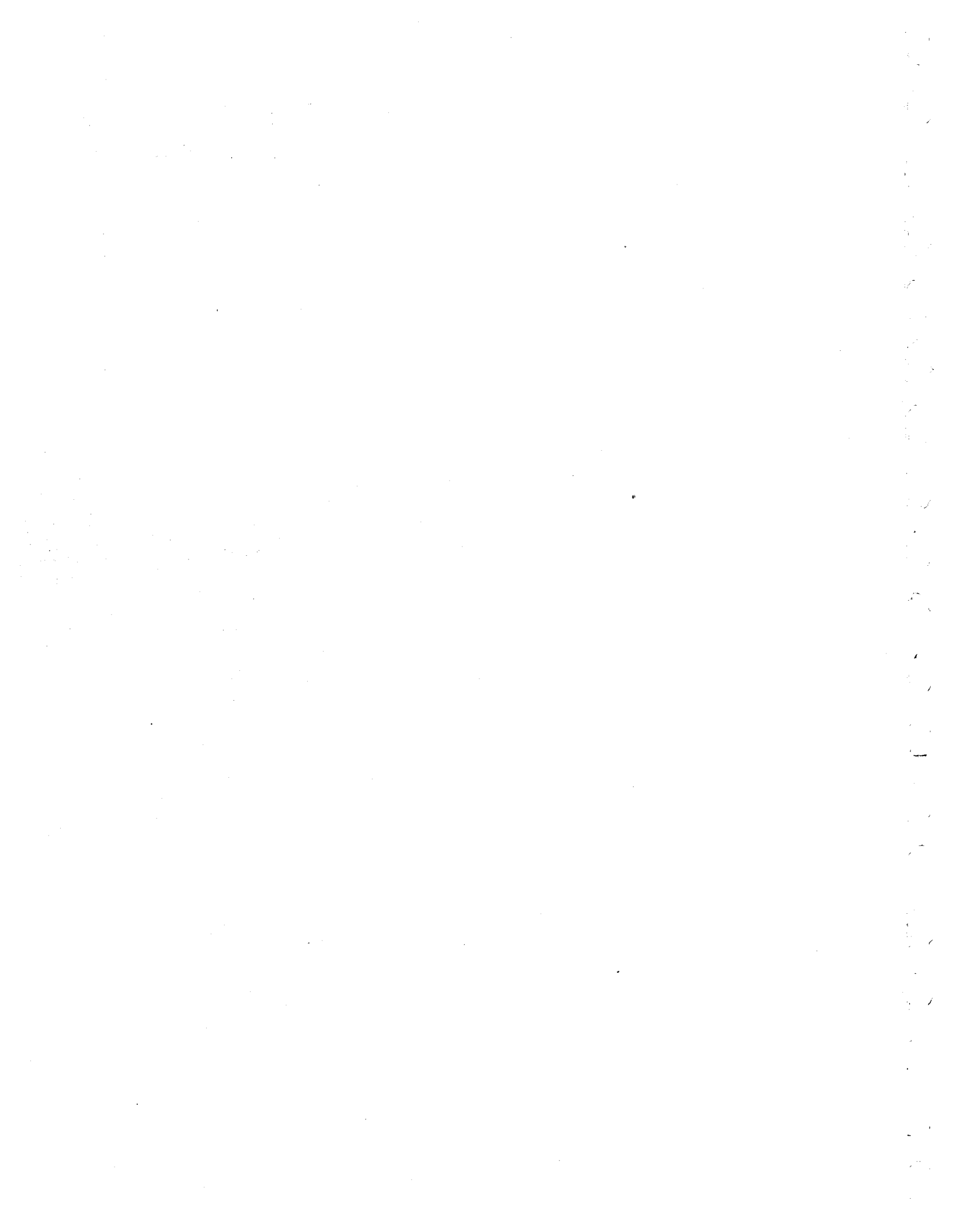

## **SECTION 1: ADMINISTRATIVE DATA**

### **I. Project Identification**

The steam schooner WAPAMA is drydocked on Barge 214, which is berthed on the north side of the United States Army Corps of Engineers (COE) Pier at the Bay Model Visitor Center (BMVC) Marinship Way, Sausalito, California. The docking agreement between the National Park Service (NPS) and the Bay Model Visitor Center was approved by the Superintendent of Golden Gate National Recreation Area and the COE District Engineer, San Francisco, and determined legally sufficient by the NPS Field Solicitor. Barge 214 is owned by the Harbor Tug and Barge Company and is rented to the NPS on a monthly basis. A long term bareboat charter between the NPS and owner is currently under negotiation.

The WAPAMA is No. SS-02 on the NPS List of Classified Structures (LCS) and was entered on the National Register of Historic Places on 04/24/73. In June of 1984 the WAPAMA was declared a National Historical Landmark.

### **II. Proposed Use of the Structure**

The WAPAMA is listed on the LCS as in Management Category A: Must be preserved. Currently the WAPAMA and Barge 214 are unsafe for public access. The proposed treatment for the historic ship is stabilization/preservation as the vessel currently sits atop Barge 214. Successful implementation of this treatment plan over a three to five year period will permit an increase in the areas of the ship open to public access for interpretive purposes.

### **III. Justification for Such Use**

Stabilization/preservation of the WAPAMA with an ongoing interpretive commitment is in keeping with NPS policies and guidelines and is consistent with the Golden Gate National Recreation Area General Management Plan, (Sept. 1980). The GGNRA National Maritime Museum draft Interpretive Prospectus (Oct. 1986) supports the concept of stabilization/preservation and makes specific recommendations for interpretation.

### **IV. Recommendations for Preservation of the Work Products of this Study**

It is recommended that all objects, documents, records, photographs, negatives and files collected or produced as a result of this study be conserved and stored with the Division of Museum Storage within the National Maritime Museum, GGNRA, at the conclusion of this study.



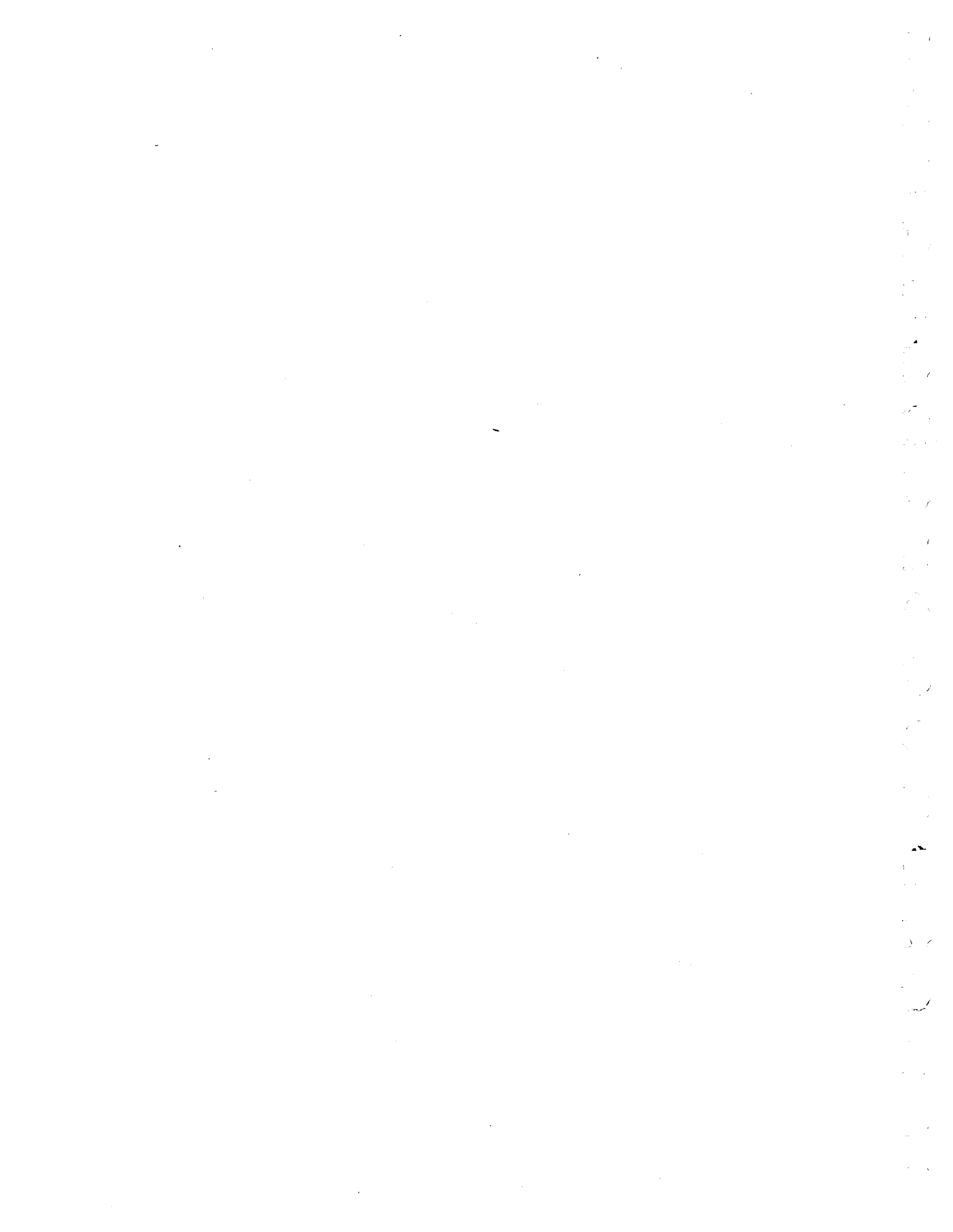

Section 2  
**PHYSICAL HISTORY and ANALYSIS**

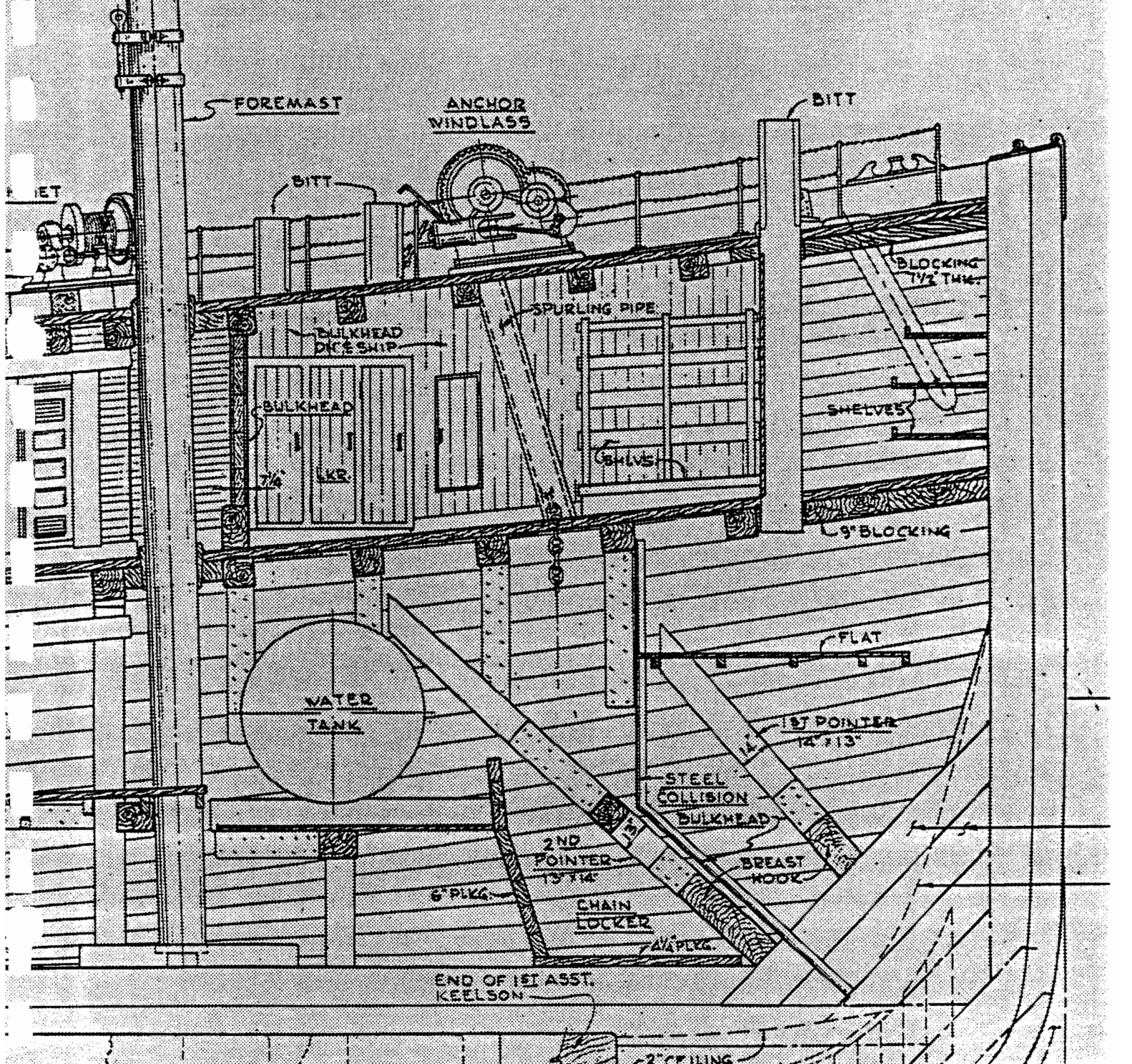

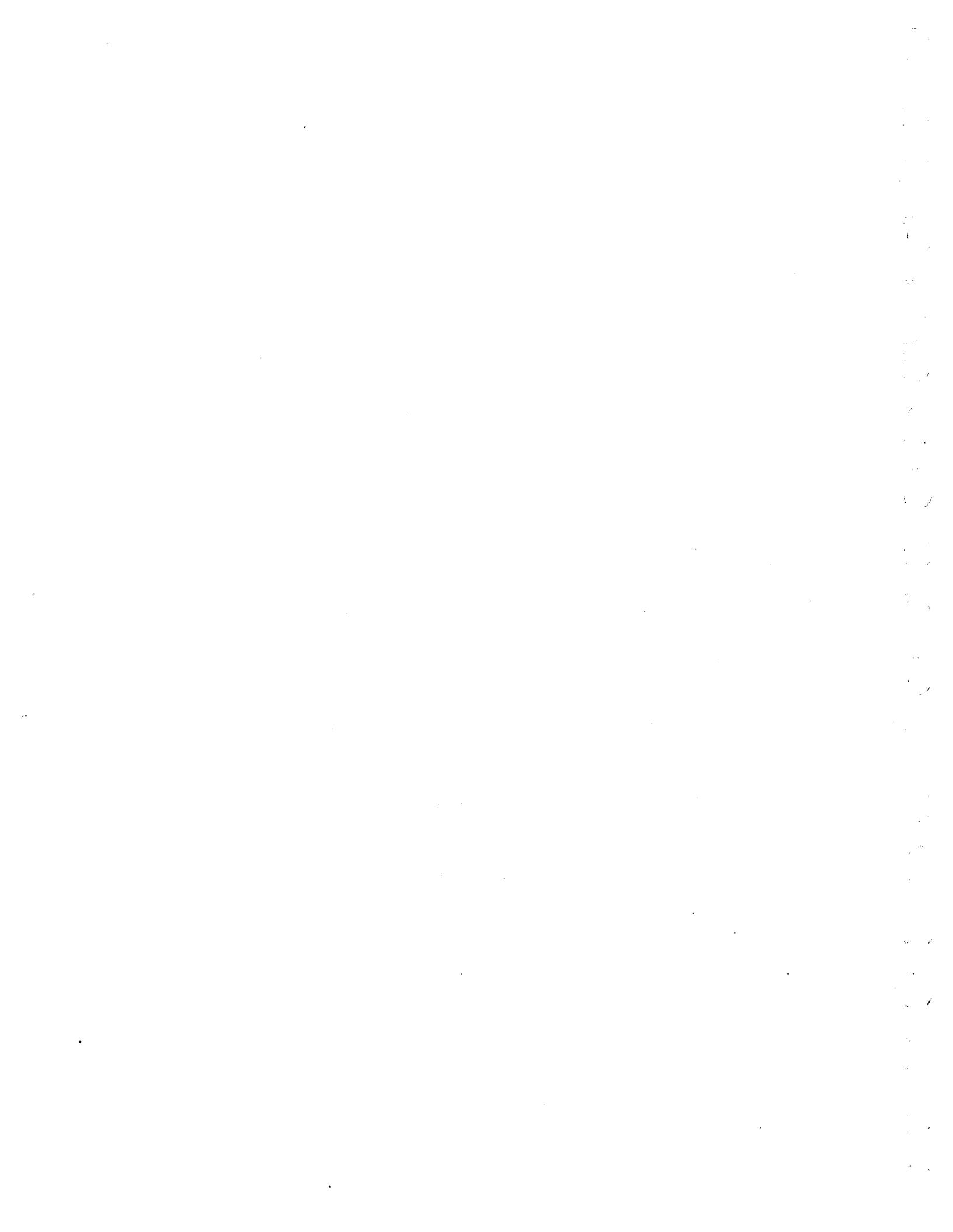

**SECTION 2:  
PHYSICAL HISTORY  
AND ANALYSIS**

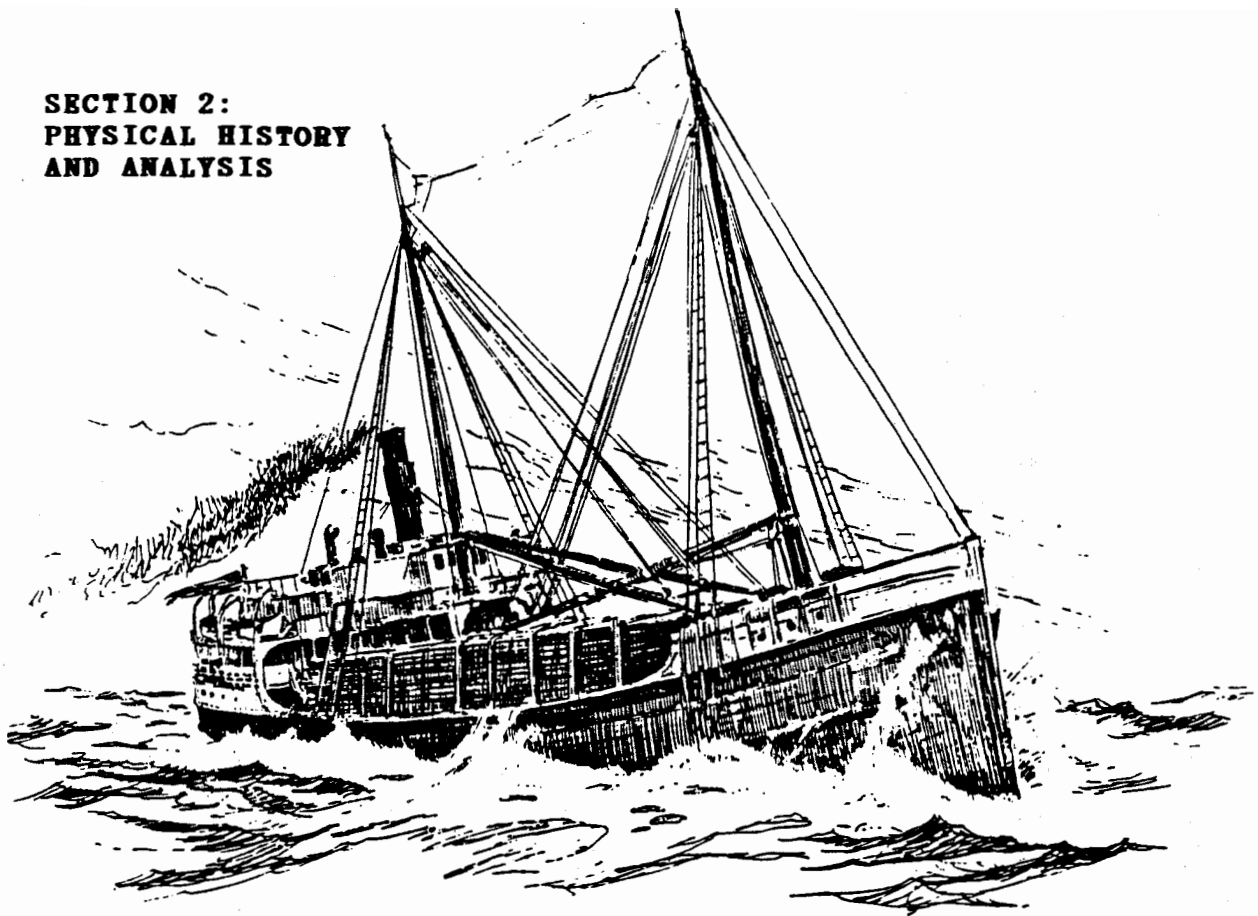

**I. HISTORICAL SIGNIFICANCE**

Fig. 1.  
--Lyle Galloway

**A. Statement of Significance**

The WAPAMA is an artifact of the highest historical significance, important on world-wide, national and local levels, and in multiple contexts of culture and technology.

On an international level she is a significant artifact of naval architecture as one of the largest surviving wooden ships in the world. The warships U.S.S. CONSTITUTION, U.S.S. CONSTELLATION, H.M.S. VICTORY, H.M.S. FOUDROYANT, JYLLAND (Denmark), and the steam ferry EUREKA, are the only larger wooden vessels remaining today.

On a national level the WAPAMA is significant as one of the last American coastwise passenger steamers. The coastwise and overnight services were once a vital part of America's transportation system. On the West Coast in particular, such vessels were the only effective passenger service from the 1880s through the 1930s.

On a regional level the WAPAMA is a significant artifact of the lumber industry which dominated the economic development of the Pacific Northwest. The cities of California were built with lumber brought primarily by schooner from the coastal regions north of San Francisco. The steam schooners greatly aided the rapid growth of coastal cities.

The WAPAMA is the last survivor of the approximately 235 steam schooners built. Among the last large wooden vessels ever constructed, these vessels were a distinct and unique American type, evolved to meet very specific local conditions, yet expressive of the development of wooden shipbuilding over millenia. They were built almost entirely of indigenous wood, and were anachronistic in the substitution of massive amounts of timber in place of the steel strap reinforcement which was commonly used in ocean going vessels of the period. This reflected the scarcity of steel on the West Coast at the time. Steam schooners were among the first vessels to be oil fired, again reflecting local conditions such as availability of fuel oil compared to coal, and the labor saving benefits of oil firing in a labor scarce market. All of these factors make her representative of distinct regional conditions.

On a local level the WAPAMA, partially built (machinery and joinerwork) in San Francisco and serving the city in the lumber and passenger trade, is highly significant in a number of aspects. She is an important artifact of local social history in that the steam schooner fleet was the path to citizenship for countless seamen from northern Europe who found lasting employment in these vessels. Indeed, this fleet was known on the West Coast as the "Scandinavian Navy". The practice, almost unique to steam schooners, of having the crew rather than shore labor work the cargo, along with the frequent and relatively short passages and extremely rapid turn-around, developed a fleet which was respected as harder working and higher paying than other seafaring trades. The seamen attracted to this trade became a prominent part of their era's waterfront.

Nor was the waterfront the only aspect of life in the region affected by the steam schooner; as the principal means of travel along the rugged Northwest Coast well into the 1930s, steam schooners were known to a broad population who had occasion to voyage in them, either as first class or steerage passengers. To the isolated coastal communities they served, steam schooners were a lifeline, the sole means of marketing their forest and agricultural products and of importing the rewards of their prosperity. The arrival of a steam schooner at such a town was as important an event as that of a Mississippi steamboat to Hannibal, Missouri.

WAPAMA's local significance is further enhanced by the prominence of her original builder/owner, Charles R. McCormick, whose lumber and coastal shipping businesses grew to include one of America's largest steamship lines.

For all of these reasons the WAPAMA merits preservation and offers rich opportunities for interpretation. As the merchant seaman becomes an ever scarcer and less distinct part of our national workforce, the seafaring life and all its artifacts will become a rarer facet of our cultural resources.



Fig. 2. WAPAMA immediately after launching. She will be loaded with lumber and towed to San Francisco for completion. A bare hull with only partly completed accommodations, the vessel will hold more lumber on her delivery trip than she will ever carry again, helping to offset the cost of her tow.

More than half of the work lies ahead. Tanks, bulkheads, engine and auxiliaries, shafting, propeller, rudder and steering gear, boilers and stack, piping, wiring gratings, deck machinery, masts, booms, rigging, deck houses, interior joiner-work, boats, davits and miscellaneous gear are still to be fitted.

A hull even as large as WAPAMA's could be built virtually on a riverband with simple machinery, and was more cheaply built near the lumber supply. The remainder of the ship, products of industry, were more available in a large port city. As this post-launch fitting-out typically amounted to about 75% of the cost of a vessel, WAPAMA may well be considered to have been built in San Francisco on a hull provided by the lumber yard she was to service.

--Photo, National Maritime Museum at San Francisco (NMMSF)

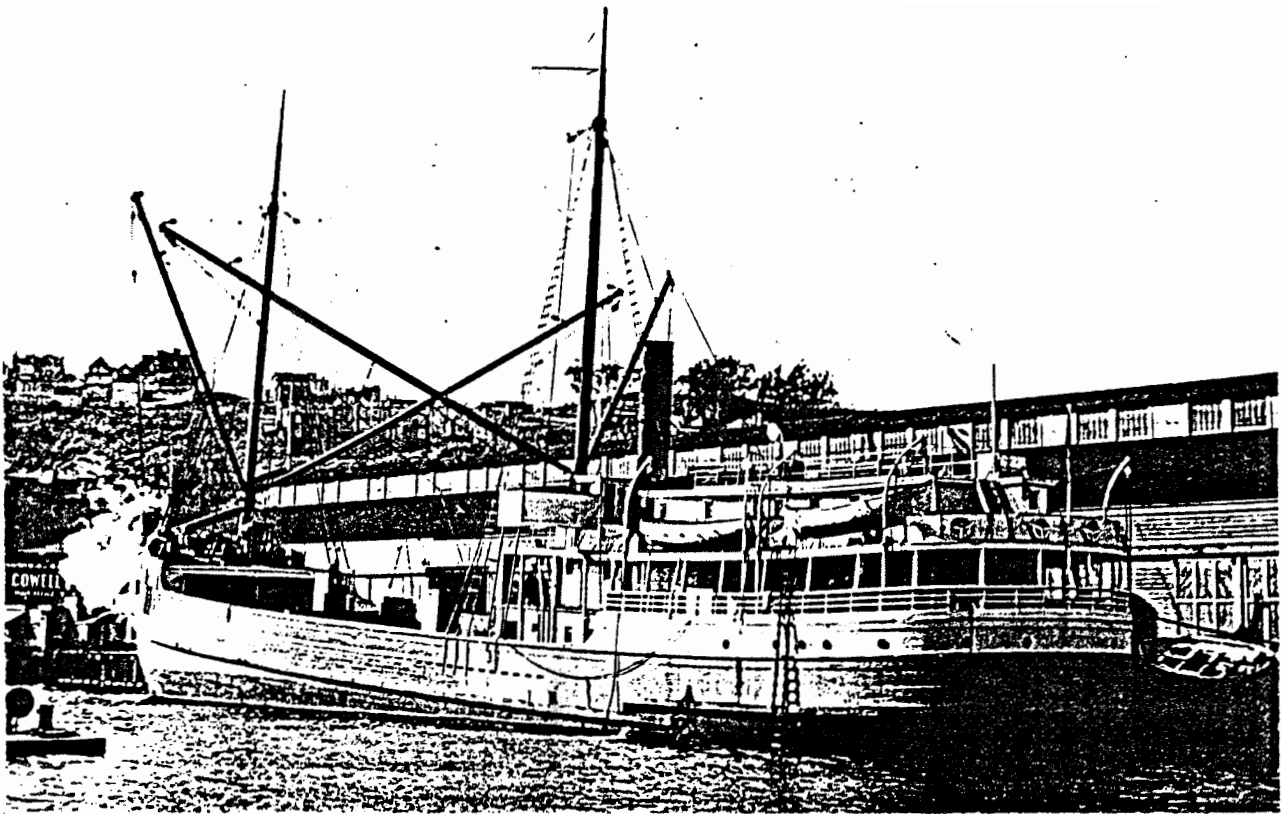
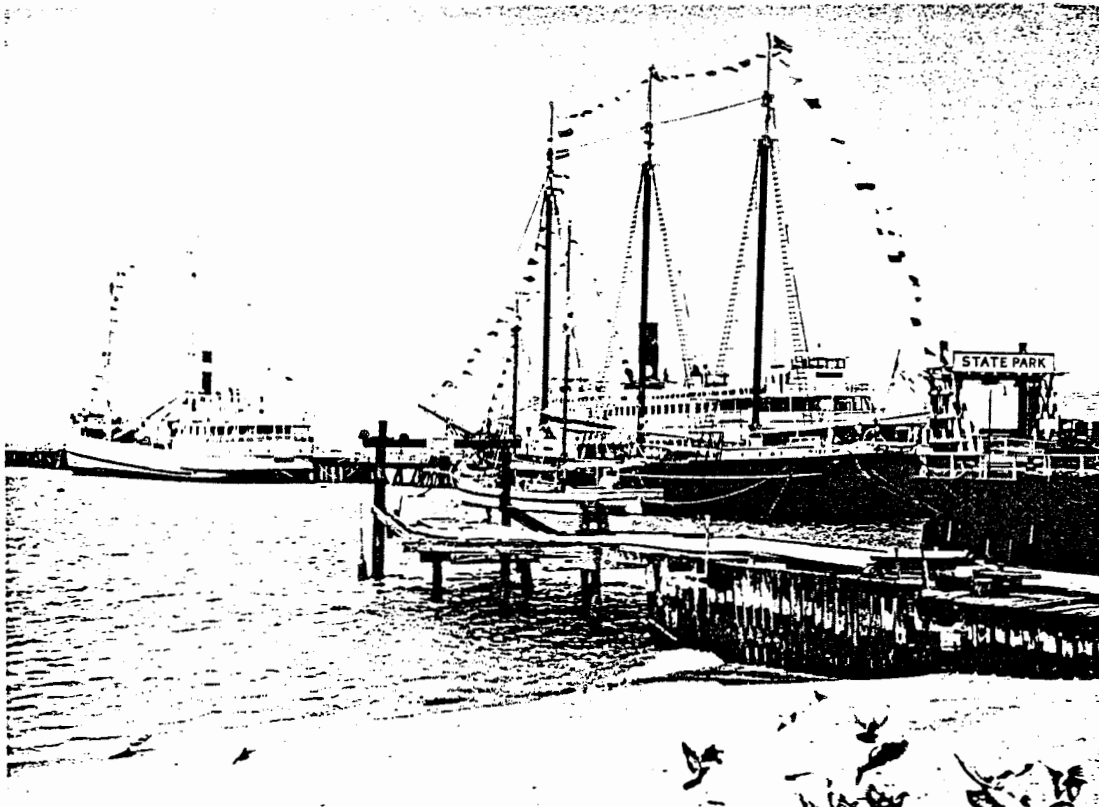

Fig. 3. WAPAMA at a San Francisco pier in 1931. Note steam from forward winches. --Photo by John W. Proctor. (NMMSF)

Fig. 4. WAPAMA on exhibit at Hyde Street Pier in 1963. Also seen are the other ships of the "State Historic Monument" fleet: the Ferry EUREKA, the Schooner C.A. THAYER, and the Scow Schooner ALMA. --Photo by Karl Kortum (NMMSF)



## B. Chronology

**Launched Jan. 20, 1915:** Built by St. Helens Shipbuilding Company, St. Helens, Oregon, for Charles R. McCormick Lumber Co. Required 8 months, and about \$150,000 to build.

**1915, February:** Arrived with full cargo at San Francisco, without engines, under tow of steam schooner MULTNOMAH. Triple expansion engine, 825 h.p., built and installed by Main Street Iron Works of San Francisco; Boilers built by Babcock & Wilcox.

**1915-1930:** In service of Charles R. McCormick Lumber Co., coastwise passenger and lumber trade, Portland-Astoria-San Francisco-San Pedro-San Diego. Called as far north as Vancouver, B.C., and as far south as Guaymas, Mexico.

**1930:** Sold to Los Angeles Steamship Co (the "White Flyer Line"), in passenger service to Southern California.

**1937:** Sold to Viking Steamship Co. for \$12,500. Overhauled at Bethlehem Shipyard for \$10,000 additional. In passenger service to Los Angeles. Laid up after two trips.

**1937:** Sold to Alaska Transportation Co. for \$30,000; Seattle-S.E. Alaska passenger and cargo service. Renamed TONGASS.

**1947:** Laid up in Lake Union after striking rock on last Alaskan trip, sustaining damage to forward section of hull.

**1949:** Sold for scrap, laid up in Seattle. Damage sustained by fire in engine room.

**1957:** "One used steam schooner" purchased by State of California Division of Beaches and Parks for \$16,000, under 1955 legislation establishing the San Francisco Maritime State Historic Monument, within the State Park System.

**1959:** Extensive restoration begins, including new spars and some rebuilding of decks and passenger accommodations.

**1963:** WAPAMA opened to the public at Hyde St. Pier, San Francisco.

**1977:** "State Historic Ships" transferred to U.S. Department of the Interior, Golden Gate National Recreation Area. Survey of WAPAMA identifies severe structural deterioration.

**1979:** Deterioration advancing, WAPAMA moved to AAA Shipyard, S.F.

**1980:** Can no longer remain afloat due to severe deterioration. Hauled out on Barge 214, berthed at Pacific Drydock Co., Alameda,

**1986, August:** Shifted on Barge 214 to the Bay Model site, U.S. Army Corps of Engineers, Sausalito, California.





## II. GENERAL PHYSICAL DESCRIPTION

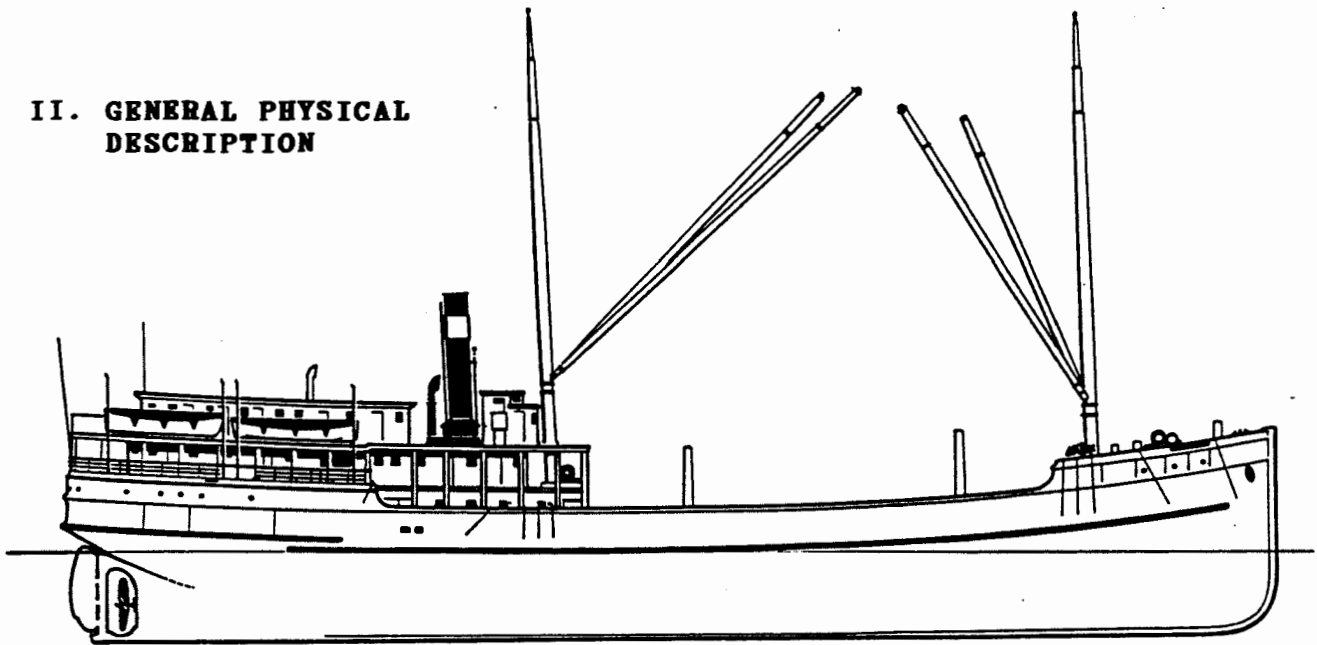

LBP (length between perpendiculars): 212.5'

LWL (length waterline): 212.5'

LOA (length overall): 216' 11"

Beam: moulded - 40' 4" extreme - 42' 4"

Depth (base line to top of deck on center line): 19'

Draft to present ABS plimsoll: 17'

Tonnage: gross - 945 net - 524

Displacement: light ship estimated at 1360 L.T.  
(exact displacement unknown without lines)

Cargo Capacity: 1,100,000 board feet, about 1600 long tons

Passenger Capacity: cabin (1st Class): 44 steerage: 12 - 22

Propulsion System: single screw, steam triple expansion, 800 IHP

Boilers: 2 oil fired water tube

### DESIGN and ARRANGEMENT

WAPAMA is a wooden steamship of typical steam schooner proportions. The hull is single decked and characterized by a plumb stem, full bows, straight keel, moderate deadrise and an easy turn of bilge. The run is moderately full and the counter meets the round stern at a knuckle line at main deck level. WAPAMA is very beamy for her depth. This feature was due to the draft restrictions of the small lumber ports she was built to service.

There is a forecastle head forward with a steam anchor windlass, two cargo winches, mooring bits, samson post, and a small capstan. The aft end of this deck overhangs the main deck. The forecastle is divided into port crew quarters and starboard steerage passenger quarters. The forepeak and steel collision bulkhead are under the forecastle. Aft the forecastle are lockers and heads in small enclosures, port and starboard.

The main deck is notable for very heavy waterways, bulwarks, and full-length longitudinal stringers enclosing the main hatch. A single large cargo hatch is located amidships. Aft of the cargo hatch and between the longitudinal stringers is a deck house containing cabins for the firemen, winchmen, and oilers. Aft of this is the upper flat of the engine room.

The poop bulkhead runs thwartship abaft the engine room house and has a doorway to the accommodation only on the port side. Although referred to as the poop bulkhead the deck above was more often referred to as the cabin deck rather than the poop deck in steam schooners. On the main deck aft of the poop bulkhead are the crew's mess to port, galley midships, and steward's stores and pantry to starboard. Aft of this is the passenger dining saloon which runs thwartship the width of the vessel, with fixed seating for thirty-three on swivel stools at three tables with additional seating at two settees. Aft of the saloon are small cabins for members of the stewards department.

A curved staircase, located on centerline at the forward end of the saloon, leads up to the social hall on the cabin deck. Running forward on the cabin, the house contains a smoking room, and four cabins for the three engineers, two wireless operators, and two mates. All cabins open onto the narrow side decks, port and starboard. At the forward end of the house are the two steam cargo winches which served the mainmast booms. Rising through the center of the house is the engine room fidley enclosing the funnel.

The cabin deck house aft of the social hall held two cabins accommodating three passengers each. There are two heads at the aft end of the house. The cabin deck is enclosed by a heavy wood taffrail on turned stanchions above a log rail. Turned stanchions support the boat deck above. Skylights which open into the saloon are located port and starboard against the house side. Access ladders to the boat deck are positioned thwartship, port and starboard of the house. Behind the house is the rudder head and quadrant under a grating, and a steam capstan to port of centerline.

The boatdeck extends to the sides of the vessel aft and narrows to small side decks forward of the poop bulkhead. The forward end of the deck forms a roof over the winch platform and has small hatches which allowed the winchmen to keep an eye on gear aloft.

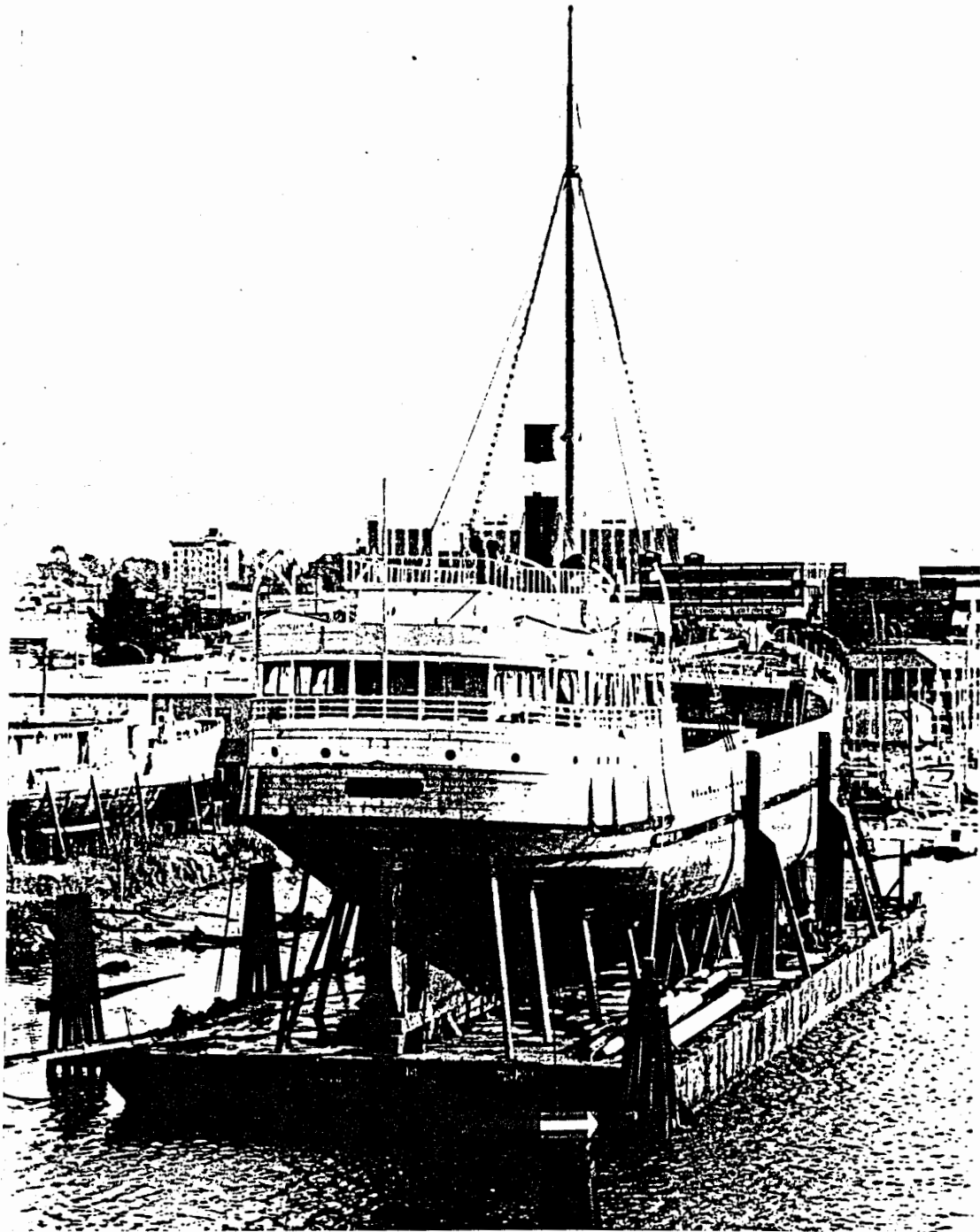

Fig. 5. WAPAMA on Barge 214, Alameda, December 1985.  
Photo, Tri-Coastal Marine, Inc. (TCM)

(General description, cont.)

The pilot house is on two levels, a lower forward one for the helmsman and an elevated chart room for use of the master or mate on watch. This upper level has doors opening onto narrow bridge wings. The bridge wings cantilevered out over the main deck and were hinged to swing up clear of the deck cargo below for loading and unloading.

Aft of the wheelhouse is the stack and steel stack casing, with cowl ventilators for the engine room. Aft of this is a house containing the captain's cabin and ten additional cabins which accommodated three passengers each. On the sides of the boat deck are chocks and radial davits for four lifeboats. Except in way of the boats, the deck is enclosed by iron pipe handrails and stanchions.

The roof of the boat deck house, enclosed by another level of handrail, was used as a sun deck by passengers. A ladder at the aft end of the boat deck house originally provided access to the house top, but is no longer in place.

The galley stack and a cowl ventilator come through this deck house. Formerly there were combination lifejacket boxes and seats, and a standard compass (now in Museum storage) mounted on top of the house. The deckhouse roofs, boat deck, and cabin deck are canvas covered.

Below the maindeck, the forepeak has one large breast hook and the steel collision bulkhead is sloped forward at the lower end to clear the second pointer. Aft of the collision bulkhead is a wooden chain locker, divided port and starboard. Aft of the chain locker is a framework supporting a thwartship cylindrical water tank which is not original equipment for the lumber trade but must have been installed during her days in the Alaskan trade. Aft of the tank is a 'tweendeck constructed of wood planking on composite steel angle and wood beams and secured to the ceiling by steel brackets. The 'tweendeck was a modification for passenger and general cargo service during her years as TONGASS. This deck formerly extended to the aft end of the the main hatch but, at some period, was cut back to the forward end of the main hatch.

Aft of the 'tweendeck the hold is open for its full depth. Along centerline the rider keelsons project well above the sister keelsons. Outboard of the flat tops of the sister keelsons the ceiling rises to turn into the sides where hanging knees connect the clamp to the deck beams. There is also a row of centerline wood stanchions. The steel engine room bulkhead, just aft of midships, has been largely scrapped. There were originally four riveted steel fuel oil tanks. The two tanks forward of the boilers have been removed and scrapped. The remaining two tanks are located outboard, to port and starboard of the boilers, and are built to fit the curve of the bilge.

The two oil fired water tube boilers are placed close together, near centerline, with furnaces facing aft. Aft of the boilers is a flat diamond plate grating area from which the boilers and main engine were operated. To starboard are the fuel oil transfer pumps and manifold, while to port is the bilge system manifold.

Next aft is the main engine, a steam triple expansion, 800 IHP. Aft of the engine is a thrust bearing and intermediate shaft coupling. Behind these is the steel after engine room bulkhead.

Aft of the starboard fuel oil tank are bins for spares. In the starboard aft corner of the engine room are two steam dynamos and the ship's electrical distribution panel on a platform about five feet above engine bed level.

Across the after bulkhead are lube oil tanks on center and to port, as well as a refrigeration compressor. On the port side of the engine room aft of the fuel oil tank are mounted the evaporator, feedwater pump, condensate pump, main circulating pump, and an electric fire and bilge pump installed after she became a museum ship.

On the starboard side, a steel ladder rises to an intermediate grating level for accessing the upper portions of the engine. A second run of ladder continues up to the main deck engine flat at the main deck level. The engine cylinder heads and steam chest occupy the forward center of the main deck engine flat. The original steam fire pump is located to port, and the present shore power distribution panel and disconnect are mounted on the starboard cabin bulkhead. Forward of the engine is a thwartship passage with doors out to the main deck. Forward of the passage, and slightly to port, is a donkey boiler which supplied steam for the dynamos and winch engines while WAPAMA was in port. Forward of the donkey boiler is the breeching of the main boilers which rises up to the funnel.

Aft of the engine room is the after peak, reached by manholes in the engine room bulkhead or small scuttles in the saloon. The after peak has the stuffing box for the shaft and two riveted steel water tanks, port and starboard, fit to the rise of the hull. The rudder trunk is located aft of the water tanks, and a large stern pointer crosses the deadwood beneath the tanks.

## CONSTRUCTION

WAPAMA is built almost entirely of Douglas fir. The stern post and rudder post are ironbark. Ironbark is also used for battens and guards in high chafe locations. Inboard joinery work in the social hall and other compartments is of oak. With these exceptions, the ship is structurally a product of the lumber industry she was built to serve.

Bottom planking is fastened by both trunnels and spikes. Most of the structure is fastened with clinched bolts. Douglas fir is much softer than oak or other hardwoods that were used in framing East Coast vessels. To compensate for the reduced holding power of fastenings in fir the number of fastenings is about 25% greater than for a hardwood framed vessel.

Another construction feature that reflects her regional origin is the lack of diagonal iron strapping placed between the frames and planking in order to improve longitudinal strength. This was standard practice in large wooden vessel construction by the time the WAPAMA was built, but was seldom used in steam schooners. As compensation, the size of her timbers was increased and the spacing of frames decreased. This construction method resulted as much from the greater expense of importing iron or steel to remote building sites in the Pacific Northwest as from the cheapness and abundance of timber in the area. Steam schooners had to be strongly built for their hard trade but were also cheaply built through maximum use of indigenous material.

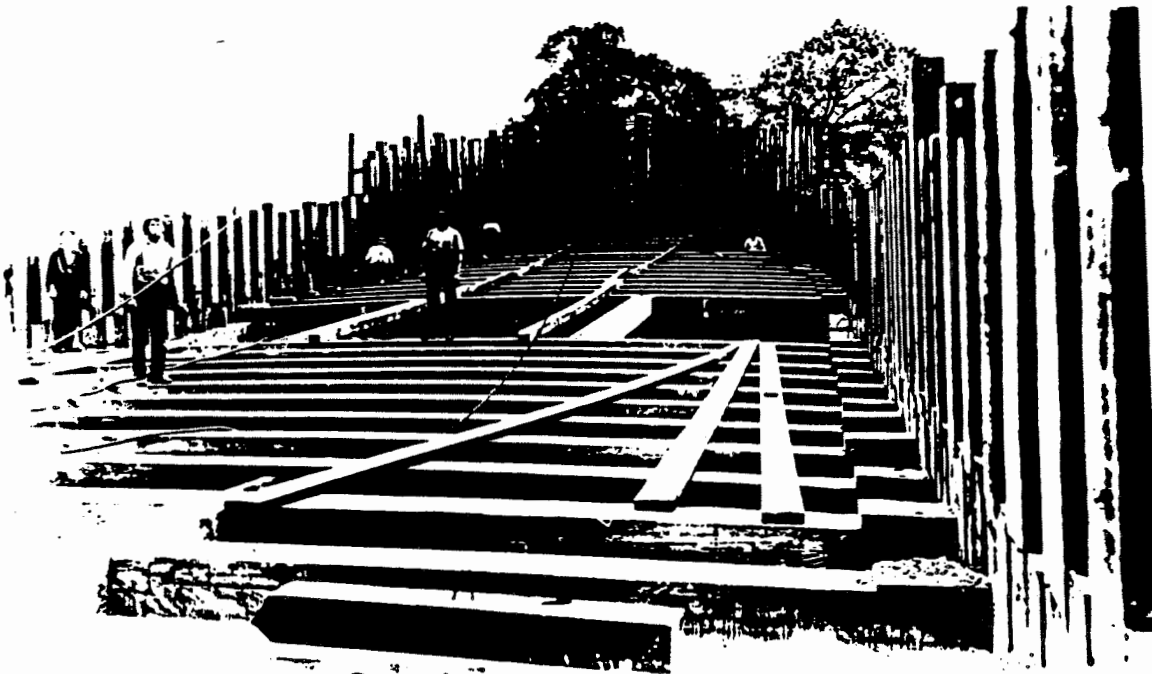

Fig. 6. Deck of an unidentified steam schooner under construction at St. Helens Shipbuilding Co. --Photo, NMMSF

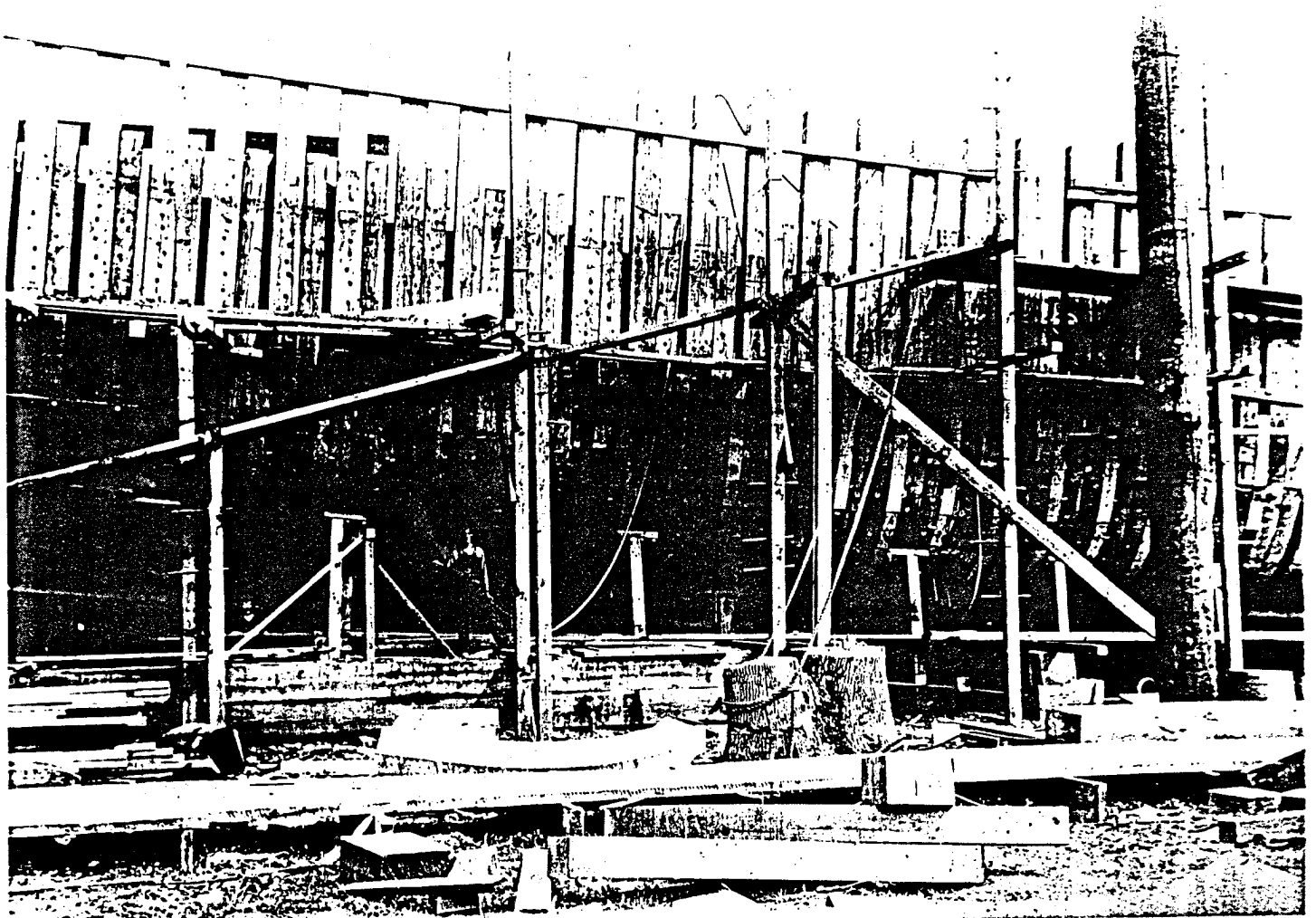

Fig. 7. An unidentified steam schooner under construction at St. Helens Shipbuilding Co.

Note the size of the timbers in relation to the men seen at left of center. Filler frames can be seen between the main framing. These were used in lieu of the diagonal steel strapping which was more common in large wooden ship construction in areas where steel was more cheaply available. When the exterior planking goes on, the midship area will be an almost solid mass of timber. This massive construction is now a liability as water leaking past the covering boards becomes trapped in the framing and promotes rot.

Note also the long overlaps of frame members and the multiplicity of heavy fastenings. Many are at right angles to the ones shown. Many of the features which built strength into the ship now add to the difficulty of rebuilding.

The photo suggests how much removal would be necessary to renew any one timber in this type of structure.

--Photo, NMMSF



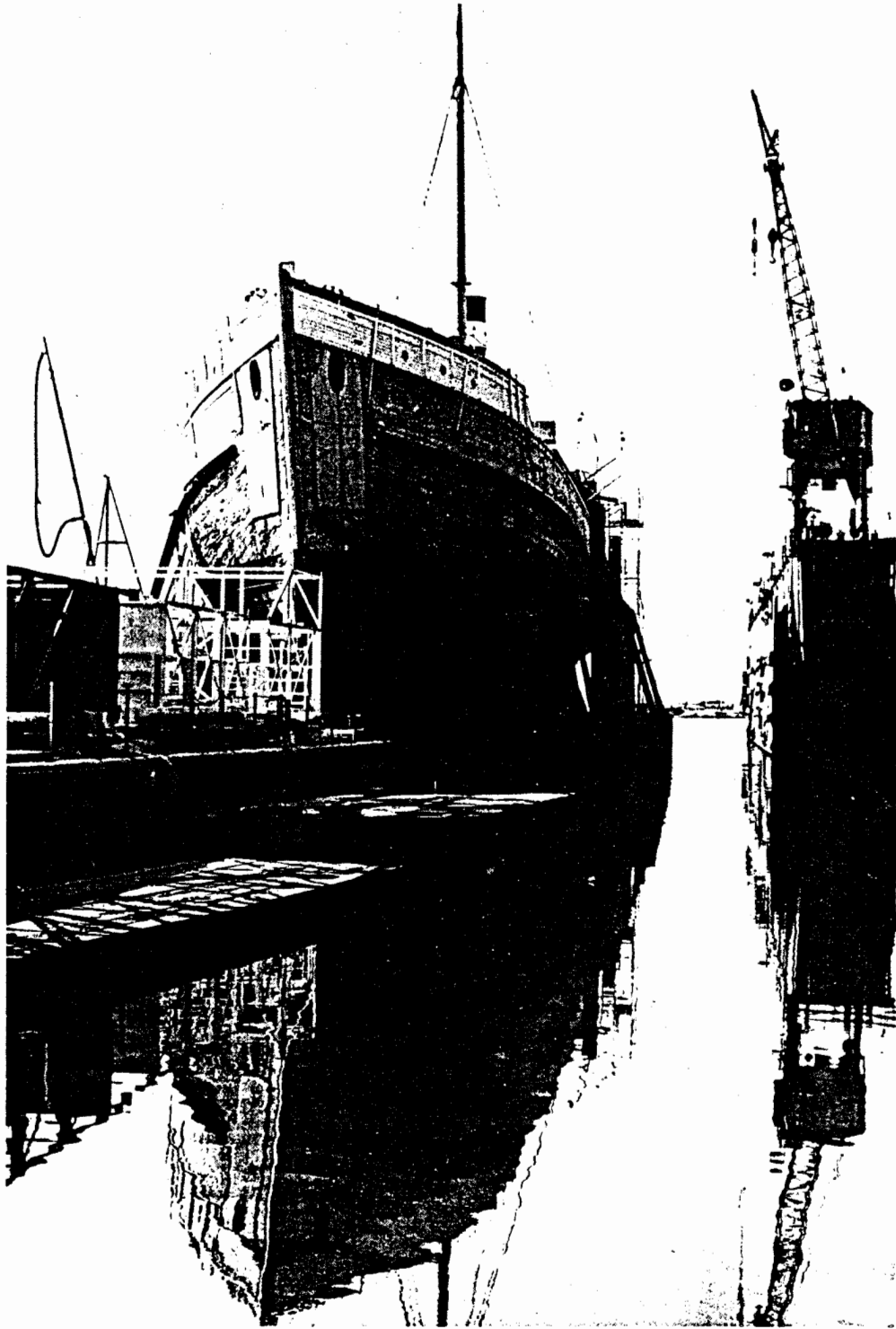

Fig. 8. WAPAMA on Barge 214 at Pacific Drydock, Alameda, California, December, 1985. --Photo TCM

**III. Description of Existing Condition:  
Steam Schooner WAPAMA on Barge 214**

**A. Summary of Existing Condition**

The WAPAMA is presently in a state of advanced deterioration and attendant dilapidation for which there is no easy or quick cure. Rampant fungal decay is by far the the most significant cause of this deterioration. Severe structural weakening of the steam schooner necessitated her removal from the water in 1980. In the absence of ongoing maintenance, fungal decay has gone virtually unchecked since that time. At present, decay fungi permeate more than 80 percent of the Douglas fir structure. Recent efforts have resulted in some progress in slowing deterioration of the ship's structure, primarily through addition of supports and weather covers. Preserving the remaining historic fabric will require a much greater effort. The observed physical condition of WAPAMA leads to the following conclusions:

**1. WAPAMA should not be refloated without a complete rebuild.**

Due to extensive deterioration, a partial rebuild would not be durable or cost-effective. A proper rebuild would essentially involve the building of a replica hull and salvaging the original machinery and portions of the superstructures. This can only be accomplished at great expense.

**2. WAPAMA is effectively "married" to Barge 214.**

Moving the structurally weakened WAPAMA off the barge, either by skidding her off or temporarily refloating her, can only be accomplished at considerable effort and some level of risk.

**3. WAPAMA is not presently suitable for public access.**

Difficulties with access, and dangers due to weakened and collapsing structure prevent the public from viewing much of WAPAMA's interior spaces. In addition, visible deterioration will make a positive interpretation effort difficult.

**4. A comprehensive program will be needed for long term preservation and interpretation of WAPAMA.**

Essential elements of this program are: rot treatment, weather protection, structure support system, and partial renewal of severely deteriorated structure.

**B. Survey Background and Procedures**

**1. Previous Surveys and Studies**

The general physical condition of the WAPAMA has been assessed and monitored at periodic intervals since the acquisition of the vessel by the State Maritime Historical

Park in 1957. The reports and surveys produced since that time are varied in their focus, yet they provide a valuable chronological record of the extent and rate of deterioration of the physical fabric.

The condition of the WAPAMA, with the exception of inaccessible areas, was assessed during the initial restoration period, 1959 to 1960. This information was detailed in a report to the State of California in 1960. In addition, the report concluded that much deteriorated structure would have to remain. "The salient fact in the restoration of the WAPAMA is that there is not enough money available to do an entirely complete job" (S.F. Maritime Museum, 1960). This fact has largely guided the fate of the WAPAMA during her last 26 years as a museum ship.

By the late 1970s, surveys and reports had determined that the WAPAMA was neither seaworthy nor able to remain afloat at her berth. Following a 1978 survey of the vessel, surveyor Richard J. Lally concluded "The vessel [WAPAMA] at present, is in danger of basically breaking in half unless some means can be found to protect her from the surge and anchor gear pressures presently acting on her" (Lally, 1978). A year later, naval architect Zachary Reynolds stated "The vessel as it floats is in danger of becoming a complete loss" (Reynolds, 1979).

In 1980, WAPAMA was drydocked on Barge 214, initially for the purpose of repairs. The reports and surveys produced since that time have not been directed at preservation, but rather at a partial rebuilding for the purpose of refloating the vessel. In the course of these investigations, the continuing physical decline of WAPAMA was noted. In a survey performed two years after the drydocking of WAPAMA on Barge 214, Mr. Reynolds "detected a continued deterioration of the vessel's main timbers and further relaxation of her structure" (Reynolds, 1982). More recently, a report by Maynard Bray found WAPAMA's rate of deterioration "alarming" (Bray, 1983).

## **2. Focus of Existing Condition Survey**

The present survey of WAPAMA, conducted by Tri-Coastal Marine in 1985, considered the ship more as a shore based structure than a floating vessel. Factors affecting a vessel afloat (watertight integrity, hull bending moment, trim and ballast) are of little relevance to a dry berthed WAPAMA. Instead, the survey and report focused on the following:

- a. Ability of WAPAMA's structure to resist distortion and collapse as she sits on Barge 214.
- b. Retention and long term preservation of historic fabric.
- c. Public safety onboard the vessel.
- d. Visitor access for interpretation.

### 3. Survey Methodology

Inspection of the steam schooner WAPAMA was carried out by surveyors Capt. Giffy Full and Don Birkholz, Jr., between November 21 and 28, 1985. All accessible structure and surfaces were inspected. Methods of inspection included:

- visual examination
- sounding and probing of surfaces
- wood sample boring (1/2" x 14" auger)
- wood sample coring (5.5 millimeter increment borer)

With the exception of corings and borings, only non-destructive methods were used. The vessel inspection took place during several days of heavy rain, thus allowing observance of leaks and drainage problems.

### 4. Organization of Report

The existing condition report is organized around the physical subdivisions or compartments of the vessel. The major structural components are covered as elements in the subdivisions, rather than having their own headings. A brief description is given for each subdivision, and "key diagrams" are included to assist in cross referencing with the drawings. An itemized and detailed list of structural condition has been compiled in the supplement "Existing Condition Survey Data". This information has also been placed on a data base (dbase III - PC) to facilitate usage for future preservation efforts.

### 5. List of Terms

|                |  |
|----------------|--|
| rot, rotten    | denotes fungal decay of wood or other natural fibers such as rope and canvas |
| incipient rot  | initial decay fungus infestation, precedes degradation of wood structure     |
| deterioration  | loss of fabric or form due to decay, abrasion, corrosion, etc.               |
| disintegration | total loss of fabric due to decay or corrosion                               |
| nail sickness  | the degradation of wood in contact with corroding iron or iron oxides.       |

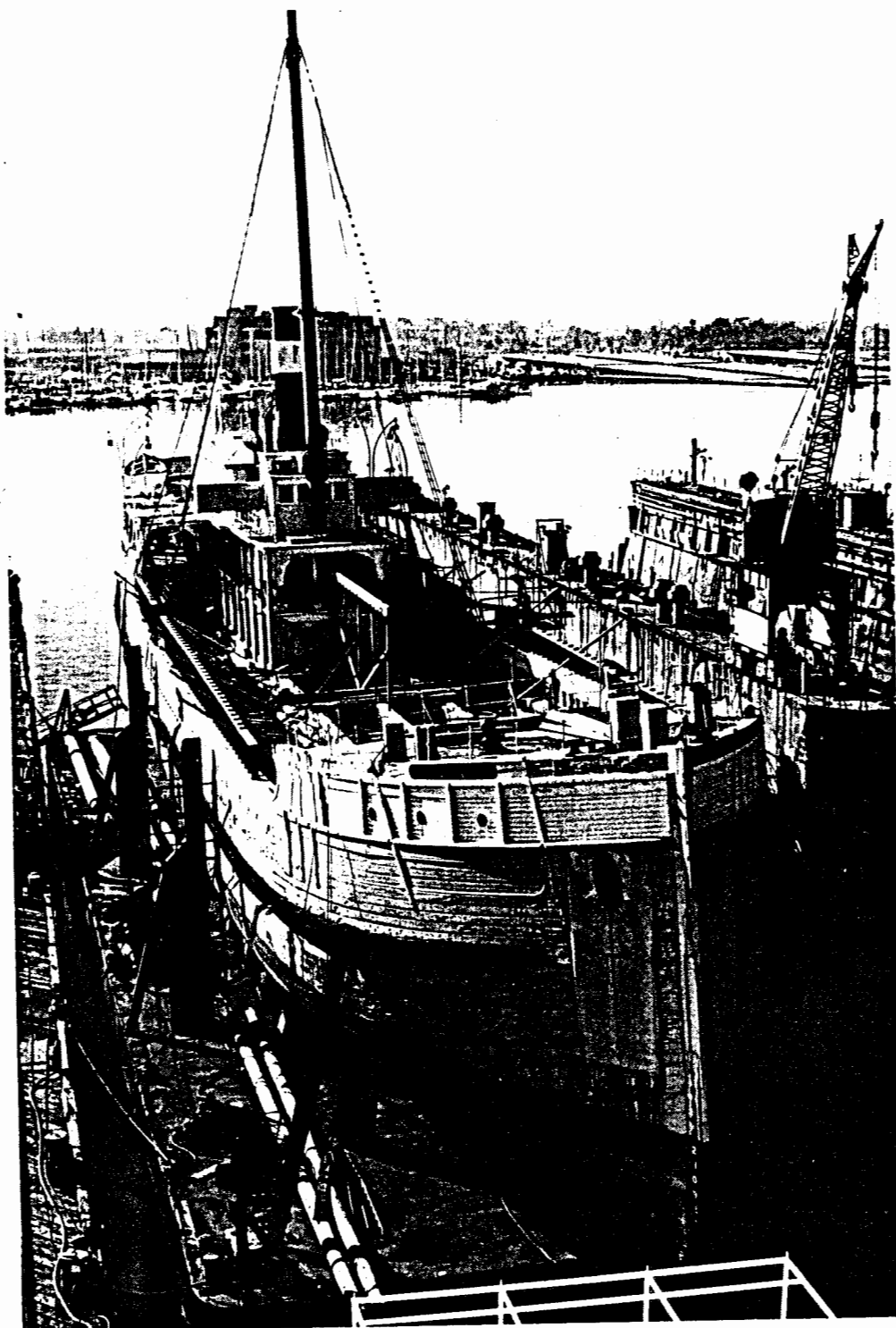

Fig. 9. WAPAMA at Pacific Drydock, December, 1885. Weather cover over main deck in process of installation.

-- Photo, TCM

**C. EXISTING CONDITION SURVEY**

**1. FORECASTLE HEAD**

See Sheets 3, 9, and 11

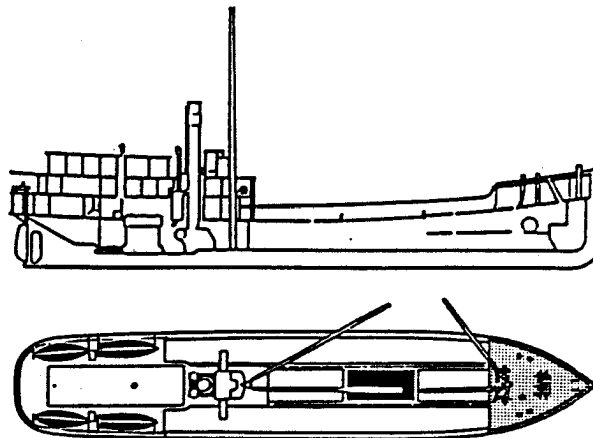

**Description**

The forecastle head deck is the raised weather deck over the forecastle, consisting of a 4" x 4" planked deck supported by deck beams which are 12" to 13" square. A low, solid wood bulwark runs the length of the deck, port and starboard. Deck gear originally mounted here included the windlass, two cargo winches for the foremast, a manual capstan (later addition), two pairs of large wood bitts, and a wood samson post. The foremast was stepped through this deck. Access ladders, which were museum ship additions, are mounted at the aft end of the deck, port and starboard.

**Condition**

This deck is severely deteriorated and is presently unsafe for access. The foremast, windlass and cargo winches have been removed to relieve the load on the deck and forebody (see Machinery section for condition of gear). Deck planking is generally rotten and is collapsing in several locations, particularly in way of the windlass and winch foundations. Plank seams are open and leaking throughout. Although a weather cover has been placed over the deck, driving rain still reaches much of the surface. Most of the deck beams are in poor condition with beams #1 thru #5 (counting from forward) rotten almost to the point of collapse. Temporary shores have been placed under the deck in way of these beams. The clamp supporting the deck beams is showing advanced rot in various locations on the port side. The starboard clamp has a rotten area at beam #4, and sounds hollow throughout. The starboard bulwark and covering board, as well as the transverse covering board and molding pieces at the aft end of the deck, are severely rotten and disintegrating. The port bulwark and covering board are in better condition, though advanced rot is seen throughout. The pipe stanchions and chain handrails are adrift and unsafe due to rot in the bulwarks. The two access ladders are in good condition, though in need of maintenance.

(Forecastle Head cont.)

### Conclusions

In order to achieve even the modest goal of public access, the forecastle head deck would have to be rebuilt, including replacement of deck beams, clamps, planking, bulwarks and covering boards. Remounting of the mast and deck gear would require additional work to further support the forebody. Alternately, this deck could be preserved as is by extending weather protection and treating existing rot, though public access would have to be limited.

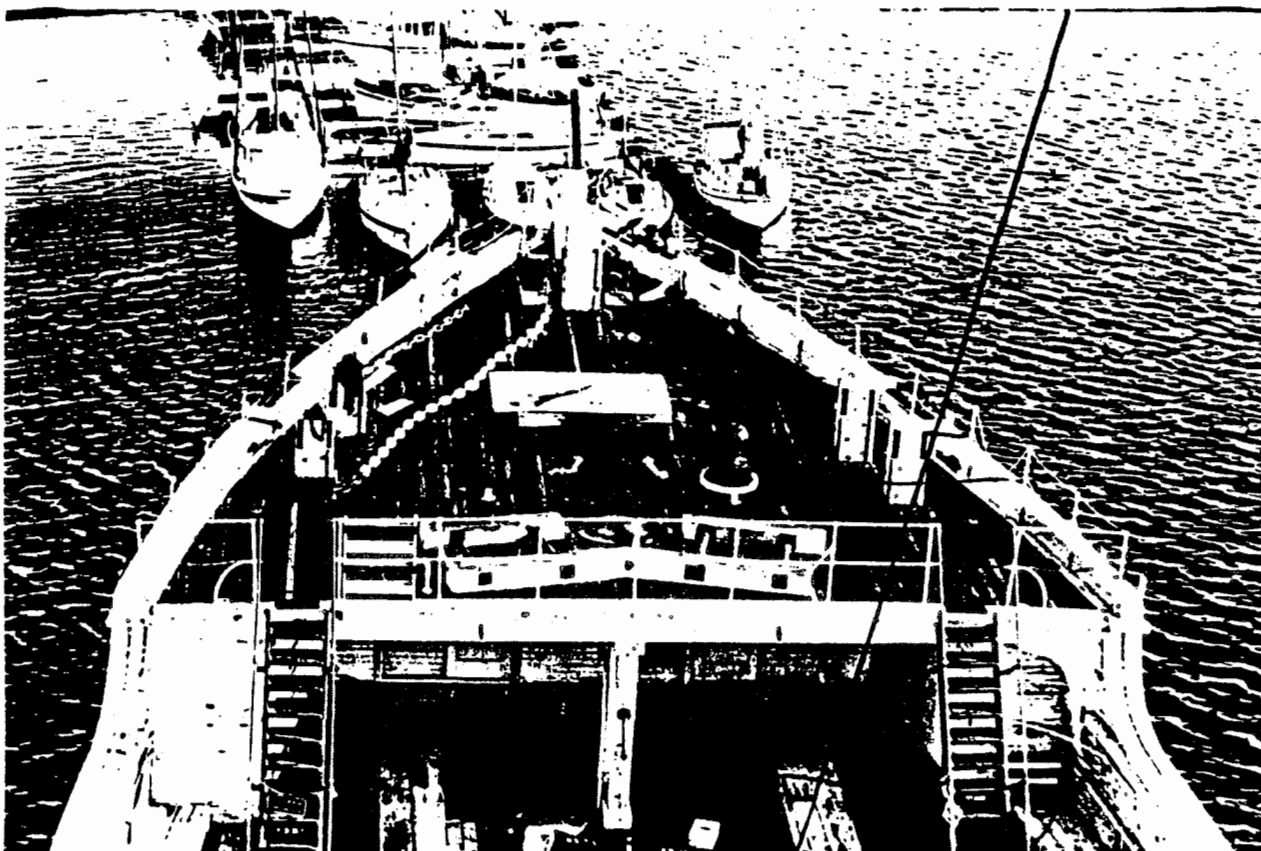
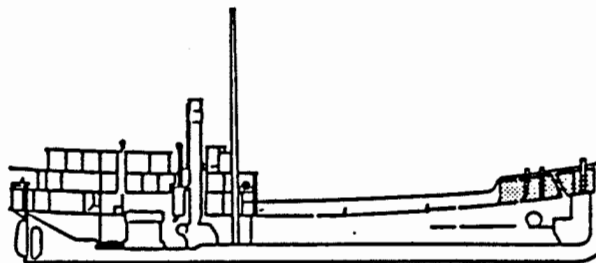

Fig. 10. View of forecastle head deck. Sliding doors to forecastle are visible under overhanging after end of deck. Note winch foundations at after end of deck. This deck is now covered by a roof structure. --Photo, TCM

## 2. FORECASTLE

See Sheets 4 and 6



### Description

The forecastle is the sheltered portion of the main deck between frame 1 (aft side of stem) and the forecastle bulkhead at frame 11. The forecastle originally provided accommodations for 8 deckhands on the port side and steerage passengers on the starboard side. Six berths are mounted along the hull on each side of the forecastle, which is divided by a lightly constructed, longitudinal centerline bulkhead. Lockers are mounted against this centerline bulkhead. Access is through sliding doors in the forecastle bulkhead, port and starboard.

### Condition

The forecastle remains surprisingly free of deterioration, despite leakage through the deteriorated forecastle head deck above. Deck plank ends are generally rotten along and under the aft bulkhead on the starboard side. The waterway timber (a continuation of the main deck waterway) sounds hollow on the starboard side, from the bulkhead to five feet forward. Aside from these areas, the deck planking, deck beams, and waterways appear in good condition. The stem is rotten internally, from the forecastle head to the forecastle deck. The 2" thick ceiling appears in fair condition. The framing could not be viewed (obscured by ceiling). Although borings taken in several frames show good wood, some deterioration is suspected due to open seams in topside planking. The two pairs of large wood bits projecting through the forecastle head deck, port and starboard, are rotten variously, particularly the forward bitt of each pair. The bulkheads, bunks and lockers are in good condition, but are dirty and in need of paint.

### Conclusions

The forecastle is presently suitable for public access, though the temporary support timbers for the forecastle head are distracting and make access somewhat inconvenient. This situation would be remedied by a rebuilding of the overhead (see section on Forecastle Head). The areas of rot noted do not present a safety hazard at this time, and could be treated with the appropriate wood preservatives. Treatment of the forecastle framing would require removal of some of the ceiling. A thorough cleaning and repainting of the forecastle is recommended. The condition of the 110 volt lighting circuitry is not known, but it is presently operable. An inspection of the electrical system and correction of any deficiencies is advised.



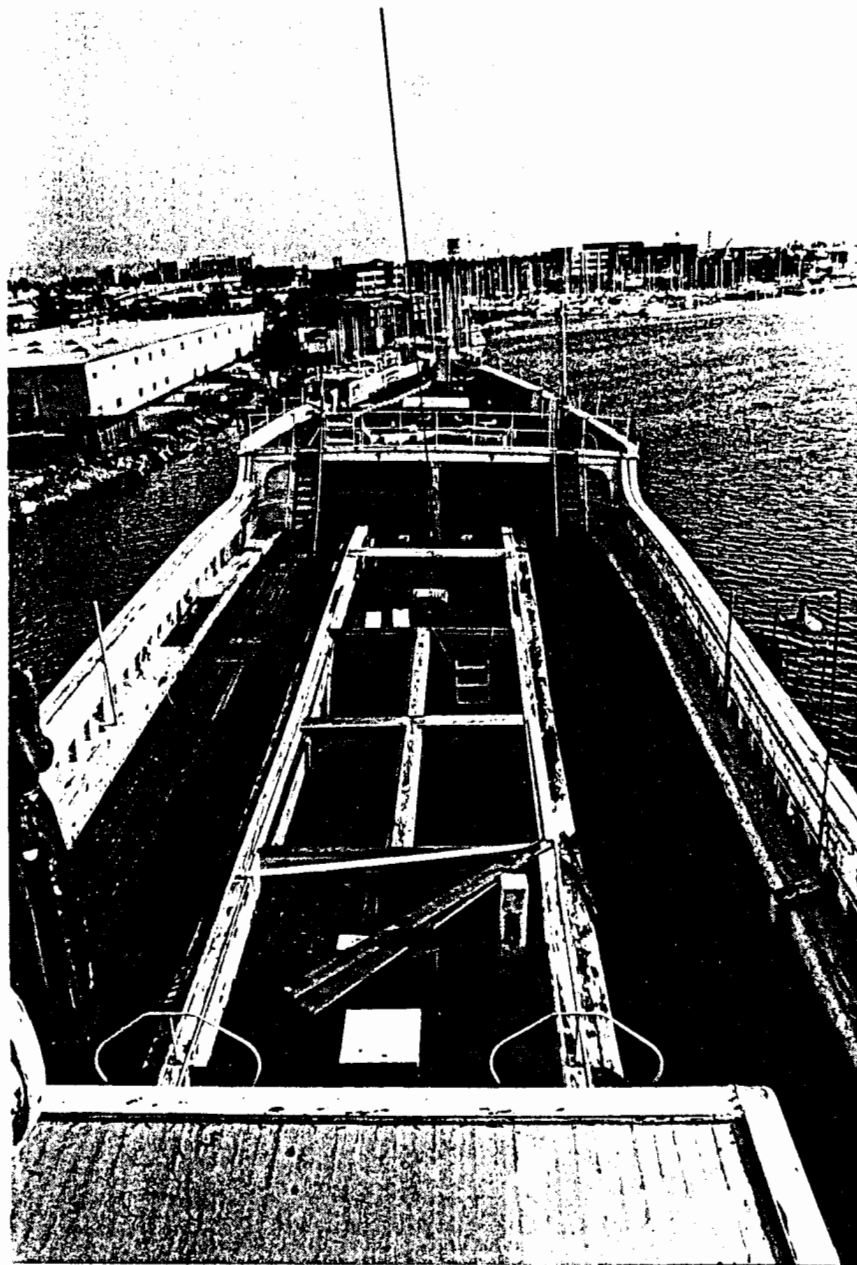
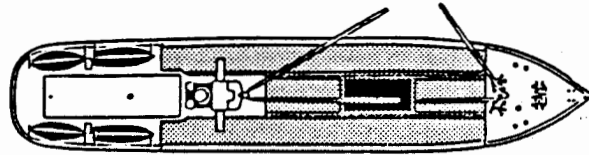

Fig. 11. View of main deck from top of wheel house. This deck is presently covered by roof structure. --Photo, TCM

### 3. MAIN DECK

See Sheets 4, 6, and 10



#### Description

As a structure, the main deck runs from stem to stern. This report section covers only the exposed area of main deck between the forecastle bulkhead at frame 11 and the poop bulkhead abaft frame 69. This portion of the deck was designed to support deck cargo and is heavily constructed. Construction is 4" x 4" planking laid on single piece deck beams supported by hanging knees, clamps and centerline hold stanchions. A heavy 3-piece timber deck girder and 2-piece waterway run full length, port and starboard. The main hatch is situated between frames 26 and 37, and is surrounded by a solid timber coaming. Two samson posts were formerly stepped through the deck, fore and aft of the hatch. Now, only their partner timbers remain.

#### Condition

The overall condition of the main weather deck is poor. All major timbers in this area show some degree of rot. The 4" x 4" deck planking, much of which was renewed in the early 1960s, is rotten variously, with only limited areas still sound. The seams are generally open, with pitch gone or cracked. Many bungs are loose or missing, and approximately 40% of the iron spike fastenings are wasted at the heads.

Some areas of decking are deteriorated almost to the limit of safety for foot traffic. Most deck beams show rot, with those in way of the hatch being severely rotten and weakened (see sections "Cargo Hold" and "Engine Room" for condition of deck beams). The deck shows severe sagging from frame 22 to 40. This condition is due to the weakened beams and failure of the longitudinal deck girder which is the primary support member for the deck in way of the hatch. Shoring has been placed under the hatch carlings, port and starboard, though advanced rot in the hatch beams leaves this area of the deck less than secure. The condition of the deck girder timbers ranges from soft to severely rotten, port and starboard, from the forecastle bulkhead to the poop bulkhead, with some portions disintegrating and losing form. This condition presents a serious problem in way of the house, from frame 50 to 69, where the girders act as a sill for the house. The waterways are generally severely rotten from the aft end of the deck lockers at frame 15, to the poop bulkhead, with sections showing severe disintegration. Two sections of the waterways are in better condition, though soft: port side, frame 62 to 67, and starboard side, frame 24 to 44.

The hatch coaming is generally rotten all around. The side members of the coaming are formed by the deck girders, which

are in poor condition in way of the hatch. The transverse hatch coaming members show severe rot in the lower timbers in way of the deck plank ends, while the upper timbers are moderately rotten. The iron bark sheathing on the inboard face of the coaming appears in good condition, though one piece is missing. The removable hatch beams are in generally good condition with exception of a rot pocket in the aft longitudinal beam. Many of the hatch boards are rotten. All hatch boards have been removed to the 'tween deck.

### **Conclusions**

The main deck is presently only marginally safe for foot traffic. Shoring should be added to insure against failure of rotten deck beams, and areas of severely rotten decking should be covered with plywood to guard against collapse of planking. In addition to safety problems, the severe disintegration of deck girders, waterways, and bulwark stanchions will make weather-proofing and proper interpretation difficult. Many areas would have to be reconstructed with filler materials in order to retain original fabric with any degree of form.

An alternative preservation method would be renewal of all major members of the deck, as well as the deck planking. This would necessitate replacement of approximately 20 deck beams, as well as waterway timbers, deck girders and possibly some frame futtocks. The relative advantages of this alternative are discussed in section VI.D.6, Structural Renewals.



Fig. 12. View of main deck, port side, showing deck stringer and side stringer, area of severe rot localized around fastenings. Note former deck opening at samson post partners, upper right of photo. Beginning of main deck roof structure seen alongside side stringer. --Photo, TCM

#### 4. BULWARKS

See Sheets 6 and 10

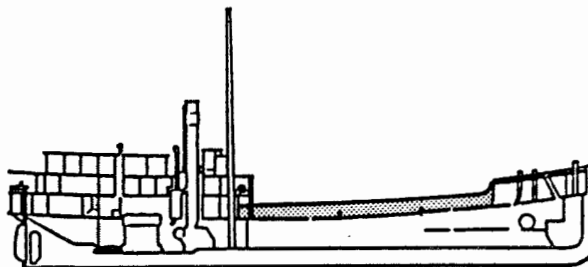

#### Description

The main bulwarks are heavily constructed, being formed by 9" x 14" futtocks (continuation of frames) on 30" centers, with a single outwale, 2-piece inwale, a cap timber and outboard planking. A wood chafe plate, with 2 semi-oval iron chafing straps, is fitted on top of the bulwark cap. Large iron ring bolts for securing deck loads are fitted on alternate stanchions.

#### Condition

The bulwarks are rough and weathered due to years of hard service. Almost all stanchion timbers show some rot. Approximately 50 % of the stanchions are severely rotten and many have been patched with cement (circa 1961). The covering boards between stanchions have leaked, allowing rain water to get in and rot the stanchions at and below the main deck level. Many of the adjacent frame heads show rot as well. The bulwark inwales are rough from years of service but are in generally fair condition. Small rot pockets are seen throughout, and larger areas of advanced rot were found on the starboard side, frames 14 to 19 and 27 to 39, and on the port side at frame 14. Although the bulwark cap was partially renewed in 1960, most of it has gone soft, probably due to rainwater being trapped under the chafing plate on top. Severely rotten areas are seen on the port side at frames 41, 51 and 55, and on the starboard side, frames 23 to 25 and 30 to 39. The bulwark planking is soft throughout, but few areas of severe rot were seen.

#### Conclusions

The bulwarks retain adequate strength to stay in place and are not a safety concern at this time. Extensive deterioration seen in the bulwark stanchions present a problem for interpretation. As in the early 1960s, these rotten timbers could be patched with cement or similar filler material, though this would be a stopgap measure and would do nothing to arrest ongoing rot. Any major rebuilding of the main deck should include renewal of at least some of the deteriorated stanchions. A rebuild of the bulwarks would necessitate loss of most of the weathered original fabric, such as the inwales, which are illustrative of the hard working life of the vessel.

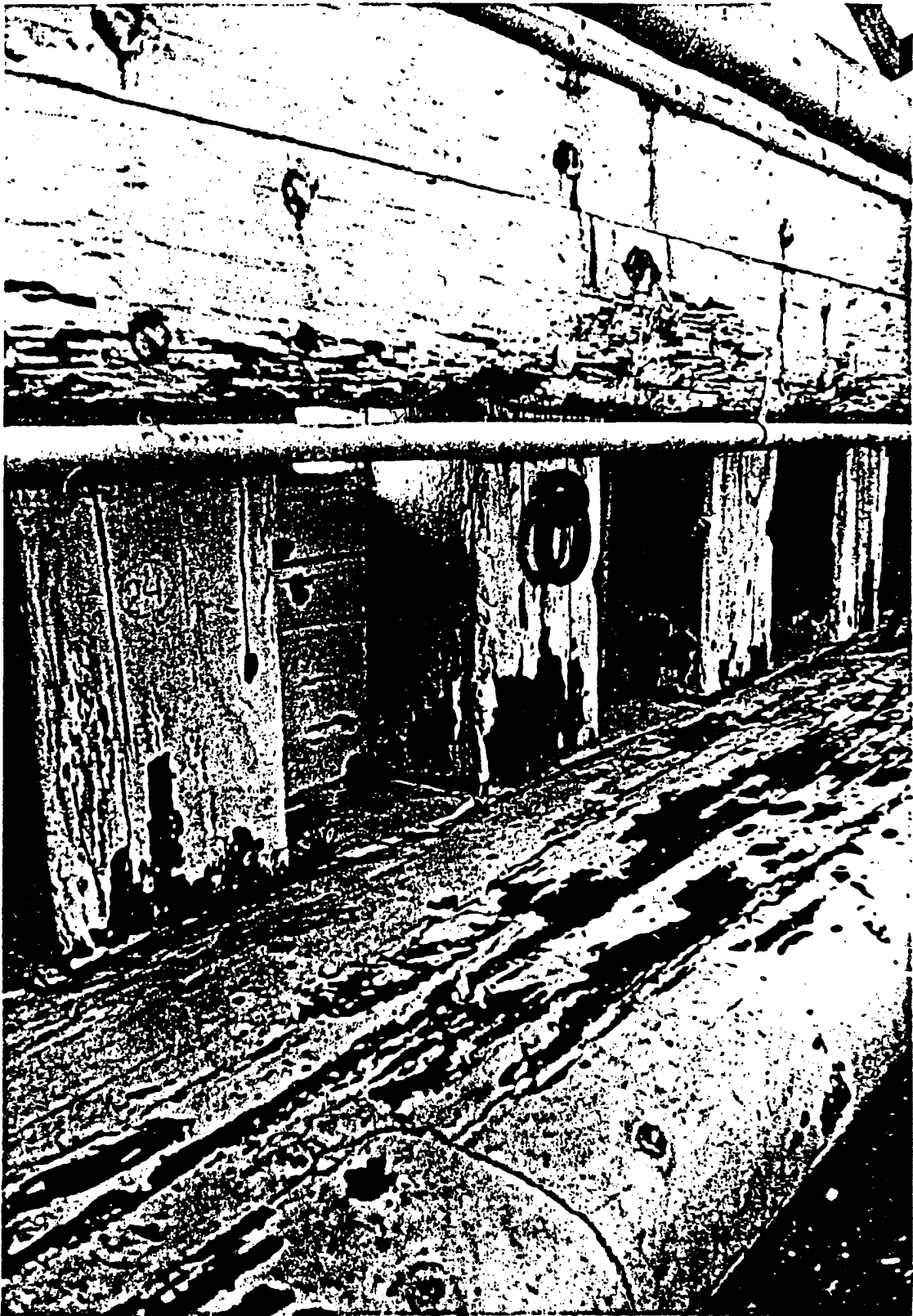
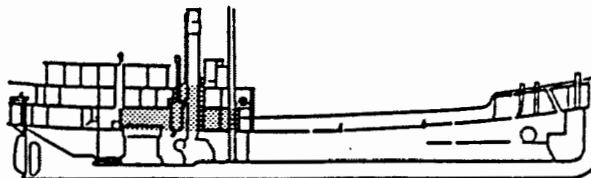

Fig. 13. Deteriorated bulwark stanchions. Most severe rot is seen at the waterway timber, where moisture remains trapped.  
--Photo, TCM

5. **MAIN DECK HOUSE: ENGINE FLAT, FIDLEY, ACCOMMODATIONS**

See Sheets 4, 6, and 11.



**Description**

The engine flat, fidley and crew accommodations comprise the area enclosed by the main deck house, extending from frame 50 aft to the poop bulkhead. The engine flat encloses the upper works of the engine, as well as associated machinery and a donkey boiler which provided steam for the cargo winches. The present electrical shore power distribution and disconnect boxes are located in this compartment. The fidley, forward of the engine flat, between frames 55 and 60, acts as a duct for the stack and ventilators. The forward end of the house is divided into three small compartments which were accommodations for the watchman, winch drivers and oilers.

The main deck house sits on top of the main deck girders and is sheathed inside and out with tongue and groove paneling. Four pairs of large posts, 15-1/2" square, extend up from the lower engine room to support the house and cabin deck above.

**Condition**

The main deck engine flat and fidley, formerly weather-tight compartments, show significant damage due to rainwater seepage which has entered primarily through the wasted steel fidley trunk on the boat deck, and leaking decking of the catwalks on the cabin deck above. This condition is worst in way of the fidley, where the weight of the collapsing stack has sagged cabin deck beams and decking, thus preventing proper runoff of rainwater. Cabin deck beams in way of the stack are severely rotten and the lower stack, boiler breeching and tops of boilers are severely corroded, largely due to seepage.

Scattered areas of rot are seen in the house structure. The most significant rot is seen in the sill timbers which are a continuation of the main deck girders. The sills have been repaired with "dutchmen" in previous restoration efforts. Rot in the sills has progressed considerably, but no settling of the house is seen. The large support post at the port forward end of the house is rotten at the main deck level. This member is structurally important as it supports the weight of the cargo winches on the cabin deck. The interior and exterior tongue and groove sheathing is generally intact with only localized rot, mostly just above the sills.

The firemen's, winchmen's, and watchman's accommodations are in good condition.

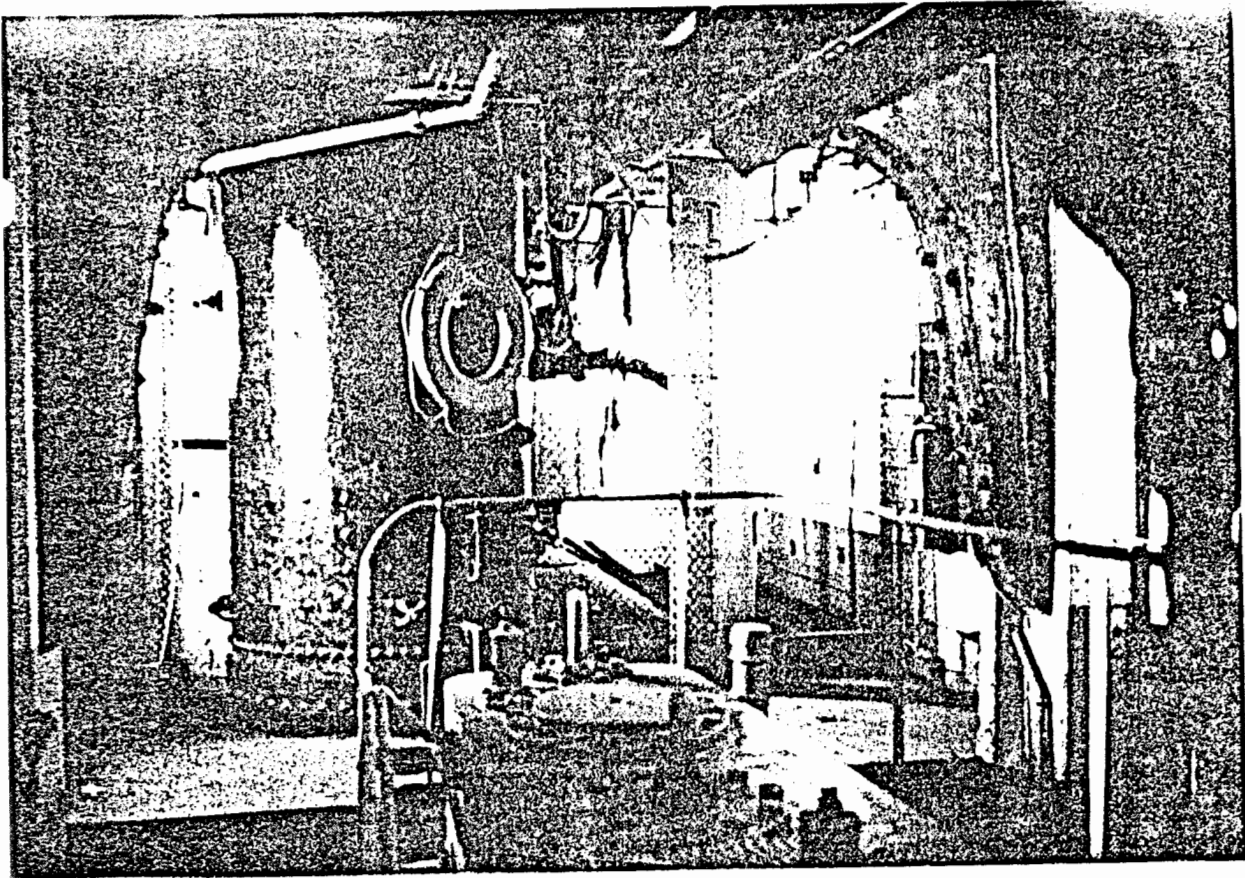

Fig. 14. Main deck engine flat, looking forward. Steam chest is in center foreground, donkey boiler past it to the left. Ventilators port and stbd, and stbd side of boiler breeching visible beyond. Note heavy knees port and stbd.

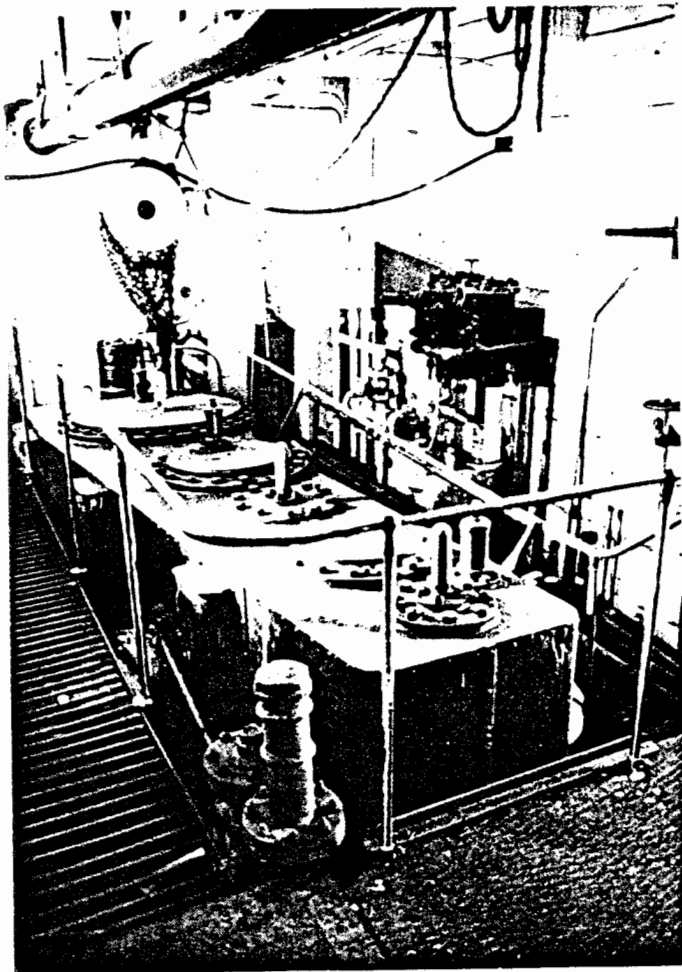

Fig. 15. Main deck engine flat, looking aft. Top of engine, steam chest, is enclosed by pipe rail.

Photos, TCM



### Conclusions

Overall, the main deck house is in marginal condition. This structure is not presently in danger of collapse, but additional support or repairs will be necessary if ongoing deterioration is not abated. Of primary concern here is the collapsing stack and boiler breeching. Though the stack can be temporarily supported by adding steel brackets, a permanent solution will involve removal and rebuilding of the stack, and renewal of wood structure in the fidley. The recently installed covers have partially alleviated rainwater seepage, though additional covers are needed over the steel fidley trunk and boat deck. Removal and replacement of rotten tongue and groove sheathing will help make the house weather-tight again, and will allow inspection of timber studs in the sides of the house.



Fig. 16. Dining saloon, looking aft and to stbd. Note fixed seating, radiator under thwartships table. Curtained doorway in aft bulkhead leads to former passenger cabin and steward's accommodation. --Photo, TCM

## 6. AFT COMPARTMENTS: SALOON, MESS, GALLEY, PANTRY, LAZARETTE

See Sheets 4 and 6

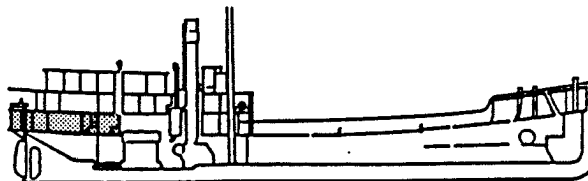

### Description

The aft accommodations are defined as the sheltered portion of the main deck, aft of the poop bulkhead and below the cabin deck. This area includes Galley, Dining Saloon, Pantry, Crew's Mess, and six compartments in the stern, which were originally for passengers and steward's department. All of the compartments, with the exception of those in the stern, were restored for public display in the early 1960s and are complete with major appointments, including galley stove, sink and water pump, cabinets, saloon and mess tables and seating. The Dining Saloon shows the highest level of refinement seen in WAPAMA, with raised paneling throughout and upholstered benches. The compartments in the stern (lazarette) appear to have been overlooked by previous restorations, and remain undeveloped for display. Access to the aft accommodations is through a sliding door in the port poop bulkhead, and via staircase from the Social Hall on the cabin deck.

### Condition

The aft accommodations are largely intact, though as in many other areas of WAPAMA, these compartments are suffering from rainwater incursion. The major cause is the poor condition of the cabin deck above, as noted in the section "Cabin Deck". Rainwater may also be entering through the topside planking.

Localized rot was found in several major structural members, including waterway timbers, deck beams, stringers and decking. Much of the rot seen in these larger members may be old, owing to the fact that little rebuilding was done here during the restoration efforts of the 1960s.

### Crew's Mess

The waterway timbers show local rot spots on the port side, at the poop bulkhead, along the Crew's Mess. An adjacent deck plank is also rotten at the aft bulkhead of the mess. Cabin deck beams #1, 2, 3 and 4 (counting back from the poop bulkhead) are moderately rotten at the outboard ends. The cabin deck clamp is also rotten in way of these beams. The overhead sheathing is rotten over the outboard three feet at beams #1, 2 and 3. The cabin deck longitudinal stringer, between the Crew's Mess and the Galley, is rotten locally at beams #2 and 4.

## **Dining Saloon**

The cabin deck beams in this compartment are sheathed and their condition cannot be determined without destructive testing. These beams are suspected of being rotten at the port outboard ends, as were those in the Crew's Mess. The port and starboard waterway timbers, under the saloon benches, have scattered rot pockets, and standing water was seen on both. The interior paneling along the port and starboard sides shows signs of water damage and incipient rot. The paneling inside the port and starboard skylights is rotten at the aft corners. Overall, the interior paneling is in fair condition. The dining tables, stools, benches and main deck planking are in good condition.

## **Galley, Pantry, Reefer**

A considerable amount of standing water was seen on the port forward side of the galley sole. This condition is common during the rainy season as seepage occurs throughout the galley. The cabin deck beam at the poop bulkhead shows rot in an area over the galley sink. All of the galley equipment is intact.

The reefer box is in poor condition, with sheathing torn away and rotted variously. There are signs of fire damage on the forward outboard side of the reefer. Here, the cabin deck beam at the poop bulkhead has been improperly repaired using a short, butted timber.

The cabin deck clamp is rotten in way of the reefer box and pantry. In the pantry, the inwale behind the sink, and overhead sheathing are rotten. Standing water was seen on the waterway timber here, though no rot was found.

## **Lazarette**

The compartments of the lazarette are in relative disarray compared with those forward. The deterioration here is mostly in the overhead cabin deck structure. The cabin deck clamp is rotten at the port and starboard quarters. The cabin deck beams in the port side compartment (Cabin #4) overhead show rot at the port outboard ends. In the port aft compartment, a longitudinal deck member and an area of deck planking and overhead sheathing have localized rot. The ends of ceiling strakes, which project up through the main deck at the stern, sound hollow and have nail sickness around fastenings. The stern shows evidence of sagging. This is indicated by the rudder trunk which has been sprung aft, apparently by movement of the stern section.

There is some asbestos insulation on piping in the lazarette area. This should be removed or sealed before allowing public access in these compartments. Crew and volunteers should consider using respirators while working in this compartment.

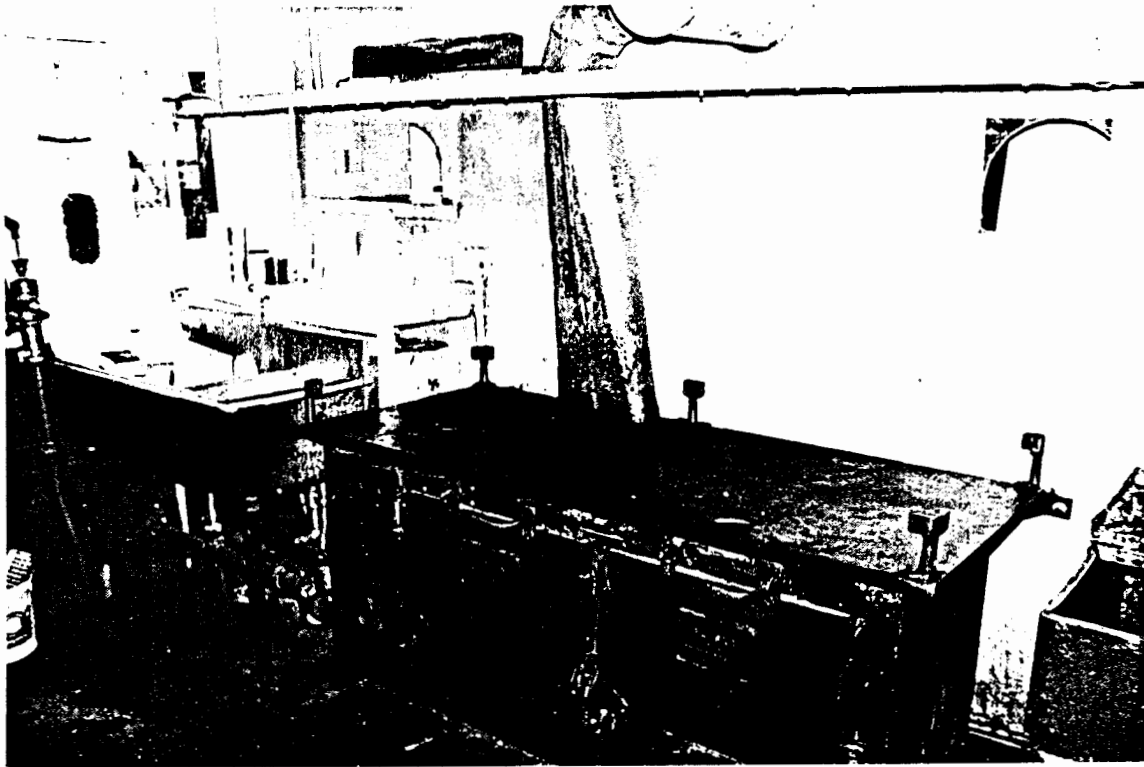
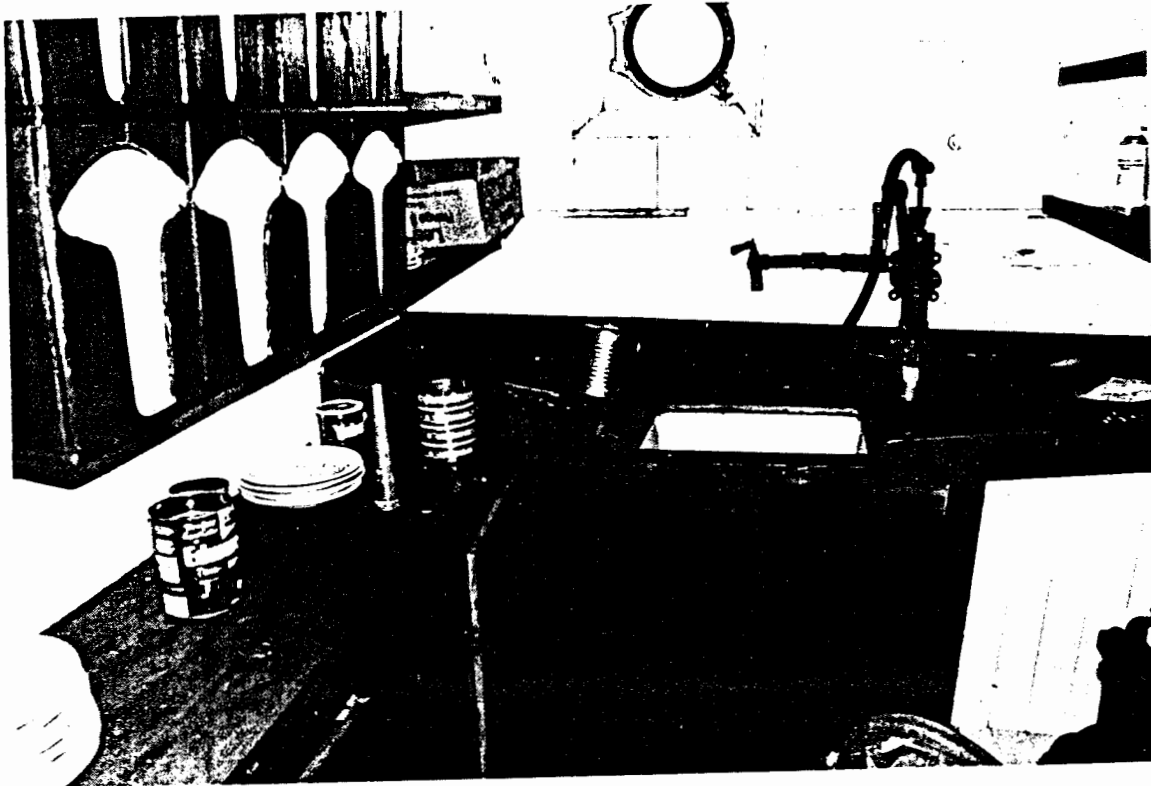

Fig. 17. Galley looking fwd. Stove pipe pierces steel blkhd into engine room fwd.

Fig. 18. Pantry, looking to stbd.

--Photos, TCM



(Aft compartments, cont.)

### **Conclusions**

As one of the most attractive, original and intact areas of WAPAMA, the aft accommodations should be considered a high priority for preservation. With the exception of asbestos insulation in the lazarette, this area is safe for public access.

The major concern in the aft accommodations is the extensive seepage and resultant ongoing rot. Little structural restoration work has been done in this area in the past because of the high cost of removing and replacing paneling in order to renew structural members. Stopping seepage and preventing further damage is therefore considered very important. The most expedient solution would be to install weather covers over the exposed cabin deck above. Ideally, the covers would extend down to protect the leaking topside planking as well. The more aesthetic solution, repairing or rebuilding the deteriorated decks and topside to restore their weather-tightness, would constitute a major restoration effort in itself.

## 7. FOREPEAK

See Sheets 4 and 5

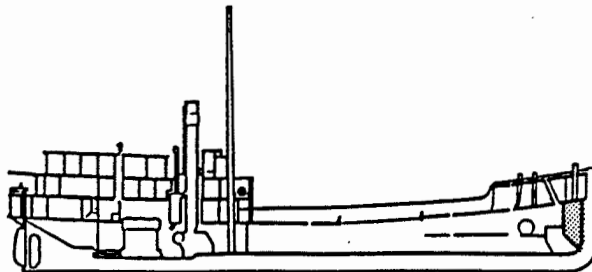

### Description

The forepeak is the small compartment in the bow of the ship, below the main deck and forward of the collision bulkhead at frame 5. It is accessed through a hatch in the port forecastle deck. There is a flat (or platform) built into the upper forepeak, which was likely used for ship's stores. The stem, bow ceiling, bow deadwood, and pointers can be seen in this compartment.

### Condition

Most of the interior structure of the forepeak remains in good condition due to the weather protection provided by the two decks above. All major members appear to be original and most are intact. No rot was seen in the two pointers or the deadwood. Though the inboard face of the ceiling appears sound, borings show the outer 50% of the ceiling, as well as the framing, to be rotten. This deterioration is probably the result of fresh water seepage through open topside seams, or under the bulwark timbers on the forecastle head. Borings show the stem to be in similar condition, with all but the aft face showing severe rot. The keel in way of the forepeak overhangs the barge deck and is presently unsupported. The visible signs of sagging of the forebody are likely the result of this condition.

### Conclusions

The forepeak is not easily accessible to the public and is therefore not considered a safety problem. Preservation of this compartment should include treatment with the appropriate wood preservative. The exterior rot can be slowed or abated by addition of weather protection over the bow topsides.

8. **HOLD**

See Sheets 4, 5, and 10

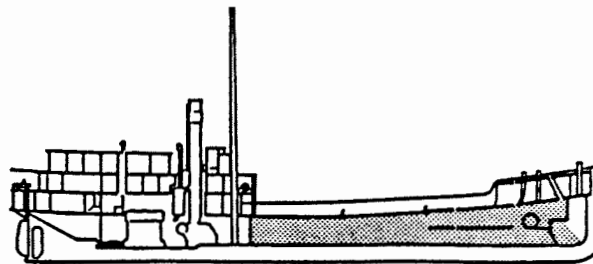

**Description**

The cargo hold extends from the collision bulkhead at frame 5 to the engine room bulkhead at frame 49. The hold is a single open space, though a 'tween deck has been added. This deck extends from frame 11 to the forward end of the hatch at frame 26. It is a plank deck on composite steel and wood beams. The forward end of the hold is occupied by the chainlocker and a large riveted iron water tank supported on a platform. The hold is now empty except for some gear which has been stowed on the 'tween deck. Access to the hold is by ladder through the main hatch and through a breach in the previously watertight engine room bulkhead. The main structural members of the midbody: the ceiling, clamps, keelsons, deck beams, pillars and knees are viewed in this area.

**Condition**

The main hull structure is seen to be in generally poor condition in the hold area, particularly in way of the main hatch. This condition is due primarily to continued rainwater saturation. Exposure to rainwater likely occurred over the years in way of the hatch, and more recently, throughout the area beneath the exposed main deck due to open seams and rotting deck planking. Ceiling strakes between the assistant keelsons and the lower ends of the hanging knees (13 strakes per side) are generally rotten with severe nail sickness around approximately 80% of the iron fastenings. The upper two ceiling strakes and the three clamps are in better condition, port and starboard, yet rot was seen behind the hanging knees in many locations.

An area of severe deterioration and disintegration of ceiling is seen at frame 36, below the aft end of the hatch. This condition is likely due to dripping of condensation saturated with iron oxide from the rusting channel iron reinforcing the deck beam above. The keelsons and assistant keelsons, which form the main backbone of the ship, are rotten variously in the hold area. Borings revealed rot in both keelsons and assistants in the area of frames 11 to 12. The top two keelson timbers are severely rotten in way of the hatch, and "dutchmen" have been fitted as a partial repair. A break is seen in the top keelson timber at frame 37, probably the result of deterioration combined with severe hogging strains when afloat.



Fig. 19. Hold, looking to port.

- |                                |                           |
|--------------------------------|---------------------------|
| a. Hanging knees at deck beams | b. Hold pillars           |
| c. 10" ceiling, port side      | d. Top of rider keelson   |
| e. Main keelson, 20"x37"       | f. 1st. assistant keelson |
| g. 2nd. ass't keelson.         | h. 3rd. ass't keelson     |
| i. 10" ceiling, stbd.          | --Photo, TCM              |

All deck beams supporting the weather deck show at least some rot as a result of leaking decking. Rot is generally found at the point where the deck beams contact the deck girders and waterway timbers. The beams in way of the hatch are in the worst condition, with two full beams and ten half-beams severely weakened and needing support. The major hatch structure is also in poor condition, with carlings and lodging knees severely rotten, port and starboard. An additional seven deck beams in the mid-body are weakened due to rot and will need repair or shoring.

The forty-eight hanging knees, which tie the deck beams into the hull in the hold, are in fair condition, though many sound hollow at the corners. These are large, grown fir "crooks" or roots and are generally denser wood, which may account for the relative absence of severe rot. Small rot



(Hold, cont.)

pockets were seen in several knees, and the knee at frame 26 on the port side, is in poor condition due to rot. All other knees retain adequate strength to remain in place and support the minimal loads imposed by present usage.

The hold stanchions, which support the deck beams on centerline, were found to be in good condition with the exception of the one at the forward end of the hatch, which is badly worn due to years of cargo loading and off loading. The stanchion at the aft end of the hatch has previously been renewed.

The 'tween deck is in marginal condition. The steel angle deck beams are wasted from 20% to 50% and the steel brackets and bolts attaching beams to hull are badly wasted. The wood deck beam at the aft end of the 'tween deck is severely rotten and weakened. The two steel pillars supporting this beam are wasted away at the bottoms and are no longer effective. The 'tween deck planking is rotten across the aft end of the deck, and is collapsing in some areas and considered dangerous. Numerous small rot pockets were seen elsewhere in the deck, though none constitute a safety hazard. Wood deck beams, other than the aftermost beam, are in fair condition.

The chain locker and water tank platform, at the forward end of the hold, are in good condition.

The access ladders in way of the hatch, though adequate for the present limited usage, are not considered suitable for heavy use.

### **Conclusions**

The hold remains relatively intact and original, yet much deterioration is seen. Almost all rot in this area can be attributed to the leaking main deck. The rotten main deck structure overhead presents a structural problem which will have to be corrected by shoring or renewals. All structure in the hold should receive wood preservative treatment. The addition of passive and forced air ventilation will also help prevent further decay. Ventilation can be facilitated by removal of certain ceiling strakes, and by drilling of vent holes.



Fig. 20. In hold, looking up at deck beams, lodging knees and underside of deck planking, in way of main hatch. Note iron tie-rod through hatch sill and lodging knees, connecting to clamp (not seen). Members at top of photo are deck bracing at side of hatch, installed in 1985. --Photo, TCM

## 9. ENGINE ROOM

See Sheets 4, 5, and 11.

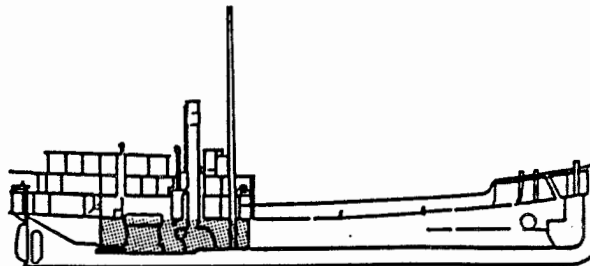

### Description

The engine room is located below the main deck, between the steel bulkheads at frames 49 and 72. This area of the hull houses the fuel tanks(2), boilers(2), the main engine, auxiliary machinery, and associated piping and electrical systems (see sections "Machinery and Tankage" and "Electrical System" for condition of this equipment). All major hull members of the mid-body extend into this compartment, though much of this structure is obscured by tankage and machinery. Access is by ladder from the main deck engine flat, and through a breach in the forward bulkhead.

### Condition

Most major internal members: keelsons, ceiling, frames, and deck beams and knees are in generally worse condition in the engine/boiler room than in the cargo hold. Probable causes for this are reduced ventilation and limited access for maintenance. The alternate heating and cooling of the compartment over the years the vessel was in operation may also have contributed to the rot and surface deterioration seen throughout. As in other areas, rainwater seepage is seen throughout the engine room.

The hull has suffered damage due to a fire in way of the starboard fuel tank. In this area, frames 61 to 63, eight ceiling strakes have been almost completely burned away, frames are damaged, and the fuel tank foundation timber is burned and decaying. Much of the ceiling below the turn-of-bilge could not be inspected due to limited access in way of the fuel tanks, boilers, and machinery flats. Where inspection was possible, these strakes appeared much like those in the cargo hold, with extensive rot, and nail sickness around fastenings.

The upper ceiling strakes and clamps, and the underside of the main deck are suffering from severe surface deterioration, primarily in way of the fuel tanks. This deterioration, which appears as a "fraying" of the surface grain, is thought to be non-fungal in nature. All three clamps and the upper three ceiling strakes are generally rotten behind the hanging knees from frame 56 to 67 on the port side, and from frame 51 to 63 on the starboard side. Areas of advanced rot were also seen in the lower ceiling strakes at the aft bulkhead, port and starboard.

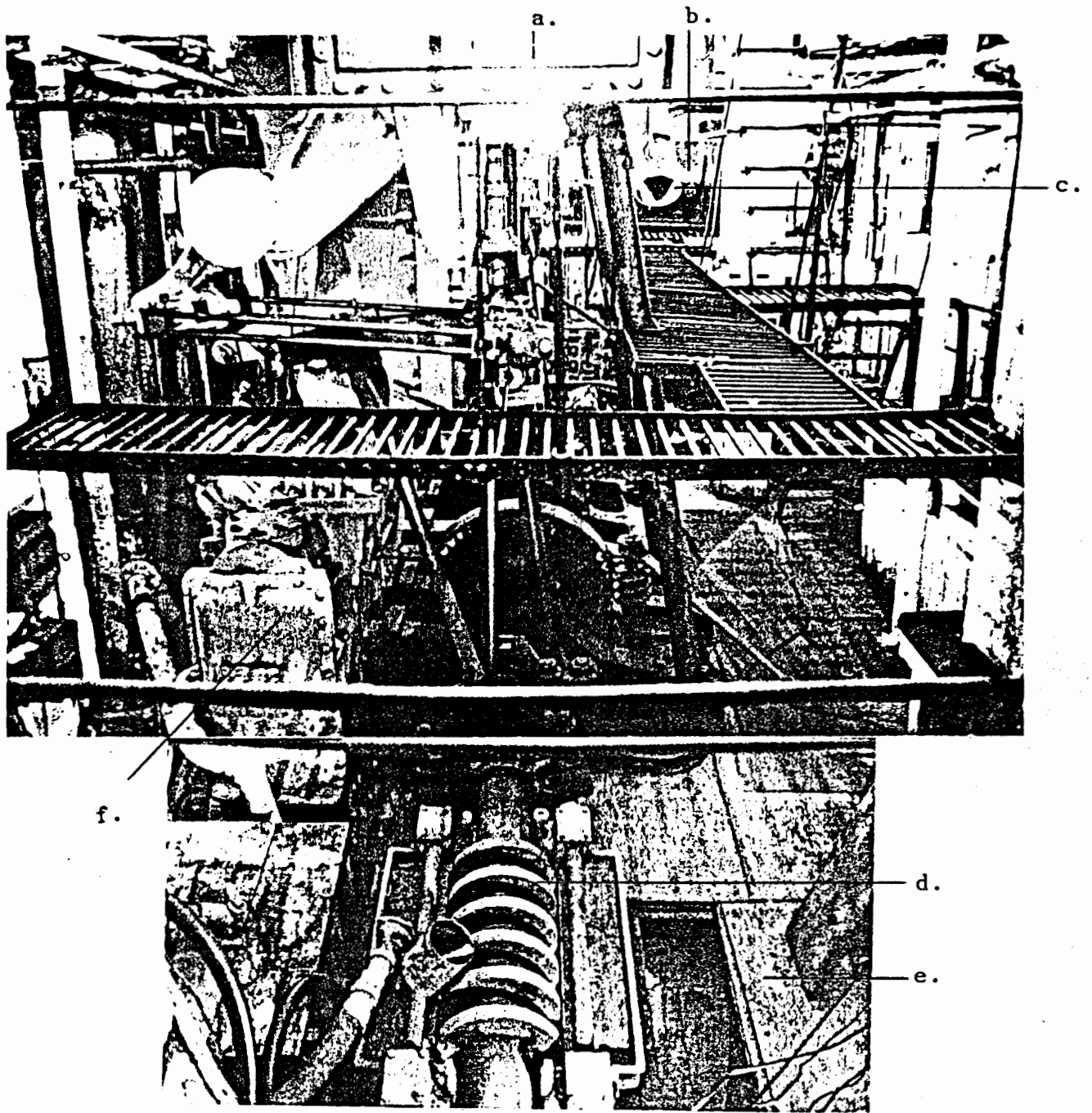

Fig. 21. Engine room, looking fwd. (Composite photo)  
 a. steam chest. b. stbd steam drum c. bottom of ventilator  
 d. thrust bearing e. engine room flat f. condenser

--Photo, TCM

(Engine Room - Condition cont.)

The keelson, rider keelsons, and assistant keelsons could not be viewed in some areas. Generally these members are in fair condition in way of the engine, and in poor condition under the boilers. The first rider keelson is badly deteriorated where it ends at frame 54, between the boilers. The keelson is soft and limnoria damage can be seen at frames 69 to 71, aft of the engine. The two longitudinal boiler bearer timbers under each boiler are severely rotten and collapsing. The engine foundation timbers are in good condition. The machinery flat (platform) on the starboard side is in fair condition.

Extensive and ongoing rot is seen in the main deck structure in way of the engine room. Of the fifteen main deck beams in this compartment, twelve are severely rotten at the port and starboard outboard ends, and variously along the inboard lengths. All full deck beams and half-beams in way of the engine and boiler "hatches" are moderately to severely rotten at the carlings. The carlings are also in generally poor condition due to rot, and all adjacent lodging knees have been affected. The beam at the forward bulkhead, and the aftermost two beams show only moderate rot. Previous attempts have been made to reinforce weakened deck beams. The beams at frames 60 and 69 have been sistered with steel plates, and shoring has been installed inboard and in way of the fuel tank. Additional measures will be necessary as decay progresses.

Eleven out of the fourteen hanging knees on the starboard side, from frames 49 to 67, show rotten areas, mostly on the outboard edges. Seven knees on the port side are in this condition. These are between frames 53 and 62, and at frame 69. Knees have been sistered with steel plates at frames 60 and 62 on the port side and at frame 65 starboard. Several of the massive stanchions supporting the main deck are hollow sounding, mostly at the main deck level. The port and starboard stanchions at the forward end of the engine hatch, at frame 62, are rotten or hollow sounding at the main deck. Similarly, the port, starboard and centerline stanchions at the forward end of the boiler hatch, at frame 53, are hollow and rotten at main deck. A shore timber inboard of the port fuel tank, at frame 57, is rotten.

All machinery, tankage and piping in the engine room is suffering ongoing corrosion and is in need of preservation (see section Machinery and Tankage). Much of the piping is severely corroded and collapsing, creating a safety hazard in many areas. Asbestos insulation is seen throughout the engine room. Some of this is disintegrating and dispersing.

## Conclusions

The engine room presents a challenge for both preservation and interpretation. This compartment is presently considered unsafe, even for volunteers and crew. The first priority should be to correct safety deficiencies in order to begin preservation work. A major program of documentation and removal of wasted machinery and piping should be undertaken before further collapse prevents proper recording of these artifacts.

Preservation of the wood structure should begin with weatherproofing. This can be achieved in the short term by addition of covers over the decks and fidley above. Even if freshwater is stopped, drying will be slow due to the poor ventilation here. The drying process can be speeded up by selective use of forced air ventilation. Even so, ongoing decay will likely necessitate some repair, and possibly renewal, of deck beams and stanchions.

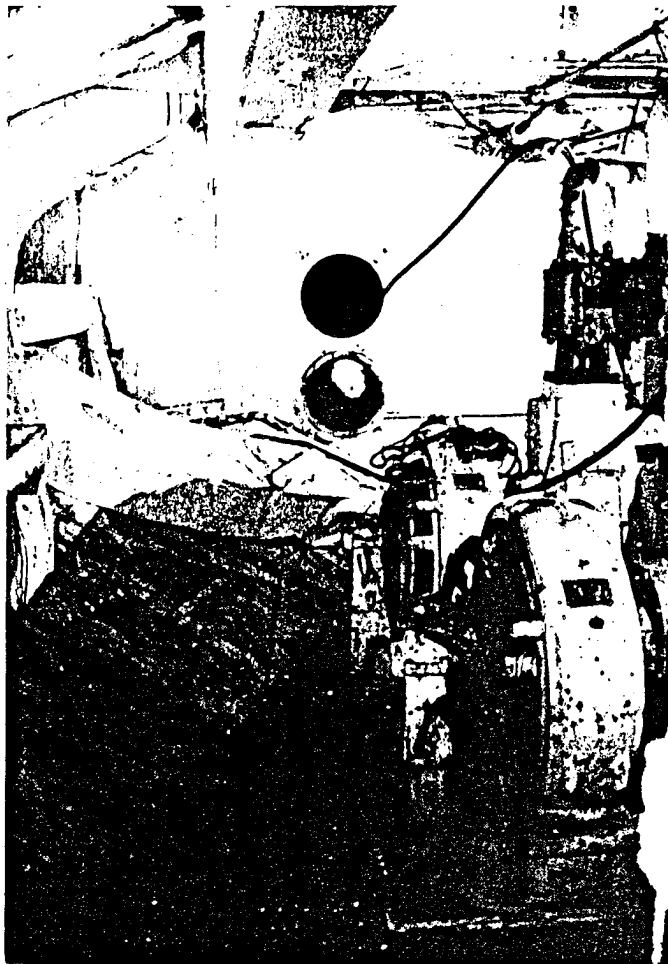
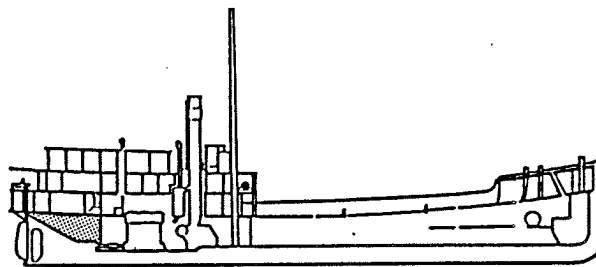

Fig. 22. Engine room, stbd side looking aft. Curving pointer can be seen piercing afterpeak blkhd. Twin dynamos, right foreground. --Photo, TCM

## 10. AFTERPEAK

See Sheets 4 and 5



### Description

The afterpeak is the aftermost compartment in the hull below the main deck. It is separated from the engine room by a steel bulkhead at frame 72, and extends from this bulkhead to the stern. The counter rises rapidly to meet the main deck at the stern, thus rendering the after portions of this compartment difficult for access. Two steel water tanks are housed in the forward end of the afterpeak. These are mounted on wood beams, port and starboard. The major longitudinal hull member, including ceiling, clamps and keelsons, extend into the afterpeak. In addition, the horn timber, shaft log, stern pointer, rudder trunk and trunk partner are located here. Access is by manhole in the steel bulkhead and by escape hatches in the main deck under the dining saloon.

### Condition

The afterpeak appears untouched by previous restoration, and much old decay can be seen. Most rot is located at the forward end of the compartment, between frames 72 and 75. Here, the lower ceiling strakes, the frames, and lower ends of the pointer are severely rotten. Cement has been poured over the ceiling in this area, presumably to consolidate the deteriorated timbers. This cement was incorrectly noted as ballast in the Lally survey of 1979.

The frames and interior surfaces of hull planking, visible along the horn timber aft of the water tanks (frames 78 and 81) show severe surface deterioration. This decay appears old and is probably the result of slow acting soft rot, and erosion from sloshing bilge water.

The visible portions of horn timber, shaft log, and keelson appear in fair condition with some surface deterioration. All of the upper ceiling strakes, clamps, main deck beams and planking appear in good condition. Many loose clinch rings were seen on ceiling fastenings. This may indicate shrinkage or movement of structure.

The propeller tailshaft is still in place, but has been cropped off at the stern bearing. The tail shaft coupling has been disconnected to allow the engine to turn freely. It was noted that the shaft coupling is now offset approximately one inch, indicating hogging or movement of the stern section. The steel bulkhead also shows movement, with the hull appearing to have dropped away from below the bulkhead by about one to two inches. The bulkhead steel boundary angle is badly wasted, and the foundation timber beneath is severely rotten.

The water tanks show only moderate external corrosion and the support timbers appear sound. There is approximately four to six inches of water in bottom of each tank.

### Conclusions

The afterpeak is, by design, not suitable for public access or viewing. Most of the deterioration seen in this compartment is old, though seepage through the main deck will eventually cause additional damage. A major concern in this area of WAPAMA is the movement seen in the stern section. Additional shoring will be needed under the counter in order to prevent further collapse of the structurally weakened stern. To help prevent further decay in the afterpeak, seepage should be stopped by repairing or covering leaking areas above. Forced air ventilation will also help to slow decay by moving stagnant air in this enclosed space.

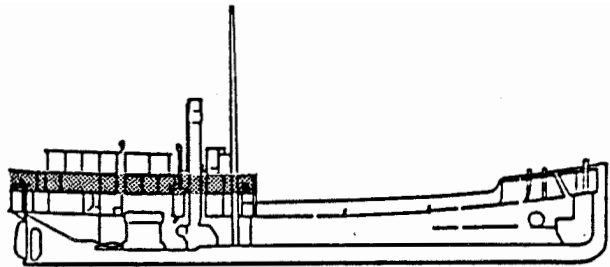

Fig. 23. Afterpeak, looking aft; stuffing box and shaft coupling. Pointer butt is seen over horn timber at top of photo. Note offset in coupling due to hull distortion. --TCM



## 11. CABIN DECK

See Sheets 3, 4, 7, and 11



### Description

The cabin deck is the raised deck extending from the forward end of the house at frame 48 to the stern. The winch platform, with two steam cargo winches and the mainmast partners, is located at the forward end of the deck. The cabin deck house, extending from frame 53 to 81, houses two passenger cabins, the engineers', mates' and wireless operator's cabins, social hall, smoking room, and three heads. The steering gear and a steam capstan are mounted at the aft end of the deck. Access to the cabin deck is via a staircase from the dining saloon below, and via ladders at the poop bulkhead, port and starboard.

### Condition

The worst deterioration seen in the cabin deck is found in the exposed exterior areas, particularly on the port side, from the poop bulkhead to the stern. Here, the solid bulwark timber is severely rotten and disintegrated over a distance of 24 feet, from the port quarter chock to the stern. The port covering boards are rotten variously with the worst area at the quarter. The poop bulkhead covering board is rotten at the port outboard end. The cap of the raised bulwark, forward of the poop bulkhead on the port side, is rotten variously from frame 64 to 70. Localized areas of rot are seen in the deck planking near the deck edge on the port quarter, and around bitts and skylights.

Four of the turned pillars supporting the boat deck on the port side, number 2, 3, 4 and 5 counting from the poop bulkhead, are rotten at the bases and structurally unsound. The aftermost of the port side davits is adrift at the base and presents a hazard.

On the starboard side of the after cabin deck, the second pillar and knee aft of the poop bulkhead are split and weakened. The third davit aft is loose at the base, and sitting on a rotten section of covering board. Another section of rotten covering board is seen at the quarter. The starboard bulwark has been renewed from the poop bulkhead to the stern, but even these newer sections show incipient rot in numerous large checks. A severely rotten area is seen in the bulwark at the poop bulkhead.



Fig. 24. Cabin deck, port side, looking aft.

--Photos, TCM

Fig. 25. Social hall, looking forward. Mirror is on bulkhead to smoking room, railing over double staircase down to dining saloon.

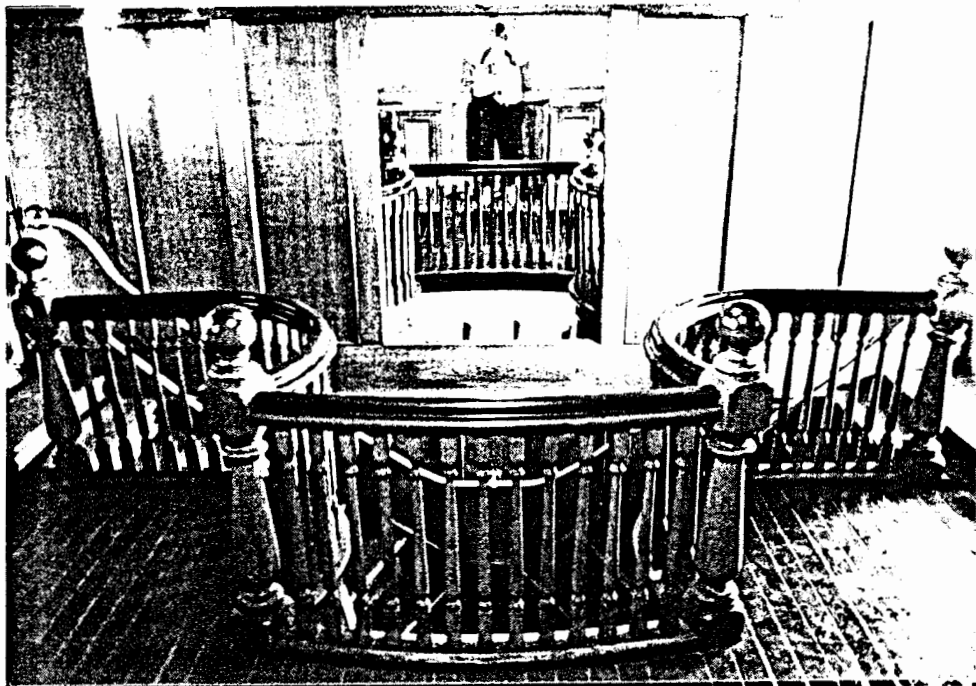

(Cabin Deck - Condition cont.)

The cabin deck planking aft of the poop bulkhead is only marginally sound, though no areas were seen to be seriously weakened. Numerous rotten deck planks were noted, particularly outboard on the port side. The entire exterior cabin deck is open at the seams and leaking rainwater into the vessel interior.

The port and starboard decking, forward of the poop bulkhead, is dished in way of the fidley, due to the weight of the stack and rotten interior structure. The starboard side decking is badly opened up, with much of the pitch and caulking gone. At the forward end of the deck, a section of the port longitudinal deck stringer is rotten at the forward corner post. Areas of rotten decking were found under the port cargo winch and at the forward end of the deck.

The worst damage seen inside the cabin deck house is in the fidley, where the half-beams in way of the stack, and the full beam aft of the stack are severely rotten and sagging. The cabin deck beam forward of the stack is rotten at the port side. Other members in way of the fidley are in poor condition due to rot. These include the deck planking and the port and starboard stack stay stringers, cabin sills, and deck stringers.

The social hall is in good condition and quite presentable, though oak paneling has been removed from the tops of the settees to the wainscotting, and the nickelodeon or piano has been removed. The smoking room (doors #8 and #9), heads (doors #14, #16 and #17), and cabin #12 are basically sound, but in need of ventilation

The mate's cabin (door #1) is basically sound, except for seepage seen along deck beams of the overhead. The engineer's cabin (door #5) and cabin #13 were not accessible and could not be inspected.

### **Conclusions**

The overall condition of the cabin deck is fair and the house and interior spaces, with the exception of the fidley, are in generally good condition. With a minimal amount of effort, the cabin deck can be opened to the public.

The boat deck should be temporarily shored in way of the rotten pillars on the port side, until the pillars can be repaired. Loose davits should be secured or removed. The severe rot seen in the fidley will require attention. This structure is a prime candidate for rebuilding because of its role in supporting the weight of the stack in the original manner.

The leaking deck could be rewalked with minimum plank renewals, though this alone would not prevent rainwater seepage into the accommodations areas. The severe deterioration along the port side of the deck will necessitate at least partial renewal in order to achieve this. In the short term, the addition of weather covers over the fidley trunk on the boat deck, and side curtains around the exposed areas of the cabin deck will do much to keep water out and slow the ongoing deterioration.



Fig. 26. Stairway from social hall down to dining saloon, looking down. (Top of photo is forward.) --Photo, TCM

## 12. BOAT DECK

See Sheets 3, 4, 8, and 11

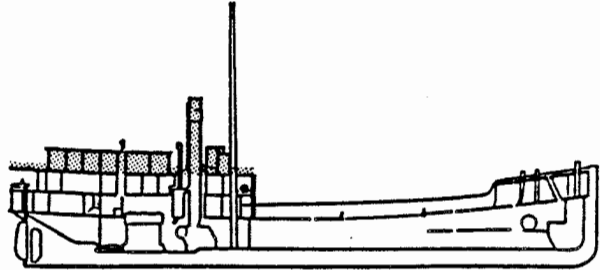

### Description

The boat deck extends from frame 48 to the stern and is the uppermost weather deck, not counting the boat deck house top. This deck is lightly constructed with canvas covered tongue and groove decking. The wood superstructures are sheathed inside and out with tongue and groove. The pilot/chart house is located at the forward end of the boat deck, followed by the fidley trunk and boat deck house. The captain's cabin and ten passenger cabins occupy the boat deck house. Four boats, two port and two starboard, were formerly stowed on the deck, each with a pair of davits. Access to the deck is by ladders through wells in the boat deck, port and starboard. Pipe handrails run the entire perimeter of the deck except in way of the boats.

### Condition

The boat deck is in generally good condition, primarily due to the extensive rebuild undertaken in the early 1960s. Although the deterioration seen on this deck is relatively minor, it appears to be advancing at a rapid rate, a result of improper drainage of rainwater. Drainage has become a problem because the WAPAMA is not trimmed by the stern, as she was when afloat. This means that the scuppers and drains are no longer at the lowest points in the deck and house tops, and standing water results. This water eventually seeps down into the structure and the rot process begins.

Most boat deck beams and decking are in good condition, with the exception of an area at the starboard deck edge between frames 58 and 61, in way of the fidley trunk. Here the deck edge stringer, two deck beams and outer deck planks are rotten due to poor drainage.

Torn areas are seen in the canvas deck covering, forward of the pilot house and in several areas near the deck edge. The quarter-round molding at the covering boards is soft or rotten throughout. The covering boards themselves are generally sound, except for the rot seen around the port access ladder deck opening.

The pilot/chart house, also rebuilt in the 1960s, is beginning to rot. On the aft side of the chart house, the port and starboard corner posts show rot, as well as adjacent exterior sheathing. The molding pieces along the roof edge are also rotting at the aft corners and are generally going soft all around. The starboard after door to the chart room is

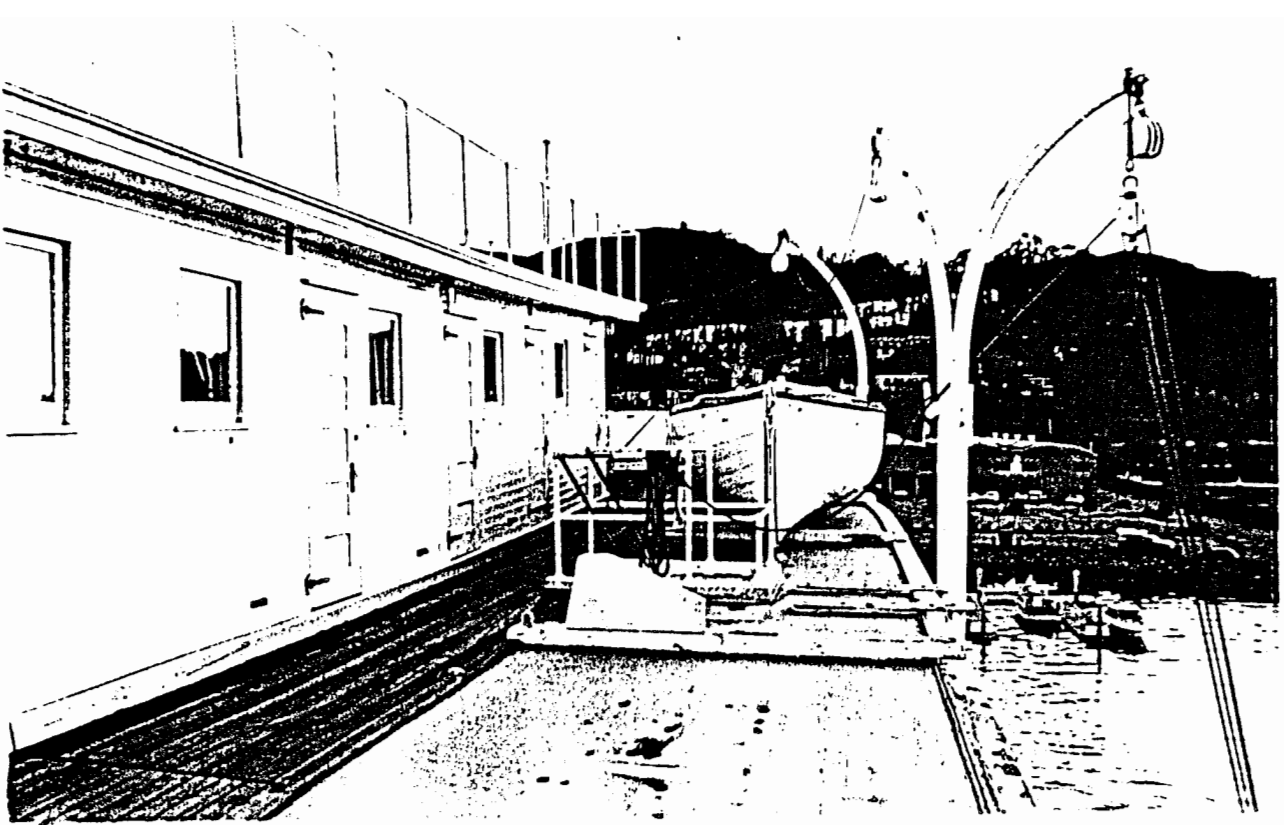
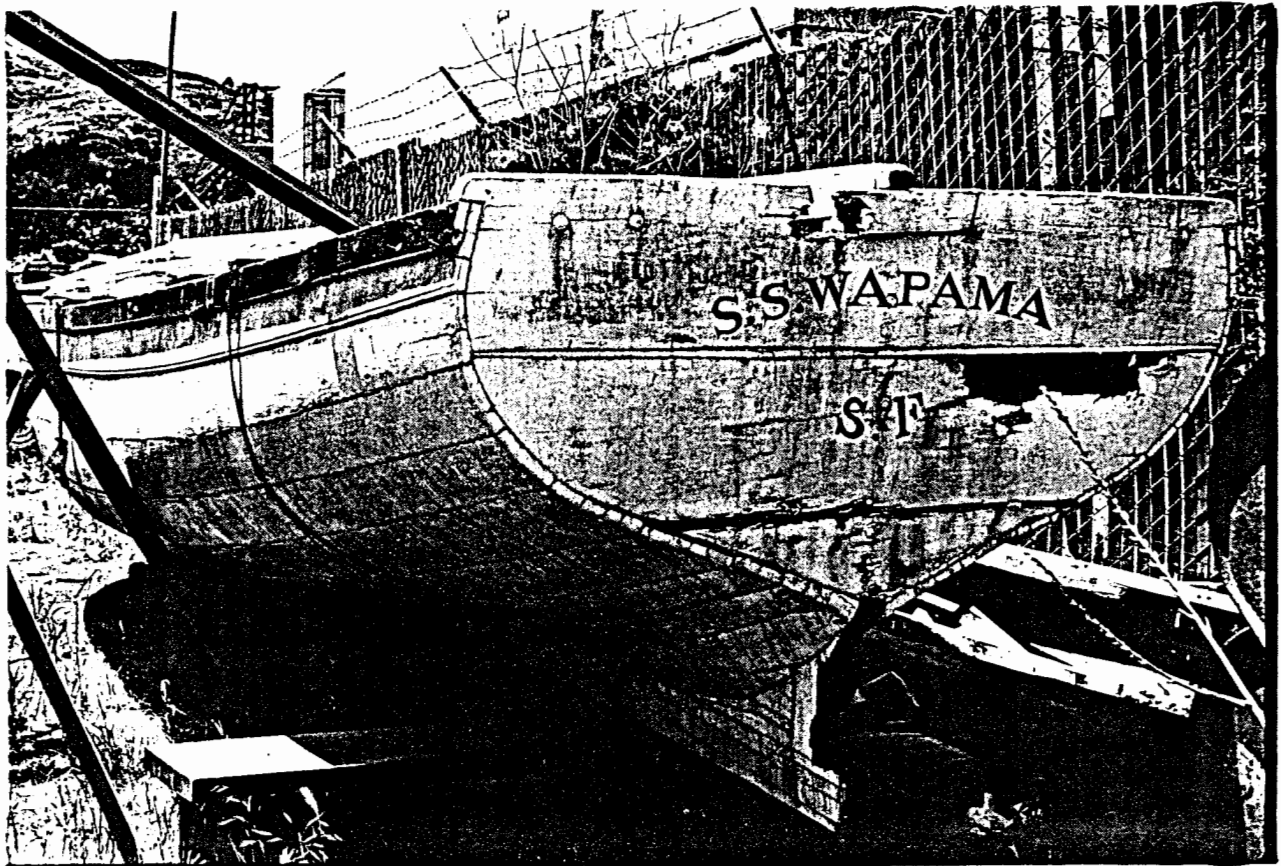

Fig. 27. View of boat deck, port side, looking aft.

Fig. 28. Transom stern launch removed to shore. --TCM



(Boat deck, cont.)

severely rotten at the top and bottom. The interior of the pilot/chart house is intact.

The steel fidley trunk has rusted through in local pits on the top, and active corrosion is seen on the ventilators. The stack above the fidley trunk is in good condition, though the iron pipes running up the aft side of the stack are corroded and coming adrift. The stack stay wires show signs of corrosion but are considered adequate for the time being.

The boat deck house is in good condition, but improper drainage and waterproofing on the house top is promoting rot. Standing water is seen at the forward corners of the house top, where the covering board and moldings are going soft.

The canvas covering on the house top is torn in several locations. Evidence that the house top is leaking is seen in cabins #7, #9, and #10, where there is standing water on the cabin soles. The decking and sill are beginning to rot in cabin #7.

The exterior sheathing, doors and windows of the house are in good condition, except for the doors to cabins #8 and #12 which are rotten at the bottom. The captain's cabin and cabin #1 are in good condition. Cabins #5 and #11 were not accessible and were not inspected.

The two composite wood and steel lifeboats are in poor condition and are exposed to the weather. The wood portions, including stem, keel and sternpost are rotting, and the sheet steel hulls are rusting. The two transom stern wood boats, formerly stowed on the boat deck, have been moved ashore where they also remain exposed to the weather.

### **Conclusions**

The boat deck area should be considered a preservation priority because of the relatively intact state of the structure. The ongoing deterioration, due to rainwater seepage, will eventually result in costly repairs or loss of structure. The most effective means of preventing this would be to place a weather cover over the entire deck. If this cannot be done, individual covers should be placed over the pilot/chart house, fidley trunk, and boat deck house. In addition, areas of torn canvas decking should be repaired, and standing water eliminated by installation of scuppers. The two lifeboats should be covered or removed to protective storage. The two transom boats should also be protected, even if rebuilding or replication is planned.

Although the boat deck is presentable for public display at this time, access should be limited until the weakened support pillars on the port side (noted in section Cabin Deck) are repaired or reinforced.

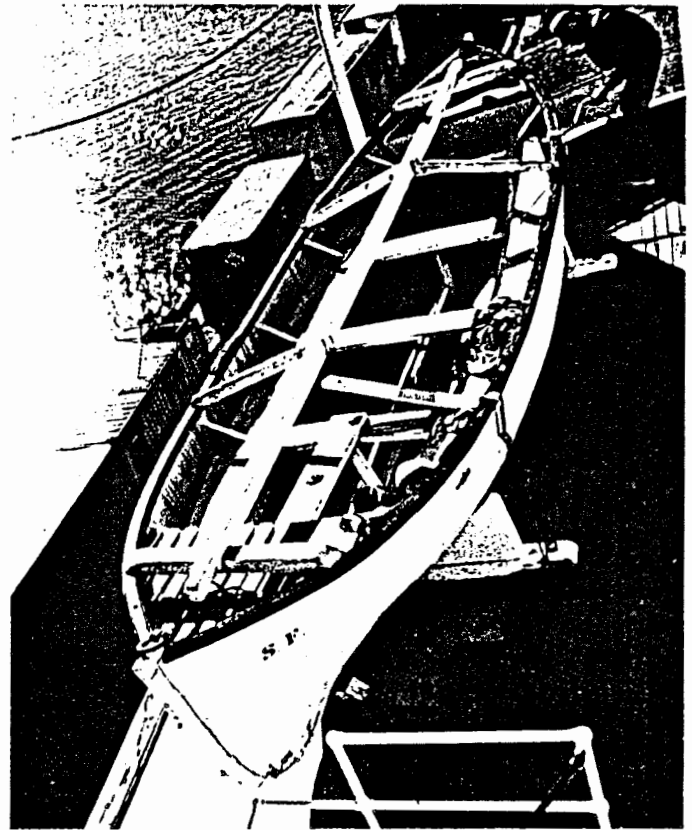
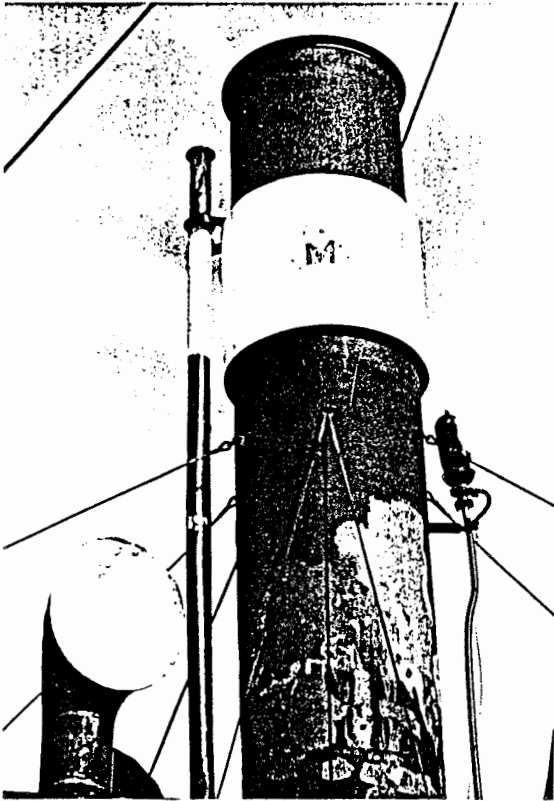
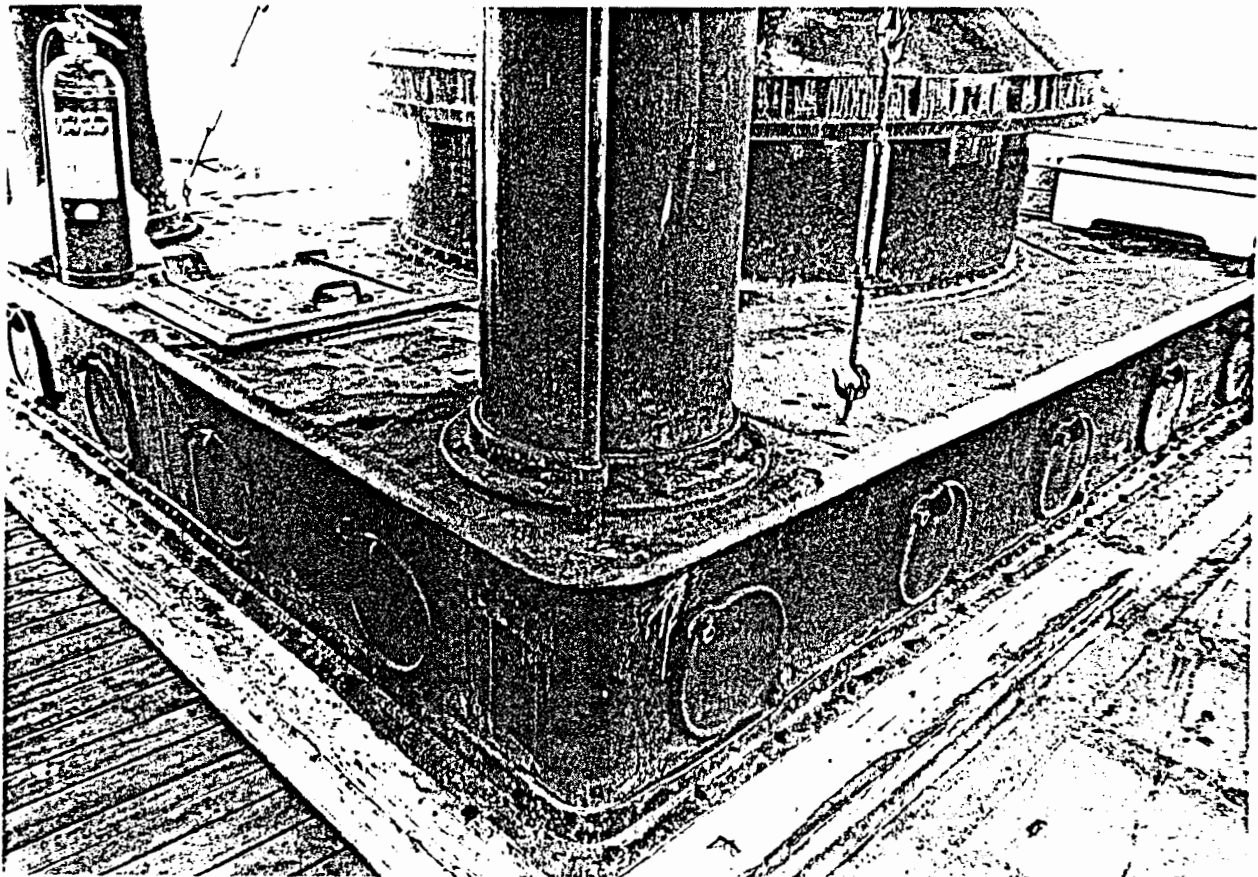

Fig. 29. Stack.

Fig. 30. Steel double-ender in place.

Fig. 31. Steel fidley trunk. Note covered deadlights over portholes.

--Photos, TCM





### 13. HULL: TOPSIDES AND BOTTOM

See Sheets 3 and 11

#### Description

The "topsides" includes all the exterior hull surfaces outboard of the rails and above the waterline. The "bottom" is defined as the hull surfaces below the waterline at which WAPAMA floated during her years as a museum ship. All hull planking is 4-1/2" thickness except for the first and second garboards, which are 8" and 6" respectively. Width of strakes varies from 9" to 18", and some older planks are seen to be in excess of 72' in length. The entire waterline and the rudder have been sheathed with 1/2" plywood bedded in irish felt. A "guard", or rubrail, with ironbark chafing plate, extends from just aft of the bow to the stern. A 3" thick worm shoe is fitted to the bottom of the keel. The stern post and rudder post are hardwood, presumably ironbark.

The hull is presently supported on keel blocks, from frame 6 to the rudder post, and on seven bilge blocks, located just below the turn-of-bilge, between frames 24 and 56, port and starboard. Additional support is provided by a single shore forward, and four shores aft, port and starboard. A scaffold stairwell on the port side provides the only means of access from the barge deck to WAPAMA's main deck.

#### Condition

##### a. Below the Waterline

The hull surfaces below the waterline appear in surprisingly good condition considering age and length of time WAPAMA has been out of water.

The bottom planking remains generally free of rot, probably due to residual effects of years of salt water saturation. Some local areas of minor and incipient rot were seen, mostly at plank butts. Sections of hull planking were removed in 1982, at four areas of the bottom, in order to allow inspection of internal structure: frames, planks, ceiling. The inboard surfaces of many planks are seen to be abraded away between frames, by as much as 1/2". This condition may be due to a combination of decay and erosion from sloshing bilge water. The outboard planking surfaces appear rough, with widely scattered worm damage (primarily Limnoria tripunctata) up to 1" deep or 25% of total plank thickness. Most worm damaged wood has been cropped out and filled with putty, epoxy or "Portland" cement. Several planks have sprung loose at the butts, particularly at the bow and stern. Oakum caulking is generally rotten.

Many seams have been paid with cement. The majority of seams are open, particularly at the bow and stern, where oakum and cement is falling out.

Approximately 40% to 50% of the iron spike plank fastenings show moderate nail sickness extending 1" to 2" around fastenings, and up to 3/4" deep. Most trunnels are still effective, though a few are seen to be partially decayed or abraded at the plank-to-frame faying surface.



Fig. 32. Bottom, stbd side, on barge, Nov, 1985. Double-sawn frames may be seen where planking has been removed (see Fig. 33). Note hog in keel. --Photo, TCM

(Hull condition below the waterline, cont.)

The keel is generally free of decay, though it, along with the worm shoe, is being crushed by uneven loading on keel blocks. The stern and rudder posts are sound with the exception of local worm damage seen around the gudgeons. The rudder, mostly obscured by plywood sheathing, shows severe worm damage, particularly on the leading edge.

The propeller has been removed and is laying on the barge deck. The tail shaft and stern bearing are still in place, but the shaft has been cropped off and the bearing housing capped. Considerable distortion is seen in the hull, including hog at the keel, and a starboard twist of the forebody. The unsupported bow section appears to be settling as evidenced by crushing at the forward keel block.

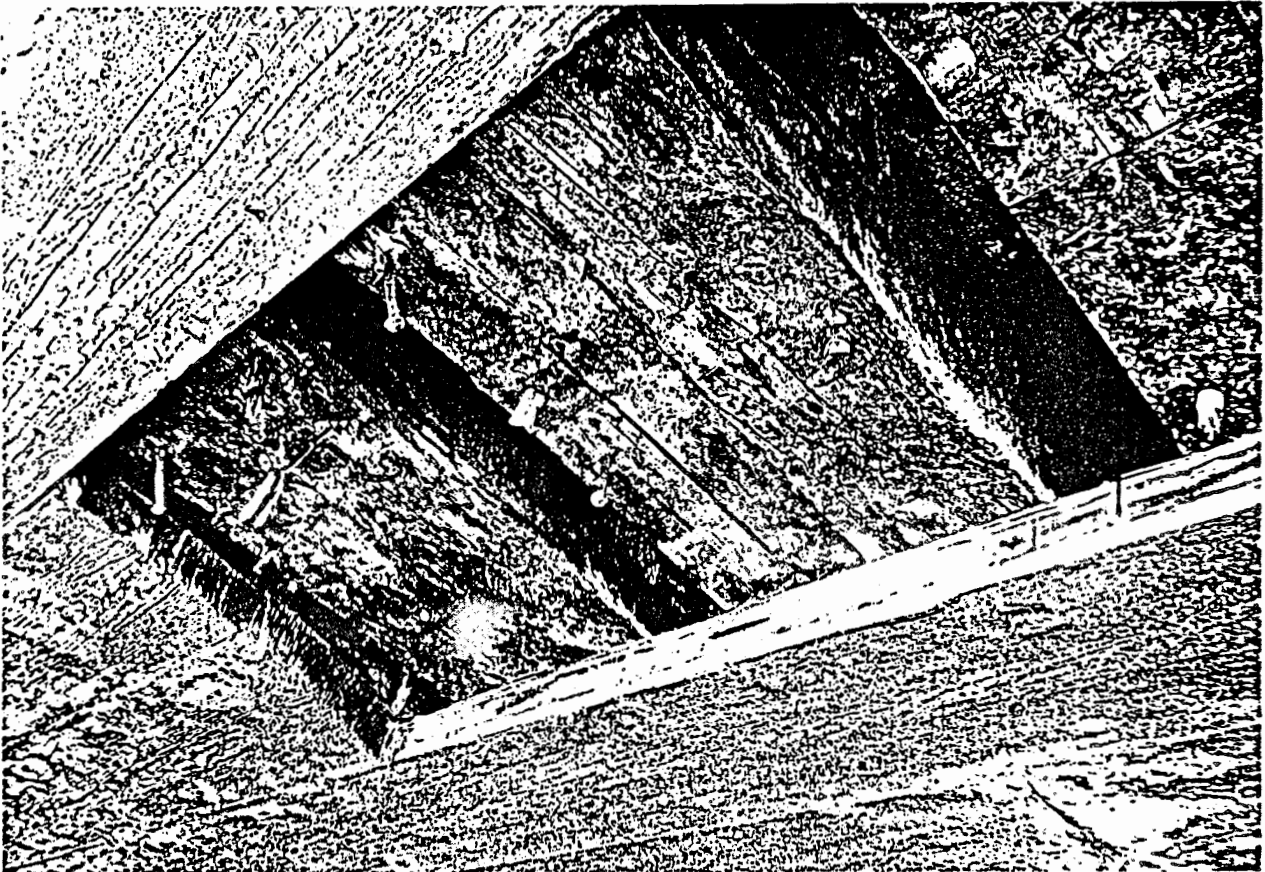

Fig. 33. Section of bottom planking removed for inspection during 1982 survey. Double-sawn frames can be seen with iron spikes and trunnels (wooden planking fasteners) projecting. --Photo, TCM

## **b. Topsides**

In contrast to the bottom, the topsides are in very poor condition. Most planking above the waterline ranges from moderately to severely rotten. The surface of the planking is rough and checked, paint is cracked and peeling, and seams are open. About 50% of the planking in way of the forecastle and poop is rotten. The planking under the anchor striker plates is severely rotten. A half-dozen planks in the forebody have been renewed within the last twenty years. These remain the only relatively sound planks in the topsides. The planking in the midbody is generally severely rotten, both port and starboard.

Almost 100% of the trunnels are loose and rotten at the plank-to-frame faying surfaces. Approximately 50% to 75% of the iron spikes are loose, with bungs missing and heads corroded. Nail sickness is also seen around most iron fastenings.

Though some sections of the guard rail were renewed in museum ship days, most is rotten, with the worst area on the starboard bow, where a section is severely rotten and collapsing. The stem is rotten and badly checked from the waterline up.

## **Conclusions**

The bottom is the only major area of WAPAMA which remains relatively sound. The topsides, on the other hand, present a major preservation problem. Unless weather tightness of topside planking is achieved, rain will continue to enter through checks and open seams, resulting in continued decay of planking, framing, and ceiling. Though wood consolidation techniques could help to seal the planking, this method alone is not considered a thorough or cost-effective long-term solution.

Renewal of weather surfaces and/or erection of a protective cover structure are viable, though expensive, long term solutions. A difficulty with retention of original fabric will be the eventual drying out and shrinkage of planking, with resultant springing of plank ends. Where this occurs, planking will have to be refastened or renewed.

The hull is presently in need of additional support, particularly at the bow and stern. In the short term, this can take the form of additional wood shoring, though in the long term, interpretation would be best served by an engineered support system.



Fig. 34. View of starboard quarter showing decay in  
 rubstrake. Fig. 35. (below) Topsides at midships. Note  
 open seams in topside planking. --Photos, TCM

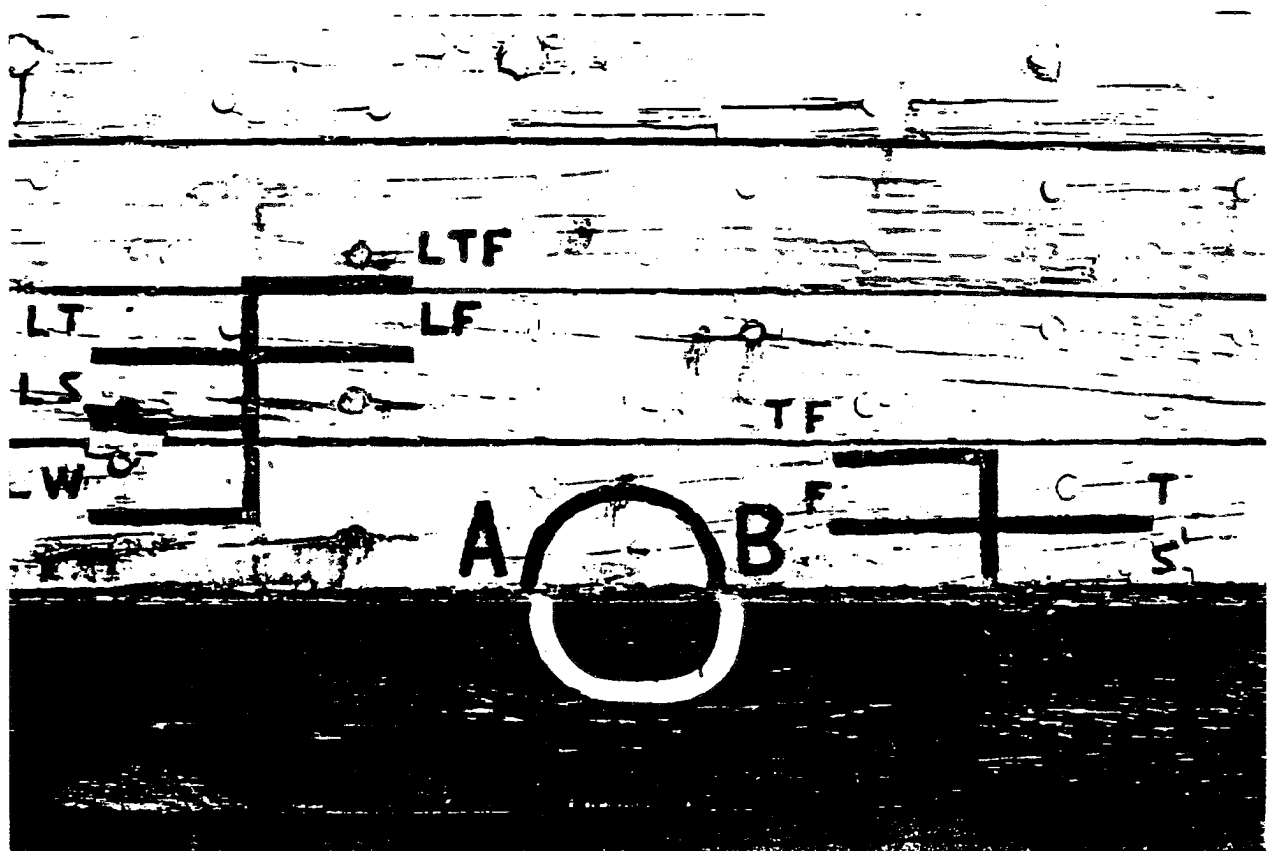

## 14. RIG

### Description

WAPAMA's rig, consisting of two masts, with two booms each, was strictly for cargo handling. All rigging and spars were renewed in the early 1960s. The foremast was cut up and removed from the ship in 1983. The lower section of this mast is presently on the deck of the barge, as are all four cargo booms. The mainmast remains in place, supported by three pairs of 1", 6 x 7 wire shrouds, and a temporary forestay.

### Condition

Inspection revealed rot in the foremast section and all four booms, though the fittings are mostly intact. The mainmast appears sound from the heel to above the boat deck. Moisture readings near the heel were over 25%, indicating possible incipient decay. The upper portion of the mast was not inspected. The wire shrouds appear in good condition, despite the dry and rotting service. The ratline seizings are also rotting and the ratlines are not considered safe. The shroud turnbuckles show considerable corrosion.

### Conclusions

The foremast section and all four booms are considered a total loss, with exception of the fittings. The mainmast may be salvageable. Repair of the ratlines will be necessary in order to fully inspect and maintain the mast and rigging. The turnbuckles should be scaled and coated.



Fig. 36. Winch pit at fwd end of cabin deck, serving main mast.

Fig. 37. Hand-forged clevis in turnbuckle on main shrouds. --TCM

## 15. MACHINERY AND TANKAGE

### a. Main Engine

The main propulsion unit is a triple expansion reciprocating steam engine manufactured by Main Street Iron Works of San Francisco. This engine developed 800 horse power and turned a single, four-bladed iron propeller through an in-line shaft. The pistons have been removed, the shaft disconnected, and an electric jacking gear installed to turn the engine over for display purposes.

The engine is in generally good condition and was easily rotated three to four degrees by use of the hand jacking gear. The electric jacking gear was not tested. The propeller has been cut off of the shaft and presently lies on the deck of Barge 214.



Fig.38. Main engine bed and crank shaft, port side looking fwd. Note worm-drive manual jacking gear in center of photo. Fig. 39. (next pg.) Aft side boilers, looking to port. Doors have corroded away, exposing boiler tubes. --TCM

## **b. Boilers**

The two main boilers are oil fired, water tube type, manufactured by Babcock & Wilcox. Each boiler is fired by two burners by Ray Oil Burner Co. of San Francisco. The boilers sit on longitudinal wood bearers.

Both boilers are in poor condition with severe corrosion throughout. The boilers are continuing to deteriorate due to rainwater incursion from the fidley above. The two doors on the front of the starboard boiler are missing, and those on the port boiler are coming adrift. The sides of the boilers are opening up at the seams and the bottoms are bulging. The burners are corroded and frozen in position. All wood bearers show advanced decay. Asbestos insulation is being scattered as the boilers disintegrate.

The stack and boiler breaching are wasted through in several locations and are collapsing. The breaching is probably beyond the point of salvage. The stack is wasted around its entire circumference in two locations: just above the breaching and up above the boat deck level. The upper section of stack has been renewed and is in good condition. Steam whistle and vent piping attached to the upper stack are wasted and adrift. The stack guy wires are in fair condition.

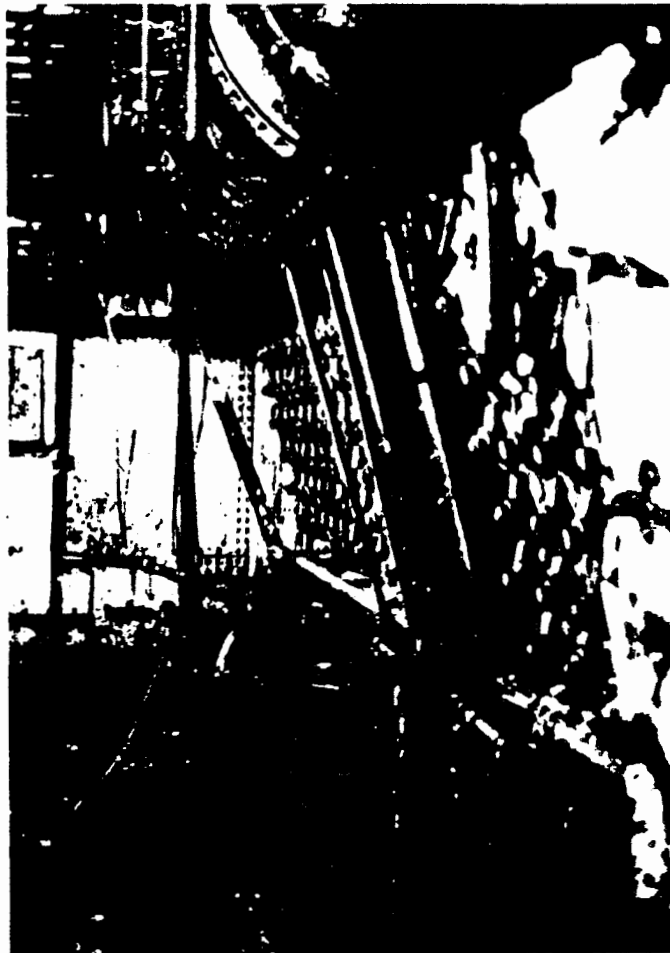



### **c. Auxiliary Machinery**

The auxiliary machinery includes original equipment and items installed during WAPAMA's museum ship era. This equipment performed a variety of functions. Items are as follows:

#### **Evaporator**

Manufactured by: GRISCOM - RUSSELL CO., New York  
Location: engine room, port aft  
Description: iron, black enamel paint  
Condition: good

#### **Feed Water Filter & Heater**

Manufactured by: MAIN STREET IRON WORKS, San Francisco  
Location: engine room, port midships  
Description: iron, black enamel paint  
Condition: fair, some corrosion

#### **Main Saltwater Circulating Pump**

Manufactured by: unknown  
Location: engine room, port aft  
Description: 1 cylinder steam engine; centrifugal pump,  
gray and black enamel  
Condition: fair, engine turns, disconnected from pump,  
corroding

#### **Steam Pump**

Manufactured by: WORTHINGTON  
Location: engine room, port aft  
Description: 2 cylinder, horizontal, gray and black enamel  
Condition: fair to poor, corrosion and pitting,  
piping crumbling

#### **Feedwater Filter/Heater Pump**

Manufactured by: BLAKE & KNOWLES  
Location: engine room, port mid  
Description: 2 cylinder, vertical, yellow and black enamel  
Condition: fair to poor, corroding, pipes removed and capped

#### **Oil Feed Pumps (2)**

Manufactured by: WORTHINGTON  
Location: engine room, port forward  
Description: 2 cylinder, horizontal steam powered pumps  
Condition: fair, corroding, coated with soot or fuel oil

#### **Electric Bilge Pump (later addition)**

Manufactured by: CONTINENTAL  
Location: engine room, port midships  
Description: 220 VAC motor; 4" centrifugal pump,  
yellow enamel  
Condition: poor, frozen and corroding

**Dynamos (2)**

Manufactured by: B. F. STURTEVANT, Boston  
Location: engine room, starboard raised flat  
Description: 1 cylinder engine; 110 VDC generator, 7.5 Kw,  
68 amp., 450 rpm., gray enamel paint  
Condition: fair, both dynamos corroding, aft dynamo frozen

**Electric Engine Jacking Gear (later addition)**

Manufactured by: WESTINGHOUSE motor;  
STRAIGHT-LINE reduction gear  
Location: engine room, aft.  
Description: 220 VAC/36 Amp motor (model ABDP);  
56.12 to 1 reduction gear, 15 hp. input;  
triple chain drive to sprockets on shaft  
Condition: appears in fair condition, chain drive good

**Fire Pump**

Manufactured by: BLAKE & KNOWLES  
Location: main deck engine flat, port side  
Description: steam powered, vertical 2 cylinder,  
yellow enamel  
Condition: good, piping disconnected

#### **d. Deck Gear**

Deck gear, both original and additional, includes cargo gear, anchor and line handling gear, and miscellaneous deck gear. Fittings, such as bitts and chocks, have not been listed.

##### **Windlass**

Manufactured by: MAIN STREET IRON WORKS, San Francisco  
Location: removed, stored on deck of barge  
Description: steam powered, cast iron, 2 chain drums,  
4 gypsy heads, black enamel coating  
Condition: poor, exposed to weather, scattered corrosion  
and pitting, mechanisms frozen

##### **Steam Capstan**

Manufactured by: unknown (name plate reads "A2254")  
Location: cabin deck, at stern  
Description: single capstan driven by horizontal steam engine;  
cast iron and steel, black enamel coating  
Condition: exterior corroding, good internally

##### **Cargo Winches (4)**

Manufactured by: LIDGEWOOD, New York  
Location: 2 for mainmast are at forward end of cabin deck;  
2 for foremast were on forecastle head, now removed  
to barge deck  
Description: steam powered, single drum, single gypsy head,  
cast iron and steel, black enamel coating  
Condition: 2 mainmast winches fair with minor corrosion,  
brake and control handles missing; 2 foremast  
winches in poor cond., corrosion and pitting,  
exposed to weather

##### **Manual Capstan (later addition)**

Manufactured by: HYDE, Bath, Maine  
Location: forecastle head deck, starboard aft  
Description: cast iron, 25" high by 23" dia.,  
black enamel coating  
Condition: fair, badly corroded dogs and bar sockets

##### **Manual Bilge Pump (later addition)**

Manufactured by: MARINE FITTINGS CO., Everett, Wash  
Location: main deck, at forward end of house  
Description: one cylinder diaphragm type, cast steel,  
galvanized  
Condition: good

##### **Hand Winch (later addition)**

Manufactured by: BLACKBURN  
Location: 'tween deck, starboard forward  
Description: ratchet type, single drum, steel,  
fitted with 1/2" stainless cable  
Condition: good, some corrosion

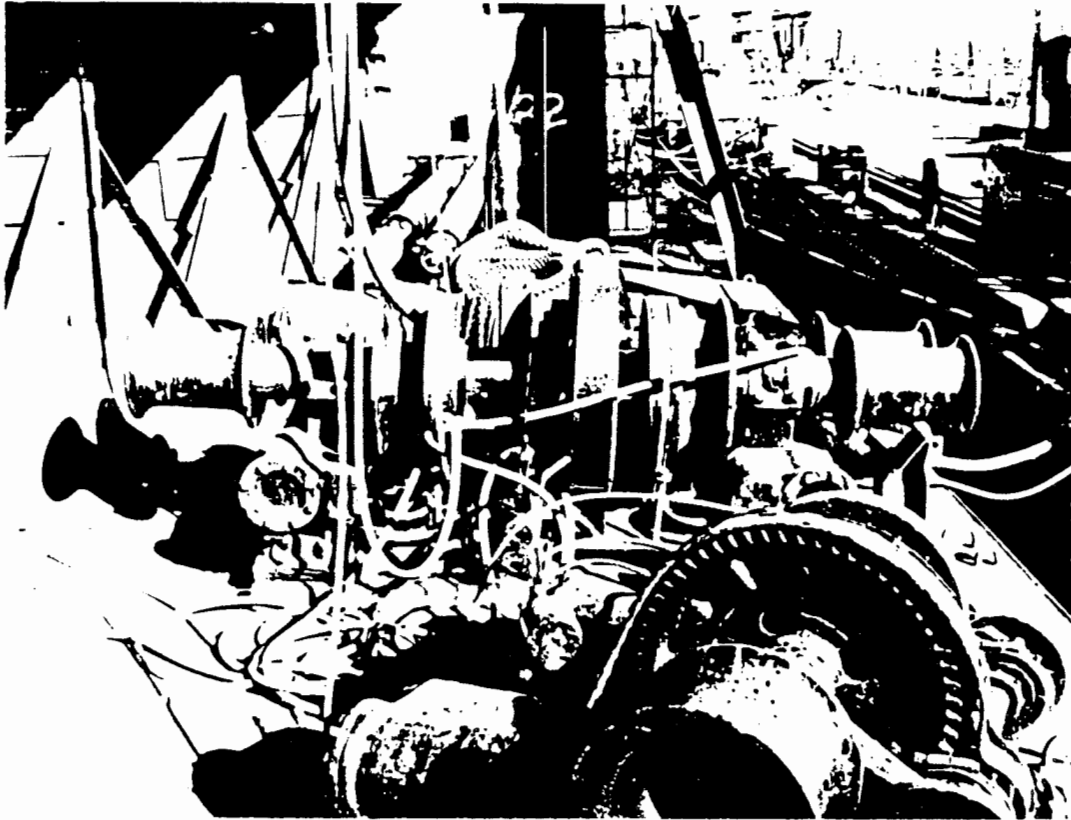
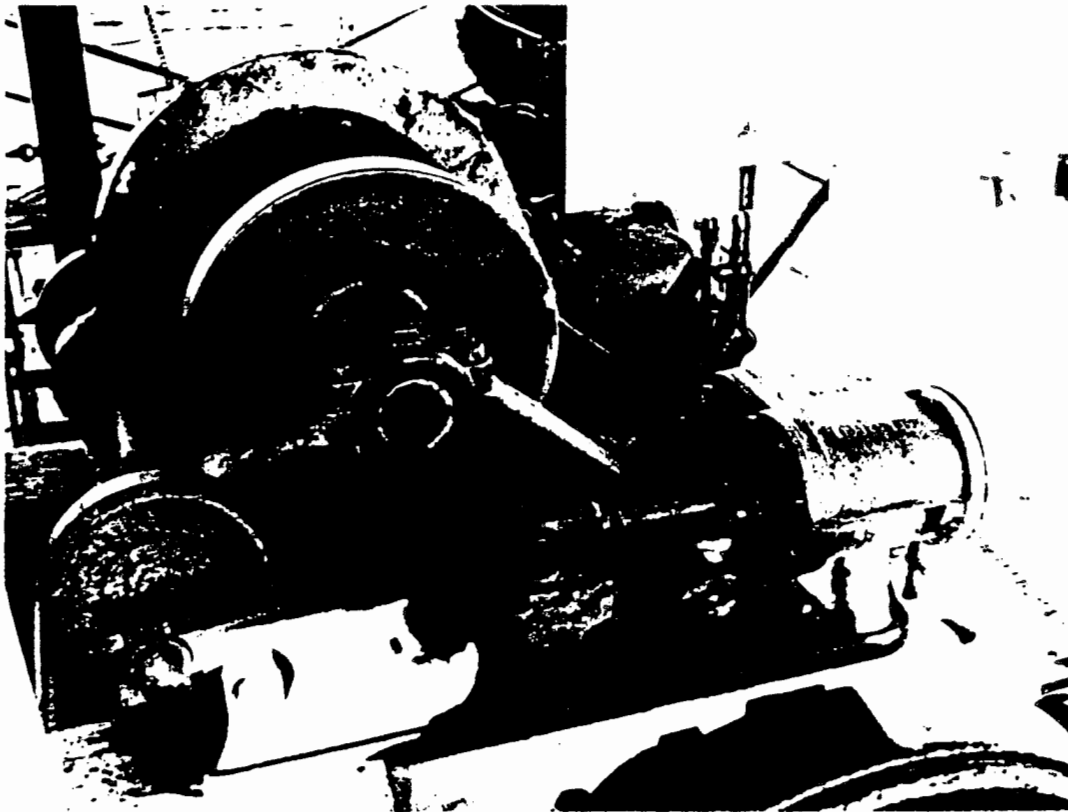

Fig. 40. Steam windlass on deck of Barge 214. One of steam winches from fore mast seen in foreground.  
Fig. 41. Inbd. side, main mast winch, in place. --Photos, TCM



#### **e. Fuel Tanks**

WAPAMA was originally fitted with four fuel oil tanks, though two have been removed and scrapped. The remaining two tanks are located to port and starboard of the boilers. These tanks are riveted steel construction, and designed to conform to the hull shape. They are secured to the hull with iron stay rods. The tanks are believed to be empty.

The tanks are in poor condition due to corrosion. Only the inboard sides and ends of the tanks retain any coatings (yellow enamel). All other surfaces are corroding. The tops have partially rusted through due to standing water from the deck overhead.

#### **f. Water Tanks**

A large, cylindrical, riveted steel tank is located on a platform forward of the 'tween deck. The exterior of the tank is in generally good condition with only surface corrosion seen. The tank appears empty, though the interior could not be inspected.

Two riveted steel water tanks are located in the afterpeak. These tanks are shaped to fit the hull and are secured by wood bracing. Both tanks are in good condition. Only a few inches of water remains in these tanks.

#### **Conclusions**

All machinery and tankage has been without maintenance for some time. In some cases, the result has been severe deterioration. The following general recommendations:

Secure all machinery and tankage from exposure to weather and seepage.

On all auxiliary machinery and deck gear, coat exposed shafting, gears and other "moving" parts with grease or EUREKA fluid. Use heavy oil on main engine.

Scale, treat and coat boilers, tankage, and painted portions of machinery and deck gear. Hard coatings should be used for these items.

Rotate all free machinery on a regular basis.

## 16. ELECTRICAL SYSTEM

### a. Original Shipboard System

The original electrical system received power from two STURTEVANT steam generator sets (dynamos) which are located in the engine room. Each of these sets produced 7.5 kilowatts of 110 volt direct current. Electricity was controlled at a fused control panel with exposed knife switches and 3 voltmeters. The control panel, located on the aft engine room bulkhead, bears the name HERZOG & DAHL, San Francisco. This electrical system is no longer functional. Much of the original wiring and conduit has been removed and the original extent of this circuitry cannot be determined.

### b. Shore Power System

The present electrical system was installed in WAPAMA's early museum ship days. This is an AC shore power system with the main disconnect and distribution panels located in the main deck engine flat. The shore power cable comes aboard on the starboard side at the poop bulkhead. Most of the circuits are for lighting and receptacles. The exterior lighting fixtures are the shielded bronze type, and the receptacles are dual outlet, weather-tight boxes. The shore power system also provided power for the electric jacking gear and bilge pump. A separate switch for the jacking gear is located in the engine room.

### System Specifications

**Type:** 208 volt AC, 3 phase

**Distribution Panel:** (31) 20 amp breakers (lighting and outlets)  
(1) 30 amp breaker (for bilge pump)  
(1) 70 amp breaker (for jacking gear)

**Main Disconnect:** 200 amp, 3 fuse switch panel

**Shore Power Cable:** 4 conductor, 0000 gauge copper

**Wiring:** 12 AWG, single strand copper, oil and water resistant, plastic insulated.

**Conduit:** mostly 1/2" and 3/4" metal conduit.

### Condition

The wiring is in poor condition in many areas, with sections of conduit badly corroded and adrift. Some of the circuits have been partially disconnected. Many of the fixtures show corrosion and weather insulation gaskets are dried and cracked. The distribution panel faceplate has been opened and the interior of the box is exposed to moisture. The main disconnect box is improperly wired.

(Electrical System cont.)

**Conclusions**

Portions of the shore power system may be unsafe to operate at this time. The entire system should be inspected by qualified marine electricians, and all deficiencies documented. This system will require some repairs and upgrades in order to be safe and useful for work or visitation aboard the vessel.

## 17. PIPING

### Original Piping

The original piping, including steam, water and fuel oil systems, is inactive. Some elements of these systems have been removed. Much of the remaining piping is in poor condition, particularly in the engine room. Many of the anchors securing the piping to bulkheads and overhead are corroded and the piping adrift and collapsing.

### Fire System

A fire fighting system was installed at the time WAPAMA was placed on line as a museum ship. This system consisted of a 1-1/2" main with water supply coming from shore via a flexible coupling. A backup water supply was provided by the electric bilge pump. Fire stations are located in the following areas:

- forecastle head, port aft
- main deck, starboard midships
- main deck, starboard forward
- 'tween deck, aft
- engine room, forward of engine
- cabin deck, starboard of winch pit
- cabin deck, starboard poop bulkhead
- cabin deck, port poop bulkhead
- boat deck, aft of house

The fire system appears in good condition and most valves still rotate, but the fire hoses have been removed. The only fire station operable at this time is located on the starboard main deck in way of the hatch. This station remains charged.

### Conclusions

Portions of the original piping system present a safety hazard and should be documented and removed before they collapse entirely. The fire system is considered worth salvaging and should be overhauled and made active.



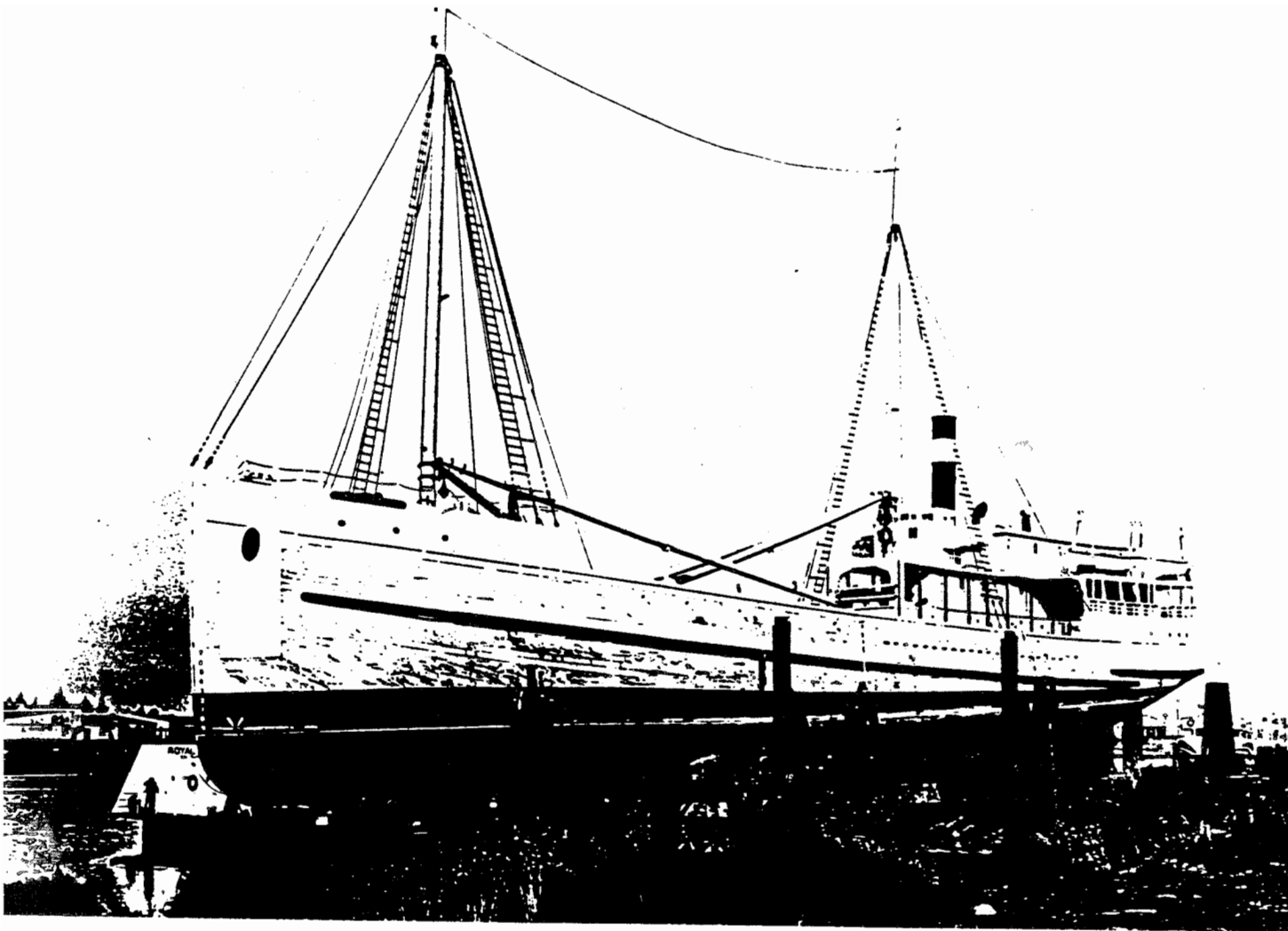
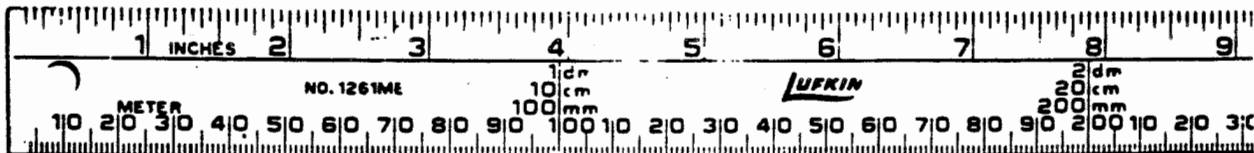

Fig. 42. WAPAMA on Barge 214 in 1980. This photo gives a good idea of the area of underwater hull relative to exposed decks and topsides. The badly weathered and rotten topside planking is visible, but the deckhouses still appear in fair condition. The masts and booms have not yet been removed and the slack in the spring stay may be indicative of the degree of hog that settled out when she was drydocked. --Photo, NMMSF



Fig. 43. Rotten trunnel, taken from topsides, port, frame 36, strake 19. Section was in way of plank. --Photo, TCM



## **D. LOAD BEARING LIMITS OF STRUCTURE**

### **1. Existing Distortion**

Most of the distortion (deflection) seen in WAPAMA has been caused by forces which are no longer acting on the vessel. Hog, loss of deadrise, and twist (see fig. 44) are largely the result of loads imposed on her while she was afloat.

Hog and loss of deadrise are attributable to uneven loading (primarily lack of ballast), and weakening (effects of decay) of the hull girder. This distortion was arrested in its present state as WAPAMA sat down on the keel and bilge blocks positioned on the deck of Barge 214. A considerable amount of hog (approximately 18") was removed at the time of drydocking by setting keel blocks to a lower profile.

The cause of the twist seen in the bow is harder to establish, though weakening of the hull is certainly a major contributing factor. This distortion actually increased after drydocking, but was checked by removal of weight on the forecastle head, and addition of a shore on the starboard bow.

### **2. Ongoing Distortion**

While the vessel is no longer subjected to sagging/hogging strains, lack of bouyancy now leaves the hull evenly supported. Portions of the hull, including the bow and stern which are not directly supported by shoring, are in effect acting as cantilevered structures. As the hull continues to weaken due to decay, these unsupported areas begin to deflect. In addition, increased decay of deck structures has resulted in noticeable deflection of decks in some locations. The following are areas of distortion which remained unchecked at the time of survey.

#### **a. Drooping of the unsupported forward 17 feet of the bow.**

Signs of this movement are seen in the opening up of joints in the forefoot and crushing of the keel at the bow of the barge. This condition is presently being remedied by addition of a steel bow support girder and poppet arrangement.

#### **b. Drooping of the stern.**

Although the keel presently sits firmly on the barge deck, the overhang of the stern abaft the rudder post is largely unsupported. Movement of the stern is evidenced by a 2 inch separation of the rudder trunk from surrounding structure in the lazarette. A 1 to 2 inch gap is also seen under the aft engine room bulkhead. Shoring has been added at the stern quarters. An additional support will be placed across the extreme end of the stern as part of an ongoing contract.

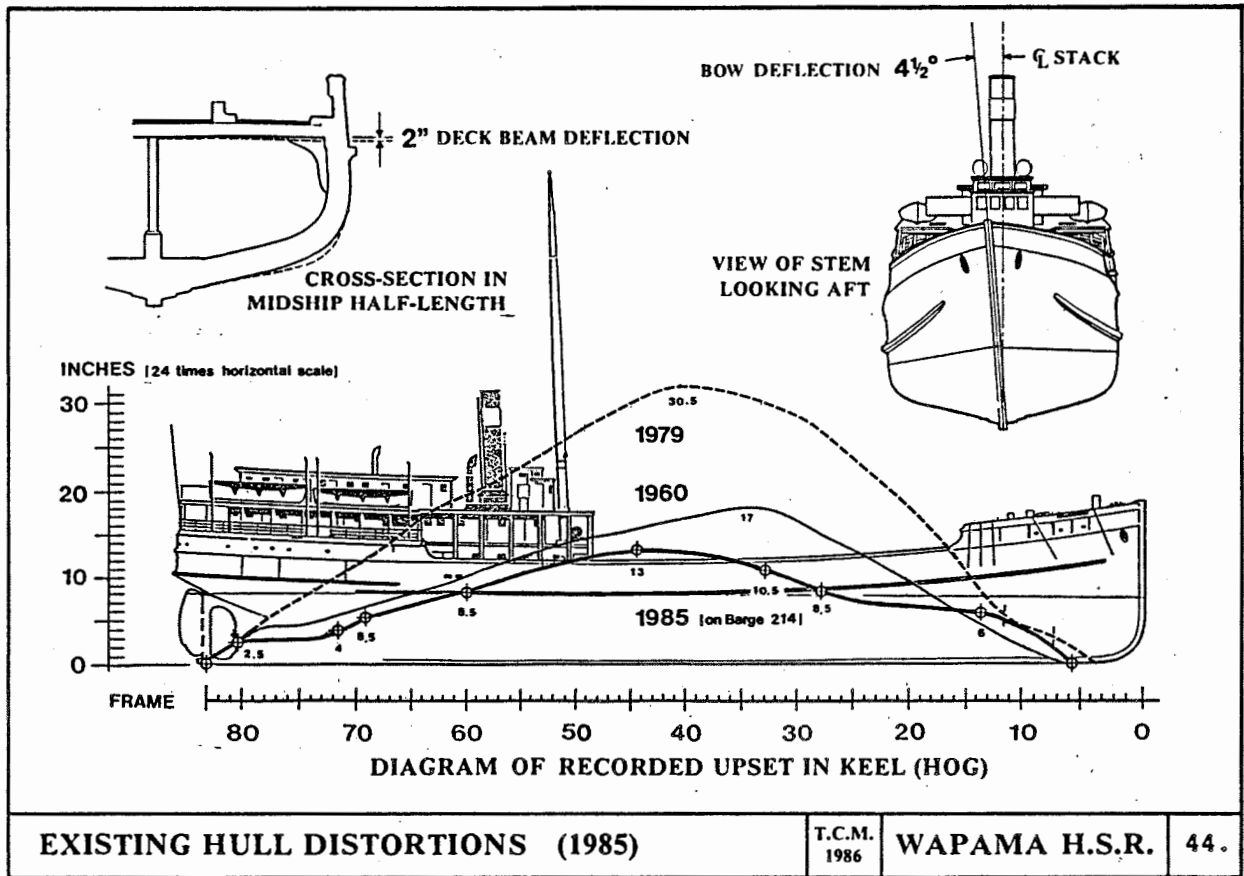
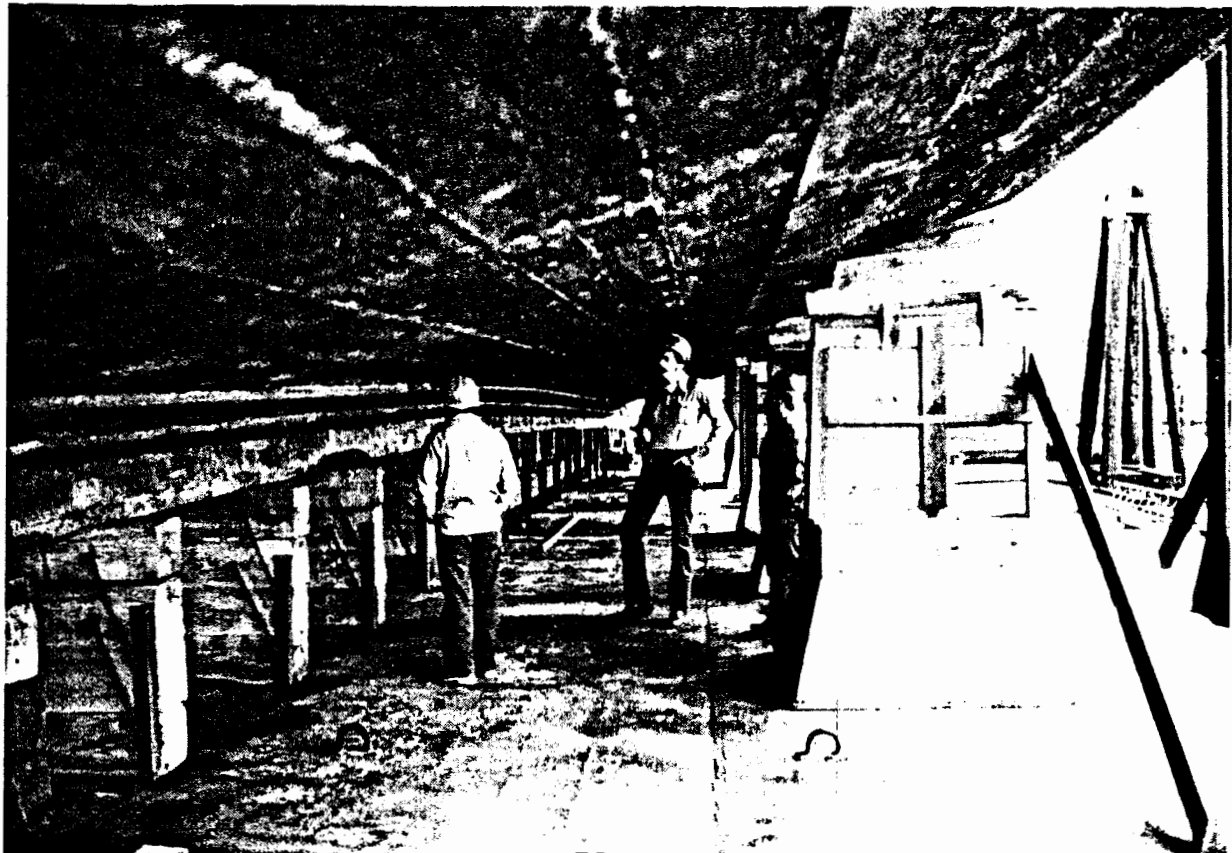

Fig. 45. View of bottom, stbd. side looking fwd, 1985. --TCM



**c. Sagging of the main deck in way of the hatch.**

This is the result of severely weakened half-beams, carlings, and deck stringers in way of the hatch. Shoring has been placed under the hatch, and more shoring is planned for weakened deck beams fore and aft of the hatch.

**d. Dishing of the cabin deck in way of the fidley.**

The weight of the stack, and the poor condition of cabin deck beams at the fidley have resulted in local dishing of the cabin deck. This depressed area holds rainwater and causes further deterioration of the deck structure. A contract has been awarded to brace the stack and relieve the load on deck beams.

**3. Determining Strength of Deteriorated Structure**

The strength of deteriorated wood is difficult to assess. The science of engineering is exacting when applied to new wood or more predictable and homogeneous materials such as steel, but is not so precise when applied to situations like WAPAMA. The need to accurately assess the strength of severely deteriorated wood structures has rarely arisen in the past. This has changed somewhat recently as more efforts are made to preserve historic structures. An estimation of strength can be made through visual inspection, sounding, and probing (methods used in the survey). In WAPAMA's case, an accurate assessment using this method is complicated by the following factors.

**a. Decay and weakening are sometimes hard to see.**

Although a timber may be 95% sound, local deterioration at a critical point can render the timber structurally ineffective. What is more, the weakening effects of this decay may not be detectable. In a deck beam, for example, decay located in or near the middle of the unsupported span will cause weakening that would likely result in noticeable deflection of the beam. If, on the other hand, decay is localized at the end of the deck beam, near the point of shear, deflection may not be noticeable until ultimate failure of the beam. Visible signs of decay are often hidden by surrounding structure, requiring extensive removals for inspection.

**b. Holding power of fastenings is questionable**

Strength and holding power of fastenings is critical to structural strength. Iron bolts and wood trunnel fastenings are buried deep inside timbers and cannot be easily inspected. It is the buried portion of fastenings that usually suffers most from decay or corrosion (see figs. 43 and 47). Removal of selected sample fastenings for inspection may give a general idea of the overall condition of fastenings. A large number of fastenings would have to be removed in order to fully assess their condition.

The holding power of fastenings is also greatly affected by the condition of the surrounding wood. Again, this cannot be determined with removal of fastenings or cutting away the surrounding timber.

**c. Rate of deterioration is uncertain**

Ongoing deterioration can render strength assessments invalid in a relatively short period of time. The rate of deterioration, particularly fungal decay, can vary considerably depending on factors including weather, temperature, and level of maintenance.

**4. Conclusions**

An estimation of structural strength is felt to be adequate for the presently planned usage of WAPAMA, particularly if coupled with the philosophy: "when in doubt, renew or add support". The decision on which option to take will depend on relative cost, interpretation goals, and the historical value of the fabric in question.

It should be noted that structural loading discussed here is not that for which the vessel was designed. The stresses imposed on the vessel while in service, or merely afloat, are much greater than those now experienced. Now, the structure has only to support itself and the gear remaining onboard. The loads imposed by public access are far less than design loads. The structure is, therefore, extremely overbuilt for the present usage.

In the event that new and greater loads are planned for the vessel, or deterioration progresses significantly, a more precise structural assessment should be considered. Two methods, other than visual inspection, are now used to determine strength in wood structural members: the load testing method and the stress-wave method (Lanius 1982). The load method involves introducing a load to the member in question and measuring the deflection (Suter 1982). Stress-wave testing measures a shock wave as it passes through the test member. One or both of these methods could be used to determine the strength of selected load-bearing members.

#### IV. MEASURED DRAWINGS

##### Explanation of Measured Drawings

The measured drawings of the WAPAMA produced for this Report are the result of field measurements taken on board the vessel and Barge 214 in December of 1985. The drawings, principally produced by Don Birkholz, Sr. of Galveston, Texas, have been field checked against the ship and revised before completion.

A lines take-off of the ship and production of two sets of lines were originally intended. One set would have been strictly the existing condition, showing all the distortions of hog, twist, loss of deadrise, sagging, racking, and bending. The other set was intended to remove these distortions on paper and project the lines back to best estimate of as-built.

Unfortunately, the funds available precluded this degree of documentation. At first glance it may seem that if only partial recording was fundable the place to start would be with the basic hull form, and leave the details to a later date. This HSR, however, is intended primarily for use in planning the stabilization, preservation, and interpretation of the WAPAMA. For these purposes arrangement and construction drawings were considered more useful than an exact record of hull form.

The value of the lines is chiefly in documentation of the history of ship design, and fortunately the lines of several other steam schooners are in existence. But the WAPAMA represents the last chance to record the details of construction and arrangement of the type. If she were to be lost to fire or other causes in the near future, the knowledge of her is best preserved in the type of drawings produced for this HSR.

These drawings do not strictly conform to HABS-HAER standards in that the drawings show the ship as believed to be built, rather than in her existing condition. Dashed lines and notes identify structures added during the vessel's working life and subsequent years as a museum ship, as well as equipment original to the ship but not in place at the time of survey.

The two major structural distortions, hog and twist, were measured and noted, and the hog indicated on the Inboard Profile (Sheet 4) by dotted line. A diagrammatic representation of these distortions is provided in Fig. 44. The existing condition of the vessel is described in detail in Section III of this report.

Another departure from existing condition is that the drawings show the ship with all equipment onboard. The ship is more readily understood with her working machinery in place rather than disassembled on the deck of the barge. The present location of various items of equipment is a temporary requirement of preservation rather than a matter of historic record. Therefore these drawings represent the WAPAMA as a whole ship.



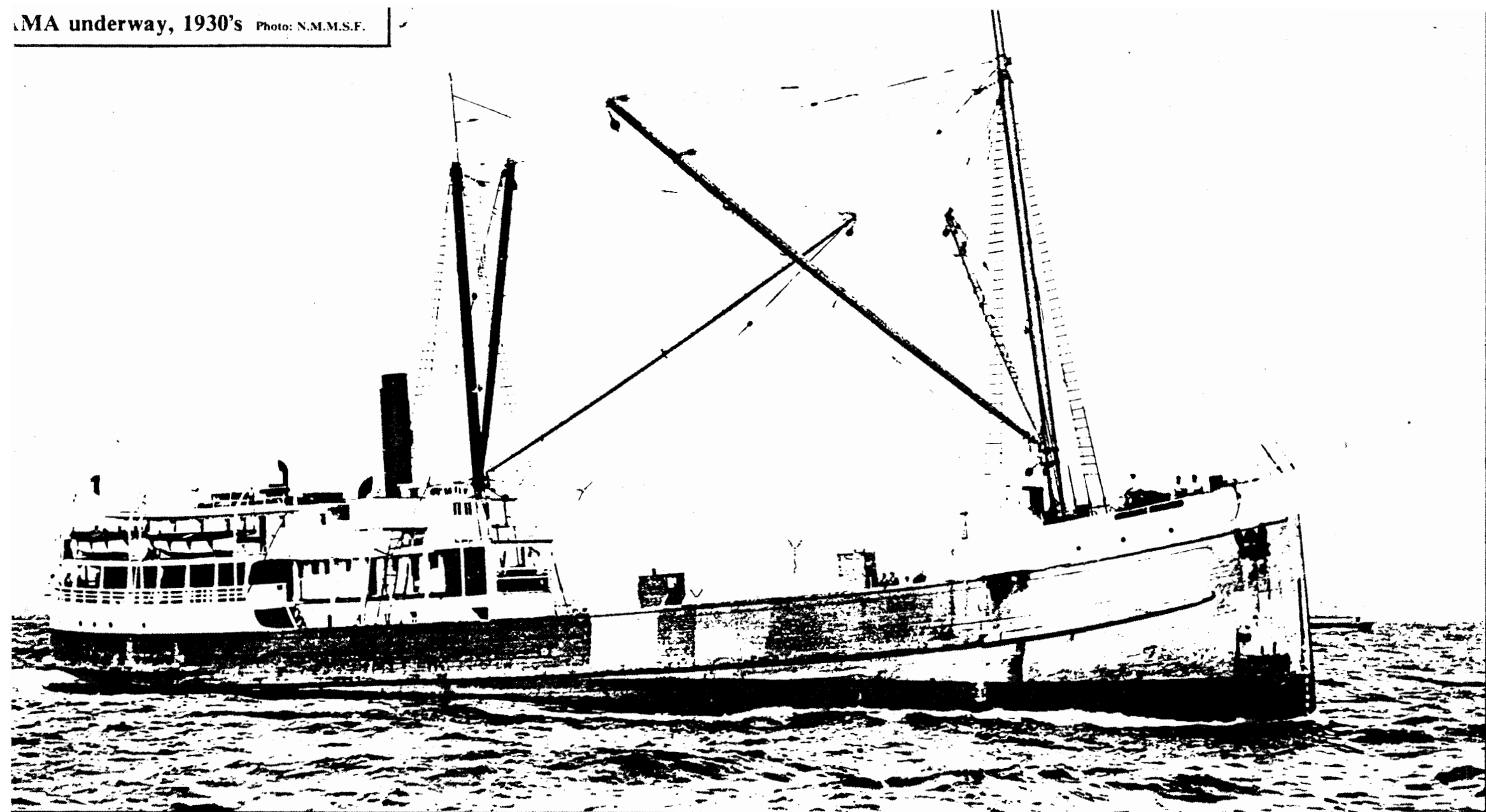

**SHEET INDEX**

- 1. COVER SHEET
- 2. PROFILE VIEW
- 3. OUTBOARD PROFILE
- 4. INBOARD PROFILE
- 5. PLAN OF HOLD ON BARGE
- 6. PLAN OF MAIN DECK
- 7. PLAN OF CABIN DECK
- 8. PLAN OF BOAT DECK AND HOUSE TOPS
- 9. PLAN OF FO'C'SLE DECK
- 10. PLAN OF TWEEN DECK
- 11. MIDSHIP SECTION
- 12. CROSS SECTIONS
- 13. RIGGING ARRANGEMENT

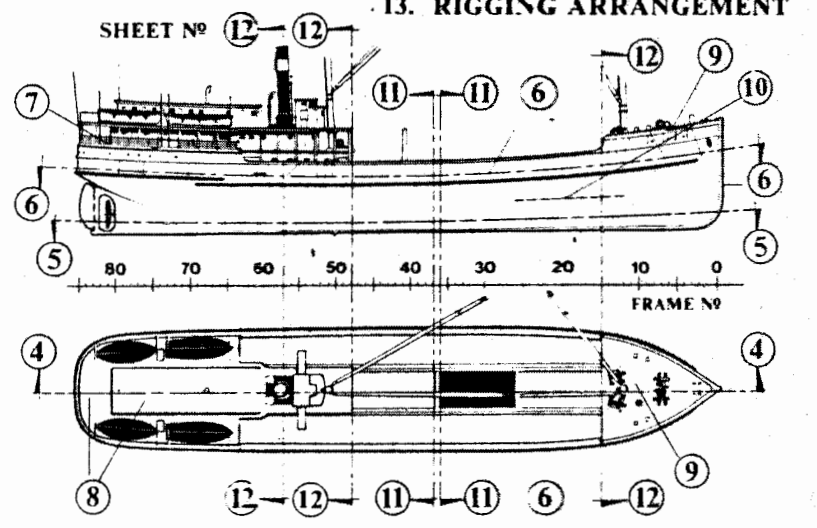

**BASIC DATA**

OFFICIAL No: 213092 NET TON.: 524 GROSS TON.: c.945  
 LENGTH OVERALL: 216'-11" BEAM: 41'-1"  
 BUILT: 1915, St. Helens Shipbuilding Co., St. Helens, Oregon  
 for Charles R. McCormick Co.  
 ENGINE: Steam, triple-expansion, built by Main Street Iron Works,  
 San Francisco. 2 water-tube boilers, built by Babcock & Wilcox

ERN CALIFORNIA

THE GOLDEN GATE showing part of the G.G.N.R.A.

THE BAY MODEL Sausalito, California

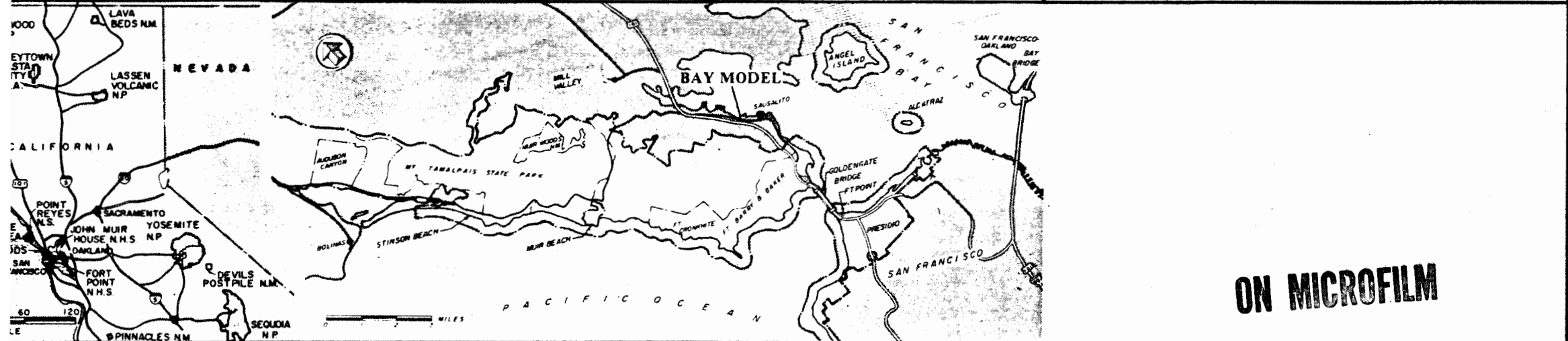

**ON MICROFILM**

**ABBREVIATIONS AND SYMBOLS**

|                    |                             |               |
|--------------------|-----------------------------|---------------|
| BHD Bulkhead       | LKR Locker                  | TYP Typical   |
| BLWK Bulwark       | OA Overall                  | VERT Vertical |
| CL Centerline      | OPG Opening                 |               |
| DK Deck            | OUTBD Outboard              |               |
| FR Frame           | P & S Port & Starboard      |               |
| F & A Fore-and-Aft | RAD Steam Radiator          |               |
| FWD Forward        | SHLVS Shelves               |               |
| INBD Inboard       | STBD Starboard              |               |
| KLSN Keelson       | STL Steel                   |               |
| LGL Longitudinal   | T & G Tongue & Groove       |               |
| LONG SECTION       | SECTION LINE                |               |
| CROSS SECTION      | ADDED STRUCTURE             |               |
| UNDEFINED          | HISTORIC (FORMER) STRUCTURE |               |
| BULKHEAD STRUCTURE |                             |               |

**STEAM SCHOONER WAPAMA**

Prepared by  
 TRI-COASTAL MARINE, INC.  
 (WHITE ELEPHANT MANAGEMENT CO.)  
 GALVESTON, TEXAS  
 1986

HISTORIC STRUCTURE REPORT

UNITED STATES  
 DEPARTMENT OF THE INTERIOR  
 NATIONAL PARK SERVICE  
 DENVER SERVICE CENTER

PREPARED

TITLE OF DRAWING  
**COVER SHEET**  
 LOCATION WITHIN PARK  
 (SURVEYED, PACIFIC DRYDOCK, ALAMEDA)  
 NAME OF PARK  
**GOLDEN GATE NAT. REC. AREA**  
 WESTERN MARINE SAN FRANCISCO CALIF. STATE  
 REGION COUNTY STATE

641/80,048

PCIP PKG 557

SHEET 1 OF 13



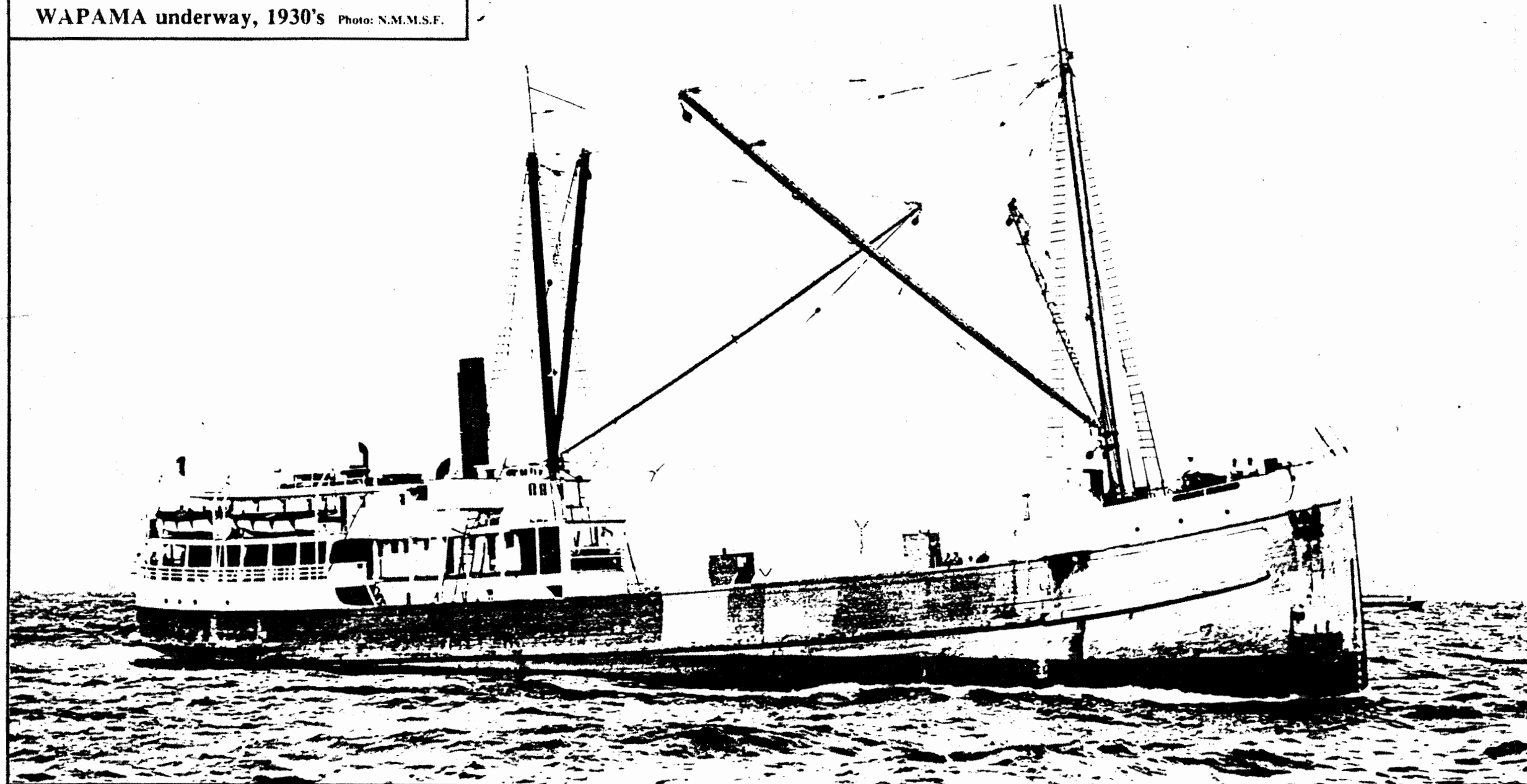

**SHEET INDEX**

- 1. COVER SHEET 7. F
- 2. PROFILE VIEW 8. F
- 3. OUTBOARD PROFILE A
- 4. INBOARD PROFILE 9. F
- 5. PLAN OF HOLD ON BARGE 10. F
- 6. PLAN OF MAIN DECK 12. C
- 13. I

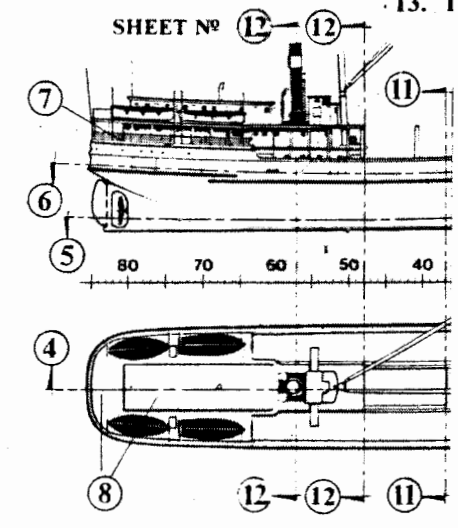

**BASIC DATA**

OFFICIAL No: 213092 NET TON.  
 LENGTH OVERALL: 216'-11" BE  
 BUILT: 1915, St. Helens Shipbuilding  
 for Charles R. McCormick Co.  
 ENGINE: Steam, triple-expansion, bu  
 San Francisco. 2 water-tube boilers.

**ABBREVIATIONS AN**

|                    |              |       |       |
|--------------------|--------------|-------|-------|
| BHD                | Bulkhead     | LKR   | 1     |
| BLWK               | Bulwark      | OA    | C     |
| CL                 | Centerline   | OPG   | C     |
| DK                 | Deck         | OUTBD | C     |
| FR                 | Frame        | P & S | F     |
| F & A              | Fore-and-Aft | RAD   | S     |
| FWD                | Forward      | SHLVS | S     |
| INBD               | Inboard      | STBD  | S     |
| KLSN               | Keelson      | STL   | S     |
| LGL                | Longitudinal | T & G | T     |
| LONG SECTION       |              |       | SEC   |
| CROSS SECTION      |              |       | ADD   |
| UNDEFINED          |              |       | HIST  |
| BULKHEAD STRUCTURE |              |       | (FOF) |

**NORTHERN CALIFORNIA**

**THE GOLDEN GATE showing part of the G.G.N.R.A.**

**THE BAY MODEL Sausalito, California**

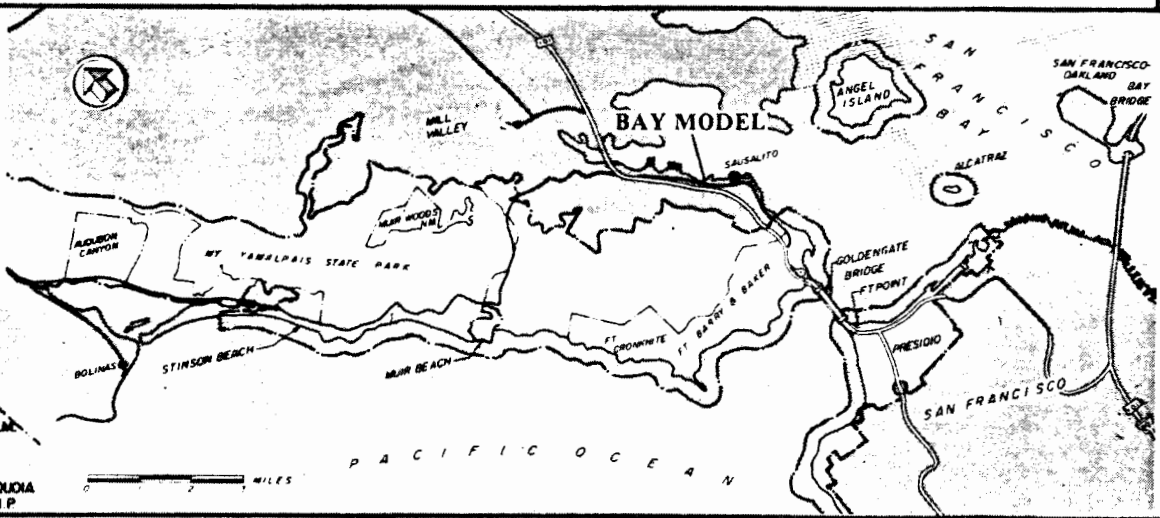
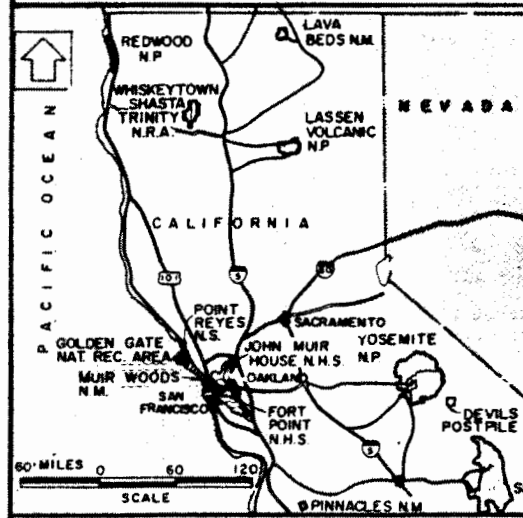

**ON MICROFILM**

**STEAM SCHOONER WAPAMA**

Prepared by  
 TRI-COASTAL MARINE, INC.  
 (WHITE ELEPHANT MANAGEMENT CO.)  
 GALVESTON, TEXAS  
 1986

**HISTORIC STRUCTURE REPORT**  
 UNITED STATES  
 DEPARTMENT OF THE INTERIOR  
 NATIONAL PARK SERVICE  
 DENVER SERVICE CENTER

PREPARED  
 DRAWN  
 CHECKED  
 DATE

TITLE OF DRAW  
**COVER SH**  
 LOCATION WITHIN  
 (SURVEYED, PACIFIC DRY  
 NAME OF PAI  
**GOLDEN GATE NAT**  
 WESTERN MARINE SAN FRA  
 REGION COUNTY

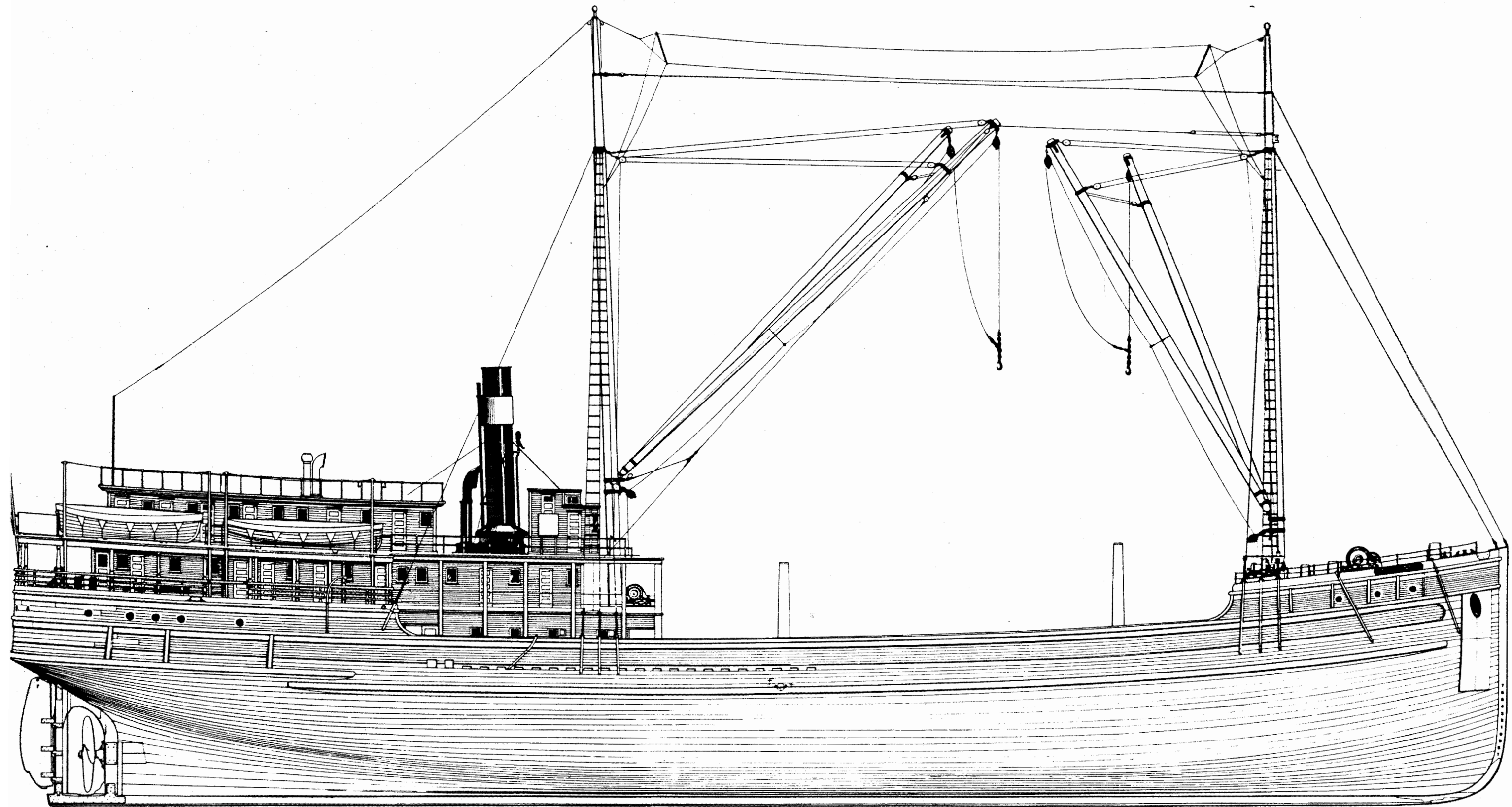

SCALE OF FEET

|          |                           |            |
|----------|---------------------------|------------|
| PREPARED | TITLE OF SHEET            | DRAWING NO |
| DRAWN    | Steam Schooner WAPAMA     | 641/80,048 |
| CHECKED  | PROFILE VIEW              | PCIP       |
| DATE     | Historic Structure Report | PKG 557    |
|          |                           | SHEET 2    |
|          |                           | OF 13      |

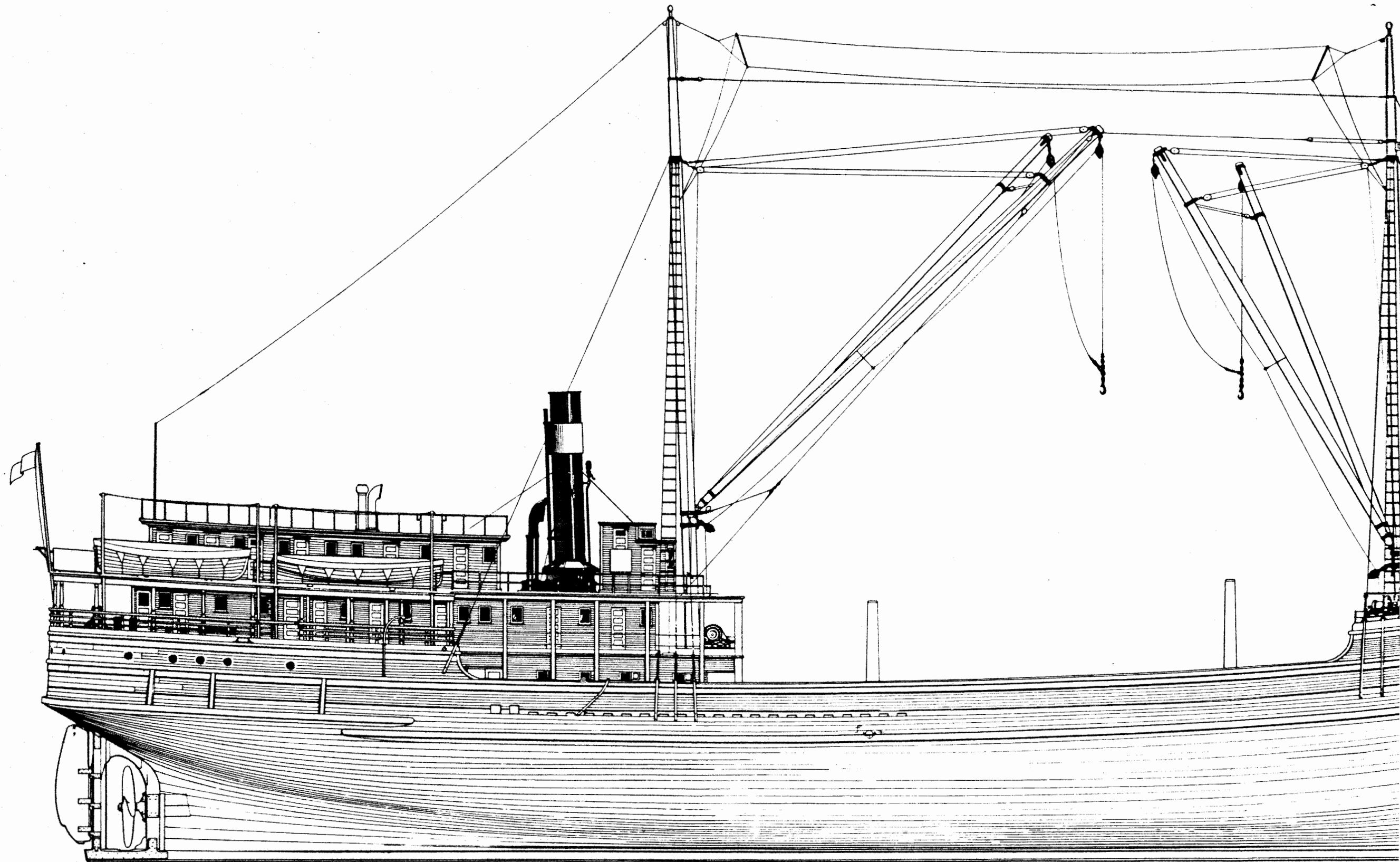

4 0 4 0 12  
SCALE OF FEET

PREPARED

DRAWN

CHECKED

DATE

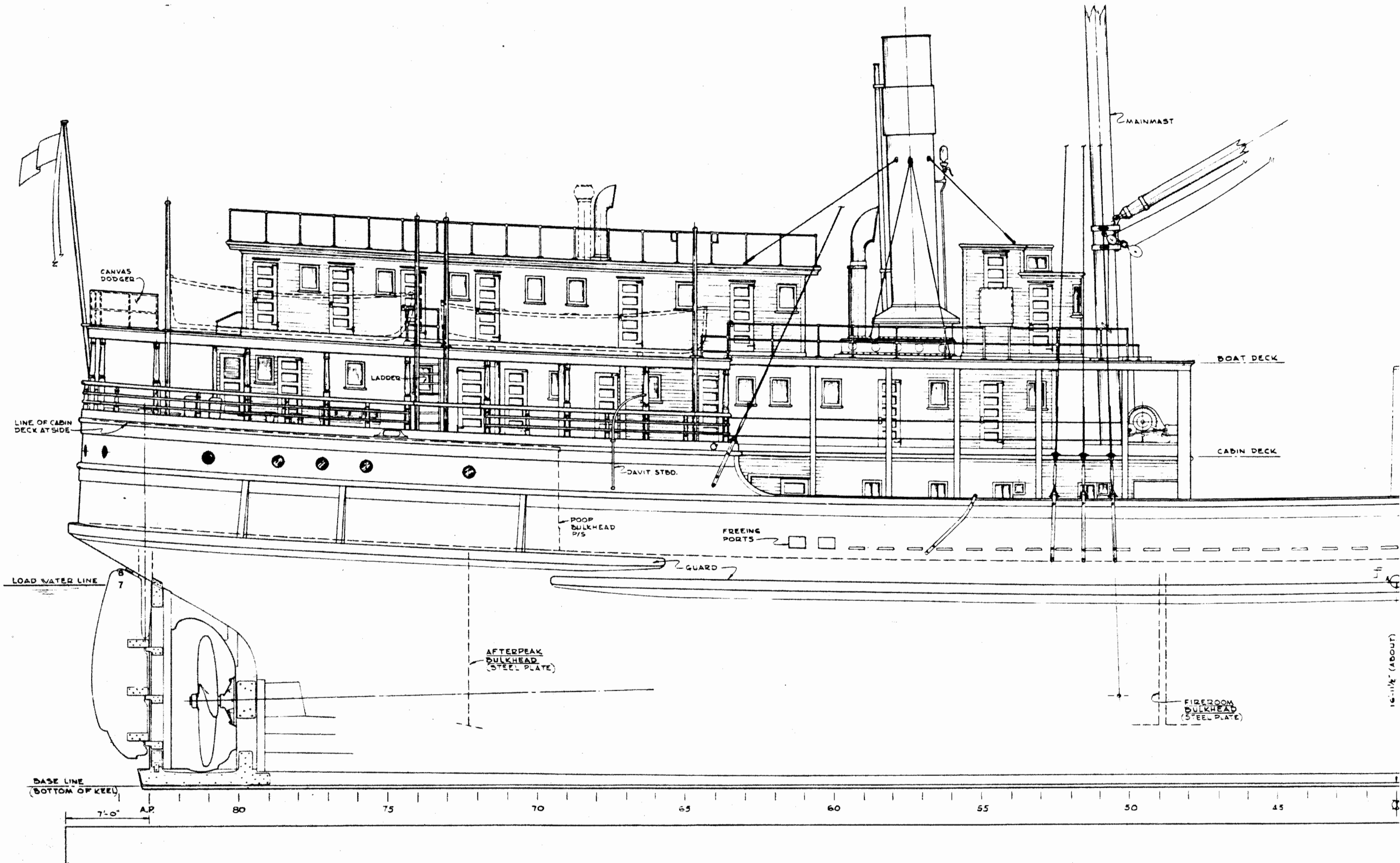

4 0 4 8 12  
SCALE OF FEET

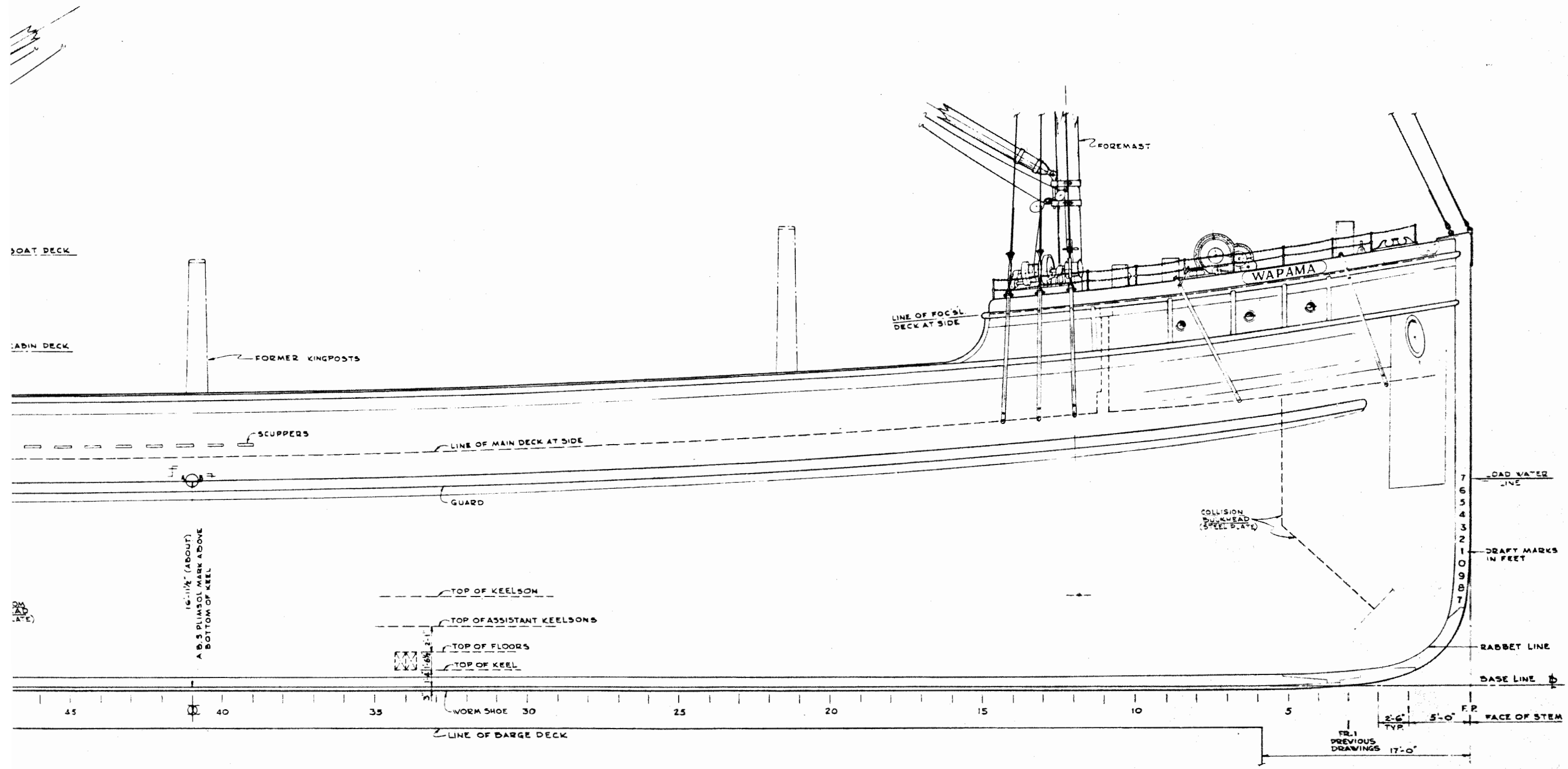

|          |                           |               |
|----------|---------------------------|---------------|
| PREPARED | TITLE OF SHEET            | DRAWING NO.   |
| DRAWN    | Steam Schooner WAPAMA     | 641780,048    |
| CHECKED  | OUTBOARD PROFILE          | 0491          |
| DATE     | Historic Structure Report | PCIP PKB. 557 |
|          |                           | SHEET 3       |
|          |                           | OF 13         |

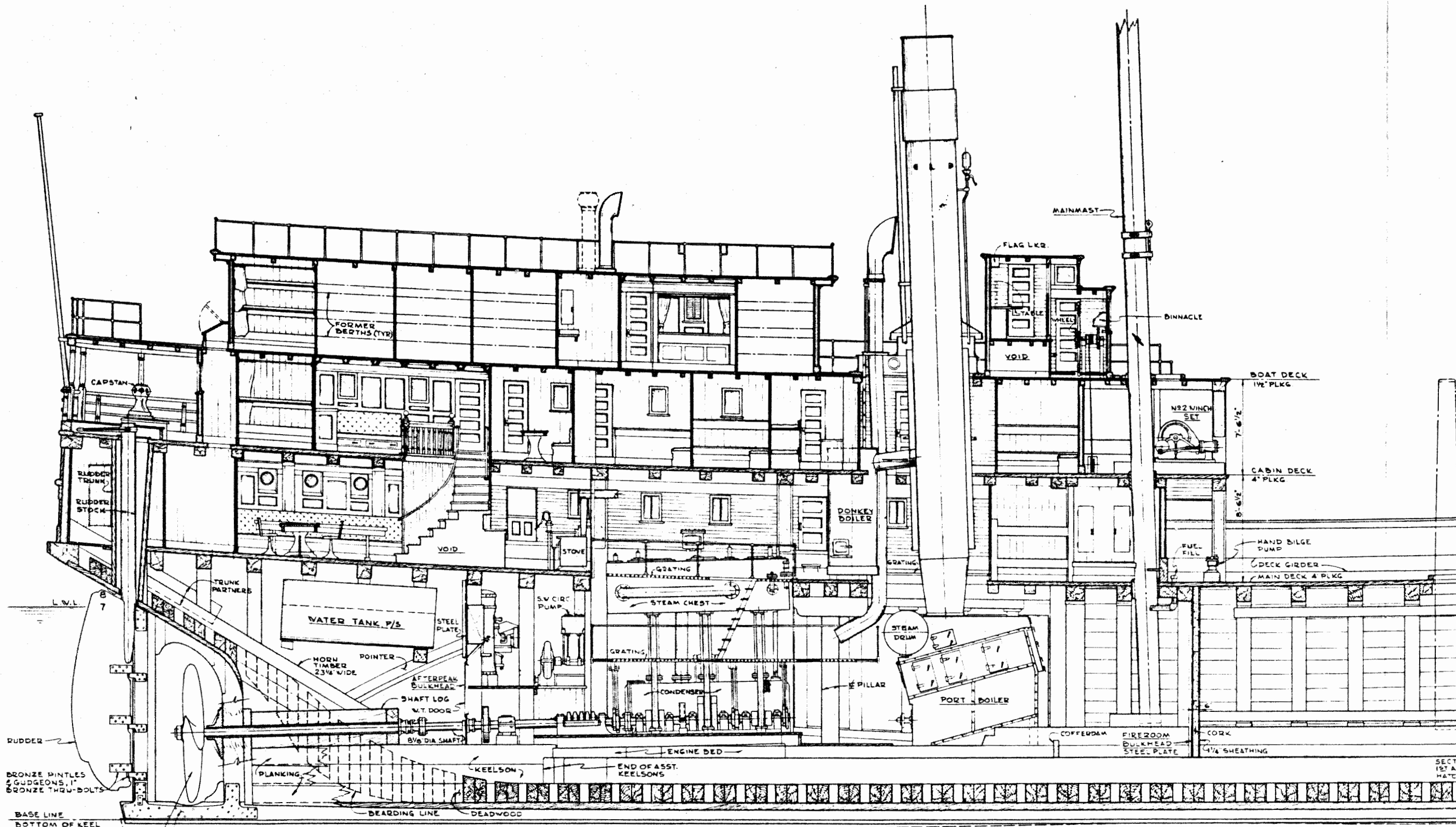

BASE LINE BOTTOM OF KEEL  
 A.P. IRON OR STEEL PROPELLER  
 80 LINE OF HOG AT KEEL, DEC., 1985  
 75  
 70  
 65  
 60  
 55  
 50  
 45

4 0 4 8 12  
 SCALE OF FEET

SECT  
 187 A  
 HATE

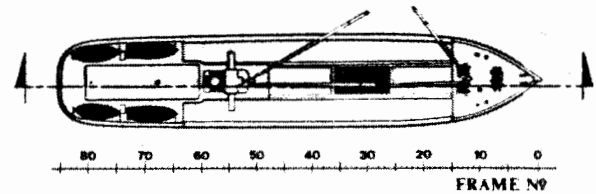
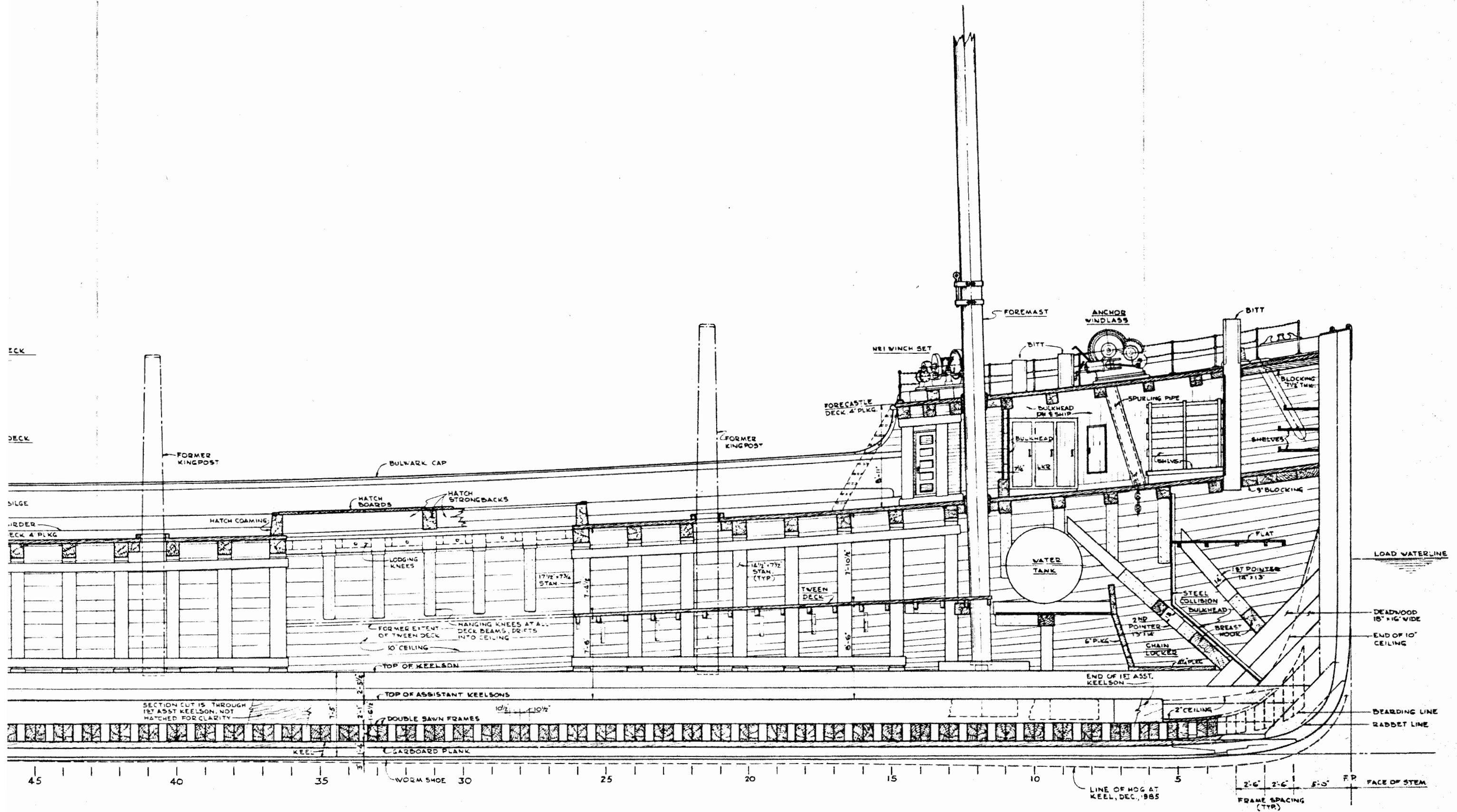

|          |                           |               |
|----------|---------------------------|---------------|
| PREPARED | TITLE OF SHEET            | DRAWING NO    |
| DRAWN    | Steam Schooner WAPAMA     | 641/80,048    |
| CHECKED  | INBOARD PROFILE           | PCIP PKG 557  |
| DATE     | Historic Structure Report | SHEET 3 OF 13 |

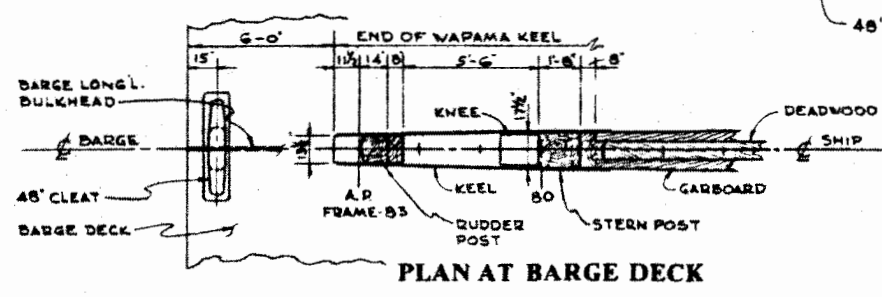
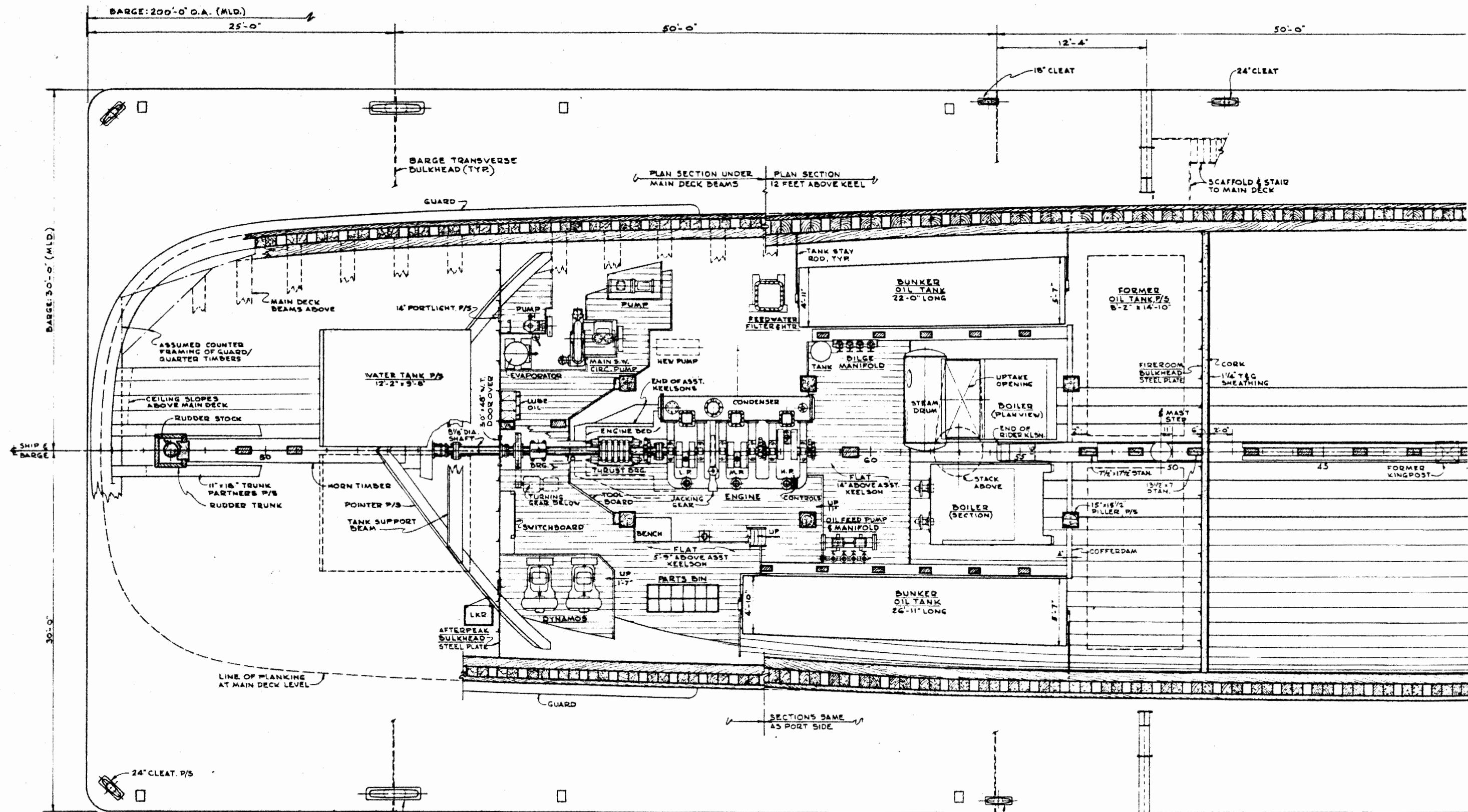



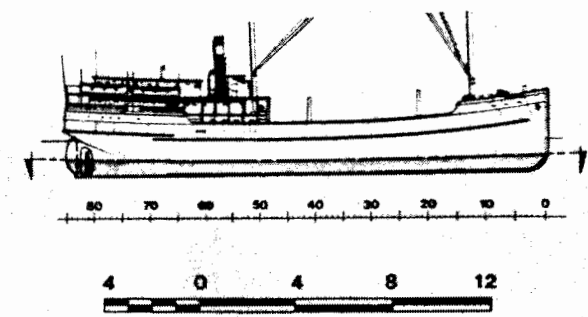
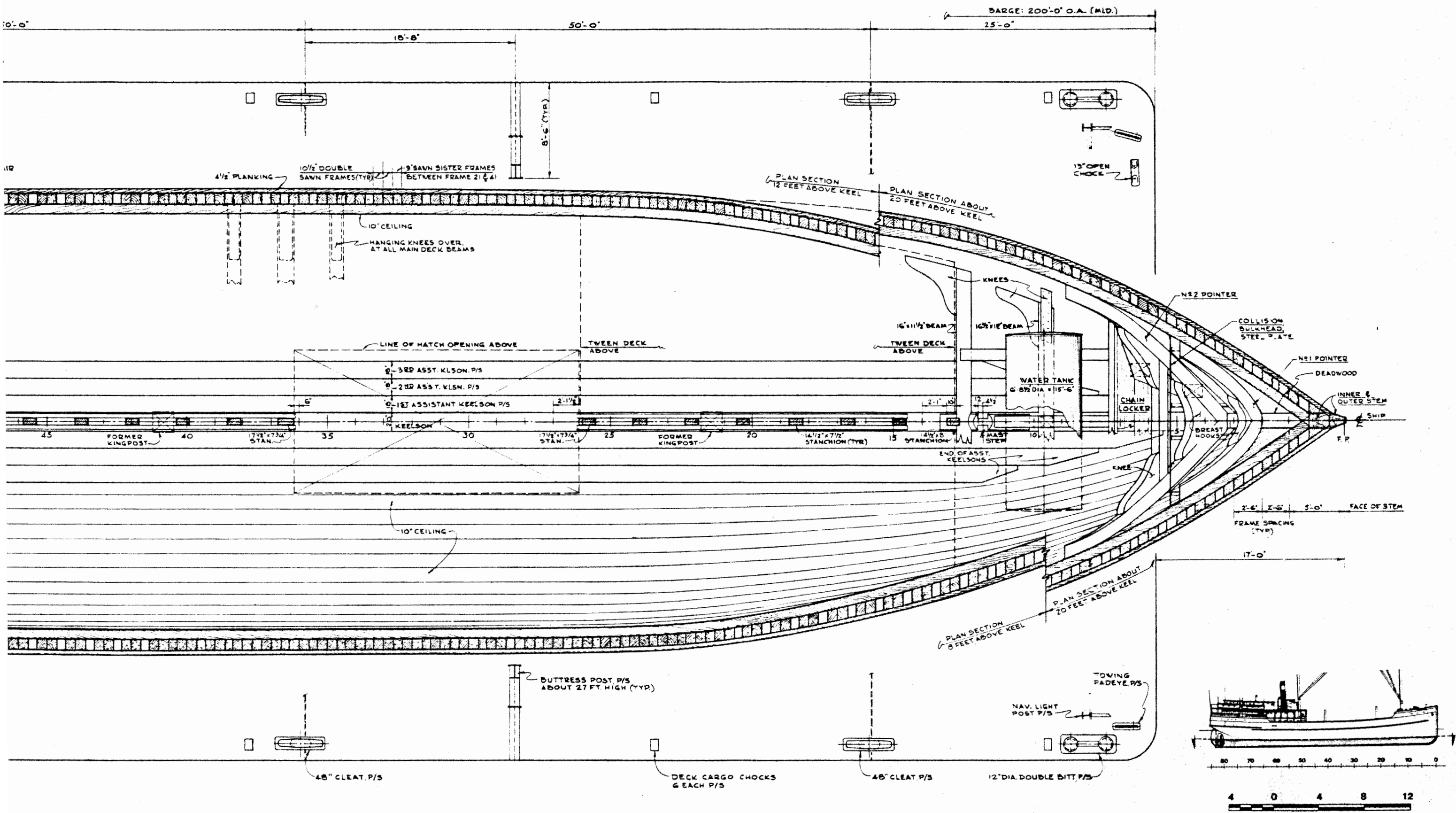

|          |                           |               |
|----------|---------------------------|---------------|
| PREPARED | TITLE OF SHEET            | DRAWING NO.   |
| DRAWN    | Steam Schooner WAPAMA     | 641/80,048    |
| CHECKED  | PLAN OF HOLD              |               |
| DATE     | ON BARGE                  |               |
|          | Historic Structure Report |               |
|          | PCIP Pkg 557              | SHEET 5 OF 13 |

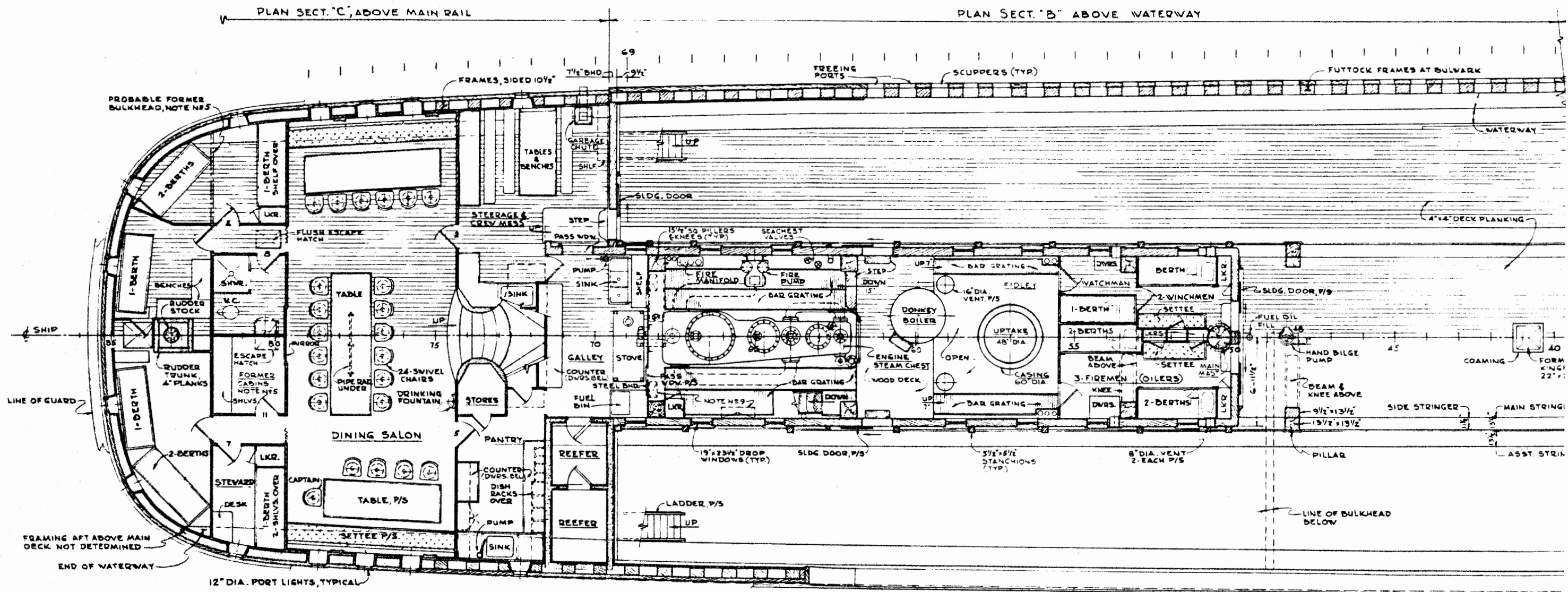

STARBOARD SIDE: PLAN SECT. 'C' ABOVE MAIN RAIL

**PASSENGERS (25)**

44 - CABIN (1st CLASS)  
12 TO 22 - STEERAGE  
56 TO 66 - TOTAL PASSENGERS

**CREW (LUMBER/PASSENGER TRADE)**

MASTER  
1st AND 2nd MATE  
2 - RADIO OPERATORS  
2 - WINCH DRIVERS  
3 - ABLE SEAMEN  
1 - WATCHMAN  
  
CHIEF ENGINEER  
1st AND 2nd ASST. ENGINEER  
3 - FIREMEN (OILERS)  
  
STEWARD  
COOK  
PANTRYMAN  
2 - WAITERS  
27 - TOTAL CREW

**GENERAL NOTES**

1. NOTATIONS BELOW CONCERNING ORIGINAL ACCOMMODATIONS, ETC ARE FROM K. KORTUM INTERVIEW WITH NEILS ZONBERG, 1959.
2. FORECASTLE: PORT FOCSL HAS BEEN RESTORED AS FOUND, BUT ORIGINALLY ACCOMMODATED 8 - SEAMEN. STBD FOCSL IS NOT RESTORED. NUMBER OF STEERAGE PASSENGERS WAS VARIOUSLY LISTED FROM 12 TO 22.
3. LOCKERS FRAME 11 TO 15: ORIGINALLY A PAINT LOCKER AND HEAD TO PORT, AND A GEAR LOCKER AND HEAD TO STBD. THUS THE CREWS HEAD WAS TO PORT, AND THE STEERAGE TO STBD.
4. STEERAGE AND CREW MESS: ORIGINAL ARRANGEMENT IS NOT KNOWN. EVIDENCE REMAINS THAT THE PASS WINDOW AT FRAME 70-71 WAS AT ONE TIME A SLIDING DOOR (TO WEATHER). THE TOWARD SHIP BULKHEAD PRESENTLY AT FRAME 69 1/2 MAY HAVE BEEN AT FRAME 71 1/2. ORIGINALLY THERE WAS NO DOOR (NE 2) FROM CREWS MESS TO DINING SALON.
5. CABINS AFT OF DINING SALON (FRAME 80-82): ORIGINALLY THERE WERE FOUR 2-BERTH PASSENGER CABINS, TWO INBOARD AND TWO OUTBOARD (DOOR 4, 7, 8 AND 11).
6. STERN CABINS, AFT OF FRAME 82: ORIGINALLY THERE WERE TWO CABINS AFT; THE STEWARD TO STBD., AND THE COOK PANTRYMAN AND 2-WAITERS TO PORT.
7. THE WATCHMAN WAS A CLEAN-UP AND MAINTENANCE MAN AT SEA.
8. THE FORECASTLE BULKHEAD (FRAME 11) HAS 6" HIGH SOLID HORIZONTAL PLANKING WITH 3/4" SHEATHING EACH SIDE.
9. IN THE ENGINE CASING, THE RECTANGULAR DUCTS FRAME 88 P/S AND THE ELECTRIC PANEL, FRAME 65-66 S/SD, ARE NEW ADDITIONS.

PLAN SECT. "A" AT TOP OF DECK BEAMS

PLAN SECT. "B" ABOVE WATERWAY

TYPICAL DECK FRAMING

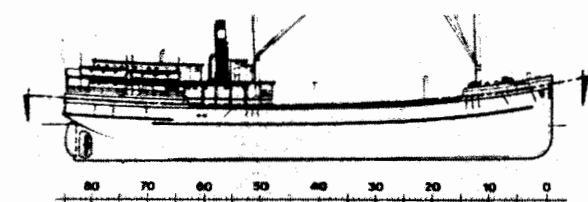
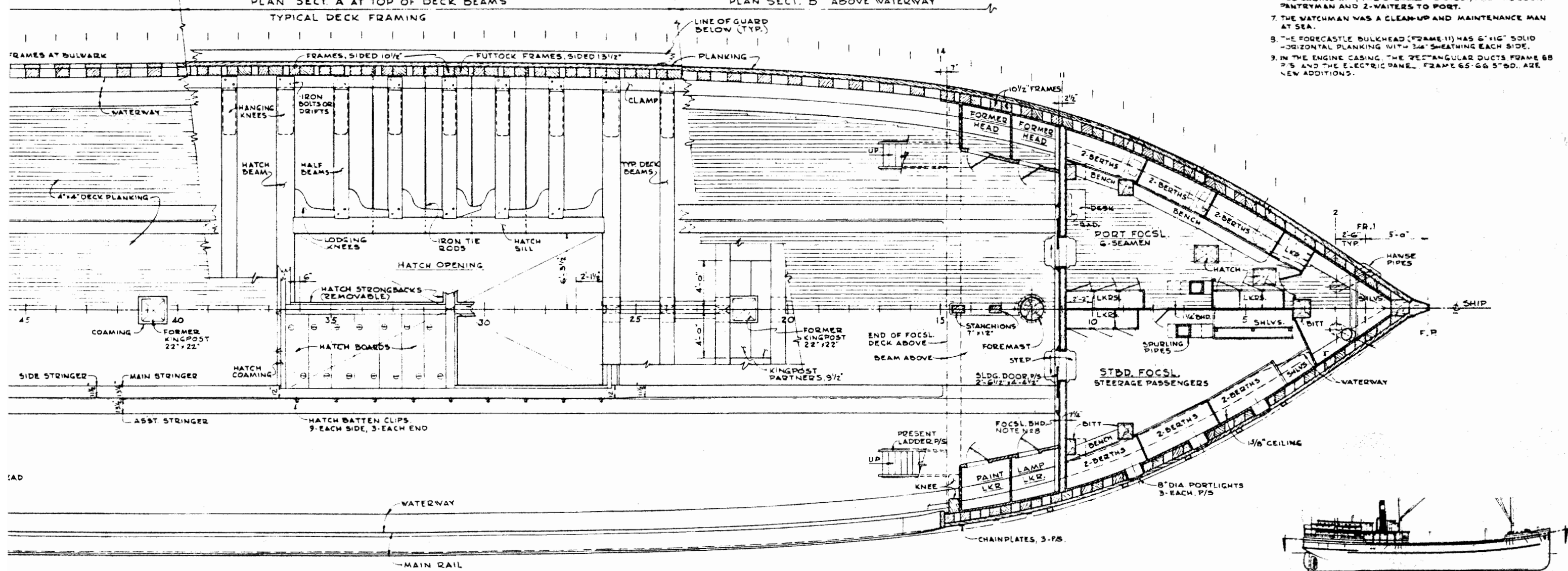

4 0 4 8 12  
SCALE OF FEET

|          |                           |                            |
|----------|---------------------------|----------------------------|
| PREPARED | TITLE OF SHEET            | DRAWING NO.                |
| DRAWN    | Steam Schooner WAPAMA     | 641/80,048                 |
| CHECKED  | PLAN OF MAIN DECK         | 041                        |
| DATE     | Historic Structure Report | PCIP PKB 557 SHEET 6 OF 13 |

**GENERAL NOTES**

1. NUMBERS NOTED AT EXISTING DOOR NUMBER ON SHIP. TYPICAL DOOR
2. FIRST CLASS PASSENGER PASSENGER CABIN (ARE SAME AS ON BOAT NO 7, NOTE NO 2) EXCEPT SETTEE.
3. PHOTOS SHOW THAT (TO BREAK OF BULWARK FROM CIRCA 1931 TO A)
4. BATHROOMS AFT (FROM K. KORTUM DATE WERE 4. BATHROOMS AND 1. FOR OFFICERS)
5. ALL WINDOWS ARE 1'-
6. FRAME CENTERS ARE WITH OTHER DRAWING OTHER THAN HULL THESE CENTERS.

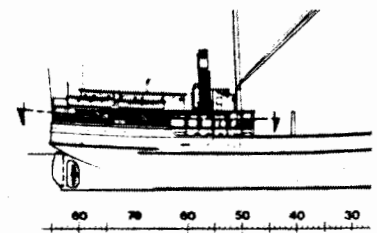
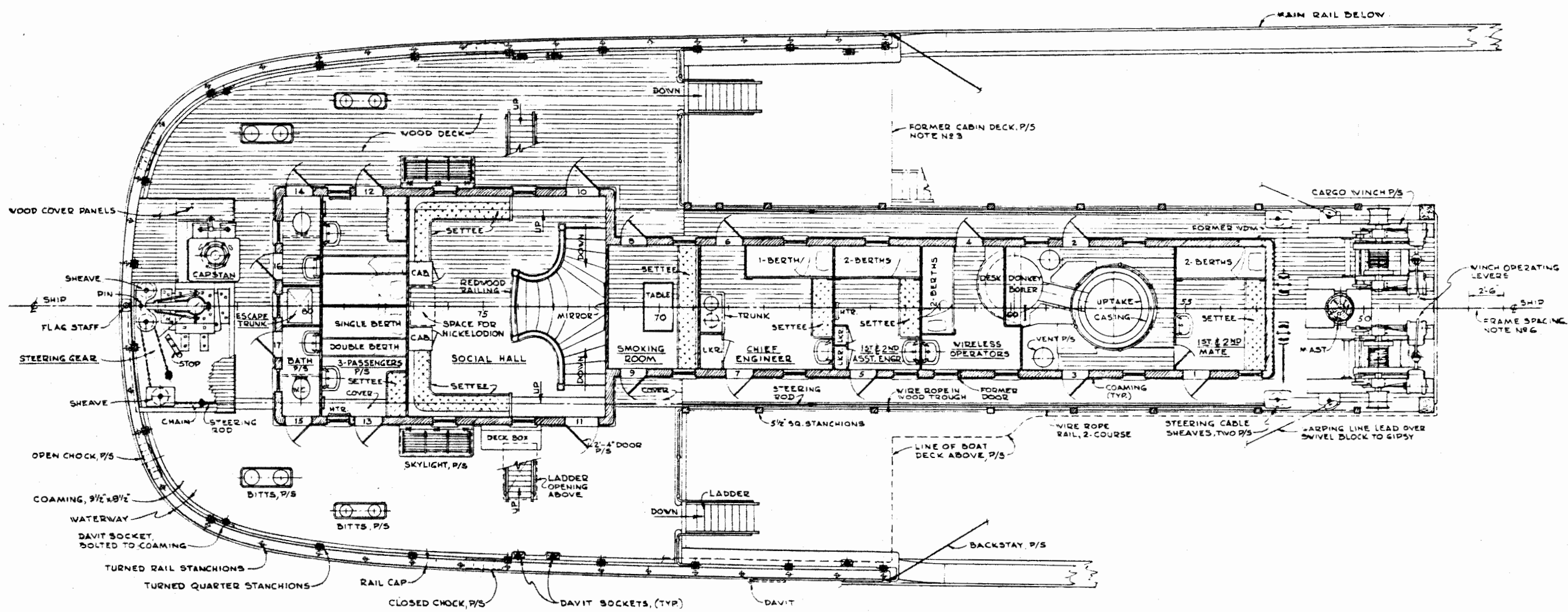

60 70 80 90 100

4 0 4  
SCALE OF FEET

|          |                      |
|----------|----------------------|
| PREPARED | TITLE OF SHEET       |
| DRAWN    | Steam Schooner WA    |
| CHECKED  | PLAN OF CABIN        |
| DATE     | Historic Structure I |

### GENERAL NOTES

1. NUMBERS NOTED AT DOORS REFLECT EXISTING DOOR NUMBER LABEL PLATES ON SHIP. TYPICAL DOORS ARE 1'-10 1/2" x 5'-8 1/2".
2. FIRST CLASS PASSENGERS ON CABIN DECK - 6. PASSENGER CABIN (NO 12 & 13) FURNISHINGS ARE SAME AS ON BOAT DECK (SEE SHEET 47, NOTE NO 2) EXCEPT FOR BERTHS AND SETTEE.
3. PHOTOS SHOW THAT CABIN DECK EXTENDED TO BREAK OF BULWARK WITH LADDER INBOARD FROM CIRCA 1931 TO AFTER 1937.
4. BATHROOMS AFT (FRAME 80-81): FROM V. KORTUM DATA, ORIGINALLY THERE WERE 4. BATHROOMS, 3 - FOR PASSENGERS AND 1 - FOR OFFICERS.
5. ALL WINDOWS ARE 1'-7" x 2'-3 1/2" DROP TYPE.
6. FRAME CENTERS ARE SHOWN FOR COMPARISON WITH OTHER DRAWINGS ONLY. NO STRUCTURE OTHER THAN HULL FRAMES IS LOCATED ON THESE CENTERS.

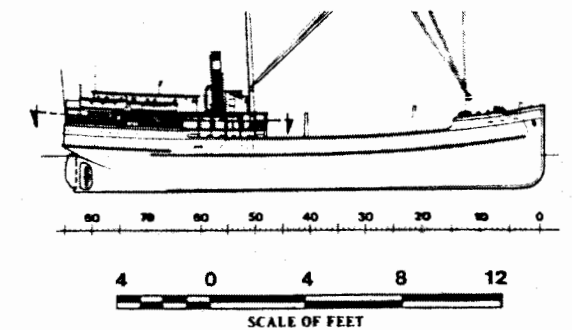
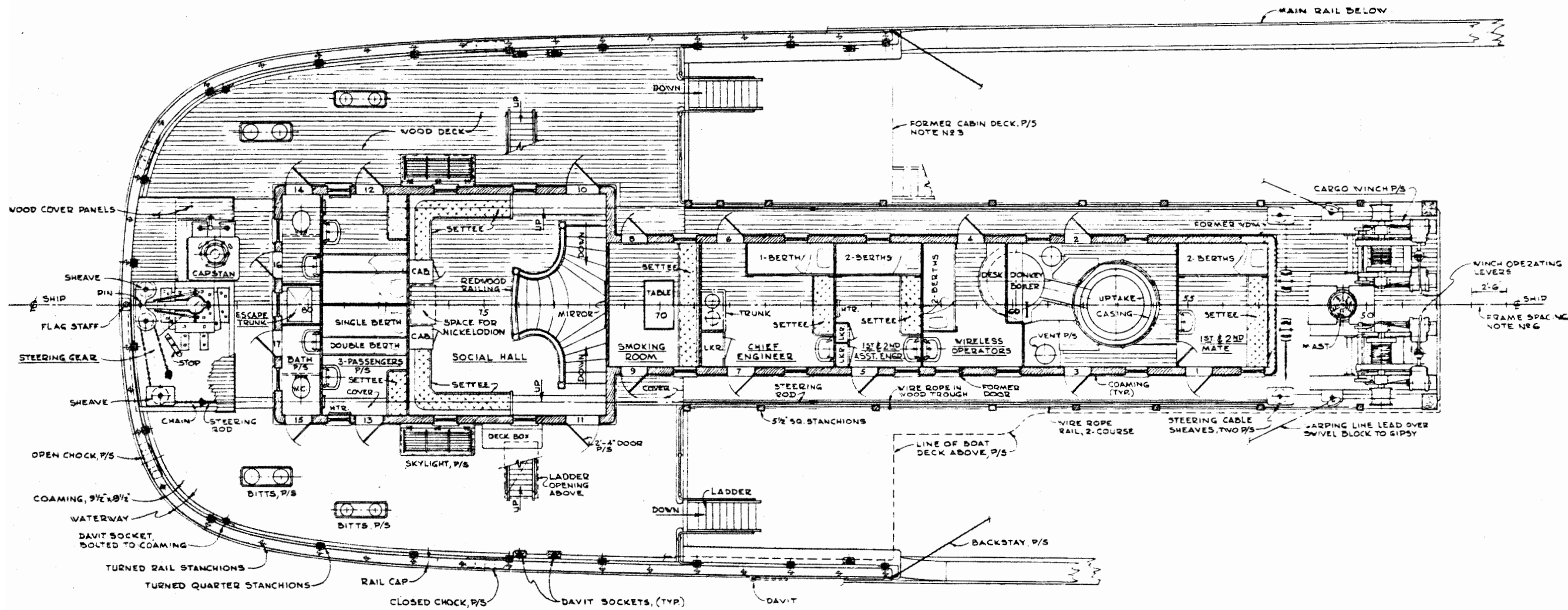

|          |                           |            |
|----------|---------------------------|------------|
| PREPARED | TITLE OF SHEET            | DRAWING NO |
| DRAWN    | Steam Schooner WAPAMA     | 641/80,048 |
| CHECKED  | PLAN OF CABIN DECK        | PCIP       |
| DATE     | Historic Structure Report | 557        |
|          |                           | SHEET      |
|          |                           | 7          |
|          |                           | OF 13      |

**GENERAL NOTES**

1. NUMBERS NOTED AT DOOR NUMBER LABEL
2. CABINS NR11 AND NR12 3-HIGH BERTHS ARE REMAINING ON THE EX WASH BASIN AND 5MA HISTORIC. THERE IS A PHOTO OF THESE CABIN WATER TANK ABOVE THE CURTAIN ON A ROD FOR
3. FIRST CLASS PASSENGER
4. STEERING WHEEL: TOP PORT AND STBD. DRU WHEEL SHAFT, AS SHK WHEEL ARE REQUIRED STBD. RUDDER. TIE
5. FROM INTERVIEW BY EXTENSION AFT. 3750 (ADDED CIRCA 1930).
6. DUCKBOARDS IN REMO PROBABLY A RECENT CANVAS ON 1 1/8" T&G
7. LIFEBOATS: BOAT FALL WITH HAULING PART C BOATS NR1 & NR2 ARE CARVEL PLANKED. BOATS NR3 & NR4 - PLANKED HULLS WITH ALL BOATS HAVE 12" ON THE SIDE BENCHES. AN TANKS UNDER THE BO
8. FRAME CENTERS ARE WITH OTHER DRAW OTHER THAN HULL FR THESE CENTERS.
9. BRIDGE WINGS ARE 4 1/2 FEET WIDE TO BE ALONGSIDE THE DECK

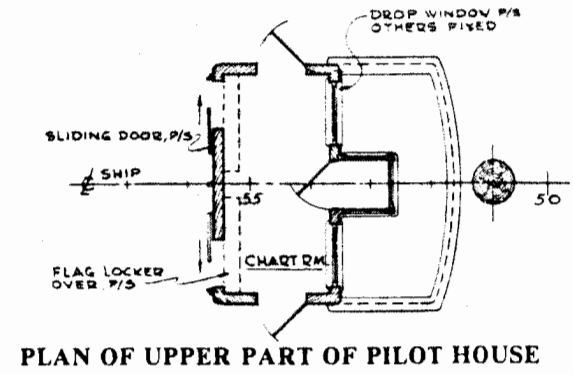
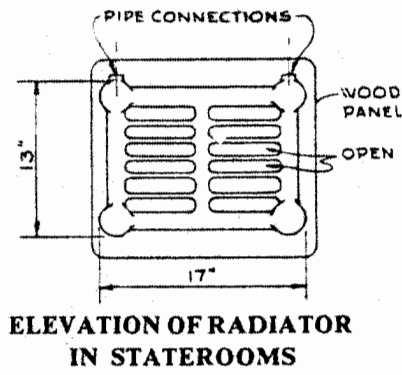

**ELEVATION OF RADIATOR IN STATEROOMS**

**PLAN OF UPPER PART OF PILOT HOUSE**

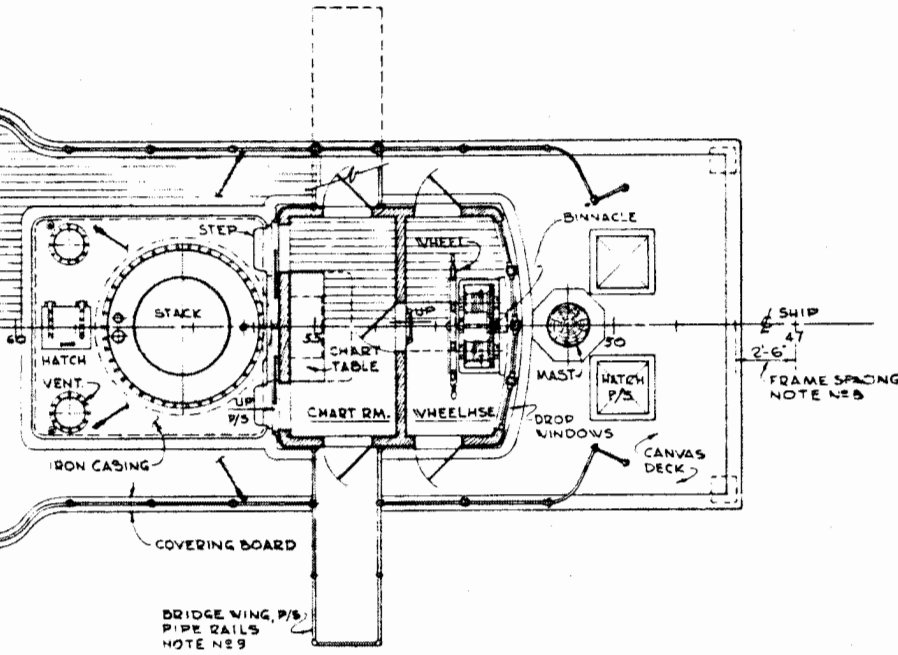
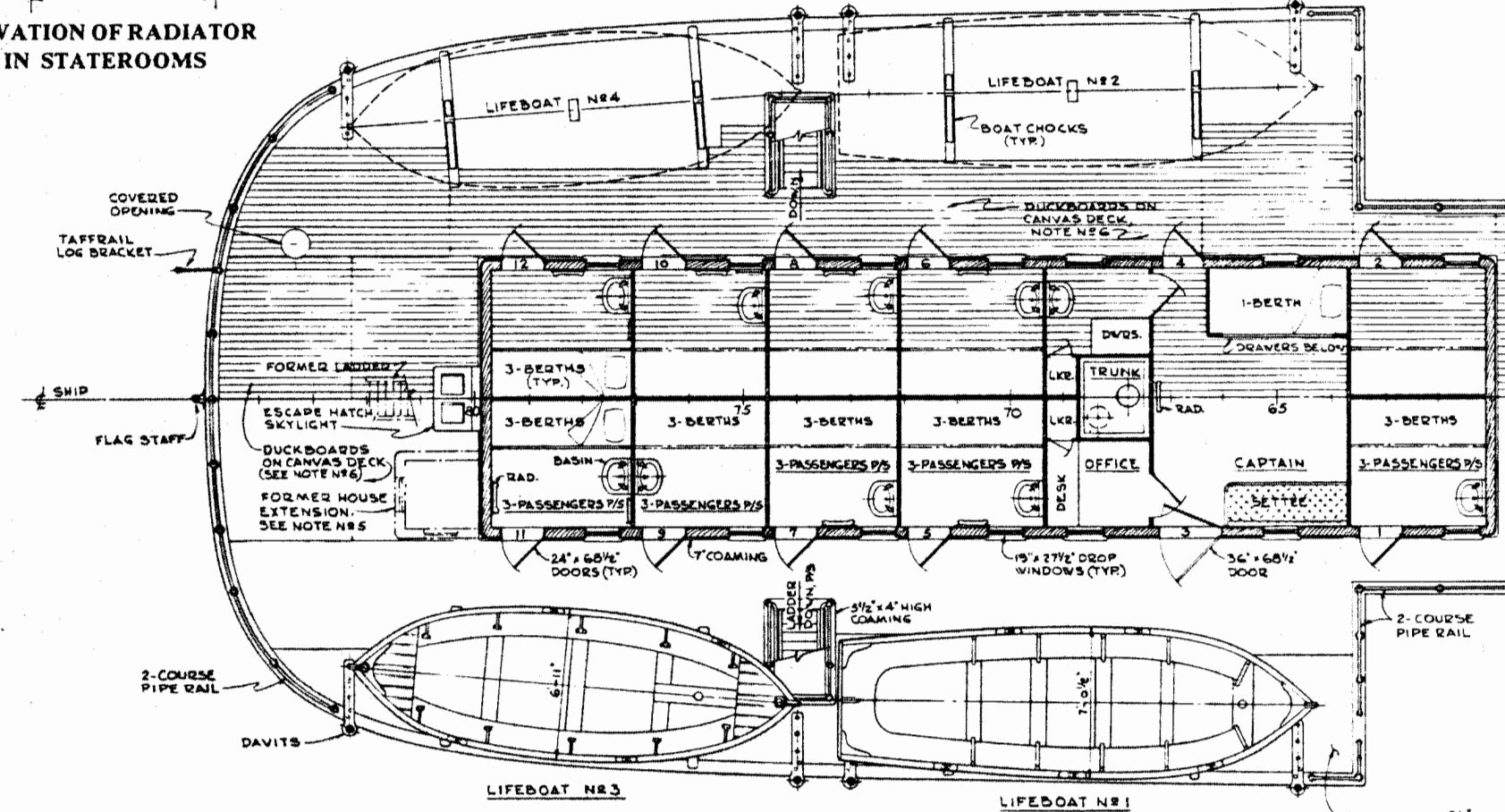

**BOAT DECK PLAN**

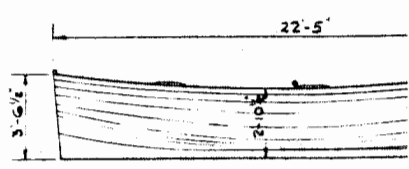
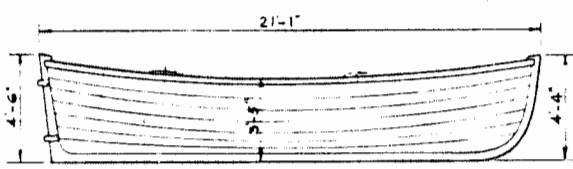

**ELEVATION OF No 3 & No 4 BOAT**

**ELEVATION OF No 1 & No 2 BOAT**

**PROFILE OF BOAT DECK HOUSE TOP**

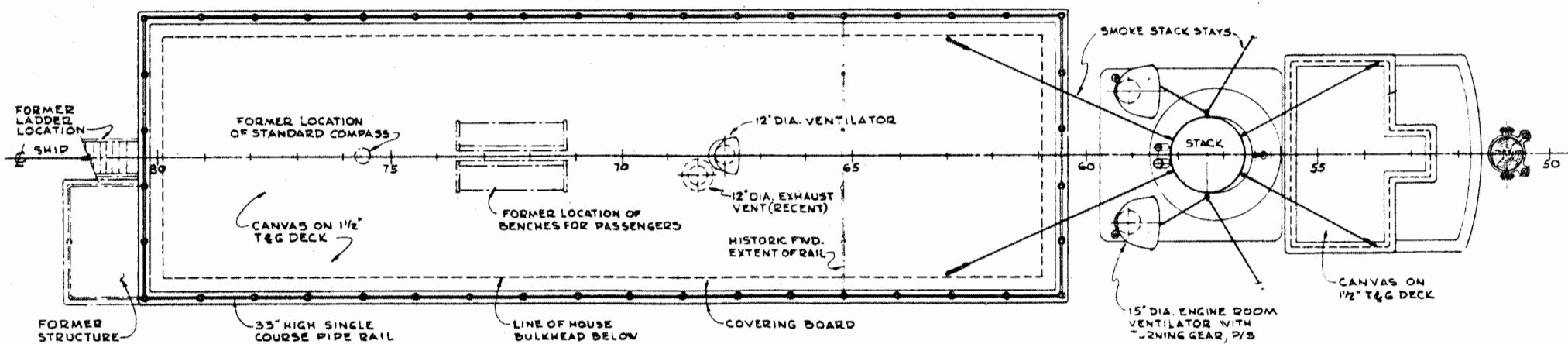
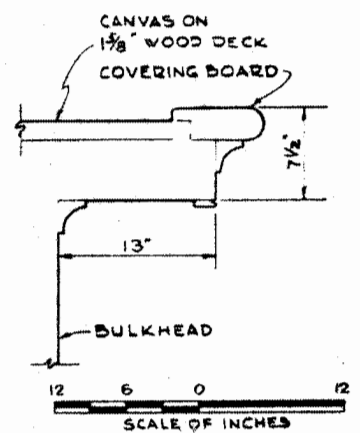

**PLAN OF BOAT DECK HOUSE & PILOT HOUSE TOPS**

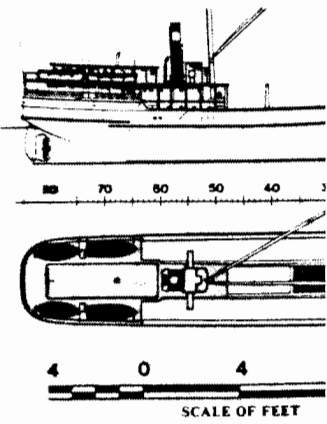

|          |                          |
|----------|--------------------------|
| PREPARED | TITLE OF SHEET           |
| DRAWN    | Steam Schooner WA        |
| CHECKED  | PLAN OF BOAT AND HOUSE T |
| DATE     | Historic Structure R     |

**GENERAL NOTES**

- NUMBERS NOTED AT DOORS REFLECT EXISTING DOOR NUMBER LABEL PLATES ON SHIP.
- CABINS NR11 AND NR12 HAVE BEEN RESTORED. THE 3-HIGH BERTHS ARE THE ONLY PASSENGER BERTHS REMAINING ON THE BOAT DECK. THE PORCELAIN WASH BASIN AND SMALL STEAM HEATER ARE HISTORIC. THERE IS A WREATH AND WOOD SHELF ABOVE THE BASIN. AN HISTORIC MCCORMICK PHOTO OF THESE CABINS SHOWS A SMALL POTABLE WATER TANK ABOVE THE BASIN AND A DRAW CURTAIN ON A ROD FOR EACH BERTH.
- FIRST CLASS PASSENGERS ON BOAT DECK - 30.
- STEERING WHEEL: TOWER CABLE RUNS OVER PORT AND STBD DRUMS WHICH ARE GEARED TO WHEEL SHAFT. AS SHOWN. ABOUT 12 TURNS OF WHEEL ARE REQUIRED FROM 40° PORT TO 40° STBD. RUDDER TOWER IS SHOWN ON SHEET NR 7.
- FROM INTERVIEW BY KORTUM: DECKHOUSE EXTENSION AFT STBD WAS A BATHROOM (ADDED CIRCA 1930).
- DUCKBOARDS IN REMOVABLE PANELS ARE PROBABLY A RECENT ADDITION OVER ORIGINAL CANVAS ON 15/8" T&G DECK.
- LIFEBOATS: BOAT FALLS HAD TRIPLE BLOCKS WITH HAULING PART COILED DOWN IN TUBS. BOATS NR1 & NR2 ARE WOOD CONSTRUCTION CARVEL PLANKED. BOATS NR3 & NR4 HAVE ZINCED SHEET METAL PLANKED HULLS WITH WOOD THWARTS & TRIM. ALL BOATS HAVE 12" DIA FLOATION TANKS UNDER THE SIDE BENCHES, AND NR3 & 4 HAVE FITTED TANKS UNDER THE BOW AND STERN DECKS.
- FRAME CENTERS ARE SHOWN FOR COMPARISON WITH OTHER DRAWINGS ONLY. NO STRUCTURE OTHER THAN HULL FRAMES IS LOCATED ON THESE CENTERS.
- BRIDGE WINGS ARE DESIGNED TO FOLD UPWARD TO PERMIT CARGO TO BE LOADED OR OFF-LOADED ALONGSIDE THE DECKHOUSE.

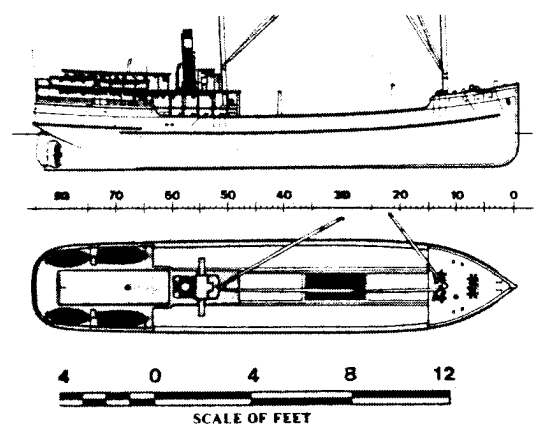
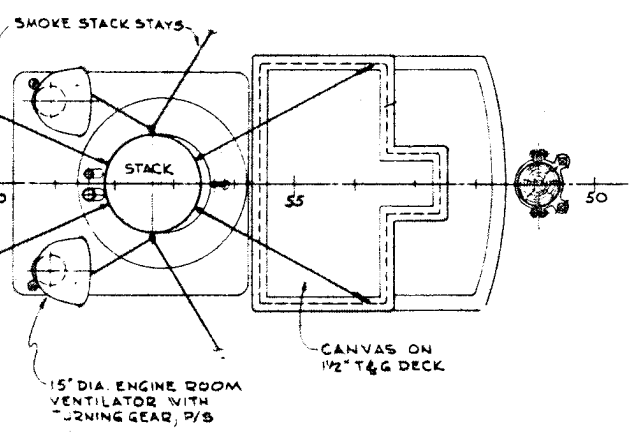
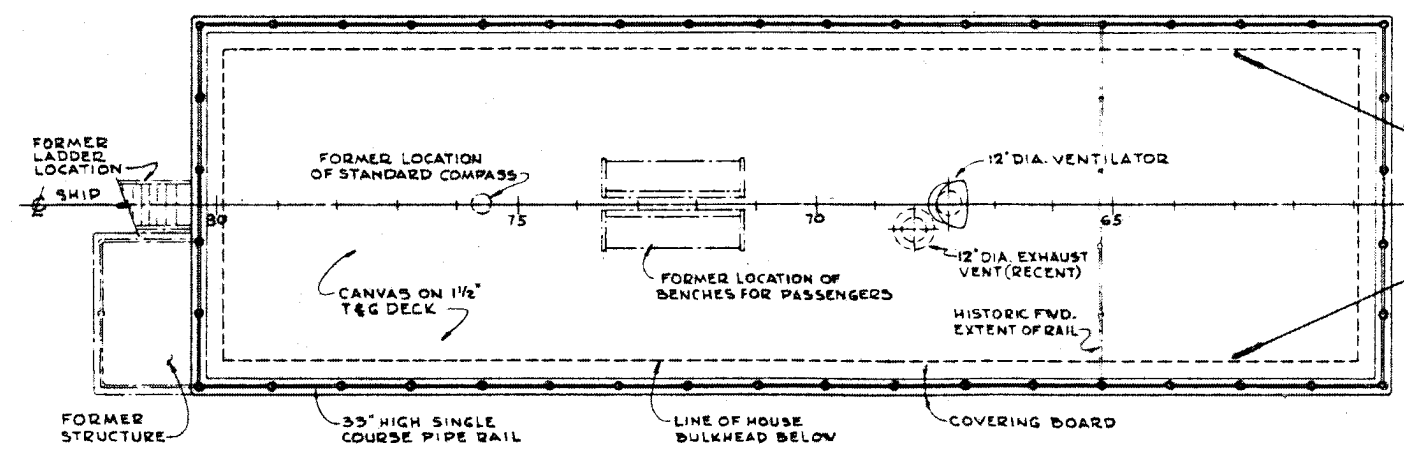
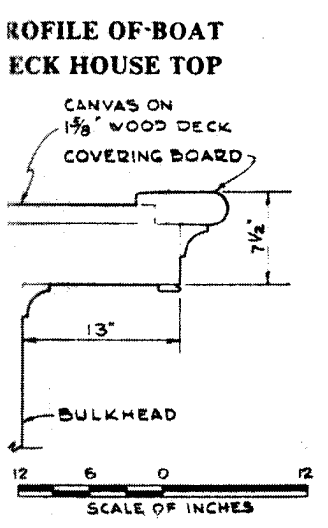
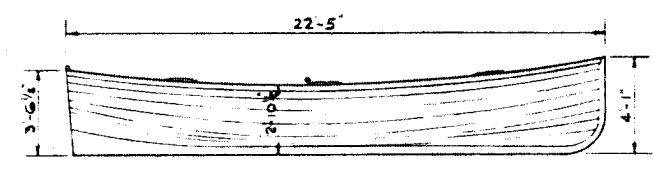
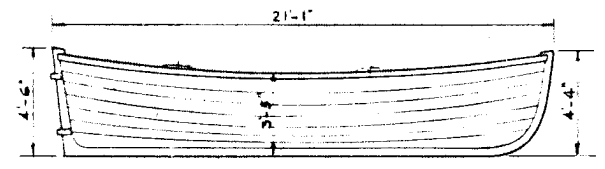
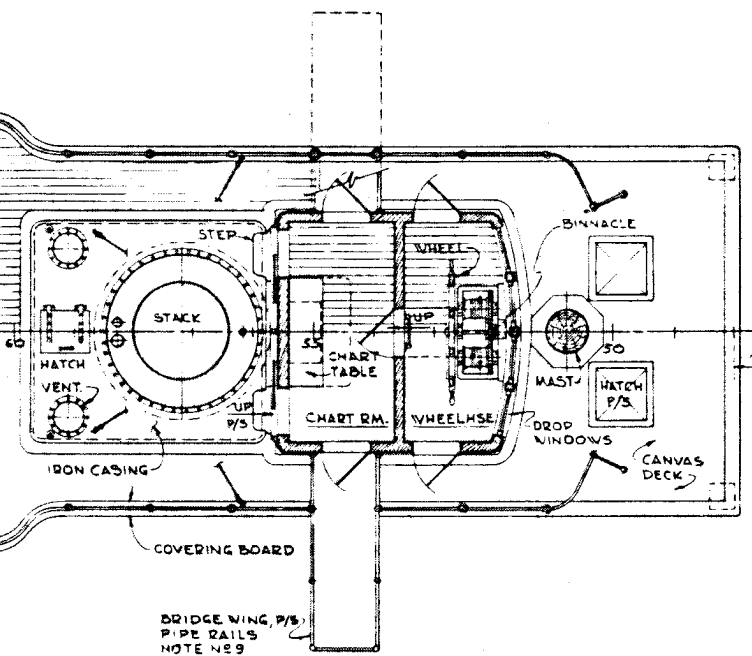
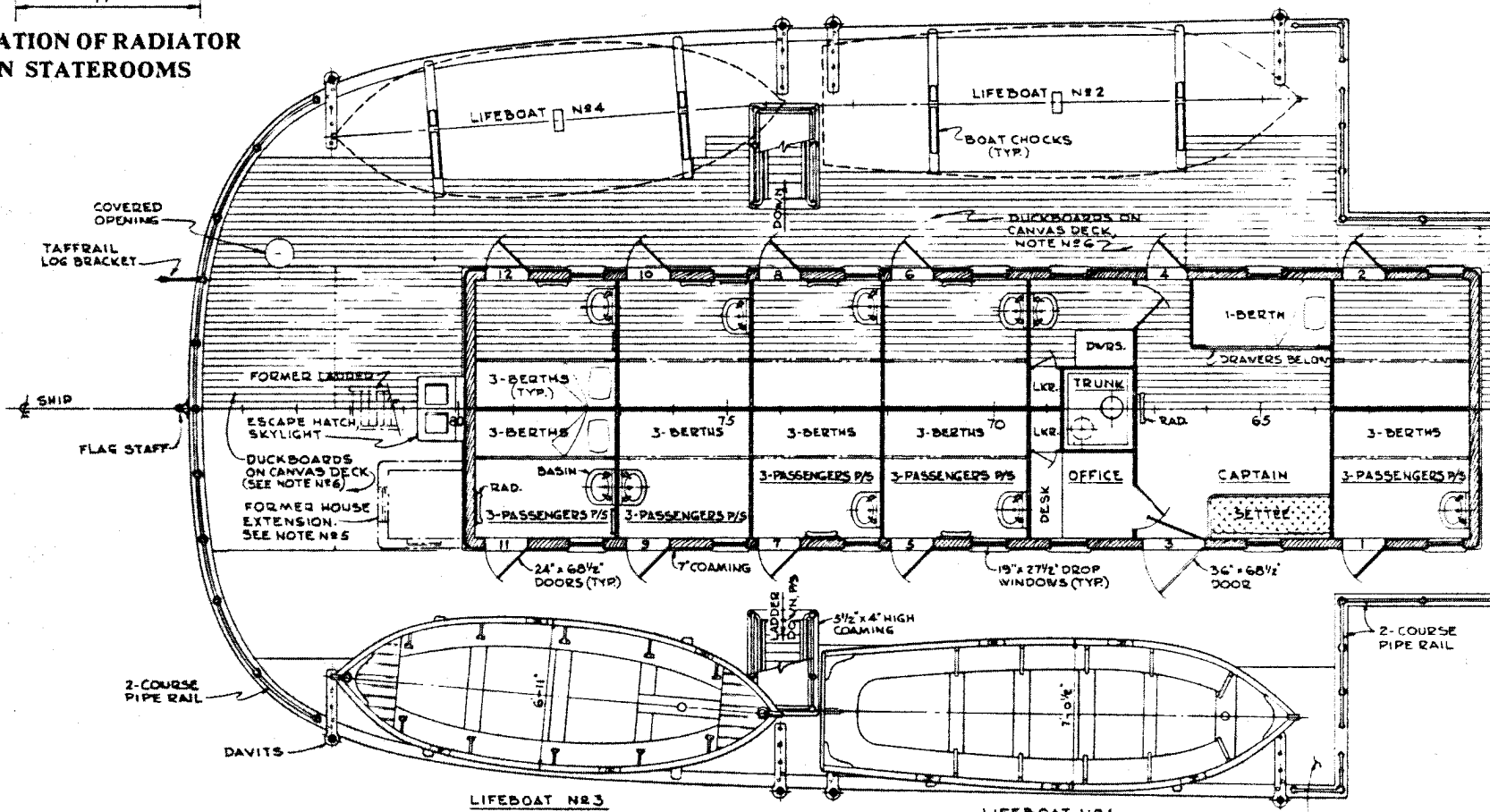
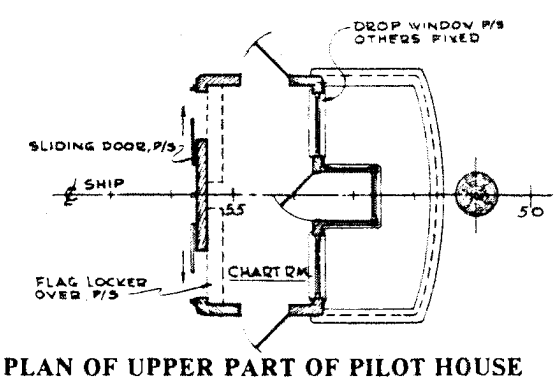
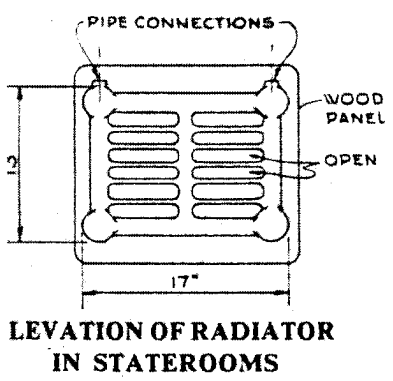

**PLAN OF BOAT DECK HOUSE & PILOT HOUSE TOPS**

|          |   |               |
|----------|---|---------------|
| PREPARED | TITLE OF SHEET                          | DRAWING NO    |
| DRAWN    | <b>Steam Schooner WAPAMA</b>            | 641/80,048    |
| CHECKED  | <b>PLAN OF BOAT DECK AND HOUSE TOPS</b> | PCIP PKB 557  |
| DATE     | Historic Structure Report               | SHEET 8 OF 13 |

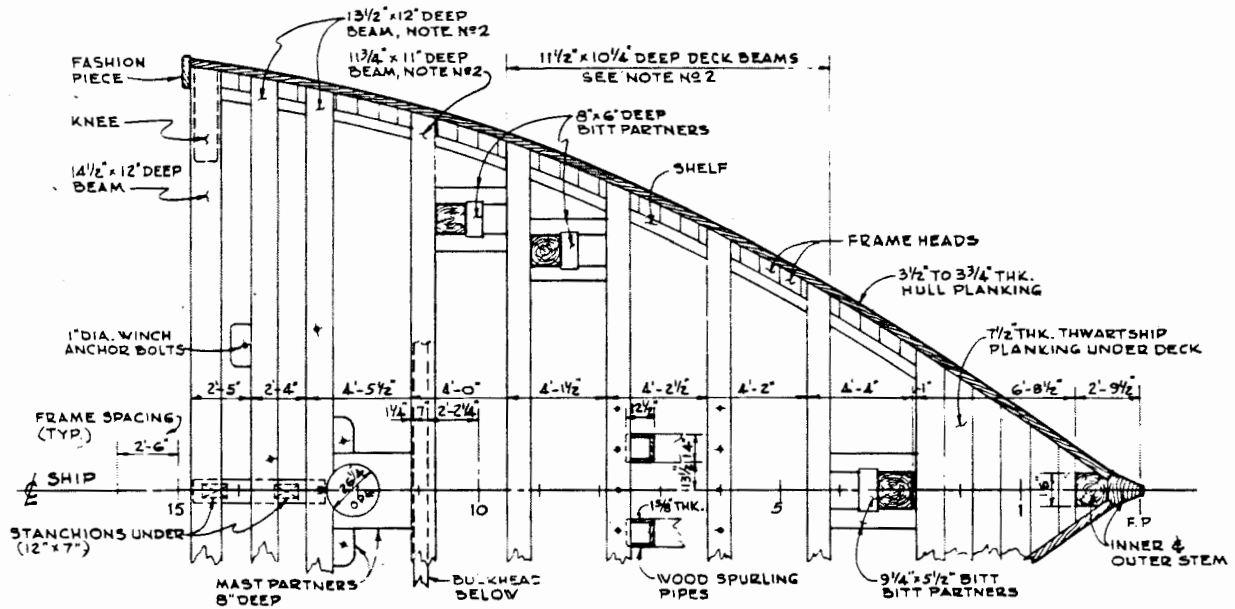

**FORECASTLE DECK FRAMING PLAN**

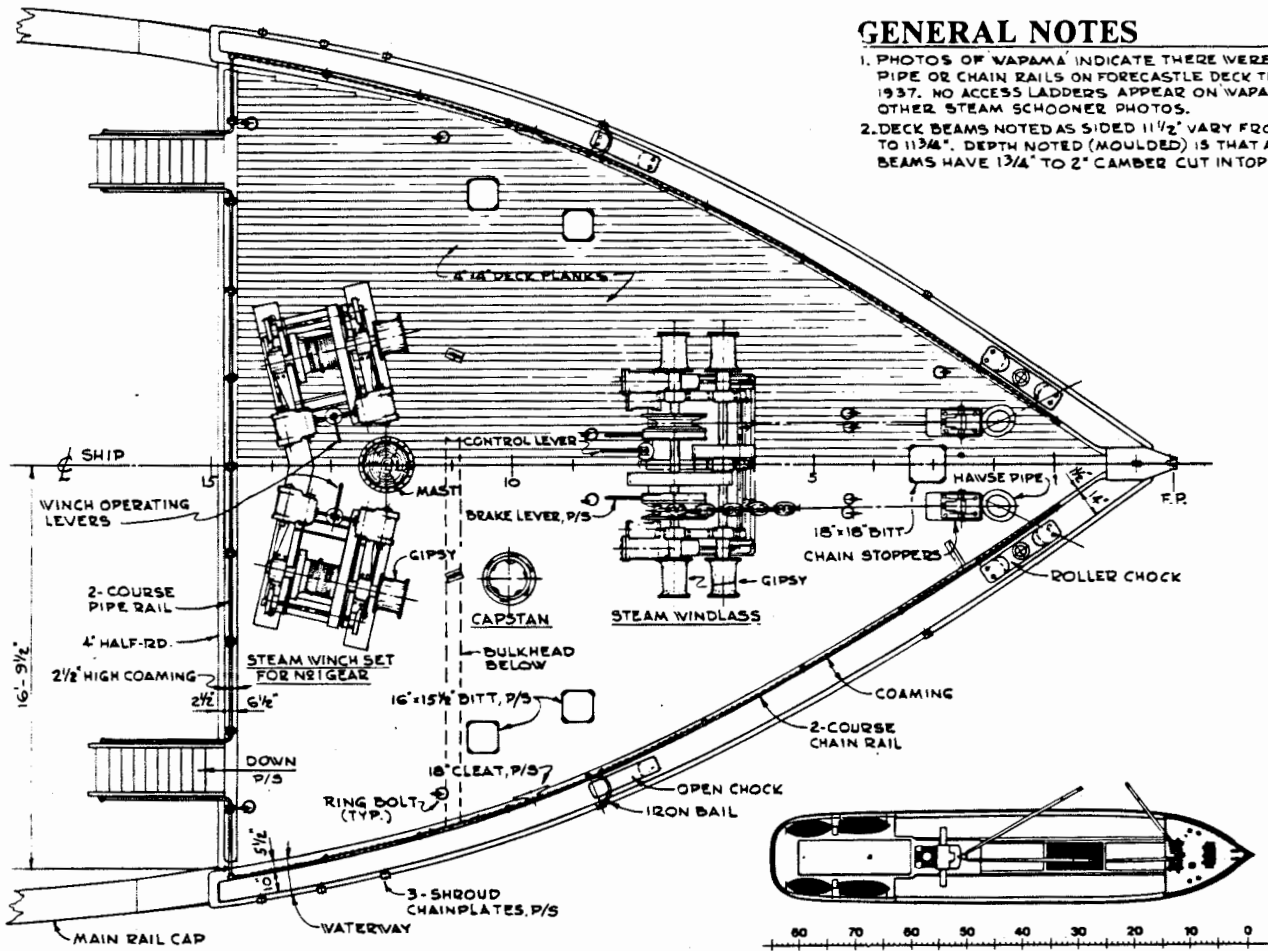

**GENERAL NOTES**

- PHOTOS OF WAPAMA INDICATE THERE WERE NO PIPE OR CHAIN RAILS ON FORECASTLE DECK THROUGH 1937. NO ACCESS LADDERS APPEAR ON WAPAMA OR OTHER STEAM SCHOONER PHOTOS.
- DECK BEAMS NOTED AS SIDED 11 1/2" VARY FROM 11 3/8" TO 11 3/4". DEPTH NOTED (MOULDED) IS THAT AT Q. BEAMS HAVE 1 3/4" TO 2" CAMBER CUT IN TOP SURFACE

**FORECASTLE DECK PLAN**

PREPARED  
 DRAWN  
 CHECKED  
 DATE

TITLE OF SHEET  
**Steam Schooner WAPAMA**  
**PLAN OF FO'C'SLE DECK**  
 Historic Structure Report

DRAWING NO. 641/80,048  
 PCIP PKG. 557  
 SHEET 9 OF 13



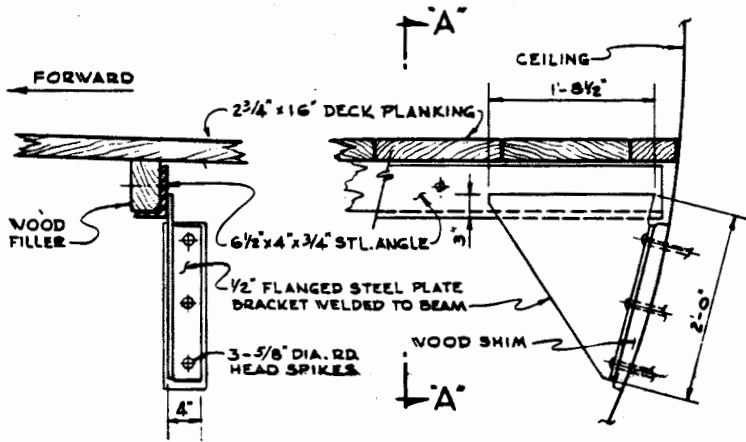

SECTION "A-A"

DETAIL OF BEAM BRACKET

FRAME 26, STBD. LOOKING FORWARD



**GENERAL NOTES**

1. TWEEN DECK WAS ADDED AT A LATER DATE, PROBABLY DURING SERVICE IN ALASKA.
2. DECK HAS STRAIGHT SHEER AND NO CAMBER.
3. EVIDENCE REMAINS THAT TWEEN DECK AT ONE TIME EXTENDED AFT TO FRAME 36 ON PORT & STBD. SIDE OF HATCH OPENING, AND HAD STRONGBACKS AND HATCH BOARDS IN WAY OF MAIN DECK HATCH.

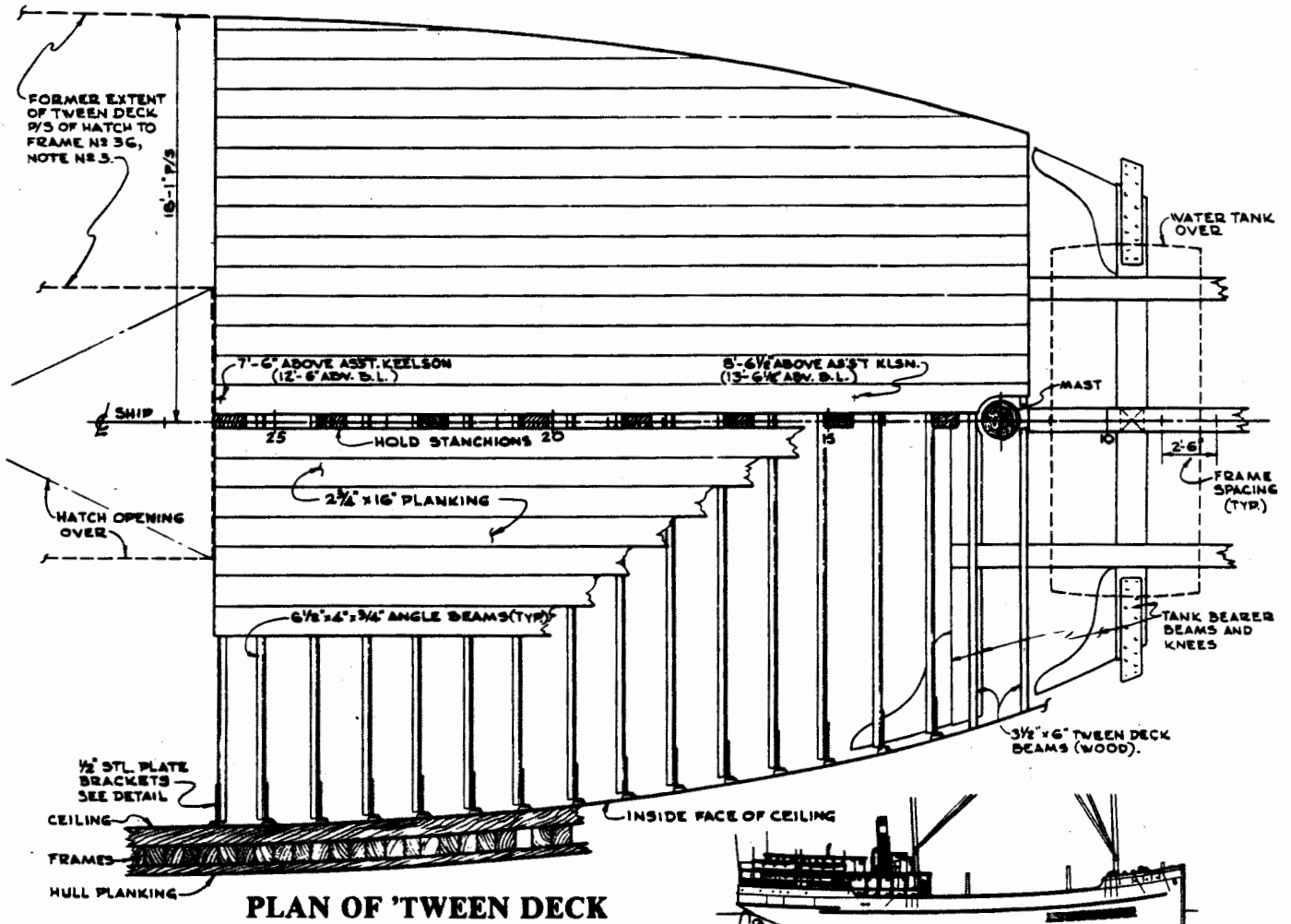

PLAN OF 'TWEEN DECK

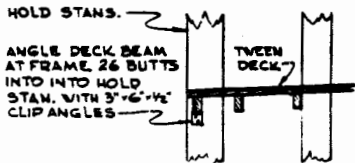
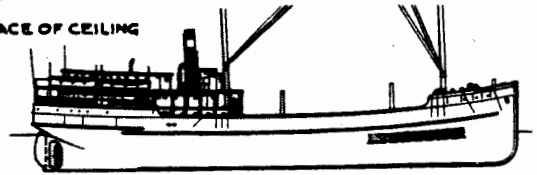

|          |                           |                              |
|----------|---------------------------|------------------------------|
| PREPARED | TITLE OF SHEET            | DRAWING NO.                  |
| DRAWN    | Steam Schooner WAPAMA     | 641/80,048                   |
| CHECKED  | PLAN OF 'TWEEN DECK       | 041                          |
| DATE     | Historic Structure Report | PCIP Pkg. 557 SHEET 10 OF 13 |

**GENERAL NO**

1. DEADRISE AND SHA FROM ORIGINAL (1916). THE PRESE OF TOPSIDES IN EXACT DETERMINA SECTION.
2. DECK BEAMS HAVE IN TOP FACE FROM SPACING VARIES I HOLD AREA.
3. FRAME SPACING OF ACCURATELY ALONG
4. SCANTLINES: MAIN  $\frac{1}{4}$ " AND  $\frac{1}{2}$ " IN DIMEN LESS THAN SIZES. DRAWING OF "WAH
5. NOMENCLATURE O USAGE OF PERIOD I CIRCULAR GRAIN M CROSS-SECTION B
6. HULL PARTICULARS: DEAM - MOULDED TO OUTSIDE TO OUTSIDE DEPTH - MINIMUM . B.L. TO TOP DEPTH OF HOLD - FR KEELSONS TO TOP C AT MIDDPOINT MINIMUM - A MAXIMUM - A HATCH - FRAMED OPE PRESENT A.D.S. PLIMS

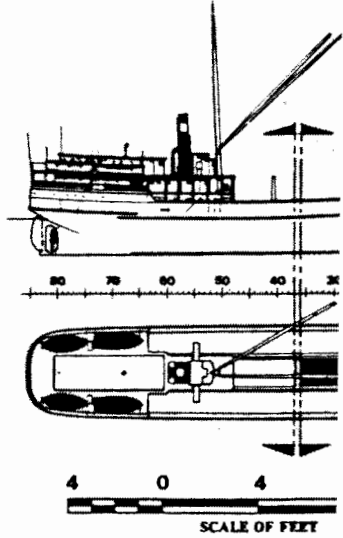
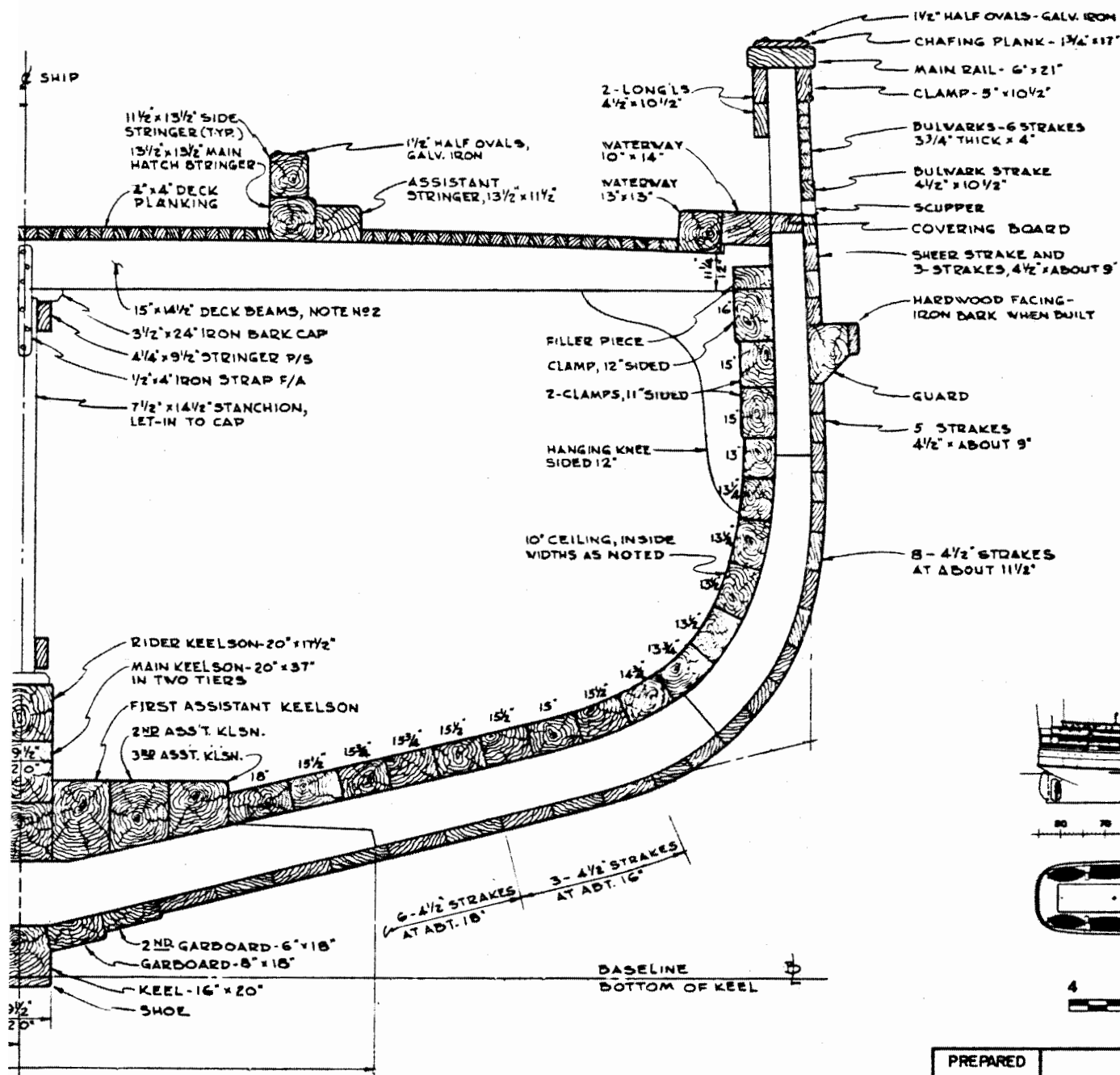

**MIDSHIP SECTION  
FRAME 37, PORT LOOKING AFT**

|          |                      |
|----------|----------------------|
| PREPARED | TITLE OF SHEET       |
| DRAWN    | Steam Schooner WA    |
| CHECKED  | MIDSHIP SEC          |
| DATE     | Historic Structure I |

# GENERAL NOTES

1. DEADRISE AND SHAPE OF BILGE ARE TAKEN FROM ORIGINAL "WAPAMA" DRAWING (1916). THE PRESENT HOG, TWIST, AND SAG OF TOPSIDES IN "WAPAMA" PRECLUDES EXACT DETERMINATION OF HER ORIGINAL SECTION.
2. DECK BEAMS HAVE 3" TO 3 1/2" CAMBER CUT IN TOP FACE FROM CENTER TO 'HOOK'. SPACING VARIES FROM 4'-5" TO 4'-7 1/2" IN HOLD AREA.
3. FRAME SPACING OF 30" AVERAGES OUT ACCURATELY ALONG KEEL.
4. SCANTLINGS: MAIN MEMBERS VARY BETWEEN 1/4" AND 1/2" IN DIMENSION AND GENERALLY ARE LESS THAN SIZES CALLED FOR ON ORIGINAL DRAWING OF "WAPAMA".
5. NOMENCLATURE OF MEMBERS FOLLOWS USAGE OF PERIOD AND LOCALE, WHERE KNOWN. CIRCULAR GRAIN MATCHING OF MEMBERS IN CROSS-SECTION WAS TYPICAL OF THE PERIOD.
6. HULL PARTICULARS:
 

|   |                   |
|---|-------------------|
| BEAM - MOULDED  | — 40'-4"          |
| TO OUTSIDE OF PLANKING  | — 41'-1"          |
| TO OUTSIDE OF GUARDS  | — 42'-9"          |
| DEPTH - MINIMUM (AT FRAME 48)                                   |                   |
| B.L. TO TOP OF DECK AT $\frac{1}{2}$                            | — 19'-0"          |
| DEPTH OF HOLD - FROM TOP OF ASST. KEELSONS TO TOP OF DECK BEAM: |                   |
| AT MIDDPOINT OF HATCH/HOLD                                      | — 14'-4"          |
| MINIMUM - AT FRAME 48   | — 13'-8"          |
| MAXIMUM - AT FRAME 13   | — 16'-10"         |
| HATCH-FRAMED OPENING  | — 12'-7" x 24'-9" |
| PRESENT A.D.S. PLIMSOL ABOVE B.L.                               | — 17'-0"          |

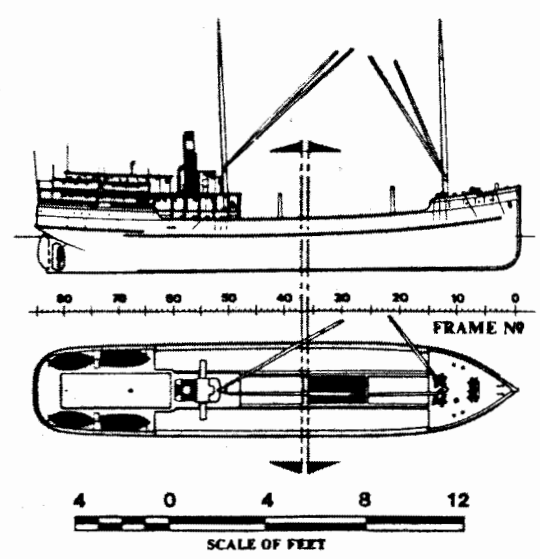
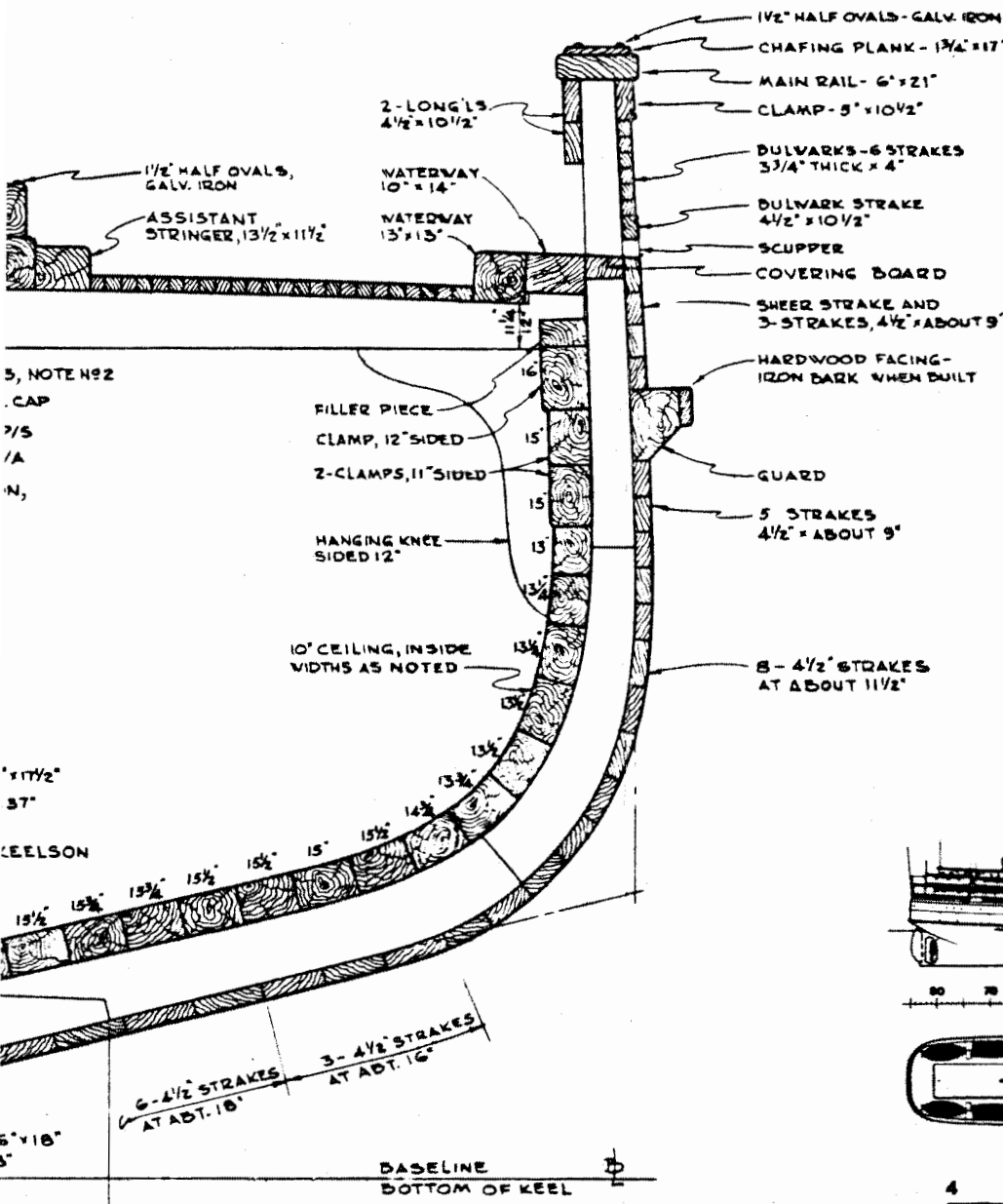

5, NOTE #2  
 .CAP  
 7/5  
 /A  
 N,

11 1/2"  
 37"  
 KEELSON

5' x 18"  
 5"  
 BASELINE  
 BOTTOM OF KEEL

## SECTION 7, PORT LOOKING AFT

|          |                           |                |
|----------|---------------------------|----------------|
| PREPARED | TITLE OF SHEET            | DRAWING NO.    |
| DRAWN    | Steam Schooner WAPAMA     | 641/80,048     |
| CHECKED  | MIDSHIP SECTION           | PCIP PKG. 557  |
| DATE     | Historic Structure Report | SHEET 11 OF 13 |

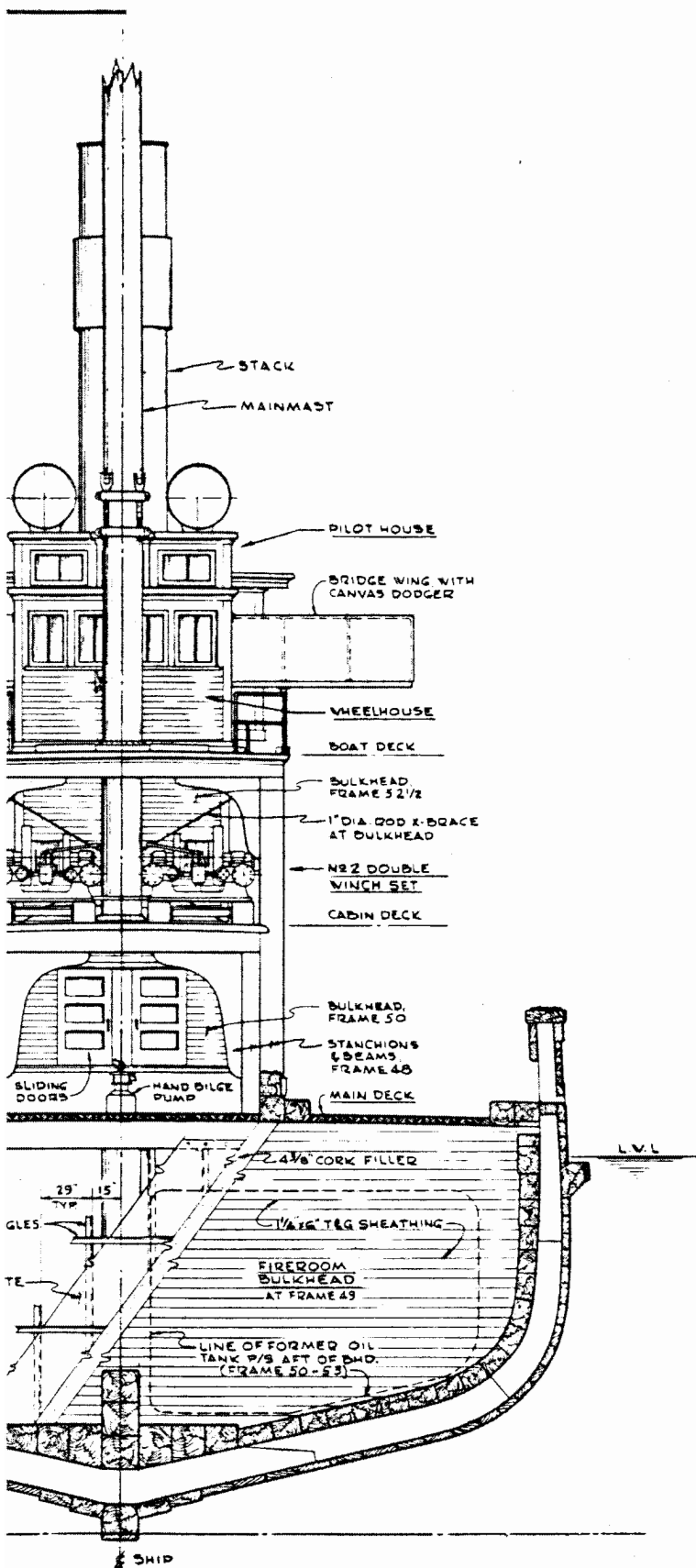

**C: SECTION AT FRAME No 47  
RIGHT SIDE LOOKING AFT**

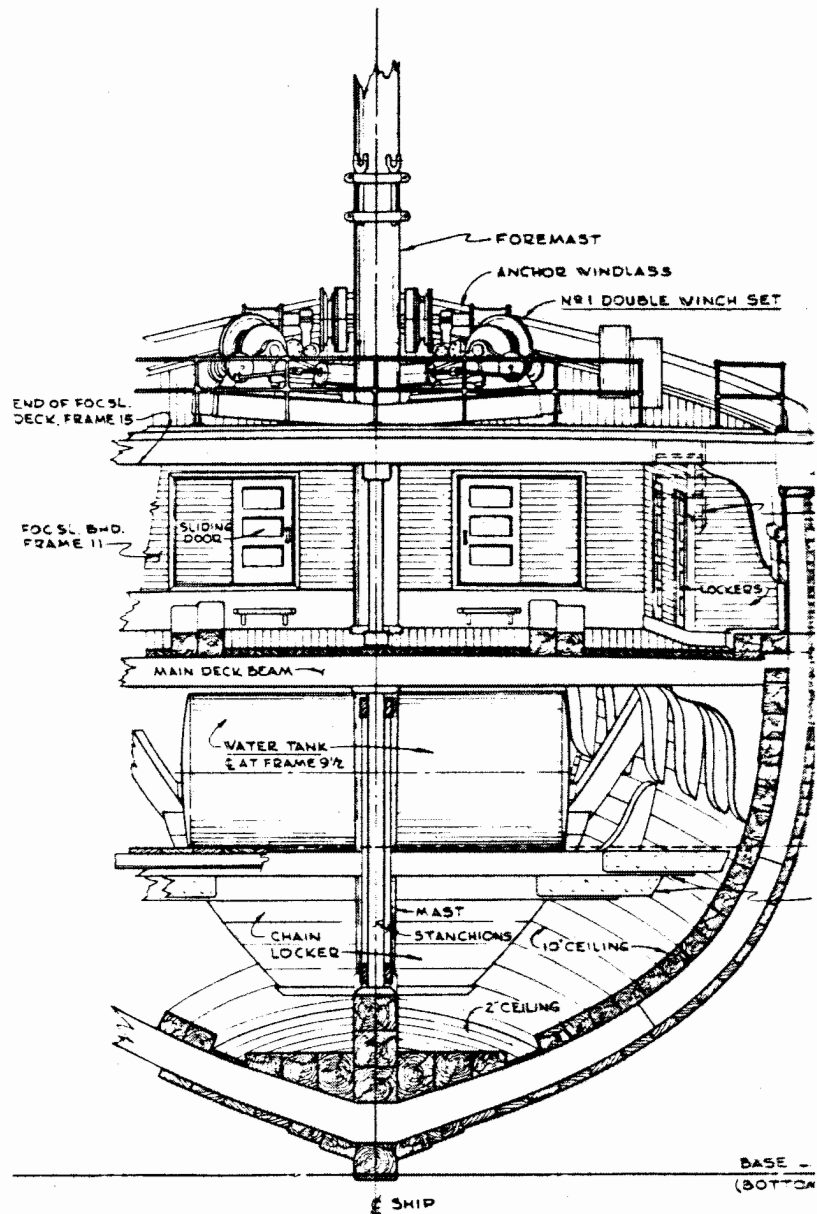
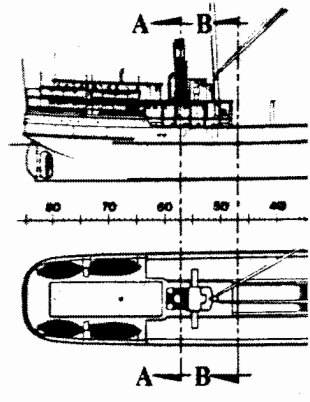
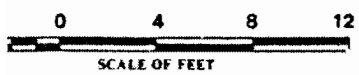

**C: SECTION AT FRAME No 15  
STARBOARD SIDE LOOKING FORWARD**

|          |                      |
|----------|----------------------|
| PREPARED | TITLE OF SHEET       |
| DRAWN    | Steam Schooner WA    |
| CHECKED  | CROSS SECTION        |
| DATE     | Historic Structure I |

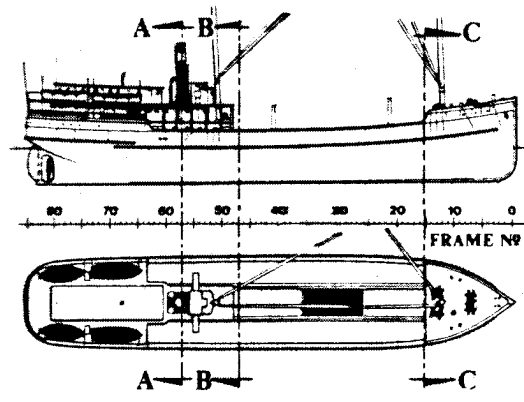

- PILOT HOUSE
- BRIDGE WING WITH ANVAS DODGER
- WHEELHOUSE
- COAT DECK
- BULKHEAD, FRAME 52 1/2
- 1" DIA. ROD X-BRACE AT BULKHEAD
- 18" Z DOUBLE VINCH SET
- ABIN DECK

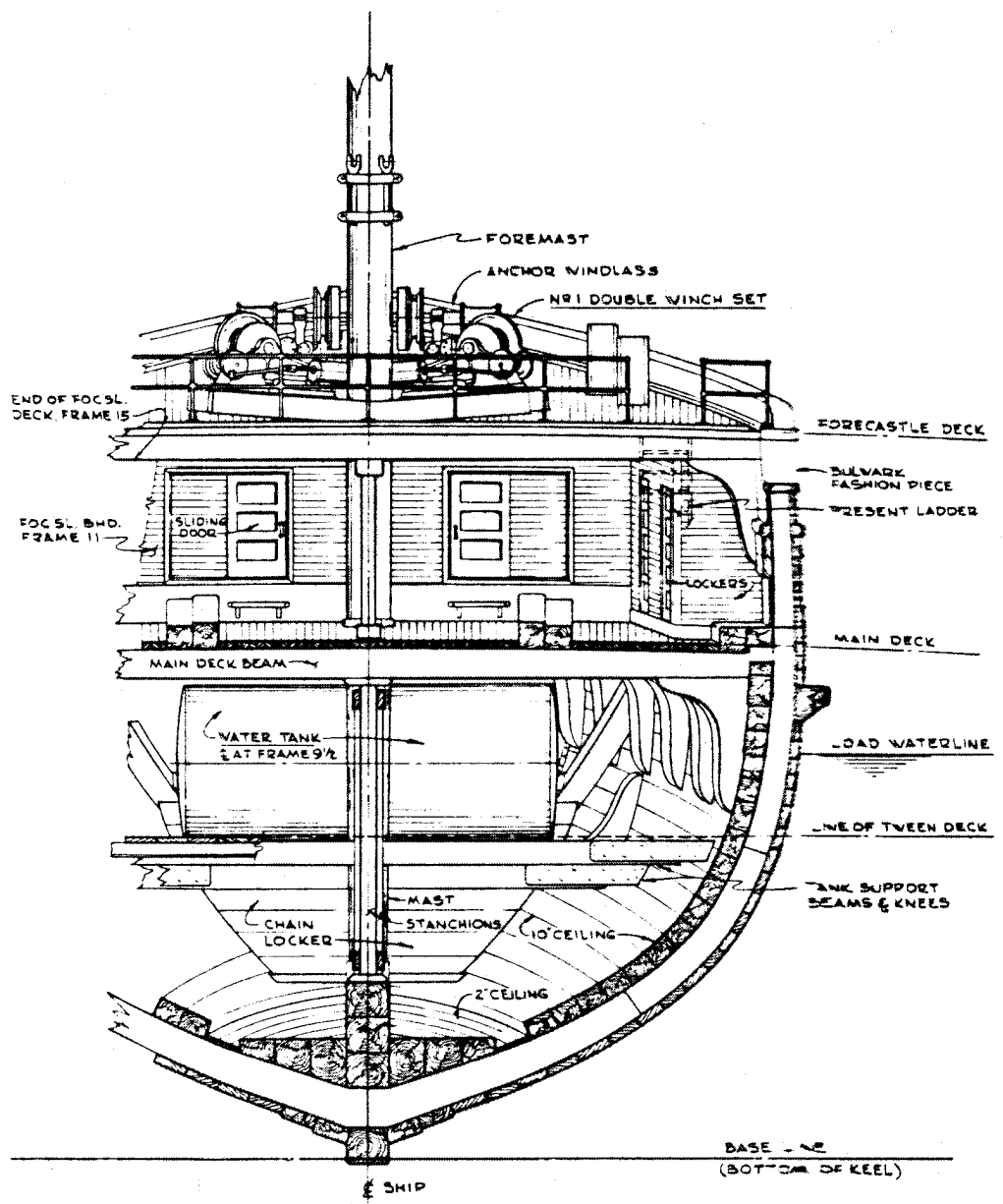
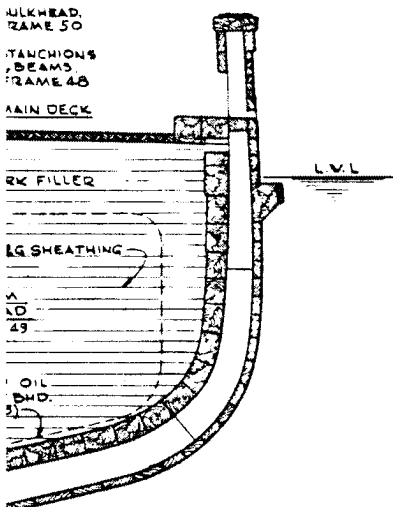

17

**C: SECTION AT FRAME No 15  
STARBOARD LOOKING FORWARD**

|          |                           |            |
|----------|---------------------------|------------|
| PREPARED | TITLE OF SHEET            | DRAWING NO |
| DRAWN    | Steam Schooner WAPAMA     | 641780,048 |
| CHECKED  | <b>CROSS SECTIONS</b>     | 041        |
| DATE     | Historic Structure Report | PCIP PKG   |
|          |                           | 557        |
|          |                           | SHEET      |
|          |                           | 12         |
|          |                           | OF 13      |

# GENERAL NOTES

1. WAPAMA WAS TEQMED A SINGLE CARGO GEAR FORWARD OF THE S MAIN MAST GEAR (FORE AND AFT).
2. THE CARGO HANDLING SYSTEM WITH WINCHES ON ONE MAST WAS TIED ON THE WEST COAST. THE TWO WINS ON CONNECTED TO A HOOK WITH HOOK AND RINGS (CALLED A BLACKSMITH FALLS UNREEL WITH NO LOAD).
3. THE WINCHES ARE "COG WINCHES" AND REVERSIBLE. ONE WING OF THE TWO WINCHES OF A SET, HAD THE FALLS TO RAISE, SWING AND LOWER IN THE RIGGING ELEVATION. THE OTHER ONLY SHOWN ON THE INBOARD AND THE GUY IS SHOWN ON THE OUTBOARD.
4. THE BOOM GUYS WERE USUALLY SET TO MAKE THEM LEAD PROPERLY, AS SHOWN IN THE RIGGING SKETCH BY DAVID SCOOONER BUILDER.
5. THE GEAR IS SAID TO HAVE HAD NO WITHOUT UNDUE STRAIN.
6. FEARE MARKS ON PLAN CENTERLINE SPACING FOR REFERENCE WITH THE PLAN.
7. STANDING RIGGING WIRE SIZES: WAPAMA RIGGING SKETCH BY DAVID SCOOONER BUILDER.
8. RIGGING: THE FOREMAST RAKE MAINMAST AND STACK RAKE 2°.
9. THE SPRING STAY WAS SET UP BY OR A SIZING. THE METHOD USED FROM REMAINING PHOTOGRAPH.

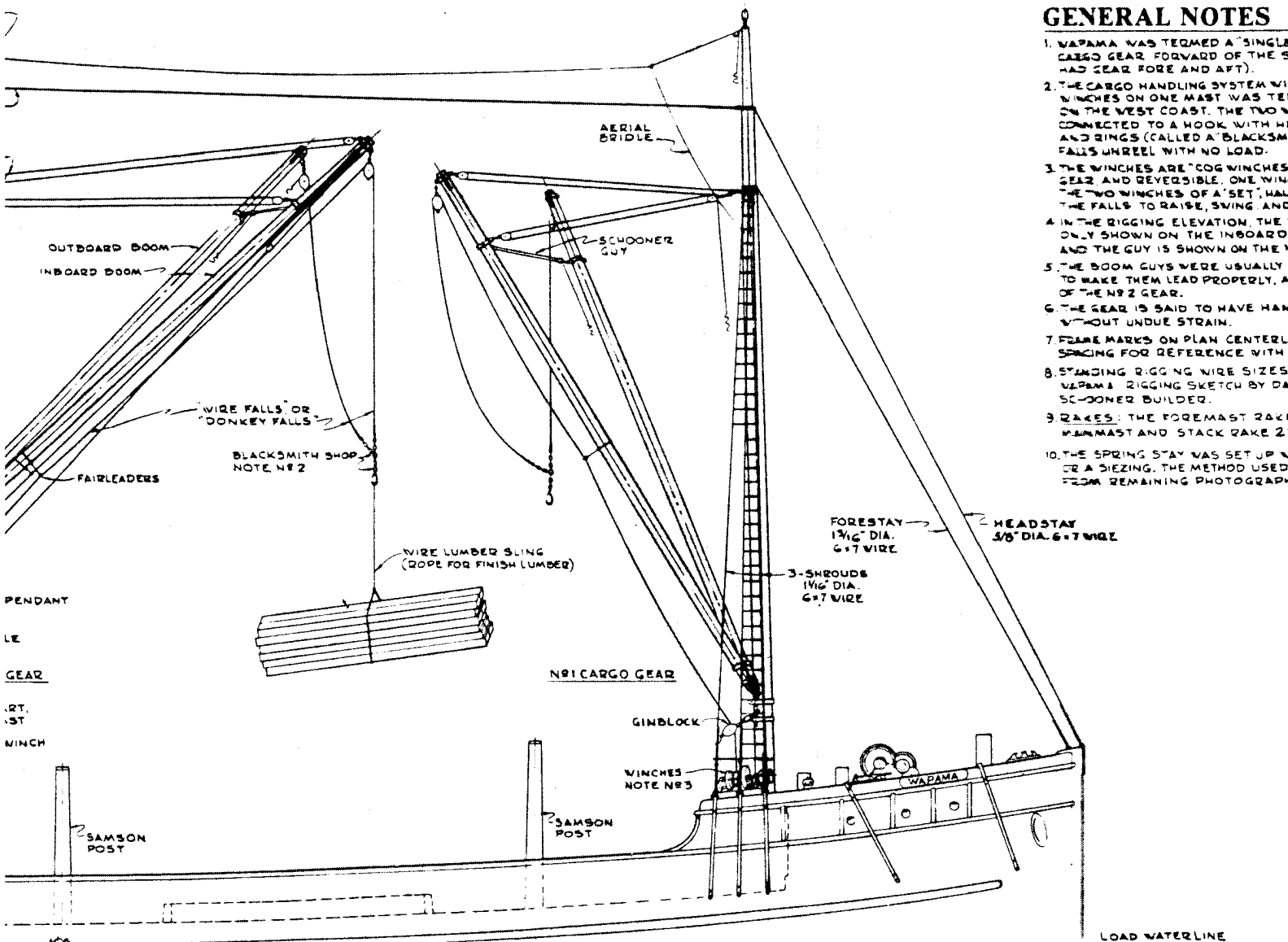

PENDANT  
LE  
GEAR  
RT.  
ST  
WINCH

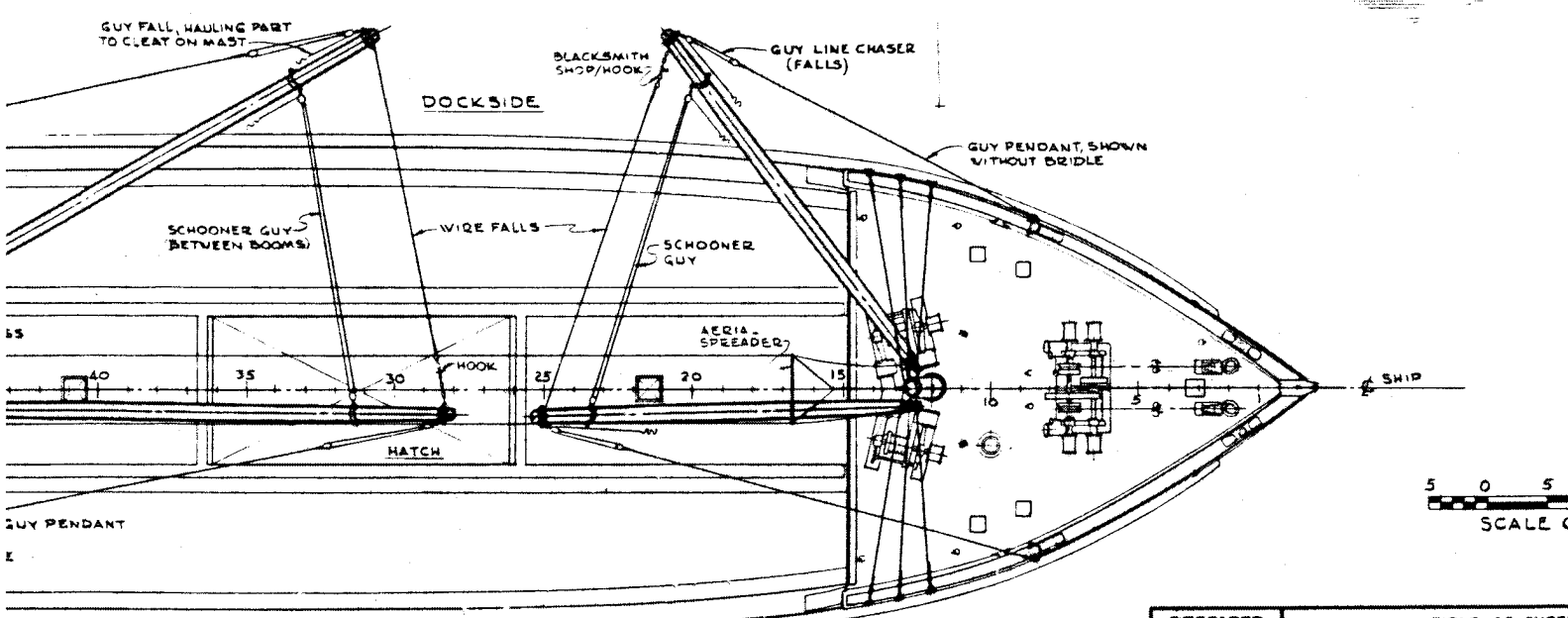

GUY PENDANT

|          |                       |
|----------|-----------------------|
| PREPARED | TITLE OF SHEET        |
| DRAWN    | Steam Schooner Wapama |
| CHECKED  | RIGGING ARRANGEMENT   |
|          | Historic Structure    |

## GENERAL NOTES

1. WAPAMA WAS TERMED A "SINGLE-ENDED", HAVING ALL CARGO GEAR FORWARD OF THE STACK, A "DOUBLE-ENDED" HAD GEAR FORE AND AFT).
2. THE CARGO HANDLING SYSTEM WITH TWO BOOMS AND WINCHES ON ONE MAST WAS TERMED "DOUBLE GEAR" ON THE WEST COAST. THE TWO WIRE FALLS WERE CONNECTED TO A HOOK WITH HEAVY SWIVELS, SHACKLES AND RINGS (CALLED A "BLACKSMITH SHOP") TO MAKE THE FALLS UNREEL WITH NO LOAD.
3. THE WINCHES ARE "COG WINCHES". THEY ARE ALWAYS IN GEAR AND REVERSIBLE. ONE WINCH DRIVER OPERATED THE TWO WINCHES OF A "SET", HAULING AND SLACKING THE FALLS TO RAISE, SWING AND LOWER A LOAD.
4. IN THE RIGGING ELEVATION, THE TOPPING LIFTS ARE ONLY SHOWN ON THE INBOARD BOOMS FOR CLARITY, AND THE GUY IS SHOWN ON THE #2 GEAR ONLY.
5. THE BOOM GUYS WERE USUALLY SET UP WITH A BRIDLE TO MAKE THEM LEAD PROPERLY, AS SHOWN ON THE PLAN OF THE #2 GEAR.
6. THE GEAR IS SAID TO HAVE HANDLED 6 TO 7 TONS WITHOUT UNDUE STRAIN.
7. FRAME MARKS ON PLAN CENTERLINE SHOW 2'-6" FRAME SPACING FOR REFERENCE WITH OTHER DRAWINGS.
8. STANDING RIGGING WIRE SIZES ARE FROM AN UNDATED WAPAMA RIGGING SKETCH BY DAVID W. D'OKIE, STEAM SCUNNER BUILDER.
9. RAKES: THE FOREMAST RAKE IS ABOUT 1/2°; THE MAINMAST AND STACK RAKE 2°.
10. THE SPRING STAY WAS SET UP WITH BLOCKS, DEADEYES OR A SIZING. THE METHOD USED CANNOT BE DISCERNED FROM REMAINING PHOTOGRAPHS.

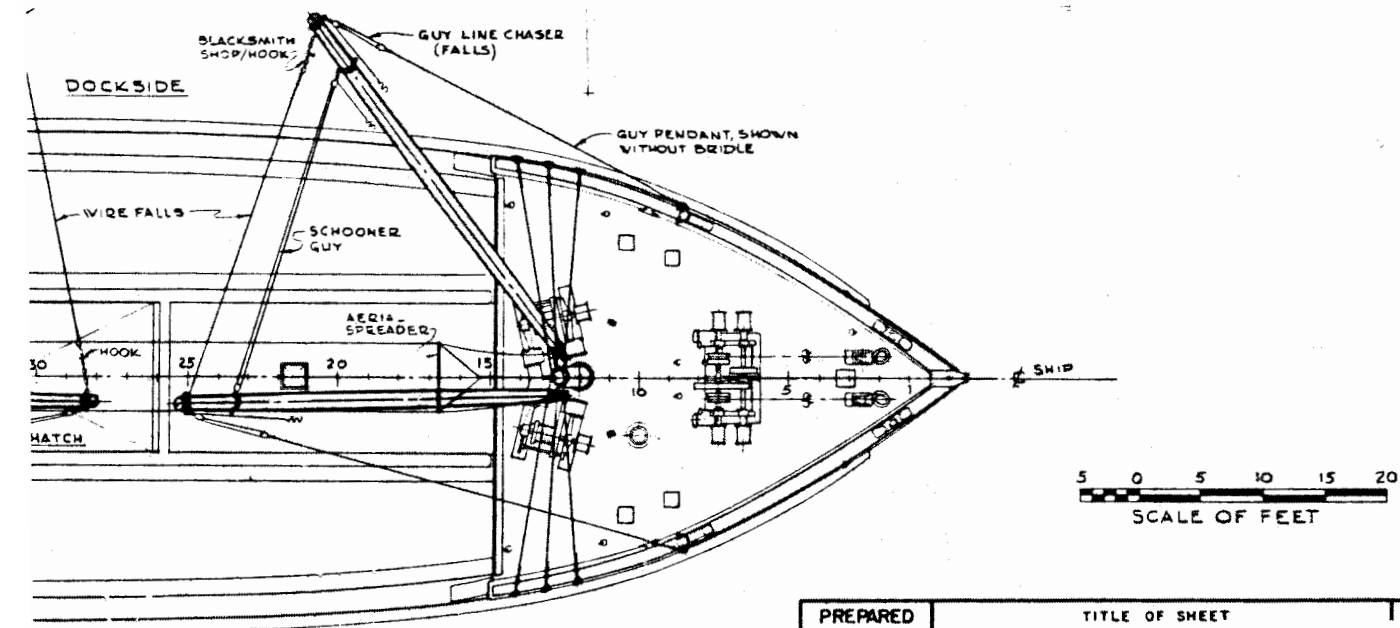
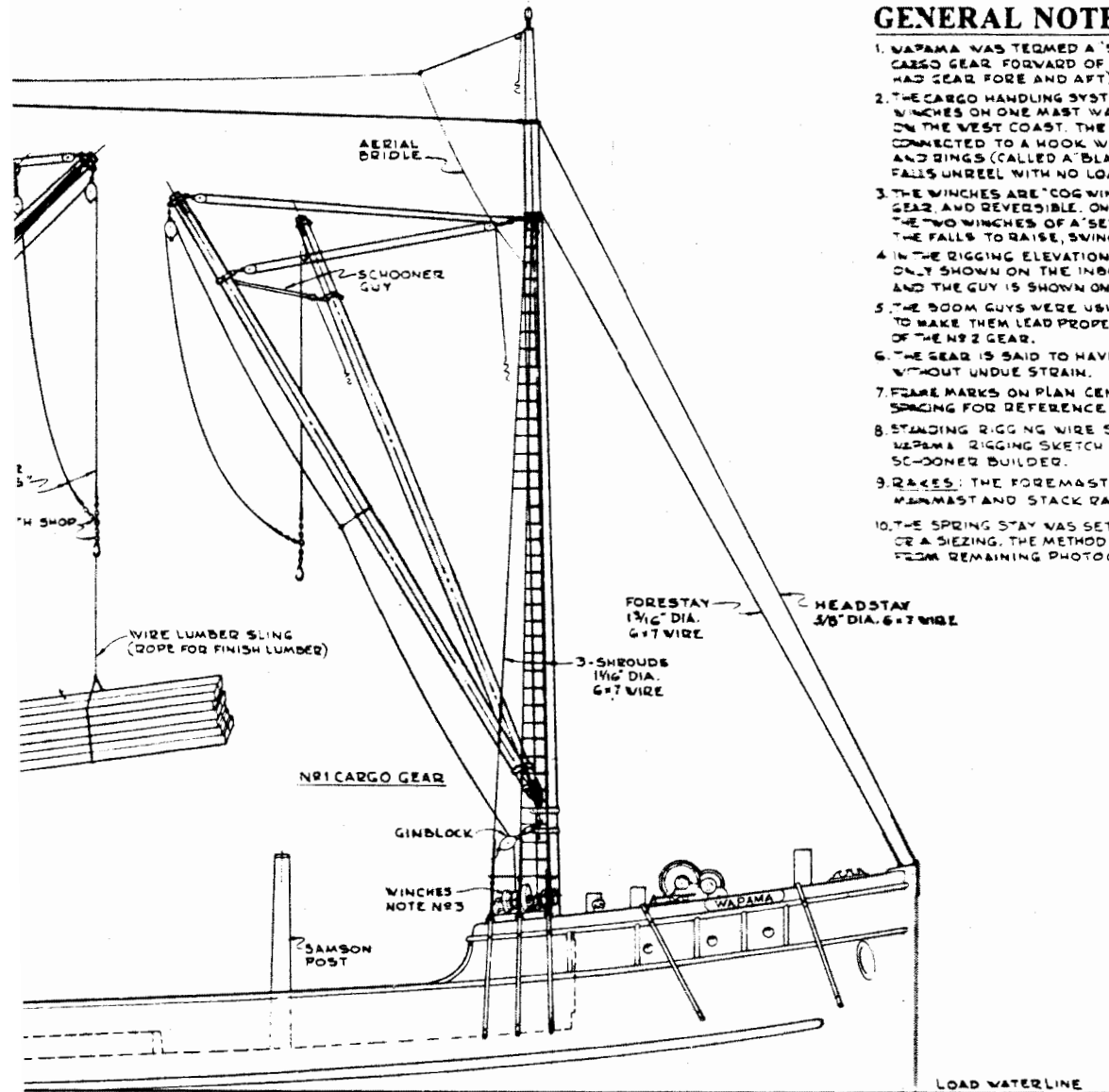

|          |                           |              |
|----------|---------------------------|--------------|
| PREPARED | TITLE OF SHEET            | DRAWING NO.  |
| DRAWN    | Steam Schooner WAPAMA     | 641/80.048   |
| CHECKED  | RIGGING ARRANGEMENT       | PCIP PKG 557 |
| DATE     | Historic Structure Report | SHEET 13     |

## V. EVALUATION OF TREATMENT ALTERNATIVES

### Three Basic Alternatives

The following alternatives assume the goal of preserving WAPAMA for future generations. Options which forego long term preservation have not been explored.

- A. **Restoration**, for refloating WAPAMA, is examined because it was the focus of earlier planning efforts. This option is not currently considered viable and is not recommended.
- B. **Stabilization** is considered achievable and is recommended as the responsible short term goal. Stabilization should be a precondition for any more ambitious preservation goals.
- C. **Long term preservation with public access** is considered the best possible end use. Uncertainties as to the viability of preservation can best be assessed after stabilization. These last two alternatives can be viewed as two phases of one operation, with the second contingent upon the success of the first.

#### A. Restoration as a Floating Museum Ship

Many ship preservation efforts in this country have been directed at the goal of presenting the vessel in a condition which approaches, as close as is practicable, that of a given period of her working life. Some notable examples, including the USS CONSTITUTION, the CHARLES W. MORGAN, and the JEREMIAH O'BRIEN have achieved some degree of success. To succeed at this goal a restored museum ship should be structurally sound, yet retain as much of her original fabric as possible. She should be effectively interpreted to the public, yet have the appearance of a working ship, "ready for sea". She should live as a ship, in her natural environment, yet be saved for future generations to learn from.

Only through extensive rebuilding have large wooden vessels, such as the CONSTITUTION and the MORGAN, been able to succeed as floating museum ships. These vessels still float on their wooden bottoms, and although stationary, they provide their visitors a reasonably accurate idea of the spaces and structures of life at sea during their historic periods.

Creation of a floating museum ship was the objective which guided the initial restoration of the WAPAMA. For almost 20 years she floated in her correct setting. Her spaces were dressed and interpreted on a number of levels. Extensive restoration and renewals to her deckhouse, pilothouse, rigging, and foredeck brought the ship close to her original



appearance. Yet original appearance and original condition are vastly different.

The average working life for commercial wooden vessels was seldom over thirty years. When the WAPAMA was laid up in 1947 she was an old vessel that was probably already suffering from advanced rot. She would have required extensive rebuilding to remain in service. In the decade that followed she received no maintenance and decay advanced very rapidly, leading to the need for major restoration work when she became a museum ship.

Unfortunately, the scope of work done in the initial restoration was determined by the funds available rather than the extent of the ship's needs. The complete restoration of a wooden vessel of WAPAMA's size was beyond the resources of the California Maritime State Historic Park, nor was it undertaken by the National Park Service in its turn. For the entire time that the WAPAMA was a museum ship her custodians lacked the resources to maintain, let alone rebuild, the ship. After deterioration has advanced far enough a ship becomes unmaintainable and ordinary cyclical maintenance and routine shipkeeping procedures have little effect on slowing the cycle of decay.

The steady deterioration eventually led to the ship's drydocking on Barge 214 in 1980. Since then, decay has rapidly accelerated. In 1986, returning WAPAMA to the condition of a floating museum ship would be extremely difficult.

Two approaches to this end are available. One is to carry out the 1984 Restoration Plan, followed by further phased restoration over a number of years. The other would be to undertake a complete rebuilding of the vessel.

Neither of these options is considered viable at this time, for reasons discussed below.

#### **1. The 1984 Restoration Plan**

The scope of work in this plan was narrowly defined as repairs needed to restore the girder strength of the hull. This was based on a correct identification of the vessel's most severe structural problems but did not address serious rot in areas not immediately critical to hull girder strength. Structural members with ongoing rot were to remain if they retained an estimated 50% of original strength (Reynolds 1984). Seriously rotten members in non-critical areas were not scheduled for renewal. The consequence of work of this limited scope would be to return the vessel afloat with ongoing rot that would be extremely difficult to arrest. The ship would be in need of additional major repairs in a very few years, with the possibility that even the restored areas would become reinfested with rot. The plan addressed the engineering problems of repairing a weak structure without addressing

the organic problems of maintaining that structure afloat with serious rot remaining.

Furthermore, the degree and rate of deterioration have advanced so far since the formulation of the plan that the intended work may not be achievable for lack of sound existing material to which connections can be made. The scope of work would need to be expanded for the vessel to be refloated. Even if the cost estimate (c.\$6 million) was accurate, it would surely be invalidated by the increased scope of work now needed for the vessel to be refloated.

There is nothing inherently infeasible in phasing restoration work over a number of years. A good example of this is the work carried out by Mystic Seaport Museum on their ships. The wooden whaler CHARLES W. MORGAN had major rebuilding in 1973-74, and twice again since then. The Schooner L.A. DUNTON has undergone major repairs in 1972, 1976, and 1986. At each of these work phases it was known that further restoration would be required in the not too distant future.

The ships at Mystic, however, are much smaller than the WAPAMA, and had more sound material remaining. The difficulty of applying this approach to WAPAMA is one of degree rather than of kind. The advanced level of deterioration coupled with the size of the ship make it questionable that funding in seven figures can reliably be projected through a multi-phased restoration extending over decades.

## **2. A Total Rebuild**

The November 1985 survey revealed rot in nearly every major member of the vessel. Rebuilding to the extent that would allow the ship to remain afloat, with only normal maintenance, would require replacing about 90% of the ship. The effort to retain the remaining intact original fabric and equipment would make a rebuild considerably more costly. A conservative estimate places the cost at 30 to 40% above that of replication. The cost of replicating WAPAMA can be roughly estimated in the range of 8 to 12 million dollars, and assumes retention of inboard joinerwork, machinery, and fittings. The unit costs of the 1984 restoration plan anticipated the work being done in a major shipyard and reflects typical pricing for such yards. However, no commercial yard is equipped for such an effort in wooden shipbuilding today. It would be far better to create a yard and crew for the job at a far lower overhead, in fact this is the only way we could envision the job being done properly. Ref. J. Ehrhorn Estimate, Appendix C. The 1984 restoration plan identified timber quantity requirements by board foot, but did not address the particular nature of the procurement problem.

One of WAPAMA's most noteworthy features is the massive size of her timbers. Consider the following examples:

Keelson: 20"x20"x70-80' lengths  
Asst. Keelson: 18"x25"  
Deck Beams: 15"x14.5"x40'  
Ceiling: 10"x10"x60'

Such timber must be resawn out of even larger balks; no modern lumber or construction business deals with such dimensions on a routine basis. There are still stands of old growth sufficient to provide large timbers but these trees are generally in areas remote enough to make transportation commercially prohibitive.

Therefore procuring the timber for rebuilding WAPAMA would require special ordering to allow lead time for selection before felling and milling, in addition to the time required for seasoning.

The long lead time and special logging effort to procure timber for her massive scantlings is only one reason that the process of removals and restoring the shape of WAPAMA would be a very slow one. In any nonstandard procedure delays can be anticipated. As the overall project time increases, the confidence factor in initial cost estimates decreases. Any start-stop cycles due to lack of funding would result in inefficiencies and consequent cost overruns. The time required for a complete rebuilding would very likely be 8 to 10 years.

The rebuilt vessel would essentially be a new ship, with minimal retention of original fabric. There is considerable division of opinion in the field of historic preservation on whether the loss of historic fabric outweighs the benefits of having an historic structure restored to its proper appearance and setting. Present NPS policy does not support replication of large historic structures as a preservation alternative.

Finally, questions of policy aside, it must be recognized that rebuilding the WAPAMA does not permanently solve the problem of her preservation. With the proper maintenance of the rebuilt vessel requiring resource allocations well beyond any level that has been available in the past, our successors would eventually face nearly the same problem with WAPAMA that we do today.

In the present context of the immediate and critical needs of the entire fleet of historic ships entrusted to the NPS, and the finite resources available for this purpose, the commitment of major funds to a rebuilding of the WAPAMA is not seen as a practical option.

## **B. Stabilization, No Public Access**

This alternative is an interim solution for a period of one to five years. After the survey in 1985 it was clear that without increased efforts at stabilization the WAPAMA cannot be expected to survive more than a few years, with her rapidly weakening condition resulting in eventual collapse of the structure. Carrying out stabilization measures is a straightforward process and some work recommended in a preliminary version of this report has been done. It must be understood, however, that the deterioration of the WAPAMA is so far advanced that there is no guarantee that stabilization measures will be fully effective.

The basic requirements for stabilization are increased structural support, protection from weather, and arresting rot. For a detailed discussion of ways to meet these requirements, reference section VI. "Factors Affecting Preservation."

## **C. Preservation with Interpretation**

This alternative is seen as the optimum long term goal and is contingent on successful stabilization of the structure. Displaying a vessel the size of the WAPAMA out of the water and so far above viewing level is an interpretive anomaly but also an opportunity to show aspects of the vessel's construction and design that are otherwise not apparent to the public. A discussion of interpretation options follows in part G. of section VI. "Factors Affecting Preservation."

The three areas of greatest concern in permanent maintenance of the WAPAMA out of the water are location, method of protection from the weather, and public safety. In addition to identifying a long term site, the question of location requires a decision on whether to keep the WAPAMA aboard Barge 214, or shift her to another barge, or ashore. The condition of the barge and implications for siting are discussed in part E. and F. of section VI.

Weather protection can be accomplished either by construction of a permanent cover, continued use of temporary covers, or by carrying out sufficient renewals to permit maintaining the exposed weather surfaces of decks and topsides as a normal ship. These options are elaborated in part C. of section VI.

The problems of providing for public safety are proportional to the level of accessibility desired to maximize interpretation. A very limited tour can be provided with minimum upgrading of existing condition. Allowing the public in other areas will require extensive structural support or renewals, reference item VI.D.



## VI. FACTORS AFFECTING PRESERVATION

### A. WOOD PRESERVATION

#### 1. Factors Affecting Wood Structure

WAPAMA is a wood structure held together with iron fastenings and trunnels ("tree nails" or wood dowels). Portions of the structure (sternpost, rudder post, chafing planks) are of hardwood, primarily ironbark, the trunnels are locust, and some interior joinery is oak or mahogany. The remainder of the structure, over 95%, is douglas fir. WAPAMA's preservation will therefore depend largely on the successful stabilization of this type of wood. All of the deterioration seen in WAPAMA's wood structure can be attributed to the following factors.

##### a. "Dry" or brown rot fungus decay (Basidiomycetes).

Cause: fresh water saturation to above 25 % moisture content.  
Effect: weakening of wood with eventual disintegration.  
Area Affected: throughout vessel, 80-90 % of structure affected  
Status: very active, progressing

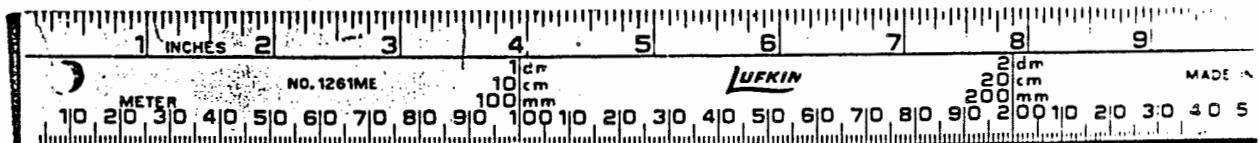

Fig. 46. Typical occurrence of brown rot decay. Sample section from covering board, port side of main deck. TCM

b. **"Wet" or soft rot fungus decay (Ascomycetes).**

Cause: fresh water saturation.  
Effect: slow softening and weakening of affected member.  
Area Affected: minor occurrences, scattered areas of lower hull, mostly internal structure where high moisture or standing water is found.  
Status: slowly progressing.

c. **Wood hydrolysis, "nail sickness"**

Cause: corrosion of metal, particularly fastenings, in contact with wood and in presence of moisture.  
Effect: discoloration, softening, and eventual disintegration of wood in vicinity of corroding metal.  
Area Affected: lower decks and hull, generally within 1 to 2 inches of iron fastenings.  
Status: moderately active where moisture is still present.

d. **Surface deterioration of wood, appearing as "fraying" of wood surface.**

Cause: probably caused by salt crystallization on wood surface.  
Effect: disintegration of wood surface to limited depth.  
Area Affected: wood surfaces, primarily in engine room and other interior compartments  
Status: unknown

e. **Weathering**

Cause: exposure of wood surfaces to weather  
Effect: warpage, shrinkage, checking and abrasion of wood surface.  
Area affected: exterior surfaces exposed to weather; hull, decks, houses.  
Status: active where surfaces are not properly coated or protected.

**2. Nature and Cause of Fungus Decay**

**Brown rot decay is by far the most insidious and destructive factor affecting WAPAMA at present (the effects of this type of decay are noted as "rot" in the Existing Condition Survey). Brown rot is the product of attack of wood by a decay fungi known as Basidiomycetes. This**

organism can inhabit wood, primarily softwood, which has a moisture content of 25% or greater. It first arrives as a spore, being airborne or waterborne to the wood's surface. Under favorable conditions (temperature and moisture) the spore germinates and penetrates the wood surface to begin digesting the wood by dissolving the cell walls. Brown rot is so called because of the brown color the wood acquires from the predominately lignin residue left after fungal metabolism (Morrell, Helsing, Graham 1984).

In WAPAMA's case, the cause of brown rot is poor ventilation coupled with fresh water saturation from exposure to rain.

### **3. Rot Treatment Options**

The following methods are commonly used to arrest rot:

- **Renewals:** replacing all or part of an affected member.
- **Drying of wood:** reducing the moisture content of wood to below 25% will prevent growth of most decay fungi.
- **Treatment with chemicals:** topical applications, fumigants, pressure treatment.

Each of these methods has particular advantages and limitations. Long term preservation of WAPAMA will likely depend on a combination of all three.

#### **a. Renewal of Decayed Structure.**

The most effective method of arresting fungal decay is to replace all infested wood with properly treated and installed new material. Due to the extent of decay, both advanced and incipient, this method would necessitate rebuilding almost the entire vessel. Renewal of all decay infested material is not considered practical. In some cases severe deterioration and weakening of structural members or desire to achieve weather-proofing will favor renewal (see item D.6., Structural Renewals). Where renewals are made, care should be taken to prevent the spread of decay from adjacent infested members.

#### **b. Reducing Moisture Content**

Drying of wood, for the purpose of arresting and preventing dry rot, involves reducing the moisture content of each wood member in the structure to below 25%. This can be done by preventing direct contact of the wood with fresh water, primarily rainwater, and by providing adequate ventilation to wood surfaces. Once this is achieved, the wood will eventually dry until the moisture content approaches the ambient moisture level of the surrounding atmosphere, about 12% to 14% in the



Bay Area, a level which is below the threshold for most decay fungi growth.

**The drying method is considered the best long term solution to the fungal decay problem.** In WAPAMA's case, this will not be easy to achieve. In the first place, many of the weather surfaces; topsides and decks, are so deteriorated that they cannot be made weatherproof while still retaining their original fabric and appearance. Secondly, some surfaces within the hull, such as frame spaces between planking and ceiling, are totally enclosed and receive no ventilation at all. These areas will need to be exposed through selective removals in order to achieve drying. Thirdly, the unprotected vessel has been thoroughly saturated with rainwater for several years. Most of the larger timbers (ceiling, frames, keelsons) show extremely high moisture content (see Appendix C, Results of Moisture Readings) and will take years to dry to an acceptable level. In the mean time, decay will continue, with resultant loss of fabric. A rot treatment program will be necessary in order to reduce fungal decay during this interim period. Options for rot treatment are covered under the heading Chemical Treatment in this section. The following measures can be taken to begin the drying process.

**(1). Keeping Rain out of Structure**

Weather covers, such as those recently placed over the main and forecastle head decks, are a reasonable interim solution. These covers have helped to begin the drying process, though to be effective, they will need to be extended to cover all weather surfaces, including topside planking (weather protection options are discussed in item C, Weather Protection). Another option is renewal of deteriorated structure in order to achieve weather tight surfaces on the vessel itself (see item D.6., Structural Renewals).

**(2). Improving Ventilation**

After securing the structure from the weather, the drying process will begin. In order to maintain a low moisture level in the vessel interior, and therefore speed up the drying process, ventilation should be improved. This can be accomplished by passive or active means.

**Passive Ventilation:** Ventilation can be improved immediately by opening all hatches, doors, ports, windows, and ventilators in areas protected from the weather. The totally enclosed spaces between the frames will need venting. This can be achieved by drilling holes or removing sections of planking

and ceiling (see item D.5., Fabric and Equipment Removals).

**Active Ventilation:** In areas where adequate air flow cannot be achieved by passive means, air moving equipment should be used. Fans can be used in compartments such as the hold, engine room, and afterpeak. These should be of the low velocity, high volume type. Small spaces, such as the voids between frames, may require a different type of air mover. Air pumps, which can deliver small metered amounts of air to specific areas, would be more effective in these locations. It will be important to carefully monitor and regulate ventilation to avoid excessive drying of wood.

### **c. Chemical Treatment**

Once protected from the weather, WAPAMA will begin to dry out. It will likely take years before the moisture level drops below the threshold for fungal growth. In the interim, decay fungi will continue to weaken the structure. Chemical treatment will be necessary to arrest or slow the rate of decay.

The larger timbers are of primary concern for ongoing decay because of their long drying time. Unfortunately, these are also the hardest to treat with fungicidal chemicals. The various chemical treatments for decay fungi can be grouped into two major categories: 1) fumigants, and 2) topically applied liquids and solids. Several examples of both types of treatments were investigated and their applicability assessed.

#### **(1). Fumigants**

Fumigants have come into wider use in recent years, both for preventative and remedial treatment of wood. They are favored primarily because of their ability to penetrate soft woods such as douglas fir. Most of the fumigants considered here are applied as solids or liquids which become a gas after insertion into wood. This process requires the drilling and plugging of holes at various intervals along the length of the wood member being treated. Chemicals of this type include:

##### **(a). Chloropicrin**

This fumigant is considered to be one of the most effective and durable fungicides. The major drawback is the high level of toxicity. There appears to be no definite answer on how long significant and hazardous levels of the

chemical will continue to leach out of the wood. For this reason alone the use of chloropicrin is not advised.

**(b). VAPAM**

Studies show VAPAM to be effective in stopping most decay fungi in douglas fir. This fumigant penetrates well in wet wood, traveling approximately 2ft. from injection sites, and remains effective for 12 to 16 months (Esllyn and Highly, 1984). Treatment of WAPAMA would involve drilling timbers and injecting the chemical at numerous locations. This is only considered practical on the larger members such as keelsons, ceiling and framing. Questions have been raised concerning the effectiveness of this chemical in WAPAMA's checked and fastening-riddled timbers, where the gas may escape prematurely. VAPAM is the safest of the effective fumigants and has been used in habitable structures. Health safety is nevertheless a concern with this chemical when used in enclosed spaces. Its use is therefore not recommended at this time.

**(c). Methyl Bromide**

Although methyl bromide is not used commercially for eradication of decay fungi, research has shown some success for this application (Richard and Bollen 1967). This fumigant was considered as an alternative because of its potential advantage in treating inaccessible areas of the structure. Methyl bromide differs from the other fumigants in that its use does not require drilling of timbers. The treatment process involves introducing this chemical as a low pressure gas to the enclosed or tented structure.

Given high enough concentration and long enough duration, methyl bromide would presumably penetrate into all wood surfaces. It has no residual effect but could possibly give decay fungi a "knockout punch" that would slow or prevent re-infestation until the structure dries adequately. Questions have been raised concerning the ability of methyl bromide to penetrate WAPAMA's highly water saturated wood. In addition, there are technical difficulties with effectively tenting the entire vessel for treatment. Methyl bromide is not presently approved by the State of California for use against decay

fungi. A special permit would be required for its use in this application. Though not the recommended treatment, methyl bromide has not been ruled out as a possible option.

## **(2). Topically Applied Chemicals**

Several oilborne and waterborne preservatives have been considered for topical application. Many of these preservatives are used commercially in pressure treating of new lumber. Unfortunately, pressure treatment is not practical for a large existing structure like WAPAMA. Some of the waterborne chemicals show promise because of their ability to diffuse into moist wood.

### **(a). Oilborne Preservatives:** Tributyltin oxide, copper naphthenate, pentachlorophenol.

Oilborne preservatives are not considered effective at stopping existing rot because they do not penetrate very far into douglas fir when topically applied, thus leaving active fungi in the wood interior. The more effective chemicals, such as pentachlorophenol are extremely hazardous for skin contact or inhalation. Their use on contact surfaces exposed to the public would not be advisable. The less toxic oilborne preservatives, such as copper naphthenate, may be useful in protecting replacement timbers. Aside from this limited applications, oilborne preservatives are not recommended.

### **(b). Waterborne Preservatives:** Ammoniacal copper arsenate (ACA), chromated copper arsenate (CCA), ammonium biflouride (ABF), flour-chrome-arsenic-phenol (FCAP), sodium borate (TIM-BOR).

Of the waterborne preservatives investigated, only sodium borate (TIM-BOR) is considered as a treatment alternative for WAPAMA. CCA and ACA contain hazardous chemicals which rule them out for use on contact surfaces. Ammonium biflouride has excellent penetration qualities but is corrosive to iron, a factor which could severely degrade WAPAMA's metal fastenings.

Sodium borate, by contrast, presents virtually no health hazard. For this reason, it has found wider acceptance in Europe, where the more hazardous preservatives are no longer in use. In addition to low toxicity, sodium borate acts as a fire retardant and corrosion

inhibitor. It has been shown to be effective in treating a variety of decay fungi, both soft rot and Basidiomycetes, that attack soft woods (Dickerson, et al. 1983). The noted British wood preservation expert Dr. W.P.K. Findley has stated "It [boron] is ... perhaps unique amongst toxicants, that a material which is so innocuous to man is so effective against microorganisms" (ibid., 80).

Treatment of WAPAMA would involve brushing or spraying an aqueous solution of sodium borate on all exposed surfaces. Because sodium borate penetrates by diffusion, the wood to be treated must have a high moisture content. This can be achieved by soaking the structure with water prior to application of preservative. In addition to topical application, sodium borate can be applied by drilling and inserting solid rods of the chemical into timber interiors. This method would likely be necessary on the larger timbers where full penetration cannot be achieved through surface application. Painted surfaces, such as the topsides, may present a problem for application of sodium borate.

Though questions remain, the positive aspects of this chemical treatment suggest further study. A comprehensive treatment plan should be developed before implementation. Testing is presently underway, at U.S. Borax Laboratories, to determine the effectiveness and best method of sodium borate application for WAPAMA's particular wood fabric.

#### **4. Other Wood Preservation Concerns**

Although brown rot fungal decay is of primary concern, other wood-degrading factors will have to be addressed in the course of long term preservation of WAPAMA.

**Soft Rot:** This form of decay is slower acting and fewer occurrences were noted. Because the favorable environment for soft rot is an extremely moist one, the drying process chosen as a treatment for brown rot should also eliminate this type of fungal infestation. The effectiveness of various chemical treatments on soft rot has not been addressed, but should be determined before commitment to a particular chemical treatment.

**Nail Sickness:** The adverse effects of corroding iron on wood (wood hydrolysis) was noted throughout the vessel. This process requires the presence of moisture and

should therefore slow down as the structure dries out. Nail sickness is difficult to treat because much of it is occurring at fastenings deep within timbers. The recommended chemical treatment for brown rot, sodium borate, is reported to have anti-corrosive properties (U.S.BORAX, 1986). If significant penetration is achieved with this chemical it may help to slow the rate of corrosion of fastenings.

**Warping and Shrinkage:** Change in shape and bulk of wood is considered by many to be a major drawback to dry-berthing of wooden vessels. In WAPAMA's case, this has not yet occurred in a serious way. One reason may be that she remains relatively moist due to rainwater saturation. The hull bottom, the only portion of the vessel which was formerly immersed in water, has undergone some shrinkage and opening of seams, but remains relatively sound. All other exposed surfaces remain in much the same environment as when WAPAMA was afloat. Warpage and shrinkage seen in these areas are more likely due to a reduced maintenance of coatings rather than changes in environment.

Because the recommended treatment for rot is drying of the structure, some wood consolidation or stabilization treatment will probably be necessary to prevent debulking of timbers, particularly those damaged by decay. PEG (polyethleneglycol) has been ruled out as not suitable for application on WAPAMA (Grattan, 1986). Several epoxy wood consolidation products are now available, and have been used with success in numerous preservation applications. These products may have application here, but are expensive. Product testing is recommended on WAPAMA. Any wood consolidation effort should be made in conjunction with the rot treatment program.

## **5. Coatings**

Wood coatings are essential for two major reasons: to protect wood surfaces from weathering and decay, and to improve appearance. WAPAMA is in need of coating for both reasons. Much of her exterior remains exposed to the weather, and coatings have broken down. In addition, the vessel's high visibility at the Bay Model site warrants some effort to improve her appearance in the near term.

Many of the wood surfaces can be coated as they were previously. This includes the interior and exterior surfaces where rot has not encroached. Surfaces where rot is present will require special treatment. These surfaces should not be coated with any material which will inhibit the drying process or prevent treatment with surface applied preservatives. Where there is an immediate need to

improve the appearance of painted surfaces, a breathable stain, with appropriate color pigment, might be used. This type of coating would allow drying, and some penetration of preservatives, but would be primarily decorative, providing little protection and having minimal durability. This application should be considered for the following areas:

| <b>Area</b>                   | <b>Coating</b>       |
|-------------------------------|----------------------|
| wheel house                   | white stain          |
| boat deck covering boards     | white stain          |
| cabin deck rails, stanchions  | white and gray stain |
| main deck bulwarks, bulkheads | white and gray stain |
| topsides                      | white and gray stain |
| bottom                        | red stain            |
| forecastle covering boards    | white stain          |
| forecastle bulwarks           | white stain          |

A coatings schedule, specifying types of coatings and sequence of application, should be developed in conjunction with the rot treatment program.

## **5. Recommended Wood Preservation Treatment**

The permanent reduction of moisture content is recommended as the best long term treatment for WAPAMA's wood fabric. Interim treatment with preservatives will be necessary to slow decay during the drying period. The following steps are recommended. Cost estimates and sequences are given in the section VII, Recommended Treatment.

### **Procedures**

- a. Erect weather protection over all exposed surfaces:

Temporary covers (stabilization)  
Permanent shed (long term)

- b. Increase ventilation:

Passive ventilation (removals)  
Active ventilation (fans, air pumps)

- c. Remedial chemical treatment of wood:

Sodium borates: 1) further research  
2) application  
3) monitoring

- d. Apply protective coatings:

Breathable stains (prior to rot treatment)  
Paints and wood sealers (after rot treatment)  
Wood consolidating epoxy (as needed)

## **D. METAL PRESERVATION**

### **1. The Major Factor: Corrosion**

Metal components of WAPAMA include machinery, tankage, piping, deck gear, wire rigging, iron fastenings, and innumerable fittings. Corrosion is the primary degrading factor for all these items. Some galvanic action is seen where dissimilar metals are in contact with one another (mostly iron and bronze), though these incidents are minor.

The chief cause of metal corrosion in WAPAMA is excessive moisture, primarily from rainwater. Unlike decay in wood, some metal corrosion can be stopped almost immediately by use of anti-corrosive coatings, though coatings alone will not provide adequate long term protection. The high level of moisture that all metal components are now subjected to will reduce the effective life of most coating systems. **The recommended long term treatment is reduction of moisture level through provision of weather protection, coupled with application of anti-corrosive coatings.** Routine maintenance is a necessity for all machinery.

### **2. Recommended Treatment**

#### **a. Main Engine**

Of all the machinery aboard WAPAMA, the main engine has the most historic value and interpretive potential. It is probably due to the fact that the engine has been maintained in better condition than the other machinery. Only light surface rust is seen on the exposed metal surfaces, and the engine appears to rotate freely. Treatment should include frequent wipe down of exposed metal parts with oil, greasing of bearing surfaces, and periodic rotation of the engine. The electric jacking gear should be inspected and tested by an electrician. After the engine is known to rotate freely, the electric jacking gear could be used for display and maintenance.

#### **b. Auxiliary Machinery**

Auxiliary machinery is located in the engine room. Items include pumps, dynamos, electric motors, filter/heater, and evaporator. This equipment suffers from rainwater seepage and lack of maintenance. Stopping seepage is considered most important. If this cannot be achieved immediately, temporary covers should be placed over all equipment to keep water off. WAPAMA's machinery will never again receive the care it did when the vessel was operational. It should nevertheless be maintained on a regular basis. This includes painting and lubrication. Assignment of a part time "engineer" is recommended for required maintenance.



### **c. Boilers and Stack**

The boilers and lower end of the stack are severely corroded and continue to deteriorate. Though the upper end of the stack is being secured as part of the stabilization effort, the lower section and breaching are too deteriorated to maintain in place. These sections should be thoroughly documented and removed before they collapse entirely.

Removal of all asbestos and fire brick from the boilers is recommended. This will reduce weight on vessel structure and allow better access for preservation work. The boilers are coming apart at the seams and will require welded or mechanical repair to consolidate them. The extreme corrosion and wastage will make them difficult to prepare for coating. Wet grit blasting should be considered as an alternative to mechanical cleaning. Sandblasting is not recommended for interior spaces, but might be considered for dismantled sections of the boilers.

### **d. Tankage**

The two main fuel tanks in the engine room are in poor condition and are rapidly deteriorating. These show heavy scale on the sides, and are rusting through on top. These tanks would benefit greatly from weather protection. All tanks, including the fuel tanks (2), 'tween deck tank, and afterpeak tanks (2) should be scaled and treated with a corrosion inhibitor. Coatings could then be applied.

### **e. Piping**

The majority of piping is in the engine room. This includes steam, water, and fuel oil piping. Much of the piping is badly corroded and collapsing. Collapsing sections should be documented and removed. Remaining piping and valving should be scaled, and coated.

### **f. Deck Gear**

Deck gear, including capstans, winches, and windlass, are presently exposed to the weather. This gear should be protected with covers during the rainy season. Recommended maintenance includes scaling, priming and coating, and greasing of moving parts.

### **g. Fastenings**

The fastenings are the most difficult metal components to treat. This is due to the fact that most are buried deep in large wood timbers that are moisture saturated. The rate of corrosion of these fasteners cannot be slowed without reducing the moisture content of the wood, a process which will take time. In addition, thorough coating is not an

option due to the inaccessibility of most fastenings. The use of sodium borate for rot treatment may help to reduce the corrosion rate of fastenings during the drying period of the wood structure.

#### **h. Wire Rigging**

Wire rigging includes the mainmast shrouds and the stack guys. A temporary stay is rigged on the mainmast. The stack guys are in fair condition, the condition of the shrouds is not known. Sound ratlines should be rigged for inspection and maintenance of the mainmast rigging. A more permanent main stay should be rigged to a secure anchor point on the vessel. Penetrating wire preservative is recommended for all wire rigging. The shrouds' service should also receive a coat of tar.

### **3. Recommended Metal Coatings**

- a. Main engine / auxiliary machinery  
preparation: scale, wire brush  
coatings: red lead primer, enamel finish,  
grease or oil on moving parts
- b. Boilers  
preparation: needle scale, wire brush (or dismantle and sandblast)  
coatings: manganese-phospholene #7 (or zinc primer if blasted), tie coat, enamel
- c. Stack  
preparation: manual scale, wire brush  
coatings: red lead, enamel
- d. Fuel tanks  
preparation: needle scale, wire brush  
coatings: manganese-phospholene #7, red lead, enamel
- e. Water tanks  
preparation: manual scale, wire brush  
coatings: manganese-phospholene #7, dark red lead
- f. Piping  
preparation: manual scale, wire brush  
coatings: manganese-phospholene #7, red lead, enamel
- g. Deck Gear  
preparation: manual scale, wire brush  
coatings: red lead, enamel
- h. Wire Rigging  
preparation: wire brush  
coating: wire preservative, tar

**4. Metal Preservation Recommendations & Cost Estimates**

The following are general recommendations for treatment of metal fabric. Cost estimates are given in parenthesis where they are included in other recommended preservation work (i.e. weather protection, ventilation).

|   |                |
|---|----------------|
| a. Stop all rainwater incursion into vessel<br>(extended weather covers). | (\$ 50,000.00) |
| b. Provide covers for all exposed machinery.                              | \$ 1,500.00    |
| c. Provide ventilation or dehumidification<br>in engine room.             | (\$ 10,000.00) |
| d. Provide proper lighting in engine room.                                | (\$ 2,000.00)* |
| c. Assign an "engineer" to maintain all<br>machinery on a regular basis.  | \$ 5,000.00**  |
| e. Coat all accessible metal as recommended.                              | \$ 32,000.00   |
| -----   |                |
| Total (other preservation work included)                                  | (\$100,500.00) |
| Total (other preservation work <u>not</u> included)                       | \$ 38,500.00   |

\* work in progress  
\*\* per year

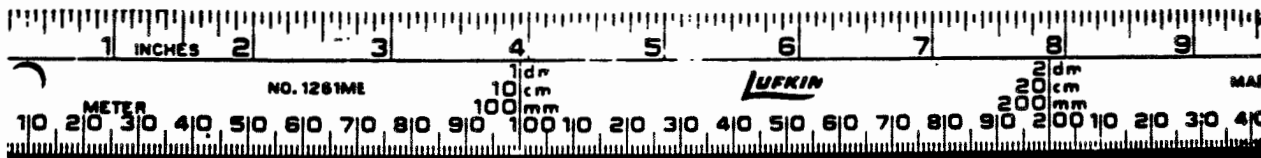
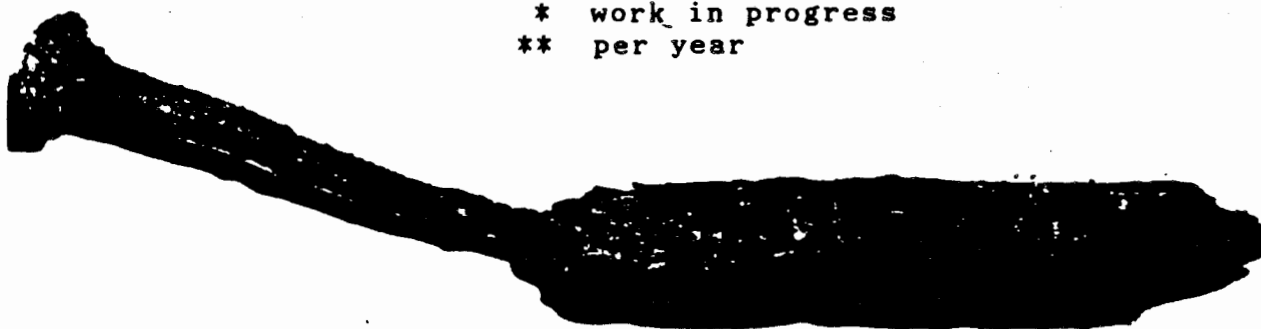

Fig. 47. Corroded iron spike plank fastening, taken from topsides, port side, frame 45, strake 22. --Photo, TCM

**C. WEATHER PROTECTION**

Any effective effort to stabilize and preserve WAPAMA should begin by stopping the intrusion of rainwater into the vessel. Arresting rot and preventing corrosion will be impossible unless this is achieved. Three approaches to this problem have been explored.

**1. Extended Nonpermanent Covers**

The present cover is a good start but provides only limited protection to the main deck and forecastle head, and none for the rest of the ship. The cover, as it is now, has very little overhang and even a slight angle of wind driven rain will soak the decks and pass on to the interior of the ship. In addition, protection should be provided for the porous topsides as well as the superstructure aft. This protection would be neither expensive nor difficult to achieve if use is made of reinforced plastic sheeting held in tension by a simple frame.

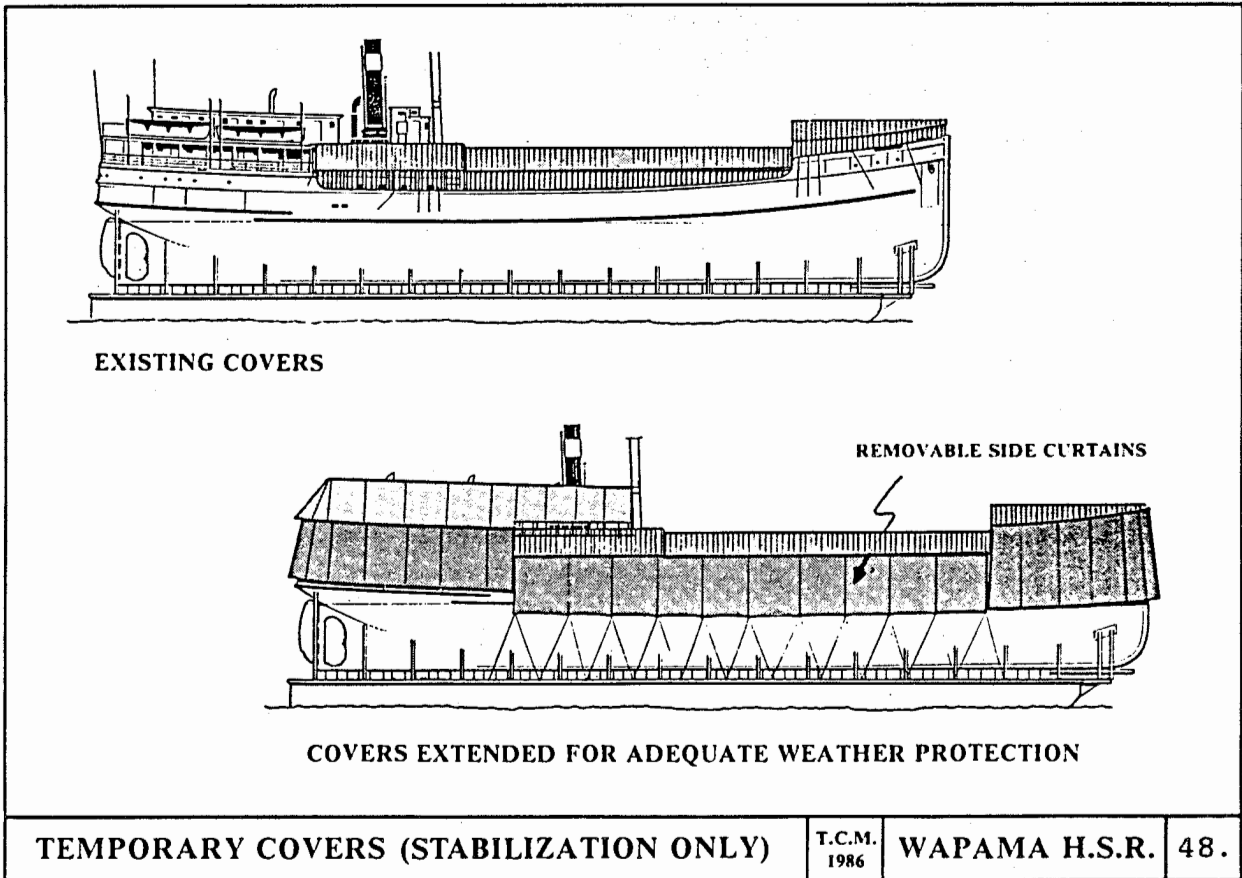

(Extended covers, cont.)

From a preservation standpoint, coverage of the entire vessel is highly desirable. There is rot in the wheelhouse roof, doors, and aft corner posts. The engine room stack casing is riddled with rust holes. The boat deck and covering board are rotten in places, as is the boat deck house (see Section 2, item III.C., "Existing Condition Survey" for an inclusive list of defects). For all of these reasons, a roof of some kind over the entire boat deck level will best save the structure and minimize maintenance needs in the future.

Placing the entire vessel under cover carries the aesthetic disadvantage of obscuring the lines of the ship under a very large, cocoon like structure. A compromise position would be to repair the boat deck level structures to a weather tight condition and build covers for the cabin deck level, which suffers far more serious decay. A detailed listing of the repairs required on the boat deck level was submitted in January 1986, in a preliminary draft of this report under the heading of Immediate Recommendations. Since then further examination and ongoing deterioration indicate extensive repairs will be needed to seal this area effectively enough to permit it to remain uncovered.

## **2. Removable Fabric Awnings**

A fabric cover suspended as an awning, without an extensive rigid frame, is not considered a viable alternative. This is because awnings are normally not expected to withstand severe weather and are typically taken in during such conditions. Yet severe weather is precisely when such a cover would be needed most on the WAPAMA. The windage of an awning type cover would require strong support and rigging of a suspension system which would have to be mounted from the barge deck to keep the wind loading off of the weakened ship.

The primary difficulty is that the fewer the points of attachment the greater the strain that will come on these points. Therefore very strong rigging and canopy construction will be required. Any canopy that can stay up in 50 knots of wind will represent as much sail area as the full-rigged ship BALCLUTHA could carry in such conditions. A quick glance at the rig required to support these loads on the BALCLUTHA will give an idea of the practical requirements to keep cloth standing broadside on to a gale.

Such a structure can also be expected to require far more maintenance in any given year than a fixed cover.

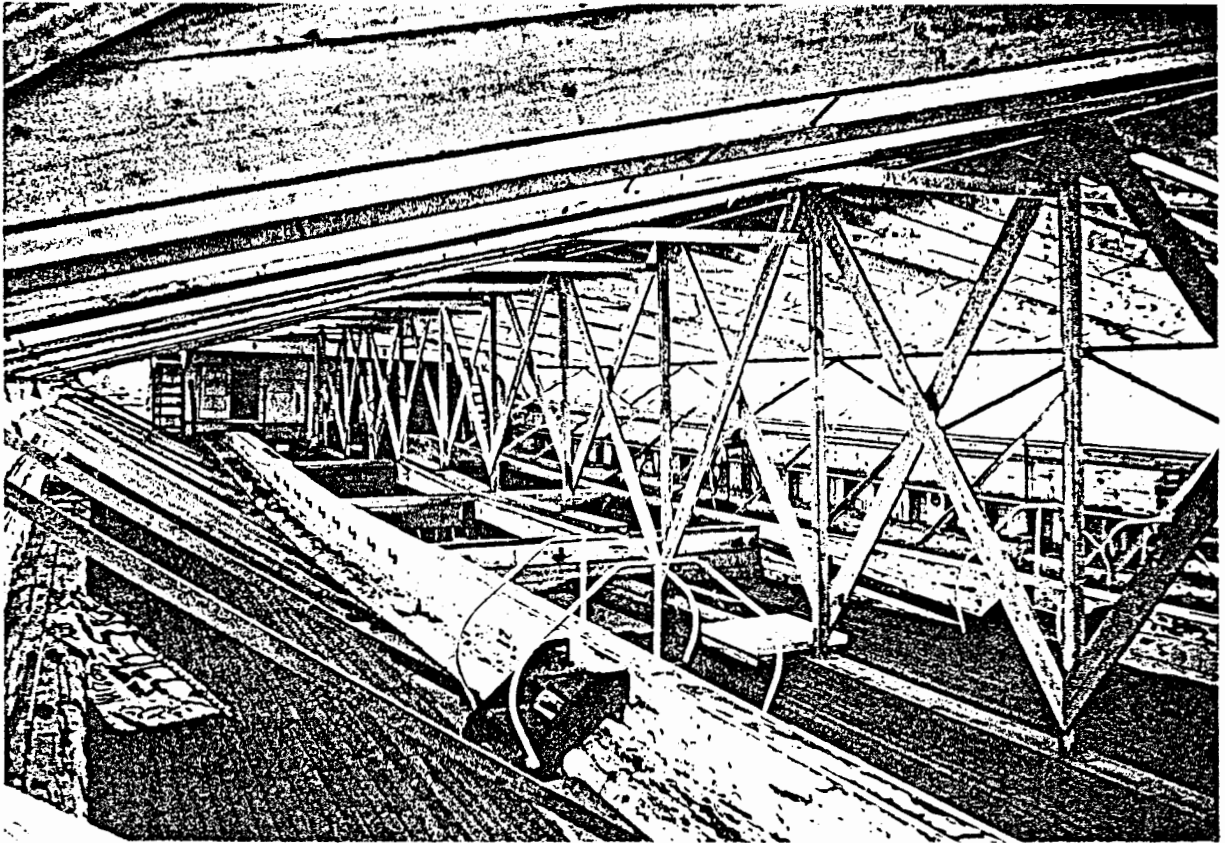
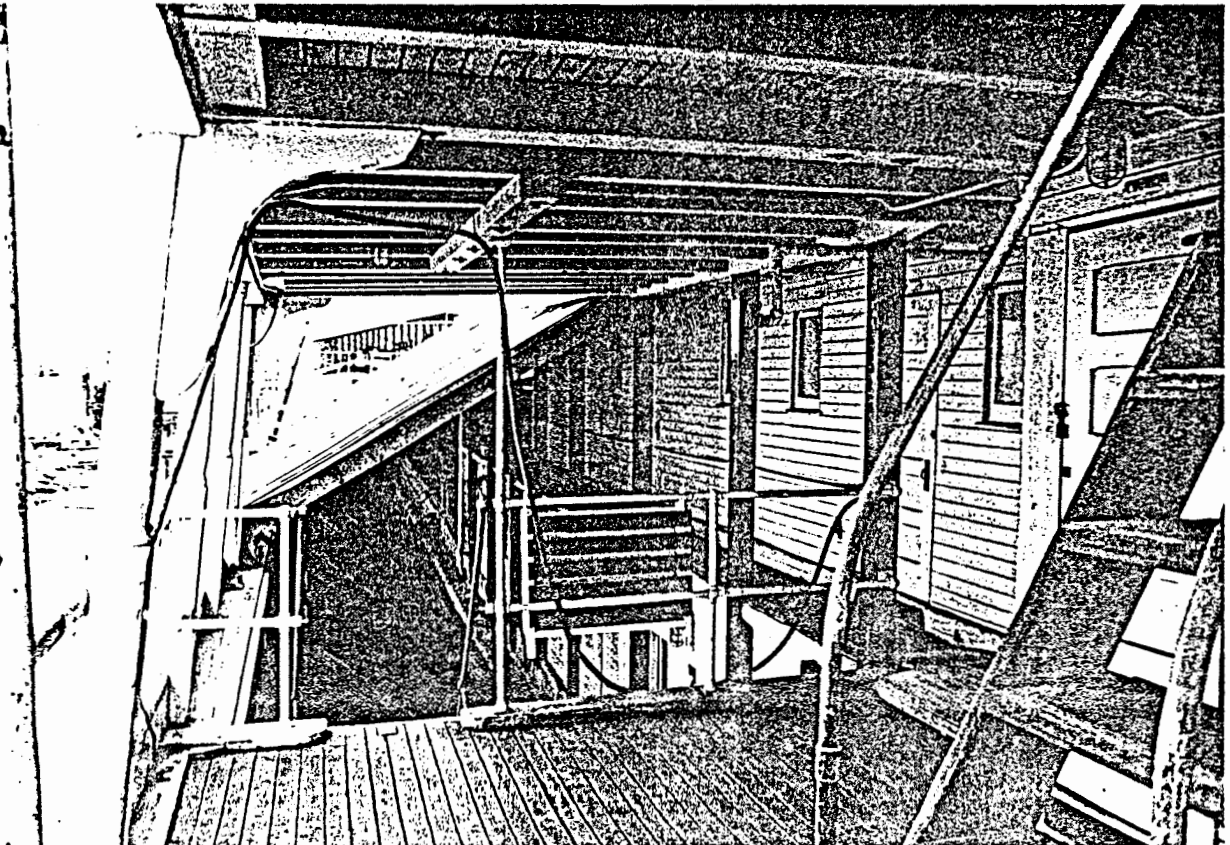

Fig. 49. Present cover over main deck. (1986)

--TCM

Fig. 50. View forward, port side, from cabin deck, showing compromised visitor circulation and sight lines.

--TCM



### 3. Encompassing Structure

The need for weather protection coupled with the desirability of public viewing of the WAPAMA may best be met by construction of an open sided shed over the entire vessel. The roof portion would be a permanent structure. To protect the topsides from wind driven rain, removable side panels could be put up during the rainy season. (Figures 51, 52, 58 and 60.)

The use of an inflatable building was investigated and deemed impractical. The height requirement compared to the base available was found to be beyond the stability limits of such structures. The appearance of such a large balloon like structure would have no relationship to the historic vessel and look out of scale in any site under consideration.

A related solution would be the use of a rigid frame-tensioned membrane type structure. Such a structure is technically possible, though cost would be in the range of \$25 to \$35 per square foot for the size and strength required on this scale. This is considerably more expensive than the \$7 to \$12 commonly quoted for ordinary roof construction. Questions of cost aside, the appearance of such a large and unconventional structure may be hard to rationalize next to the historic ship.

The best long term solution to out-of-the water preservation of the WAPAMA appears to be building a traditional open sided building over the vessel, perhaps with a clerestory in the roof for improved ventilation and lighting. There is historical precedent for the appearance of the ship in a shed. Many vessels in the Northwest were built under sheds similar to the conceptual proposal shown. Any future renewal or repair work would be most efficiently done under the protection of such a structure.

The construction cost of an adequate shed would likely be in the range of \$200,000 to \$350,000, based on costing of a similar work shed as part of the 1984 Restoration Plan. While this is higher than for frame and fabric covers the maintenance requirements would be much lower.

The primary advantage of the shed is that it provides the maximum protection combined with the maximum visibility from the eye level of visitors near the vessel. All other systems that provide adequate protection do so at the expense of interpretation.

The primary disadvantage is the requirement for base area. Providing a good base for such a shed will require modifications to the barge. Two approaches to increasing the deck area of Barge 214 are explored in Section 2, item VI.E.

#### 4. Renewals of Exposed Surfaces

The third method of excluding rain from the interior of the ship would be to carry out partial restoration to permit the weather surfaces to be maintained as if the ship were afloat (see item VI.D.6.). The renewed portions of the ship would require the same level of maintenance as any other vessel in the fleet of historic ships. Experience to date does not support any expectation that this level of maintenance would be sustainable.

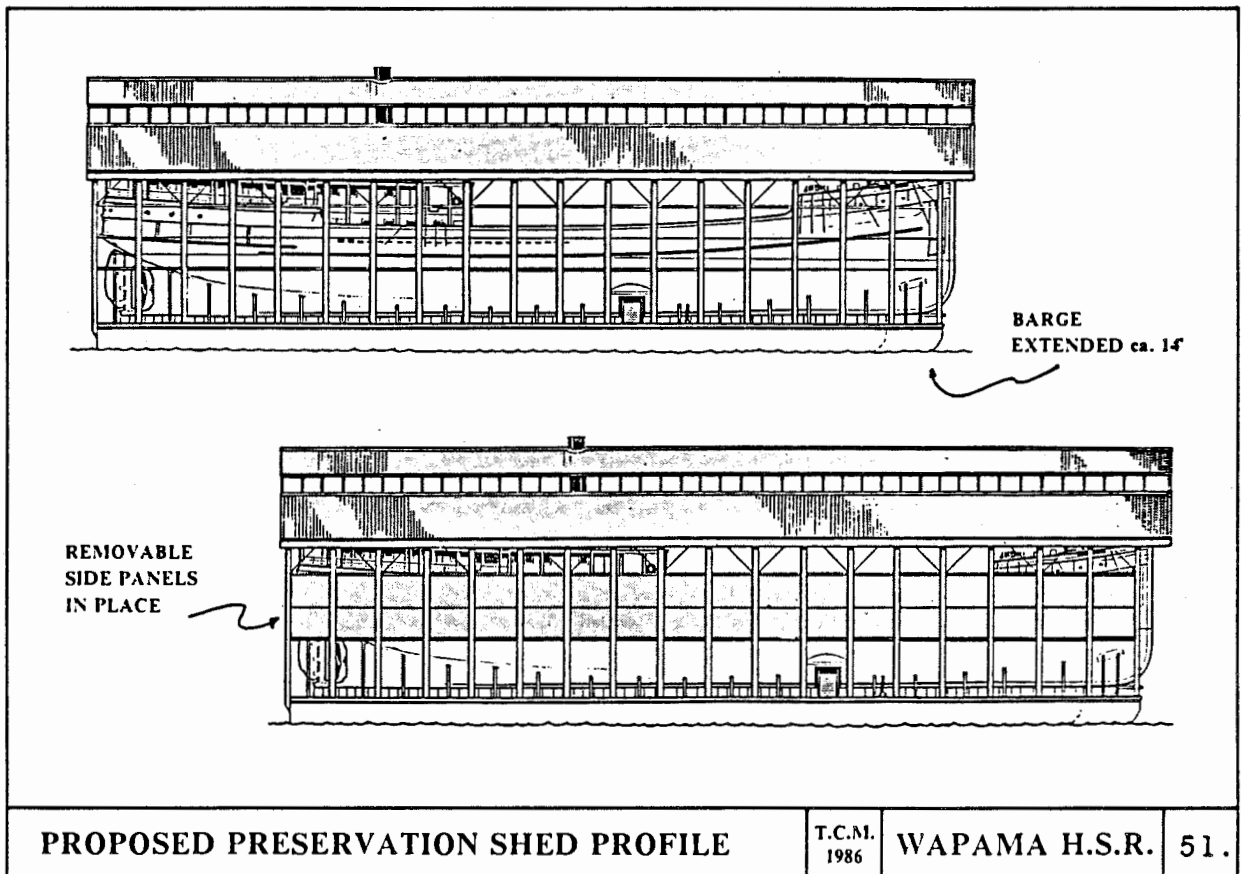



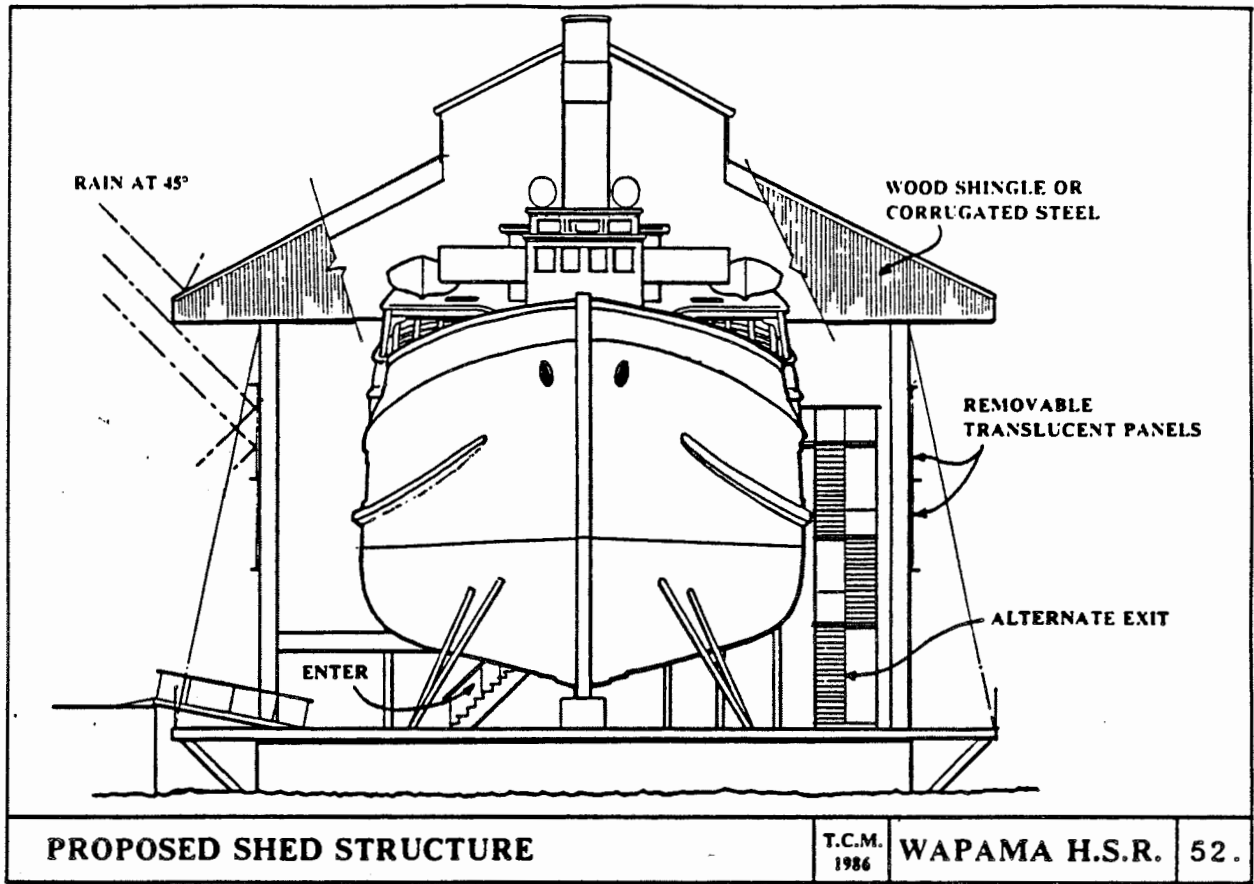

## **D. STRUCTURAL INTEGRITY AND SUPPORT**

The overall physical fabric of the WAPAMA has decayed to the point that in some areas the structure's own weight is a liability. Stabilization and preservation efforts will have to address the following problems.

### **1. Continuing Deterioration and Effects of Drying**

The process of drying the ship out to arrest rot presents some associated problems. The larger the timber, the longer it takes to dry out. For many of WAPAMA's major timbers this could take up to ten years. During this time ongoing rot may continue with attendant loss of structural strength.

Another structural problem arises from the fact that the most rotten and saturated members are, to some extent, holding their dimension from the bulk of the water in them. When the water is gone the cell walls may collapse and the wood shrink. This is a frequently encountered problem in the treatment of historic fabric recovered by underwater archeology. In the WAPAMA this may show up as plank fastenings letting go from rotten frames, or rotten floors crushing under the compression of deck shores or keelsons. Structural support of the vessel during stabilization must be periodically monitored and modified as needed.

### **2. Bow Support**

The forward 17 feet of the WAPAMA's bow overhangs the end of the Barge 214. This is because the ship is longer than the barge. In view of the weakened condition of the upper members of the hull girder and the extent of rot in the stem and topside planking, the recommendations of the Preliminary Report included installation of welded steel supports for the bow. These supports consist of poppets to the topside planking and an extension of the keel blocking. As of September 1986 a contract has been awarded for construction of the bow supports.

### **3. Additional Exterior and Interior Timber Shoring**

In December 1985, additional shores were placed under the WAPAMA fore and aft of the bilge blocks. Also, the counter was shored up from the deck of the barge, the main deck hatch girder was shored up from the ceiling, and the forecastle head was shored up from the main deck within the forecastle. The beams in the fidley were observed to be very rotten and sagging under the weight of the stack and boiler breeching. A contract was awarded in September 1986 for external support to relieve these beams of the weight of the stack. It is expected that other parts of the structure will require shoring as the ship suffers further deterioration before stabilization is achieved.

(structural integrity and support, con.)

Bulky timber shoring may not be very attractive from an interpretive standpoint, but is both necessary and cheap, and therefore likely to be relied on for the foreseeable future.

#### **4. Long Term Support System**

Normally, a vessel out of water places about 90% of its weight on the keel blocks. Strictly speaking this is still true of the WAPAMA but there are enough severe weaknesses in her timbers to allow localized sagging strains from simple gravity to open joints and add to existing distortions. This problem will become worse as the vessel dries out and fastenings lose more of their holding power. Placement of additional shores against the exterior planking will be of some help but will not relieve rotten floors of the weight of the ceiling. Shoring from deck beams to ceiling will add to compression of the floors.

The ship is held together principally by the combination of the clamps, ceiling, and major framing members. A good long range support system should penetrate through the planking in selected places in order to transfer the weight of these major internal members to the deck of the barge. If the relatively intact upper ceiling strakes can be supported directly from the barge deck, the bilge blocks will only be carrying the weight of the bottom outboard of the keelsons.

Ships are designed to be supported evenly and continuously by water. When out of water for prolonged periods of time and supported on only a few points, their own weight works very much against them. Therefore an optimum support system for the WAPAMA would simulate the support of water by providing multiple points of support rather than a few concentrated areas such as her present bilge blocking system.

Another design criteria for a permanent support system should be unobtrusiveness for the sake of interpretation. The added support should block or distract viewing of hull form as little as possible. Designing a system that is visually minimal and structurally adequate will require an engineering effort beyond the scope of this report. A suggested concept for such a system is given in figure 53.

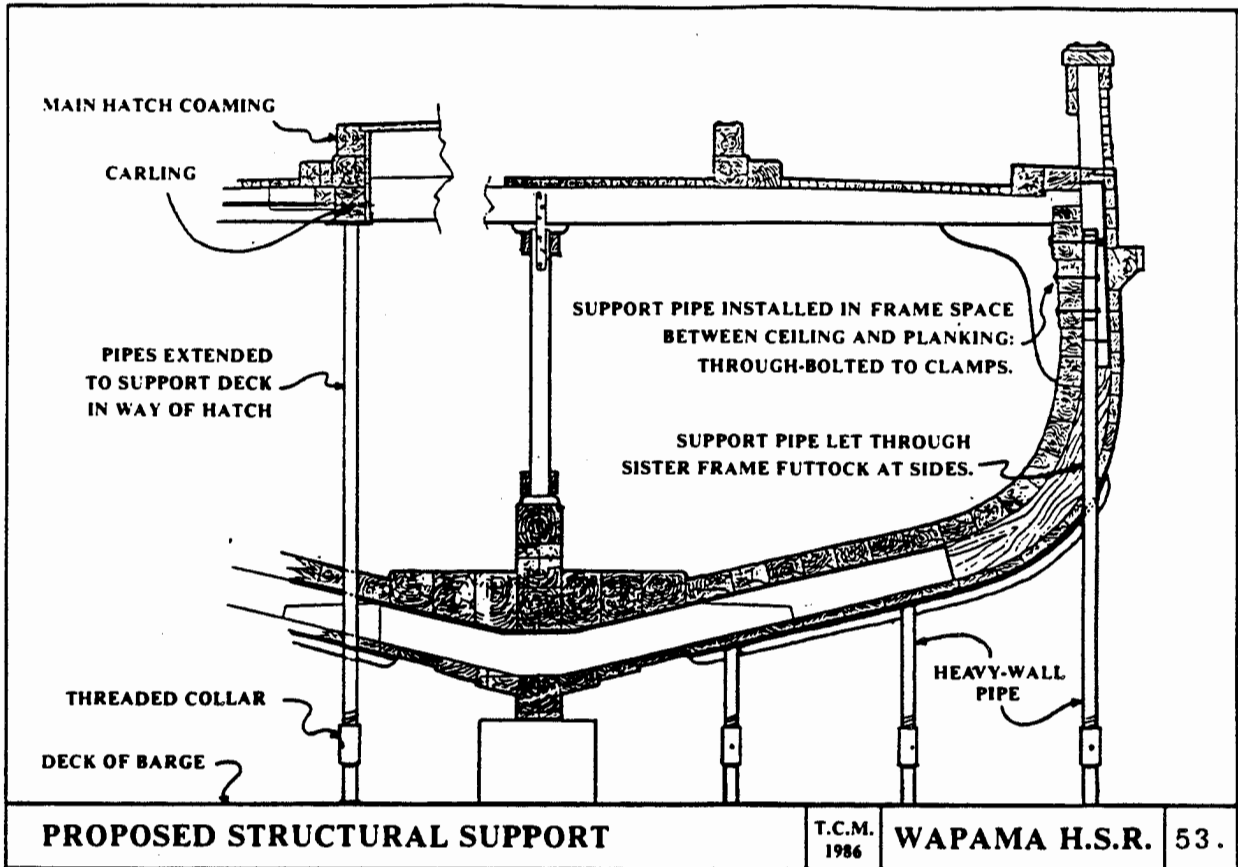

## 5. Fabric and Equipment Removals

- a. For relieving the structure of concentrated loads:  
 WAPAMA has already had a portion of her equipment removed in order to relieve the structure of weights that were exacerbating distortion. The anchor windlass and forward cargo winches have been removed to the deck of the barge due to the extremely marginal condition of the forecastle head deck. The foremast and fore and main cargo booms have been removed, as well as the boats. In the near future the davits should be removed as they place a strain on the weakened boat deck. Removal of the davits will also facilitate building temporary covers on the boat deck.
- b. For Improving Ventilation:  
 To facilitate ventilation for drying, we have recommended the removal of covering board blocking, the third strake of bottom planking, and the first strake of ceiling planking. A contract for this work was awarded in September 1986.

## **6. Structural Renewals**

A compromise, between rebuilding the WAPAMA as a floating ship and propping up her remains under cover, could be renewal of certain weather surfaces and supporting structure. This would be a positive step from the standpoint of interpretation and visitor safety. The following portions of the ship are considered for renewal.

### **a. The Main Deck**

Renewal of the main deck would include deck beams, stringers, waterways, planking, and hatch. The most significant issue to resolve is whether the option of eventually rebuilding the entire vessel is to be kept open, or renewals made solely for the sake of weatherproofing, interpretation and visitor safety.

If the option of rebuilding the ship is taken seriously, the scope of work for main deck renewals must address the distortions of hog and twist in the hull. Removing these distortions, by shifting blocking to allow hog to settle out and jacking the fore body to correct twist, are major efforts in themselves. The earlier rebuilding plans called for correction of these distortions but envisioned the work being done after removals had been made of large portions of timber, and the hull thereby rendered more limber. Attempts to force the vessel back into shape without removing planking, reefing out caulking, removing ceiling wedges, etc. will place great strains on the structure and may not be successful.

If the work of removing distortions is not undertaken the new main deck will conform to the distorted hull. Since the new deck and supporting structure will then be the strongest part of the ship, the distortions will be locked in and may prove impossible to correct by subsequent work on other parts of the hull.

### **b. The Forecastle Head**

Rebuilding the forecastle would offer several benefits. The forecastle would be best protected in the long run by sound structure over it. A renewed forecastle head would permit remounting the anchor windlass and cargo winches for interpretive purposes. Visitor access could be permitted onto this deck and the forecastle cleared of the shoring that is presently necessary. These benefits to interpretation will only be realized if they are part of an overall plan to allow public access aboard the ship.

The limited area and location of this deck would permit its renewal without affecting possible future efforts at correcting distortion in the hull. Restoring this deck as a weather-tight structure could eliminate the need for a cover on this part of the ship.

**c. The Deckhouses**

Though still vulnerable and continuing to deteriorate, the superstructure remains the most intact part of the ship, primarily due to an extensive rebuild in the early 1960s. These portions of the structure are, in comparison with the hull, still easily repairable. Repair of these areas would offer interpretive benefits in terms of appearance and safe public access, as well as long term preservation of the structure.

The following materials take-off defines the scope of renewal work required to insure safe access to the main deck, cabin deck, and forecastle head.

**Renewals for Public Safety - Forecastle Head Deck**

| Item                     | Dimensions   | Linear Ft. | Board Ft.      |
|--------------------------|--|------------|----------------|
| Forecastle Head Planking | 4" x 4"  | 2,376      | 3,168          |
| Forecastle Head Beams    | (3) 13-1/2" x 13-1/2" x 33' nom.<br>(5) 11-1/2" x 11-1/2" x 22' nom. | 99<br>110  | 1,504<br>1,212 |
| Forecastle Head Bulwarks | 12" x 12" nom.   | 84         | 1,008          |
| Misc. (add 15%)          |  |            | 6,892<br>1,034 |
| Total Board Footage      |  |            | 7,926          |

**Estimated Cost of Forecastle Head Renewals:**

|  |            |
|--|------------|
| @ \$ 17.00 per b.f. (consistent with 1984 plan, and major shipyard pricing)  | \$ 138,000 |
| @ \$ 9.00 per b.f. (1986 estimate of independent contractor at present site) | \$ 71,000  |
| @ \$ 12.00 per b.f. (median rate estimate)                                   | \$ 96,000  |

(Structural Renewals, cont'd.)

**Renewals for Public Safety - Main & Cabin Decks**

| <b>Item</b>         | <b>Dimensions</b>    | <b>Linear Ft.</b> | <b>Board Ft.</b>       |
|---------------------|----------------------|-------------------|------------------------|
| Main Deck Planking  | 4" x 4"              | 9,643             | 12,857                 |
| Main Deck Girders   | 13-1/2" x 13-1/2"    | 294               | 4,466                  |
|                     | 12" x 13-1/2"        | 294               | 3,970                  |
|                     | 13-1/2" x 11-1/2"    | 276               | 3,570                  |
| Waterways           | 13" x 13"            | 294               | 4,140                  |
|                     | 10" x 15"            | 294               | 3,675                  |
| Hatch Coaming       | 11" x 22"            | 25                | 504                    |
| Hatch Carings       | 12" x 15-1/2"        | 51                | 790                    |
| Main Deck Beams     | (2) 15" x 18" x 38'  | 76                | 1,710                  |
|                     | (14) 15" x 14" x 38' | 532               | 9,310                  |
|                     | (10) 15" x 14" x 12' | 120               | 2,100                  |
| Poop Deck Bulwarks  | 12" x 12" nom.       | 150               | 1,800                  |
| Misc. (add 15%)     |                      |                   | <u>48,892</u><br>7,334 |
| Total Board Footage |                      |                   | <u>56,226</u>          |

**Estimated Cost of Main and Cabin Deck Renewals:**

|                    |            |
|--------------------|------------|
| ① \$16.00 per b.f. | \$ 920,000 |
| ② \$ 9.00 per b.f. | \$ 504,000 |
| ③ \$12.00 per b.f. | \$ 672,000 |

Achieving a weather tight structure will require the following renewals in addition to those specified for safety concerns.

**Weather Surface Renewals**

| <b>Item</b>                              | <b>Dimensions</b>   | <b>Linear Ft.</b> | <b>Board Ft.</b> |
|--|---------------------|-------------------|------------------|
| Bulwark Stanchions                       | (94) 15" x 9" x 10' | 940               | 9,870            |
| Bulwark Wales                            | 3-1/2" x 11"        | 560               | 1,797            |
|  | 4-1/2" x 12"        | 240               | 1,080            |
|  | 6" x 12"            | 240               | 1,440            |
| Bulwark Planking                         | 4" x 4"             | 1,440             | 1,920            |
| Bulwark Cap                              | 6" x 22-1/2"        | 254               | 2,858            |
| Topside Planking                         | 4-1/2" x 9" and     | 5,460             | 18,454           |
|  | 4-1/2" x 11-1/2"    |                   |                  |
| Rubrail                                  | 13" x 18" approx.   | 500               | 9,750            |
| Misc. (add 15%)                          |                     |                   | 47,169<br>7,075  |
| Total Additional Board Footage           |                     |                   | 54,244           |
| Board Footage from Safety Renewals       |                     |                   | 64,152           |
| Total Board Footage for Weather Renewals |                     |                   | 118,396          |

**Estimated Cost for Weather Surface Renewals:**

- \$ 16.00 per b.f. \$ 1,900,000
- \$ 9.00 per b.f. \$ 1,066,000
- \$ 12.00 per b.f. \$ 1,421,000



## **E. BARGE 214**

### **1. Particulars**

Length: 200 ft.  
Breadth: 60 ft.  
Depth: 12 ft.  
Net/Gross Tonnage: 1,255  
Present Draft: 5 ft., 7 in.  
Material: mild steel plating and internals  
Classification: none at present

### **2. Background**

Barge 214 was built in 1970 to American Bureau of Shipping class +A1 for oceangoing barges. She was designed to carry deck loads, with a maximum capacity of 1500 lbs. per sq. ft. In 1977, Barge 214 was damaged while in service in Alaskan waters. Though the damage was partially repaired, the barge was no longer considered suitable for ocean going service.

In 1980, WAPAMA was placed on the deck of Barge 214. Since that time, the barge has not been drydocked, nor has any major maintenance been performed. A survey of the barge conducted in 1985 found the barge to be "... in suitable condition as a dry berth and within limitations as a work platform for renovation of the WAPAMA" (Hull & Cargo, 1985,17). This was contingent on drydocking, inspection of the bottom, and completion of any necessary repairs.

A subsequent study was performed by naval architect, D. J. Seymour to determine the stability of the barge with WAPAMA on deck. This study considered the vessel/barge to be in protected waters, and anticipated loads from winds of approximately 50 knots. Stability was found to be adequate to prevent heel in excess of 5 degrees (criteria similar to houseboat stability), even with one of the three major watertight compartments flooded (see Appendix B).

### **3. Conclusions**

The aforementioned reports indicate that Barge 214 is adequate by design, but will need drydocking, further inspection, and possibly, repairs. As an interim measure, bilge alarms are being installed in all compartments of Barge 214 to provide warning in event of leakage.

Barge 214 has been under lease to the National Park Service since 1980. The decision of whether to acquire the barge, or to negotiate a long-term lease with the owners, will determine who will be responsible for drydocking and maintenance. This decision will also have an effect on the projected cost of maintenance and repairs.

**a. Maintenance of Barge 214**

The following actions will need to be taken in order to prevent further deterioration of Barge 214 and to insure its suitability as a long term support and restoration platform for WAPAMA.

- (1). Drydock the barge and inspect the bottom.
- (2). Sandblast wetted surface (bottom and sides) of barge; apply 2 coats of epoxy for a total thickness of 12-16 mils.
- (3). Sandblast deck and topsides; apply 1-2 coats of anti-corrosive paint.
- (4). Remove loose scale from the interior of the barge and coat with EUREKA FLUID FILM or equivalent rust inhibitor.
- (5). Repair shell plating as necessary to insure watertight integrity.

**b. Modifications to Barge 214**

Public access and interpretation may necessitate the following modifications:

- (1). Removal of all weldments on barge deck which may be tripping hazards.
- (2). Installation of safety handrails around perimeter of barge deck.
- (3). Increase deck area as base for permanent shed.

**(a). Deck Extensions**

It is technically feasible to increase the length and beam of the deck area by building side decks cantilevered out from the sides and ends of the barge. The barge has considerable reserve stability and can support such a structure. The cost of steel deck extensions has been estimated in the range of \$200,000 to \$250,000.

**(b). Barge Hull Extensions**

A superior but more expensive method of increasing the deck area would be to build extensions onto the barge hull. The primary advantage of such construction would be to increase the stability of the barge against wind heeling forces on the shed and the ship. The reserve buoyancy in case of damage would be increased as well. The cost of increasing the beam by 20' is estimated at around \$400,000.

(Barge 214, cont.)

A possibility that has not been researched would be to acquire a larger barge and shift the WAPAMA over to it. The above mentioned costs for improvements to Barge 214 are greatly in excess of the commercial value of the barge in today's market. More importantly, NPS does not own the barge. Until acquisition or a lease agreement is finalized, questions concerning capital improvements cannot be resolved.

Shifting the WAPAMA would be costly and would have to be approached with extreme care. An inquiry into surplus government property should be made to determine if a more suitable barge may not be available for less than the cost of acquisition and improvement of Barge 214.

#### 4. Cost Estimates for Work on Barge 214

##### a. Maintenance and Repairs

|  |                   |                      |
|--|-------------------|----------------------|
| (1). Towing to and from shipyard                       |                   | \$ 6,000.00          |
| (2). Drydocking, including shifting and<br>10 lay days |                   | 8,500.00             |
| (3). Sandblast and coat exterior:                      | labor             | 55,000.00            |
|  | material          | 11,000.00            |
| (4). Scale and coat interior                           | labor             | 30,000.00            |
|  | material          | 8,000.00             |
| (5). Steel work (3,000 lbs. estimated)                 | labor             | 16,000.00            |
|  | material          | 1,000.00             |
|  | <b>Total Cost</b> | <b>\$ 135,500.00</b> |

##### b. Modification

|  |                   |                      |
|--|-------------------|----------------------|
| (1). Removal of weldments                            |                   | \$ 1,600.00          |
| (2). Installation of handrails                       | labor             | 3,200.00             |
|  | material          | 2,500.00             |
| (3). Deck extensions (156,000 lbs. x \$1.35 per lb.) |                   | 210,600.00           |
|  | <b>Total Cost</b> | <b>\$ 217,900.00</b> |

Alternately hull extensions would cost about \$ 400,000 in place of deck extensions for a total estimate of \$ 417,000.

## **F. LOCATION**

Finding a permanent berth for the WAPAMA/barge combination is more a political than a technical problem. The requirements of barge modifications and mooring arrangements are straightforward in their solutions. Persuading the owners or managers of a given site, and the surrounding community, that the WAPAMA should be permitted there may be another matter. For this reason the only sites that have been seriously considered in this report are areas that are already government controlled.

### **1. The Bay Model Site**

Early in 1986 agreement was reached between NPS and the U.S. Army Corps of Engineers to berth WAPAMA, aboard Barge 214, at one of the piers adjoining the Corps' Bay Model Visitor Center in Sausalito. She was shifted to this site in August, 1986. This is an excellent solution to the previously vexing problem of public visibility, and offers benefits to both governmental agencies, and to the public.

Some of the factors which recommend the Bay Model as a site for WAPAMA are:

- a. It provides a relatively protected berth, sheltered from prevailing westerly winds. Although there is some exposure to northerly storms, this berth is considered superior to her former Hyde Street Pier location.
- b. The pier is sound and will not require modification for berthing of the WAPAMA/Barge. An anchor system to hold the barge off of the pier has been installed by NPS.
- c. The site has an established visitors center, including restrooms, parking facilities, and some indoor and outdoor exhibit areas. The ship can be interpreted from the pier initially. In the long run, if visitor access can be achieved, the pier provides an easy approach to the barge.
- d. While tool storage and machinery installation are to be restricted to the vessel and barge, this site will provide the opportunity to continue work on the WAPAMA without the high lay-charges (rental of pier space, etc.) which have been a drain on her budget for over six years. It will also allow a wide range of contractors to bid on preservation work. This was not the case while WAPAMA was at the Pacific Drydock shipyard site. Pier access is available for deliveries as needed.
- e. Security for the site as a whole is provided by the Corps of Engineers, but additional security against theft, vandalism and fire aboard WAPAMA and her barge will be provided by the NPS. Water and electrical service are being installed by the NPS.

(The Bay Model site, cont.)

There are two disadvantages to this site. One is that the increased visibility of WAPAMA to the public creates pressure to place interpretive concerns ahead of preservation measures, such as adding weather covers which may be unsightly. The other disadvantage of the Bay Model site lies in the sixty-day termination clause of the present berthing agreement. This site is not a guaranteed home for the WAPAMA over the long term of her preservation. Given a reasonable pace of preservation and interpretation, and continued inter-agency good faith, this should not be an immediate problem.

## **2. Other Government Sites Considered**

Because of the impermanence of the Bay Model site, we include here a discussion of other sites which have been considered for WAPAMA.

The scope of investigation of potential sites has been limited to the San Francisco Bay Area. To be a viable location, a potential site must provide:

- protection from wind and wave action (if afloat)
- proper mooring facility (if afloat)
- adequate public access
- adequate security
- reasonable long term availability.

Almost all existing sites would need some degree of modification to meet these requirements. The following sites are considered because they would require the least amount of modification.

### **a. East Fort Baker**

The primary advantages of Ft. Baker are its availability to the NPS (though subject to agreements with the U.S. Army and Coast Guard) and the relative protection from wind and wave that it would provide WAPAMA. The two most viable locations here would be: (1) afloat at the western extremity of the cove, and (2) ashore just east of Bldg. 670.

- (1). This site would place the WAPAMA/barge at the concrete bulkhead on the west side of the cove. She would be moored end-on to the bulkhead, approximately 15 feet off, and 60 to 80 feet north of the breakwater apron. Adequate mooring could be achieved by installing bitts on the bulkhead and securing the offshore end with 2 anchors. The immediate area would have to be dredged deep enough to prevent the barge from grounding at

tides somewhat below mean low water. Grounding of the barge would cause damage to the anti-corrosive bottom coatings. Access to the barge would be provided by a brow from the bulkhead. Electrical and water service would need to be extended to the site.

- (2). This site would locate the vessel ashore, parallel to building 670 and approximately 100 to 200 feet to the east. A 250' x 70' shed could be built between the waterfront roadway and the large trees to the north. Shifting the vessel ashore would require dredging in order to float the barge close in to the shoreline. Driving of temporary pilings may be required to achieve sound foundation on which to move WAPAMA.

Among several disadvantages of both locations at Ft. Baker is the visual impact that the vessel and its shed would impose on the area. A 70' x 250' structure would appear out of scale to the surroundings and would partially block the view of the bay in either location. The present General Management Plan intends to convert Ft. Baker to a more natural recreational configuration, a plan which appears to run counter to the placement of large structures on the site. The area is also under consideration for a U.S. Coast Guard facility.

#### **b. Hyde Street Pier**

Locating the WAPAMA with the rest of the fleet would consolidate the interpretive and maintenance efforts and increase staff efficiency. Berthing space is available, though some modification would be necessary. The site presents some very serious drawbacks:

- (1). The housing structure would dominate the site and would appear out of place in the historic setting of the pier. While the pier is historically appropriate for the ship, her appearance there would not be at all "natural" while she is elevated at least 20' above where she would be if afloat on her own bottom.
- (2). The housing structure would violate the 40 foot height restriction. Though a floating structure might not be covered by the restriction, it would likely be opposed by local residents.
- (3). Even after completion of the new breakwater, the wind and wave action may be in excess of that encountered at either the Bay Model or Fort Baker sites.
- (4). The space taken by WAPAMA might be more suitable for BALCLUTHA.

(Location, cont.)

### **3. Availability of Non-Government Sites**

It is physically possible to locate the WAPAMA at many other sites along the San Francisco waterfront, some of which offer better protection than those now available to the NPS. All of the other possibilities are either currently tenanted or will require major capital improvements, or both.

A good example of such a site is Pier 46, China Basin. This location offers much more secure berthing than Hyde Street Pier but is currently in use by several businesses, is in an out-of-the-way and rundown part of town, and lacks parking or any other facilities that would be desirable for visitation.

Future availability and development of any such site is entirely speculative and could not be solely an NPS project. For the foreseeable future it is to be hoped that the Bay Model remains available.

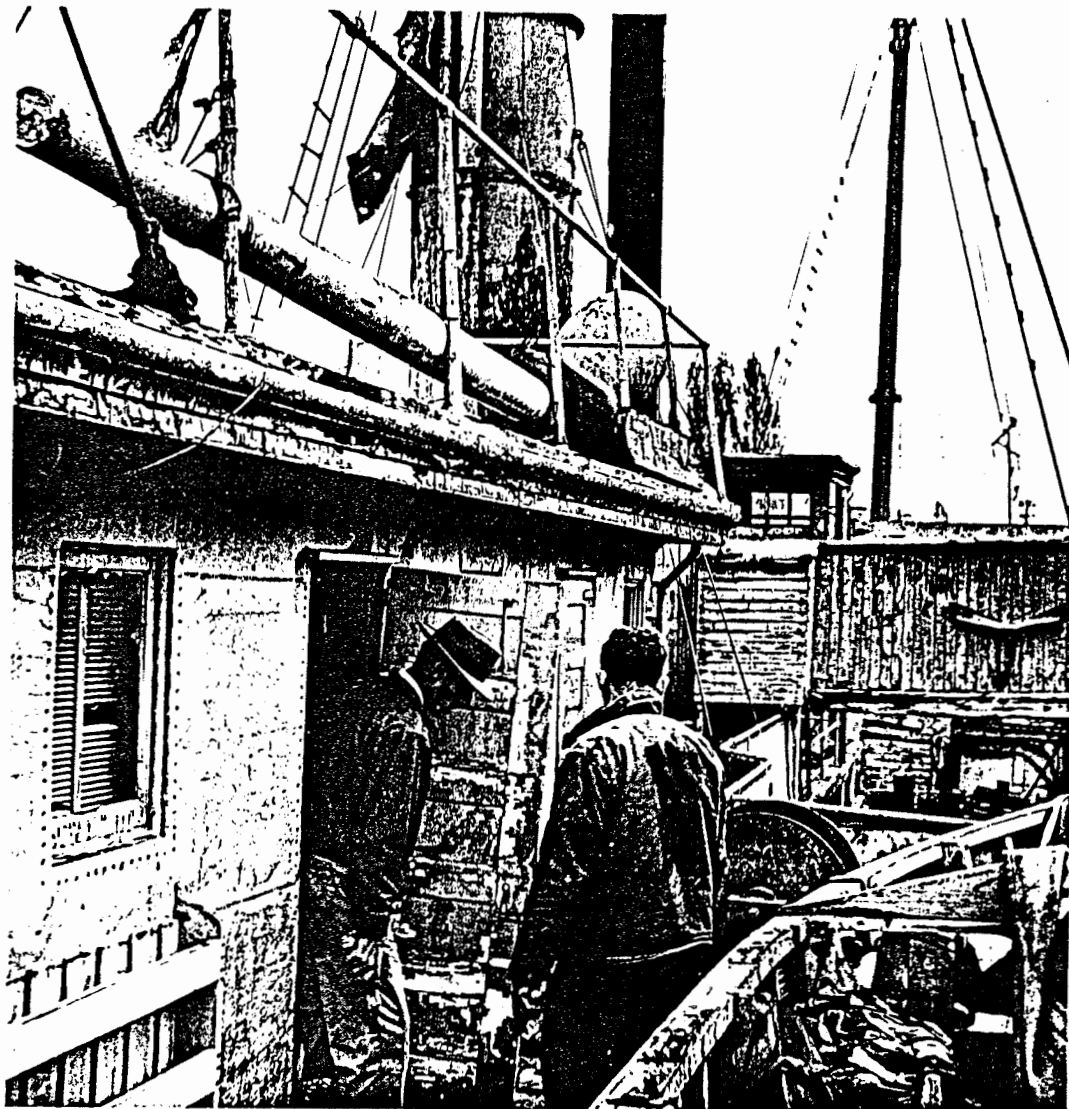

Fig. 54. WAPAMA in the 1950s, before initial restoration had begun. The canvas tacked over the deck house siding bespeaks an attempt to deal with rot and leaks that were present before she was laid up in 1947. The effects of years of lay up with no maintenance are plainly visible. The deck house had to be completely rebuilt in 1960.

--Photo, Karl Kortum, NMMSF



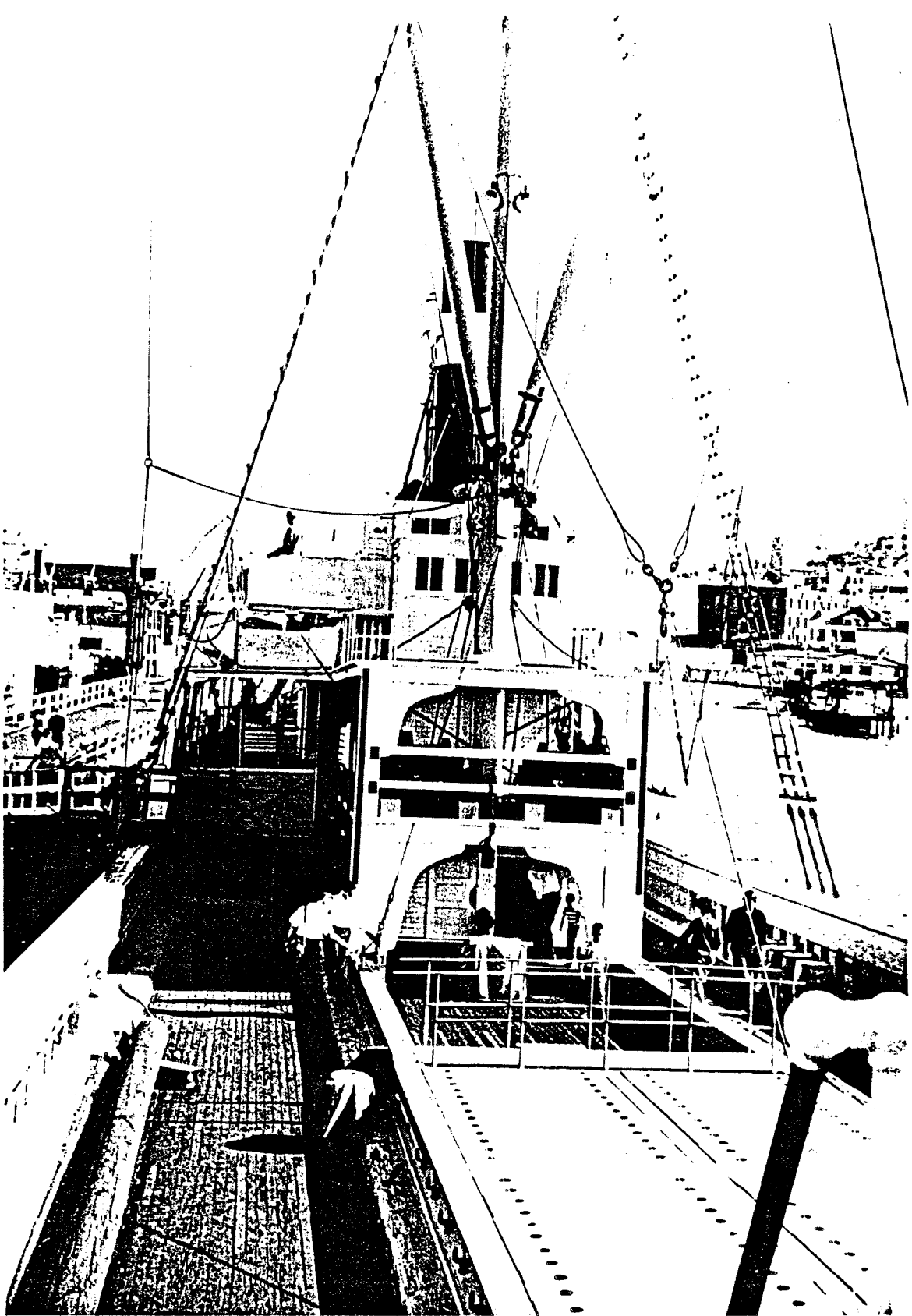

Fig. 55. Wapama in the 1960s. Her rigging is in place and functioning; she is well interpreted, and has a glistening coat of paint. She has undergone considerable restoration, but deterioration is here evident in her main deck. Rot is progressing.

## **G. INTERPRETATION**

### **1. Virtue in Necessity**

WAPAMA can and should be interpreted at every stage of her stabilization and restoration. To whatever degree she can safely be presented to the public, that presentation should be provocative, informative, and respectful of the artifact.

While on exhibit at Hyde St. Pier during the 1960s and 1970s, WAPAMA was very effectively interpreted. Crew and passenger spaces were restored and dressed; informative captions were available, some illustrated; a self-guided audio tour was in place, using dramatized narrative from interviews with steam schooner men and passengers. This material forms a basis for future interpretation.

Afloat at the pier, WAPAMA was encountered in her natural element, as though ready to return north for another cargo of lumber. Visitors boarded her as they would a ship, via a gangway to the main deck, and felt her move in the swell coming through the Golden Gate. This experience of the ship may never be available again.

The interpretive advantages of presenting an historic ship in almost original condition, afloat on the water, are evident (although the true context and design imperatives of an oceangoing ship can probably only be fully appreciated on the open ocean). There are important virtues, however, in the necessity of interpreting WAPAMA in her present situation.

WAPAMA is one of the largest wooden structures in existence. Hauled out on her barge, the full magnitude of the artifact is impressed on the visitor far more vividly than is otherwise possible. Supported and protected, her structure can be shown and appreciated in new ways. WAPAMA will be presented as the product of a process which began with her building (under a shed roof similar to the one proposed in this Report). She has followed the inevitable path of a large wooden vessel; years of hard work and exposure to the elements have left their mark. Interpretation of this process will explore the interrelated nature of design, materials, method of construction, operation, maintenance and inevitable deterioration of a ship. It will be appreciated as a process with a beginning, a middle, and, though in this case artificially arrested, an end.

A comprehensive discussion of themes, media, philosophy and procedures for interpretation of the NPS. fleet of historic ships may be found in the "Interpretive Prospectus, 1986" produced under the direction of the Harpers Ferry Center, Division of Interpretive Planning. The following are aspects of interpretation which relate directly to planning for WAPAMA's stabilization and preservation.

## **2. Interpretation in the Near-Term**

The most immediate task of interpretation is to give some meaning to this massive object, and to demonstrate the importance of her preservation. In her present location, WAPAMA is highly visible, though she cannot be boarded by the general public. Wayside panels and a small installation in the Visitor Center now serve to introduce her significance and some issues in her preservation. This effort is very important and should be sustained and augmented by supervised tours given as frequently as possible, positive media attention, and a variety of museum publication. Visible on-going work by volunteers and GGNRA staff is also important. A coat of paint applied to her topsides today (if it does not interfere with preservation efforts) may have negligible effect in preserving her fabric, yet have considerable benefit in conveying her value.

Should the stabilization phase of the ship's preservation be prolonged, a great deal more may be done in exhibiting machinery, such as winches and windlass, in the Visitor Center or similar shore installation. Interpretation facilities of the ship will continue to be valuable for orientation and for such vivid but intrusive media as film, large graphics and dioramas.

## **3. Public Access**

As indicated in Section 2, item III.A., "Summary of Existing Conditions," much of the vessel is presently unsafe for public access. Considerable work will be required in supporting structures, renewals and removals before the public can be allowed on board on a regular basis. Even in a safe state of repair, however, the position of the ship on Barge 214 will present problems of access not encountered in a ship afloat at a pier. It will present some opportunities as well.

The main deck is now high above the visitors as they stand on the barge. A climb up the narrow outside stairway is required in order to reach this deck. A visit the hold requires a steep climb down again, and again back up. To alleviate this problem, it is proposed that a 7 foot square access be opened in the bottom of the hull, in way of the main hatch. (see fig. 56 and 57). The visit then begins with a dramatic view of the wooden expanse of the ship's bottom, goes through a cross-section view of the structure of the bottom, and enters several steps up into the vast curving hall that is the ship's hold. Another comfortable stairway would then lead to the main deck by way of the 'tweendeck and main hatch.

It is in the hold that the message of the ship as a large wooden structure can be conveyed. The various removals of ceiling and planking recommended for ventilation, drying of

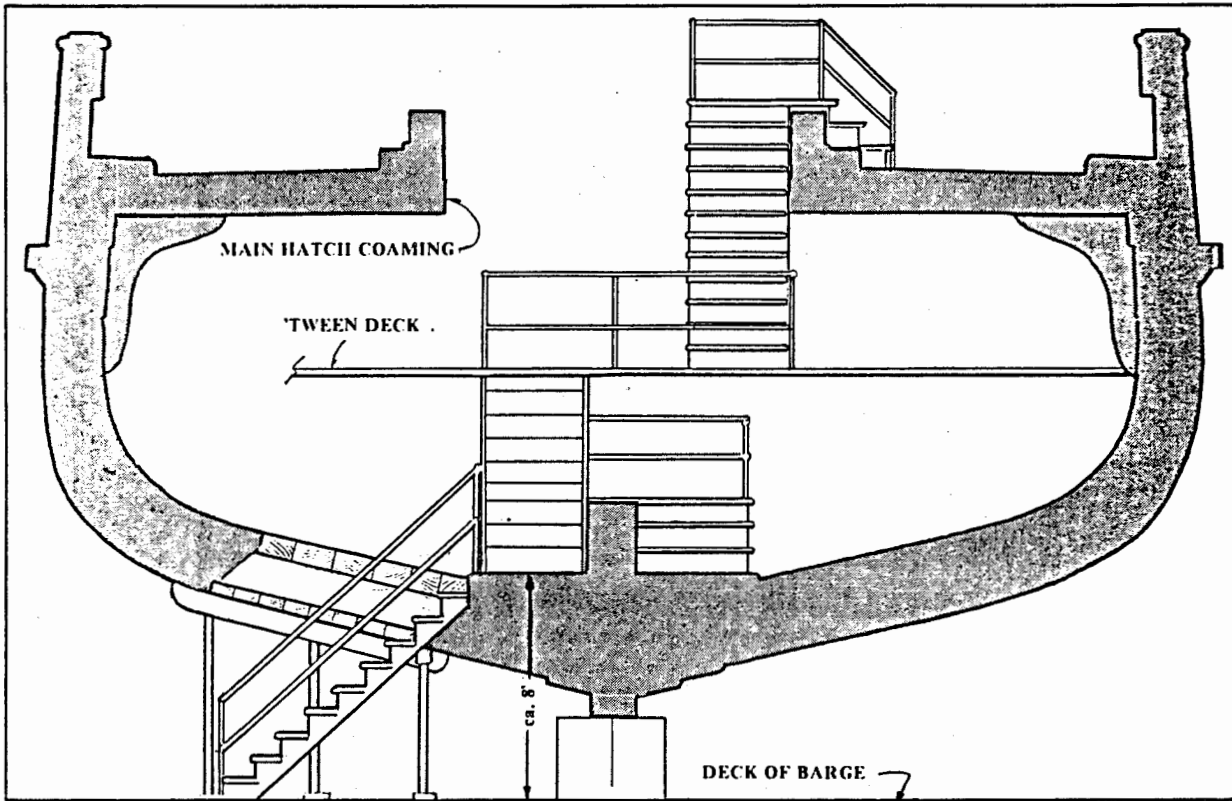

PROPOSED HOLD AND MAINDECK ACCESS

T.C.M.  
1986

WAPAMA H.S.R. 56.

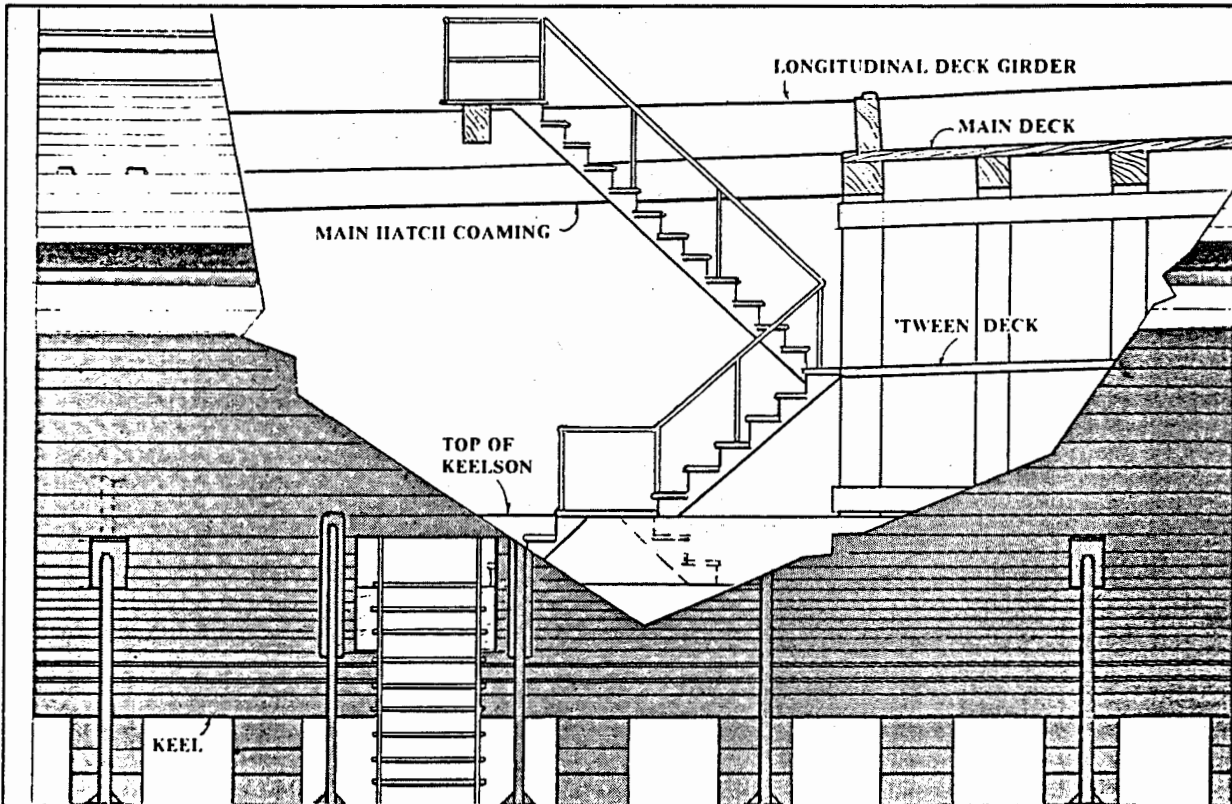

PROPOSED HOLD AND MAINDECK ACCESS

T.C.M.  
1986

WAPAMA H.S.R. 57.

the structure, and access can be turned to interpretive service, allowing viewing of previously hidden internal structure.

An additional safety egress will be required; this could be a sturdier version of the existing scaffold stairwell. Barge deck safety railings and a two-lane gangway will be needed for safe boarding and circulation on the barge.

#### **4. Circulation**

Access will at first be limited to the hold, 'tweendeck, main deck, accommodation areas and portions of the barge deck. Visitor circulation on the main deck is at present severely compromised by the diagonal bracing of the main deck cover. This arrangement will have to be modified for any reasonable access to this area. The accommodation spaces on the main, cabin and boat deck are relatively intact, and with unobtrusive weather protection, structural reinforcement and cosmetic refurbishment, they could be interpreted much as they were before.

The forecastle can be rendered accessible by improved structural support of the overhead. The forecastle head deck will require extensive rebuilding to safely support visitor access, and to allow reinstatement of the machinery which constitutes the significance of the area.

Visitor access to the engine room is a difficult problem for most museum ships. The steep and narrow steel ladders, which steam engineers were expected to negotiate, serve to screen out a significant percentage of the visiting public, and can be hazardous for anyone who is unused to them. In WAPAMA, with an extremely interesting example of steam propulsion, the opportunity exists to provide comfortable access from hold to engine room by removing one of her badly corroded boilers. The interpretive reward could be vastly increased if, instead of removing the boiler, the interior were cut away, thus providing access through the interior of the boiler, and an insight to an artifact whose workings can hardly be guessed at from the outside. Aside from access difficulties, the engine room is presently unsafe, primarily due to asbestos and collapsing piping (see item VI.H, Safety).

Circulation can continue up the engine room ladder ways (a far easier direction to negotiate them), or back to the stairway in the main hatch.

## **5. Interpretive Aspects of Structural Support Systems**

Like a jack-o'-lantern in December, WAPAMA's fabric can no longer support her structure. Some degree of additional permanent support will be necessary to avoid further distortion and eventual collapse.

In the near term, this support will likely be in the form of wooden shoring and bracing. Interpretation is best served, however, by a system of structural support which 1) imposes a minimum visual intrusion, 2) is clearly distinguishable from original fabric and structure, yet 3) is aesthetically compatible with its surrounding artifact. The use of structural pipe, extra thick walled to reduce its required dimension, painted a color consistent with other non-original supporting structures (a dark green, for example), would fulfill these requirements.

The hold, whose emptiness is so expressive of the purpose of the ship, must be carefully considered in an optimum system of structural support. It should not remain a forest of added wooden members as it is at present. An optimum system is outlined in item VI.C., and illustrated in concept in fig. 53.

In this again, the preservation of the ship on a barge offers interpretive benefits. The presence of a steel foundation, in the form of the barge deck, will facilitate erection of a steel support structure for the hull. It also makes possible the reinstatement or retention of heavy machinery on deck, the support of the stack and boats, and the option to retain original structural members whose strength is compromised but in which further deterioration has been contained.

## **6. Weather Protection and Interpretation**

From an interpretation standpoint, the proposed large shed roof with removable side panels is preferable to the jumble of roofs and awnings built on to the ship herself, or to a system of removable covers. The latter two solutions make a one-view appreciation of the vessel's configuration impossible. The present roof over the main deck, with its extensive diagonal bracing, prevents visitor circulation around the deck and blocks a clear view of one deck from another. To be fully effective, it would require extensions and additions for protection of the upper superstructure and to keep driven rain from the topsides. This would make a even denser puzzle of the ship's visual aspect. (see figures 48 and 49)

A system of temporary or seasonal covers would provide a clearer view of the ship's silhouette only in the dry season, although this would presumably coincide with the vessels highest visitation. (See Section 2, item VI.C. for a discussion of the practical aspects of weather protection options)

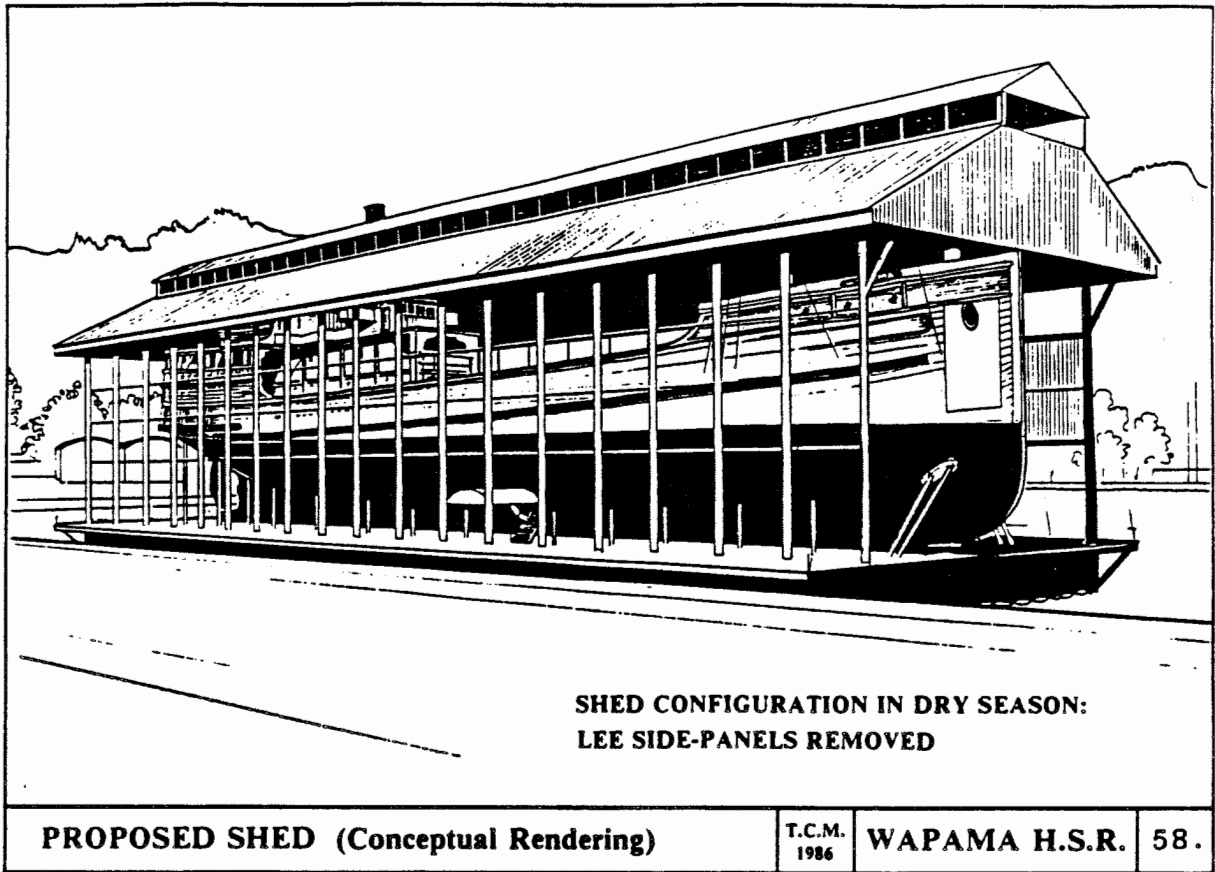
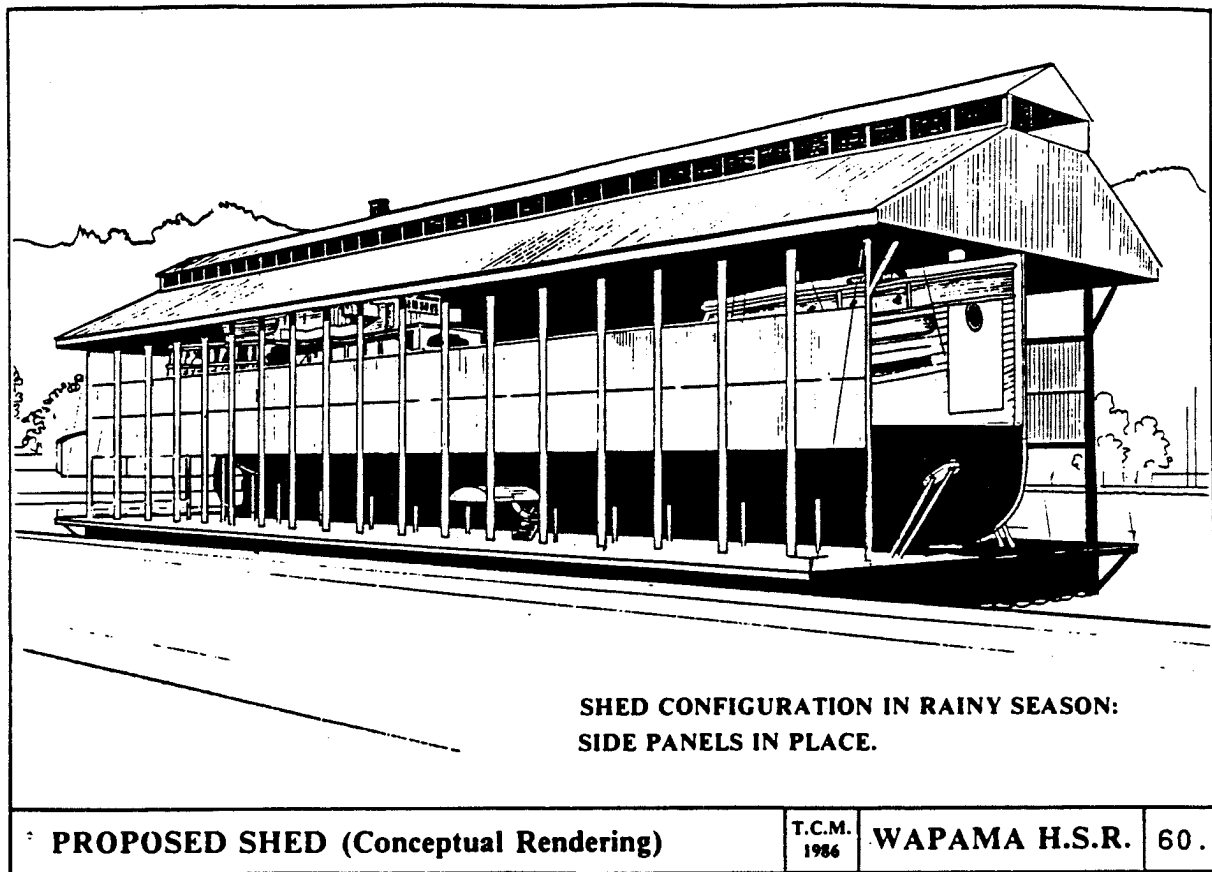

Fig. 59. St. Helens Shipbuilding Co., St. Helens, Oregon, at about the time of WAPAMA's building. --Photo, NMMSF





Interpretive disadvantages of the single shed roof include the fact that the whole structure becomes a higher, more imposing presence, out of scale for many potential sites. The view of the ship from some distance and elevation (as from the Waldo Grade while WAPAMA is at the Bay Model) becomes a view of a large roof. In addition, her remaining mast would probably have to be removed.

From the pier alongside, however, a clear view of the ship is afforded under the roof, and even when the side panels are in place, the ship is only partially obscured. This presentation of the ship is entirely in keeping with the theme of the ship as subject to a life cycle and suggestive of the structure under which that cycle began. The shed is not a completely foreign context to WAPAMA.



## **H. SAFETY**

Safety is considered a high priority in all phases of WAPAMA's preservation. This section addresses both long and short term safety concerns.

### **1. Immediate Safety Concerns**

Although the general public is not presently allowed access to WAPAMA, safety concerns exist for staff, volunteers, and contractors who are involved in preservation work at this time. Many of the existing safety hazards will be corrected during the course of stabilization and preservation. In the mean time the following immediate actions are recommended.

- a. Rope off all unsafe areas of decks and compartments, provide warning signs.
- b. Assign a "safety officer" to all large groups working aboard the vessel.
- c. Clean up and remove all debris which may present a falling or tripping hazard.
- d. Secure all weak handrails or provide rope backup.
- e. Limit access of existing scaffold stairwell to one or two persons at a time.
- f. Secure main electrical switch panel, limit usage to personnel knowledgeable with electrical system.

### **2. Public Access and Egress**

The extent and method of public access will depend on interpretation goals. Regardless of how and where the public enters and tours WAPAMA, the following general safety requirements will apply.

- a. Reduce or eliminate tripping and striking hazards.
- b. Provide access stairs and ramps with an easy pitch and proper hand rails (this may be difficult in limited spaces such as the engine room).
- c. Provide an emergency egress.
- d. Install adequate lighting and emergency lighting system for enclosed passage ways.

### **3. Structural Deficiencies**

Structural deficiencies are the result of wood decay and corrosion of metal fittings and equipment. Specific corrective measures are covered in other sections of this report. The following recommendations reflect general safety concerns, and should be carried out prior to allowing public access in these areas.

- a. Repair or renew weakened decking and deck supports for main, forecastle head, and boat decks.

- b. Remove or secure all collapsing piping in engine room.
- c. Remove or secure the stack, breeching, and loose boiler doors.
- d. Remove or secure davits.

#### **4. Electrical System Deficiencies**

Of concern here are deficiencies in the existing electrical system which present fire and electrocution hazards. These deficiencies should be considered highest priority in any upgrade of the system. The present damp condition of WAPAMA's interior increases the danger of electrocution, and short circuits which could result in fires. These dangers will be greatly diminished following repair of the electrical system. This work is presently under contract. Until corrective work can be completed, the electrical system should be used only with extreme caution.

#### **5. Fire Safety**

At present, the threat of fire is of concern primarily for preservation of the structure. As access is increased, public safety and evacuation in the event of a fire will become a greater concern. In addition, the recommended preservation treatment for WAPAMA, including drying of the structure and improving ventilation, will increase the possibility of destructive fires. There are presently two major potential sources for fire: vandalism, and an electrical fire due to a short circuit in the faulty electrical system. These threats can be reduced by upgrading security, and repairing the electrical system. A smoke detection and alarm system is planned for WAPAMA. This system will reduce fire department response time. Additional measures can be taken to prevent destructive fires.

- a. Make the existing 1-1/2" fire lines operational.
- b. Place an adequate number of charged fire extinguishers aboard vessel and barge. These should be approved type AB fire extinguishers (type ABC in engine room) of appropriate size.
- c. Develop a fire safety plan in cooperation with local fire department.
- d. Provide emergency egress aboard vessel, including directing signs.
- e. Investigate feasibility of installing an effective fire suppression system aboard the vessel.

#### **6. Asbestos**

Asbestos presents both a real and perceived health hazard aboard WAPAMA. This material was used liberally for insulation of boilers and steam piping. It is found primarily in the engine room, but can also be seen in the lazarette and other areas where steam piping is located. Most of the asbestos insulation around pipes is encased in canvas which has been

doped or painted. As such, it probably presents little or no hazard. On the other hand, the insulation around the boilers is becoming exposed as boiler plating and doors come loose and collapse. This asbestos is turning to dust and may easily become airborne. Removal of the boiler insulation should be considered before other major work is performed in the engine room. Partial dismantling of the boilers may be required to remove all insulation. This is considered feasible and might be compatible with plans to modify the boilers for interpretation.

Although the steam pipe insulation presents less of a threat, public concern over asbestos may dictate abatement prior to allowing public access. Methods and cost of asbestos abatement should be determined through consultation with companies specializing in this process.

## VII. Recommended Treatment for Preservation of the WAPAMA

### A. Justification

The alternatives listed earlier are restoration, stabilization, and preservation with interpretation. The recommended treatment is stabilization leading to long term preservation with interpretation. An option of eventual restoration is not precluded. Even if restoration was considered the immediate preferred alternative, stabilization would still be necessary because funding on the scale needed for restoration has not been identified. Add to this problem the lead time on material procurement and it becomes clear that major restoration could not begin for at least another year.

If restoration funding were immediately available the funds would be better spent on stabilization of the fleet as a whole. The forces that reduced the WAPAMA to her present state are operating largely unchecked on the C.A. THAYER, EUREKA, and ALMA, with similarly predictable results. Therefore recommendations in this report are based on considering the WAPAMA as one ship in an endangered fleet.

The difficulty of making concrete recommendations beyond stabilization measures results from the uncertainties that exist in three crucial areas:

1. The degree of rot in the structure is so far advanced that it will not be stopped instantly by any process. The effectiveness of stabilization measures and the condition of the ship after their completion cannot be immediately assessed.
2. If the WAPAMA is to be preserved without total rebuilding she will require a permanent platform. The long term availability and adequacy of Barge 214 for this use are as yet undetermined. The cost/benefit of ownership of the barge cannot be established prior to: a) A better survey of shell condition, preferably on a drydock, b) Negotiation with the owners regarding responsibility for maintenance and cost of purchase or long term lease.

Despite the difficulty of moving WAPAMA to another platform, a study of other options is recommended prior to making a permanent commitment to Barge 214.

3. The combination unit of the WAPAMA upon a barge must have adequate berthing. No site has yet been identified that combines suitability with known long term availability. The Bay Area Model is by far the best site identified to date. It is to be hoped WAPAMA can remain there indefinitely.

For these reasons the recommendations concentrate on indisputable needs for which specific action can be taken.

## B. Preservation Plan

### 1. What has been done to date:

- a. WAPAMA was drydocked on barge 214 in 1980. This relocation avoided possible hull failure and sinking.
- b. Removals of masts, booms, forward winches and windlass took place between 1980-82. Relieving the structure of these weights lessened strains that were increasing local distortions.
- c. A fabric and frame cover was built over the main deck and forecastle head in 1985. This was a first step to limit intrusion of rainwater in these areas.
- d. Increased shoring was placed along the hatch, under the stern and under the main deck in 1985. This shoring was added to help support the cover and to resist further distortion of the hull.
- e. WAPAMA was shifted from Oakland Creek to the Corps of Engineers Pier at the Bay Model Site in August 1986. This site is currently available rent free with a sixty day termination clause; long term availability remains unknown.
- f. A start on interpretation at the Bay Model has been made by production of a brochure and installation of a way-side panel on the pier.

### 2. Further Stabilization Work

- a. Drydock Barge 214 for survey and maintenance.

The most recent survey of the barge did not provide very much information on condition of the underwater shell. What is known is that the barge has had no maintenance since 1980 or earlier and that the safety of the WAPAMA is dependent upon the barge remaining afloat. **Estimated cost: \$135,500** Ref. item E. of Factors Affecting Preservation

- b. Additional interior and exterior support.

Contracts now in progress are providing additional shoring and support for bow, stern, deck beams, and stack, **cost: \$40,000**. The vessel will need to be monitored during the stabilization period to determine if further shoring will be required.

c. Safety upgrades

- (1) The current access scaffold is suitable for workmen only. Any project to allow visitation must address this. Cutting an access portal in the bottom of the ship has been priced at **\$5,000**. Building stairs up from the hold and a stronger external stair or ramp would be in the range of **\$20,000 to \$30,000**.
- (2) The current access scaffold is the sole egress from the vessel. From a fire safety standpoint a second egress should be provided. The simplest solution would be to place vertical steel ladders at bow and stern. Such egress would be suitable for workmen only. **Estimated cost: \$2,000**
- (3) The engine room has crumbling asbestos insulation in many places that has fallen from rusted out and falling piping, or from crumbling boilers. Some of the piping is weak enough to be in danger of falling. This does not have to be addressed immediately if the engine room is kept off limits to visitors, and staff should take proper precautions when entering the area. Restoration of the engine room is considered a long term goal, three to five years in the future. No costing of asbestos abatement has been done for this report.
- (4) At a minimum the ship's fire main should be overhauled and kept charged from shore water. Modern ABC fire extinguishers should be placed aboard and prominently marked. A smoke detector system is being installed under an in progress contract, **cost \$ 14,000**.
- (5) The ship's electrical system is a corroded mess of original and modified wiring. A contract to survey the system and identify and correct the worst deficiencies is in progress, **cost \$11,000**.

d. Increase ventilation

Selected removals of ceiling and bottom planking are in progress to aid in drying out the structure. The following measures are also recommended:

- (1) Open doors, windows, skylights, drawers, etc. in all areas under cover.
- (2) Install large volume, low velocity fans in the hold, engine room, and afterpeak to increase the flow of air through the vessel.
- (3) Cut an opening in the lower portion of the collision bulkhead to permit through ventilation from hold.  
**Estimated Cost: Under \$10,000**

(Preservation plan, cont.)

e. Coatings

- (1) Machinery, boilers and tankage should be scaled, coated, and lubricated. **Estimated Cost: \$32,000**  
Reference item B. in Factors Affecting Preservation
- (2) Coating of weather surfaces for protection and improving appearance. **Estimated Cost: \$45,000**

f. Rot arresting treatment

An inhouse study is currently being performed by U.S. Borax on the usefulness of large scale application of borates to arrest rot in WAPAMA's timbers. This path appears to offer the best combination of effectiveness and lack of toxicity to humans found to date.

**Estimated Cost of application: \$40,000 to \$60,000**  
Reference item A. in Factors Affecting Preservation

g. Increased Weather Protection

Weather protection was discussed in item C of Factors Affecting Preservation. Options are as follows:

- (1) Extension of the present type of cover over the entire vessel: **Estimated Cost: \$ 50,000**
- (2) Construction of a permanent shed over the entire vessel  
**Estimated Cost: Barge modifications \$200-250,000**  
**Shed construction \$200-350,000**
- (3) Partial restoration through renewals of weather surfaces.  
**Estimated Cost : \$1,000,000 to \$2,000,000**

For both the shed construction and partial renewal option there will be a requirement for greatly increased funding as well as design and construction time. The practical result will likely be a lead time of years rather than months. The need for increased protection is immediate. We therefore recommend accomplishing this by extensions of the present system.

h. Assign ship keeper

The numerous maintenance and small preservation tasks could best be performed by a part-time staff person. Assignment of a retired engineer or person with similar background would be appropriate.

**Estimated Cost : \$15,000 per year**

### 3. Further Studies

- a. Complete documentation
  - (1) Take the lines of the WAPAMA
  - (2) Record historic fabric to be removed or altered. This should be done prior to removal of deteriorated piping and boiler breaching for safety considerations. Other equipment removals may become necessary during stabilization and should be preceded by documentation.
- b. Experimental application of wood consolidation products and rot arresting treatments in selected locations.
- c. Investigation of alternative siting should the Corps of Engineers require that the pier be vacated.
- d. Survey Barge 214 during drydocking to establish suitability for long term storage of the WAPAMA.
- e. Study availability and acquisition cost of an alternative to Barge 214 should the survey reveal serious problems or lease/purchase negotiations fail to produce an acceptable arrangement. Part of this study would be designing and costing a procedure for shifting WAPAMA to another barge or site should Barge 214 prove unusable for long term storage.
- f. Design increased coverage.
  - (1) Short term fabric and frame covers over more of vessel.
  - (2) Permanent shed structure.
  - (3) Modifications to Barge 214 to support permanent shed.
- g. Design fire suppression system. (ventilation and protection from the weather will increase WAPAMA's vulnerability to fire.)
- h. Update the vessel survey periodically to monitor the effectiveness of stabilization measures.
- i. Design permanent structural support system.
- j. Design interpretive scheme and modifications to permit public access.



(Preservation plan, cont.)

**4. Long Range Preservation with Onboard Interpretation.**

We recommend that long term preservation be adopted as a goal but do not consider it feasible to develop a detailed plan beyond current recommendations at this time. Effectiveness of stabilization measures, long term suitability of Barge 214, and long term availability of a site will all need to be established before a definitive plan can be developed.

**5. Recommended Sequence of Work: The Next Five Years**

The following schedule is obviously flexible and some items may need to be deferred when measured against the needs of the rest of the fleet. However, the condition of the WAPAMA is so marginal that saving her will require a minimum level of effort each year. Items in this critical category have been denoted by an asterisk.

If resources cannot be found to accomplish minimum stabilization requirements, preserving the WAPAMA will become an unrealistic expectation.

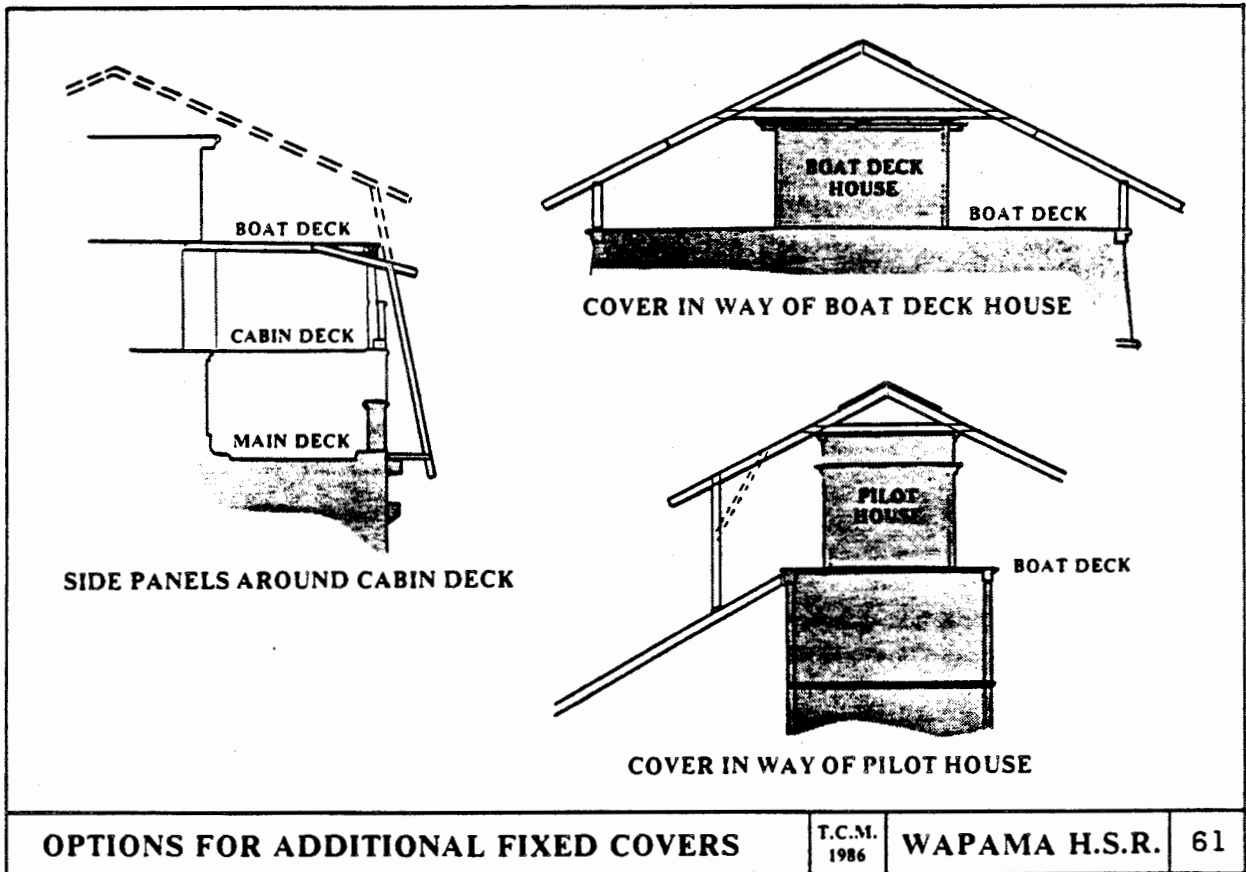

**Preservation Chronology**

- FY 80 WAPAMA was docked on Barge 214, rental begins at \$8,300 per month.
- FY 81-84 Removals of some equipment, survey and restoration plan by Z. Reynolds.
- FY 85 Historic Structures Report commissioned, cover built and some shoring added, barge rental continues at \$8,300 per month.
- FY 86 WAPAMA moved to Bay Area Model and barge rent reduced to \$3,000 month, mooring system installed. Stabilization begun; contracts let for fire alarms, survey of electrical hazards, construction of bow support, increased shoring, and removals for ventilation.

**FY 87 Recommended Work**

**Cost Estimate**

|   |                  |
|---|------------------|
| * Reactivate shipboard firemains  | \$ 1,000 ✓       |
| * Build additional covers over vessel   | \$ 50,000 ✓      |
| * Rot arresting treatment (borates)   | \$ 50,000 ✓      |
| * Increase ventilation  | \$ 10,000        |
| * Minimum additional survey of barge shell by diver and internal ultrasonic testing | \$ 3,000         |
| * Misc. repairs and maintenance   | \$ 5,000 ✓       |
| * 10% of above for tech. consultants  | \$ 12,000 ✓      |
| * Barge rental, 12 mo. @ \$3,000 per  | \$ 36,000 ✓      |
| * Shipboard staff position, "engineer"  | \$ 15,000 ✓      |
|   | -----            |
| <b>Total</b>  | <b>\$182,000</b> |

**Further Research and Design Work**

|  |                  |
|--|------------------|
| * Experiments in alternate rot treatments and wood consolidation methods | \$ 10,000        |
| * Design additional covers over vessel                                   | \$ 2,000         |
| * Update survey, monitor change of condition                             | \$ 2,000         |
| Investigate alternative barge should 214 not continue to be available.   | \$ 10,000        |
| Investigate alternative berths   | \$ 5,000         |
|  | -----            |
| <b>Total Research &amp; Design</b>                                       | <b>\$ 29,000</b> |

|                               |                           |
|-------------------------------|---------------------------|
| <b>Total All Expenditures</b> | -----<br><b>\$211,000</b> |
| <b>Total Essential Items</b>  | <b>\$196,000</b>          |

| <b>FY 88      Recommended Work</b>  | <b>Cost Estimate</b> |
|---|----------------------|
| * Drydock Barge 214 for survey, maintenance and repair. (If condemned expect equivalent cost for shifting to another barge) | \$140,000            |
| * Barge rental or purchase  | \$ 36,000            |
| * Machinery preservation  | \$ 10,000            |
| * Painting of exterior ship   | \$ 45,000            |
| * Misc. repairs and maintenance   | \$ 5,000             |
| * Shipboard staff position, "engineer"  | \$ 15,000            |
| * Technical consultants   | \$ 5,000             |
| * Build minimum public access   | \$ 50,000            |
|   | -----                |
| <b>Total</b>  | <b>\$306,000</b>     |

**Further Research and Design Work**

|  |                  |
|--|------------------|
| Assess success to date of stabilization and choose between a.) build permanent shed<br>b.) renewal of weather surfaces | \$ 5,000         |
| Design modifications to Barge 214 (or other)   | \$ 5,000         |
| Design permanent shed structure  | \$ 10,000        |
| Load bearing study & hull support design   | \$ 15,000        |
| Design public access   | \$ 10,000        |
| Design sprinkler system  | \$ 3,000         |
|  | -----            |
| <b>Total Research &amp; Design</b>   | <b>\$ 48,000</b> |

|                               |                  |
|-------------------------------|------------------|
| <b>Total All Expenditures</b> | <b>\$354,000</b> |
| <b>Total Essential Items</b>  | <b>\$306,000</b> |

| <b>FY 89      Recommended Work</b>  | <b>Cost Estimate</b> |
|---|----------------------|
| * Metal preservation (boiler, tanks, stack)   | \$ 22,000            |
| * Asbestos abatement  | \$ 20-30,000         |
| * Shipboard staff position, "engineer"  | \$ 15,000            |
| Carry out Barge 214 modifications<br>(obviated if shifted to larger barge)  | \$200-250,000        |
| Build permanent shed on barge<br>(Or, commit this level of expenditure to weather surface renewals with equivalent expenditures carried into FY 90 and FY 91) | \$200-350,000        |
|   | -----                |
| <b>Total All Expenditures</b>   | <b>\$457-667,000</b> |
| <b>Total Essential Items</b>  | <b>\$ 57- 67,000</b> |

(Preservation chronology, cont.)

| <b>FY 90 Recommended Work</b>                      | <b>Cost Estimate</b>        |
|--|-----------------------------|
| Increase public access (includes partial renewals) | \$200-300,000               |
| Build permanent hull supports                      | \$150-200,000               |
| Develop Interpretation                             | \$100-200,000               |
| <b>Total</b>                                       | <b><u>\$550-700,000</u></b> |

**FY 91** Projects from FY 87 on may take until the mid-nineties or later to accomplish unless funding improves, by which time the planning outlined in this report may be invalid.

By FY 91 another assessment should be made of preservation success to date. A revision of the present plan can then be made in light of the level of success achieved, and the needs of the rest of the historic fleet at that time.



## VIII. IMPACT OF PROPOSED TREATMENT

### A. Historic Fabric

The recommended stabilization measures are aimed at conserving as much original material as possible. The selected removals of planking are small in area but considered essential to achieve the ventilation necessary for preservation of the whole ship. The recommended removals of loose asbestos and crumbling piping from the engine room are safety requirements. The increased structural supports and the cover systems will require penetrations for attachment to the ship. For the support systems these are unavoidable. For the covers these attachments could be minimized if the permanent shed could be built immediately. The shed cannot be built, however, without resolving the long term availability of Barge 214 and in any case will have considerable lead time. The need for protection from the weather is immediate and pressing. Therefore the penetrations of historic fabric for the temporary covers are considered necessary.

Determination of specific renewals need not be made until the survivability of the whole structure has been established.

### B. Appearance

In the short term, the stabilization measures of **complete coverage**, increased shoring, and selected removals will make the WAPAMA **even more unsightly than she is now**. We do not see an alternative to this **if she is to be saved**.

While the stabilization measures are being implemented it is to be hoped that simultaneous efforts will determine the long range plan for Barge 214. This will make it possible to proceed with design work for a permanent shed and structural support system.

The shed envisioned is to resemble the type of shed under which vessels like the WAPAMA were originally built. The recommended support system would replace bulky wooden shoring with visually less obtrusive members of heavy wall steel pipe. The system is similar in concept to the support system used on the Viking Ship remains in Scandinavian museums.

The principal advantage to interpretation of having the ship out of the water is that it gives an appreciation of the true size and construction complexity of this wooden structure. The disadvantage is that the ship on the barge and within a shed will take up a significant piece of the waterfront panorama with a nonoriginal structure that may seem out of scale.

### C. Long Term Preservation

All of the recommendations in the Proposed Treatment are intended to secure long term preservation of the vessel. Stabilization is a prerequisite for any of the options discussed. Haste has been recommended in all tasks that arrest deterioration, and caution has been urged in all options that will result in major alterations to the historic fabric of the vessel.

We do not know if in the long run the ship will not require major renewals in any case; in the long run rebuilding her thoroughly and maintaining her afloat may be a better alternative than maintaining a wreck, a shed, and a barge with difficult berthing requirements. The recommended treatment in no way precludes this possibility.

We do know that rebuilding the ship at this time is beyond the resources currently available. Furthermore, we believe that the problems encountered in preserving the WAPAMA are common to the fleet of historic ships and that finite resources should not be concentrated on one project if doing so may jeopardize the survival of other ships.

## IX. CREDITS AND REFERENCES

### A. CREDITS

|  |   |
|--|---|
| <b>Project Manager:</b>                                      | Don Birkholz, Jr.   |
| <b>Research and Report Development:</b>                      | Walter Rybka<br>David Canright                                |
| <b>Technical Assistance:</b>                                 | Jessie Brady  |
| <b>Documentation Drawings:</b>                               | Don Birkholz, Sr.   |
| <b>Graphic Design and Renderings:</b>                        | David Canright  |
| <b>Production Assistance:</b>                                | Arden C. Rembert  |
| <b>Vessel Survey:</b>  | Capt. Giffy Full,<br>Marine Surveyor<br><br>Don Birkholz, Jr. |
| <b>Machinery Survey:</b>                                     | James Brogan  |
| <b>Stability and Structural Support Studies:</b>             | David J. Seymour,<br>Naval Architect                          |
| <b>Technical Consulting, and Study of Rebuilding Option:</b> | Jack Ehrhorn,<br>Master Shipwright,<br>Marine Surveyor        |

### B. REFERENCES

#### Load Bearing Strength

- Lanius, R. M. "Evaluating Residual Strength and Repair of Structures" in Structural Uses of Wood in Adverse Environments Ed. R. W. Meyer and R. M. Kellogg. N.Y., N.Y.: Van Nostrand Reinhold Co., 1982, pp 436-50.
- Suter, G. T. "Evaluation of In Situ Strength of Aged Timber Beams" in Structural Uses of Wood in Adverse Environments Ed. R. W. Meyer and R. M. Kellogg. N.Y., N.Y.: Van Nostrand Reinhold Co., 1982, pp 472-79.



## Survey Summary

"Restoration of the Steam Schooner WAPAMA, Report #1 to the State of California". San Francisco, CA.: S.F. Maritime Museum, 1960.

Reynolds, Z. M. "S.S. WAPAMA Condition Survey", Zachary M. Reynolds, 1982.

Reynolds, Z. M. "S.S. WAPAMA Restoration, Phase I - Scientific Survey of Hull Deflection and Structural Condition", Zachary M. Reynolds, 1979.

Lally, R. J. "Survey, Steam Schooner WAPAMA", survey report, Richard J. Lally, Marine Surveyor, 1979

## Barge 214

Cibley, B. " Barge 214 Report of Condition", survey report, Hull and Cargo, Inc., 1985

Seymour, D. J. "WAPAMA Stability Check", Dwg. No. 2041-2, study of vessel/barge stability, D.J. Seymour, 1986.

## Wood Sciences

Morrell, Jeff, Guy Helsing, and Robert Graham Marine Wood Maintenance Manual, Research Bulletin 48, Oregon State U., 1984.

Eslyn, W. E. and Terry L. Highly "Efficacy of Various Fumigants in the Eradication of Decay Fungi Implanted in Douglas-fir Timbers" in Phytopathology, American Phytopathological Society, vol. 75, No. 5, 1985, pp. 588-92.

Ricard, J. L., T. E. See, and W. B. Bollen "Control of Incipient Decay With Gases in Douglas-fir Poles" in Forest Products Journal, vol 18, No. 4, 1968, pp. 45-51.

Dicker, P. E., et al. "Borates Diffusion Techniques For In-Situ Treatment of Joinery" in Record of the 1983 Annual Convention of the British Wood Preserving Assoc. Cambridge, England: British Wood Preserving Assoc., 1983, pp 73-81.

Service Bulletin - Tim-Bor as a Wood Preservative, No. WP-10, U.S. BORAX & Chemical Corp., 1986.

Grattan, D. W., personal communication, letter, Ontario, Ottawa, Canada, 5,26,86.



MARINE SURVEYOR • Jack W. Ehrhorn, 117 Ironwood Rd., Alameda, CA 94501 • 415-523-8156

14 January 1987

Dear Don,

I hope that the enclosed figures will be of some help to you. I enjoyed reading over the many pages of reports of survey. They are very comprehensive and informative. The drawings, I thought, are particularly good and accurate. I wonder what the old time builders would think of all this dedication and detail given to their fine work?

Much thought was given to my estimates and in my advanced years I am inclined to lean on the heavy side despite my penchant for being optimistic when it comes to the building of boats. Most new building projects have a history of exceeding early estimates and therefore I am reluctant to paint a rosier picture. Let's hope that something good comes of all your fine efforts.

Sincerely,

*Jack*

14 January 1957

"S S WAPAMA"

Recent surveys of the S S WAPAMA have shown a seriously weakened condition of the wood hull structure due to wood rot and corrosion of metal fasteners. It is doubtful, at this time, that enough of the existing hull can be salvaged and used as a base for rebuilding. The main structural members such as keel, keelsons, frames, ceiling, deck beams, planking, knees and deckhouses are deteriorated to the extent that it is not feasible to try to retain any of these members as part of a rebuilt vessel. The rot in these members plus warping and old fastening holes would not permit their being used again. To rebuild the vessel would require an almost total replacement of old wood with new with the result that much of structure in evidence now would be either replaced or hidden from view.

For all practical purposes it would seem logical to build a new vessel and to salvage all usable metal fittings and equipment which would be reinstalled in and on the new vessel. In effect, the new vessel would be a sister ship to WAPAMA and be an exact duplicate with the advantage of having complete integrity of the hull and all components. Certain parts of WAPAMA would be salvageable such as interior joinerwork and perhaps some of the hanging knees which would be installed in the new vessel. With a full size model to work from the many details of construction and methodology can be referred to

which would be a great aid for duplication. This of course, assumes that construction of a new vessel would be started before the S S WAPAMA becomes so wasted that she no longer is available for salvage of parts or serves as a model.

A new vessel would have the advantage of being moved on her own bottom to different viewing sites if need be and the added burden of maintaining the barge upon which WAPAMA now rests is eliminated. With the use of wood preservatives in the course of the newly constructed vessel and proper and adequate maintenance the life expectancy of the vessel should be 100 years plus.

Aside from using preservatives in building a new vessel a few concessions to modernity might have to be used to work around the problem of not being able to locate all of the large sized timbers which were available at the time of the building of WAPAMA. These large structural members would have to be built up by laminating smaller pieces to gain the needed sizes. With good modern glues there would be no loss of strength and in all probability there would be a gain in strength. Hanging and lodging knees as used in WAPAMA might be a thing of the past and would also need to be fabricated of smaller pieces. But the size and shapes would be maintained.

A diesel generator would be needed for fire fighting pumps and bilge pumps as well as ship's service lighting

but these more modern devices could be installed without detracting from the appearance of the original vessel.

Authenticity should and would be adhered to regarding details of size, shape and fitting of wood members as well as types and methods of fastening using locust trunnels and metal fasteners. It is expected that needed materials will have to be manufactured in most cases and in effect, with the exception of a very few people, the shipwright's trade will have to be revitalized. These problems should only increase the desire to create something new while using time proven methods and materials to carry on the traditions and interests of this nation's maritime history.

A building site would be needed that would afford access to water for an end-on launching, side launching or a graving dock. A large enough area would be needed for machining metal parts, a wood working mill, small shops for pipefitters, electricians, painters, tools, caulkers, joiners, an office and room for a mobile truck crane to serve both sides of the vessel. It is doubtful if a building shed is needed if the vessel were to be built in this area. Large wooden vessels built in this area were seldom constructed in shops or enclosed areas. There is a definite advantage in building in the open where the vessel will spend her life. Lumber has a better chance to season and adapt to climatic conditions when built in the open. The building site would also have<sup>to</sup> be large enough to permit the storage of lumber.

Modern tools such as electric and pneumatic drills, saws, etc would take away some of the time-consuming and hard work associated with wooden shipbuilding. The bulk of the work still requires good fits at all faying surfaces of timbers which can only be accomplished with hand crafted methods. A building crew will have to be dedicated and hard-working. In the days of WAPAMA's build, men worked 9 to 10 hours a day and for 6 days a week. A lot was accomplished in a month's time. In this age we are looking at a 40 hour work week. Coffee breaks also take away from productivity and are not easy to incorporate into a shipbuilder's normal working day.

Vessels like WAPAMA were constructed in 8 to 14 months at a time when experienced craftsmen were plentiful and very capable. Modern craftsmen are certainly able to do this work once they have been exposed to it. But until men have had the chance to work with and in this medium a training and learning period must be figured into the building time. Availability of many bits of hardware and materials will be scarce and will entail time to procure. These things will add to building time and costs but should not of themselves discourage the pursuit of such a project.

Time for curing and seasoning of large dimensioned lumber will be from 3 to 5 years minimum and lead time for this and milling have to be a consideration for possible building plans.

A projected building time for a replacement vessel for S S WAPAMA would be 30 months to 36 months. This time would allow for the dismantling of usable hardware, equipment and interior joiner work and related items.

It is anticipated that an average of 50 men would be employed on the average during the time of construction. A breakdown of trades and services are as follows.

1 foreman, 3 leadermen, 12 journeyman shipwrights, 2 blacksmiths, 3 machinists, 2 riggers, 2 pipefitters, 2 electricians, 6 caulkers, 6 joiners, 8 apprentice carpenters, 4 painters, 1 crane operator and office personnel.

50 men working for 125 weeks @ 40 hrs per week would add up to 250,000 hrs of labor.

Hopefully this amount of time could be decreased if building conditions were good. Taking into account probable delays of some needed materials from time to time and the time of training and orientation then the time indicated is perhaps realistic.

But- to use an oft-used phrase of Lester Stone's--  
"There is nothing finer than a new ship."

Jack W. Ehrhorn  
Marine surveyor

# WAPAMA

## STABILITY CHECK

### ④ DAMAGED STABILITY

ASSUME ONE COMPARTMENT  
FLOOD NO. 1 TANK

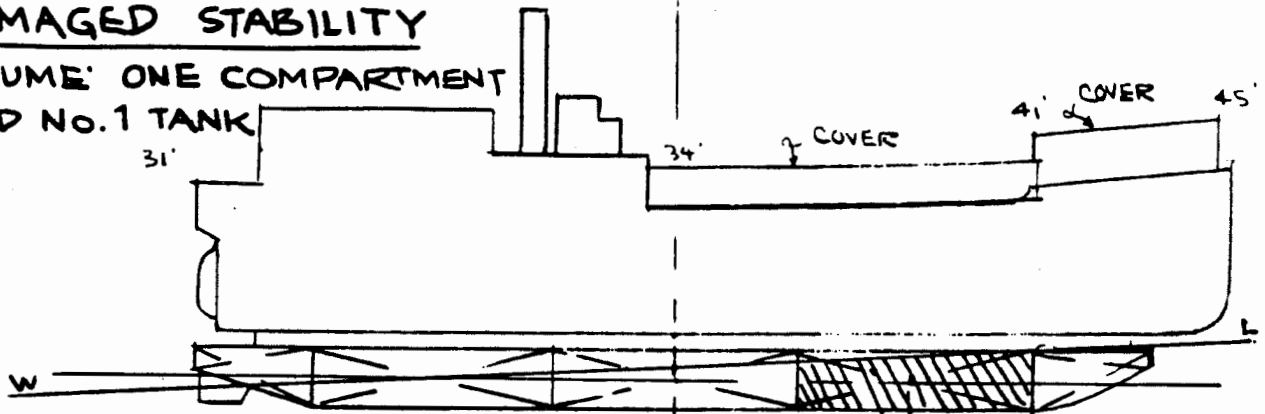

BARGE 214 - 200' x 60' x 12'

Arm 50'

$$H_{\text{INTACT}} = 5.65' \quad H_{\text{DAMAGED}} = 7.53'$$

$$WT \text{ FLOODED WATER} = 12' \times 50' \times 60' / 35 = 1038 \text{ LSW}$$

$$MT1 = \frac{I_L}{420L} = \frac{60 \times 200^3}{12 \times 420 \times 200} = 476$$

$$TRIM = \frac{50' \times 1038 \text{ LT}}{(MT1) 476} = 109 \text{ in.} = 9.1 \text{ ft.}$$

$$H_F = 7.5 + 4.5 = 12.0$$

$$F.B. @ \text{BOW} = \underline{0' \text{ O.K.}}$$

$$H_A = 7.5 - 4.5 = 3.0$$

$$H_M = 7.5 + 0 = 7.5$$

$$GM_T = \underline{31.0 \text{ ft.}}$$

| WT            | KG   | VM     |
|---------------|------|--------|
| 1790          | 26.0 | 46,620 |
| 1038          | 6.0  | 6230   |
| $\Delta$ 2828 | 18.7 | 52,850 |

$$\textcircled{3} \Delta GM_T = 20.2 - 18.7 = +1.5$$

$$GM_T = 29.5 + 1.5 = 31.0$$

APPLY WIND HEEL (SIM ③)

$$\tan \theta = \frac{PAh}{\Delta GM_T} = \frac{.00446 \times 10,450 \times 27.3}{2828 \times 31.0}$$

$$= \underline{0.83 \text{ DEG. O.K.}}$$

**David J. Seymour, Ltd.**

Naval Architects - Marine Consultants

DESIGN CALCULATION SHEET

Subject: WAPAMA STABILITY

Job No: 2041 Date: 1 MAR 50

By: D.S. Check: \_\_\_\_\_

Sheet 4 of 4



# WAPAMA

## STABILITY CHECK

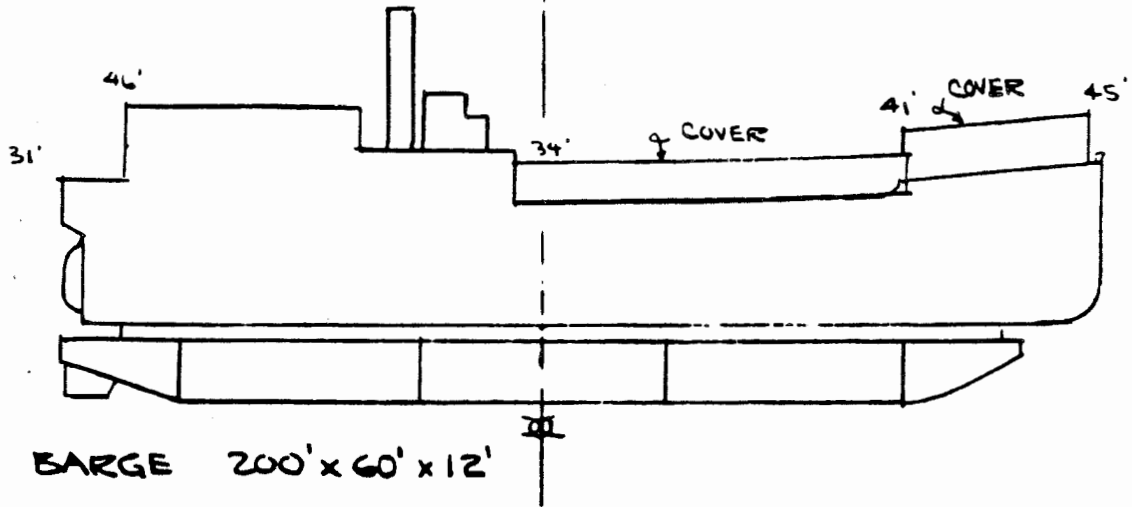

**David J. Seymour, Ltd.**

Naval Architects - Marine Consultants

DESIGN CALCULATION SHEET

Subject: WAPAMA STABILITY

Job No: 2041 Date: 1 MAR 68

By: DC Check: \_\_\_\_\_

# WAPAMA

## STABILITY CHECK

### ② WEATHER CRITERIA

LIMIT HEEL  
TO 5 DEG.  
 $\frac{1}{2}$  F.B. = 6 DEG.

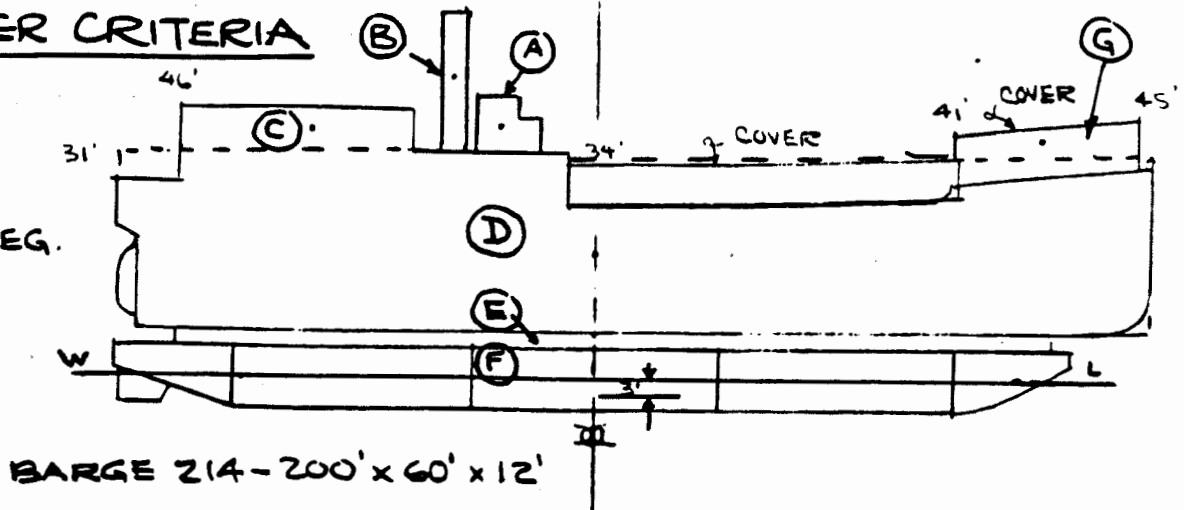

| ITEM              | AREA - $\text{ft}^2$ | ARM-FT. | VERT. MOM - $\text{ft}^3$ |
|-------------------|----------------------|---------|---------------------------|
| (A) PILOT HSE     | 8 x 10 = 80          | 55.0    | 4,400                     |
| (B) STACK         | 4 x 30 = 120         | 65.0    | 7,800                     |
| (C) ACCOM.        | 50 x 8 = 400         | 55.0    | 22,000                    |
| (D) HULL + COVER  | 215 x 35 = 7530      | 29.0    | 218,370                   |
| (E) BLOCKS        | 200 x 4 = 800        | 11.0    | 8,800                     |
| (F) HULL BARGE    | 200 x 6 = 1200       | 6.0     | 7,200                     |
| (G) COVER FOC'SLE | 40 x 8 = 320         | 53.0    | 16,960                    |
| TOT               | = 10,450             | 27.3    | 285,530                   |

### USCG WEATHER CRITERIA Protected Waters.

$$GM_{\text{req'd}} = \frac{PAh}{\Delta \tan \theta}$$

$$= \frac{.00446 \cdot 10,450 \cdot 27.3}{1790 \times .08749}$$

$$= 8.2 \text{ ft.}$$

$$GM_{\text{avail}} = 33.3$$

$$\text{MARGIN} = \underline{25.1 \text{ ft}} \quad \text{O.K.}$$

$$P = 10 \text{ pct } (.00446 \frac{\text{L.T.}}{\text{ft}})$$

$$A = 10,450 \text{ ft}^2$$

$$h = 27.3$$

$$\theta = 5 \text{ deg.}$$

$$\Delta = 1790 \text{ L.T.}$$

**David J. Seymour, Ltd.**

Naval Architects - Marine Consultants

DESIGN CALCULATION SHEET

Subject: WAPAMA STABILITY

Job No: 2041 Date: 1 MAR 61

By: D.S. Check:

# WAPAMA

## STABILITY CHECK

③ DAMAGED STABILITY  
 ASSUME ONE COMPARTMENT  
 FLOOD NO. 2 TANK

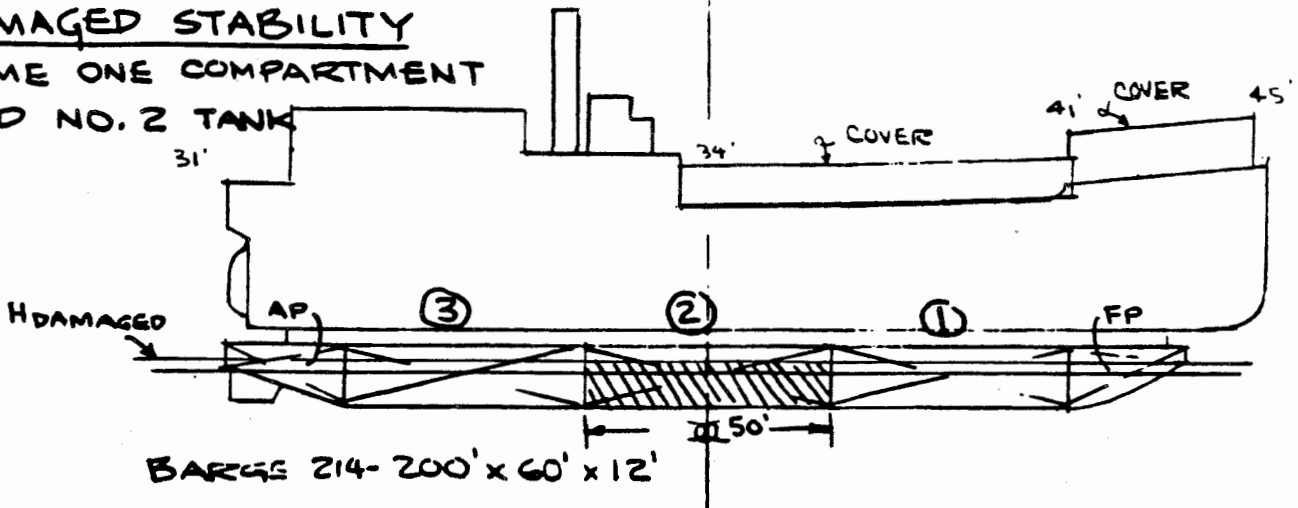

BARGE 214-200' x 60' x 12'

H INTACT = 5.65 ft

FLOOD No. 2 P/S ASSUME  $\phi$  LONG'L BHD NONTIGHT

$$\text{LOST BUOY} = 50' \times 60' \times \frac{5.65'}{35} = 484 \text{ LT SW}$$

$$H_{\text{DAMAGED}} = 5.65' + \frac{484 \times 35}{(200-50)60} \quad 0 \text{ TRIM.}$$

$$= 5.65' + 1.88' = \underline{\underline{7.53 \text{ FT}}}$$

$$\text{Add Water} = \frac{7.53 \times 50 \times 60}{35} = 645 \text{ LT SW}$$

ASSUME SAME W.P.

$$BM_T = 57.5$$

$$KB = + 3.8$$

$$KM_T = 61.3$$

| WT             | KG   | V.M.   |
|----------------|------|--------|
| 1790           | 26.0 | 46,620 |
| 645            | 3.8  | 2450   |
| $\Delta: 2435$ | 20.2 | 49,070 |

GM<sub>T</sub> AFTER DAMAGE

$$KM_T = 61.3 \text{ ft.}$$

$$KG = \underline{20.2} "$$

$$GM = 41.1 "$$

$$F.S. = \underline{-11.6} "$$

$$GM_T = \underline{\underline{29.5 \text{ ft}}}$$

O.K.

FREE SURF. CORR.

$$F.S. \text{ No. 2} = \frac{50 \times 60^3}{12 \times 2435 \times 35}$$

$$= 10.56'$$

$$F.S. \text{ OTHER} = + 1.00'$$

$$F.S. \text{ CORR. TOT. } 11.56'$$

**David J. Seymour, Ltd.**

Naval Architects - Marine Consultants

DESIGN CALCULATION SHEET

Subject: WAPAMA STABILITY

Job No: 2041 Date: 1 MAR

By: D.S. Check:

## STABILITY CHECK

THESE CALCULATIONS HAVE BEEN PREPARED TO CHECK STABILITY OF BARGE 214 SUPPORTING STEAM SCHOONER WAPAMA.

DATA USED FOR VESSEL & BARGE WERE DRAFT READINGS FROM HULL & CARGO SURVEYOR'S REPORT DATED 19 JUL 85, ZACK REYNOLDS INFO & A PROFILE DWG. OF WAPAMA FROM GGNRA.

STABILITY CRITERIA USED WERE:

1. INTACT STABILITY - GM TO LIMIT HHEEL FROM WEATHER CRITERIA TO 5 DEGREES.
2. USCG WEATHER CRITERIA - 46 CFR SUBPART E 170.160
3. DAMAGED STABILITY - ONE COMPT. FLOODING - MARGIN LINE - HHEEL LIMIT 5 DEGREES.

RESULTS OF CALCULATIONS INDICATE BARGE 214 SUPPORTING WAPAMA COMPLIES WITH ABOVE CRITERIA. EXCESS MARGIN OF STABILITY OF BARGE 214 MORE THAN ADEQUATE FOR ERROR IN ESTIMATE OF VCG FOR LIGHTSHIP WEIGHT OF WAPAMA.

NOT NECESSARY AT THIS TIME BUT RECOMMENDED WHEN FINAL CONFIGURATION OF WAPAMA RESTORATION ESTABLISHED IS AN INCLINING TEST & COMPUTER STABILITY CALCS.

### PRINTS ISSUED

| DATE TO  | 3 MAR 86 |  |  |  |  |  |  |  |  |  |  |  |  |  |  |  |  |  |  |  |  |
|----------|----------|--|--|--|--|--|--|--|--|--|--|--|--|--|--|--|--|--|--|--|--|
| BIRKHOLZ | 2        |  |  |  |  |  |  |  |  |  |  |  |  |  |  |  |  |  |  |  |  |
| FILE     | 1        |  |  |  |  |  |  |  |  |  |  |  |  |  |  |  |  |  |  |  |  |
| TOTAL    | 3        |  |  |  |  |  |  |  |  |  |  |  |  |  |  |  |  |  |  |  |  |
| ALT.     | 0        |  |  |  |  |  |  |  |  |  |  |  |  |  |  |  |  |  |  |  |  |

## David J. Seymour, Ltd.

Naval Architects - Marine Consultants

San Francisco

CA.

Designed for

# G G N R A

SAN FRANCISCO

CA.

SCALE: 40 FT = 1 IN

DATE: 1 MAR 86

DRAWN BY: DS

FILE NO.: 2041

CHECKED BY: -

APPD BY: NS

STEAM SCHOONER

# WAPAMA

## STABILITY CHECK

DWG. NO. 2041-2

ALT. ○

# WAPAMA

## STABILITY CHECK

### ① GM AVAILABLE

WAPAMA L.S.  
EST. @ 1380 LT.  
KG = KD = .8 x 19'  
= 15.5'  
K<sub>G</sub> = 31.5'

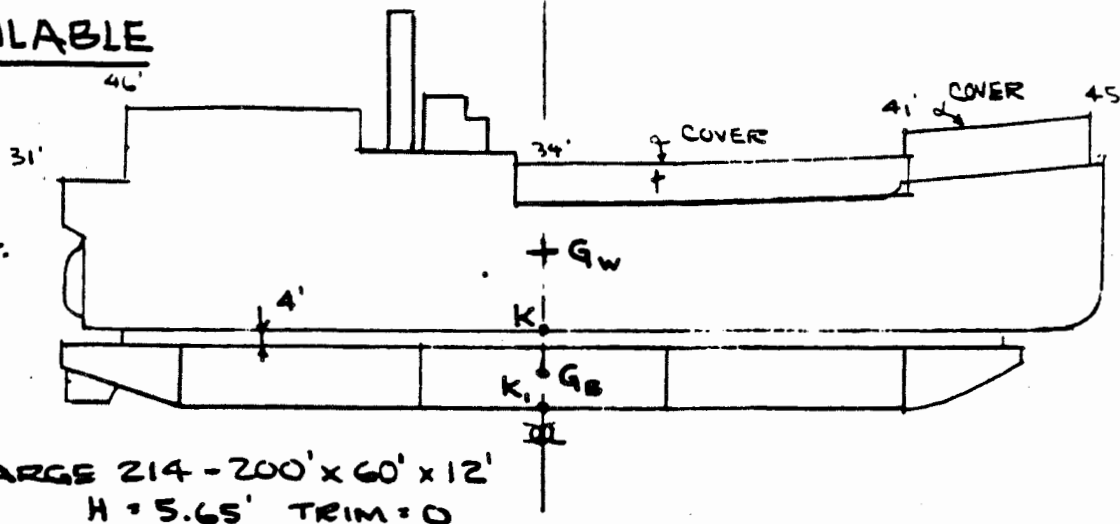

BARGE 214 - 200' x 60' x 12'  
H = 5.65' TRIM = 0

WITH WAPAMA ON BOARD  $\Delta$  BARGE @ H = 5.65' =  $\frac{200 \times 60 \times 5.7 \times 9}{35}$   
= 1760 LT.  
BARGE L.S. = 400 "  
WAPAMA L.S. = 1360 LT.

| ITEM        | WT (LT) | K <sub>G</sub> (FT) | VERT MOM |
|-------------|---------|---------------------|----------|
| WAPAMA L.S. | 1360    | 31.5                | 42,840   |
| COVER       | 30      | 46.0                | 1380     |
| BARGE L.S.  | 400     | 6.0                 | 2400     |
| $\Delta$    | 1790    | 26.0                | 46,620   |

$KM_T = 60.3$

$K_G = 26.0$

$GM = 34.3$

$F.S. = -1.0$

$GM_{T \text{ Avail}} = 33.3 \text{ ft.}$

O.K.

$BM_T = \frac{1}{12} \frac{200 \times 60^3}{1790 \times 35}$

= 57.5

$KB = 2.8$

$KM_T = 60.3$

**David J. Seymour, Ltd.**

Naval Architects - Marine Consultants

DESIGN CALCULATION SHEET

Subject: WAPAMA STABILITY

Job No: 2041 Date: 1 MAR

By: D.S. Check:

Sheet 1 of 4

| <u>LOCATION</u> | <u>CONDITION</u>   |
|-----------------|--|
| S36-10-F        | FULL 5": ROTTEN, FEW FIBERS, DARK AND POWDERY              |
| S36-14-C        | FULL 10": GOOD, FIBERS DARK ON OUTBOARD 1"                 |
| S36-14-F        | FULL 5": ROTTEN, WOOD FIBERS DARK AND POWDERY              |
| S39-K2          | 0" TO 2": FAIR >> 2" TO 14": ROTTEN, NO FIBERS             |
| S39-S3          | FULL 14": SEMI-SOFT, WOOD FIBERS DARK AND SLIGHTLY MUSHY   |
| S39-2-C         | FULL 10": SOFT, FIBERS DARK AND MUSHY                      |
| S39-2-F         | FULL 5": ROTTEN, FIBERS DARK AND MUSHY                     |
| S39-2-F         | FULL 6": SOFT, FIBERS DARK AND MUSHY                       |
| S39-5-C         | FULL 10": ALL GOOD   |
| S39-5-F         | FULL 5": ROTTEN, FIBERS MUSHY                              |
| S39-9-C         | 0" TO 7": GOOD >> 7" TO 10": SOFT, FIBERS MUSHY            |
| S39-9-F         | FULL 14": ROTTEN, FIBERS DARK                              |
| S39-12-C        | 0" TO 8": GOOD >> 8" TO 10": SOFT, FIBERS POWDERY          |
| S39-12-F        | FULL 14": ROTTEN, WOOD FIBERS DARK AND MUSHY               |
| S42-S1          | FULL 14": ALL GOOD   |
| S42-1-C         | 0" TO 7": SOFT, FIBER DARK AND MUSHY >> 7" TO 10": FAIR    |
| S42-1-F         | FULL 6": ROTTEN, FEW FIBERS, DARK AND MUSHY                |
| S42-6-C         | 0" TO 7": GOOD >> 7" TO 10": SOFT                          |
| S42-6-F         | FULL 6": ROTTEN, FEW FIBERS, DARK AND MUSHY                |
| S42-13-C        | FULL 10": ALL GOOD   |
| S42-13-F        | FULL 6": SOFT, FIBERS DARK AND MUSHY                       |
| S45-S2          | 0" TO 10": FAIR >> 10" TO 15": SOFT, FIBERS DARK AND MUSHY |
| S45-3-C         | 0" TO 7": GOOD >> 7" TO 10": SOFT, FIBERS DARK AND MUSHY   |
| S45-3-F         | FULL 6": ROTTEN, NO FIBERS                                 |
| S45-7-C         | 0" TO 6": GOOD >> 6" TO 10": SOFT, FIBERS DARK             |
| S45-11-C        | FULL 10": ALL GOOD   |

LOCATIONCONDITION

|          |  |
|----------|--|
| S45-11-F | FULL 6": SUFT. FIBERS DARK AND MUSHY                                     |
| S48-S3   | 0" TO 12": SEMI-SOFT >> 12" TO 14": SOFT,<br>FIBER DARK AND MUSHY        |
| S48-2-C  | 0" TO 4": FAIR, FIBERS DARK >> 4" TO 10": SOFT,<br>FIBERS DARK AND MUSHY |
| S48-2-F  | FULL 6": ALL ROTTEN, FIBERS DARK AND POWDERY                             |
| S48-6-C  | FULL 10": ALL ROTTEN   |
| S48-6-F  | FULL 6": ALL ROTTEN, FEW FIBERS  |
| S48-12-C | FULL 10": ALL GOOD   |
| S48-12-F | 0" TO 3": GOOD >> 3" TO 11": SEMI-SOFT                                   |
| S77-4-P  | 0" TO 4.5": ALL GOOD   |

LOCATIONCONDITION

S21-1-F FULL 5": ROTTEN, FIBERS DARK AND MUSHY  
S21-9-C FULL 10": ROTTEN, FIBERS DARK AND MUSHY  
S21-9-F FULL 5": ROTTEN, NO FIBERS  
S21-11-C 0" TO 4": FAIR >> 4" TO 10": ROTTEN, FIBERS DARK AND MUSHY  
S21-11-F FULL 5": ROTTEN, FIBERS DARK AND MUSHY  
S23-K2 FULL 14": ALL GOOD, FIBERS LIGHT AND DRY  
S24-S1 FULL 14": ALL GOOD  
S24-1-C FULL 10": ROTTEN, FIBERS DARK AND POWDERY  
S24-1-F 0" TO 6": SOFT, FEW FIBERS  
S24-2-C FULL 10": ALL GOOD  
S24-6-C FULL 10": ALL GOOD  
S24-7-C 0" TO 5": SOFT >> 5" TO 10": ROTTEN, FIBERS DARK AND MUSHY  
S24-7-F 0" TO 6": SOFT, FIBERS DARK AND MUSHY  
S24-9-C FULL 10": ROTTEN, FIBERS DARK AND MUSHY  
S24-11-C 0" TO 2": SOFT >> 2" TO 10": ROTTEN, FIBERS DARK AND MUSHY  
S24-11-F FULL 5": ROTTEN, FIBERS DARK AND MUSHY  
S25-1-F FULL 6": SOFT, FIBERS DARK AND MUSHY  
S25-3-F 0" TO 4": SOFT >> 4" TO 8": ROTTEN, FIBERS DARK AND MUSHY (BORING TAKEN FROM OUTSIDE)  
S25-14-C 0" TO 7": FAIR >> 7" TO 10": SOFT, FIBERS DARK AND POWDERY  
S26-K2 FULL 14": ALL GOOD, WOOD FIBERS DRY AND LIGHT IN COLOR  
S27-S2 FULL 14": GOOD, WOOD FIBERS GREY  
S27-4-C 0" TO 5": GOOD >> 5" TO 10": ROTTEN, FIBERS DARK AND MUSHY  
S27-4-F FULL 14": ROTTEN, FEW MUSHY FIBERS  
S27-9-C 0" TO 5": GOOD >> 5" TO 10": SOFT  
S27-9-F FULL 14": ROTTEN, FIBERS DARK AND MUSHY  
S27-13-C 0" TO 4": GOOD >> 4" TO 10": ROTTEN, FIBERS DARK AND MUSHY



| <u>LOCATION</u> | <u>CONDITION</u>   |
|-----------------|--|
| S27-13-F        | FULL 14": ROTTEN, FIBERS DARK AND MUSHY                          |
| S28-4-F         | FULL 5": SEMI-SOFT, FIBERS DARK<br>(BORING TAKEN FROM OUTSIDE)   |
| S29-K2          | 0" TO 2": SOFT >> 2" TO 14": ROTTEN                              |
| S30-S3          | FULL 14": SEMI SOFT, SOME DARK FIBERS                            |
| S30-2-C         | 0" TO 7": GOOD >> 7" TO 10": SOFT, FIBERS DARK AND MUSHY         |
| S30-2-F         | FULL 5": ROTTEN, FEW FIBERS, DARK AND MUSHY                      |
| S30-6-C         | 0" TO 5": GOOD >> 5" TO 10": SEMI-SOFT,<br>FIBERS DARK AND MUSHY |
| S30-6-F         | FULL 5": ROTTEN, FIBERS DARK AND MUSHY                           |
| S30-12-C        | FULL 10": GOOD, FIBERS DARK FOR LAST 1"                          |
| S30-12-F        | FULL 5": ROTTEN, FIBERS DARK AND MUSHY                           |
| S32-K2          | FULL 14": ROTTEN, FIBERS DARK AND MUSHY                          |
| S33-S2          | FULL 14": VERY SOFT, WOOD FIBERS DARK AND MUSHY                  |
| S33-S2          | FULL 5": SOFT, WOOD FIBERS DARK AND MUSHY                        |
| S33-1-C         | 0" TO 4": GOOD >> 4" TO 10": SOFT, FIBERS DARK AND MUSHY         |
| S33-1-F         | FULL 5": ROTTEN, WOOD FIBERS DARK AND MUSHY                      |
| S33-7-C         | FULL 10": VERY SOFT, FIBERS DARK AND MUSHY                       |
| S33-7-F         | FULL 5": SOFT, WOOD FIBERS DARK AND MUSHY                        |
| S33-11-C        | 0" TO 6": SEMI-SOFT >> 6" TO 10":SOFT,<br>FIBERS DARK AND MUSHY  |
| S33-11-F        | FULL 5": ROTTEN, FEW FIBERS, DARK AND POWDERY                    |
| S36-S1          | FULL 14": ALL GOOD, WOOD FIBERS LIGHT IN COLOR                   |
| S36-3-C         | FULL 10":VERY SOFT, FIBERS DARK AND MUSHY                        |
| S36-3-F         | FULL 5": ROTTEN, FEW FIBERS. DARK AND MUSHY                      |
| S36-7-C         | 0" TO 4":SOFT >> 4" TO 10":ROTTEN, FIBERS DARK AND MUSHY         |
| S36-7-F         | FULL 5": SOFT, FIBERS DARK AND MUSHY                             |
| S36-10-C        | 0" TO 4":SOFT >> 4" TO 10": ROTTEN, FIBERS MUSHY                 |

LOCATIONCONDITION

P40-12-F FULL 6": SOFT, FIBERS DARK AND MUSHY  
P43-1-C FULL 10": FAIR, FIBERS DARK  
P43-1-F FULL 6": SOFT, FIBERS DARK AND POWDERY  
P43-10-C FULL 10": ALL GOOD  
P43-10-F FULL 6": SOFT, FEW FIBERS  
P43-14-C 0" TO 7" : GOOD >> 7" TO 10": SOFT, FIBERS DARK AND MUSHY  
P43-14-F FULL 6": ROTTEN, FIBERS DARK AND POWDERY  
P46-2-C 0" TO 6": FAIR >> 6" TO 10": SOFT, FIBERS DARK AND MUSHY  
P46-2-F FULL 6": SOFT, FIBERS DARK AND MUSHY  
P46-8-C FULL 10": ROTTEN, FEW FIBERS  
P46-8-F FULL 6": SOFT, FIBERS DARK AND MUSHY  
P46-13-C FULL 10": ALL GOOD  
P46-13-F FULL 6": SOFT, FEW FIBERS, DARK AND MUSHY  
P52-2-F FULL 5": ROTTEN, FIBERS DARK AND MUSHY (OUTSIDE)  
P54-1-F FULL 6": SOFT, FIBERS DARK AND MUSHY (OUTSIDE)  
P54-KEEL FULL 14": FAIR, FIBERS DARK

STARBOARD

S3-12-F FULL 6": SOFT, FIBERS DARK AND POWDERY  
S9-S1 FULL 14": FAIR, FIBERS LIGHT IN COLOR,  
SOME SLIGHTLY MUSHY  
S9-2-C FULL 10": ALL GOOD  
S9-5-C FULL 10": ALL GOOD  
S9-6-C 0" TO 8": GOOD >> 8" TO 10": ROTTEN, FIBERS POWDERY  
S9-6-F FULL 5": SOFT, FEW FIBERS, POWDERY  
S11-K2 0" TO 6": GOOD >> 6" TO 8": ROTTEN, FIBERS MUSHY  
S11-K3 0" TO 5": GOOD >> 5" TO 9": ROTTEN, FIBERS DARK AND MUSHY

LOCATIONCONDITION

|          |  |
|----------|--|
| S12-S3   | 0" TO 2": GOOD >> 2" TO 15": ROTTEN, NO FIBERS           |
| S12-2-C  | 0" TO 5": GOOD >> 5" TO 10": SOFT, FIBERS MUSHY          |
| S12-2-F  | FULL 5": ROTTEN, FEW FIBERS, DARK AND MUSHY              |
| S12-5-C  | 0" TO 4": FAIR >> 4" TO 10": SOFT, FIBERS MUSHY          |
| S12-5-F  | FULL 5": ROTTEN, FEW FIBERS, DARK AND MUSHY              |
| S12-8-C  | 0" TO 4": GOOD >> 4" TO 10": SOFT, FIBERS DARK AND MUSHY |
| S12-8-F  | FULL 5": ROTTEN, FEW FIBERS, DARK AND MUSHY              |
| S15-S3   | FULL 14": ALL GOOD                                       |
| S15-1-C  | 0" TO 4": FAIR >> 4" TO 10": SOFT, FIBERS DARK AND MUSHY |
| S15-1-F  | FULL 5": ROTTEN, FIBERS DARK AND MUSHY                   |
| S15-5-C  | 0" TO 4": GOOD >> 4" TO 10": SOFT, FIBERS DARK AND MUSHY |
| S15-5-F  | FULL 5": ROTTEN, FEW FIBERS, DARK AND POWDERY            |
| S15-7-C  | 0" TO 2": GOOD >> 2" TO 10": SOFT, FIBERS DARK AND MUSHY |
| S15-7-F  | FULL 5": ROTTEN, NO FIBERS                               |
| S15-10-C | 0" TO 7": SOFT, FIBERS DARK AND MUSHY >> 7" TO 10": GOOD |
| S15-10-F | FULL 5": ROTTEN, FIBERS DARK AND MUSHY                   |
| S17-K2   | FULL 14": GOOD   |
| S17-K2   | FULL 14": ALL GOOD, FIBERS LIGHT AND DRY                 |
| S18-3-C  | 0" TO 2": GOOD >> 2" TO 10": ROTTEN, FEW FIBERS          |
| S18-3-F  | FULL 5": ROTTEN, FIBERS DARK AND MUSHY                   |
| S18-9-C  | FULL 10": SOFT, FIBERS DARK AND MUSHY                    |
| S18-9-F  | FULL 5": ROTTEN, FIBERS DARK AND MUSHY                   |
| S18-12-C | FULL 10": SOFT, FIBERS DARK AND MUSHY                    |
| S18-12-F | FULL 5": ROTTEN, FIBERS DARK AND MUSHY                   |
| S21-S1   | FULL 14": ALL GOOD                                       |
| S21-1-C  | FULL 10": ROTTEN, FIBERS DARK AND MUSHY                  |

Structural Survey : Steam Schooner WAPAMA

RECORD OF FABRIC ANALYSIS : Wood Borings in Hull

| <u>LOCATION</u> | <u>CONDITION</u>   |
|-----------------|--|
| STEM            | 0" TO 6": GOOD >> 6" TO 14": ROTTEN. NO FIBERS           |
| P7-FOCSL        | 0" TO 3": FAIR >> 3" TO 8": SOFT. FIBERS DARK            |
| P8-1-F          | FULL 6": SOFT, FIBERS DARK AND POWDERY                   |
| P9-FOCSL        | FULL 8": ALL GOOD  |
| P12-14-F        | FULL 6": FAIR. FIBERS DARK                               |
| P22-16-C        | FULL 10": FAIR   |
| P22-16-F        | FULL 6": ROTTEN. FIBERS DARK AND POWDERY                 |
| P25-1-C         | FULL 10": FAIR. FIBERS DARK                              |
| P25-1-F         | FULL 6": SOFT, FIBERS DARK AND MUSHY                     |
| P25-3-F ??      | 0" TO 10": SOFT. FIBERS DARK >> 10" TO 14": FAIR         |
| P25-5-C         | FULL 10": ALL GOOD                                       |
| P25-5-F         | FULL 6". SOFT, FIBERS POWDERY                            |
| P25-9-C         | 0" TO 2": FAIR >> 2" TO 10": SOFT, FIBERS MUSHY          |
| P25-9-F         | FULL 6": ALL ROTTEN. FEW FIBERS                          |
| P25-12-C        | 0" TO 6": GOOD >> 6" TO 10": SOFT, FIBER POWDERY         |
| P25-12-F        | FULL 6": ROTTEN, FIBERS DARK AND MUSHY                   |
| P27-3-C         | FULL 14": FAIR. FIBERS DARK BUT SOUND (OUTSIDE)          |
| P27-3-F         | 0" TO 6": FAIR. FIBERS DARK                              |
| P28-4-C         | 0" TO 4": FAIR >> 4" TO 10": SOFT. FIBERS DARK AND MUSHY |
| P28-9-C         | 0" TO 7": FAIR >> 7" TO 10": ROTTEN, FIBERS MUSHY        |
| P28-9-F         | FULL 6": ROTTEN, NO FIBERS                               |
| P28-12-C        | 0" TO 7": FAIR >> 7" TO 10": ROTTEN. FEW FIBERS          |
| P28-12-F        | FULL 6": ROTTEN. NO FIBERS                               |

LOCATIONCONDITION

P31-2-C FULL 10": SOFT, FIBERS DARK AND MUSHY

P31-2-F FULL 6": ROTTEN. FIBERS DARK AND MUSHY

P31-10-C 0" TO 4": GOOD >> 4" TO 10": ROTTEN, FEW FIBERS (?)

P31-10-F FULL 6": SOFT, FEW FIBERS

P31-14-C 0" TO 4": FAIR >> 4" TO 10": SOFT. FIBERS DARK AND MUSHY

P31-14-F FULL 6": SOFT AND MUSHY

P33-1-C FULL 10": SEMI-SOFT, FIBERS DARK

P34-2-C FULL 10": SOFT, FIBERS DARK AND MUSHY

P34-2-F FULL 6": ROTTEN. FIBERS DARK AND MUSHY

P34-9-C 0" TO 5": GOOD >> 5" TO 10": SOFT AND MUSHY

P34-9-F FULL 6": ALL ROTTEN, FIBERS DARK AND MUSHY

P34-13-C 0" TO 2": GOOD >> 2" TO 10": SOFT AND MUSHY

P34-13-F FULL 6": ALL ROTTEN, FEW FIBERS

P37-3-C 0" TO 4": FAIR >> 4" TO 10": ROTTEN, FIBERS DARK AND MUSHY

P37-3-F FULL 6": ROTTEN, FEW FIBERS

P37-7-C 0" TO 2": FAIR >> 2" TO 10": ROTTEN, FEW FIBERS(?)

P37-7-F FULL 6": ROTTEN, NO FIBERS

P37-13-C FULL 10": ROTTEN, FIBERS DARK AND POWDERY

P37-13-F FULL 6": ALL ROTTEN, NO FIBERS

P40-3-C 0" TO 7": GOOD >> 7" TO 10": SOFT, FIBERS DARK

P40-3-F FULL 6": ROTTEN, FEW FIBERS

P40-7-C 0" TO 7": GOOD >> 7" TO 10": SOFT

P40-7-C FULL 10": ROTTEN, FEW FIBERS. DARK AND MUSHY

P40-10-C FULL 10": GOOD

P40-10-F FULL 6": ROTTEN, FIBERS DARK AND MUSHY

P40-12-C 0" TO 6": GOOD >> 6" TO 10": SOFT

Structural Survey : Steam Schooner WAPAMA

WOOD TEST BORINGS IN HULL

PROCEEDURES

The following is a record of wood borings taken in order to determine the condition of WAPAMA's larger structural members. This work was performed by Tri-Coastal Marine, Inc. during the structural survey of the vessel on November 23, 1985. Borings were taken using a 1/2" x 16" auger bit and electric drill. Condition of wood shavings was determined by visual and tactile observation.

LEGEND

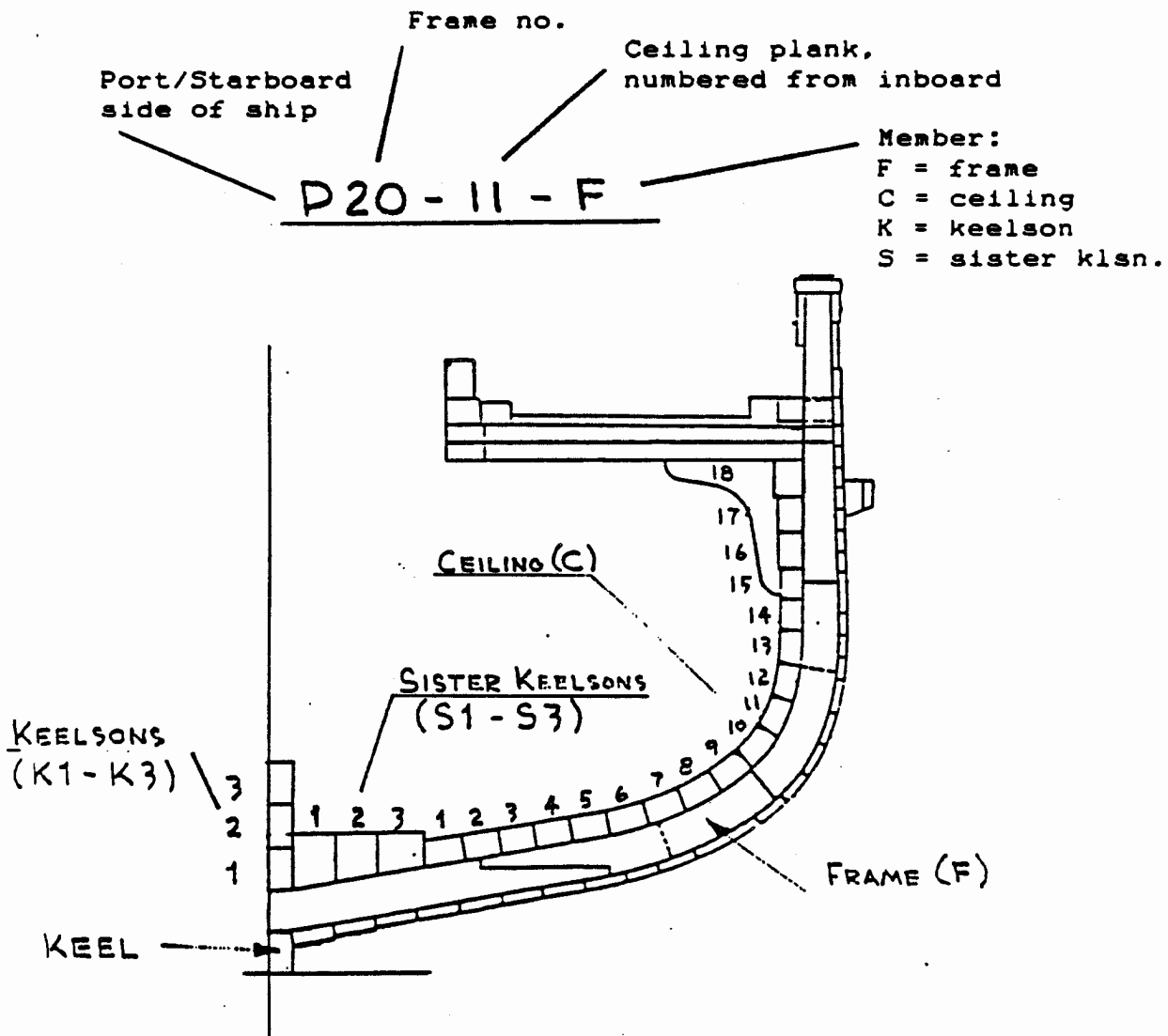



# Section 3 APPENDICES

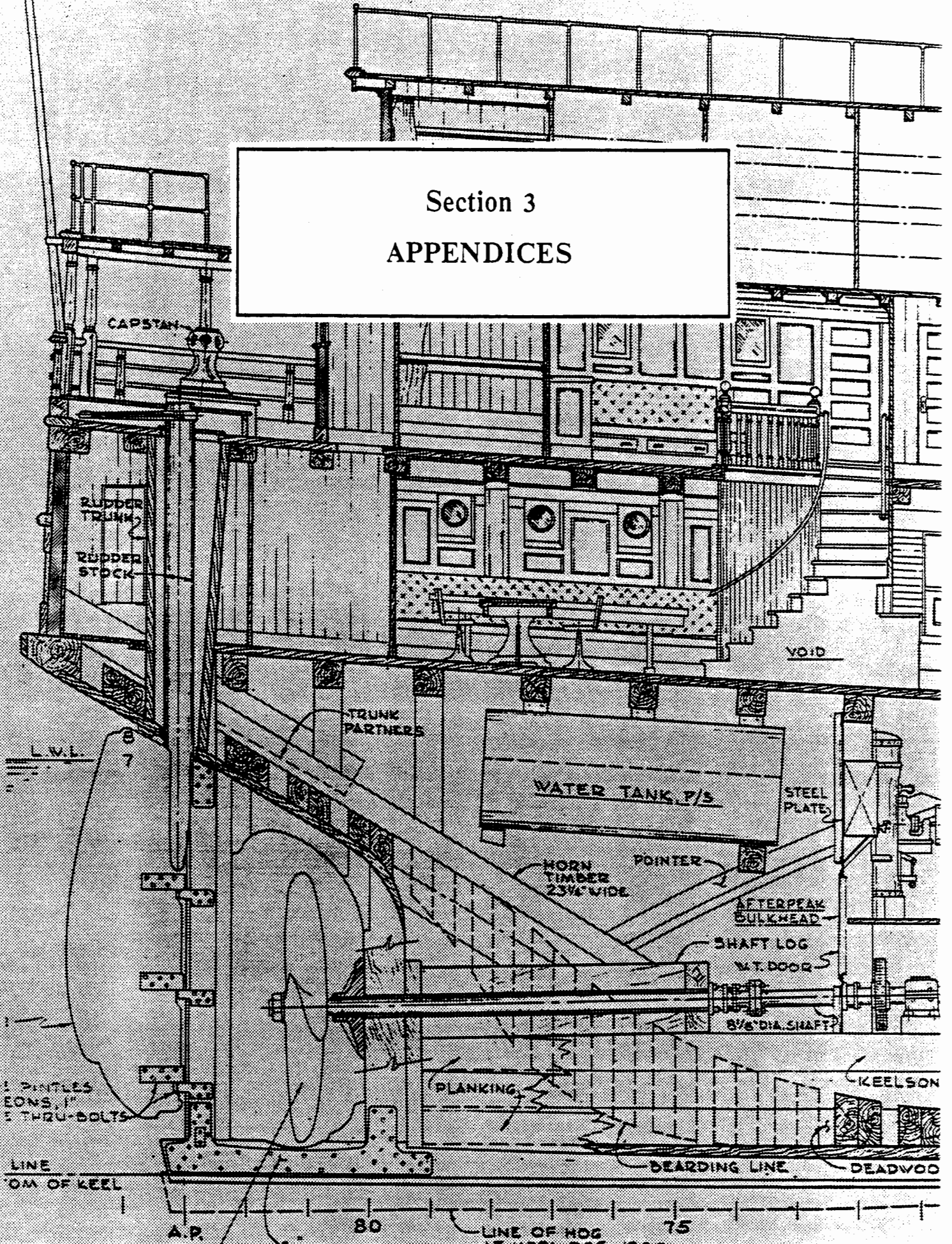



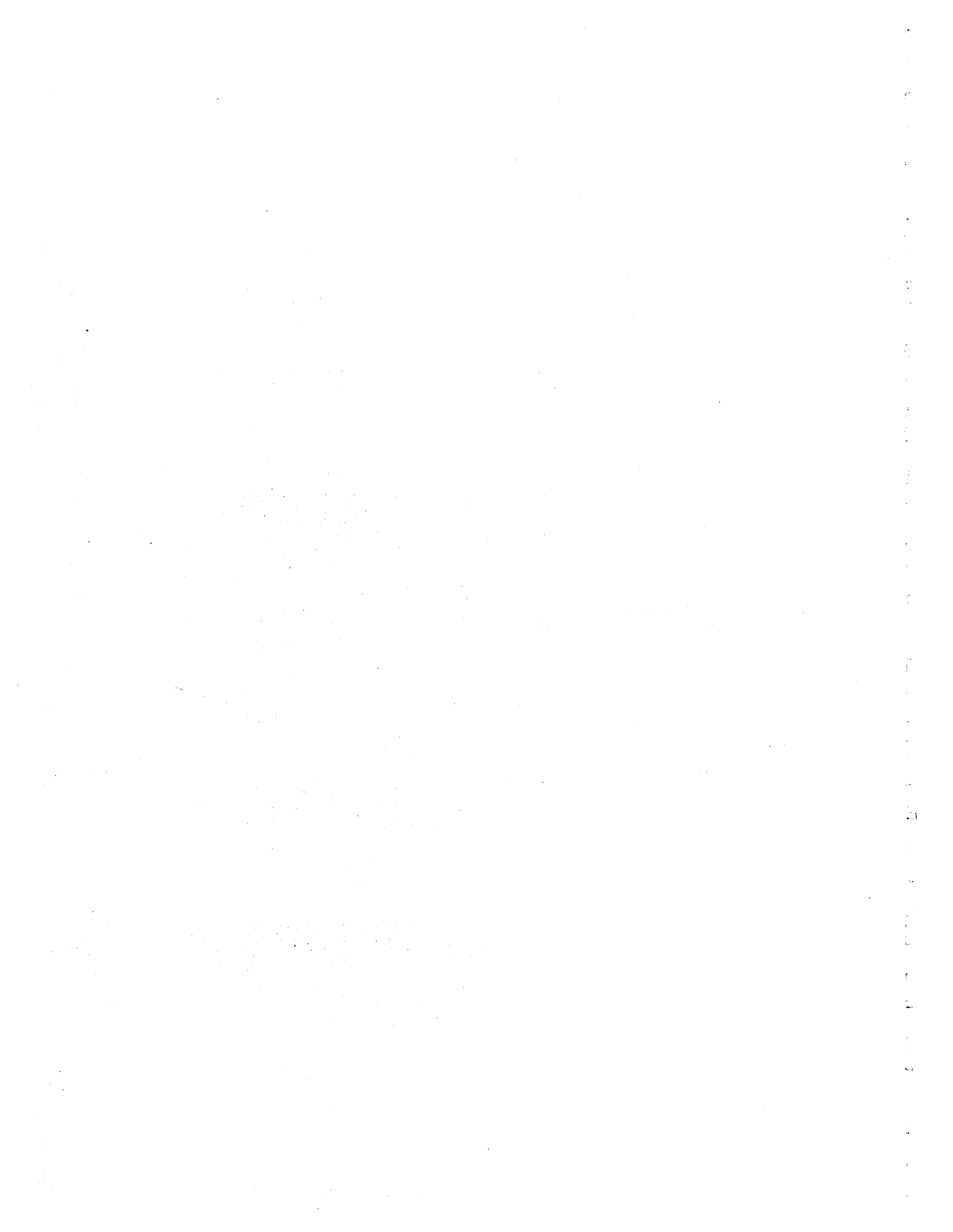

### **Section 3: Appendices**

#### **A. Record of Fabric Analysis**

##### **1. Wood Test Boring Results**

##### **2. Wood Moisture Reading**

#### **B. Stability Calculations**

#### **C. Replication vs. Restoration; Jack Ehrhorn**

