

646 / D-11663

historic structure report  
historical data section

november 1980

**GATEWAY**  
FORT TILDEN



NATIONAL RECREATION AREA / NEW YORK

ON MICROFILM

NATIONAL PARK SERVICE  
DENVER SERVICE CENTER  
BRANCH OF MICROGRAPHICS  
LIBRARY COPY

**Color Scans**  
4/19/2005

209p

209p

H30-DSC-TNE

December 22, 1980

Memorandum

To: Regional Director, North Atlantic Region

From: Assistant Manager, Mid-Atlantic/North Atlantic Team, DSC

Reference: Gateway, Pkg. No. 109, Park General, Historic Structures Report,  
Fort Tilden

Subject: Transmittal of Final Report

We are pleased to forward herewith five copies of the report, "Historic Structure Report, Historical Data Section, Gateway, Fort Tilden" by Historian Louis Torres.

(sgd) Gerald D. Patten  
Gerald D. Patten

Enclosures

cc.  
WASO-560-Mr. Holland, w/encs.  
Supt., Gateway, w/encs.  
Mgr., Harpers Ferry Center, w/encs.  
Mark Carroll-125-WASO-Room 4117

bcc:  
RMR-Library, w/enc.  
DSC-PG, w/enc.  
DSC-TNE-PIFS, w/enc.

TNE:ecs:12/22/80:5545



HISTORIC STRUCTURE REPORT  
HISTORICAL DATA SECTION  
OF  
FORT TILDEN  
GATEWAY NATIONAL RECREATION AREA  
NEW YORK

Prepared by  
Louis Torres

DENVER SERVICE CENTER  
MID-ATLANTIC/NORTH ATLANTIC TEAM  
BRANCH OF HISTORIC PRESERVATION  
NATIONAL PARK SERVICE  
UNITED STATES DEPARTMENT OF THE INTERIOR  
DENVER, COLORADO

KEY MAP OF STRUCTURES  
FORT TILDEN  
Conditions as of July 31, 1975

A T L A N T I C O C E A N

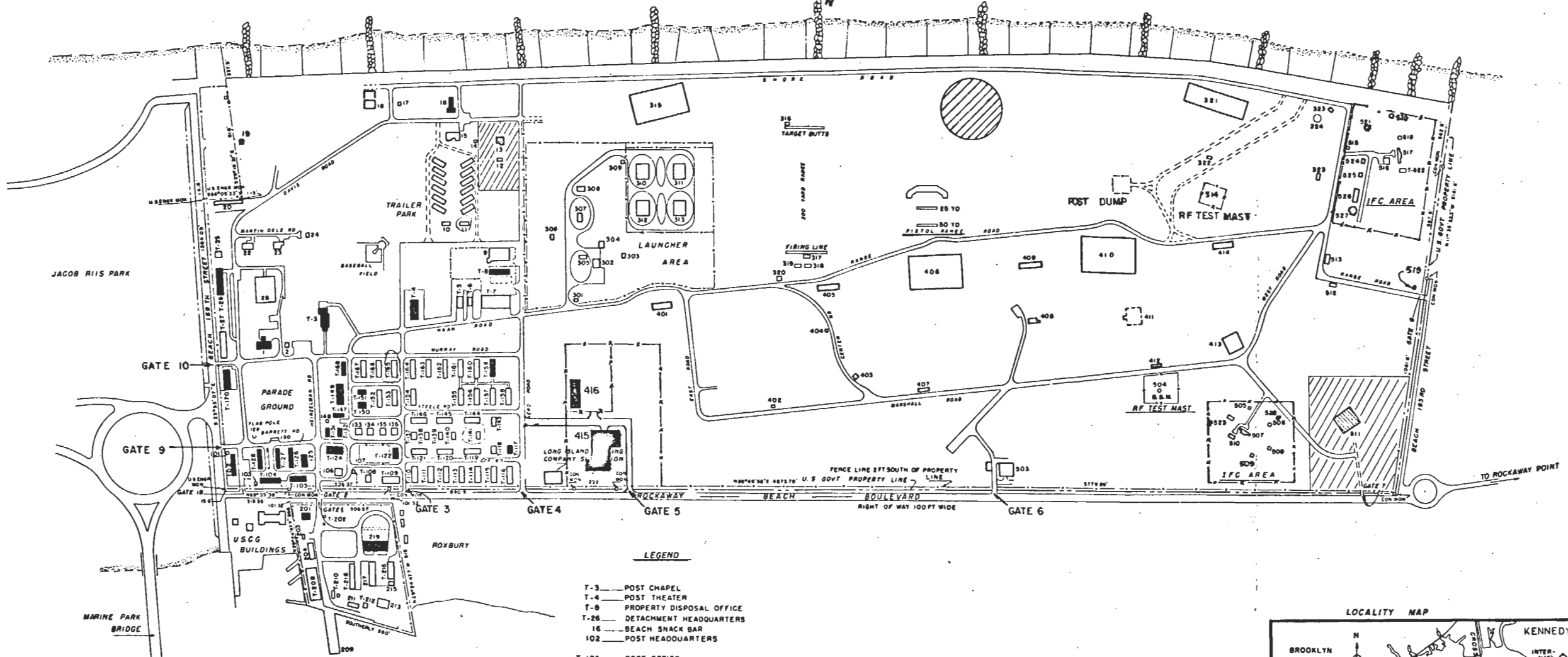

**LEGEND**

- T-3 — POST CHAPEL
- T-4 — POST THEATER
- T-8 — PROPERTY DISPOSAL OFFICE
- T-26 — DETACHMENT HEADQUARTERS
- 16 — BEACH SNACK BAR
- 102 — POST HEADQUARTERS
  
- T-105 — POST OFFICE
- T-122 — POST NURSERY
- T-124 — MCO CLUB
- 125 — POST DISPENSARY
  
- T-127 — CRAFT SHOP
- T-128 — PROVOST MARSHAL
  
- T-132 — MCO OFFICE
- T-147 — ENLISTED MEN'S CLUB
- T-149 — SERVICE CLUB
- T-159 — BATTERY HEADQUARTERS
- T-168 — POST LIBRARY
- T-170 — OFFICERS CLUB
- T-117 — RESERVE SUB CENTER
  
- 801 — QM & POST MOTOR TRANSPORTATION
- 219 — POST ENGINEER
- T-104 — POST EXCHANGE, TAILOR SHOP, & BARBER SHOP
- 415, 416 — U.S. ARMY RESERVE CENTER

▨ — LEASED TO U.S. NAVY

**SITE PLAN OF FORT TILDEN**

ROCKAWAY POINT, N.Y.  
OCTOBER 1964



PREPARED UNDER THE DIRECTION OF  
FIRST U.S. ARMY ENGINEER  
BY THE  
ENGINEER INTELLIGENCE BRANCH  
GOVERNORS ISLAND  
NEW YORK, N.Y.

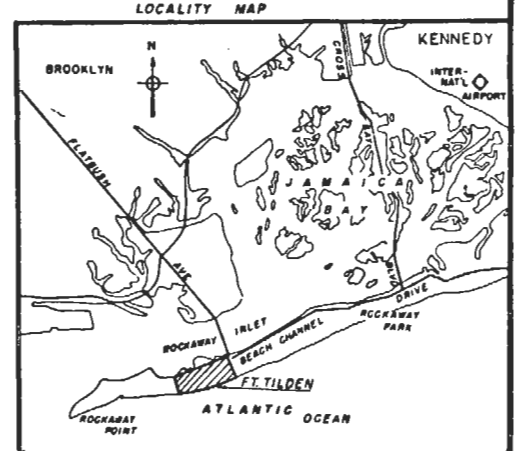

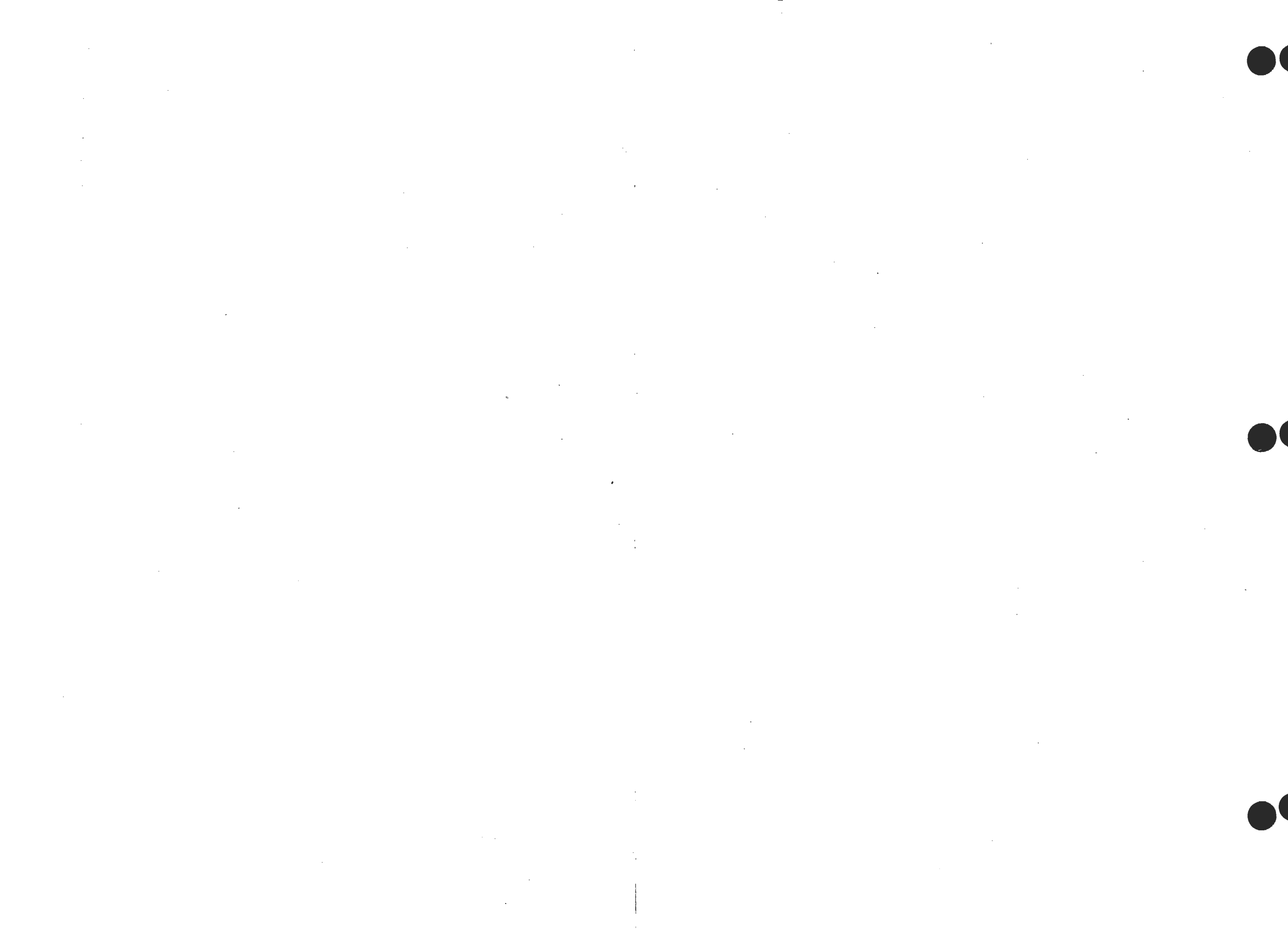



## PREFACE

The Historic Structure Report (Historical Data Section) of Fort Tilden, Gateway National Recreation Area, was completed under Account Numbers 0857-402 and 0860-402 in accordance with the provisions of the Task Directive of September 1978, as revised by Denver Service Center memorandum of February 28, 1979. The purpose of the study is to provide the basic historical data concerning certain specified structures at Fort Tilden scheduled for preservation.

Much of the source data for this study has come from the National Archives and Records Service and from the park. The park has recently acquired a large collection of drawings and plans from Fort Hamilton, an active U. S. Army installation in Brooklyn, New York. Unfortunately, as is frequently true in cases where several structures of a park are involved, there are always structures where the historical data are either too meager or unavailable. In this case, records, other than drawings, plans, and illustrations, dealing with the Nike-Hercules Missile operation at Fort Tilden were extremely scarce. If a Historic Resource Study of Fort Tilden is ever programmed, as this writer strongly recommends, it is possible that a more extensive search for source materials might turn out to be more successful.

The U.S. Army's present use of certain buildings, especially Buildings T-216, 219, 201, and 204, prevented the author from gaining complete access to them in order to provide a description of existing conditions. For these structures he had to rely essentially on available documents, which in most cases provided descriptions of an earlier period, and upon on-the-spot observations of the exterior.

This writer is grateful to a number of institutions and individuals who came to his aid in the quest for data. In addition to those people in the Old Army Branch of the National Archives, who must take most of the credit for this assistance, there are the librarians of the Queens Public Library (Queens, New York) and Brooklyn Public Library (Brooklyn, New York), who were instrumental in leading the writer to pertinent periodicals and newspaper articles dealing with Fort Tilden. He is also grateful to the Audio-Visual Agency of the Department of the Army for providing him with several excellent photographs of the Nike-Hercules site at Fort Tilden. A word of appreciation must also go to the historians in the Historical Division of the U.S. Army's Office of Chief Engineer in Washington, D.C. for the several leads which they gave the writer into records at the National Archives.

The writer is indebted to Messrs. Sam Holmes and Frank D. Escalet of Gateway National Recreation Area for the innumerable ways in which they came to his assistance. Finally, a word of thanks must go to Evelyn Steinman of the Denver Service Center who typed the manuscript.

Louis Torres  
July 1980

## TABLE OF CONTENTS

|   |      |
|---|------|
| PREFACE . . . . .   | v    |
| LIST OF ILLUSTRATIONS . . . . .   | xi   |
| STATEMENT OF SIGNIFICANCE . . . . .   | xiii |
| I. A HISTORY OF FORT TILDEN . . . . .   | 1    |
| The General Area . . . . .  | 1    |
| Brief Early History of the Site . . . . .                                     | 3    |
| The Rise of Fort Tilden . . . . .   | 5    |
| World War I and Initial Construction . . . . .                                | 8    |
| The Years Between . . . . .   | 15   |
| World War II . . . . .  | 23   |
| The Cold War Years . . . . .  | 25   |
| II. FORTIFICATIONS AND SUPPORTING ELEMENTS . . . . .                          | 29   |
| Battery Harris (Structures 406 and 410) . . . . .                             | 29   |
| Six Inch Gun Batteries (Structures 315 and 321) . . . . .                     | 40   |
| Magazines of Battery Harris and Other Ammunition Storage . . . . .            | 60   |
| A. Battery Harris Magazines (Buildings 401, 405, 409, 414) . . . . .          | 60   |
| B. Igloo Magazines (Buildings 403 and 404) . . . . .                          | 63   |
| C. Buildings 322 and 402 . . . . .  | 63   |
| Power Plants (Buildings 407, 408, 412) . . . . .                              | 68   |
| Fire Control and Plotting Room (Building 413) . . . . .                       | 70   |
| Mine Casemate and Plotting Room (Building 511) . . . . .                      | 75   |
| Groupment Command Post (Building 13) . . . . .                                | 75   |
| Nike-Hercules Structures . . . . .  | 79   |
| III. THE POST . . . . .   | 111  |
| Chapel (Building T-3) . . . . .   | 111  |
| Recreation Building (Building T-149) . . . . .                                | 112  |
| Barracks (Building 1) . . . . .   | 116  |
| Theater (Building T-4) . . . . .  | 123  |
| Two Officers Quarters (Buildings 22 and 23) . . . . .                         | 128  |
| Double NCO Quarters (Building 60A and 60B with Garage, Building 11) . . . . . | 132  |
| Parade Ground . . . . .   | 137  |
| Motor Repair Shop (Building T-216) . . . . .                                  | 140  |
| Ordnance Building (Building 219) . . . . .                                    | 143  |
| Engineer's Office (Building 201) . . . . .                                    | 145  |
| Engineer Storehouse (Building 204) . . . . .                                  | 146  |
| Wharf (Dock 209) . . . . .  | 147  |

|   |     |
|---|-----|
| IV. RECOMMENDATIONS . . . . .   | 149 |
| BIBLIOGRAPHY . . . . .  | 153 |
| APPENDIX . . . . .  | 157 |
| 1. Drawing, Fort Tilden Reservation, 1918 . . . . .   | 159 |
| 2. Drawing, Battery Harris Emplacement, 1924 . . . . .  | 160 |
| 3. Post Map of Fort Tilden, 1920 . . . . .  | 161 |
| 4. Drawing, Emplacements for Two 16-inch Guns, 1926 . . . . .                                   | 162 |
| 5. Drawing, Emplacements, Fire Control Aparatus, 1924 . . . . .                                 | 163 |
| 6. Drawing, Battery No. 220, Central Traverse Magazine<br>Location, Sheet No. 1, 1944 . . . . . | 164 |
| 7. Drawing, Battery No. 220, General Plans and Details, Sheet<br>No. 2, 1942 . . . . .          | 165 |
| 8. Drawing, Battery No. 220, Structural Details, Sheet No. 3,<br>1942 . . . . .                 | 166 |
| 9. Drawing, Battery No. 220, Gas-proofing Details, Sheet No. 19,<br>1942 . . . . .              | 167 |
| 10. Drawing, Battery No. 220, Plumbing and Electrical Systems,<br>Sheet No. 20, 1942 . . . . .  | 168 |
| 11. Drawing, Battery No. 220, Water and Power Systems, Sheet<br>No. 21, 1942 . . . . .          | 169 |
| 12. Drawing, Magazine for 16-inch Ammunition, 1924 . . . . .                                    | 170 |
| 13. Drawing, Power House for 90 K.W. Diesel Unit, Power Houses<br>Nos. 1 and 2, 1924 . . . . .  | 171 |
| 14. Drawing, Power House for 90 K.W. Diesel Unit, Power House<br>No. 3, 1924 . . . . .          | 172 |
| 15. Drawing, Protected Plotting Room and Switchboard Room,<br>Sheet 1, 1922 . . . . .           | 173 |
| 16. Drawing, Protected Plotting Room and Switchboard Room,<br>Sheet 2, 1922 . . . . .           | 174 |
| 17. Drawing, Protected Plotting Room and Switchboard Room,<br>Sheet 3, 1922 . . . . .           | 175 |

|     |   |     |
|-----|---|-----|
| 18. | Drawing, Service Command Project, Modifications to Heating and Ventilating System, Plan and Details, 1945 . . . . .     | 176 |
| 19. | Drawing, Service Command Project, Modifications to Heating and Ventilating System, Sections and Details, 1945 . . . . . | 177 |
| 20. | Drawing, Groupment Command Post, Grading Plan, 1943 . . . . .   | 178 |
| 21. | Drawing, Groupment Command Post, General Plan, 1943. . . . .  | 179 |
| 22. | Drawing, Groupment Command Post, Gas-proofing and Heating Detail, 1943 . . . . .  | 180 |
| 23. | Drawing, Groupment Command Post, Electrical and Plumbing Details, 1943 . . . . .  | 181 |
| 24. | Drawing, Regimental Chapel, Plans and Electrical Drawings, 1942 . . . . .   | 182 |
| 25. | Drawing, Regimental Chapel, 1941 . . . . .  | 183 |
| 26. | Drawing, Detachment Barracks, Heating Layout, 1938 . . . . .  | 184 |
| 27. | Drawing, Detachment Barracks, Plans and Typical Wall Section, 1938 . . . . .  | 185 |
| 28. | Drawing, Detachment Barracks, Footings and Foundations, 1928 . . . . .  | 186 |
| 29. | Drawing, Detachment Barracks, Plans of Door Locations, 1938 . . . . .   | 187 |
| 30. | Drawing, Detachment Barracks, Sections and Elevations, 1938 . . . . .   | 188 |
| 31. | Drawing, Proposed [Plan] For Conversion of Barracks [to Auxiliary Hospital] n.d., . . . . .                             | 189 |
| 32. | Drawing, Company Officers Quarters, Elevations, ca. 1938 . . . . .  | 190 |
| 33. | Drawing, Miscellaneous Repairs and Replacement, Officers Quarters, ca. 1939 . . . . .                                   | 191 |
| 34. | Drawing, [Ordinance Building], Second Floor Plan, 1937 . . . . .  | 192 |
| 35. | Drawing, Office at Rockaway Point, Cellar Floor Plan, ca. 1918 . . . . .  | 193 |
| 36. | Drawing, Office at Rockaway Point, First Floor Plan, ca. 1918 . . . . .   | 194 |

|     |  |     |
|-----|--|-----|
| 37. | Drawing, Store House, Sheet 1, 1923 . . . . .  | 195 |
| 38. | Drawing, Store House, Sheet 2, 1923 . . . . .  | 196 |
| 39. | Drawing, Repairs and Reinforcement of Wharf and Installation<br>of Derrick, 1944 . . . . . | 197 |
| 40. | Drawing, Fort Tilden Wharf, 1951 . . . . .   | 198 |

## LIST OF ILLUSTRATIONS

### ILLUSTRATION NO.

|  |              |     |
|--|--------------|-----|
| Key Map of Structures, Fort Tilden, 1975                                   | Frontispiece | ii  |
| 1. Sixteen-inch Gun, Fort Tilden 1935                                      |              | 36  |
| 2. Plan of Casemate No. 1, Battery Harris, 1944                            |              | 39  |
| 3. Northeast view of Casemate 1, Battery Harris, 1979                      |              | 41  |
| 4. Closeup view of Structure 410, Battery Harris, 1979                     |              | 42  |
| 5. Concrete overhang of Structure 410, Battery Harris, 1979                |              | 43  |
| 6. West entrance view into Structure 410, 1979                             |              | 44  |
| 7. South view of Structure 410, 1979                                       |              | 45  |
| 8. View of main corridor looking northwest, Structure 410, 1979            |              | 46  |
| 9. Path of train track inside Structure 410, 1979                          |              | 47  |
| 10. Name of battery inscribed over north entrance, Structure 410, 1979     |              | 48  |
| 11. Plan of Battery Construction 220, 1944                                 |              | 55  |
| 12. Plan of Battery Kessler, 1944  |              | 56  |
| 13. South entrance of Battery Kessler, 1979                                |              | 57  |
| 14. Passageway in Battery Kessler, 1979                                    |              | 57  |
| 15. Exhaust vent of Structure 321, Battery Kessler, 1979                   |              | 58  |
| 16. Roof of fire control station, Battery Construction 220, 1979           |              | 58  |
| 17. Electrical station behind Battery Construction 220, 1979               |              | 59  |
| 18. Front and side of fire control station, Battery Construction 210, 1979 |              | 59  |
| 19. Magazine, Building 405, Battery Harris, 1979                           |              | 64  |
| 20. Interior of Building 405, Battery Harris, 1979                         |              | 64  |
| 21. Transverse rails in Building 405, Battery Harris, 1979                 |              | 65  |
| 22. Igloo magazine, Building 403, 1979                                     |              | 66  |
| 23. Entrance to igloo magazine, Building 403, 1979                         |              | 66  |
| 24. Entrance to fire control and plotting room, Building 413, 1979         |              | 74  |
| 25. Section of mine casemate, Building 511, 1979                           |              | 76  |
| 26. Entrance to mine casemate, 1979  |              | 76  |
| 27. Section of Groupment Command Post, Building 13, 1979                   |              | 78  |
| 28. Entrance to Groupment Command Post, Building 13, 1979                  |              | 78  |
| 29. Missile in firing position, 1967                                       |              | 82  |
| 30. Aerial view of Nike-Hercules launch area, 1959                         |              | 84  |
| 31. A second aerial view of Nike-Hercules launch area, 1959                |              | 86  |
| 32. A third aerial view of Nike-Hercules launch area, 1959                 |              | 88  |
| 33. Close-up of a Nike-Hercules launch pad, 1959                           |              | 90  |
| 34. Radar operator checks MTR in radar tracking station, 1967              |              | 92  |
| 35. Section of target tracking radar, 1967                                 |              | 94  |
| 36. Section of missile tracking radar, 1967                                |              | 96  |
| 37. Radar operator's equipment in missile tracking radar, 1967             |              | 98  |
| 38. PPI Scope in directory station in integrated fire control unit, 1967.  |              | 100 |

|     |  |     |
|-----|--|-----|
| 39. | Radar dome in fire control center, 1966 . . . . .                                  | 102 |
| 40. | View of silo doors, 1979 . . . . .   | 105 |
| 41. | Another view of silo doors, 1979. . . . .  | 105 |
| 42. | Silo entrance hatch, 1979 . . . . .  | 106 |
| 43. | Stairwell leading to underground compartments Nike-Hercules<br>Site, 1979. . . . . | 106 |
| 44. | Radar tracking platforms, 1979 . . . . .   | 107 |
| 45. | Another view of radar tracking platforms, 1979 . . . . .                           | 107 |
| 46. | Radar station center, 1979 . . . . .   | 108 |
| 47. | Structure in radar tracking area, 1979 . . . . .                                   | 108 |
| 48. | Unit insignia on command center, 1979 . . . . .                                    | 109 |
| 49. | Chapel, 1979 . . . . .   | 113 |
| 50. | Chapel, looking towards sanctuary, 1979 . . . . .                                  | 113 |
| 51. | Interior view of chapel windows, 1979 . . . . .                                    | 114 |
| 52. | Interior rafters and chandeliers of chapel, 1979 . . . . .                         | 114 |
| 53. | Recreation building, looking west, ca. 1941 . . . . .                              | 117 |
| 54. | Recreation building, looking east, ca. 1941 . . . . .                              | 117 |
| 55. | Recreation building, looking west, 1979 . . . . .                                  | 118 |
| 56. | Stage in recreation building, 1979 . . . . .                                       | 118 |
| 57. | Dance floor in recreation building, 1979 . . . . .                                 | 119 |
| 58. | Interior of recreation building, 1979 . . . . .                                    | 119 |
| 59. | Interior view of windows of recreation building, 1979 . . . . .                    | 120 |
| 60. | Rear of barracks, Building 1, ca. 1939 . . . . .                                   | 121 |
| 61. | Front of Building 1, 1979 . . . . .  | 124 |
| 62. | Another front view of Building 1, 1979 . . . . .                                   | 124 |
| 63. | Theater, Building T-4, ca. 1941 . . . . .  | 127 |
| 64. | Commanding officer's quarters, 1979 . . . . .                                      | 129 |
| 65. | Front view of commanding officer's quarters, 1979 . . . . .                        | 131 |
| 66. | Rear view of commanding officer's quarters, 1979 . . . . .                         | 131 |
| 67. | Front view of officer's quarters, 1979 . . . . .                                   | 133 |
| 68. | Rear view of officer's quarters, 1979 . . . . .                                    | 133 |
| 69. | Double NCO quarters, Building 60A and B, ca. 1919 . . . . .                        | 135 |
| 70. | Double NCO quarters, viewed from southeast, 1979 . . . . .                         | 135 |
| 71. | Double NCO quarters, viewed from northeast, 1979 . . . . .                         | 136 |
| 72. | Double NCO quarters, viewed from northwest, 1979 . . . . .                         | 136 |
| 73. | NCO garage, Building 11, 1979 . . . . .  | 138 |
| 74. | Section of parade ground, looking northwest, 1979 . . . . .                        | 141 |
| 75. | Parade ground, looking north to flagpole, 1979 . . . . .                           | 141 |
| 76. | Base of flagpole, 1979 . . . . .   | 142 |
| 77. | Ordnance Building, later a headquarters, Building 219,<br>1939 . . . . .           | 144 |
| 78. | Wharf, showing railroad tracks, 1938 . . . . .                                     | 148 |
| 79. | Wharf, showing piles, 1938 . . . . .   | 148 |



## STATEMENT OF SIGNIFICANCE

Fort Tilden, which was established as a permanent post in the coastal defenses of southern New York in 1917, served, along with Fort Hancock on Sandy Hook, New Jersey, and Fort Wadsworth on Staten Island, New York, as part of the outer network of defenses in the New York City area and its harbor from World War I through the Cold War era. During the years of its active service Fort Tilden reflected the several changes taking place in tactics and technology of modern warfare especially in harbor defenses. The armament that was once installed at Fort Tilden has ranged from the massive sixteen-inch guns of Battery Harris, emplaced in the early 1920s and remodeled in World War II, to guns of a lesser caliber including mines, and finally to the Nike-Hercules missiles, with and without atomic warheads, installed in underground silos in the late 1950s. In spite of all this defensive preparation, the fort was never called upon in any active engagement against an enemy.



## CHAPTER I: A HISTORY OF FORT TILDEN

### The General Area

The area encompassing Fort Tilden is situated on a strip of land referred to as Rockaway Peninsula, part of the county and borough of Queens in New York City. The Atlantic Ocean borders the fort on the south. While only a small tongue of land on the northeast corner of the fort borders on Jamaica Bay, most of the northern portion of the fort is bounded by Rockaway Beach Boulevard. On the east side of the fort is Jacob Riis Park, formerly a city beach and now part of Gateway National Recreation Area. On the west side is Breezy Point, an area consisting largely of privately owned beach houses and private clubs.

At the time that the fort was established in 1917 the area consisted largely of tidal marsh. Only along the Atlantic Ocean was there a relatively stable strip of sand that continued across to the inlet at the eastern end of the reservation. The beaches were first formed by wave action, leaving a swampy lagoon in between that was subsequently filled in by Army engineers utilizing discharge pipe lines from dredges digging a channel through Jamaica Bay. A large part of the lagoon was below the mean water level, being at all times covered to depths of two or three feet of water. No vegetation other than some marsh grass grew there. There was no more than a few inches of silt or decayed vegetation covering the underlying sand.

The average elevation of the ground surface was about eleven feet, varying locally according to the dunes or depressions that were formed by the action of the wind on the very loose sand of which the reservation was composed. In reporting on foundation tests

that were made in preparation for the emplacement of sixteen-inch gun batteries, one Army engineer had this to say about the land:

In general . . . from the above tests it would appear that the Fort Tilden reservation, in the vicinity of the gun locations at least, is underlaid, first of all by about seven feet more or less of very fine, loose, white sand, interspersed here and there with shell deposits from the dredge pipes; then three or four inches of decayed vegetation, and from there (+3.5 ft.) to -40.00 feet with firm, clean, fine, white sand. The ground water level is at +4.00 feet. The thick bed of sand underlying the decayed vegetation is only broken by some few scattered shells, although from the wood and charcoal traces at -10.00 feet there is the possibility that there may be an old beach at that level. The fine white sand is followed by a sharper, coarser, reddish sand to a depth of -52 feet at least.<sup>1</sup>

The unstable condition of the sand was to become a source of extreme frustration to Army officials particularly as it affected the operation of the guns and the life of the soldier. The resolution of this problem during the early years was to be a costly one. An early report made by the Army Quartermaster described the problem of the soil at Fort Tilden in the following language:

Before the Government took possession of this tract of land it was never more than a sandy waste and of no

---

1. Corps of Engineers to District Engineer, N.Y., subject: Report on Foundation Tests for 16 inch Guns at Fort Tilden, N.Y., March 18, 1921, RG 77, Federal Record Center, Bayonne, N.J. (hereafter records deposited at this center will be referred to by their record group number followed by FRC, Bayonne, N.J.)

commercial value. The soil consists of very white beach sand and whenever a storm arises which is quite frequently, due to the location with reference to the ocean, this sand is blown around to a great extent, making it difficult for men to work without serious interference.

The general cantour [sic] of the land is level, the highest points being approximately fifteen feet above sea level.

Due to frequent wind storms, the shifting of this sand has caused much damage to buildings and roadways and in many instances has undermined concrete foundations of the buildings and caused serious settlement. Surface water is found at a depth of five-feet below grade.<sup>2</sup>

#### Brief Early History of the Site

Fort Tilden was not the first fortification on Rockaway Peninsula. The first evidence of any fortification was the erection of a blockhouse during the War of 1812. The following extract from the Army's Engineer Land Papers describes the circumstances surrounding this situation:

The entrance to Jamaica Bay, on the south side of Long Island, affording to the enemy a safe landing for boats of

---

2. Completion Report, Fort Tilden, Coast Defenses of New York, Part II, ca. 1919, RG 407, National Archives and Records Center (hereafter all records deposited with the National Archives will bear the record group number followed by NA).

small burthen to within a few miles of the Navy Yard, it was judged prudent to fortify that passage, as well as to guard that landing, as to afford protection to our coasters, who frequently take shelter in that bay from the enemy's cruisers. This according with your Excellency's sentiments, we caused a strong blockhouse, mounting a 24-pounder in the top, to be erected on the west end of Rockaway Beach, at the entrance of that bay. This has been taken charge of by the United States and an adequate force is stationed thereat....<sup>3</sup>

The United States acquired the land for the blockhouse from Nathaniel Ryder on or near the present site in 1812 and it was surveyed by Morris Fosdick the same year. Title to the land remained with the United States for when the Treasury Department requested transfer of the land for a Life Saving Station, to be moved from Barren Island to Rockaway Point, the Secretary of War, Jefferson Davis, granted the request, noting that

Certain points along the shore of Long Island, including Rockaway Beach, will need to be occupied in time of war by blockhouses or other temporary defenses. This can be done as well with the land in possession of the Treasury Department as if we held it....<sup>4</sup>

---

3. Report of the Commissioners of Fortifications to Governor Tompkins, September 23, 1814, as contained in "Notes Concerning Government Land," Land Papers, Rockaway Beach, 1903, RG 77, NA.

4. Land Papers, January 9, 1856, RG 77, NA, cited in Tony P. Wrenn, "General History of the Jamaica Bay, Breezy Point and Staten Island Units, Gateway National Recreation Area, New York, N.Y." October 1975, p. 64, a National Park Service study.

This is the only known evidence of any type of fortification built on or near the existing site of Fort Tilden before 1917.

### The Rise Of Fort Tilden

World War I had been in progress three years. It was evident to many that the war would not escape America. Anticipating American entry into the war national defense efforts were spurred on at a quickening pace. As part of the establishment of a number of coastal fortifications containing the latest equipment in modern weaponry, the result of findings of the Endicott Board of the 1880s and recommendations of the Taft Board of 1904, Fort Tilden was organized and established effective February 19, 1917.<sup>5</sup>

It was not until August 1, 1917 that the reservation was officially designated Fort Tilden in honor of a former governor of New York State, Samuel J. Tilden.<sup>6</sup> The new post was placed directly under the jurisdiction of the commander of the Coast Defenses of Southern New York.

The choice of the site on Rockaway Point climaxed a six-month survey conducted by Army engineers. Their main concern was to find a site containing a soil that would support the strain of heavy gun firing. The topography of the chosen site was not by any

---

5. Commanding Officer, Ft. Tilden, to Adjutant General, Army, subject: Designation of Organization Day, November 30, 1920, RG 77, NA.

6. General Order, War Department, August 1, 1917, cited in Major V.T. Terrible, "Rockaway's Neighbor: Fort Tilden," Rockaway Review, December 1949, pp. 21, 57.

means ideal for the purpose, as the land was low-lying and consisted almost entirely of sand, offering no foundation for a depth of ten feet. To correct this deficiency, however, it was essential to provide an artificial bedrock, and the Army contracted with the firm of William D. Reilly of Cederhurst, Long Island, to do the work.<sup>7</sup>

The land upon which the fort was established consisted partly of land owned by the United States, partly of land owned by the City of New York and leased to private corporations, partly of land owned by private corporations, and partly of accretions built into the original land by the construction over the years of bulkheads, jetties, and other beach protective measures.

The facts surrounding the land transferred from the City of New York to the Army are not entirely clear. From what is known in reports, the city had difficulty proving title to the land -- an amount said to be approximately 120 acres. The question of title was said to hinge on certain conflicting claims made by the Long Island Railroad and the City of New York. The problem eventually was solved, for according to one writer the land was finally purchased on May 1, 1917 for the sum of \$705,000.<sup>8</sup>

The land that was purchased from the Rockaway Park Corporation had been leased to the Rockaway Park Association. Although the

---

7. The New York Times, February 9, 1917.

8. "Start Defences of City," unidentified newspaper article, n.d., copy in RG 77, FRC, Bayonne, N.J.; New York American, February 9, 1917; The New York Times, February 9, 1917; Edwin A. Osborne, "Rockaway--One of the Major Protection Points of New York Harbor," Rockaway Review, June 1941.



lease had still several years to run, a clause in the lease permitted cancellation of the contract at any time.<sup>9</sup>

There are conflicting reports concerning the total number of acres purchased by the United States at that time. One official report prepared in 1919 noted that "the Reservation proper" consisted of approximately 175 acres.<sup>10</sup>

Since part of Fort Tilden was being used by the United States Coast Guard for a Life Saving Station, this report may have been referring to the land actually used by the Army at the time. A letter written in 1922 by the Secretary of the Navy noted more accurately that Fort Tilden comprised 303.5 acres.<sup>11</sup> This amount increased somewhat over the years with the construction of water barriers of one kind or another. A detailed description of the reservation in 1938 reveals that the fort consisted of 309.9 acres plus an easement of 1.63 acres of filled land. Thus, together this gave the reservation 311.53 acres.<sup>12</sup> This agrees with an earlier document which stated that Fort Tilden was about 311 acres. This document, which was written in 1937, noted that the land's value, with its improvements, was estimated at \$4,400,000.<sup>13</sup>

---

9. The Sun, New York City, February 9, 1917.

10. Completion Report, Fort Tilden, Coast Defenses of New York, Part II, p. 67, RG 407, NA.

11. Secretary of the Navy to Secretary of War August 11, 1922, RG 407, NA.

12. "Fort Tilden, New York--Metes and Bounds, Description of Boundary," March 1, 1938, RG 407, NA.

13. 4th Indorsement, Magruder to Commanding General, Second Corps Area, January 25, 1937, RG 77, NA.

## World War I and Initial Construction

The original plans for arming the new fort revealed an elaborate system of guns. A War Department drawing of 1918 noted that as many as four sixteen-inch (four emplacements) guns, eight six-inch guns (four emplacements), and three mortar pits, consisting of twelve-inch mortars, in addition to a fourth mortar pit located outside the installation on what is now Jacob Riis Park, were to be mounted at Fort Tilden.<sup>14</sup>

One newspaper reported that the sixteen-inch guns were to be of the "disappearing" type, the latest in coast artillery defenses. "In range and power they can easily cope with the largest guns on any superdreadnoughts that are afloat," said this newspaper.<sup>15</sup> Another newspaper stated that these big guns had a range of 21 miles.<sup>16</sup>

A garrison consisting of four officers and 130 enlisted men was quickly established at the new installation on February 19, 1917. These soldiers immediately went to work constructing barracks, mess halls, and other living quarters and servicing facilities. These facilities were needed immediately even before contracts could be

---

14. Drawing, 1918, Fort Tilden Reservation, RG77, Cartographic Branch, Fortifications Files, NA (Appendix I). A document in the National Archives conflicts with this when it states that a "Board of Review project contemplated the installation at Fort Tilden, N.Y. of eight 16" mortars, four 16" guns, and four 6" guns." However, it added that "All Board of Review projects have been suspended for the present." Record Card, Memorandum for the Secretary of War by Major General F. W. Coe, July 11, 1918, RG 77, NA.

15. The Sun, New York City, February 9, 1917.

16. New York American, February 9, 1917.

issued for construction at Fort Tilden. As a result, they were very often of the makeshift type and of a very poor quality. When the Army Quartermaster arrived in November 1917 he found that post labor had already constructed seven officers' quarters, two enlisted mens' barracks, seven non-commissioned officers' quarters, one headquarters building, one hospital, one commissary, two mess halls, one lavatory, one stable and wagonshed, and a number of roadways. A dock had also been constructed by the Army Corps of Engineers that jutted into Rockaway Inlet, with railroad tracks, affording excellent docking facilities.<sup>17</sup>

The land acquired for the new installation was joined on the east by a narrow stretch of land that extended from the Atlantic Ocean to Jamaica Bay which was owned and operated by the United States Coast Guard as a Life Saving Station. In February 1917, the Coast Guard granted the Army permission to erect some temporary buildings on the land it operated. The reason for this unusual practice was to give the Army greater flexibility in the use of permanent utilities already built such as roads, water, sewer, and lighting facilities. There was also another advantage by doing this in that the housing facilities would not be in the direct line of the shifting sands.<sup>18</sup> Thus, although the structures on the Coast Guard land were built by the Army and were the property of the Army, the land and its utilities were operated and controlled by the Coast Guard, a situation that did not always contribute to good operation and maintenance.

---

17. Major V. T. Terrible, "Rockaway's Neighbor: Fort Tilden," Rockaway Review, December 1949; Completion Report, Coast Defenses of New York, Part II, RG 407, NA.

18. Secretary of War to Secretary of the Treasury, May 22, 1928, Box 85, RG 77, NA.

After the garrison had undertaken to build its makeshift facilities, in November 1917, a contract was awarded to James Steward and Company of New York City to construct new buildings as well as to improve what the garrison had already built. The delivery of supplies was of vital importance, but the contractor was handicapped to a great extent by poor roads, long distances, and severe winter weather. The nearest freight station was three miles away and it had a siding capacity to handle only five freight cars at one time. Moreover, the freight station was also shared by the United States Navy and commercial establishments, a situation that tended to slow down the unloading process.<sup>19</sup>

The contractor immediately set about to construct concrete roads and walks connecting all buildings. As the land consisted largely of sand, it was necessary to construct the roads with eight-inch concrete slabs laid directly on the sand. In all, 1,250 feet of 14 feet-wide roads; 1,575 feet of 10 feet-wide roads; and 215 feet of 30 feet-wide roads were constructed.<sup>20</sup>

The first living quarters authorized to be constructed consisted of two 66 man barracks, one officers' quarters, one mess hall, and one lavatory. From time to time authorizations were granted for the construction of other units such as additional officers' quarters, guardhouse, ordnance building, post exchange, a carpenter-paint-plumbing shop, oil house, fire house, stable, forage barn, incinerator, coal pockets, storehouses, hospital annex, and one permanent NCO (non-commissioned officers) quarters.<sup>21</sup>

---

19. Completion Report, Coast Defenses of New York, Part II, RG 407 NA.

20. Ibid.

21. Ibid.

As the layout of the permanent post had already been determined, all temporary buildings were located so as not to encroach upon the permanent area. One of the earliest permanent structure--the NCO quarters (presently Building No. 60A and 60B)--was erected on the site laid aside for the permanent post. This structure was made of fireproof construction consisting of concrete and terra-cotta blocks.<sup>22</sup>

All the buildings originally built by the garrison had been sheathed on the outside with paper and batten, but this construction afforded practically no protection from the severe weather. These buildings were then covered with novelty siding by the contractor. The wood-type ventilators installed by the garrison were also found to be unsatisfactory, and metal ones were installed in their place. Several other facilities originally built by the garrison were also altered and made weatherproof.<sup>23</sup>

For the storage of mortar ammunition, a storage shed, connected to the battery by platforms, was built. Additional storage space to safeguard various supplies was also provided with the construction of two large, 20 by 196 feet, warehouses. All emergency buildings were painted a dull gray, improving their appearance greatly.<sup>24</sup>

Under the direction of the Army Corps of Engineers, a small standard gauge railroad was constructed, connecting the dock on Jamaica Bay, coal pockets and large warehouses with the western end of the reservation. The railroad could then distribute the supplies that were left on the dock after the boats were unloaded.

---

22. Ibid.

23. Ibid.

24. Ibid.

In order to supply water to the post a three-inch water main was run from the village of Roxbury. This water was found to be very poor and at times unfit for drinking purposes. Because of the shifting sands, this line was often exposed overnight with the result that the water became frozen. This proved to be a serious problem which caused delays in construction. The pipe was later abandoned and an entirely new system was employed that connected the water main to the water conduits of the Queens County Water Company at Rockaway Beach. This new connection was made by an eight-inch main having a pressure of 45 pounds which was gradually reduced in size, providing the necessary requirements for all the newly erected buildings. Water mains were also run parallel to the south shore for the new bulkheads, dock, and gun emplacements that were being erected. Connections were made from this water main to take care of the future water needs of the permanent post. Approximately 9,850 feet of water main were constructed.<sup>25</sup>

A six-inch sewer pipe was also laid that discharged into Jamaica Bay. This was accomplished by the Post Quartermaster. New sewer lines, up to 1600 feet, were run to all the newly erected buildings and connected to the old sewerage system.<sup>26</sup>

All the temporary buildings were at first illuminated by means of kerosene lamps, because the electric lines of the nearest lighting company ended some two miles away from the post. Due to the great fire hazard and unsatisfactory lighting conditions that kerosene lamps presented, a small power plant was authorized for

---

25. Ibid.

26. Ibid.

the post. However, this was soon found to be too costly, and this also was abandoned. In its place a plan to extend lines from the Queens Borough Gas and Electric Company to the post was considered. Since the cost of an underground system appeared excessive, permission was obtained from New York City to run overhead wires to the post. All the buildings on the post were connected and essential fixtures were installed. Approximately 3,400 feet of electric lines were installed in this operation.<sup>27</sup>

Other utilities were also constructed. A galvanized iron fence was constructed around the entire reservation with gates at various locations. The fence was necessary to keep intruders off the reservation and to protect government property. The fence posts were not encased in concrete bases, however. Eleven hundred feet of fencing and twelve single and nine double type gates were erected. An incinerator with a capacity to handle three tons of disposable waste every twenty four hours was also constructed about 1,000 feet from the northwest corner of the permanent area.<sup>28</sup>

At the northeastern end of the post, adjoining Rockaway Inlet, six large modern coal pockets with a capacity of 3,000 tons were built in such a way that they could be filled by hoists directly from the boats. The coal stored in these pockets was ejected into railroad cars from the bottom of the pockets by means of a pair of iron gates and distributed throughout the post. The foundation of these pockets consisted of piles that had been sunk by a jet driver.<sup>29</sup> It should be noted, however, that these coal pockets

---

27. Ibid.

28. Ibid.

29. Ibid.

were never really completed, and remained unused until they were finally razed in later years.

The Young Mens Christian Association (Y.M.C.A.) and Knights of Columbus erected buildings on the post for the benefit of the enlisted men. The general construction of these buildings followed the lines of the cantonement buildings.

The entire construction undertaken by the Quartermaster Corps in November 1917 was finally completed in February 1919. By then the war was over.

Work on the fortifications at Fort Tilden began on February 8, 1917, only eight days after Congress had voted to appropriate \$51,000,000 for coastal defenses throughout the United States. Of this sum, about \$2,000,000 was to be expended for Fort Tilden.<sup>30</sup> On that day eleven carloads of cut blue stone arrived at the nearest railway station, and about 40 horse-drawn and motor trucks, with 150 workmen, carted the stone to the fort. Their job was to build foundations and platforms that would hold gun emplacements for the heavy guns. During these early months four six-inch guns, which came from West Point, were emplaced, consisting of two batteries. Two of these guns were later dismantled and sent to France for experimental purposes.<sup>31</sup> In the meantime, platforms for twelve-inch mortars were also constructed on the adjoining city park land, now known as Jacob Riis Park.<sup>32</sup>

---

30. The Sun, New York City, February 9, 1917.

31. Record Card, Memorandum for the Secretary of War, from Major General F. W. Coe, July 11, 1918. RG 77, NA.

32. Drawing, "1918, Fort Tilden Reservation," Cartographic Branch, Fortification File, RG 77, NA; The Sun, New York City, (Continued)



## The Years Between

With the war ended, what started out as an emergency effort at Fort Tilden now slowed down to a snail's pace. Following the end of the war, the fort's garrison was gradually reduced to a small complement of caretakers. The reservation remained in a caretaker status for most of the following two decades. Throughout these years there seemed to be an ambivalence and uncertainty concerning the mission, treatment, and operation of the fort. The record's familiar to this writer have led him to conclude that the Army vacillated between making Fort Tilden a permanent installation and abandoning it after it had served some temporary purpose. Although two sixteen-inch guns were finally emplaced at Fort Tilden by 1924, permanent quarters and servicing facilities were never made available to adequately service these guns. The dilapidated condition of the temporary buildings went almost entirely unheeded. Few attempts were made to replace temporary facilities with permanent ones despite frequent pleas from the commander of the post, other Army officials in the upper echelons of command, and congressmen for more adequate and permanent facilities.

Yet, in spite of this seemingly lack of interest in Fort Tilden, when New York City requested in 1922 that the Army turn over to it 94 acres of land for purposes of enlarging the adjoining city park, the War Department flatly refused, stating that Fort Tilden was "an active post not having been abandoned."<sup>33</sup>

---

32. February 9, 1917; The New York Times, February 9, 1917; Edwin A. Osborne, "Rockaway--One of the Major Protection Points of the New York Harbor," Rockaway Review, June 1941, p. 39; V. T. Terrible, "Rockaway's Neighbor: Fort Tilden," Rockaway Review, December 1949.

33. Secretary of War to Secretary of the Navy, September 23, 1922, RG 407, NA.

The War Department, meanwhile, continued to give the impression that it indeed had permanent designs for Fort Tilden. In 1920 it strengthened the bulkheads and jetties at a cost of \$5,644. Railroad tracks were installed to carry ammunition and supplies to the mortar battery, and apparently it was at this time that armament was transferred from New York City to the fort. The East Battery (six-inch guns) received high beam lights, and two power houses were modified with the conversion to gas motors.<sup>34</sup>

In 1920 Fort Tilden had two six-inch gun batteries, unofficially referred to as East Battery and West Battery until more permanent facilities were constructed. Each battery had two guns of the 1900 model on barbette carriages, also of the 1900 model. Both batteries were built in the open, unprotected by drifting sand. Each battery had a magazine, a temporary structure containing a corrugated iron roof. The fire control installation for these batteries consisted of two coincidence range finders (CRF), one nine feet long and the other twenty-two feet long. A spotting board was also provided for each battery.<sup>35</sup>

In 1920 the mortar battery which had been emplaced in the city park in 1917 was removed, and in its place Fort Tilden received four twelve-inch mortars on railroad mounts. Although railroad tracks for this purpose were still being laid by the end of 1920,<sup>36</sup> there does not appear any evidence that the mortars were finally installed.

---

34. Analysis of Expenditures, Calendar year ending December 31, 1920, Fortification and other Military Works, Coast Defenses of Eastern New York, RG 77, NA.

35. District Commander to Adjutant General, subject: Technical Inspection, Fort Tilden, New York, May 12, 1920, RG 407, NA.

36. Ibid.

Two three-inch anti-aircraft guns were also mounted at Fort Tilden in 1919. These guns were mounted on 1917 model carriages. In 1938 a third three-inch gun was also mounted at Fort Tilden, forming what was known as Anti-aircraft Battery No. 5. This battery lasted throughout World War II and it was located somewhere in the northeast corner of the tactical area. The guns were continuously disturbed by the shifting sands particularly during winter months when the sand froze interfering with the operation of the guns.<sup>37</sup>

In December 1920 an allotment of \$70,000 was approved to cover the current fiscal year's expenses for building emplacements for two sixteen-inch guns.<sup>38</sup> It was apparent by now that instead of the proposed four sixteen-inch guns there would now be only two. In 1922 designs for the two emplacements were approved, and two years later the emplacements were completed. These were known as Gun Emplacement Nos. 1 and 2. Together they formed part of Battery Harris, named in honor of Colonel Henry L. Harris who died March 8, 1920.<sup>39</sup> The concrete emplacements built at this time were far different from those that were eventually built during World War II, the remains of which exist today. At Fort Tilden the

---

37. Ibid. Emplacement Book, Anti-aircraft Battery No. 5, Fort Tilden, New York, Entry 225, RG 392, NA. The period of the 1920s witnessed an increased emphasis on the use of anti-aircraft weaponry in the U.S. Army Coast Artillery. Many fixed anti-aircraft weapons were emplaced, usually in three-gun batteries, in order to protect the more permanent and larger seacoast guns. Most of the guns were three-inch models but some were of a later 105 millimeter type. See Emanuel Raymond Lewis, Seacoast Fortifications of the United States (Washington: Smithsonian Institution Press, 1970), p. 102.

38. Weaver to New York District Engineer, subject: Report on Foundations Tests for 16 Inch Guns at Fort Tilden, New York, March 18, 1921, RG 77, FRC, Bayonne, New Jersey.

39. War Department General Order 13, March 1922, RG 77, NA.

two guns were located about 850 feet apart and the emplacement itself consisted of a large circular concrete platform with deep wells in the center where part of the gun carriage rested.<sup>40</sup>

Railroad tracks were also laid during this period connecting the wharf on Jamaica Bay to the two big guns and their separate magazines and power plants that were also built about this time to service the two guns. The trains carried large ammunition and related supplies to all those dispersed areas forming Battery Harris.<sup>41</sup>

Even after the two gun emplacements at Battery Harris were completed in 1924 additional work on the battery continued in later years. Telephone and fire control instruments were installed in plotting and switchboard rooms, in magazines, and in other related facilities. In addition, four lights mounted on pipe frames, which in turn were mounted on concrete bases, were erected on the two platforms (two to each gun).<sup>42</sup>

One of the biggest problems encountered at Fort Tilden during the 1920s and 1930s was the deteriorated condition of many of the temporary structures that were built during the emergency. Either because of lack of appropriations or because of the uncertain status and future of the fort little was done to improve the situation. As a result, the fort was subjected to serious criticism on several

---

40. Drawing No. 646/63003, Fort Tilden, New York (Battery Harris) Emplacement for Two 16 Inch guns and Rail Road Trackage for Same, November 19, 1924, in park files (Appendix 2).

41. Ibid.

42. Summary of Appropriations -- Work in Progress, September 1924; ibid., October 1925; ibid., January 1926, all in RG 77, NA.

occasions. In 1927 the Acting Secretary of War, Hanford MacNider, ordered an investigation into the condition of the fort, the result of a strong complaint made by Congressman J. J. Kindread on behalf of residents of the Rockaways. According to Congressman Kindread, the buildings at Fort Tilden were not fit for human habitation.<sup>43</sup> Among those structures cited as in poor state were a number of structures which had never been utilized for the purpose they had been intended. The large frame coal pocket (28 feet by 234 feet), for example, had cost the Army \$40,000 to build, but it was never used. The Quartermaster Corps believed that in its existing condition it constituted a menace to adjacent property.<sup>44</sup> Other structures built during the 1920s that were never used as had been intended were the large balloon hangar and its generator house. They had been built originally with the idea of serving the Army's air arm, but this never materialized. As a result, the hangar was sometimes used for general storage, but it soon became evident that this was not practical. Like the coal pockets, without adequate maintenance, this structure soon deteriorated.<sup>45</sup>

What contributed so severely to the deterioration of facilities and particularly to the fortifications and their related equipment was the condition of the soil and sand at Fort Tilden. This problem had been the subject of several investigations ever since the fort had

---

43. The New York Times, November 10, 1927.

44. Office of Quartermaster to Adjutant General, March 5, 1925, AGO Central Decimal Files, Project Files, RG 407, NA.

45. Record Card, District Engineer, New York, January 26, 1926, RG 77, NA. A map drawn in 1920 reveals the location of the hangar and generator house as being close to the state highway, now Rockaway Beach Boulevard, and about one-third of the way from the northwest corner of the fort. See map, "Fort Tilden, New York, Post Map, Job No. 6169, March 25, 1920, RG 177, NA (Appendix 3).

been established. In 1925 and 1926 Marran and Amarilla grasses, beach-type vegetation, were planted in certain critical areas, but it soon became apparent that this effort was not enough for in 1928 the Commanding General of the Second Coast Artillery District gave the following account:

The drifting sand due to wind, is a serious menace to armaments and a source of great discomfort to personnel. The planting of beach grass in the vicinity of the batteries has been undertaken with success by the Engineer Department, and should be vigorously and incessantly continued on the rest of the post to a conclusion. Attention is invited to attached map. Plot shows grassed and bare areas. Other plots show areas that should be grassed without delay, in order of priority -- shown by the inclosed numbers. Approximate cost \$300 per acre. Total that has to be grassed about 55 acres. Areas 1 and 2 should be grassed at once, and area 3 put on high priority. The acreage of (1) is about 2-1/2 acres, and area (2) about 7 acres.<sup>46</sup>

The same year that this was written one general officer described the appearance of the fort in the following terms:

The general appearance of Fort Tilden is of much concern. It is a forlorn looking plot due to the sand dunes and neighboring squalor and the old ramshackle war-time buildings, and particularly the fence being eaten away with rust, making the post most unsightly. In the

---

46. Memorandum for Chief of Staff, subject: Planting of Beach Grass at Fort Tilden, July 27, 1928, with 3rd Indorsement, July 31, 1928, RG 407, NA.

midst of this, two of the most modern highpower guns, with their various installations, are located. At present these are, generally in good condition because of recent installation and projects calling for completion of the fire control system; but a most casual inspection will convince any one that the balance of the post must be brought up to equal the well kept appearance of the guns and other accessories or this modern armament will run a constant danger of deterioration. Nothing but the best foresight will keep a small caretaking detachment, living in and surrounded by rundown buildings, fenced in by dilapidated fence, over run [sic] with sand, and at the same time maintain this modern equipment in first class condition.<sup>47</sup>

By the end of the 1920s two things were happening at Fort Tilden. First, the rundown condition of the World War I structures with the accompanying menace of drifting sand was directing more attention to the plight of the fort, so much so that the Army felt constrained to act in some positive manner. Second, the Army was looking towards Fort Tilden as playing a greater role in the coastal defenses of New York, so that it was now leaning towards the construction of more permanent facilities.

Moreover, the Army felt the need to bring under its jurisdiction the 13 acres of Coast Guard land upon which stood the old Army cantonment buildings. Without control of this stretch of land it would make construction of permanent facilities, especially utilities

---

47. Ely to Adjutant General, subject: Fort Tilden, February 16, 1928, RG 407, NA.

and roads, difficult. In view of the importance of Fort Tilden in the defense of New York City, the Secretary of War was convinced that the Coast Guard area containing the Army facilities should be transferred to Army jurisdiction.<sup>48</sup>

Secretary of the Treasury Andrew Mellon, who was opposed to any such transfer of property, gave favorable consideration instead to the extension of water, sewer, and other essential utilities to the Army. His objection made little difference for by executive order dated November 2, 1928, the land was transferred to the Army and to Fort Tilden.<sup>49</sup>

The transfer of this land to the Army left the Coast Guard reservation divided into two sections, one fronting Jamaica Bay and the other fronting the ocean on the south. They were linked together, however, by the city-owned road running north and south on the east. In 1936, the Army sought to acquire both properties, but succeeded in acquiring only the one fronting the ocean.<sup>50</sup>

Following the acquisition of this land and on the eve of World War II, an intensive period of construction got underway to build badly needed permanent type facilities.

---

48. Secretary of War to Secretary of the Treasury, May 22, 1928, Box 85, RG 77, NA.

49. Secretary of the Treasury to Secretary of War, July 3, 1928, Box 85, RG 77, NA; Executive Order No. 4987, November 2, 1928, as amended by Executive Order No. 5044, February 16, 1929, Box 85, RG 77, NA.

50. Secretary of War to Secretary of the Treasury, May 18, 1936, Box 85, RG 77, NA; Carpenter to Chief of Staff, subject: Acquisition of lands -- Fort Tilden, New York, May 11, 1936, Box 85, RG 77, NA.



## World War II

As it was becoming more and more apparent that the United States would ultimately be drawn into the European conflict, preparations were underway to strengthen certain strategic locations along the Atlantic seaboard, and New York City was one of these areas. By January 1, 1941, military personnel at Fort Tilden was increased from a small caretaker staff to seven officers and 170 enlisted men. By March 1 of the same year, the number grew to 30 officers and 500 enlisted men, and by June 1, personnel rose to about 1,000 men.<sup>51</sup> It was obvious that the time was more than appropriate to make the extensive changes at Fort Tilden that had long been sought but had never materialized. Approval for the construction of numerous facilities was quickly granted and work, much of it through the Works Progress Administration (W.P.A.), began at a rapid pace.

In commenting upon the extent of construction at Fort Tilden during this period, one source had this to say in 1941:

To accommodate the rapidly increasing personnel, the housing facilities at the fort also had to be expanded. This included over 90 barracks and other new buildings erected within the past year or so. In 1939 the Ordnance Building and station hospital were completed and by December last [1940] the Post Exchange, dispensary and six of the cantonment buildings were completed. Fifty-five more of the cantonment type buildings were completed by February 26th 1940 [1941?].

---

51. Edwin A. Osborne, "Rockaway -- One of the Major Protection Points of New York Harbor," Rockaway Review, June 1941, p. 39.

At the present time there are more than 90 of the cantonment buildings erected at fort, ample to accommodate approximately 1,800 men.

. . . while the inadequate gun equipment at several of the Coast Artillery forts in the New York area were scored by Congressman J. Parnell Thomas following his recent tour of the Harbor Defenses of New York, he found at Fort Tilden a battery of the finest and most powerful guns along either coast of the United States. Work on the installation of these guns was completed in 1924. Among the big weapons at the fort are two 16 inch guns, capable of carrying shells at a distance of over 25 miles, in addition to 6 inch guns and a number of smaller caliber weapons.<sup>52</sup>

In 1938 a brick barracks, serving 49 enlisted men, was constructed. This was later converted to the hospital auxiliary, and in much later years, it became a headquarters, which is still used for such a purpose by an Army Reserve unit. This building became known as Building No. 1. Two brick officers quarters -- one for the commanding officer, the other for his executive--were also built about this time and still exist. Other facilities built at this time, many of which still exist, were recreation buildings, a chapel, car garages, enlisted men's barracks, and mess halls. Roads were also rebuilt, and trees and shrubs were planted to control the ever-ending problem of erosion and sandstorms.

While it was true that the sixteen-inch guns had been emplaced in 1924, during World War II their emplacements underwent extensive

---

52. Ibid.

changes involving an entirely new concept of casemate in which nearly all components--weapons, and other supporting elements -- were provided with substantial overhead coverage. Large sums of monies were approved for this construction.

The six-inch gun batteries also underwent remodeling at this time. All batteries were emplaced within reenforced concrete casemates. Meanwhile, antiaircraft guns began to play a major role in the defenses of Fort Tilden. During this period, there were three antiaircraft guns (forming a battery) of the 50-caliber size installed at Fort Tilden.

### The Cold War Years

The end of World War II witnessed a rush to decommission military installations and convert them to civilian use. At the same time there were those who, fearing Soviet Russian expansionism, believed that the United States should move slowly in this direction and that our military installations might still play a major role in American military strategy.

While a solution to these questions remained unanswered, the shortage of housing, particularly near large urban areas, brought about by the war led state and local governments to consider the facilities of military installations for use as emergency housing for veterans and their families. Fort Tilden, located in a densely populated urban area, was one such installation that was considered for such a purpose.

What prompted to channel thoughts along these lines was a change in attitudes concerning military tactics and technology during the post war years. It was becoming apparent to many that the

traditional defenses as exemplified by coastal fortifications were becoming obsolete. Any attack if made upon the shores of the North American continent in all probability would be made by aircraft because of their velocity and high altitude capabilities rather than by a naval armada. In such a case, the antiaircraft gun rather than the sixteen, twelve, or six-inch guns would be more effective to fend off any enemy attack. In the light of these shifts in tactics, a general dismantling of harbor defense commands got underway, and the Coast Artillery, now exclusively an antiaircraft service, was merged with the Field Artillery into a single artillery branch of the Army.<sup>53</sup>

It was easy at this point for the Army to turn over sections of Fort Tilden for civilian purposes. It did not mean, however, that the fort would be decommissioned as others had sought to do after the war.

Meanwhile, the State of New York, which had assumed responsibility for the civilian emergency housing in the state, had plans to convert surplus barracks at Fort Tilden into 400 apartments.<sup>54</sup> In 1946 Federal permits were obtained and work began on the conversion of facilities. By this time, the number of apartments planned for veterans was reduced to 350. Fort Tilden had 46 wooden Army facilities converted.<sup>55</sup> Each dwelling unit consisted of one, two, or three-room apartments. While the units were of a temporary construction, they were winterized and heated by a central heating system. Each unit was equipped with kitchen facilities. Because of their seaside location, a warm sand color was

---

53. Lewis, pp. 124-125.

54. New York City Plans Housing at Military Posts, New York Herald Tribune, November 29, 1945.

55. Brooklyn Eagle, New York City, January 25, 1946.

decided upon as the paint for all the apartments in the project. The woodwork was kept a natural birch color.<sup>56</sup>

During the postwar years anti-aircraft guns remained the only viable weapons of any sizeable caliber at Fort Tilden. In December 1950, the Army announced, for the first time since World War II, that a regular anti-aircraft group, consisting of two battalions, would be assigned to the New York Metropolitan area. One of the battalions, numbering 1,000 men, would be assigned to Fort Tilden. The group was to have two missions--one to train and the other to provide anti-aircraft protection for New York City. The 69th AAA Battalion, as the unit was called, was responsible for four batteries of 90 mm guns, each battery consisting of four guns. The guns were controlled by automatic devices consisting of radar and computers. They could detect the approach of any aircraft up to a distance of 40 miles, and at a distance of 20 miles the guns could keep an approaching target on site even at an altitude of 40,000 feet.<sup>57</sup>

With Fort Tilden once again placed on a wartime footing, especially with the assignment of 1,000 men, the veterans and their families who had been assigned emergency housing only a few years before had to leave to make way for the new military mission. A total of 281 families were eventually forced out. The facilities that once housed those families were again converted to enlisted men's barracks and other military uses.<sup>58</sup>

---

56. Ibid; Brooklyn Tablet, New York City, January 26, 1946; New York Herald Tribune, May 21, 1946.

57. New York Herald Tribune, December 31, 1950; "Anti-Aircraft Guns Moved to Fort Tilden," Rockaway Review, January 1951; Brooklyn Eagle, New York City, January 8, 1951.

58. The New York Times, January 19, 1951; "Army Vacates Tenants," Rockaway Review, February 1951.

The Korean War had generated deep concern over the defenses of the New York City area. In the light of the higher ceiling, greater speed, and greater maneuverability of modern bombers, even anti-aircraft artillery was not considered sufficient air defense. In the mid-1950s the construction of surface-to-air missile silos was begun at Fort Tilden. The first missiles used were the Nike-Ajax guided missiles, which had a range of 25 miles. In 1958 the Nike-Ajax gave way to the Nike-Hercules. This improved and enlarged missile had a range of more than 75 miles and was capable of carrying an atomic warhead. Four underground silos and six radar stations were constructed in three areas of Fort Tilden.<sup>59</sup>

By 1967, even these advanced weapons had outlived their usefulness and were eventually decommissioned. Since that date and to the present, even while under National Park Service jurisdiction, parts of Fort Tilden are used by Army Reserve units under a special use permit.

---

59. New York Herald Tribune, June 5, 1958; ibid., September 26, 1958.

## CHAPTER II: FORTIFICATIONS AND SUPPORTING ELEMENTS

### Battery Harris (Structures 406 and 410)

Under the latest numerical designation of structures within Fort Tilden, the two sixteen-inch gun casemates that made up Battery Harris are known as structures Nos. 406 and 410. Located just to the north of Range Road, Casemate No. 406 (housing Gun No. 2) was on the east and Casemate No. 410 (housing Gun No. 1) was on the west. The two casemates were separated by about 850 feet.<sup>1</sup>

In February 1917, even before most of the land at Fort Tilden had been acquired, a New York newspaper announced that "Sixteen-inch disappearing rifles of the very latest coast defense type will be installed."<sup>2</sup> When this announcement was made the Washington Armament Conference had yet to take place. Such type of gun may have been planned for Fort Tilden as well as at other defense sites but may never have become a reality. The same announcement noted that work was already underway to cart bluestone to the site and that excavation of foundations for the big guns would soon start. Nevertheless, it would be several months yet before the guns would be emplaced.<sup>3</sup> This reference to work underway in order to mount the "big guns" may be misleading. Since plans for the sixteen-inch guns were not, as we shall see, finalized until

---

1. Drawing No. 142-75-16, Fort Tilden, New York: Railroad Tracks, Magazines, Etc. For Sixteen-Inch Rifles, February 11, 1922, Cartographic Branch RG 77, NA.

2. The Sun, New York City, February 9, 1917.

3. Ibid.

1921-1922, work could not very well have begun in 1917. In all probability this newspaper mistook work on the mounting of six-inch guns and twelve-inch mortars, the latter on city park land adjoining Fort Tilden, for work on the sixteen-inch guns. As we have already noted earlier, the six-inch guns and twelve-inch mortars were actually mounted in 1917-1918, and therefore it is reasonable to assume that the bluestone and work on foundations was intended for these guns and not the sixteen-inch guns as this newspaper was led to believe.

Elaborate plans for the emplacement of sixteen-inch guns were well underway in 1917, and despite the cessation of hostilities in 1918, planning, albeit haltingly, continued. Emanuel Lewis in his excellent work on coastal fortifications in the United States has stated that early sixteen-inch gun batteries were essentially a simple undertaking. The guns were placed on a huge circular platform made of reenforced concrete, while a deep well in the center of the platform served to hold the gun breech. The gun itself was exposed without benefit of any protection overhead or side coverage.<sup>4</sup>

In spite of this prevailing design, the records reveal that more elaborate emplacements were planned for the big guns at Fort Tilden although the simplified version suggested above was ultimately accepted. The batteries suggested in the earlier plans combined plotting rooms, power rooms, powder magazines, and shell rooms, as well as accommodations for soldiers, all under one roof. The gun platform was reached by a long ramp connecting it to the

---

4. Emanuel Raymond Lewis, Seacoast Fortifications of The United States (Washington: Smithsonian Institution Press, 1970), p. 114.



battery. The gun, meanwhile, remained with no overhead or side cover.<sup>5</sup>

The actual construction of the battery was postponed several times largely because of inadequate funding. This provided opportunities for further planning. In the meantime, by January 1920 the production of the guns was already in progress and the War Department had tentatively approved the installation of two sixteen-inch guns on barbette carriages at Fort Tilden. Estimates were even submitted to Congress to cover the cost of construction beginning July 1, 1920.<sup>6</sup>

The reference to the sixteen-inch guns being manufactured undoubtedly referred to the Army model, which only two years later was to be discontinued because of the Washington Armament Conference.

Design changes on the batteries continued almost constantly and these were concerned with such factors as gun location, dispersed or unified facilities, and camouflage, all very practical questions related to the development of aerial bombing and sea operations. One of the more important questions under consideration at the time was the combining of two guns into a single battery or separating

---

5. Chief of Engineers to Adjutant General, subject: Typical design of employment for 16-inch gun on disappearing carriage, model 1917, April 24, 1917, RG 77, FRC, Bayonne, N.J.; Abbot to Chief Engineers, subject: 16-inch batteries, Fort Tilden, New York, August 6, 1917, RG 77, NA; Drawing 2 sheets, "Emplacement for 16-inch Gun Mounted on Barbette Carriage, Model of 1919," August 1920, Cartographic Branch, RG 77, NA.

6. Sherrill to District Engineer, subject: Sixteen-inch rifles for Fort Tilden, January 9, 1920, RG 77, FRC, Bayonne, N.J.

the guns each having its own battery. Placing two guns under one battery, some believed, would produce a savings in construction costs amounting to 33 percent.<sup>7</sup>

By 1921, planning was in such an advanced stage that thinking was slanted towards the construction of emplacements based upon the concept of simple gun blocks mounted on concrete platforms with dispersed magazines and other facilities. At Fort Tilden the two guns originally were to be mounted 600 feet apart; however, this was later changed to 850 feet.<sup>8</sup>

In December 1920 an allotment of \$70,000 was authorized to cover expenses for the remaining portion of Fiscal Year 1921 for the construction of the two emplacements, and authority was finally granted to commence operation.<sup>9</sup> Two months later the Corps of Engineers estimated they would need 5,400 barrels of American Portland cement (cost: \$16,200) and 4,000 cubic yards of crushed stone (cost: \$16,000) for constructing the two gun emplacements.<sup>10</sup>

---

7. Ibid.

8. Weaver to District Engineer, subject: Report on Foundation Tests for 16-Inch Guns at Fort Tilden, N.Y. March 18, 1921, RG 77 NA. A drawing in the National Archives reveals the general plan of 2 guns in relation to such dispersed facilities as 3 magazines, 3 power houses (one a reserve), and plotting and switchboard rooms. See Drawing. "Fort Tilden, New York: Sixteen-Inch Rifles", February 11, 1922, RG 77, Cartographic Branch, N.A.

9. Weaver to District Engineer, subject: Report on Foundation Tests for 16 Inch Guns at Fort Tilden, N.Y., March 18, 1921, RG 77, N.A.

10. Winslow to District Engineer, February 19, 1921, RG 77, FRC Bayonne, N.J.

By February 1922, the New York District Engineer was informed that the two guns and their carriages would soon be shipped from Watervliet Arsenal and Watertown Arsenal respectively. Each gun weighed 165 tons and each carriage weighed 100 tons. In addition to these main sections, a miscellaneous assortment of parts, each weighing from 110 pounds to three tons, were also being shipped.<sup>11</sup> One news item published in 1935 stated that the guns fired a 2,100 pound projectile a distance of 50,000 yards.<sup>12</sup> Another news article published in 1940 noted that the guns had a fifty-foot long barrel with a maximum firing range of more than 30 miles.<sup>13</sup>

By mid-1923 the District Army Engineer had announced that he needed more money to complete the sixteen-inch battery at Fort Tilden. By this time Gun No. 2 had been mounted and only some ordnance work remained to be done. Gun No. 1, on the other hand, required much work yet; tube, side arm, and breech block remained to be mounted. The winter months, which brought on severe weather, had seriously interfered with the completion of work outdoors.<sup>14</sup>

---

11. Memorandum, Frank to Winslow, February 18, 1922, RG 77, FRC, Bayonne, N.J. Lewis has stated that the barrel alone weighed 200 tons and cost over \$300,000. The carriage weighed over one million pounds. Manufacture required about 3 years for each gun. See Lewis, p. 113. Lewis' figure of one million pounds for the carriage is in considerable conflict with the 100 tons provided by the Army for the Fort Tilden guns. It is probable that Lewis may have been mistaken since one million pounds would place the carriage at about 500 tons.

12. New York Herald Tribune, July 23, 1935.

13. Ibid., May 30, 1940.

14. Chaffee to Chief of Engineers, subject: Completion of 16 Inch Battery Project, Fort Tilden, N.Y., July 7, 1923, RG 77, FRC, Bayonne, N.J.

Although by 1924 the two guns had been completely mounted, there was more related work to be accomplished before the guns could be declared fully operational. Platform lights were installed about this time. There were four lights in all, consisting of pipe frame supports and concrete abutments, among other items at each gun emplacement.<sup>15</sup>

Soon after the guns were mounted, they were proof-fired in 1924, but as late as 1934 they had never again been proof-fired.<sup>16</sup>

There is some conflicting evidence as to whether the sixteen-inch guns were of the Army type or Navy type. The Washington Armament Conference took place between November 1921 and February 1922. It was in February 1922, however, that the New York District Engineer received official word that the barrels and carriages were being shipped from Watervliet Arsenal and Watertown Arsenal. The time period of the Washington Conference was too close to expect that its treaties could be put into effect permitting Navy guns to be installed at Fort Tilden. It is this writer's conclusion therefore that Army type guns were initially installed at Fort Tilden and remained there until World War II, despite one newspaper's assertion that guns were of the Navy

---

15. Ladue to Chief of Engineer, subject: Report of Operations, Fortifications, September 1924, October 9, 1924, RG 77, NA. There are 2 drawings made in 1924 that describe the two emplacements, gun wells, railroad tracks that carried the heavy ammunition, and other related accessories. See Drawing, Fort Tilden, N.Y. (Battery Harris): Emplacements for Two 16 Inch Guns and Railroad Trackage for Same, November 19, 1924 (Appendix 4), and Drawing, Fort Tilden, N.Y. (Battery Harris), Emplacements for 2-16" Guns; Fire Control Apparatus, Wiring and Platform Lights, November 19, 1924 (Appendix 5), RG 77, Cartographic Branch, NA.

16. Record of Communication Received, letter, Office of Coast Artillery to adjutant General December 24, 1934, Box 3107, RG 407, NA.

type.<sup>17</sup> This conclusion is supported in part by an Army document of 1941 which clearly states that the guns at Fort Tilden "were of the Army type mounted on MK 11 carriages."<sup>18</sup> (Illustration I)

This same document does note, however, that plans which proposed new batteries also contemplated the use of Navy type guns.<sup>19</sup> In the multitude of World War II records searched at the National Archives this writer has never come across any references to Navy guns being actually installed at Fort Tilden. Moreover, it is difficult to imagine that guns of this size and complexity were actually changed from an Army type to a Navy type, even though the casemates were being altered, since the expense would have been prohibitive.

Between 1924 and mid-1930s little was done to modify or improve Battery Harris. Although Fort Tilden was in a caretaker status, the guns were maintained in good operational condition despite the drifting sands that frequently played havoc with equipment.

In 1939, the Army's Harbor Defense Board recommended several changes in the coastal defenses of the United States. Among the many proposals made at this time was the construction of casemated batteries for the two sixteen-inch guns, rebuilding the two six-inch gun batteries, and the bombproofing of other structures at Fort Tilden. These proposals all stemmed from an increased awareness of the advanced development of aircraft bombing and the construction of large aircraft carriers that could conceivably bring aircraft within bombing range of America's coastline. An entirely

---

17. New York Herald Tribune, July 23, 1935.

18. 6th Indorsement, Blood to [unknown], February 19, 1941, RG77, NA.

19. Ibid.

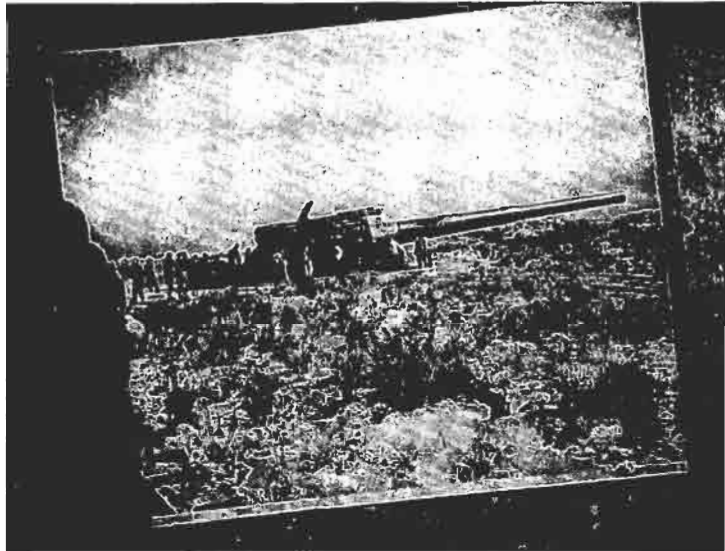

Illustration 1

Sixteen-inch gun  
Army model  
Fort Tilden  
1935  
Park files

new type of battery was conceived in which all components--armament, magazines (powder as well as shell), and various other types of facilities--were provided with substantial overhead and side protection. The entire battery structure designed to withstand direct hits from enemy aircraft or battleships was roofed along its full length by eight to ten feet of reenforced concrete and up to 20 additional feet of earth. Most of these fortifications in the United States and its possessions were standarized to a very large extent.

Another revolutionary change seen at this time was the method of transporting ammunition to the big guns. With huge overhead ceiling covers, the one-tone shells were transported to the guns by overhead trolleys on rails suspended from the ceiling.<sup>20</sup>

The matter of casemating Battery Harris, like that of Batteries Kingman and Mills at Fort Hancock, had the highest priority. By March 1941, the New York District Engineer had a staff of draftsmen ready to proceed with designs. The two casemates were finally constructed in 1943.<sup>21</sup>

Made of solid reenforced concrete, the thickest walls of the two casemates were ten feet thick and the thinnest walls were four feet thick.

The huge gun stood in the center of the casemate, its carriage and part of its barrel hidden beneath a large concrete overhang, while

---

20. Battery Richmond P. Davis, San Francisco, California, was the first such battery built in 1937. See Lewis, p. 117.

21. The inscription over the casemate entrances gives the date as 1941, but this was probably done to denote the beginning of construction.

the remainder of the barrel was exposed. Underneath the ceiling of the overhang were strong iron tracks with pulleys that carried the large caliber ammunition to the gun.

A diagram of Casemate No. 1 reveals the layout of rooms, corridors, and other facilities. There were powder rooms and shell rooms on both sides of the main (southern) entrance to the casemate. Behind these rooms, and to the north, was a wide, long corridor that ran east and west the full length of the casemate with entrances at each end. The ceiling of this corridor was 13 feet high. A small gauge track ran through the center of this corridor bearing the railroad that carried ammunition from the magazines to the casemates.<sup>22</sup>

Opposite the two powder rooms, to the north of the wide corridor, was a tool room and latrine. The thick concrete roof of the casemate was covered with a heavy layer of dirt, sod, brush, and small trees. The casemate, particularly from the rear, looked like a hill. The rear, or north entrances, to both casemates have inscribed above "Battery Harris -1941" in recessed lettering. Soon after the casemates were completed dehumidification units were installed in order to control the humidity.<sup>23</sup>

Today the casemates have deteriorated considerably, although the main walls appear structurally sound. The iron has rusted badly and much needs to be done to arrest further deterioration. Both

---

22. Diagram, Casemate No. 1, Moisture Control Study, Battery Harris, Ft. Tilden, N.Y., Fortification Branch, Engineer Division, U.S.E.D., N.Y. (1944), RG 77, NA (Illustration 2). See also 4th Indorsement, N.Y. District Engineer to Chief Engineers, subject: Condensation Control - Seacoast Batteries, February 25, 1944, Box 86, RG 77, NA.

23. Ibid.



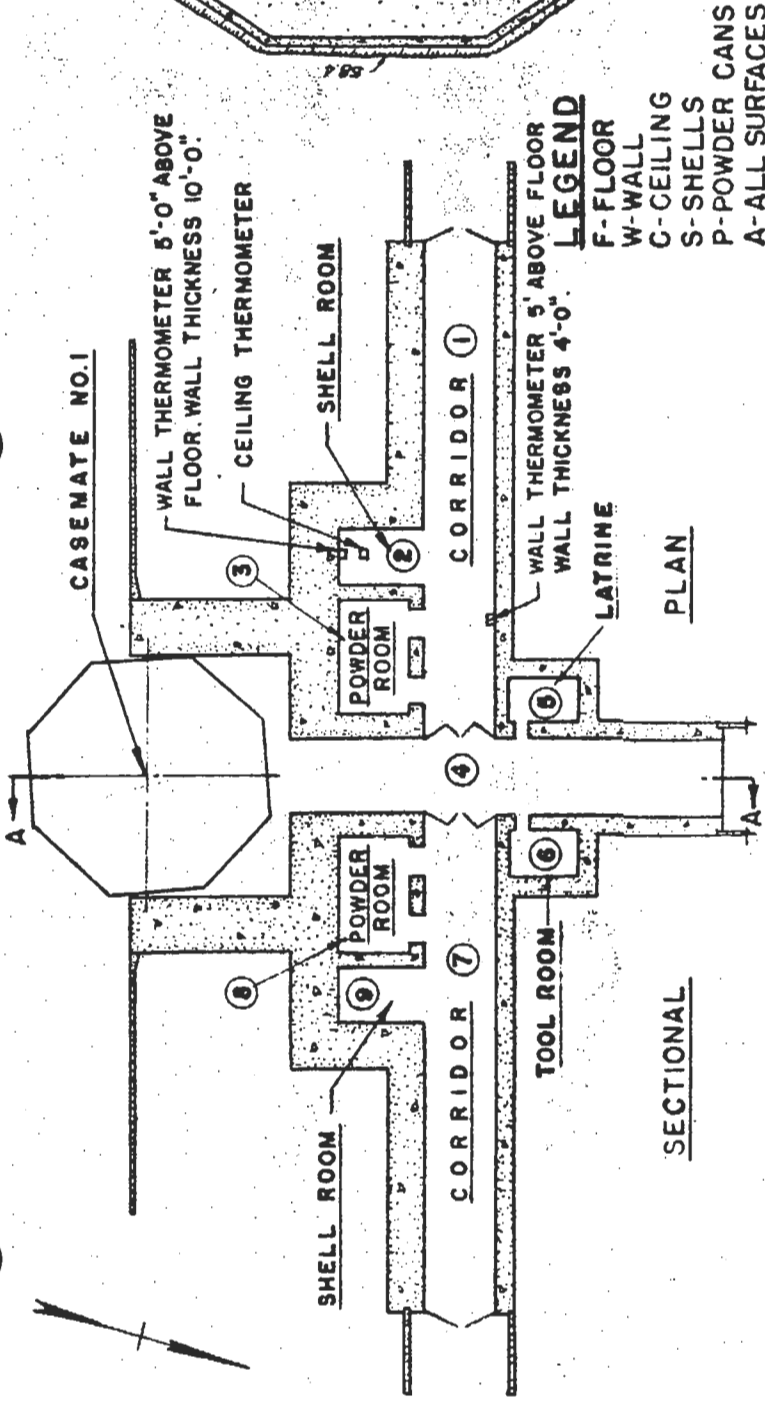

NOTE  
 WALL THERMOMETER 42.0' BELOW GRADE OF FILL  
 CEILING THERMOMETER 38.5' BELOW GRADE OF FILL  
 CEILING THICKNESS 8.0'

SECTION A-A

**MOISTURE CONTROL STUDY**  
 FORTIFICATION BRANCH, ENG. DIV., U.S.E.D., N.Y.  
 BATTERY HARRIS, FT. TILDEN, N.Y.

Illustration 2

Floor plan, Casemate no.  
 Battery Harris  
 1944

Courtesy National Archives

casemates have retained the 1924 circular concrete platforms; however, the one in Structure No. 410 is in better condition than the one in Structure No. 406. The platform in the former structure has two mounds, one on the east side, the other on the west side of the old platform. These mounds were probably part of the railroad tracks which encircled the platform when delivering ammunition (Illustrations 3, 4, 5, 6, 7, 8, 9, 10).

#### Six-Inch Gun Batteries (Structures 315 and 321)

The four six-inch guns were the first coastal guns emplaced at Fort Tilden in 1917. These guns came from West Point and were proof-fired on May 14, 1917. They were fired twice at a range of 12,000 yards, and it took 23-1/10 seconds for each projectile to travel from the gun barrel to the target.<sup>24</sup>

There were two batteries each containing two guns of the 1900 model on barbette carriages. These batteries were called East Battery and West Battery, a temporary designation given them until more permanent emplacements were constructed. The East Battery was located on the southeast corner of the fort and the West Battery was located near the southwest corner. The guns were mounted entirely in the open, unprotected from the drifting sands. Each battery had a separate magazine, a temporary structure with a corrugated iron roof. The fire control installation for these batteries consisted of two coincidence range finders (CRF), one nine feet long the other twenty-two feet.<sup>25</sup> The

---

24. Anonymous, "Uncle Sam's Acres", Rockaway Review, June 1948.

25. District Commander to Adjutant General, subject: Technical Inspection, Fort Tilden, N.Y., May 12, 1920, RG 77, NA.



Illustration 3

Northeast view of Casemate 1  
Battery Harris  
1979



Illustration 4

Closeup view of Structure 410  
Battery Harris  
1979



Illustration 5

Concrete overhang, Structure 410  
Battery Harris  
1979



Illustration 6

West entrance view into Structure 410  
Battery Harris  
1979



South view of Structure 410  
Battery Harris  
1979



Illustration 8

View of main corridor looking northwest  
Structure 410  
Battery Harris  
1979





Illustration 9

Inside Structure 410  
Looking east with railroad track  
Battery Harris  
1979



Illustration 10

Inscription of battery at north entrance to  
Structure 410  
Battery Harris  
1979

installation of pent houses, or halfway structures, over each gun in 1922 in order to protect them from the heavy drifting sands did not change the nature of their temporary emplacement.<sup>26</sup>

When the batteries were first proposed early in 1917, it was recommended that suitable concrete gun platforms be constructed for each of the four guns. This did not materialize, however, perhaps because the emplacements for these guns at this time were only a temporary measure. What the Army did accomplish instead was to build the central portion of the platforms of concrete and the outer portion of wood.<sup>27</sup> The concrete portion of the platforms was 15 feet 9 inches in diameter, while the wooden portion extended the diameter of the platform to 34 feet, 9 inches. The emplacements were cut out to permit a 20 degree gun elevation.<sup>28</sup>

The East Battery was located about 300 feet behind the ocean front near the Coast Guard reservation. The West Battery was located about 300 feet from the ocean front and 800 feet from the fort's western boundary. The two guns at each battery were 330 feet apart.<sup>29</sup>

---

26. Memorandum for the Chief of Staff, subject: Construction of Pent Houses at Fort Tilden, N.Y., January 9, 1922, RG 77, NA; drawing "Fort Tilden, N.Y., Shelter for 6" guns on Barbette Carriage Model 1900," March 27, 1922, RG 77, Cartographic Branch, NA.

27. Record Card, N.Y. District Engineer, February 3, 1925, RG 77, NA.

28. Ladue to Commander, Harbor Defense of Sandy Hook, subject: 6 Inch Gun Batteries, Fort Tilden, N.Y., March 29, 1926, RG 77, FRC, Bayonne, N.J.

29. Ladue to District Engineer, Fort Norfolk, subject: 6-Inch Battery, Fort Tilden, N.Y., September 29, 1925, RG 77, FRC, Bayonne, N.J.

Although the magazines and gun platforms had deteriorated badly soon after they were constructed, little was done for many years to improve the situation. The reason may have been due to the fact that the emplacements had been considered temporary, and until permanent sites were selected, it seemed wasteful to make repairs of any sizeable magnitude. Nevertheless, engineers did go ahead with their designs and plans for new batteries that would contain the latest thinking in coastal defenses. Not only was serious consideration given to overcoming some of the perennial problems brought on by the temporary emplacements, but attention also turned to the construction of a concrete coincident range finder station and a plotting room for each battery. In both instances, however, these facilities were to be made separate from the gun casemates.

Although extensive plans were being developed and modified from time to time, none were ever realized for one reason or another not the least being the economic depression that the country had found itself in at the time. In 1928, the Chief of Engineers noted that the batteries had so deteriorated "as to be no longer serviceable and the batteries are without plotting rooms or C.R.F. station." He went on to say that "these guns can be permanently installed at a reasonable cost...."<sup>30</sup> Despite this serious criticism on the part of the Chief of Engineers, nothing happened to make the much-needed changes.

Planning did continue, however, and a Board of Officers, convening at Fort Hancock on August 14, 1928, concluded to accept changes to the future permanent batteries planned up to then. It

---

30. Record of Communication Received, subject: Installation of 6-Inch Guns at Fort Tilden, Har. Def. of Sandy Hook, January 21, 1928, RG 77, NA.

concluded: (1) to combine plotting room and observation station and to combine the B.C. station with tool and oil house; (2) that the general design and details of the emplacements and magazines were satisfactory; (3) that all walks between magazines and emplacements should consist of concrete, those for the shell magazine being eight feet wide and those for the powder magazines to be not more than five feet wide.

A fourth recommendation, and perhaps the most important of all, was concerned with the relocation of the East Battery. The board was of the opinion that the central point of the East Battery should be moved about 600 feet west of its existing location, the axis of the battery remaining parallel to its existing position and about the same distance from the shore line. This meant the construction of two new gun blocks which would be separated about 250 feet. There were two reasons for the suggested change in the position of the East Battery. The first was the fact that the Coast Guard had objected to the existence of the Army's 60-inch search-light which was on their land on the grounds that the light obstructed observation in a very important sector. The board agreed with the Coast Guard that the searchlight should be moved, but moving it further west would place it objectionably close to the existing East Battery. However, relocating the battery as proposed would eliminate this problem.

A second reason for relocating the East Battery was to place the proposed east powder magazine farther away from the Coast Guard Station and the public highway along the east side, thereby eliminating any possible hazard.<sup>31</sup>

---

31. "Proceedings of a Board of Officers Convened at Fort Hancock, New Jersey, 14th of August 1928 . . . To prepare a project for the permanent installation of 6-inch guns and accessories at Fort Tilden, N.Y.," August 20, 1928, RG 407, NA.

Several years passed without much action taken to implement what the Board of Officers had recommended in 1928. In 1935, the Office of the Chief, Coast Artillery unhappily noted that "the project for permanent emplacement has a low priority. . . . Funds for this project probably will not be available for several years."<sup>32</sup> In spite of this hesitancy, planning for the two batteries continued. In the latest planning developments that took place at this time the East Battery was to be abandoned and in its place, but at a considerable distance away from its present site, was to rise a new battery designated Battery Construction No. 220. While anticipating the construction of permanent batteries, in 1939 the two batteries were renamed: East Battery became Battery Fergusson and West Battery was renamed Battery Kessler.<sup>33</sup>

With war slowly approaching the Secretary of War finally gave his approval for the construction of two permanent six-inch batteries in September 1940. His approval of this construction was part of a modernization program anticipated for all harbor defenses in the United States. Most important of all, the program provided for a new six-inch gun battery (Battery Construction No. 220) to replace Battery Fergusson, which was to be abandoned, while retaining a modern Battery Kessler. The latter was to continue to utilize the existing gun blocks.<sup>34</sup>

---

32. 6th Indorsement, Office, Chief of Coast Artillery, December 28, 1935, RG 407, NA.

33. Adjutant General to Commanding General, Second Corps Area, subject: Naming Batteries at Fort Tilden, N.Y., December 1, 1939, RG 407, NA.

34. 17th Indorsement, Chief of Engineers to Chief, Coast Artillery October 22, 1940, to letter, subject: Rebuilding Batteries East and West, Fort Tilden, N.Y., RG 407, NA.

Under the new construction, the guns themselves were not to be casemated, but instead were to remain in the open on gun platforms. The remaining sections of the batteries, however, basically followed the concept of the sixteen-inch Battery Harris. The earth-covered concrete structures to be located between each of the two guns would house most of the ancillary components -- magazine, power generator, air conditioning equipment, communications, storage, and service rooms, and in the case of Battery Construction No. 220, the fire control plotting room.

Construction of the two permanent batteries began soon after the Site Board had approved the permanent installations. Specific evidence is not available but construction of the two batteries was probably completed in 1942. Battery Construction No. 220 was the larger of the two, and the distinctive difference in the two batteries was the addition of the fire control unit at the top center of Battery Construction No. 220. Two diagrams containing simplified versions of the floor plans and cross sections of each of the batteries, with some dimensions, are in the National Archives. The front wall of Battery Construction No. 220 is seven feet thick while the rear wall is six feet thick. This battery had, in addition to other areas, two shell rooms and two powder rooms.

Battery Kessler was a smaller structure than the other although it had the same type of guns. The front walls of this battery were three feet thick while the rear walls were two feet thick. This battery had two powder rooms in the front, a shell room just to the rear of these two rooms, and a wide corridor directly behind the shell room. On either side of the shell room were two smaller rooms both used for storage.<sup>35</sup>

---

35. Drawing, "Moisture Control Study, Battery No. 220, Ft. Tilden, N.Y., Fortification," Branch, Eng. Div., U.S.E.D., N.Y., (Continued)

Today Battery Construction No. 220's gun platforms are still visible under the heavy brush that has grown about them. They are roughly 25 feet in diameter and are located in front and to the side of the huge underground bunker. The two entrances to the bunker, one at each end, are inaccessible because of drifting sand and dense growth. On top and on the front center of the bunker is the square heavy concrete structure known as the fire control station. It is partly exposed and the slit from which the enemy was observed is still intact. With constant erosion, this structure has become more exposed and subject to the elements.

Today, Battery Kessler's gun platforms are about the same dimensions as those of Battery Construction No. 220. They are also in the same position in relation to the rest of the battery. Like the other six-inch gun battery, the two entrances are almost entirely hidden by the shifting sands and dense growth (Illustrations 13, 14, 15, 16, 17, 18).

---

35. (Illustration 11), and drawing, "Moisture Control Study, Battery Kessler, Ft. Tilden, N.Y., Fortification Branch, Eng. Div., U.S.E.D., N.Y." (Illustration No. 12) both, enclosures to Office Memorandum, Hedger to Smith, subject: Condensation Control Sea-Coast Batteries, January 14, 1944, RG 77, NA. The following drawings show in greater detail the floor plan and cross section of Battery Construction No. 220 as it was ultimately constructed: (1) Battery No. 220 Central Traverse Magazine Location Map and Index, Sheet No. 1, April 27, 1944; (2) Battery No. 220 Central Traverse Magazine, General Plans and Details, Sheet No. 2, September 14, 1942; (3) Battery No. 220, Central Traverse Magazine, Structural Details, Sheet No. 3, September 14, 1942; (4) Battery No. 220, Central Traverse Magazine, Gas - Proofing Details, Sheet No. 19, September 14, 1942; (5) Battery No. 220, Central Traverse Magazine, Plumbing and Electrical Systems, Sheet No. 20, September 14, 1942; (6) Battery No. 220, Central Traverse Magazine, Water and Sewer Systems, Sheet No. 21, September 14, 1942, all in Park files, (Appendixes 6, 7, 8, 9, 10, and 11).



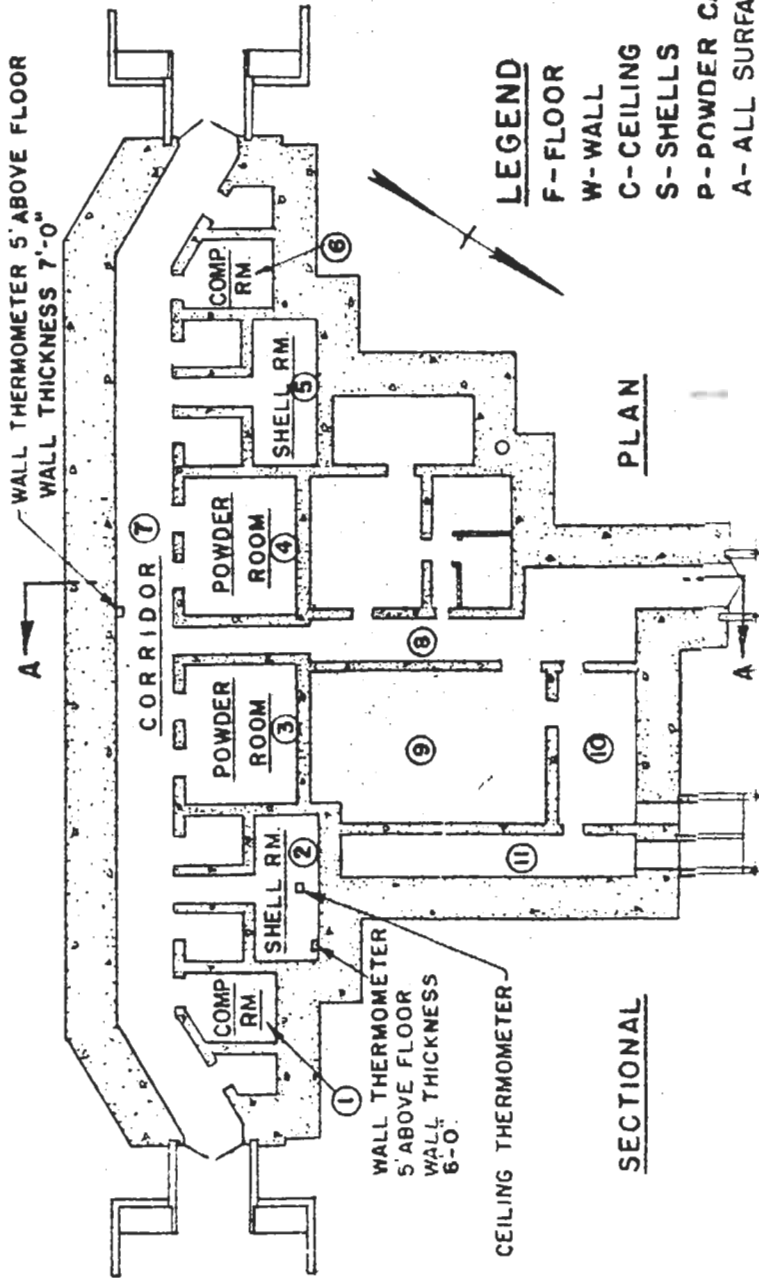

**MOISTURE CONTROL STUDY**  
**BATTERY NO. 220, FT. TILDEN, N.Y.**  
**FORTIFICATION BRANCH, ENG. DIV., U.S.E.D., N.Y.**

Illustration 11  
 Floor plan, Battery Construction 220  
 1944  
 Courtesy National Archives

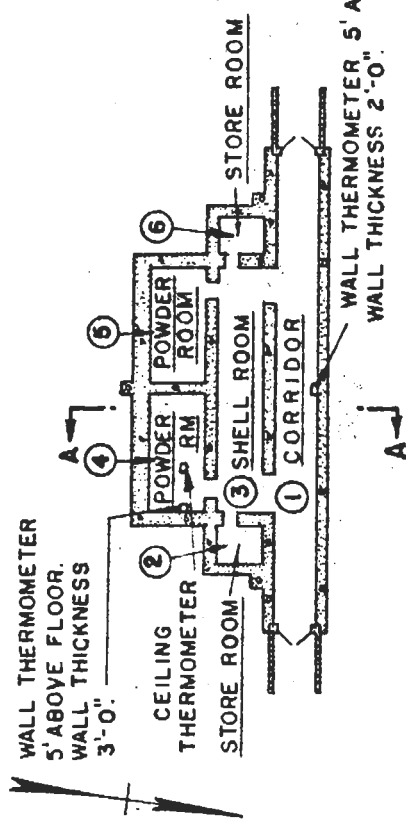

**LEGEND**

- F - FLOOR
- W - WALL
- C - CEILING
- S - SHELLS
- P - POWDER CANS
- A - ALL SURFACES

**SECTIONAL PLAN**

NOTE  
 WALL THERMOMETER 16.5' BELOW GRADE OF FILL.  
 CEILING THERMOMETER 13.5' BELOW GRADE OF FILL.  
 CEILING THICKNESS 3.5'

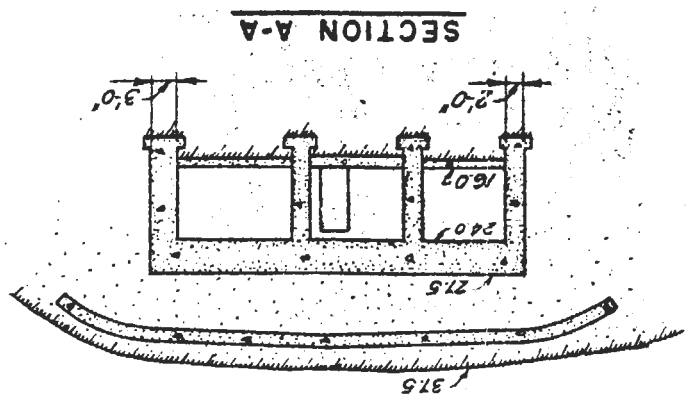

**BATTERY KESSLER, FT. TILDEN, N.Y.**  
**MOISTURE CONTROL STUDY**  
**FORTIFICATION BRANCH, ENG. DIV., U.S.E.D., N.Y.**

Illustration 12

Floor plan, Battery Kessler  
 1944  
 Courtesy National Archives



Illustration 13

South entrance to Structure 321  
Battery Kessler  
1979



Illustration 14

Interior of Structure 321  
Battery Kessler  
1979



Illustration 15  
Exhaust vent of Structure 321  
Battery Kessler  
1979

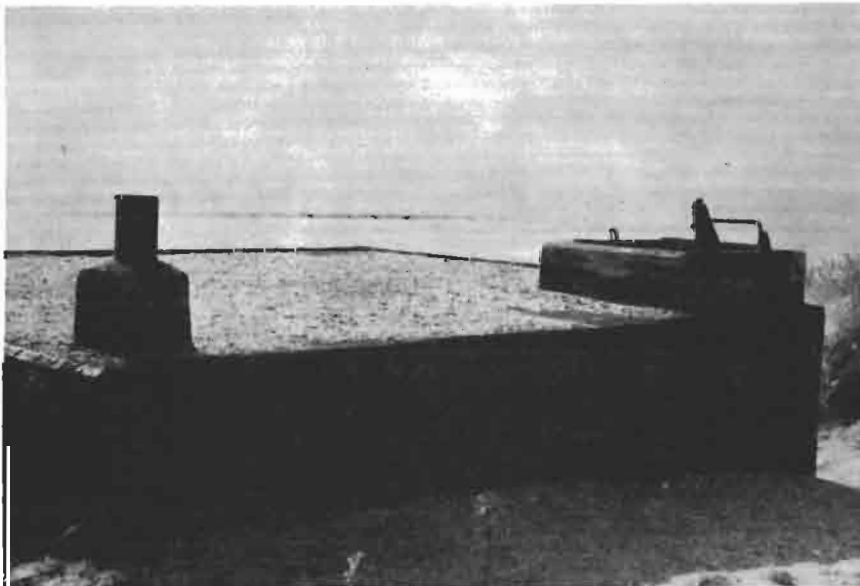

Illustration 16  
Roof of fire control station  
Structure 315  
Battery Construction 210  
1979



Illustration 17

Electrical station at rear of  
Structure 315  
Battery Construction 210  
1979



Illustration 18

Front and side of fire control station  
Structure 315  
Battery Construction 210  
1979

## Magazines of Battery Harris and Other Ammunition Storage

### A. Battery Harris Magazines (Buildings 401, 405, 409, 414)

Buildings 405, 409, and 414, in the current enumeration of buildings at Fort Tilden, were built in the early 1920s as part of Battery Harris. The fourth structure -- Building 401 -- was built in the early 1930s, also to serve Battery Harris.

The general plan of these magazines, as in the case of the two early gun emplacements and other components, was based upon the theory of dispersion, that is, all components, including guns, were separated rather than under one roof. There appeared to be general agreement in this concept for Battery Harris. When it came, however, to agreement on how the huge projectiles were to be moved from the magazines to the guns, the story was somewhat different. Many points of view had to be reconciled before a final plan could be devised. In February 1922, the Office of the Chief of Engineers finally concluded a plan for the magazines that was ultimately accepted.

The plan offered by the Chief of Engineers proposed a type of magazine that would be both economical to build and at the same time offer the best service for the guns. The magazines were designed so that they could be used for storing either shell or powder or both. Conversion from shell to powder storage was accomplished by the installation of a removable wooden floor, which was considered desirable from the standpoint of safety and dryness of the powder. In the magazine shells were stored on rails embedded transversely in the concrete floor, twelve shells per bay, six bays on each side of the track. From the rails, the shells were rolled onto the shell trucks, connection being made between the rails and the trucks by a bridge hinged to the trucks. The

powder was stored in containers sitting on end on the wooden floor sections, each bay holding 60 containers, 30 on each side of the track.<sup>36</sup>

Bids for the construction of the three magazines were opened on May 19, 1922 and the lowest bid of \$11,000 was accepted from the Concord Construction Company of Brooklyn, New York.<sup>37</sup>

The three magazines were about 900 feet apart. The superstructure of each magazine was built upon a concrete foundation. the walls above the concrete water table were eight inches thick and built of eight by twelve by eight-inch hollow tiles with glazed smooth faces. The roofs were constructed of Pyrobar Long Span Reinforced Gypsum Roof Tile without lap joints, manufactured by the United States Gypsum Company. Each magazine was fitted with two rolling lift steel doors and one kalamine door. A flight of concrete steps was built in front of the swing door with a one and one-half-inch pipe hand rail. Three ten-inch galvanized iron ventilators were set in each roof.<sup>38</sup>

The three magazines constructed at this time for Battery Harris were not intended to hold the complete battle allowances of ammunition. They were designed to hold a limited quantity only -- the remainder being stored at such central storage points as Raritan Arsenal and Fort Hancock, both in New Jersey, and brought up as needed. (Each sixteen-inch gun had a battle

---

36. Ibid.

37. Abstract of Proposals by Col. E. E. Winslow, June 10, 1922, RG 77, FRC Bayonne, N. Y.

38. Detailed Specifications, enclosure to Advertisement, RG 77, FRC, Bayonne, N.J.; Drawing, "Fort Tilden, N.Y., Battery Harris, Magazine for 16 Inch Ammunition," May 22, 1924, RG 77, Cartographic Branch, Fortifications file, NA (Appendix 12).

allowance of 250 rounds.) To some this did not appear practical in the event of an emergency when more ammunition might be needed in a hurry. In 1929 the New York District Engineer recommended that additional magazines be constructed for Battery Harris.<sup>39</sup>

Apparently, these complaints were heard by higher headquarters for in 1931 additional storage space was provided at a cost of \$36,000 by enlarging the three existing magazines and constructing one additional barricaded splinter-proof magazine (Building No. 401 or Magazine No. 4), thereby providing storage for 125 rounds per gun at Battery Harris. A sanded barricade was constructed for this new magazine because of its proximity to the Post area in order to minimize the blast effects of any accidental explosion.<sup>40</sup>

Today the four magazines may be described as basically identical. Each building is a rectangular, single-story structure with a low gable roof. The roof decks consist of precast planks and are supported by steel joints. The tile block curtain walls are supported by paired columns, the inner of steel, the outer of concrete. The buildings rest on concrete wall footings. The floors consist of concrete slabs, with steel rails for the shell moving machinery set into them. There are raised concrete docks on either side of each building which run the length of the interiors. There are rolling overhead doors on each end of the buildings.

---

39. New York District Engineer to Chief of Engineers, subject: Storage of war allowance of ammunition for 16" guns, Battery Harris, Fort Tilden, March 6, 1929, RG 77, NA.

49. 7th Indorsement, Hannum to Adjutant General, April 13, 1936, to letter Commander, Harbor Defenses of Sandy Hook to Adjutant General subject: Storage of Ammunition at Fort Tilden, N.Y., RG 77, NA; 2nd Wrapper Indorsement, Second Corps Area to Chief of Engineers, May 4, 1939, Box 83, RG 77, NA.



Each magazine also has a steel plate door in one gable end, which is reached by a flight of concrete steps. These doors open into the storage docks. There are no mechanical facilities, other than accessories such as tracks, in any of these buildings (Illustrations 19, 20, and 21).

The condition of the four magazines ranges from poor to fair.

B. Igloo Magazines (Buildings Nos. 403 (F-9) and 404 (F-10))

The National Register of Historic Places Inventory Nomination Form describes these structures as partially sunken concrete structures of the semi-cylindrical type known as Igloo magazines. These two basically identical structures are barrel vaulted structures with bulkhead entryways. They are constructed of concrete and have been partially covered with earth. They both have double wooden doors covered with tarpaper. There are no electrical or mechanical facilities in either structure (Illustrations 22 and 23).

This writer was unable to find any historical evidence that may shed light on the use or construction of these small buildings. It is very probable, however, judging from their location, that they served to store ammunition for the three-inch antiaircraft battery that was located nearby.

C. Buildings Nos. 322 and 402

Building No. 322 is located just behind Battery Kessler. It is almost similar to Building No. 402, which is just off of Marshall Road between East Road and Center Road. Building No. 322 was probably the temporary tool shed constructed around 1940 to house



Illustration 19  
Magazine, Building 405  
Battery Harris  
1979



Illustration 20  
Interior view of magazine  
Building 405  
Battery Harris  
1979



Illustration 21

Detail of platform with track  
in magazine, Building 405  
Battery Harris  
1979



Illustration 22

Igloo magazine  
Building 403  
1979

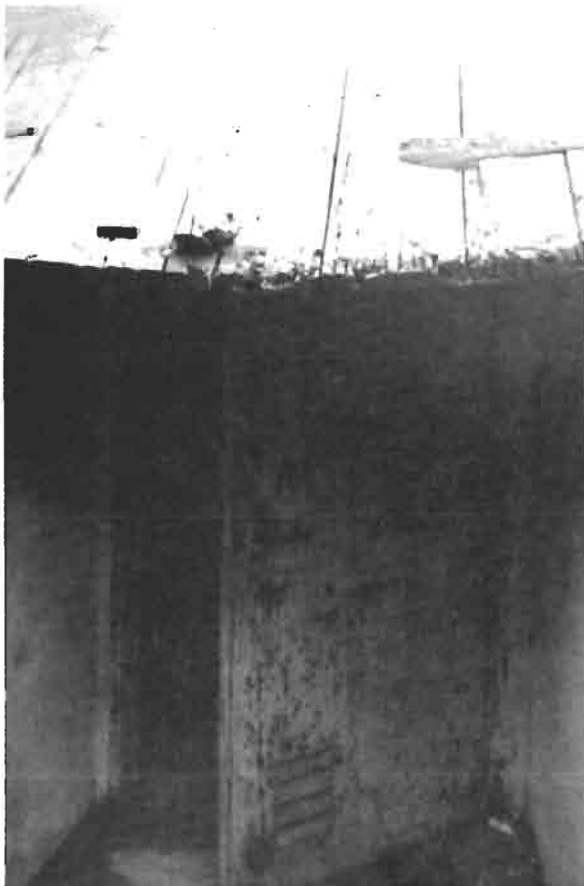

Illustration 23

Entrance to igloo magazine  
Building 403  
1979

tools, cleaning and preserving materials, and such other items as the fifteen-foot self-contained range finder. When planned the structure was to be approximately 12 by 18 feet and made of a reenforced concrete foundation and concrete blocks. It was to have a three-foot door at one end, and it was to be located directly behind Battery Kessler.<sup>41</sup>

The evidence does not indicate what this structure was used for, but judging from its location, it was probably used to support Battery Kessler.

There may have been a second similar structure behind Battery Construction No. 220, but this may have been razed at some time to make room for other facilities.

Although similar to Building 322, Building 402 was somewhat smaller in size. In the commander's request for the construction of this shed he indicated that it was needed to house tools and cleaning and preserving equipment for the antiaircraft battery. The size, he thought, was sufficient to house a portable power plant to be furnished for powering the fire control equipment. The structure was to be 12 by 14 feet, and it was to consist of a reinforced concrete floor and foundation and concrete block walls. There was to be a double door at one end to allow for an opening of six feet. This structure was to be located about 100 yards from the guns.<sup>42</sup>

---

41. Jaccard to Commander, Harbor Defense of Sandy Hook, subject: Authority for new Construction at Fort Tilden, N.Y., February 28, 1939; Plan "6-inch Gun Tool Shed (Two Required), No. D-70 and 71-1, October 23, 1939; Project Estimate, "Construct tool shed for East Btry (6"SC)...," February 28, 1940, all in Box 83, RG 77, NA.

42. Jaccard to Commander, Harbor Defenses of Sandy Hook, Subject: Authority for new construction at Fort Tilden, N.Y., (Continued)

Today the two structures may be described as rectangular, single story buildings with concrete block walls and flat concrete slab roofs.

#### Power Plants (Building Nos. 407, 408, 412)

Building Nos. 407, 408, and 412 were known historically as Power Plants 2, 3, and 1 respectively. The three formed part of Battery Harris. Power Plants 1 and 2 each supplied power to one of the big guns and Power Plant 3 was a reserve unit to be placed in operation in the event the other power plants were temporarily out of commission. Power Plant 1, which powered Gun No. 1, is located to the south of Marshall Road on the west side of the reservation. Power Plant 2, which powered Gun No. 2, is located off of Marshall Road not far from where Center Road begins. Power Plant 3 is located almost behind Building No. 409 (No. 2 magazine for Battery Harris).

The construction of these three relatively small structures was part of that whole plan developed in the early 1920s to build Battery Harris. Thus, in outlining the facilities which needed to be built the Chief of Engineers wrote:

The accessories provided in this layout consist of a bombproof plotting and switchboard room; three unprotected power plants, one for each gun and one reserve; and three unprotected magazines with a capacity

---

42. February 28, 1939; Plan, "3-inch Anti Aircraft Tool Shed, No. D-69-1," October 28, 1939; Project Estimate, "Construct tool shed for 3" AA btry, to house necessary tools and equipment and cleaning and preserving materials required at guns," February 28, 1940, all in RG 77, NA.

of 30 rounds each. A single track railroad runs in rear of the guns, connecting the latter with the magazine and wharf. Two of the power plants are located on a spur track to facilitate the transportation of bottles of compressed air to the guns for charging the recuperators.<sup>43</sup>

In July 1922, the Chief of Engineers completed the designs for the three power plants. Plants 1 and 2 would each house one 90 kw. Diesel engine generator and one 3,000 pound air compressor. Plant 3, the reserve unit, was to house a 90 kw. Diesel engine generator and a 25 kw. gasoline generator. Each plant was to furnish sufficient power for one gun, leaving one in reserve. The 3,000 pound air compressors were for the purpose of furnishing necessary air for charging the recuperators of the guns. The three plants were estimated to cost \$60,000. The plans were quickly approved by the Secretary of War.<sup>44</sup>

Delays occurred in the construction of the power plants. In July 1923, the New York District Engineer noted that in addition to

---

43. 2nd Indorsement, Chief of Engineers to Adjutant General, February 11, 1922, to letter N.Y. District Engineer to Chief of Engineers, subject: Designs for 16-inch emplacements, Ft. Tilden, N.Y., September 21, 1921, RG 77, NA.

44. Record of Communication Received, Chief of Engineers to Adjutant General, subject: Unprotected power plant, Battery Harris, July 17, 1922, RG 77, NA; 2nd Indorsement, Adjutant General to Chief of Engineers, July 31, 1922, RG 77, NA. See also the following (1) Plan, Fort Tilden, N.Y. - Battery Harris, Power House for 90 K.W. Diesel Unit, General Plan - Power Houses Nos. 1 & 2, May 22, 1924; (2) Plan, Fort Tilden, N.Y. - Battery Harris, Power House for 90 K.W. Diesel Unit, Reserve Power House No. 3, Electric Light and Power Wiring, May 22, 1924, both in RG 77, NA (Appendixes 13 and 14).

connecting the Diesel engines, switchboard wiring, and other electrical items, hardware and windows had yet to be installed and concrete floors, septic tanks, oil and gasoline tank pits, and a number of miscellaneous items had to be constructed. However, by the end of 1923 the plants were completed.<sup>45</sup>

There was some evidence that in 1937 a radiator was installed in Plant 3 for cooling water in the circulating system of the 90 K.W. Diesel unit.<sup>46</sup>

With the construction of a new complex for Battery Harris in 1943, the question of whether or not the power plants still remained to serve the guns must remain unanswered. Were the functions of the power units transferred to the new casemates? If so, what were the three structures housing the power plants used for? Until more evidence is available, these questions must remain unanswered.

#### Fire Control and Plotting Room (Building No. 413)

The fire control and plotting room was still another separate facility which made up part of Battery Harris. This structure, which has been designated in the current listing of structures at Fort Tilden as Building No. 413, is located at the juncture of Marshall Road and West Road, almost directly north of Magazine No. 1 (Building No. 414) of Battery Harris.

---

45. New York District Engineer to Chief of Engineers, subject: Completion of 16" Battery Project, Fort Tilden, N.Y., July 7, 1923, with 2nd and 3rd indorsements, RG 77, FRC, Bayonne, N.J.

46. Drawing in 2 sheets: Fort Tilden, N.Y., Battery Harris, Radiator for Cooling Water, Circulating System -- 90 K.W. Diesel Unit, May 26, 1937, RG 77, NA.



In commenting upon the proposed Battery Harris in early 1921 the New York District Engineer had this to say:

It is noted from the correspondence that it is proposed that in connection with these emplacements, based primarily upon the idea of simplicity and dispersion, there is to be included at least one bombproof and shellproof structure. This structure is to contain a switchboard room, one or more plotting rooms, and a power room: or, if it is to be decided that the installation of the generating sets in such a small concrete bombproof will make so much noise as to interfere with operations in the plotting and switchboard rooms, then the power room is to be installed in a separate structure.<sup>47</sup>

The question of the power room, as we have seen, was settled with the construction of the three power plants. Concerning the question of dispersion, the New York District Engineer had this to say:

. . . there appears to me to be no very good reason why the plotting room should necessarily be built in close proximity to the guns. It is understood that no mechanical connection for indicating apparatus between the plotting room and gun is to be attempted, and that communication between the plotting room and gun is to be by telephone. Under these conditions, the plotting rooms could well be located at a considerable distance from the

---

47. N.Y. District Engineer to Chief of Engineers, subject: Plans for 16-inch emplacements at Fort Tilden, N.Y. January 5, 1921, RG 77, FRC, Bayonne, N.Y.

guns, where it might be possible to give them incidental protection as may be available or desirable without marring the essential character of the emplacement. This is likewise true of the switchboard room and the power room.<sup>48</sup>

The plan that was ultimately approved by the Chief of Engineers envisioned a bombproof plotting and switchboard room that was separate from the main battery structure. The detailed plans were drawn in late 1922.<sup>49</sup> On February 10, 1923, bids were opened, and the lowest bidder (\$29,457), Pearce Brothers Incorporated, a New York firm, was awarded the contract.<sup>50</sup>

The construction of this bombproof structure was to follow the designs of those drawn in late 1922. Some of the basic materials that went into its construction consisted of reinforced concrete and its component parts, hollow tiles (12 by 8 inches thick), clear wire glass for windows, and sand cover. The sand, which was to come from Fort Tilden, was to be placed at the sides, front, and top of the completed structure. An allowance of six percent was to be

---

48. Ibid.

49. 2nd Indorsement, Chief of Engineers to Adjutant General, February 11, 1922, to letter, N.Y. District Engineer to Chief of Engineers, subject: Designs for 16-inch emplacements, Ft. Tilden, N.Y. September 21, 1921, RG 77, NA; drawing in 3 sheets under the following heading; "Fort Tilden, N.Y., Protected Plotting Room and Switchboard Room Type A," sheets 1, 2 and 3, December 11, 1922, RG 77, NA (Appendixes 15, 16 and 17).

50. War Department Gun and Mortar Batteries, 1923, Battery Construction, Proposed for Constructing One Concrete Plotting Room and Switchboard Room; Abstract of Proposals, February 13, 1923, both in RG 77, FRC, Bayonne, N.J.

made for shrinkage. Steel doors were to be hung at all door openings in the rear of the structure, the doors to be made of steel plates 5/16 of an inch thick. All window openings at the rear of the building were to be provided with steel gratings.<sup>51</sup>

The structure itself was probably completed in 1924. There is evidence, however, that even as late as 1925, electrical work was still going on at the structure.<sup>52</sup>

There is also some evidence, albeit fragmentary, that in the early 1940s some work was accomplished on this structure in order to "modernize" that facility.<sup>53</sup> This may account for the changes that clearly exist today, especially as the rear of the structure is effected. The structure today can be described as an earthcovered and concrete casemate. It is roughly a rectangular, one-story building covered with earth and sand. The walls, floor, and roof are all concrete. There is only one entrance to the bunker, which is equipped with steel grille gates. There are several rooms inside off of the main corridor. There are no operating mechanical or electrical facilities. The major changes made to the structure since it was first built seem to be in the rear where there are now no doors or windows (Illustration 24).

---

51. Proposal for Constructing One Concrete Plotting Room and Switchboard Room, n.d., RG 77, FRC, Bayonne, N.J.

54. 3rd Indorsement, N.Y. District Engineer to Chief of Engineer, July 17, 1923, to letter, N.Y. District Engineer to Chief of Engineer, subject: Completion of 16" Batttery Project, Fort Tilden, N.Y., July 7, 1923, RG 77, FRC, Bayonne, N.J.; N.Y. District Engineer to Chief of Engineer, subject: Report of Operations, Fortifications, September, 1924, October 9, 1924, RG 77, NA; N.Y. District Engineer to Chief of Engineers subject: Report of Operations, Fortifications, October 1925, November 9, 1925, RG 77, N.A.

53. Annex F, Gas Defense, n.d., Miscellaneous Papers, RG 407, N.A.



Illustration 24

Entrance to fire control  
and plotting room  
Building 413  
1979

### Mine Casemate and Plotting Room (Building No. 511)

This writer was unable to find much written evidence concerning the physical history of Building No. 511. Referred to as the Mine Casemate and Plotting Room, this structure, built during World War II, formed part of a mine battery consisting of three tactical units each of which was located at Fort Hancock, Fort Wadsworth, and Fort Tilden. The mine casemate was the command post for the Fort Tilden branch of the submarine defenses. One of the few known documents uncovered by this writer refers to the mine casemate as a "new concrete" structure and as being "bombproof" and containing 11,150 cubic feet.<sup>54</sup>

Today the mine casemate can be described as a structure consisting largely of reinforced concrete covered by sand and sod. The casemate has a number of flues extending from the roof, which probably served as ventilators. There are two entrances on the north side, but access through these doorways is difficult because of heavy underbrush and debris from fallen members which block their passage (Illustrations 25 and 26).

This structure is in poor condition.

### Groupment Command Post (Building No. 13)

The Groupment Command Post (Building No. 13), the facility in which the operational activities of Fort Tilden were coordinated, is not listed in the Inventory Form of the National Register of Historic

---

54. Annex F, "Gas Defense", n.d., Miscellaneous Documents, RG 407, NA. See also map, "Harbor Defenses of New York: Mine Shore Installations Fort Tilden, N.Y.", August 1943, RG 407, NA.



Illustration 25

Section of mine casemate  
Building 511  
1979



Illustration 26

Entrance to mine casemate  
Building 511  
1979

Places, but because of its important historic mission and its reasonably good condition, the Park has properly requested that this study treat the structure to some degree. It is, therefore, recommended that this structure be included in the Inventory Form of the National Register of Historic Places.

Fortunately, there are a number of early drawings of this structure that have recently come to light which clearly depict its details and what each room was used for. The existing conditions of the structure reveal that it was largely built according to plan.

A Groupment Command Post had been located in a temporary building at Fort Tilden before World War II. Planning to construct a permanent facility did not take place until about 1942. Before this facility could be permanently located, however, the question of locating a structure housing an SCR 582 at the rear of the Groupment Command Post had also to be settled. After disagreements ensued, the existing location was finally settled upon.<sup>55</sup>

According to one drawing the proposed Groupment Command Post was to be about 50 by 50 feet.<sup>56</sup> Because of the highly technical nature of this facility, it would be extremely difficult to provide a description of its various parts (Illustrations 27 and 28). However, this writer was fortunate to uncover a set of six detailed drawings which describe the structure as it was built during World War II.

---

55. Map, "Proposed Location of C-2 C.P. and SCR 582 at Fort Tilden, N.Y., RG 407, N.A.

56. Ibid.



Illustration 27

Section of Groupment Command Post  
Building 13  
1979



Illustration 28

Entrance to Groupment  
Command Post  
Building 13  
1979



These should be extremely helpful to architects, engineers, and preservationists in general.<sup>57</sup>

### Nike - Hercules Structures

The remains of the Nike-Hercules structures at Fort Tilden are concentrated in three areas. One of these, the launching area where the missiles were stored, serviced, and launched, was almost a square section bounded on the east and south by Hero Road and Haan Road respectively. The beach and ocean front was to the south.<sup>58</sup>

A second area was a radar tracking station which was located at the southwest corner of the reservation. The third area, a second tracking station, which was smaller than the first, was located almost at the northwest corner of Fort Tilden. To the west of this site was the old mine casemate (Building no. 511), and to the north was Rockaway Beach Boulevard.

Because of the highly classified nature of this military operation, the author was unable to gain access to official documents dealing with the Nike-Hercules Missile operation at Fort Tilden. Ironically,

---

57. See the following drawings: (1) Service Command Project No. 986, October 26, 1945, in 2 sheets (a) Modifications to Heating and Ventilating System, Plan and Details (b) Modifications to Heating and Ventilating System, Sections and Details; (2) Groupment Command Post, December 17, 1943, in 4 sheets: (a) Grading Plan (b) General Plan (c) Gasproofing and Heating Details (d) Electrical and Plumbing Details, all formerly in the files of Fort Hamilton, N.Y., but now in Park files (Appendixes 18, 19, 20, 21, 22, and 23).

58. See frontispiece map for these three areas.

however, he was fortunate, to have uncovered a large collection of detailed drawings of many of the structures.<sup>59</sup>

Since these drawings are in such great detail and deal with a multitude of highly technical subjects, this writer has concluded that the treatment of these documents in any narrative form should be left to engineers and to other related professionals with a technical background.

The writer was also very fortunate to have uncovered a sizeable number of photographs depicting the Nike-Hercules site at Fort Tilden during its historic period.<sup>60</sup>

The launch area consisted of four elevators, two in front and two in the rear. There were four underground rooms where the missiles were stored. The missiles were brought to the surface by the four elevators and launched from pads on the ground. There was a total of sixteen launches or pads, counting the four elevators which also acted as launch pads. Eight of the launch pads were in front and eight were in the rear, forming two rows. Each row had a track extending the full length of the launches. Upon reaching the surface by elevator, the missile would be carried along the track to

---

59. These drawings, numbering about 20, have recently been acquired by the park from Fort Hamilton. Most of them appear under the general heading of Improved Nike-Hercules System.

60. The negatives of 12 photographs are stored in the Audio-Visual Branch, Department of the Army, The Pentagon, Washington, D.C. The accession numbers of 11 illustrations included herein are SC 638174 (March 24, 1967) (Illustration 29), SC 549837 (July 7, 1959) (Illustration 30), SC 549839 (July 7, 1959) (Illustration 31), SC 549838 (July 7, 1959) (Illustration 32), SC 575228 (1959) (Illustration 33), SC 638173 (March 24, 1967) (Illustration 34), SC 638172 (March 24, 1967) (Illustration 35), SC 638171 (March 24, 1976) (Illustration 36), SC 638170 (March 24, 1967) (Illustration 37), SC 638169 (March 24, 1967) (Illustration 38), and SC 634345 (October 17, 1966) (Illustration 39).



Illustration 29

Missile in firing position

Fort Tilden

1967

Courtesy U.S. Army

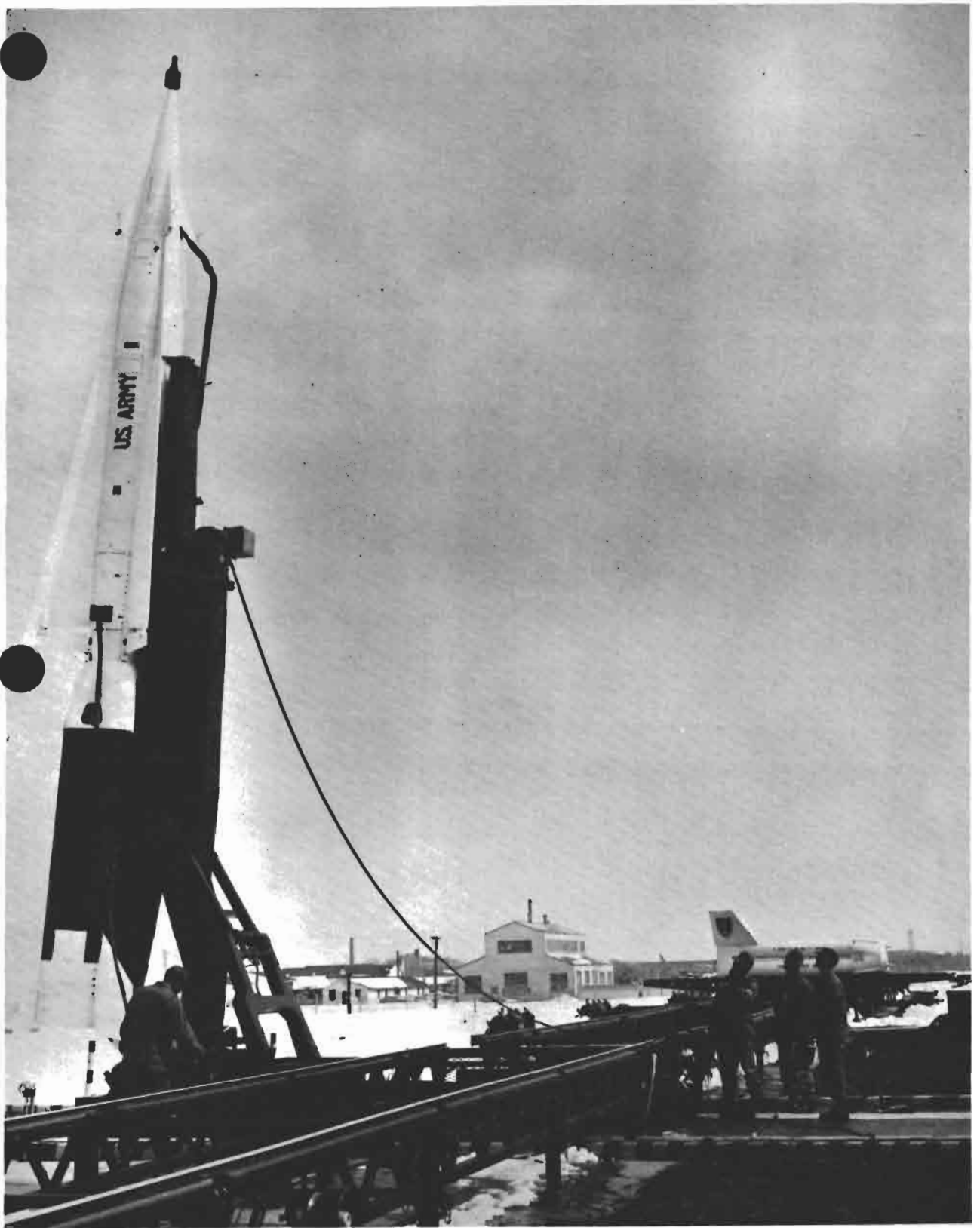

Illustration 30

Aerial view of Nike-Hercules launch area

Fort Tilden

1959

Courtesy U.S. Army

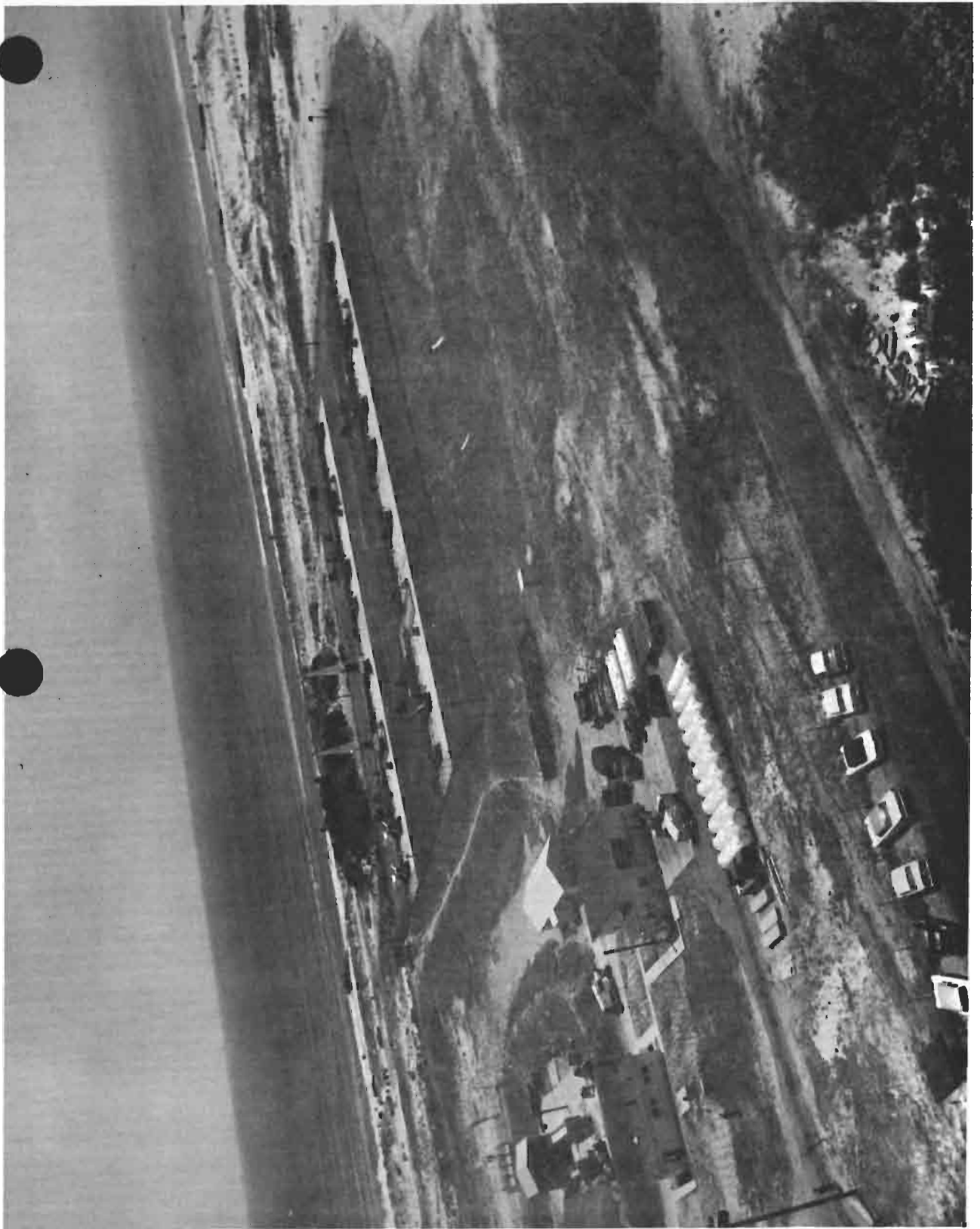

Illustration 31

A second aerial view of Nike-Hercules launch area

Fort Tilden

1959

Courtesy U.S. Army



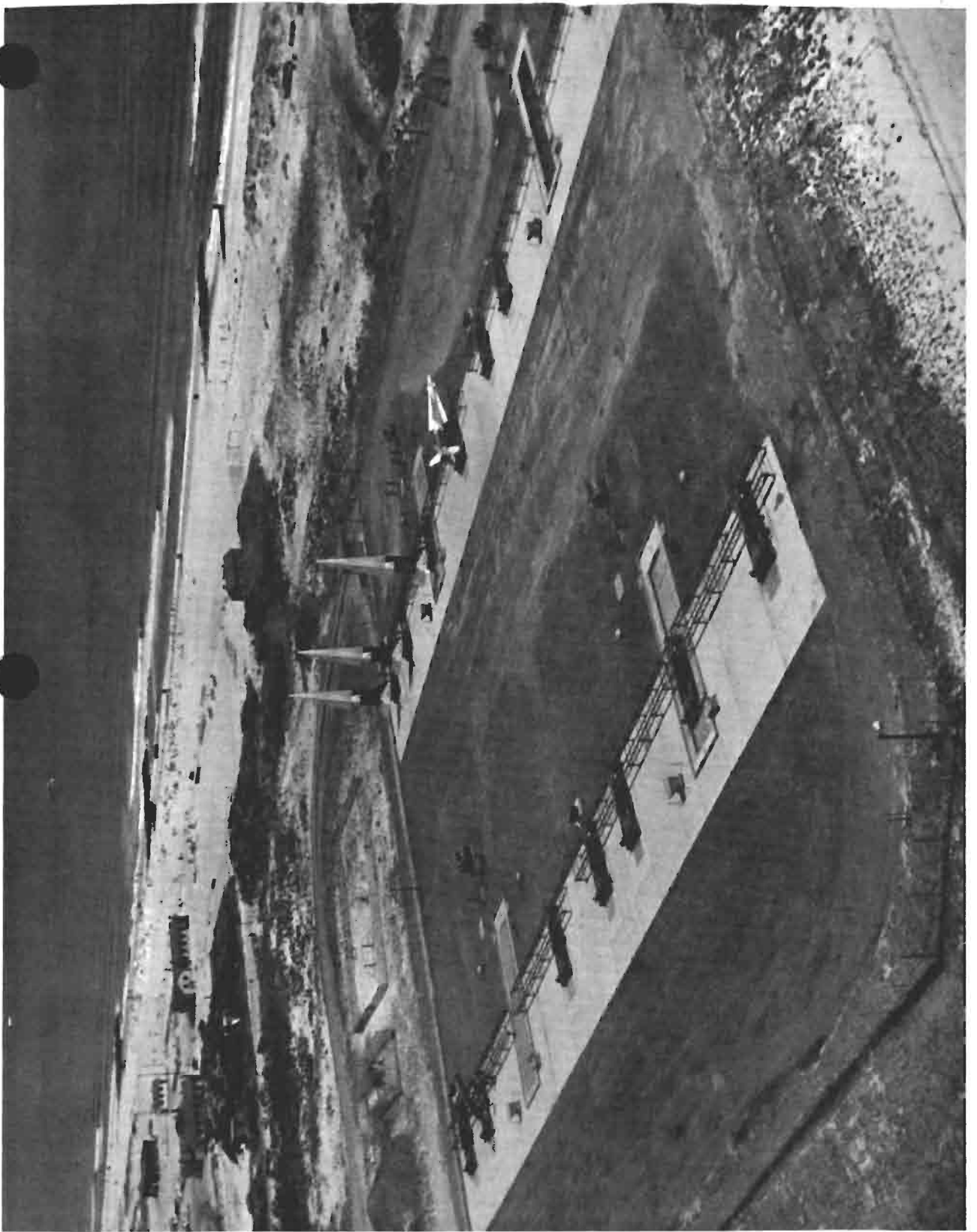

Illustration 32

A third aerial view of Nike-Hercules launch area

Fort Tilden

1959

Courtesy U.S. Army

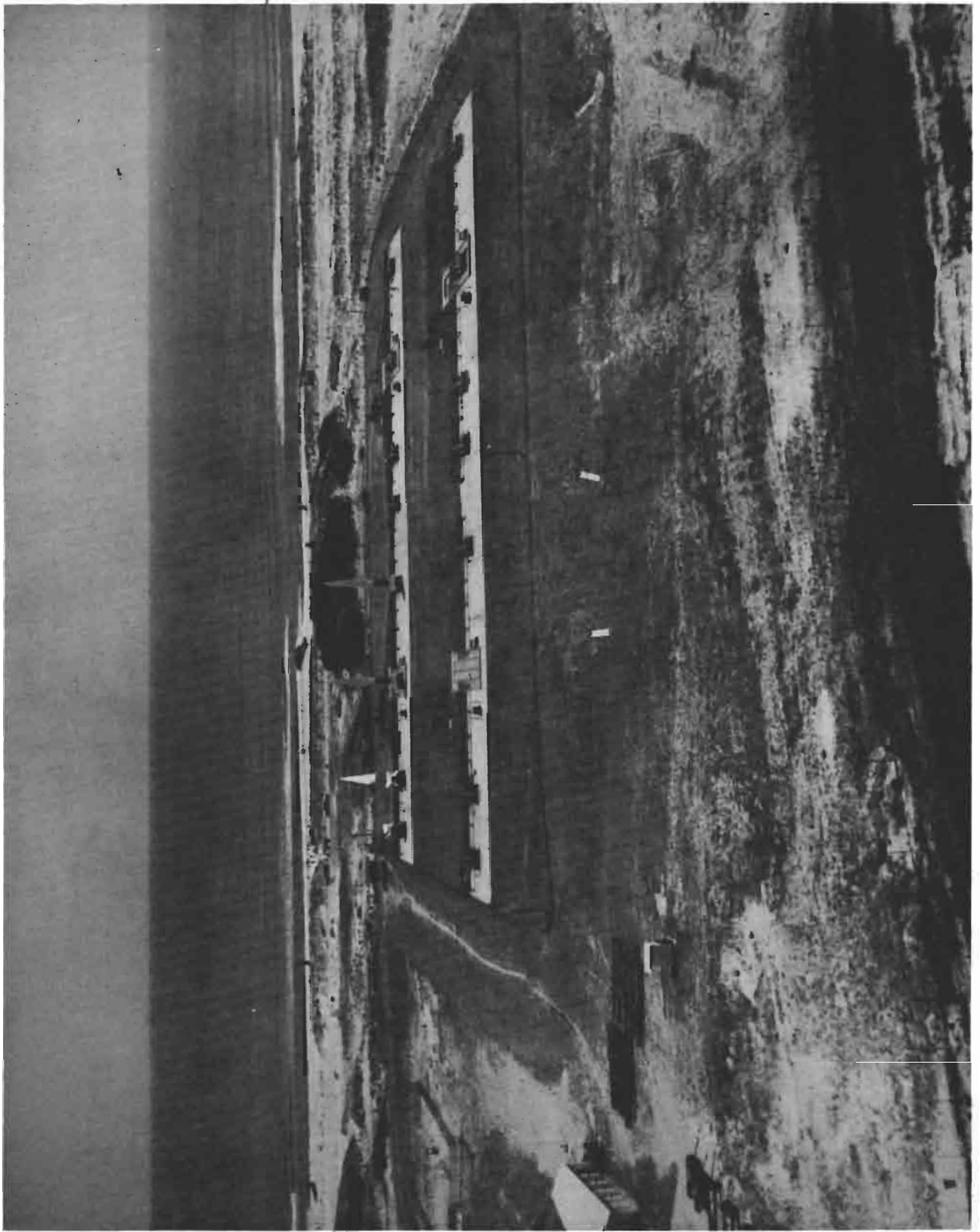

Illustration 33

Close-up of a Nike-Hercules launch pad

Fort Tilden

1959

Courtesy U.S. Army

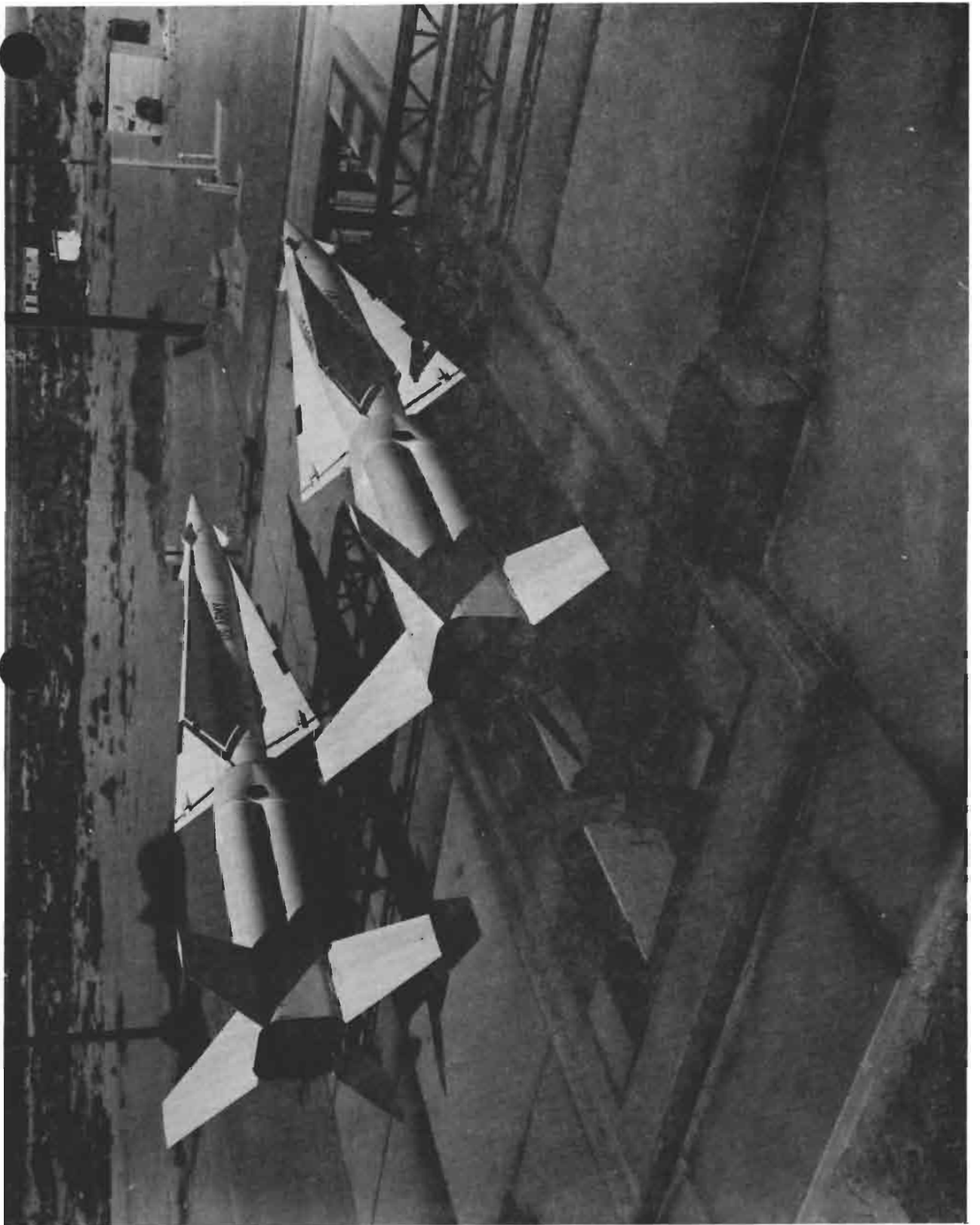
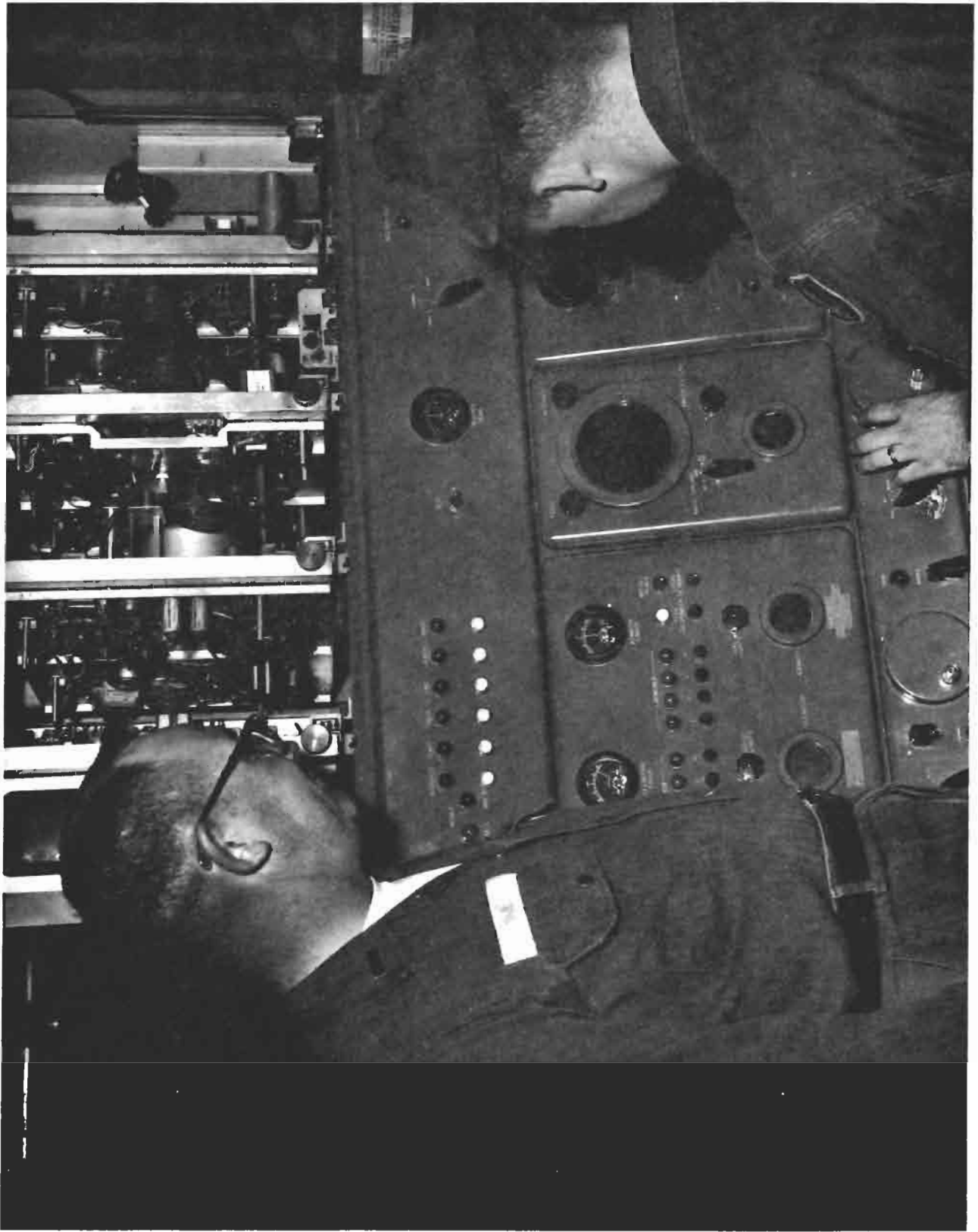

Illustration 34

Radar operator checks MTR in  
Radar tracking station  
Fort Tilden  
1967  
Courtesy U.S. Army



94015

Illustration 35

Section of target tracking radar

Fort Tilden

1967

Courtesy U.S. Army





Illustration 36

Section of missile tracking radar

Fort Tilden

1967

Courtesy U.S. Army

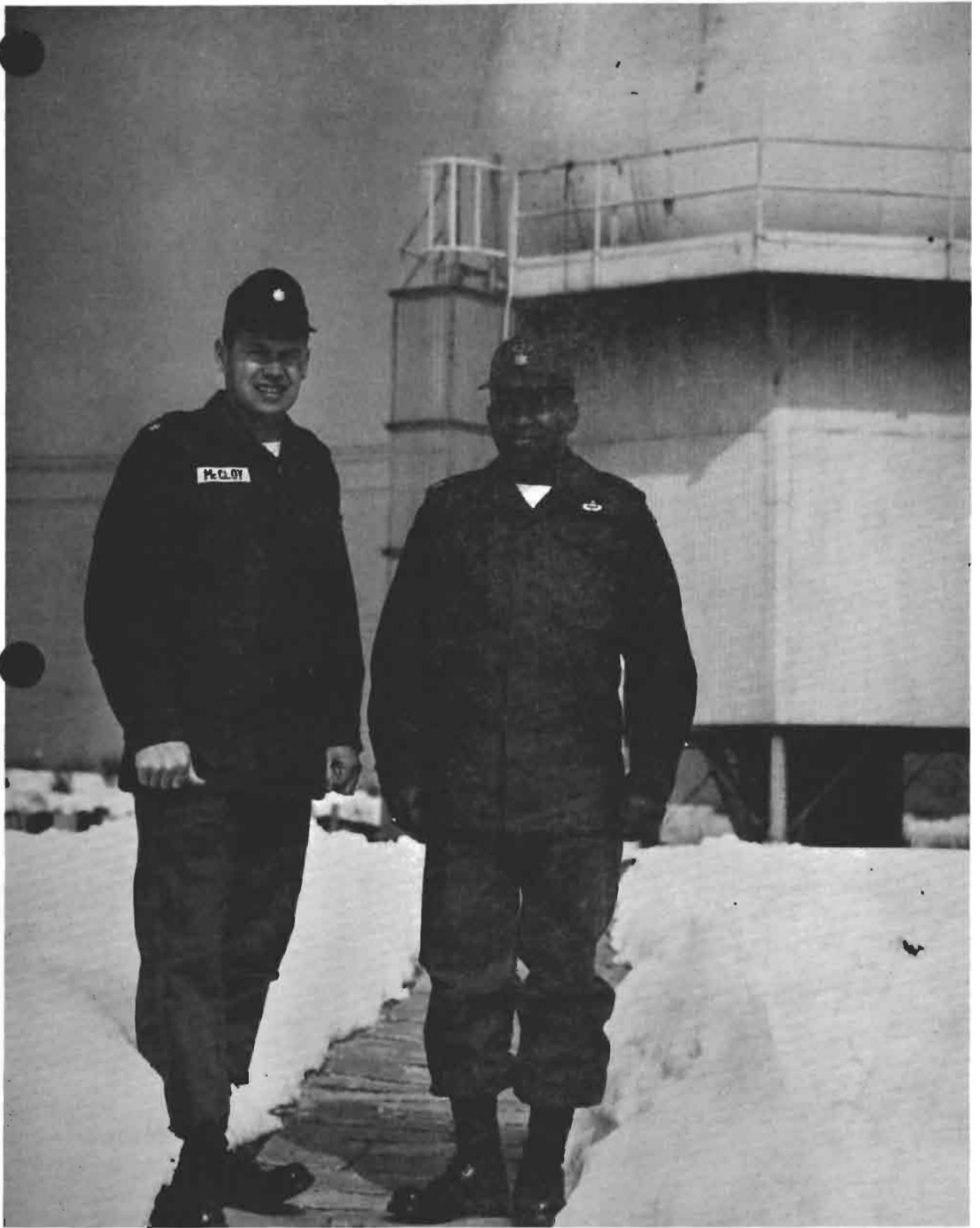

Illustration 37

Radar operator's equipment in missile  
tracking radar

Fort Tilden

1967

Courtesy U.S. Army

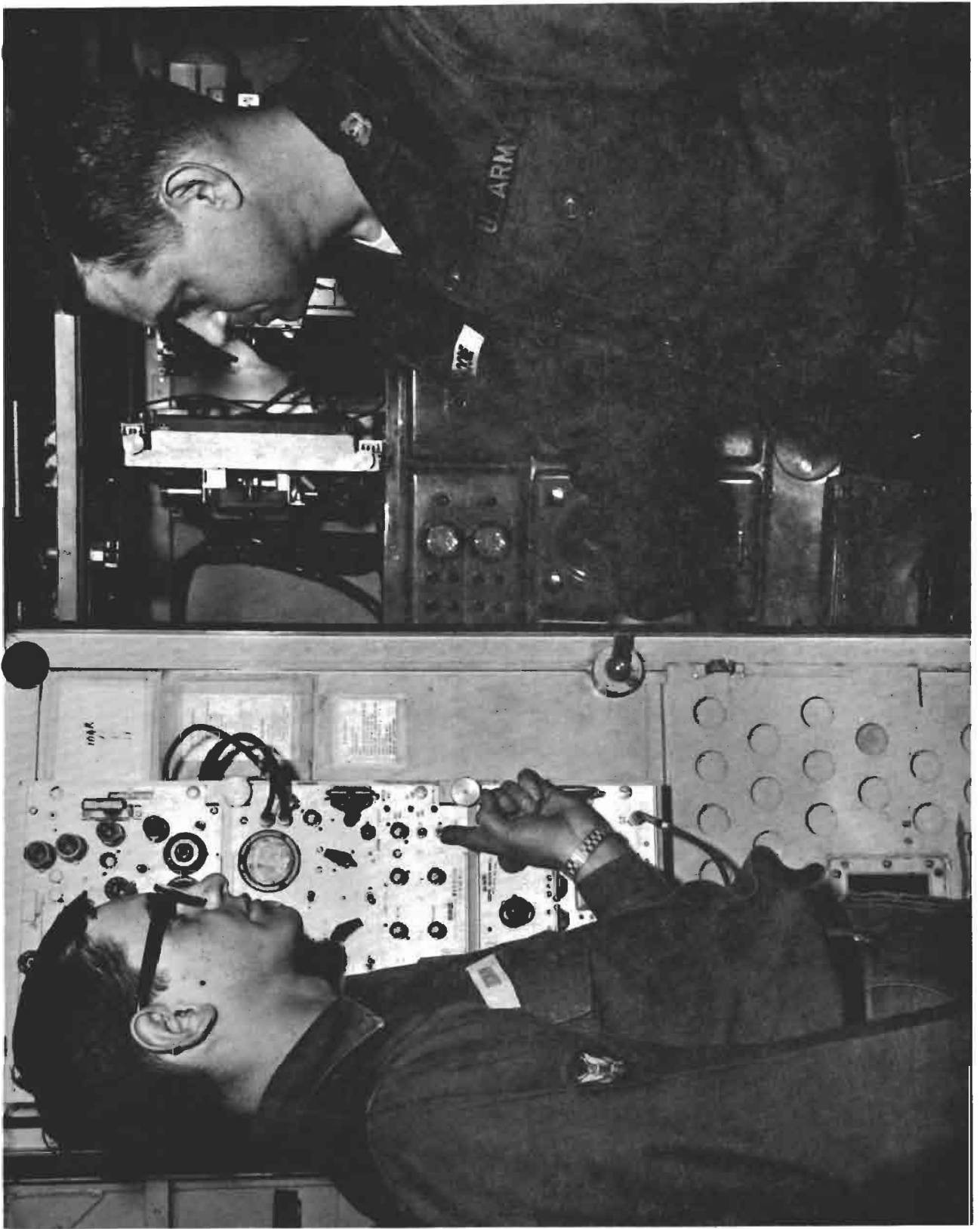

Illustration 38

PPI scope in directory station of  
integrated fire control unit

Fort Tilden

1967

Courtesy U.S. Army



Illustration 39

Radar dome in fire control center

Fort Tilden

1966

Courtesy U.S. Army



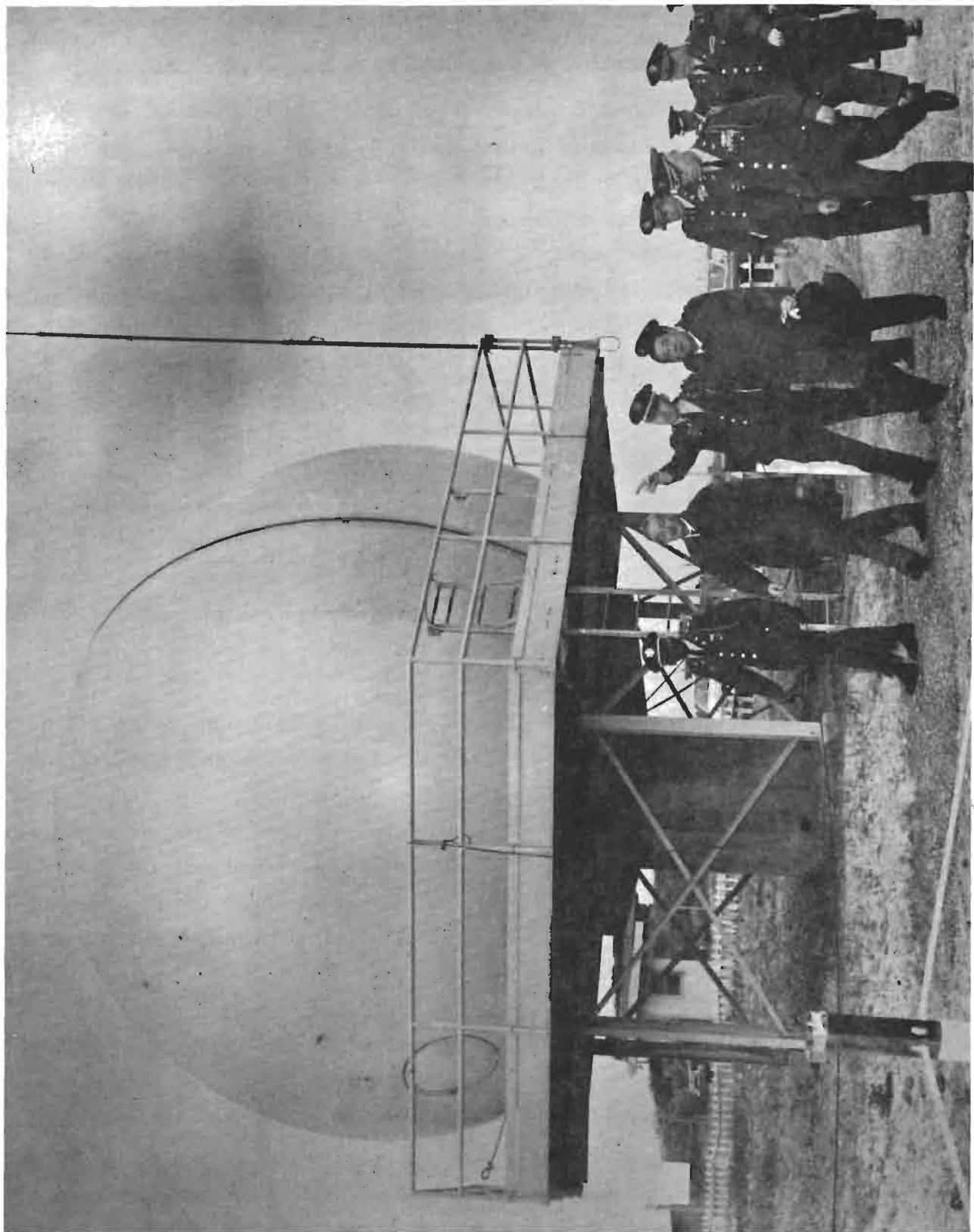

the proper launcher. The area containing the launchers and elevators, or the launch area proper, was enclosed by a high wired fence. Outside this highly restricted area but still within the missile launch site were several structures some built with concrete blocks and others with wood. They were all single story. These structures contained maintenance shops, storage space, and sentry boxes for servicing and policing both the missiles and launchers. Within the larger area, which was also enclosed by a wire fence, was a dog kennel containing watch dogs employed to police the launcher site.

The two radar tracking stations contained the radar domes (held up by steel and concrete towers), fire control units, command post, shelters, sentry boxes, and maintenance and storage areas. Most of these structures were constructed of concrete blocks and some consisted of wood.

Today these three areas are in very poor condition. Two of the underground rooms of the launcher area are flooded, much of the steel equipment on the surface is missing, and what remains is rusted and deteriorated. The radar domes are no longer in place and the highly technical equipment has been removed, presumably by the U.S. Army, from the buildings. Many of the wooden structures have fallen almost entirely to the ground (Illustrations 40, 41, 42, 43, 44, 45, 46, 47, and 48).

Many of the structures, particularly the wooden ones, are beyond salvage. Indeed, it might be questioned whether these structures are entirely essential for the interpretation of the Nike-Hercules missile site at Fort Tilden. However, every effort should be made to stabilize and interpret the underground rooms, elevators, radar towers, and some of the concrete buildings and fixed steel structures that remain above ground.

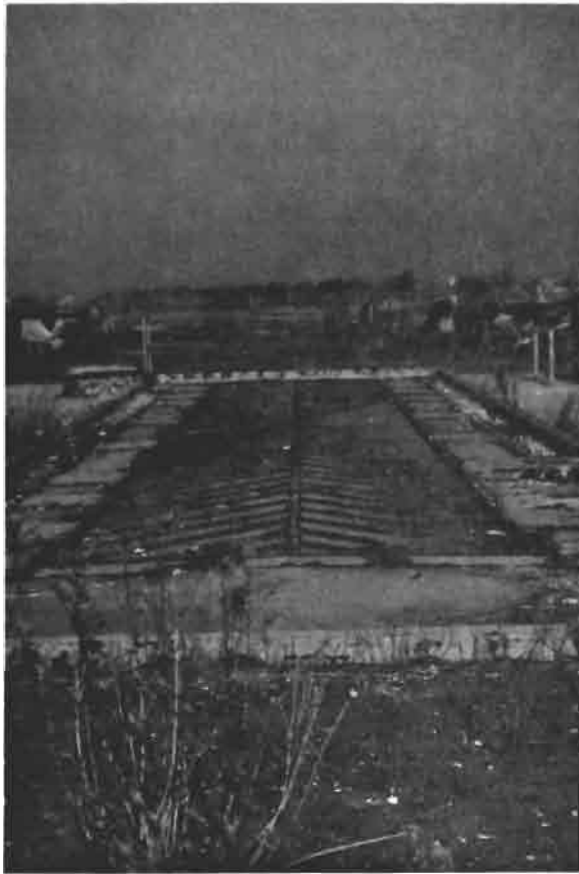

Illustration 40  
Silo doors in  
launcher area  
Nike-Hercules Site  
1979



Illustration 41  
Silo doors in  
launcher area  
Nike-Hercules Site  
1979

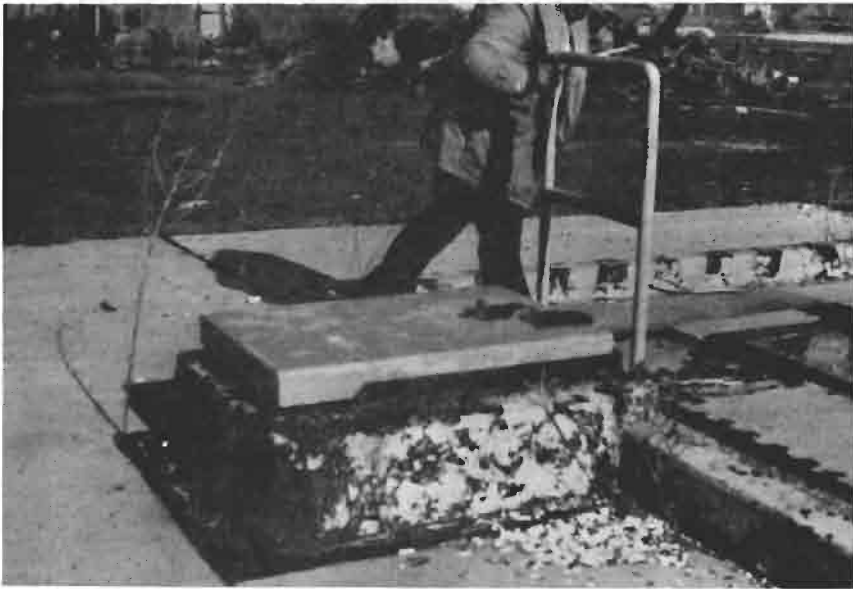

Illustration 42

Silo entrance hatch  
launcher area  
Nike-Hercules Site  
1979

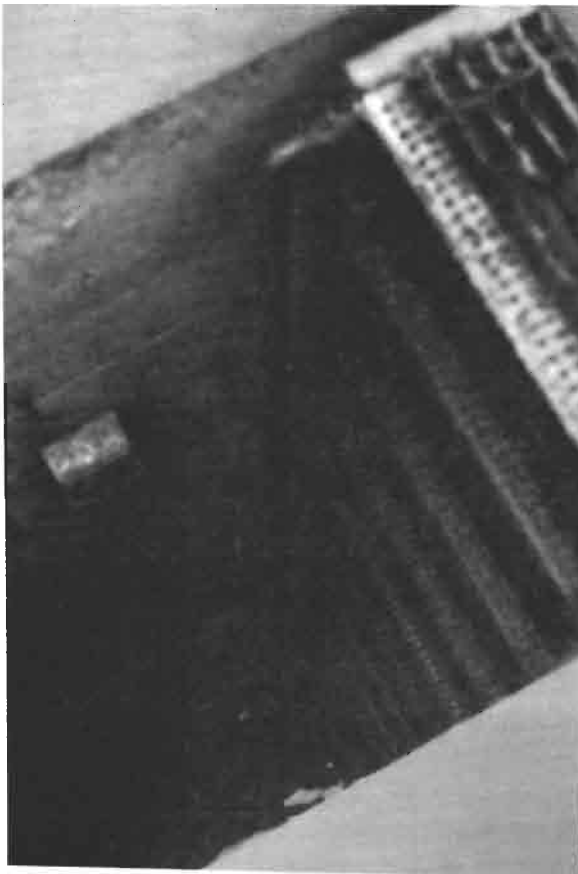

Illustration 43

Stairwell leading to  
underground compartment  
launcher area  
Nike-Hercules Site  
1979



Illustration 44

Radar tracking platforms  
tracking area  
Nike-Hercules Site  
1979



Illustration 45

Radar tracking platforms  
tracking area  
Nike-Hercules Site  
1979



Illustration 46

Radar station center  
tracking area  
Nike-Hercules Site  
1979

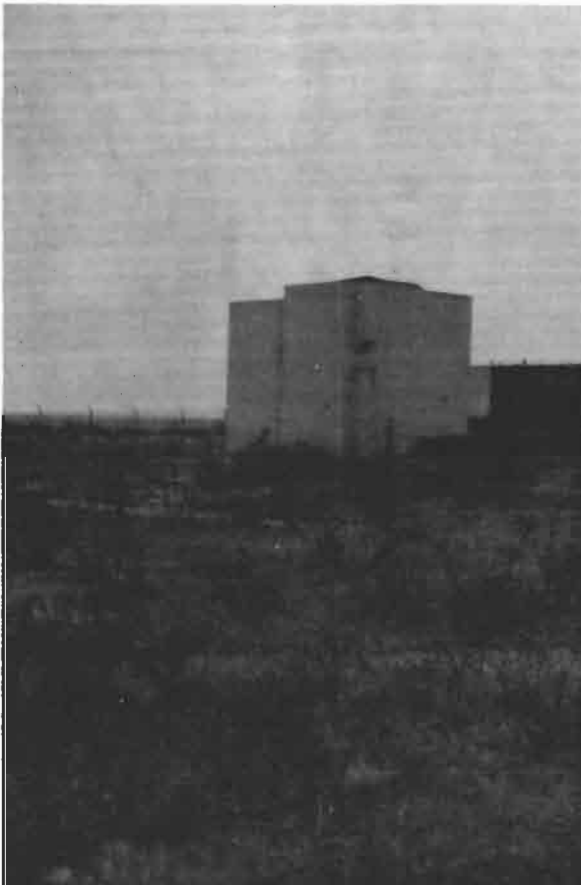

Illustration 47

Concrete structure  
tracking area  
Nike-Hercules Site  
1979

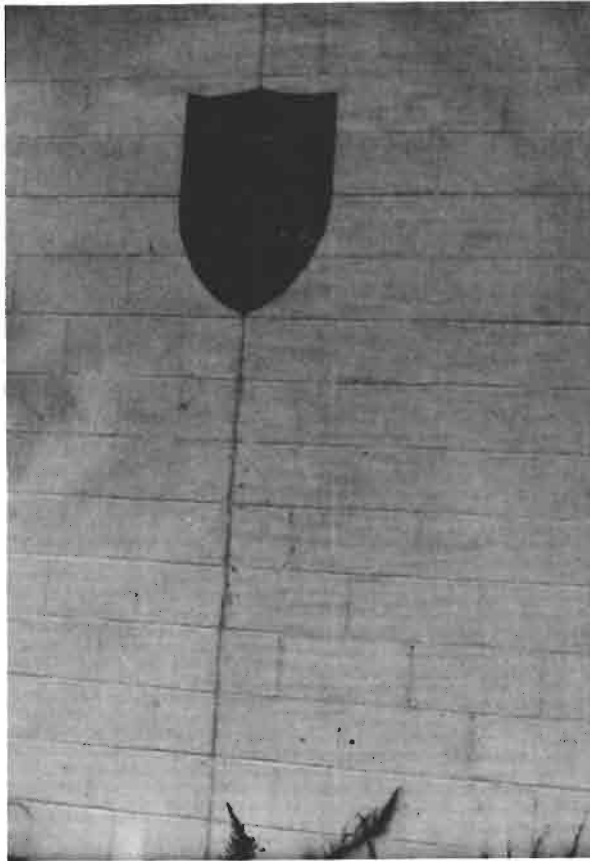

Illustration 48

Insignia on command center  
tracking area  
Nike-Hercules Site  
1979





## CHAPTER III: THE POST

### Chapel (Building T-3)

The chapel (Building T-3) at Fort Tilden is typical of the design of Army chapels built during World War II. It was dedicated on October 12, 1941 during a very impressive ceremony. At the time it was briefly described as follows:

The new chapel, which will seat 400, is designed in the rustic manner. . . . The chapel interior is in knotted pine with antique rafters and chandeliers, and the pews are in walnut. A sliding panel will conceal the altar when it is not in use. An electric organ is part of the chapel equipment.<sup>1</sup>

Additional pertinent details are to be found in drawings. The dimensions of the chapel are about 81 feet long by 62 feet at its widest point. Upon entering the chapel, there is a small vestibule. On the right side of the vestibule is a consultation room and on its left a cloak room. On both sides of the sanctuary are the chaplains' offices, and behind the sanctuary is the boiler room.<sup>2</sup> The chapel also had a balcony that hung from the rear, access through which was from the cloak room.

The chapel is largely built of timber siding. The roof was made of green asphalt shingle. The square base of the steeple had timber

---

1. Brooklyn Eagle, New York City, October 9, 1941; New York Herald Tribune, October 13, 1941.

2. Drawing, "Regimental Chapel, Type CH-1 (modified), Plans and Electrical Drawing No. 800-550M," June 1, 1942, in park files. (Appendix 24).

siding on three sides and a lower window on the front. The top of the steeple, like the roof, consisted of green asphalt shingles.<sup>3</sup>

The chapel does not appear to have undergone any major alterations since it was built. It appears to be in good to fair condition. (Illustrations 49, 50, 51, and 52).

#### Recreation Building (Building T-149)

Unfortunately, no plans were found of the recreation building (Building T-149); however, we were fortunate to have come across a completion report of the construction in the National Archives. The structure was actually completed in February 1941 under a contract drawn up in November 1940 to construct 68 buildings of varying sizes at Fort Tilden.<sup>4</sup> Under this large contract two recreational buildings of the same type (Type RB-1) were built. One of these, the structure being considered in this study, was referred to as the Regimental Recreation Building and the other was referred to as the Officers' Recreation Building. When they were first built, the former was listed as Building T-158. It was then described as being 25 feet east of Burgess Road.<sup>5</sup>

When constructed this building was 99 by 37 feet in dimensions, and it was intended to hold a capacity crowd of 1,000.<sup>6</sup> It

---

3. For complete details of the chapel, see ibid. and Drawing, No. 800-551, "Regimental Chapel, Type CH-1," September 3, 1941, in park files (Appendix 25).

4. Completion Report For Construction and Completion of Temporary Housing at Fort Tilden, New York, Contract No. W 6511 gm-99, Ql. 136 Dated November 12, 1940, RG 77, NA.

5. Ibid.

6. Ibid.



Illustration 49

Chapel  
1979



Illustration 50

Looking towards sanctuary  
Chapel  
1979



Illustration 51

Interior view of chapel windows  
1979

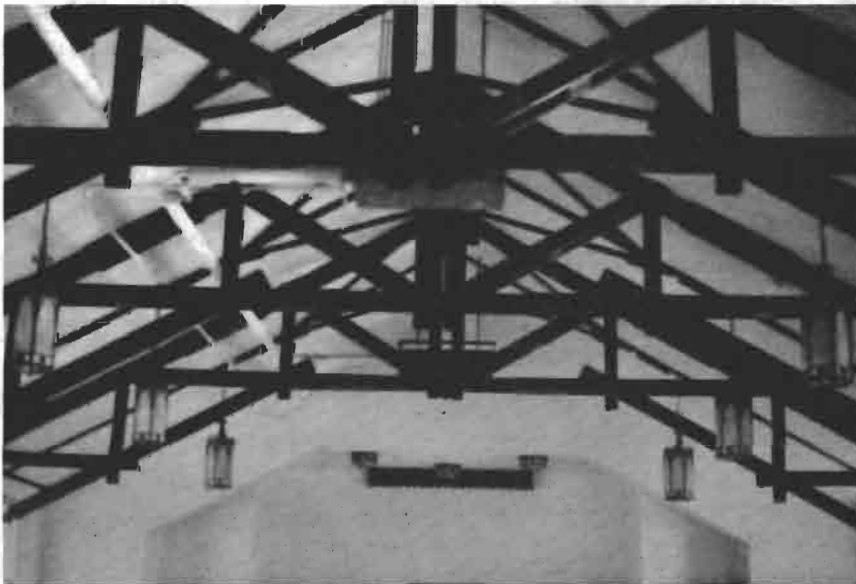

Illustration 52

Ceiling rafters and chandeliers  
of Chapel  
1979

consisted of a one-story frame building. All footings were excavated to a depth of about three feet, six inches below grade. The superstructure was constructed on concrete piers and walls, and it was framed in with lumber. The exterior sidewalls were built of one by eight-inch drop siding applied horizontally over gypsum sheathing nailed at all bearings over waterproof sheathing. The ceiling was finished with Can-ite Insulating Board, and the walls, with the exception of the heater and projection rooms, were finished with one by six T and G wood wainscot and Can-ite Insulating Board above it.<sup>7</sup>

The floors were constructed of "No. 2" pine laid on standard one-inch pine sub-flooring with the exception of the projection room and lobby which were made of cement and concrete respectively. The roof was framed in and covered with asphalt-prepared roofing. No interior painting was done on the building, but the exterior was painted a light buff. The doors and platforms were painted gray. A twenty-foot ladder and two coal boxes were installed inside the building. A furnace and a ticket window were also provided. The structure had no toilet. The total cost of construction was \$10,409.<sup>8</sup>

It is obvious, even to the layman viewing this building, that some changes to the recreation building have been made over the years. Today the floor reveals that a large rectangular segment was converted to a dance floor. Interior views of the structure also show that changes were made to the walls and possibly to the

---

7. Ibid.

8. Ibid.

ceiling and fixtures. A comparison of early photographs of the exterior with more recent ones reveal little change on the exterior.<sup>9</sup>

### Barracks (Building No. 1)

Building No. 1 is a large permanent brick structure which served several purposes at different periods: first, it was built to be used as an enlisted mens' barracks; later it was converted to serve as a hospital annex; and finally, it was used as a headquarters. This building is located to the south of the parade ground just off of Murray Road.

Work to construct this structure was begun on August 10, 1938 and completed on May 25, 1939 (Illustration 60). When first built it was called the New Detachment Barracks. It was built essentially to provide much-needed permanent quarters for enlisted men who up to that time were living in old cantonment quarters built in 1917. The structure was built through W.P.A. funds and labor but under the supervision of the Post Quartermaster of Fort Tilden. Briefly described, the barracks was a two-story, permanent brick building with dimensions of 40 by 87 feet, containing sleeping and eating facilities for 49 men.<sup>10</sup>

The completion report describes the work accomplished in some detail if not with great clarity:

---

9. See illustrations 53 and 54, RG77, NA, and illustrations 55, 56, 57, 58, and 59 taken by author.

10. 5th Indorsement, Quartermaster Corps to Commanding General, Second Corps Area, subject: Housing at Fort Tilden, New York, November 28, 1940, RG 5, NA; Completion Report of Erection of New Barracks, Building No. 1 at Fort Tilden, New York by W.P.A. of the City of New York, n.d., RG 77, NA.



Illustration 53

Recreation building  
looking west  
ca. 1943  
Courtesy National Archives



Illustration 54

Recreation building  
looking east  
ca. 1943  
Courtesy National Archives

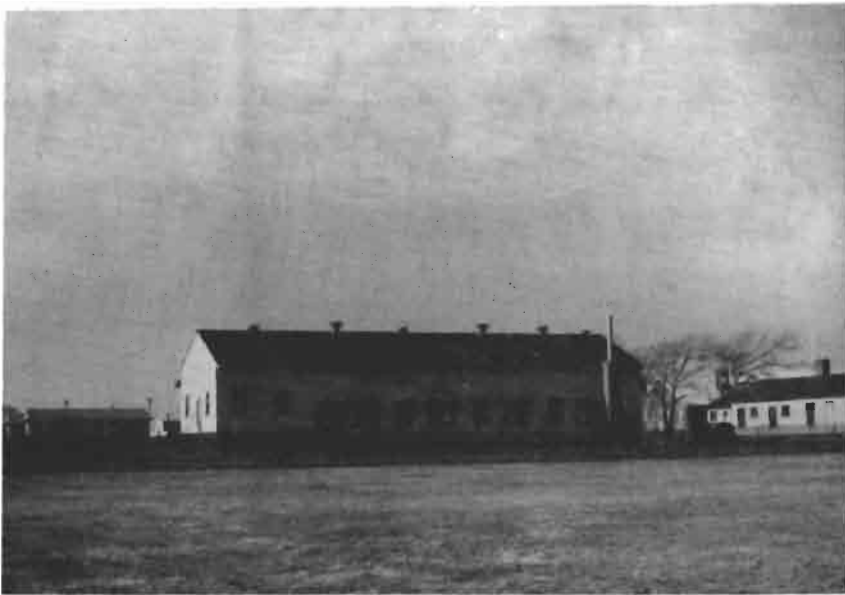

Illustration 55

Recreation building  
looking west  
1979



Illustration 56

Recreation building  
stage  
1979





Illustration 57  
Recreation building  
dance floor  
1979



Illustration 58  
Recreation building  
interior  
1979

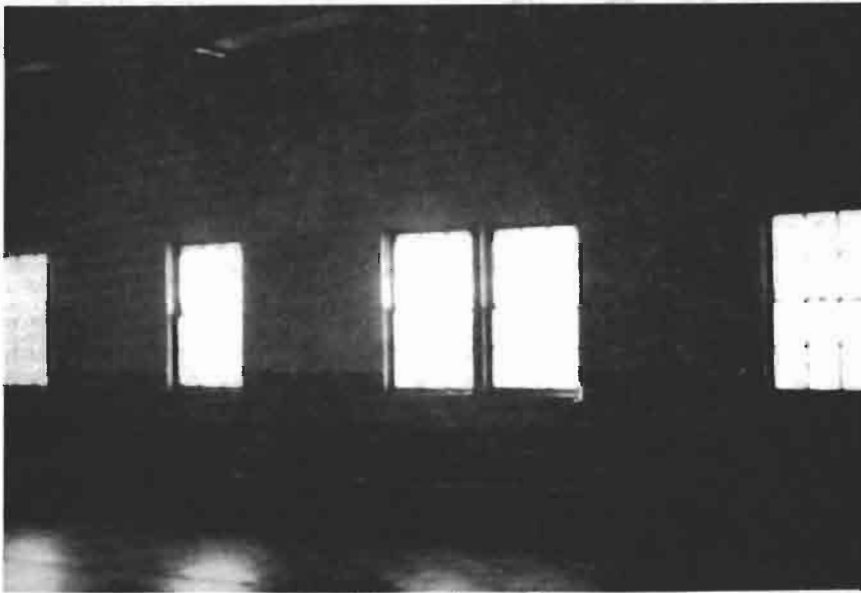

Illustration 59

Recreation building  
another interior view  
1979



Illustration 60

Building No. 1  
rear view  
ca. 1943  
Courtesy National Archives

General construction consists of exterior 12" brick walls, 4" face brick, 8" common brick, reinforced concrete footings, foundation walls to 1st floor line, column and stairs, interior 4" T.C. [terra cotta] and glazed 4" T.C. partitions, wood ridge construction for roof including dormers, gables, and pediments, bangor slate roof over slaters felt and sheathing, copper flashing, gutters, and downspouts, necessary mill work for eaves, gables pediments, dormer windows, double hung windows, door and trim, kalamine door and trim, steel sash for basement windows; misc. [sic] iron consisting of coal chutes [,] basement window guards, pipe railings in yard and for concrete stairs in building, pipe ash hoist, clean out doors, and wrought iron front railings; cement plaster coat for all interior partitions and ceilings, cast stone sills, band course, main entrance headstones and pillars; misc. [sic] steel consisting of lintels, bolts, anchor straps, etc., wheather stripping [sic] of windows and doors; necessary hardware, sewer and water lines from main sanitary sewer and main water line respectively; painting three (3) coats interior walls, interior and exterior of windows and doors including trim.<sup>11</sup>

The basement contained the following rooms and areas: boiler room, fuel room, open basement area, issue room, coal chutes, and kitchen stores. The first floor contained a squad room, day room, mess hall, kitchen, pantry, barber shop, battery commander's office, and orderly room. The second floor consisted of two squad

---

11. Ibid.

rooms, NCO (non-commissioned officers) rooms, cooks' room, and latrine. The third floor consisted of an open attic.<sup>12</sup>

The building cost the government \$102,186.97.<sup>13</sup>

The structure did not serve as a barracks for very long for in 1941 it was converted into a much-needed auxiliary hospital, serving as part of a hospital complex at Fort Tilden.<sup>14</sup>

In later years, perhaps in the 1960s, the structure was converted to a headquarters. It now serves as the headquarters of an Army Reserve engineer unit. (Illustrations 61 and 62).

#### Theater (Building T-4)

In 1940 the commander of Fort Tilden had this to say about conditions at the fort:

Reference is again made to the isolation of this post.  
The nearest motion picture is at least two miles distant

---

12. Ibid.

13. Ibid. There are several drawings of the building made just before it was constructed which should be consulted for further details. These are numbered 646/63028 (6 of 6), 646/62990 (1 of 5), 646/63028 (5 of 6), 646/62990 (3 of 5), and 646/62990 (4 of 5), all dated September 3, 1938, in park files. (Appendixes 26, 27, 28, 29, and 30).

14. 5th Indorsement, Quartermaster Corps to Adjutant General, January 22, 1941, to letter 7th Coast Artillery to Second Corps Area, subject: Housing at Fort Tilden, New York, November 28, 1940, RG5, NA; memorandum, Hall to Adjutant General, subject: Hospitalization at Fort Tilden, New York, February 19, 1941, RG 77, NA; see also drawing No. 646/62990 (2 of 5), n.d., in park files which was concerned with the conversion of the barracks to an auxiliary hospital. (Appendix 31)



Illustration 61  
Front of Building No. 1  
1979



Illustration 62  
Building No. 1  
another view  
1979

from the post, and admission prices are considerably higher than the usual rates at War Department theaters. . . .In brief it must be said that the members of this command are thrown almost entirely upon their own resources for recreation, exercise, and amusement, and it is therefore believed that the construction of a theater and a gymnasium is an imperative necessity.<sup>15</sup>

The Commanding General of the Second Corps Area, through whom all such requests funneled, agreed that the conditions outlined by the commander of Fort Tilden "fully justify the construction of this theater."<sup>16</sup> The request for a theater was ultimately granted along with the major construction that was being considered at this time for Fort Tilden.<sup>17</sup>

The new theater (at first numbered Building 174 but now Building T-4) was completed on February 28, 1941. At the time it was completed its dimensions were 99 by 37 feet, and it seated 350 persons.<sup>18</sup> It was a one-story frame building, the superstructure

---

15. Commander, Fort Tilden, to Commanding General, Second Corps Area, subject: Housing at Fort Tilden, New York, November 28, 1940, RG 77, NA.

16. 1st Indorsement, Commanding General, Second Corps Area to Adjutant General, December 12, 1940, to letter, Commander, Fort Tilden, to Commanding General, Second Corps Area, subject: Housing at Fort Tilden, New York, November 28, 1940, RG 77, NA.

17. 6th Indorsement, Adjutant General to Quartermaster General, March 1, 1941, to letter Commander, Fort Tilden, to Commanding General, Second Corps Area, subject: Housing at Fort Tilden, New York, November 28, 1940, RG 77, NA.

18. Completion Report for Construction and Completion of Temporary Housing at Fort Tilden, New York, contract dated November 12, 1940, RG 77, NA.

of which was built on concrete walls. The wall sidings were hung in the same manner as the recreation building, that is, applied horizontally over gypsum sheathing nailed at bearings over waterproof sheathing paper, which in turn covered the wall sheathing. The walls at the stage end of the auditorium and the stage front were finished with plywood wainscot over Can-ite insulating board to a height of three feet. The walls at the entrance end of the auditorium and in the lobby, office sacristy, and consultation room were finished with plywood wainscot over Can-ite insulating board to a height of four feet. Walls and ceilings in the toilet and storage rooms were finished with one by six T and G boards. The walls and ceilings throughout the remainder of the building were finished with Can-ite insulating board.<sup>19</sup>

The interior was left unpainted at the time the theatre was finished, but the exterior was painted a light buff by W.P.A. labor. The doors and platforms were painted gray. The roof was framed in and covered with asphalt-prepared roofing. The exterior platforms were concrete with wooden steps. The theater was supplied with three coal boxes and a ticket window. (Illustration 63). The total cost of construction was \$14,600.<sup>20</sup>

There is some evidence that alterations were made to the theater over the years. An on-site examination of the interior reveals that the existing cushioned seats were a later addition. In fact, the seats of most World War II Army theaters were made entirely of wood. In the existing concrete floor of the theater one can observe iron strips imbedded in the concrete, indicating where the original seats had been anchored.

---

19. Ibid.

20. Ibid.



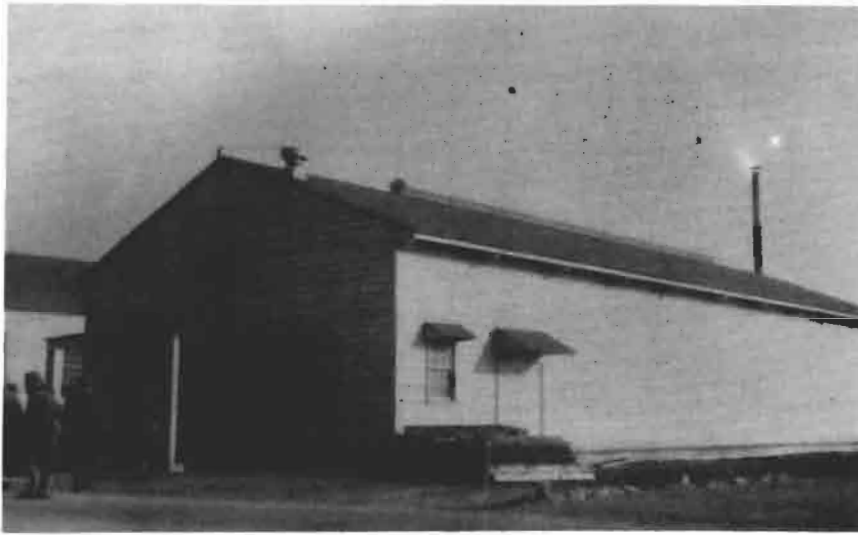

Illustration 63

Theater  
ca. 1943  
Courtesy National Archives

Another change that took place during the 1950s was the addition or, perhaps more properly stated, the modification of the air conditioning system in the theater. There is a drawing in existence that provides the details for the changes.<sup>21</sup>

With the exception of the changes noted above, the appearance of the theater did not change noticeably.

#### Two Officers Quarters (Building Nos. 22 and 23)

Building No. 22 (originally listed as Building No. 30) was the commander's family quarters. This building was constructed by the W.P.A. from designs made by the Army, and it cost \$32,312.48. It was begun on January 10, 1938 and completed on August 20, 1938. (Illustration 64)<sup>22</sup>

When first built it was a two-story brick building with a one-story attached garage and a two-story sleeping and sun porch. The basement consisted of a boiler room, coal storage, open basement area, coal door, laundry trays, and ash pit. The foundations consisted of reenforced concrete and the floor of concrete. The first floor consisted of a living room with a brick hearth and concealed radiators. The front porch was open having wooden pilasters, brick steps, and a metal roof over a pediment. This floor also contained a dining room, kitchen, maid's room, and bathroom. The kitchen contained space for a refrigerator, range,

---

21. Drawing, "Installation of Air Conditioning and Modifications to Post Theater Building T-174 - Ft. Tilden, N.Y.," January 17, 1956, No. 481, in park files.

22. Completion Report of Erection of New Officers' Quarters. Building No. 30 at Fort Tilden, New York. By W.P.A. of the City of New York, n.d., RG 77, NA.



Illustration 64

Commanding officer's quarters  
Building No. 22  
ca. 1943  
Courtesy National Archives

sink, and closets, and its floor was covered with a linoleum carpet. An enclosed sun porch on the east side of the house on this level had double-hung windows. The garage, which was attached to the house, had an entrance from the service stairs. The garage consisted of a cement floor, metal roof, and roll-up doors. There were brick steps in the rear of the house leading up to the sun porch.<sup>23</sup>

The second floor contained a master bedroom, with closet, concealed radiation, and an attached bathroom. There were two smaller bedrooms, also with closets, on this floor. The sleeping porch on this level was directly over the sun porch. The roof of this structure consisted of Bangor slate over slaters' felt, copper leaders, and gutters. The roof contained dormer windows, consisting of shiplap board siding.<sup>24</sup>

The year after this structure was completed, certain minor changes and additions were made to it in the form of weatherproofing, cupboards, storm doors, and other minor items.<sup>25</sup> The structure's appearance today does not differ substantially from when it was first built. (Illustrations 65 and 66).

---

23. Ibid.

24. Ibid. There is an excellent drawing of this building, done by the W.P.A., which provides a front view, rear view, and side elevations. See drawing, "Second Corps Area, Fort Tilden, New York, Company Officers Quarters, Elevations," No. 61-2, ca. 1938, in park files. (Appendix 32)

25. Drawing, "Second Corps Area, Fort Tilden, New York, Alteration to Post Buildings, Misc. Repairs and Replacements, Officers Quarters No. 30," No. D-63-9, ca. 1939, in park files. This drawing also shows the floor plans of each story. (Appendix 33)



Illustration 65

Commanding officer's quarters  
Building No. 22  
front view  
1979



Illustration 66

Commanding officer's quarters  
Building No. 22  
rear view  
1979

This writer was unable to find any historical evidence dealing with Building No. 23. It must therefore leave any description of the historic fabric of this structure up to the historical architect. It is obvious that the structure was built around the same time as Building No. 22, although a much smaller structure. (Illustrations 67 and 68).

Double NCO Quarters (Building 60A and 60B, with Garage, Building II)

The double NCO (non-commissioned officers) quarters (Building 60A and 60B) was perhaps the first permanent type quarters to be built on the post. Built in 1918-1919 this well-built structure consisted of fireproof materials and terra cotta blocks and concrete.<sup>26</sup>

An illustration of the building taken just after it was completed reveals a two-story structure with attic and basement. One open wooden porch fronted the full length of the building and almost a similar porch was at the rear. At each end of the front porch were steps leading up to the porch. From the porch were two doorways leading to two apartments. On the first level were four windows and on the second level were four windows overlooking the roof of the porch. On the south side of the structure were three large windows, two on the first level and one on the second. At the same end of the building and as part of the attic there was a semicircular window.

---

26. Completion Report, Coast Defenses of New York, Part II, RG 407, NA; 2nd Indorsement, Headquarters, Second Corps Area to Adjutant General, October 26, 1927, RG 77, NA.



Illustration 67

Officer's quarters  
Building No. 23  
front view  
1979



Illustration 68

Officer's quarters  
Building No. 23  
rear view  
1979

The terra cotta tiles of which the structure is built and the semi-circular windows of the attic gave the building a distinctive sense of beauty.<sup>27</sup> From the standpoint of architectural uniqueness and age this structure far surpasses any of the other structures at Fort Tilden, and is therefore worthy of preservation.

It was probably not until 1937-1938 that extensive alterations were made to the double NCO quarters. By this time the interior was in very bad condition, making it necessary to rehabilitate the entire interior. The exterior brick walls, through which water leaked during heavy rains, were painted and waterproofed. The heating system was improved. The old lath and plaster were removed from the walls and ceilings and replaced with metal lath, new plaster, and craftex. The lighting fixtures were replaced with modern fixtures, and convenience outlets were installed in all rooms. Old wood trim was also replaced and painted. The walls and floors of both rooms were tiled, and new plumbing and electrical fixtures were installed. Finally, the porches were remodeled and enclosed, and new floors were put in. The total cost of this major alteration was \$10,327.94.<sup>28</sup> (Illustrations 70, 71, and 72).

The garage (Building No. 11) was built in September-November 1937 to house staff non-commissioned officers' privately owned automobiles. It held two automobiles. It was 21 feet, 9 inches long, 21 feet, 2 inches wide, and 16 feet high. Each bay was 20 feet by 9 feet, 8 inches. The structure consisted of a concrete

---

27. Illustration 69, RG 77, NA.

28. Completion Report of Rehabilitation of N.C.O.'s Quarters, Building No. 60 A and 60B at Fort Tilden, New York, ca. 1938, RG 77, NA. See also 10 blueprints titled "Double Set of N.C.O. Quarters," drawn up by the Second Corps Area, n.d., W.P.A. Administration, City of New York, Official Project No. 365-97-2-12, in park files.





Illustration 69

Double NCO quarters  
ca. 1919  
Courtesy National Archives



Illustration 70

Double NCO quarters  
viewed from southeast  
1979



Illustration 71

Double NCO quarters  
viewed from northeast  
1979



Illustration 72

Double NCO quarters  
viewed from northwest  
1979

foundation, concrete ramp, and a floor with a wire mesh reinforcement. The outside walls were made of cinder blocks covered with cement stucco. The inside partition consisted of wood frame with corrugated steel on one side. There were roll-up entrance doors and double-hung windows. The roof had asbestos shingle, copper gutters, and leaders. The building cost \$2,130.97.<sup>29</sup>

There were probably no significant alterations made to the garage since it was first built. (Illustration 73).

### Parade Ground

In a strong plea to gain the support of higher headquarters for much-needed construction, the commander of Fort Tilden stated in a letter that "the most striking commentary relative to the physical plant of this station is that the post is forced to use one of the masts of the inactive radio station as a flagpole."<sup>30</sup> In his letter he strongly recommended the construction of a flagpole in addition to other important facilities.

The establishment of a flagpole, as well as a parade ground, had never been made a part of any permanent type construction at Fort Tilden. Indeed, as we have already seen, it was not until 1938

---

29. Completion Report of Two Car Garage Building No. 11 at Fort Tilden, New York, Built by W.P.A. of the City of New York, n.d., RG 77, NA. There is one blueprint titled "Plan-Elevation and Section, Two Car-Garage," date approved July 29, 1937, in park files.

30. Commander, 7th Coast Artillery to Commanding General, Second Corps Area, subject: Housing at Fort Tilden, New York, November 28, 1940, RG 5, NA.



Illustration 73

NCO garage  
Building 11  
1979

that a permanent enlisted men's barracks had been built. The inactive status of Fort Tilden for more than 20 years was a mitigating factor against the construction of a permanent parade ground. Nevertheless, this did not hide the fact that the facilities built during World War I were now so deteriorated that some drastic measures were needed to place Fort Tilden in a better shape if it was to serve its mission in World War II.

In spite of the inactive status of Fort Tilden following World War I, a section of the eastern part of the reservation had been set aside for permanent facilities of the post. The permanent parade ground was one of these facilities. It was not until 1941, however, that the construction of this parade ground, including a 75-foot steel flagpole, was finally authorized.<sup>31</sup>

The parade ground, which was square-shaped and described by one newspaper as being three acres in size, was bounded by Barret Road on the north, Heinzelman Road on the west, Murray Road on the south, and Davis Road on the east. There is little historical data on the parade ground, but we do know that the ground was to be seeded, rolled hard, and landscaped. In order to construct the parade ground it was necessary to demolish eleven World War I cantonment buildings.<sup>32</sup>

The flagpole itself was to be set in a handsomely-cut stone with inscriptions of the installation, organization, and United States Coast Artillery insignia. The stone was cut in a shop in New York

---

31. 5th Indorsement, Quartermaster General to Adjutant General, January 22, 1941, to letter, Commander, 7th Coast Artillery to Commanding General, Second Corps Area, subject: Housing at Fort Tilden, New York, November 28, 1940, RG 5, NA.

32. "Fort Tilden Work Pushed by WPA Men," The New York Times, April 13, 1941.

City. The flagpole stood, as it still does today, at the northeast corner of the parade ground.<sup>33</sup> (Illustrations 74, 75, and 76).

#### Motor Repair Shop (Building No. T-216)

The Motor Repair Shop, formerly Building No. 164 but now Building No. T-216, was completed in February 1941 at about the same time that extensive construction was going on at Fort Tilden. The shop is located about fifteen feet from the northwesterly end of Dunn Circle in the area once occupied by the Corps of Engineers.

When built, its dimensions were 84 by 37 feet. It was a one-story frame building, the superstructure of which rested on concrete foundation walls. The exterior side walls were constructed of one by eight-inch drop siding applied horizontally over gypsum sheathing, driven up tight and securely nailed. The interior walls were generally unfinished except for the walls of the store room and office which were lined with wood sheathing. The ceilings were generally finished with gypsum sheathing. The floors of the storeroom, office, and shop consisted of cement. The building was provided with sliding doors constructed of two thicknesses laid diagonally and vertically. The exterior was painted a light buff with the exception of the doors and platforms which were painted gray. The roof was framed in and covered with asphalt-prepared roofing. The structure was provided with a 17-foot ladder and two coal boxes. It had no toilet. The cost of construction was \$7,383.<sup>34</sup>

---

33. "Flagpole Rites Set At Fort Tilden," an unidentified news article in park files.

34. Completion Report For Construction and Completion of Temporary Housing at Fort Tilden, New York, Contract No. W 6511 qms -99, O.I. 136, dated November 12, 1940, RG 77, NA.



Illustration 74

Section of Parade Ground  
looking northwest  
1979



Illustration 75

Parade Ground  
looking north with  
flagpole in the distance  
1979



Illustration 76

Base of flagpole  
1979



Because this structure is used by the U.S. Army, the writer was unable to gain access to the interior in order to describe its present appearance and condition.

#### Ordnance Building (Building No. 219)

The construction of the Ordnance Building (formerly Building No. 20 but now Building No. 219) was begun in February 1937 and completed in January 1938. Built with W.P.A. labor, it cost \$73,413.<sup>35</sup>

The new structure was built to replace an old ordnance machine shop and storeroom buildings built during World War I. The dimensions of the structure were 42 by 127 feet. It consisted of reenforced concrete footings, cinder concrete blocks, face brick exterior walls, and a reenforced concrete first floor. The plan of the first story consisted of right and left wings, each the same size, and a central section. The second story extended only over the central section. The floor plan of the second story was therefore much smaller than the lower story. The lavatories and showers were tiled. All doors, door frames, windows, window frames, and interior trim were made of wood.<sup>36</sup> (Illustration 77).

---

35. Completion Report of Erection of New Ordnance Building, Building No. 20, at Fort Tilden, New York, By W.P.A. of the City of New York, n.d., RG 77, NA.

36. *Ibid.* There are six drawings on linen, including elevations and floor plans, made before the building was constructed. These should be consulted for a detailed explanation of the building's description. See drawing, Project Number 265-97-2000, General revision made January 8, 1937, in park files, which shows second story plan and roof of first story. (Appendix 34)



Illustration 77

Ordnance Bulding  
(Later a headquarters)  
1939  
Courtesy National Archives

There is evidence that in 1939 this structure served an entirely different purpose than when it was originally built by becoming the headquarters of Fort Tilden. In making this functional change it was probably necessary to make extensive alterations so that it could be used essentially for offices. There is some concrete evidence found in drawings that in the 1960s certain windows of the structure were closed in by red brick, an attempt to match the brick of the rest of the structure. Other changes were also made at this time.<sup>37</sup>

#### Engineer's Office (Building No. 201)

The Engineer's Office (formerly Building No. 49 but now Building No. 201) was built soon after World War I. It is therefore one of the few oldest buildings still remaining at Fort Tilden. There is little documentary evidence concerning this structure, but we are fortunate to have two drawings of its floor plans. The first floor plan indicates that in addition to a wide piazza extending the full length of the building on the front, this floor contained a clerk's office, drafting room, vault, large hall, and two small toilets, presumably one for enlisted men, the other for officers. All the exterior walls consisted of red terra cotta blocks while the corners and chimney stack were made of red brick. The interior partitions were made of frame. The superstructure rested on concrete walls, and the six square columns that held up the porch were made of brick.<sup>38</sup>

---

37. Drawing, "Repairs to Bldg. No. 219, Fort Tilden, N.Y.," approved March 1, 1968, in park files.

38. Drawing No. 1, Cellar Floor Plan, and Drawing No. 2, First Floor Plan, ca. 1918, RG 77, Cartographic Branch, NA. (Appendixes 35 and 36)

The architectural style of this structure and the materials that were used in its construction resemble those of the Double NCO Quarters. Therefore, it is strongly believed that these permanent structures were built at about the same time, that is, at the end of 1918, beginning of 1919.

The structure is now covered with stucco, which was probably a later alteration.

#### Engineer Storehouse (Building No. 204)

The Engineer Storehouse, formerly Building No. 44 but now Building 204, was built about 1923-1924. Except for two early drawings, this writer was unable to find much documentary evidence concerning the building's appearance. Nevertheless, the two drawings reveal that it was 27 feet high (one story) and 78 feet, 3 inches long by 39 feet, 6 inches wide. It had three windows in the front and three in the rear. It also had two steel rollaway doors in the front. Also in the front of the building was a long platform about eight feet wide by about 45 feet long. The structure was made of hollow tile set on a concrete foundation. There were no partitions in the interior.<sup>39</sup>

Today, there are some differences in the appearance of this building from the time when it was first built. First of all, there is now a stepped gable roof instead of the pitched roof observed in the drawings. Secondly, the porch now runs the full length of the building.

---

39. Drawing in 2 sheets: "Fort Tilden, N.Y., U.S. Engineer Department Store House," October 18, 1923, RG 77, Cartographic Branch, NA. (Appendixes 37 and 38)

### The Wharf (Dock No. 209)

A wharf (formerly Dock No. 70 but now Dock No. 209) existed from the very beginning when Fort Tilden was established. It provided a very important facility in that everything that was shipped to Fort Tilden had to come by way of the wharf. Hence, with such heavy traffic, it was inevitable that the dock would be in need of constant repair and replacement of parts. The first evidence of major repairs made to the wharf was in 1937-1938. The repairs were extensive judging from the cost of \$35,042.56. The work consisted of the replacement of all rotted piles, timbers, creosoted timbers, docking, dock sheathing, bolts, nuts, cross bracing, and a miscellaneous assortment of materials. At this time a standard gauge railroad track was also laid to the full length of the dock. The dock itself was 180 feet long by 33 feet wide.<sup>40</sup> (Illustrations 78 and 79).

There is evidence of further repairs made to the wharf in 1944 and again in 1951.<sup>41</sup>

---

40. Completion Report of Dock No. 70 At Fort Tilden, New York Built by W.P.A. of the City of New York, n.d., RG 77, NA.

41. Drawing, "Repairs and Reinforcement of Wharf and Installation of Derrick, Fort Tilden, N.Y.," April 15, 1944, in park files; drawing, "Fort Tilden Wharf," August 7, 1951, in park files. (Appendixes 39 and 40)



Illustration 78

Wharf  
showing railroad tracks  
1938  
Courtesy National Archives



Illustration 79

Wharf  
showing piles  
1938  
Courtesy National Archives

## CHAPTER IV: RECOMMENDATIONS

1. An historic resource study is strongly recommended for Fort Tilden. The research that would be undertaken would not only bring to light data dealing with the military history of the fort (an attempt only briefly made in Chapter I of this study), but would in all probability add to the knowledge of the physical history of cultural properties.
2. Much needs to be done to preserve the casemates of Battery Harris, but it is recommended that they only be stabilized and interpreted in their present condition. If one sixteen-inch gun is available somewhere, which is doubtful, it would complement one of the casemates and contribute enormously to the interpretation of Battery Harris.
3. As important elements of the coastal defenses of Fort Tilden both Battery Construction No. 220 and Battery Kessler should be stabilized to prevent further deterioration. If a six-inch gun of the period can be obtained, it would contribute to the interpretation of this cultural resource.
4. Some adaptive use can be made of the four magazines (Buildings 401, 405, 409, 414) of Battery Harris, while retaining the small gauge tracks and other parts of the interior of at least one of the magazines for interpretive purposes.
5. At least one of the three power plants (Buildings 407, 408, 412) used to support the guns of Battery Harris should be retained and preserved for some adaptive use.

6. A partial restoration of the fire control and plotting room (Building 413) would provide the park with an excellent interpretive facility, since this structure played an important role in the operation of Battery Harris.

7. Stabilizing and partially restoring the facade of the mine casemate (Building 511) will contribute to the interpretation of the mine defense mission of Fort Tilden.

8. Because of its important historic mission and its reasonably good condition, Building 13 (Groupment Command Post) should be included in the Inventory Form of the National Register of Historic Places.

9. Although many of the structures, especially the wooden ones, in the Nike-Hercules missile site are beyond repair and should be removed with little loss, every effort should be made to stabilize and interpret the launch pads, underground rooms, elevators, radar towers, and a few of the concrete and steel structures that remain above ground.

10. The chapel (Building T-3) could be restored to serve its original purpose, that is, as a place of worship and interfaith activities. There are only two or three of the original pews remaining, but other pews could be duplicated to furnish the chapel as it looked during World War II.

11. The recreation building (Building T-149) should be stabilized and repaired for a variety of different uses ranging from recreation to education.

12. The theater (Building T-4) should be stabilized and preserved without removing any of the fixed seats. It can be used for a variety of functions ranging from movies and plays to education and interpretive programs.



13. Because it is the oldest permanent structure at Fort Tilden and because of its architectural uniqueness, the double NCO quarters (Building 60A and 60B) should receive extensive preservation treatment. It could be used as quarters for park personnel although other uses can also be found.

14. When complete access is possible to Buildings T-216, 219, 201, and 204, structures in the old Corps of Engineers area, it is strongly recommended that they be carefully examined by architectural historians for further information on the historical fabric. In the meantime, every effort should be made to preserve the permanent structures, particularly Building 201, which was the Post Engineer's office.



## BIBLIOGRAPHY

### Manuscript Materials

Arlington, Virginia. The Pentagon, Department of the Army. Audio-Visual Agency. Historic photographs of the Nike-Hercules site at Fort Tilden. Contains several very useful photographs of the site showing missiles in readiness. These photographs not only provide description, and therefore are useful in any preservation program, but should be excellent material for an interpretive program.

Bayonne, New Jersey. Federal Records Center. Records of the Office of the Chief of Engineers, Record Group 77. This is a large collection of records dealing primarily with construction and administration at Fort Tilden. This was part of an effort by the National Archives to transfer some of its holdings to the Federal Records Center. This effort has stopped in recent months. These records do not differ materially from other records in Record Group 77 at the National Archives. These records are extremely important to a history of Fort Tilden.

New York, New York. Gateway National Recreation Area. Originals and copies of maps, plans, drawings, and photographs of Fort Tilden, N.Y., 1918-1967. Most of this large collection was recently obtained from Fort Hamilton, N.Y. and is yet to be completely cataloged by the park. The collection deals with many structures at Fort Tilden and will be invaluable not only to the preservationist but also to management in its attempts to improve utilities for future use. Among this collection is a large number of drawings dealing with the Nike-Hercules site, drawings that could not be found in the National Archives.

Washington, D. C. National Archives and Records Service. Records of the Office of the Chief of Engineers. General Correspondence. Record Group 77. Records in this group dating up to 1923 are in the National Archives on Pennsylvania Avenue, but after this date, they are in the Washington Federal Records Center, Suitland, Maryland. This group of papers forms the corps of historical data needed to prepare histories of Fort Tilden. Of great importance to this study were the several Completion Reports in this collection dealing with construction at Fort Tilden. Dates of construction, descriptions, contractors, and materials employed are some of the valuable information contained in these reports. These reports are listed by fort. Without them, it would be almost impossible to learn the physical history of Fort Tilden.

- Washington, D. C. National Archives and Records Service. Records of the Chief of Engineers. Fortification File. Cartographic Branch. Record Group 77. This group contains a large number of original drawings mostly pertaining to fortifications. One must be careful not to mistake some of the drawings for the executed plan, however.
- Washington, D. C. National Archives and Records Service. Records of the Adjutant General's Office, 1917 -. Administrative Services Division, Operations Branch, Special Projects, Harbor Defense. Record Group 407. A valuable collection of documents dealing with harbor defenses and other related matters.
- Washington, D. C. National Archives and Records Service. Records of United States Army Coast Artillery Districts and Defenses, 1901-1942. Record Group 392. This collection contains Battery Emplacement Books and was of some use in the preparation of the Historic Structure Report of Fort Tilden.
- Washington, D. C. National Archives and Records Service. Records of the War Department General and Special Staffs. Record Group 165. Contains some material useful to a history of Fort Tilden.
- Washington, D. C. National Archives and Records Service. Records of the Chiefs of Arms. Record Group 177. These are of minimal use to a physical history of Fort Tilden.

#### Publications

- Anonymous. "Anti-aircraft Guns moved to Fort Tilden." Rockaway Review. January 1951.
- Anonymous. "Army Vacates Tenants." Rockaway Review. February 1951.
- Anonymous. "Uncle Sam's Acres." Rockaway Review. June 1948.
- Osborne, Edwin A. "Rockaway -- One of the Major Protection Points of New York Harbor." Rockaway Review. June 1941.
- Terrible, V. T. "Rockaway's Neighbor: Fort Tilden." Rockaway Review. December 1949.
- Lewis, Emanuel Raymond. Seacoast Fortifications of the United States. Washington, D. C.: Smithsonian Institution Press, 1970. An excellent treatise on the general subject of coastal artillery but contains nothing on Fort Tilden.

### Newspapers

The New York Times. February 9, 1917. November 10, 1927.  
June 19, 1951. April 13, 1941.

New York Herald Tribune. November 29, 1945. December 31,  
1950. May 21, 1946. June 5, 1958. September 26, 1958.  
July 23, 1935. May 30, 1940. October 13, 1941.

New York American. February 9, 1917.

The Sun. New York City. February 9, 1917.

Brooklyn Eagle. New York City. January 25, 1946. January 8,  
1951. October 9, 1941.

Brooklyn Tablet. New York City. January 26, 1946.

### National Park Service Studies

Wrenn, Tony P. "General History of the Jamaica Bay, Breezy Point,  
and Staten Island Units, Gateway National Recreation Area,  
New York N. Y." October 1975. A study prepared for the  
North Atlantic Region, N.P.S.



APPENDIX







JAMAICA BAY

STATE RIGHT OF WAY

100 FEET WIDE

16 FOOT CONCRETE ROADWAY

PLOTTING ROOM

MAIN BATTERY

PROPOSED MORTARS

PROPOSED MORTARS

NEW SITE FOR MORTAR BATTERY PROPOSED MAY 1918

PROPOSED 6 INCH GUNS

PROPOSED 16 INCH GUNS

PROPOSED 6 INCH GUNS

6 INCH GUNS

25 KW SET SEARCH LIGHT

25 KW SET

SEARCH LIGHT

6 INCH GUNS DISAPPOINTED

MARK HIGH WATER - MARCH 1918

MARK LOW WATER - MARCH 1918

SEAN LOW WATER

ATLANTIC OCEAN

1918  
FORT TILDEN RESERVATION  
Scale: 1 inch = 500 Feet



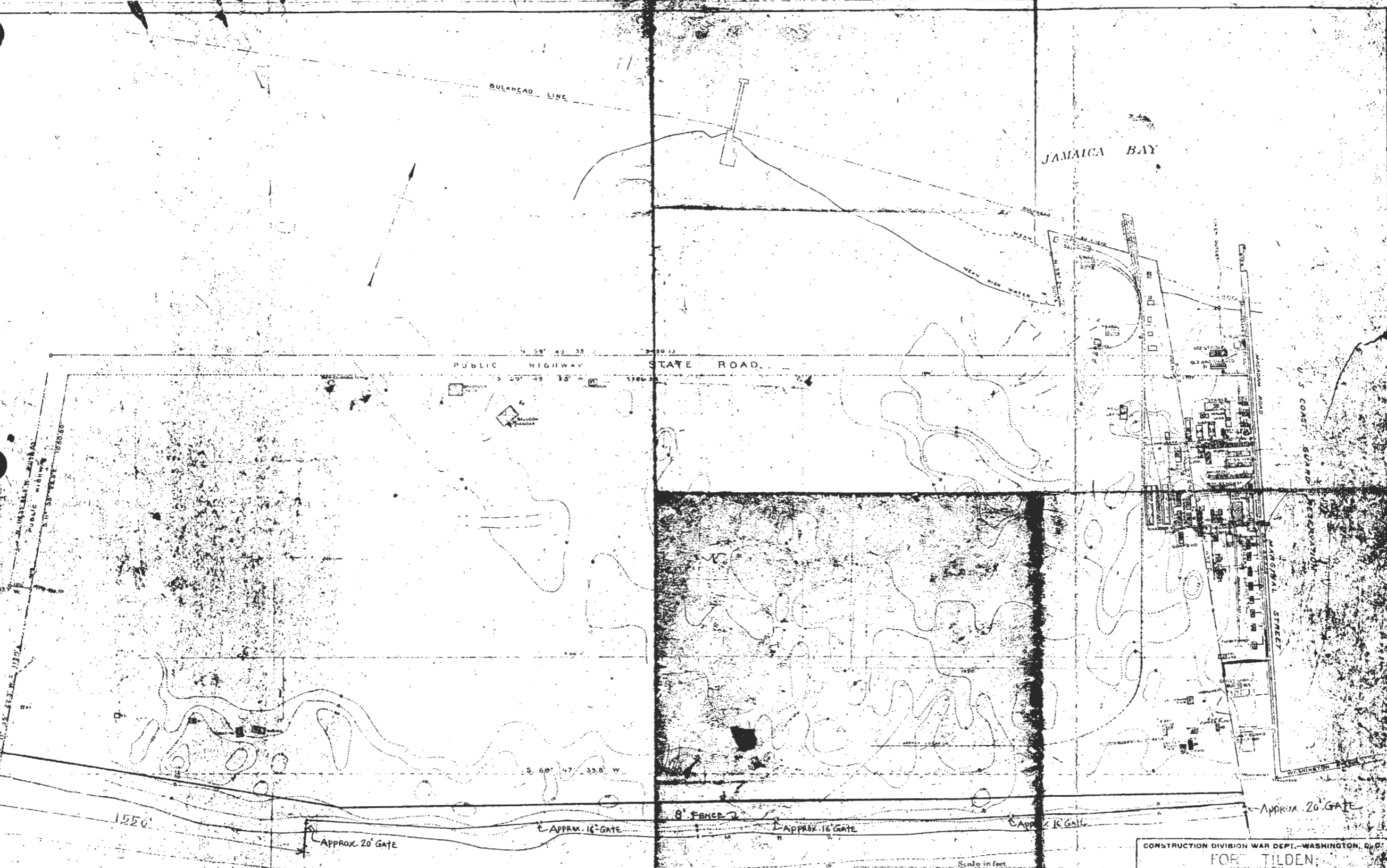

JAMAICA BAY

PUBLIC HIGHWAY STATE ROAD

ATLANTIC OCEAN

RED-DENOTES APPROX. BOUNDARY LINE OF AREA REQUESTED BY CONG. ROSES.  
 YELLOW-DENOTES APPROX. LINE PROPOSED BY WAR DEPARTMENT

- Scale in feet
- LEGEND
- Water Main
  - Meter
  - Fire Hydrant
  - Roadway
  - Tramway Building
  - Iron
  - Sidewalk
  - Sewer Main
  - Manhole
  - Hailroad
  - Electric Light Line
  - Fence
  - Building Limit

CONSTRUCTION DIVISION WAR DEPT.-WASHINGTON, D.C.

FOR TILDEN  
 NEW YORK  
 POST MAP

JOB NO. 6189. DATE: Mar. 25, 1940

PLAN NO. 10: APPROVED BY: *J.B.M. [Signature]*

DATE: [ ]

CONTRACT NO. [ ]

DRAWN BY: [ ] CHECKED BY: [ ]

APPROVED BY: [ ]

Boundaries and levels taken April 12, 1939  
 May 19, 1939 and refer to the plans of M.L.W.  
 1. Five lines referred to S.W. 107, 2023 Harbor NY  
 2. Stationed by the Board of Estimates and Apportionment  
 of New York City, L.C. 10-107 above M.S.L.

U.S. ENGINEER OFFICE  
 200 Broadway, New York City

U.S. National Archives

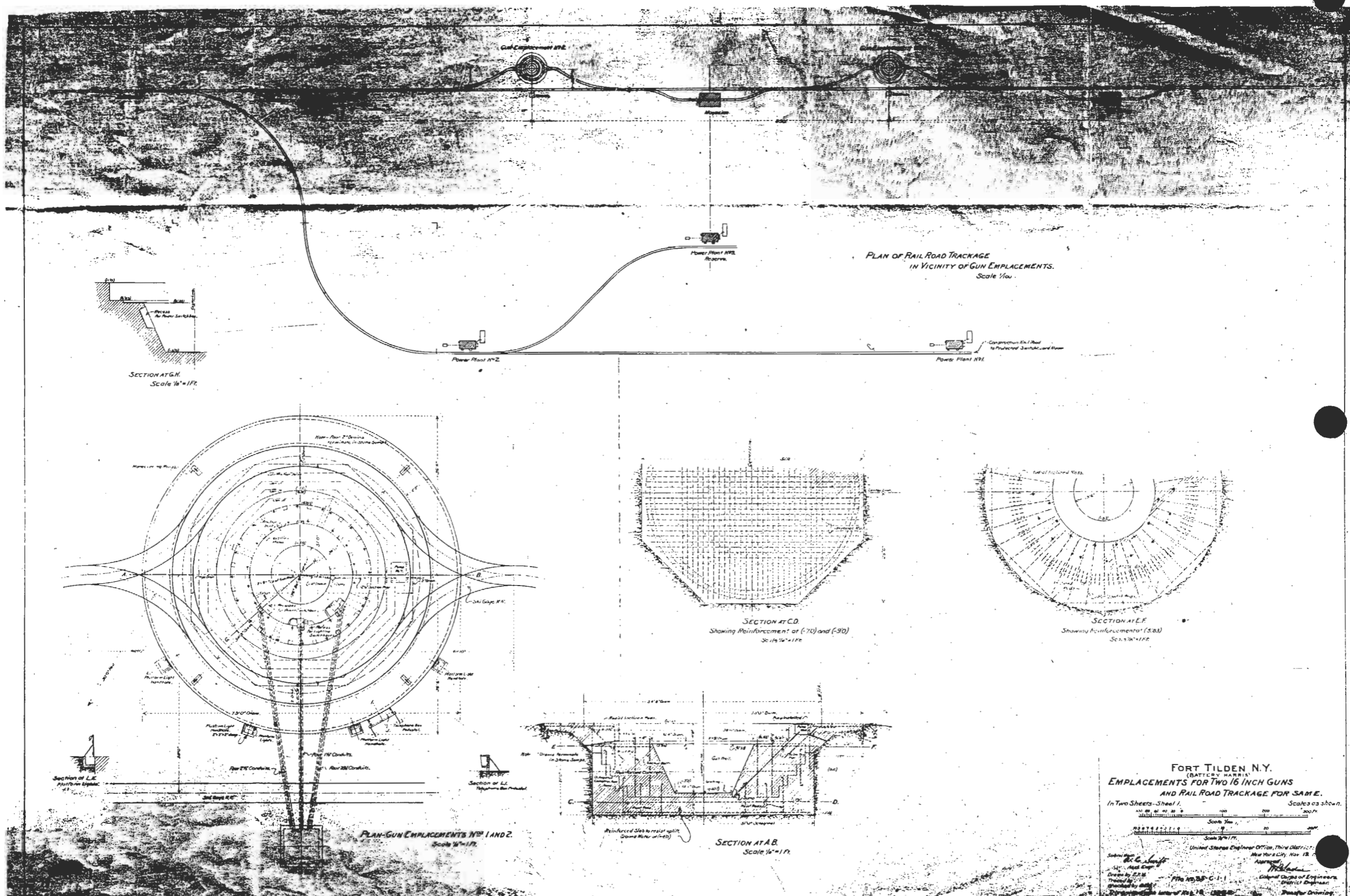

**FORT TILDEN N.Y.**  
(BATTERY HARBOR)  
**EMPLACEMENTS FOR TWO 16 INCH GUNS**  
**AND RAIL ROAD TRACKAGE FOR SAME.**

In Two Sheets—Sheet 1. Scales as shown.

Scale 1/4" = 1 FT.

Scale 1/8" = 1 FT.

Scale 1/16" = 1 FT.

Submitted by: *[Signature]*  
 Drawn by: *[Signature]*  
 Checked by: *[Signature]*  
 Approved by: *[Signature]*

United States Engineer Office, Third District,  
New York City, Nov. 18, 1917.

Approved by: *[Signature]*  
 Colonel George of Engineers,  
District Engineer.

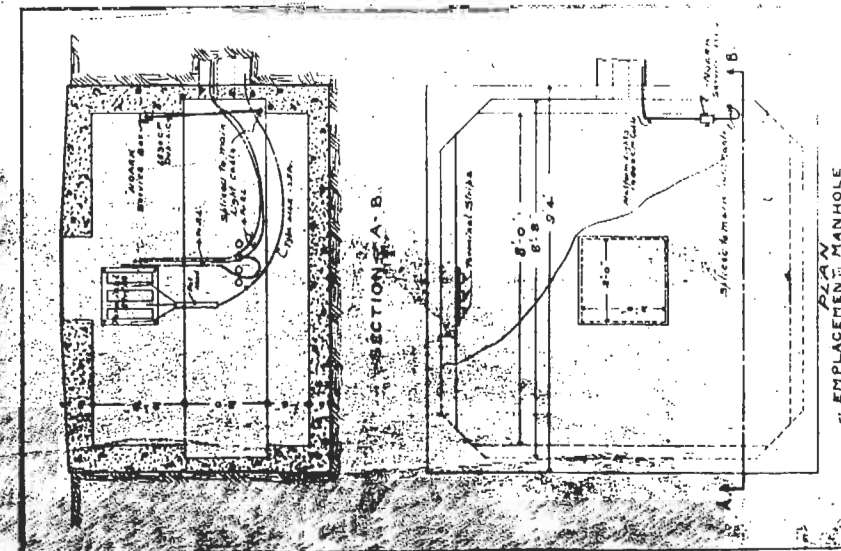
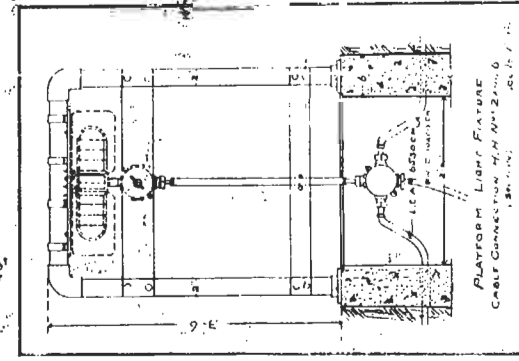
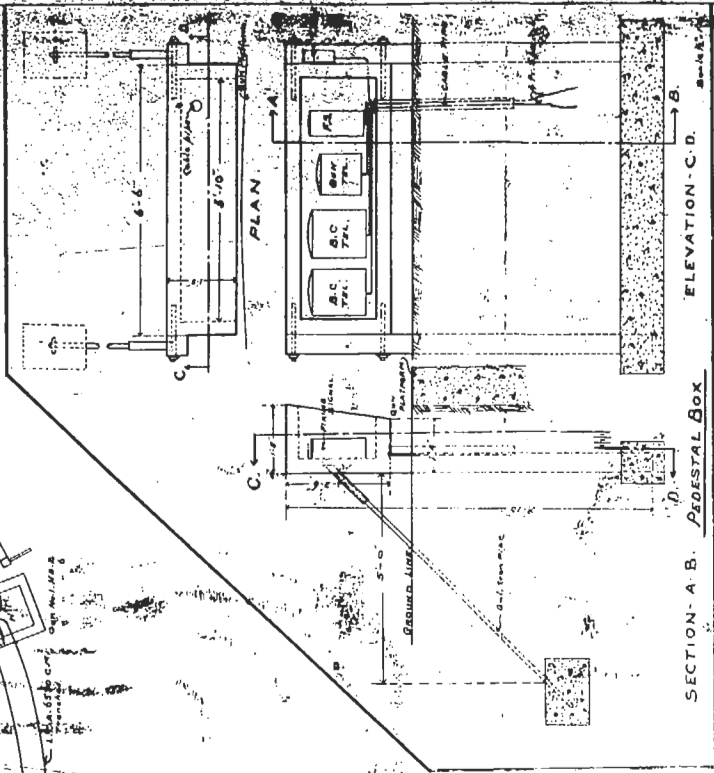
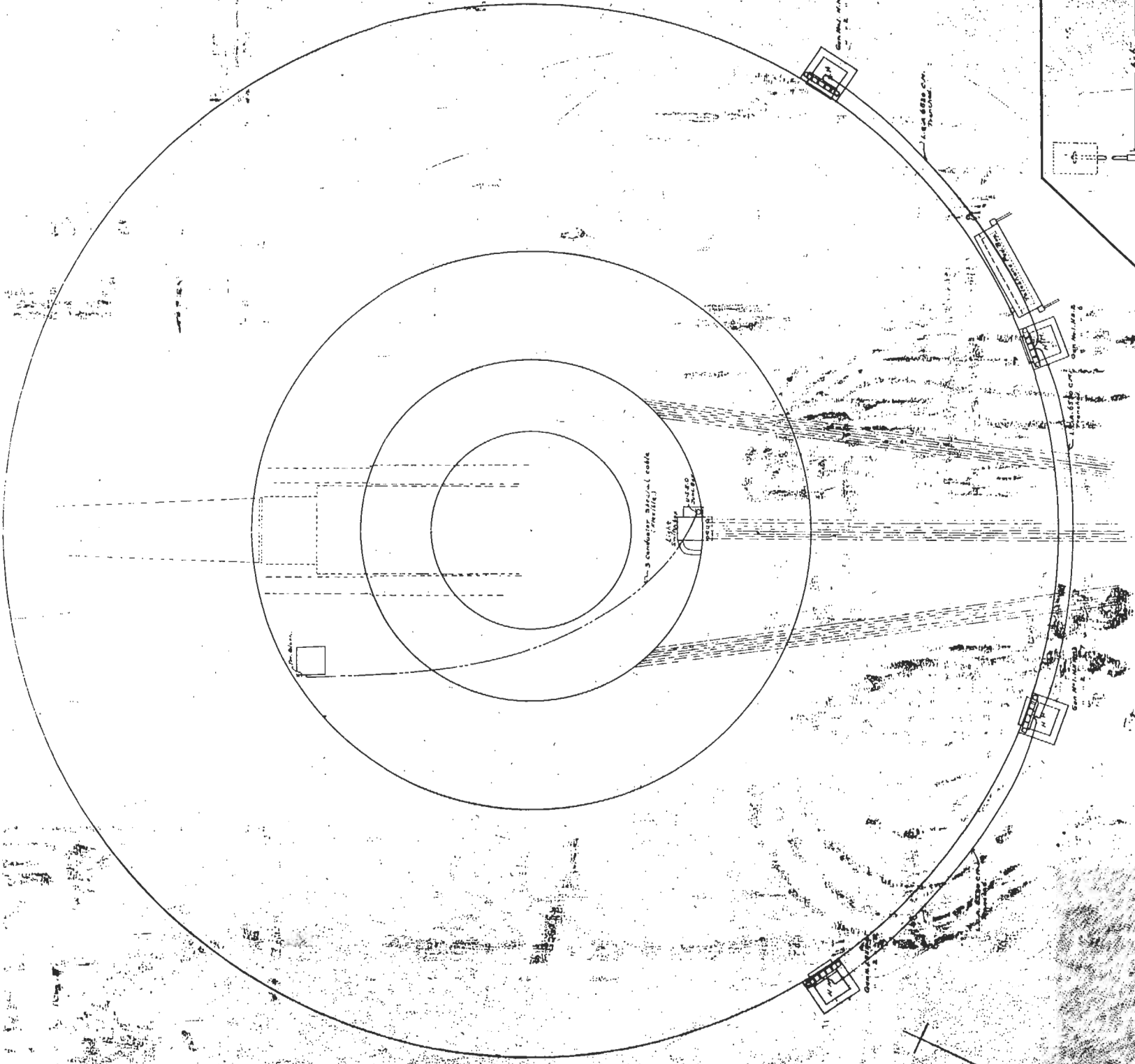

**FORT TILDEN, N. Y.**  
**BATTERY HARRIS**  
**EMPLACEMENTS FOR 2-16" GUNS**  
**FIRE CONTROL APPARATUS, WIRING AND PLATFORM LIGHTS**

IN 2 SHEETS SHEET NO. 2. SCALE 1/4" = 1'-0"

NOTE: HAND MADE DRAWING. 5' TYPICAL SPACING. 3' TYPICAL SPACING. 1' TYPICAL SPACING.

United States Engineer Office Third District, New York City, Nov. 19, 1924.  
 Approved: *Sturgeswood* Assistant Recommended  
 Checked: *W. H. M. U.* District Engineer



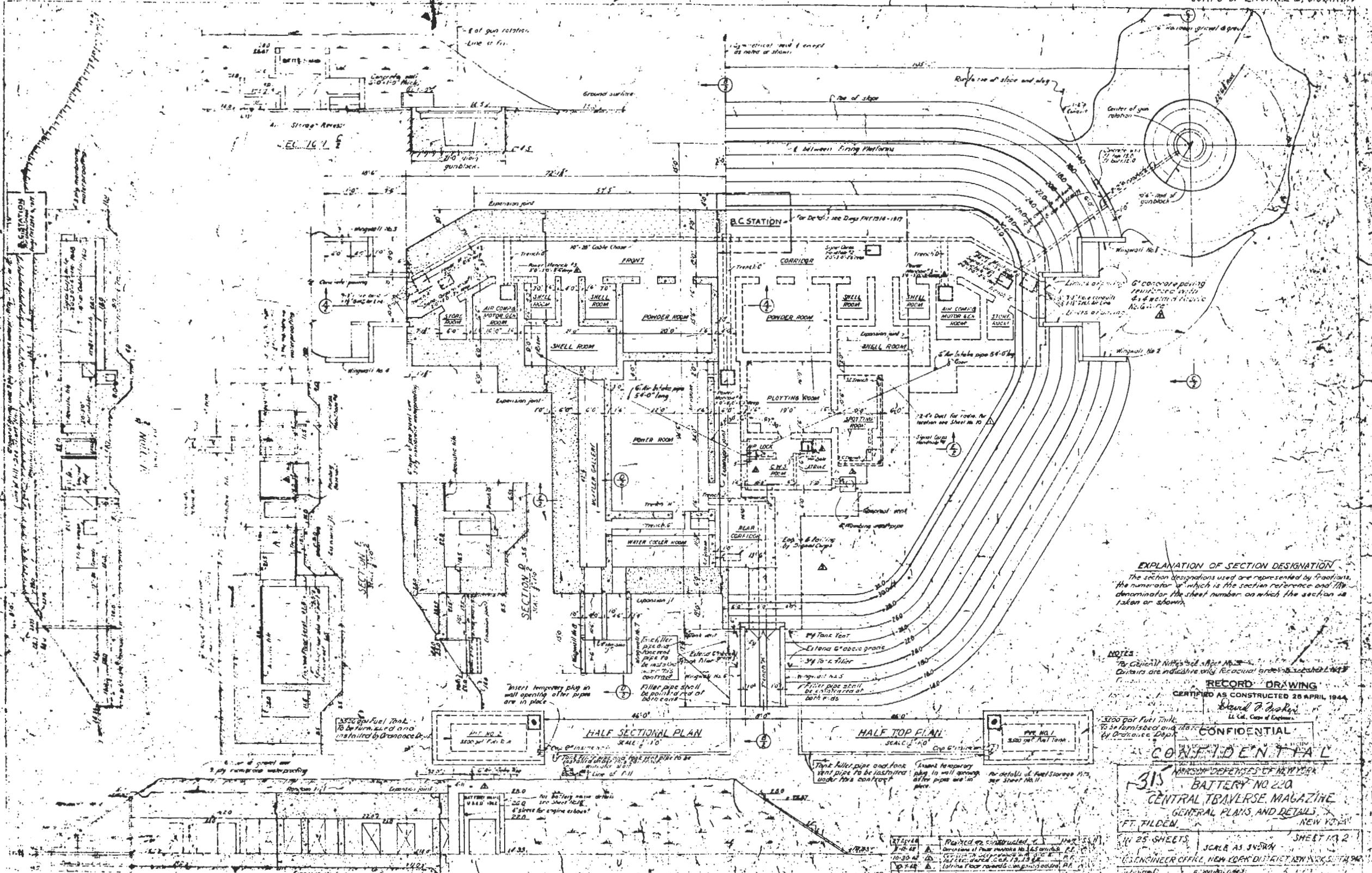

**EXPLANATION OF SECTION DESIGNATION**  
 The section designations used are represented by fractions, the numerator of which is the section reference and the denominator the sheet number on which the section is taken or shown.

**NOTES**  
 To General Notes see Sheet No. 2  
 Contents are indicative only for actual work see sheet No. 2  
**RECORD DRAWING**  
 CERTIFIED AS CONSTRUCTED 28 APRIL 1944  
 David P. Baker  
 Lt. Col., Corps of Engineers

**CONFIDENTIAL**  
**CONFIDENTIAL**  
 315 MARKSMAN DEFENSES OF NEW YORK  
 BATTERY NO. 220  
 CENTRAL TRANSVERSE MAGAZINE  
 GENERAL PLANS AND DETAILS  
 FT. TILDEN, NEW YORK  
 IN 25 SHEETS SCALE AS SHOWN SHEET NO. 2  
 ENGINEER OFFICE, NEW YORK DISTRICT NEW YORK, N.Y.  
 64663022 2066

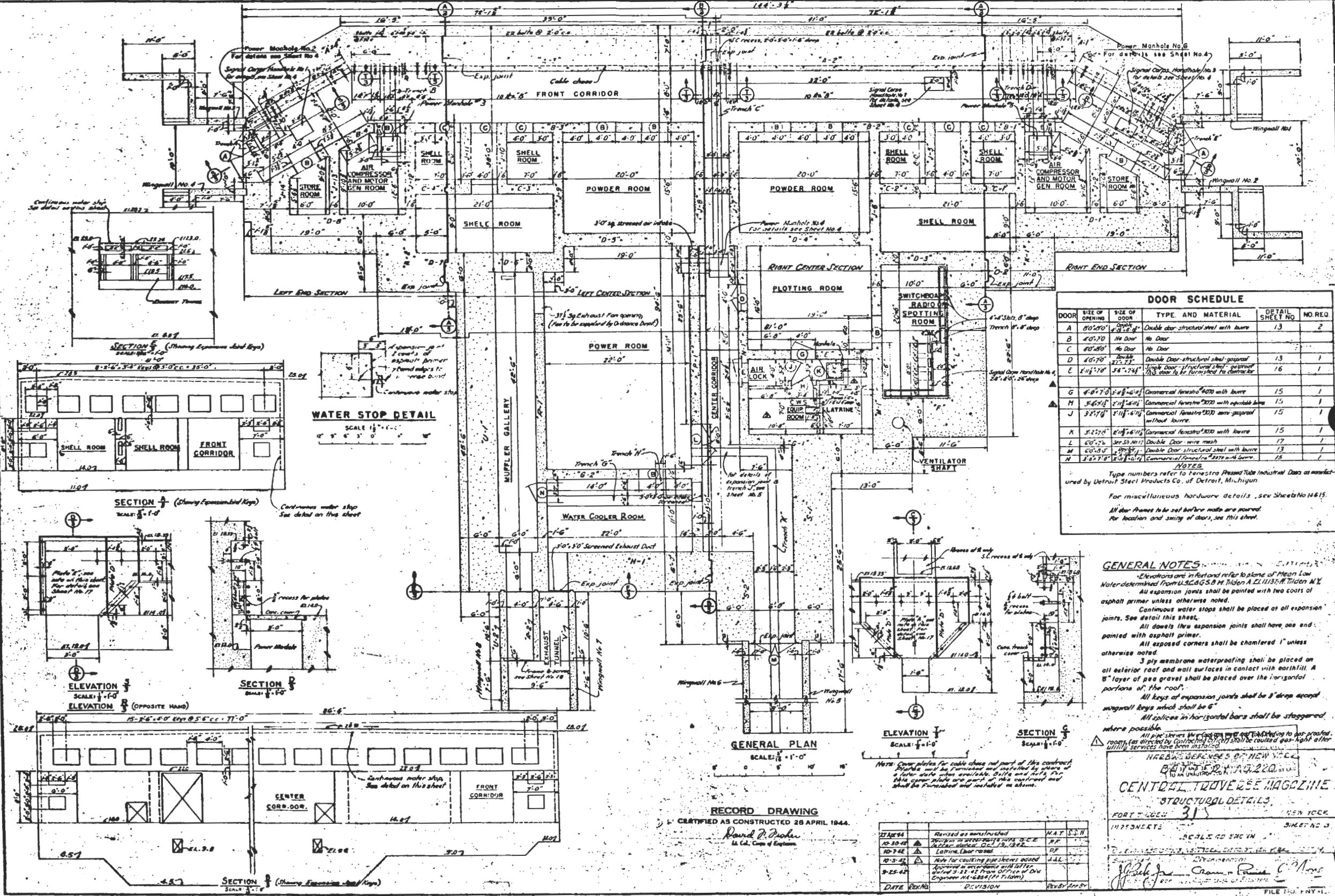

| DOOR SCHEDULE |                 |                 |  |                  |          |
|---------------|-----------------|-----------------|--|------------------|----------|
| DOOR          | SIZE OF OPENING | SIZE OF DOOR    | TYPE AND MATERIAL  | DETAIL SHEET NO. | NO. REQ. |
| A             | 8'0" x 7'0"     | 4'0" x 6'8"     | Double door structural steel with louvre   | 13               | 2        |
| B             | 4'0" x 7'0"     | No Door         | No Door  |                  |          |
| C             | 4'0" x 7'0"     | No Door         | No Door  |                  |          |
| D             | 4'0" x 7'0"     | 2'0" x 6'8"     | Double Door structural steel gasproof  | 13               | 1        |
| E             | 4'11" x 7'0"    | 3'6" x 7'4"     | Single Door structural steel gasproof<br>This door to be furnished to contractor | 16               | 1        |
| G             | 4'0" x 7'0"     | 3'2" x 6'4"     | Commercial fenestra 3000 with louvre   | 15               | 1        |
| H             | 3'6" x 7'6"     | 2'11" x 6'11"   | Commercial fenestra 3000 with operable louvre                                    | 15               | 1        |
| J             | 3'2" x 7'6"     | 2'11" x 6'11"   | Commercial fenestra 3000 with operable louvre                                    | 15               | 1        |
| K             | 3'2" x 7'6"     | 2'11" x 6'11"   | Commercial fenestra 3000 with louvre   | 15               | 1        |
| L             | 6'0" x 7'6"     | See S.D. No. 17 | Double Door wire mesh  | 17               | 1        |
| M             | 6'0" x 7'6"     | See S.D. No. 17 | Double Door structural steel with louvre   | 13               | 1        |
| N             | 3'0" x 7'0"     | 2'0" x 6'8"     | Commercial fenestra 3000 with louvre   | 15               | 1        |

NOTES:  
Type numbers refer to Fenestra Pressed Tube Industrial Data as manufactured by Detroit Steel Products Co. of Detroit, Michigan.  
For miscellaneous hardware details, see Sheet No. 11615.  
All door frames to be set before masonry are poured.  
For location and swing of doors, see this sheet.

**GENERAL NOTES:**

- Elevations are in feet and refer to plane of Mean Low Water determined from U.S.C.G.S. M. Tides A. L. 11137-A. Tides M. T. All expansion joints shall be painted with two coats of asphalt primer unless otherwise noted.
- Continuous water stops shall be placed at all expansion joints. See detail on this sheet.
- All dowels thru expansion joints shall have one end painted with asphalt primer.
- All exposed corners shall be chamfered 1" unless otherwise noted.
- 3 ply membrane waterproofing shall be placed on all exterior roof and wall surfaces in contact with earthfill. A 6" layer of pea gravel shall be placed over the horizontal portions of the roof.
- All keys of expansion joints shall be 8" deep except wingwall keys which shall be 6".
- All splices in horizontal bars shall be staggered where possible.
- All pipe sleeves thru concrete walls and ceilings to gas proofed rooms, gas directed by Code Book 101.101 shall be caulked gas-tight after utility services have been installed.

REVISIONS:

| DATE     | REVISION   | BY | APP'D. |
|----------|--|----|--------|
| 12-30-42 | Revised as constructed   |    |        |
| 10-3-42  | Written in accordance with S.D. No. 17, 18, 19, 20, 21, 22, 23, 24, 25, 26, 27, 28, 29, 30, 31, 32, 33, 34, 35, 36, 37, 38, 39, 40, 41, 42, 43, 44, 45, 46, 47, 48, 49, 50, 51, 52, 53, 54, 55, 56, 57, 58, 59, 60, 61, 62, 63, 64, 65, 66, 67, 68, 69, 70, 71, 72, 73, 74, 75, 76, 77, 78, 79, 80, 81, 82, 83, 84, 85, 86, 87, 88, 89, 90, 91, 92, 93, 94, 95, 96, 97, 98, 99, 100, 101, 102, 103, 104, 105, 106, 107, 108, 109, 110, 111, 112, 113, 114, 115, 116, 117, 118, 119, 120, 121, 122, 123, 124, 125, 126, 127, 128, 129, 130, 131, 132, 133, 134, 135, 136, 137, 138, 139, 140, 141, 142, 143, 144, 145, 146, 147, 148, 149, 150, 151, 152, 153, 154, 155, 156, 157, 158, 159, 160, 161, 162, 163, 164, 165, 166, 167, 168, 169, 170, 171, 172, 173, 174, 175, 176, 177, 178, 179, 180, 181, 182, 183, 184, 185, 186, 187, 188, 189, 190, 191, 192, 193, 194, 195, 196, 197, 198, 199, 200, 201, 202, 203, 204, 205, 206, 207, 208, 209, 210, 211, 212, 213, 214, 215, 216, 217, 218, 219, 220, 221, 222, 223, 224, 225, 226, 227, 228, 229, 230, 231, 232, 233, 234, 235, 236, 237, 238, 239, 240, 241, 242, 243, 244, 245, 246, 247, 248, 249, 250, 251, 252, 253, 254, 255, 256, 257, 258, 259, 260, 261, 262, 263, 264, 265, 266, 267, 268, 269, 270, 271, 272, 273, 274, 275, 276, 277, 278, 279, 280, 281, 282, 283, 284, 285, 286, 287, 288, 289, 290, 291, 292, 293, 294, 295, 296, 297, 298, 299, 300, 301, 302, 303, 304, 305, 306, 307, 308, 309, 310, 311, 312, 313, 314, 315, 316, 317, 318, 319, 320, 321, 322, 323, 324, 325, 326, 327, 328, 329, 330, 331, 332, 333, 334, 335, 336, 337, 338, 339, 340, 341, 342, 343, 344, 345, 346, 347, 348, 349, 350, 351, 352, 353, 354, 355, 356, 357, 358, 359, 360, 361, 362, 363, 364, 365, 366, 367, 368, 369, 370, 371, 372, 373, 374, 375, 376, 377, 378, 379, 380, 381, 382, 383, 384, 385, 386, 387, 388, 389, 390, 391, 392, 393, 394, 395, 396, 397, 398, 399, 400, 401, 402, 403, 404, 405, 406, 407, 408, 409, 410, 411, 412, 413, 414, 415, 416, 417, 418, 419, 420, 421, 422, 423, 424, 425, 426, 427, 428, 429, 430, 431, 432, 433, 434, 435, 436, 437, 438, 439, 440, 441, 442, 443, 444, 445, 446, 447, 448, 449, 450, 451, 452, 453, 454, 455, 456, 457, 458, 459, 460, 461, 462, 463, 464, 465, 466, 467, 468, 469, 470, 471, 472, 473, 474, 475, 476, 477, 478, 479, 480, 481, 482, 483, 484, 485, 486, 487, 488, 489, 490, 491, 492, 493, 494, 495, 496, 497, 498, 499, 500, 501, 502, 503, 504, 505, 506, 507, 508, 509, 510, 511, 512, 513, 514, 515, 516, 517, 518, 519, 520, 521, 522, 523, 524, 525, 526, 527, 528, 529, 530, 531, 532, 533, 534, 535, 536, 537, 538, 539, 540, 541, 542, 543, 544, 545, 546, 547, 548, 549, 550, 551, 552, 553, 554, 555, 556, 557, 558, 559, 560, 561, 562, 563, 564, 565, 566, 567, 568, 569, 570, 571, 572, 573, 574, 575, 576, 577, 578, 579, 580, 581, 582, 583, 584, 585, 586, 587, 588, 589, 590, 591, 592, 593, 594, 595, 596, 597, 598, 599, 600, 601, 602, 603, 604, 605, 606, 607, 608, 609, 610, 611, 612, 613, 614, 615, 616, 617, 618, 619, 620, 621, 622, 623, 624, 625, 626, 627, 628, 629, 630, 631, 632, 633, 634, 635, 636, 637, 638, 639, 640, 641, 642, 643, 644, 645, 646, 647, 648, 649, 650, 651, 652, 653, 654, 655, 656, 657, 658, 659, 660, 661, 662, 663, 664, 665, 666, 667, 668, 669, 670, 671, 672, 673, 674, 675, 676, 677, 678, 679, 680, 681, 682, 683, 684, 685, 686, 687, 688, 689, 690, 691, 692, 693, 694, 695, 696, 697, 698, 699, 700, 701, 702, 703, 704, 705, 706, 707, 708, 709, 710, 711, 712, 713, 714, 715, 716, 717, 718, 719, 720, 721, 722, 723, 724, 725, 726, 727, 728, 729, 730, 731, 732, 733, 734, 735, 736, 737, 738, 739, 740, 741, 742, 743, 744, 745, 746, 747, 748, 749, 750, 751, 752, 753, 754, 755, 756, 757, 758, 759, 760, 761, 762, 763, 764, 765, 766, 767, 768, 769, 770, 771, 772, 773, 774, 775, 776, 777, 778, 779, 780, 781, 782, 783, 784, 785, 786, 787, 788, 789, 790, 791, 792, 793, 794, 795, 796, 797, 798, 799, 800, 801, 802, 803, 804, 805, 806, 807, 808, 809, 810, 811, 812, 813, 814, 815, 816, 817, 818, 819, 820, 821, 822, 823, 824, 825, 826, 827, 828, 829, 830, 831, 832, 833, 834, 835, 836, 837, 838, 839, 840, 841, 842, 843, 844, 845, 846, 847, 848, 849, 850, 851, 852, 853, 854, 855, 856, 857, 858, 859, 860, 861, 862, 863, 864, 865, 866, 867, 868, 869, 870, 871, 872, 873, 874, 875, 876, 877, 878, 879, 880, 881, 882, 883, 884, 885, 886, 887, 888, 889, 890, 891, 892, 893, 894, 895, 896, 897, 898, 899, 900, 901, 902, 903, 904, 905, 906, 907, 908, 909, 910, 911, 912, 913, 914, 915, 916, 917, 918, 919, 920, 921, 922, 923, 924, 925, 926, 927, 928, 929, 930, 931, 932, 933, 934, 935, 936, 937, 938, 939, 940, 941, 942, 943, 944, 945, 946, 947, 948, 949, 950, 951, 952, 953, 954, 955, 956, 957, 958, 959, 960, 961, 962, 963, 964, 965, 966, 967, 968, 969, 970, 971, 972, 973, 974, 975, 976, 977, 978, 979, 980, 981, 982, 983, 984, 985, 986, 987, 988, 989, 990, 991, 992, 993, 994, 995, 996, 997, 998, 999, 1000 |    |        |

RECORD DRAWING  
CERTIFIED AS CONSTRUCTED 28 APRIL 1944.  
David P. Proker  
Lt. Col., Corps of Engineers

DATE REVISION REVISION BY



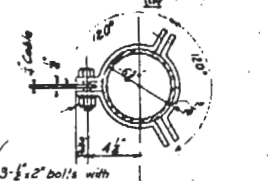
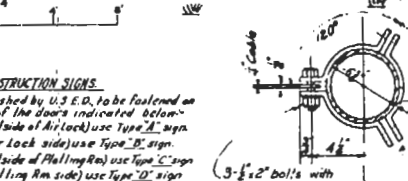
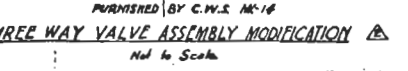
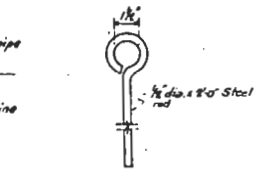
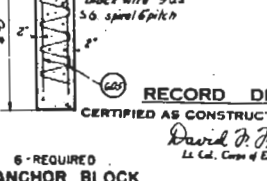
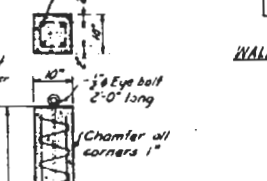
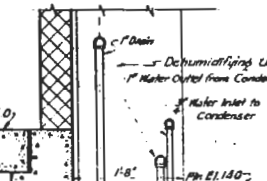
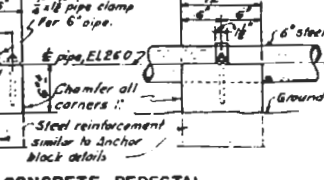
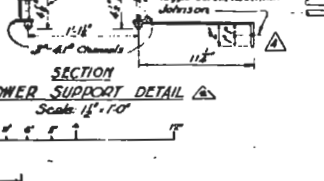
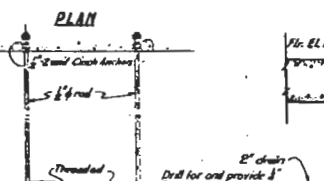
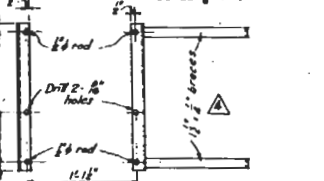
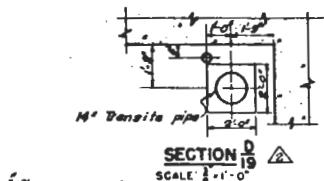
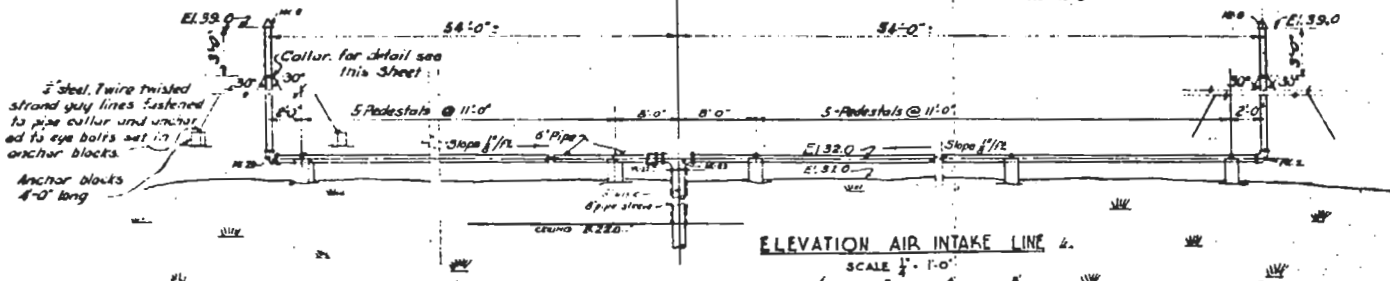
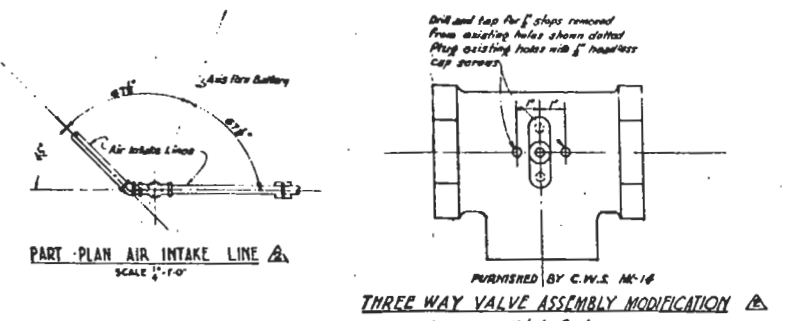
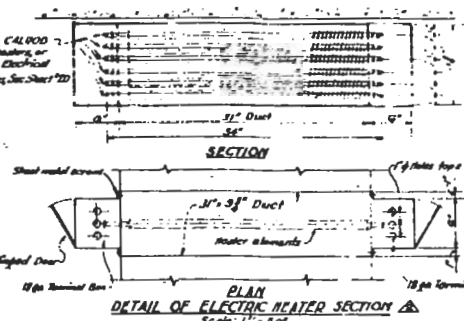
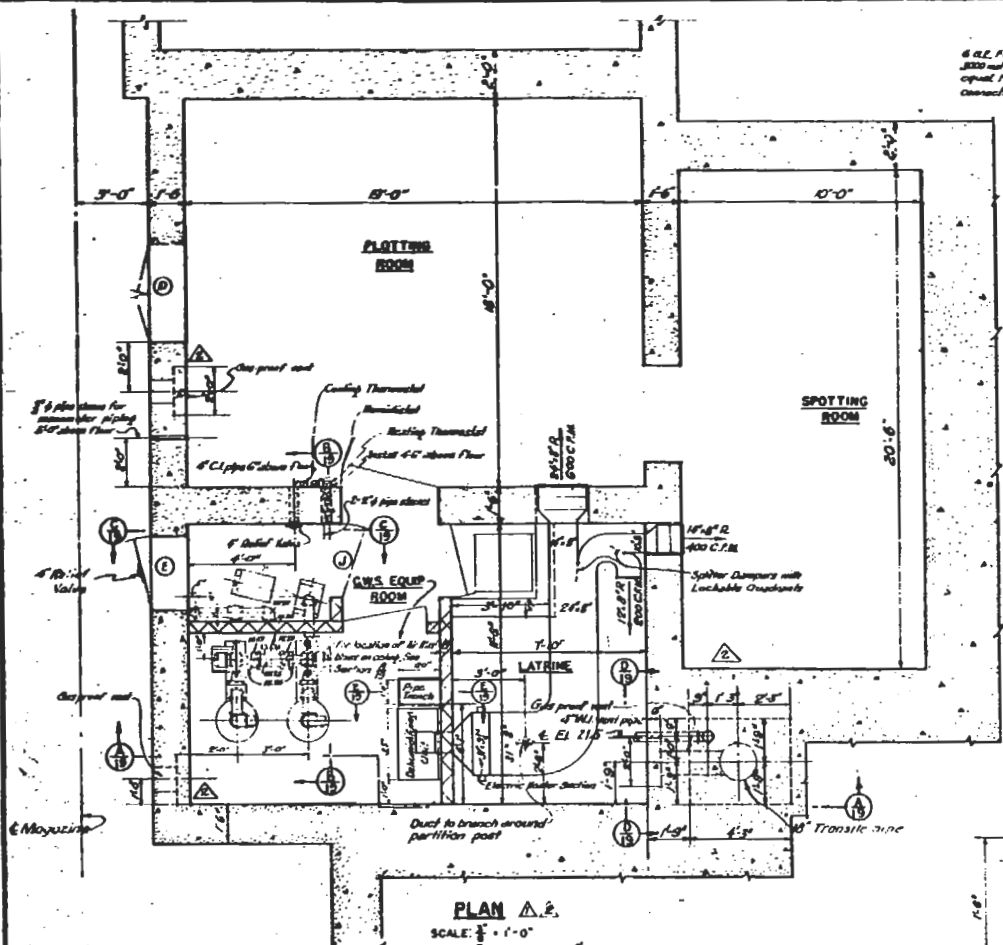

**GASPROOFING INSTRUCTION SIGNS**  
 Signs, as furnished by U.S.E.D. to be fastened on the upper half of the doors indicated below:  
 On Door (1) (outside of Airlock) use Type "A" sign.  
 On Door (2) (Air Lock side) use Type "B" sign.  
 On Door (3) (outside of Plotting Room) use Type "C" sign.  
 On Door (4) (Plotting Room side) use Type "D" sign.  
 For details of gasproofing instruction signs see sheet 1817.

**NOTES**

For General Notes see sheet No. 3.  
 For additional Gasproofing details see sheet No. 17.  
 Pipe sleeves for pipes extending through concrete and tile walls shall be black steel, standard weight.  
 All pipe sleeves extending through walls of air lock shall be caulked gas tight after piping has been installed.  
 For painting surfaces of gasproof pipe see specifications.  
 For Bill of Materials of gasproofing equipment and parts not detailed see sheet No. 18.

Pipe for gasproofing system shall be standard black steel pipe with standard 125 pound cast iron fittings, except where otherwise shown.  
 Gas proofing equipment and piping not part of this Contract. See specifications and Bill of Material, sheet No. 18.  
 For use see sheet No. 25.  
 All pipe shown on drawings, with and without roof tanking to gas proofing, must be directed by the Construction Engineer shall be caulked gas tight after all dry services have been installed.

RECORD DRAWING  
 CERTIFIED AS CONSTRUCTED 28 APRIL 1944.  
 David P. Proker  
 Lt. Col., Corps of Engineers.

| DATE     | REVISION  | REVISION | BY   |
|----------|---|----------|------|
| 3-21-43  | Revised as constructed  |          | A.B. |
| 3-21-43  | Hand of Blower changed  |          | A.B. |
| 4-2-43   | Blower Support revised. Delayed Action Valve added. Additional reinforcement  |          | A.B. |
| 12-11-42 | Revisions in accordance with O.C.E. Letter dated Oct. 13, 1942 includes: Revision of Gas proofing layout, and Air Blast Blower Support. Replacing existing Air Blast Blower. Relocation of Gas proof feet. Revision for 3 Gas proof feet increased. Addition of 3 man water modification (dehumidifier). System with steam and piping, and electric wiring. |          | A.B. |
| 10-1-49  | Latrine gasproofing called revised. 1/2" pipe hanger abandoned. Floor raised  |          | A.B. |
| 8-25-43  | Approved in accordance with letter dated 9-22-43 from CITTON of District Engineer. (A. E. S. G. (L. T. L. S. G.))   |          | A.B. |

DATE REVISION REVISION BY

646/63022 4 of 6

168 FILE NO. F.I.V. 115

HARBOR DEFENSES OF NEW YORK  
 BATTERY NO. 220  
 CENTRAL TRAVERSE MAGAZINE  
 GAS-PROOFING DETAILS  
 FORT TILDEN 315 NEW YORK  
 IN 66 SHEETS SHEET NO. 19  
 SCALE AS SHOWN  
 U.S. ENGINEER OFFICE, NEW YORK DISTRICT, NEW YORK, N.Y. 10038  
 Submitted: [Signature] Recommended: [Signature] Approved: [Signature]  
 Senior Engineer Major, Corps of Engineers Col., USA

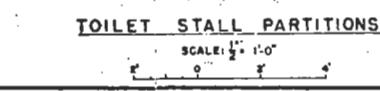
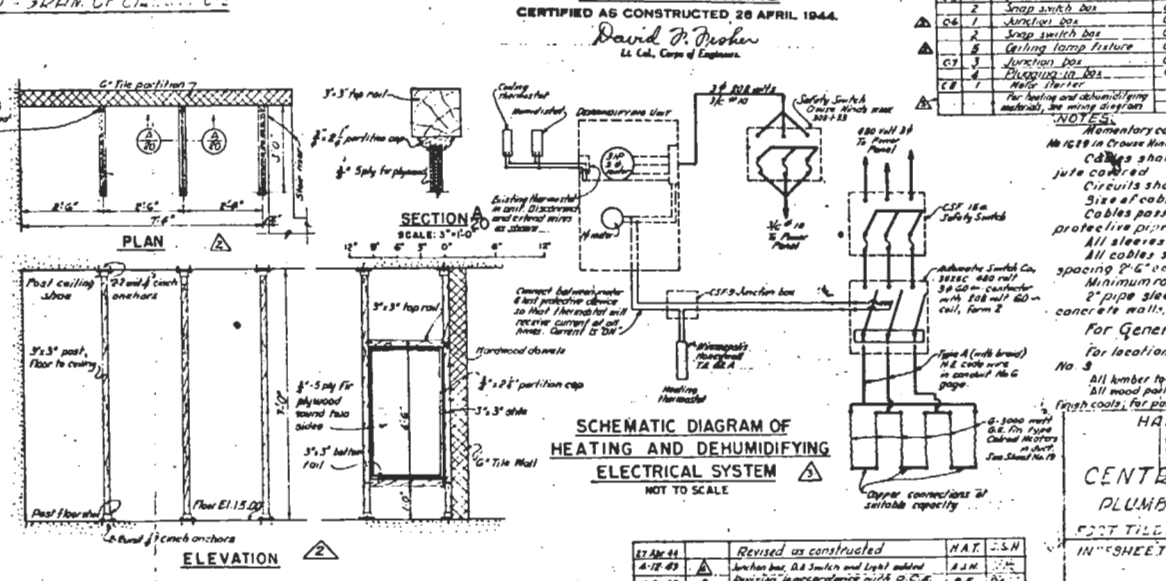
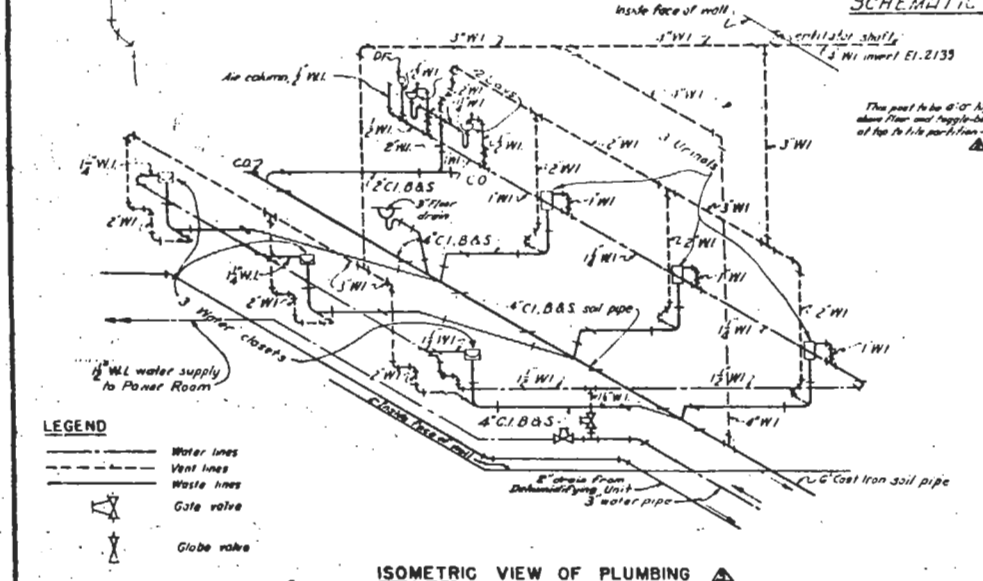
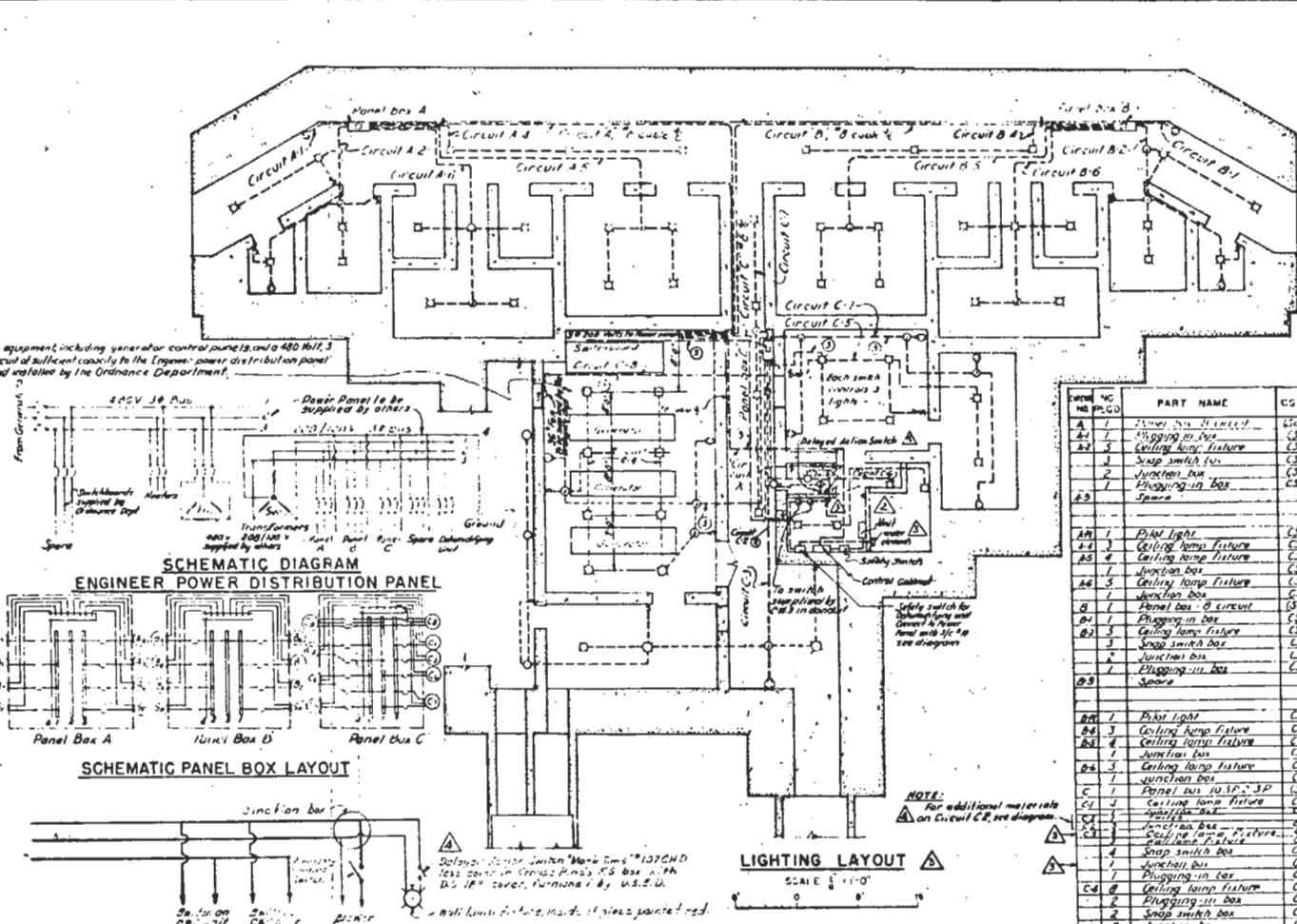
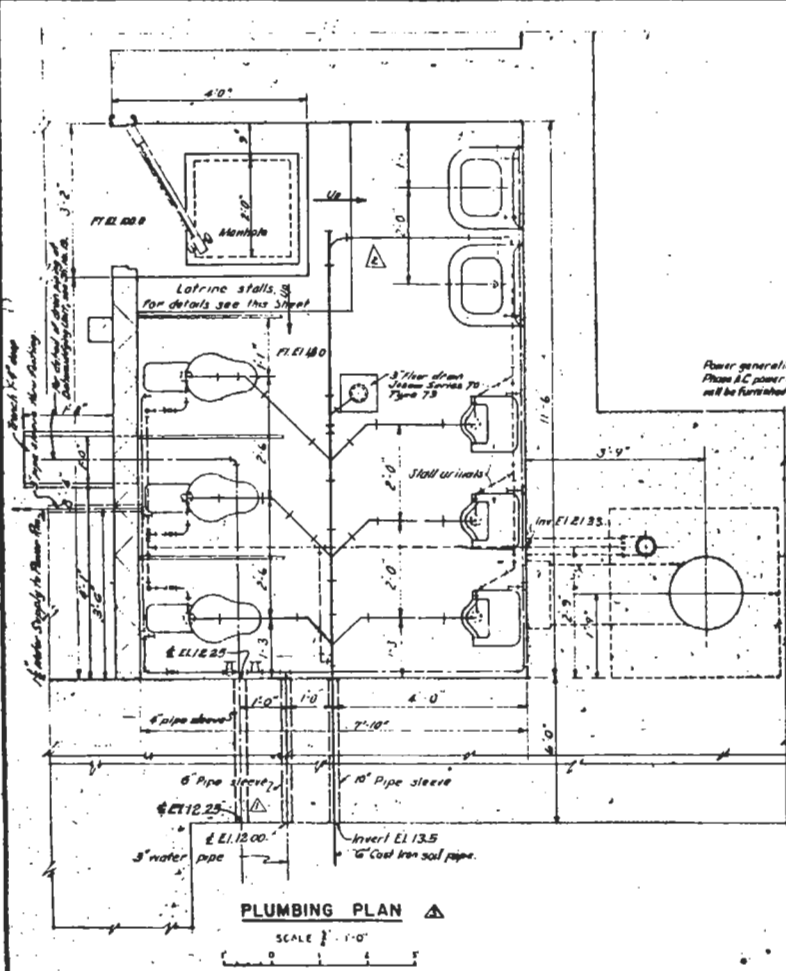

**LEGEND**

- Ceiling lamp fixture - CSF-0 or CSF-1
- Junction box - CSF-9
- ⊕ Plugging-in box - CSF-10
- ⊖ Snap switch box - CSF-8
- ⊕ Electric heater elements
- ⊕ Pilot light on panel box
- ⊕ Meter light and shut-light Cruise Wards Over
- ⊕ 3 wire fuse
- ⊕ Wall lamp fixture

| QTY | NO | PART NAME            | CSF NO. | QUANTITY | REMARKS |
|-----|----|----------------------|---------|----------|---------|
| 1   | 1  | Power Box 1000/100   | CSF-10  | 1        |         |
| 1   | 2  | Plugging-in box      | CSF-10  | 2        |         |
| 1   | 3  | Ceiling lamp fixture | CSF-0   | 3        |         |
| 1   | 4  | Plug-in box          | CSF-10  | 4        |         |
| 1   | 5  | Junction box         | CSF-9   | 5        |         |
| 1   | 6  | Plugging-in box      | CSF-10  | 6        |         |
| 1   | 7  | Spares               |         |          |         |
| 1   | 8  | Pilot light          | CSF-1   | 1        |         |
| 1   | 9  | Ceiling lamp fixture | CSF-1   | 1        |         |
| 1   | 10 | Ceiling lamp fixture | CSF-1   | 2        |         |
| 1   | 11 | Junction box         | CSF-9   | 1        |         |
| 1   | 12 | Junction box         | CSF-9   | 1        |         |
| 1   | 13 | Panel box 8 circuit  | CSF-9   | 1        |         |
| 1   | 14 | Plugging-in box      | CSF-10  | 1        |         |
| 1   | 15 | Ceiling lamp fixture | CSF-0   | 1        |         |
| 1   | 16 | Plug-in box          | CSF-10  | 1        |         |
| 1   | 17 | Junction box         | CSF-9   | 1        |         |
| 1   | 18 | Plugging-in box      | CSF-10  | 1        |         |
| 1   | 19 | Spares               |         |          |         |
| 1   | 20 | Pilot light          | CSF-1   | 1        |         |
| 1   | 21 | Ceiling lamp fixture | CSF-1   | 1        |         |
| 1   | 22 | Ceiling lamp fixture | CSF-1   | 2        |         |
| 1   | 23 | Junction box         | CSF-9   | 1        |         |
| 1   | 24 | Ceiling lamp fixture | CSF-1   | 1        |         |
| 1   | 25 | Junction box         | CSF-9   | 1        |         |
| 1   | 26 | Panel box 10/3P-3P   | CSF-9   | 1        |         |
| 1   | 27 | Ceiling lamp fixture | CSF-1   | 1        |         |
| 1   | 28 | Spares               |         |          |         |
| 1   | 29 | Plugging-in box      | CSF-10  | 1        |         |
| 1   | 30 | Plugging-in box      | CSF-10  | 1        |         |
| 1   | 31 | Junction box         | CSF-9   | 1        |         |
| 1   | 32 | Plugging-in box      | CSF-10  | 1        |         |
| 1   | 33 | Plugging-in box      | CSF-10  | 1        |         |
| 1   | 34 | Junction box         | CSF-9   | 1        |         |
| 1   | 35 | Plugging-in box      | CSF-10  | 1        |         |
| 1   | 36 | Plugging-in box      | CSF-10  | 1        |         |
| 1   | 37 | Junction box         | CSF-9   | 1        |         |
| 1   | 38 | Plugging-in box      | CSF-10  | 1        |         |
| 1   | 39 | Plugging-in box      | CSF-10  | 1        |         |
| 1   | 40 | Plugging-in box      | CSF-10  | 1        |         |
| 1   | 41 | Plugging-in box      | CSF-10  | 1        |         |
| 1   | 42 | Plugging-in box      | CSF-10  | 1        |         |
| 1   | 43 | Plugging-in box      | CSF-10  | 1        |         |
| 1   | 44 | Plugging-in box      | CSF-10  | 1        |         |
| 1   | 45 | Plugging-in box      | CSF-10  | 1        |         |
| 1   | 46 | Plugging-in box      | CSF-10  | 1        |         |
| 1   | 47 | Plugging-in box      | CSF-10  | 1        |         |
| 1   | 48 | Plugging-in box      | CSF-10  | 1        |         |
| 1   | 49 | Plugging-in box      | CSF-10  | 1        |         |
| 1   | 50 | Plugging-in box      | CSF-10  | 1        |         |

**RECORD DRAWING**  
CERTIFIED AS CONSTRUCTED 28 APRIL 1944.  
David P. Prober  
Lt. Col., Corps of Engineers.

**NOTES**

Momentary contact switch shall consist of Hart & Hoffman switch No. 1019 in Cruise Wards type 15 box with 1/2" x 1/2" cover.

Cables shall be varnished cambric in suitably sized and jacketed.

Cables shall be No. 12 cable except as shown. See specs.

Size of cable connectors to be determined in field.

Cables passing thru wall partitions etc. shall have protective pipe sleeve.

All sleeves to be gasketed or capped gas tight.

All cables shall be supported by cable hangers maximum spacing 24" c/c. For cable hangers see spec. locations.

Minimum radius of bends shall be 6".

2" pipe sleeves shall be located where cables pass thru concrete walls. (See reinforcement drawings).

For General Notes see Sheet No. 3.

For location of trenches, manholes & ducts see Sheet No. 3.

All lumber to be dressed, sizes given are nominal.

All wood partitions & panels shall be painted one prime coat and two finish coats, for paint & colors see spec. MAT-341.

| DATE     | BY | REVISION  | BY | APP'D |
|----------|----|---|----|-------|
| 11-24-41 |    | Revised as constructed  |    |       |
| 4-12-43  |    | Junction box, D8 switch and light added   |    |       |
| 11-3-43  |    | Plugging-in box added   |    |       |
| 10-1-44  |    | Latrine floor removed   |    |       |
| 9-30-44  |    | Water pipe & sleeve revised   |    |       |
| 8-25-44  |    | Approved as constructed with letter dated 9-22-44 From Office of Dir. Engineer, H-6858 (P1) T1000 |    |       |

HARBOR DEFENSES OF NEW YORK  
BATTERY NO. 220  
CENTRAL UNIVERSE MAGAZINE  
PLUMBING & ELECTRICAL SYSTEMS  
FIRST FLOOR  
IN SHEETS  
SCALE AS SHOWN  
U.S. ENGINEER OFFICE NEW YORK DISTRICT NEW YORK, N.Y.  
315  
315 SHEET 20

646/63022 5 of 6

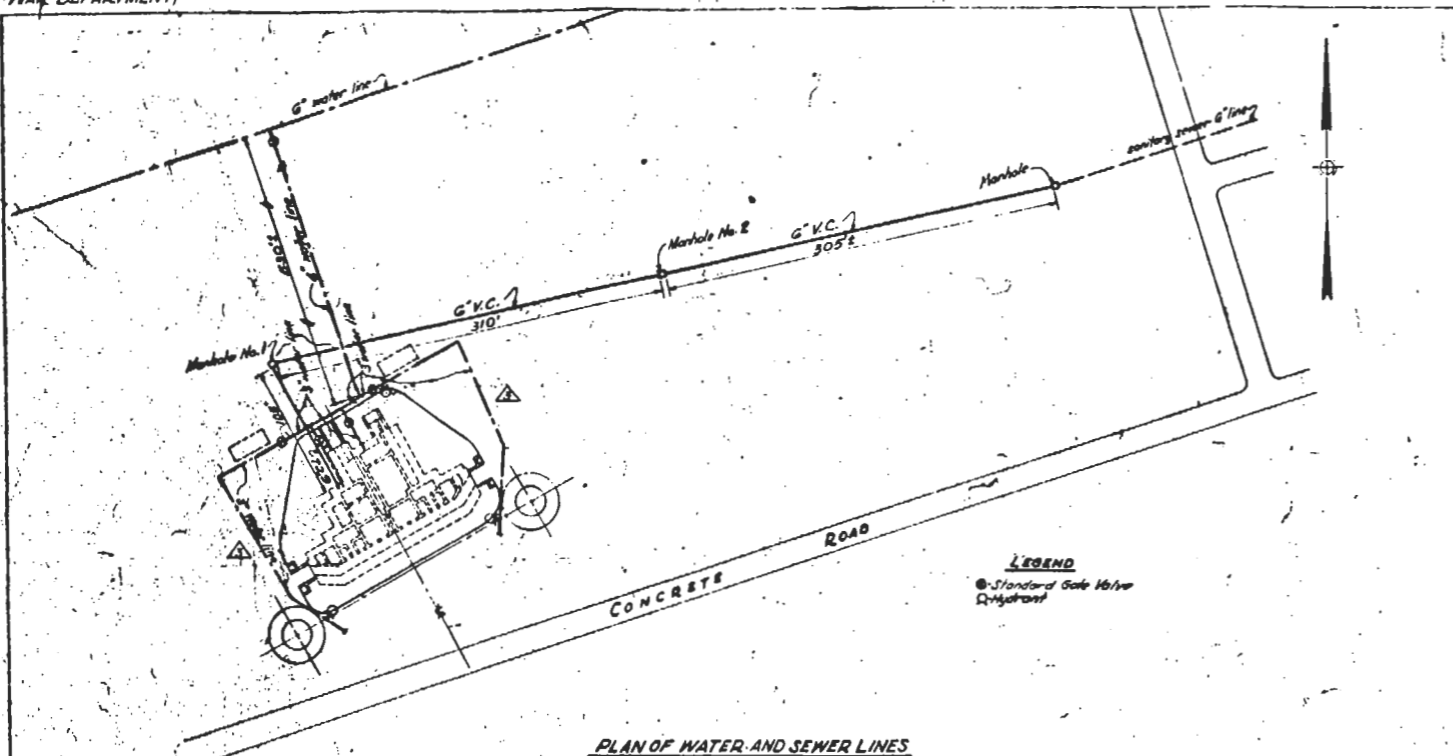

**LEGEND**  
 ● Standard Gate Valve  
 △ Hydrant

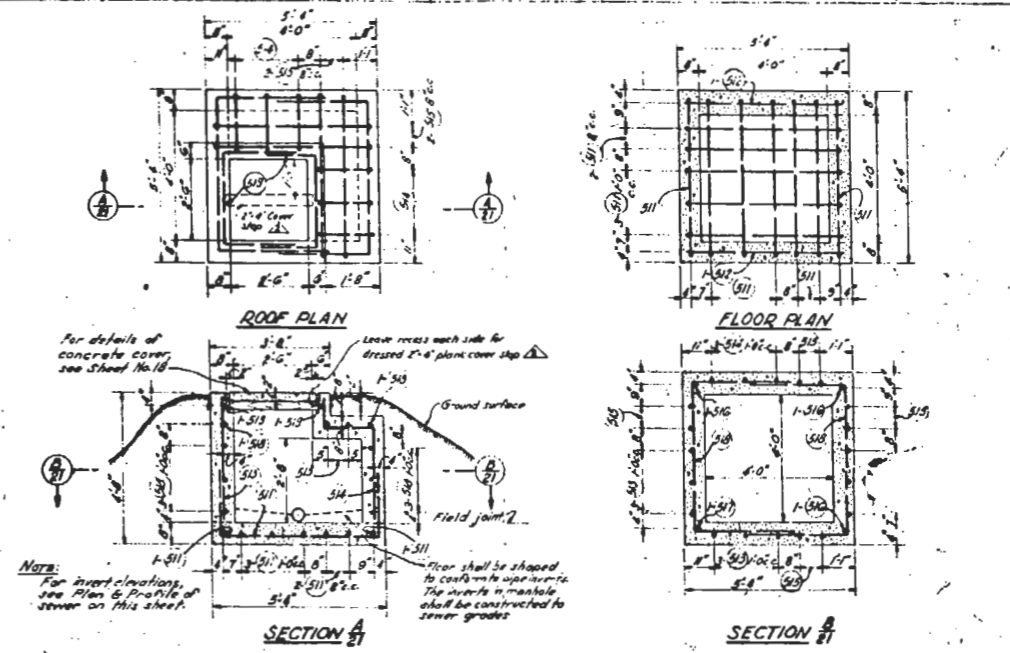

**NOTE:**  
 For invert elevations, see Plan & Profile of sewer on this sheet.  
 Floor shall be shaped to conform to slope inverts. The inverts in manhole shall be constructed to sewer grades.

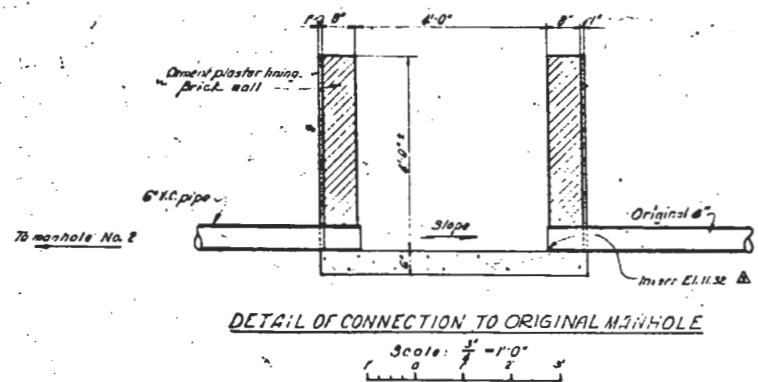
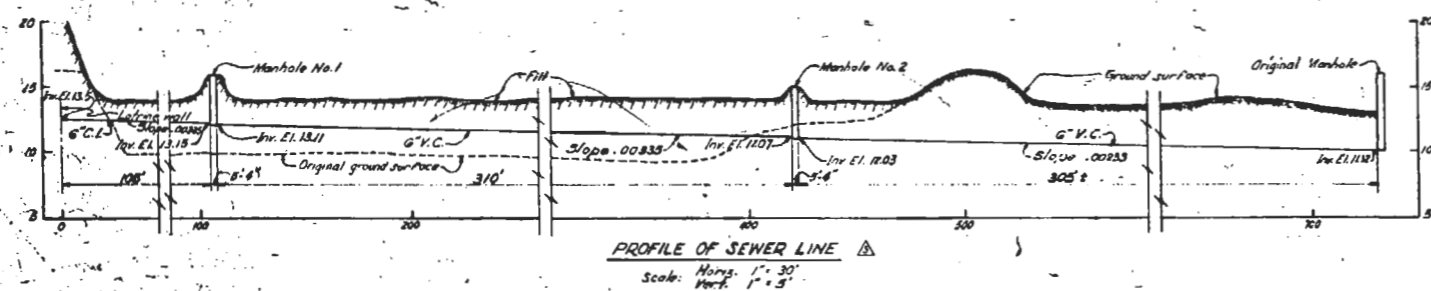

**NOTES**  
 All reinforcing steel shown on this sheet shall be #4 bars unless otherwise noted.  
 For general notes applying to this sheet, see Sheet No. 3.  
 Elevations shown on this sheet refer to plane of Mean Low Water as shown on Sheet No. 1.  
 For manhole frame & cover detail, see Sheet No. 18.  
 Water mains shall be laid with a minimum cover of 36". Gate valves shall be provided with standard adjustable valve boxes.  
 For Bar List, see Sheet No. 25.

**RECORD DRAWING**  
 CERTIFIED AS CONSTRUCTED 28 APRIL 1944.  
 David P. Proffer  
 Lt. Col., Corps of Engineers.

**CONFIDENTIAL**

HARBOR DEFENSES OF NEW YORK  
 BATTERY NO. 229  
 CENTRAL TRAVERSE MAGAZINE  
 WATER AND SEWER SYSTEMS  
 FT. TILDEN 31 NEW YORK  
 125 SHEETS SHEET NO. 31  
 SCALE AS SHOWN  
 U.S. ENGINEER OFFICE, NEW YORK DISTRICT, NEW YORK, SEPTEMBER 1948  
 Submitted: Recommended: Approved:

|         |   |     |     |
|---------|---|-----|-----|
| 7-21-48 | Revised as constructed  | HAY | SJH |
| 10-2-48 | Water line & Sewer line revised   | PE  | SA  |
| 9-30-48 | Manhole details revised   | JLL | SA  |
| 9-24-48 | Specified in order direct with letter dated 9-22-48 from OFFICE of En. Engineer 2nd DISTRICT Tilden | JLL | SA  |
| 9-28-48 | Division  | RM  | SA  |

646/63022 6066 1CR FILE NO. HWY-1331

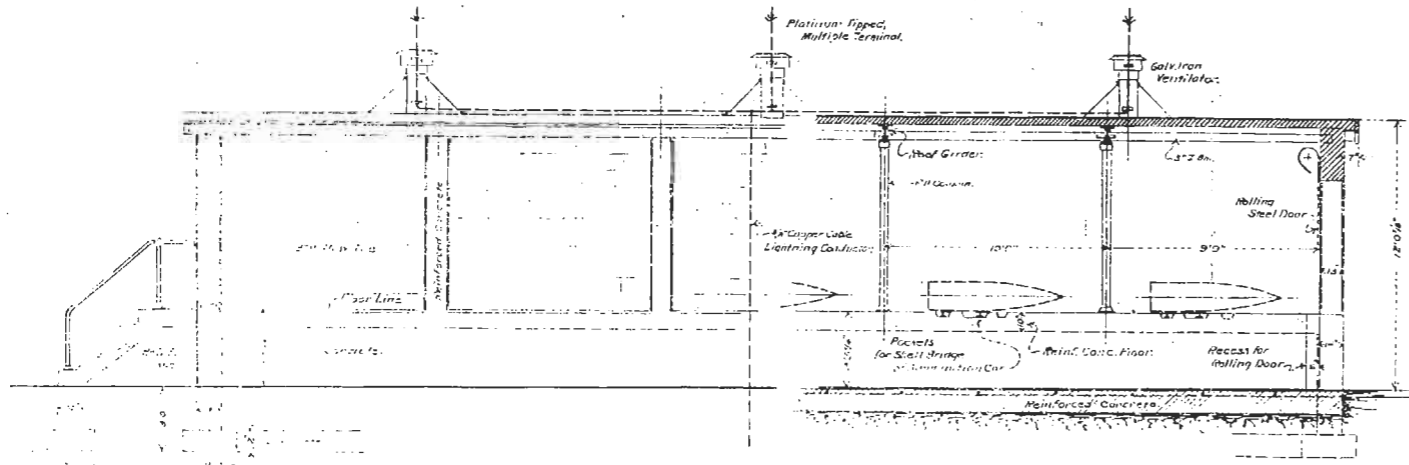

PARTIAL SIDE ELEVATION.

PARTIAL LONGITUDINAL SECTION.

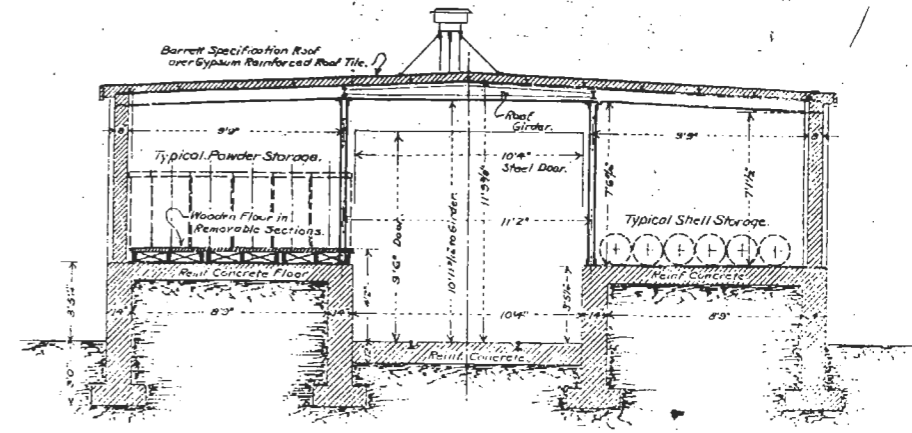

CROSS SECTION.

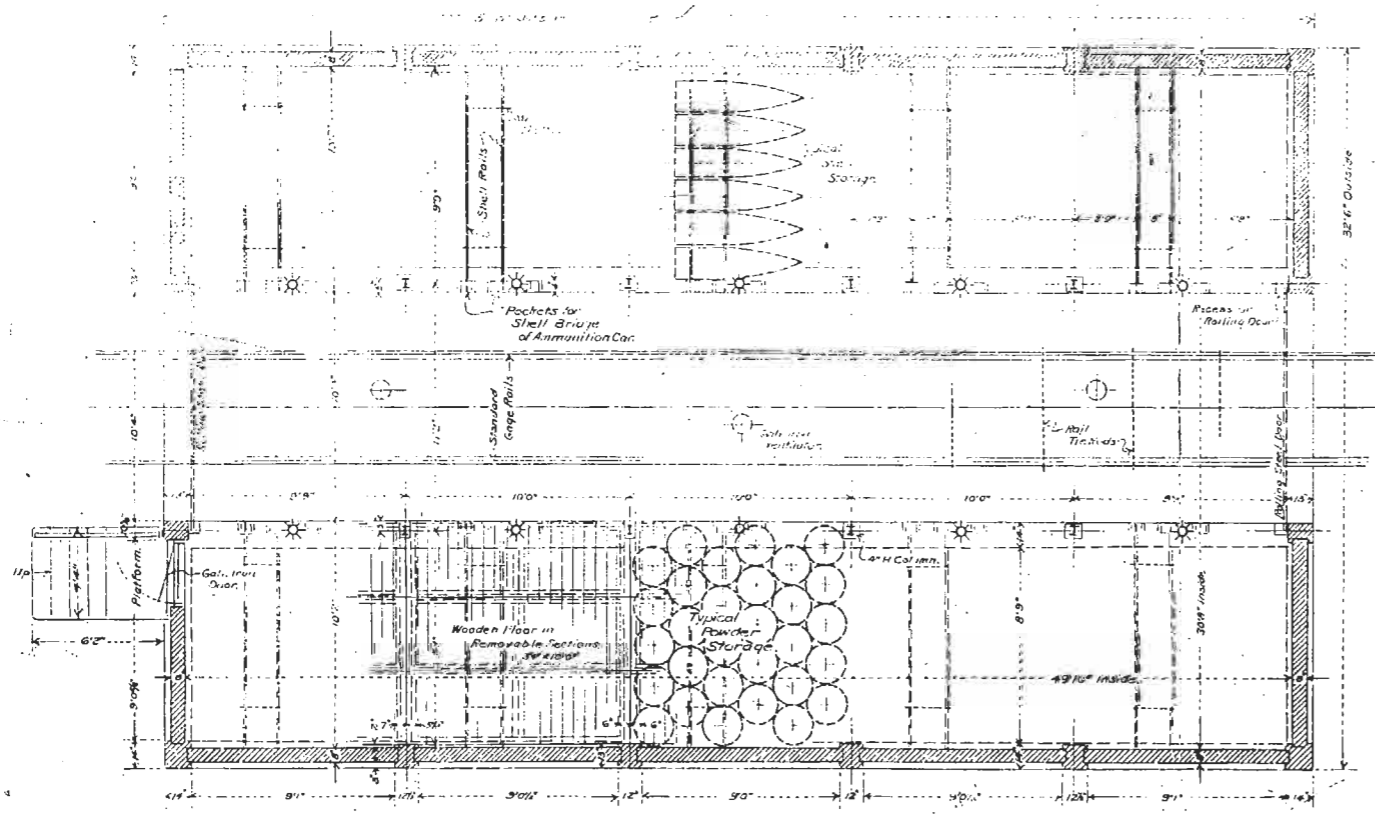

Lights shown thus \*

PLAN.

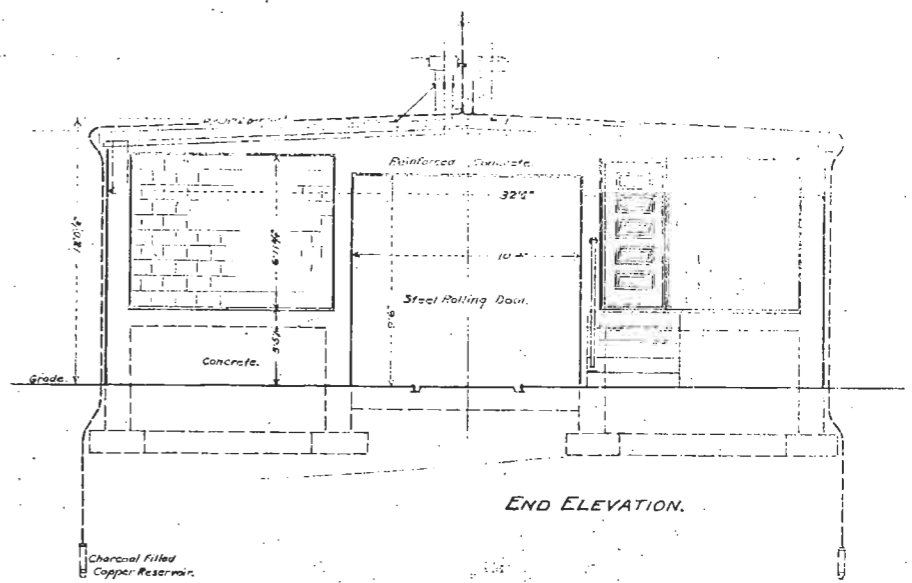

END ELEVATION.

**NOTE.**  
T-rails are provided in all bays of magazines upon which shells are to be stored, for powder storage the sectional wooden floors are to be used.

**FORT TILDEN, N. Y. - BATTERY HARRIS**  
**MAGAZINE FOR 16 INCH AMMUNITION**  
IN 1 SHEET SCALES AS SHOWN

United States Engineer Office, Third District, New York City, May 22, 1924.  
Submitted by *A. G. Swift* Approved by *W. J. Johnson*  
Checked by *W. J. Johnson* Major, Corps of Engineers.  
Drawn by *E. S. W.*  
Transmitted with letter dated May 22, 1924.

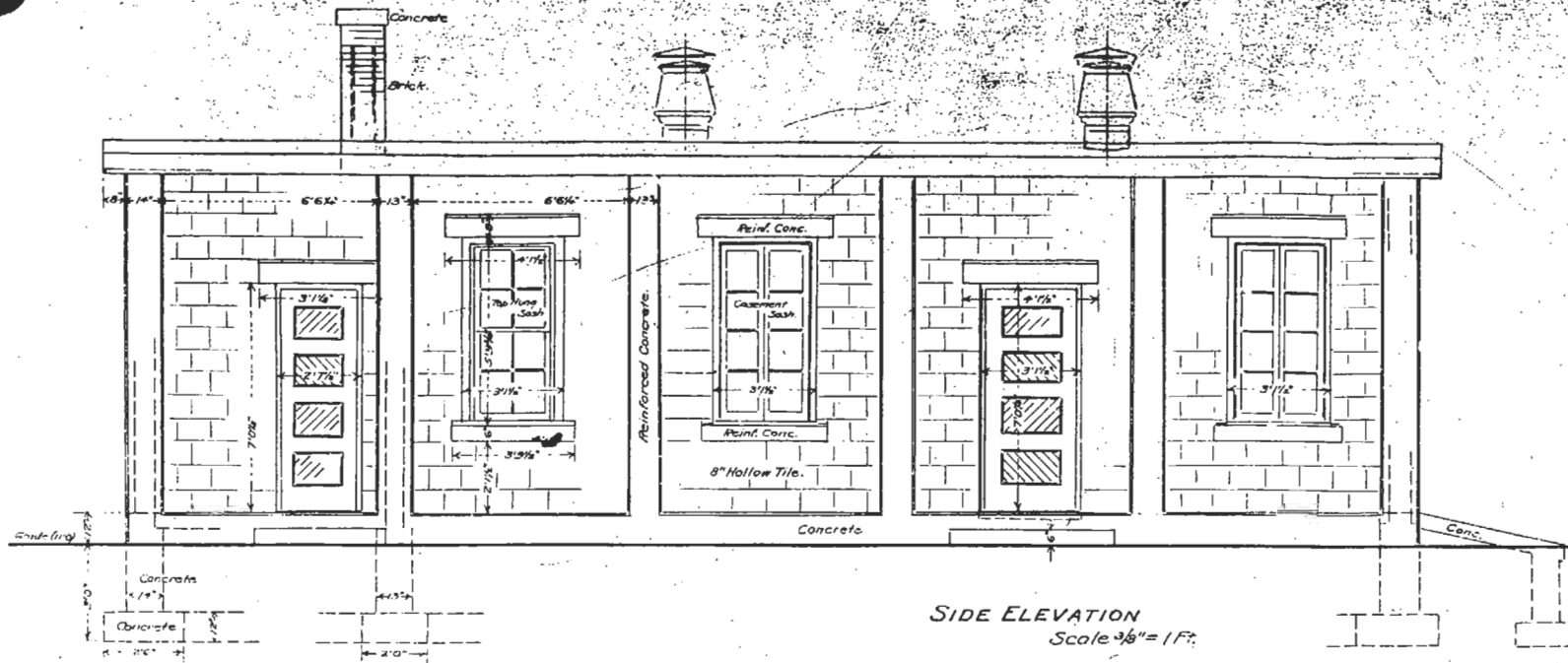

SIDE ELEVATION  
Scale 3/8" = 1 Ft.

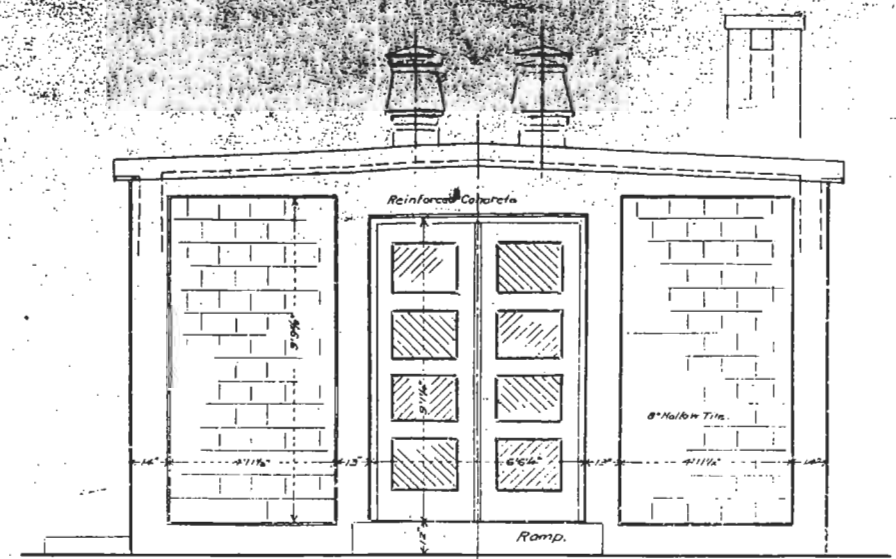

END ELEVATION  
Scale 3/8" = 1 Ft.

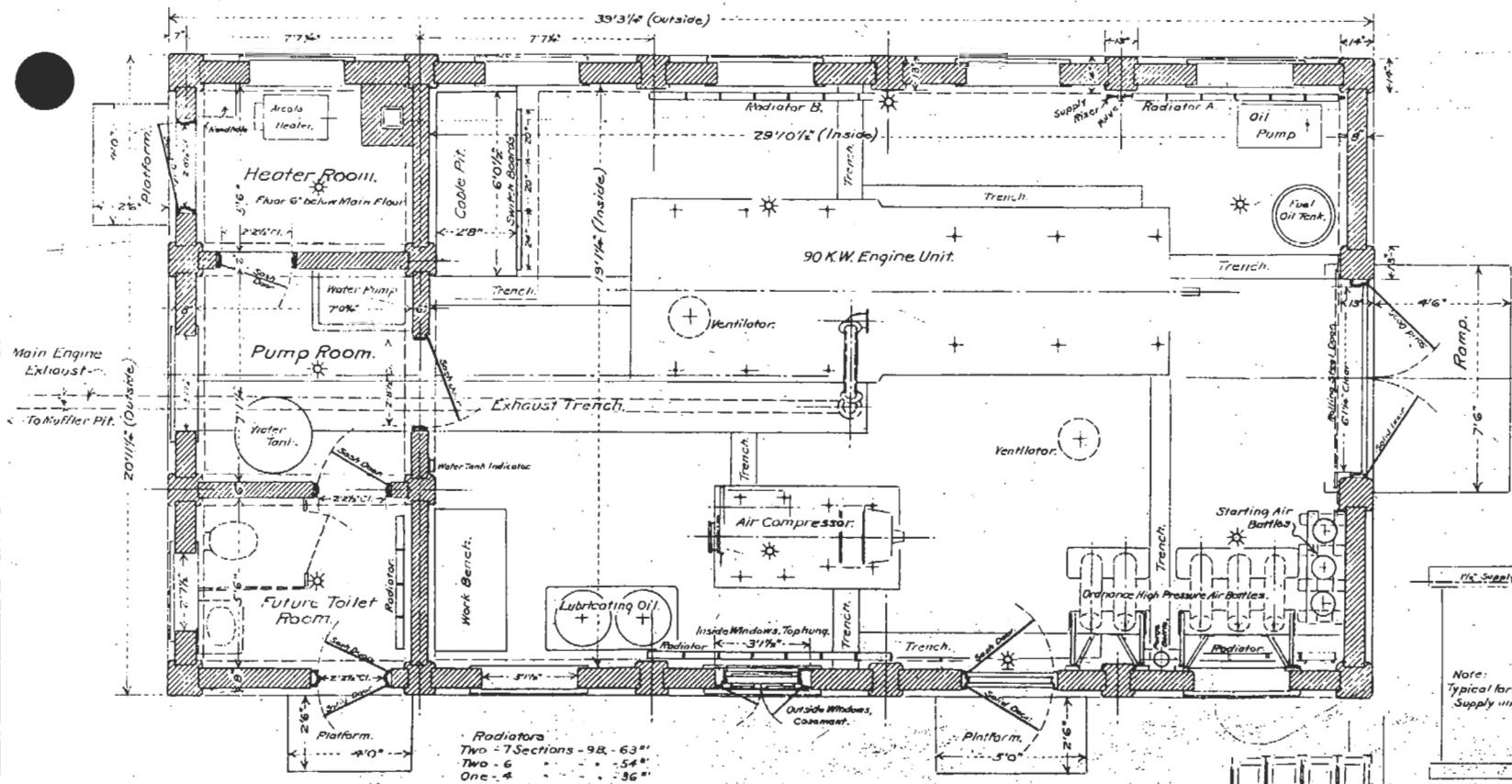

PLAN - Scale 1/8" = 1 Ft.  
(Power Houses No's 1 and 2)

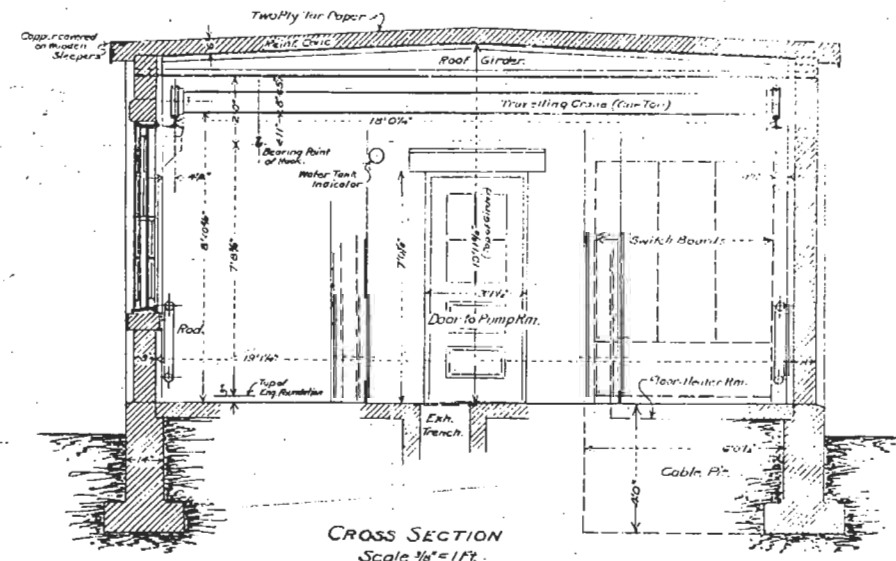

CROSS SECTION  
Scale 1/8" = 1 Ft.

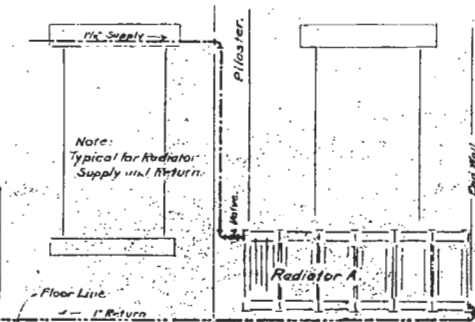

Elevation - Radiators

FORT TILDEN, N. Y. - BATTERY HARRIS  
**POWER HOUSE FOR 90 K. W. DIESEL UNIT**  
 (AND 3000 LB. AIR COMPRESSOR OR 25 K. W. GASOLINE SET.)  
**GENERAL PLAN - POWER HOUSES NO'S. 1 & 2**  
 (WITH AIR COMPRESSOR)

IN 3 SHEETS SHEET NO. 1 SCALE AS SHOWN

United States Engineer Office, Third District, New York City, May 22, 1924.  
 Submitted *A. C. Smith* Approved *M. J. Williams*  
 Major, Corps of Engineers.

Drawn by *A. C. Smith*  
 Checked by *ACE* File No. 5- C-4-2 Transmitted with letter dated May 22, 1924.

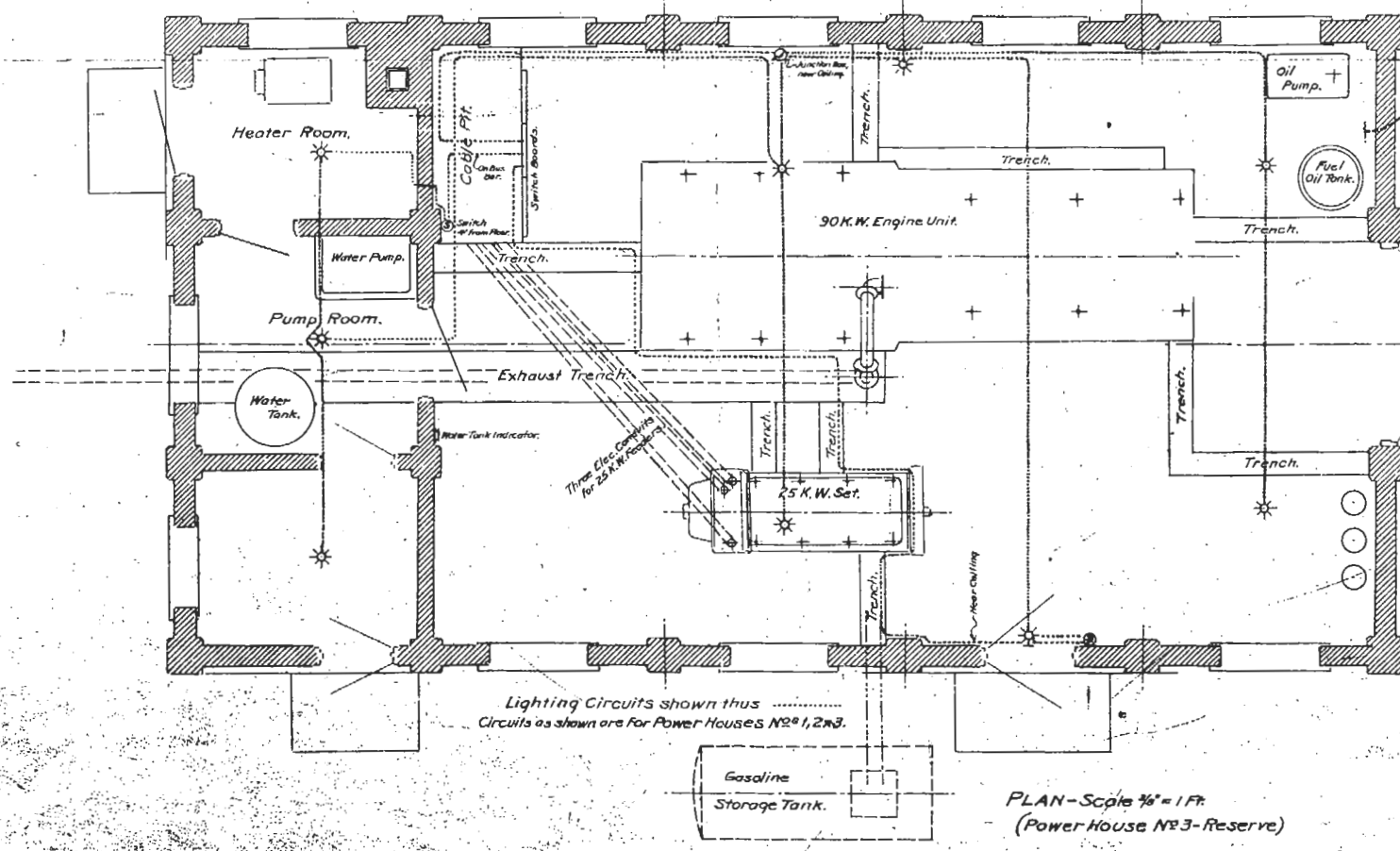
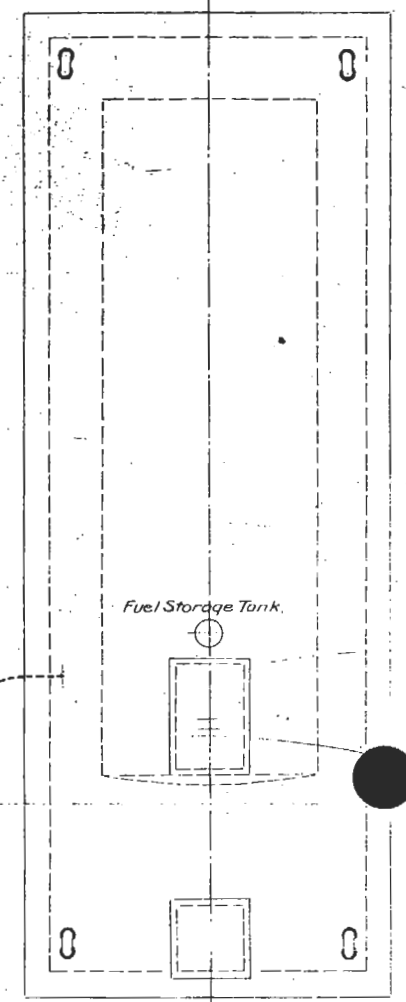
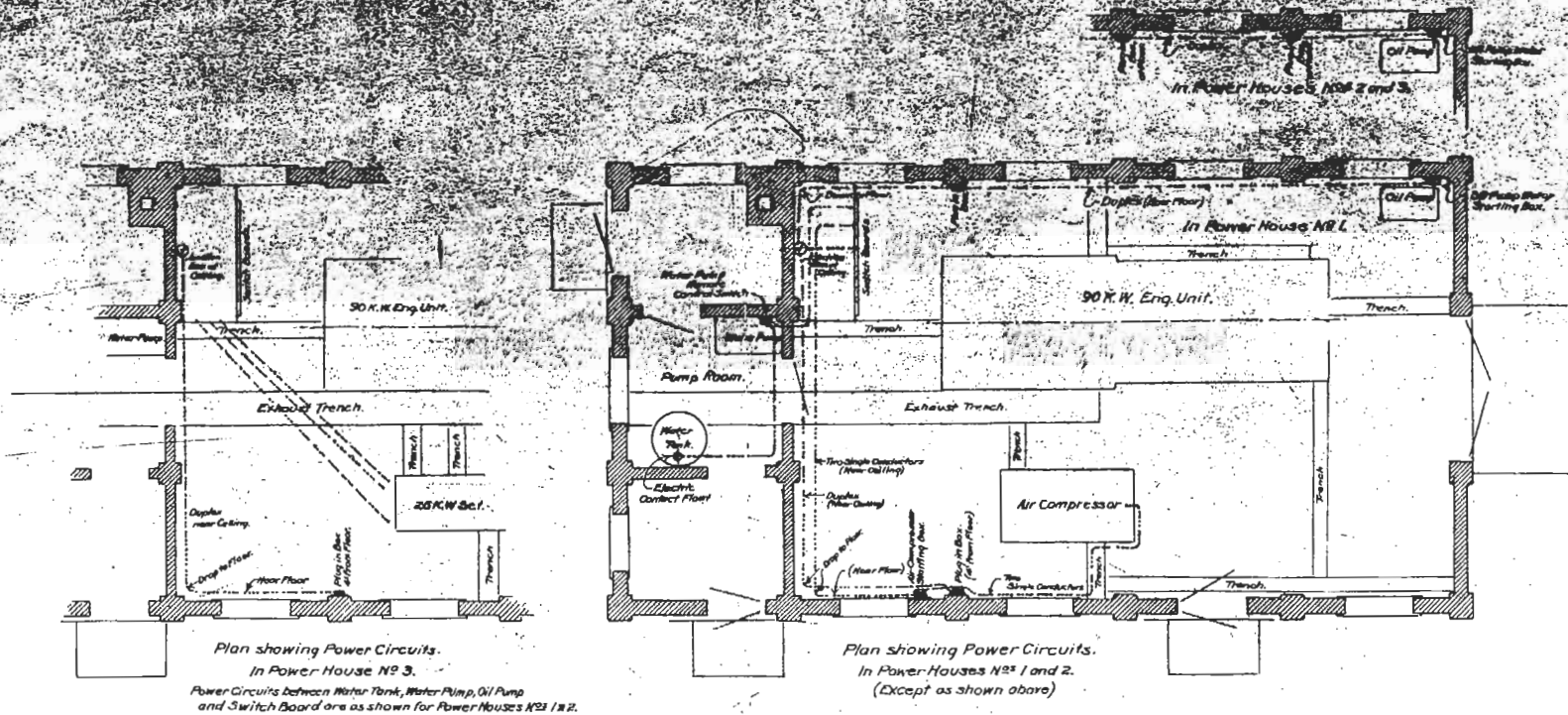

FORT TILDEN, N. Y. - BATTERY HARRIS  
**POWER HOUSE FOR 90 K. W. DIESEL UNIT**  
 (AND 3000 LB. AIR COMPRESSOR OR 25 K. W. GASOLINE SET.)  
**RESERVE POWER HOUSE NO. 3**  
 (WITH 25 K. W. SET)  
**ELECTRIC LIGHT & POWER WIRING**  
 IN 3 SHEETS SHEET NO. 2 SCALES AS SHOWN

United States Engineer Office, Third District, New York City, May 22, 1924.  
 Submitted *Almwood* Approved *Johnson*  
*Asst. Engineer* *Major, Corps of Engineers.*  
 Drawn by *E.R.M.*  
 Traced by *[Signature]*  
 Checked by *[Signature]* File No. 5<sup>b</sup>-C-4-2, Transmitted with letter dated May 22, 1924.

6-C-42

SECTION THROUGH GULLING OVER ROOFS  
Scale 1/4" = 1 Ft.



SECTION AT 3.4  
Scale 1/2" = 1 Ft.

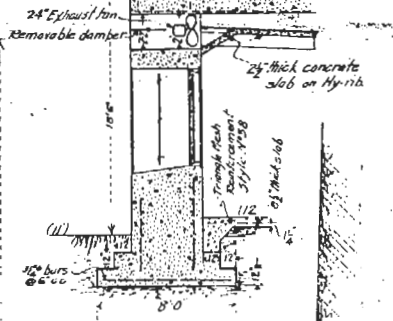

SECTION AT 1.2 - Scale 1/4" = 1 Ft.

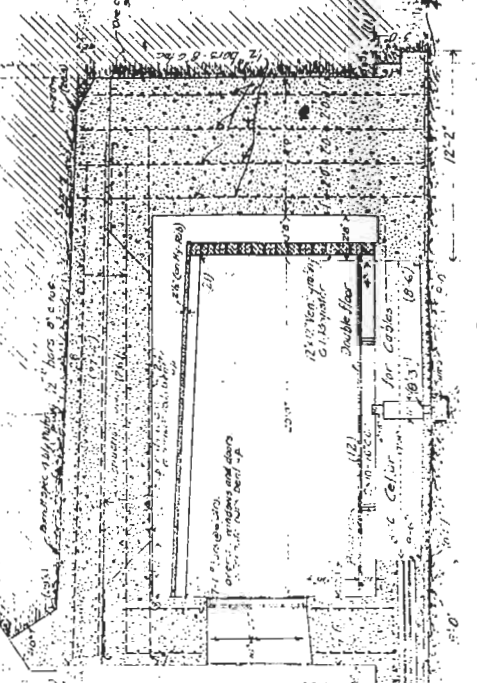

SECTION AT 5.6  
Scale 1/2" = 1 Ft.

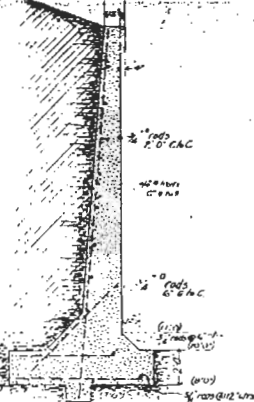

PLAN - Scale 1/4" = 1 Ft.

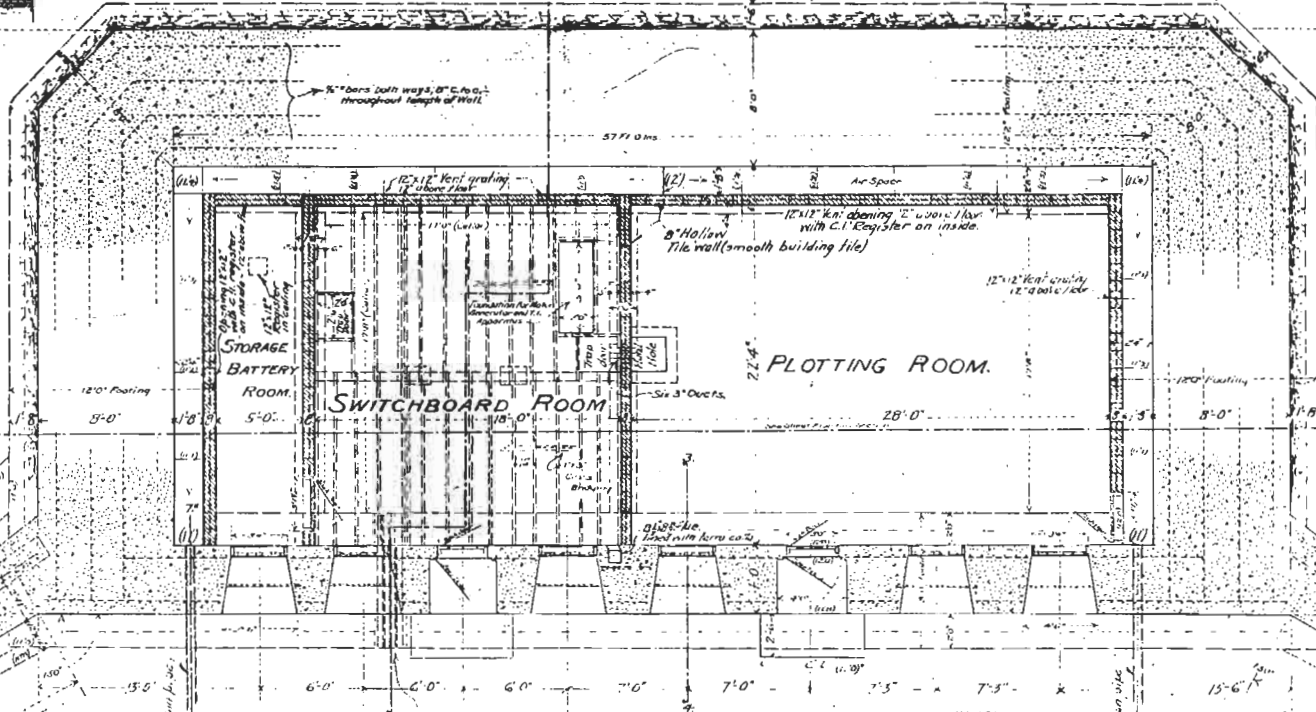

EXCAVATION PLAN  
Scale 3/4" = 1 Ft.

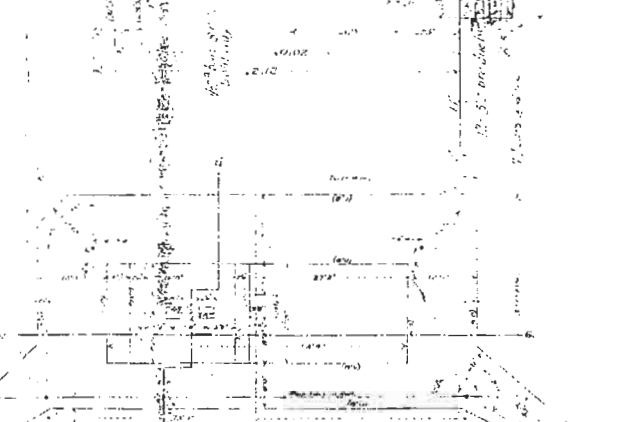

REAR ELEVATION - Scale 1/4" = 1 Ft.

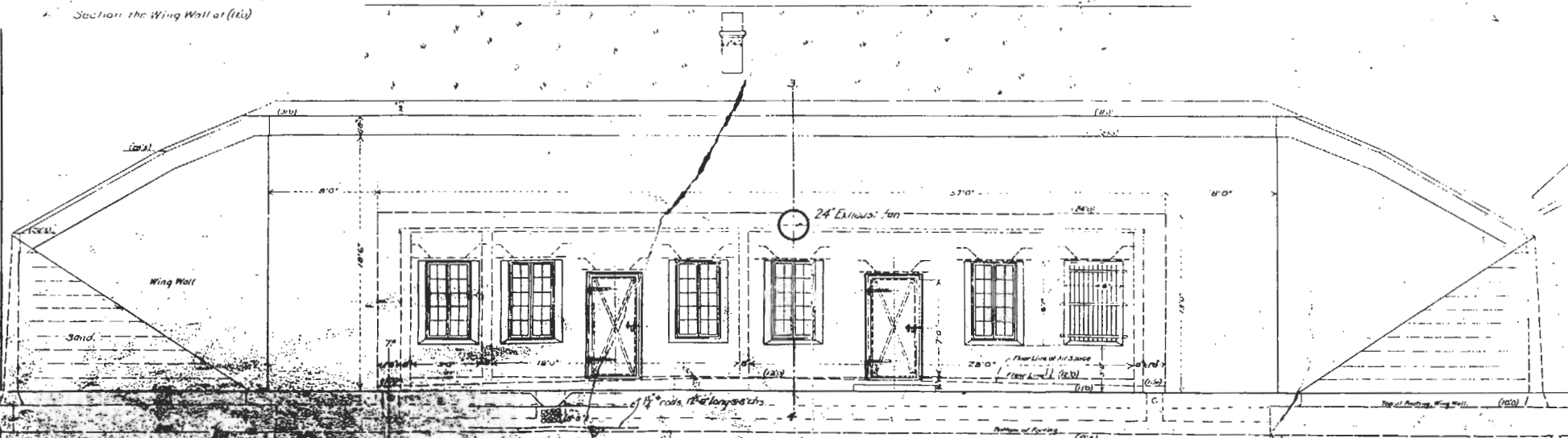

FORT TILDEN, N.Y.  
PROTECTED PLOTTING ROOM  
AND SWITCHBOARD ROOM  
TYPE A.

Sheets, Sheet 1. Scale 1/4" = 1 Foot.  
United States Engineer Office  
Third District New York City, Dec 11, 1922

*J. S. ...*  
Civil Engineer  
File 6-C-42

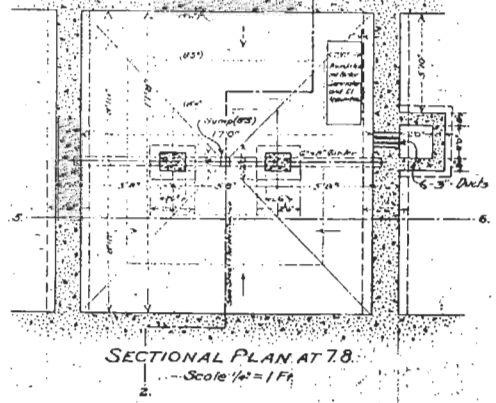
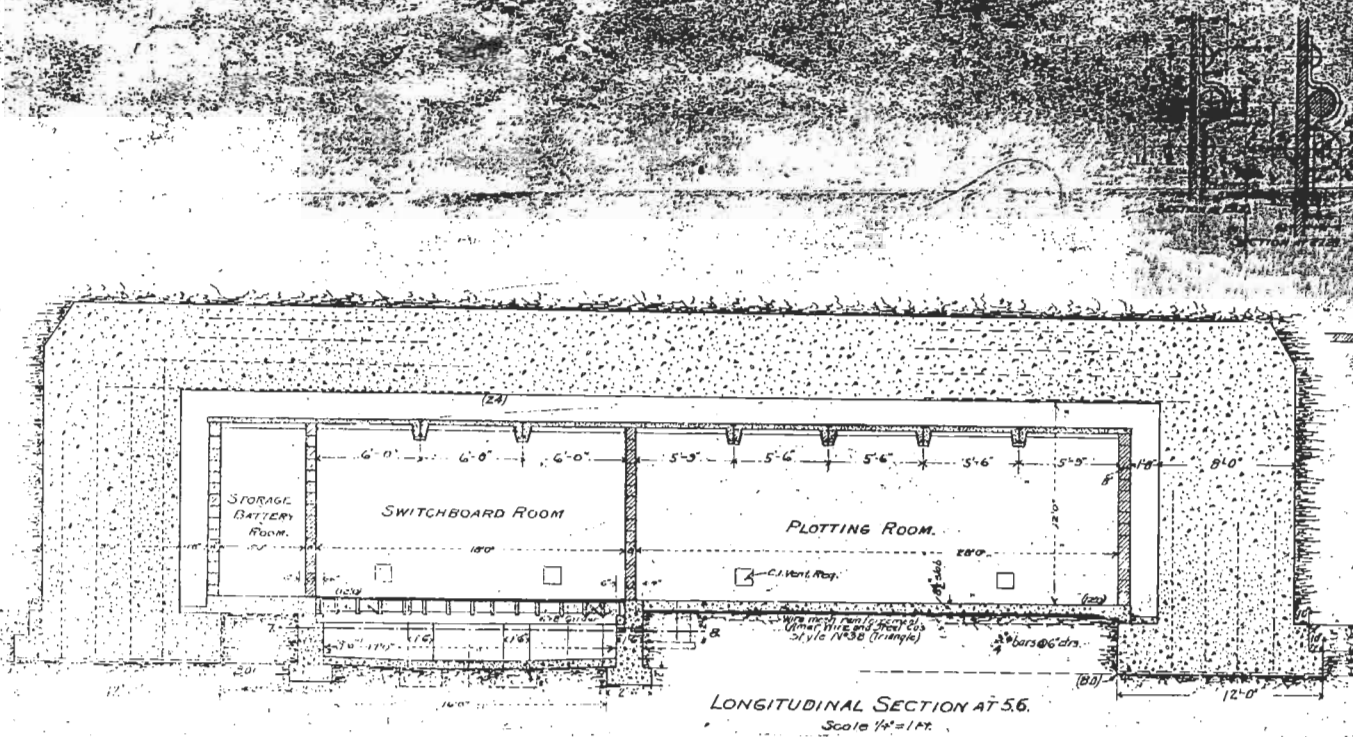

DETAIL AT C.  
Scale 1/2" = 1 Inch.



DETAIL AT B.  
Scale 1/2" = 1 Inch.



DETAIL AT A.  
Scale 1/2" = 1 Inch.

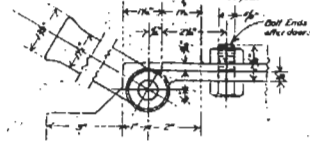

SECTION AT 2.24.  
Scale 1/2" = 1 Inch.

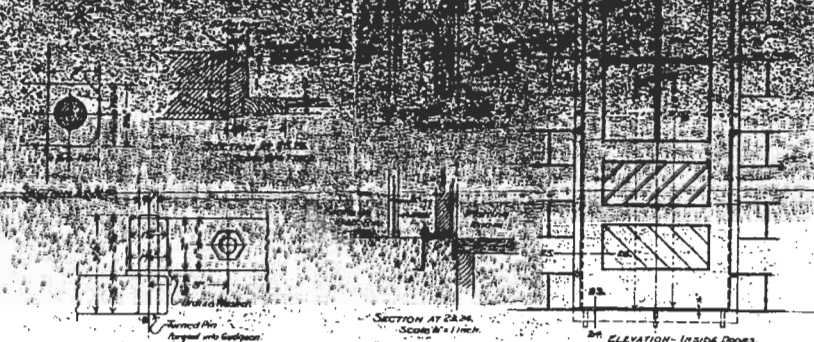

SECTION AT 17.18.  
Scale 1/2" = 1 Inch.

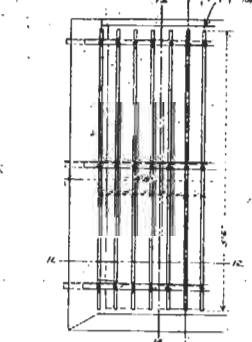
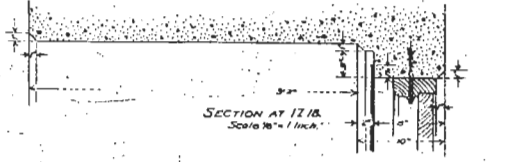

PARTIAL ELEVATION - WINDOW GRATING.  
Scale 1/2" = 1 Ft.

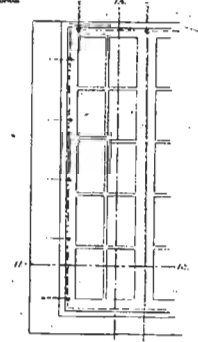

PARTIAL ELEVATION - WINDOW SASH.  
Scale 1/2" = 1 Ft.

SECTION AT 15.16.  
Scale 1/2" = 1 Ft.

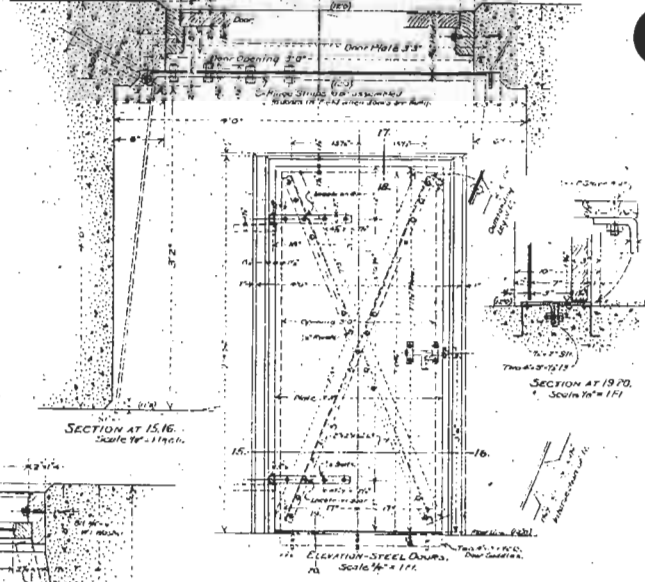

SECTION AT 19.20.  
Scale 1/2" = 1 Ft.

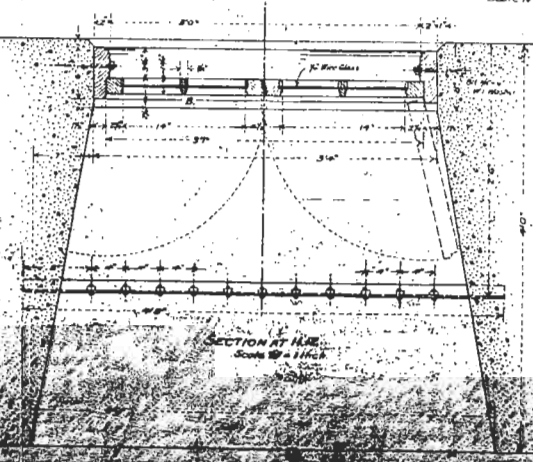

SECTION AT 14.2.  
Scale 1/2" = 1 Ft.

FORT TILDEN, N.Y.  
PROTECTED PLOTTING ROOM  
AND SWITCHBOARD ROOM  
TYPE A.

In 3 Sheets, Sheet 2. Scale 1/4" = 1 Foot.  
United States Engineers Office  
Third District, New York City, Dec. 11, 1922.

Submitted: *[Signature]*  
Checked by: *[Signature]*  
Approved by: *[Signature]*

The National Archives



Edg. Marine  
Hills  
Station, N.Y.

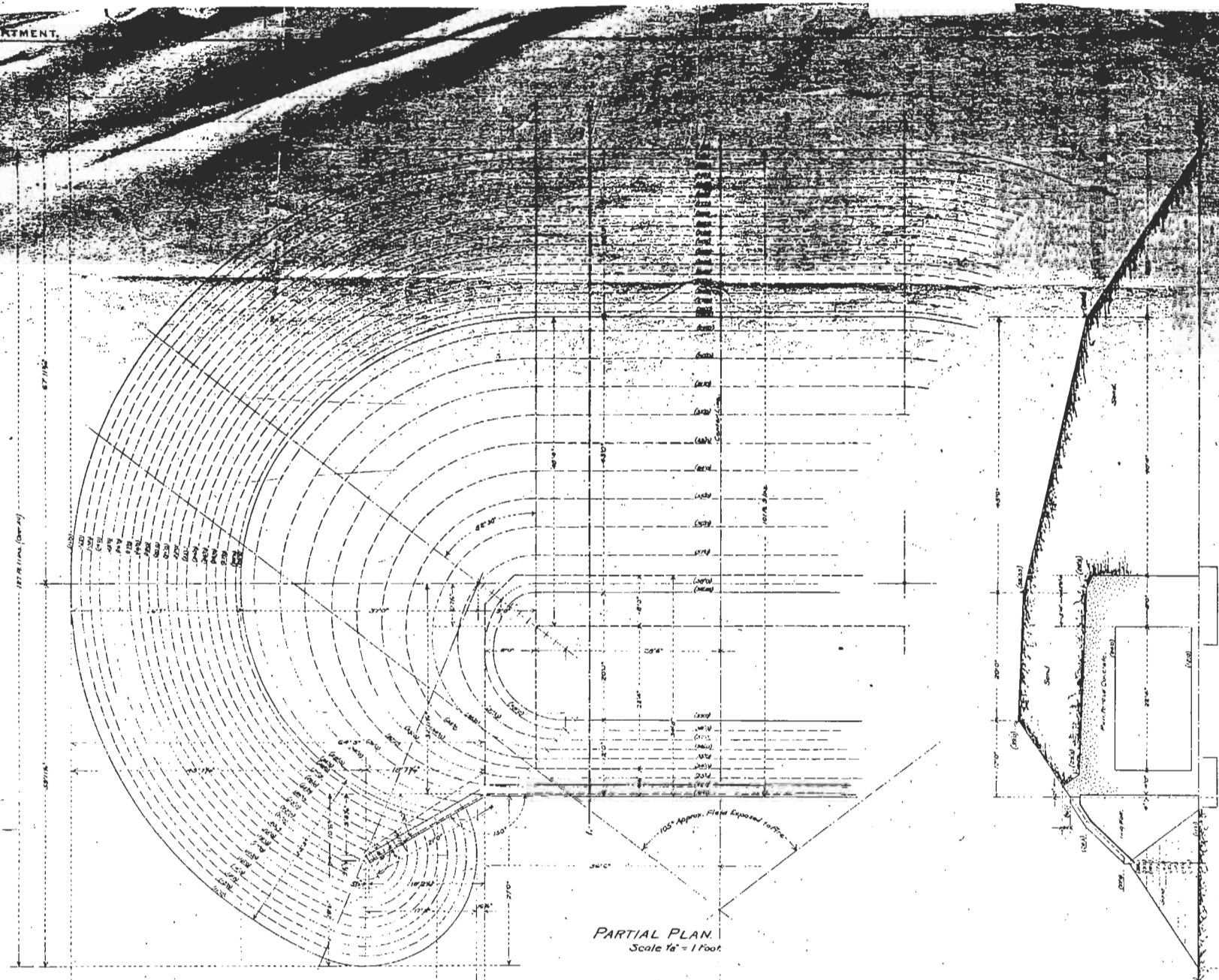

PARTIAL PLAN  
Scale 1/4" = 1 Foot

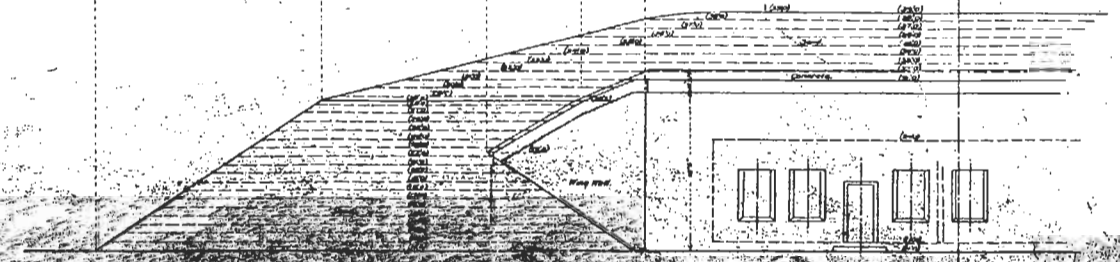

PARTIAL REAR ELEVATION  
Scale 1/4" = 1 Foot

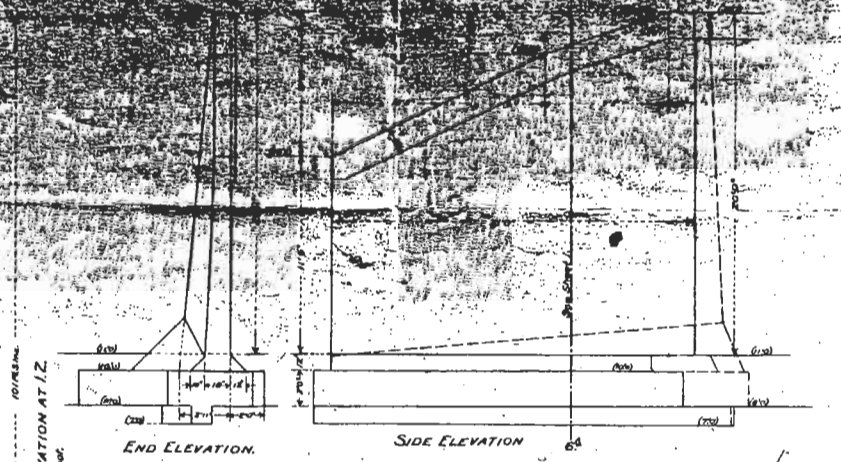

END ELEVATION

SIDE ELEVATION

SECTIONAL ELEVATION AT 1/2  
Scale 1/8" = 1 Foot

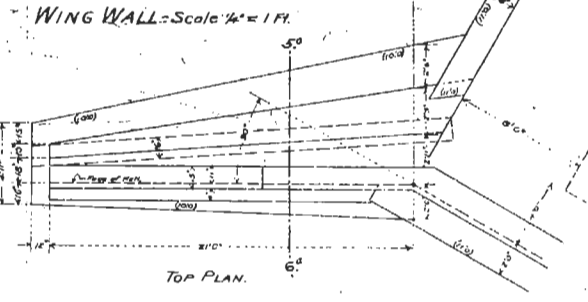

WING WALL - Scale 1/4" = 1 FT.

TOP PLAN

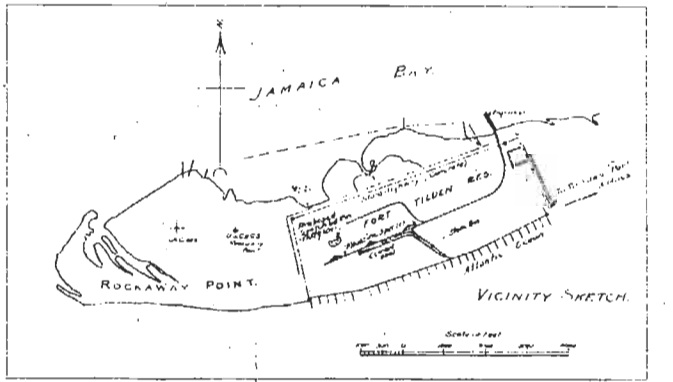

VICINITY SKETCH

FORT TILDEN, N.Y.  
PROTECTED PLOTTING ROOM  
AND SWITCHBOARD ROOM  
TYPE A.

In 3 Sheets, Sheet 3. Scale 1/4" = 1 Foot

United States Engineer Office  
Third District New York City, Dec 11, 1922.

Submitted by  
Designed by  
Checked by  
J. C. Clarke  
Col. Corps of Engineers

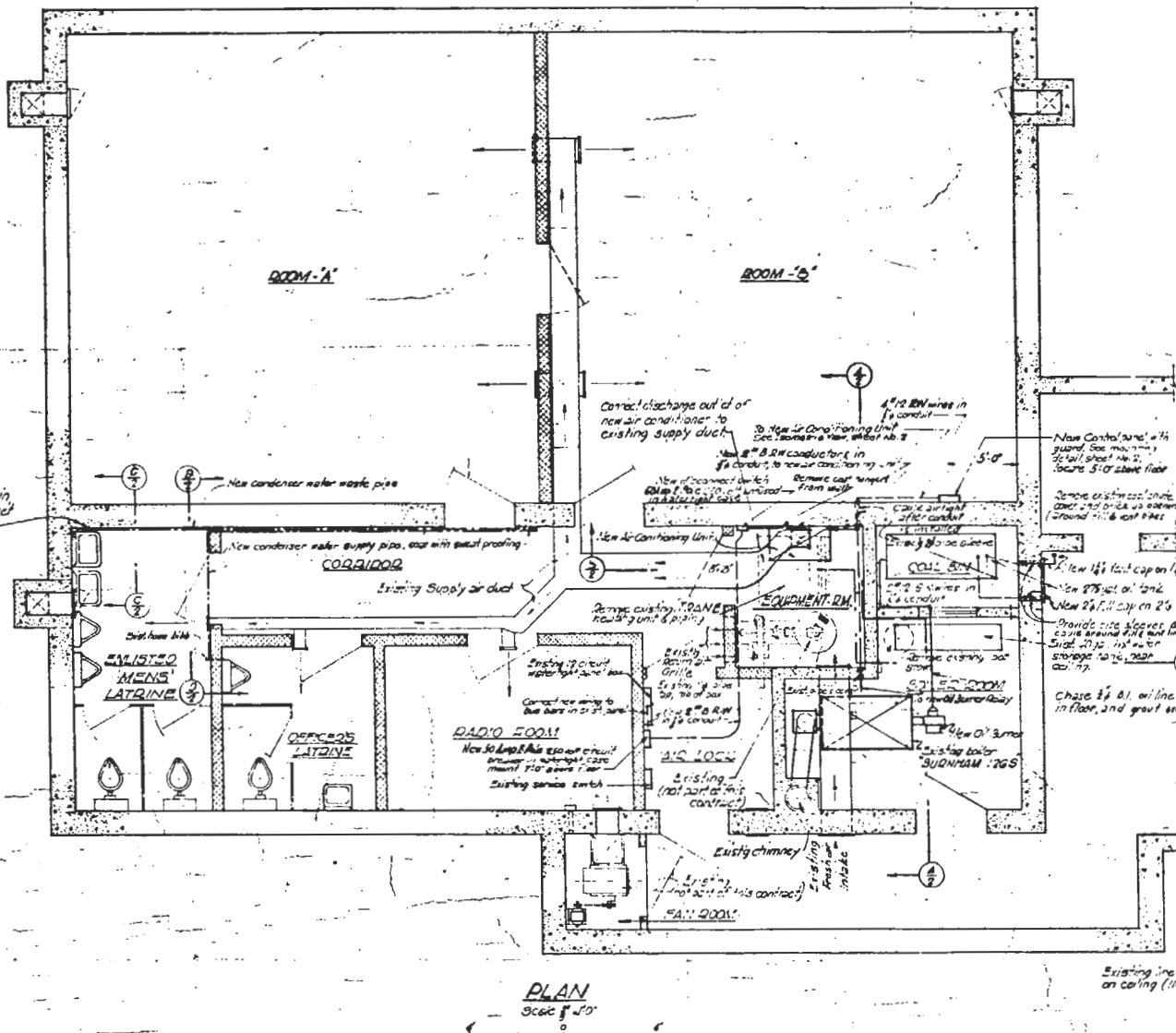

EQUIPMENT SCHEDULE

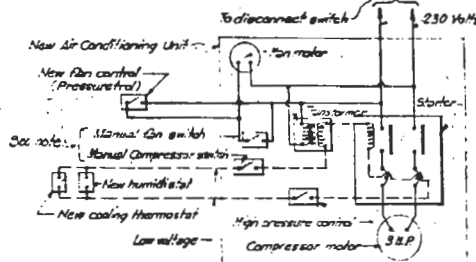
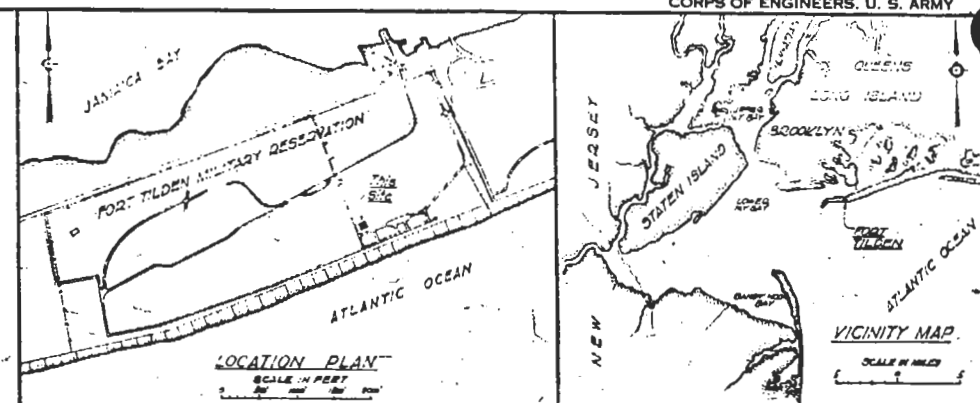

WIRING DIAGRAM FOR COOLING SYSTEM

**REQUIRED OPERATION:**  
 The fan shall automatically deliver heat in response to the fan control. It shall also be possible to operate fan constantly to provide continuous ventilation. During winter compressor shall not operate. Summer, the fan shall run constantly. The compressor shall not operate unless the fan is running and the cooling thermostat humidifier, the pressure control and compressor ON/OFF switch are all in make position.

**CONFIDENTIAL**  
 THIS IS UNCLASSIFIED INFORMATION BECAUSE IT DOES NOT RELATE TO THE NATIONAL DEFENSE AND IS NOT SO SENSITIVE THAT UNAUTHORIZED DISCLOSURE COULD BE DETRIMENTAL TO THE NATIONAL DEFENSE.

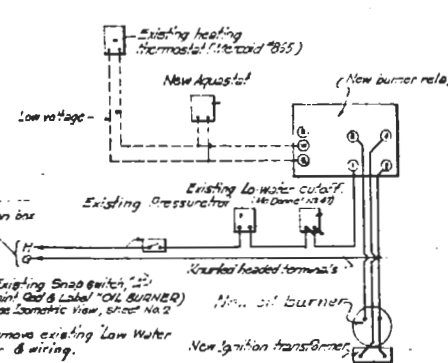

WIRING DIAGRAM FOR HEATING SYSTEM

**EXPLANATION OF SECTION DESIGNATION**  
 The section designations used are represented by fractions, the numerator of which is the section reference and the denominator the sheet number on which the section is taken or shown.

**RECORD DRAWING**  
 CERTIFIED AS CONSTRUCTED 26 MAR. 1948.

| DATE | REV. NO. | REVISION | BY | APP. BY |
|------|----------|----------|----|---------|
|      |          |          |    |         |
|      |          |          |    |         |
|      |          |          |    |         |
|      |          |          |    |         |

**COOLING & DEHUMIDIFYING EQUIPMENT**

**Air Conditioner:**  
 The conditioner shall consist of a fan with motor, heating coil, cooling coil, thermal expansion valve air filter, drop-in compressor with motor, condenser-receiver, automatic water regulating valve, copper refrigerant piping, high pressure cut-out liquid and suction line strainers, automatic compressor-motor starter all enclosed in a finished steel cabinet and shall be Chrysler Airtemp Model 3500.

**Fan:**  
 The fan shall have a minimum delivery of 1000 C.F.M. against the internal resistance of the conditioner with heating coil and an external duct resistance of 1/4 of water.

**Fan Motor with Drive:**  
 The fan motor with drive shall be 230 volt, 60 cycle, 1 phase continuous duty type motor with thermal overload protection and shall be of sufficient size to drive the fan at its required speed without overload. The motor duty shall be adjustable and shall connect to the fan pulley with a heat resistant V belt.

**Heating Coil:**  
 Capacity 13,000 BTU/Hr. for 1000 C.F.M. & 45° entering air & 2 lbs steam pressure. The coil shall have copper tubes and fins.

**Cooling Coil:**  
 Capacity 22,000 BTU/Hr. S.H. & 12,000 BTU/Hr. L.H. for 1000 C.F.M. 64.5° D.B. 63.5° W.B. entering air, 53° refrigerant temperature and minimum face velocity of 400 F.P.M. The coil shall have copper tubes with aluminum fins.

**Compressor:**  
 Capacity 32,000 BTU/Hr. for 35° suction temperature & 92° condensing temperature.

**Compressor Motor:**  
 Mfg. Esco Model # EBS-64  
 Compressor motor shall be 3HP, 230 volts, 30 cycle, single phase.

**Condenser Receiver:**  
 Shall be water-cooled shell & tube type condenser with necessary refrigerant shut-off & test valves, to permit its use as a liquid receiver. The valves & fins shall be copper. Condenser capacity 38,500 BTU/Hr. heat dissipation for 75° inlet water & 92° condensing temperature.

**Cooling Thermostat:**  
 Shall have mercury tube type switch making contact on temperature rise 40° to 80° range with 2 1/2" x 3/4" terminals and shall be, Minneapolis Honeywell No. T-42 B.

**Humidifier:**  
 Shall have human hair element actuating a mercury tube type switch making contact on humidity rise 20 to 80% range with 3/4" x 1 1/2" terminals and shall be, Minneapolis Honeywell No. 25111 A.

**Fan Control:**  
 Shall have mercury tube type switch breaking contact on steam pressure drop 0.10 lbs. with 1/2" x 1/2" terminals and shall be, Minneapolis Honeywell No. 25111 A.

**Oil Burner:**  
 The oil burner shall be a pressure-resisting type with 12,000 v. ignition transformer & electrodes. 30 G.P.M. oil, single burner, pressure regulating valve, single stage oil pump, combustion unit.

**NOTES:**  
**SCOPE:**  
 Contractor shall furnish labor and material necessary for the installation of a new set of air conditioning unit, new oil burner and hot water generator in the existing boiler including the removal of the existing existing hung indirect cabinet and the existing hot water boiler.  
 The new unit shall be connected to the existing duct system, heating system, water supply and water and drain piping.  
 The new hot water generator shall be connected to the existing water tank.  
 A new oil storage tank shall be installed and connected to the new oil burner.  
 New controls in conjunction with existing controls shall be used to provide the required operation of the air conditioning unit and the oil burner.

**DESIGN CONDITIONS:**  
 Summer - Maximum 80° D.B. & 50% D.H. inside structure with 25° D.B. & 75° W.B. outside. Outside Air 300 C.F.M. Recirculated air 700 C.F.M. Room 200 sq ft. Load 11,000 BTU/Hr. & Room latent heat load 5000 BTU/Hr. Boiler - Maximum 70° D.B. inside structure with 0° D.B. outside. Outside Air 300 C.F.M. Recirculated Air 700 C.F.M. Total load 12,000 BTU/Hr.

**GENERAL NOTES:**  
 Items not marked new shall be considered as existing.  
 The necessary repair, #10201, #112 shall be executed by this contractor.

**REFERENCE DRAWINGS**

GROUPMENT COMMAND POST - PH1081 (Thru 1091)  
 (HARBOR ENTRANCE CONTROL POST)

SERVICE COMMAND PROJECT NO 586 DATED 25 OCTOBER 1947  
**CONFIDENTIAL**

HARBOR DEFENSES OF NEW YORK  
 HARBOR ENTRANCE CONTROL POST  
 MODIFICATIONS TO HEATING & VENTILATING SYSTEM  
 PLAN & DETAILS

|  |                              |
|--|------------------------------|
| FORT TILDEN  | NEW YORK                     |
| IN 2 SHEETS  | SHEET NO. 1                  |
| SCALES AS SHOWN  |                              |
| U.S. ENGINEER OFFICE, NEW YORK DISTRICT, NEW YORK, N.Y. 13 NOV. 1947 |                              |
| Submitted<br>H. J. ...   | Recommended<br>C. ...        |
| Approved<br>L. Col., Corps of Engineers.                             | Colonel, Corps of Engineers. |

REDUCED SIZE REPRODUCTION

646/63018

1 of 2

1000

FILE NO. FNY - 3825

ON MICROFILM APPENDIX 18



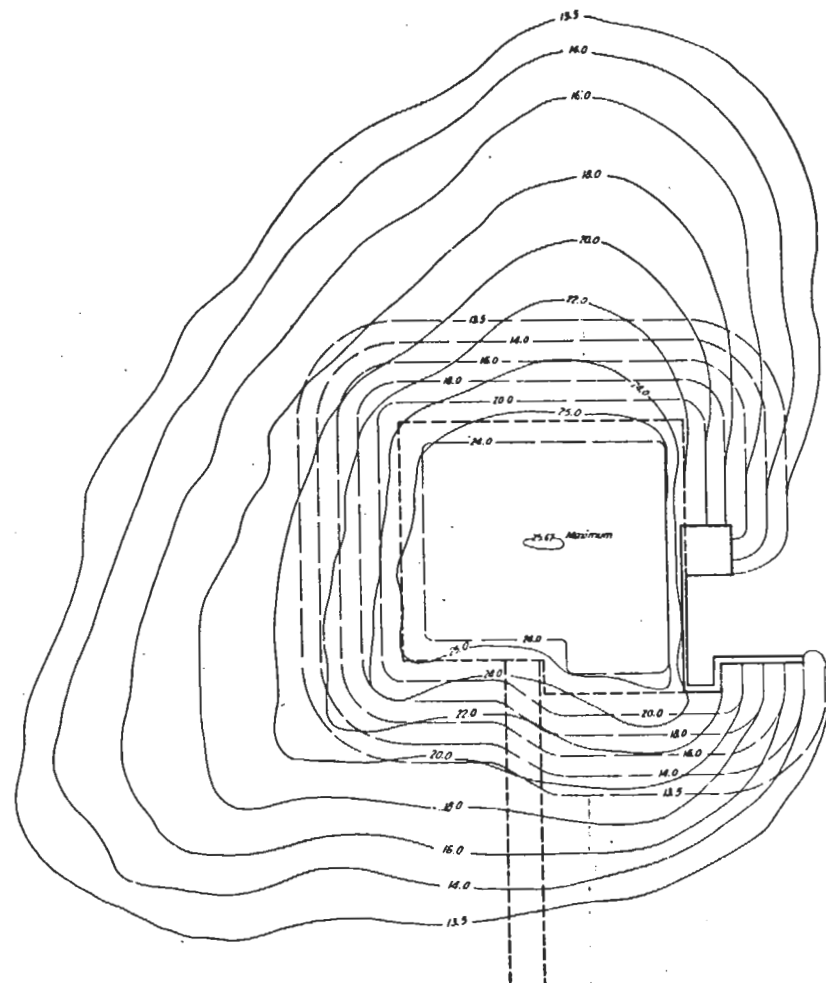

**PLAN**  
SCALE: 1" = 10'

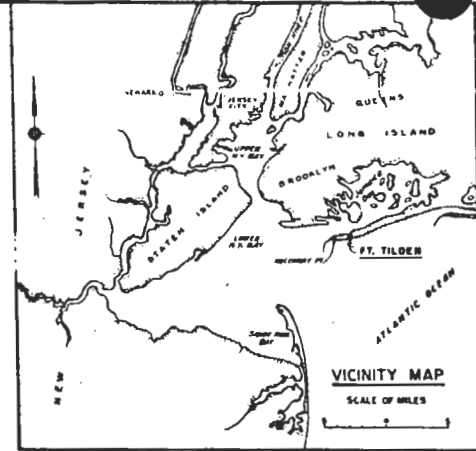

**INDEX TO DRAWINGS**

| SHEET NO. | TITLE                         | FILE NO. |
|-----------|-------------------------------|----------|
| 1         | GRADING PLAN                  | FNY-3511 |
| 2         | GENERAL PLAN                  | FNY-3512 |
| 3         | GASPROOFING & HEATING DETAILS | FNY-3513 |
| 4         | ELECTRICAL & PLUMBING DETAILS | FNY-3514 |

**GENERAL NOTES**  
Elevations shown refer to the plane of Mean Low Water which is 2.33 feet below Mean Sea Level at Sandy Hook New Jersey.  
True North conforms to the Special Lambert Conformal Projection as determined by the U. S. C. & G. Survey.

**NOTES**  
The maximum depth of fill on the roof is two feet.  
No additional live load permitted on the roof slab.

**CONFIDENTIAL**

HARBOR DEFENSES OF NEW YORK  
**GROUPMENT COMMAND POST**  
GRADING PLAN

FORT TILDEN NEW YORK  
IN 4 SHEETS SHEET NO. 17

SCALE AS SHOWN  
U. S. ENGINEER OFFICE, NEW YORK DISTRICT, NEW YORK, 170

Submitted: *Charles H. ...* Senior Engineer  
Reviewed: *James P. ...* Lt. Col., Corps of Engineers  
Approved: *Albert J. ...* Major General, Corps of Engineers

**CONFIDENTIAL**  
THIS DOCUMENT CONTAINS NEITHER RECOMMENDATIONS NOR CONCLUSIONS OF THE ENGINEERING DIVISION OF THE ARMY. IT IS THE PROPERTY OF THE ARMY AND IS LOANED TO YOUR ORGANIZATION; IT AND ITS CONTENTS ARE TO BE RETURNED TO AN AUTHORIZED PERSONAL REPRESENTATIVE OF THE ARMY.

REDUCED SIZE REPRODUCTION

646163017 1 of 4

TRANSFER DRAWING - FILE NO. FNY-3511

**ON MICROFILM APPENDIX 20**

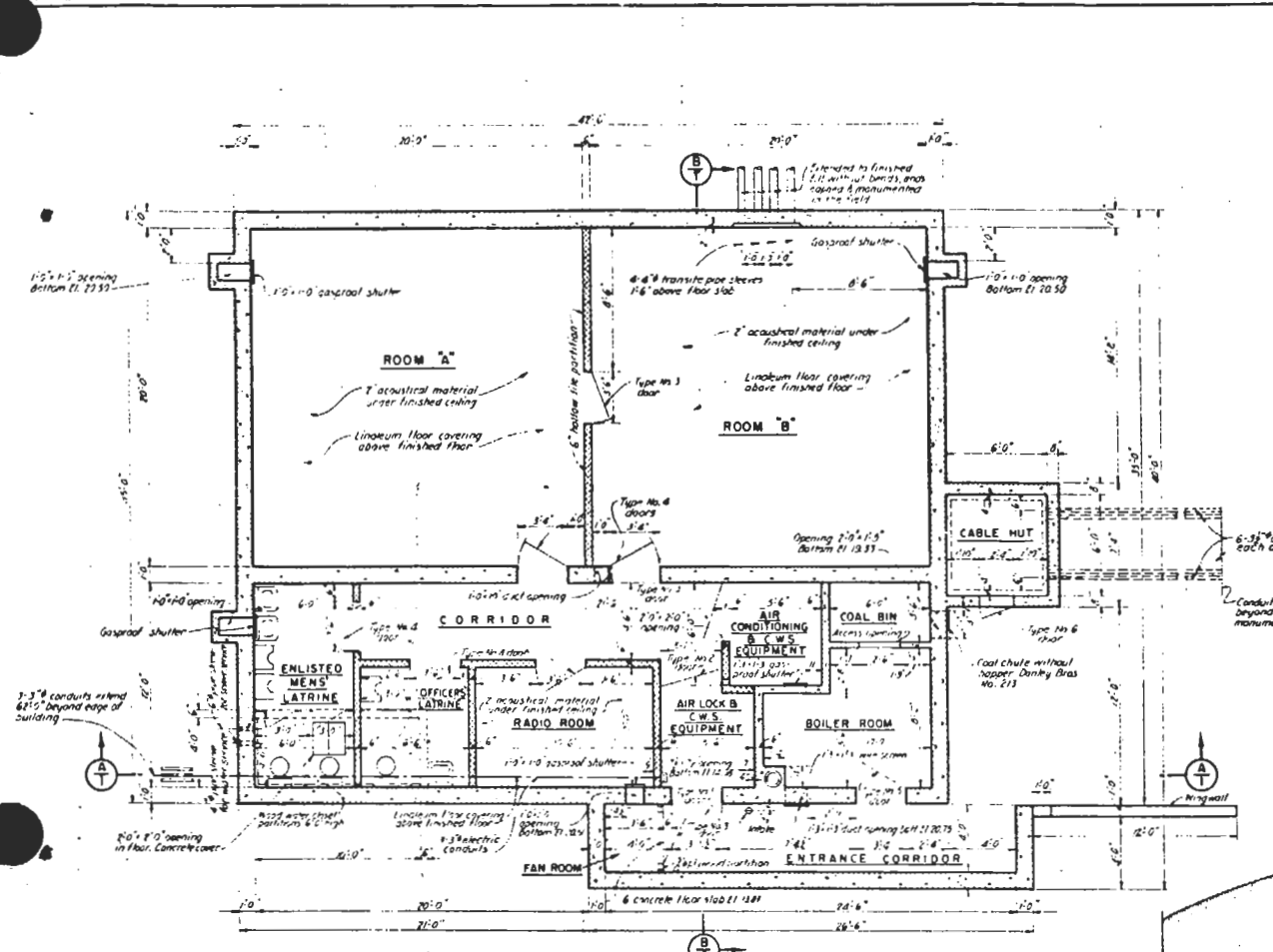

PLAN  
SCALE: 1/4" = 1'-0"

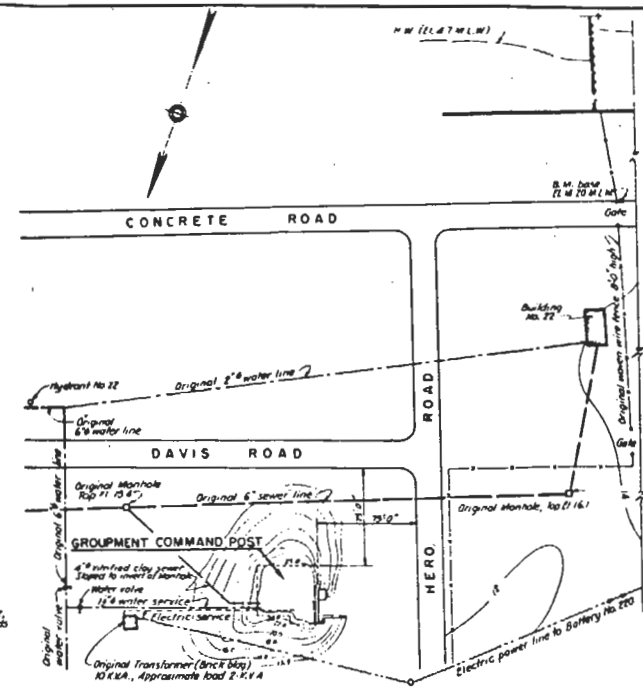

LAYOUT PLAN  
SCALE: 1" = 50'-0"

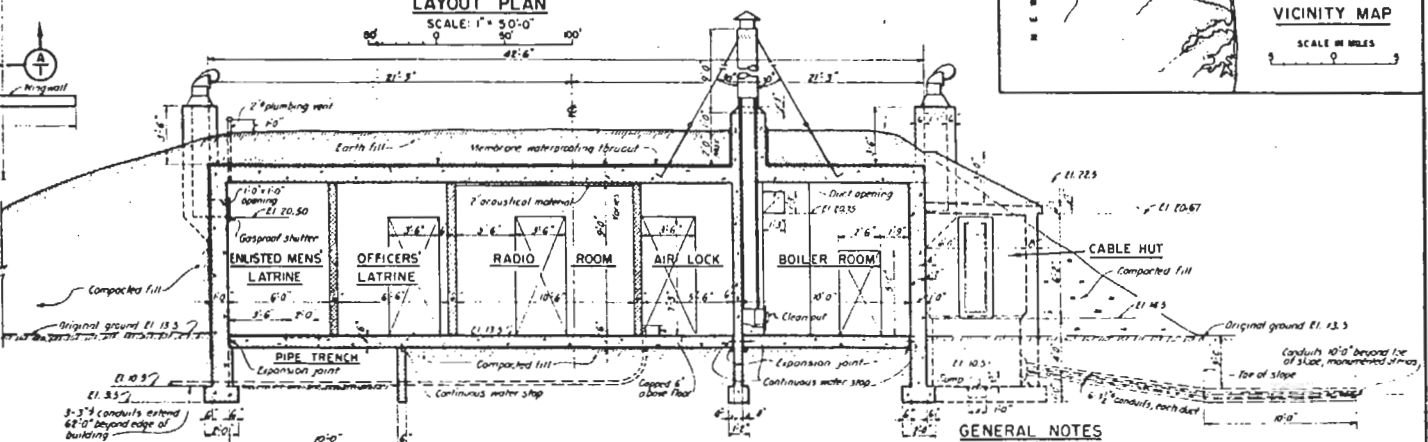
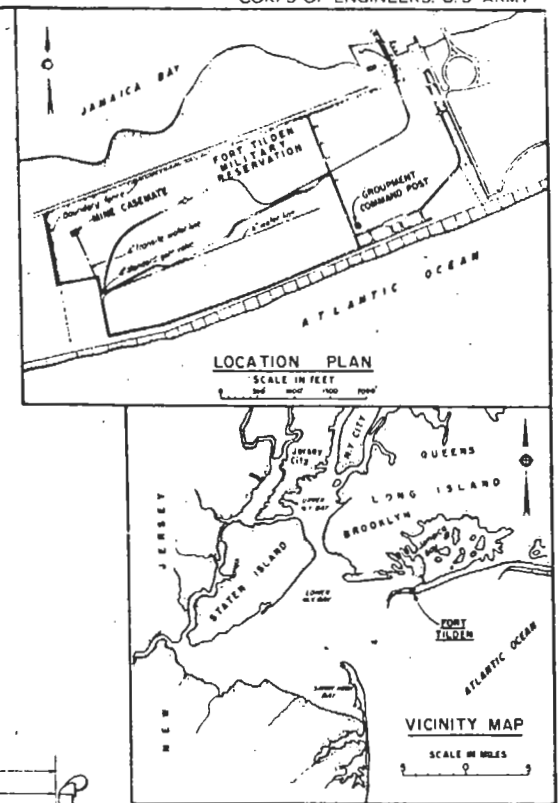

SECTION A-T  
SCALE: 1/4" = 1'-0"

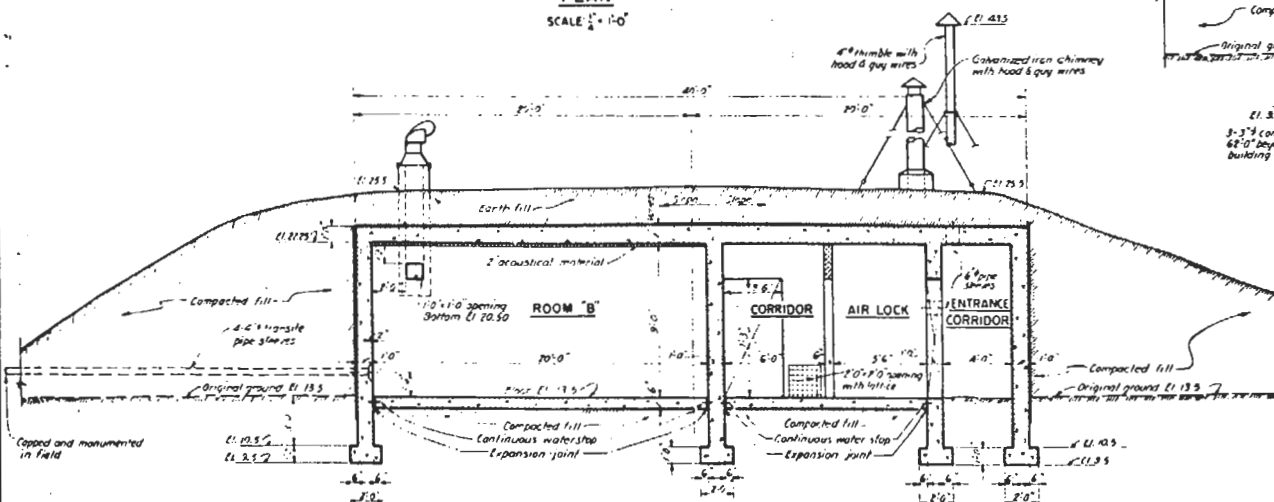

SECTION B-T  
SCALE: 1/4" = 1'-0"

**GENERAL NOTES**

Elevations shown refer to the plane of Mean Low Water which is 2.33 feet below Mean Sea Level at Sandy Hook New Jersey. True North conforms to the Special Lambert Conformal Projection as determined by the U.S.C. & G. Survey.

All exterior concrete surfaces in contact with earth fill are coated with membrane waterproofing.

All exposed concrete corners have 1" chamfer.

Expansion joints are painted with two coats of asphalt primer.

Minimum cover of steel reinforcement is 3" unless otherwise noted.

Welding symbols conform to the standards of the American Welding Society.

All metals are structural steel unless otherwise noted.

All pipe sleeves and openings into gasproofed area are caulked gastight after installation of pipes, ducts, etc.

**CONFIDENTIAL**

13

**CONFIDENTIAL**

HARBOR DEFENSES OF NEW YORK

**GROUPMENT COMMAND POST**

GENERAL PLAN

FORT TILDEN NEW YORK

IN 4 SHEETS SHEET NO. 2

**EXPLANATION OF SECTION DESIGNATION**

The section designations used are represented by fractions, the numerator of which is the section reference and the denominator the sheet number on which the section is taken or shown.

SCALE AS SHOWN

U.S. ENGINEER OFFICE, NEW YORK DISTRICT, NEW YORK, 17 DEC. 1943

Submitted: *Henry J. Hunsicker* Senior Engineer  
 Recommended: *Samuel R. Paine* Lt. Col., Corps of Engineers  
 Approved: *W.B. Jones* Lt. Col., Corps of Engineers

64663017

2 of 4

F-100

TRANSFER DRAWING - FILE NO FNY-3512

ON MICROFILM APPENDIX 21

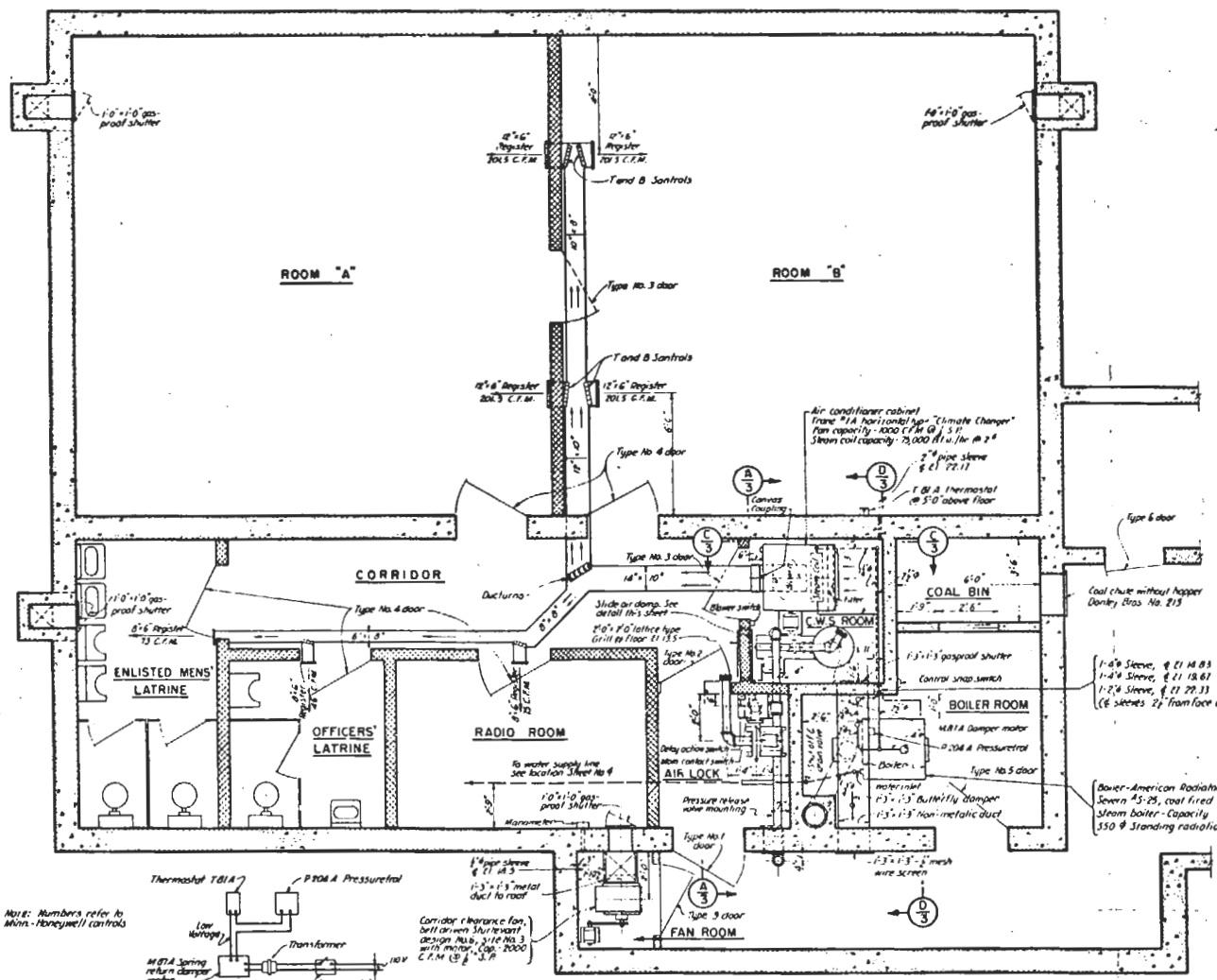

**WIRING DIAGRAM FOR AUTOMATIC DRAFT DAMPER CONTROL**  
NOT TO SCALE

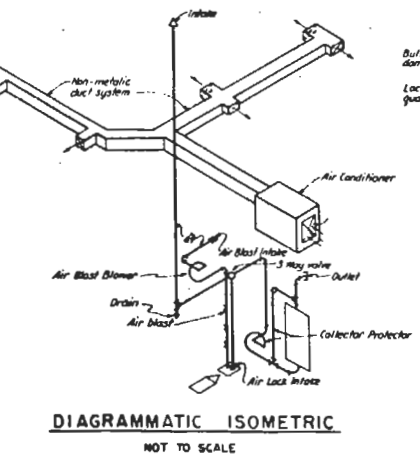

**DIAGRAMMATIC ISOMETRIC**  
NOT TO SCALE

**PLAN**  
SCALE: 1/8" = 1'-0"

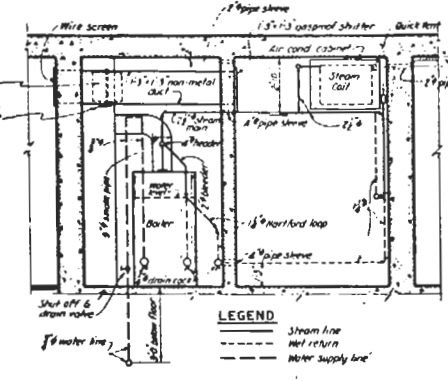

**SECTION D 3**  
SCALE: 1/8" = 1'-0"

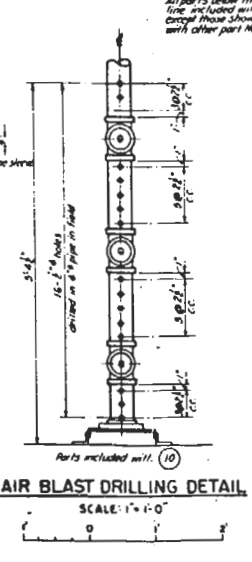

**AIR BLAST DRILLING DETAIL**  
SCALE: 1/8" = 1'-0"

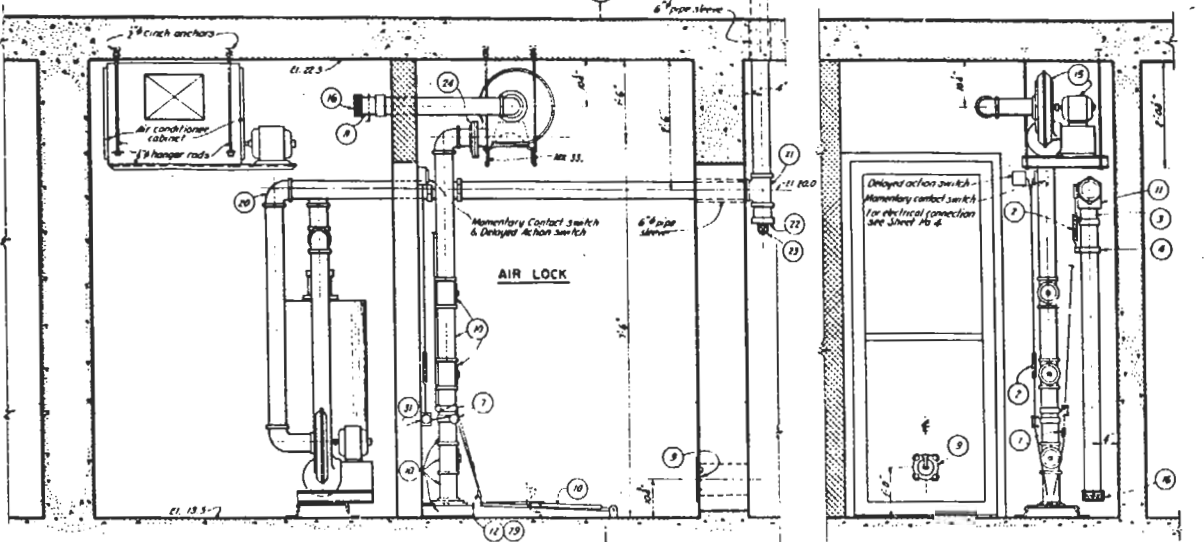

**SECTION A 3**  
SCALE: 1/8" = 1'-0"

**SECTION B 3**  
SCALE: 1/8" = 1'-0"

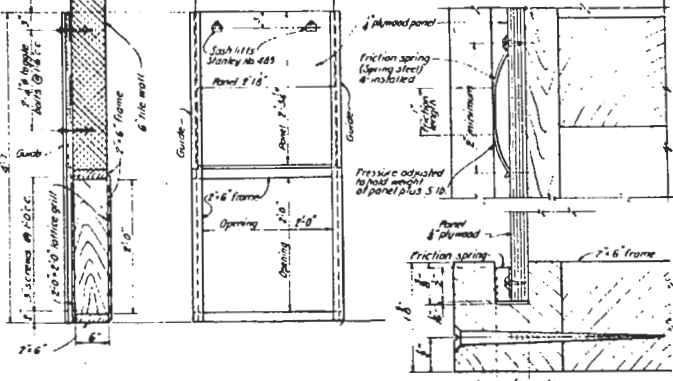

**DETAIL OF SLIDE AIR DAMPER**  
SCALE: 1/8" = 1'-0"

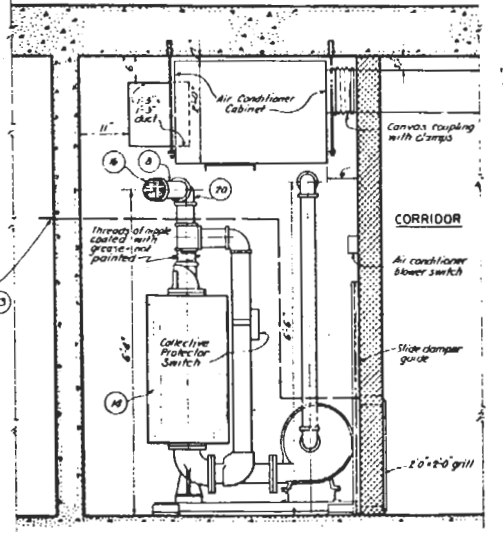

**SECTION C 3**  
SCALE: 1/8" = 1'-0"

**CONFIDENTIAL**

**NOTES**  
For general notes applying to this sheet see Sheet No. 1  
Registers are Tuttle and Bailey No 62 Flexair adjustable.  
All pipe sleeves and openings into gasproofed area are caulked gasight after installation of pipes, ducts, cables etc.

HARBOR DEFENSES OF NEW YORK  
**GROUPMENT COMMAND POST**  
GASPROOFING & HEATING DETAILS  
FORT TILDEN NEW YORK  
IN 4 SHEETS SHEET NO. 3  
SCALE AS SHOWN  
U. S. ENGINEER OFFICE, NEW YORK DISTRICT, NEW YORK, 17 DEC. 1944  
Schaum, Ream, and Jones  
Senior Engineer Lt. Col., Corps of Engineers

646/63017 3044 7-100



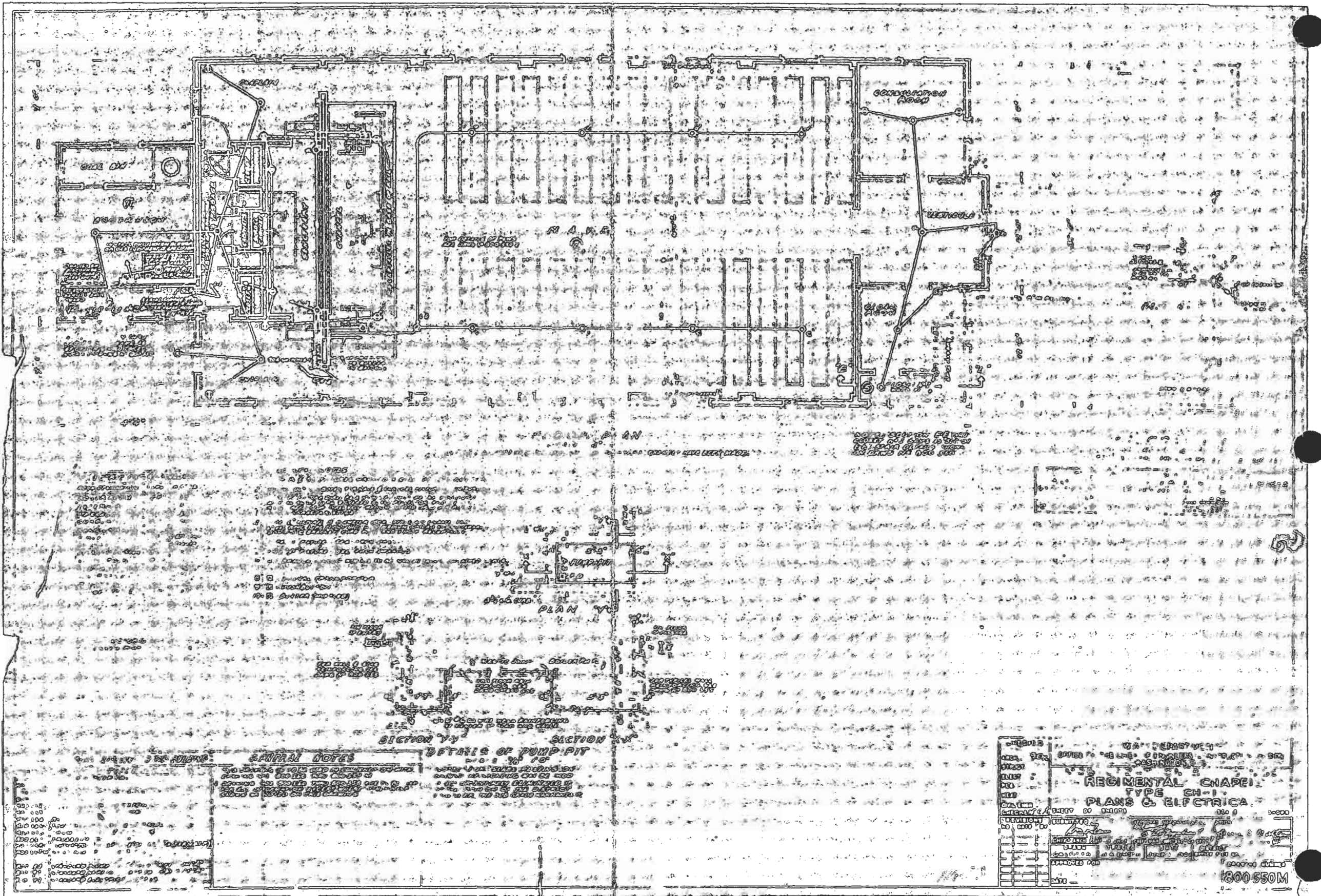

ON MICROFILM

646/62994 A







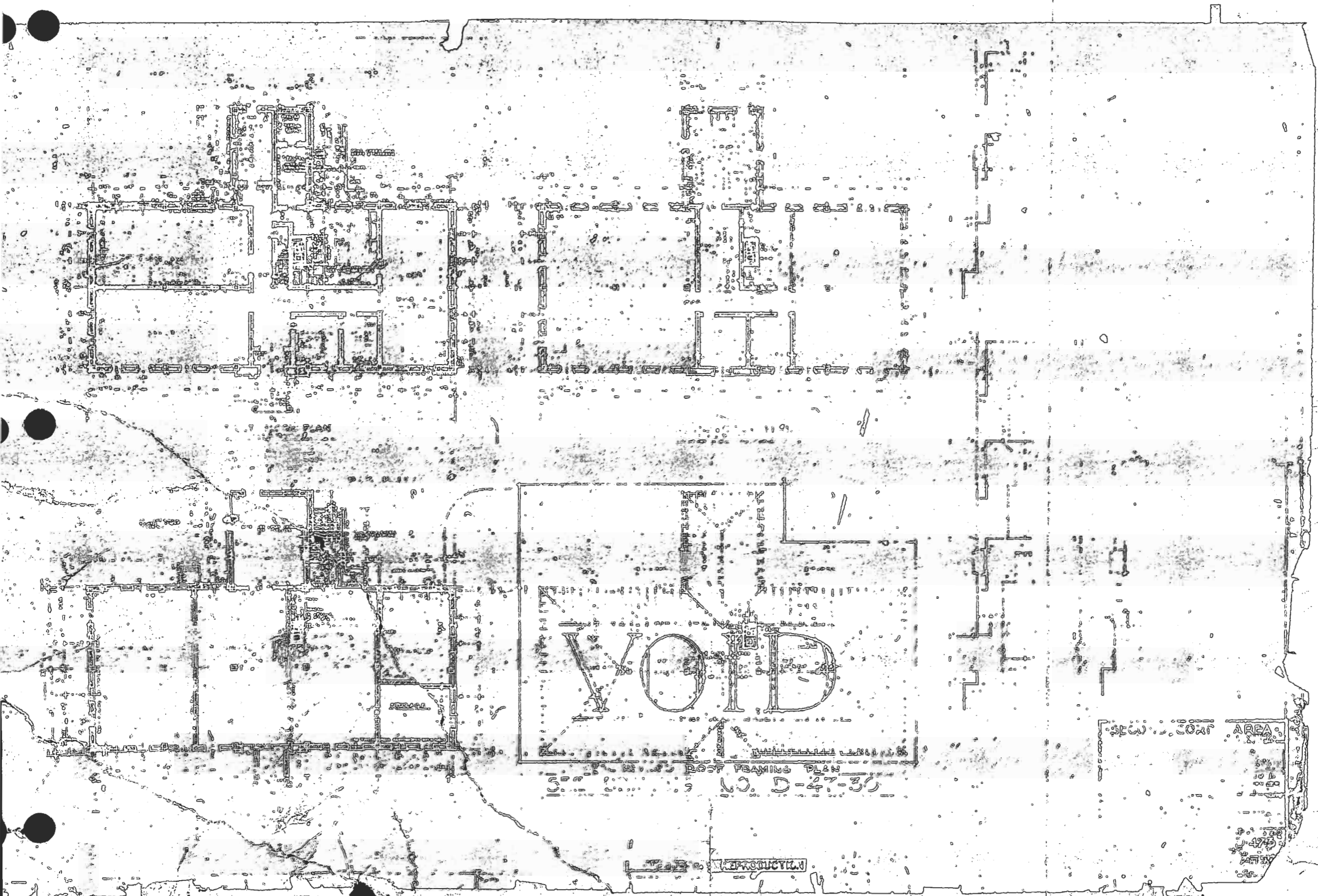

VOID

SECURITY AREA

SECURITY AREA

ROOT FRAMING PLAN

NO. D-47-35

REPRODUCTION

ON MICROFILM

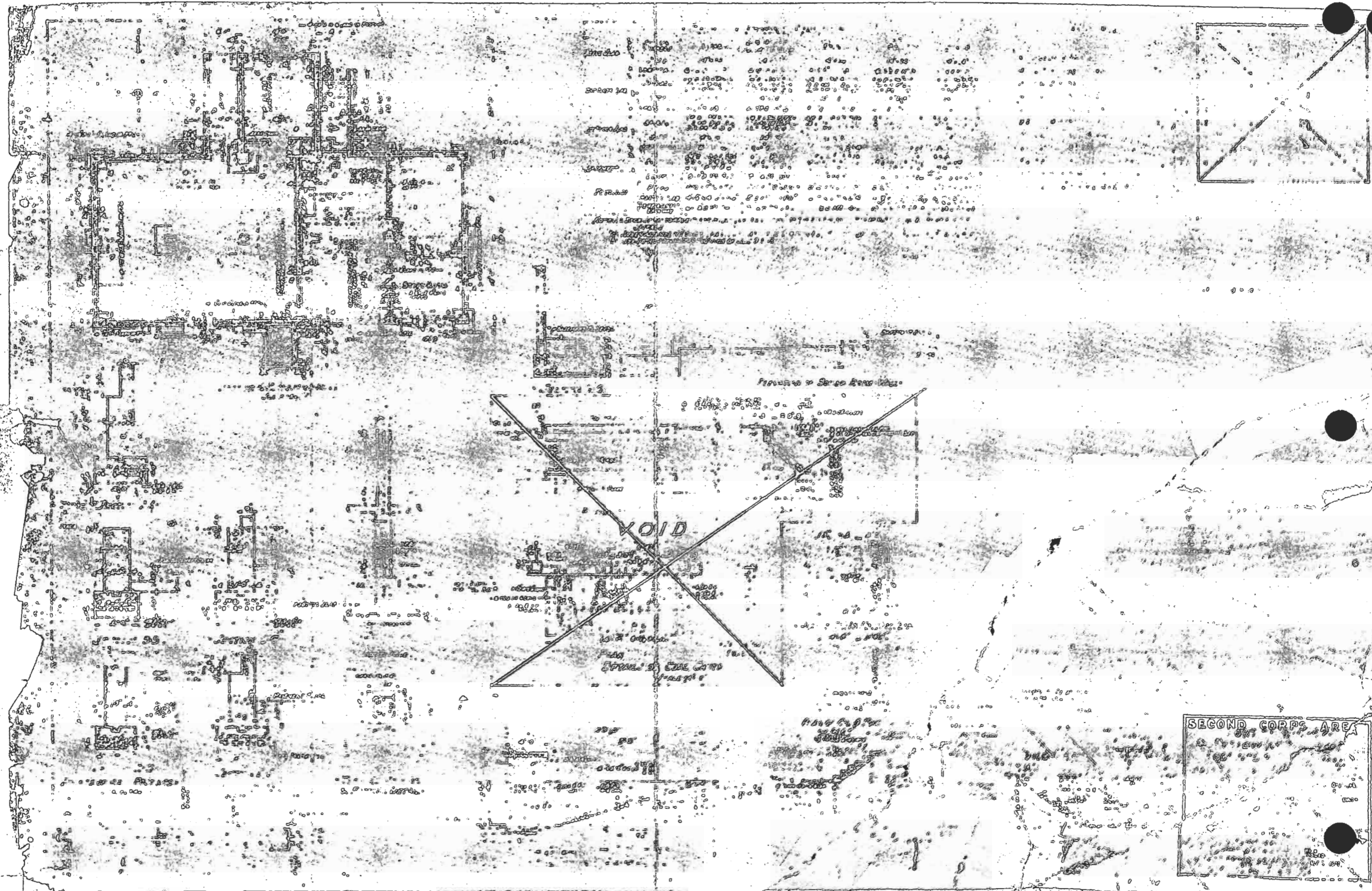

VOID

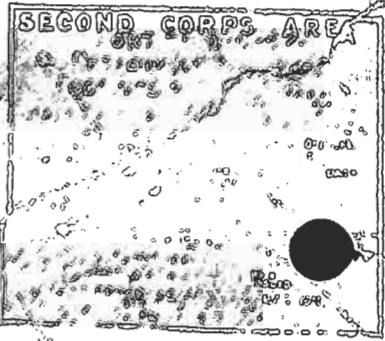

ON MICROFILM

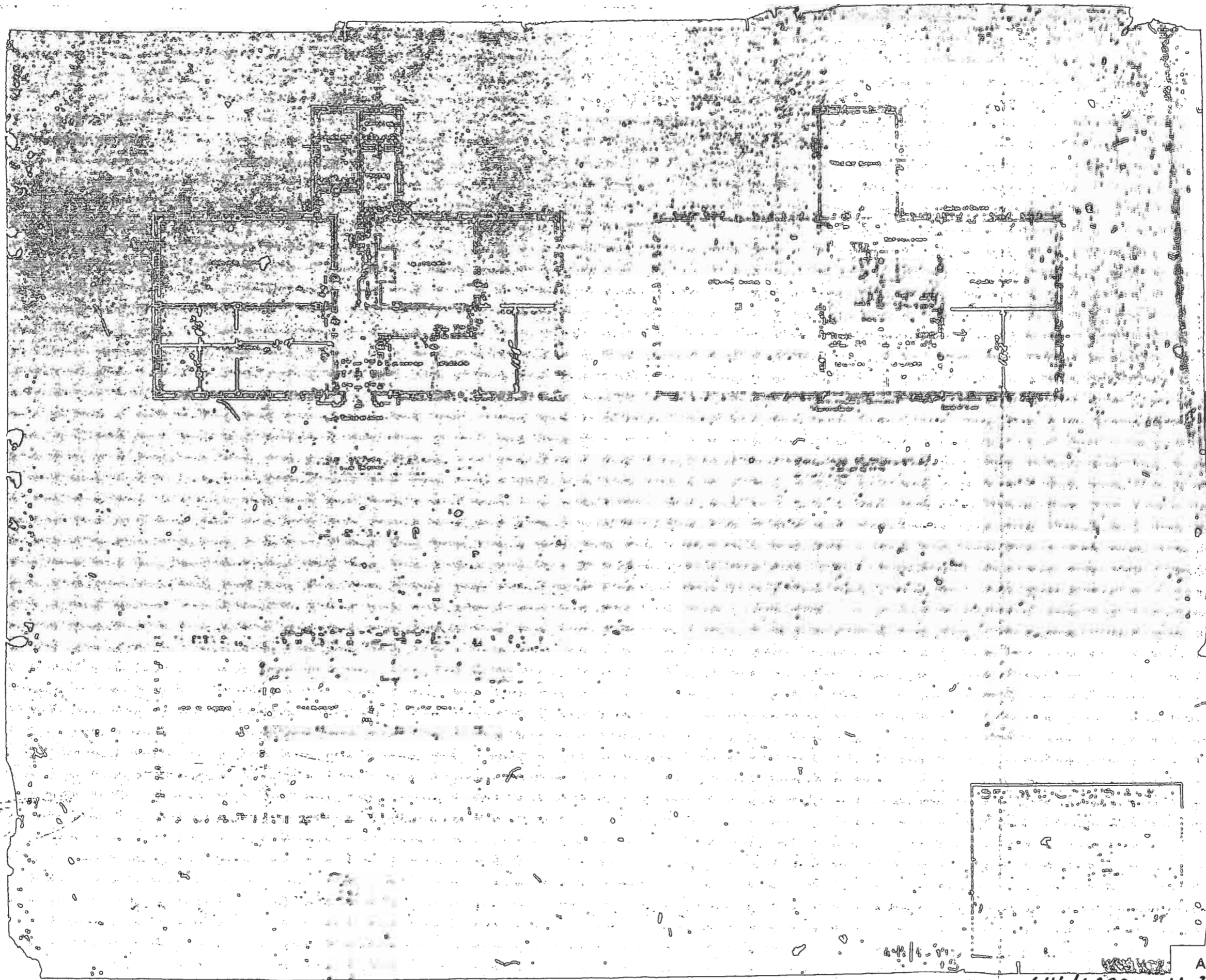

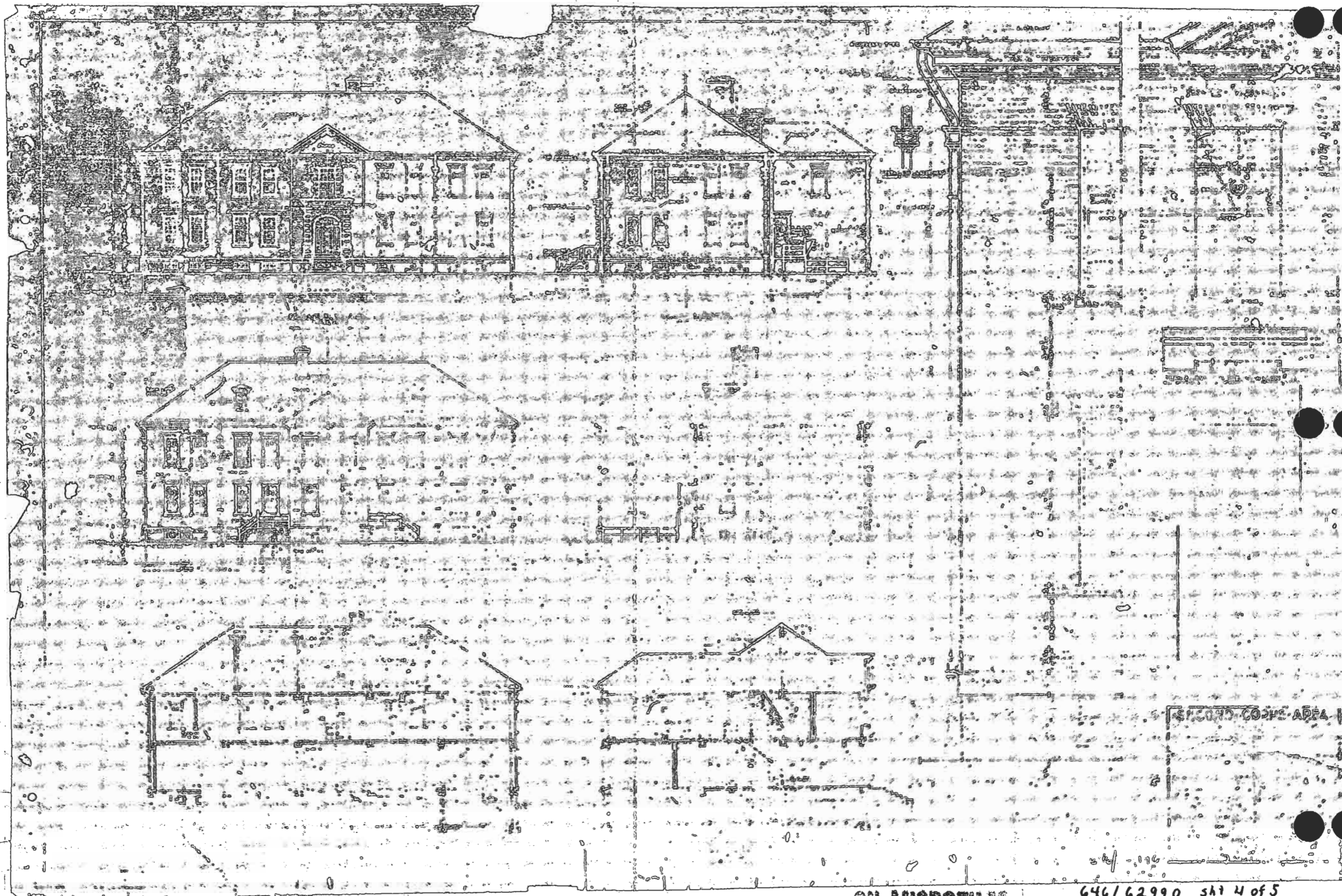

SECOND COORS AREA

ON MICROFILM

646/62990 SH 4 of 5

APPENDIX 30

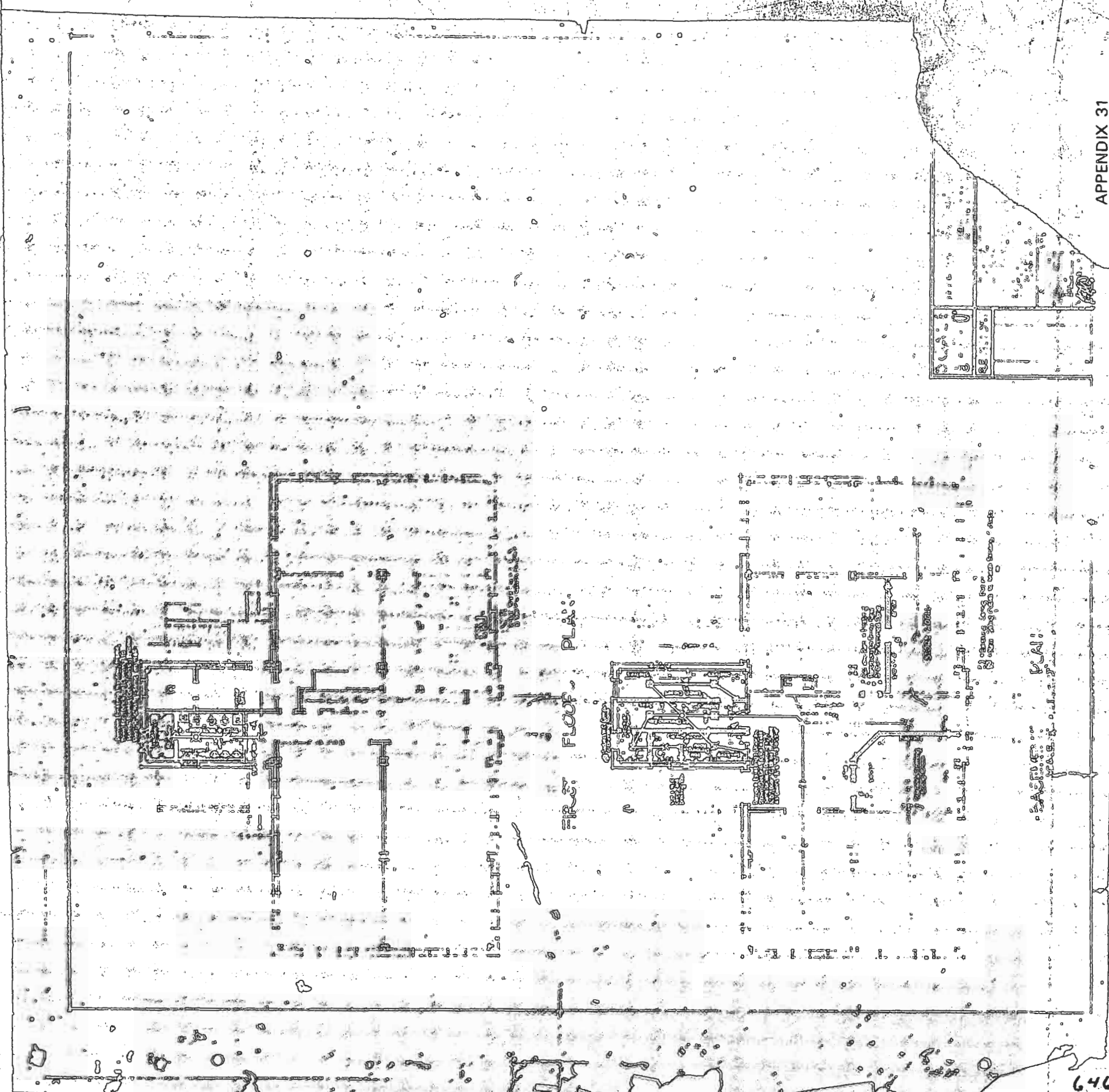

FIRST FLOOR PLAN

BASELINE PLAN

APPENDIX 31

ON MICROFILM

646/62990 sheet 5 of 5

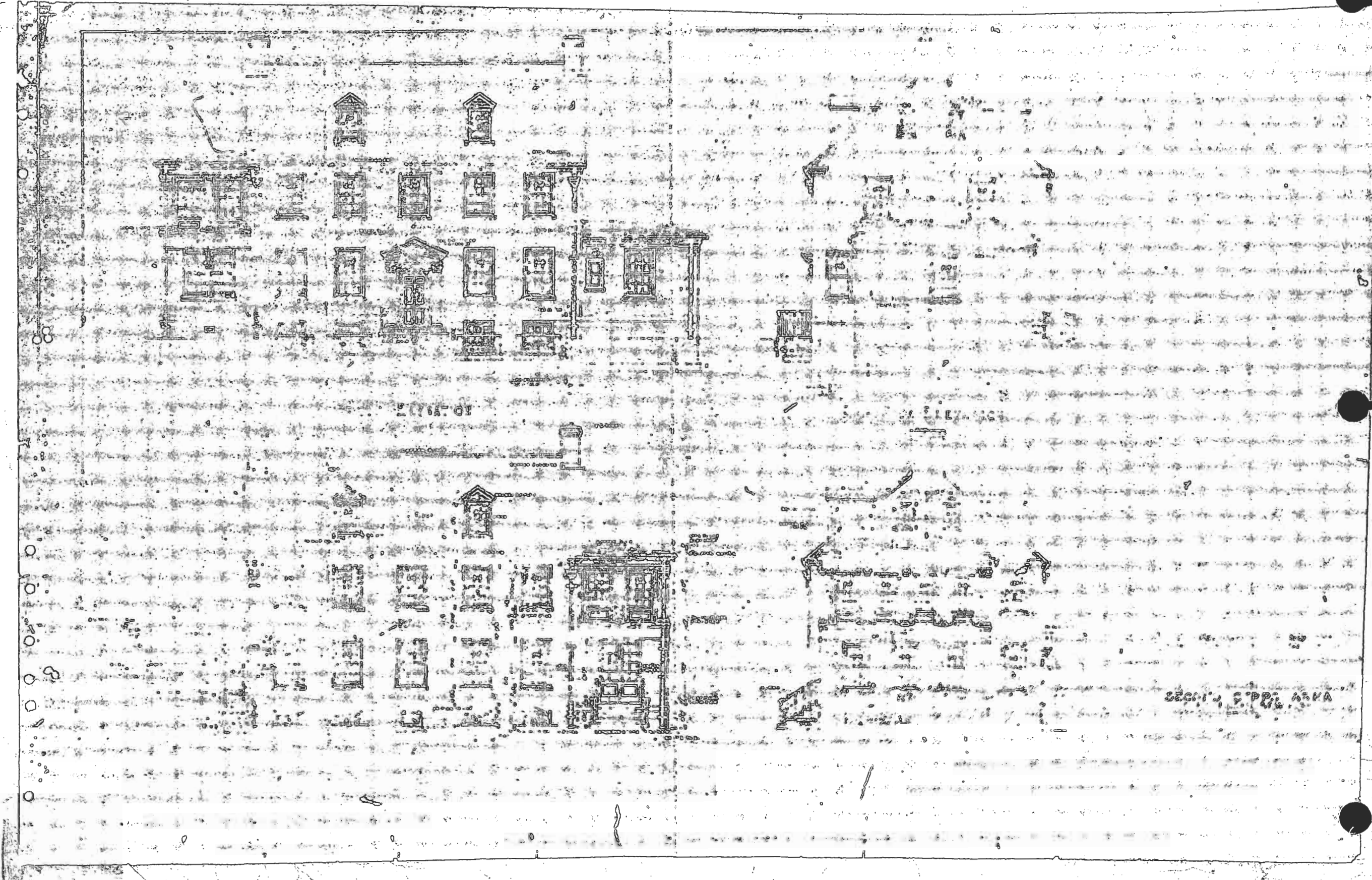

SECTION 3, P. 15, 16



On entering through main entrance of apartment building to 1st floor...

From north of the main entrance of building...

The entrance to the main entrance of building...

The entrance to the main entrance of building...

The entrance to the main entrance of building...

The entrance to the main entrance of building...

The entrance to the main entrance of building...

The entrance to the main entrance of building...

The entrance to the main entrance of building...

The entrance to the main entrance of building...

The entrance to the main entrance of building...

The entrance to the main entrance of building...

The entrance to the main entrance of building...

The entrance to the main entrance of building...

The entrance to the main entrance of building...

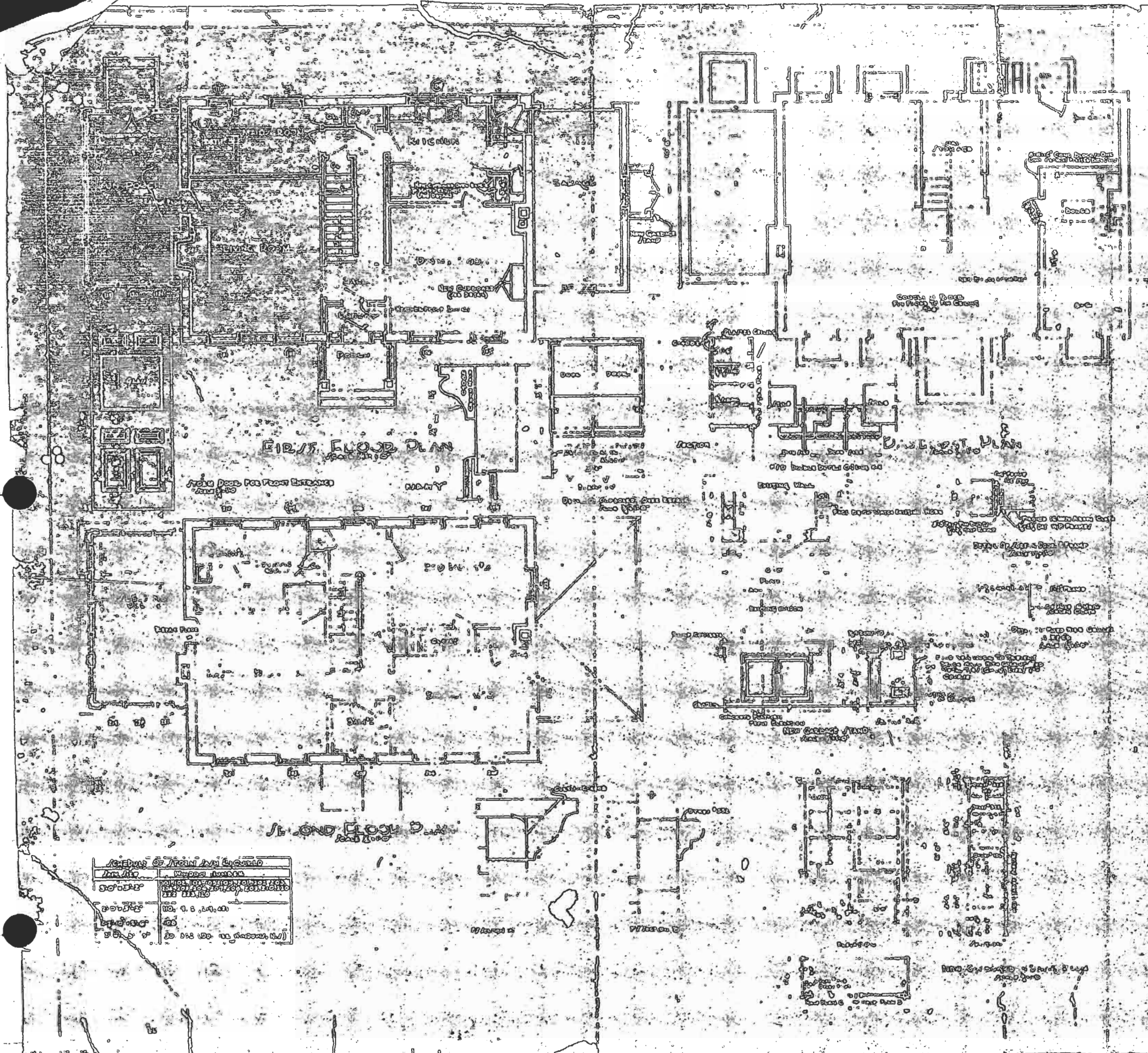

FIRST FLOOR PLAN

SECOND FLOOR PLAN

| SCHEDULE OF ROOMS AND FINISHES |                   |
|--------------------------------|-------------------|
| NO.                            | DESCRIPTION       |
| 1                              | Living Room       |
| 2                              | Dining Room       |
| 3                              | Kitchen           |
| 4                              | Bathroom          |
| 5                              | Bedroom           |
| 6                              | Hallway           |
| 7                              | Staircase         |
| 8                              | Entry             |
| 9                              | Storage           |
| 10                             | Laundry           |
| 11                             | Garage            |
| 12                             | Basement          |
| 13                             | Attic             |
| 14                             | Roof              |
| 15                             | Foundation        |
| 16                             | Structural        |
| 17                             | Mechanical        |
| 18                             | Electrical        |
| 19                             | Plumbing          |
| 20                             | HVAC              |
| 21                             | Fire Protection   |
| 22                             | Security          |
| 23                             | Accessibility     |
| 24                             | Energy Efficiency |
| 25                             | Other             |

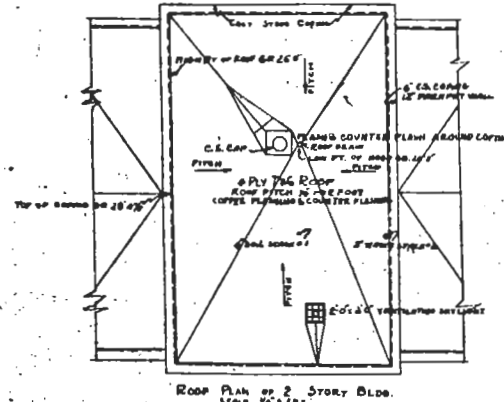
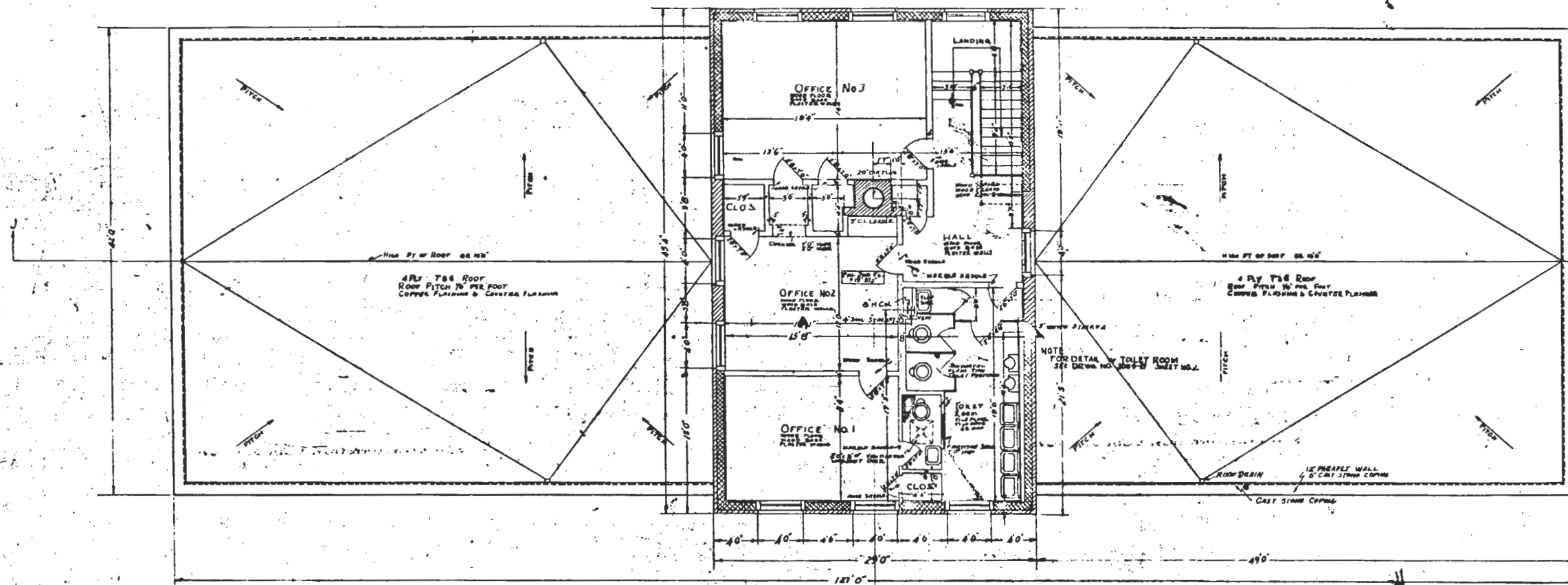

SECOND FLOOR PLAN  
SCALE 1/8" = 1'-0"

NOTE EVERY 4TH COURSE OF BRICKWORK TO BE BONDED INTO WALL

- LEGEND
- BRICK & PLASTER
  - BRICK
  - GINDER CONCRETE BLOCKS

NOTE GENERAL REVISIONS MADE 4-20-37

Bldg 219

|  |  |
|--|--|
| USA<br>WORK PROGRAM<br>WPA   | 2ND CORPS AREA<br>FORT TILDEN<br>PROJECT 245-97-2000 |
| CAPT. A. BOWERS<br>C. A. C.<br><small>SPON. SRS REPRESENTATIVE<br/>DATE APPROVED</small> |  |
| JE WHITNEY<br>PROJECT ENGINEER   |  |
| ORDNANCE MACHINE SHOP<br>SECOND FLOOR PLAN   |  |
| JJ SCHLICK<br>CHIEF PLANNING SECTION<br><small>DATE 1-24-37</small>                      | DRAWING NO<br>2009-25                                |

REDUCED SIZE REPRODUCTION

646/63020

1 of 1

ON MICROFILM

APPENDIX 34





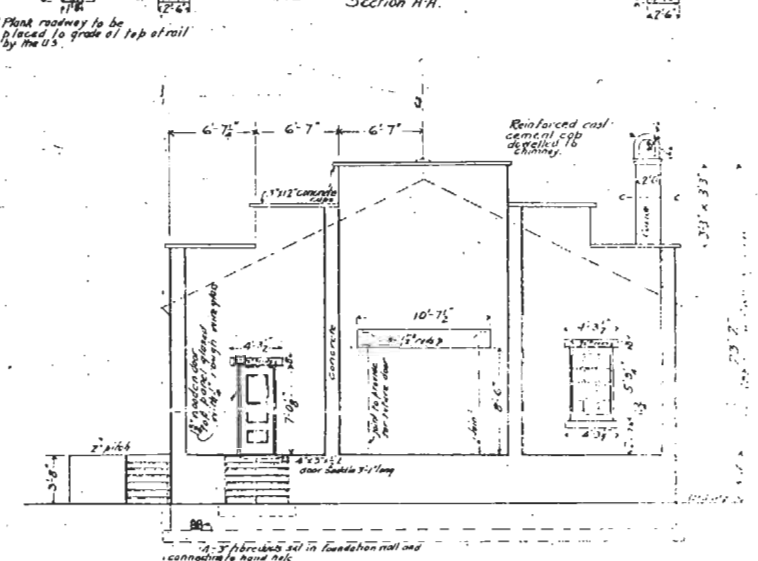
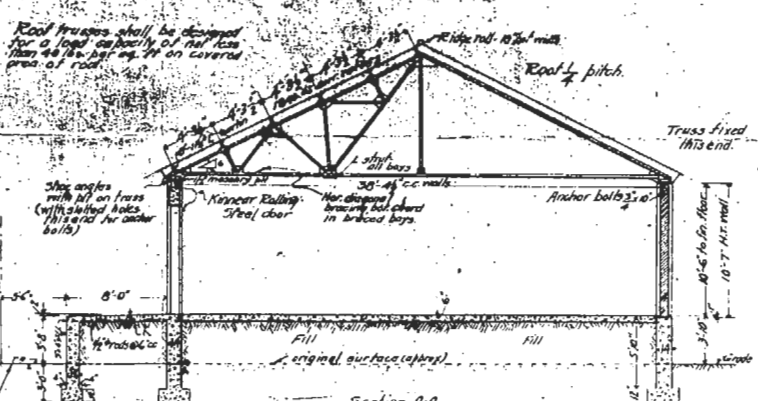
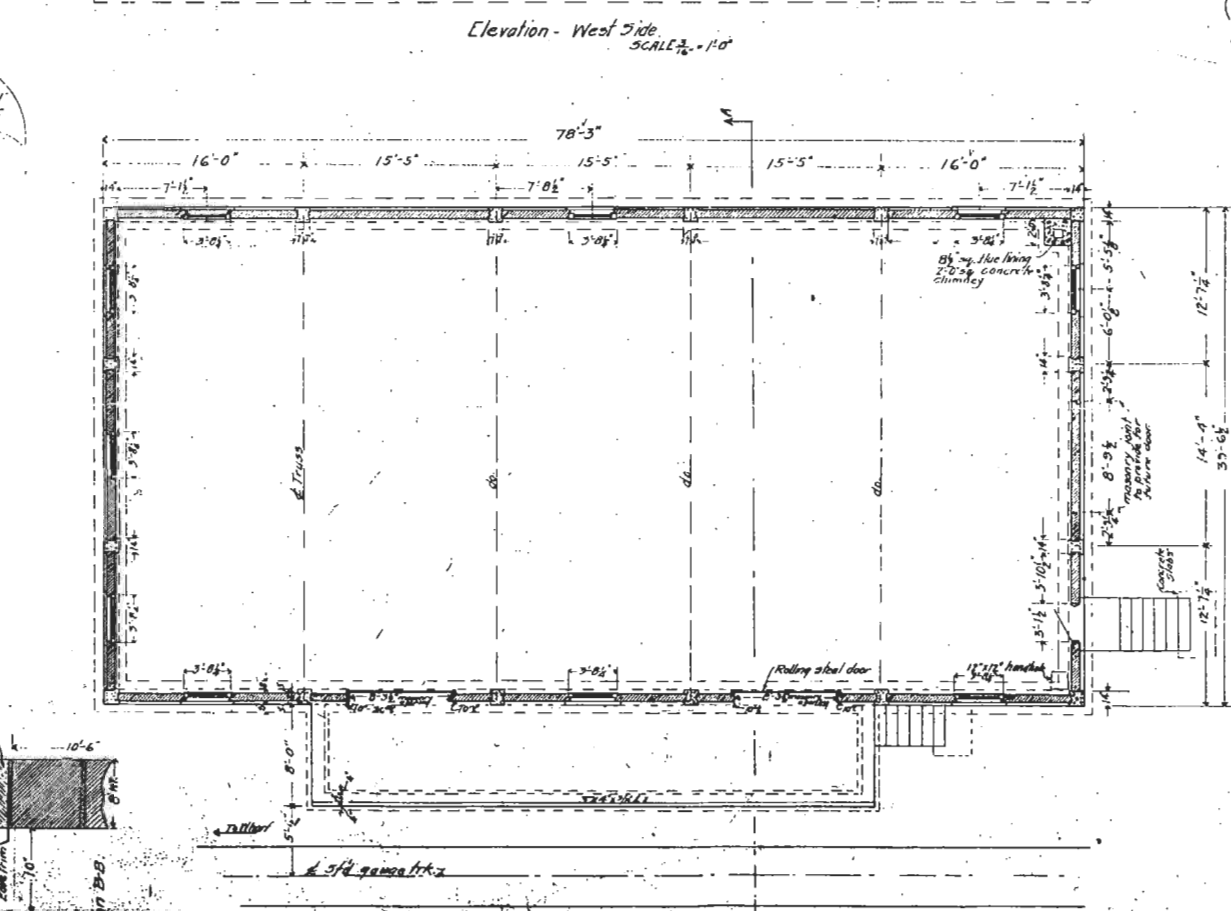
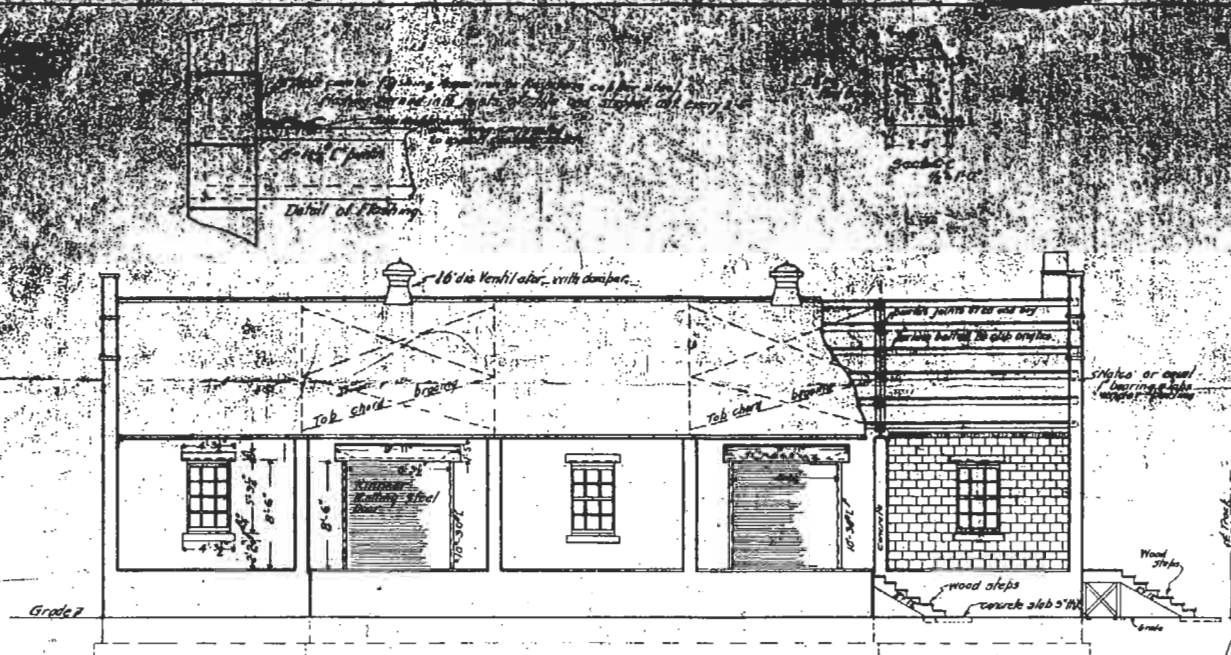
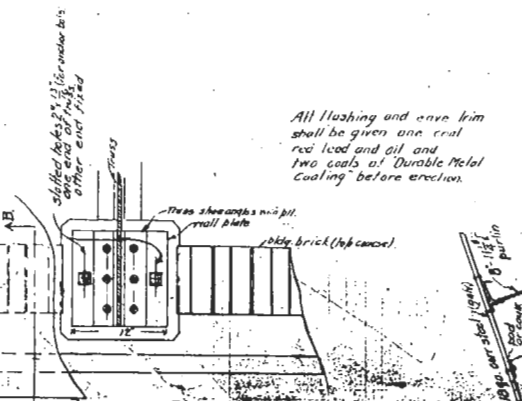
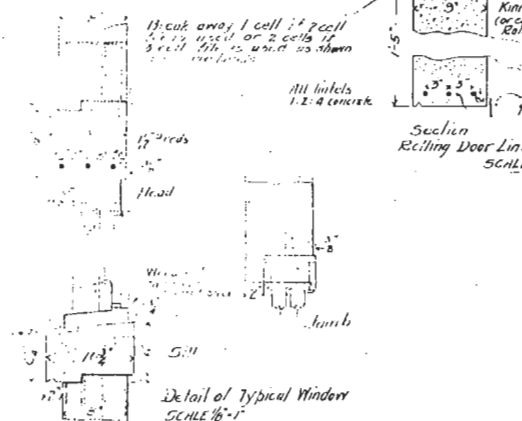
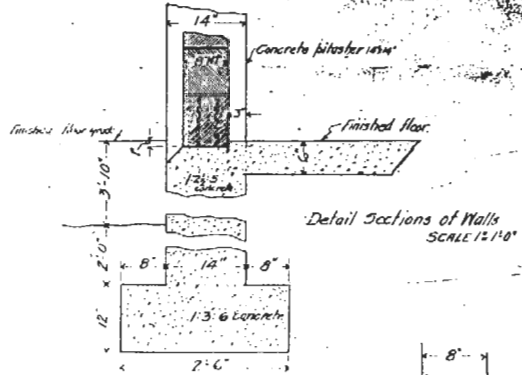
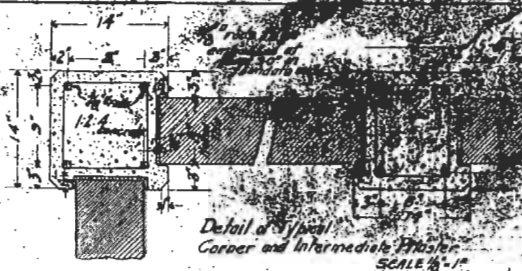

FORT TILDEN, N. Y.  
U. S. ENGINEER DEPARTMENT  
STORE HOUSE

31 SHEETS 3071 SCALES AS SHOWN  
United States Engineer Office, Third District, New York City, Oct. 18, 1923.  
Submitted *A. G. Swift* Approved *J. C. ...*

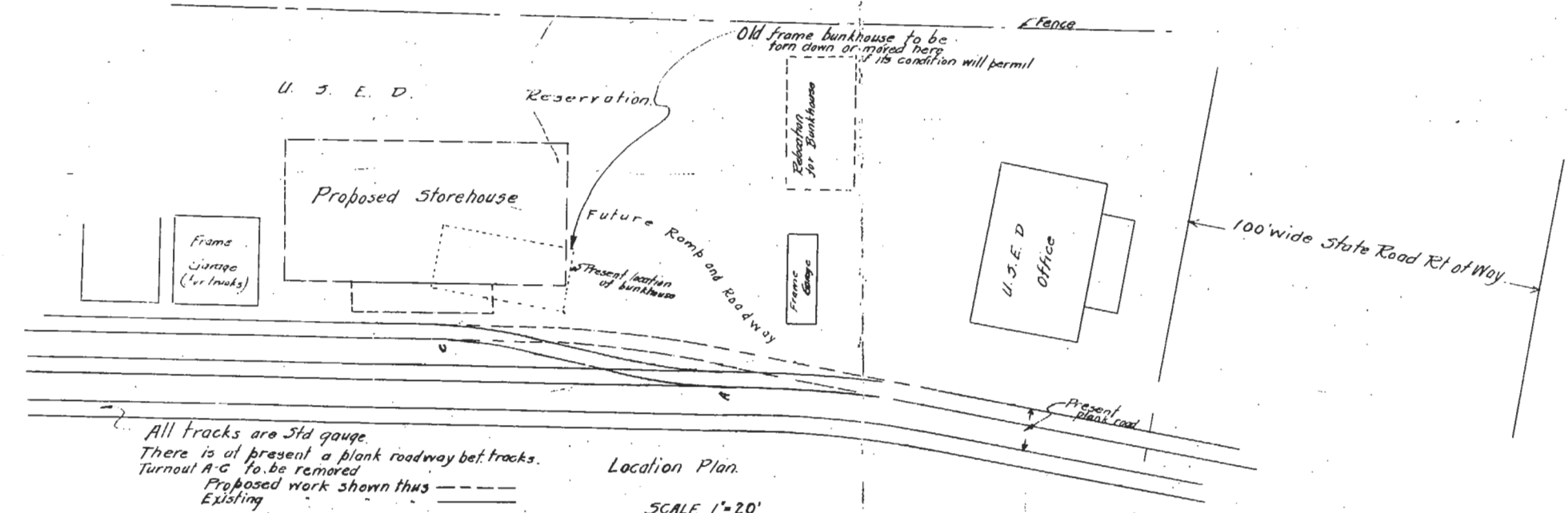
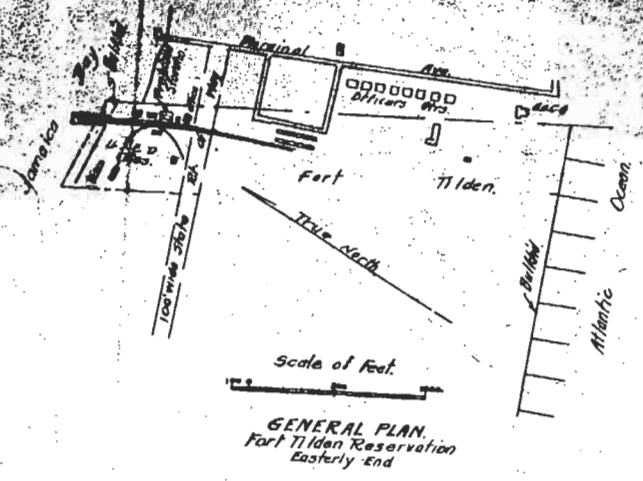

All tracks are Std gauge.  
 There is at present a plank roadway bet. tracks.  
 Turnout A-G to be removed  
 Proposed work shown thus -----  
 Existing -----

NOTE:  
 Trackwork and removal of Bunkhouse  
 to be done by the U.S.

FORT TILDEN, N. Y.  
 U. S. ENGINEER DEPARTMENT  
 STORE HOUSE  
 IN 2 SHEETS SHEET NO. 2 SCALES AS SHOWN  
 LOCATION PLAN.

United States Engineer Office, Third District, New York City, Oct 18, 1923.  
 Submitted A. C. Swift Junior Engineer. Approved J. C. [Signature] Colonel, Corps of Eng.  
 Drawn by ACS  
 Traced by ACS  
 Checked by ACS File No. 17-C-3-2 Transmitted with letter dated Oct 18, 1923.  
 This plan forms a part of specifications for 'Hollow Tile and Concrete Storehouse at Fort Tilden' dated 1923, Advertisement 24-10.

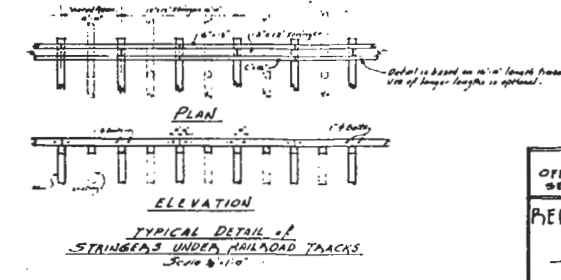
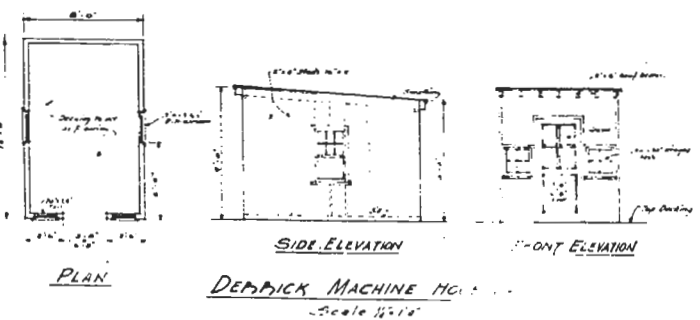
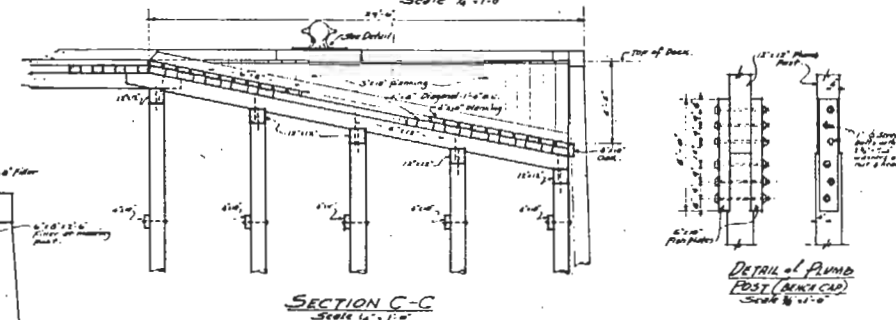
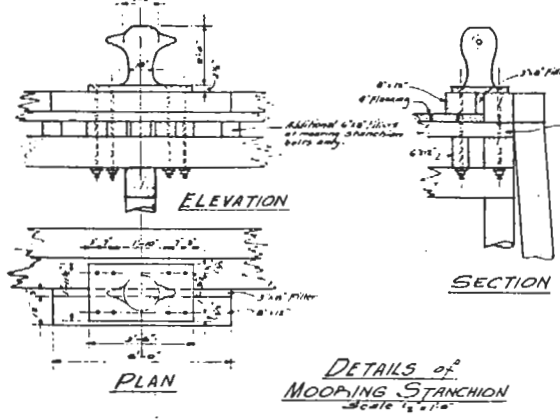
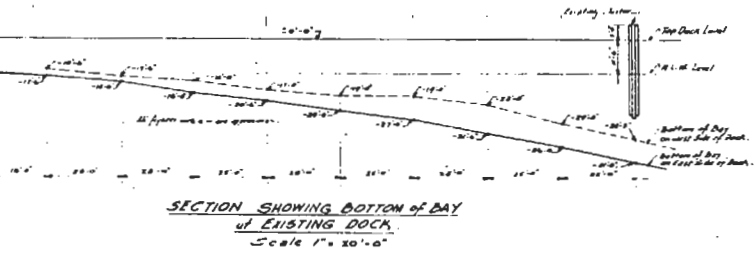
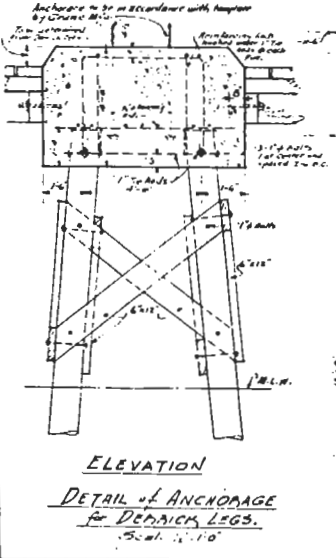
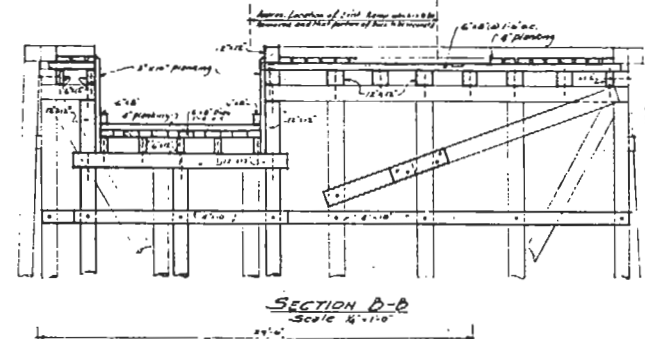
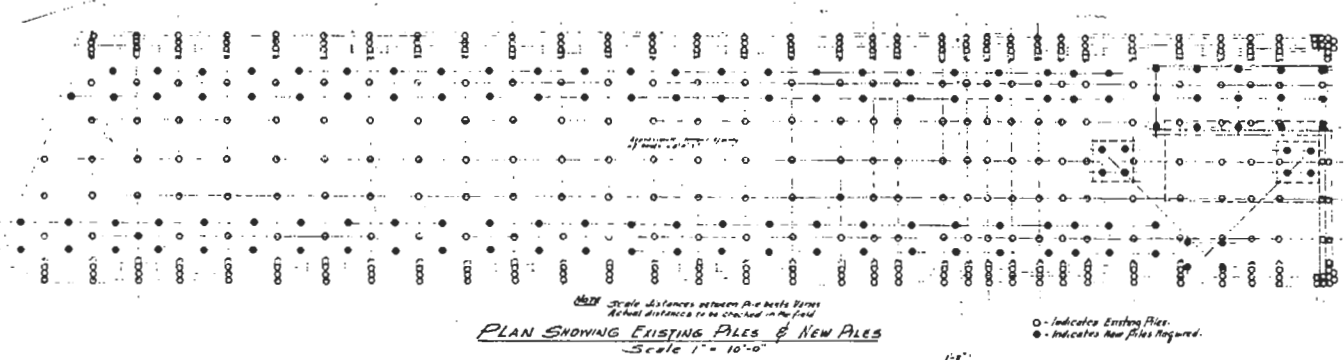
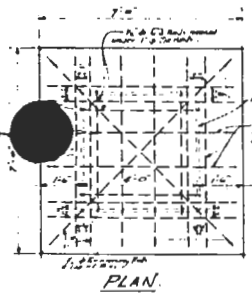
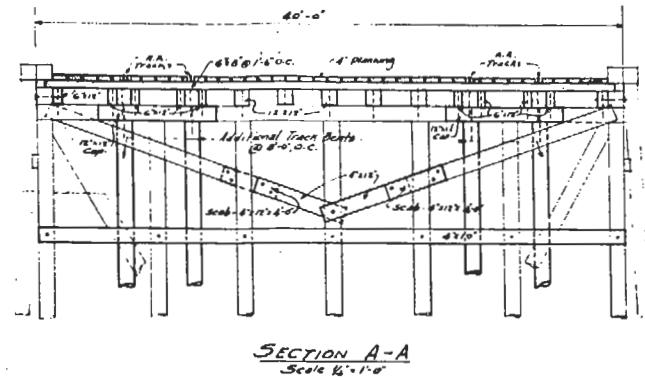
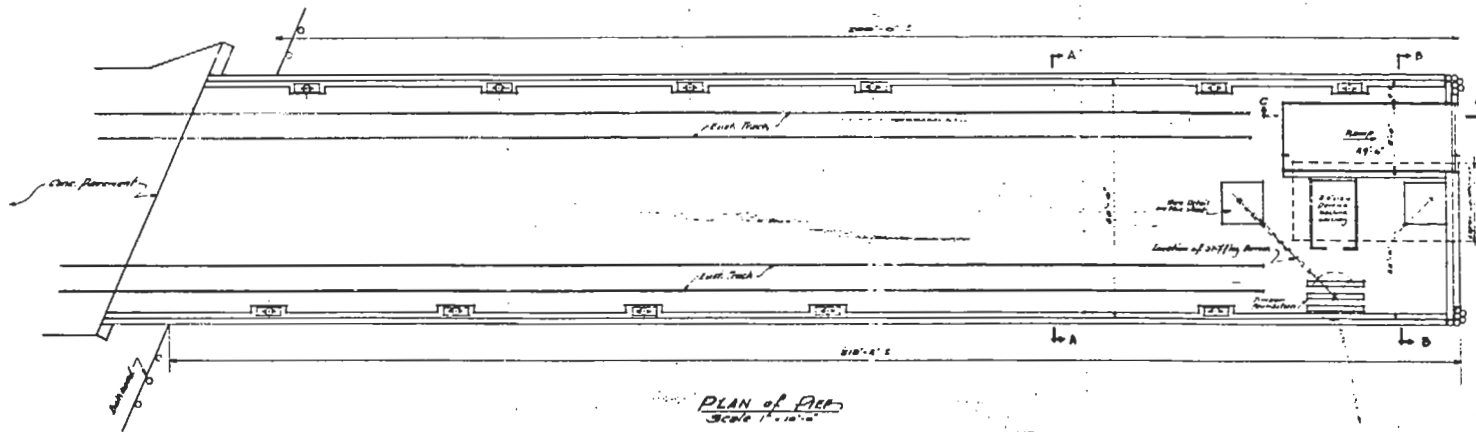

WAR DEPARTMENT  
OFFICE OF THE REPAIRS COMMAND ENGINEER  
SECOND SERVICE ENGINEER - 270 BUNNY NEW YORK, NY

REPAIRS & REINFORCEMENT OF WHARF  
AND  
INSTALLATION OF DERRICK.  
- FORT TILDEN, N. Y. -

DRAWING NO. O.S.C.E-100 SCALE AS SHOWN DATE 15 APRIL 1944

PREPARED BY S. BELMONT & ASSOCIATES, INC. 100 N. BROAD ST. NEW YORK, N. Y.

CH. D. THOMAS, JR. 100 N. BROAD ST. NEW YORK, N. Y.

REDUCED SIZE REPRODUCTION

64663009 104 4-1

ON MICROFILM

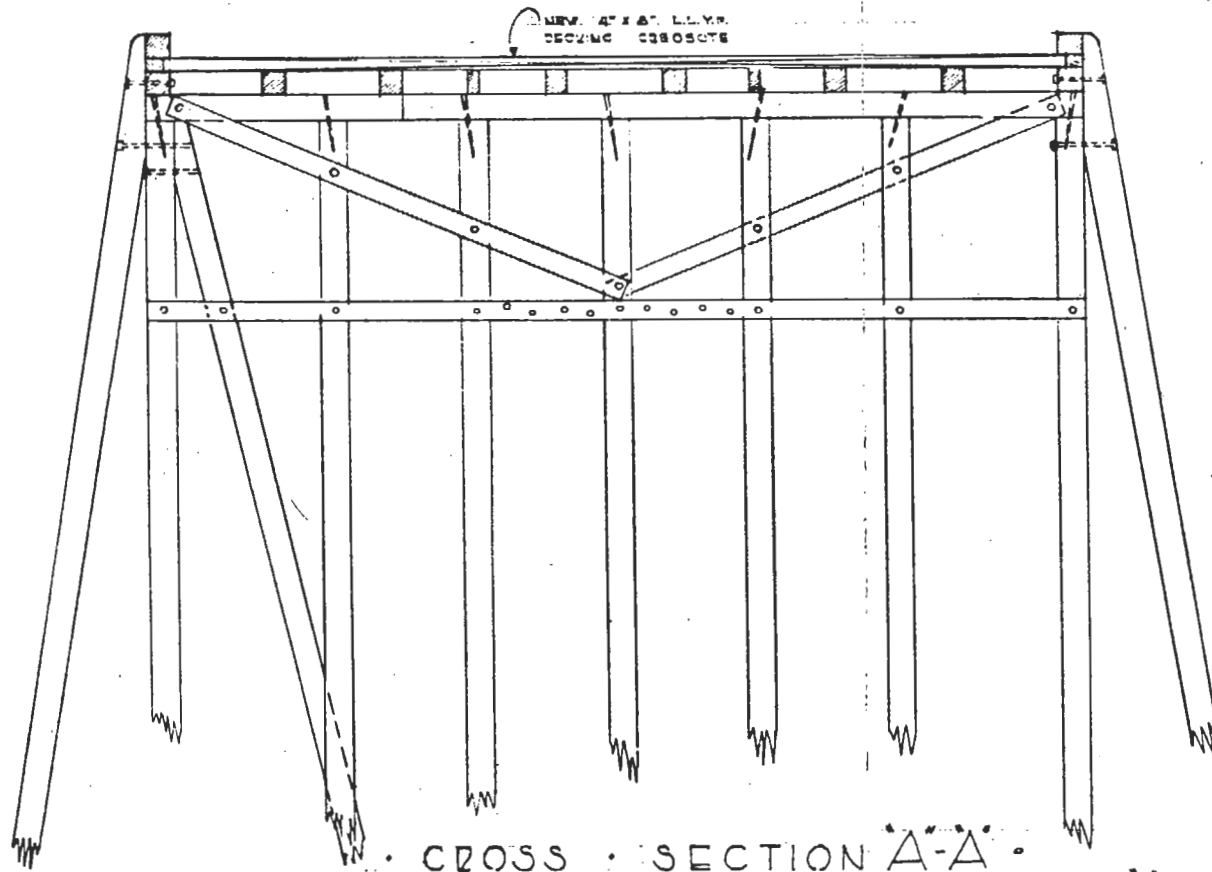

CROSS SECTION A-A

SCALE: 1/4" = 1'-0"

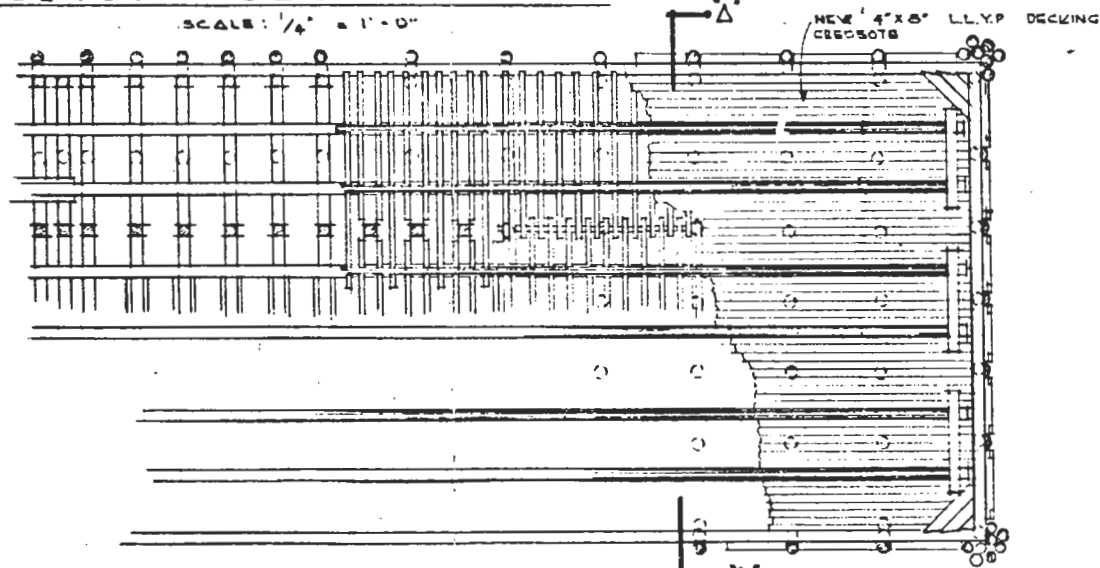

PLAN

SCALE: 1/8" = 1'-0"

**NOTE**

- REMOVE PRES. WHARF DECKING
- AND REPLACE WITH NEW 4' X 8'
- LLYP CREOSOTE
- REPLACE ALL DEFECTED SUPPORTING
- DOCK HEADERS SUCH AS BENTS,
- STRINGERS, PILE CAPS, BACKING LOGS,
- SWAY BRACES, ETC.

|                         |                    |          |
|-------------------------|--------------------|----------|
| DEPARTMENT OF THE ARMY  |                    |          |
| FORT HAMILTON, NEW YORK |                    |          |
| COL. J. C. BUDEL, T.C.  | COMMANDING OFFICER |          |
| POST ENGINEER OFFICE    |                    |          |
| LT. COL. L. SHAW, CE.   | POST ENGINEER      |          |
| FT. TILDEN WHARF        |                    |          |
| DRAWN BY: JANTOG        | DATE: 7 AUG 1951   | DWG. NO. |
| SCALE AS NOTED          | APPROVED:          | FT-70-1  |

REDUCED SIZE REPRODUCTION

646/63007 1 of 1

ON MICROFILM

APPENDIX 40



Publication services were provided by the graphics staff of the  
Denver Service Center. NPS 1663

