Abraham Lincoln Birthplace National Historic Site

Boyhood Home Unit

Lincoln Tavern

Historic Structure Report

2006

Historical Architecture, Cultural Resources Division

Southeast Regional Office

National Park Service



The historic structure report presented here exists in two formats. A traditional, printed version is available for study at the park, the Southeastern Regional Office of the NPS (SERO), and at a variety of other repositories. For more widespread access, the historic structure report also exists in a web-based format through ParkNet, the website of the National Park Service. Please visit www.nps.gov for more information.

**Cultural Resources
Southeast Region
National Park Service
100 Alabama St. SW
Atlanta, GA 30303
(404) 562-3117**

2006
Historic Structure Report
Lincoln Cabin
Abraham Lincoln National Historic Site
Boyhood Home Unit
Hodgenville, KY
LCS#: 473357

Cover image: Undated postcard of Cabin from
KYGenWeb Special Collections

**Abraham Lincoln Birthplace National Historic Site
Boyhood Home Unit
Lincoln Tavern
Historic Structure Report
2006**

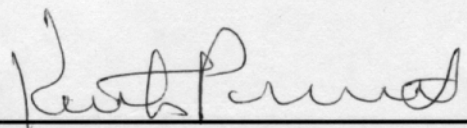
Approved by:  06/09/06
Superintendent, Abraham Lincoln NHS Date

Recommended by:  6-19-06
Chief, Cultural Resource Division Date
Southeast Region

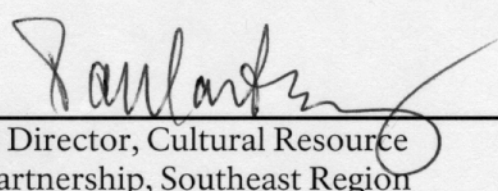
Recommended by:  6-19-06
Associate Regional Director, Cultural Resource Date
Stewardship and Partnership, Southeast Region

Approved by:  Acting 6/22/06
Regional Director, Southeast Region Date

TABLE OF CONTENTS

MANAGEMENT SUMMARY

Executive Summary.....	1
Administrative Data.....	4

PART I – DEVELOPMENTAL HISTORY

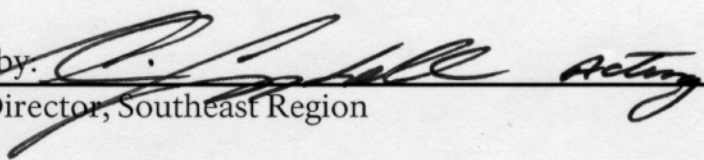
A. Historical Background and Context.....	I.A.1
Kentucky.....	I.A.1
The Lincoln Family.....	I.A.1
Knob Creek Farm.....	I.A.2
Life in Indiana.....	I.A.4
Political Aspirations.....	I.A.4
Civil War.....	I.A.5
A National Hero.....	I.A.6
Birthplace Memorial.....	I.A.6
Other Memorials.....	I.A.7
Knob Creek after the Lincolns.....	I.A.7
Growing Tourism.....	I.A.8
The Lincoln Boyhood Home.....	I.A.8
The Tavern.....	I.A.9
Site Managers.....	I.A.10
Growing Significance.....	I.A.10
Changing Hands.....	I.A.10
National Register Nomination.....	I.A.11
A Secure Future.....	I.A.11
ABLI Boyhood Home Unit.....	I.A.11
Other Studies.....	I.A.12
B. Chronology of Development and Use.....	I.B.1
Initial Construction and Early Operation.....	I.B.1
1950s: Conversion to Gift Shop.....	I.B.3
1986: New Ownership.....	I.B.3
2001: National Park Service.....	I.B.3
Chronology.....	I.B.5

C. Physical Description.....I.C.1

 General Description..... I.C.1

 Construction Characteristics..... I.C.2

 Utility Systems..... I.C.31

 Summary of Conditions..... I.C.31

PART II – TREATMENT & USE

A. Introduction..... II.A.1

B. Ultimate Treatment & Use..... II.B.1

C. Requirements for Treatment II.C.1

D. Alternatives for Treatment II.D.1

E. Recommendations..... II.E.1

 General..... II.E.1

 Site..... II.E.1

 Tavern..... II.E.2

REFERENCES

APPENDICES

- A. As-found Floor Plans and Details
- B. Interview Transcripts
- C. Structural Report
- D. MEP Report

PROJECT TEAM

Project Manager

Tommy H. Jones, Architectural Historian
National Park Service
Southeast Regional Office
Atlanta, GA

Program Review Coordination

Sandy Brue, Chief of I & RM
Abraham Lincoln Birthplace National Historic Site
Hodgenville, KY

Tommy H. Jones, Architectural Historian
Southeast Regional Office

*Building Investigation/
Building Condition Assessment*

Joseph K. Oppermann, FAIA
Joseph K. Oppermann – Architect, P.A.
Winston-Salem, NC

Research

Joseph K. Oppermann, FAIA, Historical Architect
Joseph K. Oppermann – Architect, P.A.
Winston-Salem, NC

Building Recordation

Joseph K. Oppermann, FAIA, Historical Architect
Jennifer Plocher Wilkins, Assoc. AIA
Joseph K. Oppermann – Architect, P.A.
Winston-Salem, NC

Document Layout

Jennifer Plocher Wilkins, Assoc. AIA
Amanda R. Lynn
Joseph K. Oppermann – Architect, P.A.
Winston-Salem, NC

Report Editor

Jane Kelly
Message Makers
Winston-Salem, NC

EXECUTIVE SUMMARY

In 1911, a grand Memorial Building was constructed near Hodgenville, Kentucky, at the site of Sinking Spring Farm, the birthplace of Abraham Lincoln. The building and 110 acres was donated to the Federal Government in 1916, forming Abraham Lincoln National Park; in 1939 the National Park Service became steward of the park. The park was renamed Abraham Lincoln Birthplace National Historic Site in 1959.

This site honoring one of the nation's best-loved presidents, coupled with improved road and highway systems, greatly increased tourism to the area in the 1920s and 30s. Hattie and Chester Howard were one of several families that tried to capitalize on the booming tourist trade and honor the local hero. The Howards purchased Knob Creek Farm in 1931 with the intention of creating another memorial to Lincoln. This land was the Lincoln family's home from 1811 to 1816, and by Lincoln's own admission was the site of some of his earliest memories. Here, the Howards used the logs of a cabin belonging to the family of Lincoln's childhood friend Austin Gollaher to re-build a hewn-log cabin said to resemble Lincoln's boyhood home. Then in 1933, they followed in the established theme of Lincoln's rustic log structure and built the adjacent Lincoln Tavern. This second structure, made of exposed round logs purportedly cut from trees felled on the site, was a popular dance hall and nightclub for travelers. After the sale of alcohol became illegal, the tavern was converted to restaurant and gift shop in the 1950s. In recognition of their significant role in Larue County tourism the site containing the cabin and tavern was listed in the National Register of Historic Places in

1988 as the Lincoln Boyhood Home. The National Park Service acquired the site from members of the Howard family in 2001 for inclusion in the Abraham Lincoln Birthplace National Historic Site (ABLI) and named it the Boyhood Home Unit.

The bicentennial of Lincoln's birth falls on February 12, 2009; a two-year celebration of this event will kick off at ABLI on that date in 2008. In anticipation of the commencement of this celebration, the National Park Service contracted with Joseph K. Oppermann – Architect, P.A. (JKOA) in November 2005, for the purpose of preparing an historic structure report with Class C cost estimate for repairs for the Tavern and another for the Cabin. The study team included Joseph K. Oppermann, FAIA, historical architect, and Jennifer Plocher Wilkins, intern architect, of JKOA; Langdon Edmunds Oppermann, architectural historian; Ronald W. Brown, P.E., mechanical/electrical/plumbing engineer of Ronald W. Brown Consulting Engineers; and David C. Fischetti, P.E., structural engineer of DCF Engineering, Inc.

In the preparation of these historic structure reports, Sandy Brue, Chief of Interpretation & Resource Management of ABLI, provided from that office's files copies of earlier reports, the draft General Management Plan (GMP) for the park and other relevant documents. Tommy Jones, architectural historian of the National Park Service's Southeast Regional Office (SERO), provided technical data and leads for additional sources of information regarding some early twentieth century building materials. Mary Brooks Howard graciously submitted digital copies of early family

photographs and offered her recollections of the property. Milburn Howard likewise generously gave of his time to be interviewed regarding his involvement with the site. Wilkins reviewed the historic documents, located other secondary sources, retrieved maps and other iconographic images. She also took measurements and produced measured drawings of floor plans and architectural details. J. Oppermann and Wilkins prepared the digital photo-documentation of the building and site. L. Oppermann prepared the architectural description of the building. J. Oppermann, Fischetti and Brown investigated the building fabric and building equipment to determine the building's evolutionary history and assess condition. Besides several small samples of wood taken from the perimeter walls, no other historic fabric was removed. No other invasive method of investigation was employed. No equipment was tested. Dr. Joseph Loferski of the Brooks Forest Products Center at the Virginia Polytechnic Institute & State University analyzed the species from the wood samples. J. Oppermann, Fischetti and Brown prepared the cost estimates.

The investigating team found that the tavern retains a large percent of its original building fabric with relatively few replacements or modifications. Further, its large building footprint with two levels of generously sized rooms can be easily adapted for a variety of valuable park activities.

However, there are some deficiencies as well as deteriorated physical conditions that merit attention. On the exterior, there are two significant issues. One is the significant deterioration of some logs of the exterior walls; this is long term damage that should be addressed soon with Dutchman repairs and in some instances with full unit replacement. The second issue is the roof. Originally wood shingle consistent with the

rustic theme of the architecture, the roofing material has been for several decades a somewhat less aesthetically desirable composition shingle. The current roof is seriously lacking in desirable installation characteristics, including an effective flashing material.

Inside, the equipment to provide heating for the occupants is inefficient and largely ineffective. There is no system to provide cooling. Both the electrical and plumbing systems are antiquated and in need of replacement. Access by the handicapped to the interior of the building does not meet design standards and the restrooms are not configured for accessibility. In addition, the ceiling beam that runs the length of the first floor dance hall needs additional bracing; temporary bracing was installed by NPS when the building was first acquired. Finally, consideration needs to be given to additional issues of life, safety and welfare of the public including emergency lighting, exit signage, emergency generators, security and fire detection/suppression.

The General Management Plan (GMP) for ALBI, now in draft form, calls for the interior/exterior rehabilitation of the tavern with visitor services on the first floor and offices for staff support on the second floor.

While this Historic Structure Report is in agreement with the GMP's overall recommendations for the use of the tavern, the recommended treatments are different. The period of significance for this property according to the approved National Register Nomination Form is 1933-38. A large percent of the original building fabric, both interior and exterior, remains intact. Some features, such as exterior lights and the paired main entrance doors, have been removed but are on site. For other features that have been removed or modified, such as the front steps and the rear screened-in porch, there is documentation and/or

physical evidence to permit accurate restoration. Much is to be gained by interpreting tourism of the early twentieth century as it relates to historical personage, as is the case with this property. It is a dimension of tourism not commonly emphasized. This building presents that opportunity for restoration at a financial cost comparable to rehabilitation. The recommended exterior treatment, therefore, is restoration of the tavern to its original 1933 appearance.

For the same reasons, the recommended treatment of the interior is restoration of the dance hall, the principal room and major public space, to its original 1933 appearance for visitor services and rehabilitation of the secondary spaces as support areas. By restoring this large room, the opportunity to interpret early twentieth century tourism can be addressed, in building treatment but even in interpretive devices, while providing modern visitor services as well. The remaining original room configurations at the first and that of the second floor work well for the uses envisioned by the park staff. The first floor public restrooms can be readily rearranged for modern handicapped accessibility needs, and the kitchen could be up-fitted for occasional food service events and serve in a multitude of other functions as well. On the second floor, the large rooms can be easily adapted for offices and support spaces with the bathroom serving as staff restroom.

ADMINISTRATIVE DATA

Locational Data

Building Name: Lincoln Tavern
Building Address: 7120 Bardstown Road, Hodgenville, KY 42748
NPS Orgcode: 5540
Location: Abraham Lincoln Birthplace NHS
County: LaRue
State: Kentucky

Related Studies

Brown, Kent Masterson. *Report on the Title of Thomas Lincoln to, and the History of, the Lincoln Boyhood Home Along Knob Creek in LaRue County, Kentucky.* Atlanta: National Park Service, Southeast Regional Office, 1998.

National Register of Historic Places Registration Form: Lincoln Boyhood Home. Athertonville, KY: United States Department of the Interior, National Park Service, 1988.

Nickel, Robert K. *A Ground-Penetrating Radar Survey at the Knob Creek Farm Unit: Abraham Lincoln Birthplace National Historic Site, Kentucky.* Tallahassee, Florida: Southeast Archeological Center, National Park Service, 2005.

Sculle, Keith A. "The Howard Family Legacy at the Knob Creek Farm." *Journal of the Abraham Lincoln Association*, Vol. 26, No. 2 (2005): 23-48.

Real Property Information

Acquisition Date: November 6, 2001

Numbering Information

LCS #: 07238
Structure Number: HS-1A

Size Information

Total Floor Area: 4870 sq. ft.
First Floor Area: 3050 sq. ft.

<i>Additional Floor Area:</i>	1158 sq. ft. upstairs (not including closets)
<i>Crawl Space Area:</i>	1994 sq. ft.
<i>Basement Area:</i>	662 sq. ft.
<i>Roof Area:</i>	70 sq.
<i>Perimeter Length:</i>	264'-6"
<i>Number of Stories:</i>	1.5
<i>Number of Rooms:</i>	11
<i>Number of Bathrooms:</i>	3

Cultural Resource Data

<i>National Register Status:</i>	Listed
<i>National Register Date:</i>	1988
<i>Period of Significance:</i>	1933- c. 1938

Proposed Treatment

Exterior restoration to original 1930s appearance; interior restoration of the principal room, the hall, to original 1930s appearance, to use as a visitors reception center; and rehabilitation of tavern's other interior spaces for ancillary support areas and staff offices.

PART I. DEVELOPMENTAL HISTORY

A. HISTORICAL BACKGROUND AND CONTEXT

The sixteenth president of the United States, born into simple surroundings, grew to lead this country through its most divisive time. The stories of Abraham Lincoln's birth in a log cabin in Kentucky, youth largely without formal education, and early political defeats are well known. His leadership through the Civil War and issuance of the Emancipation Proclamation were turning points in the history of this country. Lincoln's untimely death further contributed to his status as an American icon.

Kentucky

The area that is now Kentucky was largely opened by land companies through surveying beginning in the 1750s, and later by explorers such as Daniel Boone, who helped to blaze the Wilderness Road in 1775. There were few settlements but Native Americans used the lands for hunting; broad expanses of forest supported such game as deer, buffalo, bears, turkeys, and other wild fowl. Salt licks, natural salt deposits, drew buffalo in great numbers, their traffic creating natural roadlike traces. A vast area south of the Ohio River called the "Pennyryle" was clear of trees and covered with grass, where Native Americans supposedly had cut the trees to entice buffaloes to graze.¹ The name was taken from the pennyroyal, a plant in the mint family. Geologically, the Pennyryle is a karst region, where soluble limestone bedrock creates frequent caves and sinkholes.

Virginia claimed the land as part of that state in 1776, and called it Kentucky County. As settlement increased, Kentucky County was subdivided in 1780, creating Jefferson, Fayette, and Lincoln counties. Individual statehood was first addressed at a convention in Danville in 1784. Virginia passed a law for Kentucky's independence in January 1786, and on June 1, 1792, the Commonwealth of Kentucky officially became the fifteenth state in the Union.

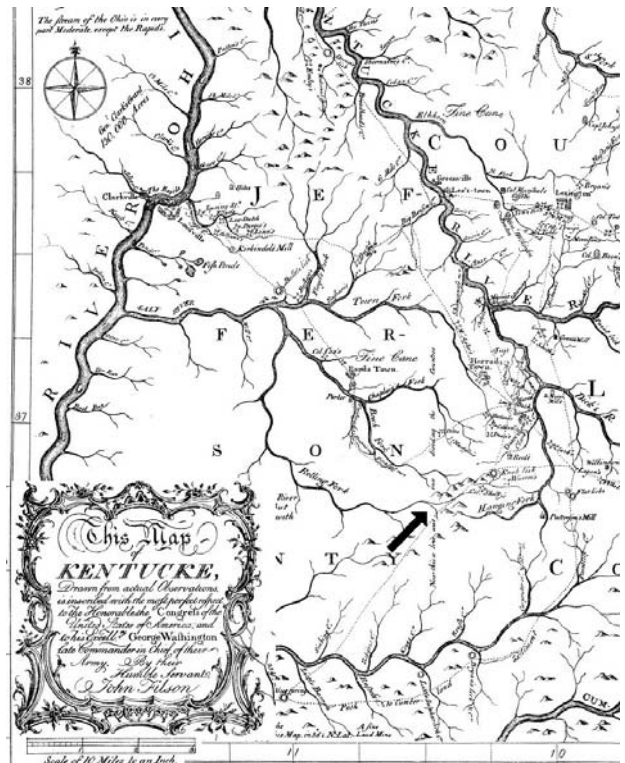

Figure A-1 Map of Kentucky with Knob Creek site indicated, 1784 (Filson)

The Lincoln Family

The Lincoln family traces its roots back to Samuel Lincoln, who immigrated to Salem, Massachusetts, from England in 1637. Samuel's descendant Captain Abraham

¹ R.S. Cotterill, *History of Pioneer Kentucky* (Cincinnati: Johnson & Hardin, 1917), 3.

Lincoln served in the Virginia Militia during the Revolution, that service providing him treasury warrants for land in Kentucky. Abraham's first wife died in 1776, leaving him with four young children. With his new wife Bersheba, son Thomas was born on January 6, 1778. The opportunities of the picturesque Kentucky frontier drew Lincoln and his family to relocate there in 1782.

The family eventually settled in what is now Jefferson County, Kentucky. Thomas and his father were tending fields in 1785 when raiding Indians killed Abraham. Thomas then moved with his mother to what is now Washington County, where they lived on a small farm provided by his half-brothers. Thomas moved to Elizabethtown as early as 1796, where he trained as a carpenter and later is listed on tax records as a farmer.²

Thomas Lincoln married Nancy Hanks on June 12, 1806, in Washington County. Hanks is said to have been born in 1784 in Virginia; evidence suggests that she was the daughter of Lucy Shipley Hanks Sparrow and James Hanks. Neither Thomas nor Nancy had a formal education; it is said that they were nearly illiterate. Nancy was very religious. The new family returned to Elizabethtown where Thomas continued his carpentry trade. Their first child Sarah was born February 10, 1807.

In December 1808, Thomas purchased 300 acres called Sinking Spring Farm,³ which was named for a sinkhole and natural spring located on the property. The farm was about two miles from Hodgen's Mill (now called Hodgenville), established on the Nolin River in 1788 by Robert Hodgen. Hodgen's Mill initially was in Nelson County, carved out of

Jefferson County in 1785. By the time the Lincolns arrived, the land was in Hardin County, which was created out of Nelson County in 1793; Elizabethtown was the county seat. Thomas cleared and worked the land at Sinking Spring Farm, a common occupation in that area. Their second child Abraham was born in the family's log cabin on the farm on February 12, 1809.

In 1811 a legal dispute over the title for the farm caused the Lincoln family to move to a new farm on Knob Creek when young Abraham was just two years old. Legal proceedings regarding the rightful ownership of Sinking Spring farm continued in Hardin County Circuit Court.



*Figure A-2 Sinking Spring Farm, 1895
(National Park Service)*

Knob Creek Farm

The Knob Creek Farm was a 228-acre tract owned by George Lindsey, located about seven miles north of Hodgen's Mill. Thomas Lincoln was one of several leaseholders and held thirty acres in his parcel.⁴ The Bardstown and Green River Turnpike ran along the east side of the farm, connecting Nashville, Tennessee, to Louisville, Kentucky. The family's log cabin most likely faced the turnpike.

Many of Lincoln's neighbors were also small farmers and leaseholders rather than land owners. Tax records show that only

² Kent Brown, *Report on the Title of Thomas Lincoln to, and the History of, the Lincoln Boyhood Home Along Knob Creek in LaRue County, Kentucky* (Atlanta: National Park Service, Southeast Regional Office, 1998), 5.

³ *Ibid.*, 20.

⁴ *Ibid.*, 31.

one neighbor, tanner William Brownfield, had a specific profession listed. As one of more prosperous men in the area, Brownfield owned several horses and reported the custody of one slave in 1805, though he also leased land as opposed to owning it.⁵ Only one neighbor, George Redmon, was shown in tax records as owning a wagon.⁶ Other neighbors such as John Dye and William Ash held slaves, one in 1806 and four in 1808, respectively.⁷ In much of Kentucky, slave labor was not as prevalent as in the Deep South owing to the smaller size of most farms.

Located on Knob Creek, a tributary of the Rolling Fork River, the bottomland in Thomas Lincoln's parcel provided fertile soil for farming. Muldraugh's Hill, a limestone cliff and ridge extending across the state, surrounded the farm on the north, east, and west sides. This hill and the other "knobs" in the area caused the creek to swell quickly with rain. In a later conversation at the White House, Abraham Lincoln recounted his memories of farming at Knob Creek:

I remember that old home very well! Our farm was composed of three fields. It lay in the valley surrounded by high hills and deep gorges. Sometimes when there came a big rain in the hills the water would come down through the gorges and spread all over the farm. The last thing that I remember doing there was one Saturday afternoon. The other boys planted the corn in what we called the big field - it contained seven acres - and I dropped the pumpkin seeds. I dropped two seeds every other hill and every other row. The next Sunday morning there came a big rain in the hills. It did not rain a drop in the valley, but the water coming down through the gorges washed ground, corn, pumpkin seed and all clear off the field.⁸

⁵ Ibid, 53.

⁶ Ibid, 56.

⁷ Ibid, 54-55.

⁸ Ibid; also Ida Tarbell, *The Life of Abraham Lincoln* (New York: Lincoln History Society, 1900), 17.



Figure A-3 View of the Knob Creek farm, December 2005

Another traditional story of Abe's youth at the Knob Creek farm has him playing near the rain-swollen creek with Austin Gollaher, a neighbor, when the future president fell in. Gollaher helped Abraham out of the water with a branch, saving him from drowning.⁹ This event was said to have occurred around 1812.

Though the setting of the farm was rural, the proximity to the turnpike, a primary travel artery, would have exposed the family to a variety of people. Tradition holds that Abe witnessed slaves being driven to market down the road, which affected his later views on slavery. Thomas Lincoln was appointed surveyor for part of the road near the cabin in 1816, demonstrating his standing within the area.

Abraham and his sister Sarah attended ABC schools in Kentucky, one of them in a log building about two miles down the turnpike from Knob Creek. Lincoln called this the "blab school" because of the recitation required of the students. Though life on the frontier required manual labor, Abraham was said to have preferred intellectual

⁹ William H. Herndon, *Herndon's Lincoln* (Springfield, Illinois: The Herndon's Lincoln Publishing Company, 1888), vol. 1, p. 18.

pursuits, even though he probably had in all only one year of formal schooling.

Abraham's younger brother Thomas was born in the Knob Creek cabin, presumably two or three years after Abe's birth. Thomas died in infancy and was buried in the nearby Redmon Cemetery, because the Lincoln family did not own the Knob Creek land.

Thomas Lincoln had tried to buy the Knob Creek farm from Lindsey in 1815 but was unsuccessful.¹⁰ That same year landowner George Lindsey, Lincoln, and nine neighbors were served with a notice of ejection from the Knob Creek land by a group asserting a prior claim. The subsequent lawsuit, settled in 1818, found in favor of Lindsey and his tenants. Meanwhile, Lincoln was still involved in legal proceedings regarding the Sinking Spring farm. Lincoln tried unsuccessfully to repurchase the land at Sinking Spring while living at Knob Creek. When it was finally settled in 1816 that Lincoln had no rightful claim to the land, the family moved to Indiana.¹¹ Abraham Lincoln later wrote in a biographical sketch for John Scripps:

From this place he removed to what is now Spencer county Indiana, in the Autumn of 1816. This removal was partly on account of slavery; but chiefly on account of the difficulty in land titles in Ky.¹²

Life in Indiana

Spencer County was the site of the first Indiana home of the Lincoln family. This location was chosen because the state had just been surveyed, and land titles were more secure. The family built a cabin, and Abraham helped to clear fields and tend crops at the new farm. Abraham's mother

Nancy died in October of 1818. Thomas Lincoln later married Sarah Bush Johnston from Elizabethtown in December of the following year. Abraham and his new stepmother got along very well; she is said to have encouraged his taste in reading. Neighbors remembered that he would go to great lengths in order to borrow a book.



Figure A-4 Boyhood of Lincoln, 1868 (painting by Eastman Johnson)

In 1830, the family moved again, this time to Illinois. Abraham drove the team of oxen during the trip. He arrived in New Salem, Illinois, in 1831, and held a variety of jobs including rail splitter, storekeeper, postmaster, and surveyor. On a trip to New Orleans as a flatboatman on the Mississippi, he again remembered seeing slaves mistreated. In 1832 he enlisted as a volunteer for the Black Hawk War and was named captain of his company.

Political Aspirations

Abraham first ran for the state legislature in 1832 and was defeated. He ran again in 1834 and was elected at the age of twenty-five. After personal study of law and being

¹⁰ Keith Sculle, "The Howard Family Legacy at the Knob Creek Farm," *Journal of the Abraham Lincoln Association* (Vol. 26, No. 2, 2005), 22.

¹¹ Brown, 48.

¹² Zall, 9.

admitted to the bar in 1836, he began to practice as a lawyer and became known for his skill in the courtroom. He campaigned successfully to have Springfield succeed Vandalia as the Illinois state capitol, and he moved there in 1837. He was re-elected to the Illinois state legislature in 1838 and 1840, eventually becoming minority leader of the Whig party in the legislature.

Lincoln married Mary Todd in 1842. Born in Lexington, Kentucky, Todd had moved to Springfield to live with relatives in 1839 and had become active in social circles. Lincoln focused on his law practice, and served as counsel for railroads, banks, insurance companies, and the like. Though very successful, Lincoln was known for his common sense and honesty. He and his wife eventually had four sons.

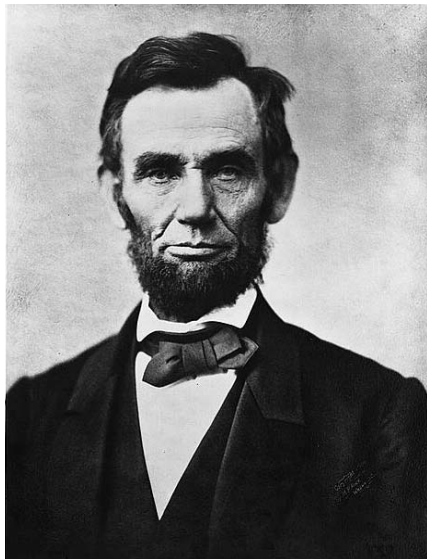

*Figure A-5 Lincoln, November 8, 1863
(Library of Congress)*

Lincoln was elected to the U.S. House in 1847 and served a single term. His votes recorded in those two years show him to be against the spread of slavery. In 1856 he joined the newly formed Republican Party, established to prevent the extension of slavery; he became that party's senatorial candidate two years later. His 1858 debates with Democrat Stephen A. Douglas, who

had called for slavery to be permitted in territories of the Louisiana Purchase, were legendary, even though Douglas won the election. The presidential election of 1860 again pitted these two men against each other, with Lincoln on the Republican ticket.

Lincoln frequently wrote biographical sketches for campaign use. In these short documents he often fondly recalled his Kentucky upbringing. In one biography, Lincoln wrote, "I was born and have ever remained in the most humble walks of life."¹³ In a letter to Samuel Haycraft, he continued:

At this time his father resided on Knob-creek, on the road from Bardstown Ky. To Nashville Tenn. At a point three, or three and a half miles South or South-West of Atherton's ferry on the Rolling Fork. (I was born on Nolin, very much nearer Hodgin's-Mill than the Knob Creek place is. My earliest recollection, however, is of the Knob Creek place.)¹⁴

His image as a self-made man with a modest background stayed with him throughout his political campaigns.

Civil War

Lincoln was victorious in the presidential election, but even before his inauguration, seven southern states had moved to secede from the Union. The generally accepted start of the Civil War, the bombardment of Ft. Sumter in Charleston Harbor, began just after Lincoln's inauguration March 4, 1861.

Lincoln's primary goal was to preserve the Union. Though he did not want war, he felt the goal was worthy of the risk. He even said that preservation of the Union was the higher priority over the issue of slavery. With antislavery sentiment rising, he issued the Emancipation Proclamation on January 1, 1863. The Thirteenth Amendment was

¹³ Paul M. Zall, ed., *Lincoln on Lincoln* (Lexington: The University Press of Kentucky, 1999), 25.

¹⁴ *Ibid*, 9.

later passed to ensure slavery would never again be permitted.

It is in parts of Lincoln's eloquent Gettysburg Address, delivered at that battlefield on November 19, 1863, that one can see the conviction with which Lincoln approached the issues of slavery and the Union:

Fourscore and seven years ago our fathers brought forth, upon this continent, a new nation, conceived in liberty and dedicated to the proposition that all men are created equal. Now we are engaged in a great civil war, testing whether that nation, or any nation so conceived and so dedicated, can long endure... we here highly resolve that these dead shall not have died in vain, that this nation shall have a new birth of freedom, and that government of the people, by the people, and for the people shall not perish from the earth.

Lincoln managed to lead the Union in spite of massive war losses and won reelection in 1864 based on the perception that victory was at hand. Indeed, Robert E. Lee surrendered at Appomattox Courthouse on April 9, 1865. It was only five days later, on Good Friday, April 14, that Lincoln was shot at the Ford Theater in Washington by John Wilkes Booth, an actor and staunch Confederate sympathizer. Lincoln died the next morning. It was the first presidential assassination.

A National Hero

Lincoln's determination to preserve the Union, and his respect for basic human rights in freeing the slaves, earned him high esteem among the American people. His untimely death elevated his stature even more. The legends of his rural boyhood coincided with a general idealization of the past, brought about by technological advances of the late nineteenth century, the country's centennial, and urban growth. Curious travelers began to seek out the supposed site of Lincoln's birth, and local residents would lead them to a chimney

where the cabin once stood at Sinking Spring Farm.

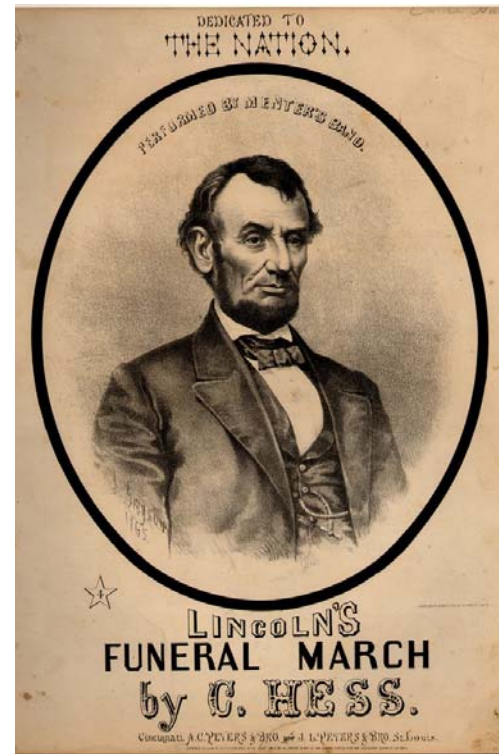

Figure A-6 One of many published songs commemorating Lincoln, c. 1865 (Library of Congress)

Local tradition states that the cabin of Lincoln's birth was dismantled before 1860, and the logs were re-used in a nearby house. These logs, now known through further study to be later than the period of Lincoln's birth, were sold in the 1890s and re-configured into a cabin for exhibition at various sites. The Tennessee Centennial Exposition featured the reconstructed replica cabin in 1897; later the cabin was shown at the 1901 Pan-American Exposition in Buffalo, New York.¹⁵

Birthplace Memorial

Robert J. Collier, publisher of New York's *Collier's* magazine, raised funds for the

¹⁵ Dwight T. Pitcaithley, "Abraham Lincoln's Birthplace Cabin: The Making of an American Icon" in *Myth, Memory, and the Making of the American Landscape*, ed. Paul A. Shackel, 244 (Gainesville: University Press of Florida, 2001).

purchase of the supposed cabin logs and the farm of Lincoln's birth in order to construct a memorial there. He established the nonprofit Lincoln Farm Association to oversee the purchase and solicit designs for the memorial.

Collier planned a grand memorial building and landscape. A granite and marble building, designed by John Russell Pope, consisted of one large interior room to house the birth cabin, although the logs actually had to be cut down in order to fit inside. President Theodore Roosevelt laid the cornerstone of the memorial building on the centennial of Lincoln's birth, February 12, 1909. The completed building was dedicated by President Taft on November 9, 1911.



Figure A-7 Memorial building at birthplace site, undated (Rinehart, National Park Service)

The Lincoln Farm Association donated the site to the United States government in 1916, along with an endowment of \$50,000, to form Abraham Lincoln National Park. The War Department managed the site until 1933, when it was acquired by the National Park Service. It was designated a National Historical Park on August 11, 1939, and later renamed Abraham Lincoln National Historic Site on September 8, 1959. The site was listed on the National Register of Historic Places on October 15, 1966. Today the Birthplace National Historic Site contains 116.5 acres, one third of the original Sinking Spring farm tract.

Other Memorials

As early as 1867, Congress authorized the formation of the Lincoln Memorial Association to raise private funds for a monument in Washington, but it would not be completed until 1922.

Formal efforts to memorialize Lincoln in Kentucky began in 1904, when the legislature established the Lincoln Monument Commission. The efforts of this group produced a statue of the seated Lincoln by sculptor Adolph Weinmen, dedicated in Hodgenville on May 31, 1909.

Knob Creek after the Lincolns

The rural nature of Knob Creek continued after Thomas Lincoln moved his family to Indiana in 1816. Lincoln's landlord, George Lindsey, was forced by the court to sell 230 acres of his tract to William Bush in June of 1831. One month later, a deed is recorded transferring the land from Bush to Charles Boon.

The heirs of Charles Boon sold two tracts of land at auction, containing 328 acres and 163 acres, respectively. Purchaser Nicholas A. Rapier was given title to the land on April 20, 1850. Rapier expanded his holdings when the heirs of Charles Boon transferred an adjacent fifty acre tract to him on April 17, 1858.

The heirs of Nicholas A. Rapier represent the next series of changes, though the land remained in the family. Charles H. Rapier purchased five-sixth interest in roughly 352 acres on February 5, 1891, from five heirs of N.A. Rapier. That same day, Frank X. Rapier acquired five-sixth interest in an adjacent 158 acre tract, from five heirs of N.A. Rapier. Sylvester Rapier & Co. received one-sixth interest in 380 acres on September 20, 1910, from F. Boone Rapier, who had inherited it from N.A. Rapier.

John W. Crady acquired full rights to the 380 acres in 1911 by way of a four-sixth interest from the heirs of N.A. Rapier on March 23; one-sixth interest from Sylvester Rapier & Co. on April 18; and one-sixth interest from Joseph C. Rapier on April 24.

In May 1918, Crady purchased an adjacent 62.5 acres from Robert and Blanche Enlow and G.W. and Lourena Baird. This adjacent tract was originally held by John J. Larue, and was sold after his death to James W. Larue on March 6, 1866. Larue sold a portion known as the “James Cap farm” to John O’Brian on July 11, 1877. O’Brian sold 125.86 acres to John Lavey on January 28, 1880. Lavey passed away in May 1913, and his son Charles purchased a four-sixth interest in the land from other heirs on August 14, 1915, along with the one-sixth interest he inherited. Lavey conveyed the title to his five-sixth interest to Nick Greenwell on April 15, 1916. Greenwell transferred his interest on the 125.86 acres to Robert Enlow and G.W. Baird on January 28, 1918. It is not known how Enlow and Baird received the remaining one-sixth interest on the 62.5 acre portion deeded to John W. Crady.¹⁶

LaRue County was created from Hardin County in 1843, with Hodgenville named as the county seat. The Knob Creek land was included in the new LaRue County. The land was apparently always dedicated to farming.

Growing Tourism

Federal Aid Road acts were passed in 1916 and 1921 to accommodate a growing number of automobiles. The turnpike adjacent to the farm, now Highway 31E, was paved in 1926, along with Highway 31W. These easily-traveled roads brought increasing numbers of tourists to LaRue

County and the birthplace memorial. With increased traffic and the reverence for Lincoln as strong as ever, more county residents began to capitalize on the Lincoln tourist trade. The Lincoln Trail was established in the 1930s as a way for travelers to follow the same route that the Lincoln family took through Kentucky, Indiana, and Illinois; part of the trail ran along Highway 31E and the Knob Creek farm.

Hattie Howell Howard was one of the many in the area seeking to both memorialize Lincoln and create a career in tourism. Hattie already had a family connection to Lincoln tourism. Her brother James R. Howell owned a successful restaurant and gift shop next to the birthplace memorial called the Nancy Lincoln Inn, which he operated until his death in 1957.

Hattie and her husband Chester bought 380 acres containing the original Knob Creek farm on August 26, 1931 from John W. Crady, along with Crady’s adjacent 62.5 acre tract. Chester Howard came from an established family that had founded Howardstown in 1833 and started a successful distillery supply store, the income from which provided the funds for the Knob Creek farm purchase.

The Lincoln Boyhood Home

At Knob Creek, the Howards planned a site that would serve both as a memorial to Lincoln and a business profiting from the growing tourist trade. They enlisted the help of Louis A. Warren, a historian and former editor for the *LaRue County Herald* in Hodgenville. Warren became an expert in all things Lincoln and searched local courthouse records for information with which to separate factual occurrences from traditional stories. The result of his efforts, *Lincoln’s Parentage and Childhood*, was published as a book in 1926. He argued that not only had the fertile bottomland of the

¹⁶ All deed information from Brown’s *Report on the Title of Thomas Lincoln*.

Knob Creek farm increased the prosperity of the Lincoln family, but that the landscape had had an impact on Lincoln's personality.¹⁷ Warren and Howard both argued that the Knob Creek site was tremendously significant, even more so than the birthplace site, because of Lincoln's personal remembrances of the farm. Warren wrote in *Lincoln's Parentage and Childhood*:

The Knob Creek home on the highway from Louisville to Nashville was the first home that Abraham remembered and the home which exerted the greatest influence on his young life. This site was the most picturesque of the three home-sites that Thomas and Nancy had occupied, situated as it was between the forks of Knob Creek, the fertile bottoms extending from the home in three different directions. The knobs of mountainous proportions, with their steep inclines to the creek-bed below, offered all that nature could provide to challenge the adventurous spirit of a growing boy.

The original Lincoln cabin at Knob Creek supposedly had been dismantled in the 1870s, reportedly by Steve Thompson and his son Robert. In 1895 a newspaper writer said that the logs from the original Knob Creek cabin were used by Charles Rapier to build a stable at his farm, later washed away by a flood. Thus, the Howards had to start anew. In 1931 they dismantled a single-pen log cabin thought to date from the early 1800s from the Gollaher farm, which was included in the land purchase. With the logs they constructed a cabin said to resemble Lincoln's. Their neighbor Robert Thompson, who said that he remembered the Lincoln family's cabin, assisted the Howards in the construction. The result was a one-room cabin situated near Highway 31E, with one door and window on the east wall, a fireplace on the north wall, and a small loft accessed via a peg ladder.



*Figure A-8 Postcard of replica cabin, undated
(KyGenWeb Special Collections)*

The Tavern

Construction on an adjacent building was begun soon after the cabin was completed. Meant to accommodate visitors' requests for refreshments at the site, this tavern, reportedly built with logs taken from the farm's forests, cost \$4,200 to build and also had gas pumps to serve the tourist trade.



*Figure A-9 Tavern, undated but presumed c. 1933
(photo courtesy of Mary Brooks Howard)*

The tavern consisted of a large room on the first floor, with public restrooms and a

¹⁷ Sculle, 27.

kitchen. Upstairs were three rooms and a private bathroom, which served as the residence of the site manager. The site was operated as Abraham Lincoln's Boyhood Home.

In 1934 a nightclub was established in the tavern. Open from late April to late October, live entertainment and dancing were events enjoyed by tourists and locals alike. This use provided additional revenue to the site, until LaRue County prohibited liquor sales in November 1942, at which time the nightclub closed. Under the management of Fred Howard, the tavern was converted to a museum and gift shop in the early 1950s. Howard purchased local historical artifacts for display in the cabin and tavern, including a slave trap, arrowhead collection, guns, tools, household artifacts from Lincoln's era, and other Americana.¹⁸ Kentucky crafts were sold in the gift shop, along with souvenirs. Hattie and C.F. Howard officially sold the site with 200 acres to Fred Howard on October 20, 1964.



Figure A-10 Photo of tavern bar, undated (photo courtesy of Mary Brooks Howard)

Site Managers

The Howard family administered the site for seventy years, usually with the manager living in the quarters above the tavern. Hattie and Chester's son Paul Howard managed the site starting in 1932, when he graduated from the University of Kentucky; he was the only manager not to live on-site. Helen Howard Peake, the eldest daughter of Hattie and Chester, managed the site in two separate periods between 1935 and 1949; Millburn Howard, the next son, also managed for a time. Nell and Earl W. Everly, the only non-family managers, came in 1940. Fred Howard, the youngest son of Hattie and Chester, began managing the site in 1950; his wife Mary Brooks Howard assumed management duties upon his death in 1980.

Growing Significance

The Boyhood Home became a successful tourist site and began to garner recognition for its significance in Lincoln's life. Beginning in 1942, the Boy Scouts used the site as a stopping point on their Lincoln Heritage Trail from Elizabethtown to Hodgenville. Stanley Kubrick's film, *Mr. Lincoln*, was shot in part at the picturesque Knob Creek farm in 1952; the site also served to represent the Indiana frontier in the film. In 1958 the Boyhood Home was included in a re-enacted trip of the Lincoln family's journey from Hodgenville to Indiana.

Changing Hands

Mary Brooks Howard, daughter-in-law of Hattie and Chester Howard, tried to sell the site in 1981 and 1985 for an asking price of \$1 million. The highest offer received was \$250,000. Low visitation was part of the reason for the attempted sale. In 1985 only 16,283 paid visitors were recorded at the Boyhood Home, while 300,000 visited the Birthplace National Historic Site in Hodgenville.

¹⁸ Ibid, 40.

When no better offers were made, the site and its contents were put up for auction. On January 11, 1986, a group of Howard family members submitted the top bid for the site and contents together at \$120,500, after no bids were submitted for the property or contents separately. The family members established Lincoln Boyhood Home, Inc., with fifteen members. They officially re-opened the site on April 1 of that year, after some cleaning and painting work. Fabian Howard, the son of Fred and Brooks, took over management duties. The group also built an open picnic pavilion and log restrooms. It was then estimated that 30,000 to 40,000 people visited the Boyhood Home site annually.

National Register Nomination

Under the management of the Lincoln Boyhood Home, Inc., a new nomination of the site to the National Register of Historic Places was submitted in 1988. The first nomination attempt in 1981 had been unsuccessful. In that nomination, the period of significance had been listed as Lincoln's boyhood, though the site did not actually contain any structures from that period. When the nomination was reworked to highlight the site's prominent role in LaRue County tourism and its stature as a monument to Lincoln, the nomination was successful. The Boyhood Home site was officially listed on the National Register of Historic Places as a district on October 4, 1988. The cabin and tavern are the two contributing buildings, while a modern pavilion (c. 1988) and shed (c. 1950s) are listed as non-contributing.

A Secure Future

Though the Howard family had reacquired the property, they were concerned about the long-term future of the Boyhood Home site. Offers to buy the site had come from philanthropist Philip R. Jonsson and author Judy Potts, but the family had refused, favoring a more stable preservation of the

site, preferably with the National Park Service. A group called the Friends of Abe Lincoln formed to lobby for legislation to allow the Park Service to accept the property if it were donated. Congress authorized the acquisition of the site on November 6, 1998, with the stipulation that it be accepted by donation only. Various state and local organizations contributed funds to the cause, including a \$500,000 appropriation in the Commonwealth of Kentucky's 2001-02 budget authorized by Governor Patton. The land was purchased by a group called Preservation of Lincoln's Kentucky Heritage, Inc., for \$1 million. The site was then donated the National Park Service as stipulated in the authorization. The NPS officially assumed management duties on November 6, 2001, when it became a unit of Abraham Lincoln National Historic Site (ABLI). The dedication ceremony took place on February 12, 2002.

ABLI Boyhood Home Unit

The earliest letters of report written by NPS staff after the 2002 transfer indicated moisture problems in the tavern and cabin, and suggested stabilization work. This work was accomplished in September 2003. In October 2004, a ground-penetrating radar survey was undertaken in an attempt to locate features from the Lincoln period, such as privy pits, wells, trash dumps, or the original cabin site. Thirteen grids were studied by a crew from NPS SEAC, covering 10,017 square meters. Unfortunately, no significant features were located.



Figure A-11 Boyhood Home site, December 2005

In 2003 work was begun on a new General Management Plan for ABLI. Public meetings were held in November of that year, and the majority felt that the natural and historic landscape was the primary value at the Boyhood Home unit. Alternatives were published in a newsletter in fall 2004, with a draft GMP and environmental impact statement due in 2006. Alternative A is referred to as the “no action alternative.” Alternative B considers rehabilitation of the tavern for visitor services and park operations, restoration of the cabin, and marking of the original cabin site if it is located. Alternative C builds on Alternative B, but opens the cabin to the public, and adds more trails, restrooms, signs, and picnic tables. Alternative D considers removal of the tavern and replacement with a modern visitor information building, and construction of an “outdoor pioneer lifestyle exhibit.”

A small office was placed at the site between the cabin and tavern, and is staffed from April thorough the last week of October. Though the tavern and cabin are both currently closed to the public, visitors are welcome at the site. Like Louis Warren and the Howard family, the NPS brochure for the Knob Creek site places significance in the landscape and location, stating that young Abe would have experienced a

diversity of both nature and ideals at the Knob Creek Farm.

Other Studies

Two additional studies provide a wealth of information about the Boyhood Home site. Keith Sculle’s 2005 article “The Howard Family Legacy at the Knob Creek Farm” provides insight into the daily operations of the site under the Howard family management. In 1998 Kent Brown completed a study on the land titles of Thomas Lincoln, including information from tax records and court records, which confirm the Lincoln family’s ties to the site.

B. CHRONOLOGY OF DEVELOPMENT AND USE

Initial Construction and Early Operation

Construction of the Lincoln Tavern began in 1931, three years after Hattie and Chester Howard purchased the Knob Creek farm. The Howards had completed the construction of a replica cabin on the property in 1930, and visitors began to request a place for refreshments.¹ A family tradition, as reported by Milburn Howard, holds that an architect or builder had prepared a set of plans for the tavern. Chester Howard rejected the design, however, and proceeded with his own. Family lore also says that the logs for the building were reportedly harvested from trees on the property. The tavern, completed in 1933, offered a restaurant as well as gas for travelers. Early photographs, including one dated 1933 (Figure B-1) and an undated photograph in the possession of Mary Brooks Howard (Figure B-4), indicate a split wood shingle roof. The site, including the cabin and the tavern, was operated as Abraham Lincoln's Boyhood Home by the Howard family.



Figure B-1 Cabin and tavern looking west, September 23, 1933 (photo by Beuer)

The tavern consisted of one large room on the first floor, called the dance hall or

simply the hall. A stone fireplace was at the south wall of the hall, and two alcoves at opposite ends of the east wall flanked an exterior entrance porch. Double sash doors gave entry to the hall from the sheltered front porch. Double-hung wood windows in groups of two or three provided natural light. An awning window was situated high on the wall on both the north wall and the west wall, near the northwest corner. Undated, but presumably early family photographs of the interior reveal that very early on a bar was in place near this corner of the hall. The bar reportedly was used originally in the Seelbach Hotel in Louisville.² The flooring was milled, tongue-and-groove pine, and columns, beams, and joists were exposed round logs. The log structure of the building was exposed in the interior rooms of the first floor, and sticks mounted on the wall of the hall provided for hanging displays such as guns and other artifacts. Overall, the interior of the hall and the exterior of the tavern reflected a rustic appearance compatible with the adjacent cabin and rural setting.



Figure B-2 Photo of bar on west wall of hall, undated (courtesy of Mary Brooks Howard)

¹ Keith Sculle, "The Howard Family Legacy at the Knob Creek Farm," *Journal of the Abraham Lincoln Association* (Vol. 26, No. 2, 2005), 33.

² Millburn Howard, interview with Joseph K. Oppermann, FAIA, 10 March 2006.

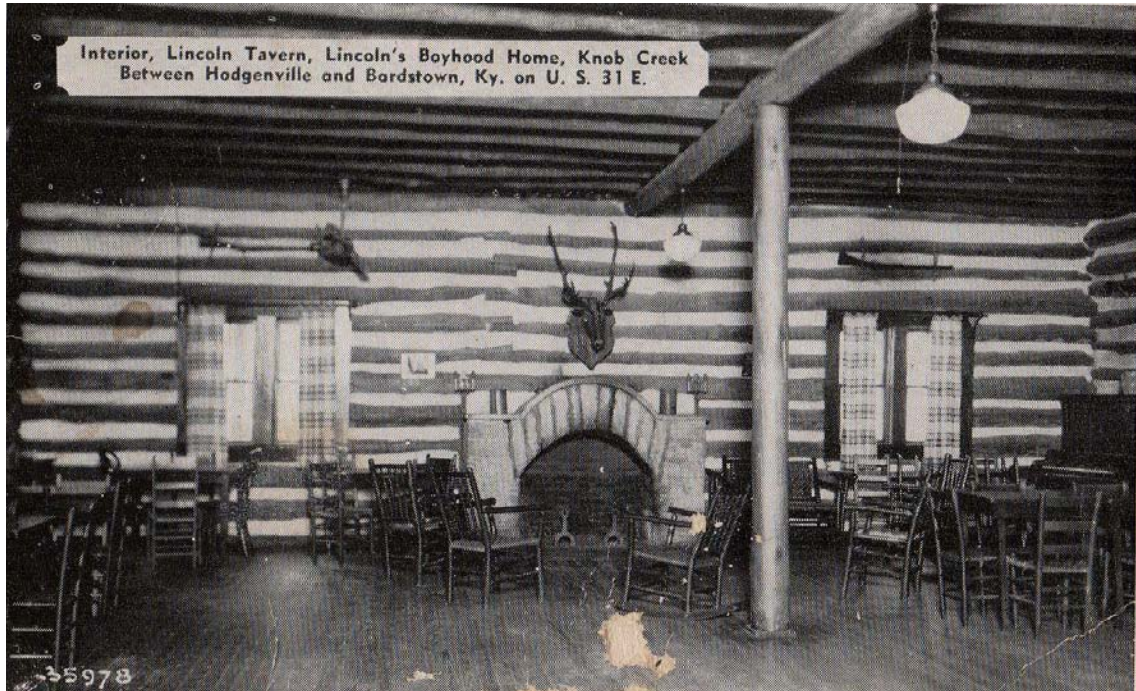

*Figure B-3 Postcard of the Lincoln Tavern Interior, undated
(from "The Howard Family Legacy at the Knob Creek Farm" by Keith A. Sculle)*

Men's and women's restrooms as well as a kitchen were accessed at the west wall of the hall, through varnished five-panel doors. These rooms had linoleum tile flooring and, like the hall, had exposed log walls and ceilings. A sash door in the kitchen served as a back entrance to the building, leading to a screened-in porch.

A partial basement was accessed from the kitchen and extended under the central portion of the large hall. A gas furnace in the basement provided heat for the building. Water service was provided from a well, and there was a water pump and propane water heater in the basement. A sump pump was in the southwest corner of the basement, at the foot of the stairs to the kitchen; a bullfrog was known to live in the sump for many years.

The upstairs rooms typically served as the residence of the manager of the Boyhood Home site and were accessed by a wood staircase from the kitchen. Three main rooms were lit by dormer windows, and a

bathroom was located in the gable end above the kitchen. Double-hung windows, the same as those used in the first floor, were used in pairs or alone. These residential rooms had tongue-and-groove pine flooring, and random sized wood wall studs and ceiling framing, sheathed with fiberboard panels. Fiberboard, made of organic material, usually from wood products, became readily available in the early twentieth century. It was also relatively inexpensive and became a popular interior surface material during the Great Depression.



*Figure B-4 Southeast oblique of tavern, undated
(courtesy of Mary Brooks Howard)*

The fiberboard wall surfaces of the second floor were likely with wallpaper soon after construction, if not from the time of initial construction. Several generations of wallpaper are still in place on the walls; Brooks Howard reports that they all were installed prior to 1950.

1950s: Conversion to Gift Shop

Fred Howard began to manage the site in 1950, eventually resulting in the longest tenure of any site manager. Fred and his wife Mary Brooks Howard lived in the quarters on the second floor of the tavern from June of 1950 until October 1953, when their son was born. Under Fred's management, the tavern was converted to a museum and gift shop in the early 1950s. The wood entry porch was replaced with concrete, and new composition shingle roofing was installed. New beech flooring was installed in the hall; it was mopped with red oil periodically as a finish. The bar's mirror was removed, though the cabinets remained. A paneled stud wall was constructed to enclose one of the hall alcoves, which functioned as an office. An L-shaped counter was also built near the door to receive visitors. Spotlights were installed in the hall c. 1955, to supplement the original schoolhouse globes suspended along the center beam of the room.



*Figure B-5 East elevation of tavern, undated
(courtesy of Mary Brooks Howard)*

Fred Howard also improved the residential spaces of the tavern. The kitchen cabinets and peninsula were installed in the 1950s, as was the shower and tub in the second-floor bathroom.

In 1953 the furnace in the tavern failed. The following year two ceiling-mounted kerosene heaters were installed in the hall and the old furnace was left in place.

After Fred Howard's death in 1980, his wife Brooks assumed management duties at the Boyhood Home site. She directed the installation of a concrete ramp at the front porch for handicapped accessibility.

1986: New Ownership

The Boyhood Home site was sold at auction in January 1986 to a group of Howard family members, who formed the Lincoln Boyhood Home, Inc. Fabian Howard served as the on-site manager and lived in the north room of the second-floor quarters; the other two rooms were used for storage. Fabian used a kerosene heater in his small quarters. The family enclosed the screened-in porch on the west side of the tavern with rough-cut vertical board siding in 1988, at which time the exterior pavilion was also constructed. Fluorescent lighting was installed in the hall. Sheet vinyl was installed in the two first-floor restrooms.

In 1998, the group hired a roofer to install new composition shingle roofing on the tavern.

2001: National Park Service

After transfer of the site to the National Park Service in late 2001, stabilization work was the first priority. In September 2003, interior bracing was added in the hall to support the second floor. In addition, the original front doors were placed in storage and solid wood doors installed in their place. The original pendant light fixtures in the hall

were removed, and temporary lighting was installed.

Several items were removed from the tavern in 2004 by the Howard family, at the request of the NPS. The bar was removed, along with artifacts including tools, guns, and traps. The Howard family is still in possession of these artifacts and is considering their sale.



Figure B-6 View of added bracing inside hall, 2005

Chronology

- 1778 Thomas Lincoln, Abraham's father, is born in Virginia to Abraham and Bersheba Lincoln.
- 1782 Thomas Lincoln moves to Jefferson County, Kentucky, with his parents.
- c. 1796 Thomas Lincoln moves to Elizabethtown, Kentucky.
- 1801 Thomas Lincoln purchases and settles on land in Cumberland County, Kentucky.
- 1806 Thomas Lincoln marries Nancy Hanks.
- 1807 February 10 Sarah Lincoln is born to Thomas and Nancy Lincoln.
- 1808 December Thomas Lincoln purchases and relocates to the Sinking Spring farm in LaRue County, Kentucky.
- 1809 February 12 Abraham Lincoln is born at Sinking Spring farm to Thomas and Nancy Lincoln.
- 1811 A dispute over the Sinking Spring land title forces the Lincoln family to move to Knob Creek farm when Abraham is two years old. Thomas Lincoln did not buy this land; rather, he leased 30 acres from the owner, George Lindsey.
- c. 1811 A son, Thomas, is born to Thomas and Nancy Lincoln; he dies in infancy.
- 1815 Thomas Lincoln unsuccessfully tries to buy Knob Creek farm. Litigation regarding the title to Sinking Spring continues.
- George Lindsey, Thomas Lincoln, and other leaseholders are served with a notice of ejection from the Knob Creek land by people in Pennsylvania with a prior claim. The matter goes to court, and Lindsey prevails. The Lincolns are allowed to stay as the "tenant in possession."
- 1816 Lincoln family leaves Knob Creek farm after the court finds that Thomas has no claim to the Sinking Spring land. The Lincolns and their two children move to Spencer County, Indiana, where recent surveying has made land titles more stable.
- 1818 October 5 Nancy Lincoln dies.
- 1819 December Thomas Lincoln marries Sarah Bush Johnston.
- 1830 The Lincoln family moves to Illinois.

- 1831 Abraham makes his home in New Salem, Illinois, where he reads law and keeps a store.
- 1832 Lincoln is defeated in his first bid for the state legislature.
- 1833 The Howard family founds Howardstown, Kentucky, where they own a store for distillery supplies.
- 1834 Lincoln is elected to the Illinois state legislature.
- 1836 Abraham Lincoln is admitted to the bar, having been completely self-taught.
- 1837 Lincoln moves to Springfield, Illinois.
- 1847 Lincoln begins a single term in the United States House of Representatives.
- 1854 The Missouri Compromise is repealed, heightening the growing tension regarding slavery.
- 1856 Lincoln joins the newly formed Republican Party.
- 1858 Lincoln is nominated as Republican candidate for the Senate from Illinois. He debates Democratic opponent Stephen Douglas over the slavery issue.
- 1860 Lincoln is nominated as the Republican presidential candidate.
- December 20 South Carolina is the first state to secede from the Union.
- 1861 January-
March 4 Alabama, Florida, Georgia, Louisiana, Mississippi, and Texas secede from the Union.
- March 4 Abraham Lincoln assumes office as President.
- March 4-
November Arkansas, North Carolina, Tennessee, and Virginia secede from the Union.
- 1863 January 1 The Emancipation Proclamation is issued.
- c. 1865 Tradition states that Abraham Lincoln's birthplace cabin at Sinking Spring farm is dismantled and the logs are used in a nearby house.
- 1865 April 9 Confederate General Robert E. Lee surrenders to Union General Ulysses S. Grant at the Appomattox courthouse in Virginia.
- April 14 President Lincoln is shot by John Wilkes Booth on Good Friday at Ford's Theater in Washington, D.C.

- April 15 Abraham Lincoln dies in a house across the street from the theater.
- 1867 Congress authorizes Lincoln Memorial Association to raise funds for a monument in Washington, D.C.
- c. 1870 Tradition states that Lincoln's Knob Creek cabin is torn down.
- 1874 The first Lincoln monument—a tomb marker—is dedicated in Springfield, Illinois.
- 1889-1890 Several books on the life and legacy of Abraham Lincoln are published.
- 1896 A cabin reputed to be the original Sinking Spring cabin is exhibited at Tennessee Centennial Exposition and New York's Central Park.
- 1904 The Lincoln Monument Commission is established by the Kentucky legislature.
- 1905 Robert Collier purchases the Sinking Spring farm at a public sale and establishes a nonprofit Lincoln Farm Association to construct a memorial there.
- 1909 February 12 President Theodore Roosevelt lays the cornerstone of the memorial building designed by John Russell Pope at Lincoln's birthplace site.
- May 31 A statue of Lincoln by sculptor Adolph Weinman is dedicated in Hodgenville, Kentucky.
- 1911 November 9 The completed memorial building is dedicated by President William Howard Taft.
- 1920 James R. Howell builds Nancy Lincoln Inn next to the birthplace site and memorial building.
- 1922 The Lincoln Memorial in Washington, D.C., is dedicated.
- 1926 Highway 31E opens and increases tourism in Kentucky.
- Historian Louis A. Warren publishes a book on the life of Abraham Lincoln.
- 1928 Hattie Howell Howard and her husband Chester purchase 380 acres including the Knob Creek farm.
- 1930 The Howards move to a farmhouse across from Knob Creek site.

- 1931 The Howard family constructs a replica of Abraham Lincoln's boyhood home cabin using logs from the Gollaher cabin under the guidance of Robert Thompson, who remembers the original cabin. They begin to operate the Knob Creek site as a tourist destination known as Abraham Lincoln's Boyhood Home.
- Because visitors to the cabin frequently request refreshments, the Howards begin construction of a tavern.
- 1932 Son Paul Howard begins to manage the Boyhood Home property.
- 1933 The birthplace Memorial Building at Sinking Spring Farm is acquired by the National Park Service.
- The tavern, including a restaurant and gas station, opens to the public.
- 1934 A nightclub with live entertainment and dancing opens in the tavern.
- 1935 Helen Howard Peake takes over management of the Boyhood Home.
- 1939 August 11 Abraham Lincoln's birthplace is named a National Historical Park.
- 1940 The Boyhood Home is managed by Nell and Earl W. Everly.
- 1942 Boy Scouts begin to use the site as a halfway stop on the Lincoln Heritage Trail from Elizabethtown to Hodgenville, Kentucky.
- 1942 The nightclub is closed when liquor sales are prohibited in LaRue County.
- 1950 Fred Howard takes over management. The tavern is converted to a museum and gift shop.
- A new beech floor is installed in the hall, on top of the original wood floor.
- The bar's mirror is removed.
- The wood front-entrance porch is replaced with a concrete porch.
- New composition shingle roofing is installed.
- A shower and tub is installed in the private bathroom on the second floor.
- 1952 Stanley Kubrick films part of *Mr. Lincoln*, a biographical movie, at the Boyhood Home site.
- The southeast alcove in the hall is partitioned off with a new paneled wall.

- New cabinets, counters, and peninsula are installed in the kitchen.
- 1953 The original gas-fired heater fails.
- 1954 Two gas-fired unit heaters are installed in the hall, suspended from the ceiling.
- 1955 c. Additional lighting in the form of tear-drop pendants is added in the hall.
- 1958 The Boyhood Home is included in a reenacted trip of the Lincolns' journey from Hodgenville, Kentucky, to Indiana.
- 1959 September 8 Lincoln's birthplace is named Abraham Lincoln National Historic Site.
- 1966 October 11 Abraham Lincoln National Historic Site is listed on the National Register of Historic Places.
- 1980 Fred Howard's wife, Mary Brooks, begins management of the Boyhood Home after his death.
- 1981 Knob Creek's nomination to National Register fails because the site contains no original buildings from Lincoln's boyhood, the declared period of significance.
- Brooks Howard unsuccessfully tries to sell the site, asking \$1 million.
- 1982 Concrete ramp added to front entrance porch.
- 1985 16,283 paid visitors come to the Boyhood Home, while 300,000 visit the nearby birthplace.
- 1986 January 11 The Boyhood Home site and contents are put up for auction; a group of Howard family members submits the highest bid of \$120,500 for both.
- April 1 The Boyhood Home reopens. Julian Howard, Fred and Brooks's son, manages the site.
- 1988 Lincoln's Boyhood Home is listed on the National Register of Historic Places for its significance to LaRue County tourism.
- A picnic pavilion and log restrooms are built on site.
- Original screened porch at west side of tavern is enclosed.
- Sheet vinyl flooring is installed in the first-floor restrooms.
- 1998 Composition shingle roofing is installed at the tavern, along with new galvanized steel gutters and downspouts.

C. PHYSICAL DESCRIPTION

General Description

The Lincoln Tavern is a one-and-one-half story, five-bay log building built in 1932-33 as part of a site commemorating Lincoln's boyhood home. The building faces southeast towards Highway 31E and was sited to complement the adjacent replica log cabin and to attract tourists. Generally unaltered, the exterior is unhewn logs with saddle- and V-notching with cement chinking set on a foundation of hollow core concrete block. The main block has a composition-shingle hipped roof with projecting one-story front-gabled end bays, two gable dormers at the front, two at the rear and a gable dormer at each side. On the south side is a prominent limestone block chimney.



Figure C-1 Tavern from the southeast

Across the three central bays of the main (east) façade is a one-story shed porch supported by unhewn log posts and flanked by the projecting side bays. The porch floor was replaced with concrete in the 1950s, and a concrete handicap ramp was added in about 1982. The central entrance has replacement double doors installed in 2003. Windows of the main block are triple, paired, and single window units of double-hung, four-over-four sashes. These double-hung, four-over-four light window units appear in the gable dormers and on all

facades with the exception of eight-light awning sashes in two windows near the northwest back corner and a modified four-light fixed sash in a south-facing dormer over the stairs.

Projecting from the rear façade is a one-and-one-half-story gable wing with interior brick chimney; attached to the south of this gable wing is a one-story shed wing containing public restrooms, and a one-story shed porch, now enclosed. The enclosed porch has vertical board siding and a metal roof. All the other roofing materials are composition shingle. The exterior windows consist of pairs of the original double-hung, four-over-four sash units, some of which have been modified, and a modern aluminum sash unit in the 1988 enclosure of the porch.



Figure C-2 Tavern from the southwest

Inside the main block is a large open room built as a tavern for tourists and local residents. The interior retains its exposed logs and exposed round log ceiling joists. A row of log posts supports the central ceiling beam; the posts are supplemented by temporary diagonal 4 by 4 braces, installed in 2003. On the south wall is an arched fireplace of limestone blocks with a poured-in-place hearth. In the early 1950s the beech

floor was installed on top of the original wood floor, and the south gable bay was partitioned with pine board paneling to create an office space. The tavern had served as a local “watering hole” until LaRue County’s 1940s prohibition against liquor sales led to its conversion to a museum and gift shop. In 2001 the property was donated to the National Park Service, which closed the commercial operation. In 2004 at the request of the NPS, the previous owners removed the wood bar from along the west wall of the room, along with the many pioneer-era artifacts that hung on the walls and from the display canopies.

In the rear gable ell is a kitchen with stairs to the basement mechanical room and another run of stairs to the second floor. The kitchen was updated in 1952 with the addition of a peninsula, countertop, and cabinets extending from the center of the north wall and a countertop with double-sink and cabinets added to the west wall at the southwest corner of the room. A door, the original rear exterior door, leads from the kitchen to the former porch, originally screened but enclosed in 1988. The new room retains the porch’s original concrete floor.

The upper story has three rooms and a private bathroom in the rear ell, built for residential use by the original owners. The two southernmost rooms were later used as supply rooms for the gift shop; only the north room remained in residential use. The building is currently vacant.

Construction Characteristics

Structural Systems

Foundation Walls & Piers: The foundation walls and piers are cast-in-place concrete. The cast-in-place concrete walls are topped with two courses of eight-inch concrete masonry units. The masonry units are a

“panel” type 8 inches high by 16 inches long by 4 inches deep; the exposed face has smooth surfaces, the four perimeter edges chamfered to form a raised panel 6 inches high by 14 inches long.



Figure C-3 Concrete masonry units and vent

Cast iron vents with a diamond-pattern grille measuring 8” by 14” are located periodically at the perimeter of the crawl space, taking the place of one concrete masonry unit. A coal scuttle is located on the west elevation of the rear ell.



Figure C-4 Basement interior showing cast-in-place concrete and concrete masonry units

Exterior Walls: In the original building (except the south and west walls of Room 105, an early screened-in porch enclosed in ca. 1988), logs stripped of their bark are stacked horizontally and joined at

intersecting walls using the sharp notch style of log construction. Samples taken randomly from several of the logs identified the wood species as yellow poplar (*Liriodendron tulipifera*).



Figure C-5 Log joinery and chinking

Small sections of limestone approximately one half inch wide by varying lengths are set in a diagonal pattern as the “stone chinking” or “filler” between the logs.

The “mud chinking” or “mortar chinking” is a sand and Portland cement mortar troweled over the filler to close the gaps between the logs.



Figure C-6 East-facing dormer

The dormers are formed with conventional stud framing and sheathed on the sides with well-worn, wood shingles that are probably

original. The gable ends of the dormers are formed with logs stacked horizontally.

The exterior walls of the storage room, Room 105, are comprised of conventional framing sheathed with rough-cut boards set vertically in a modified board-and-batten manner, as shown in the detail drawing below.



Figure C-7 Vertical board siding

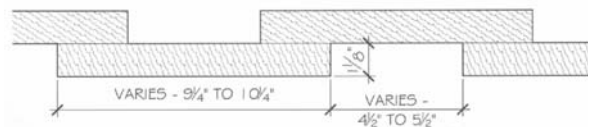

Figure C-8 Vertical board siding detail drawing

Flooring Systems: The first floor framing of the building consists of 2" by 7 1/8" deep joists spaced at 16" on center.

The floor of the basement room is a poured-in-place concrete slab, as is the floor of the storage room, Room 105. The concrete floor of the storage room is the floor of the former screened-in porch. The previous owners believe both floors to be original features of the building.

The porch deck of the front entrance porch is poured-in-place concrete. It was installed in the early 1950s when the original wood porch deck was replaced.

The second floor above Room 102 is supported by a spine of posts and beams extending north-south the full length of the room. The posts are 10 inches in diameter set approximately 16 feet apart. The beams consist of 10 inch diameter round logs. This spine supports the second-floor framing of 6 inch to 8 inch diameter log joists spaced at 24" on center. Similar log joists spanning north-south support the second floor above the kitchen.

In 2003 the National Park Service added a temporary framing system of 6" by 6" conventional lumber to provide supplemental support to the beams of the spine in Room 102.



Figure C-9 Log joists, beams, and posts, with modern temporary supports

Roof Framing: The roof structure of the original building consists of wood sheathing supported by 1 5/8" by 5 1/2" deep rafters spaced 24 inches on center. Many of the sheathing boards appear to be recycled material. Most of the roof framing and deck are concealed by fiberboard and cardboard materials nailed to the underside of the rafters.

The roof structure of the screened-in porch, now the storage room, consists of apparently salvaged deck boards of random widths supported by conventional framing with

rafters measuring 1 1/2" by 5 1/2" set 24 inches on center.



Figure C-10 Rafters and sheathing visible in attic

Exterior Features

Roof and Rainwater Collection/Dispersal:

The roofing material of the original building is composition shingle installed in 1998.

A modern, steel-panel roofing material is on the storage room. This roofing material was installed in 1988 when the screened-in porch was enclosed.

Aluminum flashing is used at the dormers and the secondary chimney at the back of the building that vented the basement furnace. The galvanized flashing at the primary chimney located on the south elevation appears to have been retained from a previous roofing campaign.

The machine-formed, half-round gutters and round downspouts are made of galvanized steel. They were installed in 1998 when the current composition shingle roof was installed. Remnants of the previous gutters

and downspouts of same design and material are stored in the hall.



Figure C-11 Composition shingle roofing and galvanized steel gutters and downspouts

Chimneys: The building has two chimneys. One is relatively small, straightforward in design, and easily unnoticed at the rear of the tavern. Its purpose, strictly utilitarian, was to vent the basement furnace. Set inside and against a section of the building's west wall, it rises directly through the kitchen, Room 101, and the attic kneewall space of the bathroom above, Room 201, exiting on the north side of the gable roof. Made of an early twentieth-century, red-brown, pressed brick, it is just two bricks wide in both directions, measuring approximately 1'-5" by 1'-5", as it rises some three feet above the roofline without variation of its simple rectilinear form. It is capped with a simple metal rain diverter.



Figure C-12 Brick chimney at kitchen

The other chimney is large, handsomely proportioned in its massing, and prominently located on the exterior of the south elevation, highly visible to travelers along the adjoining highway. It is a major architectural feature inside the tavern as well, where it provides a large fireplace at the center of the south wall of the hall, Room 102. The chimney is constructed of broken-face blocks of limestone in irregular sizes, measuring from 5" to 7" in height and from 10" to 19" in width. The footprint of the base measures 4'-10" by 7'-3". As it approaches the roof the chimney tapers to approximately 4'-0" wide. A corbelled row of stones accentuates the top.



Figure C-13 Limestone chimney on south wall

Fascia Boards: The fascia board of the original building is a plain, unmodified plank board measuring 1 1/2" by 5". The fascia board of the shed addition is also a plank board; it measures 1 1/2" by 6 1/2". None of the fascia boards appear to have had trim.

Walls: The stacked round logs of the original building's exterior walls not only serve as part of the structural system but also, exposed as they are, constitute the exterior appearance.

The exterior stud walls enclosing the storage room, Room 105, are sheathed with two rows of overlapping, plank boards. Set in a vertical pattern, the rough-cut, square-edged boards of each row measures from 9 ¼" to 10 ¼" by 1 ⅛". The boards of the outer row are spaced approximately 4 ½" to 5 ½" apart, each gap exposing the face of a plank board of the second row.

Doorways: The main entrance doorway is located off the porch at the center of the east elevation. The doorway is framed for double doors. The current wood slab doors (also called flush doors) and door framing were installed by the National Park Service as a security measure in 2003. Each door measures 2'-9" wide by 6'-8" tall by 1 ¾" thick.



Figure C-14 Modern front doors

The original sash doors are in generally good condition and are stored in the hall, Room 102. Each door measures approximately 2'-10" wide by 6'-9" high by 1 ⅜" thick. Though the doors are now painted, it appears that they were originally varnished.



Figure C-15 Original front door, stored in the hall

A secondary doorway is at the rear of the building. It is located in the west exterior wall of the storage room. It is a modern, metal door unit installed in 1988 when the screened-in porch was enclosed to become the current storage room. Its six-panel door measures 3'-0" wide by 6'-8" high, with modern casings.



Figure C-16 Original rear doorway in kitchen

It should also be noted that the original rear doorway, which exits from the south side of the kitchen, is still intact. The door is a

six-light sash door with three panels below, now painted to obscure the glass. It became an interior doorway when the screened-in porch into which it exited was enclosed.

The door casing of the two original exterior doorways is made up of plank boards measuring $4 \frac{3}{4}$ " by $\frac{3}{4}$ ". The casing is assembled so that the head casing sits square above the side casings. There is no evidence of trim pieces having been present.

Windows: The window units of the original building are wood. Some consist of a single sash; these always occur as a single window unit apart from other windows. Other window units consist of double-hung sash; these occur as a single unit, paired units separated by a mullion, or three units divided by two mullions.



Figure C-17 Paired double-hung unit

The window muntins of the double-hung sash window units appear in three variations, the variation based on the width of the flat center field of the interior section. Two muntin types typically appear in each sash of the double-hung sash units.

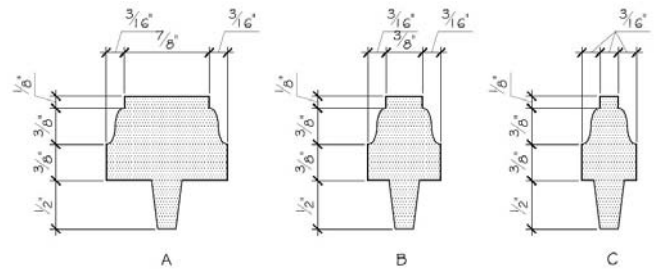

Figure C-18 Muntin details

The single sash window units have just one muntin type. The two, single-sash window units of the first floor hall have the Type B muntin. These sashes are hinged at the top, and swing inward. The single-sash, window unit on the second floor above the stair landing was a four-light sash that now is a one-light version. This fixed sash was not accessible to determine the original muntin type.



Figure C-19 Single sash awning unit

Porches: The inset front porch is framed on the sides by two small projecting corner pavilions to the north and to the south, and above by the low sloping roof extending from the east exposure of the building's hip roof. Measuring approximately 40'-0" in width and 8'-0" deep, the porch is centered on the symmetrical east elevation, the building's most prominent façade, the one

facing towards the highway. The original wood deck was severely deteriorated by the early 1950s when the current poured-in-place concrete porch was installed.

Other Features: A poured-in-place concrete wheelchair ramp is located on the south end of the main entrance porch. It was added in 1982. It does not meet current design standards.

In the chinking above the main entrance doorway, are two round imprints. Both are three inches in diameter. Both are reversed images. The one to the south reads, "SOUVENIR PENNY OF CHICAGO"; the other reads, "LINCOLN ESSAY MEDAL AWARDED TO."



Figure C-21 Early light fixture on east façade



Figure C-20 Imprint above main entrance doorway

Two wall-mounted incandescent light fixtures were mounted on the east façade of each projecting pavilion. One was placed on each side of the triple grouping of window units. Portions of these early, if not original fixtures, remain; other remnants are stored in the hall, Room 102.

Interior Features

Room 001: This, the single basement level room, is immediately below the kitchen (Room 101) and part of the hall (Room 102.) It measures approximately 18'-7" wide by 31'-0" long and houses the mechanical and electrical equipment for the building.

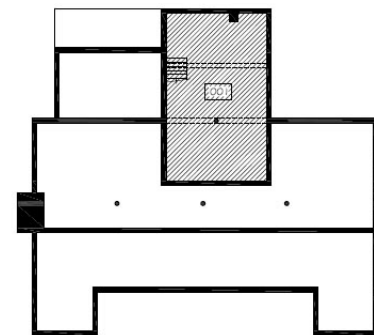

Figure C-22 Basement plan with Room 001 shaded

- **Flooring:** The floor is a poured concrete slab that dates to the original construction of the building.
- **Walls:** Poured-in-place concrete topped with two courses of architectural concrete masonry units constitute the perimeter walls

of this room. These walls also form the foundation walls for three sides of the kitchen (Room 101).

- *Doors:* A set of wood stairs along the south wall leads to the sole doorway, connecting with the first-floor kitchen.
- *Windows:* There are no windows in this room.
- *Ceiling:* The underside of the first-floor joists and flooring constitute the ceiling. The height from the top of the concrete slab to bottom of the first-floor joists is approximately 6'-0".
- *Baseboards:* No baseboards are present.
- *Finishes:* There are no finishes applied to the concrete flooring slab, concrete walls, or wood first-floor joists/underside of floor boards.



Figure C-23 Room 001, looking northwest

- *Mechanical Systems:* A gas-fired, unit heater is suspended from the floor joists above near the center of the room. Galvanized vent pipe connects to the brick flue. When the heater failed in 1953, it was abandoned in place.

Near the center of the room a metal grille is installed in the first-floor flooring above. The grille measures 1'-2" by 1'-4". A

second floor grille measuring 2'-8" by 2'-8" is located further east. The purpose of these grilles was to allow heated air to rise to the rooms above.

- *Electrical Systems:* Electrical service enters the building from a service line to the northwest. A panel box is located on the north wall near the northwest corner.

The electrical wiring is surface mounted. Most of it appears to be original. Some wiring recently installed by the National Park Service in 2003 provides temporary service. Utility lights mounted on the bottom of the floor joists above provide the lighting of this room.



Figure C-24 Room 001

- *Plumbing Systems:* A water heater is located along the west wall, next to the brick chimney flue.
- *Other Features:* A brick flue for venting the furnace is located adjacent to the west wall. The footprint of the flue is approximately 1'-5" by 1'-5".

A sump pump and pit are located near the southwest corner of the room.

A mobile dehumidifier installed by NPS is currently located near the center of the room and drains to the sump pump pit.

Room 101: The kitchen is square in plan and measures approximately 20'-0" by 20'-0". The height of the room from floor to bottom of exposed ceiling joists is 10'-6". The kitchen is located outside of and centered on the west wall of the hall, Room 102.

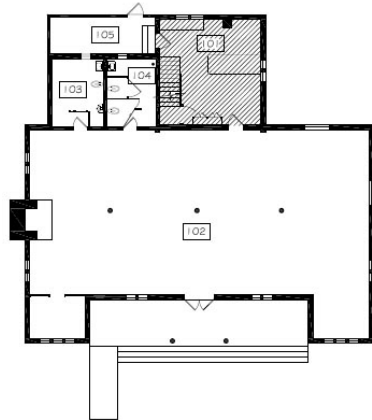

Figure C-25 First floor plan with Room 101 shaded

- **Flooring:** The flooring consists of 9" by 9" linoleum tiles, which are original.
- **Walls:** The log construction of the four perimeter walls is exposed. In the southeast corner, a tongue-and-groove board partition wall forms an enclosure for the stairway leading to the basement and a partial enclosure for the stairs leading to the second floor.



Figure C-26 Room 101, looking southwest

- **Doors:** At the west end of the south wall a six-light, three-panel door leads to the storage room, Room 105. This doorway is the original rear entrance and this is the original rear door. The door measures 2'-10" wide, 6'-9" tall, and 1 3/8" thick.

This doorway retains both of its original steel, five-knuckle, 4" wide by 3 1/2" high hinges with decorative ball pins. The door retains its original steel mortise lock and doorknobs. There are two modern deadbolts.

The door casing is made up of plank boards measuring 5 3/4" by 3/4". The casing is assembled so that the head casing sits square above the side casings. There is no evidence of trim pieces having been present.



Figure C-27 Original mortise lock on original rear entrance door

The door that opens from the stairway from the basement appears to be the original board-and-batten door. The door measures 3'-3 1/2" wide, 6'-3" tall, and 3/4" thick.

The doorway retains two early, 3" by 3" steel butt hinges, face-mounted. The door has its original steel box lock and two white porcelain knobs.

There is no door casing at this doorway. The door is flush with the board wall enclosure.



Figure C-28 Door to basement, with original box lock

The door that leads from the hall (Room 102) is an original, wood, five-panel door. It measures 2'-9 3/4" wide, 6'-9 1/4" tall, and 1 3/8" thick. It retains both of its original steel, five-knuckle, 3 1/2" by 3 1/2" butt hinges with decorative ball pin. It also retains its original steel mortise lock and doorknobs.

The door casing is made up of plank boards measuring 5 3/4" by 3/4". The casing is assembled so that the head casing sits square above the side casings. There is no evidence of trim pieces having been present.

- *Windows:* There are two pairs of double-hung sash window units in the room. One pair is located on the west wall and the second is centered on the north wall.

On the west wall, the south window unit has a 4/4 light configuration with both sashes having Type C muntins. The north window unit has a four-light top sash and one-light bottom sash. The top sash has Type B muntins; the bottom sash had Type B muntins which have now been removed.

On the north wall, both window units have a 4/4 light configuration with all four sashes having a Type A vertical muntin and a Type C horizontal muntin.



Figure C-29 Window on north wall of kitchen

The window casing of both sets of windows is made up of plank boards measuring 5 3/4" by 3/4". The casing is assembled so that the head casing sits square above the side casings and the side casings sit square atop the apron. A 3/4" stool extends 3/4" past the face of the casing. There is no evidence of trim pieces having been present.

Two-inch wide iron bars are mounted on all interior window casings for security.

- *Ceiling:* Exposed second-floor, log floor joists and the underside of the second-floor flooring constitute the ceiling for this room.



Figure C-30 Ceiling of the kitchen, showing exposed plumbing

- *Baseboards:* No baseboards are present. However, a $\frac{3}{4}$ " quarter round shoe molding trims out the board wall stair enclosure.
- *Finishes:* The logs of the perimeter walls are exposed and have no applied finish except for those logs inside the stair enclosure leading to the basement; these logs are painted.

The board-wall stair enclosure has a varnish finish.

The doors to the basement stairs and to the hall are varnished and appear to have always been varnished. Their door casings are also varnished.

The door from the storage room and its casing are currently painted. However, physical evidence indicates they were originally varnished.

The two pairs of window units are painted as are their casing elements.

The hanging wall cabinet is painted.

The bases of the kitchen counter and the peninsula are painted.

The brick flue for the basement furnace is painted.



Figure C-31 Wall cabinet on east wall of kitchen

- *Mechanical Systems:* A metal floor register near the center of the room allows warm air to rise from the basement. A similar floor register in the second-floor bathroom immediately above (Room 201) allows warm air to rise to the second floor.

The brick chimney stack servicing the basement furnace extends through this room at the west wall.

- *Electrical Systems:* Lighting is provided by a modern, multi-light, 2'-0" by 2'-0" fluorescent ceiling fixture.

- *Plumbing Systems:* The stainless-steel double sink has both hot and cold water supply.

Early steel supply pipes and a cast-iron waste pipe for the second-floor bathroom enter this room along the west wall and travel along the ceiling to the south wall.

- *Other Features:* At the south end of the west wall is an 8'-0" long section of modern kitchen counter and cabinets. It has a laminate counter top and a stainless-steel double sink.

A modern, peninsula counter and cabinet extends into the room from the midsection of the north wall. The counter top is butcher block and measures approximately 3'-7" wide by 9'-10" long. The open cabinet is 10" deep and 5'-0" long.

A wood wall cabinet with two pairs of side-by-side doors hangs on the east wall. This cabinet measures 1'-5" deep by 5'-6" wide and appears to be original.

Room 102: This hall is the largest room of the building, measuring about 40 feet by 60 feet, plus two alcoves of about 8 feet by 12 feet each. These alcoves are off the northeast and southeast corners of the room. The southeast alcove has been separated from the hall with an eight-foot tall partition wall with cased doorway; the board paneling used to construct this partition was popular in the 1950s when it was installed.

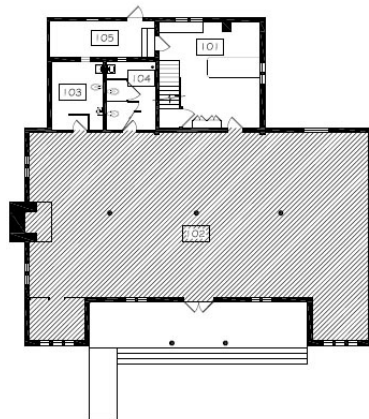

Figure C-32 First floor plan with Room 102 shaded

- *Flooring:* The current flooring is tongue-and-groove, beech boards measuring 1 ½" wide by ¾" thick. This flooring runs east-west.

Underneath the current flooring is the original, a portion of which is exposed along the west wall near the north wall. The exposed section measures 1'-6" wide by 6'-2 ½" long, and was covered by the bar until it was removed in 2004. The original flooring runs north-south and is pine, but the tongue-and-groove boards are wider, measuring 3 ¼" wide by ¾" thick.

Immediately north of this exposed original flooring is a longer section of dissimilar flooring measuring 1'-9 ½" by 11'-3 ½". This area is covered by two boards, one 1'-0" wide and the other 9 ½" wide.

Uneven wear marks on the floor indicate the location of the bar and other fixtures.



Figure C-33 Room 102, looking northeast

- *Walls:* The log construction of the four perimeter walls, as well as that of the two pavilion extensions, is exposed.

An eight-foot tall, partition wall of pine paneling was installed in 1952 to create an office in the southeast alcove. The paneling measures ¾" thick and has varying widths of 11", 7", and 5". It is assembled in a vertical pattern and is nailed onto the west side of a

stud wall; no sheathing material is attached to the east side of the stud wall. The stud framing measures 1 ½" by 3 ½" and the studs are set only at the two wall ends and at the center opening that serves as a passageway.

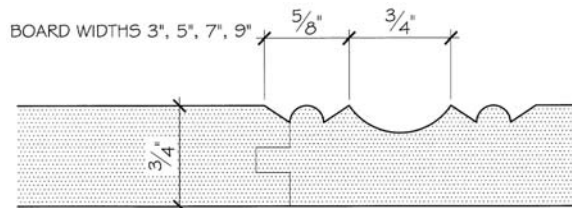

Figure C-34 Section of paneling



Figure C-35 Added paneled wall in Room 102

- **Doors:** In addition to the doorway with an apparently original five-panel door that leads to the kitchen, there are two other interior doorways. One of the other doorways leads to the public men's restroom, Room 103. The other leads to the public women's restroom, Room 104. Both doorways have a five-panel door of the same design, method of construction, and trim details as the door to the kitchen. Apparently original doors, these two restroom doors also appear to be in their

original locations. Both doors measure 2'-8" by 6'-7" by 1 ¼".

Both doors retain two original, steel, five-knuckle, 3 ½" high by 3 ½" wide, butt hinges with decorative ball pins.



Figure C-36 Door to women's restroom, Room 104

The door to the men's restroom retains its original steel mortise lock and doorknobs; the door to the women's restroom has a modern replacement locking mechanism and door knobs.

The door to the women's restroom also has replacement trim in the second-from-top door panel.

The door casings of the three interior doorways and the door leading to the front porch are made up of plank boards measuring 5 ¾" by ¾". The casing is assembled so that the head casing sits square above the side casings. There is no evidence of trim pieces having been present.

- **Windows:** On each side of the main entrance doorway there is a pair of double-hung sash window units. Each window unit has a 4/4 light configuration with both

sashes having a Type A vertical muntin and a Type C horizontal muntin.

On this same east elevation, each of the two corner pavilions has a grouping of three double-hung sash window units. Each window unit has a 4/4 light configuration with both sashes having a Type A vertical muntin and a Type C horizontal muntin.

On the south wall of the hall, there is a pair of double-hung sash window units on each side of the fireplace. Each window unit has a 4/4 light configuration with both sashes having a Type A vertical muntin and a Type C horizontal muntin.



Figure C-37 Paired double-hung window, with early sticks installed as display brackets above

Approximately opposite, on the north wall there are two window openings. The east opening has a pair of double-hung sash window units. Each window unit has a 4/4 light configuration with both sashes having a Type A vertical muntin and a Type C horizontal muntin. The west window opening has a single, eight-light, awning sash with Type B muntins. This window has two 2 ¾" butt hinges at its top rail, and a

2" barrel bolt at the bottom. It appears to be a reused casement sash.

On the west elevation is a similar feature. The window opening has a single, eight-light, awning sash with Type B muntins. It also has two 2 ¾" butt hinges at its top rail, but is missing its bolt closure.

The window casings of all window units of this room are constructed the same. The casing is formed of plank boards measuring 5 ¾" by ¾". It is assembled so that the head casing sits square above the side casings and the side casings sit square atop the apron. A ¾" stool extends ¾" past the face of the casing. There is no evidence of trim pieces having been present.

- *Ceiling:* The exposed log second-floor joists and underside of the flooring constitute the ceiling.
- *Baseboards:* No baseboards are present except at the 1952 partition wall. Along the west elevation of this wall, plank boards measuring ¾" by 3 ¾" form the baseboard.
- *Finishes:* The logs of the perimeter walls and the two pavilion extensions have a varnish finish. The chinking is painted.

The doors to the two public restrooms and the door to the kitchen are varnished and appear to have always been varnished. Their door casings are also varnished.

All the window units are painted as are their casing components.

The floor and the baseboard along the partition wall are varnished.

The three posts of the central spine supporting the second-floor joists are varnished. However, the interconnected log beams of the spine, the log second-floor joists and the underside of the second-floor

flooring do not appear to have had a varnish or other finish applied.

- *Mechanical Systems:* An early, metal floor grate measuring 2'-8" by 2'-8" is set off-center of the room towards the kitchen. Above in the second-floor flooring is another grate measuring 1'-0" by 1'-6". The purpose of the two grates is to allow warm air from the basement mechanical room to rise to the floor levels above.

Two gas-fired unit heaters are suspended from the floor framing above. One is located in the northwest corner, the other in the southeast corner. These units were installed in 1954 when the forced air heater in the basement failed.



Figure C-38 Unit heater in Room 102

One electric fan is suspended from the floor framing above. It is located near the northeast corner of the room.

- *Electrical Systems:* Eight modern, two-bulb open fluorescent lighting fixtures provide the majority of lighting for the main section of the room. These fixtures were installed in 1988.

An enclosed modern, four-bulb fluorescent lighting fixture lights the northeast alcove. Like the other fluorescent lighting fixtures of the room, it was installed in late 1988.

A modern, tear-drop design, incandescent lighting fixture illuminates the southeast alcove. Two additional modern, tear-drop design incandescent lighting fixtures provide supplemental lighting in the southeast quadrant of the room. These fixtures were added ca. 1955.

A single utility light was installed at the center of the room in 2003 by NPS when temporary supplemental wiring was added.

- *Plumbing Systems:* A water fountain is located in the west portion of the room, near the door to the kitchen.

- *Other Features:* A large, stone fireplace is centered on the south wall. Measuring 7'-3" across and 5'-1" in height, it is made of blocks of limestone. The mantel is formed by sections of the stone measuring 2" thick by 1'-4 1/2" deep and various lengths, the center portion rising in an arch reflecting the shape of the firebox lintel. The hearth, reportedly original, is made of poured-in-place concrete. A 1 1/2" strip of pine forms the perimeter of the hearth, its corners being joined with a miter cut.



Figure C-39 Fireplace in Room 102

Near the top of each of the three columns arranged in a north-south line down the center of the room, hangs a four-sided, pyramidal canopy. These canopies were installed in the early 1950s to display collections of early-settler tools and other items of everyday life.



Figure C-40 Display canopy in Room 102

Along the walls, at a height above that of the door and window lintels, are groups of brackets. Each bracket is formed from a cut section of a small tree limb with a shorter section of a clipped branch. These rustic hooks held more collected pioneer artifacts.

Room 103: The men's restroom, measuring about 10' wide and 12' long, is located next to the women's restroom. Both public restrooms adjoin the west wall of the hall south of the kitchen. The height from top of floor to bottom of board ceiling is 7'-7 1/2".

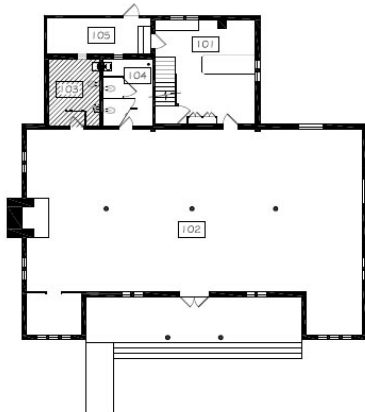

Figure C-41 First floor plan with Room 103 shaded



Figure C-42 Room 103, looking northwest

- **Flooring:** The floor is a poured concrete slab that dates to the original construction of the building. Adhesive residue remains, indicating a 9" by 9" tile once was applied.
- **Walls:** The log construction of the three perimeter walls is exposed. The fourth wall, to the north, is a stud wall with a modern 4'-0" by 8'-0" paneling embossed to resemble wood boards.
- **Doors:** The sole access is the doorway at the middle of the east wall. This doorway connects to the hall.

The door and hardware are discussed under Room 102.

The door casing is made up of plank boards measuring 5 3/4" by 3/4". The casing is assembled so that the head casing sits square above the side casings. There is no evidence of trim pieces having been present.

- **Windows:** On the west wall is a double-hung sash window unit. The window unit originally had a 4/4 light configuration with both sashes having a Type A vertical muntin

and a Type C horizontal muntin. Both sashes have been modified. In the bottom sash, the vertical and horizontal muntins have been removed. In the top sash, the horizontal muntin has been removed.

Three ¾" diameter steel bars have been installed vertically across the casing for security.

The window casing of the one window unit of this room is made up of plank boards measuring 3 ¾" by ¾". The casing is assembled so that the head casing sits square above the side casings and the side casings sit square atop the apron. A ¾" stool extends ¾" past the face of the casing. There is no evidence of trim pieces having been present.

- *Ceiling:* Exposed log floor joists and underside of the second-floor flooring constitute the ceiling.
- *Baseboards:* At the north wall a 1 ¼" by 6 ½" plank board is the baseboard. No baseboards are present at the other three walls.



Figure C-43 Room 103, looking northeast

- *Finishes:* The exposed logs of three perimeter walls have been painted dark brown. The chinking has been painted white.

The fourth perimeter wall, the north wall, has paneling with its mill finish of surface texture resembling a random-width board wall.

The door and the door casing are painted, as are the elements of the window unit.

The entrance partition wall is painted, both the panels and exposed framing.

The exposed second-floor log joists and underside of floor boards do not have an applied finish.

- *Mechanical Systems:* No elements of a mechanical system are present.
- *Electrical Systems:* One 2' by 2' fluorescent fixture is presumed to date from 1986.
- *Plumbing Systems:* Plumbing fixtures include a lavatory, a flush toilet, and a urinal. All are located along the north wall.
- *Other Features:* An L-shaped partition wall just inside the doorway visually shields the interior of the room from view by those in the hall. This partition wall is made of wood studs measuring 1 ⅝" by 3 ½" with ⅝" plywood. On the east surface of the north-south portion, ⅛" paneling has been applied over the plywood.

Room 104: The women's restroom, measuring about 10-feet wide and 12-feet long, is located next to and north of the men's restroom. Both public restrooms adjoin the west wall of the hall south of the kitchen. The height from top of floor to bottom of board ceiling is 7'-7 ½".

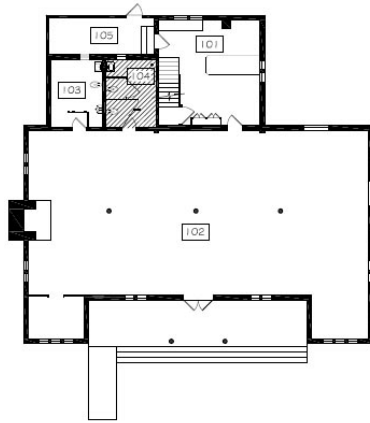

Figure C-44 First floor plan with Room 104 shaded

- **Flooring:** The floor is a poured concrete slab that dates to the original construction of the building. Adhesive residue remains, indicating a 9" by 9" tile once was applied.



Figure C-45 Room 104, looking southwest

- **Walls:** The log construction of the three perimeter walls is exposed.

The fourth wall, the south wall separating this room from the men's restroom, is a stud wall. The top portion is sheathed with 3 1/4" wood boards applied vertically. The bottom portion has the same 1/8" modern paneling with an embossed wood-board design as is found in the men's restroom.

- **Doors:** The sole access is the doorway at the middle of the east wall. This doorway connects to the hall.

The door and hardware are discussed under Room 102.

The door casing is made up of plank boards measuring 5 3/4" by 3/4". The casing is assembled so that the head casing sits square above the side casings. There is no evidence of trim pieces having been present.

- **Windows:** On the west wall is a double-hung sash window unit. The window unit originally had a 4/4 light configuration with both sashes having a Type A vertical muntin and a Type C horizontal muntin. The bottom sash has been modified; both the vertical and horizontal muntins have been removed.

Three 1" diameter steel bars have been applied vertically across the opening and four 1" bars horizontally.

The window casing of the one window unit of this room is made up of plank boards measuring 3 3/4" by 3/4". The casing is assembled so that the head casing sits square above the side casings, and the side casings sit square atop the apron. A 3/4" stool extends 3/4" past the face of the casing. There is no evidence of trim pieces having been present.

- **Ceiling:** Exposed log floor joists and underside of the second-floor flooring constitute the ceiling.

- **Baseboards:** At the south wall a 1 1/4" by 6 1/2" plank board is the baseboard. No baseboards are present at the other three walls.



Figure C-46 Room 104 looking east

- *Finishes:* The exposed logs of three perimeter walls have been painted dark brown. The chinking has been painted white.

At the fourth perimeter wall, the south wall, the vertical boards of the upper section have been painted and the paneling below retains its mill finish of surface texture resembling a random-width board wall.

The door and the door casing are painted, as are elements of the window unit.

The entrance partition wall and the toilet partitions are painted. For each of these partition walls, both the panels and exposed framing are painted

The exposed second-floor log joists and underside of floor boards do not have an applied finish.

- *Mechanical Systems:* No elements of a mechanical system are present.
- *Electrical Systems:* Four single-bulb incandescent fixtures are in place.

- *Plumbing Systems:* A lavatory and two toilets are located against the south wall.

A four-inch diameter, cast iron waste pipe is located in the northwest corner of the room.

- *Other Features:* Two sections of partition wall just inside the doorway visually shield the interior of the room from view by those in the hall. These partition walls and two others attached to the south wall to serve as toilet partitions are made of wood studs measuring 1 5/8" by 3 1/2" with 5/8" plywood.

Room 105: This room was created in 1988 when the screened-in porch was enclosed, to create a secondary service kitchen for use by groups renting the new pavilion. Now the storage room, it measures approximately 6'-10" by 20'-0" with a top of floor to bottom of rafter height of 8'-9".

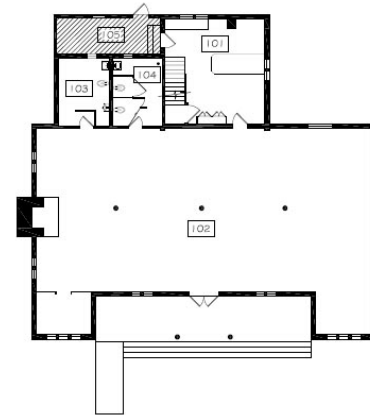

Figure C-47 First floor plan with Rom 105 shaded

- *Flooring:* The floor is a poured concrete slab that dates to the initial construction of the tavern.
- *Walls:* The log construction of the east and north walls, two original exterior walls of the building, is exposed. The screened-in south and west walls, enclosed in 1988, are constructed of wood studs and sheathed with plank boards of random width set vertically.



Figure C-48 Room 105 looking south

- **Doors:** The doorway to the exterior is a modern door unit installed in 1988. The doorway is described under Exterior Features.

The one interior doorway was originally the rear exterior doorway. It opens into the kitchen and is described under Room 101. Its door casing is made up of plank boards measuring 4 3/4" by 3/4". The casing is assembled so that the head casing sits square above the side casings. There is no evidence of trim pieces having been present.

- **Windows:** A modern, aluminum, double-hung sash window is located approximately in the middle of the west wall. It was installed in 1988. The window measures 2'-6" wide by 3'-0" high.

- **Ceiling:** The roof rafters and deck boards of random widths form the ceiling.

- **Baseboards:** No baseboards are present.

- **Finishes:** The two original walls on the east and south are painted brown. Both the logs and the chinking are painted. There are no other applied finishes in this room.

- **Mechanical Systems:** No elements of a mechanical system are present.
- **Electrical Systems:** There is a single incandescent fixture in the room.
- **Plumbing Systems:** A stainless steel double sink is in the counter.
- **Other Features:** An 8' long by 2' wide wood counter and base cabinets are in place along the east wall, with wood wall cabinets above. Parts comprising the original floor of the cabin are currently stored in the room.

Room 201: This room served as the private bathroom for the second-floor apartment. This bathroom dates to the original construction of the Tavern. The room measures 7'-5" by 15'-9". The height from top of floor to ceiling at its highest level is 7'-1 1/2"; the height from floor to the springline at the north and south walls is 5'-5 3/4".

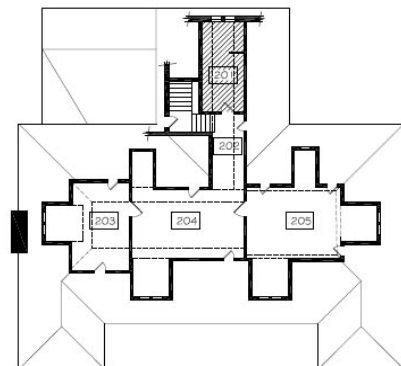

Figure C-49 Second floor plan with Room 201 shaded

- **Flooring:** The flooring material is tongue-and-groove pine boards measuring 3 1/4" wide by 3/4" thick. This flooring runs east-west. Remnants of tile adhesive on top of this flooring reveal a pattern of 9" by 9" tiles that once were present.



Figure C-50 Room 201, looking east

- **Walls:** The walls of the room are sheathed with $\frac{5}{8}$ " fiberboard nailed to wood stud framing.
- **Doors:** The one doorway in the room leads from the hallway, Room 202. The door, measuring 2'-3" by 6'-3" is constructed of $\frac{3}{4}$ " by 2 $\frac{1}{4}$ " wood framing covered on this room's side by $\frac{5}{8}$ " fiberboard.

The door retains its two original, steel, five-knuckle, 2 $\frac{1}{2}$ " wide by 2 $\frac{1}{2}$ " high butt hinges. A loop of wire serves as the door catch.

The door casing is made up of plank boards measuring 3" by $\frac{3}{4}$ ". The casing is assembled so that the head casing sits square above the side casings. There is no evidence of trim pieces having been present.

- **Windows:** The only windows in the room are a pair of double-hung, sash window units in the center of the west wall. Each window unit has a 4/4 light configuration with both sashes having a Type A vertical muntin and a Type C horizontal muntin.

The window casing is made of plank boards measuring 4 $\frac{1}{2}$ " by $\frac{3}{4}$ " with a dividing mullion 5 $\frac{1}{4}$ " wide. The unit is assembled so that the head casing sits square above the side casings and the side casings sit square atop the apron. A $\frac{3}{4}$ " stool extends $\frac{3}{4}$ " past

the face of the casing. There is no evidence of trim pieces having been present.

- **Ceiling:** The ceiling is composed of both horizontal and diagonal sections following the contours of the roof framing. The ceiling material is $\frac{5}{8}$ " fiberboard nailed to the framing.

- **Baseboards:** A wooden plank baseboard measuring $\frac{3}{4}$ " by 4 $\frac{3}{4}$ " is present on all four walls. There is no evidence of a baseboard cap. A $\frac{3}{4}$ " quarter round shoe molding appears on all walls but the north one.



Figure C-51 Room 201, looking southeast

- **Finishes:** The perimeter wall and ceiling surfaces of fiberboard are covered with multiple layers of wallpaper, the earliest probably dating to the original 1933 construction.

The shower enclosure is sheathed on three sides by plywood paneling embossed to look like wood boards. The shower trim boards are painted.

The baseboards are painted.

The door and casing leading from the hallway, Room 202, is painted.
The window unit and casing is painted.

The floors have remnants of glue from the 9" by 9" tiles.

- *Mechanical Systems:* A 1'-0" by 1'-0" metal floor register is located near the center of the room.
- *Electrical Systems:* None are present.
- *Plumbing Systems:* A toilet and lavatory are located along the south wall. The shower and tub along the north wall was installed ca. 1950.
- *Other Features:* No other significant features are present.

Room 202: This hallway contains the stairs to the first floor as well as serving as a passageway between the bathroom and the other rooms of the second-floor apartment. The passageway measures 5'-8" by 13'-3". The floor to ceiling height is 7'-2 1/4".

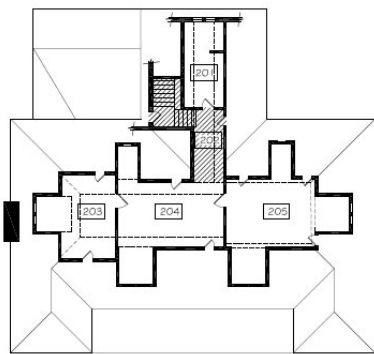

Figure C-52 Second floor plan with Room 202 shaded

- *Flooring:* The flooring material is tongue-and-groove pine boards measuring 3 1/4" wide by 3/4" thick. This flooring runs east-west from the bathroom (Room 201) doorway to a line near the east edge of the

stairs where the direction of the flooring changes to north-south.

- *Walls:* The walls of the room are sheathed with 5/8" fiberboard nailed to wood stud framing.



Figure C-53 Room 202, looking west

- *Doors:* The door that leads to the bathroom is described in Room 201. The door casing is made up of plank boards measuring 2 7/8" by 3/4". The casing is assembled so that the head casing sits square above the side casings. There is no evidence of trim pieces having been present.

A doorway on the north wall opens out from the kneewall area. The door, like the one to the bathroom, has wood framing members measuring 3/4" by 2 1/4" and is sheathed on hallway side with 5/8" fiberboard. The door measures 1'-10" by 5'-1 1/2". The door casing is made up of plank boards measuring 2 7/8" by 3/4". The casing is assembled so that the head casing sits square above the side casings. There is no evidence of trim pieces having been present.

At the stair landing, there is a small board-and-batten door that opens into an attic space above the first floor restrooms. The door measures 2'-0" wide by 1'-11" tall, with two 2 1/2" by 2 1/2" butt hinges. It is composed of 3 1/4" wide by 3/4" thick tongue-and-groove boards. It is secured by a cabinet latch.

- *Windows:* There is a fixed, single-sash window in a small, south-elevation dormer above the stairs. It was originally a four-light sash. The muntins are now missing and the sash is glazed as a single light. The sash measures 1' by 8" wide by 2'-0" tall. Iron bars have been installed on the interior for security.

- *Ceiling:* The ceiling is composed of both horizontal and diagonal sections following the contours of the roof framing. The ceiling material is 5/8" fiberboard nailed to the framing.

- *Baseboards:* A wooden plank baseboard measuring 3/4" by 4 3/4" is present on all three walls. There is no evidence of a baseboard cap or shoe molding having been present.

- *Finishes:* The walls and ceilings have multiple layers of wallpaper now painted over.

The wood baseboards are painted.

The door and window unit and casing elements are painted.

The wood floor has no applied finish. There is no evidence of carpeting.

- *Mechanical Systems:* A metal floor grille measuring 8" by 1'-0" is located near the center of the room.

- *Electrical Systems:* A single incandescent fixture provides light. A smoke detector is installed.

- *Plumbing Systems:* There are no elements of a plumbing system.



Figure C-54 Room 202 looking southwest to stair

- *Other Features:* As the stairs turn west going to the first floor, the second-floor flooring forms a ledge. Set back from the ledge is the fiberboard wall that seals off the kneewall space south of the bathroom.

The attic area behind the north partition wall is unfinished space. The flooring extends into this area but the interior has no applied finish material or finishes. The bare backside of the stud partition walls, roof rafters, and roof deck boards define the space.

Room 203: This south room is the southmost of three large, general purpose rooms that are immediately above the hall of the first floor. The main portion of the room measures approximately 9'-11" by 15'-5" and has a floor to ceiling height of 8'-2". At the large, south dormer which encloses a space measuring 4'-8" by 6'-5", the floor-to-ceiling height is 6'-10 1/2".

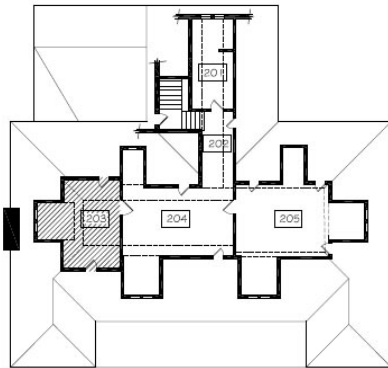

Figure C-55 Second floor plan with Room 203 shaded

- **Flooring:** The flooring material is tongue-and-groove, pine boards measuring 3 ¼" width by ¾" thickness. This flooring runs north-south.
- **Walls:** The walls of the room are sheathed with ⅝" fiberboard nailed to wood stud framing.



Figure C-56 Room 203, looking southeast

- **Doors:** A doorway on the north wall opens into the center room of the three general purpose rooms. This door that leads to the middle room is described in Room 204. The door casing on this side is made up of plank boards measuring ½" by 2". The casing is assembled so that the head casing sits square above the side casings. There is no evidence of trim pieces having been present.

A doorway on the west wall opens out from the unfinished attic area. The door is made of wood framing members measuring ¾" by 2 ¼" and is sheathed on the room side with ⅝" fiberboard. The door measures approximately 1'-10" by 5'-7 ½". The door casing is made up of salvaged tongue-and-groove floorboards measuring 3 ¼" by ¾". The casing is assembled so that the head casing sits square above the side casings. There is no evidence of trim pieces having been present. The door has a pair of 2 ½" by 2 ½" steel butt hinges and a carved wooden latch.

A doorway on the east wall opens out from the attic area. The board-and-batten door is made of salvaged 3 ¼" by ¾" boards. The door measures approximately 1'-10" by 5'-0". The door casing is made up of salvaged tongue-and-groove floorboards measuring 3 ¼" by ¾". The casing is assembled so that the head casing sits square above the side casings. There is no evidence of trim pieces having been present. The door has a pair of 2 ½" by 2 ½" steel butt hinges, a carved wooden latch, and a knob pull.



Figure C-57 Room 203, looking northwest

- **Windows:** There is a pair of double-hung sash window units in the south dormer. Each window unit has a 4/4 light configuration with both sashes having a Type A vertical muntin and a Type C horizontal muntin.

The window casing is composed of plank boards measuring 4 1/2" by 3/4" with a dividing mullion 5 1/4" wide. The unit is assembled so that the head casing sits square above the side casings, and the side casings sit square atop the apron. A 3/4" stool extends 3/4" past the face of the casing. There is no evidence of trim pieces having been present.

- *Ceiling:* The ceiling is composed of both horizontal and diagonal sections following the contours of the roof framing. The ceiling material is 5/8" fiberboard nailed to the framing.
- *Baseboards:* A wooden plank baseboard measuring 1/2" by 5 3/4" is present on all four walls. There is no evidence of a baseboard cap or shoe molding having been present.
- *Finishes:* The walls and ceiling have layers of wallpaper now painted over.

The baseboards are painted.

The doors and door casings are painted.

The pair of window units and casing elements are painted.

The wood floor lacks an applied finish. There is no evidence of carpeting.

- *Mechanical Systems:* No elements of a mechanical system are present.
- *Electrical Systems:* An early ceramic utility light with a bare bulb is mounted as a ceiling light.
- *Plumbing Systems:* No elements of the plumbing system are present.
- *Other Features:* The attic area behind the east room wall is largely unfinished space. The flooring extends into this area. A section of cardboard with applied wallpaper forms an enclosure to the north and a five-

panel door matching others in the tavern is wedged on its side against rafters to provide an east terminus. Beyond these makeshift enclosing elements, the bare backside of the stud partition walls, roof rafters, and roof deck boards largely define the space.

The attic area accessible behind the west room wall is enclosed space measuring about 3'-0" by 3'-0". The flooring extends into this area and presumably beyond. Sections of cardboard with applied wallpaper form west and south walls. The studs and backsides of the partition walls to the north and east are also wallpapered.

Room 204: This room is the middle one of three large, general-purpose rooms that are immediately above the hall of the first floor. The main portion of the room measures approximately 19'-8" by 11'-11" and has a floor to ceiling height of 8'-2". At the large, east dormer which encloses a space measuring 6'-4" by 6'-10", the floor to ceiling height is 6'-8 3/4". At the smaller, west dormer which encloses a space measuring 3'-9" by 6'-8", the floor to ceiling height is 6'-8 1/2".

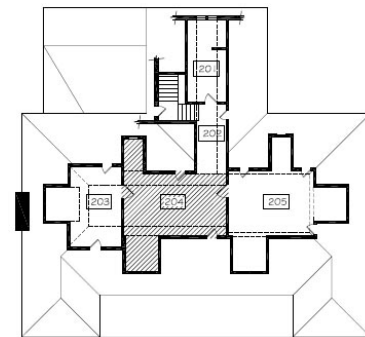

Figure C-58 Second floor plan with Room 204 shaded

- *Flooring:* The flooring material is tongue-and-groove pine boards measuring 3 1/4" wide by 3/4" thick. This flooring runs north-south.



Figure C-59 Room 204, looking southwest

- **Walls:** The walls of the room are sheathed with $\frac{5}{8}$ " fiberboard nailed to wood stud framing.
- **Doors:** Into this room from the south room opens a five-panel door of the same design, method of construction, and trim details as the doors to the public restrooms and to the kitchen from the hall. (A matching door opens from this room to the north room.) Apparently original, this door also appears to remain in its original location. The door measures 2'-8" by 6'-8" by 1 $\frac{1}{4}$ ". It has two original, steel, five-knuckle, 3 $\frac{1}{2}$ " high by 4" wide, butt hinges with decorative ball pin. It also has its original steel box lock with porcelain doorknobs.

The door casing is made up of plank boards measuring 4" by $\frac{3}{8}$ ". The casing is assembled so that the head casing sits square above the side casings. There is no evidence of trim pieces having been present.

Two board-and-batten doors also open into this room from attic areas to the east and west. Both doors are made of boards measuring $\frac{3}{8}$ " by 5 $\frac{1}{2}$ " or 6" and battens of salvaged $\frac{3}{4}$ " by 3 $\frac{1}{4}$ " floor boards. Both retain their steel, five-knuckle, 2 $\frac{1}{2}$ " by 2 $\frac{1}{2}$ " butt hinges. Neither door has a latch; both are 6'-0 $\frac{1}{2}$ " tall.

A doorway on the north wall opens into the north room of the three general-purpose rooms. This door is described in Room 205. The door casing on the Room 204 side is made up of plank boards measuring $\frac{3}{4}$ " by 4 $\frac{1}{2}$ ". The casing is assembled so that the head casing sits square above the side casings. There is no evidence of trim pieces having been present.



Figure C-60 Room 204, looking southeast

- **Windows:** There is a pair of double-hung, sash window units in the east dormer. Each window unit has a 4/4 light configuration with both sashes having a Type A vertical muntin and a Type C horizontal muntins.

The window casing is composed of plank boards measuring 4 $\frac{3}{4}$ " by $\frac{3}{4}$ " with a dividing mullion 5 $\frac{1}{4}$ " wide. The unit is assembled so that the head casing sits square above the side casings, and the side casings sit square atop the apron. A $\frac{3}{4}$ " stool extends $\frac{3}{4}$ " past the face of the casing. There is no evidence of trim pieces having been present.

There is a single, double-hung, sash window unit in the west dormer. The window unit has a 4/4 light configuration with both sashes having a Type A vertical muntin and a Type C horizontal muntin.

The window casing is made of plank boards measuring 4 $\frac{3}{4}$ " by $\frac{3}{4}$ ". The unit is

assembled so that the head casing sits square above the side casings, and the side casings sit square atop the apron. A $\frac{3}{4}$ " stool extends $\frac{3}{4}$ " past the face of the casing. There is no evidence of trim pieces having been present.

- *Ceiling:* The ceiling is composed of both horizontal and diagonal sections following the contours of the roof framing. The ceiling material is $\frac{5}{8}$ " fiberboard nailed to the framing.

- *Baseboards:* A wooden plank baseboard measuring $\frac{3}{8}$ " by 6" is present on all four walls. There is no evidence of a baseboard cap or shoe molding having been present.

- *Finishes:* The walls and ceiling have layers of wallpaper now painted over.

The baseboards are painted.

The doors and door casings are painted.

The window units and casing elements are painted.

The wood floor has no applied finish. There is no evidence of carpeting.

- *Mechanical Systems:* No elements of a mechanical system are present.



Figure C-61 Light fixture in Room 204

- *Electrical Systems:* An early three-bulb, cast-metal, ceiling fixture is located near the center of the room.

- *Plumbing Systems:* No elements of the plumbing system are present.

- *Other Features:* The accessible attic area to the east is framed by the wall studs and backside of the fiberboard sheathing of the middle room's east wall, of the north wall of the east dormer, and of the south wall of the east dormer of Room 205. A section of cardboard with applied wallpaper forms the east wall. The roof rafters and underside of roof decking completes the enclosure. Wallpaper is applied to these surfaces.

The accessible attic area to the west is framed by the wall studs and backside of the fiberboard sheathing of the middle room's west wall, of the north wall of the west dormer, and of the south wall of the hallway, Room 202. A board wall of 3 $\frac{1}{4}$ " wide boards placed horizontally forms the west wall. The roof rafters and underside of roof decking completes the enclosure. The west board wall is painted; the other portions of the enclosure are wallpapered.

Room 205: This room is the northernmost of three large, general-purpose rooms that are immediately above the hall of the first floor. The main portion of the room measures approximately 16'-4" by 12'-7" and has a floor-to-ceiling height of 7'-6". At the large, north dormer which encloses a space measuring 6'-3" by 6'-5", the floor-to-ceiling height is 6'-9 $\frac{1}{2}$ ". At the large, east dormer which encloses a space measuring 6'-4" by 6'-9", the floor-to-ceiling height is 6'-11 $\frac{1}{4}$ ". At the small, west dormer which encloses a space measuring 3'-9" by 6'-5", the floor-to-ceiling height is 6'-10".

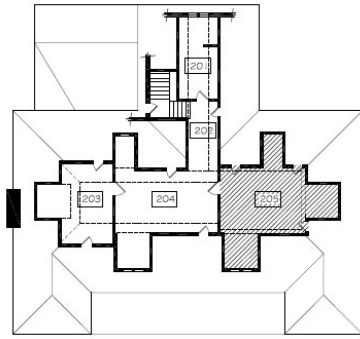

Figure C-62 Second floor plan with Room 205 shaded

- **Flooring:** The flooring material is tongue-and-groove pine boards measuring 3 1/4" wide by 3/4" thick. This flooring runs north-south.
- **Walls:** The walls of the room are sheathed with 5/8" fiberboard nailed to wood stud framing.



Figure C-63 Room 205, looking northwest

- **Doors:** From the middle room into this room opens a five-panel door of same design, method of construction, and trim details as the doors to the public restrooms and to the kitchen from the hall. (A matching door also opens from the south room into the middle room.) Apparently original, this door also appears to remain in its original location. The door measures 2'-10" by 6'-8" by 1 1/4". This door has two original steel, five-knuckle, 3 1/2" high by 4" wide butt hinges with decorative ball pin. It

also has its original steel box lock with porcelain doorknobs.

The door casing is made of plank boards measuring 3/4" by 4 1/2". The casing is assembled so that the head casing sits square above the side casings. There is no evidence of trim pieces having been present.

There are also three doors that open from the attic areas into this room. Each door is made of wood framing members measuring 3/4" by 2 1/4" and is sheathed on the north room side with 5/8" fiberboard. Each door measures approximately 1'-10" by 6'-2". The door casing is made up of salvaged tongue-and-groove floorboards measuring 3 1/4" by 3/4". The casing is assembled so that the head casing sits square above the side casings. There is no evidence of trim pieces having been present. Each door has a pair of five-knuckle, steel, 2 1/2" by 2 1/2" butt hinges and a cabinet latch.

- **Windows:** There is a pair of double-hung, sash window units in both the north and east dormers. Each window unit has a 4/4 light configuration with both sashes having a Type A vertical muntin and a Type C horizontal muntin.

For both pairs of window units the casings are made of plank boards measuring 4 3/4" by 3/4" with a dividing mullion 5 1/4" wide. The unit is assembled so that the head casing sits square above the side casings, and the side casings sit square atop the apron. A 3/4" stool extends 3/4" past the face of the casing. There is no evidence of trim pieces having been present.

There is a single double-hung sash window unit in the west dormer. The window unit has a 4/4 light configuration with both sashes having a Type A vertical muntin and a Type C horizontal muntin.

The window casing is made of plank boards measuring 4 ¾" by ¾". The unit is assembled so that the head casing sits square above the side casings, and the side casings sit square atop the apron. A ¾" stool extends ¾" past the face of the casing. There is no evidence of trim pieces having been present.

- *Ceiling:* The ceiling is composed of both horizontal and diagonal sections following the contours of the roof framing. The ceiling material is ⅝" fiberboard nailed to the framing.

- *Baseboards:* A wooden plank baseboard measuring ¾" by 4 ¾" is present on all four walls. There is no evidence of a baseboard cap or shoe molding having been present.



Figure C-64 Room 203, looking southeast

- *Finishes:* The walls and ceiling have layers of wallpaper.

The baseboards are painted.

The doors and door casings are painted.

The window units and casing elements are painted.

The wood floor lacks an applied finish. There is no evidence of carpeting.

- *Mechanical Systems:* No elements of a mechanical system are present.

- *Electrical Systems:* An early two-bulb, cast-metal, ceiling fixture is located near the center of the room.

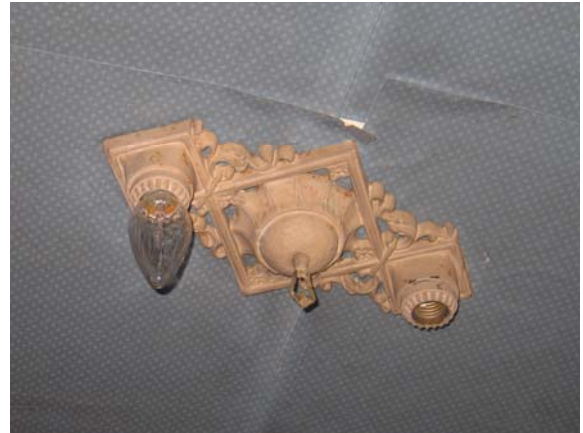

Figure C-65 Light fixture in Room 203

- *Plumbing Systems:* No elements of the plumbing system are present.

- *Other Features:* The accessible attic area to the east is framed by the bare wall studs and backside of the fiberboard sheathing of the north room's east wall, and those of the north wall of the east dormer. Sections of corrugated cardboard form partial enclosing walls to the east and north. The roof rafters and underside of roof decking form the overhead enclosure.

The accessible attic area to the west, south of the dormer, is framed by the wallpapered wall studs and backside of the fiberboard sheathing of the north room's west wall, of the south wall of the west dormer, and of the north wall of the hallway, Room 202. A low stud wall of wallpapered fiberboard forms the west wall. The wallpapered roof rafters and underside of roof decking complete the enclosure.

The accessible attic area to the west, north of the dormer, is framed by the wallpapered wall studs and backside of the fiberboard sheathing of a section of the north room's west wall, and of the north wall of the west dormer. A low stud wall of wallpapered

fiberboard forms the west wall. A partially intact board wall is to the north. The roof rafters and underside of roof decking complete the enclosure.

Utility Systems

The site relies on a well for its water supply and a soils field for removal of waste. The tavern contains a kitchen, bathroom, and two public restrooms with running water and waste disposal.

A water heater in the basement provides hot water. City water lines will soon be installed along US Highway 31E, providing the opportunity to improve both of these services.

Electricity is available from power lines that parallel US Highway 31E. From its earliest days, the tavern has had electricity. The tavern receives electricity from an overhead supply line that enters the building at its northwest corner. A panel box along the north wall of the basement distributes power throughout all levels of the building. Most lines are early. All are surface mounted. In addition to lighting, the electricity powers the water heater, smoke-detection system and intrusion-detection system.

Propane gas fueled an early unit heater in the basement. Floor registers allowed the heated air to rise to the first and second floors. When the heater failed in 1953, it was abandoned and two suspended heaters were installed in the most important room, the hall where customers gathered. A fan suspended from the ceiling of this room provided the only mechanical cooling. Movable kerosene heaters provided heat for the owners and staff.

A large fireplace at the center of the south wall of the hall can provide a measure of heat for the occupants of this large room.

Summary of Conditions

At first glance, the building envelope appears to be not only largely intact as initially constructed but physically sound as well. Indeed, much of the exterior appears to be generally well maintained. However, closer inspection reveals a couple of serious concerns. First and foremost, deterioration in the log walls is widespread, and in some instances, it is fairly advanced. Both construction details and choice of materials have contributed to the deteriorated conditions. This is the most serious problem with the exterior of the building and, fortunately, there are proven remedies.

The second concern is the water-shedding capacity of the roofing systems. Roofing systems form one of the most critical lines of defense for a building. While these are generally sound, except for a leak in the 1988 metal roof over the storage room, there are suspect areas that should be monitored for durability and performance. These areas include the 1998 composition shingle roofing. It was installed with an excessive weather exposure that will hasten failure. Its flashing is also problematic. Aluminum is easily damaged, and it is used awkwardly to flash some critical roof penetrations which need a durable material and careful installation technique.

Inside, there are inadequacies as well. The insufficient structural loading capacity in the main room, the hall, is apparent as one major concern. Temporary shoring is in place to support sagging beams supporting the second-floor rooms. Rectification is critical to the continued use of the second floor.

The heating and cooling of the interior are also serious deficiencies. Neither has been adequately addressed with the occupants in mind at any time in the past. In addition, insulation beyond the inherent

qualities of the original building material is virtually nonexistent. Improving thermal performance will be a challenge given the openness of the design and exposed structural elements. If housing of museum collections is an option, temperature control may be an even greater concern, as well as humidity and lighting control.

Both the electrical and plumbing systems have considerable age to them. In addition to replacement due to age, both systems also need complete reassessment in terms of capacities.

Accessibility to and within the facilities is another issue to be addressed. Access into the building is far from meeting current recommended standards of design for the handicapped. The public restrooms also need reconfiguration.

Additionally, consideration needs to be given to other issues of life, safety, and welfare of the public involving emergency lighting, exit signage, emergency generators, security, and fire detection/suppression.

PART II: TREATMENT & USE

A. INTRODUCTION

The rural countryside where Abraham Lincoln spent part of his youth appears in the early twenty-first century much the same as it did when young Lincoln was there two centuries earlier. It is a rolling landscape of thick woods punctuated with the open meadows of small farms.

Since his assassination in 1865, Lincoln has held a special place of fascination in the American psyche. He was born of modest means and largely self-educated. He had had a moderately successful career in law and politics. He joined in 1856 the newly formed Republican Party established to oppose the spread of slavery. He became that party's senatorial candidate two years later. He lost, but his debates with Stephen Douglas became legendary. Then, improbably, in 1860 the awkwardly tall attorney from Illinois became president at an important crossroads in his country's history. The country soon fell, perhaps inevitably, into a terrible civil war. Lincoln issued the Emancipation Proclamation and prevailed upon the Union troops to fight until the Union was secure. His oratory was simple, direct, and morally powerful, in retrospect some of the finest prose ever written by any American. Lincoln was and is still considered to have been one of the country's most important leaders.

By the second quarter of the twentieth century, the automobile had become the preferred means of travel in America. Its widespread popularity made possible frequent movement of large numbers of people for purely recreational purposes over much longer distances than ever imagined.

Automobile tourism became a major economic activity.

People were arriving from all over the country to visit the birthplace of Abraham Lincoln near Hodgenville, Kentucky. Robert J. Collier, publisher of *Collier's* magazine, had raised the money to purchase farm of Lincoln's birth, along with what were thought at the time to be the original cabin logs. He had established a nonprofit group to acquire the property and solicit designs for a memorial. An impressive design of John Russell Pope, one of the nation's most prominent architects, had been erected. The new memorial complex had then been given to the federal government in 1916.

It was in this atmosphere of adulation and economic opportunity that the Howard family purchased the site of Lincoln's boyhood home in 1931. The Lincoln cabin had long since disappeared but an elderly neighbor felt certain he remembered it. And the site hadn't seen much development since young Lincoln lived there. In addition, the property adjoined a major highway.

The Howard family took the logs from another cabin on their new property, one that was believed to date to the same period as the Lincoln occupancy, and guided by the memory of the neighbor, recreated a representation of the Lincoln boyhood cabin for all to see. Soon, they added the tavern to serve refreshments to visitors. The site manager lived in an apartment upstairs over the tavern. Year after year, the family members made repairs to the cabin. As

people came to see the cabin memorial, they stopped for refreshments and souvenirs that economically sustained the Howard family. This almost symbiotic relationship of cabin and tavern was critical to their mutual survival from the beginning and continued until the property was deeded to the federal government in 2001. The significance of this cultural phenomenon of tourism was formally recognized when the property was listed in the National Register of Historic Places in 1988.

B. ULTIMATE TREATMENT AND USE

The undeveloped farmland at Knob Creek, much as it was when the Lincoln family lived on the land, attracted tourists and was a critical factor in the decision to promote the property for tourism.



Figure B-1 View to fields west of tavern

The “Lincoln cabin” is a representation of the one Abraham Lincoln would have known, assembled from the parts, sometimes modified, from another cabin and repaired over time with parts salvaged from still other cabins. The methods of salvage have been driven by utilitarian purpose without the documentation commonly associated with such disassembly by today’s standards. The choice of location and the design for the reconstructed memorial cabin was likewise based on a casual understanding of the original, without benefit of professional investigations. Furthermore, the resultant construction incorporated the salvaged pieces using 1930s building techniques and materials.

The original purpose of the tavern was economical: to tap into the occasion of the tourist visit by providing additional reasons to linger. The tavern offered refreshments and curios for purchase, and historical “artifacts” of farm living for viewing. A

secondary use was living quarters, the upstairs being a residence for site personnel. Because this was a family owned and operated business, the residents were typically members of the family. Common 1930s materials and techniques were utilized here also, including fiberboard panels and logs in the round.

The two buildings are tangible artifacts of the popular 1930s interpretation of Lincoln’s life as a young boy and the development of tourism focused on this important historical figure.

Both buildings retain a large amount of building material from the initial 1930s construction. Both buildings and the site have a considerable amount of documentation concerning the appearance of the complex at that time. Opportunities remain for additional investigation and testing of the building fabric of both buildings in order to gain an even better understanding of this period. Considering these circumstances, the following recommendation is made.

The Recommended Ultimate Treatment includes the exterior and interior restoration of the cabin to its original 1930s appearance; the exterior restoration of the tavern to its original 1930s appearance; the interior restoration of the tavern’s principal public room, the hall, to its original 1930s appearance, to use as a visitors reception center; and the rehabilitation of the tavern’s other interior spaces for ancillary support areas and staff offices.

This approach would have the following advantages:

- Interprets the buildings and site as tangible cultural resources in a manner that is consistent with the property's nomination to the National Register of Historic Places. The cabin is representative of early, twentieth-century Americans' understanding of what life must have been like for a young Abraham Lincoln. The complex is representative of burgeoning, early twentieth-century tourism based on the fascination with a nationally important historical personage;
- The large size of the hall allows the tavern building to reflect its 1930s characteristics while incorporating other functions within the space, including current-day interpretations of young Lincoln's life as well as the country's evolving fascination with historical personages, and the advent of automobile tourism;
- The hall also lends itself well to the inclusion of a visitors' information desk, gift shop, and other important functions of a modern park;
- The abundantly large restrooms lend themselves well for rehabilitation as modern ADA-accessible restrooms;
- The abundantly large original kitchen can accommodate rehabilitation for modern staffing and ancillary functions, such as a handicapped accessible workstation, staff break room, and a food-preparation area for the occasional hosting of catered public events in the hall;
- The large second-floor area lends itself well for rehabilitation for staff offices, staff restroom, and ancillary spaces;
- The open, undeveloped space in front of and around the tavern and cabin is

available for interpretation more consistent with the 1930s characteristics of the complex.



Figure B-2 Postcard of Boyhood Home site, undated

There would be disadvantages to this approach as well:

- Presents a less than pristine appearance of the Lincoln farm site.

C. REQUIREMENTS FOR TREATMENT

The Tavern and Lincoln Boyhood Cabin are addressed as a single complex in the park's Draft General Management Plan.

The National Park Service Cultural Resources Management Guideline (DO – 28) requires planning for the protection of cultural resources on park property.

In addition, Section 106 of the National Historic Preservation Act (NHPA) mandates that federal agencies, including the National Park Service, take into account the effects of their actions on properties listed or eligible for listing in the National Register of Historic Places and give the Advisory Council on Historic Preservation a reasonable opportunity to comment.

Treatment of the building and site are to be guided by *The Secretary of Interior's Standards for Historic Preservation Projects*, the Americans with Disability Act, and the International Building Code. Threats to public life, safety and welfare are to be addressed; however, because this is an historic building, alternatives to full legislative and code compliance are recommended where compliance would needlessly compromise the integrity of the historic building.

D. ALTERNATIVES FOR TREATMENT

In addition to the Ultimate Treatment discussed in Section II.B above, three other alternatives are discussed below.

Alternative #1: Rehabilitate the exterior and interior of the tavern.

This approach would have the following advantages:

- Allows retention of modern features such as the concrete front entrance porch. Retention means cost savings in both saved demolition cost and less construction/maintenance costs than reconstructing the original wooden porch;
- Allows retention or modernization of modern features such as the enclosed back porch;
- Allows use of initially less expensive replacement materials such as composition instead of wood shingles;
- Allows redesign of the hall to give greater emphasis to modern interpretations of the Lincoln occupancy;
- Allows greater flexibility in the development of adjoining exterior spaces for parking and other park activities.

This approach would have the following disadvantages as well:

- Downplays or further removes characteristics of the complex that contribute to the listing of the property in the National Register of Historic

Places, characteristics associated with major social trends of the 1930s;

- Misses the opportunity to spotlight those 1930s social trends of tourism and interest in historical personages, trends which are not now well-interpreted at many historic sites.

Alternative #2: Restore the exterior and interior of the tavern to its 1930s appearances, incorporate functions comparable to the originals.

This approach would have the following advantages:

- Interprets the buildings and site as tangible cultural resources in a manner that is consistent with the property's nomination to the National Register of Historic Places. The cabin is representative of early twentieth-century Americans' understanding of what life must have been like for a young Abe Lincoln. The complex is representative of the burgeoning, early twentieth-century tourism based on the fascination with a nationally important historical personage;
- The large size of the hall allows the tavern building to reflect its 1930s characteristics and reestablish important period functions such, food service, gift shop, and display areas of "farm antiques;"
- The abundantly large restrooms lend themselves well for modern ADA-accessible restrooms;

- The abundantly large original kitchen can accommodate food-service activities as permitted by health officials and building code;
- The second floor provides ample space for reuse as staff housing and business storage;
- The open, undeveloped space in front of and around the tavern and cabin provides the opportunity for interpretation more consistent with the 1930s characteristics of the complex.
- Adversely affects cultural resources which contribute to the property's listing in the National Register of Historic Places;
- Minimizes the opportunity to interpret the 1930s social trends which produced the cabin and tavern;
- Disrupts the traditional functional relationship between the cabin and the tavern;
- Introduces a major new feature to the site.

There would be disadvantages to this approach as well:

- Presents a less than pristine appearance of the Lincoln farm site;
- May be difficult to secure and maintain the necessary permits for food-service activities;
- May require expensive equipment for food-service activities;
- May be difficult to find appropriate tenants for the residential portion.

**Alternative #3: Demolish Tavern.
Construct modern interpretive center.**

This approach would have the following advantages:

- Allows the flexibility to design an interpretive center around the currently anticipated park functions;
- Provides the opportunity to design a facility to maximize energy efficiency.

This approach would have the following disadvantages:

E. RECOMMENDATIONS

General

It is important to think of the cabin, tavern, and site as an inseparable complex, developed in the 1930s to operate as a single unit. These characteristics are inherent in the property's listing in the National Register of Historic Places.



Figure E-1 Current setting of tavern and cabin, 2005

Whatever the chosen treatment(s) for the site and the buildings, it is recommended that prior to the commencement of work, the complex be fully documented in accordance with Historic American Building Survey (HABS) and Historic American Landscape Survey (HALS) standards.

Also, dendrochronology studies should be conducted for the log walls of both buildings. Oral histories hold that the logs of the tavern were harvested on site at the time of construction; the logs of the replica cabin taken from the Gollaher family's cabin date to the early nineteenth century; and later repairs used salvaged cabin logs of unknown dates. Documentation of both log ages and wood species would be most valuable to compare with extant information and to prepare for future repairs and interpretation.

It is further recommended that a Historic Paint and Finish Analysis be completed for each building, both to document the finishes before they incur any additional damage during repairs and to guide the further restoration and interpretive efforts.

Finally, oral histories should be collected soon. There are quite a few family members who can shed light on the operation of the cabin and tavern. However, several are advanced in age and others are in poor health.

Site

As it is adapted for use as a national park facility, it would be desirable to promote an immediate setting for the cabin and tavern that resembles the original one of the 1930s. This would be the setting most compatible with the interpretive period of the buildings.



Figure E-2 Tavern, undated but presumed c. 1933 (photo courtesy of Mary Brooks Howard)



Figure E-3 Tavern east elevation, 2005

Tavern

To achieve the recommended Ultimate Treatment the following actions should be taken:

- Remove 1950s vintage concrete front entrance porch and 1980s vintage wheelchair ramp; reconstruct wood porch to match original 1930s design. Install wheelchair ramp or lift that meets American with Disabilities Act (ADA) design criteria for access to the first-floor level spaces;
- Remove porch enclosure at rear of building. Reconstruct original 1930s screened-in porch;
- Remove 1990s vintage composition roofing. Install split shingle roofing to match the size and weather exposure of the original 1930s roofing;
- As part of the stabilization repairs to the exterior wall logs, make Dutchmen repairs using wood of same cut, joinery, and wood specie(s) as the original 1930s logs;
- Repair/reinstall original exterior lights at east pavilions;
- Remove c. 2003 era double entrance doors at front of building; repair and reinstall the original doors;
- Remove 1950s era pine board wall in the hall;
- As part of the stabilization repairs to the center ceiling beam of the hall, make structural repairs as recommended in the structural report attached;
- Remove the 1950s era tear-drop lights and 1980s era fluorescent lights of the hall. Reinstall the original incandescent lighting fixtures;
- Acquire and reinstall in the hall the original 1930s vintage bar. Reconstruct/install the bar mirror from photographs and physical evidence;
- Remove modern door and window hardware in the hall; replace with hardware to match the original 1930s designs as evidenced by other examples in the room and physical evidence;
- Rehabilitate two public restrooms to meet current building codes and ADA design criteria;
- Rehabilitate the original kitchen space to meet new operational needs and code requirements;
- Consider disconnecting but leaving in place the original 1930s vintage surface-attached electrical wiring as a building artifact, evidence of the original system for interpretation purposes; install all new electrical service;
- Install new central heating and cooling system but utilizing the original 1930s registers as located if possible;

- Make permanent stabilization repairs to the basement's 1950s era temporary repairs;
- Rehabilitate the second-floor rooms for staff offices, restroom, and ancillary spaces. This may involve removing the original 1930s vintage fiberboard and cardboard wall materials; if so, preserve examples of original finishes, especially if they are removed in their entirety and strive to follow the wall configuration of the original floor plan and record/conservate samples of wallpaper finishes and fiberboard panels. Retain original doorway units in their original locations. Install insulation;
- When building materials are to be removed, as in the cases of the fiberboard wall and ceiling panels and the kitchen flooring, a sample of each material should be removed, labeled with a unique number, catalogued, and retained in a stable environment, preferably on site;
- Install sprinkler system;
- Apply finishes to the restored areas as determined by the Historic Paint and Finishes Analysis.

REFERENCES

Primary Sources

“Auction: Selling Lincoln’s Boyhood Home.” *The LaRue County Herald News*, 9 Jan. 1986.

Buono, Jon. 21 April, 2003. National Park Service, Southeast Regional Office. letter to Jim Creech and Dan Scheidt.

Eddins, Mary Jean. “Celebration Marks Deed Transfer.” *Land, Air and Water*, Spring 2002.

Eddins, Mary Jean. “Two Projects Become a Reality.” *Land, Air and Water*, Winter 2002.

Filson, John. *The Discovery, Settlement, & Present State of Kentucky*. Wilmington: James Adams, 1784.

General Management Plan/Alternatives Newsletter. National Park Service, U.S Department of the Interior, Abraham Lincoln Birthplace National Historic Site, Kentucky. Issue 2, Fall 2004.

“Historic Property To Go Under Gavel.” *The LaRue County Herald News*, 9 Jan. 1986.

Howard, Mary Brooks. Interview by Joseph K. Oppermann, FAIA. Frankfort, KY. 28 February 2006.

Howard, Millburn. Interview by Joseph K. Oppermann, FAIA. City, KY. 02 and 10 March 2006.

“Lincoln National Helps Fund Purchase of Boyhood Home.” *The LaRue County Herald News*, 12 Dec. 2001.

Manning, Stacy S. “New Haven Receives County Occupational, Recreational Funds.” *The Kentucky Standard*, 28 March. 2003.

McDonald, Bob. “Howard Family Members pay \$120,500 to Keep Lincoln Property in Family; Many are Surprised at Low Sale Price.” *The LaRue County Herald News*, 20 Jan. 1986.

Raisor, Christine. “Knob Creek Officially Open.” *The LaRue County Herald News*. April. 1986.

Sites, William H. 2 Feb, 2002. United States Department of Agriculture. letter to Gary Talley: Chief of Operations, Abraham Lincoln Birthplace NHS.

Slinker, John. “Boyhood Home Cabin, Tavern, Receive Nominations.” *The LaRue County Herald News*, 3 Sept. 2003.

Secondary Sources

- Abraham Lincoln Birthplace Brochure. National Park Service, U.S. Department of the Interior. 2002.
- Abraham Lincoln Birthplace: Lincoln Boyhood Home at Knob Creek Brochure. National Park Service, U.S. Department of the Interior. n.d.
- Abraham Lincoln's Boyhood Home Brochure. c. 1986.
- Blythe, Robert W., Maureen Carroll, and Steven H. Moffson. *Historic Resource Study, Abraham Lincoln Birthplace National Historic Site*. National Park Service, Southeast Regional Office, Cultural Resources Stewardship, 2001.
- Brown, Kent Masterson. *Report on the Title of Thomas Lincoln to, and the History of, the Lincoln Boyhood Home Along Knob Creek in LaRue County, Kentucky*. Atlanta: National Park Service, Southeast Regional Office, 1998.
- Cagle, Brian. *Public Health Assessment Report, Abraham Lincoln Birthplace NHS*. National Park Service, Southeast Regional Office. 12 Dec. 2001.
- Cotterill, R.S. *History of Pioneer Kentucky*. Cincinnati: Johnson & Hardin, 1917.
- Fehrenbacher, Don E., ed. *Abraham Lincoln: A Documentary Portrait Through his Speeches and Writings*. California: Stanford University Press, 1994.
- Herndon, William H. *Herndon's Lincoln*. Springfield, Illinois: The Herndon's Lincoln Publishing Company, 1888.
- "Historic Property To Go Under Gravel." *The LaRue County Herald News*, 9 Jan. 1986.
- Hudson, Karen E. *Architectural Evaluation: Lincoln Boyhood Home, Knob Creek Farm, LaRue County, Kentucky*. National Park Service, Southeast Regional Office, 1997.
- KyGenWeb Special Collections. *Kentucky Postcards, Knob Creek*.
<www.rootsweb.com/~kygenweb/KyPostCards/KnobCreek/> November 2003.
- "Lincoln's 'Old Kentucky Home'." *County Line*, March-April. 2002.
- Lounsbury, Carl R. *An Illustrated Glossary of Early Southern Architecture & Landscape*. New York and Oxford: Oxford University Press, 1994.
- National Register of Historic Places Registration Form: Lincoln Boyhood Home. Athertonville, KY: United States Department of the Interior, National Park Service, 1988.
- National Park Service. *Historic Structure Report, Abraham Lincoln Birthplace Memorial Building*. Hodgenville, Kentucky, 2001.

National Park Service. *Historic Resource Study, Abraham Lincoln Birthplace*.
<www.nps.gov/abli/hrs/hrs2c.htm> January 2003.

Nickel, Robert K. *A Ground-Penetrating Radar Survey at the Knob Creek Farm Unit: Abraham Lincoln Birthplace National Historic Site, Kentucky*. Tallahassee, Florida: Southeast Archeological Center, National Park Service, 2005.

Montell, William Lynwood and Michael Lynn Morse. *Kentucky Folk Architecture*. Lexington: The University Press of Kentucky, 1995.

Pitcaithley, Dwight T. "Abraham Lincoln's Birthplace Cabin: The Making of an American Icon." In *Myth, Memory, and the Making of the American Landscape*, edited by Paul A. Shackel, 240-254. Gainesville: University Press of Florida, 2001.

Sculle, Keith A. "The Howard Family Legacy at the Knob Creek Farm." *Journal of the Abraham Lincoln Association*, Vol. 26, No. 2 (2005): 23-48.

Tarbell, Ida M. *In the Footsteps of the Lincolns*. New York: Harper and Brothers, 1924.

Tarbell, Ida M. *The Life of Abraham Lincoln*. New York: Lincoln History Society, 1900.

Warren, Louis Austin. *Lincoln's Parentage and Childhood*. New York: The Century Company, 1926.

Zall, Paul M. *Lincoln on Lincoln*. Lexington: The University Press of Kentucky, 1999.

APPENDIX A

As-Found Floor Plans and Details

1. Basement Plan
2. First Floor Plan
3. Second Floor Plan
4. Door Panel and Muntin Profiles

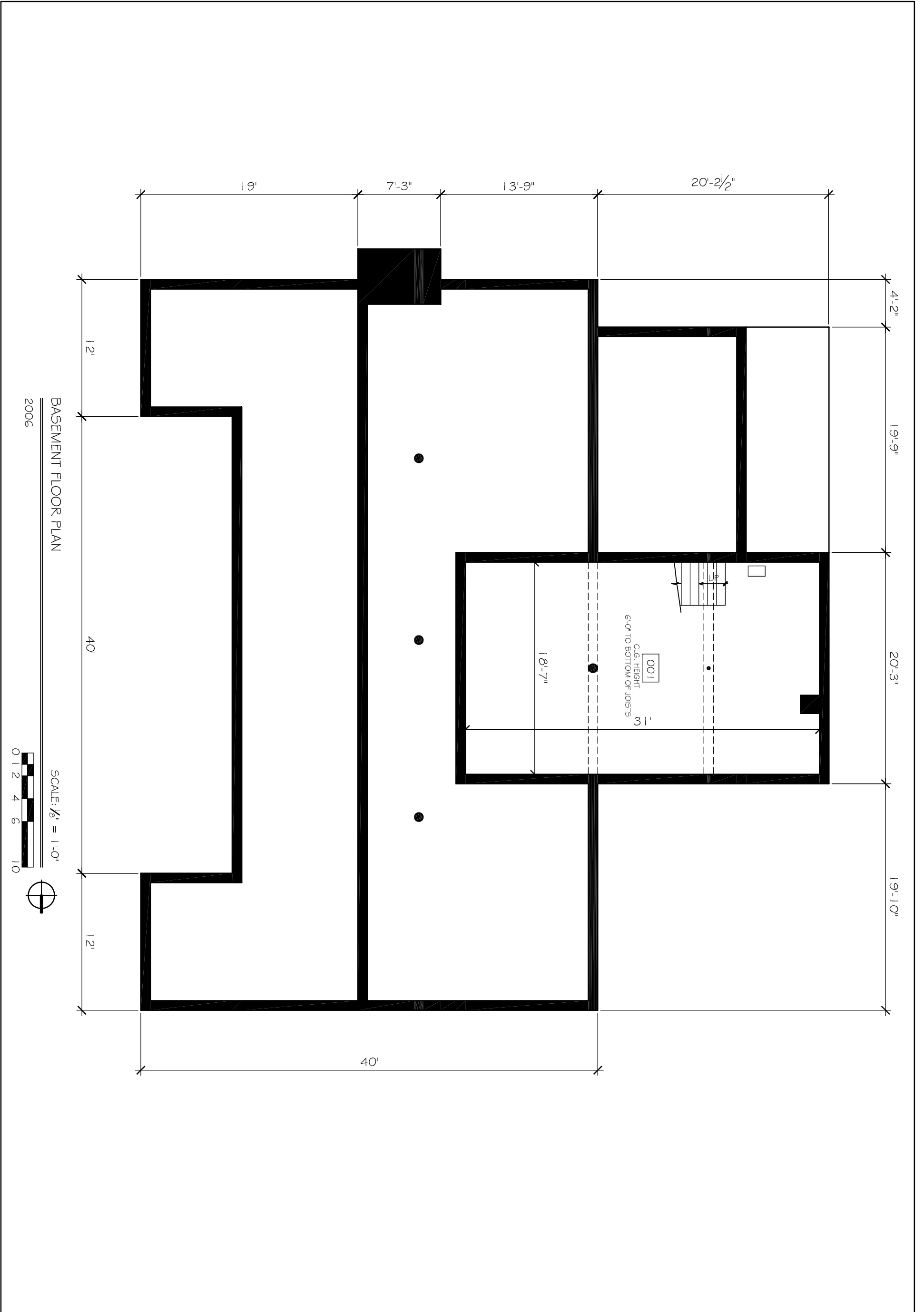

JOB #:	0506
DATE:	04-01-2006
DRAWN BY:	JLP/v
REVISIONS:	
SHEET #:	1

LINCOLN TAVERN
 ABRAHAM LINCOLN BIRTHPLACE
 KNOB CREEK, KENTUCKY

JOSEPH K. OPPERMANN-ARCHITECT, P.A.
 WINSTON-SALEM, NORTH CAROLINA

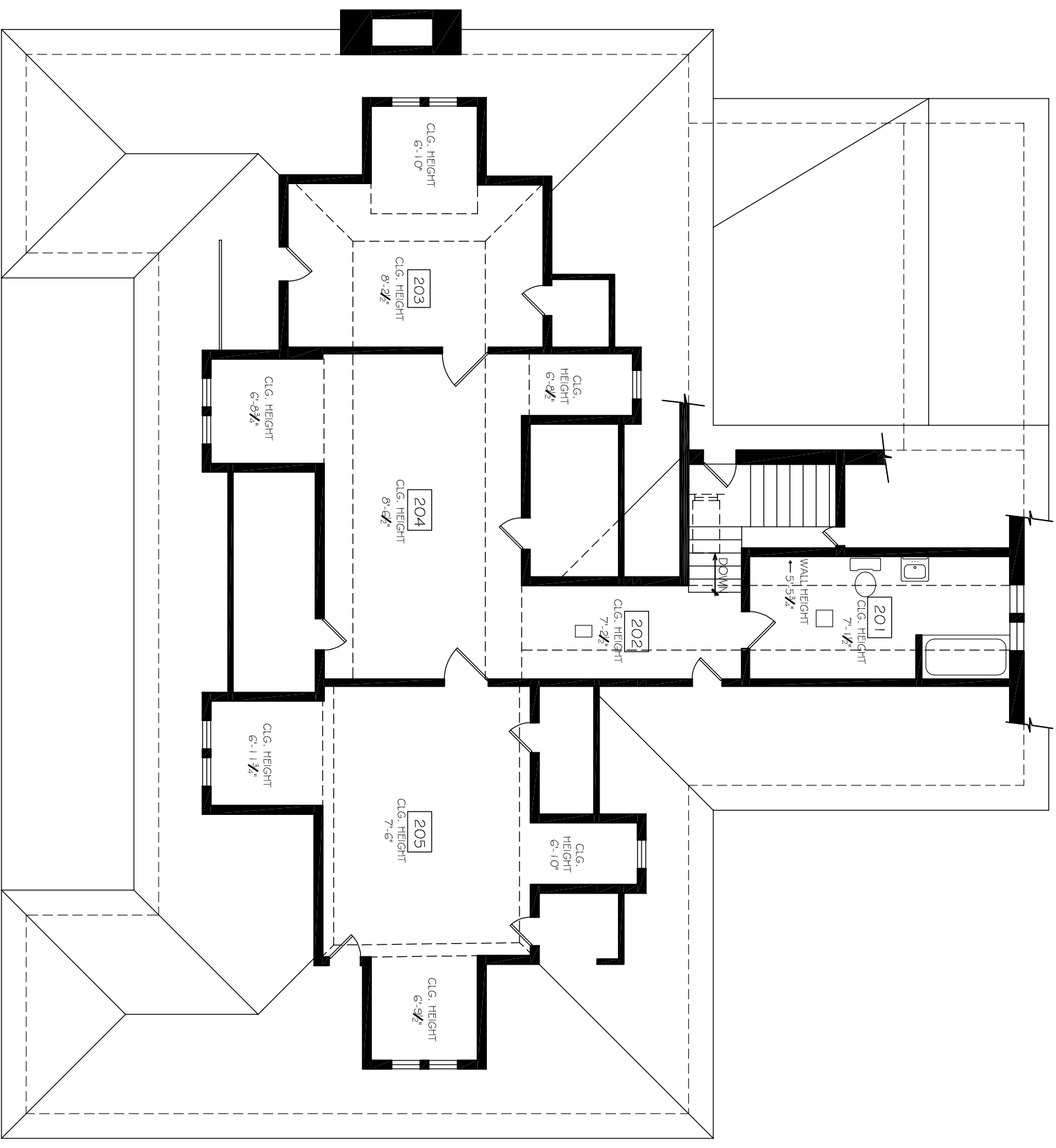

SECOND FLOOR PLAN

2006

SCALE: 1/8" = 1'-0"

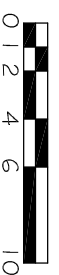

JOSEPH K. OPPERMANN-ARCHITECT, P.A.
WINSTON-SALEM, NORTH CAROLINA

LINCOLN TAVERN
ABRAHAM LINCOLN BIRTHPLACE
KNOB CREEK, KENTUCKY

JOB #: 0506

DATE: 04-01-2006

DRAWN BY: JLP/V

REVISIONS:

SHEET #:

3

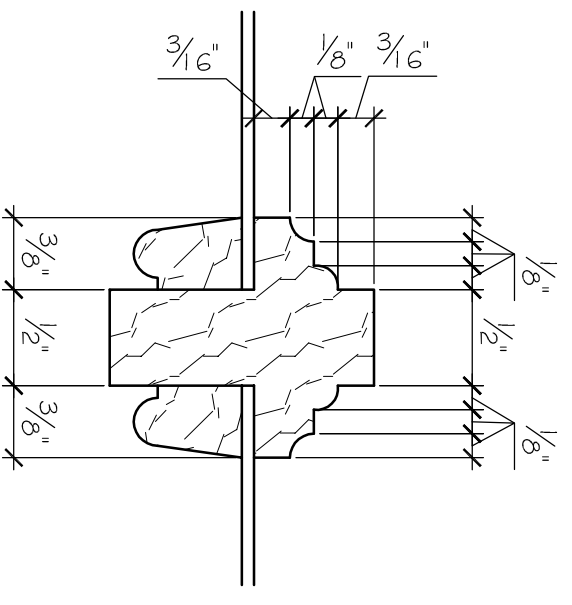

ORIGINAL FRONT DOOR MUNTIN

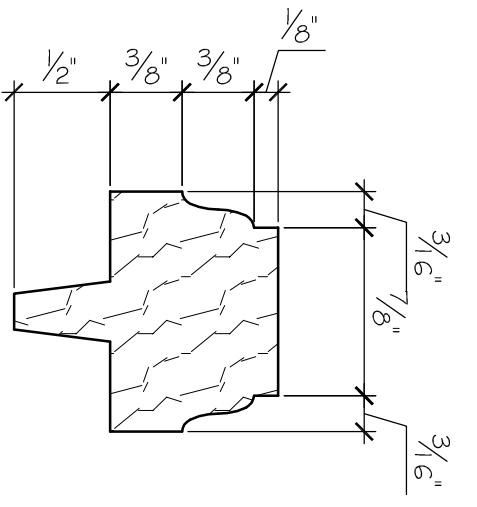

A

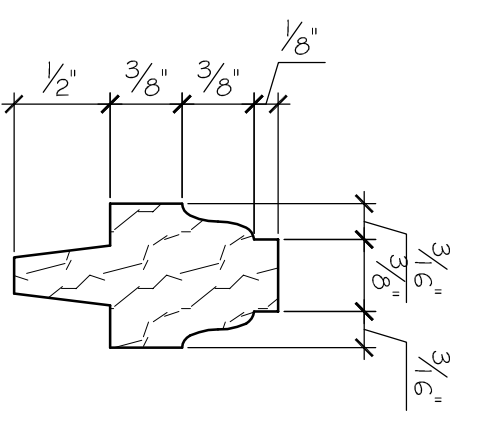

B

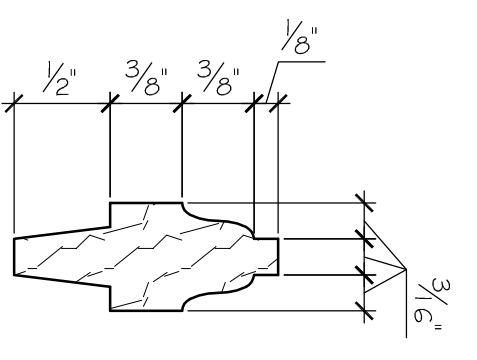

C

WINDOW MUNTIN TYPES

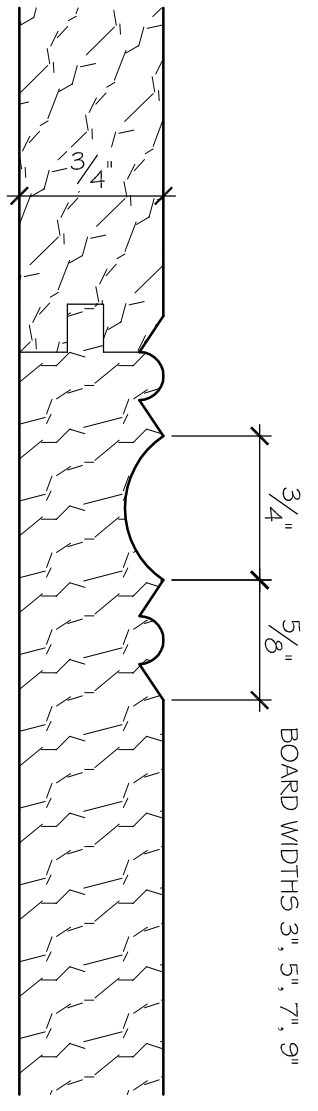

PANELING AT ROOM 102 ALCOVE WALL, C. 1950s

BOARD WIDTHS 3", 5", 7", 9"

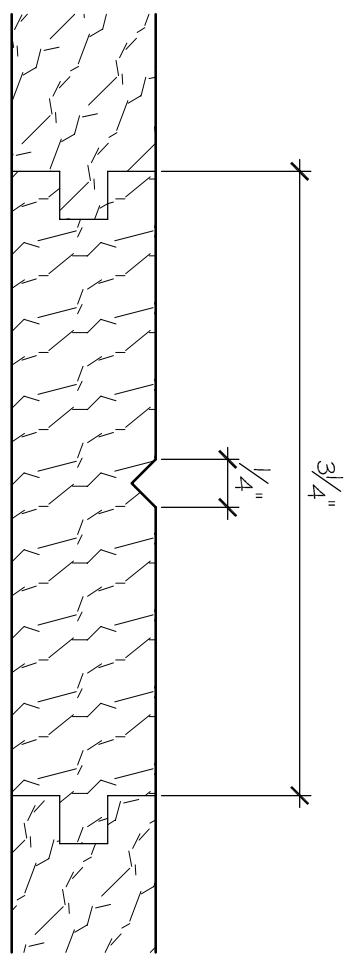

FLOOR, WALL, AND CEILING BOARDS OF HALL

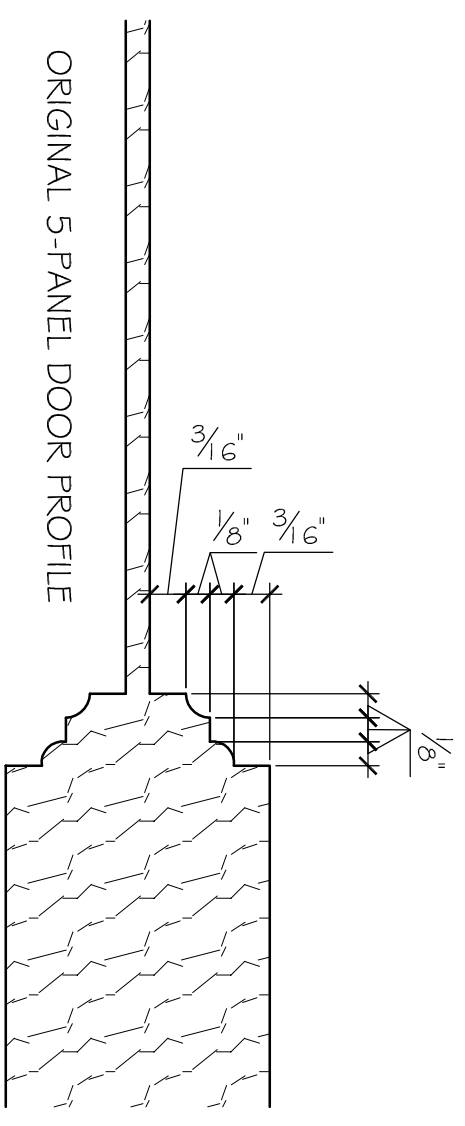

ORIGINAL 5-PANEL DOOR PROFILE

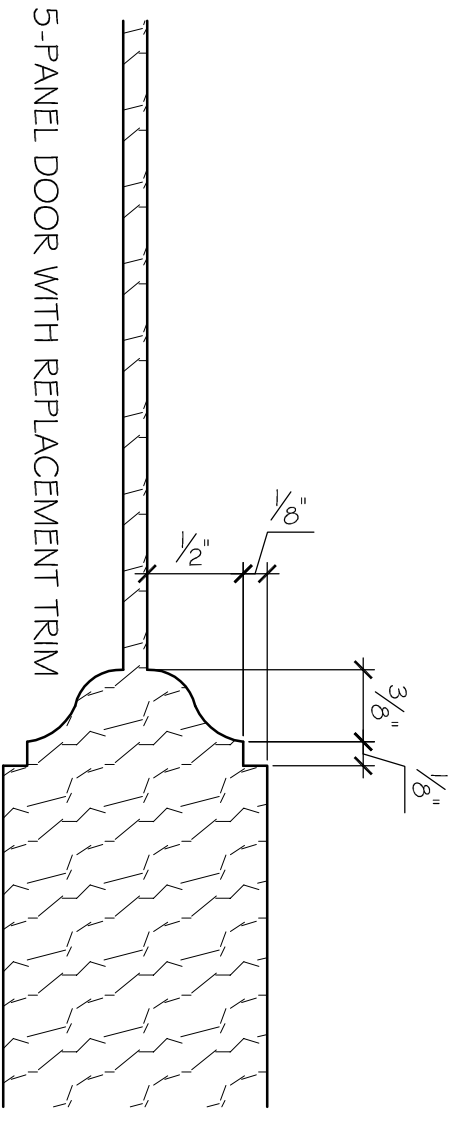

5-PANEL DOOR WITH REPLACEMENT TRIM

DOOR PANEL AND MUNTIN PROFILES

FULL SCALE

2006

JOSEPH K. OPPERMANN-ARCHITECT, P.A.
WINSTON-SALEM, NORTH CAROLINA

LINCOLN TAVERN
ABRAHAM LINCOLN BIRTHPLACE
KNOB CREEK, KENTUCKY

JOB #:	0506
DATE:	04-01-2006
DRAWN BY:	JLP/v
REVISIONS:	
SHEET #:	4

APPENDIX B

Interview Transcripts

1. February 28, 2006 – Mary Brooks Howard
2. March 2, 2006 – Milburn Howard
3. March 10, 2006 – Milburn Howard

TELEPHONE INTERVIEW

Date: February 28, 2006

Subject: Lincoln Boyhood Home
Cabin & Tavern

Interviewee: Mrs. Fred (Mary "Brooks") Howard
Previous Owner

Interview by: Joseph K. Oppermann, FAIA
Historical Architect

JO: *Mrs. Howard, in calling for you I am afraid that I asked for Mary Howard but I now understand that you go by Brooks, not Mary.*

BH: Yes, everyone calls me Brooks.

JO: *And you were married to Fred Howard and lived above the Tavern, I understand.*

BH: Yes, we married in June, 1950 and lived in the apartment upstairs until October, 1953 when our son was born. We never moved back to the apartment. Our house that we were building was ready by then and we moved to it. But Fred lived in the apartment for a while before we got married.

JO: *Could you describe the Tavern when you first lived there and the changes you and Fred made as well as changes by others?*

BH: I used to go there a lot before we got married. Everyone did. It's really very much the same.

The screened-in porch is different now. It was enclosed as a storage room after I sold it in 1986. But as long as I can remember it was a screened-in porch. It was like that when the Tavern was first built, I believe.

Fred put in the shower upstairs in the apartment bathroom in about 1950, just before we got married and moved in.

He built that pine board wall in the hall about then too. It created an office off in that side area near the fireplace. It's still there.

He must have put the cabinets with sink in the back of the kitchen along the west wall by the back door about the same time. Also the peninsula on the north wall. I can't remember cooking in there without them. The wall cabinet on the east wall was always there. The flooring I can't remember.

The two ceiling heaters were installed in the hall in early 1954. I remember because the big furnace in the basement burned out in 1953 about the time our son was born. We never replaced the furnace. Just left it there and those vents that were in the floors. Put the heaters in the hall instead of installing a new furnace.

Fred took the mirror off the bar in the early 1950s. The family story is that the bar came out of a Louisville hotel.

In the mid-1950s we put down a new floor on top of the existing floor in the hall.

Those globe lights were always there in the hall. After 1986 the fluorescent lights were added.

Outside, those lights that are on the front to the sides were there as long as I can remember.

Fred died in 1980. I added the wheelchair ramp about 1982. It doesn't meet codes today but it was an improvement when put in. I don't remember about the concrete porch. Seems like it has always been there.

Family members did install the composition shingle roof. I am not sure when. Don't remember wood shingles being on there before.

One story I remember hearing about the construction of the Tavern is that the mason was convicted of murder before he could complete the work. The family had to find someone else to finish.

JO: What about the Cabin?

MH: I remember that we put on a wood shingle roof in the mid-1950s.

JO: There was a mason jar with a message inside found in 2003 by the contractor working for the National Park Service. The message says that the cabin was rebuilt.

MH: That's fictitious. They were doing repairs and did that as a prank. They certainly didn't rebuild the cabin.

TELEPHONE INTERVIEW

Date: March 2, 2006

Subject: Lincoln Boyhood Home
Cabin & Tavern

Interviewee: Milburn Howard
Previous Owner

Interview by: Joseph K. Oppermann, FAIA
Historical Architect

JO: Mr. Howard, I understand that you were part of the group that bought the property at auction from your aunt, Brooks Howard, in 1986.

MH: Yes, there was a group of us that got together to try to buy it.

JO: Could you describe what changes the group made to the Tavern and when?

MH: We did most of the work in the first few years and then the enthusiasm just sort of dropped off.

About 1988 we enclosed the screened-in porch. Just reused the concrete floor and enclosed the walls. Our plan was to have a counter with a sink and cabinets. Something for people to use without having to come inside if they rented the pavilion and grounds for a party. We built the pavilion then too. And the outside public restrooms. It never quite worked that way, though. People still wanted to come inside to use the kitchen.

About the same time we took out the tile floors in the two in public restrooms inside the Tavern. A bunch of the tiles were cracked or had missing pieces. We put sheet vinyl down as a replacement. The tiles matched the flooring tiles in the kitchen but those were in better condition and we left them in place.

We installed the fluorescent lights in the hall and kitchen. The globe lights had always been in the hall, as far as I know. My Uncle Fred installed the tear-drop lights in the hall to spotlight his exhibits of artifacts.

In 1998 we had a roofer replace the composition roof with a new composition roof.

Two years ago the National Park Service called and told us we had to remove the rest of our things. That they couldn't be responsible for them. The artifacts that my Uncle Fred collected were just two weeks ago turned over to an antique dealer for selling. Some of the things that were originally on display in the Cabin may be donated to a museum. The bar is in my barn.

JO: How about at the Cabin?

MH: Every year we would go down to the creek to get mud for chinking the logs. It was an annual event.

At least twice we replaced logs in the chimney stack. Once we replaced the bottom log at the door to the Cabin. We would find other cabins in the area where we could salvage the logs we needed.

Never did anything to the wood shingle roof except put bleach on it to kill the moss. Uncle Fred put that shingle roof just before he died in 1980.

TELEPHONE INTERVIEW

Date: March 10, 2006
(Continuation of the Conversation of March 2.)

Subject: Lincoln Boyhood Home
Cabin & Tavern

Interviewee: Milburn Howard
Previous Owner

Interview by: Joseph K. Oppermann, FAIA
Historical Architect

JO: Mr. Howard, could you continue with your recollections of the Tavern and the Cabin? Any information you may have about the construction, use or changes over time would be helpful.

MH: My family told me that the bar my grandfather installed in the Tavern had come out of the Seelbach Hotel in Louisville. After the sale of alcohol became illegal, he removed the mirror atop the bar and sold it to "Scorchy" Greenwell who wanted it for his tavern in New Haven, KY. His place later burned and the mirror was lost in that fire.

The wood type of the flooring installed in the hall on top of the original is beech. It was not varnished or shellacked but oiled. Every year my cousins and I had to mop on "red oil."

There never was any heat in the upstairs apartment until my cousin "Fabe" Howard (nickname for Fabian) lived there after we bought the place. He lived in the north room for about 15 years and used the other two rooms for storage. He used a kerosene heater. In about 1990 our cousin Julian Howard, who worked for the Louisville & Nashville Railroad, salvaged a new natural gas furnace from one of the company's buildings that was about to be torn down. Fabe hung it in the basement from the first-floor floor joists and hooked it up to the propane gas. He never switched out the natural gas valve for one designed for propane gas and the furnace clogged. Never worked after that. He just left it. That is the furnace in the basement now. Got pretty cold in the Tavern. Sometimes you would go in and Fabe's dishes would be in the kitchen sink and the water would be frozen solid. But he never seemed to mind too much.

Julian also got for us sinks out of a 1905 railroad building that was being demolished. We put them in the outdoor restrooms that we built but the Park Service removed them.

In the basement is a propane gas water heater next to the brick flue. And next to it is the pump for the well water. Both work fine.

There is a sump pump there, too, in the southwest corner of the room near the bottom of the stairs. For as long as I can remember there was a bull frog that lived in the sump. He would be sitting on the edge when you came down the stairs and would jump into the water and disappear. Next time you went down the stairs, he would be sitting there again.

I'm pretty sure that there never was natural gas on the site. My father went to Columbia Military School in Tennessee and everything had to be just so-so. He always said that he was afraid of natural gas. I am pretty certain that the first furnace was coal burning. Next came propane with Uncle Fred and the heaters on the hall ceiling.

Something else about the site. My cousins and I built the log pavilion on a piece of flat ground. The Park Service tore it down. But some older family members said that the reason it was flat was because it used to be a clay tennis court back when the Tavern was first starting out.

JO: What about the Cabin? What about that Mason jar with a message in it saying the cabin was rebuilt?

MH: It was in the summer of 1986. We had just acquired the property in January and we were anxious to get going. The cabin was in bad shape. We replaced part of the wood floor. Treated for termites. Replaced the bottom logs of the chimney. Got square logs from another cabin. When we had the floor up we thought we would leave a message. Someone got a mason jar out of the gift shop. We made up this story and put it under the flooring. Didn't know it would be found so soon.

The next time we worked on the Cabin was about 1990. Using a log from another cabin we replaced the bottom log on the east side, where the door is. It needs replacing again. Replaced some of the smaller logs in the chimney, too.

JO: What kind of wood is in the Cabin, do you think?

MH: The logs are oak, I think. In the chimney it's a combination of oak and cedar. The cedar holds up pretty well. The cedar is mostly in the smaller branches higher in chimney stack.

I don't know if you have seen the picture of the Cabin in National Geographic Magazine. About 1963, I think it was. But if you look at the chimney, it doesn't look like it does now. The logs of the chimney were much smaller than the ones in there now.

JO: What about in the Tavern? Do you know what kind of wood is used there?

MH: Mostly white oak, I believe. Except for some of those real long logs. They're poplar.

APPENDIX C

Structural Report

DCF Engineering, Inc.

December 8, 2005

05017.C

Joseph K. Oppermann
Joseph K. Oppermann – Architect
Salem Station
PO Box 10417
Winston-Salem, NC 27108

Re: Lincoln Tavern
Knob Creek Farm
White City, Kentucky

Dear Joe:

The purpose of this report is to provide a concise description of the Lincoln Tavern to be included in the Historic Structures Report. The report is based on our December 6, 2005 inspection.

DESCRIPTION

The Lincoln Tavern structure at Knob Creek is a story and a half log structure with a partial basement built in 1933. The basement walls and crawl space walls and piers are cast-in-place concrete. The cast-in-place concrete walls are topped with two eight inch courses of concrete masonry units. The masonry units are smooth faced, chamfered, architectural units.

The Tavern is constructed using the sharp-notch style of log construction which can be accomplished with an axe. Samples from a few of the logs obtained at random, have been identified as Yellow Poplar (*Liriodendron tulipifera*).

The chinking material is a Portland cement, sand-cement mortar that was troweled into the gaps between the logs. The chinking has a relatively smooth finish. It is sloped to encourage water to run off. Although the chinking may be more permanent than the traditional formula of mud, lime, and animal hair or straw, it is not totally compatible with wood because of its ability to absorb and retain moisture.

The post and beam "spine" of the building consists of 10 inch diameter round log beams supporting a floor framed with 6 inch to 8 inch diameter log joists spaced at 24 inches on center. The log beams span approximately 16 feet between 10 inch diameter posts. The log beams support a portion of the second floor and roof above.

The first floor framing consists of 2" x 7 1/8" joists spaced at 16 inches on center.

The roof structure consists of wood sheathing supported by 1 5/8" x 5 1/2 " deep rafters spaced at 24 inches on center. Many of the sheathing boards appear to be recycled material. Most of the roof framing is concealed by gypboard, hardboard, or cardboard materials fastened to the underside of the rafters.

CONDITION

The first floor framing appears to be in good condition except that no headers were provided where the floor joists have been cut for floor grills. The second floor log beams which constitute the "spine" of the building are visibly bowed 1 ½ to 2 ½ inches between supports.

The existing logs are in fair to good condition depending on their location. Logs located at the base of the wall or beneath a window or other obstructions are, in many cases, moderately or severely decayed. The ends of some logs have been attacked by wood destroying fungi. Many of the logs contain numerous small holes associated with post hole borer insects.

The roof structure appears to be in fair to good condition without roof leaks.

DISCUSSION

Traditional log walls pose many problems for owners and those responsible for maintenance of buildings of this type. Log walls are very inefficient from an energy standpoint. Although wood is a good natural insulation material, the gaps between the logs have always caused problems. Many solutions have emerged through the years. These have ranged from using natural insulating material such as moss or Spanish moss as a back up for the chinking.

RECOMMENDATIONS

Repairs to the logs can be accomplished in various ways. Severe surface deterioration can be cut away and replaced with a dutchman repair. If a log is decayed completely through, then the decayed portion of length can be cut out leaving scarf joint cuts at both ends of the piece to be repaired. The replacement segment will have to be shaped to fit the cross section of both ends remaining. Of course, a complete, full length log can be replaced in its entirety.

The timber log beams which constitute the "spine" of the building in support of the second floor, should be replaced with a steel member installed after the second floor is jacked to above the horizontal in each bay. The sequence of structural work should be as follows:

1. The steel replacement member consisting of a W12x26, W10x30, or W8x48 should be placed in position on the first floor in the appropriate bay.
2. After shoring on both sides of each beam, the log beams should be removed and the second floor leveled by jacking to slightly above horizontal. The existing diagonal 6x6 bracing can be removed from the shored bay.
3. The steel beam should be lifted into place and secured to the floor joists and the supporting posts or building endwall.
4. Each log beam can be replaced in turn with steel. The steel beams can be boxed out with wood to match the décor.
5. The decayed logs in the exterior walls should be repaired or replaced where severely deteriorated. Replacement will require needling the structure in places.
6. Miscellaneous repairs can be made, including repairs at the hips, valleys, ridges, and eaves of the roof. Re-roofing should not occur until after the interior work, including all shoring and jacking is complete.

By replacing the round beam with a steel member, the second floor can be made adequate for the support of a 50 psf live load required for occupancy as office space.

ACKNOWLEDGMENT

This report has been prepared for the exclusive use of the Joseph K. Opperman – Architect, and your assignees for specific application to the referenced property in accordance with generally accepted engineering practice.

Our inspection consisted of visual observation only, made solely to determine the structural integrity of the described building. Neither the inspection nor the report covers plumbing, mechanical, electrical, hydrological or geotechnical features.

No other warranty, expressed or implied, is made. These conclusions and recommendations may not reflect variations in conditions which could exist intermediate of the observed locations or in unexplored areas of the building. Should such variations become apparent during construction, it may be necessary to re-evaluate our conclusions and recommendations based upon an on-site observation of the conditions.

We very much appreciate this opportunity to be of service. If you have comments or questions regarding this report, please do not hesitate to contact us.

Sincerely,
DCF Engineering, Inc.

David C. Fischetti

David C. Fischetti, PE
President

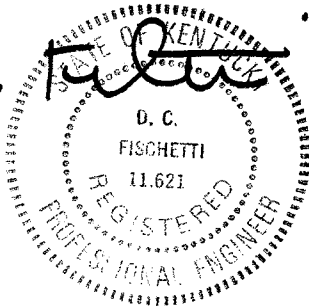



Figure 1 The Tavern is a story and a half log structure with two dormers and two gable endwalls facing the road.

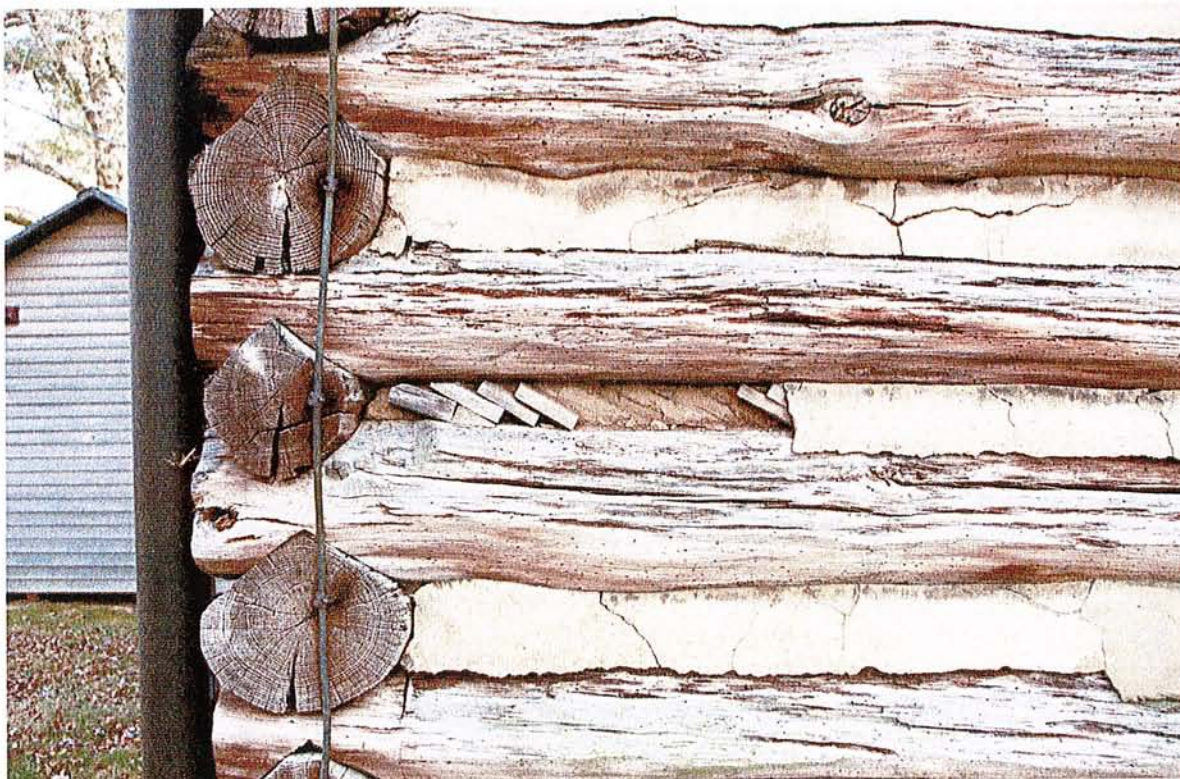

Figure 2 The structure was built using the sharp notch method of joining the logs.



Figure 3 The log walls rest on a cast-in-place concrete perimeter wall with two eight inch courses of block.

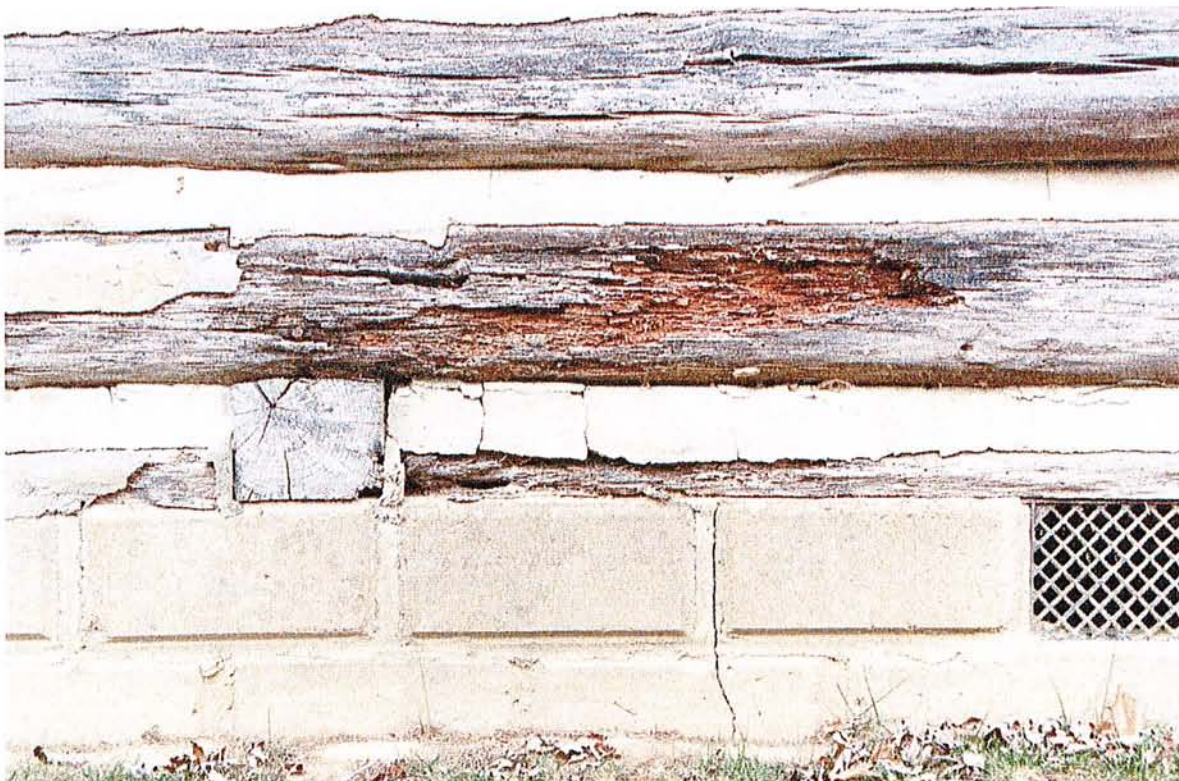

Figure 4 Many of the lower logs are badly deteriorated. Resistance drilling can be used to quantify the amount of material to be replaced.



Figure 5 The bow in the bottom logs and the wide band of chinking indicates that severe deterioration is present at the base of this wall.



Figure 6 Stains and cracks in the chinking are clues to possible wood deterioration.



Figure 7 This vent was added without a header provided where the floor joists were cut.



Figure 8 The screw jack was added to supplement the original support.



Figure 9 Large diagonal 6 x 6 braces were added to reinforce the second floor log beams.



Figure 10 The logs at the top of the wall, under the shed roof of the porch, have rolled out of a plumb position.

APPENDIX D

Mechanical, Electrical, and Plumbing Report

RONALD W. BROWN, P.E.

Consulting MEP Engineers

3200 Southwest Freeway
Suite 2121
Houston, TX 77027-7525

713 621 5660
fax 713 621 5816
cell 832 338 3300

February 1, 2006

Mr. Joseph K. Oppermann, AIA
P.O. Box 10417
Salem Station
Winston-Salem, North Carolina 27108

**REF: MEP SYSTEM OBSERVATION
LINCOLN'S BOYHOOD HOME
HODGENVILLE, KENTUCKY**

Dear Mr. Oppermann:

In accordance with your request, we have performed a visual observation of the "MEP" systems on the above referenced project. This was performed during the month of December 2005.

The purpose of this project was to review the installation of the MEP systems in the tavern and cabin and issue a written report documenting our observations as to the nature of the construction and maintenance of the installed systems.

In addition, our scope included recommending proposed solutions to any problems we may discover and estimating the cost of repair or replacement.

Enclosed please find the results of this observation. Should you have any questions, please do not hesitate to call. Once again, thank you for utilizing our services and look forward to working with you again in the near future.

Yours truly,

Ronald W. Brown, P.E.
Principal

RWB/shg
File 05-0062 Enclosure

TABLE OF CONTENTS

- I. PURPOSE AND SCOPE OF REPORT
- II. PROJECT INVESTIGATION
- III. LIMITATIONS OF REPORT
- IV. PICTURES

Building MEP Observation Report

*LINCOLN'S BOYHOOD HOME
HODGENVILLE, KENTUCKY*

I. PURPOSE/SCOPE:

The purpose of the observation was to observe the readily visible components of the mechanical, electrical and plumbing (MEP) systems installed in the Main Building and to provide a written report stating our professional opinion of the general quality of the workmanship and of the nature of the construction of the building. In addition, it was our purpose to develop a list of substandard quality of workmanship items or code violation items for the client's information.

Due to the fact that the project was complete and there were numerous areas that were inaccessible, the observation consisted of reviewing any available "MEP" plans and observing systems that were readily visible or easily accessible. We cannot guarantee the continued operation of any item of equipment or system. We did not perform any capacity tests or detailed observation on each item of equipment. Our observation is only intended to be a rough overview of the installation and maintenance of the systems as installed. No attempt was made to determine the cause of any system malfunction.

HVAC

The HVAC (Heating, Ventilation, Air Conditioning) systems' functions were observed as much as possible. All equipment should be annually serviced to assure that all components are functioning properly.

Electrical

Outlets and light fixtures were randomly checked. Circuit breaker panel box covers were opened and wire sizes were inspected if possible.

Plumbing

The plumbing functions were randomly checked.

II. PROJECT INVESTIGATION

A. GENERAL

1. There are four significant buildings on the site. The Tavern, a small Log Cabin to the north, a small Pavilion, and a framed storage shed. In addition to these four buildings there is a small, Park Ranger building, located adjacent to the Tavern, which evidently is used as an office.
2. There were no "MEP" drawings available for review.
3. Each of the different buildings has a different type of HVAC system. The Tavern has a Gas Fired unit heater in the Basement. The Office Area has a small window unit. The Log Cabin and Pavilion does not have any HVAC system.
4. Please note the Building has bare minimum insulation in the walls and roof area. We recommend the insulation system be upgraded.
5. Please note the building does not have a vapor barrier installed.
6. Please note there is also no attic ventilation provided.
7. This report will respond to the condition of the MEP systems in the Tavern Building.

B. Tavern Building

1. GENERAL

- a. The building has two gas fired unit heaters on the ground floor and a forced air unit heater in the basement.
- b. . We could not discover the source of the gas. We understand there is a propane storage bottle on site, but we could not locate it.
- c. The forced air heater in the basement area appears to be non functional.

2. GAS FIRED UNIT HEATERS

- a. The two gas fired unit heaters appear to be in fair working condition.
- b. These type of heating systems generally provide 20-25 years of dependable operation with proper maintenance.
- c. The gas fired unit heaters appear to be operational. However, the gas supply appears to have been abandoned.
- d. The unit heaters should provide minimum heat and freeze protection.
- e. If the HVAC system is upgraded and cooing is provided, then the Heaters may be

removed from the site and heating can be provided with the new cooling units.

3. FORCED AIR UNIT HEATER:

- a. The forced air unit heater system appears to be more than 20 years old, and is indicating signs of system failure.
- b. The unit heats the building by means of hot air rising thru a grille located in the first floor, then up thru another grille to the second floor.
- c. This system provides bare minimum building heating. We recommend the system be removed and upgraded

4. OUTSIDE AIR SYSTEM

- a. There is no existing outside air system provided for this building. The building code permits operable windows to be utilized in lieu of having a ducted outside air system. The windows on this building are operable, but this permits uncontrolled outside air into the space. We recommend a conventional ducted outside system to the building thru the HVAC system.
- b. The amount of outside air is very controversial. ASHRAE has issued a standard (ASHRAE std. 62-2000) in which the amount of outside is specified. It states 20 cfm per person.
- c. However, the Building Code states the building may remain as is with the assumption that the building meets the requirements of the Building Code in effect at the time the building was constructed.
- d. The majority of the controversy is: Do you leave the building as is, or do you upgrade the outside air quantity to meet the current building code. Please note the building code changed because the previous outside air quantity proved to be insufficient.
- e. As a Professional Engineer, we have to recommend the upgrade as recommended by the current Building Code in order to reduce our liability.
- f. The pricing exercise we provided includes the recommended upgrade.

5. DUCTING SYSTEM

- a. The duct work that was visible was constructed with sheet metal.
- b. Obviously if there are new HVAC systems proposed and installed, the existing duct will be removed and not reused. It is not capable of being retro fit into the

new systems.

6. AUTOMATIC CONTROLS

- a. The control system consists of primarily self contained thermostats.
- b. The proposed HVAC automatic control system should be upgraded to a DDC system to permit remote monitoring and operation.

7. PROPOSED NEW HVAC SYSTEMS:

- a. Provide two new ducted supply air and return air systems located in the basement to serve the first floor. The two new systems would be similar in design and duplicated in capacity to provide some sort of redundancy.
- b. Provide two new ducted supply air and return air systems located on the second floor that would serve the North side and South side of the building. The systems would be similar in design, and each sized to maintain temperature in their respective zones. There are areas on the second floor where the units could be located and permit access space for maintenance.
- c. Our preliminary calculations indicate 20 tons required on the first floor, and 15 tons required on the second floor.
- d. We recommend Heat Pump units to reduce energy costs. The heat source should be electric to provide for removing the hidden propane storage bottles.

C. ELECTRICAL SYSTEM

1. The Main Electrical service is located at the North West corner, exterior of the Tavern building. The electrical service is conventional overhead service from the North side of the site.
2. The service size was unmarked but appeared to be 200 amps, at 120/240 volt, single phase. It does not appear to be overloaded. (Ref: Picture E-1 & E-2)
3. The electrical service for the entire project is located here.
4. The ground wire was reviewed and appears to be properly sized and installed.
5. The electrical system has been added on to over the years. Very little of it is concealed. There was exposed wiring and some romex utilized in the project. This should be removed as soon as possible. It will be very difficult to conceal the wiring but a better attempt can be made.

6. The light fixtures in the building may be upgraded to energy efficient fluorescent type. There should be automatic controls provided to operate the lights and maintain some security.
7. There were no exit signs in the building. The pricing exercise included the cost of adding exit lights.
8. There are no emergency egress lights in the building.
9. There is no Emergency Generator associated with the site.
10. There are no apparent problems with the electrical service.

D. PLUMBING

1. The plumbing systems are extremely old and appear to be barely serviceable.
2. The water heater also has a minor water leak.
3. Note the water source is well water and is supplied thru a water pressure booster system. This will be eliminated after the water source from the city is provided.
4. The sanitary sewer system is a septic tank system, with the drain field located to the south. It was investigated but because of the concealed nature it could not be found.

E. FIRE PROTECTION SYSTEM

1. There is no automatic fire sprinkler system provided for this building.
2. There is a small Fire Detection system install but it could not be determined if it was functional or not. It appears to be a very minimal system.
3. The Fire Alarm system had been evidently recently installed. It should be inspected by a qualified Fire Detection Contractor. It should also be annually serviced by a Qualified Fire Detection Contractor.

III. LIMITATIONS OF REPORT

Opinions and comments stated in the report are based solely on our visual survey. This observation does not constitute a guarantee or warranty, expressed or implied, regarding the current or future performance of any item inspected.

We have inspected each item, available, to the best of our ability, and unless otherwise stated the systems were operating satisfactorily during our observation.

The construction cost estimates included in this report are our approximations of the cost of the work in accordance with our professional opinion and previous experience of construction costs on projects of a similar nature.

All construction cost estimates are approximations only and shall not be construed as a bid nor an offer to perform the work. The scope of work must be itemized prior to a firm price commitment and bids must be submitted by a qualified contractor.

IV. PHOTOGRAPHS

See Following Pages

END OF REPORT



As the nation's principal conservation agency, the Department of the Interior has responsibility for most of our nationally owned public lands and natural resources. This includes fostering sound use of our land and water resources; protecting our fish, wildlife, and biological diversity; preserving the environmental and cultural values of our national parks and historical places; and providing for the enjoyment of life through outdoor recreation. The department assesses our energy and mineral resources and works to ensure that their development is in the best interests of all our people by encouraging stewardship and citizen participation in their care. The department also has a major responsibility for American Indian reservation communities and for people who live in island territories under U.S. administration.

NPS D- 36 June 2006