

NIST

Vehicle Scale Training

Kansas City – September 24, 2003



Key Elements In Selecting The Right Vehicle Scale Solution



Transducer Type



Weighbridge Style



Lightning Protection



Terminal Functionality



Information Management



Delivery & Installation



Service



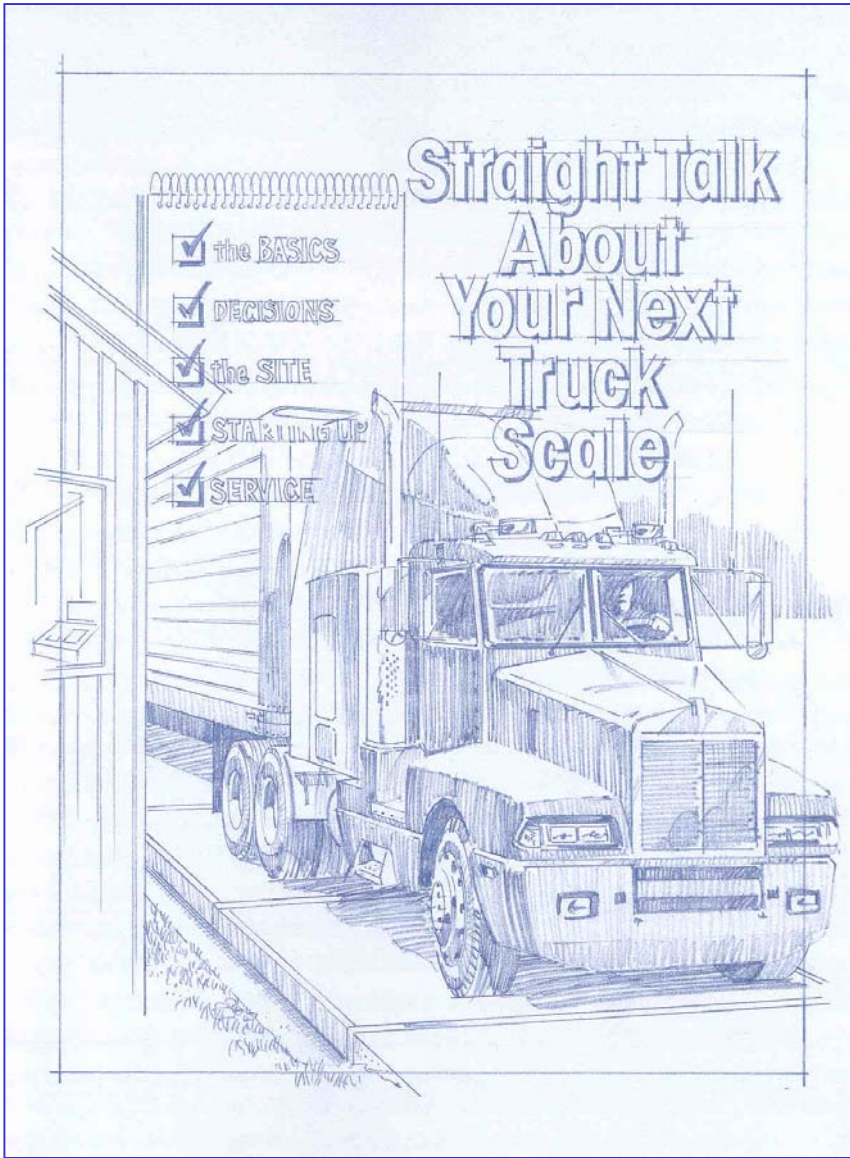

METTLER TOLEDO

*Competency & Confidence
Through Education...*



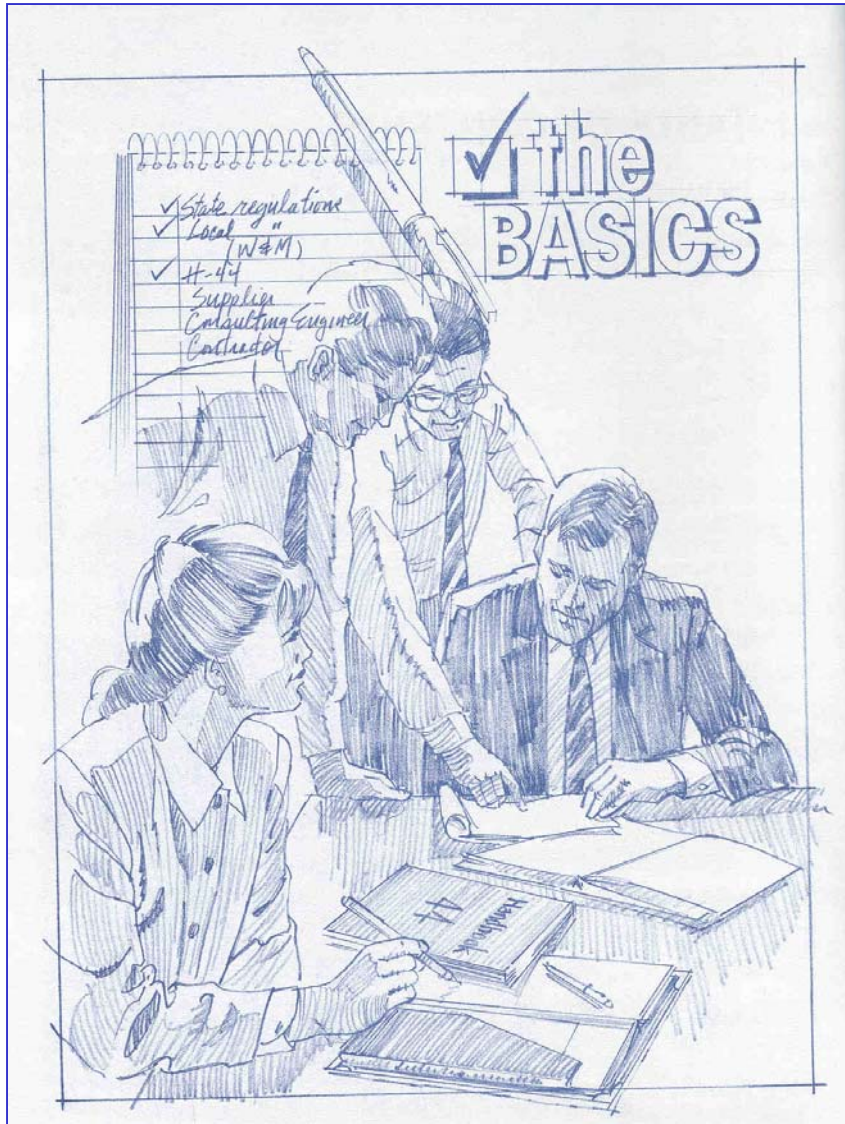

- **Regulatory Considerations**
 - State, Federal, Local
- **Selecting The Right Team**
 - Scale Supplier
 - Engineer
 - Contractor
- **ROI & Downtime Calculations**
 - Value of the transaction, inventory, wear & tear on vehicles, etc...



✓ DECISIONS

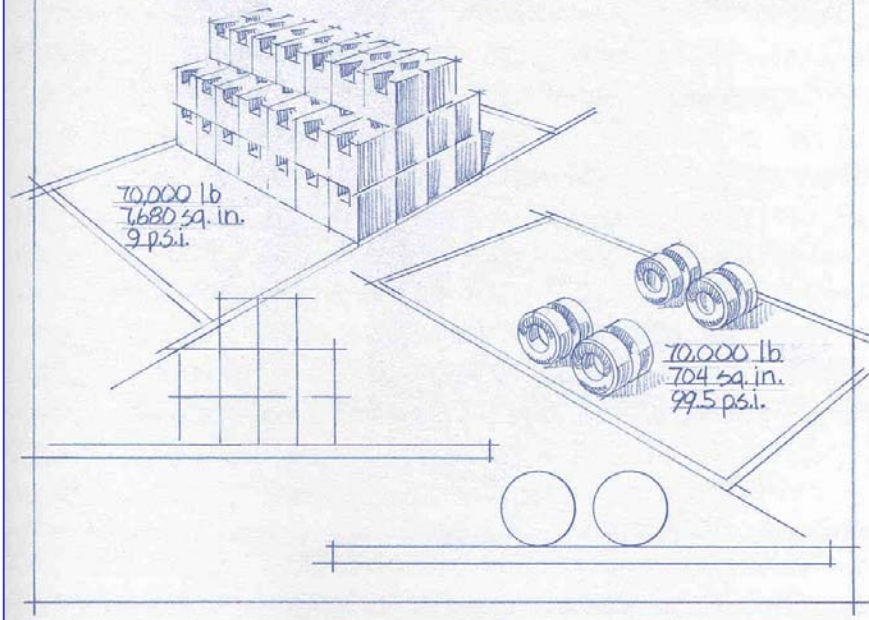
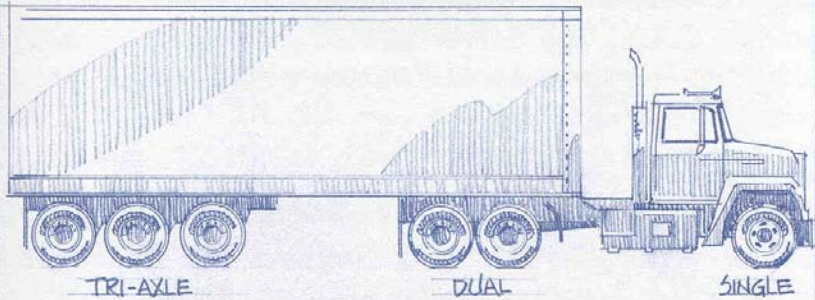

- **Foundation Type**
 - Pit, pitless, temporary, permanent
- **Size & Capacity**
 - Gross & DTA
- **Deck Construction**
 - Concrete, steel,
- **Weighing Technology**
 - Mechanical, electro – mechanical, analog, hydraulic, digital
- **Terminal & Data Handling**
- **Equipment Certifications**



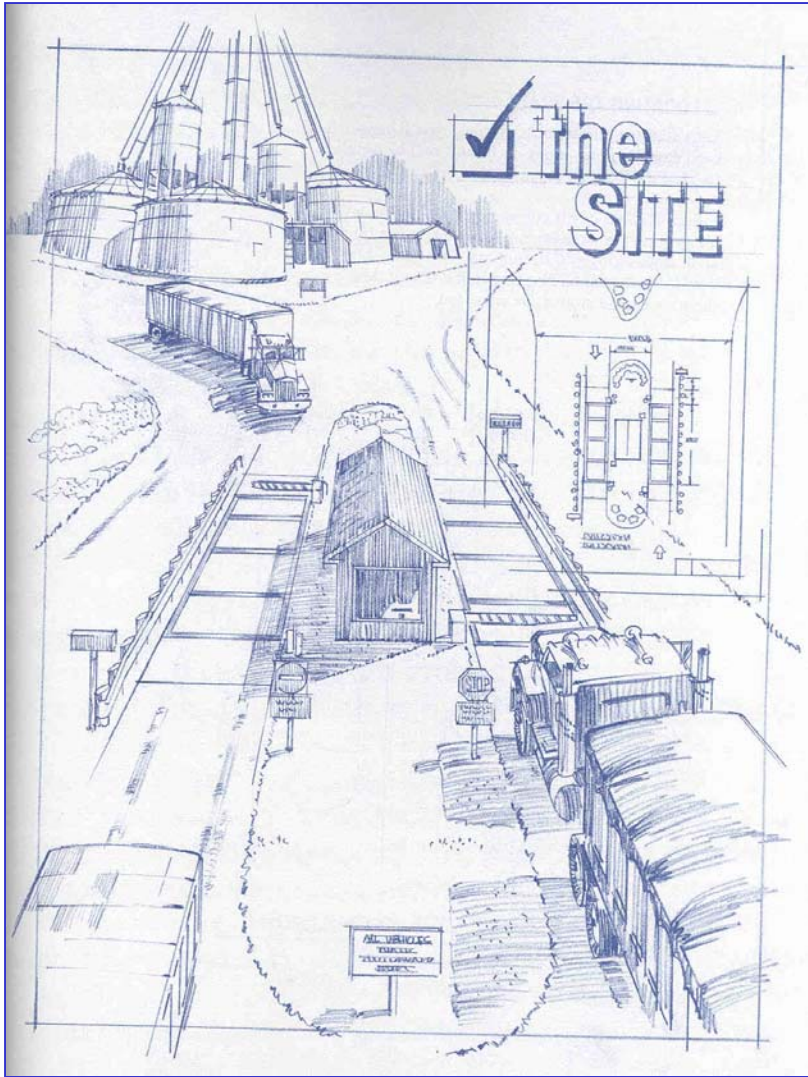

- **Locating The Scale**
 - Low or high volume sites
- **Site Conditions**
 - Drainage & Sub-surface obstructions
- **The Foundation**
- **Locating The Scale House**
 - 24 Hour operation?
 - Remote monitoring
- **Approaches**
- **Hazardous Materials**



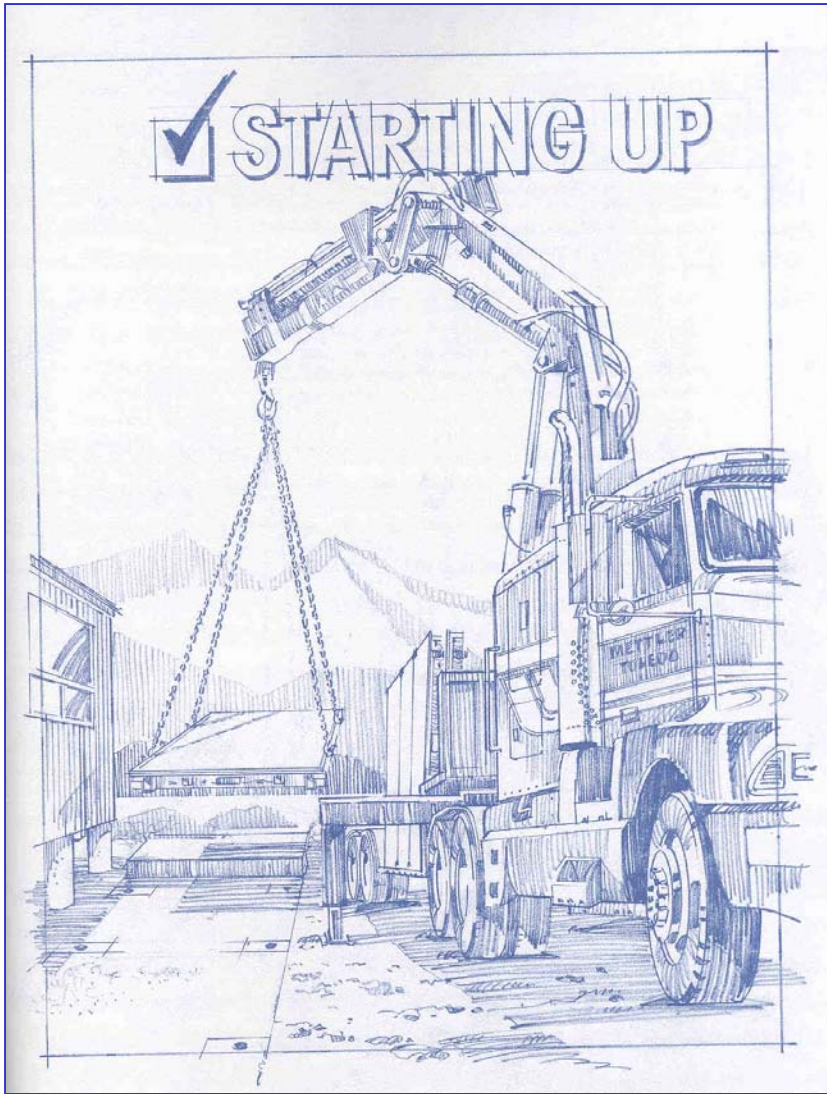

- **Scale Installation**
- **Calibration**
- **W&M Approval & Certification**



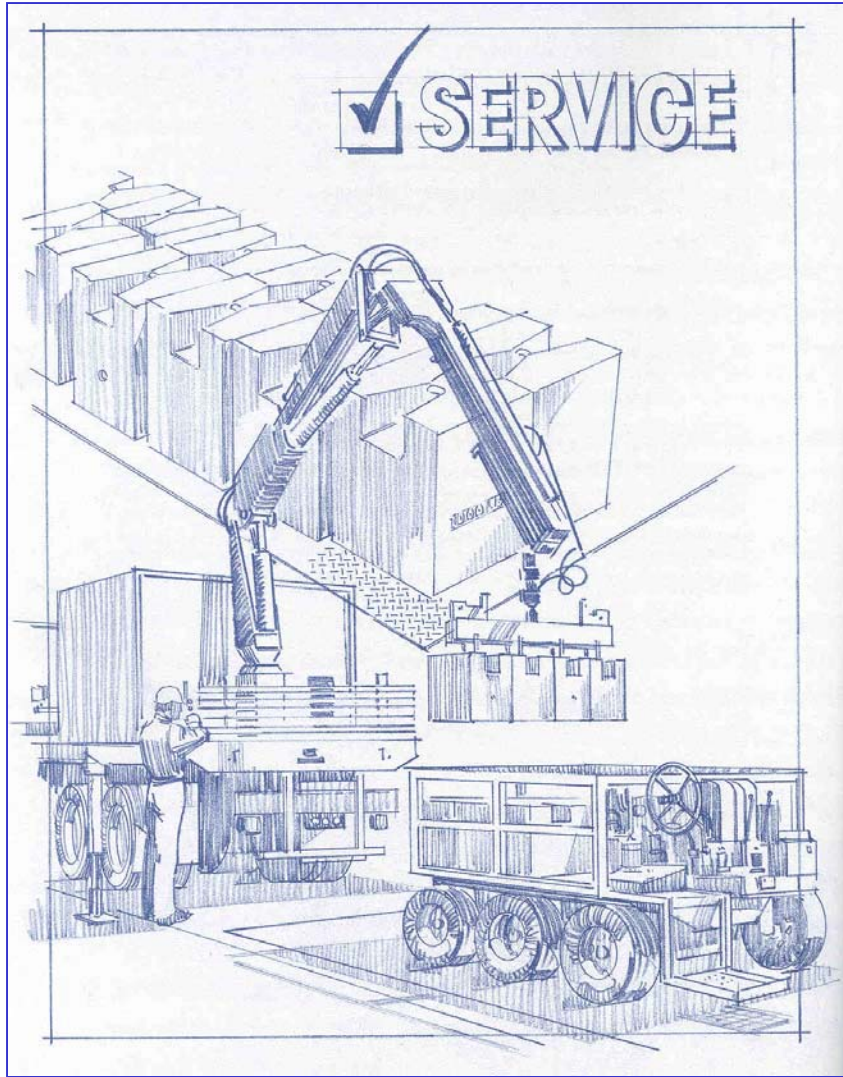

- **Scheduled Maintenance**
- **Emergency Service**
- **ISO Certification & Support**



CHECKLIST

THE BASICS

- Federal Scale Specifications
- State, Local, and Other Regulatory Bodies
- The Scale Team
- Downtime Calculations

TRUCK SCALE DECISIONS

- Pit vs. Pitless
- Weighbridge Size
- Scale Capacity
- Deck Construction
- Weighing Technology
 - Mechanical
 - Analog Load Cell
 - Hydraulic
 - Electromechanical
 - DigitTOL® Digital Load Cell
- Data Handling
- NTEP Certification

THE SITE

- Locating the Scale
- Site Conditions
- The Foundation
- Locating the Scale House
- Approaches
- Hazardous Materials

STARTING UP

- Scale Installation
- Testing and Calibration
- Weights and Measures Approval and Certification

SERVICE

- Scheduled Maintenance
- Emergency Service
- ISO 9000 Support

METTLER TOLEDO

Mettler-Toledo, Inc. Scales & Systems

USA
350 W. Wilson Bridge Rd.
Worthington, Ohio 43085
TEL (800) 786-0038
FAX (614) 438-4783

Mettler-Toledo Inc. Canada

TEL (800) 263-6593
FAX (905) 681-1511

Mettler-Toledo Ltd. Australia

TEL (61) 3 9646 4551
FAX (61) 3 9645 3835

International Operations

Americas and Pacific Rim
TEL (614) 438-4801
FAX (614) 438-4755

Europe, Africa, Near East
TEL (41) 1 944 22 11
FAX (41) 1 944 30 60

Specifications subject to change without notice.
© 1998 Mettler-Toledo, Inc.
METTLER TOLEDO, DigitTOL and
Pitless® are registered trademarks
of Mettler-Toledo, Inc.
Printed on recycled paper
with a vegetable-based
ink.
Printed in USA.
020087
1200C 0001

- **Checklist Provides...**
 - Great way to step through the process with the user.
 - Makes sure all competitors provide the same information
 - Prompts structured discussion & dialog
 - Sets the user up for acceptance of more technical/sales information





Transducer Positioning





Model 7461

Model 0782 Analog Load Cell

- 30t Capacity
- 400 Series
Stainless Steel
- 40' Integrated
Cable
- Output Resistance
1000Ω
- IP68 Protection
Class
- NTEP COC #01-





POWERCELL® Brand

Load Cell

DIGITAL POWERCELL®
Vehicle Scale Load Cell

Provides Better Performance
than Conventional Analog Load Cells

METTLER TOLEDO

- Introduced March 1988
- Tremendous Impact!
- Trusted Product
- Over 250,000 Installed!
- Global Approvals & Acceptance
- Best In Class...Even Today
- Flagship Product





POWERCELL® Brand



- Secondary Message:

- Performance Acceptance

- Tantalum

- Cost
- Accuracy
- Stability
- Growth

- Only Digital Vehicle Scale Transducer In Wide Spread Use On ALL CONTENIENTS!



MTX[®] Brand Load Cells

2nd Generation DigiTOL Transducers



25t & 45t Capacity

***Our Next Generation While
Others Learn From Their 1st!***



MTX™ Brand Load Cell

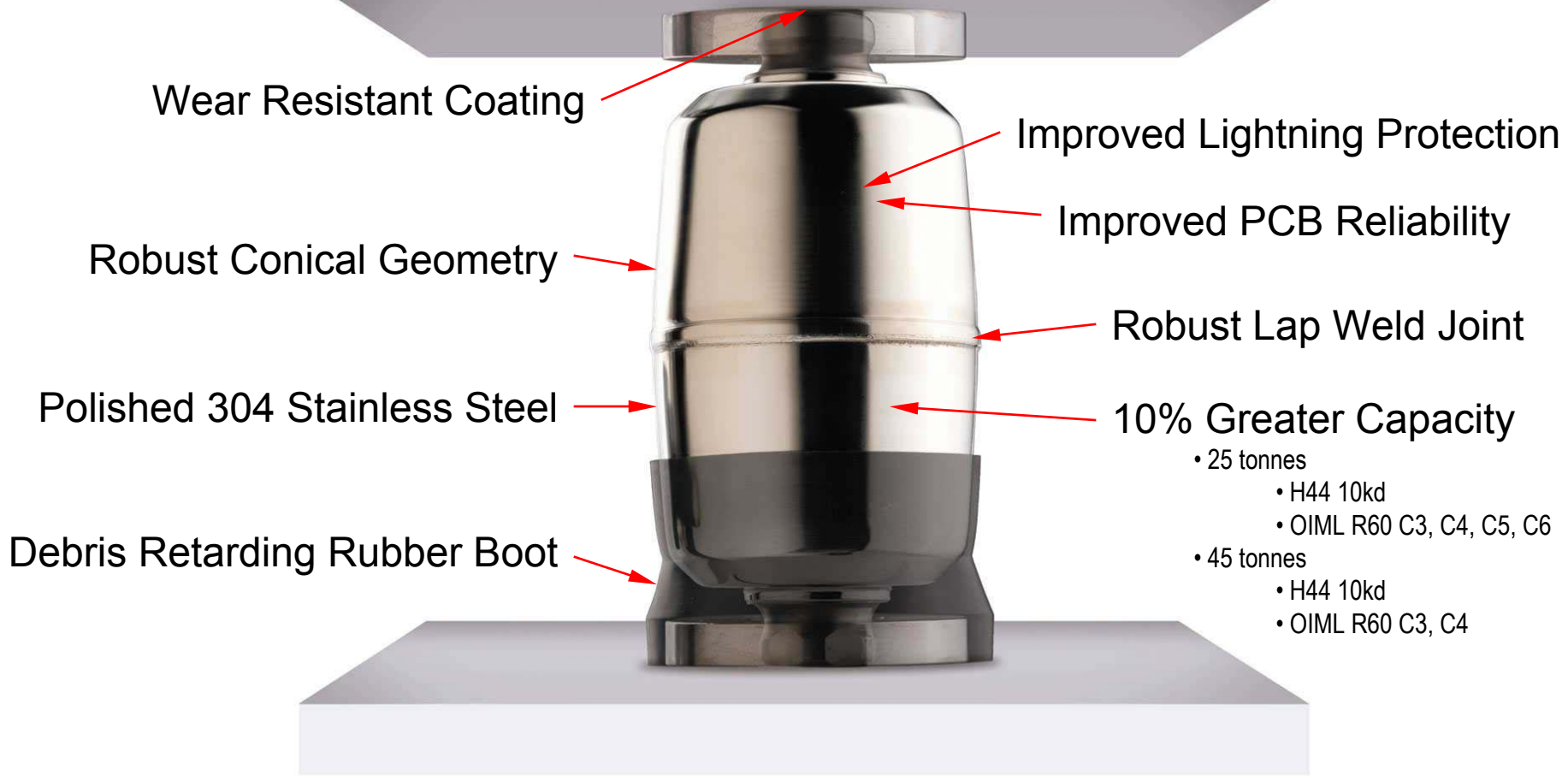



Truck Scale Product Positioning

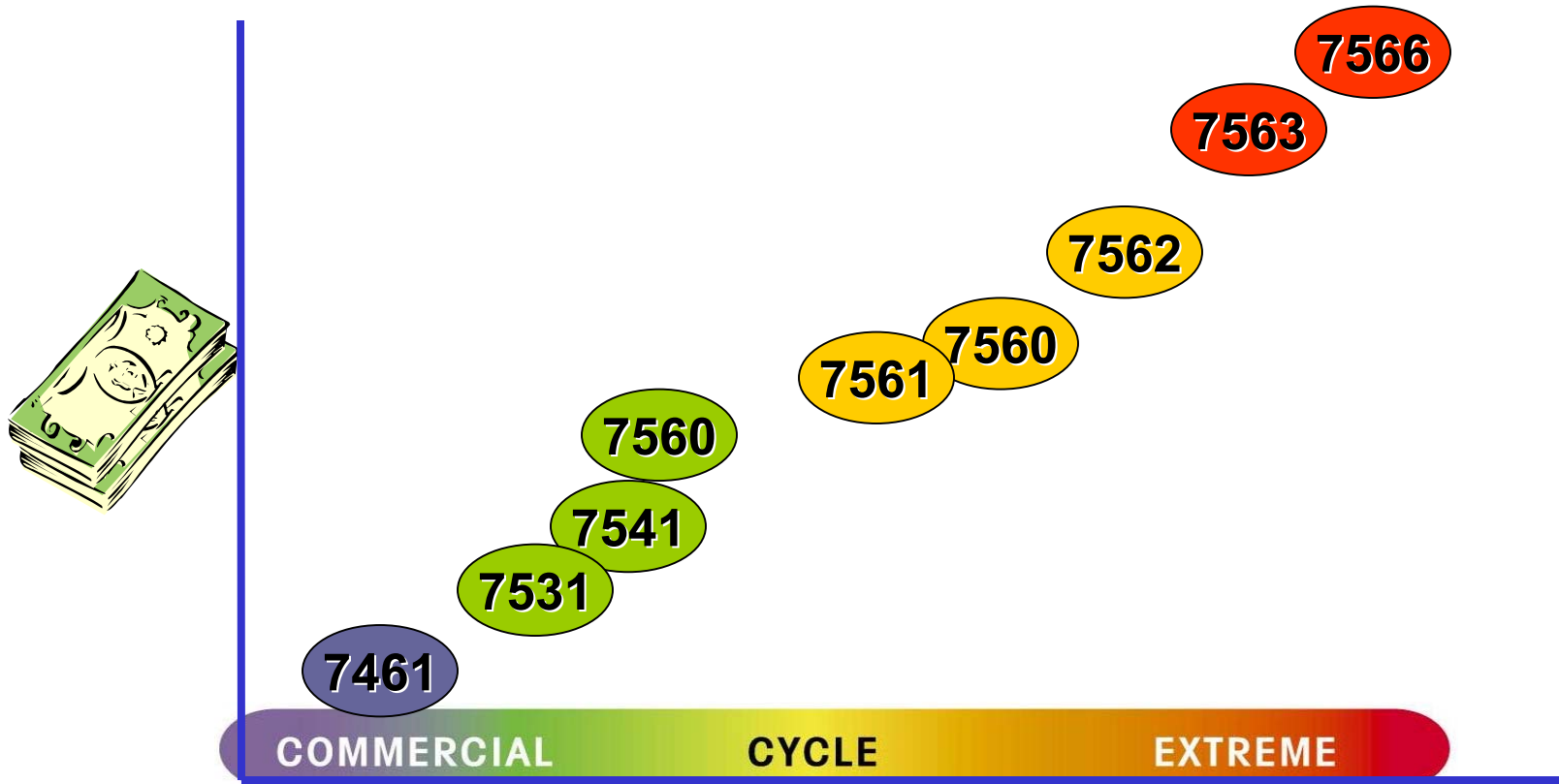



Steel Deck Truck Scales

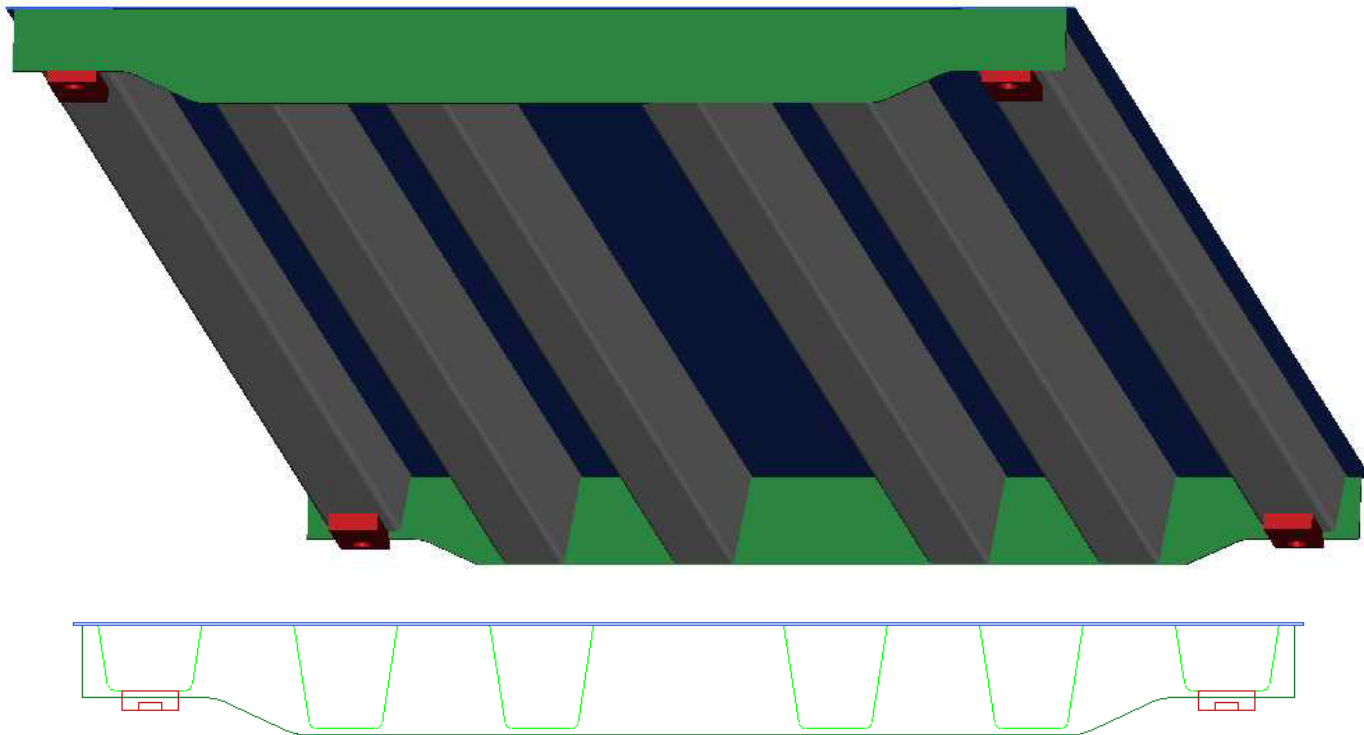



Orthotropic Design

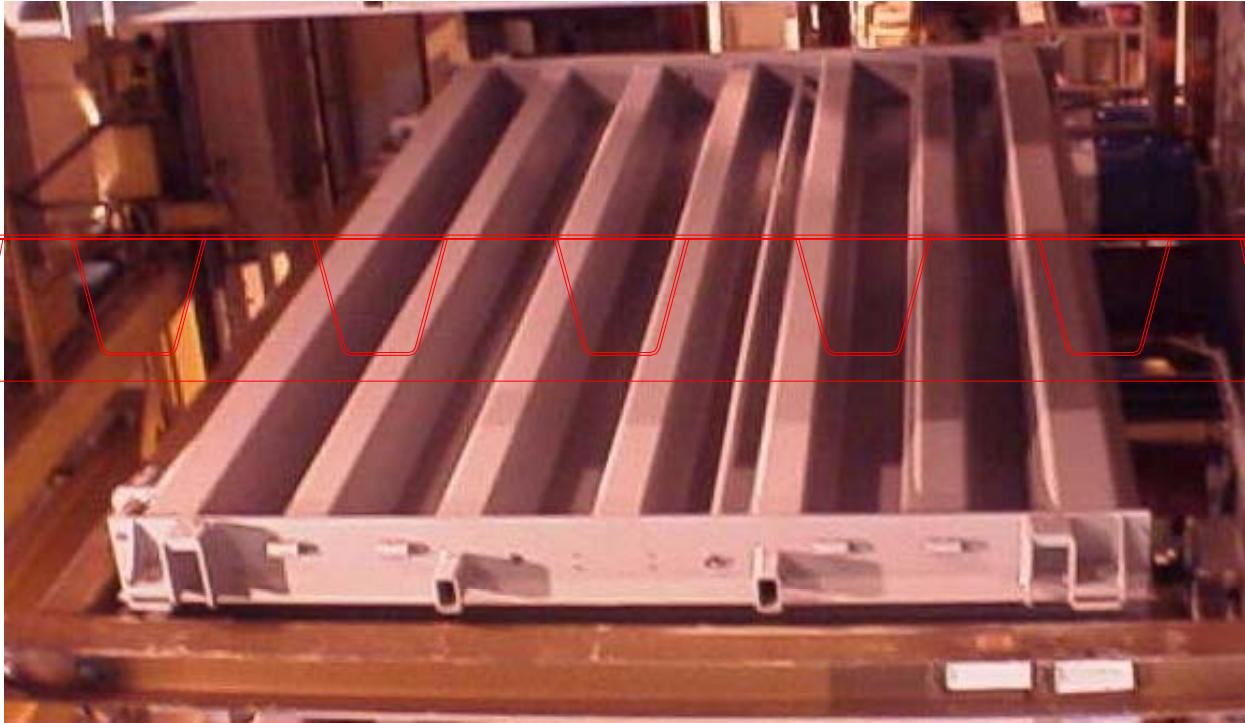

Proven Design...Exceptional Strength





Model 7461 Truckmate®



- Analog Operation
- Steel Deck
- 60,000 lb. CLC
- 17'-6" and 20' Modules
- 10' or 11' Widths
- 5 Year Limited Warranty
- Lightning Protection (Optional)



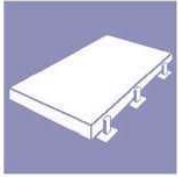

Model 7560 Truckmate®



- **DigiTOL POWERCELL Operation**
- **Concrete Deck**
- **60,000 lb. CLC**
- **17'-6" and 20' Modules**
- **10' or 11' Widths**
- **5 Year Risk Free Guarantee**
- **Lightning Protection Standard**





Model 7562 Truckmate®

- DigiTOL MTX Operation
- 80,000 lb. CLC
- 17'-6", 20', & 23'-4" Modules
- 10', 11', or 12' widths
- 5 Year Risk Free Guarantee
- Lightning Protection Standard





Model 7562 Truckmate® Portable

- DigiTOL MTX Operation
- 80,000 lb. CLC
- 35', 70', & 105' Modules
- 10' width
- Easy & Quick Set-up
- Aggregate Base
- 5 Year Risk Free Guarantee
- Rent, Lease, Or Buy
- Lightning Protection Standard



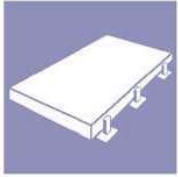

Model 7563 Truckmate®

- DigiTOL MTX Operation
- 80,000 lb. CLC
- 17'-6" and 20' Modules
- 10', 11', or 14' widths
- 5 Year Risk Free Guarantee
- Lightning Protection Standard





Model 7566 Truckmate®

- DigiTOL MTX Operation
- 130,000 lb. CLC
- 17'-6" and 20' Modules
- 11' or 20' Widths
- Extreme Duty
- 5 Year Risk Free Guarantee
- Lightning Protection Standard



Concrete Deck Scales

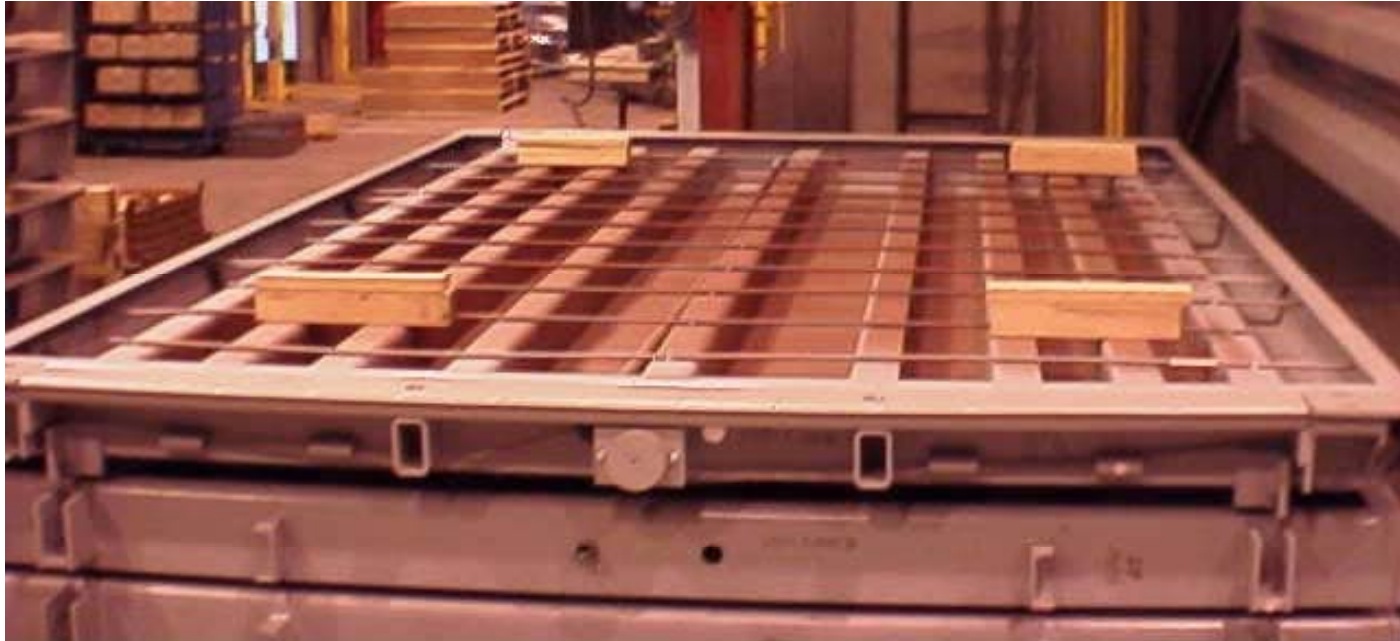

Model 7560 Truckmate® Pour-In-Place Module





Model 7560 Truckmate®



- 60,000 lb. CLC
- 15', 17.5', and 20' Modules
- 10', 11', 12' Widths
- 5 Year Risk Free Guarantee
 - DigiTOL POWERCELLS
 - Lighting Protection





Model 7531 Truckmaster®



- 45,000 lb. CLC
- DigiTOL POWERCELL Operation
- 20' and 25' Modules
- 10', 11', 12' or 14' Widths
- Pit-less Installation
- Bolt-Together Design
- 5 Year Risk Free Guarantee
- Lightning Included



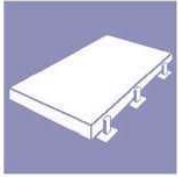

Model 7531 Truckmaster®

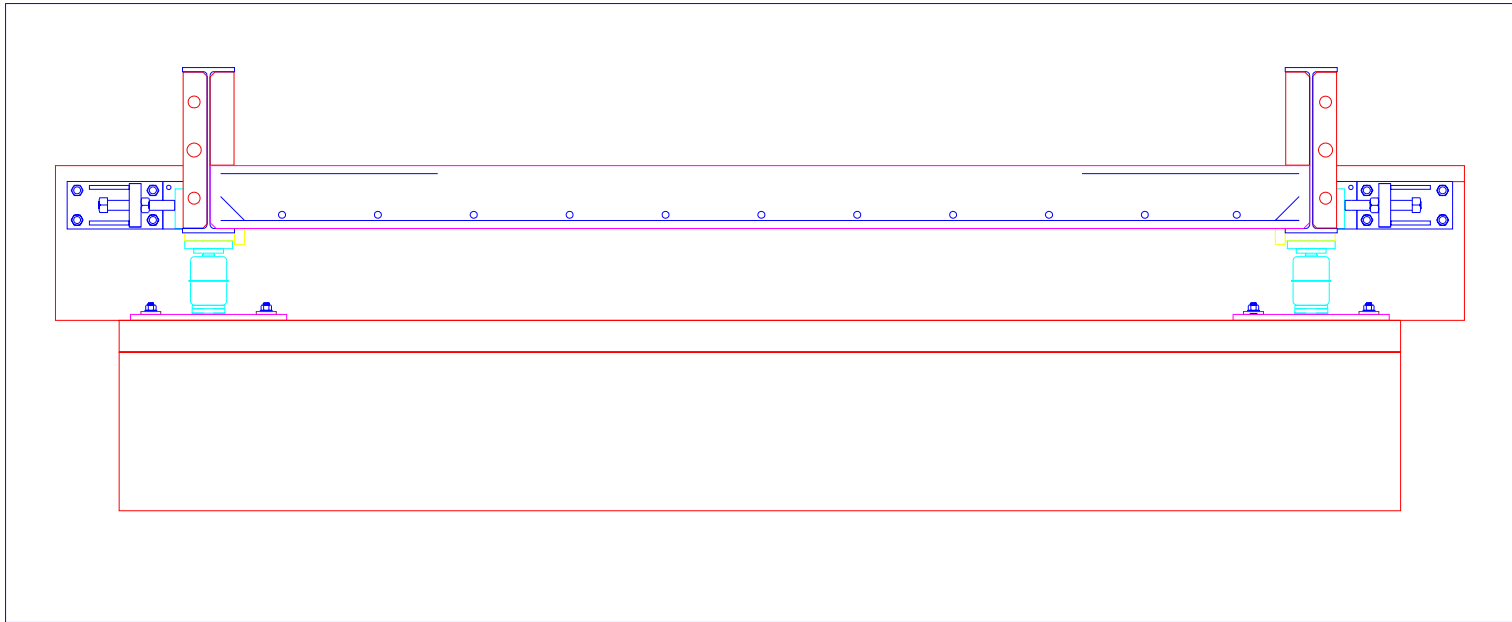



Model 7541 Truckmaster®



- 45,000 lb. CLC
- 20' and 25' Modules
- 10', 11', & 12' Widths
- Commercial Duty
- Optional Cycle Duty
- DigiTOL POWERCELL Operation
- Bolt Together Design
- Pit Installation
- 5 Year Risk Free Guarantee
- Lightning Included





Model 7541 Truckmaster®

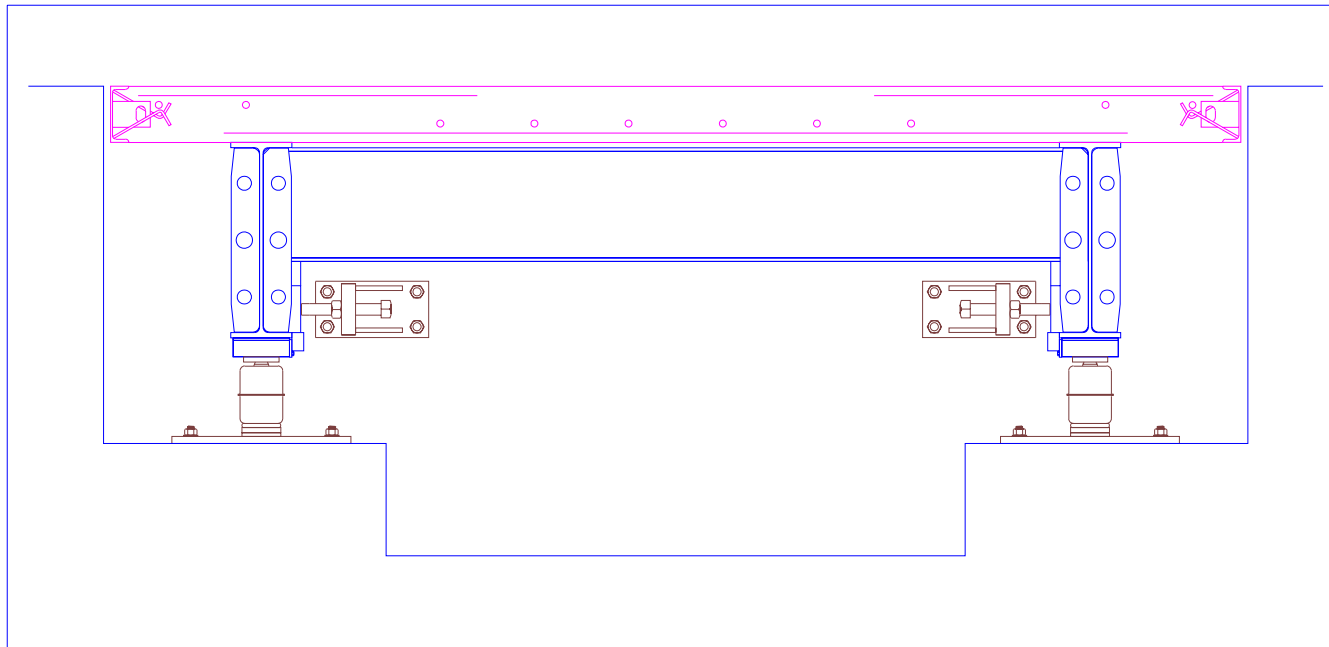

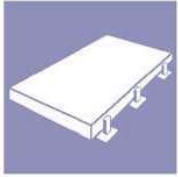

Railmate® & Railmaster®



Railmate®

- Static or Coupled In-Motion
- Single or Dual Draft Weighing
- 12' or 25' Modules
- Pit or Pit-less Installation
- DigiTOL MTX Operation
- 5 Year Risk Free Guarantee W/ Lightning Protection

Railmaster®

- Combination Rail / Truck Scale
- 75' Standard, Custom Lengths Available
- Pit Installation
- DigiTOL MTX Operation
- 5 Year Risk Free Guarantee W/ Lightning Protection



Being Best In Class

**Lightning Protection Is
A Challenge For Anyone!**





StrikeShield™

For POWERCELL & MTX Best In Class Protection!

Power line
surge protection



Gas discharge
tubes – sense
current and
short to ground.

Robust load cell
PCBs – designed
to withstand surges
in this system

Single point
ground – provides
path of least
resistance away
from electronics.

Stainless steel shielded cable
with drain wire – carries surge
on outside of cable

Independently Tested & Verified!

Competitive LPO

Traditional Method – Single Stage Protection

Components:

- Ground Rod
- Input Surge Protector
- Surge Protected J-Box PCB

Advantages:

- Cheap
- Limited Protection

Disadvantages:

- Gas Discharge Tubes Slow To React
- No Protection On Terminal Side Of Home Run Cable
- Loss of “Trim” Settings When PCB Is Replaced – Recalibration Required

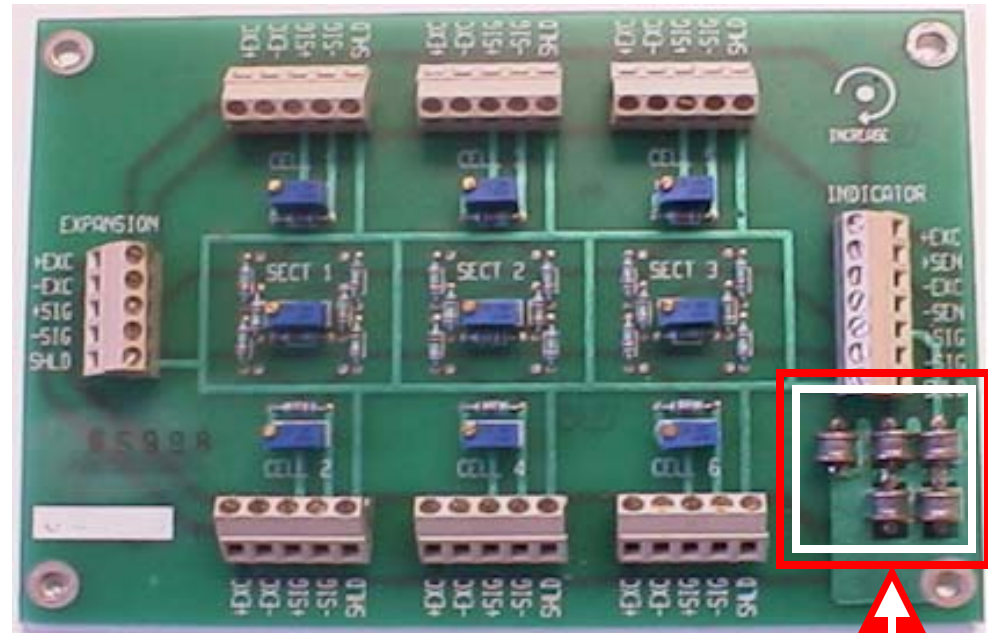

Gas Discharge Tubes



New Standard Of Protection For Analog Scales Typical Configuration

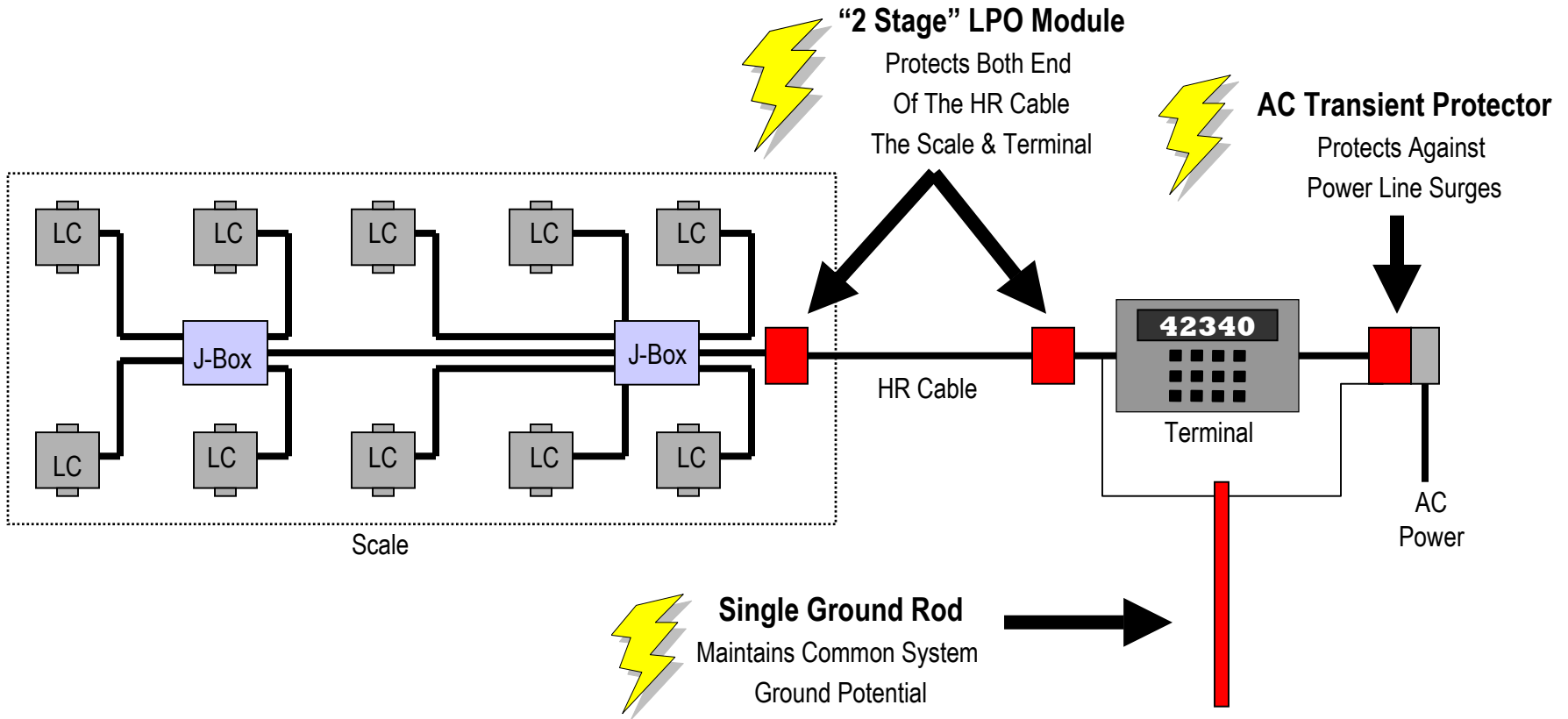

StrikeShield™ - 2 Stage Protection

Operation:

- Stage 1: Diodes Takes The Initial Surge
- Stage 2: Gas Discharge Tubes = Staying Power

Advantages:

- Best in Class Protection Against Surges
- 2 Modules Protects Both Ends Of The Home Cable
- Replacement Without Effecting J-Box PCB
 - No Loss Of Calibration Or Trim Values
 - Lower Downtime
 - Lower Total Cost Of Ownership
- Use On Existing Scales, Tank & Hopper Systems

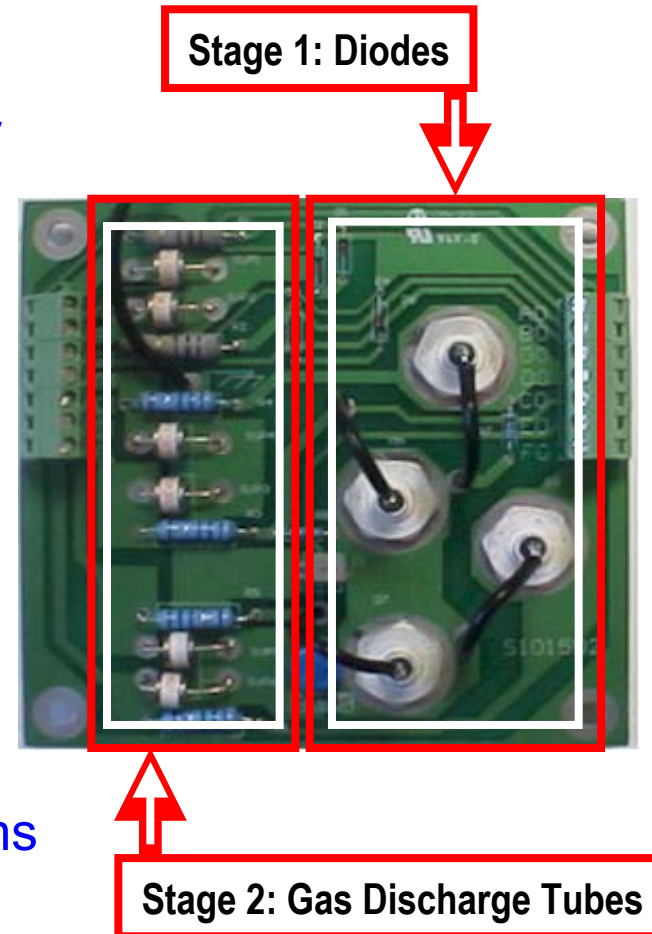

Terminals & Software





Process - Goods in/Out and Add/Subtract

Inbound

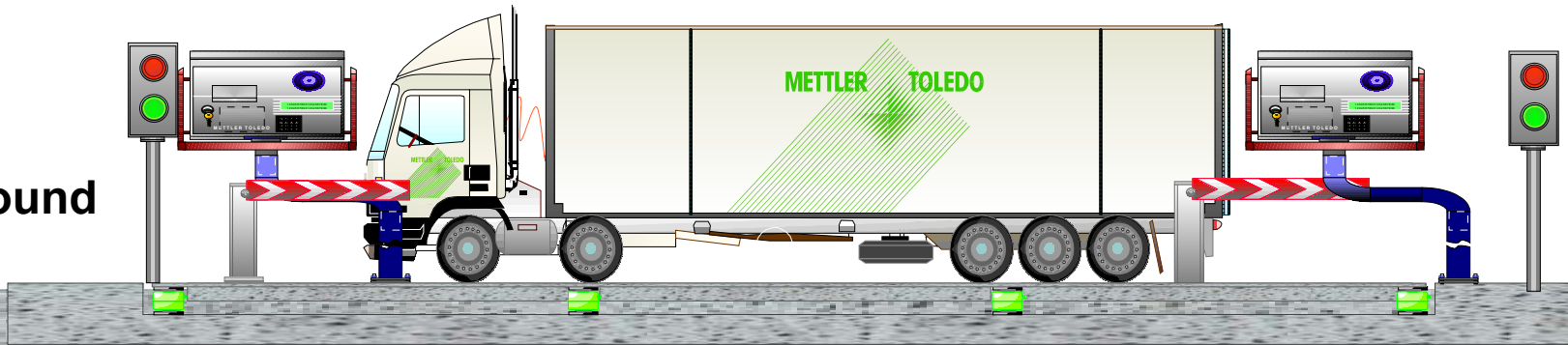

Outbound

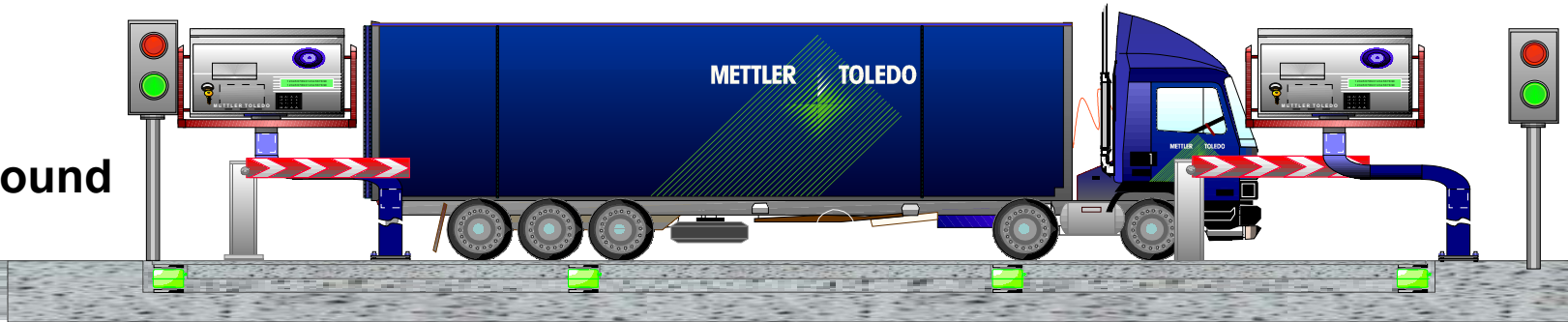

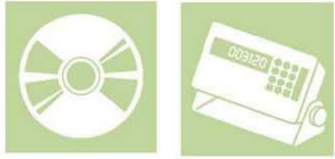

Process - Data Capture

Inputs



- Material Type
- Material Characteristics
- Manual Labor
- Automation
- Containers
- Transportation
- Identification
- Record/Data
- Visual queues
- Payment
- IT transfer
- Vehicle characteristics

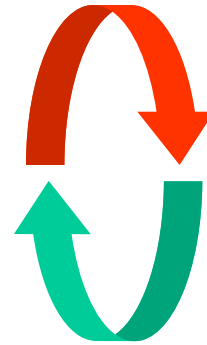

Measurement

- Weight
- Volume
- Other...

Outputs

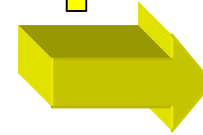

- Control parameters
- Record - tracking
- Record - copy
- Transaction - Data
- Completed Vehicle
- Visual queues
- Error queues
- Alibi
- IT transfer
- Payment
- Legal status





Basic Solution

Terminal and Printer

- G-T-N, ID, CN, T&D, simple terminal or journal



Standard Solution

Advanced Terminal and Printer

- JagXtreme
- Function as Basic, plus In-Out, multiple printers, access control I/O, HMI option



Professional Solution

PC Software & eSolutions OverDrive

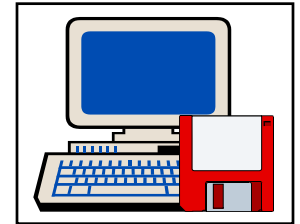

Attended

FirstLine Solution

Terminal and Printer



MidLine Solution

Integrated OP Terminal - PC

- Optional
- RFID
- Access



TopLine Solution

Integrated Terminal including PC

- Optional
- RFID
- Credit Card
- Access Control



Unattended





Single Scale Unattended Model

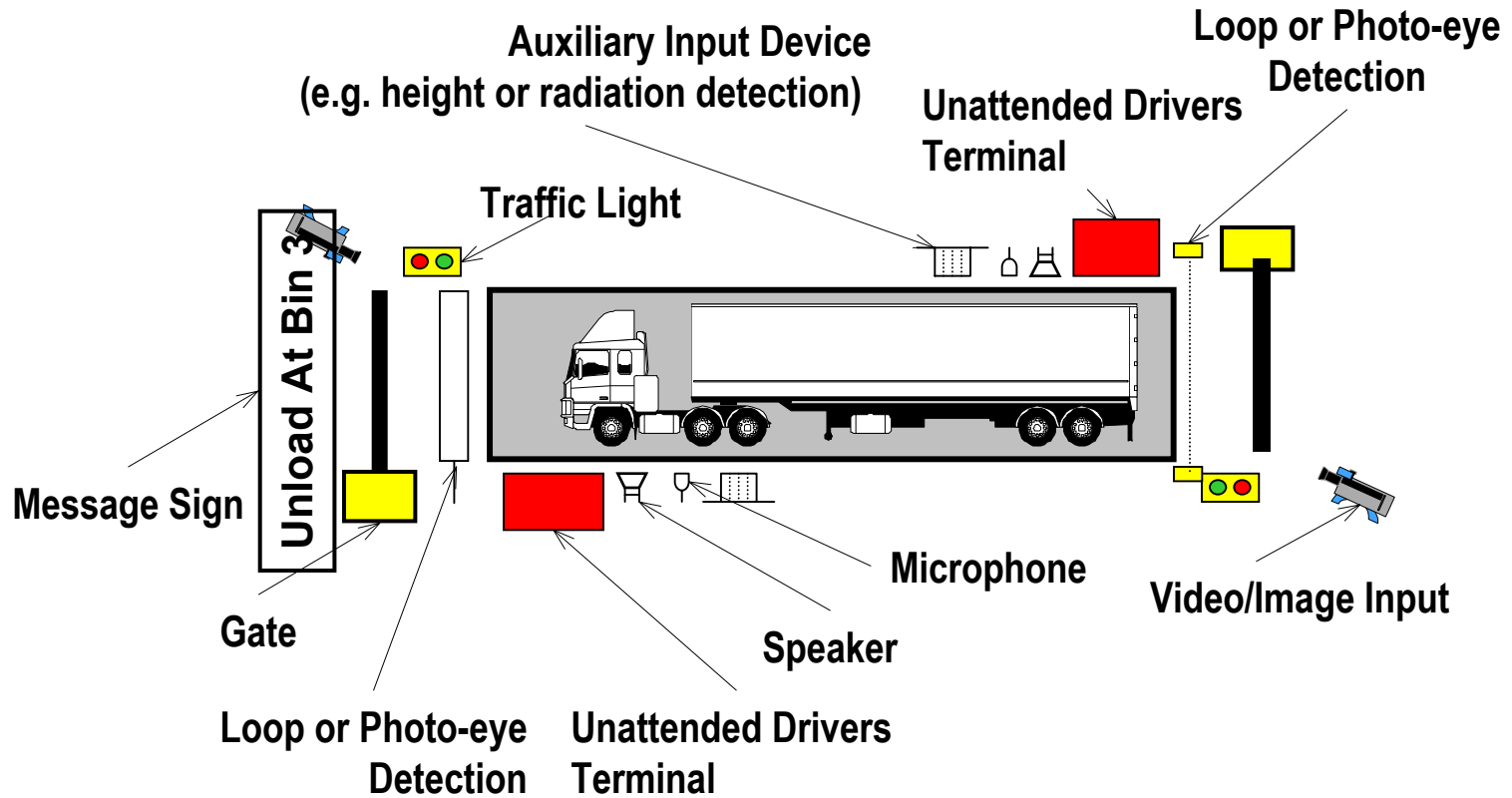



Unattended Benefits



On Behalf of Mettler Toledo

Thank you!

