

1957

px

TC202
N46L3P6
no. 3
1966

Property of the United States Government

Chef Nertear

U. S. ARMY, CORPS OF ENGINEERS

New Orleans St. Bern. G 1 to G 105
LAKE PONTCHARTRAIN, LA. AND VICINITY
CHALMETTE AREA PLAN

- 1
- 2-U
- 3
- 3-T
- 4
- 4-T
- 5
- 6-U
- 7-T
- 8
- 9
- 9-A
- 10
- 11
- 14-U

- G-100
- G-3
- G-4
- U-1
- G-14
- G-20
- G-30
- U-2
- U-3
- U-4

The borings listed are useful for Pleistocene

DESIGN MEMORANDUM No. 3
GENERAL DESIGN

study

RESEARCH CENTER LIBRARY
US ARMY ENGINEER WATERWAYS EXPERIMENT STATION
VICKSBURG, MISSISSIPPI

Prepared by:

Waldemar S. Nelson & Company, Inc.
Engineers & Architects
New Orleans, La.

U. S. Army Engineer District, New Orleans
Corps of Engineers, U. S. Army
New Orleans, La.

NOVEMBER 1966

00063



DEPARTMENT OF THE ARMY
NEW ORLEANS DISTRICT, CORPS OF ENGINEERS
P. O. BOX 60267
NEW ORLEANS, LOUISIANA 70160

IN REPLY REFER TO
LMNED-PP

1 November 1966

SUBJECT: Lake Pontchartrain, La. and Vicinity, General Design Memorandum
No. 3, Chalmette Area Plan

TO: Acting Division Engineer, Lower Mississippi Valley
ATTN: LMVED-TD

1. The subject design memorandum is submitted herewith for review and approval in accordance with the provisions of EM 1110-2-1150 dated 1 July 1966.
2. Waldemar S. Nelson and Company, Inc., Engineers and Architects, New Orleans, Louisiana, prepared this design memorandum under the provisions of Contract No. DA-16-047-CIVENG-66-320.
3. The initial draft of the design memorandum was reviewed concurrently by the staffs of the Division and District Engineers. In addition, the office of the Chief of Engineers was afforded an opportunity to examine the draft memorandum, and a field review was held on 27-28 September 1966, in which representatives of OCE, LMVD, NOD, and the Nelson firm participated. All comments and suggestions deriving from the above reviews have been considered in preparing the memorandum submitted herewith.
4. Approval of the subject design memorandum is recommended. Review should be expedited to the maximum extent practicable in order that commitments to initiate construction in St. Bernard Parish in the current fiscal year can be met.

1 Incl (14 cys)
GDM No. 3 fwd sep

THOMAS J. BOWEN
Colonel, CE
District Engineer

LMVED-TD (NOD 1 Nov 66) 1st Ind
SUBJECT: Lake Pontchartrain, La. and Vicinity, General Design Memorandum
No. 3, Chalmette Area Plan

DA, Lower Miss. Valley Div, CE, Vicksburg, Miss. 39180 1 Dec 66

TO: Chief of Engineers, ATTN: ENGCW-V/ENGCW-E

1. Subject design memorandum is forwarded for review and approval pursuant to para 17, ER 1110-2-1150. Approval is recommended, subject to the comments below and to minor annotations in red on pages 9, 17, 21, 22, and 27.

2. In current studies for a survey report on additional hurricane protection in St. Bernard Parish, the District has stated in Status Report for 30 Sep 66 that preliminary studies indicate a combination of the Chalmette Area and the Violet to Verret Area (Reach E) (HD 550, 87th Congress, 2d Session) is justified. Since this combination would eliminate the need for a levee between the Mississippi River at Violet and the levee along the Mississippi River Gulf Outlet, the GDM should discuss this combination as a probable modification to the Chalmette Area plan.

3. Para 33, page 19. The advisability of using material in the borrow pit below el 0 is questioned. Most of the material between el 0 and the bottom of the pit (el -12, Plate 22) is unsuitable for levee fill, based on boring logs on Plate 6. If the volume of material between el 0 and el -12 is needed for levee fill, it should be obtained from another source, or the area of the borrow pit on Plate 6 should be increased so that the additional material can be obtained from above el 0.

4. Para 37, page 20. Settlement observations should include an initial survey just prior to driving the sheet piling. After the levee fill is placed, settlement observations should be made more frequently than yearly to help determine the time rate of settlement as these data would be used in determining the required gross grade of the concrete cap.

5. Para 38, pages 20-28. a. General. As indicated in subpara 21, the data are not completely adequate to permit the levee to be constructed in stages to final grade without additional studies. It is likely that the first lift can be constructed without difficulty. After this construction, the levee should be divided into reaches, the added studies made for each reach, and the resulting recommended first shaping or next lift and subsequent lifts or shapings for each reach should be submitted to LMVD for approval. This procedure would be similar to that adopted for Atchafalaya guide levees.

b. First subparagraph, page 20. (1) The fifth sentence should be expanded to provide a clearer explanation. A large enough excavation could be made which when backfilled with shell or sand would greatly increase

SUBJECT: Lake Pontchartrain, La. and Vicinity, General Design Memorandum
No. 3, Chalmette Area Plan

the stability of the levee, reduce foundation settlement, and permit constructing the levee to ultimate grade in a single construction. However, it is understood that the cost of this foundation treatment per linear foot of levee, excluding the cost of levee, greatly exceeds the cost of levee with lift construction proposed in this design memorandum. The relative costs should be cited for the record.

(2) The results of the statistical analyses including the detailed foundation shear strength with and without spoil fill should be presented. This should include a list of borings and shear strength data used to establish the gain in shear strength. The gain in shear strength from the statistical analyses should be compared with that estimated from the shear test data as shown in Plate 68, if this has not already been done.

c. Sixth subparagraph, page 21. This subparagraph should indicate the shape of the fill assumed when computing the total consolidation in a stratum. It is not clear whether the fill was assumed to be semi-infinite in extent or shaped like one of the lifts or embankment sections shown on Plate 69.

d. Seventh subparagraph, page 21. (1) The word "normally" should be inserted in the first sentence after "nearly,"

(2) In the second sentence, delete "in the soils."

(3) It is likely that Recent soils beneath the Gulf Outlet spoil are underconsolidated as a result of the spoil placement and not normally consolidated as assumed in the design memorandum.

e. The second complete sentence on page 23 should be expanded. The volume of fill placed in the first shaping appears to have been affected by arbitrarily selected rights-of-way for construction in addition to stability requirements. For example, a fill considerably larger than that shown could be constructed with adequate stability if the required right-of-way and construction easements were available. These right-of-way limitations should be discussed.

f. Unnumbered 13th, 14th, 15th subparagraphs, page 23; Figure 11, Plate 69. The percent of consolidation after a given time interval and time-rate of settlement should be checked using procedures set forth for stage construction in para 4-07b, EM 1110-2-1904, Soil Mechanics Design, Settlement Analysis.

SUBJECT: Lake Pontchartrain, La. and Vicinity, General Design Memorandum
No. 3, Chalmette Area Plan

g. 16th subparagraph, page 23; Plate 68. (1) It should be noted that the R test envelope is considerably above that for the Q tests and thus, the data are questioned. As a result of the 27-28 Sep 66 conference among engineers of OCE, LMVD, and NOD, it was agreed that additional undisturbed borings and soil tests would be made by the Government to check the soil test data. Until this is done, it appears that the gain in shear strength can be estimated as on Plate 68 except that the R envelope for design should be drawn parallel to the R envelope shown on Plate 68 so as to pass through the point labeled SS₁. This will result in a lower estimated gain in strength caused by consolidation. Such a strength gain assumes that the additional load causes pure two-dimensional consolidation of the foundation. This may not be conservative because it does not consider the possibility of plastic lateral deformations and shear strains. Such deformations have been observed in similar soft soils in the Atchafalaya Basin. Also, this procedure does not consider the variation in pore pressure (and strength) with depth within the stratum proper because it uses the average percent consolidation for the entire stratum.

(2) The results of the additional explorations and tests referred to in subpara (1) above should be presented in a supplement to this DM. Corresponding revisions to the stability analyses and designs in the GDM should be included in the supplement.

h. 21st subparagraph, page 24. Piezometers and settlement plates should be installed and observed prior to placing the first lift of fill because the existing foundation beneath the spoil may be underconsolidated. After the first lift is placed, observations should be made with such frequency to evaluate the time rate of settlement and determine the field coefficient of consolidation, C_v.

i. 24th and 27th subparagraphs, page 25. The reason for assuming that soils below Stratum 4 do not affect surface settlement is not apparent. Stratum 4 extends to el -39.7, whereas boring logs indicate the presence of compressible soils at greater depths.

j. 31st subparagraph, page 26. Explain the reason for assuming a 10-ft fill height for the first shaping. Data on Plate 69 indicate the first lift is 6 ft thick, which is to be constructed to el 13 and will settle to an el 9.1 at the end of two years. Figure 14 on Plate 69 shows that a crown el 13 will be achieved in the first shaping. This constitutes adding 3.9 ft of fill at the centerline of the embankment. Possibly the 10 ft is the rounded sum of 6 ft plus 3.9 feet. Similarly, procedures for arriving at the 12-ft fill in subpara 42 should be explained.

6. For clarity, the subparagraphs under para 38 should have been lettered consecutively, as discussed in para 1-19b, EM 1120-2-101.

SUBJECT: Lake Pontchartrain, La. and Vicinity, General Design Memorandum
No. 3, Chalmette Area Plan

7. Para 39, page 28. Consideration should be given to obtaining larger temporary easements if this will permit raising the levee to final grade sooner.
8. Para 61, pages 47 and 50. The unit price shown for treated timber, 3 x 10 and 12 x 12, is excessive and should be reconsidered.
9. Para 62a, page 55. The portion of this paragraph pertaining to "for providing I-type floodwall along the IHNC in lieu of steel sheet piling with concrete cap" is not understood.
10. Plates 7 through 15. The alignment of the levee is considered closer to the MR-GO than desirable. The alignment should be selected using stability analyses and taking into account possible loss of foreshore due to propeller and wavewash.
11. Plate 22. Consideration should be given to a wall section using a pile arrangement as shown on Incl 2. This type section will provide a greater vertical component of the wall load and reduce or eliminate tension in the piles battered upstream. The pile loads would be determined by the Culmann method.
12. Plate 26. a. In lieu of the miter gates, consider double-leaf hinged gates supported at the center by a removable post or frame anchored to the sill. This will avoid the high thrust of the miter gates and result in a more uniform distribution of the gate load to the supporting sill and foundation.
b. The cantilever wall at either side varies in height from about 10 ft to zero. With a height of 10 ft, the wall deflection may be excessive, thus creating a problem at the joint with the gate structure. A wall section similar to that shown on Incl 2 may be necessary for the higher reaches of the wall.
13. Plate 38. Although the stability analyses of the landside levee slope along the IHNC indicate adequate factor of safety with respect to sliding into the landside drainage ditch, a recent field inspection of this reach indicates numerous shallow slides are occurring in the ditch bank. Such slides could endanger the stability of the landside levee slope. The need for remedial work and possible replacement or restoration of the existing bulkhead along the ditch should be considered to help insure that the levee section will remain stable.
14. Plate 39. In the table, it is believed that "Bayou Bienvenue" should be changed to "Outfall Channel" as the sections on this plate refer to the outfall channel.

LMVED-TD (NOD 1 Nov 66) 1st Ind 1 Dec 66
SUBJECT: Lake Pontchartrain, La. and Vicinity, General Design Memorandum
No. 3, Chalmette Area Plan

15. Plate 63. The comment pertaining to Plate 22 is also applicable to the "T"-type wall indicated here. Deflection may govern the maximum height of the concrete sheet pile wall.

16. a. The abbreviation "U.S.E.D." as used on Plate 1 should be deleted. The right-of-way line can be designated "Miss. R.-Gulf Outlet R/W."

b. The degree of curvature on Plates 9, 10, 11, and 17, computed to odd seconds, is poor practice.

17. EM 1110-2-1150, referred to in para 1, basic letter, should be ER 1110-2-1150.

18. Pursuant to para 8b, ER 1110-2-1150, the DM's for this project should be numbered in sequence, generally as submitted for approval, including those for Seabrook Lock.

19. Pursuant to para 17c, ER 1110-2-1150, all DM's for this project are expected to be approved by the Chief of Engineers.

20. Pursuant to para 16, ER 1110-2-1150, general design memoranda should be submitted to OCE in 14 copies. In future submissions, GDM's should be submitted to LMVD in 16 copies.

FOR THE ACTING DIVISION ENGINEER:

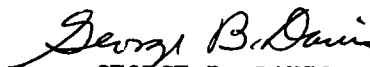

GEORGE B. DAVIS
Acting Chief, Engineering Division

2 Incl (12 cy)
wd 2 cy incl 1
Added 1 incl
2. Sketch (bound in front of DM)

Copy furnished:
New Orleans District
ATTN: LMNED-PP
w/marked cy incl 1 & incl 2

ENGCW-EZ (1 Nov 66) 2nd Ind
SUBJECT: Lake Pontchartrain, La. and Vicinity, General Design Memorandum
No. 3, Chalmette Area Plan

DA, CofEngrs, Washington, D. C., 20315, 31 January 1967 *Rec LMVD 6 Feb*

TO: Division Engineer, Lower Mississippi Valley Division

1. Reference 2nd indorsement ENGCW-EZ, 27 October 1966 on letter LMNED-PP, 18 August 1966 subject: "Lake Pontchartrain, Louisiana and Vicinity, Design Memorandum No. 1, Hydrology and Hydraulic Analysis, Part I - Chalmette."

2. General Design Memorandum No. 3 is approved, subject to the comments of the Division Engineer, the comments in OCE 2nd indorsement referenced in paragraph 1 above, and the following additional comments.

3. Paragraphs 11 and 43 and Plates 5 and 6. Design and alignment in the vicinity of Florida Avenue are not satisfactory. They should be restudied to develop a plan which is compatible with proposed improvement of the navigation canal, which will require a new longer lift bridge at Florida Avenue or a separate higher level highway bridge and a movable bridge span for the railroad. In this connection, reference is made to 2nd Indorsement ENGCW-EZ, 8 December 1966 on letter LMNED-PP, 15 September 1966, subject: "Mississippi River-Gulf Outlet, La. - Report on Need for New Ship Lock", (especially paragraph 5a(3) and (6)). If interim protection is required, it should be recognized as such and the plan for permanent protection developed compatible with the navigation canal improvement.

4. Paragraph 45, Page 32.

a. The information given in this paragraph as to what may be the cause of corrosion of the sheet steel piling is questioned. Stray current corrosion is caused primarily by direct current that returns to the negative bus of the source by other than the intended path. Stray alternating current causes very little corrosion damage (about 1% of that caused by an equivalent amount of direct current). Unless there is a source of direct current in the area where the piling is to be installed, such as a direct current railway, electroplating plant or large electric welding installations, the possibility of corrosion by stray direct currents is considered to be nil. Usually, natural earth currents are not important from a corrosion standpoint because the magnitude is small or the duration is short. When stray currents are the cause of corrosion of a buried steel structure, the conventional cathodic protection means are not applicable.

b. The corrosion of buried steel is, almost without exception, caused by the local action of the anodic and cathodic areas that are always present on the surface of formed or wrought steel materials.

ENGCW-EZ (1 Nov 66)

2nd Ind

31 January 1967

SUBJECT: Lake Pontchartrain, La. and Vicinity, General Design Memorandum
No. 3, Chalmette Area Plan

Investigations made by the Corps and the National Bureau of Standards have shown that oxygen must be present for corrosion to occur on buried steel; also, that when piling is driven in undisturbed earth, corrosion very seldom occurs even though the soil in which the piling is driven may be exceedingly aggressive from a corrosion standpoint. Complete information regarding the above investigation is given in NBS Monograph 58.

c. In view of the findings of the above investigation, it is now the practice not to provide protection against corrosion of piling when it is driven in undisturbed earth. When the piling is to be driven in disturbed earth or when backfill is to be placed against the upper part of the piling, means of protection should be provided. In most cases the most economical means of providing protection against corrosion is to coat the exposed surfaces only with coal tar-epoxy and apply cathodic protection, using magnesium or zinc galvanic anodes.

d. Since the information presented in the subject design memorandum is not satisfactory, it is requested that a feature design memorandum be prepared immediately, evaluating the possibility of the occurrence of corrosion damage to the piling, and, if such damage is likely to occur, information as to the proposed means of corrosion mitigation should be included.

5. Plates 23 and 24. The tables showing riprap gradation when plotted result in a single gradation curve which is too stringent a contract requirement. In the interest of uniformity, it is suggested that the following table form be used:

<u>Percent by Weight (SSD) Lighter</u>	<u>Stone Weight in Pounds</u>
100	(150-650)
50	(130-200)
15	(40-170)

The above form will plot two gradation curves as limits which allows for reasonable variation between test samples. The theoretical spherical diameter of the maximum allowable size stone should not exceed the layer thickness and preferably, for wave protection, should be considerably less.

6. Plate 27. In view of the major settlement anticipated under levee surcharge (anding), all water lines and other utility pressure lines should be routed over the top of floodwall where feasible. If utilities must cross through the line of protection, consideration should be given

ENGW-EZ (1 Nov 66)

2nd Ind

31 January 1967

SUBJECT: Lake Pontchartrain, La. and Vicinity, General Design Memorandum
No. 3, Chalmette Area Plan

to providing a lateral offset loop along the wall that will permit rotation to take up some of the differential movement of the connection.

7. Figures 1 and 2. In design of the I-wall, consideration should be given to stability under hurricane conditions with the land-side saturation line at levels above mean sea level within the levee. The structure may be subject for several hours to heavy rainfall and high water levels where a saturation level as high as El. 5 or 7 might develop. Use of a Net Pressure Diagram (F.S. = 1.3) would be more meaningful for design security than the one shown with a safety factor of 1.0.

8. 1st Indorsement, Paragraph 2. Modification of the Chalmette area plan as discussed in this paragraph was requested in letter LMNED-PR, 29 November 1966, subject: "Lake Pontchartrain, Louisiana and Vicinity - Modification of the Chalmette Area Plan to Include Larger Area" and was approved, subject to several comments. Supplementary information to incorporate this change into the General Design Memorandum plan should be furnished.

FOR THE CHIEF OF ENGINEERS:

wd Incl

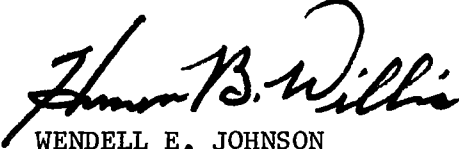
WENDELL E. JOHNSON
Chief, Engineering Division
Civil Works

LMVED-TD (NOD 1 Nov 66)

3d Ind

SUBJECT: Lake Pontchartrain, La. and Vicinity, General Design Memorandum
No. 3, Chalmette Area Plan

DA, Lower Miss. Valley Div, CE, Vicksburg, Miss. 39180 23 Feb 67

TO: District Engineer, New Orleans District, ATTN: LMNED-PP

1. Referred to note approval, subject to comments of 1st and 2d Indorsements. Guidance to assist in complying with these indorsements is furnished below.

2. We have made a preliminary analysis to determine the effect of assuming a higher water table on the landside of the wall in accordance with para 7 of the 2d Indorsement. The analysis was made for the west levee, IHNC, stations 70+00 to 77+00. In this reach, the levee consists of sand on an upper foundation stratum of sand. The computed required penetration is 10 feet for a factor of safety of 1.5 using a shear strength of $\phi = 30^\circ$, $c = 0$ and water level at el -3 on the landside of the wall. Assuming the water level on the landside of the wall at el 7 reduces the factor of safety to 1.3.

3. a. OCE has been informed of these results and agreed that for a sandy levee, the design should be based on a factor of safety of 1.5 with a low tailwater and a factor of safety of 1.3 with a high tailwater due to saturation from rainfall. It will not be necessary to assume a high saturation line on the landside of a clay levee when using the S shear strength since it is unlikely that the clay could adjust to the high tailwater during the short duration of a hurricane.

b. The pile section used should be selected based on stresses produced for a loading with factor of safety of 1.5 with low tailwater and a factor of safety of 1.3 with high tailwater, whichever governs. In the case of the west levee, IHNC, from stations 70+00 to 77+00 the design penetration will not change as a result of assumption of the higher tailwater. However, the adequacy of the pile section will have to be reevaluated.

4. a. The new criteria may be more critical and may limit the height for which an I-type steel sheet pile wall would be considered suitable or economical. For example, the higher saturation level will reduce the passive earth resistance which, in turn, will increase the pile penetration, stress, and deflection. The amount of deflection considered acceptable may govern.

b. In view of the possible impact of the new criteria discussed in para 3 above, you should investigate the economic feasibility of a wall as illustrated in the attached sketch, Incl 3. The dependence on passive lateral earth pressure would only be as required to balance the moment

LMVED-TD (NOD 1 Nov 66)

3d Ind

23 Feb 67

SUBJECT: Lake Pontchartrain, La. and Vicinity, General Design Memorandum
No. 3, Chalmette Area Plan

of eccentric active loads about the elastic center. The savings in sheet piling may more than offset the cost of timber piling and additional concrete. In reaches where the levee is being raised, the possible adverse effects due to settlement of the fill, which will induce a drag force and bending in the batter piles, should be considered.

5. The above discussion is also applicable to the sections of wall included in the specifications and drawings for "Interim Floodwall Construction on Inner Harbor Navigation Canal," for which the design, specifications, and drawings have been approved for advertising. You should review the design thereof using criteria comparable to that indicated to assure that pile section is adequate.

6. Inform LMVD by separate correspondence the expected date of submission of the DM on corrosion protection required by para 4d, 2d Indorsement.

FOR THE DIVISION ENGINEER:

1 Incl (dupe)
3. Sketch

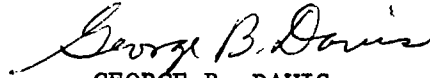

GEORGE B. DAVIS
Acting Chief, Engineering Division

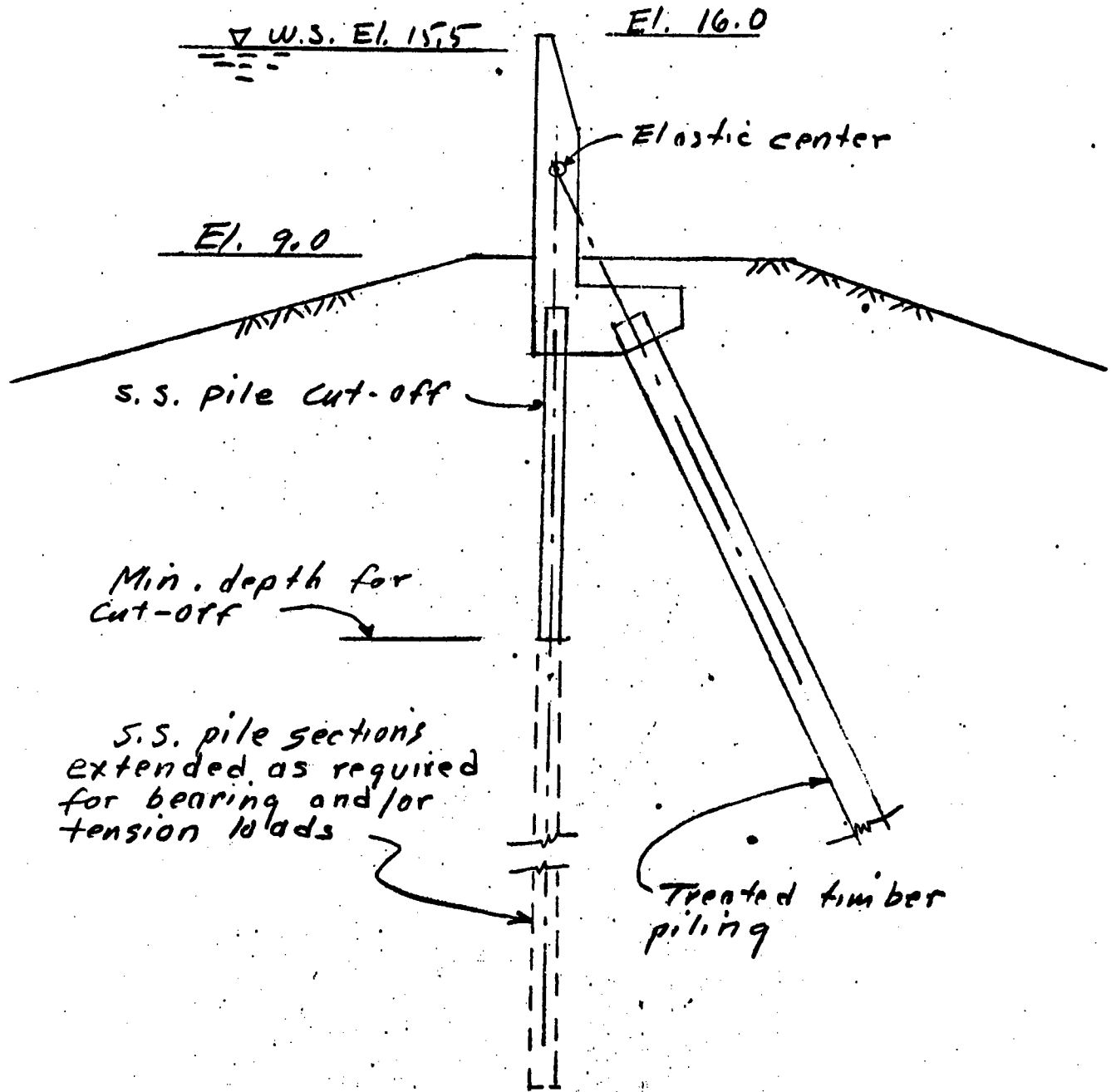

LMVED-TP

8 November 1966

SUBJECT: Lake Pontchartrain, La. and Vicinity - Revised Approach to Advance Supplement on Inner Harbor Navigation Canal Levees

TO: Acting Division Engineer, Lower Mississippi Valley
ATTN: LMVED-TP

1. The advance supplement on the Inner Harbor Navigation Canal (IHNC) levees is presently scheduled for submission on 31 December 1966. As you know, this supplement is being prepared as a means of accelerating construction in an area proven to be critical by the passage of hurricane "Betsy" in September 1965. Preparation of the supplement has proceeded on the basis of having it cover all of the IHNC levees except those on the east bank between the IHNC lock and Florida Avenue, which segment is included in the GDM for the Chalmette area plan submitted to you under date of 1 November 1966 (see incl). As planning has progressed, it has become apparent that certain alignment and design problems would not permit coverage of some areas in sufficient detail for preparation of plans and specifications to follow directly from the advance supplement, and that additional design reports of a detailed nature would be required. Coverage in the advance supplement for such areas (which include the siphon crossings at Florida Avenue, all work on the west bank between the IHNC lock and Florida Avenue, and work on both banks in the vicinity of Interstate Highway 10 and U. S. Highway 90) was, accordingly, to have been limited to survey report scope, with detail design memoranda to follow as required.

2. On 24 October 1966, Mr. Armand Willoz, Chief Engineer of the Orleans Levee District, local cooperators for the project, expressed grave concern over the fact that current schedules would not result in Federal construction on the west bank of the Canal between the IHNC lock and Florida Avenue prior to the next hurricane season. Mr. Willoz explained that construction by the Orleans Levee District since "Betsy" has resulted in a significant increase in the degree of protection in all other areas which proved to be critical in "Betsy," and pointed out the technical factors which render impracticable an interim approach to providing protection such as has been applied in other areas. He also described the difficulties experienced and the disruption involved in providing emergency protection in the area by makeshift means during the hurricane season just past.

Engineering Division
File Copy

LSWED-PP

8 November 1966

SUBJECT: Lake Pontchartrain, La. and Vicinity - Revised Approach to Advance Supplement on Inner Harbor Navigation Canal Levees

3. We pointed out to Mr. Willox that, if our planning were revised to emphasize work in the subject area and all preconstruction planning completed in time to permit start of construction prior to next hurricane season, the fiscal outlook was such that construction funds in the amount required might not be available. Mr. Willox indicated that the Levee District would be happy to undertake the construction with their own funds (subject to credit as in the case of the interim work already done by them), provided we gave them authority to do so. He further offered to have the necessary engineering done by architect-engineers if such action would expedite the production of approved plans.

4. In view of the above, we propose to modify our present planning schedules as follows:

a. The advance supplement will be modified so as to cover only that portion of the Canal between IHNC lock and Florida Avenue on the west bank. Coverage will be in sufficient detail to permit preparation of plans and specifications directly from the advance supplement.

b. Available in-house capability in the structural design area will be concentrated on preparation of the modified advance supplement. We expect that, under these conditions, the advance supplement can be submitted on or before 15 February 1967. Assuming normal review time, an approved set of plans and specifications for the work could be available by 15 June 1967.

c. Two additional supplements to the GDM for the barrier plan will be prepared for other segments of the IHNC levees. One would cover the Florida Avenue siphon crossings, and the other the remainder of the work on the Canal.

d. The emphasis placed on completing the advance supplement will result in slippage of the present schedule for the GDM for the barrier plan. However, this memorandum will cover in detail only the levee on the north bank of the Mississippi River-Gulf Outlet between the IHNC and Michoud. This levee has been raised to elevation 13 feet m.s.l. by the Levee District and currently affords a very high degree of protection. We plan to submit, at an early date, and prior to completion of the barrier plan GDM, a letter report on evaluation of alternate barrier locations, approval of which will permit site selection studies for the barrier structures to proceed without delay. This progress on planning for these structures, which are crucial to the project, will not be delayed by slippage of the barrier plan GDM. We expect that this GDM, presently scheduled for submission on 31 January 1967, can be submitted on or before 1 September 1967. In view of the above, it is considered that this delay can be tolerated.

LMCED-PP

8 Nov 66
8 November 1966 Chantry/kn/239

SUBJECT: Lake Pontchartrain, La. and Vicinity - Revised Approach to
Advance Supplement on Inner Harbor Navigation Canal Levees

5. Based on the foregoing, it is recommended that the advance supplement for the Inner Harbor Navigation Canal levees presently scheduled for submission on 31 December 1966 cover only the work between the IHNC lock and Florida Avenue on the west bank of the Canal, and that revised submission dates of 15 February 1967 and 1 September 1967, respectively, for this supplement and the GDM for the barrier plan, be approved.

1 Incl
Mosaic fwd sep

THOMAS J. BOWEN
Colonel, CE
District Engineer

Mask
/
Hudson

Exe Ofc

LMNED-PP (NOD 1 Nov 66) 4th Ind
SUBJECT: Lake Pontchartrain, La. and Vicinity, General Design Memorandum
No. 3, Chalmette Area Plan

DA, New Orleans District, CE, New Orleans, La. 70160 10 Mar 67

TO: Division Engineer, Lower Miss. Valley, CE, ATTN: LMVED-TD

1. Reference is made to the following:
 - a. Paragraph 7 of 2d Ind of this chain of correspondence.
 - b. Paragraphs 1 through 5 of 3d Ind of this chain of correspondence.
 - c. DIVR 1110-1-400 dated November 1966.
 - d. Discussions in office, LMVD, on 7 March 1967, involving Messrs. A. J. Davis, G. Davis, Kaufman, and Weaver, LMVD, and Colonel Bowen and Mr. Hudson, NOD.
2. Inasmuch as all floodwall included in the Chalmette Area Plan is located in clay-type soil, the stability analyses presented in the GDM for the determination of pile penetrations are valid. Further, this type of analysis may be used in all locations where clay-type soils are encountered.
3. Interim I-type floodwall construction on both banks of the IHNC north of U. S. Highway 90 is currently under advertisement with bid opening scheduled for 21 March 1967. The soils in a number of the locations involved are generally sandy. Investigations just completed indicate that required pile penetrations for the case with high tailwater and a soil shear strength factor of safety of 1.3 would be on the order of one foot greater than those for the case with minimum tailwater and a factor of safety of 1.5. The computed soil shear strength factors of safety for the penetrations shown on the contract drawings for the work under advertisement are on the order of 1.2. The small difference between the factor of safety theoretically desired (1.3) and the computed factor of safety (1.2) is insufficient to warrant cancellation of the current advertisement, redesign of the floodwall, and consequent material delay in initiating and completing the work involved.
4. Based on the discussion referred to in paragraph 1.d., we understand that DIVR 1110-1-400 dated November 1966, which currently specifies the use of a soil shear strength factor of safety of 1.0 in evaluating deflections and stresses in the piling of I-type floodwalls, is being revised, at the direction of OCE, to require the use of a factor of safety of 1.3. Use of the higher factor of safety in determining the structural adequacy of the piling in the I-type walls previously constructed, and those to be constructed, along the Inner Harbor Navigation Canal, would not have a serious impact in any area other than that on the west bank of the IHNC between the IHNC lock and Florida Avenue.

SUBJECT: Lake Pontchartrain, La. and Vicinity, General Design Memorandum No. 3, Chalmette Area Plan

5. The above area is a most critical one with respect to hurricane exposure and one in which local interests have expressed particular concern that construction be initiated at the earliest practicable date. To expedite matters, the Orleans Levee District has offered to construct the required improvements, and, if such action will serve to expedite construction, to contract with Architect-Engineers for the planning as well. (See LMNED-PP letter dated 8 November 1966, subject "Lake Pontchartrain, La. and Vicinity - Revised Approach to Advance Supplement on Inner Harbor Navigation Canal Levees," copy attached.)

6. Development of the alignment in the reach in question was a most complex and painstaking process which was initiated in November 1965 and not completed until January 1967. The alignment now agreed to includes I-type wall in a number of locations, and would not be feasible if T-type or other pile-supported wall were required. Our studies indicate that use of a factor of safety of 1.3 would, in effect, prohibit use of I-type wall in at least two locations. Alignment studies would, accordingly, have to be reopened. As alluded to previously, the alignment now agreed upon involves numerous compromises, and an attempt to alter it would result in vehement objection by local interests and the introduction of protracted delay in construction.

7. The advance supplement to the GDM for the Lake Pontchartrain Barrier Plan, covering the design of the above protection, has been completed and is being reproduced. All analyses therein relating to the structural adequacy of the sheet piling in I-type walls are based on a soil shear strength factor of safety of 1.0. Because of the urgency of the work involved, and our prior commitments to local interests to make available construction plans and specifications at the earliest practicable date, we do not consider that retroactive application of the new criteria is appropriate. We believe that the design as presented in the supplement is adequate. In this connection, attention is invited to the fact that "kicker" piles will be provided in the most critical locations to limit deflection. Further, it is pointed out that "S" soil strengths were used in determining deflections and stresses; this procedure, in effect, introduces a factor of safety, since the higher "Q" strengths in the range of overburden pressure involved are more representative of the actual strengths under the short-term loading anticipated under hurricane conditions.

8. Based on the above, we shall, within the next day or two, submit, for your review and approval, the advance supplement covering the design of the protective works on the west bank of the IHNC between the IHNC lock and Florida Avenue, with design of I-type walls based on the criteria and procedures outlined in reference l.c.

LMNED-PP (NOD 1 Nov 66)

4th Ind (cont'd)

10 Mar 67

SUBJECT: Lake Pontchartrain, La. and Vicinity, General Design Memorandum
No. 3, Chalmette Area Plan

9. In the future, design of the floodwalls will conform to the criteria contained in reference l.a., as regards pile penetration, and those to be incorporated in the revised version of reference l.c., as regards the structural adequacy of the steel sheet piling. In the supplement covering the remaining levees on the IHNC; i.e., those not included in the Chalmette Area Plan or the Advance Supplement referred in paragraph 7 above, the actual design analyses for walls already in place, and for those to be constructed under the contract now being advertised, will be presented. However, computed factors of safety for the case with high tailwater will be included for comparison.

10. We shall, by separate correspondence, report on the disposition of other comments contained in the first through third indorsements of this chain of correspondence, and provide a submission date for the memorandum on corrosion protection.

1 Incl
3. wd
Added 1 incl (dupe)
4. Cy LMNED-PP ltr dtd
8 Nov 66



THOMAS J. BOWEN
Colonel, CE
District Engineer

LMVED-TD (NOD 1 Nov 66) 5th Ind
SUBJECT: Lake Pontchartrain, La. and Vicinity, General Design Memorandum
No. 3, Chalmette Area Plan

DA, Lower Miss. Valley Div, CE, Vicksburg, Miss. 39180 22 Mar 67

TO: District Engineer, New Orleans District, ATTN: LMNED-PP

1. The actions you have taken and propose to take to satisfy comments of previous indorsements are satisfactory except as discussed below. Paragraph numbers refer to those in 4th Indorsement.

2. Para 4. Section 5, part 5, item 1, DIVR 1110-1-400 was revised in March 1967. The revision indicates that bending moments, stresses, and wall deflections for I-type floodwalls should be computed using the same earth and water pressure diagrams as those used in determining the pile penetration. In the case of hurricane protection for Lake Pontchartrain and Vicinity, earth pressures computed from the S shear strength are governing the design. It is considered that a 1/3 overstress can be permitted in the sheet piling in clay because the duration of water loading on the wall is very short. Where the piling is in clean sand, normal stress would be used.

3. Paras 5-8. The design of I walls on the west bank of the IHNC between the lock and Florida Avenue is being reviewed. Our comments on these designs will be furnished you soon. Our preliminary review to date indicates that the wall designs should be checked using the criteria in the revised DIVR, but with sheet pile stresses as discussed in para 2 above. When this is done, it will be found that deflections and stresses are large in a few reaches; however, in these reaches, it will be possible to use batter piles to reduce deflection of the wall. Where batter piles are used, their influence on stabilizing the wall and on the loads applied to the sheet piling should be properly considered. In the designs under review, the wall was designed as though the batter piles would have no effect on stress in the piling or on deflection. The piles were merely added as insurance against deflection. This procedure is unduly ~~un~~conservative and unrealistic.

4. Para 9. Computed factors of safety for the case with high tailwater need be presented only where the levee consists of sandy soils. Where the levee consists of clay, it will not be necessary to assume a high tailwater, and the design should be based on a factor of safety of 1.5 with a low tailwater as set forth in para 3a of the 3d Indorsement.

5. Para 10. Your report on disposition of other comments should be made as a continuation of this chain of correspondence.

FOR THE ACTING DIVISION ENGINEER:

wd all incl

GEORGE B. DAVIS

Acting Chief, Engineering Division

LMNED-PP (NOD 1 Nov 66) 6th Ind
SUBJECT: Lake Pontchartrain, La. and Vicinity, General Design Memorandum
No. 3, Chalmette Area Plan

DA, New Orleans District, CE, New Orleans, La. 70160 12 Apr 67

TO: Division Engineer, Lower Miss. Valley, CE, ATTN: LMVED-TD

1. Proposed disposition of comments in the 1st, 2d, 3d, and 5th Indorsements of this chain of correspondence is as follows:

a. 1st Ind. Par. 2. LMNED-PR letter dated 29 November 1966, subject "Lake Pontchartrain, Louisiana and Vicinity - Modification of the Chalmette Area Plan to Include Larger Area," recommended that the levee extend to the southeast along the Mississippi River-Gulf Outlet, rather than turning southwest along Bayou Dupre, approximately six miles to the southeast of Bayou Dupre, thence southwest to Verret, thence west south of Highway 46 and tying into the Mississippi River levee at Caernarvon. The modification was approved by OCE on 31 January 1967. A supplement to GDM No. 3 will be prepared covering the modification. The supplement is scheduled for submission in February 1968.

Par. 3. In preparation of the plans and specifications, consideration will be given to enlargement of the borrow area or obtaining borrow from another source.

Par. 4. It is likely that the location of the protective works involved will be incompatible with the construction of the new ship lock authorized under the Mississippi River-Gulf Outlet project (see LMNED-PP letter dated 15 September 1966 and indorsements thereto). An appropriate settlement observation program will be set up when a coordinated design for the lock and hurricane protection is developed in this area. No further construction work is planned prior to the completion of the above design.

Par. 5.a. Additional undisturbed borings, tests, and analyses will be performed and submitted for review prior to constructing succeeding lifts. A design analysis will accompany each set of plans and specifications forwarded for approval.

Par. 5.b.(1). The construction costs for the multiple lift earthfill method for levee construction presented in the GDM is approximately \$70.00 per linear foot. Studies indicate that the construction costs for the shell fill method would be about \$370.00 per linear foot.

Par. 5.b.(2) & 5.g.(1). The statistical analysis referred to in paragraph 5.b.(2) is inclosed. Inasmuch as design analyses will be prepared for each construction lift, no further action is considered necessary in connection with these comments.

Par. 5.c. The fill was assumed to be semi-infinite in extent.

Par. 5.d. These comments are concurred in.

Par. 5.e., 5.f., 5.i., & 7. The comments contained in these paragraphs were considered in plans and specifications already prepared, and will be considered in all future design analyses.

Par. 5.g.(2). As pointed out previously, design analyses will be prepared for each construction lift. These design analyses will contain all applicable soils data and studies. It is planned to file copies of all design analyses in the GDM, so that complete design coverage for the levees will be available in a single document. Estimates of time and costs for completing the levee construction will be revised as soon as sufficient information is available for firm revisions to be made. Such revisions will be made the subject of letter reports, copies of which will be filed in the GDM.

Par. 5.h. Piezometers and settlement plates referred to in this paragraph are presently being installed. Observations will be made just prior to construction of each lift, upon completion of each lift, and periodically after each lift as follows: two, four, eight, sixteen, thirty-two, and seventy-eight weeks. Inclinator pipes will be installed at the most critical locations upon completion of the first lift construction and data collected therefrom. All of the above data will be utilized in subsequent design analyses and will be presented in these analyses when submitted.

Par. 5.j. The height of fill was determined by assuming that the elevation of the original ground surface was lowered by the amount of total consolidation and subtracting this corrected elevation from the elevation of the fill crown and rounding this to the nearest foot. It was felt that further refinement of this quantity was not warranted.

Par. 6. This comment is concurred in.

Par. 8. The unit price for the treated timber is being reconsidered in preparation of the DDM for the Bayous Bienvenue and Dupre Control Structures.

Par. 9. The "I-type wall" used in the GDM is a cantilever wall consisting of a lower portion of steel sheet piling supporting a reinforced concrete upper portion which extends from two feet below ground surface to the design grade. The "steel sheet piling with concrete cap" on which the PB-3 estimate was based is also a cantilever

wall; however, the concrete cap serves no structural function and consists of a cover atop the steel sheet piling.

Par. 10. (1) As agreed to at the conference in New Orleans on 4 April 1967, which was attended by Messrs. Kaufman and Weaver, LMVD, and Messrs. Hudson, Huesmann, Worley, Henderson, Cannon, Smith, Lee, and Chatry, NOD, we shall check the final levee location for stability assuming erosion of the entire foreshore to elevation -3 (bottom of foreshore protection). It is pointed out that plans and specifications for two items of work between Bayous Bienvenue and Dupre recently approved by your office involve a landward shift of the final levee centerline of 50 feet, as compared with the GDM. Design analyses accompanying these plans and specifications demonstrate the stability of the final levee section recommended in the GDM against failure into the MR-GO with the channel widened to the maximum width including boat slips. Future design analyses will deal with the above consideration for all levees located along the MR-GO.

(2) It should be stressed that the availability of rights-of-way along the MR-GO is highly restricted. Local interests have repeatedly requested that requirements be held to 300 feet landward of the existing MR-GO rights-of-way limit.

Par. 11. Our studies utilizing the Hrennikoff method have produced a satisfactory wall section which will require much less piling and can be constructed at a lower cost than the section shown on inclosure 2 of the 1st Ind. The design for this section is covered in detail in "Design Memorandum No. 2, General, Advance Supplement, Inner Harbor Navigation Canal West Levee Florida Avenue to IHNC Lock." The final location and type of protection in the vicinity of Florida Avenue cannot be determined until coordinated design studies for hurricane protection and the new ship lock have been made. (See par. 3 of 2d Ind.)

Par. 12.a. The comment relative to the use of miter gates is concurred in. However, a removable center post is not permissible in this location due to a requirement for rapid closure. The mitered swing gate was selected to provide unlimited vertical clearance; however, the same result can be achieved with an overhead roller gate with removable overhead beam. The need for a gate in this location has been obviated by the modification of the Chalmette Area Plan to include a larger area. A similar gate will, however, be required where the modified levee alignment crosses Highway 39 and the Louisiana Southern Railroad near Caernarvon, La. We plan to use the overhead roller gate at this location.

SUBJECT: Lake Pontchartrain, La. and Vicinity, General Design Memorandum
No. 3, Chalmette Area Plan

Par. 12.b. The comment is concurred in, particularly in view of the recent revision of DIVR 1110-1-400 which requires use of a safety factor of 1.5 in computing bending moments, stresses, and wall deflections. (See comment on par. 11 above.)

Par. 13. We do not consider that the ditch would pose any threat to the final wall in this reach that could not be taken care of under normal maintenance. Inasmuch as the location of the wall is likely to be incompatible with construction of the new ship lock, the final protective works in this area will probably be constructed elsewhere. We have checked the stability of the existing levee and interim floodwall (sheet pile to elevation 11.5 feet m.s.l.), with water at the top of the wall and found the minimum factor of safety to be 1.3.

Par. 14-17, 19-20. These comments are concurred in.

Par. 18. Inasmuch as Seabrook Lock is a feature not only of the hurricane project, but of the MR-GO project as well, it is considered that the design memoranda for it should be grouped in a separate series.

b. 2d Ind. Par. 3. The comment is concurred in (see District comments above on par. 4 and 13 of 1st Ind.). The interim protection has been provided by the Orleans Levee District, the project sponsor, and is satisfactory to the Levee District.

Par. 4. In future work, all steel piling in contact with backfill or new levee fill will be coated with 20 mils of coal tar epoxy. This includes steel sheet piling of cantilever I-type floodwalls, and steel sheet pile cutoff of T-type floodwalls. Considerable direct current equipment is in use by industries along the canal and stray current corrosion may be a problem. A detail design memorandum covering corrosion protection in general will be prepared. Inasmuch as subterranean electrical measurements subsequent to the construction of the walls are considered to be an essential element of the studies required in preparing the design memorandum, this memorandum cannot be completed until the protective works have been constructed. Submission of the design memorandum will be scheduled at a later date.

Par. 5. The comment is concurred in and will be considered in the preparation of plans and specifications.

Par. 6. The congested nature of the area, the excessive cost involved, and vehement objection by the utility owners all combine to make routing of the utilities over the floodwall impracticable. The

slip joint provided will adequately accommodate any settlement which may be anticipated.

Par. 7. This comment was disposed of in paragraphs 3 and 2, respectively, of the 3d and 4th Indorsements.

Par. 8. A supplement to GDM No. 3 will be prepared covering the Chalmette modification. The supplement is scheduled for submission in February 1968.

c. 3d Ind. Par. 2. & 3.a. Comments in these paragraphs are discussed in paragraphs 3 and 9 of the 4th Indorsement, and par. 4 of the 5th Indorsement. The comments are not pertinent to the Chalmette Area Plan, which contains no wall in sandy levees, but are applicable to a number of locations on the IHNC. As pointed out in paragraph 3 of the 4th Indorsement, in no location within the limits of interim construction on the IHNC north of U. S. Highway 90 will the application of the high tailwater case yield a factor of safety less than 1.22. Studies made subsequent to preparation of the 4th Indorsement show that about 90% of the interim work will have a factor of safety, for the high tailwater case, of greater than 1.3. As stated in paragraph 9 of the 4th Indorsement future design will be based on the revised criteria.

Par. 3.b. & 5. The structural adequacy of the interim wall constructed in the Chalmette Area Plan and of the interim wall on the IHNC to be constructed north of U. S. Highway 90 has been checked for both the high and low tailwater cases, and stresses and deflections found to be within allowable limits.

Par. 4.a. This comment is concurred in.

Par. 4.b. The suggested wall section will be considered in future wall designs. Attention is invited to the fact that recommendations for adoption of similar designs have been rejected by reviewing authorities on the basis that the differing reactions of the sheet pile and the bearing pile made their use in combination inadvisable.

Par. 6. See comment on paragraph 4 of 2d Indorsement.

d. 5th Ind. Par. 2. The comment is noted.

Par. 3. This comment is noted.

Par. 4. This comment is noted.

Par. 5. This comment is concurred in.

LMNED-PP (NOD 1 Nov 66)

6th Ind (cont'd)

12 Apr 67

SUBJECT: Lake Pontchartrain, La. and Vicinity, General Design Memorandum
No. 3, Chalmette Area Plan

2. As agreed to in the conference of 4 April 1967, we shall, in future designs, investigate the stability for I-type floodwalls for both the "S" and "Q" soil strengths.

3. In order to avoid interference with the piers of the Paris Road bridge, we plan to utilize a 300-foot long section of floodwall in the alignment at the bridge. A supplement to the GDM covering the design of this wall will be submitted for review and approval in August 1967.

4. Approval of the disposition of comments presented herein is recommended.

FOR THE DISTRICT ENGINEER:

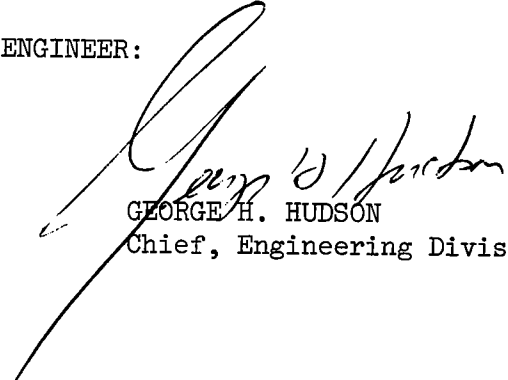

GEORGE H. HUDSON

Chief, Engineering Division

1 Incl

Added 1 Incl (trip)

5. Statistical shear
strength data

LMVED-TD (NOD 1 Nov 66) 7th Ind
SUBJECT: Lake Pontchartrain, La. and Vicinity, General Design Memorandum
No. 3, Chalmette Area Plan

DA, Lower Miss. Valley Div, CE, Vicksburg, Miss. 39180 1 May 67

TO: Chief of Engineers, ATTN: ENGCW-EZ

1. The action taken by the District Engineer to satisfy comments of previous indorsements is considered satisfactory, and approval is recommended, subject to the following additional comments.

2. Para 1a, 6th Ind, regarding para 5h. Since stability problems may develop during construction of a lift, the measurement devices should be observed at intervals while the lift is being placed.

3. Para 1b, 6th Ind, regarding para 4. Provision should be made for future cathodic protection of all piles exposed to fill, including those already driven.

FOR THE DIVISION ENGINEER:

1 Incl
wd 1 cy

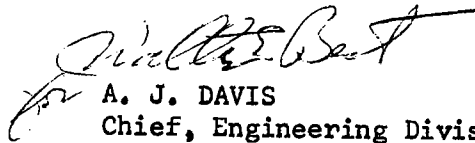
A. J. DAVIS
Chief, Engineering Division

Copy furnished:
NOD, ATTN: LMNED-PP

ENGW-EZ (LMNED-PP, 1 Nov 66) 8th Ind
SUBJECT: Lake Pontchartrain, La. and Vicinity, General Design Memorandum
No. 3, Chalmette Area Plan

Da, CofEngrs, Washington, D.C. 20315, 15 June 1967 *Rec. LMNED 21 June 67*

TO: Division Engineer, Lower Mississippi Valley Division

1. Reference 2nd indorsement ENGW-EZ, 31 May 1967 on letter LMNED-PP, 13 March 1967, subject: "Lake Pontchartrain, La. and Vicinity, Lake Pontchartrain Barrier Plan, Design Memorandum No. 2 - General, Advance Supplement, IHNC West Levee - IHNC Lock to Florida Avenue."

2. The actions taken in the 4th through 6th indorsements are satisfactory as the basis for further planning, subject to the comments of the Division Engineer in the 7th indorsement and the following:

a. The comments included in paragraph 1a of the 2nd indorsement referenced above apply to the following paragraphs in the indorsements of this chain of correspondence:

- (1) 3rd indorsement, paragraphs 4a and 4b.
- (2) 4th indorsement, paragraphs 2 and 4 through 7, inclusive.
- (3) 5th indorsement, paragraph 2.
- (4) 6th indorsement, paragraph 1b.

b. Refer to paragraph 1b of the 6th indorsement, (concerning paragraph 4 of the 2nd indorsement, this chain) and to paragraph 1b of the 2nd indorsement referenced in paragraph 1, above. Providing for future installation of a cathodic protection system, may or may not be necessary. A sound decision regarding the steps to be taken in regard to the corrosion mitigation solution can only be made from an evaluation of information obtained from an adequate survey. It is not necessary for the contemplated structure to be completed before a corrosion survey (including the determination of the presence of stray currents) can be made. An adequate survey of any given site to determine the possibilities of corrosion being a consideration can be and should be made prior to construction.

3. Reference paragraph 1a of the 6th indorsement (concerning paragraphs 5a and 5g(2) of the 1st indorsement, this chain). In accordance with paragraphs 4 and 18, ER 1110-2-1150 and paragraph 2b, ER 1110-2-1200, the "design analysis" mentioned in this paragraph should be prepared as a supplement to the

ENGW-EZ (LMNED-PP, 1 Nov 66) 8th Ind
SUBJECT: Lake Ponchartrain, La. and Vicinity, General Design Memorandum
No. 3, Chalmette Area Plan

general design memorandum and, if based on approved OCE guidelines, may be approved by the Division Engineer (see paragraph 17b(10), ER 1110-2-1150).

FOR THE CHIEF OF ENGINEERS:

wd incl

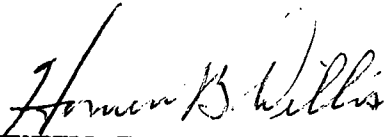
WENDELL E. JOHNSON
Chief, Engineering Division
Civil Works

LMVED-TD (NOD 1 Nov 66) 9th Ind
SUBJECT: Lake Pontchartrain, La., and Vicinity, General Design Memorandum
No.3, Chalmette Area Plan

DA, Lower Miss. Valley Div, CE, Vicksburg, Miss. 39180 22 Jun 67

TO: District Engineer, New Orleans, ATTN: LMNED-PP

1. Referred for necessary action.
2. Reference paragraph 2b, previous indorsement. Guidance was furnished you for conducting the corrosion survey by LMVED-TE letter 24 May 67, subject: Lake Pontchartrain, La. and Vicinity, General Advance Supplement, Design Memorandum No. 2.

FOR THE DIVISION ENGINEER:



A. J. DAVIS
Chief, Engineering Division

1507-03 (Lake Pontchartrain) 22 Nov 67

LMVED-TD (NOD 29 Nov 66)

11th Ind

SUBJECT: Lake Pontchartrain, Louisiana and Vicinity - Modification of
the Chalmette Area Plan to Include Larger Area

DA, Lower Miss. Valley Div, CE, Vicksburg, Miss. 39180 22 Nov 67

TO: District Engineer, New Orleans, ATTN: LMNED-PP

Referred to note approval of action indicated in 9th Indorsement.

FOR THE DIVISION ENGINEER:

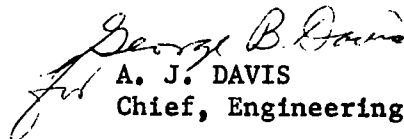
A. J. DAVIS
Chief, Engineering Division

ENGCW-EZ (LMNED-PR, 29 Nov 66) 10th Ind
SUBJECT: Lake Pontchartrain, Louisiana and Vicinity - Modification of
the Chalmette Area Plan to Include Larger Area

DA, CofEngrs, Washington, D. C., 20315, 16 November 1967

TO: Division Engineer, Lower Mississippi Valley Division

1. The action indicated in paragraph 2 of the 9th indorsement is satisfactory.

2. It is proposed to notify the Committees of Congress at an early date of the modifications of the projects, indicated in paragraph 1 of the 9th indorsement, which are considered to be within the discretionary authority of the Chief of Engineers.

FOR THE CHIEF OF ENGINEERS:

wd Incls

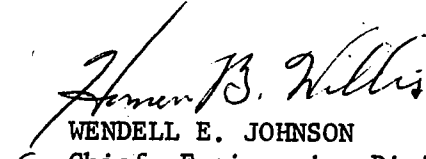
WENDELL E. JOHNSON
Chief, Engineering Division
Civil Works

LMVED-TD (NOD 29 Nov 66)

9th Ind

SUBJECT: Lake Pontchartrain, Louisiana and Vicinity - Modification of
the Chalmette Area Plan to Include Larger Area

DA, Lower Miss. Valley Div, CE, Vicksburg, Miss. 39180 14 Aug 67

TO: Chief of Engineers, ATTN: ENGCW-EZ

1. In our opinion the drafts of letters as prepared by the New Orleans District, mentioned in paragraph 2, 8th Ind, are not fully responsive to the request of the Chief of Engineers in his 2d and 6th Ind. Actually there are 3 projects being modified under the discretionary authority of the Chief of Engineers. Modification of the Chalmette Area affects both the Lake Pontchartrain and Vicinity project and the New Orleans to Venice project. Modification of the Mississippi River-Gulf Outlet project includes levee protection affecting the Lake Pontchartrain and Vicinity project. In addition the New Orleans to Venice project is being modified because of need to change net levee grade and construct levees on modified alignments. Thus, it is our opinion that each of these projects should be covered separately but concurrently. For this reason we are forwarding for each of the three projects the following:

a. Draft of proposed letter from the Chief of Engineers to the Special Assistant to the Secretary of the Army for Civil Functions.

b. Draft of proposed letter from the Special Assistant to the Director, Bureau of the Budget.

c. Draft of proposed letter to the Committees.

2. The course of action outlined in paragraph 3 of 8th Ind is concurred in except we recommend proceeding with preparation of the supplement to the general design memorandum for the Mississippi River-Gulf Outlet project without waiting for notification of the Congressional Committee.

ACTING
FOR THE/DIVISION ENGINEER:



A. J. DAVIS
Chief, Engineering Division

9 Incl (dupe)

wd Incl 7, 8, and 9

Added: 10 thru 18, as listed *u/s*

Copy furnished:

NOD, ATTN: LMNED-PP

LMXED-PP (NOD 29 Nov 66)

8th Ind

SUBJECT: Lake Pontchartrain, Louisiana and Vicinity - Modification of
The Chalmette Area Plan to Include Larger Area

DA, New Orleans District, CE, New Orleans, La. 70160 14 Jul 67

TO: Division Engineer, Lower Miss. Valley, CE, ATTN: LMVED-TD & LMVBC

1. In addition to the prior elements of this chain, reference is made to LMVBC letter dated 24 April 1967, subject "Hurricane Protection - Lake Pontchartrain and Vicinity," and 1st through 3d Indorsements thereto.

2. Forwarded herewith are the following:

a. Draft of proposed letter from the Chief of Engineers to the Special Assistant to the Secretary of the Army for Civil Functions explaining the inclusion of foreshore protection costs in the "Mississippi River-Gulf Outlet, La.," project.

b. Draft of proposed letter from the Special Assistant to the Director, Bureau of the Budget, transmitting a draft of proposed letters to the Public Works and Appropriations Committees of the United States Congress notifying them of the increase in cost of the "Mississippi River-Gulf Outlet, La.," project as a result of including foreshore protection in the plan of improvement, and requesting information as to whether there is any objection by the Bureau to the submission of the proposed letters to the respective committees.

c. Draft of proposed letter to the Committees.

3. Design for a portion of the foreshore protection has been covered in the general design memorandum (No. 3) for the Chalmette Area Plan. Inasmuch as the foreshore protection is more or less integral to and must be coordinated with the levee construction, it is planned to cover the design of the remaining foreshore protection in the general design memorandum for the Lake Pontchartrain Barrier Plan (No. 2) and in Supplement No. 1 to the general design memorandum for the Chalmette Area Plan. In addition a very brief letter-type supplement to the general design memorandum for the Mississippi River-Gulf Outlet (MR-GO) will be prepared and submitted for approval. This supplement, which will present the bases for inclusion of foreshore protection in the MR-GO project, the location of such protection, and a revised cost estimate for the overall project, will be prepared and submitted for approval after the notification of the Congressional Committees has been effected.

13 Jul 67
Chatry/kn/239
14 Jul 67

LMNED-PP (NOD 29 Nov 66)

8th Ind (contd)

SUBJECT: Lake Pontchartrain, Louisiana and Vicinity - Modification of
the Chalmette Area Plan to Include Larger Area

4. Approval of the course of action outlined in paragraph 3.
above is recommended.

3 Incl (dupe)
7, 8, & 9 as listed

GEORGE H. HUDSON
Acting District Engineer

Mask

Hudson

67-877

St Bernard

LMVED-PR

29 November 1966

SUBJECT: Lake Pontchartrain, Louisiana and Vicinity - Modification of the Chalmette Area Plan to Include Larger Area

TO: Acting Division Engineer, Lower Mississippi Valley
ATTN: LMVED-TD and LMVPD-F

1. Reference is made to the following:
 - a. Flood Control Act of 1965 authorizing subject project.
 - b. Project document for subject project (H.Doc. 231/89th Congress).
 - c. Design Memorandum No. 3, General Design for Lake Pontchartrain, La. and Vicinity, Chalmette Area Plan, submitted 1 November 1966.
 - d. Flood Control Act of 1962 authorizing hurricane protection for the Mississippi River Delta Area at and below New Orleans, Louisiana, and Reach E, Violet to Verret, in particular.
 - e. Project document for Mississippi River Delta at and below New Orleans, La. (New Orleans to Venice, La.) (H.Doc. 550/87th Congress).
 - f. Resolution adopted 8 May 1964 by the House Public Works Committee authorizing a restudy of hurricane protection in St. Bernard Parish.
 - g. Paragraph 2 of 1st Ind file LMVED-PR dated 25 February 1966 to NOD letter of 21 February 1966 subject "Review of St. Bernard Parish, Louisiana - Plan of Survey."
 - h. Paragraph 9.b. of ER 1110-2-1150 dated 1 July 1966.

2. Hurricane protection for the Chalmette area was authorized as an item of the "Lake Pontchartrain, Louisiana and Vicinity," project by the Flood Control Act of 1965 (page 5 of PL 89-298) "...substantially in accordance with the recommendations of the Chief of Engineers in House Document Numbered 231, Eighty-Ninth Congress, except that the recommendations of the Secretary of the Army in that document shall apply with respect to the Seabrook Lock feature of the project...."

29 November 1966

SUBJECT: Lake Pontchartrain, Louisiana and Vicinity - Modification of the Chalmette Area Plan to Include Larger Area

3. The recommendations of the Board as stated in paragraph 4 of the report are as follows:

"Subject to re-examination of the levee alignment in the preconstruction stage with a view to protecting additional lands, and to certain requirements of local cooperation, the Board recommends authorization for construction of the improvements, essentially as planned by the reporting officers, provided...."

The Chief of Engineers concurred in the recommendations of the Board subject to certain modifications pertaining to the Rigolets lock as a result of a change in the interest rates.

4. The present plan of improvement for the Chalmette area is shown in Design Memorandum No. 3, General Design (reference l.c.). This plan, also shown on the attached map, provides for protection of the Chalmette area against a standard project hurricane (described in paragraph 14 of the DM) having an estimated frequency of about once in 200 years.

5. Protection for the Reach E area, Violet to Verret, against a hurricane having a frequency of about once in 100 years was authorized as a feature of the project "New Orleans to Venice, La.," by the Flood Control Act of 1962. The plan of improvement provided for raising existing back levees from the Mississippi River at Violet to the highway at Verret (see attached map).

6. St. Bernard Parish interests were dissatisfied with this plan and secured authorization for a restudy (reference l.f.) which was initiated in FY 1966 and is being continued in FY 1967. At the public hearing in Chalmette on 15 December 1965, the Parish Police Jury, State of Louisiana, Department of Public Works, and others requested hurricane protection for a much larger area in St. Bernard Parish including the settlements of Caernarvon, Reggio, Delacroix, Yscloskey, and Hopedale. The locations of the levees proposed by the sponsors at the public hearing are shown on the attached map.

7. After preliminary examination of the requested levee alignment, previous studies, and damages caused by hurricane "Betsy" (9 September 1965), it was deemed advisable to move the levee about halfway between the requested location and the highway from Poydras to Verret because of better levee construction conditions (Reach A-B on the inclosed map). The area thus deleted from the proposed protected area is entirely undeveloped marsh in which only minor enhancement benefits would be

29 November 1966

SUBJECT: Lake Pontchartrain, Louisiana and Vicinity - Modification of the Chalmette Area Plan to Include Larger Area

obtained from hurricane protection. It was also deemed advisable to consider the initial plan as protection for the Poydras to Verret area which, if added to the Chalmette area, would eliminate the need for the return levee between the Mississippi River-Gulf Outlet spoil bank and the Mississippi River levee at Violet, a very expensive section of levee to construct and maintain (see reference l.c.). The remainder of the requested levees would be considered as increments thereto. The plan of survey recommending this approach was submitted 21 February 1966 and approved 25 February 1966 (see reference l.g.).

8. Initial studies of the additional protection requested for St. Bernard Parish have been essentially completed. Maximum utilization has been made of the data developed during preparation of the design memorandum for the Chalmette area. The levee sections and estimated construction requirements and unit prices for comparable areas in the Chalmette plan have been used for cost estimates. Hydraulic studies have been made to estimate levee grades. Field reconnaissance and hydraulic studies have been made for benefit estimates.

9. The net levee grade for the Chalmette area plan levee along the spoil banks of the Mississippi River-Gulf Outlet gulfward of Paris Road is 17.5 feet m.s.l. (plates 10 through 15 of design memorandum, reference l.c.). Hydraulic studies have been made and levee grades established for the additional area under study as follows: along the entire spoil bank, 17.5 feet m.s.l.; Caernarvon to the highway at Verret, 16.5 feet; Verret to spoil bank, 17.5 feet; and Verret to Reggio, and thence along Bayou LaLoutre to the Mississippi River-Gulf Outlet spoil bank, 17.0 feet. Levees to these grades would provide the same degree of protection for the entire area as that under the existing Chalmette area plan.

10. The estimated cost of modifying the Chalmette area plan to include the settlements of Caernarvon, Poydras, and Verret (by levees A, B, C, D) in the protected area is as shown below. A detailed estimate of the costs is inclosed.

LMNED-PR

29 November 1966

SUBJECT: Lake Pontchartrain, Louisiana and Vicinity - Modification of the Chalmette Area Plan to Include Larger Area

<u>Item</u>	<u>Estimated cost</u>
Levee construction	\$ 9,548,500
Foreshore protection along MR-GO	703,000
Drainage structure	146,000
Relocations	
Highway crossings(2)	93,800
Pipelines(7)	295,000
Subtotal	<u>\$10,786,300</u>
Contingencies (20%+)	2,157,700
Subtotal	<u>\$12,944,000</u>
Engineering and design	776,000
Supervision and administration	<u>1,099,000</u>
 Total construction cost	 \$14,819,000
 Rights-of-way	 537,000
 Total estimated cost of additional levees	 \$15,356,000(1)
Less levee from Bayou Lawler (Point D) to Violet made unnecessary	 <u>7,212,000(2)</u>
 Total increased cost for additional protection	 \$ 8,144,000(1)

- (1) Includes \$966,000 for foreshore protection along Mississippi River-Gulf Outlet, Reach C-D on the inclosed map.
(2) Section IV, pages 52-53 of D.M. reference l.c.

11. The estimated annual charges based on the increased costs in the preceding paragraph, a 100-year life, and an interest rate of 3-1/8% are:

<u>Item</u>	<u>Amount</u>
Interest	\$255,000
Amortization	12,000
Maintenance and operation	
16 miles levee @ \$5,000/mile	80,000
Less: maintenance levee--Bayou Lawler to Violet(par. 65 D.M. ref. 1)	<u>42,000</u>
 Increased levee maintenance	 <u>38,000</u>
 Increased annual charges	 \$305,000

29 November 1966

SUBJECT: Lake Pontchartrain, Louisiana and Vicinity - Modification of
The Chalmette Area Plan to Include Larger Area

12. The benefits from the additional protection are estimated at \$359,200 average annually, consisting of \$13,100 crop, \$178,600 non-crop, and \$167,500 land enhancement. A detailed computation of the benefits is inclosed.

13. Based on annual charges in paragraph 11 and annual benefits in paragraph 12, the benefit-cost ratio for the protection of the additional area is 1.2.

14. Consideration was given to extending the protection eastward and southward of Verret generally as requested by the local sponsors and shown on the attached map. However, these studies indicate protection for a larger area cannot be justified in the foreseeable future. The length of levee required would be relatively large in relation to the levee eliminated and the increased area protected. The area is sparsely inhabited and the improvements are of low value. Reconnaissance scope studies show that the estimated incremental first costs and annual charges for extending the hurricane protection from the Poydras-Verret area to include Yscloskey (excludes Hopedale and Delacroix), generally as shown on the inclosed map (levees B, E, F, I, C), are \$18,000,000 and \$670,000, respectively. The estimated incremental first costs and annual charges for extending the hurricane protection from Verret to Hopedale (levees F, G, H, I) are \$28,000,000 and \$1,000,000, respectively. The average annual benefits for extending the hurricane protection from Verret to Hopedale are only \$195,000 (exclusive of Delacroix) (\$5,000 crop, \$140,000 non-crop, and \$50,000 land enhancement). In view of the very small benefit-cost ratio for the area from Verret to Yscloskey (less than 0.2), no studies were made of the levees along Bayou Terre aux Boeufs to include Delacroix in the protected area.

15. A survey of the highway from Poydras to Verret shows the controlling elevation to be about 5 feet mean sea level. Over two miles of the highway have a controlling elevation of less than 6.0 feet m.s.l. Hurricane "Betsy" produced stillwater elevations in excess of 10.0 feet m.s.l. in the Poydras-Verret-Hopedale area. The protection to be provided under the authorized project "Reach E" is obviously inadequate for a residential area. In recognition of this, the State of Louisiana, Department of Public Works, at the request of the Board of Commissioners of the Lake Borgne Levee District, has recently (about 1 November 1966) initiated the construction of a small levee to elevation 10.0 feet m.s.l. (by dragline) from Caernarvon to Verret generally along the alignment proposed herein and shown on the attached map. The alignment and levee section have been examined in this office. The work being accomplished, unless enlarged and raised, will soon settle

RMB

LMNED-PR

29 November 1966

SUBJECT: Lake Pontchartrain, Louisiana and Vicinity - Modification of
the Chalmette Area Plan to Include Larger Area

until it would provide only a small amount of additional protection. However, it will be of substantial value in expediting the construction of the levee to the full grade and section recommended herein. Local interests should be given credit for the work accomplished on their Caernarvon to Verret levee.

16. It is recommended that the presently approved plan of hurricane protection for the Chalmette area contained in the general design memorandum (reference l.c.) be modified under the authority quoted in paragraphs 2 and 3 to provide for the construction of the levee from Caernarvon via Verret and the Mississippi River-Gulf Outlet spoil bank to the approved plan levee at Bayou Lawler (Point D) generally along the alignment shown on the attached map and for the elimination of the levee in the approved plan from Bayou Lawler to Violet (Section IV in reference l.c.). This modification will increase the total estimated cost of the Chalmette area plan from \$29,552,200 to \$37,697,800, which includes \$4,337,400 for foreshore protection along the Mississippi River-Gulf Outlet (an increase of \$966,000). The estimated Federal cost will be increased from \$21,697,952 to \$27,689,000 and the estimated non-Federal cost from \$7,854,236 to \$10,008,000.

17. It is further recommended that, when the modification in the authorized plan is approved, this District be authorized to proceed with work necessary to prepare a supplement to the general design memorandum for the Chalmette area (reference l.c.) on the modified plan.

- 4 Incl (quint)
- 1. Map
- 2. Cost est.
- 3. Benefit est.
- 4. Apportionment of costs

THOMAS J. ROWEN
Colonel, CE
District Engineer

Jm
SHATRY

WDM
Mask

CWA
Hudson

Exe Ofc

hu
B

LMVED-TD (NOD 29 Nov 66) 1st Ind
 SUBJECT: Lake Pontchartrain, Louisiana and Vicinity - Modification of
 the Chalmette Area Plan to Include Larger Area

DA, Lower Miss. Valley Div, CE, Vicksburg, Miss. 39180 13 Dec 66

TO: Chief of Engineers, ATTN: ENGCW-V/ENGCW-E

1. The recommendations of the District Engineer in paras 16 and 17 of basic communication are concurred in, subject to the comments below. General Design Memorandum No. 3 (reference 1c) was forwarded to OCE by our 1st Ind, LMVED-TD, dated 1 Dec 66, on NOD letter, dated 1 Nov 66, subject: Lake Pontchartrain, La. and Vicinity, General Design Memorandum No. 3, Chalmette Area Plan.

2. Para 1f, basic letter. In connection with studies being made in response to referenced resolution, present indications are that the part of the area below Verret will probably have a very low B/C ratio.

3. Para 16, basic letter. The estimate of \$29,552,200 is that shown in General Design Memorandum No. 3 and has not been approved in a Project Cost Estimate (PB-3). The estimate of \$37,697,000 should be designated as approximate in view of the comment in para 5 below.

4. Incl 1. a. Location of drainage structure should be shown.

b. Upon approval of enlarged Chalmette Area, consideration should be given to locating the east-west portion of levee A-E approximately 2,000 feet north of the recommended alignment in order to provide a slightly better foundation and to place the levee on somewhat higher ground.

5. Incl 2. It should be noted that levee fill volumes and costs are based on data furnished in General Design Memorandum No. 3. As pointed out in para 5 of our 1st Ind dated 1 Dec 66, cited in para 1 above, the data and analyses presented in the GDM are not completely adequate to permit the levee to be constructed in stages to final grade without additional studies. As a result, at this time we do not actually know the volume of levee fill required to construct the levee to an ultimate grade taking into account all future settlement and displacement. Thus, the cost estimate for the levee is based on the best information available at this time.

6. Incl 4. Upon approval of the modified plan, local interests should be apprised of the plan including the increase in required

LMVED-TD (NOD 29 Nov 66) 1st Ind 13 Dec 66
SUBJECT: Lake Pontchartrain, Louisiana and Vicinity - Modification of
the Chalmette Area Plan to Include Larger Area

non-Federal contribution and their views discussed in the proposed
supplement to the general design memorandum.

FOR THE DIVISION ENGINEER:

4 Incl (quad)
wd 1 cy ea

A. J. DAVIS
Chief, Engineering Division

~~Copy~~ furnished:
NOD, ATTN: LMNED-PR

EEOCW-EZ

2nd Ind

Mr. Hanscomb/jh/55104

SUBJECT: Lake Pontchartrain, Louisiana and Vicinity - Modification of
the Chalmette Area Plan to Include Larger Area

Da, ColEngrs, Washington, D.C. 20315, 31 January 1967

TO: Division Engineer, Lower Mississippi Valley Division

1. References:

a. 2nd Indorsement, EEOCW-EZ, 27 October 1966, on letter LMOED-PP, 18 August 1966, subject: "Lake Pontchartrain, Louisiana and Vicinity, Design Memorandum No. 1, Hydrology and Hydraulic Analysis, Part I - Chalmette."

b. 2nd Indorsement, EEOCW-EZ, 31 January 1967 on letter LMOED-PP, 1 November 1966, subject: "Lake Pontchartrain, Louisiana and Vicinity, General Design Memorandum No. 3, Chalmette Area Plan."

2. The modification recommended by the District Engineer in paragraph 16 of the basic letter is approved subject to the comments of the Division Engineer, the comments in OCE 2nd indorsement referenced in paragraph 1a above, and the following additional comment.

3. Since the modification involves a significant increase in the project cost, the Appropriations Committees of Congress will have to be notified by this office. For this purpose the views of local interests on the plan and the increase in the non-Federal contribution is necessary. It is requested that the modification be discussed with local interests and this office be advised of the results thereof.

4. Cost for Reach E, shown in orange on Inclosure No. 1, should be stated in the supplement mentioned below, since the levee ABCD will replace this authorized levee as well as that shown in green.

5. Preparation of the supplement recommended in paragraph 17 of the basic letter is approved.

FOR THE CHIEF OF ENGINEERS:

wd incl

DANIEL D. HALL
Major, Corps of Engineers
Assistant Director of Civil Works
for Mississippi Valley

VF
SKR
MSG
WME

LMVED-TD (NOD 29 Nov 66)

3d Ind

SUBJECT: Lake Pontchartrain, Louisiana and Vicinity - Modification
of the Chalmette Area Plan to Include Larger Area

DA, Lower Miss. Valley Div, CE, Vicksburg, Miss. 39180 9 Feb 67

TO: District Engineer, New Orleans District, ATTN: LMNED-PR

1. Referred to note approval, subject to comments of 1st and
2d Indorsements.

2. Early action should be taken in regard to para 3, 2d Ind so
that OCE may be furnished required information prior to impending
Appropriations Hearings. In addition to a statement setting forth
the views of local interests on the proposed modification and the
increase in local costs, the submittal should clearly show that the
modification of the Chalmette Area levee plan will obviate the need
for the "Reach E" feature of the New Orleans to Venice hurricane
protection project at a saving of \$ _____ to that project.
Furthermore, the modified levee plan will eliminate the Bayou Lawler
to Violet segment of the Chalmette Area as now planned at a saving
of \$ _____. This proposed addition to the Chalmette Area will
provide protection to all areas in St. Bernard Parish that can be
economically justified at this time.

FOR THE DIVISION ENGINEER:

A. J. DAVIS
Chief, Engineering Division

23 Feb 67
Chatry/kn/239

LMVED-PP (NOD 29 Nov 66) 4th Ind
 SUBJECT: Lake Pontchartrain, Louisiana and Vicinity - Modification
 of the Chalmette Area Plan to Include Larger Area

DA, New Orleans District, CE, New Orleans, La. 70160 23 Feb 67

TO: Division Engineer, Lower Miss. Valley, CE, ATTN: LMVED-TD

1. In accordance with paragraph 3 of the 2d Indorsement, the State of Louisiana, Department of Public Works, which was designated by the Governor of Louisiana on 2 November 1965 as "...the agency to coordinate the efforts of local interests and to see that the local commitments are carried out promptly....," was requested to comment on the acceptability of the subject modification to local interests and their willingness to provide an additional local contribution therefor of approximately \$2,150,000, inclusive of the value of lands, damages, relocations, and a cash contribution (or equivalent work) amounting to \$1,080,000. A copy of our telegraphic request is inclosed.
 \$2,470,000

2. By letter dated 13 February 1967, the Department of Public Works concurred in the modification and gave assurance that "...the requirements made of local interests will be carried out by the appropriate local governmental units." A copy of this response is inclosed.

3. The modified Chalmette Area Plan will extend hurricane protection to all areas in St. Bernard Parish for which such protection can be economically justified at this time. Since the entire Reach "E" feature of the "New Orleans to Venice, La.," project is located within the protected area of the modified Chalmette Area Plan, construction of this plan will, in addition to producing other benefits, generate all of the benefits realizable through construction of the Reach "E" feature, thus obviating the need for construction of the feature at a saving of \$1,316,000 (\$921,900 Federal, \$394,100 non-Federal, based on PB-3 approved 2 June 1966). In addition, the return levee along Bayou Dupre, a segment of the Chalmette Area Plan as originally authorized, is not required with the modified plan, and its elimination results in an additional saving of \$7,212,000 (\$5,048,400 Federal and \$2,163,600 non-Federal, based on DM No. 3, 1 November 1966).

2 Incl (dupe)

5. NOD telegram LMVED-PP-6,
7 Feb 67

6. DPW ltr dtd 13 Feb 67

THOMAS J. BOWEN
Colonel, CE
District Engineer

WJM
Mask

JACB
Hudson

Exe Ofc
W

67-265

LMVED-TD (NOD 29 Nov 66) 5th Ind
 SUBJECT: Lake Pontchartrain, Louisiana and Vicinity - Modification of
 the Chalmette Area Plan to Include Larger Area

DA, Lower Miss. Valley Div, CE, Vicksburg, Miss. 39180 27 Feb 67

TO: Chief of Engineers, ATTN: ENGCW-EZ

Information requested by OCE 2d Ind is forwarded for your information. To avoid misinterpretation of the last sentence of para 3, 4th Ind, and to correct minor discrepancies, a summary of costs rounded to nearest \$1,000 is furnished below.

Cost of Modifying Chalmette Area Plan

Total Const. Cost	\$14,819,000
Right of Way	<u>537,000</u>
Total Cost	\$15,356,000
Less Levee Violet to Point D	<u>7,212,000</u>
Total Cost of Modifying Plan	\$ 8,144,000

Cost of Chalmette Area Plan as Modified

Total Cost of Modified Plan	\$37,697,000
Previous Estimate	<u>29,553,000</u>
Increase	\$ 8,144,000

Federal Cost of Modified Plan	\$27,689,000
Previous Estimate	<u>21,698,000</u>
Increase	\$ 5,991,000

Non-Federal Cost of Modified Plan	\$10,008,000
Previous Estimate	<u>7,854,000</u>
Increase	\$ 2,154,000

Additional Saving

Elimination of Reach E of New Orleans to Venice
 Hurricane Protection Project

Total Savings	\$ 1,316,000
Federal Cost	\$ 922,000
Non-Federal Cost	\$ 394,000

FOR THE DIVISION ENGINEER:

2 Incl
 Dupe of wd

GEORGE B. DAVIS
 Acting Chief, Engineering Division

Copy furnished:
 NOD, ATTN: LMNED-PP

Rec'd NO 11
5/5/67

ENG CW-EZ (LMVED-PR, 29 Nov 66) 6th Ind
SUBJECT: Lake Pontchartrain, Louisiana and Vicinity - Modification of
the Chalmette Area Plan to Include Larger Area

DA, CofEngrs, Washington, D.C. 20315, 12 April 1967

TO: Division Engineer, Lower Mississippi Valley Division

1. Reference is made to letter, LMVED-A, 21 March 1966, subject:
"Hurricane Protection - Lake Ponchartrain and Vicinity - Chalmette
Area" and 1st indorsement, ENG CW-OM, 15 April 1966 thereon.

2. The construction costs presented in the 4th and 5th indorsements
and in the GDM (DM #3) include costs for riprap foreshore protection along
the Mississippi River - Gulf Outlet reach of the project. 1st indorsement
ENG CW-OM, 15 April 1966, referenced in paragraph 1 above, directed that
these costs be charged to the navigation project (MR-GO) as a Federal cost
for wave protection. These costs, including the modified plan, are in
excess of \$4,000,000. The estimated costs should be adjusted by the District
and revised estimates submitted to OCE, together with draft of letters to
Congressional Committees. Since the riprap should be included in the Gulf
Outlet (MR-GO) project, the necessary revisions to the design memorandum
for the Gulf Outlet project should be made, or a supplement be prepared,
and furnished OCE.

FOR THE CHIEF OF ENGINEERS:

wd incl

WENDELL E. JOHNSON
Chief, Engineering Division
Civil Works

LMVED-7D (MOD 29 Nov 66)

7th Ind

SUBJECT: Lake Pontchartrain, Louisiana and Vicinity - Modification of
the Chalmette Area Plan to Include Larger Area

DA, Lower Miss. Valley Div, CE, Vicksburg, Miss. 39180 2 May 67

TO: District Engineer, New Orleans, ATTN: LMVED-PR

1. Referred for necessary action.
2. The question of charging the cost of riprap protection along the GIWW has been submitted to OCE by letter, LMVBC, SUBJECT: Hurricane Protection, Lake Pontchartrain and Vicinity, 24 Apr 67 for guidance. You will be advised when a decision is reached.

FOR THE ACTING DIVISION ENGINEER:

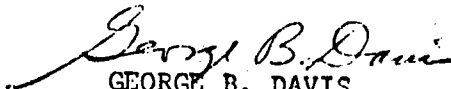

GEORGE B. DAVIS

Acting Chief, Engineering Division

**DETAILED ESTIMATED FIRST COST
FOR
ADDING BOYDRAS-VERRET AREA TO THE
CHALMETTE AREA PLAN**

1. ESTIMATES OF FIRST COSTS

The estimates of first cost for the plan of improvement for the Peydras to Verret area, based on October 1966 prices, are as follows:

a. REACH A-B.

Estimated first cost

Cost sect. No.	Item	Quantity	Unit cost	Estimated cost
FEDERAL CONSTRUCTION				
11	Levees and floodwalls			
	Levee			
	Hydraulic fill	8,212,000 cu.yd.	\$ 0.60	\$4,927,200
	Shape up	1,026,000 cu.yd.	0.40	410,400
	Cast fill for dikes	385,000 cu.yd.	0.30	115,500
	Haul fill for levee	313,000 cu.yd.	1.50	469,500
	Seeding	264 acre	75.00	19,800
	Subtotal			<u>\$5,942,400</u>
	Contingencies (20%)			<u>1,188,600</u>
	Subtotal			<u>\$7,131,000</u>
15	Floodway control and diversion structures			
	Drainage structure	job		\$ 146,000
	Contingencies (20%)			<u>29,000</u>
	Subtotal			<u>\$ 175,000</u>
30	Engineering and design (6%)			<u>\$ 438,000</u>
31	Supervision and administration (8%)			<u>620,000</u>
	Total estimated Federal construction first cost			<u>\$8,364,000</u>

Incl 2

a. REACH A-B (cont'd)

Cost acct. No.	Item	Quantity	Unit cost	Estimated cost
RELOCATIONS				
02.3	Relocation of pipelines			
	3-20" gas pipeline	L.S.		\$ 161,000
	2-16" gas pipeline	L.S.		86,000
	1-12" gas pipeline	L.S.		32,000
	1-6" gas pipeline	L.S.		16,000
	Subtotal			<u>\$ 295,000</u>
	Contingencies (20%)			59,000
	Subtotal			<u>\$ 354,000</u>
02.1	Relocation of roads			
	La. Hwy. 39 (Caernarvon)			
	Earthfill	26,200 cu.yd.	\$ 1.50	\$ 39,300
	Asphalt ramp	630 ft.	12.00	7,600
	Subtotal			<u>\$ 46,900</u>
	Contingencies (20%)			9,100
	Subtotal			<u>\$ 56,000</u>
30	Engineering and design (6%)			25,000
31	Supervision and administration (8%)			35,000
	Total estimated cost of relocations			<u>\$ 470,000</u>
01	Lands and damages			
	Fee area	928 acres		\$ 269,000
	Improvements			20,000
	Severance			10,000
	Contingencies (15%)			45,000
	Acquisition costs (83 tracts)			17,000
	Total cost for rights-of-way			<u>\$ 361,000</u>
	TOTAL ESTIMATED COST FOR REACH A-B			\$9,195,000

b. REACH B-C.

Estimated first cost

Cost acct. No.	Item	Quantity	Unit cost	Estimated cost
FEDERAL CONSTRUCTION				
11	Levees and floodwalls			
	Levee			
	Hydraulic fill	3,032,000 cu.yd.	\$ 0.60	\$1,819,200
	Shape up	379,000 cu.yd.	0.40	151,600
	Cast fill for dikes	142,000 cu.yd.	0.30	42,600
	Haul fill for levee	313,000 cu.yd.	2.50	782,500
	Seeding	140 acres	75.00	10,500
	Subtotal			\$2,806,400
	Contingencies (20%)			561,600
	Subtotal			\$3,368,000
30	Engineering and design (6%)			\$ 202,000
31	Supervision and administration (8%)			285,000
	Total estimated Federal construction first cost			<u>\$3,855,000</u>
RELOCATIONS				
02.1	Relocations			
	LA.Hwy. 46 (Verret)			
	Earthfill	26,200 cu.yd.	\$ 1.50	\$ 39,300
	Asphalt ramp	630 ft.	12.00	7,600
	Subtotal			\$ 46,900
	Contingencies (20%)			9,100
	Subtotal			\$ 56,000
30	Engineering and design (6%)			4,000
31	Supervision and administration (8%)			5,000
	Total estimated first cost for relocations			\$ 65,000
01	Lands and damages			
	Fee area	306 acres		\$ 85,000
	Improvements			3,000
	Severances			5,000
	Contingencies (15%)			14,000
	Acquisition costs			1,000
	Total costs for rights-of-way			\$ 108,000
	TOTAL COST FOR REACH B-C			<u>\$4,028,000</u>

c. REACH C-D.

Estimated first cost

Cost acct. No.	Item	Quantity	Unit cost	Estimated cost
FEDERAL CONSTRUCTION				
11	Levees and floodwalls			
	Levee			
	Hydraulic fill	1,198,000 cu.yd.	\$ 0.60	\$ 718,800
	Shape up	150,000 cu.yd.	0.40	60,000
	Cast fill for dikes	56,000 cu.yd.	0.30	16,800
	Seeding	54 acres	75.00	4,100
	Subtotal			\$ 799,700
	Contingencies (20%)			160,300
	Subtotal			\$ 960,000
30	Engineering and design (6%)			57,000
31	Supervision and administration (8%)			82,000
	Total estimated cost of levee			\$1,099,000
11	Foreshore protection along NR-00			
	Excavation & backfill	121,000 cu.yd.	1.00	121,000
	Riprap	54,000 ton	10.00	540,000
	Shell	12,000 cu.yd.	3.50	42,000
	Subtotal			\$ 703,000
	Contingencies (20%)			141,000
	Subtotal			\$ 844,000
30	Engineering and design (6%)			50,000
31	Supervision and administration (8%)			72,000
	Total estimated costs for foreshore protection			\$ 966,000
	Total estimated Federal construction cost			\$2,065,000
01	Leads and damages			
	Fee area	116 acres		\$ 58,000
	Improvements			None
	Severance			None
	Contingencies (15%)			9,000
	Acquisition costs			1,000
	Total estimated costs for rights-of-way			\$ 68,000
	TOTAL ESTIMATED COST REACH C-D			\$2,133,000

d. Summary.

	<u>A-B</u>	<u>B-C</u>	<u>C-D</u>	<u>Total</u>
Federal construction	\$8,364,000	\$3,855,000	\$2,065,000	\$14,284,000
Relocations	470,000	65,000	None	535,000
Leads & damages	<u>361,000</u>	<u>108,000</u>	<u>68,000</u>	<u>537,000</u>
Total	\$9,195,000	\$4,028,000	\$2,133,000	\$15,356,000

ESTIMATE OF BENEFITS
FOR
POYDRAS-VERRET AREA

DESCRIPTION

The study area is rural in nature and is characterized by several small communities located along the highways which traverse the area. Along La. State Highway 39 are the settlements of Violet, Poydras, and Caernarvon. St. Bernard, Toca, Estopinal, and Verret are situated along La. State Highway 46. Estimated total population (1960 census) is 3,100 representing a growth rate of approximately 3½% in the last decade. Improvements are generally located on high ground along the alluvial banks of the Mississippi River and Bayou Terre aux Boeufs, a former distributary of the Mississippi River at Poydras.

ECONOMIC DEVELOPMENT

Railway transportation is provided by the Louisiana Southern Railroad track (Southern Railway System) running along the west side of La. State Highway 39 and south of La. State Highway 46 as far east as the community of Toca. The Mississippi River-Gulf Outlet, a tidewater channel deep enough to accommodate seagoing vessels, borders on the northeastern boundary of the study area; to the north, Bayou Dupre and connecting Lake Borgne Canal afford a shallow navigation channel for smaller boats.

Economic activity in the area is primarily agricultural with truck crops and the production of beef cattle predominating. One industrial natural gas plant and one petroleum plant are in operation at Toca; no mineral production exists at this time. A few small, local business establishments are scattered along the highways. A large part of the income enjoyed by residents is derived outside of the area; primary sources include business and industrial establishments in metropolitan New Orleans, nearby oil production facilities, commercial fishing, sport fishing services, and fur trapping.

Development within the area has shown consistent gains over the past 25 years despite inadequate flood protection; its geographic position within the Greater New Orleans area indicates sustained future growth.

EXTENT AND CHARACTER OF FLOODSDAREA

Within the project area are some 17,900 acres of land subject to inundation, including 3,800 acres cleared, 9,500 acres woods, and 4,600 acres marshland. About 6,300 acres lying north of La. State Highway 46 receive some protection from flooding as a result of the Bayou Terre aux Boeufs alluvial ridge to the south and a protection levee up to +8 feet above mean sea level to the north. Nearly all improvements in the

area are residential, with a few small commercial businesses and two industrial plants. These improvements are generally located on the alluvial ridges at elevation +5 feet to +10 feet above mean sea level. Agricultural production is based primarily on small farm truck crop production and the raising of beef cattle.

The present estimated land value within the project area is \$16,750,000 and the improvements are valued at \$18,050,000 for a total valuation of \$34,800,000. Annual value of agricultural production, under flood-free conditions, is about \$250,000.

Due to the extreme peril to life and property in the area because of possible tidal overflow, it becomes necessary for a mass evacuation whenever there is an indication of approaching hurricanes or severe tropical disturbances. Highway and railway access is subject to disruption during these periods.

FLOOD DAMAGES

As a result of hurricane tidal overflows, damages are sustained by residences, house trailers, small business establishments, two industries, schools, churches, utilities, highways, and the railroad. Additional losses are suffered to truck crops, pastures, drowned livestock, fowl, and wildlife. Mass evacuation costs, flood fighting costs, business and personal income losses are also incurred.

Flood damages determined during surveys following hurricanes "Floesy" (September 1956) and "Betsy" (September 1965) were adjusted to reflect present conditions and used as a basis for developing stage-damage curves for agricultural and non-agricultural damages. In turn, average annual damages were determined by combining stage-damage and stage-frequency curves to obtain damage-probability curves.

Under present conditions, average annual losses within the project area are estimated at \$13,100 crop and \$119,600 non-crop for a total of \$132,700.

Analysis of the growth trend for the metropolitan New Orleans area indicates continued growth for the next 50 years in this region. It was assumed that future improvements would take place in proportion to population increases and that the population within the study area would double by the end of a 50-year period and remain constant thereafter. No increase for agricultural production was assumed. On this basis of future development, average annual damages discounted for a 50-year growth and 100-year project life are estimated to be \$13,100 crop and \$178,600 non-crop for a total of \$191,700.

ESTIMATES OF BENEFITS

Protection of the area from storms up to SPH frequency (about 200 years) will be afforded by the proposed works. Residual damages with the improvement are considered to be negligible; therefore, average annual flood damages prevented are estimated to be \$13,100 crop and \$178,600 non-crop or a total of \$191,700.

The present appraised value of lands in the study area are estimated at \$16,750,000; with protection from tidal overflow the value is anticipated to approximate \$20,100,000 or an increase of \$3,350,000. Annual value of land enhancement is estimated (at a 5 percent interest rate) to be \$167,500.

Total average annual benefits attributable to the proposed project are \$359,200, composed of \$191,700 flood damage prevented and \$167,500 enhancements.

**Apportionment of Increased First Costs
for
Poydras to Verret Area**

Project first cost	
Increased first cost (including riprap foreshore protection along MR-GO)	\$ 8,144,000
Less foreshore protection	<u>966,000</u>
Total cost for additional levees	\$ 7,178,000

Apportionment of costs

<u>Item</u>	<u>Federal</u>	<u>Non-Federal</u>
Levees	\$ 5,024,600 (70%)	\$ 2,153,400 (30%)
Foreshore protection	<u>966,000 (100%)</u>	-
Total incremental cost	\$ 5,990,600	\$ 2,153,400
 Existing plan (cost from p. 40 of ref. l.e.)	 <u>\$21,697,952</u>	 <u>\$ 7,854,236</u>
Total for modified project	\$27,688,552	\$10,007,636
Round to	\$27,689,000	\$10,008,000
 Cost for lands & relocations	 (orig. project) modification)	 3,968,755 <u>1,072,000</u> \$ 5,040,755 *
 Contribution required for modified project		 \$ 4,966,881
Round to		\$ 4,967,000

*This is in error in that it includes \$1,393,400 for lands & damages and relocations (MR-GO to Violet) which will be eliminated under the modification. Correct total should be \$3,647,355.

Incl A

32603660

1507-03 (Lake Pontchartrain)

TC202
N4643P6
no.3
1966

LMVED-TD (NOD 1 Nov 66) 9th Ind
SUBJECT: Lake Pontchartrain, La., and Vicinity, General Design Memorandum
No.3, Chalmette Area Plan

DA, Lower Miss. Valley Div, CE, Vicksburg, Miss. 39180 22 Jun 67

TO: District Engineer, New Orleans, ATTN: LMNED-PP

1. Referred for necessary action.
2. Reference paragraph 2b, previous indorsement. Guidance was furnished you for conducting the corrosion survey by LMVED-TE letter 24 May 67, subject: Lake Pontchartrain, La. and Vicinity, General Advance Supplement, Design Memorandum No. 2.

FOR THE DIVISION ENGINEER:



A. J. DAVIS
Chief, Engineering Division

ENGW-EZ (LMNED-PP, 1 Nov 66) 8th Ind
SUBJECT: Lake Pontchartrain, La. and Vicinity, General Design Memorandum
No. 3, Chalmette Area Plan

Da, CofEngrs, Washington, D.C. 20315, 15 June 1967 21 June 67

TO: Division Engineer, Lower Mississippi Valley Division

1. Reference 2nd indorsement ENGW-EZ, 31 May 1967 on letter LMNED-PP, 13 March 1967, subject: "Lake Pontchartrain, La. and Vicinity, Lake Pontchartrain Barrier Plan, Design Memorandum No. 2 - General, Advance Supplement, IHNC West Levee - IHNC Lock to Florida Avenue."

2. The actions taken in the 4th through 6th indorsements are satisfactory as the basis for further planning, subject to the comments of the Division Engineer in the 7th indorsement and the following:

a. The comments included in paragraph 1a of the 2nd indorsement referenced above apply to the following paragraphs in the indorsements of this chain of correspondence:

- (1) 3rd indorsement, paragraphs 4a and 4b.
- (2) 4th indorsement, paragraphs 2 and 4 through 7, inclusive.
- (3) 5th indorsement, paragraph 2.
- (4) 6th indorsement, paragraph 1b.

b. Refer to paragraph 1b of the 6th indorsement, (concerning paragraph 4 of the 2nd indorsement, this chain) and to paragraph 1b of the 2nd indorsement referenced in paragraph 1, above. Providing for future installation of a cathodic protection system, may or may not be necessary. A sound decision regarding the steps to be taken in regard to the corrosion mitigation solution can only be made from an evaluation of information obtained from an adequate survey. It is not necessary for the contemplated structure to be completed before a corrosion survey (including the determination of the presence of stray currents) can be made. An adequate survey of any given site to determine the possibilities of corrosion being a consideration can be and should be made prior to construction.

3. Reference paragraph 1a of the 6th indorsement (concerning paragraphs 5a and 5g(2) of the 1st indorsement, this chain). In accordance with paragraphs 4 and 18, ER 1110-2-1150 and paragraph 2b, ER 1110-2-1200, the "design analysis" mentioned in this paragraph should be prepared as a supplement to the

ENGOW-22 (LMNED-PP, 1 Nov 66) 3th Ind

SUBJECT: Lake Ponchartrain, La. and Vicinity, General Design Memorandum
No. 3, Chalmette Area Plan

general design memorandum and, if based on approved OCE guidelines, may be
approved by the Division Engineer (see paragraph 17b(10), ER 1110-2-1150).

FOR THE CHIEF OF ENGINEERS:

wd incl

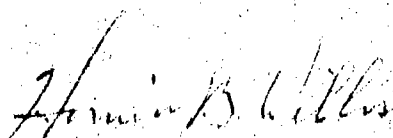

WENDELL E. JOHNSON

Chief, Engineering Division
Civil Works

LMVED-TD (NOD 1 Nov 66) 7th Ind
SUBJECT: Lake Pontchartrain, La. and Vicinity, General Design Memorandum
No. 3, Chalmette Area Plan

DA, Lower Miss. Valley Div, CE, Vicksburg, Miss. 39180 1 May 67

TO: Chief of Engineers, ATTN: ENGCW-EZ

1. The action taken by the District Engineer to satisfy comments of previous indorsements is considered satisfactory, and approval is recommended, subject to the following additional comments.

2. Para 1a, 6th Ind, regarding para 5h. Since stability problems may develop during construction of a lift, the measurement devices should be observed at intervals while the lift is being placed.

3. Para 1b, 6th Ind, regarding para 4. Provision should be made for future cathodic protection of all piles exposed to fill, including those already driven.

FOR THE DIVISION ENGINEER:

1 Incl
wd 1 cy

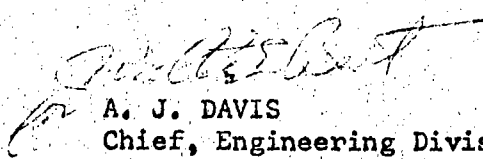
A. J. DAVIS
Chief, Engineering Division

Copy furnished:
NOD, ATTN: LMNED-PP

LMNED-PP (NOD 1 Nov 66) 6th Ind
SUBJECT: Lake Pontchartrain, La. and Vicinity, General Design Memorandum
No. 3, Chalmette Area Plan

DA, New Orleans District, CE, New Orleans, La. 70160 12 Apr 67

TO: Division Engineer, Lower Miss. Valley, CE, ATTN: LMVED-TD

1. Proposed disposition of comments in the 1st, 2d, 3d, and 5th Indorsements of this chain of correspondence is as follows:

a. 1st Ind. Par. 2. LMNED-PR letter dated 29 November 1966, subject "Lake Pontchartrain, Louisiana and Vicinity - Modification of the Chalmette Area Plan to Include Larger Area," recommended that the levee extend to the southeast along the Mississippi River-Gulf Outlet, rather than turning southwest along Bayou Dupre, approximately six miles to the southeast of Bayou Dupre, thence southwest to Verret, thence west south of Highway 46 and tying into the Mississippi River levee at Caernarvon. The modification was approved by OCE on 31 January 1967. A supplement to GDM No. 3 will be prepared covering the modification. The supplement is scheduled for submission in February 1968.

Par. 3. In preparation of the plans and specifications, consideration will be given to enlargement of the borrow area or obtaining borrow from another source.

Par. 4. It is likely that the location of the protective works involved will be incompatible with the construction of the new ship lock authorized under the Mississippi River-Gulf Outlet project (see LMNED-PP letter dated 15 September 1966 and indorsements thereto). An appropriate settlement observation program will be set up when a coordinated design for the lock and hurricane protection is developed in this area. No further construction work is planned prior to the completion of the above design.

Par. 5.a. Additional undisturbed borings, tests, and analyses will be performed and submitted for review prior to constructing succeeding lifts. A design analysis will accompany each set of plans and specifications forwarded for approval.

Par. 5.b.(1). The construction costs for the multiple lift earthfill method for levee construction presented in the GDM is approximately \$70.00 per linear foot. Studies indicate that the construction costs for the shell fill method would be about \$370.00 per linear foot.

Par. 5.b.(2) & 5.g.(1). The statistical analysis referred to in paragraph 5.b.(2) is inclosed. Inasmuch as design analyses will be prepared for each construction lift, no further action is considered necessary in connection with these comments.

Par. 5.c. The fill was assumed to be semi-infinite in extent.

SUBJECT: Lake Pontchartrain, La. and Vicinity, General Design Memorandum
No. 3, Chalmette Area Plan

Par. 5.d. These comments are concurred in.

Par. 5.e., 5.f., 5.i., & 7. The comments contained in these paragraphs were considered in plans and specifications already prepared, and will be considered in all future design analyses.

Par. 5.g.(2). As pointed out previously, design analyses will be prepared for each construction lift. These design analyses will contain all applicable soils data and studies. It is planned to file copies of all design analyses in the GDM, so that complete design coverage for the levees will be available in a single document. Estimates of time and costs for completing the levee construction will be revised as soon as sufficient information is available for firm revisions to be made. Such revisions will be made the subject of letter reports, copies of which will be filed in the GDM.

Par. 5.h. Piezometers and settlement plates referred to in this paragraph are presently being installed. Observations will be made just prior to construction of each lift, upon completion of each lift, and periodically after each lift as follows: two, four, eight, sixteen, thirty-two, and seventy-eight weeks. Inclinator pipes will be installed at the most critical locations upon completion of the first lift construction and data collected therefrom. All of the above data will be utilized in subsequent design analyses and will be presented in these analyses when submitted.

Par. 5.j. The height of fill was determined by assuming that the elevation of the original ground surface was lowered by the amount of total consolidation and subtracting this corrected elevation from the elevation of the fill crown and rounding this to the nearest foot. It was felt that further refinement of this quantity was not warranted.

Par. 6. This comment is concurred in.

Par. 8. The unit price for the treated timber is being reconsidered in preparation of the DDM for the Bayous Bienvenue and Dupre Control Structures.

Par. 9. The "I-type wall" used in the GDM is a cantilever wall consisting of a lower portion of steel sheet piling supporting a reinforced concrete upper portion which extends from two feet below ground surface to the design grade. The "steel sheet piling with concrete cap" on which the PB-3 estimate was based is also a cantilever

SUBJECT: Lake Pontchartrain, La. and Vicinity, General Design Memorandum
No. 3, Chalmette Area Plan

wall; however, the concrete cap serves no structural function and consists of a cover atop the steel sheet piling.

Par. 10. (1) As agreed to at the conference in New Orleans on 4 April 1967, which was attended by Messrs. Kaufman and Weaver, LMVD, and Messrs. Hudson, Huesmann, Worley, Henderson, Cannon, Smith, Lee, and Chatry, NOD, we shall check the final levee location for stability assuming erosion of the entire foreshore to elevation -3 (bottom of foreshore protection). It is pointed out that plans and specifications for two items of work between Bayous Bienvenue and Dupre recently approved by your office involve a landward shift of the final levee centerline of 50 feet, as compared with the GDM. Design analyses accompanying these plans and specifications demonstrate the stability of the final levee section recommended in the GDM against failure into the MR-GO with the channel widened to the maximum width including boat slips. Future design analyses will deal with the above consideration for all levees located along the MR-GO.

(2) It should be stressed that the availability of rights-of-way along the MR-GO is highly restricted. Local interests have repeatedly requested that requirements be held to 300 feet landward of the existing MR-GO rights-of-way limit.

Par. 11. Our studies utilizing the Hrennikoff method have produced a satisfactory wall section which will require much less piling and can be constructed at a lower cost than the section shown on inclosure 2 of the 1st Ind. The design for this section is covered in detail in "Design Memorandum No. 2, General, Advance Supplement, Inner Harbor Navigation Canal West Levee Florida Avenue to IHNC Lock." The final location and type of protection in the vicinity of Florida Avenue cannot be determined until coordinated design studies for hurricane protection and the new ship lock have been made. (See par. 3 of 2d Ind.)

Par. 12.a. The comment relative to the use of miter gates is concurred in. However, a removable center post is not permissible in this location due to a requirement for rapid closure. The mitered swing gate was selected to provide unlimited vertical clearance; however, the same result can be achieved with an overhead roller gate with removable overhead beam. The need for a gate in this location has been obviated by the modification of the Chalmette Area Plan to include a larger area. A similar gate will, however, be required where the modified levee alignment crosses Highway 39 and the Louisiana Southern Railroad near Caernarvon, La. We plan to use the overhead roller gate at this location.

SUBJECT: Lake Pontchartrain, La. and Vicinity, General Design Memorandum
No. 3, Chalmette Area Plan

Par. 12.b. The comment is concurred in, particularly in view of the recent revision of DIVR 1110-1-400 which requires use of a safety factor of 1.5 in computing bending moments, stresses, and wall deflections. (See comment on par. 11 above.)

Par. 13. We do not consider that the ditch would pose any threat to the final wall in this reach that could not be taken care of under normal maintenance. Inasmuch as the location of the wall is likely to be incompatible with construction of the new ship lock, the final protective works in this area will probably be constructed elsewhere. We have checked the stability of the existing levee and interim floodwall (sheet pile to elevation 11.5 feet m.s.l.), with water at the top of the wall and found the minimum factor of safety to be 1.3.

Par. 14-17, 19-20. These comments are concurred in.

Par. 18. Inasmuch as Seabrook Lock is a feature not only of the hurricane project, but of the MR-60 project as well, it is considered that the design memoranda for it should be grouped in a separate series.

b. 2d Ind. Par. 3. The comment is concurred in (see District comments above on par. 4 and 13 of 1st Ind.). The interim protection has been provided by the Orleans Levee District, the project sponsor, and is satisfactory to the Levee District.

Par. 4. In future work, all steel piling in contact with backfill or new levee fill will be coated with 20 mils of coal tar epoxy. This includes steel sheet piling of cantilever I-type floodwalls, and steel sheet pile cutoff of T-type floodwalls. Considerable direct current equipment is in use by industries along the canal and stray current corrosion may be a problem. A detail design memorandum covering corrosion protection in general will be prepared. Inasmuch as subterranean electrical measurements subsequent to the construction of the walls are considered to be an essential element of the studies required in preparing the design memorandum, this memorandum cannot be completed until the protective works have been constructed. Submission of the design memorandum will be scheduled at a later date.

Par. 5. The comment is concurred in and will be considered in the preparation of plans and specifications.

Par. 6. The congested nature of the area, the excessive cost involved, and vehement objection by the utility owners all combine to make routing of the utilities over the floodwall impracticable. The

SUBJECT: Lake Pontchartrain, La. and Vicinity, General Design Memorandum
No. 3, Chalmette Area Plan

slip joint provided will adequately accommodate any settlement which may be anticipated.

Par. 7. This comment was disposed of in paragraphs 3 and 2, respectively, of the 3d and 4th Indorsements.

Par. 8. A supplement to GDM No. 3 will be prepared covering the Chalmette modification. The supplement is scheduled for submission in February 1968.

c. 3d Ind. Par. 2. & 3.a. Comments in these paragraphs are discussed in paragraphs 3 and 9 of the 4th Indorsement, and par. 4 of the 5th Indorsement. The comments are not pertinent to the Chalmette Area Plan, which contains no wall in sandy levees, but are applicable to a number of locations on the IHNC. As pointed out in paragraph 3 of the 4th Indorsement, in no location within the limits of interim construction on the IHNC north of U. S. Highway 90 will the application of the high tailwater case yield a factor of safety less than 1.22. Studies made subsequent to preparation of the 4th Indorsement show that about 90% of the interim work will have a factor of safety, for the high tailwater case, of greater than 1.3. As stated in paragraph 9 of the 4th Indorsement future design will be based on the revised criteria.

Par. 3.b. & 5. The structural adequacy of the interim wall constructed in the Chalmette Area Plan and of the interim wall on the IHNC to be constructed north of U. S. Highway 90 has been checked for both the high and low tailwater cases, and stresses and deflections found to be within allowable limits.

Par. 4.a. This comment is concurred in.

Par. 4.b. The suggested wall section will be considered in future wall designs. Attention is invited to the fact that recommendations for adoption of similar designs have been rejected by reviewing authorities on the basis that the differing reactions of the sheet pile and the bearing pile made their use in combination inadvisable.

Par. 6. See comment on paragraph 4 of 2d Indorsement.

d. 5th Ind. Par. 2. The comment is noted.

Par. 3. This comment is noted.

Par. 4. This comment is noted.

Par. 5. This comment is concurred in.

LMNED-PP (NOD 1 Nov 66)

6th Ind (cont'd)

12 Apr 67

SUBJECT: Lake Pontchartrain, La. and Vicinity, General Design Memorandum
No. 3, Chalmette Area Plan

2. As agreed to in the conference of 4 April 1967, we shall, in future designs, investigate the stability for I-type floodwalls for both the "S" and "Q" soil strengths.

3. In order to avoid interference with the piers of the Paris Road bridge, we plan to utilize a 300-foot long section of floodwall in the alignment at the bridge. A supplement to the GDM covering the design of this wall will be submitted for review and approval in August 1967.

4. Approval of the disposition of comments presented herein is recommended.

FOR THE DISTRICT ENGINEER:

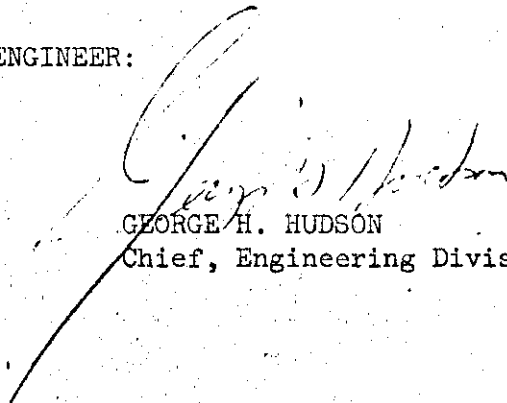
GEORGE H. HUDSON
Chief, Engineering Division

1 Incl
Added 1 Incl (trip)
5. Statistical shear
strength data

LMVED-TD (NOD 1 Nov 66)

5th Ind

SUBJECT: Lake Pontchartrain, La. and Vicinity, General Design Memorandum
No. 3, Chalmette Area Plan

DA, Lower Miss. Valley Div, CE, Vicksburg, Miss. 39180 22 Mar 67

TO: District Engineer, New Orleans District, ATTN: LMNED-PP

1. The actions you have taken and propose to take to satisfy comments of previous indorsements are satisfactory except as discussed below. Paragraph numbers refer to those in 4th Indorsement.

2. Para 4. Section 5, part 5, item 1, DIVR 1110-1-400 was revised in March 1967. The revision indicates that bending moments, stresses, and wall deflections for I-type floodwalls should be computed using the same earth and water pressure diagrams as those used in determining the pile penetration. In the case of hurricane protection for Lake Pontchartrain and Vicinity, earth pressures computed from the S shear strength are governing the design. It is considered that a 1/3 overstress can be permitted in the sheet piling in clay because the duration of water loading on the wall is very short. Where the piling is in clean sand, normal stress would be used.

3. Paras 5-8. The design of I walls on the west bank of the IHNC between the lock and Florida Avenue is being reviewed. Our comments on these designs will be furnished you soon. Our preliminary review to date indicates that the wall designs should be checked using the criteria in the revised DIVR, but with sheet pile stresses as discussed in para 2 above. When this is done, it will be found that deflections and stresses are large in a few reaches; however, in these reaches, it will be possible to use batter piles to reduce deflection of the wall. Where batter piles are used, their influence on stabilizing the wall and on the loads applied to the sheet piling should be properly considered. In the designs under review, the wall was designed as though the batter piles would have no effect on stress in the piling or on deflection. The piles were merely added as insurance against deflection. This procedure is unduly unconservative and unrealistic.

4. Para 9. Computed factors of safety for the case with high tailwater need be presented only where the levee consists of sandy soils. Where the levee consists of clay, it will not be necessary to assume a high tailwater, and the design should be based on a factor of safety of 1.5 with a low tailwater as set forth in para 3a of the 3d Indorsement.

5. Para 10. Your report on disposition of other comments should be made as a continuation of this chain of correspondence.

FOR THE ACTING DIVISION ENGINEER:

wd all incl

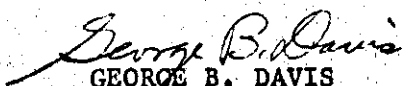
GEORGE B. DAVIS

Acting Chief, Engineering Division

LMVED-PP (NOD 1 Nov 66) 4th Ind
SUBJECT: Lake Pontchartrain, La. and Vicinity, General Design Memorandum
No. 3, Chalmette Area Plan

DA, New Orleans District, CE, New Orleans, La. 70160 10 Mar 67.

TO: Division Engineer, Lower Miss. Valley, CE, ATTN: LMVED-TD

1. Reference is made to the following:
 - a. Paragraph 7 of 2d Ind of this chain of correspondence.
 - b. Paragraphs 1 through 5 of 3d Ind of this chain of correspondence.
 - c. DIVR 1110-1-400 dated November 1966.
 - d. Discussions in office, LMVD, on 7 March 1967, involving Messrs. A. J. Davis, G. Davis, Kaufman, and Weaver, LMVD, and Colonel Bowen and Mr. Hudson, NOD.
2. Inasmuch as all floodwall included in the Chalmette Area Plan is located in clay-type soil, the stability analyses presented in the GDM for the determination of pile penetrations are valid. Further, this type of analysis may be used in all locations where clay-type soils are encountered.
3. Interim I-type floodwall construction on both banks of the IHNC north of U. S. Highway 90 is currently under advertisement with bid opening scheduled for 21 March 1967. The soils in a number of the locations involved are generally sandy. Investigations just completed indicate that required pile penetrations for the case with high tailwater and a soil shear strength factor of safety of 1.3 would be on the order of one foot greater than those for the case with minimum tailwater and a factor of safety of 1.5. The computed soil shear strength factors of safety for the penetrations shown on the contract drawings for the work under advertisement are on the order of 1.2. The small difference between the factor of safety theoretically desired (1.3) and the computed factor of safety (1.2) is insufficient to warrant cancellation of the current advertisement, redesign of the floodwall, and consequent material delay in initiating and completing the work involved.
4. Based on the discussion referred to in paragraph 1.d., we understand that DIVR 1110-1-400 dated November 1966, which currently specifies the use of a soil shear strength factor of safety of 1.0 in evaluating deflections and stresses in the piling of I-type floodwalls, is being revised, at the direction of OCE, to require the use of a factor of safety of 1.3. Use of the higher factor of safety in determining the structural adequacy of the piling in the I-type walls previously constructed, and those to be constructed, along the Inner Harbor Navigation Canal, would not have a serious impact in any area other than that on the west bank of the IHNC between the IHNC lock and Florida Avenue.

LMNED-PP (NOD 1 Nov 66)

4th Ind (cont'd)

10 Mar 67

SUBJECT: Lake Pontchartrain, La. and Vicinity, General Design Memorandum
No. 3, Chalmette Area Plan

5. The above area is a most critical one with respect to hurricane exposure and one in which local interests have expressed particular concern that construction be initiated at the earliest practicable date. To expedite matters, the Orleans Levee District has offered to construct the required improvements, and, if such action will serve to expedite construction, to contract with Architect-Engineers for the planning as well. (See LMNED-PP letter dated 8 November 1966, subject "Lake Pontchartrain, La. and Vicinity - Revised Approach to Advance Supplement on Inner Harbor Navigation Canal Levees," copy attached.)

6. Development of the alignment in the reach in question was a most complex and painstaking process which was initiated in November 1965 and not completed until January 1967. The alignment now agreed to includes I-type wall in a number of locations, and would not be feasible if T-type or other pile-supported wall were required. Our studies indicate that use of a factor of safety of 1.3 would, in effect, prohibit use of I-type wall in at least two locations. Alignment studies would, accordingly, have to be reopened. As alluded to previously, the alignment now agreed upon involves numerous compromises, and an attempt to alter it would result in vehement objection by local interests and the introduction of protracted delay in construction.

7. The advance supplement to the GDM for the Lake Pontchartrain Barrier Plan, covering the design of the above protection, has been completed and is being reproduced. All analyses therein relating to the structural adequacy of the sheet piling in I-type walls are based on a soil shear strength factor of safety of 1.0. Because of the urgency of the work involved, and our prior commitments to local interests to make available construction plans and specifications at the earliest practicable date, we do not consider that retroactive application of the new criteria is appropriate. We believe that the design as presented in the supplement is adequate. In this connection, attention is invited to the fact that "kicker" piles will be provided in the most critical locations, to limit deflection. Further, it is pointed out that "S" soil strengths were used in determining deflections and stresses; this procedure, in effect, introduces a factor of safety, since the higher "Q" strengths in the range of overburden pressure involved are more representative of the actual strengths under the short-term loading anticipated under hurricane conditions.

8. Based on the above, we shall, within the next day or two, submit, for your review and approval, the advance supplement covering the design of the protective works on the west bank of the IHNC between the IHNC lock and Florida Avenue, with design of I-type walls based on the criteria and procedures outlined in reference 1.c.

LMNED-PP (NOD 1 Nov 66)

4th Ind (cont'd)

10 Mar 67

SUBJECT: Lake Pontchartrain, La. and Vicinity, General Design Memorandum
No. 3, Chalmette Area Plan

9. In the future, design of the floodwalls will conform to the criteria contained in reference l.a., as regards pile penetration, and those to be incorporated in the revised version of reference l.c., as regards the structural adequacy of the steel sheet piling. In the supplement covering the remaining levees on the IHNC; i.e., those not included in the Chalmette Area Plan or the Advance Supplement referred in paragraph 7 above, the actual design analyses for walls already in place, and for those to be constructed under the contract now being advertised, will be presented. However, computed factors of safety for the case with high tailwater will be included for comparison.

10. We shall, by separate correspondence, report on the disposition of other comments contained in the first through third indorsements of this chain of correspondence, and provide a submission date for the memorandum on corrosion protection.

1 Incl
3. wd
Added 1. incl (dupe)
4. Cy LMNED-PP ltr dtd
8 Nov 66

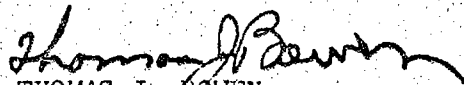
THOMAS J. BOWEN
Colonel, CE
District Engineer

LMNED-TD (NOD 1 Nov 66) 3d Ind
SUBJECT: Lake Pontchartrain, La. and Vicinity, General Design Memorandum
No. 3, Chalmette Area Plan

DA, Lower Miss. Valley Div, CE, Vicksburg, Miss. 39180 23 Feb 67

TO: District Engineer, New Orleans District, ATTN: LMNED-PP

1. Referred to note approval, subject to comments of 1st and 2d Indorsements. Guidance to assist in complying with these indorsements is furnished below.

2. We have made a preliminary analysis to determine the effect of assuming a higher water table on the landside of the wall in accordance with para 7 of the 2d Indorsement. The analysis was made for the west levee, IHNC, stations 70+00 to 77+00. In this reach, the levee consists of sand on an upper foundation stratum of sand. The computed required penetration is 10 feet for a factor of safety of 1.5 using a shear strength of $\phi = 30^\circ$, $c = 0$ and water level at el -3 on the landside of the wall. Assuming the water level on the landside of the wall at el 7 reduces the factor of safety to 1.3.

3. a. OCE has been informed of these results and agreed that for a sandy levee, the design should be based on a factor of safety of 1.5 with a low tailwater and a factor of safety of 1.3 with a high tailwater due to saturation from rainfall. It will not be necessary to assume a high saturation line on the landside of a clay levee when using the S shear strength since it is unlikely that the clay could adjust to the high tailwater during the short duration of a hurricane.

b. The pile section used should be selected based on stresses produced for a loading with factor of safety of 1.5 with low tailwater and a factor of safety of 1.3 with high tailwater, whichever governs. In the case of the west levee, IHNC, from stations 70+00 to 77+00 the design penetration will not change as a result of assumption of the higher tailwater. However, the adequacy of the pile section will have to be reevaluated.

4. a. The new criteria may be more critical and may limit the height for which an I-type steel sheet pile wall would be considered suitable or economical. For example, the higher saturation level will reduce the passive earth resistance which, in turn, will increase the pile penetration, stress, and deflection. The amount of deflection considered acceptable may govern.

b. In view of the possible impact of the new criteria discussed in para 3 above, you should investigate the economic feasibility of a wall as illustrated in the attached sketch, Incl 3. The dependence on passive lateral earth pressure would only be as required to balance the moment

LMVED-TD (NOD 1 Nov 66)

3d Ind

23 Feb 67

SUBJECT: Lake Pontchartrain, La. and Vicinity, General Design Memorandum
No. 3, Chalmette Area Plan

of eccentric active loads about the elastic center. The savings in sheet piling may more than offset the cost of timber piling and additional concrete. In reaches where the levee is being raised, the possible adverse effects due to settlement of the fill, which will induce a drag force and bending in the batter piles, should be considered.

5. The above discussion is also applicable to the sections of wall included in the specifications and drawings for "Interim Floodwall Construction on Inner Harbor Navigation Canal," for which the design, specifications, and drawings have been approved for advertising. You should review the design thereof using criteria comparable to that indicated to assure that pile section is adequate.

6. Inform LMVD by separate correspondence the expected date of submission of the DM on corrosion protection required by para 4d, 2d Indorsement.

FOR THE DIVISION ENGINEER:

1 Incl (dupe)
3. Sketch

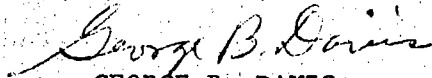

GEORGE B. DAVIS

Acting Chief, Engineering Division

ENG CW-EZ (1 Nov 66)

2nd Ind

SUBJECT: Lake Pontchartrain, La. and Vicinity, General Design Memorandum No. 3, Chalmette Area Plan

DA, CofEngrs, Washington, D. C., 20315, 31 January 1967 *Rec LHMUD 6 Feb*

TO: Division Engineer, Lower Mississippi Valley Division

1. Reference 2nd indorsement ENG CW-EZ, 27 October 1966 on letter LMNED-PP, 18 August 1966 subject: "Lake Pontchartrain, Louisiana and Vicinity, Design Memorandum No. 1, Hydrology and Hydraulic Analysis, Part I - Chalmette."

2. General Design Memorandum No. 3 is approved, subject to the comments of the Division Engineer, the comments in OCE 2nd indorsement referenced in paragraph 1 above, and the following additional comments.

3. Paragraphs 11 and 43 and Plates 5 and 6. Design and alignment in the vicinity of Florida Avenue are not satisfactory. They should be restudied to develop a plan which is compatible with proposed improvement of the navigation canal, which will require a new longer lift bridge at Florida Avenue or a separate higher level highway bridge and a movable bridge span for the railroad. In this connection, reference is made to 2nd Indorsement ENG CW-EZ, 8 December 1966 on letter LMNED-PP, 15 September 1966, subject: "Mississippi River-Gulf Outlet, La. - Report on Need for New Ship Lock", (especially paragraph 5a(3) and (6)). If interim protection is required, it should be recognized as such and the plan for permanent protection developed compatible with the navigation canal improvement.

4. Paragraph 45, Page 32.

a. The information given in this paragraph as to what may be the cause of corrosion of the sheet steel piling is questioned. Stray current corrosion is caused primarily by direct current that returns to the negative bus of the source by other than the intended path. Stray alternating current causes very little corrosion damage (about 1% of that caused by an equivalent amount of direct current). Unless there is a source of direct current in the area where the piling is to be installed, such as a direct current railway, electroplating plant or large electric welding installations, the possibility of corrosion by stray direct currents is considered to be nil. Usually, natural earth currents are not important from a corrosion standpoint because the magnitude is small or the duration is short. When stray currents are the cause of corrosion of a buried steel structure, the conventional cathodic protection means are not applicable.

b. The corrosion of buried steel is, almost without exception, caused by the local action of the anodic and cathodic areas that are always present on the surface of formed or wrought steel materials.

ENGCW-EZ (1 Nov 66)

2nd Ind

31 January 1967

SUBJECT: Lake Pontchartrain, La. and Vicinity, General Design Memorandum
No. 3, Chalmette Area Plan

Investigations made by the Corps and the National Bureau of Standards have shown that oxygen must be present for corrosion to occur on buried steel; also, that when piling is driven in undisturbed earth, corrosion very seldom occurs even though the soil in which the piling is driven may be exceedingly aggressive from a corrosion standpoint. Complete information regarding the above investigation is given in NBS Monograph 58.

c. In view of the findings of the above investigation, it is now the practice not to provide protection against corrosion of piling when it is driven in undisturbed earth. When the piling is to be driven in disturbed earth or when backfill is to be placed against the upper part of the piling, means of protection should be provided. In most cases the most economical means of providing protection against corrosion is to coat the exposed surfaces only with coal tar-epoxy and apply cathodic protection, using magnesium or zinc galvanic anodes.

d. Since the information presented in the subject design memorandum is not satisfactory, it is requested that a feature design memorandum be prepared immediately, evaluating the possibility of the occurrence of corrosion damage to the piling, and, if such damage is likely to occur, information as to the proposed means of corrosion mitigation should be included.

5. Plates 23 and 24. The tables showing riprap gradation when plotted result in a single gradation curve which is too stringent a contract requirement. In the interest of uniformity, it is suggested that the following table form be used:

<u>Percent by Weight (SSD) Lighter</u>	<u>Stone Weight in Pounds</u>
100	(150-650)
50	(130-200)
15	(40-170)

The above form will plot two gradation curves as limits which allows for reasonable variation between test samples. The theoretical spherical diameter of the maximum allowable size stone should not exceed the layer thickness and preferably, for wave protection, should be considerably less.

6. Plate 27. In view of the major settlement anticipated under levee surcharge landing, all water lines and other utility pressure lines should be routed over the top of floodwall where feasible. If utilities must cross through the line of protection, consideration should be given

ENCCW-EZ (1 Nov 66)

2nd Ind

31 January 1967

SUBJECT: Lake Pontchartrain, La. and Vicinity, General Design Memorandum
No. 3, Chalmette Area Plan

to providing a lateral offset loop along the wall that will permit rotation to take up some of the differential movement of the connection.

7. Figures 1 and 2. In design of the I-wall, consideration should be given to stability under hurricane conditions with the land-side saturation line at levels above mean sea level within the levee. The structure may be subject for several hours to heavy rainfall and high water levels where a saturation level as high as El. 5 or 7 might develop. Use of a Net Pressure Diagram (F.S. = 1.3) would be more meaningful for design security than the one shown with a safety factor of 1.0.

8. 1st Indorsement, Paragraph 2. Modification of the Chalmette area plan as discussed in this paragraph was requested in letter LMNED-PR, 29 November 1966, subject: "Lake Pontchartrain, Louisiana and Vicinity - Modification of the Chalmette Area Plan to Include Larger Area" and was approved, subject to several comments. Supplementary information to incorporate this change into the General Design Memorandum plan should be furnished.

FOR THE CHIEF OF ENGINEERS:

wd Incl

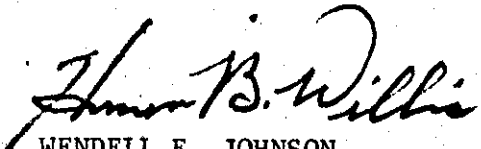
WENDELL E. JOHNSON
Chief, Engineering Division
Civil Works

LMVED-TD (NOD 1 Nov 66) 1st Ind
SUBJECT: Lake Pontchartrain, La. and Vicinity, General Design Memorandum
No. 3, Chalmette Area Plan

DA, Lower Miss. Valley Div, CE, Vicksburg, Miss. 39180 1 Dec 66

TO: Chief of Engineers, ATTH: ENGOW-V/ENGOW-E

1. Subject design memorandum is forwarded for review and approval pursuant to para 17, ER 1110-2-1150. Approval is recommended, subject to the comments below and to minor annotations in red on pages 9, 17, 21, 22, and 27.

2. In current studies for a survey report on additional hurricane protection in St. Bernard Parish, the District has stated in Status Report for 30 Sep 66 that preliminary studies indicate a combination of the Chalmette Area and the Violet to Verret Area (Reach E) (HD 550, 87th Congress, 2d Session) is justified. Since this combination would eliminate the need for a levee between the Mississippi River at Violet and the levee along the Mississippi River Gulf Outlet, the GDM should discuss this combination as a probable modification to the Chalmette Area plan.

3. Para 33, page 19. The advisability of using material in the borrow pit below el 0 is questioned. Most of the material between el 0 and the bottom of the pit (el -12, Plate 22) is unsuitable for levee fill, based on boring logs on Plate 6. If the volume of material between el 0 and el -12 is needed for levee fill, it should be obtained from another source, or the area of the borrow pit on Plate 6 should be increased so that the additional material can be obtained from above el 0.

4. Para 37, page 20. Settlement observations should include an initial survey just prior to driving the sheet piling. After the levee fill is placed, settlement observations should be made more frequently than yearly to help determine the time rate of settlement as these data would be used in determining the required gross grade of the concrete cap.

5. Para 38, pages 20-28. a. General. As indicated in subpara 21, the data are not completely adequate to permit the levee to be constructed in stages to final grade without additional studies. It is likely that the first lift can be constructed without difficulty. After this construction, the levee should be divided into reaches, the added studies made for each reach, and the resulting recommended first shaping or next lift and subsequent lifts or shapings for each reach should be submitted to LMVD for approval. This procedure would be similar to that adopted for Atchafalaya guide levees.

b. First subparagraph, page 20. (1) The fifth sentence should be expanded to provide a clearer explanation. A large enough excavation could be made which when backfilled with shell or sand would greatly increase

SUBJECT: Lake Pontchartrain, La. and Vicinity, General Design Memorandum
No. 3, Chalmette Area Plan

the stability of the levee, reduce foundation settlement, and permit constructing the levee to ultimate grade in a single construction. However, it is understood that the cost of this foundation treatment per linear foot of levee, excluding the cost of levee, greatly exceeds the cost of levee with lift construction proposed in this design memorandum. The relative costs should be cited for the record.

(2) The results of the statistical analyses including the detailed foundation shear strength with and without spoil fill should be presented. This should include a list of borings and shear strength data used to establish the gain in shear strength. The gain in shear strength from the statistical analyses should be compared with that estimated from the shear test data as shown in Plate 68, if this has not already been done.

c. Sixth subparagraph, page 21. This subparagraph should indicate the shape of the fill assumed when computing the total consolidation in a stratum. It is not clear whether the fill was assumed to be semi-infinite in extent or shaped like one of the lifts or embankment sections shown on Plate 69.

d. Seventh subparagraph, page 21. (1) The word "normally" should be inserted in the first sentence after "nearly."

(2) In the second sentence, delete "in the soils."

(3) It is likely that Recent soils beneath the Gulf Outlet spoil are underconsolidated as a result of the spoil placement and not normally consolidated as assumed in the design memorandum.

e. The second complete sentence on page 23 should be expanded. The volume of fill placed in the first shaping appears to have been affected by arbitrarily selected rights-of-way for construction in addition to stability requirements. For example, a fill considerably larger than that shown could be constructed with adequate stability if the required right-of-way and construction easements were available. These right-of-way limitations should be discussed.

f. Unnumbered 13th, 14th, 15th subparagraphs, page 23; Figure 11, Plate 69. The percent of consolidation after a given time interval and time-rate of settlement should be checked using procedures set forth for stage construction in para 4-07b, EM 1110-2-1904, Soil Mechanics Design, Settlement Analysis.

SUBJECT: Lake Pontchartrain, La. and Vicinity, General Design Memorandum
No. 3, Chalmette Area Plan

g. 16th subparagraph, page 23; Plate 68. (1) It should be noted that the R test envelope is considerably above that for the Q tests and thus, the data are questioned. As a result of the 27-28 Sep 66 conference among engineers of OCE, LMVD, and NOD, it was agreed that additional undisturbed borings and soil tests would be made by the Government to check the soil test data. Until this is done, it appears that the gain in shear strength can be estimated as on Plate 68 except that the R envelope for design should be drawn parallel to the R envelope shown on Plate 68 so as to pass through the point labeled SS₁. This will result in a lower estimated gain in strength caused by consolidation. Such a strength gain assumes that the additional load causes pure two-dimensional consolidation of the foundation. This may not be conservative because it does not consider the possibility of plastic lateral deformations and shear strains. Such deformations have been observed in similar soft soils in the Atchafalaya Basin. Also, this procedure does not consider the variation in pore pressure (and strength) with depth within the stratum proper because it uses the average percent consolidation for the entire stratum.

(2) The results of the additional explorations and tests referred to in subpara (1) above should be presented in a supplement to this DM. Corresponding revisions to the stability analyses and designs in the GDM should be included in the supplement.

h. 21st subparagraph, page 24. Piezometers and settlement plates should be installed and observed prior to placing the first lift of fill because the existing foundation beneath the spoil may be underconsolidated. After the first lift is placed, observations should be made with such frequency to evaluate the time rate of settlement and determine the field coefficient of consolidation, C_v .

i. 24th and 27th subparagraphs, page 25. The reason for assuming that soils below Stratum 4 do not affect surface settlement is not apparent. Stratum 4 extends to el -39.7, whereas boring logs indicate the presence of compressible soils at greater depths.

j. 31st subparagraph, page 26. Explain the reason for assuming a 10-ft fill height for the first shaping. Data on Plate 69 indicate the first lift is 6 ft thick, which is to be constructed to el 13 and will settle to an el 9.1 at the end of two years. Figure 14 on Plate 69 shows that a crown el 13 will be achieved in the first shaping. This constitutes adding 3.9 ft of fill at the centerline of the embankment. Possibly the 10 ft is the rounded sum of 6 ft plus 3.9 feet. Similarly, procedures for arriving at the 12-ft fill in subpara 42 should be explained.

6. For clarity, the subparagraphs under para 38 should have been lettered consecutively, as discussed in para 1-19b, EM 1120-2-101.

SUBJECT: Lake Pontchartrain, La. and Vicinity, General Design Memorandum
No. 3, Chalmette Area Plan

7. Para 39, page 28. Consideration should be given to obtaining larger temporary easements if this will permit raising the levee to final grade sooner.

8. Para 61, pages 47 and 50. The unit price shown for treated timber, 3 x 10 and 12 x 12, is excessive and should be reconsidered.

9. Para 62a, page 55. The portion of this paragraph pertaining to "for providing I-type floodwall along the IHNC in lieu of steel sheet piling with concrete cap" is not understood.

10. Plates 7 through 15. The alignment of the levee is considered closer to the MR-GO than desirable. The alignment should be selected using stability analyses and taking into account possible loss of foreshore due to propeller and wavewash.

11. Plate 22. Consideration should be given to a wall section using a pile arrangement as shown on Incl 2. This type section will provide a greater vertical component of the wall load and reduce or eliminate tension in the piles battered upstream. The pile loads would be determined by the Culmann method.

12. Plate 26. a. In lieu of the miter gates, consider double-leaf hinged gates supported at the center by a removable post or frame anchored to the sill. This will avoid the high thrust of the miter gates and result in a more uniform distribution of the gate load to the supporting sill and foundation.

b. The cantilever wall at either side varies in height from about 10 ft to zero. With a height of 10 ft, the wall deflection may be excessive, thus creating a problem at the joint with the gate structure. A wall section similar to that shown on Incl 2 may be necessary for the higher reaches of the wall.

13. Plate 38. Although the stability analyses of the landside levee slope along the IHNC indicate adequate factor of safety with respect to sliding into the landside drainage ditch, a recent field inspection of this reach indicates numerous shallow slides are occurring in the ditch bank. Such slides could endanger the stability of the landside levee slope. The need for remedial work and possible replacement or restoration of the existing bulkhead along the ditch should be considered to help insure that the levee section will remain stable.

14. Plate 39. In the table, it is believed that "Bayou Bienvenue" should be changed to "Outfall Channel" as the sections on this plate refer to the outfall channel.

LMVED-TD (NOD 1 Nov 66) 1st Ind 1 Dec 66
SUBJECT: Lake Pontchartrain, La. and Vicinity, General Design Memorandum
No. 3, Chalmette Area Plan

15. Plate 63. The comment pertaining to Plate 22 is also applicable to the "T"-type wall indicated here. Deflection may govern the maximum height of the concrete sheet pile wall.

16. a. The abbreviation "U.S.E.D." as used on Plate 1 should be deleted. The right-of-way line can be designated "Miss. R.-Gulf Outlet R/W."

b. The degree of curvature on Plates 9, 10, 11, and 17, computed to odd seconds, is poor practice.

17. EM 1110-2-1150, referred to in para 1, basic letter, should be ER 1110-2-1150.

18. Pursuant to para 8b, ER 1110-2-1150, the DM's for this project should be numbered in sequence, generally as submitted for approval, including those for Seabrook Lock.

19. Pursuant to para 17c, ER 1110-2-1150, all DM's for this project are expected to be approved by the Chief of Engineers.

20. Pursuant to para 16, ER 1110-2-1150, general design memoranda should be submitted to OCE in 14 copies. In future submissions, GDM's should be submitted to LMVD in 16 copies.

FOR THE ACTING DIVISION ENGINEER:

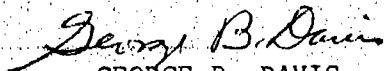

GEORGE B. DAVIS
Acting Chief, Engineering Division

2 Incl (12 cy)
wd 2 cy, incl 1
Added 1 incl
2. Sketch (bound in front of DM)

Copy furnished:
New Orleans District
ATTN: LMNED-PP
w/marked cy incl 1 & incl 2



DEPARTMENT OF THE ARMY
NEW ORLEANS DISTRICT, CORPS OF ENGINEERS
P. O. BOX 60267
NEW ORLEANS, LOUISIANA 70160

IN REPLY REFER TO
LMNED-PP

1 November 1966

SUBJECT: Lake Pontchartrain, La. and Vicinity, General Design Memorandum
No. 3, Chalmette Area Plan

TO: Acting Division Engineer, Lower Mississippi Valley
ATTN: LMVED-TD

1. The subject design memorandum is submitted herewith for review and approval in accordance with the provisions of EM 1110-2-1150 dated 1 July 1966.

2. Waldemar S. Nelson and Company, Inc., Engineers and Architects, New Orleans, Louisiana, prepared this design memorandum under the provisions of Contract No. DA-16-047-CIVENG-66-320.

3. The initial draft of the design memorandum was reviewed concurrently by the staffs of the Division and District Engineers. In addition, the office of the Chief of Engineers was afforded an opportunity to examine the draft memorandum, and a field review was held on 27-28 September 1966, in which representatives of OCE, LMVD, NOD, and the Nelson firm participated. All comments and suggestions deriving from the above reviews have been considered in preparing the memorandum submitted herewith.

4. Approval of the subject design memorandum is recommended. Review should be expedited to the maximum extent practicable in order that commitments to initiate construction in St. Bernard Parish in the current fiscal year can be met.

1 Incl (14 cys)
GDM No. 3

THOMAS J. BOWEN
Colonel, CE
District Engineer

WALDEMAR S. NELSON AND COMPANY
INCORPORATED
ENGINEERS AND ARCHITECTS

Waldemar S. Nelson, P.E.
Tilghman G. Chachere, Jr., A.I.A.
Joseph T. Montgomery, P.E.
Henry I. Madden, P.E.
Lawrence A. Waite,
Aviation Consultant

1200 ST. CHARLES AVENUE
NEW ORLEANS, LA. 70130
Telephone: 523-5281
Cable: NELSENG

William K. Becnel, P.E.
Lew J. Bremenstul, P.E.
Earl S. Dobbs, P.E.
John D. Fernandez, Jr., P.E.
Alvin S. Flettrich, A.I.A.
Charles H. Weatherly, P.E.
Burton L. Thomas, P.E.

October 31, 1966

District Engineer
U. S. Army Engineer District, New Orleans
Foot of Prytania Street
New Orleans, Louisiana

Job No. 66016
RE: Chalmette Area Plan of the Lake
Pontchartrain, La. and Vicinity
Hurricane Protection Project
Contract No. DA-16-047-CIVENG-66-320

Dear Sir:

We transmit herewith in accordance with the subject contract thirty-five (35) copies of Design Memorandum No. 3 for the Chalmette Area Plan of the Lake Pontchartrain, Louisiana and Vicinity Hurricane Protection Project, developed in accordance with your letter of October 5, 1966, and conferences and letters subsequent thereto reviewing the preliminary draft submitted under date of August 20, 1966. This completes preparation of Design Memorandum No. 3 to the best of our knowledge, subject to review and comment by higher authority. We await your further instructions or comment on this project.

Yours very truly,

WALDEMAR S. NELSON AND COMPANY
Incorporated
Engineers and Architects

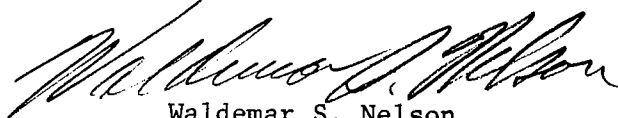

Waldemar S. Nelson
President

WSN:gs

Enclosures

LAKE PONTCHARTRAIN, LA. AND VICINITY
CHALMETTE AREA PLAN
DESIGN MEMORANDUM NO. 3
GENERAL DESIGN

STATUS OF DESIGN MEMORANDA

<u>Design memo No.</u>	<u>Title</u>	<u>Status</u>
1	Hydrology and Hydraulic Analysis Part 1 - Chalmette Part 2 - Barrier Part 3 - Lakefront	Submitted 3 Aug 66 Scheduled 15 Feb 67 Scheduled 1 Sep 67
2	Lake Pontchartrain Barrier Plan, GDM, Advance Supplement, Inner Harbor Navigation Canal Levees	Scheduled Jan 67
2	Lake Pontchartrain Barrier Plan, GDM, Citrus Back Levee	Scheduled Mar 67
2	Lake Pontchartrain Barrier Plan, GDM, Supplement No. 1, Barrier Embankments	Scheduled Jan 68
2	Lake Pontchartrain Barrier Plan, GDM, Supplement No. 2, New Orleans East Back Levees	Scheduled Jul 69
2	Lake Pontchartrain Barrier Plan, GDM, Supplement No. 3, Orleans Parish Lakefront Levees	Scheduled Jan 70
2	Lake Pontchartrain Barrier Plan, GDM, Supplement No. 4, St. Charles Parish Lakefront Levees	Scheduled Jul 70
2	Lake Pontchartrain Barrier Plan, GDM, Supplement No. 5, St. Tammany Parish, Mandeville Seawall	Scheduled Feb 71

STATUS OF DESIGN MEMORANDA (cont'd)

<u>Design memo No.</u>	<u>Title</u>	<u>Status</u>
3	Chalmette Area Plan, GDM	Submitted Nov 66
4	Chalmette Area Plan, DDM, Inner Harbor Navigation Canal T-Type Floodwall - Siphon Crossing	Scheduled Jul 67
5	Chalmette Area Plan, DDM, Bayous Bienvenue and Dupre Control Structures	Scheduled Jul 67
6	Lake Pontchartrain Barrier Plan, DDM, Rigolets Control Structure and Closure	Scheduled Jan 69
7	Lake Pontchartrain Barrier Plan, DDM, Chef Menteur Control Structure and Closure	Scheduled Apr 69
8	Lake Pontchartrain Barrier Plan, DDM, Rigolets Lock	Scheduled Jan 70
9	Lake Pontchartrain Barrier Plan, DDM, Chef Menteur Navigation Structure	Scheduled Apr 70
10	Lake Pontchartrain Barrier Plan, DDM, Gantry Crane - Chef Menteur Control Structure	Scheduled Apr 70
11	Lake Pontchartrain Barrier Plan, DDM, St. Charles Parish Drainage Structure	Scheduled Jun 71
12	Sources of Construction Materials	Approved 30 Aug 66
13	Lake Pontchartrain Barrier Plan, DDM, Gantry Crane - Rigolets Control Structure	Scheduled Feb 71
14	Beautification	Not scheduled

STATUS OF DESIGN MEMORANDA (cont'd)

<u>Design memo No.</u>	<u>Title</u>	<u>Status</u>
1	Lake Pontchartrain, La. and Vicinity, and Mississippi River-Gulf Outlet, La., GDM, Seabrook Lock	Scheduled Jul 67
2	Lake Pontchartrain, La. and Vicinity, and Mississippi River-Gulf Outlet, La., DDM, Seabrook Lock	Scheduled Mar 68

LAKE PONTCHARTRAIN, LA. AND VICINITY
CHALMETTE AREA PLAN
DESIGN MEMORANDUM NO. 3 - GENERAL DESIGN

TABLE OF CONTENTS

<u>Paragraph No.</u>	<u>Title</u>	<u>Page</u>
	PERTINENT DATA	A, B
	PROJECT AUTHORIZATION	
1.	Authority	1
2.	Local Cooperation	1 - 3
	INVESTIGATIONS	
3.	Project Document Investigation	3
4.	Investigations Made Subsequent to Project Authorization	3 - 4
	LOCAL COOPERATION	
5.	Local Cooperation Requirements	4
6.	Status of Local Cooperation	4 - 5
7.	Views of Local Interests	5
8.	Estimated Cost to Local Interests	5
	LOCATION OF PROJECT AND TRIBUTARY AREA	
9.	Location of Project	6
10.	Tributary Area	6
	PROJECT PLAN	
11.	Project Works	6
	DEPARTURES FROM DOCUMENT PLAN	
12.	General	6 - 7
	HYDROLOGY	
13.	General	7 - 8

TABLE OF CONTENTS (cont'd)

<u>Paragraph No.</u>	<u>Title</u>	<u>Page No.</u>
14.	Design Elevations	8
	DRAINAGE	
15.	Description	8 - 9
16.	Ponding	9
17.	Hydraulics of Structures	10 - 11
	GEOLOGY	
18.	Physiography	11 - 12
19.	General Geology	12
20.	Subsidence	12
21.	Mineral Deposits	12 - 13
22.	Investigations Performed	13
23.	Foundation Conditions	13
	SOILS	
24.	Field Investigation	14
25.	Laboratory Tests	14
26.	Foundation and Soil Conditions	15 - 17
27.	Design and Construction Problems (IHNC Lock to Sta. 90+25 = 7+52.9)	17
28.	Type of Protection	17
29.	Location of Protection	17 - 18
30.	Stability	18
31.	Seepage and Uplift	18
32.	Foundation for T-type Floodwall at Florida Avenue	18
33.	Source of Fill Material	19
34.	Methods of Construction	19

TABLE OF CONTENTS (cont'd)

<u>Paragraph No.</u>	<u>Title</u>	<u>Page No.</u>
	SOILS (cont'd)	
35.	Settlement	19
36.	Erosion Protection	19
37.	Settlement Observations	20
38.	Levee Stability Analyses (Sta. 90+25 = 7+52.9 to Sta. 1050+57.7)	20 - 28
39	Levee Construction (Sta. 90+25=7+52.9 to Sta. 1050+57.7)	28 - 29
40.	Structures	29 - 30
41.	Approach Channels	30
	DESCRIPTION OF PROPOSED STRUCTURES AND IMPROVEMENTS (Sta. 1+82 to 0+00=1+46.6 to Sta. 90+25=7+52.9)	
42.	Criteria for Structural Design	30 - 31
43.	Floodwalls and Levees	31 - 32
44.	Utility Crossings	32
45.	Corrosion Protective Measures	32
	DESCRIPTION OF PROPOSED STRUCTURES AND IMPROVEMENTS (Sta. 90+25=7+52.9 to Sta. 1050+57.7)	
46.	Levees	32 - 33
47.	Structures	33 - 34
48.	Approach Channels	34
49.	Access to Drainage Structures	34 - 35
50.	Foreshore Protection	35
51.	Gap Closure	35
	SOURCES OF CONSTRUCTION MATERIALS	
52.	Sources of Construction Materials	35

TABLE OF CONTENTS (cont'd)

<u>Paragraph No.</u>	<u>Title</u>	<u>Page No.</u>
COORDINATION WITH OTHER AGENCIES		
53.	General	35
54.	U. S. Department of the Interior	35
55.	State of Louisiana, Wild Life & Fisheries Commission	36
56.	Board of Commissioners, Port of New Orleans	36
REAL ESTATE REQUIREMENTS		
57.	General	36
RELOCATIONS		
58.	Florida Avenue Bridge Approach	36
59.	Utility Crossings	36- 37
COST ESTIMATES		
60.	General	39
61.	Summary of First Cost (Aug 1966 Price Level)	39- 53
62.	Comparison of Estimated Cost with Latest Approved Estimate	55- 56
SCHEDULES FOR DESIGN AND CONSTRUCTION		
63.	Schedule	57- 62
OPERATION AND MAINTENANCE		
64.	Federal	63
65.	Non-Federal	63
ECONOMICS		
66.	Benefits	63 - 64

TABLE OF CONTENTS (cont'd)

<u>Paragraph No.</u>	<u>Title</u>	<u>Page No.</u>
	ECONOMICS (cont'd)	
67.	Annual Charges	64
68.	Economic Justification	64
	RECOMMENDATIONS	
69.	Recommendations	64 -65

APPENDIX A

Fish and Wildlife Studies

LIST OF PLATES

<u>Plate No.</u>	<u>Title</u>
1	GENERAL PLAN, INDEX AND VICINITY MAP
2 - 18	PLAN AND PROFILE
19	TOPOGRAPHIC DETAILS - VIOLET
20 - 26	DESIGN SECTIONS
27	DETAILS OF I-TYPE WALL & UTILITY CROSSINGS
28 - 29	GENERALIZED SOIL & GEOLOGIC PROFILE
30	UNDISTURBED BORING 2-U, TEST DATA
31	UNDISTURBED BORING 6-U, TEST DATA
32	UNDISTURBED BORINGS 2-UT, 6-UT, & 14-UT, TEST DATA
33	UNDISTURBED BORING U-1, TEST DATA
34	UNDISTURBED BORING U-2, TEST DATA
35	UNDISTURBED BORING U-3, TEST DATA
36	UNDISTURBED BORING U-4, TEST DATA
37	STABILITY ANALYSIS STA. 1+82 TO 0+00=1+46.6 TO STA. 16+08.85
38	STABILITY ANALYSIS STA. 16+08.85 TO STA. 58+12.0

LIST OF PLATES (cont'd)

<u>Plate No.</u>	<u>Title</u>
39	STABILITY ANALYSIS STA. 67+94 to STA. 90+25=7+52.9
40	STABILITY ANALYSIS STA. STA. 7+52.9 TO STA. 357+05
41	STABILITY ANALYSIS STA. 368+00 TO STA. 574+00
42	STABILITY ANALYSIS STA. 593+00 TO STA. 807+00
43	STABILITY ANALYSIS STA. 807+00 TO STA. 1020+00
44	STABILITY ANALYSIS STA. 1020+00 TO STA. 1050+00 AND TYPICAL STREAM CLOSURES
45	DETAILS SHEAR STRENGTH DATA BORINGS 2U-6U
46 - 47	DETAILS SHEAR STRENGTH DATA BORING U-1
48 - 49	DETAILS SHEAR STRENGTH DATA BORING U-2
50 - 51	DETAILS SHEAR STRENGTH DATA BORING U-3
52 - 53	DETAILS SHEAR STRENGTH DATA BORING U-4
54	UTILITIES-LOCATION PLAN
55	UTILITIES-DETAILS AND SECTIONS
56	UTILITIES-DETAILS AND SECTIONS
57	UTILITIES-DETAILS AND SECTIONS
58	UTILITIES-DETAILS AND SECTIONS
59	DRAINAGE STRUCTURES - LOCATION PLAN
60	DRAINAGE STRUCTURE - SITE PLANT BAYOU BIENVENUE
61	DRAINAGE STRUCTURE - SITE PLAN BAYOU DUPRE
62	DRAINAGE STRUCTURES - DETAIL PLAN AND ELEVATION
63	DRAINAGE STRUCTURES - DETAIL SECTIONS AND ELEVATIONS
64	EXISTING GROUND PROFILE

LIST OF PLATES (cont'd)

<u>Plate No.</u>	<u>Title</u>
65	LIFT AND SHAPING DETAILS
66 - 67	STAGE CONSTRUCTION SECTIONS
68 - 69	DESIGN PROCEDURE - FIGURES AND TABLES
70 - 71	DESIGN PROCEDURE - STABILITY ANALYSIS
A	SOIL BORING LEGEND

Figure No.

1	I WALL DESIGN ANALYSIS STA 1+57 TO STA 0+00 = 1+46.6 TO STA 58+12
2	I WALL DESIGN ANALYSIS STA. 67+94 TO STA. 79 +62

PERTINENT DATA (cont'd)

Paris Road to Violet, La. El. 17.5

Drainage structures

Location: One (1) at Bayou Bienvenue
One (1) at Bayou Dupre

Structure: "U" frame, reinforced concrete on timber piling.

Gates: Sector type

Guidewalls: Timber on sector gates and 95 feet each end of gate bay.

Dimensions:

Width (inside) 56 feet
Length 76 feet

Elevations:

Top of gates El. 17.5
Sill elevation El. -10.0 MLG

Hydraulic Design Criteria

Maximum tide 13.0 feet
Minimum tide -2.0 feet
Maximum direct head (Outlet to landside) 13.0 Outlet El.
2.0 Landside El.
Maximum reverse head (landside to Outlet) 5.0 Landside El.
-1.0 Outlet El.

Rights of-way

Floodwalls 17.5 acres
Levee, as finally constructed 801 acres
Road Easement 0.5 acres
Temporary easement for levee material storage 554 acres
Structures 11 acres
Drainage canal relocations 31 acres
Borrow area for levee material 450 acres

Area Benefited

Flood damage prevented 30,800 acres
Increased land utilization 20,300 acres

Estimated First Cost

Federal \$25,583,400
Non-Federal 3,968,800
Total \$29,552,200

LAKE PONTCHARTRAIN, LA. AND VICINITY
CHALMETTE AREA PLAN
DESIGN MEMORANDUM NO. 3

PROJECT AUTHORIZATION

1. Authority. Public Law 298 - 89th Congress, 1st Session, approved 27 October 1965, authorized the Lake Pontchartrain, Louisiana and Vicinity, hurricane protection project, substantially in accordance with the recommendations of the Chief of Engineers in House Document No. 231, Eighty-Ninth Congress, except that the recommendations of the Secretary of the Army in that document shall apply with respect to the Seabrook Lock feature of the project.

The report of the Chief of Engineers dated 4 March 1964 printed in House Document No. 231, 89th Congress, 1st Session, submitted for transmission to Congress, the report of the Board of Engineers for Rivers and Harbors, accompanied by the reports of the District and Division Engineers and the concurring report of the Mississippi River Commission for those areas under its jurisdiction. The report of the Chief of Engineers stated:

"...For the Chalmette area, the reporting officers find that the most suitable plan would consist of about 17.3 miles of new and enlarged levees extending generally along the southerly banks of the Gulf Intracoastal Waterway and the Mississippi River-Gulf Outlet channel to Bayou Dupre and thence westerly to the Mississippi River levee at Violet....The Board (of Engineers for Rivers and Harbors) recommends authorization for construction essentially as planned by the reporting officers.... I concur in the recommendation of the Board of Engineers for Rivers and Harbors."

2. Local Cooperation. The conditions of local cooperation specified in the Report of the District Engineer, further stated in the Report of The Board of Engineers for Rivers and Harbors, and concurred in, in the Report of the Chief of Engineers, are as follows:

"It is proposed that construction of the barrier plan of protection for the areas around Lake Pontchartrain, and of the plan of protection for Chalmette shall be subject to the conditions that prior to initiation of construction on each separable independent feature, local interests give assurances satisfactory to the

"Secretary of the Army that they will without cost to the United States:

- (1) Provide all lands, easements, and rights-of-way, including borrow and spoil-disposal areas necessary for construction, operation, and maintenance of the project;
- (2) Accomplish all necessary alterations and relocations to roads, railroads, pipelines, cables, wharves, drainage structures, and other facilities required by the construction of the project;
- (3) Hold and save the United States free from damages due to the construction works;
- (4) Bear 30 per cent of the first cost, to consist of the fair market value of the items listed in subparagraphs (1) and (2) above and a cash contribution as presently estimated below, to be paid either in a lump sum prior to initiation of construction or in installments at least annually in proportion to the Federal appropriation prior to start of pertinent work items, in accordance with construction schedules as required by the Chief of Engineers, or as a substitute for any part of the cash contribution, accomplish in accordance with approved construction schedules items of work of equivalent value as determined by the Chief of Engineers, the final apportionment of costs to be made after actual costs and values have been determined:

<u>Project</u>	<u>Total Contribution for Construction</u>	<u>Lands and Relocations</u>	<u>Cash Contribution for Construction</u>
Lake Pontchartrain Barrier Plan	\$19,411,000	\$5,027,000	\$14,384,000
<u>Chalmette</u>	<u>4,543,000</u>	<u>899,000</u>	<u>3,644,000</u>

- (5) Provide for the Lake Pontchartrain Barrier plan an
- (6) Provide all interior drainage and pumping plants

"required for reclamation and development of the protected areas;

(7) Maintain and operate all features of the project in accordance with regulations prescribed by the Secretary of the Army, including levees, floodgates, and approach channels, drainage structures, drainage ditches or canals, floodwalls, seawalls, and stoplog structures, but excluding Rigolets navigation lock and its appurtenant navigation channels and the modified Seabrook Lock; and

(8) Acquire adequate easements or other interest in land to prevent encroachment on existing ponding areas unless substitute storage capacity or equivalent pumping capacity is provided promptly."

INVESTIGATIONS

3. Project Document Investigations. Studies and investigations made in connection with the project document (H.D. No. 231, 89th Congress, 1st Session) consisted of: research of information which was available from previous reports and existing projects in the area; extensive research in history and records of hurricane damage and characteristics of hurricanes; extensive tidal hydraulics investigations involving both office and model studies; an economic survey; preliminary design and cost studies. A public hearing was held in New Orleans on 13 March 1956 to determine the views of local interests.

4. Investigations Made Subsequent to Project Authorization. Surveys and studies made subsequent to project authorization include:

a. Aerial and topographic surveys of the Chalmette Area levee locations and adjacent areas;

b. Soil investigations including general type borings and laboratory evaluation of undisturbed boring cores;

c. Detailed design studies for levee and I-type floodwall construction including bank and levee section stability determinations;

d. General studies to establish the required sizes for floodgate structures and general features of T-type floodwalls and relocation of the Florida Avenue bridge approach;

e. Tidal hydraulics studies required for establishing design grades for levees and structures;

Par. 4.f.

- f. Real Estate requirements;
- g. Cost estimates for levees, structures and relocations;
- h. Economic studies for evaluation of justification of proposed works.

LOCAL COOPERATION

5. Local Cooperation Requirements. The conditions of local cooperation as specified by the authorized law are quoted in Paragraph 2. Essentially local interests must:

- a. Provide all lands, easements, and rights-of-way, including borrow and spoil-disposal areas;
- b. Accomplish necessary alterations and relocations to existing facilities required by construction of the project;
- c. Hold and save the United States free from damages due to the construction works;
- d. Bear 30 per cent of the first cost including the fair market value of items (a) and (b) above;
- e. Provide all interior drainage facilities necessary for reclamation and development of the protected areas;
- f. Maintain and operate the project works in accordance with regulations prescribed by the Secretary of the Army.

6. Status of Local Cooperation.

a. On 2 November 1965 the Governor of the State of Louisiana designated the Louisiana Department of Public Works as "... the agency to coordinate the efforts of local interest and to see that the local commitments are carried out promptly...." By State of Louisiana Executive Order dated 17 January 1966, the Board of Commissioners of the Orleans Levee District was designated as the local agency to provide the required local cooperation for all portions of the Lake Pontchartrain, La. and Vicinity, project in Orleans, Jefferson, St. Charles, and St. Tammany Parishes. Assurances were requested through the Louisiana Department of Public Works from the Board of Commissioners of the Orleans Levee District for the section of the Chalmette area plan falling in Orleans Parish on 21 January 1966, and from the St. Bernard Parish Police Jury and the Board of Commissioners of the Lake Borgne Basin Levee

District for the remainder of the Chalmette area plan on 8 February 1966. An acceptable joint act of assurance for the portion of the Chalmette area plan located in St. Bernard Parish, supported by resolutions adopted by the St. Bernard Parish Police Jury and the Board of Commissioners of the Lake Borgne Basin Levee District on 15 and 16 August 1966, respectively, was approved and accepted on behalf of the United States on 28 September 1966. An act of assurance for the portion of the Chalmette area plan located in Orleans Parish, supported by a resolution of the Board of Commissioners of the Orleans Levee District dated 28 July 1966, was approved and accepted on behalf of the United States on 10 October 1966.

b. The principal officers responsible for the fulfillment of the conditions of local cooperation are as follows:

Mr. Leon Gary, Director
State of Louisiana
Department of Public Works
Baton Rouge, Louisiana

Mr. Milton E. Dupuy, President
Board of Levee Commissioners
Orleans Levee District
Room 200, Wild Life and Fisheries Building
418 Royal Street
New Orleans, Louisiana

Mr. Irvin J.G. Janssen, President
Board of Commissioners
Lake Borgne Basin Levee District
104 Bergeron Building
2006 Packenham Drive
Chalmette, Louisiana

Mr. Valentine Riess, President
St. Bernard Parish Police Jury
Chalmette, Louisiana

7. Views of Local Interests. The Board of Commissioners of the Orleans Levee District, the Board of Commissioners of the Lake Borgne Basin Levee District, and the St. Bernard Parish Police Jury represent local interests and are in agreement with the general plan.

8. Estimated Cost to Local Interests. The total non-Federal cost is estimated to be \$7,854,236 , which includes \$3,968,755 , for lands, damages, and relocations, and \$3,885,481 cash contribution. The estimated annual charge to local interests is \$459,000.

LOCATION OF PROJECT AND TRIBUTARY AREA

9. Location of Project. The project area is located in southeast Louisiana on the left descending bank of the Mississippi River in Orleans Parish (City of New Orleans) and St. Bernard Parish. The area is bounded on the south and southwest by the Mississippi River, on the west by the Inner Harbor Navigation Canal and the Mississippi River-Gulf Outlet (MR-GO); on the north and northeast by the MR-GO and on the southeast by a line drawn from the Mississippi River at Violet, La., to a point on the MR-GO at Lawler Bayou. A General Plan, Index and Vicinity Map is shown on Plate 1.

10. Tributary Area. The total area of lands within the Chalmette Area Plan is approximately 30,800 acres, comprised of 3,200 acres residential, 1,300 acres commercial and industrial, 2,000 acres open land, 4,000 acres woodland and approximately 20,300 acres of undeveloped swamp and marsh lands. It is expected that approximately 5,000 acres of the undeveloped area west of Paris Road will be improved at an early date by industrial and port facilities. The improvement of the remaining 15,300 acres of undeveloped area is more remote.

PROJECT PLAN

11. Project Works. The project plan presented herein and indicated on Plate 1 provides for the construction of an I-type floodwall with the steel sheet piling driven in the levee extending northward from the IHNC lock to Florida Avenue along the east bank of the IHNC; thence a T-type wall crossing the Florida Avenue drainage canal; thence an I-type floodwall with the steel sheet piling driven in the levee for approximately 1,200 feet tying into a levee along the north bank of the Outfall Canal; thence a new levee extending northward to the MR-GO; thence eastward along the south bank of the MR-GO to the junction of the channel and the Gulf Intracoastal Waterway; thence to the southeast along the south bank of the MR-GO to Bayou Lawler; then turning south and tying into the east bank Mississippi River levee near Violet, La. Sector-gated structures will be provided at Bayous Bienvenue and Dupre for the passage of small boats and intercepted drainage flows. Alteration of four (4) water and ten (10) gas pipelines, and four (4) telephone cable crossings will be required along the IHNC. Alteration of twelve (12) gas pipeline crossings and two (2) aerial electric power transmission lines will be required to clear the levee through the remainder of the alignment.

DEPARTURES FROM PROJECT DOCUMENT PLAN

12. General. The project plan presented herein is generally the same as the plan presented in the project document. The following minor

changes which are considered to be within the discretionary authority of the Chief of Engineers were made:

a. The net levee grades were revised upward in accordance with the results of tidal hydraulic studies utilizing the latest hurricane parameters developed by the U. S. Weather Bureau and information derived from the passage of the major hurricane "Betsy" in September 1965.

b. At the request of the State of Louisiana, Department of Public Works, a minor modification in alignment, locating the return levee to Violet, La., on the south bank of Bayou Dupre, was adopted.

c. Based on a re-analysis of future navigation requirements, the dimensions of the floodgates at Bayous Bienvenue and Dupre were changed to provide a width of 56 feet with sill elevation at -10 feet MLG. Present traffic in Bayou Dupre includes tank barges ranging up to 209.7 feet long by 44.1 feet wide, by 12.4 feet deep (hull depth). It is anticipated that future traffic in both Bayous Bienvenue and Dupre will involve similar barges up to 52 feet in width. The 56 foot width is a standard lock dimension and will facilitate future conversion of the flood gates to locks if required.

d. Along the IHNC, the "sheet piling wall with concrete cap" provided in the project document plan has been replaced by an "I"-type floodwall. The required height of the wall above the ground (6') made use of the capped sheet pile wall inadvisable. Further, the water in the canal is highly corrosive and would cause rapid deterioration of any exposed sheet piling.

e. At Florida Avenue, the protection will consist of a bearing pile supported concrete T-type floodwall. The height of the wall above ground in this area will be in excess of 10 feet, rendering capped sheet pile or "I"-type wall unacceptable.

HYDROLOGY

13. General. The Hydrology and Hydraulic Analysis Design Memorandum for the Lake Pontchartrain, Louisiana and Vicinity, project will be presented in three separate reports --- Parts I, II, and III entitled "Chalmette", "Barrier" and "South Shore", respectively. The data for the Chalmette Area Plan are covered in "Design Memorandum No. 1, Hydrology and Hydraulic Analysis, Part I-Chalmette", and detailed descriptions and analyses of the tidal hydraulic methods and procedures used in the tidal hydraulic design are presented therein. Included in the descriptions and analyses are the essential data, climatology, assumptions and criteria used, and the results of studies

Par. 13

which provide the bases for determining surges, routing, wind tides, run-up, overtopping and frequencies.

14. Design Elevations. The design hurricane critical to the Chalmette Area Plan is a Standard Project Hurricane (SPH) having a frequency of about one in 200 years, a central pressure index of 27.6, a maximum 5-minute average wind velocity of 100 m.p.h., 30 feet above ground level, at a radius of 30 nautical miles from the center, a forward speed of 11 knots, on a track critical to the area in question. Detailed information on the design hurricane is contained in "Design Memorandum No. 1, Hydrology and Hydraulic Analysis, Part I - Chalmette". The design hurricane will produce maximum wind tide levels as follows: IHNC to Paris Road, 13.0 feet; Paris Road to Bayou Lawler, 13.0-12.5 feet; and Bayou Lawler to Violet, 13.0-12.5 feet. From the IHNC to Paris Road, waves are not a factor and one foot of freeboard was added to the wind tide level producing a net grade of 14.0 feet. Between Paris Road and Violet, where wave action will occur, an allowance varying from 4.3 to 4.7 feet was made for computed wave runup, yielding a net grade of 17.5 feet. The controlling elevation of the structures at Bayou Bienvenue and Bayou Dupre has been set at 17.5 feet. Other design elevations relative to the structures are covered in succeeding paragraphs.

DRAINAGE

15. Description. Upon completion of the project, the Chalmette Area, comprising a total of about 30,800 acres will be drained through two structures, one at Bayou Bienvenue and one at Bayou Dupre. The structures will have an inside width of 56 feet, a length of 76 feet, a top of gate elevation of 17.5 and a sill elevation of -10.0 MLG. In addition to handling all runoff from within the area, the structures will also be required to discharge about 2,000 c.f.s. of drainage water originating outside the area. This 2,000 c.f.s. of water is siphoned under the IHNC into the Sewerage and Water Board Pumping Station No. 5. This water is discharged into Bayou Bienvenue together with 500 c.f.s. of drainage from the 1,900 acres within the Chalmette Area adjacent to this station No. 5. As indicated in the following tabulation, the drainage runoff from the project area is not equally divided between Bayou Bienvenue and Bayou Dupre under existing conditions. This imbalance will probably diminish as improvements in the area tributary to Bayou Dupre increase the runoff from this portion of the project. Presently, the existing dredged canal between Bayou Bienvenue and Bayou Dupre, located approximately 4,000 feet south of and parallel to MR-60, serves as an equalizer between drainage outlets. An average cross-sectional flow area of 490 s.f. below elevation 1.5 will produce a discharge of 980 c.f.s. at a velocity of 2 feet per second which indicates that, after levee construction is completed and secondary drainage outlets are thereby intercepted, the canal will serve to distribute the runoff between the two (2) main drainage outlets. Research

indicates that for the past 10 years a runoff factor of 0.05 c.f.s. has been used by the following local agencies to evaluate drainage runoff in areas having topography similar to that in the subject area:

Jefferson-Plaquemines Drainage District
 Fourth Drainage District of Jefferson Parish
 New Orleans Sewerage and Water Board

CHALMETTE AREA DRAINAGE RUNOFF

<u>Source</u>	<u>Acreage</u>	<u>Flow</u>
<u>TRIBUTARY TO BAYOU BIENVENUE</u>		
(1) S&WB Pump, Sta. #5	1,900	* 2,500 c.f.s
(2) St. Bernard Pump, Sta. #1	3,800	635
(3) 10,000 acres in Orleans and St. Bernard not under pump. Runoff at .05 c.f.s. per acre.	<u>10,000</u>	<u>500</u>
	15,700	3,635

*This includes 2,000 c.f.s. originating west of the IHNC.

TRIBUTARY TO BAYOU DUPRE

(1) St. Bernard Pump Sta. #2	5,200	445
(2) 10,300 acres in St. Bernard not under pump. Runoff at .05 c.f.s. per acre.	<u>10,300</u>	<u>515</u>
	15,500	960
AREA TOTALS	31,200	4,595

16. Ponding. The ponding area (approximately 13,200 acres) will be the lowlying area between the existing back levees and the levees built more or less parallel to the north bank of Bayou Bienvenue and the MR-GO to retain the hydraulic spoil from the MR-GO channel excavation. This area is presently subject to inundation by tides flowing

in through the uncontrolled channels of Bayou Bienvenue, Bayou Dupre, Bayou Villere and the Pipeline Canal (See Plate 1).

When the drainage structure gates are closed to prevent rising tides from entering the protected area, ponding in the lower parts of the area will result. The depth of ponding will be dependent on the length of time the gates are closed and the amount of rainfall during the closed period. The rainfall accompanying a hurricane is usually heavy. However, its distribution during the passage of the hurricane is not uniform.

Although 14 inches of rain in 24 hours has occurred (April 1927), it is improbable that more than 12 inches in 72 hours would occur during the passage of the design hurricane over the area. This assumption is based on 25 year frequency data (a 12.5 inch rainfall in 3 days) as outlined in Weather Bureau Technical Paper No. 49 entitled "Two to Ten Day Precipitation for Return Period of 2-100 Years in the Contiguous United States". Assuming that the drainage structures would be closed when the tide inside the gates reaching El. 2.0 in a 72 hour period, the three (3) pumping stations listed in Paragraph 15 would discharge into the ponding area 928,000,000 c.f. of water. Assuming a 12 inch rainfall on 20,300 acres, not under pump, with a 100% runoff factor, the ponding area would receive an additional 885,000,000 c.f. of water. This total amount of water will theoretically cause the 13,200 acre ponding area water level to rise 3.0 feet or to an elevation of approximately 5.0. The daily rise would depend on the rainfall. If enough rain fell to keep the three pumping stations running, approximately 0.5 feet of rise would result per day from water discharged from these stations.

Shortly after the passage of the design hurricane, the tides will begin to fall. As soon as the water elevation in the MR-GO falls to the elevation of the impounded water, the drainage gates will be opened and the impounded water released. Depending on the stages of the tide in the MR-GO, the impounded water will flow out through the drainage gates in about 3 or 4 days. The combined capacity of the structures is such that they could dispose of the total discharge from the pumping stations plus 12.1 inches per day from the area not under pump on a head of 2 feet. Due to the size of the ponding area, high intensity rains of short duration are not critical to the structural design.

Hydraulic studies made for both uniform and non-uniform flow in open channels were based on the Manning Formula as outlined and developed in the Handbook of Hydraulics by Horace W. King.

17. Hydraulics of Structures. The purpose of the structures is

to protect the area from excessive flooding associated with hurricane tides. The drainage gates in Bayou Dupre and Bayou Bienvenue will be kept open for the free discharge of drainage waters and navigation except when the rising tide in advance of an approaching hurricane exceed El. 2.0. When a hurricane is approaching and the tide in advance of the approaching hurricane exceeds El. 2.0, the gates shall be closed and kept closed until the hurricane threat passes and the tide elevation in the MR-GO falls below the level of the impounded waters.

During any operating cycle the maximum head against the gated structures will occur when the storm tides in the MR-GO rise to a still water elevation of 13.0 and the water inside the gates is at El. 2.0.

The maximum reverse head, landside to the MR-GO, would occur when the tide descends faster than the impounded storm drainage water can flow through the gated structures. With impounded water at El. 5.0 and the tide in the MR-GO falling, the head will decrease as the impounded water flows into the MR-GO. As soon as the falling outside tide becomes level with the landside stage, the gates will be opened to release the impounded water. The rate of flow through the gates will depend on the difference in water levels inside and outside the gated structures. If the tide falls rapidly in the MR-GO, or if there is some delay in opening the gates, there is a possibility that a condition of impounded water at El. 5.0 and an outside elevation of 1.0 could exist. If the gates are then opened, there would be a discharge of 10,300 c.f.s. for each of the two structures. Approximately 2,400,000,000 c.f. of water above existing ground would be discharged in about three days at an average discharge rate of 5,000 c.f.s. per structure. The maximum velocity at a static head differential of 4 feet (5 to 1) would be about 15.6 feet per second. This maximum discharge from the gated structure will result in a velocity of 9.8 f.p.s. in the outflow channel approximately 200 feet downstream from said structure. Velocities would, of course, decrease as the static head differential decreased.

GEOLOGY

18. Physiography. The Chalmette Area project is located within the Central Gulf Coastal Plain. Specifically, the area is located on the eastern flank of the Mississippi River Deltaic Plain. The dominant physiographic features are swamps, marshes, natural levees and abandoned distributaries. Elevations of about 4 are found at the southern end at the distal edge of the slope of the natural levee of the Mississippi River near the IHNC Lock. Minimum elevations of -2 are found in the area near 90 + 25 = 7 + 52.9. The Chalmette area slopes from the alluvial ridge along the Mississippi River to the Lake Borgne basin which is a part of the Lake Pontchartrain Basin. The

land adjacent to the Mississippi River ranges in elevation from 4 to 10 and slopes away from the river at about 1 foot per 1,000 feet. The area adjacent to the Mississippi River, comprising about 10,000 acres, is presently protected from tidal inundation by back levees approximately paralleling the Mississippi River Levee. The central part of the Chalmette area, comprising about 13,200 acres of marsh land, is only a foot or two above sea level and is subject to the tidal flooding from the MR-GO through connecting canals and bayous. The balance of the Chalmette area along the MR-GO and bounded by Bayou Bienvenue and a line about 4,000 feet landward of the MR-GO right-of-way has been filled hydraulically to elevations 4 to 10 with material excavated from the MR-GO Channel.

19. General Geology. Only the geologic history since the end of the Pleistocene period is significant for this project. At that time, with sea level about 450 feet below its present level, the present project area was a flat high land plain bordering the deeply entrenched Mississippi River. During this period, the upper part of the Pleistocene was desiccated and weathered. About 5,000 years ago, sea level reached its present stand and the Mississippi River filled its entrenchment, then began to migrate laterally back and forth across the deltaic plain. Approximately 4,500 to 4,000 years ago, the first Recent deltaic and alluvial sediments were carried into the project area when the Mississippi River occupied the Cocodrie course. About 3,500 years ago, the Mississippi shifted its course to the western margin of the valley and occupied the Teche course until approximately 2,800 years ago. During this period, the project area was subjected to erosion and subsidence. The river then shifted eastward again to the LaLoutre or St. Bernard course and sediments were once again carried into the area. About 1,500 years ago, the river shifted westward to its Lafourche course and, for a period of several hundred years, the project area was not subjected to heavy sedimentation. When the Mississippi River again shifted eastward into the project area, about 1,200 years ago, and began to occupy the present Plaquemines course, sediments were again introduced into the project area. Construction of levees along the Mississippi River has eliminated floodwaters from the region and, at present, no sediments are being introduced into the project area.

20. Subsidence. Progressive subsidence in the vicinity of the project has been recorded by many observers. It is estimated that the regional subsidence is at the rate of about 0.4 feet per century.

21. Mineral Deposits. Although oil and gas production does not presently exist in the immediate vicinity of the project, oil, gas, salt, sulphur and other minerals may exist in the subsurface. Exploration for and production of these minerals will not be aversely

affected by the proposed hurricane protection structures.

22. Investigations Performed. General type and undisturbed borings to a maximum depth of 88 feet were made in connection with the project from Sta. 1 + 82 to 0 + 00 = 1 + 46.6 to Sta. 90 + 25 = 7 + 52.9. From Sta. 90 + 25 = 7 + 52.9 to the end of the project at Sta. 1050 + 57.7, general type borings were made to a depth of 60 feet and undisturbed borings were made to a depth of 100 feet below existing ground surface. In addition, geologic information from other sources was available for the interpretation of the physiography, subsurface, and foundation conditions of the area.

23. Foundation Conditions. From the IHNC Lock to Sta. 90 + 25 = 7 + 52.9, the subsurface, as shown on Plate 28, consists of Recent deposits varying in thickness from about 63 feet at the northeastern end of this portion of the project to about 75 feet at the southern or IHNC Lock end. Underlying the Recent are deposits of Pleistocene Age (Prairie Formation). The Recent consists generally of a 4- to 14-foot strata of very soft organic clays underlying 7 to 20 feet of fill material except between the IHNC Lock and Sta. 30 + 00 where a thin layer of natural levee material 5 to 10 feet thick underlies the fill material. Underlying the marsh deposits is a 20- to 35-foot strata of very soft to soft interdistributary clays containing lenses of silt and silty sand. From the IHNC Lock to approximately Sta. 64 + 92, a 20- to 40-foot layer of estuarine deposits, consisting generally of soft to medium clays with silt and sand lenses and shell fragments, directly underlies the interdistributary clays. From Sta. 50 + 00 to Sta. 64 + 92, a wedge of sand, 7 to 15 feet thick, exists within the estuarine deposits. Along the Outfall Canal, from Sta. 74 + 85 to Sta. 90 + 25, the estuarine deposits grade into nearshore-gulf sands containing shell and shell fragments. The estuarine and nearshore-gulf lie directly over the stiff Pleistocene. From Sta. 90 + 25 = 7 + 52.9 to the end of the project at Sta. 1050 + 57.7, the subsurface is shown on Plate 29 which is a generalized soil profile. The soft Recent soils overlying the stiffer Pleistocene clays which occur from El. -55 to El. -65 consist generally of organic clays, peat, fat clays, some lean clays, some clayey sands, and rare spots of sand. Along the project alignment paralleling the MR-GO, the natural Recent soils have been covered with hydraulic spoil from the excavation of the MR-GO Channel. A detailed description of the subsurface from Sta. 90 + 25 = 7 + 52.9 to the end of the project at Sta. 1050 + 57.7, is included in the soils section of this Design Memorandum.

SOILS

24. Field Investigation. From Sta. 1 + 82 to Sta. 0 + 00 = 1 + 46.6 to Sta. 90 + 25 = 7 + 52.9, five 5-inch diameter undisturbed soil borings and sixteen 1 and 7/8 inch I.D. core barrel general type borings were made at intervals varying from about 200 to 1,000 feet along this project location. The borings were made through the existing levee and at the toe of the levee at selected locations, and extended in depth to elevations -40 and -88. The locations of the borings are shown on Plates 2, 3, 4, 5 and 6. From Sta. 90 + 25 = 7 + 52.9 to the project end at Sta. 1050 + 57.7, one hundred and three 3 inch I.D. core barrel general type soil test borings extending to a depth of 60 feet below existing ground surface were made at 1,000 foot intervals along the proposed levee location. In addition to these 60 foot borings, two 5-inch diameter undisturbed type soil test borings 100 feet deep were made along the levee alignment; one in the section adjacent to the MR-GO and one along the Bayou Dupre-Violet alignment.

Two additional 5-inch diameter undisturbed type soil test borings were made, one at the Bayou Bienvenue control structure site and one at the Bayou Dupre control structure site.

The locations and logs of the general type soil borings taken along the project alignment are shown on Plates 2 to 18 inclusive.

The logs and locations of the 5-inch undisturbed soil borings are shown on Plates 30 - 36 and Plates 2, 4, 6, 8, 10, 14 and 17, respectively.

25. Laboratory Tests. From the IHNC Lock to Sta. 90 + 25 = Sta. 7 + 52.9, visual classification and water content determinations were made on all samples obtained from these borings. Consolidations (C) tests, unconfined compression (UC), unconsolidated-undrained (Q), consolidated-undrained (R), and consolidated-drained (S) shear tests were performed on samples from the undisturbed borings that were representative of the soils encountered in the borings. Liquid and plastic limits were determined for all samples on which consolidation and shear tests were performed. The locations and results of the consolidation and shear tests are indicated on the boring logs on Plates 30, 31 and 32. From Sta. 90 + 25 = Sta. 7 + 52.9 to the end of the project at Sta. 1050 + 57.7, visual classification and water content determinations were made on soil samples obtained from the general type and undisturbed borings. Unconfined compression shear tests on samples from general type borings and undisturbed borings were made. Consolidation tests, Triaxial shear tests ("Q" type), Triaxial shear tests ("R" type) and direct shear tests ("S" type) were made. The results of these tests are shown on Plates 33 - 36 inclusive and 46 - 53 inclusive.

26. Foundation and Soil Conditions. There is an existing levee with crown at approximate elevation 9 along the project alignment between the lock and Florida Avenue, and there is some existing fill at approximate elevation 7 north of Florida Avenue and at about elevation 5 along the north bank of the Outfall Canal. The existing levee and fill material is mostly fat clays with water contents ranging from about 40% to 60%. The foundation below natural ground surface (El. 0) is predominantly very soft to soft fat clays down to approximate elevations -50 to -60 where generally lean clays, silts and fine sands were encountered which overlie the stiff clays of the Pleistocene deposit at elevations varying from about -70 near the lock to about -55 at Sta. 90 + 25 = 7 + 52.9. The very soft fat clay from natural ground surface to about elevation -16 contains appreciable amounts of wood and organic matter with water contents of about 60% to 300%. The water content of the clays below about elevation -16 range from about 50% to 80%. Water contents of the Pleistocene clays range from about 30% to 45%.

a. A generalized soil profile of the subsurface along the proposed alignment from Sta. 90 + 25 = 7 + 52.9 to Sta. 1050 + 57.7 is shown on Plate 29. The profile indicates the soft Recent soils that overlie the stiffer Pleistocene clays which occur generally at El. -55 at Sta. 90 + 25 = 7 + 52.9 down to -65 at Sta. 1050 + 57.7. The Recent soils consist generally, and in varying strata, of organic clays (OH), peat (PT), fat clays (CH), some lean clays (CL), some clayey sands (SC) and rare spots of fine sand (SP). Along the levee alignment paralleling the MR-GO, the natural Recent soils have been covered with hydraulic spoil from the excavation of the MR-GO channel. From Sta. 90 + 25 = Sta. 7 + 52.9 to Sta. 270 + 00 near Paris Road, the upper 10 feet of existing subsoil is primarily very soft organic clay, except for a thin surface layer of fine sand about 2 to 3 feet in thickness occurring from Sta. 185 + 00 to Sta. 260 + 00 near Paris Road. Under the upper organic clays lies an irregular stratum of very soft brown peat varying in thickness from 4 feet to 13 feet. Under the peat lies a stratum of fat clays, generally from El. -13 to El. -45, and generally at El. -45 a stratum of clayey sand occurs. From Sta. 270 + 00 near Paris Road to Sta. 620 + 00 just south of Pipe Line Canal the upper 18 - 20 feet of subsoil is a fairly uniform stratum of very soft gray clay with organic matter. In this stratum there is a surface deposit of fine sand from Sta. 290 + 00 to Sta. 340 + 00 and an irregular deposit of peat near Sta. 440 + 00 between Bayou Bienvenue and Bayou Villere. Under the upper organic stratum in this stretch is a fairly uniform stratum of fat clays approximately 30 - 35 feet in thickness overlying a lower stratum of clayey sand. From Sta. 620 + 00 to Bayou Dupre at about Sta. 690 + 00, the subsoil is all very soft to soft gray clay with medium stiff gray clay occurring at El. -55. From Bayou Dupre to approximately Sta. 800 + 00, the

Par. 26.a.

upper 5 to 10 feet of subsoil varies from fat clays to fine sand to organic clays all lying over a deposit of peat 10 to 15 feet in thickness. Under the peat is a 25 foot stratum of clayey sand from El. -15 to El. -40 and then from -40 to -55 there is a stratum of soft gray clay. Continuing on the reach back toward Sta. 1050 + 57.7 from Sta. 800 + 00, this area has not received any spoil deposition and the upper 10 to 12 feet of subsoil is a fairly uniform stratum of very soft, brown peat. Under the peat lies a stratum of organic clays approximately 4 to 9 feet in thickness. The lower stratum is a stratum of fat clays 40 to 45 feet in thickness. At about Sta. 960 + 00, the upper layer of peat ends and from that point on to the Mississippi River, the upper stratum is a stratum of organic clays approximately 26 feet thick. Under this stratum there are two irregular strata of clayey sands about 8 feet in thickness and the remainder of the lower subsoil down to El. -60 consists of fat clays. The Pleistocene soils underlying the Recent soils consist predominantly of stiff to very stiff clays that are over-consolidated as a result of desiccation during their past history. The water contents and consistencies of the soils along the proposed levee from Sta. 90 + 25 = 7 + 52.9 to Sta. 1050 + 57.7 are shown on the profiles on Plates 7 - 18 inclusive. The boring logs on Plates 10, 34 and 35 show the subsurface conditions at the sites of the two drainage structures.

b. The subsurface soils at the vicinity of the Bayou Bienvenue drainage structure are shown on the log of Boring U-2 at Sta. 370 + 00 on Plate 34 and on the log of Boring G-29 at Sta. 360 + 00 on Plate 10. From approximate existing ground El. 5.5 down to about El. -8, the stratum consists of very soft clays (OH) with organic matter peat and some silt and fine sand near the surface. Water content in the clays from El. 0 to El. -8 averages about 105%. Beneath this organic clay stratum lies a stratum of very soft, fat clays (CH) from El. -8 to El. -30. Water contents range from 39% to 118% in this stratum. At El. -30, there is a very dense fine sand stratum about 2 feet in thickness overlying loose fine sand with clay layers down to El. -36. From El. -36 to El. -41, there is a stratum of soft, gray clay (CH) with some fine sand lenses. Water content in the upper part of this stratum is 158% and in the lower part, 47%. From El. -41 to El. -55, there is a stratum of medium, stiff gray clay (CH) with fine sand lenses and water contents ranging from 42% to 78%. Within this stratum, from El. -48 to El. -51, there is a stratum of medium, stiff gray, sandy clay, water content 40%. Below El. -55, reference is made to Boring U-2. The medium, stiff, gray clay (CH) stratum extends on down to El. -59 to a stratum of very stiff tan and gray, sandy clay (CL) which is the top of the Pleistocene. Here the water content is 21%. From the top of the Pleistocene at El. -59 on down to El. -97.5, the very stiff clays (CL) extend for about 10 feet and primarily medium, stiff clays (CH) are encountered on down to El. -84.5 where the stratum becomes stiff, gray clay with silt lenses and remains the same to El. -97.5. The water contents in the Pleistocene clays range from 21% to 45%.

c. The subsurface soils at the vicinity of Bayou Dupre drainage structure are indicated in the log of Boring U-3 at Sta. 700 + 00 shown on Plate 35. The upper stratum, from ground El. 8 to El. -3 consists of very soft gray clays (CH) with roots, peat and organic matter with water contents varying from 43% to 85%. From El. -3 to El. -23, there are alternating layers of soft clays (CL) and soft silty clays with clayey silt layers. Water contents in these layers range from 34% to 45%. From El. -23 to El. -58, there are layers of gray clays (CH) with some fine sand, salt lenses, and shell fragments. Consistency varies from soft to medium stiff and water contents from 46% to 65%. From El. -58 to El. -64, a medium dense fine gray sand stratum occurs just on top of the Pleistocene formation at El. -64. Except for a soft dark gray clay stratum occurring between El. -65.5 and El. -67.5, average water content 30%, the remainder of the subsoil on down to El. -91 consists of layers of medium stiff to stiff clays, CL and CH with water contents varying from 23% to 45%.

27. Design and Construction Problems (IHNC Lock to Sta. 90 + 25 = 7 + 52.9). Because of the low shear strengths of the foundation soils, and the limited space available for the construction of the required protection, the following were the principal design and construction problems on the part of the project from the IHNC lock to Sta. 90 + 25 = 7 + 52.9:

- a. Type of protection
- b. Location of protection
- c. Stability
- d. Seepage and uplift
- e. Foundation for structures
- f. Sources of fill material
- g. Methods of construction
- h. Erosion protection

28. Type of Protection. Because of the limited space available between the existing plants along the IHNC and the established drainage systems on the protected side of the existing levee, it will be necessary that protection consist of a cantilever "I"-type floodwall driven through the existing levee from the lock northward to Florida Avenue; inverted "T" wall and cofferdam structure across Florida Avenue; and a new levee constructed to El. 9 with an "I" type floodwall driven through it from Florida Avenue northeastward to the north bank of the Outfall Canal. Sufficient space is available to construct a new levee to the required grade and section eastward along the north bank of the Outfall Canal to Sta. 90 + 25 = 7 + 52.9.

29. Location of Protection. The protection along this portion of

the project is located so that it has an adequate factor of safety with respect to failure into the existing drainage ditches on the protected side and the IHNC on the floodside. Insofar as possible, this protection is located so that it will preserve and not interfere with plant facilities and existing drainage systems.

30. Stability.

a. Cantilever "I"-type floodwall. The cantilever "I"-type floodwalls were designed for a water level 6" below the top of the floodwall. The required penetrations for the stability of the walls were determined by the method of planes using the (S) shear strengths shown on Plate 45. A factor of safety of 1.5 was applied to the design shear strength. Using the resulting shear strength, net horizontal water and earth pressure diagrams were determined for movement towards each side of the sheet pile. Using these distributions of pressures, summations of horizontal forces were equated to zero for various tip penetrations. At these penetrations, summations of overturning moments about the bottom of the pile were determined. The required depth of penetration was determined as that where the summation of moments were equal to zero. These analyses are shown on Plates 38 and 39.

b. Levees. The stability of the levees in the portion of the project from Sta. 1 + 82 to 0 + 00 = 1 + 46.6 to Sta. 90 + 25 = 7 + 52.9 was determined by the method of planes using the design (Q) shear strengths shown on Plates 30, 31, 32 and applying a minimum factor of safety of 1.3 with respect to shear strength. The levee slopes and berm distances were designed for a hurricane water condition at stillwater level for the project hurricane and assumed failure toward the protected side, and a mean low water condition and failure toward the flood side. The stability of the wall was checked for the case with water at the top of the wall, as initially constructed, and factors of safety of 1.23 and 1.30, respectively, were computed for the reaches from Sta. 1 + 82 to Sta. 0 + 00 = 1 + 46.6 to Sta. 58 + 11, and Sta. 57 + 94 to Sta. 79 + 62. These analyses are shown on Plates 37, 38 and 39.

31. Seepage and Uplift. Based on the soil conditions along this part of the project and the short duration of hurricane floods, hazardous seepage or hydrostatic uplift on the protected side is not anticipated.

32. Foundation for T-Type Floodwall at Florida Avenue. The foundation design for the T-type floodwall will be presented in a detail design memorandum. A preliminary section of the floodwall is shown on Plate 22.

33. Sources of Fill Material. The earthfill for completing the existing levee portion of the protection between the IHNC lock and Florida Avenue will be obtained from a borrow area in the bottom of Lake Pontchartrain along the north shore. This material, consisting of stiff Pleistocene clays will be transported to the project on barges. A borrow area located on the floodside of the new levee between Sta. 81 + 38 and Sta. 89 + 45, as shown on Plate 22, will provide all the earthfill required for the construction of the new levee between Florida Avenue and the north bank of the Outfall Canal (Sta. 67 + 94 to Sta. 79 + 62), and the first lift earthfill for the new levee along the north bank of the Outfall Canal (Sta. 79 + 62 to Sta. 90 + 25). For the former section of levee no borrow will be taken below elevation 0. The borrow area will be refilled by hydraulic methods during construction of the levee north of Sta. 90 + 25. Earthfill for the second and third lifts of the latter section of levee will be obtained from the bottom of Lake Pontchartrain and transported to the work site on barges.

34. Methods of Construction. Local interests have driven steel sheet pile through the existing levee from the lock to Florida Avenue to provide temporary protection for the 1966 hurricane season. The necessary additional earthfill in the existing levee will be placed by semi-compacted fill methods and a concrete cap will be constructed on the steel sheet pile. The new levee with an "I"-type floodwall from Florida Avenue to the north bank of the Outfall Canal will be constructed by contract. This new levee will be constructed in one lift by semi-compacted methods to elevation 9, the sheet pile wall driven, and the concrete cap placed. Due to the weak foundation soils, the new levee along the north bank of the Outfall Canal will be constructed to the net grade and section with cast fill and maintained by adding the necessary fill at 2-year intervals which will provide a stable levee section at the net grade within an estimated period of five years.

35. Settlement. It is estimated that the existing levee from the IHNC lock to Florida Avenue will settle one foot after the sheet pile wall is driven and the concrete cap is completed. The new levee with the sheet pile wall and concrete cap from Florida Avenue to the north bank of the Outfall Canal will settle an estimated two feet after it is completed. It is estimated that the new levee along the north bank of the Outfall Canal will settle a total of approximately five and one half feet during construction, due to consolidation of the foundation. The lift construction methods will compensate for this settlement and for the consolidation and shrinkage that occurs within the fill.

36. Erosion Protection. Due to the short duration of hurricane floods and the generally erosion resistant nature of the soil along this project, no erosion protection is considered necessary along the leveed portion of the project. Riprap protection is considered necessary around the structures at Florida Avenue.

37. Settlement Observations. Settlement observations will be made along the sheet pile wall as follows: after the sheet pile is driven, after the levee fill is placed, after concrete cap is placed, and yearly thereafter until settlement is essentially complete. Before and after construction, profiles and sections will be obtained during stage lifting of the new levee along the Outfall Canal.

Instrumentation and schedules of observations for the structures and inverted "T" wall at Florida Avenue will be presented in the detail design memorandum.

38. Levee Stability Analyses (Sta. 90+25=7+52.9 to Sta. 1050+57.7. Preliminary stability analyses were conducted to compare stabilities of various trial levee sections and also to consider the feasibility of mucking out and backfilling for the levee base. For the preliminary analyses, shear strengths from unconfined compression tests on samples from the general type borings were utilized. This method of planes was employed for the analyses. The analyses indicated that the shear strengths "in situ" were inadequate for proper stability if the levee were constructed to final section in one operation. They also indicated that the mucking out and backfilling scheme did not increase stability results sufficiently to justify the construction expense. They further indicated that a "stage" or "lift" construction scheme was necessary so that gains in subsoil shear strength could be made through consolidation under the intermittent "lifts" of embankment material so as to arrive at proper stability for the final levee section. It should be noted that the levee construction from Sta. 7 + 52.9 to 807 + 00 is over an area where spoil from the dredging of the MR-GO has been placed over a 5 to 7 year period to an elevation varying from 5.0 to 12.0. This area is from 2,000 to 4,000 feet in width. There has been considerable consolidation of the underlying strata as evidenced by the general borings which indicate that the original ground has been depressed from 5 to 10 feet by the surcharge of the spoil. Furthermore, a statistical analysis of over 30 general borings made along the levee centerline at 3,000 foot intervals indicate an average sub-surface strata strength 15% higher in areas with overburden as compared to areas without overburden and, in the top 30 feet of strata, this strength increase was approximately 25%. Increase in strength is further evidenced by the spoil bank itself which is standing, in some cases, up to elevation 10.0 or 11.0, on slopes steeper than 1 on 3.

After a detailed study of the soil boring information for the area under consideration, a diagram was prepared showing the typical variations with depth in the soils. Values for the soil constants were assigned to each stratum with due regard to material classification, depth, Atterburg Limits, etc. The constants used are:

- C_Q - Apparent cohesion from "Q" tests.
 C_R - Apparent cohesion from "R" tests.
 ϕ_R - Apparent angle of internal friction from "R" tests.
 γ - Unit weight of the material.

Also used were the results of the consolidation tests. This was in the form of Void Ratio (e) vs. Logarithm of Pressure curves, and coefficient of Consolidation (C_v) vs. Logarithm of Pressure curves.

Several sets of graphs were prepared using this data. One set, Figure 1, shows the relationship between the "Q" and "R" test results. All figures, tables, graphs, etc., mentioned are to be found on Plates 68 and 69. Data for the "Q" values were obtained from the general borings, which had unconfined compression tests, and from the undisturbed borings with "Q" tests. The "R" data were obtained by correlating the data from the undisturbed borings with the general borings.

To estimate consolidation and rates of consolidation each stratum was identified with one or more of the e -Log P and C_v -Log P curves prepared from the results of consolidation tests on samples from the undisturbed borings. In the case where no direct correlation could be made with a material that had been tested, an estimate of the material's behavior was made by using information from tests run on several similar materials.

A table was prepared for each stratum, see Table A, showing the total consolidation expected in that stratum for various heights of fill. Values of C_v are also listed in each table. Graphs, such as Fig. 2, were prepared, showing the relationship between time and per cent consolidation. A table similar to Table E was prepared to facilitate construction of the Time-Consolidation curves. For the purpose of estimating the relationship between time and consolidation, it was assumed that the soils possessed internal drainage and that the maximum distance to a free draining surface within a stratum was equal to the thickness of the stratum. If C_v showed a significant change with a variation in applied pressure, several curves corresponding to several fill heights were prepared.

A comparison of the existing over-burden loads with the pre-consolidation loads obtained from the e -log P curves showed that the soils were very nearly consolidated. The notable exceptions to this were soils at the surface and soils in the Pleistocene deposits.

These soils show evidence of being over-consolidated. No evidence was available to indicate that the over-consolidation near the surface is extensive enough to be used in design considerations. Therefore, all soils above the Pleistocene were assumed to be normally consolidated.

It was then possible to begin selecting a sequence of construction operations, i.e. lifts, shapings, time intervals, etc. A "lift" was considered to be an operation in which new material was deposited on the levee site. This could be hydraulic or hauled fill. A "shaping" is an operation in which material previously deposited is reworked into a different cross-sectional shape. For example, a fill 200 feet wide and 5 feet deep at the centerline may be shaped into a fill 150 feet wide and 7 feet deep at the centerline.

The selection of the intermediate levee sections was made on the basis of the following considerations:

- 1) All material required for the final cross section and intermediate shapeups would be placed in one or more lifts.
- 2) Each lift or shaping would consolidate the foundation soils and cause a predictable increase in strength.
- 3) Each shaping would utilize all material remaining from the previous lift or shaping.
- 4) Each lift or shaping would be stable with a factor of safety (FOS) of 1.3 or greater when checked with the predicted average shear strengths applicable.
- 5) A gross grade approximately equal to project net grade would be attained in approximately five years.

To begin the design procedure, a trial first lift was selected that provides about 3 times the material needed for the final cross section. This lift was proportioned so as to be stable when checked with the shear strengths estimated on the basis of the "Q" tests. Next, the consolidation in each stratum was calculated for some arbitrary time interval, i.e. 2 years. The per cent increase in shear strength from the "Q" strength to the "R" strength was based on the per cent consolidation under the first lift load.

The total settlement at the levee centerline was computed and the settlement at any other point on the cross section was assumed to be proportional to the fill height at that point. The material remaining

above the original ground elevation was calculated using the assumed settlements.

The first shaping was then selected. The first shaping consists of the material remaining from the first lift and should have a centerline height as high as stability requirements permit. The stability of this must be checked using the interim shear strengths calculated previously. If the section is stable, the consolidation, after a second arbitrary time interval, must be calculated.

In order to use the consolidation vs. time curves previously prepared to estimate the additional consolidation to be expected at the end of the second time interval, a "Zero Time" was determined. This "Zero Time" was the time required for the first shaping to consolidate each stratum an amount equal to the amount of consolidation achieved in each stratum under the first lift.

This "per cent previous consolidation" was determined by relationship A:

$$P.P.C. = \frac{S_p \times 100}{S_2} \dots \dots \dots A$$

Where P.P.C. is the per cent consolidation at Zero Time,

S_p is the previous consolidation in a stratum,

and S_2 is the total consolidation expected in the same stratum due to the weight of the new fill.

Fig. 11 shows how the P.P.C. was used to determine zero time and how this, in turn, was used to determine the per cent consolidation to be expected at the end of the second time interval.

The total settlement at the end of the second time interval was determined, and the area remaining was calculated. The new, increased shear strengths were calculated by increasing the "Q" shear strengths by an amount equal to a percentage of the difference of the "R" strengths and the "Q" strengths. The percentage was equal to the percentage consolidation complete. Another shape, the second shape, was chosen with an area equal to that remaining in the first shaping. This second shaping also satisfied the conditions of stability with the latest increased soil constants.

A third time interval was selected and consolidation, by stratum, was tabulated for the second shaping. The P.P.C. was determined

by the relationship A and the zero time and per cent consolidation were determined as shown in Fig. 11.

The values of the strength constants at the end of the third time interval were determined as previously outlined. These strength constants at this point were then used to check the stability of the final cross section.

The area remaining in the second shaping, after settlement, was sufficient to provide enough area for the Third, or Final, Shaping. If, at any time, it became apparent that the area available for the final cross section was too great, or too small, then the first lift was adjusted accordingly and the entire procedure started again.

Variations in the procedure to optimize the sequencing of lifts and shapings included:

- 1) Variations in the number of initial lifts to provide the necessary material for the Final Levee Section,
- 2) Variations in the length of the time intervals between lifts and shapings, and
- 3) Variations in the heights, widths, etc., of the interim shapings.

The settlements and gains in shear strength used in the stability analyses are based on assumptions and theoretical analyses which are of necessity imprecise, and may vary from values experienced during and after construction. Accordingly, settlement monuments and piezometers will be installed upon completion of the first lift, and undisturbed borings will be made prior to proceeding with additional lifts and/or shaping operations, in order that actual settlements and gains in shear strength may be determined. The data thus obtained may require some alteration of the time intervals between successive construction phases used in this memorandum. Major revisions of these intervals are not, however, anticipated.

To illustrate the design technique, a detailed discussion will be given for the design of a levee similar to that required along the MR-GO from Sta. 7 + 52.9 to Sta. 268 + 00. Data for the example problem were chosen so as to best illustrate the design technique and may vary somewhat from the actual case.

The average existing ground elevation in this reach of the levee is approximately 7.0 feet. With this ground elevation and the recommended berm slopes for the final cross section, the required end area

was calculated, See Fig. 12. By multiplying this area by 3, an approximate end area of 1,245 square feet for the first lift was obtained. The trial First Lift shown in Fig. 13 was chosen.

The settlement expected at the end of 2 years was predicted by using Tables A through D and the curves in Figs. 2 through 5. From Table A the total settlement under a 6 ft. fill for stratum 1 is 0.79 ft. From Fig. 2, using the curve for a 4 ft. fill, the per cent consolidation in stratum 1, after 24 months, is 68%. Therefore, the consolidation in stratum 1 is $(0.68) \times (0.79)$ or about 0.5 ft. Likewise, for stratum 2, using Table B and Fig. 3, the consolidation is $(0.59) \times (3.27)$ or 1.9 ft. For stratum 3, using Table C and Fig. 4, the consolidation is $(0.27) \times (1.93)$ or 0.5 ft. For stratum 4, the deepest considered to affect surface settlement, the consolidation is $(0.80) \times (1.25)$ or 1.0 ft. This gives a surface settlement of approximately 3.9 ft. For the purpose of computing the amount of material still above original ground, the settlement is considered to decrease in proportion to decrease in height of fill. On this basis, the first lift has 698 sq. ft. of usable material at the end of 2 years, and the crown elevation is 9.1.

A stability analysis of the first lift is shown on Plate 70. The Method of Planes used for the stability studies was applied to the problem by using an electronic computer to perform the computations necessary to calculate each factor of safety (FOS). Various trial planes are shown, and the FOS for each trial is listed.

The stability analysis of the first lift was made using the "Q" shear strengths, SS_1 of Figs. 6 through 10. The increased shear strengths, $SS_2 - SS_4$, in each stratum, was determined by using these same figures. The effective stress at the center of each stratum, due to the combined weight of the over-burden and the levee, is indicated by the vertical lines. In Fig. 6, the vertical line marked first lift intersects the "Q" line at a shear strength of 175 psf and the "R" line at 350 psf. The increased shear strength, SS_2 , at the end of 2 years, when the per cent consolidation is 68%, is $(175) + (0.68) \times (350-175)$ or 294 psf. For stratum 2, the "Q" and "R" intercepts are 70 psf and 215 psf, respectively. Shear strength SS_2 is then equal to $(70) + (0.59) \times (215-70)$ or 156 psf. For stratum 3, the intercepts are 144 psf and 327 psf with the shear strength equal to $(144) + (0.27) \times (327-144)$ or 193 psf. For stratum 4, SS_2 is equal to $(244) + (0.80) \times (452-244)$ or 410 psf.

The consolidation of stratum 5 would not be large enough to affect the magnitude of the surface settlement, but it is assumed that the per cent consolidation, at any time, is equal to that of stratum 4. Therefore, SS_2 for stratum 5 is equal to $(225) + (0.80) \times (472-225)$ or 422 psf.

The strength increases are assumed to vary linearly to the toe of

Par. 38

the levee, that is, beginning with a maximum at the lift centerline and decreasing to Zero at the toe of the lift.

With a stable trial first lift determined, a trial first shaping was chosen. The first shaping will be shaped by reworking the material from the first lift above the original ground. This material was previously estimated to have an area of 698 sq. ft. Fig. 14 shows the trial first shaping.

The second time interval is again chosen as 2 years. The total accumulated settlement from the beginning of the first time interval to the end of the second was estimated.

The total fill height was increased to 10 ft. From Table A, the consolidation of stratum 1, with fill height equal to 10 ft., is 0.95 ft. The previous consolidation was 0.5 ft. The P.P.C., using relationship A, is equal to $(0.5) \times (100)/(0.95)$ or 52.6%.

Using Fig. 2, as previously demonstrated with Fig. 11, the "Zero Time" is approximately 11 months. This was obtained by using the 12 ft. fill curve. Moving along the time axis 24 months to time = 35 months and then vertically to the 12 ft. fill curve, the per cent consolidation at the end of the second time interval is found to be 85%. The accumulated consolidation in stratum 1 is now $(0.85) \times (0.95)$ or 0.8 ft.

Using Table B, the P.P.C. for stratum 2 is $(1.9) \times (100)/(4.15)$ or 45.8%. In Fig. 3, the zero time is 15 months, and the final per cent consolidation is 72%. The accumulated consolidation is $(0.72) \times (4.15)$ or 3.0 ft.

Using Table C and Fig. 4, the P.P.C. for stratum 3 is $(0.5) \times (100)/(2.5)$ or 20 %, zero time is 14 months, and the final per cent consolidation is 25%. The accumulated consolidation is $(0.25) \times (2.5)$ or 0.6 ft.

For stratum 4, using Table D and Fig. 5, P.P.C. = $(1.0) \times (100)/(1.53) = 65.3%$, zero time = 15 months, and the per cent consolidation is 92%. The accumulated consolidation is $(0.92) \times (1.53)$ or 1.4 ft.

The surface settlement is 5.8 ft., and the settlement of the first shaping is the difference between this 5.8 ft. and the 3.9 ft. settlement of the first lift.

The amount of material above original ground was calculated with the 1.9 ft. of new settlement decreasing to the toe of the first shaping. The end area of this material, see Fig. 14, is 503 sq. ft.

The percentage increases in strength from the "Q" to the "R" strengths are, as before, the same as the percentages of consolidation completed. For stratum 1, it is 85%; strata 2, 72%; stratum 3, 25%; and stratum 4, 92%. Stratum 5 is again assumed to be the same as stratum 4.

These increases, marked SS₃, on Figures 6 through 10, are assumed to decrease proportionately to the height of the fill to the toe of the first shaping.

The stability of the first shaping was checked using shear strengths SS₂. To facilitate use of the computer, these varying shear strengths are averaged and used as indicated on Plate 70.

With the first lift and first shaping stable and with strength increases predicted for the end of the second time interval, the second shaping can be selected. The first shaping, after settlement, has an area of 503 sq. ft. A trial second shaping, see Fig. 15, with an area of 502 sq. ft., and a third time interval of 2 years, is chosen.

The procedure for calculating the accumulated settlement is followed once again. Thus the consolidations, by stratum, with a fill height of approximately 12 ft. are:

Stratum 1,	94%	or	0.9 ft.
"	2,	84%	" 3.7 ft.
"	3,	28%	" 0.8 ft.
"	4,	95%	" 1.6 ft.

The shear strengths, by stratum, are:

Stratum 1,	424 psf
"	2, 241 psf
"	3, 211 psf
"	4, 496 psf
"	5, 515 psf

The second shaping was checked for stability, see Plate 71, using shear strengths shown on Plates 70 and 71. The end area, remaining after settlement, see Fig. 15, is somewhat longer than that required

for the final cross section.

The stability of the final cross section was checked with averages shown on Plate 71.

If the minimum FOS is approximately 1.3, the preceding completes the design procedure for determining the lifts and shapings required to attain the final levee cross section. Final levee sections are shown on Plates 23 - 26 inclusive. Stability analyses for the final levee sections are shown on Plates 40 - 44 inclusive.

39. Levee Construction (Sta. 90+25=7+52.9 to Sta. 1050+57.7). The levee will be constructed in lifts and shapeups. It is proposed that the lifts will be made hydraulically except for the final 3,000 feet (approximately) of the project, which will be made with truck-hauled fill. From the IHNC to Sta. 807+00, borrow will be made from the MR-GO channel on a selected material basis. From Sta. 807+00 to 1020+00, material will be obtained from the Violet Canal or from adjacent borrow areas, as shown on Plates 16 and 17. Material for the final 3,000 foot reach to Violet will be truck-hauled fill obtained from the Mississippi River batture or other suitable areas. The lifts will be made as high and as narrow as stability considerations and subsequent material requirements will allow. From Sta. 90+25=7+52.9 to Sta. 362+95, Sta. 519+00 to 574+00, Sta. 593+00 to 687+00, Sta. 692+00 to 697+05, and Sta. 702+95 to 807+00, all of the material required for the ultimate levee section will be placed in the first lift. It will be necessary to place some of the first lift material outside the final rights-of-way limits. Temporary easements will be required. After the required time interval, the initial lift material will be shaped upward by removing material from the edges and placing it toward the levee center. Through successive shapeups and subsequent time intervals, the levee will be brought to its final section. The shapeups may be performed by conventional earth-moving equipment depending on the condition of the material being moved. Retaining dikes for placing the lifts may be constructed by dragline operation obtaining borrow from inside the area to be covered with hydraulic embankment material. Sufficient hydraulic runoff overflow structures or weirs will be installed to assure proper removal of water. These structures will discharge into a system of open ditches leading back into the MR-GO or into nearby drainage canals. After completion of each hydraulic fill lift, the retaining dikes will be cut to provide positive drainage of the fill soil.

a. From Sta. 368+00 to 516+00, the levee was designed to utilize two hydraulic lifts before subsequent shapeups can be made. However, recently completed maintenance dredging along this reach, for which spoil area surveys are not yet available, may eliminate the necessity for one of the hydraulic lifts. If the deposition of spoil from the maintenance

dredging raises the elevation of the existing ground to 10.0 or above, an interim shaping operation will replace the design first lift. This shaping operation will conform to template criteria as outlined for the first lift from Sta. 368+00 to 516+00 on Plate 65. At the stream closures, three lifts prior to shapeups will be required, from Sta. 807+00 to Sta. 1020+00 along the MR-GO to Violet reach, two lifts prior to shapeups will be required. From Sta. 1020+00 to Sta. 1050+57.7, two lifts and no shapeups are required. The required number of lifts and shapeups, the approximate ground width required, the crown elevations, the expected settlements for each lift and shapeup and the lengths of time required between lifts and shapeups are shown in template and tabular form on Plate 65.

40. Structures. The Bayou Bienvenue structure will be constructed on the north side of Bayou Bienvenue at levee centerline Sta. 360+00 (approximately) and the Bayou Dupre structure on the south side of Bayou Dupre at levee centerline Sta. 700+00 (approximately). The proposed structures are shown on Plates 59 - 63 inclusive.

The concrete structures will be supported on timber piles driven into the stiff Pleistocene soils to tip elevations -75. Tension anchors consisting of a galvanized steel strap bolted to the piles with galvanized through bolts will be provided on all piles under the drainage structures to resist the uplift pressure which will occur when the structure is unwatered. Shell backfill will be used against the outside of the structure walls. Erosion protection will consist of 3 feet of derrick stone on one foot of shell extending 100 feet from the gate bays and then 2 feet of riprap on one foot of shell extending 100 feet from the derrick stone on the flood side and 2 feet of riprap on one foot of shell extending 150 feet from the gate bays on the protected side. Sheet pile floodwalls (with clay backfill 5 feet thick on each side) will be used to tie the structures into the adjacent levee sections. Sheet piling will also be used for cutoff walls and retaining walls as shown on Plates 62 and 63. The drainage structure slabs will be poured on 6" concrete stabilization slabs. There will be a sand and shell filter drainage blanket to provide relief when the structures are unwatered and to facilitate construction.

a. The drainage structures will be constructed in the dry in open excavations with average side slopes of approximately 1 on 8. The initial excavations will be accomplished under water with a small hydraulic dredge to within approximately 3 feet of grade. The initial excavated material shall be pumped and wasted out on the MR-GO channel spoil area. The access channels to the wet excavation areas will then be closed with shell and earth dams, and the partial excavations will be unwatered. The remaining 3 feet of excavation will be completed in the dry and this material will be used to provide a small levee around

Par. 40.a.

the excavation as a protection against high tides occurring during the construction. After the structures have been completed and water allowed to enter the chamber area, the remainder of the excavation required for the approach channels can be completed. Suitable material from this excavation, a hydraulic operation, will be placed in the levee construction. Unsuitable material shall be wasted on the MR-GO spoil area. Closures of Bayous Bienvenue and Dupre with levee construction will not be made until the structures and approach channels have been completed.

b. Conventional sumps and pumps in conjunction with shallow well points where required due to local sand strata will provide necessary drainage for surface and ground water during the construction of the drainage structures.

41. Approach Channels. Due to the locations of the drainage structures at Bayou Bienvenue and Bayou Dupre, it will be necessary to relocate the outfall reaches of these two streambeds into the new drainage structures. The approach channels are shown on Plate 59. These channels are to be excavated to a depth of -11; bottom widths to be 170 and sideslopes 1 on 3. The excavated material shall be disposed of as described in Paragraph 40 and closures of Bayou Bienvenue and Bayou Dupre with the new levee construction will not be made until the drainage structures and approach channels are complete and open. Erosion protection shall consist of 3 feet of derrick stone on one foot of shell extending 100 feet from the gate bays and then 2 feet of riprap on one foot of shell extending 100 feet from the derrick stone on the flood side and 2 feet of riprap on one foot of shell extending 150 feet from the gate bays on the protected side. Protection of the channel sideslopes beyond these areas against erosion caused by passing boats is not included and will be provided by local interests if required.

DESCRIPTION OF PROPOSED STRUCTURES AND IMPROVEMENTS

(Sta.1+82 to 0+00=1+46.6 to Sta.90+25=7+52.9)

42. Criteria for Structural Design.

a. General. Structural design has been made in accordance with standard practice and with criteria set forth in Engineering Manuals for Civil Works Construction published by the Office, Chief of Engineers.

b. Unit Weight. The following values of unit weights, earth pressures, and soil pressures were used in the design:

<u>Unit Weights</u>	<u>Lb. per Cu. Ft.</u>
Water	62.5
Concrete	150
Earth	See Plates 37 - 39

c. Design Loads. Listed below are the assumed design loads used in the design of the structure:

- (1) Earth Pressure (lateral). See figures Nos. 1 and 2 .
- (2) Water loads
 - (a) No wave forces will occur.
 - (b) A surge to within 6 inches of the top of the wall will occur.

d. Allowable Working Stresses. The allowable working stresses for concrete and structural steel are in accordance with those recommended in "Working Stresses for Structural Design" EM-1110-1-2101 of 6 January 1958, revised August 1963. Concrete will be designated by basic minimum strength 3,000 pound concrete. Steel sheet piling meeting the requirements of ASTM A328-54. "Standard Specifications for Steel Sheet Piling" will be used.

43. Floodwalls and Levees.

a. From Sta. 1+82 to Sta. 0+00 = 1+46.58 to Sta. 58+12, the protection will consist of an I-type floodwall with the sheet piling driven in an existing levee which will be raised approximately 2 feet and reshaped. Design analysis of the floodwall is shown on figure No. 1. Bending moments and deflections for structural design are based on a factor of safety of 1.0 applied to the soils, since the structural steel has an inherent safety factor of about 2.0. Sections of the floodwall and levee are shown on Plates 20, 21 and 22, and details of the floodwall are shown on Plate 27. The strength of the wall was checked for the case with water at the top of the wall, as initially constructed, and found to be adequate as shown on figure 1.

b. From Sta. 58+12 to Sta. 67+94, the protection will consist of a bearing pile supported inverted T-type floodwall. A new trestle span approach bridge, a 25-foot swing gate for closing a gap at Surekote Road, and a 17-foot overhead roller gate for closing a railroad gap will also be required. A typical section of the inverted

Par. 43.b.

T-wall is shown on Plate 22. Due to the complex design problems encountered, this reach will be included in a detail design memorandum.

c. From Sta. 67+94 to Sta. 79+62, the protection will consist of an I-type floodwall. For the first 278 feet, the sheet piling will be driven in an existing shell road. The floodwall will then extend along the Outfall Canal with the sheet piling driven into a new levee. An analysis of design of the floodwall is shown on figure No. 2. Bending moments and deflections for structural design are based on a factor of safety of 1.0 applied to the soils, since the structural steel has an inherent safety factor of about 2.0. Sections of the floodwall and levee are shown on Plate 22, Details of the floodwall are shown on Plate 27. The strength of the wall was checked for the case with water at the top of the wall, as initially constructed, and found to be adequate as shown on figure 1.

d. From Sta. 79+62 to Sta. 90+25, a levee will be built along the Outfall Canal using canal side borrow material. A section of the levee is shown on Plate 22.

44. Utility Crossings. Details of cables and water and gas pipelines passing through the floodwall are shown on Plate 27.

45. Corrosion Protective Measures. After the steel sheet pile section of the I-type floodwall from the lock to Florida Avenue is completed and before the concrete wall is placed, stray current measurements will be made to determine if cathodic protection is required. If the measurements show that cathodic protection is required, a sacrificial metal system will be installed. All piles will be bonded together near the top and the anodes will be buried in coke breeze backfill at such distance from the wall and at such intervals parallel to the wall as to produce a protection current density of not less than 0.003 amperes per square foot of section protected.

DESCRIPTION OF PROPOSED STRUCTURES AND IMPROVEMENTS
(Sta. 90+25=7+52.9 to Sta. 1050+57.7)

46. Levees. Proposed levee sections are shown on Plates 23 - 26 inclusive. Beginning at Sta. 90+25=7+52.9, at the north bank of the Outfall Canal, the new levee will extend northward to the south bank of the MR-60 and then eastward to Paris Road. The details of this portion of the levee construction are shown on Plate 23. This section of the levee will finally have a crown elevation of 14.0. The crown width will be 10 feet. From the crown edges the side slopes will be 5 on 1 down to the berms at El. 9.0. The berms will slope 30 on 1. Berm toe slopes, where required, will be 5 on 1. The centerline of the levee, where it parallels

the MR-GO is located, for the most part, 150 feet landward of the MR-GO channel right-of-way line. The levee, when finally constructed, will be contained with a 300 ft. right-of-way adjacent to the MR-GO channel right-of-way line, except where the levee alignment is adjusted to pass between the piers of the high level bridge crossing the MR-GO at Paris Road. At Sta. 268+00, just west of Paris Road, the levee section changes in height and width. The crown elevation will increase from El. 14.0 to El. 17.5. The transition will take place from Sta. 268+00 to Sta. 270+00. Also at Sta. 260+24.72, the levee alignment will curve landward to pass in between Bents 30 and 31 of the new high level bridge across the MR-GO bridge at Paris Road, and having passed under the bridge, will then curve back toward the MR-GO and become parallel to and 150 ft. landward of the MR-GO channel right-of-way line at Sta. 289+69.04 (See Plate 9). From this point on to the proposed drainage structure at Sta. 360+00 on the northwest side of Bayou Bienvenue, the proposed levee continues parallel to the MR-GO channel and the levee centerline is 150 feet from the MR-GO right-of-way line. From the transition at Sta. 270+00, the levee will have a crown elevation of 17.5, the levee crown width will be 10 ft. From the crown edges, the side slopes will be 5 on 1 down to the berms at El. 9.0. The berms will slope 30 on 1. Berm toe slopes, where required, will be 5 on 1. See Plate 23 for levee details. From the drainage structure near Bayou Bienvenue, the proposed levee alignment crosses Bayou Bienvenue and continues in a southeasterly direction, parallel to and 150 ft. landward of the MR-GO right-of-way line. From Bayou Bienvenue on down to the Bayou Dupre drainage structure, the levee configuration is as described above for the reach beginning at the Paris Road transition from crown elevation 14.0 to crown elevation 17.5, and as shown on Plate 24. After crossing Bayou Dupre structure at Sta. 700+00 on the southeastern side of the bayou, the levee alignment proceeds on to Sta. 769+92 and then turns back toward Violet. This part of levee alignment is shown on Plates 11 - 15 inclusive. After the turn back toward Violet, the levee alignment generally follows the line of the south bank of the Violet Canal. See Plates 15-18 inclusive. The crown elevation of this section of the levee is El. 17.5. The crown width is 10 ft. and, from the edges of the levee crown, the side slopes are 5 on 1 down to the berms at El. 9.0. The berms slope 30 on 1. Berm toe slopes, where required, are 5 on 1. See Plate 25 for levee details. At Violet, where the protection levee intersects State Highway 39 and the Louisiana Southern Railroad tracks, a gap closure structure will be required. See Plates 18; 19 and 26.

47. Structures. Two (2) structures, for area drainage and for navigation purposes, will be provided in the protection levee. One of these structures will be located at Sta. 360+00 on the northwest side of Bayou Bienvenue and the other will be located at Sta. 700+00 on the southeast side of Bayou Dupre. The two structures are essentially

Par. 47

identical and will be situated and constructed as indicated on Plates 59, 60, 61, 62 and 63. The inside width of the structures will be 56 ft. and the elevation of the sill will be -10.78. The structure at each location will consist of a reinforced concrete gate bay 76 ft. in length and a 95 foot long timber guide wall at each end of the gate bay. The gate bay will be designed as a reinforced concrete "U" frame. The gate bay will be supported on untreated wood piling driven to El. -75. Steel sector-type gates will be used. The elevation of the top of the gates, the gate bay walls, and the floodwalls connecting the structure to the adjacent protection levees will be 17.5. The piling under the main width of the gate bays will be driven on a batter to resist the lateral thrust from differential heads acting on the gates. The remainder of the piling, under the sector gate recesses will be driven vertical. The gate bay will be provided with slots for needle beams and needles so that the gate bay can be dewatered for repair or painting of the gates. At the ends of the gate bay, there will be prestressed concrete sheet pile bulkheads installed with tie-backs into the gate bay walls. These bulkheads serve as 90° wing walls to retain the adjacent backfill. The earthen approach channels abut the drainage structures at these bulkheads. The approach channel bottoms and side slopes will be lined with riprap to minimize erosion from high stream velocities. Initial excavation for the drainage structures will be done by small hydraulic dredges. After damming off the initial excavation area, the final excavation will be done in the dry. Details of the excavation work are given in the "Soils" section of this memorandum. Operation of the sector gates will be by electric motors through a speed reducer and pull cables storing on a cable drum. Machinery for manual operation of the gates will also be provided for emergencies. An engine driven generator will provide power for normal operation of the gates and lighting requirements. Two small control houses will be provided for each drainage structure. These houses, constructed of reinforced concrete will be located above the machinery spaces on each side of the gate bay. The houses will be equipped with emergency type facilities to accommodate personnel at the structures during a hurricane. The detail design of the structures will be covered in a future design memorandum.

48. Approach Channels. Due to the location of the structures at Bayous Bienvenue and Dupre, approach channels from the existing bayous to the structures and from the structures to the MR-GO will be constructed.

The approach channels to the structures will be constructed as shown on Plates 59, 60 and 61. Other features are described in "Soils" section of this memorandum.

49. Access to Drainage Structures. Since these structures are normally unattended, it will be necessary to provide access for inspection, operation and maintenance. Access to the structures will be by boat prior to the completion of the final levee section. The levee crown, after final

construction, will be surfaced with shell so as to provide a satisfactory access roadway to the structures. Access to the structure at Bayou Bienvenue would require about 1.8 miles of roadway from Paris Road. Access to the structure at Bayou Dupre would require about 6.5 miles of roadway from Violet.

50. Foreshore Protection. Ultimately, the banks of the MR-GO will stabilize generally at a slope not flatter than 1 on 3. However, erosion of the foreshore area between the levee and the channel bank by ship-generated waves will pose a threat to the integrity of the levee. Accordingly, a stabilization dike to protect the levee from such erosion will be provided on the channelward slope of the existing front retaining dike. Based on experience on the Mississippi River below New Orleans, the stabilization dike will consist of 2.0 feet of riprap on 0.75 foot of shell, placed on a 1 on 3 slope, between elevations -3.0 and approximately 5.0. Details of the foreshore protection, including gradation of the riprap, are shown on Plates 23, 24 and 25.

51. Gap Closure. A steel miter gate type of gap closure will be constructed at Violet, Louisiana, where the proposed protection levee crosses Louisiana State Highway 39 and the Louisiana Southern Railroad track. Details of this structure are shown on Plate 26.

SOURCES OF CONSTRUCTION MATERIALS

52. Sources of Construction Materials. "Lake Pontchartrain and Vicinity, Louisiana, Design Memorandum No. 12, Sources of Construction Materials", dated June 1966.

COORDINATION WITH OTHER AGENCIES

53. General. As previously mentioned, the State of Louisiana, Department of Public Works, was appointed project coordinator for the State by Governor McKeithen. This agency has functioned to coordinate the needs, desires, and interests of State agencies, and provided liaison between these agencies and the Corps of Engineers. The Orleans Levee District, which will provide the local cooperation for all features of the project other than those located in St. Bernard Parish, possesses an excellent engineering staff and actively assisted in coordinating the project planning. The project plan presented herein is acceptable to both of the above agencies.

54. U. S. Department of the Interior. Extensive coordination with the U. S. Fish and Wildlife Service was accomplished during preauthorization studies leading to authorization of the project. By letter dated 15 June 1966, the Regional Director, U. S. Fish and Wildlife Service, Atlanta, Georgia, was informed that detailed planning for the Chalmette

Area Plan was in progress; apprised of anticipated departures from the project document plan; and requested to submit views and comments on the modified plan. In a report dated 10 August 1966, the Regional Director states "... the existing brackish water circulatory system will be essentially maintained. It does not, therefore, appear that the modified hurricane levee alignment will directly affect fish and wildlife resources to any great extent." The report is included in Appendix A.

55. State of Louisiana, Wild Life & Fisheries Commission. This agency was included in the extensive preauthorization coordination referred to in paragraph 54. By letter dated 15 June 1966, the Director, Wild Life and Fisheries Commission, was informed of anticipated departures from the project document plan for the Chalmette Area, and requested to submit views and comments on the modified plan. The Director concurs in the report of the U. S. Fish and Wildlife Service and a copy of his letter of concurrence is included as an attachment to that report (see Appendix A).

56. Board of Commissioners, Port of New Orleans. This agency has jurisdiction over the IHNC and the lands adjacent thereto. The levee alignment along the Canal was developed in cooperation with the Board and is approved by them.

REAL ESTATE REQUIREMENTS

57. General. All rights of way will be acquired by the local agencies involved and furnished without cost to the United States. There will be no acquisition by the United States.

RELOCATIONS

58. Florida Avenue Bridge Approach. The existing steel and concrete trestle approach to the Florida Avenue bridge will be relocated approximately 50 feet to the east of its present location in lieu of constructing a gap closure in the protective system. The elimination of the gap closure will allow traffic access to the Florida Avenue bridge should a hurricane critical to the project area occur. The estimated cost of relocating the Florida Avenue bridge approach is \$235,160.

59. Utility Crossings. The project document specifies that local interests, prior to construction, agree to "accomplish all necessary alterations and relocations to roads, railroads, pipelines, cables, wharves, drainage structures and other facilities required for the construction of the project." Modifications and/or relocations of utilities will be required for the following:

IHNC Lock to Sta. 90+25=7+52.9. Modifications are required for the 10 gas lines, 4 water lines, and 4 telephone cables that pass through the present levee system. The gas and water lines will be cut, spliced and passed through the new levee wall and sealed with concrete and plastic sealers respectively. The telephone cables will be pulled aside, the sheet piling driven, then the cable will be passed through a slot cut in the sheet piling and sealed with a plastic sealer. The estimated cost for this work is \$6,712.

Sta. 90+25=7+52.9 to Sta. 1050+57.7

(1) Orleans Parish

(a) One 24 inch gas main at Sta. 269+15 and an aerial power line crossing at Paris Road, Sta. 270+00, owned by New Orleans Public Service, Inc.

(2) St. Bernard Parish

(a) Two 12 inch gas mains crossing at Sta. 416+00 and one 8 inch and one 16 inch gas mains crossing at Sta. 810+00, all owned by Creole Gas Pipeline Co.

(b) One 20 inch and one 24 inch gas main crossing at Sta. 583+04 and again at Sta. 867+85, being owned by Southern Natural Gas Co.

(c) One 20 inch gas main crossing at Sta. 968+90 and one 16 inch gas main crossing at Sta. 1015+00, both owned by United Gas Pipeline Co.

(d) An aerial power line at Sta. 970+00 owned by Louisiana Power and Light Co.

The gas mains will be relocated over the new levee rather than remain in place under same. The existing pipe under the levee area will be removed and the excavation therefor back-filled with suitable material. The aerial power line crossing at Paris Road, Sta. 270+00, is to be removed when the proposed new power line crossing at Sta. 301+00 is completed (September 1967). The pole type structures for the power line at Sta. 970+00 are to be relocated as required by the alignment of the levee. Reference is made to Plates 54 - 58 inclusive. The estimated cost for this work is \$699,019.

COST ESTIMATES

60. General. The total estimated first cost of the authorized project, based on August 1966 price levels, is \$29,552,188, of which \$25,583,433 is Federal first cost and \$3,968,755 is non-Federal first cost. A summary of first cost by Sections is shown in Table 1. Summaries of first cost, per Section, both Federal and non-Federal, are shown in Table 2, with each Section summary of costs being followed by a detailed estimate of said costs.

TABLE 1

61. SUMMARY OF FIRST COST
(Aug 1966 Price Level)

<u>Item</u>	<u>FEDERAL</u>	<u>Total cost</u>
Section I		\$ 1,944,450
Section II		5,885,555
Section III		11,935,026
Section IV		<u>5,818,402</u>
	Total (Federal)	\$25,583,433
	<u>NON-FEDERAL</u>	
Section I		\$ 999,960
Section II		1,033,041
Section III		542,334
Section IV		<u>1,393,420</u>
	Total (Non-Federal)	<u>\$ 3,968,755</u>
	TOTAL FEDERAL AND NON-FEDERAL	\$29,552,188

TABLE 1 (cont'd)
ESTIMATE OF APPORTIONMENT OF COSTS BETWEEN
FEDERAL AND NON-FEDERAL INTERESTS

<u>Project First Cost</u>	
Construction (includes riprap foreshore protection for bank stabilization along MR-GO)	\$25,583,433
Lands, damages and relocations	<u>3,968,755</u>
	\$29,552,188
Less Riprap Foreshore Protection	<u>3,371,400</u>
	<u>\$26,180,788</u>
	TOTAL
<u>Apportionment of Costs</u>	<u>Non-Federal</u>
	30%
Less lands, damages and relocations	\$ 7,854,236
Cash Contribution	<u>3,968,755</u>
Add Riprap Foreshore Protection	<u>\$ 3,885,481</u>
	<u>\$18,326,552</u>
	70%
	<u>3,371,400</u>
	<u>\$21,697,952</u>

TABLE 2
DETAILED ESTIMATE OF FEDERAL FIRST COST

SECTION I
(Sta.1+82 to 0+00=1+46 to 90+25=7+52.9)

SUMMARY OF FIRST COST

FEDERAL

<u>Item</u>	<u>Total cost</u>
Levee & floodwalls	\$1,864,300

NON-FEDERAL

Lands	\$ 758,000
Relocation	225,400
Utility Crossings	6,800
	<u>\$ 990,200</u>

<u>Item</u>	<u>Quantity</u>	<u>Unit</u>	<u>Unit price</u>	<u>Total cost</u>
Levee enlargement & "I"-type floodwall(Sta.1+82 to 0+00=1+46.6 to 58+11)				
Levee fill	19,390	c.y.	\$ 3.00	\$ 58,170.00
Z-27 steel sheet piling	105,270	s.f.	3.25	342,127.50
Concrete	2,517	c.y.	50.00	127,650.00
Reinforcing steel	209,900	lb.	0.14	29,386.00
Cement	3,510	bbl.	5.00	17,550.00
Fertilizing	8.62	acres	35.00	301.70
Seeding	8.62	acres	75.00	646.50
Cathodic protection	L. S.	L.S.	L.S.	50,000.00
Subtotal				<u>\$625,831.70</u>
Inverted "T" floodwall(Sta. 58+11 to 67+94)				
Excavation	4,720	c.y.	\$ 1.50	\$ 7,080.00
MA-22 sheet pile (cutoff)	14,553	s.f.	3.00	43,659.00
Z-27 sheet pile (temp. cofferdam)	35,280	s.f.	2.45	86,436.00
Z-38 sheet pile (foundation cell)	21,000	s.f.	4.20	88,200.00
Structural steel(misc.)	87,060	lb.	0.50	43,530.00
Sand	115	c.y.	10.00	1,150.00
Gravel	230	c.y.	10.00	2,300.00
Timber piling,treated	36,720	l.f.	2.50	91,800.00
Riprap	5,070	ton	10.00	50,700.00

Par. 61

SECTION I - TABLE 2 (cont'd)

<u>Item</u>	<u>Quantity</u>	<u>Unit</u>	<u>Unit price</u>	<u>Total cost</u>
Backfill	5,060	c.y.	\$ 2.00	\$ 10,120.00
Concrete	2,050	c.y.	50.00	102,500.00
Reinforcing steel	266,140	lb.	0.14	37,259.60
Cement	2,800	bb1.	5.00	14,000.00
Dewatering	L.S.	L.S.	L.S.	10,000.00
Shell (under riprap & in found. cell)	1,720	c.y.	3.50	6,020.00
Structural steel-overhead roller gate (R.R.)	10,000	lb.	0.50	5,000.00
Structural steel-swing gate (access R.)	16,000	lb.	0.50	8,000.00
Subtotal				<u>\$607,754.60</u>
Levee & "I"-type floodwall (Sta. 67+94 to 79+62)				
Levee fill	3,910	c.y.	1.50	\$ 5,865.00
Z-27 sheet pile	28,032	s.f.	3.25	91,104.00
Concrete	560	c.y.	50.00	28,000.00
Reinforcing steel	46,070	lb.	0.14	6,449.80
Cement	770	bb1.	5.00	3,850.00
Fertilizing	1.03	acres	35.00	36.05
Seeding	1.03	acres	75.00	77.25
Subtotal				<u>\$135,382.10</u>
Levee (Sta. 79+62 to 90+25)				
Initial construction	21,800	c.y.	0.35	\$ 7,630.00
1st Haul	7,300	c.y.	3.00	21,900.00
2nd Haul	2,200	c.y.	3.00	6,600.00
Refill borrow pit	25,700	c.y.	0.65	16,705.00
Fertilizing	2.34	acres	35.00	81.90
Seeding	2.34	acres	75.00	175.50
Subtotal				<u>\$ 53,092.40</u>
Total				\$ 1,422,060.80
15% Contingencies				213,339.20
Total construction cost				<u>\$ 1,635,400.00</u>
10.9% E&D				178,250.00
8% S&A				<u>130,800.00</u>
Total cost				<u>\$ 1,944,450.00</u>

SECTION I - TABLE 2 (cont'd)

<u>Item</u>	<u>Quantity</u>	<u>Unit</u>	<u>Unit price</u>	<u>Total cost</u>
Lands				
"I"-type floodwall & levee	2.3	acres	\$40,000	\$ 92,000.00
	13.3	acres	35,000	465,000.00
	1.3	acres	15,000	19,500.00
Inverted "I"-type floodwall	0.6	acre	40,000	24,000.00
Road easement	0.5	acre	40,000	20,000.00
Earth levee	2.6	acres	10,000	26,000.00
Borrow(temporary easement)	3.8	acres	500	1,900.00
Total				<u>\$648,400.00</u>
Improvements				None
Severance				10,000.00
Total land value				<u>\$658,400.00</u>
Contingencies				98,600.00
Real estate hired labor cost(5 tracts)				125.00
Acquisition costs by others (5 tracts)				<u>875.00</u>
Total costs				<u>\$758,000.00</u>
Modification of existing utility crossings				
6" water lines	3	ea.	450.00	\$ 1,350.00
10" water line	1	ea.	450.00	450.00
2" gas lines	3	ea.	300.00	900.00
3" gas line	1	ea.	300.00	300.00
4" gas lines	4	ea.	300.00	1,200.00
16" gas lines	2	ea.	300.00	600.00
Telephone cables	4	ea.	80.00	320.00
Subtotal				<u>\$ 5,120.00</u>
15% contingencies				780.00
Total construction cost				<u>\$ 5,900.00</u>
6% E&D				400.00
8% S&A				<u>500.00</u>
Total cost				<u>\$ 6,800.00</u>
Modification of approach to Florida Ave. bridge				
Treated timber piling	5,580	l.f.	2.50	\$ 13,950.00
12"x12" concrete piling	1,200	l.f.	6.00	7,200.00
Concrete	454	c.y.	50.00	22,700.00
Portland cement	624	bb1.	5.00	3,120.00
Reinforcing steel	88,348	lb.	0.14	12,368.72
Structural steel	202,390	lb.	0.40	80,895.00
Asphalt roadway	140	ton	15.00	2,100.00
Roadway fill	2,900	c.y.	3.25	9,425.00
Remove old approach (350 l.f.)	L.S.	L.S.	L.S.	17,500.00

SECTION I - TABLE 2 (cont'd)

<u>Item</u>	<u>Quantity</u>	<u>Unit</u>	<u>Unit price</u>	<u>Total cost</u>
Remove old piling; 50' long ea.	110	ea.	\$25.00	\$ 2,750.00
Subtotal				\$ 172,008.72
15% contingencies				25,791.28
Total construction cost				\$ 197,800.00
10.9% E&D				21,560.00
8% S&A				15,800.00
Total cost				\$ 235,160.00

SECTION II - TABLE 2

- (1) Sta. 90+25=7+52.9 to Sta. 270+00 at Paris Road.
- (2) Sta. 270+00 to Sta. 365+50 at Bayou Bienvenue.

SUMMARY OF FIRST COST

FEDERAL

<u>Item</u>	<u>Total cost</u>
(1) Levees & Bank Stabilization	\$ 2,835,765
(2) Levees, Bank Stabilization, Floodgate, & Channel Changes	3,049,790
	\$ 5,885,555

NON-FEDERAL

(1) Utility Crossings	\$ 82,041
(1) & (2) Lands	951,000
	\$ 1,033,041

SECTION II - TABLE 2 (cont'd)

<u>Item</u>	<u>Quantity</u>	<u>Unit</u>	<u>Unit price</u>	<u>Total cost</u>
<u>(1)</u>				
Embankment (Hydraulic)	1,816,741	c.y.	\$0.65	\$ 1,180,882
First shapeup	74,675	c.y.	0.45	33,604
Second shapeup(Final)	46,184	c.y.	0.60	27,710
Fertilizing	165.27	acre	35.00	5,784
Seeding	165.27	acre	75.00	12,395
Clearing & snagging	Lump Sum	L.S.	L.S.	50,000
Bank Stabilization along MR-GO				
a) Excavation & Backfill	62,300	c.y.	1.00	62,300
b) Riprap	63,900	ton	10.00	639,000
c) Shell	17,800	c.y.	3.50	62,300
Subtotal				\$ 2,073,975
Contingencies(15%)				311,025
Total Construction Cost				\$ 2,385,000
10.9% E&D				259,965
8% S&A				190,800
<u>TOTAL COST SECTION II(1)</u>				<u>\$ 2,835,765</u>

<u>(2)</u>				
Embankment (Hydraulic)	361,928	c.y.	\$0.65	\$ 235,253
First shapeup	81,527	c.y.	0.45	36,687
Second shapeup	80,341	c.y.	0.45	36,153
Third shapeup(Final)	8,096	c.y.	0.60	4,858
Stream Closure:				
Embankment (Hydraulic)				
1st Lift	42,900	c.y.	0.65	27,885
2nd Lift	12,000	c.y.	0.65	7,800
Embankment (Shell)1st Lift	29,700	c.y.	3.00	89,100
Embankment (Shell)2nd Lift	33,600	c.y.	5.00	168,000
Embankment (Shell)Shapeup	16,800	c.y.	1.00	16,800
Embankment (Clay)	18,500	c.y.	1.50	27,750
Fertilizing	82.88	acre	35.00	2,900
Seeding	82.88	acre	75.00	6,216
Clearing	Lump Sum	L.S.	L.S.	1,000

SECTION II - TABLE 2 (cont'd)

<u>Item</u>	<u>Quantity</u>	<u>Unit</u>	<u>Unit price</u>	<u>Total cost</u>
Bank Stabilization along MR-GO				
a)Excavation and Backfill	26,600	c.y.	\$ 1.00	\$ 26,600
b)Riprap	27,100	c.y.	10.00	271,000
c)Shell	7,600	c.y.	3.50	26,600
Subtotal				\$ 984,602
Contingencies(15%)				147,693
Subtotal				\$ 1,132,295
Floodgate	1	L.S.		1,266,900
Channels & Levees		L.S.		153,565
Access Road - shell	3,500	c.y.	3.50	12,250
Total Construction cost				\$ 2,565,010
10.9% E&D				279,580
8% S&A				205,200
				<u>\$ 3,049,790</u>
				<u>2,835,765</u>
				<u>\$ 5,885,555</u>

BAYOU BIENVENUE FLOODGATE STRUCTURE

A. Structure

1. Masonry

Initial excavation	128,500	c.y.	\$0.75	\$ 96,375
Dewatering	Job		L.S.	70,000
Final Struct. excavation	20,000	c.y.	2.00	40,000
Clay Backfill	94,400	c.y.	2.00	188,800
Riprap	5,640	ton	10.00	56,400
Shell Filter Blanket	2,600	c.y.	6.00	15,600
Conc. in Stabilization Slab	117	c.y.	40.00	4,680
Conc. in Base Slab	935	c.y.	60.00	56,100
Conc. in Walls & Caps	670	c.y.	90.00	60,300
Inverted "T" type				
Floodwall(conc.)	331	c.y.	90.00	29,790
Embedded Metal,Misc.	24,000	lb.	0.40	9,600
Untreated Timber Piling,				
Foundation	22,900	1.f.	2.00	45,800
Treated Timber Piling,				
Floodwall Foundation	32,500	1.f.	2.50	81,250
Pile Clusters	4	ea.	2,250.00	9,000
MA 22 Sheet Pile	14,350	s.f.	3.50	50,225
Control Houses	2	ea.	4,000.00	8,000
Seeding Embankment	24.8	acre	75.00	1,860

SECTION II - TABLE 2 (Cont'd)BAYOU BIENVENUE FLOODGATE STRUCTURE (Cont'd)

<u>Item</u>	<u>Quantity</u>	<u>Unit</u>	<u>Unit price</u>	<u>Total cost</u>
Handrail	812	l.f.	\$ 6.00	\$ 4,872
Treated Timber, 12x12	35	M.F.B.M.	1,000.00	35,000
Treated Timber, 3x10	22	M.F.B.M.	1,000.00	22,000
Subtotal				\$ 885,652
Contingencies(15%)				132,848
Subtotal				\$ 1,018,500
2. Gates & Operating Machinery				
Sector Gates	Lump Sum		L.S.	135,000
Electric System	Lump Sum		L.S.	15,000
Operating Machinery	Lump Sum		L.S.	60,000
Lights on Dolphins	Lump Sum		L.S.	6,000
Subtotal				\$ 216,000
Contingencies(15%)				32,400
Subtotal				\$ 248,400
Total				\$ 1,266,900
B. CHANNELS & LEVEES				
Dredging	356,450	c.y.	0.30	\$ 106,935
Levees	13,300	c.y.	2.00	26,600
Subtotal				\$ 133,535
Contingencies(15%)				20,030
Total				\$ 153,565
C. RELOCATION				
Light #115	1	L.S.	L.S.	\$ 2,000
D. SUMMARY OF COSTS				
1. Structure				\$ 1,266,900
2. Channels & Levees				153,565
3. Relocation				2,000
Total				\$ 1,422,465

SECTION II - TABLE 2 (cont'd)

MODIFICATION OF EXISTING UTILITY CROSSINGS

<u>Item</u>	<u>Quantity</u>	<u>Unit</u>	<u>Unit price</u>	<u>Total cost</u>
<u>(1)</u>				
1 @ 24" Gas Main		L.S.		\$ 60,000
Contingencies(15%)				<u>9,000</u>
Total Construction Cost				\$ 69,000
10.9% E&D				7,521
8% S&A				<u>5,520</u>
Total Cost				\$ 82,041

LANDS

Right of Way:				
7+52.9-10+00	1.08	acre	\$10,000	\$ 10,800
10+00 - 46+00	9.92	acre	10,000	99,200
46+00 - 60+00	9.64	acre	10,000	96,400
60+00 - 357+05	204.92	acre	2,500	512,300
Bienvenue Floodgate & stream closure	5.48	acre	2,500	13,700
Bienvenue Approach Channel	17.11	acre	2,500	42,775
Easements	83.15	acre	100	<u>8,315</u>
Total Land Value				\$ 783,490
Contingencies(15%)				<u>117,510</u>
Subtotal				\$ 901,000
Acquisition Costs				<u>50,000</u>
Total Land Costs				\$ 951,000

SECTION III - TABLE 2

(Sta. 365+50(Bayou Bienvenue) to 770+00(Bayou Lawler))

SUMMARY OF FIRST COSTFEDERAL

<u>Item</u>	<u>Total cost</u>
Levees & Bank Stabilization	\$10,582,779
Floodgate & Channel Changes	<u>1,352,247</u>
	\$11,935,026

NON-FEDERAL

Relocations	\$ 12,000
Utility Crossings	215,358
Lands	<u>314,976</u>
	\$ 542,334

<u>Item</u>	<u>Quantity</u>	<u>Unit</u>	<u>Unit price</u>	<u>Total cost</u>
Embankment(Hydraulic)1st Lift	3,300,019	c.y.	\$0.65	\$ 2,145,012
Embankment(Hydraulic)2nd Lift	577,971	c.y.	0.65	375,681
First shapeup	378,554	c.y.	0.45	170,349
Second shapeup(Final)	128,938	c.y.	0.60	77,363
Stream Closure:				
Embankment(Hydraulic)1st Lift	313,400	c.y.	0.65	203,710
Embankment(Hydraulic)2nd Lift	137,500	c.y.	0.65	89,375
Embankment(Shell) 1st Lift	206,900	c.y.	3.00	620,700
Embankment(Shell) 2nd Lift	388,800	c.y.	5.00	1,944,000
Embankment(Shell) Shapeup	194,400	c.y.	1.00	194,400
Embankment(Clay)	213,000	c.y.	1.50	319,500
Fertilizing	225.23	acre	35.00	7,883
Seeding	225.23	acre	75.00	16,892
Clearing	Lump Sum	L.S.	L.S.	10,000
Bank Stabilization along MR-GO				
a) Excavation & Backfill	112,500	c.y.	1.00	112,500
b) Riprap	115,300	ton	10.00	1,153,000
c) Shell	32,100	c.y.	3.50	<u>112,350</u>
Subtotal				\$ 7,552,715
Contingencies(15%)				<u>1,132,907</u>
Subtotal				\$ 8,685,622

SECTION III - TABLE 2 (cont'd)

(Sta. 365+50(Bayou Bienvenue) to 770+00(Bayou Lawler))

<u>Item</u>	<u>Quantity</u>	<u>Unit</u>	<u>Unit price</u>	<u>Total cost</u>
Subtotal (carried forward)				\$ 8,685,622
Floodgate	1	L.S.		1,265,910
Channels & Levees		L.S.		86,337
Total Construction Cost				\$10,037,869
10.9% E&D				1,094,128
8% S&A				803,029
Total Cost				\$11,935,026

BAYOU DUPRE FLOODGATE STRUCTURE

A. STRUCTURE

1. Masonry

Initial Excavation	125,500	c.y.	\$0.75	\$ 96,375
Dewatering	Job		L.S.	70,000
Final Struc.Excavation	20,000	c.y.	2.00	40,000
Clay Backfill	94,400	c.y.	2.00	188,800
Riprap	5,640	ton	10.00	56,400
Shell Filter Blanket	2,600	c.y.	6.00	15,600
Conc. in Stabilization				
Slab	117	c.y.	40.00	4,680
Conc. in Base Slab	935	c.y.	60.00	56,100
Conc. in Walls & Caps	670	c.y.	90.00	60,300
Inverted "T" type				
(Floodwall(conc.))	331	c.y.	90.00	29,790
Embedded Metal, Misc.	24,000	lb.	0.40	9,600
Untreated Timber Piling,				
Foundation	22,900	l.f.	2.00	45,800
Treated Timber Piling,				
Floodwall Foundation	32,500	l.f.	2.50	81,250
Pile Clusters	4	ea.	2,250.00	9,000
MA22 Sheet Pile	14,350	s.f.	3.50	50,225
Control Houses	2	ea.	4,000.00	8,000
Seeding Embankment	13.33	acre	75.00	1,000
Handrail	812	l.f.	6.00	4,872
Treated Timber, 12x12	35	M.F.B.M.	1,000.00	35,000
Treated Timber, 3x10	22	M.F.B.M.	1,000.00	22,000
Subtotal				\$ 884,792
Contingencies(15%)				132,718
Subtotal				\$ 1,017,510

SECTION III - TABLE 2 (cont'd)BAYOU DUPRE FLOODGATE STRUCTURE(cont'd)

<u>Item</u>	<u>Quantity</u>	<u>Unit</u>	<u>Unit Price</u>	<u>Total cost</u>
Subtotal(carried forward)				\$ 1,017,510
2. Gates & Operating Machinery				
Sector Gates	Lump Sum		L.S.	\$ 135,000
Electric System	Lump Sum		L.S.	15,000
Operating Machinery	Lump Sum		L.S.	60,000
Lights on Dolphins	Lump Sum		L.S.	6,000
Subtotal				\$ 216,000
Contingencies				32,400
Subtotal				\$ 248,400
Total				\$ 1,265,910
B. CHANNELS & LEVEES				
Dredging	161,586	c.y.	\$ 0.30	\$ 48,476
Levees	13,300	c.y.	2.00	26,600
Subtotal				\$ 75,076
Contingencies(15%)				11,261
Total				\$ 86,337
C. RELOCATION				
Camps	6	ea.	2,000.00	\$ 12,000
D. SUMMARY OF COSTS				
1. Structure				\$ 1,265,910
2. Channels & Levees				86,337
3. Relocation				12,000
Total				\$ 1,364,247

MODIFICATION OF EXISTING UTILITY CROSSINGS

2-12" Gas Pipelines		L.S.	\$ 67,500
1 @ 20" & 1 @ 24" Gas Pipelines		L.S.	90,000
Subtotal			\$ 157,500
Contingencies(15%)			23,625
Total Construction Cost			\$ 181,125
10.9% E&D			19,743
8% S&A			14,490
Total Cost			\$ 215,358

SECTION III - TABLE 2 (cont'd)

MODIFICATION OF EXISTING UTILITY CROSSINGS (cont'd)

LANDS

<u>Item</u>	<u>Quantity</u>	<u>Unit</u>	<u>Unit price</u>	<u>Total cost</u>
Right-of-Way:				
365+50 - 770+00	225.23	acre	\$750.00	\$ 168,923
Stream Closures, Dupre				
Floodgate & Channel Change	38.09	acre	750.00	28,568
Easements	329.23	acre	100.00	32,923
Total Land Value				\$ 230,414
Contingencies(15%)				34,562
Subtotal				\$ 264,976
Acquisition Costs				50,000
				\$ 314,976

SECTION IV - TABLE 2

(Sta.770+00(Bayou Lawler) to 1050+57.7(Violet))

SUMMARY OF FIRST COST

FEDERAL

<u>Item</u>	<u>Total cost</u>
Levees and Gap Closure Structure	\$ 5,818,402

NON-FEDERAL

Utility Crossings	\$ 401,620
Lands	991,800
	\$ 1,393,420

<u>Item</u>	<u>Quantity</u>	<u>Unit</u>	<u>Unit price</u>	<u>Total cost</u>
Embankment (Hydraulic)1st Lift	3,243,209	c.y.	\$0.60	\$ 1,945,925
Embankment (Hydraulic)2nd Lift	2,879,548	c.y.	0.60	1,727,729
First shapeup	152,592	c.y.	0.45	68,666
Second shapeup	75,980	c.y.	0.45	34,191
Third shapeup (Final)	121,690	c.y.	0.60	73,014
Embankment (Haul)1st Lift	92,733	c.y.	1.50	139,100
Embankment (Haul)2nd Lift	43,181	c.y.	1.50	64,772

SECTION IV - TABLE 2 (cont'd)

<u>Item</u>	<u>Quantity</u>	<u>Unit</u>	<u>Unit price</u>	<u>Total cost</u>
Fertilizing	311.30	acre	\$ 35.00	\$ 10,896
Seeding	311.30	acre	75.00	23,347
Clearing & Snagging	Lump Sum	L.S.	L.S.	74,000
Access Road - shell	13,000	c.y.	3.50	45,500
Gap Closure Structure	Lump Sum	L.S.	L.S.	48,100
Subtotal				\$ 4,255,240
Contingencies(15%)				638,286
Total Construction Cost				\$ 4,893,526
10.9% E&D				533,394
8% S&A				391,482
Total Cost Section IV				\$ 5,818,402

MODIFICATION OF EXISTING UTILITY CROSSINGS

1 @ 8" & 1 @ 16" Gas Pipelines		L.S.		\$ 83,722
1 @ 20" & 1 @ 24" Gas Pipelines		L.S.		90,000
1 @ 20" Gas Pipeline		L.S.		60,000
1 @ 16" Gas Pipeline		L.S.		60,000
Subtotal				\$ 293,722
Contingencies(15%)				44,058
Total Construction Cost				\$ 337,780
10.9% E&D				36,818
8% S&A				27,022
Total Cost				\$ 401,620

LANDS

Right-of-Way				
Borrow Area	450.18	acre	\$ 750.00	\$ 337,635
770+00 - 807+00	33.97	acre	750.00	25,478
807+00 - 920+00	142.67	acre	1,000.00	142,670
920+00 - 978+00	73.23	acre	1,500.00	109,845
978+00 - 1020+00	53.03	acre	2,000.00	106,060
1020+00- 1050+57	21.05	acre	5,000.00	105,250
Easements	137.39	acre	100.00	13,739
Subtotal				\$ 840,677
Contingencies(15%)				126,123
Total Land Value				\$ 966,800
Acquisition Costs				25,000
Total Land Costs				\$ 991,800

COMPARISON OF COSTS62. Comparison of Estimated Costs with Latest Approved Estimate.

The cost of the plan recommended in this Design Memorandum is \$29,552,200 or \$10,121,700 greater than the latest approved PB-3. Table 3 shows a comparison of the project document PB-3 and Design Memorandum estimates. Reasons for the increase are as follows:

a. Levees & Floodwalls. The increase of \$6,101,300 reflects the added cost for revising the net levee grades upward in accordance with the results of tidal hydraulic studies utilizing the latest hurricane parameters developed by the U. S. Weather Bureau; for extending the levee along the MR-GO past Bayou Dupre to Bayou Lawler; for increasing the size of the floodgates at Bayous Bienvenue and Dupre to a clear width of 56 feet with sill elevation at -10 feet m.l.g.; for providing "I" type floodwall along the IHNC in lieu of steel sheet piling with concrete cap; and for providing a bearing pile supported concrete "T"-type floodwall at the Florida Avenue siphon crossing.

b. Engineering and Design. The increase of \$665,700 reflects the Engineering and Design on the increased construction costs.

c. Supervision and Administration. The increase of \$484,800 reflects the supervision and administration on the increased construction costs.

d. Lands and Damages. The increase of \$2,450,800 reflects the added cost (\$1,265,976) of levee rights-of-way along the MR-GO (project document included no lands in this reach on the assumption existing MR-GO spoil easements would permit levee construction without further acquisition) and increases in unit costs and adjustments on other lands required.

e. Relocations. The increase of \$419,100 reflects an increase of \$ 235,160 for modifying the approach to the Florida Avenue bridge, and an increase of \$ 183,940 for relocating additional facilities discovered during detailed planning.

TABLE 3

COMPARISON OF ESTIMATES
(Total Chalmette Area Plan Costs)

	Project Document	PB-3 app. 2 Jun 66 effective 1 Jul 66	Design Memo No. 3	Difference DM No. 3-PB 3
11 Levees and Floodwalls	\$ 12,921,000	\$ 15,415,500	\$ 21,516,800	+ \$ 6,101,300
30 Engineering and Design	518,000	1,679,600	2,345,300	+ 665,700
31 Supervision and Administration	805,000	1,236,500	1,721,300	+ 484,800
Subtotal*	\$ 14,244,000	\$ 18,331,600	\$ 25,583,400	+ \$ 7,251,800
Lands and Damages	452,000	565,000	3,015,800	+ 2,450,800
Relocations	447,000	533,900	953,000	+ 419,100
Subtotal	\$ 899,000	\$ 1,098,900	\$ 3,968,800	+ \$ 2,869,900
Total Chalmette Area Plan Cost	\$ 15,143,000	\$ 19,430,500	\$ 29,552,200	+ \$10,121,700

*Includes non-Federal Cash Contribution
\$ 3,644,000 \$ 4,730,300 \$ 3,885,500 - \$ 844,800

LAKE PONTCHARTRAIN, LA, & VICINITY
CHALMETTE AREA PLAN
GENERAL DESIGN MEMORANDUM

63. SCHEDULE FOR DESIGN AND CONSTRUCTION

	Design*	Construction	Construction	Award	Complete:	Estimated Construction Cost
Contracts:	: Start	: Complete:	: Advertise	: Award	: Complete:	(includes contingencies)

Floodwall, siphon crossing, and Fla. Ave. bridge approach relocation(Sta. 58+11 to Sta. 67+94)	1966	Feb 69	Mar 69	Apr 69	Aug 70	\$ 896,800
Concrete capping, "I"-type floodwall and levee shaping (Sta. 1+82 to Sta. 0+00= Sta. 1+46.58, Sta. 1+46 to Sta. 58+11, Sta. 67+94 to Sta. 79+62) and levee 1st lift(Sta. 79+62 to Sta. 90+25)	1966	Sep 67	Oct 67	Nov 67	Jun 68	884,200**
Levee, 2d lift(Sta. 79+62 to Sta. 90+25)	1966	Mar 69	Apr 70	May 70	Jul 70	25,200
Levee, 3d lift, fertilizing and seeding(Sta. 79+62 to Sta. 90+25)	1966	May 71	Jun 72	Jul 72	Sep 72	7,900

* Includes general design memo, detail design memo, and plans and specifications for the period from start to final approval.
 ** Includes Orleans Levee District work in Jun-Jul 66 of placing steel sheet piling between Sta. 1+82 to Sta. 0+00=1+46.58 and Sta. 1+46.58 to Sta. 58+11 at a cost of \$399,300.

<u>SCHEDULE FOR DESIGN AND CONSTRUCTION(cont'd)</u>									
Contracts	Design	Construction	Estimated Construction Cost	Start	Complete	Advertise	Award	Complete	(includes contingencies)
:	:	:	:	:	:	:	:	:	:
Bayou Bienvenue and Bayou Dupre Drainage Structures incl. Bayou Relocation work.	1966	Jan 69	Feb 69	Mar 69	Dec 70				\$2,772,712
Levee, 1st lift(Sta. 90+25 =7+52.9 to 357+05), Clearing & Snagging	1966	Nov 67	Dec 67	Jan 68	Oct 69				1,717,910
Levee, 1st lift(Sta.368+00 to 516+00*and Sta. 519+00 to 574+00), Clearing & Snagging	1966	Nov 67	Dec 67	Jan 68	Oct 69				1,611,270
Levee, 1st lift(Sta.593+00 to 687+00; 692+00 to 697+05; 702+95 to 876+00), Clearing & Snagging	1966	Nov 69	Dec 69	Jan 70	Oct 71				1,498,676
Levee, 1st lift(Sta.876+00 to 1050+57), Clearing & Snagging	1966	Nov 69	Dec 69	Jan 70	Oct 71				1,516,093

* This reach may be modified due to maintenance work now in progress.

SCHEDULE FOR DESIGN AND CONSTRUCTION(cont'd)

Contracts	Design	Construction	Estimated Construction Cost
: Start	: Complete	: Advertise Award	: Complete
: (includes contingencies)			
Levee, 1st shaping (Sta. 7+52.9 to 357+05); Levee 2nd lift (Sta. 368+00 to 516+00); Levee 1st shaping (Sta. 519+00 to 574+00). Stream closures, 1st lift (Sta. 362+95 to 368+00, 516+00 to 519+00, 574+00 to 593+00 and 687+00 to 692+00)	1966 Nov 69	Dec 69 Jan 70 Oct 71	\$ 1,624,580
Foreshore protection (Sta. 7+52.9 to 357+05 and 519+00 to 574+00)	1966 Nov 69	Dec 69 Jan 70 Oct 71	1,468,050
Levee, 1st shaping (Sta. 593+00 to 687+00 and 692+00 to 697+05); Levee, final shaping (Sta. 702+95 to 807+00); Stream closures, 2nd lift (Sta. 362+95 to 368+00 and 516+00 to 519+00, and 687+00 to 692+00). Foreshore protection (Sta. 593+00 to 687+00, 692+00 to 697+05 and 702+95 to 770+00)	1966 Nov 71	Dec 71 Jan 72 Oct 73	1,929,956
Stream closure-2nd lift (Sta. 574+00 to 593+00)	1966 Nov 71	Dec 71 Jan 72 Oct 73	1,503,280

SCHEDULE FOR DESIGN AND CONSTRUCTION (cont'd)

Contracts	Design	Construction	Estimated Construction Cost
: Start	: Complete	: Award	: Complete
: (includes contingencies)			
Levee, 2nd lift Sta. 978+00 to 1020+00; Levee Final lift 1020+00 to 1050+57; Gap closure structure at Violet Seeding & Fertilizing	1966 Nov 73	Jan 74 Oct 75	\$ 402,834
Levee, Final Shaping (Sta. 7+52.9 to 270+00); 2nd shaping (Sta. 270+00 to 357+05; 1st shaping 368+00 to 516+00; Final shaping 519+00 to 574+00; Levee, 2nd lift. 807+00 to 978+00;	1966 Nov 74	Dec 74 Jan 75 Oct 76	1,926,327
Foreshore protection 368+00 to 516+00			
Seeding & Fertilizing	1966 Nov 74	Dec 74 Jan 75 Oct 76	784,353
Levee, final shaping (Sta. 593+00 to 687+00 and 692+00 to 697+05). Stream closures, final lift (Sta. 362+95 to 368+00, 516+00 to 519+00, 574+00 to 593+00, and 687+00 to 692+00)			
Seeding and Fertilizing	1966 Nov 76	Dec 76 Jan 77 Oct 78	711,630

SCHEDULE FOR DESIGN AND CONSTRUCTION (cont'd)

Contracts	Design		Construction		Estimated Construction Cost
	: Start	: Complete	: Advertise Award	: Complete	
Levee, final shaping (Sta. 270+00 to 357+05; 368+00 to 516+00); Levee, 1st shaping (Sta. 807+00 to 978+00 to 1020+00)	1966	Nov 78	Dec 78	Jan 80	\$ 93,229
Levee, final shaping (Sta. 978+00 to 1020+00) Seeding & Fertilizing	1966	Nov 80	Dec 80	Jan 81	21,980
Levee, 2nd shaping (Sta. 807+00 to 978+00)	1966	Nov 82	Dec 82	Jan 83	39,320
Levee, final shaping (Sta. 807+00 to 978+00) Seeding & Fertilizing	1966	Nov 86	Dec 86	Jan 87	80,500
TOTAL					\$21,516,800

SCHEDULE FOR DESIGN AND CONSTRUCTION (cont'd)

To maintain the schedule for the Chalmette Area Plan as shown above, Federal Funds will be required by Fiscal Years as follows:

	F.Y.	\$	F.Y.	\$
Estimated cost through F.Y.	1967	600,000	1979	145,000
Appropriation required	1968	1,550,000	1980	40,000
	1969	2,800,000	1981	18,000
	1970	5,060,000	1982	0
Local cash-	1971	4,060,000	1983	32,000
	1972	1,770,000	1984	0
	1973	1,740,000	1985	0
	1974	655,000	1986	0
	1975	770,000	1987	65,000
	1976	1,460,000		
	1977	605,000		
	1978	330,000		
			TOTAL	<u>\$21,700,000</u>

OPERATION AND MAINTENANCE

64. Federal. All operational and maintenance costs are the responsibility of local interests.

65. Non-Federal. As specified in the authorizing act, local interests are required to maintain and operate the completed work in accordance with regulations prescribed by the Secretary of the Army. Maintenance of the levee from IHNC Lock to Sta. 90+25=7+52.9 is estimated to cost \$4,000 annually. Maintenance of the two gap closure gates at Florida Avenue is estimated to cost \$400 annually. In addition, it is estimated that replacement of these gates will be necessary at 30-year intervals. The annual charge for these replacements is \$350. Maintenance of the levee from Station 90+25=7+52.9 to the structure at Bayou Bienvenue is estimated to cost \$35,250 annually. Maintenance of the levee from the structure at Bayou Bienvenue to Bayou Lowler just south of Bayou Dupre at the point of turn back toward Violet is estimated to cost \$37,000 annually. Maintenance of the levee from Bayou Lawler to the Mississippi River Levee at Violet is estimated to cost \$42,000 annually. Maintenance and periodic operation of the drainage structures at Bayou Bienvenue and at Bayou Dupre is estimated to cost \$2,650 annually at each structure (\$2,000 maintenance and \$650 operation). Maintenance of the access road to the Bayou Bienvenue structure is estimated to cost \$1,000 annually. Maintenance of the access road to the Bayou Dupre structure is estimated to cost \$2,800 annually. It is estimated that replacement of the gates and machinery of the Bayou Bienvenue and Bayou Dupre structures will be necessary in 50 years. The average annual charge for these replacements is \$5,000.

ECONOMICS66. Benefits.

a. The plan of improvement will provide protection to some 30,800 acres from hurricane tides of frequencies up to once in about 200 years. Approximately 10,500 acres are within the existing Chalmette back levee; this area includes 3,200 acres residential development, 1,300 acres commercial and industrial development, 200 acres other development, and 5,800 acres of undeveloped land. The remaining 20,300 acres are undeveloped marshland outside the existing protected area. Benefits will consist of flood damage prevented on existing and future development within the present leveed area and enhancements on the additional marshland to be protected. Average annual damage under present conditions of \$2,556,000 will be reduced to \$23,000 with the proposed improvements in place. An additional \$4,722,000 damage will be prevented on future development; the overall average annual flood damage prevented will amount to \$7,255,000. Net annual value of enhancement is estimated at \$383,000; total project benefits amount to \$7,629,000 based on July 1966 price levels.

ECONOMICS (cont'd)66. Benefits (continued)

b. Occurrence of recent hurricanes in the Gulf of Mexico (1957-1965) necessitated an upward revision of wind speeds previously furnished by the United States Weather Bureau. Corresponding wind tide levels for specific synthetic hurricanes used in the computation of stage frequencies were raised. Benefits as shown in the project document were increased as a result of these higher stage frequencies and increased price levels.

67. Annual Charges. Details of the annual charges for the Chalmette Area Plan of \$1,254,800 are shown in Table 4.

TABLE 4
CHALMETTE AREA PLAN
ESTIMATE OF ANNUAL ECONOMIC COST

<u>Summary of Project Costs</u>	<u>Federal</u>	<u>Non-Federal</u>	<u>Total</u>
Construction	\$25,583,400	\$ -	\$25,583,400
Lands, Damages, Relocations	-	3,968,800	3,968,800
	\$25,583,400	\$ 3,968,800	\$29,552,200
Less Cash Contribution	-3,885,500	3,885,500	-
First Cost	\$21,697,900	\$ 7,854,300	\$29,552,200
Interest During Construction (7 yr.)	2,592,100	685,700	3,277,800
TOTAL PROJECT INVESTMENT	\$24,290,000	\$ 8,540,000	\$32,830,000
<u>Annual Economic Costs</u>			
Interest (3-1/8 per cent)	\$ 759,100	266,900	1,026,000
Amortization (100 yr.)	36,700	12,900	49,600
Maintenance and Operation	-	125,100	125,100
Replacements	-	4,600	4,600
Economic Loss on Lands	-	49,500	49,500
TOTAL ANNUAL ECONOMIC COST	\$ 795,800	\$ 459,000	\$ 1,254,800

68. Economic Justification. The average annual benefits of \$7,629,000 and average annual charges of \$1,254,800 result in a favorable benefit-cost ratio of 6.1 to 1.

RECOMMENDATIONS

69. Recommendations. The plan of improvements presented herein consists of a cantilever "I"-type floodwall from the IHNC lock to Florida Avenue, thence an inverted "T"-type floodwall across Florida Avenue; thence a cantilever "I"-type floodwall driven in a new levee from Florida Avenue to the outfall canal; thence a new levee extending

RECOMMENDATIONS (cont'd)

69. Recommendations (cont'd)

northward to the MR-GO; thence along the south bank of the MR-GO to the junction of the channel and the Gulf Intracoastal Waterway; thence to the southeast along the south bank of the Mississippi River-Gulf Outlet to Bayou Lawler; then turning south and tying into the Mississippi River levee near Violet, La.; with sector-gated structures for drainage and navigation at Bayous Bienvenue and Dupre. This plan is considered to be the best means of accomplishing the project objectives and is recommended for approval.

LAKE PONTCHARTRAIN, LA. AND VICINITY

CHALMETTE AREA PLAN

DESIGN MEMORANDUM NO. 3

GENERAL DESIGN

APPENDIX A

FISH AND WILDLIFE STUDIES



UNITED STATES
DEPARTMENT OF THE INTERIOR
FISH AND WILDLIFE SERVICE
BUREAU OF SPORT FISHERIES AND WILDLIFE
PEACHTREE-SEVENTH BUILDING
ATLANTA, GEORGIA 30323

August 10, 1966

District Engineer
U. S. Army, Corps of Engineers
New Orleans, Louisiana

Dear Sir:

This is in reply to your letter of June 15, 1966, requesting our views and comments on the fish and wildlife aspects of the modified Chalmette area plan of the project for Lake Pontchartrain and Vicinity, Louisiana. The Bureau's comments, submitted in accordance with the Fish and Wildlife Coordination Act (48 Stat. 401, as amended; 16 U.S.C. 661 et seq.), have been prepared in cooperation with the Louisiana Wild Life and Fisheries Commission.

The Bureau provided you with a letter report dated October 22, 1962, concerning this project segment. That report considered the construction of new levees along the south side of the Gulf Intracoastal Waterway from the Inner Harbor Navigation Canal eastward to Paris Road, thence along the south side of the Mississippi River-Gulf Outlet to Bayou Dupre, thence westward along the north bank of Bayou Dupre to Violet, Louisiana. Also included in the protection plan was a 48-foot-wide floodgate in Bayou Bienvenue and a 48-foot-wide floodgate in Bayou Dupre, with sill elevations of both structures at -8 feet m.l.g.

The modified plan provides for the extension of the proposed levee along the Mississippi River-Gulf Outlet across Bayou Dupre, with the return levee to Violet being located along the south bank of Bayou Dupre. The two water-control structures considered in the modified plan have been enlarged to a width of 56 feet, with sill elevations at -10 feet m.l.g.

Our study of this modified plan indicates that the existing brackish water circulatory system will be essentially maintained. It does not, therefore, appear that the modified hurricane levee alignment will directly affect fish and wildlife resources to any great extent.

The Bureau does not propose further study of this project segment at this time. However, as your studies progress into detailed planning for the two proposed floodgates, we would like to discuss the design of these structures with personnel of your staff.

This report has been reviewed and concurred in by the Bureau of Commercial Fisheries and the Louisiana Wild Life and Fisheries Commission. A copy of Director Hair's letter is attached.

We appreciate the opportunity to comment on this modified plan.

Sincerely yours,

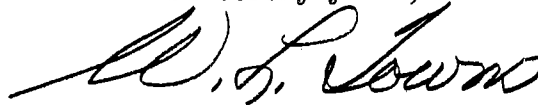
A handwritten signature in cursive script, appearing to read "W. L. Towns".

W. L. Towns
Acting Regional Director

Attachment

LOUISIANA WILD LIFE AND FISHERIES COMMISSION

WILD LIFE AND FISHERIES BUILDING
400 ROYAL STREET
NEW ORLEANS, LOUISIANA 70130

July 15, 1966

James R. Fielding
Assistant Regional Director
Bureau of Sport Fisheries and Wildlife
Peachtree-Seventh Building
Atlanta, Georgia 30323

Dear Mr. Fielding:

Reference is made to your letter of July 12, 1966, and attached report concerning the Chalmette area plan of the project for Lake Pontchartrain and vicinity. This report has been reviewed by members of my staff and we are in accord with its contents and provisions.

It appears the present hydrographic pattern and salinity regimen will not be materially affected by the proposed project modification, and since our comments regarding this project and your earlier project report have been submitted, we do not have any additional comments to make.

We appreciate the opportunity to review and comment on this project report.

Sincerely yours,

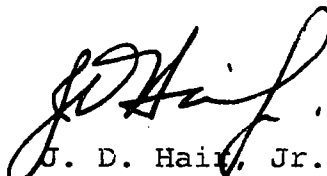

J. D. Hair, Jr.
Director

JDH:as

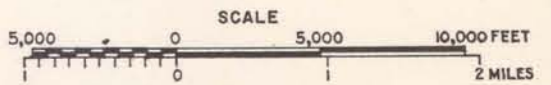
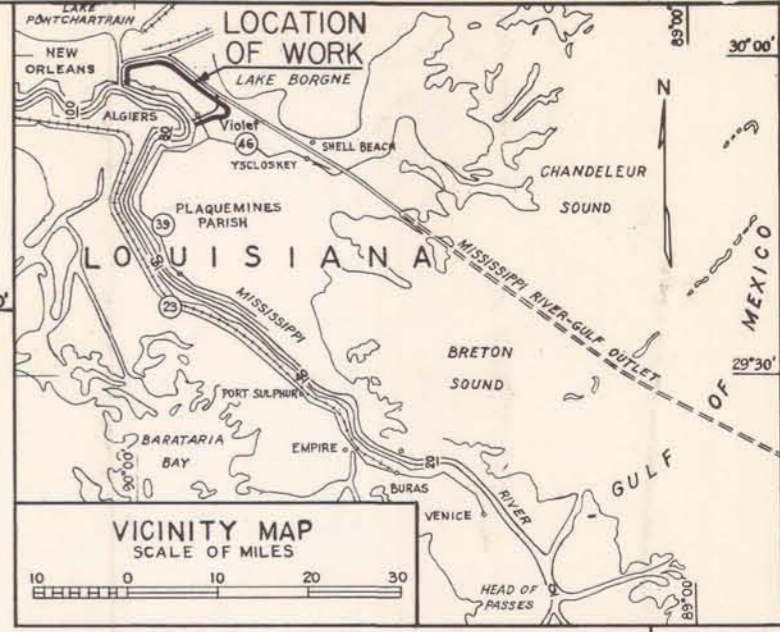
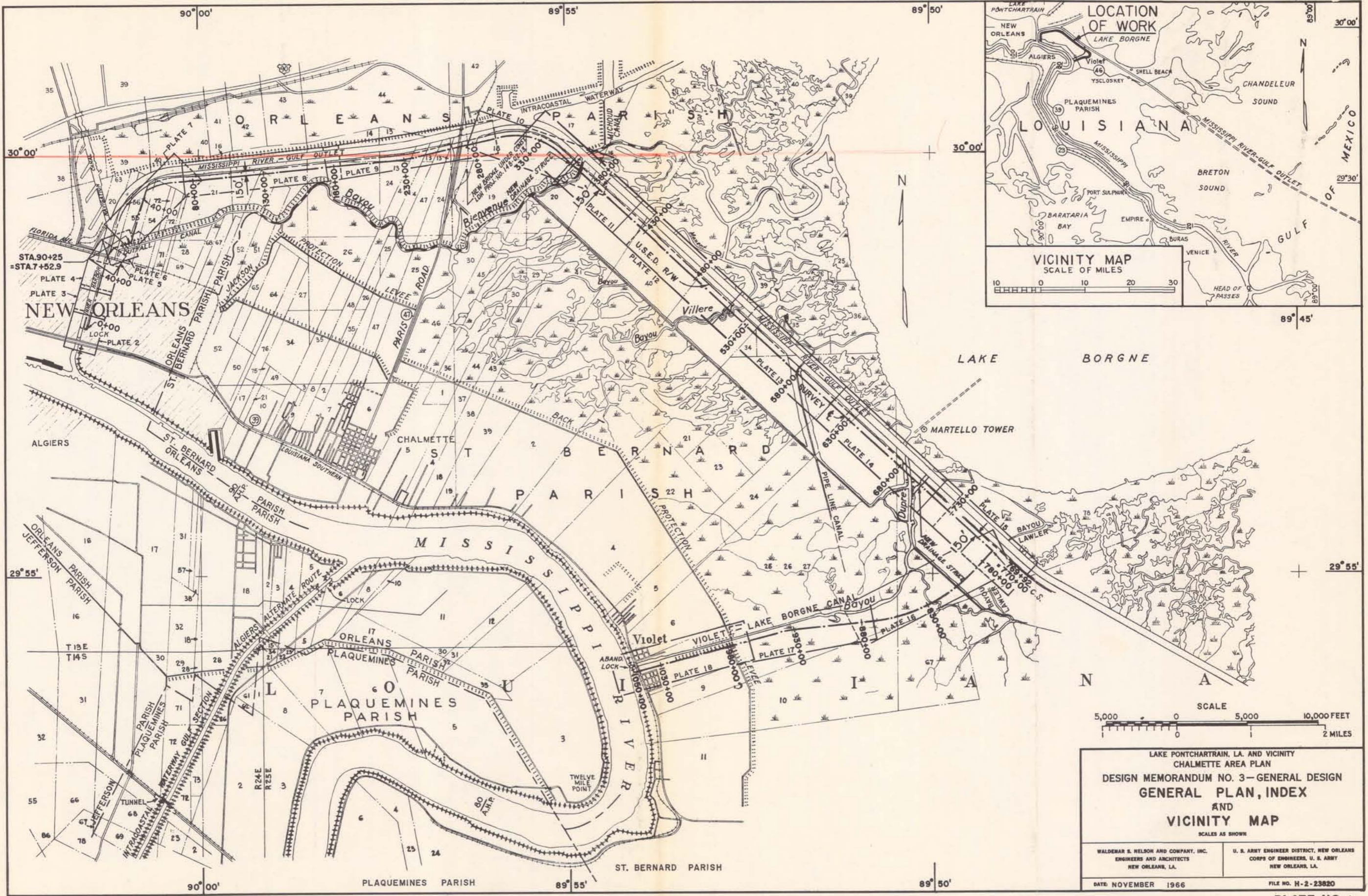

LAKE PONTCHARTRAIN, LA. AND VICINITY
CHALMETTE AREA PLAN
DESIGN MEMORANDUM NO. 3—GENERAL DESIGN
**GENERAL PLAN, INDEX
AND
VICINITY MAP**
SCALES AS SHOWN

WALDEMAR S. NELSON AND COMPANY, INC. ENGINEERS AND ARCHITECTS NEW ORLEANS, LA.	U. S. ARMY ENGINEER DISTRICT, NEW ORLEANS CORPS OF ENGINEERS, U. S. ARMY NEW ORLEANS, LA.
DATE: NOVEMBER 1966	FILE NO. H-2-23820

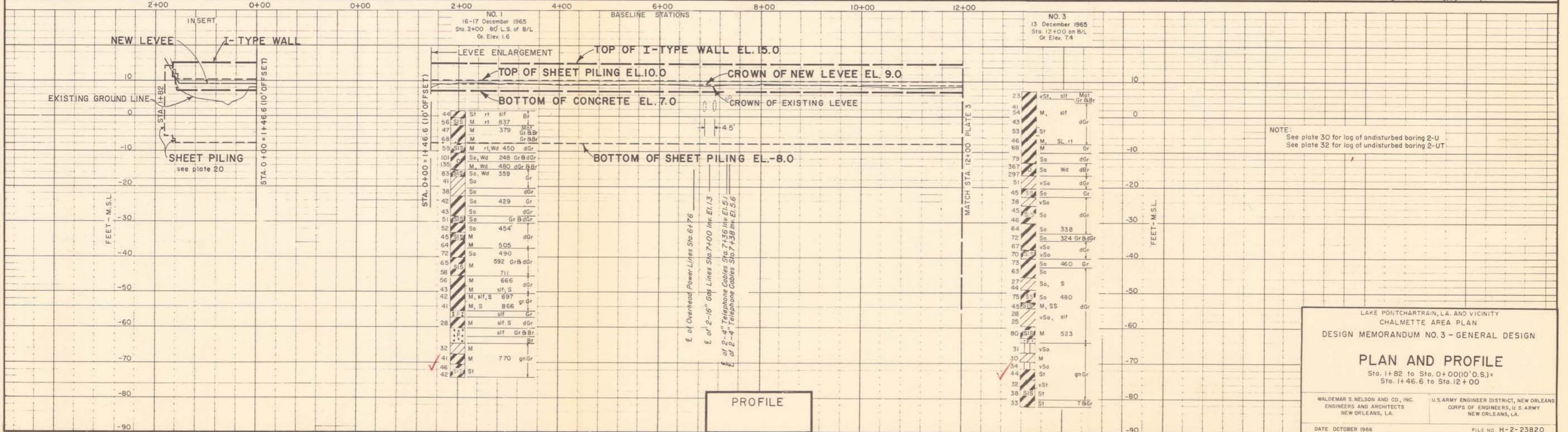
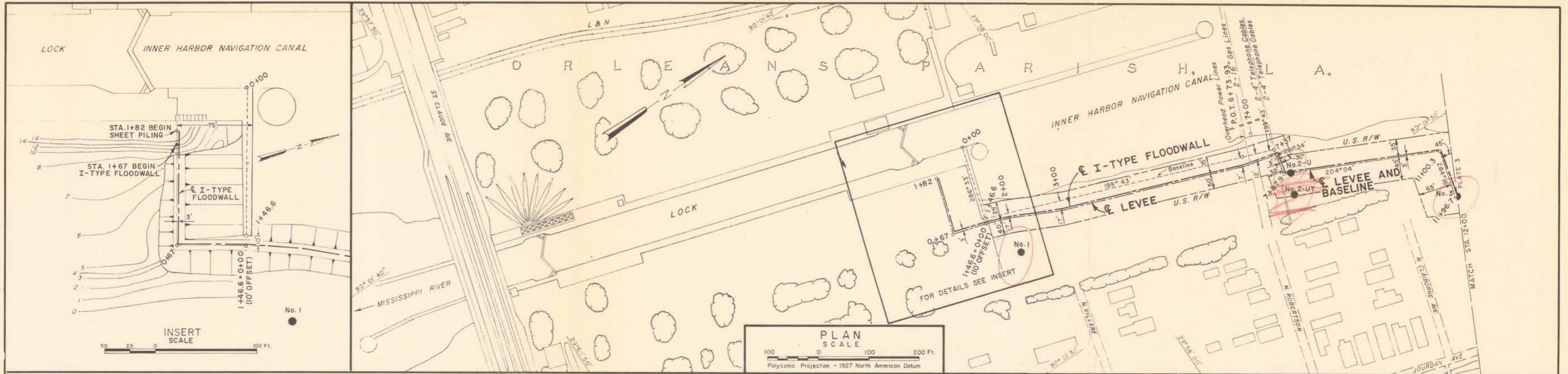

LAKE PONTCHARTRAIN, LA. AND VICINITY
CHALMETTE AREA PLAN
DESIGN MEMORANDUM NO. 3 - GENERAL DESIGN

PLAN AND PROFILE
Sta. 1+82 to Sta. 0+00 (10' O.S.) =
Sta. 1+46.6 to Sta. 12+00

WALDEMAR S. NELSON AND CO., INC.
ENGINEERS AND ARCHITECTS
NEW ORLEANS, LA.

U.S. ARMY ENGINEER DISTRICT, NEW ORLEANS
CORPS OF ENGINEERS, U.S. ARMY
NEW ORLEANS, LA.

DATE: OCTOBER 1966
FILE NO: H-2-23820

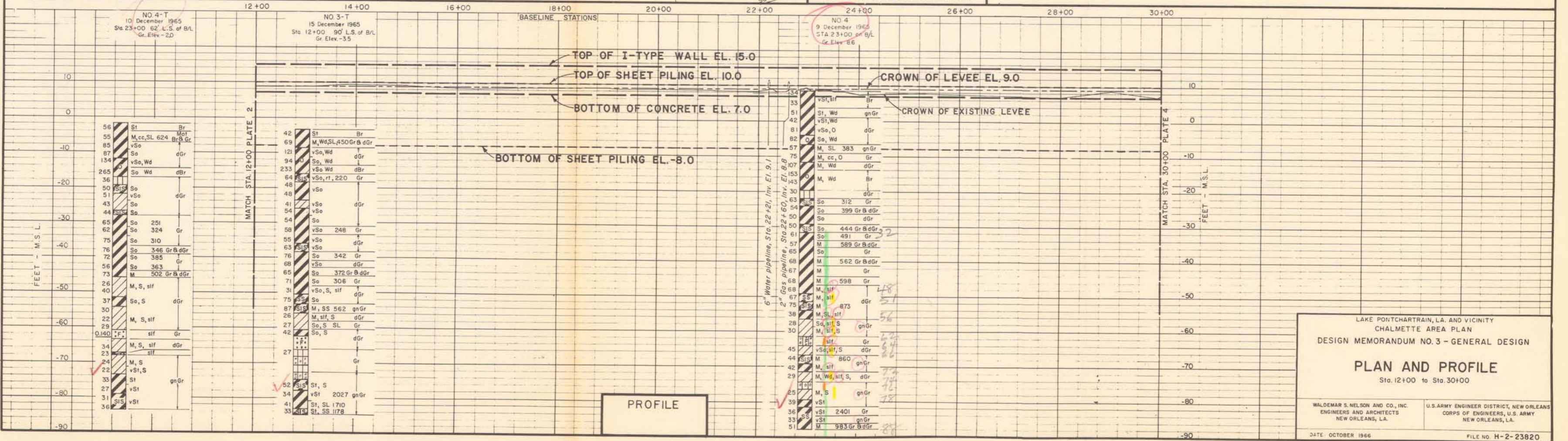
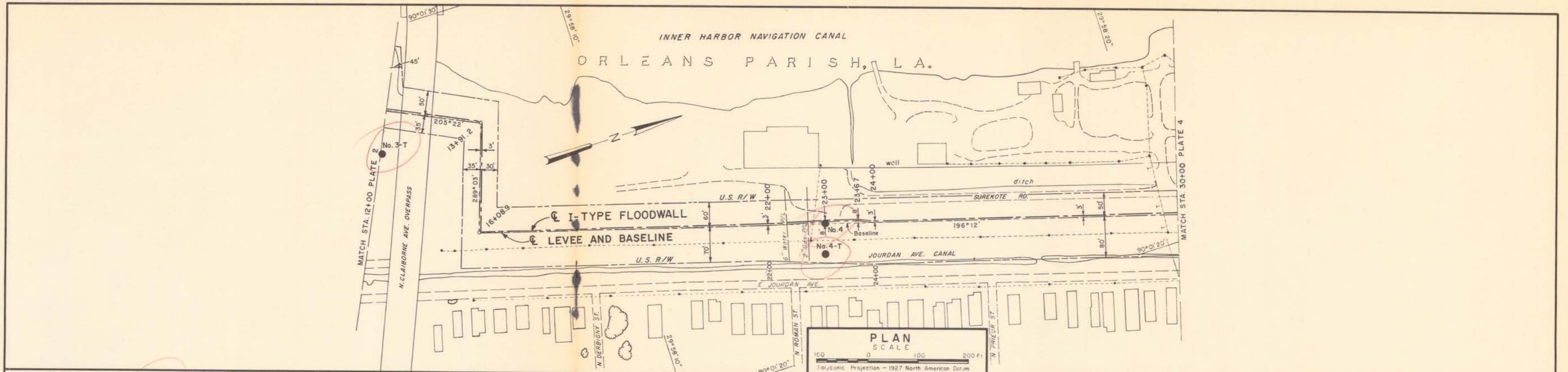

LAKE PONTCHARTRAIN, LA. AND VICINITY
CHALMETTE AREA PLAN
DESIGN MEMORANDUM NO. 3 - GENERAL DESIGN

PLAN AND PROFILE
Sta. 12+00 to Sta. 30+00

WILDEMAR S. NELSON AND CO., INC. ENGINEERS AND ARCHITECTS NEW ORLEANS, LA.	U.S. ARMY ENGINEER DISTRICT, NEW ORLEANS CORPS OF ENGINEERS, U.S. ARMY NEW ORLEANS, LA.
--	---

DATE: OCTOBER 1966 FILE NO. H-2-23820

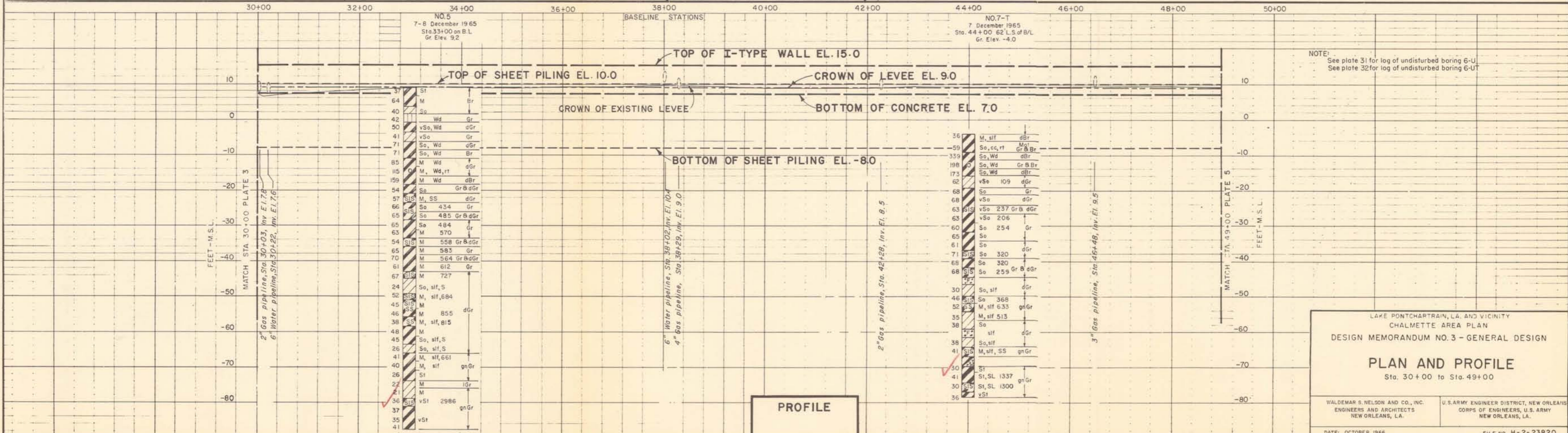
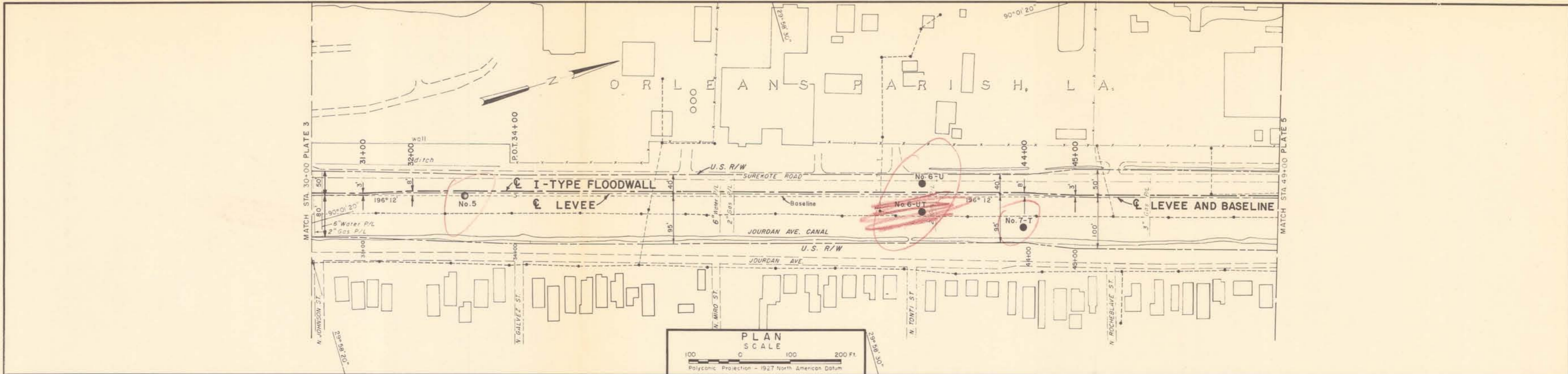

NOTE:
See plate 31 for log of undisturbed boring 6-U
See plate 32 for log of undisturbed boring 6-UT

LAKE PONTCHARTRAIN, LA. AND VICINITY
CHALMETTE AREA PLAN
DESIGN MEMORANDUM NO. 3 - GENERAL DESIGN

PLAN AND PROFILE
Sta. 30+00 to Sta. 49+00

WALDEMAR S. NELSON AND CO., INC. ENGINEERS AND ARCHITECTS NEW ORLEANS, LA.	U.S. ARMY ENGINEER DISTRICT, NEW ORLEANS CORPS OF ENGINEERS, U.S. ARMY NEW ORLEANS, LA.
DATE: OCTOBER 1966	FILE NO. H-2-23820

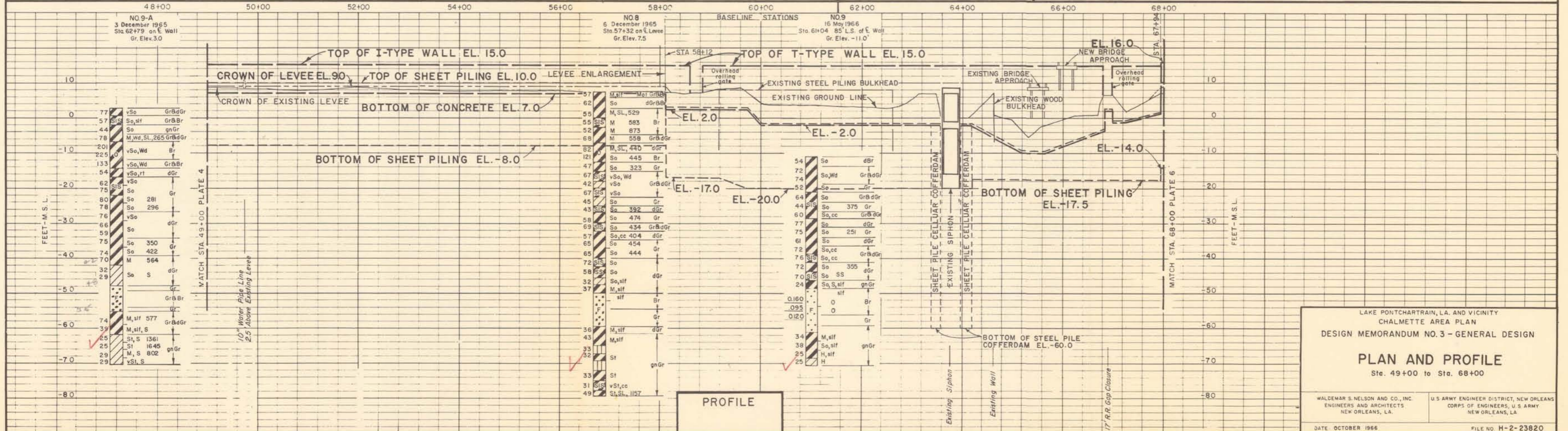
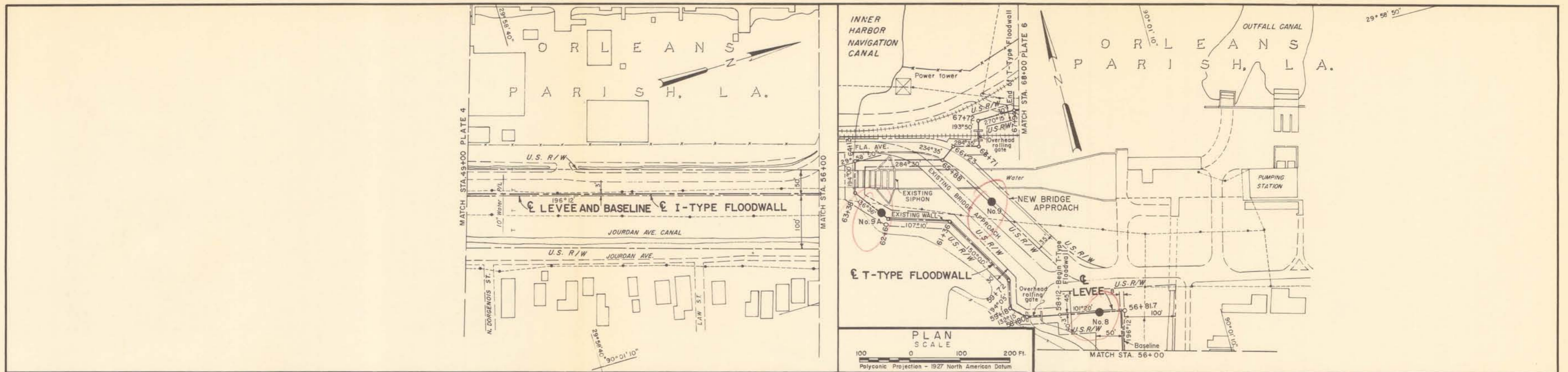

LAKE PONTCHARTRAIN, L.A. AND VICINITY
 CHALMETTE AREA PLAN
 DESIGN MEMORANDUM NO. 3 - GENERAL DESIGN
PLAN AND PROFILE
 Sta. 49+00 to Sta. 68+00

WALDEMAR S. NELSON AND CO., INC.
 ENGINEERS AND ARCHITECTS
 NEW ORLEANS, LA.

U.S. ARMY ENGINEER DISTRICT, NEW ORLEANS
 CORPS OF ENGINEERS, U.S. ARMY
 NEW ORLEANS, LA.

DATE: OCTOBER 1966
 FILE NO. H-2-23820

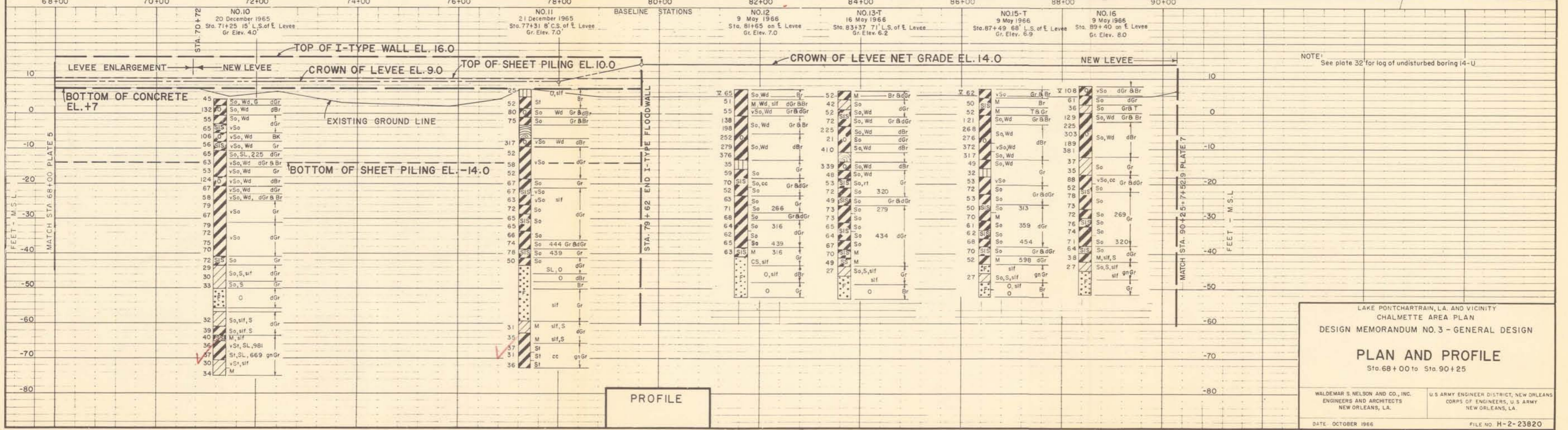
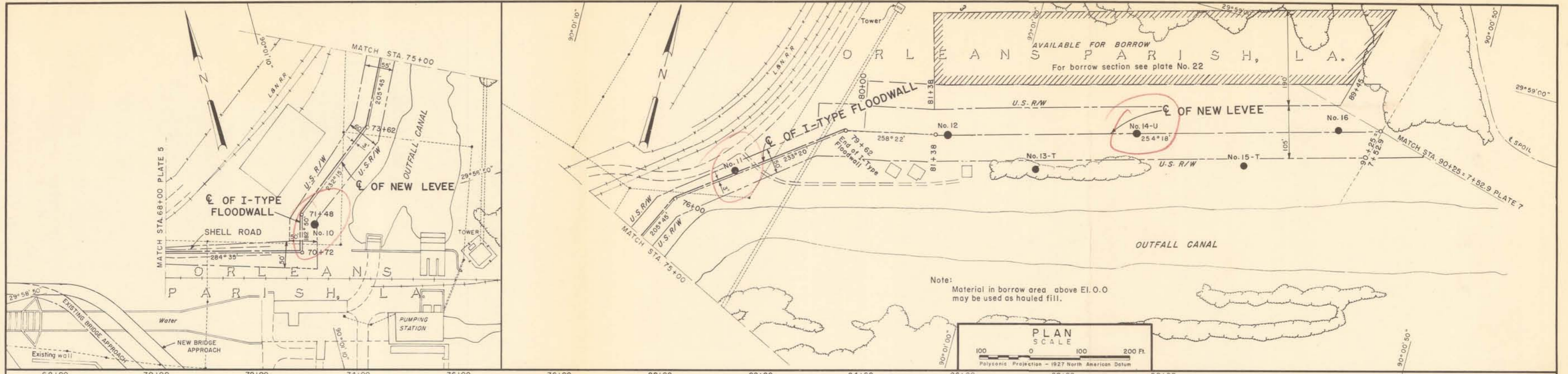

LAKE PONTCHARTRAIN, L.A. AND VICINITY
CHALMETTE AREA PLAN
DESIGN MEMORANDUM NO. 3 - GENERAL DESIGN

PLAN AND PROFILE
Sta. 68+00 to Sta. 90+25

WALDEMAR S. NELSON AND CO., INC.
ENGINEERS AND ARCHITECTS
NEW ORLEANS, LA.

U.S. ARMY ENGINEER DISTRICT, NEW ORLEANS
CORPS OF ENGINEERS, U.S. ARMY
NEW ORLEANS, LA.

DATE: OCTOBER 1966 FILE NO: H-2-23820

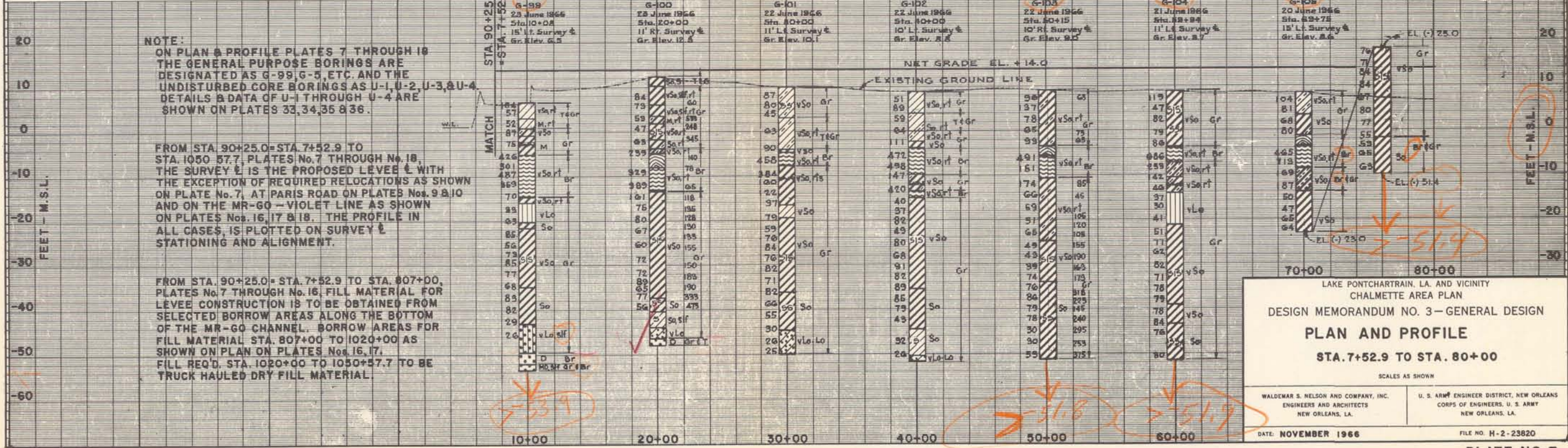
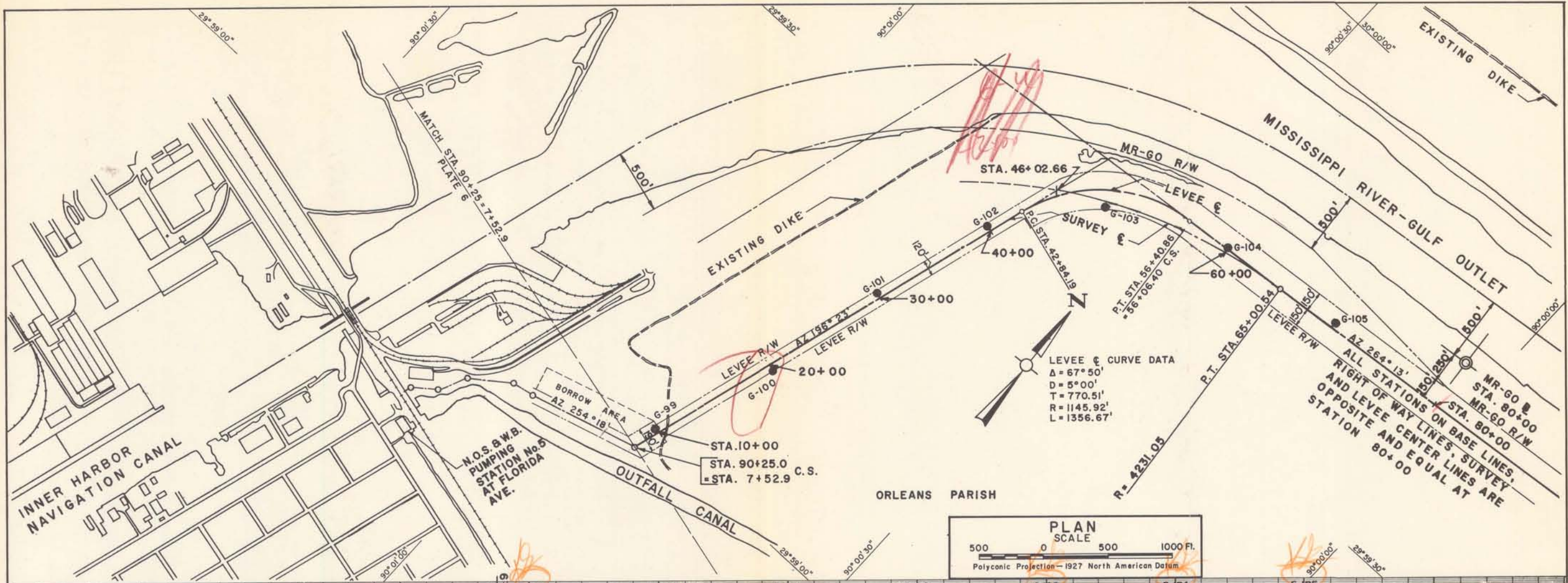

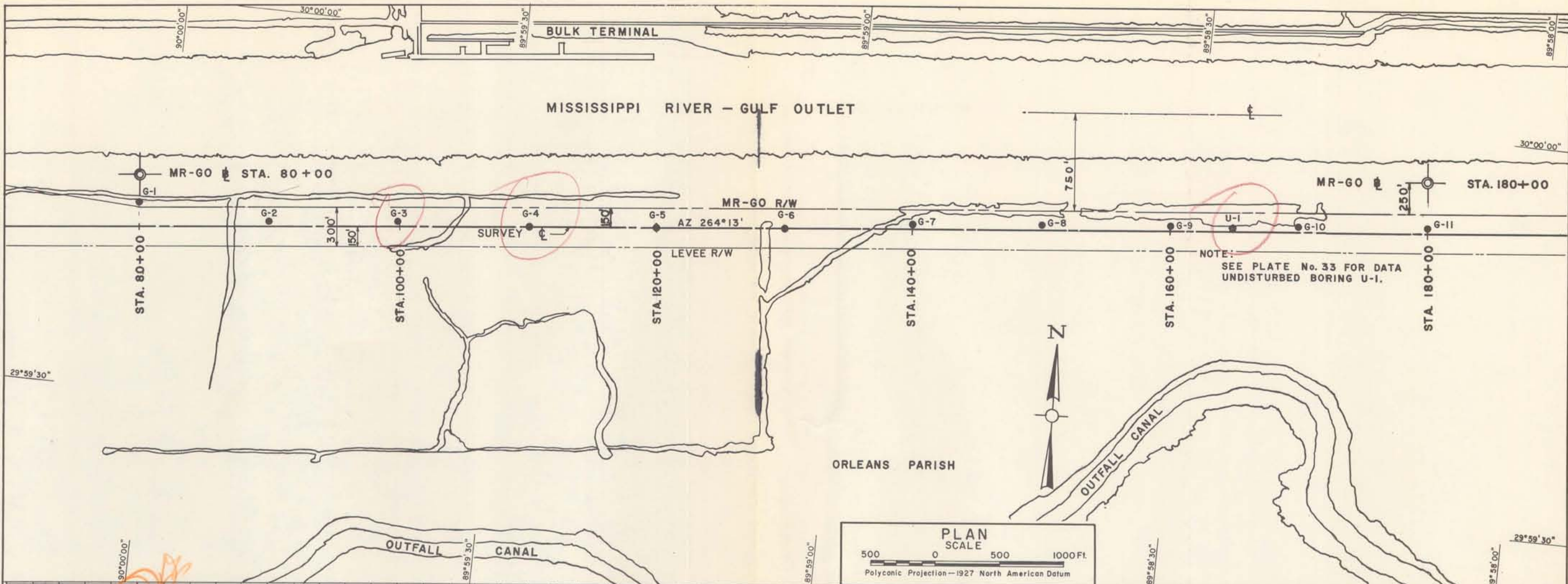

NOTE:
SEE PLATE No. 33 FOR DATA
UNDISTURBED BORING U-1.

PLAN SCALE
500 0 500 1000 FT.
Polyconic Projection - 1927 North American Datum

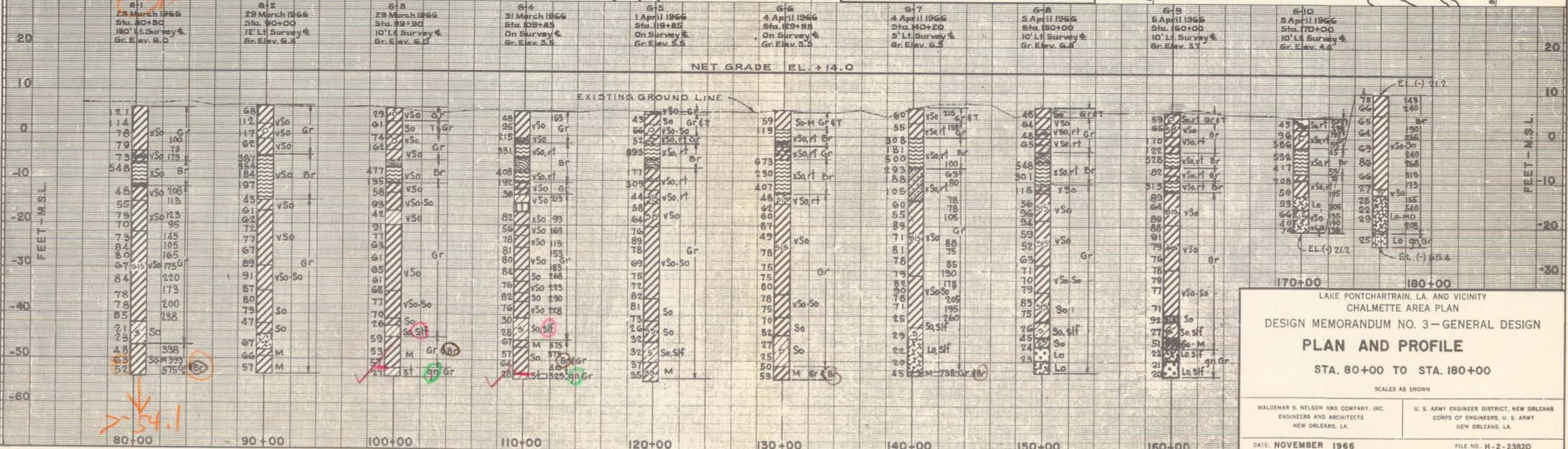

LAKE PONTCHARTRAIN, LA. AND VICINITY
CHALMETTE AREA PLAN
DESIGN MEMORANDUM NO. 3 - GENERAL DESIGN
PLAN AND PROFILE
STA. 80+00 TO STA. 180+00
SCALES AS SHOWN

WALDENAR S. NELSON AND COMPANY, INC.
ENGINEERS AND ARCHITECTS
NEW ORLEANS, LA.

U. S. ARMY ENGINEER DISTRICT, NEW ORLEANS
CORPS OF ENGINEERS, U. S. ARMY
NEW ORLEANS, LA.

DATE: NOVEMBER 1966
FILE NO. H-2-23820

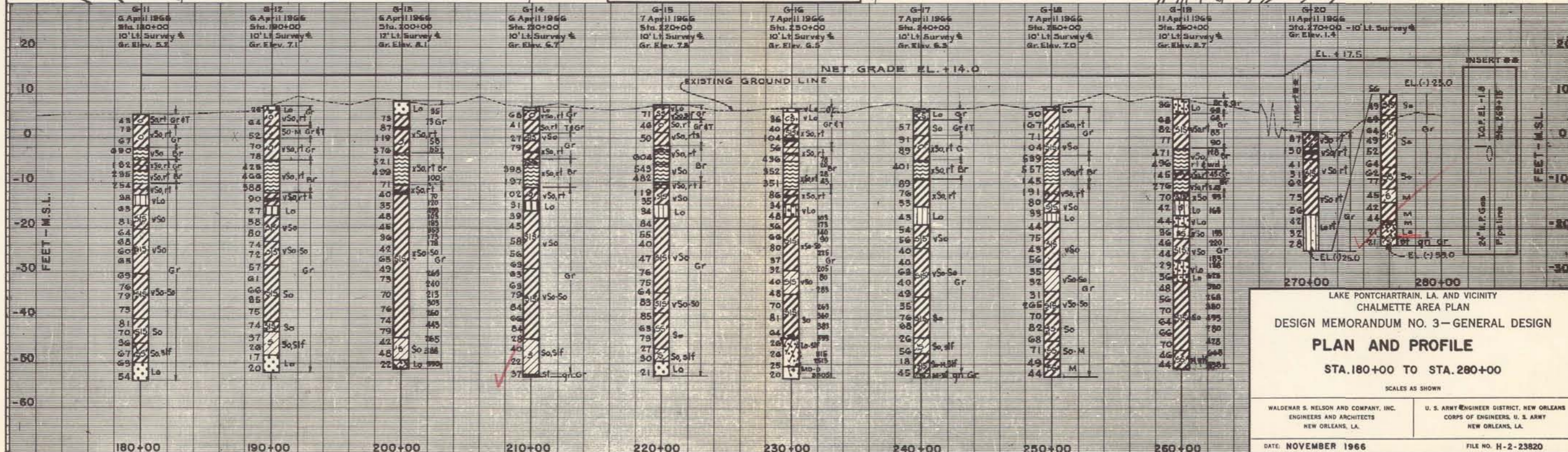
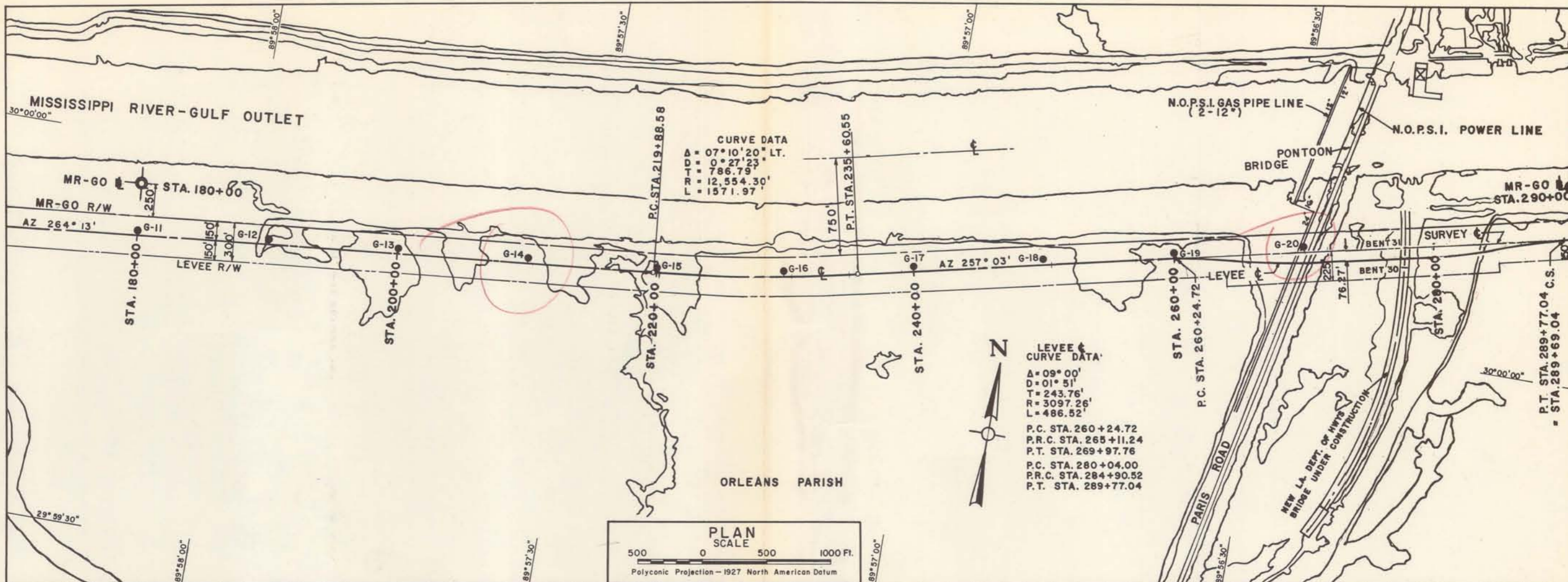

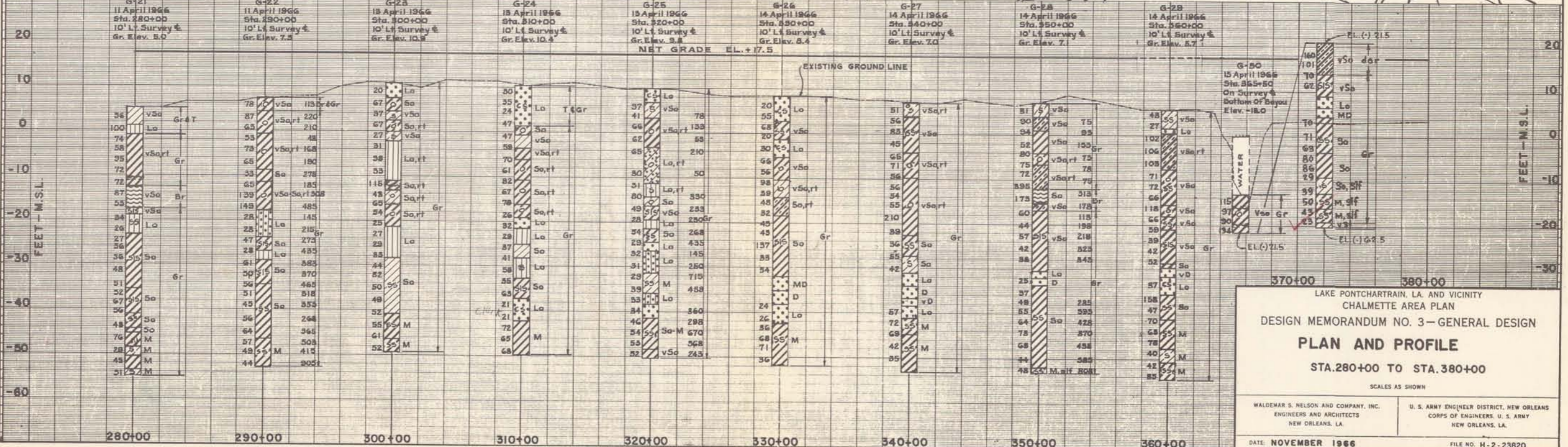
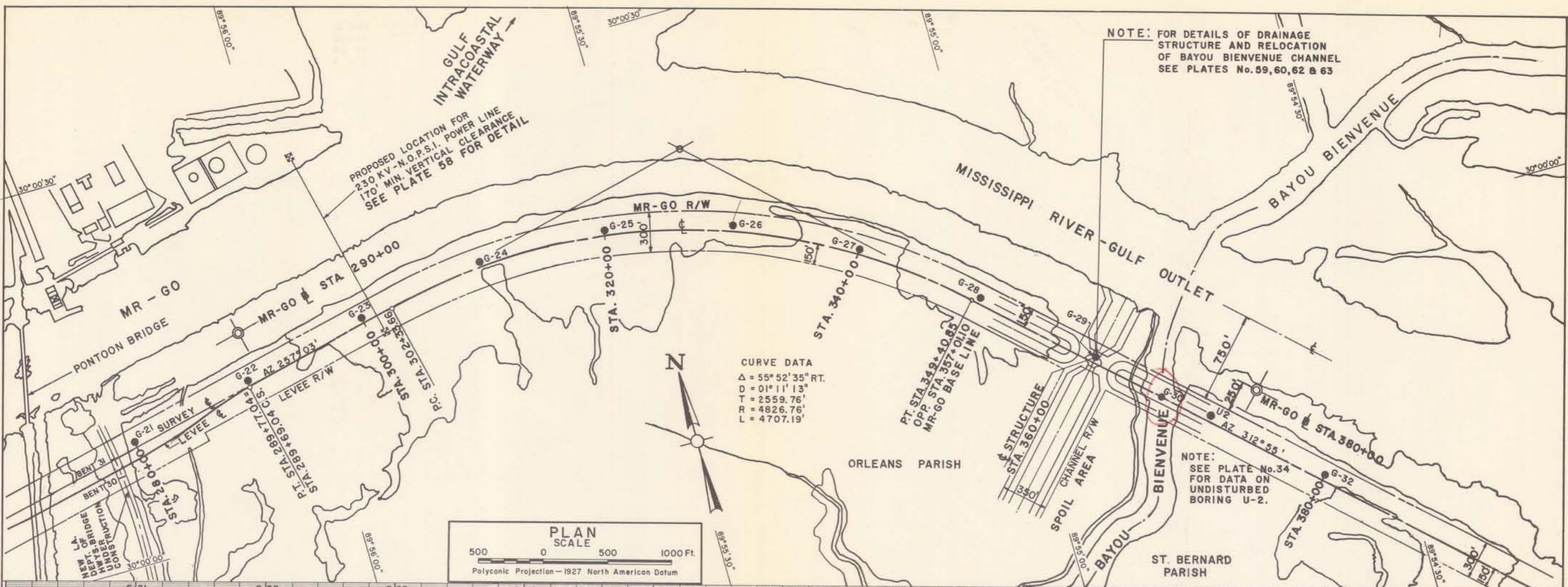

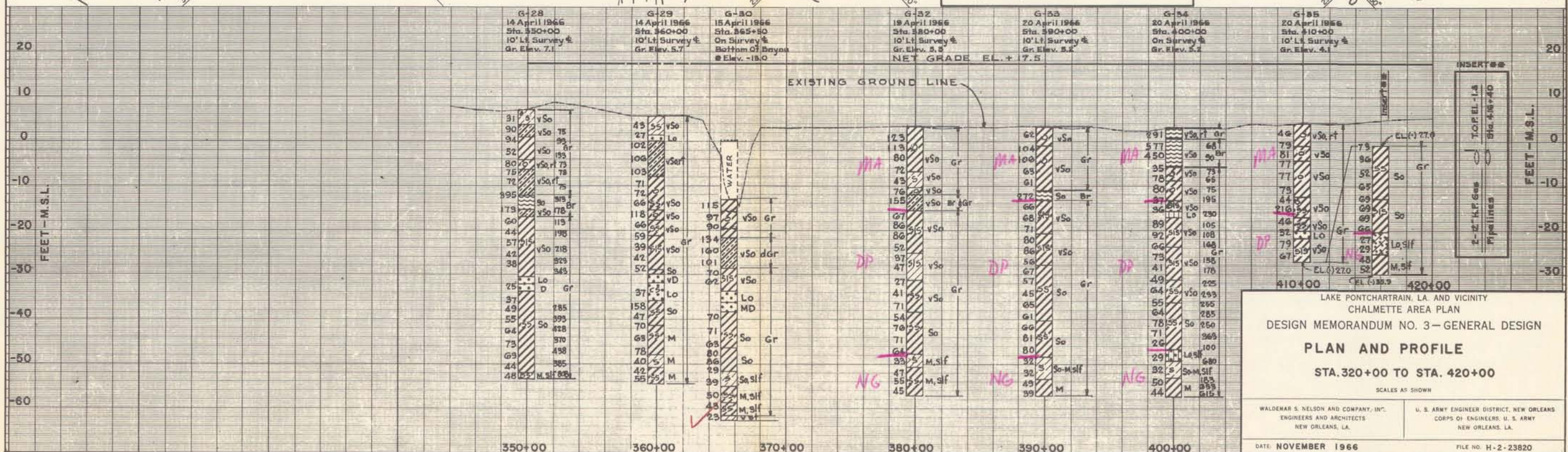
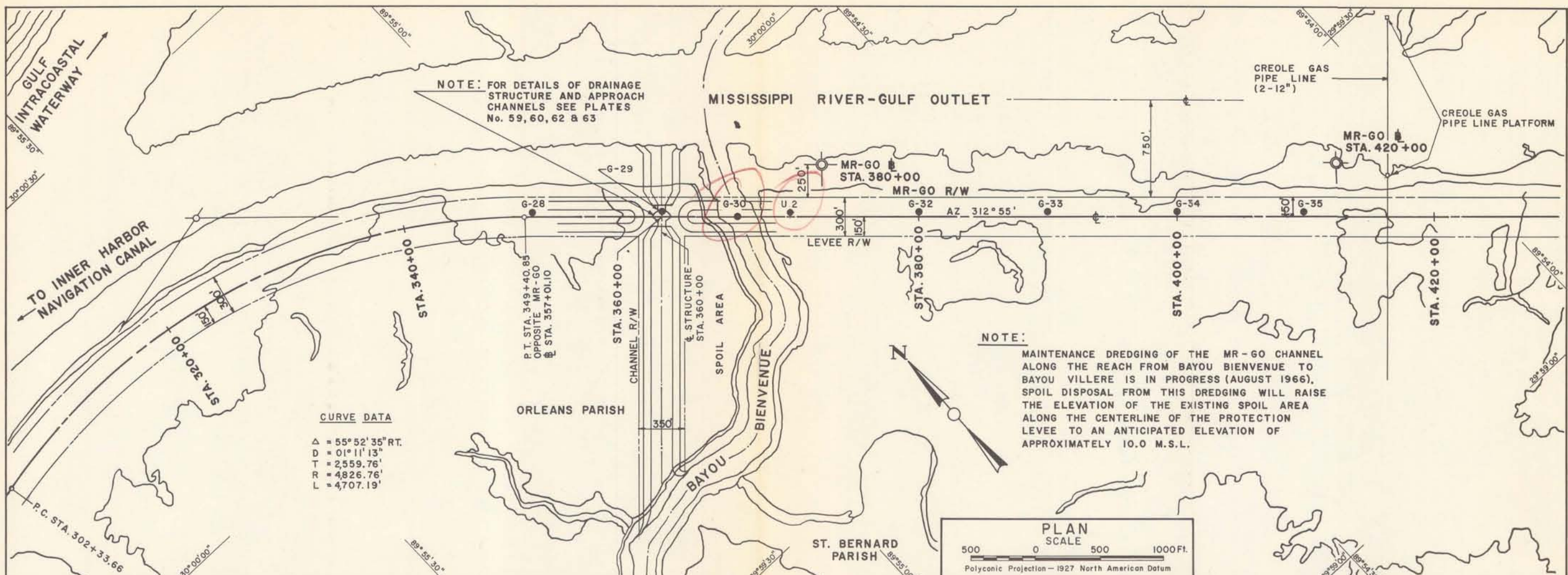

LAKE PONTCHARTRAIN, LA. AND VICINITY
 CHALMETTE AREA PLAN
 DESIGN MEMORANDUM NO. 3 - GENERAL DESIGN
PLAN AND PROFILE
 STA. 320+00 TO STA. 420+00
 SCALES AS SHOWN

WALDEMAR S. NELSON AND COMPANY, INC.
 ENGINEERS AND ARCHITECTS
 NEW ORLEANS, LA.

U. S. ARMY ENGINEER DISTRICT, NEW ORLEANS
 CORPS OF ENGINEERS, U. S. ARMY
 NEW ORLEANS, LA.

DATE: NOVEMBER 1966 FILE NO. H-2-23820

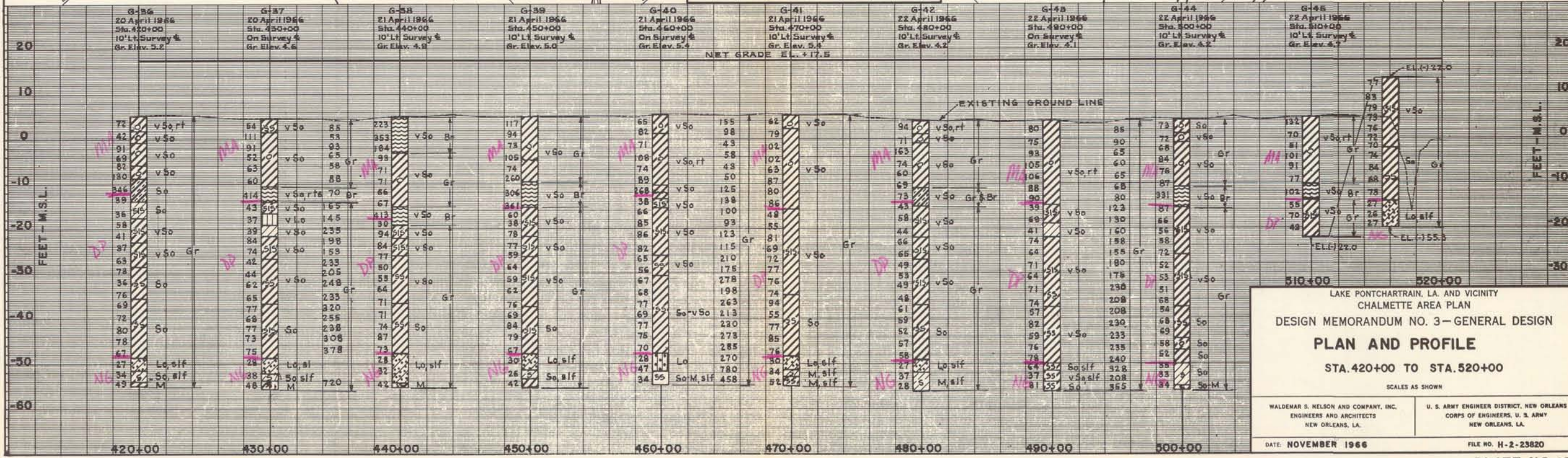
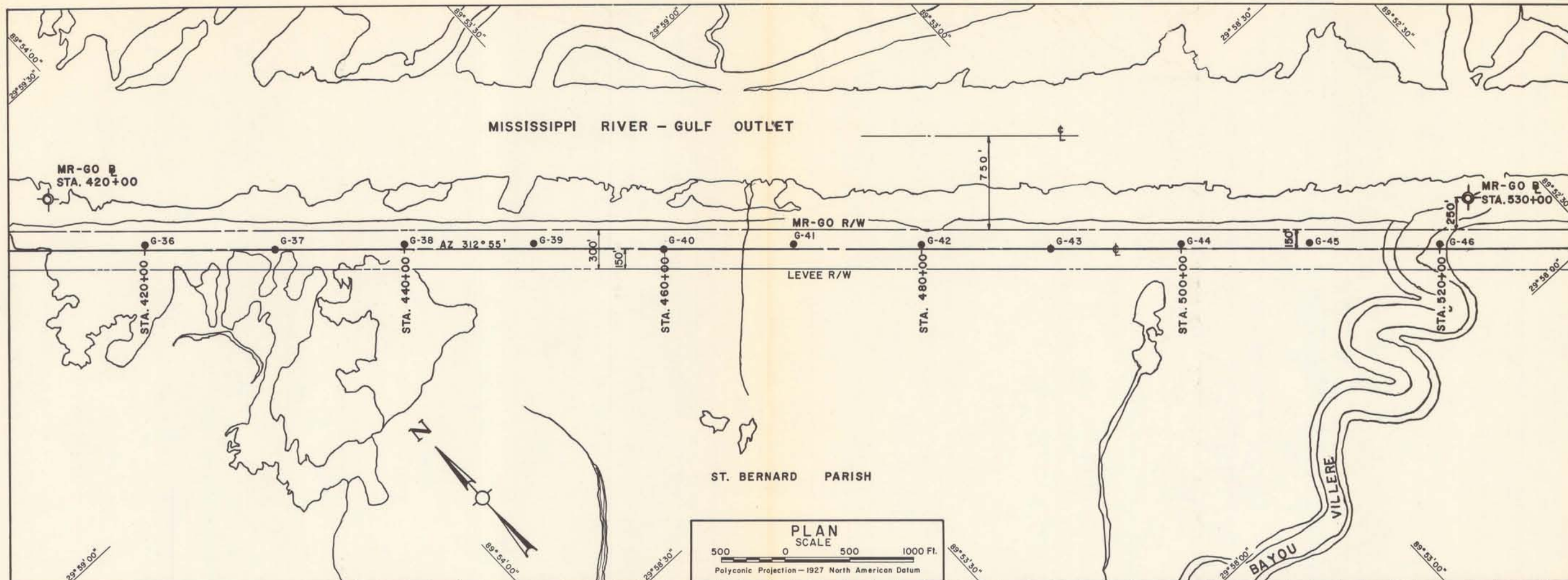

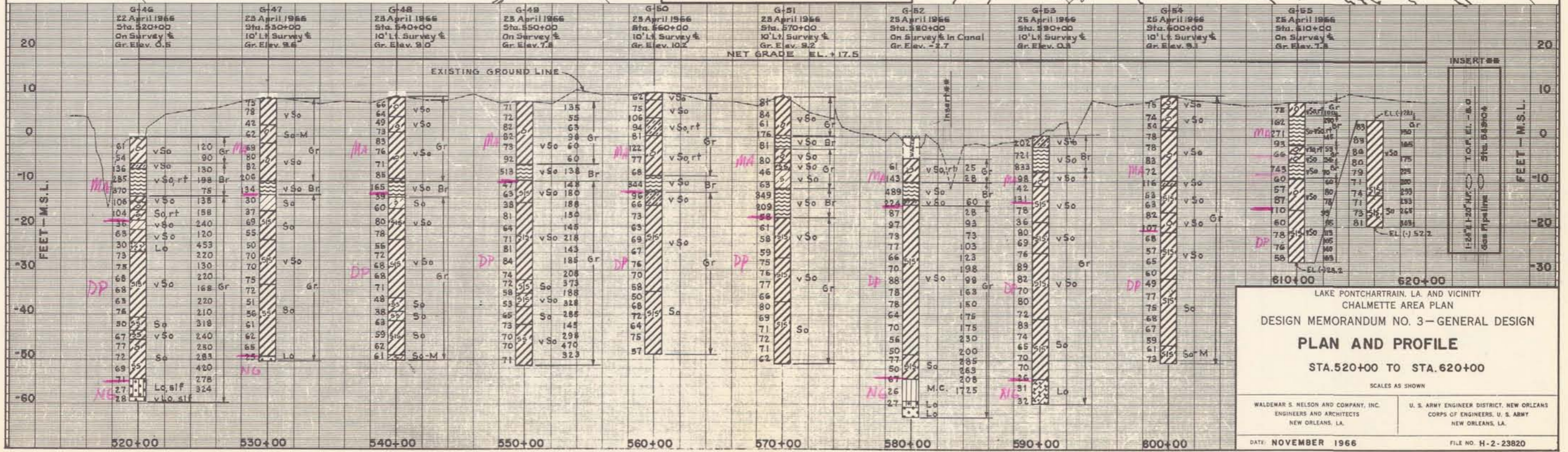
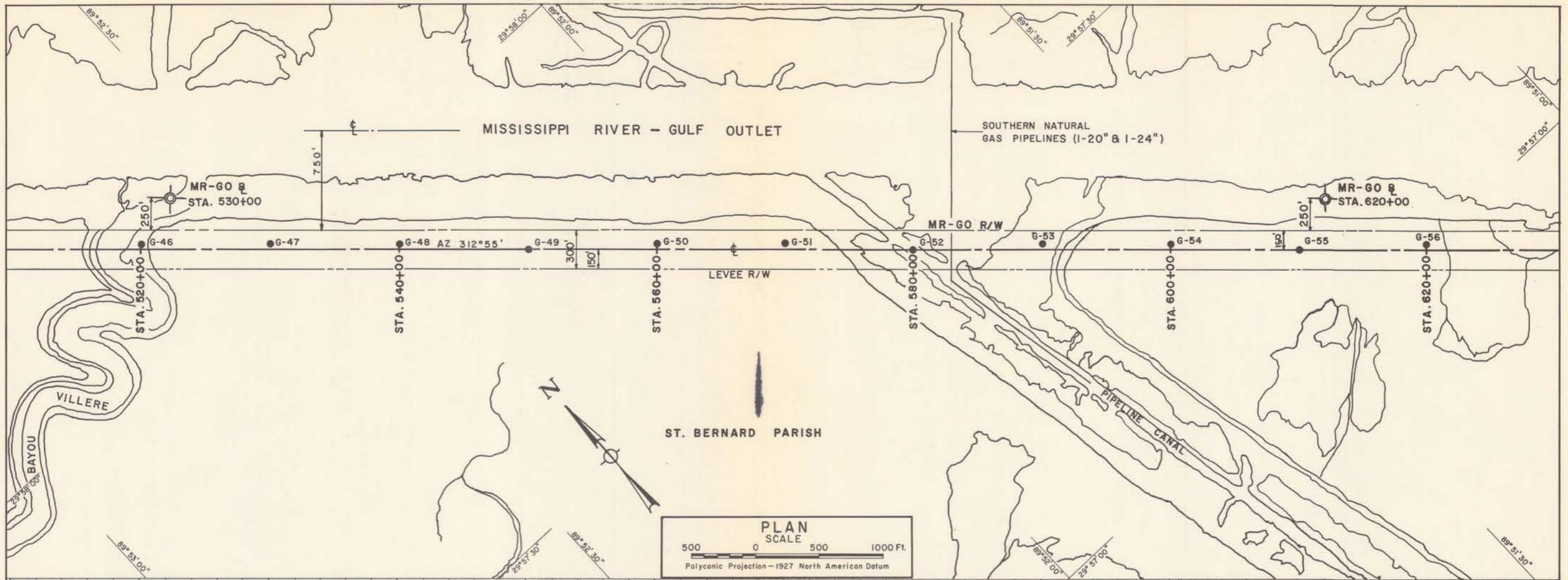

LAKE PONTCHARTRAIN, LA. AND VICINITY
 CHALMETTE AREA PLAN
 DESIGN MEMORANDUM NO. 3—GENERAL DESIGN
PLAN AND PROFILE
 STA. 520+00 TO STA. 620+00
 SCALES AS SHOWN

WALDEMAR S. NELSON AND COMPANY, INC.
 ENGINEERS AND ARCHITECTS
 NEW ORLEANS, LA.

U. S. ARMY ENGINEER DISTRICT, NEW ORLEANS
 CORPS OF ENGINEERS, U. S. ARMY
 NEW ORLEANS, LA.

DATE: NOVEMBER 1966 FILE NO. H-2-23820

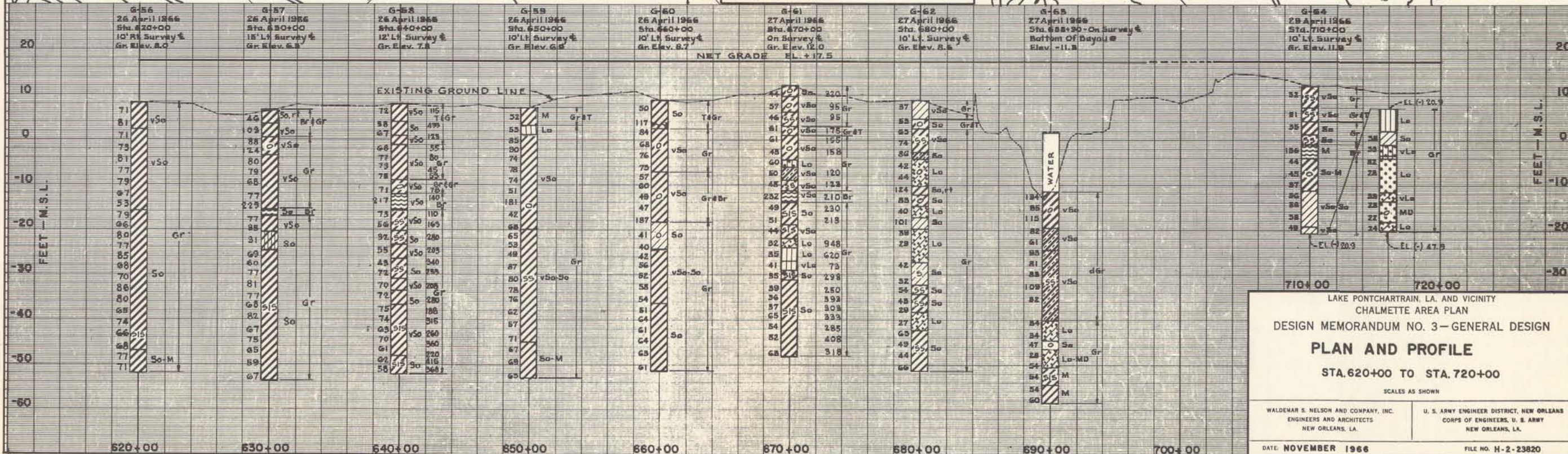
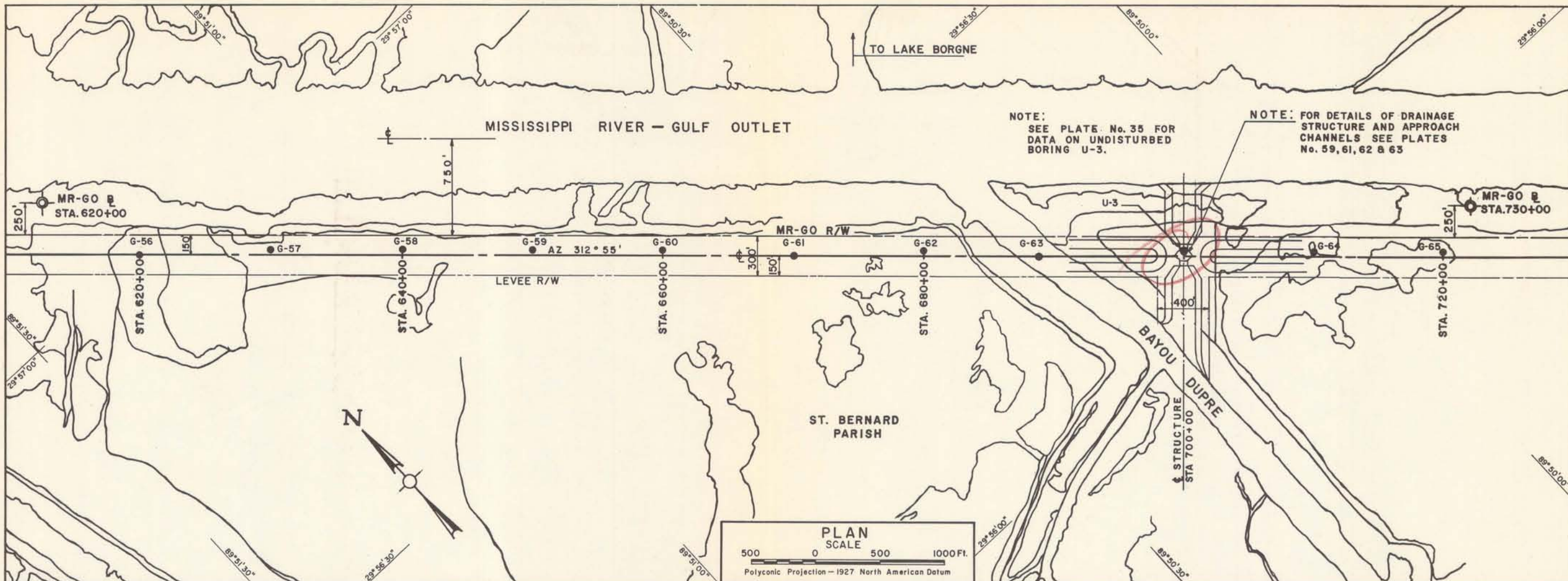

LAKE PONTCHARTRAIN, LA. AND VICINITY
 CHALMETTE AREA PLAN
 DESIGN MEMORANDUM NO. 3 - GENERAL DESIGN
PLAN AND PROFILE
 STA. 620+00 TO STA. 720+00
 SCALES AS SHOWN

WALDENAR S. NELSON AND COMPANY, INC.
 ENGINEERS AND ARCHITECTS
 NEW ORLEANS, LA.

U. S. ARMY ENGINEER DISTRICT, NEW ORLEANS
 CORPS OF ENGINEERS, U. S. ARMY
 NEW ORLEANS, LA.

DATE: NOVEMBER 1966 FILE NO. H-2-23820

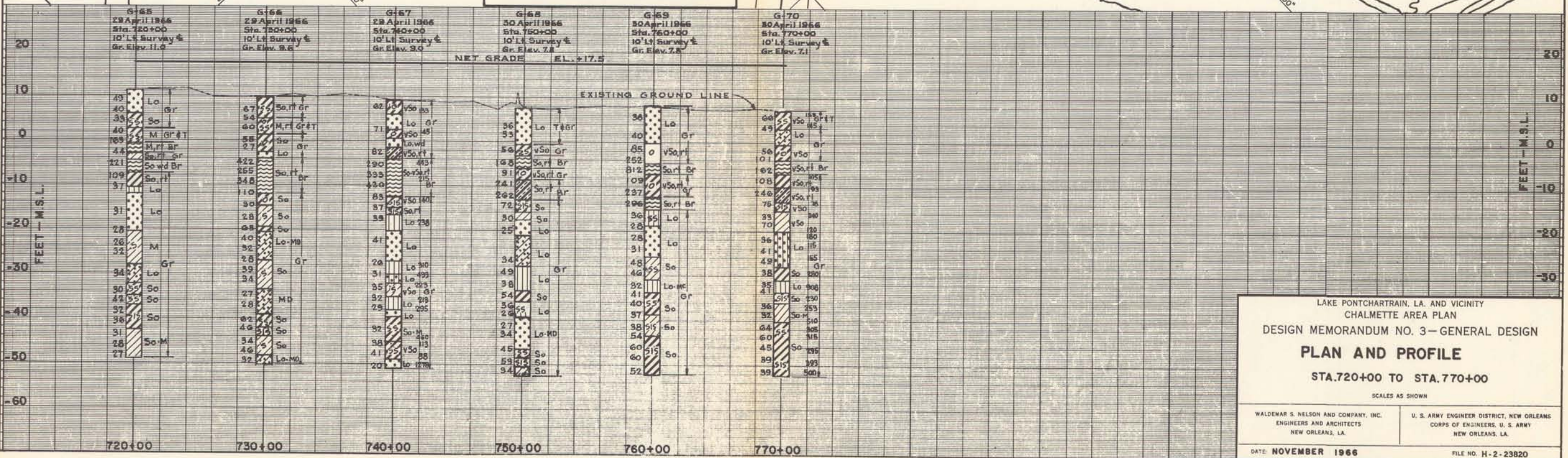
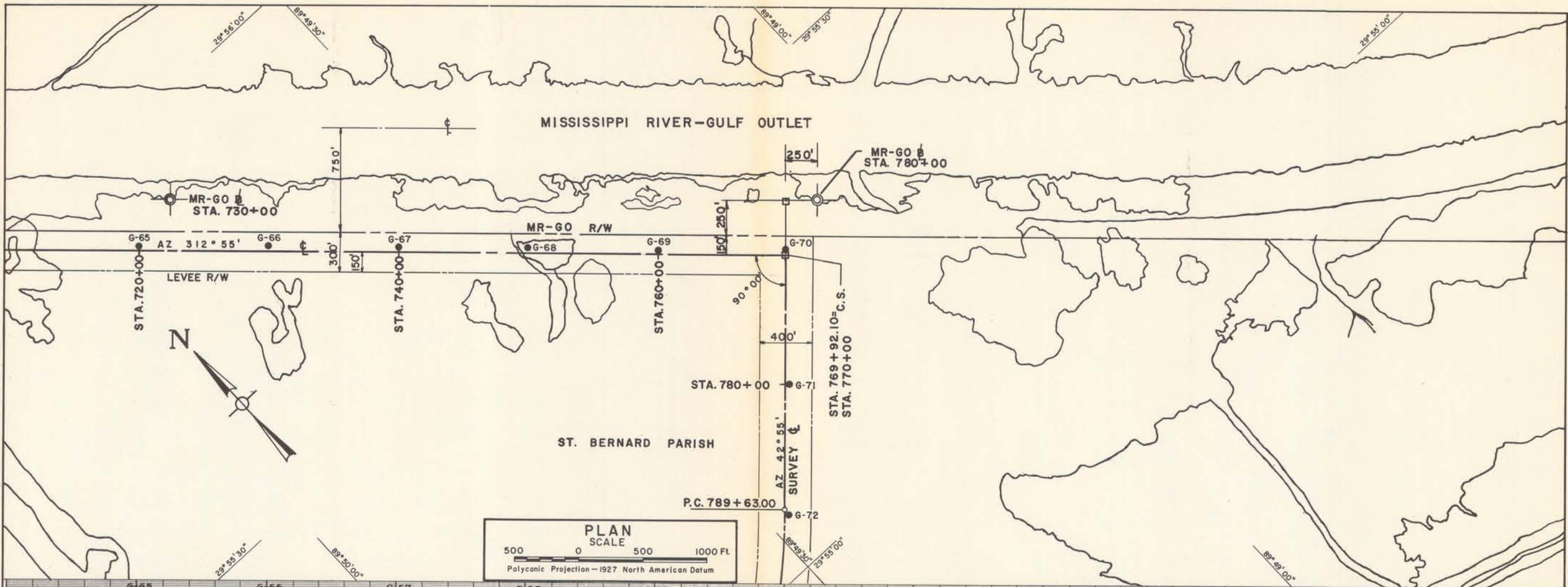

LAKE PONTCHARTRAIN, LA. AND VICINITY
CHALMETTE AREA PLAN
DESIGN MEMORANDUM NO. 3—GENERAL DESIGN
PLAN AND PROFILE
STA. 720+00 TO STA. 770+00
SCALES AS SHOWN

WALDEMAR S. NELSON AND COMPANY, INC.
ENGINEERS AND ARCHITECTS
NEW ORLEANS, LA.

U. S. ARMY ENGINEER DISTRICT, NEW ORLEANS
CORPS OF ENGINEERS, U. S. ARMY
NEW ORLEANS, LA.

DATE: NOVEMBER 1966
FILE NO. H-2-23820

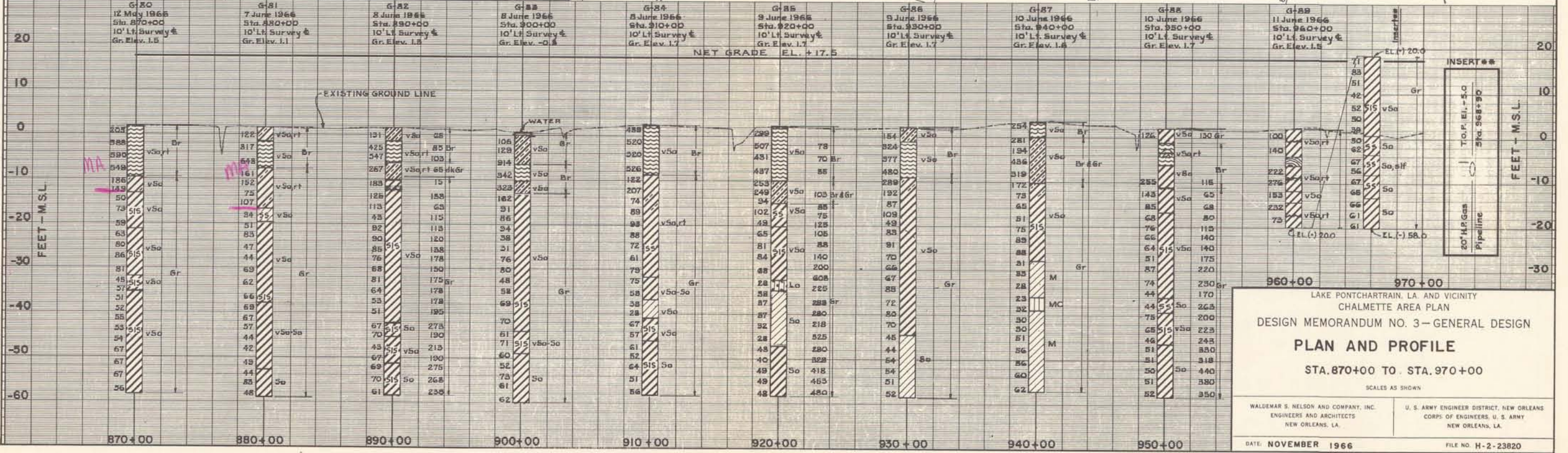
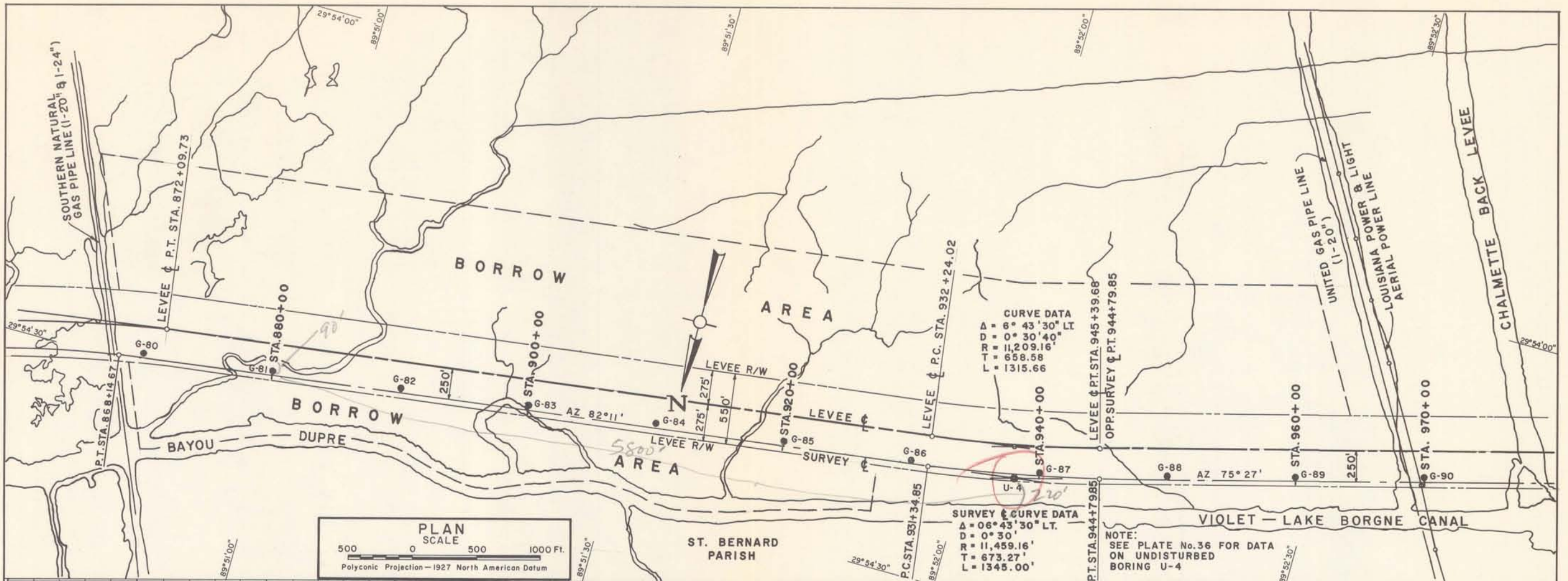

LAKE PONTCHARTRAIN, LA. AND VICINITY
 CHALMETTE AREA PLAN
 DESIGN MEMORANDUM NO. 3 - GENERAL DESIGN
PLAN AND PROFILE
 STA. 870+00 TO STA. 970+00
 SCALES AS SHOWN

WALDEMAR S. NELSON AND COMPANY, INC.
 ENGINEERS AND ARCHITECTS
 NEW ORLEANS, LA.

U. S. ARMY ENGINEER DISTRICT, NEW ORLEANS
 CORPS OF ENGINEERS, U. S. ARMY
 NEW ORLEANS, LA.

DATE: NOVEMBER 1966 FILE NO. H-2-23820

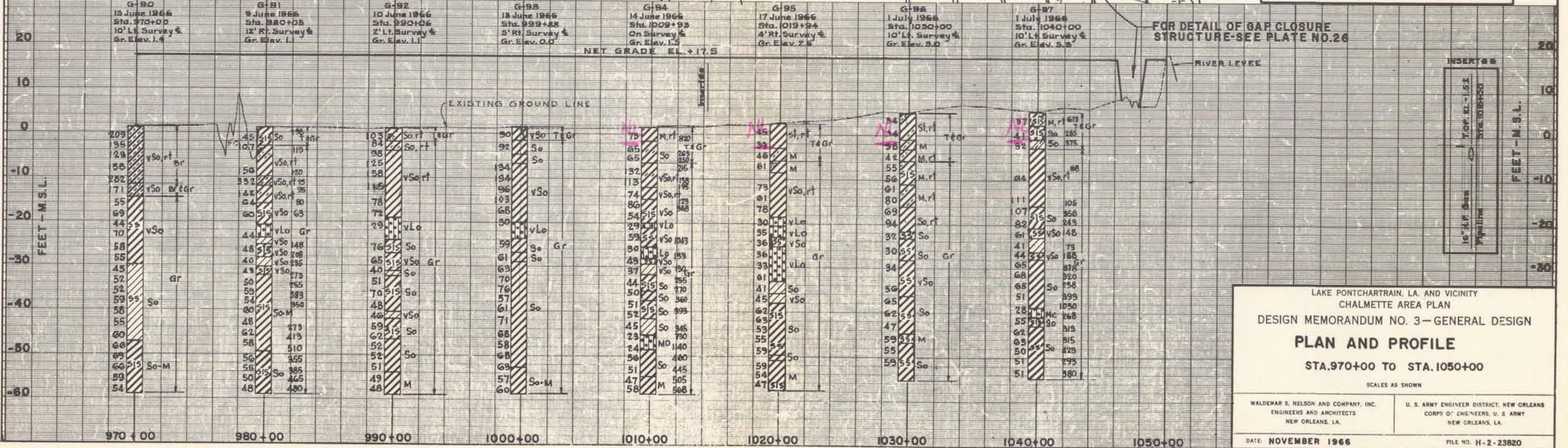
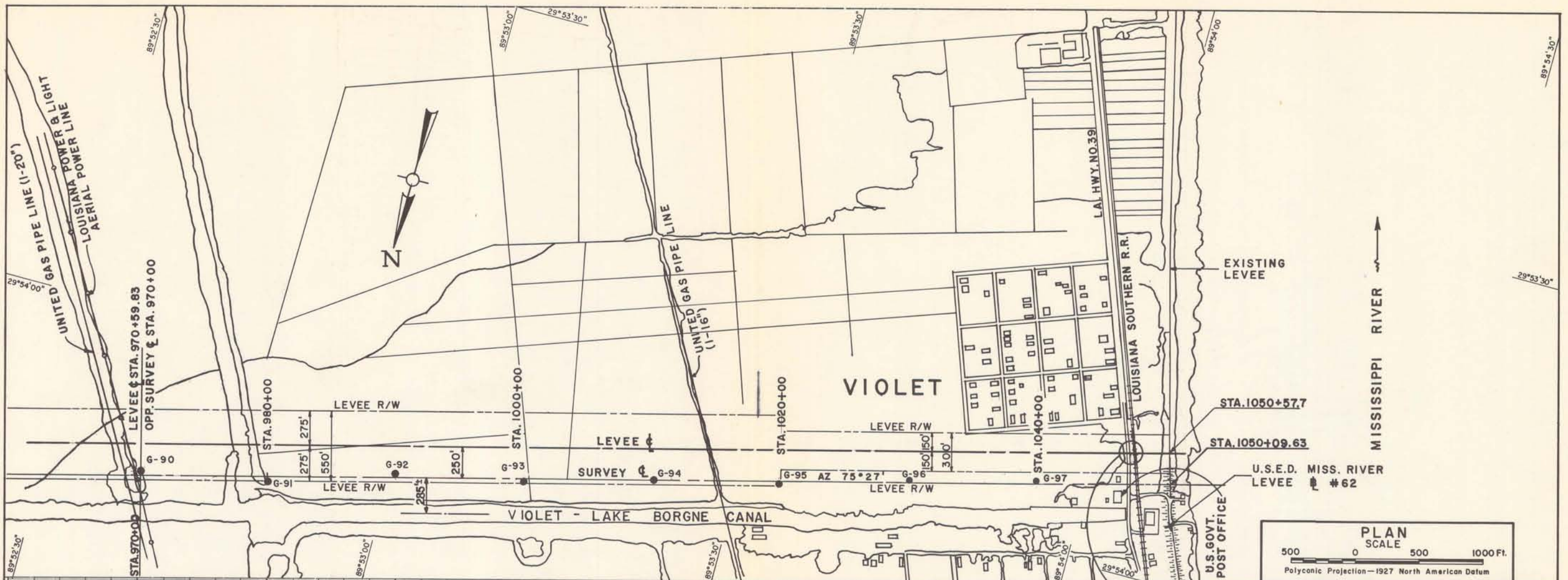

PLAN SCALE 500 0 500 1000 Ft.
 Polyconic Projection—1927 North American Datum

LAKE PONTCHARTRAIN, LA. AND VICINITY
 CHALMETTE AREA PLAN
 DESIGN MEMORANDUM NO. 3—GENERAL DESIGN
PLAN AND PROFILE
 STA. 970+00 TO STA. 1050+00
 SCALES AS SHOWN

WALDEMAR S. NELSON AND COMPANY, INC.
 ENGINEERS AND ARCHITECTS
 NEW ORLEANS, LA.

U. S. ARMY ENGINEER DISTRICT, NEW ORLEANS
 CORPS OF ENGINEERS, U. S. ARMY
 NEW ORLEANS, LA.

DATE: NOVEMBER 1966 FILE NO. H-2-23820

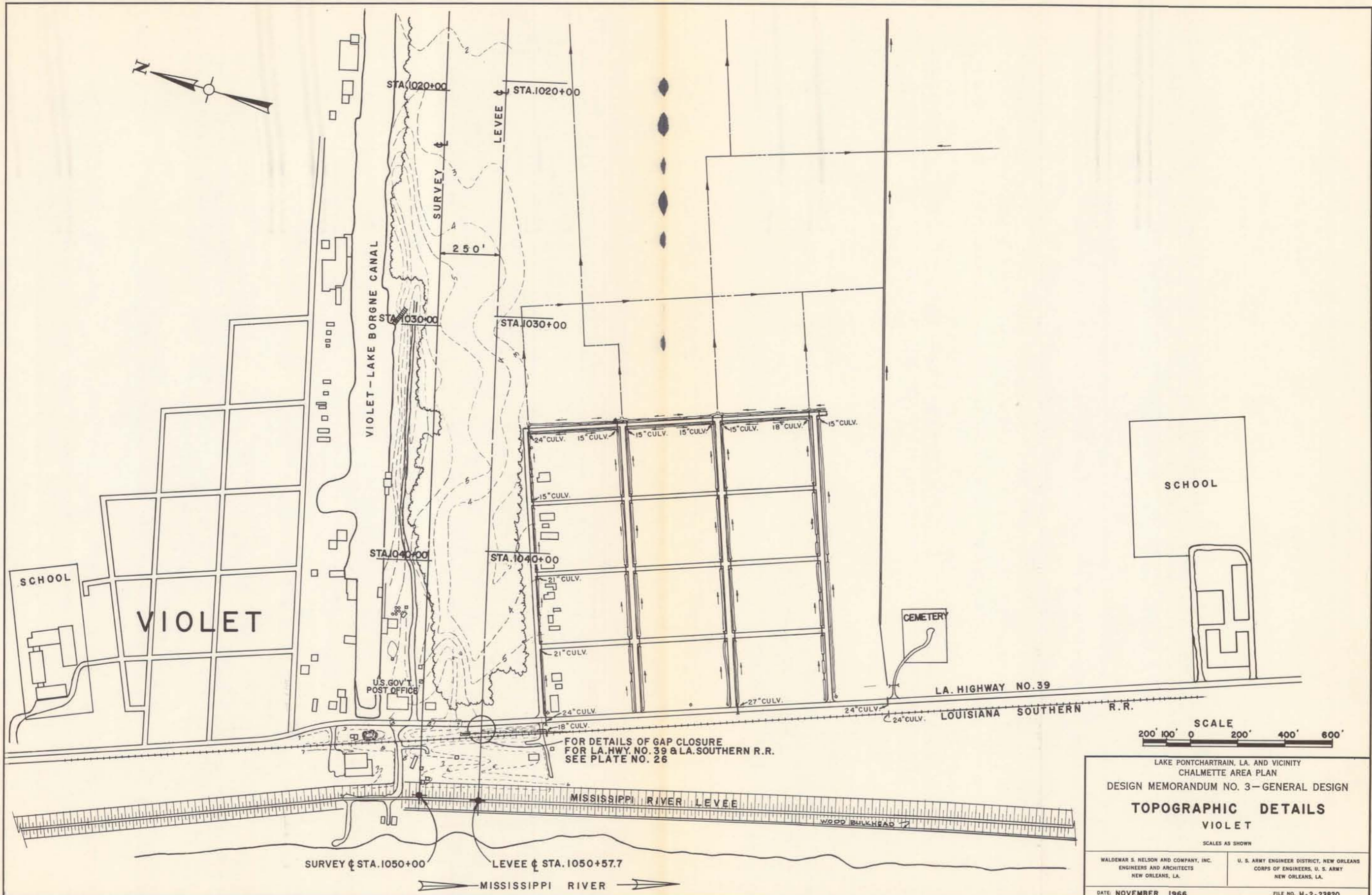

LAKE PONTCHARTRAIN, LA. AND VICINITY
 CHALMETTE AREA PLAN
 DESIGN MEMORANDUM NO. 3—GENERAL DESIGN
TOPOGRAPHIC DETAILS
 VIOLET
 SCALES AS SHOWN

WALDEMAR S. NELSON AND COMPANY, INC.
 ENGINEERS AND ARCHITECTS
 NEW ORLEANS, LA.

U. S. ARMY ENGINEER DISTRICT, NEW ORLEANS
 CORPS OF ENGINEERS, U. S. ARMY
 NEW ORLEANS, LA.

DATE: NOVEMBER 1966 FILE NO. H-2-23820

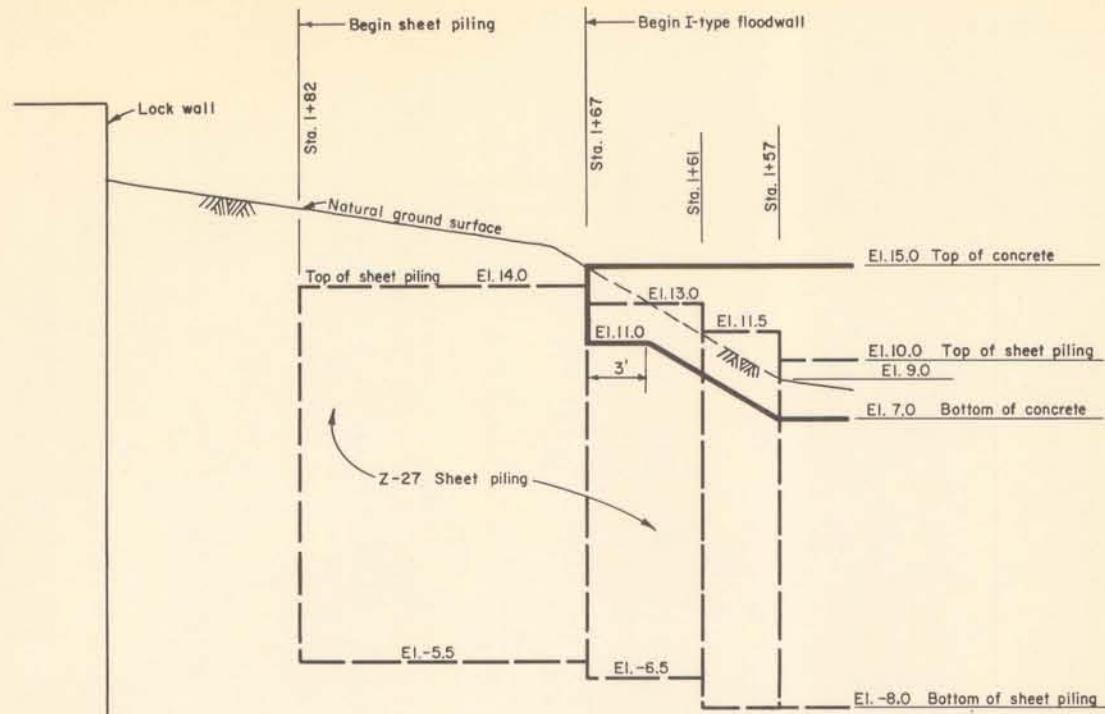

ELEVATION
 STA. 1+82 to 1+57
 (See Insert on Plate No. 2)
 SCALE IN FEET
 5 0 5 10

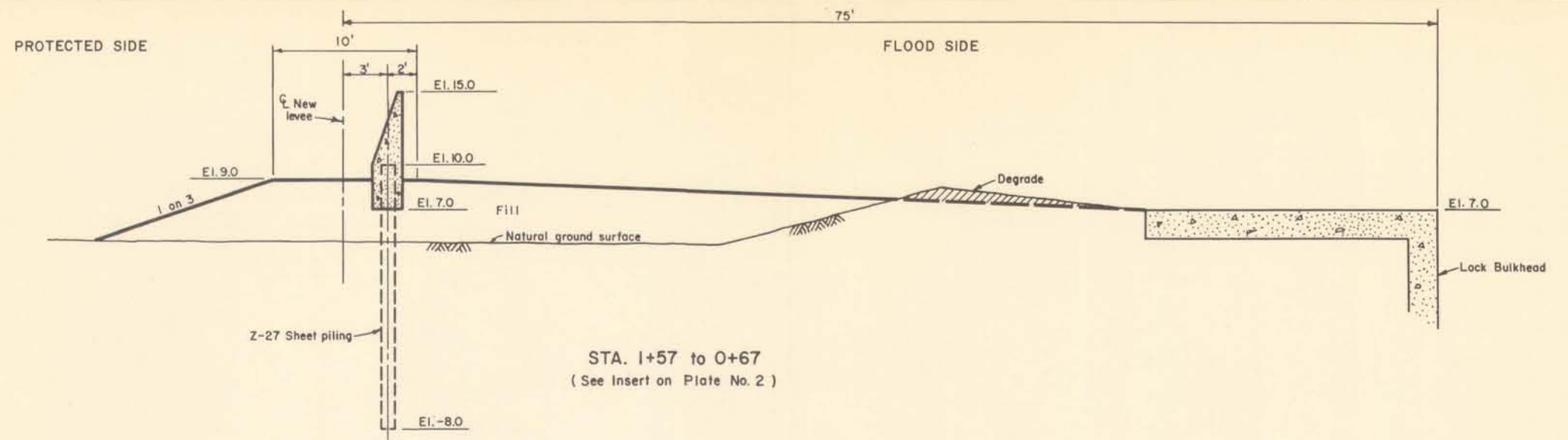

STA. 1+57 to 0+67
 (See Insert on Plate No. 2)

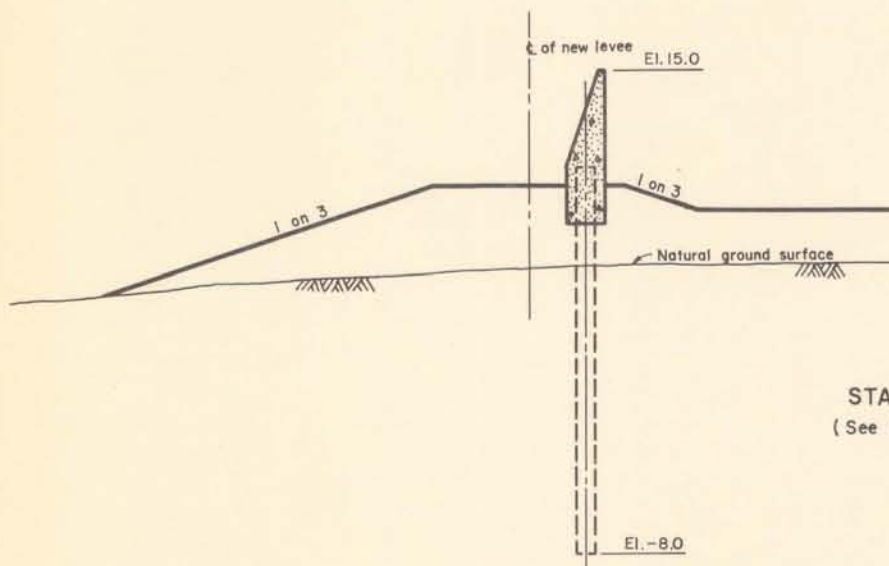

STA. 0+67 to 0+20
 (See Insert on Plate No. 2)

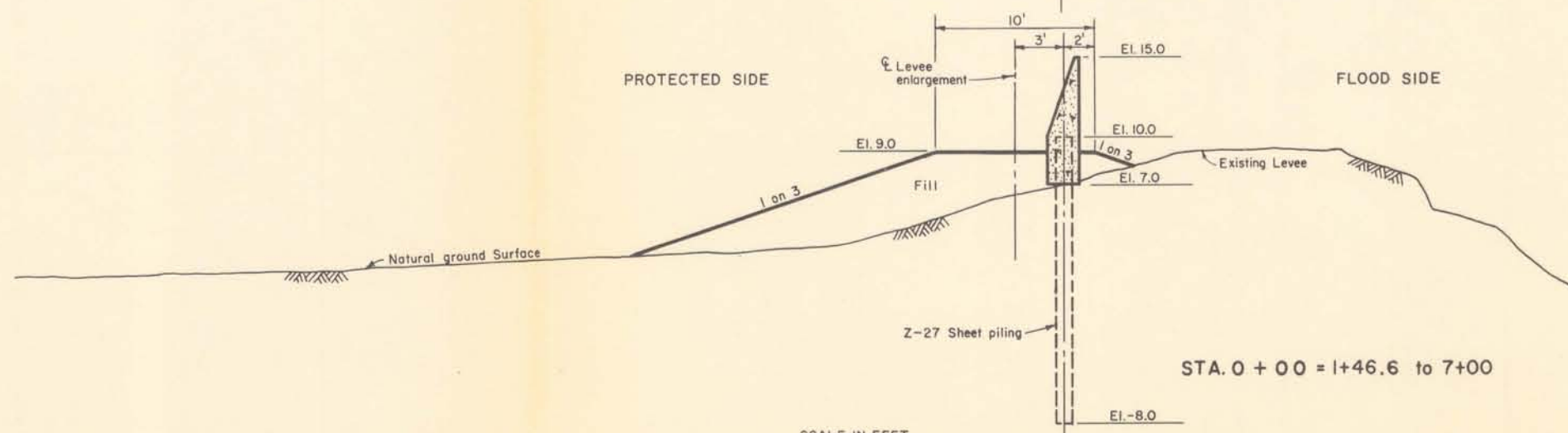

STA. 0 + 00 = 1+46.6 to 7+00

SCALE IN FEET
 5 0 5 10

Elevations are in feet referred to M.S.L.
 Smooth transition between Sta. 0+20 to
 0+00 = 1+46.6.

LAKE PONTCHARTRAIN, L.A. AND VICINITY CHALMETTE AREA PLAN DESIGN MEMORANDUM NO. 3 - GENERAL DESIGN	
DESIGN SECTIONS	
WALDEMAR S. NELSON AND CO., INC. ENGINEERS AND ARCHITECTS NEW ORLEANS, L.A.	U.S. ARMY ENGINEER DISTRICT, NEW ORLEANS CORPS OF ENGINEERS, U.S. ARMY NEW ORLEANS, L.A.
DATE: OCTOBER 1966	FILE NO. H-2-23820

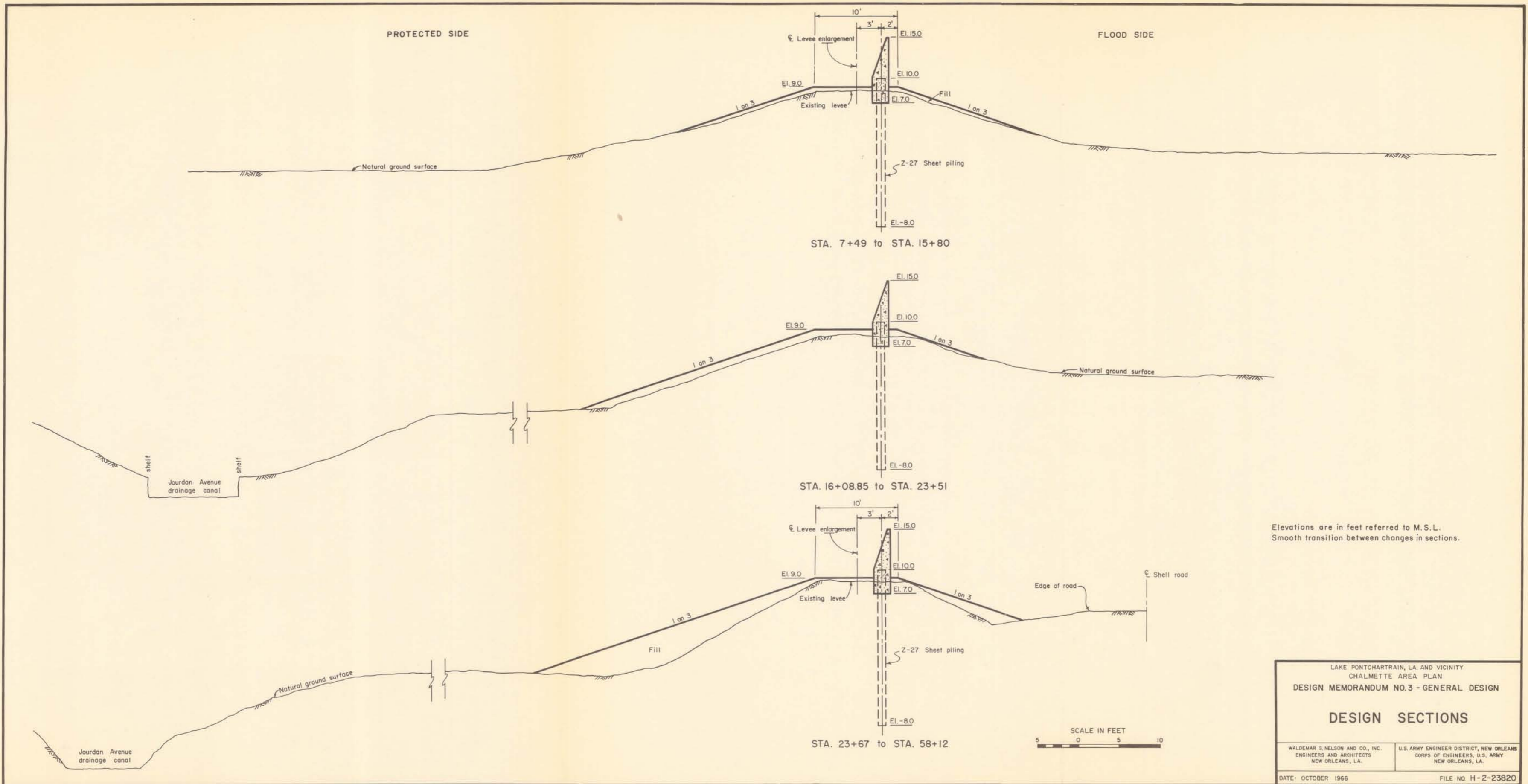

Elevations are in feet referred to M.S.L.
Smooth transition between changes in sections.

LAKE PONTCHARTRAIN, LA. AND VICINITY CHALMETTE AREA PLAN DESIGN MEMORANDUM NO. 3 - GENERAL DESIGN	
DESIGN SECTIONS	
WALDEMAR S. NELSON AND CO., INC. ENGINEERS AND ARCHITECTS NEW ORLEANS, LA.	U.S. ARMY ENGINEER DISTRICT, NEW ORLEANS CORPS OF ENGINEERS, U.S. ARMY NEW ORLEANS, LA.
DATE: OCTOBER 1966	FILE NO. H-2-23820

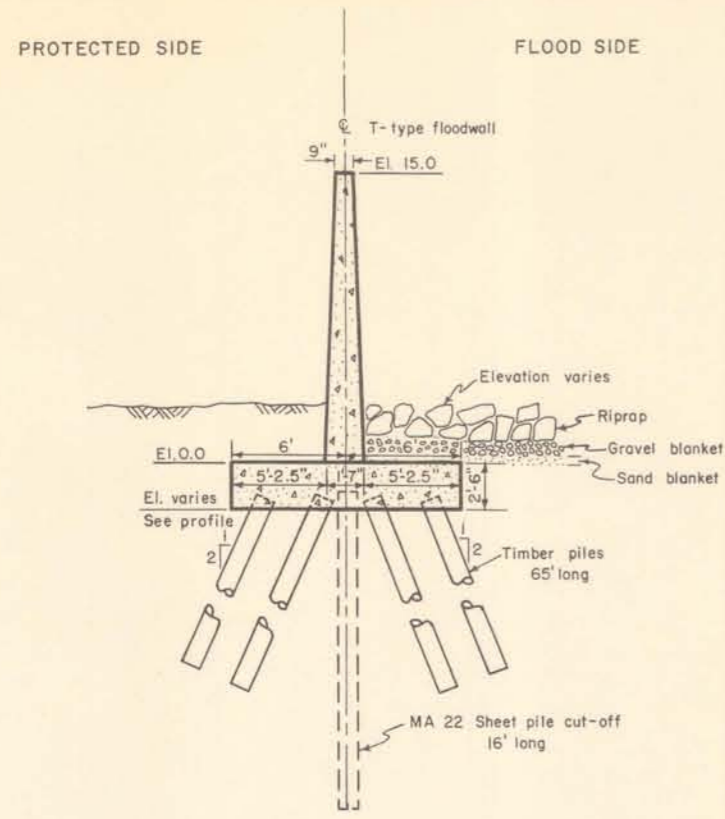

STA. 58+12 to 67+94

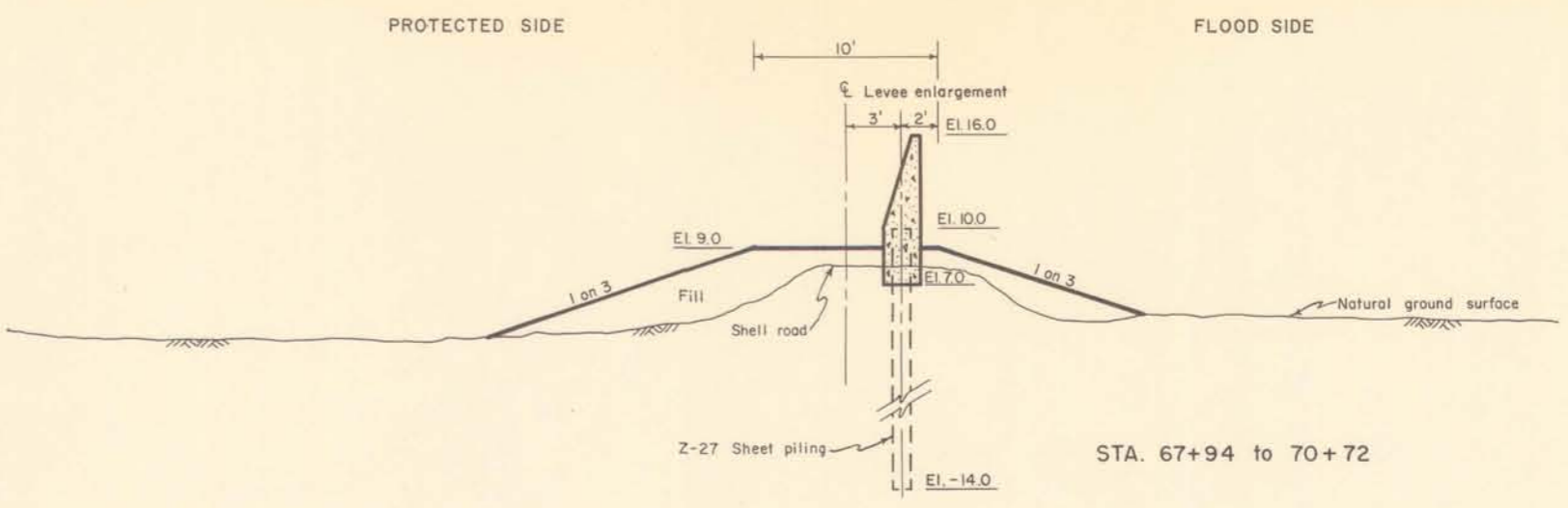
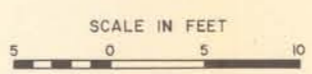

STA. 67+94 to 70+72

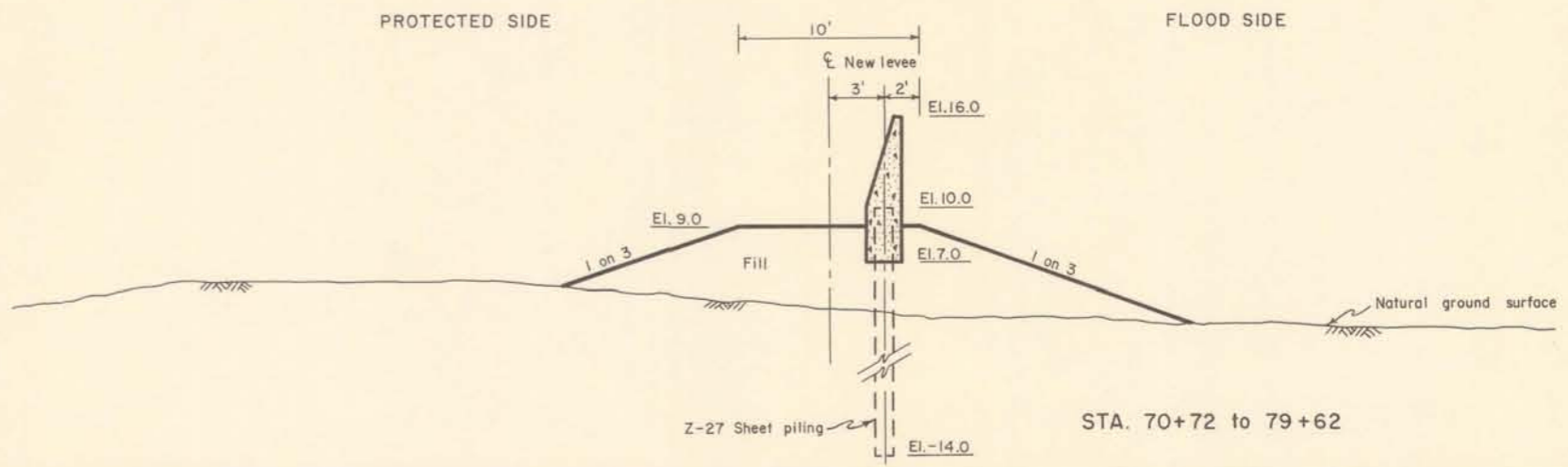

STA. 70+72 to 79+62

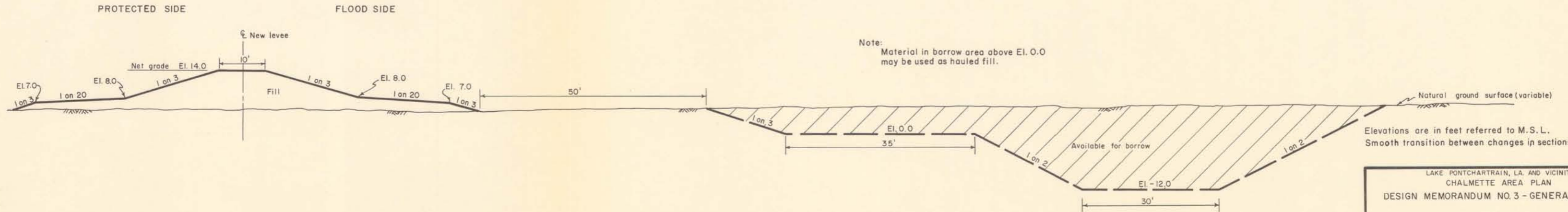

STA. 79+62 to 90+25 = 7+52.9



Elevations are in feet referred to M.S.L.
Smooth transition between changes in sections.

LAKE PONTCHARTRAIN, LA. AND VICINITY CHALMETTE AREA PLAN	
DESIGN MEMORANDUM NO. 3 - GENERAL DESIGN	
DESIGN SECTIONS	
WALDEMAR S. NELSON AND CO., INC. ENGINEERS AND ARCHITECTS NEW ORLEANS, LA.	U.S. ARMY ENGINEER DISTRICT, NEW ORLEANS CORPS OF ENGINEERS, U.S. ARMY NEW ORLEANS, LA.
DATE: OCTOBER 1966	FILE NO. H-2-23820

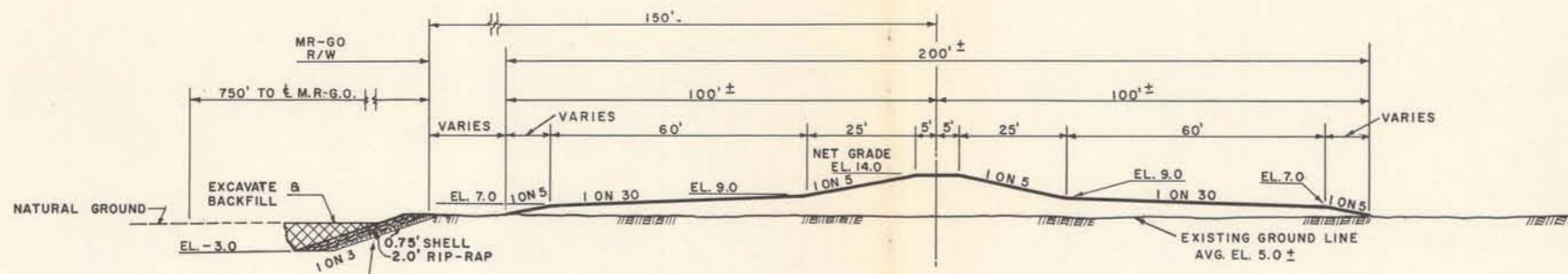

STA. 7+52.9 TO STA. 10+00
 STA. 78+00 TO STA. 140+00
 STA. 146+00 TO STA. 188+00
 STA. 264+00 TO STA. 268+00

NOTE:
 SLOPE PROTECTION AND R/W DATA SHOWN ON THESE TWO SECTIONS NOT APPLICABLE FROM STA. 7+52.9 TO STA. 46+02.66 AS LEVEE ALIGNMENT BETWEEN THESE STATIONS IS ON LINE FROM OUT FALL CANAL (AT FLORIDA AVE.) NORTH TO M R-G-O AND IS NOT PARALLEL OR ADJACENT TO M R-G-O R/W.

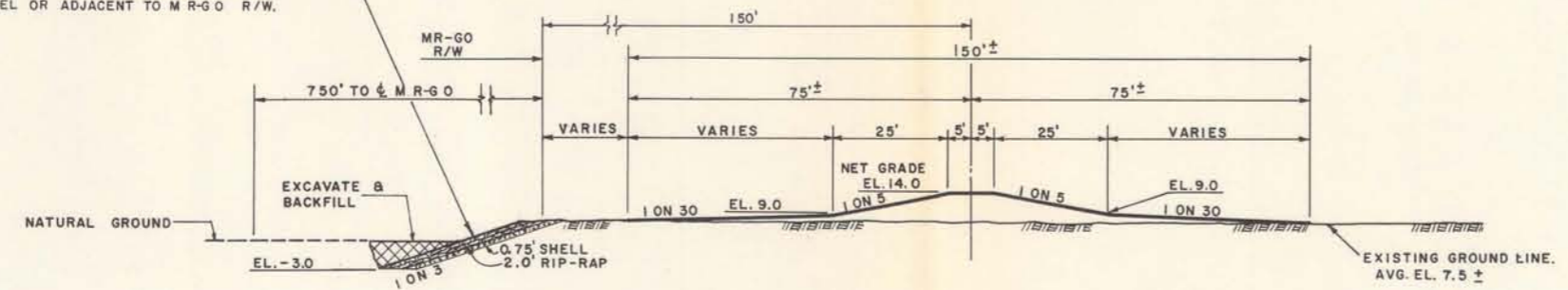

STA. 10+00 TO STA. 78+00
 STA. 140+00 TO STA. 146+00
 STA. 188+00 TO STA. 264+00

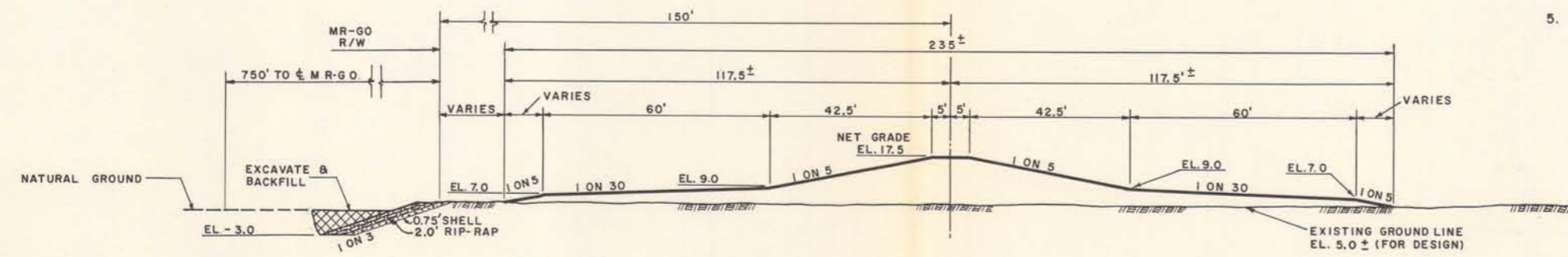

STA. 270+00 TO STA. 357+05



RIPRAP		
WEIGHT OF PIECES IN LBS.		PERCENT OF TOTAL WEIGHT
TYPE A	TYPE B	
24" LAYERS	18" LAYERS	
800-1400	350-600	15
400-800	200-350	20
150-400	60-200	25
35-150	15-60	25
LESS THAN 35	LESS THAN 15	15
TYPE C		
12" LAYERS		
75-150		NOT MORE THAN 10
25-75		50
6-25		30
UNDER 6		NOT MORE THAN 15

The least dimension of any stone shall not be less than one-third its greatest dimension.

GENERAL NOTES

1. FROM STA. 7+52.9 TO 807+00, PLATES 7-16, FILL MATERIAL FOR LEVEE CONSTRUCTION IS TO BE OBTAINED FROM SELECTED BORROW AREAS ALONG THE BOTTOM OF THE MR-GO CHANNEL. BORROW AREAS FOR FILL MATERIAL STA. 807+00 TO 1020+00 AS SHOWN ON PLAN ON PLATES 16 & 17. FILL REQ'D. STA. 1020+00 TO 1050+57.7 TO BE TRUCK HAULED DRY FILL MATERIAL.
2. THERE SHALL BE A MINIMUM 100 FT. BERM BETWEEN THE TOE OF LEVEE AND THE TOP OF CUT SLOPE OF ANY BORROW AREA.
3. ± DENOTES APPROXIMATE DIMENSIONS.
4. FOR LOCATION OF CONSTRUCTION RETAINING DIKES, SEE STAGE CONSTRUCTION SECTIONS, PLATES 66 & 67.
5. FOR LIFT AND SHAPING DIMENSIONS AND CONSTRUCTION CRITERIA, SEE PLATE NO. 65.

NOTE:
 TRANSITION CROWN OF LEVEE FROM ELEVATION 14.0 M.S.L. AT STA. 268+00 TO ELEVATION 17.5 M.S.L. AT STA. 270+00.

LAKE PONTCHARTRAIN, LA. AND VICINITY
 CHALMETTE AREA PLAN
 DESIGN MEMORANDUM NO. 3—GENERAL DESIGN

DESIGN SECTIONS

SCALES AS SHOWN

WALDEMAR S. NELSON AND COMPANY, INC. ENGINEERS AND ARCHITECTS NEW ORLEANS, LA.	U. S. ARMY ENGINEER DISTRICT, NEW ORLEANS CORPS OF ENGINEERS, U. S. ARMY NEW ORLEANS, LA.
--	---

DATE: NOVEMBER 1966 FILE NO. H-2-23820

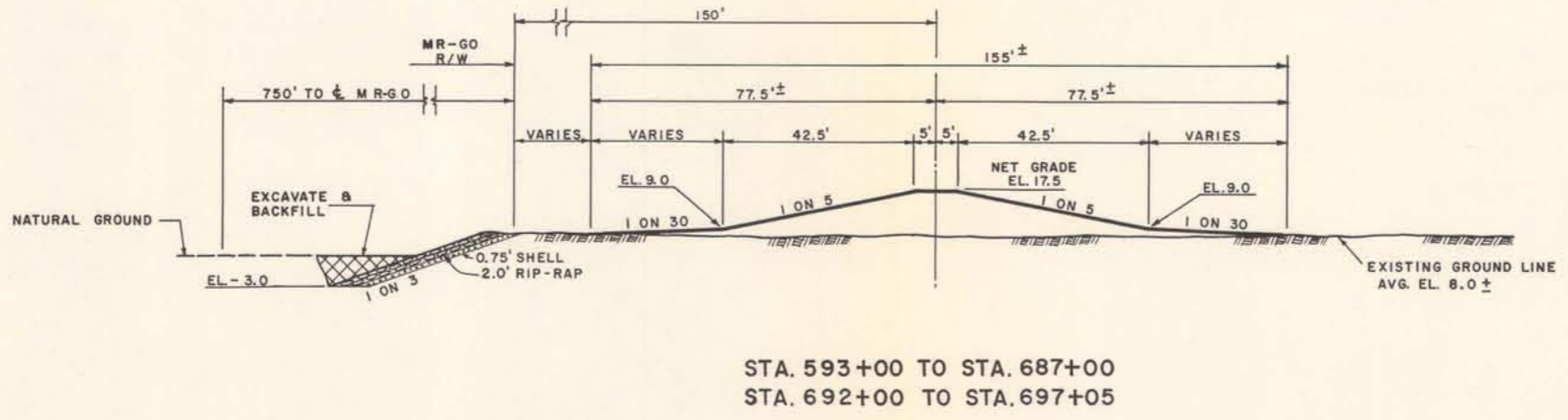
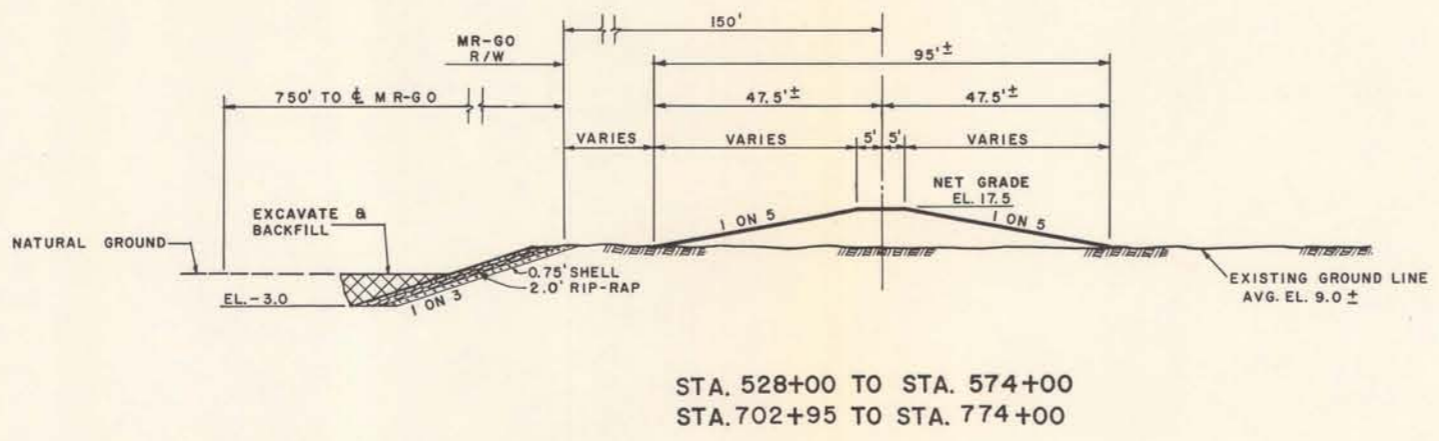
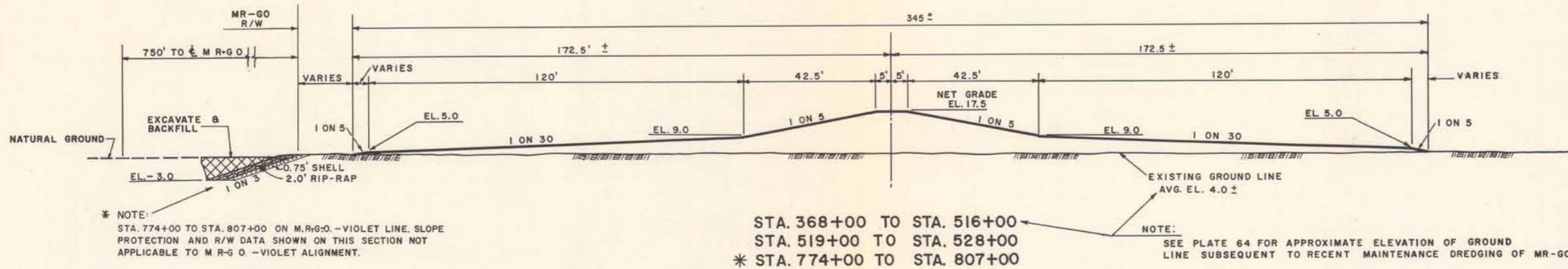

NOTE:
 SEE PLATE 23 FOR RIPRAP SPECIFICATIONS
 SEE PLATE 23 FOR BORROW AREA LOCATIONS

LAKE PONTCHARTRAIN, LA. AND VICINITY
 CHALMETTE AREA PLAN
 DESIGN MEMORANDUM NO. 3—GENERAL DESIGN
DESIGN SECTIONS
 SCALES AS SHOWN
 WALDEMAR S. NELSON AND COMPANY, INC.
 ENGINEERS AND ARCHITECTS
 NEW ORLEANS, LA.
 U. S. ARMY ENGINEER DISTRICT, NEW ORLEANS
 CORPS OF ENGINEERS, U. S. ARMY
 NEW ORLEANS, LA.
 DATE: NOVEMBER 1966
 FILE NO. H-2-23820

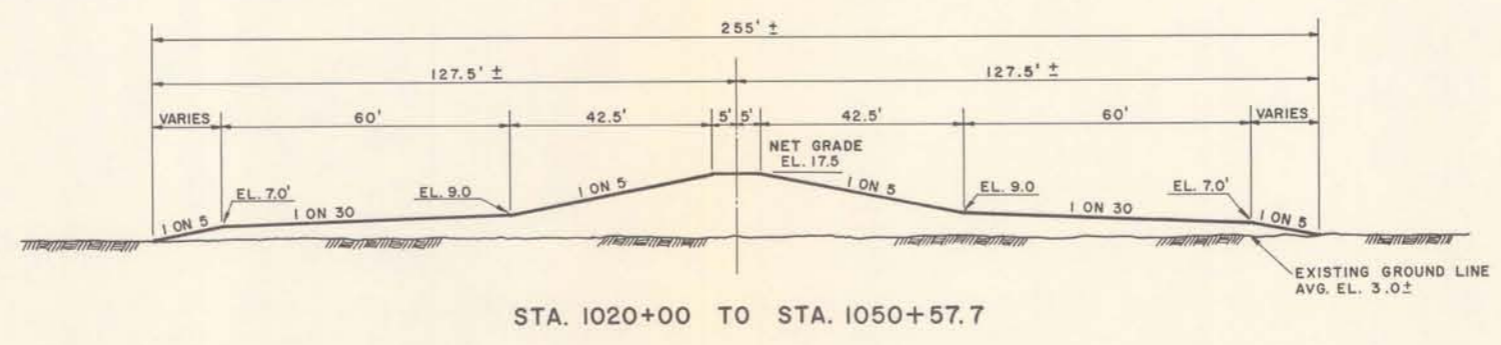
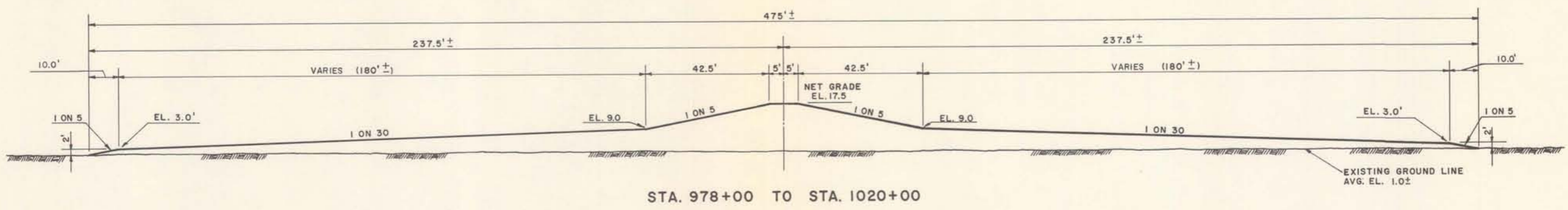
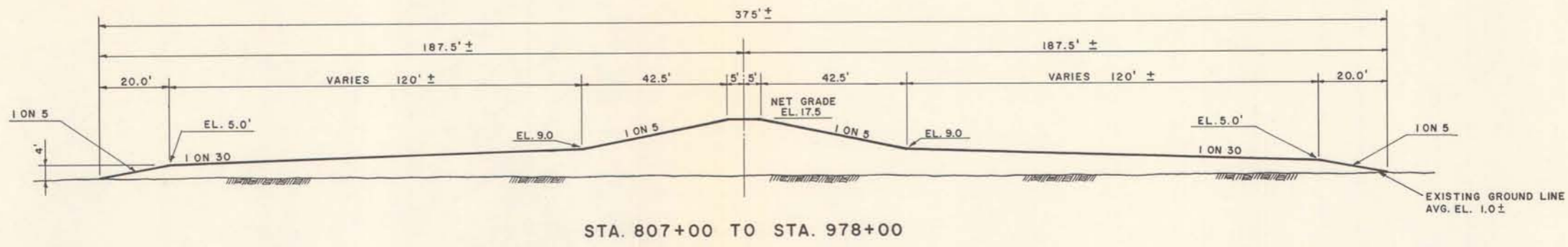

NOTE:
SEE PLATE 23 FOR BORROW AREA LOCATIONS



LAKE PONTCHARTRAIN, LA. AND VICINITY
CHALMETTE AREA PLAN
DESIGN MEMORANDUM NO. 3—GENERAL DESIGN

DESIGN SECTIONS

SCALES AS SHOWN

WALDEMAR S. NELSON AND COMPANY, INC. ENGINEERS AND ARCHITECTS NEW ORLEANS, LA.	U. S. ARMY ENGINEER DISTRICT, NEW ORLEANS CORPS OF ENGINEERS, U. S. ARMY NEW ORLEANS, LA.
DATE: NOVEMBER 1966	FILE NO. H-2-23820

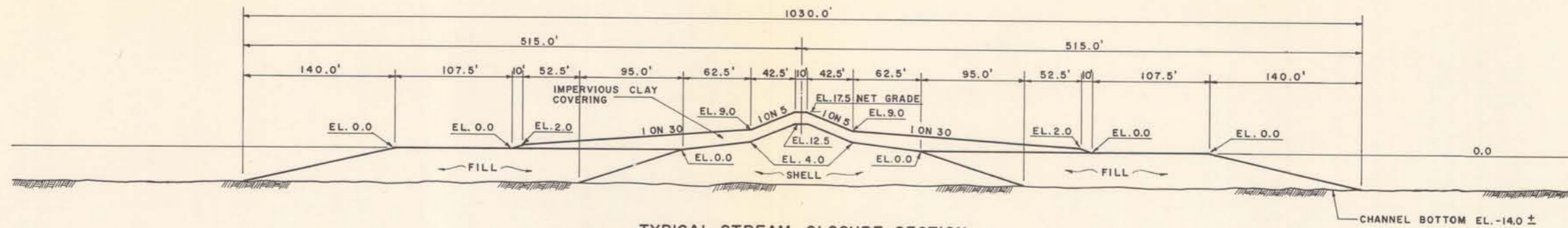

TYPICAL STREAM CLOSURE SECTION

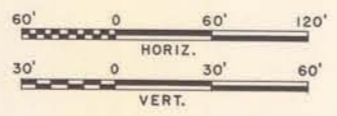

STA. 362 +95 TO 368 +00
 STA. 516 +00 TO 519 +00
 STA. 574 +00 TO 593 +00
 STA. 687 +00 TO 692 +00

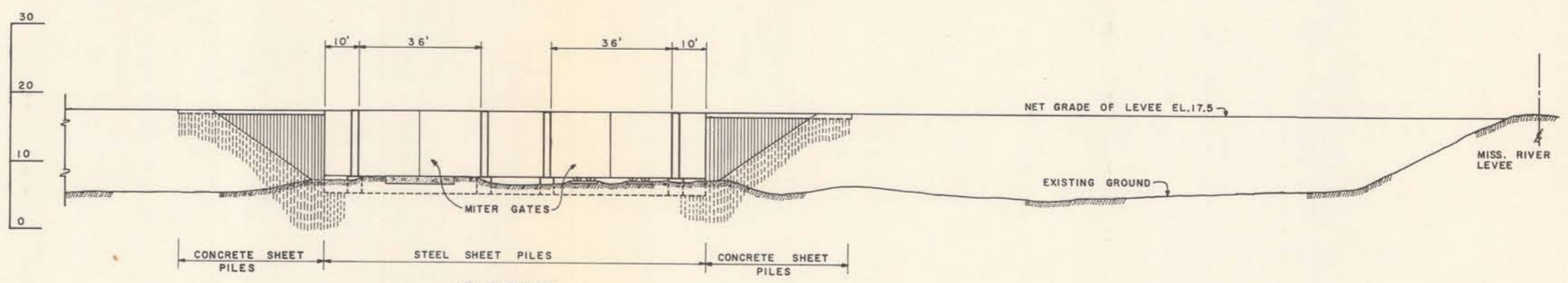

ELEVATION

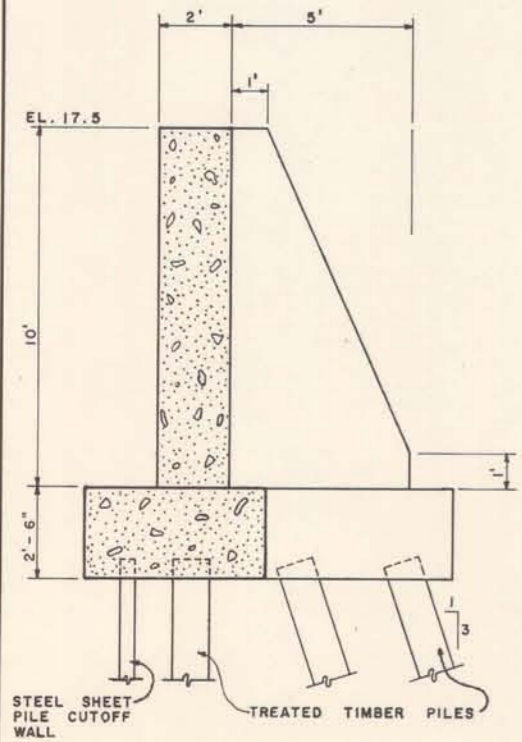

SECTION A-A
 NO SCALE

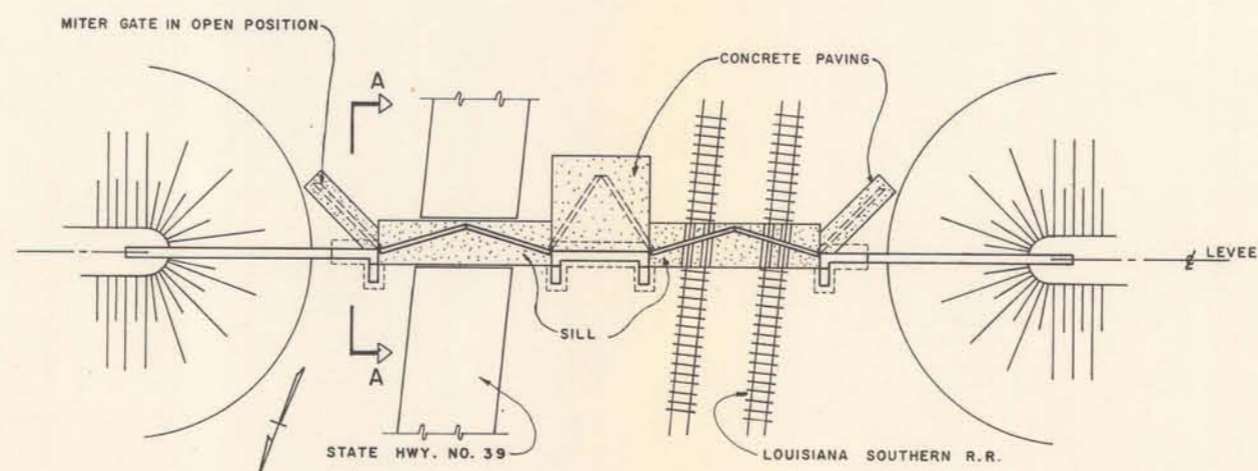

PLAN

DETAIL OF GAP CLOSURE AT VIOLET, LA.

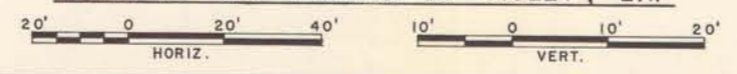

NOTE:
 SEE PLATE 23 FOR GENERAL NOTES

LAKE PONTCHARTRAIN, LA. AND VICINITY
 CHALMETTE AREA PLAN
 DESIGN MEMORANDUM NO. 3—GENERAL DESIGN
DESIGN SECTIONS

SCALES AS SHOWN

WALDEMAR S. NELSON AND COMPANY, INC. ENGINEERS AND ARCHITECTS NEW ORLEANS, LA.	U. S. ARMY ENGINEER DISTRICT, NEW ORLEANS CORPS OF ENGINEERS, U. S. ARMY NEW ORLEANS, LA.
DATE: NOVEMBER 1966	FILE NO. H-2-23820

NOTE:
 If the wall must be raised due to settlement, the top 2' of concrete will be broken off. The surface of the break will be coated with epoxy and the reinforcing steel will be extended. Then new concrete will be poured as shown by the dashed lines.

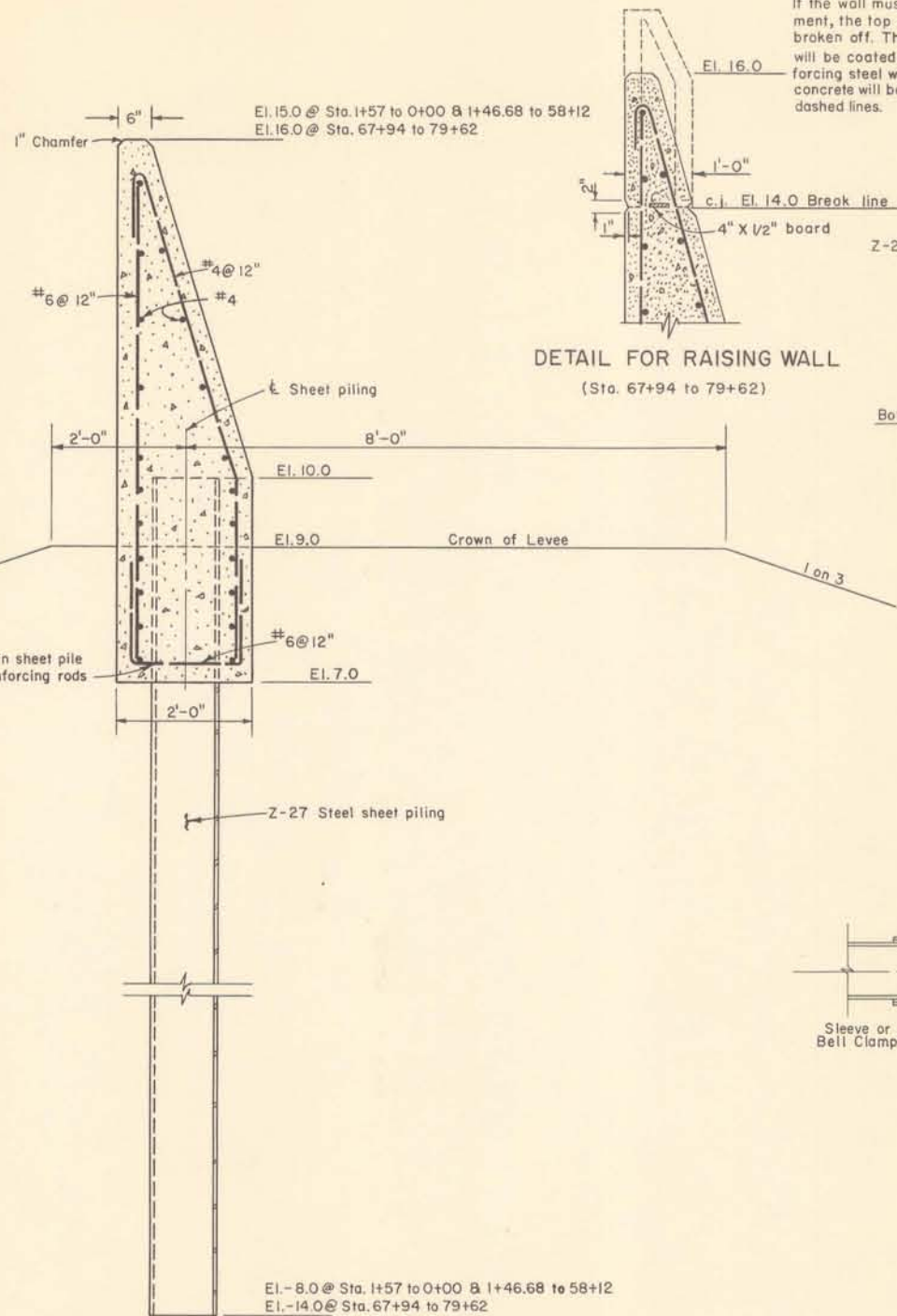

TYPICAL DETAIL I-TYPE WALL

DETAIL FOR RAISING WALL
 (Sta. 67+94 to 79+62)

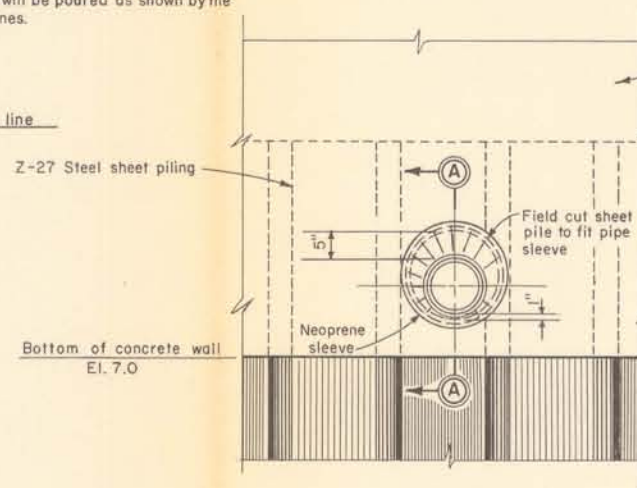
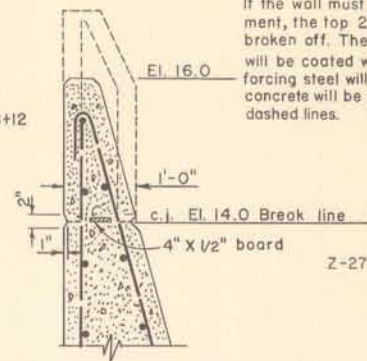

ELEVATION

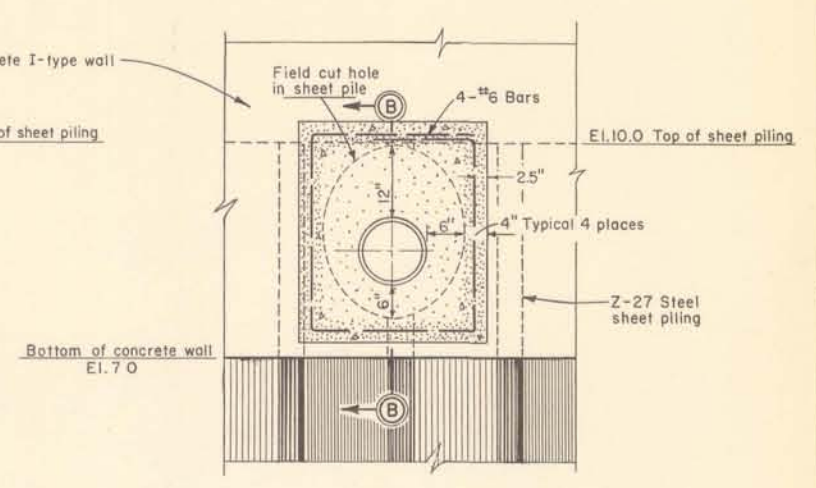

ELEVATION

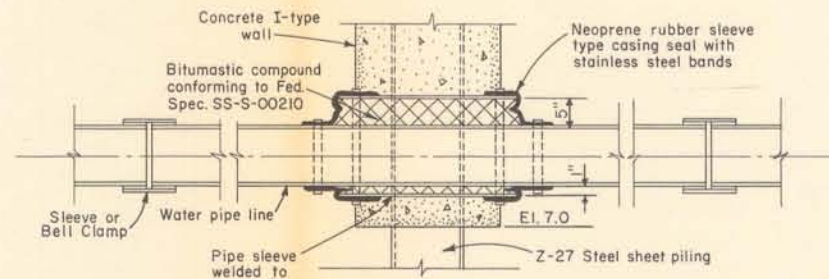

SECTION "A"-A

DETAILS OF WATER PIPE LINE AND CABLE CROSSING

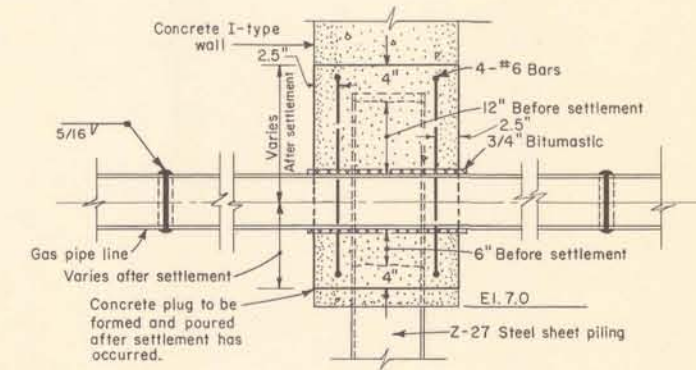

SECTION "B"-B

DETAILS OF GAS PIPE LINE CROSSING

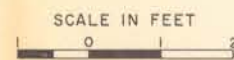

LAKE PONTCHARTRAIN, LA. AND VICINITY
 CHALMETTE AREA PLAN
 DESIGN MEMORANDUM NO. 3 - GENERAL DESIGN
 DETAILS OF I-TYPE WALL AND UTILITY CROSSINGS
 SCALES AS SHOWN
 WALDEMAR S. NELSON AND CO., INC. ENGINEERS AND ARCHITECTS NEW ORLEANS, LA.
 U.S. ARMY ENGINEER DISTRICT, NEW ORLEANS CORPS OF ENGINEERS, U.S. ARMY NEW ORLEANS, LA.
 DATE: OCTOBER 1966 FILE NO. H-2-23820

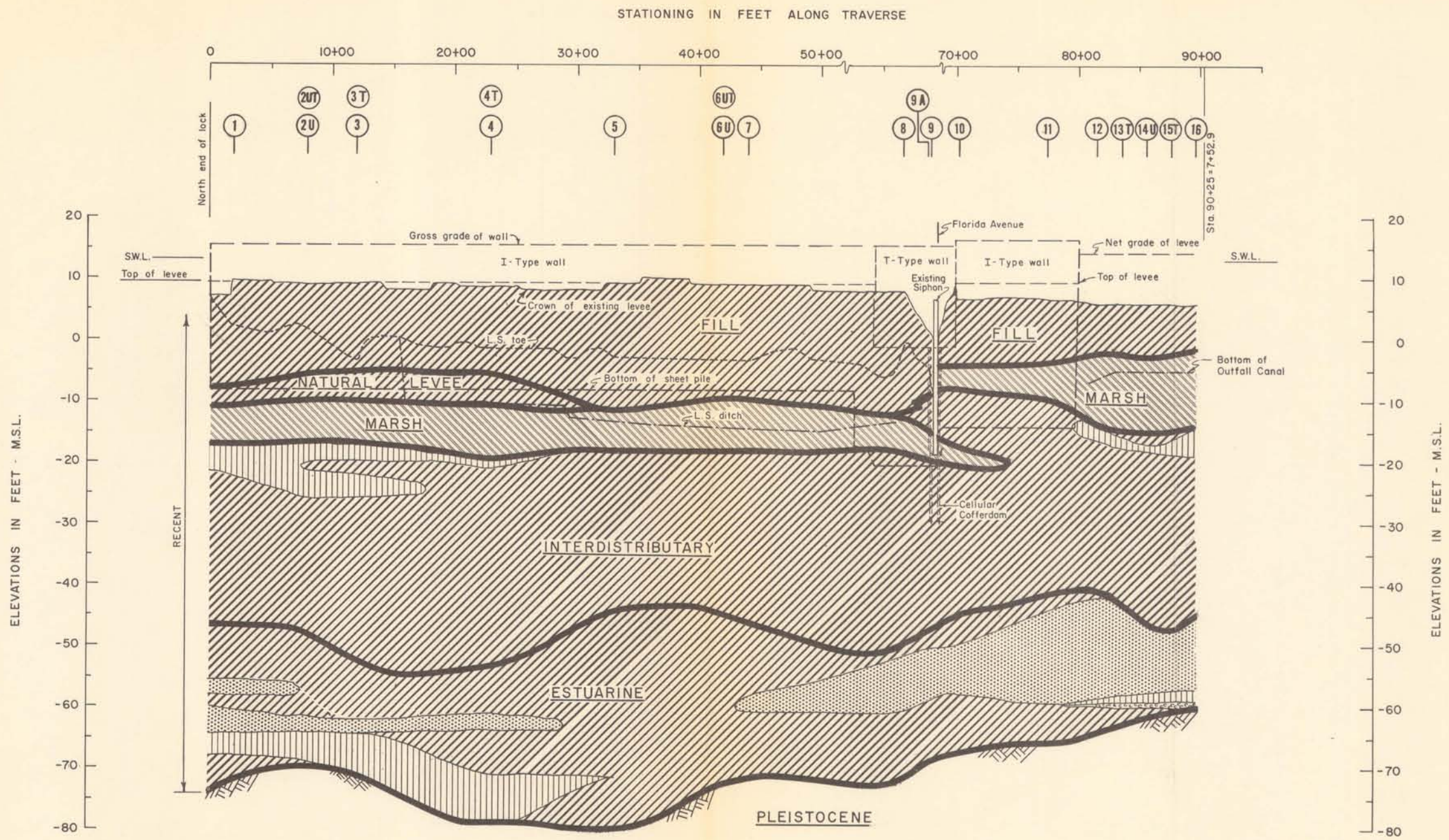

For location of soil borings see plates 2 thru 6
 For general type boring logs see plates 2 thru 6
 For undisturbed boring data see plates 30 thru 32

LAKE PONTCHARTRAIN, LA. AND VICINITY
 CHALMETTE AREA PLAN
 DESIGN MEMORANDUM NO. 3 - GENERAL DESIGN
**GENERALIZED SOIL &
 GEOLOGIC PROFILE**
 SCALES AS SHOWN

WALDEMAR S. NELSON AND CO., INC. ENGINEERS AND ARCHITECTS NEW ORLEANS, LA.	U.S. ARMY ENGINEER DISTRICT, NEW ORLEANS CORPS OF ENGINEERS, U.S. ARMY NEW ORLEANS, LA.
DATE: OCTOBER 1966	FILE NO. H-2-23820

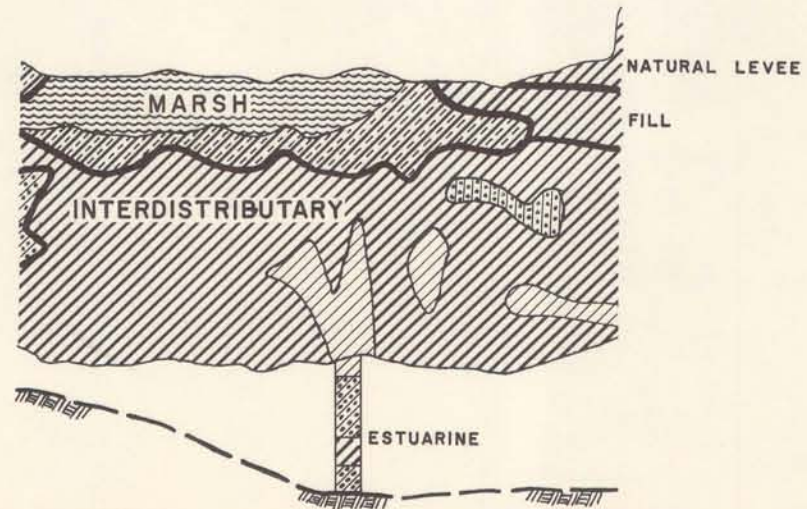
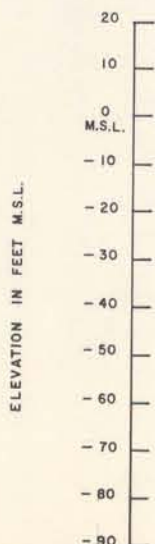
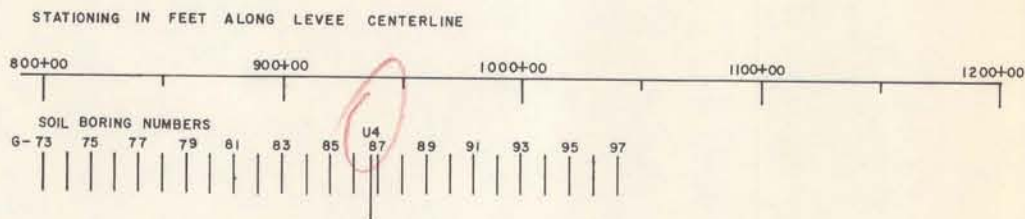
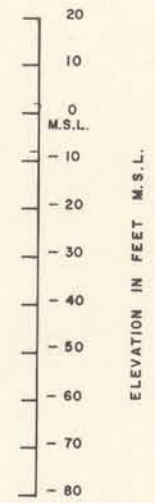
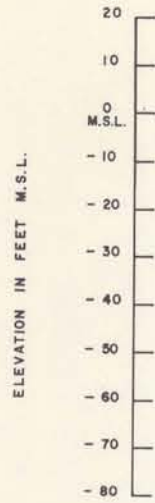
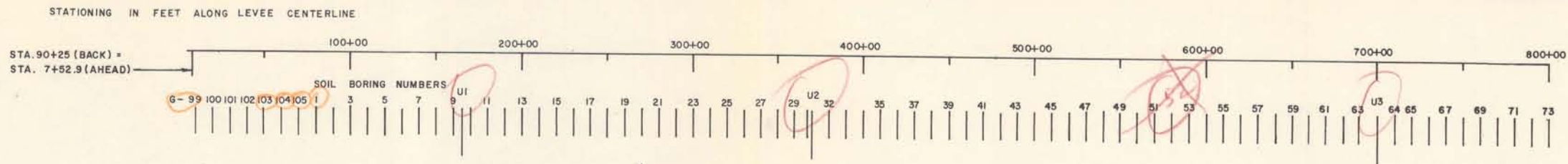

LEGEND

- (PI) PEAT
- (OH) ORGANIC CLAYS
- (CH) FAT CLAY
- (CL) LEAN CLAY
- (SC) CLAYEY SAND
- (SP) SAND, FINE (POORLY GRADED)
- (SM) SILTY SAND
- APPROX. TOP OF PLEISTOCENE

NOTE:
 THE GENERAL PURPOSE BORINGS ARE DESIGNATED AS G-99, G-5, G-73, ETC. AND THE UNDISTURBED CORE BORINGS AS U-1, U-2, U-3, & U-4. DETAILS OF U-1 THROUGH U-4 ARE SHOWN ON PLATES NO. 33-36 INCLUSIVE. DETAILS OF GENERAL PURPOSE BORINGS ARE SHOWN ON PLAN AND PROFILE SHEETS, PLATES NO. 7-18 INCLUSIVE. FOR GEOLOGIC INTERPRETATION SEE LEGEND ON PLATE NO. 28

LAKE PONTCHARTRAIN, LA. AND VICINITY
 CHALMETTE AREA PLAN
 DESIGN MEMORANDUM NO. 3—GENERAL DESIGN
**GENERALIZED SOIL AND
 GEOLOGIC PROFILE-2**

SCALES AS SHOWN

WALDEMAR S. NELSON AND COMPANY, INC.
 ENGINEERS AND ARCHITECTS
 NEW ORLEANS, LA.

U. S. ARMY ENGINEER DISTRICT, NEW ORLEANS
 CORPS OF ENGINEERS, U. S. ARMY
 NEW ORLEANS, LA.

DATE: NOVEMBER 1966 FILE NO. H-2-23820

2-U
STA. 8+00
ON C and B/L
12-13 Nov. 1965

WATER CONTENT, "W"
(Percent dry weight)

SHEAR STRENGTH, "C"
(Pounds/sq. ft.)

WET DENSITY, "γ"
(Pounds/cu. ft.)

NORMAL STRESS, "σ"
(Tons/sq. ft.)

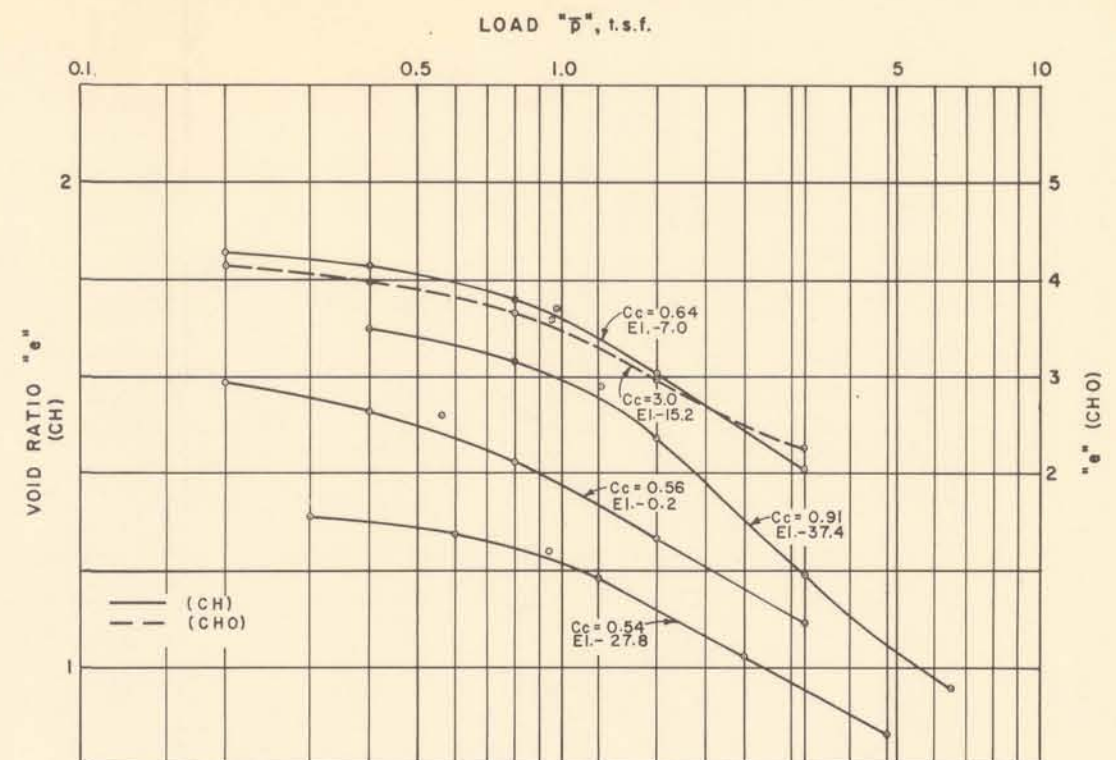
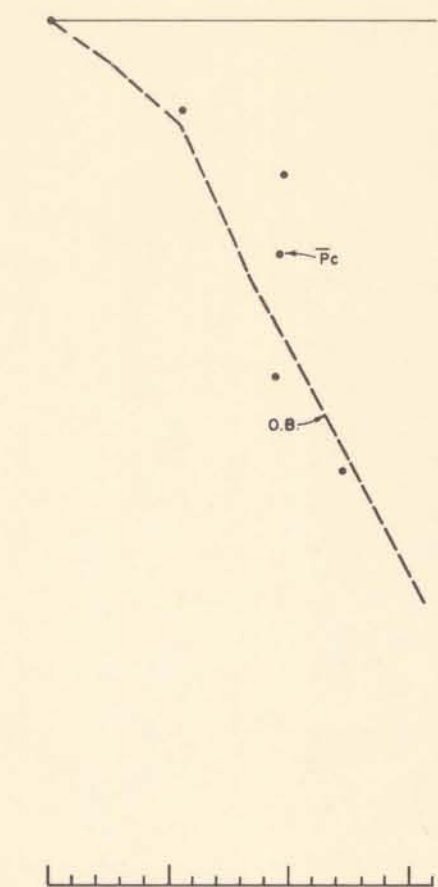
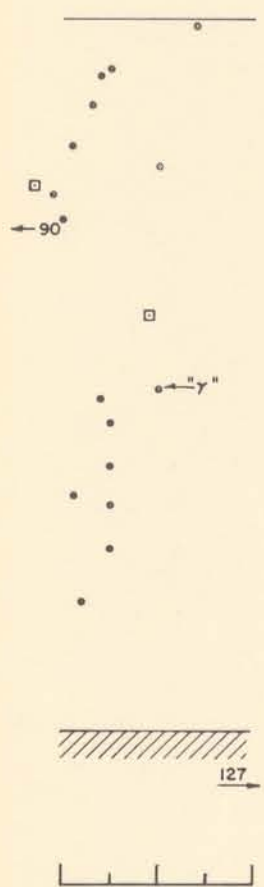
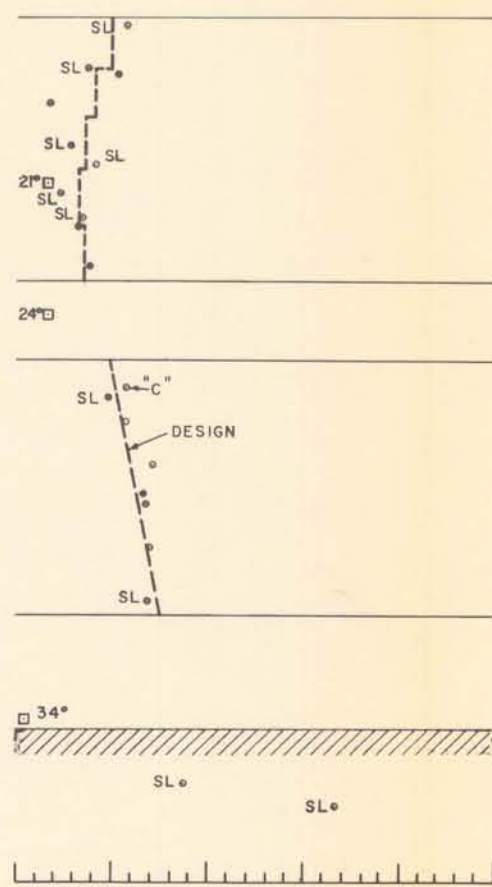
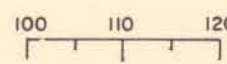
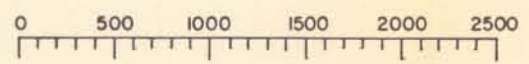
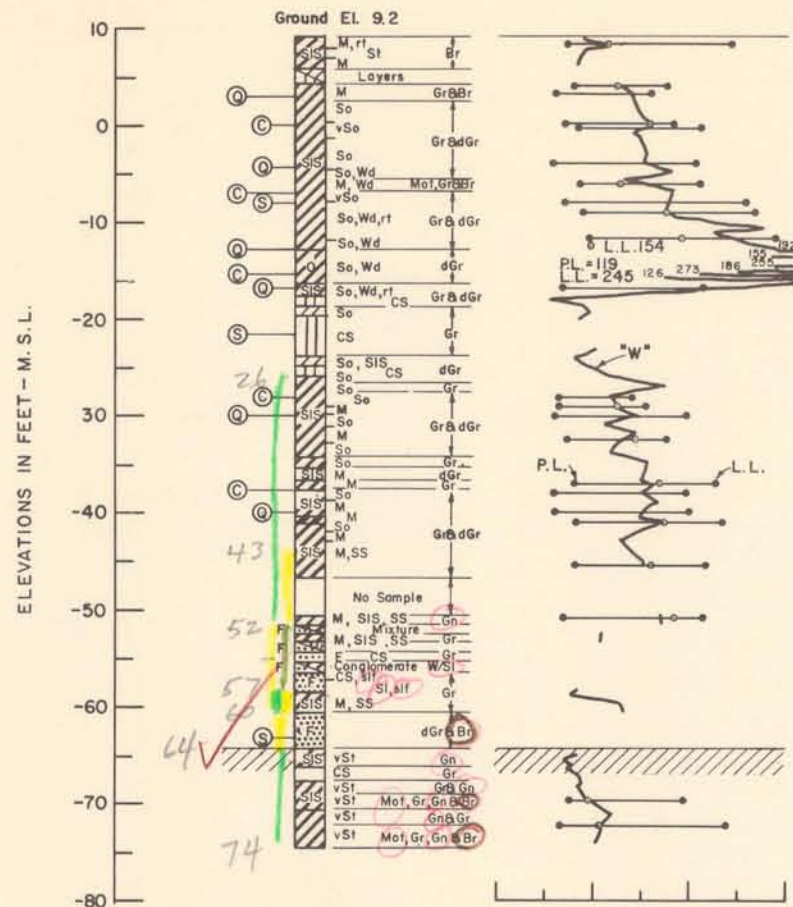

CONSOLIDATION DATA

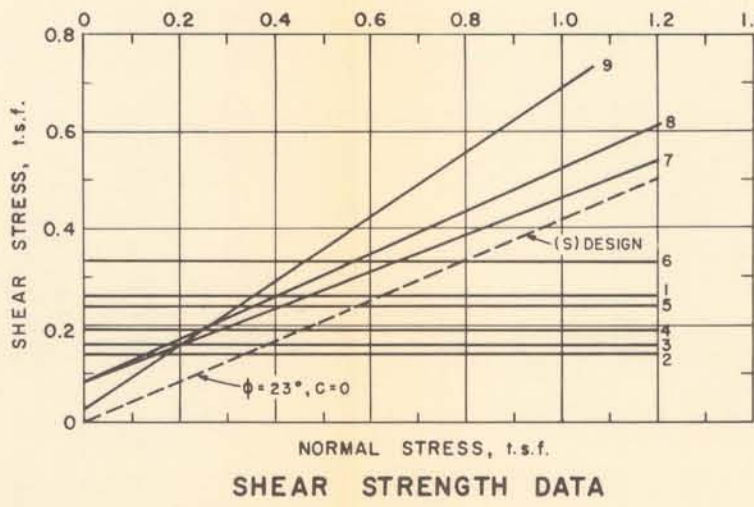
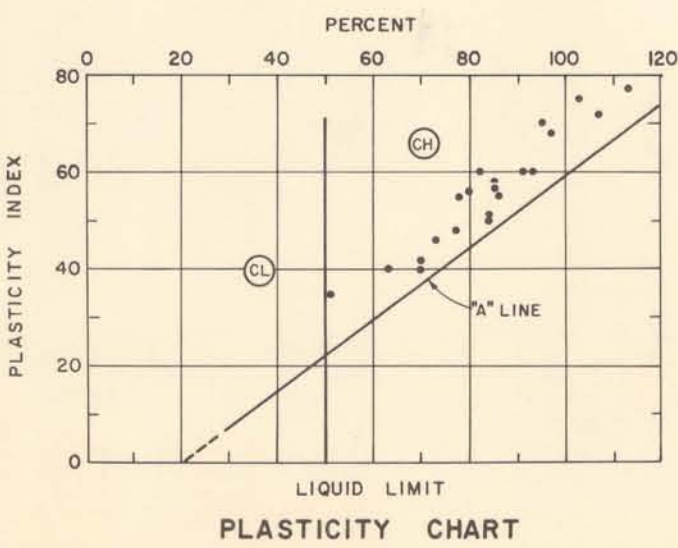

ENVELOPE NO.	EL.	TYPE	STRENGTH φ°	STRENGTH c (t.s.f.)	CLASSIFICATION
1	3.2			0.26	CH
2	-4.0			0.14	CH
3	-12.4			0.16	CHO
4	-16.6	Q	0	0.19	CH
5	-29.8			0.24	CH
6	-39.9			0.33	CH
7	-80		21	0.08	CH
8	-21.6	S	24	0.08	CH
9	-63.2		34	0.02	SP-F

See Plate A for soil boring legend
See Plate 31 for general notes
See Plate 45 for detail shear test data
See Plate 2 for location of undisturbed boring 2-U

LAKE PONTCHARTRAIN, LA. AND VICINITY
CHALMETTE AREA PLAN
DESIGN MEMORANDUM NO. 3 - GENERAL DESIGN

UNDISTURBED BORING 2-U DATA
SCALES AS SHOWN

WALDEMAR S. NELSON AND CO., INC.
ENGINEERS AND ARCHITECTS
NEW ORLEANS, LA.

U.S. ARMY ENGINEER DISTRICT, NEW ORLEANS
CORPS OF ENGINEERS, U.S. ARMY
NEW ORLEANS, LA.

DATE: OCTOBER 1966 FILE NO. H-2-23820

6-U
 STA. 42+00
 26' Canal side B/L
 12-13 Nov. 1965

WATER CONTENT, "W"
 (Percent dry weight)



SHEAR STRENGTH, "C"
 (Pounds/sq. ft.)

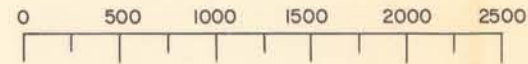

WET DENSITY, "γ"
 (Pounds/cu. ft.)



NORMAL STRESS, "σ"
 (Tons/sq. ft.)

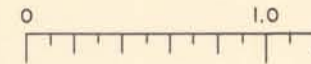

ELEVATIONS IN FEET - M.S.L.

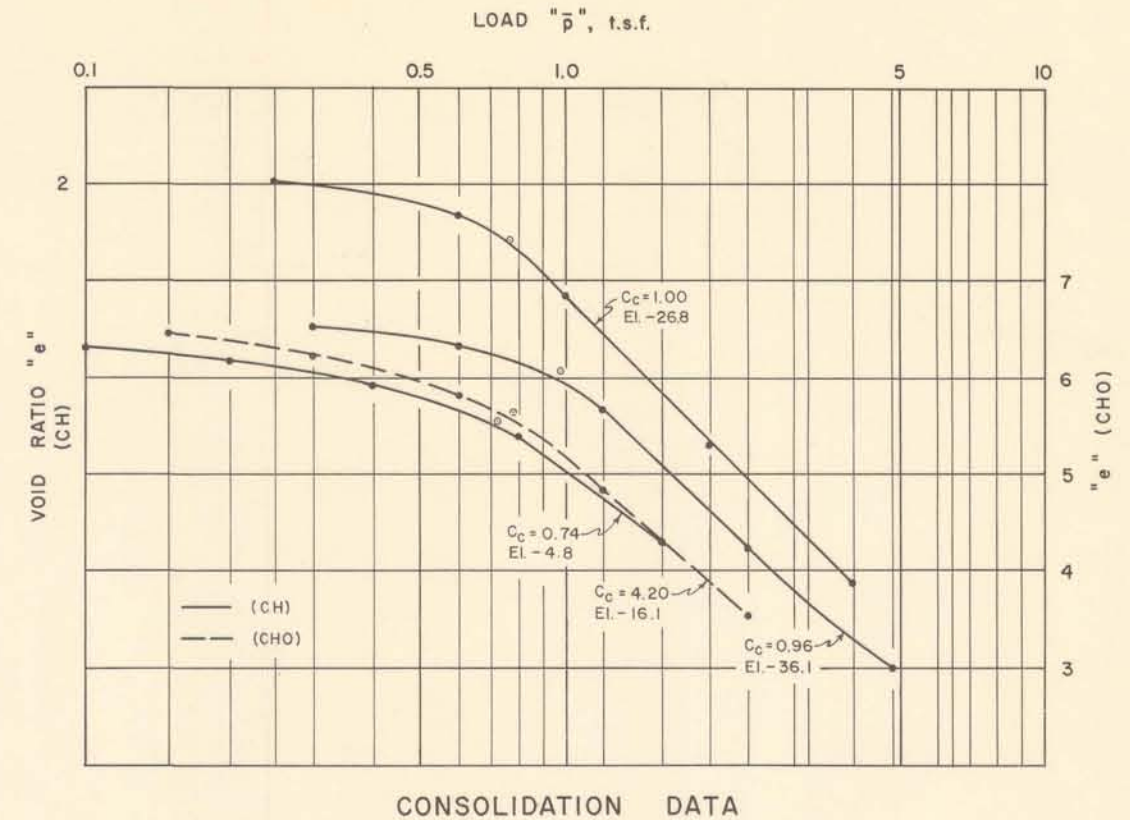
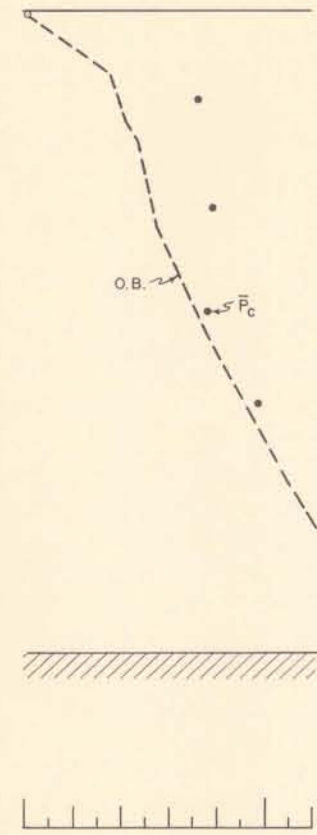
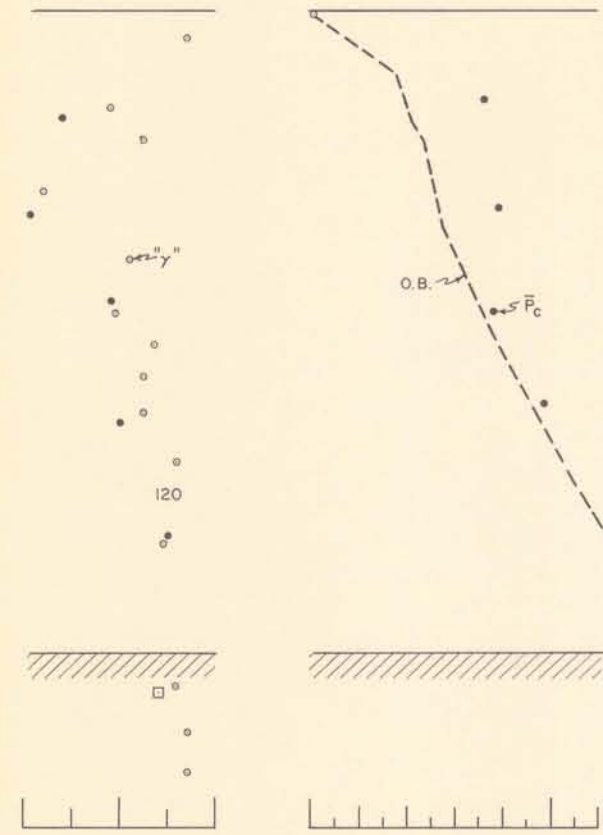
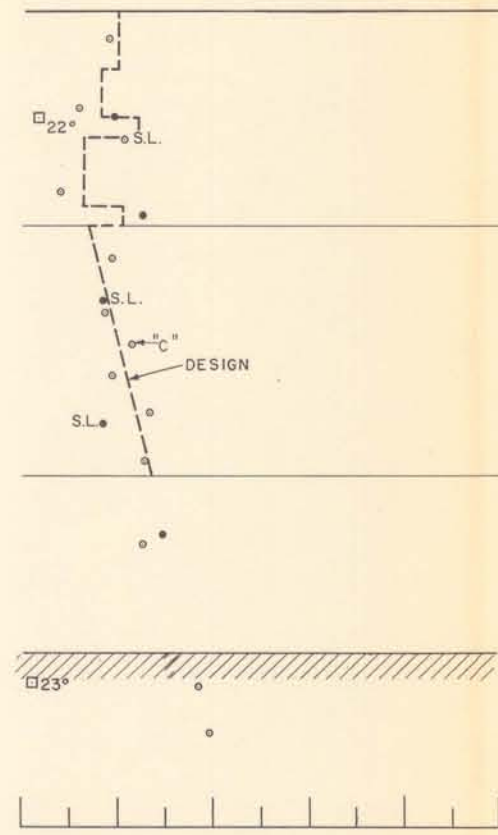
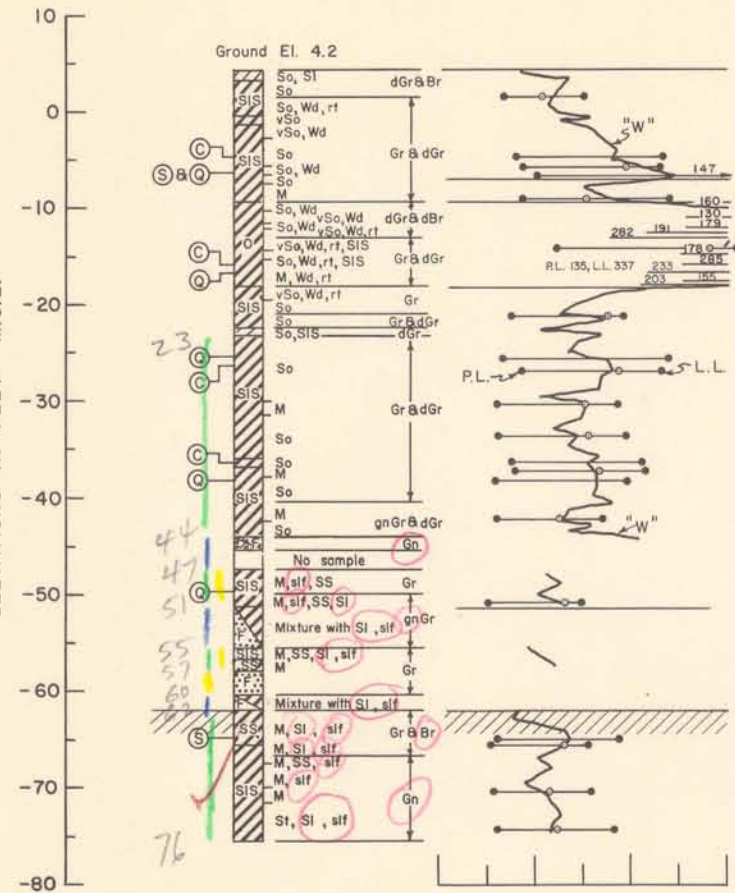

GENERAL NOTES

- UC - Unconfined compression shear
- ⊙ - Unconsolidated undrained triaxial shear
- ⊙ - Consolidated drained direct shear
- ⊙ - Consolidation test
- w - Natural water content
- LL - Liquid limit
- P.L. - Plastic limit
- c - Unit cohesion
- φ - Angle of friction
- γ - Unit weight of soil-water system
- σ - Normal stress
- O.B. - Overburden
- P_c - Preconsolidation pressure
- e - Void ratio
- C_c - Compression index

See plate A for soil boring legend
 See plate 45 for detail shear test data
 See plate 4 for location of undisturbed boring 6-U.

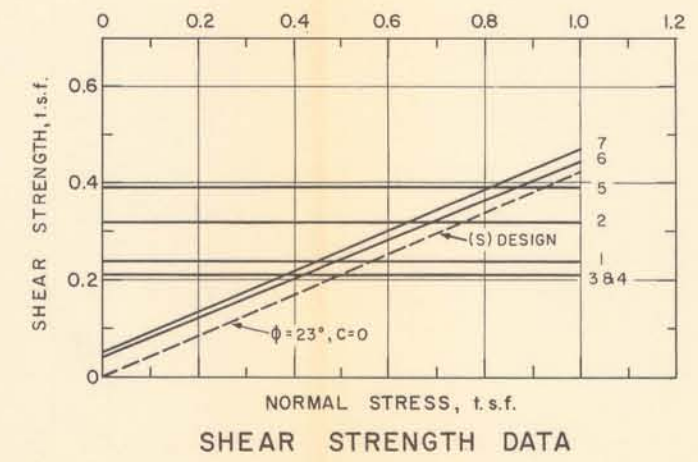
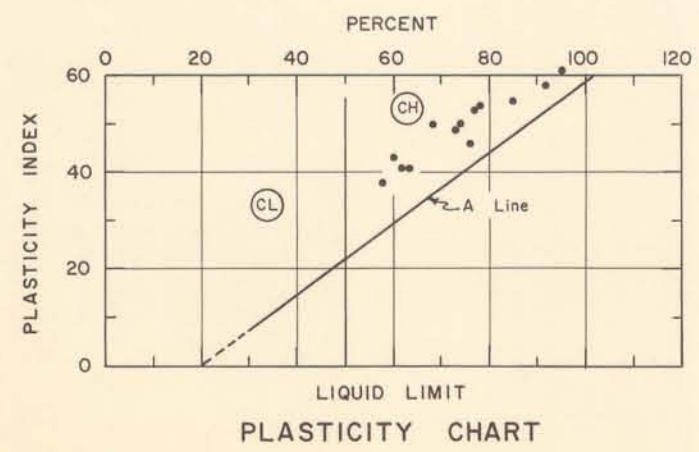

ENVELOPE No.	EI.	TYPE	STRENGTH		CLASS
			φ°	c (t.s.f.)	
1	-6.7			0.24	CH
2	-16.8			0.32	CHO
3	-25.7	Q	0	0.21	CH
4	-38.3			0.21	CH
5	-49.8			0.39	CH
6	-6.7	S	22	0.04	CH
7	-65.1		23	0.05	CH

LAKE PONTCHARTRAIN, LA. AND VICINITY
 CHALMETTE AREA PLAN
 DESIGN MEMORANDUM NO.3- GENERAL DESIGN

**UNDISTURBED BORING
 6-U DATA**

SCALES AS SHOWN

WALDEMAR S. NELSON AND CO., INC. ENGINEERS AND ARCHITECTS NEW ORLEANS, LA.	U.S. ARMY ENGINEER DISTRICT, NEW ORLEANS CORPS OF ENGINEERS, U.S. ARMY NEW ORLEANS, LA.
DATE: OCTOBER 1966	FILE NO. H-2-23820

6-UT
STA. 42+00
56' Landside B/L
28 Mar. 1966

WATER CONTENT, "W"
(Percent dry weight)

SHEAR STRENGTH, "C"
(Pounds/sq. ft.)

WET DENSITY, " γ "
(Pounds/cu. ft.)

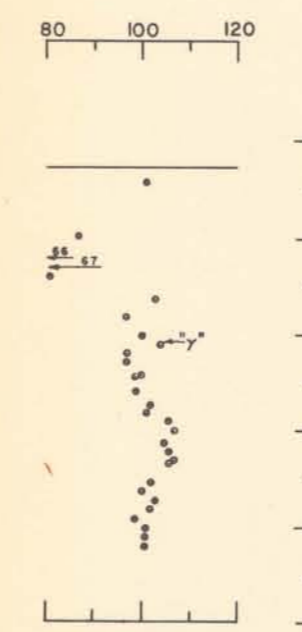
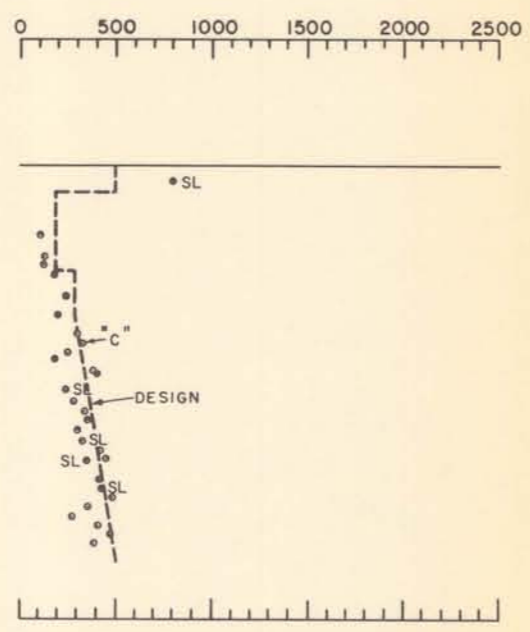
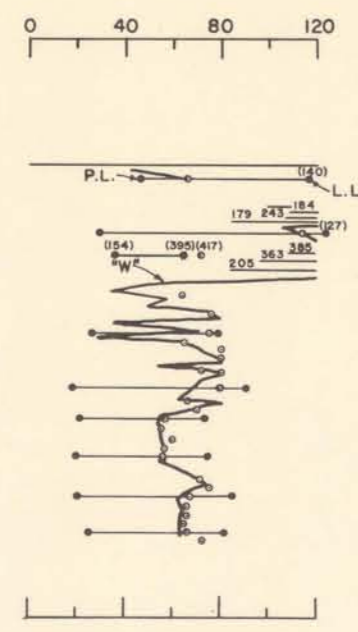
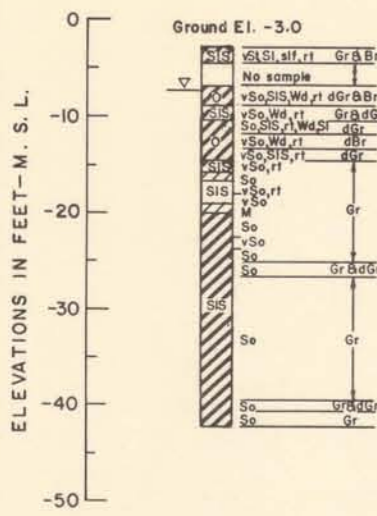

14-U
STA. 85+40
on Centerline B/L
4-5 May 1966

WATER CONTENT, "W"
(Percent dry weight)

SHEAR STRENGTH, "C"
(Pounds/sq. ft.)

WET DENSITY, " γ "
(Pounds/cu. ft.)

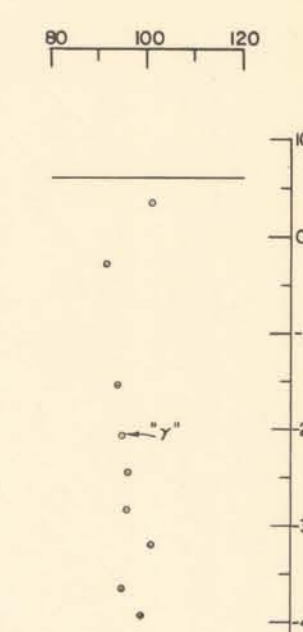
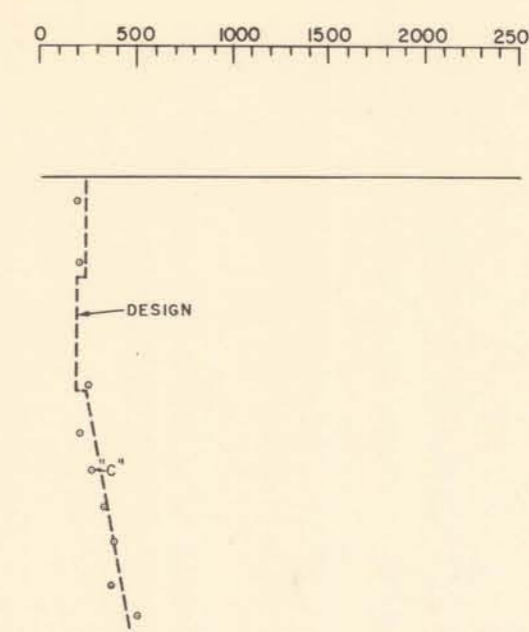
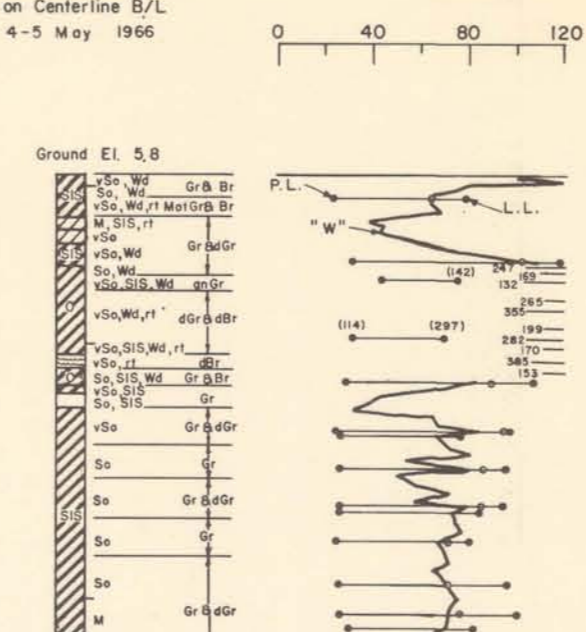
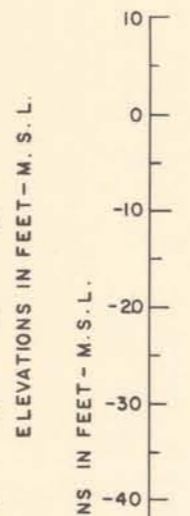

2-UT
STA. 8+00
42' Landside B/L
28-29 Mar. 1966

WATER CONTENT, "W"
(Percent dry weight)

SHEAR STRENGTH, "C"
(Pounds/sq. ft.)

WET DENSITY, " γ "
(Pounds/cu. ft.)

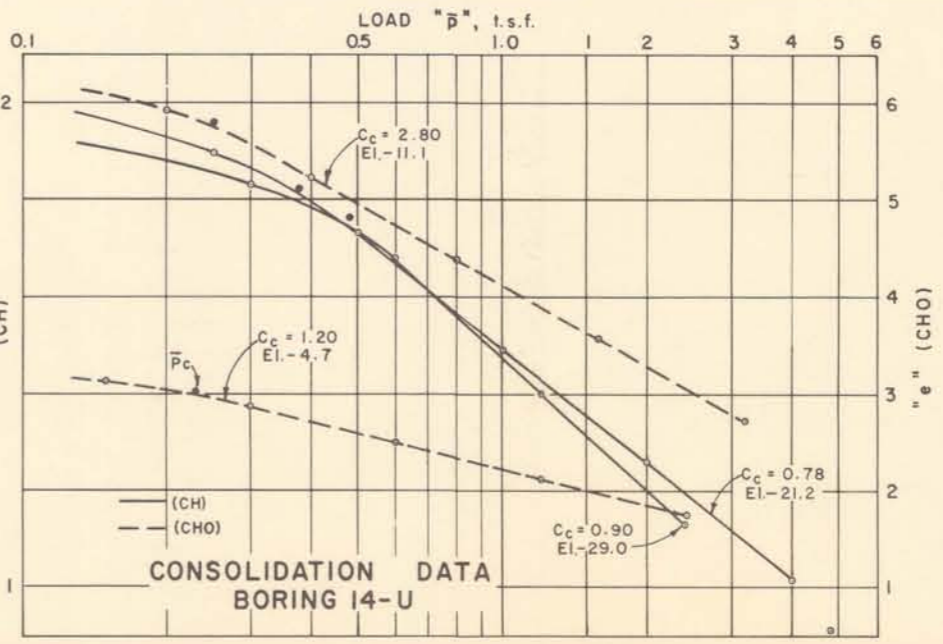
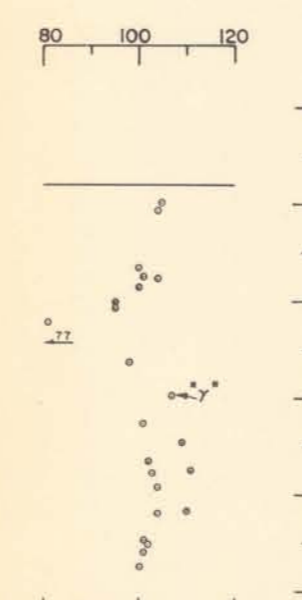
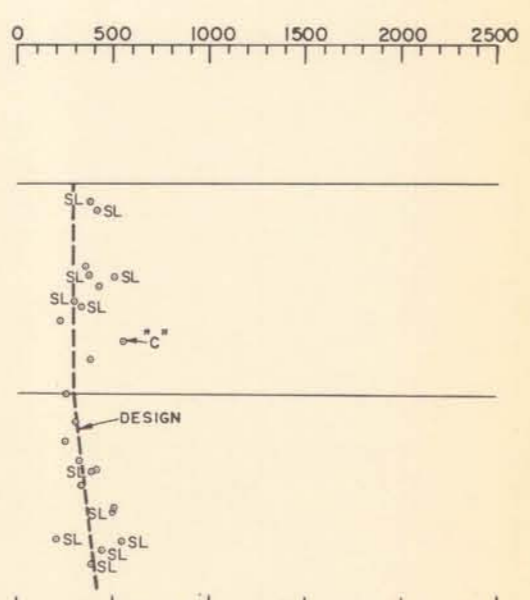
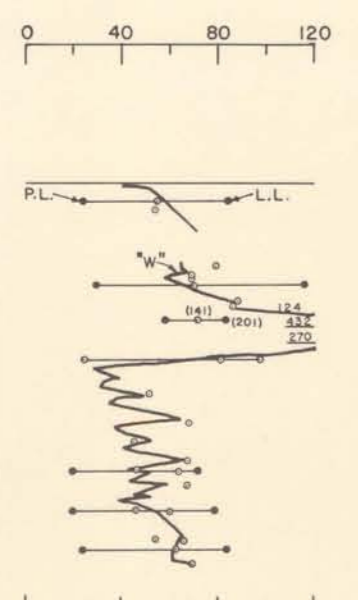
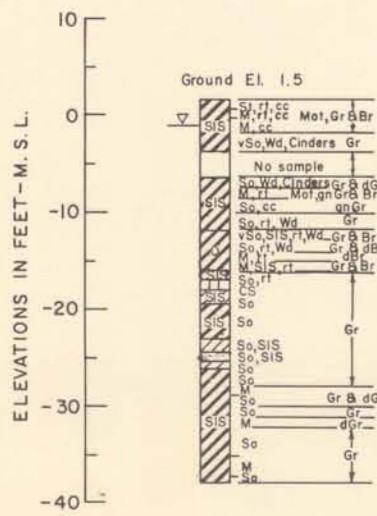

See Plate 4 for location of undisturbed boring 6-UT.
See Plate 2 for location of undisturbed boring 2-UT.
See Plate 6 for location of undisturbed boring 14-U.
See Plate A for soil boring legend.
See Plate 31 for general notes.

LAKE PONTCHARTRAIN, LA. AND VICINITY
CHALMETTE AREA PLAN
DESIGN MEMORANDUM NO. 3 - GENERAL DESIGN

**UNDISTURBED BORINGS
2-UT, 6-UT AND 14-U DATA**

SCALES AS SHOWN

WALDEMAR'S NELSON AND CO., INC.
ENGINEERS AND ARCHITECTS
NEW ORLEANS, LA.

U.S. ARMY ENGINEER DISTRICT, NEW ORLEANS
CORPS OF ENGINEERS, U.S. ARMY
NEW ORLEANS, LA.

DATE: OCTOBER 1966 FILE NO. H-2-23820

BORING NO. U-1
 STA. 165+00 10' L.T. \pm
 APRIL 16-18, 1966
 Ground El. 5.2 M.S.L.

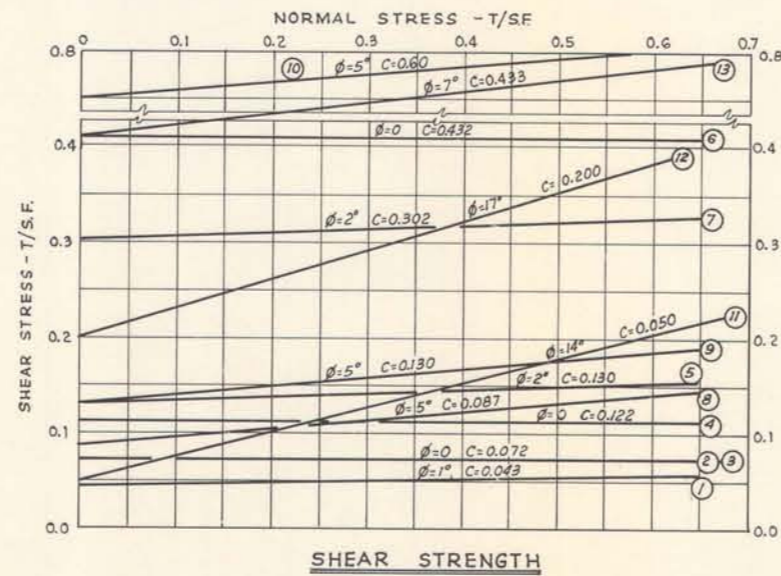
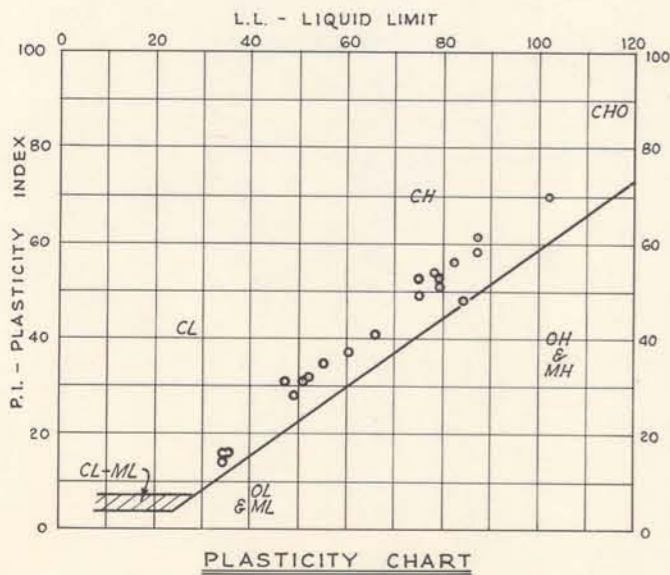
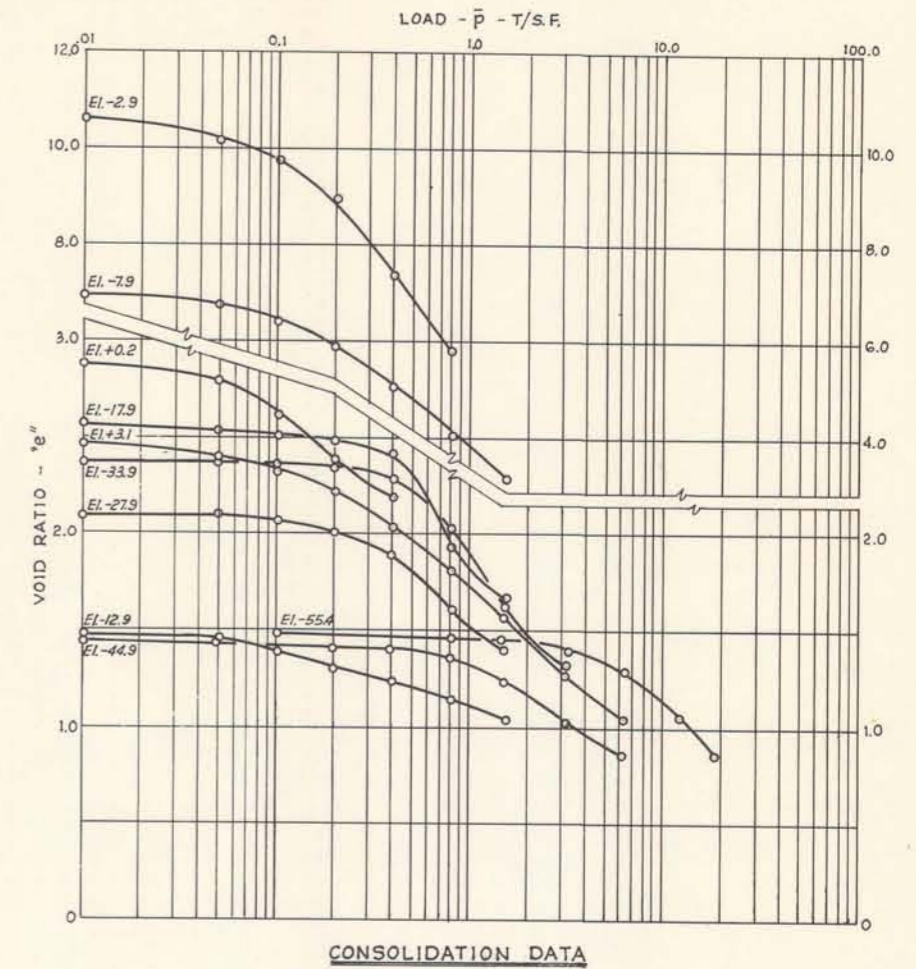
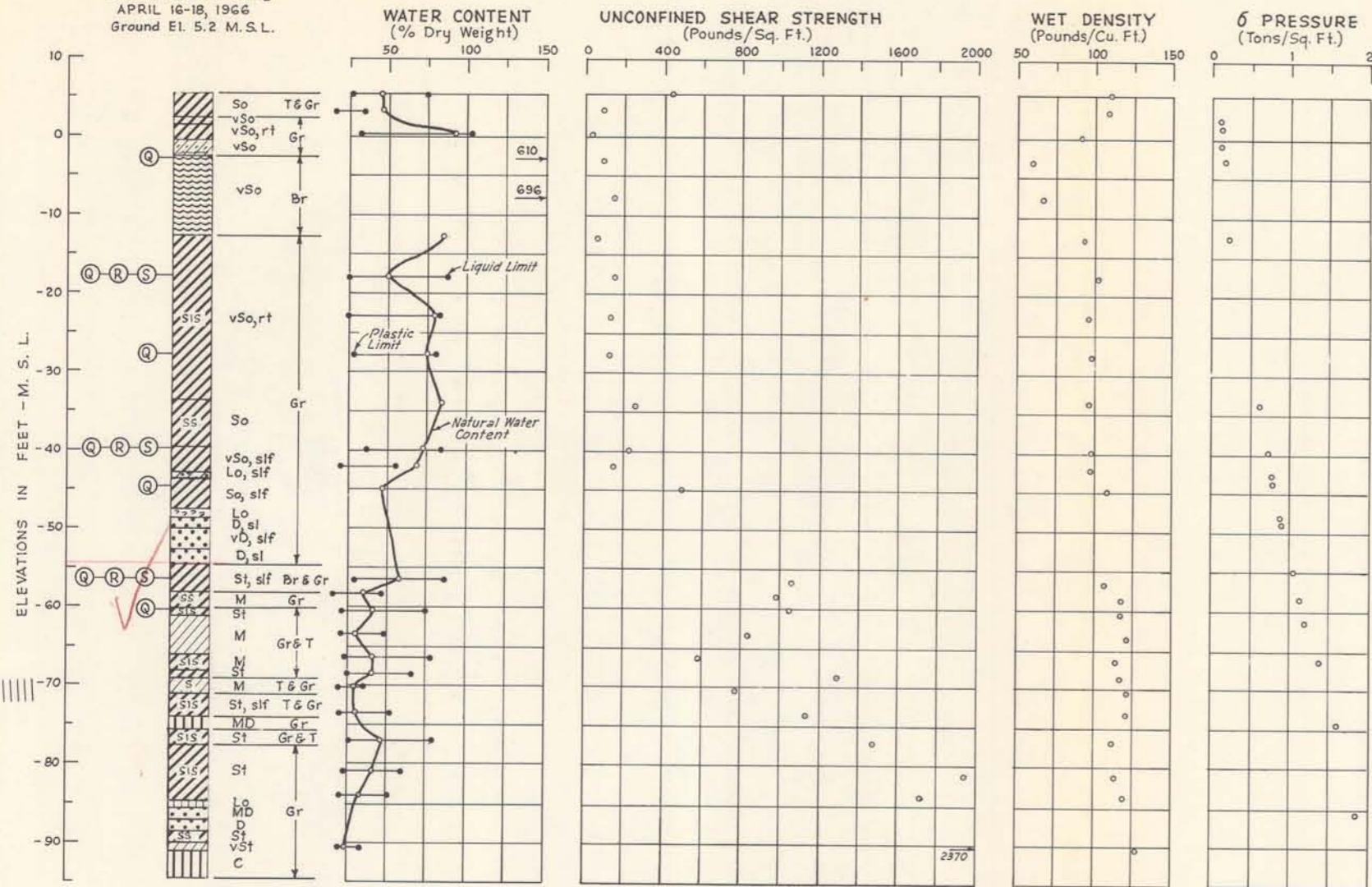

EL. M.S.L.	Q (UU)	R (CU)	S (CD)
-2.8	(1)		
-17.8	(2)	(8)	(11)
-27.8	(3)	(9)	(12)
-39.8	(4)	(10)	(13)
-44.8	(5)		
-56.3	(6)		
-60.3	(7)		

See Plate A for soil boring legend
 See Plate 31 for general notes
 See Plates 46 & 47 for detail shear test data
 See Plate 8 for location of undisturbed boring U-1

LAKE PONTCHARTRAIN, LA. AND VICINITY
 CHALMETTE AREA PLAN
 DESIGN MEMORANDUM NO. 3—GENERAL DESIGN
**UNDISTURBED BORING U-1
 TEST DATA**

SCALES AS SHOWN

WALDEMAR S. NELSON AND COMPANY, INC. ENGINEERS AND ARCHITECTS NEW ORLEANS, LA.	U. S. ARMY ENGINEER DISTRICT, NEW ORLEANS CORPS OF ENGINEERS, U. S. ARMY NEW ORLEANS, LA.
DATE: NOVEMBER 1966	FILE NO. H-2-23820

BORING NO. U-2

STA. 370+00 10' LT. &
 APRIL 15-16, 1966
 Ground El. 3.1 M.S.L.

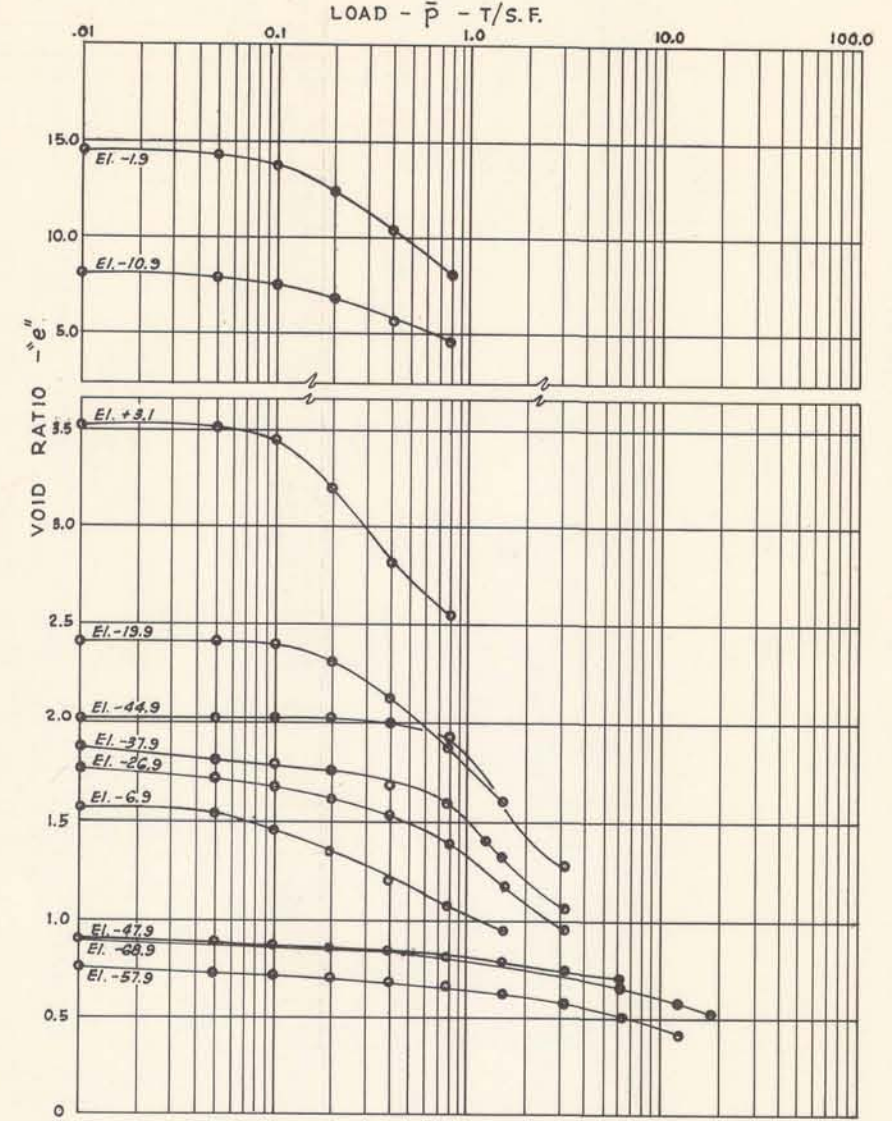
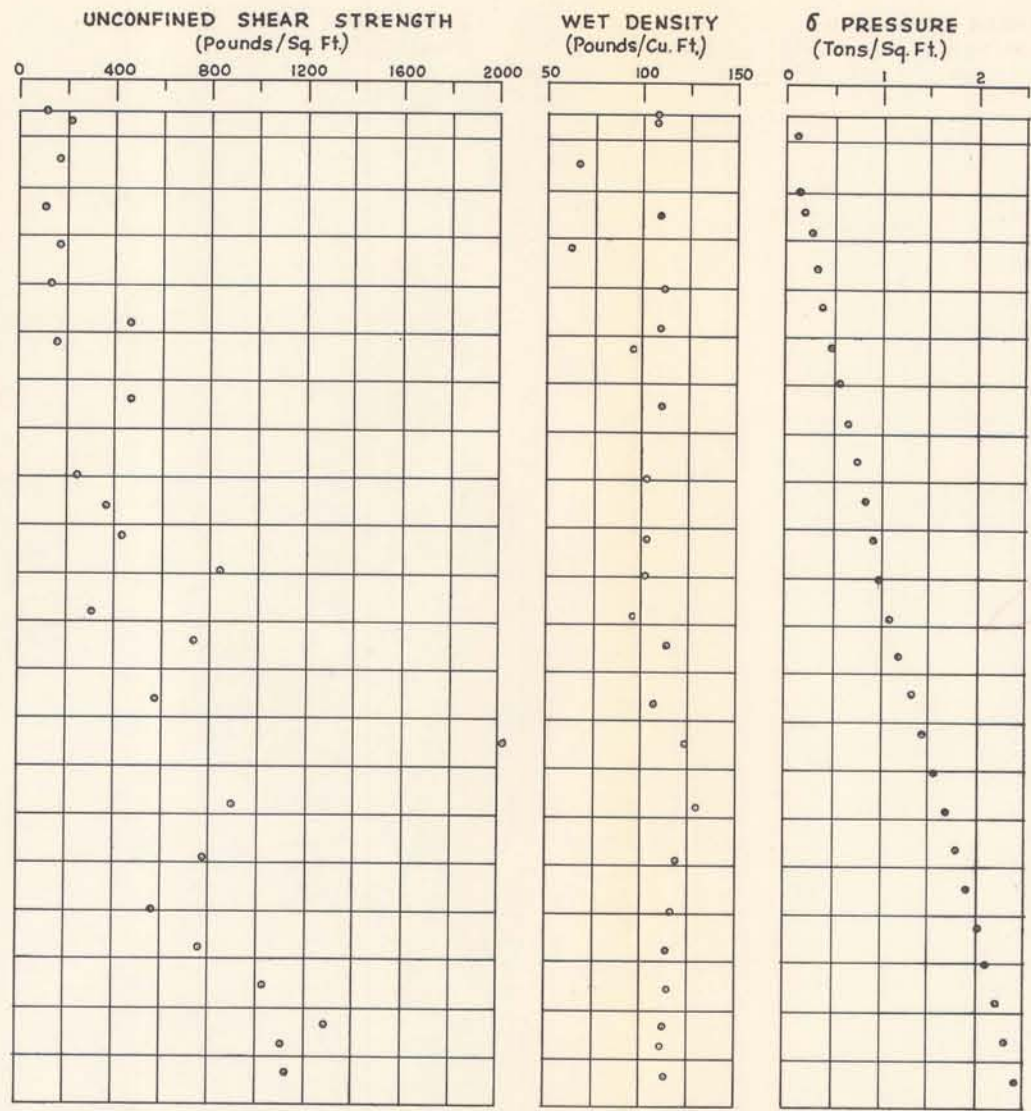
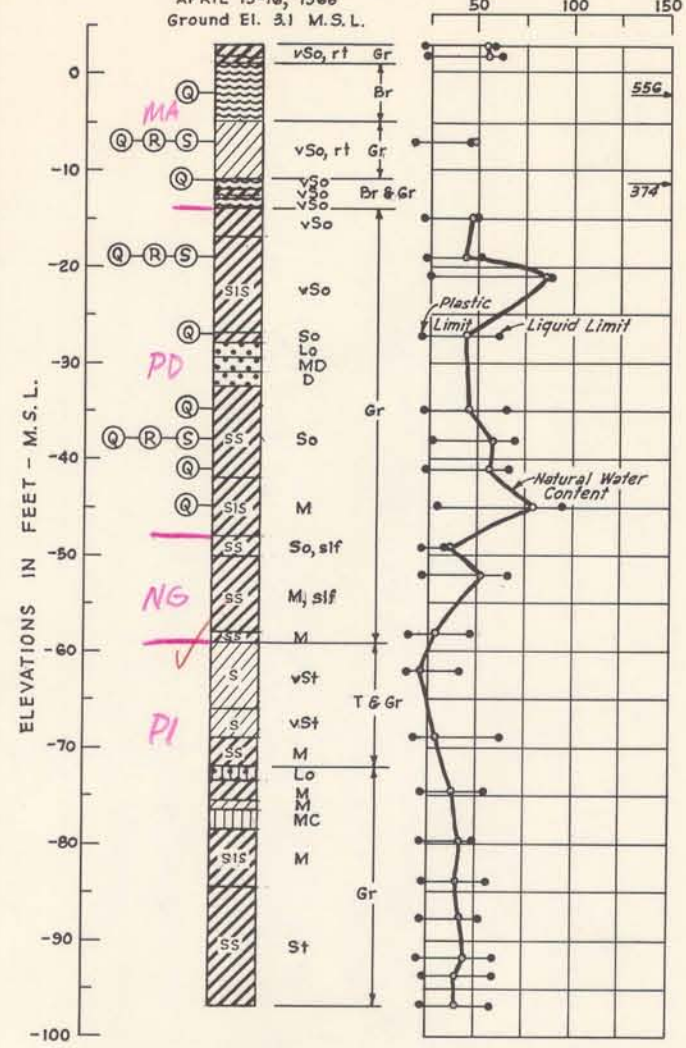

CONSOLIDATION DATA

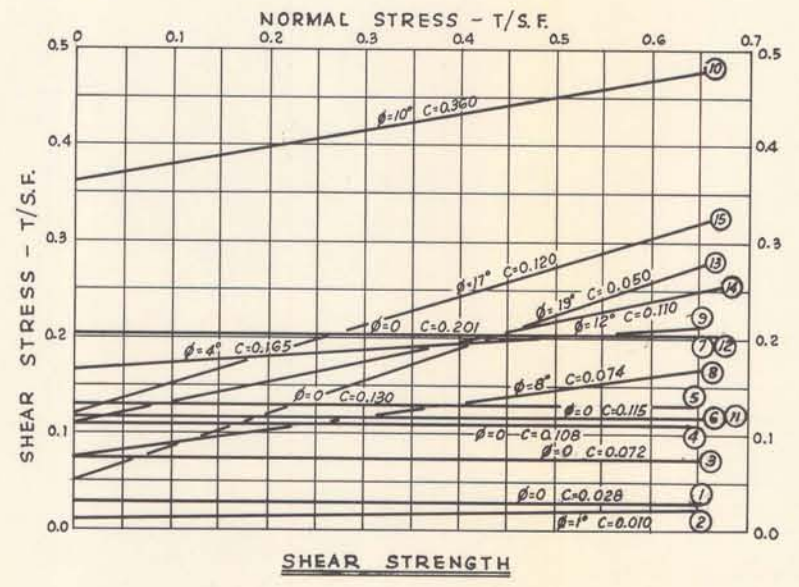
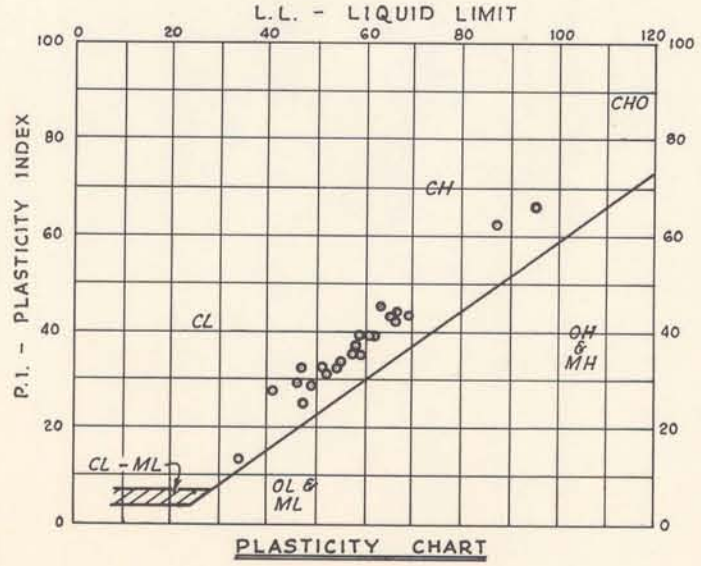

EL. M.S.L.	Q(UU)	R(CU)	S(CD)
- 1.9	(1)		
- 6.9	(2)	(8)	(13)
-10.9	(3)		
-18.9	(4)	(9)	(14)
-26.9	(5)		
-37.9	(6)	(10)	(15)
-44.9	(7)		
-34.9	(11)		
-40.9	(12)		

See Plate A for soil boring legend
 See Plate 31 for general notes
 See Plates 48 & 49 for detail shear test data
 See Plate 10 for location of undisturbed boring U-2

LAKE PONTCHARTRAIN, LA. AND VICINITY
 CHALMETTE AREA PLAN
 DESIGN MEMORANDUM NO. 3—GENERAL DESIGN
**UNDISTURBED BORING U-2
 TEST DATA**
 SCALES AS SHOWN
 WALDEMAR S. NELSON AND COMPANY, INC.
 ENGINEERS AND ARCHITECTS
 NEW ORLEANS, LA.
 U. S. ARMY ENGINEER DISTRICT, NEW ORLEANS
 CORPS OF ENGINEERS, U. S. ARMY
 NEW ORLEANS, LA.
 DATE: NOVEMBER 1966
 FILE NO. H-2-23820

BORING NO. U-3
 STA. 700+00 ON ϕ
 APRIL 27, 1966
 Ground El. 8.2 M.S.L.

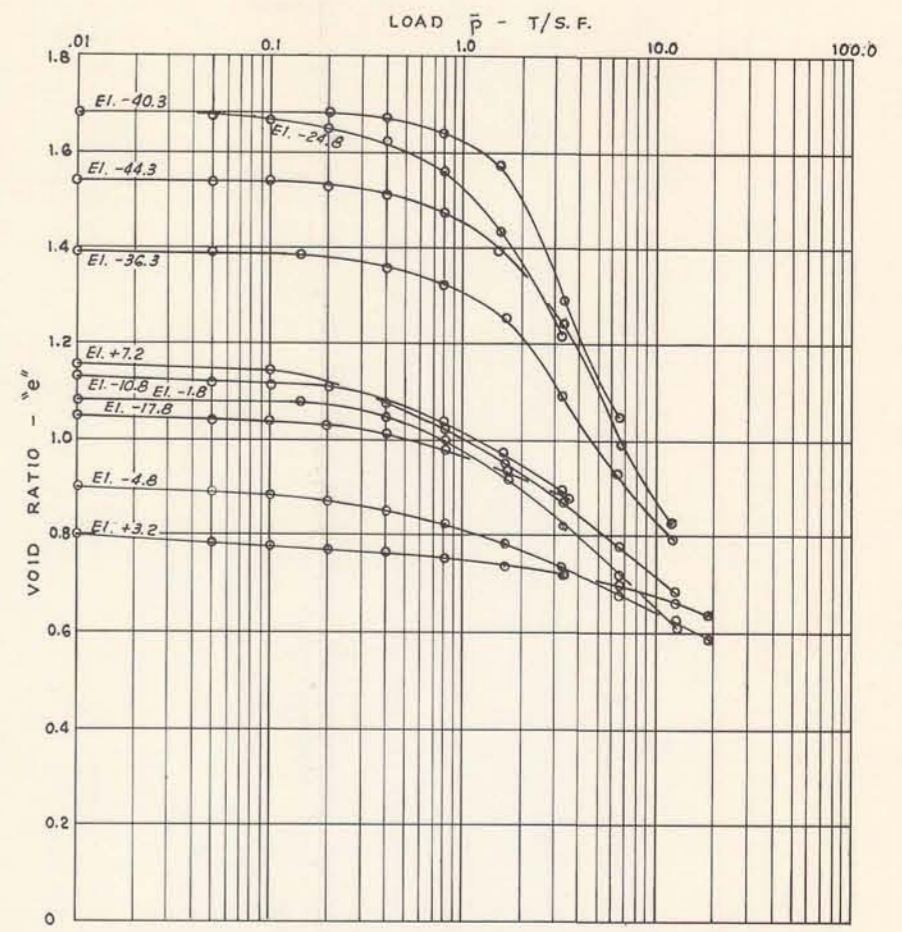
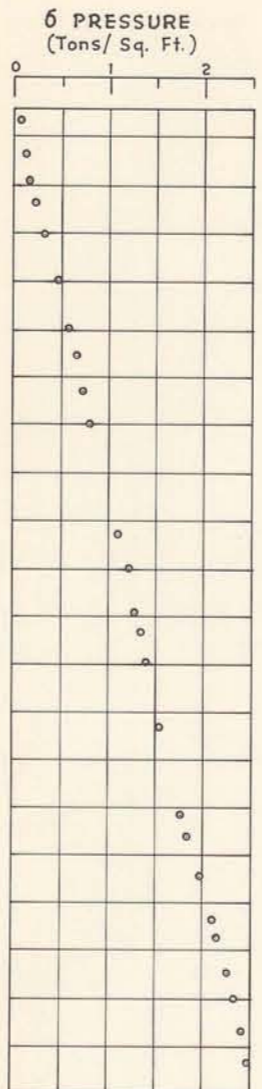
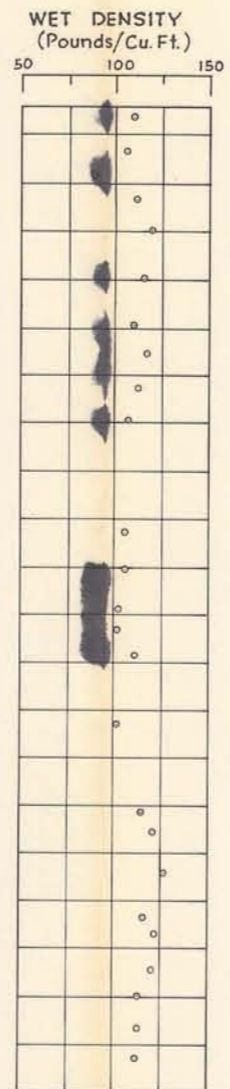
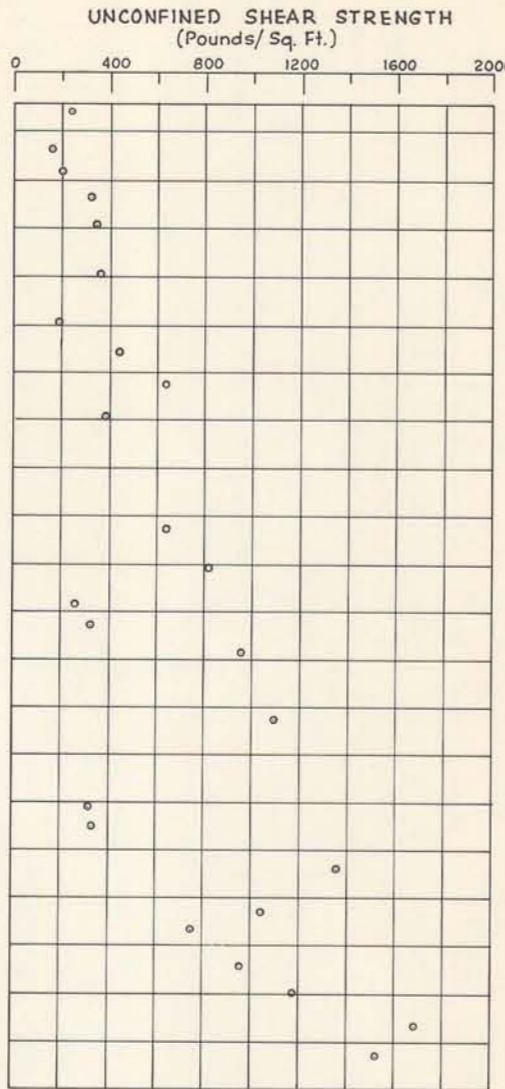
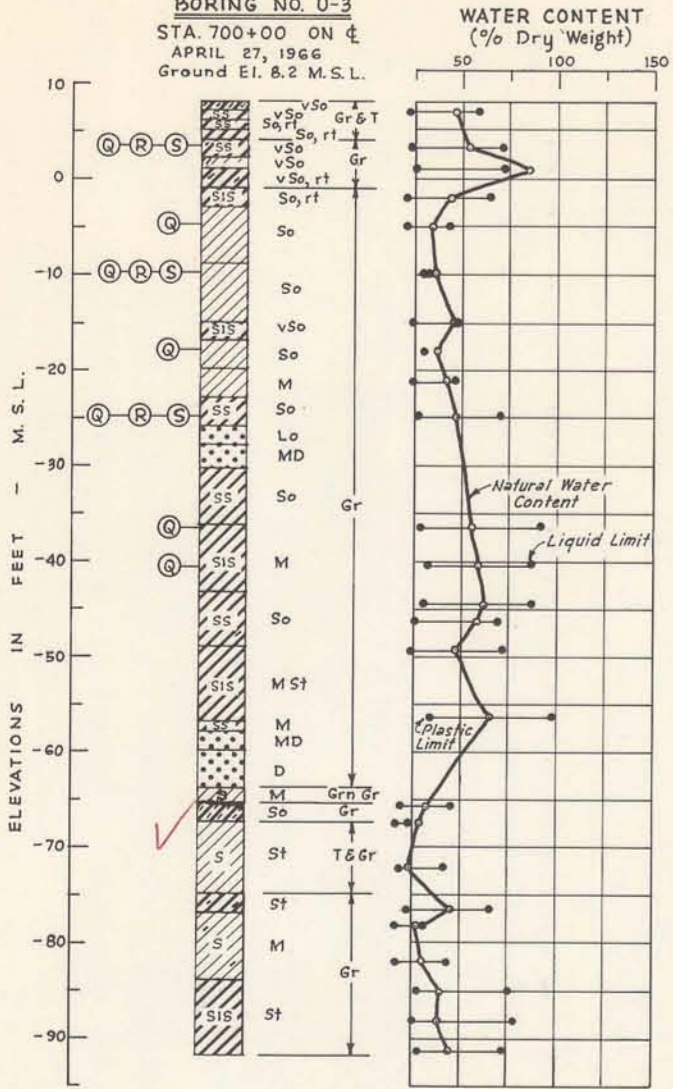

CONSOLIDATION DATA

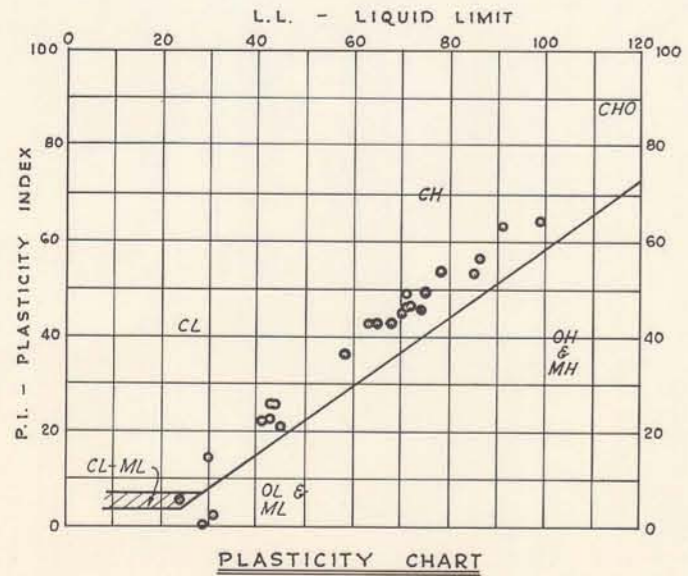

PLASTICITY CHART

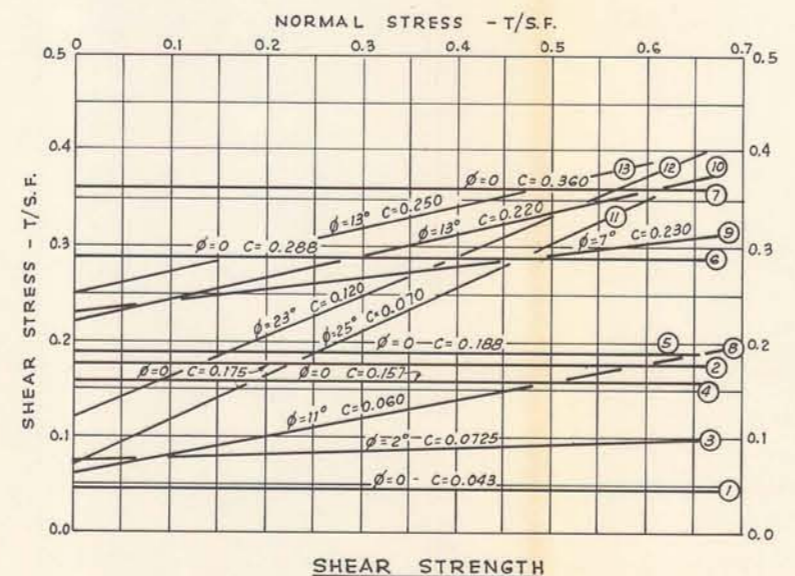

SHEAR STRENGTH

EL. M.S.L.	Q(UU)	R(CU)	S(CD)
3.7	(1)	(8)	(11)
-4.8	(2)		
-9.8	(3)	(9)	(12)
-17.8	(4)		
-24.8	(5)	(10)	(13)
-36.3	(6)		
-40.3	(7)		

See Plate A for soil boring legend
 See Plate 31 for general notes
 See Plates 50 & 51 for detail shear test data
 See Plate 14 for location of undisturbed boring U-3

LAKE PONTCHARTRAIN, LA. AND VICINITY
 CHALMETTE AREA PLAN
 DESIGN MEMORANDUM NO. 3—GENERAL DESIGN
**UNDISTURBED BORING U-3
 TEST DATA**

SCALES AS SHOWN

WALDEMAR S. NELSON AND COMPANY, INC. ENGINEERS AND ARCHITECTS NEW ORLEANS, LA.	U. S. ARMY ENGINEER DISTRICT, NEW ORLEANS CORPS OF ENGINEERS, U. S. ARMY NEW ORLEANS, LA.
--	---

DATE: NOVEMBER 1966 FILE NO. H-2-23820

BORING NO. U-4
 STA. 938+07 10' RT. ϕ
 MAY 9-10, 1966
 Ground El. 1.6 M.S.L.

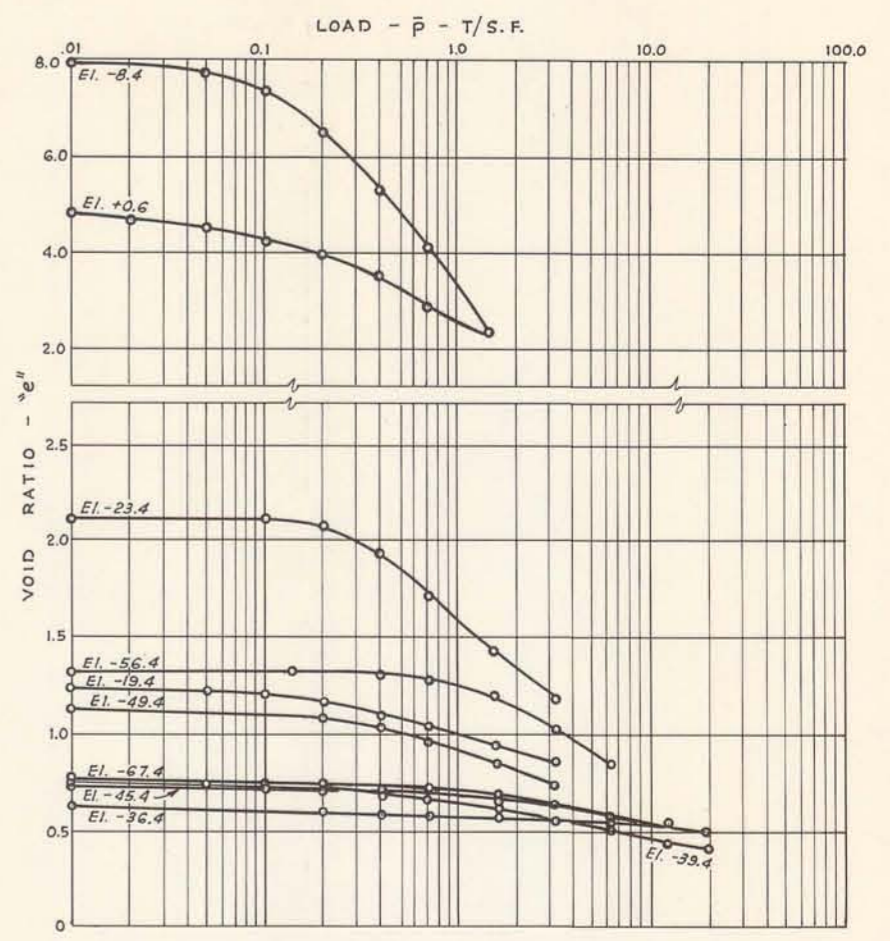
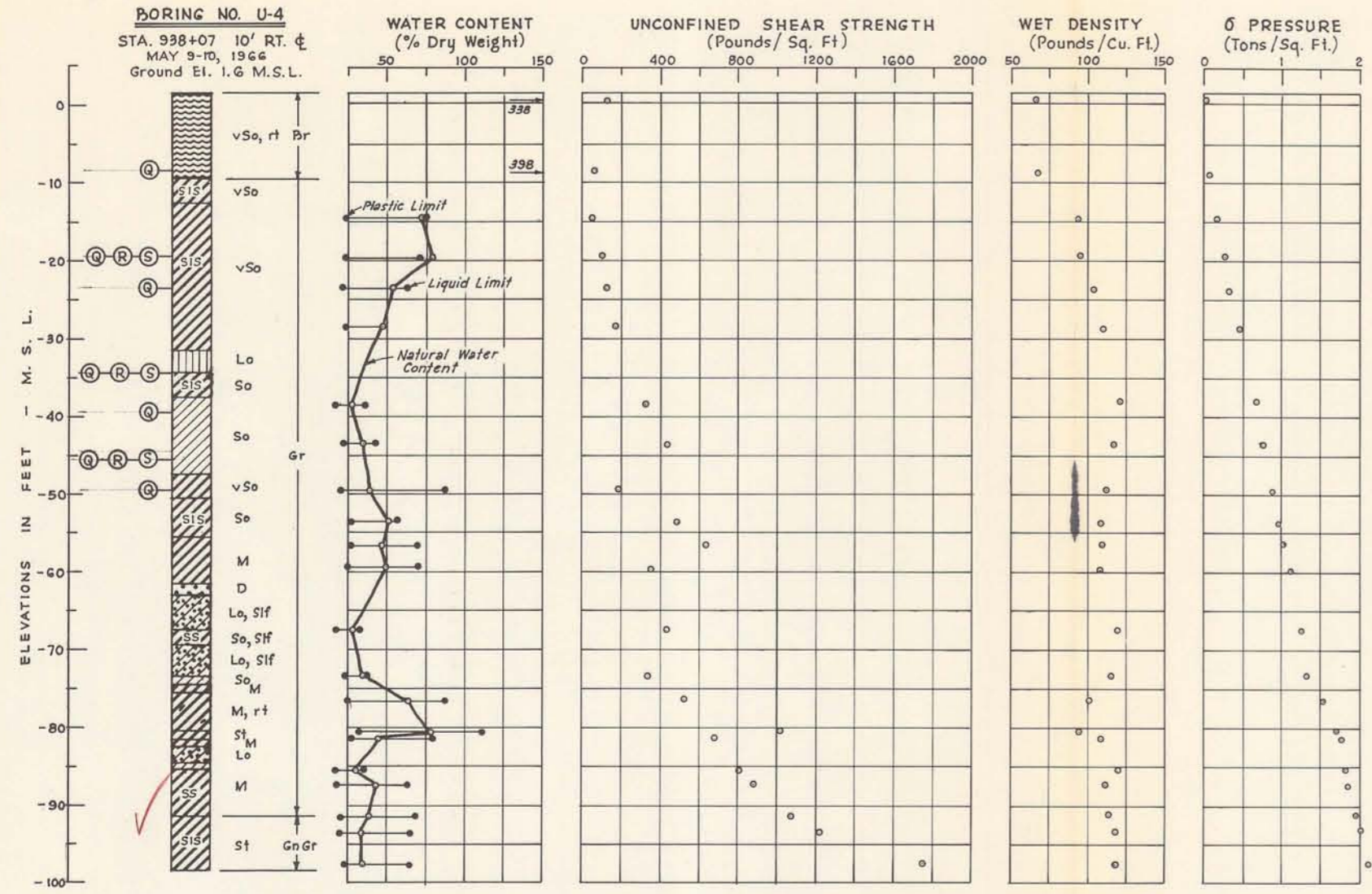

CONSOLIDATION DATA

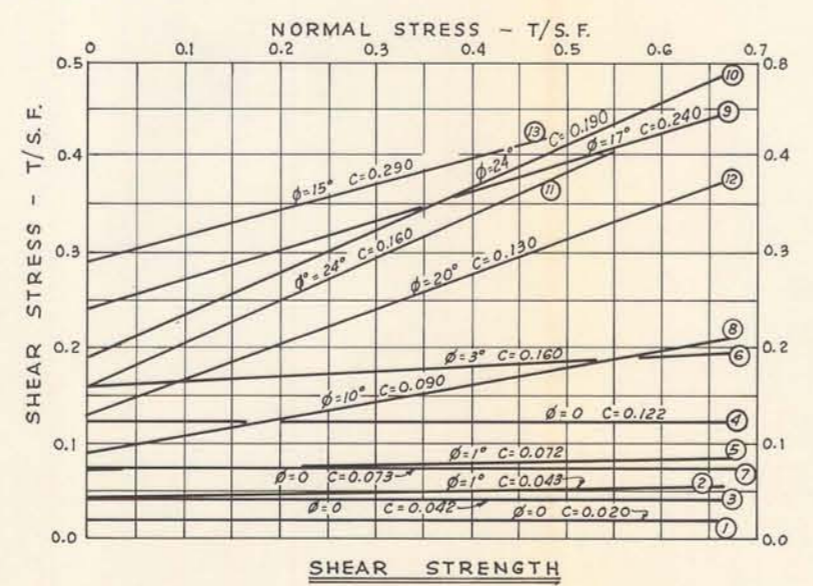
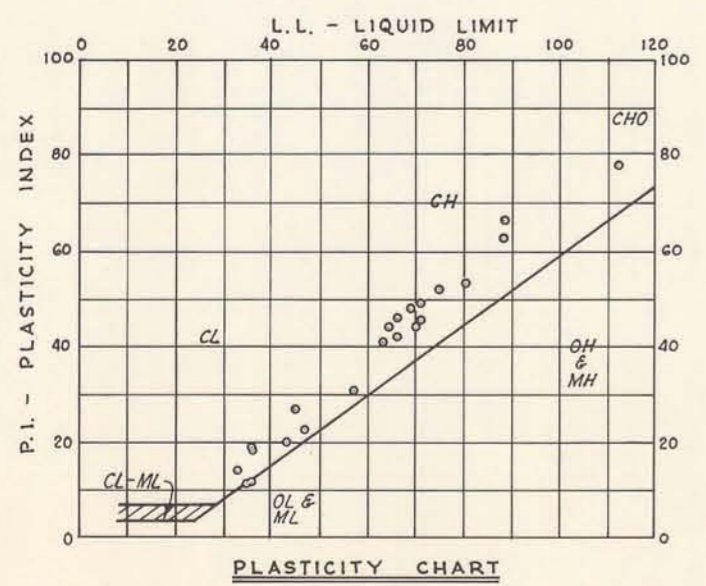

EL. M.S.L.	Q(UU)	R(CU)	S(CD)
- 8.4	(1)		
- 19.4	(2)	(8)	(11)
- 23.4	(3)		
- 34.4	(4)	(9)	(12)
- 39.4	(5)		
- 45.4	(6)	(10)	(13)
- 49.4	(7)		

See Plate A for soil boring legend
 See Plate 31 for general notes
 See Plates 52 & 53 for detail shear test data
 See Plate 17 for location of undisturbed boring U-4

LAKE PONTCHARTRAIN, LA. AND VICINITY
 CHALMETTE AREA PLAN
 DESIGN MEMORANDUM NO. 3—GENERAL DESIGN

**UNDISTURBED BORING U-4
 TEST DATA**

SCALES AS SHOWN

WALDEMAR S. NELSON AND COMPANY, INC.
 ENGINEERS AND ARCHITECTS
 NEW ORLEANS, LA.

U. S. ARMY ENGINEER DISTRICT, NEW ORLEANS
 CORPS OF ENGINEERS, U. S. ARMY
 NEW ORLEANS, LA.

DATE: NOVEMBER 1966

FILE NO. H-2-23820

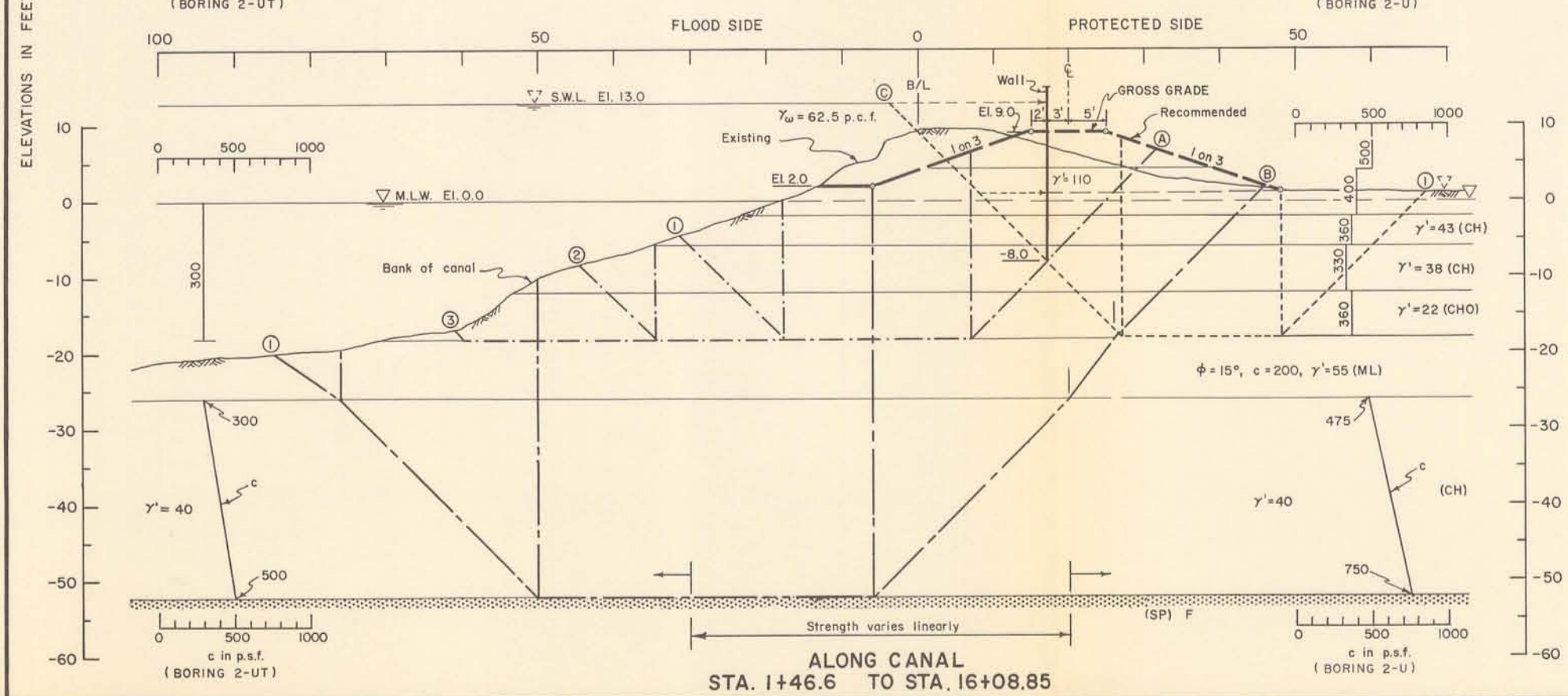
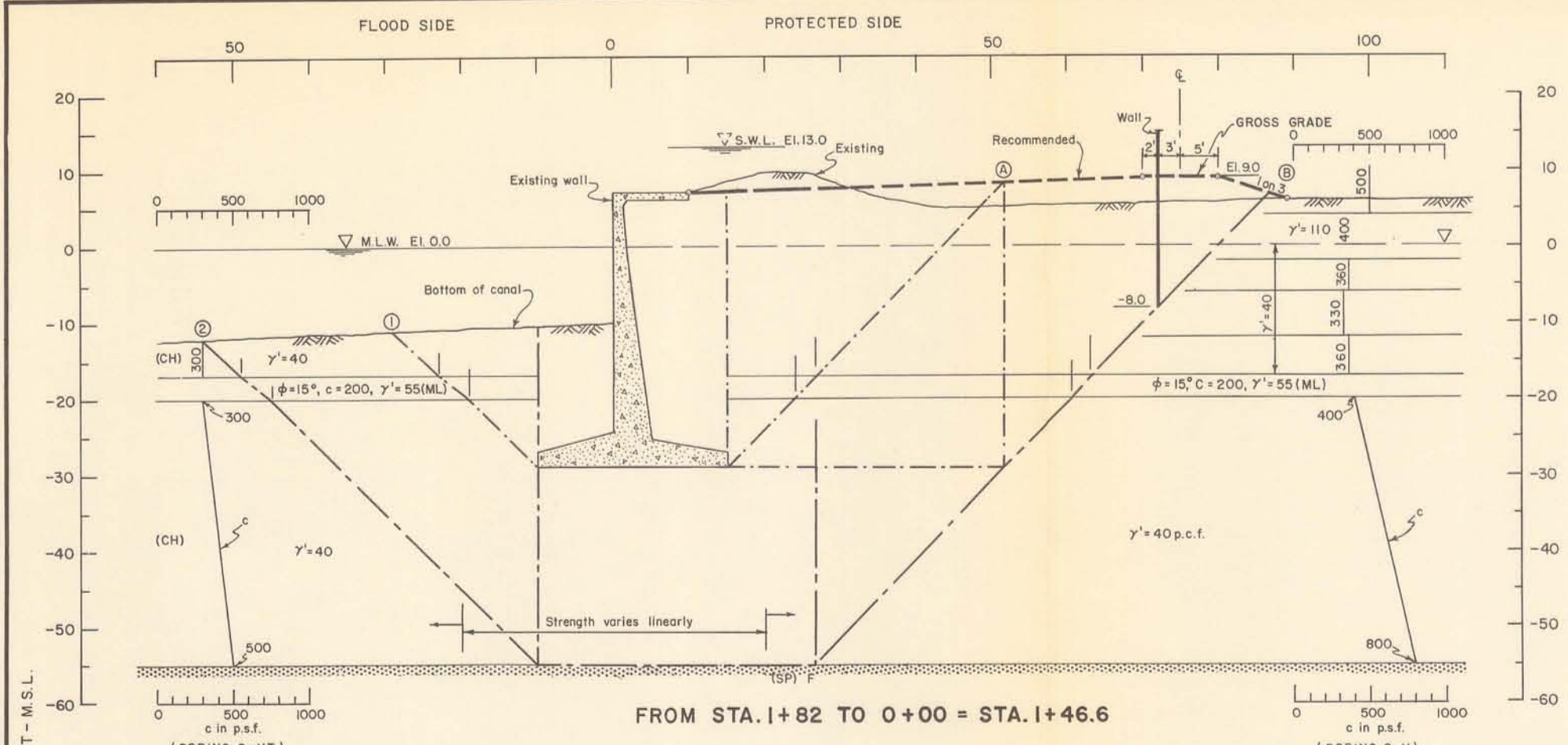

FAILURE SURFACE	No.	EL.	DRIVING FORCES			RESISTING FORCES			FACTOR OF SAFETY $\Sigma R / \Sigma D$		
			+D _A	-D _P	ΣD	+R _A	+R _B	+R _P		ΣR	
AT LOCK											
A	1	-29	46,923	7,082	39,841	30,066	10,850	11,941	52,857	1.33	
B	1	-29	50,800		43,718	27,758	26,320		66,019	1.51	
B	2	-55	118,530	38,675	79,855	61,558	24,424	28,121	114,103	1.43	
ALONG CANAL											
A	1				4,598	21,740		8,250	8,256	29,898	1.38
A	2	-18	26,338		1,954	24,384	13,392	13,414	5,700	32,506	1.33
A	3				33	26,305		19,926	900	34,218	1.30
B	1	-52	91,187	27,322	63,865	46,238	23,440	24,860	94,538	1.48	
C	1	-18	32,079	8,518	23,561	16,812	7,119	11,896	35,827	1.52	

STABILITY CALCULATIONS

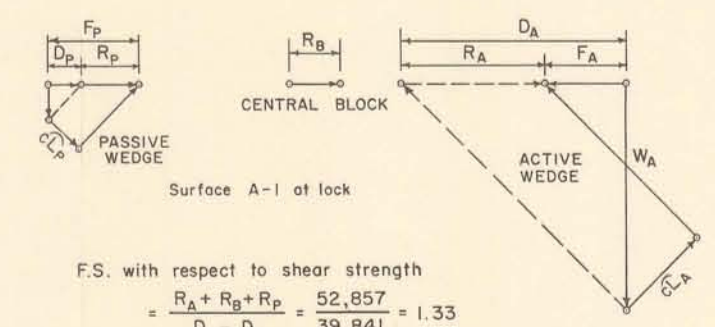

F.S. with respect to shear strength

$$= \frac{R_A + R_B + R_P}{D_A - D_P} = \frac{52,857}{39,841} = 1.33$$

VECTOR DIAGRAM (Method of planes)

GENERAL NOTES

- ▽ - Mean low water stage, M.L.W.
 - ▽ - Hurricane still water level, S.W.L.
 - γ - Unit weight of soil-water system
 - γ' - Submerged unit weight of soil
 - γ_w - Unit weight of water
 - φ - Angle of internal friction of soil
 - c - Unit cohesion of soil
 - (U) - Unconsolidated-undrained strength
 - (S) - Consolidated-drained strength
- For soil classification see plate A
 For undisturbed soil boring data see plates 30 thru 32

LAKE PONTCHARTRAIN, LA. AND VICINITY
 CHALMETTE AREA PLAN
 DESIGN MEMORANDUM NO. 3 - GENERAL DESIGN

STABILITY ANALYSIS
SOUTH OF FLORIDA AVENUE
SCALES AS SHOWN

WALDEMAR S. NELSON AND CO., INC. ENGINEERS AND ARCHITECTS NEW ORLEANS, LA.	U.S. ARMY ENGINEER DISTRICT, NEW ORLEANS CORPS OF ENGINEERS, U.S. ARMY NEW ORLEANS, LA.
DATE: OCTOBER 1966	FILE NO. H-2-23820

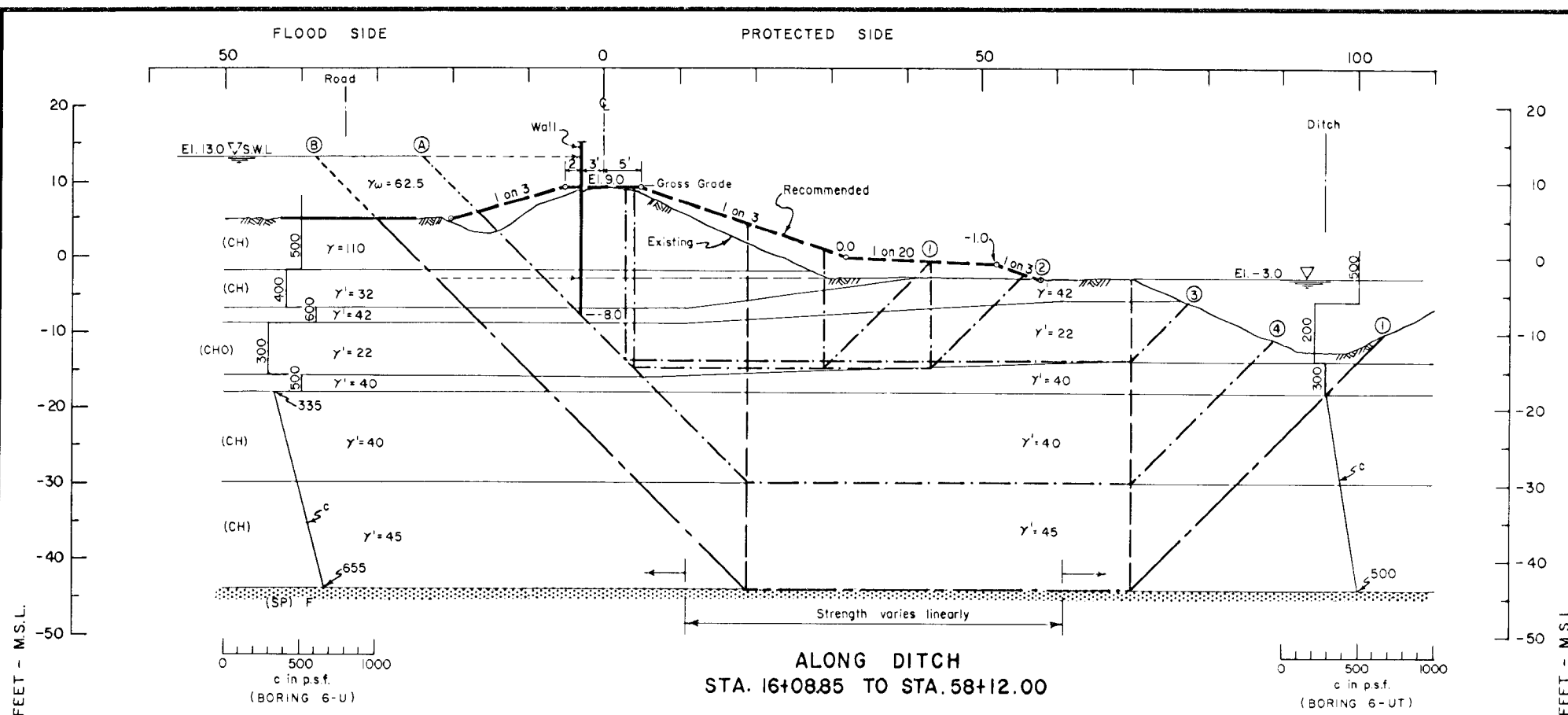

ALONG DITCH

FAILURE SURFACE	No.	EL.	DRIVING FORCES			RESISTING FORCES			FACTOR OF SAFETY	
			+D _A	-D _P	ΣD	+R _A	+R _B	+R _P		ΣR
A	1	-15	31,987	6,422	25,565	17,400	7,176	10,950	35,526	1.39
	2	-15	4,987	27,000	17,400	10,548	7,988	35,936	1.33	
	3	-14	30,356	1,140	29,216	16,800	16,700	3,000	36,500	1.25
	4	-14	30,356	121	30,235	19,900	1,100	37,800	1.25	
B	1	-30	56,993	8,159	48,834	29,840	21,630	11,900	63,370	1.30
		-44	93,470	22,145	71,325	45,050	28,230	24,000	97,280	1.36

LEVEE STABILITY CALCULATIONS
(Q) Stability

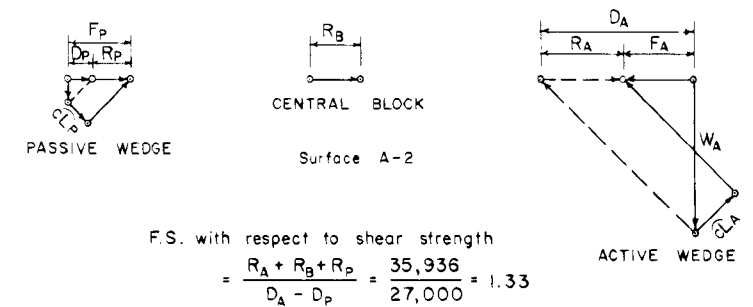
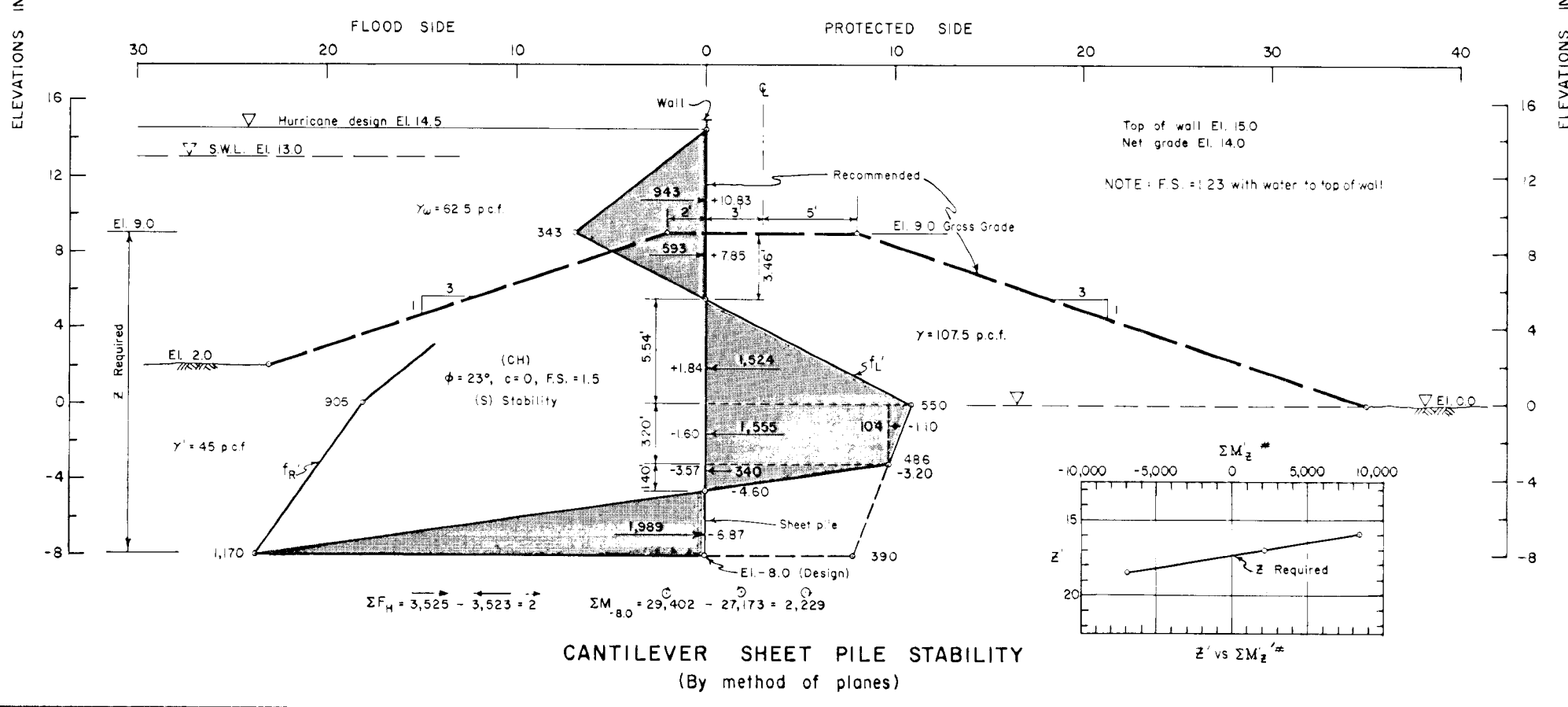

VECTOR DIAGRAM
(Method of planes)

For General Notes see plate 37
For undisturbed soil boring data see plates 30, 31 & 32

LAKE PONTCHARTRAIN, L.A. AND VICINITY
CHALMETTE AREA PLAN
DESIGN MEMORANDUM NO. 3 - GENERAL DESIGN

STABILITY ANALYSIS
SOUTH OF FLORIDA AVENUE

SCALES AS SHOWN

WALDEMAR S. NELSON AND CO., INC. ENGINEERS AND ARCHITECTS NEW ORLEANS, LA.	U.S. ARMY ENGINEER DISTRICT, NEW ORLEANS CORPS OF ENGINEERS, U.S. ARMY NEW ORLEANS, LA.
--	---

DATE: OCTOBER 1966 FILE NO: H-2-23820

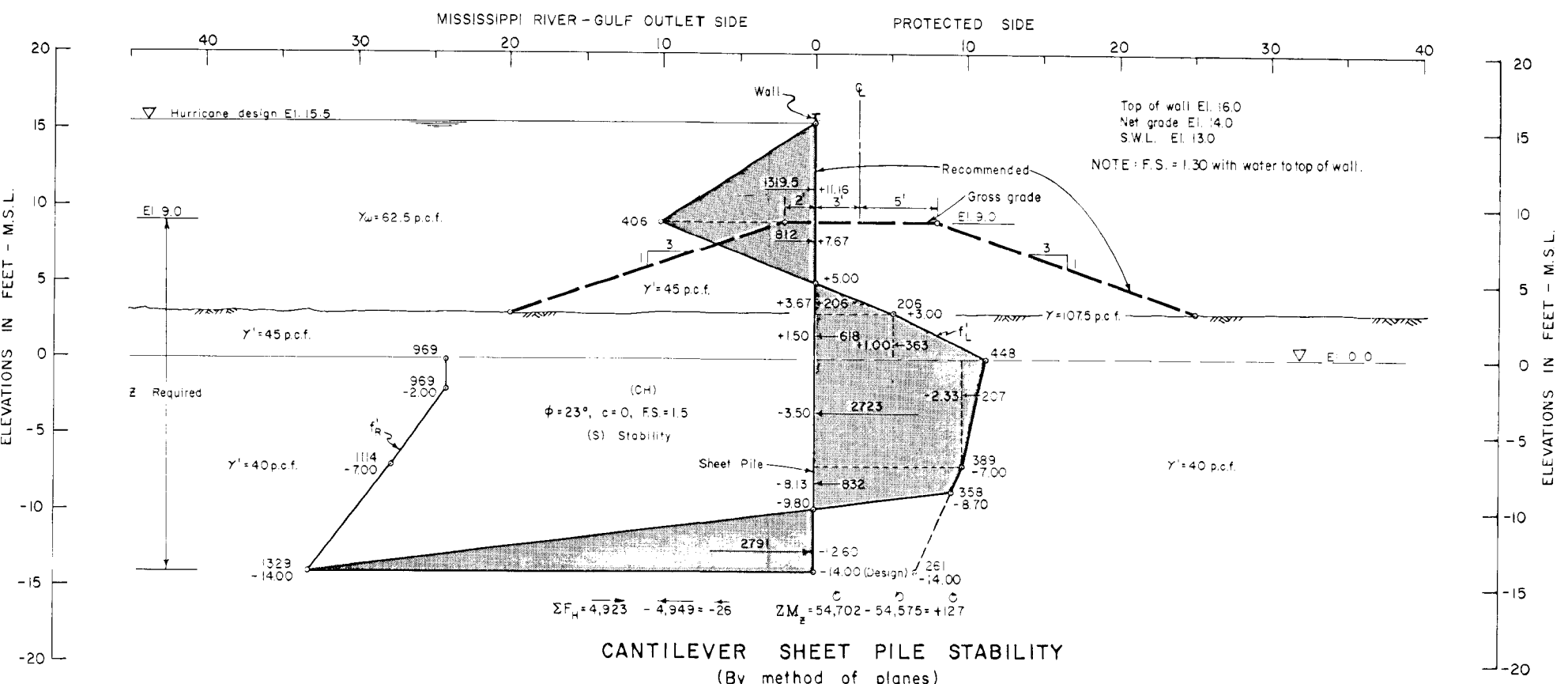
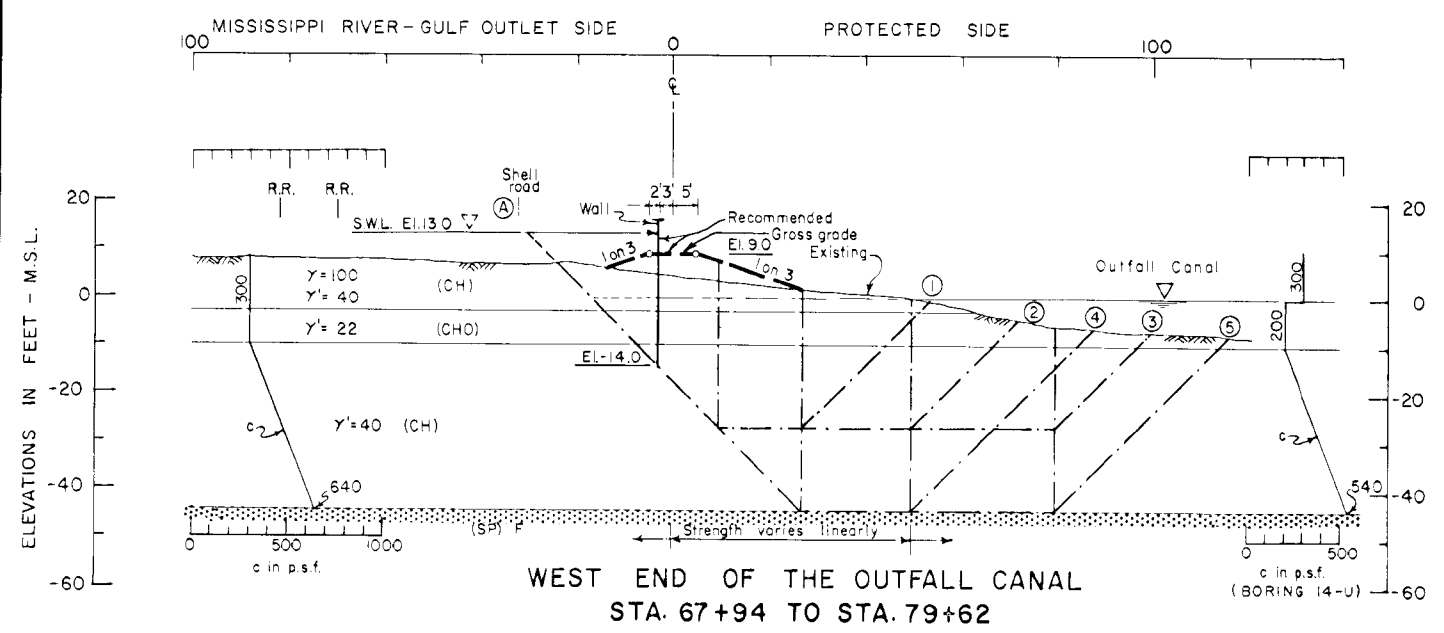
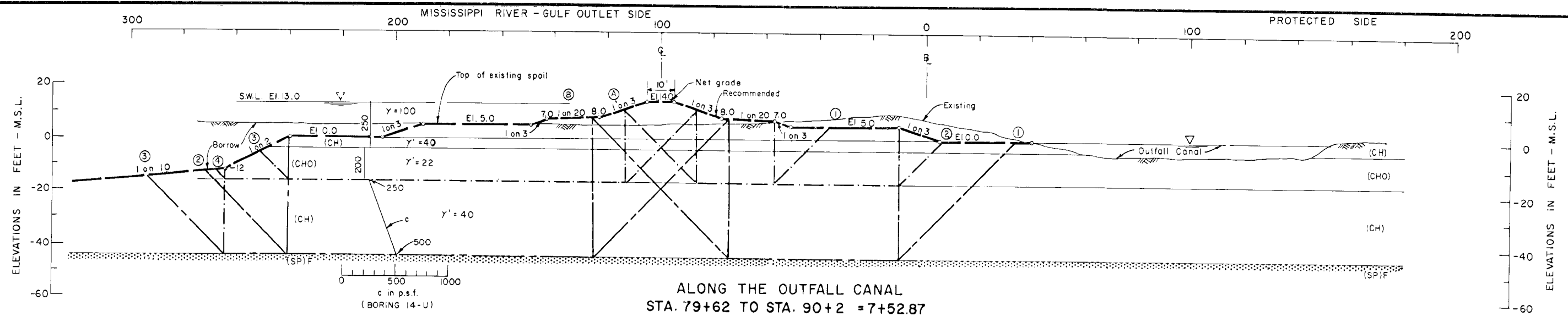

SECTION	FAILURE SURFACE		DRIVING FORCES			RESISTING FORCES				FACTOR OF SAFETY	
	No.	EL.	+D _A	-D _P	ΣD	+R _A	+R _B	+R _P	ΣR		
ALONG BAYOU BIENVENUE	A	1	-16.0	33,797	14,016	19,963	11,375	5,800	9,300	27,075	1.36
		2			7,734	26,063		15,200	6,800	33,975	1.30
		3			2,136	31,661		25,200	4,200	41,375	1.31
		4			154	33,643		30,000	1,400	43,375	1.29
WEST END OF BAYOU BIENVENUE	B	1	-44.0	97,289	35,126	52,163	31,800	32,000	27,800	91,600	1.76
		2			21,732	65,557		57,000	22,200	111,000	1.69
		3			17,343	69,946		69,000	21,400	122,200	1.75
WEST END OF BAYOU BIENVENUE	A	1	-27.0	44,276	14,147	30,129	21,714	11,379	14,242	47,334	1.57
		2			9,601	34,675		16,618	11,690	50,022	1.44
		3			7,221	37,055		27,718	10,890	60,322	1.63
		4			26,232	50,792		12,582	26,560	78,706	1.55
		5			23,412	53,612		39,564	28,782	25,960	94,306

LEVEE STABILITY CALCULATIONS
(Q) Stability

For General Notes see plate 37

LAKE PONTCHARTRAIN, LA AND VICINITY
CHALMETTE AREA PLAN
DESIGN MEMORANDUM NO 3 - GENERAL DESIGN

STABILITY ANALYSIS
NORTH OF FLORIDA AVENUE
SCALES AS SHOWN

WALDEMAR S. NELSON AND CO., INC.
ENGINEERS AND ARCHITECTS
NEW ORLEANS, LA.

U.S. ARMY ENGINEER DISTRICT, NEW ORLEANS
CORPS OF ENGINEERS, U.S. ARMY
NEW ORLEANS, LA.

DATE: OCTOBER 1966 FILE NO. H-2-23820

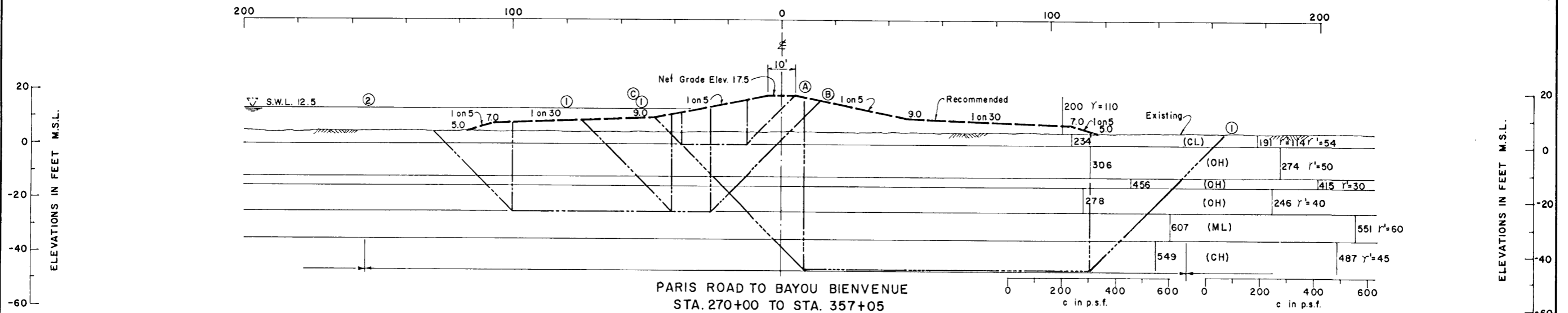
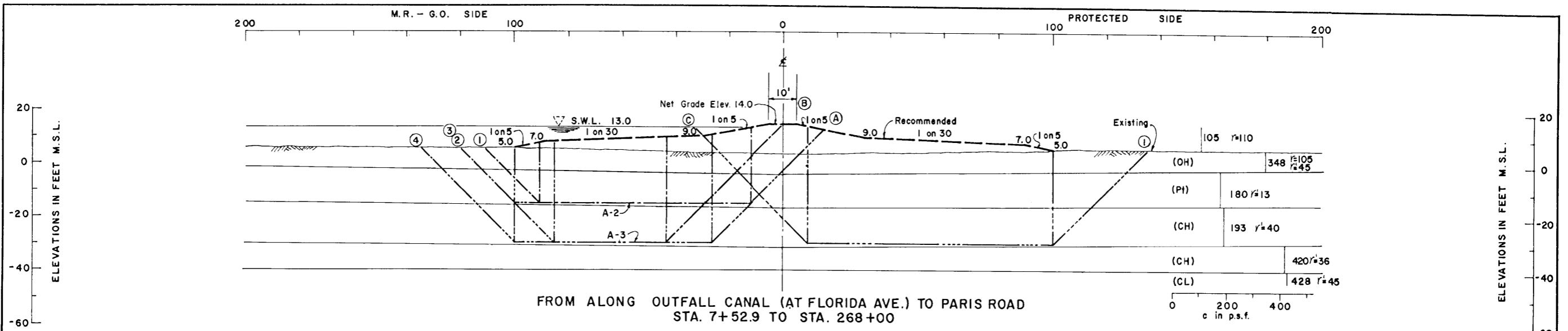

SECTION	FAILURE SURFACE	DRIVING FORCES				RESISTING FORCES				FACTOR OF SAFETY		
		No.	EI.	+D _A	-D _P	Σ D	+R _A	+R _B	+R _P		Σ R	
ALONG OUTFALL CANAL TO PARIS ROAD	A	1	-15.0	42,119	20,214	21,905	9,691	13,824	8,553	32,068	1.46	
		2	-15.0	42,119	19,065	23,054	9,691	15,444	8,584	33,719	1.46	
		3	-30.0	89,288	58,632	30,656	15,446	10,769	14,352	40,567	1.32	
		4	-30.0	89,288	56,015	33,273	15,446	13,471	14,402	43,319	1.30	
PARIS ROAD TO BAYOU BIENVENUE	A	1	-30.0	81,158	56,015	25,143	15,844	10,422	14,402	40,668	1.62	
		C	1	-30.0	90,687	56,015	34,672	14,862	17,370	14,402	46,274	1.34
			2	+0.1	16,097	5,276	10,821	7,293	6,131	3,893	17,317	1.60
	B	1	-24.9	92,353	61,479	30,874	22,178	4,619	19,212	46,009	1.49	
		2	-24.9	92,353	51,373	40,980	22,178	20,766	17,978	60,922	1.49	
		C	1	-46.9	204,685	145,905	58,780	44,906	57,479	42,321	144,706	2.46

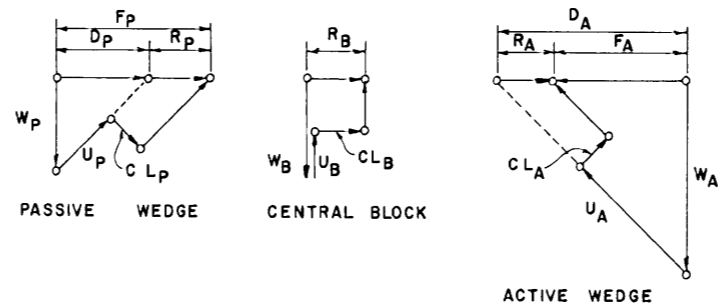

Surface A-4
F.S. with respect to shear strength

$$\frac{R_A + R_B + R_P}{D_A - D_P} = \frac{43,319}{33,273} = 1.30$$
VECTOR DIAGRAM
(Method of planes)

LEVEE STABILITY CALCULATIONS

LAKE PONTCHARTRAIN, LA. AND VICINITY
CHALMETTE AREA PLAN
DESIGN MEMORANDUM NO. 3—GENERAL DESIGN
STABILITY ANALYSIS

SCALES AS SHOWN

WALDEMAR S. NELSON AND COMPANY, INC. ENGINEERS AND ARCHITECTS NEW ORLEANS, LA.	U. S. ARMY ENGINEER DISTRICT, NEW ORLEANS CORPS OF ENGINEERS, U. S. ARMY NEW ORLEANS, LA.
--	---

DATE: NOVEMBER 1966 FILE NO. H-2-23820

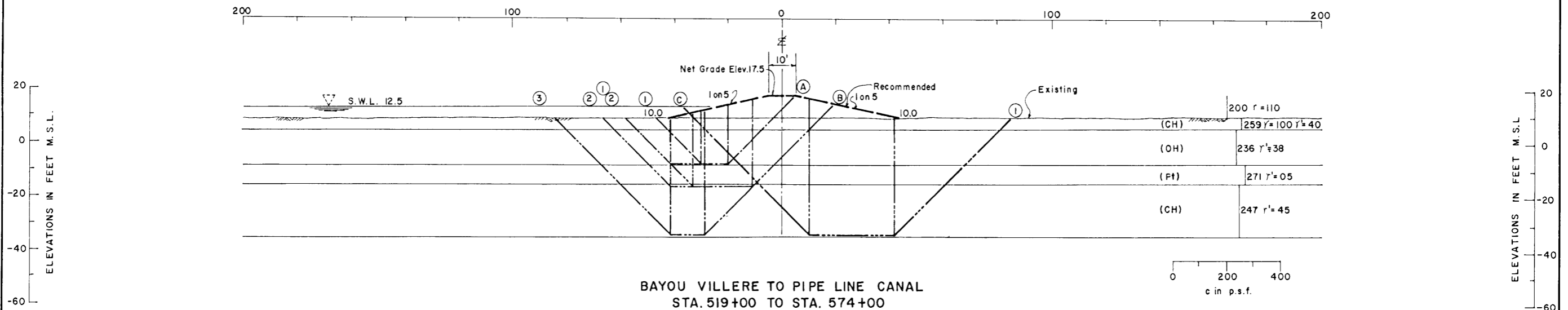
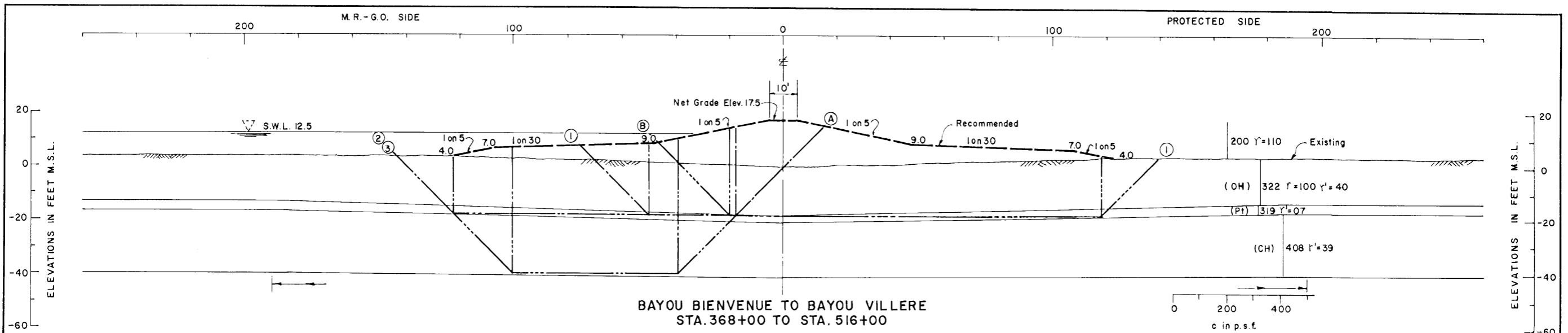

SECTION	FAILURE SURFACE NO.	E.I.	DRIVING FORCES			RESISTING FORCES				FACTOR OF SAFETY
			+D _A	-D _P	Σ D	+R _A	+R _B	+R _P	Σ R	
BAYOU BIENVENUE TO BAYOU VILLERE	A-1	-17.8	64,093	36,537	27,556	16,669	10,192	14,268	41,129	1.49
	A-2	-17.8	64,093	24,094	39,999	16,669	33,176	13,342	63,187	1.58
	A-3	-39.0	152,736	95,967	56,769	33,630	25,091	30,677	89,398	1.57
BAYOU VILLERE TO PIPE LINE CANAL	B-1	-17.7	48,646	24,222	24,424	14,389	44,054	13,271	71,714	2.94
	A-1	-7.9	31,877	18,498	13,379	11,089	2,053	8,089	21,231	1.59
	A-2	-7.9	31,877	16,037	15,840	11,089	4,649	8,679	24,417	1.54
	B-1	-15.1	51,993	31,758	20,235	13,779	5,755	12,569	32,103	1.59
	B-2	-15.1	51,993	30,299	21,694	13,779	7,978	12,569	34,326	1.58
C	-34.9	127,926	95,373	32,553	23,560	2,643	22,350	48,553	1.49	
C	-34.9	125,744	95,373	30,371	22,427	6,842	22,350	51,619	1.70	

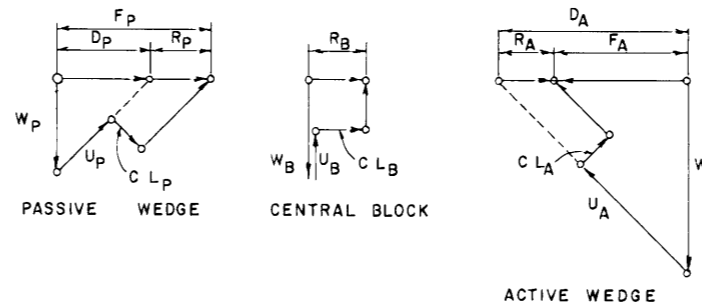

Surface B-1
 F.S. with respect to shear strength

$$= \frac{R_A + R_B + R_P}{D_A - D_P} = \frac{71,714}{24,424} = 2.94$$
VECTOR DIAGRAM
 (Method of planes)

LEEVE STABILITY CALCULATIONS

LAKE PONTCHARTRAIN, LA. AND VICINITY
 CHALMETTE AREA PLAN
 DESIGN MEMORANDUM NO. 3—GENERAL DESIGN
STABILITY ANALYSIS

SCALES AS SHOWN

WALDEMAR S. NELSON AND COMPANY, INC. ENGINEERS AND ARCHITECTS NEW ORLEANS, LA.	U. S. ARMY ENGINEER DISTRICT, NEW ORLEANS CORPS OF ENGINEERS, U. S. ARMY NEW ORLEANS, LA.
DATE: NOVEMBER 1966	FILE NO. H-2-23820

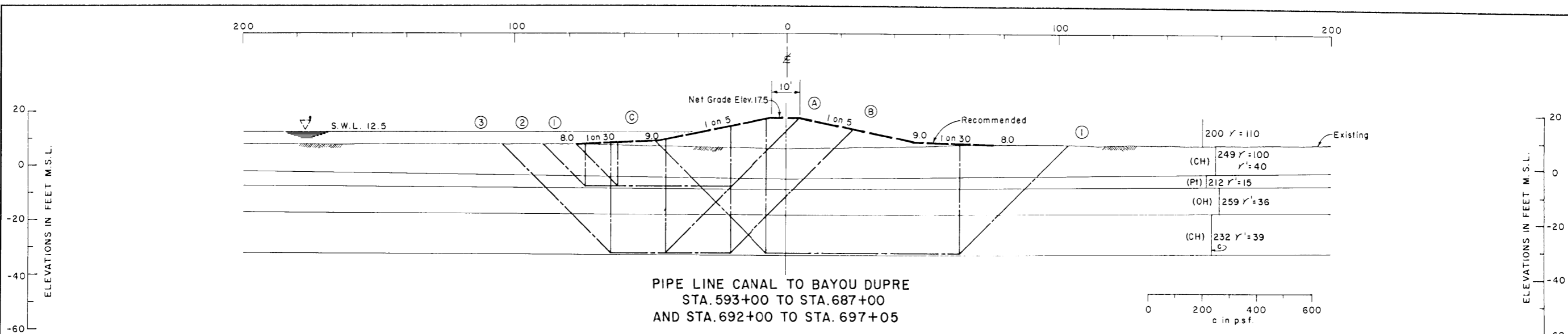

PIPE LINE CANAL TO BAYOU DUPRE
STA. 593+00 TO STA. 687+00
AND STA. 692+00 TO STA. 697+05

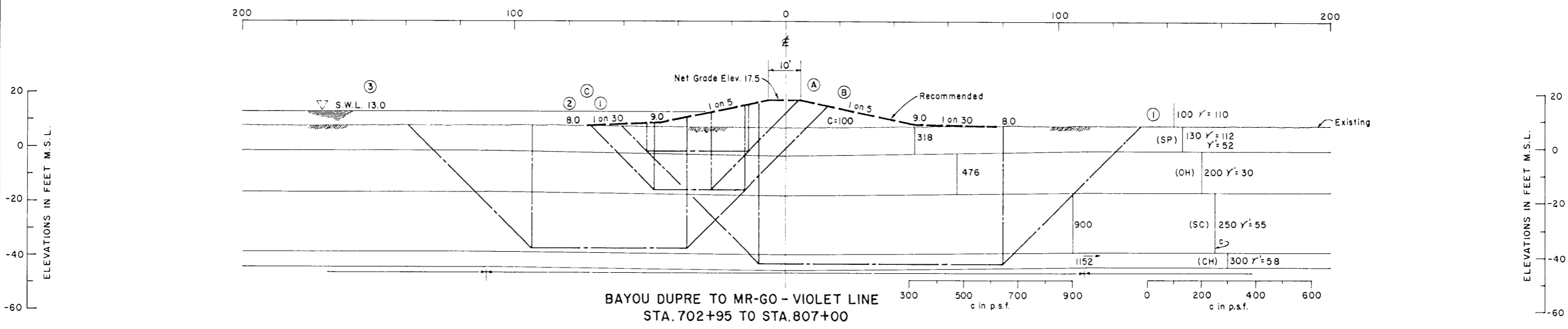

BAYOU DUPRE TO MR-GO-VIOLET LINE
STA. 702+95 TO STA. 807+00

SECTION	FAILURE SURFACE	DRIVING FORCES				RESISTING FORCES				FACTOR OF SAFETY		
		No.	El.	+D _A	-D _P	ΣD	+R _A	+R _B	+R _P		ΣR	
												ΣR / ΣD
PIPE LINE CANAL TO BAYOU DUPRE	A	1	-7.7	31,435	14,040	17,395	11,104	8,641	7,682	27,427	1.58	
		2	-7.7	31,435	13,883	17,552	11,104	11,305	7,660	30,069	1.71	
		3	-32.4	108,865	82,289	26,576	23,048	4,409	19,610	47,067	1.77	
	B	3	-32.4	118,489	82,289	36,200	21,464	9,977	19,610	51,051	1.41	
		C	1	-32.4	104,878	82,289	22,589	19,688	16,241	19,610	55,539	2.46
			2	-16.0	54,156	31,612	22,544	21,297	9,194	19,588	50,079	2.22
BAYOU DUPRE TO MR-GO-VIOLET LINE	A	1	-1.0	18,075	5,212	12,863	7,560	12,397	5,567	25,524	1.98	
		2	-16.0	54,156	31,612	22,544	21,297	9,194	19,588	50,079	2.22	
		3	-16.0	57,523	31,612	25,911	20,590	15,478	19,588	55,656	2.15	
	B	3	-38.0	149,850	112,114	37,736	59,392	62,522	39,638	161,552	4.28	
		C	1	-44.0	168,875	143,320	25,555	72,439	99,708	65,477	237,624	9.30
			2	-44.0	168,875	143,320	25,555	72,439	99,708	65,477	237,624	9.30

LEEVE STABILITY CALCULATIONS

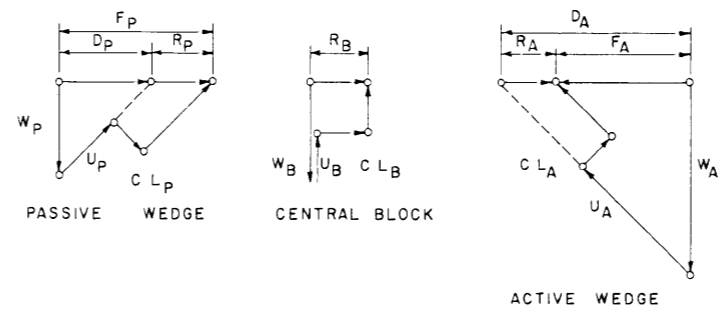

Surface B-3
 F.S. with respect to shear strength

$$= \frac{R_A + R_B + R_P}{D_A - D_P} = \frac{51,051}{36,200} = 1.41$$
VECTOR DIAGRAM
 (Method of planes)

LAKE PONTCHARTRAIN, LA. AND VICINITY
 CHALMETTE AREA PLAN
 DESIGN MEMORANDUM NO. 3—GENERAL DESIGN
STABILITY ANALYSIS

SCALES AS SHOWN

WALDEMAR S. NELSON AND COMPANY, INC.
 ENGINEERS AND ARCHITECTS
 NEW ORLEANS, LA.

U. S. ARMY ENGINEER DISTRICT, NEW ORLEANS
 CORPS OF ENGINEERS, U. S. ARMY
 NEW ORLEANS, LA.

DATE: NOVEMBER 1966

FILE NO. H-2-23820

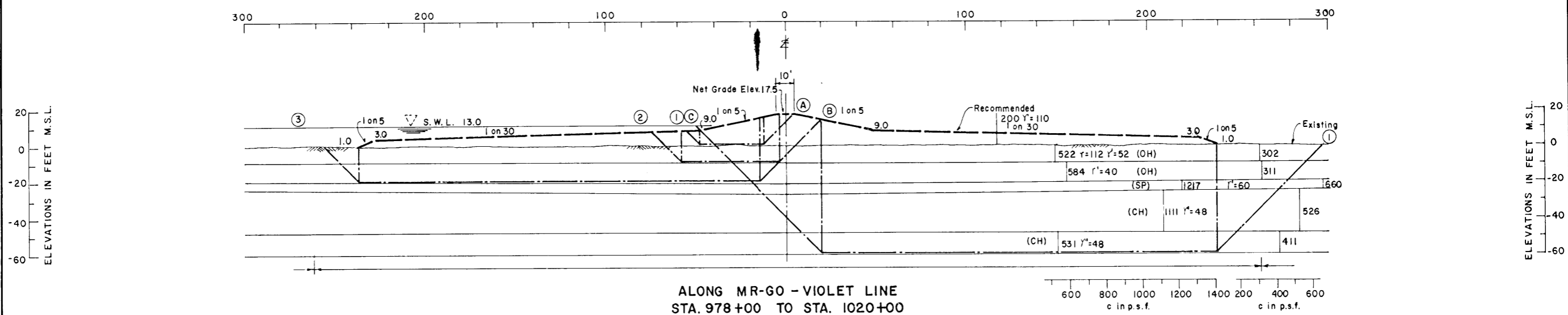
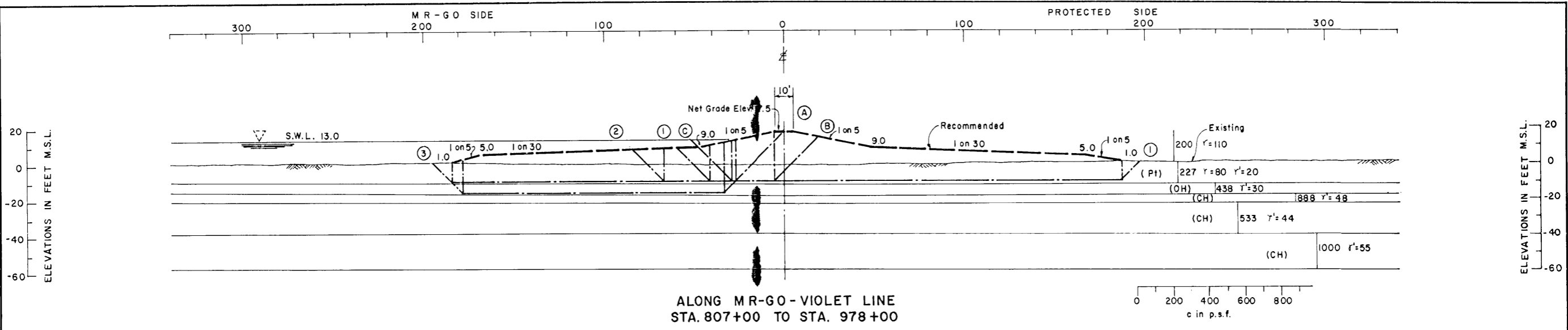

SECTION	FAILURE SURFACE		DRIVING FORCES			RESISTING FORCES				FACTOR OF SAFETY	
	No.	EI.	+D _A	-D _P	Σ D	+R _A	+R _B	+R _P	Σ R		
ALONG MR-GO VIOLET LINE STA. 807+00 TO STA. 978+00	A	1	+0.5	15,356	3,873	11,483	6,800	6,950	3,300	17,050	1.48
	B	2	-9.0	35,735	17,259	18,476	15,196	23,551	12,906	51,653	2.80
		3	-19.5	71,344	22,904	48,440	27,253	129,940	15,010	172,203	3.55
C	1	-59.5	295,420	195,363	100,057	99,479	114,961	66,710	281,150	2.81	
ALONG MR-GO VIOLET LINE STA. 978+00 TO STA. 1020+00	A	1	-10.4	36,353	19,363	16,990	11,524	4,150	7,918	23,592	1.39
		2	-10.4	36,353	17,801	18,552	11,524	9,076	7,657	28,257	1.52
		3	-16.4	51,628	13,749	37,879	15,943	64,401	9,934	90,278	2.38
	B	3	-10.4	39,222	5,821	33,401	10,307	41,246	5,074	56,627	1.70
		C	1	-10.4	27,025	5,821	21,204	8,131	48,850	5,074	62,055

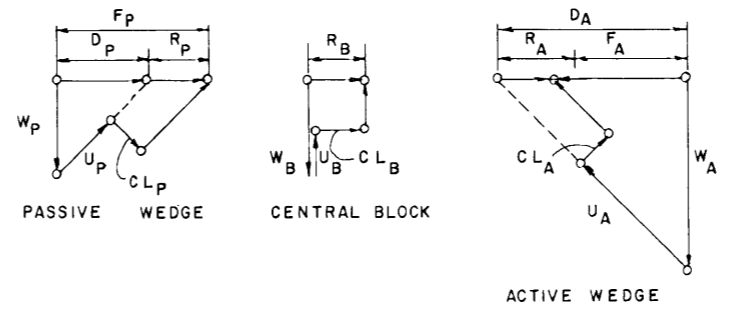

Surface B-2
 F.S. with respect to shear strength

$$= \frac{R_A + R_B + R_P}{D_A - D_P} = \frac{51,653}{18,476} = 2.80$$

VECTOR DIAGRAM
(Method of planes)

LEVEE STABILITY CALCULATIONS

LAKE PONTCHARTRAIN, LA. AND VICINITY
 CHALMETTE AREA PLAN
 DESIGN MEMORANDUM NO. 3—GENERAL DESIGN
STABILITY ANALYSIS

SCALES AS SHOWN

WALDEMAR S. NELSON AND COMPANY, INC. ENGINEERS AND ARCHITECTS NEW ORLEANS, LA.	U. S. ARMY ENGINEER DISTRICT, NEW ORLEANS CORPS OF ENGINEERS, U. S. ARMY NEW ORLEANS, LA.
--	---

DATE: NOVEMBER 1966 FILE NO. H-2-23820

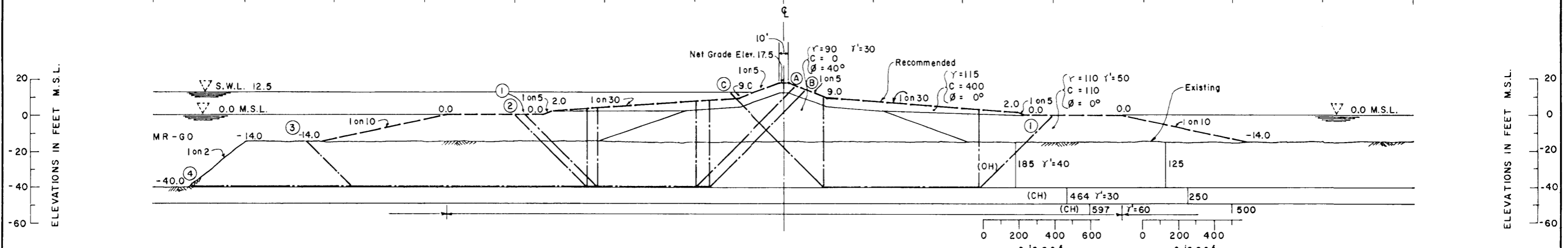
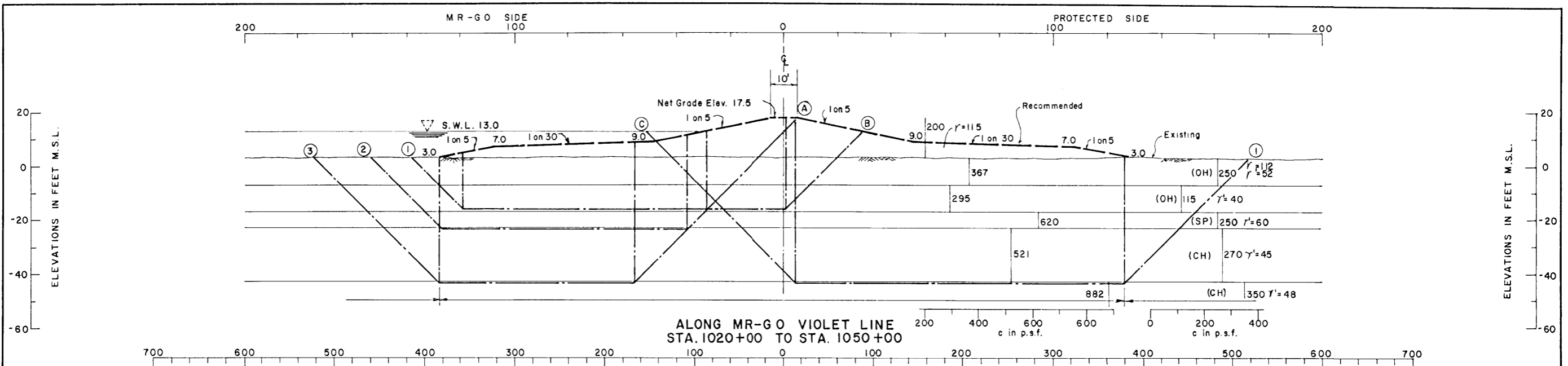

TYPICAL STREAM CLOSURE

SECTION	FAILURE SURFACE	DRIVING FORCES			RESISTING FORCES				FACTOR OF SAFETY			
		No.	EI.	+D _A	-D _P	ΣD	+R _A	+R _B		+R _P	ΣR	
ALONG MR-GO VIOLET LINE	A	1	-16.9	60,317	22,907	37,410	19,413	26,166	10,571	56,150	1.50	
		2	-23.1	82,333	38,154	44,179	27,016	43,920	16,920	87,856	1.99	
		3	-43.1	176,365	116,224	60,141	47,928	62,885	25,022	135,835	2.26	
	B	1	-16.9	58,539	22,907	35,632	17,413	35,016	10,571	63,000	1.77	
		C	1	-43.1	182,549	116,224	66,325	44,528	107,867	25,022	177,417	2.67
			2	-39.9	152,544	87,154	65,390	43,698	41,296	12,663	97,657	1.49
TYPICAL STREAM CLOSURE	A	1	-39.9	150,305	84,835	65,470	39,591	45,168	12,663	97,422	1.49	
		B	3	-39.9	150,305	63,758	86,547	39,591	87,718	6,475	133,784	1.55
			4	-39.9	150,305	49,671	100,634	39,591	117,688	0	157,279	1.56
	C	1	-39.9	132,840	84,835	48,005	31,724	51,198	12,663	95,585	1.99	

LEVEE STABILITY CALCULATIONS

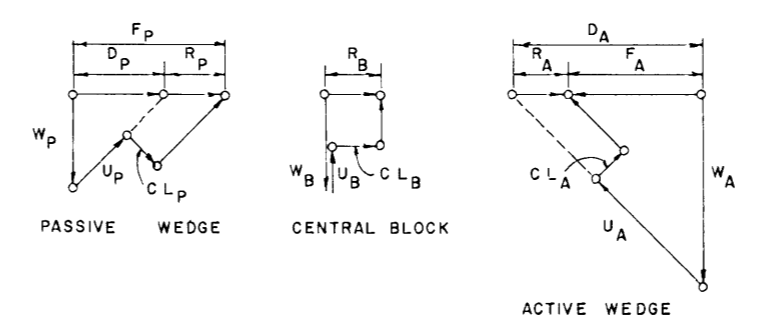

Surface B-1
 F.S. with respect to shear strength

$$= \frac{R_A + R_B + R_P}{D_A - D_P} = \frac{63,000}{35,632} = 1.77$$

VECTOR DIAGRAM (Method of planes)

LAKE PONTCHARTRAIN, LA. AND VICINITY
 CHALMETTE AREA PLAN
 DESIGN MEMORANDUM NO. 3—GENERAL DESIGN
STABILITY ANALYSIS

SCALES AS SHOWN

WALDEMAR S. NELSON AND COMPANY, INC.
 ENGINEERS AND ARCHITECTS
 NEW ORLEANS, LA.

U. S. ARMY ENGINEER DISTRICT, NEW ORLEANS
 CORPS OF ENGINEERS, U. S. ARMY
 NEW ORLEANS, LA.

DATE: NOVEMBER 1966 FILE NO. H-2-23820

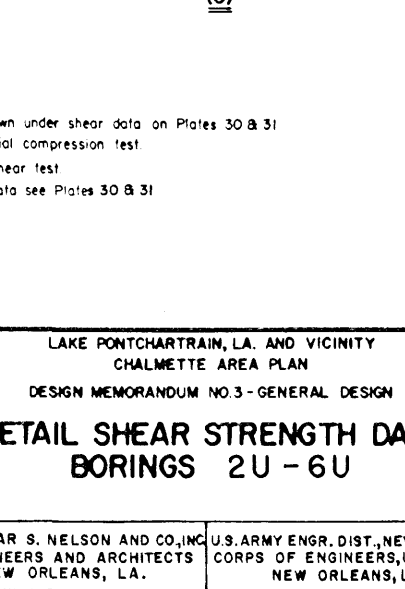
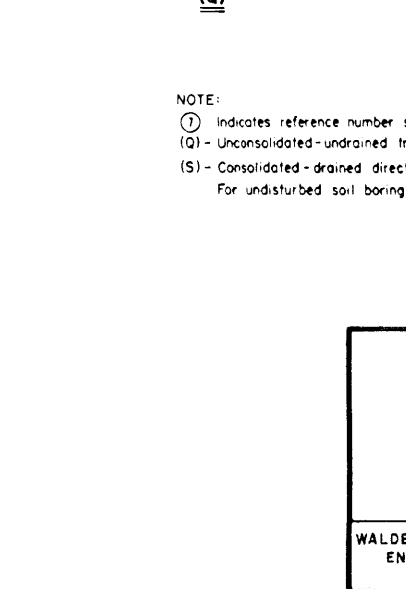
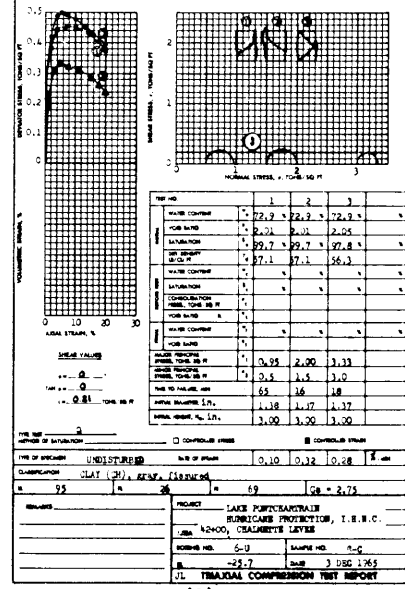
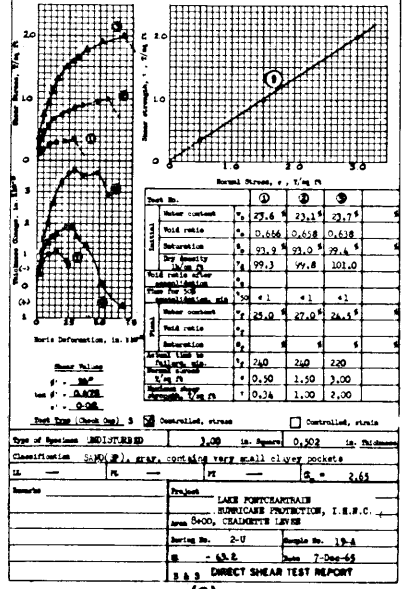
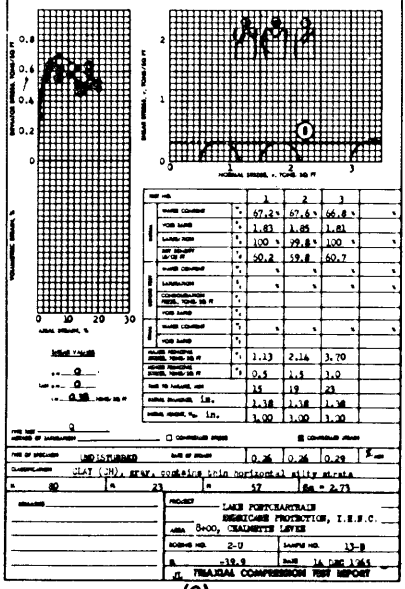
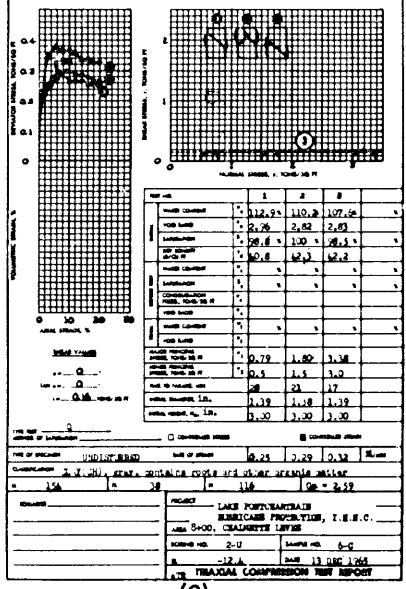
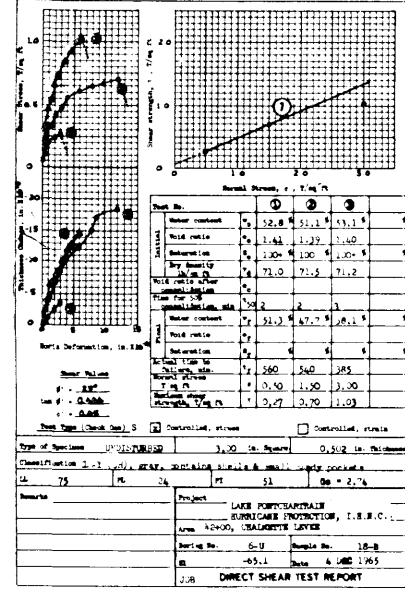
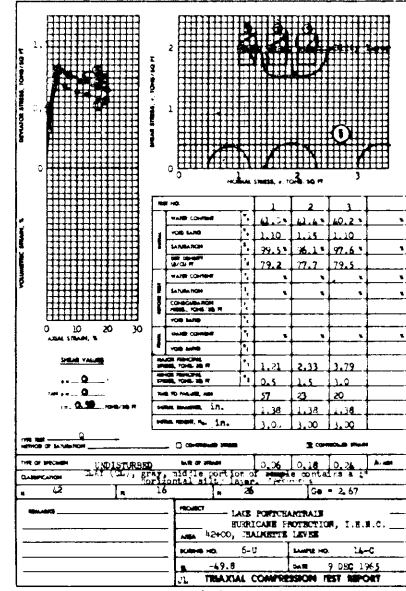
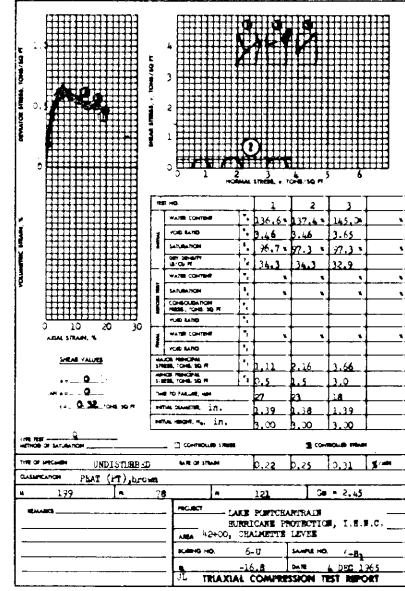
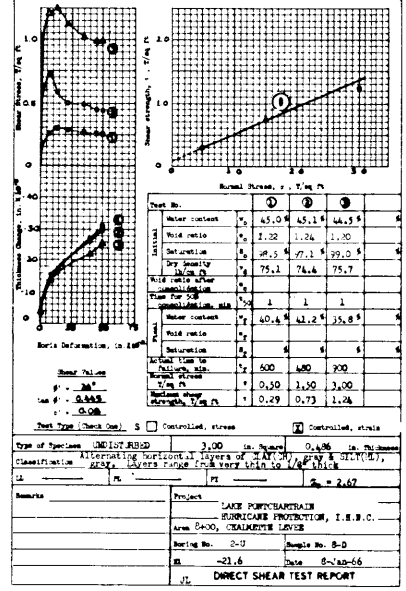
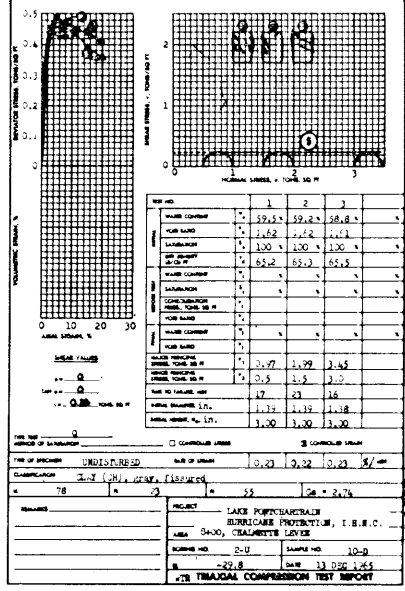
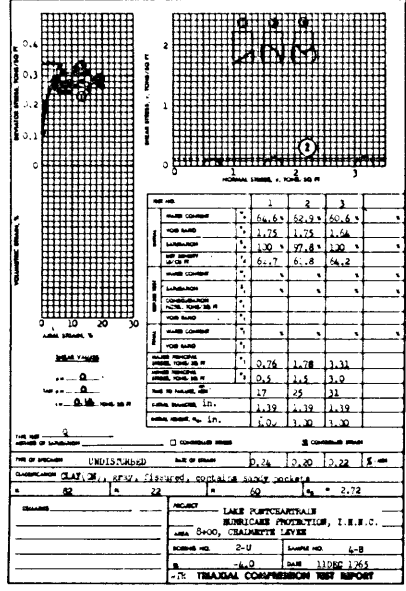
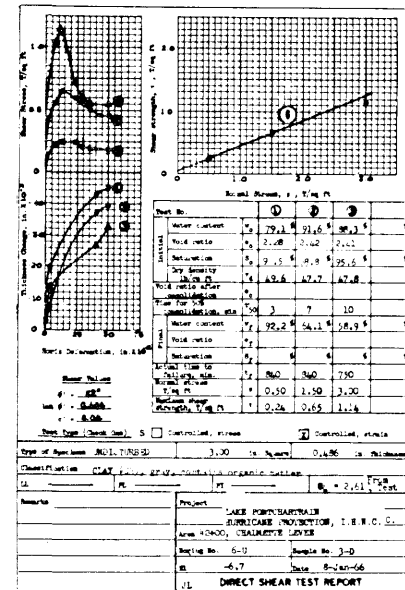
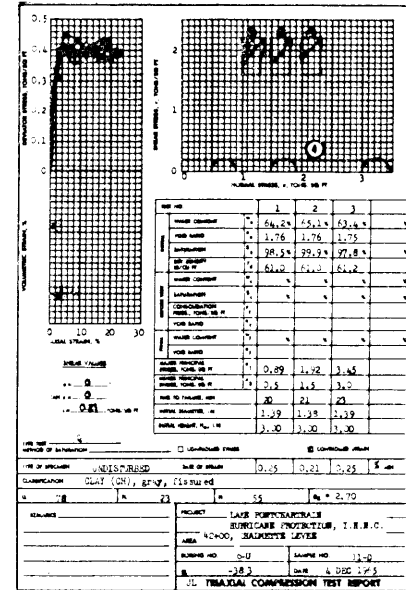
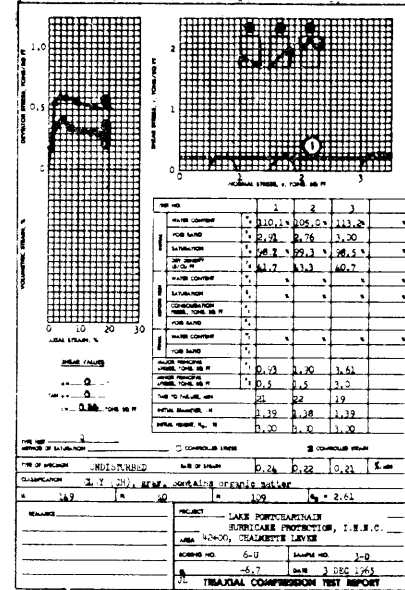
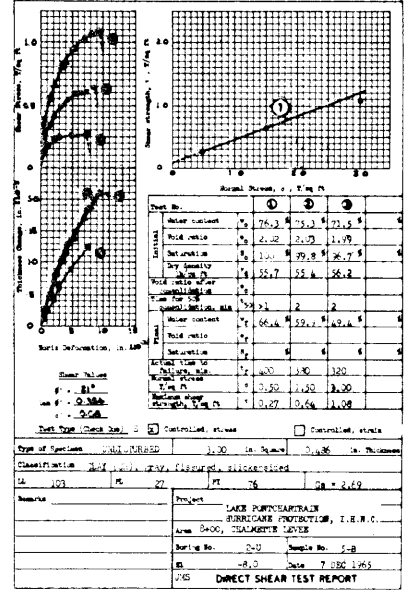
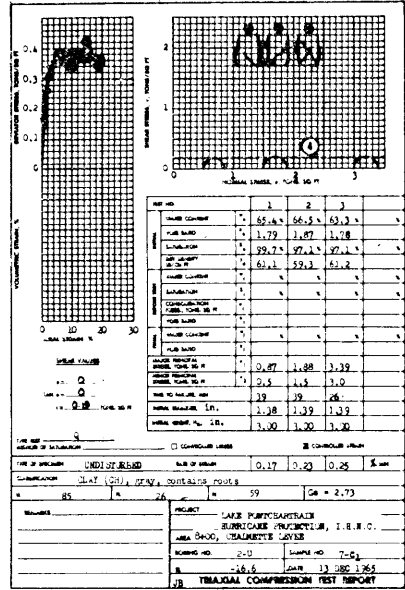
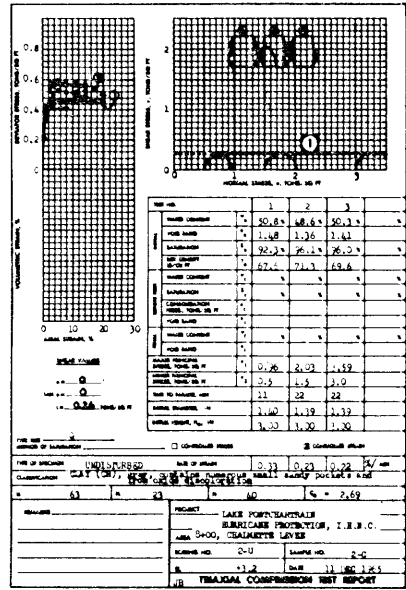

NOTE:
 (1) indicates reference number shown under shear data on Plates 30 & 31
 (Q) - Unconsolidated-undrained triaxial compression test
 (S) - Consolidated-drained direct shear test
 For undisturbed soil boring data see Plates 30 & 31

LAKE PONTCHARTRAIN, LA. AND VICINITY
 CHALMETTE AREA PLAN
 DESIGN MEMORANDUM NO. 3 - GENERAL DESIGN

DETAIL SHEAR STRENGTH DATA BORINGS 2U - 6U

WALDEMAR S. NELSON AND CO., INC. U.S. ARMY ENGR. DIST., NEW ORLEANS
 ENGINEERS AND ARCHITECTS CORPS OF ENGINEERS, U.S. ARMY
 NEW ORLEANS, LA. NEW ORLEANS, LA.

DATE: OCTOBER 1966 FILE NO. H-2-23820

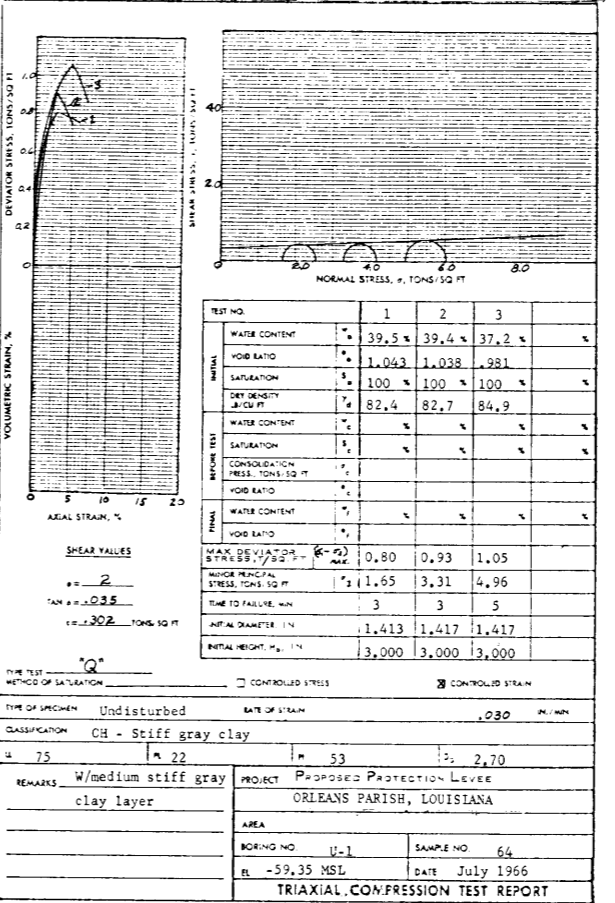
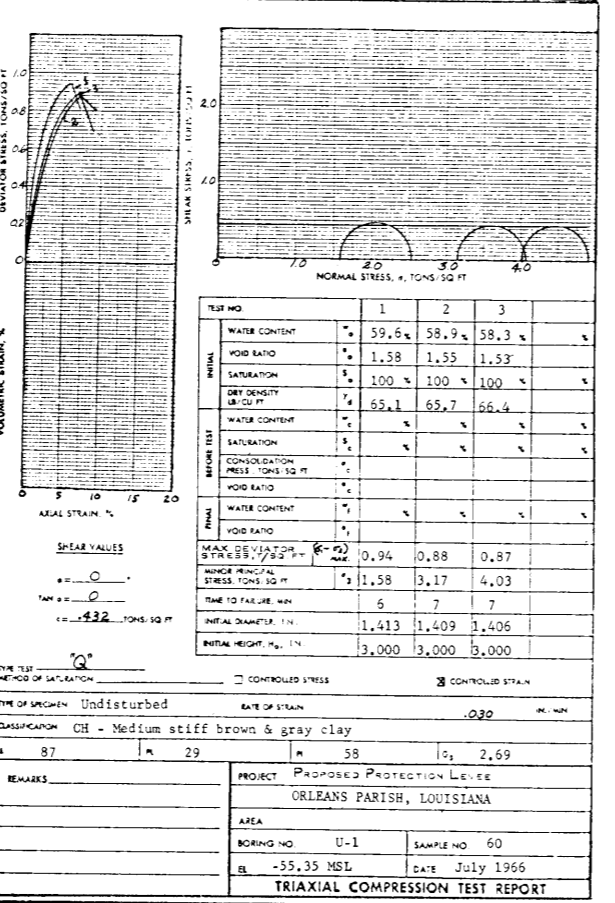
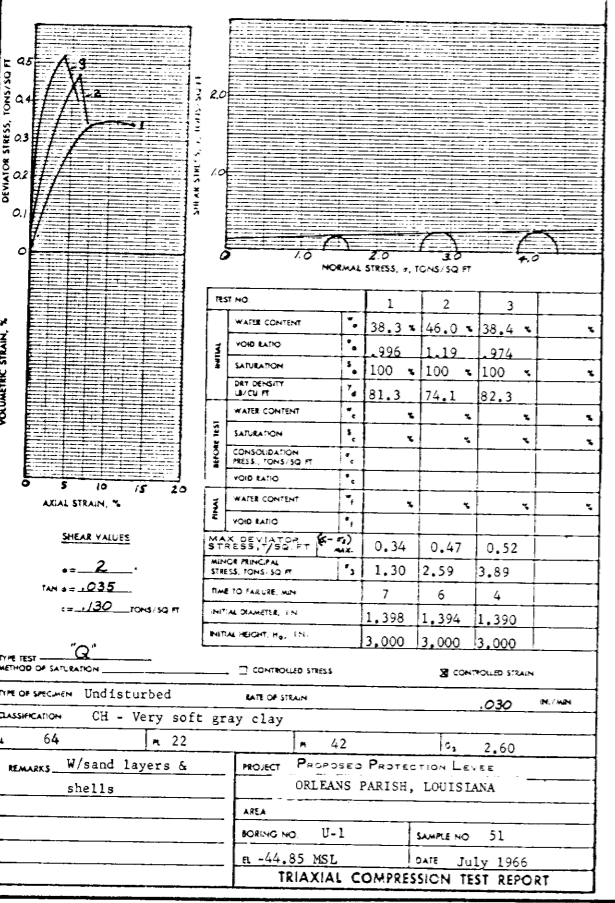
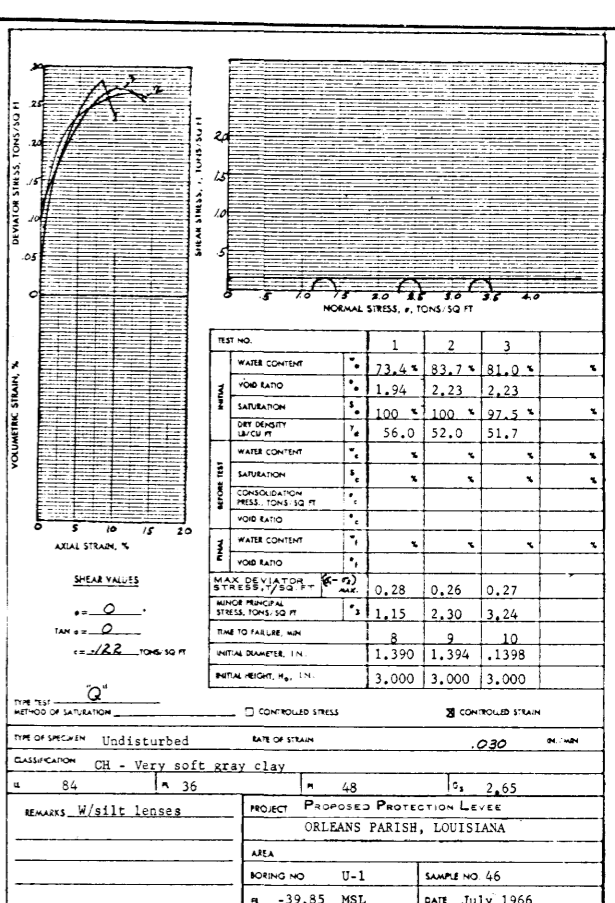
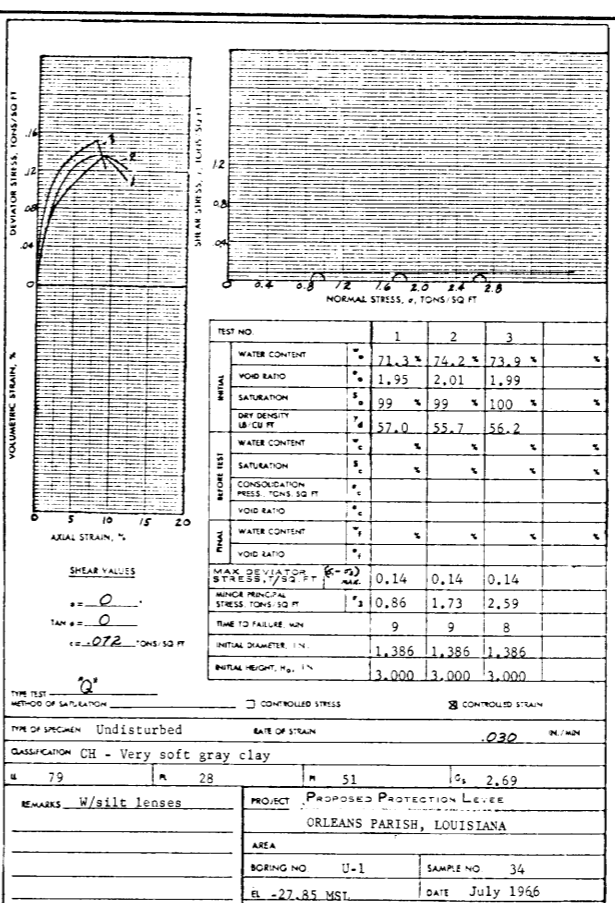
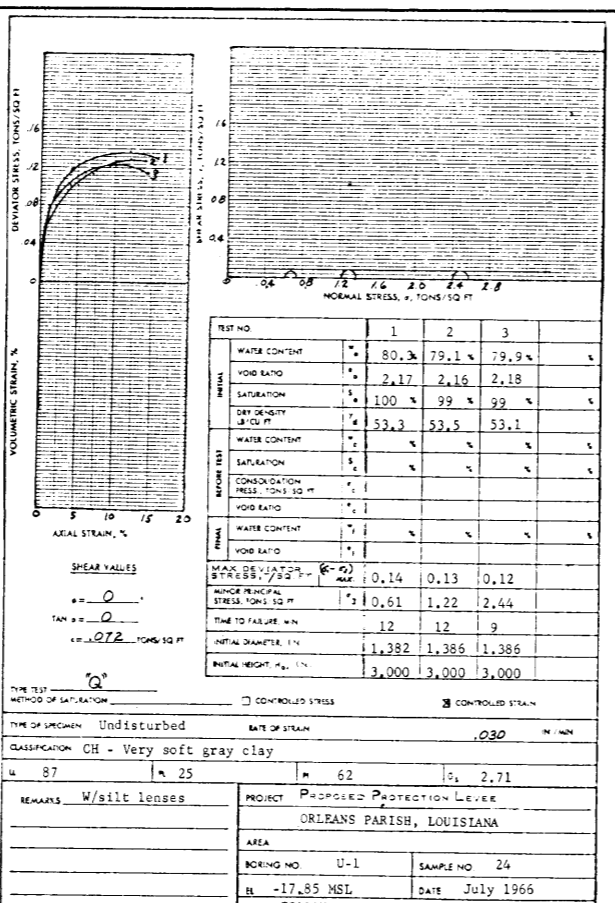
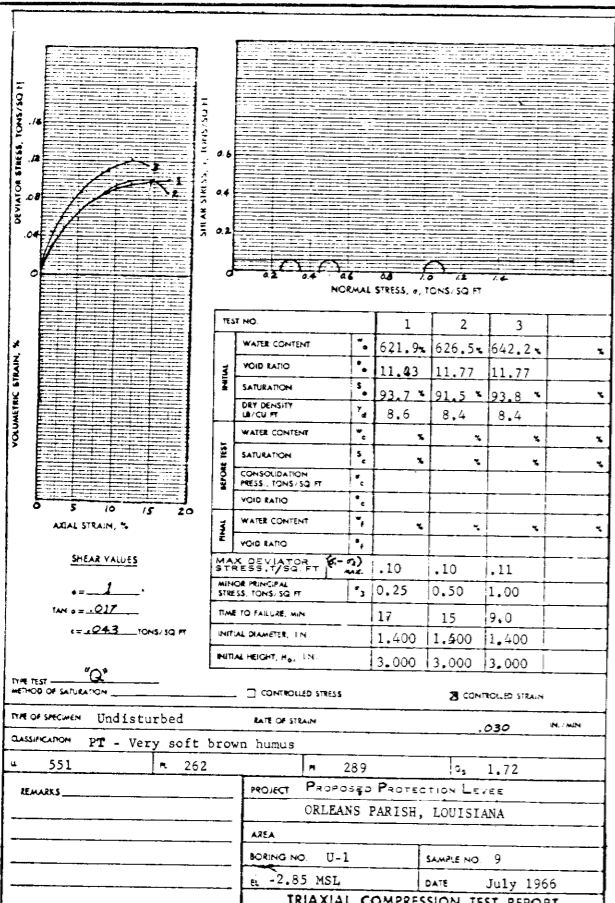

LAKE PONTCHARTRAIN, LA. AND VICINITY
CHALMETTE AREA PLAN
DESIGN MEMORANDUM NO. 3—GENERAL DESIGN
DETAIL SHEAR STRENGTH DATA
BORING U-1 "Q" TESTS
SCALES AS SHOWN

WALDEMAR S. NELSON AND COMPANY, INC.
ENGINEERS AND ARCHITECTS
NEW ORLEANS, LA.

U. S. ARMY ENGINEER DISTRICT, NEW ORLEANS
CORPS OF ENGINEERS, U. S. ARMY
NEW ORLEANS, LA.

DATE: NOVEMBER 1966
FILE NO. H-2-23820

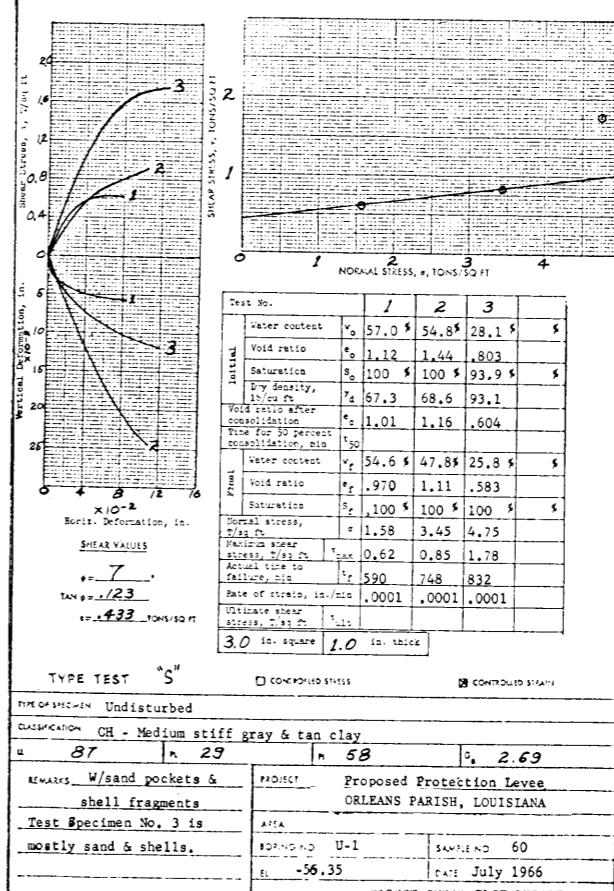
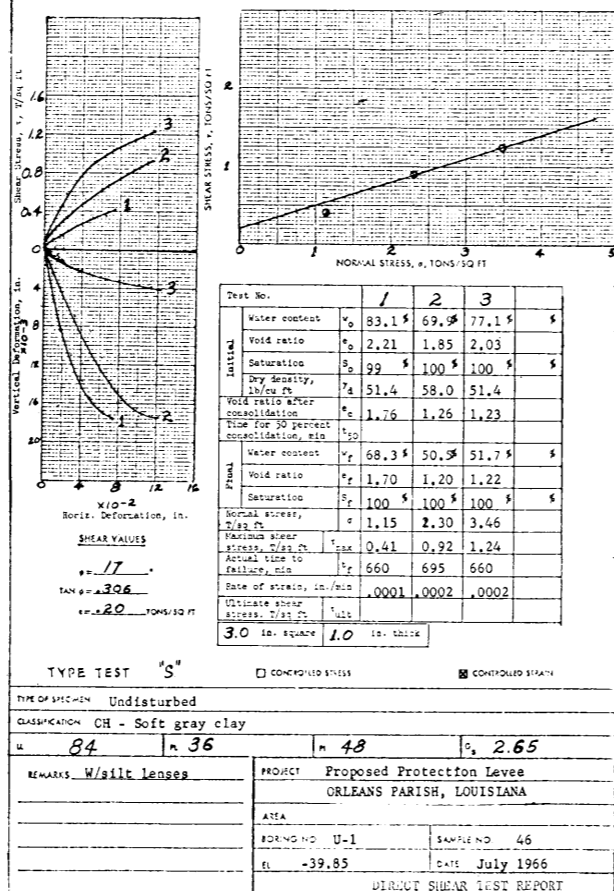
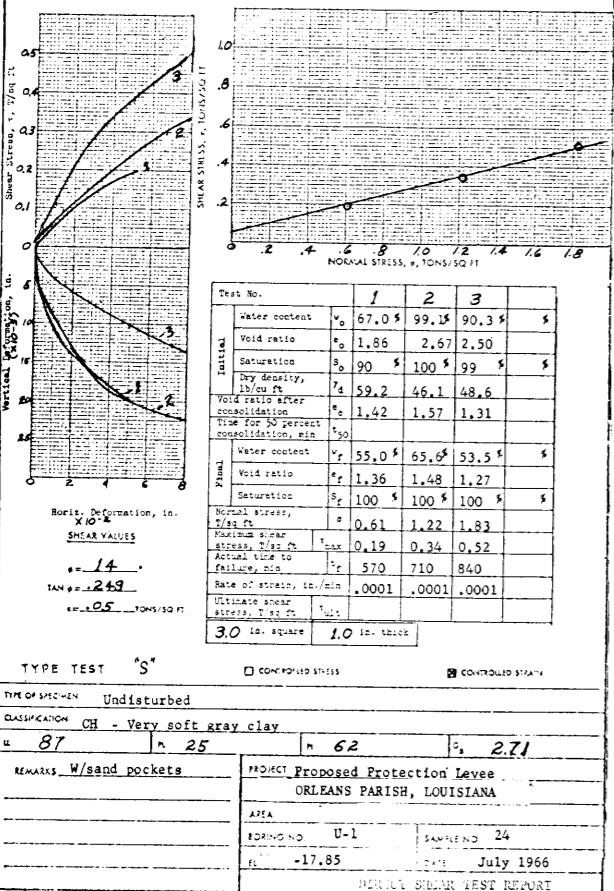
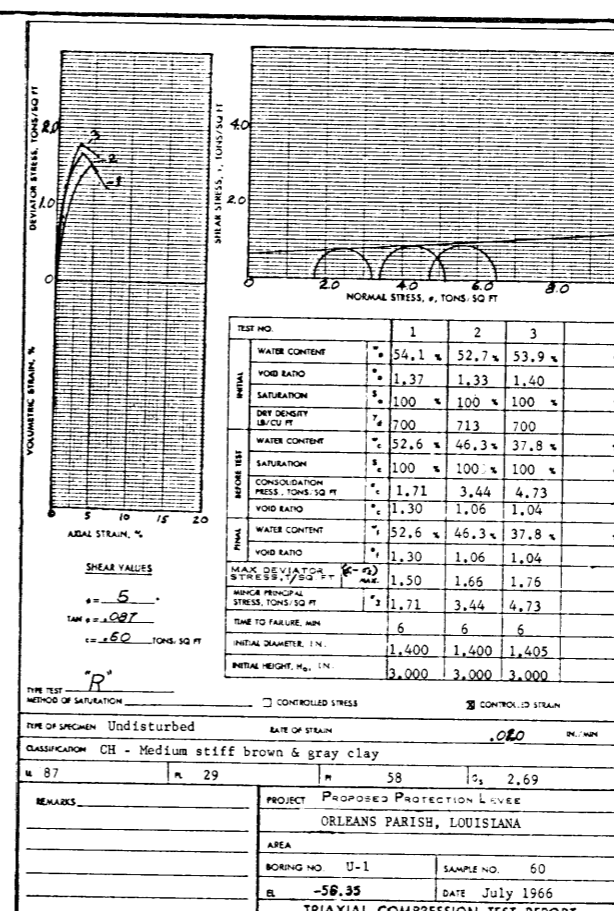
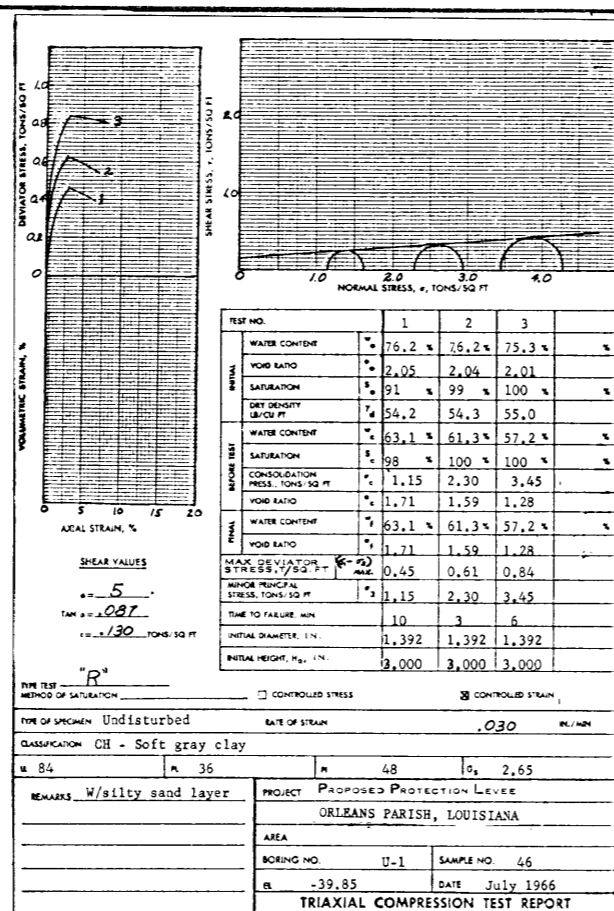
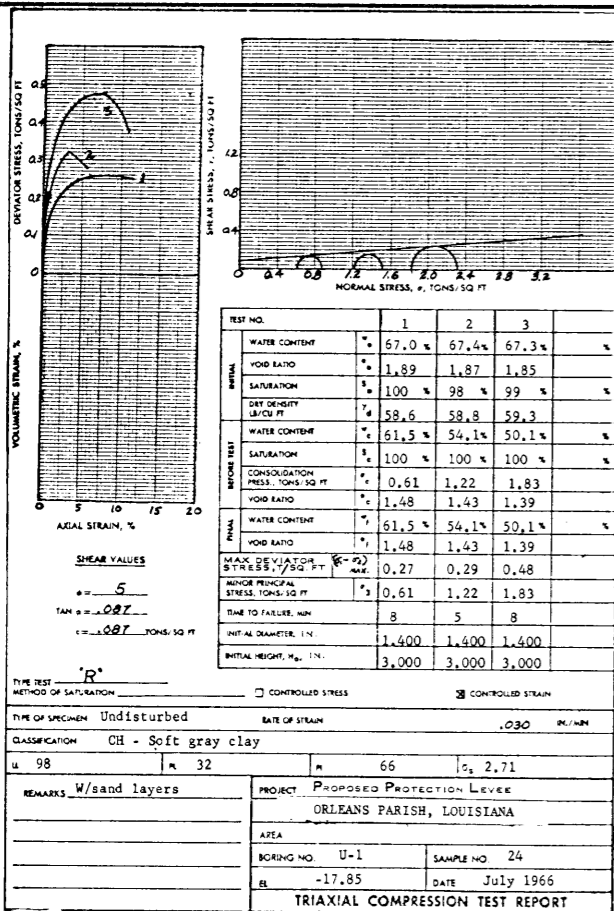

LAKE PONTCHARTRAIN, LA. AND VICINITY
 CHALMETTE AREA PLAN
 DESIGN MEMORANDUM NO. 3—GENERAL DESIGN
DETAIL SHEAR STRENGTH DATA
 BORING U-1 "R" & "S" TESTS
 SCALES AS SHOWN
 WALDENAR B. NELSON AND COMPANY, INC.
 ENGINEERS AND ARCHITECTS
 NEW ORLEANS, LA.
 U. S. ARMY ENGINEER DISTRICT, NEW ORLEANS
 CORPS OF ENGINEERS, U. S. ARMY
 NEW ORLEANS, LA.
 DATE: NOVEMBER 1966
 FILE NO. H-2-23820

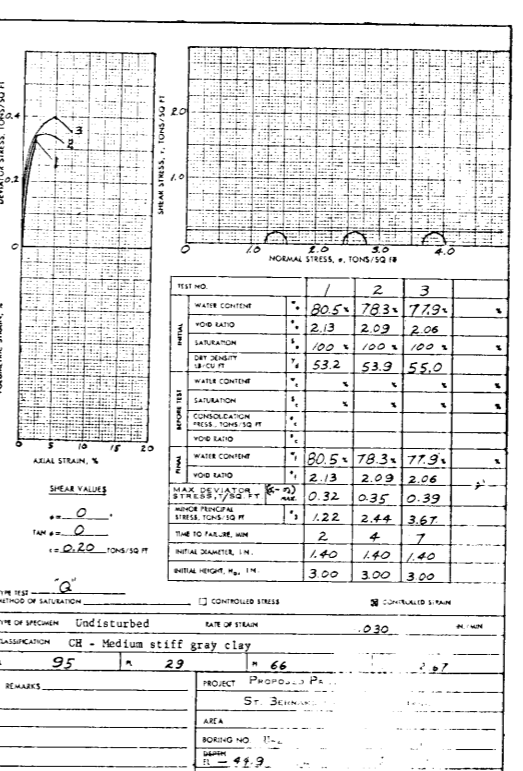
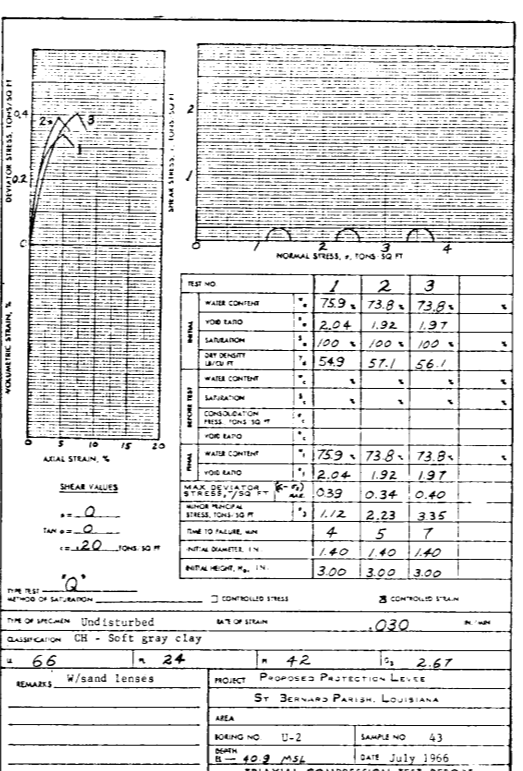
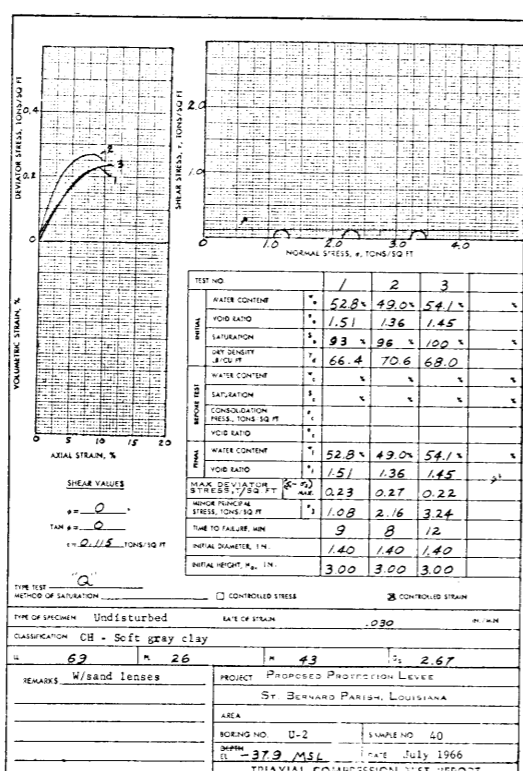
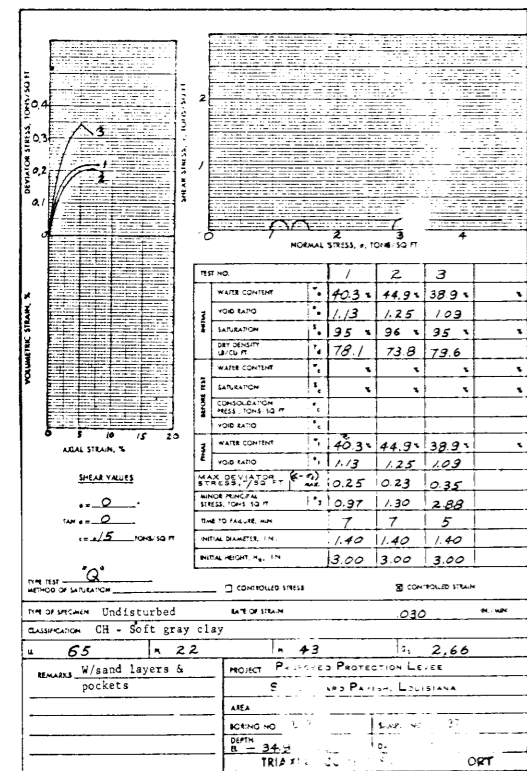
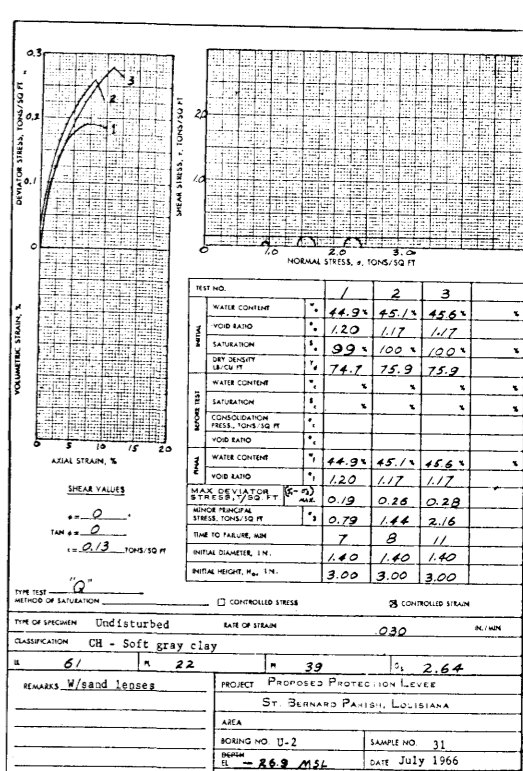
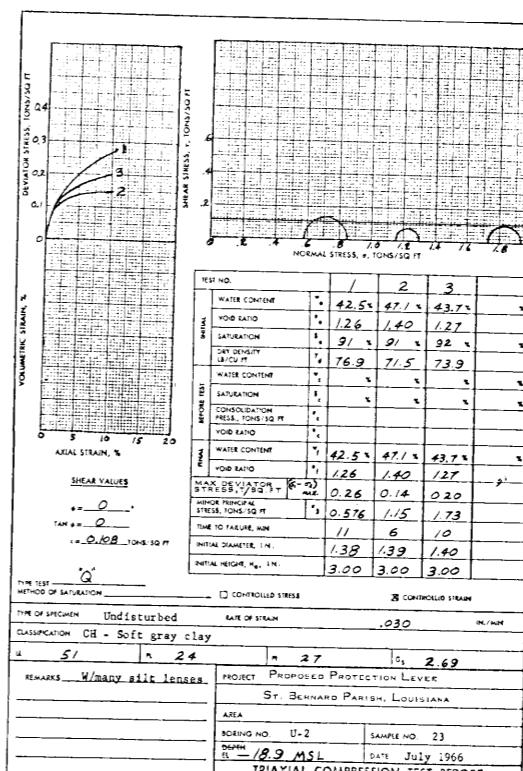
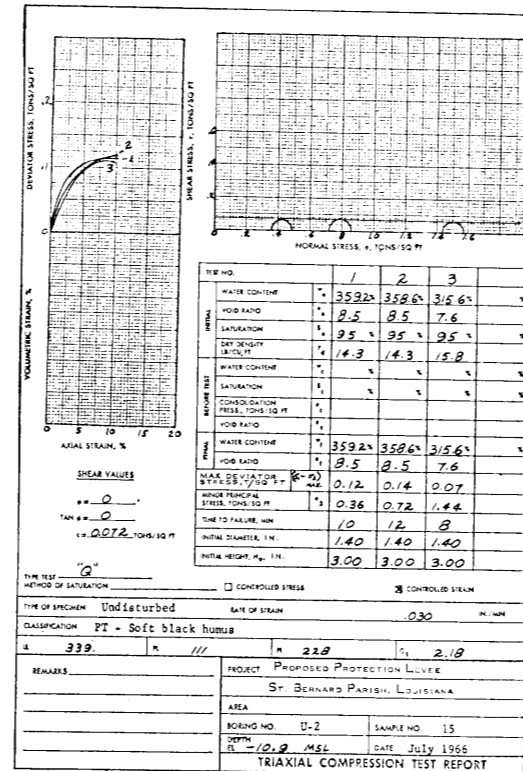
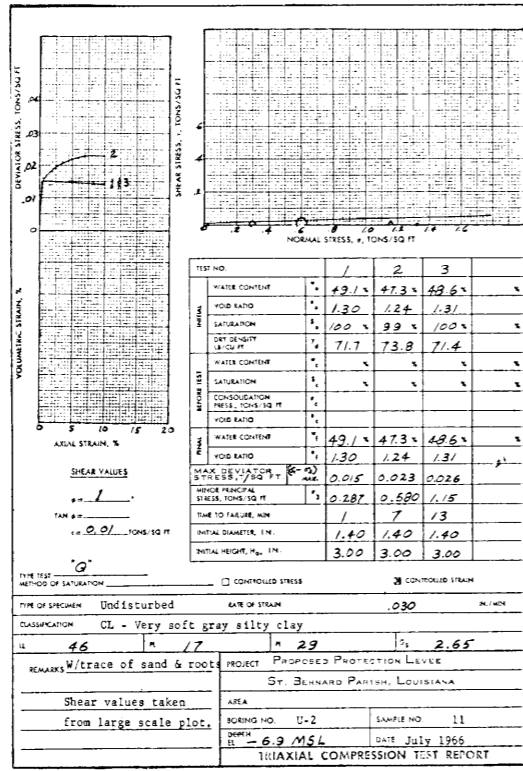
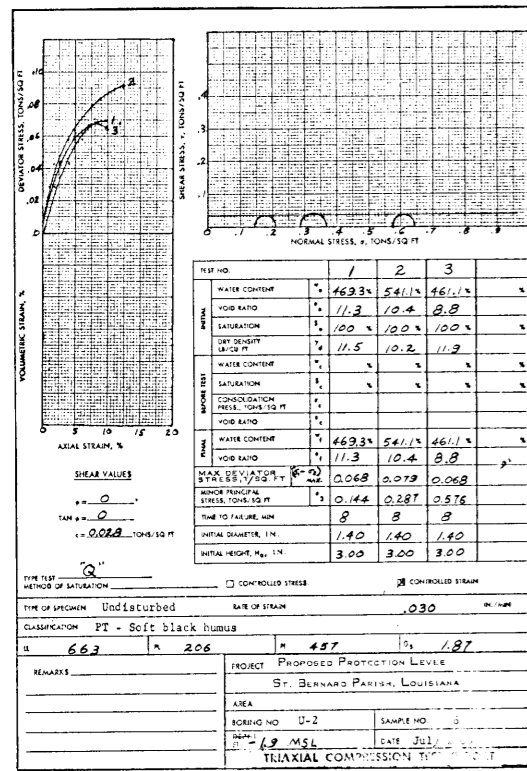

LAKE PONTCHARTRAIN, LA. AND VICINITY
CHALMETTE AREA PLAN
DESIGN MEMORANDUM NO. 3 - GENERAL DESIGN
DETAIL SHEAR STRENGTH DATA
BORING U-2 "Q" TESTS
SCALES AS SHOWN
WALDEMAR S. NELSON AND COMPANY, INC.
ENGINEERS AND ARCHITECTS
NEW ORLEANS, LA.
U. S. ARMY ENGINEER DISTRICT, NEW ORLEANS
CORPS OF ENGINEERS, U. S. ARMY
NEW ORLEANS, LA.
DATE: NOVEMBER 1966
FILE NO. H-2-23820

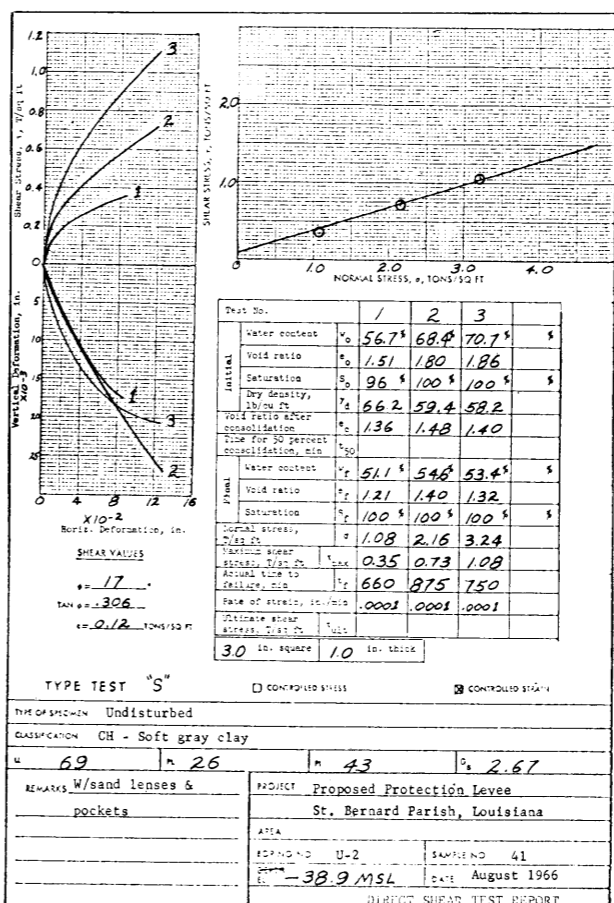
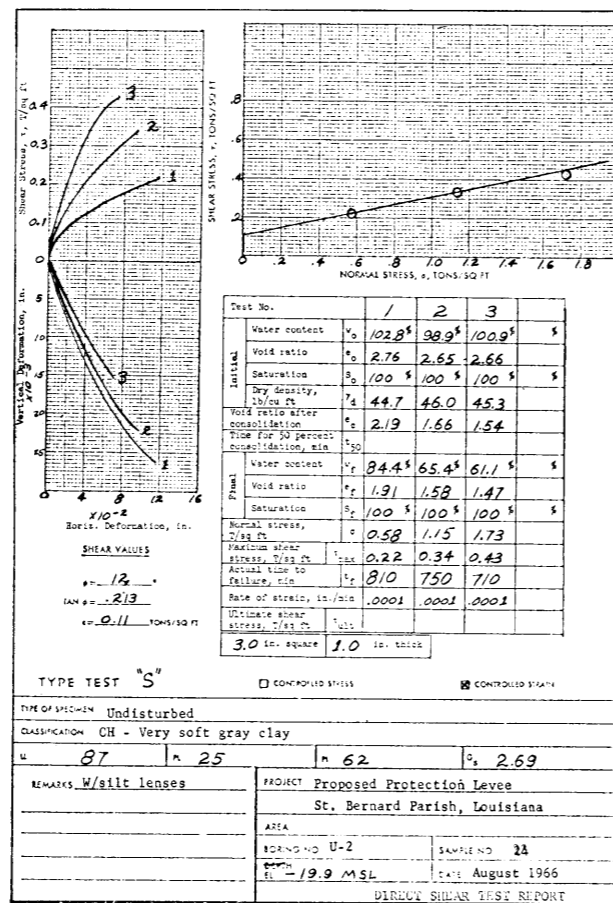
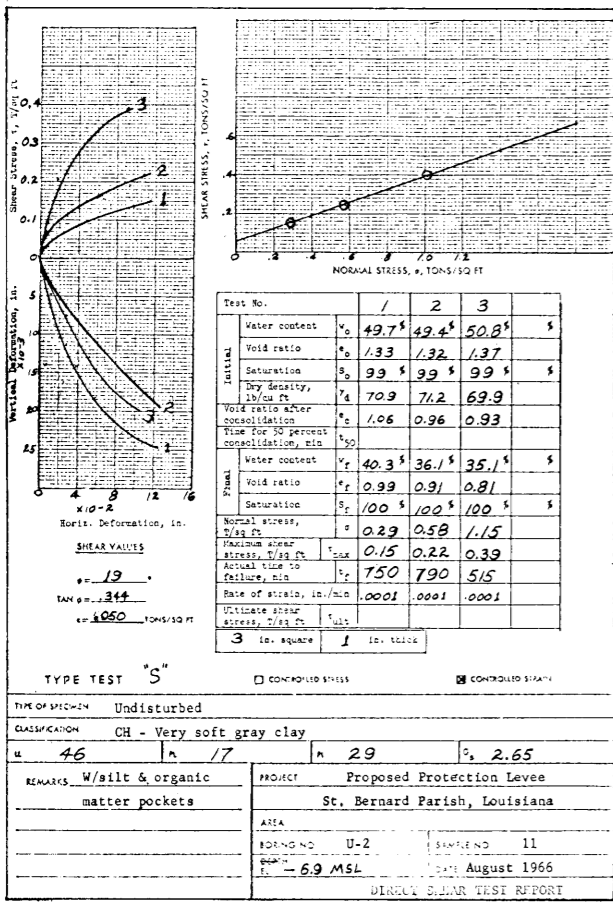
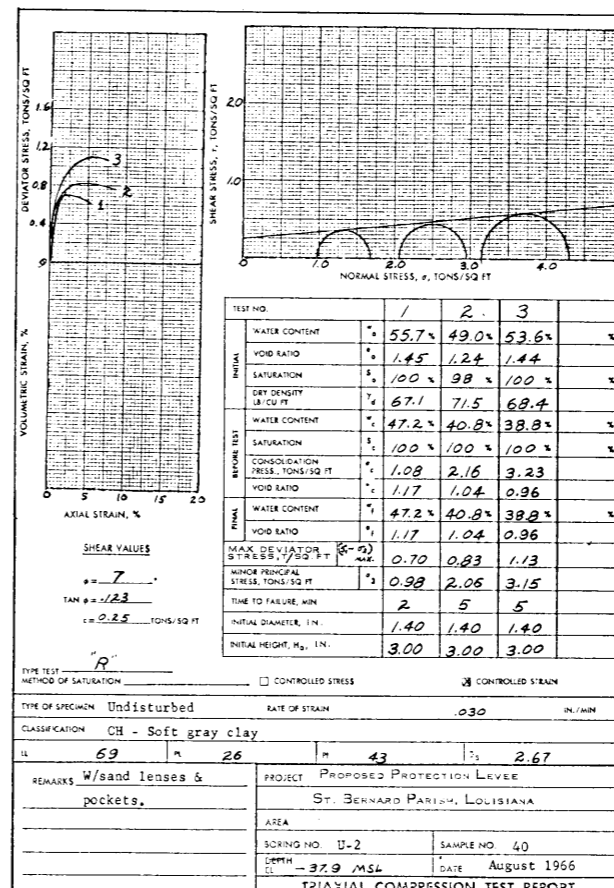
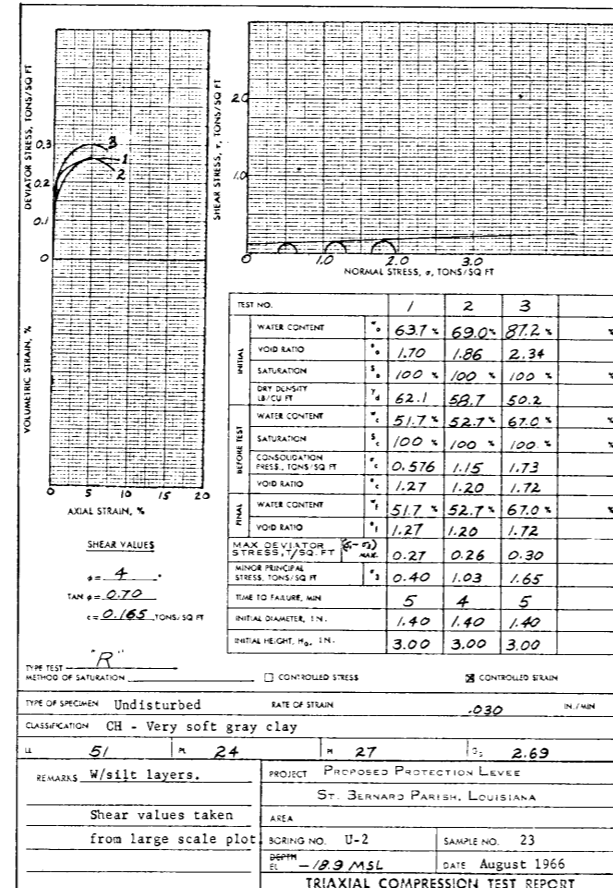
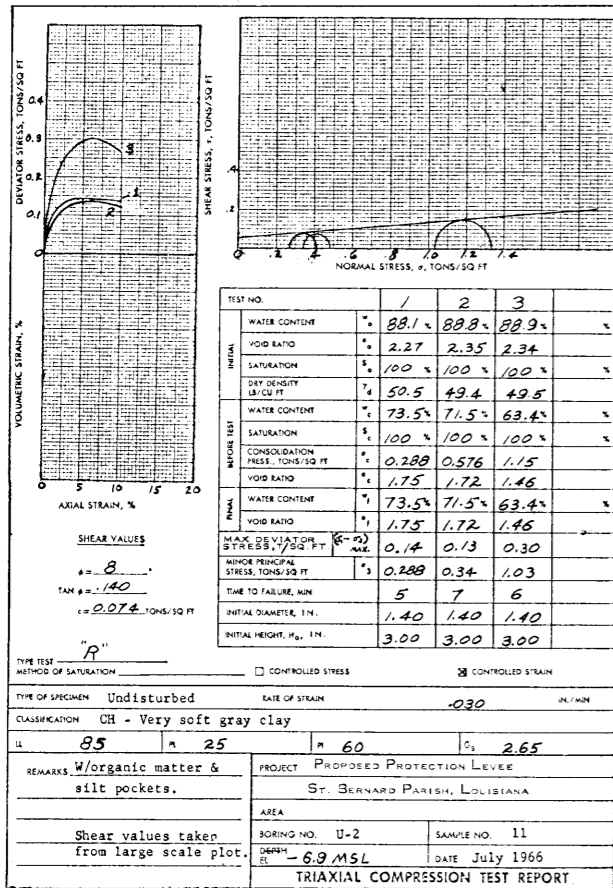

LAKE PONTCHARTRAIN, LA. AND VICINITY
CHALMETTE AREA PLAN
DESIGN MEMORANDUM NO. 3—GENERAL DESIGN
DETAIL SHEAR STRENGTH DATA
BORING U-2 "R" & "S" TESTS
SCALES AS SHOWN
WALDEMAR S. NELSON AND COMPANY, INC.
ENGINEERS AND ARCHITECTS
NEW ORLEANS, LA.
U. S. ARMY ENGINEER DISTRICT, NEW ORLEANS
CORPS OF ENGINEERS, U. S. ARMY
NEW ORLEANS, LA.
DATE: NOVEMBER 1966
FILE NO. H-2-23820

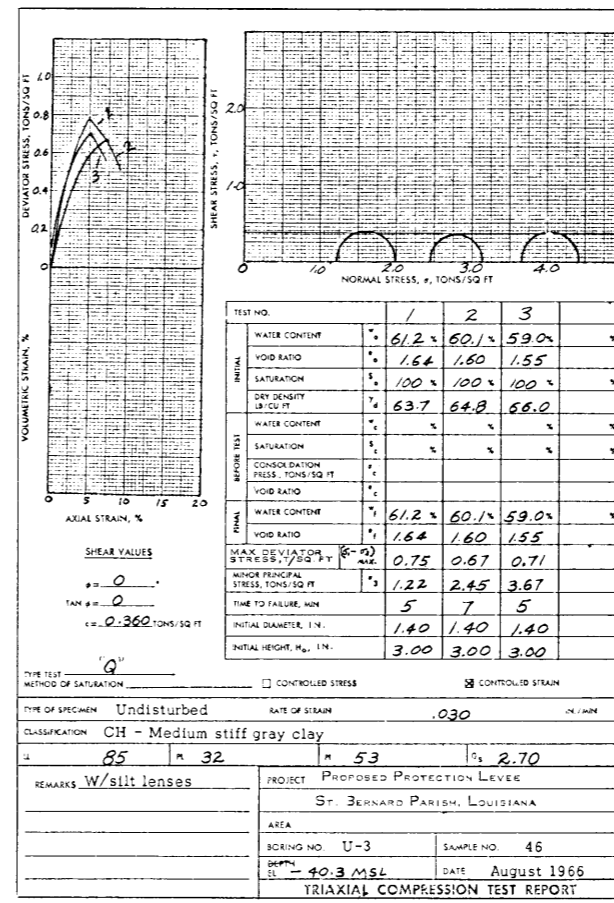
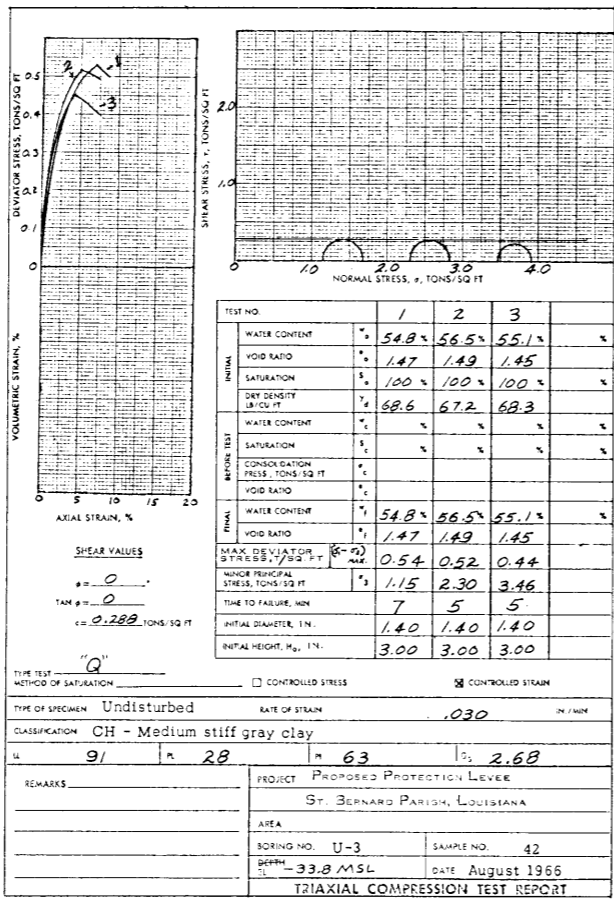
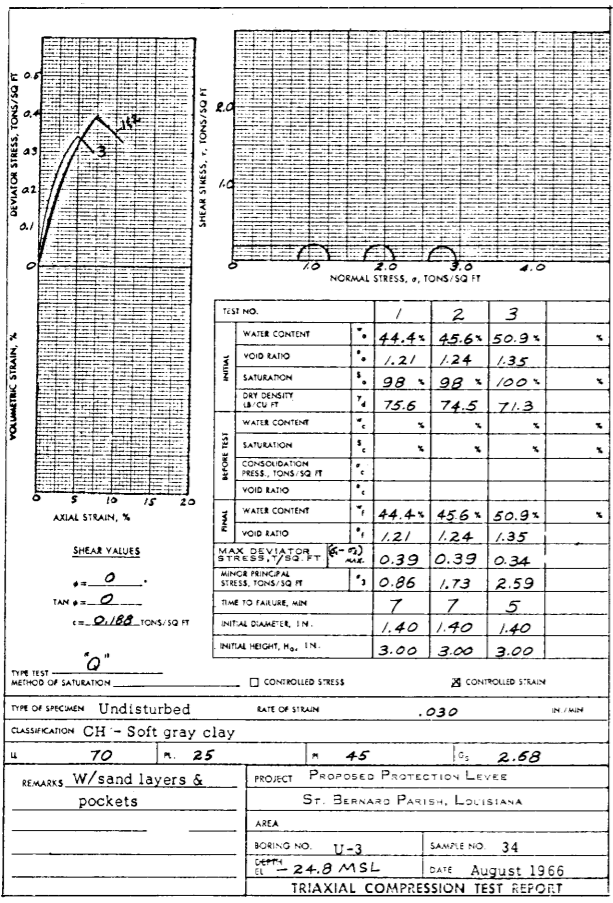
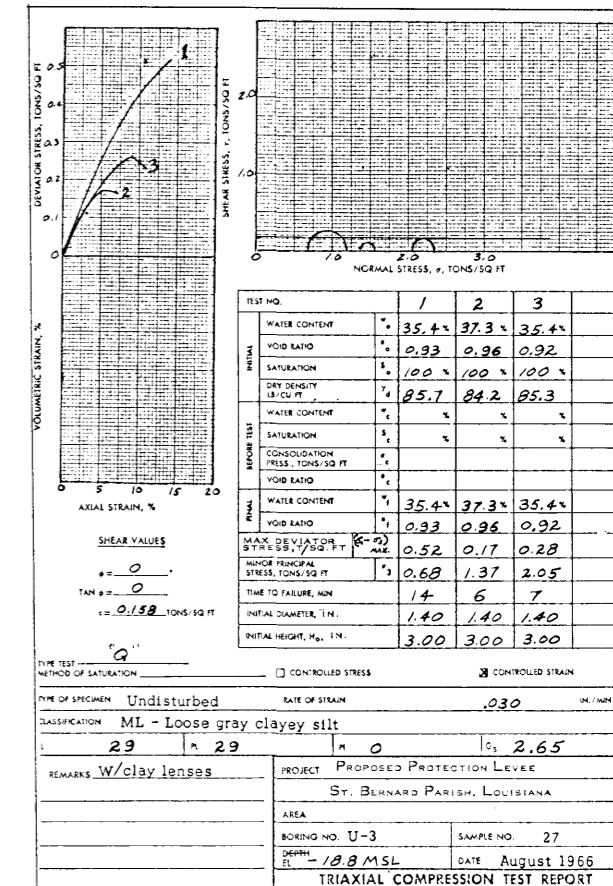
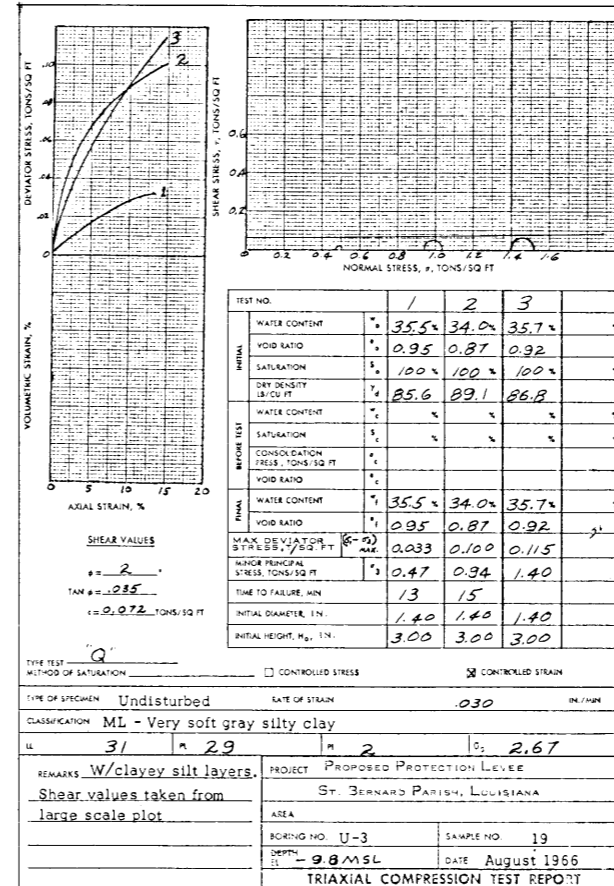
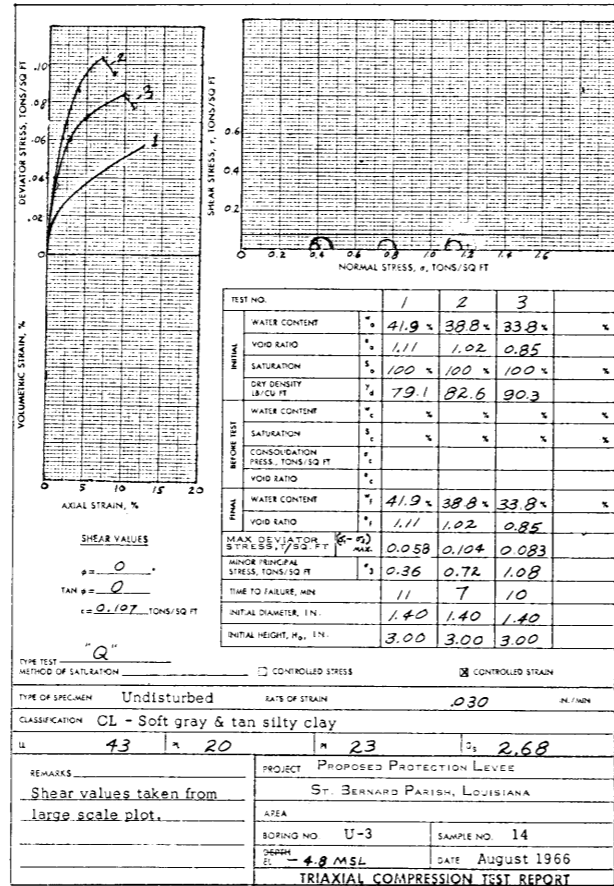
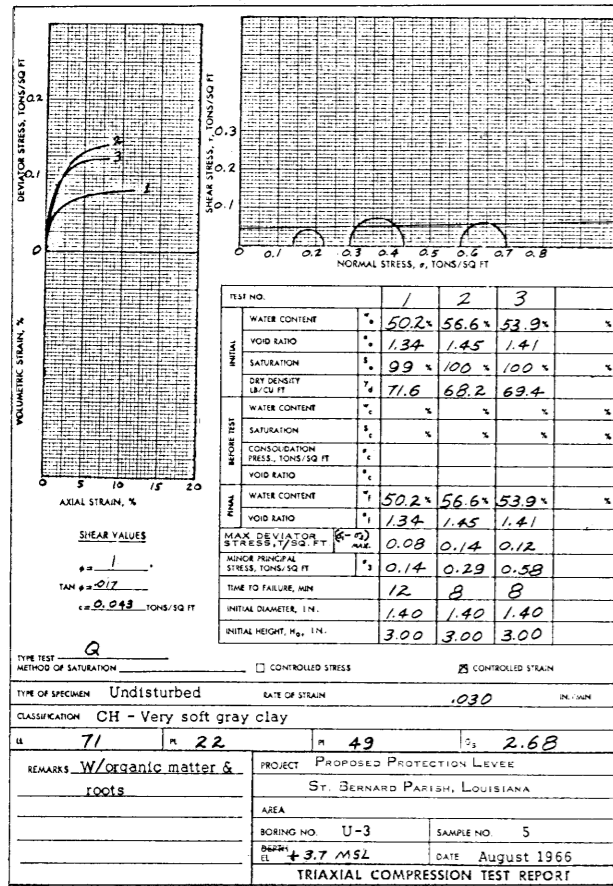

LAKE PONTCHARTRAIN, LA. AND VICINITY
CHALMETTE AREA PLAN
DESIGN MEMORANDUM NO. 3—GENERAL DESIGN
DETAIL SHEAR STRENGTH DATA
BORING U-3 "Q" TESTS
SCALES AS SHOWN
WALDEMAR S. NELSON AND COMPANY, INC.
ENGINEERS AND ARCHITECTS
NEW ORLEANS, LA.
U. S. ARMY ENGINEER DISTRICT, NEW ORLEANS
CORPS OF ENGINEERS, U. S. ARMY
NEW ORLEANS, LA.
DATE: NOVEMBER 1966
FILE NO. H-2-23820

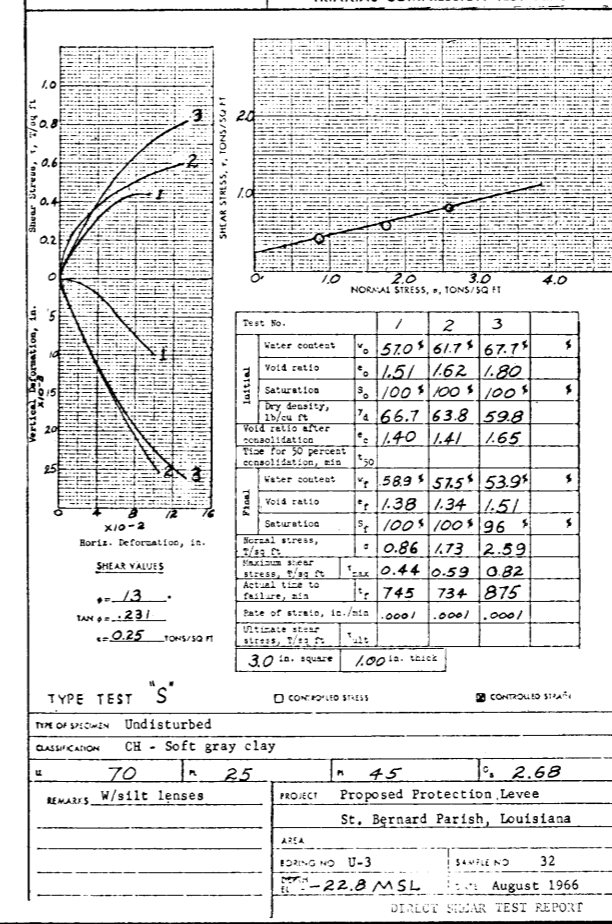
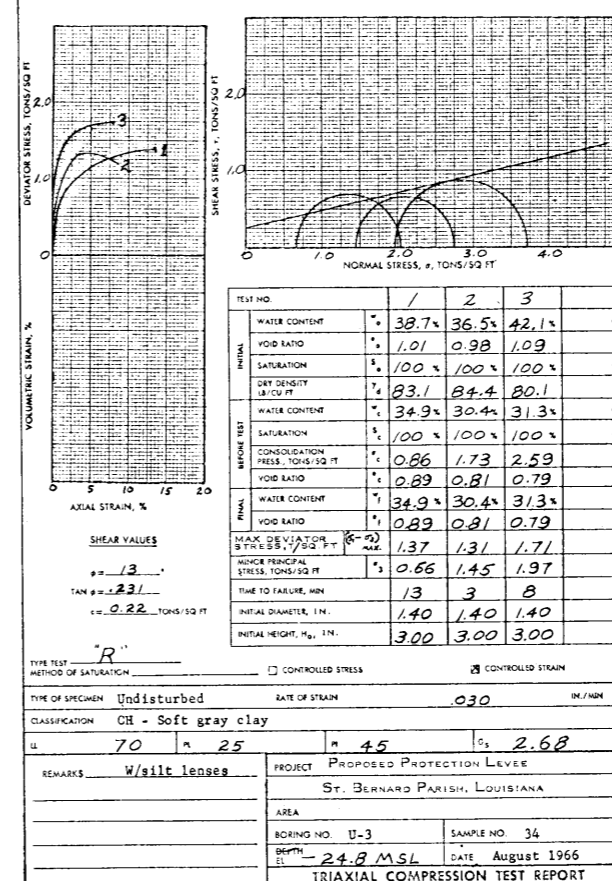
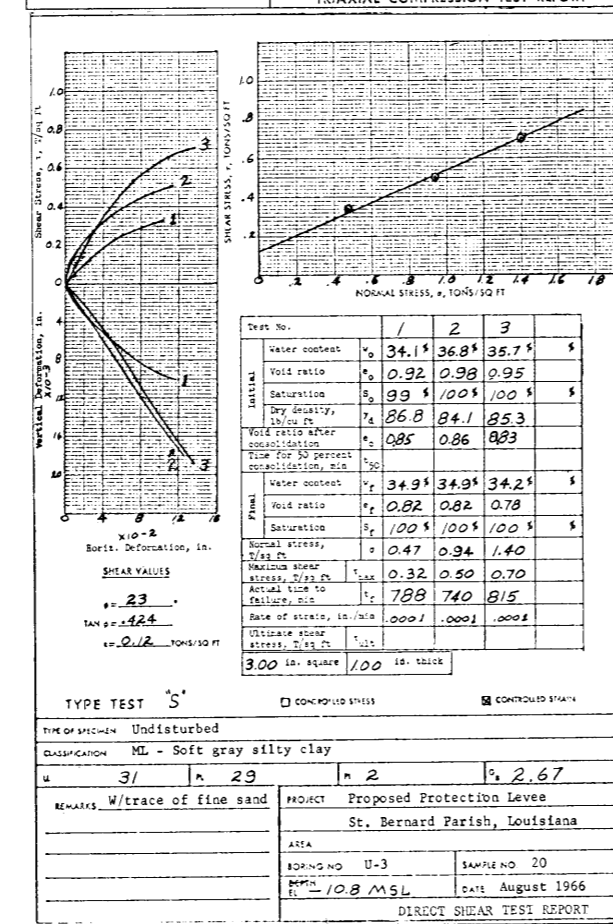
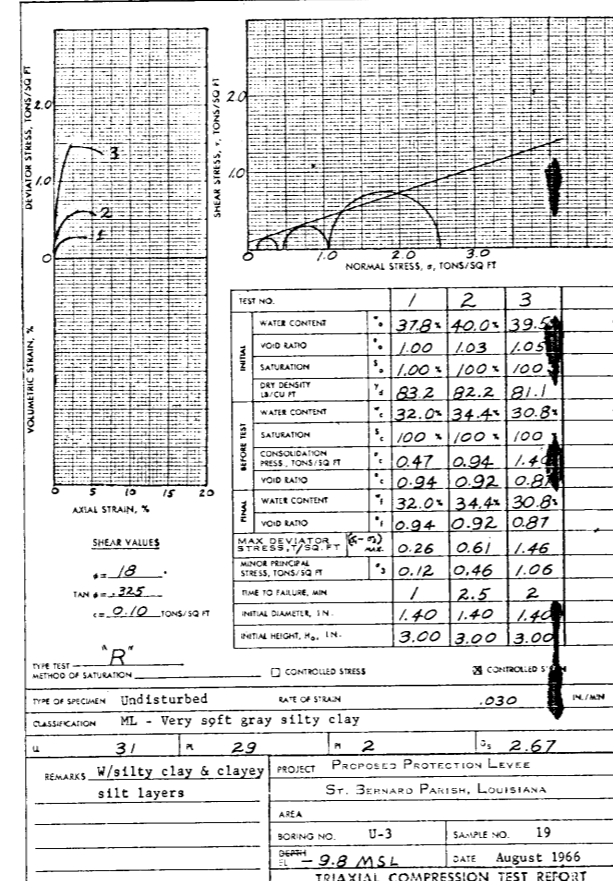
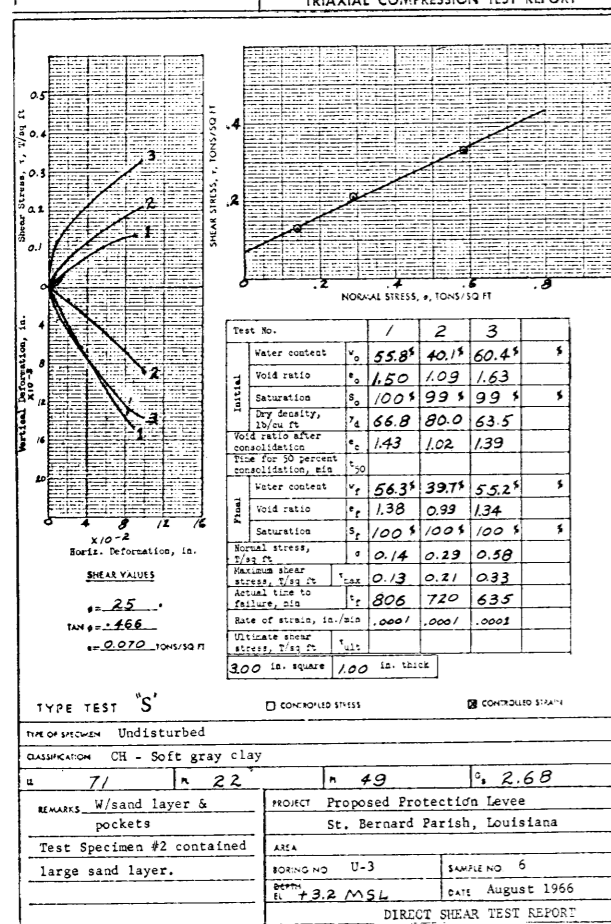
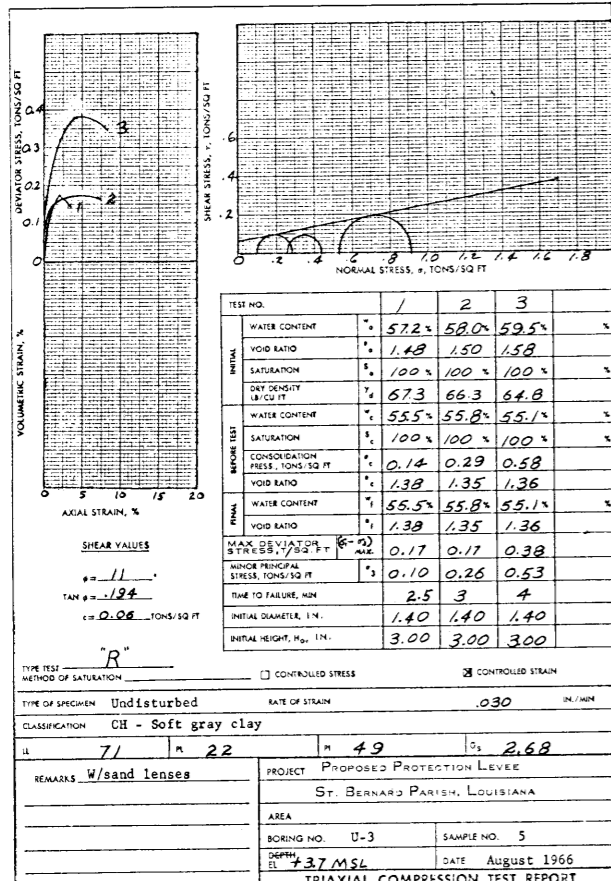

LAKE PONTCHARTRAIN, LA. AND VICINITY
CHALMETTE AREA PLAN
DESIGN MEMORANDUM NO. 3—GENERAL DESIGN
DETAIL SHEAR STRENGTH DATA
BORING U-3 "R" & "S" TESTS

SCALES AS SHOWN

WALDEMAR S. NELSON AND COMPANY, INC. ENGINEERS AND ARCHITECTS NEW ORLEANS, LA.	U. S. ARMY ENGINEER DISTRICT, NEW ORLEANS CORPS OF ENGINEERS, U. S. ARMY NEW ORLEANS, LA.
--	---

DATE: NOVEMBER 1966 FILE NO. H-2-23820

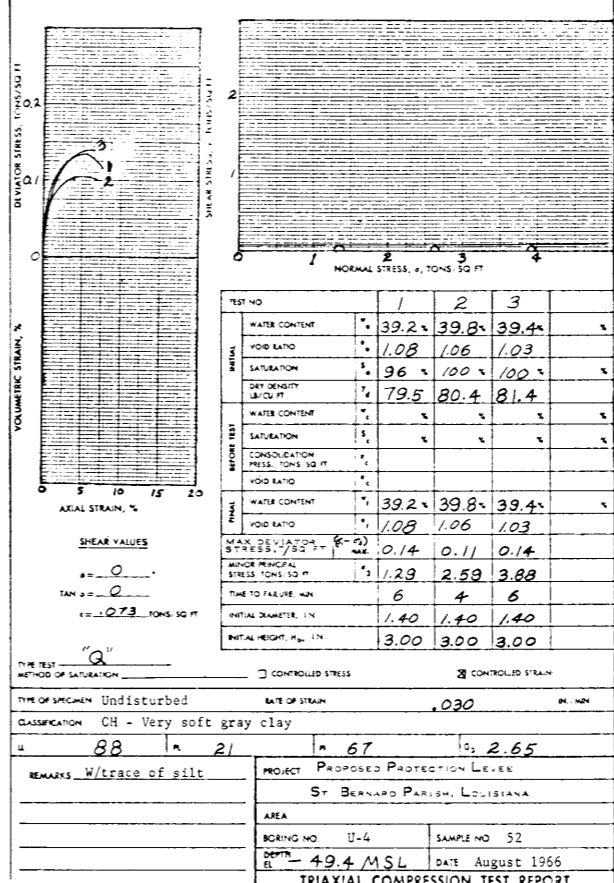
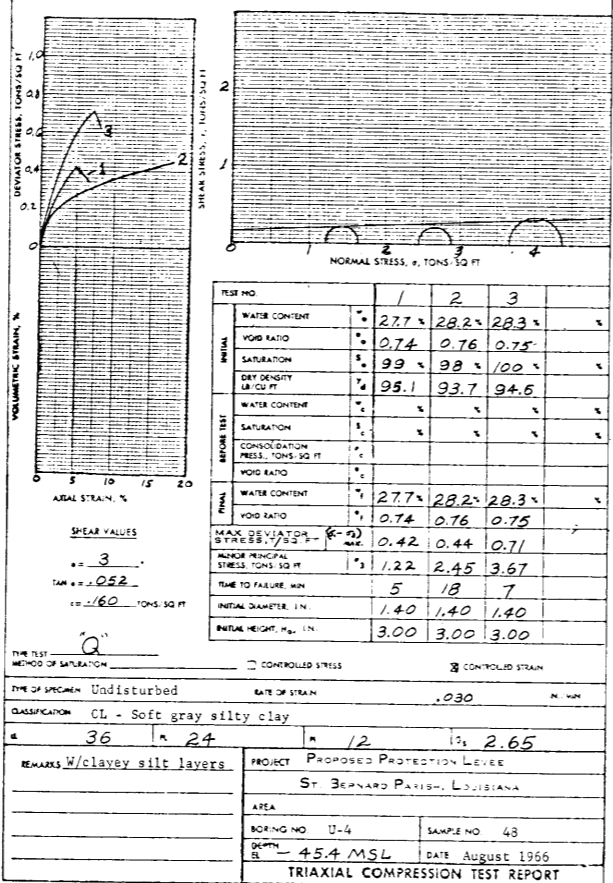
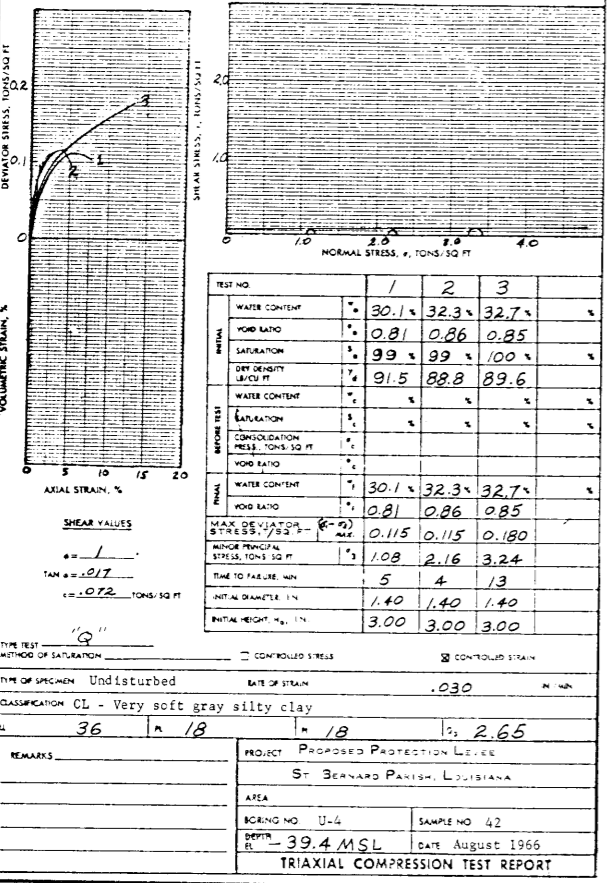
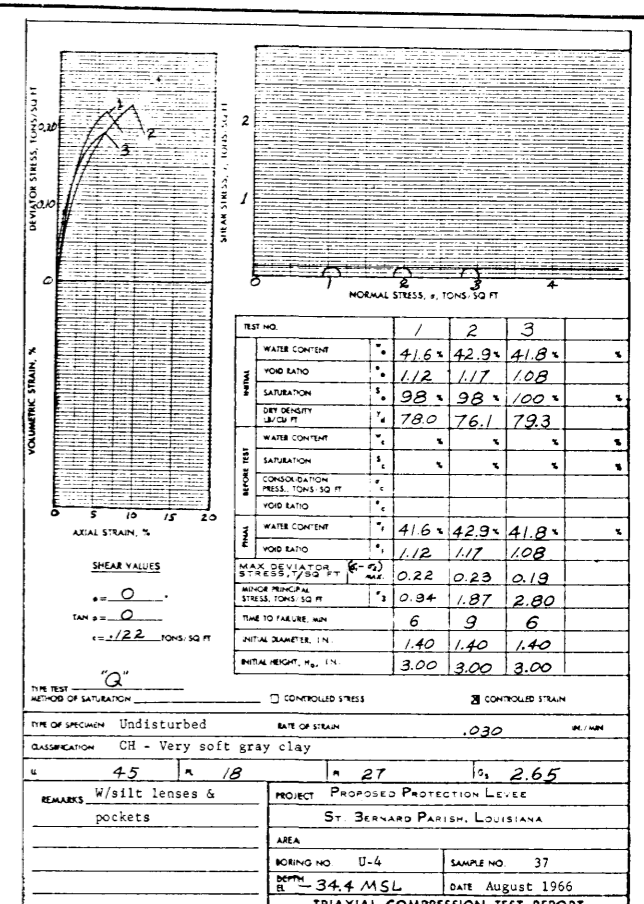
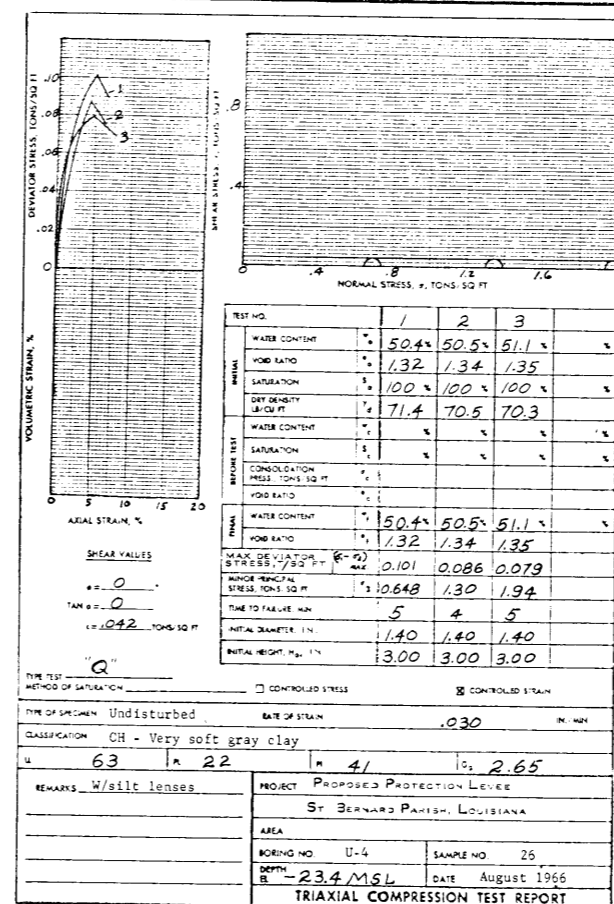
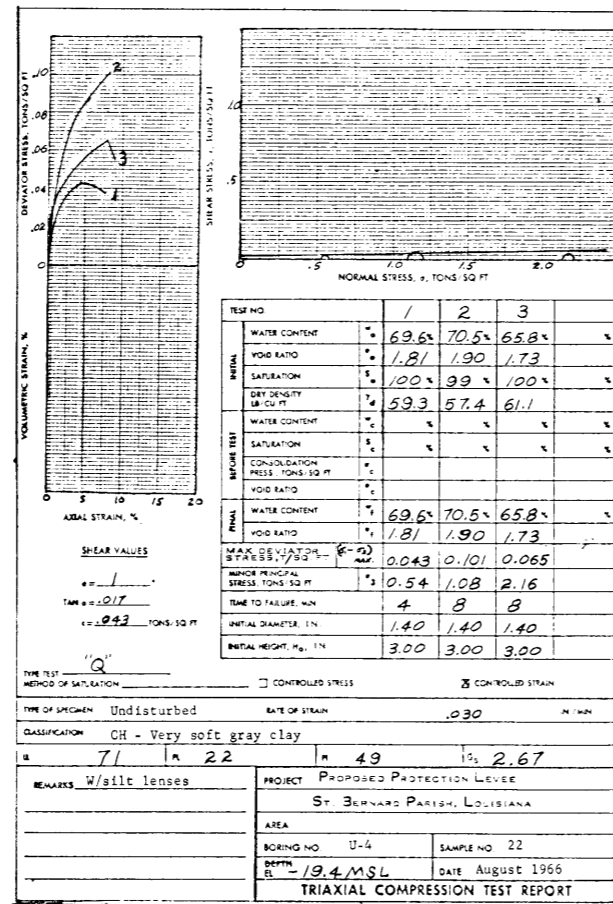
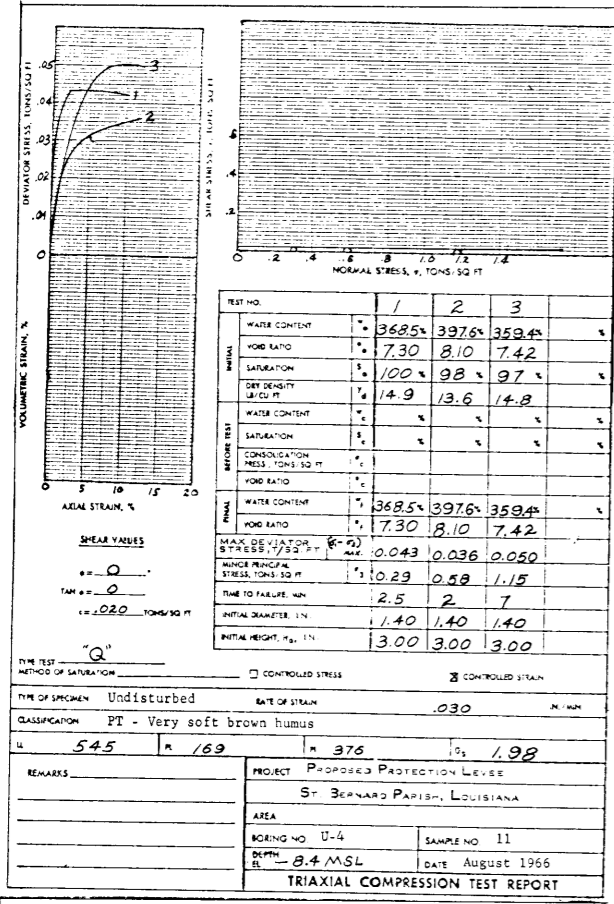

LAKE PONTCHARTRAIN, LA. AND VICINITY
CHALMETTE AREA PLAN
DESIGN MEMORANDUM NO. 3—GENERAL DESIGN
DETAIL SHEAR STRENGTH DATA
BORING U-4 "Q" TESTS
SCALES AS SHOWN
WALDEMAR S. NELSON AND COMPANY, INC.
ENGINEERS AND ARCHITECTS
NEW ORLEANS, LA.
U. S. ARMY ENGINEER DISTRICT, NEW ORLEANS
CORPS OF ENGINEERS, U. S. ARMY
NEW ORLEANS, LA.
DATE: NOVEMBER 1966
FILE NO. H-2-23820

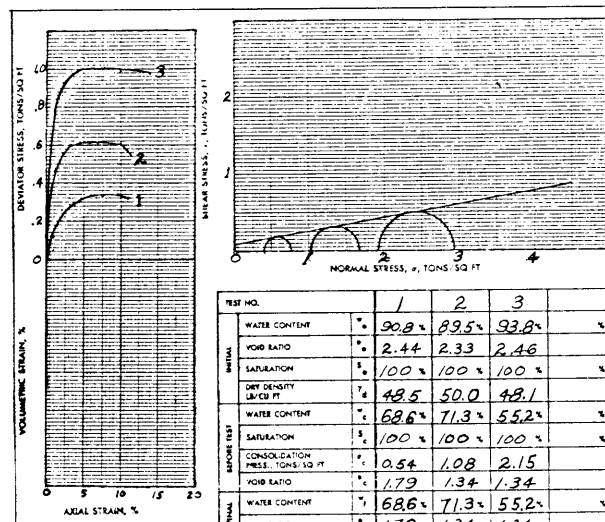

TEST NO.	1	2	3
INITIAL WATER CONTENT %	90.8	89.5	93.8
VOID RATIO	2.44	2.33	2.48
SATURATION %	100	100	100
DRY DENSITY lb/cu ft	48.5	50.0	48.1
BEFORE TEST WATER CONTENT %	68.6	71.3	55.2
SATURATION %	100	100	100
CONSOLIDATION PRESS. TONS/SQ FT	0.54	1.08	2.15
VOID RATIO	1.79	1.34	1.34
FINAL WATER CONTENT %	68.6	71.3	55.2
VOID RATIO	1.79	1.34	1.34
MAX. DEVIATOR STRESS (TONS/SQ FT)	0.34	0.61	1.00
MINOR PRINCIPAL STRESS (TONS/SQ FT)	0.42	1.04	1.91
TIME TO FAILURE MIN	9	9	5
INITIAL DIAMETER IN.	1.40	1.40	1.40
INITIAL HEIGHT, H ₀ IN.	3.00	3.00	3.00

SHEAR VALUES
 $\phi = 10^\circ$
 $\tan \phi = 0.176$
 $c = 0.09$ TONS/SQ FT

TYPE TEST **"R"**
 METHOD OF SATURATION CONTROLLED STRESS CONTROLLED STRAIN

TYPE OF SPECIMEN Undisturbed RATE OF STRAIN 0.030 IN./MIN

CLASSIFICATION CH - Very soft gray clay

u 7.9 n 23 m 5.6 s 2.67

REMARKS PROJECT Proposed Protection Levee
 St. Bernard Parish, Louisiana

AREA BORING NO U-4 SAMPLE NO 22
 DEPTH EL -19.4 MSL DATE August 1966

TRIAXIAL COMPRESSION TEST REPORT

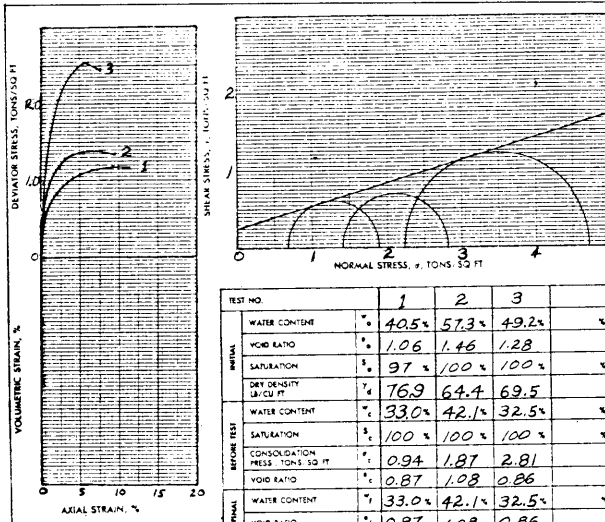

TEST NO.	1	2	3
INITIAL WATER CONTENT %	40.5	57.3	49.2
VOID RATIO	1.06	1.46	1.28
SATURATION %	97	100	100
DRY DENSITY lb/cu ft	76.9	64.4	69.5
BEFORE TEST WATER CONTENT %	33.0	42.1	32.5
SATURATION %	100	100	100
CONSOLIDATION PRESS. TONS/SQ FT	0.94	1.87	2.81
VOID RATIO	0.87	1.08	0.86
FINAL WATER CONTENT %	33.0	42.1	32.5
VOID RATIO	0.87	1.08	0.86
MAX. DEVIATOR STRESS (TONS/SQ FT)	1.19	1.37	2.51
MINOR PRINCIPAL STRESS (TONS/SQ FT)	0.68	1.41	2.23
TIME TO FAILURE MIN	9	7	5
INITIAL DIAMETER IN.	1.40	1.40	1.40
INITIAL HEIGHT, H ₀ IN.	3.00	3.00	3.00

SHEAR VALUES
 $\phi = 17^\circ$
 $\tan \phi = 0.306$
 $c = 0.24$ TONS/SQ FT

TYPE TEST **"R"**
 METHOD OF SATURATION CONTROLLED STRESS CONTROLLED STRAIN

TYPE OF SPECIMEN Undisturbed RATE OF STRAIN 0.030 IN./MIN

CLASSIFICATION CL - Soft gray silty clay

u 4.5 n 18 m 2.7 s 2.54

REMARKS W/sandy silt & organic matter layers. Specimen for Test No. 2 contained thick layer of organic matter

AREA BORING NO U-4 SAMPLE NO 37
 DEPTH EL -34.4 MSL DATE August 1966

TRIAXIAL COMPRESSION TEST REPORT

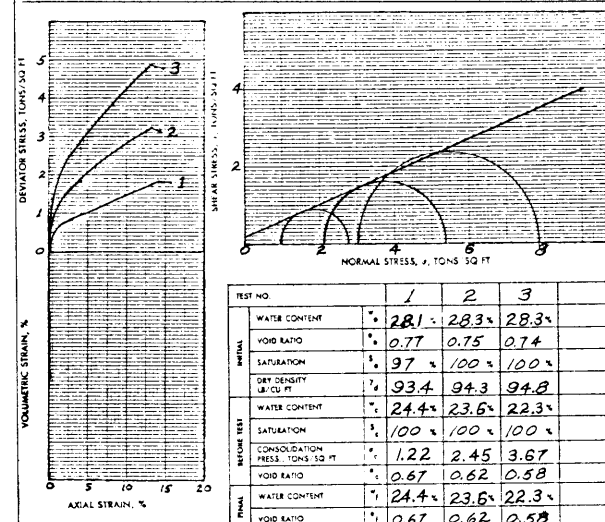

TEST NO.	1	2	3
INITIAL WATER CONTENT %	28.1	28.3	28.3
VOID RATIO	0.77	0.75	0.74
SATURATION %	97	100	100
DRY DENSITY lb/cu ft	93.4	94.3	94.8
BEFORE TEST WATER CONTENT %	24.4	23.6	22.3
SATURATION %	100	100	100
CONSOLIDATION PRESS. TONS/SQ FT	1.22	2.45	3.67
VOID RATIO	0.67	0.62	0.58
FINAL WATER CONTENT %	24.4	23.6	22.3
VOID RATIO	0.67	0.62	0.58
MAX. DEVIATOR STRESS (TONS/SQ FT)	1.83	3.21	4.87
MINOR PRINCIPAL STRESS (TONS/SQ FT)	0.96	2.12	3.02
TIME TO FAILURE MIN	15	13	13
INITIAL DIAMETER IN.	1.40	1.40	1.40
INITIAL HEIGHT, H ₀ IN.	3.00	3.00	3.00

SHEAR VALUES
 $\phi = 24^\circ$
 $\tan \phi = 0.445$
 $c = 0.190$ TONS/SQ FT

TYPE TEST **"R"**
 METHOD OF SATURATION CONTROLLED STRESS CONTROLLED STRAIN

TYPE OF SPECIMEN Undisturbed RATE OF STRAIN 0.030 IN./MIN

CLASSIFICATION CL - Soft gray silty clay

u 3.6 n 24 m 12 s 2.65

REMARKS PROJECT Proposed Protection Levee
 St. Bernard Parish, Louisiana

AREA BORING NO U-4 SAMPLE NO 48
 DEPTH EL -45.4 MSL DATE August 1966

TRIAXIAL COMPRESSION TEST REPORT

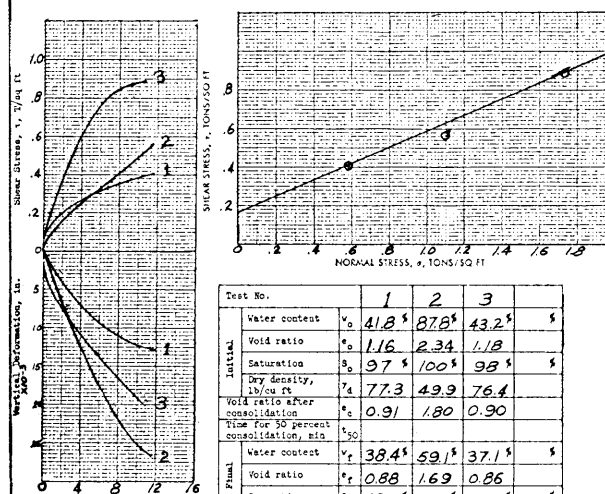

Test No.	1	2	3
INITIAL Water content %	41.8	87.8	43.2
VOID RATIO	1.16	2.34	1.18
SATURATION %	97	100	98
DRY DENSITY, lb/cu ft	77.3	49.9	76.4
VOID RATIO AFTER CONSOLIDATION	0.91	1.80	0.90
TIME FOR 50 PERCENT CONSOLIDATION, MIN			
FINAL Water content %	38.4	59.1	37.1
VOID RATIO	0.88	1.69	0.86
SATURATION %	100	100	100
NORMAL STRESS, TONS/SQ FT	0.58	1.15	1.73
MAXIMUM SHEAR STRESS, TONS/SQ FT	0.40	0.57	0.90
ACTUAL TIME TO FAILURE, MIN	858	860	795
RATE OF STRAIN, IN./MIN	0.0001	0.0001	0.0001
ULTIMATE SHEAR STRESS, TONS/SQ FT	1.0	1.0	1.0

SHEAR VALUES
 $\phi = 24^\circ$
 $\tan \phi = 0.445$
 $c = 0.16$ TONS/SQ FT

TYPE TEST **"S"**
 CONTROLLED STRESS CONTROLLED STRAIN

TYPE OF SPECIMEN Undisturbed

CLASSIFICATION CH - Very soft gray clay

u 4.7 n 24 m 2.3 s 2.67

REMARKS W/silt lenses & sand pockets

PROJECT Proposed Protection Levee
 St. Bernard Parish, Louisiana

AREA BORING NO U-4 SAMPLE NO 23
 DEPTH EL -20.4 MSL DATE September 1966

DIRECT SHEAR TEST REPORT

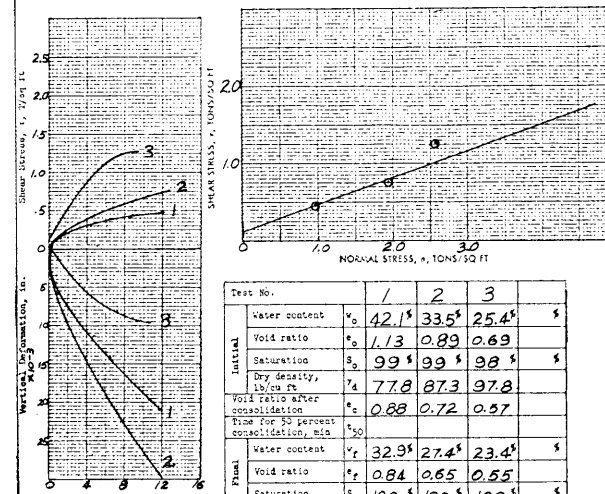

Test No.	1	2	3
INITIAL Water content %	42.1	33.5	25.4
VOID RATIO	1.13	0.89	0.69
SATURATION %	99	99	98
DRY DENSITY, lb/cu ft	77.8	87.3	97.8
VOID RATIO AFTER CONSOLIDATION	0.88	0.72	0.57
TIME FOR 50 PERCENT CONSOLIDATION, MIN			
FINAL Water content %	32.9	27.4	23.4
VOID RATIO	0.84	0.65	0.55
SATURATION %	100	100	100
NORMAL STRESS, TONS/SQ FT	0.97	1.94	2.59
MAXIMUM SHEAR STRESS, TONS/SQ FT	0.47	0.75	1.26
ACTUAL TIME TO FAILURE, MIN	835	875	750
RATE OF STRAIN, IN./MIN	0.0001	0.0001	0.0001
ULTIMATE SHEAR STRESS, TONS/SQ FT	1.0	1.0	1.0

SHEAR VALUES
 $\phi = 20^\circ$
 $\tan \phi = 0.364$
 $c = 0.13$ TONS/SQ FT

TYPE TEST **"S"**
 CONTROLLED STRESS CONTROLLED STRAIN

TYPE OF SPECIMEN Undisturbed

CLASSIFICATION CH - Soft gray clay

u 4.5 n 18 m 2.7 s 2.65

REMARKS W/silt pockets & lenses. Test specimen 3 contained large silt layer

PROJECT Proposed Protection Levee
 St. Bernard Parish, Louisiana

AREA BORING NO U-4 SAMPLE NO 39
 DEPTH EL -36.4 MSL DATE September 1966

DIRECT SHEAR TEST REPORT

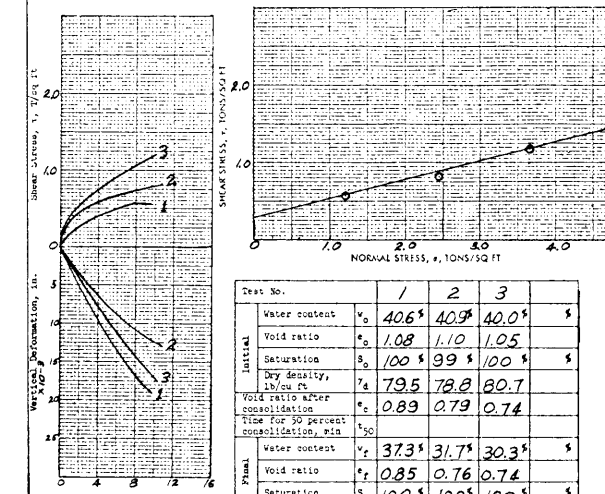

Test No.	1	2	3
INITIAL Water content %	40.6	40.9	40.0
VOID RATIO	1.08	1.10	1.05
SATURATION %	100	99	100
DRY DENSITY, lb/cu ft	79.5	78.8	80.7
VOID RATIO AFTER CONSOLIDATION	0.89	0.79	0.74
TIME FOR 50 PERCENT CONSOLIDATION, MIN			
FINAL Water content %	37.3	31.7	30.3
VOID RATIO	0.85	0.76	0.74
SATURATION %	100	100	100
NORMAL STRESS, TONS/SQ FT	1.22	2.45	3.67
MAXIMUM SHEAR STRESS, TONS/SQ FT	0.56	0.81	1.19
ACTUAL TIME TO FAILURE, MIN	760	785	757
RATE OF STRAIN, IN./MIN	0.0001	0.0001	0.0001
ULTIMATE SHEAR STRESS, TONS/SQ FT	1.0	1.0	1.0

SHEAR VALUES
 $\phi = 15^\circ$
 $\tan \phi = 0.268$
 $c = 0.23$ TONS/SQ FT

TYPE TEST **"S"**
 CONTROLLED STRESS CONTROLLED STRAIN

TYPE OF SPECIMEN Undisturbed

CLASSIFICATION CH - Soft gray clay

u 4.8 n 18 m 2.3 s 2.65

REMARKS W/clayey silt layers

PROJECT Proposed Protection Levee
 St. Bernard Parish, Louisiana

AREA BORING NO U-4 SAMPLE NO 49
 DEPTH EL -46.4 MSL DATE September 1966

DIRECT SHEAR TEST REPORT

LAKE PONTCHARTRAIN, LA. AND VICINITY
 CHALMETTE AREA PLAN
 DESIGN MEMORANDUM NO. 3—GENERAL DESIGN
DETAIL SHEAR STRENGTH DATA
 BORING U-4 "R" & "S" TESTS

SCALES AS SHOWN

WALDEMAR S. NELSON AND COMPANY, INC.
 ENGINEERS AND ARCHITECTS
 NEW ORLEANS, LA.

U. S. ARMY ENGINEER DISTRICT, NEW ORLEANS
 CORPS OF ENGINEERS, U. S. ARMY
 NEW ORLEANS, LA.

DATE: NOVEMBER 1966 FILE NO. H-2-23820

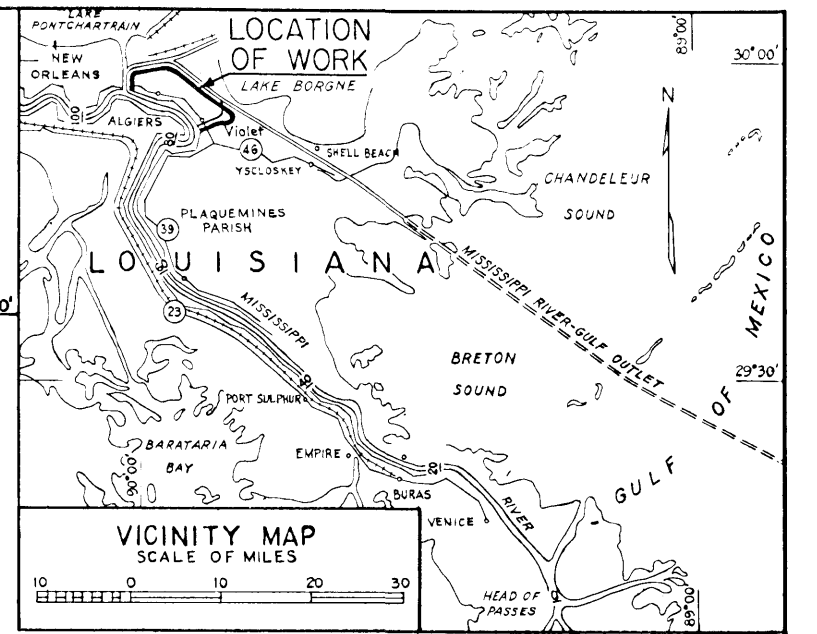
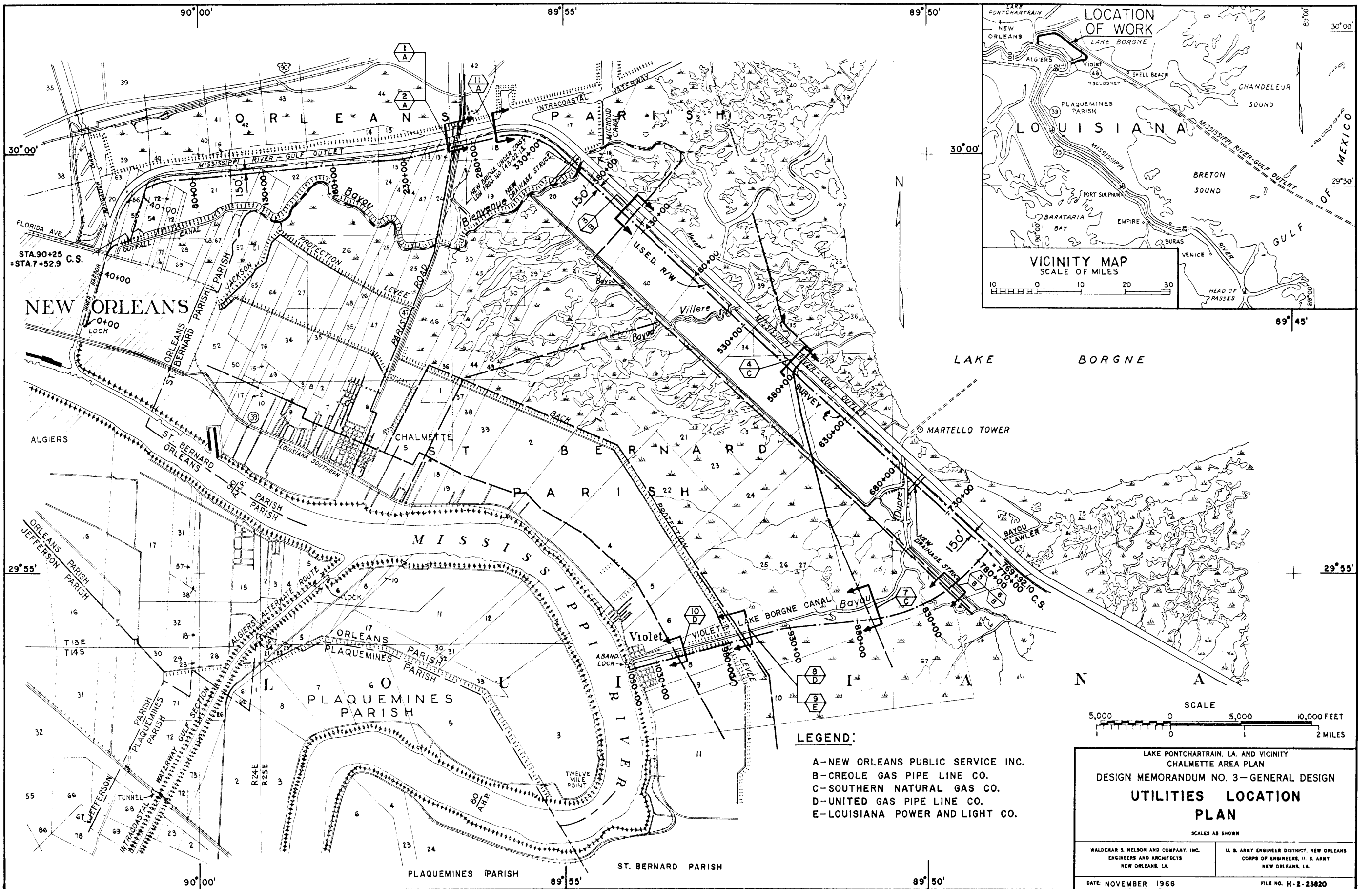

LEGEND:

- A-NEW ORLEANS PUBLIC SERVICE INC.
- B-CREOLE GAS PIPE LINE CO.
- C-SOUTHERN NATURAL GAS CO.
- D-UNITED GAS PIPE LINE CO.
- E-LOUISIANA POWER AND LIGHT CO.

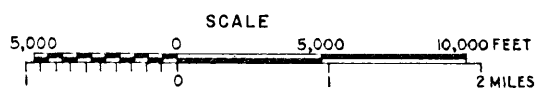

LAKE PONTCHARTRAIN, LA. AND VICINITY
CHALMETTE AREA PLAN
DESIGN MEMORANDUM NO. 3—GENERAL DESIGN
**UTILITIES LOCATION
PLAN**
SCALES AS SHOWN

WALDEMAR S. NELSON AND COMPANY, INC. ENGINEERS AND ARCHITECTS NEW ORLEANS, LA.	U. S. ARMY ENGINEER DISTRICT, NEW ORLEANS CORPS OF ENGINEERS, 11. S. ARMY NEW ORLEANS, LA.
DATE: NOVEMBER 1966	FILE NO. H-2-23820

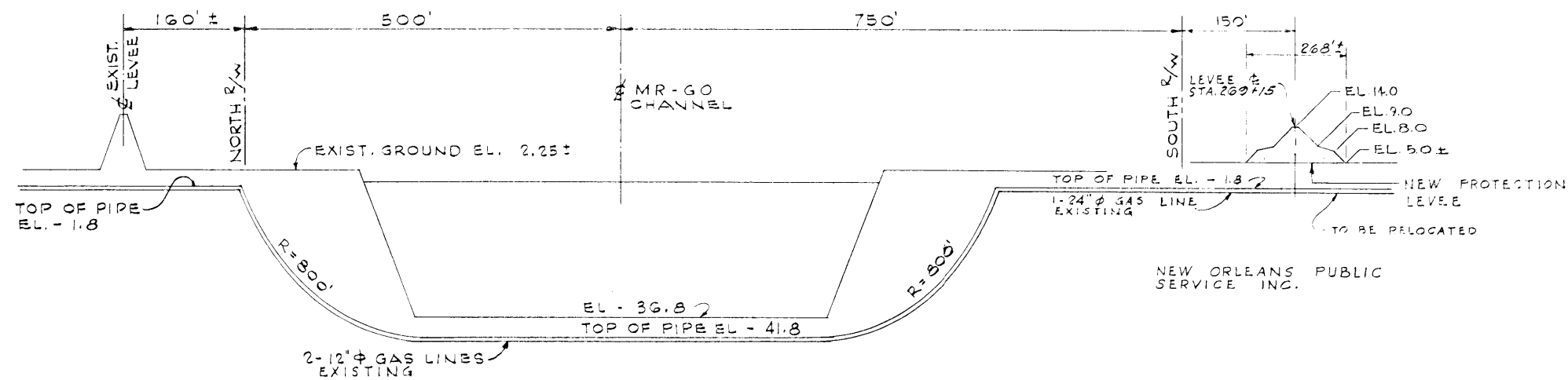

SECTION I A
HOR. SCALE "a"
VERT. SCALE "b"

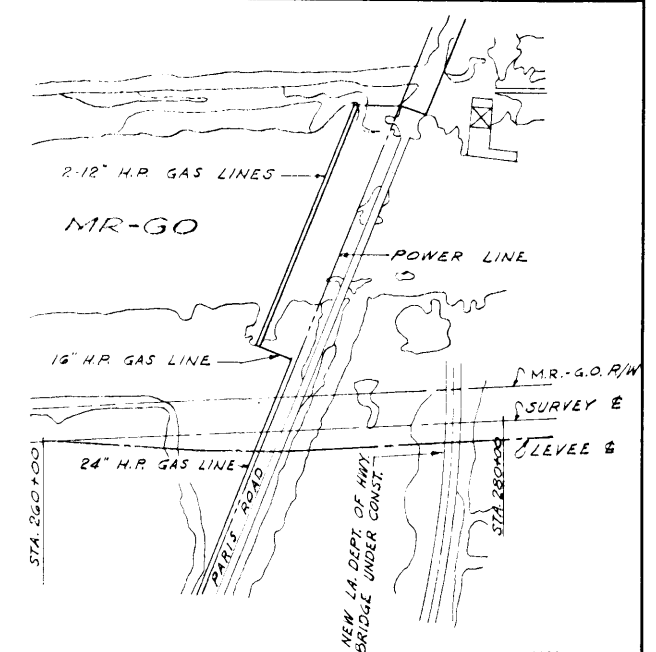

PLAN OF SECTION I A

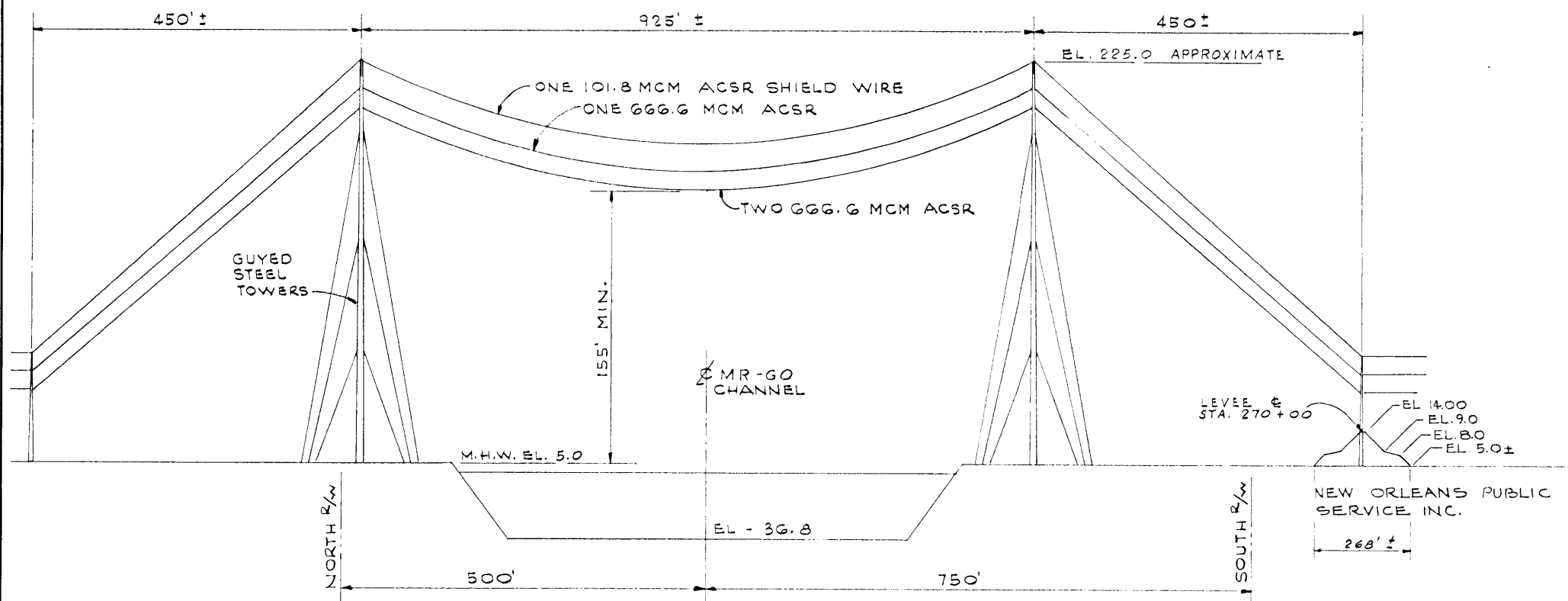

SECTION 2 A
HOR. SCALE "a"
VERT. SCALE "c"

NOTE: EXISTING POWER LINE THAT WILL BE REMOVED UPON COMPLETION OF NEW POWER LINE AS SHOWN ON SECTION II A

NOTE:
NO BORROW EXCAVATION WILL BE ALLOWED WITHIN 100 FT. EACH SIDE OF E OF PIPELINE CROSSING.

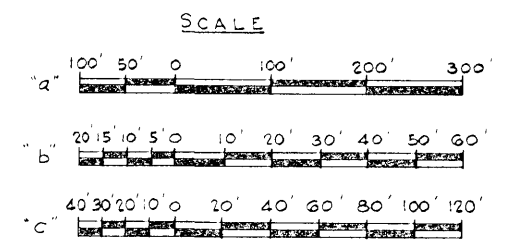

LAKE PONTCHARTRAIN, LA. AND VICINITY
CHALMETTE AREA PLAN
DESIGN MEMORANDUM NO. 3 - GENERAL DESIGN
**UTILITIES DETAILS
AND SECTIONS**
SCALES AS SHOWN

WALDEMAR S. NELSON AND COMPANY, INC.
ENGINEERS AND ARCHITECTS
NEW ORLEANS, LA.

U. S. ARMY ENGINEER DISTRICT, NEW ORLEANS
CORPS OF ENGINEERS, U. S. ARMY
NEW ORLEANS, LA.

DATE: NOVEMBER 1966 FILE NO. H-2-23820

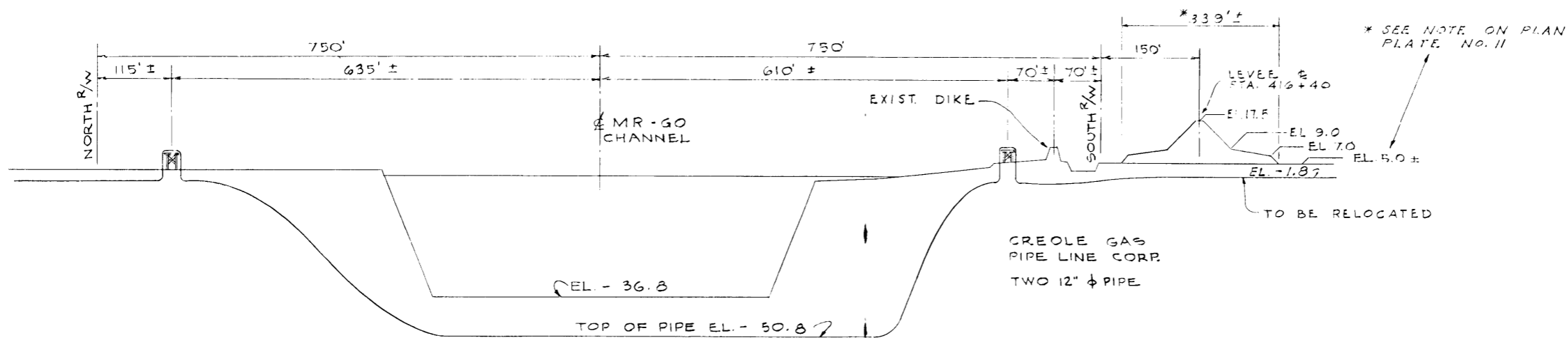

SECTION $\frac{3}{B}$
 HOR. SCALE "a"
 VERT. SCALE "b"

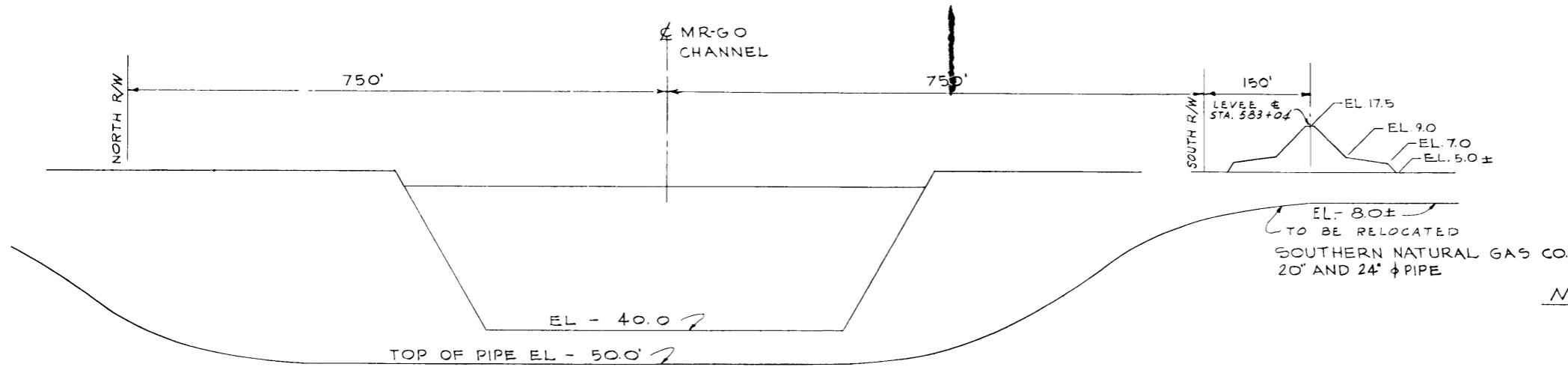

SECTION $\frac{4}{C}$
 HOR. SCALE "a"
 VERT. SCALE "b"

NOTE:
 NO BORROW EXCAVATION WILL BE ALLOWED WITHIN 100 FT. EACH SIDE OF $\frac{1}{2}$ OF PIPELINE CROSSING.

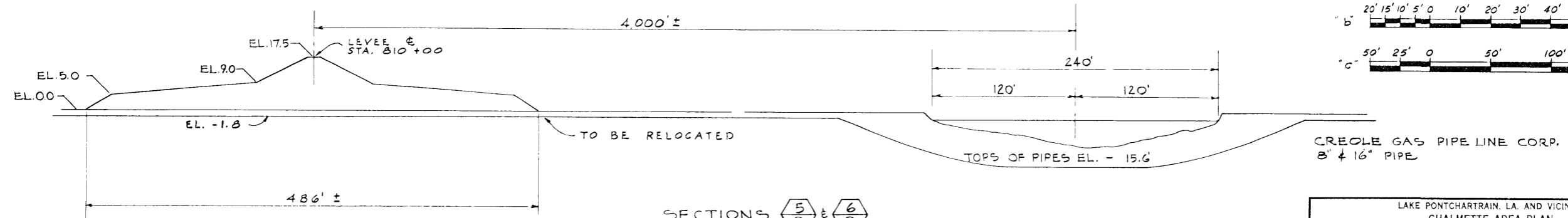
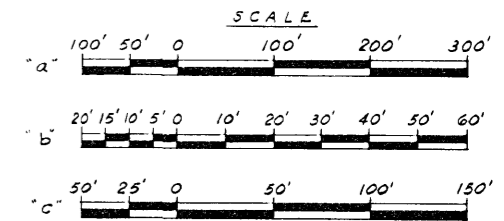

SECTIONS $\frac{5}{B}$ & $\frac{6}{B}$
 HOR. SCALE "c"
 VERT. SCALE "b"

LAKE PONTCHARTRAIN, LA. AND VICINITY
 CHALMETTE AREA PLAN
 DESIGN MEMORANDUM NO. 3—GENERAL DESIGN
**UTILITIES DETAILS
 AND SECTIONS**
 SCALES AS SHOWN

WALDEMAR S. NELSON AND COMPANY, INC. ENGINEERS AND ARCHITECTS NEW ORLEANS, LA.	U. S. ARMY ENGINEER DISTRICT, NEW ORLEANS CORPS OF ENGINEERS, U. S. ARMY NEW ORLEANS, LA.
DATE: NOVEMBER 1966	FILE NO. H-2-23820

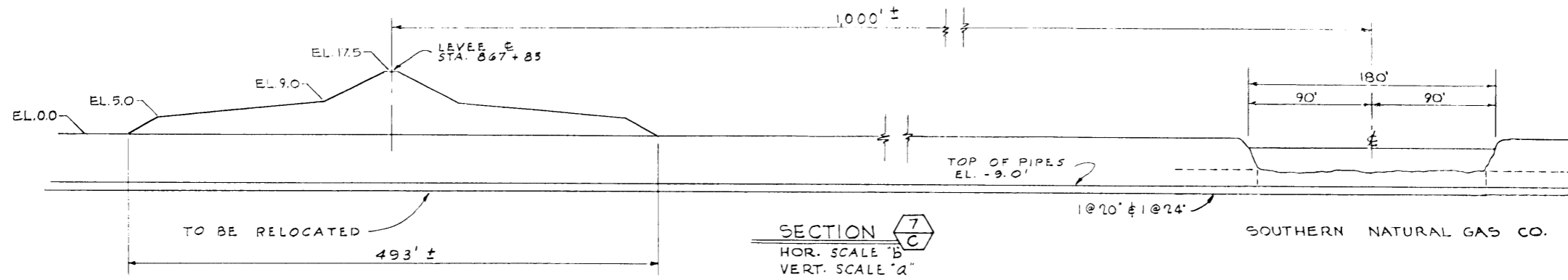

SOUTHERN NATURAL GAS CO.

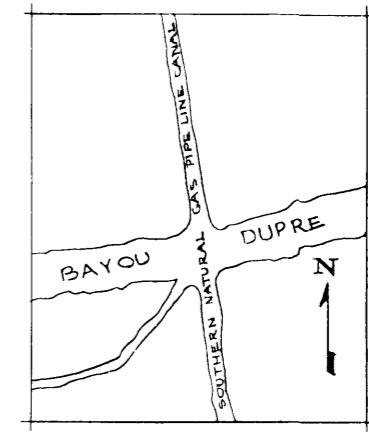
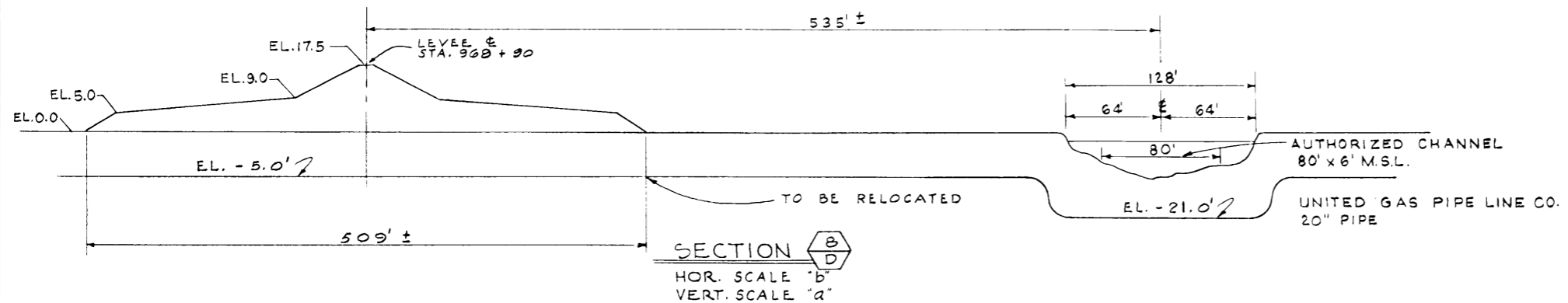

PARTIAL PLAN

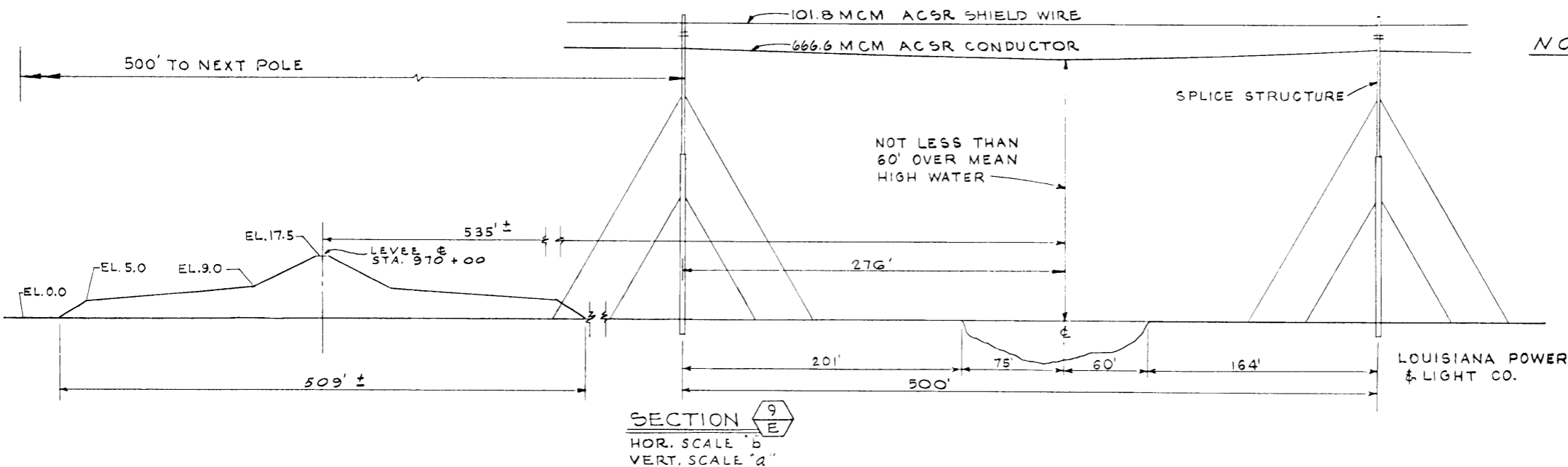

LOUISIANA POWER & LIGHT CO.

NOTE:
NO BORROW EXCAVATION WILL BE ALLOWED WITHIN 100 FT. EACH SIDE OF \bar{E} OF PIPELINE CROSSING.

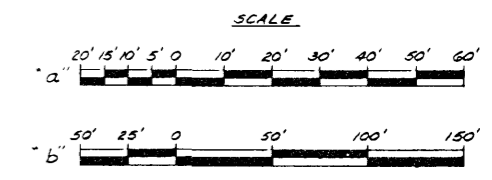

LAKE PONTCHARTRAIN, LA. AND VICINITY
CHALMETTE AREA PLAN
DESIGN MEMORANDUM NO. 3—GENERAL DESIGN
**UTILITIES DETAILS
AND SECTIONS**
SCALES AS SHOWN

WALDEMAR S. NELSON AND COMPANY, INC. ENGINEERS AND ARCHITECTS NEW ORLEANS, LA.	U. S. ARMY ENGINEER DISTRICT, NEW ORLEANS CORPS OF ENGINEERS, U. S. ARMY NEW ORLEANS, LA.
DATE: NOVEMBER 1966	FILE NO. H-2-23820

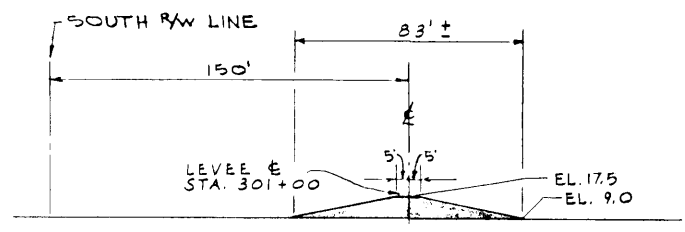
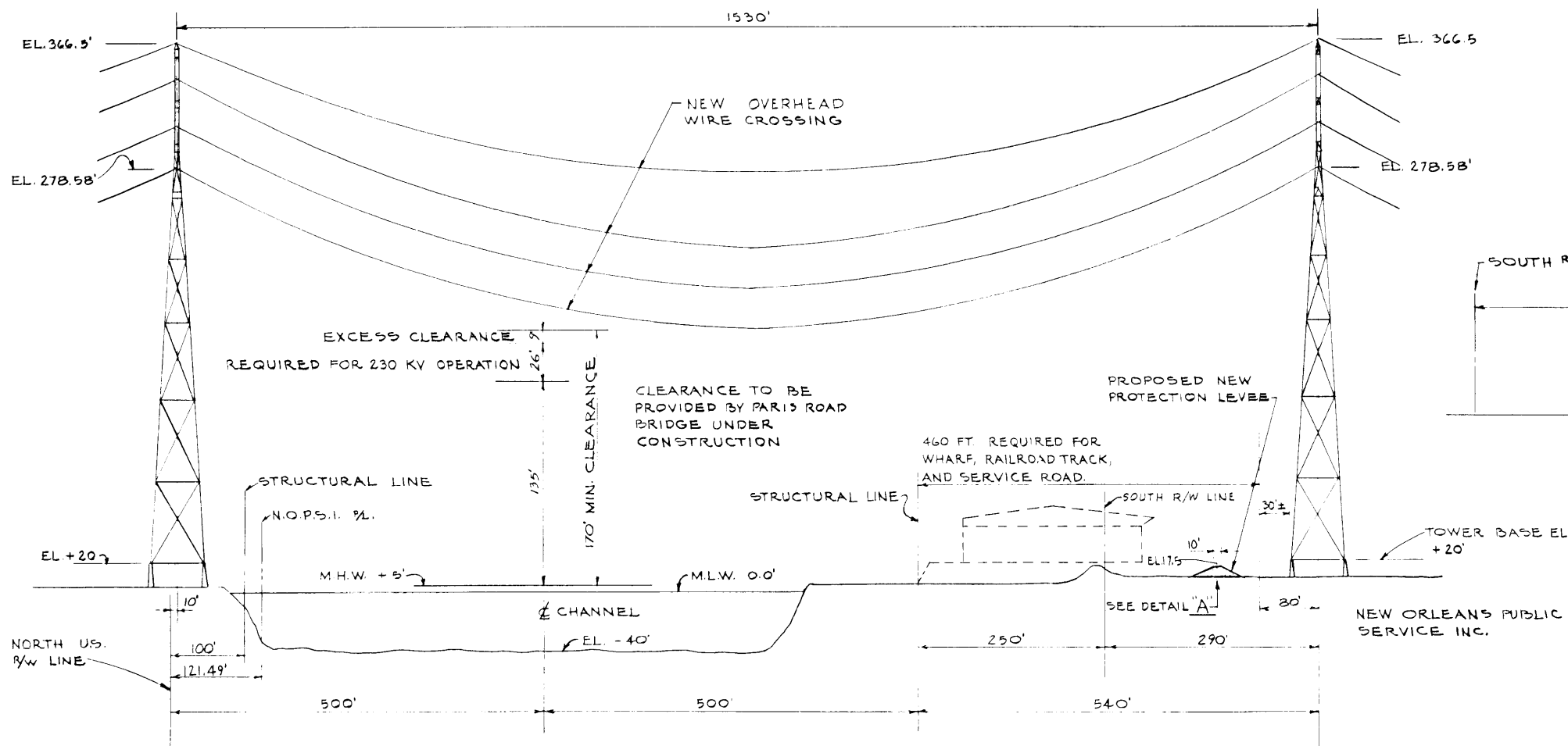
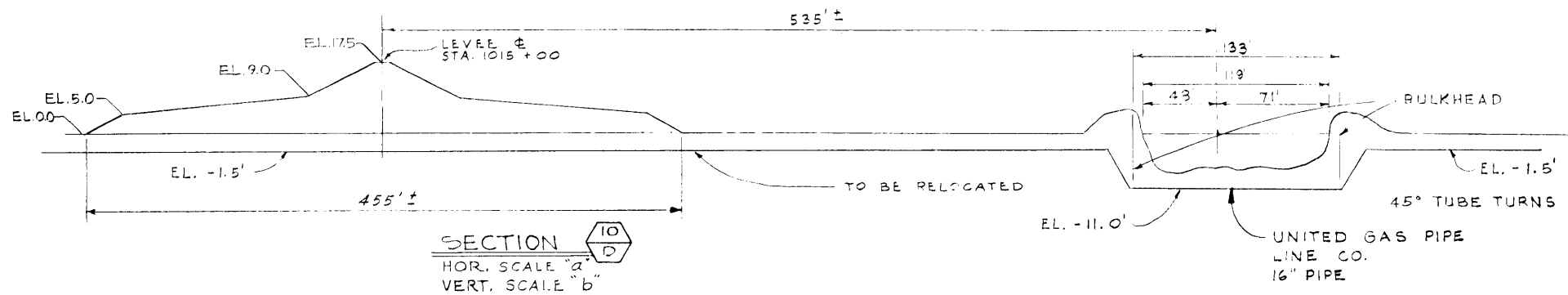

TYPICAL DESIGN SECTION
PARIS ROAD TO BAYOU DUPRE
DETAIL "A" SCALE "d"

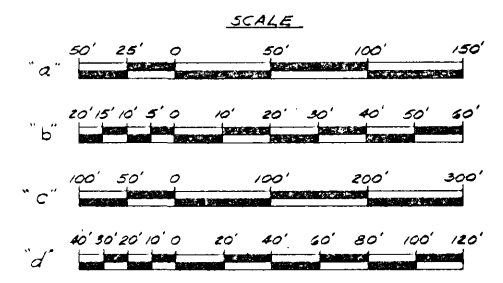

NOTE: SCHEDULED COMPLETION SEPTEMBER 1967

SECTION 11/A
HOR. SCALE "c"
VERT. SCALE "a"

NOTE:
NO BORROW EXCAVATION WILL BE
ALLOWED WITHIN 100 FT. EACH SIDE
OF & OF PIPELINE CROSSING.

LAKE PONTCHARTRAIN, LA. AND VICINITY
CHALMETTE AREA PLAN
DESIGN MEMORANDUM NO. 3—GENERAL DESIGN
**UTILITIES DETAILS
AND SECTIONS**
SCALES AS SHOWN

WALDEMAR S. NELSON AND COMPANY, INC.
ENGINEERS AND ARCHITECTS
NEW ORLEANS, LA.

U. S. ARMY ENGINEER DISTRICT, NEW ORLEANS
CORPS OF ENGINEERS, U. S. ARMY
NEW ORLEANS, LA.

DATE: NOVEMBER 1966 FILE NO. H-2-23820

MISSISSIPPI RIVER — GULF OUTLET

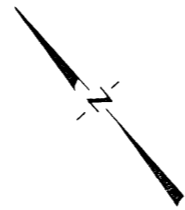
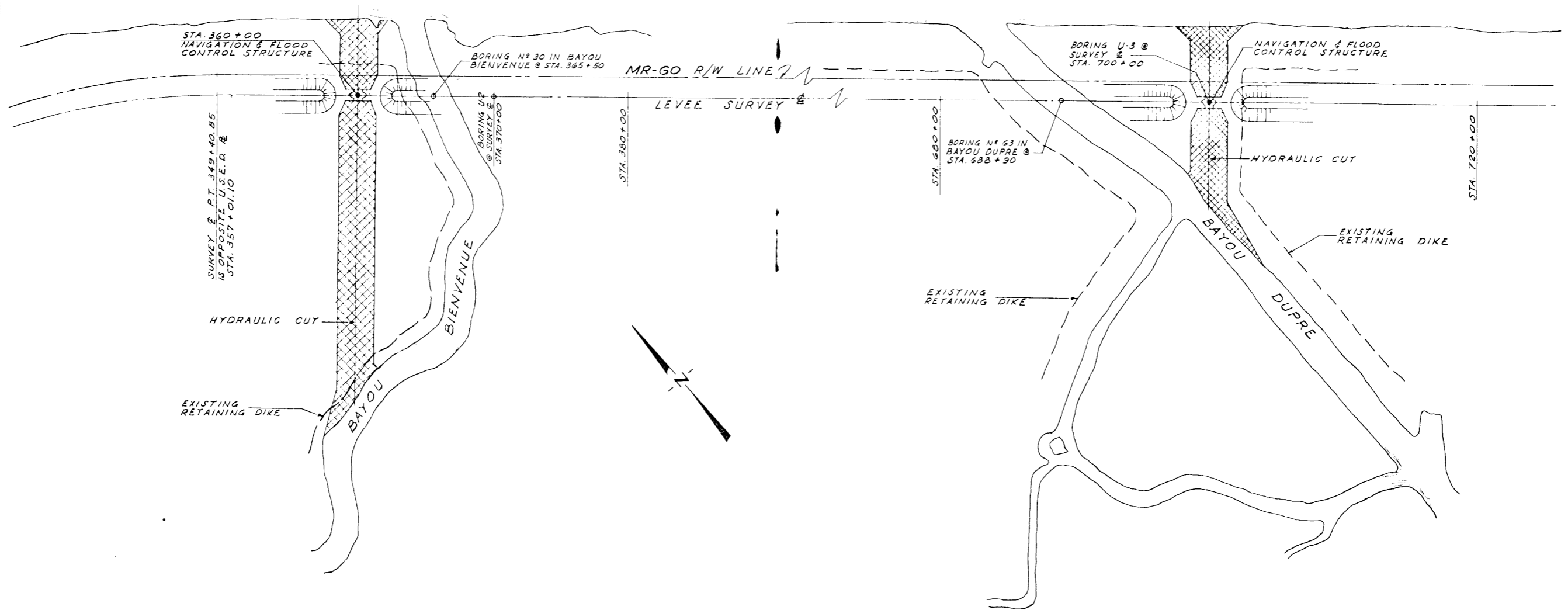

LAKE PONTCHARTRAIN, LA. AND VICINITY
 CHALMETTE AREA PLAN
 DESIGN MEMORANDUM NO. 3—GENERAL DESIGN
DRAINAGE STRUCTURES
LOCATION PLAN
 SCALES AS SHOWN

WALDEMAR S. NELSON AND COMPANY, INC. ENGINEERS AND ARCHITECTS NEW ORLEANS, LA.	U. S. ARMY ENGINEER DISTRICT, NEW ORLEANS CORPS OF ENGINEERS, U. S. ARMY NEW ORLEANS, LA.
DATE: NOVEMBER 1966	FILE NO. H-2-23820

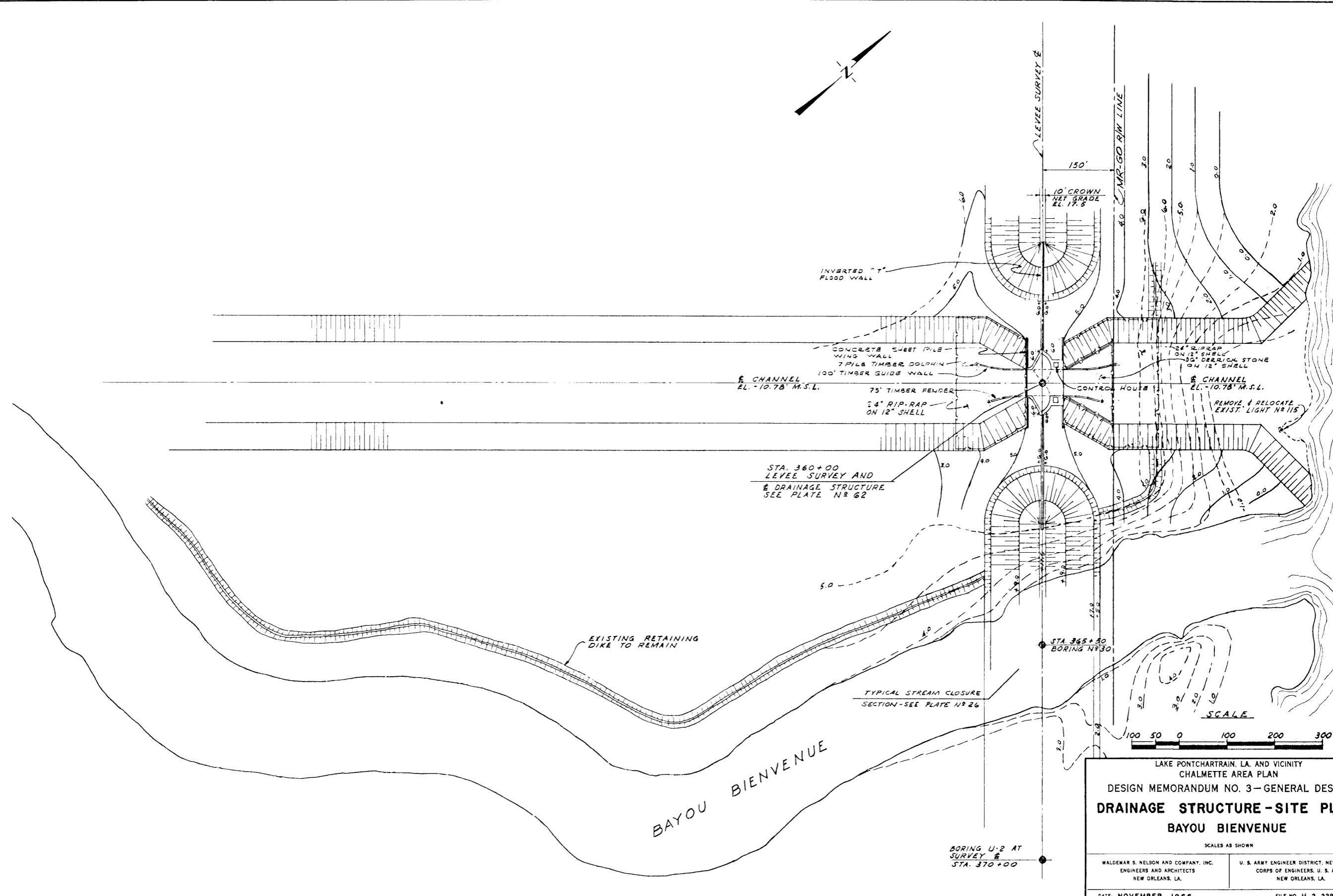
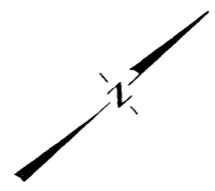

E CHANNEL
EL. -10.78' M.S.L.

E CHANNEL
EL. -10.78' M.S.L.

STA. 360+00
LEVEE SURVEY AND
DRAINAGE STRUCTURE
SEE PLATE N° 62

EXISTING RETAINING
DIKE TO REMAIN

TYPICAL STREAM CLOSURE
SECTION - SEE PLATE N° 26

STA. 365+30
BORING N° 30

BORING U-2 AT
SURVEY &
STA. 370+00

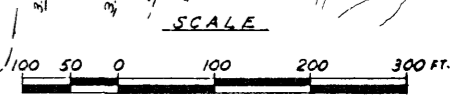

LAKE PONTCHARTRAIN, LA. AND VICINITY
CHALMETTE AREA PLAN
DESIGN MEMORANDUM NO. 3 - GENERAL DESIGN
DRAINAGE STRUCTURE - SITE PLAN
BAYOU BIENVENUE

SCALES AS SHOWN

WALDEMAR S. NELSON AND COMPANY, INC. ENGINEERS AND ARCHITECTS NEW ORLEANS, LA.	U. S. ARMY ENGINEER DISTRICT, NEW ORLEANS CORPS OF ENGINEERS, U. S. ARMY NEW ORLEANS, LA.
--	---

DATE: NOVEMBER 1966 FILE NO. H-2-23820

MISSISSIPPI RIVER - GULF OUTLET

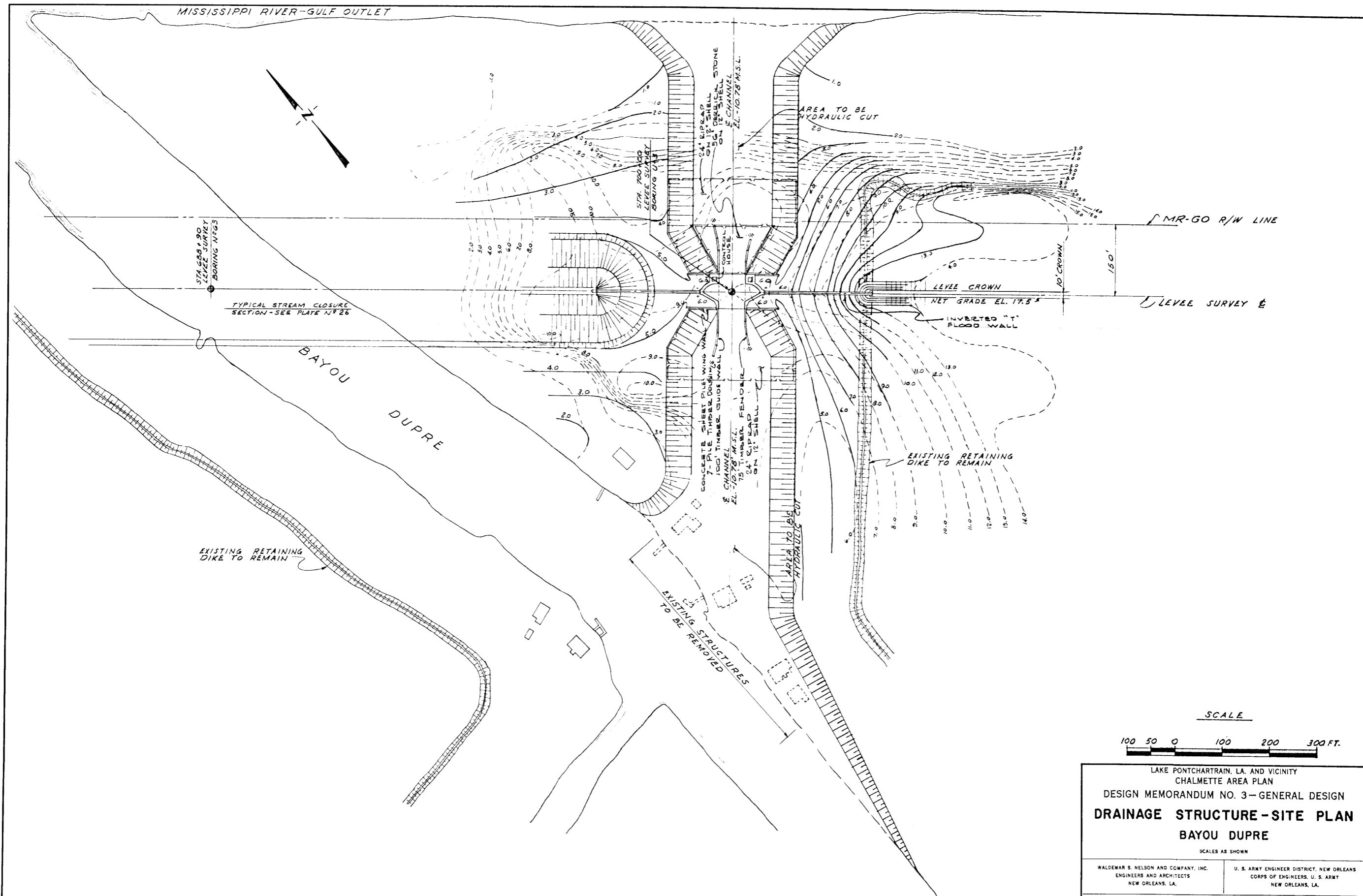

MISSISSIPPI RIVER-GULF OUTLET

STA 1285+00
LEVEL SURVEY
BORING NFG3

TYPICAL STREAM CLOSURE
SECTION-SEE PLATE N° 26

BAYOU
DUPRE

EXISTING RETAINING
DIKE TO REMAIN

EXISTING STRUCTURES
TO BE REMOVED

AREA TO BE
HYDRAULIC CUT

LEVEE CROWN
NET GRADE EL. 17.5'

EXISTING RETAINING
DIKE TO REMAIN

MR-GO R/W LINE

LEVEE SURVEY

SCALE

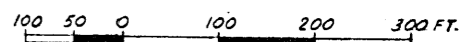

LAKE PONTCHARTRAIN, LA. AND VICINITY
CHALMETTE AREA PLAN
DESIGN MEMORANDUM NO. 3—GENERAL DESIGN
DRAINAGE STRUCTURE—SITE PLAN
BAYOU DUPRE
SCALES AS SHOWN

WALDEMAR S. NELSON AND COMPANY, INC. ENGINEERS AND ARCHITECTS NEW ORLEANS, LA.	U. S. ARMY ENGINEER DISTRICT, NEW ORLEANS CORPS OF ENGINEERS, U. S. ARMY NEW ORLEANS, LA.
DATE: NOVEMBER 1966	FILE NO. H-2-23820

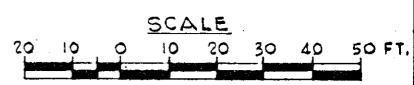
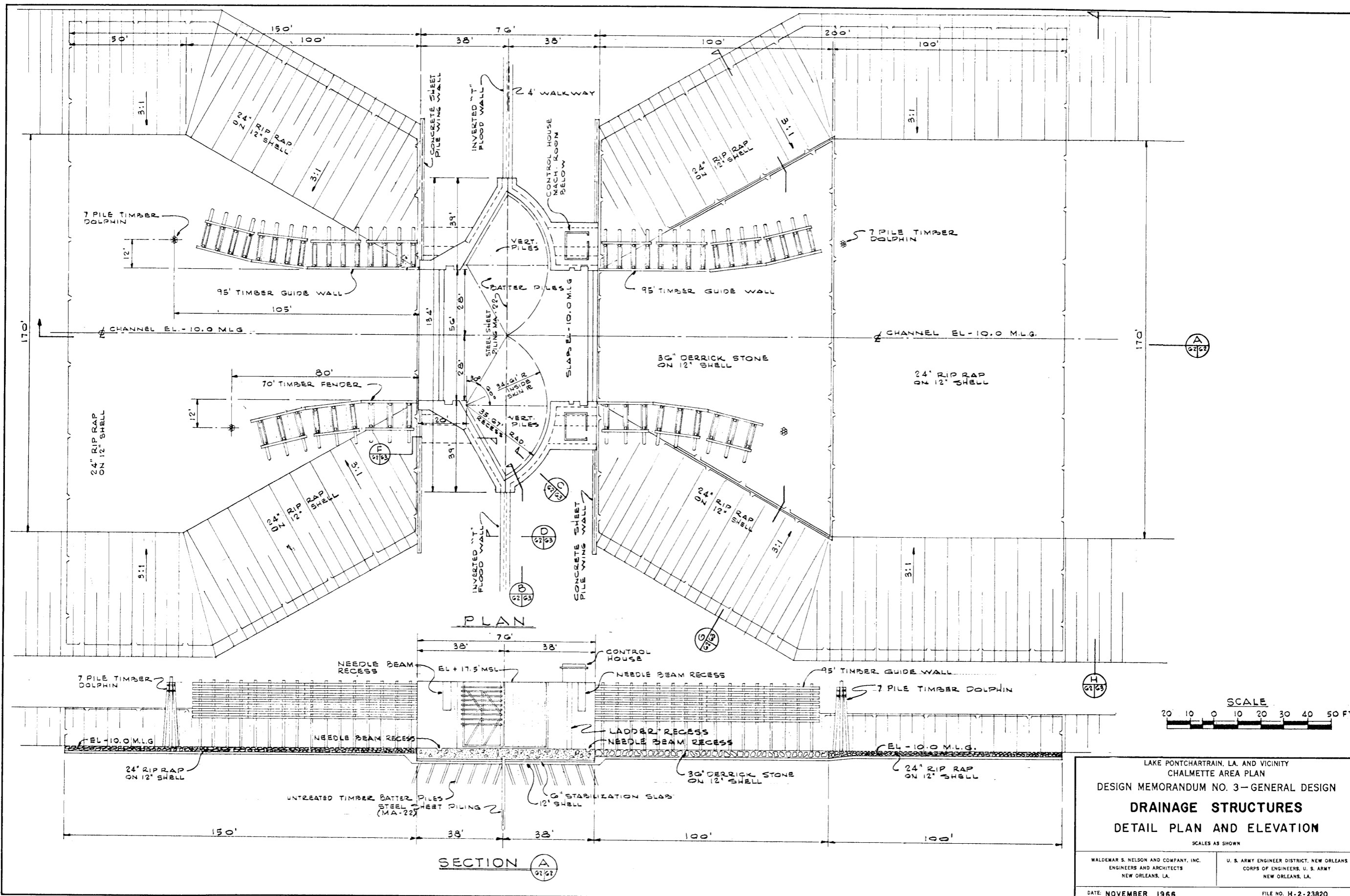

LAKE PONTCHARTRAIN, LA. AND VICINITY
 CHALMETTE AREA PLAN
 DESIGN MEMORANDUM NO. 3—GENERAL DESIGN
DRAINAGE STRUCTURES
 DETAIL PLAN AND ELEVATION
 SCALES AS SHOWN

WALDEMAR S. NELSON AND COMPANY, INC. ENGINEERS AND ARCHITECTS NEW ORLEANS, LA.	U. S. ARMY ENGINEER DISTRICT, NEW ORLEANS CORPS OF ENGINEERS, U. S. ARMY NEW ORLEANS, LA.
DATE: NOVEMBER 1966	FILE NO. H-2-23820

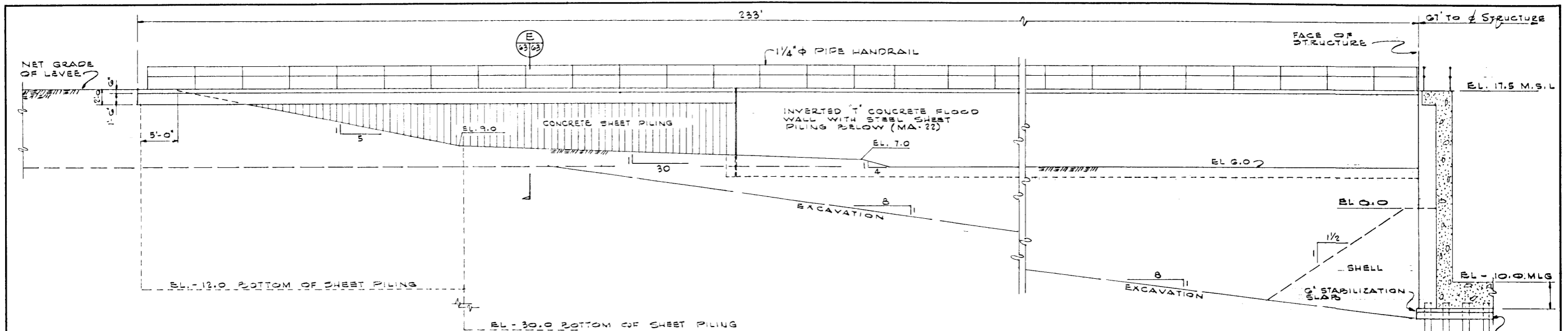

SECTION B
SCALE: B

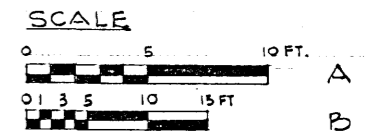
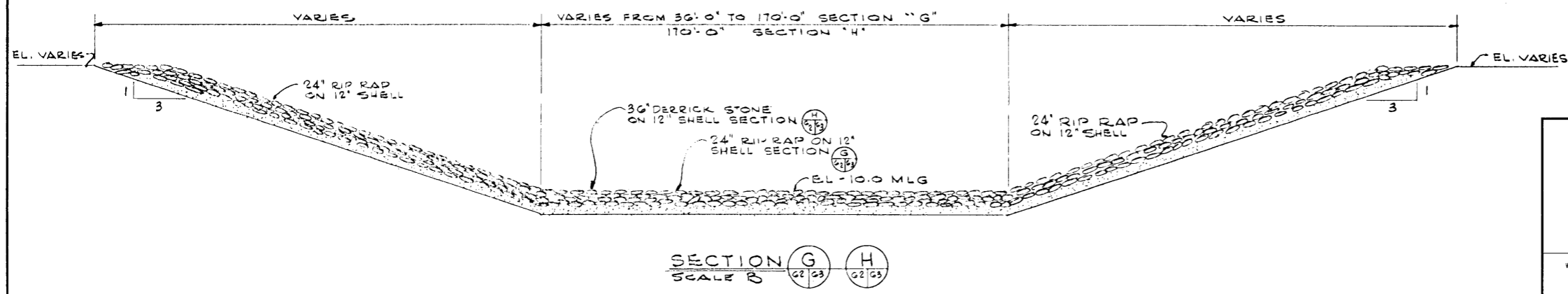
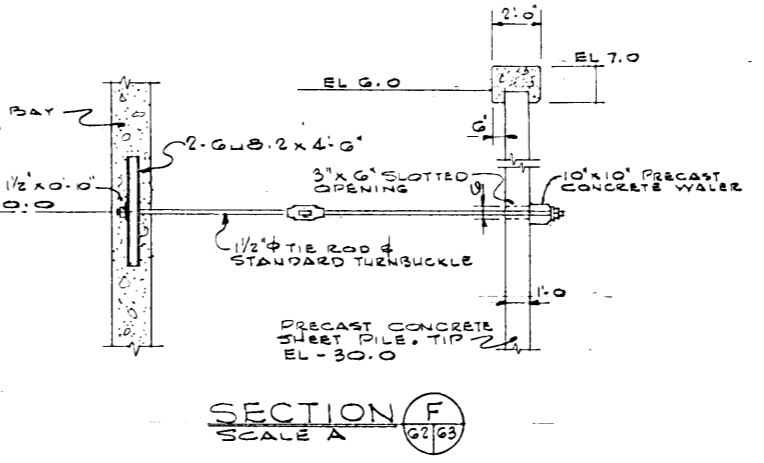
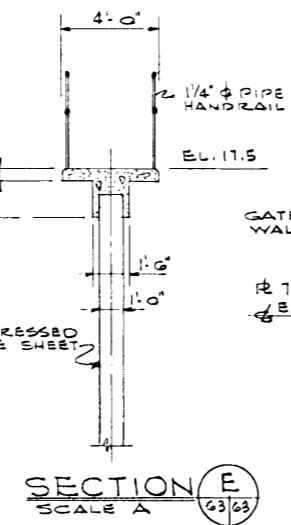
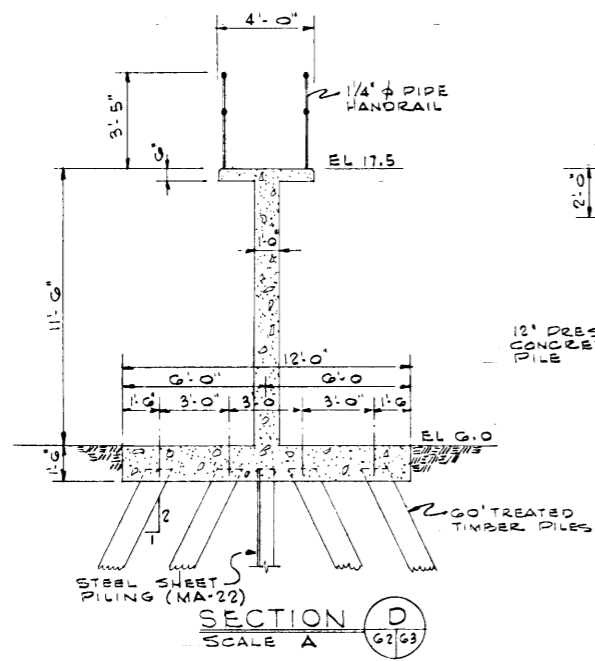
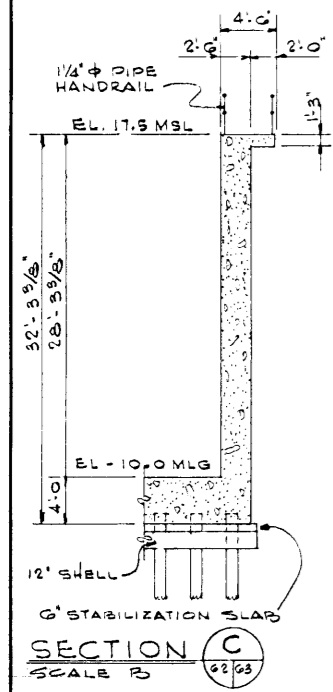

LAKE PONTCHARTRAIN, LA. AND VICINITY
CHALMETTE AREA PLAN
DESIGN MEMORANDUM NO. 3—GENERAL DESIGN
DRAINAGE STRUCTURES
DETAIL SECTIONS AND ELEVATIONS
SCALES AS SHOWN

WALDEMAR S. NELSON AND COMPANY, INC. ENGINEERS AND ARCHITECTS NEW ORLEANS, LA.	U. S. ARMY ENGINEER DISTRICT, NEW ORLEANS CORPS OF ENGINEERS, U. S. ARMY NEW ORLEANS, LA.
DATE: NOVEMBER 1966	FILE NO. H-2-23820

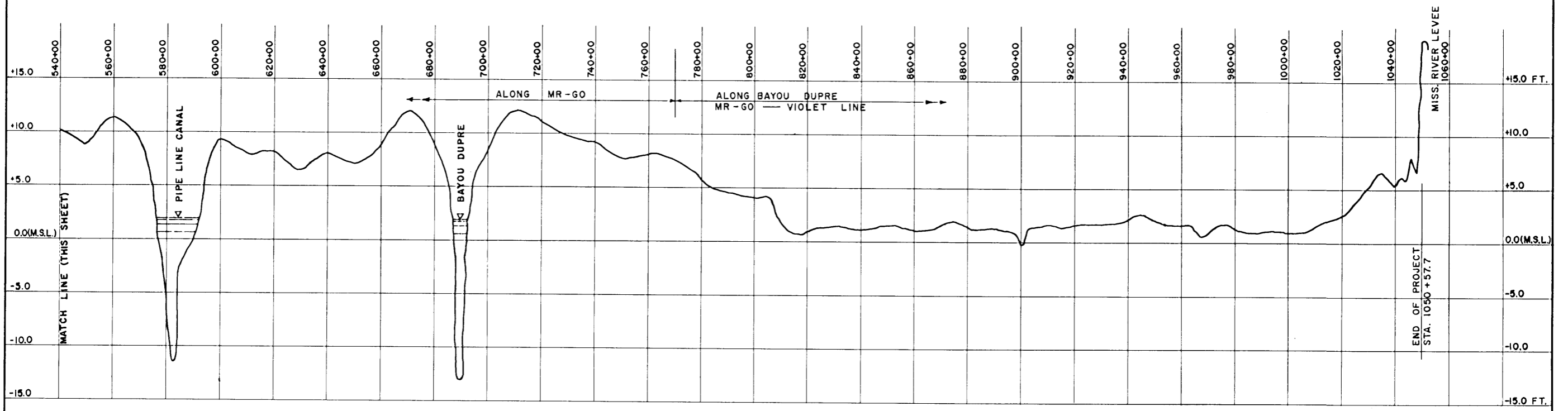
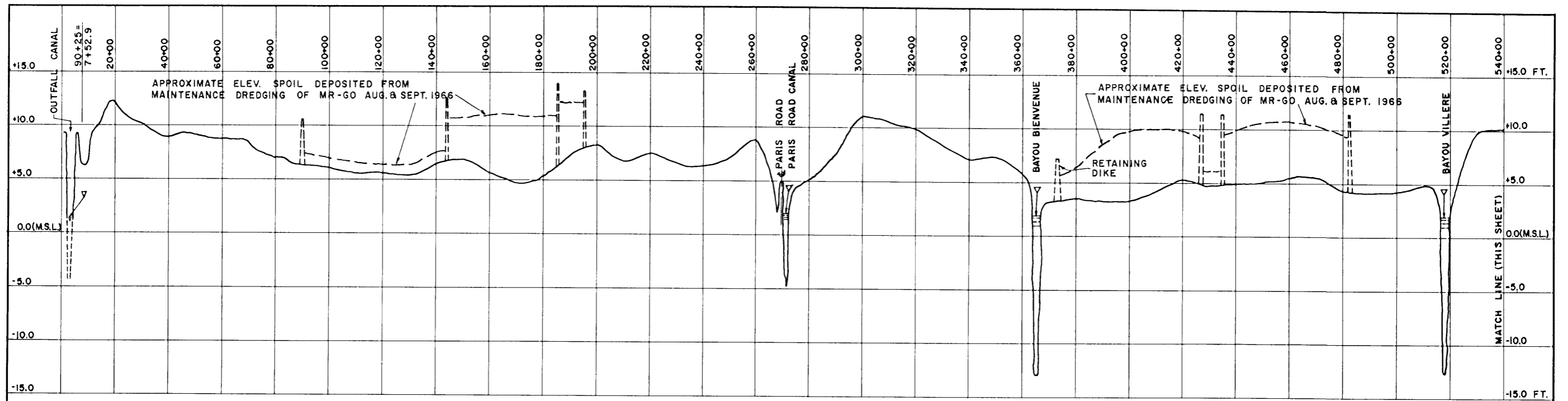

LAKE PONTCHARTRAIN, LA. AND VICINITY
CHALMETTE AREA PLAN
DESIGN MEMORANDUM NO. 3—GENERAL DESIGN

EXISTING GROUND PROFILE
STA. 7+52.9 TO STA. 1050+57.7

SCALES AS SHOWN

WALDEMAR S. NELSON AND COMPANY, INC. ENGINEERS AND ARCHITECTS NEW ORLEANS, LA.	U. S. ARMY ENGINEER DISTRICT, NEW ORLEANS CORPS OF ENGINEERS, U. S. ARMY NEW ORLEANS, LA.
--	---

DATE: NOVEMBER, 1966 FILE NO. H-2-23820

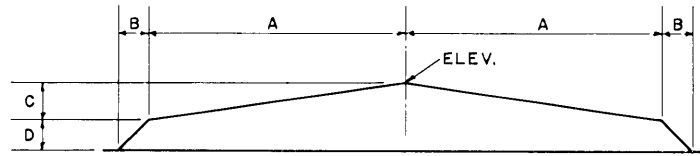

TEMPLATE I

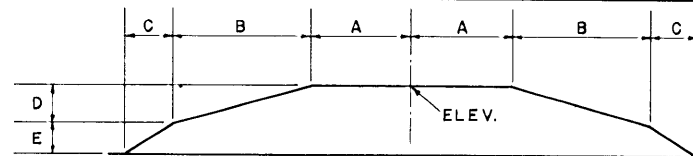

TEMPLATE II

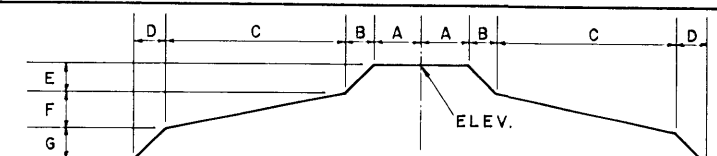

TEMPLATE III

STATION TO STATION	LIFT OR SHAPING	TEMPLATE	ELEVATION	TIME TO NEXT LIFT	SETTLEMENT AT 4'	A	B	C	D	E	F	G
7+52.9 TO 10+00	FIRST LIFT	I	14.0	2 YRS.	4.67	275.0	10.0	7.0	2.0	—	—	—
78+00 TO 140+00	FIRST SHAPING	III	13.0	3 YRS.	2.67	5.0	30.0	140.0	10.0	3.0	3.0	2.0
146+00 TO 188+00	FINAL	III	14.0	—	—	5.0	25.0	60.0	10.0	5.0	2.0	2.0
264+00 TO 268+00												
10+00 TO 78+00	FIRST LIFT	I	14.0	2 YRS.	4.11	190.0	10.0	5.0	2.0	—	—	—
140+00 TO 146+00	FIRST SHAPING	III	14.0	2 YRS.	1.93	5.0	15.0	77.5	10.0	3.0	2.0	2.0
188+00 TO 264+00	FINAL	III	14.0	—	—	5.0	25.0	60.0	0.0	5.0	2.0	0.0
270+00 TO 357+05	FIRST LIFT	I	12.5	2 YRS.	1.49	242.0	10.0	5.5	2.0	—	—	—
	FIRST SHAPING	I	14.0	3 YRS.	0.83	166.0	10.0	7.0	2.0	—	—	—
	SECOND SHAPING	III	17.5	2 YRS.	0.62	5.0*	30.0	110.0	10.0	6.0	4.5	2.0
	FINAL	III	17.5	—	—	5.0	42.5	60.0	10.0	8.5	2.0	2.0
368+00 TO 516+00	FIRST LIFT	I	12.0	2 YRS.	4.00	290.0	10.0	6.0	2.0	—	—	—
	SECOND LIFT	I	14.0	3 YRS.	2.60	225.0	0.0	8.0	0.0	—	—	—
	FIRST SHAPING	III	17.5	2 YRS.	1.50	5.0	25.0	144.0	10.0	5.0	6.5	2.0
	FINAL	III	17.5	—	—	5.0	42.5	60.0	15.0	8.5	2.0	3.0
519+00 TO 574+00	FIRST LIFT	I	15.0	2 YRS.	1.70	190.0	7.5	3.5	1.5	—	—	—
	FIRST SHAPING	III	17.0	3 YRS.	1.67	5.0	30.0	72.5	10.0	3.0	2.0	2.0
	FINAL	II	17.5	—	—	5.0	37.5	0.0	7.5	0.0	—	—
593+00 TO 687+00	FIRST LIFT	I	14.0	2 YRS.	3.06	225.0	10.0	4.0	2.0	—	—	—
692+00 TO 697+05	FIRST SHAPING	I	14.5	3 YRS.	1.72	115.0	10.0	4.5	2.0	—	—	—
	FINAL	II	17.5	—	—	5.0	42.5	30.0	8.5	1.0	—	—
702+95 TO 807+00	FIRST LIFT	I	16.0	2 YRS.	2.55	100.0	10.0	6.0	2.0	—	—	—
	FINAL SHAPING	II	17.5	—	—	5.0	42.5	30.0	8.5	1.0	—	—
807+00 TO 978+00	FIRST LIFT	I	9.0	3 YRS.	3.00	442.5	7.5	6.5	1.5	—	—	—
	SECOND LIFT	I	14.0	2 YRS.	2.00	390.0	10.0	9.6	2.0	—	—	—
	FIRST SHAPING	III	17.5	4 YRS.	1.79	5.0	17.5	322.5	10.0	3.5	11.0	2.0
	SECOND SHAPING	III	17.5	4 YRS.	1.16	5.0	17.5	282.5	10.0	3.5	11.0	2.0
	FINAL	III	17.5	—	—	5.0	42.5	120.0	20.0	8.5	4.0	4.0
978+00 TO 1020+00	FIRST LIFT	I	12.0	2 YRS.	2.61	290.0	10.0	9.0	2.0	—	—	—
	SECOND LIFT	I	16.0	3 YRS.	0.99	255.0	10.0	10.0	2.0	—	—	—
	FIRST SHAPING	II	17.5	2 YRS.	0.36	5.0	240.0	10.0	14.5	2.0	—	—
	FINAL	III	17.5	—	—	5.0	42.5	180.0	10.0	8.5	6.0	2.0
1020+00 TO 1050+00	FIRST LIFT	III	11.0	2 YRS.	2.35	37.5	10.0	60.0	20.0	2.0	2.0	4.0
	FINAL LIFT	III	17.5	—	—	5.0	42.5	60.0	20.0	8.5	2.0	4.0
362+95 TO 368+00	FIRST LIFT	*	4.0	2 YRS.	2.00	*	*	*	*	*	*	*
516+00 TO 519+00	SECOND LIFT	*	12.5	3 YRS.	2.00	*	*	*	*	*	*	*
574+00 TO 593+00	FINAL LIFT	*	17.5	—	—	*	*	*	*	*	*	*
687+00 TO 692+00												
* SEE NOTES THIS SHEET FOR SHAPES AND DIMENSIONS												

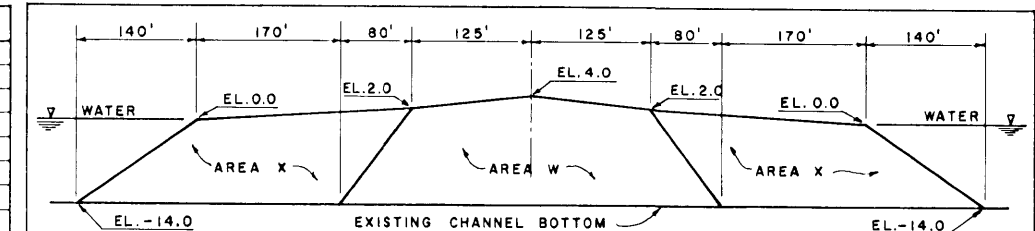

FIRST LIFT

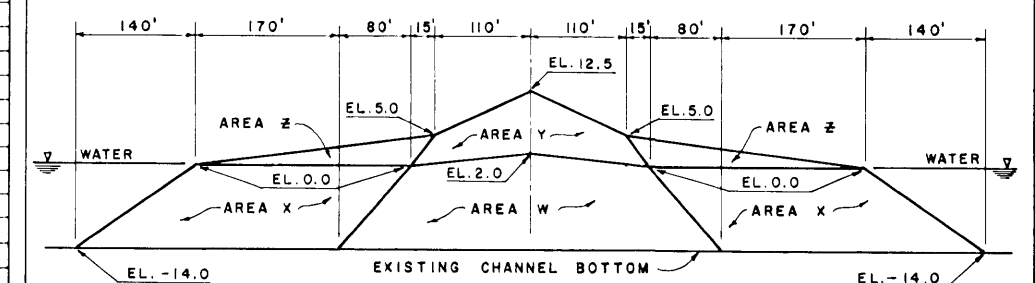

SECOND LIFT

STREAM CLOSURE CONSTRUCTION

1. FIRST LIFT: PLACE SHELL IN AREA W THEN HYDRAULIC FILL IN AREA X.
2. SECOND LIFT: TWO YEARS AFTER CONSTRUCTION OF FIRST LIFT PLACE SHELL IN AREA Y THEN HYDRAULIC FILL IN AREA Z.
3. FINAL LIFT: THREE YEARS AFTER CONSTRUCTION OF SECOND LIFT AND FIVE YEARS AFTER CONSTRUCTION OF FIRST LIFT RESHAPE AREA Y THEN PLACE IMPERVIOUS CLAY LAYER AS SHOWN ON PLATE 26.

TYPICAL STREAM CLOSURE

NOTES:
 FIGURES SHOWN NOT TO SCALE.
 TRANSITION CROWN OF LEVEE FROM ELEVATION 14.0 M.S.L. AT STA. 268+00 TO ELEVATION 17.5 M.S.L. AT STA. 270+00.

LAKE PONTCHARTRAIN, LA. AND VICINITY
 CHALMETTE AREA PLAN
 DESIGN MEMORANDUM NO. 3—GENERAL DESIGN

LIFT AND SHAPING DETAILS

SCALES AS SHOWN

WALDEMAR S. NELSON AND COMPANY, INC.
 ENGINEERS AND ARCHITECTS
 NEW ORLEANS, LA.

U. S. ARMY ENGINEER DISTRICT, NEW ORLEANS
 CORPS OF ENGINEERS, U. S. ARMY
 NEW ORLEANS, LA.

DATE: NOVEMBER 1966 FILE NO. H-2-23820

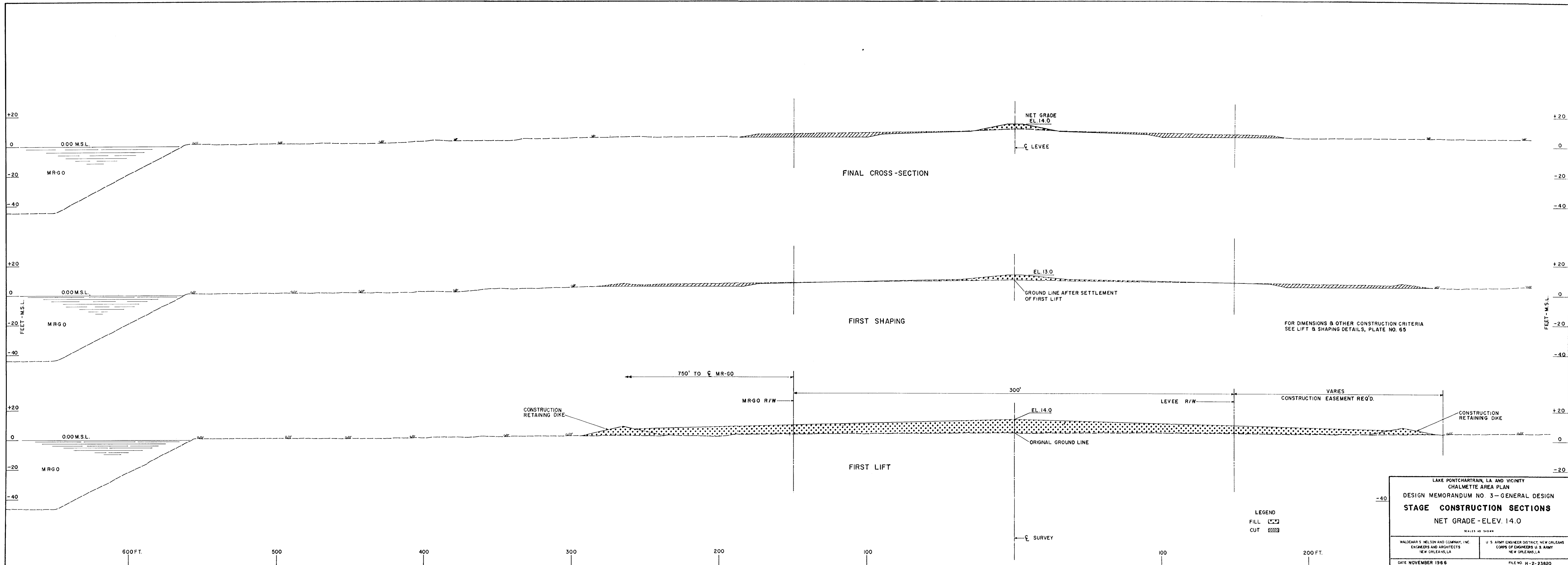

LEGEND
 FILL [diagonal lines]
 CUT [stippled]

LAKE PONTCHARTRAIN, LA. AND VICINITY CHALMETTE AREA PLAN	
DESIGN MEMORANDUM NO. 3 - GENERAL DESIGN	
STAGE CONSTRUCTION SECTIONS	
NET GRADE - ELEV. 14.0	
SCALE AS SHOWN	
WALDEMAR S. NELSON AND COMPANY, INC. ENGINEERS AND ARCHITECTS NEW ORLEANS, LA.	U. S. ARMY ENGINEER DISTRICT, NEW ORLEANS CORPS OF ENGINEERS U. S. ARMY NEW ORLEANS, LA.
DATE: NOVEMBER 1966	FILE NO. H-2-23820

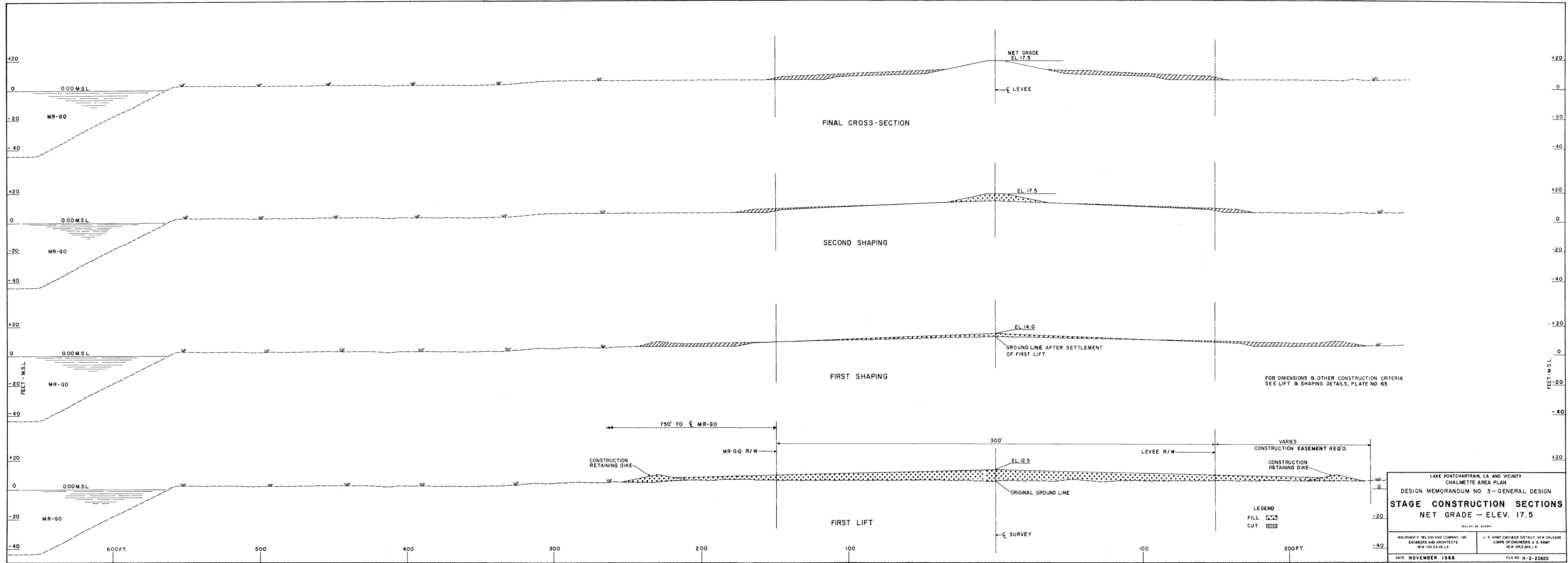

LAKE PONTCHARTRAIN, LA AND VICINITY CHALMETTE AREA PLAN DESIGN MEMORANDUM NO 3—GENERAL DESIGN	
STAGE CONSTRUCTION SECTIONS NET GRADE — ELEV. 17.5	
SCALES AS SHOWN	
WALDEMAR S. NELSON AND COMPANY, INC. ENGINEERS AND ARCHITECTS NEW ORLEANS, LA	U. S. ARMY ENGINEER DISTRICT, NEW ORLEANS CORPS OF ENGINEERS, U. S. ARMY NEW ORLEANS, LA
DATE: NOVEMBER 1966	FILE NO. H-2-23820

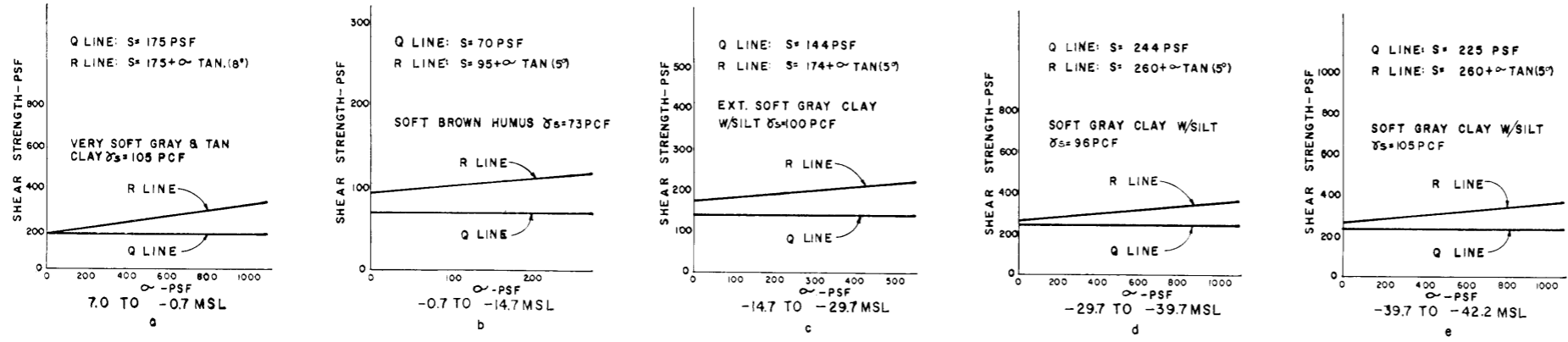

FIG. 1

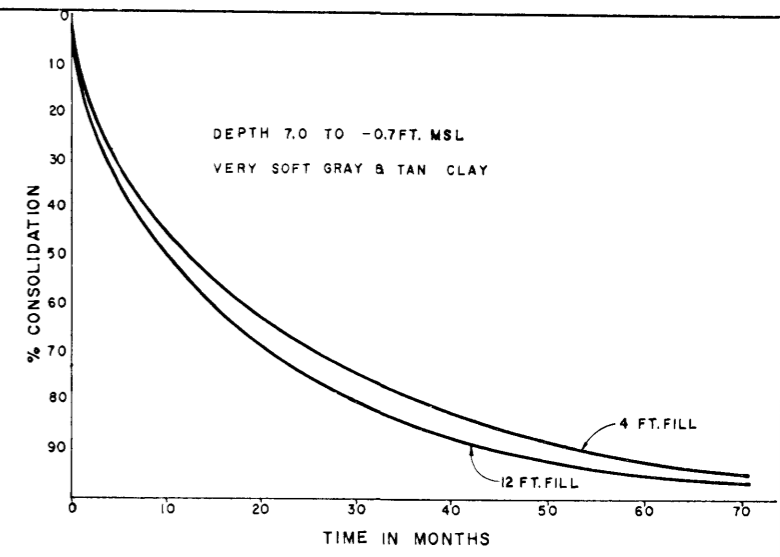

FIG. 2

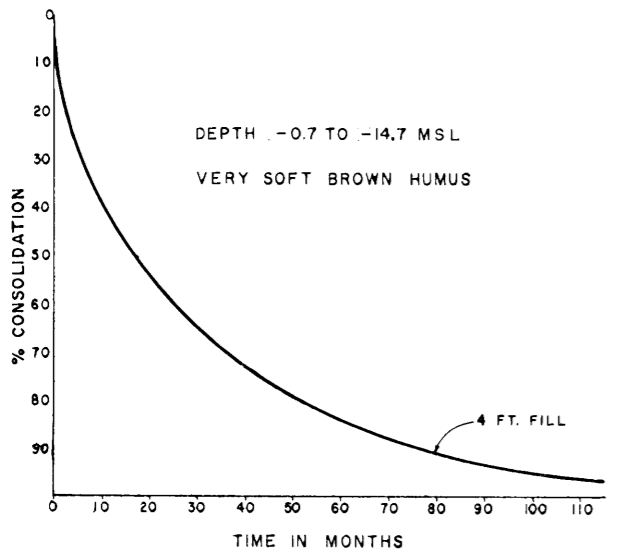

FIG. 3

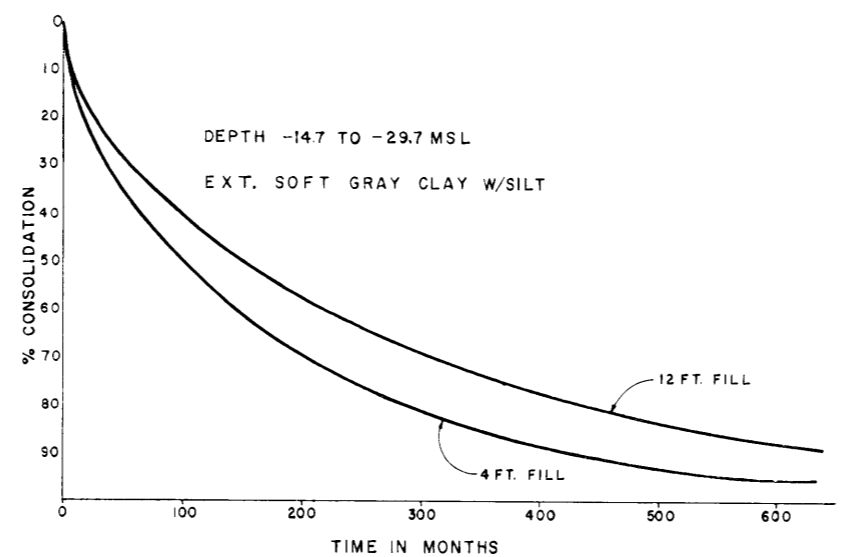

FIG. 4

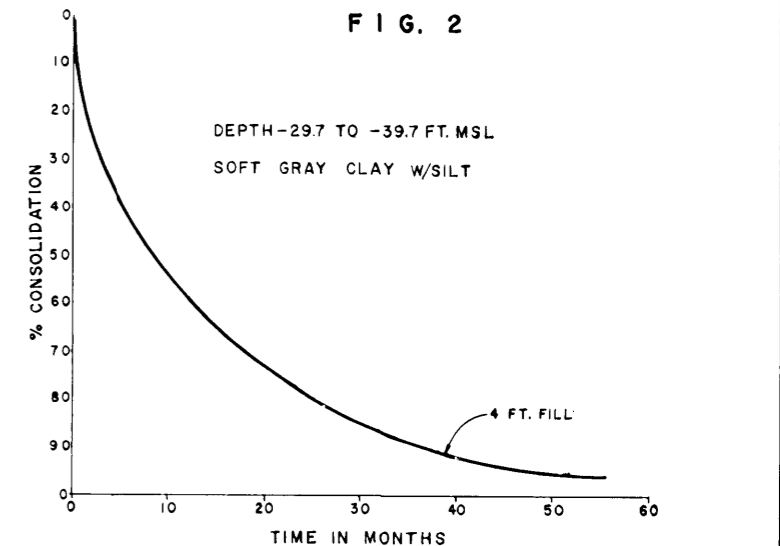

FIG. 5

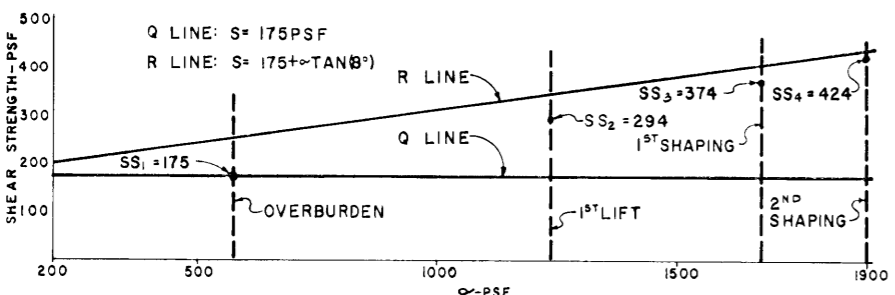

FIG. 6

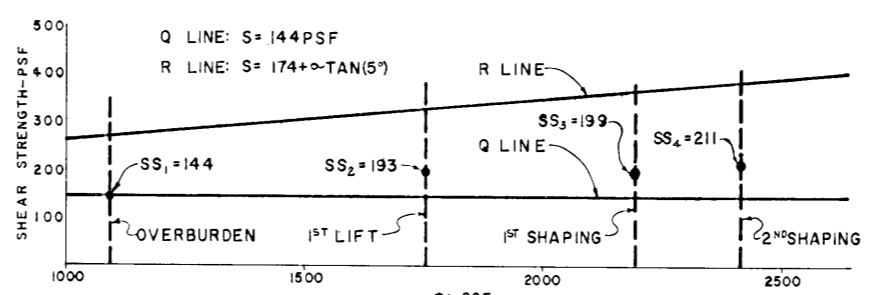

FIG. 8

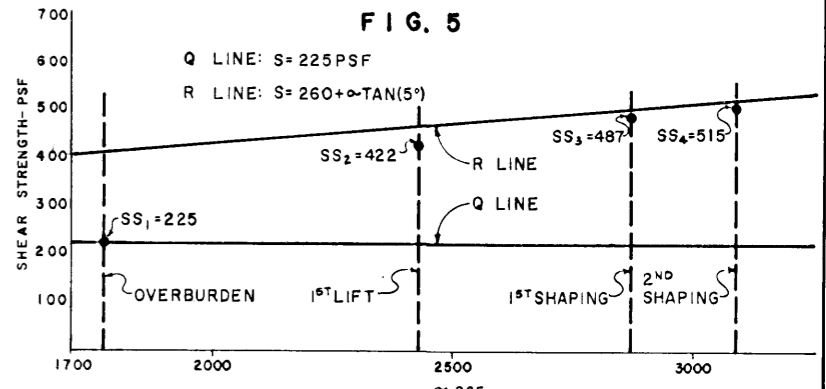

FIG. 10

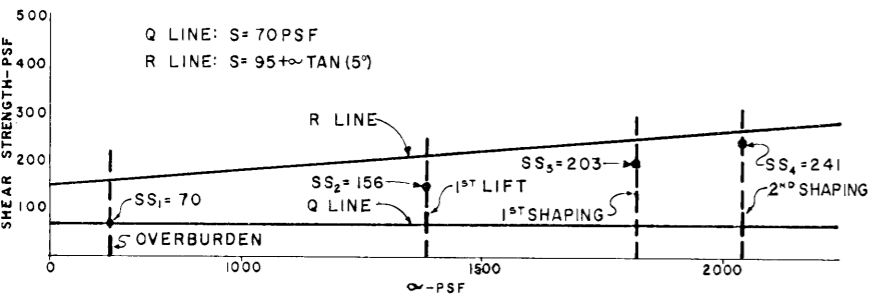

FIG. 7

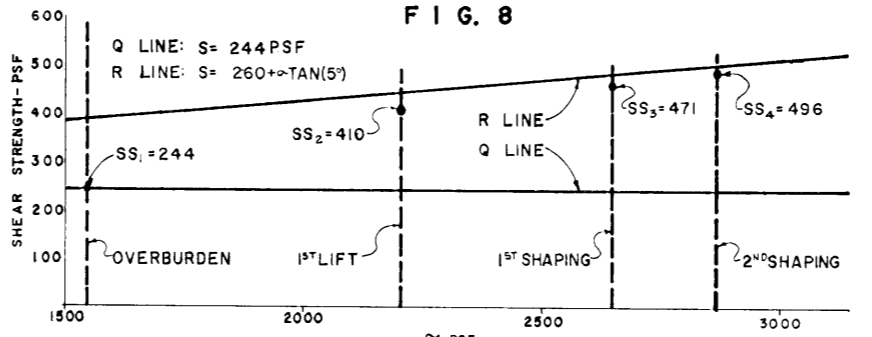

FIG. 9

LAKE PONTCHARTRAIN, LA. AND VICINITY
CHALMETTE AREA PLAN
DESIGN MEMORANDUM NO. 3—GENERAL DESIGN

DESIGN PROCEDURE
FIGURES AND TABLES

SCALES AS SHOWN

WALDEMAR S. NELSON AND COMPANY, INC. ENGINEERS AND ARCHITECTS NEW ORLEANS, LA.	U. S. ARMY ENGINEER DISTRICT, NEW ORLEANS CORPS OF ENGINEERS, U. S. ARMY NEW ORLEANS, LA.
DATE: NOVEMBER 1966	FILE NO. H-2-23820

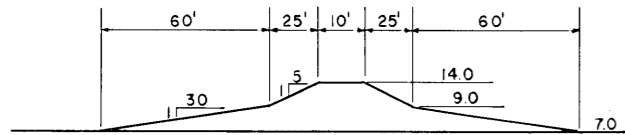

AREA = 415 SQ. FT.
FINAL CROSS SECTION
FIG. 12

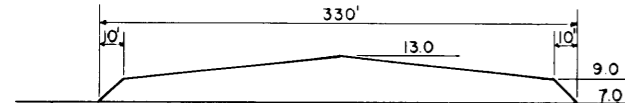

S(2YR) = 3.9 FT.
INITIAL AREA = 1260 SQ. FT.
FINAL AREA = 698 SQ. FT.
FIRST LIFT
FIG. 13

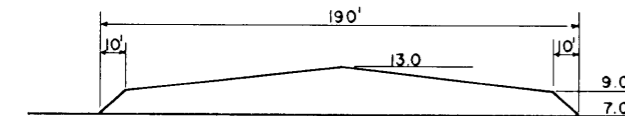

S(4YR) = 5.8 FT.
 $\Delta S = 5.8 - 3.9 = 1.9$ FT.
INITIAL AREA = 700 SQ. FT.
FINAL AREA = 503 SQ. FT.
FIRST SHAPING
FIG. 14

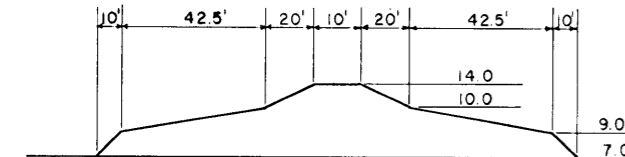

S(6YR) = 7.0 FT.
 $\Delta S = 7.0 - 5.8 = 1.2$ FT.
INITIAL AREA = 502 SQ. FT.
FINAL AREA = 426 SQ. FT.
SECOND SHAPING
FIG. 15

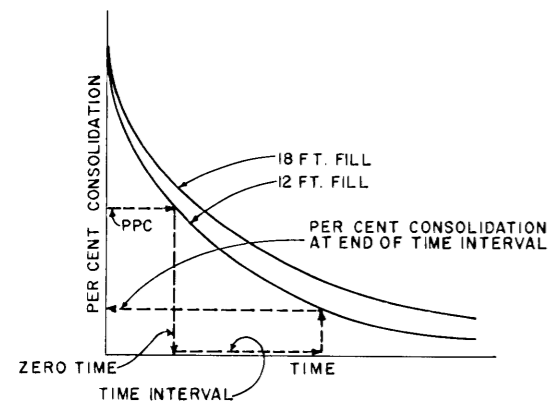

FIG. 11

STRATUM 1
 $e_0 = 2.52$ $H = 5.7$ FT.

HEIGHT OF FILL	e_f	Δe	S
4	2.12	0.40	0.65 FT.
6	2.03	0.49	0.79 FT.
8	1.93	0.59	0.92 FT.
10	1.92	0.60	0.95 FT.
12	1.90	0.62	1.00 FT.
16	1.83	0.69	1.10 FT.
20	1.76	0.76	1.23 FT.

4 FT. FILL $C_v = 0.51 \text{ FT}^2/\text{MO.}$
12 FT. FILL $C_v = 0.61 \text{ FT}^2/\text{MO.}$

TABLE A

STRATUM 2
 $e_0 = 8.0$ $H = 14$ FT.

HEIGHT OF FILL	e_f	Δe	S
4	6.85	1.15	1.79 FT.
6	5.90	2.10	3.27 FT.
8	5.50	2.50	3.90 FT.
10	5.40	2.60	4.15 FT.
12	5.20	2.80	4.36 FT.
16	4.60	3.40	5.29 FT.
20	4.10	3.90	6.06 FT.

4 FT. FILL $C_v = 2.16 \text{ FT}^2/\text{MO.}$
12 FT. FILL $C_v = 2.25 \text{ FT}^2/\text{MO.}$

TABLE B

STRATUM 3
 $e_0 = 2.42$ $H = 15$ FT.

HEIGHT OF FILL	e_f	Δe	S
4	2.08	0.34	1.49 FT.
6	1.98	0.44	1.93 FT.
8	1.90	0.52	2.28 FT.
10	1.85	0.57	2.50 FT.
12	1.80	0.62	2.72 FT.
16	1.72	0.70	3.07 FT.
20	1.53	0.89	3.91 FT.

4 FT. FILL $C_v = 0.45 \text{ FT}^2/\text{MO.}$
12 FT. FILL $C_v = 0.29 \text{ FT}^2/\text{MO.}$

TABLE C

STRATUM 4
 $e_0 = 2.12$ $H = 10$ FT.

HEIGHT OF FILL	e_f	Δe	S
4	1.76	0.36	1.15 FT.
6	1.73	0.39	1.25 FT.
8	1.67	0.45	1.44 FT.
10	1.64	0.48	1.53 FT.
12	1.60	0.52	1.67 FT.
16	1.58	0.54	1.72 FT.
20	1.57	0.55	1.76 FT.

4 FT. FILL $C_v = 2.25 \text{ FT}^2/\text{MO.}$
12 FT. FILL $C_v = 2.16 \text{ FT}^2/\text{MO.}$

TABLE D

% CONSOL.	T	STRATUM 1		STRATUM 2		STRATUM 3		STRATUM 4	
		4' FILL t-mon.	12' FILL t-mon.	4' FILL t-mon.	12' FILL t-mon.	4' FILL t-mon.	12' FILL t-mon.	4' FILL t-mon.	12' FILL t-mon.
10	0.008	0.52	0.43	0.73	0.70	4.00	6.24	0.35	0.37
20	0.031	2.00	1.65	2.81	2.70	15.50	24.18	1.38	1.43
30	0.071	4.57	3.78	6.44	6.19	35.50	55.38	3.15	3.29
40	0.126	8.11	6.72	11.43	10.99	63.00	98.28	5.59	5.83
50	0.196	12.62	10.45	17.78	17.09	98.00	152.88	8.70	9.07
60	0.287	18.48	15.30	26.03	25.03	143.50	223.86	12.74	13.29
70	0.403	25.95	21.48	36.55	35.14	201.50	314.34	17.89	18.65
80	0.567	36.51	30.22	51.43	49.44	283.50	442.26	25.17	26.25
90	0.848	54.61	45.20	76.91	73.94	424.00	661.44	37.65	39.25
95	1.125	72.45	59.96	102.03	98.10	562.50	877.50	49.95	52.09

W - TSF 0.377 0.818 0.36 0.70 0.676 1.116 0.901 1.341
Cv - SF/mon. 0.51 0.61 2.16 2.25 0.45 0.29

Hd = 57 FT. 14 FT. 15 FT. 10 FT.

TABLE E

TABLE F

TABLE G

TABLE H

LAKE PONTCHARTRAIN, LA. AND VICINITY
CHALMETTE AREA PLAN
DESIGN MEMORANDUM NO. 3—GENERAL DESIGN
DESIGN PROCEDURE
FIGURES AND TABLES

SCALES AS SHOWN

WALDEMAR S. NELSON AND COMPANY, INC. ENGINEERS AND ARCHITECTS NEW ORLEANS, LA.	U. S. ARMY ENGINEER DISTRICT, NEW ORLEANS CORPS OF ENGINEERS, U. S. ARMY NEW ORLEANS, LA.
--	---

DATE: NOVEMBER 1966

FILE NO. H-2-23820

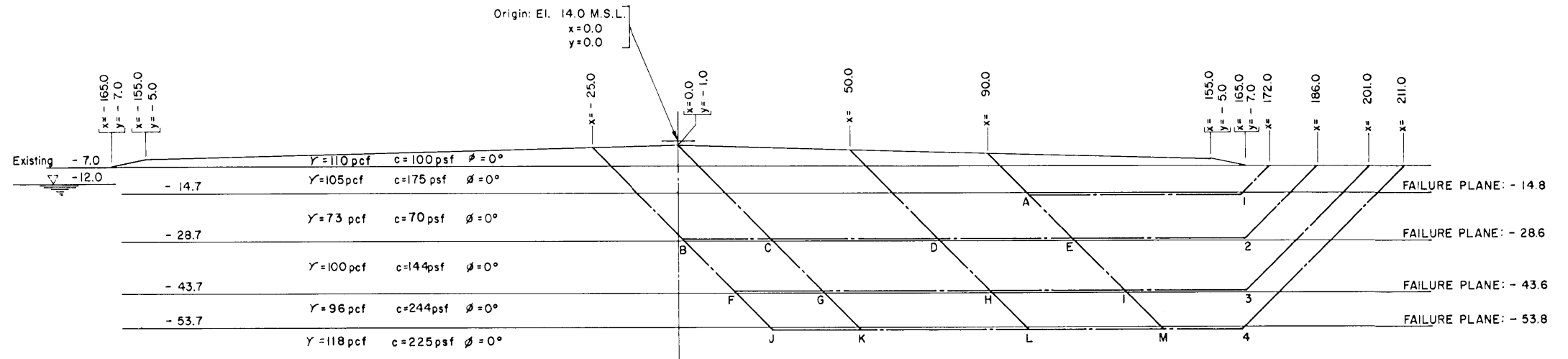

FIRST LIFT

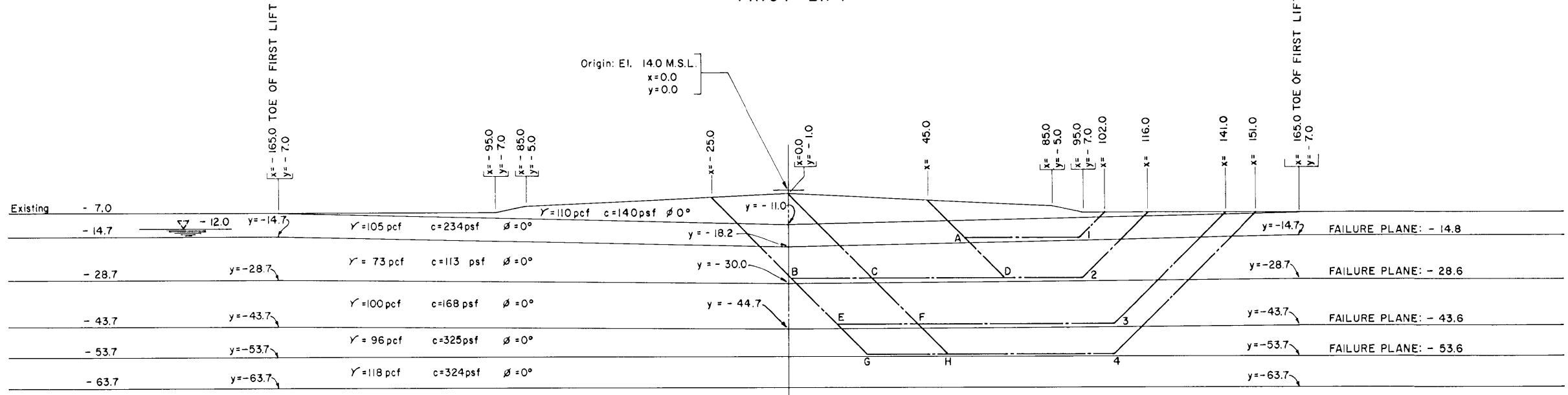

FIRST SHAPING

FIRST LIFT

CASE	F.O.S.
A 1	2.91
B 2	1.48
C 2	1.39
D 2	1.53
E 2	1.70
F 3	1.75
G 3	1.69
H 3	1.84
I 3	2.06
J 4	2.13
K 4	2.08
L 4	2.28
M 4	2.57

FIRST SHAPING

CASE	F.O.S.
A 1	4.27
B 2	1.65
C 2	1.51
D 2	1.98
E 3	1.53
F 3	1.53
G 4	1.95
H 4	1.95

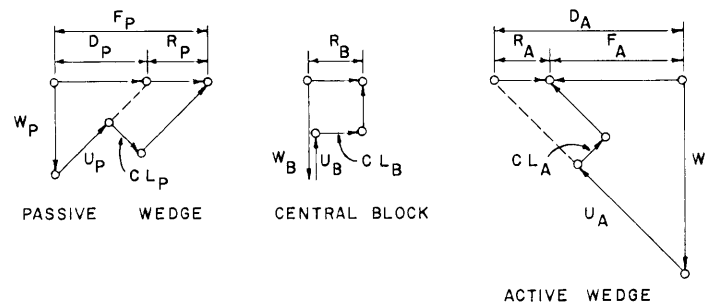

Surface C-2
F.S. with respect to shear strength

$$= \frac{R_A + R_B + R_P}{D_A - D_P} = \frac{5,841 + 9,538 + 4,229}{36,558 + 21,993} = 1.39$$

VECTOR DIAGRAM
(Method of planes)

LAKE PONTCHARTRAIN, LA. AND VICINITY
CHALMETTE AREA PLAN
DESIGN MEMORANDUM NO. 3—GENERAL DESIGN

DESIGN PROCEDURE
STABILITY ANALYSES

SCALES AS SHOWN

WALDEMAR S. NELSON AND COMPANY, INC.
ENGINEERS AND ARCHITECTS
NEW ORLEANS, LA.

U. S. ARMY ENGINEER DISTRICT, NEW ORLEANS
CORPS OF ENGINEERS, U. S. ARMY
NEW ORLEANS, LA.

DATE: NOVEMBER 1966

FILE NO. H-2-23820

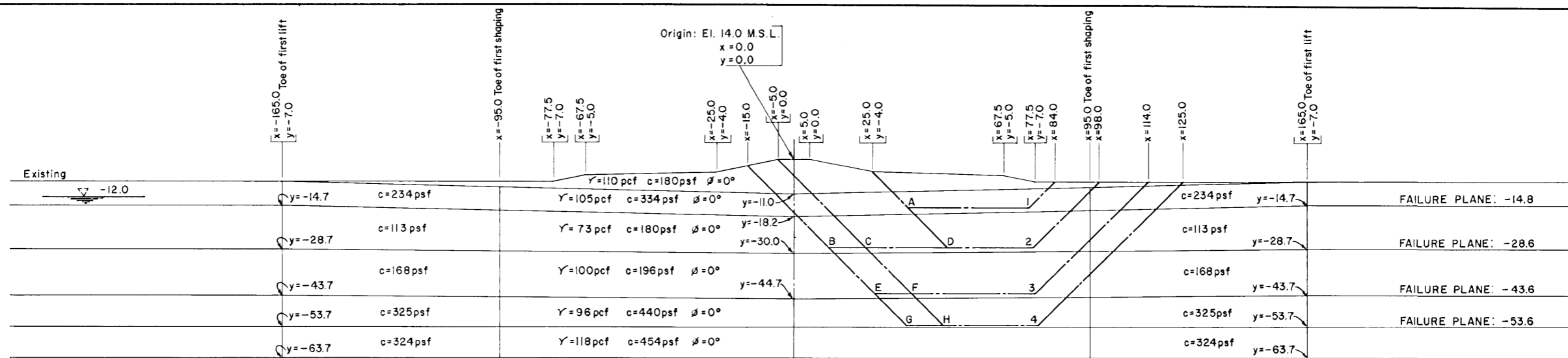

SECOND SHAPING

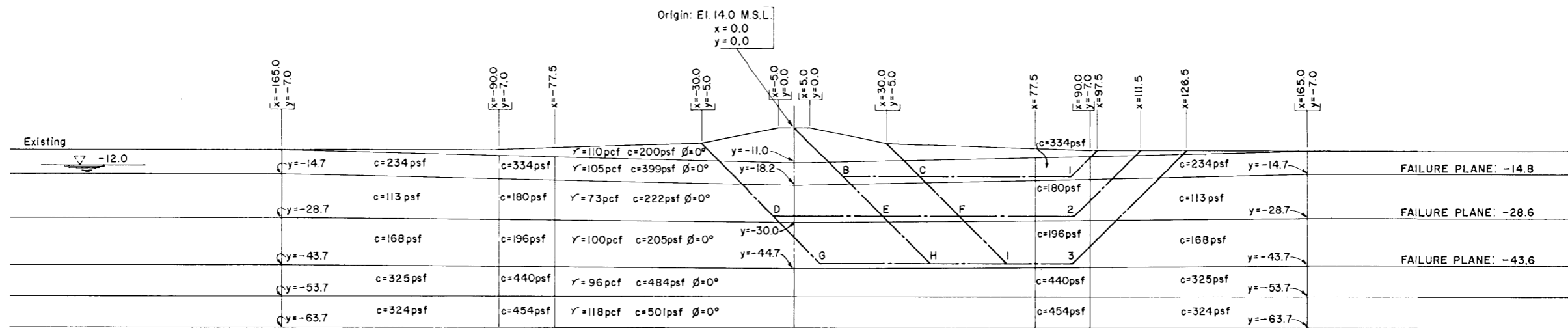

FINAL CROSS SECTION

SECOND SHAPING

CASE	F.O.S.
A 1	7.96
B 2	1.86
C 2	2.00
D 2	3.65
E 3	1.67
F 3	1.93
G 4	2.32
H 4	2.58

FINAL CROSS SECTION

CASE	F.O.S.
B 1	5.46
C 1	16.78
D 2	2.62
E 2	2.11
F 2	5.57
G 3	1.93
H 3	2.38
I 3	5.34

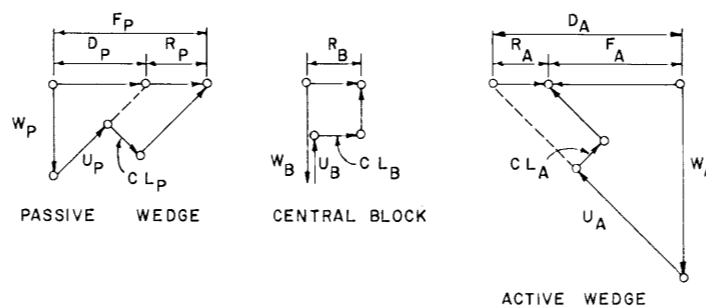

Surface E 3

F.S. with respect to shear strength

$$= \frac{R_A + R_B + R_P}{D_A - D_P} = \frac{17,674 + 9,957 + 14,654}{87,537 - 62,200} = 1.67$$

VECTOR DIAGRAM
(Method of planes)

LAKE PONTCHARTRAIN, LA. AND VICINITY
CHALMETTE AREA PLAN
DESIGN MEMORANDUM NO. 3—GENERAL DESIGN

**DESIGN PROCEDURE
STABILITY ANALYSES**

SCALES AS SHOWN

WALDEMAR S. NELSON AND COMPANY, INC.
ENGINEERS AND ARCHITECTS
NEW ORLEANS, LA.

U. S. ARMY ENGINEER DISTRICT, NEW ORLEANS
CORPS OF ENGINEERS, U. S. ARMY
NEW ORLEANS, LA.

DATE: NOVEMBER 1966

FILE NO. H-2-23820

UNIFIED SOIL CLASSIFICATION

MAJOR DIVISION	TYPE	LETTER SYMBOL	SYM BOL	TYPICAL NAMES	
COARSE - GRAINED SOILS More than half of material is larger than No. 200 sieve size.	GRAVELS More than half of coarse fraction is larger than No. 4 sieve size.	CLEAN GRAVEL (Little or No Fines)	GW	GRAVEL, Well Graded, gravel-sand mixtures, little or no fines	
		GRAVEL WITH FINES (Appreciable Amount of Fines)	GP	GRAVEL, Poorly Graded, gravel-sand mixtures, little or no fines	
		GRAVEL WITH FINES (Appreciable Amount of Fines)	GM	SILTY GRAVEL, gravel-sand-silt mixtures	
	SANDS More than half of coarse fraction is smaller than No. 4 sieve size.	CLEAN SAND (Little or No Fines)	SW	SAND, Well - Graded, gravelly sands	
		SAND WITH FINES (Appreciable Amount of Fines)	SP	SAND, Poorly - Graded, gravelly sands	
		SANDS WITH FINES (Appreciable Amount of Fines)	SM	SILTY SAND, sand-silt mixtures	
		CLAYEY SAND, sand-clay mixtures	SC		
		FINE - GRAINED SOILS More than half the material is smaller than No. 200 sieve size.	SILTS AND CLAYS (Liquid Limit < 50)	ML	SILT & very fine sand, silty or clayey fine sand or clayey silt with slight plasticity
				CL	LEAN CLAY; Sandy Clay; Silty Clay, of low to medium plasticity
OL	ORGANIC SILTS and organic silty clays of low plasticity				
SILTS AND CLAYS (Liquid Limit > 50)	MH		SILT, fine sandy or silty soil with high plasticity		
	CH		FAT CLAY, inorganic clay of high plasticity		
OH	ORGANIC CLAYS of medium to high plasticity, organic silts				
HIGHLY ORGANIC SOILS		Pt	PEAT, and other highly organic soil		
WOOD		Wd	WOOD		
SHELLS		SI	SHELLS		
NO SAMPLE					

NOTE: Soils possessing characteristics of two groups are designated by combinations of group symbols

DESCRIPTIVE SYMBOLS

COLOR		CONSISTENCY FOR COHESIVE SOILS			MODIFICATIONS	
COLOR	SYMBOL	CONSISTENCY	COHESION IN LBS./SQ. FT. FROM UNCONFINED COMPRESSION TEST	SYMBOL	MODIFICATION	SYMBOL
TAN	T	VERY SOFT	< 250	vSo	Traces	Tr-
YELLOW	Y	SOFT	250 - 500	So	Fine	F
RED	R	MEDIUM	500 - 1000	M	Medium	M
BLACK	BK	STIFF	1000 - 2000	St	Coarse	C
GRAY	Gr	VERY STIFF	2000 - 4000	vSt	Concretions	cc
LIGHT GRAY	lGr	HARD	> 4000	H	Rootlets	rt
DARK GRAY	dGr				Lignite fragmen.	lg
BROWN	Br				Shale fragments	sh
LIGHT BROWN	lBr				Sandstone fragments	sds
DARK BROWN	dBr				Shell fragments	sif
BROWNISH-GRAY	brGr				Organic matter	O
GRAYISH-BROWN	gyBr				Clay strata or lenses	CS
GREENISH-GRAY	gnGr				Silt strata or lenses	SIS
GRAYISH-GREEN	gyGn				Sand strata or lenses	SS
GREEN	Gn				Sandy	S
BLUE	Bl				Gravelly	G
BLUE-GREEN	BlGn				Boulders	B
WHITE	Wh				Slickensides	SL
MOTTLED	Mot				Wood	Wd
					Oxidized	Ox

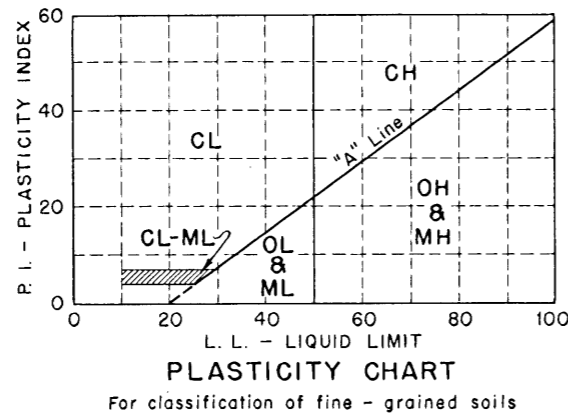

NOTES:

FIGURES TO LEFT OF BORING UNDER COLUMN "W OR D₁₀"
Are natural water contents in percent dry weight
When underlined denotes D₁₀ size in mm*

FIGURES TO LEFT OF BORING UNDER COLUMNS "LL" AND "PL"
Are liquid and plastic limits, respectively

SYMBOLS TO LEFT OF BORING

- ▽ Ground-water surface and date observed
- ⊙ Denotes location of consolidation test **
- ⊙ Denotes location of consolidated-drained direct shear test **
- ⊙ Denotes location of consolidated-undrained triaxial compression test **
- ⊙ Denotes location of unconsolidated-undrained triaxial compression test **
- ⊙ Denotes location of sample subjected to consolidation test and each of the above three types of shear tests **
- FW Denotes free water encountered in boring or sample

FIGURES TO RIGHT OF BORING

Are values of cohesion in lbs./sq. ft. from unconfined compression tests
In parenthesis are driving resistances in blows per foot determined with a standard split spoon sampler (1 3/8" I.D., 2" O.D.) and a 140 lb. driving hammer with a 30" drop

Where underlined with a solid line denotes laboratory permeability in centimeters per second of undisturbed sample
Where underlined with a dashed line denotes laboratory permeability in centimeters per second of sample remoulded to the estimated natural void ratio

* The D₁₀ size of a soil is the grain diameter in millimeters of which 10% of the soil is finer, and 90% coarser than size D₁₀.

**Results of these tests are available for inspection in the U.S. Army Engineer District Office, if these symbols appear beside the boring logs on the drawings.

GENERAL NOTES:

While the borings are representative of subsurface conditions at their respective locations and for their respective vertical reaches, local variations characteristic of the subsurface materials of the region are anticipated and, if encountered, such variations will not be considered as differing materially within the purview of clause 4 of the contract.

Ground-water elevations shown on the boring logs represent ground-water surfaces encountered on the dates shown. Absence of water surface data on certain borings implies that no ground-water data is available, but does not necessarily mean that ground water will not be encountered at the locations or within the vertical reaches of these borings.

Consistency of cohesive soils shown on the boring logs is based on driller's log and visual examination and is approximate, except within those vertical reaches of the borings where shear strengths from unconfined compression tests are shown.

SOIL BORING LEGEND

REVISION	DATE	DESCRIPTION	BY
2	6-8-64	SYMBOL FW, NOTE REVISED	ORAL FROM L.M.V.G.G. 5 JUNE 1964
1	9-17-63	1ST PAR. OF GENERAL NOTES REVISED	L.M.V.D. MULTIPLE LETTER, DATED 9 SEPT., 1963

U.S. ARMY ENGINEER DISTRICT, NEW ORLEANS
CORPS OF ENGINEERS
FILE NO. H-2-21800

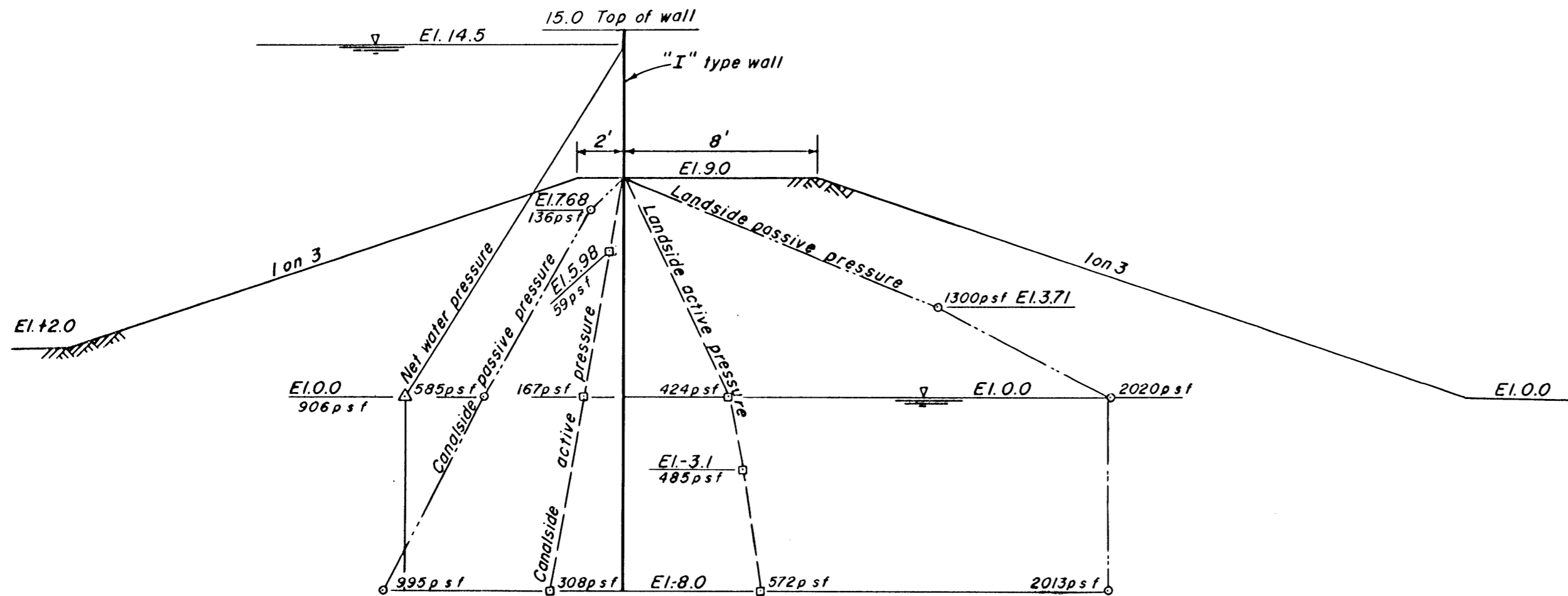

PRESSURE DIAGRAM (F.S. = 1.0)

SCALES: 1" = 5', 1" = 500 p s f #
 NOTE: WITH WATER AT EL. 15.0 OF MAX. = 10016' AT EL. 2.29

STA. 1+57 TO STA. 0+00 (10' O.S.)
STA. 1+46.6 TO STA. 58+12

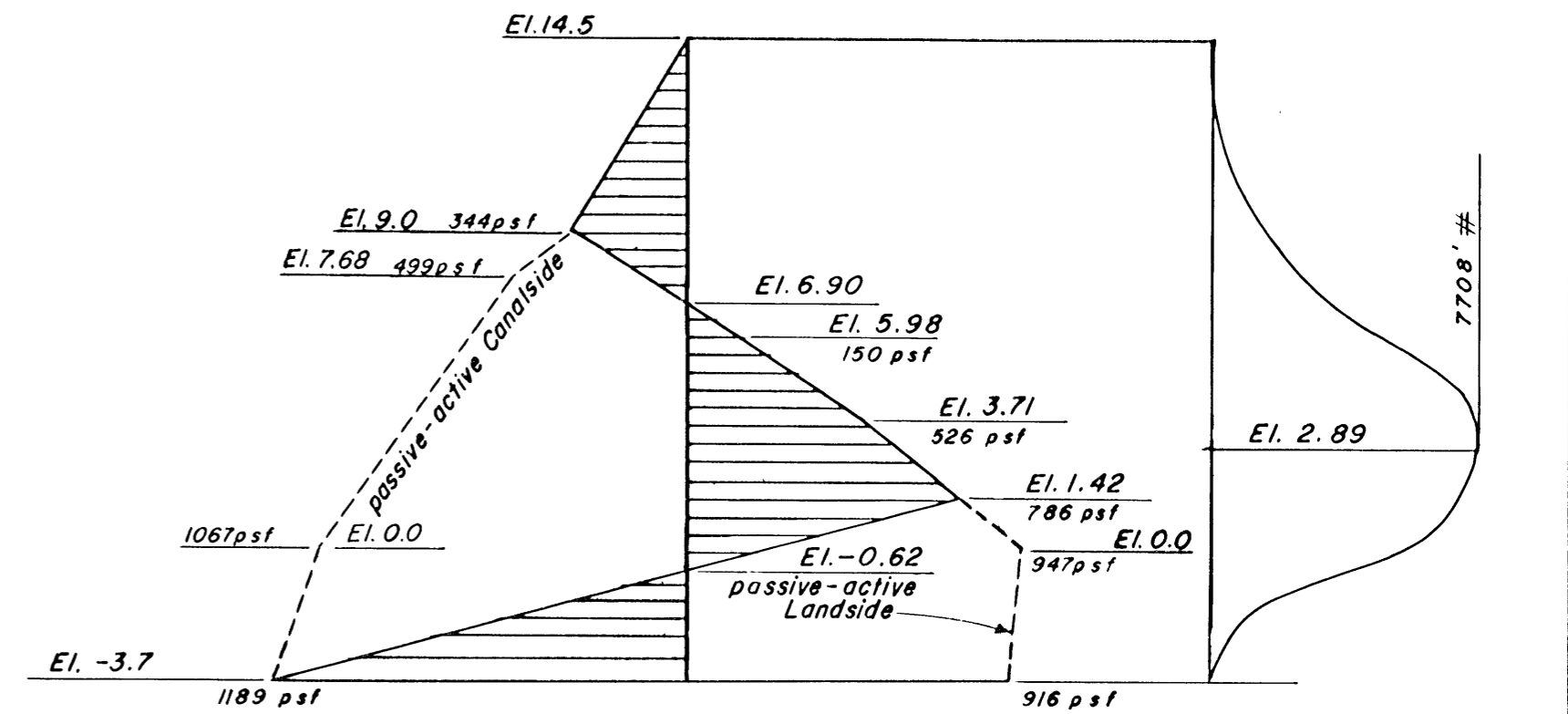

NET PRESSURE DIAGRAM (F.S. = 1.0)

SCALES: 1" = 5', 1" = 500 p s f

MOMENT DIAGRAM

SCALES: 1" = 5', 1" = 5,000 ft. #

LAKE PONTCHARTRAIN, LA. AND VICINITY CHALMETTE AREA PLAN DESIGN MEMORANDUM NO.3-GENERAL DESIGN	
I-WALL DESIGN ANALYSIS	
WALDEMAR S. NELSON & CO., INC. ENGINEERS AND ARCHITECTS NEW ORLEANS, LA.	U.S. ARMY ENGR. DIST., N.O. CORPS OF ENGINEERS, U.S. ARMY NEW ORLEANS, LA.
DATE: OCTOBER 1966	FILE NO. H-2-23820

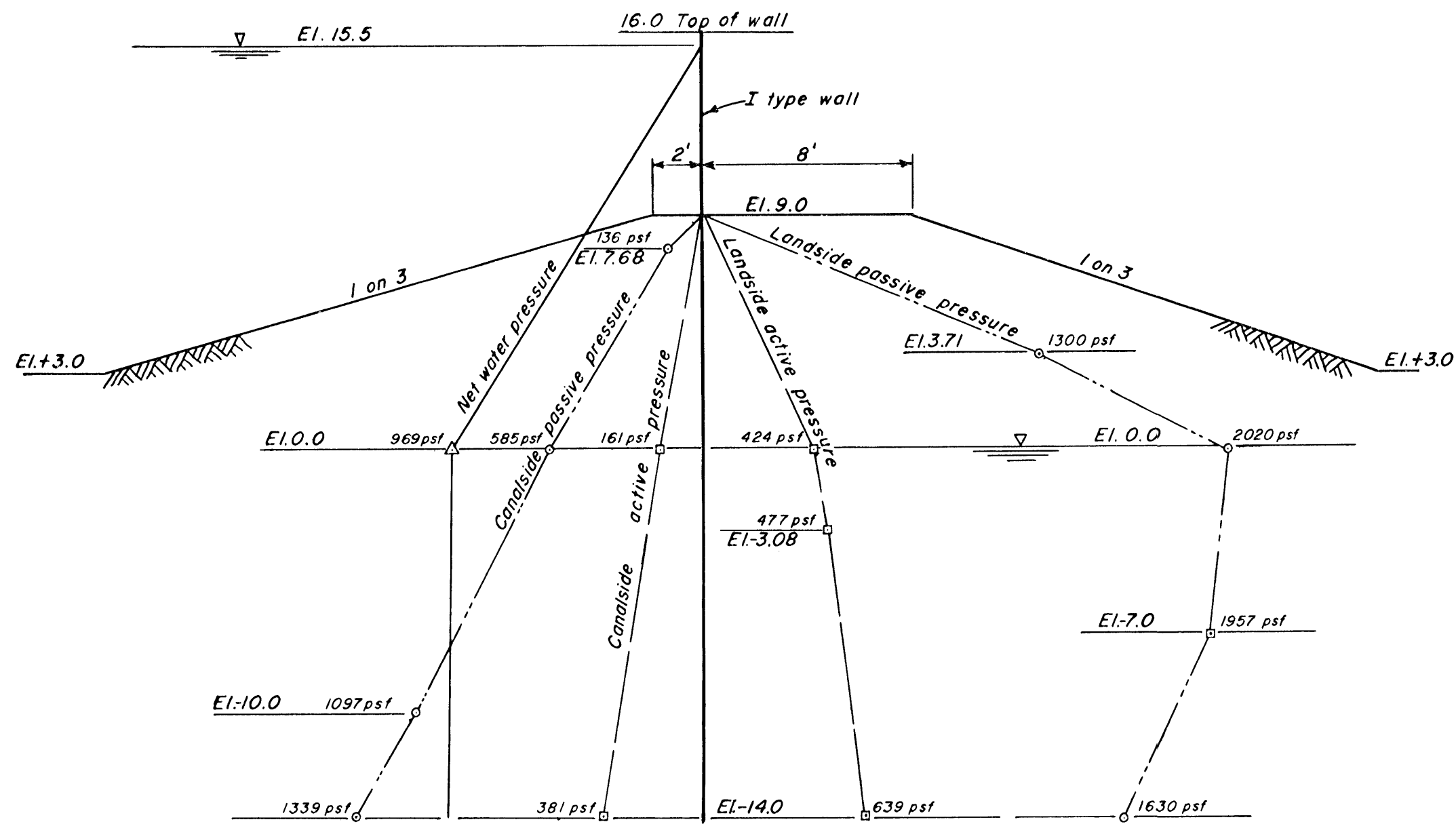

PRESSURE DIAGRAM (F.S. = 1.0)

SCALES: 1" = 5', 1" = 500 p s f

NOTE: WITH WATER AT EL. 16.0 OF MAX. = 15917[#] AT EL. 1.09

STA. 67 + 94 TO STA. 79 + 62

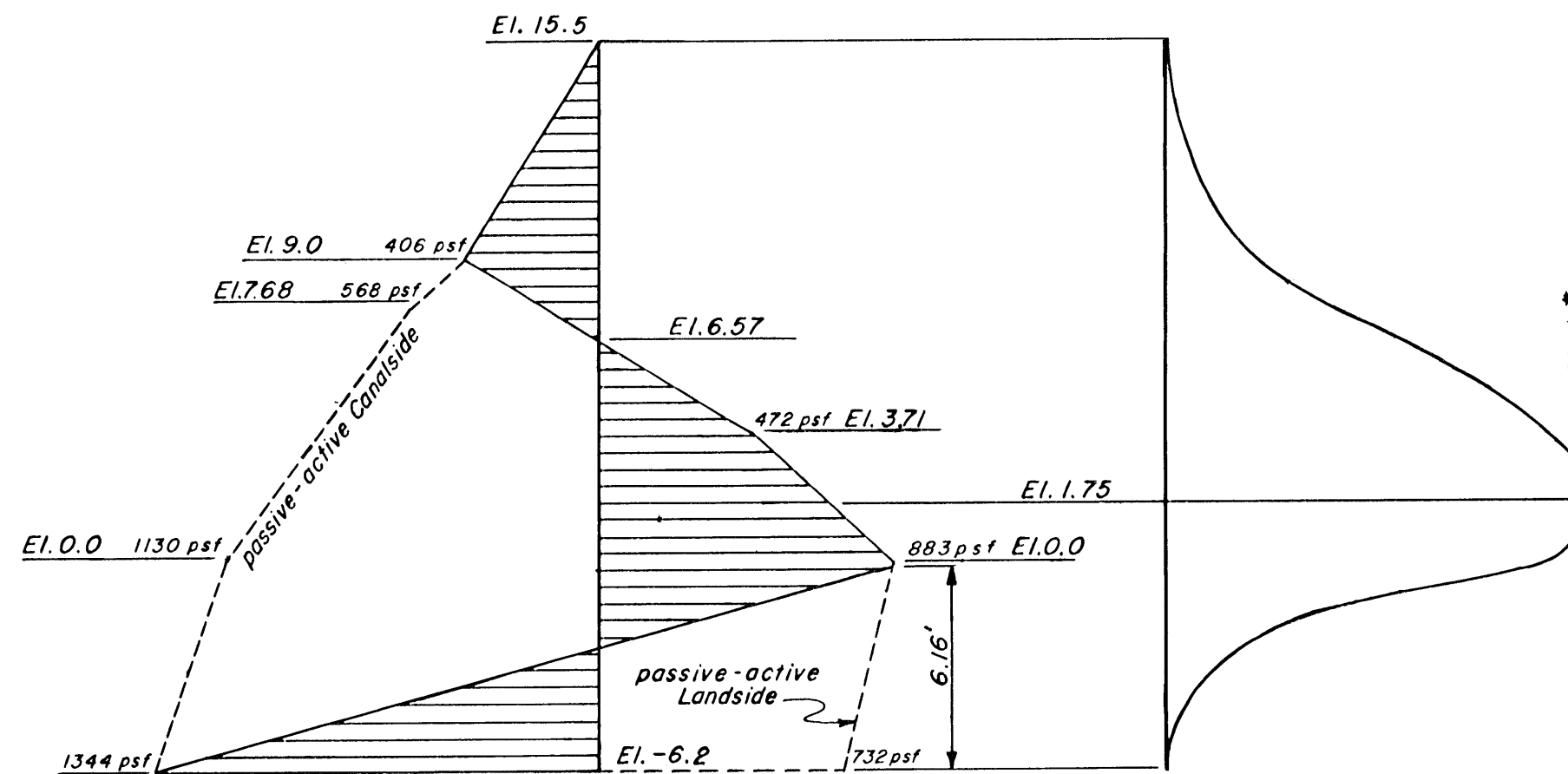

NET PRESSURE DIAGRAM (F.S. = 1.0)

SCALES: 1" = 5', 1" = 500 p s f

MOMENT DIAGRAM

SCALES: 1" = 5', 1" = 5,000 ft.-kips

LAKE PONTCHARTRAIN, LA. AND VICINITY
CHALMETTE AREA PLAN
DESIGN MEMORANDUM NO. 3 - GENERAL DESIGN
I - WALL DESIGN ANALYSIS

WALDEMAR S. NELSON & CO., INC.
ENGINEERS AND ARCHITECTS
NEW ORLEANS, LA.

U.S. ARMY ENGR. DIST., N.O.
CORPS OF ENGINEERS, U.S. ARMY
NEW ORLEANS, LA.

DATE: OCTOBER 1966 FILE NO. H-2-23820