



DEPARTMENT OF DEFENSE

TECHNICAL ASSESSMENT REPORT

**PROCUREMENT OF COLD EXPANSION TOOL KITS BY THE
OKLAHOMA CITY AIR LOGISTICS CENTER**

Report No. 94-018

December 6, 1993

*Office of the
Inspector General*



Acronyms

FTI
RFP
WCI

Fatigue Technology, Incorporated
Request for Proposals
West Coast Industries, Incorporated



**INSPECTOR GENERAL
DEPARTMENT OF DEFENSE
400 ARMY NAVY DRIVE
ARLINGTON, VIRGINIA 22202-2884**

December 6, 1993

**MEMORANDUM FOR ASSISTANT SECRETARY OF THE AIR FORCE
(FINANCIAL MANAGEMENT AND COMPTROLLER)**

**SUBJECT: Report on the Technical Assessment of the Procurement of Cold Expansion
Tool Kits by the Oklahoma City Air Logistics Center, Tinker Air Force
Base, Oklahoma (Report No. 94-018)**

We are providing this final report for your information and use. Since we found no deficiencies and our assessment did not result in any recommendations, no comments from the Air Force are necessary.

If you have any questions about this technical assessment, please contact Mr. Kenneth H. Stavenjord, Technical Director, at (703) 614-8174 or Mr. Gregory R. Donnellon, Project Manager, at (703) 614-6210. The planned distribution of this report is listed in Appendix C.

David K. Steensma

David K. Steensma
Deputy Assistant Inspector General
for Auditing

Office of the Inspector General, DoD

Report No. 94-018
Project Number 3PT-5017

December 6, 1993

TECHNICAL ASSESSMENT OF THE PROCUREMENT OF COLD EXPANSION TOOL KITS BY THE OKLAHOMA CITY AIR LOGISTICS CENTER, TINKER AIR FORCE BASE, OKLAHOMA

EXECUTIVE SUMMARY

Introduction. This technical assessment was initiated by the Office of the Inspector General, DoD, in response to a request by Senator Slade Gorton of Washington State that we review the procurement of some tooling used for cold expansion by the Oklahoma City Air Logistics Center.

Objectives. The objective of the technical assessment was to decide whether the Air Force had made a proper determination of the technical qualifications of the suppliers of the tooling. We also evaluated whether the Air Force handled the proprietary data of one of the suppliers in such a manner as to jeopardize the company's competitive position.

Technical Assessment Results. The Oklahoma City Air Logistics Center properly qualified a second source, West Coast Industries, for the procurement of cold expansion tool kits. The qualification action of the Air Logistics Center saved over a million dollars.

Table of Contents

Executive Summary	i
Part I - Introduction	
Background	2
Objectives and Scope	6
Part II - Results of Technical Assessment	
Technical Qualification of Second Source of Cold Expansion Tool Kit	8
Part III - Additional Information	
Appendix A. Senator Gorton's Request, January 12, 1993	14
Appendix B. Activities Visited or Contacted	16
Appendix C. Report Distribution	17

This report was prepared by the Technical Assessment Division, Audit Planning and Technical Support Directorate, Office of the Assistant Inspector General for Auditing, DoD. Copies of this report can be obtained from the Secondary Reports Distribution Unit, Audit Planning and Technical Support Directorate, at (703) 614-6303 (DSN 224-6303).

Part I - Introduction

Background

This technical assessment was made in response to a request by Senator Slade Gorton (Appendix A). Senator Gorton made his request in reaction to a complaint from one of the small businesses offering cold expansion tool kits for sale to the Air Force. Specifically, the complainant expressed concerns about the safety of flight for aircraft repaired with the tooling supplied by a rival firm. The complainant alleged that the tooling supplied by the rival firm had not been tested by the Air Force and was not interchangeable with the existing Air Force cold expansion tool kits. Furthermore, the allegation contended that the Air Force gave away proprietary technical data about cold expansion tool kits to the rival firm.

Aircraft Structural Fatigue

The Air Force inventory includes two aircraft, the B-52 bomber and the KC-135 aerial tanker, developed more than 40 years ago. The B-52 bomber has flown longer than any other combat aircraft in history. The KC-135 transport was a forerunner of Boeing's B-707. The two aircraft are operating far longer than envisioned by their designers. One of the problems flying aircraft past their expected useful life is that normal flying produces fatigue in the aircraft's structure. Structural fatigue was the cause of explosive decompression of the British Comet jet aircraft in the early 1950s. Aircraft such as the KC-135 and the B-52 are regularly inspected for signs of fatigue and for cracks.

Any technique that strengthens the structure of an aircraft without expensive redesigning or rework is attractive to aircraft owners. Cold expansion is a structural strengthening technique that does not require aircraft redesign and has proved popular with both the Defense and civilian aircraft maintenance community and is used on a wide variety of military and commercial airplanes.

Strengthening Aircraft Structures Through Cold Expansion

Cold expansion is a process of strengthening aircraft structures without adding metal to the aircraft, without redesigning the aircraft outer surfaces (skin), or without redesigning the supporting aircraft structure. Instead, fastener holes, either existing or new, are radially expanded. The metal surrounding the holes is compressively stressed. Treated fastener holes in aircraft structures are less likely to exhibit fatigue and cracks.

The Cold Expansion Process

In cold expansion, a tapered spindle, called a mandrel, is inserted into a fastener hole in the aircraft structure and is then drawn back through the hole to expand it. A number of methods can be used to cold-expand the fastener hole. The most common method is to first insert a lubricated metal split sleeve in the fastener hole. The metal sleeve, a cylinder split along one edge, expands as the mandrel is drawn back through the hole.

If done correctly, drawing the mandrel back through the fastener hole expands the size of the hole by about 6 percent (this percentage varies depending on the size of the hole and the type of metal). As the mandrel is withdrawn from the hole, the surrounding metal elastically rebounds; however, the hole does not fully return to its original dimension. The fastener hole retains an area of residual compressive stress, generally extending for one radius beyond the expanded fastener hole (the amount of compressive stress varies). The permanently affected area surrounding the hole is called the zone of compression. The amount of residual expansion is normally about 4 percent (as opposed to the initial expansion of 6 percent); however, the actual degree of expansion depends on properties such as the type of metal, the thickness of the material, and the size of the fastener hole.

Cold Expansion Tools

To perform the cold expansion process, maintenance personnel use specially engineered tools. The cold expansion tooling can be purchased separately or in sets called tool kits. The Oklahoma City Air Logistics Center, Tinker Air Force Base, Oklahoma (the Center), utilized three types of cold expansion tool kits: depot, field, and countersink.

Depot Tool Kit. A depot cold expansion tool kit normally consists of technical manuals, starting drills and reamers, check gages, nose caps, jaw assemblies, mandrels of various sizes, metal split sleeves, final reamers, puller guns, and power packs. The nose caps and jaw assemblies hold the mandrels and metal split sleeves in place as the mandrels are drawn back through the fastener holes. Nose caps can be made straight or for countersink holes. Jaw assemblies can be built in a number of ways. The most common type of jaw assembly is divided into either three or four segments. The metal split sleeve is a single piece of metal bent in a circle with a slight overlap. Most split sleeves are lubricated inside. If the sleeve is not prelubricated, lubrication must be applied to the inside of the sleeve to allow the mandrel to pass through and properly expand the hole. Depot tool kits are designed to cold expand fastener holes up to 1 inch in diameter.

Introduction

Drawing the mandrel through the metal split sleeve requires a puller gun. The puller gun can be either manually or hydraulically operated. Hydraulic puller guns require power packs to provide hydraulic pressure. The power packs utilize air motors.

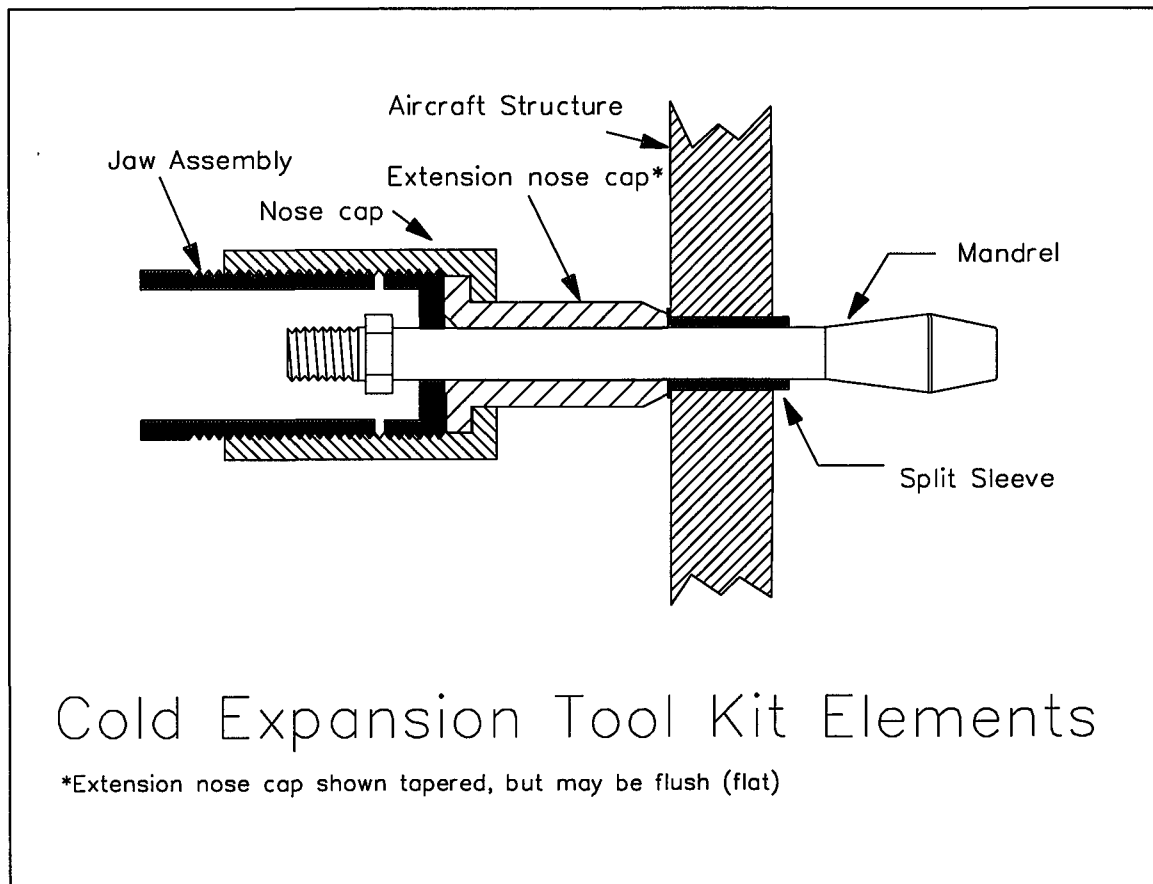

Field Tool Kits. Field tool kits consist of the same basic tools as the depot kit, however, the field tool kits are designed to cold expand fastener holes from 3/16" inch to 3/8" inch diameter.

Countersink Nose Cap Kits. Countersink nose cap kits are used in specialized applications where the hole to be cold expanded is countersunk. Countersink nose cap kits use different mandrels and nose caps. A countersink nose cap kit consists of nose caps, split sleeves and backup blocks (used to prevent the nose cap and sleeve from buckling).

Application of the Cold Expansion Process

To achieve the benefits of cold expansion, fastener holes must be predrilled to specific sizes. The holes are then checked with a gage. All tooling used must be matched to the initial hole to ensure that proper amount of expansion takes place. Following the initial check using the gage, the puller gun is fitted with a nose cap, and a mandrel of the proper size for the hole is secured in the nose

cap by tightening a jaw assembly. A split sleeve is slid over the mandrel and down its shaft until the sleeve comes in contact with the nose cap. The joined gun, nose cap, jaw assembly, mandrel, and split sleeve is then inserted in such a way that the split sleeve rests in the hole with the nose cap holding the split sleeve tightly in place. The mandrel is pulled through the split sleeve, thus expanding the hole. The split sleeve is removed from the hole and thrown away. The hole is then checked for the proper amount of expansion. If the proper amount of expansion is achieved, the hole is reamed to size to receive the fastener. A well-trained operator can cold-work a hole in a matter of seconds.

Cold Expansion Technology Development

Boeing Aircraft's engineers conceptualized the cold expansion process in 1965. Boeing then licensed the technology to several small businesses.

Accordingly, Boeing transferred the tool technology and methodology to International Wire and Metal Forming, Incorporated, which became Fatigue Technology, Incorporated (FTI), and to West Coast Industries, Incorporated (WCI). The two firms became the main sources of cold expansion tools, sometimes cooperating with each other through subcontracting arrangements. However, the two firms competed against each other for contracts.

In 1980, International Wire and Metal Forming, Incorporated, was renamed FTI as the nature of its business became more exclusively associated with cold expansion. FTI's business expanded in volume, and FTI filed patents covering a number of tools used in the cold expansion technology, including the nose caps, the split sleeves, and the mandrels. The puller guns and power packs, while used in the cold expansion process tooling, were not unique to the cold expansion process and as a result were never patented.

In cooperation with Boeing, FTI developed many of the standard repair manuals and technical orders used to define the cold expansion process. For example, FTI wrote the technical order for cold expansion on the B-52 aircraft, technical order 1B-52G-3. In writing the B-52 and other technical orders, FTI naturally referred to its own proprietary tools and processes.

However, by the 1980s, other manufacturers offered designs for cold expansion tools. In 1983, Boeing licensed the rights to build a three-piece nose cap to WCI. When FTI's patent on the split sleeve expired, WCI was able to supply the split sleeve as well.

Objectives and Scope

The objective of the technical assessment was to decide whether the Air Force had made a proper determination of the qualification of vendors for a procurement of cold expansion tool kits. The procurement was made by the Oklahoma Air Logistics Center, Air Force Material Command, Tinker Air Force Base, Oklahoma. We also assessed how the Air Force handled the technical data associated with cold expansion tools.

Our assessment focused on the technical qualification used to designate a second source of cold expansion tool kits. We assessed the background and development of the technology, interviewed the major suppliers, spoke with procurement officials at Tinker Air Force Base, and Hill Air Force Base, Utah, and studied the aircraft structural working applications to determine the effect on the safety of flight (Appendix B). We also evaluated the Air Force handling of cold expansion tooling technical data to determine if the Air Force gave FTI's proprietary information to WCI. Although competition in the field of cold expansion tooling is fierce and encompasses a number of issues such as patent infringement, we limited our assessment to review the procurement, the technical requirements and the acquisition of technical data used in procurement of the technology.

Part II - Results of Technical Assessment

Technical Qualifications of Second Source of Cold Expansion Tool Kits

The Center beneficially utilized a second source, WCI, to supply cold expansion tool kits. Lacking military specifications to serve as the basis for technical qualifications, the Center properly relied on the tool criteria employed by Boeing. Boeing was the primary developer of cold expansion methodology and also was a major user of the technique. Using Boeing's criteria, Center officials found WCI qualified. The resulting procurement action with WCI saved the Government at least \$1 million over the cost of procuring cold expansion field tool kits from a single source.

History of the Procurement

The Center established a requirement for 70 field kits, 10 depot kits, and 70 countersink hole kits. Initially, the Center planned to procure the required kits by issuing a single-sole source procurement to FTI because only FTI could supply the 70 countersink nose caps needed. In the process of securing the justification and authorization, the Center's competition advocate realized that, by separating the requirement into three separate procurement actions, the field and depot tool kit procurements could be competitively bid, and the costs of developing the competitive bid would be offset by a lower total contract cost.

Accordingly, Center officials broke the procurement for the 70 countersink nose caps, the 10 depot tool kits, and the 70 field kits into three procurements. The 70 countersink nose caps were procured sole source from FTI. On September 30, 1992, FTI was awarded the contract for this portion of the Center's overall cold expansion requirement.

For the 10 depot tool kits, FTI won the competitive contract with a bid that was less than that submitted by WCI. The contract was awarded on May 22, 1992.

The third procurement action for the 70 field tool kits was also competitively bid. Once the Center officials qualified WCI as a second source to supply the 70 field tool kits, both FTI and WCI submitted bids for the field kits. On October 27, 1992, WCI was awarded a contract for 70 field tool kits at a total cost of about \$1.04 million (about \$15,000 per kit). The field kits were shipped to the Center February 1, 1993.

Qualification Process for West Coast Industries

Qualification requirements were defined in Federal Acquisition Regulation Part 9, "Contractor Qualifications." Federal Acquisition Regulation Part 9 gives discretion to the contracting office for setting qualification requirements. The main emphasis was on giving each potential supplier an opportunity to demonstrate the qualifications notification of the intention to purchase goods and services.

Federal Acquisition Regulation FAR 52 209-1, "Qualification Requirements," states that the "product, manufacturer, or source must have demonstrated that it meets the standards prescribed for qualification before the award of this contract." To Center officials, WCI had established its technical qualifications before the procurement of the depot kits and field kits began. During the procurement, Center officials reviewed the technical qualifications of WCI.

Center engineering personnel began their review of the qualifications of WCI while the decision was being made to split the tool kit requirement into three procurements. One step in the review process was to determine if WCI cold expansion tool kits satisfied the Center's requirement for interchangeability with the tool kits of FTI. Sensing the Center's concerns in this area, WCI officials visited the Center on December 20, 1991, and demonstrated how puller guns, nose caps, and mandrels could be interchanged for those of FTI.

From January through May of 1992, Center engineers reviewed the technical specifications and tool kits supplied by WCI. The engineers satisfied themselves that the tools met the Center's cold expansion process requirements.

As part of the qualification, a Center engineer contacted Boeing, General Dynamics, TWA, Chrysler Technologies, LTV Corporation, Federal Aviation Administration, and American Airlines for information on their use of cold expansion tool kits. He found that the firms used both FTI and WCI tool kits from both manufacturers, though the tools from each manufacturer are kept in kits, and components of kits from different manufacturers are not mixed. In some instances, tools from both companies were used but not interchangeably. In some cases, corporate policies and not engineering merit determined which manufacturer's tools would be used.

Based on the information obtained from industry, and based on the internal engineering appraisal, Center officials decided to procure tool kits from both WCI and FTI. Accordingly, on May 15, 1992, the Center published notification of intention in the Commerce Business Daily to buy the tools competitively.

Because of protests by FTI, the Center revised the request for proposals (RFP) to include a patent indemnity clause. The purpose of issuing the patent clause modification to the RFP was to remind WCI of FTI's patent claims and to remind FTI that the Air Force had no jurisdiction regarding FTI's patents. The

Technical Qualifications of Second Source of Cold Expansion Tooling by the Oklahoma City Air Logistics Center

modification was issued July 6, 1992, and included Federal Acquisition Regulation 52.227-3, "Patent Indemnity." The closing date of the solicitation was extended by 8 days to July 17, 1992.

Use of Non-Government Specifications and Standards as Qualification Criteria and the Handling of Technical Data

No military specifications exist for cold expansion tool kits. Cold expansion tool kits were meant to conform to the specifications and technical orders written by airframe manufacturers. In its instructions, the Center encouraged suppliers to obtain copies of any Air Force technical orders from the Center that pertained to the items the vendor might want to supply. A technical order was, therefore, a document that the Center circulated among potential suppliers. Because the technical orders were routinely released to others, the Center took precautions to ensure that the technical orders did not contain proprietary information.

The Center was also aware of the history of cold expansion. They knew that Boeing developed the technology and licensed the product to both FTI and WCI. The qualification to build the tools was implicit in the licensing agreement. The tools had to conform to Boeing's specifications and had to meet the quality assurance checks for material delivered to the plant.

In the absence of military standard documents or specifications, the Center used as its design documents technical order 1B-52G-3, and Boeing's process specification 5973. While technical order 1B-52G-3 specifically referred to tools made by FTI, the technical order was designed as a general specification with generic tool sizes. Center personnel showed us FTI certifications that the information contained in the technical order was not proprietary. No evidence was found that the Center released proprietary technical data belonging to FTI to the competitor WCI.

In the absence of military specifications and documents, Center's reliance on Boeing's technical orders and procedures was correct. The Center knew that Boeing was the original developer of the technology. The Center was also aware that Boeing's practice was to treat technical requirements for tools differently from the technical requirements used to qualify the manufacturers of parts that will be used on the aircraft. Parts used on the aircraft were subjected to a process of formal qualification, whereas tools used to build the aircraft were not. Tools were manufactured to Boeing Aircraft specifications and subjected to quality checks on delivery.

Prior to the procurement of depot kits and field kits, the Center requested copies of Boeing's service manuals for commercial aircraft. These service manuals cited tools made by both FTI and WCI. Center personnel provided us with copies of the portions of the structural repair manuals for the B-707, B-727, and B-737 aircraft, all of which mention WCI.

Use of a Pre-Award Survey by the Center

Another element of the qualification for a second source of cold expansion tool kits was the use of a pre-award survey by the Center. At the request of the Center, Defense Logistics Agency personnel visited the WCI plant in Seattle, Washington, and reviewed the quality assurance procedures. Defense Logistics Agency personnel also examined WCI's financial records. All were found to be satisfactory. A pre-procurement estimate of savings was calculated and was based on an analysis of the cataloged prices of the tool kits from WCI and FTI.

Based on the results of the pre-award survey and the results of the competitive bids for the 70 field kits, the contract was awarded to WCI. The reported savings on the procurement was \$1 million.

Safety of Flight and the Process of Cold Expansion

It was alleged that the use of WCI's tool kits by the Air Force compromised the safety of flight of repaired aircraft. We found that the main determinant of the safety of flight is the quality of the work performed by the aircraft maintenance staff, both engineers and technicians.

An engineer is necessary, because cold expansion demands forethought about the areas of the aircraft that would benefit from the process. Very frequently the cold expansion needs to be integrated into other repair work done on the airframe structure. An engineer selects the specific holes on which to perform the cold expansion, then writes the process sheets detailing the tools to be used and the fasteners to be replaced.

The technician's role in the quality of the cold expansion process working is also important because visual inspection alone cannot ascertain whether the work has been done properly. As a result, cold expansion processing demands the technician select the proper size tools and frequently check the dimensions of the tooling and holes during the process. Both FTI and WCI supplied manuals describing the tool selection process and the quality checks to be performed. Once a hole had been cold expanded and a fastener inserted, only a complete teardown of the original work could determine if the cold expansion process was done properly.

For example, our visit to the Center included an inspection of a B-52 aircraft under repair. The scope of cold expansion ranged from areas of nine holes to areas of thousands of holes on parts of the aircraft structure. Cold expansion was part of the structural repairs planned by the engineering staff and performed by the aircraft maintenance technicians. Interviews with both the engineering staff and technical staff revealed no problems with the tooling supplied by either FTI or WCI. With the proper quality checks and the amount of cold working that was done on areas of the aircraft, differences in quality of tooling have not shown themselves on the flight line.

Technical Qualifications of Second Source of Cold Expansion Tooling by the Oklahoma City Air Logistics Center

Following our inspection of the repair area, we held further discussions with Center engineering and maintenance personnel about the quality of products offered by FTI and WCI. The staff told us that FTI made fine tools that have been problem-free over the years. Although experience with WCI's products was more limited because WCI was a new supplier of complete tool kits, to date the Center's personnel reported that no problems have been encountered.

Because FTI was the only supplier of countersink nose caps, any reworking of countersink holes required the use of FTI tooling.

FTI's corporate officials and engineers contended that the FTI tool kits were not interchangeable with those of WCI tool kits, therefore, WCI tool kits should not be purchased. Although Center engineering personnel had witnessed a demonstration of interchangeability in December of 1991, our observations of the cold expansion process led us to conclude that the interchangeability issue was moot, because in the aircraft maintenance work, the components of tool kits were not normally interchanged. At the Center, each manufacturer's tools were stored separately in cabinets containing the tool kits. The technician first referred to the technical order to select the proper size tool kit. The technical order in turn directed the technician to a set of manuals which were stored in the cabinets. The manuals directed the technician to the exact tool kits to be used. Due to different nomenclature used by FTI and WCI for determining dimensions and tolerances in the technical manuals, great care needed to be exercised in switching the tool kit components of FTI and WCI.

Conclusion

The decision by Center officials to purchase tools from WCI was proper. The Center verified the technical qualifications of WCI in a number of ways. Considerable time and effort went into assuring that WCI as a supplier was able to meet the Center's cold expansion tool kit requirements. Safety of flight for repaired aircraft was not compromised by using WCI's tool kits. In addition, the Center did not provide FTI's proprietary technical data to WCI.

Part III - Additional Information

Appendix A. Chairman Gorton's Request, January 12, 1993

SLADE GORTON
WASHINGTON
730 HART SENATE OFFICE BUILDING
(202) 224-3441
TOLL FREE ISSUES HOTLINE
1-800-282-8098
TDD 202-224-8273

United States Senate
WASHINGTON, DC 20510-4701

COMMITTEES:
APPROPRIATIONS
COMMERCE, SCIENCE,
AND TRANSPORTATION
ETHICS
INDIAN AFFAIRS
INTELLIGENCE

January 12, 1993

Derek J. Vander Schaaf
Acting Inspector General
U.S. Department of Defense
400 Army Navy Drive, Room 1000
Arlington, Virginia 22202

Dear Mr. Vander Schaaf:

My constituents, Bruce F. Gibson and Len Reid of Fatigue Technology Incorporated (FTI) have contacted me regarding Department of the Air Force contract procurement. A copy of my constituent's correspondence is enclosed for your information.

I recently contacted the Office of the Secretary of the Air Force on behalf of FTI and received the enclosed response. My constituent's have contacted me again with their rebuttal to this response.

From what I have learned, Fatigue Technology Incorporated developed technology and holds several patents for Cold Expansion Kits specifically designed to enhance the fatigue life of B-52 and KC-135 aircraft. Recently, FTI lost a contract from The Directorate of Contracting at Oklahoma City Air Logistics Center, Tinker Air Force Base, Oklahoma for Cold Expansion Kits.

Fatigue Technology Incorporated disputes this loss of contract and sights specific, safety-related issues to support their position. Mr. Gibson and Mr. Reid are particularly concerned with the Air Force's contention that FTI Cold Expansion Kit tooling is interchangeable with West Coast Industry's tooling.

In their correspondence, FTI executives point out that their company has been developing and testing the Cold Expansion process and tooling for six years. Mr. Gibson and Mr. Reid claim that no drawings or specifications for FTI tooling have ever been released; therefore, the tooling procured by the USAF in this contract is not identical to or interchangeable with FTI tooling. In addition, three Freedom of Information Act Requests made by FTI provided no evidence that West Coast Industries tooling has ever been formally tested.

3306 JACOBSON FEDERAL BUILDING
918 SECOND AVENUE
SEATTLE, WA 98114
(206) 563-0350

130 FEDERAL BUILDING
600 WEST 12TH STREET
VANCOUVER, WA 98660
(206) 986-7838

897 U.S. COURT HOUSE
W. 820 RIVERBEND AVENUE
SPOKANE, WA 99201
(809) 363-2607

MOORE BUILDING, ROOM 118
23 SOUTH WENATCHEE AVENUE
WENATCHEE, WA 98801
(809) 683-2118

PRINTED ON RECYCLED PAPER

In light of these facts, my constituents are very concerned about the safety of the tooling procured by the United States Air Force in the contract in question.

I would appreciate your further review of this matter, with specific attention to the safety concerns sighted. Please direct a reply to me in care of Susan Wunderly in my Seattle office.

Thank you for your prompt attention to this request.

Sincerely,



SLADE GORTON
United States Senator

SG:zsw
Enclosures

Appendix B. Activities Visited or Contacted

Department of the Air Force

Air Force Materiel Command, Wright-Patterson Air Force Base, OH
Oklahoma City Air Logistics Center, Tinker Air Force Base, OK
Ogden Air Logistics Center, Hill Air Force Base, UT

Non-DoD Federal Organizations

Fatigue Technology, Incorporated, Seattle, WA
West Coast Industries, Incorporated, Seattle, WA
Boeing Aircraft, Seattle, WA

Appendix C. Report Distribution

Department of the Air Force

Assistant Secretary of the Air Force (Financial Management and Comptroller)
Commander, Air Force Materiel Command
Commander, Oklahoma City Air Logistics Center

Non-DoD Federal Organizations

U. S. General Accounting Office
Senator Slade Gorton, U.S. Senate

Team Members

**Michael G. Huston
Kenneth H. Stavenjord
Gregory R. Donnellon
Erogers Stinson
Jacob E. Rabatin**

**Director
Technical Director
Project Manager
Procurement Analyst
General Engineer**