

Appendix I: Curatorial Care of Archeological Objects

A. Overview	I:1
A. What is an archeological object?.....	I:1
What does this appendix cover?	I:2
What makes archeological objects different from other materials commonly found in museum collections?	I:2
How can I minimize deterioration of archeological objects?	I:3
B. Handling and Cleaning of Archeological Objects	I:3
B. How should I handle the objects?.....	I:3
How should I clean the artifacts in museum collections?	I:4
C. C. Storage Conditions for Archeological Objects	I:4
How should I organize archeological collections in storage for best preservation?	I:4
What are the environmental requirements?.....	I:5
What are the storage requirements for each of the three levels of climate sensitivity?	I:6
A. D.	Sto
Storage Techniques for Archeological Collections	I:7
What type of storage container should I use to store archeological objects?.....	I:7
D. Why is silica gel often used in archeological storage?.....	I:8
How should I cushion my objects?.....	I:8
How should I organize the box contents?	I:8
How do I keep track of what's in the box?.....	I:9
How do I protect and store larger archeological objects?	I:9
How should I store very weak and fragile objects?.....	I:11
How and when should I design special containers?	I:13
How should I store items subject to the Native American Graves Protection and Repatriation Act of 1990 (NAGPRA)?.....	I:13
E. Selected Bibliography	I:19

List of Figures

Figure I.1. Deterioration of Archeological Objects through Time	I:2
Figure I.2. Vertical Stacking of Small Objects within Standard Containers.....	I:7
Figure I.3. Organization and Layering of Objects within a Storage Box.....	I:9
Figure I.4. A Support Tray for Fragile Material.....	I:10
Figure I.5. Customized Support Blocks for a Fragile Glass Bottle to be Fitted in a Museum Specimen Tray.....	I:10
Figure I.6. Cavity Packing Technique for Small Objects.....	I:11
Figure I.7. Construction of a Cradle Mount for Objects with Round Bases	I:12
Figure I.8. Construction of a Portfolio Mount for Archeological Textile Fragments	I:14
Figure I.9. Recommended Storage Materials	I:15

APPENDIX I: CURATORIAL CARE OF ARCHEOLOGICAL OBJECTS

B. Overview

1. *What is an archeological object?*

Archeological objects are the result or product of an activity in the past that has been recovered from an archeological site. Archeological objects may have originated in the ancient past or quite recently. Depending upon the soil and climate of the site, a wide variety of materials may be excavated.

- ***Inorganic*** artifacts include:
 - metal
 - ceramics
 - glass
 - stone

- ***Organic*** artifacts include:
 - leather
 - basketry
 - textiles
 - modern plastics and other synthetics
 - bone
 - teeth

Archeological collections may also contain non-artifactual samples, such as botanical material, soils, pollen, phytoliths, oxylate crystals, snails, insect remains, and parasites.

While some individual archeological objects are found in NPS collections, the majority have been recovered as part of systematic archeological excavation. Preservation and care of individual objects must also consider the impact on the collection as a whole.

An important part of archeological collections are the associated archival records (for example, field notes, photographs, maps, digital documentation). For information on managing and preserving these archival records see *Museum Handbook*, Part II (*MH-II*), Appendix D: Museum Archives and Manuscript Collections and *Museum Handbook*, Part I (*MH-I*), Appendix J: Care of Paper Objects, Appendix M: Management of Cellulose Nitrate and Cellulose Ester Film, and Appendix R: Curatorial Care of Photographic Collections.

2. *What does this appendix cover?*

This appendix provides guidance only on the care of objects excavated from the ground. For guidance on collections from marine excavations, consult an archeological objects conservator with experience in the treatment of waterlogged materials. See Chapter 3: Preservation: Getting Started, Chapter 8: Introduction to Museum Object Conservation Treatment, and Conserve O Grams 6/1-6/6 for more information.

This appendix does not cover field treatment of objects when first excavated. Good sources of information on this topic include Sease (1987) and Watkinson and Neal (1998) listed in the references.

3. *What makes archeological objects different from other materials commonly found in museum collections?*

What makes archeological objects different is that at some point they were lost or abandoned and buried underground or in water.

The condition of these objects depends entirely on their reaction with the environmental conditions to which they have been exposed through time. Underground the object reaches a kind of equilibrium with the surrounding soil. Then, when the object is excavated, it must adjust to a new and radically different environment. Reactions can involve both physical and chemical changes. Regardless of the condition of the object before excavation, the moment it becomes exposed it is vulnerable to rapid deterioration. Figure I.1 illustrates the deterioration rate of archeological objects through time.

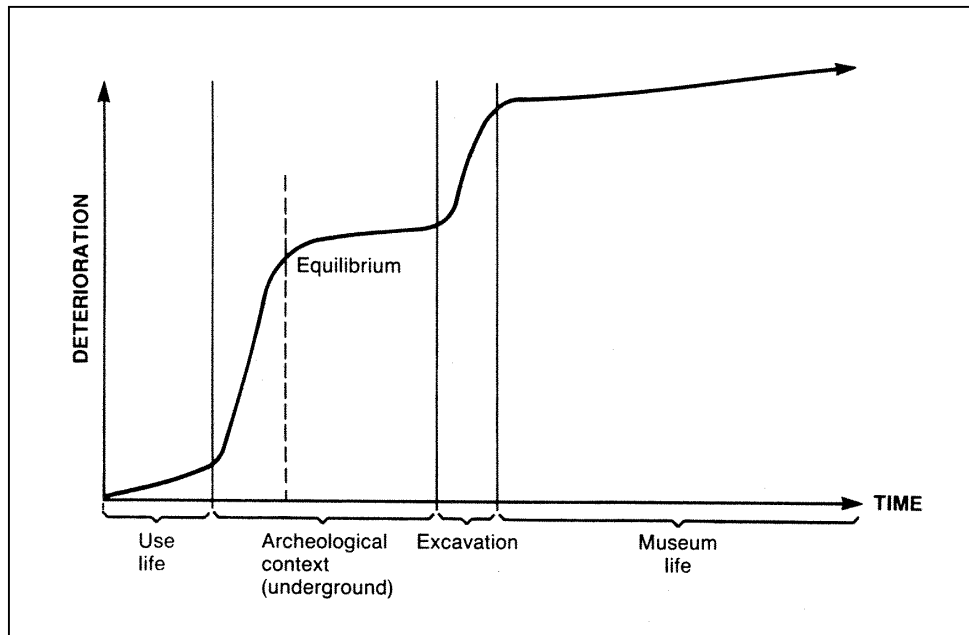

Figure I.1. Deterioration of Archeological Objects through Time

4. *How can I minimize deterioration of archeological objects?*

Preservation of archeological collections is a collaboration between archeologists, curatorial staff and conservators. Each person brings a different perspective and expertise to the problem. It is important to understand the concerns and needs of these other professionals when making decisions about how to care for archeological objects.

Preservation must begin in the field. Curatorial staff should work with archeologists depositing collections to make sure that preservation concerns are addressed during archeological procedures at the site and in the processing laboratory. Work with conservators both in the field and at the repository to ensure preservation choices are based on current research. Follow through with proper curatorial care in museum collections storage.

Refer to Director's Order #28 and Chapter 6: Management of Archeological Resources of the *Cultural Resources Management Guideline*, for guidance on the responsibilities of the archeologist before selecting a repository and depositing collections. See Director's Order #24, NPS Museum Collections Management, for park management's responsibility to ensure appropriate care and management of archeological collections.

C. Handling and Cleaning of Archeological Objects

1. *How should I handle the objects?*

Because the research value of archeological material may be lessened or destroyed by unnecessary handling and inappropriate treatment, preservation of these materials should be based on preventive care. Careful handling, packaging, and storing of archeological objects are crucial for the survival of the material as an artifact. Mishandling and storage will encourage deterioration and can reduce the material to nothing more than powder.

Archeological objects can have a deceptive appearance of strength when first uncovered. All excavated materials have undergone some form of alteration during the equilibration process underground and during the recovery process. This alteration has physically weakened the object. While underground, objects are supported by the surrounding soil, and when excavated, they may be unable to support their own weight. For this reason, archeologists and conservators often use specialized lifting techniques to excavate fragile and potentially fragile objects. During and after excavation, continue to support these objects on a tray or pallet or in a container that distributes weight properly.

An archeological object must always be fully supported. Use both hands, a tray, or a supporting container to lift and carry an object, whether it is large or small. Always assume that an excavated object is weak.

Review the guidelines for handling museum objects in Chapter 6: Handling, Packing, and Shipping Museum Objects.

2. *How should I clean the artifacts in museum collections?*

Cleaning of archeological material should be kept to a minimum. The cleaning process may destroy important archeological evidence such as surface decorations and composite or associated materials that often exist only as impressions on the surface of the object or in the surrounding soil. Original surfaces of metal objects may lie within layers of corrosion. Evidence of use (for example, food residue in containers, pigment traces on stone palettes, or blood traces on stone projectile points) may be removed by unnecessary cleaning.

Cleaning may also interfere with scientific analysis. For example, the use of acid to remove deposits on ceramics may also remove acid-soluble compounds in the ceramic paste and as a result, invalidate compositional analysis used to determine the prehistoric source of clay. See *Conserve O Gram* 6/6, "Long-term Effects of Acid-Cleaning Archeological Ceramics." Water can also remove amino acid traces used to date bone. Washing may also hasten deterioration of salt-contaminated material and can be disastrous to metal objects if they are not carefully and completely dried afterward.

Avoid any treatment that alters the chemical or physical integrity of the artifact. Don't risk losing valuable information or inflicting irreversible damage.

Once an object has reached the repository and is in curatorial care, remove only loose dust and dirt by dry brushing or vacuuming. ***Don't*** wash the object and ***don't*** apply pressure. The surface of an archeological object is often fractured or friable and may be easily dislodged by rubbing. Carefully assess an object's surface ***before*** you start to clean it. If additional cleaning, stabilization, or repair is necessary, consult an experienced conservator.

D. Storage Conditions for Archeological Objects

1. *How should I organize archeological collections in storage for best preservation?*

Archeological collections are often large and contain a variety of materials with different environmental storage requirements and with different research values. Physical organization of the collections by research values, such as source or cultural affiliation, will not necessarily meet preservation needs. It is better to organize the materials by environmental requirements and maintain the research integrity of the collection through good museum records.

Ideally, all archeological objects should be stored in climate-controlled areas, but this often is not practical. Most archeological collections are large and not all storage facilities have enough climate-controlled storage space to house entire collections. In such cases, it is possible to maximize preservation while minimizing utility costs by implementing a storage strategy based on the environmental requirements of various archeological materials.

2. *What are the environmental requirements?* See the chart below for a system to organize archeological material by environmental sensitivity.

Organization of Archeological Material	
<i>Level I: Negligibly climate-sensitive materials</i>	
<p>Materials:</p> <ul style="list-style-type: none"> • stable stone and fired ceramics • stable inorganic architectural materials (plaster, mud, daub, brick, and stone) • dry pollen, flotation, and unprocessed soil samples • faunal remains 	<p>Required Climate: Gradual daily and seasonal fluctuations of temperature and relative humidity can be tolerated.</p> <ul style="list-style-type: none"> • Relative Humidity: Above 30% and below 65%. Mold may become a problem above 65%. • Temperature: Freezing to 100°F. Moderate and cool temperatures are preferred. High temperatures increase deterioration of all materials.
<i>Level II: Climate-sensitive materials</i>	
<p>Materials:</p> <ul style="list-style-type: none"> • stable metal • stable glass • worked bone, antler, and shell • botanical specimens • textiles • wood • skin, leather, and fur • feathers and horn • natural gums, resins, and lacquer • human remains 	<p>Required Climate:</p> <ul style="list-style-type: none"> • Relative Humidity: Determine a stable point based on the object's environmental history and current regional climate. If the materials will be stored near the collection site, you may follow these guidelines. 30-40%--semi-arid areas and deserts 40-50%--central and eastern plains and woodlands 45-55%--seacoast and lakeshore <p>Keep conditions as stable as possible. Many organic materials are more sensitive to fluctuations of relative humidity than to any one unchanging level in the moderate range. Do not allow daily fluctuations of more than 3%. From summer to winter, keep the change to no more than a slow 10% drift.</p> <ul style="list-style-type: none"> • Temperature: Above 50° F and below 75° F. You may adjust the temperature slightly to control the relative humidity, but do not exceed changes of 5° daily.
<i>Level III: Significantly climate-sensitive materials</i>	
<p>Materials:</p> <ul style="list-style-type: none"> • unstable (salt-contaminated) ceramics, stone, and bone • unstable glass (glass that appears damp or "weeping") • unstable metal, particularly iron • mummified human and animal remains • composite objects (objects made of several different materials) 	<p>Required Climate:</p> <ul style="list-style-type: none"> • Relative Humidity: Keep the RH within the restricted range determined by the object's composition and condition. Follow these guidelines. <ul style="list-style-type: none"> – metal—under 30%. Unstable iron is best stored below 15%. – unstable glass—30% to 40% – naturally mummified animal remains—15% to 20% – unstable ceramics, stone and bone (salt contaminated)—below 50% (<i>Note:</i> Keep the RH as steady as possible to avoid damage by the hydration cycling of soluble salts.) • Temperature: Choose a point between 60° and 72° and keep the temperature steady. Allow it to fluctuate only enough to keep the RH in check.

3. *What are the storage requirements for each of the three levels of climate sensitivity?*

Each level of climate sensitivity requires a different type of storage.

- **Level I:** General storage for Level I materials should meet the *minimum* overall standards for all NPS storage spaces as outlined in Chapter 7: Museum Collections Storage.

- Store materials that do not need special attention in boxes on open shelves.
- Store loose material, including the following, in bags within boxes:
 - bulk botanical specimens
 - unprocessed soil samples
 - dry pollen and flotation samples
 - slag
 - unworked bone
 - lithic cores and debitage
 - ceramic sherds

Make sure the bags are strong and will not tear or puncture. Bags made of Tyvek®, a strong spun polyethylene plastic that allows water vapor to escape, are a good choice. Canvas bags and resealable polyethylene bags can also be used.

- **Level II:** Climate-controlled storage for Level II materials should comply with the *optimum* standards for NPS storage areas as outlined in Chapter 7.

If your park has no currently available area where the environment can be controlled, consider putting up a prefabricated, climate-controlled structure. See *Conserve O Gram* 4/7, “Museum Collection Storage Space: Is an Insulated Modular Structure Right for your Collection?” Consult your regional or support office curator, conservators specializing in environmental or preventive conservation, or the Museum Management Program for guidance in developing an acceptable storage area.

- **Level III:** Microclimate storage for some Category III materials can be created within the climate-controlled storage area used for Category II materials.
 - Place objects requiring an extremely stable environment within a closed well-gasketed museum cabinet that will shield them from even slight fluctuations in relative humidity.
 - Place metals and unstable glass, which require a relative humidity quite different from other objects in storage, in tightly sealed boxes with moisture-sensitive materials called *sorbents*. Sorbents, such as *silica gel*, buffer the interior of the container against changes in the relative humidity of the enclosed objects.

E. Storage Techniques for Archeological Collections

1. *What type of storage container should I use to store archeological objects?*

There are many different types of standard boxes and bags that are appropriate for general storage. **Note: These are not for microclimate storage.** See Chapter 4 for information on microclimate storage.

- Use acid-free boxes with lids rather than self-closing boxes with flaps that will wear out over time.
- Store small objects like lithic points and nails in boxes manufactured for the storage of archival and photographic collections.
- Use small resealable polyethylene bags for individual specimens and stack them vertically within each section of the box. You can staple them to acid-free index cards to make them easier to stack. If the objects are not numbered, include an acid-free tag with an identification number inside each bag and also be sure to write the number on the outside of the bag or on the card.

See Figure I.2. Note the easy visual access and consistent packaging technique illustrated. Never wrap objects in padding material. Wrapping and unwrapping requires excessive handling.

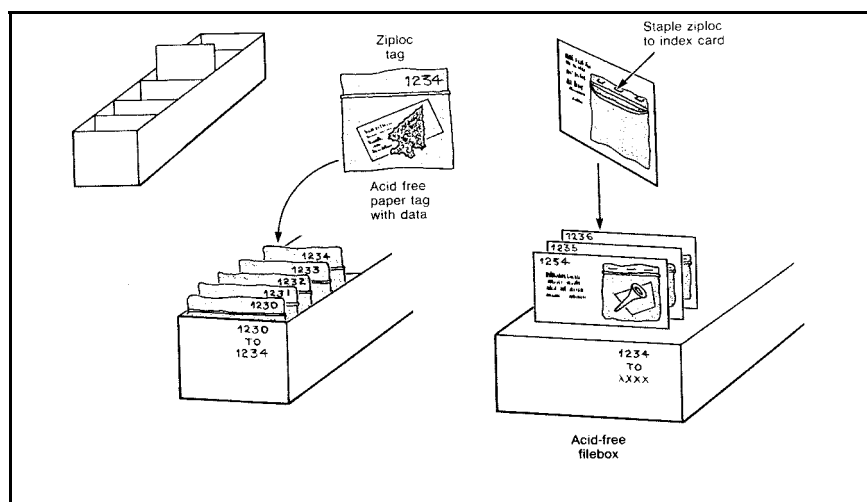

Figure I.2. Vertical Stacking of Small Objects Within Standard Containers

2. *Why is silica gel often used in archeological storage?*

Archeological objects are often unstable and very sensitive to changes in relative humidity. Silica gel can moderate fluctuations in relative humidity within a closed container.

Silica gel is inert, amorphous silicon dioxide in a porous granular form that is able to adsorb moisture from the air. It can adsorb 30-40% of its dry weight and responds more quickly than other sorbents to variations in relative humidity. The gel rapidly senses, corrects, and stabilizes fluctuations in relative humidity by humidifying or dehumidifying the air around it to maintain its own preferred environment. See Chapter 4: Museum Collections Environment, for information on use of silica gel in microclimates.

3. *How should I cushion my objects?*

Use padding material to prevent the contents of a container from shifting when it is moved. Be careful not to overstuff the box with crumpled tissue or other padding material that could exert damaging pressure on fragile objects. Use either of these cushioning techniques:

- Make smooth pillows to place against the surface of the object by folding wadded acid-free *unbuffered* tissue paper within loose rolls of tissue. Wrapping the crumpled tissue will keep it from expanding and exerting pressure.
- Fill resealable sandwich-sized polyethylene bags with cotton.

Don't use cotton or polyester wool alone. Cotton is an excellent sorbent and may hold moisture directly against the object. Fibers from these materials may snag and damage delicate artifacts.

4. *How should I organize the box contents?*

Organize your artifacts so that each object can be easily retrieved without disturbing the rest. One technique is to layer your items. If they are small and lightweight, they can be organized into three or four layers separated by specimen trays within your storage box. Specimen trays make lifting safer. Cushion each layer with a sheet of stable polyethylene foam shelf liner. See Figure I.3. Museum supply companies manufacture acid-free boxes with fitted trays equipped with adjustable interior compartments. These are ideal for the storage of archeological material.

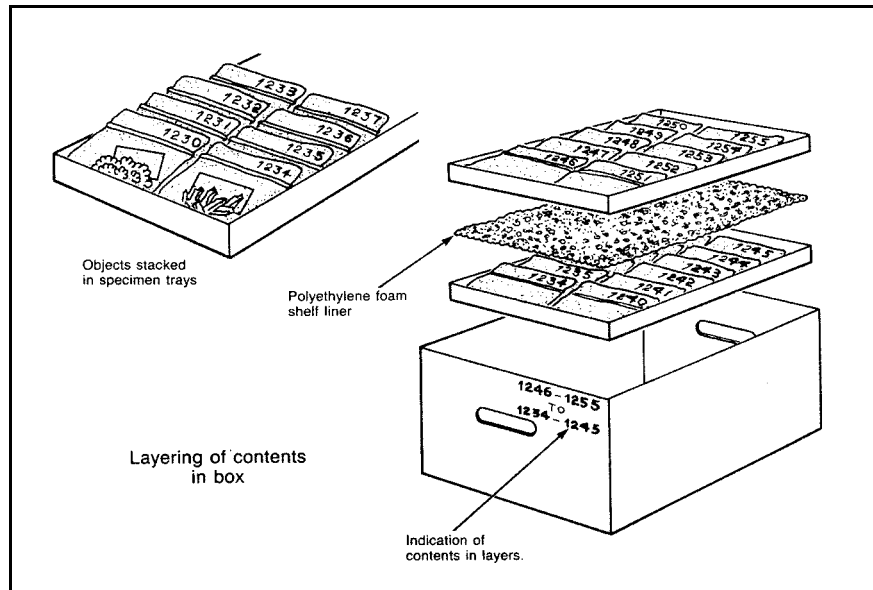

Figure I.3. Organization and Layering of Objects within a Storage Box

5. *How do I keep track of what's in the box?*

Make an inventory:

- First, make sure that the identification numbers you have written on each bag show clearly.
- Next, label the outside of the box with the numbers by layer.
- Prepare a more detailed list of the contents and place it in the box on top of the contents.

6. *How do I protect and store larger archeological objects?*

If the objects are too large for standard specimen trays, you can make custom trays from padded, acid-free board fitted with cotton twill-tape handles. See Figure I.4 for an illustration. There are many acid-free boards, including matboard, cardboard, foamboard, and honeycomb board, that can be used to make support trays. Make sure you select a board heavy enough not to bend under the weight of the object. Tie the object to the tray with cotton twill tape to keep it from sliding.

Use rigid polyethylene foam to make tray supports and trays with cavities for fragile three-dimensional objects. You can easily cut large blocks of foam with an electric carving knife and thin sheets with a sharp X-acto knife. Figure I.5 illustrates the use of rigid polyethylene foam blocks to support a fragile bottle. Figure I.6 shows the cavity-packing technique to restrict the movement of smaller, rounded items. Cavity-packing is an excellent way to store objects that are moved periodically for research. Make sure that the fit of the object in the cavity is not too tight and that the object may be safely removed from the tray. The cut edge of the rigid foam block can be abrasive so use thin, soft, polyethylene foam (like Volara®) for objects with fragile surfaces. If necessary, carve a finger grip on each side of the object to make grasping easier.

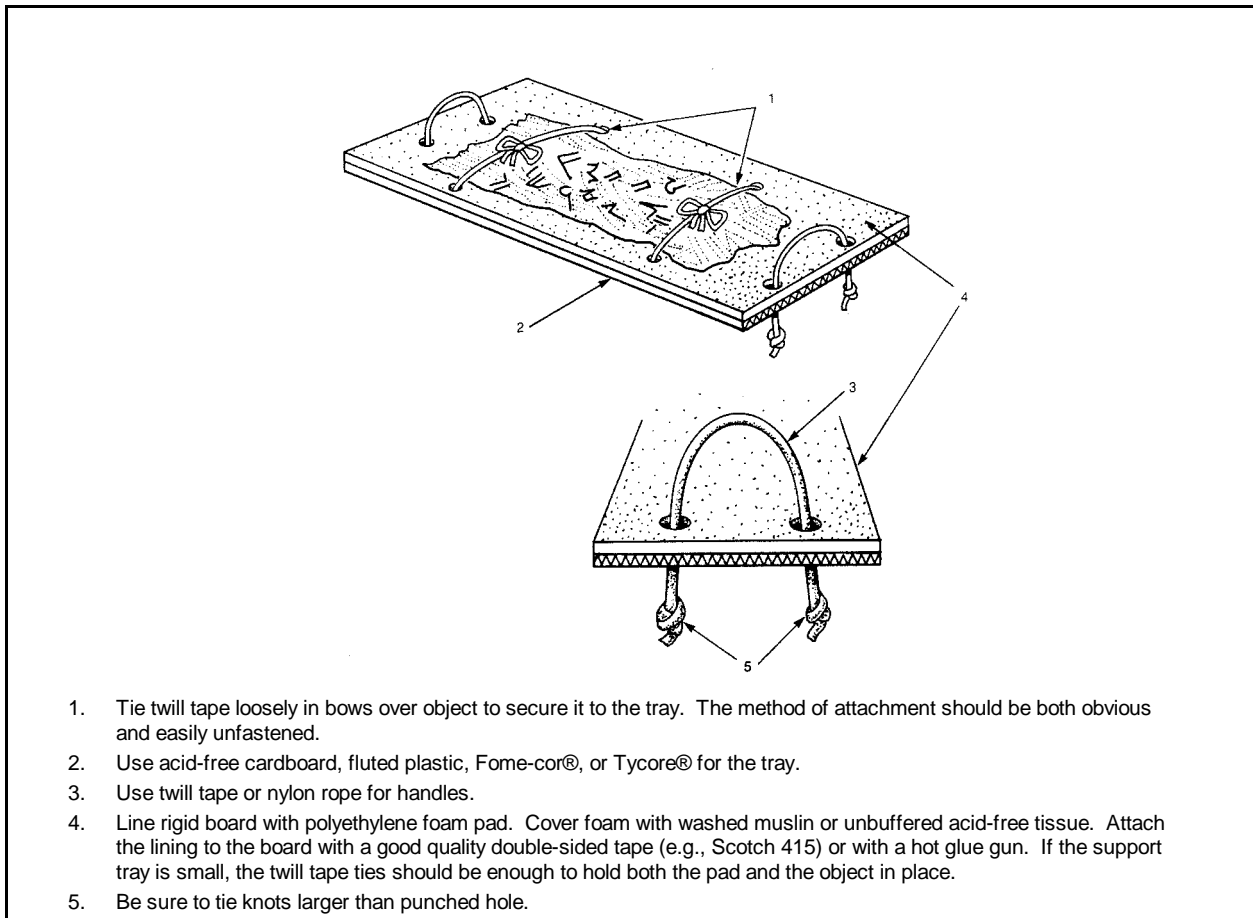

Figure I.4. A Support Tray for Fragile Material

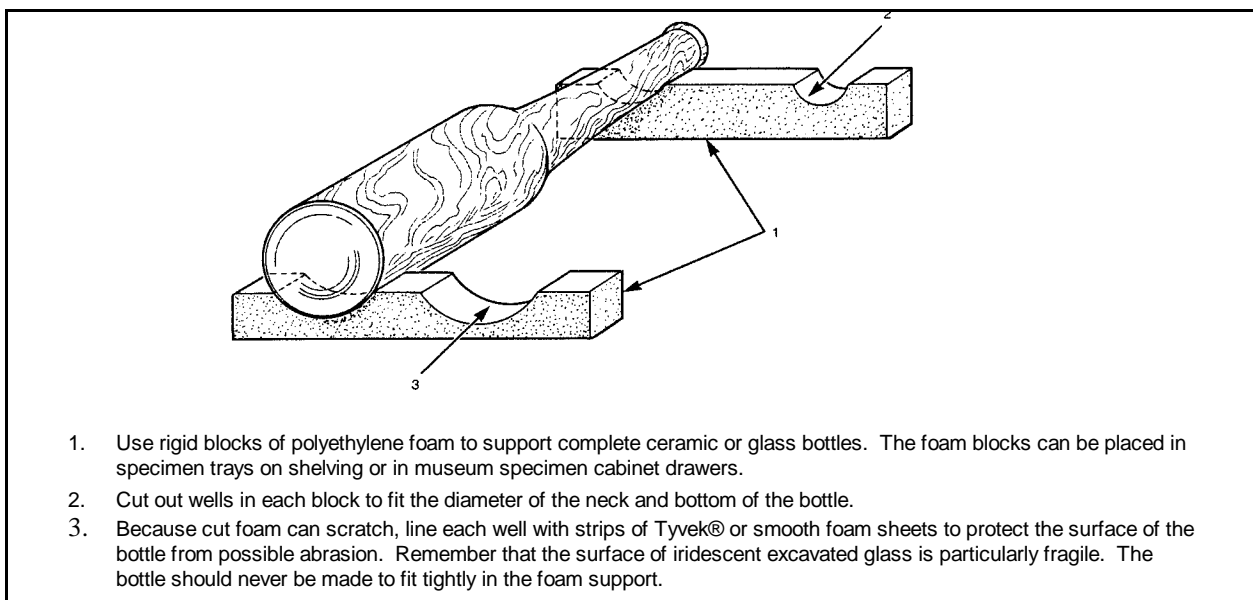

Figure I.5. Customized Support Blocks for a Fragile Glass Bottle to be Fitted in a Museum Specimen Tray

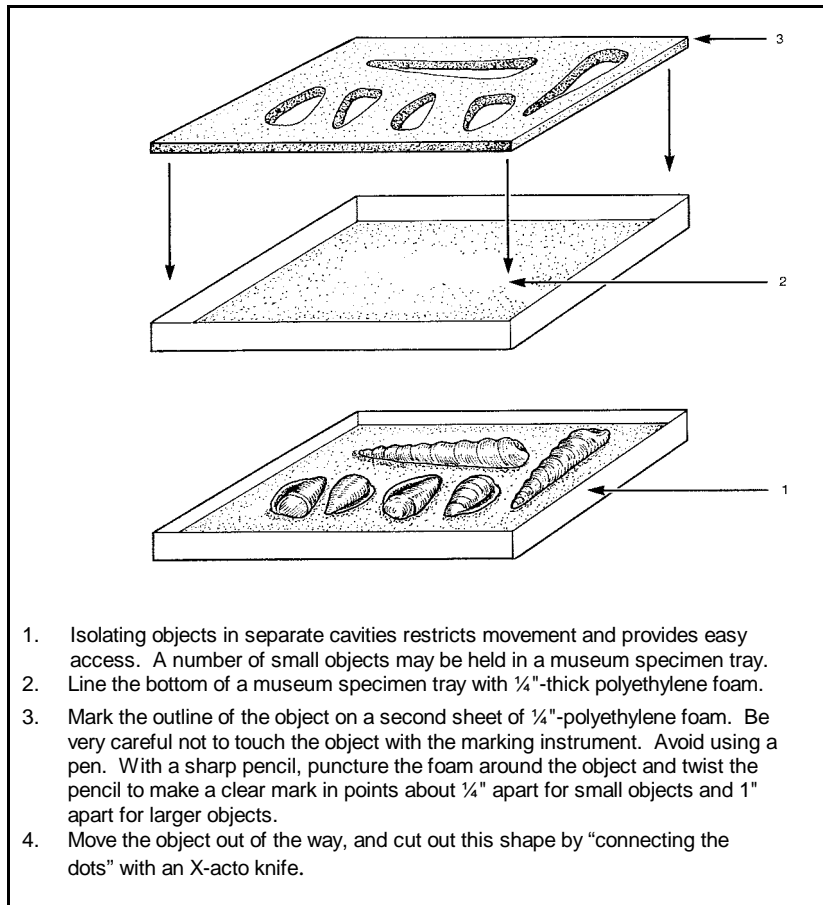

Figure I.6. Cavity Packing Technique for Small Objects

7. *How should I store very weak and fragile objects?*

Archeological objects that are weak from deterioration may require specialized supports to maintain their structural integrity. Before designing a special mount, evaluate the object's strong and weak structural points. Determine:

- what the object is
- how it was used or worn
- how it was made

For example, cone-shaped baskets, worn like backpacks, were used to carry heavy objects. Load stresses were distributed down the sides of the basket and concentrated in the bottom. Though the rim is the weakest part of these baskets, they are frequently, but incorrectly, stored upside down like traffic cones.

A good storage mount takes into account the *form* and *function* of the object and eliminates stress on the weakest parts. A cradle mount like the one illustrated in Figure I.7 will evenly distribute the weight of an object with an unstable base while keeping it upright as originally used.

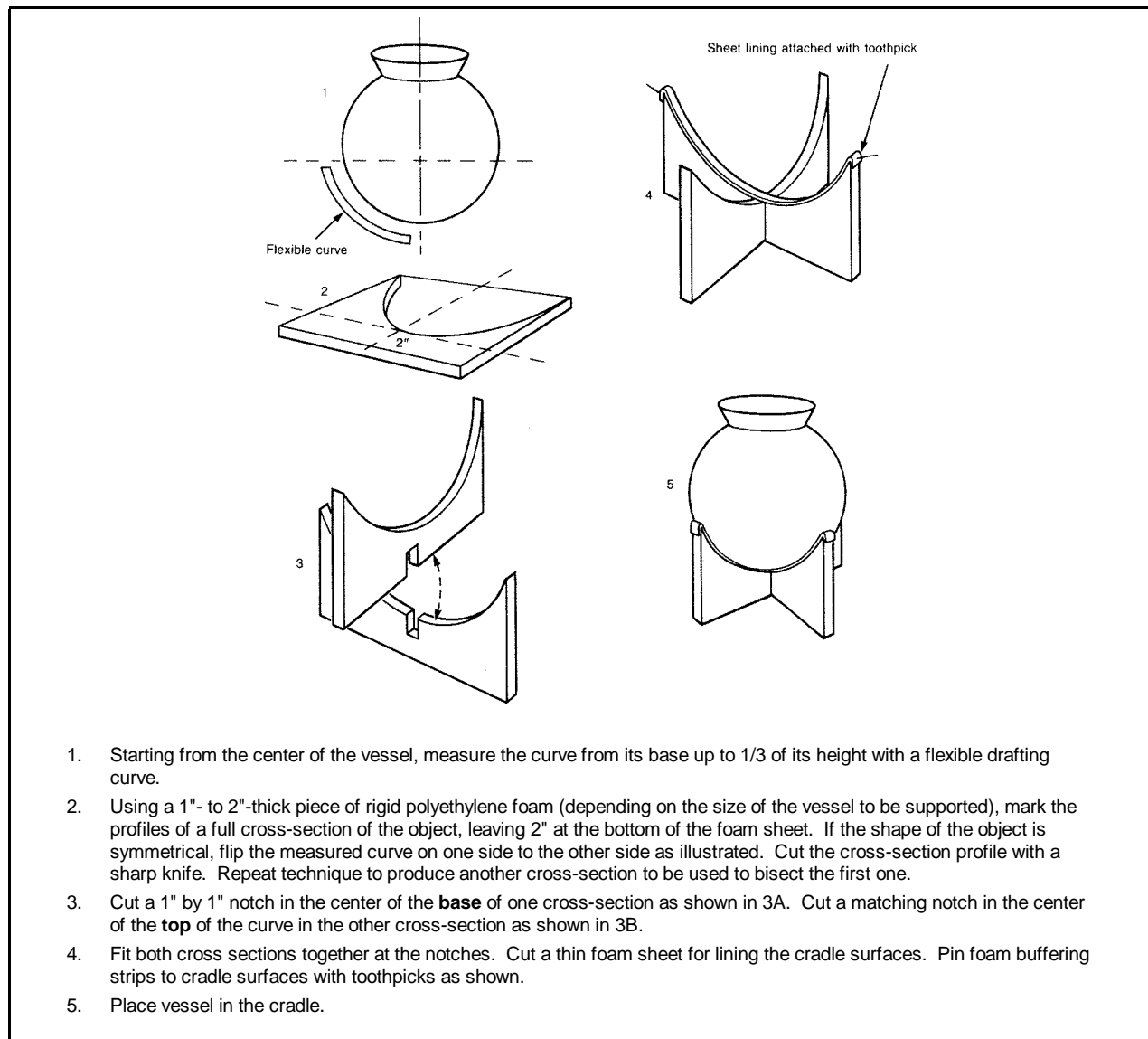

Figure I.7. Construction of a Cradle Mount for Objects with Round Bases

8. *How and when should I design special containers?*

When making a special box or storage container for an archeological object, keep these things in mind.

- Protect the object from dust and light.
- Provide it with good support.
- Allow researchers maximum visual access.
- Discourage any handling of the object.

In the case of a textile fragment, for example, a researcher will want to examine both sides. The container must permit close examination of the contents, but minimize the need to actually handle the object. A portfolio mount, illustrated in Figure I.8, is a good solution to this problem. This technique can also be used to store other flat objects like basketry fragments, thick cordage, and other fragile materials. Adjust the thickness of the interior mat to accommodate the dimensions of the object, avoiding any unsafe pressure or crushing of brittle elements.

Boxes for other types of artifacts should have a drop front so that the tray supporting the item can be slid out onto a stable surface. An accident is more likely to happen if the object must be lifted up and out through the top.

You may need to provide special containers and mounts that will protect fragile, unstable, and top-heavy objects during an earthquake.

There is much published information containing instructions for building specialized storage mounts. Two very good references are *Storage of Natural History Collections: Ideas and Practical Solutions* (Rose and de Torres, 1995) and *Working with Polyethylene Foam and Fluted Plastic Sheet* (Schlichting, 1994).

To help you select stable materials for constructing containers and mounts for storage see *Materials for Exhibit, Storage, and Transportation and Packing* (Tétreault and Williams, 1992) and “Guidelines for Selecting Materials for Exhibit, Storage, and Transportation” by Jean Tétreault, available on the Web at <http://www.cci-iic.gc.ca/frameset_e.shtml> under Conservation Information.

9. *How should I store items subject to the Native American Graves Protection and Repatriation Act of 1990 (NAGPRA)?*

Your park’s archeology collection may contain NAGPRA-related items such as human remains, associated funerary objects, unassociated funerary objects, sacred objects, and objects of cultural patrimony. These collections should be housed and handled with great sensitivity. You may need to store NAGPRA items separately from other collections and limit access to them.

Consult with the lineal descendants, culturally affiliated Indian tribes, Native Alaskan villages or corporations, or Native Hawaiian organizations to ascertain their preferences related to storage techniques and materials. You may need to use alternative storage methods and materials in response to these consultations. See Chapter 7: Museum Collections Storage, for additional information concerning consultation and storage of NAGPRA collections.

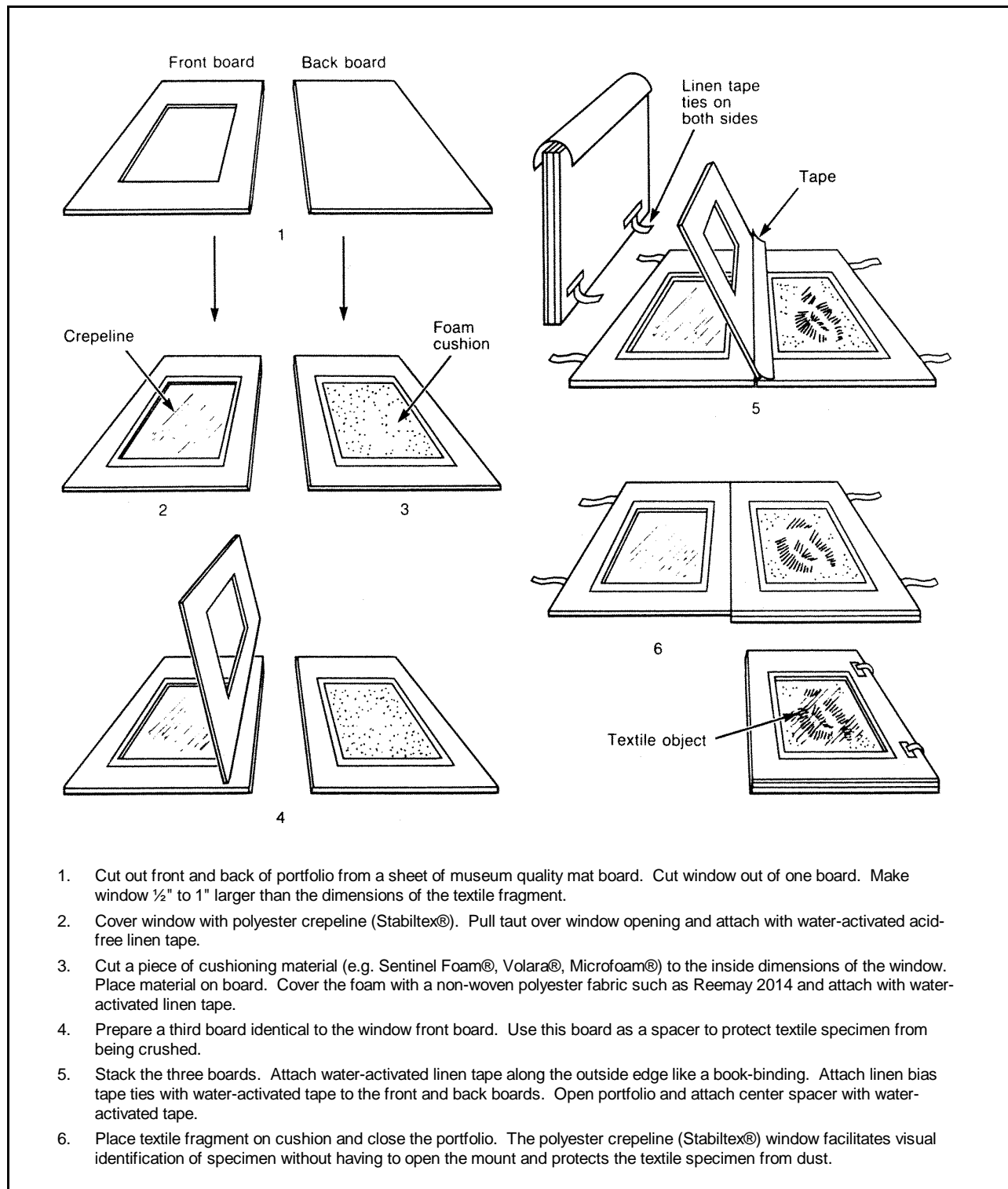

Figure I.8. Construction of a Portfolio Mount for Archeological Textile Fragments

Recommended Storage Materials

Bags

Use:	Don't Use:
<ul style="list-style-type: none"> • Resealable polyethylene bags (Ziploc®, Baggies®, Whirl-pak®) • Spun polyethylene bags (Tyvek®) • Bags made from heat-sealable clear plastic laminate film 	<ul style="list-style-type: none"> • Kraft lunch bags • Waxed paper • Envelopes <p>None allow visual inspection and all are made from unstable materials. Waxed paper may leave a coating on the object.</p>

Padding

Use:	Don't Use:
<ul style="list-style-type: none"> • Acid free tissue • Cotton or polyester batting in plastic or muslin bags • Polyester felt • Bubble-pak or air-cap 	<ul style="list-style-type: none"> • Loose cotton <p>Brittle materials may snag on the loose fibers. Cotton will almost certainly leave lint on the objects.</p> <ul style="list-style-type: none"> • Paper towels or facial or toilet tissue <p>Papers are not durable and contain impurities.</p> <ul style="list-style-type: none"> • Newspaper <p>Newsprint smears easily and may leave ink on objects. Newspaper is also very acidic.</p> <ul style="list-style-type: none"> • Excelsior <p>Material is very acidic.</p> <ul style="list-style-type: none"> • Vermiculite <p>Substance generates dust that not only is difficult to remove, but also hazardous to museum workers</p>

Figure I.9. Recommended Storage Materials

Plastic Foams	
Use:	Don't Use:
<ul style="list-style-type: none"> • White polyethylene closed-cell foam (Polyfoam) • Crosslinked polyethylene foam (Plastazote®, Volara®) • Ethylene/vinyl acetate copolymers (Evazote®, Volara®) • Extruded plank polystyrene (Styrofoam) • Polypropylene closed-cell foam (Microfoam) 	<ul style="list-style-type: none"> • Blue polyethylene foam (fire retardant) Fire retardant additives can migrate to materials. • Pink polyethylene foam (antistatic) Conductor in foam absorbs water from the air and can become soapy. • Chlorinated or nitrated plastic (for example, PVC–polyvinyl chloride) Plastic outgases hydrogen chloride, which can become hydrochloric acid. • Polyurethane This is unstable and may offgas harmful products.

Clear Plastic Sheets	
Use:	Don't Use:
<ul style="list-style-type: none"> • Polyethylene terephthalate clear polyester (Mylar®) • Clear polyester and fluorocarbon laminate (Film-O-Wrap®) • Clear polyester/polyolefin laminate (Scotchpak®) 	<ul style="list-style-type: none"> • Polyvinylidene chloride (for example, Saranwrap®) PVC is unstable, chlorinated plastic. • Cellophane Sulphuric acid used in manufacturing process generates acidic by-products.

Figure I.9 Recommended Storage Materials (continued)

Boards	
Use	Don't Use
<ul style="list-style-type: none"> • Acid-free mat board • Acid-free corrugated board • Acid-free Fome-Cor® (International Paper Co.); extruded polystyrene with polystyrene skin • Honeycomb boards <ul style="list-style-type: none"> – acid-free rigid paperboard (Tycoré®) – aluminum-board (Hexcel Honeycomb®) • Corrugated polypropylene boards (Cor-X®, Coroplast®) • Double-walled polycarbonate (Lexan®) 	<ul style="list-style-type: none"> • Regular cardboard or matboard <p style="margin-left: 20px;">Non-archival cardboard and matboard are acidic.</p> <ul style="list-style-type: none"> • Urea formaldehyde impregnated paper laminated panel board (Gatorfoam®)

Tape/Ties	
Use	Don't Use
<ul style="list-style-type: none"> • Water-activated paper or linen tape • Cotton or polyester twill tape 	<ul style="list-style-type: none"> • Pressure sensitive tapes, including: <ul style="list-style-type: none"> – cellophane – masking – strapping – duct – electrical <p style="margin-left: 20px;">The adhesive degrades and the carrier peels off leaving residues and stains.</p> <ul style="list-style-type: none"> • Rubber bands <p style="margin-left: 20px;">Rubber degrades and sticks to the surface.</p>

Figure I.9. Recommended Storage Materials (continued)

Fabric	
Use	Don't Use
<ul style="list-style-type: none"> • Polyester Stabiltex • Reemay 2014 • Washed muslin 	<ul style="list-style-type: none"> • Wool fabric • Unwashed muslin <p style="margin-left: 20px;">Sizing may attract pests.</p>

Figure I.9. Recommended Storage Materials (continued)

F. Selected Bibliography

- Adamson, Helen. "Storage of Archaeological Material: The Problems." *Museum Archaeologist* 3 (1979): 3-9.
- Christenson, Andrew L. "Cultural Resource Management; The Role of Museums in Cultural Resource Management." *American Antiquity* 44, no. 1 (1979): 161-163.
- Dowman, Elizabeth A. *Conservation in Field Archaeology*. London: Methuen and Co., 1970.
- Ford, Richard I. "A Three-Part System for Storage of Archeological Collections." *Curator* 23, no. 1 (1980): 55-62.
- Hodges, H. W. M. "Problems and Ethics of the Restoration of Pottery." Conservation in Archaeology and the Applied Arts, *Contributions to the Stockholm Congress, IIC, June 2-6, 1975*: 37-38.
- Johnson, Jessica S. "Soluble Salts and Deterioration of Archeological Materials." *Conserve O Gram* 6/5. Washington, D.C.: National Park Service, 1998.
- . "Long-Term Effects of Acid-Cleaning Archeological Ceramics." *Conserve O Gram* 6/6. Washington, D.C.: National Park Service, 1999.
- Keene, S., ed. "Conservation Archaeology and Museums." *Occasional Papers* No. 10. London: United Kingdom Institute for Conservation, 1980.
- Lafontaine, R.H. "Silica Gel." *Technical Bulletin* 10. Ottawa, Ontario: Canadian Conservation Institute, 1984.
- Leigh, David. "The Selection, Conservation and Storage of Archaeological Finds." *Museums Journal* 82, no. 2 (1982): 115-116.
- Majewski, Lawrence. "On Conservation: Archaeological Sites." *Museum News* 51, no. 3 (1972): 11-12.
- Moyer, Curt. Archaeological Conservation Forum: "This is not a Fixit Shop!" *Society for Historical Archaeology Newsletter* 19, no. 2 (1986): 33-36.
- Pye, Elizabeth. "Conservation and Storage: Archaeological Material." In *Manual of Curatorship*, 203-238. London: Butterworths, 1986.
- Raphael, Toby. *Exhibit Conservation Guidelines*. CD-ROM. Harpers Ferry, W.V.: Division of Conservation, Harpers Ferry Center, NPS, 1999.
- . "Using Silica Gel in Microenvironments." *Conserve O Gram* 1/8. Washington, D.C.: National Park Service, 1999.
- Riss, Dan. "First Aid for Wet-Site Objects." *Conserve O Gram* 6/1. Washington, D.C.: National Park Service, 1993.
- . "Desalinization: Passive Alkaline Soak." *Conserve O Gram* 6/2. Washington, D.C.: National Park Service, 1993.
- . "Testing for Chlorides with Silver Nitrate." *Conserve O Gram* 6/3. Washington, D.C.: National Park Service, 1993.
- . "Making Percent Solutions of Chemicals." *Conserve O Gram* 6/4. Washington, D.C.: National Park Service, 1993.

Rose, C.L., and A.R. de Torres, eds. *Storage of Natural History Collections: Ideas and Practical Solutions*. Iowa City, Iowa: Society for the Preservation of Natural History Collections, 1995.

Schlichting, Carl. "Working with Polyethylene Foam and Fluted Plastic Sheet." *Technical Bulletin* 14. Ottawa, Ontario: Canadian Conservation Institute, 1994.

Sease, Catherine. A Conservation Manual for the Field Archeologist. *Archeological Research Tools*, Vol. 4, University of California, Los Angeles: Institute of Archeology, 1987.

Singley, Katherine R. "Caring for Artifacts After Excavation—Some Advice for Archaeologists." *Historical Archaeology* 15, no. 1 (1981): 36-48.

Stanley Price, Nicholas, ed. *Conservation on Archaeological Excavations*. Rome: International Center for the Study of Preservation and Restoration of Cultural Property (ICCROM), 1984.

Tétreault, Jean. "Guidelines for Selecting Materials for Exhibit, Storage, and Transportation." Conservation Information. <<http://www.cci-icc.gc.ca>> Canadian Conservation Institute, 1993.

Tétreault, Jean, and R. Scott Williams. "Materials for Exhibit, Storage and Packing." In: *A Systematic Approach to the Conservation (Care) of Museum Collections*. Edited by Stefan Michalski. Ottawa, Ontario: Canadian Conservation Institute, 1992.

United Kingdom Institute for Conservation

"Excavated Artifacts for Publication." Archaeological Excavations. *Conservation Guidelines* No. 1, 1983.

"Packaging and Storage of Freshly Excavated Artifacts from Archaeological Sites." *Conservation Guidelines* No. 2, 1983.

"Environmental Standards for the Permanent Storage of Excavated Material from Archaeological Sites." *Conservation Guidelines* No. 3, 1984.

Watkinson, David E. and Virginia Neal. *First Aid for Finds*. 3d ed. London: UKIC Archaeology Section/RESCUE, 1998.