

MASTERS *of the* BUILDING ARTS

ACTIVITY GUIDE



Smithsonian
Center for Folklife and Cultural Heritage



Smithsonian Institution

ACTIVITY GUIDE

MASTERS *of the* BUILDING ARTS

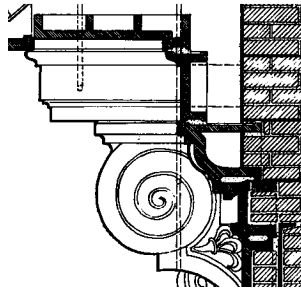

The *Masters of the Building Arts Activity Guide* is made possible by a grant from the Smithsonian Women's Committee.

This guide is adapted from a family activity guide produced to accompany the *Masters of the Building Arts* program for the 2001 Smithsonian Folklife Festival, organized by the Center for Folklife and Cultural Heritage. The *Masters of the Building Arts* program was produced in collaboration with the International Union of Bricklayers and Allied Craftworkers and the International Masonry Institute, the National Trust for Historic Preservation, the National Building Museum, the American Institute of Architects, the Preservation Trades Network, and the Timber Framers Guild.

Major funding for the program was provided by the International Union of Bricklayers and Allied Craftworkers and the International Masonry Institute, Homestore.com, the Marble Institute of America, Allied Stone Industries, the Building Stone Institute, the Indiana Limestone Institute, and the National Building Granite Quarries Association. Major contributors include Target Stores, the Associated General Contractors of America, the National Association of Realtors, and the Smithsonian Women's Committee. Additional donors include the School of the Building Arts, Duron, Inc., the Brick Industry Association, the Laborers' International Union of North America, the Smithsonian Educational Outreach Fund, and the Copper Development Association, Inc.

By Betty Belanus and Marjorie Hunt
Center for Folklife and Cultural Heritage
© 2001 by the Smithsonian Institution

MASTERS *of the* BUILDING ARTS
ACTIVITY GUIDE

TABLE *of* CONTENTS

- 5 Introduction
- 6 Dry Stone Walls
- 11 Stained Glass Windows
- 14 Architectural Terra Cotta
- 19 Ornamental Ironwork
- 24 Building with Adobe
- 28 Stone Masonry and Stone Carving
at Washington National Cathedral
- 32 Traditional Timber Framing
- 36 Glossary
- 38 To Learn More
- 39 Credits

MASTERS *of the* BUILDING ARTS ACTIVITY GUIDE

INTRODUCTION

From the soaring skyscrapers of New York City to the adobe churches of New Mexico, from the sturdy stone walls of New England to the majestic monuments of the nation's capital, master craftworkers in the building arts have brought enduring beauty to our built environment. The *Masters of the Building Arts Activity Guide* celebrates the artistry and skill of master craftspeople in the building trades and their important contributions to our architectural heritage.

In this Guide you can learn about the important role that artisans play in building. Meet stained glass artisans and blacksmiths, stone masons and stone carvers, timber framers, adobe builders, and terra cotta craftsmen. Learn about their heritage and traditions, their skills and working knowledge, their tools, materials, and techniques. Try your hand at crafting a gargoyle out of clay, creating a tissue paper stained glass window, designing a wrought-iron gate, and much more. Each section includes a list of questions to consider and an activity for young people to do at school or with their families at home. The Guide concludes with a glossary of building arts terms and a selection of readings and resources for those who want to learn more.

Have fun learning about master craftworkers in the building trades!

*“When you start,
Mother Nature tells
you where to go with it.
I like to do a good job,
the best that I can.”*

— STONEY MASON



DRY STONE WALLS

From the green mountains and granite hills of New England to the volcanic slopes of Hawai'i, dry stone walls are part of America's historic landscape. This type of wall building is called dry because no mortar or cement is used to keep the stones together. The **mason*** must rely on his skill in “setting” the stones to keep the wall from tumbling down. Some stone walls have lasted for hundreds of years.

Learn more about dry stone wall masonry from David “Stoney” Mason from Starksboro, Vermont, Scott and Rick King from Holderness, New Hampshire, and Billy Fields from Kailua-Kona, Hawai'i.

David “Stoney” Mason

David Mason started building dry stone walls in his native Vermont after he was 40 years old. Now, in his 70s, “Stoney” (as he is known to friends) has built hundreds of walls all around Starksboro and other parts of Vermont.

In earlier days, New England stone masons used stones found in the rocky fields to build walls. Nowadays, they must buy stones from **quarries**. Stoney likes to make different types of walls, experimenting by building steps and seats into the walls, leaving holes for display, or setting in toys or trinkets.

Stoney lets the stones “tell” him how a wall is to be built. His only tool is a hammer that he uses in case a rock needs to be broken into smaller pieces. The bottom of the wall is made from flatter or bigger rocks, and the wall tapers (gets thinner) as it is built up. The stones must be able to withstand the heavy frosts, ice, and snow of the Vermont winters.

Stoney Mason likes building walls so much, his wife Bette says he sometimes talks about rocks in his sleep!

Scott and Rick King

The King brothers from Holderness, New Hampshire, also build dry stone walls. They learned their traditional masonry skills from their father, Norman Ezra “Bud” King, who learned from his own father. “My Dad was the kind of person who didn’t want to tell you much. He’d show you and then you pay attention and you’d get the gist of it,” recalls Scott. They use a special stone called Winnepesaukee feldspar granite, found in the area of Lake Winnepesaukee near the center of New Hampshire. They both love the out-of-doors, and take great pleasure in finding stones for their work in the woods, mountains, and fields of their home region. “There’s no two (stones) alike! That’s what makes it so enjoyable,” says Rick.

*“Ua ho’ono’ono niho
‘ia...ho’oku’u ka hana:
Only when the stones are
properly stacked is the
work done.”*

— HAWAIIAN PROVERB

George William (“Billy”) Fields III

In Hawai’i, dry stone (called dry stack) building is an ancient art, used to construct or restore temples, ritual platforms, and agricultural walls. In the Hawaiian language, this type of wall building is called *uhau humu pohaku*. Like Stoney Mason, Billy Fields worked at other jobs before he began learning to build with stone. He had been around construction all his life, though, and he is also skilled at building traditional thatched roofs made with native grasses.

Billy explains that Hawaiian stone masonry requires certain basic skills, but each mason has his own style, “like a person’s handwriting.” In Hawai’i, a Mason’s **Guild** helps preserve the old skills of building with rock (called *pohaku* in Hawaiian). Older masons are interviewed, and they help teach younger craftspeople.

Billy likes to play Hawaiian music while building walls. He tells about the proper way to prepare a sacred building site with prayers and chants. He feels that the knowledge of building with volcanic rocks is an important part of the Hawaiian culture and should be preserved. Says Billy, “Stones are really the foundation of our culture. When we’re working on an existing site, we only use the stones that are already there. If you do it wrong, the stones will let you know about it right away.”

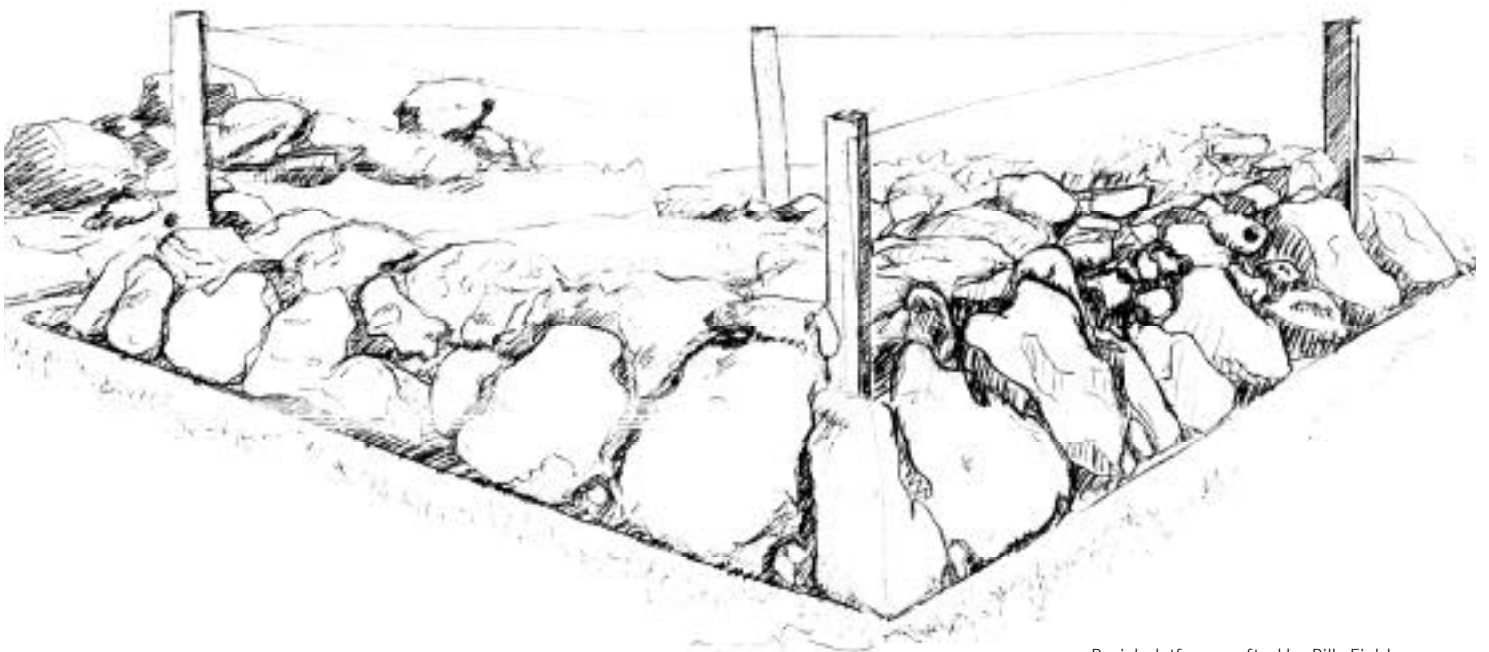

Burial platform crafted by Billy Fields

QUESTIONS TO CONSIDER:

Do you think individual masons have different styles of building?

What size and shape stones go into different parts of a wall?

Where do the stones come from? What are considered the "best" stones?

How can masons tell where to put the stones?

How do the stones stay together without mortar or cement?

How does a dry stone mason learn his or her craft?

How long does it take to build a wall or platform?

Master masons make it look easy to fit stones together! Can you do it?

ACTIVITY:

"Build" a Stone Wall

One magazine article about Stoney Mason compared his walls to jigsaw puzzles! Make your own "wall" puzzle.

You will need:

the stone wall drawing provided here

a pair of scissors

a glue stick

a blank piece of white or colored paper

crayons or colored pencils (optional)

1. Cut out the individual stones in this drawing of a wall section, along the bold black lines.

2. See if you can piece the right stones together again into a solid wall. When you have completed the puzzle, glue the "stones" together onto a piece of paper. Draw a scene from New England or Hawai'i as a background if you like.

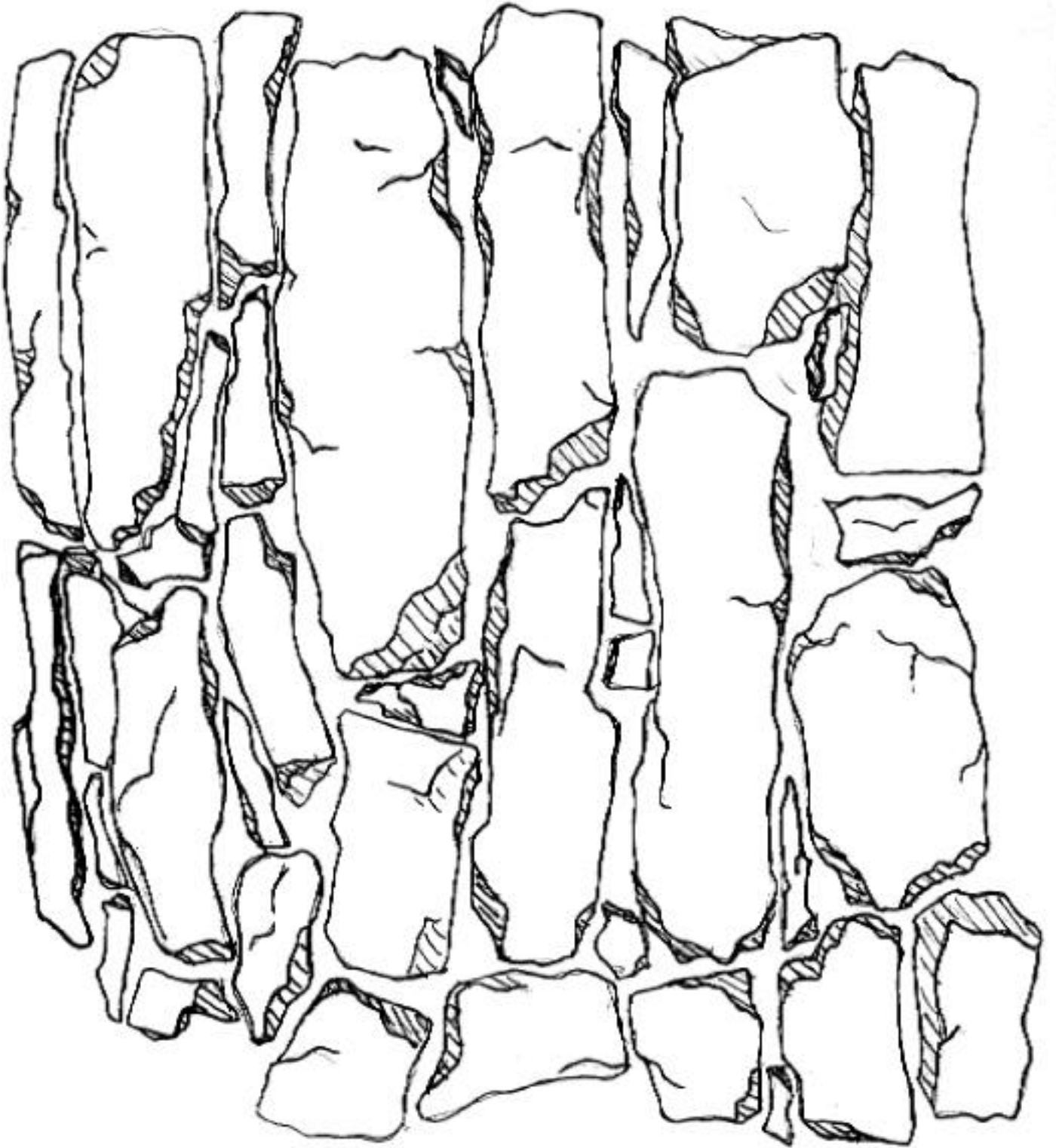



West rose window
Washington
National Cathedral

STAINED GLASS WINDOWS

The technique of making stained glass windows has not changed much in the past thousand years. Stained glass artisans must be skilled at such things as drawing, cutting glass, **leading**, and painting. The end result is a magnificent blend of color and light. Learn more about making stained glass windows from artisan Dieter Goldkuhle from Reston, Virginia, whose creations can be seen at Washington National Cathedral.

“It is never static, it’s always changing in subtle ways. And that to me is really the poetry of stained glass.”

— DIETER GOLDKUHLE

Dieter Goldkuhle

Dieter comes from a family of commercial glass tradesmen from northern Germany. As a teenager, he was fascinated by the way stained glass changed as light passed through it, and he decided to become a stained glass artisan. He served a three-year apprenticeship with master teachers in the Rhineland (an area of Germany), learning every aspect of the trade.

In 1962, Dieter came to America, working first in New York City and later in Washington, D.C. He often works with stained glass artist Rowan LeCompte, but also on his own. Dieter has crafted several windows for Washington National Cathedral, including the beautiful rose window designed by Rowan LeCompte on the Cathedral’s west facade (side). He also restores older windows and enjoys the special challenges and skills involved in the restoration process. “It broadens me and gives me new experiences in my field,” he says.



Cartoon for a stained glass window

Stained glass artisans first make a drawing, or work from one designed by another artist. Then, a “cartoon,” or full-scale working drawing, is done. The glass is then cut, guided by a pattern made from the cartoon. Painting of details such as hands and faces, and staining to give the glass different color effects is done next, and the glass is exposed to a high temperature to seal the paint or stain.

The complicated job of leading comes next. That is, the glass is put together with strips of lead, a bendable metal. The lead is then sealed or “cemented” with a special mixture.

The installation of the window into its space in a wall is one of the hardest but most rewarding parts of the process. As Dieter says, when an installation is done right, “there is a harmony of material — the limestone, the light reflecting off the surface of the glass, the lead lines. To me that is such a beautiful marriage.”

QUESTIONS TO CONSIDER:

What are the different steps it takes to make a stained glass window?

What is a “cartoon”? How is it used by a stained glass artisan?

How are the different colors of glass used to make a design for a window?

How is the glass cut and fit together?

What do you think would be the most difficult part of making a stained glass window?

What would be the most fun part?

SEE IT:

Visit Washington National Cathedral and ask a docent to show you some of the many stained glass windows designed by Rowan LeCompte and crafted and installed by Dieter Goldkuhle, including the rose window on the west facade and windows on the north side of the **nave**.

Are there churches in your community with stained glass windows? Who made them?

STAINED GLASS ACTIVITY:
Make Your Own
“Stained Glass” Window

You can get the feeling of designing and making a stained glass window working with tissue paper “glass” and black construction paper “leading.” This activity was developed by the National Capital Art Glass Guild, with special thanks to Jean Lee.

You will need:

- assorted colors of tissue paper
- tracing paper or waxed paper cut into sheets approximately 9” by 6”
- strips of black construction paper, 1.2”wide and approximately 12” to 15”long
- scissors
- a glue stick
- string or ribbon (optional)

1. Choose several different colors of tissue paper for the “glass” (no more than five different colors works best). Cut the tissue into random geometric pieces, no larger than 4” wide and long. (Triangles, squares, rectangles,

etc., work best. Circles are harder to “lead” with construction paper.) Select about ten tissue paper pieces for your design.

With as little glue as possible, tack the chosen pieces onto the wax paper or tracing paper. You can overlap some pieces to create another color (for example, blue over red will make purple). If you hold your piece up to the light, you will see how magical the illumination is!

2. “Lead” your stained glass piece by gluing down the black strips of construction paper around the colors of your design, cutting or tearing them to fit. Use just enough “leading” to create your design.

3. “Frame” your design with additional strips of black construction paper around the edges of the tracing or waxed paper. If you like, you may punch a hole at the top, put ribbon or string through, and hang it in a window!

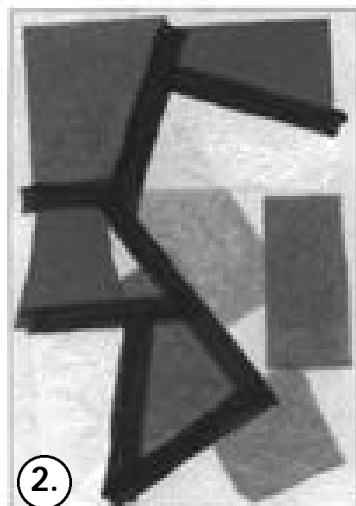
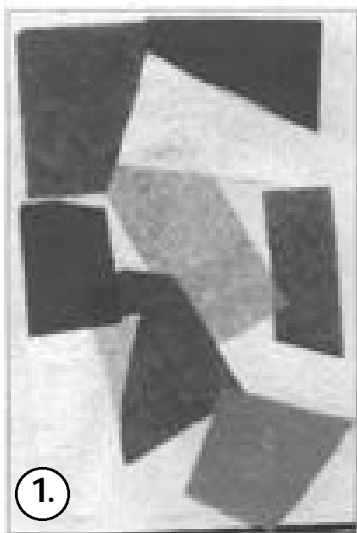

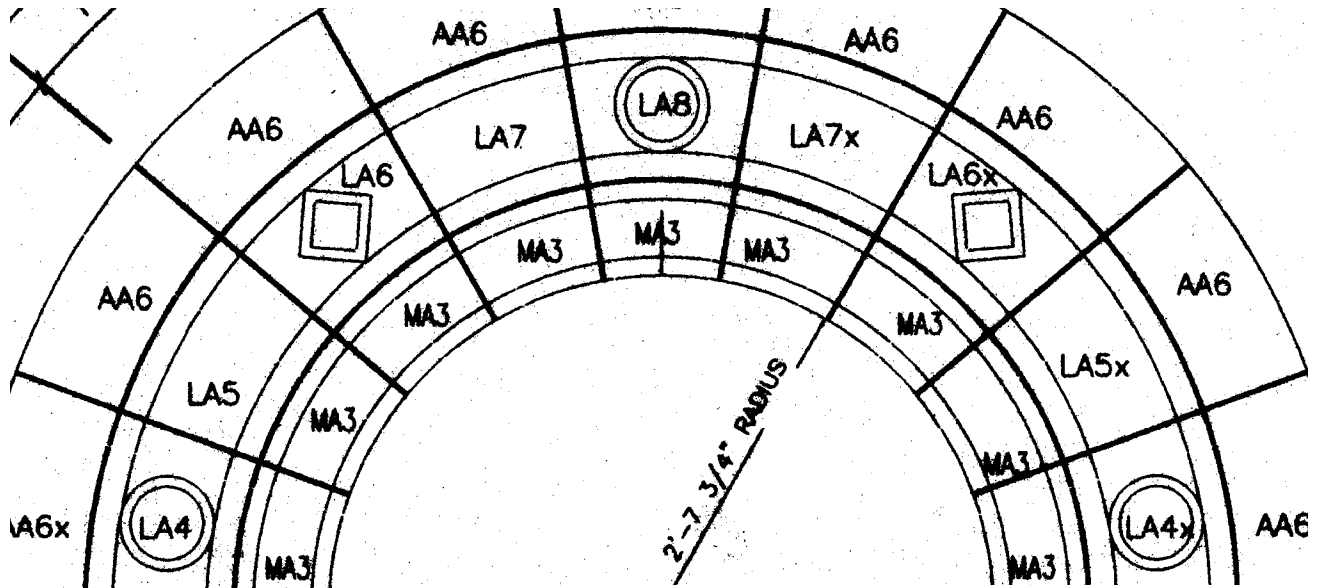

ARCHITECTURAL TERRA COTTA

The term *terra cotta* comes from a Latin phrase meaning "cooked earth." Like bricks, terra cotta is made from clay which is baked hard. Terra cotta is made from a finer grade of clay, and can be baked at higher temperatures. This allows it to be molded into many different shapes — gargoyles, cherubs, lions, crests, and many others — used to decorate the facades (front sides) of buildings. Terra cotta can be **glazed**, like pottery, to produce a wide range of colors and textures. It can also be finished to look like granite or limestone.

The terra cotta company Gladding, McBean is the one of the oldest and best-known producers of this building material. This company has been producing terra cotta from its factory in Lincoln, California, since 1875. Gladding, McBean began by making clay pipes that carry water and sewage underground, but by the 1880s they also became known for their architectural terra cotta (that is, ornamental terra cotta made for buildings). Terra cotta ornamentation reached its peak of popularity as a building material in the 1910s and 1920s. Today, many of the older buildings that used terra cotta as ornaments are being restored to their original beauty. Let's learn a little more about how terra cotta is made.

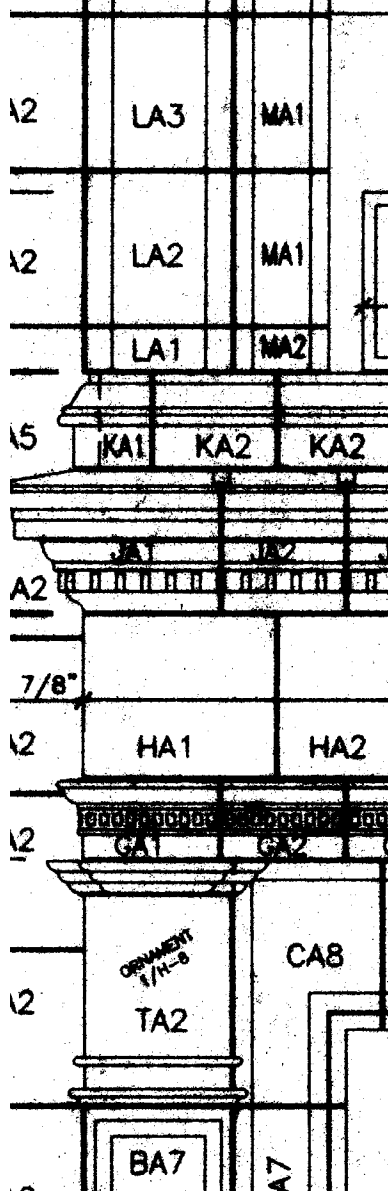

Making Architectural Terra Cotta

The process of making architectural terra cotta at Gladding, McBean has changed little since the 1880s.

First, a **draftsman** makes a **scale** drawing. Then, a “model” of the design in the drawing is hand-made from clay, which takes a lot of artistic talent. A plaster “mold” is made, which duplicates the design of the model. Next, special terra cotta clay is “pressed” into the mold. The clay doesn’t fill the whole mold, it only creates a sort of shell, and getting just the proper thickness is very important.

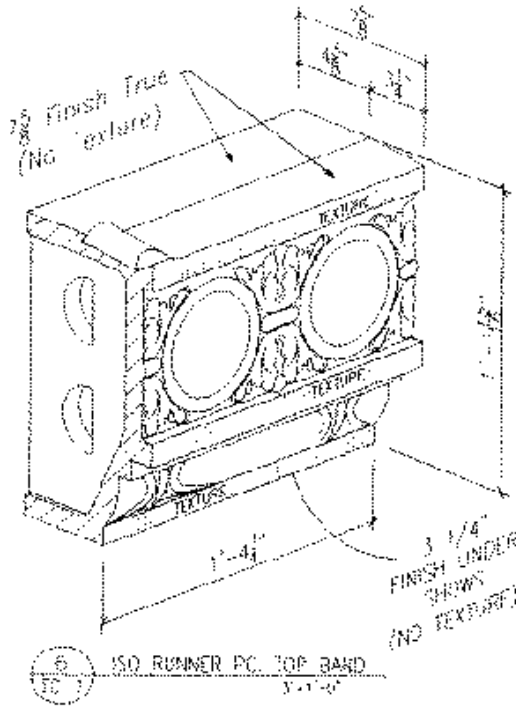

When the clay is partially dried, it is removed from the mold. It is then “hand-finished” with a variety of tools. A large design, which can stretch across a whole building, needs to be made in many pieces, repeating the pattern over and over. After they are totally dry, the terra cotta pieces are treated with different colored glazes. Then, they are fired in a **kiln** like other types of pottery, except terra cotta pieces for a large building facade need a kiln that can hold 35 to 45 tons of pottery! Finally, before the order is shipped to the builder, the pieces must be laid out and fitted together to make sure they form a continuous design.

Gladding, McBean has produced and restored terra cotta for many famous buildings around the country. These include Carnegie Hall in New York City, the Wrigley Building in Chicago, and the Warner Theater in Washington, D.C. Many skilled employees have been with the company for years and years, and some learned from family members who also worked at Gladding, McBean. Let’s meet some of Gladding, McBean’s terra cotta craftsmen.

“Your art is viewed by millions of people, but people don’t associate it with the maker, with the craftsman. You remain anonymous.”

—RAY JOHNSON

Ray Johnson is the company's former chief **draftsman** and modeler. He has worked for Gladding, McBean since 1948, and even though he "retired" in 1992, he still comes in three days a week! Ray learned his modeling skills from a sculptor named Ernest Kadel, who started at the company in the 1920s and learned from older craftsmen who had worked there at the turn of the century. As Ray says, "The work we do here, most of it is learned on the job and just passed down from generation to generation. You're always learning."

David Martinez, who has been working at the company for 24 years, is a draftsman who learned from Ray Johnson. To reproduce a design from an older building which needs **restoration** work, David sometimes has only small pieces of the original terra cotta. He also works from photographs and architect's drawings. An important part of his work is calculating how much the terra cotta will shrink when its fired. If this is not figured in, the piece will not fit the building! Today, this can be calculated on a computer.

Terra cotta lion,
Sacramento
Public Library



Jesus Cardenas is a modeler and moldmaker. Born in Mexico in 1948, he started working at Gladding, McBean in 1968. He learned how to make models from Ray Johnson and from many years of hands-on experience, picking up skills on his own. He loves making the models from clay. He says, "I like the creativity and the challenge. Every piece is different. You have to be able to improvise — to figure out the best approach."

*"It's a great feeling
when you unmold
a piece and you can say,
'This is beautiful!'"*

—HUMBERTO MIRANDA

Humberto Miranda is a hand presser and moldmaker. Like Jesus Cardenas, he was born in Mexico. He has been working at Gladding, McBean since 1977, and worked his way up through many jobs. As a presser, he's responsible for making sure there are no air pockets between the clay and the mold. This takes experience, and a "feel" for the clay. Humberto enjoys working on the hand-finishing of the terra cotta pieces when they come out of the molds. Some of the tools he uses have been handed down from craftsperson to craftsperson for generations.

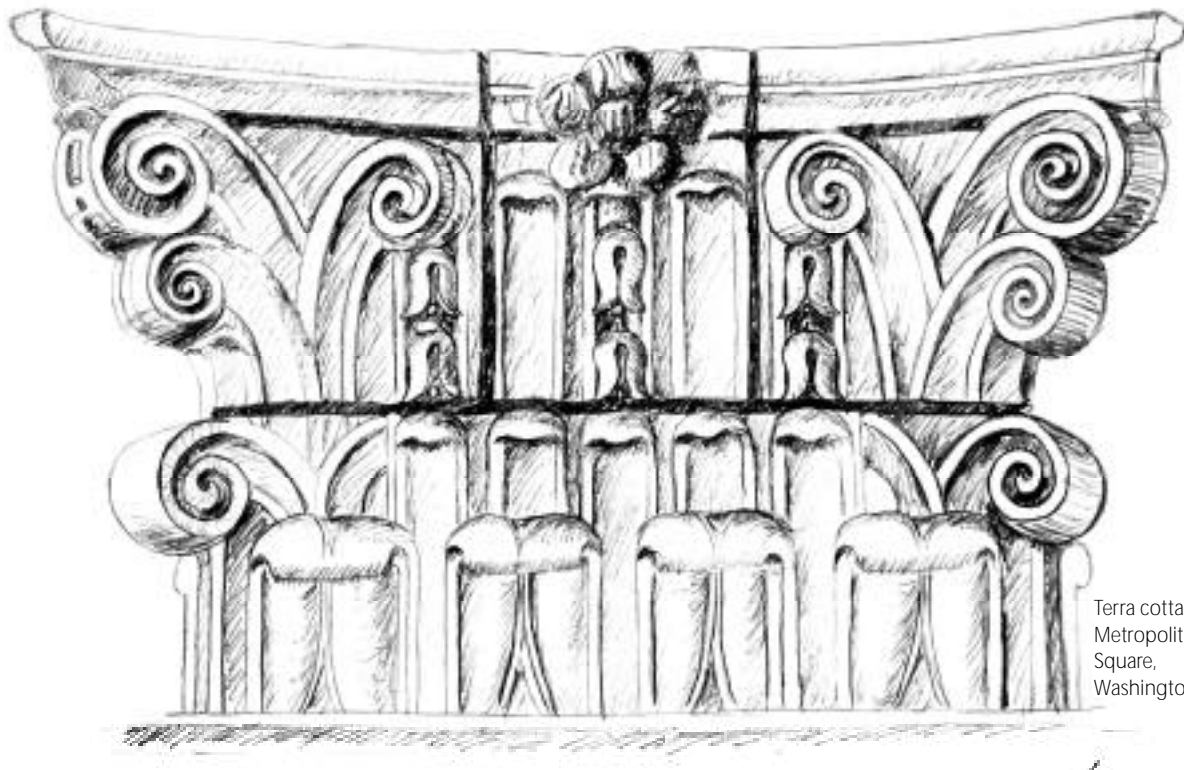

Terra cotta capital,
Metropolitan
Square,
Washington, D.C.

QUESTIONS TO CONSIDER:

What are the different types of skills needed to make a piece of terra cotta? What are the steps of the process?

Where does terra cotta clay come from?

How is the clay specially prepared for terra cotta? What is the difference between the clay used in terra cotta and brick making?

What are some of the different terra cotta designs used to decorate buildings?

Why is it important to get just the right thickness of clay into the mold?

How are different glazes and textured finishes used to make terra cotta look like pottery or stone?

How are the plaster molds made?

SEE IT:

Terra cotta work done by Gladding, McBean & Company craftsmen can be seen on the Warner Theater Building and the Investment Building in Washington, D.C.; the Wrigley Building in Chicago; the Children's Museum in Indianapolis; Carnegie Hall and the Mabel Dean Bacon High School in New York City; and many other buildings across the nation. Do you have any buildings in your community that are decorated with ornamental terra cotta?

ACTIVITY: Make Your Own Terra Cotta Mold

The craftsmen at Gladding, McBean make models from clay and then make a plaster mold around that model. Then, they press terra cotta clay into the mold, let it dry for awhile, and fire it. You can get a feel for part of this process by filling a mold with a type of clay, then drying and decorating it.

You will need:

a mold (see below for ideas)

oven-drying clay

tempera paint (optional)

1. Find a mold: clear plastic molds for making plaster castings or soap are sold at most craft shops. Also, there might be something around your house you can use as a mold: a seashell, a tart pan or jello mold, or anything else that has a pattern and can be filled with clay.
2. Use oven-drying (such as Sculpey or other brands) or air-drying (Crayola's Model Magic, or even Play-Dough) clay. If the clay sticks to the mold, try "greasing" it with a little non-stick baking spray before you press it in.
3. Try pressing the clay into the mold the way a terra cotta "presser" does: not to fill the whole mold with clay, but press in as thin a layer as you can. (You will appreciate the work of terra cotta craftsmen even more after trying this!)
4. With air-drying clay, let it dry for several hours before attempting to unmold. With oven-drying clay, pull the clay carefully out of the mold and, with a grown-up's help, use the instructions to "fire" it hard in the oven.
5. Decorate your finished piece with paint if desired.

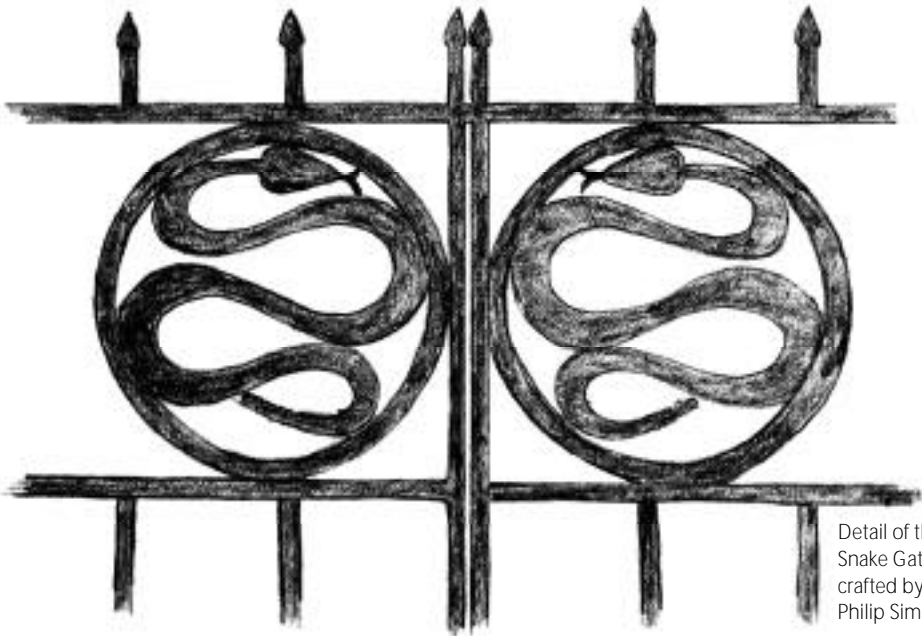

Detail of the Snake Gate crafted by Philip Simmons

ORNAMENTAL IRONWORK

A blacksmith works with iron*, heated to a very high temperature over a **forge** and hammered into various shapes on an **anvil**. This ancient art has included the building and repair of wagons, plows, and other agricultural tools as well as fitting horses with new shoes. But blacksmiths can also be artists in iron. Architectural blacksmiths craft metal into beautiful ornamental pieces, such as intricate hand-forged gates, fences, and railings. Learn more about decorative wrought-ironwork from master blacksmiths Philip Simmons, Nol Putnam, and Patrick Cardine.

*Generally, most blacksmiths now work in a metal called mild steel, but we will continue to use the term iron here to avoid confusion.

Philip Simmons

Philip Simmons was born on a small rural island near Charleston, South Carolina, in 1912, and moved to the city when he was 8 years old. From a young age, he took an interest in the work of local blacksmiths, and at the age of 13, he was taken on as an **apprentice** by Peter Simmons (no relation), a former slave who ran a busy blacksmith's shop in the heart of Charleston's waterfront.

“I build a gate, I build it to last two hundred years. If it looks good, you feel good. I build a gate, and [I’m just] thinking about two hundred years. If you don’t, you’re not an honest craftsman.”

— PHILIP SIMMONS

When Philip began, blacksmiths in Charleston still shod horses and repaired wagons and equipment used in unloading the many freight ships that came to Charleston Harbor. But as cars and trucks took over the work of wagons, Philip needed to find another use for his skills. Fortunately, in the late 1930s, someone came to him with a broken gate piece. Soon, Philip began repairing more gates and creating new ones. Today more than 500 pieces of his ornamental ironwork decorate the city of Charleston.

Philip is known for creating designs based on forms from nature that he had loved as a child and saw around him in the South Carolina “low country” — fish, pecan leaves, egrets, snakes, magnolias, and tulips. As he says, “You take what God gives you, and work with what you have.”

Although he is now officially “retired,” Philip continues to guide younger blacksmiths, including Joseph Pringle and Carlton Simmons, the talented **journeymen** who carry on the work and traditions of the Simmons shop today. “You got to teach kids while the sap is young, just like you got to beat the iron while it’s hot,” he says of his passion for passing on the skills of his trade.

Nol Putnam

Nol Putnam of White Oak Forge in The Plains, Virginia, has worked as an architectural blacksmith for more than 30 years. As a young man he taught school, but he really wanted to work with his hands. He learned the art of blacksmithing through a long process of trial and error — reading books, watching and getting advice from more experienced blacksmiths, and studying with the renowned ornamental ironworker Francis Whitaker. “You need a good eye,” he says. “It’s all about eye-hand control — developing dexterity and using the anvil to give shape and movement and life to the metal.” A master of his trade, Nol specializes in large hand-forged architectural pieces, such as gates, railings, and balconies. He designed and crafted three magnificent memorial gates for Washington National Cathedral. Nol is a dedicated teacher and generously shares his knowledge and skills with others who are eager to learn the craft.



Detail of Memorial Gate crafted by Nol Putnam for Washington National Cathedral

Patrick Cardine

Patrick Cardine is an architectural blacksmith from Chantilly, Virginia. He began learning the trade when he was 16 years old, teaching himself at first, and then working with master blacksmith Nol Putnam. "The learning process is a lifetime, really," he says. "You never stop." Like Nol, Patrick also specializes in large-scale architectural ironwork. "I enjoy the creativity," he says of his trade. "And I get the greatest thrill out of moving hot metal. You take this hard, cold, lifeless thing. You fill it with fire. You hit it with a hammer, and it moves and comes alive. It's just magical." Patrick is currently designing and crafting decorative wrought-iron railings for Washington National Cathedral.

QUESTIONS TO CONSIDER:

What are some of the different tools that blacksmiths use? Where do they get their tools?

How long does it take to heat a piece of iron enough for a blacksmith to hammer it into shapes? How does a blacksmith know when the iron is hot enough to work?

How does a blacksmith get his or her ideas for designs?

What are the steps involved in making a wrought-iron gate?

SEE IT:

Visit Washington National Cathedral to see the wrought-iron railings crafted by Patrick Cardine and the three memorial gates crafted by Nol Putnam, which are located near St. Joseph's Chapel. Philip Simmons's hand-forged ornamental pieces decorate the city of Charleston, South Carolina. See John Vlach's book *Charleston Blacksmith* and/or visit the Philip Simmons Foundation web site (www.philipsimmons.org) to find out where to see his work.

ACTIVITY:

Design Your Own
Wrought-Iron Gate

You will need:

blank white paper and a pencil
black pipe cleaners (optional)

Philip Simmons sketches out his designs before he works them into iron. His inspiration is often shapes from nature: stars, fish, leaves, birds.

Using the outline provided here, make your own sketch for an iron gate. Remember to keep the lines simple, or a blacksmith will never be able to turn the sketch into a finished iron piece!

If you like, you can try your design out with some black pipe cleaners, bending them into the shapes you have drawn.



Star and Fish Gate crafted by Philip Simmons

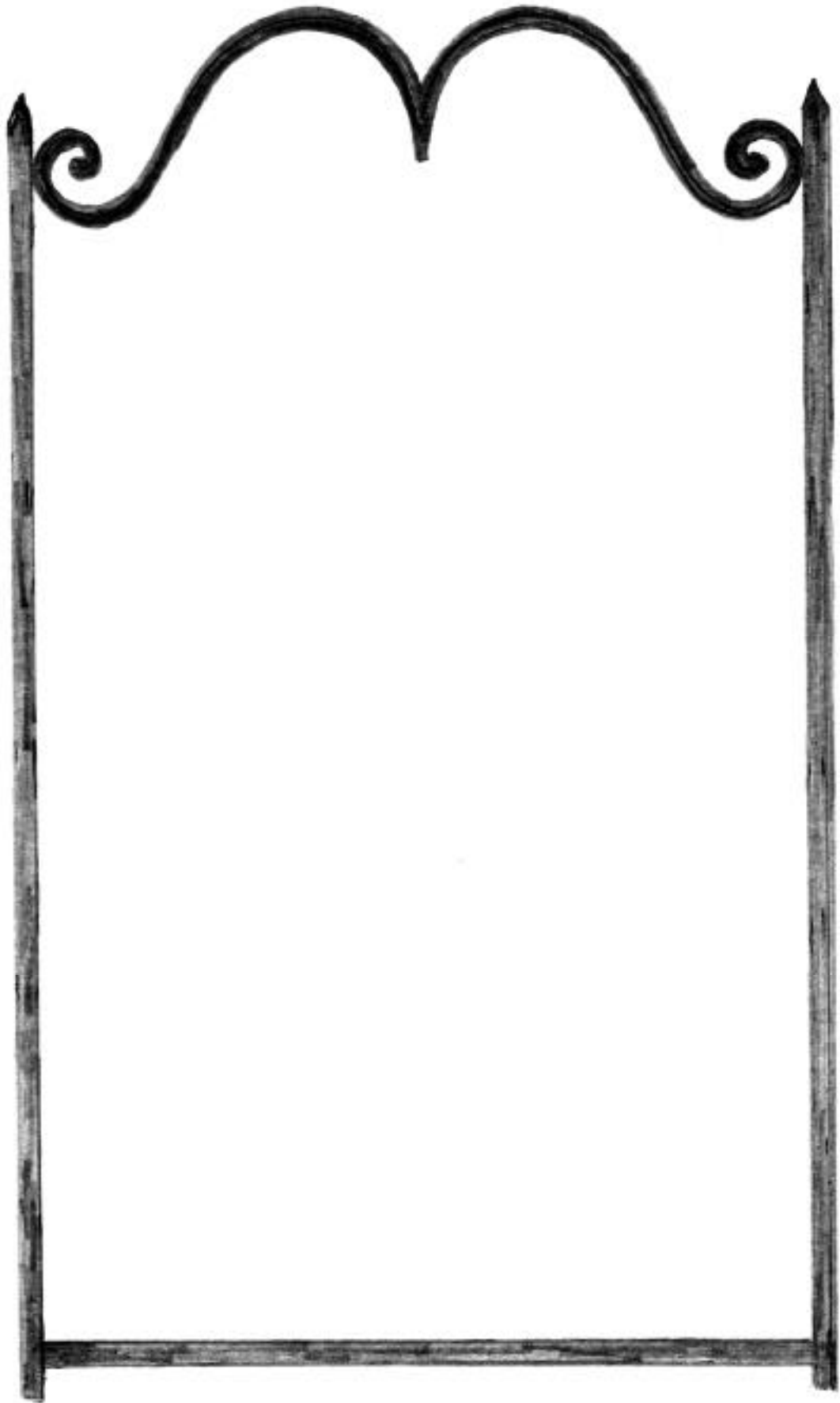

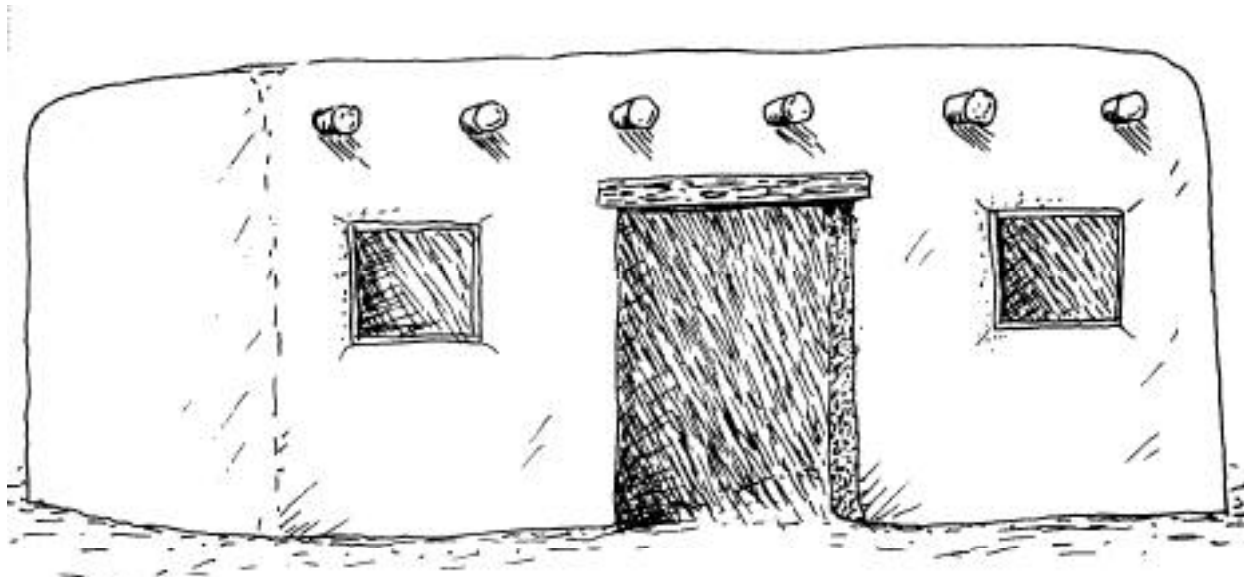

BUILDING WITH ADOBE

Adobe is a building material made from a mixture of mud, clay, and straw. The word *adobe* comes from the ancient Arabic building tradition called *al-tob*. The Spanish, because of their contact with the Moors of North Africa, knew the process and called it adobe. When they arrived in the New World, the Spanish colonists found that the Pueblo Indians in the Southwest had been using the same process for centuries. The adobe building tradition in the southwestern United States is a unique blend of Native American and Spanish ideas and techniques.

Albert Parra

Albert Parra is a master adobe builder from Albuquerque, New Mexico. As a boy Albert loved the smell of earth. He grew up in Old Town Albuquerque with his great-grandmother. When he was around 9 years old he met Don Gaspar Garcia, an adobe maker. Don Gaspar became Albert's **mentor**. As Albert says, "He took me under his wing, and life was never the same again."

After working as a lumberjack, which took him away from the Southwest, Albert found himself missing New Mexico and his work with adobe. He returned, received a license to build structures, and began building with adobe. His knowledge of cutting trees helped, since strong timber beams called *vigas* are

"Adobe is of the earth and built with earth, and when it's over with, it goes back to the earth. It's a very simple way of living. It's a clean way of living."

— ALBERT PARRA

used for roof supports in adobe building, and Albert often cuts these himself.

For Albert, building with adobe is not just another building technique, it is a philosophy of life. Adobe, he explains, is made of natural materials and is environmentally friendly. It absorbs heat during the day, and releases it at night, cutting down on heating and cooling expenses and conserving energy. But for Albert, adobe buildings are also in tune with the landscape, their rounded walls and natural colors blending in with the land that surrounds them.

Albert also explains the way people have traditionally made building with adobe a community activity. Entire communities joined together to construct new buildings. Men built the walls and raised the roof beams, while women plastered the outside with adobe, whitewashed the inside, and packed down the roof materials with their feet.

Albert has four sons. All of them know how to build with adobe. "They know the cutting in the forest, they know the earth smell, they know the clinking of the **trowels**."

QUESTIONS TO CONSIDER:

What are the ingredients that go into the mixture for adobe bricks? How are the bricks made?

Why is the outside of an adobe building plastered? What are the different "finishes" that can be done with the plastering?

How do adobe builders learn their trade?

What makes an adobe house beautiful?

Why do you think a traditional adobe house has thick walls?

Why is the Southwest a good climate for adobe structures?

ACTIVITY:
Build a Model Adobe House

If you take the time to complete this activity, you can begin to understand the hard work and fun of building an adobe house!

You will need:

- clay
- a rolling pin
- newspapers to work on
- a plastic knife
- a cup of water
- 2 wooden strips
which are 11"long and 1/4"thick
- 18 headless nails 1 1/2"long
- cardboard for a base
- sticks and twigs

Making the Bricks

You will need approximately three pounds of clay, the natural kind that is used for making pottery, which hardens upon drying. In this case, as with real adobe, the clay will be dried in the sun.

1. Get some grown-up help to build two "combs" out of wooden strips and nails. Use two wooden strips 11"long and 1/4"thick, and 18 headless nails. Have an adult help measure and hammer in headless nails 1 1/2"long into one of the strips, at intervals of one inch. On the other, hammer the remaining nails in the strip at 2"intervals.

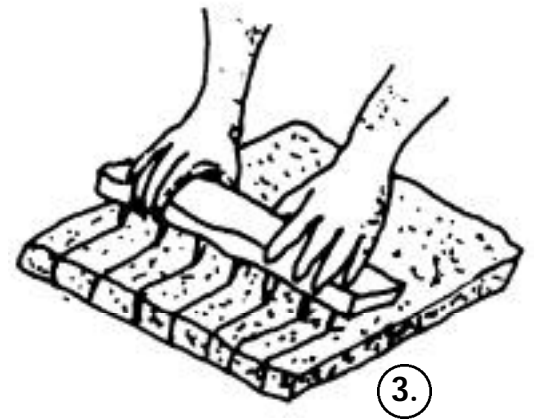

2. Roll a slab of clay that is about 1/2" thick, 8"long and 11"wide.

3. Score the clay using your combs. Do this by dragging the 1"interval comb across the surface of the clay in one direction, and then making lines with the other comb in the other direction, at right angles. Pry the bricks apart with a plastic knife. Keep them moist under plastic or a damp towel until you're ready to work with them.

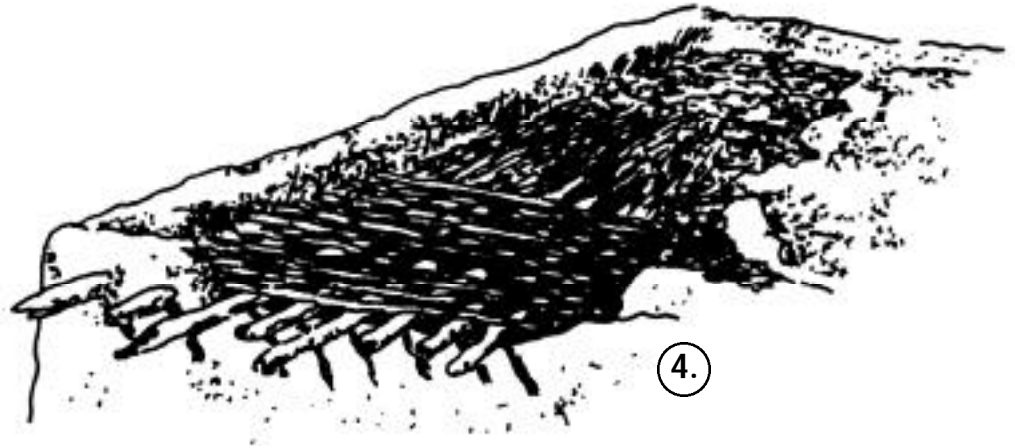
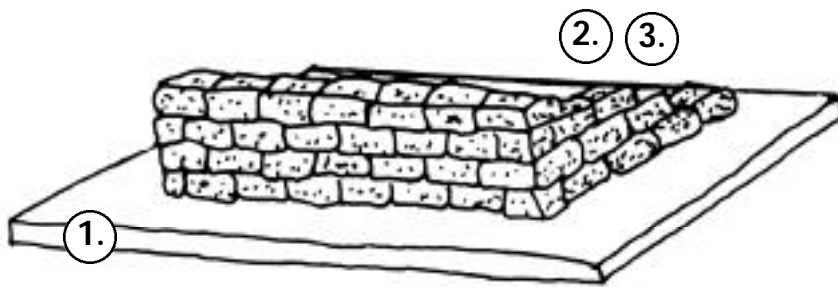

Building the House

1. Roll another slab of clay that is about $\frac{3}{8}$ " thick, 4" long, and 8" wide. This will be the floor of the house.

2. To set the first layer of bricks, moisten one edge of the floor with water to make slip (watery clay). This will serve as mortar to stick the bricks to the floor. Score (make cuts in) the moistened edge with your fingernail (but don't cut all the way through). Then moisten and score the adobe brick (without cutting all the way through) and place the brick on the base. Continue to place bricks next to each other all around the base, being careful to moisten and score the adjoining sides of the bricks. Leave a space for the doorway.

3. Place the second layer of bricks on top of the first, laying them over the places where the bricks on the first layer connect (see illustration). After completing the second layer, lay the third, fourth, etc., until the wall stands approximately 6" high. Leave window spaces as desired.

4. For the roof: gather some fairly straight sticks and twigs. First, place strong sticks across the width of the buildings and allow the ends to stick out over the walls. Add twigs at right angles to the sticks. Next, cover the twigs with a layer of grass. Finally, smear a thin layer of clay over the whole roof.

5. Dry your house in the sun.

*This activity is from Art in the School, Inc., "The Pueblo: Architecture for a Natural World" by Sara Otto-Dinez. Adapted and reprinted with permission.



STONE MASONRY and STONE CARVING at WASHINGTON NATIONAL CATHEDRAL

Standing on top of Mount St. Alban in the nation's capital, Washington National Cathedral is an impressive landmark. Construction of the Cathedral began in 1907 and finished in 1990. Built in the 14th century Gothic style, it is the sixth largest cathedral in the world. The stone used for building the Cathedral, and carving its many decorative statues, **gargoyles**, **grotesques**, and countless other ornamental works, is Indiana limestone. The stonemasons and carvers who worked on the Cathedral feel a special pride in the job they did there.

Learn more about the Cathedral's stone masonry from Billy Cleland and Joe Alonso, and about stone carving from Walter Arnold and Patrick Plunkett.

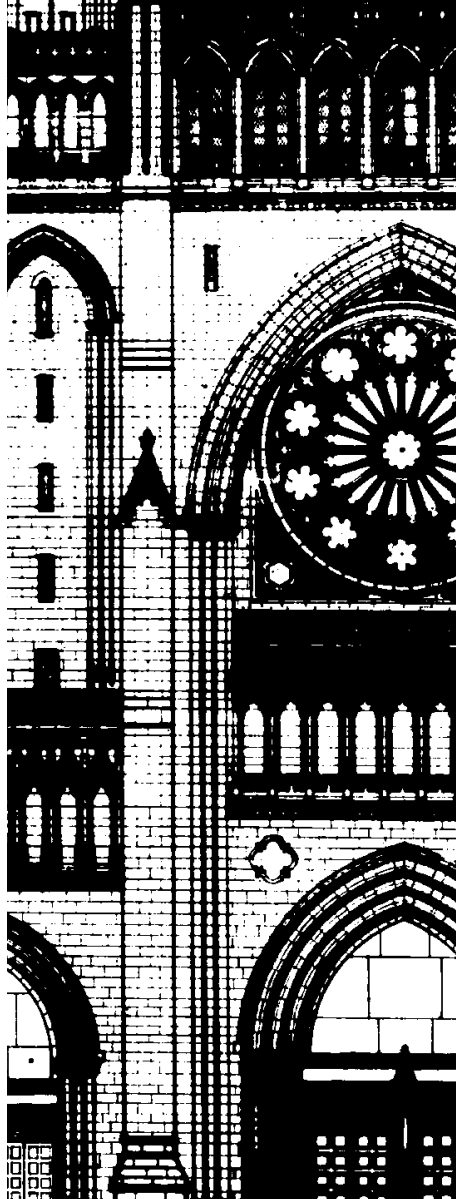

Billy Cleland and Joe Alonso
 Master mason Billy Cleland, a longtime member of the International Union of Bricklayers and Allied Craftworkers, learned to set stone from his father. As a young man, he wanted to work on the Cathedral so much that he took a cut in pay to do so. He has worked on the Cathedral for a total of 18 years, off and on from 1953 to 1989. One of his first jobs at the Cathedral involved taking the Cathedra (the Bishop's stone chair) apart and moving it 20 feet from where it originally stood.

"I just have so much emotion welling up sometimes when I think how fortunate I've been to have followed my father's trade."

— BILLY CLELAND

One of the most important tools of the mason's trade is the trowel, used to spread the mortar that holds the stone together. "The trowel becomes almost an extension of a mason's arm," says Billy. "It's like another hand." With large stones such as the limestone blocks in the Cathedral, mortar doesn't hold the stones together as much as it acts as a cushion to hold the stones apart, so one won't rub against another. Masons must know how to make sure the stones in a wall are laid straight, level, and "plumb" (perfectly vertical). "It's mathematics in motion," says Joe Alonso of the mason's work translating an architect's plan into a three-dimensional structure. "We're constantly figuring our radiuses and our dimensions."

The Cathedral draws many fine workmen, interested in a job well done. As Billy Cleland says, "Perfection is not of this world, but we strive for it." Billy has instilled this pride in Joe Alonso, the current mason foreman at the Cathedral.

Joe Alonso has worked at Washington National Cathedral for 16 years, first as a stone mason working with Billy Cleland to construct the Cathedral and now as the mason foreman in charge of restoring and caring for the Cathedral's monumental stonework. He and his talented crew are preserving the beautiful craftsmanship of the many generations of masons and carvers who built the Cathedral over the course of nearly a century.

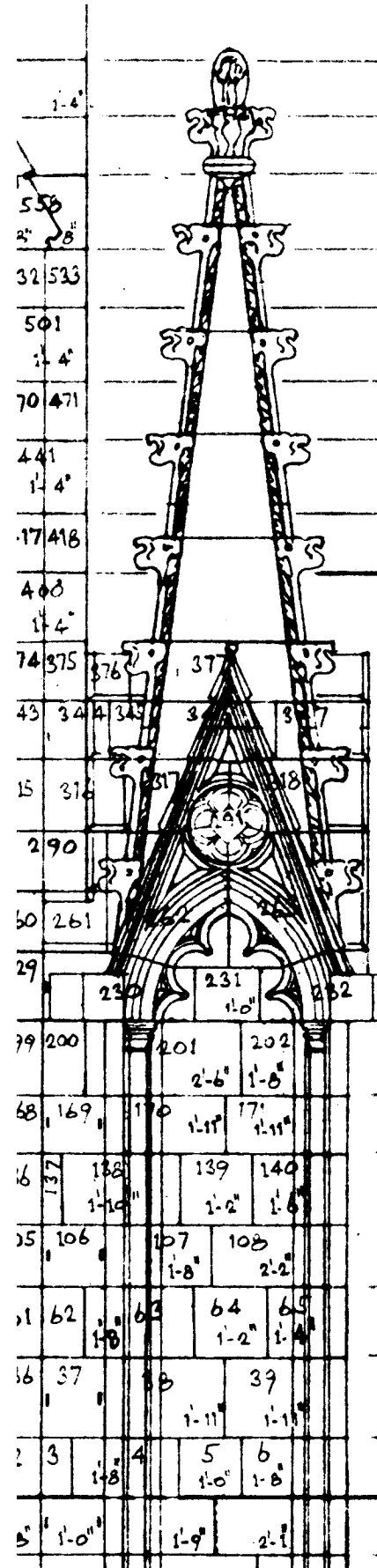

Stone setting drawing, Washington National Cathedral

Walter Arnold and Patrick Plunkett

The Cathedral has hundreds of carvings, including fanciful gargoyles and grotesques, as well as dignified statues. Indiana limestone is particularly suited to carving because it is a relatively soft stone, yet it has a tight grain and even texture that holds the cut and allows the carver to achieve sharp detail.

Walter Arnold of Skokie, Illinois, began modeling figures out of clay when he was 8 years old, and carving in stone when he was 12. Like many of the other stone carvers who worked on the Cathedral, he apprenticed in Italy. In the five years he worked at the Cathedral, he produced more than 90 architectural carvings. Stone carver Patrick Plunkett learned his trade in England. He came to the United States to work on Washington National Cathedral in 1975 and has been here ever since!

Patrick worked at the Cathedral for 12 years carving hundreds of gargoyles, grotesques, **finials**, and other ornamental works. A stone restoration specialist, he also led the team of stone-cutters who restored the stonework for the White House.

Stone gargoyles and grotesques, which are based on caricatures (exaggerated portraits) of people or animals, or are fantastic imaginary creatures, are among the favorite things many stone carvers make. Carvers often get very playful with these figures, and sometimes portray their fellow workmen, as well as popular characters and people. You can even find Darth Vader (carved by Patrick Plunkett) among the 112 gargoyles at the Cathedral!



A stone carving at Washington National Cathedral

QUESTIONS TO CONSIDER:

What are the different kinds of stone used by masons and carvers? What are the properties and characteristics of each? Do the craftsmen have a favorite kind of stone? Why?

What are the tools used by stone masons and stone carvers?

How do masons make sure a wall is going to be straight and plumb?

Where do ideas for gargoyles come from?

How is a sculptor's clay model translated into stone? What are the steps in the stone carving process?

SEE IT

Visit Washington National Cathedral at Massachusetts and Wisconsin Avenues NW in Washington, D.C. Walk all the way around the Cathedral and notice the fine stonework in the walls and in the carvings. Can you recognize any of the carved figures?

ACTIVITY:
**Design and Model
a Gargoyle or Grotesque**

Now it's time for you to design and model your own gargoyle! Remember, gargoyles are based on exaggerated features. You may pick an animal, a cartoon character, or a funny version of a friend!

You will need:
blank paper, a pencil, and modeling clay



1. Decide what you are going to make, and draw a picture of it. Since gargoyles are three-dimensional, you should sketch the gargoyle's front, sides, and back. How and where will it attach to the building?

2. Using your picture as a guide, try modeling your gargoyle out of clay. Modeling clay, which you can get at craft stores, works well.

3. If you want your gargoyle to be more permanent, try making it with air-drying or bakeable clay, also available at craft stores.

Imagine your gargoyle staring down at people visiting a huge cathedral!

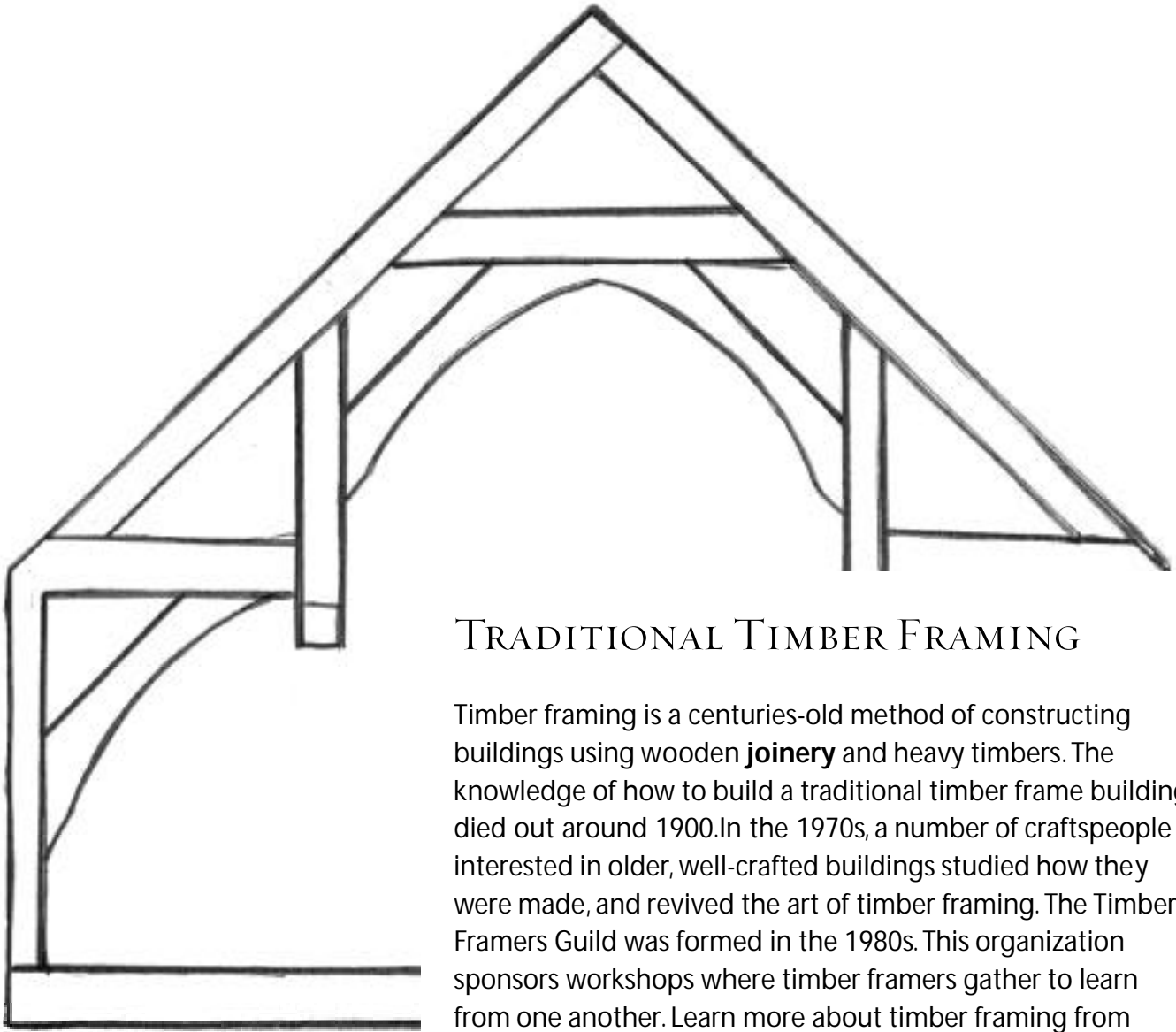

Timber frame truss

TRADITIONAL TIMBER FRAMING

Timber framing is a centuries-old method of constructing buildings using wooden **joinery** and heavy timbers. The knowledge of how to build a traditional timber frame building died out around 1900. In the 1970s, a number of craftspeople interested in older, well-crafted buildings studied how they were made, and revived the art of timber framing. The Timber Framers Guild was formed in the 1980s. This organization sponsors workshops where timber framers gather to learn from one another. Learn more about timber framing from Rudy Christian, his wife Laura Saeger, and their son Carson Christian.

Rudy Christian, Laura Saeger,
and Carson Christian

Like many timber framers, Rudy Christian and his wife Laura Saeger started out building houses in the early 1970s. Both of them came from families involved in the construction business. They both felt that modern construction methods did not produce quality buildings that would last hundreds of years, and they wanted to study and try out older ways of building.

"All the old teachers were gone," says Rudy. "The lessons came from old buildings." By studying the way timber framers built houses and barns that had been standing for generations, Rudy, Laura, and other young builders began to develop methods of reproducing the old ways. Much of their work is done by hand, with tools that were familiar to builders hundreds of years ago.

"The people that did the work back then, when you look at those old buildings, they were masters. No question about it."

— RUDY CHRISTIAN

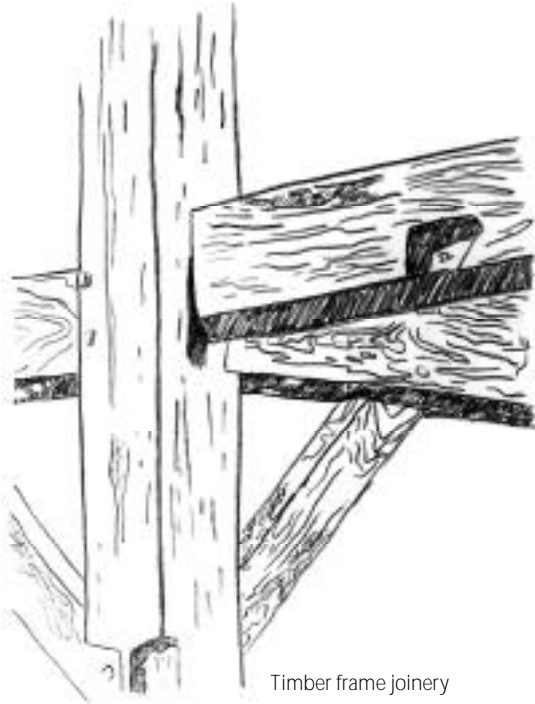

Timber frame joinery

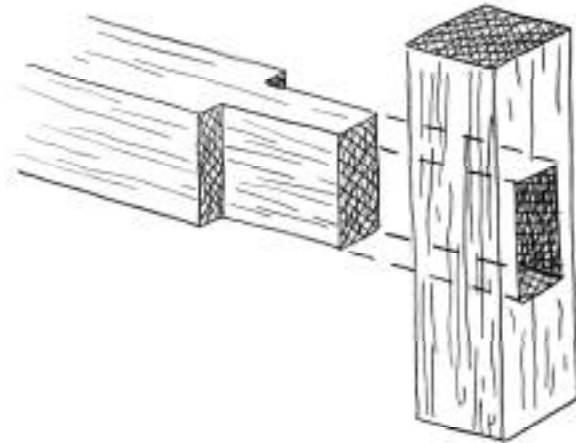

Rudy and Laura helped found the Timber Framers Guild, and feel that they are still learning from their fellow timber framers. As Rudy explains it, "We have become a community of people who share everything." They have participated in many Guild workshops and educational programs, and have personally taught many younger timber framers. Their son Carson, who began working with them as early as age ten, is also a timber framer.

A number of women, like Laura, are involved in timber framing. As she says, "A woman is just as capable of using those tools as a man is, without question."

QUESTIONS TO CONSIDER:

How are timbers put together with “**mortise and tenon**” joints?

What are the different tools used by timber framers? How are they used?

How do timber framers measure and lay out the timbers?

What kinds of wood make the best timber frame buildings? Why?

Are different techniques used for constructing new timber frame buildings and restoring old ones?

How does someone become a timber framer?

Why do timber framers tie a small tree to the top of a building after raising it?

SEE IT

Visit the *Within These Walls...* exhibition at the Smithsonian Institution National Museum of American History to see a traditional 18th-century timber frame house.

ACTIVITY:

Construct a Building Frame Out of “Timbers”

Pictured here is the working drawing for the timber frame building constructed as part of the *Masters of the Building Arts* program at the 2001 Smithsonian Folklife Festival. You can try your hand at “timber framing” by reproducing the frame of this building using drinking straws or pipe cleaners. As you assemble the building, think about being part of a timber framing crew as they “raise” a building!

You will need:

large-sized (approximately 7 1/2 inch-long) colored, non-bendable drinking straws, as follows: 11 full-length straws, 9 straws cut to 5” (Optional: use sturdy pipe cleaners instead)

Modeling clay

Gumdrops (optional)

1. Following the diagram, assemble the gable ends (either end of the building) and the middle section flat on a table, using small lumps of clay to stick the “timber” straws together. You may wish to experiment with notching (cutting away part of) the straw ends to make them easier to put together. You may also use gumdrops to put the joints together instead of clay. Stick one straw into a gumdrop, and the other at right angles. If using pipe cleaners, you may just bend the ends over each other to make the joints. Make sure the “timbers” are straight, as shown.

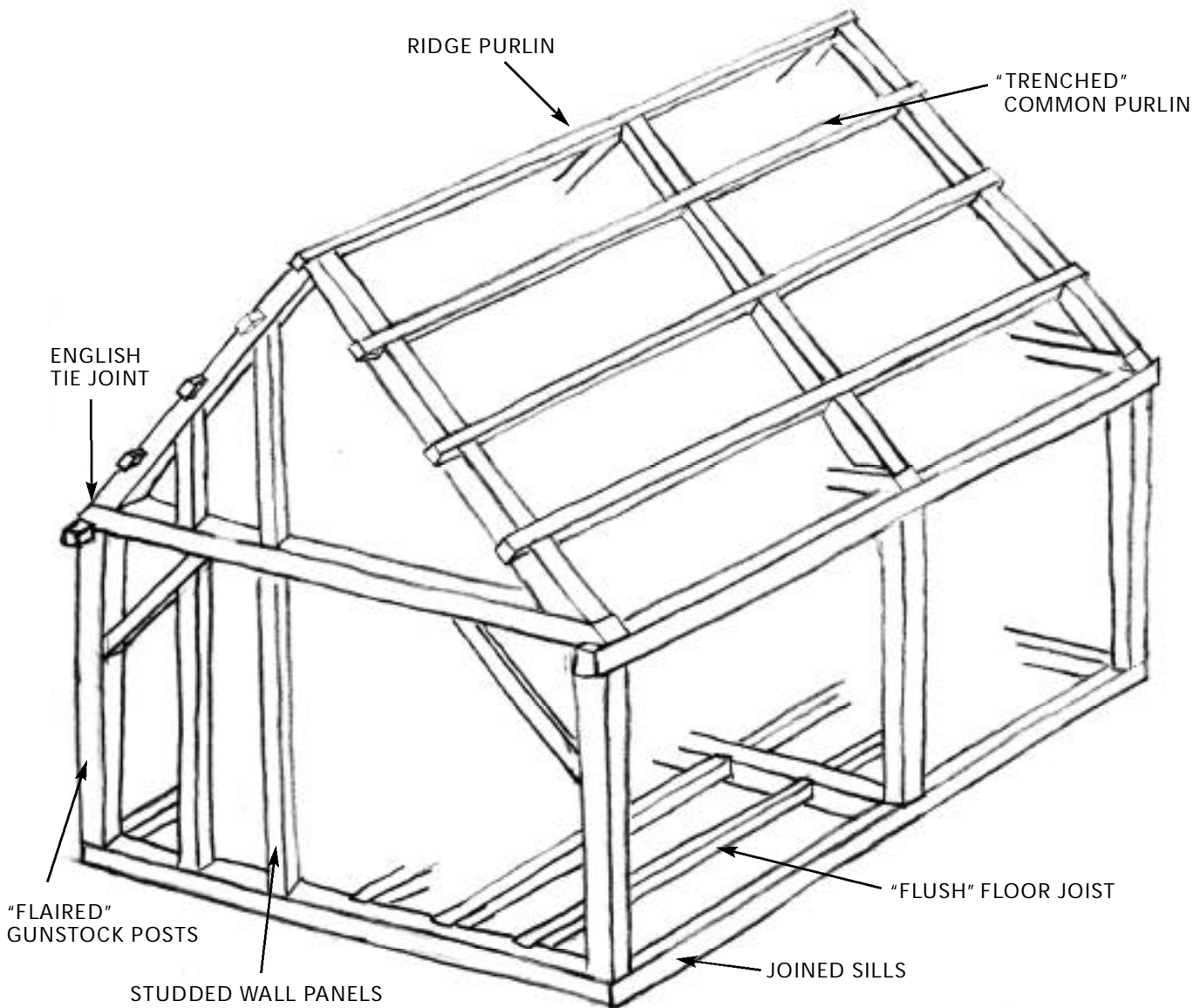

2. "Raise" the building by placing one gable end upright. Imagine how a crew of timber framers must do this with ropes and pulleys in real life! Lean this end of the building against a box or other sturdy object. Do the same with the other gable end frame.

3. Join the two gable ends together with the long "sills" (see diagram) on either side, using clay to hold in place.

4. Add the middle section, securing with clay.

5. Add the "ridge purlin" (see diagram). Then add, one by one, the rest of the roof purlins.

If you have done everything "square" (that is, nice and straight), your building should stand, just like a real timber **frame** building. (However, your clay or gum drop "joints" are nothing like the beautiful mortice and tenon joints on real timber framed buildings). Tie a little sprig of pine or other branch with small leaves at the top of one gable end, just as timber framers do when they are done with a "raising"! They call this "the blessing tree."

GLOSSARY

Anvil – a heavy iron block frequently faced with steel, on which blacksmiths and ornamental ironworkers hammer metal into desired shapes

Apprentice – a person who works for another in order to learn a trade

Draftsman – a worker skilled at drawing architectural features that will be used as a guide for building

Finial – the topmost portion of a pinnacle (decorative turret), usually sculptured as an elaborate ornament with an upright stem and cluster of crockets (curved foliage), and often carved of stone or wood

Forge – the workshop of a blacksmith, also used to indicate the place where the blacksmith heats his or her iron (open fireplace, portable heating source, etc.)

Gargoyle – a roof spout projecting from a gutter to carry rainwater away from the wall of a building, usually carved to represent a grotesque human or animal figure

Glaze – a thin layer of transparent color, added to a clay piece, usually before firing in a kiln, in order to change the appearance of the surface

Grotesque – a decorative carving fashioned with monstrous or fantastic features

Guild – an association organized to maintain standards and to protect the interests of members of a trade, and sometimes to train new people interested in the trade, or share information about the techniques of the trade

Joinery – woodwork made by a carpenter, especially at the joints, or corners, of buildings

Journeyman – a craftsman who has passed the apprentice stage and is fully qualified to work in his or her trade

Kiln – a furnace or oven for burning, baking, or drying such materials as clay

Leading (pronounced "led-ing") – a framing of lead (a soft metal); in stained glass work, the leading holds the glass pieces together

Mason – a craftsperson who builds with stone or brick

Mentor – a wise and trusted counselor or teacher

Mortise and Tenon Joint – in timber framing, a joint that is constructed so that it does not require nails or other hardware to stay together. A mortise is a hole, slot, or groove cut into a piece of timber that receives a tenon, which is a projecting member of a piece of timber (see illustration in the Timber Framing section of this guide).

Nave – the central part of a church

Quarry – an excavation or pit, usually open to the air, from which building stone, slate, or the like, is obtained by cutting, blasting, etc.

Restoration – reconstruction of an old building, as close to the original as possible

Ridge Purlin – One of several horizontal timbers supporting the rafters of a roof

Scale – making an architectural drawing that reproduces the parts of a building or its features on paper using measurements in proportion to one another, as they will appear in real life. In other words, if a wall is to be built ten feet high and a floor twenty feet long, the draftsman might draw the wall ten inches high and the floor twenty inches long, using a ratio of one inch per foot

Sill – a horizontal beam that supports the frame of a building

Trowel – a hand tool used by plasterers, bricklayers, stonemasons, and other craftworkers to spread soft or plastic material, like plaster or mortar

TO LEARN MORE

ADOBE

Bunting, Bainbridge. 1974. *Of Earth and Timbers Made: New Mexico Architecture*. Photographs by Arthur Lazar. Albuquerque: University of New Mexico Press.

Nabokov, Peter. 1981. *Adobe: Pueblo and Hispanic Folk Traditions of the Southwest*. Washington, D.C.: Smithsonian Institution, Office of Folklife Programs.

ARCHITECTURAL TERRA COTTA

Kurutz, Gary F., and Mary Swisher. 1989. *Architectural Terra Cotta of Gladding, McBean*. Sausalito, Calif.: Windgate Press.

Tunick, Susan. 1997. *Terra Cotta Skyline*. Photographs by Peter Mauss. New York: Princeton Architectural Press.

DRY STONE WALLS

Allport, Susan. 1990. *Sermons in Stone: The Stone Walls of New England and New York*. Illustrations by David Howell. New York: W.W. Norton.

Vivian, John. 1976. *Building Stone Walls*. Charlotte, Vt.: Garden Way Publishing.

ORNAMENTAL IRONWORK

Lyons, Mary E. 1997. *Catching the Fire: Philip Simmons, Blacksmith*. Illustrations by Mannie Garcia. Boston: Houghton Mifflin.

Vlach, John Michael. 1997. *Charleston Blacksmith: The Work of Philip Simmons*. Columbia: University of South Carolina Press.

Andrews, Jack. 1994. *New Edge of the Anvil: A Resource Book for the Blacksmith*. Drexel Hill, PA: Skipjack Press, Inc.

Web site for the Artist-Blacksmith's Association of North America: <http://www.abana.org>

Web site for The Philip Simmons Foundation: <http://www.philipsimmons.org>

STAINED GLASS WINDOWS

Morris, Elizabeth Ann. 2000. *Stained and Decorative Glass*. Secaucus, N.J.: Chartwell Books.

Website for the Stained Glass Association of America: <http://www.stainedglass.org>

STONE MASONRY AND CARVING

Fallen, Anne-Catherine, ed. 1995. *Washington National Cathedral*. Washington, D.C.: Washington National Cathedral Guidebooks.

Hunt, Marjorie. 1999. *The Stone Carvers: Master Craftsmen of Washington National Cathedral*. Washington, D.C.: Smithsonian Institution Press.

Web site for stone carver Walter Arnold: <http://www.stonecarver.com>

TIMBER FRAMING

Benson, Tedd. 1997. *The Timber Frame Home*. Illustrations by Brian Smeltz. Newton, Conn.: Taunton Press.

Web site for the Timber Framers Guild: <http://www.tfguild.org>

NATIONAL BUILDING MUSEUM

<http://www.nbm.org>

AMERICAN INSTITUTE OF ARCHITECTS

<http://www.aia.org>

NATIONAL TRUST FOR HISTORIC PRESERVATION

<http://www.nthp.org>

INTERNATIONAL MASONRY INSTITUTE

<http://www.imiweb.org>

PRESERVATION TRADES NETWORK

<http://www.ptn.org>

ASSOCIATED GENERAL CONTRACTORS OF AMERICA — CONSTRUCTION FUTURES PROGRAM

(educational outreach programs for elementary and high-school-level students that support school curriculum with hands-on building activities)
<http://www.constructionfutures.org>

CREDITS

Authors

Betty Belanus and Marjorie Hunt

Masters of the Building Arts Curator

Marjorie Hunt

Masters of the Building Arts Coordinator

Jim Deutsch

Editor

Carla Borden

Designer

Caroline Brownell

Illustrator

Lynn Murphy

Festival Aide/Family Activity Tent Coordinator

Tracy Clonts

Interns

Valerie Lambert, Beth Hicks, Jenni Fuchs

Activity Tester

M.E. Francis

Website

Peter Seitel and Stephanie Smith

Special thanks to Sara Otto-Dinez, Jean Lee and the National Capital Art Glass Guild, Eileen Langholtz and the Education Staff of the National Building Museum, the Timber Framers Guild, Mary Lyons, Rossie Colter, and John Vlach.

Smithsonian Institution
Center for Folklife and Cultural Heritage
www.folklife.si.edu