



US Army Corps
of Engineers®
Engineer Research and
Development Center

Strategic Environmental Research and Development Program

Distribution and Fate of Energetics on DoD Test and Training Ranges: Interim Report 6

J. C. Pennington, T. F. Jenkins, G. Ampleman, S. Thiboutot,
A. D. Hewitt, S. Brochu, J. Robb, E. Diaz, J. Lewis, H. Colby,
R. Martel, K. Poe, K. Groff, K. L. Bjella, C. A. Ramsey, C. A. Hayes,
S. Yost, A. Marois, A. Gagnon, B. Silverblatt, T. Crutcher, K. Harriz,
K. Heisen, S. R. Bigl, T. E. Berry, Jr., J. Muzzin, D. J. Lambert,
M. J. Bishop, B. Rice, M. Wojtas, M. E. Walsh, M. R. Walsh,
and S. Taylor

November 2006

Distribution and Fate of Energetics on DoD Test and Training Ranges: Interim Report 6

Judith C. Pennington, Thomas E. Berry, Jr.,
and Michael J. Bishop
*U.S. Army Engineer Research and Development
Center, Environmental Laboratory
3909 Halls Ferry Road, Vicksburg, MS 39180-6199*

Thomas F. Jenkins, Alan D. Hewitt, Dennis J.
Lambert, Marianne E. Walsh, Michael R. Walsh,
Kevin L. Bjella, Susan Bigl, and Susan Taylor
*U.S. Army Engineer Research
and Development Center
Cold Regions Research and Engineering Laboratory
72 Lyme Road, Hanover, NH 03755-1290*

Guy Ampleman, Sonia Thiboutot, Annie Gagnon,
André Marois, Sylvie Brochu, and Emmanuela Diaz
*Defence Research and Development
Canada-Valcartier
2459 Pie XI Blvd. North
Val-Bélair, Quebec, G3J 1X5*

Jeff Lewis and Richard Martel
*Institut National de la Recherche Scientifique
880 Chemin Ste-Foy, Bureau 840
490 rue de la Couronne, Quebec G1K 9A9*

Sally L. Yost and Charolett A. Hayes
*SpecPro, Inc.
4815 Bradford Dr. NW, Suite 201
Huntsville, AL 35805-1948*

Charles A. Ramsey
*Envirostat, Inc.
P.O. Box 636, Fort Collins, CO 80522-0636*

Bryan Silverblatt and Ken Poe
*Naval Explosive Ordnance Disposal
Technology Division
2008 Stump Neck Road
Indian Head, MD 20640-5070*

Thomas A. Crutcher
*U.S. Army Redstone Technical Test Center
Redstone Arsenal, AL 45898*

Herb Colby, Kimberly Groff, Joanne Muzzin,
Benjamin Rice, Joseph Robb, and Marie Wojtas
*AMEC Earth and Environmental
239 Littleton Road, Suite 1B
Westford, MA 01886-3598*

Karilyn Heisen
*AMEC Earth & Environmental
285 Davidson Avenue, Somerset, NJ 08873-4153*

J. Kimberly Harriz
*AMEC Earth and Environmental
1405 West Auto Drive, Tempe, AZ 85284-1016*

Interim report

Approved for public release; distribution is unlimited.

Abstract: Understanding the potential for generation and transport of residual explosives is necessary to sustain live-fire training ranges. The objective of this study was to characterize the distribution and fate of explosive residues from various training activities. The physical and chemical properties, concentrations, and distribution of residues in soils, and the potential for transport to groundwater were defined. Surface soils associated with impact craters, target areas, and firing points on U.S. and Canadian ranges were characterized. Residues from high-order, low-order, and blow-in-place detonations were described and quantified. Parameters suitable for use in fate and transport models and environmental risk assessments were determined for constituents of concern. Results demonstrated that residues are specific to range activities. Demolition areas, low-order detonations sites, and firing positions have great potential for accumulation of residues. Demolition typically generates small areas of relatively high concentrations. Low-order detonations generate primarily large solid particles reflecting the composition of the predetonation explosive. Artillery and mortar impact areas tend to have low concentrations of widely distributed constituents. Firing positions may exhibit high concentrations of propellants. Results of this study provide a realistic evaluation of training range residues and a scientific basis for development of control measures for explosives residues.

DISCLAIMER: The contents of this report are not to be used for advertising, publication, or promotional purposes. Citation of trade names does not constitute an official endorsement or approval of the use of such commercial products. All product names and trademarks cited are the property of their respective owners. The findings of this report are not to be construed as an official Department of the Army position unless so designated by other authorized documents.

DESTROY THIS REPORT WHEN NO LONGER NEEDED. DO NOT RETURN IT TO THE ORIGINATOR.

Contents

Figures and Tables	viii
Preface	xiii
Notation	xvii
1 Introduction	1
Background	1
Scope of Project ER-1155.....	1
Objectives	3
Related and leveraged studies.....	3
Summary of 2004 results.....	8
<i>Sampling strategies</i>	8
<i>Low-order detonations</i>	9
<i>Site characterization</i>	9
<i>Cracked shells as source for leaching</i>	11
<i>Blow-in-place detonations of 155-mm projectiles</i>	11
<i>Photochemical degradation of Composition B and its components</i>	12
<i>Conclusions</i>	12
FY05 execution.....	14
2 Update on Massachusetts Military Reservation	16
Introduction	16
Site overview.....	16
Long-term groundwater monitoring program.....	34
<i>Impact Area</i>	35
<i>Soil</i>	36
<i>Demolition Area 1</i>	40
<i>Demolition Area 2</i>	43
<i>Southeast Ranges</i>	44
<i>Former A Range Gravity Anti-tank Range</i>	48
<i>Phase IIb and munition survey project sites</i>	51
<i>Northwest Corner</i>	52
Overall conclusions for MMR.....	55
References.....	57
3 Assessment of 100 Years of Military Training in Canada: The Case of Canadian Forces Base Petawawa	60
Introduction	60
Experimental.....	61
<i>Sample handling and treatment</i>	61
<i>Sample analysis</i>	62
Range description and sampling strategy	63

<i>Impact Area 2 – Direct-fire target area</i>	64
<i>Impact Area 6 – Direct fire target area</i>	73
<i>Impact Areas 7 and 8 – Indirect fire</i>	73
<i>A Range – Anti-tank/machine gun range</i>	75
<i>Small arms ranges</i>	77
Results and discussion	79
<i>Impact Area 2 - Direct fire target area</i>	79
<i>Impact Area 6 – Direct fire target area</i>	84
<i>Impact Areas 7 and 8 - Indirect fire</i>	84
<i>A Range - Anti-tank/machine gun range</i>	85
<i>Small arms ranges</i>	87
Summary and conclusions	87
Acknowledgements	90
References.....	90
4 Assessment of the Contamination by Energetic Materials and Metals in Soil and Biomass at Western Area Training Center in Wainwright, Alberta (Phase I)	95
Introduction	95
Experimental.....	98
<i>Background sampling</i>	98
<i>Sample handling, treatment, and analytical methods</i>	98
Range descriptions and sampling strategies	100
<i>Background sampling</i>	100
<i>Grenade Range (#2)</i>	100
<i>Light/medium Mortar Range (#12)</i>	101
<i>Demolition Range (#14)</i>	101
<i>Armored Fighting Vehicle (AFV) Static Range (# 16)</i>	102
<i>Platoon Field Firing Defensive Position (#21)</i>	103
<i>Vernonburg Site (Ammunition Dump)</i>	103
<i>Small arms ranges</i>	104
<i>Anti-tank ranges</i>	106
Results and discussion	108
<i>Vegetation samples analyses</i>	108
<i>Grenade Range (#2)</i>	108
<i>Light/medium Mortar Range (#12)</i>	109
<i>Demolition Range (#14)</i>	109
<i>Armored Fighting Vehicle Static Range (#16)</i>	110
<i>Platoon Field Firing Defensive Position (#21)</i>	110
<i>Vernonburg Site (Ammunition Dump)</i>	110
<i>Small arms ranges</i>	111
<i>Anti-tank ranges</i>	113
<i>Vertical soil profiling</i>	118
Conclusion	118
References.....	121
5 Sampling Studies at an Air Force Live-Fire Bombing Range Impact Area	127
Introduction	127

Objectives	130
Methods	130
<i>Soil sampling</i>	130
<i>Sample processing and subsampling</i>	132
<i>Extract analysis</i>	133
<i>Quality Assurance/Quality Control (QA/QC)</i>	135
Results and discussion	135
<i>Crater from a low-order 2000-lb bomb</i>	135
<i>Discrete samples for 10-m × 10-m grid near low-order 2000-lb bomb crater</i>	136
<i>Variability of discrete samples within the 1-m × 1-m cells</i>	142
<i>Multi-increment samples for 10-m × 10-m Grid A near low-order 2000-lb bomb crater</i>	142
<i>Profile samples within 10-m × 10-m Grid A</i>	146
<i>10-m × 10-m Grid B not heavily impacted by low-order 2000-lb bomb crater</i>	147
<i>100-m × 100-m grids</i>	151
<i>Other crater samples</i>	153
<i>Arroyo downslope of the live-fire bombing range</i>	153
<i>Demolition range</i>	154
<i>Estimation of sample processing and determination error for these samples</i>	157
Conclusions	160
References	161
6 Explosive Residues from Blow-in-Place Detonations of Artillery Munitions	164
Introduction	164
<i>Background</i>	164
<i>Objective and approach</i>	164
<i>Benefits</i>	165
Materials and methods	165
<i>Test site</i>	165
<i>Detonations</i>	165
<i>Test protocol</i>	168
<i>Sampling</i>	169
<i>Statistical analytes</i>	173
Results and discussion	173
<i>Total mass</i>	173
<i>Mass with distance</i>	182
<i>Chemical composition of residues</i>	182
Conclusions	184
References	184
7 Occurrence of Metals and Organic Compounds Other Than Explosives in Firing Range Soils	186
Introduction	186
Methods	189
Results	190
<i>Other organics, including Halowaxes</i>	190
<i>Metals</i>	193

Explosives	200
Soil properties	202
Conclusions	203
References.....	203
8 Transport of Residues from Cracked Unexploded Ordnance Through the Vadose Zone During Springtime Aquifer Recharge	205
Introduction	205
Experimental.....	207
Source terms	207
Apparatus	208
Method.....	212
Results and discussion	212
Conclusion	222
References.....	222
9 Explosive Residues from Low-Order Detonations of Artillery Munitions	225
Introduction	225
Background	225
Objectives	227
Materials and methods.....	227
Detonations	227
Detonation properties.....	231
Detonation configurations	233
Residue recovery.....	234
Results	235
Total mass recovered.....	235
Energy yields.....	236
Relationship between energy yield and mass recovered	238
Relationship between mass recovered and areal distribution.....	239
Particle size distribution.....	241
Chemical composition of residues	241
Conclusions	245
References.....	246
10 Summary and Conclusions.....	248
Introduction	248
Summary of specific findings in 2005.....	248
Site characterization	248
Blow-in-place detonations	250
Fate and transport	250
Low-order detonations.....	251
Conclusions	251
Summary of data gaps filled and remaining to date.....	252

Appendix A: Bibliography of ER-1155 Publications.....	267
Appendix B: Bibliography of Camp Edward Publications in FY2005.....	279
Appendix C: Particle Size Distribution from 2003 Studies	283
Report Documentation Page	

Figures and Tables

Figures

Figure 1-1. Installations where characterization testing has been conducted. Munitions tests were conducted at other sites.	2
Figure 2-1. Distribution of detections of MC in soil at Camp Edwards for samples collected from 1 October 2004 through 30 September 2005.	32
Figure 2-2. Distribution of detections of MC in groundwater at Camp Edwards for samples collected from 1 October 2004 through 30 August 2005.	33
Figure 2-3. Cracked open 155-mm HE projectile with exposed Composition B behind aluminum booster charge.	37
Figure 3-1. Map of Area 2.	65
Figure 3-2. Setting of Juliet Tower Firing Point and sampling design for the main firing pad.	67
Figure 3-3. General setting and sampling pattern for Hotel Tower and old anti-tank range.	69
Figure 3-4. Delta Tower firing point.	70
Figure 3-5. Grenade Range sampling pattern.	71
Figure 3-6. Location of sampling decision units at demolition range.	74
Figure 3-7. General setting of A Range and sampling location.	76
Figure 4-1. Schematic of the sampling in Grenade Range #2.	101
Figure 4-2. Description of firing point sampling in Range 16.	102
Figure 4-3. Illustration of firing position in Range 21.	103
Figure 4-4. The 12 wooden targets and first firing position at 93 m in Range 1.	105
Figure 4-5. Representation of target area in Range 1.	105
Figure 4-6. Firing positions and shooting butt of Range 24.	106
Figure 4-7. Sampling pattern used at firing positions in anti-tank ranges.	107
Figure 4-8. Influence of distance from firing point on contamination for grenade range.	109
Figure 4-9. Contamination around target at Anti-tank Ranges #13 and #22.	116
Figure 4-10. Vertical sampling in one of two holes 60-cm deep at firing point in Range 22.	119
Figure 5-1. Sampling design used by Ampleman et al. (2003) at Cold Lake Air Weapons Range live-fire bombing range, resulting in 26 sections around a target.	128
Figure 5-2. Establishing circular sampling pattern surrounding a tank target at live-fire bombing range impact area at Cold Lake Air Weapons Range.	129
Figure 5-3. Systematic-random 50-increment sampling pattern used for collecting samples in grid areas.	132
Figure 5-4. Layout of the 100 cells (1-m × 1-m) within Grid A near 2,000-lb bomb crater at Holloman Air Force Base.	133
Figure 5-5. Sampling in front of low-order 2,000-lb bomb in crater at Holloman Air Force Base.	136
Figure 5-6. Area sampled for energetic residues near a 2,000-lb bomb crater.	137
Figure 5-7. Grid areas sampled at Holloman Air Force Base.	138

Figure 5-8. TNT concentrations (mg/kg) in 100 discrete samples collected within 10-m × 10-m Grid A (Figure 5-7) at Holloman Air Force Base near a low-order 2,000-lb bomb.....	140
Figure 5-9. TNT concentrations (mg/kg) in nine discrete samples collected at six 1-m × 1-m cells within 10-m × 10-m Grid A (Figure 5-7) near a low-order 2,000-lb bomb.	143
Figure 5-10. Depth profile of TNT concentrations (mg/kg) in selected cells within 10-m × 10-m Grid A near a low-order 2,000-lb bomb.....	147
Figure 6-1. Concentric circles for sampling sand after detonations.....	166
Figure 6-2. Field team recovers detonation residues by sweeping sand in concentric circles around detonation bucket.	167
Figure 6-3. 81-mm mortar rounds (a) with shaped charge, (b) C4, (c) TNT, and (d) 60-mm mortar rounds with binary.	169
Figure 6-4. Surface sand sampling through a 10-cm × 10-cm window cut into a 33-cm × 23-cm baking pan.	171
Figure 6-5. (a) 105-mm artillery projectile with Kinepak donor; (b) donor and projectile covered by two sand bags to promote high-order detonation by confining the donor.....	174
Figure 6-6. Total mass for each round and donor combination. No residue was observed for 60-mm mortar rounds detonated with binary charge.....	175
Figure 6-7. Mass of HMX, RDX, and TNT with distance for each donor charge tested with 60-mm mortar rounds.	176
Figure 6-8. Total mass of HMX, RDX, and TNT with distance for each donor charge tested with 81-mm mortar rounds.	179
Figure 6-9. Total mass of HMX, RDX, and TNT with distance for each donor charge tested with 105-mm projectiles.....	181
Figure 6-10. Total mass of HMX, RDX, and TNT with distance for each donor charge tested with 155-mm projectiles.....	181
Figure 8-1. Surficial deposits around CFB Valcartier.	209
Figure 8-2. Grain size distribution of soil used in unsaturated column.	210
Figure 8-3. Soil column apparatus.	210
Figure 8-4. Cumulative inflow to columns.....	211
Figure 8-5. Grain size distribution of detonation residue.....	213
Figure 8-6. Cumulative outflow from columns.	214
Figure 8-7. RDX outflow concentrations.	215
Figure 8-8. HMX outflow concentrations.....	215
Figure 8-9. TNT outflow concentrations.	216
Figure 8-10. Br outflow concentrations.....	216
Figure 8-11. Cumulative mass transport of RDX in spring effluent.	219
Figure 8-12. Cumulative mass transport of TNT in spring effluent.	219
Figure 8-13. Cumulative mass transport of HMX in spring effluent.....	220
Figure 9-1. 60-mm mortar with MK 88 shaped charge held in place by a pipe clamp and coil of wire.	228
Figure 9-2. 60-mm mortar with FLSC strapped to the side.	229
Figure 9-3. 60-mm mortar with Vulcan Shaped Charge.	229
Figure 9-4. Positioning the MCD relative to an 81-mm mortar.....	230
Figure 9-5. Steel test table that was 4.23 m ² by 0.76 m high.....	232

Figure 9-6. Configuration for sweeping residue from the tarp.....	235
Figure 9-7. Total residual mass recovered for each detonation.....	236
Figure 9-8. Mass versus energy yield for each round detonated in 2003 and 2004.	239
Figure 9-9. Mean mass with distance, 2004 data only.....	240
Figure 9-10. Distribution of particles sized for each type of round detonated in 2003 and 2004.....	243

Tables

Table 2-1. Number of samples collected from 1 October 2004 through 30 September 2005 by location and medium	17
Table 2-2. Summary of Camp Edwards validated soil data from 1 October 2004 through 30 September 2005.....	18
Table 2-3. Summary of Camp Edwards validated groundwater data from 1 October 2004 through 30 September 2005.....	25
Table 4-1. Soil and biomass samples collected during the campaign at WATC Wainwright.	107
Table 4-2. Concentrations of NG obtained for samples collected at 100- and 200-m firing lines of the small arms ranges.....	111
Table 4-3. Approximate number of munitions fired in anti-tank ranges.	114
Table 4-4. Concentrations (mg/kg) of NG and HMX found behind (BFP) and in front of (FFP) the firing point in anti-tank Ranges #13 and #22.	115
Table 4-5. Metal concentrations around targets at anti-tank ranges.....	115
Table 4-6. Concentration around targets at anti-tank ranges.....	117
Table 5-1. Concentrations of energetic compounds in multi-increment soil samples from a crater containing a low-order 2,000-lb bomb.....	139
Table 5-2. Concentrations of energetic compounds in 100 discrete samples collected in 1-m × 1-m cells within 10-m × 10-m Grid A near low-order 2,000-lb bomb crater.....	141
Table 5-3. Concentrations of energetic compounds in replicate samples from individual cells within 10-m × 10 m Grid A near low-order bomb crater.	144
Table 5-4. Concentrations of energetic compounds in multi-increment soil samples for a 10-m × 10-m area (Grid A) impacted by low-order 2,000-lb bomb.	146
Table 5-5. Concentrations of energetic compounds in profile samples within 10-m × 10-m Grid A near the low-order bomb crater.	148
Table 5-6. Results for 25 discrete samples collected in 2-m × 2-m cells within 10-m × 10-m Grid B about 20 m north-northeast from low-order 2,000-lb bomb crater.....	150
Table 5-7. Concentrations of energetic compounds in multi-increment samples from 10-m × 10-m Grid B about 20 m north-northeast from low-order bomb crater.	151
Table 5-8. Concentrations of energetic compounds in 100-increment soil samples from two 100-m × 100-m grids.....	152
Table 5-9. Concentrations of energetic compounds in multi-increment soil samples from other craters.	153
Table 5-10. Concentrations of energetic compounds in multi-increment soil samples from arroyos north and south of access road.	155
Table 5-11. Concentrations of energetic compounds in multi-increment samples from a demolition range.	156

Table 5-12. Results for energetic compounds in replicate laboratory subsamples.	158
Table 6-1. Description of test rounds, donor charges, and number of sandbags.	168
Table 6-2. Detonation supporting hardware.....	170
Table 6-3. Explosives and degradation products of explosives for which samples were analyzed.	172
Table 6-4. Results of statistical analyses of the 60- and 81-mm mortar rounds data by donor for detections of HMX, RDX, TNB, and TNT.....	177
Table 6-5. Results of statistical analyses of the 105- and 155-mm mortar round data by donor for detections of HMX, RDX, and TNT.	180
Table 6-6. Detections of analytes other than RDX, HMX, and TNT.	183
Table 7-1. Abbreviations and chemical names of organic compounds other than explosives for which firing range soils were analyzed.....	187
Table 7-2. Abbreviations and chemical names of Halowaxes for which firing range soils were analyzed.....	187
Table 7-3. Abbreviations and chemical names of metals for which firing range soils were analyzed.	188
Table 7-4. Abbreviations and chemical names of explosives and explosives-related compounds for which firing range soils were analyzed.....	188
Table 7-5. Analytical methods.....	189
Table 7-6. Organic compounds other than explosives that were detected in firing range soils, mg/kg.	191
Table 7-7. Detections in soils (mg/kg) of metals for which USEPA has established Primary Drinking Water Standards.	194
Table 7-8. Detections in soils (mg/kg) of metals for which USEPA has established Secondary Drinking Water Standards.	195
Table 7-9. Other metals for which soil samples were analyzed.....	197
Table 7-10. Background metals concentrations on several Canadian ranges, mg/kg.....	199
Table 7-11. Detections of explosives, explosives-related compounds, and two propellant components in firing range soils, mg/kg.	200
Table 7-12. Properties of test soils that may affect bioavailability and transport of contaminants.....	202
Table 8-1. Source terms used on columns.	208
Table 8-2. Energetic material concentrations in first autumn outflow.	220
Table 9-1. Mean mass balance of explosive contained in each type of round.	236
Table 9-2. Energy yield and mass recovered after each detonation.	237
Table 9-3. Mean (standard deviation) of 2004 mass with distance data, g.	240
Table 9-4. Linear regression parameters of mass versus distance.	240
Table 9-5. Mass, g, of residue in each particle size fraction.....	242
Table 9-6. Average mass (standard deviation) and ratio of TNT to RDX recovered from the < 0.25 to 4-mm size fractions of each round, g.....	244
Table 9-7. Mean (standard deviation) of analytes other than RDX and TNT in residues collected in 2004, g.	244
Table 10-1. Summary of data gaps filled and remaining to date in ER-1155.....	253
Table 10-2. Data gaps beyond the scope of CP-1155.....	262

Table C1. Mass (g) of residue in each particle size fraction from 60-, 105-, and 155-mm rounds283

Preface

This report was prepared by the U.S. Army Engineer Research and Development Center (ERDC), Environmental Laboratory (EL), Vicksburg, MS, and the Cold Regions Research and Engineering Laboratory (CRREL), Hanover, NH, in partnership with Defence Research and Development Canada - Valcartier (DRDC-Val), Quebec, and AMEC Earth and Environmental, Inc. (AMEC), Westford, MA. The research was sponsored by the Strategic Environmental Research and Development Program (SERDP), Arlington, VA, Bradley P. Smith, Executive Director, and Dr. Jeff Marqusee, Technical Director, under Compliance Project Number CP-1155, now Environmental Restoration Project Number ER-1155. The principal investigator was Dr. Judith C. Pennington, Environmental Processes and Engineering Division (EPED), EL. Co-principal investigators were Dr. Thomas F. Jenkins, Environmental Sciences Branch (ESB), CRREL; Drs. Guy Ampleman and Sonia Thiboutot, DRDC-Val; and Jay Clausen, formerly at AMEC, now at CRREL, and Joe Robb, AMEC.

Various chapters of this report were reviewed by Drs. Jeff Davis, Mark Dortch, and Mansour Zakikhani, EL, Marianne Walsh, CRREL, Dr. Clarence L. Grant, Professor Emeritus, University of New Hampshire, Durham, NH, and Dr. Katerina Dontsova, SpecPro, Inc, Huntsville, AL. The study was conducted under the direct supervision of Dr. Richard E. Price, Chief, EPED, EL, and Dr. Beth Fleming, Director, EL.

COL Richard B. Jenkins was Commander and Executive Director of ERDC. Dr. James R. Houston was Director.

This report may be cited as one document or by chapters as follows:

Whole document:

Pennington, J. C., T. F. Jenkins, G. Ampleman, S. Thiboutot, A. D. Hewitt, S. Brochu, J. Robb, E. Diaz, J. Lewis, H. Colby, R. Martel, K. Poe, K. Groff, K. L. Bjella, C. A. Ramsey, C. A. Hayes, S. Yost, A. Marois, A. Gagnon, B. Silverblatt, T. Crutcher, K. Harriz, K. Heisen, S. R. Bigl, T. E. Berry, Jr., J. Muzzin, D. J. Lambert, M. J. Bishop, B. Rice, M. Wojtas, M. E. Walsh, M. R. Walsh, and S. Taylor. 2006. *Distribution and fate of energetics on DoD test and training ranges: Interim Report 6*. ERDC TR-06-12. Vicksburg, MS: U.S. Army Engineer Research and Development Center.

Chapter 1:

Pennington, J. C. 2006. Introduction, Chapter 1. In *Distribution and fate of energetics on DoD test and training ranges: Interim Report 6*. ERDC TR-06-12. Vicksburg, MS: U.S. Army Engineer Research and Development Center.

Chapter 2:

Colby, H., K. Groff, K. Harriz, K. Heisen, J. Muzzin, J. Robb, and M. Wojtas. 2006. Update on Massachusetts Military Reservation, Chapter 2. In *Distribution and fate of energetics on DoD test and training ranges: Interim Report 6*. ERDC TR-06-12. Vicksburg, MS: U.S. Army Engineer Research and Development Center.

Chapter 3:

Brochu, S., E. Diaz, S. Thiboutot, G. Ampleman, A. Marois, A. Gagnon, A. D. Hewitt, S. R. Bigl, M. E. Walsh, M. R. Walsh, K. Bjella, C. Ramsey, and S. Taylor. 2006. Assessment of 100 years of military training in Canada: The case of Canadian Force Base Petawawa, Chapter 3. In *Distribution and fate of energetics on DoD test and training ranges: Interim Report 6*. ERDC TR-06-12. Vicksburg, MS: U.S. Army Engineer Research and Development Center.

Chapter 4:

Diaz, E., S. Brochu, S. Thiboutot, G. Ampleman, A. Marois, and A. Gagnon. 2006. Assessment of the contamination by energetic materials and metals in soil and biomass at Western Area Training Center (WATC) in Wainwright, Alberta (Phase I), Chapter 4. In *Distribution and fate of energetics on DoD test and training ranges: Interim Report 6*. ERDC TR-06-12. Vicksburg, MS: U.S. Army Engineer Research and Development Center.

Chapter 5:

Jenkins, T. F., A. D. Hewitt, C. A. Ramsey, K. L. Bjella, S. R. Bigl, and D. J. Lambert. 2006. Sampling studies at an Air Force live-fire bombing range impact area, Chapter 5. In *Distribution and fate of energetics on DoD test and training ranges: Interim Report 6*. ERDC TR-06-12. Vicksburg, MS: U.S. Army Engineer Research and Development Center.

Chapter 6:

Pennington, J. C., T. Crutcher, C. A. Hayes, S. A. Yost, T. E. Berry, and M. J. Bishop. 2006. Explosive residues from blow-in-place detonations of artillery munitions, Chapter 6. In *Distribution and fate of energetics on DoD test and training ranges: Interim Report 6*. ERDC TR-06-12. Vicksburg, MS: U.S. Army Engineer Research and Development Center.

Chapter 7:

Pennington, J. C., C. A. Hayes, S. A. Yost, and T. F. Jenkins. 2006. Occurrence of metals and organic compounds other than explosives in firing range soils, Chapter 7. In *Distribution and fate of energetics on DoD test and training ranges: Interim Report 6*. ERDC TR-06-12. Vicksburg, MS: U.S. Army Engineer Research and Development Center.

Chapter 8:

Lewis, J., R. Martel, S. Thiboutot, and G. Ampleman. 2006. Transport of residues from cracked unexploded ordnance through the vadose zone during springtime aquifer recharge, Chapter 8. In *Distribution and fate of energetics on DoD test and training ranges: Interim Report 6*. ERDC TR-06-12. Vicksburg, MS: U.S. Army Engineer Research and Development Center.

Chapter 9:

Pennington, J. C., K. Poe, B. Silverblatt, C. A. Hayes, and S. A. Yost. 2006. Explosive residues from low-order detonations of artillery munitions, Chapter 9. In *Distribution and fate of energetics on DoD test and training ranges: Interim Report 6*. ERDC TR-06-12. Vicksburg, MS: U.S. Army Engineer Research and Development Center.

Chapter 10:

Pennington, J. C. 2006. Summary and conclusions, Chapter 10. In *Distribution and fate of energetics on DoD test and training ranges: Interim Report 6*. ERDC TR-06-12. Vicksburg, MS: U.S. Army Engineer Research and Development Center.

Notation

AEC	United States Army Environmental Center
AFB	Air Force Base
AP	Armor piercing
BG	Background Sample
bgs	Below ground surface
BIP	Blow-in-place
bwt	Below water table
CAS	Chemical Abstracts Service
CCME	Canadian Council of Ministers of Environment
CEC	Cation exchange capacity
CF	Canadian Forces
CFAD	Canadian Forces Ammunition Depot
CFB	Canadian Forces Base
CHPPM	Center for Health Promotion and Preventive Medicine
CIA	Central Impact Area
CLAWR	Cold Lake Air Weapons Range
COC	Contaminant of Concern
CP	Compliance Project
CRREL	Cold Regions Research and Engineering Laboratory
DCC	Defence Construction Canada
DGE	Director General Environment, Canadian Department of National Defence
DLE	Director Land Environment, Canadian Department of National Defence
DND	Department of National Defence
DNTs	Dinitrotoluenes
DoD	Department of Defense
DOCIC	Department of Defense Identification Code
DOE	Department of Energy
DRDC	Defence Research and Development Canada
DRDC-Val	Defence Research and Development Canada -Valcartier

EBW	Exploding Bridge Wire
ECO	Ecological soil screening levels
EIS	Environmental impact statement
EL	Environmental Laboratory
EOD	Explosive ordnance disposal
EPA	Environmental Protection Agency
ERDC	Engineer Research and Development Center
FB	Fort Bliss, New Mexico
FERM	Fire Ecology Range Management
FLSC	Flex Linear Shaped Charge
FP	Firing Position
FS	Feasibility Study
FY	Fiscal year
GAC	Granular Activated Carbon
GC-ECD	Gas Chromatography-Electron Capture Detection
GIS	Geographic information system
GPS	Global positioning system
HE	High explosive
HPLC	High Performance Liquid Chromatography
IAGWSP	Impact Area Groundwater Study Program
ICP-MS	Inductively Coupled Plasma- Mass Spectrometry
ID	Inside diameter
INRS-ETE	Institut National de la Recherche Scientifique Eau, Terre et Environnement
IR	Infrared
IRP	Installation Restoration Program
ISQG	Industrial Soil Quality Guidelines
IX	Ion exchange
LAW	Light Anti-tank Weapon
LC/MS	Liquid chromatography/mass spectrometry
LITR	Low-Cost Infantry Training Rounds
LRL	Laboratory Reporting Limit
LTTD	Low Temperature Thermal Desorption

MADEP	Massachusetts Department of Environmental Protection
MBG	Mean background concentrations
MC	Munitions constituents
MCD	Main Charge Disruptor
MCL	Maximum contaminant level
MDL	Method Detection Limit
MEC	Munitions and explosives of concern
MMR	Massachusetts Military Reservation
MPPEH	Material potentially presenting an explosive hazard
MW	Monitoring well
NEW	Net explosive weight
NMR	Nuclear magnetic resonance
NSN	National Stock Number
OB/OD	Open burning/open detonation
OE	Ordnance and Explosives
PAH	Polycyclic aromatic hydrocarbons
PCN	Polychlorinated naphthalenes
PETN	Pentaerythritol tetranitrate
PRG	Preliminary Remediation Goal
PVC	Polyvinyl chloride
QA/QC	Quality Assurance/ Quality Control
R&D	Research and development
RP-HPLC-UV	Reversed-phase high pressure liquid chromatography with ultraviolet detection
RPD	Relative percent difference
RRA	Rapid Response Action
RSD	Relative standard deviation
RSQG	CCME Residential Soil Quality Guideline
SD	Standard deviation
SERDP	Strategic Environmental Research and Development Program
SVOC	Semi-Volatile Organic Compounds
TCLP	Toxicity Characteristic Leaching Procedure
TDR	Time domain reflectometer

TES	Threatened and endangered species
TKN	Total Kjeldahl nitrogen
TLR	Total light radiation
TOC	Total organic carbon
TRI	Toxic Release Inventory
TTCP	The Technical Cooperation Program
USACE	United States Army Corps of Engineers
USEPA	United States Environmental Protection Agency
USGS	United States Geological Survey
UV	Ultraviolet
UXO	Unexploded ordnance
VOC	Volatile Organic Compounds
V/V	Volume to volume
XRT	Experimental Rubbery TNT
YTC	Yakima Training Center, Washington

Chemical Elements and Compounds

2ADNT	2-amino-4,6-dinitrotoluene
4ADNT	4-amino-2,6-dinitrotoluene
2A4NT	2-amino-4-nitrotoluene
4A2NT	4-amino-2-nitrotoluene
AcN	Acetonitrile
aDNTs	Aminodinitrotoluenes
Ag	Silver
Al	Aluminum
As	Arsenic
Ba	Barium
B	Boron
Be	Beryllium
Bi	Bismuth
Ca	Calcium
Cd	Cadmium
Co	Cobalt

Cr	Chromium
Cu	Copper
2,4DANT	2,4-diamino-6-nitrotoluene
2,6DANT	2,6-diamino-4-nitrotoluene
3,5DNA	3,5-dinitroaniline
1,3DNB	1,3-dinitrobenzene
2,4DNT	2,4-dinitrotoluene
2,6DNT	2,6-dinitrotoluene
Fe	Iron
Hg	Mercury
HMX	Octahydro-1,3,5,7-tetranitro-1,3,5,7-tetrazocine, or High Melting Explosive
K	Potassium
KBr	Potassium bromide
Li	Lithium
MX	Hexahydro-1-mononitroso-3,5-dinitro-1,3,5-triazine
Mg	Magnesium
Mn	Manganese
Mo	Molybdenum
3NA	3-Nitroaniline
Na	Sodium
NB	Nitrobenzene
NG	Nitroglycerin
Ni	Nickel
NT	Nitrotoluene
P	Phosphorus
Pb	Lead
Rb	Rubidium
RDX	Hexahydro-1,3,5-trinitro-1,3,5-triazine, or Research Development Explosive
S	Sulphur
Sb	Antimony
Se	Selenium
Sn	Tin

Sr	Strontium
Tetryl	n-methyl-n-2,4,6-tetranitroaniline
Te	Tellurium
Ti	Titanium
Tl	Thallium
TNB	1,3,5-trinitrobenzene
TNT	2,4,6-trinitrotoluene
U	Uranium
V	Vanadium
Zn	Zinc
Zr	Zirconium

1 Introduction

Background

The readiness of the Armed Forces of the United States and Canada is predicated on well-trained troops and continuous enhancements of our munitions arsenal. Sustained use of live-fire training ranges is especially critical to U.S. missions abroad, which currently demand rapid and effective mobilization. Concern that training activities potentially generate environmental contamination in the form of residual munitions constituents has threatened range sustainment. At the inception of Environmental Restoration (ER) Project ER-1155 in 2000, the state of knowledge concerning the nature, extent, and fate of residual munitions constituents was inadequate to ensure environmental stewardship on testing and training ranges. Addressing these issues was critical for managing training ranges in support of military readiness while simultaneously protecting the environment. Environmental Restoration Project ER-1155 was designed to characterize the distribution and fate of energetic residuals from various uses of live-fire munitions during testing and training.

Scope of Project ER-1155

This project was designed to develop techniques for assessing the potential for environmental contamination from energetic materials on testing and training ranges. Techniques were developed to define the physical and chemical properties, concentrations, and distribution of energetics and residues of energetics in soils, and the potential for transport of these materials to groundwater. Other issues, such as off-site transport in surface runoff, or as a component of airborne dust, are also important, but are beyond the scope of the project.

Surface soils associated with impact craters, targets areas, and firing points have been characterized on U.S. and Canadian ranges (Figure 1-1). Residues from high-order, low-order, unconfined charge, and blow-in-place (BIP) detonations have been collected on witness plates, snow, and/or tarps. Analyses of these residues define concentrations and spatial distribution of munitions constituents under various firing activities for specific munitions. Special emphasis has been placed on development of sampling strategies for constituent residues. Transport parameters

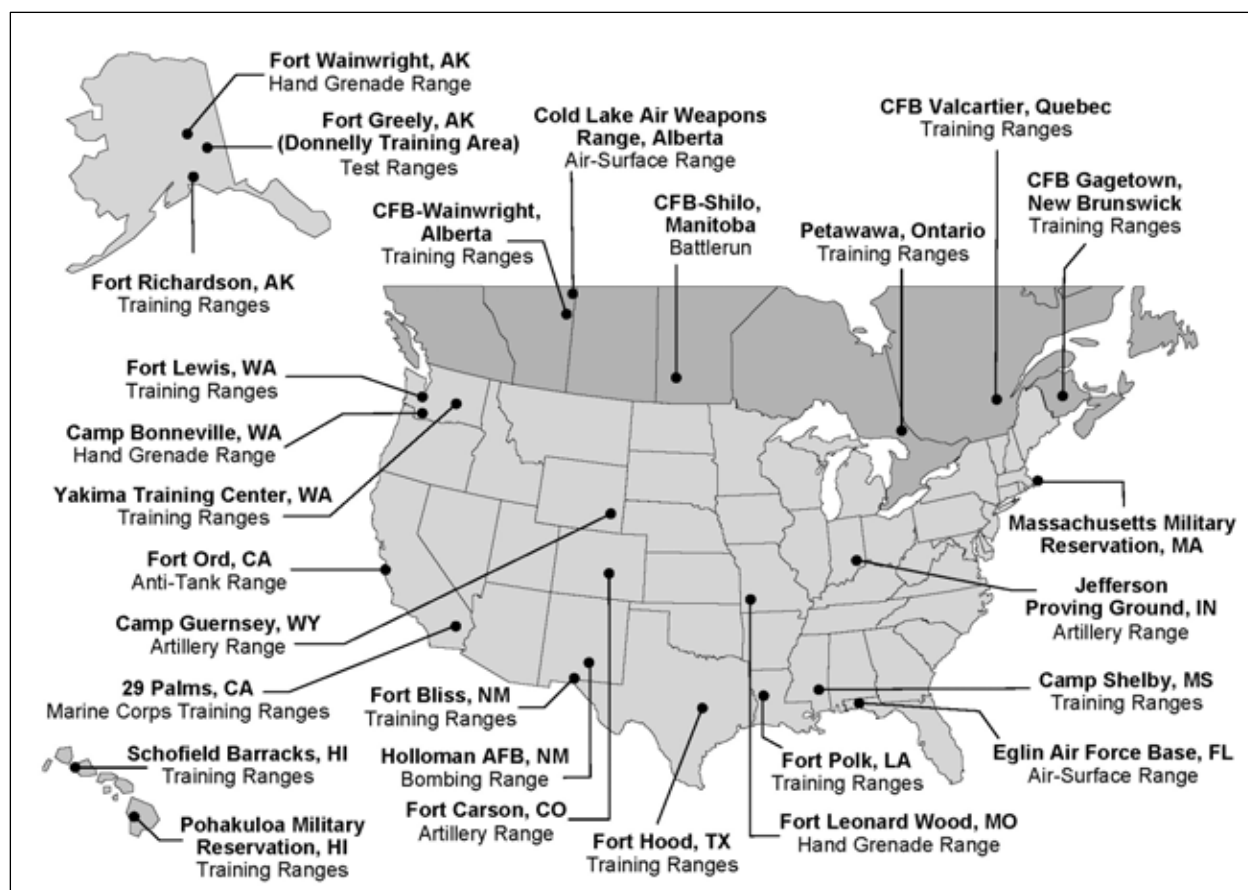

Figure 1-1. Installations where characterization testing has been conducted. Munitions tests were conducted at other sites.

(desorption kinetics, partitioning coefficients, and transformation and/or degradation rates) for munitions constituents were determined using field soils from the sites as well as laboratory spiked soils. Transport parameters of contaminants of potential concern for which data were lacking were determined by leveraging Strategic Environmental Research and Development Program (SERDP) funds with other funding sources. Long-term fate and transport of explosives from cracked shells resulting from sympathetic detonations were investigated.

Tests were conducted to reliably generate low-order detonations. Residues from such blasts were assayed to develop a source term for use in fate and transport, and risk assessment models. The source term details the mass of explosive residue and, when appropriate, its areal and particle size distribution.

As additional sites were characterized, the database expanded to determine whether certain munitions consistently contribute more contamination than others. Pertinent data from the Massachusetts Military Reservation (MMR) were reviewed and compared with the database annually to determine whether MMR residues are typical of other installations.

Objectives

The primary objective of the study was to provide the U. S. Department of Defense (DoD) with techniques to assess the potential for groundwater contamination from residues of energetic compounds (TNT, PETN, RDX, NG, 2,4DNT, and HMX) at testing and training ranges. Results of the project facilitate informed decision-making, help to minimize environmental impacts of testing and training, and contribute to continued operation of ranges.

Specific objectives include the following:

1. To develop a protocol that can be used to determine the nature and extent of surface soil contamination around impact areas and firing points. The protocol includes sampling strategies and analytical methods best suited to this application.
2. To provide source-term estimates of post-blast residues based on the extent of surface soil contamination, dissolution rates, and fate and transport process descriptors.
3. To provide data describing the relevant environmental processes controlling the fate and transport of residues of energetic compounds on ranges.

Related and leveraged studies

To meet the challenge of sustained training while protecting groundwater and other environmental resources, the DoD is funding a broad spectrum of research and development (R&D) efforts. These efforts are funded under multiple programs and through many installations and address various aspects of range sustainability. Examples of programs funding R&D efforts related to range sustainment and environmental stewardship are described below. Our collaboration and leveraging of these projects are indicated where appropriate.

1. **Strategic Environmental Research and Development Program** identifies, develops, and transitions environmental technologies that relate directly to defense mission accomplishment. SERDP is the DoD's corporate environmental R&D program, planned and executed in full partnership with the U.S. Department of Energy (DOE) and the U.S. Environmental Protection Agency (USEPA), with participation by numerous other Federal and non-Federal organizations. The DoD's environmental concerns may be viewed in terms of operational and/or cost impacts to its primary mission of maintaining military readiness for national defense. SERDP strives to minimize or remove major negative environmental impacts on DoD's ability to conduct this mission. SERDP has supported an extensive program of research related to range sustainment. SERDP projects with which we have collaborated and/or coordinated are described below.
 - a. *Compliance Project (CP)-1197* "A Field Program to Identify Toxic Release Inventory Chemicals and Determine Emission Factors from DoD Munitions Activities" (Chet Spicer, Battelle Columbus). The objective of the project was to demonstrate a methodology for measuring emissions of toxic release inventory (TRI) chemicals from DoD munitions activities and to apply the method to determine emission factors from munitions activities at DoD facilities. This study was completed in 2005.
 - b. *CP-1305* "Impacts of Fire Ecology Range Management (FERM) on the Fate and Transport of Energetic Materials on Testing and Training Ranges" (Eric Foote/Jeff Morse, Battelle Columbus). The objective of this study was to determine the impacts of prescribed burning on energetic residuals on ranges. When this project was granted access to an Eglin Air Force Base (AFB) air-to-ground munitions range in Florida, we were invited to conduct the initial soil characterization and share the data with both projects. Therefore, protocols developed in ER-1155 were used to sample surface soils on the air-to-ground range.
 - c. *CP-1330* "On-Range Treatment of Ordnance Debris and Bulk Energetics Resulting from Low-Order Detonations" (Phil Thorne, Applied Research Associates, Inc.). The objective of this project was to develop a low-cost, fieldable process for the rapid decontamination of energetic material from range scrap. We provided debris from low-order detonation tests at Blossom Point, MD, to facilitate trials of the techniques under development. This project was completed in 2004.
 - d. *CP-1159* "A Predictive Capability for the Source Terms of Residual Energetic Materials from Burning and/or Detonation Activities"

(Charles Kolb, Aerodyne). The objectives of this project were to define and model gaseous and particulate species formed by detonations. We shared range residue data with this project. Results reported at the 2004 SERDP Symposium indicated that propellant residues and their combustion products predominate in the particulate emissions and that ablated metal alloys from the munition casing were also detected. This project was completed in 2004.

- e. *CS-1395* “Development and Application of a Physiological-Based Framework for Assessing the Biological Significance of Military Activities on Threatened and Endangered Animal Species” (Marshall Adams, Oak Ridge National Laboratory). The objective of this project is to develop and apply a bioassessment tool that can be used by natural resource managers to assess the fitness of threatened and endangered species (TES) populations by measuring a suite of sensitive and rapidly responding physiological indicators, which are related to reproductive and population-level fitness. For this project we developed and applied a range characterization protocol that provided concentrations of energetic compounds at distance scales appropriate to the home range of two TES; one at Camp Shelby, MS, and the other at Eglin AFB.
2. **Defence Research and Development Canada – Valcartier (DRDC-Val).** The Director Land Environment (DLE) from the Canadian Head Quarters has tasked DRDC-Val scientists with performing research characterization of their main army training areas in order to assess the impacts of live-fire training. Part of the work conducted within ER-1155 is strongly linked with this objective. ER-1155 includes partial funding for Canadian Forces Bases (CFBs) Shilo and Gagetown and for Cold Lake Air Weapons Range for surface characterization, while the hydrogeological portion of these studies is supported by DLE. Moreover, the DLE mandate includes the analysis of other types of range contaminants such as heavy metals, petroleum products, and radioactive compounds when appropriate. Just as data generated on U.S. ranges under ER-1155 are shared with DRDC-Val, so also are all of the data generated for Canadian studies shared with the United States. The DLE mandate included other training areas such as the one at CFB Valcartier, and results obtained at this training area were added to the ER-1155 database. Future work at other Canadian training areas, such as Petawawa, Wainwright, or Suffield, will be supported by DLE. On a yearly basis, approximately 30 percent of the fund was contributed by the SERDP project. Finally, the Director General Environment (DGE) sponsors DRDC-Val for a small-scale unexploded ordnance (UXO) corrosion study. The scientific leader of this study has

liaised with the Principal Investigator of SERDP CP-1226 to discuss the data that will be acquired and to link the studies. DGE also sponsors work on the ecotoxicological properties of explosives, work that is closely linked with ER-1155. Finally, a new Sustain R&D thrust was established in 2004 and projects were approved on the development of greener weapons, on the corrosion of munition casings, and on the study of the gaseous emissions from gun firing. These projects are led by DRDC scientists involved in ER-1155, and results will be shared with SERDP through future follow-on projects.

3. **Army Environmental Quality Technology Program Focus Area on Characterization, Evaluation, and Remediation of Distributed Sources (UXO-C) on Army Ranges.** This program, initiated in Fiscal Year (FY) 2003, contains 25 to 30 work units, of which several are related to project ER-1155. The following work units are specifically relevant to project ER-1155:
 - a. *Large-scale characterization of major contamination sources on military training ranges* (Tom Jenkins, ERDC-CRREL). The objective of this work unit is to develop methods at the landscape scale for determining the types, numbers, physical dimensions, and distribution of large distributed sources of energetic compounds at various types of ranges.
 - b. *Minimization of explosive residues in blow-in-place procedures* (Judy Pennington, ERDC-EL). The objective of this work unit is to optimize BIP procedures while minimizing constituent contamination without compromising effectiveness and implementation ease. This project, conducted in coordination with the Ordnance and Explosives Center of Expertise, Huntsville, AL, and conducted at Redstone Arsenal, is heavily leveraged with ER-1155. This project will be completed in 2006.
 - c. *Range and landscape level characterization methodology* (Rose Kress, ERDC-EL). The objective of this work unit is to develop geospatial methods for predicting patterns of contaminant distribution at the landscape level.
 - d. *Surface runoff of distributed source contaminants from soils: A laboratory simulation study* (Cynthia Price, ERDC-EL). The objectives of this work unit are to describe movement of residues into the overland flow plane during rainfall/runoff events, to define stream routing relationships in surface runoff, and to develop soil infiltration and runoff extraction coefficients for modeling mass loading to surface and groundwater.

- e. *Development of a distributed source contaminant transport model for the Army Risk Assessment Model (ARAMS; Billy Johnson, ERDC-CHL).* The objective of this work unit is to develop a model to simulate transport in the watersheds, rivers, streams, and groundwater linking a geographic information system (GIS) interface and best management plans to ARAMS.
 - f. *Transport of explosives residues through the vadose zone (Judy Pennington, ERDC-EL).* The objective of this work unit is to describe transport of RDX from solid explosives compositions on the soil surface through dissolution, degradation, and transport by developing process descriptors suitable for use in groundwater and transport models. This project will be completed in 2006.
4. **U.S. Army Alaska Directorate of Public Works.** The U.S. Army Engineer Research and Development Center (ERDC) Cold Regions Research and Engineering Laboratory (CRREL) is working for the U.S. Army Alaska Directorate of Public Works at Fort Richardson and the Donnelly Training Area (formerly Fort Greely). This work is an outcome of the environmental impact statement (EIS) in support of the renewal of the lease of land from the public domain under the Military Lands Withdrawal Act (Public Law 106-65). As a portion of this EIS, the Army has pledged to implement a program to identify possible munitions contamination and evaluate the potential for surface water and groundwater contamination. Sampling experiments were conducted in FY2003 at firing points within the Donnelly Training Area to evaluate various options for collection of representative samples in areas where 105-mm howitzers were fired using single-based propellants. These samples were also used to compare various subsampling methods to maintain representativeness through the subsampling step of analysis.
 5. **U.S. Army Environmental Center (AEC) Range Sustainment Program.** The AEC (John Buck) with the Center for Health Promotion and Preventive Medicine (CHPPM, Barrett Borry) have also conducted a "Range Sustainment Program" to proactively ensure sustained training on ranges and to protect drinking water sources on active ranges. Project ER-1155 coordinated with and shared site access with this project whenever possible to benefit both efforts.
 6. **UXO in marine environments.** The Naval Facilities Engineering Service Center, Port Hueneme, CA, and the Space and Naval Warfare Systems Center, San Diego, CA, are conducting a study in conjunction with ERDC-EL to determine toxicological and geochemical interactions of ordnance and explosives in marine environments. Geochemical studies

have determined dissolution, adsorption, and transformation rates of explosives in saline systems. Process descriptors determined in freshwater were compared with those determined in salt water to determine what descriptors are affected by salinity. The toxicology studies will focus on bioavailability, toxicity, bioaccumulation, trophic transfer, and tissue concentrations of explosives in marine organisms, and the toxic effects of mixtures of explosives. This project will be completed in 2006.

7. **Range characterization at a missile demolition range.** Hill AFB, UT, destroys out-of-date missiles from the various services using either open burning or open detonation (OB/OD). Environmental personnel at Hill AFB requested assistance from ERDC to develop a range characterization protocol appropriate to the scale of these activities. ERDC applied the technology developed in ER-1155 to the problem and provided Hill AFB with the sample collection protocol and the analytical processing and analysis techniques to allow collection and analysis of representative soil samples to assess energetic residues concentrations within this range.

Summary of 2004 results

Since its inception in 2000, the study has developed an extensive database of energetic compounds in surface soils on training ranges. Progress has been made in documenting explosive and propellant residues on live-fire training ranges for various types of munitions. Identifying areas most likely to form distributed sources of contamination and focusing sampling approaches on areas associated with specific aspects of training have been significant accomplishments. Environmental fate and transport process descriptors that are suitable for use in groundwater transport and risk assessment models have also been generated.

Sampling strategies

Results of an intensive sampling exercise in 2004 around a low-order detonation at Fort Polk, LA, reaffirmed that a single surface soil sample cannot represent an area even as small as 1 square meter when the residue is deposited as particulates. Collection of a multi-increment sample containing 25 random increments was a marked improvement over collection of discrete samples; however, uncertainty remained relatively high. Collection of systematic-random multi-increment samples improved repeatability, particularly in areas that included a “hot spot” from a low-order detonation. RDX concentrations decreased with distance from the low-order detonation, unlike results observed at a tank target on an artillery

range where no concentration gradient was observed. The inconsistency is very likely a function of how the munitions impinge upon the respective sites. Results of these two studies demonstrate that collection of systematic-random multi-increment samples provides more reproducible results than either discrete samples or multi-increment samples collected using a totally random design.

Low-order detonations

Results of studies in which low-order detonations were generated for 60- and 81-mm mortars, and 105- and 155-mm artillery projectiles demonstrated the challenge in designing specific energy yields. Munitions had a tendency to detonate with either very low or very high energy yields. Nevertheless, the mass of explosive residue recovered was inversely related to the energy yield based on overpressure measurements. Although the initiating tool was consistently pointed in the same direction, the distribution of the residue was directionally inconsistent. The mass of residue from the 105-mm projectiles tended to increase with distance; however, variability was so high that differences were not significant. No significant difference in residue mass with distance for 155-mm projectiles was observed. The largest particle size fraction, > 12.5 mm, tended to predominate, especially with the 60-mm mortars and the 105-mm projectiles. Large chunks predominated over fines (< 0.25 mm). The ratio of TNT to RDX in pre-detonation Composition B was generally reflected in the post-detonation composition. Results suggest that low-order detonations will contribute predominantly large particles to chunks of solid Composition B. Because of the predominance of large chunks, transport will depend heavily on dissolution rates of TNT and RDX from the solid composition, and subsequent interactions between dissolved constituents and the soil.

Site characterization

Gagetown. Results of the third and final phase of sampling at CFB Gagetown, New Brunswick, encompassed a propellant burning pad and the following four specific types of ranges: anti-tank, hand grenade, rifle grenade, and small arms. Surface soil samples were analyzed for heavy metals and explosives. Leaching tests (Toxicity Characteristic Leaching Procedure, or TCLP) were also performed to determine concentrations and bioavailability of metals. Over the course of the three phases of the study, heavy metal concentrations increased. The following metals of concern were identified at the target area of the anti-tank range: copper, nickel,

and zinc (Cu, Ni, and Zn). Ponds in the target area contained Cu, arsenic (As), chromium (Cr), Ni, lead (Pb), and Zn concentrations that exceeded industrial threshold values. Although increasing over time, Cu, Ni, and Zn found in both grenade ranges failed to reach industrial threshold values. High levels of Pb and strontium (Sr) were detected at the burn pads and at the small arms range. Values for Cu, Zn, and antimony (Sb) exceeded the industrial threshold at the small arms range. Metal concentrations tended to decrease with soil depth. Almost no energetic residues were detected at either the hand grenade or rifle grenade ranges. At the anti-tank range, HMX predominated as the target, while nitroglycerin (NG) was detected at high levels behind the firing line. The NG was detected to a depth of 60 cm. HMX, TNT, and NG were detected in high concentrations in the small ponds located in the target area of the anti-tank range. Results of a sampling exercise using multiple increments of more than 50 in a large sampling area successfully improved the delineation of energetic residues over smaller increment sampling.

Cold Lake. Results of extensive sampling of soils, surface water, and vegetation at the Cold Lake Air Weapons Range in Alberta indicated minimal contamination. Alpha and Bravo ranges are used primarily for bombs and rockets; Shaver River and Jimmy Lake ranges for 250-, 500-, 1,000-, and 2,000-pound bombs. The very low concentrations of metals observed in the soils of these ranges are attributable to the very effective practice of frequent debris removal and tilling of the soil. Metal concentrations in surface water of Primrose and Jimmy Lakes were also low, except for elevations in cadmium (Cd) and Cu concentrations in Jimmy Lake. No explosives were found in surface water. However, in the soils of the Jimmy Lake range, propellants such as NG were found in all samples. This finding suggests the heavy use of rockets. In contrast, on the Shaver River range very little propellant was found, but TNT was found in almost all samples, which suggests heavy use of bombs. With the exception of the high TNT concentrations on the Shaver River range and limited accumulation of metals at the Jimmy Lake range, the Cold Lake ranges exhibited little contamination by metals or explosives.

Massachusetts Military Reservation. From 1 October 2003 through 30 September 2004, environmental investigations continued at Camp Edward on the MMR where site assessment was initiated in 1997. No new explosives were detected since publication of ER-1155 Interim Report 4. The most frequently detected explosives (in order of decreasing frequency)

were TNT and the amino transformation products of TNT, compounds categorized as “other,” perchlorate, dinitrotoluenes, and RDX. Compounds in the “other” category include derivatives and/or components of propellants and of waxes used in inert rounds. A significant decrease in concentrations of the propellant, NG, and compounds listed as “other” was observed this year. Unlike the previous year, no white phosphorus was detected in any soil sample. Groundwater quality exhibited no change from last year. Predominant contaminants include (in order of decreasing frequency) perchlorate, RDX, HMX, and the amino transformation products of TNT. A shift in focus from characterization/monitoring to remediation was developed this year to lay the foundation for expediting the achievement of remediation goals and to reduce long-term monitoring costs.

Other organic compounds. Concern that certain metals and organic compounds other than explosives may affect environmental quality of range soils prompted analyses of selected composite soil samples for a list of these potential contaminants. None of the organic compounds occurred with sufficient frequency or at sufficient concentrations to constitute major concern. Several metals were of potential concern, however, especially if future agricultural use of the soil is likely.

Cracked shells as source for leaching

Two approaches were developed for the generation of cracked 81-mm mortars for use in long-term transport studies. In the first approach, C4 in various amounts and configurations and shaped charges containing C4 in various stand-off distances were used. In the second approach, a mortar was detonated close to a second mortar to achieve cracking of the second mortar by fragments of the first (sympathetic detonations). Cracking was achieved by placing C4 on the first mortar; however, the shaped charges failed to pierce the shell casing. Detonations with C4 produced cracked shells even when the two mortars were separated by a distance of 157 cm. The cracked shells were used in subsequent leaching experiments, the result of which was reported in the FY05 annual report.

Blow-in-place detonations of 155-mm projectiles

Seven 155-mm projectiles were detonated on snow-covered ice at Fort Richardson, AK. Detonations were achieved almost simultaneously using standard BIP techniques. Military explosives ordnance disposal (EOD) personnel used a block of C4 initiated with a blasting cap. Residues were

collected over the visible plume to a depth of 2 cm. Two composite sampling approaches were used, one using 100 increments and one using 40 increments. Melted snow samples were analyzed by High Performance Liquid Chromatography (HPLC) and/or gas chromatography (GC) methods. All detonations were high-order. The average recovered residual mass of RDX was 14 mg, HMX was 0.84 mg, and no TNT was detected. Results for subsurface samples and samples collected beyond the plume suggested that the sampling methods captured most of the residue.

Photochemical degradation of Composition B and its components

Irradiation was performed in laboratory microcosms under controlled conditions. Exposures included solutions, solids, and both solutions and solids spiked into soils. Two approaches were used to characterize products: liquid chromatography/mass spectrometry (LC/MS) and a combination of solid and liquid state ^{13}C and ^{15}N nuclear magnetic resonance (NMR), and liquid state ^1H NMR. Irradiation of TNT in the aqueous phase generated dramatically more photolysis products than have been previously reported. Results of liquid state ^{15}N NMR indicated that the most prominent nitrogen-containing functional groups, exclusive of unreacted nitro groups, were azoxy, amide, nitrile, and azo nitrogens. TNT, alone and as a component of Composition B, generated products more readily than RDX under all test conditions. The rate of photolysis over a 16-hr period of irradiation was relatively rapid. Photolysis was faster when TNT was mixed with soil. Results suggest that Composition B photolysis, particularly the TNT component, generates a dynamic mixture of products and ions beginning on the solid surfaces before dissolution, and increasing once in solution phase.

Conclusions

Significant conclusions of the various investigations conducted in 2005 include the following:

1. Adequately characterizing the distribution and quantity of the highly distributed scattering of solid residues that are extreme in the range of particle sizes has been a prominent objective of this project. The protocol based on the collection of multi-increment samples using a systematic-random design developed for artillery ranges yielded more reproducible results than multi-increment samples using a totally random design or discrete sampling protocols.

2. Although controlling the energy yield of low-order detonations was challenging, residues were inversely related to energy yields based on pressure measurements. Directionality was unpredictable and variability was too high to identify statistically significant trends in the distribution of residue mass by distance from the point of detonation. Although the mass of residue was predominantly associated with the large particles (> 12.5 mm), few differences between particle size distributions of residues were significant. The pre-detonation ratio of TNT to RDX was conserved.
3. Heavy metal concentrations in surface soils have increased over the course of the three phases of this study at CFB Gagetown. Metals in concentrations of concern in surface soils and in surface water of ponds at the anti-tank target areas, at hand- and rifle-grenade ranges, or on small arms ranges were primarily Cu, Ni, Zn, As, Cr, Pb, and Sb. Pb and Sr were detected at the burn pads and on the small arms ranges. Metals concentrations tended to decrease with soil depth. Explosives residues varied within the anti-tank range: HMX predominated at targets, NG at the firing line, HMX, TNT, and NG in ponds in the target area. Almost no energetic residues were detected at the hand- or rifle-grenade ranges. These data illustrate the potentially dynamic character of residue constituents over time.
4. Low concentrations of metals on the ranges at Cold Lake Air Weapons Range are probably attributable to frequent debris removal and tilling of the soil. Metals were found in low concentrations in the surface water of lakes on the ranges, except for one lake where Cd and Cu were elevated. The nature of explosive residues in surface soils was consistent with range use (e.g., propellants were detected where rockets were used and TNT was found where bombs were used). In general, contamination by metals or explosives was limited on the ranges of this installation.
5. A significant decrease in concentrations of NG and organic compounds associated with inert rounds was observed at MMR. Groundwater quality exhibited no change since last year. No white phosphorus was detected in soils this year. Future assessments at MMR will shift significantly toward remediation rather than characterization and monitoring.
6. Sympathetic detonations effectively generated cracked and broken 81-mm mortars even when mortars were 157 cm apart. Block C4 was also effective. Residues from detonations were used in column leaching experiments. Results of these studies are presented in Chapter 7 of this report (Interim Report 6).
7. The nearly simultaneous detonation of seven 155-mm projectiles using C4, as is common practice for demolition of UXO by military EOD personnel, resulted in high-order detonations and very little explosives residue. Tests

were conducted on snow-covered ice, making the deposition plume visible for sampling. Average masses recovered per round were as follows: RDX 14 mg, HMX 0.84 mg, and TNT none.

Results of this study provide a technical basis for development of range-specific soil characterization approaches, process descriptors for fate and transport of constituent residues, and for assessing the exposure component of environmental risk assessments. The relationships emerging between various training activities and residues of energetics can form the basis for sound management of training ranges while maintaining environmental stewardship.

FY05 execution

The chapters in this report summarize the work conducted in FY05. Some chapters stand alone, but for others, a more comprehensive report containing the data is published under separate cover by the respective agencies conducting the work. In those cases, a reference to the annotated publication can be found at the end of the specific chapters.

Characterization of residues was conducted in FY05 at the following ranges: CFB Petawawa, Ontario; Western Area Training Center (WATC), Wainwright, Alberta; Holloman AFB, Alamogordo, New Mexico; Eglin AFB, Florida; Camp Shelby Army National Guard Training Site, Mississippi; Fort Ord Army Base, Monterey, California. The results of tests to determine residues from low-order detonations, BIP procedures, fate and transport, and photodegradation are reported here. An update of explosives-related sampling at the MMR is also included.

Accomplishments to date of SERDP Project ER-1155 include the following:

1. Data acquisition for estimating firing range source terms for various munitions and range usages including high-order detonations, low-order detonations, and munitions firing points.
2. Protocol for characterizing soil contamination for various types of ranges where high spatial and concentration variability exists (e.g., heavy artillery, anti-tank, hand grenade, and air fighter training).
3. Definition of the residues generated by various UXO demolition procedures (BIP).
4. Definition of the residues generated by low-order detonations.

5. Process descriptors for range-specific energetic residues, including dissolution rates, partition coefficients, and transformation rates.
6. Transport properties of energetic residues in soils.
7. Identification of data gaps that should be filled for future range management and remediation.

A bibliography of journal articles, technical reports, and presentations generated during execution of project ER-1155 is provided in Appendix A. Web sites where reports may be available include the following:

ER-1155 (<http://el.erd.c.usace.army.mil/serdp/>)

ERDC-CRREL (<http://www.crrel.usace.army.mil/products/products.html>)

DRDC-Val (<http://www.valcartier.drdc-rddc.gc.ca>)

2 Update on Massachusetts Military Reservation

Introduction

During 1 October 2004 through 30 September 2005, environmental investigations continued at Camp Edwards, which is located on the northern portion of the MMR near Falmouth, MA on Cape Cod. The Training Ranges and Impact Area at Camp Edwards encompass approximately 14,000 acres. The approximately 2,200-acre Impact Area contains artillery and mortar targets that have been used for training activities since 1908 (USACE 1999a). The highest frequency of use occurred during and after World War II.

Surrounding the Impact Area are numerous firing ranges, artillery and mortar positions, and training areas. Firing of high explosive (HE) artillery rounds was discontinued in 1989. Low-Cost Infantry Training Rounds (LITR) and inert and HE mortar rounds were fired until 1997 when a moratorium on artillery and mortar firing was established by the USEPA. A comprehensive site assessment has been underway since 1997. Site investigations have addressed a variety of training activities associated with firing ranges (rocket or anti-tank, artillery, mortar, and small arms), OB/OD sites, and firing positions.

More than 30 summary reports and work plans covering the activities at Camp Edwards have been prepared over the past year (Appendix B). In addition, five papers have been presented at conferences. Two significant reports are in the process of development; a Central Impact Area Soil Report and the Central Impact Area Groundwater Feasibility Study Screening Report.

Site overview

Soils at the site consist of fine to coarse-grained sands overlying very coarse sands and gravels residing at the top of the saturated zone. The base of the saturated unconsolidated material, composed of silt and clay, overlies relatively impermeable bedrock located at depths ranging from 86.9 to 111.3 meters (m) below ground surface (bgs). The unsaturated zone varies in thickness from 12.2 to 42.7 m bgs (AMEC 2003a). Camp Edwards

Training Ranges and Impact Area lie directly over the Sagamore Lens, a major groundwater recharge area and the most productive portion of the Cape Cod Aquifer. The apex of the Sagamore Lens is located near the southeast corner of the Impact Area from which groundwater flows radially in all directions. The ocean bounds the aquifer on three sides. Except on extreme slopes, surface water runoff at Camp Edwards is virtually nonexistent due to the highly permeable nature of the soils and aquifer material.

Since the last update (Pennington et al. 2005), several thousand soil and groundwater samples have been collected at Camp Edwards. Table 2–1 lists the number of samples by media and site collected from 1 October 2004 through 30 September 2005. This past year, soil sampling efforts have been focused on the Impact Area, Demo Area 1, and Southeast (SE) Ranges, and groundwater sampling efforts have been focused on the Impact Area, Demo Area 1, SE Ranges, Western Boundary, and the Northwest (NW) Corner.

Tables 2–2 and 2–3 summarize the data from these studies for soil and groundwater, respectively. No new explosives compounds were detected since the last update; however, two munitions constituents (MC) detected in soil samples collected in years prior to 2004 (2-nitrodiphenylamine and hexachlorobenzene) were detected again in soil samples collected in 2005 (Pennington et al. 2005).

Table 2-1. Number of samples collected from 1 October 2004 through 30 September 2005 by location and medium

	Impact Area	Demo 1	Demo 2	SE Ranges	Phase IIB Sites	Western Boundary	NW Corner	Other	Total
Surface Soil (0-0.6 m)	415	78	2	446	0	16	18	233	1208
Deep Soil > 0.6 ft	13	3	0	2	0	0	0	0	18
GW Well	430	233	19	869	3	550	149	128	2381
GW Profile	0	32	0	364	0	0	0	0	396

Table 2-2. Summary of Camp Edwards validated soil data from 1 October 2004 through 30 September 2005.

Analyte	Units	# Detects	# Samples	Min.	Max.	Mean
1,1,1-trichloroethane	µg/kg	0	19	ND	ND	ND
1,1,2,2-tetrachloroethane	µg/kg	0	19	ND	ND	ND
1,1,2-trichloroethane	µg/kg	0	19	ND	ND	ND
1,1-dichloroethane	µg/kg	0	19	ND	ND	ND
1,1-dichloroethene	µg/kg	0	19	ND	ND	ND
1,2,3,4,6,7,8-heptachlorodibenzo-p-dioxin	pg/g	6	6	5	170	52
1,2,3,4,6,7,8-heptachlorodibenzofuran	pg/g	6	6	0.7	19	6.13
1,2,3,4,7,8,9-heptachlorodibenzofuran	pg/g	3	6	0.78	2	1.29
1,2,3,4,7,8-hexachlorodibenzo-p-dioxin	pg/g	5	6	0.23	1.9	0.78
1,2,3,4,7,8-hexachlorodibenzofuran	pg/g	5	6	0.16	2.2	0.96
1,2,3,6,7,8-hexachlorodibenzo-p-dioxin	pg/g	5	6	0.14	6.4	2.12
1,2,3,6,7,8-hexachlorodibenzofuran	pg/g	4	6	0.08	0.74	0.45
1,2,3,7,8,9-hexachlorodibenzo-p-dioxin	pg/g	4	6	0.63	5.1	2.31
1,2,3,7,8,9-hexachlorodibenzofuran	pg/g	2	6	0.2	0.21	0.21
1,2,3,7,8-pentachlorodibenzo-p-dioxin	pg/g	5	6	0.16	1.9	0.75
1,2,3,7,8-pentachlorodibenzofuran	pg/g	2	6	0.34	0.73	0.54
1,2,4-trichlorobenzene	µg/kg	1	353	2	2	2
1,2-dibromo-3-chloropropane	µg/kg	0	5	ND	ND	ND
1,2-dibromoethane (ethylene dibromide)	µg/kg	0	12	ND	ND	ND
1,2-dichlorobenzene	µg/kg	0	353	ND	ND	ND
1,2-dichloroethane	µg/kg	0	19	ND	ND	ND
1,2-dichloropropane	µg/kg	0	19	ND	ND	ND
1,3,5-trinitrobenzene	µg/kg	0	700	ND	ND	ND
1,3-dichlorobenzene	µg/kg	0	353	ND	ND	ND
1,3-diethyl-1,3-diphenyl urea	µg/kg	0	345	ND	ND	ND
1,3-dinitrobenzene	µg/kg	0	700	ND	ND	ND
1,4-bis (p-toluidino) anthraquinone	µg/kg	0	10	ND	ND	ND
1,4-diamino-2,3-dihydroanthraquinone	µg/kg	0	10	ND	ND	ND
1,4-dichlorobenzene	µg/kg	0	353	ND	ND	ND
1-(methylamino) – anthraquinone	µg/kg	0	10	ND	ND	ND
2,2'-oxybis(1-chloro)propane	µg/kg	0	348	ND	ND	ND
2,3,4,6,7,8-hexachlorodibenzofuran	pg/g	4	6	0.12	0.5	0.34
2,3,4,7,8-pentachlorodibenzofuran	pg/g	2	6	0.3	0.73	0.52
2,3,7,8-tetrachlorodibenzo-p-dioxin	pg/g	1	6	0.39	0.39	0.39
2,3,7,8-tetrachlorodibenzofuran	pg/g	3	6	0.51	0.78	0.67
2,4 db	µg/kg	0	11	ND	ND	ND
2,4,5-t (trichlorophenoxyacetic acid)	µg/kg	0	11	ND	ND	ND
2,4,5-trichlorophenol	µg/kg	0	348	ND	ND	ND
2,4,6-trichlorophenol	µg/kg	0	348	ND	ND	ND

Analyte	Units	# Detects	# Samples	Min.	Max.	Mean
2,4,6-trinitrotoluene	µg/kg	40	707	14	15000	1586.3
2,4-d (dichlorophenoxyacetic acid)	µg/kg	0	11	ND	ND	ND
2,4-diamino-6-nitrotoluene	µg/kg	0	700	ND	ND	ND
2,4-dichlorophenol	µg/kg	0	348	ND	ND	ND
2,4-dimethylphenol	µg/kg	0	348	ND	ND	ND
2,4-dinitrophenol	µg/kg	0	348	ND	ND	ND
2,4-dinitrotoluene	µg/kg	10	1048	17	540	97.5
2,6-diamino-4-nitrotoluene	µg/kg	0	700	ND	ND	ND
2,6-dinitrotoluene	µg/kg	1	1048	61	61	61
2-amino-4,6-dinitrotoluene	µg/kg	40	702	14	4300	322.1
2-chlorobenzaldehyde	µg/kg	0	345	ND	ND	ND
2-chlorobenzoic acid	µg/kg	1	345	240	240	240
2-chloroethyl vinyl ether	µg/kg	0	5	ND	ND	ND
2-chloronaphthalene	µg/kg	0	348	ND	ND	ND
2-chlorophenol	µg/kg	0	348	ND	ND	ND
2-hexanone	µg/kg	0	19	ND	ND	ND
2-methyl-3-nitroaniline	µg/kg	0	345	ND	ND	ND
2-methyl-5-nitroaniline	µg/kg	0	345	ND	ND	ND
2-methylnaphthalene	mg/kg	0	2	ND	ND	ND
2-methylnaphthalene	µg/kg	15	348	21	2800	248.4
2-methylphenol (o-cresol)	µg/kg	0	348	ND	ND	ND
2-nitroaniline	µg/kg	0	348	ND	ND	ND
2-nitrodiphenylamine	µg/kg	3	346	40	13000	5113.33
2-nitrophenol	µg/kg	0	348	ND	ND	ND
2-nitrotoluene	µg/kg	0	700	ND	ND	ND
3,3'-dichlorobenzidine	µg/kg	0	348	ND	ND	ND
3,5-dichlorobenzoic acid	µg/kg	0	11	ND	ND	ND
3,5-dinitroaniline	µg/kg	0	345	ND	ND	ND
3-chlorobenzaldehyde	µg/kg	0	345	ND	ND	ND
3-nitroaniline	µg/kg	0	348	ND	ND	ND
3-nitrotoluene	µg/kg	0	700	ND	ND	ND
4,6-dinitro-2-methylphenol	µg/kg	0	348	ND	ND	ND
4-amino-2,6-dinitrotoluene	µg/kg	37	700	14	5000	338.51
4-bromophenyl phenyl ether	µg/kg	0	348	ND	ND	ND
4-chloro-3-methylphenol	µg/kg	0	348	ND	ND	ND
4-chloroaniline	µg/kg	0	348	ND	ND	ND
4-chlorobenzaldehyde	µg/kg	0	345	ND	ND	ND
4-chlorophenyl phenyl ether	µg/kg	0	348	ND	ND	ND
4-methylphenol (p-cresol)	µg/kg	1	348	110	110	110
4-nitroaniline	µg/kg	0	348	ND	ND	ND

Analyte	Units	# Detects	# Samples	Min.	Max.	Mean
4-nitrophenol	µg/kg	0	359	ND	ND	ND
4-nitrotoluene	µg/kg	0	700	ND	ND	ND
Acenaphthene	µg/kg	19	348	18	1000	130.05
Acenaphthene	mg/kg	0	2	ND	ND	ND
Acenaphthylene	µg/kg	43	348	20	3500	169.98
Acenaphthylene	mg/kg	0	2	ND	ND	ND
Acetone	µg/kg	12	19	12	550	166
Acifluorfen	µg/kg	0	11	ND	ND	ND
Aldrin	µg/kg	0	11	ND	ND	ND
Alpha bhc (alpha hexachlorocyclohexane)	µg/kg	0	11	ND	ND	ND
Alpha endosulfan	µg/kg	0	11	ND	ND	ND
Alpha-chlordane	µg/kg	0	11	ND	ND	ND
Aluminum	mg/kg	362	362	1050	24200	8577.79
Aniline	µg/kg	0	348	ND	ND	ND
Anthracene	µg/kg	45	348	17	6500	390.49
Anthracene	mg/kg	0	2	ND	ND	ND
Antimony	mg/kg	115	362	0.36	55.5	1.37
Arsenic	mg/kg	360	363	0.66	9.4	3.36
Azobenzene	µg/kg	0	3	ND	ND	ND
Barium	mg/kg	362	363	2.1	144	13.19
Bentazon	µg/kg	0	11	ND	ND	ND
Benanthrone	µg/kg	0	10	ND	ND	ND
Benzene	µg/kg	0	21	ND	ND	ND
Benididine	µg/kg	0	3	ND	ND	ND
Benzo(a)anthracene	mg/kg	0	2	ND	ND	ND
Benzo(a)anthracene	µg/kg	95	348	17	15000	791.96
Benzo(a)pyrene	µg/kg	94	348	16	14000	633.04
Benzo(a)pyrene	mg/kg	0	2	ND	ND	ND
Benzo(b)fluoranthene	µg/kg	92	348	22	13000	1021.73
Benzo(b)fluoranthene	mg/kg	0	2	ND	ND	ND
Benzo(g,h,i)perylene	mg/kg	0	2	ND	ND	ND
Benzo(g,h,i)perylene	µg/kg	71	348	16	5300	404.06
Benzo(k)fluoranthene	mg/kg	0	2	ND	ND	ND
Benzo(k)fluoranthene	µg/kg	88	347	24	9100	695.7
Benzoic acid	µg/kg	92	348	18	6000	265.09
Benzyl alcohol	µg/kg	0	348	ND	ND	ND
Benzyl butyl phthalate	µg/kg	1	348	52	52	52
Beryllium	mg/kg	301	362	0.06	0.71	0.27
Beta bhc (beta hexachlorocyclohexane)	µg/kg	0	11	ND	ND	ND
Beta endosulfan	µg/kg	0	11	ND	ND	ND

Analyte	Units	# Detects	# Samples	Min.	Max.	Mean
Bis(2-chloroethoxy) methane	µg/kg	0	348	ND	ND	ND
Bis(2-chloroethyl) ether (2-chloroethyl	µg/kg	0	348	ND	ND	ND
Bis(2-ethylhexyl) phthalate	µg/kg	34	348	16	630000	18908.59
Boron	mg/kg	154	362	0.72	8.6	3.65
Bromochloromethane	µg/kg	0	5	ND	ND	ND
Bromodichloromethane	µg/kg	0	19	ND	ND	ND
Bromoform	µg/kg	0	19	ND	ND	ND
Bromomethane	µg/kg	1	19	5	5	5
C11-c22 range aromatic compounds	mg/kg	0	2	ND	ND	ND
C19-c36 range aliphatic compounds	mg/kg	1	2	11	11	11
C5-c8 range aliphatic compounds	µg/kg	0	2	ND	ND	ND
C9-c10 range aromatic compounds	µg/kg	2	2	11000	29000	20000
C9-c12 range aliphatic compounds	µg/kg	2	2	34000	77000	55500
C9-c18 range aliphatic compounds	mg/kg	2	2	54	65	59.5
Cadmium	mg/kg	190	363	0.07	102	1.58
Calcium	mg/kg	291	362	31.1	8090	222.05
Carbazole	µg/kg	27	348	21	5900	415.07
Carbon disulfide	µg/kg	1	19	1.5	1.5	1.5
Carbon tetrachloride	µg/kg	0	19	ND	ND	ND
Chloramben	µg/kg	0	11	ND	ND	ND
Chlordane	µg/kg	0	4	ND	ND	ND
Chlorobenzene	µg/kg	0	19	ND	ND	ND
Chloroethane	µg/kg	0	19	ND	ND	ND
Chloroform	µg/kg	0	19	ND	ND	ND
Chloromethane	µg/kg	0	19	ND	ND	ND
Chromium, total	mg/kg	363	363	1.2	53.2	10.16
Chrysene	mg/kg	0	2	ND	ND	ND
Chrysene	µg/kg	123	346	17	20000	914.66
Cis-1,2-dichloroethylene	µg/kg	0	5	ND	ND	ND
Cis-1,3-dichloropropene	µg/kg	0	19	ND	ND	ND
Cobalt	mg/kg	347	362	0.38	13.3	2.58
Copper	mg/kg	358	362	1.3	25100	159.5
Cyanide	mg/kg	30	106	0.63	10.3	2.82
Dalapon	µg/kg	0	11	ND	ND	ND
Dcpa (dacthal)	µg/kg	0	11	ND	ND	ND
Ddd (1,1-bis(chlorophenyl)-2,2-dichloroe	µg/kg	0	7	ND	ND	ND
Dde (1,1-bis(chlorophenyl)-2,2-dichloroe	µg/kg	0	7	ND	ND	ND
Ddt (1,1-bis(chlorophenyl)-2,2,2-trichlo	µg/kg	0	7	ND	ND	ND
Delta bhc (delta hexachlorocyclohexane)	µg/kg	0	11	ND	ND	ND
Di-n-butyl phthalate	µg/kg	20	348	19	1100	197.25

Analyte	Units	# Detects	# Samples	Min.	Max.	Mean
Di-n-octylphthalate	µg/kg	1	348	140	140	140
Di-n-propyl adipate	µg/kg	0	345	ND	ND	ND
Dibenz(a,h)anthracene	µg/kg	49	348	17	2400	269.06
Dibenz(a,h)anthracene	mg/kg	0	2	ND	ND	ND
Dibenzofuran	µg/kg	21	348	17	4700	325
Dibromochloromethane	µg/kg	0	19	ND	ND	ND
Dibromomethane	µg/kg	0	5	ND	ND	ND
Dicamba	µg/kg	0	11	ND	ND	ND
Dichloroprop	µg/kg	0	11	ND	ND	ND
Dieldrin	µg/kg	0	11	ND	ND	ND
Diethyl phthalate	µg/kg	6	348	24	150000	27417.17
Dimethyl phthalate	µg/kg	2	348	610	960	785
Dinoseb	µg/kg	0	11	ND	ND	ND
Endosulfan sulfate	µg/kg	0	11	ND	ND	ND
Endrin	µg/kg	0	11	ND	ND	ND
Endrin aldehyde	µg/kg	0	11	ND	ND	ND
Endrin ketone	µg/kg	0	11	ND	ND	ND
Ethylbenzene	µg/kg	1	21	6.3	6.3	6.3
Fluoranthene	µg/kg	102	347	18	47000	1713.03
Fluoranthene	mg/kg	0	2	ND	ND	ND
Fluorene	µg/kg	23	348	20	5900	424.96
Fluorene	mg/kg	0	2	ND	ND	ND
Gamma bhc (lindane)	µg/kg	0	11	ND	ND	ND
Gamma-chlordane	µg/kg	0	11	ND	ND	ND
Heptachlor	µg/kg	0	11	ND	ND	ND
Heptachlor epoxide	µg/kg	0	11	ND	ND	ND
Heptachlorinated dibenzo-p-dioxins, (total)	pg/g	6	6	8.8	290	96.97
Heptachlorinated dibenzofurans, (total)	pg/g	6	6	1.4	89	25.57
Hexachlorinated dibenzo-p-dioxins, (total)	pg/g	6	6	1.1	44	14.37
Hexachlorinated dibenzofurans, (total)	pg/g	6	6	0.33	34	9.3
Hexachlorobenzene	µg/kg	8	360	20	85	39.5
Hexachlorobutadiene	µg/kg	0	348	ND	ND	ND
Hexachlorocyclopentadiene	µg/kg	0	348	ND	ND	ND
Hexachloroethane	µg/kg	0	348	ND	ND	ND
Hexahydro-1,3,5-trinitro-1,3,5-triazine	µg/kg	60	704	14	280000	9272.88
Ignitb	deg F	3	3	0.01	70	46.67
Indeno(1,2,3-c,d)pyrene	µg/kg	70	348	16	6600	462.44
Indeno(1,2,3-c,d)pyrene	mg/kg	0	2	ND	ND	ND
Iron	mg/kg	362	362	2190	27600	10322.15
Isophorone	µg/kg	0	348	ND	ND	ND

Analyte	Units	# Detects	# Samples	Min.	Max.	Mean
Lead	mg/kg	363	363	2.5	4660	57.74
M,p-xylene (sum of isomers)	µg/kg	1	5	23	23	23
Magnesium	mg/kg	357	362	14	3040	1006.61
Manganese	mg/kg	362	362	5.9	1060	76.66
Mcpa	µg/kg	0	11	ND	ND	ND
Mcpp	µg/kg	0	11	ND	ND	ND
Mercury	mg/kg	134	363	0.01	2.5	0.12
Methoxychlor	µg/kg	0	11	ND	ND	ND
Methyl ethyl ketone (2-butanone)	µg/kg	15	19	1	38	8.73
Methyl isobutyl ketone (4-methyl-2-penta	µg/kg	0	19	ND	ND	ND
Methylene chloride	µg/kg	0	19	ND	ND	ND
Moisture	%	404	404	1.4	37	13.5
Molybdenum	mg/kg	272	362	0.21	6.6	0.72
N-nitrosodi-n-propylamine	µg/kg	0	348	ND	ND	ND
N-nitrosodimethylamine	µg/kg	0	348	ND	ND	ND
N-nitrosodiphenylamine	µg/kg	5	348	50	210	106.6
Naphthalene	µg/kg	38	350	19	4900	205.79
Naphthalene	mg/kg	0	2	ND	ND	ND
Nickel	mg/kg	358	362	0.68	29.8	5.02
Nitrate/nitrite (as n)	mg/kg	10	11	0.04	1.1	0.31
Nitrobenzene	µg/kg	1	1048	14	14	14
Nitrogen, ammonia (as n)	mg/kg	10	11	2.6	73.8	26.06
Nitroglycerin	µg/kg	6	702	530	150000	28603.33
O-terphenyl	µg/kg	1	1	660	660	660
O-xylene (1,2-dimethylbenzene)	µg/kg	1	7	12	12	12
Octachlorodibenzo-p-dioxin	pg/g	6	6	360	1800	905
Octachlorodibenzofuran	pg/g	6	6	1.8	89	28.3
Octahydro-1,3,5,7-tetranitro-1,3,5,7-tet	µg/kg	30	700	17	20000	1709.93
P-cymene (p-isopropyltoluene)	µg/kg	1	1	120	120	120
Pcb-1016 (arochlor 1016)	µg/kg	0	13	ND	ND	ND
Pcb-1221 (arochlor 1221)	µg/kg	0	13	ND	ND	ND
Pcb-1232 (arochlor 1232)	µg/kg	0	13	ND	ND	ND
Pcb-1242 (arochlor 1242)	µg/kg	0	13	ND	ND	ND
Pcb-1248 (arochlor 1248)	µg/kg	0	13	ND	ND	ND
Pcb-1254 (arochlor 1254)	µg/kg	0	13	ND	ND	ND
Pcb-1260 (arochlor 1260)	µg/kg	0	13	ND	ND	ND
Pentachlorinated dibenzo-p-dioxins, (tot	pg/g	6	6	0.52	4.6	1.84
Pentachlorinated dibenzofurans, (total)	pg/g	5	6	0.4	6	2.98
Pentachlorophenol	µg/kg	0	359	ND	ND	ND
Pentaerythritol tetranitrate	µg/kg	0	700	ND	ND	ND

Analyte	Units	# Detects	# Samples	Min.	Max.	Mean
Percent solids	%	18	18	4	33	15.33
Perchlorate	µg/kg	50	471	0.37	351000	9633.8
Ph	ph units	3	3	6.1	7.1	6.6
Phenanthrene	µg/kg	82	348	17	45000	1135.02
Phenanthrene	mg/kg	0	2	ND	ND	ND
Phenol	µg/kg	12	348	37	230	118.25
Phosphoric acid, triphenyl ester	µg/kg	1	1	1100	1100	1100
Phosphorus, total (as p)	mg/kg	7	7	131	582	325.71
Phosphorus, total orthophosphate (as po4	mg/kg	4	4	228	324	258.75
Picloram	µg/kg	0	11	ND	ND	ND
Picric acid	µg/kg	0	700	ND	ND	ND
Potassium	µg/kg	316	362	99.8	1170	444.97
Pyrene	µg/kg	0	2	ND	ND	ND
Pyrene	µg/kg	120	348	17	40000	1528.05
Pyridine	µg/kg	0	3	ND	ND	ND
Selenium	mg/kg	136	363	0.34	3.9	1.07
Silver	mg/kg	18	363	0.11	17.5	1.38
Silvex (2,4,5-tp)	µg/kg	0	11	ND	ND	ND
Sodium	mg/kg	28	362	35	2780	334.28
Styrene	µg/kg	0	19	ND	ND	ND
Sulfide	mg/kg	0	3	ND	ND	ND
Tert-butyl methyl ether	µg/kg	0	14	ND	ND	ND
Tetrachlorinated dibenzo-p-dioxins, (total)	pg/g	4	6	0.13	6.8	2.36
Tetrachlorinated dibenzofurans, (total)	pg/g	5	6	0.24	2.6	1.31
Tetrachloroethylene(pce)	µg/kg	0	19	ND	ND	ND
Tetryl	µg/kg	1	700	85	85	85
Thallium	mg/kg	20	362	0.63	1.7	1.01
Toluene	µg/kg	1	21	8.1	8.1	8.1
Total 1,2-dichloroethene	µg/kg	0	14	ND	ND	ND
Total dichlorinated naphthalenes	µg/kg	8	34	11	60000	12260.88
Total heptachlorinated naphthalenes	µg/kg	5	34	21	2400	811.4
Total hexachlorinated naphthalenes	µg/kg	6	34	52	22000	5112.33
Total monochlorinated naphthalenes	µg/kg	4	34	16	780	389.75
Total octachlorinated naphthalenes	µg/kg	5	34	28	260	92.2
Total organic carbon	mg/kg	13	25	2000	50400	15467.69
Total pentachlorinated naphthalenes	µg/kg	9	34	30	390000	56518.78
Total tetrachlorinated naphthalenes	µg/kg	14	34	21	1200000	115642.07
Total trichlorinated naphthalenes	µg/kg	11	34	24	1100000	139701.27
Toxaphene	µg/kg	0	11	ND	ND	ND
Trans-1,2-dichloroethene	µg/kg	0	5	ND	ND	ND

Analyte	Units	# Detects	# Samples	Min.	Max.	Mean
Trans-1,3-dichloropropene	µg/kg	0	19	ND	ND	ND
Trichloroethylene (tce)	µg/kg	0	19	ND	ND	ND
Vanadium	mg/kg	362	362	3.2	42.5	16.68
Vinyl acetate	µg/kg	0	5	ND	ND	ND
Vinyl chloride	µg/kg	0	19	ND	ND	ND
Xylenes, total	µg/kg	2	21	36	130	83
Zinc	mg/kg	362	362	2.8	2400	39.43

(sheet 8 or 8)

Note: ND = nondetect; pg/g = picograms per gram; µg/L = micrograms per liter; mg/kg = milligrams per kilogram.

Table 2-3. Summary of Camp Edwards validated groundwater data from 1 October 2004 through 30 September 2005.

Analyte	Units	# Detects	# Samples	Min.	Max.	Mean
1-(methylamino) - anthraquinone	µg/L	0	21	ND	ND	ND
1,1,1,2-tetrachloroethane	µg/L	0	5	ND	ND	ND
1,1,1,1-trichloroethane	µg/L	0	216	ND	ND	ND
1,1,2,2-tetrachloroethane	µg/L	0	216	ND	ND	ND
1,1,2-trichloroethane	µg/L	0	216	ND	ND	ND
1,1-dichloroethane	µg/L	0	216	ND	ND	ND
1,1-dichloroethene	µg/L	0	216	ND	ND	ND
1,1-dichloropropene	µg/L	0	5	ND	ND	ND
1,2,3-trichlorobenzene	µg/L	0	5	ND	ND	ND
1,2,3-trichloropropane	µg/L	0	5	ND	ND	ND
1,2,4-trichlorobenzene	µg/L	2	357	0.31	0.36	0.33
1,2,4-trimethylbenzene	µg/L	0	5	ND	ND	ND
1,2-dibromo-3-chloropropane	µg/L	0	221	ND	ND	ND
1,2-dibromoethane (ethylene dibromide)	µg/L	0	221	ND	ND	ND
1,2-dichlorobenzene	µg/L	0	357	ND	ND	ND
1,2-dichloroethane	µg/L	1	216	1	1	1
1,2-dichloropropane	µg/L	0	216	ND	ND	ND
1,3,5-trimethylbenzene (mesitylene)	µg/L	0	5	ND	ND	ND
1,3,5-trinitrobenzene	µg/L	3	1394	0.33	1.1	0.72
1,3-dichlorobenzene	µg/L	0	357	ND	ND	ND
1,3-dichloropropane	µg/L	0	5	ND	ND	ND
1,3-diethyl-1,3-diphenyl urea	µg/L	0	141	ND	ND	ND
1,3-dinitrobenzene	µg/L	0	1394	ND	ND	ND
1,4-bis (p-toluidino) anthraquinone	µg/L	0	21	ND	ND	ND
1,4-diamino-2,3-dihydroanthraquinone	µg/L	0	21	ND	ND	ND
1,4-dichlorobenzene	µg/L	0	357	ND	ND	ND

(sheet 1 or 7)

Analyte	Units	# Detects	# Samples	Min.	Max.	Mean
2,2-dichloropropane	µg/L	0	5	ND	ND	ND
2,2'-oxybis(1-chloro)propane	µg/L	0	129	ND	ND	ND
2,4,5-trichlorophenol	µg/L	0	141	ND	ND	ND
2,4,6-trichlorophenol	µg/L	0	141	ND	ND	ND
2,4,6-trinitrotoluene	µg/L	11	1394	0.28	29	5.71
2,4-d (dichlorophenoxyacetic acid)	µg/L	0	5	ND	ND	ND
2,4-diamino-6-nitrotoluene	µg/L	3	1394	0.26	0.26	0.26
2,4-dichlorophenol	µg/L	0	141	ND	ND	ND
2,4-dimethylphenol	µg/L	1	141	3.9	3.9	3.9
2,4-dinitrophenol	µg/L	0	141	ND	ND	ND
2,4-dinitrotoluene	µg/L	3	1535	0.35	0.37	0.36
2,6-diamino-4-nitrotoluene	µg/L	0	1394	ND	ND	ND
2,6-dinitrotoluene	µg/L	4	1535	0.3	4	1.49
2-amino-4,6-dinitrotoluene	µg/L	18	1394	0.25	2.2	1
2-chlorobenzaldehyde	µg/L	0	141	ND	ND	ND
2-chlorobenzoic acid	µg/L	0	141	ND	ND	ND
2-chloroethyl vinyl ether	µg/L	0	211	ND	ND	ND
2-chloronaphthalene	µg/L	0	141	ND	ND	ND
2-chlorophenol	µg/L	0	141	ND	ND	ND
2-chlorotoluene	µg/L	0	5	ND	ND	ND
2-ethylhexyl adipate	µg/L	0	5	ND	ND	ND
2-hexanone	µg/L	0	211	ND	ND	ND
2-methyl-3-nitroaniline	µg/L	0	141	ND	ND	ND
2-methyl-5-nitroaniline	µg/L	0	141	ND	ND	ND
2-methylnaphthalene	µg/L	3	141	6.6	67	27.1
2-methylphenol (o-cresol)	µg/L	0	141	ND	ND	ND
2-nitroaniline	µg/L	0	141	ND	ND	ND
2-nitrodiphenylamine	µg/L	0	141	ND	ND	ND
2-nitrophenol	µg/L	0	141	ND	ND	ND
2-nitrotoluene	µg/L	0	1394	ND	ND	ND
3,3'-dichlorobenzidine	µg/L	0	141	ND	ND	ND
3,5-dinitroaniline	µg/L	0	141	ND	ND	ND
3-chlorobenzaldehyde	µg/L	0	141	ND	ND	ND
3-nitroaniline	µg/L	0	141	ND	ND	ND
3-nitrotoluene	µg/L	0	1394	ND	ND	ND
4,6-dinitro-2-methylphenol	µg/L	0	141	ND	ND	ND
4-amino-2,6-dinitrotoluene	µg/L	42	1394	0.26	3.4	0.98
4-bromophenyl phenyl ether	µg/L	0	141	ND	ND	ND
4-chloro-3-methylphenol	µg/L	0	141	ND	ND	ND

Analyte	Units	# Detects	# Samples	Min.	Max.	Mean
4-chloroaniline	µg/L	0	141	ND	ND	ND
4-chlorobenzaldehyde	µg/L	0	141	ND	ND	ND
4-chlorophenyl phenyl ether	µg/L	0	141	ND	ND	ND
4-chlorotoluene	µg/L	0	5	ND	ND	ND
4-methylphenol (p-cresol)	µg/L	0	141	ND	ND	ND
4-nitroaniline	µg/L	0	141	ND	ND	ND
4-nitrophenol	µg/L	0	141	ND	ND	ND
4-nitrotoluene	µg/L	0	1394	ND	ND	ND
Acenaphthene	µg/L	2	141	0.51	0.6	0.55
Acenaphthylene	µg/L	0	141	ND	ND	ND
Acetone	µg/L	4	211	1	24	7.6
Alachlor	µg/L	0	5	ND	ND	ND
Aldrin	µg/L	0	7	ND	ND	ND
Alpha bhc (alpha hexachlorocyclohexane)	µg/L	0	2	ND	ND	ND
Alpha endosulfan	µg/L	0	2	ND	ND	ND
Alpha-chlordane	µg/L	2	2	0.02	0.03	0.02
Aluminum	µg/L	3	33	195	875	432
Aniline	µg/L	0	141	ND	ND	ND
Anthracene	µg/L	2	141	0.24	0.32	0.28
Antimony	µg/L	2	40	0.74	3.1	1.92
Arsenic	µg/L	4	38	3.5	31.1	21.68
Atrazine	µg/L	0	5	ND	ND	ND
Barium	µg/L	7	38	2.3	23.8	12.69
Benzanthrone	µg/L	0	21	ND	ND	ND
Benzene	µg/L	2	216	67	91	79
Benzo(a)anthracene	µg/L	0	141	ND	ND	ND
Benzo(a)pyrene	µg/L	0	146	ND	ND	ND
Benzo(b)fluoranthene	µg/L	0	141	ND	ND	ND
Benzo(g,h,i)perylene	µg/L	0	141	ND	ND	ND
Benzo(k)fluoranthene	µg/L	0	141	ND	ND	ND
Benzoic acid	µg/L	0	141	ND	ND	ND
Benzyl alcohol	µg/L	0	141	ND	ND	ND
Benzyl butyl phthalate	µg/L	0	141	ND	ND	ND
Beryllium	µg/L	0	38	ND	ND	ND
Beta bhc (beta hexachlorocyclohexane)	µg/L	0	2	ND	ND	ND
Beta endosulfan	µg/L	0	2	ND	ND	ND
Bis(2-chloroethoxy) methane	µg/L	0	141	ND	ND	ND
Bis(2-chloroethyl) ether (2-chloroethyl	µg/L	0	141	ND	ND	ND
Bis(2-chloroisopropyl) ether	µg/L	0	12	ND	ND	ND

Analyte	Units	# Detects	# Samples	Min.	Max.	Mean
Bis(2-ethylhexyl) phthalate	µg/L	6	146	0.7	37	7.3
Boron	µg/L	21	33	7.1	70.7	13.18
Bromobenzene	µg/L	0	5	ND	ND	ND
Bromochloromethane	µg/L	0	216	ND	ND	ND
Bromodichloromethane	µg/L	0	216	ND	ND	ND
Bromoform	µg/L	0	216	ND	ND	ND
Bromomethane	µg/L	0	216	ND	ND	ND
Butachlor	µg/L	0	5	ND	ND	ND
Cadmium	µg/L	3	38	0.64	0.88	0.75
Calcium	µg/L	32	33	1330	8980	2972.5
Carbazole	µg/L	0	141	ND	ND	ND
Carbon disulfide	µg/L	4	211	0.24	0.94	0.45
Carbon tetrachloride	µg/L	0	216	ND	ND	ND
Chlordane	µg/L	0	5	ND	ND	ND
Chlorobenzene	µg/L	4	216	0.3	0.4	0.34
Chloroethane	µg/L	2	216	0.8	2	1.4
Chloroform	µg/L	157	216	0.2	4.1	1.15
Chloromethane	µg/L	5	216	0.2	1	0.46
Chromium, total	µg/L	6	38	1.2	26	9.83
Chrysene	µg/L	0	141	ND	ND	ND
Cis-1,2-dichloroethylene	µg/L	0	216	ND	ND	ND
Cis-1,3-dichloropropene	µg/L	0	216	ND	ND	ND
Cobalt	µg/L	3	33	12.8	14.3	13.3
Copper	µg/L	3	33	2.7	632	213.87
Cyanide	µg/L	0	5	ND	ND	ND
Dalapon	µg/L	0	5	ND	ND	ND
Ddd (1,1-bis(chlorophenyl)-2,2-dichloroe	µg/L	0	2	ND	ND	ND
Dde (1,1-bis(chlorophenyl)-2,2-dichloroe	µg/L	0	2	ND	ND	ND
Ddt (1,1-bis(chlorophenyl)-2,2,2-trichlo	µg/L	0	2	ND	ND	ND
Delta bhc (delta hexachlorocyclohexane)	µg/L	0	2	ND	ND	ND
Dibenz(a,h)anthracene	µg/L	0	141	ND	ND	ND
Dibenzofuran	µg/L	1	141	0.5	0.5	0.5
Dibromochloromethane	µg/L	0	216	ND	ND	ND
Dibromomethane	µg/L	0	216	ND	ND	ND
Dicamba	µg/L	0	5	ND	ND	ND
Dichlorodifluoromethane	µg/L	0	5	ND	ND	ND
Dieldrin	µg/L	0	7	ND	ND	ND
Diethyl phthalate	µg/L	0	141	ND	ND	ND
Dimethyl phthalate	µg/L	0	141	ND	ND	ND

Analyte	Units	# Detects	# Samples	Min.	Max.	Mean
Di-n-butyl phthalate	µg/L	0	141	ND	ND	ND
Di-n-octylphthalate	µg/L	0	141	ND	ND	ND
Dinoseb	µg/L	0	5	ND	ND	ND
Di-n-propyl adipate	µg/L	0	141	ND	ND	ND
Endosulfan sulfate	µg/L	0	2	ND	ND	ND
Endrin	µg/L	0	7	ND	ND	ND
Endrin aldehyde	µg/L	0	2	ND	ND	ND
Endrin ketone	µg/L	0	2	ND	ND	ND
Ethylbenzene	µg/L	4	216	7	110	55
Fluoranthene	µg/L	0	141	ND	ND	ND
Fluorene	µg/L	3	141	0.86	1.9	1.42
Gamma bhc (lindane)	µg/L	0	7	ND	ND	ND
Gamma-chlordane	µg/L	2	2	0.02	0.02	0.02
Hardness (as cacO ₃)	µg/L	3	33	20.3	27.3	24.07
Heptachlor	µg/L	0	7	ND	ND	ND
Heptachlor epoxide	µg/L	0	7	ND	ND	ND
Hexachlorobenzene	µg/L	0	146	ND	ND	ND
Hexachlorobutadiene	µg/L	0	146	ND	ND	ND
Hexachlorocyclopentadiene	µg/L	0	146	ND	ND	ND
Hexachloroethane	µg/L	0	141	ND	ND	ND
Hexahydro-1,3,5-trinitro-1,3,5-triazine	µg/L	382	1394	0.25	140	4.73
Hexahydro-1,3,5-trinitroso-1,3,5-triazin	µg/L	0	60	ND	ND	ND
Hexahydro-1,3-dinitroso-5-mononitro-1,3,	µg/L	0	60	ND	ND	ND
Hexahydro-1-mononitroso-3,5-dinitro-1,3,	µg/L	5	60	0.29	1.7	0.81
Indeno(1,2,3-c,d)pyrene	µg/L	0	141	ND	ND	ND
Iron	µg/L	12	33	54	90100	21173.46
Isophorone	µg/L	0	141	ND	ND	ND
Isopropylbenzene (cumene)	µg/L	1	6	9.5	9.5	9.5
Lead	µg/L	10	38	1.2	24.9	8.44
M,p-xylene (sum of isomers)	µg/L	0	132	ND	ND	ND
Magnesium	µg/L	32	33	672	3040	1458.16
Manganese	µg/L	23	33	1	1120	187.73
Mercury	µg/L	0	38	ND	ND	ND
Methoxychlor	µg/L	0	7	ND	ND	ND
Methyl ethyl ketone (2-butanone)	µg/L	1	211	4.7	4.7	4.7
Methyl isobutyl ketone (4-methyl-2-penta	µg/L	1	211	3	3	3
Methylene chloride	µg/L	1	216	4	4	4
Metolachlor	µg/L	0	5	ND	ND	ND
Metribuzin	µg/L	0	5	ND	ND	ND

Analyte	Units	# Detects	# Samples	Min.	Max.	Mean
Molybdenum	µg/L	6	33	1.6	6.7	4.12
M-xylene (1,3-dimethylbenzene)	µg/L	0	5	ND	ND	ND
Naphthalene	µg/L	4	146	11	130	46
N-butylbenzene	µg/L	0	5	ND	ND	ND
Nickel	µg/L	9	38	1.1	66	17.33
Nitrobenzene	µg/L	0	1535	ND	ND	ND
Nitrogen, nitrate (as n)	µg/L	0	5	ND	ND	ND
Nitrogen, nitrite	µg/L	0	5	ND	ND	ND
Nitroglycerin	µg/L	0	1394	ND	ND	ND
N-nitrosodimethylamine	µg/L	0	141	ND	ND	ND
N-nitrosodi-n-propylamine	µg/L	0	141	ND	ND	ND
N-nitrosodiphenylamine	µg/L	0	141	ND	ND	ND
N-propylbenzene	µg/L	0	5	ND	ND	ND
Octahydro-1,3,5,7-tetranitro-1,3,5,7-tet	µg/L	162	1394	0.25	100	5.58
O-xylene (1,2-dimethylbenzene)	µg/L	0	137	ND	ND	ND
Pcb-1016 (arochlor 1016)	µg/L	0	7	ND	ND	ND
Pcb-1221 (arochlor 1221)	µg/L	0	7	ND	ND	ND
Pcb-1232 (arochlor 1232)	µg/L	0	7	ND	ND	ND
Pcb-1242 (arochlor 1242)	µg/L	0	7	ND	ND	ND
Pcb-1248 (arochlor 1248)	µg/L	0	7	ND	ND	ND
Pcb-1254 (arochlor 1254)	µg/L	0	7	ND	ND	ND
Pcb-1260 (arochlor 1260)	µg/L	0	7	ND	ND	ND
P-cymene (p-isopropyltoluene)	µg/L	0	5	ND	ND	ND
Pentachlorophenol	µg/L	0	146	ND	ND	ND
Pentaerythritol tetranitrate	µg/L	0	1394	ND	ND	ND
Perchlorate	µg/L	507	1832	0.35	770	9.49
Phenanthrene	µg/L	2	141	1.8	2	1.9
Phenol	µg/L	2	141	0.59	0.78	0.69
Picloram	µg/L	0	5	ND	ND	ND
Picric acid	µg/L	0	1394	ND	ND	ND
Potassium	µg/L	23	33	499	5460	1160.74
Propachlor	µg/L	0	5	ND	ND	ND
P-xylene (1,4-dimethylbenzene)	µg/L	0	5	ND	ND	ND
Pyrene	µg/L	0	141	ND	ND	ND
Pyridine	µg/L	0	1	ND	ND	ND
Sec-butylbenzene	µg/L	0	5	ND	ND	ND
Selenium	µg/L	1	38	3.8	3.8	3.8
Silver	µg/L	0	33	ND	ND	ND
Silvex (2,4,5-tp)	µg/L	0	5	ND	ND	ND

Analyte	Units	# Detects	# Samples	Min.	Max.	Mean
Simazine	µg/L	0	5	ND	ND	ND
Sodium	µg/L	38	38	4880	29700	7878.42
Styrene	µg/L	0	216	ND	ND	ND
T-butylbenzene	µg/L	0	5	ND	ND	ND
Tert-butyl methyl ether	µg/L	20	216	0.1	2.7	0.52
Tetrachloroethylene(pce)	µg/L	5	216	1	2.1	1.68
Tetryl	µg/L	0	1394	ND	ND	ND
Thallium	µg/L	0	40	ND	ND	ND
Toluene	µg/L	13	216	0.21	450	54.57
Toxaphene	µg/L	0	7	ND	ND	ND
Trans-1,2-dichloroethene	µg/L	0	216	ND	ND	ND
Trans-1,3-dichloropropene	µg/L	0	216	ND	ND	ND
Trichloroethylene (tce)	µg/L	2	216	2	2	2
Trichlorofluoromethane	µg/L	0	5	ND	ND	ND
Vanadium	µg/L	0	33	ND	ND	ND
Vinyl acetate	µg/L	0	211	ND	ND	ND
Vinyl chloride	µg/L	0	216	ND	ND	ND
Xylenes, total	µg/L	4	216	12	940	391.75
Zinc	µg/L	20	33	2	70.7	15.95

(sheet 7 of 7)

Note: ND = nondetect; pg/g = picograms per gram; µg/L = micrograms per liter; mg/kg = milligrams per kilogram.

Figure 2-1 is the distribution of MC detected in surface soil (0 to 0.6 m) at Camp Edwards, and includes validated data for samples collected from 1 October 2004 through 30 September 2005. The largest number of detections of MC observed are aminodinitrotoluenes (aDNTs), followed by hexahydro-1,3,5-trinitro-1,3,5-triazine (RDX), perchlorate, 2,4,6-trinitrotoluene (TNT), the “Other” category, octahydro-1,3,5,7-tetranitro-1,3,5,7-tetrazocine (HMX), dinitrotoluenes (DNTs), nitroglycerin, nitrobenzene (NB), and tetryl in decreasing order of number of detections for MC compounds. The “Other” category includes di-n-butyl phthalate, di-n-octyl-phthalate, N-nitrosodiphenylamine, 2-nitrodiphenylamine, hexachlorobenzene and polychlorinated naphthalenes (PCNs). Di-n-butyl phthalate and N-nitrosodiphenylamine (oxidation product of diphenylamine) are propellant compounds, whereas PCNs are present in some Halowax fillers used to simulate the mass of HE. 2-Nitrodiphenylamine is used as a stabilizer in propellant mixtures and hexachlorobenzene is a degradation product of hexachloroethane,

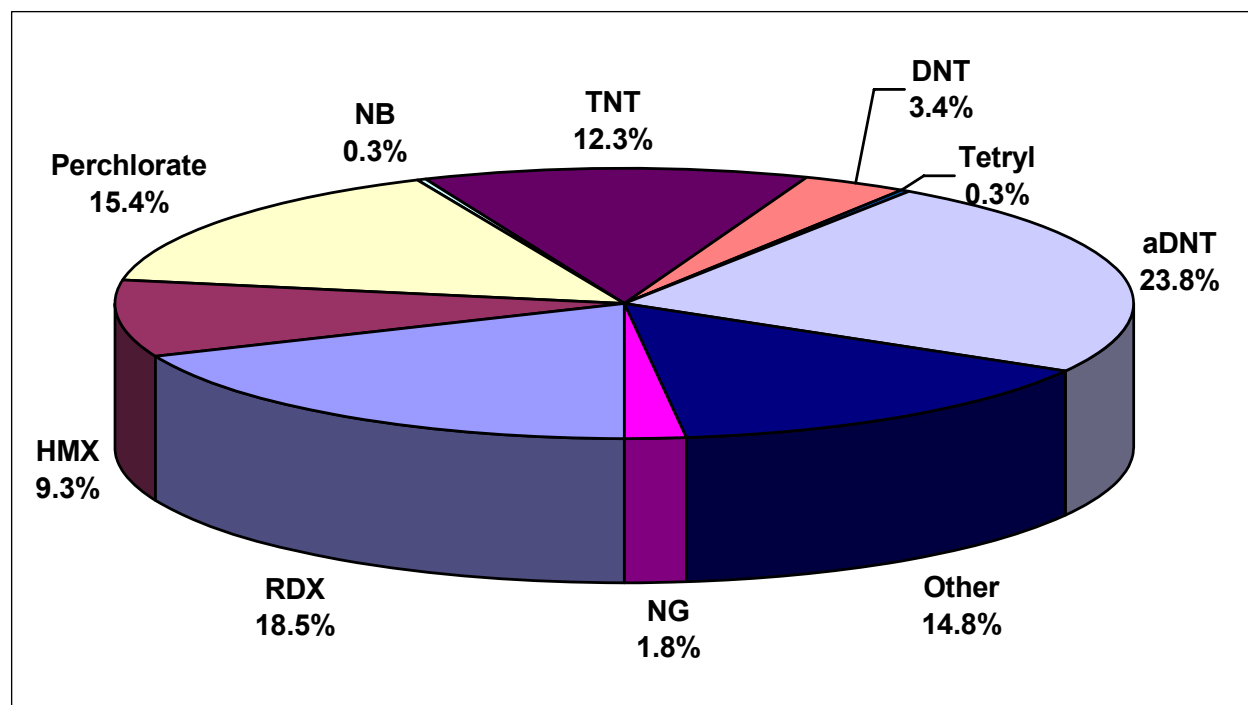

Figure 2-1. Distribution of detections of MC in soil at Camp Edwards for samples collected from 1 October 2004 through 30 September 2005.

a smoke compound. The overall distribution of MC is similar to past years (Pennington et al. 2005) with a slightly higher frequency of RDX, HMX, and perchlorate and lower frequency of detection of DNTs and aDNTs.

The soil MC findings are consistent with known activities at Camp Edwards such as the firing of munitions containing mixtures of TNT, RDX, HMX, and PCNs in the warheads, and propellants with NG, DNT, di-n-butyl phthalate, and N-nitrosodiphenylamine. The presence of the aDNTs is strongly suggestive of the aerobic transformation of TNT.

In contrast, the distribution of MC in groundwater (Figure 2-2) is different from soil, but consistent with previous groundwater findings (Pennington et al. 2005). The predominant MC observed in Camp Edwards groundwater is perchlorate followed by RDX, HMX, aDNTs, and 2,4-diamino-6-nitrotoluene (2,4DANT), in decreasing order of frequency. The TNT transformation product, 2,4DANT, is the only new MC detection in groundwater since the last update (Pennington et al. 2005). The greater preponderance of RDX and perchlorate can be explained by their conservative behavior relative to the other contaminants. As a consequence of their relatively high solubility and low to non-existent partitioning to soil,

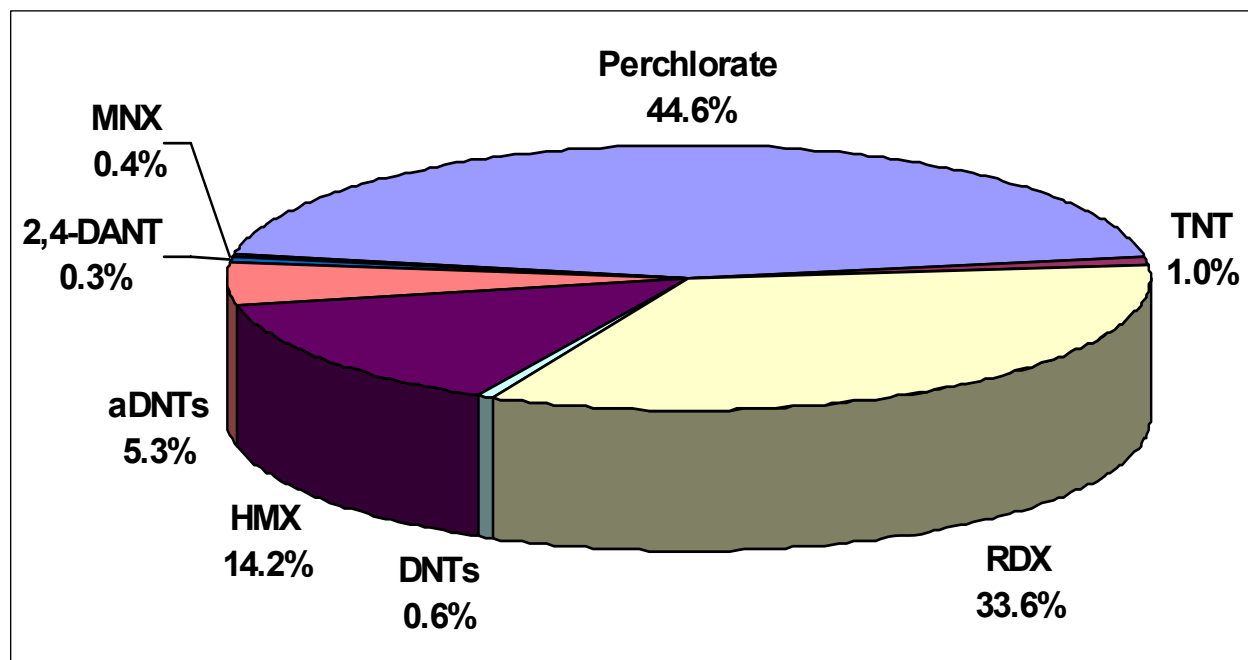

Figure 2-2. Distribution of detections of MC in groundwater at Camp Edwards for samples collected from 1 October 2004 through 30 August 2005.

RDX and perchlorate are not expected to persist in soil for any significant length of time. Once in contact with precipitation, solid particulate perchlorate is rapidly dissolved and then transported down through the vadose zone to the water table. In contrast, the dissolution kinetics of RDX are much slower, such that RDX can persist in soil as a solid for a significant length of time (decades to perhaps centuries, depending on mass released and environmental conditions). The significant decrease in TNT and aDNTs in groundwater relative to soil is a function of their susceptibility to attenuation processes and, secondarily, sorption onto shallow surface soils. Even when the TNT and aDNTs overwhelm natural microorganisms in the soil, these compounds will significantly attenuate within several hundred feet of where they are introduced into the aquifer.

One MC compound, hexahydro-1-mononitroso-3,5-dinitro-1,3,5-triazine (MNX) was detected at a low frequency in groundwater. This compound is a transformation product of RDX, and indicates that some degradation of RDX is occurring.

Also interesting is that most of the DNT observed in soil is the 2,4 isomer, whereas an equal split between the 2,4 and 2,6 isomers occurs in groundwater. The expectation is that the distribution of DNT isomers would be similar for soil and groundwater, since these isomers have similar

fate-and-transport properties. Therefore, some other process must explain the discrepancy between soil and groundwater results. The Impact Area Groundwater Study has found false positives of 2,6DNT in the groundwater samples, especially when interferences are present. It is possible the infrequent and sporadic 2,6DNT detections, which are not reproducible between different sampling events, observed in groundwater samples are false positives.

The other important observation is no detections of “Other” compounds. N-nitrosodiphenylamine and PCN are two of the “Other” compounds that have not been detected in any groundwater samples. The absence of N-nitrosodiphenylamine and PCNs is consistent with their fate and transport properties (i.e., rapid and strong sorption to soil, low solubility, and high degradation potential). Di-n-butyl phthalate and di-n-octyl phthalate are also not detected in groundwater. The phthalates would not be expected to be mobile due to their affinity for aquifer solids and thus would not be expected in groundwater. The detection of phthalates in groundwater has been spatially sporadic and nonreproducible between sampling rounds for the same monitoring well. Phthalates are a common laboratory contaminant, and it is believed that the detections in soil may represent false positives.

Long-term groundwater monitoring program

The Camp Edwards groundwater monitoring program has existed since 1997. AMEC published the 2005 annual review and plan for long-term monitoring on 8 April 2005 (AMEC 2005a). The 2005 plan continued with long-term groundwater monitoring program revisions implemented in 2004. The 2005 plan provides a framework for the shift from characterization-focused monitoring to remediation-focused monitoring. This approach serves the needs of the individual groundwater operable unit’s data quality objectives and lays the foundation for reducing future monitoring costs and supporting rapid movement toward remediation goals. The 2005 long-term groundwater monitoring plan organizes monitoring wells by operable unit, categorizes each monitoring well based on its specific objectives, and provides extensive figures including cross-sections for known contamination areas. As remedial systems are installed, operable unit-specific sections of the long-term monitoring will be replaced by operational monitoring plans. In December 2004, long-term groundwater monitoring for Demo 1 was replaced by the Demo 1 Groundwater System Performance and Ecological Impact Monitoring Plan (AMEC 2005b).

Since its inception in 1997, the Camp Edwards monitoring program has grown to include approximately 800 wells distributed geographically over 8 areas of monitoring interest. Currently, the Impact Area and SE Ranges account for the largest number of wells in the long-term monitoring plan, with approximately 230 wells monitored for the Impact Area and 270 wells monitored for the SE Ranges. Approximately 100 wells are used to monitor groundwater quality at the Western Boundary operable unit, and the remaining wells monitor smaller operable units. Samples are collected from these wells from one to three times per year based on the well's location relative to groundwater contamination and in accordance with input from both state and Federal regulators. Supply wells are monitored four times per year. The 2005 long-term monitoring plan includes the analysis of explosives in approximately 1,400 samples, perchlorate in approximately 1,600 samples, metals in 104 samples, semi-volatile organic compounds (SVOCs) in 122 samples, and volatile organic compounds (VOCs) in 159 samples. In addition, selected wells are analyzed for pesticides (three samples), dyes (six samples), and drinking water parameters (four samples) based on well-specific concerns.

After installation of a new well, groundwater samples are collected for three sampling events based on parameters specified in the various operable unit workplans. Available data from new wells are reviewed prior to the start of each trimester sampling event, and recommendations are made for inclusion into the long-term monitoring plan. As part of the ongoing review of these new wells, 45 wells were reviewed and added to the long-term monitoring plan for the August 2005 event.

Impact Area

The Impact Area is in the central portion of Camp Edwards and covers 2,200 acres. The Central Impact Area (CIA), which has been identified as a source area for groundwater contamination (AMEC 2001a, 2001b), is located within the Impact Area and encompasses approximately 134 ha. Surrounding the Impact Area are a number of artillery and mortar firing positions from which munitions were historically fired. Given the significant environmental and economic impacts of remediating a source area the size of the CIA, investigations are currently underway to further refine the source area contributing to groundwater contamination using well points to define the extent of contaminant detections in shallow groundwater (AMEC 2005c).

To date a total of 233 monitoring well screens at 100 locations have been installed within and downgradient of the Impact Area. More than 430 groundwater monitoring well samples have been collected and analyzed for explosives and VOCs during this reporting period. Extensive characterization of soil included the collection and analysis of soil at approximately 2,140 locations over the course of remedial investigation (AMEC 2001c, 2005d), with 7,582 soil samples collected at depths less than 0.6 m and 1,717 soil samples collected at depths greater than 0.6 m.

Soil

Characterization of the nature and extent of MC in the CIA is ongoing. The distribution of explosive chemicals in soil around targets is heterogeneous, as evidenced by concentrations spanning five orders of magnitude in samples located within 3.1 m of each other (AMEC 2001c).

The Draft Central Impact Area Soil Report (AMEC 2001c) identified six explosive compounds as contaminants of concern (COCs) in soil based on potential leaching to groundwater. These compounds are 2-amino-4,6-dinitrotoluene, (2ADNT), 4-amino-2,6-dinitrotoluene (4ADNT), TNT, RDX, and PETN. AMEC is preparing a Remedial Investigation Report to summarize all soil and source area characterization efforts to date within the CIA. A numerical groundwater model, based on a U.S. Geological Survey (USGS) model (Masterson et al. 2000, 1998, and 1996), calibrated to the existing RDX plume has been used to further refine our understanding of the behavior of the source over the past six decades. Efforts are under way to further define the current source area size, determine the distribution of HE unexploded ordnance (UXO) throughout the CIA, and evaluate future behavior of the source considering particulate HE material, ruptured UXO and corrosion of intact UXO. At the time this report was being finalized, 0.4 ha (1 acre) grid cells within the CIA had been ranked according to relative estimated density of HE UXO. Selected grid cells will be field investigated to both verify and calibrate the preliminary ranking.

A Focused Investigation was performed at two targets within the CIA in order to inform remediation activities. The Focused Investigation included field reconnaissance for UXO and other munitions items (by location, type, and condition), soil sampling, soil pore water sampling, and sampling of surface residues from munition casings (“munition wipe sampling”). To date, 45 lysimeters have been installed at three separate locations within the CIA (Target 23, Target 42, and High Use Target Area I) in an

effort to better understand contaminant concentrations in soil pore water. The primary goal of collecting lysimeter data was to determine pre-excavation concentrations of dissolved explosives and perchlorate migrating downward in soil pore water in the shallow unsaturated zone. An additional goal of the lysimeter sampling was to allow for comparison of co-located soil and soil pore water concentrations of munitions constituents. One cluster of six lysimeters was installed beneath a cracked open 155-mm HE projectile to evaluate the release of MC from a low order UXO. Field test kits (EXPRAY, Mistral, Washington, DC) were used to confirm that the UXO contained Composition B. The orientation of the UXO, and the geometry of the cracked casing, allow precipitation to accumulate within the UXO, in contact with the HE filler. Water containing dissolved HE could exit the UXO through the broken casing (Figure 2-3).



Figure 2-3. Cracked open 155-mm HE projectile with exposed Composition B behind aluminum booster charge.

No munitions constituents, explosives by EPA Method 8330 or perchlorate by Method 314 (USEPA 1994 and 1999, respectively), were detected in 17 wipe samples collected on the surface of munitions debris located on

the ground surface. The wipe sampling results suggest that munitions surfaces were not a significant reservoir of munitions constituents.

Soil sampling was performed in transects extending away from the two targets to evaluate the distribution of RDX in soil with distance from a target. Samples were collected as five-point composites in a series of ten grids, each 6.7 m × 6.7 m, which extended approximately 67.1 m away from the targets. Based on the lack of detections, neither target appeared to have a concentration gradient moving outward from the target.

Based on results from three clusters of six lysimeters at Target 23, and 25-point composite soil samples collected from 0 to 2 cm above each lysimeter cluster, a relationship was observed between soil and soil pore water RDX concentrations. Where RDX was not detected in soil (< 14 µg/kg), the concentration in soil pore water was also nondetect (< 0.5 µg/L). Where RDX concentrations in soil ranged from 412 to 834 µg/kg, with an average concentration of 657 µg/kg (based on three 25-point composite samples), the concentration in soil pore water ranged from 0.5 to 150 µg/L, with an average of 43 µg/L, based on 9 detections. In addition, all of the detections of RDX in soil pore water at Target 23 occurred in the area where RDX was detected in soil.

Concentrations of RDX in soil pore water beneath the cracked open 155-mm HE projectile were as high as 120 µg/L, which is approximately six times higher than the average concentration of RDX in groundwater in this area. These results confirm that cracked open HE UXO can act as long-term point sources of groundwater contamination (AMEC 2004b, 2005e). These results also provide quantitative field-based measurements of the concentration of RDX emanating from a cracked open HE ordnance item, which may enable calibration of future estimates of source loading.

After the Focused Investigation was completed, Rapid Response Actions (RRAs), which included intrusive UXO clearance and soil excavation, were completed at Targets 23 and 42. These targets were identified as the most heavily contaminated with HE based on frequency of HE detection and maximum concentration of HE (AMEC 2001c). The RRAs addressed explosives contamination in soil and munitions and explosives of concern (MEC). The RRAs removed and treated (or disposed of) a combined volume of approximately 1,000 m³ of soil and 8,290 kg of munitions debris (ECC 2005a).

Three rounds of pre-excavation lysimeter samples provide baseline data against which post-soil excavation lysimeter samples will be compared. The comparison of pre- and post-excavation soil pore water data will be used to evaluate if shallow UXO clearance and soil excavation are an effective means of removing the source of RDX and perchlorate, therefore limiting further impacts to groundwater.

A summary of corrosion mechanisms and corrosion potential of UXO at Camp Edwards was produced in 2005 (AMEC 2005e). Reconnaissance performed at the High Use Target Area (located within the CIA) revealed that 95 percent of all munitions debris are located within the top 1 m of soil (AMEC 2005c), and corrosive pits were observed in approximately 78 percent of the recovered munitions items. In general, the number of munitions items with pits increased with depth for both UXO and munitions debris. The U.S. AEC evaluated 21 ordnance items discovered as part of the High Use Target Area Investigation (Chendorain and Stewart 2004). The study focused on eleven 155-mm LITRs less than 22 years old, nine 155-mm LITRs in the ground for 10 to 17 years, and the nose cone from a 155-mm munition item that spent from 46 to 56 years on the ground surface. The study used the age of the ordnance and the maximum pit depth to estimate corrosion rate. The calculated rates of corrosion ranged from < 0.028 to 0.129 millimeters per year (mm/y), with the average being approximately 0.066 mm/y. The study concluded the approximate time to perforation of 1.27-cm steel UXO at Camp Edwards would be at least 170 years.

Groundwater

Four explosives compounds (RDX, 2ADNT, 4ADNT, and perchlorate) were identified as groundwater COCs based on a risk evaluation (AMEC 2004a). Although not present at concentrations above pertinent risk screening levels, HMX and TNT have been retained as COCs at the request of regulatory authorities. RDX represents the broadest extent of groundwater contamination and is present in the highest concentration (AMEC 2004a). RDX concentrations found in groundwater samples are generally less than 10 µg/L. Reverse particle backtracks, developed with calibrated groundwater modeling tools such as MODFLOW and MODPATH, indicate that a distributed source area is located within the CIA. Lesser extents of HMX and perchlorate groundwater contamination are observed and are generally co-located with RDX.

The Impact Area groundwater plume covers an area approximately 3,900 m long by 1,680 m wide (AMEC 2004a). Approximately 16.3 to 21.2 billion liters of water have been contaminated beneath an area of 3.6 km² (900 acres) (AMEC 2004a). The amount of RDX dissolved in this volume of contamination is approximately 27.2 to 36.3 kg (AMEC 2004a). During the reporting period, the maximum observed groundwater concentration of RDX, HMX, and perchlorate was 40, 1.8, and 3.1 µg/L, respectively (AMEC 2005d).

Demolition Area 1

Demolition Area 1 (Demo 1) is south of the Impact Area at Camp Edwards in a kettle hole that covers 0.4 ha at its base, which is 13.7 m below the surrounding grade. Demolition and EOD training began sometime in the mid-1970s, lasted until the late 1980s, and included the destruction of various types of ordnance using C4, TNT, and detonation cord. As part of a comprehensive site reconnaissance, chunks of C4 and other residual munitions were found on the ground surface and removed in accordance with approved procedures and destroyed in the on-site closed detonation chamber.

Soil

More than 600 soil samples have been collected at Demo 1. The following explosive and propellant compounds have been repeatedly detected in soil and groundwater there: perchlorate, RDX, HMX, 2ADNT, 4ADNT, TNT, and 2,4DNT (AMEC 2005f). The most frequently detected explosives compounds in soil were RDX and HMX, representing 22 and 13 percent, respectively, of all explosives detections in soil. A maximum concentration of 14,000 mg/kg of RDX was measured in the soil below a chunk of C4, which indicates that HE particulates were present in this sample. The average concentration of RDX in soil, using one-half the detection limit for nondetects and excluding three sample locations collected beneath C4 residuals, as described in the Soil RRA Plan, is 0.576 mg/kg. TNT was also heavily used in demolition training. The low frequency of TNT detection (2 percent) in soil is most likely due to the rapid degradation of TNT to the daughter products 2ADNT (7 percent) and 4ADNT (5 percent). The principal degradation products of TNT are 2ADNT, 4ADNT, and 2,6DANT. 2,4-dinitrotoluene (2,4DNT) and 2,6-dinitrotoluene (2,6DNT) are not degradation products, but are components of propellants and impurities in TNT manufacturing.

A Draft RRA Plan was prepared by AMEC and submitted to the USEPA and Massachusetts Department of Environmental Protection (MADEP) on 19 February 2003. The plan presented the conceptual design of voluntary interim actions to reduce or eliminate potential risks to human health present at Demo 1 as a result of historic OB/OD, disposal, and demolition training activities.

Low Temperature Thermal Desorption (LTTD) was the selected remedial alternative for treatment of soil contaminated with explosives and propellants. The site characterization data showed that COCs were co-located, and RDX was detected most frequently and at the highest concentrations. Also, RDX and perchlorate are the primary contaminants in groundwater at Demo 1. Therefore, RDX and perchlorate were targeted for remediation and confirmation sampling subsequent to excavation.

Several activities were conducted in preparation of soil treatment via LTTD, including the following: preparation of a Soil Treatment Plan, construction of a soil treatment facility, completion of a treatability study and associated reporting, completion of a Proof of Performance test and associated reporting, and air permitting as required by the MADEP. Prior to soil excavation, UXO clearance and anomaly removal activities were conducted at Demo 1. UXO clearance activities began in June 2003 and UXO/anomaly removal activities were conducted concurrently with excavation of soil, as safety allowed. Excavation of soil began in February 2004 and was completed in the summer of 2005. The thermal treatment unit treated approximately 24.5 million kg of contaminated soil from Demo 1. Treated soil was stockpiled on-site until restoration could commence. Sampling of treated soil was conducted to ensure contaminants were destroyed, and post-excavation confirmation samples were collected to demonstrate that remediation goals were achieved. "Burn pit" materials and metallic and other debris were disposed of at permitted off-site facilities. The soil RRA has eliminated the continuing source of groundwater contamination associated with contaminated soil and potentially with geophysical anomalies at Demo 1. The restoration of the site will be accomplished with reuse of treated soil and re-vegetation within the kettle hole.

Groundwater

A total of 108 monitoring wells at 38 locations have been installed at Demo 1. Over 1,800 groundwater samples have been collected and analyzed for explosives and/or perchlorate. Using these data as well as data

collected by pneumatic slug testing methods, a revised conceptual model was completed in 2004 and presented in the Final Groundwater Report Addendum (TM 01-2).

A groundwater containment system for the Demo 1 plume was designed and started up in September 2004 as a groundwater RRA. This interim action addresses groundwater contaminated with explosive compounds and perchlorate. The objective of the interim action is to provide hydraulic capture of the majority of the groundwater plume to control further migration and to initiate removal and treatment of dissolved contaminant mass contained within the plume. The system uses granular activated carbon (GAC) and ion exchange (IX) resin to treat contaminated groundwater. Based on the conceptual model for the site, approximately 45.4 kg of perchlorate and 30.4 kg of RDX are expected to exist within the Demo 1 groundwater plume (mass for HMX within the plume was not calculated). To date, the groundwater RRA system has removed approximately 8.8 kg perchlorate, 2.3 kg RDX, and 0.2 kg HMX from the Demo 1 groundwater plume.

In the Feasibility Study (FS) finalized in 2005, groundwater modeling and an innovative particle tracking optimization program were used to identify the most efficient extraction well locations and pumping rates required to meet project objectives. The approach for the FS was to focus on the extraction well locations and pumping rates while providing a conceptual groundwater treatment system designed to facilitate regulatory and public approval. An optimization methodology approach, Brute Force within Groundwater Vistas (Rumbaugh and Rumbaugh 2004), was used for determining the most efficient remedial scheme for containing or collapsing a groundwater plume of explosive compounds and perchlorate, and to conceptualize potential remedial alternatives. Groundwater modeling tools such as MODFLOW and MODPATH were used to assist the decision-making process of monitoring well placement and screen settings, including the installation of extraction and reinjection wells (Masterson et al. 2000, 1998, and 1996; Harbaugh and McDonald 1996; Pollack 1989, 1994).

A Remedy Selection Plan (AMEC 2005g) summarized the Demo 1 site activities and presented the proposed remedy for public comment in September 2005. Initially, a five extraction well system was proposed as the comprehensive remedy for Demo 1 groundwater. In response to new

groundwater data indicating that perchlorate was detected downgradient from the RRA extraction well, a sixth extraction well was added as a contingency option before the Remedy Selection Plan was finalized.

A Decision Document is expected to be finalized in the summer of 2006. This document summarizes the site history, enforcement actions, community participation, conceptual model, remediation objectives, and land use controls. It presents screening of the alternatives considered. The remedy for Demo 1 groundwater will be issued in this final document.

Demolition Area 2

Demolition Area 2 (Demo 2) was used from the late 1970s to the late 1980s for light demolition training. Records indicate explosive charges including C4, TNT (in quantities less than 4.540 kg), and claymore mines were used. A surface geophysical survey was conducted at the Demo 2 Area in September 2001. The area investigated was 190 m long and 60 m wide (approximately 3 acres), and was surface-cleared of any metal or other debris. Materials recovered from the surveyed areas consisted of scrap metal and barbed wire. No ordnance or ordnance-related materials were discovered. A subsequent hand-held magnetometer survey and visual inspection of a 4.1 hectare portion of the 6.1 hectare Demo 2 site was performed in 2003. No ordnance or bulk explosives materials were found.

Soil

Results for soils collected from the perimeter berm revealed the presence of four explosive compounds: RDX, HMX, 2ADNT, and 4ADNT. Nearly all of the compounds were detected in nine samples collected from four trenches excavated into a peripheral soil berm and series of soil piles that bound the western limits of the site. Trench 1 samples exhibited a single detection of RDX. The maximum concentrations of RDX and HMX (3,000 and 300J µg/kg, respectively) were reported in samples collected from Trench 2, and the maximum concentrations of the TNT degradation products 2ADNT and 4ADNT (42 and 28 µg/kg, respectively) were reported in samples obtained from Trench 4. None of these samples exhibited detectable concentrations of perchlorate.

Remnant bulk explosive chunks (both TNT and C4) associated with past engineer training activities have been found at Demo 2 and are assumed to be the source of residual RDX, HMX, 2ADNT, and 4ADNT in soil. Due to

the potential presence of additional bulk explosives chunks in the perimeter berm, an RRA soil removal was performed. Approximately 573 m³ of soil was excavated, removed from the site, and processed through the on-site thermal treatment unit. No detectable concentrations of residual explosive compounds remain in soil at the site and the Impact Area Groundwater Study Program (IAGWSP) has proposed closure of the Demo 2 soil operable unit.

Groundwater

Thirteen monitoring well locations have been installed in the Demo 2 area. RDX and HMX have been detected in groundwater, and the initial assessment is that at least 975 m of downgradient migration has occurred. RDX concentrations ranged from 0.26 to 3.2 µg/L. Additional wells are planned to better define the RDX plume configuration.

Groundwater samples collected from each of the 13 wells have also been tested for perchlorate. None has been detected at this site.

Southeast Ranges

The SE Ranges consist of four ranges used by defense contractors for munitions testing including R&D activities. The following information regarding use of the ranges was derived primarily from ordnance and explosives (OE) search reports (USACE 1999a, 1999b) and information provided by contractors who used the ranges.

The J-1 Range was used primarily as an estimation range (i.e., to practice estimating firing distances by eye), an anti-tank range, and a transition range from the mid-1930s through the 1950s. The J-1 Range was subsequently used for weapons testing by a variety of military contractors until the 1980s.

The original J-2 Range was established in the late 1940s in an area currently designated as N Range. The J-2 Range was used historically as a musketry range (1935 to 1940s), transition range (1940s to 1950s), rifle range (1960s to 1980s), and a contractor test range (1953 to 1980). Examples of activities conducted by various contractors included the following: propellant and fuze testing, penetration testing for various munitions, fragmentation testing, obscuration testing, infrared testing of tank heat

signatures, propellant and waste burning, munitions disposal, and loading of munitions with explosives.

The J-3 Range was used for mortar and machine gun practice from 1935 through the 1950s. Textron, Inc., under various military contracts, used the range from 1968 to the 1990s for the loading and testing of various munitions and fuzes, and a wide variety of other munitions-related tests.

Based on historical use and recent ordnance discoveries, all deactivated ranges with the "L" designation were used for small arms with the exception of the current L Range, which was used initially as an infiltration course (i.e., a range for practicing ground-troop infiltration of a guarded area), and most recently as a grenade launcher training range. The current L Range, which is on the western side of Greenway Road just north of the J-3 Range, has documented OE use.

Investigations in the study areas have included sampling at over 400 monitoring wells (at more than 200 locations), collection and analyses of more than 4,000 soil and 3,500 groundwater samples, biweekly sampling of Snake Pond surface water, and monthly sampling of nearby residential and irrigation wells. During early investigative activities, soil samples were analyzed using a comprehensive standard analyte list, typically consisting of explosives, volatile and semi-volatile organic compounds (VOCs, SVOCs), metals, herbicides, pesticides, ethylene dibromide, methyl tertiary butyl ether, and other miscellaneous analytes. Dioxin/furans and PCNs were added during subsequent sampling rounds. Groundwater was analyzed for the standard analyte list plus perchlorate. Recent analyses for both soil and groundwater have focused the analytes to explosives, perchlorate, and SVOCs.

During the reporting period, IAGWSP achieved substantial completion of soil RRAs at the J-2 and J-3 Ranges. The RRAs addressed perchlorate and explosives contamination in soil. Combined, the RRAs removed and treated (or disposed of) more than 6,000 m³ of soil (ECC 2005c). In addition, an RRA workplan was prepared to address groundwater contamination at the toe of the J-3 Range Demolition Area groundwater plume (ECC 2005d), and initial steps were taken to develop an RRA approach for the J-2 Range North plume.

Soil

Soil results have indicated the presence of HMX at various locations throughout these areas. At the J-3 Range, HMX and various propellants were identified at the following areas: Melt/Pour facility, where melting of explosives and loading of munitions occurred; the northeast portion of the artillery range; a munitions detonation pit and burn area; and a drywell associated with an on-site workshop. At the J-1 Range, RDX was detected in ash samples collected from a former burn kettle and from mixed soil and debris from a steel-lined pit that contained discarded munitions. Explosive residues are present in the Ammunition Storage Magazine and the Melt Pour building on the J-2 Range. PCNs were also detected in many of the soil samples, as were low levels of dioxins and furans.

Soil sampling and geophysical investigations completed within the past year have been conducted primarily to confirm the efficacy of the soil RRAs at the J-2 and J-3 Ranges, and complete characterization at the J-2, J-1, and L Ranges. Results continue to confirm that perchlorate and explosives remain the principal COCs.

Groundwater

Groundwater contaminants identified at the SE Ranges include RDX, HMX, TNT, and perchlorate. Four general regions of groundwater contamination have been identified and confirmed at the SE Ranges (AMEC 2003b, 2004c, 2005h; ECC 2005b). One plume is located downgradient of the northern end of the J-1 Range (J-1 Range North), one plume extends downgradient from the middle of the J-3 Range, and two plumes appear to emanate from the J-2 Range. While efforts completed during the past year have focused on defining the extent of the J-2 Range plumes, progress has been made in providing better definition to the boundaries of the J-1 and J-3 Range plumes. Recent groundwater sample results have identified a possible plume at the south end of the J-1 Range.

The J-1 Range North plume is located immediately downgradient (northwest) of the J-1 Range 1,000- and 150-m berms, where perchlorate, RDX, HMX, and other miscellaneous explosives have been detected in groundwater. RDX has been detected at concentrations up to 150 µg/L in this area. The highest HMX concentration observed in this area was 110 µg/L, while perchlorate has been detected at concentrations up to 37 µg/L. A calibrated numerical model of groundwater flow, created with tools such

as MODFLOW and MODPATH, suggests that the contaminants reached the water table near the 1,000-m berm. Various activities known or reported to have occurred in the area could have provided a source for the detected contaminants. These include firing and detonation of munitions, cook-off tests, burning of excess munitions in the steel-lined pit and popper kettle, disposal by burning of lead azide on the range road, disposal of J-3 Range Melt/Pour wastewater, and burial of vehicles and pails of various waste materials.

Advancement of small-diameter push probes have identified low levels of RDX and HMX contamination at the MMR base boundary immediately southeast of the south end of the J-1 Range. This J-1 Range South plume is currently being delineated.

The J-3 Range plume is located from the center of the J-3 Range down-gradient to Snake Pond, where RDX and perchlorate, and HMX to a lesser degree, have been detected in groundwater. RDX was also detected in a water sample from a septic tank at the J-3 Range. The highest RDX concentration observed was 35 µg/L, while the maximum HMX concentration was 100 µg/L. Perchlorate has been detected at concentrations up to 770 µg/L. Distribution of contaminants in groundwater, groundwater modeling, and soil data suggests that multiple source areas may exist, including a detonation pit, a former Melt/Pour building, and a drywell. Contaminants in groundwater are migrating south from the J-3 and L Ranges. Most of the contaminated groundwater discharges to or migrates beneath Snake Pond or is captured by the Installation Restoration Program (IRP) FS-12 groundwater extraction and treatment system. An RRA workplan has been developed to capture additional groundwater near the north end of Snake Pond utilizing to the extent practical the FS-12 extraction system. The recently completed soil RRA at the J-3 Range is expected to reduce or eliminate continuing releases of RDX, HMX, and perchlorate to groundwater.

Two plumes have been identified at the J-2 Range. One, the northern plume, apparently originates within an area historically used for OB/OD activities. Groundwater flow and plume orientation is toward the northeast. Perchlorate and RDX are the principal contaminants, with other explosives and dyes detected in near-source groundwater. The recent soil RRA at the J-2 Range is expected to reduce or eliminate continuing releases of these contaminants to groundwater.

The other J-2 Range plume, based on the generally lower contaminant concentrations, appears to have multiple small sources in the southern end of the range. The southern plume may be comprised of two or more discrete smaller plumes. Potential sources include former firing points, a Melt/Pour facility, and OB/OD activities. Contaminants include perchlorate and RDX, and to a lesser degree HMX. Groundwater flow and plume orientation are toward the east and northeast. Wells installed during the reporting period have served to refine the boundaries of both J-2 Range plumes.

Perchlorate has been detected at numerous widely distributed wells on the J-1, J-2, J-3, and L Ranges. The highest concentration (770 µg/L) was detected in a sample downgradient from the J-3 Range demolition area. PCNs and dioxins/furans have not been detected in groundwater.

Former A Range Gravity Anti-tank Range

The Former A Range is a currently inactive anti-tank artillery and rocket training range originally constructed in 1941 and used into the early 1960s. Tank targets were placed on specially designed rail cars and rolled on tracks, via gravity, downhill through two sets of switchbacks traversing a target area. Trainees would fire at these moving targets from gun positions located 732 m from the target area. Records indicate ordnance used during this period included 37- and 40-mm armor-piercing (AP) and HE rounds, 75-mm HE and shot rounds, 90-mm anti-aircraft rounds, and 3.5-in. practice rockets. Recent site inspections revealed the presence of 60- and 81-mm mortars and a single, inert 57-mm projectile. In the early 1960s, the range was converted for machine-gun training. Records indicate that 0.50 caliber ball and tracer rounds were used at that time. Site inspections have revealed 5.56- and 7.62-mm small caliber ammunition as well.

Investigations of the Former A Range included soil testing and groundwater monitoring to determine if past training activities conducted there have had, or may potentially have, an adverse impact on groundwater. Groundwater monitoring in the vicinity of the Former A Range has been ongoing since February 1999. Other investigative activities included a pair of ground-based electromagnetic geophysical surveys (EM-61s) in the target area to search for subsurface materials potentially presenting an explosive hazard (MPPEH). As part of these investigations, BIP operations were performed on discovered ordnance items considered unsafe to move.

Soil

A total of 197 soil samples have been collected from within the target area, firing point, and target rollout area. The most frequently detected explosives were 2ADNT and 4ADNT. Both are considered transformation products of the primary filler constituent of 40-mm HE projectiles (TNT), which are known to have been fired at Former A Range. RDX has also been detected in soil at this range; however, it is limited exclusively to post-BIP samples. Because none of the HE rounds destroyed during BIP activities at Former A Range contained RDX in their filler formulations, these results suggest the presence of RDX, a primary constituent of BIP donor charges, is likely a result of the BIP process.

A suite of SVOCs, consisting mostly of polycyclic aromatic hydrocarbons (PAHs), was detected in soils collected from the target area and rollout area of Former A Range. Most were found in samples collected from sediment deposit areas near the rail line. The link between the rail line and PAHs (typical of petroleum products) has not been confirmed. However, records suggest that maintenance of the rail line included the use of lubricants on the curved portions of the tracks for proper operation of the target cars. Two propellant-related SVOCs (N-nitrosodiphenylamine and di-n-butyl phthalate) were found in firing-point soils. The presence of these compounds at the firing-point, along with the detection of 2,4DNT is consistent with its past use.

Among the several metals detected in soil collected from the Former A Range, Pb and Cu were frequently reported at concentrations greater than background. Because Pb and Cu are typical constituents of small arms projectiles, the presence of these metals in soil is presumed to be associated with past small arms training activities performed at the site. The maximum Pb and Cu concentrations were 11,600 and 7,220 mg/kg, respectively.

Additional soil sampling is underway to better define the distribution of explosives compounds in the target area, PAHs along the rail line, and metals associated with small arms projectiles.

Groundwater

Five monitoring well locations were drilled, in part, to evaluate groundwater conditions in the vicinity of the Former A Range. Monitoring wells

were installed at three locations downgradient of the range and screened at depths selected to intercept groundwater originating beneath the target area. The two others were installed within the footprint of the target area. Of the five, only one location has shown explosives contamination associated with past training activities at Former A Range. Trace concentrations of TNT (ranging from 0.38J to 0.51J $\mu\text{g}/\text{L}$ where the J qualifier signifies an approximate concentration), 2ADNT, and 4ADNT have been reported in this downgradient well. These results are consistent with residual explosives found in soil within the target area of the site.

Geophysical survey

An EM61 survey was conducted at the Former A Range to search for subsurface ordnance and ordnance disposal sites. Surveys were performed in four separate areas within the range target area, each representing a partially exposed, up-range hillside surface where ordnance was abundant. The survey results revealed numerous anomalies suggestive of possible subsurface ordnance items; subsurface inspections were performed at 102 of these locations. Eight of these anomalies were determined to be the result of disposal sites for expended practice rounds. Most of the 247 rounds recovered from these disposal sites were inert 3.5-in. rockets. Items other than 3.5-in. rockets discovered in these disposal pits included four inert 40-mm projectiles, one inert 37-mm projectile, one inert 75-mm projectile, and one inert 90-mm projectile. Of the remaining anomalies, 33 were ordnance items, 30 of which had to be destroyed in place to render them safe; the other three were cracked-open rounds. Most of the BIP items were 37- or 40-mm projectiles.

A more recent EM61 survey was performed within the target area to map the distribution of surface and near-surface ordnance and fragmentation to better define the limits of impacted hillside. The results are being used to finalize soil sampling plans to better define the nature and extent of residual explosives contamination within the target area.

Ordnance penetration survey

Three trenches have recently been excavated into a backstop berm located in the upper portion of the target area. The objective of this excavation task was to characterize the depth of ordnance penetration and the associated distribution of residual explosives contamination at depth. Most of the ordnance items encountered during excavation were 37-mm

projectiles and 3.5-in. rockets. These findings are consistent with historical range use records. Most of these items were found in the upper 0.6 m of the 2.1-m-deep trenches. Similarly, the few explosives compounds detected in soils collected from the excavations were found in shallow samples only.

Phase IIb and munition survey project sites

The original sites identified by USEPA under Phase IIb of the IAGWSP consisted of waste oil sites (3), latrines (63), an ammunition supply point (1), cleared areas (12), general training sites (25), engineering training/demolition sites (5), and training ranges (36). The breakdown of training ranges includes small arms (22), machine gun (7), anti-tank (2), skeet (1), battle assault course (1), and grenade courts (3). After field reconnaissance inspections at each site, 12 sites were selected for the first phase of investigation. The initial results suggest very limited detections of MC. However, in some cases (i.e., certain rocket ranges, demolition training sites, and small arms ranges), further sampling was deemed necessary and additional delineation investigations at these sites are currently underway or in the planning phase.

In addition to reconnaissance and soil sampling at Phase IIb sites, a number of geophysical surveys have been performed under the Munitions Survey Program. In most cases, metal debris, small arms ammunition, or inert projectiles were found. Few HE rounds or ordnance disposal sites have been discovered at Phase IIb sites.

A total of 25 small arms ranges were evaluated as part of subsequent Phase IIb activities. The investigation consisted of review of historical activity, reconnaissance of the sites, and soil sampling. Five propellant-related SVOCs were detected at some of the ranges and included 1,3-diethyl-1,3-diphenyl urea, di-n-butyl phthalate, N-nitrosodiphenylamine, 2,4DNT, and 2-nitrodiphenylamine. Five metals—Sb, barium (Ba), Cu, Pb, and Zn—were detected at concentrations sometimes exceeding established site background values. Elevated Pb, Sb, and Cu concentrations in soil are presumed to be associated with the Pb-alloy projectiles found throughout these sites. Additional sampling is planned for those sites where significant concentrations of either propellant- or small arms projectile-related residual contaminants were found.

Northwest Corner

The NW Corner consists of property on the northwest corner of Camp Edwards as well as the adjacent property beyond the base boundary between this part of the base and the Cape Cod Canal. Within Camp Edwards, this area encompasses portions of the B-9 and B-11 Training Areas, four gun positions (GP-12, GP-14, GP-16, and GP-19) and the L-3 Range, a former infantry squad and platoon combat firing range. Commercial and private irrigation wells are located between the base boundary and the canal.

Investigation of the NW Corner was initially conducted as part of the comprehensive soil and groundwater characterization for the Gun and Mortar Firing Positions Operable Unit. With the detection of perchlorate in monitoring well (MW)-66S at GP-16 in August 2001, a focused investigation was initiated in the NW Corner specific to perchlorate. This included sampling of soil at GP-16 for perchlorate and the sampling of off-site private wells located west of and cross gradient to GP-16.

In December 2002, perchlorate was detected in an off-site commercial well within the 4-18 ppb range designated by USEPA as the interim guidance level for perchlorate in drinking water. As a result, investigation of the NW Corner expanded for plume delineation and source characterization. Monitoring well installation and sampling, identification and sampling of off-site private wells, and soil sampling were conducted in 2003 through 2005 to determine the extent of perchlorate in groundwater and soil at the NW Corner of the MMR. The area of investigation included off-site areas located mainly on U.S. Army Corps of Engineers (USACE)-managed property along the Cape Cod Canal. Explosives are also a COC based generally on the association of explosives with military training and specifically due to the detection of RDX in an off-site commercial well in an August 2002 sample.

Soil

Soil sampling was conducted at 136 locations to characterize perchlorate concentrations in shallow soil in the vicinity of Canal View Road, GP-12, GP-16, GP-19, and the L-3 Range. In addition, soil samples were collected at 10 locations from an area of fireworks debris along Canal View Road. Samples were collected both before and after an off-base annual Independence Day celebration to assess the impacts of the fireworks display to

soil. Since 1997, fireworks have been launched from an area west of the MMR boundary, 200 m northwest of GP-19 and upwind of the NW Corner of Camp Edwards. In addition to soil sampling, paper fireworks debris from the 2003 display was collected from Canal View Road and analyzed to assess the possibility that the debris represents a continuing source of perchlorate releases to soil.

Soil analytical results indicate that perchlorate in soil in the NW Corner is distributed over a wide area at low concentrations, ranging from an estimated value of 1.6 to 64 $\mu\text{g}/\text{kg}$, extending from Canal View Road just north of GP-19 northward to GP-16. Perchlorate concentrations in surface soil along Canal View Road immediately after the 2003 fireworks display were significantly higher, ranging from 4.5 to 7,560 $\mu\text{g}/\text{kg}$. Samples collected prior to the event at the same locations showed trace or no detections of perchlorate. Perchlorate concentrations in soil samples collected 2 months after the fireworks display from 3 of the highest locations and in 95 soil samples collected more than a year after the display throughout the NW Corner were significantly lower, ranging from not detected to 18 $\mu\text{g}/\text{kg}$. Samples of paper fireworks debris were characterized by perchlorate concentrations ranging from 302 $\mu\text{g}/\text{kg}$ to 34,200 $\mu\text{g}/\text{kg}$.

The data suggest both particulates of perchlorate and pieces of the mortar shell paper from the fall-out of fireworks debris containing perchlorate residues are the main source of perchlorate in the soil. The paper fireworks debris appears to be a continuing source of perchlorate leaching to groundwater several months after the debris has been deposited.

Groundwater

Forty-four monitoring wells at 19 locations have been installed within the NW Corner for characterization of explosives and perchlorate. In addition, 24 existing monitoring wells were sampled for perchlorate in conjunction with this investigation. Three commercial wells and six residential wells were sampled for both perchlorate and explosives. The groundwater data indicate the presence of a shallow wedge-shaped perchlorate plume approximately 1,200-m wide and 1,600-m long. The groundwater data also indicate a very narrow, poorly defined stringer (< 61-m wide) of RDX at the southern edge of the perchlorate plume, but 15 m deeper within the aquifer.

Within the perchlorate plume, concentrations have ranged from 0.36 to 26.3 µg/L. The highest concentrations of perchlorate are found at the water table beneath Canal View Road, just to the north of GP-19. This area coincides with high perchlorate concentrations observed in soil and the presence of paper fireworks debris after the July 2003 fireworks display. In the up-gradient portion of the plume, the highest concentrations of perchlorate are found at the water table with perchlorate present to a depth of 6.1 to 9.1 m into the aquifer. With groundwater flow, the plume migrates lower in the aquifer, extending from 6.1 to 15.0 m below water table (bwt) at the southern downgradient end at the canal and 1.5 to 9.1 m bwt at the northern downgradient end.

The source evaluation indicates that perchlorate in the shallow groundwater at the NW Corner most likely originated from fireworks debris from a series of nearby July 4th celebrations; although military use of pyrotechnics in Training Areas B-9 and B-11 cannot be conclusively ruled out at this time. The large extent and overall uniformity of the perchlorate plume suggest that the perchlorate was deposited from aerial dispersal over a large area. The distribution of the highest perchlorate concentrations in the middle of the plume at the water table suggests that the heaviest deposition of perchlorate occurred in the vicinity of Canal View Road north of GP-19, with lighter deposition up-gradient and downgradient of the Road and north along the Road. Air dispersion modeling conducted in 2005 using the CALPUFF model supports the hypothesis that the fireworks debris is the main source of perchlorate in the shallow groundwater (Earth Tech 2003). Utilizing site-specific meteorological data and an assumed particulate size distribution, the CALPUFF model output demonstrated that the area of fireworks deposition over the cumulative 8 years of the displays was consistent with the perchlorate plume source area.

RDX has been detected consistently in concentrations below 1 µg/L in three wells located off base, in both shallow and deep groundwater. RDX has been detected in three monitoring wells on base in the NW Corner, ranging in concentration from 0.44 to 9.6 µg/L. RDX has consistently been detected in only one of the locations. At this location near the base boundary, RDX was detected in profile samples at depths of approximately 12.2 to 39.6 m below the water table, with the highest concentrations at approximately 15.2 m below the water table. Groundwater modeling suggests that the source of RDX at this one location is up-gradient in the CIA. Because the plume appears to be very narrow, less than 61 m wide, and the

hydrogeologic regime is variable in this portion of the aquifer, identification of an exact source area has been problematic. Additional investigation conducted in 2005 using direct push sampling at eight locations along an up-gradient swath, identified through use of groundwater modeling, has not resulted in detection of the RDX source. Limited further investigation is pending to identify the source.

Overall conclusions for MMR

Based on studies at Camp Edwards, munitions constituents accumulate on the soil surface as a result of normal military training activities. Specifically, explosive residues were found in surface soils near indirect and direct fire fixed targets, at OB/OD areas, and at areas used for munitions testing and research. Propellant residues are found at anti-tank targets, OB/OD areas, and both artillery and mortar firing positions.

Explosives residues in the artillery and mortar Impact Area soil represent a distributed source covering a large geographic area, and higher contaminant concentrations are observed near fixed targets. The presence of perchlorate within the Impact Area is probably a result of perchlorate used in the spotting charges for LITR. Recent investigations performed outside Camp Edwards showed that debris on the land surface associated with fireworks displays is also a continuing source of perchlorate leaching to groundwater. Because munitions used at most Army ranges are similar to those used at Camp Edwards, the presence of a similar suite of compounds in soil can be expected at most Army ranges.

Explosives and propellant residues in OB/OD areas tend to be focused in smaller areas. Chunks of HE representing percent levels in soil were found in shallow soil at Demo 1. The presence of perchlorate at Demo 1, but not Demo 2, is thought to be the result of fireworks demolition activities that occurred at Demo 1. Since activities at OB/OD areas are concentrated in a small area, the residues are distributed over a small surface area. The concentrated activity will result in higher soil concentrations of residues than found at target areas. Based on the extensive OB/OD characterization efforts at Camp Edwards, residues can be expected at most Army demolition areas, with the distribution of compounds dependent on the type of munitions detonated.

Propellant residues are found at the anti-tank and artillery and mortar firing positions. In general, perchlorate was not found at the firing points,

which is consistent with the absence of perchlorate in the propellant formulations used at Camp Edwards. Considering the similarity of firing activities at Camp Edwards with other Army ranges, propellant residues can be expected at other Army firing positions, with the distribution of compounds dependent on the frequency and duration of use.

Due to the highly permeable soils and relatively abundant rainfall at Camp Edwards, some munitions constituents have migrated to groundwater. Specifically, RDX, HMX, perchlorate, TNT, and the aDNTs have been found in groundwater in the vicinity of the artillery and mortar impact area, demolition areas, and munitions testing ranges. These findings suggest that, under the right conditions (e.g., permeable soils and abundant rainfall), some explosive residues can be expected in groundwater at other Army ranges with similar environmental conditions. Plumes of explosives residues emanating from artillery and mortar impact areas are likely to be large spatially, but have low concentrations. In contrast, plumes emanating from isolated demolition areas are expected to be narrow, with the length dependent on the history of activities. Groundwater concentrations of explosives residues in demolition areas are expected to be higher than those in impact areas. Since RDX and TNT have relatively low health advisories (0.002 mg/L for both compounds in drinking water), concentrations in groundwater are likely to exceed the regulatory guidelines.

Propellant residues have not been found in groundwater at Camp Edwards' anti-tank or artillery and mortar firing positions. These findings are consistent with the physical and chemical properties of propellant compounds, which suggest that these compounds are not likely to be mobile in the environment. Since rainfall and soil permeability at Camp Edwards represent an environment favorable to contaminant mobility, the absence of propellant compounds in groundwater at Camp Edwards suggests that propellants are not likely to be an issue at other Army training ranges.

Overall, the documented soil and groundwater impacts at Camp Edwards are consistent with expectations based on known training activities, and can be applied when evaluating the potential for environmental impacts at other Army training ranges. Although residues of explosives and propellant can be expected at other Army ranges, the presence or absence in groundwater will require assessment on a case-by-case basis. Numerous interrelated factors affect the mobility of munitions constituents in the

environment; therefore, conclusions about the presence or absence of groundwater contamination should rely on site-specific data.

References

- AMEC. 2001a. Final IAGWSP Technical Team Memorandum 01-6 Central Impact Area Groundwater Report for the Camp Edwards Impact Area Groundwater Quality Study, Camp Edwards, Massachusetts Military Reservation, Cape Cod, MA. Westford, MA: AMEC Earth and Environmental, Inc.
- _____. 2001b. *Final IAGWSP Technical Team Memorandum 01-6 Central Impact Area Groundwater Report*. Massachusetts Military Reservation, Cape Cod, MA. MMR-3757. Westford, MA: AMEC Earth and Environmental, Inc.
- _____. 2001c. Draft Central Impact Area Soil Report Technical Team Memorandum 01-13 Camp Edwards Impact Area Groundwater Quality Study, Camp Edwards, Massachusetts Military Reservation, Cape Cod, MA. MMR-3915. Westford, MA: AMEC Earth and Environmental, Inc.
- _____. 2003a. Draft IAGWSP Technical Team Memorandum 03-1 Saturated Zone Flow & Transport Modeling Summary Report. 2003. Prepared for U.S. Army Corps of Engineers, New England District, by AMEC Earth and Environmental, Inc., Westford, MA.
- _____. 2003b. Final J-2 Range Supplemental Groundwater Workplan. December 2003. Prepared for U.S. Army Corps of Engineers, New England District, by AMEC Earth and Environmental, Inc., Westford, MA.
- _____. 2004a. Impact Area Groundwater Study Program, Draft Addendum to Final IAGWSP Technical Team Memorandum TM 01-6, Central Impact Area Groundwater Report. Westford, MA: AMEC Earth and Environmental, Inc.
- _____. 2004b. Agency Draft Central Impact Area Soil Focused Investigation Report, Camp Edwards, Massachusetts Military Reservation, Cape Cod, MA, MMR-9210. Westford, MA: AMEC Earth and Environmental, Inc.
- _____. 2004c. Final J-1 Range Supplemental Groundwater Workplan, Camp Edwards, Massachusetts Military Reservation, Cape Code, MA. Westford, MA: AMEC Earth and Environmental, Inc.
- _____. 2005a. Draft Long Term Groundwater Monitoring Plan (LTGM) Plan 2005, Camp Edwards, Massachusetts Military Reservation, Cape Cod, MA. MMR-9456. Westford, MA: AMEC Earth and Environmental, Inc.
- _____. 2005b. Final System Performance & Ecological Impact Monitoring (SPIEM) Plan, Rapid Response Action Systems, Demo 1 Groundwater Operable Unit, Camp Edwards, Massachusetts Military Reservation, Cape Cod, MA. MMR-9300. Westford, MA: AMEC Earth and Environmental, Inc.
- _____. 2005c. Post Screening Investigation – Central Impact Area Source Area Characterization Work Plan for the Camp Edwards, Massachusetts Military Reservation, Cape Cod, MA. Westford, MA: AMEC Earth and Environmental, Inc.

- AMEC. 2005d. AMEC Database Query. Westford, MA: AMEC Earth and Environmental, Inc.
- _____. 2005e. Summary of Corrosion Mechanisms and Corrosion Potential of Unexploded Ordnance at Camp Edwards, Camp Edwards, Massachusetts Military Reservation, Cape Cod, MA. MMR-9400. Westford, MA: AMEC Earth and Environmental, Inc.
- _____. 2005f. Final Technical Team Memorandum 01-17 Demo 1 Groundwater Feasibility Study (TM 01-17), Massachusetts Military Reservation, Cape Cod, MA. MMR-9501. Westford, MA: AMEC Earth and Environmental, Inc.
- _____. 2005g. Final Remedy Selection Plan for the Demolition Area 1 Groundwater Plume, Massachusetts Military Reservation, Cape Cod, MA. MMR-9734. Westford, MA: AMEC Earth and Environmental, Inc.
- _____. 2005h. Final J-3 Range Supplemental Groundwater Workplan, Massachusetts Military Reservation, Cape Cod, MA. MMR-9269. Westford, MA: AMEC Earth and Environmental, Inc.
- Chendorain, M., and L. Stewart. 2004. *Corrosion of Unexploded Ordnance in Soil Environments*. SERDP Final Technical Report, SFIM-AEC-PC-CR-2004007. Aberdeen Proving Ground, MD: U.S. Army Environmental Center.
- Earth Tech. 2003. Revised CALPUFF Modeling Code. April 17.
<http://www.src.com/calpuff/calpuff1.htm>.
- ECC. 2005a. CIA Targets 42 and 23 Rapid Response Action Completion of Work Report, Camp Edwards, Massachusetts Military Reservation, Cape Cod, MA, ECC, Cape Cod, MA.
- _____. 2005b. Draft L Range Groundwater Characterization Report, Camp Edwards, Massachusetts Military Reservation, Cape Cod, MA, MMR-9411. ECC, Massachusetts Military Reservation, MA.
- _____. 2005c. Draft J3 Range Rapid Response Action Completion Report, Camp Edwards, Massachusetts Military Reservation, Cape Cod, MA. MMR-9607, ECC, Massachusetts Military Reservation, MA.
- _____. 2005d. Final J-3 Range Groundwater Rapid Response Action Plan, Camp Edwards, Massachusetts Military Reservation, Cape Cod, MA. MMR-9588. ECC, Massachusetts Military Reservation, MA.
- Harbaugh, A.W., and M. G. McDonald. 1996. *User's Documentation for MODFLOW-96 and Update to the U.S. Geological Survey Modular Finite-Difference Groundwater Flow Model*. U.S. Geological Survey (USGS) Open-File Report 96-485. Reston, VA: U.S. Geological Survey.
- Masterson, J. P., and D. A. Walter. 2000. *Delineation of Ground-water Recharge Areas, Western Cape Cod, Massachusetts*. Water-Resources Investigations Report 00-4000. Northborough, MA: U.S. Geological Survey.

- Masterson, J. P., D. A. Walter, and D. R. LeBlanc. 1998. *Delineation of Contributing Areas to Selected Public-Supply Wells, Western Cape Cod, Massachusetts*. Water Resources Investigations Report 98-4237. Marlborough, MA: U.S. Geological Survey.
- Masterson, J. P., D. A. Walter, and J. Savoie. 1996. *Use of Particle Tracking to Improve Numerical Model Calibration and to Analyze Groundwater Flow and Contaminant Migration, Massachusetts Military Reservation Western Cape Cod, Massachusetts*. USGS Open-File Report 96-214. Marlborough, MA: U.S. Geological Survey.
- Pennington, J. C., T. F. Jenkins, S. Thiboutot, G. Ampleman, J. Clausen, A. D. Hewitt, J. Lewis, M. R. Walsh, M. Walsh, T. A. Ranney, B. Silverblatt, A. Marois, A. Gagnon, P. Brousseau, J. Zufelt, K. Poe, M. Bouchard, R. Martel, D. D. Walker, C. A. Ramsey, C. Hayes, S. Yost, K. L. Bjella, L. Trepanier, T. E. Berry, D. J. Lamber, P. Dube, and N. M. Perron. 2005. *Distribution and fate of energetics on DoD test and training ranges: Interim report 5*. ERDC TR-05-2. Vicksburg, MS: U.S. Army Engineer Research and Development Center.
- Pollack, D. W. 1989. Documentation of Computer Programs to Compute and Display Pathlines Using Results from the U.S. Geological Survey Modular Three-dimensional Finite-Difference Ground-Water Flow Model. USGS. Open-File Report 89-381. Reston, VA: U.S. Geological Survey.
- _____. 1994. User's Guide for MODPATH/MODPATH-PLOT, Version 3: A Particle Tracking Post-Processing Package for MODFLOW, the U.S. Geological Survey Finite Difference Ground-Water Flow Model. USGS Open-File Report 94-464. Reston, VA: U.S. Geological Survey.
- Rumbaugh, J., and M. Rumbaugh. 2004. *Groundwater Vistas*, Environmental Simulations, Inc., Reinhold, PA.
- U.S. Army Corps of Engineers (USACE). 1999a. *Archive Search Report: Findings, conclusions, and recommendations for the Massachusetts Military Reservation, Falmouth, Massachusetts*. Rock Island, IL: U.S. Army Corps of Engineers Rock Island District.
- _____. 1999b. *Ordnance and Explosives Archives Search Report: Addendum to Findings for the Massachusetts Military Reservation, Falmouth, Massachusetts*. Rock Island, IL: U.S. Army Corps of Engineers Rock Island District.
- U.S. Environmental Protection Agency (USEPA). 1994. Method 8330: *Nitroaromatics and Nitramines by HPLC in Test Methods for Evaluating Solid Waste, Physical/Chemical Methods*. SW-846 through update 4b. Washington, DC: Office of Solid Waste and Emergency Response, U.S. Environmental Protection Agency. www.epa.gov/sw-846
- _____. 1999. *Method 314.0: Determination of Perchlorate in Drinking Water Using Ion Chromatography, Revision 1.0*. Cincinnati, OH: National Exposure Research Laboratory, Office of Research and Development, USEPA.

3 Assessment of 100 Years of Military Training in Canada: The Case of Canadian Forces Base Petawawa

Introduction

The Canadian sustainable military training R&D program is aimed at maintaining both military readiness and environmentally friendly defense activities in order to ensure the long-term usage of military training areas. Moreover, as in many other countries, Canada is facing increasingly stringent environmental laws and growing public concerns. Within this context, DRDC-Val was tasked by DLE to initiate a research program for the environmental characterization of their main training areas. Many studies were conducted in the past ten years to better understand the nature and extent of contamination (Ampleman et al. 1998, 2000, 2003; Arel et al. 2002; Brochu et al. 2003; Checkai et al. 1993; Hewitt et al. 2004; Hewitt and Walsh 2003; Jenkins et al. 1997a, 1997b, 1998, 1999, 2001, 2004, 2005; Marois et al. 2004; Pennington et al. 2002, 2003, 2004; Stamfli et al. 2003; Thiboutot et al. 1997, 1998, 2000, 2001, 2003a, 2003b, 2003c, and 2004; Walsh et al. 2002, 2004, 2005). Several of these studies were also co-funded by SERDP, Arlington, VA. CFB Petawawa was selected for assessment based on its intensive use by the Canadian Forces as well as its particular geographical and geological context. Moreover, Petawawa differs from the other Canadian bases because of its high intensity of training in a relatively small area over an extensive period of time. Moreover, the screening of surface duds by visual observation of the site (level 1 clearance) was not done as often at Petawawa as at other CFBs.

The approach for the characterization of CFB Petawawa training area was the same used for areas studied previously, namely by conducting multiple-phase soil surface and hydrogeological studies under a collaborative effort of DRDC-Val and the Institut National de la Recherche Scientifique Eau, Terre et Environnement (INRS-ETE), respectively. Moreover, the characterization of CFB Petawawa was conducted in collaboration with international leading experts within the scope of a bilateral collaboration with the United States and a trilateral collaboration with Sweden and the Netherlands. Thus, scientists from ERDC-CRREL, the Swedish Defence Research Agency (Totalförsvarets forskningsinstitut, or

FOI), and The Netherlands Organization for Applied Scientific Research (Nederlandse Organisatie voor toegepast-natuurwetenschappelijk onderzoek, or TNO) participated in this project.

CFB Petawawa serves as one of the major training facilities for the Canadian Forces. It is the oldest military base still active in Canada, with more than 100 years of military presence. This 400 km²-base is in the County of Renfrew in the Ottawa Valley, approximately 160 kilometers northwest of the City of Ottawa. The base is located on the Precambrian shield, which is covered in many areas by well-drained sandy soils. The eastern part of the base is mostly a flat and sandy area; however, the western part is much hillier. The climate in this part of the country is temperate, with cold winters and warm, humid summers. The average annual temperature is approximately 5 °C, and the mean annual precipitation is 711 mm (Lavigne et al. 2000).

Experimental

Sample handling and treatment

Most of the surface samples were collected using a sampling strategy where 25 or more increments of the top 2.5 cm were obtained with stainless steel scoops. Between sampling locations, the scoops were cleaned by rinsing with water followed by acetone, then wiped dry with clean paper towels. Surface samples were mostly sands and small pebbles; however, mosses and grasses were also included in a few locations. All of the samples were stored in polyethylene bags, refrigerated, and stored in the dark as soon as possible. Samples were taken to either DRDC-Val or CRREL. DRDC's samples were air-dried, acetone-homogenized, sieved through a #25 mesh, split, and analyzed by EPA Method 8330 (EPA 1994). At CRREL, the samples were air-dried, passed through a #10 (2-mm) sieve, and the two fractions weighed. Only the smaller size fraction was analyzed by EPA Method 8330 and/or Method 8095 (EPA 1999; Walsh and Ranney 1999).

The surface and profile samples at CRREL were further processed prior to subsampling and analysis. Twelve of the multi-increment samples selected for a special study were equally split in a rotary divider (Labtech Essa Rotary Sample Divider Model RSD5, Labtech Essa Pty. Ltd., Bassendean, WA, Australia). These split multi-increment samples, the remaining multi-increment samples, and the profile samples were ground in a Labtech Essa

LM-2 ring mill equipped with a B800 bowl. These larger samples were ground in portions of no more than 500 g, then recombined and thoroughly mixed. The samples collected at the firing points and the demolition range were ground for five 1-minute intervals separated by a 1-minute cool down period between each grinding cycle. Samples from the impact ranges, the walls of the scrap metal pit, the rim of a demolition crater, and two sieved laboratory blank soils were ground for 90 seconds.

Once ground, the entire mixed sample was spread out on a large sheet of aluminum foil to conduct subsampling for extraction and analysis. Typically, a single subsample was built from 30 or more randomly located increments removed from the ground material with a small stainless spatula and combined in a 2-oz amber jar with a Teflon-lined lid. In the case of the 12 samples selected for the special study, 12 subsample replicates were removed. Triplicate subsamples were taken from the remaining firing point and demolition range samples; triplicates were taken from every fifth sample from the other ranges. After 20 mL of acetonitrile was added to the sample in each bottle, samples were extracted on a shaker table for 18 hours at 150 rpm. Following extraction, samples were vortexed, then allowed to sit prior to removing a \approx 6-mL aliquot of the solvent, which was then passed through a 0.45- μ m, 25-mm Millex FH filter (Millipore, Jaffrey, NH).

Sample analysis

At DRDC, samples were extracted using a sonication process with acetonitrile and analyzed by RP-HPLC using EPA Method 8330. Some of the samples were pre-concentrated in order to obtain a lower detection limit: a 2-mL extract was evaporated to dryness in a Zymark evaporator (model TurboVap LV), then redissolved with 0.5 mL of acetonitrile and 0.5 mL of water. This solution was directly injected in an HPLC Agilent HP 1100, equipped with a degasser G1322A, a quaternary pump model G1311A, an autosampler G1313A, and an ultraviolet (UV) diode array detector model G1315A monitoring at 210, 220, and 254 nm (Agilent Technologies, Mississauga, Ontario, Canada). The injection volume was 20 μ L and the column was a Supelcosil LC-8 column 25 cm \times 3 mm \times 5 μ m (Sigma-Aldrich Canada, Oakville, Ontario) eluted with 15:85 isopropanol/water (v/v) at a flow rate of 0.75 mL/min. The column temperature was maintained to 25 $^{\circ}$ C during the analysis.

At CRREL, the acetonitrile extracts were analyzed by HPLC and/or GC-ECD following EPA Method 8095. RP-HPLC analyses were performed on a modular system (Thermo Separation Products Inc., San Jose, CA) consisting of a P1000 isocratic pump, UV2000 dual wavelength absorbance detector set at 210 and 254 nm, and an AS3000 auto sampler. Analyte separations were performed using the 15-cm \times 3.9-mm (4- μ m) Nova Pac C8 column (Waters Chromatography Division, Milford, MA) eluted with 15:85 isopropanol/water (v/v), at 1.4 mL/min. The gas chromatograph was an HP6890 equipped with a micro-cell ^{63}Ni ECD. Primary and secondary GC-ECD analyses were performed using a 7-m \times 0.53-mm ID fused silica column, with a 0.5- μ m coating of 5 percent diphenyl – 95 percent dimethyl polysilicate (Rtx[®]-5, Restek, Bellefonte, PA) and a 6-m \times 0.53-mm inside diameter (ID) fused silica column with a 1.5- μ m coating of a proprietary phase (Rtx[®]-TNT-2, Restek), respectively.

Both standards and solvent extracts were diluted 1:3, acetonitrile to water, for HPLC analysis and were run undiluted for GC-ECD analysis. Samples with energetic residue concentrations greater than 200 $\mu\text{g/L}$ in the sample extracts were analyzed by HPLC and GC-ECD following EPA Methods 8330 and 8095.

Range description and sampling strategy

Fieldwork was conducted in October 2004 in the training areas and in the immediate vicinity of these areas for the background samples. Sampling efforts were focused on live-fire training areas, in which the probability of contamination with energetic materials and heavy metals was high. Sampling strategies were designed on site, depending on the landscape, visual observation of the area, and specific activity and setting of the training area. The surface sampling areas were judgmentally chosen based on the military training activities and knowledge of where residue concentrations were likely to accumulate. DRDC's primary objective was to get a general overview of the situation of CFB Petawawa by identifying the munitions-related contaminants and delineating the presence of energetics and metals in the main training areas. CRREL's objective was to establish the mean concentrations of energetic residues and to validate the use of different sampling patterns. Different sampling patterns were thus applied to Juliet Tower, Hotel Tower, A Range, and the grenade range.

With the exception of one profile sample, CRREL collected replicate multi-increment samples at each location using either a simple systematic or a

totally random collection design. When using the simple systematic collection design, the sampler obtained a targeted (approximate) number of increments at evenly spaced positions through the entire designated sampling unit, hereafter called “decision unit.” The increment collection point spacing was based on a predetermined number of steps to be taken between each location so as to obtain the targeted number of increments. To further randomize this sample collection design, samplers were often asked to start at different locations (usually a corner) around the perimeter of the decision unit. In the one instance when a totally random collection mode was used, increment collection locations were established by rolling dice.

For Phase 1 of the characterization, more than 200 soil samples were collected by DRDC and CRREL, with the assistance of all the other participants. Biomass (30), groundwater (40), surface water (62), and sediments (5) samples were also collected. Most were screened for the presence of energetics (275 samples) and metals (300 samples); 14 samples in the skeet and trap range were also screened for polyaromatic hydrocarbons. This report covers only the surface soil results for energetics.

Impact Area 2 – Direct-fire target area

Impact Area 2 is a direct-fire range of 12.4 km². This flat area is covered with mainly grass and has no watercourses. Until 1998 this impact area was probably the most intensively used area of the base. A wide variety of ammunition has been fired into Area 2: anything from 18- to 500-lb bombs, M72 anti-tank rockets, 40-mm grenades, 60- and 81-mm mortars, 105- and 155-mm artillery projectiles, small caliber ammunition, TOW¹ missiles, etc. To limit UXO, ammunition impacting or ricocheting into this area has been restricted since 1998.

Before 1998, common firing points were located at Hotel Tower (Range 2E), Juliet Tower (2A), Delta Tower in the Radley Walters Range, and a last one at the intersection of Baelstadt Road and the rail target. Figure 3-1 illustrates the geographic location of each of these firing points, all of which were used for artillery and mortars, except for the last one, which was used

¹ TOW = Tube-launched, Optically tracked, Wire-guided.



Figure 3-1. Map of Area 2 (T stands for telephone).

for mortars only. Today Juliet and Hotel Towers are still regularly used for blank and practice ammunition, but Delta Tower is not used anymore because of the proximity of a rail target for machine guns.

Some targets are strategically positioned in the range for direct-fire practice. Units practicing at Juliet Tower can aim at either target moving along a 750-m rail (not the same rail as near Delta Tower) located approximately 1.75 km from the firing points or some pop-up targets dispersed in the area between the firing point and the rail target. A ridge with old tanks or cars nearly 2.75 km away from Juliet Tower, near Old Barn Road, was also available for longer range weapons. Some old tanks or cars were randomly distributed in the impact area in front of Hotel Tower. A 500-m rail located about 1.5 km from Hotel Tower and, a ridge located about 3 km from the firing point were also available for longer range weapons. Other points of interests in Area 2 are the grenade range, the old anti-tank range, and a scrap pit located at Gate 1D. Indirect fire is also practiced by shooting artillery projectiles into Areas 7 and 8.

For the first phase of the characterization, only locations known to be very active (thus having the highest potential for contamination) were selected for sampling. These sites included Juliet and Hotel Towers, the grenade range, and some of the targets nearest Juliet and Hotel Towers. The scrap pit was also sampled because of its high probability of contamination. Some samples were also taken at the old anti-tank range and at Delta Tower.

Juliet Tower (Range 2A)

Juliet Tower is a firing position for artillery and mortar that is less intensively used than Hotel Tower. In the past, it has been used for firepower demonstration. Juliet Tower consists of three 200-m \times 30-m gravel pads (two in the impact area), one large sand pit, and eight bunker, from which 40-mm rifle grenades and mortars are fired (Figure 3-2). An observation tower and some bleachers are provided for spectators. The firing pads and sand pit are used mainly for artillery and mortars. The firing area is divided by the access road, the main pad being on one side of the road, while the sand pit and the bunkers are on the other side. The bunkers, some 12 m apart from each other, are positioned in a semi-circle arc that runs approximately 85 m.

A total of 35 samples were taken both at the firing points and in the impact area. First, a systematic sampling was done at the main firing pad (*FP1*). The firing pad itself was a very hard and compact surface, impossible to sample. Usually the Soldiers put their weapons on the firing pad, on the edge nearest the target. The 30-m area in front of the firing pad was subdivided into six 5- \times 200-m lanes parallel to the firing pad. Only the first 15 m behind the firing pad were sampled. The area was subdivided into two lanes, one 10-m wide for the closest lane, and the second 5-m wide. Samples consisted of 50-increment composites (DRDC) of the top 2-cm soil. CRREL sampled an area 30-m wide by 60-m long immediately down range from the edge of the pad, close to the bleachers and the observation tower. Three 50-increment samples were collected using a systematic sampling design.

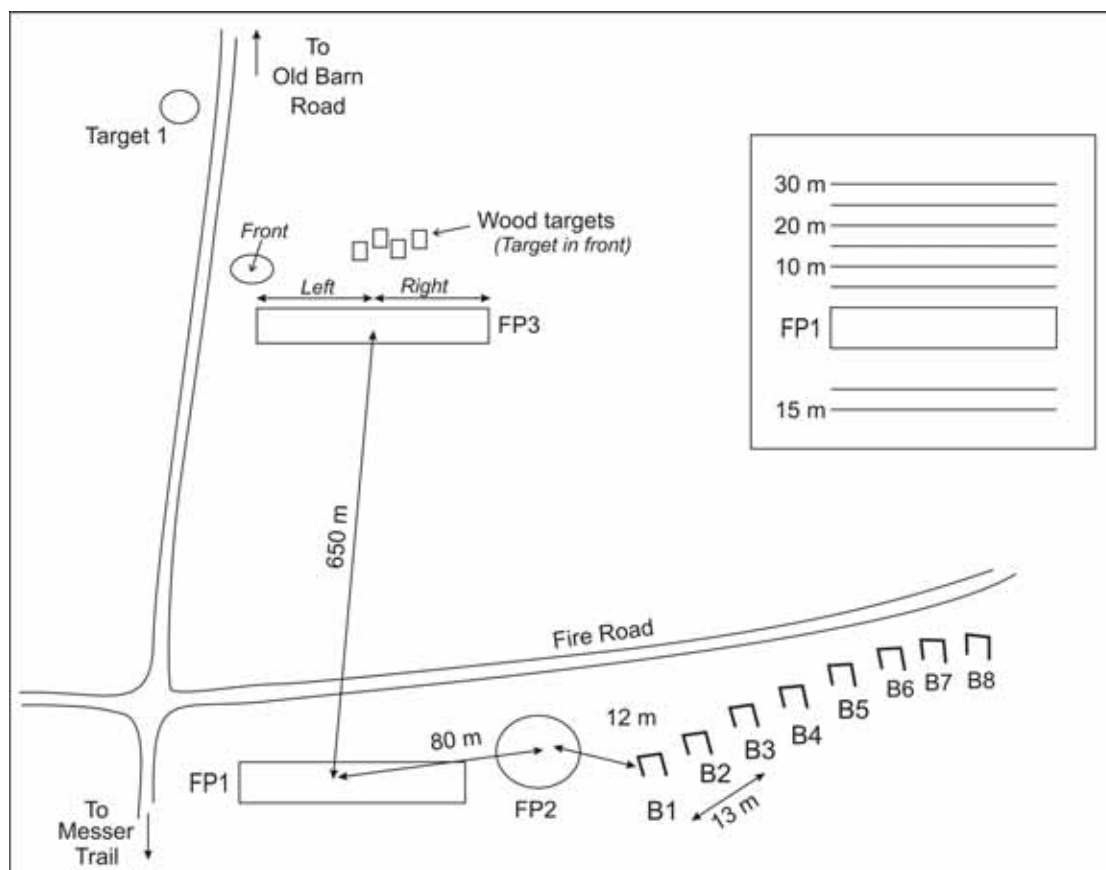

Figure 3-2. Setting of Juliet Tower Firing Point and sampling design for the main firing pad (in mortise). The text describes the abbreviations.

The sand pit (*FP2*) was sampled by taking one large 100-increment sample (DRDC) using a random sampling strategy. Six bunkers were sampled by taking a composite sample of the surface soil both inside the bunkers and in their surrounding areas. The four bunkers nearest the bleachers, the sixth bunker, and the farthest bunker were chosen for the sampling activity. CRREL sampled bunkers 1 and 8, nearest and farthest from the bleachers, respectively, by collecting 40 to 80 increments inside the bunkers (floor), within a 3-m radius of the rim, and in the open area bordered by vegetation behind the bunkers. These larger areas encompassed mortar-firing positions. At the first bunker, duplicate samples were collected within the bunker, and in the area extending some 30 m behind the bunker; one multi-increment sample was collected around the rim. At bunker 8, duplicate samples were collected at all three locations—within, rim, and greater area. Bunkers 2 to 5 were sampled by DRDC by randomly collecting a single 50-increment sample at each bunker, covering both the inside of the bunker and the first 2-m perimeter around it.

The firing pad in the impact area (*FP3*) could not be sampled because it was too hard. High grass obscured the soil surface and any potential UXO contributing to the access hazard. Therefore, only the immediate area in front of the pad, easily accessible by standing on the pad, was sampled (DRDC). The pad was divided in two equal parts, and two samples were taken, one from the left portion of the pad and the other from the right portion. A third sample was collected from a low-vegetation area just to the front-left of the pad, and a fourth around wooden targets to the front-right of the pad. Samples were built by collecting 30 subsamples from the top 2 cm of soil using a random sampling design.

Three additional 30-increment samples were collected by CRREL around a tank target. A corer was used for one of them, and the other two were collected with regular scoops. All the samples were analyzed for energetic compounds and metals.

Hotel Tower (Range 2E)

Hotel Tower is the most used static firing position of Area 2 for artillery and mortar. Many firing points were used. The main firing position is a concrete pad approximately 15-m wide by 50-m long used by vehicle-mounted guns. Other firing points are located in the impact area, as shown in Figure 3-3. They are mostly sand pits from which artillery projectiles were fired.

Sixteen samples were taken at Hotel Tower. DRDC's sampling strategy for the firing pad was very similar to the one for Juliet Tower. However, the back of the pad was not sampled, and only the first 30 m in front of the pad were sampled. CRREL sampled a 50-m × 100-m area directly down range of the pad. The soil was composed of sand and pebbles and was covered with sparse vegetation. CRREL collected four 50-increment composite samples using a systematic sampling strategy.

Old anti-tank range

The old anti-tank range was located directly in the impact area in front of Hotel Tower, 300 m from the firing pad. This old anti-tank range was built of 3 or 4 small berms on which Soldiers were lying to fire; it has not been used as a firing point for approximately 30 years, but the berms were recently used as targets. Remnants of mortar shells were clearly identifiable.

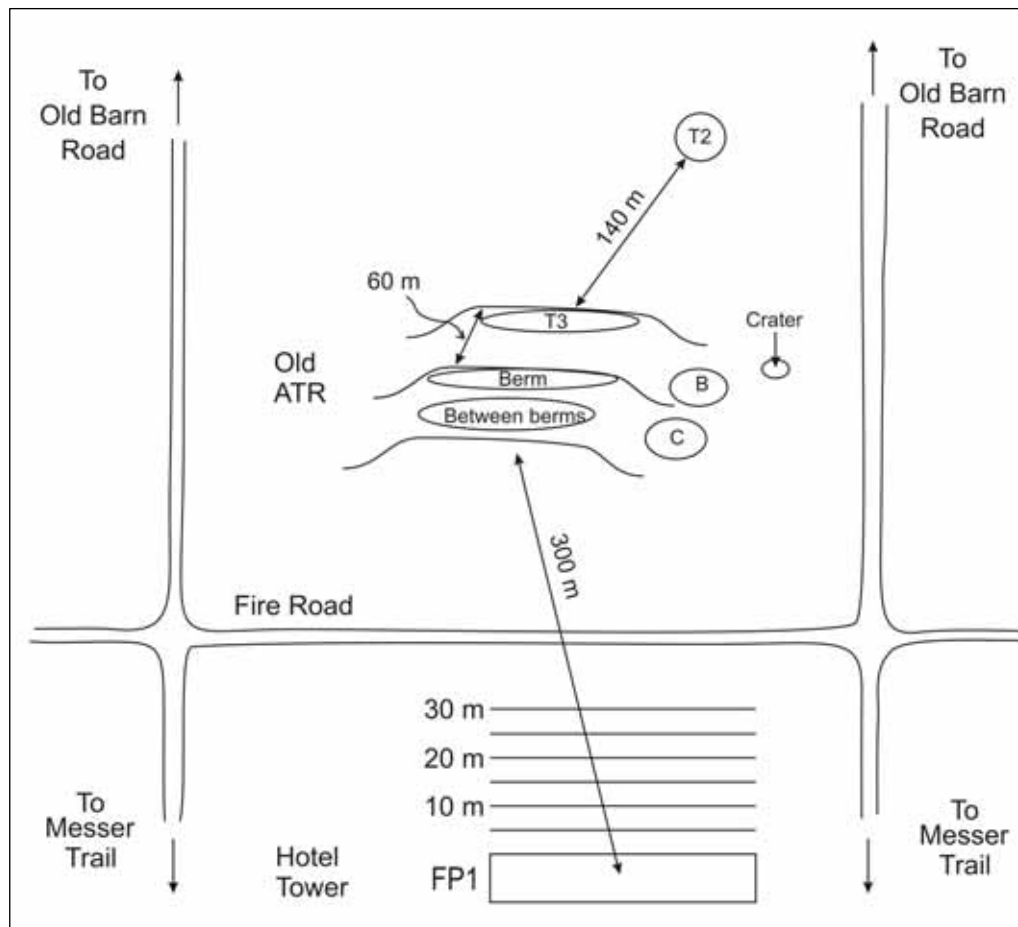

Figure 3-3. General setting and sampling pattern for Hotel Tower and old anti-tank range (ATR). The text describes the abbreviations.

Six 30-increment soil samples were collected by DRDC from the top 2 cm of soil surface using a random sampling strategy. The samples were analyzed for energetics and metals. One sample was taken directly on one of the berms (*Berm*), and two others on the right side of the berm, both in front (*B*) and behind (*C*), in a heavily impacted area with little vegetation. A fourth was collected on the flat area between two berms (*Between Berms*). A fifth was taken from another 81-mm target berm (*T3*) as indicated by the presence of many 81-mm white obturator rings and empty 81-mm shells. The last sample was collected in a nearby crater in which UXO had been blown-in-place.

Delta Tower

As already mentioned, the Delta Tower firing point is no longer in use because of the proximity (250 m) of a rail target for machine guns. The setting of this firing point was similar to Juliet and Hotel Tower, but much

simpler. Two firing positions were located on each side of the access road, near an observation tower (Figure 3–4). Four samples were taken by DRDC at this location using a random sampling strategy. The first two were collected on each side of the tower (*FPA* and *FPB*) and the last two at the rail target (*TA* and *TB*), which was divided into two 30-m sections.

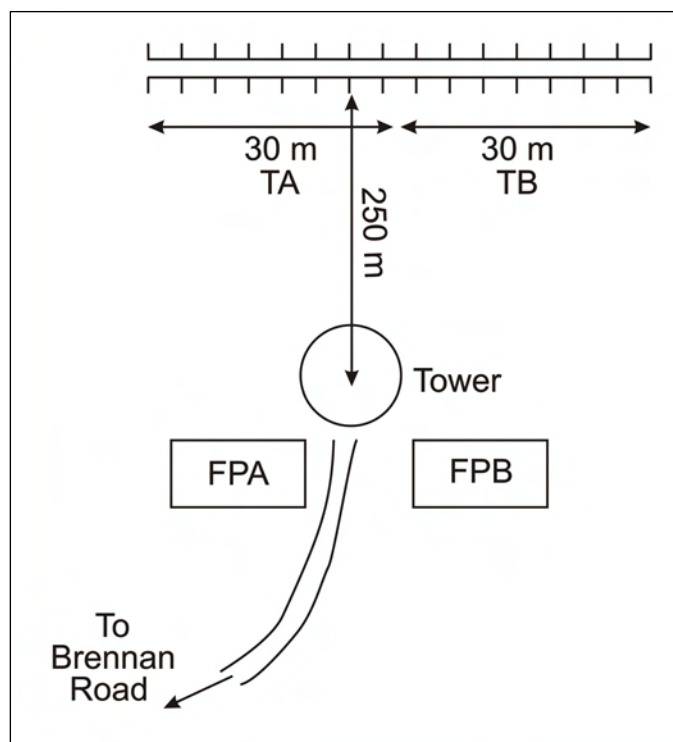

Figure 3-4. Delta Tower firing point. The text describes the abbreviations.

Grenade Range (Range 2D)

The Grenade Range is a sandy, flat area approximately 50 × 50 m surrounded by a wire fence. The sand has never been replaced in 45 years of operation, but fresh sand has been added from time to time. Evidence on site indicated that the surface of this range had been periodically graded to fill in the detonation craters.

DRDC collected 27 composite samples, including 2 field duplicates, in this range. The sampling strategy, similar to the one already reported (Thiboutot 2003b, 2003c, 2004a, 2004b), was aimed at determining the distribution of contaminants in the range and to establish a potential relationship between the concentration of contaminants and the distance

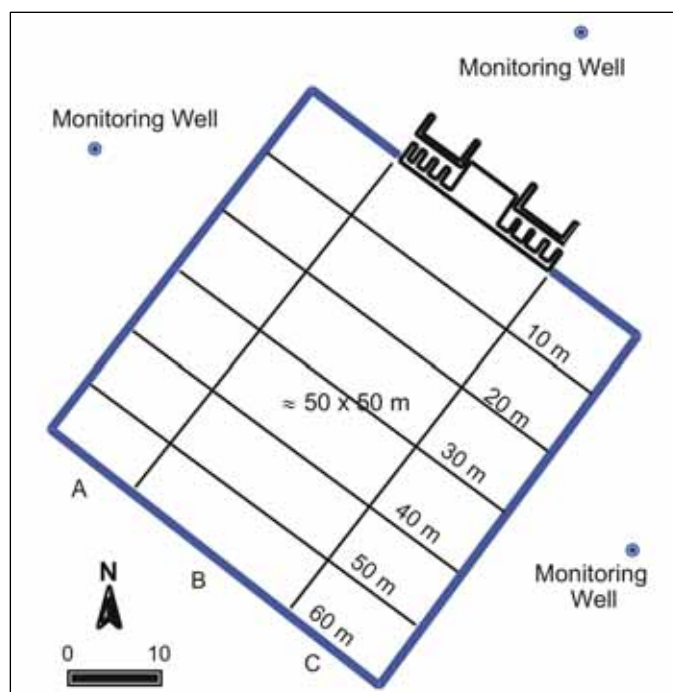

Figure 3-5. Grenade Range sampling pattern.
The blue line marks the fence.

from the bunker. The range was divided into three lanes, A, B, and C, that were delineated by the fence and the edges of the bunker (Figure 3–5). B lane was directly in front of the bunker, while A and C were on each side. These lanes were further subdivided into 10-m wide areas equally spaced from the bunker. Fifty-increment composite samples were randomly collected within each of those areas, along with two field duplicates. Additionally, one sample was taken from a crater.

CRREL tested different sampling strategies by using the fence posts to establish grid points on this range. Three sets of triplicate multi-increment samples were collected using three different sampling designs: systematic 100-increment, systematic 25-increment, and totally random 25-increment samples.

Scrap area

A large pit, accessible from Gate 1D, had been used as a dumping area for miscellaneous articles, old targets, garbage, shells, and even live rounds. This dump area was thought to have been created 25 years ago. At the time of the sampling, the dump had been excavated and most of the debris had been removed for recycling, leaving only a large pit 4-m deep and 20-m

across. The bottom of this pit contacted the groundwater, creating a pool about 0.3-m deep and 6 m in diameter. In the pool and on one side were several intact rounds believed to be inert and several other pieces of scrap metal. The walls of the pit were mostly covered with fine grain sands.

Eight composite samples were taken at the scrap pit using a systematic sampling strategy. The first three of them were 50-increment samples (CRREL) taken from the walls adjacent to the water, from the water's edge to about 1.5 m away from the water. Three other 100-increment samples were collected by CRREL in a swath 3-m wide around the water's edge. Another 100-increment sample was taken by DRDC using a random sampling strategy in the immediate area surrounding the scrap pit. The area was covered with dark particulate matter. All of the samples were analyzed for energetics and metals. The last sample was also analyzed for dioxins and furans.

A crater about 20 m west of the pit, used for BIP rounds, was suspected to contain HES. The crater was about 1-m deep and 5-m across at the opening. The rim of this demolition crater was sampled by obtaining a 50-increment sample of fine-grain sands.

Old grenade range

The old grenade range is a long-forgotten site inactive for the past 30 years, but rediscovered several years ago by a tree-cutting company. The appearance of the site is very similar to today's grenade ranges. The 42-m long \times 33-m wide impact area is sandy and nonvegetated. All kinds of debris, from old shrapnel to tires and wood pieces, are dispersed in the impact area, which is surrounded on all sides by a sparse forest. An old tower used for throwing grenades is located on one side of the impact area behind a 10-m forested lane. A long 30- to 50-cm deep by approximately 1-m wide ditch draining all the impact area runs through almost half the range from its center to the opposite side of the tower. The ditch ends in a small pool that is connected to Jorgens Lake.

This range was sampled because of the absence of vegetative growth in the impact area, even after more than 30 years of inactivity. Four 100-increment samples were randomly collected by DRDC in the impact area and analyzed for energetic materials and metals. Special precautions, including the use of a radiometer to confirm the absence of radiation, were taken on this range.

Impact Area 6 – Direct fire target area

This 20-km² range is used mainly as a battlerun for artillery, light-armored vehicles and, in the past, tanks. Live fire has been authorized only four times in the past 7 years, and no Level-1 clearance has been done. Typically, moving units fire from the road with either rifles or machine guns, on targets randomly distributed in the area. Since units can fire from anywhere, no fixed firing positions occur in the range. However, some firing points are more frequently used than others. Open House was a target on which a wide variety of ammunitions was dropped, including 500-lb bombs in the late 1970s. It is now used as a firing position. For example, howitzers are often deployed on the flat ground at the bottom of the hill. Pimple Hill is also an old target for HE rounds that now serves as an active target for battlerun operations.

The surface soil characterization of such a large area is a very challenging task. Usually only hot spots are sampled. The hydrogeology data are heavily relied upon to verify the presence of contaminants in the groundwater. For the first phase of surface soil characterization, only two areas were sampled using the random sampling strategy. Sampling consisted of collecting five 30-increment samples, including one field duplicate, at old targets in the hill at Open House. Four additional 30-increment samples were also taken at targets at the beginning of the battlerun (DRDC).

Impact Areas 7 and 8 – Indirect fire

These impact areas are located on the western part of the base. The site covers more than 56 km² and is characterized by the presence of many hills, lakes, and marshes, especially near Center Creek in the north part of Area 8 and the east part of Area 7. These areas are impact areas for long-range firing exercises and as ricochet zones for UXO-producing ammunition. The targets are usually hilltops, but munitions sometimes hit roads, marshes, or watercourses. These kinds of ranges are extremely hard to characterize because of their large sizes. For this first phase of characterization, the sampling efforts were focused on locations in which the contaminants are susceptible to concentration (i.e., the demolition ranges and a firing point for anti-tank weapons at the bottom of West Tower).

Demolition range

The demolition range, located at the southern part of Area 8, is relatively flat and sandy with very little vegetative cover. Near the middle was a 1.5-m “L”-shaped berm (Figure 3–6). Based on post-blast debris and soil surface discoloration, three separate areas, or decision units, designated Areas A to C, were selected for sampling. Triplicate, 50-increment samples were collected by CRREL in each decision unit using the previously described simple systematic collection design. In the smaller 10- × 10-m unit (C), increments were collected with every step made by the investigator; spacing was approximately every three steps in the two other larger units (A, B).

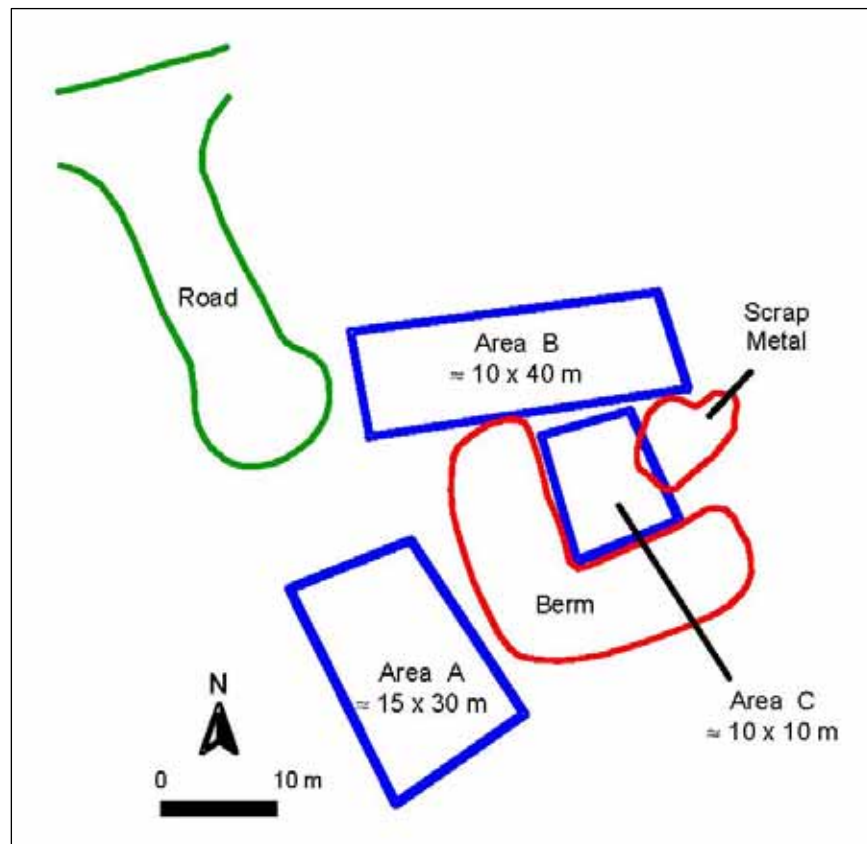

Figure 3-6. Location of sampling decision units at demolition range. Triplicate 50-increment samples were collected in Areas A to C.

Anti-tank firing point

This area is used for training with HE M72 light anti-tank weapon (LAW) rockets and 84-mm heat rounds. The fixed firing point is made of an 8-m-long wooden structure that is in direct line-of-sight with a target. The soil

behind the wooden structure was mostly sand with some grasses. Two 10- \times 8-m areas behind the firing point were designated for sampling. Five replicate 50-increment samples were collected by CRREL directly behind the wooden structure (0 to 10 m); triplicate 50-increment samples were collected between 10 and 20 m distance. The systematic sampling strategy was used in both these decision units.

A Range – Anti-tank/machine gun range

A Range is located in Area A and covers approximately 0.25 km². It has the form of a long corridor 250 m \times 1 km. This range is bisected by a service road, equally splitting a firing point berm and the impact range. A Range has five firing bays and a misfire pit, located on the left side of the firing point (illustrated in Figure 3–7). Each firing position consists of a wooden wall cut into a gravel man-made berm. Bays 1, 2, and 3 are designated for machine gun training, and Bays 4 and 5 are for anti-armor weapons training. However, the use of UXO-producing ammunition has been forbidden on that range since 1998; therefore, training with HE rounds is done at the anti-tank firing point in Area 8 instead. Running parallel behind the berm was another service road bordered on the backside by a dense growth of small trees and bushes. Another road runs through the impact area where several tanks serve as targets. No Level-1 clearance has been done, so the range still contains a large quantity of M72 empty casings and some UXO.

A total of 23 samples were taken at this range. At the firing point, a single 50-increment sample was collected by CRREL at each of the five fixed firing positions. All of the approximately 5- by 20-m areas sampled were covered with sand and gravel. In addition to the collection of surface samples, a near surface profile sample was collected by CRREL 10 m behind the first firing position left of the central access road. At the surface, a sample was collected with a stainless steel scoop from an area 20-cm square and 5-cm deep in order to obtain a 500-g sample or larger for the first depth increment. The gravelly texture of the soil interfered with the ability to carefully collect the desired 5-cm lifts. After collecting a sample from a specific depth range, a shovel was used to clear a 50-cm area surrounding the sampling site, which prevented material from the upper level being inadvertently included in the next 5-cm depth interval. This procedure was repeated until a 50-cm sampling depth was reached.

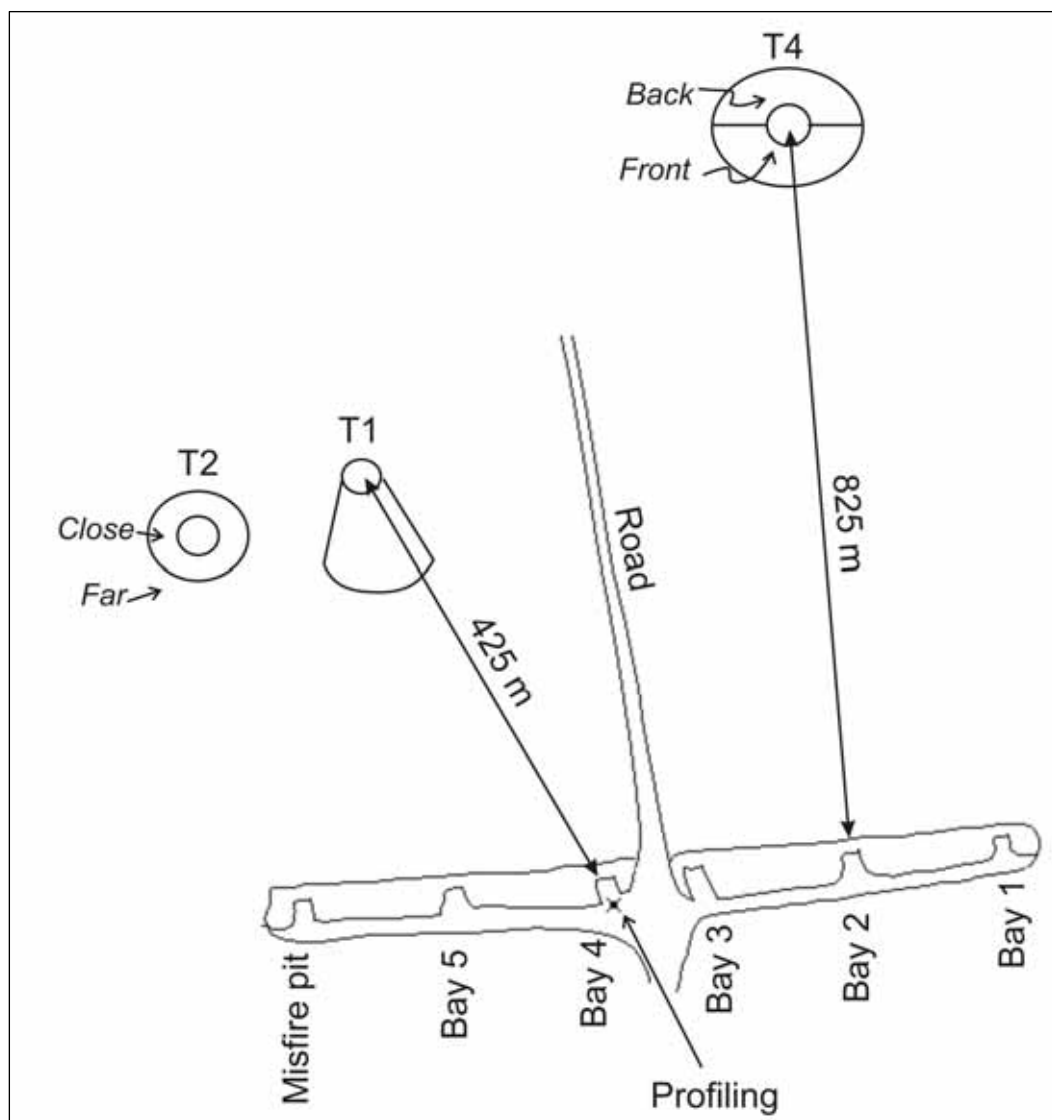

Figure 3-7. General setting of A Range and sampling location.

In the impact area, the first part of the sampling was performed at a distance of 425 m from the firing points, around the two tanks closer to Bay 4 and 40 m left of the central access road (*T1*). At this location, the ground surface dropped off rapidly to the rear; therefore, munitions missing the target would landfall approximately 40 to 50 m to the rear. The surface in front of the target was covered with gravel, sands, mosses, and grasses. The immediate vicinity of the two tanks was covered with pieces of broken shells, indicating high use. Immediately in front of one of the targets, a chunk of residue found on the surface was tentatively identified as octol (70 percent HMX and 30 percent TNT) with the Expray test kit. In addition, several pieces of propellant were found along with three LAW rockets with warheads attached, two of which were cracked open.

Triplicate 50-increment samples (CRREL) were collected in the top 1.5 cm by systematically walking back and forth between T1 and the forward edge of the strafed zone, which extended about 30 m in front of the target. Safety dictated the decreased sampling depth used at this location. Sampling behind the first target was not deemed necessary because of the steep slope. Two other 50-increment samples were collected by DRDC at the second tank using the random sampling strategy, a little farther from the road, which has quite evidently experienced less activity. One sample was taken in the first 2 m from the tank (*T2 close*); the other, farther from the tank (*T2 far*).

The third target was made of a large pile of sand bags topped with old pieces of a metallic fence. This target was 825 m from Bay 2 and was used for machine guns. Three 100-increment samples were collected by DRDC using a random sampling strategy in the nonvegetated, sandy area around the target: one behind it (*T4 back*) and two others in front of it (*T4 front*).

Small arms ranges

Rifle ranges (B, C, and D Ranges)

These 12-lane rifle ranges are in Area A. B Range is a 600-m long range, while C and D Ranges are 500-m ranges. These training areas are typical rifle ranges made of 5 to 6 firing lines (one at each 100-m distance from the target area), one stop butt with wooden targets to prevent the bullets from going further, and one berm supporting moving mechanical targets between the stop butt and the firing points. Small calibers up to 9 mm can be fired on these ranges; the use of rifles, machine guns, and pistols is allowed. The stop butts were changed in 2003 (B and D) and in 1998 (C).

DRDC collected composite soil samples using the random sampling strategy at the firing points and on the stop butts; however, for D Range, samples were taken only from the stop butt. All of the samples were checked for metals. Samples from the firing points were also analyzed for NG and 2,4DNT. At the firing points, composite soil samples were built by taking 50- or 100-increment samples randomly distributed along a single firing line. Thus, one sample per firing line was collected, for the four firing points closest to the berm (100 m to 400 m). Ten samples, including two field duplicates, were thus taken at the firing points of B and C Ranges. On the stop butts, 50-increment samples were randomly collected around groups of 4 targets. The area covered by the sampling goes from the top to

the bottom of the butt, between the selected targets. Thus, for one single stop butt, three samples were taken. For all of the rifle ranges, 11 samples were collected, including one 100-increment sample on the top of B Range and one field duplicate in C Range. Three additional samples were collected by taking 50 to 100 subsamples from the berm supporting the mechanical targets, just between the stop butt and the firing points.

The samples from the firing points were analyzed both for energetic compounds and metals, while those in the stop butts and in the berm supporting the moving targets were analyzed for metals only.

Pistol ranges (Q and E Ranges)

Q and E Ranges are 50-m- and 100-m-long pistol ranges, respectively. Although both ranges are designed mainly for pistols, shotguns can also be used in Q Range, while rifles and machine guns are authorized in E range. Q Range, located in area N, has 20 firing points. Mechanical target frames are used for lanes 1 through 10, and wooden targets for lanes 11 through 20. Shotguns can also be used on firing points 19 and 20. E Range is in Area A; it has 15 firing points and wooden targets. Both stop butts were changed in 1998. Small caliber ammunition, up to 9 mm, is allowed in both ranges. Lead bullets are allowed only for pistols. Bismuth bullets are used for shotguns in Q Range.

Only one sample was taken by DRDC at E Range, on the stop butt. A composite sample was built by taking randomly at least 30 subsamples between targets 10 and 15. Additional sampling was not deemed necessary because of the apparent lack of activity in this range. For Q range, seven 30-increment samples were taken by DRDC at the stop butt: three samples and one field duplicate were taken around groups of four targets, one large composite (> 50 increments) was taken on the top of the stop butt, and two 100-increment samples were collected from both the stop butt and its bottom. Additionally, two other 50-increment composite samples were collected using a random sampling strategy on the 5-m and 15-m firing points. The samples from the firing points were analyzed for energetic compounds and metals, while those in the stop butts were analyzed for metals only.

Results and discussion

Impact Area 2 - Direct fire target area

Hotel Tower

Both NG and 2,4DNT were detected in all the samples collected in the large area in front of a concrete pad used for training with vehicle-mounted guns. The mean concentration for NG and 2,4DNT were 44 mg/kg and 5.1 mg/kg, respectively. 2,6DNT, an impurity produced in the manufacturing of 2,4DNT, was also detected in several of the samples, ranging in concentration from below detection limit to 0.25 mg/kg. The higher concentrations of NG suggest that more double- and triple-based propellants have been used at this firing point compared with single-based propellants. The presence of these two energetic compounds at multi-purpose firing points is common (Pennington et al. 2003, 2004; Jenkins 2005). The < 15 percent relative standard deviations (RSDs) for these two analytes among the field sample replicates indicate that the systematic sampling design was appropriate for the surface distribution of energetic residues at this firing point (Walsh et al. 2005).

Results of the study on the distribution of residues with respect to the distance from the firing pad indicate that the highest concentrations of NG (145 mg/kg) and 2,4DNT (53 mg/kg) were found in the 10- to 15-m and 15- to 20-m lanes, respectively. These samples are the only two in which 2,6DNT was detected. NG and 2,4DNT were still detected in the farthest lane (25-30 m) at concentrations of 41 and 4.8 mg/kg, respectively. The overall means from this part of the study are 88, 18, and 1.7 mg/kg for NG, 2,4DNT, and 2,6DNT, respectively, which is approximately twice the numbers found with the systematic sampling design. This illustrates the effect of the size and location of the decision unit: the systematic sampling design was done up to 50 m from the pad, while the study on the distribution of residues with the distance from the pad was stopped at 30 m.

HMX, RDX, and TNT were present in the surface soils collected around the target sampled in the impact area on this range; however, only the first two energetic compounds were detected in all four of the field replicates. The mean concentration was 47 mg/kg for HMX and 2.4 mg/kg for RDX. The high concentrations of HMX on the surface most likely were due to ruptured LAW rockets, since this munition contains octol (HMX:TNT, 70:30). The RDX could be from the booster in the LAW rocket or from

some other munitions, such as a 2.75-in. rocket filled with Composition B (RDX:TNT, 60:40). RDX could also be the result of the use of C4 in the past to dispose of UXOs. TNT is much more soluble than HMX and is subject to both photo and biological degradation, two factors used to explain why it is present at much lower concentrations than HMX (Jenkins et al. 1997a; Hewitt and Bigl 2005). The less than 30 percent RSD for the principal energetic compound, HMX, around this target indicates that the systematic sampling design was adequate for this level of uncertainty.

RDX and HMX were also found in the groundwater in two locations. The first contaminated well was located in the impact area and contained 17 ppb of RDX. The second one, near Hotel Tower, was contaminated with 2 and 6 ppb of RDX and HMX, respectively. The explosive residues in the groundwater below the firing points probably leached from the impact area. Indeed, the groundwater in this area flows toward the Ottawa River, causing the firing points to be downstream from the impact area. Therefore, contaminants deposited on the surface of the impact area can leach into the groundwater and be transported far away from their source, outside the limits of the CFB. This leaching could cause a problem if the contamination impaired the activity of the surrounding civilian population, for example, by reaching the drinking water supply. This situation needs monitoring.

Juliet Tower

Similar to the Hotel Tower firing point, both NG and 2,4DNT were detected in the multi-increment samples collected in the Juliet Tower area in front of a gravel pad used by vehicle-mounted guns. However, the concentration of these propellant residues, roughly 2 and 0.5 mg/kg for NG and 2,4DNT, respectively, were an order of magnitude lower than at Hotel Tower. The higher concentrations of NG suggest that more double- and triple-based propellants have been used at this firing point compared with single-based propellants. The less than 33 percent RSD for these two analytes among the field sample replicates indicates that the systematic sampling strategy was adequate for this level of uncertainty.

The only analytes detected in every six 5-m wide by 200-m long lanes were 2,4DNT and 2,6DNT at similar mean concentrations of 0.4 mg/kg. The reason no NG could be detected, as in the above mentioned 30-m wide by 60-m long area, is unclear, but may be that NG is concentrated in that 30- \times 60-m area sampled by CRREL. Incorporating the remaining 140 m into

the sampling may induce a dilution large enough to prevent the detection of NG. Following the same reasoning, the distribution of 2,4DNT in front of the pad would be more homogeneous, since the two means are very similar, while 2,6DNT seems to accumulate in the 30- × 140-m area. These findings may be the result of different training activities at Juliet Tower, but they may also reflect the various persistencies of these compounds in the environment. Additional sampling is needed to confirm these results and to draw more accurate conclusions.

The distribution of 2,4DNT and 2,6DNT with respect to the distance from the firing pad is very similar; their concentration is nearly constant for the first 15 m, after which it drops steadily. Traces are still detected in the farthest lane (25-30 m). RDX (2.2 mg/kg) and traces of TNT were detected in one sample (10-15 m). The only analyte present behind the main firing pad was NG, at approximately 2.2 mg/kg. The sand pit contained only 2,4DNT and 2,6DNT in concentrations reaching 1.8 and 0.07 mg/kg, respectively. No energetics were detected at the third firing pad located in the impact area.

Single or duplicate multi-increment samples were collected in and around bunkers 1 and 8 used for training with 40-mm rifle grenades, and in areas that were used for training with mortars. NG was the principal detectable energetic residue in these samples, and ranged in concentration from 0.57 to 8.4 mg/kg. Probably because of less intensive use, concentrations of NG at bunker 1 were an order of magnitude higher than those at bunker 8. 2,4DNT was also detected in some of the samples, ranging in concentration from < d (below detection limit) to 0.66 mg/kg. The only DNT-containing samples at bunker 8 were in the wider area at the back of the bunker. Based on the sampling design, NG concentrations were slightly higher around the rim than on the floor of the bunkers. The less than 50 percent relative percent difference (RPD) for the NG concentrations between the sample duplicates indicates that the systematic sampling strategy was adequate.

No energetics were found at bunkers 4 and 6. The only analytes detected at bunker 2 were 2,4DNT and 2,6DNT at concentrations of 2.6 and 0.3 mg/kg, respectively. A small amount (1.6 mg/kg) of 2,4DNT was also detected at bunker 3, along with traces of RDX and HMX (< 1 mg/kg).

In the impact area, the mean concentration of RDX and HMX at the target reached 2.3 and 0.4 mg/kg, respectively, with highs of 3.7 mg/kg for RDX and 0.65 mg/kg for HMX. No significant differences were observed between the corer and the scoop to collect the samples. However, as was the case for Hotel Tower, RDX and HMX were found in the groundwater in proximity to the firing point. Concentrations reached 4 and 16 ppb, respectively.

Delta Tower

Despite its long period of inactivity, up to 227 mg/kg of NG were found at Delta Tower. Traces of 2,4DNT (1.4 mg/kg) were also detected in one sample, and a trace amount of NG was found in one of the two samples taken at the rail target. Delta Tower will have to be re-sampled to confirm these results and ensure that they are not due to the sampling of an isolated chunk of propellant. If confirmed, this result may be indicative of the long persistency of NG in the environment.

Grenade range

HMX and RDX were detected in most of the surface soil samples collected by DRDC on the hand grenade range. TNT was also detected in two samples. The likely sources of these energetic residues are Composition B, which is the main charge in the M67 hand grenade, and C4 (91 percent RDX) used for BIP of duds. RDX contains up to 10 percent HMX as a manufacturing impurity. The overall mean for RDX, HMX, and TNT concentrations was 0.87, 0.21, and 0.15 mg/kg, respectively. As on several other hand grenade ranges, RDX was present at the highest concentration (Jenkins et al. 2005), reaching 5 mg/kg. The same sample also contained the highest HMX concentration, 1.2 mg/kg. These concentrations are much higher than those typically found in Canadian grenade ranges (Thiboutot et al. 2001, 2003b, 2004; Ampleman et al. 2003). This is probably because the sand has never or seldom been replaced in 45 years of use.

HMX, RDX, and TNT were also present in all nine of the surface soils collected by CRREL. Overall, the mean RDX, HMX, and TNT concentrations were 0.65, 0.18, and 0.16 mg/kg, respectively. Three different sampling designs were used to characterize the hand grenade range. Two of the designs, systematic collection of 100-increment samples and totally random collection of 25-increment samples were performed similarly, and

appear to have less uncertainty than the systematically collected 25-increment samples. However, more replication is needed prior to drawing any valid conclusions. Since the energetic residue means for the systematic collection of the 100-increment samples (0.63, 0.21, and 0.14, for RDX, HMX, and TNT, respectively) were closest to the overall mean, this sampling design is recommended for use in the future to characterize hand grenade ranges. The field sample triplicates for both the 25- and 100-increment samples for this decision unit resulted in RSD exceeding 30 percent. This finding indicates that the compositional and distributional heterogeneity present at this site would require either a greater sample mass or greater number of sample increments, or both, to achieve a less than a 30 percent level of uncertainty among sample replicates.

Results also indicate that the distribution of contaminants within the range is very heterogeneous. Unexpectedly, the most contaminated area is the middle of Lane A (20-30 m), just beside the bunker. Except for a hit of HMX in the first 10 m from the bunker, the concentration of contaminants in Lane B, just in front of the bunker, is nearly constant up to 30 m, after which it drops to traces of explosives. The amount of residues in lane C, on the other side of the bunker, was very low. Only traces of explosives were found in the crater.

Old anti-tank range

Concentrations as high as 950 mg/kg and 276 mg/kg of NG were found in samples collected between two berms and on one of the berms, respectively. NG was detected in the five samples collected in this area, with a mean of 256 mg/kg. This level of contamination is uncommon in impact ranges and is more typical of firing points (Jenkins et al. 2005). Considering that this range has not been used as a firing point for approximately the past 30 years, these results suggest that NG is a very persistent component in the environment. More characterization will have to be done to confirm these results and delineate the extent of NG contamination.

Other components found in the area are trace amounts (< 1 mg/kg) of HMX on one of the berm impacted with 81-mm mortars, and RDX and TNT in a crater at concentrations of 2.0 and 0.7 mg/kg, respectively.

Scrap area

Only trace (< 0.2 mg/kg) quantities of HMX, 1,3,5TNB, RDX, and 2,4DNT were detected in most of the multi-increment samples collected from the walls of the scrap metal pit. These explosives residues probably come from the BIP of live rounds that had been found in the scrap pit among the debris. However, the possibility of the presence of a cracked UXO cannot be excluded. Similarly, only trace quantities of 2,4DNT were detected around the rim of the crater.

Old Grenade Range

Traces (< 1 mg/kg) of several energetic compounds (TNT, RDX, HMX, 2ADNT, and 4ADNT) were detected in all four samples collected in the Old Grenade Range. Only RDX and 2ADNT were detected in the ditch. These results are unexpected, especially the presence of TNT, considering the 30 years of inactivity of the range and the photodegradation of nitro-aromatic compounds in the environment. A second visit to this site will be needed to confirm these results and ensure that the samples were not cross-contaminated. This contamination could come from the drilling machinery used to install a well in the middle of the range just a few days before the soil sampling event.

Impact Area 6 – Direct fire target area

Except for traces of 2ADNT in one sample, no energetic residues were detected at the targets. This result is not surprising, considering that these targets are used mainly for small arms training. However, small amounts of 2,6DNT were detected in three out of five samples collected at Open House, with a maximum concentration of 6.8 mg/kg. This finding indicates that Open House was used as a firing point, because DNT is part of the double-based propellant used for small arms.

Impact Areas 7 and 8 - Indirect fire

Demolition range

All three decision units (A–C) on this demolition range contain HEs and propellants. RDX and 2,4DNT were detected in all of the samples and were present at concentrations higher than other compounds in all three areas. The mean RDX concentration within each area ranged from 0.7 to 30 mg/kg. 2,4DNT concentrations ranged from 1 to 12 mg/kg. HMX, TNT,

NG, and 2,6DNT were also detected in many of the samples at low concentrations. Similar energetic residue concentrations and many of the same compounds have been observed at other demolition ranges (Pennington et al. 2004; Jenkins et al. 2005).

The triplicate field samples for these decision units resulted in RSDs frequently exceeding 50 percent. Moreover, in a couple instances an analyte was not consistently detected in all of the field sample replicates. This finding indicates that achieving less than a 30 percent level of uncertainty among sample replicates, that is, reducing the influence of compositional and distributional heterogeneity present in these decision units, would require either a greater sample mass or a greater number of sample increments, or both.

Anti-tank firing point

NG was detected in all of the samples, in accordance with the double-based propellant that is present in M72 and 84-mm heat rounds. The decrease in NG concentration from 2,400 to 380 mg/kg as the areas sampled moved away from the firing point is consistent with other studies of this type of training facility (Thiboutot et al. 2004; Pennington et al. 2004; Jenkins et al. 2004). The occurrence of 2,4DNT in two of the field replicates collected 10 to 20 m behind the firing point indicates that this range may also be used for training with munitions that use a single-based propellant, perhaps 40-mm rifle grenades (Walsh et al. 2004). If a 30 percent sampling uncertainty is acceptable, then the systematic sampling strategy used for these decision units was adequate for establishing the mean concentration of the principal energetic residues on the surface.

A Range - Anti-tank/machine gun range

NG in concentrations ranging from 100 mg/kg to 1,230 mg/kg was either the only or the principal energetic residue present in the multi-increment samples collected behind each of five firing positions on this range. The approximately 1,000-mg/kg concentration of NG behind those firing points used for LAW rocket training was about a factor of 2 higher than behind the machine gun training positions. The presence of NG is consistent with the double-based propellant used for LAW rockets. NG is also found at concentrations of 9 to 11 percent in the propellants of some 7.52-mm ammunition.

The profile sample collected behind Bay 4, the most contaminated one, showed that NG had migrated to a depth of at least 50 cm. Overall, the profile showed about a two order of magnitude decrease in concentration from 1,000 mg/kg at the surface to 10 mg/kg at the deepest interval. However, the presence of a spike in concentration at a depth of 35 to 45 cm indicates either preferential migration pathways or lenses in the substrate that attenuate NG. It could also be attributed to intense firing activity in a short timeframe, or to a storm event. The deep penetration of NG into the subsurface is consistent with an earlier investigation (Thiboutot et al. 2004) and with a laboratory column study (Hewitt and Bigl 2005).

HMX, TNT, NG, and RDX, in decreasing amounts, were present in at least two of the three multi-increment surface soils collected in front of the first target sampled in the impact range. The mean concentrations were respectively, 750, 73, 2.5, and 0.32 mg/kg, for these four compounds. Three ruptured rockets were found near this target along with a chunk of energetic residue. Therefore, the high HMX concentration on the surface was most likely due to ruptured LAW rockets, since this munition contains octol (70:30, HMX:TNT). The presence of NG was from unconsumed rocket propellant (several chunks of it were observed); the RDX could be either from the booster of the LAW rocket or another munition. The agreement between the field sample replicates was poor, > 80 percent RSD. Therefore, the sampling design and strategy were unable to adequately address the compositional and distributional heterogeneity present. Achieving less than 30 percent uncertainty among sample replicates at this site would require either a greater sample mass or a greater number of sample increments, or both. This will be accomplished in another field event, planned for fall 2005, to further reduce the uncertainty.

The same contaminants were found at the second target, at very different concentrations. A large difference between the concentration of contaminants in the immediate vicinity of the tank and outside the first 2-m perimeter was observed. Concentrations of HMX reached 310 and 135 mg/kg in these areas, respectively. For NG, the differences were even more pronounced, with 39 mg/kg close to the tank, and 1.2 mg/kg at more than 2 m. Traces (< 1 mg/kg) of TNT and RDX were also detected, but their distribution with respect to their distance from the tank was not as clear as for NG and HMX. No energetic residues were detected at the third target, which was used for machine gun practice.

Small arms ranges

Rifle ranges (B and C Ranges)

The only energetic analyte detected at the firing points of B and C Ranges was 2,4DNT. A positive result was obtained for each line. The highest concentration was 2.30 mg/kg in the 300-m line of C Range. 2,4DNT is part of the composition of the double-based propellant used in 5.56-mm caliber ammunition, for example.

Pistol range (Q Range)

As for the rifle ranges, only 2,4DNT was detected at the firing points of Q Range. The concentrations were much higher, however, reaching 9.6 and 6.4 mg/kg for the 5- and 15-m firing lines, respectively.

Summary and conclusions

Even though the use of UXO-producing ammunition in Area 2 had been virtually forbidden for 6 years prior to the sampling event, significant amounts of RDX, HMX, and TNT are still detected in the impact area. The mean concentrations of 47 and 2.4 mg/kg found for HMX and RDX near one target, in front of Hotel Tower, are much higher than what is usually found near targets on typical artillery impact areas (Jenkins et al. 2005). The same phenomenon has been noticed in the impact area in front of Juliet Tower, but to a lesser extent, with mean concentrations of 0.65 and 3.7 mg/kg for HMX and RDX, respectively. These concentrations are believed to come from cracked UXOs or low-order detonated items, and not from normally functioning munitions, or high-order detonations. The same phenomenon has been observed in A Range in which concentrations as high as 750 mg/kg were observed for HMX near a cracked LAW rocket.

Hydrogeology results have shown small quantities of HMX and RDX in the groundwater at Hotel and Juliet Tower and in the impact area. Although the level of contamination is not critical, Area 2 must be further characterized in order to verify these findings and define the source terms. Impact Area 2 will have to be more systematically and thoroughly characterized in the next sampling campaign.

The firing positions of Area 2 were impacted by NG and 2,4DNT. The mean concentrations of NG and 2,4DNT of 88 and 18 mg/kg, respectively, in front of Hotel Tower are above typical concentrations observed at the

firing point of many other artillery ranges (Jenkins et al. 2005). This level of contamination may indicate either a very intensive use or a recent large exercise; the use of anti-tank weapons in the past may also be considered. NG was also found at levels of concern (157 mg/kg) at the firing points of Delta Tower. The high NG concentrations at Delta Tower were unexpected, considering the long period of inactivity at this firing point. Delta Tower will have to be re-sampled in order to delineate the extent of contamination.

The same analytes (NG and 2,4DNT) were detected at problem concentrations at the firing points of the three anti-tank ranges. The mean NG concentrations varied from 250 mg/kg for the oldest one in Impact Area 2, which has been closed for approximately 30 years, to 1100 mg/kg for A Range, and 1,500 mg/kg for the firing point in Area 8. The mean NG concentration of 2,240 mg/kg detected in the first 10 m behind the active firing point in Area 8 is typical of what has been found on other CFB (Marois et al. 2004; Thiboutot et al. 2004). Also, as for other anti-tank ranges, the concentration of NG decreases as the distance from the firing point increases. The 10 mg/kg of NG found at a depth of 60 cm behind the firing point of A Range is, however, well above what was found in Gagetown (Thiboutot et al. 2004) and elsewhere (Jenkins et al. 2005) at such a depth. The closed anti-tank range site will have to be more thoroughly sampled in order to determine as precisely as possible the source of contamination and to delineate its extent. NG can come either from munitions fired recently at Hotel Tower, or from older propellant chunks from the firing of munitions more than 30 years ago. This high persistency in the environment might be explained by the fact that NG is embedded in nitrocellulose, which is very stable. This latter hypothesis is supported by the fact that such high concentrations of NG were not found anywhere else in the impact zone of Area 2.

The impact area of the anti-tank A Range had HMX, TNT, NG, and RDX. HMX comes from LAW rockets that rupture on impact. The presence of high concentrations of HMX in the impact area of anti-tank ranges is very common, because of its low solubility and high stability. The level of contamination around one of the targets sampled in A Range was among the highest reported to date (Jenkins et al. 2005), especially for a range on which UXO-producing ammunition has been forbidden for the 6 years prior to the sampling event. However, the detection of TNT, especially in such large quantities (73 mg/kg), is not typical because of its high

degradation rate and exceptional binding properties to the organic soil content. The source of the TNT is primarily the cracked M72 rockets at one of the sampled targets. For example, concentrations as high as 10,400, 358, and 46 mg/kg were reported for HMX, TNT, and RDX, respectively, near a cracked M72 rocket (Pennington et al. 2002). The occurrence of NG and RDX in low concentrations found at Petawawa has also been noticed in many other anti-tank ranges (Jenkins et al. 2005).

Trace amounts of RDX, HMX, and TNT (< 5 mg/kg) were also detected at the active grenade range. This reflects the high efficiency of detonation of grenades coupled with their low dud rate. However, the concentrations of explosives residues are much higher than what was found at CFBs Gagetown (Thiboutot et al. 2004) or Valcartier (Marois et al. 2004), but very similar to CFB Shilo's (Thiboutot et al. 2001; Ampleman et al. 2003) and several other grenade ranges (Jenkins et al. 2005). This may partly be due to the fact that the hand grenade range of CFB Petawawa has been in operation for 45 years without replacing the sand, as compared to 2 and 20 years for Gagetown and Shilo, respectively. However, according to Jenkins et al. (2005), this level of contamination is also characteristic of sites on which partial detonation happened, either due to malfunctioning or BIP grenades. Trace amounts (< 1 mg/kg) of RDX, HMX, TNT, 2ADNT and 4ADNT were also detected in the old grenade range. The presence of explosives residues, especially TNT and ADNTs that are known to bind very easily to soil and to have a high attenuation rate, was unexpected. Additional sampling will have to be done to ensure that these results are not due to cross-contamination during the sample collection and handling prior to analysis.

The scrap area was contaminated by trace amounts of HMX, RDX, 2,4DNT, and 1,3,5-trinitrobenzene (TNB) that may have come from either the recent BIP of live rounds in this area, or from cracked UXO. In any event, the source of contaminants is now gone, and their concentrations should slowly decrease. Scrap areas are numerous on military bases, because this was the common way to dispose of unwanted items in the past. This scrap area is a good example of what can happen at other buried dumps.

The demolition range was more heavily impacted with energetic residues than the scrap area. RDX and 2,4DNT were the most abundant contaminants, along with HMX, TNT, NG, and 2,6DNT. The levels of RDX and

HMX are typical of what was found on other demolition ranges (Jenkins et al. 2005), but the presence of 2,4DNT tends to prove that propellants were burned on this site. The situation at CFB Petawawa should be closely monitored because of the presence of Biggar Lake less than 500 m from the range. If results prove that the risk of migration to the lake is likely, the relocation of the demolition range should be considered. An observation well should be installed in this location on the next sampling campaign.

All of the firing lines of the small arms ranges contained 2,4DNT, a relatively toxic compound. This is a situation of concern from a human health perspective because the soldiers often fire in a prone position on the ground and could be exposed to 2,4DNT on their clothes and via inhalation of dust.

The sampling design and strategy were adequate for the firing points of Juliet and Hotel Towers and the anti-tank firing point, producing results with a less than 30 percent RSD. However, they failed to produce reproducible results for the grenade range, the demolition range, and especially for the impact area of the anti-tank range. Therefore, a greater mass and/or a larger number of subsamples are required.

Acknowledgements

The authors of Chapter 3 wish to acknowledge the Director Land Environment, Ottawa, Ontario and SERDP for their vision and financial support. The authors are also grateful to Håkan Wingfors, Ulf Qvarfort, Rose-Marie Karlsson, and Mats Ahlberg from FOI and to Alain Creemers and Nico van Ham from the TNO for their priceless help and friendship during the sampling campaign. The authors also express their greatest thanks to all military and civilian personnel from CFB Petawawa for their highly valuable support and help for this study.

References

- Ampleman, G., S. Thiboutot, A. Gagnon, A. Marois, R. Martel, and R. Lefebvre. 1998. *Study of the Impacts of OB/OD Activity on Soils and Groundwater at the Destruction Area in CFAD Dundurn*. DREV R-9827, Defence Research and Development Canada (DRDC) Valcartier.
- Ampleman, G., S. Thiboutot, R. Martel, R. Lefebvre, T. Ranney, T. F. Jenkins, and J. Pennington. 2003. *Evaluation of the Impacts of Live Fire Training at CFB Shilo* (Final Report). DREV TR 2003-066, DRDC Valcartier.

- Ampleman, G., S. Thiboutot, S. Désilets, A. Gagnon, and A. Marois. 2000. *Evaluation of the Soils Contamination by Explosives at CFB Chilliwack and CFAD Rocky Point*. DREV Report TR-2000-103, DRDC Valcartier.
- Arel, N., R. Martel, R. Lefebvre, S. Thiboutot, and G. Ampleman. 2002. *Dissolved Energetic Material Transport in the Vadose Zone at the Arnhem Anti-tank Range, CFB Valcartier, Canada*. Proceedings of the 2002 Denver Annual Meeting of the Geological Society of America.
- Brochu, S., S. Thiboutot, J. Lewis, G. Ampleman, and P. Brousseau. 2003. Estimation of the Quantity of Explosive Residues Resulting From the Detonation of Unconfined Explosives Charges. Chapter 7, In *Distribution and Fate of Energetics on DoD Test and Training Ranges: Interim Report 4*, ERDC TR-04-4. Vicksburg, MS: U.S. Army Engineer Research and Development Center.
- Checkai, R. T., M. A. Major, R. O. Nwanguma, C. T. Phillips, and M. C. Sadusky. 1993. *Transport and Fate of Nitroaromatic and Nitramine Explosives in Soils From Open Burning/Open Detonation Operations*. ERDEC-TR-136. Edgewood Research Development and Engineering Center.
- Hewitt, A. D., and M. E. Walsh. 2003. *On-site Processing and Subsampling of Surface Soils Samples for the Analysis of Explosives*. ERDC TR-03-14. Hanover, NH: U.S. Army Engineer Research and Development Center.
- Hewitt, A. D., and S. Bigl. 2005. *Elution of Energetic Compounds from Propellant and Composition B Residues*. ERDC/CRREL TR-05-13. Hanover, NH: U.S. Army Engineer Research and Development Center.
- Hewitt, A. D., T. F. Jenkins, T. A. Ranney, D. Lambert, and N. Perron. 2004. Characterization of Energetic Residues at Military Firing Ranges: Schofield Barracks and Pohakuloa Training Area. Chapter 3, In *Distribution and Fate of Energetics on DoD Test and Training Ranges: Interim Report 4*, ERDC TR-04-4. Vicksburg, MS: U.S. Army Engineer Research and Development Center.
- Jenkins, T. F., C. L. Grant, G. S. Brar, P. G. Thorne, P. W. Schumacher, and T. A. Ranney. 1997a. Assessment of Sampling Error Associated with the Collection and Analysis of Soil Samples at Explosives Contaminated Sites. *Field Anal. Chem. Tech.* 1, 151-163.
- Jenkins, T. F., C. L. Grant, M. E. Walsh, P. G. Thorne, S. Thiboutot, G. Ampleman, and T. A. Ranney. 1999. Coping with Spatial Heterogeneity Effects on Sampling and Analysis at an HMX - Contaminated Anti-tank Firing Range. *Field Anal. Chem. Technol.* 3(1):19-28.
- Jenkins, T. F., J. C. Pennington, T. A. Ranney, T. E. Berry, Jr., P. H. Miyares, M. E. Walsh, A. D. Hewitt, N. Perron, L. V. Parker, C. A. Hayes, and Maj. E. Wahlgren. 2001. *Characterization of Explosives Contamination at Military Firing Ranges*. ERDC Technical Report TR-01-05. Hanover, NH: U.S. Army Engineer Research and Development Center.
- Jenkins, T. F., M. E. Walsh, P. G. Thorne, P. H. Miyares, T. A. Ranney, C. L. Grant and J. Esparza. 1998. *Site Characterization for Explosives Contamination at a Military Firing Range Impact Area*. CRREL Special Report 98-9. Hanover, NH: U.S. Army Cold Regions Research and Engineering Laboratory.

- Jenkins, T. F., M. E. Walsh, P. G. Thorne, S. Thiboutot, G. Ampleman, T. A. Ranney, and C. L. Grant. 1997b. *Assessment of Sampling Error Associated with Collection and Analysis of Soil Samples at a Firing Range Contaminated with HMX*. CRREL Special Report 97-22, Hanover, NH: U.S. Army Cold Regions Research and Engineering Laboratory.
- Jenkins T. F., S. Thiboutot, G. Ampleman, A. D. Hewitt, M. E. Walsh, T. A. Ranney, C. A. Ramsey, C. L. Grant, C. M. Collins, S. Brochu, S. R. Bigl, and J. C. Pennington. 2005. *Identity and Distribution of Residues of Energetic Compounds at Military Live-Fire Training Ranges*. ERDC/CRREL TR-05-10. Hanover, NH: U.S. Army Engineer Research and Development Center.
- Jenkins, T. F., T. A. Ranney, A. D. Hewitt, M. E. Walsh, and K. L. Bjella 2004. *Representative Sampling for Energetic Compounds at an Anti-tank Firing Range*. ERDC/CRREL TR-04-7. Hanover, NH: U.S. Army Engineer Research and Development Center.
- Lavigne, M. A., K. Champagne, R. Martel, and R. Lefebvre. 2000. *Initial Study of Terrestrial Forces Training Sites Potentially Contaminated by Energetic Materials, CFB Petawawa*. Sainte-Foy, Québec: INRS-Géoresources.
- Marois, A., A. Gagnon, S. Thiboutot, and G. Ampleman. 2004. *Caractérisation des sols de surface dans les secteurs d'entraînement, Base des Forces Canadiennes, Valcartier*. DRDC-RT-2004-206, DRDC Valcartier.
- Pennington, J. C., T. F. Jenkins, G. Ampleman, S. Thiboutot, J. Brannon, J. Clausen, A. D. Hewitt, S. Brochu, P. Dube, J. Lewis, T. Ranney, D. Faucher, A. Gagnon, J. Stark, P. Brousseau, C. Price, D. Lambert, A. Marois, M. Bouchard, M. Walsh, S. Yost, M. Perron, R. Martel, S. Jean, S. Taylor, C. Hayes, J. Ballard, M. E. Walsh, J. Mirecki, S. Downe, N. Collins, B. Porter, and K. Richard. 2004. *Distribution and fate of energetics on DoD test and training ranges: Interim Report 4*. ERDC TR-04-4. Vicksburg, MS: U.S. Army Engineer Research and Development Center.
- Pennington, J. C., T. F. Jenkins, G. Ampleman, S. Thiboutot, J. M. Brannon, J. Lewis, J. E. Delaney, J. Clausen, A. D. Hewitt, M. A. Hollander, C. A. Hayes, J. A. Stark, A. Marois, S. Brochu, H. Q. Dinh, D. Lambert, R. Martel, P. Brousseau, N. M. Perron, R. Lefebvre, W. Davis, T. A. Ranney, C. Gauthier, S. Taylor, and J. M. Ballard. 2003. *Distribution and fate of energetics on DoD test and training ranges: Interim Report 3*. ERDC TR-03-02. Vicksburg, MS: U.S. Army Engineer Research and Development Center.
- Pennington, J. C., T. F. Jenkins, G. Ampleman, S. Thiboutot, J. M. Brannon, J. Lynch, T. A. Ranney, J. A. Stark, M. E. Walsh, J. Lewis, C. A. Hayes, J. E. Mirecki, A. D. Hewitt, N. Perron, J. Clausen, and J. J. Delfino. 2002. *Distribution and fate of energetics on DoD test and training ranges: Interim Report 2*. ERDC TR-02-8. Vicksburg, MS: U.S. Army Engineer Research and Development Center.
- Stamfli, N., M. A. Carrier, R. Martel, and R. Lefebvre. 2003. *Initial Study of Terrestrial Forces Training Sites Potentially Contaminated by Energetic Materials, CFB Gagetown*. Prepared for Defence Research Establishment Valcartier (DREV), INRS-ETE report.

- Thiboutot, S., G. Ampleman, A. Gagnon, A. Marois, T. F. Jenkins, M. E. Walsh, P. G. Thorne, and T. A. Ranney. 1998. *Characterization of Anti-tank Firing Ranges at CFB Valcartier, WATC Wainwright and CFAD Dundurn*. DREV R-9809, DRDC Valcartier.
- Thiboutot, S., G. Ampleman, A. Gagnon, and A. Marois. 2000. *Characterization of an Unexploded Ordnance Contaminated Range (Tracadie Range) For Potential Contamination by Energetic Materials*. DREV Report TR-2000-102, DRDC Valcartier.
- Thiboutot, S., G. Ampleman, A. Hamel, J. M. Ballard, R. Martel, R. Lefebvre, and S. Downe. 2003a. *Research on the Environmental Conditions of Groundwater and Surface Water Prevailing in the Training Area at CFB Gagetown, New Brunswick*. TR-2003-016, DRDC Valcartier.
- Thiboutot, S., G. Ampleman, A. Marois, A. Gagnon, M. Bouchard, A. Hewitt, T. Jenkins, M. Walsh, K. Bjella, C. Ramsey, and T. A. Ranney. 2004. *Environmental Conditions of Surface Soils, CFB Gagetown Training Area: Delineation of the Presence of Munitions Related Residues (Phase III, Final Report)*. TR-2004-205, DRDC Valcartier.
- Thiboutot, S., G. Ampleman, J. Lewis, D. Faucher, A. Marois, R. Martel, J. M. Ballard, S. Downe, T. Jenkins, and A. Hewitt. 2003b. *Environmental Conditions of Surface Soils and Biomass prevailing in the Training Area at CFB Gagetown, New-Brunswick*. TR-2003-152, DRDC Valcartier.
- Thiboutot, S., G. Ampleman, R. Martel, D. Paradis, and R. Lefebvre. 2001. *Environmental Characterization of Canadian Forces Base Shilo Training Area (Battleruns) following GATES Closure*. DREV TR 2001-126. DRDC Valcartier.
- Thiboutot S., G. Ampleman, S. Brochu, R. Martel, G. Sunahara, J. Hawari, S. Nicklin, A. Provotas, J. C. Pennington, T. F. Jenkins, and A. Hewitt. 2003c. *Protocol for Energetic Materials-Contaminated Sites Characterization*. Volume 2, Final Report TTCP WPN-4 KTA 4-28.
- Thiboutot, S., G. Ampleman, T. F. Jenkins, M. E. Walsh, P. G. Thorne, T. A. Ranney, and G. L. Grant. 1997. *Assessment of Sampling Strategy for Explosives-Contaminated Soils. Proceedings of the 90th Annual Air and Waste Management Society Meeting, Paper # 94-WP 101.08, Toronto, June 1997*.
- Walsh, M. E., and T. A. Ranney. 1999. *Determination of nitroaromatic, nitramine, and nitrate ester explosives in soils using GC-ECD*. Special Report SR-99-12. Hanover, NH: U.S. Army Cold Regions Research and Engineering Laboratory.
- Walsh, M. E., C. A. Ramsey, and T. F. Jenkins. 2002. *The Effect of Particle Size Reduction by Grinding on Sub-Sampling Variance for Explosives Residues in soil*. *Chemosphere* 49:1267-1273.
- Walsh, M. E., C. A. Ramsey, C. M. Collins, A. D. Hewitt, M. R. Walsh, K. L. Bjella, D. J. Lambert, and N. M. Perron. 2005. *Collection Methods and Laboratory Processing of Samples from Donnelly Training Area Firing Points, Alaska, 2003*. ERDC/CRREL TR-05-6. Hanover, NH: U.S. Army Engineer Research and Development Center, CRREL.

Walsh M. E., C. M. Collins, A. D. Hewitt, M. R. Walsh, T. F. Jenkins, J. Stark, A. Gelvin, T. S. Douglas, N. Perron, D. Lambert, R. Bailey, and K. Myers. 2004. *Range Characterization Studies at Donnelly Training Area, Alaska: 2001 and 2002*. ERDC/CRREL TR-04-3. Hanover, NH: U.S. Army Engineer Research and Development Center, Cold Regions Research and Engineering Laboratory.

U.S. Environmental Protection Agency (EPA) 1994. Nitroaromatics and Nitramines by HPLC. Second Update SW846 Method 8330.

_____. 1999. Nitroaromatics and Nitramines by GC-ECD. Fourth Update SW846 Method 8095.

4 Assessment of the Contamination by Energetic Materials and Metals in Soil and Biomass at Western Area Training Center in Wainwright, Alberta (Phase I)

Introduction

Military training ranges on Canadian Forces Bases (CFBs) are essential to prepare troops for potential wars and/or peace missions. On the other hand, the growing concern of the leaders from the Department of National Defence (DND) and of the general population makes it necessary to evaluate the impacts of training on the environment. During the past 10 years, methods of characterization have been developed to assess the contamination by energetic materials, which is different compared with the contamination in residential or industrial scenarios (Thiboutot et al. 1998a). Testing and training ranges are key elements in maintaining the capability, readiness, and interoperability of the Armed Forces. The potential environmental impacts of live-fire training mandate that our organizations demonstrate responsible management of these facilities in order to continue military activities. Moreover, many other countries, such as the United States and the United Kingdom, use Canadian training ranges under international agreements. Recently, awareness has increased that the energetic residues and heavy metals associated with munitions can be released in the environment during training activities and, over time, can potentially contaminate the underlying groundwater. For instance, munitions training and testing exercises were suspended at the Massachusetts Military Reservation following the discovery of low concentrations of RDX in the groundwater beneath the main training area (USEPA 2000). On military training ranges, munitions-related pollutants can be released to the environment from breaches in the casings of UXO or partially exploded ordnance (low-order detonations), from poor disposal practices, such as unconfined burning operations, from BIP operations, and from live-fire operations. The SERDP funded several studies directed at the assessment of source terms, pathways of biodegradation, and fate of munitions residues on military training facilities. Moreover, DLE tasked DRDC Valcartier to initiate a research program for the environmental characterization of their main training areas. The work carried out at the Western

Area Training Center (WATC) Wainwright was co-sponsored by both programs.

The most extensive study achieved up to now was conducted at the Canadian Forces Ammunition Depot (CFAD) Dundurn open detonation range, where the impact of the open detonation of Canadian obsolete munitions was evaluated (Ampleman et al. 1998). The first training range visited was the CFB Shilo training area where research demonstrated the environmental impacts of live-fire training (Thiboutot et al. 2001; Ampleman et al. 2003). Anti-tank firing ranges across Canada were also the topic of other studies (Thiboutot et al. 1998; Arel et al. 2002; Marois et al. 2004). Moreover, many papers were written in recent years concerning the fate and analysis of explosives in various types of sites (USEPA 1993; Checkai et al. 1993; Jenkins and Walsh 1987; Jenkins et al. 1997a, 1997b, 1998a, 1998b, 1999, 2001, 2003; Miyares and Jenkins 2000; Ampleman et al. 2000; Thiboutot et al. 1997, 1998a, 2000, 2002, 2003a, 2003b; Stamfli et al. 2003; Walsh and Ranney 1998a, 1999; Pennington et al. 2002, 2003; Hewitt et al. 2004; Hewitt and Walsh 2003; Walsh et al. 2004). A protocol describing the different methods of sampling and the analytical chemistry was developed (Thiboutot et al. 1998a). This protocol was recently updated in collaboration with CRREL. It is now available on the Web under the auspices of The Technical Cooperation Program (TTCP) by the member nations (Canada, the United States, the United Kingdom, Australia, and New Zealand) in a key technical area (KTA 4-28) (Thiboutot et al. 2002). Research results to date have demonstrated that explosives exhibit limited aqueous solubility and are dispersed in a heterogeneous pattern of contamination. In the United States, concerted efforts have been made to develop analytical chemistry, to establish the best sampling procedures and to understand the complex fate of explosives in the environment (USEPA 1993; Checkai et al. 1993; Jenkins and Walsh 1987; Walsh and Ranney 1998a, 1998b, 1999; Jenkins et al. 1997a, 1997b, 1998a, 1998b; Walsh 2001; Fellows et al. 1992; Selim and Iskandar 1994; Cragin et al. 1985; Pennington et al. 2001; Walsh et al. 2001; Brannon et al. 2000).

Energetic materials are prominent components of munitions and weapons that can be found in war zones, training ranges, and on production sites. During the past decade, many requirements have emerged related to the identification, quantification, and elimination of energetic contaminants dispersed by munitions, or present in explosives dumps, trials, or destruction fields, firing areas, and production sites (Thiboutot et al. 1997, 1998a,

1998b, 2000, 2002; Ampleman et al. 1998, 2000; USEPA 1993; Checkai et al. 1993; Jenkins and Walsh 1987; Walsh and Ranney 1998a, 1998b, 1999; Jenkins et al. 1997b, 1998a, 1998b; Walsh 2001; Fellows et al. 1992; Selim and Iskandar 1994; Cragin et al. 1985; Pennington et al. 2001; Walsh et al. 2001; Brannon et al. 2000). Many Canadian Forces sites used as impact areas, training ranges, demolition and open burning/open detonation (OB/OD) ranges, which were used to destroy out-of-specification materials, were highly suspected of being contaminated with energetic constituents as described in the literature (Ampleman et al. 1998, 2000; Thiboutot et al. 1997, 1998b, 2000; USEPA 1993; Checkai et al. 1993; Jenkins et al. 1997b, 1998a, 1998b; Pennington et al. 2001; Walsh et al. 2001; Brannon et al. 2000). High explosives used by both Canada and the United States generally contain either TNT (2,4,6-trinitrotoluene) or mixtures of TNT with RDX (hexahydro-1,3,5-trinitro-1,3,5-triazine), HMX (octahydro-1,3,5,7-tetranitro-1,3,5,7-tetrazocine), or, for some older munitions, tetryl (n-methyl-n-2,4,6-tetranitroaniline). Most of the air weapons contain TNT with aluminum (triton explosives). The most powerful weapons contain Composition B (TNT with RDX) or octol (TNT with HMX). When UXOs are found on sites, they are often blown-in-place using C4, a mixture of RDX with a polymer. These BIP operations often spread explosives into the environment (Pennington et al. 2001). In addition, NG and 2,4DNT are compounds used in the propellant formulations that could be found at firing positions. Nitrocellulose is also a major ingredient in propellant formulations, but it is not characterized because it is not considered toxic. Moreover, this compound is very difficult to quantify because it is not soluble in organic solvents.

The WATC in Wainwright was opened in 1939 when World War II broke out. Before this time, the area was Buffalo National Park. Ottawa was looking for a huge area in Canada to train full brigades with all the necessary equipment. Therefore, the National Park was closed and WATC Wainwright was founded. This 614 km² base is 200 km southeast of Edmonton and 400 km northeast of Calgary.

This report describes the surface work carried out during Phase I in June 2004 at WATC Wainwright, to assess the contamination by metals and energetic materials in the soil and biomass. A previous study was performed in 1996 on the contamination of anti-tank ranges in Valcartier, Wainwright, and Dundurn (Ampleman et al. 1998), where the two anti-tank ranges in Wainwright were characterized. The objective of the study

performed in 2004 was to evaluate the approaches used to characterize WATC Wainwright. The sampling pattern was adapted for each situation (i.e., the type of fired ammunition, the concentration of contaminants—in some situations, higher concentrations could be visually located—and the size and pattern of the training sites). The training sites visited were grenade, rifle, small arms, and anti-tank ranges. Soil and biomass samples were taken using a composite approach to be statistically representative, as explained in the next experimental section. The hydrogeology study, which was performed by the Institut National de la Recherche Scientifique Eau, Terre et Environment (INRS-ETE), will not be discussed in this report. Defence Construction Canada (DCC) was responsible for hiring the analytical laboratory, providing manpower and logistics, and making the link with range control personnel.

Experimental

Background sampling

Background samples are critical for establishing the anthropogenic contribution versus the natural contribution for all metal parameters. Background composite samples were collected randomly, in circles of approximately 10-m diameter in different locations inside and outside the base at the periphery of the live-fire area. A minimum of 30 increments was collected to form each background sample. A statistical analysis was conducted to identify a mean background concentration and to define a limit for a value that can be considered normal. Values at the extremities of the lognormal curve were identified. The limits, named mean background concentrations (MBG), were chosen for a probability of 97.72 percent (two times the standard deviation). The probability of finding a result with a value higher than this limit is 2.28 percent. When the analytical laboratory did not detect a specific parameter, a value at half of the detection limit was used for the data analysis.

Sample handling, treatment, and analytical methods

The usual strategy for soil sampling included systematically sampling at firing positions, around a representative number of targets and around suspected hot spots (broken casings, UXOs, or debris, etc.) as described in the soil sampling protocol (Thiboutot et al. 1998a). Usually, surface soils were collected to a depth of 5 cm. This strategy was used in previous studies on anti-tank ranges (Thiboutot et al. 1998b). Soil sample

duplicates were taken to reach approximately 10 percent of the number of collected samples. Wherever vegetation samples were collected, the method consisted in building composite samples of indigenous living plants by randomly cutting various types of plants. A minimum of 25 to 30 increments of mixed vegetative material was collected to build the vegetation samples around targets and in transects. Only the upper part of the plants (without roots) was collected, since grazing animals rarely eat the plants' roots. Metals could bio-accumulate either in the upper plant system or in the roots, depending on the solubility of the metals. All of the composite samples were stored in polyethylene bags.

Soil samples were analyzed for metals and energetic materials, while vegetation (biomass) was analyzed for metals only. No biomass samples were analyzed for energetic materials, since no explosives were detected in other studies (Thiboutot et al. 2001; Ampleman et al. 2003). Metals were analyzed using EPA Method 3050 involving a nitric acid/hydrogen peroxide digestion followed by Inductively Coupled Plasma/Mass Spectrometry (ICP/MS) by an external laboratory (PSC Analytical Services (PSC), Edmonton, Alberta). Metals analyzed for this study were silver (Ag), aluminum (Al), As, boron (B), Ba, beryllium (Be), bismuth (Bi), calcium (Ca), Cd, Cr, cobalt (Co), Cu, iron (Fe), mercury (Hg), potassium (K), lithium (Li), magnesium (Mg), manganese (Mn), molybdenum (Mo), sodium (Na), Ni, phosphorus (P), Pb, rubidium (Rb), sulphur (S), selenium (Se), Sb, tin (Sn), Sr, tellurium (Te), titanium (Ti), thallium (Tl), uranium (U), vanadium (V), Zn, and zirconium (Zr). The samples were frozen and sent to DRDC and PSC for energetic materials and metal analyses, respectively. Samples analyzed for both types of analytes (energetic materials and metals) were first homogenized and divided at DRDC-Val before sending one portion to PSC.

For energetic materials analyses, soil samples were air-dried in the dark, and homogenized by adding acetone to form a slurry, which was then evaporated. Homogenized soils were sieved through 25-mesh sieves and extracted according to the following procedure. Eight grams of soil were put into an amber vial and mixed with acetonitrile (10 mL). A vortex was applied for 1 minute, followed by sonication for 18 hours in an ultrasonic bath in the dark. The samples were left to settle for 30 min. Acetonitrile (2 mL) was recovered from the vial and diluted with water (2 mL) containing calcium chloride (1 percent). The removed mixture was filtered on a 0.45-microns filter to get 1 mL of solution for injection into the HPLC.

Soil extracts were maintained at 4 °C until analyzed by HPLC according to EPA Method 8330.

The HPLC method was preferred to the GC method recently published, since reproducible results with the GC/ECD method were difficult to achieve and concentrations expected were in the range of the mg/kg, easily achievable by the more rugged HPLC method (Walsh 2001; Walsh and Ranney 1998). The HPLC method achieved a detection limit of 0.25 mg/kg for all analytes, which was reduced to 0.06 mg/kg when the sample extracts were concentrated in a Zymark apparatus (Turbovap evaporator, produced by Zymark Corporation, Hopkinton, MA). To obtain lower limits of detection, 2 mL of acetonitrile from the soil extract were concentrated by evaporating to dryness and adding 0.5 mL of water and 0.5 mL of acetonitrile. Analyses were performed with an HPLC Agilent HP 1100 equipped with a degasser G1322A, a quaternary pump model G1311A, an autosampler G1313A, and an ultraviolet (UV) diode array detector model G1315A monitoring at 210, 220, and 254 nm. The injection volume was 20 µL and the column was a Supelcosil LC-8 column 25 cm × 3 mm × 5 µm eluted with 15:85 isopropanol/water (v/v) at a flow rate of 0.75 mL/min. The column temperature was maintained at 25 °C during the analysis. Standards and solvents were diluted 1:2, acetonitrile to water (0.5 mL ACN/0.5 mL water).

Soil leachate tests (TCLP) were conducted (EPA Method 1311) on selected samples from the target area of the small arms training ranges and the munitions dump area. The following parameters were analyzed: Ag, As, Ba, Be, B, Cd, Cr, Co, Cu, Fe, Hg, Ni, Pb, Se, Sb, Tl, U, V, Zn, and Zr.

Range descriptions and sampling strategies

Background sampling

A total of 21 soil and biomass background samples were collected around the military training areas. The sampling was done in sections where live-fire training had never occurred. Four field replicates were also collected.

Grenade Range (#2)

One composite of 25 to 30 increments was collected in each single region, A, B, C, D, E, and F, and in each area 5 × 20 m in front of the bunker (Figure 4-1). In all, 15 soils samples were taken including one duplicate.

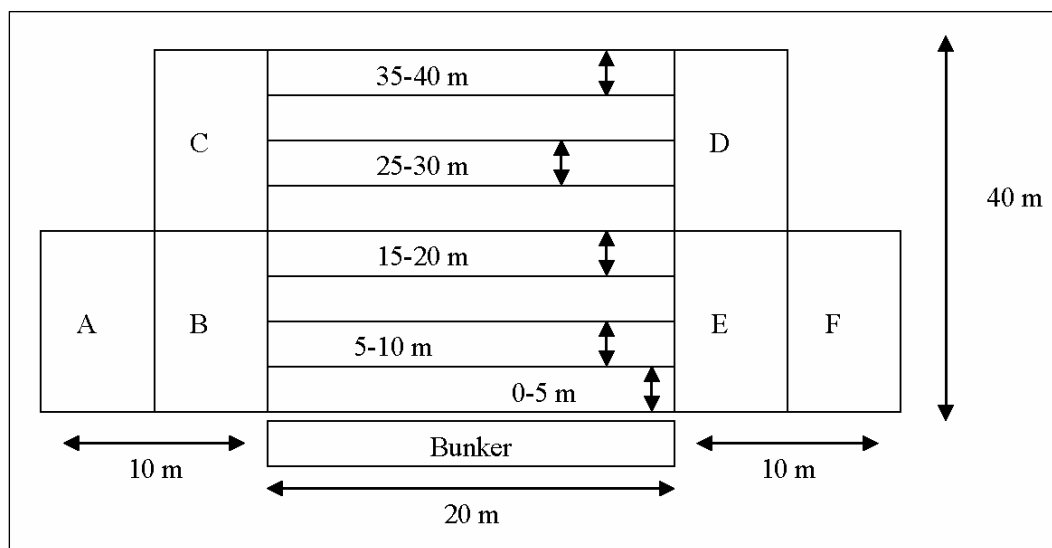

Figure 4-1. Schematic of the sampling in Grenade Range #2.

One biomass sample was also collected covering the entire surface in front of the bunker, excluding the A to F areas.

Light/medium Mortar Range (#12)

Range 12 has four firing positions identified by piles of sand bags; the total width between the first and the last bag is 40 m. The sampling was done between 0 and 5 m in front of bags 1, 2, 3, and 4 and between 0 and 5 m and 5 to 15 m behind each bag, for a total of 12 samples. In the target area, composites of 25 to 30 increments were taken around a target (tank) within a radius of 1 m. A total of 17 samples were taken in this range; 8 behind and 4 in front of the firing position, and 5 in the target area. No field replicates and no biomass samples were collected at this location.

Demolition Range (#14)

This range is divided into four sections, all of which are used for demolition activities. Three are devoted to surface charges demolition and one to depth demolition (underground). Three composites of 100 increments each were taken in each section. A composite sample was also collected in another area where craters from fresh detonations were observed. A total of 13 composite soil samples were collected. No vegetation was present in this range and, consequently, no biomass sample was collected.

Armored Fighting Vehicle (AFV) Static Range (# 16)

This AFV range contains two concrete pads from which vehicles fire (Figure 4–2). The first pad is used more frequently than the second. Each pad contains 11 concrete rectangles. The sampling was performed in front of the five rectangles located in the middle of the pad because the contamination was surmised to be concentrated in this region as mentioned by military personnel. Soil composites of 25 to 30 increments were taken in front of these pads within areas 1, 2, 3, 4, and 5 (Figure 4–2). One duplicate was taken for each pad. The surface in front of the first pad is flat; for the second pad, the surface slopes away at 35 m in front of the firing point. A total of 12 soil and 4 biomass samples were taken for both firing points (i.e., concrete pads).

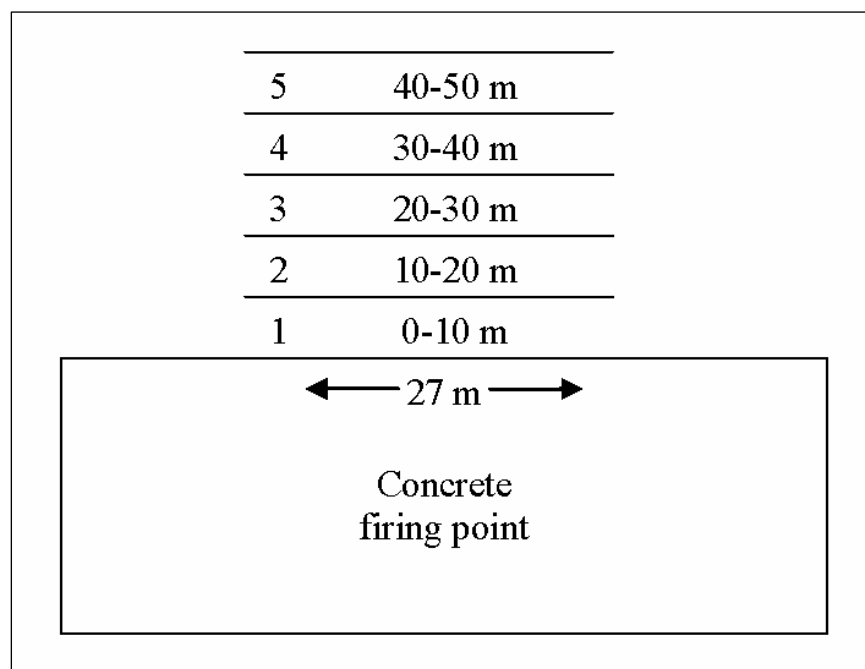

Figure 4-2. Description of firing point sampling in Range 16.

Two rails for movable targets are located behind earthen berms in this range. Two soil and one biomass samples were collected on the berm. The first berm starts at global positioning system (GPS) location 0497073-5845214 and finishes at 0497025-5845179. This berm was divided into two parts (half and half) and one composite soil sample of 25 to 30 increments was taken in each part, while the biomass sample was made with 25 to 30 increments over the entire undivided surface (10 × 60 m). The second berm is 1-km long and starts at GPS location 0497446-5844973 and finishes at 0496831-5844704. Only the 60-m long south extremity was

sampled because of visual evidence of many 25-mm bullets on the ground at that location.

Platoon Field Firing Defensive Position (#21)

Range 21 features a 300-m long trench and six lines where soldiers can shoot in the direction of the target area (Figure 4-3). The 11 concrete rectangles are grouped in the concrete firing point presented in Figure 4-3. The targets are situated in the field in front of lines 1 to 6. Soldiers use the trench when they want to change their line location. Only three lines are drawn in Figure 4-3. For the sampling, the trench was divided into three 100-m sections, and one part was not sampled. The assumption was made that the sampled 200 m was more contaminated than the 100-m unsampled section because metal casings and munitions fragments were present only in the sampled 200 m. Sixteen soil samples, including two duplicates and three biomass samples, were collected. Three of the soil and one of the biomass samples were collected in the target area. The majority of the samples were taken inside the lines and the trench. Samples were also collected outside of the mortar pit and line 1, around the hole in both cases.

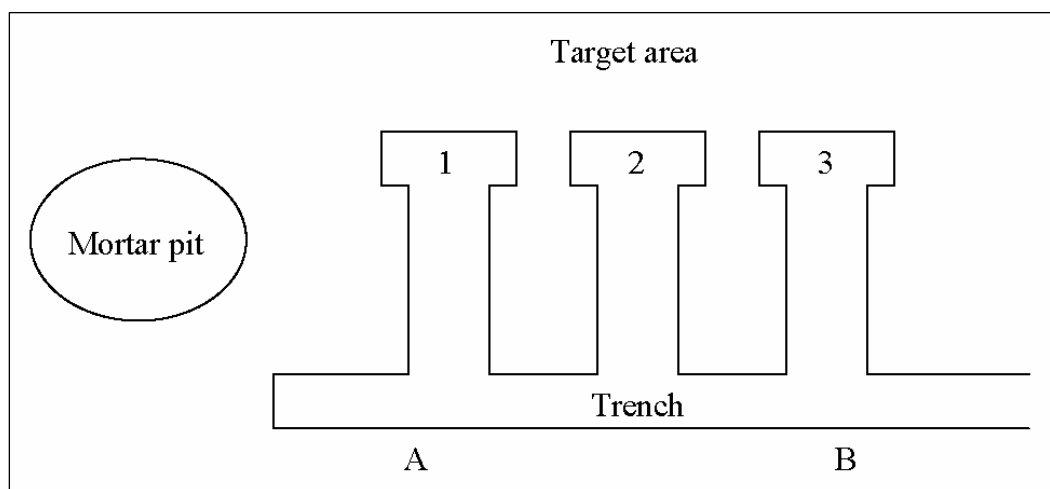

Figure 4-3. Illustration of firing position in Range 21.

Vernonburg Site (Ammunition Dump)

This area contains many obsolete munitions that have been there for at least 20 years. A large variety of munitions can be found: HE 105-mm and 155-mm, TOW missile, smoke 105-mm, etc. At the first of two dump sites, munitions are entirely covered by the ground; at the second one, most of the munitions are visible at the surface. Sampling was done only around

the second site. Three soil and one biomass samples were taken in an area safe for walking. A fence had been erected around the safe zone to protect personnel from accidental detonations of live UXO. All samples were taken inside the safe zone.

Small arms ranges

500-Yard Conventional and 600-Meter Conventional Ranges (#1 and 8)

The same sampling pattern was adopted for these two ranges. These training areas are typical rifle ranges made of 5 to 6 firing lines (one at each 100-m distance from the target), one sandy stop butt with wooden targets, and one berm supporting moving mechanical targets between the stop butts and the firing points (Figure 4-4). Ranges 1 and 8 have 12 and 24 targets with a width of 41 and 83.5 m, respectively. Figure 4-5 shows that the stop butt was divided into three sections (A, B, and C) to verify if the contamination can migrate by gravity, with the wind and/or rain, from the targets to the road. Areas in front of targets were sampled by collecting three composites of 25 to 30 increments in the regions A, B and C, respectively. The areas in front of the targets are in groups of three or four depending on the number of targets present in the range. In Range 1, composite soil samples were collected in front of targets 1 to 3, 4 to 6, 6 to 9, and 10 to 12, while in Range 8, composite soil samples were collected in front of every group of four targets (1-4, 5-8, ...). This is the only difference in the sampling strategy between Ranges 1 and 8. The same strategy (regrouping targets) was adopted for the firing position sampling without the different sections A, B, and C. A total of 23 and 34 soil samples were taken in Ranges 1 and 8, respectively, including 4 duplicates for each range. Biomass samples were collected in the target area in Ranges 1 (five samples) and 8 (six samples).

25-Meter Outdoor Range (#24) (Pistol Shooting Range)

This range is approximately 25-m long and 8-m wide. It is composed of two parts: a sand butt into which bullets are fired and firing lines at 10, 15, 20, and 25 m from the sand butt (Figure 4-6). Each firing position was sampled by taking a composite of 25 to 30 increments on the line covering the entire width of the range. The sand butt was sampled in two sections: the higher and the lower elevation of the sand. Six soil samples were taken in this range with one biomass sample (25 to 30 increments) between the sand butt and the firing position at 10 m.



Figure 4-4. The 12 wooden targets and first firing position at 93 m in Range 1.

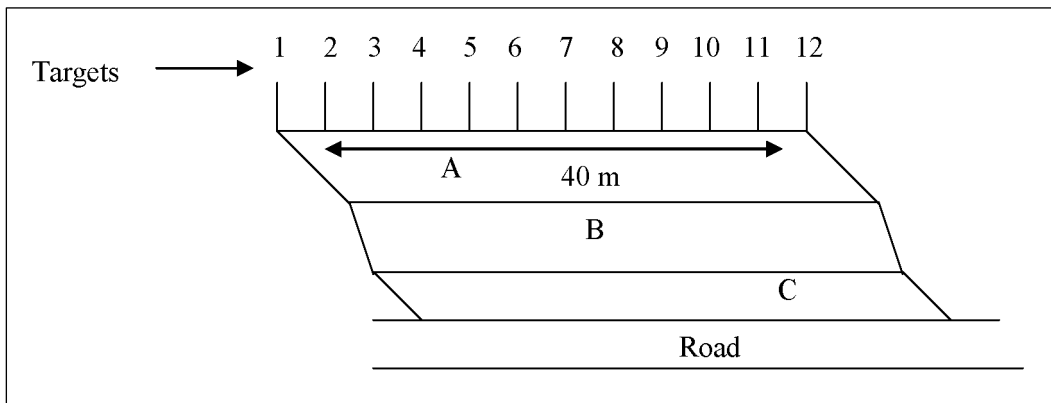

Figure 4-5. Representation of target area in Range 1 (Range 8 has same pattern, but number of targets is 24 and width is 83.5 m).



Figure 4-6. Firing positions and shooting butt of Range 24.

Anti-tank ranges

Hand-Held Anti-tank (Stationary Targets) (#13) and Hand-Held Anti-tank Weapon (#22)

Ranges 13 and 22 are divided into two principal sections, the firing point and the target area. The difference observed between these two ranges is that the firing point in Range 22 is divided into three positions, while in Range 13, the firing position structure is continuous with the possibility to fire from three different positions. For both ranges, the firing position was sampled according to Figure 4-7. In both cases, 7 soil composites of 25 to 30 increments were collected behind and in front of the firing point at various distances (0-5, 5-10, ..., up to 25-30 m) including one duplicate for each distance, for a total of 14 soil samples. In Range 13, four targets were sampled with one duplicate collected around Target 1 to give six soil samples and one biomass sample taken around Target 3.

Moreover, Target 3 was sampled in two sections, within a radius of 1 m and at 5 m from the target. In Range 22, four targets were also sampled and one biomass sample was taken around Target 2.

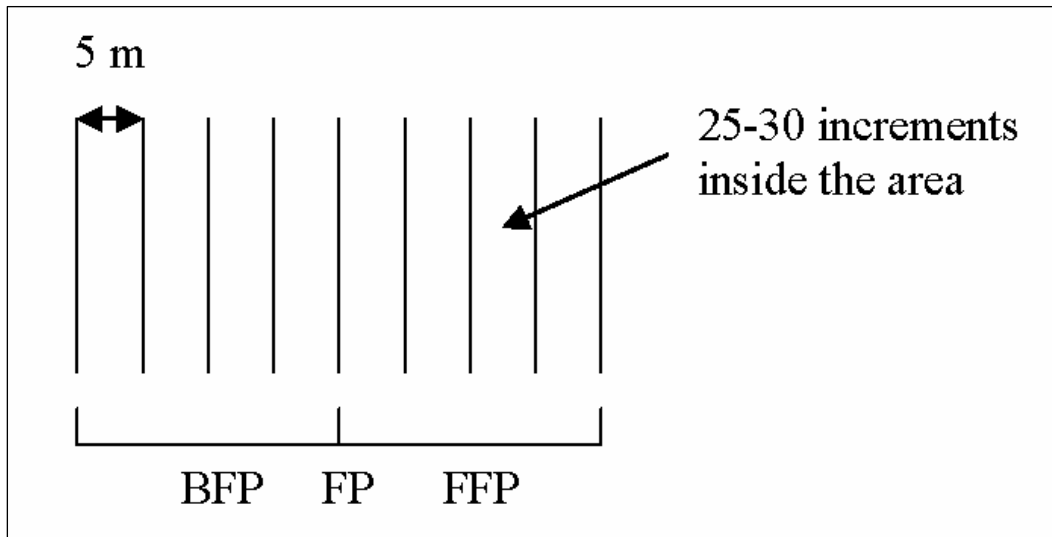

Figure 4-7. Sampling pattern used at firing positions in anti-tank ranges (BFP: behind firing point; FP: firing point; and FFP: in front of firing point).

Table 4-1 summarizes the soil and biomass samples collected at firing positions and around the targets. A total of 177 soil and 24 biomass samples were collected.

Table 4-1. Soil and biomass samples collected during the campaign at WATC Wainwright.

Range	Number of samples	
	Soil	Biomass
Background	21	21
2	15	1
12	12 (FP); 5 (targets)	0
14	12	0
16	12 (FP); 2 (rail)	4 (FP); 1 (rail)
21	13 (FP); 2 (target)	2 (FP); 1 (target)
Vernonburg	3	1
1	10 (FP); 13 (target)	5 (target)
8	14 (FP); 20 (target)	6 (target)
24	4 (FP); 2 (target)	1 (FP)
13	14 (FP); 6 (target)	1 (target)
22	14 (FP); 4 (target)	1 (target)

Note: FP means firing position.

Results and discussion

Vegetation samples analyses

As no legal threshold criteria exist for biomass samples, the MBG was used to verify the presence of anthropogenic contamination in the vegetation. Only the data for metals, which have Industrial Soil Quality Guidelines (ISQG) soil threshold criteria, were analyzed. Biomass samples from the target area of Range 1 (small arms range) showed concentrations of Sb, Cu, and Pb higher than the MBGs, which were 1, 12.4, and 10 mg/kg, respectively. The contamination was found in the same 3 biomass samples with a maximum of 5, 23.3, and 144 mg/kg of Sb, Cu, and Pb, respectively. Two samples collected in front of the concrete pad from Range 16 showed maximum concentrations of copper and lead of 19.8 and 21 mg/kg, respectively. Finally, one sample in the ammunition dump (Vernonburg), exceeded the MBG for Cu, which is 12.4 mg/kg with a concentration of 15.1 mg/kg.

Grenade Range (#2)

Since 1997 the average annual number of M67 grenades fired in this range has been 2,500 except in 2003 and 2004 when the number was 0 and 188, respectively. RDX, and consequently HMX, (an impurity of RDX production), were observed in 15 samples, while TNT was observed in 3 samples. The maximum concentration for these three compounds occurred within 20 and 25 m of the firing point. Values for RDX, HMX, and TNT were 6.7, 0.6, and 10.6 mg/kg, respectively (Figure 4–8). Most of the grenades were probably fired in this area. The results obtained for this hand grenade range are similar to other such ranges (Ampleman et al. 2003; Jenkins et al. 2006). Concentrations of HMX and RDX in the field duplicates were similar.

The results from metal analyses show significant contamination by Zn. In fact, 9 out of 15 samples were contaminated with concentrations of Zn up to 1,000 mg/kg when the ISQG soil threshold is 360 mg/kg. Contamination was found in Regions B through F and the middle section up to 15 m. The metals-contaminated region is not the same as the one contaminated by energetic materials (between 20 and 25 m as shown in Figure 4–6). Finally, the source of this contamination must be anthropogenic since the mean background of Zn is 64 mg/kg.

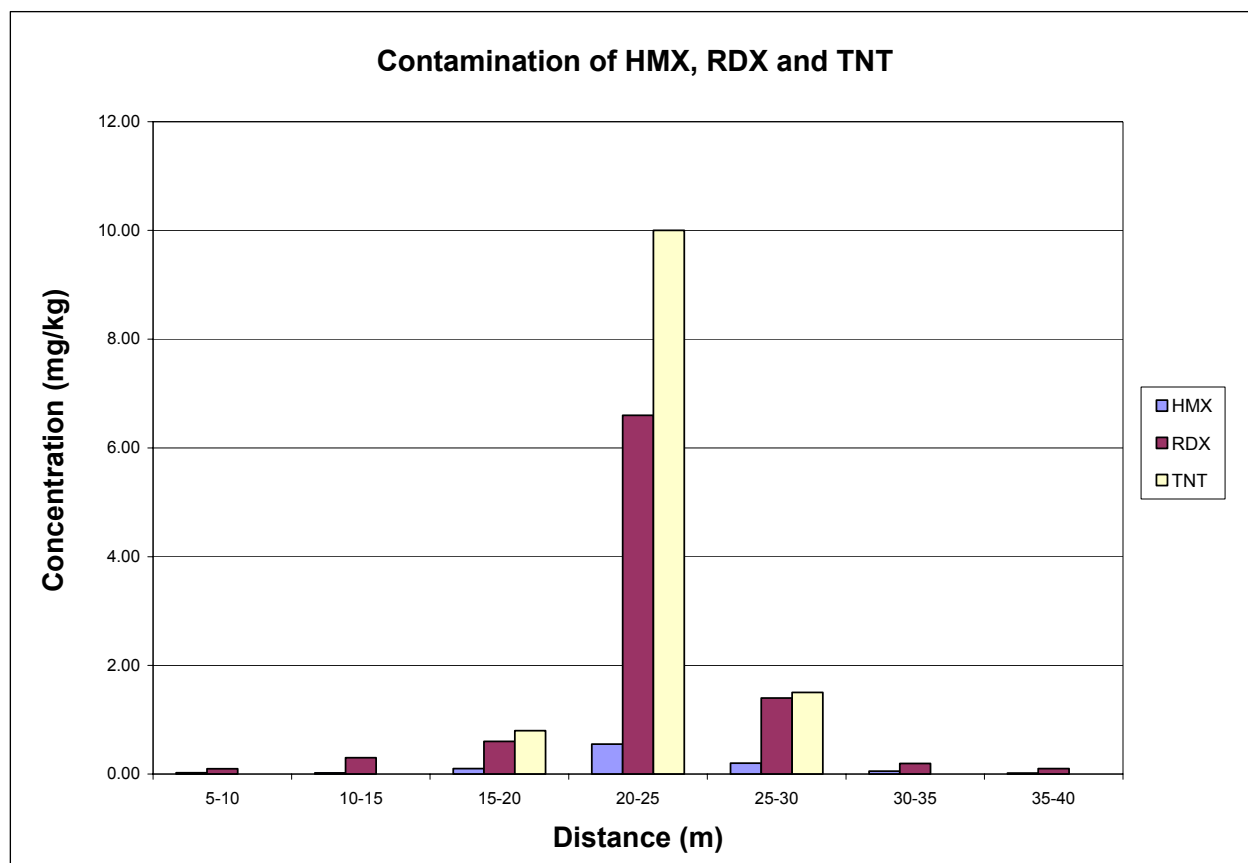

Figure 4-8. Influence of distance from firing point on contamination for grenade range.

Light/medium Mortar Range (#12)

During military training in 2001, 2002, and 2004, the number of 60-mm HE mortars fired in this range was 501, 344, and 286, respectively. For the 12 samples analyzed at the firing position, NG was the only contaminant detected. The highest concentration was approximately 4 mg/kg. No contaminants were found in the target area. No metal values exceeded the ISQG threshold criteria for soils.

Demolition Range (#14)

The demolition range is a site where many types of munitions can be destroyed by BIP procedures. The amount of C4 used to initiate the reaction is usually assumed to be high enough to ensure a high-order detonation. In some cases, the temperature, wind, weather, and condition of the munitions contribute to incomplete reactions resulting in low-order detonations and, consequently, contamination by explosives and metals. HMX was detected in 10 samples (max. 0.6 mg/kg), RDX in 12 samples (max. 13.4 mg/kg), TNT in 10 samples (max. 14 mg/kg), NG in 3 samples

(max. 2.7 mg/kg), 2,4DNT in 5 samples (max. 0.7 mg/kg), and 2ADNT and 4ADNT in 3 samples (max. 0.2 mg/kg). No metals concentrations exceeding the ISQG soil threshold criteria were found.

Armored Fighting Vehicle Static Range (#16)

In this range, many 5.56- and 7.62-mm bullets were fired (e.g., 197,957 bullets of 7.62-mm and 6,000 bullets of 0.5-mm were fired in 2001; 23,370 bullets of 5.56-mm were fired in 2004. NG, 2,4DNT, and 2,6DNT were detected in all 17 samples. NG was detected in 14 samples at a maximum concentration of 92.7 mg/kg; 2,4DNT was present in concentrations up to 10 mg/kg in 10 samples; and 2,6DNT, an impurity of military grade 2,4DNT, was detected in 2 samples at a lower concentration (max. 0.7 mg/kg). The 2,6DNT was detected in the two samples showing the highest levels of 2,4DNT. Finally, the maximum concentrations for these three contaminants were detected in the soil samples collected in the area between 10 and 20 m from the firing position. The two field duplicates gave results similar to their corresponding samples. No metals concentrations exceeding the ISQG soil threshold criteria were found.

Platoon Field Firing Defensive Position (#21)

The only contaminant found in the 13 samples collected at the firing point was NG, which is characteristic of the use of double-based propellants. In fact, the samples from the 6 firing lines showed a maximum of 3 mg/kg in Line 1, while 12.5 mg/kg of NG was found into the mortar pit. Around targets, however, HMX, RDX, and TNT were found in the three samples with maximum concentrations of 34, 7.5, and 4.6 mg/kg, respectively. Target 2 samples contained NG (1.8 mg/kg). Traces of NG in impact areas have been reported previously (Jenkins et al. 2006) and are the result of the incomplete burning of the propellant at impact. This last result will be verified during the second phase of the sampling campaign. The sample collected around Target 3 had a Cu concentration of 172 mg/kg, almost twice the ISQG soil threshold (91 mg/kg).

Vernonburg Site (Ammunition Dump)

No energetic materials contamination was found at this site. These results will be confirmed during Phase II. Finding no contamination around such a large number of dumped munitions is surprising. Our results tend to confirm that the munition pile located in Vernonburg is mainly composed

of non-HE rounds. This should be interpreted carefully, however, because if munition casings were intact, leaching of HE may have been prevented.

The three samples for metals analyses exhibited concentrations higher than the ISQG soil threshold criteria for Zn (110, 149, and 255 mg/kg) and Cu (623, 7110, and 7220 mg/kg). The ISQG soil threshold criteria are 360 and 91 mg/kg for Zn and Cu, respectively.

Small arms ranges

500-Yard Conventional and 600-Meter Conventional Ranges (#1 and 8)

In Ranges 1 and 8, military training used mainly 7.62- and 5.56-mm bullets. In 2002, 83,140 5.56-mm and 1,340 7.62-mm bullets were fired in Range 1, while in Range 8, 195,572 5.56-mm and 42,711 7.62-mm bullets were fired. The firing positions were sampled as described in the preceding section. Only the first two firing lines (100 and 200 m) were sampled to verify the extent of contamination (Table 4-2). Even though NG and 2,4DNT were found in all samples, concentrations of 2,4DNT were significantly lower than concentrations of NG. Therefore, only the results for NG were reported in Table 4-2. The maximum concentrations of 2,4DNT found in Ranges 1 and 8 were 0.5 and 1.1 mg/kg, respectively. This table

Table 4-2. Concentrations of NG obtained for samples collected at 100- and 200-m firing lines of the small arms ranges.

Range 1	NG, mg/kg	Range 8	NG, mg/kg
FP 100 T 1-3	21.7	FP 100 T 1-4	21.7
FP 100 T 4-6	17.9	FP 100 T 5-8	19.5
FP 100 T 7-9	21.0	FP 100 T 9-12	39.6
FP 100 T 10-12	9.4	FP 100 T 9-12 DUP	29.2
FP 100 T 10-12 DUP	13.3	FP 100 T 13-16	52.8
FP 200 T 1-3	9.7	FP 100 T 17-20	49.0
FP 200 T 4-6	22.6	FP 100 T 21-24	19.7
FP 200 T 4-6 DUP	8.9	FP 200 T 1-4	32.9
FP 200 T 7-9	4.1	FP 200 T 5-8	45.3
FP 200 T 10-12	1.4	FP 200 T 9-12	24.8
		FP 200 T 9-12 DUP	36.6
		FP 200 T 13-16	0.3
		FP 200 T 17-20	8.9
		FP 200 T 21-24	10.0

Note: Numbers after the character T indicate the distance (in meters) of the firing positions from the targets.

also shows that the difference between the sample and its duplicate can be important (field duplicates are identified by the letters DUP after the sample name). In fact, in Range 1, the difference between S-A1-R1 FP 200 T 4-6 and its duplicate for the concentration of NG is 14 mg/kg (60 percent), while in Range 8, the difference is 10 mg/kg (30 percent). The distance of the firing positions did not seem to have an influence on the contamination because the concentration at 200 m is sometimes higher than at 100 m. In the first range, the NG concentration is up to 22.9 mg/kg, while in Range 8, the highest NG concentration is 52.8 mg/kg. The high variation observed between field replicates tends to indicate that the sampling approach did not succeed in overcoming the high degree of heterogeneity associated with the dispersion of contaminants. Samples built of a larger number of composites should be collected in the future at this site.

Pb and Cu were also found in concentrations higher than the ISQG soil threshold criteria (600 and 91 mg/kg, respectively). In fact, at Range 1, 9 out of 12 samples taken in the target area were contaminated with Pb (616 to 66,100 mg/kg), while at Range 8, 11 out of 18 samples showed concentrations between 600 and 1,690 mg/kg. It is interesting to note that, in these ranges, only 3 and 7 samples (Ranges 1 and 8, respectively), did not have Pb concentrations higher than the ISQG soil threshold. Pb was not found at the firing positions for both ranges. In Ranges 1 and 8, copper concentrations exceeding the ISQG soil threshold criteria were found in the target area for eight and nine samples, respectively. In the target area of Range 1, a maximum concentration of 6,740 mg/kg was found, while, for the same area in Range 8, a concentration of 21,900 mg/kg and an average of 150-200 mg/kg were found for the eight other samples. In Range 1, two samples from the firing position at 100 m showed concentrations of Cu around 95 mg/kg, while in Range 8, concentrations up to 259 mg/kg were found for seven samples at 100 m and five samples at 200 m. The last metal found in concentrations higher than the ISQG soil threshold was Sb. In fact, in Range 1, four samples collected at the target area showed high Sb concentrations: 91, 474, 720, and 932 mg/kg. Sb is used at the 2 percent level in Pb bullets to improve their hardness.

Most of the samples showing high concentrations of Cu, Pb, or/and Sb were in the upper sections (A and B). Section A was more contaminated than Section B, and Section C was less contaminated than the other two. The sand in Section A was the closest to the targets and, consequently, should receive more bullets than the other regions. As Section C is located

at the extreme bottom of the butt near the road, leaching of the contamination from the sections above is probably the only source of contamination in this section.

Leachate testing gives a good indication of the concentration of metal that can be leached to the aqueous phase. The sample was thoroughly agitated in an aqueous acidic media during 24 h and analyzed for metals as described at the online source for EPA Method 1311. The results showed no concentrations above the detection limits except for Pb. The highest concentrations of Pb (790, 580, 270, and 120 mg/L) were obtained from samples collected in the target area of Range 1.

25-Meter Outdoor Range (#24) (Pistol Range)

The samples taken at the firing positions were analyzed for energetic materials and metals, while the sand butt was only characterized for metals. In the firing positions, NG was found up to a concentration of 7 mg/kg. The distance to the firing position seemed to influence results; the farthest firing positions were the least contaminated.

The sample collected from the most elevated part of the sand butt had significant concentrations of Cu (246 mg/kg) and Pb (6720 mg/kg). The ISQG soil threshold criteria are 91 and 600 mg/kg for Cu and Pb, respectively. During training, bullets are probably fired principally into the upper part of the butt.

Anti-tank ranges

Several types of munitions are fired in these anti-tank ranges (#13 and #22). The M72 LAW rocket (66-mm), practice AT4 anti-tank rocket (84-mm), HE AT4 anti-tank rocket (84-mm), and the HE 60-mm mortar are commonly used. Table 4-3 shows some data corresponding to the kind and the number of munitions fired for the past 4 years.

Table 4-3. Approximate number of munitions fired in anti-tank ranges.

	2001	2002	2004
Range 13			
M72 LAW rockets	294	205	72
Range 22			
HE 60-mm mortars	92	0	0
M72 LAW rockets	393	373	0
HE AT4 rockets	114	84	0
Practice AT4 rockets	114	937	28

Hand-held Anti-tank (Stationary Targets) (#13)

The principal contaminant at the firing position was NG with concentrations up to 4453.1 mg/kg (Table 4-4). The concentration behind the firing point did not show a trend with distance. However, the contamination was more important behind than in front of the firing point, as observed at similar sites (Thiboutot et al. 2003b). This concentration is due to the strong back blast associated with the firing of these types of weapons. In front of the firing point, the concentrations decreased with distance from the firing positions as expected. For example, the amount of NG found between 0 and 5 m was higher than the concentration between 25 and 30 m in front of the firing point. HMX was also detected between 5 and 30 m in front of the firing point with a maximum concentration of 3.8 mg/kg. This result is unusual because HMX is not present in the propellant composition.

HMX, RDX, TNT, NG, 2ADNT, and 4ADNT were detected around the targets (Table 4-5 and Figure 4-9). High concentrations of HMX were detected (up to 1,616 mg/kg). The small quantities of RDX were associated with the use of HMX. TNT was also present with a maximum concentration of 390 mg/kg around Target 4. In general, the concentration found in TNT is lower because TNT is soluble in water and its metabolite transformation starts rapidly. For example, in Gagetown (Thiboutot et al. 2003b), the anti-tank target area showed concentrations of 22.8 mg/kg of TNT. The presence of a concentration of 390 mg/kg of TNT here might indicate a recent low-order rupture of munitions in the sampling area, and TNT would still be present in a higher proportion if limited rainfall had occurred since the dispersion of the octol. The highest HMX concentration was also detected around this target (1,616 mg/kg). Similar results were obtained in 1996 in the Wainwright anti-tank ranges characterization

Table 4-4. Concentrations (mg/kg) of NG and HMX found behind (BFP) and in front of (FFP) the firing point in anti-tank Ranges #13 and #22.

Position ¹	Range #13		Range #22
	NG, mg/kg	HMX, mg/kg	NG, mg/kg
BFP 0-5	2,520.1	n.d.	697.8
BFP 0-5 DUP ²	n.a.	n.a.	699.7
BFP 5-10	1,748.2	n.d.	368.9
BFP 10-15	2,333.8	n.d.	254.5
BFP 10-15 DUP	4,453.1	n.d.	n.a.
BFP 15-20	906.3	n.d.	240.4
BFP 20-25	1,469.5	n.d.	75.7
BFP 25-30	637.2	n.d.	44.5
FFP 0-5	272.0	n.d.	100.5
FFP 0-5 DUP	136.6	n.d.	n.a.
FFP 5-10	108.8	2.4	6.7
FFP 5-10 DUP	n.a.	n.a.	9.9
FFP 10-15	28.2	0.6	5.3
FFP 15-20	13.6	0.5	2.6
FFP 20-25	6.5	3.8	2.5
FFP 25-30	2.9	2.9	0.3

Note: n.d.: not detected and n.a.: not applicable.

¹ Numbers correspond to the distance (m) of the sample from the firing point.

² DUP for Duplicate.

Table 4-5. Metal concentrations around targets at anti-tank ranges.

Targets	Cadmium mg/kg	Chromium mg/kg	Copper mg/kg	Zinc mg/kg	Molybdenum mg/kg	Nickel mg/kg
Anti-tank Range #13						
T1	26	139	10,400	1,190	105	253
T1 DUP	22	66	4,700	760	44	94
T2	4	48	1,820	412	22	55
T3-close	16	100	4,170	811	20	84
T3-far	2	14	445	144	1	23
T4	3	20	488	258	2	19

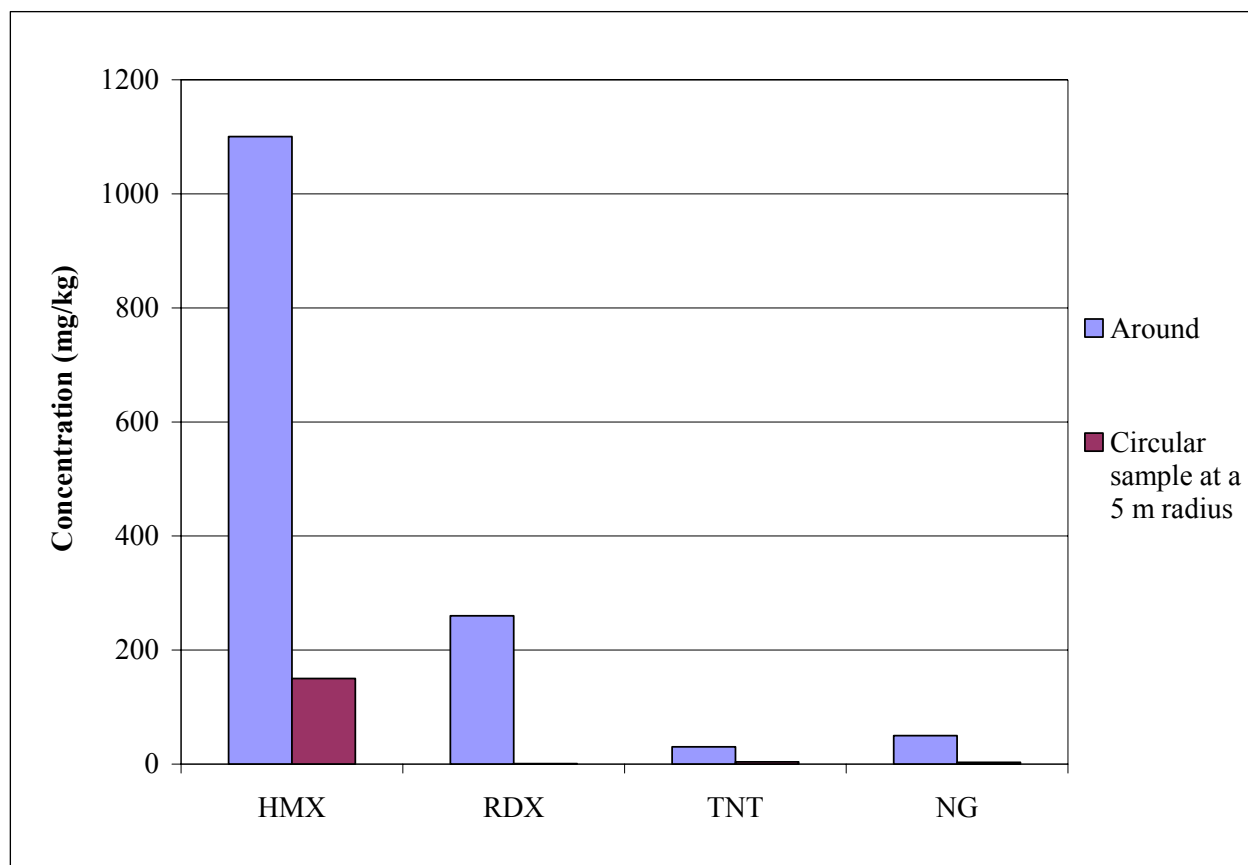

Figure 4-9. Contamination around target at Anti-tank Ranges #13 and #22.

study. In fact, HMX and TNT were found with maximum concentrations of 3,700 and 880 mg/kg, respectively. Finally, small quantities of the TNT transformation products, 2ADNT and 4ADNT, were found (maximum of 5.8 mg/kg) around targets. NG was also detected in this area. In Phase II, sampling around those targets will be repeated to confirm these results and verify whether the TNT/HMX ratio will evolve with time, as predicted. Figure 4-9 demonstrates the influence of the distance from the target on the detected concentration. Concentrations of HMX, RDX, TNT, and NG were higher directly around the target than at a 5-m radius from the target.

Five metals were detected in samples collected around the targets with concentrations higher than the ISQG soil threshold criteria (Table 4-5). Cr was found in two samples with concentrations of 100 and 139 mg/kg, Cu in six samples with a minimum and a maximum of 445 and 10,400 mg/kg, Zn in six samples with concentrations between 412 and 1190 mg/kg, Mo in two samples with concentrations of 44 and 105 mg/kg, and Ni in four samples with concentrations varying between 55 and 253 mg/kg. Finally,

two samples collected around Target 1 showed significant concentrations of Cd (22 and 26 mg/kg); the ISQG soil threshold for this metal is 22 mg/kg. Metals that do not exceed the criteria in these ranges were not included in Table 4-5.

Hand-held Anti-tank Weapon (#22)

As at Range 13, HMX, RDX, TNT, and NG were found around the four sampled targets of Range 22 (Table 4-6). Concentrations of HMX and RDX were less than in Range 13. This last observation was also made in 1996. Concentrations of HMX and TNT around targets were detected up to 60 and 3 mg/kg, as mentioned in Table 4-6, while NG was found with concentrations of 35 mg/kg. In 1996, the results obtained for HMX and TNT were 290 and 68 mg/kg, respectively.

Table 4-6. Concentration around targets at anti-tank ranges.

Targets	HMX, mg/kg	RDX, mg/kg	TNT, mg/kg	NG, mg/kg
Anti-tank Range #13				
T1	454	3	8	22
T1 DUP	294	1	4	11
T2	1,079	2	68	11
T3-close	1,192	3	28	54
T3-far	138	1	3	2
T4	1,616	14	390	3
Anti-tank Range #22				
T1	60	0.4	3	35
T2	40	0.1	2	20
T3	15	0	0.4	3
T4	30	0.2	1	20

As expected, no HMX was found at the firing point of this range. As in Range 13, the concentrations of NG were greater behind than in front of the firing point. The explanation given for Range 13 is also valid here. However, the contamination for Range 22 was less than for Range 13. The maximum concentration of NG in Range 22 was 700 mg/kg compared to 4,453 mg/kg in Range 13.

In this range, the following six metals were found with concentrations higher than the ISQG soil threshold criteria: Sb, Cr, Ni, Cu, Pb, and Zn. In

the target area, Sb and Cr were found in just one sample, each with concentrations of 59 and 94 mg/kg, respectively. Ni and Pb were detected in two samples with a maximum concentration of 54 and 1,810 mg/kg, respectively, while Cu was present in four samples (691 to 1,680 mg/kg). Finally, three samples contained high concentrations of Zn at 302, 530, and 848 mg/kg.

Vertical soil profiling

The main objective of the profiling at the firing point was to verify the vertical migration of contaminants. In Range 22, two holes were dug 60-cm deep at a distance of 2 m from each other (Figure 4-10). For each hole, one sample was collected in each 10-cm wide layer for a total of six samples. After the hole was dug completely, the sampling was started at the bottom of the hole to avoid contamination in the upper layers. Most of the samples collected in the first hole showed detectable concentrations of NG. However, establishing a trend as a function of the depth was not possible. The average concentrations of NG at the surface (between 0 and 10 cm), between 30 and 40 cm, and at the bottom (50–60 cm) were 36, 0.5, and 6.8 mg/kg. All samples collected in this hole showed NG concentrations except one (between 30 and 40 cm). No contamination was found in the second hole. Additional profiling should be conducted in the same area to improve confidence in the data.

Conclusion

In the grenade range, the maximum concentrations of RDX (6.7 mg/kg) and TNT (10.6 mg/kg) were found in the rectangular area located 20 to 25 m in front of the firing position. Data from other grenade range studies showed similar results (Jenkins et al. 2006). It would be normal to find more RDX than TNT at the surface, since degradation and transformation is greater for TNT than for RDX (Jenkins et al. 2006). As RDX is less soluble in water and does not interact well with soil, its concentration at the surface should be higher than TNT. The higher concentrations of TNT than RDX in this case can probably be explained by recent detonations of munitions containing Composition B (RDX/TNT 60/40) in the training area; the TNT did not have enough time to interact with the soil and remained intact on the surface. The second phase of the campaign will verify whether the concentration of TNT is still higher than that of RDX



Figure 4-10. Vertical sampling in one of two holes 60-cm deep at firing point in Range 22.

after a few months. The highest levels of metal analytes were found between 0 and 15 m from the firing position, where concentrations of Zn up to 1,020 mg/kg were detected.

In the demolition range, seven compounds were detected in the soil (HMX, RDX, TNT, NG, 2,4DNT, 2ADNT, and 4ADNT), while concentrations lower than the ISQG threshold were detected for all metal analytes. RDX and TNT were the two most important contaminants in this area with maximum concentrations of approximately 14 mg/kg for both. For RDX, this value is similar to those obtained for other ranges studied in this work. For TNT, however, this value is low when compared with the result obtained for Range 13 where 390 mg/kg of TNT was found in the target area.

All samples from the small arms ranges showed the presence of NG up to 52.8 mg/kg. However, the firing positions in the anti-tank ranges were the most contaminated. A maximum concentration of 4,453.1 mg/kg was found behind the firing positions; the zone in front of the firing positions showed lower concentrations (maximum of 136.6 mg/kg). 2,4DNT was

also found at the firing point of Ranges 1, 8, and 16 at concentrations up to 0.5, 1.1, and 10 mg/kg, respectively. When the concentration of 2,4DNT was around 10 mg/kg, 2,6DNT was also detected at very low concentrations (maximum of 0.7 mg/kg in Range 16). HMX detected (3.8 mg/kg) in front of the firing point in Range 13 will be verified in Phase II, since the presence of HMX outside of the impact area is unusual.

NG was found in several ranges at the various firing points sampled. For example, in Range 12 a maximum of 4 mg/kg of NG was detected, while in Range 16 concentrations up to 92.7 mg/kg were found at the firing point. In Ranges 21 and 24, 12.5 and 7 mg/kg of NG were found, respectively, always at the firing point. In the target area, HMX, RDX, and TNT were the major contaminants as observed at similar sites (Jenkins et al. 2006). Range 21 showed concentrations of 34, 7.5, and 4.6 mg/kg for HMX, RDX, and TNT, respectively. In anti-tank ranges the maximum concentrations of HMX, RDX, and TNT were 1192, 14, and 390 mg/kg, respectively. The concentrations of contaminants were significantly higher closer to the target. NG was also detected in the target area of the two anti-tank ranges (13 and 22) and Range 21, which showed concentrations of 54, 35, and 1.8 mg/kg, respectively. This result can be explained by the incomplete combustion of the propellant. The distance of the targets from the firing point did not influence the magnitude of the contamination. In fact, the highest concentrations of contaminants were sometimes found at the farthest targets.

The target area for Ranges 13 and 22, the two anti-tank ranges, showed higher concentrations of HMX than of TNT. In fact, HMX and TNT should be in the proportion of 70/30 in the soil, as in the munitions; however, the results showed a ratio of HMX to TNT between 98/2 and 80/20 (Table 4-6). This can be partially explained by the fast degradation rate and strong binding capacity of TNT and its metabolites. TNT thus vanishes rapidly from the surface soil, contrary to HMX, which is less soluble. The vertical sampling study done in Range 21 showed that NG was found at a depth of 60 cm, but no trend was observed with depth.

The highest concentrations of Zn were found in Range 2 (up to 1,000 mg/kg 0-15 m from the firing position) and in Range 13 (anti-tank range) of 1,190 mg/kg. Pb up to 66,100 mg/kg was found at small arms Ranges 1 and 8 at the target area. In Range 24 (small arms range), 6,720 mg/kg of lead was found in the sand butt (the target). Samples from

the dump site and the anti-tank range showed maximum concentrations of Cu of 7,220 and 10,400 mg/kg, respectively, while lower concentrations were found in Range 21 (172 mg/kg) and in Range 24 (246 mg/kg). Sb was also detected in small arms and anti-tank ranges with a maximum of 932 and 59 mg/kg, respectively. Finally, Cr, Ni, Mo, and Cd were detected in Anti-tank Range #13 with maximum concentrations of 139, 105, 253, and 26 mg/kg, respectively.

Leachate testing of the soil samples collected in the target zones of small arms ranges showed high concentrations of Pb (up to 790 mg/kg). This result means that lead could migrate into the groundwater. Water in proximity to these firing points must be closely monitored.

In summary, this study demonstrated that the accumulation of energetic materials and metals due to firing activities at WATC Wainwright is comparable to what was observed in similar ranges across Canada. The most impacted range was Anti-tank Range #13. High concentrations of energetic materials were found at the firing position (NG) and around targets (HMX and TNT). The high levels of NG at the firing position represent a concern for the DND since military personnel can be exposed to this compound. The deposition pattern of gun powder residues in firing positions has been studied, and remediation methods are under consideration. The highest concentration of Pb was detected in Range 1, a small arms range. Metal levels higher than the MBG were found in three biomass samples from Range 1 (Sb, Cu, and Pb), in two from Range 16 (Cu and Pb), and in one from the Vernonburg dump ammunition site (Cu). DRDC Valcartier will conduct Phase II of the study to complete the characterization of the surface soil and vegetation for metals and energetic materials. This campaign will also allow the sampling of additional ranges and confirmation of the results obtained during this first phase.

References

- Ampleman, G., S. Thiboutot, A. Gagnon, A. Marois, R. Martel, and R. Lefebvre. 1998. *Study of the impacts of OB/OD activity on soils and groundwater at the destruction area in CFAD Dundurn*. Defense Research Establishment Valcartier (DREV) R-9827.
- Ampleman, G., S. Thiboutot, J. Lewis, A. Marois, A. Gagnon, M. Bouchard, R. Martel, R. Lefebvre, C. Gauthier, J. M. Ballard, T. Jenkins, T. Ranney, and J. Pennington. 2003. *Evaluation of the impacts of live fire training at CFB Shilo (Final report)*. TR 2003-066. Valcartier, Quebec: Defence Research and Development Canada-Valcartier (DRDC-Valcartier).

- Ampleman, G., S. Thiboutot, S. Désilets, A. Gagnon, and A. Marois. 2000. *Evaluation of the soils contamination by explosives at CFB Chilliwack and CFAD Rocky Point*. DREV Report TR-2000-103. Valcartier, Quebec: DRDC-Valcartier.
- Arel, N., R. Martel, R. Lefebvre, S. Thiboutot, and G. Ampleman. 2004. Dissolved energetic material transport in the Vadose Zone at the Arnhem Anti-tank Range, CFB Valcartier, Canada. *Proceedings of the 2002 Denver Annual Meeting of the Geological Society of America*.
- Brannon, J. M., T. F. Jenkins, L. V. Parker, P. Deliman, J. A. Gerald, C. Ruiz, B. Porter, and W. M. Davis. 2000. *Procedures for determining integrity of UXO and explosives soil contamination at firing ranges*. ERDC TR-00-4 (see also ERDC/CRREL MP-01-5604. Vicksburg, MS: U.S. Army Engineer Research and Development Center.
- Checkai, R. T., M. A. Major, R. O. Nwanguma, C. T. Phillips, and M. C. Sadusky. 1993. *Transport and fate of nitroaromatic and nitramine explosives in soils from open burning/open detonation operations*. ERDEC-TR-136. Edgewood Research Development and Engineering Center.
- Cragin, J. H., D. C. Legget, B. T. Foley, and P. W. Schumacher. 1985. *TNT, RDX and HMX explosives in soils and sediments, analysis techniques and drying losses*. Report No. AMX-TH-TE-FR-85038. Aberdeen Proving Ground, MD: U.S. Army Toxic and Hazardous Materials Agency (USATHMA).
- Fellows, R. S., S. D. Harvey, and D. A. Cataldo. 1992. *An evaluation of the environmental fate and behaviour of munitions material (TNT metabolites) in soil and plant system*. Contract DE-AC06-76RLO 1830. Richland, WA: Battelle Pacific Northwest Laboratories.
- Hewitt, A. D., and M. E. Walsh. 2003. *On-site processing and subsampling of surface soils samples for the analysis of explosives*. ERDC TR-03-14. Hanover, NH: U.S. Army Engineer Research and Development Center.
- Hewitt, A. D., T. F. Jenkins, T. A. Ranney, D. Lambert, and N. M. Perron. 2004. *Characterization of explosives residues at military firing ranges: Schofield Barracks and Pohakuloa Training Area, Chapter 3*. In Pennington et al. 2004. *Distribution and fate of energetics on DoD test and training ranges: Report 4*. ERDC-TR-04-4. Vicksburg, MS: U.S. Army Engineer Research and Development Center.
- Jenkins, T. F., and M. E. Walsh. 1987. *Development of an analytical method for explosive residues in soil*. CRREL Report 87-7. USATHMA Report # AMXTH-TE-FR-86102.
- Jenkins, T. F., C. Bartolini, and T.A. Ranney. 2003. *Stability of CL-20, TNAZ, HMX, RDX, NG and PETN in moist, unsaturated soil*. ERDC/CRREL TR-03-7. Hanover, NH: U.S. Army Engineer Research and Development Center.
- Jenkins, T. F., C. L. Grant, G. S. Brar, P. G. Thorne, P. W. Schumacher, and T. A. Ranney. 1997a. Assessment of sampling error associated with the collection and analysis of soil samples at explosives contaminated sites. *Field Anal. Chem. Tech.* 1:151-163.

- Jenkins, T. F., C. L. Grant, M. E. Walsh, P. G. Thorne, S. Thiboutot, G. Ampleman, and T. A. Ranney. 1999. Coping with spatial heterogeneity effects on sampling and analysis at an HMX - Contaminated anti-tank firing range. *Field Analytical Chemistry and Technology* 3(1):19-28.
- Jenkins, T. F., J. C. Pennington, T. A. Ranney, T. E. Berry, Jr., P. H. Miyares, M. E. Walsh, A. D. Hewitt, N. Perron, L. V. Parker, C. A. Hayes, and Maj. E. Wahlgren. 2001. *Characterization of explosives contamination at military firing ranges*. ERDC TR-01-05. Hanover, NH: U.S. Army Engineer Research and Development Center.
- Jenkins, T. F., M. E. Walsh, P. G. Thorne, P. H. Miyares, T. A. Ranney, C. L. Grant, and J. Esparza. 1998a. *Site characterization for explosives contamination at a military firing range impact area*. CRREL Special Report 98-9. Hanover, NH: U.S. Army Cold Regions Research and Engineering Laboratory.
- Jenkins, T. F., M. E. Walsh, P. G. Thorne, S. Thiboutot, G. Ampleman, T. A. Ranney, and C. L. Grant. 1997b. *Assessment of sampling error associated with collection and analysis of soil samples at firing ranges contaminated with HMX*. CRREL Special Report 97-22. Hanover, NH: U.S. Army Cold Region Research and Engineering Laboratory.
- Jenkins T. F., S. Thiboutot, G. Ampleman, A. D. Hewitt, M. E. Walsh, T. A. Ranney, C. A. Ramsey, C. L. Grant, S. Bigl, and J. C. Pennington. 2006. Identity and distribution of residues of energetic compounds at military live-fire training ranges. *Chemosphere* 63:1280-1290.
- Jenkins, T. F., S. Thiboutot, G. Ampleman, C. L. Grant, P. G. Thorne, M. E. Walsh, J. R. Esparza, T. A. Ranney, and M. H. Stutz. 1998b. Sampling and analytical considerations for site characterization at military firing ranges. MP-02-5774, Proceedings of the 2nd Biennial International Conference on Chemical Measurement and Monitoring of the Environment, May 11-14, 1998, Ottawa, Canada. *EnviroAnalysis '98*, ed. Ray Clement and Bob Burk, 37-42. Ottawa, Ontario: Carleton University.
- Marois, A., A. Gagnon, S. Thiboutot, and G. Ampleman. 2004. *Caractérisation des sols de surface dans les secteurs d'entraînement, Base des Forces Canadiennes, Valcartier*. Rapport technique. DRDC-RT-2004-206. Valcartier, Quebec: DRDC. Available in French only.
- Miyares P. H., and T. F. Jenkins. 2000. *Estimating the half-lives of key components of the chemical vapor signature of land mines*. ERDC/CRREL TR-00-17. Hanover, NH: U.S. Army Engineer Research and Development Center.
- Pennington, J. C., T. F. Jenkins, G. Ampleman, S. Thiboutot, J. M. Brannon, J. Lewis, J. E. Delaney, J. Clausen, A. D. Hewitt, M. A. Hollander, C. A. Hayes, J. A. Stark, A. Marois, S. Brochu, H. O. Dinh, D. Lambert, R. Martel, P. Brousseau, N. M. Perron, R. Lefebvre, W. Davis, T. A. Ranney, C. Gauthier, S. Taylor, and J. M. Ballard. 2003. *Distribution and fate of energetics on DoD test and training ranges: Interim Report 3*. ERDC TR-03-02. Vicksburg, MS: U.S. Army Engineer Research and Development Center.

- Pennington, J. C., T. F. Jenkins, G. Ampleman, S. Thiboutot, J. M. Brannon, J. Lynch, T. A. Ranney, J. A. Stark, M. E. Walsh, J. Lewis, C. A. Hayes, J. E. Mirecki, A. D. Hewitt, N. Perron, J. Clausen, and J. J. Delfino. 2002. *Distribution and fate of energetics on DoD test and training ranges: Interim Report 2*. ERDC TR-02-8. Vicksburg, MS: U.S. Army Engineer Research and Development Center.
- Pennington, J. C., T. F. Jenkins, J. M. Brannon, J. Lynch, T. A. Ranney, T. E. Berry, Jr., C. A. Hayes, P. H. Miyares, M. E. Walsh, A. D. Hewitt, N. Perron, and J. J. Delfino. 2001. *Distributional and fate of energetics on DoD test and training ranges: Interim Report 1*. ERDC TR-01-13. Vicksburg, MS: U.S. Army Engineer Research and Development Center.
- Selim, H. M., and I. K. Iskandar. 1994. *Sorption-desorption and transport of TNT and RDX in soils*. CRREL Report AD-A-285-570. Hanover, NH: U.S. Army Cold Regions Research and Engineering Laboratory.
- Stamfli, N., M. A. Carrier, R. Martel, and R. Lefebvre. 2003. *Initial study of terrestrial forces training sites potentially contaminated by energetic materials, CFB Gagetown*. Prepared for DREV, INRS-ETE report.
- Thiboutot, S., G. Ampleman, A. Gagnon, A. Marois, T. F. Jenkins, M. E. Walsh, P. G. Thorne, and T. A. Ranney. 1998b. *Characterization of anti-tank firing ranges at CFB Valcartier*. DREV R-9809. WATC Wainwright and CFAD Dundurn.
- Thiboutot, S., G. Ampleman, A. Gagnon, and A. Marois. 2000. *Characterization of an unexploded ordnance contaminated range (Tracadie Range) for potential contamination by energetic materials*. DREV Report TR-2000-102. Valcartier, Quebec: DRDC-Valcartier.
- Thiboutot, S., G. Ampleman, A. Hamel, J. M. Ballard, R. Martel, R. Lefebvre, and S. Downe. 2003a. *Research on the environmental conditions of groundwater and surface water prevailing in the training area at CFB Gagetown, New Brunswick*. TR-2003-016. Valcartier, Quebec; DRDC Valcartier.
- Thiboutot, S., G. Ampleman, and A. Hewitt. 2002. *Guide for characterization of sites contaminated with energetic materials*. ERDC/CRREL TR-02-01. Hanover, NH: U.S. Army Engineer Research and Development Center.
- Thiboutot, S., G. Ampleman, J. Lewis, D. Faucher, A. Marois, R. Martel, J. M. Ballard, S. Downe, T. Jenkins, and A. Hewitt. 2003b. *Environmental conditions of surface soils and biomass prevailing in the training area at CFB Gagetown, New-Brunswick*. TR-2003-152. Valcartier, Quebec: DRDC Valcartier.
- Thiboutot, S., G. Ampleman, P. Dubé, T. F. Jenkins, M. E. Walsh, J. Hawari, B. Spencer, and L. Paquet. 1998a. *Protocol for the characterization of explosives contaminated sites*. DREV R-9721.
- Thiboutot, S., G. Ampleman, R. Martel, D. Paradis, and R. Lefebvre. 2001. *Environmental characterization of Canadian Forces Base Shilo Training Area (Battleruns) following GATES Closure*. DREV TR 2001-126.

- Thiboutot, S., G. Ampleman, T. F. Jenkins, M. E. Walsh, P. G. Thorne, T. A. Ranney, and G. L. Grant. 1997. Assessment of sampling strategy for explosives-contaminated soils. Paper # 94-WP 101.08. *Proceedings of the 90th Annual Air and Waste Management Society Meeting*. Toronto, Canada.
- U.S. Environmental Protection Agency (USEPA). 1993. *Approaches for the remediation of federal facility sites contaminated with explosives or radioactive wastes*. EPA Handbook # EPA/625/R-93/013.
- _____. 2000. *Administrative order for response action*. EPA Docket Number SDWA-1-2000-0014. USEPA Region 1 in the Matter of Training Range and Impact Area. Boston, MA: Massachusetts Military Reservation.
- Walsh, M. E. 2001. Determination of nitroaromatic, nitramine, and nitrate ester explosives in soil by gas chromatography and an electron capture detector. *Talanta* 54: 427-438. ERDC/CRREL MP-02-5774. Hanover, NH: U.S. Army Engineer Research and Development Center.
- Walsh, M. E., and T. A. Ranney. 1998a. *Determination of nitroaromatic, nitramine, and nitrate ester explosives in water using solid phase extraction and GC-ECD*. CRREL Report 98-2. Hanover, NH: U.S. Army Cold Regions Research and Engineering Laboratory.
- _____. 1998b. Determination of nitroaromatic, nitramine, and nitrate ester explosives in water using solid-phase extraction and gas chromatography-electron capture detection: Comparison with high-performance liquid chromatography. *Journal of Chromatographic Science* 36(8):406-416.
- _____. 1999. *Determination of nitroaromatic, nitramine, and nitrate ester explosives in soils using GC-ECD*. CRREL Report 99-12. Hanover, NH: U.S. Army Cold Regions Research and Engineering Laboratory.
- Walsh, M. E., C. A. Ramsey, and T. F. Jenkins. 2002. The effect of particle size reduction by grinding on sub-sampling variance for explosives residues in soil. *Chemosphere* 49:1267-1273.
- Walsh, M. E., C. M. Collins, A. D. Hewitt, M. R. Walsh, T. F. Jenkins, J. Stark, A. Gelvin, T. S. Douglas, N. Perron, D. Lambert, R. Bailey, and K. Myers. 2004. *Range characterization studies at Donnelly Training Area, Alaska: 2001 and 2002*. ERDC/CRREL TR-04-3. Hanover, NH: U.S. Army Engineer Research and Development Center.
- Walsh, M. E., C. M. Collins, C. H. Racine, T. F. Jenkins, A. B. Gelvin, and T. A. Ranney. 2001. *Sampling for explosives residues at Fort Greely, Alaska, Reconnaissance visit July 2000*. ERDC/CRREL TR-01-15. Hanover, NH: U.S. Army Engineer Research and Development Center.

Online Sources

- EPA Method 3050B. Acid digestion of sediments, sludge and soils, Rev. 2, December 1996. <http://www.epa.gov/epaoswer/hazwaste/test/pdfs/3050b.pdf>

EPA Method 8330. Nitroaromatics and nitramines by high performance liquid chromatography (HPLC), September 1994.

<http://www.epa.gov/epaoswer/hazwaste/test/pdfs/8330.pdf>

EPA Method 1311. Toxicity characteristic leaching procedure, July 1992.

<http://www.epa.gov/epaoswer/hazwaste/test/pdfs/1311.pdf>

5 Sampling Studies at an Air Force Live-Fire Bombing Range Impact Area

Introduction

Air Force ranges are very large, generally hundreds of square kilometers in size, but the areas used for training with HE-containing bombs is much smaller, generally only tens of hectares. Very little research has been conducted at live-fire bombing ranges to assess the levels of residue accumulation, to investigate the best approach for collecting representative soil samples, or to study methods used to process and subsample these soil samples in the laboratory.

Because bombs contain a much larger mass of explosive than artillery rounds, craters from bomb detonations are very large. The Air Force conducts regularly scheduled range maintenance activities during which craters are often filled, duds are detonated using C4 explosive, and larger-than-golf-ball-size chunks of HE observed on the surface are gathered and destroyed by detonating with C4.

The HE present in U.S. and Canadian Air Force bombs is usually either tritonal (TNT, aluminum powder) or H-6 (TNT, RDX, aluminum powder). Some older bombs contained TNT only. Although experiments have not been conducted to document the residue deposited when a bomb detonates as designed, experimental results for large artillery rounds indicate that large-mass high-explosive detonations are very efficient, dispersing only microgram-to-milligram quantities of residue when they explode with a high-order detonation (Hewitt et al. 2003, M. R. Walsh et al. 2005).

One Canadian Armed Forces installation where research has been conducted is Cold Lake Air Weapons Range (CLAWR) in Alberta, Canada. At CLAWR, Ampleman et al. (2003, 2004) collected soil samples at the Shaver River Range, the only live-fire bombing range on the installation. Here 250-, 500-, and 1,000-lb HE-containing bombs are dropped regularly at a stationary tank target and the surface of the range is tilled to reduce vegetation, thus alleviating the risk of forest fires in this remote area.

To study the distribution of energetic residues around the target at this range, Ampleman used a segmented halo sampling design. Three rings at radii of 10, 30, and 50 m around the single target were established and subdivided into 26 sections as shown in Figure 5-1. Two of these sections were 157 m² and the others were 314 m² in area. Thirty-increment surface soil samples (0- to 5-cm depth) were collected in each of the 26 sections (Figure 5-2). Several field replicate samples also were collected. A 10-m × 10-m grid also was established about 15 m from the target. Four replicate 30-increment samples were collected in this grid using a totally random sampling design. This grid also was subdivided into 100 1-m × 1-m cells and a single discrete sample was collected in each. Also, a set of seven discrete surface soil samples was collected using a wheel sampling pattern (Jenkins et al. 1997) to further investigate the short-range heterogeneity in residue concentration near the target.

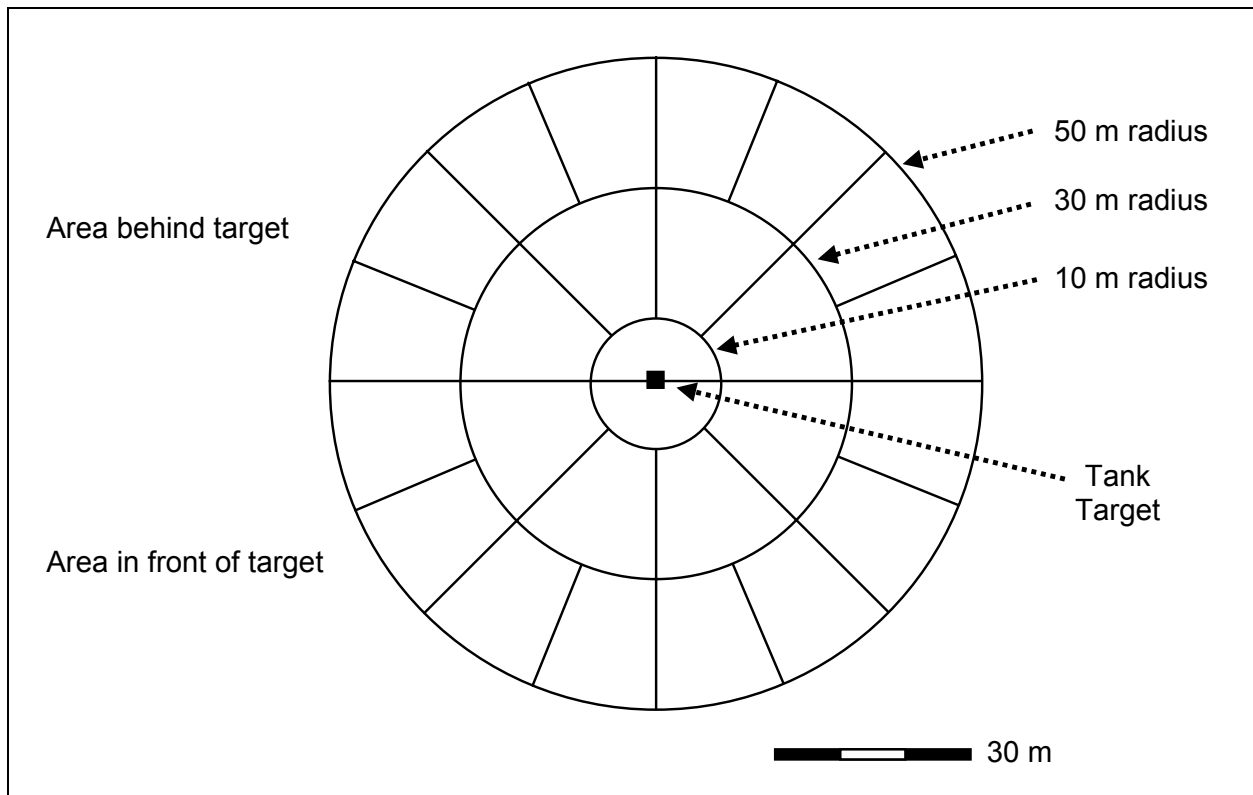

Figure 5-1. Sampling design used by Ampleman et al. (2003) at Cold Lake Air Weapons Range live-fire bombing range, resulting in 26 sections around a target.



Figure 5-2. Establishing circular sampling pattern surrounding a tank target at live-fire bombing range impact area at Cold Lake Air Weapons Range.

TNT was found to be the residue present at the highest concentration at the Shaver River Range. RDX concentrations generally were below detection in these samples with only an occasional detection at low concentration. Because of the lack of RDX in these samples, we believe that the residue observed at CLAWR is from tritonal-containing bombs that underwent low-order detonations. Communication with personnel at CLAWR indicates that several low-order bomb detonations are observed each year at the Shaver River Range.¹ Several small pieces of tritonal were observed on the surface of this range during sampling.

TNT concentrations among the 26 multi-increment section samples around the target ranged from 2.2 to 408 mg/kg for samples collected in 2002 (Ampleman et al. 2003) and from 1.3 to 165 mg/kg for samples collected in 2003 (Ampleman et al. 2004). Duplicate soil samples for nine different sections were collected over these 2 years, and the TNT concentrations for the duplicates were always within a factor of three, except for one sample collected in 2003, where they differed by a factor of 7.2. The

¹ Personal communication, Jeffrey Lewis, DRDC-Valcartier, 2005.

mean concentration for four replicate samples for the 10-m × 10-m grid was 10.7 mg/kg, with an RSD of 5.5 percent. The TNT concentrations in the 100 discrete samples varied from 0.38 to 290 mg/kg within this same 10-m × 10-m area. The range in TNT concentration for the seven discrete samples varied from 6.6 to 62 mg/kg, even though these samples were collected within a 1.5-m-diameter circle.

The level of agreement among replicate multi-increment samples at this range was excellent; this may be the result of a management practice in which the surface of the soil is periodically tilled. Doing so tends to mix the soil and homogenize the residue concentrations better than if tilling were not done. Even so, the variability among discrete samples collected in close proximity indicates that short-range heterogeneity remains very large.

Objectives

This research project was conducted to assess the reproducibility of a sampling strategy employing a systematic-random design and multi-increment samples for the collection of representative soil samples for grids as large as 10,000 m² (one hectare) where HE-containing bomb detonations occur. Samples also were obtained from a number of large craters, and from an arroyo downhill of the live-fire bombing ranges. The arroyo samples were used to assess whether surface runoff could transport residues of energetic compounds off range. An additional set of samples was obtained to estimate the level of accumulation of residues at a demolition range where practice bombs are detonated with C4 to ensure that they contain no energetic compounds prior to recycling of the metal casings.

Methods

Soil sampling

Soil sampling was conducted at the live-fire bombing range impact area and the demolition range at Holloman AFB, Alamogordo, New Mexico, from 3 to 5 May 2005. GPS positions for all sampling locations were obtained using a Trimble ProXR global positioning system with a TSC1 data collector, which has about 1-m accuracy. Several samples also were collected at the demolition range. A second set of samples from the demolition range was collected on 11 May 2005.

Soil samples were collected from several-sized grids (1 m × 1 m, 10 m × 10 m, 100 m × 100 m) within craters and along an arroyo that was downslope of the impact area on a live-fire bombing range. Several additional samples were collected at a small demolition range. All soil samples were collected using metal scoops (AMS). The scoops were cleaned with deionized water, wiped with a disposable paper towel, and rinsed with acetone between samples.

Within craters, arroyos, square grids, and at the demolition range, soil samples were collected by combining multiple increments from the surface to a 2.5-cm depth and placed in clean polyethylene bags (KNF Clean Room Products Corporation). The number of increments for a given sample varied from 30 to 100 depending on the size of the area being sampled. Sample masses varied from 1 to 5 kg.

Individual increments within a grid were collected using a systematic sampling pattern with a random starting point (Hewitt et al. 2005). This sampling design is referred to as a systematic-random design. This was accomplished by walking from one corner of the grid systematically back and forth across the entire grid area, collecting an increment of soil every so many paces, depending on the grid size and number of increments to be collected (Figure 5-3). Within arroyos, samples were collected linearly along the bottom in areas where deposition of particles from runoff was expected, and where standing water would tend to deposit solutes as the water evaporated. Individual increments were collected from a 10-m length, 5 m on either side of the designated location. Craters were sampled by starting at a random location at the top edge and proceeding in a spiral pattern from the top to bottom, collecting individual increments from the side walls and bottom.

One 10-m × 10-m grid was divided into 100 cells (1 m × 1 m) and a discrete soil sample was collected from an area near the center of each cell (Figure 5-4). Within six of these 1-m × 1-m cells, nine separate discrete surface soil samples were also collected. We divided a second 10-m × 10-m grid into 25 2-m × 2-m cells and collected a discrete sample near the center of each cell. All discrete soil samples were collected from the top 2.5 cm of soil and placed in Ziploc plastic bags. Several profile samples also were collected within these cells and in the lowest lying location within the arroyo at depths as deep as 40 cm below surface. These samples were collected using stainless steel scoops. After each depth increment was

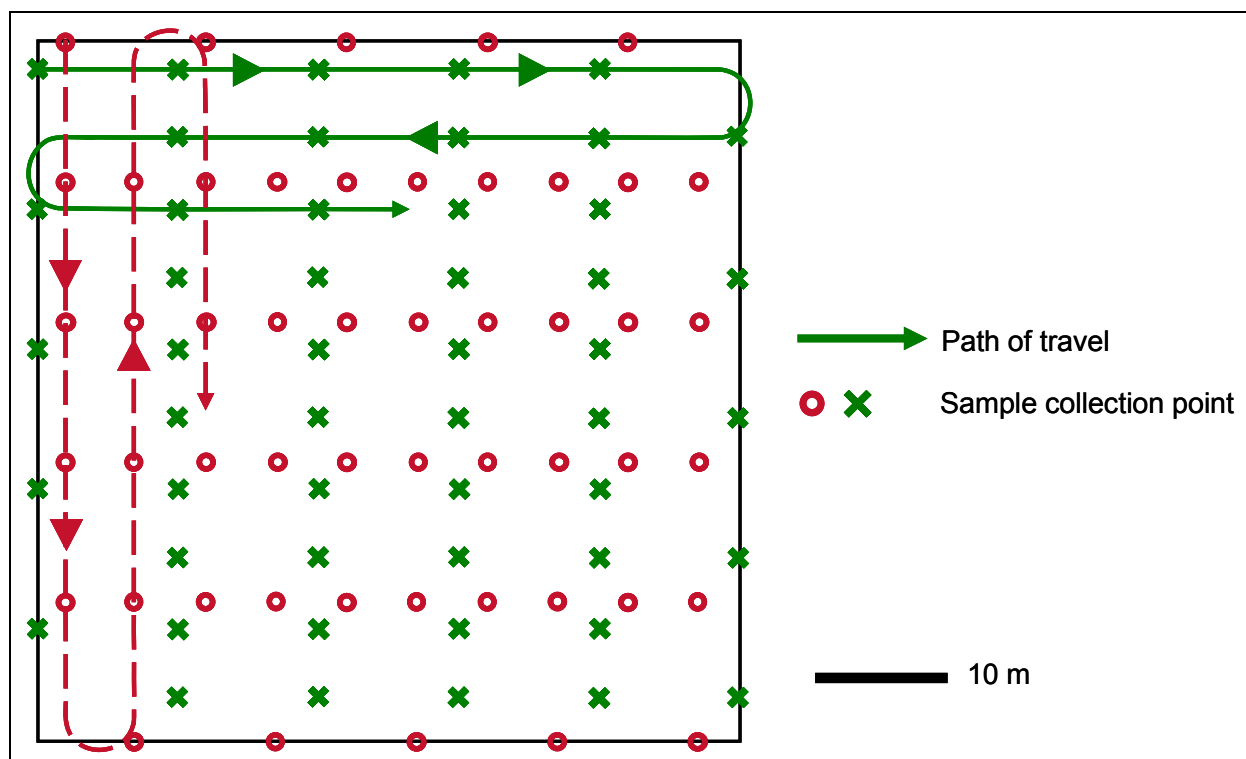

Figure 5-3. Systematic-random 50-increment sampling pattern used for collecting samples in grid areas.

collected, the soil was carefully swept away from the hole to minimize any deposition from above as deeper soil was collected.

Sample processing and subsampling

All soil samples were returned to CRREL by overnight carrier. Multi-increment soil samples were spread out on trays and allowed to air dry. Discrete samples were placed in 4-oz glass jars and air dried. Each sample was then passed through a 10-mesh (2-mm) sieve in its entirety to remove oversized material.

For the multi-increment samples, the entire < 2-mm fraction was ground on a LabTech Essa LM2 (LabTech Essa Pty. Ltd., Bassendean, WA, Australia) puck-mill grinder for 90 seconds, thereby reducing the particle size of the material to a flour (< 75 μm). After grinding, samples were mixed thoroughly and spread to form a 1-cm-thick layer, and subsamples were obtained by collecting 30 increments randomly through the entire thickness of the layer of ground material. Each subsample (about 10 g) was placed in a 2-oz jar and extracted on a shaker table for 18 hours using 20 mL of acetonitrile (AcN).

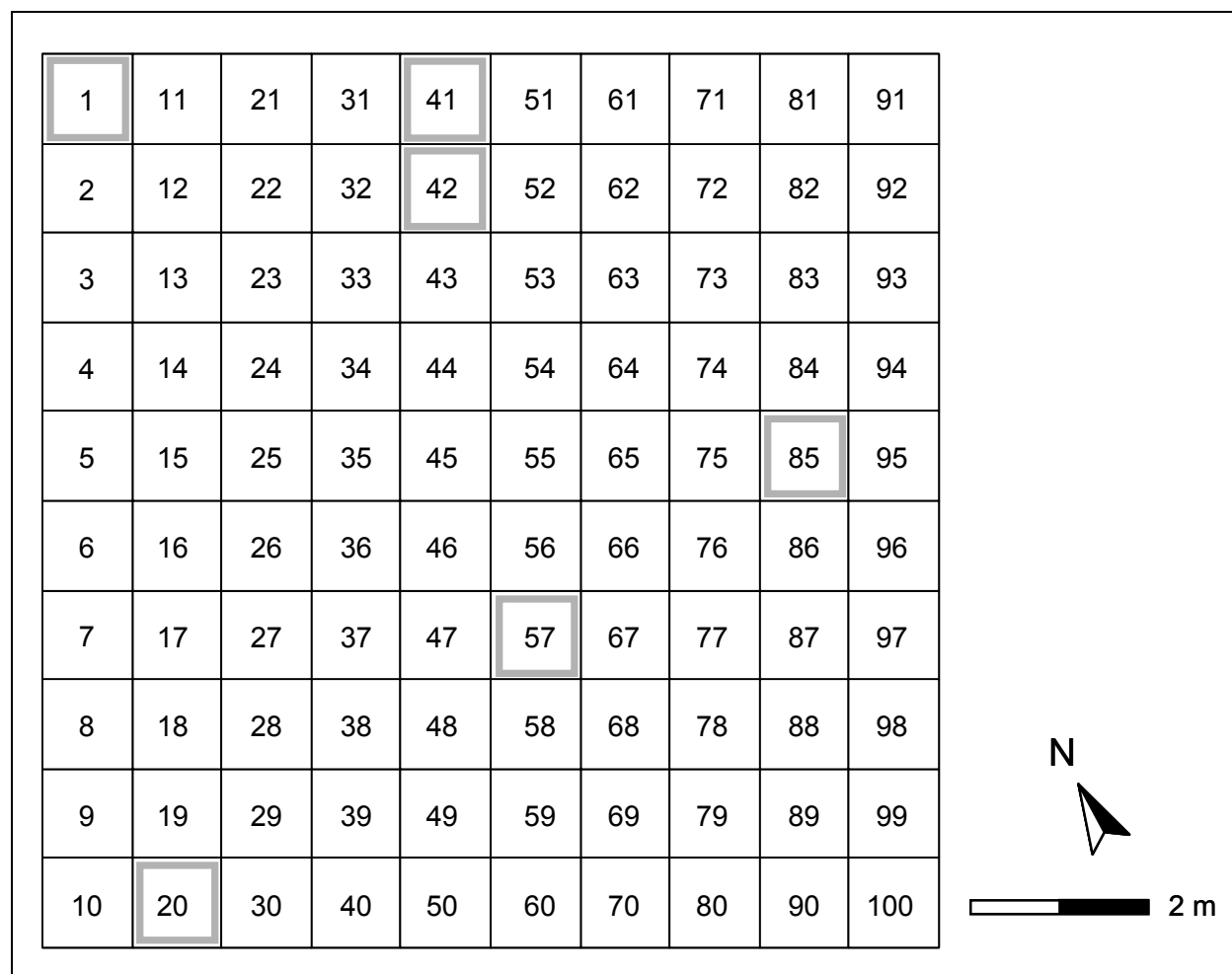

Figure 5-4. Layout of the 100 cells (1-m × 1-m) within Grid A near 2,000-lb bomb crater at Holloman Air Force Base. Gray-outlined cells were selected for collection of nine discrete samples within each 1-m cell.

For the discrete samples, the entire < 2-mm portion was weighed in a 4-oz jar and a volume of AcN (in mL) about twice the mass of soil (in g) was added. These samples were also extracted on the shaker table for 18 hours. All extracts were filtered by passing each through a Millex-FH PTFE 0.45 µm syringe filter (Millipore Corp.). For GC-ECD analysis, this extract was injected without further dilution. For RP-HPLC-UV analysis, this extract was diluted 1 to 4 with deionized water to match the solvent strength of the HPLC eluent.

Extract analysis

All sample extracts were analyzed using RP-HPLC-UV according to the general procedures outlined in EPA SW846 Method 8330 (USEPA 1994). Analysis was conducted on a modular RP-HPLC system from Thermo

Finnigan composed of a SpectraSYSTEM Model P1000 isocratic pump, a SpectraSYSTEM UV2000 dual wavelength UV/VS absorbance detector set at 210 and 254 nm (cell path 1 cm), and a SpectraSYSTEM AS300 auto-sampler. Samples were introduced by overfilling a 100- μ L sampling loop. Separations were made on a 15-cm \times 3.9-mm (4- μ m) NovaPak C-8 column (Waters Chromatography Division, Milford, Massachusetts) maintained at 28 °C and eluted with 15:85 isopropanol/water (v/v) at 1.4-mL/min. Concentrations were estimated from peak heights compared to commercial multi-analyte standards (Restek). Reporting limits for RP-HPLC-UV analyses on a soil weight basis were 0.01 mg/kg for all target analytes. The target analytes for RP-HPLC-UV analyses were the 14 energetic compounds of EPA Method 8330 with the addition of nitroglycerin and PETN.

Selected sample extracts were analyzed by GC-ECD according to EPA SW846 Method 8095 (USEPA 1999). These were either extracts where analyte concentrations were near or below the detection limits for the RP-HPLC-UV method, or where additional analyte confirmation was desired.

The GC-ECD analyses were conducted on an HP 6890 GC equipped with a micro ECD detector. Direct injection of 1 μ L of soil extract was made into a purged packed inlet port (250 °C) equipped with a deactivated Restek Uniliner. Primary separation was conducted on a 6-m- \times 0.53-mm-ID fused-silica column, with a 0.5- μ m film thickness of 5 percent diphenyl-95 percent dimethyl polysilicate (Rtx-5, Restek, Bellefonte, Pennsylvania). The GC oven was temperature-programmed as follows: 100 °C for 2 min, 10 °C/min ramp to 280 °C. The carrier gas was hydrogen at 10 mL/min (linear velocity approximately 90 cm/sec). The ECD detector temperature was 310 °C and the makeup gas was nitrogen flowing at 45 mL/min. All GC-ECD samples were reanalyzed on a confirmation column, 6-m \times 0.53-mm ID, having a 1.5- μ m film thickness of a proprietary polymer (Rtx-TNT-2 from Restek). The GC oven was temperature-programmed as follows: 130 °C for 1 min, 10 °C/min ramp to 160 °C, followed by a 30 °C/min ramp to 270 °C, which is then held for 2.33 min. The carrier gas was hydrogen at 15 mL/min (linear velocity approximately 147 cm/sec) and the nitrogen makeup gas was flowing at 60 mL/min. Inlet and detector temperatures were the same as above. Multi-analyte standards were purchased from Restek and the instrument was calibrated over five concentrations. The reporting limits for GC-ECD analysis on a soil concentration basis were 0.01 mg/kg.

Quality Assurance/Quality Control (QA/QC)

Replicate soil samples from eight sampling areas were obtained at the same time, often by different individuals. Triplicate multi-increment samples were collected for seven areas, but only duplicates were collected for one area. These samples provide an assessment of total characterization error because they include components from sampling, sample processing, subsampling, extraction, and determination. Triplicate laboratory subsamples were analyzed from 12 different multi-increment samples to assess the error associated with sample processing, subsampling, extraction, and determination.

Six blank soil samples were processed and analyzed along with those from the range to assess the potential carryover between samples. Three matrix spiked samples were prepared and analyzed to estimate analyte recovery for a soil sample from this site.

Results and discussion

Crater from a low-order 2000-lb bomb

During an initial survey of the live-fire bombing range at Holloman Air Force Base (HAFB), an area with a very large number of pieces of explosive lying on the surface was observed. Further investigation of the area revealed a 2000-lb bomb with most of its casing intact near the bottom of a large crater. The EOD team believed that the bomb originally had been a dud. Then a nearby explosion of a second bomb ruptured this bomb's side wall, resulting in a low-order detonation and dispersing chunks of explosive in a direction uphill (southeast) from the crater (Figure 5-5). Inspection of the surface southeast of this crater revealed hundreds of small pieces of explosive fill scattered over the soil surface for tens of meters in that direction. However, no pieces were observed on the surface within the crater. Subsequent analysis indicated that these chunks of explosive were tritonal (TNT and aluminum). Diagrams of the area investigated at HAFB are shown in Figures 5-6 and 5-7. The largest craters delineated in these diagrams were the ones we sampled; hundreds of other craters were present in the area depicted by these two figures.



Figure 5-5. Sampling in front of low-order 2,000-lb bomb in crater at Holloman Air Force Base.

Triplicate 50-increment surface soil samples were collected within the crater from the sidewalls and crater bottom using a systematic-random sampling design described previously (Table 5–1). Analysis of these three samples yielded TNT concentrations that varied from 42.8 to 89.8 mg/kg with a mean concentration of 60.0 mg/kg and an RSD of 43.2 percent. Other energetic compounds detected in these crater samples included TNB, 2,4DNT, DNA, 1,3-dinitrobenzene (1,3DNB), 2ADNT, and 4ADNT. Concentrations of these other energetic compounds were always less than 1 mg/kg in these crater samples. These compounds are either impurities in the manufacture of TNT or environmental transformation products of TNT. Even at these low concentrations, however, the RSD for these compounds, when a detectable concentration was found for all three replicates, ranged from 38 to 68 percent. Overall, the 50-increment samples appear to provide adequate characterization for the TNT present in the soil size fraction (< 2 mm) in this crater.

Discrete samples for 10-m × 10-m grid near low-order 2000-lb bomb crater

A 10-m × 10-m grid was established about 20 m uphill (southeast) from the 2000-lb low-order bomb crater in the direction of the residue fallout (Figure 5–7, Grid A). This grid was subdivided into 100 1-m × 1-m cells, and a discrete soil sample was collected from an area near the center of each cell.

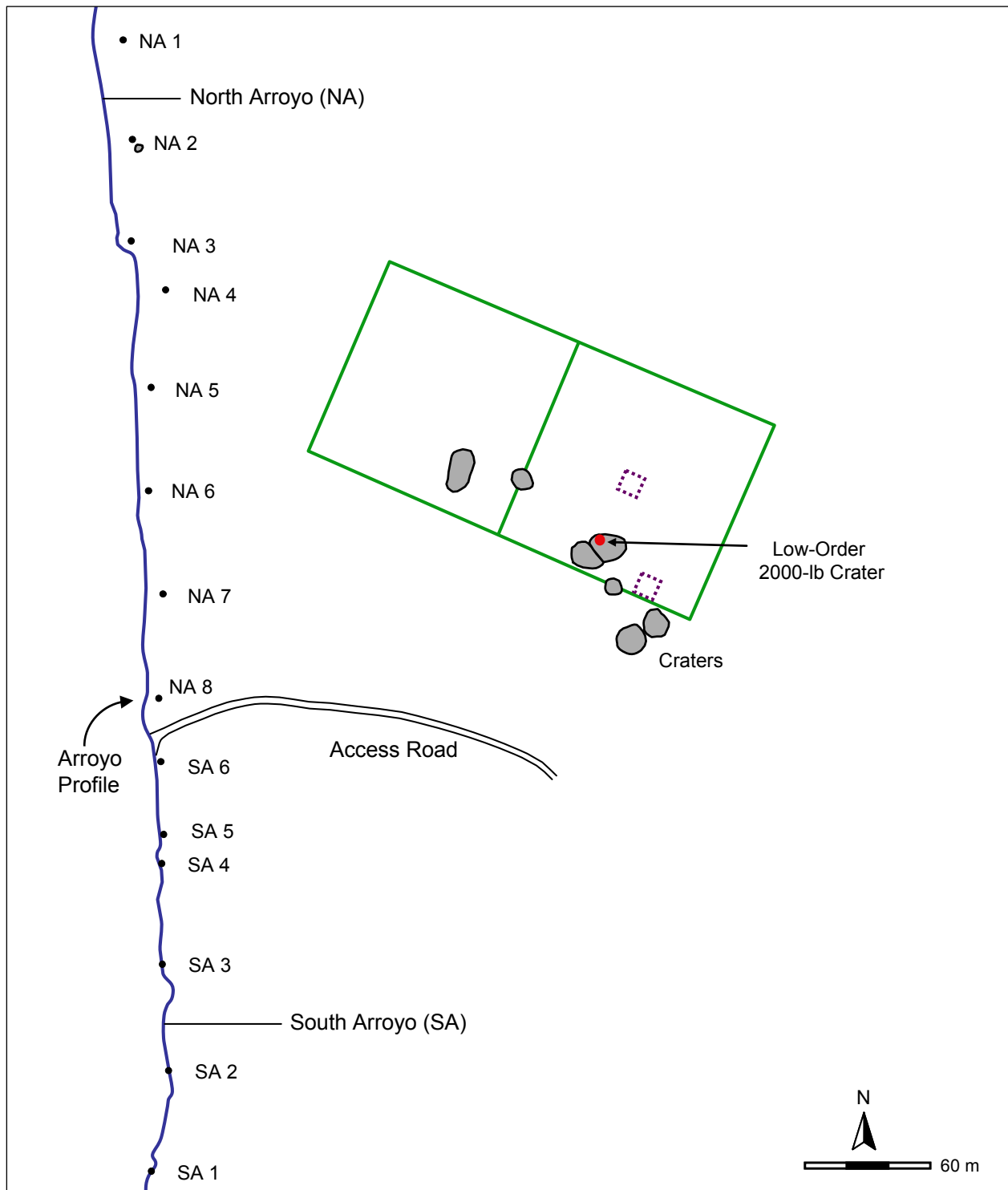

Figure 5-6. Area sampled for energetic residues near a 2,000-lb bomb crater (solid red circle) at Holloman Air Force Base. Samples were collected in the arroyo (solid black circles). Multiple sampling strategies were used within the green- and purple-outlined grids.

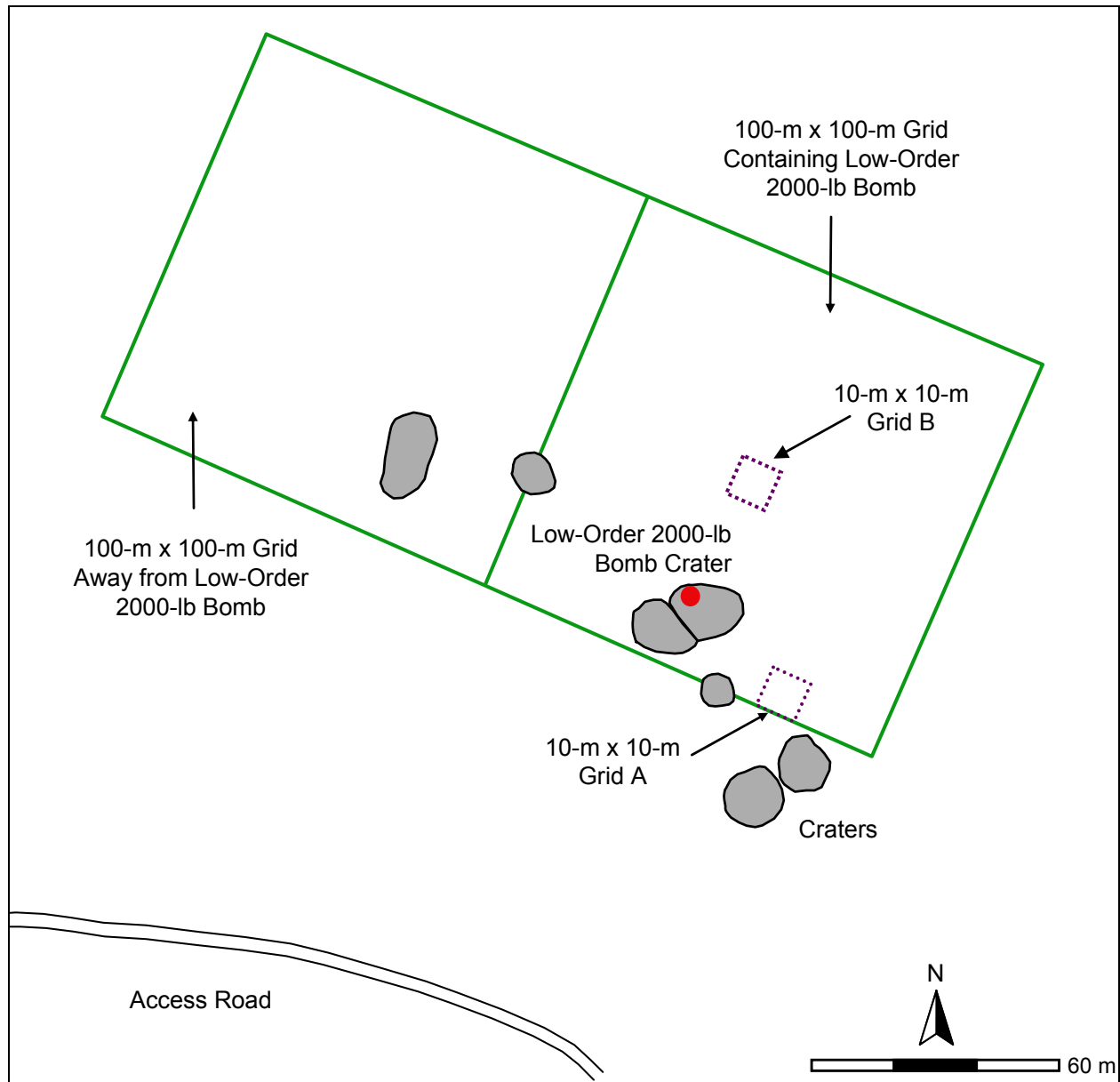

Figure 5-7. Grid areas sampled at Holloman Air Force Base. Multi-increment samples were collected in 100-m x 100-m green-outlined grids, located near to and away from a 2,000-lb bomb that exploded low order and in Grids A and B. One hundred discrete samples were collected from 1-m x 1-m cells in Grid A, near the low-order crater. Twenty-five discrete samples were collected from 2-m x 2-m cells in Grid B, away from the low-order bomb. Multi-increment samples also were collected within the grey-shaded craters.

Table 5-1. Concentrations of energetic compounds in multi-increment soil samples from a crater containing a low-order 2,000-lb bomb.

Sample	Number of Increments	Concentration (mg/kg)							
		TNT	TNB	2,4DNT	2ADNT	4ADNT	DNB	DNA	RDX
Low-order crater									
Replicate 1	50	89.8	0.95	0.35	0.29	0.29	0.03	0.05	<d
Replicate 2	50	42.8	0.28	0.08	0.15	0.15	<d	<d	<d
Replicate 3	50	47.4	0.83	0.18	0.16	0.17	<d	0.04	<d
Mean		60.0	0.69	0.20	0.20	0.20	0.01*	0.03*	<d
Std dev		25.9	0.36	0.14	0.077	0.076			
% RSD		43.2	52	68	39	38			

* When one or two replicate values were <d, a value equal to half the detection limit of 0.01 mg/kg was used to compute the mean.

The same suite of energetic compounds detected in the crater was also detected in these samples, and likewise, TNT was present at the highest concentration, varying from a minimum of 0.12 mg/kg to a maximum of 778 mg/kg (Figure 5–8) with a mean value of 31.8 mg/kg and an RSD of 274 percent (Table 5–2). Clearly these data are not normally distributed and thus, while we can compute a mean, a standard deviation, and an RSD, these statistics are not valid descriptors of this data. Seventy-five of the 100 TNT values are below the mean, thus the distribution is skewed right. Estimating the mean for this 10-m × 10-m grid from a single discrete sample would be extremely unreliable and would underestimate the mean about 75 percent of the time.

The maximum-to-minimum ratio for TNT concentrations for this set of 100 discrete samples is about 6,480. The maximum-to-minimum TNT ratio from an identical study conducted at the CLAWR was 932 (Ampleman et al. 2004). The lower ratio obtained at CLAWR is probably due to the practice of tilling the soil to reduce vegetation in an area prone to forest fires.

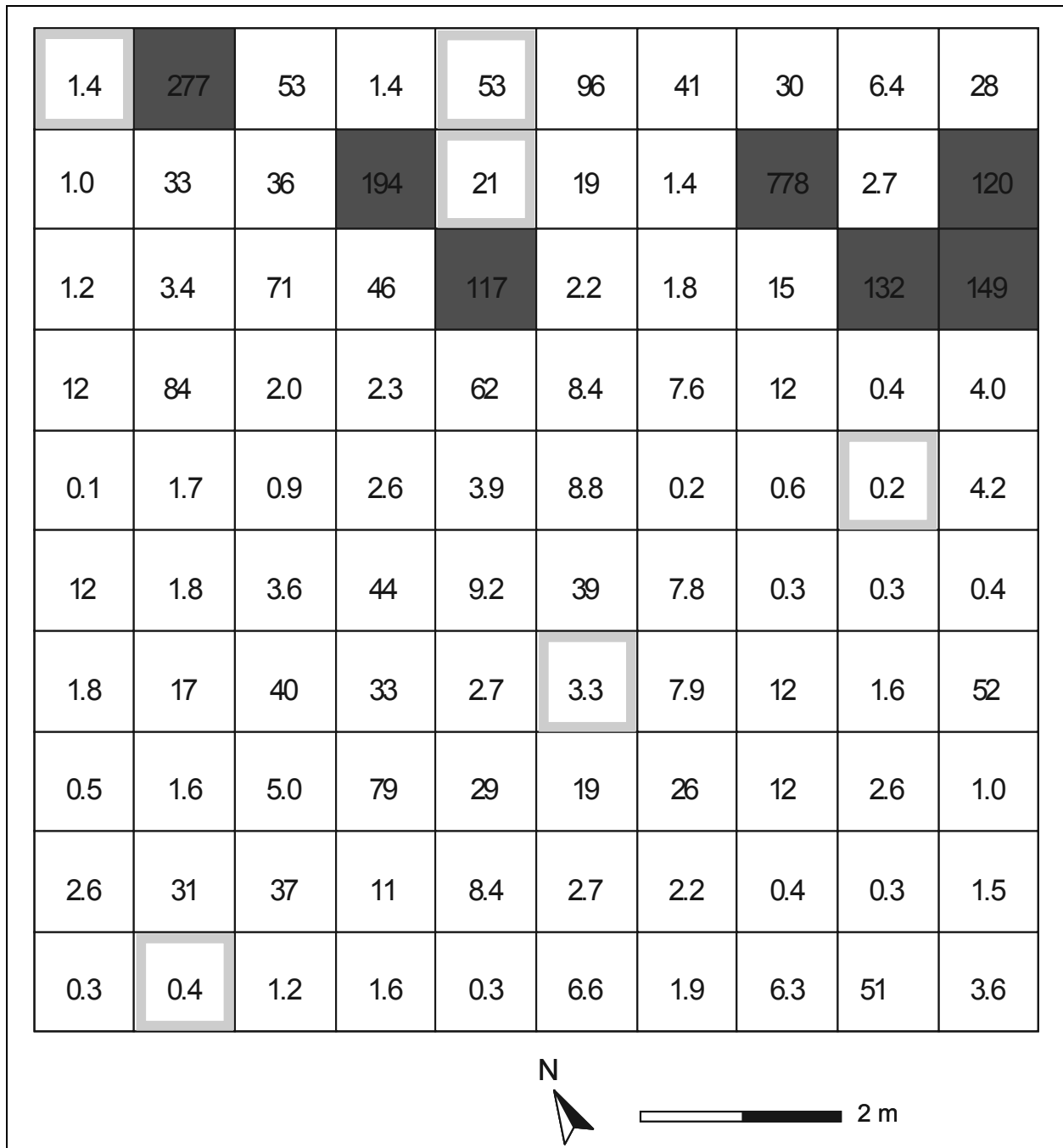

Figure 5-8. TNT concentrations (mg/kg) in 100 discrete samples collected within 10-m × 10-m Grid A (Figure 5-7) at Holloman Air Force Base near a low-order 2,000-lb bomb. Dark gray-shaded cells have concentrations greater than 100 mg/kg. Light gray-outlined cells were sampled with nine increments.

Table 5-2. Concentrations of energetic compounds in 100 discrete samples collected in 1-m × 1-m cells within 10-m × 10-m Grid A near low-order 2,000-lb bomb crater.

Parameter	Concentration (mg/kg)						
	TNT	TNB	2,4DNT	2ADNT	4ADNT	DNB	DNA
Maximum	778	0.22	0.43	3.49	2.78	<d	0.23
Minimum	0.12	<d	<d	0.02	0.03	<d	0.01
Mean ^a	31.8 ^b	0.04	0.08	0.62	0.59		0.03
Std dev	87.0	0.04	0.07	0.46	0.38		0.04
Median	6.36	0.03	0.06	0.52	0.53		0.02
RSD (%)	274	104	81.5	73.6	64.4		116
n (values >0.01)	100	67	93	100	100		57
Values <mean	75	66	62	64	61		60
Value >100	7						

^a Mean values for sets of data containing <d values were obtained using one-half the detection limit for these values.

^b Because the distribution of TNT values is non-Gaussian, the mean is not a valid estimate of central tendency.

The maximum-to-minimum ratio for TNT concentrations for this set of 100 discrete samples is about 6,480. The maximum-to-minimum TNT ratio from an identical study conducted at the CLAWR was 932 (Ampleman et al. 2004). The lower ratio obtained at CLAWR probably is due to the practice of tilling the soil to reduce vegetation in an area prone to forest fires.

The chunks of tritonal in cells 1 through 42 (Figure 5-4) were also collected and weighed, and the mass was greater than 459 g. For several chunks of tritonal, the masses were greater than the 150-g upper limit on our scale, so this total mass should be considered a minimum. The mean concentration measured for the soil samples from cells 1 to 42 was 29 mg/kg. If we estimate the mass of TNT in the soil size fraction (< 2 mm) in the surface 2.5 cm of soil (bulk density = 1.7 g/cm³) in these 42 cells, the mass is 123 g. Thus we estimate that about 80 percent of the mass of TNT in these 42 cells is still present as chunks of tritonal, and about 20 percent is present in the soil-size material. The ratio of the mass of energetic residues present as chunks relative to that present in the less-than-2-mm-size fraction at this site is similar to what was measured at 29 Palms, California, in an area where pieces of H6 from a bomb detonation were present on the surface (Hewitt et al. 2005). Both of these training facilities are in arid regions.

Variability of discrete samples within the 1-m × 1-m cells

Within the 10-m × 10-m grid described above, a set of nine equally spaced (systematic) replicate discrete soil samples was also collected within six 1-m × 1-m cells (cells 1, 20, 41, 42, 57, and 85). Cells 41, 42, and 57 were selected because they had many pieces of tritonal on the surface, and cells 1, 20, and 85 were selected because they did not. Even so, the highest concentration for any discrete sample was found in cell 85 (Figure 5–9). Therefore, the presence of visible pieces of energetic residues on the surface does not necessarily correlate to the highest soil concentrations, although the trend is clearly evident. The mean TNT concentrations for these groups of nine discrete samples ranged from 1.04 to 52.4 mg/kg (Table 5–3). The maximum-to-minimum ratios for individual discrete samples within these six cells ranged from 17.7 to 2,871. These ratios are somewhat higher than the ratio of 9.3 for discrete samples collected from within a similar-sized area at CLAWR (Ampleman et al. 2004). Thus, even within an area as small as 1 m × 1 m, a single discrete sample does not provide a reliable estimate of the mean concentration. The maximum-to-minimum ratio for the 100 discrete samples from the entire 10-m × 10-m grid was 5,190. The short-range variability within 1-m × 1-m cells was generally one to two orders of magnitude less than within the 10-m × 10-m grid, except for cell 85, where it was similar in magnitude. One reason for the lower variability within most of the 1-m × 1-m areas is due to the lower number of observations in the 1-m × 1-m areas relative to that for the 10-m × 10-m areas (9 vs. 100).

Multi-increment samples for 10-m × 10-m Grid A near low-order 2000-lb bomb crater

Four multi-increment samples were also collected within the 10-m × 10-m grid using a systematic-random design (Table 5–4, Figure 5–3). One sample was built from 100 increments, one increment from the back left corner of each cell. The other three multi-increment samples were built from 33 (or 34) increments and were built using the systematic-random sampling design by collecting an increment in every third cell from the back right corner of every third cell.

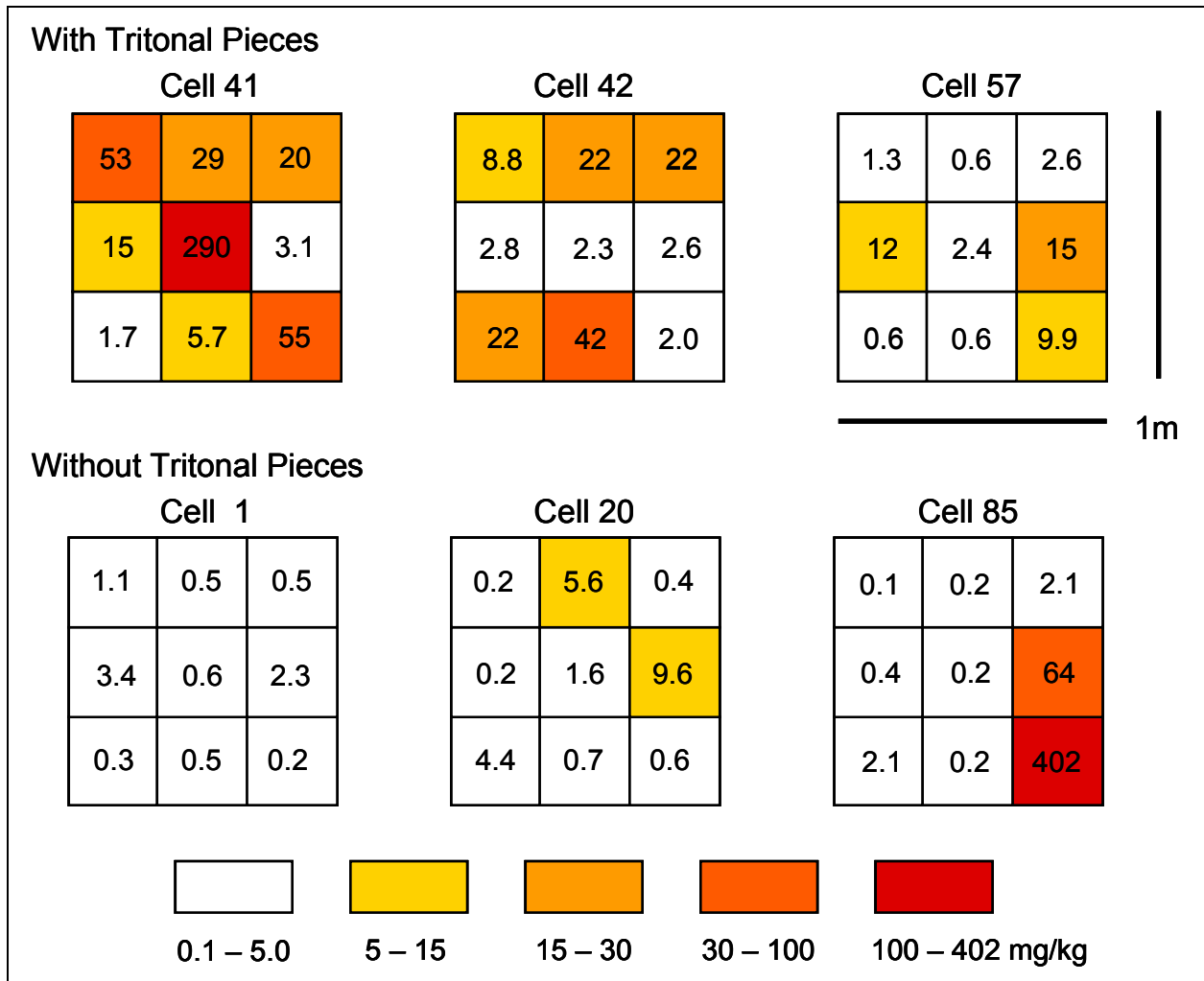

Figure 5-9. TNT concentrations (mg/kg) in nine discrete samples collected at six 1-m x 1-m cells within 10-m x 10-m Grid A (Figure 5-7) near a low-order 2,000-lb bomb. Upper three cells were collected where tritonal pieces were visible at the surface; lower three cells had no visible tritonal.

Table 5-3. Concentrations of energetic compounds in replicate samples from individual cells within 10-m × 10 m Grid A near low-order bomb crater.

Cell #	Replicate	Concentration, mg/kg								
		TNT	TNB	2,4DNT	2ADNT	4ADNT	DNB	DNA	RDX	NG
1	1	1.13	0.02	0.05	0.37	0.50	<d	0.04	<d	<d
	2	3.37	0.03	0.05	0.47	0.68	<d	0.04	<d	<d
	3	0.27	<d	0.35	0.18	0.28	<d	<d	<d	<d
	4	0.46	<d	0.05	0.30	0.34	<d	0.03	<d	<d
	5	0.62	<d	0.06	0.48	0.70	<d	0.04	<d	<d
	6	0.54	0.02	0.08	0.35	0.50	<d	0.05	<d	<d
	7	0.46	<d	0.16	0.52	0.76	<d	0.06	<d	<d
	8	2.28	<d	0.09	0.31	0.46	<d	<d	<d	<d
	9	0.19	<d	0.07	0.39	0.46	<d	0.05	<d	<d
	Maximum	3.37	0.03	0.35	0.52	0.76	<d	0.06	<d	<d
	Minimum	0.19	0.02	0.05	0.18	0.28	<d	<d	<d	<d
	Mean*	1.04	0.02	0.11	0.37	0.52	<d	0.04	<d	<d
20	1	0.23	<d	<d	0.13	0.21	<d	<d	<d	<d
	2	0.21	<d	<d	0.05	0.14	<d	<d	<d	<d
	3	4.42	<d	0.10	0.45	0.67	<d	<d	<d	<d
	4	5.61	<d	0.19	0.63	0.95	<d	<d	<d	<d
	5	1.57	<d	0.05	0.28	0.36	<d	<d	<d	<d
	6	0.70	<d	<d	0.03	0.07	<d	<d	<d	<d
	7	0.36	<d	<d	0.04	0.21	<d	<d	<d	<d
	8	9.61	<d	0.05	0.15	0.29	<d	<d	<d	<d
	9	0.55	<d	<d	0.02	0.05	<d	<d	<d	<d
	Maximum	9.61	<d	0.19	0.63	0.95	<d	<d	<d	<d
	Minimum	0.21	<d	<d	0.02	0.05	<d	<d	<d	<d
	Mean	2.59	<d	0.10	0.20	0.33	<d	<d	<d	<d
41	1	52.9	0.06	0.16	0.66	0.59	<d	0.03	<d	<d
	2	14.8	0.09	0.09	1.06	0.91	<d	0.05	<d	<d
	3	1.75	0.03	0.11	0.66	0.61	<d	0.05	<d	<d
	4	28.7	0.08	0.10	1.34	1.16	<d	0.07	<d	<d
	5	290	1.16	0.31	1.09	0.91	0.019	<d	<d	<d
	6	5.67	0.04	0.05	0.67	0.62	<d	0.04	<d	<d
	7	20.4	0.14	0.15	0.97	0.89	<d	0.05	<d	<d
	8	3.12	0.04	0.05	0.61	0.52	<d	0.03	<d	<d
	9	54.6	0.07	0.09	1.00	0.84	<d	0.05	<d	<d
	Maximum	290	1.16	0.31	1.34	1.16	0.02	0.07	<d	<d
	Minimum	1.75	0.03	0.05	0.61	0.52	<d	<d	<d	<d
	Mean	52.4	0.19	0.12	0.90	0.78	0.02	0.05	<d	<d

(continued)

Cell #	Replicate	Concentration, mg/kg								
		TNT	TNB	2,4DNT	2ADNT	4ADNT	DNB	DNA	RDX	NG
42	1	8.75	0.04	0.04	0.60	0.62	<d	0.06	<d	<d
	2	2.78	0.05	0.06	0.73	0.65	<d	0.04	<d	<d
	3	22.4	0.07	0.09	1.12	1.02	<d	0.06	<d	<d
	4	21.8	0.05	0.05	0.71	0.60	<d	0.06	<d	<d
	5	2.26	0.06	0.20	0.20	0.17	<d	<d	<d	<d
	6	42.2	0.11	0.23	0.99	0.90	0.02	<d	<d	0.05
	7	21.5	0.09	0.12	0.89	0.79	<d	0.07	<d	<d
	8	2.62	0.04	0.07	0.70	0.58	<d	0.03	<d	<d
	9	1.99	0.02	0.07	0.82	0.69	<d	0.02	<d	<d
	Maximum	42.2	0.11	0.23	1.12	1.02	0.02	0.07	<d	0.05
	Minimum	1.99	0.02	0.04	0.20	0.17	<d	<d	<d	<d
	Mean	14.0	0.06	0.10	0.75	0.67	0.02	0.05	<d	0.05
57	1	1.28	<d	0.08	0.53	0.56	<d	<d	<d	<d
	2	12.1	<d	0.04	0.69	0.81	<d	<d	<d	<d
	3	0.62	<d	0.06	0.12	0.11	<d	<d	<d	<d
	4	0.56	<d	0.04	0.22	0.19	<d	<d	<d	<d
	5	2.43	0.05	0.14	0.36	0.36	<d	<d	<d	<d
	6	0.64	0.02	<d	0.25	0.36	<d	<d	<d	3.99
	7	2.63	<d	0.03	0.17	0.15	<d	<d	<d	<d
	8	15.5	0.02	0.13	0.69	0.63	<d	<d	<d	0.05
	9	9.90	0.05	0.05	0.49	0.40	<d	0.04	<d	<d
	Maximum	15.5	0.05	0.14	0.69	0.81	<d	0.04	<d	3.99
	Minimum	0.56	0.02	0.03	0.12	0.11	<d	<d	<d	<d
	Mean	5.07	0.04	0.07	0.39	0.40	<d	0.04	<d	2.02
85	1	0.14	<d	<d	0.06	0.07	<d	<d	<d	<d
	2	0.37	<d	<d	0.22	0.24	<d	<d	<d	<d
	3	2.12	<d	0.04	0.65	0.56	<d	0.02	<d	<d
	4	0.20	<d	<d	0.22	0.20	<d	<d	<d	<d
	5	0.23	<d	<d	0.18	0.16	<d	<d	<d	<d
	6	0.16	<d	<d	0.25	0.25	<d	<d	<d	<d
	7	2.11	<d	0.03	0.52	0.52	<d	<d	<d	<d
	8	63.7	0.04	0.07	0.91	1.03	<d	<d	<d	<d
	9	402	0.37	0.28	1.58	1.63	<d	0.14	<d	0.08
	Maximum	402	0.37	0.28	1.58	1.63	<d	0.14	<d	0.08
	Minimum	0.14	0.04	0.03	0.06	0.07	<d	<d	<d	<d
	Mean	52.4	0.21	0.11	0.51	0.52	<d	0.08	<d	0.08

* Mean values for sets of data containing <d values were obtained using one-half the detection limit for these values.

Table 5-4. Concentrations of energetic compounds in multi-increment soil samples for a 10-m × 10-m area (Grid A) impacted by low-order 2,000-lb bomb.

Sample	Number of increments	Concentration, mg/kg							
		TNT	TNB	2,4DNT	2ADNT	4ADNT	DNB	DNA	RDX
10-m × 10-m grid									
Replicate 1	33	13.5	0.06	0.09	0.55	0.54	<d	0.04	<d
Replicate 2	33	12.5	0.05	0.08	0.62	0.59	<d	0.04	<d
Replicate 3	34	17.2	0.05	0.08	0.64	0.61	<d	0.04	<d
Mean		14.4	0.05	0.08	0.61	0.58		0.04	
Std dev		2.45	0.005	0.002	0.047	0.035		0.001	
% RSD		17.0	11	2.6	7.7	6.1		2.8	
10-m × 10-m grid	100	21.2	0.05	0.09	0.63	0.66	<d	0.04	<d

The mean value for TNT from the three 33- (or 34-) increment replicate samples of this 10-m × 10-m grid was 14.4 mg/kg with an RSD of 17 percent. The mean values for the other detectable energetic compounds were all less than 1 mg/kg with RSDs of 11 percent or less. Thus the 33-increment systematic-random sampling strategy employed provided much more reproducible results for this 10-m × 10-m area than the discrete samples that ranged from 0.12 to 778 mg/kg. This improvement in reproducibility using multi-increment samples is consistent with results reported by Ampleman et al. (2004) for a bombing range impact area at CLAWR. The mean TNT concentration for the 100-increment sample from this same area was 21.2 mg/kg, which was about 50 percent more than the mean of the 33- (34-) increment samples. The concentrations for the other energetic compounds in the 100-increment samples, however, were nearly identical to those for the mean of the 33-increment samples. The higher TNT concentration in the 100-increment sample was probably due to the inclusion of a small piece of tritonal in this sample.

Profile samples within 10-m × 10-m Grid A

Sets of depth profile samples were also collected within the 10-m × 10-m grid, in the same six 1-m × 1-m cells where multiple discrete samples were collected. Samples were collected up to 40-cm deep. Concentration versus depth profiles from several cells are presented in Figure 5-10. In most cases, the TNT concentrations decline rapidly below the 5- to 7-cm depth, with concentrations less than 0.5 mg/kg at greater depth (Table 5-5).

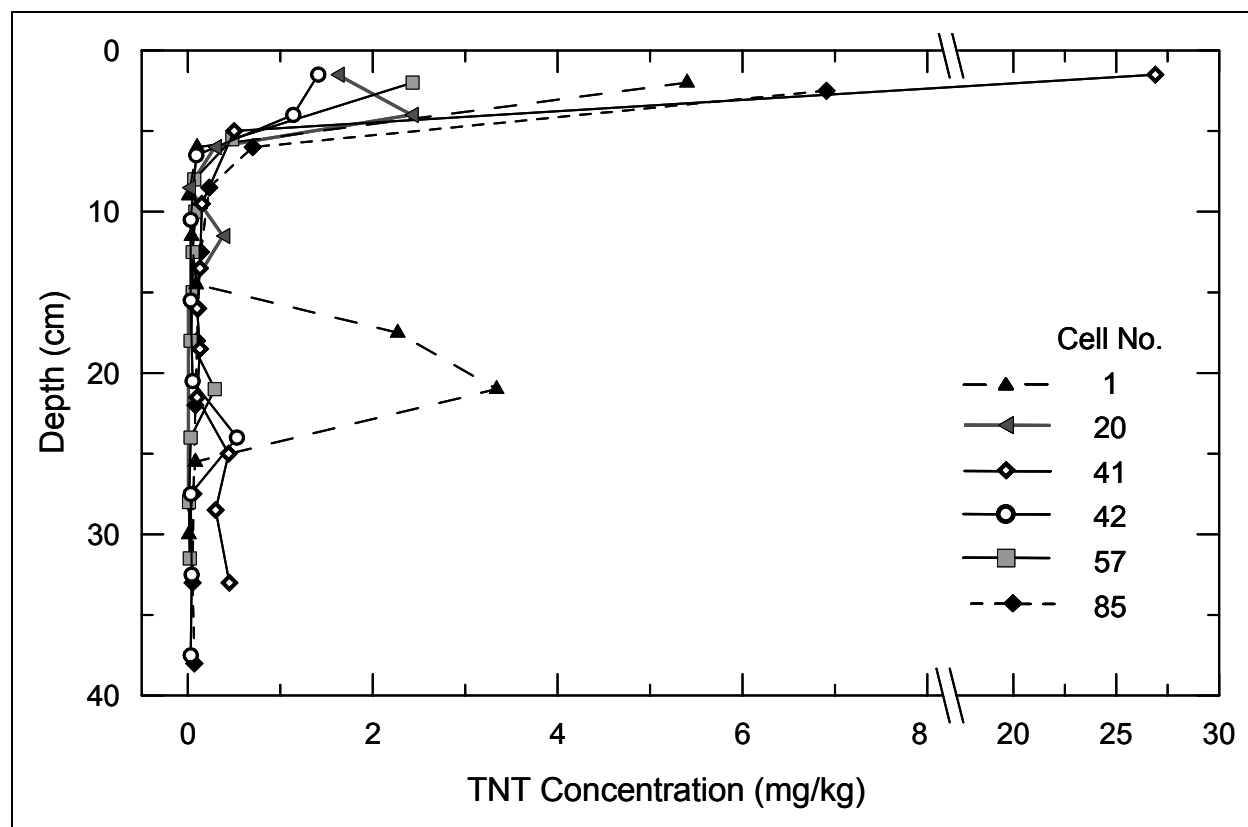

Figure 5-10. Depth profile of TNT concentrations (mg/kg) in selected cells within 10-m \times 10-m Grid A near a low-order 2,000-lb bomb.

For the profile in cell #1, however, samples from the 16- to 19-cm- and 19- to 23-cm-depth intervals had TNT concentrations of 2.27 and 3.34 mg/kg, respectively. It is likely that these concentrations represent small pieces of energetic residue that had been buried by the large number of individual detonations that have occurred in this area over time, rather than leaching from the surface (due to the arid nature of this site).

In general, though, it does not appear that TNT is leaching downward to any extent into the soil profile, even in this area where large numbers of chunks of tritonal are present on the surface.

10-m \times 10-m Grid B not heavily impacted by low-order 2000-lb bomb crater

A second 10-m \times 10-m grid also located about 20 m from the low-order bomb crater also was sampled (Figure 5-7, Grid B). This grid, however, was located north-northeast of the crater containing the low-order 2000-lb bomb and inspection of the surface indicated that only a few small chunks of tritonal were present compared with many hundred in the grid located southeast of the crater.

Table 5-5. Concentrations of energetic compounds in profile samples within 10-m × 10-m Grid A near the low-order bomb crater.

Cell #	Depth cm	Concentration, mg/kg								
		TNT	TNB	2,4DNT	2ADNT	4ADNT	DNB	DNA	RDX	NG
1	0-4	5.40	<d	0.13	0.76	0.74	<d	0.06	<d	<d
	4-8	0.10	0.03	0.03	0.18	0.22	<d	<d	<d	<d
	8-10	0.01	<d	0.01	0.02	0.04	<d	<d	<d	0.04
	10-13	0.04	<d	<d	0.02	0.03	<d	<d	<d	<d
	13-16	0.09	<d	0.01	0.08	0.12	<d	<d	<d	<d
	16-19	2.27	<d	<d	0.10	0.09	<d	<d	<d	<d
	19-23	3.34	<d	<d	<d	<d	<d	<d	<d	<d
	23-28	0.08	<d	0.01	0.03	0.05	<d	<d	<d	<d
	28-32	0.01	<d	<d	0.01	0.02	<d	<d	<d	<d
20	0-3	1.62	<d	0.08	0.14	0.20	<d	<d	<d	<d
	3-5	2.42	<d	0.06	0.31	0.39	<d	<d	<d	<d
	5-7	0.29	<d	0.02	0.20	0.32	<d	<d	<d	0.13
	7-10	0.01	<d	<d	0.02	0.08	<d	<d	<d	<d
	10-13	0.38	<d	<d	0.02	0.04	<d	<d	<d	<d
	13-17	<d	<d	<d	<d	<d	<d	<d	<d	0.02
	17-20	<d	<d	<d	<d	0.01	<d	<d	<d	0.1
	20-23	<d	<d	<d	<d	<d	<d	<d	<d	<d
	23-27	<d	<d	<d	<d	<d	<d	<d	<d	<d
	27-30	<d	<d	<d	<d	<d	<d	<d	<d	<d
41	0-3	26.9	0.06	0.07	0.77	0.76	<d	0.08	<d	<d
	3-7	0.50	0.01	0.01	0.17	0.25	<d	<d	<d	<d
	7-12	0.15	<d	<d	<d	<d	<d	<d	<d	0.03
	12-15	0.13	<d	<d	0.01	0.01	<d	<d	<d	<d
	15-17	0.10	<d	<d	<d	<d	<d	<d	<d	<d
	17-20	0.13	<d	<d	0.01	0.01	<d	<d	<d	<d
	20-23	0.10	<d	<d	0.04	0.03	<d	<d	<d	<d
	23-27	0.44	<d	0.01	0.10	0.08	<d	<d	<d	<d
	27-30	0.30	<d	<d	0.05	0.04	<d	<d	<d	<d
30-36	0.45	<d	0.01	0.08	0.07	<d	<d	<d	<d	

(continued)

This grid was divided into 25 2-m × 2-m cells and a discrete sample was collected from each. TNT was also the energetic compound present at the highest concentration here, but the concentrations ranged from only 0.01 to 0.70 mg/kg (Table 5–6). The distribution of TNT concentrations was non-Gaussian, as seen by an RSD of 135 percent and a median value that was only about half the mean.

Table 5-6. Results for 25 discrete samples collected in 2-m × 2-m cells within 10-m × 10-m Grid B about 20 m north-northeast from low-order 2,000-lb bomb crater.

Cell #	Concentration, mg/kg							
	TNT	TNB	2,4DNT	2ADNT	4ADNT	DNB	DNA	RDX
1	0.05	0.01	<d	0.01	0.01	<d	<d	<d
2	0.20	0.02	<d	0.03	0.02	<d	<d	<d
3	0.01	<d	<d	<d	<d	<d	<d	<d
4	0.06	<d	<d	0.01	<d	<d	<d	<d
5	0.05	<d	<d	0.01	0.01	<d	<d	<d
6	0.05	<d	<d	0.01	0.01	<d	<d	<d
7	0.06	0.01	<d	0.03	0.02	<d	<d	<d
8	0.06	<d	<d	0.02	0.01	<d	<d	<d
9	0.13	<d	<d	0.02	0.02	<d	<d	<d
10	0.04	<d	<d	0.01	0.01	<d	<d	0.01
11	0.09	0.01	<d	0.02	0.02	<d	<d	<d
12	0.09	<d	0.01	0.02	0.02	<d	<d	<d
13	0.06	0.01	<d	0.02	0.02	<d	<d	<d
14	0.05	<d	<d	0.01	0.01	<d	<d	<d
15	0.48	0.02	<d	0.04	0.04	<d	<d	<d
16	0.09	<d	<d	0.03	0.03	<d	<d	<d
17	0.04	0.01	<d	0.01	0.01	<d	<d	<d
18	0.07	0.01	0.01	0.04	0.04	<d	<d	<d
19	0.05	<d	0.01	0.02	0.01	<d	<d	<d
20	0.05	<d	<d	<d	0.01	<d	<d	<d
21	0.06	<d	<d	0.03	0.01	<d	<d	<d
22	0.03	<d	<d	0.01	0.01	<d	<d	<d
23	0.70	0.03	0.01	0.13	0.24	<d	<d	<d
24	0.15	0.01	<d	0.10	0.06	<d	<d	<d
25	0.09	0.01	<d	0.06	0.02	<d	<d	<d
Maximum	0.70	0.03	0.01	0.13	0.24	<d	<d	0.01
Minimum	0.01	<d	<d	<d	<d	<d	<d	<d
Mean*	0.11			0.03	0.03			
Std dev	0.15			0.03	0.05			
% RSD	135			100	170			
Median	0.06							

* Mean values for sets of data containing values <d were obtained by replacement with a value of half the detection limit.

Three replicate 30-increment samples were also collected from this grid (Table 5–7). The TNT estimates for these samples ranged from 0.15 to 2.02 mg/kg with an RSD of 109 percent. All three values exceeded the mean of the 25 discrete samples; the reason for this is uncertain, but probably due to presence of random nuggets that were not captured with the 25 discrete samples. When concentrations are low, the presence of a few random nuggets can have a much greater influence than when concentrations are more elevated. More mass and/or more increments would be required to provide a more reliable estimate of the mean concentration in this area.

Table 5-7. Concentrations of energetic compounds in multi-increment samples from 10-m × 10-m Grid B about 20 m north-northeast from low-order bomb crater.

Sample	Number of increments	Concentration, mg/kg							
		TNT	TNB	2,4DNT	2ADNT	4ADNT	DNB	DNA	RDX
10-m × 10-m grid									
Replicate 1	30	0.15	0.01	<d	0.03	0.04	<d	<d	<d
Replicate 2	30	0.54	0.01	<d	0.02	0.02	<d	<d	<d
Replicate 3	30	2.02	<d	<d	0.02	0.04	<d	<d	<d
Mean*		0.90	0.01		0.02	0.03			
Std dev		0.99			0.01	0.01			
% RSD		109			25	33			

* Mean values for sets of data containing values <d were obtained by replacement with a value of half the detection limit.

100-m × 100-m grids

Three replicate 100-increment samples were collected from two 100-m × 100-m grids (Figure 5–7). The first grid encompassed both the low-order 2000-lb crater and the two 10-m × 10-m grids discussed above. TNT was the energetic compound detected at the highest concentration with values ranging from 2.60 to 12.5 mg/kg (Table 5–8). The mean TNT concentration was 5.94 mg/kg with an RSD of 95 percent. The mean concentrations of the other energetic compounds associated with TNT were all either 0.10 mg/kg or less. In this grid, RDX was detectable, but the mean concentration was only 0.10 mg/kg. The presence of RDX may be due to the BIP practices for dud bombs using C4 when EOD personnel conduct their semi-annual range maintenance.

Table 5-8. Concentrations of energetic compounds in 100-increment soil samples from two 100-m × 100-m grids.

Sample	Number of increments	Concentration, mg/kg								
		TNT	TNB	2,4DNT	2ADNT	4ADNT	DNB	DNA	RDX	HMX
100-m × 100-m grid encompassing low-order 2000-lb bomb										
Replicate 1	100	12.5	0.03	<d	0.11	0.11	<d	<d	0.25	<d
Replicate 2	100	2.60	0.03	0.08	0.12	0.09	<d	0.03	0.04	<d
Replicate 3	100	2.76	0.01	<d	0.12	0.11	<d	<d	0.01	<d
Mean*		5.94	0.02	0.03	0.12	0.10	<d	0.01	0.10	<d
Std dev		5.65	0.01		0.01	0.01			0.13	
% RSD		95.1	62		4.5	11			135	
100-m × 100-m grid with no visible low-order debris										
Replicate 1	100	0.58	0.08	<d	<d	<d	<d	<d	<d	<d
Replicate 2	100	0.19	0.03	<d	0.06	<d	<d	<d	<d	<d
Replicate 3	100	0.08	0.02	0.01	0.11	0.03	<d	0.01	0.02	0.01
Mean		0.28	0.04	<d	0.06	0.01	<d	<d	0.01	<d
Std dev		0.26	0.03							
% RSD		93	71							

* Mean values for sets of data containing values <d were obtained by replacement with a value of half the detection limit.

Three replicate 100-increment samples were also collected from the second 100-m × 100-m grid located west–northwest of the first 100-m × 100-m grid. No low-order debris was observed in this area, and it was located in the opposite direction from the low-order detonation observed above. The TNT concentrations for these samples ranged from 0.08 to 0.58 mg/kg with a mean value of 0.28 mg/kg and an RSD of 93 percent (Table 5–8). The mean concentrations for the other energetic compounds were less than 0.06 mg/kg.

The maximum-to-minimum ratios for TNT concentration estimates from the 100-increment samples from these two 100-m × 100-m grids are 4.8 and 7.25, respectively, for the grids with and without low-order debris. While these ratios are larger than we might like, we must keep in mind that they are for only three replicates and yet they are many times smaller than found for discrete samples, even within an area as small as 1 m × 1 m. Thus, concentration estimates based on multi-increment samples provide a higher level of confidence in the estimate of the mean than can be achieved with mean estimates based on one or several discrete samples.

Other crater samples

Multi-increment surface soil samples were collected from six other craters within the live-fire bombing area at Holloman AFB (Table 5–9). The concentrations of individual energetic compounds for these samples were less than 0.2 mg/kg in all but one case; one of the 2000-lb bomb craters had a TNT concentration of 3.55 mg/kg. Thus it appears that these craters were formed by bombs that probably detonated high-order and deposited only microgram-to-milligram quantities of energetic residues (Hewitt et al. 2003; M. R. Walsh et al. 2005).

Arroyo downslope of the live-fire bombing range

An arroyo is located downslope of the live-fire bombing range at HAFB (Figure 5–6). If energetic residue in either particulate form or dissolved in precipitation is running off the range, the runoff would be captured within the channel of this arroyo. A set of 14 multi-increment sediment samples was collected beginning beyond the north edge of the live-fire range and continuing south along the channel for about 550 m. Each sample was built from 30 increments taken from the surface 0–2.5 cm. A set of profile samples was also collected from the lowest-lying location within the arroyo.

Table 5-9. Concentrations of energetic compounds in multi-increment soil samples from other craters.

Sample	Number of increments	Soil concentration, mg/kg								
		TNT	1,3,5 TNB	2,4DNT	2ADNT	4ADNT	1,3DNB	3,5DNA	RDX	NG
Old 500-lb bomb crater ^a	30	0.14	0.01	0.01	0.03	0.04	<d	<d	<d	<d
Old 2,000-lb bomb crater 1 ^b	56	3.55	0.17	0.02	0.14	0.15	<d	0.03	<d	<d
Old 2,000-lb bomb crater 2	26	0.09	0.03	<d	0.19	0.02	<d	0.01	<d	<d
Old 2,000-lb bomb crater 3	45	0.05	<d	<d	<d	<d	<d	<d	<d	0.01
Old 2,000-lb bomb crater 4	31	0.04	<d	<d	<d	<d	<d	<d	<d	<d
Old 2,000-lb bomb crater 5	45	<d	<d	0.02	<d	<d	<d	<d	<d	0.18

^a Mean of lab triplicates.

^b Mean of field duplicates.

Analytical results for these samples are presented in Table 5–10. The concentration of energetic compounds in the surface sediment samples from the arroyo was always less than 0.2 mg/kg, except for one sample collected 210 m north of the access road, where the TNT concentration was 2.28 mg/kg. This high concentration area appears to be isolated either from up- or downstream samples and may be due to a small piece of tritonal from a low-order detonation landing within or near the arroyo.

A set of depth profile samples up to 35 cm deep was also collected within the arroyo, 15 m north of the access road (Table 5–10). Energetic compounds within these samples were generally below the detection limit of 0.01 mg/kg. In three samples, TNT in one, 2,4DNT in another, and 4ADNT in the third, the concentration was detected at 0.01 mg/kg. In the third sample, 2ADNT was also detected at 0.02 mg/kg.

It does not appear that TNT or any other energetic compound is running off the range to an off-site location, or is penetrating downward within the channel of the arroyo.

Demolition range

Two sets of multi-increment samples were collected within a 20-m radius of a demolition area where C4 was used to ensure that practice bombs contained no residual explosive prior to removal of metal scrap from the range. The first set of samples was collected on 5 May 2005 during our visit to the site; the second set of multi-increment samples was collected by EOD personnel on 11 May 2005 after a demolition event in which C4 was used to blow holes in several types of practice bombs containing no HE.

Results for triplicate 30-increment samples before and after the demolition event are presented in Table 5–11. In all cases, the major energetic compounds present are RDX and HMX. RDX concentrations ranged from 2.04 to 27.8 mg/kg prior to the demolition event and from 4.07 to 12.5 mg/kg afterward. Similarly, HMX concentrations ranged from 0.59 to 3.98 mg/kg prior to demolition and from 1.02 to 2.43 mg/kg after demolition. TNT concentrations for five of these six samples ranged from < 0.01 to 0.15 mg/kg, but one sample had a TNT concentration of 2.05 mg/kg.

Table 5-11. Concentrations of energetic compounds in multi-increment samples from a demolition range.

Sample	Number of increments	Concentration, mg/kg									
		RDX	HMX	TNT	TNB	2,4DNT	2ADNT	4ADNT	DNB	DNA	NG
Demolition range before mid-May 2005 BIP											
Replicate 1	30	2.04	0.59	0.02	<d	0.04	0.02	0.04	<d	<d	<d
Replicate 2	30	27.8	3.98	0.15	<d	0.06	0.05	0.05	<d	<d	<d
Replicate 3	30	4.39	0.96	<d	<d	0.02	0.02	0.02	<d	<d	0.70
	Mean	11.4	1.8	0.06*		0.04	0.03	0.04			0.24
	Std dev	14.2	1.9			0.02	0.02	0.02			
	% RSD	125	101			50	67	50			
Demolition range after mid-May 2005 BIP											
Replicate 1	30	12.0	2.16	0.05	0.02	<d	<d	<d	<d	0.04	<d
Replicate 2	30	12.5	2.43	2.05	0.02	<d	<d	<d	<d	0.01	<d
Replicate 3	30	4.07	1.02	0.12	<d	<d	<d	<d	<d	0.06	<d
	Mean	9.50	1.87	0.74	0.01	<d	<d	<d	<d	0.04	<d
	Std dev	4.71	0.75	1.14						0.02	
	% RSD	50	40	153						61	

* Mean values for datasets containing values <d were obtained by replacement with a value of half the detection limit.

The reproducibility of RDX and HMX concentrations for five of these six 30-increment samples was quite good, ranging from 2.04 to 12.5 mg/kg and 0.59 to 2.44 mg/kg, respectively. The concentrations in the sixth sample are about two times higher than in any other sample and this is likely due to the incorporation of a small piece of C4 within an increment used to build that sample. Overall though, the ability to provide reproducible estimates of the mean concentration for this area is quite good.

The source of the RDX and HMX at this site is certainly the C4 used as the demolition charge. C4 is composed of 91 percent military-grade RDX, of which HMX is present as impurity in excess of 10 percent. The fact that the RDX and HMX concentrations did not appear to increase after the most recent demolition event indicates that the major residues are not deposited every time an event occurs, but rather when an individual detonation does not proceed properly. The reason for the presence of TNT in one sample, however, is unclear. TNT is not a component of C4 and should not be present in these practice bombs. It is possible it could have been tracked into this area from EOD personnel who had been conducting clearance activities within the live-fire bombing area where pieces of

tritonals were widely dispersed. The demolition area is the only area at HAFB where significant residues of RDX and HMX were detected.

Estimation of sample processing and determination error for these samples

Triplicate subsamples from 12 soil samples from Holloman AFB were used to assess the contribution of a combination of laboratory processing, subsampling, and determination to the total characterization error (Table 5-12). The mean concentration of TNT in the sample from the low-order crater was 89.8 mg/kg with an RSD of 0.67 percent. Clearly, for this high-concentration sample, the contribution from the laboratory error (including subsampling) was insignificant compared with total error estimate of RSD = 43.2 percent (Table 5-1). Thus, the major portion of the total error was sampling error, even when sampling was conducted using multi-increment samples. This was also the case for the other energetic compounds in these subsamples, even though the concentrations of these analytes were at least two orders of magnitude less than TNT.

Triplicate laboratory subsamples from the only sample collected in a second crater with much lower TNT concentrations are also presented in Table 5-12. The mean TNT concentration for these subsamples was 0.14 mg/kg with an RSD of 25 percent. Even though the absolute standard deviation is much lower for this set of three laboratory subsamples compared with those from a sample collected from the crater with the low-order bomb, the much lower mean concentration inflates the RSD estimate. This is typically found as concentrations decline toward detection limits because, in this concentration range, the absolute standard deviation often becomes constant. Also, when the contaminant is present as discrete particles, the number of these particles becomes quite small and difficult to reproduce as you approach the detection limit. Overall, however, the error due to sample processing, subsampling, and analysis in this study is minor compared to sampling error as shown for the other 11 sets of lab replicates in Table 5-12.

Table 5-12. Results for energetic compounds in replicate laboratory subsamples.

Sample	Concentration, mg/kg									
	TNT	TNB	2,4 DNT	2ADNT	4ADNT	DNB	DNA	RDx	NG	HMX
Low-order crater										
Replicate 1	89.2	0.03	0.35	0.29	0.29	0.03	0.05	<d	<d	<d
Replicate 2	89.8	0.03	0.35	0.29	0.29	0.03	0.05	<d	<d	<d
Replicate 3	90.4	0.03	0.36	0.29	0.29	0.03	0.05	<d	<d	<d
Mean	89.8	0.03	0.35	0.29	0.29	0.03	0.05			
Std dev	0.60	0.002	0.01	0.001	0.001	0.002	0.001			
% RSD	0.67	7.1	1.7	0.40	0.40	7.1	2.4			
Crater sample										
Replicate 1	0.18	<d	0.01	0.03	0.02	<d	<d	<d	<d	<d
Replicate 2	0.13	0.01	0.01	0.06	0.05	<d	<d	<d	<d	<d
Replicate 3	0.11	0.01	0.01	<d	0.05	<d	<d	<d	<d	<d
Mean	0.14		0.01	0.03	0.04					
Std dev	0.03		0.001	0.03	0.01					
% RSD	25		4.6	85	33					
Sample collected 5 m from a crater										
Replicate 1	<d	<d	<d	<d	<d	<d	<d	<d	<d	<d
Replicate 2	<d	<d	<d	<d	<d	<d	<d	<d	0.02	<d
Replicate 3	<d	<d	<d	<d	<d	<d	<d	<d	<d	<d
Mean										
Std dev										
% RSD										
South Arroyo #4										
Replicate 1	<d	<d	0.01	0.01	<d	<d	<d	<d	<d	<d
Replicate 2	<d	<d	<d	0.01	<d	<d	<d	<d	<d	<d
Replicate 3	<d	<d	<d	0.01	<d	<d	<d	<d	<d	<d
Mean				0.01						
Std dev				0.001						
% RSD				13						
North Arroyo #5										
Replicate 1	0.07	<d	<d	<d	0.01	0.01	<d	<d	<d	<d
Replicate 2	0.05	<d	<d	<d	<d	<d	<d	<d	<d	<d
Replicate 3	0.03	<d	<d	<d	<d	<d	<d	<d	<d	<d
Mean	0.05									
Std dev	0.02									
% RSD	38									

(sheet 1 of 3)

Sample	Concentration, mg/kg									
	TNT	TNB	2,4 DNT	2ADNT	4ADNT	DNB	DNA	RDX	NG	HMX
10-m × 10-m grid near 2,000-lb bomb										
Replicate 1	17.2	0.05	0.08	0.63	0.61	<d	0.04	<d	<d	<d
Replicate 2	17.1	0.05	0.08	0.64	0.61	<d	0.04	<d	<d	<d
Replicate 3	17.3	0.05	0.08	0.64	0.60	<d	0.04	<d	<d	<d
Mean	17.2	0.05	0.08	0.64	0.61		0.04			
Std dev	0.09	0.00	0.00	0.01	0.01		0.00			
% RSD	0.5	0.00	1.4	0.8	0.8		3.1			
10-m × 10-m grid away from 2,000-lb bomb										
Replicate 1	0.50	0.01	<d	0.02	0.02	<d	<d	<d	<d	<d
Replicate 2	0.54	0.01	<d	0.02	0.02	<d	<d	<d	<d	<d
Replicate 3	0.58	0.01	<d	0.01	0.02	<d	<d	<d	<d	<d
Mean	0.54	0.01		0.02	0.02					
Std dev	0.04	0.001		0.004	0.002					
% RSD	6.7	14		19	8.9					
100-m × 100-m grid near 2,000-lb bomb										
Replicate 1	2.76	0.02	<d	0.12	0.11	<d	<d	<d	<d	<d
Replicate 2	2.74	<d	<d	0.12	0.11	<d	<d	<d	<d	<d
Replicate 3	2.78	<d	<d	0.11	0.10	<d	<d	0.02	<d	<d
Mean	2.76			0.12	0.11					
Std dev	0.02			0.01	0.01					
% RSD	0.7			5.5	4.6					
100-m × 100-m grid away from 2,000-lb bomb										
Replicate 1	<d	0.02	0.01	0.12	0.04	<d	0.01	0.02	0.09	0.01
Replicate 2	<d	0.02	0.01	0.10	0.03	<d	0.01	0.02	0.01	0.01
Replicate 3	<d	0.02	0.00	0.09	0.03	<d	0.01	0.02	0.01	0.01
Mean		0.02	0.01	0.11	0.03		0.01	0.02	0.04	0.01
Std dev		0.00	0.00	0.02	0.01		0.001	0.004	0.05	0.001
% RSD		14	14	16	18		11	20	126	11
Demolition area #1										
Replicate 1	<d	<d	0.01	0.01	0.02	<d	<d	4.80	0.60	1.12
Replicate 2	<d	<d	0.02	0.01	0.02	<d	<d	4.48	0.39	0.95
Replicate 3	<d	<d	0.03	0.02	0.02	<d	<d	3.88	1.12	0.81
Mean			0.02	0.01	0.02			4.39	0.70	0.96
Std dev			0.011	0.001	0.002			0.47	0.37	0.16
% RSD			55	8.2	7.8			11	53	17

(sheet 2 of 3)

Sample	Concentration, mg/kg									
	TNT	TNB	2,4 DNT	2ADNT	4ADNT	DNB	DNA	RDX	NG	HMX
Demolition area #2										
Replicate 1	0.06	0.02	<d	<d	<d	<d	0.06	12.70	<d	2.3
Replicate 2	0.05	<d	<d	<d	<d	<d	0.03	10.98	<d	1.93
Replicate 3	0.04	0.02	<d	<d	<d	<d	0.04	12.24	<d	2.24
Mean	0.05	0.02					0.04	11.97		2.16
Std dev	0.01	0.01					0.02	0.89		0.20
% RSD	12	61.3					37	7.4		9.2
Demolition area #3										
Replicate 1	2.02	0.02	<d	<d	<d	<d	0.03	13.32	<d	2.32
Replicate 2	2.10	<d	<d	<d	<d	<d	<d	15.42	<d	2.56
Replicate 3	2.04	0.02	<d	<d	<d	<d	<d	8.66	<d	2.42
Mean	2.05	0.02						12.47		2.43
Std dev	0.04	0.01						3.46		0.12
% RSD	2.0	57.7						28		5.0
Demolition area #4										
Replicate 1	0.13	<d	<d	<d	<d	<d	<d	4.42	<d	1.10
Replicate 2	0.12	<d	<d	<d	<d	<d	0.04	4.04	<d	1.01
Replicate 3	0.12	<d	<d	<d	<d	<d	0.14	3.76	<d	0.93
Mean	0.12						0.06	4.07		1.02
Std dev	0.01						0.07	0.33		0.08
% RSD	5.7						116	8.1		8.3
Summary Statistics										
<i>n</i>	9*	6	5	8	7	0	5	5	2	5
Mean % RSD	10.2	25.8	15.2	18.5	10.5		34.0	14.7	89.6	10.1
Minimum % RSD	0.52	0.00	1.40	0.40	0.40		2.44	7.44	53.2	4.95
Maximum % RSD	38.3	61.3	54.5	84.9	33.2		116	27.8	126	16.6
Mean concentration	12.5	0.02	0.09	0.15	0.16		0.04	6.58	0.37	1.31

(sheet 3 of 3)

* One additional sample analyzed by GC-ECD had a mean TNT concentration of 0.08 mg/kg, with an RSD of 17 percent.

Conclusions

Results from this study indicate that discrete surface soil samples collected from a live-fire bombing range are not normally distributed. The variability among discrete samples is very large even for areas as small as 1 m × 1 m. This is consistent with results from a variety of other types of military firing range impact areas (Ampleman et al. 2003; Jenkins et al. 1999, 2001, 2004a, b; Hewitt et al. 2005; M.E. Walsh et al. 2004, 2005). Using a

sampling strategy based on a few discrete samples or a multi-increment sample using only a few increments would provide estimates of the mean concentration with a very large uncertainty. Much more reliable estimates of the mean concentrations were achieved using a stratified systematic random sampling design with collection of multi-increment samples with at least 30 increments.

TNT was the energetic compound detected at the highest concentration in surface and shallow subsurface samples from the live-fire range. RDX was generally below analytical detection limits in these samples, although it was occasionally detected at trace levels, perhaps due to the use of C4 demolition explosive to destroy duds during semi-annual range maintenance activities. No evidence of off-site migration of residues was found in either depth profile samples or samples collected along an arroyo that drains the entire live-fire range.

RDX and HMX were the two energetic compounds detected at the highest concentration at a small demolition range used to ensure that practice bombs do not contain energetic compounds prior to removal for metal recycling. C4 demolition explosive is the most likely source of these residues.

Sample processing and subsampling protocols used in this work were adequate to maintain the laboratory contribution to total characterization uncertainty at acceptable levels. These protocols used a 2-mm sieve to remove oversized material, machine grinding for material that passed the 2-mm sieve, a subsampling procedure that combined 30-increments from the ground soil, and a subsample mass of 10 grams.

References

- Ampleman, G., S. Thiboutot, J. Lewis, A. Marois, A. Gagnon, M. Bouchard, T. Jenkins, T. A. Ranney, and J. C. Pennington. 2004. Evaluation of the contamination by explosives and metals in soils, vegetation, surface water, and sediment at Cold Lake Air Weapons Range (CLAWR), Alberta: Phase II Final Report. Technical Report 2004-204. Defence Research and Development Canada–Valcartier.
- Ampleman, G., S. Thiboutot, J. Lewis, A. Marois, S. Jean, A. Gagnon, M. Bouchard, T.F. Jenkins, J.C. Pennington, and T.A. Ranney. 2003. *Evaluation of the contamination by explosives in soils, biomass and surface water at Cold Lake Air Weapons Range (CLAWR), Alberta: Phase I Report*. Technical Report TR 2003-208. Defence Research Development Canada–Valcartier.

- Hewitt, A. D., T. F. Jenkins, C. A. Ramsey, K. L. Bjella, T. A. Ranney, and N. Perron. 2005. *Estimating energetic residue loading on military artillery ranges: Large decision units*. Technical Report ERDC/CRREL TR-05-7. Hanover, NH: U.S. Army Engineer Research and Development Center.
- Hewitt, A. D., T. F. Jenkins, T. A. Ranney, J. A. Stark, M. E. Walsh, S. Taylor, M. R. Walsh, D. J. Lambert, N. M. Perron, N. H. Collins, and R. Karn. 2003. *Estimates for explosives residues from the detonation of Army munitions*. Technical Report ERDC/CRREL TR-03-16. Hanover, NH: U.S. Army Engineer Research and Development Center.
- Jenkins, T. F., C. L. Grant, G. S. Brar, P. G. Thorne, P. W. Schumacher, and T. A. Ranney. 1997. Assessment of sampling error associated with the collection and analysis of soil samples at explosives-contaminated sites. *Field Analytical Chemistry and Technology* 1: 151–163.
- Jenkins, T. F., C. L. Grant, M. E. Walsh, P. G. Thorne, S. Thiboutot, G. Ampleman, and T. A. Ranney. 1999. Coping with spatial heterogeneity effects on sampling and analysis at an HMX-contaminated anti-tank firing range. *Field Analytical Chemistry and Technology* 3: 19–28.
- Jenkins, T. F., J. C. Pennington, T. A. Ranney, T. E. Berry, Jr., P. H. Miyares, M. E. Walsh, A. D. Hewitt, N. Perron, L. V. Parker, C. A. Hayes, and E. Wahlgren. 2001. *Characterization of explosives contamination at military firing ranges*. Technical Report ERDC TR-01-05. Hanover, NH: U.S. Army Engineer Research and Development Center.
- Jenkins, T. F., T. A. Ranney, A. D. Hewitt, C. A. Ramsey, D. Lambert, K. L. Bjella, and N. Perron. 2004b. *Sampling strategies near a low-order detonation and a target at an anti-tank impact area*. Technical Report ERDC/CRREL TR-04-14. Hanover, NH: U.S. Army Engineer Research and Development Center.
- Jenkins, T. F., T. A. Ranney, A. D. Hewitt, M. E. Walsh, and K. L. Bjella. 2004a. *Representative sampling for energetic compounds at an anti-tank firing range*. Technical Report ERDC/CRREL TR-04-7. Hanover, NH: U.S. Army Engineer Research and Development Center.
- U.S. Environmental Protection Agency (1994) Nitroaromatics and Nitramines by HPLC, Second Update SW846 Method 8330.
- U.S. Environmental Protection Agency (1999) Nitroaromatics and Nitramines by GC-ECD, Fourth Update SW846 Method 8095.
- Walsh, M. E., C. A. Ramsey, C. M. Collins, A. D. Hewitt, M. R. Walsh, K. L. Bjella, D. J. Lambert, and N. M. Perron. 2005. *Collection methods and laboratory processing of samples from Donnelly Training Area firing points, Alaska, 2003*. Technical Report ERDC/CRREL TR-05-6. Hanover, NH: U.S. Army Engineer Research and Development Center.
- Walsh, M. E., C. M. Collins, A. D. Hewitt, M. R. Walsh, T. F. Jenkins, J. Stark, A. Gelvin, T. Douglas, N. Perron, D. Lambert, R. Bailey, and K. Myers. 2004. *Range characterization studies at Donnelly Training Area, Alaska 2001 and 2002*. Technical Report ERDC/CRREL TR-04-3. Hanover, NH: U.S. Army Engineer Research and Development Center.

Walsh, M. R., M. E. Walsh, T. F. Jenkins, A. D. Hewitt, and C. A. Ramsey. 2005. *Optimization of explosives residues collection from the detonation of munitions on snow-covered ice*. Technical Report ERDC/CRREL TR-05-8. Hanover, NH: U.S. Army Engineer Research and Development Center.

6 Explosive Residues from Blow-in-Place Detonations of Artillery Munitions

Introduction

Background

The preferred protocol for eliminating the explosion hazard of UXO on training ranges when the UXO cannot be safely moved is to detonate, or blow, the UXO in place, hence the designation BIP. For the safety of disposal personnel, the objective is often to create the smallest explosion that is sufficient to deactivate the ordnance. Detonation is accomplished by initiating a donor explosive charge (e.g., a block of C4 or a shaped charge) placed on or near the UXO. When incomplete explosions result, such BIP procedures scatter residual explosive material from the UXO across the soil surface. The dispersed particles are distributed sources for migration of explosive residues in the environment. Furthermore, residues from C4, which contains primarily RDX, may also be left on the soil surface. Since RDX has been detected in groundwater associated with training ranges and is known to be extremely mobile through the soil, introduction of RDX into the environment is undesirable.

Objective and approach

The objective of this study was to optimize BIP practices by determining which of four donor explosives produced the greatest consumption of explosive constituents, leaving behind the smallest amount of residue. Mortar rounds and heavy artillery projectiles were selected for study because they are among the largest and most heavily used munitions on artillery training ranges. In this study, the explosive residues associated with BIP of 60- and 81-mm mortar rounds, and 105- and 155-mm artillery projectiles were determined. Residues resulting from BIP practices were quantified for the following donor charges: C4, shaped charges, block TNT, and a binary explosive. Detonations were executed on the surface of clean sand contained in a steel bucket. The bucket was placed on a tarp to facilitate recovery of residues. The mass was collected with respect to distance from the detonation center. These tests were performed at the U.S. Army Redstone Technical Test Center, Redstone Arsenal, AL.

Benefits

Optimizing BIP practices will make a significant contribution to training range sustainment. Benefits include:

1. minimizing/avoiding the introduction of RDX into the environment,
2. minimizing the scattering of explosives, which increases dissolution rate, transport rate, bioavailability, and groundwater contamination potential, and complicates recovery/remediation of residues, and
3. protecting the environment while ensuring range explosive safety.

Materials and methods

Test site

The test site was covered by a 30.5-m × 30.5-m (100-ft × 100-ft) vinyl tarp. Concentric circles were marked on the tarp to facilitate collection of residue with respect to distance from the detonation (Figures 6–1 and 6–2). Detonations were executed on a bed of clean masonry sand in a 1 m (length) × 1.8 m (width) × 2.7 m (height) bucket resting on wooden blocks over a 10.2-cm × 15.2-cm × 1.9-cm (4-in. × 6-in. × 0.75-in.) steel plate (Figure 6–2). The sand was used to simulate the effects of soil on the blasts; post-blast entrainment of soil into the fireball potentially quenches the afterburn resulting in less effective consumption of explosives. After sampling, the sand remaining in the bucket was removed, the bucket was washed with a pressure hose and refilled with clean sand.

Detonations

Rounds. The following four Composition B-filled rounds were tested: 60-mm and 81-mm mortar rounds, 105-mm and 155-mm artillery projectiles (Table 6–1).

Donor charges. The donor charges were selected on the basis of frequency of use by EOD personnel for BIP operations as determined in a previous study by the Ordnance and Explosives Team at the U.S. Army Corps of Engineers Huntsville Center, Huntsville, AL. Detonations were typical of configurations used by EOD personnel for the specific donor and munition combinations (Table 6–1, Figure 6–3). They included shaped charges (30 and 36 g RDX, Halliburton Energy Services, Houston, TX), C4 (91 percent RDX, 5.3 percent plasticizer, 2.1 percent binder, and

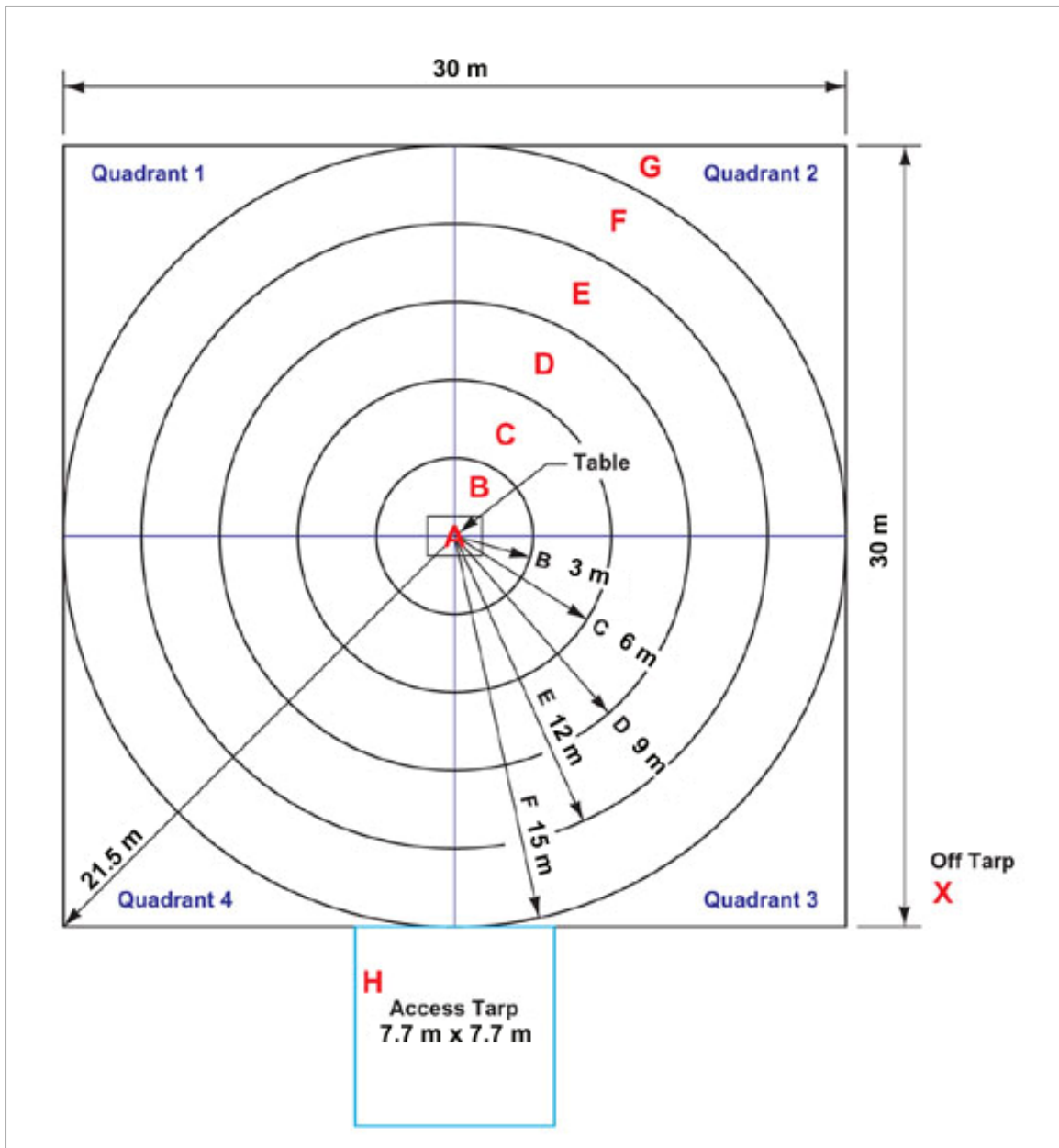

Figure 6-1. Concentric circles for sampling sand after detonations. This configuration was used for 60- and 81-mm mortar rounds. For 105- and 155-mm artillery projectiles, crater (A), 3-, 9-, and 18-m circles were used. Additional tarp was added to expand the circle. These received new sequential designations A, B, C, and D.



Figure 6-2. Field team recovers detonation residues by sweeping sand in concentric circles around detonation bucket.

1.6 percent petroleum oil) in 1.25-lb (0.567-kg) blocks, Block TNT (1 lb, or 0.454 kg), and a binary explosive (Kinepak, Slurry Explosive Corp., Oklahoma City, OK) consisting of a solid base (K-1-S, 99-100 percent ammonium nitrate, Chemical Abstracts Service (CAS) No. 6484-52-2) and a liquid activator (K-1-L, minimum of 95-100 percent nitromethane, CAS No. 75-52-5).

Supporting hardware. Detonation of the 60-mm mortar rounds with the shaped charge used two M60 igniters, two M14 blasting caps, and a 12-in. (30.5-cm) detonation cord (Halliburton) containing 80 grains (5.5 g) of penta erithrol tetranitrate (PETN) per inch (Table 6–2). Detonation of the 81-mm mortar rounds used two M81 igniters, two M14 blasting caps, and a 16-in. 80-grain detonation cord. All detonations of 105- and 155-mm rounds used two M81 igniters, two M7/M131 blasting caps, and two 90-in. (2.31-m) lengths of M700 time fuse (5 minutes).

Table 6-1. Description of test rounds, donor charges, and number of sandbags.

Round		Donor		Sandbags ³
Size mm	NSN ¹ and/or DODIC ² , (Mass Comp B, g)	Quantity/Description	NSN and/or DODIC	
60	M49A4/M632 (191)	Halliburton Shaped Charge, 30 g RDX	137501-299-5872 or IMU92A001-002	None
		C-4, 1 1¼-lb block, M112	M023	None
		1 1-lb block TNT	1375-00-028-5142/M032	None
		2 dry and 2 wet Kinepak	K-1-S/K-1-L	None
81	1315-00-563-7067/M374A3/M374A2 (726)	Halliburton Shaped Charge, 36 g RDX DP-36	137501-299-5872 or IMU92A001-002	None
		C-4, 1 1¼-lb block	M023	None
		1 1-lb block TNT	1375-00-028-5142/M032	None
		2 dry and 2 wet Kinepak	K-1-S/K-1-L	None
105	1315-00-028-4857/C445 (2,304)	Halliburton Shaped Charge, 36 g RDX DP-36	137501-299-5872 or IMU92A001-002	None
		C-4, 2 1¼-lb blocks	M023	1
		2 1-lb blocks TNT, stacked	1375-00-028-5142/M032	1
		2 dry and 2 wet Kinepak	K-1-S/K-1-L	2
155	1320-01-257-4222/D544 (6,985)	Halliburton Shaped Charge, 36 g RDX DP-36	137501-299-5872 or IMU92A001-002	None
		C-4, 2 1¼-lb blocks	M023	None

¹ National Stock Number.

² Department of Defense Identification Code.

³ Number of sandbags placed over the donor charge prior to initiation.

Test protocol

With the exception of the 155-mm artillery projectile, each round was tested with each donor charge in seven replicates. The 155-mm artillery projectile was tested with C4 and the shaped charge only and in five replicates only. The performance of the binary charge and the TNT block with the 105-mm round suggested that these two donors would be ineffective with the larger 155-mm round. Therefore, except for one detonation of the 155-mm round with block TNT, these donors were not tested with the 155-mm round.



Figure 6-3. 81-mm mortar rounds with (a) shaped charge, (b) C4, and (c) TNT; (d) 60-mm mortar round with binary charge.

Sampling

Samples were collected by sweeping and collecting all of the sand in each concentric circle (Figures 6–1 and 6–2). The crater, A, was sampled by removing the top 1-cm of sand. Samples were placed into 19-L buckets lined with plastic bags labeled according to shot number (consecutively starting with Shot 1), and the tarp area from which the sample was collected. After weighing and with quantity permitting, all of the sample bags from the same tarp area of a single detonation were combined in a 0.14 m³ cement mixer (IMER, San Francisco, CA) and allowed to tumble for 10 min. When samples were larger than 0.07 m³, they were mixed in two lots combined and remixed. Very small samples were hand mixed in a

Table 6-2. Detonation supporting hardware.

Round mm	Donor	Igniter, quantity	Blasting Cap, quantity, DODIC ¹ or NSN ²	Time Fuse, number of pieces, length, time, NSN	Detonation Cord, number of pieces, length, NSN
60	Shaped Charge (Halliburton)	M60, 2, DODIC: M766	M14, 2, NSN: 1375-01-482-7380	None	1, 12-inch, 80 grain, NSN: 1375-01-X02-8146
	C-4	M60, 2,	None	2, M-14, 7.5 feet, 5-minute, NSN: 1375-01-482-7380	None
	Block TNT	M60, 1	None	1, M-14	None
	Binary Charge (Kinopak)	M81, 2, NSN: 1375-01-415-1235	M14, 2	None	None
81	Shaped Charge (Halliburton)	M81, 2	M14, 2	2, M14	1, 16-inch
	C-4	M81, 2	None	2, M14, 7.5 feet, 5-minute	None
	Block TNT	M60, 1	None	1, M-14	None
	Binary Charge (Kinopak)	M81, 2	M14, 2	None	None
105	Shaped Charge (Halliburton)	M81, 2	M7/M131, 2	M700, 2, 90-inch, 5-minute	1, 18-inch
	C-4	M81, 2	M7/M131, 2	M700, 2, 90-inch, 5-minute	None
	Block TNT	M81, 2	M7/M131, 2	M700, 2, 90-inch, 5-minute	None
	Binary Charge (Kinopak)	M81, 2	M7/M131, 2	M700, 2, 90-inch, 5-minute	None
155	Shaped Charge (Halliburton)	M81, 2	M7/M131, 2	M700, 2, 90-inch, 5-minute	1, 18-inch
	C-4	M81, 2	M7/M131, 2	M700, 2, 90-inch, 5-minute	None

¹ National Stock Number.² Department of Defense Identification Code.

stainless steel bowl before subsampling. A 1-L subsample was obtained by taking a minimum of 10 increments throughout the mixed sample. These were combined in a glass sample jar, sealed, labeled, and refrigerated until shipped on ice to the analytical chemistry laboratory. Sample buckets were rinsed and towel dried after each use. The cement mixer was unplugged, and the inside washed with a pressure hose and towel dried between uses.

A modification of the sampling protocol was required for sampling residues from the two largest artillery munitions. The volume of sand within the 3-m and occasionally within the 9-m circle was too large to sample in its entirety. Therefore, incremental surface sampling was conducted within the rings near the detonation center where the sand was approximately 5 cm deep. Ten increments were obtained, provided that the surface area was sufficiently large. These were combined to generate a single sample for that ring. Where sand was not sufficiently deep for surface increment sampling, the ring was swept as per the previous protocol. Surface increments were collected in a 33-cm \times 23-cm baking pan with a 10-cm \times 10-cm window cut into the bottom (Figure 6-4). The pan was placed on the sand surface and a sample obtained by dragging the flat sampling tool over the surface to a depth of approximately 1 cm (Figure 6-4).



Figure 6-4. Surface sand sampling through a 10-cm \times 10-cm window cut into a 33-cm \times 23-cm baking pan.

Sample analysis

Samples were analyzed according to EPA Method 8330 (USEPA 1994) and/or EPA Method 8095 (USEPA 2000) (Table 6–3). Standards for the nitroso derivatives of RDX, which are not included in the standard methods, were added to these two protocols.

Table 6-3. Explosives and degradation products of explosives for which samples were analyzed.

Compound	Abbreviation/Short Designation	Description
Hexahydro-1,3,5-trinitro-1,3,5-triazine	RDX ^{1,2}	A principal explosive component (59.5 %) of Composition B fill in mortar rounds and artillery projectiles
2,4,6-Trinitrotoluene	TNT ^{1,2}	A principal explosive component (39.5 %) of Composition B fill in mortar rounds and artillery projectiles
Octahydro-1,3,5,7-tetranitro-1,3,5,7-tetrazocine	HMX ^{1,2}	An impurity in military grade TNT
N-methyl-n,2,4,6-tetranitroaniline	Tetryl ^{1,2}	Used as a booster, a small charge placed next to the detonator; the standard bursting charge for small-caliber projectiles
Pentaerythritol tetranitrate	PETN ²	Propellant
Nitroglycerin	NG ²	Component of certain propellants
2-Amino-4,6-dinitrotoluene	2ADNT ^{1,2}	Mono amino transformation product of TNT
4-Amino-2,6-dinitrotoluene	4ADNT ^{1,2}	Mono amino transformation product of TNT
2,4-Dinitrotoluene	2,4DNT ^{1,2}	Incomplete nitration products of TNT synthesis; component of certain propellants
2,6-Dinitrotoluene	2,6DNT ^{1,2}	Incomplete nitration products of TNT synthesis
1,3,5-Trinitrobenzene	TNB ^{1,2}	Photodecomposition product of TNT
1,3-Dinitrobenzene	DNB ^{1,2}	Photodecomposition product of TNT
Nitrobenzene	NB ^{1,2}	Photodecomposition product of TNT
3,5-dinitroaniline	3,5DNA ²	Photodecomposition product of TNT
2-Nitrotoluene	2NT ^{1,2}	Incomplete nitration products of TNT synthesis
3-Nitrotoluene	3NT ^{1,2}	Incomplete nitration products of TNT synthesis
4-Nitrotoluene	4NT ^{1,2}	Incomplete nitration products of TNT synthesis
Hexahydro-1-nitroso-3,5-dinitro-1,3,5-triazine	MNX	Mono nitroso derivative of RDX produced by microbial degradation
Hexahydro-1,3-dinitroso-5-nitro-1,3,5-triazine	DNX	Di nitroso derivative of RDX produced by microbial degradation
Hexahydro-1,3,5-trinitroso-1,3,5-triazine	TNX	Tri nitroso derivative of RDX produced by microbial degradation

¹ Standard analytes of EPA Method 8330 (USEPA 1994).

² Standard analytes of EPA Method 8095 (USEPA 2000).

Statistical analytes

Prior to comparison of donors, data for each round and analyte were tested for normality using Shapiro-Wilk's test and QQ plots, and equality of variances using Levene's test. All data were severely non-normal, due mainly to the occurrence of many zero values and a few high outliers. Several data transformations were tried in an attempt to achieve normality and equality of variances. These included square root, double square root, $\ln(\text{mass} + 1)$, normalized ranks (i.e., rankits), exponential, and Box-Cox. The latter two are iterative families of transformations described in Blackwood (1995).

Results and discussion

Total mass

Although no blast pressure readings were obtained, almost all detonations were considered high-order by EOD personnel based on visual observation of the blasts via closed circuit video camera. In general, total explosive residues from all of the rounds with all of the donors were less than 100 mg per shot. Exceptions were detonations executed with the binary explosives, Kinepak, on the 105-mm projectiles (Figure 6–5). Residues from these detonations were a significant three orders of magnitude greater than residues from any of the other donor charges (Figure 6–6). Tests with this donor charge were not conducted with the 155-mm projectile. Results for the 81-mm mortar rounds detonated with C4 were consistent with those of Hewitt et al. (2005) on snow, which estimated, on the basis of sampling approximately 10 percent of the soot-covered snow, an average of 35 mg of RDX and 0.24 mg of TNT with high variability among the five replicates. Values for RDX and TNT were 46.8 ± 45.9 and 15.1 ± 21.0 mg, respectively. Hewitt et al. (2005) also detonated five replicate 155-mm rounds with a single block of C4 and based residue estimates on sampling of 1 percent of snow cover. They estimated no RDX residue and 20 g of TNT residue. Our values were 2.09 ± 4.33 mg for RDX and 0.05 ± 0.06 mg for TNT. Our lower value for TNT is likely due to use of two blocks of C4.

These results demonstrate consumption of nearly all of the original mass of Composition B, typically more than 99.99 percent, by high-order BIP detonations. The only exception was the binary charge tested with the 105-mm projectile, which consumed an average of 97.05 percent of the Composition B.



a.



b.

Figure 6-5. (a) 105-mm artillery projectile with Kinepak donor; (b) donor and projectile covered by two sand bags to promote high-order detonation by confining the donor.

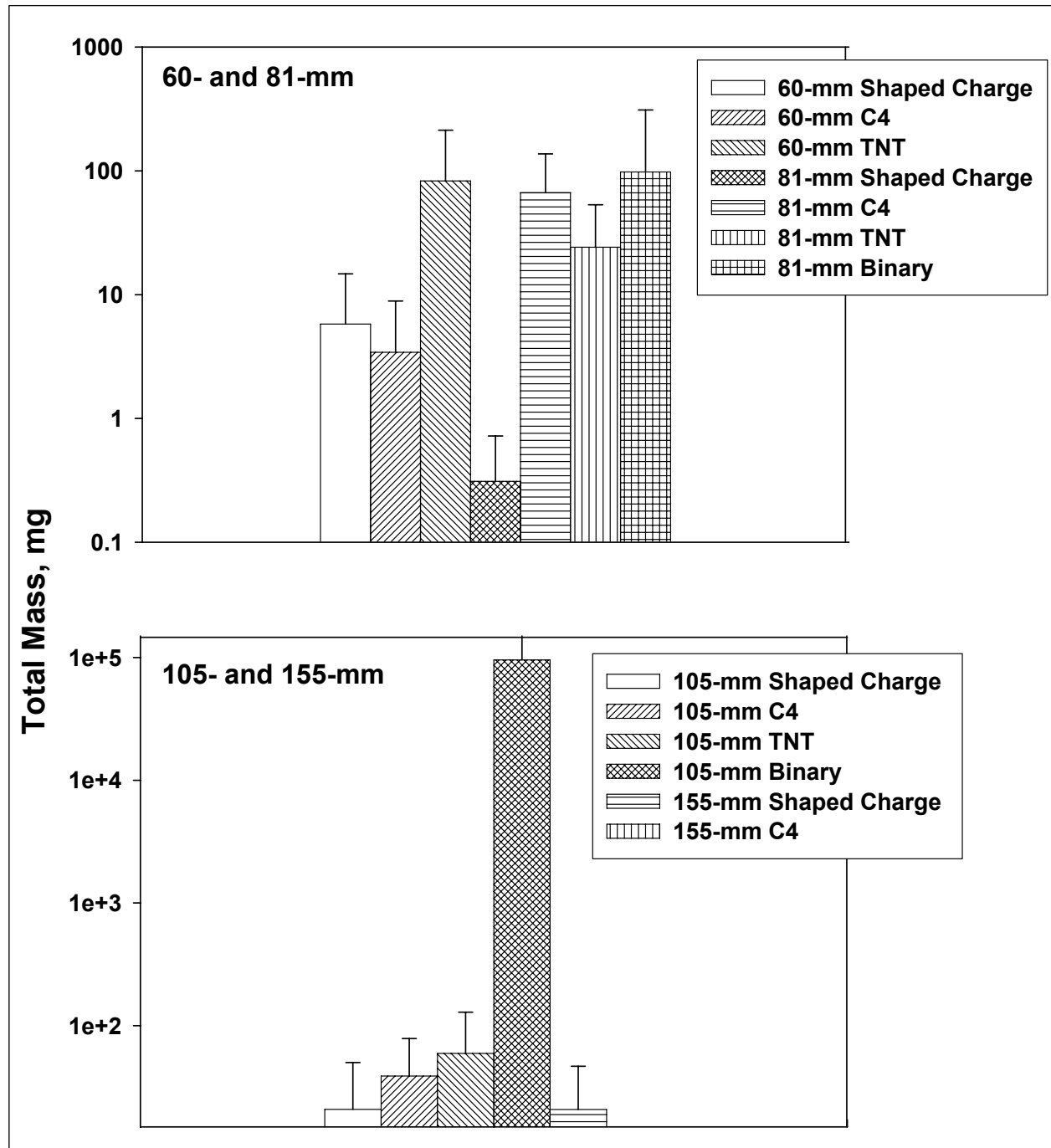

Figure 6-6. Total mass (sum of RDX, TNT, and HMX, average of replicates with standard deviation error bars) for each round and donor combination. No residue was observed for 60-mm mortar rounds detonated with binary charge. Mean total residue from 155-mm rounds detonated with C4 was 2.13 ± 4.38 mg (not visible on log y-axis scale).

60-mm mortar round. The most successful donor charge for the 60-mm mortar rounds was the binary. No constituent residue was detected in any replicates of the mortar rounds with this donor. All other donors left milligram (mg) quantities of RDX and microgram (μg) to mg quantities of TNT (Figure 6–7). Without considering the binary charge, the C4 donor produced the smallest quantity of residue and the TNT donor produced the greatest (Table 6–4). The TNT donor also generated significant TNT residues. When residue mass was analyzed by analyte (RDX, HMX, and TNT) and donor (TNT, shaped charge, C4, > binary charge), differences between donors were significant for RDX (TNT, shaped charge, C4 > binary charge) and TNT (TNT > shaped charge, C4 > binary charge) (Table 6–4).

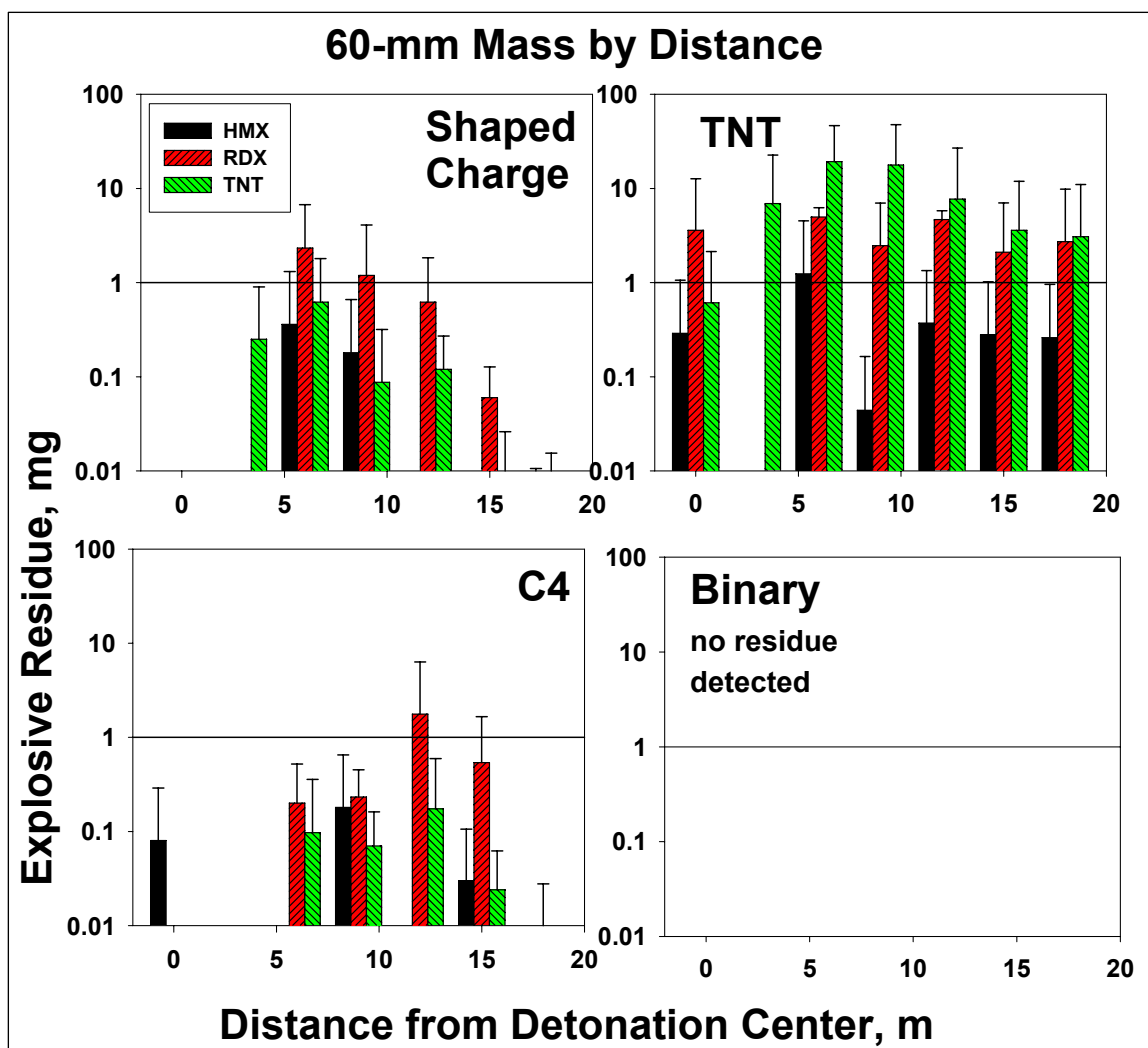

Figure 6-7. Mass of HMX, RDX, and TNT with distance for each donor charge tested with 60-mm mortar rounds.

Table 6-4. Results of statistical analyses of the 60- and 81-mm mortar rounds data by donor for detections of HMX, RDX, TNB, and TNT¹.

Round	Analyte	Donor	Mean mg	Std Err	N	Skewness	Kurtosis	Transformation	Test	Anova		
										F	P	
60	HMX	C	0.287	0.178	7	1.798	2.910	rankit ²	Fisher's protected LSD alpha = 0.05	1.2	0.3325	
60	HMX	H	0.544	0.374	7	1.744	2.267					
60	HMX	K	0.000	0.000	7							
60	HMX	T	2.488	2.487	7	2.646	7.000					
60	RDX	C	2.710 ⁴	1.900	7	2.270	5.231	rankit		one-directional Bonferroni t-test ³	4.66	0.0106
60	RDX	H	4.110 ⁴	2.552	7	1.264	-0.606					
60	RDX	K	0.000	0.000	7							
60	RDX	T	20.535 ⁴	17.171	7	2.550	6.580					
60	TNB	C	0.041	0.027	7	1.523	0.963	exponential	Fisher's protected LSD alpha = 0.05			
60	TNB	H	0.048	0.048	7	2.646	7.000					
60	TNB	K	0.000	0.000	7							
60	TNB	T	0.076	0.039	7	1.242	0.729					
60	TNT	C	0.184 ⁴	0.130	7	2.024	3.870	rankit		Fisher's protected LSD alpha = 0.05	22.79	<0.0001
60	TNT	H	1.067 ⁴	0.501	7	0.963	-0.253					
60	TNT	K	0.000	0.000	7							
60	TNT	T	58.867 ⁵	31.349	7	1.655	2.195					
81	HMX	C	4.741 ⁶	1.963	7	0.386	-2.683	exponential	Fisher's protected LSD alpha = 0.05		8.33	0.0006
81	HMX	H	0.000	0.000	7							
81	HMX	K	14.163 ⁶	13.853	6	2.449	5.998					
81	HMX	T	0.059	0.047	7	2.457	6.138					
81	RDX	C	46.794 ⁶	17.358	7	0.943	0.533	rankit		one-directional Bonferroni t-test ³	8.03	0.0008
81	RDX	H	0.306	0.154	7	0.751	-1.698					
81	RDX	K	76.600 ⁷	69.858	6	2.435	5.942					
81	RDX	T	1.640 ⁷	0.884	7	2.398	6.009					
81	TNB	C	0.012	0.011	7	2.629	6.927	exponential	Fisher's protected LSD alpha = 0.05		2.44	0.0901
81	TNB	H	0.000	0.000	7							
81	TNB	K	0.181	0.181	6	2.449	6.000					
81	TNB	T	0.036	0.020	7	1.323	0.265					
81	TNT	C	15.100 ⁷	7.922	7	1.385	1.173	rankit		Fisher's protected LSD alpha = 0.05	10.86	0.0001
81	TNT	H	0.000	0.000	7							
81	TNT	K	2.786 ⁷	2.464	6	2.426	5.905					
81	TNT	T	22.449 ⁷	10.739	7	1.385	1.678					

Note: N = number of replicates.

¹ For both 60- and 81-mm mortar rounds, normality was achieved using the rankit transformation for analytes RDX and TNT. TNB in both mortar rounds and HMX in the 81-mm mortar rounds were normalized using an exponential transformation e^{Mass} / λ with parameter $\lambda = -960$ (TNB, 60-mm), -21 (HMX, 81-mm), and -403 (TNB, 81-mm). No transformation was successful in achieving normality for HMX in 60-mm mortar rounds, so rankits were used. Equality of variances could not be attained for TNB in 60-mm mortar rounds, so these comparisons were conducted using transformed data in one-directional t-tests, with a one-tailed α adjusted for the number of comparisons ($\alpha = 0.05/6 = 0.0083$). All other comparisons were conducted using transformed data in two-tailed Fisher's protected LSD tests with $\alpha = 0.05$.

² No transformation achieved normality.

³ Alpha = $0.10/6 = 0.0167$.

⁴ Donor significantly greater than K (Kinopak binary).

⁵ Donor significantly greater than K, C (C4), and H (Halliburton shaped charge).

⁶ Donor significantly greater than T (TNT) and H.

⁷ Donor significantly greater than H.

81-mm mortar round. This mortar round generated more residue than any other round. Hewitt et al. (2003) also observed that the detonation efficiency for the 81-mm round was significantly less than for the 105- or 155-mm rounds. The shaped charge was the most effective donor for the 81-mm mortar rounds (Figure 6–8). Only μg to low mg quantities of RDX were deposited after detonations with the shaped charge. Differences between donors were significant for HMX (C, K>T, H), RDX (C>T>H, K>H), and TNT (T, C, K>H) (Table 6–4). The binary charge, so successful with the 60-mm mortar rounds, produced significant (mg) quantities of RDX. C4 produced mg quantities of both RDX and TNT. As observed with the 60-mm mortar rounds, the TNT donor left mg quantities of TNT.

105-mm projectile. The smallest amount of residue from 105-mm projectiles was produced by the Halliburton shaped charge; however, except for the Kinepak binary charge, which generated significantly greater residue than other donors, differences among donor charges for the 105-mm were not significant (Table 6–5). Unlike with the mortar rounds, the TNT donor generated almost no TNT residue but mg quantities of RDX (Figure 6–9). The shaped charge produced only μg quantities of TNT, but mg quantities of RDX. C4 generated both RDX and TNT in mg quantities. The binary charge was too small for the 105-mm projectiles, often resulting in low-order detonations. The replicates sampled were considered high-order by EOD personnel, but residues of RDX, TNT, and HMX were in the g levels. In general the shaped charge left little residue of each of these analytes (Table 6–5). The donors may be listed in order of decreasing residue mass as follows: binary charge>>shaped charge>TNT>C4.

155-mm projectile. Of the two donor charges used to detonate 155-mm projectiles, the C4 generated less residue than the shaped charge; however, differences between the two donors were not significant (Figure 6–10, Table 6–5). Both the shaped charge and the C4 were more effective with this large round than with the previous smaller ones. The significantly greater mass of the 155-mm projectile promotes the consumption of explosives in the detonation and in the afterburn. Nearly all of the observed residue was generated by only two of the five replicate detonations. All of the residue was RDX and TNT; no HMX was detected.

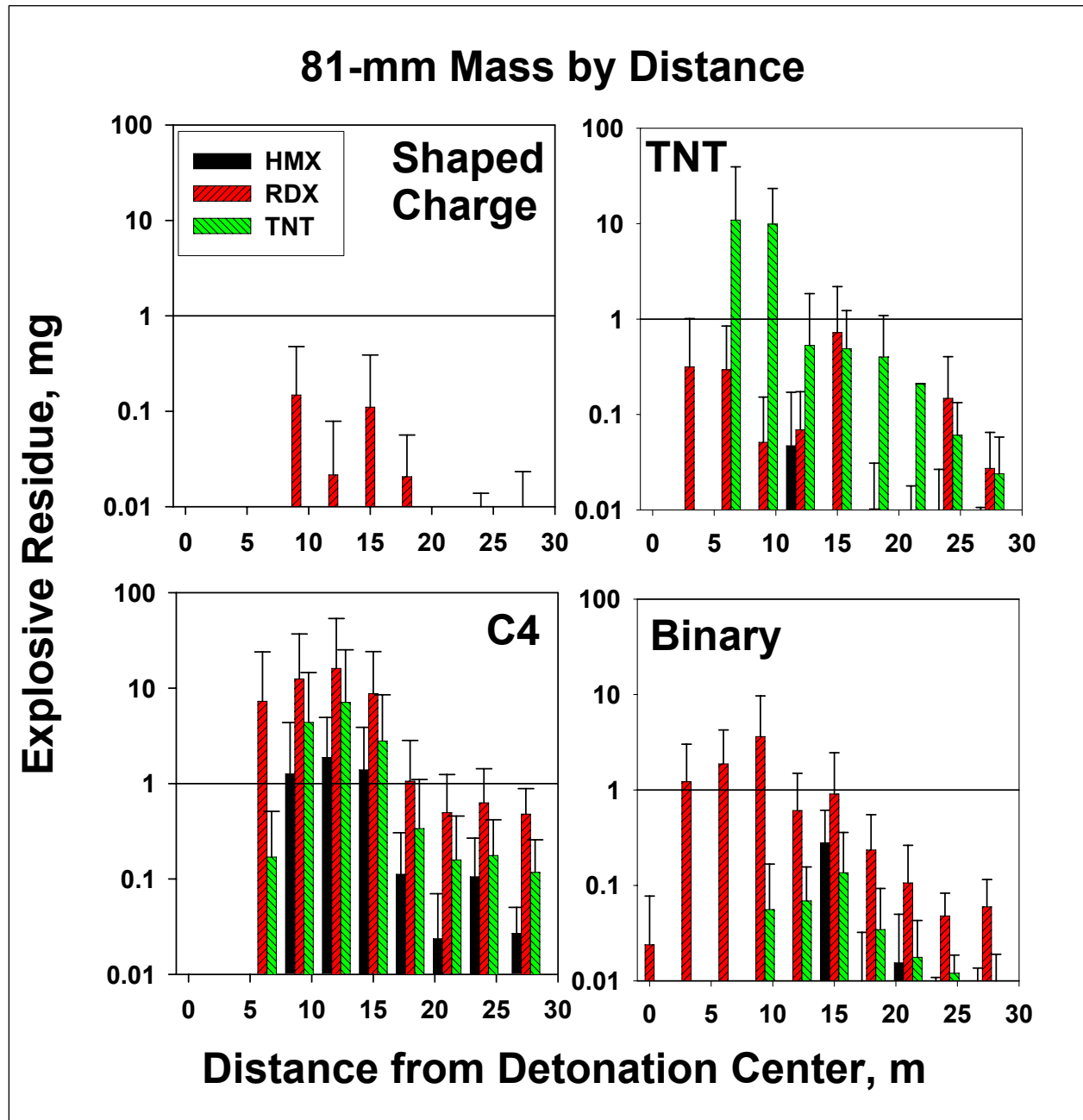

Figure 6-8. Total mass of HMX, RDX, and TNT with distance for each donor charge tested with 81-mm mortar rounds.

Table 6-5. Results of statistical analyses of the 105- and 155-mm mortar round data by donor for detections of HMX, RDX, and TNT¹.

Round	Analyte	Donor	Mean Mg	Std Err	N	Skewness	Kurtosis	Transformation	Test	Anova	
										F	P
105	HMX	C	0.000	0.000	7			rankit	one-directional Bonferroni t-test ²	(no significant differences)	
105	HMX	H	0.022	0.022	7	2.646	7.000				
105	HMX	K	5248.314	2226.359	7	0.847	-0.136				
105	HMX	T	0.835	0.519	5	0.746	-2.534				
105	RDX	C	28.023 ³	15.238	7	1.297	0.054	rankit	Fisher's protected LSD alpha = 0.05	3.33	0.0383
105	RDX	H	17.204 ³	9.098	7	1.176	-0.830			K > (T, H, C)	
105	RDX	K	53696.386	22936.934	7	0.850	-0.176				
105	RDX	T	58.599 ³	30.230	5	1.078	0.285				
105	TNT	C	10.780 ³	6.971	7	1.246	-0.741	rankit ⁴	Fisher's protected LSD alpha = 0.05	3.55	0.0309
105	TNT	H	0.725 ³	0.468	7	1.233	-0.816			K > (C, T, H)	
105	TNT	K	36829.230	14384.138	7	0.218	-2.231				
105	TNT	T	0.578 ³	0.471	5	2.052	4.239				
155	HMX	C	0.000	0.000	5						
155	HMX	H	0.000	0.000	5						
155	RDX	C	2.089	1.937	5	2.215	4.920	sq rt (mass)	Fisher's protected LSD alpha = 0.05	0.59	0.217
155	RDX	H	9.836	7.855	5	2.005	4.032			rankit	3.91
155	TNT	C	0.045	0.028	5	0.665	-3.005				
155	TNT	H	10.915	9.286	5	2.138	4.610				

Note: N = number of replicates.

¹ Normality was achieved using the rankit transformation for HMX and RDX in the 105-mm rounds, and/or TNT in the 155-mm rounds, and using sq rt (mass) for the RDX in the 155-mm rounds. No transformation was completely successful in achieving normality for TNT in the 105-mm rounds, so rankits were used. Equality of variances could not be attained for HMX in the 105-mm rounds, so these comparisons were conducted using transformed data in one-directional t-tests, with a one-tailed α adjusted for the number of comparisons ($\alpha = 0.05/6 = 0.0083$). All other comparisons were conducted using transformed data in two-tailed Fisher's protected LSD tests with $\alpha = 0.05$.

² Alpha = $0.10/6 = 0.0167$.

³ Donor significantly less than K.

⁴ No transformation achieved normality.

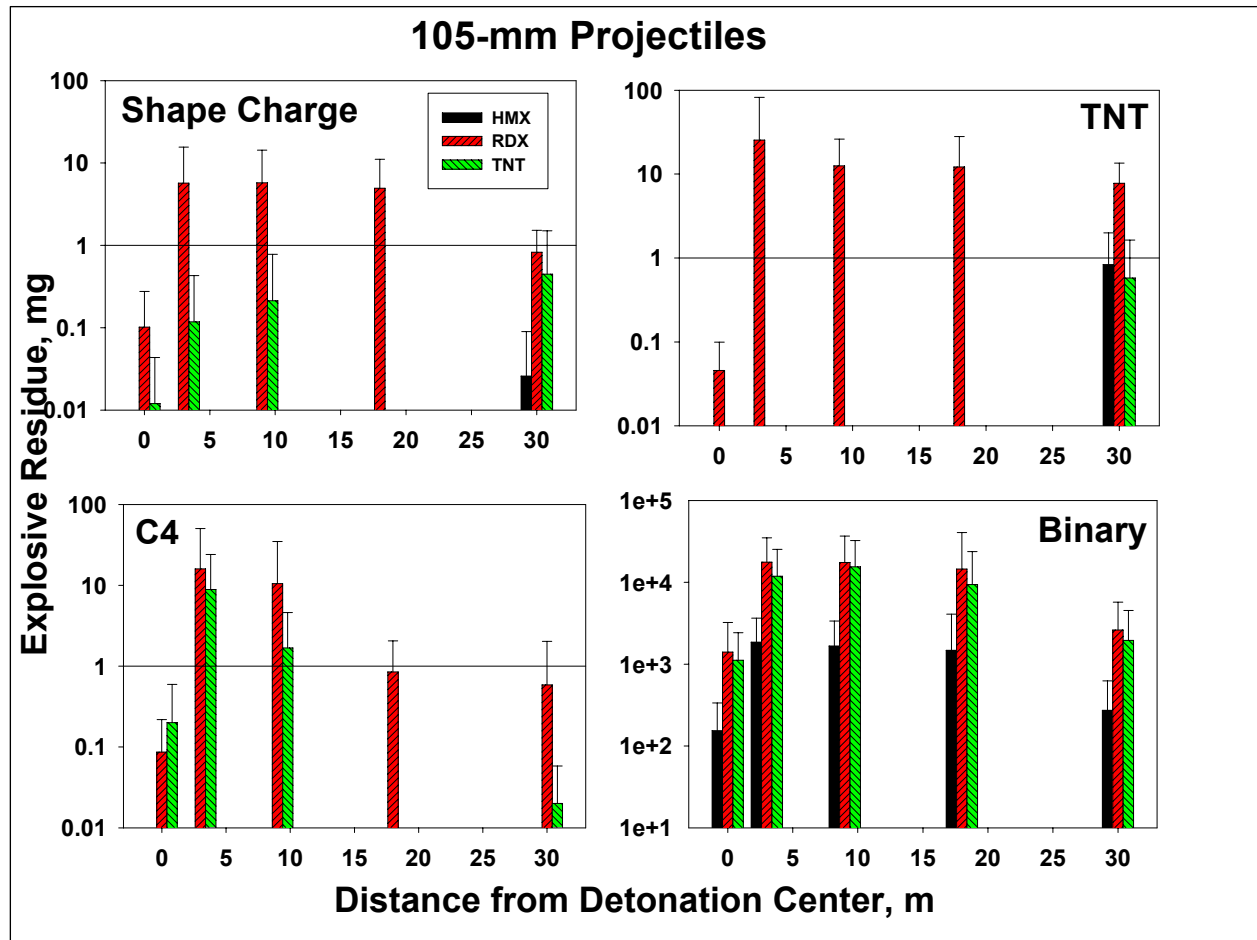

Figure 6-9. Total mass of HMX, RDX, and TNT with distance for each donor charge tested with 105-mm projectiles.

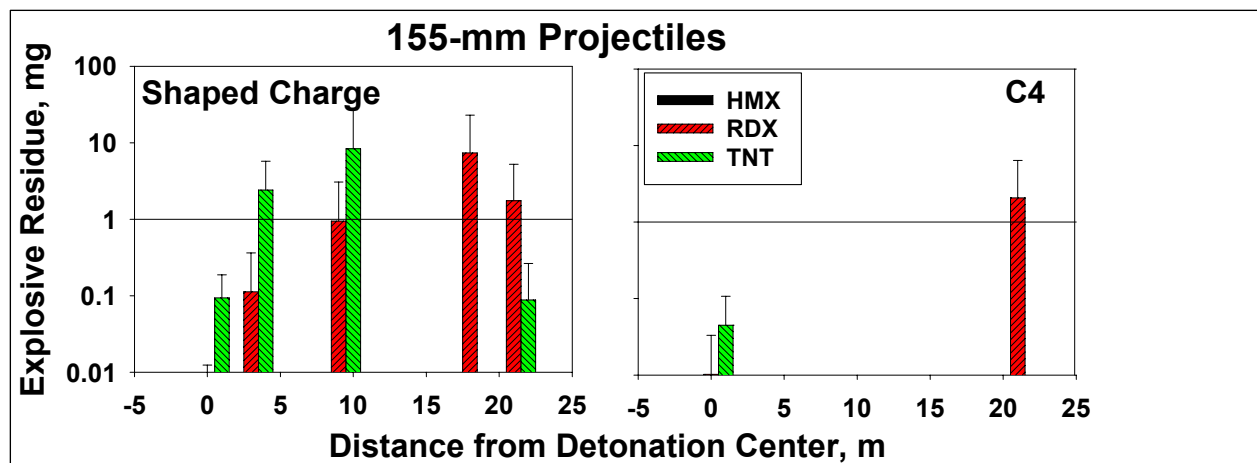

Figure 6-10. Total mass of HMX, RDX, and TNT with distance for each donor charge tested with 155-mm projectiles.

Mass with distance

Examination of mass of RDX, TNT, and HMX with distance reveals very little mass within 5 m of the detonation center for mortar rounds or for the 155-mm projectile (Figures 6–7 to 6–10). The 105-mm rounds exhibited mg quantities of RDX and TNT within the crater and at 3 m. For the mortar rounds, a tendency toward peak mass at a distance of 5 to 15 m was evident. For the larger rounds, RDX mass exhibited less of a trend. Although mass of RDX recovered from 105- and 155-mm detonations was generally greatest in the B-ring (within 3 m of the detonation center), variability was so high that differences were not statistically significant (Figures 6–9 and 6–10).

Chemical composition of residues

The only compounds other than RDX that were detected in significant quantities were TNT and HMX (Figures 6–7 to 6–10). Both compounds were significant in residues from the 105-mm round detonated with the Kinepak. Since the Kinepak performed well with smaller rounds (60- and 81-mm mortar rounds), the charge may be too small to effectively initiate the larger rounds. The same may be true for the shaped charge, which generated TNT residue with the 155-mm round. Detections of other analytes were sporadic and highly variable (Table 6–6). TNB and 2,4DNT were detected in the most replicates, 29 and 22, respectively. Three analytes, 2ADNT, 4ADNT, and 2,4DNT, were highest for the TNT donor with the 60-mm mortar rounds. Two analytes, 2,6DNT and TNB, were highest for the binary donor with the 81-mm mortar rounds. Only one compound, 2ADNT, was detected with the 105-mm mortar rounds. The donor was the binary charge. The greatest number of detections was for TNT as donor for the 60- and 81-mm mortar rounds; 24 and 19 detections, respectively. No analytes other than TNT, RDX, and HMX were detected for any donors with the 155-mm mortar rounds.

Table 6-6. Detections of analytes other than RDX, HMX, and TNT¹.

	60-mm			81-mm			105-mm
	Shaped Charge	C4	TNT	C4	TNT	Binary	Binary
2ADNT							
Replicates ²	1/7	0/7	2/7	3/7	5/7	4/6	1/7
Detections	1	0	5	12	17	21	3
Range (mg)	na ³	na	19.32 - 158.022	0.172 - 677.508	0.807 - 222.960	0.508 - 1846.246	210.74 - 1553.860
Median (mg)	na	na	82.210	32.117	3.090	53.572	976.169
4ADNT							
Replicates	0/7	2/7	5/7	4/7	2/7	0/7	0/7
Detections	0	2	21	12	9	0	0
Range (mg)	na	1.393 - 1.782	0.126 - 787.980	0.196 - 192.966	1.991 - 279.606	na	na
Median (mg)	na	1.588	64.446	5.045	5.349	na	na
2,4DNT							
Replicates	3/7	3/7	6/7	1/7	6/7	2/6	1/7
Detections	4	4	20	1	17	4	1
Range (mg)	1.636 - 11.541	0.382 - 97.675	0.066 - 830.426	na	0.017 - 198.448	5.900 - 101.067	na
Median (mg)	2.490	9.659	30.139	na	1.633	23.840	na
2,6DNT							
Replicates	0/7	0/7	1/7	0/7	5/7	2/6	0/7
Detections	0	0	1	0	12	4	0
Range (mg)	na	na	na	na	0.304 - 16.119	24.050 - 51.375	na
Median (mg)	na	na	na	na	2.397	30.288	na
TNB							
Replicates	1/7	3/7	4/7	2/7	4/7	1/6	0/7
Detections	2	6	6	4	9	2	0
Range (mg)	28.336 - 337.705	0.553 - 168.378	2.765 - 113.388	0.530 - 79.817	0.283 - 87.199	87.037 - 1005.643	na
Median (mg)	183.020	21.295	21.042	2.586	21.700	546.340	na
DNB							
Replicates	0/7	0/7	0/7	0/7	2/7	1/7	0/7
Detections	0	0	0	0	3	1	0
Range (mg)	na	na	na	na	2.278 - 25.093	na	na
Median (mg)	na	na	na	na	3.609	na	na
Tetryl							
Replicates	0/7	1/7	1/7	0/7	0/7	0/7	0/7
Detections	0	1	1	0	0	0	0
Range (mg)	na	na	na	na	na	na	na
Median (mg)	na	na	na	na	na	na	na

¹ Undetected analytes included the following: nitrobenzene, 2-nitrotoluene, 3-nitrotoluene, 4-nitrotoluene, 3,5-dinitroaniline, and PETN. Analyses for the following compounds were performed on a limited number of samples without detections: MNX, DNX, and TNX.

² The top number is the number of replicates in which the analyte was detected; the bottom number is the number of replicate detonations performed.

³ Not applicable.

Conclusions

Results of this study demonstrated that high-order detonations are critical to minimizing constituent residues during BIP demolition. Another important result is that donors must be specifically matched with rounds. The binary donor charge was effective for the mortar rounds, but insufficient in the quantities used for the larger rounds. Since the TNT donor left significant quantities of TNT, especially with the mortar rounds, TNT is a poor choice as a donor charge. The C4 was effective for the larger rounds. Except for the Kinepak binary charge with the 60-mm mortar rounds, all of the donors left some residue in at least some of the replicates. The principal residue was RDX followed by TNT and HMX. Detections of other analytes were less consistent, but generally in mg quantities. Detections in the crater were rare. Most of the mass was within 15 m of the detonation center. In general, total residue mass from high-order detonations was less than 100 mg.

High-order BIP detonations generated μg to mg quantities of constituents in most of the replicates. RDX, an environmentally undesirable constituent, predominated detections. When investigating residues associated with specific BIP actions, a radius of at least 15 m should be sampled. Results suggest that donors should be matched to the round to achieve high-order detonations, thereby minimizing constituent residues.

References

- Blackwood, L. G. 1995. Normality transformations for environmental data from compound normal-lognormal distributions. *Environmental Monitoring and Assessment* 35:55-75.
- Hewitt, A. D., T. F. Jenkins, M. E. Walsh, M. R. Walsh, and S. Taylor. 2005. RDX and TNT residues from live-fire and blow-in-place detonations. *Chemosphere*, 61:888-894.
- Hewitt, A. D., T. F. Jenkins, T. A. Ranney, J. A. Stark, M. E. Walsh, S. Taylor, M. R. Walsh, D. J. Lambert, N. M. Perron, N. H. Collins, and R. Karn. 2003. *Estimates for explosives residue from the detonation of army munitions*. ERDC/CRREL TR-03-16. Hanover, NH: U.S. Army Engineer Research and Development Center, Cold Regions Research and Engineering Laboratory. http://www.crrel.usace.army.mil/techpub/CRREL_Reports/reports/TR03-16.pdf
- U.S. Environmental Protection Agency. 1994. *Nitroaromatics and nitramines by HPLC*. Second Update, SW846 Method 8330. Washington, DC: Office of Solid Waste and Emergency Response. <http://www.epa.gov/epaoswer/hazwaste/test/pdfs/8330.pdf>

U.S. Environmental Protection Agency. 2000. *Explosives by gas chromatography*. Method 8095. Washington, DC: Office of Solid Waste and Emergency Response. <http://www.epa.gov/epaoswer/hazwaste/test/pdfs/8095.pdf>

7 Occurrence of Metals and Organic Compounds Other Than Explosives in Firing Range Soils

Introduction

Various metals and organic compounds other than explosives are an integral part of range activities. Concern that these compounds persist in the environment and may migrate to groundwater or affect environmental receptors resulted in the addition of a large battery of such analytes to the list for soils and groundwater evaluation at the MMR (see Chapter 2, Table 2–2 for an annotated list of organic compounds for which soils were analyzed). In addition to explosives, other organic compounds of interest include propellants, pyrotechnics, waxes and binders, smokes and obscurants, SVOCs, PAHs, PCNs, and Halowax fillers used to simulate the mass of HE in practice rounds. Some of these compounds are potentially hazardous to the environment. Heavy metals are also of interest as potential groundwater contaminants.

The principal objective of this study was to identify analytes of potential concern that are related to firing range activities. Based on issues related to some of these analytes in soil and groundwater at MMR, a list of “other organics” and metals was compiled for use on selected surface soil composites collected during range characterization studies in ER-1155 (Tables 7–1 to 7–3). For convenience, concentrations were compared with Region 9 Preliminary Remediation Goals. Since certain properties of soils influence bioavailability and transport of contaminants, several soil property tests were performed on these soils, including total Kjeldahl nitrogen (TKN), TOC, cation exchange capacity (CEC), and particle size distribution. The samples were also analyzed for explosives, perchlorate, and NG (Table 7–4).

Table 7-1. Abbreviations and chemical names of organic compounds other than explosives for which firing range soils were analyzed.

Abbreviation	Chemical Name	Abbreviation	Chemical Name
4NPHE	4-Nitrophenol	ANTRAC	Anthracene
PCLPHE	Pentachlorophenol	BAANTHR ¹	Benzo(a)anthracene
NITROBEN	Nitrobenzene	BAPYRE	Benzo(a)pyrene
1,2,4TCLB	1,2,4-Trichlorobenzene	BBFLANT	Benzo(b)fluoranthene
7H-BENZ ¹	7H-Benz(de)-anthracene-7-one	B-GHI-PY	Benzo (g,h,i) perylene
BCLIPrE	Bis (2-chloroisopropyl) ether	BKFLANT	Benzo(k)fluoranthene
1,2DCLB	1,2-Dichlorobenzene	BENZOAC ¹	Benzoic Acid
1,3DCLB	1,3-Dichlorobenzene	BZLAL	Benzyl alcohol
1,3-UREA ¹	1,3-Diethyl-1,3-diphenyl Urea	BCLEtoME	Bis (2-chloroethoxy) methane
1,4DCLB	1,4-Dichlorobenzene	BCLETE	Bis (2-chloroethyl) ether
2,4,5TCLPH	2,4,5-Trichlorophenol	B2EHPH ¹	Bis (2-ethylhexy) phthalate
2,4,6TCLPH	2,4,6-Trichlorophenol	BuBePHTH	Butylbenzylphthalate
2,4DCLPHE	2,4-Dichlorophenol	CARBOZOL	Carbozole
2,3DINIT	2,3-Dimethyl butane	CHRYSE ¹	Chrysene
2,4DMePHE	2,4-Dimethylphenol	DBAHANT	Dibenzo(a,h)anthracene
2,4DNPH	2,4-Dinitrophenol	DBENZOFU	Dibenzofuran
1,2DPHYD	1,2-Diphenylhydrazine	DEtPHTH ¹	Diethyl phthalate
2-CHLBEN	2-Chlorobenzaldehyde	DMePHTH ¹	Dimethyl phthalate
2CLNAPH	2-Chloronaphthalene	DBuPHTH ¹	Dibutylphthalate
2CLPHEN	2-Chlorophenol	DNOcPHT	Di-n-octylphthalate
1-METHYL	1-Methylamino anthraquinone	FLANTHE ¹	Fluoranthene
2M4,6DNPH	2-Methyl-4,6-dinitrophenol	FLUORE	Fluorene
2MeNAPH ¹	2-Methylnaphthalene	HCLBEN	Hexachlorobenzene
2MEPHE	2-Methylphenol	HCLBU	Hexachlorobutadiene
2NANIL ²	2-Nitroaniline	HCLCYPD	Hexachlorocyclopentadiene
2NIPHE	2-Nitrophenol	HCLETA	Hexachloroethane
3,3'DCLBEZ	3,3'Dichlorobenzidine	I1,2,3PYR	Indeno (1,2,3-c,d) pyrene
4BrPHET	4-Bromophenyl phenyl ether	ISOPHOR ¹	Isophorone
4CL3MePH	4-Chloro-3-methylphenol	NAPHTH ¹	Naphthalene
4CLANIL	4-Chloroaniline	NNDMeAM	N-Nitrosodimethylamine
4CLPHPHE	4-Chlorophenyl phenyl ether	NNDNPAM	N-Nitroso-di-N-propylamine
4MEPHE	4-Methylphenol	NNDPHAM ¹	N-Nitrosodiphenyl amine
4NANIL ²	4-Nitroaniline	PHENAN ¹	Phenanthrene
ACENAP	Acenaphthene	PHENOL ¹	Phenol
ACENAY	Acenaphthylene	PYRENE ¹	Pyrene
ANILINE ²	Aniline		

¹ Compounds detected in firing range soils in ER-1155.

Table 7-2. Abbreviations and chemical names of Halowaxes for which firing range soils were analyzed.

Abbreviation	Chemical Name	Abbreviation	Chemical Name
TcLXYLS	2,4,5,6-Tetrachloro-m-xylene (surrogate 40-140 WS)	H-1000	Halowax 1000
H-1001	Halowax 1001	H-1013	Halowax 1013
H-1051	Halowax 1051	H-1099	Halowax 1099

Table 7-3. Abbreviations and chemical names of metals for which firing range soils were analyzed.

Abbreviation	Chemical Name	Abbreviation	Chemical Name
Al ²	Aluminum	Hg ¹	Mercury
Sb ¹	Antimony	Mo	Molybdenum
As ¹	Arsenic	Ni	Nickel
Ba ¹	Barium	K	Potassium
Be ¹	Beryllium	Se ¹	Selenium
Cd ¹	Cadmium	Ag ²	Silver
Ca	Calcium	Na	Sodium
Cr ¹	Chromium	Tl ¹	Thallium
Co	Cobalt	W	Tungsten
Cu ¹	Copper	U	Uranium
Fe ²	Iron	V	Vanadium
Pb ¹	Lead	Zn	Zinc
Mg	Magnesium	Zr ²	Zirconium
Mn ²	Manganese		

¹ Metals for which USEPA has established Primary Drinking Water Standards or Maximum Contaminant Levels (USEPA 2003b).

² Metals for which USEPA has established Secondary Drinking Water Standards (USEPA 2003b).

Table 7-4. Abbreviations and chemical names of explosives and explosives-related compounds for which firing range soils were analyzed.

Abbreviation	Chemical Name	Abbreviation	Chemical Name
2ADNT	2-Amino-4,6-dinitrotoluene	3NA	3-Nitroaniline
4ADNT	4-Amino-2,6-dinitrotoluene	NB	Nitrobenzene
2,4DAT	2,4-Diaminotoluene	NG	Nitroglycerin
2,6DAT	2,6-Diaminotoluene	NTRGUD	Nitroguanidine
3,5DNA	3,5-Dinitroaniline	2NT	2-Nitrotoluene
DNB	1,3-Dinitrobenzene	3NT	3-Nitrotoluene
2,4DNT	2,4-Dinitrotoluene	4NT	4-Nitrotoluene
2,6DNT	2,6-Dinitrotoluene	HMX	Octahydro-1,3,5,7-tetranitro-1,3,5,7-tetrazocine
RDX	Hexahydro-1,3,5-trinitro-1,3,5-triazine	Perchlorate	Perchlorate
2MH3	2-Methyl-3-nitroaniline	4,4AZOXY	2,2',6,6'-Tetranitro-4,4'-Azoxytoluene
2M5N	2-Methyl-5-nitroaniline	2,2AZOXY	4,4',6,6'-Tetranitro-2,2'-Azoxytoluene
4M3N	4-Methyl-3-nitroaniline	TNB	1,3,5-Trinitrobenzene
Tetryl	<i>n</i> -Methyl- <i>n</i> -2,4,6-tetranitroaniline	TNT	2,4,6-Trinitrotoluene

Methods

Soil samples were composites from various sites characterized during testing for SERDP ER-1155. Some samples were insufficient in quantity for all analyses. Table 7-5 presents a list of analytes, methods, and references to methods.

Table 7-5. Analytical methods.

Test	Method	Reference
Semi-volatile organic compounds, SVOCs	USEPA Method 8270D	USEPA 1998c
Halowaxes	USEPA Method 8081	USEPA 1999b
Metals (Sb, Cr, Ni, Al, Ba, Ca, Mn)	USEPA Method 6010 C	USEPA 1996a
Metals (As, Be, Cd, Cu, Pb, Se, Ag, Tl, Zn, Co, Fe, Mg, Mo, Na, V, U, W)	USEPA Method 6020 ICP/MS	USEPA 1994a
Metals (Hg)	USEPA Method 7471	USEPA 1998b
Explosives (HPLC)	USEPA Method 8330	USEPA 1994b
Explosives (GC)	USEPA Method 8095	USEPA 1998a
Total Kjeldahl nitrogen (TKN) ¹	Bremner and Mulvaney	Bremner and Mulvaney 1982
Total organic carbon (TOC)	USEPA Method 9060	USEPA 1986b
Cation exchange capacity (CEC)	USEPA Method 9081	USEPA 1986a
Particle size distribution	Gee and Bauder	Gee and Bauder 1986
pH	McLean	McLean 1982
Perchlorate	USEPA Method 314.0M on aqueous extracts	USEPA 1999a
Nitroglycerin	USEPA Method 8332	USEPA 1996b

¹ A wet oxidation method for obtaining total nitrogen, including natural organic nitrogen, but not N-N or N-O linkages present in nitroaromatic and nitramine sources.

Values for organic compounds and explosives are discussed in terms of detection above laboratory reporting limits and as compared with the Preliminary Remediation Goals (PRGs) set by USEPA Region 9 (USEPA 2004). These PRGs were selected since they apply to MMR. However, soil properties and geological settings vary across the Nation. Therefore, the relevance of exceedances of Region 9 PRGs for samples from other locations is uncertain. Values for metals are presented in three tables listing those metals for which USEPA has:

- established Primary Drinking Water Standards (Maximum Contaminant Levels, or MCLs);
- established Secondary Drinking Water Standards (MCLs); and

- not established standards in drinking water.

Although these standards are for drinking water and our values were obtained in soils, the drinking water standards are given to provide an awareness of the level of concern warranted by detections of specific metals. Detections of metals were compared with national background values reported by the U.S. Geological Survey (USGS 2001). The tables provided the maximum national background level; however, comparisons were made according to the general location of specific installations. Metal detections were also compared with USEPA Region 9 PRGs and Canadian Council Ministers of Environment (CCME), Guidelines for Agricultural Soil Thresholds Criteria (CCME 2003). Background values for several Canadian ranges (data from results of SERDP ER-1155) are given to provide comparisons to ranges similar to those sampled. Mean values from results of a critical review of soil criteria for establishment of ecological soil screening levels (ECO-SSLs) by USEPA (2003a) are also provided for metals comparisons. A general description of the test soils in the form of several soil properties is provided, since these properties potentially influence transport and environmental fate of the detected compounds.

Results

Other organics, including Halowaxes

Eight of the 71 organic analytes other than explosives and propellants were detected at concentrations above laboratory reporting limits (Table 7–6). The following four compounds were detected in only one composite sample: Bis(2-ethylhexyl)phthalate (B2EHPPH), isophorone (ISOPHOR), diethyl phthalate (DEtPHTH), and benzo(a)anthracene (BAANTHR).

Bis(2-ethylhexyl)phthalate and diethyl phthalate are oxidative derivatives of propellants. Isophorone is sometimes used as a solvent for the propellant nitrocellulose and is also present in paints and other metal coatings. Benzo(a)anthracene is an emission product from some gasoline engines.

Table 7-6. Organic compounds other than explosives that were detected in firing range soils, mg/kg.

Location, Sample No.	2MeNAPH	1,3-UREA	B2EHPH	ISOPHOR	7H-BENZ	PHENOL	BENZOAC	BAANTHR
Region 9 PRGs	NA	NA	35	510	NA	18,000	100,000	0.62
Camp Guernsey 32 ¹	<0.34	<0.39	<0.34	<0.34	ND	<0.34	<0.68	<0.34
Camp Guernsey 45 ¹	<0.34	<0.38	<0.34	<0.34	ND	<0.34	<0.68	<0.34
Camp Guernsey 46 ¹	<0.34	<0.38	<0.34	<0.34	ND	<0.34	<0.68	<0.34
Camp Guernsey 48 ¹	<0.33	<0.38	<0.33	<0.34	ND	<0.34	<0.67	<0.33
Camp Guernsey 51 ¹	<0.34	<0.38	<0.34	<0.34	ND	<0.34	<0.68	<0.34
Camp Guernsey 52 ¹	<0.34	<0.38	<0.34	<0.34	ND	0.069 ²	<0.68	<0.34
Wainwright 20 M-B ¹	<0.33	<0.38	<0.33	0.068 ²	ND	<0.33	<0.67	<0.33
Wainwright 25 M-A ¹	<0.33	<0.38	<0.33	<0.33	ND	<0.33	<0.67	<0.33
Wainwright 25 M-B ¹	<0.33	<0.38	<0.33	0.08 ²	ND	<0.33	<0.67	<0.33
Yakima 1 ¹	0.1 ²	0.1 ²	0.29 ²	<0.34	ND	<0.33	<0.68	<0.34
Yakima 2 ¹	0.11 ²	0.3 ²	0.200 ²	<0.34	ND	<0.34	0.45 ²	<0.34
Yakima 4 ¹	<0.34	0.11 ²	0.140 ²	<0.34	ND	<0.34	<0.68	<0.34
Yakima 6 ¹	<0.34	<0.38	0.30 ²	<0.34	ND	<0.34	<0.68	<0.34
Yakima 28 ¹	<0.34	<0.38	<0.34	<0.34	ND	<0.34	<0.68	<0.34
Yakima 33 ¹	<0.33	<0.38	<0.33	<0.33	ND	<0.33	<0.67	0.82
Yakima 60 ¹	<0.34	<0.38	<0.34	<0.34	ND	<0.34	0.36 ²	<0.34
Fort Bliss 17	<0.33	<0.33	<0.67	<0.33	<0.33	<0.33	<0.67	<0.67
Fort Bliss 18	<0.33	<0.33	<0.67	<0.33	<0.33	<0.33	<0.67	<0.67
Fort Bliss 38	<0.33	<0.33	0.32 ²	<0.33	0.121 ²	<0.33	7.22	<0.67
Fort Bliss 81	<0.33	<0.33	<0.67	<0.33	<0.33	<0.33	<0.67	<0.67
Fort Bliss 87	<0.33	<0.33	<0.67	<0.33	<0.33	<0.33	<0.67	<0.67
Fort Hood	<0.33	<0.33	<0.67	<0.33	<0.33	<0.36	<0.67	<0.67
Fort Lewis Artillery	ND	ND	ND	ND	ND	ND	ND	ND
Fort Lewis Firing	ND	ND	ND	ND	ND	ND	ND	ND
Fort Lewis Hand G S	ND	ND	ND	ND	ND	ND	ND	ND
Fort Lewis Hand G Sub	ND	ND	ND	ND	ND	ND	ND	ND
Valcartier B3-AT	<0.34	<0.34	0.25 ²	<0.34	<0.34	<0.34	<0.68	0.25 ²
Valcartier C15-AT	<0.33	0.13 ²	1.23	<0.33	<0.67	<0.33	<0.67	<0.33
Pokakuloa PTA-20	<0.34	<0.34	<0.34	<0.34	<0.68	<0.34	<0.68	<0.34
Pokakuloa PTA-22	<0.34	<0.34	<0.34	<0.34	<0.68	<0.34	<0.68	<0.34
Jefferson PG 64-1	<0.33	<0.33	<0.33	<0.33	<0.67	<0.33	<0.67	<0.33
Jefferson PG 12	<0.34	<0.34	<0.34	<0.34	<0.68	<0.34	9.56	<0.34
Jefferson PG 18	<0.34	<0.34	0.14 ²	<0.34	<0.68	<0.34	4.7	<0.34
Schofield Barracks 15	<0.67	<0.67	<0.67	23.6	<1.3	<0.67	<1.3	<0.67
Schofield Barracks 44	<0.34	<0.34	<0.34	0.12 ²	<0.68	<0.34	<0.68	<0.34
Eglin AFB A1	<0.33	<0.33	<0.33	0.15 ²	<0.66	<0.33	<0.66	<0.33
Eglin AFB B4	<0.33	<0.33	<0.33	<0.33	<0.65	<0.33	<0.65	<0.33
Fort Polk G1-4	<0.33	<0.33	<0.33	<0.33	<0.66	<0.33	<0.66	<0.33
Cold Lake, Shaver	<0.33	<0.33	<0.33	<0.33	<0.67	<0.33	<0.67	<0.33

(continued)

CRREL, Sample Number	NAPHTH	DMePHTH	NNDPHAM	DEtPHTH	PHENAN	DBuPHTH	FLANTHE	PYRENE	CHRYSE
Region 9 PRGs	56	100,000	99	49,000	NA	6,100	2,300	2,300	62
Camp Guernsey 32*	<0.34	<0.30	<0.34	<0.34	<0.34	<0.34	<0.34	<0.34	<0.34
Camp Guernsey 45*	<0.34	<0.34	<0.34	<0.34	<0.34	<0.34	<0.34	<0.34	<0.34
Camp Guernsey 46*	<0.34	<0.34	<0.34	<0.34	<0.34	<0.34	<0.34	<0.34	<0.34
Camp Guernsey 48*	<0.33	<0.33	<0.33	<0.33	<0.33	<0.33	<0.33	<0.33	<0.33
Camp Guernsey 51*	<0.34	<0.34	<0.34	<0.34	<0.34	<0.34	<0.34	<0.34	<0.34
Camp Guernsey 52*	<0.34	<0.34	<0.34	<0.34	<0.34	<0.34	<0.34	<0.34	<0.34
Wainwright 20 M-B*	<0.33	<0.34	<0.33	<0.33	<0.33	<0.33	<0.33	<0.33	<0.33
Wainwright 25 M-A*	<0.33	<0.34	<0.33	<0.33	<0.33	<0.33	0.17 ²	0.19 ²	0.75
Wainwright 25 M-B*	<0.33	<0.34	<0.33	<0.33	<0.33	<0.33	0.13 ²	0.15 ²	<0.33
Yakima 1*	0.065 ²	<0.33	0.088 ²	<0.34	0.14 ²	0.71	<0.34	0.13 ²	<0.34
Yakima 2*	<0.34	<0.34	<0.34	<0.34	0.12 ²	<0.34	<0.34	0.12 ²	<0.34
Yakima 4*	<0.34	<0.34	<0.34	<0.34	<0.34	0.74	<0.34	<0.34	<0.34
Yakima 6*	<0.34	<0.34	<0.34	<0.34	<0.34	0.96	<0.34	<0.34	<0.34
Yakima 28*	<0.34	0.072 ²	<0.34	0.32 ²	<0.34	0.96	<0.34	<0.34	<0.34
Yakima 33*	<0.33	0.081 ²	3.69	0.366 ²	0.21 ²	7.09	0.19 ²	0.12 ²	0.91
Yakima 60*	<0.34	0.074 ²	2.92	0.31 ²	<0.34	5.4	<0.34	<0.34	<0.34
Fort Bliss 17	<0.33	<0.33	<0.33	<0.33	<0.33	<0.33	<0.33	<0.33	<0.33
Fort Bliss 18	<0.33	<0.33	<0.33	<0.33	<0.33	<0.33	<0.33	<0.33	<0.33
Fort Bliss 38	<0.33	<0.33	<0.33	<0.33	<0.33	<0.33	<0.33	<0.33	<0.33
Fort Bliss 81	<0.33	<0.33	<0.33	<0.33	<0.33	<0.33	<0.33	<0.33	<0.33
Fort Bliss 87	<0.33	<0.33	<0.33	<0.33	<0.33	<0.33	<0.33	<0.33	<0.33
Fort Hood	<0.33	<0.33	<0.33	<0.33	<0.33	<0.33	<0.33	<0.33	<0.33
Fort Lewis Artillery	ND	ND	ND	ND	ND	ND	ND	ND	ND
Fort Lewis Firing	ND	ND	ND	ND	ND	ND	ND	ND	ND
Fort Lewis Hand G S	ND	ND	ND	ND	ND	ND	ND	ND	ND
Fort Lewis Hand G Sub	ND	ND	ND	ND	ND	ND	ND	ND	ND
Valcartier B3-AT	<0.34	<0.34	<0.34	0.27 ²	<0.34	<0.34	<0.34	<0.34	<0.34
Valcartier C15-AT	<0.33	<0.33	<0.33	3.29	<0.33	<0.33	<0.33	<0.33	<0.33
Pokakuloa PTA-20	<0.34	<0.34	<0.34	<0.34	<0.34	0.66	<0.34	<0.34	<0.34
Pokakuloa PTA-22	<0.34	<0.34	<0.34	<0.34	<0.34	<0.34	<0.34	<0.34	<0.34
Jefferson PG 64-1	<0.33	<0.33	<0.33	<0.33	<0.33	<0.33	<0.33	<0.33	<0.33
Jefferson PG 12	<0.34	<0.34	<0.34	<0.34	<0.34	<0.34	<0.34	<0.34	<0.34
Jefferson PG 18	<0.34	0.16 ¹	<0.34	<0.34	<0.34	<0.34	<0.34	<0.34	<0.34
Schofield Barracks 15	<0.67	<0.67	<0.67	<0.67	<0.67	<0.67	<0.67	<0.67	<0.67
Schofield Barracks 44	<0.34	<0.34	<0.34	<0.34	<0.34	<0.34	<0.34	<0.34	<0.34
Eglin AFB A1	<0.33	<0.33	<0.33	<0.33	<0.33	<0.33	<0.33	<0.33	<0.33
Eglin AFB B4	<0.33	<0.33	<0.33	<0.33	<0.33	<0.33	<0.33	<0.33	<0.33
Fort Polk G1-4	<0.33	<0.33	<0.33	<0.33	<0.33	<0.33	<0.33	<0.33	<0.33
Cold Lake, Shaver	<0.33	<0.33	<0.33	<0.33	<0.33	<0.33	<0.33	<0.33	<0.33

¹ Guernsey, Wainwright, and Yakima samples were not analyzed for 2,3DINNIT (2,3-dimethyl butane), 1-METHYL (1-methylamino anthraquinone), and 7H-BENZ (7H-benz(de)-anthracene-7-one).

² J-values, which are estimated concentrations that are above the Method Detection Limit (MDL), but below the Laboratory Reporting Limit (LRL).

The benzo(a)anthracene detection (0.82 mg/kg, which exceeded the PRG of 0.621 mg/kg) was the only analyte and the only sample to exceed the USEPA Region 9 PRGs (USEPA 2004). Since this value was detected in an entirely different geological and climatic setting from Region 9, the relevance of the exceedances is uncertain. Two compounds were detected only twice. One of these compounds, N-nitrosodiphenylamine (NNDPHAM), is an oxidative derivative of the propellant diphenylamine. The other, chrysenes (CHRYSE), is a component of fuel oil and is common in gasoline engine exhausts. Benzoic acid (BENZOAC), a plasticizer and a component of certain dyes, was detected three times at less than 10 mg/kg. Benzoic acid also occurs widely in vegetation. The most frequently detected compound was dibutyl phthalate (DBuPHTH), which was detected seven times, six of them in composite soil samples from Yakima Training Center, WA. This is another oxidative product of the propellant diphenylamine. No halowaxes were detected (detection limits ranged from 8 to 9 µg/kg). Based on these results, none of these organic compounds occur with sufficient frequency or at sufficient concentration to constitute major concern. These findings are consistent with the finding at MMR (Chapter 2) and are consistent with activities common to firing ranges.

Metals

No background samples were collected at the ranges characterized. However, 18 of the metals for which soils from the ranges were analyzed are among the 22 elements for which background soil concentrations are reported by USGS (2001) (Tables 7-7 through 7-9). Samples assayed for seven of these metals—Al, As, Ba, Mg, S, K, and Zr—never exceeded background levels in their respective geographic areas. Two, Ca and Hg, exceeded background only once. Nine others—Cr, Cu, Pb, Se, Ni, V, Fe, Mn, and Zn—exceeded background in two or more samples. Scholfield Barracks (HI) exhibited exceedances for the most metals, nine; however, this is likely due to the volcanic origin of the soil. Soils of volcanic origin are typically high in CEC and TOC, both of which may modulate the availability of certain metals (Miller and Gardiner 1998; Dixon and Weed 1982). Pb background was exceeded 17 times (8 installations) and Zn 15 times (7 installations), which was more often than any other metal. Cu and Se were next with 10 and 7 exceedances, respectively. The USEPA Region 9 PRGs for soils were set below maximum national background

Table 7-7. Detections in soils (mg/kg) of metals for which USEPA¹ has established Primary Drinking Water Standards (MCLs, or Maximum Contaminant Levels, mg/L).

Soil Location, Sample No.	Sb	As	Ba	Be	Cd	Cr	Cu	Pb	Hg	Se	Tl
MCLs, mg/L Drinking Water ¹	0.006	0.010	2.00	0.004	0.005	0.10	1.3 ²	0.015 ²	0.002	0.05	0.002
USGS Maximum ³ (soil)	NA ⁴	11.0	945	NA	NA	129	63.3	30.1	0.382	0.74	NA
Region 9 PRGs ⁵ (soil)	31	0.39	5400	150	37	210	3,100	400	23	390	5.2
CCME ⁶ (soil)	20.00	12.00	750	4	1.40	64	63	70	6.60	1.00	1.00
Camp Guernsey 32	0.57	4.49	161	0.599	0.679	20	32.6	13.5	0.012	0.999	0.200
Camp Guernsey 45	0.30	3.30	154	0.599	0.839	19.7	24.4	12.2	0.012	0.999	0.200
Camp Guernsey 46	<0.30	3.00	135	0.500	0.659	15.4	21.0	11.1	0.011	0.500	0.200
Camp Guernsey 48	<0.30	3.50	155	0.599	0.649	18.3	32.7	12.5	0.011	1.10	0.200
Camp Guernsey 51	0.37	4.90	165	0.700	0.880	19.7	26.6	12.5	0.012	1.10	0.200
Camp Guernsey 52	0.33	4.40	161	0.600	0.780	19.5	25.0	12.0	0.011	0.6	0.200
Wainwright 20 M-B	<0.30	3.89	117	0.100	0.290	22.2	31.0	38.7	0.0085	0.300	<0.200
Wainwright 25 M-A	<0.30	3.80	120	0.100	0.190	20.2	31.7	31.5	0.012	0.200	<0.200
Wainwright 25 M-B	<0.30	3.90	127	0.100	0.248	26.0	31.2	39.9	0.010	0.200	<0.200
Yakima 1	0.95	1.99	112	0.399	13.6	23.4	315	167	0.028	0.598	<0.200
Yakima 2	0.94	2.19	121	0.398	20.3	31.9	443	175	0.020	0.399	<0.200
Yakima 4	0.67	1.89	120	0.399	6.25	20.6	191	49.2	0.023	0.399	<0.200
Yakima 6	0.35	1.80	105	0.300	4.65	13.1	151	34.3	0.017	0.500	<0.200
Yakima 28	0.30	2.09	152	0.399	0.219	14.6	30.4	27.5	0.012	0.498	<0.200
Yakima 33	0.37	2.39	156	0.499	0.209	14.6	34.1	17.0	0.014	0.897	<0.200
Yakima 60	0.43	2.70	146	0.500	0.100	20.3	40.7	8.10	0.022	0.500	<0.200
Fort Bliss 17	<0.30	2.66	103	0.619	0.446	16.9	19.2	18.3	0.015	<0.200	<0.200
Fort Bliss 18	<0.30	2.46	96.7	0.638	0.449	17.5	19.6	18.0	0.014	<0.200	<0.200
Fort Bliss 38	0.62	2.97	147	1.53	3.62	84.8	180	181	0.024	0.449	0.23
Fort Bliss 81	0.44	2.98	99.8	0.699	0.457	53.3	28.2	14.1	0.015	<0.200	<0.200
Fort Bliss 87	0.36	2.90	98.7	0.699	0.509	45.8	27.7	13.4	0.014	<0.200	<0.200
Fort Hood	11.0	7.38	89.4	1.03	0.539	35.4	11.2	11.3	0.0099	<0.200	0.354
Fort Lewis Artillery	ND ⁷	7.1	154	ND	1.79	20.2	ND	66.7	0.049	<4.0	ND
Fort Lewis Firing	ND	10.1	131	ND	1.0	15.3	ND	119	0.067	<4.0	ND
Fort Lewis Hand G S	ND	4.0	108	ND	1.2	37.5	ND	35.9	<0.040 ⁸	<4.0	ND
Fort Lewis Hand G Sub	ND	3.8	92.4	ND	1.60	31.6	ND	25.5	<0.040 ⁸	<4.0	ND
Valcartier B3-AT	0.41	0.556	38.9	0.196	0.906	29.0	208	50.0	0.016	0.210	<0.200
Valcartier C15-AT	1.20	1.09	73.4	0.602	4.45	61.9	922	262	0.027	0.357	<0.200
Pokakulua PTA-20	<0.30	0.254	217	0.802	0.830	33.4	49.7	9.90	0.024	0.345	<0.200

(continued)

Soil Location, Sample No.	Sb	As	Ba	Be	Cd	Cr	Cu	Pb	Hg	Se	Tl
Pokakuloa PTA-22	1.89	0.614	210	1.51	0.350	18.6	36.1	205	0.020	0.491	<0.200
Jefferson PG 64-1	0.39	10.2	48.4	0.641	0.071	54.9	6.16	19.4	0.023	0.340	<0.200
Jefferson PG 12	<0.30	3.03	189	0.413	0.543	34.4	8.40	22.1	0.063	0.474	0.240
Jefferson PG 18	<0.30	2.99	99.9	0.374	0.150	43.0	7.64	18.9	0.058	0.418	<0.200
Schofield Barracks 15	2.36	1.24	59.8	0.768	0.194	264	55.2	15.4	0.021	5.14	<0.200
Schofield Barracks 44	3.41	7.89	17.7	0.421	1.83	661	301	83.0	1.0	4.53	<0.200
Eglin AFB A1	0.43	1.64	13.3	<0.200	3.20	35.4	65.3	124	0.017	<0.200	<0.200
Eglin AFB B4	0.46	1.36	8.78	<0.200	2.00	35.1	128	59.2	0.019	<0.200	<0.200
Fort Polk G1-4	<0.30	0.624	21.0	<0.200	2.84	19.0	17.1	22.0	0.010	<0.200	<0.200
Cold Lake, Shaver	<0.30	0.918	26.4	0.110	1.99	54.3	12.1	13.5	0.005 ⁹	<0.200	<0.200

¹ USEPA (2003b).

² Pv and Cu are regulated by a treatment technique that requires systems to control the corrosiveness of their water. If more than 10% of tap water samples exceed the action level, water systems must take additional steps. For Cu, the action level is 1.3 mg/L, and for Pb it is 0.015 mg/L. Cu also appears on the Secondary Drinking Water Standard at 1.0 mg/L.

³ USGS maximum background (USGS 2001).

⁴ No standard has been established.

⁵ USEPA Region 9 Preliminary Remediation Goals (USEPA 2004).

⁶ Canadian Council Ministers of Environment (CCME 2003).

⁷ Not done because sample size was insufficient.

⁸ Detection limits of Hg for these two samples were higher (0.040 mg/kg) than for all other samples (0.005 mg/kg).

⁹ J-value, which is an estimated concentration that is above the MDL but below the LRL.

Table 7-8. Detections in soils (mg/kg) of metals for which USEPA¹ has established Secondary Drinking Water Standards (MCLs, or Maximum Contaminant Levels, mg/L).

Soil Location, Sample No.	Ag	Al	Fe	Mn	Zn
<i>MCLs, mg/L Drinking Water¹</i>	0.10	0.05 -0.2	0.3	0.05	5
<i>USGS Maximum²(soil)</i>	NA ³	100,000	57,000	881	92
<i>Region 9 PRGs⁴(soil)</i>	390	76,000	23,000	1,800	23,000
<i>CCME⁵(soil)</i>	20.00	NA	NA	NA	200.00
Camp Guernsey 32	0.400	16800	16900	264	58.1
Camp Guernsey 45	0.999	14100	15400	298	61.6
Camp Guernsey 46	0.400	11800	13400	266	52.8
Camp Guernsey 48	0.300	14000	15600	296	72.4
Camp Guernsey 51	0.300	16800	17400	268	60.8
Camp Guernsey 52	0.300	16200	16400	257	61.1
Wainwright 20 M-B	0.200	7000	14700	194	1260

(continued)

Soil Location, Sample No.	Ag	Al	Fe	Mn	Zn
Wainwright 25 M-A	0.200	6670	14500	185	1160
Wainwright 25 M-B	0.200	7160	14600	200	1540
Yakima 1	1.60	15300	26300	478	310
Yakima 2	0.698	15900	28000	507	526
Yakima 4	0.498	15700	27500	484	171
Yakima 6	0.599	14100	25300	454	121
Yakima 28	0.399	15100	41200	800	112
Yakima 33	0.299	15900	38500	803	95.1
Yakima 60	0.200	19200	26300	432	54.2
Fort Bliss 17	0.110	12800	16100	250	48.6
Fort Bliss 18	0.130	12300	15600	242	46.5
Fort Bliss 38	1.30	17900	39700	78.4	189
Fort Bliss 81	0.12	12500	16500	254	54.9
Fort Bliss 87	0.100	1120	15100	244	51.7
Fort Hood	0.176	31300	20700	215	34.4
Fort Lewis Artillery	ND ⁶	ND	ND	ND	ND
Fort Lewis Firing	ND	ND	ND	ND	ND
Fort Lewis Hand G S	ND	ND	ND	ND	ND
Fort Lewis Hand G Sub	ND	ND	ND	ND	ND
Valcartier B3-AT	1.13	4600	14400	96.00	64.8
Valcartier C15-AT	2.86	7170	22200	614	173
Pokakuloa PTA-20	0.292	14800	43200	1160	104
Pokakuloa PTA-22	0.354	28600	60700	1220	85
Jefferson PG 64-1	0.133	7870	25100	475	22.1
Jefferson PG 12	0.153	8980	11600	875	68.0
Jefferson PG 18	0.148	7820	9320	154	26.7
Schofield Barracks 15	0.122	84700	131000	479	119
Schofield Barracks 44	0.558	47600	277000	605	198
Eglin AFB A1	0.183	3600	9510	720	102
Eglin AFB B4	0.253	3510	8970	862	51.1
Fort Polk G1-4	0.265	2000	4260	154	33.7
Cold Lake, Shaver	<0100	2920	5500	93.2	23.1

¹ USEPA (2003b).

² USGS maximum background (USGS 2001).

³ No standard has been established.

⁴ USEPA Region 9 Preliminary Remediation Goals (USEPA 2004).

⁵ Canadian Council Ministers of Environment (CCME 2003).

⁶ Not done because sample size was insufficient.

Table 7-9. Other metals for which soil samples were analyzed.

Location, Sample No.	Ni	Co	Ca	Mg	Mo	Na	K	V	W	Zr	U
USGS Maximum ⁴ (soil)	46.9	NA ²	86,100	15,000	NA	22,800	27,800	161	NA	474	NA
Region 9 PRGs ³ (soil)	1,600	900	NA	NA	390	NA	NA	78	NA	NA	16
CCME ⁴ (soil)	50	40.00	NA	NA	5.00	NA	NA	130.0	NA	NA	NA
Camp Guernsey 32	11.6	5.29	14800	6440	0.300	76.9	2920	19.8	ND ⁵	ND	ND
Camp Guernsey 45	10.5	5.59	4450	3980	0.399	74.2	3430	24.3	ND	ND	ND
Camp Guernsey 46	8.89	4.90	4030	3340	0.300	58.8	2960	17.6	ND	ND	ND
Camp Guernsey 48	9.49	5.09	4340	3980	0.399	88.8	3440	21.7	ND	ND	ND
Camp Guernsey 51	13.9	6.40	14600	6370	0.300	89.7	3290	26.7	ND	ND	ND
Camp Guernsey 52	11.3	5.30	14900	6330	0.300	88.4	2990	19.1	ND	ND	ND
Wainwright 20 M-B	28.9	4.69	4690	3600	0.499	201	631	19.8	ND	ND	ND
Wainwright 25 M-A	25.0	4.00	4460	3380	0.500	190	525	14.8	ND	ND	ND
Wainwright 25 M-B	25.2	3.90	4780	3580	0.400	172	497	12.6	ND	ND	ND
Yakima 1	9.47	8.78	4470	3130	0.499	213	2060	30.4	ND	ND	ND
Yakima 2	11.3	9.87	4670	3260	0.598	335	2260	40.2	ND	ND	ND
Yakima 4	8.97	7.97	4850	3270	0.498	317	2280	35.7	ND	ND	ND
Yakima 6	8.19	7.99	4520	2900	0.400	239	1930	33.7	ND	ND	ND
Yakima 28	11.0	12.1	8530	4700	0.399	141	1740	37.1	ND	ND	ND
Yakima 33	10.7	12.7	7620	4550	0.199	136	1990	37.2	ND	ND	ND
Yakima 60	14.0	7.90	17500	5520	0.200	219	2010	28.4	ND	ND	ND
Fort Bliss 17	11.7	5.35	30000	6880	0.299	116	3070	27.4	<0.100	11.2	0.549
Fort Bliss 18	11.6	4.71	27500	6600	0.389	114	3020	27.2	<0.100	12.0	0.708
Fort Bliss 38	42.7	14.7	7670	6760	1.39	244	4330	77.8	<0.100	10.1	2.43
Fort Bliss 81	13.8	6.11	49800	930	0.499	181	3190	29.4	<0.100	10.2	0.679
Fort Bliss 87	13.0	5.82	57600	10200	0.399	165	2800	28.4	<0.100	8.65	0.629
Fort Hood	16.2	5.63	172000	5500	1.28	166	3850	63.2	<0.100	19.3	1.06
Fort Lewis Artillery	ND	ND	ND	ND	ND	ND	ND	ND	ND	ND	ND
Fort Lewis Firing	ND	ND	ND	ND	ND	ND	ND	ND	ND	ND	ND
Fort Lewis Hand G S	ND	ND	ND	ND	ND	ND	ND	ND	ND	ND	ND
Fort Lewis Hand G Sub	ND	ND	ND	ND	ND	ND	ND	ND	ND	ND	ND

(continued)

Location, Sample No.	Ni	Co	Ca	Mg	Mo	Na	K	V	W	Zr	U
Valcartier B3-AT	3.85	1.73	1180	1070	1.09	117	421	15.0	<0.100	1.92	0.323
Valcartier C15-AT	21.6	4.15	1070	1370	15.7	132	666	18.5	0.138	1.81	1.52
Pokakuloa PTA-20	78.2	14.8	10500	14200	0.974	1430	1080	41.7	0.269	96.8	0.235
Pokakuloa PTA-22	28.3	13.6	10700	12400	0.650	2510	1640	56.7	0.586	230	0.640
Jefferson PG 64-1	5.48	56.5	65.9	636	0.857	28.5	490	45.5	<0.100	7.04	0.930
Jefferson PG 12	8.0	4.63	3770	1230	0.592	43.3	816	21.3	0.679	140	0.679
Jefferson PG 18	4.66	2.80	373	676	0.483	35.5	622	21.2	<0.100	3.37	0.578
Schofield Barracks 15	107	7.41	<20.0	425	0.260	25.3	53.3	280	0.470	140	0.470
Schofield Barracks 44	152	9.32	68.6	7023	3.02	63.9	603	496	0.636	<0.100	0.636
Eglin AFB A1	5.43	0.878	<20.0	105	1.33	5.58	<20.0	5.77	0.174	12.0	0.174
Eglin AFB B4	4.75	0.736	<20.0	96.3	1.22	3.70	<20.0	4.96	0.187	25.3	0.187
Fort Polk G1-4	3.43	0.999	<20.0	105	0.355	7.69	37.1	3.38	0.137	0.166	0.137
Cold Lake, Shaver	4.12	1.43	159	551	0.587	78.0	296	5.73	0.105	2.75	0.303

¹ USGS maximum background (USGS 2001).

² No standard has been established.

³ USEPA Region 9 Preliminary Remediation Goals (USEPA 2004).

⁴ Canadian Council Ministers of Environment (CCME 2003).

⁵ Not done because sample size was insufficient.

levels for Al, As, Fe, and V. Background values in some parts of the country may greatly exceed values for others. Therefore, regional PRGs may not be consistent with national background values. Values for As exceeded the PRG in all but one sample. Values for Fe exceed PRGs in 13 samples (5 installations). Values for Cr, V, and Al exceeded PRGs in one or two samples.

The relative significance of detections above background can be inferred from the CCME criteria, one of the few soil criteria available for comparisons. Cd, Cu, Pb, and Zn exceeded the CCME criteria more frequently than other metals. Cd exceeded the criterion in 13 samples (8 installations), Cu in 10 samples, and Pb in 8 samples (5 and 7 installations, respectively), and Zn in 5 (2 installations). Mean exceedances were, respectively, 4, 5, 2, and 5 times the CCME. Several other metals—Cr, Se, Ni, Co, Mb, and V—exceeded the criteria at one or more sites. Except for Co, which was detected once slightly above the criterion, exceedances were at least twice the CCME. Mean values from the USEPA review of soil criteria were

relatively high (Table 7–10). Only two samples exceeded these values, both of them soils from Schofield Barracks. Metals for which values exceed the review criteria means were Cr, Se, Ni, and V.

Table 7-10. Background metals concentrations on several Canadian ranges, mg/kg.

Soil Location, Sample No.	Sb	As	Ba	Be	Cd	Cr	Cu	Pb	Hg	Se	Tl
EPA Review ¹	16.7960	60.00	811.94	3.17	4500	495.93	90,000	30,000	4.75	5.08	1.93
Shilo	NA ²	6.28	162.3	0.33	0.38	11.9	29.4	18.9	NA	0.5	0.2
Gagetown 1	0.05	0.333	104	0.055	0.23	13	5	0.619	NA	1.00	0.021
Gagetown 2	0.10	4.00	44.0	1.00	0.100	19	8	11	0.03	1.00	0.100
Gagetown 3	0.10	7.00	74	0.879	0.100	27	12	16	0.063	1.00	0.100
Cold Lake	0.09	0.36	30.36	0.46	0.21	4.46	4.23	2.25	0.021	0.20	0.38
Location, Sample No.	Ni	Co	Ca	Mg	Mo	Na	K	V	W	Zr	U
EPA Review	87.61	NA	NA	NA	17.23	NA	NA	89.91	400	NA	5.00
Shilo	18.6	6.63	15,694	4,184	1.36	83	1,038	13.67	NA	NA	0.737
Gagetown 1	6.0	0.701	4,616	1,560	0.487	55	6,895	2.0	NA	NA	0.056
Gagetown 2	18	10	809	4,079	0.183	50	737	29	NA	NA	0.700
Gagetown 3	26	14	1,843	5,876	0.403	59	1,028	37	NA	NA	1.100
Cold Lake	2.50	1.38	NA	NA	0.44	NA	NA	7.05	NA	NA	0.15
Soil Location, Sample No.	Ag	Al	Fe	Mn	Zn						
EPA Review	21.31	114.47	200	294.28	NA						
Shilo	1.00	4,691	15,446	1,130	53						
Gagetown 1	0.023	1,228	1,300	694	45						
Gagetown 2	0.100	14,911	13,950	418	48						
Gagetown 3	0.100	24,400	32,596	644	60						
Cold Lake	0.41	NA	4,575	NA	19.84						

¹USEPA (2003a). Note that the CCME values were among criteria reviewed.

²No background data available for this metal at this site.

Considering the low PRG for Al, As, Fe, and V and detections above these values, these metals are of potential concern on installations. Of these, only V values also exceeded the CCME. The frequency of detections of Cd, Cu, Pb, and Zn above the CCME may be justification for adding these metals to the list of concerns, particularly if agricultural use of the soil is likely.

Explosives

TNT was the most frequently detected explosive appearing in 21 of the 39 samples. Detections were from 10 of the 13 sites (Table 7–11). Concentrations were generally < 25 mg/kg. RDX and HMX were the second most frequently detected explosives appearing in samples from 10 sites. Concentrations of both were generally < 50 mg/kg. The mono-amino transformation products of TNT, 4ADNT, and 2ADNT, were detected in samples from eight sites. Concentrations were generally less than 2 mg/kg. 2,4DNT was detected at two sites, but 2,6DNT at only one. Perchlorate was detected at two sites at concentrations up to about 50 µg/kg (ppb). NG was detected only once.

Table 7-11. Detections of explosives, explosives-related compounds, and two propellant components in firing range soils, mg/kg.

Location, Sample No.	HMX	RDX	TNB	TNT	4ADNT	2ADNT	2,6DNT	2,4DNT	NG	Perchlorate
<i>Region 9 PRGs¹</i>	3,100	4.4	1,800	16	12 ²	12 ²	61	120	35	7.8
Camp Guernsey 32	<0.200	<0.100	<0.100	24.8	1.97	1.46	<0.100	<0.100	<0.500	<0.04
Camp Guernsey 45	8.06	91.3	<0.100	25.4	<0.100	<0.100	<0.100	<0.100	<0.500	<0.04
Camp Guernsey 46	13.6	155	<0.100	57.3	<0.100	<0.100	<0.100	<0.100	<0.500	<0.04
Camp Guernsey 48	6.82	49.4	<0.100	15.4	<0.100	<0.100	<0.100	<0.100	<0.500	ND
Camp Guernsey 51	<0.200	<0.100	1.39	159	1.37	1.02	<0.100	<0.100	<0.500	ND
Camp Guernsey 52	<0.200	<0.100	0.148	29.3	1.08	842	<0.100	<0.100	<0.500	ND
Wainwright 20 M-B	3.71	14.0	0.399	0.729	<0.100	<0.100	<0.100	<0.100	<0.500	<0.04
Wainwright 25 M-A	2.12	13.8	0.450	0.292	<0.100	<0.100	<0.100	<0.100	<0.500	<0.04
Wainwright 25 M-B	1.91	12.4	0.314	0.186	<0.100	<0.100	<0.100	<0.100	<0.500	0.021 ³
Yakima 1	32.4	3.50	<0.100	<0.100	<0.100	<0.100	<0.100	<0.100	<0.500	0.031 ³
Yakima 2	41.6	35.7	<0.100	<0.100	<0.100	<0.100	<0.100	<0.100	<0.500	0.049
Yakima 4	17.7	<0.100	<0.100	<0.100	<0.100	<0.100	<0.100	<0.100	<0.500	0.030 ³
Yakima 6	2.86	<0.100	<0.100	<0.100	0.079 ³	<0.100	<0.100	<0.100	<0.500	<0.04
Yakima 28	<0.200	<0.100	<0.100	<0.100	<0.100	<0.100	<0.100	<0.100	1.71	0.042
Yakima 33	<0.200	<0.100	<0.100	<0.100	<0.100	<0.100	0.422	28.5	<0.500	<0.04
Yakima 60	<0.200	<0.100	<0.100	<0.100	<0.100	<0.100	0.345	57.0	<0.500	<0.04

(continued)

Location, Sample No.	HMX	RDX	TNB	TNT	4ADNT	2ADNT	2,6DNT	2,4DNT	NG	Perchlorate
Fort Bliss 17	<0.194	<0.097	<0.097	<0.097	<0.097	<0.097	<0.097	<0.097	<0.485	0.14
Fort Bliss 18	<0.195	<0.098	<0.098	<0.098	<0.098	<0.098	<0.098	<0.098	<0.488	<0.04
Fort Bliss 38	2.87	1.98	<0.099	1.86	0.223	0.178	<0.099	<0.099	<0.495	0.13
Fort Bliss 81	<0.191	<0.096	<0.096	2.20	0.388	0.364	<0.096	<0.096	<0.478	<0.04
Fort Bliss 87	<0.195	<0.098	<0.098	71.4	0.946	0.922	<0.098	<0.098	<0.500	<0.04
Fort Hood	48	414	0.394	70.2	4.54	3.78	<0.100	<0.100	<2.50	ND
Fort Lewis Artillery	<0.200	<0.100	<0.100	<0.100	<0.100	<0.100	<0.100	<0.100	ND ⁴	ND
Fort Lewis Firing	<0.200	<0.100	<0.100	<0.100	<0.100	<0.100	<0.100	98.5	ND	ND
Fort Lewis Hand G S	3.50	22.5	0.165	2.61	0.405	0.345	<0.100	<0.100	ND	ND
Fort Lewis Hand G Sub	0.12 ³	0.510	<0.100	0.040 ³	0.100	0.100	<0.100	<0.100	ND	ND
Valcartier B3-AT	169	0.076	<0.100	0.73	0.387	0.317	<0.100	<0.100	<0.500	<0.04
Valcartier C15-AT	276	0.228	<0.100	4.88	1.02	0.723	<0.100	<0.100	<0.500	0.03 ³
Pokakuloa PTA-20	<0.200	0.013	<0.100	<0.100	<0.100	0.292	<0.100	<0.100	<0.500	<0.04
Pokakuloa PTA-22	0.328	0.0077	<0.100	<0.100	<0.100	<0.100	<0.100	<0.100	<0.500	0.02 ³
Jefferson PG 64-1	<0.200	<0.100	<0.100	0.060 ²	<0.100	<0.100	<0.100	<0.100	<0.500	<0.04
Jefferson PG 12	<0.200	<0.100	<0.100	<0.100	<0.100	<0.100	<0.100	<0.100	<0.500	<0.04
Jefferson PG 18	<0.200	<0.100	<0.100	0.405	<0.100	<0.100	<0.100	<0.100	<0.500	<0.04
Schofield Barracks 15	<0.200	<0.100	<0.100	<0.100	<0.100	<0.100	<0.100	<0.100	<0.500	<0.04
Schofield Barracks 44	<0.200	<0.100	<0.100	<0.100	<0.100	<0.100	<0.100	<0.100	<0.500	<0.04
Eglin AFB A1	<0.200	0.338	0.259	3.18	<0.100	<0.100	<0.100	<0.100	<0.500	<0.04
Eglin AFB B4	4.75	<0.100	0.921	5.81	<0.100	<0.100	<0.100	<0.100	<0.500	<0.04
Fort Polk G1-4	29.2	278	0.158	93.3	2.29	1.58	<0.100	<0.100	<0.500	<0.04
Cold Lake, Shaver	<0.200	<0.100	0.303	10.1	0.736	1.06	<0.100	<0.100	<0.500	<0.04

¹ USEPA Region 9 Preliminary Remediation Goals (USEPA 2004).

² Sum for all aminodinitrotoluenes.

³ J-value, which is an estimated concentration that is above the MDL, but below the LRL.

⁴ Not done because sample size was insufficient.

TNT and RDX values exceeded USEPA Region 9 PRGs 18 times (4 and 6 installations, respectively) with concentrations one or two orders of magnitude greater than the goal. The only other exceedance was for 2ADNT at Camp Guernsey, Wyoming National Guard installation, Guernsey, WY (one sample).

Soil properties

Values for all of the soil properties were typical of the areas from which samples were derived. They were consistent with values expected in uncultivated soils (Table 7–12).

Table 7-12. Properties of test soils that may affect bioavailability and transport of contaminants.

Location, Sample No.	pH	TKN ¹ , mg/kg	TOC ² %	CEC ³ meq/100g	Particle Size Distribution		
					Sand, %	Silt, %	Clay, %
Yakima 34, 35	6.6	805	1.91	15.7	51.6	30.1	18.3
Yakima 11, 13, 14	6.6	1000	1.46	16.7	44.4	39.2	16.4
Yakima 41, 42, 43,	6.2	1115	2.0	19.6	48.5	31.4	20.1
Yakima 24, 25, 26, 27	6.2	1318	1.72	17.2	56.5	20.5	23.0
Yakima 9, 10	6.7	1644	2.31	16.3	50.9	28.9	20.2
Yakima	6.8	940	1.06	23.6	40.0	45.0	15.0
Camp Guernsey G6, G7	7.7	1214	1.60	30.3	26.0	49.0	25.0
Wainwright	ND ⁴	1026	0.88	4.0	54.0	42.0	4.0
Fort Bliss	ND	641	0.028	9.6	54.0	5.0	41.0
Ft Hood	6.8	2.50	0.038	4.4	23.8	45.0	31.2
Fort Lewis Artillery	5.7	3484	7.38	38.0	64.7	19.2	16.1
Fort Lewis Firing	5.6	55.89	11.3	47.4	63.2	17.5	19.3
Fort Lewis Hand G S	6.8	175	0.26	6.8	82.3	7.8	9.9
Fort Lewis Hand G Sub	7.0	151	0.12	6.8	84.6	4.5	10.9
Valcartier B3-AT	ND	515	1.2	13.2	ND	ND	ND
Valcartier C15-AT	ND	515	2.0	17.2	52.0	28.0	20.0
Pokakuloa PTA-20	ND	3077	4.0	47.4	ND	ND	ND
Pokakuloa PTA-22	ND	2038	2.5	52.0	24.0	50.0	26.0
Jefferson PG 64-1	ND	836	1.3	16.6	13.3	53.3	33.3
Jefferson PG 12	ND	4530	7.7	52.0	10.0	35.0	55.0
Jefferson PG 18	ND	3284	7.5	38.5	10.0	50.0	40.0
Schofield Barracks 15	ND	308	0.3	37.6	10.0	22.5	67.5
Schofield Barracks 44	ND	2593	5.0	58.5	13.8	24.1	62.1
Eglin AFB A1	ND	469	0.6	2.8	62.0	20.0	18.0
Eglin AFB B4	ND	329	0.6	2.6	62.2	17.8	20.0
Fort Polk G1-4	ND	315	0.9	5.6	66.0	14.0	20.0
Cold Lake, Shaver	ND	193	0.4	3.6	50.0	30.0	20.0

¹Total Kjeldahl nitrogen.

²Total organic carbon.

³Cation exchange capacity.

⁴Not done because sample size was insufficient.

Conclusions

Although these composite samples were not as high in explosives concentrations as may be observed at range “hot spots,” all but 6 of the 39 samples contained detectable levels of one or more explosives. The samples represent a relatively large range of soil properties typical of uncultivated soils. If these samples are representative of ranges having explosives residues, organic compounds other than explosives are not typically an issue. None of the “other organic” compounds, including the halowaxes, occurred with sufficient frequency or at sufficient concentration to constitute major concern.

Considering the low PRG for Al, As, Fe, and V and detections above these values, these metals are of potential concern on installations. Of these, only V values also exceeded the CCME. Local PRGs, if available, should be consulted for comparisons to range-specific data. The frequency of detections of Cd, Cu, Pb, and Zn above the CCME may be justification for adding these metals to the list of concerns, particularly if agricultural use of the soil is likely and no local guidance is available.

References

- Bremner, J. M., and C. S. Mulvaney. 1982. Nitrogen-Total, Chapter 31. In *Methods of Soil Analysis, Part 2, Chemical and Microbiological Properties* 2nd ed. Madison, WI: American Society of Agronomy, Inc.
- Canadian Council Ministries of Environment (CCME). 2003. Canadian Council Ministers of Environment (CCME), Guidelines for Agricultural Soil Thresholds Criteria. www.ccme.ca.
- Dixon, J. B., and S. B. Weed, eds. 1982. *Minerals in the Soil Environment*. Madison, WI: Soil Science Society of America.
- Gee, G. W., and J. W. Bauder. 1986. Particle-size analysis, Chapter 15. In *Methods of Soil Analysis Part 1. Physical and Mineralogical Methods*, 2nd ed. Madison, WI: American Society of Agronomy, Inc.
- McLean, E. O. 1982. Soil pH and lime requirement, Chapter 12. In *Methods of Soil Analysis Part 2, Chemical and Microbiological Properties*, 2nd ed, ed. C. A. Black, et al. Madison, WY: American Society of Agronomy.
- Miller, R. W., and D. T. Gardiner, D. T. 1998. *Soils in Our Environment*, 8th ed., Upper Saddle River, NJ: Prentice Hall.
- U.S. Environmental Protection Agency (USEPA). 1986a. *Cation exchange capacity*. Method SW-9081. Washington, DC: Office of Solid Waste and Emergency Response.

- U.S. Environmental Protection Agency. 1986b. *Total organic carbon*. Method SW-9060. Washington, DC: Office of Solid Waste and Emergency Response.
- _____. 1994a. *Metals by ICP/MS*. SW-846 6020, Ch 3.3. Washington, DC: Office of Solid Waste and Emergency Response.
- _____. 1994b. *Nitro aromatics and nitramines by HPLC*. 2nd update, SW846. Method 8330. Washington, DC: Office of Solid Waste and Emergency Response.
- _____. 1996a. *Inorganics by ICP – Atomic Emission Spectroscopy*. SW-846, Method 6010C, Ch 3.3, Update IVB. Washington, DC: Office of Solid Waste and Emergency Response.
- _____. 1996b. *Nitroglycerin by high performance liquid chromatography*. SW846 Method 8332. Washington, DC: Office of Solid Waste and Emergency Response. www.epa.gov/epaoswer/hazwaste/test/pdfs/8332.pdf
- _____. 1998a. *Explosives by gas chromatography*. SW-846, Method 8095, Update IVB. Washington, DC: Office of Solid Waste and Emergency Response.
- _____. 1998b. *Mercury in solid/semisolid waste*. Manual Cold-Va SW-846, Ch 3.3, Update IVA. Washington, DC: Office of Solid Waste and Emergency Response.
- _____. 1998c. *Semivolatile organic compounds by GC/MS*. SW-846, Method 8270, Ch 4.3.2 Update IVA. Washington, DC: Office of Solid Waste and Emergency Response.
- _____. 1999a. *Determination of perchlorate in drinking water using ion chromatography*. Method 314.0. Washington, DC: Office of Solid Waste and Emergency Response.
- _____. 1999b. *Organochlorine pesticides by GC with ECD or ELCD*. SW-846, Method 8081, Update IVB. Washington, DC: Office of Solid Waste and Emergency Response.
- _____. 2003a. *Guidance for developing ecological soil screening levels (Eco-SSLs), Review of existing soil screening benchmarks*. OSWER Directive 92857-55, Attachment 1-1, Appendix D: Published soil values for use in screening, cleanup, or monitoring contaminated sites. Washington, DC: Office of Solid Waste and Emergency Response.
- _____. 2003b. *List of contaminants and their MCLs*. 816-F03-016. www.epa.gov/safewater/mcl.html.
- _____. 2004. *Region 9 Preliminary Remediation Goals Table*. www.epa.gov/region09/waste/sfund/prg/index.html.
- U.S. Geological Survey (USGS). 2001. *Geochemical landscapes of the conterminous United States – New map presentations for 22 elements*. Professional Paper 1648. Denver, CO: U.S. Geological Survey.

8 Transport of Residues from Cracked Unexploded Ordnance Through the Vadose Zone During Springtime Aquifer Recharge

Introduction

High explosive compounds such as TNT, RDX, and HMX have entered the environment where these compounds have been manufactured, stored, disposed of, or used (Best et al. 1999). TNT has been associated with abnormal liver function and anemia, while both TNT and RDX have been classified as potential human carcinogens (ATSDR 1996a and 1996b). Available information is currently limited concerning the health effects of HMX (ATSDR 1996c). In response, the USEPA has established lifetime exposure drinking water health advisory limits for TNT, RDX, and HMX at 2, 2, and 400 µg/L, respectively (Crockett et al. 1999).

Of particular interest are the explosive compounds in UXO found on former and current military training ranges (MacDonald 2001). UXO are produced when military ordnance fails to detonate, or fails to detonate completely. These unexploded projectiles are often difficult to locate, and may be scattered randomly over hundreds of square kilometers. Due to the kinetic energy they have when they strike the ground, UXOs are often buried, which complicates clean-up efforts. They may be physically damaged upon impact, or they may be ruptured from a low-order detonation. Given enough time, they may be penetrated by corrosion. Recently, it has been speculated that UXO may be damaged and cracked open by other rounds that detonate nearby (Pennington et al. 2005). This heterogeneity in physical condition and spatial distribution greatly complicates clean-up and modeling efforts.

The bulk charge in all Canadian and U.S. Army fragmentary ordnance is either TNT or Composition B. Composition B is a 60 to 39 percent mixture of RDX and TNT, which contains ~ 1 percent wax. However, all weapons grade RDX contains 8-10 percent HMX as an impurity, which means that Composition B is actually composed of about 55.2 percent RDX, 39 percent TNT, 4.8 percent HMX, and 1 percent wax. Composition B has been

used in military ordnance since World War II due to its HE yield and melt cast characteristics.

Dissolution is the primary method by which solid explosive compounds are made available to the environment (Brannon et al. 1999). The dissolution of RDX rather than its aqueous transport probably controls the entry of this compound into the environment. This is because its adsorption coefficient in soil is quite low, indicating that it will travel through the vadose zone at the infiltration rate (Brannon et al. 1999). Several studies have measured the dissolution rate of Composition B (Lynch et al. 2001, 2002; Phelan et al. 2003; Lever et al. 2005), and Lynch et al. (2002) published data on the effects of component interactions on the dissolution of Composition B.

Brannon and Pennington (1999) have compiled a comprehensive summary of the fate and transport process descriptors for energetic materials. Unfortunately, no work has been done to date on possible component interactions on the adsorption coefficients (K_d) or transformation rate coefficients (K) for energetic compounds such as Composition B.

This chapter expands the laboratory findings identifying the extent and rate at which a buried, cracked UXO will contaminate the pore water of the vadose zone with energetic materials. Although this experiment is tailored to the conditions at CFB Valcartier near Quebec City, the results are applicable to many other bases in Canada that have sandy soil, including CFB Wainwright, Shilo, Suffield, Petawawa, and CLAWR. Large-scale unsaturated columns of soil have been constructed and housed in a refrigerated laboratory. This set-up simulates the conditions found in the vadose zone below the frost line. In Quebec City, the frost line is found at a depth of between 1.4 to 1.8 m.

An automated sprinkler system was designed to reproduce the annual aquifer recharge cycle in Quebec City. Cracked UXO and detonation residues were used as sources, rather than pure explosives, to measure the mass of energetic materials that may be expected to infiltrate the vadose zone and subsequently the water table from a single cracked 81-mm mortar shell. This apparatus enabled period measurement of the concentration of explosive species in the pore water in the vadose zone around buried, cracked UXO, from which was extrapolated the mass of energetic materials lost in the effluent. These results were compared with published data

on the fate and transport parameters of TNT, RDX, and HMX. This information was used to suggest a dissolution model for detonation residue, which could explain these results.

Experimental

Source terms

The explosives source terms used in this experiment were derived from cracked 81 mm mortar rounds. The production of these cracked rounds was described in chapter 7 of the SERDP Distribution and Fate of Energetics on DoD Test and Training Ranges: Interim Report 5 (Pennington et al. 2005). The hypothesis that guided this work was that UXOs might be cracked open by other rounds that detonate nearby. By being cracked open in this fashion, the UXOs would be expected to scatter substantial amounts of explosive filler or detonation residue into the surrounding area. The rounds used were 81-mm mortar rounds, and the detonation trials were performed on uncontaminated snow. Jenkins et al. (2000) discuss the advantages of collecting detonation residue on snow. Following each detonation, the explosive filler and detonation residue were collected by scraping the snow down to a depth of 10 cm and collecting the contaminated snow in opaque plastic bags. The surface area of the snow that was collected was measured in order to calculate the mass of detonation residue per square meter. The collected snow samples were stored frozen in commercial freezers, and the detonation residues were subsequently extracted by freeze-drying the snow using a LABCONCO Lyph-Lock 4.5 freeze dry system which operated at a vacuum of 5 to 8 microns Hg and temperatures of -40 to -50 °C. Freeze drying allowed collection of the solid detonation residue without ever exposing it to liquid water. As a result, the physical structure of the detonation residue was not lost through dissolution. The detonation residue was separated into a fine fraction (< 0.5 cm diameter) and a coarse fraction (> 0.5 cm diameter) in order to improve grain size characterization of the finer fraction.

Both an inert tracer and pure Composition B were used as controls. The inert tracer was a brine of 0.41 m potassium bromide (KBr) (10.00 g KBr dissolved in 200 mL of distilled water). The pure Composition B was weapons grade, and was crushed to a powder on a milling machine. The grain size distribution of the Composition B was heterogeneous, and varied from 5 microns to 0.85 mm. Table 8–1 describes the source terms that were used on each column.

Table 8-1. Source terms used on columns.

Column	Detonation Residue Fine Fraction <0.75 mm diam	Detonation Residue Coarse Fraction >0.75 mm diam	Cracked Mortar Round	Pure Crushed Composition B	Inert Tracer KBr
A	0	0	No	0	200 mL
B	20.00 g	25.00 g	No	0	0
C	20.00 g	25.00 g	No	0	0
D	20.00 g	25.00 g	Yes	0	0
E	0	0	No	20.00	0
F	20.00 g	25.00 g	Yes	0	0

Apparatus

The soil used in the columns was sieved prior to use to remove all stones larger than 0.8 cm. The soil was uncontaminated quartz sand obtained near an active range on CFB Valcartier. This sand came from an alluvial formation around the Jacques Cartier River, shown on the map in Figure 8–1. The sand was well mixed and screened manually prior to use to ensure homogeneity and to remove any stones larger than 0.7 cm diameter. The soil was then loaded into the columns in 4,600 g lifts, and was compacted with a jackhammer fitted with a metal ram. Each lift was approximately 1-cm thick, and, following compaction, the surface of each layer was lightly scarified to provide hydraulic linkage. Figure 8–2 shows the grain size distribution of the sand.

Six stainless steel columns packed with this soil were used for the leaching trials. These cylindrical columns were Teflon-lined and measured 0.62 m in diameter and 0.6 m in depth. Figure 8–3 shows a schematic. Each column was constructed with seven outflow nozzles on the bottom of the column. These outflow nozzles were equipped with fibreglass wicks, which were embedded in the sand. The capillary action of these wicks provided a head of -3 cm, which was sufficient to draw out the unsaturated pore water and cause it to flow from the column. A graduated cylinder was placed under each nozzle, and the water level was measured daily in order to calculate the rate of flow from each nozzle and from the column as a whole.

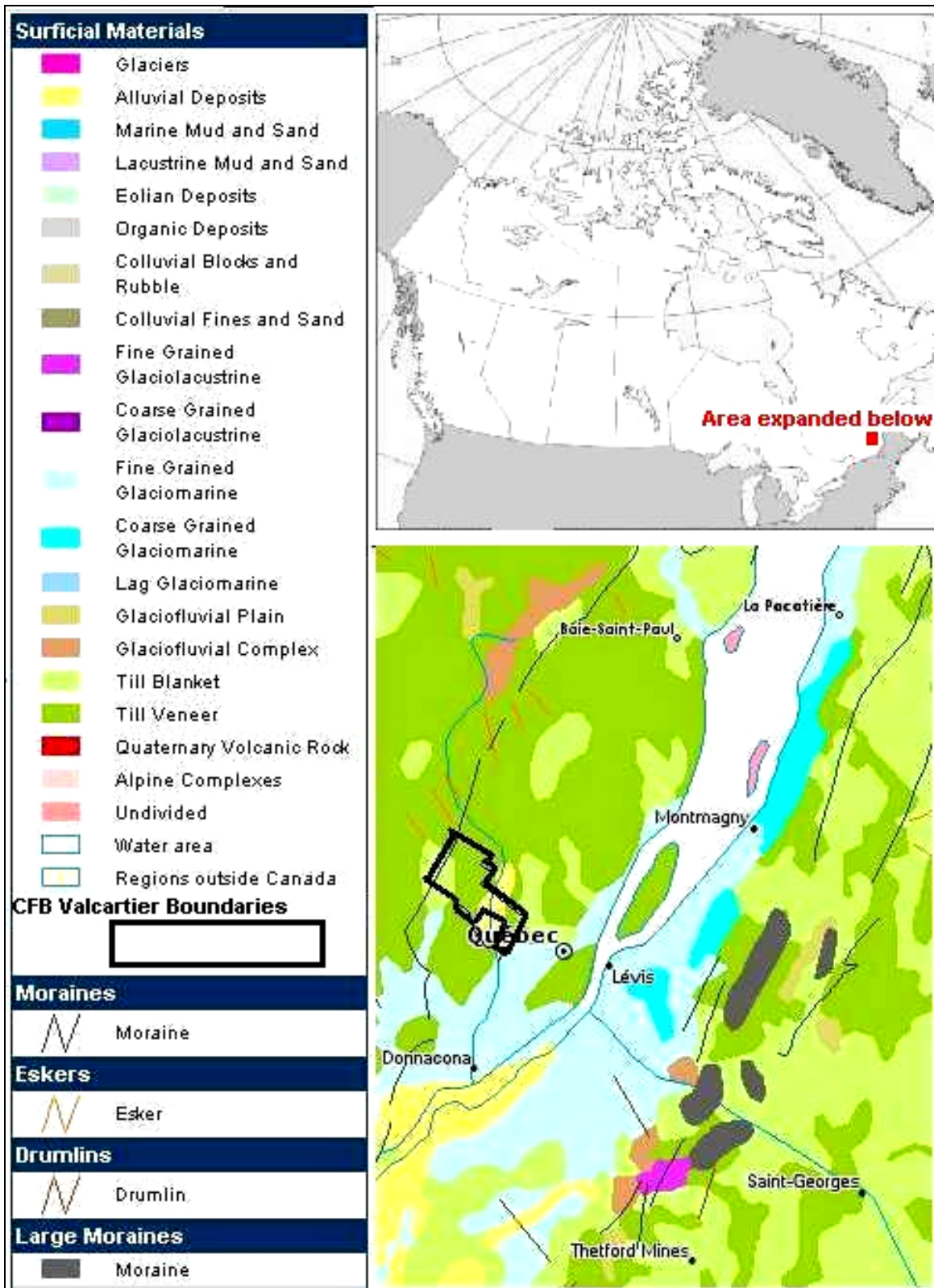

Figure 8-1. Surficial deposits around CFB Valcartier (adapted from Natural Resources of Canada surficial deposits map of Canada). The Jacques Cartier River cuts across the soil sampling site.

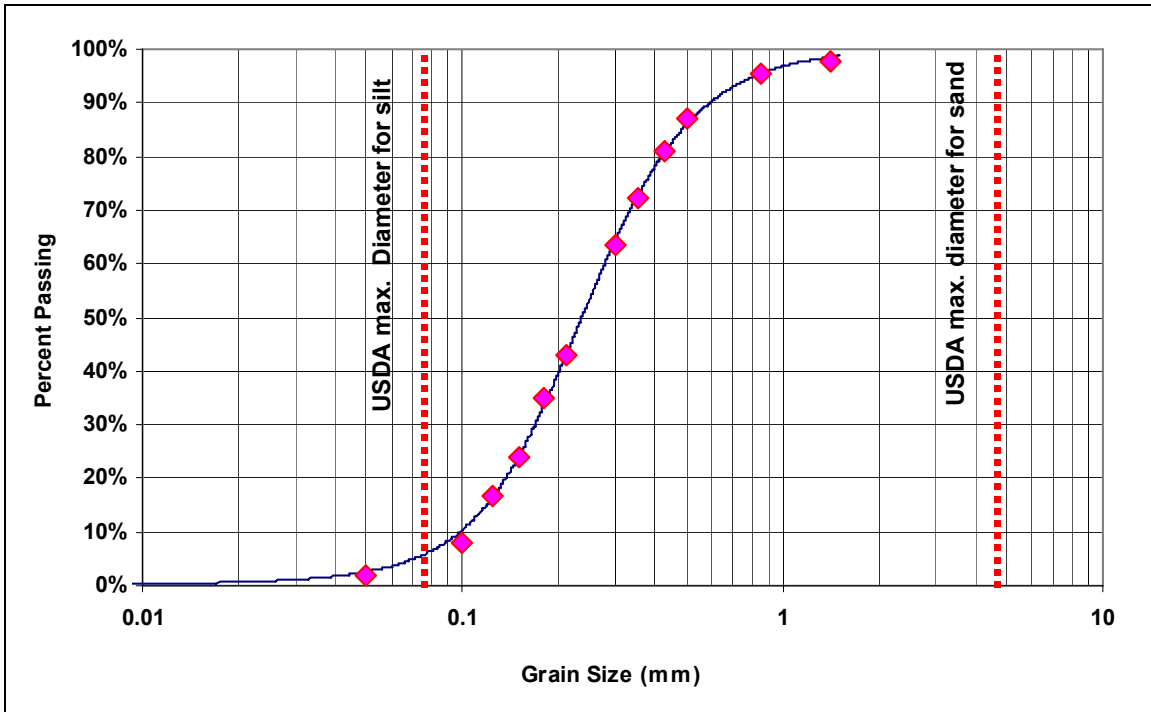

Figure 8-2. Grain size distribution of soil used in unsaturated column.

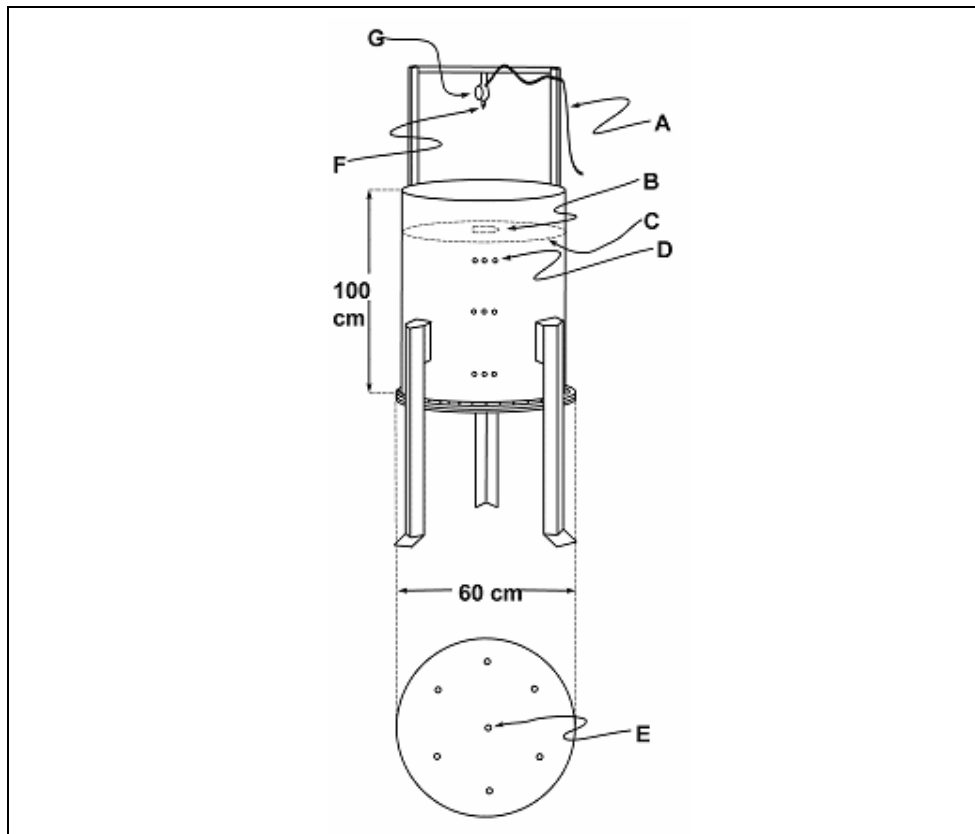

Figure 8-3. Soil column apparatus. (A) Inflow tube; (B) Cracked UXO; (C) Soil surface; (D) TDR access holes; (E) Outflow nozzle; (F) Spray nozzle; (G) Electric valve.

Three triple-pronged time domain reflectometers (TDRs) were inserted in each column at depths of 10, 30, and 50 cm from the surface to measure the saturation of the soil at these depths. The data from the TDRs were recorded automatically at 15-min intervals for the duration of the experiment.

An automated system sprayed distilled water with the pH adjusted to 4.7 (simulated rainwater) onto the surface of the columns in a cycle designed to reproduce annual springtime groundwater recharge for the Quebec City area. Figure 8-4 shows the inflow rate.

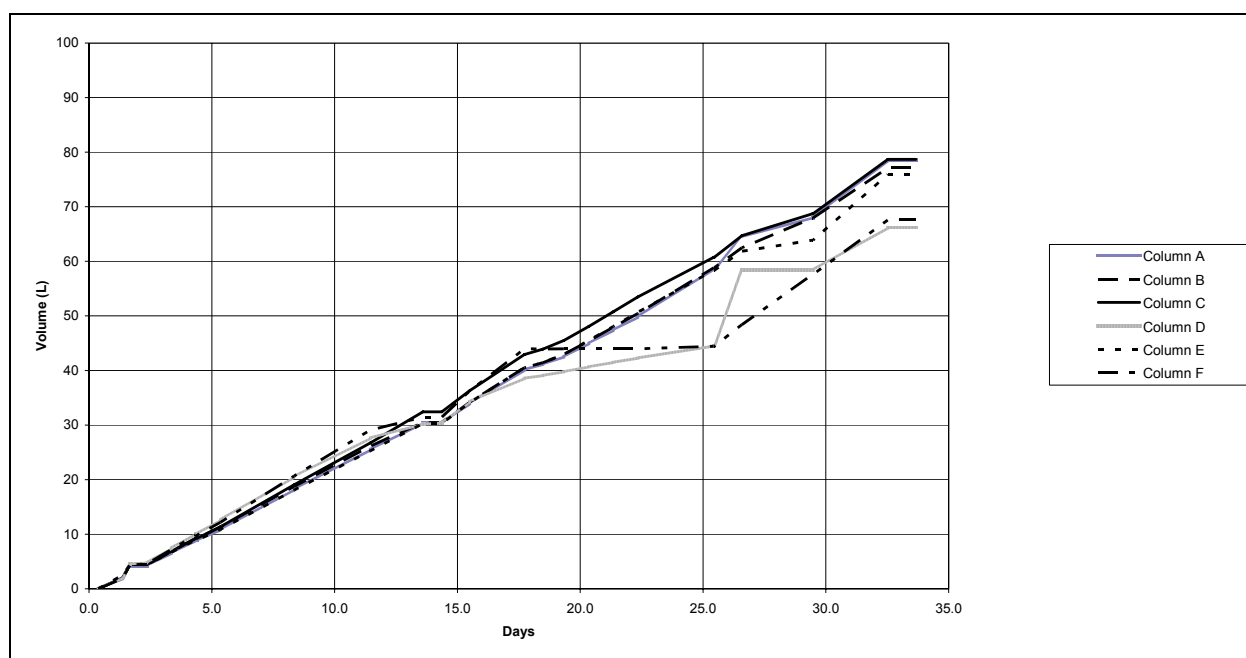

Figure 8-4. Cumulative inflow to columns.

The cracked mortar rounds were placed centrally on the surface of Columns D and F. The inert tracer was uniformly sprayed onto the surface of Column A with a spray bottle. The fine fraction of detonation residue and the pure Composition B were distributed on the surface of the columns with a saltshaker. Similarly, the coarse fraction of the detonation residue (> 5 mm) was uniformly distributed by shaking the pieces from a glass bottle onto the column surface. The detonation residue was placed on the columns using the same density found around the cracked shells: 150 to 200 g of residue found in the square meter immediately surrounding the cracked shell. This worked out to be 45 g of detonation residue distributed on the 0.3 m² columns (Table 8-1).

Method

The columns were brought to a steady state (spray inflow = leachate outflow) and refrigerated to 8 °C (the perennial deep subsurface temperature in Quebec City) prior to the experimental source terms being deposited in the columns.

Simulated springtime recharge started immediately once the source terms were placed in the soil columns. For the Quebec City area, the springtime aquifer recharge caused by the snowmelt is 253 mm of water (Mailloux 2002). This snowmelt occurs over a period of roughly 30 days in March and April. The columns, having surface areas of 0.322 m², required a total of 81.3 L to be sprayed over this 30-day period.

The spray cycle was programmed to operate only between 08:00 and 16:00 hours, which are typically the hours in the springtime when it is above zero. Figure 8–4 shows the cumulative inflow. A daily log was kept to monitor both the inflow to each column and outflow from each individual nozzle. Leachate was collected in 500-mL composite samples six times over the 30-day period. These samples were analyzed for energetic materials with HPLC according to EPA Method 8330 (USEPA 1994). The samples from Column A, which contained the bromide tracer, were collected the same way as the other columns, but the leachate was analyzed with a Dionex ICS using an AS14 column for bromides. Total energetic material outflow was extrapolated by correlating the six values of measured outflow concentrations with the total outflow volumes.

Results and discussion

The automated spray apparatus proved difficult to control. As shown in Figure 8–4, the cumulative inflow to Column E and Column D was erratic due to difficulties with the electric valves. Both valves failed on the 17th day of infiltration, and were not fully operational on the 25th day. Rather than increase the flow rate in these two columns to catch up to the volumes sprayed in the other four columns during this period, it was decided to maintain the same flow rate. For this reason, Columns D and E had 10 L less of infiltration during the simulated spring recharge.

The grain size of the residue was heterogeneous, and varied between 5 microns to several cm in diameter, with the largest pieces being pure Composition B. Figure 8–5 shows the grain size distribution plot of the

composite detonation residue. Pieces of explosive larger than 5 mm were removed prior to the measurement of the grain size distribution. These pieces were removed because grain size distribution is measured on a mass basis, and one or two large pieces could skew the results in a non-reproducible fashion.

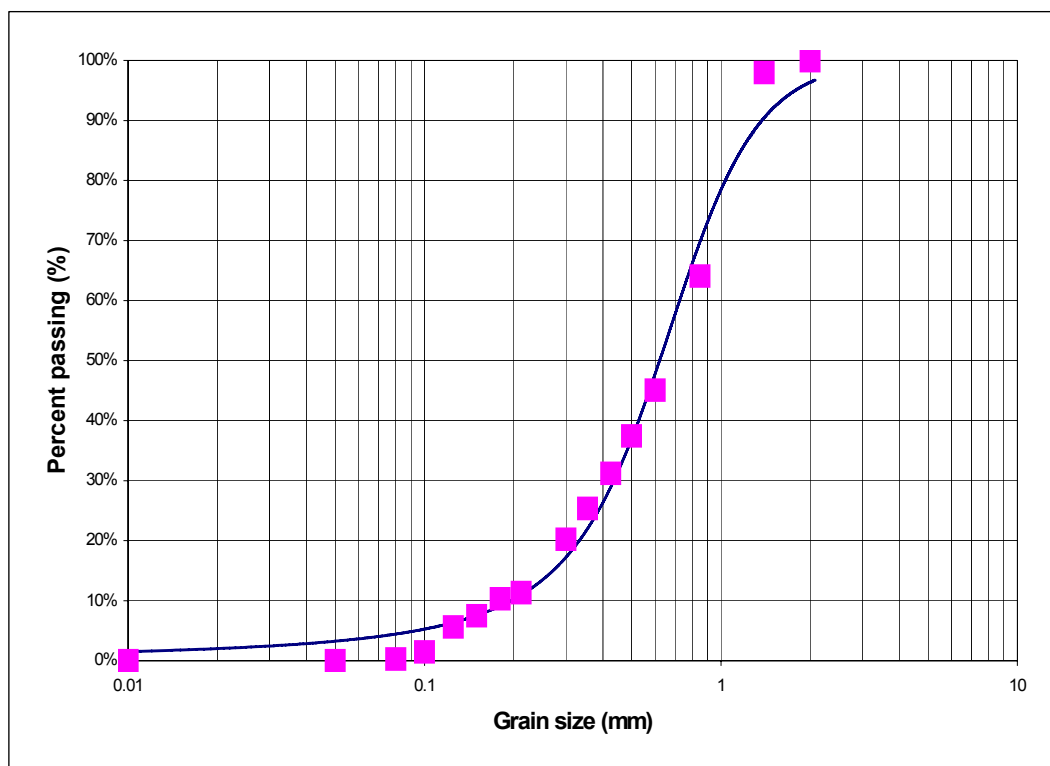

Figure 8-5. Grain size distribution of detonation residue.

Cumulative outflow volumes are shown in Figure 8–6. The outflow of the columns is nearly identical to the inflow (Figure 8–4), as the columns were brought to steady-state conditions prior to the start of the experiment. The saturated hydraulic conductivity (K_{sat}) of the columns was measured using Guelph permeameters to be on the order of 10 cm/hr. Unsaturated hydraulic conductivity was between 1 cm/hr at a moisture content of 0.05 percent and 8 cm/hr for a moisture content of 0.2 percent. The permeameter readings that formed the basis for these figures had an error range of ± 25 percent. The calculated conductivities, therefore, indicate only the order of magnitude of the conductivities, but these conductivities are consistent with the observed breakthrough times observed for the inert tracer KBr.

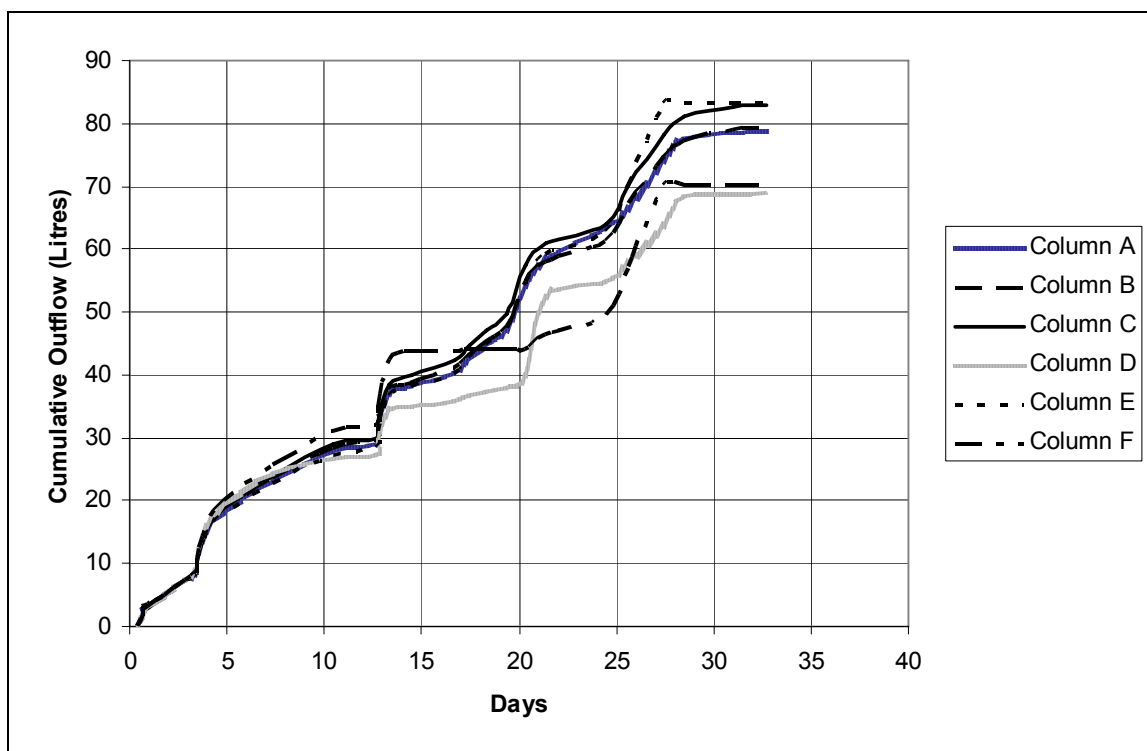

Figure 8-6. Cumulative outflow from columns.

The time domain reflectometers showed that steady-state unsaturated conditions were maintained in the columns for the duration of the experiment, with moisture contents in all columns remaining at 0.15 ± 0.02 at a depth of 10 cm, 0.24 ± 0.03 at a depth of 30 cm, and 0.35 ± 0.02 at a depth of 50 cm. Even Columns D and F, which experienced failure of the inflow valves, showed very little change in the unsaturated moisture content of the soil during the period in which they did not undergo infiltration.

Elution curves of the concentration of TNT, RDX, and HMX in the outflow with respect to the volume of inflow are shown in Figures 8-7, 8-8, and 8-9. The elution curve for the inert tracer in Column A is shown in Figure 8-10. TNT transformation products were detected as well, but the concentrations of these were two or three orders of magnitude below the concentration of TNT. This suggests that, as expected, transformation, biodegradation and photolysis exerted a minimal effect. For clarity and brevity, TNT transformation products will not be addressed here.

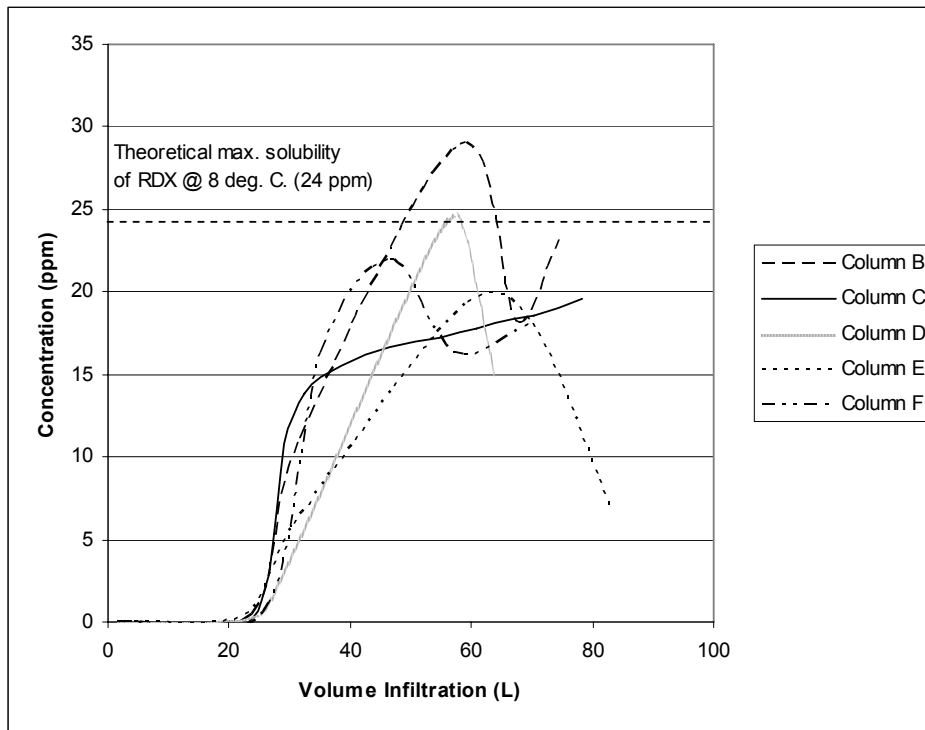

Figure 8-7. RDX outflow concentrations.

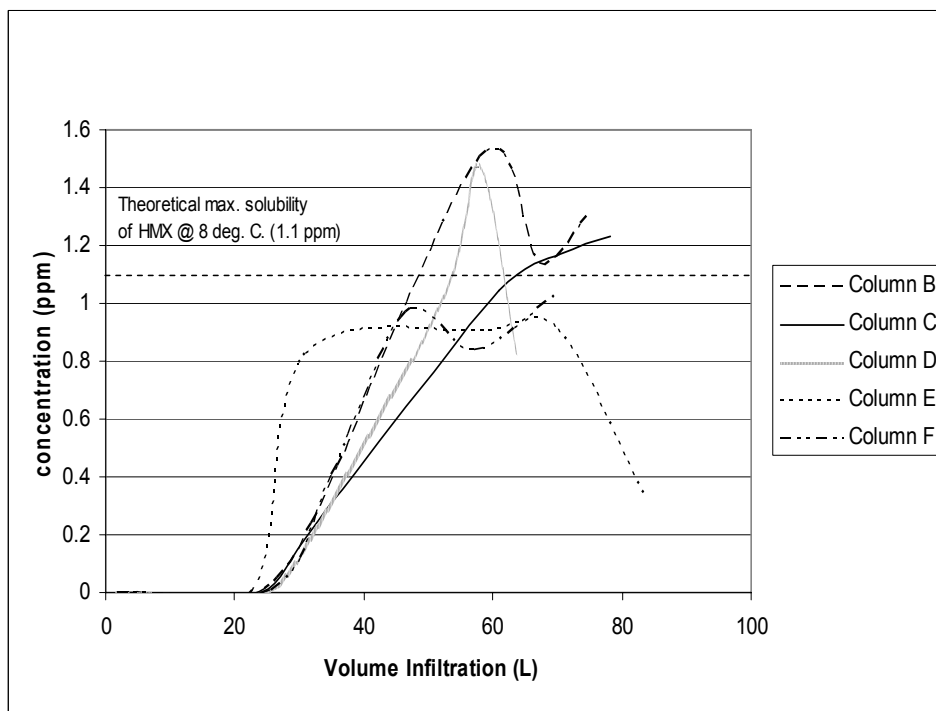

Figure 8-8. HMX outflow concentrations.

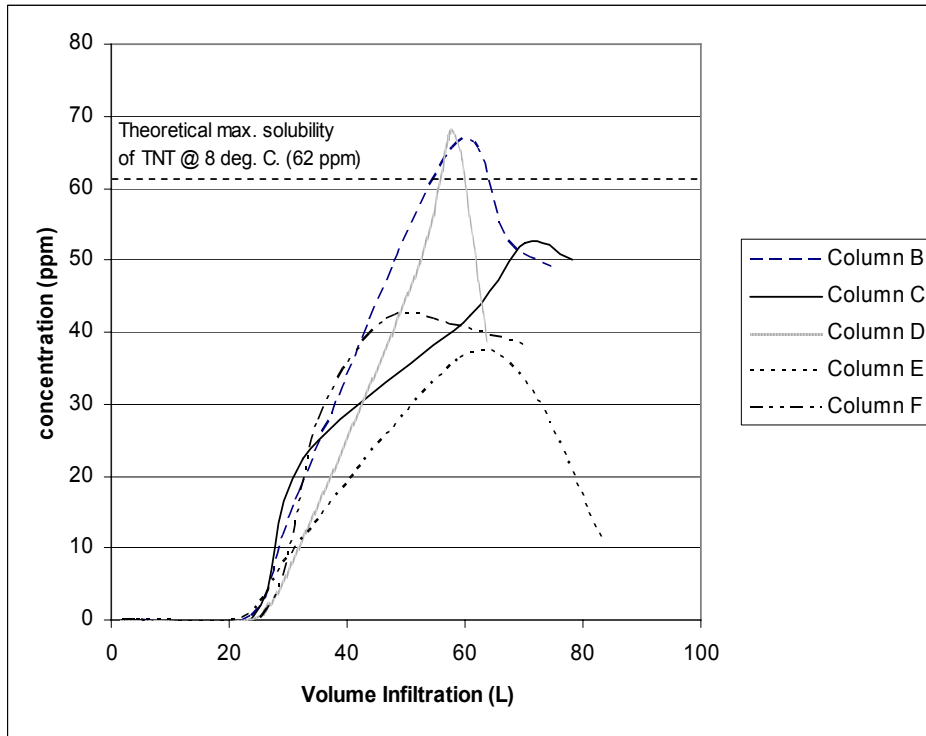

Figure 8-9. TNT outflow concentrations.

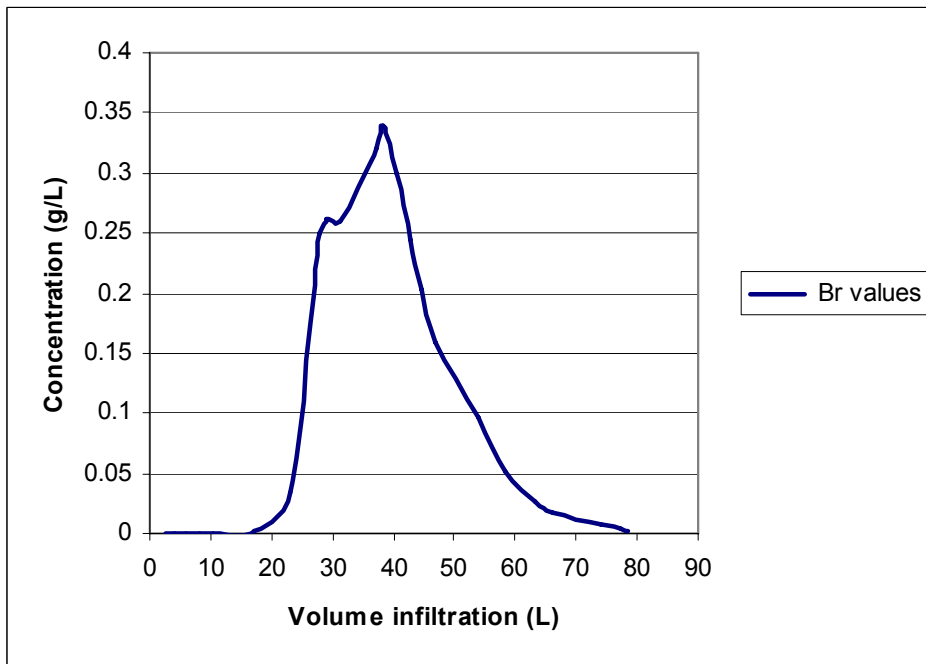

Figure 8-10. Br outflow concentrations.

The data in Figures 8–7, 8–8, and 8–9 suggest that mobilization of energetic materials is significant during the first groundwater recharge event following detonation or partial detonation. Energetic material concentrations are detected at infiltration volumes of approximately 24 L for all explosive species. In comparison, the inert KBr has breakthrough at 15 L.

The retardation factor R_f may be calculated from these data. The retardation factor describes how many times faster a nonsorbing tracer is moving relative to the contaminant being sorbed. Since all columns have the same physical dimensions and the same infiltration rate, the outflow rate (L/hr) is a direct function of the hydraulic conductivity (m/hr). The inert tracer will travel through the column faster than a species that is being sorbed, so breakthrough for the inert tracer will occur at a lower volume of cumulative outflow. Therefore, the ratio between the outflow volumes at which breakthrough occurs will be the inverse of the ratio of transport velocities. This ratio, R_f , is called the retardation factor. In the experimental columns, R_f was 1.56 (nondimensional).

R_f may also be defined according to the retardation equation (Domenico and Schwartz 1990). This equation (Equation 1) allows us to calculate K_d if the porosity (n) and the bulk density (ρ_s) are known. The soil used in the column study had a measured porosity of 0.42 and a bulk density of 1.3 g/cm³. This gives us a calculated K_d of 0.27 mL/g (or L/kg) for all energetics (TNT, RDX, and HMX). This value fits closely with the literature values for K_d in sand for TNT of 1.5 L/kg (Townsend and Myers 1996), 0.47 L/kg (Brannon et al. 1999), and 1.3 L/Kg (Cattaneo et al. 2000). Fewer literature values are available for the K_d of RDX and HMX in sand, but available values are also on the order of magnitude of 0 to 1 L/kg (Brannon and Pennington 2002).

$$R_f = 1 + \left(\frac{1-n}{n} \right) \rho_s K_d \quad (1)$$

Equation 1. Retardation factor R_f as a function of porosity n , bulk soil density ρ_s , and adsorption coefficient K_d (Equation 18.5 in Domenico and Schwartz 1990).

Myers et al. (1998) reported 100 percent recovery of RDX and HMX during saturated column studies using Ottawa sand, and 97.5 percent recovery of TNT. The subsurface, alluvial soil that was used for this experiment, while not as homogenous as the river sand used in Myer's experiment, was a medium to fine sand (Figure 8–3) with a very small silt

fraction and effectively zero clay content. The comparison with Ottawa sand, which had 0 percent clay content, should therefore be reasonably good, although Ottawa sand is coarser than sand used in the columns. Myers' results indicate that, in both batch and column experiments in the saturated regime, energetic materials will not undergo significant transformation or adsorption in sands. Although Myers' source term was already dissolved prior to injection into the columns and his columns operated in the saturated regime, our observations are very complementary. Very low concentrations of TNT transformation products were measured, as was substantial recovery of energetic materials in the effluent. The measured transformation product concentrations were 2 to 3 orders of magnitude below measured TNT concentrations.

Given the weak adsorption and transformation of RDX, HMX, and TNT in sandy soils, the rate-limiting step to contaminant transport in our columns should be dissolution. Lynch et al. (2001) published solubility data for TNT, RDX, and HMX over a range of pH's and temperature. From Lynch's data, predicted solubility at pH 4.7 and 8 °C is 61.6 mg/L (ppm) for TNT, 21.0 mg/L (ppm) for RDX, and 1.58 mg/L (ppm) for HMX (shown as dashed horizontal lines in Figures 8-7, 8-8, and 8-9). From this we can see that measured concentrations approach or surpass predicted solubility with a peak value occurring when approximately 50 L of water has flowed through the columns. The concentrations then tend to drop off at the end of the infiltration period. This dropoff suggests a slug type input, as opposed to continuous input, which would be expected if a solid source were dissolving in a uniform fashion and at a uniform rate. One explanation for this occurrence is that the extremely fine fraction of detonation residue is dissolving preferentially due to its very high surface area, creating a "slug" of dissolved energetic material. This hypothesis will be further explored later in the report.

The extrapolated cumulative energetic material mass transport during the spring infiltration period is shown in Figures 8-11, 8-12, and 8-13. The figures indicate that, despite the weak solubility of TNT, RDX, and HMX, a substantial amount of energetic material flowed out in the effluent. The sharp drop in the elution curves in Figures 8-7, 8-8, and 8-9 suggests that this rate of recovery will not be sustained. Table 8-2 shows the concentrations of energetic materials measured during the first outflow of the autumn infiltration, which took place 4 months after the spring infiltration

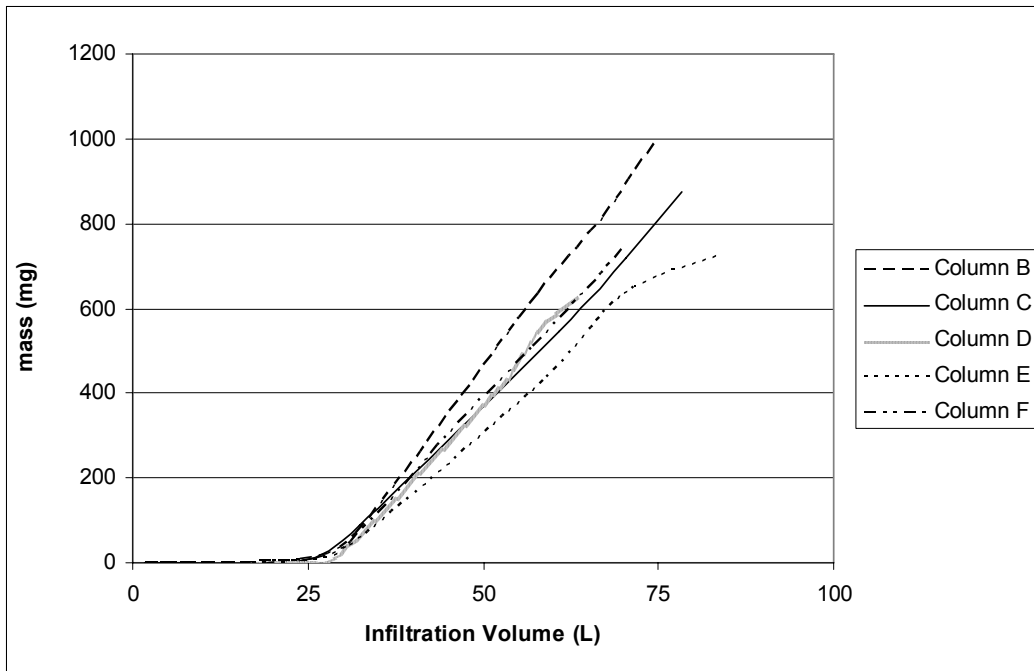

Figure 8-11. Cumulative mass transport of RDX in spring effluent.

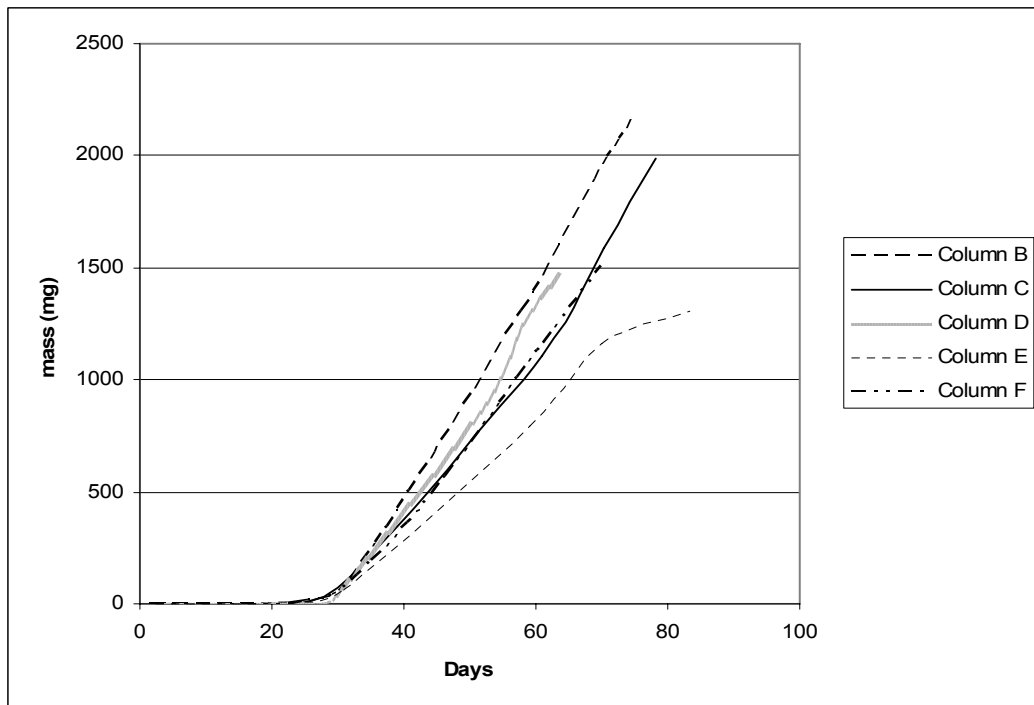

Figure 8-12. Cumulative mass transport of TNT in spring effluent.

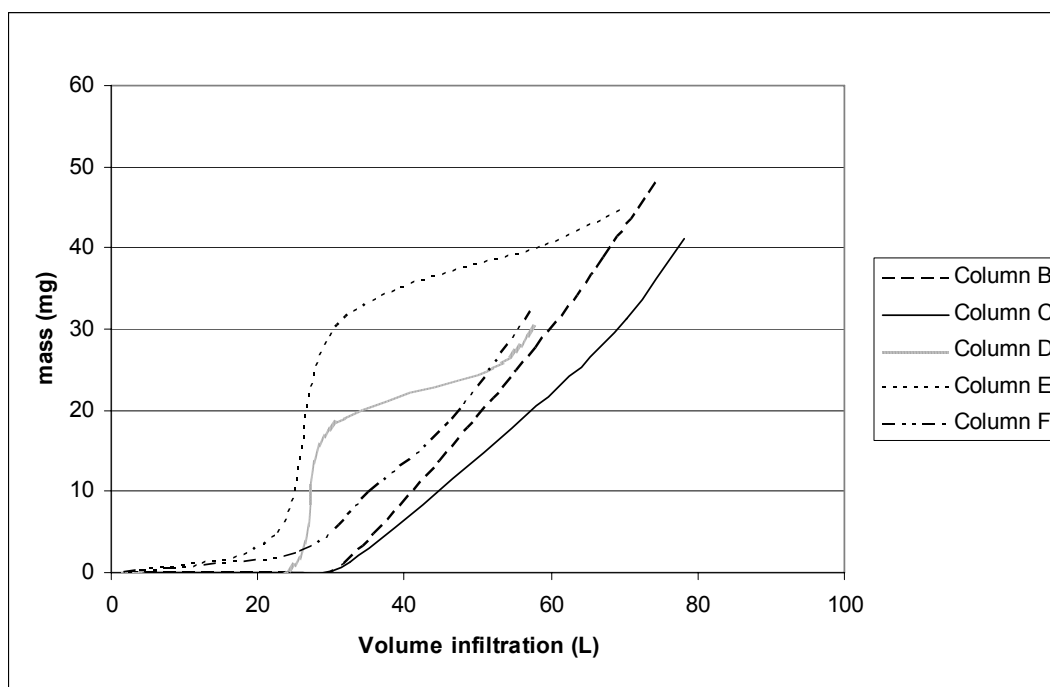

Figure 8-13. Cumulative mass transport of HMX in spring effluent.

Table 8-2. Energetic material concentrations in first autumn outflow.

Column	TNT Concentration ppb	RDX Concentration ppb	HMX Concentration ppb
B	364.58	211.5	12.0
C	Not Available	278.1	40.76
D	263.1	146.3	35.29
E	5281	2857	158.2
F	393.9	232.0	13.31

described in this report. The measured concentrations are, in general, two orders of magnitude lower than the peak concentrations detected during the spring infiltration, and one order of magnitude lower than the final springtime analyses. Further autumn effluent analyses support this observation. The peak in energetic material concentration seen in the springtime infiltration was not reproduced in the autumn infiltration event, indicating a one-time occurrence. This supports the fine-fraction dissolution hypothesis.

The columns with energetic materials as source terms all show essentially the same results. Columns B and C contained only detonation residues. Columns D and F contained detonation residues and a cracked mortar shell. The most important features of these sets of curves are the uniform

breakthroughs, concentrations that approach saturation, and the drop off in concentrations toward the end of the infiltration period. Small variations in the curves, such as the small increase in concentrations observed in the final analyses of Columns B and F, should be interpreted with caution, since there are observed variations in the curves between columns having identical source terms. For example, the energetic material in Column C appears to be somewhat slower in achieving maximum concentration, and Figure 8–11 suggests that peak RDX concentrations were reached just as the springtime infiltration came to an end. However, Column B, which had the exact same source term, showed the most pronounced peak and the highest concentrations of all columns. Similarly, Column D shows a very sharp peak in concentration followed by a rapid decline, while Column F achieved its peak earlier than all other columns. These differences are likely related to such factors as small differences in the bulk density of the soil achieved during compaction, small differences in the outflow nozzles, and of course the troubles experienced with the inflow spray system. Given these factors, small changes in the effluent concentration curves in Figures 8–7, 8–8, and 8–9 are not significant.

The detonation residue in Columns B, C, D, and F did not show effluent concentrations that were substantially different from the control: the pure, crushed Composition B that was placed on Column E. This suggests that the small amounts of impurities found in the detonation residue (soot, metal fragments) do not have a substantial impact on mass transport. Similarly, the cracked mortar shells in Columns D and F did not show a substantial impact on mass transport when compared with Columns B and C, which did not contain the UXOs. While the cracked shells themselves represent a large potential source of energetic materials, it would appear that the small surface area of the solid energetic material filling and the protection afforded by the metal casing prevent the energetic materials inside the munition from contributing to the initial slug of dissolved explosives. The energetic material found inside the shell may be a long-term source of explosives, but the material does not contribute substantially during the first infiltration event.

The observations concerning the high concentrations of energetic materials found in the effluent, coupled with the mass transport of TNT, RDX, and HMX in the effluent, support the hypothesis that the extremely fine detonation particles are dissolving preferentially. As observed, these fine

particles should enter into solution quite quickly and, once they are gone, the concentration in the effluent should drop off.

The data in Figures 8–11, 8–12, and 8–13 indicate that up to 1000 mg of RDX, 2200 mg of TNT, and 48 mg of HMX may be lost through the effluent in springtime infiltration. The total mass of energetic materials lost from Column B is therefore around 3.2 g out of an initial mass of 45 g, or 7.1 percent. This rate of mass transport would appear unsustainable, or very little energetic materials would be found on the surface of training ranges – it would all be transported through the vadose zone within 15 years. This is not the case (Thiboutot et al. 1998). If the fine fraction of explosives is dissolving preferentially, then we would anticipate a high initial rate of mass transport followed by a significant slow down when the fine fraction is exhausted. This would suggest that substantial amounts of the coarser fractions of detonation residue would still be found in surface soils, which is the case.

Conclusion

High concentrations of energetic materials were found in the effluent of the soil columns during the initial groundwater recharge event that reproduced the springtime snowmelt. The retardation factor was 2.4 and the K_d of the sandy soil was 0.94 L/kg for TNT, RDX, and HMX. No significant difference was observed between the three energetic materials in terms of the volume of infiltration prior to breakthrough at the bottom of the sand column. Very little transformation of TNT occurred as it passed through the sand, with TNT transformation species concentrations two to three orders of magnitude lower than the concentration of TNT. It is proposed that the dissolution behaviour of the energetic materials may be explained by the fine fraction of energetic materials dissolving preferentially due to their very high surface areas.

References

- Agency for Toxic Substances and Disease Registry (ATSDR). 1996a. 2,4,6-Trinitrotoluene (TNT) fact sheet (on-line), <http://www.atsdr.cdc.gov/tfacts81.html> (accessed 25 May 2005).
- _____. 1996b. RDX fact sheet (on-line), <http://www.atsdr.cdc.gov/tfacts78.html> (accessed 25 May 2005).
- _____. 1996c. HMX fact sheet (on-line), <http://www.atsdr.cdc.gov/tfacts98.html> (accessed 25 May 2005).

- Arel, N. 2004. Étude du comportement des matériaux énergétiques dans la zone non saturée du champs de tirs anti-chars Arnhem, Valcartier, Masters Thesis, Institut national de la recherche scientifique – Géoressources, Québec, Québec
- Best, E., S. Sprecher, S. Larson, I. Frederickson, and D. Bader. 1999. Environmental Behaviour of Explosives in Groundwater from the Milan Army Ammunition Plant in Aquatic and Wetland Plant Treatment. Removal, Mass Balances, and Fate in Groundwater of TNT and RDX. *Chemosphere* 38: 3383-3396.
- Brannon, J., P. Deliman, C. Ruiz, C. Price, M. Qasim, J. Gerald, C. Hayes, and S. Yost. 1999. *Conceptual Model and Process Descriptor Formulations for Fate and Transport of UXO*. Technical Report IRRP-99-1. Vicksburg, MS: U.S. Army Engineer Research and Development Center.
- Brannon, J. M., and J. C. Pennington. 2002. *Environmental fate and transport process descriptors for explosives*. ERDC/EL TR 02-10. Vicksburg, MS: U.S. Army Engineer Research and Development Center.
- Cattaneo, M. V., J. C. Pennington, J.M. Brannon, D. Gunnison, D. W. Harrelson, and M. Zakikhani. 2000. Natural attenuation of explosives. *Remediation of hazardous waste contaminated soils*. Marcel Dekker, Inc. New York
- Crockett, A., H. Craig, and T. Jenkins. 1999. Field Sampling and Selecting On-site Analytical Methods for Explosives in Water. Report EPA/600/S-99/002. Washington, DC: U.S. Environmental Protection Agency, U.S. Government Printing Office.
- Domenico, P. A., and F. W. Schwartz. 1990. *Physical and Chemical Hydrogeology*. ISBN 0-0471-59762-7. John Wiley and Sons, Inc. Toronto.
- Jenkins, T. F., T. A. Ranney, M. E. Walsh, P. H. Miyares, A. D. Hewitt, and N. H. Collins. 2000. Evaluating the use of snow-covered ranges to estimate the explosives residues that result from detonation of Army munitions. ERDC/CRREL TR-00-15. Hanover, NH: U.S. Army Engineer Research and Development Center.
- Lever, J. H., S. Taylor, L. Perovich, K. Bjella, and B. Packer. 2005. Dissolution of Composition B detonation residuals. *Environmental Science and Technology* 39:8803-8811.
- Lynch, J. C., K. F. Myers, J. M. Brannon, and J. J. Delfino. 2001. Effects of pH and temperature on the aqueous solubility and dissolution rate of TNT, RDX and HMX. *J. Chem. Eng. Data* 46: 1549-1555.
- Lynch, J. C., J. M. Brannon, and J. J. Delfino. 2002. Effect of component interactions on the aqueous solubilities and dissolution rates of the explosive formations octol, Composition B and LX-14. *J Chem. Eng. Data* 47: 542-549.
- MacDonald, J. 2001. Cleaning up unexploded ordnance. *Environ. Sci. Technol.* 35: 372a-376a.
- Mailloux, M. 2002. Caractérisation et modélisation numérique du comportement des matériaux énergétiques dans les sols et l'eau souterraine d'un site d'entraînement anti-char., Masters Thesis, Institut national de la recherche scientifique – Géoressources, Québec, Québec.

- Myers, T. E., J. M. Brannon, J. C. Pennington, D. M. Townsend, W. M. Davis, M. K. Ochman, C. A. Hayes, and K. F. Myers. 1998. *Laboratory studies of soil sorption/transformation of TNT, RDX, and HMX*. Technical Report IRRP-98-8. Vicksburg, MS: U.S. Army Engineer Waterways Experiment Station.
- Pennington, J. C., T. F. Jenkins, S. Thiboutot, G. Ampleman, J. Clausen, A. D. Hewitt, J. Lewis, M. R. Walsh, M.E. Walsh, T. A. Ranney, B. Silverblatt, A. Marois, A. Gagnon, P. Brousseau, J. E. Zufelt, K. Poe, M. Bouchard, R. Martel, D. D. Walker, C. A. Ramsay, C. A. Hayes, S. L. Yost, K.L. Bjella, L. Trepanier, T. E. Berry, D. J. Lambert, P. Dubé, and N. M. Perron. 2005. *Distribution and fate of energetics on DoD test and training ranges: Interim Report 5*. ERDC TR-05-02. Vicksburg, MS: U.S. Army Engineer Research and Development Center, Strategic Environmental Research and Development Program.
- Phelan J. M., S. W. Webb, J. L. Romero, F. Barnett, F. Griffin, and M. Eliassi. 2003. Measurement and modeling of energetic material mass transfer to soil pore water – Project CP-1227, Sandia Report 2003-0153.
- Thiboutot, S., G. Ampleman, A. Gagnon, A. Marois, T. Jenkins, M. E. Walsh, P. G. Thorne, and T. A. Rainey. 1998. *Characterization of anti-tank firing ranges at CFB Valcartier, WATC Wainwright and CFAD Dundurn*. DREVR- 9809, Valcartier, Quebec: Defence Research Establishment Centre de Recherches Pour La Defence.
- Townsend, D. M., and T. E. Myers. 1996. Recent developments in formulating model descriptors for subsurface transformation and sorption of TNT, RDX, and HMX. Technical Report IRRP-96-1, Vicksburg, MS: U.S. Army Engineer Waterways Experiment Station.
- U.S. Environmental Protection Agency (USEPA). 1994. *Nitro aromatics and nitramines by HPLC*. 2nd update, SW846, Method 8330, September 1994. Washington, DC: Office of Solid Waste and Emergency Response.

9 Explosive Residues from Low-Order Detonations of Artillery Munitions

Introduction

Background

Results of range characterization studies conducted under ER-1155 (formerly CP-1155) indicate that residues from low-order detonations (i.e., munitions that explode incompletely leaving scattered HE compositions on the soil surface) are a potentially significant point source of environmental contamination on training ranges (Pennington et al. 2001 through 2005). Characteristics of these residues and their relationship to the overpressure or other characteristics of the blast are unknown. Therefore, these studies were conducted to characterize the nature and quantity of residues from low-order detonations of selected artillery munitions.

To maximize safety and reduce hazards associated with render-safe procedures for UXO, the EOD community has developed a method to neutralize UXO without releasing maximum energy. The method results in nondetonative reactions, or low-order detonations. In previous studies, the Naval EOD Technical Division developed the Main Charge Disrupter (MCD) to produce low-order detonations (Baker et al. 1997; Blankenbiller 1999). Various energy yields were achieved with the MCD by varying the explosive load and placement of the tool relative to the UXO. Therefore, the MCD was selected to provide controlled yields for the low-order detonation studies in ER-1155. The MCD subsequently proved too large for controlled energy yields of 60-mm mortars, so other secondary (donor) charges were evaluated in the 2004 studies reported here.

The following are three typical situations in which low-order detonations occur:

1. The explosive train (fuze, booster, or main charge) of a fired round malfunctions.
2. A piece of UXO low-orders (a secondary detonation) as a result of a fragment impact from a nearby high-order detonation (primary detonation). (See Chapter 7 in Pennington et al. 2005.)

3. EOD personnel intentionally neutralize a UXO by initiating a low-order detonation (the purpose for development of the MCD tool).

In a low-order detonation, consumption of the explosive filler is typically less than 100 percent. A low-order detonation is characterized by increased burn time, increased light intensity, reduced blast pressure, reduced impulse, and the presence of unreacted residual explosive (i.e., explosive that was not consumed during the detonation, nor burned afterwards in the fireball). The amount of unreacted residual explosive is likely to be a function of the energy yield of the detonation, the overall size of the reaction, and the intensity and burn time of the fireball.

Previous testing. A series of detonation tests have been conducted under ER-1155. All were conducted at the Army Research Laboratory Blossom Point Research Facility near La Plata, MD. In May 2002 attempts to produce low-order yields ranging from 25 to 75 percent on 81-mm mortars and 155-mm artillery projectiles resulted in unpredictable yields in the range of 25 to 50 percent (Pennington et al. 2003). Residues were collected from witness plates (pans) placed on a tarp surrounding the detonation center. Determinations of overpressure were complicated by interferences. Therefore, additional pressure gauges were added to achieve better determinations of energy yields. In September 2002 four additional 81-mm mortars were detonated with the goal of achieving 100 percent in one and 75 percent energy yields in three. Yields were 100, 28, 73, and 68 percent. Residues recovered from witness plates were not sufficiently representative of the mass generated by the detonations. In subsequent tests, residue was recovered by sweeping the tarp. In August 2003 three 60-mm mortars were detonated with a desired energy yield of 75 percent to determine directionality, particle size distribution, and chemical composition of residues. Seven replications of 155-mm rounds and five replicates of 105-mm rounds at 75 percent energy yield and five replicates of 105-mm rounds at 50 percent energy yields were also attempted (Pennington et al. 2004). Average energy yields for all detonations were lower than desired. Results with the three 60-mm rounds were either too high (96 percent from one detonation) or too low (2.1 and 2.4 percent for the other two detonations). Results for the 105-mm detonations averaged 26.6 ± 29.2 percent rather than the desired 50 percent, and 66.6 ± 9.3 percent rather than the desired 75 percent. Results for the 155-mm averaged 26.4 ± 10.8 percent rather than 75 percent. Directionality in the distribution of residues by quadrants of the tarp was inconsistent. The

> 12.5-mm size fraction contained the greatest mass, and the < 0.25-mm fraction contained the smallest mass for each munition. The ratio of TNT to RDX in predetonation Composition B was generally reflected in the post detonation composition. Based on these results, subsequent testing was focused on replicating detonation configurations to improve overall data quality.

Objectives

Objectives were (1) to determine the relationship between mass of residues and distance from the detonation center, (2) to determine particle size distribution of residues, and (3) to relate residue mass to over-pressure, a measurable characteristic of the blast.

Materials and methods

Detonations

Low-order detonations of artillery munitions were achieved using the following EOD tools: MK 88 Shaped Charge, Flex Linear Shaped Charge (FLSC), the Vulcan®, and the MCD. Although the MK 88 (shot 3), the FLSC with 125 grains/ft of H-6 explosive (a castable mixture: 45 RDX/30 TNT/20 aluminum/5 wax) (shot 4), and the Vulcan® (shots 6 and 7) were used to initiate some of the 60-mm mortars. The replicated shots were initiated by the FLSC with 500 grains H-6 explosive per 0.3 m (1 ft). All of the 120-mm mortar, and the 105- and 155-mm artillery projectiles were initiated using configurations of the MCD.

The MK 88, or Mod 0 “Lipstick” charge, is approximately 60 mm long and 16 mm in diameter. The conical shaped charge contains 1 gram of CH6 explosive (97.5 RDX/0.5 polyisobutylene/0.5 calcium stearate/0.5 graphite) formed around a copper cone and sealed in a waterproof aluminum case (Figure 9–1). The MK 88 is initiated by a blasting cap or sensitized detonating cord. The charge is designed to penetrate 13 mm of mild steel. The standoff is preset by the tool’s cap. The charge was held in place using a pipe clamp and a small coil of wire.



Figure 9-1. 60-mm mortar with MK 88 shaped charge held in place by a pipe clamp and coil of wire. Mortar rests on a metal plate to maintain upright orientation.

The FLSC charges are intended to produce a linear cutting action. The charge is a continuous explosive core of H-6 enclosed in a seamless lead sheath (Figure 9–2). The soft sheath allows forming of this tool to the contour of an ordnance item. For the 60-mm mortar, 15-cm (6-in.) lengths (250 grains of H-6 explosive) were used.

The Vulcan® charge consists of a polyvinyl chloride (PVC) body, spacers, consolidating ring, and a dummy detonator (Figure 9–3). The hand-loaded tool system uses C4 or PE 4 (88 RDX/12 plasticizer) and either a magnesium jet-forming cone, a copper jet-forming cone, or a copper explosively formed penetrator depending on its intended UXO target. The magnesium cone was designed to penetrate conventional steel ordnance casings and initiate the explosive filler contained inside. Against the 60-mm mortars, the magnesium jet-forming cone was used with a 25- or 40-gram load. The Vulcan® body is approximately 4 cm (1.5 in.) in diameter and 15 cm (6 in.) long.



Figure 9-2. 60-mm mortar with FLSC strapped to the side.



Figure 9-3. 60-mm mortar with Vulcan Shaped Charge. Standoff distance and elevation relative to the mortar were maintained by two wire legs secured to the mortar with a pipe clamp.

The MCD tool is another hand-loaded tool system consisting of an aluminum cylinder 4.62 cm in diameter, containing a dish shaped (radius of curvature ~3.3 cm) copper liner (99.9 percent copper) in one end (Figure 9-4). Nylon attenuators were added behind the copper liner as needed to slow the velocity of the penetrator (typically ~1,829 m/sec [$\sim 6,000$ ft/sec]), thus reducing the energy being imparted to the ordnance. A variable number of attenuators (0 to 3) were used to change the velocity of the penetrator. The attenuators were injection molded from nylon and were shaped to cover the convex surface of the liner. Each attenuator weighed approximately 2 g. The velocity of the penetrator was also adjusted by varying the explosive load (typically 57 to 170 g of C4).



Figure 9-4. Positioning the MCD relative to an 81-mm mortar.

The tools cause initiation of an energetic reaction within the explosive filler upon impact or penetration. The selection of tools was based on the size of the munition to be detonated. The standoff distance, the angle of the tool relative to the munition, and the impact point on the casing can be varied in an effort to achieve various specific over-pressure levels, or energy yields, from the detonations. Several configurations of steel stands

were used to support the position of the various tools relative to the munitions, which were positioned with the fuze end pointing upward.

An exploding bridge wire (EBW; RP-83, Reynolds Industries Systems Incorporated, San Ramon, CA) was used to initiate all of the energetic EOD tools. A foam plug inserted into the MCD held the EBW against the surface of the explosive fill. A screw-down adapter held the detonator in place on the Vulcan®. Tape attached the detonator to the MK 88 and the FLSC. Munitions tested (nomenclature and quantity of fill) included the following: 60-mm mortars (M720, 190g Composition B), 81-mm mortars (M889, 725.74 g Composition B), 105-mm projectiles (M1, 2.3 kg Composition B), 120-mm mortars (M933, 3.0 kg Composition B), and 155-mm projectiles (M107/D544, 6.6 kg TNT and M107, 7.0 kg Composition B).

The tests were conducted on a 184-cm × 230-cm (4.23 m²) × 3.81-cm thick elevated steel table. In the center of the table was a 60-cm × 91-cm × 10-cm thick T1 armor plate. The plate was used to repair damage from previous trials, and served as the platform where all tests were conducted (Figure 9–5). The table was supported by stacked 15-cm × 15-cm timbers to create a square perimeter 200.67 cm on each side. Overall elevation of the tests was 0.76 m. Four solid steel cylindrical columns, 15.24 cm in diameter and approximately 1-m tall, were supported by angled braces welded to the table at the center of each side. These columns were used to protect pressure gauges from fragments created during the detonations. For the smaller munitions, an additional set of four 3.81-cm diameter steel poles were threaded into a welded flange near the corners of the table. These poles were used when the pressure gauges were moved closer to the table. The detonation table was placed in the center of a 30.5-m × 30.5-m (approximately 930 m²) tarp made of 18-ounce (509-g) flame resistant white vinyl. The tarp was used to facilitate recovery of residues.

Detonation properties

Applied Research Associates (ARA, Denver, CO) supplied the instrumentation for these tests. Instrumentation included eight PCB Piezotronics model 137M25 and 137A23 pressure transducers, or gauges (PCB Piezotronics, Depew, NY) to measure overpressure. A total light radiation (TLR) unit was used to collect photoemission data. All data were recorded on a 16-channel data acquisition system sampling at 500,000 samples per data collection as well as the fire set (FS-10). The pressure gauges were

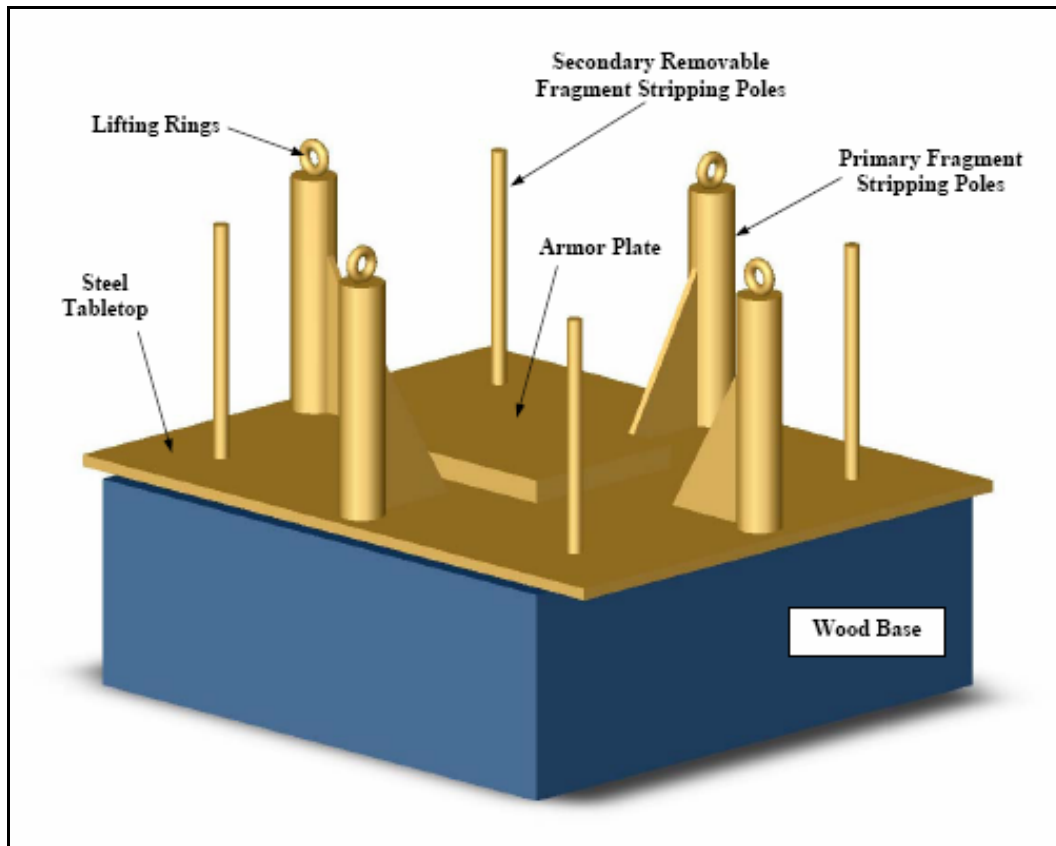

Figure 9-5. Steel test table that was 4.23 m² by 0.76 m high.

second. A sequencer was used to trigger all of the various instruments located at several different distances (1.8, 3, 4.57 m, or 6, 10, and 15 ft, measured from the center of the table to the center of the sensing element of the pressure gauge), depending on which ordnance item was tested. Two high-speed cameras positioned at 78 and 241 m recorded detonations. Cameras recorded at approximately 10,000 frames per second and were protected in large portable steel bombproof shelters equipped with Lexan windows.

A TLR unit was used to collect the broadband spectrum of light during the detonation process. Differences between the pre- and post-detonation light were intended to estimate the duration of the event. Although data were recorded, a high level of background noise prevented fireball durations from being obtained. Interaction with the test platform and burning aluminum from some of the EOD tools are thought to have contributed to the signal noise. A 30,000-volt pulse from a fire-set device connected to the EBW initiated detonation. An electronic sequencer was used to trigger all of the various instruments and initiate the fire set.

Detonation configurations

To achieve higher confidence in yields obtained in previous tests (2003), low-order procedures from prior tests were duplicated against specific targets. Ideally, the identical test setup would produce similar yields. However, shot to shot variations in the ignition, burning, and venting of the targets altered the anticipated yield. When no previous testing of a specific round had occurred, approximately half of the available rounds were used to define the test configuration needed to achieve the selected yields. Once the desired yield was approximated, remaining shots were dedicated to replication of the yield. The objectives of testing were as follow:

1. Measure and replicate 50 percent energy yields for 105-mm projectiles using configurations from previous studies (2003).
2. Achieve 25, 50, and 75 percent yields of the 120-mm mortars and 155-mm projectiles using the MCD and one-half of the available rounds.
3. Achieve 25, 50, and 75 percent yields against one half of the 60-mm mortar using various EOD tools.
4. Measure and replicate specific energetic yields from 120- and 60-mm mortars, and 155-mm projectiles using selected configurations with the remaining half of available rounds.
5. Measure and replicate energetic yields from 81-mm mortars using configurations from previous tests (2003).

The first detonation test was a 25-g ball of C4 for verification of equipment performance. No residue data were collected from this detonation; however, all residue was removed from the tarp. In past trials, the next tests conducted were against inert ordnance items to determine the contribution of the EOD tool to energy/yield measured during a detonation. The explosive charge in most of the EOD tools was insignificant relative to the explosive weight in the rounds and should not, therefore, add to the energy. However, the MCD contained a significant amount of explosive. Data from prior trials were used to subtract out the MCD contribution. Against the 120-mm mortar, no previous data existed, and no inert items were available. Therefore, data from MCD used against the 105-mm projectile, which is similar in height and diameter to the 120-mm mortar, was subtracted from the measured energy/yield.

To obtain maximum pressure/yield results, an intentional, or high-order, detonation was conducted on each type of ordnance. The detonations were initiated by 25 g of C4 packed into the fuze well of the munition. Although

so called “high-order” detonations are likely to generate a range of energy yields around 100 percent rather than a perfect maximum of 100 percent every time, this detonation was designed to represent the highest possible yield. Instrument responses for this detonation were taken to represent 100 percent pressure/energy yield calibration. Theoretically, this detonation consumed 100 percent of the explosive in the munition.

All attempted low-order tests were conducted with inert “dummy” fuzes installed in the munitions to ensure the safety of EOD personnel. Previous experimentation with 155-mm artillery munitions had established that fuzed rounds detonated using an M42 shaped charge to penetrate through the side of the casing caused a full yield detonation (Blakenbiller and Lukens 1998). Detonators remaining in the fuzes after an attempted low-order test can also pose a significant hazard to personnel. To assure safe access to the rounds, high-order detonations were unfuzed.

Residue recovery

Concentric circles were drawn on the surface of the tarp at 3-m (10-ft) intervals (Figure 9–6). The table (A), these donut-shaped areas (B-F), the remaining corners of the tarp (G), and the access tarp (H) were swept separately, and the residues weighed and sieved. For larger projectiles, a concerted effort was made to retrieve visible residues landing beyond the tarp (X).

Debris was manually removed from the > 12.5-mm and four 12.5-mm size fractions. The explosive residue remaining was weighed and assumed to be Composition B on the basis of visual inspection. Five-gram subsamples of each of the remaining size fractions were extracted three times with 50-mL acetone. Preliminary tests indicated that three extractions were sufficient to dissolve the explosive residue. Any unextractable residue, generally consisting of soil, gravel, metal fragments, grass, and bits of tarp, was weighed and considered nonexplosive. The extracts were combined, further diluted, and analyzed by EPA Method 8330 for explosives and transformation products (USEPA 1994).

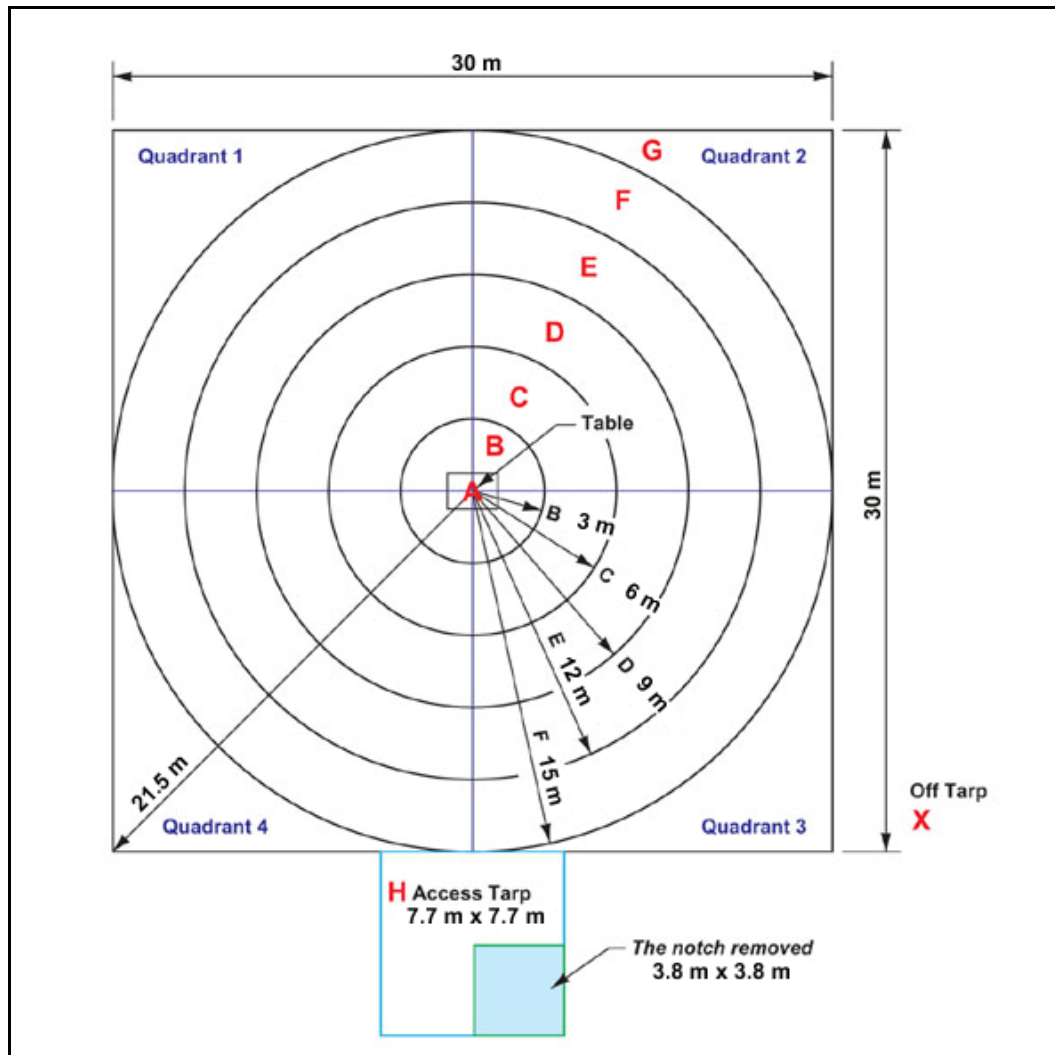

Figure 9-6. Configuration for sweeping residue from the tarp.

Results

Total mass recovered

As expected, the total mass recovered generally increased with the size of the round (Figure 9-7). When the detonation energy, or yield, was added to the total mass recovered, mass balance ranged from 64 to 90 percent (Table 9-1). Mass balance was likely affected by variability in detonations of the same kind of rounds, experimental error in pressure determinations, and limitation in recovery of residue mass.

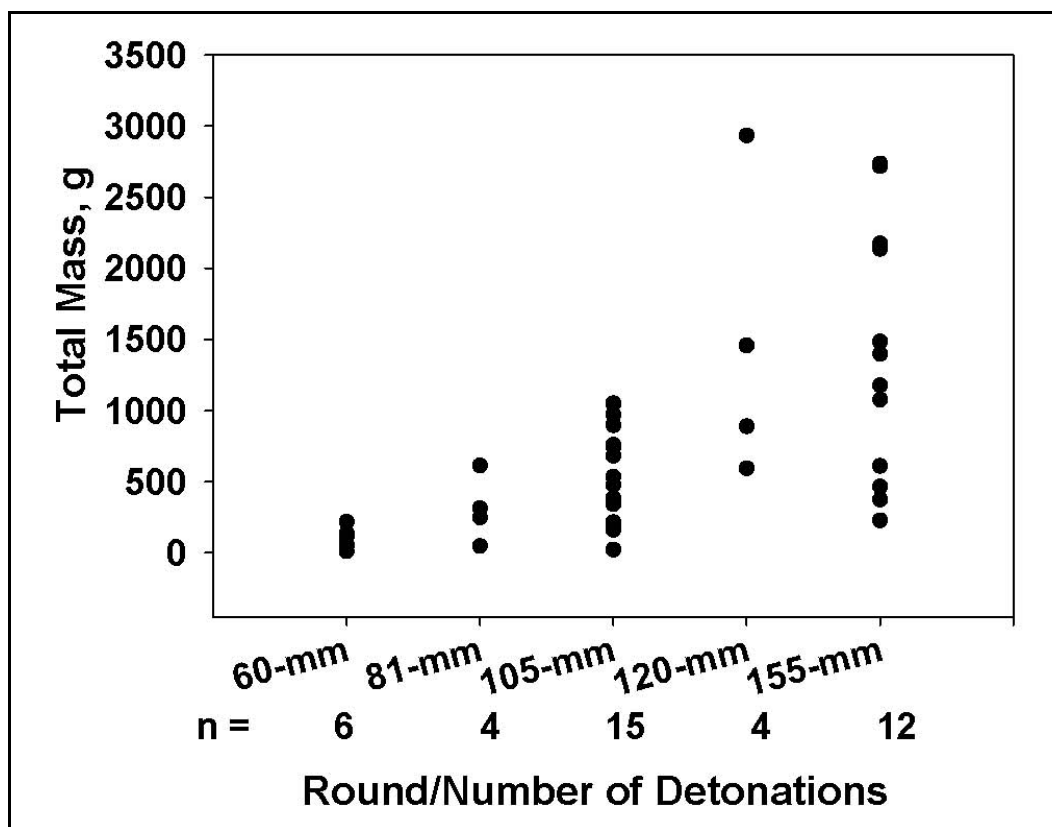

Figure 9-7. Total residual mass recovered for each detonation. Data set includes detonations conducted in 2003 and 2004. The number of rounds detonated (n) appears below the x-axis.

Table 9-1. Mean mass balance of explosive contained in each type of round.

Round	60-mm	81-mm	105-mm	120-mm	155-mm
Total Explosive in Round, g	190.50	725.74	2,304.24	2,989.16	6,985.29
Residue Recovered, %	35	42	27	49	29
Estimated mass consumed based on pressure data, %	24	39	43	15	61
Total, %	59	81	70	64	90

Energy yields

Peak pressure, incident impulse, and incident impulse truncated at 500 μ sec (see Silverblatt 2004 for a description of specific test configurations, donor charges, and rounds) were averaged to generate the percentage yield (Table 9–2). Achieving a specific low-order energy yield was challenging for all of the rounds, but had been particularly difficult for the 60-mm mortars in 2003 when either very high (96 percent) or very low (2 percent) yields, but nothing in between, were obtained. To achieve low-order detonations, a balance between forces that sustain and those

Table 9-2. Energy yield and mass recovered after each detonation.

Detonation Number	Desired Energy Yield, %	Actual Energy Yield, % ¹	Recovered Residue Mass, g
60-mm			
5	75	19	56.08
8	75	34	47.2
9	75	28	111.2
10	75	72	nd ²
81-mm			
34	75	16	248.3
35	75	19	612.4
36	75	21	314.3
105-mm			
20	50	69	385.5
21	50	16	896.8
22	50	65	758.7
23	50	64	683.4
24	50	52	477.6
120-mm			
13	75	8	2,832.4
16	75	18	594.5
17	75	17	888.9
18	75	18	1,457.6
155-mm			
26	75	51	2,174.8
27	75	93	227.6
28	75	13	5,942.2
29	75	97	373.8
30	75	75	nd
31	75	66	1,396.8
32	75	69	1,485.6

¹ The MCD was used to initiate detonations for all rounds except the 60-mm mortars for which the FLSC was used. The desired energy yield for all detonations was 75 percent except for that of the 155-mm rounds for which a yield of 50 percent was targeted.

² Samples for this detonation were lost.

that quench the detonation reactions must occur. Use of a penetrator creates a vent hole in the casing of the round to aid in quenching the reaction. The venting can allow for quick release of the confined pressure, which normally sustains or accelerates the reaction up to transition into a

high-order detonation. When the vent is large enough to allow pressure to dissipate too quickly, very low-order performance is observed. When the vent is insufficient, the pressure propagates until all, or nearly all, of the energetic material is consumed resulting in a high-order detonation. Yields in the 60-mm mortars were somewhat better controlled by use of the FLSC 500 grains/ft (DODIC/Naval Ammunition Logistics Code ML18) in 2004 rather than the MCD (Silverblatt 2004). The average yield was 38 percent with a standard deviation (SD) of 23 percent ($n = 3$). This average represents an improvement over the 2003 data, which had a mean of 33 percent with an SD of 54 percent ($n = 3$). Yields for the 81-mm mortars and 120-mm artillery projectiles tended to be small, but reproducible in the 2004 tests (mean = 18.7 percent, SD = 2.5 percent, $n = 3$ and mean = 15.2 percent, SD = 4.6 percent, $n = 4$, respectively). Since only a few of these rounds were available, testing different configurations to improve control and increase replication was not an option. Results of previous testing (2003) with the 105- and 155-mm rounds ($n = 10$ and 8, respectively) formed the basis for improving reproducibility in the 2004 testing, even though the 155-mm rounds tested in 2003 were TNT-filled and those tested in 2004 were Composition B-filled. The SDs in the 2003 105- and 155-mm data were 29.3 and 27.9 percent, respectively (mean = 46.6 and 35.6 percent, respectively). In the 2004 data set, SDs for these two rounds were 21.7 and 28.3 percent, respectively (mean = 53.2 and 66.3 percent, respectively; $n = 4$ and 7, respectively). Therefore, while the average yield was closer to 50 percent in 2004, reproducibility around 50 percent was relatively good in both years. While achieving a specific energy yield was a challenge, a range of yields for the various rounds was achieved. For all of the 2004 energy yield data (Table 9–2), test configurations for each type of round were kept constant to replicate the detonations as nearly as possible. Nevertheless, uncontrolled variables exerted pronounced effects on results.

Relationship between energy yield and mass recovered

Although a general trend of increasing mass with decreasing energy yield was evident, the small sample size, high variability, and non-normal distributions of the 2004 data sets restricted statistical comparisons of energy yield to mass recovered by type of round. Only the data for the 155-mm rounds showed a significant inverse relationship between energy and mass (Pearson Product Moment Correlation, $P = 0.0015$, correlation coefficient = -0.968 , $n = 6$). When all of the 2003 and 2004 data were combined, an

inverse relationship was found ($P = 0.034$, correlation coefficient = -0.329 , $n = 42$, Figure 9–8). However, the correlation was not strong enough to justify predictions of mass from energy yields.

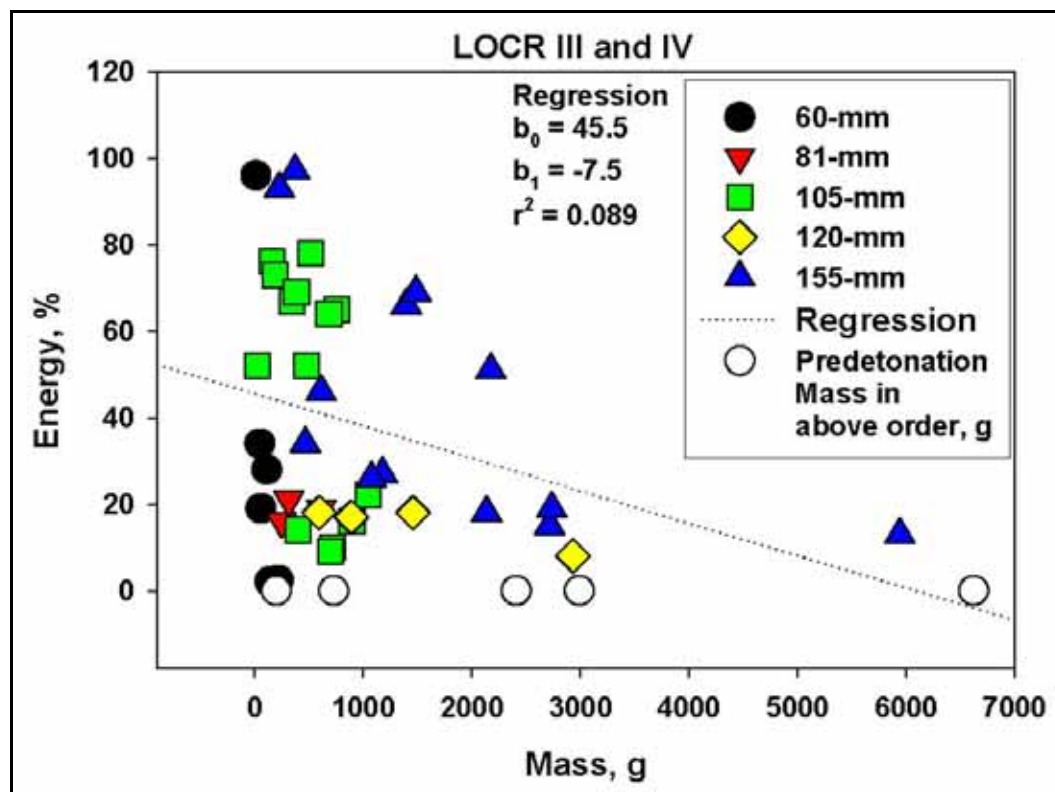

Figure 9-8. Mass versus energy yield for each round detonated in 2003 and 2004.

Relationship between mass recovered and areal distribution

The distribution of mass with distance from the detonation center was relatively uniform for the 60- and 81-mm mortars (Figure 9–9). Other rounds seemed to reach a peak beyond the 3-m interval and before 12 m. However, differences were not statistically significant (Table 9–3). As can be seen from the linear regression data, the distribution with distance was not very linear even when data for 2003 (60-, 105-, and 155-mm) were included (Table 9–4). Although some mass is likely to have remained unaccounted for because it traveled beyond the area of the tarp or was unrecoverable (i.e., small amounts were melted onto the surface of the table or tarp), the peaks with distance suggest that most of the residue fell on rather than beyond the tarp. The mass balance data (Table 9–1) supports this suggestion. In planning remediation strategies for residues from low-order detonations, an 18-m radius around a low-order detonation impact point seems a reasonable starting area.

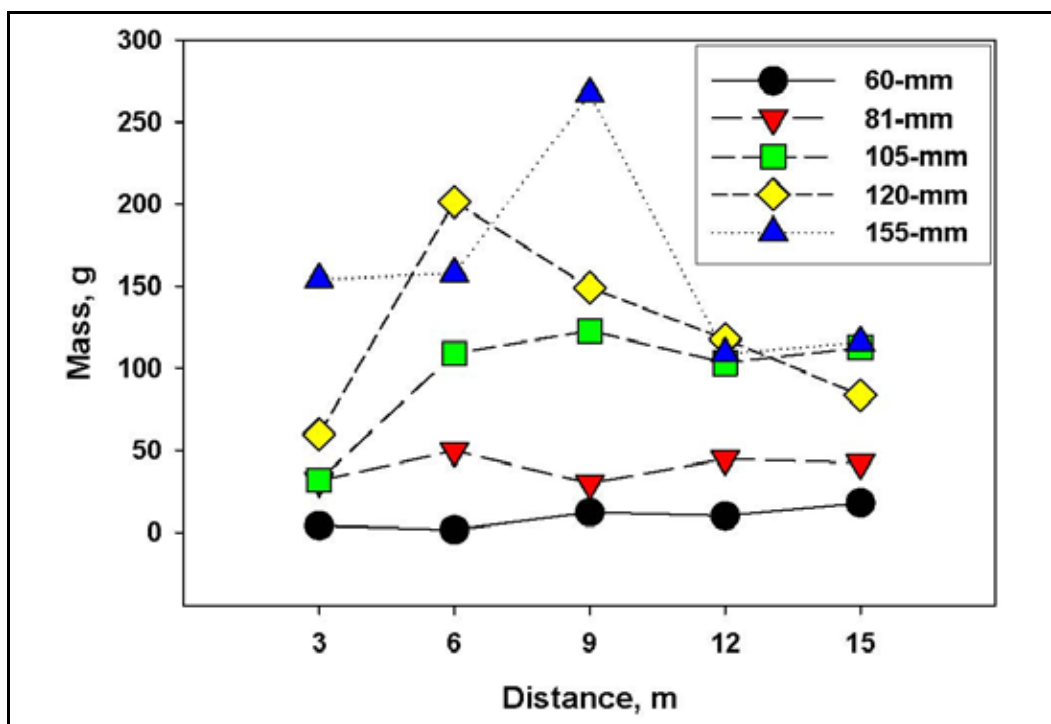

Figure 9-9. Mean mass with distance, 2004 data only. One outlier data point was removed from the 120-mm data set prior to plotting this graph. Residue data from the detonation center (the table) and for residue recovered beyond the tarp (>15 m from the detonation center) are not included.

Table 9-3. Mean (standard deviation) of 2004 mass with distance data, g.

Round	Distance, m				
	3	6	9	12	15
60-mm	4.1 (1.4)	1.4 (6.2)	12.2 (3.2)	10.0 (1.30)	17.7 (12.6)
81-mm	24.8 (16.8)	38.2 (28.0)	24.6 (14.1)	35.8 (28.5)	34.1 (35.4)
105-mm	31.6 (18.5)	108.9 (69.8)	122.7 (71.5)	103.1 (66.1)	112.4 (47.9)
120-mm	59.6 (45.5)	825.4 (1256.6) ¹	148.8 (174.0)	117.6 (79.4)	83.5 (47.6)
155-mm	154.0 (173.5)	157.5 (140.0)	267.1 (259.9)	108.6 (57.3)	115.6 (56.2)

¹ Contains a large chunk in one sample. Mean and standard deviation without this outlier were 201.4 and 179.1, respectively.

Table 9-4. Linear regression parameters of mass versus distance (data were from 2004 tests except where noted).

Round	Number of Detonations	Intercept, b ₀	Slope, b ₁	Coefficient, r ²
60-mm	3	-1.7	0.36	0.76
81-mm	3	34.50	0.16	0.093
105-mm	5	49.06	1.56	0.45
105-mm ¹	12	22.2	1.28	0.72
120-mm ²	6	129.02	-0.26	0.0052
155-mm	6	198.26	-1.26	0.098
155-mm ¹	13	82.47	2.32	0.47

¹ Includes 2003 and 2004 data.

² One outlier removed. (See Table 9-3, footnote.)

Particle size distribution

The > 12.5-mm particle size fraction tended to predominate other size fractions in mass (Table 9–5). Except for the 60-mm mortars, the < 0.25-mm fraction contained the smallest mass. The fact that the 60-mm mortar is the smallest round (only 199 g of Composition B) may contribute to greater fracturing of the Composition B during low-order detonations. Statistical comparisons showed no differences among masses by particle size for the 60-mm mortars; however, the data set contained only three detonations. When the 2003 data for the 60-, 105-, and 155-mm rounds (see Appendix C for 2003 data) were included, the > 12.5-mm fraction contained the greatest mass and the < 0.25-mm fraction contained the smallest (Figure 9–10). Differences between the > 12.5-mm and the < 0.25-mm fractions were significant except for the 60-mm mortars and 155-mm projectiles. High variability in the data obscured differences for these. The mass in the > 12.5-mm size fraction was inversely related to the energy yield (Correlation coefficient = -0.327, $P = 0.04$, $n = 40$); therefore, larger particles were associated with lower energy. The 2- to 0.25-mm size fraction seems to represent a lower nominal limit in particle size. The paucity of < 0.25-mm particles may be related to the structural characteristics of the Composition B matrix. For modeling, particle size should focus on particles, or chunks, ranging from 12.5 mm up to the diameter of the round (i.e., 60, 81, 105, 120, and 155 mm). The influence of surface area on dissolution rate for Composition B has been reported by Lynch, Brannon, and Delfino (2002a, 2002b, 2003) and should be useful for modeling dissolution from low-order residues.

Chemical composition of residues

The average ratio of TNT to RDX in residues for all rounds was 1 to 1.7 ± 0.3 (Table 9–6). The ratio in undetonated Composition B is typically about 1 to 1.5. The slight elevation in the ratio may indicate a slight preferential consumption or burning of TNT. However, when the experimental error is taken into account, the observed ratio does not differ significantly from the typical composition ratio. When the ratio of TNT to RDX in each particle size fraction is compared, the < 0.25-mm fraction exhibited significantly less TNT than other size fractions. Perhaps the TNT is more efficiently consumed than RDX when the particles are fine. This reduction in TNT may be related to the much lower melting point of TNT (80 °C) relative to RDX (205 °C). Finer particles not only melt more readily than

Table 9-5. Mass, g, of residue in each particle size fraction.¹

Shot Number	Energy Yield (%) ²	Size, mm					
		>12.5	4-12.5	2-4	0.25-2	<0.25	Total
60-mm							
5	19	0	2.334	11.86	31.51	10.38	56.084
8	34	4.8	7.5	13.65	19.65	1.58	47.18
9	28	5.6	0	5.47	95.57	4.52	111.16
Mean		3.4667 a ¹	3.278 a	10.3267 a	48.91 a	5.4933 a	P = 0.053
Standard Error		1.7507	2.2185	2.4856	23.6078	2.5896	
80-mm							
33	100	0	7.57	6.02	28.24	4.52	46.35
34	16	124.818 ²	80.97	12.69	26.70	3.18	248.35
35	19	501.96 ²	60.33	15.87	32	2.12	612.28
36	21	175.86	77.72	16.65	40.41	3.69	314.33
Mean		87.93 a	42.645 ab	11.335 ab	34.325 ab	4.105 b	P = 0.009
Standard Error		107.01	169.75	2.419	3.0666	0.5019	
105-mm							
20	69	69.92	98.65	44.68	159.25	12.99	385.49
21	16	515.38	176.6	78.24	104.78	21.81	896.81
22	65	502.55 ²	79.79	57.64	100.39	18.34	758.71
23	64	288.56	123.03	65.53	181.17	25.08	683.37
24	52	120.25	145.19	53.31	148.17	10.67	477.59
Mean		299.332 a	124.652 a	59.88 a	138.752 ab	17.778 b	P = <0.001
Standard Error		92.7859	17.0167	5.6831	15.679	2.6724	
120-mm							
13	8	2,696.38 ²	69.2	60.58	65.15	41.10	2,932.41
16	18	72.8 ²	172.46	135.61	188.78	24.86	594.51
17	17	449.73 ²	125.61	120.91	137.68	55.02	888.95
18	18	644.46 ²	487.57	126.43	147.50	51.63	1,457.59
Mean		1,670.42 a	278.385 ab	93.505 ab	106.325 ab	46.365 b	P = 0.019
Standard Error		588.9216	93.695	17.0393	25.7140	6.7795	
155-mm							
26	51	1,458.76	363.21	103.65	197.0	52.17	2,174.79
27	93	0	18.16	38.83	155.77	14.88	227.64
28	13	5,229.81 ²	169.22	90.12	392.98	60.066	5,942.196
29	97	0	20.13	43.51	277.20	32.62	373.46
31	66	677.17 ²	97.18	104.36	448.62	69.50	1,396.83
32	69	759.18 ²	350.86	88.15	265.23	22.22	1,485.64
Mean		1,354.153 a	169.7933 a	78.685 a	291.4783 a	150.5967 a	P = 0.055
Standard Error		809.5983	63.7186	12.21591	5.9104	112.9759	

¹ Means followed by the same letter are not significantly different. Levels of significance are given in the last column on the same line as means.

² Mass includes some very large chunks.

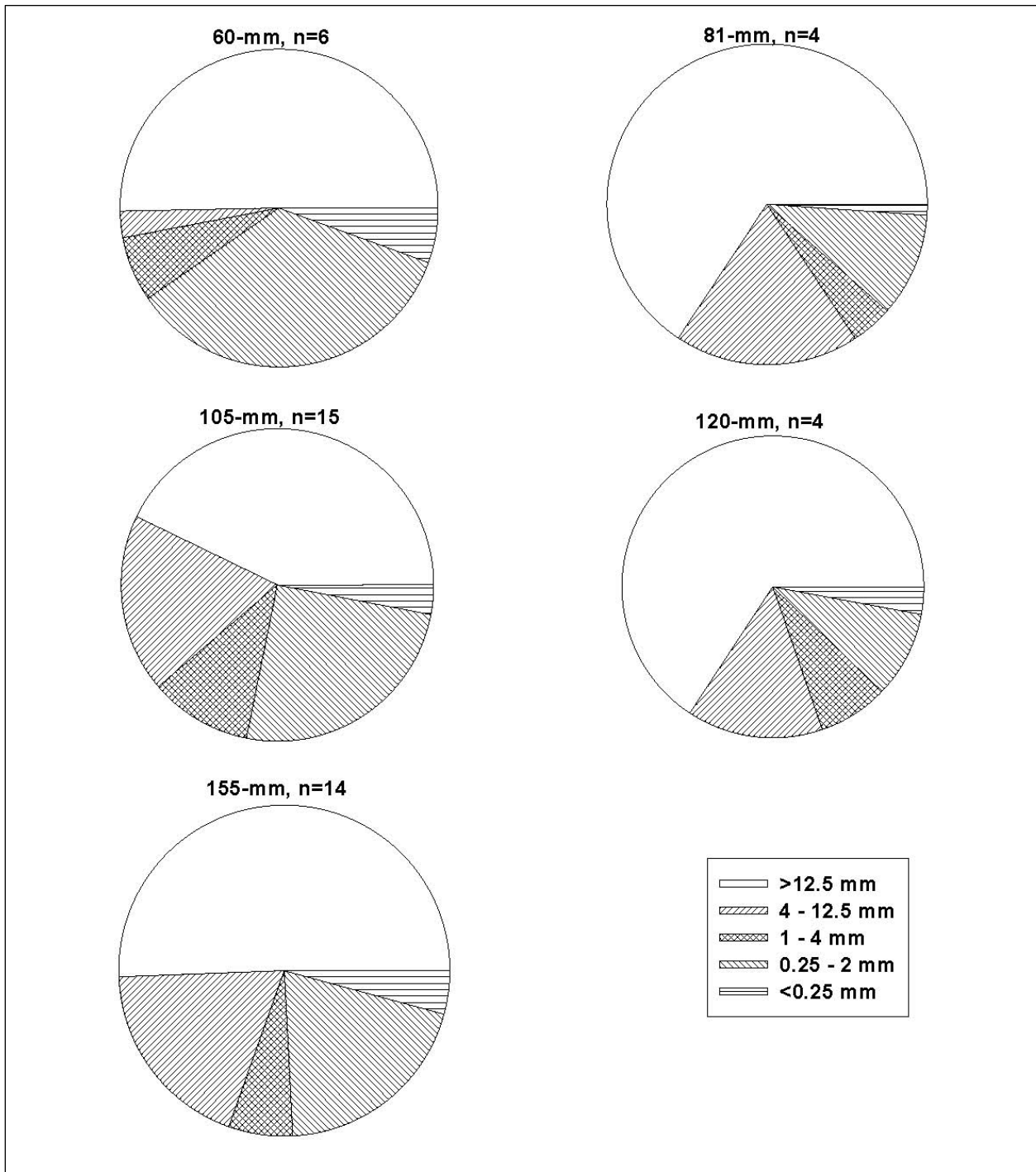

Figure 9-10. Distribution of particles sized for each type of round detonated in 2003 and 2004.

Table 9-6. Average mass (standard deviation) and ratio of TNT to RDX recovered from the < 0.25 to 4-mm size fractions of each round, g.

Round	TNT	RDX	Average Ratio
60-mm	24.08 (14.4)	36.87 (20.67)	1.54
81-mm	58.86 (83.49)	109.11 (155.69)	1.84
105-mm	71.88 (25.12)	127.78 (12.42)	2.04
120-mm	114.26 (41.20)	149.79 (52.52)	1.39
155-mm	91.01 (57.24)	169.08 (105.95)	1.92

larger particles, but melted TNT is also more sensitive to detonation forces than solid TNT (Urbanski 1964).

HMX, a common impurity in Composition B, was detected in residues from every detonation (Table 9-7). Other detected analytes included milligram quantities of TNB (all but one detonation), DNB (27 percent of detonations), MNX (73 percent), 2ADNT (18 percent), and 2,4DNT (14 percent). The TNB and DNB are photodegradation products of TNT. These may have formed while residues were being recovered from the tarp. MNX is a transformation product of RDX; 2ADNT is a transformation product of TNT. The 2,4DNT, which was detected in residues from the three larger rounds, may have come from booster and supplemental charges in the rounds.

Table 9-7. Mean (standard deviation) of analytes other than RDX and TNT in residues collected in 2004, g.

Round	HMX	TNB	MNX	2ADNT	2,4DNT	DNB
60-mm	4.26 (2.24)	0.0040 (0.0040)	0.018 (0.031)	nd ¹	nd	nd
81-mm	4.18 (1.66)	0.026 (0.016)	0.034 (0.019)	0.0048 (0.0076)	0.00010 (0.00020)	nd
120-mm	38.94 (4.17)	0.028 (0.029)	0.13 (0.21)	nd	nd	0.016 (0.019)
105-mm	20.70 (2.90)	0.030 (0.034)	0.26 (0.023)	nd	nd	0.0030 (0.0076)
155-mm	47.26 (26.17)	0.061 (0.035)	0.79 (0.70)	0.016 (0.029)	0.0072 (0.011)	0.00033 (0.00050)

¹ nd = not detected.

Conclusions

Achieving a specific energy yield was challenging, especially for the smaller rounds. Use of the FLSC 500 improved reproducibility slightly for the 60-mm mortars. Reproducibility of yields with the 81- and 120-mm mortars was good. Reproducibility of the data for other rounds improved from previous tests. A range of yields for the various rounds was achieved. Although a general trend of increasing mass with decreasing energy was evident, the relationship was significant for the 155-mm rounds only.

Mass distribution within 3 m of the table was typically small. Distribution with distance for the smaller rounds was relatively uniform, while the larger rounds tended to reach a maximum at 6–9 m. In planning remediation strategies, a 15-m radius around low-order detonation debris seems a reasonable starting area. Most of the residue mass was in the > 12.5-mm particle size fraction, while the smallest mass was in the < 0.25-mm particles size fraction. The mass in the > 12.5-mm fraction was inversely related to the energy yield. Therefore, larger particles were associated with lower energy. For modeling, particle size should focus on particles, or chunks, ranging from 12.5 mm up to the diameter of the round (i.e., 60, 81, 105, 120, and 155 mm).

The ratio of TNT to RDX in the original Composition B is conserved in the residue. However, the ratio in the < 0.25-mm size fraction exhibited significantly less TNT than is typical of Composition B. This reduction in TNT may be related to the much lower melting point of TNT (80 °C) relative to RDX (205 °C). Finer particles not only melt more readily than larger particles, but melted TNT is also more sensitive to detonation forces than solid TNT (Urbanski 1964).

Analytes other than TNT and RDX detected in residues included HMX, an impurity in Composition B, which was detected in every detonation. Other detections were in milligram quantities only and included transformation products of TNT (2-amino-4,6-dinitrotoluene) and RDX (MNX), 2,4DNT, and two photodegradation products of TNT (1,3,5-trinitrobenzene and 1,3-dinitrobenzene) that probably formed during sample recovery. The source of the 2,4DNT may be boosters or supplemental charges in certain rounds.

Low-order detonations potentially produce sufficient quantities of high explosives to serve as point sources of environmental contamination. Results of these studies establish that residues are of relatively large

particle size, retain their original composition, and are deposited within about 15 m of the detonation center. Large chunks were occasionally ejected to greater distances. Remediation efforts should focus on locating low-order detonations, removing or treating relatively large particles of TNT or Composition B within at least 15 m of the impact center. When modeling environmental fate processes, the source term for low-order detonations can be described as predominantly large solid particles ranging in size from > 12.5 mm to the diameter of the round and typically scattered over an 18-m (50-ft) area. Average total mass varies with the size of the round and is influenced by currently unpredictable properties of the blasts.

References

- Baker, P., G. Randers-Pehrson, K. Benjamin, and D. Serrano. 1997. *Characterization, modeling, and testing of the Baldrick and Naval Surface Warfare Center (NSWC) explosively formed penetrators (EFPs) Main Charge Disruptor (MCD) candidates*. ARL-TR-1363. Aberdeen Proving Ground, MD: Army Research Laboratory.
- Blankenbiller, D. C. 1999. *Final report for the Phase IIA Developmental Test Series (DT-IIA) of the Main Charge Disruptor (MCD)*. ATC-8163. Aberdeen Proving Ground, MD: U.S. Army Aberdeen Test Center.
- Blankenbiller, D. C., and L. K. Lukens. 1998. *Volume I: First partial report for the Phase IIA developmental test series (DT-IIA) of the Main Charge Disruptor (MCD)*. ATC-8096. Aberdeen Proving Ground, MD: U.S. Army Aberdeen Test Center. This report is classified as "For Official Use Only."
- Lynch, J. C., J. M. Brannon, and J. J. Delfino. 2002a. Dissolution rates of three high explosive compounds: TNT, RDX, and HMX. *Chemosphere* 47:725-734.
- _____. 2002b. Effects of component interactions on the aqueous solubility and dissolution rates of the explosive formulations Octol, Composition B, and LX-14. *Journal of Chemical and Engineering Data* 47(3):542-549.
- Lynch, J. C., J. M. Brannon, K. Hatfield, and J. J. Delfino. 2003. An exploratory approach to modeling explosive compound persistence and flux using dissolution kinetics. *Journal of Contaminant Hydrology* 66:147-159.
- Pennington, J. C., T. F. Jenkins, G. Ampleman, S. Thiboutot, J. M. Brannon, J. Clausen, A. D. Hewitt, S. Brochu, P. Dubé, J. Lewis, T. A. Ranney, D. Faucher, A. Gagnon, J. A. Stark, P. Brousseau, C. B. Price, D. J. Lambert, A. Marois, M. Bouchard, M. E. Walsh, S. L. Yost, N. M. Perron, R. Martel, S. Jean, S. Taylor, C. Hayes, J. M. Ballard, M. R. Walsh, J. E. Mirecki, S. Downe, N. H. Collins, B. Porter, and R. Karn. 2004. *Distribution and fate of energetics on DoD test and training ranges: Interim Report 4*. ERDC TR-04-4. Vicksburg, MS: U.S. Army Engineer Research and Development Center.

- Pennington, J. C., T. F. Jenkins, G. Ampleman, S. Thiboutot, J. M. Brannon, J. Lewis, J. E. DeLaney, J. Clausen, A. D. Hewitt, M. A. Hollander, C. A. Hayes, J. A. Stark, A. Marois, S. Brochu, H. Q. Dinh, D. Lambert, A. Gagnon, M. Bouchard, R. Martel, P. Brousseau, N. M. Perron, R. Lefebvre, W. Davis, T. A. Ranney, C. Gauthier, S. Taylor, and J. M. Ballard. 2003. *Distribution and fate of energetics on DOD Test and training ranges: Interim Report 3*. ERDC TR-03-2. Vicksburg, MS: U.S. Army Engineer Research and Development Center.
- Pennington, J. C., T. F. Jenkins, G. Ampleman, S. Thiboutot, J. M. Brannon, J. Lynch, T. A. Ranney, J. A. Stark, M. E. Walsh, J. Lewis, C. A. Hayes, J. E. Mirecki, A. D. Hewitt, N. Perron, D. Lambert, J. Clausen, and J. J. Delfino. 2002. *Distribution and fate of energetics on DOD Test and training ranges: Interim Report 2*. ERDC TR-02-8. Vicksburg, MS: U.S. Army Engineer Research and Development Center.
- Pennington, J. C., T. F. Jenkins, J. M. Brannon, J. Lynch, T. A. Ranney, T. E. Berry, Jr., C. A. Hayes, P. H. Miyares, M. E. Walsh, A. D. Hewitt, N. Perron, and J. J. Delfino. 2001. *Distribution and fate of energetics on DoD test and training ranges: Interim Report 1*. ERDC TR-01-13. Vicksburg, MS: U.S. Army Engineer Research and Development Center.
- Pennington, J. C., T. F. Jenkins, S. Thiboutot, G. Ampleman, J. Clausen, B. Silverblatt, A. Marois A. Gagnon, P. Brousseau, J. E. Zufelt, K. Poe, M. Bouchard, R. Martel, D. D. Walker, T. A. Ramsey, C. A. Hayes, S. Yost, K. L. Bjella, L. Trepanier, T. E. Berry, D. J. Lambert, P. Dubé, and N. M. Perron. 2005. *Distribution and fate of energetics on DoD test and training ranges: Interim Report 5*. ERDC TR-05-2. Vicksburg, MS: U.S. Army Engineer Research and Development Center.
- Silverblatt, B. 2004. *Test report for low order chemical release: Phase IV (LOCR IV)*. NAVERDTECHDIV Library Call Number 95-263. Indian Head, MD: Naval Explosive Ordnance Disposal Technology Division.
- Urbanski, T. 1964. *Chemistry and technology of explosives*. MacMillan, NY.
- U.S. Environmental Protection Agency. 1994. *Nitroaromatics and nitramines by HPLC*. Second Update SW846, Method 8330. Washington, DC: Office of Solid Waste and Emergency Response.

10 Summary and Conclusions

Introduction

Characterization of residues at the following ranges was conducted in FY05: CFB) Petawawa, Ontario; WATC, Wainwright, Alberta; Holloman AFB, Alamogordo, New Mexico; Eglin AFB, Florida; Camp Shelby Army National Guard Training Site, Mississippi; Fort Ord Army Base, Monterey, California. In addition to results of characterization testing at these ranges, the results of tests to determine residues from low-order detonations, BIP procedures, and fate and transport are reported. An update of explosives-related sampling at the MMR is also included.

A general picture of the nature and distribution of explosive residues resulting from live-fire training exercises is emerging. Below is (1) a summary of specific findings this year followed by (2) a summary of data gaps addressed and remaining.

Summary of specific findings in 2005

Site characterization

MMR. Groundwater at MMR has been contaminated by RDX, HMX, perchlorate, TNT and the aDNTs. MMR exhibits optimal local transport conditions (i.e., highly permeable soils and relatively abundant rainfall). These conditions create a “worst case” for contamination of groundwater by munitions constituents moving from the surface soils. The characteristics of surface soil contamination, as demonstrated repeatedly at other sites studied in this project, are dependent on the nature of the training or testing activities. Plumes of explosives residues emanating from artillery and mortar impact areas are likely to be large spatially, but have low concentrations. Plumes from demolition tend to be narrow and have relatively high concentrations. Therefore, demolition areas have greater potential for groundwater contamination that exceeds regulatory health advisories (e.g., concentrations greater than 2 ppb for RDX and TNT). The absence of propellants in groundwater at MMR, where migration potential is high, suggests that propellants are less likely to be a groundwater issue at other Army training ranges.

CFB Petawawa. RDX, HMX, and TNT from cracked UXO or low-order detonations were persistent over time in the soil surface near targets in the artillery impact areas. HMX and RDX (up to 17 ppb) appear in the ground-water of these impact areas. The propellants, NG and 2,4DNT, were present at 1 to 100 mg/kg levels at firing positions. Most of this residue may be attributed to recent intense range use. On the anti-tank ranges, these propellants were observed at very high concentrations (e.g., up to 2,240 mg/kg NG). High concentrations of HMX were associated with ruptured LAW rockets at anti-tank ranges. RDX, HMX, and TNT were detected at a hand grenade range in relatively low concentrations (< 5 mg/kg). The demolition range exhibited a suite of explosives and propellants typical of such ranges, principally RDX and HMX.

WATC Wainwright. At the most highly impacted range, Anti-tank Range #13, NG was found at the firing position, while HMX and TNT were found around targets. NG concentrations are of particular concern due to the potential for exposure to Soldiers. High lead concentrations were detected at a small arms range. Furthermore, metals (Sb, Cu, and Pb) concentrations in excess of mean background levels were found in several vegetation samples. Results of these sampling studies demonstrated that accumulation of energetics and metals at CFB Wainwright is comparable to that observed at similar ranges.

Holloman AFB. TNT was the energetic compound detected at the highest concentrations in surface and shallow subsurface samples from the bombing impact range. RDX was generally below detection limits, although occasional trace levels were seen, perhaps due to the use of C4 to destroy duds during semi-annual range maintenance. No evidence of off-site migration of residues was found in either depth profile samples or samples collected along an arroyo that drains the entire impact range. RDX and HMX, probably from C4, were detected at the highest concentrations at a small demolition range. Sample processing and subsampling protocols were adequate to maintain the uncertainty associated with laboratory methods to acceptable levels. The methods used a 2-mm sieve to remove oversized material, machine grinding for material that passed the 2-mm sieve, subsampling by combining 30 increments from the ground soil, and a subsample mass of 10 grams. Results of this study indicate that values of discrete surface soil samples collected from a live-fire bombing range are not normally distributed. The variability among discrete sample data is very large even for areas as small as 1 m × 1 m. This is consistent

with results from other types of military firing range impact areas. Using a sampling strategy based on a few discrete samples or a multi-increment sample using only a few increments produces estimates of the mean concentration with a very large uncertainty. Much more reliable estimates of the mean concentrations were achieved using a stratified systematic random sampling design with collection of multi-increment samples of at least 30 increments.

Blow-in-place detonations

Results demonstrated that high-order detonations are critical to controlling energetic residues during BIP demolition. In general, total residue mass from high-order detonations was less than 100 mg. Another important result is that donors must be specifically matched with rounds. The binary donor charge was effective for the mortars, but insufficient for the larger rounds. Since the TNT donor left significant quantities of TNT, especially with the mortars, TNT is a poor choice as a donor charge. The C4 was effective for the larger rounds. Except for the Kinepak binary charge with the 60-mm mortars, all of the donors left some energetic residue in at least some of the replicates. The principal residue was RDX followed in quantity by TNT and HMX. Detections of other analytes were less consistent, but generally in mg quantities. Detections in the crater were rare. Most of the mass was within 15 m of the detonation center. BIP detonations generated μg to mg quantities of energetic residues in most of the replicates. RDX, an environmentally undesirable constituent, predominated detections. When investigating residues associated with specific BIP actions, a radius of at least 15 m should be sampled. Results indicate that donors should be matched to the round to achieve high-order detonations and, thereby, minimize constituent residues.

Fate and transport

High concentrations of energetic materials were found in the effluent of the soil columns during the initial groundwater recharge event that reproduced the springtime snowmelt. The retardation factor was 2.4 and the K_d of the sandy soil was 0.94 L/kg for TNT, RDX, and HMX. No significant difference was observed between the three energetic compounds in terms of the volume of infiltration prior to breakthrough. Rather than continuous, uniform dissolution, results suggest mobilization of a nearly instantaneous initial mass of explosive as very fine solids dissolved relatively quickly due to their extensive surface area. Very little transformation

of TNT occurred as evidenced by concentrations of TNT transformation products that were 2 to 3 orders of magnitude lower than the concentration of TNT.

Low-order detonations

Achieving a specific energy yield was challenging, especially for the smaller rounds. Although a general trend of increasing mass with decreasing energy was evident, the relationship was significant for the 155-mm rounds only. Most of the residue mass was in the > 12.5-mm particle size fraction, while the smallest mass was in the < 0.25-mm particles size fraction. The mass in the > 12.5-mm fraction was inversely related to the energy yield. Therefore, larger particles were associated with lower energy. The ratio of TNT to RDX in the original Composition B was conserved in the residue. However, the residue in the < 0.25-mm size fraction exhibited significantly less TNT than was typical of Composition B. TNT has a much lower melting point (80 °C) than RDX (205 °C), and melted TNT is more sensitive to detonation forces than the solid, which suggests that small particles of TNT may be consumed preferentially during the blast. In summary, low-order detonations potentially produce sufficient quantities of high explosives to serve as distributed sources of environmental contamination. When modeling environmental fate processes, the source term for low-order detonations can be described as predominantly large solid particles ranging in size from > 12.5 mm to the diameter of the round and typically scattered over a 700 m² area. Average total mass varies with the size of the round.

Conclusions

Accomplishments to date of SERDP Project ER-1155 include the following:

1. Data acquisition for estimating firing range source terms for various munitions and range usages including high-order detonations, low-order detonations, and a munitions firing point.
2. Specialized protocols for characterizing soil contamination for various types of ranges where high spatial and concentration variability exists (e.g., heavy artillery, anti-tank, hand grenade, and air fighter training).
3. Definition of the residues generated by various UXO demolition procedures (BIP).
4. Definition of the residues generated by low-order detonations.

5. Process descriptors for range-specific energetic residues, including dissolution rates, partition coefficients, and transformation rates.
6. Transport properties of energetic residues in soils.
7. Identification of data gaps that should be filled for future range management and remediation.

Summary of data gaps filled and remaining to date

A summary of data gaps filled and remaining reveals that much has been accomplished in ER-1155 (Table 10–1). This study has developed technical protocols for characterizing the explosives residues on various types of training ranges, specifically artillery and grenade ranges and air-to-ground bomb and rocket ranges. The significant database developed in this study provides a realistic reference for estimating the source term of explosives residues for specific types of training. An understanding of the significant contribution of residues associated with low-order detonations and with residues resulting from BIP was developed. The relationships emerging between various training activities and residues of energetic materials provide a basis for sound management strategies that will protect the environment without interfering with the training mission.

Results of the project have also focused attention on the kinds of information yet needed but not yet acquired (Table 10–1). Some of the data gaps are beyond the scope of ER-1155 (Table 10–2), but are identified for future consideration.

Table 10-1. Summary of data gaps filled and remaining to date in ER-1155.

I. Distribution of Energetic Residues on the Surface Soil of Various Types of Ranges			
IA. Impact Areas			
Data GAP	Filled	Unfilled	Reference
1. Distribution and concentrations of HMX and TNT at anti-tank rocket range impact areas.	Six anti-tank range impact areas were studied. Residues were mainly from ruptured LAW rockets. HMX was often present at >1,000 mg/kg and was 100 times the concentration of TNT. At CFB Petawawa the ratio was often 10. The distribution of residues was spatially heterogeneous; however, a declining concentration gradient extended from targets.		ERDC TR-02-8 ERDC TR-03-2 ERDC/CRREL TR-04-7 ERDC TR-04-4 DRDC TR 2003-152 DRDC TR 2004-205 DRDC TR 2004-206 MMR-1903 ERDC TR-05-10 <i>Chemosphere</i> 2006 <i>Environmental Forensics</i> 2005
2. Distribution and concentrations of RDX and TNT at hand grenade ranges.	Eleven hand grenade ranges were studied. The major sources of energetic residues were low-order detonations or duds that were blown in place with C4. RDX and TNT concentrations were often in the low mg/kg range.	Residue particle size distribution.	ERDC TR-01-5 ERDC TR-01-13 ERDC TR-03-2 ERDC TR-04-4 DRDC TR 2003-152 DRDC- TR 2004-205 ERDC TR-05-10 <i>Chemosphere</i> 2006
3. Distribution and concentrations of residues of energetic compounds at artillery range impact areas.	The residues of energetic compounds within artillery impact ranges were largely present as small distributed point sources from low-order detonations and breached casings of artillery and mortar rounds. Most of the impact range was uncontaminated, but chunks of pure explosive (TNT, Composition B) and soil concentrations in the percent level were present.		ERDC TR-01-5 ERDC TR-01-13 ERDC TR-02-8 ERDC TR-04-4 DRDC TR 2003-152 MMR-4217 MMR-3915 MMR-3439 DRDC TR 2004-205 DRDC TR 2004-206 <i>Environmental Forensics</i> 2005
4. Distribution and concentrations of residues of energetic compounds at air force bombing ranges, missile ranges and rocket ranges.	One Canadian and one U.S. Air Force HE bombing range were sampled. TNT from tritonal was widespread in the 10s of mg/kg at the Canadian range. TNT was also the HE predominating at the U.S. range. The sources of the residues at these ranges were bombs that either underwent low-order detonations or duds that were ruptured by nearby detonations. Results from Holloman AFB were compared with those from Cold Lake Air Weapons Range. The results were nearly identical.		DRDC TR-2003-208 DRDC TR-2004-204 ERDC/CRREL TR-04-14 ERDC/CRREL TR-06-2
5. Distribution and concentrations of residues of energetic compounds at naval air ground ranges.	Multipurpose ranges were sampled at 29 Palms. Composition B and H6 were distributed near low-order detonations of 155-mm rounds and 500-lb bombs.	No sampling of Navy impact ranges has been conducted on U.S. ranges. Sampling at naval ranges is necessary to understand whether accumulation of energetic residues is substantial. Negotiations are ongoing to gain access to Navy ranges.	ERDC/CRREL TR-05-7

IB. Firing Points			
Data GAP	Filled	Unfilled	Reference
1. Distribution and concentrations of propellants at anti-tank rocket range firing points.	Six anti-tank range firing points were studied. Residues occur as slivers of unconsumed propellant eject from the rocket motor. NG was present in surface soils in front of and behind the firing line. The highest concentrations of NG (up to 0.2%) were found behind the firing line. Concentrations up to 1.7% have since been detected at Gagetown firing points. Additional firing point sampling events have been conducted on snow at Fort Richardson and Fort Greeley, AK.	The quantity and distribution of nitrocellulose and perchlorate have been determined at firing points. Results suggest a high level of contamination resulting from firing. This should be examined in more details with witness plates associated with firing. Environmental load per firing per type of munition should be measured. These issues will be addressed by our new start SERDP ER-1481. Trials will be conducted on snow and by using witness plates with gun and rocket propellants ammunition. The health impacts on soldiers should be examined since they might be exposed to contaminated dust upon firing.	ERDC TR-02-8 ERDC/CRREL TR-04-7 ERDC TR-03-2 ERDC TR-04-4 DRDC TR 2003-152 DMMR-1903 ERDC TR-05-10 ERDC/CRREL TR-05-14 DRDC TR 2004-205 <i>Environmental Forensics</i> 2005
2. Distribution and concentrations of propellant residues at artillery and mortar range firing points.	NG and 2,4DNT have been frequently detected at artillery and mortar firing points. These energetic compounds are retained (long half-lives) within unconsumed fibers and slivers of nitrocellulose. Detectable concentrations of these residues were found up to 100 m from the firing point. Concentrations of NG and 2,4DNT were as high as the tens of mg/kg. At Petawawa concentrations of NG reached hundreds of mg/kg at two ranges. The ratio of NG/DNT was often about 10.	Quantity and distribution of residues of nitroguanidine, nitrocellulose, and perchlorate at firing points of mortars, various artillery calibers (e.g., 2.75-inch rockets) and 155-mm howitzer should be determined by sampling immediately after firing. Witness plates trials will be conducted for many types and caliber of weapons to learn more about their respective environmental impacts as a part of SERDP ER-1481.	ERDC TR-01-5 ERDC TR-01-13 ERDC TR-02-8 ERDC/CRREL TR-04-3 ERDC TR-04-4 DRDC TR 2003-152 DRDC TR-2004-205 MMR-4342 ERDC TR-05-10 ERDC/CRREL TR-05-14 DRDC TM 2005-284
IC. Demolition Ranges			
1. Distribution and concentrations of residues of energetic compounds at demolition ranges.	Only a few demolition ranges have been evaluated, but the demolition range at MMR is a major source zone for groundwater contamination with RDX, HMX, aDNTs, and perchlorate. Studies at two other demo ranges have confirmed the presence of RDX in surface soils, likely from use of C4. NG, 2,4DNT and 2,6DNT were found at Petawawa. Energetic compounds were identified in runoff at one demolition range.	Sampling at additional demolition ranges is needed to better understand the potential for off-site migration of residues from these types of ranges.	ERDC TR-04-4 Draft MMR Link report, MMR-8830 ERDC TR-03-2 MMR-4158 ERDC TR-05-10 ERDC/CRREL TR-06-2
II. Sampling Considerations when Characterizing Distribution of Residues on Firing Ranges			
IIA. Sampling Approaches and Protocols			
1. Sampling strategies to obtain representative surface soil samples at anti-tank rocket ranges.	Sampling strategies at anti-tank rocket ranges for the impact areas and firing points were developed. Both should be characterized using a multi-increment sampling strategy. Different sampling designs should be used in these two areas since concentration gradients are anticipated around the target and either side of the firing line. Around the target, the area should be divided into concentric circles or segmented halos. Sampling should be performed directly in front of and behind the firing line using a segmented area design. Protocols for sampling at various ranges in the U.S. and Canada, including anti-tank rocket ranges, were integrated.		CRREL Technical Report 98-9 ERDC TR-02-8 ERDC/CRREL TR-04-7 <i>Environmental Forensics</i> 2005

IIA. Sampling Approaches and Protocols (cont)			
Data GAP	Filled	Unfilled	Reference
2. Sampling strategy to obtain representative surface soil samples at hand grenade ranges.	A protocol for sampling hand grenade ranges was developed. Multi-increment samples should be collected to estimate the average concentration of energetic residues in impact areas. The entire impact area can be treated as a single decision unit or a segmented area sampling design can be used to determine if there are concentration gradients. Results indicated that hand grenade ranges have the least spatial heterogeneity of any of the training ranges investigated. Protocols were developed by integrating data bases from U.S. and Canadian ranges, including hand grenade ranges.		ERDC TR-01-5 ERDC TR-01-13 ERDC TR-03-2 ERDC TR-03-16 ERDC TR-04-4
3. Sampling strategy to characterize the firing points at artillery/mortar ranges.	A sampling strategy was developed for firing points. Multi-increment samples should be collected to estimate the average concentration of energetic residues at firing points. The entire impact area can be treated as a single decision unit or a segmented area sampling design can be used to determine if there are concentration gradients. Studies have also generated data concerning dissolution rates for components from single-, double-, and triple-base propellants. Protocols were developed by integrating databases from U.S. and Canadian ranges, including artillery/mortar ranges.	As a portion of ER-1481 more depth sampling will be conducted to better define the vertical profile for concentrations of contaminants. Fate studies of propellant compositions will be initiated to understand the presence of NG at depth on firing positions. The rate of release of NG and 2,4DNT from the NC matrix will be defined as will the depth of penetration into the soil profile.	ERDC/CRREL TR-01-15 DRDC TR-2003-152 ERDC/CRREL TR-05-7 <i>Environmental Forensics</i> 2005 DRDC TM 2005-284
4. Sampling strategies to characterize the impact areas at artillery/mortar ranges and air force bombing ranges.	Sampling strategies were developed for artillery/mortar and Air Force bombing ranges. Partial detonations can in some cases be visually located. Chunks of energetic residues should be weighed. A multi-increment sampling strategy should be used to establish energetic residue soil concentration to estimate the mass loading. The areas in vicinities of targets should be divided into decision units ranging in size from 100 to 10,000 m ² . Multi-increment samples with increments ranging from 30 to 100 increments should be collected using a systematic-random design within each decision unit. Protocols were developed by integrating databases from U.S. and Canadian ranges.	Because of the size and possibility of surface vegetation on these ranges, a real time sensor would facilitate the detection of areas with high concentrations of energetic residues. Assessment of the relationship between residues and crater/UXO density to evaluate the utility of airborne sensor technologies (e.g., digital infrared photogrammetry, laser imaging detection and ranging [LIDAR], hyperspectral imaging spectroscopy [HIS], and synthetic aperture radar [SAR]) for initial range assessment and for guiding field sampling should be conducted.	ERDC/CRREL TR-04-14 ERDC/CRREL TR-05-7 <i>Environmental Forensics</i> 2005 DRDC TR-2004-205 DRDC TR-2003-152 DRDC TR-2004-204 DRDC TR-2003-205
5. Sampling strategies to characterize explosives contaminated soil.	A product of The Technical Cooperative Program (TTCP) via an international collaboration of scientists from Canada, UK, U.S., Australia, and New Zealand has been posted to a website. (Several members of the ER1255 team participated.) The publication includes range sampling and fate and process information.		http://www.em-guidelines.org/ FATE Encyclopedia http://clu-in.org <i>Environmental Forensics</i> 2005

IIB. Sample Processing			
Data GAP	Filled	Unfilled	Reference
1. Particle size distribution of energetic residues present in surface soil samples from training ranges.	Particle size distribution was defined in surface soils. Surface soil samples from firing points and impact areas often contained particles of energetic residues larger than 0.6 mm. Therefore, samples should be sieved to 2.0 mm to capture the energetic residues in these soils.	A modification to the sample size cut off should be addressed in Method 8330 and 8095 for characterizing military training ranges.	ERDC TR-04-4 Chapter 3 FATE Encyclopedia http://clu-in.org ERDC/CRREL TR 05-6
2. Strategies to maintain representativeness of energetic residues in multi-increment samples.	The following strategies were developed for maintaining representativeness: The particle size of multi-increment samples must be reduced to enable collection of representative subsamples for extraction and analysis. This can be achieved by grinding the entire sample to a fine powder. Samples containing fibrous propellant residues require more grinding cycles than samples containing crystalline high explosives. Replicate subsamples must be taken to demonstrate that reproducible subsampling was achieved.	Modifications to the sample processing and analysis protocols in for Methods 8330 and 8095 for characterizing military training ranges will be demonstrated in a new ESTCP project.	<i>Chemosphere</i> 49: 1267-1273 (2002) ERDC/CRRELTR-01-15 FATE Encyclopedia http://clu-in.org ERDC/CRREL TR-05-6 <i>Chemosphere</i> 2006
IIC. Analytical			
1. Analytes not included in the standard EPA Method 8330		Modifications to Method 8330 are necessary for characterization of soil samples from training ranges. Analytes to be added to the method include the following: nitroglycerin, picric acid, dinitrophenols, mono-, di-, and trinitro derivatives of RDX, diphenylamine, and ethyl centralite. These changes will be made as a part of a new ESTCP project.	
2. Method confirmation		Method 8330 will be modified to recommend the use of a photo diode array (PDA) to confirm uncertain analytical results from the primary/secondary columns. This will be addressed as a portion of the new ESTCP project.	
III. Residues Associated with Specific Firing Events			
IIIA. Residues from High-Order Detonation of Fired Rounds			
1. Mass of unconsumed RDX and TNT from the live-fire detonation of Composition B high explosive (HE) 40-mm rifle grenades.	RDX and TNT were detected in the detonation residues from live-fire high-order detonations. The average mass of RDX for three replicates was 1.6 mg, or 8×10^{-3} % of the original mass. The average mass of TNT was 0.0052 mg or 4×10^{-5} % of the original mass.		ERDC/CRREL TR-03-16 ERDC TR-04-4 <i>Chemosphere</i> 2005
2. Mass of unconsumed RDX and TNT from the live-fire detonation of Composition B HE M67 hand grenades.	RDX was detected in the detonation residues. The average mass of RDX for seven replicates was 0.025 mg or 2×10^{-5} % of the original mass.		ERDC/CRREL TR-03-16 ERDC TR-04-4 <i>Chemosphere</i> 2005
3. Mass of unconsumed RDX and TNT from the live-fire detonation of Composition B HE 60-mm mortar.	Only RDX was consistently detected in the detonation residues. The average mass of RDX for seven replicates was 0.10 mg or 5×10^{-5} % of the original mass.		<i>Thermochemica Acta</i> 2002 ERDC/CRREL TR-03-16 ERDC TR-04-4 <i>Chemosphere</i> 2005

IIIA. Residues from High-Order Detonation of Fired Rounds (cont)			
Data GAP	Filled	Unfilled	Reference
4. Mass of unconsumed RDX and TNT from the live-fire detonation of Composition B HE 81-mm mortar.	RDX and TNT were detected in the detonation residues. The average mass of RDX for fourteen replicates was 8.5 mg, or 2×10^{-3} % of the original mass. The average mass of TNT was 1.1 mg or 3×10^{-4} % of the original mass.		ERDC/CRREL TR-03-16 ERDC TR-04-4 <i>Chemosphere</i> 2005
5. Mass of unconsumed RDX and TNT from the live-fire detonation of Composition B HE 120-mm mortar.	RDX and TNT were detected in the detonation residues. The average mass of RDX for seven replicates was 4.2 mg, or 2×10^{-4} % of the original mass. The average mass of TNT was 0.32 mg or 2×10^{-5} % of the original mass.		ERDC/CRREL TR-03-16 ERDC TR-04-4 ERDC/CRREL TR-05-15
6. Mass of unconsumed RDX and TNT from the live-fire detonation of Composition B HE 105-mm howitzer round.	RDX and TNT were detected in the detonation residues. The average mass of RDX for seven replicates was 0.095 mg, or 7×10^{-6} % of the original mass. The average mass of TNT was 0.17 mg or 2×10^{-5} % of the original mass.		ERDC/CRREL TR-03-16 ERDC TR-04-4 <i>Chemosphere</i> 2005
7. Mass of unconsumed RDX and TNT from the live-fire detonation of Composition B HE 155-mm howitzer round.	Live-fire trials have been completed. Only RDX was detected in the residue deposited. The average mass of RDX was 0.19 mg per round detonated. This amounts to 10^{-5} % of the mass of RDX originally present in the round.		ERDC/CRREL TR-05-14
8. Mass of unconsumed TNT from the live-fire detonation of TNT HE 155-mm howitzer round.	Live-fire trials have been completed. No TNT or TNT by-products were detected.		ERDC/CRREL TR-05-14
IIIB. Residues from Blow-in-Place Demolition of Specific Munitions			
1. Mass of unconsumed explosive from the EOD detonation of mortars and artillery rounds.	The following four sets of experiments were conducted: 1) Seven replicate C4-initiated detonations of 81-mm mortars, 105-mm artillery rounds, and 155-mm artillery rounds as well as eight replicate detonations of C4 alone. Several 1-m ² samples were randomly collected to a depth of 0.5-2 cm over the visible plume. Results indicated that RDX was the principal constituent in the residue. Average mass was in milligrams. 2) Detonations of 60- and 81-mm mortars, M67 hand grenades, and PMA-1A land mines with C4, various shaped charges and a binary charge. Residues were collected on 1- × 1-m witness plates over a tarp. When high-order detonations were achieved, TNT was present in the highest concentration, which came from a mine. The greatest concentrations of RDX and HMX were produced by the M67 grenade. 3) Seven simultaneous replicates of C4-initiated detonations of 155-mm artillery projectiles on snow. Surface snow within the visible plume was sampled to a depth of 1 cm using multi-increment sampling methods. Only mg quantities of RDX, µg quantities of HMX, and no TNT were detected.		ERDC/CRREL TR-03-16 ERDC TR-04-4 <i>Chemosphere</i> 2005 ERDC TR-05-8 DRDC TR 2003-370 ERDC TR-04-4, Chapter 8 ERDC TR-05-2, Chapter 8 ERDC TR-06-12, Chapter 6

IIIB. Residues from Blow-in-Place Demolition of Specific Munitions (cont)			
Data GAP	Filled	Unfilled	Reference
	4) Seven replicates of two artillery rounds (105- and 155-mm) and two mortars (60- and 81-mm) with four donor charges (block C4, shaped charges, a binary charge, and block TNT). Residues were collected in concentric rings at various distances, up to 18 m, from the detonation center. Total residue was less than 100 mg. Block TNT was a poor donor, leaving TNT residue. Matching donor to round to achieve high-order detonations was critical to minimizing residue. Most of the mass was within 15 m of the detonation center.		
7. Optimal secondary charge for BIP of heavy artillery rounds and mortars to minimize residues.		Optimization of the configuration of C4 for minimizing residues will be tested with 81-mm mortars in FY06 under EQI funding	Report in FY06/07.
IIIC. Residues Associated with Low-Order Detonations of Specific Munitions			
1. Mass and particle size distribution of residues from low-order detonations of heavy artillery munitions.	Testing of four rounds (60- and 81-mm mortars, 105 and 155-mm artillery projectiles) was conducted at various energy yields. The residues were recovered as a function of distance from the detonation. Particle size distribution was determined by sieving of residues. Most of the mass was in the >12.5-mm size fraction and was recovered within 15 m of the detonation center. Mass within each distance was general in the gram to 100 gram range.		ERDC TR-03-2 ERDC TR-05-2, Chapter 3 ERDC TR-05-10, Chapter 8
IIID. Residues Associated with Unconfined Charge			
Data GAP	Filled	Unfilled	Reference
1. Residues associated with blow-in-place demolition of unconfined UXO	Detonations were conducted with C4, TNT, Composition B, Octol, a PBX, and an insensitive melt-cast explosive (XRT) formed into spheres, cylinders, and blocks. Residues were collected on witness plates. C4 blocks yielded greater RDX residues than spheres or cylinders. The PBX and XRT produced more residues than the other explosives.		DRDC TR 2003-270 ERDC TR-04-4, Chapter 7
IIIE. Residues Generated by Sympathetic Detonations			
1. The contribution of sympathetic detonation to explosive source term on range	Detonation or rupturing of a round by fragments from the detonation of another round near the first is considered <i>sympathetic</i> detonation or rupture. Many such ruptured and broken rounds were generated by blow-in-place detonation of 81-mm mortars. Various standoff distances and test configurations of both C4 and shaped charges were used to detonate the primary round.	Similar trials should be conducted with other munitions to determine their response to fragments from incoming rounds.	ERDC TR-04-4, Chapter 7
IV. Fate and Transport Processes of Energetic Residues			
IVA. Soil/Water Partitioning Process Descriptors			
1. Adsorption coefficients, i.e., K_{ds} , and transformation rates for primary high explosives	Literature review revealed adequate data for TNT and RDX, but insufficient data for TNT transformation products and several other explosives and explosives-related compounds		ERDC TR-01-13 ERDC/EL TR-02-10 Pennington and Brannon (2002) ERDC TR-03-02

IVA. Soil/Water Partitioning Process Descriptors (cont)			
Data GAP	Filled	Unfilled	Reference
2. Adsorption coefficients and transformation rate coefficients for 2,4DNT and 2,6DNT, 1,35TNB and 1,3DNB	These parameters were determined by laboratory batch studies in one surface and two aquifer soils		ERDC/EL TR-02-10
3. Process descriptors for transformation products of RDX (MNX, DNx, TNX) and nitroglycerin (NG)	Adsorption kinetics, desorption kinetics and partition coefficients were determined on these compounds in two surface and one aquifer soil		ERDC TR-02-8 Brannon, Price, and Yost (2002)
4. Process descriptors for tetryl and PETN	Adsorption /transformation rate coefficients and adsorption coefficients, i.e., K_{ds} , were determined for these compounds in two surface and one aquifer soil		ERDC TR-03-02
5. Process descriptors for nitrobenzene, perchlorate, nitroguanidine, diphenylamine, N-nitrosodiphenylamine, and ethyl centralite	Adsorption kinetics, adsorption partition coefficients, and transformation rate coefficients were determined for these compounds in an aquifer and two surface soils		ERDC TR-04-4
6. Effects of Eh and pH on degradation of perchlorate	Perchlorate was tested in two surface soils at 3 pH (5.5, 7.0, 10.0) and two Eh values (+500 and -150 mV).		ERDC TR-04-4
7. Effects of Eh and pH on degradation of nitroglycerin	Nitroglycerin degradation was examined in stirred reactors using a high organic carbon surface soil and a low organic carbon aquifer soil under aerobic and anaerobic conditions at three pH levels. The only nitroglycerin remaining in solution appeared at pH 6 under aerobic conditions in both test soils. The addition of glucose as a carbon co-substrate did not exert a substantial effect on the rate of nitroglycerin degradation. Results from this study demonstrated that nitroglycerin degrades readily in both anaerobic and aerobic environments (except in acidic locations), with carbon content having little influence on degradation rates.		Masters thesis, Yost (2004)
IVB. Dissolution Kinetics			
1. Rates for TNT, RDX, and HMX	1) These explosives were tested at three temperatures (10, 20, and 30 °C) and three pH values (4.2, 5.7, and 6.2) with constant surface area and stirring rate.		ERDC TR-01-13 ERDC TR-02-8 Lynch et al. (2001) Lynch, Brannon and Delfino (2002a, b) Lynch et al. 2003
2. Rates for explosives compositions	Three compositions were tested, Octol, Composition B, and LX14, at various temperatures (10, 20, 30 °C) and at constant surface area and stirring rate.	Relationship between laboratory and field-derived rates are unknown. Meteorological impacts as well as degree of weathering that control rates are unknown.	ERDC TR-01-13 ERDC TR-02-8 Lynch, Brannon, and Delfino (2002b) Lynch et al. 2003

IVB. Dissolution Kinetics (cont)			
Data GAP	Filled	Unfilled	Reference
3. Dissolution rates for NG, 2,4DNT and NQ from single-, double-, and triple-base propellants	Dissolution rates for these propellants were completed for M1, M9, M10, and M30. 2,4DNT was released into water from both M1 and M10 single-base propellants. NG was released from the M9 double-base propellant. Both NG and NC were released from the triple-base propellant. EC was released in trace amounts only.		Work in progress under SERDP ER-1481
4. Solubility of diphenylamine, N-nitrosodiphenylamine, and ethyl centralite	Solubilities were determined at three temperatures (10, 24, and 30 °C) over a 14-day period.		ERDC TR-04-4, Chapter 9
IVC. Photolysis			
1. Effects of photolysis on explosives residuals on surface soils.	The following tests have been completed: Characterization of extractable photo products of TNT by using negative ion electrospray ionization ion trap mass spectrometry (ESI-MS) in addition to standard HPLC analyses. Characterization of insoluble residue from aqueous TNT photolysates by liquid state nuclear magnetic resonance (NMR), and by infrared, elemental, and molecular weight analyses. Characterization of photo products on weathered chunks of TNT and Composition B by solid state NMR. Characterization of aqueous photolysates of RDX and HMX by NMR, HPLC and/or ESI-MS. Definition of decomposition products from a solid explosive formulation, Composition B, and from TNT and RDX solids and solutions in soils.	Photolytic properties of DNT, NG, NQ, and perchlorate	ERDC TR-06-XX (Photolysis, in review)
IVD. Transport Behavior of Energetics and Energetic Formulations			
1. Fate and transport of explosives	The following two studies have been completed: 1) Large-scale lysimeter columns studies with broken Composition B-containing rounds generated in sympathetic detonations. 2) Transport properties of solution and solid phase explosives and explosive compositions in soil columns under saturated and unsaturated conditions under EQI funding.	1) Similar large-scale studies should be conducted with various weapons having various explosive filling, e.g., Composition B, Octol, TNT. 2) Column studies with propellants will be conducted under SERDP new start ER-1481.	ERDC TR-04-4, Chapter 7. <i>Journal of Environmental Quality</i> (accepted) PhD Thesis, Jeffrey Lewis
IVE. Metals Associated with Firing Ranges			
1. Provide an initial assessment of the nature of metal contamination associated with various live-fire range activities	Metal analyses have been systematically conducted on various Army and Air Force ranges in Canada. Specific metal species associated with each type of range was determined. Metals were also assayed in selected composite samples of soils from various U.S. ranges.		DRDC TR 2004-206 DRDC TR 2004-205 DRDC TR 2003-152 DRDC TR 2004-204 DRDC TR 2003-208 ERDC TR-06-12 (Chapter 7, this report)

IVF. Organic Contaminants Other than Explosives Associated with Firing Ranges			
Data GAP	Filled	Unfilled	Reference
1. Organic contaminants other than explosives associated with firing ranges	Selected composite samples of soils from various ranges investigated in the characterization studies were analyzed for an extensive list of organic contaminants selected on the basis of detections at the MMR. Results from three CFB Canadian ranges indicated polynuclear aromatic hydrocarbons (PAHs) at skeet/trap ranges.		ERDC TR-06-XX (Chapter 7, this report)
IVG. Mobilization Assessment Based on Field Observations			
1. An initial assessment of the mobility of energetic and propellant compounds occurring in the field	Lysimeter and monitoring well samples from MMR indicated that some energetic compounds had migrated below surface soils.	1) Define energetic compounds in sub-surface soils, groundwater and surface water. 2) Lysimetry at target locations and firing points will be conducted under SERDP new start ER-1481.	Related research is in progress under the Army EQI program
2. The distribution and concentration of energetic compounds in surface and groundwater	Results of groundwater sampling from a limited number of sites, such as MMR and Fort Lewis, suggest that some energetic compounds are mobile enough to reach the aquifers.	Additional studies should be conducted to assess energetics in surface and groundwater	Various MMR reports ERDC TR-01-13 ERDC TR-06-13 Related surface runoff research is in progress under the Army EQI program
V. Protocols			
1. Protocol for firing range characterization and management		USACE protocol/guidance document, decision-tree outlining in detail soil sampling approaches for different source areas (e.g., hand grenade courts, impact area targets, rocket firing points), as well as soil sample preparation methodologies and analytical methods	http://www.em-guidelines.org/ http://clu-in.org

Table 10-2. Data gaps beyond the scope of CP-1155.

1. Health risks to the soldier in the field	<p><i>Propellant residues/health risks.</i> Based on the residues observed at firing positions, gunners may be regularly exposed to burned propellant dust. The dust can be composed of many things including PAHs, micron-sized particulates of various compositions, and NC fibers imbedded with NG and 2,4 DNT. Air sampling should be conducted at firing positions to learn more about soldier exposure.</p> <p><i>Propellant residues in closed firing scenarios.</i> Tank firing potentially allows accumulation of high levels of propellant residues inside the tank, which is a completely closed vessel. Wiping of tank interiors before and after firing and air sampling should be conducted in tanks.</p> <p><i>Small arms firing lines.</i> Various concentrations of lead and NG have been observed in the surface soils at small arms firing lines. Soldiers often lie on the ground when firing and are, therefore, in close contact with potentially contaminated soil. The potential adverse health impact should be determined.</p>
2. Surface water	<p><i>Ponds in impact area.</i> Often the highest levels of contaminants are found in the sediment and water of ponds in the impact areas of anti-tank ranges. Surface water runoff in impact area should be controlled to prevent the migration of contamination from this source.</p>
3. Range design	<p><i>Grenade ranges.</i> Various contaminants (RDX, TNT, TNT derivatives, Cu, Zn, and Cd) accumulate in grenade ranges. Since grenade ranges are not very large, an underground catchment system for capturing contaminants should be designed and adopted. Such a system would protect surface and groundwater.</p>
4. Remediation	<p><i>Small arms ranges.</i> Very high levels of lead and other heavy metals are detected in the small arms range firing berms. Results of TCLP tests demonstrate that these metals are leachable. Treatment techniques are needed to immobilize these metals in the berm to prevent migration to ground and surface water and uptake by vegetation.</p> <p><i>Firing positions:</i> Remediation methods should be studied to decontaminate firing positions. Lime treatment is a promising option. Small-scale studies could be undertaken followed by field trials.</p>
5. TCLP testing	<p><i>Metals in impact area.</i> Grenade ranges, anti-tank impact area, and artillery range impact areas present concentrations of concern for various heavy metals. No TCLP tests have been conducted to define the potential for migration of these metals. Future sampling should include TCLP testing.</p>
6. Corrosion Rate of metal casing material of munitions	<p>A database of all DoD munitions that specifies periods of use, metal casing compositions, wall thickness, etc., should be developed.</p>

References

- Ampleman, G., S. Thiboutot, J. Lewis, A. Marois, A. Gagnon, M. Bouchard, T. Jenkins, T. A. Ranney, and J. C. Pennington. 2004. *Evaluation of the contamination by explosives in soils, vegetation, surface water and sediment at Cold Lake Air Weapons Range (CLAWR), Alberta, Phase II Final Report*. DRDC TR 2004-204. Val-Bélair, Quebec: Defence Research and Development Canada - Valcartier.
- Ampleman, G., S. Thiboutot, J. Lewis, A. Marois, A. Gagnon, M. Gagnon, S. Jean, T. F. Jenkins, A. Hewitt, J. C. Pennington, and T. A. Ranney. 2003. *Evaluation of the contamination by explosives in soils, biomass and surface water at Cold Lake Air Weapons Range (CLAWR), Alberta, Phase I Report*. DRDC TR 2003-208. Val-Bélair, Quebec: Defence Research and Development Canada - Valcartier.
- Clausen, J.L., N. Korte, M. Dodson, J. Robb, and S. Rieven, S. (in press). Conceptual model for the transport of energetic residues from surface soil to groundwater by range activities. ERDC/CRREL TR-06-18. Hanover, NH: U.S. Army Engineer Research and Development Center.
- Dontsova, K. M., S. L. Yost, J. Šimuněk, J. C. Pennington, and C. W. Williford. (accepted). Dissolution and transport of TNT, RDX, And Composition B in saturated soil columns. *Journal of Environmental Quality*.
- Dubé, P., S. Brochu, P. Brousseau, S. Thiboutot, G. Ampleman, J. Lewis, M. Bouchard, A. Gagnon, and A. Marois. 2004. *Study of the environmental impacts of the blow-in place procedure of various explosives, munitions, and charges*. DRDC-Valcartier TR 2003-370. Val-Bélair, Quebec: Defence Research and Development Canada - Valcartier.
- Dubé, P., S. Thiboutot, G. Ampleman, A. Marois, and M. Bouchard. 2005. *Preliminary assessment of the dispersion of propellant residues from the static live firing of 105 MM Howitzer*. DRDC-Valcartier TM 2005-284. Val-Bélair, Quebec: Defence Research and Development Canada - Valcartier.
- Hewitt, A. D., T. F. Jenkins, C. A. Ramsey, K. L. Bjella, T. A. Ranney, and N. Perron. 2006. *Estimating energetic residue loading on military artillery ranges: Large decision units*. ERDC/CRREL TR-05-7, Hanover, NH: U.S. Army Engineer Research and Development Center.
- Hewitt, A. D., T. F. Jenkins, M. E. Walsh, M. R. Walsh, and S. Taylor. 2005. RDX and TNT residues from live-fire and blow-in-place detonations. *Chemosphere* 61, 888-894.
- Hewitt, A. D., T. F. Jenkins, T. A. Ranney, J. A. Stark, M. E. Walsh, S. Taylor, M. R. Walsh, D. J. Lambert, N. M. Perron, N. H. Collins, and R. Karn. 2003. *Estimates of explosives residue from the detonation of army munitions*. ERDC/CRREL TR-03-16. Hanover, NH: U.S. Army Engineer Research and Development Center.
- Jenkins, T. F., A. D. Hewitt, C. A. Ramsey, K. S. Bjella, S. R. Bigl, and D. J. Lambert. 2006. *Sampling studies at an Air Force Live-Fire Bombing Range Impact Area*. ERDC/CRREL TR-06-2. Hanover, NH: U.S. Army Engineer Research and Development Center.

- Jenkins, T. F., A. D. Hewitt, C. L. Grant, S. Thiboutot, G. Ampleman, M. E. Walsh, T. A. Ranney, C. A. Ramsey, A. Palazzo, and J. C. Pennington. 2006. Identity and distribution of residues of energetic compounds at army live-fire training ranges. *Chemosphere* 63:1280-1290.
- Jenkins, T. F., A. D. Hewitt, M. E. Walsh, T. A. Ranney, C. A. Ramsey, C. L. Grant, and K. L. Bjella. 2005. Representative sampling for energetic compounds at military training ranges. *Journal of Environmental Forensics* 6: 45-55.
- Jenkins, T. F., A. D. Hewitt, T. A. Ranney, C. A. Ramsey, D. J. Lambert, K. L. Bjella, and N. M. Perron. 2004. *Sampling strategies near a low-order detonation and a target at an artillery impact area*. ERDC/CRREL TR-04-4. Hanover, NH: U.S. Army Engineer Research and Development Center.
- Jenkins, T. F., J. C. Pennington, T. A. Ranney, T. E. Berry, Jr., P. H. Miyares, M. E. Walsh, A. D. Hewitt, N. Perron, L. V. Parker, C. A. Hayes, and Maj. E. Wahlgren. 2001. *Characterization of explosives contamination at military firing ranges*. ERDC TR-01-05. Hanover, NH: U.S. Army Engineer Research and Development Center.
- Jenkins, T. F., S. Thiboutot, G. Ampleman, A. D. Hewitt, M. E. Walsh, T. A. Ranney, C. A. Ramsey, C.L. Grant, C.M. Collins, S. Brochu, S. R. Bigl, and J. C. Pennington. 2005. *Identity and distribution of residues of energetic compounds at Military Live-Fire Training Ranges*. ERDC TR-05-10. Hanover, NH: U.S. Army Engineer Research and Development Center.
- Jenkins, T. F., T. A. Ranney, A. D. Hewitt, M. G. Walsh, and K L. Bjella. 2004. *Representative sampling for energetic compounds at an anti-tank firing range*. ERDC/CRREL TR-04-7. Hanover, NH: U.S. Army Engineer Research and Development Center.
- Lynch, J. C., J. M. Brannon, and J. J. Delfino. 2002a. Dissolution rates of three high explosive compounds: TNT, RDX, and HMX. *Chemosphere* 47: 725-734.
- _____. 2002b. Effects of component interactions on the aqueous solubilities and dissolution rates of the explosive formulation Octol, Composition B, and LX-14. *Journal of Chemical and Engineering Data* 47, 542-549.
- Lynch, J. C., J. M. Brannon, K. Hatfield, and J. J. Delfino. 2003. An exploratory approach to modeling explosive compound persistence and flux using dissolution kinetics. *Journal of Contaminant Hydrology* 127: 1-13.
- Lynch, J. C., K. F. Myers, J. M. Brannon, and J. J. Delfino. 2001. Effects of pH and temperature on the aqueous solubility and dissolution rate of 2,4,6-trinitrotoluene (TNT), hexahydro-1,3,5-trinitro-1,3,5-triazine (RDX), and octahydro-1,3,5,7-tetranitro-1,3,5,7-tetrazocine (HMX). *Journal of Chemical and Engineering Data* 46: 1549-1555.
- Marois, A., A. Gagnon, S. Thiboutot, G. Ampleman, and M. Bouchard. 2004. *Caractérisation des sols de surface et de la biomasse dans les secteurs d'entraînement, Base des Forces Canadiennes, Valcartier*. DRDC-Valcartier TR 2004-206. Val-Bélair, Quebec: Defence Research and Development Canada - Valcartier.

- Mirecki, J. E., B. Porter, and C. A. Weiss. 2006. *Environmental transport and fate process descriptors for propellant compounds*. ERDC/EL TR-06-7. Vicksburg, MS: U.S. Army Engineer Research and Development Center.
- Pennington, J. C., and J. M. Brannon. 2002. Environmental fate of explosives. *Thermochimica Acta* 384: 163-172.
- Pennington, J. C., D. K. MacMillan, K. A. Thorne, and S. Yost. (in review). *Photo-decomposition of munition constituents in solid Composition B exposed in surface soils*. Vicksburg, MS: U.S. Army Engineer Research and Development Center.
- Pennington, J. C., T. F. Jenkins, G. Ampleman, S. Thiboutot, A. D. Hewitt, S. Brochu, J. Robb, E. Diaz, J. Lewis, H. Colby, R. Martel, K. Poe, K. Groff, K. L. Bjella, C. A. Ramsey, C. A. Hayes, S. Yost, A. Marois, A. Gagnon, B. Silverblatt, T. Crutcher, K. Harriz, K. Heisen, S. R. Bigl, T. E. Berry, J. Muzzin, D. J. Lambert, M. J. Bishop, B. Rice, M. Wojtas, M. E. Walsh, M. R. Walsh, and S. Taylor, S. 2006. *Distribution and fate of energetics on DoD test and training ranges: Interim Report 6*. ERDC TR-06-12. Vicksburg, MS: U.S. Army Engineer Research and Development Center.
- Pennington, J. C., T. F. Jenkins, G. Ampleman, S. Thiboutot, J. M. Brannon, A. D. Hewitt, J. Lewis, S. Brochu, E. Diaz, M. R. Walsh, M. E. Walsh, S. Taylor, J. C. Lynch, J. Clausen, T. A. Ranney, C. A. Ramsey, C. A. Hayes, C. L. Grant, C. M. Collins, S. R. Bigl, S. L. Yost, and K. Dontsova. 2006. *Distribution and fate of energetics on DoD test and training ranges: Final Report*. ERDC TR-06-13. Vicksburg, MS: U.S. Army Engineer Research and Development Center.
- Pennington, J. C., C. A. Hayes, S. A. Yost, and T. F. Jenkins. 2006. Occurrence of metals and organic compounds other than explosives in firing range soils, Chapter 7. In *Distribution and fate of energetics on DoD test and training ranges; Interim Report 6*. ERDC TR-06-12. Vicksburg, MS: U.S. Army Engineer Research and Development Center.
- Pennington, J. C., T. F. Jenkins, G. Ampleman, S. Thiboutot, J. M. Brannon, J. Lewis, J. E. Delaney, J. Clausen, A. D. Hewitt, M. A. Hollander, C. A. Hayes, J. A. Stark, A. Marois, S. Brochu, H. Q. Dinh, D. Lambert, R. Martel, P. Brousseau, N. M. Perron, R. Lefebvre, W. Davis, T. A. Ranney, C. Gauthier, S. Taylor, and J. M. Ballard. 2003. *Distribution and fate of energetics on DoD test and training ranges: Interim Report 3*. ERDC TR-03-2. Vicksburg, MS: U.S. Army Engineer Research and Development Center.
- Pennington, J. C., T. F. Jenkins, G. Ampleman, S. Thiboutot, J. M. Brannon, J. Lynch, T. A. Ranney, J. A. Stark, M. E. Walsh, J. Lewis, C. A. Hayes, J. E. Mirecki, A. D. Hewitt, N. Perron, D. Lambert, J. Clausen, and J. J. Delfino. 2002. *Distribution and fate of energetics on DoD test and training ranges: Interim Report 2*. ERDC TR-02-8. Vicksburg, MS: U.S. Army Engineer Research and Development Center.
- Pennington, J. C., T. F. Jenkins, J. M. Brannon, J. Lynch, T. A. Ranney, T. E. Berry, Jr., C. A. Hayes, P. H. Miyares, M. E. Walsh, A. D. Hewitt, N. Perron, and J. J. Delfino. 2001. *Distribution and fate of energetics on DoD Test and training ranges: Interim Report 1*. ERDC TR-01-13. Vicksburg, MS: U.S. Army Engineer Research and Development Center.

- Thiboutot, S., G. Ampleman, A. Marois, A. Gagnon, M. Bouchard, A. Hewitt, T. Jenkins, M. Walsh, K. Bjella, C. Ramsey, and T. A. Ranney. 2004. *Environmental conditions of surface soils, CFB Gagetown, training area: Delineation of the presence of munitions related residues (Phase III, Final Report)*. DRDC-Valcartier TR 2004-205. Val-Bélair, Quebec: Defence Research and Development Canada - Valcartier.
- Walsh, M. E., C. A. Ramsey, C. M. Collins, A. D. Hewitt, M. R. Walsh, K. Bjella, D. Lambert, and N. Perron. 2005. *Collection methods and laboratory processing of samples from Donnelly Training Area Firing Points, Alaska, 2003*. ERDC/CRREL TR-05-6. Hanover, NH: U.S. Army Engineer Research and Development Center.
- Walsh, M. R., M. E. Walsh, C. A. Ramsey, and T. F. Jenkins. 2005. *An examination of protocols for the collection of munitions-derived residues on snow-covered ice*. ERDC/CRREL TR-05-8. Hanover, NH: U.S. Army Engineer Research and Development Center.
- Walsh, M. R., M. E. Walsh, C. M. Collins, S. P. Saari, J. E. Zufelt, A. B. Gelvin, and J. W. Hug. 2005. *Energetic residues from live-fire detonations of 120-mm mortar rounds*. ERDC/CRREL TR-05-15. Hanover, NH: U.S. Army Engineer Research and Development Center.
- Walsh, M. R., S. Taylor, M. E. Walsh, S. Bigl, K. Bjella, T. Douglas, A. Gelvin, D. Lambert, N. Perron, and S. Saari. 2005. *Residues from live fire detonations of 155-mm Howitzer rounds*. ERDC/CRREL TR-05-14. Hanover, NH: U.S. Army Engineer Research and Development Center.

Masters Thesis

- Yost, S. 2004. Effects of redox potential and pH on the fate of nitroglycerin in a surface and aquifer soil. Master's Thesis, Department of Environmental Studies, Louisiana State University, Baton Rouge, LA.

PhD Thesis

- Lewis, J. 2007. Energetic materials fate and transport in the vadose zone, PhD Thesis, INRS-Eau, Terre et Environnement, Université du Québec, Québec, Canada.

Online Resources

- Characterization of sites contaminated with energetic materials (EM). The Technical Cooperation Program (TTCP) Key Technical Area (KTA)4-28 Working Group.
<http://www.em-guidelines.org>
- USEPA Clean-up Information (CLU-IN), Characterization and Monitoring, Publications.
<http://clu-in.org>

Appendix A: Bibliography of ER-1155 Publications

Unpublished, Accepted, or Submitted:

- Lewis, J., R. Martel, L. Trépannier, S. Thiboutot, and G. Ampleman. 2005. Transport of residues from cracked unexploded ordnance through the vadose zone during springtime aquifer recharge. Submitted to *Hydrogeology Journal*, August 2005.
- Martel, R., T. Robertson, D. M. Quan, S. Thiboutot, G. Ampleman, A. Provatas, and T. Jenkins. 2006. 2,4,6-Trinitrotoluene in soil and groundwater under a waste lagoon at the former explosives factory Maribyrnong, (EFM), Victoria, Australia. Submitted to *Hydrogeology Journal*.
- Robertson, T., R. Martel, D. M. Quan, G. Ampleman, S. Thiboutot, T. Jenkins, and A. Provatas. 2005. Fate and transport and persistence of 2,4,6-trinitrotoluene in loams at the former explosives factory Maribyrnong, Australia. Accepted in *Soil and Sediment Contamination*, November 2005.

Referred Journal Articles:

- Hewitt, A. D., T. F. Jenkins, M. E. Walsh, M. R. Walsh, and S. Taylor. 2005. RDX and TNT residues from live-fire and blow-in-place detonations. *Chemosphere* 61:888-894.
- Jenkins, T. F., A. D. Hewitt, C. L. Grant, S. Thiboutot, G. Ampleman, M. E. Walsh, T. A. Ranney, C. A. Ramsey, A. J. Palazzo, and J. C. Pennington. 2006. Identity and distribution of residues of energetic compounds at army live-fire training ranges. *Chemosphere* 63: 1280-1290.
- Jenkins, T. F., A. D. Hewitt, M. E. Walsh, T. A. Ranney, C. A. Ramsey, C. L. Grant, and K. L. Bjella. 2005. Representative sampling for energetic compounds at military training ranges. *Journal of Environmental Forensics* 6: 45-55.
- Jenkins, T. F., M. E. Walsh, P. Miyares, A. D. Hewitt, N. H. Collins, and T. A. Ranney. 2002. Evaluation of the use of snow-covered ranges to estimate the explosives residues that result from high order detonations of army munitions. *Thermochimica Acta* 384: 173-185.
- Jenkins, T. F., A. D. Hewitt, M. E. Walsh, C. L. Grant, and C. A. Ramsey. 2005. Comment on data representativeness for risk assessment by Rosemary Mattuck et al. 2005. *Journal of Environmental Forensics* 6: 321-323.

- Lynch, J. C., J. M. Brannon, and J. J. Delfino. 2002a. Dissolution rates of three high explosive compounds: TNT, RDX, and HMX. *Chemosphere* 47: 725-734.
- _____. 2002b. Effects of component interactions on the aqueous solubilities and dissolution rates of the explosive formulations Octol, Composition B, and LX-14. *Journal of Chemical and Engineering Data* 47: 542-549.
- Lynch, J. C., J. M. Brannon, K. Hatfield, and J. J. Delfino. 2003. An exploratory approach to modeling explosive compound persistence and flux using dissolution kinetics. *Journal of Contaminant Hydrology* 1927: 1-13.
- Lynch, J. C., K. F. Myers, J. M. Brannon, and J. J. Delfino. 2001. Effects of pH and temperature on the aqueous solubility and dissolution rate of 2,4,6-trinitrotoluene (TNT), hexahydro-1,3,5-trinitro-1,3,5-triazine (RDX), and octahydro-1,3,5,7-tetranitro-1,3,5,7-tetrazocine (HMX). *Journal of Chemical and Engineering Data* 46: 1549-1555.
- Pantea, D., S. Brochu, S. Thiboutot, G. Ampleman, and G. Scholz. 2006. A morphological investigation of soot coming from the detonation of munitions. Submitted to *Chemosphere* 65:821-831.
- Pennington, J. C., and J. M. Brannon. 2002. Environmental fate of explosives. *Thermochimica Acta* 384: 163-172.
- Ramsey, C. A., and A. D. Hewitt. 2005. A methodology for assessing sample representativeness. *Journal of Environmental Forensics* 6: 71-76.
- Taylor, S., A. Hewitt, J. Lever, C. Hayes, L. Perovich, P. Thorne, and C. Daghljan. 2004. TNT particle size distributions from detonated 155-mm howitzer rounds. *Chemosphere* 55: 357-367.
- Walsh, M. E., C. A. Ramsey, and T. F. Jenkins. 2003. The effect of particle size reduction on subsampling variance for explosives residues in soil. *Chemosphere* 49: 1265-1271.

Government Documents:

- Ampleman, G., D. Faucher, S. Thiboutot, J. Hawari, and F. Monteil-Rivera. 2004. *Evaluation of underwater contamination by explosives and metals at Point Amour Labrador and in Halifax Harbour area*. DRDC-TR-2004-125. Val-Belair, Quebec: Defence Research and Development Canada – Valcartier.
- Ampleman, G., S. Thiboutot, J. Lewis, A. Marois, A. Gagnon, M. Bouchard, T. Jenkins, T. A. Ranney, and J. C. Pennington. 2004. *Evaluation of the contamination by explosives in soils, vegetation, surface water and sediment at Cold Lake Air Weapons Range (CLAWR), Alberta, Phase II Final Report*. DRDC-Valcartier TR-2004-204. Val-Belair, Quebec: Defence Research and Development Canada - Valcartier.
- Ampleman, G., S. Thiboutot, J. Lewis, A. Marois, A. Gagnon, M. Bouchard, R. Martel, R. Lefebvre, C. Gauthier, J. M. Ballard, T. Jenkins, T. Ranney, and J. Pennington. 2003. *Evaluation of the impacts of live fire training at CFB Shilo (Final report)*. DRDC-Valcartier TR-2003-066. Val-Belair, Quebec: Defence Research and Development Canada - Valcartier.

- Ampleman, G., S. Thiboutot, J. Lewis, A. Marois, A. Gagnon, M. Gagnon, S. Jean, T. F. Jenkins, A. Hewitt, J. C. Pennington, and T. A. Ranney. 2003. Evaluation of the contamination by explosives in soils, biomass and surface water at Cold Lake Air Weapons Range (CLAWR), Alberta, Phase I Report. DRDC-TR-2003-208. Val-Belair, Quebec: Defence Research and Development Canada - Valcartier.
- Bjella, K. L. 2005. *Pre-screening for explosives residues in soil prior to HPLC analysis utilizing expray*. ERDC/CRREL TN-05-2. Hanover, NH: U.S. Army Engineer Research and Development Center.
- Brannon, J. M., and J. C. Pennington. 2002. *Environmental fate and transport process descriptors for explosives*. ERDC TR-02-10. Vicksburg, MS: U.S. Army Engineer Research and Development Center.
- Dubé, P., S. Brochu, P. Brousseau, S. Thiboutot, G. Ampleman, J. Lewis, M. Bouchard, A. Gagnon, and A. Marois. 2003. *Study of the environmental impacts of the blow-in-place procedure of various explosives, munitions and charges*. DRDC-TR-2003-370. Val-Belair, Quebec: Defence Research and Development Canada - Valcartier.
- Hewitt, A. D., and S. R. Bigl. 2005. *Elution of energetic compounds from propellant and Composition B residues*. ERDC/CRREL TR-05-13. Hanover, NH: U.S. Army Engineer Research and Development Center.
- Hewitt, A. D., T. F. Jenkins, C. A. Ramsey, K. L. Bjella, T. A. Ranney, and N. Perrin. 2005. *Estimating energetic residue loading on military artillery ranges: Large decision units*. ERDC/CRREL TR-05-7. Hanover, NH: U.S. Army Engineer Research and Development Center.
- Hewitt, A. D., T. F. Jenkins, T. A. Ranney, J. A. Stark, M. E. Walsh, S. Taylor, M. R. Walsh, D. J. Lambert, N. M. Perron, N. H. Collins, and R. Karn. 2003. *Estimates of explosives residue from the detonation of Army munitions*. ERDC/CRREL TR-03-16. Hanover, NH: U.S. Army Engineer Research and Development Center.
- Jenkins, T. F., J. C. Pennington, T. A. Ranney, T. E. Berry, Jr., P. H. Miyares, M. E. Walsh, A. D. Hewitt, N. Perron, L. V. Parker, C. A. Hayes, and MAJ E. Wahlgren. 2001. *Characterization of explosives contamination at military firing ranges*. ERDC TR-01-05. Hanover, NH: U.S. Army Engineer Research and Development Center.
- Jenkins, T. F., A. D. Hewitt, T. A. Ranney, C. A. Ramsey, D. J. Lambert, K. L. Bjella, and N. M. Perron. 2004. *Sampling strategies near a low-order detonation and a target at an artillery impact area*. ERDC/CRREL TR-04-4, Hanover, NH: U.S. Army Engineer Research and Development Center.
- Jenkins, T. F., A. D. Hewitt, C. A. Ramsey, K. L. Bjella, S. R. Bigl, and S. J. Lambert. 2005. *Sampling studies at an air force live-fire bombing range impact area*. ERDC/CRREL TR-06-2. Hanover, NH: U.S. Army Engineer Research and Development Center.
- Jenkins, T. F., P. H. Miyares, M. E. Walsh, N. H. Collins, and T. A. Ranney. 2000. *Evaluation of the use of snow covered ranges to estimate the explosives residues that result from detonation of army munitions*. ERDC/CRREL TR-00-15. Hanover, NH: U.S. Army Engineer Research and Development Center.

- Jenkins, T. F., T. A. Ranney, A. D. Hewitt, M. G. Walsh, and K. L. Bjella. 2004. *Representative sampling for energetic compounds at an anti-tank firing range*. ERDC/CRREL TR-04-7. Hanover, NH: U.S. Army Engineer Research and Development Center.
- Lewis, J., S. Thiboutot, G. Ampleman, R. Martel, L. Ssi Ait, J. M. Ballard, M. Parent, and S. Downe. 2005. *Research on the environmental conditions of ground and surface water prevailing in the training area at CFB Gagetown, New Brunswick-Part II*. DRDC-Valcartier TR-2004-456. Val-Belair, Quebec: Defence Research and Development Canada - Valcartier.
- Marois, A., A. Gagnon, S. Thiboutot, G. Ampleman, and M. Bouchard. 2004. *Characterization of the surface soil and biomass in the training area of Canadian Forces Base Valcartier*. DRDC-TR-2004-206. Val-Belair, Quebec: Defence Research and Development Canada - Valcartier.
- Martel, R., L. Ssi Ait, G. Bordeleau, V. Cloutier, U. Gabriel, J. Lewis, M. Ross, G. Ampleman, and S. Thiboutot. 2005. *Groundwater and surface water study for potential contamination by energetic material, metals and related compounds at the Cold Lake Air Weapon Range (CLAWR)-Phase II Report*. INRS-ETE Report R-000237. Quebec: Institut National de la Recherche Scientifique.
- Pennington, J. C., T. F. Jenkins, G. Ampleman, S. Thiboutot, J. M. Brannon, J. Clausen, A. D. Hewitt, S. Brochu, P. Dubé, J. Lewis, T. A. Ranney, D. Faucher, A. Gagnon, J. A. Stark, P. Brousseau, C. B. Price, D. J. Lambert, A. Marois, M. Bouchard, M. E. Walsh, S. L. Yost, N. M. Perron, R. Martel, S. Jean, S. Taylor, C. Hayes, J. M. Ballard, M. R. Walsh, J. E. Mirecki, S. Downe, N. H. Collins, B. Porter, and R. Karn. 2004. *Distribution and fate of energetics on DoD test and training ranges: Interim Report 4*. ERDC TR-04-4. Vicksburg, MS: U.S. Army Engineer Research and Development Center.
- Pennington, J. C., T. F. Jenkins, G. Ampleman, S. Thiboutot, J. M. Brannon, J. Lewis, J. E. Delaney, J. Clausen, A. D. Hewitt, M. A. Hollander, C. A. Hayes, J. A. Stark, A. Marois, S. Brochu, H. Q. Dinh, D. Lambert, R. Martel, P. Brousseau, N. M. Perron, R. Lefebvre, W. Davis, T. A. Ranney, C. Gauthier, S. Taylor, and J. M. Ballard. 2003. *Distribution and fate of energetics on DoD test and training ranges: Interim Report 3*. ERDC TR-03-2. Vicksburg, MS: U.S. Army Engineer Research and Development Center.
- Pennington, J. C., T. F. Jenkins, G. Ampleman, S. Thiboutot, J. M. Brannon, J. Lynch, T. A. Ranney, J. A. Stark, M. E. Walsh, J. Lewis, C. A. Hayes, J. E. Mirecki, A. D. Hewitt, N. Perron, D. Lambert, J. Clausen, and J. J. Delfino. 2002. *Distribution and fate of energetics on DoD test and training ranges: Interim Report 2*. ERDC TR-02-8. Vicksburg, MS: U.S. Army Engineer Research and Development Center.
- Pennington, J. C., T. F. Jenkins, G. Ampleman, S. Thiboutot, J. Clausen, A. D. Hewitt, J. Lewis, M. R. Walsh, M. E. Walsh, T. A. Ranney, B. Silverblatt, A. Marois, A. Gagnon, P. Brousseau, J. E. Zufelt, K. Poe, M. Bouchard, R. Martel, D. D. Walker, C. A. Ramsey, C. A. Hayes, S. L. Yost, K. L. Bjella, L. Trepanier, T. E. Berry, D. J. Lambert, P. Dubé, and N. M. Perron. 2005. *Distribution and fate of energetics on DoD test and training ranges: Interim Report 5*. ERDC TR-05-2. Vicksburg, MS: U.S. Army Engineer Research and Development Center.

- Pennington, J. C., T. F. Jenkins, J. M. Brannon, J. Lynch, T. A. Ranney, T. E. Berry, Jr., C. A. Hayes, P. H. Miyares, M. E. Walsh, A. D. Hewitt, N. Perron, and J. J. Delfino. 2001. *Distribution and fate of energetics on DoD Test and training ranges: Interim Report 1*. ERDC TR-01-13. Vicksburg, MS: U.S. Army Engineer Research and Development Center.
- Thiboutot, S., G. Ampleman, A. Hamel, J. M. Ballard, R. Martel, R. Lefebvre, and S. Downe. 2003. *Research on the environmental conditions prevailing in the training area at Canadian Force Base Gagetown, New Brunswick*. DRDC-Valcartier TR-2003-016. Val-Belair, Quebec: Defence Research and Development Canada - Valcartier.
- Thiboutot, S., G. Ampleman, and A. Hewitt. 2002. *Guide for characterization of sites contaminated with energetic materials*. ERDC/CRREL TR-02-01. Hanover, NH: U.S. Army Engineer Research and Development Center.
- Thiboutot, S., G. Ampleman, J. Lewis, D. Faucher, A. Marois, R. Martel, J. M. Ballard, S. Downe, T. Jenkins, and A. Hewitt. 2003. *Environmental conditions of surface soils and biomass prevailing in the training area at CFB Gagetown, New Brunswick*. DRDC-Valcartier TR- 2003-152. Val-Belair, Quebec: Defence Research and Development Canada - Valcartier.
- Thiboutot, S., G. Ampleman, A. Marois, A. Gagnon, M. Bouchard, A. Hewitt, T. Jenkins, M. Walsh, K. Bjella, C. Ramsey, and T. A. Ranney. 2004. *Environmental conditions of surface soils, CFB Gagetown, training area: Delineation of the presence of munitions related residues (Phase III, Final Report)*. DRDC-Valcartier TR-2004-205. Val-Belair, Quebec: Defence Research and Development Canada - Valcartier.
- Walsh, M. E., C. A. Ramsey, C. M. Collins, A. D. Hewitt, M. R. Walsh, K. Bjella, D. Lambert, and N. Perron. 2005. *Collection methods and laboratory processing of samples from Donnelly Training Area firing points, Alaska*. ERDC/CRREL TR-05-6. Hanover, NH: U.S. Army Engineer Research and Development Center.
- Walsh, M. R., M. E. Walsh, C. M. Collins, S. P. Saari, J. E. Zufelt, A. B. Gelvin, and J. W. Hug. 2005. *Energetic residues from Live-fire detonations of 120-mm mortar rounds*. ERDC/CRREL TR-05-15. Hanover, NH: U.S. Army Engineer Research and Development Center.
- Walsh, M. R., M. E. Walsh, C. A. Ramsey, and T. F. Jenkins. 2005a. *An examination of protocols for the collection of munitions-derived explosives residues on snow-covered ice*. ERDC/CRREL TR-05-8. Hanover, NH: U.S. Army Engineer Research and Development Center.
- Walsh, M. R., M. E. Walsh, C. A. Ramsey, and T. F. Jenkins. (2005b). *Optimization of explosives residues collection from the detonation of munitions on snow-covered ice*. ERDC/CRREL TR-05-8. Hanover, NH: U.S. Army Engineer Research and Development Center.

Conference Presentations:

- Ampleman, G., and S. Thiboutot. 2004. Overview of R&D in sustainable training programme. NATO AVT-155. Prague, Czech Republic. October 2004.

- Ampleman, G., S. Thiboutot, J. Lewis, A. Marois, A. Gagnon, M. Bouchard, S. Jean, T. Jenkins, A. Hewitt, T. A. Ranney, and J. Pennington. 2004. Evaluation of the contamination by explosives and metals at Cold Lake Air Weapons Range (CLAWR). *Proceedings of the Battelle Conference on Sustainable Range Management, January 5-8, New Orleans, LA.*
- Ampleman, G., S. Thiboutot, J. Lewis, A. Marois, A. Gagnon, M. Bouchard, T. Jenkins, T. A. Ranney, and J. C. Pennington. 2005. Characterization of Cold Lake Air Weapons Range, Alberta, Canada. JSEM Symposium, Tampa, FL.
- Ampleman, G., S. Thiboutot, J. Lewis, A. Marois, R. Martel, R. Lefebvre, C. Gauthier, J. M. Ballard, T. Jenkins, T. A. Ranney, and J. Pennington. 2004. Evaluation of the environmental impact of live firing training at Canadian Force Base Shilo. *Proceedings of the Battelle Conference on Sustainable Range Management, January 5-8, New Orleans, LA.*
- _____. 2003. Evaluation of the environmental impact of live firing training at Canadian Force Base Shilo. Poster at Session D: Risk Based Land Management (Soil and Groundwater), FZK/TNO International Conference on Contaminated Land Management, May 12-16, Kent, Belgium.
- Ampleman, G., S. Thiboutot, J. Lewis, R. Martel, R. Lefebvre, C. Gauthier, J. M. Ballard, T. Jenkins, T. Ranney, A. Hewitt, and J. Pennington. 2002. Evaluation of the impacts of live fire training in Canadian ranges. SERDP Partners in Environmental Technology Technical Symposium and Workshop, December 3-5, Washington, DC.
- Ampleman, G., S. Thiboutot, A. Marois, A. Gagnon, M. Bouchard, S. Brochu, J. Lewis, T. Jenkins, A. Hewitt, J. Pennington, and T. A. Ranney. 2003. Canadian Sustainable Training Programme. *Proceedings of the Green Armaments Technology (GAT) Range Contamination Working Group Meeting, Cambridge, November, Boston, MA.*
- Arel, N., R. Martel, R. Lefebvre, S. Thiboutot, and G. Ampleman. 2002a. Dissolved energetic material transport in the vadose zone at the Arnhem Anti-Tank Range, CFB Valcartier, Canada. *Proceedings of the Annual Meeting of the Geological Society of America, October 7-9, 2002, Denver, CO.*
- _____. 2002b. Dissolved energetic material transport under unsaturated conditions at an anti-tank range. *Proceedings of the 3rd Joint IAH-CNC/CGS Conference, Ground and Water: Theory to Practice, October 28-31, 2002, Niagara Falls, Ontario, Canada.*
- Brannon, J. M., J. C. Pennington, S. Yost, and C. Hayes. 2004. Fate and transport of explosives. Battelle Conference on Sustainable Range Management, January 5-8, 2004, New Orleans, LA.
- Brochu, S., E. Diaz, S. Thiboutot, and G. Ampleman. 2005. Environmental impact of military training at CFB Petawawa, Ontario, Canada. SERDP Partners in Environmental Technology Technical Symposium and Workshop, November 28-December 2, Washington, DC.

- Brousseau, P., J. Lewis, G. Ampleman, S. Thiboutot, and P. Dubé. 2004. Experimental study of the cracked shell phenomenon. AIChE Symposium, November, 2004, San Francisco, CA.
- Clausen, J., D. Curry, J. Robb, and B. Gregson. 2002a. Comprehensive list of chemicals likely to be found at military ranges – A case study of Camp Edwards Massachusetts. SERDP Partners in Environmental Technology Technical Symposium and Workshop, December 3-5, 2002, Washington, DC.
- Clausen, J., D. Curry, J. Robb, and B. Gregson. 2002b. Environmental fate and transport modeling of explosives and propellants in the vadose zone. 18th Annual International Conference on Contaminated Sols, Sediments and Water, October 21, 2002, Amherst, MA.
- Clausen, J., and B. Gallagher. 2003. Contaminants of concern for military ranges. Joint Services Pollution Prevention and Hazardous Waste Management Conference, August 11, 2003, San Antonio, TX.
- Clausen, J., J. Robb, D. Curry, M. Wojtas, and B. Gallagher. 2003. Analytes of interest at military ranges. National Defense Industry Association Annual Meeting, April 1, 2003, Arlington, VA.
- Curry, D. M., J. Zaidel, A. Laase, J. L. Clausen, and D. Hill. 2002. Environmental fate and transport modeling of explosives and propellants in the saturated zone. 18th Annual International Conference on Contaminated Soils, Sediments and Water, October 21, 2002, Amherst, MA.
- Diaz, E., S. Brochu, S. Thiboutot, and G. Ampleman. 2004. Assessment of the contamination by explosives and metals in soils and biomasses at Western Area Training Centre (WATC) in Wainwright, Alberta. SERDP Partners in Environmental Technology Technical Symposium and Workshop, December 2-4, 2003, Washington, DC.
- Foote, E., R. Hinchee, J. Abbott, B. Alleman, J. C. Pennington, T. Jenkins, J. Oxley, and D. Ficklen. 2004. Fire ecology range management (FERM). Poster at Battelle Conference on Sustainable Range Management, January 5-8, 2004, New Orleans, LA.
- Foote, E., R. Hinchee, B. Alleman, J. Abbott, J. C. Pennington, T. Jenkins, J. Oxley, J. Smith, D. Thurber, and D. Ficklen. 2003. Impacts of fire ecology range management (FERM) on the fate and transport of energetic materials on testing and training ranges. Poster at SERDP Partners in Environmental Technology Technical Symposium and Workshop, December 2-4, 2003, Washington, DC.
- Gauthier, C., R. Lefebvre, R. Martel, G. Ampleman, and S. Thiboutot. 2003. Evaluation of impacts of live fire training on groundwater and the environment at Canadian Forces Base Shilo, Manitoba. 4th Joint IAH-CNC/CGS Conference, November 30, 2003, Winnipeg, Manitoba.
- Hewitt, A. D., T. F. Jenkins, T. A. Ranney, S. Taylor, M. R. Walsh, and M. E. Walsh. 2004. Detonation residues from live-fire vs. blow-in-place operations. Battelle Conference on Sustainable Range Management, January 5-8, 2004, New Orleans, LA.

- Hewitt, A. D., T. F. Jenkins, M. R. Walsh, M. E. Walsh, T. A. Ranney, S. Taylor, and J. C. Pennington. 2003. Deposition of explosives residues from live fire of Army munitions and UXO disposal using C4. Poster at SERDP Partners in Environmental Technology Technical Symposium and Workshop, December 2-4, 2003, Washington, DC.
- Hewitt, A. D., J. Pennington, T. Jenkins, J. Brannon, and S. Thiboutot. 2003. Distribution and fate of explosives on military ranges. Green Armaments Technology (GAT) Range Contamination Working Group Meeting, November 18-20, 2003, Cambridge, MA.
- Jenkins, T. F. 2001a. Characterization of sites potentially contaminated with explosives. SERDP Partners in Environmental Technology Technical Symposium and Workshop, November 26-29, 2001, Washington, DC.
- _____. 2001b. Use of snow-covered ranges to determine the amount of explosives residues deposited from high-order detonations of Army munitions. Keynote presentation at SERDP Partners in Environmental Technology Technical Symposium and Workshop, November 28-30, 2001, Washington, DC.
- _____. 2005. Chemical Residues of Energetic materials on DoD Training Ranges. Training Course at the 2005 NARPM Annual Training Conference, Phoenix, AZ.
- Jenkins, T. F., A. D. Hewitt, M. E. Walsh, and C. A. Ramsey. 2005. Improved sampling and subsampling protocols to minimize total characterization error for energetic compounds in soil from training ranges. 6th Annual Louisville Chemistry Conference, Louisville, KY.
- Jenkins, T. F., A. D. Hewitt, M. E. Walsh, T. A. Ranney, J. C. Pennington, S. Thiboutot, G. Ampleman, and M. H. Stutz. 2002. Explosive contamination at DoD firing ranges. UXO/Countermining Forum, September 3-6, 2002, Orlando, FL.
- Jenkins, T. F., A. D. Hewitt, M. E. Walsh, S. Thiboutot, G. Ampleman, T. A. Ranney, and J. C. Pennington. 2003. Distribution and fate of explosives on military ranges. Green Armament Technology (GAT) Range Contamination Working Group Meeting, November 18-20, 2003, Cambridge, MA.
- Jenkins, T. F., A. D. Hewitt, T. A. Ranney, M. E. Walsh, S. Thiboutot, G. Ampleman, T. A. Ranney, and J. C. Pennington. 2004. Distribution of energetic compounds in soils at training ranges. Battelle Conference on Sustainable Range Management, January 5-8, 2004, New Orleans, LA.
- Jenkins, T. F., J. C. Pennington, A. D. Hewitt, M. E. Walsh, S. Thiboutot, G. Ampleman, J. Clausen, and T. A. Ranney. 2002. Distribution and fate of energetics on DoD test and training ranges: Characterization of explosives contamination. SERDP Partners in Environmental Technology Technical Symposium and Workshop, December 3-5, Washington, DC.
- Jenkins, T. F., T. A. Ranney, A. D. Hewitt, M. E. Walsh, J. Stark, and J. C. Pennington. 2001. Use of snow-covered ranges to determine the amount of explosives residues deposited from high-order detonations of Army munitions. Geological Society of American National Meeting, November 5-9, 2001, Boston, MA.

- Jenkins, T. F., S. Thiboutot, A. D. Hewitt, G. Ampleman, M. E. Walsh, M. Walsh, S. Taylor, J. L. Clausen, and J. C. Pennington. 2005. An overview on the deposition of residues of energetic materials at U.S. and Canadian live-fire training ranges. Environmental Technology Symposium and Workshop, Portland, OR.
- Jenkins, T. F., M. E. Walsh, A. D. Hewitt, and T. A. Ranney. 2005. Sampling and subsampling error, the major contributor to total characterization error for energetic compounds in soil. Environmental Technology Symposium and Workshop, Portland, OR.
- Lewis, J., R. Martel, L. Trépanier, S. Thiboutot, G. Ampleman, and P. Brousseau. 2004. Energetic materials fate and transport in the vadose zone. SERDP Partners in Environmental Technology Technical Symposium and Workshop, December 2-4, 2003, Washington, DC.
- Lewis, J., R. Martel, L. Trépanier, S. Thiboutot, and G. Ampleman. 2005a. Transport of residues from cracked unexploded ordnance through the vadose zone during springtime aquifer recharge. SERDP Symposium, Washington, DC, 29th November-1st December 2005.
- _____. 2005b. Transport of residues from cracked unexploded ordinance through the vadose zone during springtime aquifer recharge. *Proceedings of the 6th International Association of Hydrogeologists, Canadian National Chapter (IAH-CNC) and CGS Groundwater Specialty Conference, 58th Canadian Geotechnical Conference, Saskatoon, Canada, September 2005.*
- Martel, R., T. Robertson, M. Q. Duan, S. Thiboutot, G. Ampleman, A. Provatas, and T. Jenkins. 2004. Energetic materials contaminated site characterization at the former explosives factory, Maribyrnong (EFM), Victoria, Australia. AIH Symposium, October 2004, Quebec, Canada.
- Pantea, D., S. Brochu, S. Thiboutot, G. Ampleman, and G. Scholz. 2005. A morphological investigation of soot coming from the detonation of munitions. *Proceedings of the American Institute of Chemical Engineering (AIChE), Annual Meeting, Cincinnati, OH.*
- Pennington, J. C. 2001. Defining environmental fate parameters for new energetic materials. Army Industrial Ecology Information Exchange, July 2001, Pocono Manor, NJ.
- _____. 2001. Environmental fate and transport of explosives. 17th International Conference on Contaminated Soils, Sediments, and Water, October 24, 2001, Amherst, MA.
- _____. 2002a. Fate and transport of explosives in soil and ground water. U.S. EPA Technical Support Project Semi-Annual Meeting, November 19, 2002, Pensacola, FL.
- _____. 2002. Sustainable ranges, Part I: Characterization, fate and transport, and effects. Keynote at SERDP Partners in Environmental Technology Technical Symposium and Workshop, December 3-5, 2002, Washington, DC.

- Pennington, J. C. 2003. Distribution of energetic compounds in soils at training ranges in the United States and Canada. Tri-Service Ecological Risk Assessment Work Group, June 3, 2003, Vicksburg, MS.
- _____. 2003. Environmental impact of munitions and propellant disposal. Applied Vehicle Technology Panel (AVT), Research and Technology Agency (RTA), North Atlantic Treaty Organization (NATO), October 6-10, 2003, Warsaw, Poland.
- _____. 2003. Environmental impacts of munitions on ranges. Session Chair at SERDP Partners in Environmental Technology Technical Symposium and Workshop, December 2-4, 2003, Washington, DC.
- _____. 2003. Live-fire range sustainment: Energetic materials as environmental contaminants. Keynote at JANNAF (Joint Army, Navy, NASA, Air Force) 31st Propellant Development and Characterization, and 20th Safety and Environmental Protection Subcommittees Joint Meeting, March 25-27, 2003, Charlottesville, VA.
- _____. 2003. Research perspectives. Long-Term Monitoring Workshop, January 15, 2003, Vicksburg, MS.
- _____. 2004. Army range assessment: Fate and transport. DoD Unregulated and Emerging Contaminants Working Group, May 25, 2004, Washington, DC.
- _____. 2004. Constituent residues from low-order detonations. 2004 ASA-CSSA-SSSA Annual Meetings, October 31 – November 4, 2004, Seattle, WA.
- _____. 2004. Distribution and fate of energetics on DoD testing and training ranges. JANNAF (Joint Army, Navy, NASA, Air Force) 32nd Propellant Development and Characterization, and 21st Safety and Environmental Protection Subcommittees Joint Meeting, July 27-29, 2004, Seattle, WA.
- _____. 2005. Characterization of ranges. NATO RTA subcommittee on Applied Vehicle Technology Panel 115. Environmental Impacts of Munitions and Propellants, April 22-25, 2005, Budapest, Hungary.
- _____. 2005. Characterization of range contamination. U.S. Army Corps of Engineers 2005 Environmental and Natural Resources Conference, May 2-5, 2005, St. Louis, MO.
- Pennington, J. C., J. M. Brannon, T. F. Jenkins, A. Hewitt, S. Thiboutot, G. Ampleman, K. Poe, B. Silverblatt, M. Hollander, J. Clausen, and J. Lynch. 2003. Distribution and fate of explosives on military ranges. Green Armament Technology (GAT) Range Contamination Working Group Meeting, November 18-20, 2003, Cambridge, MA.
- Pennington, J. C., T. F. Jenkins, J. M. Brannon, G. Ampleman, S. Thiboutot, K. Poe, and B. Silverblatt. 2004. Distribution and fate of energetics on DoD test and training ranges," Poster at Battelle Conference on Sustainable Range Management, January 5-8, 2004, New Orleans, LA.

- Pennington, J. C., T. F. Jenkins, J. M. Brannon, S. Thiboutot, G. Ampleman, and J. Clausen. 2003. Distribution and fate of energetics on DoD test and training ranges. Poster at SERDP Partners in Environmental Technology Technical Symposium and Workshop, December 2-4, 2003, Washington, DC.
- Pennington, J. C., T. F. Jenkins, J. M. Brannon, S. Thiboutot, G. Ampleman, J. Clausen, J. Lynch, A. D. Hewitt, and M. Hollander. 2003. Distribution and fate of explosives on military ranges. 2003 ASA-CSSA-SSSA Annual Meetings, November 2-6, Denver, CO.
- Pennington, J. C., T. F. Jenkins, J. M. Brannon, S. Thiboutot, G. Ampleman, J. E. Delaney, J. Q. Dinh, M. A. Hollander, J. Lynch, and J. Clausen. 2002. Distribution and fate of energetics on DoD test and training ranges: Detonation tests and explosives fate. Poster at SERDP Partners in Environmental Technology Technical Symposium and Workshop, December 3-5, 2002, Washington, DC.
- Pennington, J. C., T. F. Jenkins, J. M. Brannon, S. Thiboutot, J. E. Delaney, J. Lynch, and J. L. Clausen. 2001a. Distribution and fate of energetics on DoD test and training ranges. Geological Society of America Annual Meeting, November 5, 2001, Boston, MA.
- Pennington, J. C., T. F. Jenkins, J. M. Brannon, S. Thiboutot, J. E. Delaney, J. Lynch, and J. J. Delfino. 2001b. Distribution and fate of energetics on DoD test and training ranges. SERDP Partners in Environmental Technology Technical Symposium and Workshop, November 27-29, 2001, Washington, DC.
- Robb, J., J. L. Clausen, and B. Gallagher. 2002. Environmental fate and transport modeling of explosives and propellants in the unsaturated zone. National Defense Industry Association Annual Meeting, April 7, 2003, Arlington, VA.
- Taylor, S., J. Lever, L. Perovich, E. Campbell, and J. Pennington. 2004. A study of composition B particles from 81-mm mortar detonations. Battelle Conference on Sustainable Range Management, January 5-8, 2004, New Orleans, LA.
- Thiboutot, S., and G. Ampleman. 2004. Overview of R&D in sustainable training programme. DLE and U.S Army G3, April 2004, DRDC Valcartier, Quebec.
- _____. 2004. Overview of R&D in sustainable training programme. NATO ETWG 2/04, October 2004, CFB Valcartier, Quebec.
- _____. 2004. Towards military sustainable ranges: Canadian R&D Program. Keynote presentation at ASA-CSSA-SSSA Annual Meetings, October 31 – November 4, 2004, Seattle, WA.
- Thiboutot, S., G. Ampleman, A. D. Hewitt, T. F. Jenkins, M. Walsh, K. Bjella, C. Ramsey, and T. A. Ranney. 2005. Delineation of the presence of munitions related residues at CFB Gagetown live-fire training area. JSEM Symposium, Tampa, FL.
- Thiboutot, S., G. Ampleman, R. Lefebvre, R. Martel, A. Hamel, J. M. Ballard, and S. Downe. 2003. Evaluation of the environmental impact of live firing training at Canadian Forces Base Gagetown. *Proceedings of the FZK/TNO International Conference on Contaminated Land, Consoil 2003, May 2003, Gent, Belgium.*

- Thiboutot, S., G. Ampleman, J. Lewis, A. Marois, T. Jenkins, A. Hewitt, and J. Pennington. 2004. Characterization of Canadian Force Base Gagetown Training Area for potential contamination by explosives and heavy metals. *Proceedings of the Battelle Conference on Sustainable Range Management, January 5-8, New Orleans, LA.*
- Thiboutot, S., G. Ampleman, J. Lewis, R. Martel, D. Paradis, J. M. Ballard, R. Lefebvre, and C. Gauthier. 2002. Assessment of the environmental impact of the firing activity on active Canadian firing ranges. *Proceedings of the 33rd International ICT Conference, Karlsruhe, Germany, June 2002*, p 55-1.
- Thiboutot, S., G. Ampleman, J. Tessier, and J. Audi. 2004. Sustainable training. DRDC-DVD, May 2004, CFB Valcartier, Quebec.
- Walker, D. D., T. F. Jenkins, and J. C. Pennington. 2004. Environmental impacts of blow-in-place detonations. Battelle Conference on Sustainable Range Management, January 5-8, 2004, New Orleans, LA.
- Walker, D. D., T. F. Jenkins, and J. C. Pennington. 2003. Environmental impacts of blow-in-place detonations. Poster at SERDP Partners in Environmental Technology Technical Symposium and Workshop, December 2-4, 2003, Washington, DC.
- Walsh, M. R., A. D. Hewitt, and S. Taylor. 2004. Determination of explosives residues from winter live-fire exercises. Battelle Conference on Sustainable Range Management, January 5-8, 2004, New Orleans, LA.

Appendix B: Bibliography of Camp Edward Publications in FY2005

Government Documents

- AMEC. 2004. Draft J-1 Range Supplemental Geophysical Anomaly Investigation Work Plan, Camp Edwards, Massachusetts Military Reservation, Cape Cod, Massachusetts, MMR-9220, AMEC Earth and Environmental, Inc. Westford, MA.
- _____. 2004. Final J-3 Supplemental Soil Work Plan, Camp Edwards, Massachusetts Military Reservation, Cape Cod, Massachusetts, MMR-9218, AMEC Earth and Environmental, Inc. Westford, MA.
- _____. 2004. Draft CIA Soil Focused Investigation Report (Target 23 & 42), Camp Edwards, Massachusetts Military Reservation, Cape Cod, Massachusetts, MMR-9210, AMEC Earth and Environmental, Inc. Westford, MA.
- _____. 2004. Final Technical Team Memorandum 04-1, Demo 2 Interim Groundwater Data Summary, Camp Edwards, Massachusetts Military Reservation, Cape Cod, Massachusetts, MMR-9252, AMEC Earth and Environmental, Inc. Westford, MA.
- _____. 2004. Draft October to December 2003 BIP Report, Camp Edwards, Massachusetts Military Reservation, Cape Cod, Massachusetts, MMR-8972, AMEC Earth and Environmental, Inc. Westford, MA.
- _____. 2004. Draft Demo 2 Soil RRA Data Summary Update Letter, Camp Edwards, Massachusetts Military Reservation, Cape Cod, Massachusetts, MMR-9283, AMEC Earth and Environmental, Inc. Westford, MA.
- _____. 2005. Final System Performance and Ecological Impact Monitoring (SPIEM) Plan Rapid Response Action Systems, Demo 1 Groundwater Operable Unit, Camp Edwards, Massachusetts Military Reservation, Cape Cod, Massachusetts, MMR-9300, AMEC Earth and Environmental, Inc. Westford, MA.
- _____. 2005. Final Soil Sampling Plan for Delineation of Explosive Compounds and Perchlorate within the HUTA II and SCAR Site, Camp Edwards, Massachusetts Military Reservation, Cape Cod, Massachusetts, MMR-9316, AMEC Earth and Environmental, Inc. Westford, MA.
- _____. 2005. Draft Remedial Design Work Plan, Remedial Design, Demo 1, Groundwater Operable Unit, Camp Edwards, Massachusetts Military Reservation, Cape Cod, Massachusetts, MMR-9333, AMEC Earth and Environmental, Inc. Westford, MA.
- _____. 2005. Final J-3 Range Supplemental Groundwater Work Plan Camp Edwards, Massachusetts Military Reservation, Cape Cod, Massachusetts, MMR-9269, AMEC Earth and Environmental, Inc. Westford, MA.

- AMEC. 2005. Engineer Training Site Soil Results and Continued Demo 2 Groundwater Investigation, Camp Edwards, Massachusetts Military Reservation, Cape Cod, Massachusetts, MMR-9385, AMEC Earth and Environmental, Inc. Westford, MA.
- _____. 2005. Draft Training Areas Data Summary Report, Camp Edwards, Massachusetts Military Reservation, Cape Cod, Massachusetts, MMR-9382, AMEC Earth and Environmental, Inc. Westford, MA.
- _____. 2005. Draft Long Term Groundwater Monitoring Plan (LTGM) for 2005, Camp Edwards, Massachusetts Military Reservation, Cape Cod, Massachusetts, MMR-9456, AMEC Earth and Environmental, Inc. Westford, MA.
- _____. 2005. Summary of Corrosion Mechanisms and Corrosion Potential of Unexploded Ordnance, Camp Edwards, Massachusetts Military Reservation, Cape Cod, Massachusetts, MMR-9400, AMEC Earth and Environmental, Inc. Westford, MA.
- _____. 2005. Completion of Work Report, Rapid Response Action Systems, Demolition Area 1, Groundwater Operable Unit, Camp Edwards, Massachusetts Military Reservation, Cape Cod, Massachusetts, MMR-9583, AMEC Earth and Environmental, Inc. Westford, MA.
- _____. 2005. Draft Demo 2 Soil RRA Completion of Work Report and Operable Unit Closure Report, Camp Edwards, Massachusetts Military Reservation, Cape Cod, Massachusetts, MMR-9584, AMEC Earth and Environmental, Inc. Westford, MA.
- _____. 2005. Final Generic Quality Assurance Project Plan (QAPP), Camp Edwards, Massachusetts Military Reservation, Cape Cod, Massachusetts, MMR-9612, AMEC Earth and Environmental, Inc. Westford, MA.
- _____. 2005. Final Demo 1 RRA ETR Systems 6 Month Performance Monitoring Evaluation Report, Camp Edwards, Massachusetts Military Reservation, Cape Cod, Massachusetts, MMR-9686, AMEC Earth and Environmental, Inc. Westford, MA.
- _____. 2005. Draft Demo 2 Groundwater Remedial Investigation Work Plan, Camp Edwards, Massachusetts Military Reservation, Cape Cod, Massachusetts, MMR-9687, AMEC Earth and Environmental, Inc. Westford, MA.
- _____. 2005. Draft Work Plan Treatability Studies, Camp Edwards, Massachusetts Military Reservation, Cape Cod, Massachusetts, MMR-9570, AMEC Earth and Environmental, Inc. Westford, MA.
- _____. 2005. Draft Post Screening Investigation Central Impact Area Source Area Characterization Work Plan, Camp Edwards, Massachusetts Military Reservation, Cape Cod, Massachusetts, MMR-9711, AMEC Earth and Environmental, Inc. Westford, MA.
- _____. 2005. Final Technical Team Memorandum 01-17 Demo 1 Groundwater Feasibility Study, Camp Edwards, Massachusetts Military Reservation, Cape Cod, Massachusetts, MMR-9501, AMEC Earth and Environmental, Inc. Westford, MA.

- AMEC. 2005. Final Remedy Selection Plan for the Demolition Area 1 Groundwater Plume, Camp Edwards, Massachusetts Military Reservation, Cape Cod, Massachusetts, MMR-9734, AMEC Earth and Environmental, Inc. Westford, MA.
- ECC. 2005. Draft L Range Groundwater Characterization Report, Camp Edwards, Massachusetts Military Reservation, Cape Cod, Massachusetts, MMR-9411, Environmental Chemical Corporation Otis ANGB, MA.
- _____. 2005. Final J-2 Range Supplemental Geophysical Anomaly Investigation Work Plan, Camp Edwards, Massachusetts Military Reservation, Cape Cod, Massachusetts, MMR-9347, Environmental Chemical Corporation Otis ANGB, MA.
- _____. 2005. Final J-3 Range Groundwater Rapid Response Action (RRA) Plan, Camp Edwards, Massachusetts Military Reservation, Cape Cod, Massachusetts, MMR-9588, Environmental Chemical Corporation Otis ANGB, MA.
- _____. 2005. Draft J-2 Range North Groundwater Rapid Response Action (RRA) Plan, Camp Edwards, Massachusetts Military Reservation, Cape Cod, Massachusetts, MMR-9647, Environmental Chemical Corporation Otis ANGB, MA.
- _____. 2005. Draft J-3 Range Rapid Response Action Completion Report, Camp Edwards, Massachusetts Military Reservation, Cape Cod, Massachusetts, MMR-9607, Environmental Chemical Corporation Otis ANGB, MA.
- _____. 2005. Draft MMR TTU (Thermal Treatment Unit) Completion Report, Camp Edwards, Massachusetts Military Reservation, Cape Cod, Massachusetts, MMR-9680, Environmental Chemical Corporation Otis ANGB, MA.
- _____. 2005. Draft Gun Position 6 Soil Removal and Thermal Treatment Letter Report, Camp Edwards, Massachusetts Military Reservation, Cape Cod, Massachusetts, MMR-9662, Environmental Chemical Corporation Otis ANGB, MA.
- _____. 2005. Final J-1 Supplemental Geophysical Anomaly Investigation Work Plan, Camp Edwards, Massachusetts Military Reservation, Cape Cod, Massachusetts, MMR-9736, Environmental Chemical Corporation Otis ANGB, MA.
- _____. 2005. Draft CIA Target 42 & 23 Rapid Response Action Completion of Work Report, Camp Edwards, Massachusetts Military Reservation, Cape Cod, Massachusetts, MMR-9735, Environmental Chemical Corporation Otis ANGB, MA.
- MACTEC Engineering and Consulting, Inc. 2005. Final Summary Report for the Melt-Pour and Explosive Bunker Building Decontamination, Camp Edwards, Massachusetts Military Reservation, Cape Cod, Massachusetts, MMR-9360, MACTEC Engineering and Consulting, Inc. Wakefield, MA.

Conference Presentations in FY2005

- Robb, J., and J. L. Clausen. 2005. Field Scale Evaluation of Energetic Material in Training Range Soil and Soil Pore Water presented at the Battelle 2nd Conference on Sustainable Ranges Initiative, August 22-25, 2005, San Antonio, TX.

- Weeks, K., F. Cannon, and I. Osgerby. 2005. Removal of Perchlorate and RDX in Groundwater presented at the National Groundwater Association 2005 Conference on MTBE and Perchlorate, May 27, 2005, San Francisco, CA.
- Clausen, J. L., and J. Robb. 2004. Characterization of Ranges, Lessons Learned presented at Geo Quebec 2004, 57th Canadian Geotechnical Conference, October 25-27, 2004, Quebec City, Quebec, Canada.
- Christopher Abate, A. D. Laase, M. Applebee, J. Muzzin, and D. J. Adilman. 2004. Use of Brute Force Optimization Modeling for Design of Extraction Well Fields, 20th Annual Conference on Soils, Sediment, and Water, October 18-21, 2004. Amherst, MA.
- Hoyt, M., B. Pugh, and M. Wojtas. 2004. Characterization of Tentatively-Identified Compounds (TICs) and Data Usage Issues 20th Annual International Conference on Contaminated Soils, Sediments, and Water, October 18-21, 2004. Amherst, MA.

Appendix C: Particle Size Distribution from 2003 Studies

Table C1. Mass (g) of residue in each particle size fraction from 60-, 105-, and 155-mm rounds¹ (2003 Data)

Shot Number	Energy Yield (%) ²	Size, mm					Total
		>12.5	4-12.5	2-4	0.25-2	<0.25	
60-mm³							
6	2.1	93.6 ⁴	2.9 ⁵	3.3 ⁵	24.4	2.8	136.8
7	96	0	0	0.5 ⁵	7.1	2.7	10.3
8	2.4	183.0 ⁴	2.7	3.1	19.9	9.8	218.5 ⁶
Mean	33.4	92.2	1.9	2.3	17.1	8.5	121.9
Standard Deviation	54.1	91.5	1.6	1.6	9.0	5.2	104.9
105-mm							
12	65	0.2	3.7	27.5	169.2	13.8	214.4
13	10	274.1	160.2	143.4	130.1	37.3	745.2
14	22	671.8 ⁴	131.9	73.5	150.0	17.9	1,045.08
15	14	648.0 ⁴	79.2	101.0	208.4	14.6	1,051.0
16	9	498.7 ⁴	220.5	85.8	130.5	35.2	970.2
17	78	19.9	258.9	45.0	199.4	11.6	534.9
27	76	0	4.0	22.9	124.7	9.4	161.0
28	73	0	23.7	35.3	120.6	6.7	186.3
29	67	21.9	55.8	56.1	191.3	18.0	343.0
30	52	0	3.4	4.8	9.5	5.8	23.4
Mean	46.6	213.5	94.1	59.5	143.4	17.03	527.4
Standard Deviation	29.3	286.8	94.4	41.9	57.3	11.0	397.5
155-mm							
19	100	0	0	1.8	7.1	4.4	13.3
20	15	738.0	1,310.9	149.9	499.5	16.9	2,715.2
21	19	1,264.0 ⁴	1,138.6	278.8	ND ⁵	54.3	2,735.7
22	18	1,022.0 ⁴	297.4	141.4	591.8	83.7	2,136.4
23	27	62.9	127.4	126.9	422.7	437.2	1,177.2
24	26	99.5	151.0	175.6	584.9	64.7	1,075.7
25	34	35.4	78.9	37.5	291.9	21.6	465.2
26	46	55.6	147.7	27.3	359.6	20.7	611.0
Mean	35.6	409.7	406.5	117.4	393.9	87.93	1,366.2
Standard Deviation	27.9	515.8	513.9	91.8	203.6	143.2	1,043.4

¹ Data presented are the sum of all explosives in each fraction from the table, the tarp, the access apron, and off the tarp.

² Values are average of peak pressure, incident impulse, and incident impulse at 500 μ sec.

³ Data from shots 4 and 5 were lost.

⁴ Represents a single chunk of explosives.

⁵ No visible explosive in residue; however, HPLC analysis resulted in detection of explosives.

⁶ Although this value exceeds the quantity of explosive in the mortar, 199 g, the value is within experimental error.

REPORT DOCUMENTATION PAGE

Form Approved
OMB No. 0704-0188

Public reporting burden for this collection of information is estimated to average 1 hour per response, including the time for reviewing instructions, searching existing data sources, gathering and maintaining the data needed, and completing and reviewing this collection of information. Send comments regarding this burden estimate or any other aspect of this collection of information, including suggestions for reducing this burden to Department of Defense, Washington Headquarters Services, Directorate for Information Operations and Reports (0704-0188), 1215 Jefferson Davis Highway, Suite 1204, Arlington, VA 22202-4302. Respondents should be aware that notwithstanding any other provision of law, no person shall be subject to any penalty for failing to comply with a collection of information if it does not display a currently valid OMB control number. **PLEASE DO NOT RETURN YOUR FORM TO THE ABOVE ADDRESS.**

1. REPORT DATE (DD-MM-YYYY) November 2006			2. REPORT TYPE Interim Report 6		3. DATES COVERED (From - To)	
4. TITLE AND SUBTITLE Distribution and Fate of Energetics on DoD Test and Training Ranges: Interim Report 6					5a. CONTRACT NUMBER	
					5b. GRANT NUMBER	
					5c. PROGRAM ELEMENT NUMBER	
6. AUTHOR(S) J. C. Pennington, T. F. Jenkins, G. Ampleman, S. Thiboutot, A. D. Hewitt, S. Brochu, J. Robb, E. Diaz, J. Lewis, H. Colby, R. Martel, K. Poe, K. Groff, K. L. Bjella, C. A. Ramsey, C. A. Hayes, S. Yost, A. Marois, A. Gagnon, B. Silverblatt, T. Crutcher, K. Harriz, K. Heisen, S. R. Bigl, T. E. Berry, Jr., J. Muzzin, D. J. Lambert, M. J. Bishop, B. Rice, M. Wojtas, M. E. Walsh, M. R. Walsh, and S. Taylor					5d. PROJECT NUMBER	
					5e. TASK NUMBER	
					5f. WORK UNIT NUMBER	
7. PERFORMING ORGANIZATION NAME(S) AND ADDRESS(ES) See reverse.					8. PERFORMING ORGANIZATION REPORT NUMBER ERDC TR-06-12	
9. SPONSORING / MONITORING AGENCY NAME(S) AND ADDRESS(ES) Strategic Environmental Research and Development Program Arlington, VA 22203					10. SPONSOR/MONITOR'S ACRONYM(S)	
					11. SPONSOR/MONITOR'S REPORT NUMBER(S)	
12. DISTRIBUTION / AVAILABILITY STATEMENT Approved for public release; distribution is unlimited.						
13. SUPPLEMENTARY NOTES						
14. ABSTRACT Understanding the potential for generation and transport of residual explosives is necessary to sustain live-fire training ranges. The objective of this study was to characterize the distribution and fate of explosive residues from various training activities. The physical and chemical properties, concentrations, and distribution of residues in soils, and the potential for transport to ground-water were defined. Surface soils associated with impact craters, target areas, and firing points on U.S. and Canadian ranges were characterized. Residues from high-order, low-order, and blow-in-place detonations were described and quantified. Parameters suitable for use in fate and transport models and environmental risk assessments were determined for constituents of concern. Results demonstrated that residues are specific to range activities. Demolition areas, low-order detonations sites, and firing positions have great potential for accumulation of residues. Demolition typically generates small areas of relatively high concentrations. Low-order detonations generate primarily large solid particles reflecting the composition of the predetonation explosive. Artillery and mortar impact areas tend to have low concentrations of widely distributed constituents. Firing positions may exhibit high concentrations of propellants. Results of this study provide a realistic evaluation of training range residues and a scientific basis for development of control measures for explosives residues.						
15. SUBJECT TERMS See reverse.						
16. SECURITY CLASSIFICATION OF:				17. LIMITATION OF ABSTRACT	18. NUMBER OF PAGES	19a. NAME OF RESPONSIBLE PERSON
a. REPORT UNCLASSIFIED	b. ABSTRACT UNCLASSIFIED	c. THIS PAGE UNCLASSIFIED	19b. TELEPHONE NUMBER (include area code)			

7. (Concluded)

U.S. Army Engineer Research and Development Center, Environmental Laboratory
3909 Halls Ferry Road, Vicksburg, MS 39180-6199;
U.S. Army Engineer Research and Development Center, Cold Regions Research Laboratory
72 Lyme Road, Hanover, NH 03755-1290;
Defence Research and Development Canada-Valcartier
2459 Pie XI Blvd North, Val-Bélair, Québec, G3J 1X5;
Institut National de la Recherche Scientifique, 880 Chemin Ste-Foy, Bueau 840
490 rue de la Couronne, Quebec G1K 9A9;
SpecPro Inc., 4815 Bradford Dr. NW, Suite 201, Huntsville, AL 35805;
Envirostat Inc., P.O. Box 636, Fort Collins, CO 80522-0636;
Naval Explosive Ordnance Disposal Technology Division
2008 Stump Neck Road, Indian Head, MD 20640-5070;
U.S. Army Redstone Technical Test Center
Redstone Arsenal, AL 45898;
AMEC Earth and Environmental
239 Littleton Road, Suite 1B, Westford, MA 01886-3598;
AMEC Earth & Environmental
285 Davidson Avenue, Somerset, NJ 08873-4153;
AMEC Earth and Environmental
1405 West Auto Drive, Tempe, AZ 85284-1016

15. (Concluded)

Anti-tank ranges
Battleruns
Blow-in-place
Detonation residues
Explosives
Fate and transport of explosives
High-order detonations
HMX
Low-order detonations
Propellants
RDX
Test ranges
TNT
Training ranges