

NBS SPECIAL PUBLICATION 260-87

U.S. DEPARTMENT OF COMMERCE/National Bureau of Standards

*SRM 1969: RUBIDIUM TRIPLE - POINT
STANDARD — A TEMPERATURE
REFERENCE STANDARD
NEAR 39.30 °C*

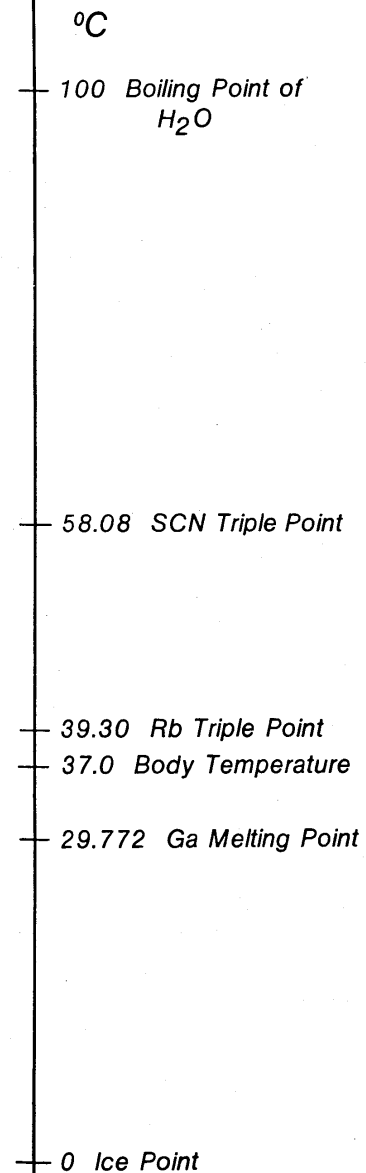
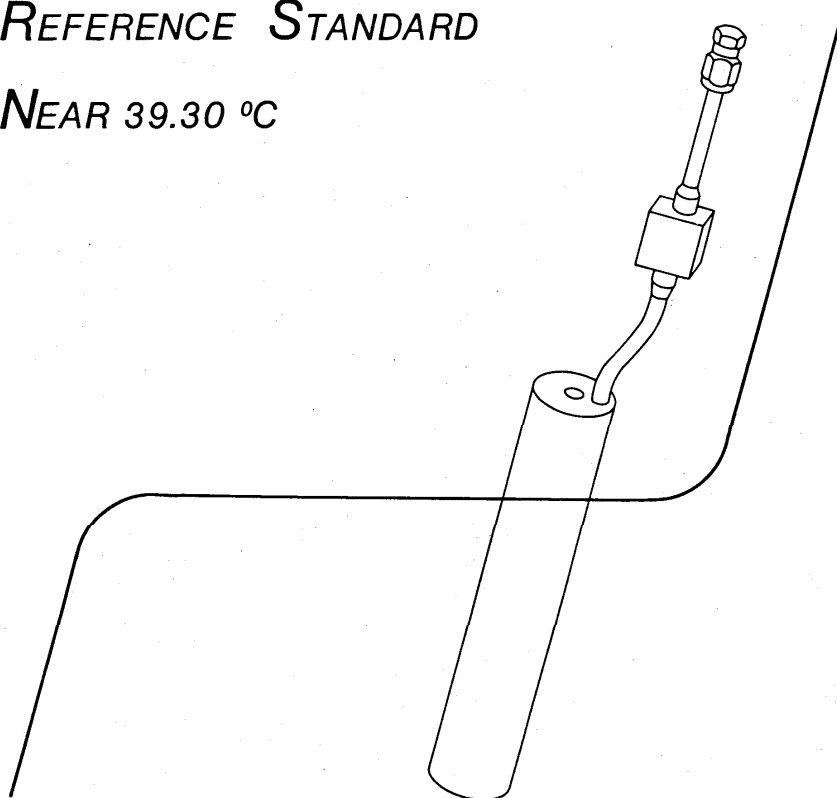

NATIONAL BUREAU OF STANDARDS

The National Bureau of Standards¹ was established by an act of Congress on March 3, 1901. The Bureau's overall goal is to strengthen and advance the Nation's science and technology and facilitate their effective application for public benefit. To this end, the Bureau conducts research and provides: (1) a basis for the Nation's physical measurement system, (2) scientific and technological services for industry and government, (3) a technical basis for equity in trade, and (4) technical services to promote public safety. The Bureau's technical work is performed by the National Measurement Laboratory, the National Engineering Laboratory, and the Institute for Computer Sciences and Technology.

THE NATIONAL MEASUREMENT LABORATORY provides the national system of physical and chemical and materials measurement; coordinates the system with measurement systems of other nations and furnishes essential services leading to accurate and uniform physical and chemical measurement throughout the Nation's scientific community, industry, and commerce; conducts materials research leading to improved methods of measurement, standards, and data on the properties of materials needed by industry, commerce, educational institutions, and Government; provides advisory and research services to other Government agencies; develops, produces, and distributes Standard Reference Materials; and provides calibration services. The Laboratory consists of the following centers:

Absolute Physical Quantities² — Radiation Research — Chemical Physics — Analytical Chemistry — Materials Science

THE NATIONAL ENGINEERING LABORATORY provides technology and technical services to the public and private sectors to address national needs and to solve national problems; conducts research in engineering and applied science in support of these efforts; builds and maintains competence in the necessary disciplines required to carry out this research and technical service; develops engineering data and measurement capabilities; provides engineering measurement traceability services; develops test methods and proposes engineering standards and code changes; develops and proposes new engineering practices; and develops and improves mechanisms to transfer results of its research to the ultimate user. The Laboratory consists of the following centers:

Applied Mathematics — Electronics and Electrical Engineering² — Manufacturing Engineering — Building Technology — Fire Research — Chemical Engineering²

THE INSTITUTE FOR COMPUTER SCIENCES AND TECHNOLOGY conducts research and provides scientific and technical services to aid Federal agencies in the selection, acquisition, application, and use of computer technology to improve effectiveness and economy in Government operations in accordance with Public Law 89-306 (40 U.S.C. 759), relevant Executive Orders, and other directives; carries out this mission by managing the Federal Information Processing Standards Program, developing Federal ADP standards guidelines, and managing Federal participation in ADP voluntary standardization activities; provides scientific and technological advisory services and assistance to Federal agencies; and provides the technical foundation for computer-related policies of the Federal Government. The Institute consists of the following centers:

Programming Science and Technology — Computer Systems Engineering.

¹Headquarters and Laboratories at Gaithersburg, MD, unless otherwise noted; mailing address Washington, DC 20234.

²Some divisions within the center are located at Boulder, CO 80303.

Standard Reference Materials:

SRM 1969: Rubidium Triple-Point Standard — A Temperature Reference Standard Near 39.30 °C

B. W. Mangum

Temperature and Pressure Division
Center for Basic Standards
National Measurement Laboratory
National Bureau of Standards
Washington, D.C. 20234



U.S. DEPARTMENT OF COMMERCE, Malcolm Baldrige, Secretary
NATIONAL BUREAU OF STANDARDS, Ernest Ambler, Director

Issued December 1983

Library of Congress Catalog Card Number: 83-600621

National Bureau of Standards Special Publication 260-87
Natl. Bur. Stand. (U.S.), Spec. Publ. 260-87, 36 pages (Dec. 1983)
CODEN: XNBSAV

U.S. GOVERNMENT PRINTING OFFICE
WASHINGTON: 1983

For sale by the Superintendent of Documents, U.S. Government Printing Office, Washington, DC 20402

PREFACE

Standard Reference Materials (SRM's) as defined by the National Bureau of Standards are well-characterized materials produced in quantity and certified for one or more physical or chemical properties. They are used to assure the accuracy and compatibility of measurements throughout the Nation. SRM's are widely used as primary standards in many diverse fields in science, industry, and technology, both within the United States and throughout the world. They are also used extensively in the fields of environmental and clinical analysis. In many applications, traceability of quality control and measurement processes to the national measurement system are carried out through the mechanism and use of SRM's. For many of the Nation's scientists and technologists it is therefore of more than passing interest to know the details of the measurements made at NBS in arriving at the certified values of the SRM's produced. An NBS series of papers, of which this publication is a member, called the NBS Special Publication - 260 Series, is reserved for this purpose.

This 260 Series is dedicated to the dissemination of information on different phases of the preparation, measurement, certification and use of NBS-SRM's. In general, much more detail will be found in these papers than is generally allowed, or desirable, in scientific journal articles. This enables the user to assess the validity and accuracy of the measurement processes employed, to judge the statistical analysis, and to learn details of techniques and methods utilized for work entailing the greatest care and accuracy. These papers also should provide sufficient additional information not found on the certificate so that new applications in diverse fields not foreseen at the time the SRM was originally issued will be sought and found.

Inquiries concerning the technical content of this paper should be directed to the author. Other questions concerned with the availability, delivery, price, and so forth will receive prompt attention from:

Office of Standard Reference Materials
National Bureau of Standards
Washington, D.C. 20234

Stanley D. Rasberry
Acting Chief
Office of Standard Reference Materials

OTHER NBS PUBLICATIONS IN THIS SERIES

- Catalog of NBS Standard Reference (1981-83 edition). R. W. Seward, ed., NBS Spec. Publ. 260 (November 1981).
- Michaelis, R. E. and Wyman, L. L., Standard Reference Materials: Preparation of White Cast Iron Spectrochemical Standards. NBS Misc. Publ. 260-1 (June 1964) COM74-11061**
- Michaelis, R. E., Wyman, L. L., and Flitsch, R., Standard Reference Materials: Preparation of NBS Copper-Base Spectrochemical Standards. NBS Misc. Publ. 260-2 (October 1964) COM74-11063**
- Michaelis, R. E., Yakowitz, H., and Moore, G. A., Standard Reference Materials: Metallographic Characterization of Steel Standard. NBS Misc. Publ. 260-3 (October 1964) COM74-11060**
- Hague, J. L. Mears, T. W., and Michaelis, R. E., Standard Reference Materials: Sources of Information. NBS Misc. Publ. 260-4 (February 1965) COM74-11059
- Alvarez, R. and Flitsch, R., Standard Reference Materials: Accuracy of Solution X-Ray Spectrometric Analysis of Copper-Base Alloys. NBS Misc. Publ. 260-5 (March 1965) PB168068**
- Shultz, J. I., Standard Reference Materials: Methods for the Chemical Analysis of White Cast Iron Standards. NBS Misc. Publ. 260-6 (July 1975) COM74-11068**
- Bell, R. K., Standard Reference Materials: Methods for the Chemical Analysis of NBS Copper-Base Spectrochemical Standards. NBS Misc. Publ. 260-7 (October 1965) COM74-11067**
- Richmond, M. S., Standard Reference Materials: Analysis of Uranium Concentrates at the National Bureau of Standards. NBS Misc. Publ. 260-8 (December 1965) COM74-11066**
- Anspach, S. C., Cavallo, L. M., Garfinkel, S. B., Hutchinson, J. M. R. and Smith, C. N., Standard Reference Materials: Half Lives of Materials Used in the Preparation of Standard Reference Materials of Nineteen Radioactive Nuclides Issued by the National Bureau of Standards. NBS Misc. Publ. 260-9 (November 1965) COM74-11065**
- Yakowitz, H., Vieth, D. L., Heinrich, K. F. J., and Michaelis, R. E., Standard Reference Materials: Homogeneity Characterization on NBS Spectrometric Standards II: Cartridge Brass and Low-Alloy Steel. NBS Misc. Publ. 260-10 (December 1965) COM74-11064**
- Napolitano, A. and Hawkins, E. G., Standard Reference Materials: Viscosity of Standard Lead-Silica Glass. NBS Misc. Publ. 260-11 (November 1966) NBS Misc. Publ. 260-11**
- Yakowitz, H., Vieth, D. L., and Michaelis, R. E., Standard Reference Materials: Homogeneity Characterization of NBS Spectrometric Standards III: White Cast Iron and Stainless Steel Powder Compact. NBS Misc. Publ. 260-12**
- Spijkerman, J. L., Snediker, D. K., Ruegg, F. C., and DeVoe, J. R., Standard Reference Materials: Mossbauer Spectroscopy Standard for the Chemical Shift Compounds. NBS Misc. Publ. 260-13** (July 1967)
- Menis, O. and Sterling, J. T., Standard Reference Materials: Determination of Oxygen in Ferrous Materials - SRM 1090, 1091, and 1092. NBS Spec. Publ. 260-14** (September 1966)
- Passaglia, E. and Shouse, P. J., Standard Reference Materials: Recommended Method of Use of Standard Light-Sensitive Paper for Calibrating Carbon Arcs Used in Testing Textiles for Colorfastness to Light. NBS Misc. Publ. 260-15 (June 1967) (Replaced by NBS Spec. 260-41.)
- Yakowitz, H., Michaelis, R. E. and Vieth, D. L., Standard Reference Materials: Homogeneity Characterization of NBS Spectrometric Standards IV: Preparation and Microprobe Characterization of W-20% MO Alloy Fabricated by Powder Metallurgical Methods. NBS Spec. Publ. 260-16 (January 1969) COM74-11062**
- Catanzaro, E. J., Champion, C. E., Garner, E. L., Marinenko, G., Sappenfield, K. M. and Shields, W. R., Standard Reference Materials: Boric Acid: Isotopic and Assay Standard Reference Materials. NBS Spec. Publ. 260-17 (February 1970) Out of Print

- Geller, S. B., Mantek, P. A., and Cleveland, N. G., Standard Reference Materials: Calibration of NBS Secondary Standard Magnetic Tape (Computer Amplitude Reference) Using the Reference Tape Amplitude Measurement "Process A." NBS Spec. Publ. 260-18 (November 1969) (See NBS Spec. Publ. 260-29.)
- Paule, R. C. and Mandel, J., Standard Reference Materials: Analysis of Interlaboratory Measurements on the Vapor Pressure of Gold (Certification of Standard Reference Material 745). NBS Spec. Publ. 260-19 (January 1970) PB190071**
- Paule, R. C. and Mandel, J., Standard Reference Materials: Analysis of Interlaboratory Measurements on the Vapor Pressures of Cadmium and Silver NBS Spec. Publ. 260-21 (January 1971) COM74-11359**
- Yakowitz, H., Fiori, C. E., and Michaelis, R. E., Standard Reference Materials: Homogeneity Characterization of Fe-3 Si Alloy. NBS Spec. Publ. 260-22 (February 1971) COM74-11357**
- Napolitano, A. and Hawkins, E. G., Standard Reference Materials: Viscosity of a Standard Borosilicate Glass. NBS Spec. Publ. 260-23 (December 1970) COM71-00157**
- Sappenfield, K. M., Marinenko, G. and Hague, J. L., Standard Reference Materials: Comparison of Redox Standards. NBS Spec. Publ. 260-24 (January 1972) COM72-50058**
- Hicho, G. E., Yakowitz, H., Rasberry, S. D., and Michaelis, R. E., Standard Reference Materials: A Standard Reference Material Containing Nominally Four Percent Austenite. NBS Spec. Publ. 260-25 (February 1971) COM74-11356**
- Martin, J. F., Standard Reference Materials: National Bureau of Standards-US Steel Corporation Joint Program for Determining Oxygen and Nitrogen in Steel. NBS Spec. Publ. 260-26 (February 1971) 85 cents* PB81176620
- Garner, E. L., Machlan, L. A., and Shields, W. R., Standard Reference Materials: Uranium Isotopic Standard Reference Materials. NBS Spec. Publ. 260-27 (April 1971) COM74-11358**
- Heinrich, K. F. J., Myklebust, R. L., Rasberry, S. D., and Michaelis, R. E., Standard Reference Materials: Preparation and Evaluation of SRM's 481 and 482 Gold-Silver and Gold-Copper Alloys for Microanalysis. NBS Spec. Publ. 260-28 (August 1971) COM71-50365**
- Geller, S. B., Standard Reference Materials: Calibration of NBS Secondary Standard Magnetic Tape (Computer Amplitude Reference) Using the Reference Tape Amplitude Measurement "Process A-Model 2". NBS Spec. Publ. 260-29 (June 1971) COM71-50282
- Gorozhanina, R. S., Freedman, A. Y., and Shaievitch, A. B. (translated by M. C. Selby), Standard Reference Materials: Standard Samples Issued in the USSR (A Translation from the Russian). NBS Spec. Publ. 260-30 (June 1971) COM71-50283**
- Hust, J. G. and Sparks, L. L., Standard Reference Materials: Thermal Conductivity of Electrolytic Iron SRM 734 from 4 to 300 K. NBS Spec. Publ. 260-31 (November 1971) COM71-50563**
- Mavrodineanu, R. and Lazar, J. W., Standard Reference Materials: Standard Quartz Cuvettes for High Accuracy Spectrophotometry. NBS Spec. Publ. 260-32 (December 1973) 55 cents* SNO03-003-01213-1
- Wagner, H. L., Standard Reference Materials: Comparison of Original and Supplemental SRM 705, Narrow Molecular Weight Distribution Polystyrene. NBS Spec. Publ. 260-33 (May 1972) COM72-50526**
- Sparks, L. L. and Hust, J. G., Standard Reference Materials: Thermoelectric Voltage. NBS Spec. Publ. 260-34 (April 1972) COM72-50371**
- Sparks, L. L. and Hust, J. G., Standard Reference Materials: Thermal Conductivity of Austenitic Stainless Steel, SRM 735 from 5 to 280 K. NBS Spec. Publ. 260-35 (April 1972) 35 cents* COM72-50368**
- Cali, J. P., Mandel, J., Moore, L. J., and Young, D. S., Standard Reference Materials: A Referee Method for the Determination of Calcium in Serum, NBS SRM 915. NBS Spec. Publ. 260-36 (May 1972) COM72-50527**
- Shultz, J. I., Bell, R. K., Rains, T. C., and Menis, O., Standard Reference Materials: Methods of Analysis of NBS Clay Standards. NBS Spec. Publ. 260-37 (June 1972) COM72-50692**

- Richmond, J. C. and Hsia, J. J., Standard Reference Materials: Preparation and Calibration of Standards of Spectral Specular Reflectance. NBS Spec. Publ. 260-38 (May 1972) COM72-50528**
- Clark, A. F., Denson, V. A., Hust J. G., and Powell, R. L., Standard Reference Materials: The Eddy Current Decay Method for Resistivity Characterization of High-Purity Metals. NBS Spec. Publ. 260-39 (May 1972) COM72-50529**
- McAdie, H. G., Garn, P. D., and Menis, O., Standard Reference Materials: Selection of Thermal Analysis Temperature Standards Through a Cooperative Study (SRM 758, 749, 760). NBS Spec. Publ. 260-40 (August 1972) COM72-50776**
- Wood, L. A. and Shouse, P. J., Standard Reference Materials: Use of Standard Light-Sensitive Paper for Calibrating Carbon Arcs Used in Testing Textiles for Colorfastness to Light. NBS Spec. Publ. 260-41 (August 1972) COM72-50775**
- Wagner, H. L. and Verdier, P. H., eds., Standard Reference Materials: The Characterization of Linear Polyethylene, SRM 1475. NBS Spec. Publ. 260-42 (September 1972) COM72-50944**
- Yakowitz, H., Ruff, A. W., and Michaelis, R. E., Standard Reference Materials: Preparation and Homogeneity Characterization of an Austenitic Iron-Chromium-Nickel Alloy. NBS Spec. Publ. 260-43 (November 1972) COM73-50760**
- Schooley, J. F., Soulen, R. J., Jr., and Evans, G. A., Jr., Standard Reference Materials: Preparation and Use of Superconductive Fixed Point Devices, SRM 767. NBS Spec. Pub. 260-44 (December 1972) COM73-50037**
- Greifer, B., Maienthal, E. J., Rains, T. C., and Rasberry, S. D., Standard Reference Materials: Powdered Lead-Based Paint, SRM 1579. NBS Spec. Publ. 260-45 (March 1973) COM73-50226**
- Hust, J. G. and Giarratano, P. J., Standard Reference Materials: Thermal Conductivity and Electrical Resistivity Standard Reference Materials: Austenitic Stainless Steel SRM's 735 and 798, from 4 to 1200 K. NBS Spec. Publ. 260-46 (March 1975) SN-003-003-01278-5
- Hust, J. G., Standard Reference Materials: Electrical Resistivity of Electrolytic Iron, SRM 797, and Austenitic Stainless Steel, SRM 798, from 5 to 280 K. NBS Spec. Publ. 260-47 (February 1974) COM74-50176**
- Mangum, B. W. and Wise, J. A., Standard Reference Materials: Description and Use of Precision Thermometers for the for the Clinical Laboratory, SRM 933 and SRM 934. NBS Spec. Publ. 260-48 (May 1974) 60 cents* SNO03-003-01278-5
- Carpenter, B. S. and Reimer, G. M., Standard Reference Materials Calibrated Glass Standards for Fission Track Use. NBS Spec. Publ. 260-49 (November 1974) COM74-51185
- Hust, J. G. and Giarratano, P. J., Standard Reference Materials: Thermal Conductivity and Electrical Resistivity Standard Reference Materials: Electrolytic Iron, SRM's 734 and 797 from 4 to 1000 K. NBS Spec. Publ. 260-50 (June 1975) \$1.00* SNO03-003-01425-7
- Mavrodineanu, R. and Baldwin, J. R., Standard Reference Materials: Glass Filters As a Standard for Spectrophotometry; Selection; Preparation; Certification; Use-SRM 930. NBS Spec. Publ. 260-51 (November 1975) \$1.90* SNO03-003-01481-8
- Hust, J. G. and Giarratano, P. J., Standard Reference Materials: Thermal Conductivity and Electrical Resistivity Standard Reference Materials 730 and 799, from 4 to 3000 K. NBS Spec. Publ. 260-52 (September 1975) \$1.05* SNO03-003-01464-8
- Durst, R. A., Standard Reference Materials: Standardization of pH Measurements. NBS Spec. Publ. 260-53 (December 1975, Revised) \$1.05 SNO03-003-01551-2
- Burke, R. W. and Mavrodineanu, R., Standard Reference Materials: Certification and Use of Acidic Potassium Dichromate Solutions as an Ultraviolet Absorbance Standard. NBS Spec. Publ. 260-54 (August 1977) \$3.00* SNO03-003-01828-7
- Ditmars, D. A., Cezairliyan, A., Ishihara, S., and Douglas, T. B., Standard Reference Materials: Enthalpy and Heat Capacity: Molybdenum SRM 781, from 273 to 2800 K. NBS Spec. Publ. 260-55 (September 1977) \$2.20* SNO03-003-01836-8
- Powell, R. L., Sparks, L. L., and Hust, J. G., Standard Reference Materials: Standard Thermocouple Materials, Pt.67: SRM 1967. NBS Spec. Publ. 260-56 (February 1978) \$2.20* SNO03-003-018864
- Cali, J. P. and Plebanski, T., Guide to United States Reference Materials. NBS Spec. Publ. 260-57 (February 1978) \$2.20* PB 277173
- Barnes, J. D. and Martin, G. M., Standard Reference Materials: Polyester Film for Oxygen Gas Transmission Measurements, SRM 1470. NBS Spec. Publ. 260-58 (June 1979) \$2.00* SNO03-003-02077

- Chang, T. and Kahn, A. H., Standard Reference Materials: Electron Paramagnetic Resonance Intensity Standard; SRM 2601. NBS Spec. Publ. 260-59 (August 1978) \$2.30* SN003-003-01975-5
- Velapoldi, R. A., Paule, R. C., Schaffer, R., Mandel, J., and Moody, J. R., Standard Reference Materials: A Reference Method for the Determination of Sodium in Serum. NBS Spec. Publ. 260-60 (August 1978) \$3.00 SN003-003-01978-0
- Verdier, P. H. and Wagner, H. L., Standard Reference Materials: The Characterization of Linear Polyethylene (SRM 1482, 1483, 1484). NBS Spec. Publ. 260-61 (December 1978) \$1.70* SN003-003-02047-8
- Soulen, R. J. and Dove, R. B., Standard Reference Materials: Temperature Reference Standard for Use Below 0.5 K (SRM 768). NBS Spec. Publ. 260-62 (April 1979) \$2.30* SN003-003-02047-8
- Velapoldi, R. A., Paule, R. C., Schaffer, R., Mandel, J., Machlan, L. A., and Gramlich, J. W., Standard Reference Materials: A Reference Method for the Determination of Potassium in Serum. NBS Spec. Publ. 260-63 (May 1979) \$3.75* SN003-003-02068
- Velapoldi, R. A. and Mielenz, K. D., Standard Reference Materials: A Fluorescence Standard Reference Material Quinine Sulfate Dihydrate (SRM 936). NBS Spec. Publ. 260-64 (January 1980) \$4.25* SN003-003-02148-2
- Marinenko, R. B., Heinrich, K. F. J., and Ruegg, F. C., Standard Reference Materials: Micro-Homogeneity Studies of NBS Standard Reference Materials, NBS Research Materials, and Other Related Samples. NBS Spec. Publ. 260-65 (September 1979) \$3.50* SN003-003-02114-1
- Venable, W. H., Jr. and Eckerle, K. L., Standard Reference Materials: Didymium Glass Filters for Calibrating the Wavelength Scale of Spectrophotometers (SRM 2009, 2010, 2013). NBS Spec. Publ. 260-66 (October 1979) \$3.50* SN003-003-02127-0
- Velapoldi, R. A., Paule, R. C., Schaffer, R., Mandel, J., Murphy, T. J., and Gramlich, J. W., Standard Reference Materials: A Reference Method for the Determination of Chloride in Serum. NBS Spec. Publ. 260-67 (November 1979) \$3.75* SN003-003-02136-9
- Mavrodineanu, R. and Baldwin, J. R., Standard Reference Materials: Metal-On-Quartz Filters as a Standard Reference Material for Spectrophotometry-SRM 2031. NBS Spec. Publ. 260-68 (April 1980) \$4.25* SN003-003-02167-9
- Velapoldi, R. A., Paule, R. C., Schaffer, R., Mandel, J., Machlan, L. A., Garner, E. L., and Rains, T. C., Standard Reference Materials: A Reference Method for the Determination of Lithium in Serum. NBS Spec. Publ. 260-69 (July 1980) \$4.25* SN003-003-02214-4
- Marinenko, R. B., Biancanello, F., Boyer, P. A., Ruff, A. W., DeRobertis, L., Standard Reference Materials: Preparation and Characterization of an Iron-Chromium-Nickel Alloy for Microanalysis. NBS Spec. Publ. 260-70 (May 1981) \$2.50* SN003-003-02328-1
- Seward, R. W. and Mavrodineanu, R., Standard Reference Materials: Summary of the Clinical Laboratory Standards Issued by the National Bureau of Standards. NBS Spec. Publ. 260-71 (November 1981) \$6.50* SN003-003-02381-7
- Reeder, D. J., Coxon, B., Enagonio, D., Christensen, R. G., Schaffer, R., Howell, B. F., Paule, R. C., and Mandel, J., Standard Reference Materials: SRM 900. Antiepilepsy Drug Level Assay Standard. NBS Spec. Publ. 260-72 (June 1981) \$4.25* SN003-003-02329-9
- Interrante, C. G. and Hicho, G. E., Standard Reference Materials: A Standard Reference Material Containing Nominally Fifteen Percent Austenite (SRM 486). NBS Spec. Publ. 260-73 (January 1982) \$2.75* SN003-003-02386-8
- Marinenko, R. B., Standard Reference Materials: Preparation and Characterization of K-411 and K-414 Mineral Glasses for Microanalysis: SRM 470. NBS Spec. Publ. 260-74 (April 1982) \$3.50 SN003-003-023-95-7
- Weidner, V. R. and Hsia, J. J., Standard Reference Materials: Preparation and Calibration of First Surface Aluminum Mirror Specular Reflectance Standards (SRM 2003a). NBS Spec. Publ. 260-75 (May 1982) \$3.75 SN003-003-023-99-0

- Hicho, G. E. and Eaton, E. E., Standard Reference Materials: A Standard Reference Material Containing Nominally Five Percent Austenite (SRM 485a). NBS Spec. Publ. 260-76 (August 1982) \$3.50 SN003-003-024-33-3
- Furukawa, G. T., Riddle, J. L., Bigge, W. G., and Pfeiffer, E. R., Standard Reference Materials: Application of Some Metal SRM's as Thermometric Fixed Points. NBS Spec. Publ. 260-77 (August 1982) \$6.00 SN003-003-024-34-1
- Hicho, G. E. and Eaton, E. E., Standard Reference Materials: Standard Reference Material Containing Nominally Thirty Percent Austenite (SRM 487). NBS Spec. Publ. 260-78 (September 1982) \$3.75 SN003-003-024-35-0
- Richmond, J. C., Hsia, J. J., Weidner, V. R., and Wilmering, D. B., Standard Reference Materials: Second Surface Mirror Standards of Specular Spectral Reflectance (SRM's 2023, 2024, 2025). NBS Spec. Publ. 260-79 (October 1982) \$4.50 SN003-003-024-47-3
- Schaffer, R., Mandel, J., Sun, T., Cohen, A., and Hertz, H. S., Standard Reference Materials: Evaluation by an ID/MS Method of the AACC Reference Method for Serum Glucose. NBS Spec. Publ. 260-80 (October 1982) \$4.75 SN003-003-024-43-1
- Burke, R. W. and Mavrodineanu, R. (NBS retired), Standard Reference Materials: Accuracy in Analytical Spectrophotometry. NBS Spec. Publ. 260-81 (April 1983) \$6.00 SN003-003-024-84-8
- Weidner, V. R., Standard Reference Materials: White Opal Glass Diffuse Spectral Reflectance Standards for the Visible Spectrum (SRM's 2015 and 2016). NBS Spec. Publ. 260-82 (April 1983). \$3.75 SN003-003-024-89-9
- Bowers, G. N., Jr., Alvarez, R., Cali, J. P. (NBS retired), Eberhardt, K. R., Reeder, D. J., Schaffer, R., Uriano, G. A., Elser, R., Ewen, L. M., McComb, R. B., Rej, R., Shaw, L. M., Standard Reference Materials: The Measurement of the Catalytic (Activity) Concentration of Seven Enzymes in NBS Human Serum SRM 909. NBS Spec. 260-83 (June 1983) \$4.50 SN003-003-024-99-6
- Gills, T. E., Seward, R. W., Collins, R. J., and Webster, W. C., Standard Reference Materials: Sampling, Materials Handling, Processing, and Packaging of NBS Sulfur in Coal Standard Reference Materials, 2682, 2683, 2684, and 2685. NBS Spec. Publ. 260-84 (August 1983) \$4.50 SN003-003-025-20-8
- Swyt, D. A., Standard Reference Materials: A Look at Techniques for the Dimensional Calibration of Standard Microscopic Particles. NBS Spec. Publ. 260-85 (September 1983) \$5.50 SN003-003-025-21-6
- Hicho, G. E. and Eaton, E. E., Standard Reference Materials: A Standard Reference Material Containing Two and One-Half Percent Austenite, SRM 488. NBS Spec. Publ. 260-86 (In Press).
- Mangum, B. W., SRM.1969: Rubidium Triple-Point Standard - A Temperature Reference Standard Near 39.30 °C. NBS Spec. Publ. 260-87 (In Press).

* Send order with remittance to Superintendent of Documents, US Government Printing Office, Washington, DC 20402. Remittance from foreign countries should include an additional one-fourth of the purchase price for postage.

**May be ordered from: National Technical Information Services (NTIS). Springfield, VA 22151.

TABLE OF CONTENTS

	PAGE
I. INTRODUCTION	1
II. EXPERIMENTAL DETAILS	5
II.1. Samples	5
II.2. Sample Holders.	5
II.3. Tests of Samples.	7
II.4. Apparatus Used in Testing	7
a. Constant-Temperature Bath	7
b. SRM 1969 Cell Holder.	9
c. Thermometers.	9
d. Temperature Measurement System.	11
III. RESULTS AND DISCUSSION	11
IV. RECOMMENDED PROCEDURE FOR USE OF SRM 1969 IN CALIBRATION OF THERMOMETERS	20
V. SUMMARY AND CONCLUSIONS.	21
VI. ACKNOWLEDGMENTS.	22
VII. REFERENCES	23

LIST OF TABLES

TABLE NO.	PAGE
I. Defining Fixed Points of the IPTS-68	2
II. Some Secondary Reference Points	3
III. Analytical Report of Rubidium Used to Fill SRM 1969 Cells. . .	6
IV. Ancillary Equipment Needed When Using SRM 1969 to Calibrate Thermometers.	20

LIST OF FIGURES

FIGURE NO.	PAGE
1. Cross-sectional drawing of SRM 1969, Rubidium Triple-Point Standard	8
2. Drawing of Plexiglas holder assembly for SRM 1969 cells	10
3. Typical melting curves for two SRM 1969 cells in an oil bath at 39.450 °C	12
4. Typical melting curves for two SRM 1969 cells in an oil bath at 39.450 °C	13
5. Melting curves for three SRM 1969 cells in an oil bath at 39.400 °C.	14
6. Histogram of the observed midpoint temperatures of 100 SRM 1969 cells.	15
7. Typical melting curves of rubidium obtained with an SRM 1969 cell in baths at three different temperatures.	17
8. Typical melting curves of rubidium obtained with an SRM 1969 cell in baths at three different temperatures.	18
9. Typical melting curves of rubidium obtained with an SRM 1969 cell in baths at three different temperatures.	19

SRM 1969: Rubidium Triple-Point Standard - A Temperature Reference
Standard Near 39.30 °C

B. W. Mangum
Center for Basic Standards
National Bureau of Standards
Washington, DC 20234

ABSTRACT

Previous work has demonstrated the practicability of using the triple point of rubidium as a temperature reference point. As a result of that work, a Standard Reference Material (SRM) has been developed. It is designated SRM 1969 - the Rubidium Triple-Point Standard. This publication reports results of an investigation of 100 SRM 1969 cells; it describes SRM 1969, the tests which were performed on the cells, the conditions under which the cells were tested, the results of the tests, and the recommended procedure for the use of SRM 1969 in calibrating thermometers. For the 100 cells, the temperatures of the midpoints of the plateaus of the melting curves ranged from 39.280 °C to 39.313 °C, with a mean value of 39.303 °C. The melting ranges of the samples varied from approximately 8 mK to approximately 24 mK, with a mean value of 14 mK. Only two cells had melting ranges greater than 20 mK, one being 21 mK and the other 24 mK. An estimated uncertainty of ± 0.010 °C is assigned to the midpoint temperatures of the plateaus of all cells except for those two cells. Thus, in using SRM 1969 cells for the calibration of thermometers, a calibration at any point on the plateau of the melting curve should provide a temperature (the value specified on the Certificate accompanying each cell) with an uncertainty no greater than ± 0.010 °C. With special care, a thermometer can be calibrated against an SRM 1969 cell to an uncertainty as small as ± 0.005 °C in the National Bureau of Standards (NBS) assigned value.

The use of these SRM 1969 rubidium triple-point temperature standards in clinical and biomedical laboratory applications should significantly enhance the accuracy of temperature measurements in the region of body temperature.

I. INTRODUCTION

Melting-point, freezing-point and triple-point temperatures of high-purity metals are widely used as temperature fixed points in high-precision thermometry.¹⁻⁴ Some fixed points serve as defining fixed points for the International Practical Temperature Scale of 1968 (IPTS-68)⁵ (see Table I) and a large number of others serve as secondary fixed points^{5,6} (see Table II for a list of some of them). Within the past few years, the melting point of gallium has been developed⁷⁻⁹ as an easy-to-use temperature fixed point for use in the clinical, biomedical and chemical laboratories, and to provide a point needed for the calibration of or for checking the calibration of thermometers.^{1,10-12}

Clinical and biomedical laboratories need temperature fixed points as references for specific tests, for calibration of thermometers, and for checking thermometers for calibration drift. The feasibility of the use of

Table I. Defining Fixed Points of the IPTS-68^a

<u>Fixed points</u>	<u>Assigned value of International Practical Temperature</u>	
	$T_{68}(\text{K})$	$t_{68}(^{\circ}\text{C})$
Triple point of equilibrium hydrogen ^b	13.81	-259.34
Boiling point of equilibrium hydrogen at a pressure of 33330.6 Pa (25/76 standard atmosphere) ^{b,c}	17.042	-256.108
Boiling point of equilibrium hydrogen ^{b,c}	20.28	-252.87
Boiling point of neon ^c	27.102	-246.048
Triple point of oxygen	54.361	-218.789
Triple point of argon ^d	83.798	-189.352
Condensation point of oxygen ^{c,d}	90.188	-182.962
Triple point of water	273.16	0.01
Boiling point of water ^e	373.15	100
Freezing point of Tin ^e	505.1181	231.9681
Freezing point of zinc	692.73	419.58
Freezing point of silver	1235.08	961.93
Freezing point of gold	1337.58	1064.43

^aExcept for the triple points and the equilibrium hydrogen point at 17.042 K, the assigned values of temperature are for equilibrium states at a pressure of 101325 Pa (1 standard atmosphere). If differing isotopic abundances could significantly affect the fixed point temperatures, the abundances are specified.

^bEquilibrium hydrogen means that the hydrogen has its equilibrium ortho-para composition at the relevant temperature. "Ortho" and "para" are the designations for the molecular configurations (nuclear spin arrangements) of hydrogen.

^cFractionation of isotopes or impurities dictate the use of boiling points (vanishingly small vapor fractions) for hydrogen and neon and condensation point (vanishingly small liquid fraction) for oxygen.

^dThe triple point of argon may be used as an alternative to the condensation point of oxygen.

^eThe freezing point of tin may be used as an alternative to the boiling point of water.

Table II. Some Secondary Reference Points

<u>Equilibrium state</u>	<u>International Practical Temperature</u>	
	$T_{68}(\text{K})$	$t_{68}(\text{°C})$
Triple point of normal hydrogen ^a	13.956	-259.194
Boiling point of normal hydrogen ^a	20.397	-252.753
Triple point of neon	24.561	-248.589
Triple point of nitrogen	63.146	-210.004
Boiling point of nitrogen	77.344	-195.806
Boiling point of argon	87.294	-185.856
Sublimation point of carbon dioxide	194.674	- 78.476
Freezing point of mercury	234.314	- 38.836
Ice point ^b	273.15	0
Triple point of phenoxybenzene (diphenyl ether)	300.02	26.87
Melting point of gallium	302.922	29.772
Triple point of gallium	302.924	29.774
Triple point of benzoic acid	395.52	122.37
Freezing point of indium	429.784	156.634
Freezing point of bismuth	544.592	271.442
Freezing point of cadmium	594.258	321.108
Freezing point of lead	600.652	327.502
Boiling point of mercury	629.81	356.66
Boiling point of sulfur	717.824	444.674
Melting point of the copper-aluminum eutectic	821.41	548.26
Freezing point of antimony	903.905	630.755
Freezing point of aluminum	933.61	660.46
Freezing point of copper	1358.03	1084.88
Freezing point of nickel	1728	1455
Freezing point of cobalt	1768	1495
Freezing point of palladium	1827	1554
Freezing point of platinum	2042	1769
Freezing point of rhodium	2236	1963

(continued)

Table II. Some Secondary Reference Points (cont'd)

<u>Equilibrium state</u>	<u>International Practical Temperature</u>	
	$T_{68}(\text{K})$	$t_{68}(\text{°C})$
Melting point of aluminum oxide	2327	2054
Freezing point of iridium	2720	2447
Melting point of niobium	2750	2477
Melting point of molybdenum	2896	2623
Melting point of tungsten	3695	3422

^aNormal hydrogen is a mixture of 75% orthohydrogen and 25% parahydrogen.

^bThe ice point is a very close approximation to the temperature defined as being 0.01 K below the triple point of water.

the triple-point temperature of rubidium as a temperature reference point near body temperature has been investigated previously by us¹³ and others¹⁴. We found¹³ that it would meet the need for such a reference point, although the uncertainty in the definition of its triple point is considerably greater than that of some other metals, e.g., gallium¹. The uncertainty is, nevertheless, not so great as to make the triple-point temperature of rubidium unsuitable as a reference point, particularly if each cell is measured and the reference temperature is certified, as is the case for SRM 1969.

Based on our previous work¹³, we have now developed a rubidium triple-point Standard Reference Material (SRM). It is designated SRM 1969 - the Rubidium Triple-Point Standard - and it is available from the Office of Standard Reference Materials of the National Bureau of Standards (NBS). Provided that care is exercised in using these SRM devices, the user can confidently expect to achieve a calibration point near 39.30 °C for which the uncertainty is no greater than ± 0.010 °C. The most reproducible point of the melting curve for calibration work is the midpoint temperature of the plateau. Since the variation of this temperature among the SRM 1969 cells is larger than either the irreproducibility of the midpoint temperature of any given cell or the melting ranges of the samples in the cells, each SRM 1969 is accompanied by a calibration certificate, which includes the value of the midpoint temperature and a copy of the melting curve of the sample, as obtained at NBS.

The remainder of this publication describes SRM 1969, the tests performed on the SRM 1969 cells, the conditions under which the cells were tested, the results obtained from testing 100 SRM 1969 cells, and the recommended procedure for using the cells in calibration work.

II. EXPERIMENTAL DETAILS

II.1. Samples

The rubidium used in preparing SRM 1969 was supplied by MSA Research Corporation. All cells were prepared from the same lot of material, which was stated by the supplier to be 99.9+% pure rubidium; the emission spectroscopic analysis (provided by MSA Research Corporation) of that material is given in Table III. Although the rubidium used in preparing the SRM 1969 was taken from the same lot of material and presumably had the same chemical composition, the SRM 1969 stainless-steel containers themselves may have contaminated the rubidium put into them and by different amounts. This would be reflected in the triple-point temperature and also in the melting range of each cell. Preliminary measurements on the SRM 1969 cells indicated that the plateaus of their melting curves occurred over a range of temperatures which was considerably greater than the irreproducibility of any given cell, and this made it necessary to test the melting behavior of each cell so that a certificate could be provided for it.

II.2. Sample Holders

The Type 304 stainless-steel containers were fabricated and filled with the 99.9+% pure rubidium by MSA Research Corporation. The containers are of

Table III. Analytical Report of Rubidium Used to Fill SRM 1969 Cells

Type of Material Rubidium Lot No. D-447-980-1

Grade of Material High Purity

<u>Element</u>	<u>ppm</u>	<u>Element</u>	<u>ppm</u>	<u>Element</u>	<u>ppm</u>
Fe	-5	Cr	-5	Sr	-1
B	-5	Si	-5	Ba	-3
Co	-5	Ti	-5	Ca	1
Mn	-1	Ni	-5		
Al	-5	Mo	-5	Na	-5
Mg	-2	V	-5	K	-5
Sn	-5	Be	-1	Rb	Balance
Cu	-2	Ag	-1	Cs	700
Pb	-5	Zr	-10	O ₂	
				C	

Remarks: The prefix - indicates less than.

Metallic impurity levels reflect analysis of the chloride form of the metal.

Reference: Emission Spec Analysis - NUMEC Plate No. 12850-51-63

an all-welded construction and their dimensions are as indicated in Figure 1. They were thoroughly cleaned, evacuated and then baked to remove adsorbed oxygen and other volatile materials. While under vacuum and at a temperature above the melting point of rubidium, the cells were completely filled with liquid rubidium and the stainless-steel bellows valve of each cell was then tightly closed. The rubidium in the tube above the valve was removed and the tube sealed with a stainless-steel plug in an argon atmosphere. Each cell contains approximately 154 g of rubidium. The plug should not be removed nor should the valve be opened. Extreme caution is essential in handling rubidium. Rubidium ignites on contact with air and reacts violently with water, the liberated hydrogen being burned simultaneously. Consequently, the valve must be kept closed and the plug in place.

II.3. Tests of Samples

The melting behavior of each SRM 1969 cell was determined in a well-stirred constant-temperature oil bath at a temperature of 39.450 °C. This temperature was selected for testing after obtaining melting curves of several samples at 39.400 °C, 39.450 °C, 39.500 °C and 39.700 °C.

Prior to the beginning of the melting of the rubidium in each of the SRM 1969 cells, calibrated thermistor thermometers were inserted into the thermometer wells of the cells while the cells were in air at about 22 °C. The thermometers were positioned such that they rested on the bottom of the well. The cells containing the thermometers were then placed in plastic cell holders located in the oil bath. Measurements of the temperatures with the thermistor thermometers were then begun, and measurements continued to be made every four minutes until most, or all, of the rubidium had melted. This process was repeated at least once for each SRM 1969 cell. The temperature of the mid-point of the plateau of the melting curves, which is specified on the SRM Certificate as the temperature calibration point, was obtained from these melting experiments. Reproductions of the melting curves are provided as part of the SRM certificates.

The freezing behavior of several cells was obtained by placing them, containing the thermistor thermometers, in an oil bath maintained at 39.100 °C. The cells were held in the bath by plastic cell holders. Prior to putting the cells in the 39.100 °C bath, the rubidium samples had been totally melted by placing the cells in an oil bath at about 70 °C, and leaving them there until they reached the bath temperature, as indicated by a small platinum resistance thermometer.

II.4. Apparatus Used in Testing

a. Constant-Temperature Bath

The constant-temperature bath used for all of the melting and freezing experiments on the SRM 1969 cells was a commercially available bath having a volume of about 14 liters. A low-viscosity oil (a dimethylpolysiloxane) was used as the bath fluid. The temperature of the oil bath was maintained at the selected values to within ± 0.002 °C by means of a commercially available proportional controller, using a thermistor as the sensor. Compressed air, which passed through a heat exchanger (located in an ice bath) before entering

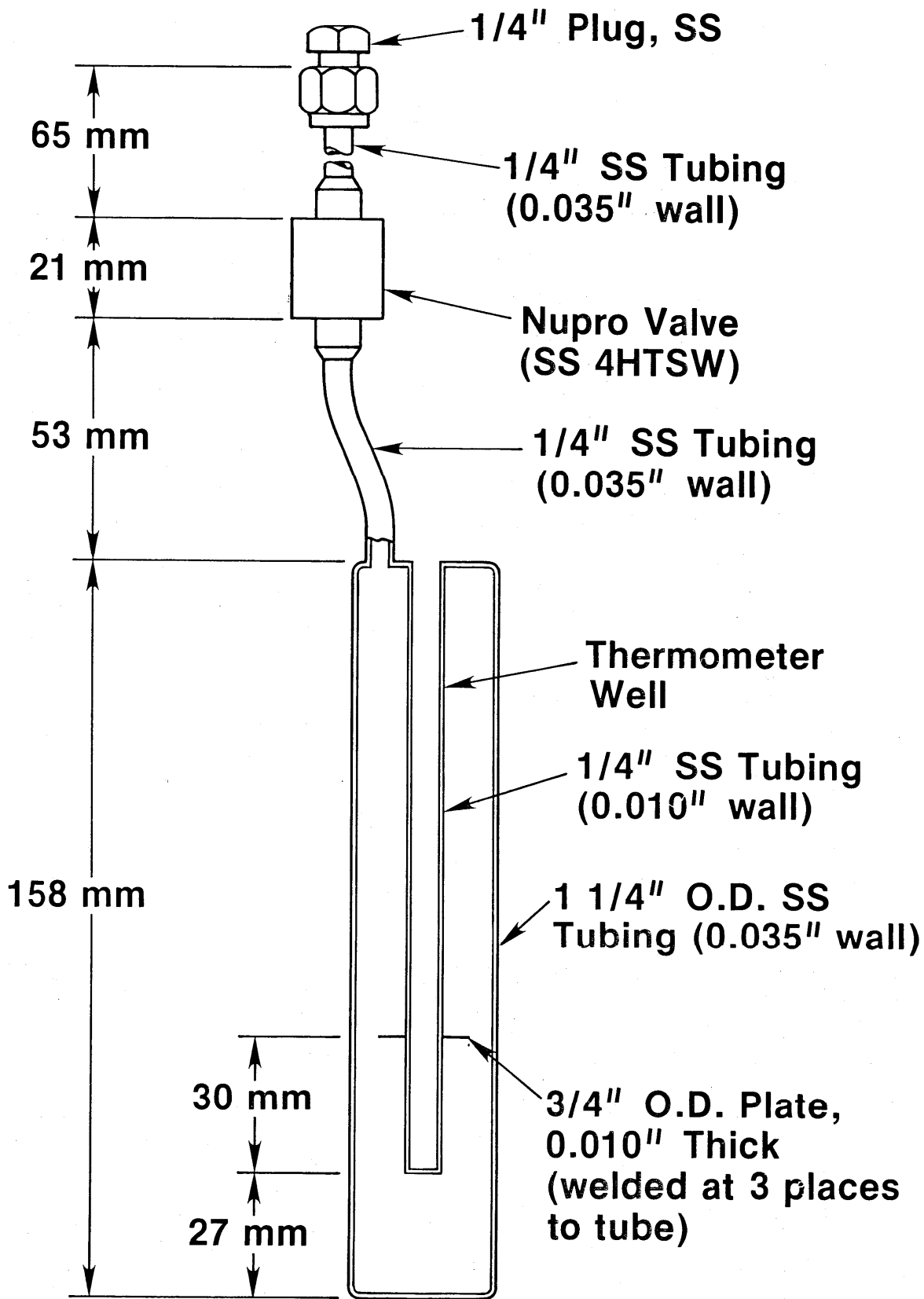

Figure 1. Cross-sectional drawing of SRM 1969, Rubidium Triple-Point Standard.

the bath cooling coil, was used to provide the requisite cooling. Although the temperature of the oil bath was maintained within ± 0.002 °C of the temperature selected for a melting or freezing experiment for the duration of the experiment, such precise control is not necessary in the normal use of SRM 1969. This will become evident in Section III and is indicated graphically by the figures of that section.

b. SRM 1969 Cell Holder

Holder for the rubidium SRM 1969 cells, shown in Figure 2, were constructed of Plexiglas tubes attached to a Plexiglas base plate (attached by using a glue made by dissolving Plexiglas in dichloromethane). This assembly was suspended in the constant-temperature oil bath from a Plexiglas top plate by means of three Plexiglas rods. Holes were drilled in the base plate, as shown in Figure 2, to permit oil flow around the cells. The cell holders were immersed sufficiently deep in the bath oil that the tops of the stainless-steel plugs on the tops of the SRM 1969 cells were about 2 cm below the top surface of the oil. All immersion problems then were negligible and temperature gradients along the cells were minimized (except at the boundary where the cells extended from the cell holders). The cell holders (i.e., the Plexiglas tubes) provided some slight insulation around the bottom 5 cm of the cells and this caused the duration of the melts to be somewhat greater than it would have been if the oil were constantly flowing over the entire cell. Plexiglas tubes which covered more of the cells could have been used to further extend the duration of the melt, but this would have caused an undue amount of time to be spent in testing the cells.

c. Thermometers

The thermometers used in this investigation were bead-in-glass probe-type thermistor thermometers^{15,16} which had been calibrated over the temperature range from 0 °C to 70 °C against a standard platinum resistance thermometer¹⁷ (SPRT) in a temperature-regulated oil bath. The thermistor thermometers and the SPRT were located in adjacent wells of a copper block in the oil bath during the calibration. This insured temperature equilibrium among the thermometers and also damped any sudden temperature fluctuations. Measurements of the SPRT resistances were made with an ac resistance bridge.¹⁸ The SPRT had been calibrated previously by the NBS Platinum Resistance Thermometer Calibration Laboratory using the same ac bridge. Fluctuations in temperature during calibrations at a given calibration temperature, as measured by the SPRT, were about ± 0.1 mK. The uncertainty in the resistance measurements of the thermistor thermometers corresponded to about ± 0.25 mK. By fitting the equation

$$1/T = A + B \log R + C(\log R)^2 + D(\log R)^3$$

where T is the temperature in kelvins and R is the thermistor resistance in Ohms, to the calibration data, the constants A, B, C and D were determined. The temperature value then derived from this equation for a measured thermistor-thermometer resistance agreed with that measured with the SPRT to within ± 1 mK.

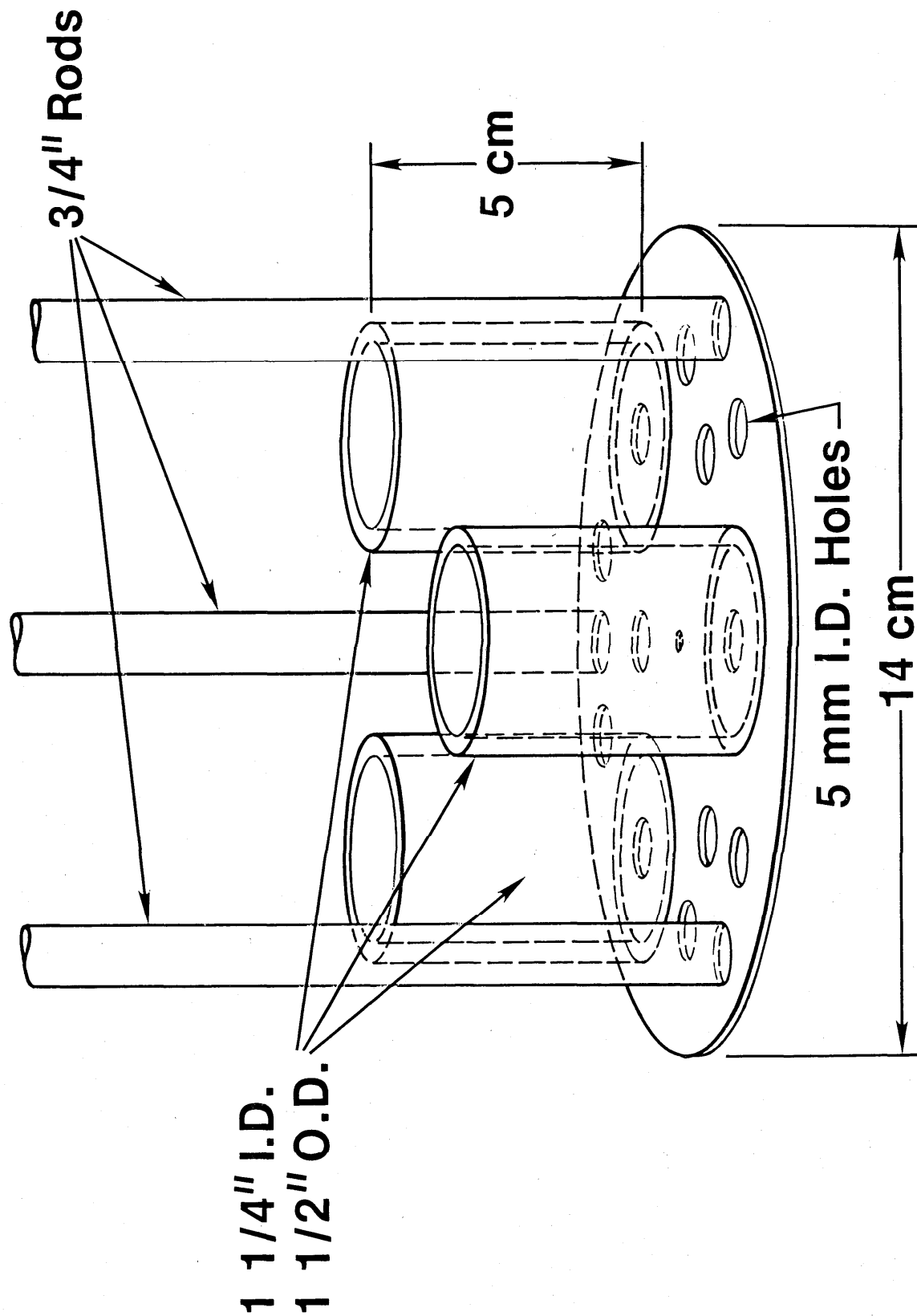

Figure 2. Drawing of Plexiglas holder assembly for SRM 1969 cells.

d. Temperature Measurement System

The temperature measurement system used in testing the SRM 1969 cells was an automated system consisting of a microcomputer, a 6-1/2-digit digital voltmeter, a constant-current source, a standard resistor, and the calibrated thermistor thermometers.

III. RESULTS AND DISCUSSION

Some typical melting curves are shown in Figures 3, 4, and 5. Included in these figures are melting curves of some of the samples having the lowest and the highest midpoint melting temperatures. The two curves of Figure 3(a) represent the melting behavior and the reproducibility of that behavior for a single sample. Similar data for three other samples are presented in Figures 3(b), 4(a) and 4(b). Three melting curves of one sample are shown in Figure 4(b). The melting curves of most of the samples (about 70 of them) exhibit an initial behavior such as that shown in Figure 3(a), i.e., the initial rise in temperature to a fairly broad peak. This peak is attributed to the hot bath oil which flowed into the thermometer well of the cell when the cell was placed in the oil bath for melting. After some time, temperature equilibrium was reached as the rubidium melted. The temperature in the well decreased slightly as equilibrium was approached. Following the peak, the temperature was rather constant for a time before increasing relatively rapidly. The latter temperature rise is typical behavior of samples melting when perhaps 75% of the sample has melted and the remaining solid is at or near the bottom part of the cell. The top part of the sample, which was liquid, was warming from effects of the bath and the sample's finite thermal conductivity, and the thermometer was beginning to sense the bath. When all of the sample had melted, the sample temperature rose exponentially to the bath temperature. All of these features of melting are depicted in Figure 5, which has curves which represent the melting behavior of three samples of rubidium. Note the rapid temperature rise of the samples to the bath temperature after all of the solid had melted. Also note the good agreement of the melting curves of these three samples.

Although the melting-point temperature of a sample is the temperature at the liquidus point, the position along the melting curve that is most reproducible and, consequently, most useful for calibration purposes is not at the liquidus point but at or in the region of a point approximately midway along the plateau of the melting curve (i.e., in the vicinity of a point approximately midway between the liquidus and the solidus points). In the region of that point, which we will call the midpoint temperature, the curve is most flat and any small changes in the fraction of material melted has only a small effect on the liquid-solid equilibrium temperature. The Certificate gives the value of the midpoint temperature. The reproducibility of the melting curves for each of the 100 SRM 1969 cells is rather good. For the worst case, the spread in the values of the temperature at the midpoints of the plateaus of the melting curves of that sample was less than 10 mK. The spread was 1 mK to 3 mK for most of the cells.

The distribution of midpoint temperatures for the 100 cells is shown in Figure 6. The mean value of the midpoint temperatures is 39.303 °C and the

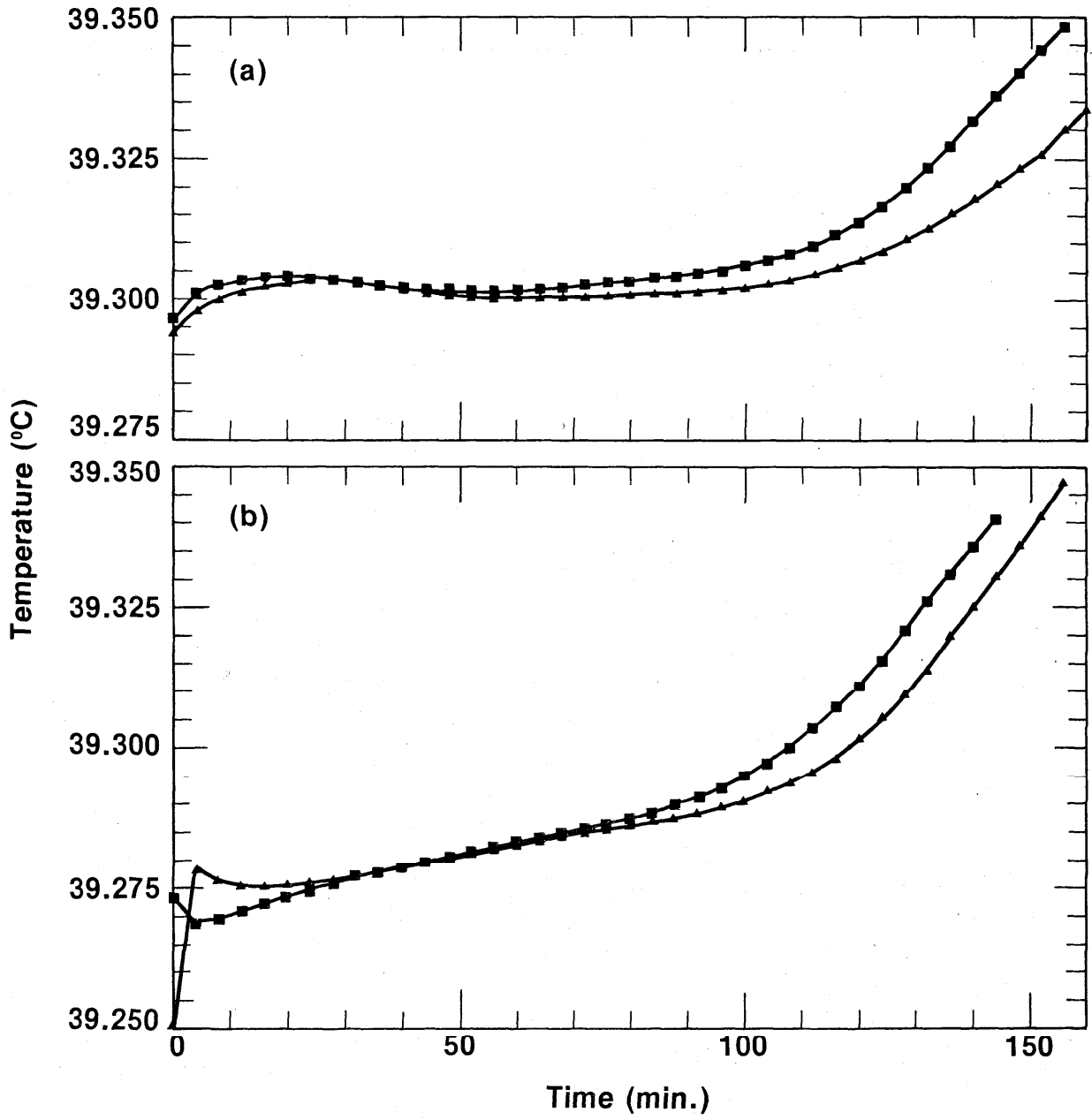

Figure 3. Typical melting curves for two SRM 1969 cells in an oil bath at 39.450 °C. The two curves in (a) are for one cell; the two curves in (b) are for another cell.

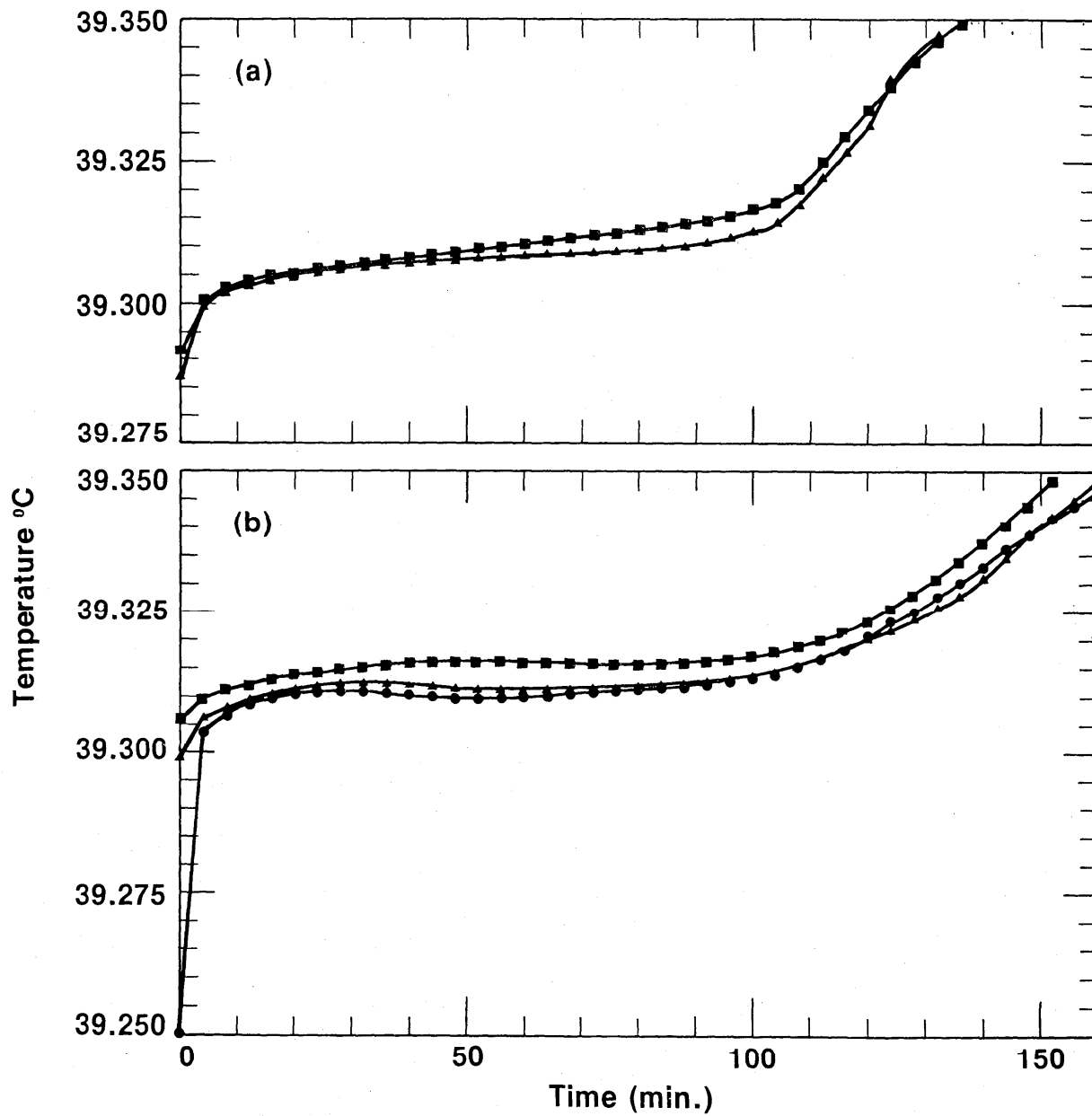

Figure 4. Typical melting curves for two SRM 1969 cells in an oil bath at 39.450 °C. The two curves in (a) are for one cell and the three curves in (b) are for another cell.

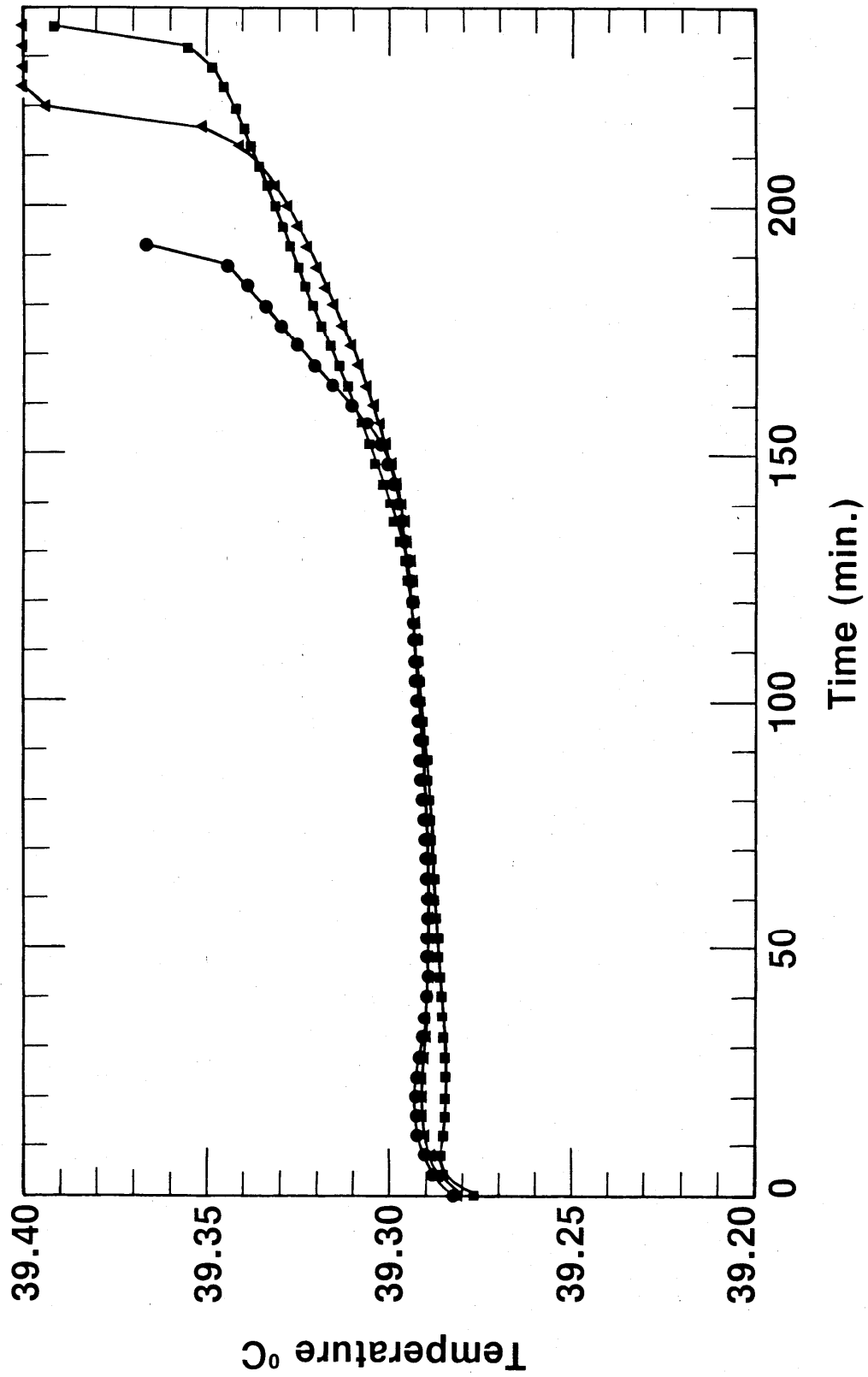

Figure 5. Melting curves for three SRM 1969 cells in an oil bath at 39.400 °C.

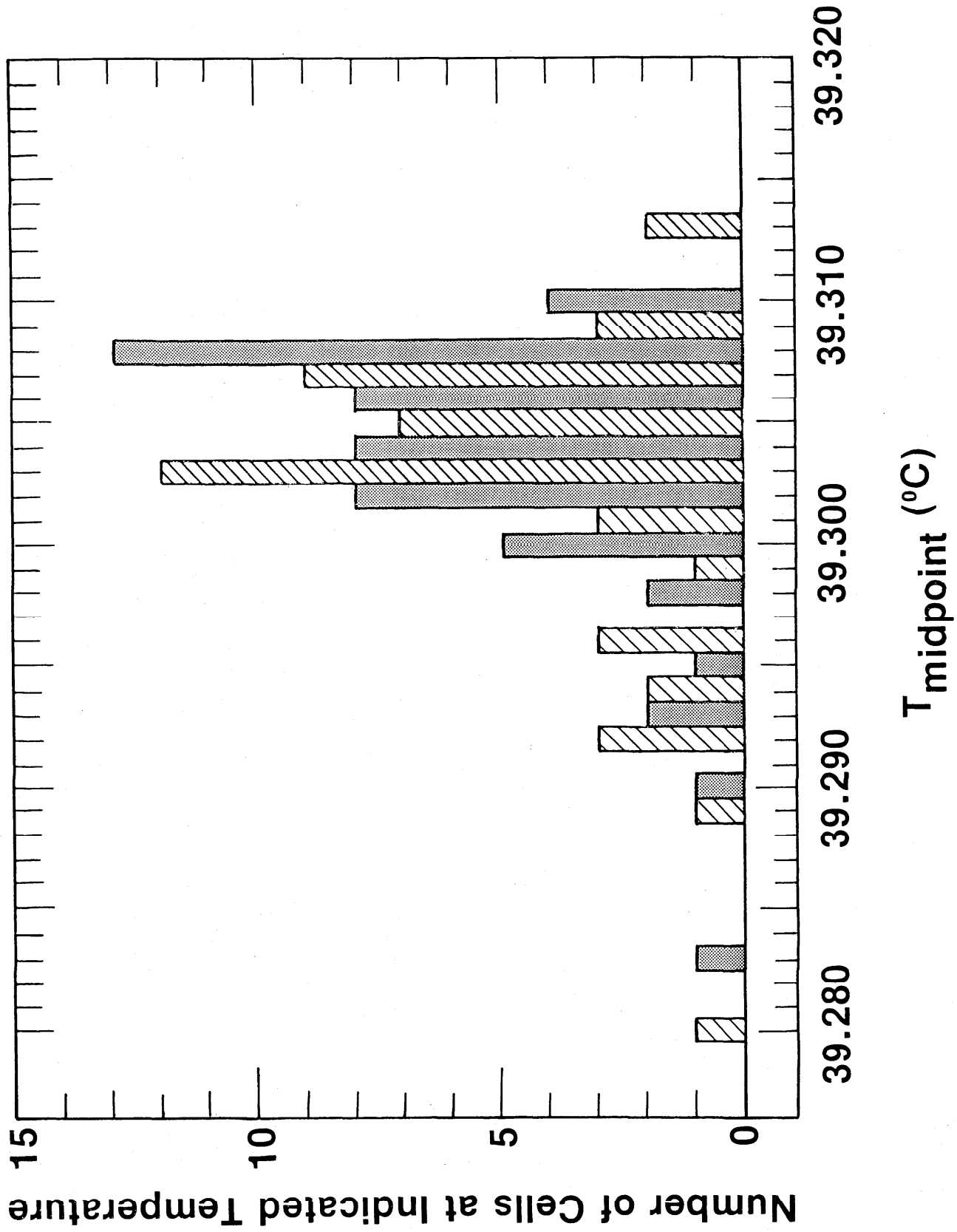

Figure 6. Histogram of the observed midpoint temperatures of the 100 SRM 1969 cells.

median value is 39.305 °C. The highest midpoint temperature was 39.313 °C and the lowest was 39.280 °C, there being a total spread of 0.033 °C in the midpoint temperatures for the 100 cells.

The melting range of a sample, as well as its melting point, is an indication of the purity of the sample, the smaller the range, the higher the purity. For the 100 SRM 1969 cells tested, the melting ranges varied from 8 mK to 24 mK, with a mean value of 14 mK. This is an indication that the rubidium samples comprising the 100 cells of SRM 1969 have a higher purity than the samples tested previously.¹³ Higher melting-point temperatures for the SRM 1969 cells indicate higher purity also.

The duration of a melt for any given sample (which requires a fixed quantity of heat for fusion) depends on the difference between the temperature of the environment of the cell and the melting-point temperature. Results obtained during melting of three samples in oil baths at three different temperatures are shown in Figures 7, 8 and 9. The bath temperatures for these experiments were 39.400 °C, 39.500 °C and 39.700 °C, giving temperature differences of approximately 0.11 °C, 0.21 °C, and 0.41 °C, respectively. Although there is some scatter in the midpoint temperatures of the plateaus, it is not large, the spread being approximately 3 mK for the sample of Figure 7, approximately 2 mK for the sample of Figure 8, and approximately 6 mK for the sample of Figure 9. One can see from Figures 7, 8 and 9 that, when a cell was placed in a bath maintained constant at 39.400 °C, the temperature in the well of the cell was at the plateau of the melting curve for about 2 hours. That was the amount of time available for calibrating a thermometer with those cells. Over a span of 2 hours from the time the cells were placed in the 39.400 °C bath, the maximum change in the observed temperature of either of these three cells was about 9 mK (Figure 7). The changes were about 5 mK for the cells of Figures 8 and 9. Consequently, if one had calibrated a thermometer or thermometers in either of these three cells and assumed the cell temperature to be the midpoint temperature, the maximum error incurred would have been no greater than 6 mK.

When the three samples of Figures 7, 8 and 9, as well as the other 97 SRM 1969 cells, were placed in a bath at 39.450 °C and held in holders as shown in Figure 2, the amount of time that the temperature in the well of any given cell was at the plateau of the melting curve was reduced to about 100 minutes. This, then, is the amount of time available for calibrating thermometers with the SRM 1969 cells when the cells are used in the manner just indicated. If the SRM 1969 cells are placed in baths at temperatures other than the four reported here, the length of time that the temperatures of the samples are at the plateaus of the melting curves, and, thus, the cells are at the temperatures for calibrating thermometers, can be estimated from the curves of Figure 7, 8 or 9.

The uncertainties in the temperatures measured in our experiments were estimated as follows. The resolution of the thermistor thermometer system was approximately ± 0.0001 °C, and the overall statistical uncertainty in the temperatures measured with that system was estimated to be approximately ± 0.00025 °C. There is a systematic uncertainty of approximately ± 0.0006 °C relative to the IPTS-68, due to the calibration¹⁷ of SPRTs and the fact that the platinum elements are "real" (as opposed to theoretically performing) materials.¹ The errors due to differences in self-heating in the calibrations and in the experiments, and those due to immersion of the thermistors are

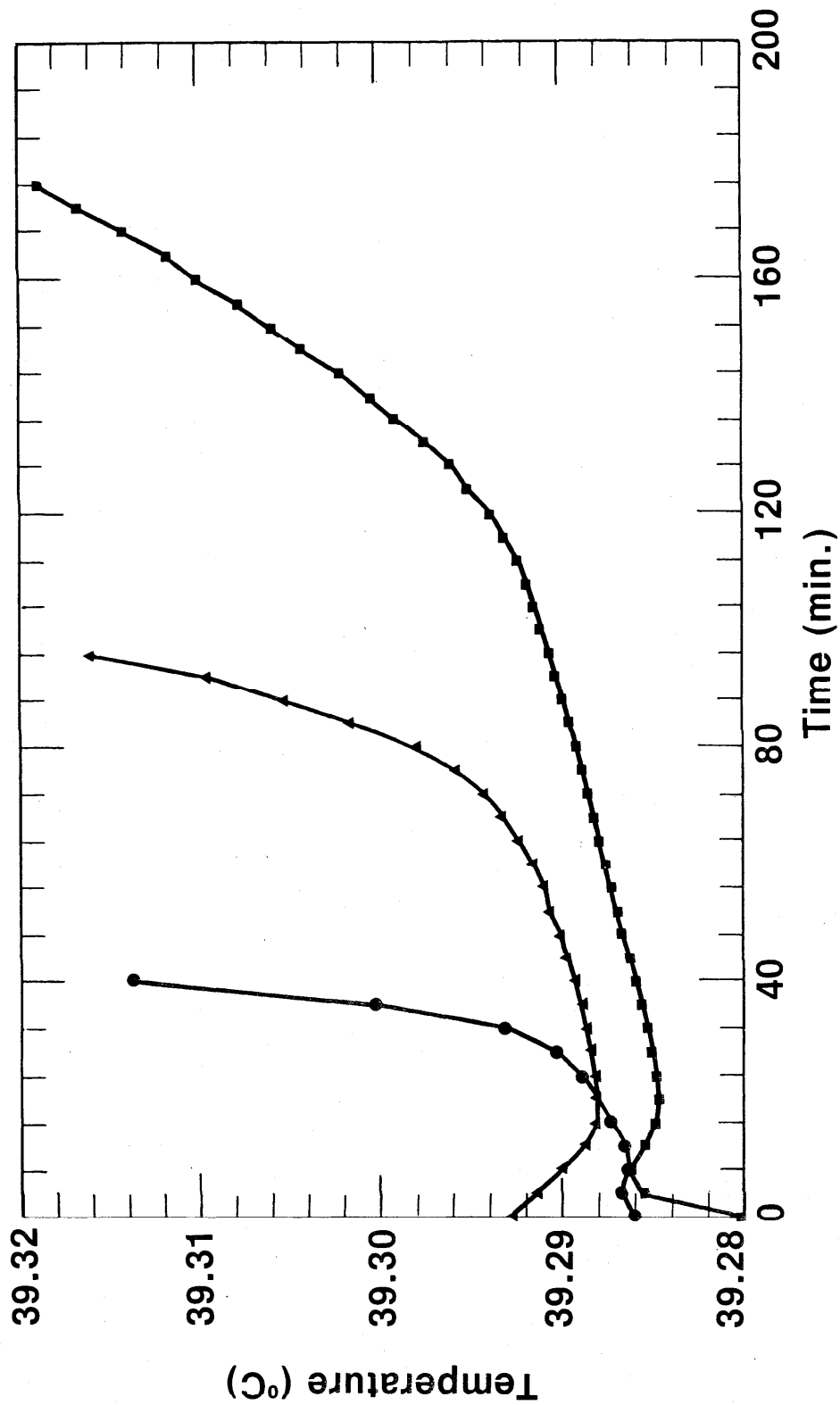

Figure 7. Typical melting curves of rubidium obtained with an SRM 1969 cell in baths at three different temperatures. ■ represents data obtained in a bath at 39.400 °C; ▲ represents data obtained in a bath at 39.500 °C; ● represents data obtained in a bath at 39.700 °C.

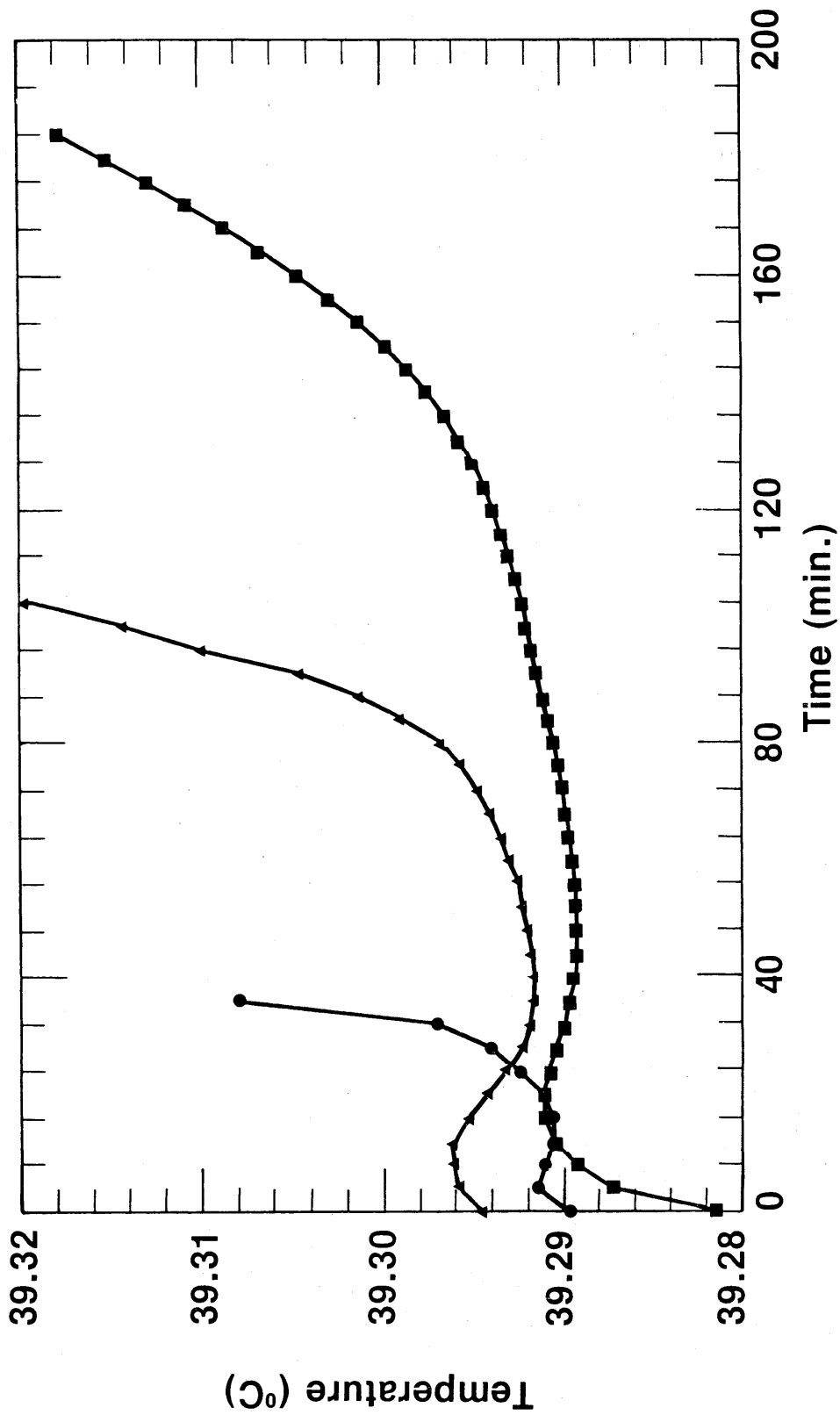

Figure 8. Typical melting curves of rubidium obtained with an SRM 1969 cell in baths at three different temperatures. ■ represents data obtained in a bath at 39.400 °C; ▲ represents data obtained in a bath at 39.500 °C; ● represents data obtained in a bath at 39.700 °C.

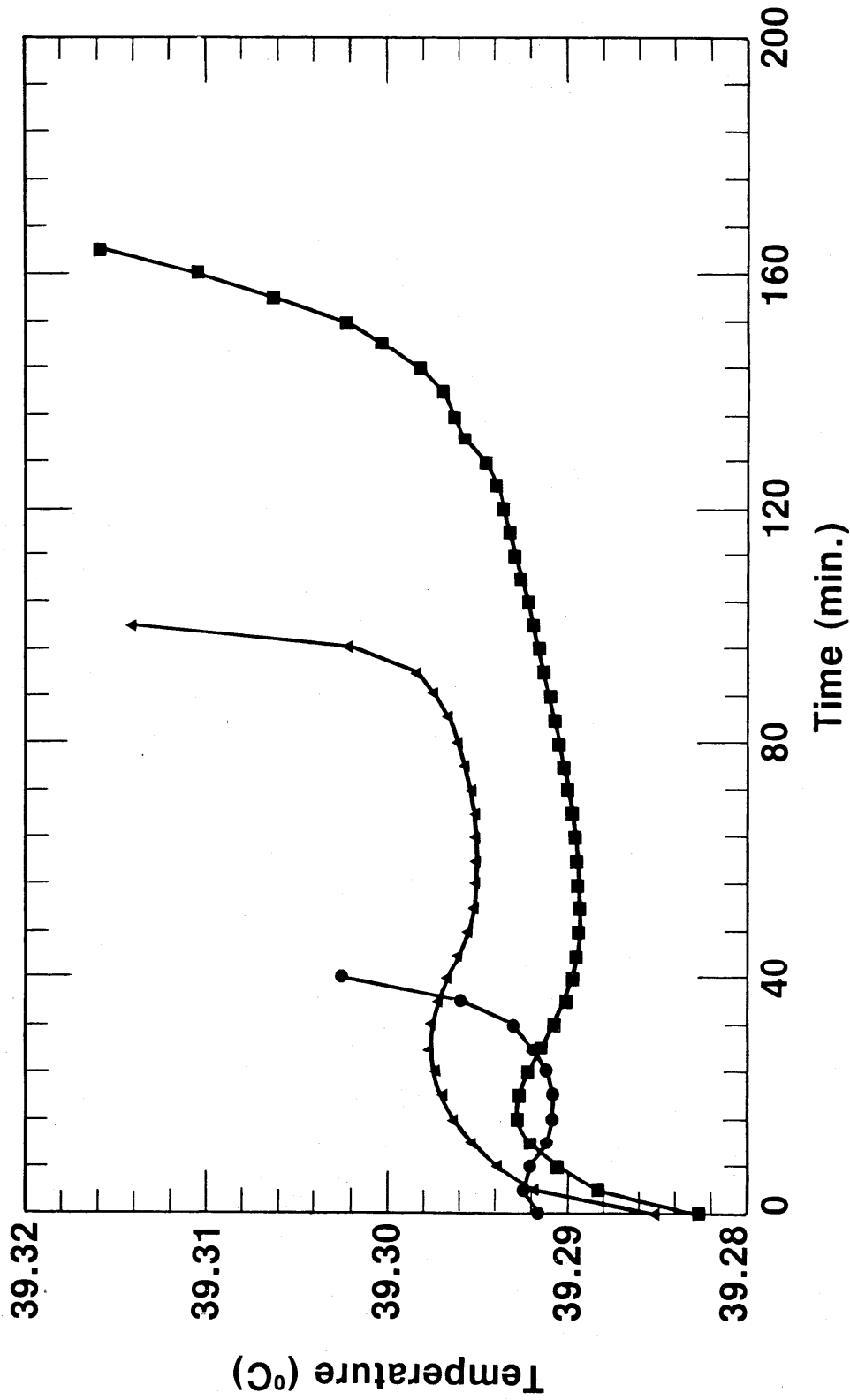

Figure 9. Typical melting curves of rubidium obtained with an SRM 1969 cell in baths at three different temperatures. ■ represents data obtained in a bath at 39.400 °C; ▲ represents data obtained in a bath at 39.500 °C; ● represents data obtained in a bath at 39.700 °C.

negligible. Thus, the total uncertainty in our determination of temperatures on the IPTS-68 with the thermistor thermometers was about ± 0.0015 °C.

IV. RECOMMENDED PROCEDURE FOR USE OF SRM 1969 IN CALIBRATION OF THERMOMETERS

To obtain the best results in the calibration of thermometers using SRM 1969, the rubidium cells must be totally immersed in a well-stirred fluid bath (preferably a light purified mineral oil) maintained at 39.45 ± 0.05 °C. Since the SRM 1969 cells are approximately 30 cm long, a fluid bath somewhat deeper than 30 cm should be used for the calibration. The cell or cells should be mounted in a holder such as that shown in Figure 2 (which holds 3 cells). If only one cell is being used, then a holder similar to that shown in Figure 2, but modified to hold only one cell, could be used (such a holder is provided with each SRM 1969 cell). As described in Section II, the cell holders are easy to construct. A tabulation of the equipment which is needed to obtain the best results when using SRM 1969 in the calibration of thermometers is given in Table IV.

Table IV. Ancillary equipment needed when using SRM 1969 to calibrate thermometers.

Well-stirred fluid (oil) bath, approximately 32 cm in depth from top of fluid surface.

Light purified mineral oil for the bath.

Temperature controller (± 0.02 °C preferably, but could use ± 0.05 °C).

SRM 1969 holder (e.g., Plexiglas), such as provided with the cell.

Means of suspending SRM 1969 holder in the bath (e.g., Plexiglas rods attached to a bath cover plate, which could be Plexiglas also).

Thermometer(s) to be calibrated (diameter less than 5 mm).

The preferred procedure for calibrating a thermometer through the use of an SRM 1969 rubidium triple-point cell is as follows. First, get the well-stirred oil bath to a temperature of 39.45 ± 0.05 °C and maintain it at that point. Put the thermometer to be calibrated in the thermometer well of the SRM 1969 cell (which has previously been placed in the Plexiglas holder). Next, place (suspend) the cell holder, with the SRM cell and thermometer, in the temperature-controlled oil bath. Wait 10 to 15 minutes, then read the indication of the thermometer being calibrated. The correct temperature of the thermometer is the value indicated on the certificate for the particular SRM 1969 cell being used for the calibration. If other thermometers are to be calibrated, they may then be placed successively in the thermometer well of the SRM cell. There should be a minimum time of about 70 minutes available for calibration from the time the cell was placed in the oil bath. If more than one thermometer is to be calibrated, the second and succeeding thermometers should be allowed 5 to 10 minutes time to reach temperature equilibrium with the melting rubidium in the cell before performing the calibration. The smaller the mass of a thermometer, the shorter the length of time required for equilibration.

After the calibrations have been completed, or if the length of time that the SRM cell has been in the bath is approaching that value at which the temperature is near the end of the plateau region, remove the cell from the oil bath and permit it to cool. The rubidium will freeze fairly rapidly and the cell will be ready within 10 to 15 minutes to put back into the oil for further calibration work. This melting and freezing process may be repeated as often as required.

V. SUMMARY AND CONCLUSIONS

In testing 100 SRM 1969 rubidium triple-point cells, we have found that the samples in the different cells were not of uniform purity, although the rubidium metal used to fill the cells was taken from only one lot of material. Either the rubidium became slightly contaminated during filling or by the presence of different amounts of contaminants in the cells themselves.

The total range of the temperatures of the midpoints of the plateaus of the melting curves was from 39.280 °C to 39.313 °C, or a spread of 0.033 °C, with a mean value of 39.303 °C. The melting ranges of the samples varied from approximately 8 mK to approximately 24 mK among the cells, with a mean value of 14 mK. Only 2 cells had a melting range greater than 20 mK, one being 21 mK and the other 24 mK. Thus, with the exception of those two cells, an estimated uncertainty of ± 0.010 °C in the midpoint temperature of the plateau of the melting curve of each SRM 1969 cell will encompass the entire melting range of each cell. Since the value of the midpoint temperature and a copy of the melting curve will be provided with each of the SRM 1969 cells, the user will be able to calibrate thermometers easily at the rubidium point to an uncertainty no greater than ± 0.010 °C.

If the entire melting curve of an SRM 1969 cell is obtained with a thermometer to be calibrated and if the midpoint of the plateau of that curve is used as the reference, it is possible for a user to calibrate that thermometer to an uncertainty that is no greater than ± 0.005 °C. For a pure material with infinite thermal conductivity and no supercooling, the plateau

is perfectly flat throughout the liquid-solid transition. For a slightly impure material that has a finite thermal conductivity, however, the plateau will not be flat and the material will have a finite melting range.⁸ The midpoint of that range is the point of reference here and the thermometer indication at that point of the plateau, rather than that at some arbitrarily selected point anywhere along the plateau, is the value to be used in the calibration. The temperature value in the vicinity of that midpoint is the temperature specified on the calibration certificate for that particular SRM. Thus, by ensuring that a thermometer is calibrated at the same, or very nearly the same, position on the melting curve of an SRM 1969 cell as that determined by NBS, rather than at just any position within the melting range, the uncertainty of calibration can be reduced to ± 0.005 °C.

In conclusion, by following the procedure outlined in Section IV, the user of SRM 1969 will be able to quickly and easily realize the rubidium triple-point temperature and use that to calibrate his thermometers. The calibration procedure is straightforward and does not require the use of complicated and expensive apparatus or the expertise of trained workers. The calibration point provided by any one of the SRM 1969 cells is at an important value for clinical laboratory applications, for use in hyperthermia applications, for use with clinical (fever) thermometers, and for general laboratory calibrations. Through the use of these devices, the accuracy of temperature measurements in this region of temperature should be significantly enhanced.

VI. ACKNOWLEDGMENTS

The partial financial support by the Office of Standard Reference Materials for some of the work leading to the development of SRM 1969 is gratefully acknowledged.

DISCLAIMER

In order to describe materials and experimental procedures adequately, it was occasionally necessary to identify commercial products by the manufacturer's name or label. In no instances does such identification imply endorsement by the National Bureau of Standards nor does it imply that the particular products or equipment are necessarily the best available for that purpose.

VII. REFERENCES

1. B. W. Mangum and D. D. Thornton, Determination of the Triple-Point Temperature of Gallium; *Metrologia* 15, 201-215 (1979).
2. G. T. Furukawa, J. L. Riddle, W. R. Bigge and E. R. Pfeiffer, Application of Some Metal SRM's as Thermometric Fixed Points. NBS Special Publication 260-77, August 1982, Superintendent of Documents, U. S. Government Printing Office, Washington, DC 20402.
3. E. H. McLaren, The Freezing Points of High Purity Metals as Precision Temperature Standards, in American Institute of Physics, Temperature, Its Measurement and Control in Science and Industry, (Reinhold Publishing Corp., New York, NY, 1962), Vol. 3, Part 1, pp. 185-198.
4. E. H. McLaren and E. G. Murdock, The Freezing Points of High Purity Metals as Precision Temperature Standards. V., Thermal analysis on 10 Samples of Tin with Purities Greater than 99.99+ Percent. *Can. J. Phys.* 38, 100-118 (1960).
5. The International Practical Temperature Scale of 1968, Amended Edition of 1975. *Metrologia* 12, 7-17 (1976).
6. Procès Verbaux du CCT, Document No. CCT/82-31, 1982; also, Procès Verbaux du CCT, Document No. CCT/80-12, 1980.
7. D. D. Thornton and B. W. Mangum, Procès Verbaux du CCT, Document No. CCT/76-13, 1976.
8. B. W. Mangum and D. D. Thornton, Editors, The Gallium Melting Point Standard. NBS Special Publication 481, June 1977, Superintendent of Documents, U. S. Government Printing Office, Washington, DC 20402.
9. H. E. Sostman, Melting Point of Gallium as a Temperature Calibration Standard, *Rev. Sci. Instrum.* 48, 127-130 (1977).
10. B. W. Mangum, Triple Point of Gallium as a Temperature Fixed Point, in Temperature, Its Measurement and Control in Science and Industry, (American Institute of Physics, New York, NY, 1982), Vol. 5, pp. 299-309.
11. M. V. Chattle, R. L. Rusby, G. Bonnier, A. Moser, E. Renaot, P. Marcarino, G. Bongiovanni and G. Frassinetti, An Intercomparison of Gallium Fixed Point Cells, in Temperature, Its Measurement and Control in Science and Industry, (American Institute of Physics, New York, NY, 1982), Vol. 5, pp. 311-316.
12. J. Bonhoure et R. Pello, Température du Point Triple du Gallium. *Metrologia* 19, 15-20 (1983).

13. J. M. Figueroa and B. W. Mangum, The Triple Point of Rubidium: A Temperature Fixed Point for Biomedical Applications, in Temperature, Its Measurement and Control in Science and Industry (American Institute of Physics, New York, NY, 1982), Vol. 5, pp. 327-337.
14. D. L. Martin, Specific Heat Below 3 K, Melting Point, and Melting Heat of Rubidium and Cesium. Can. J. Phys. 48, 1327-1339 (1970).
15. M. Sapoff, Thermistors for Biomedical Use, in Temperature, Its Measurement and Control in Science and Industry, (Instrument Society of America, Pittsburgh, PA, 1972), Vol. 4, pp. 2109-2121.
16. H. B. Sachse, Semiconducting Temperature Sensors and Their Applications (Wiley-Interscience, New York, NY, 1975).
17. J. L. Riddle, G. T. Furukawa and H. H. Plumb, Platinum Resistance Thermometry, NBS Monograph 126, April 1973, Superintendent of Documents, U. S. Government Printing Office, Washington, DC 20402.
18. R. D. Cutkosky, An ac Resistance Thermometer Bridge. J. Res. Nat'l. Bur. Stand. (U.S.) 74C, 15-18 (1970).