

PREFACE

Standard Reference Materials (SRM's) as defined by the National Bureau of Standards are "well-characterized materials, produced in quantity, that calibrate a measurement system to assure comparability of measurement in the nation." SRM's are widely used as primary standards in many diverse fields in science, industry, and technology, both within the United States and throughout the world. In many industries traceability of their quality control process to the national measurement system is carried out through the mechanism and use of SRM's. For many of the nation's scientists and technologists it is therefore of more than passing interest to know the details of the measurements made at NBS in arriving at the certified values of the SRM's produced. An NBS series of papers, of which this publication is a member, called the NBS Special Publication - 260 Series is reserved for this purpose.

This 260 Series is dedicated to the dissemination of information on all phases of the preparation, measurement, and certification of NBS-SRM's. In general, much more detail will be found in these papers than is generally allowed, or desirable, in scientific journal articles. This enables the user to assess the validity and accuracy of the measurement processes employed, to judge the statistical analysis, and to learn details of techniques and methods utilized for work entailing the greatest care and accuracy. It is also hoped that these papers will provide sufficient additional information not found on the certificate so that new applications in diverse fields not foreseen at the time the SRM was originally issued will be sought and found.

Inquiries concerning the technical content of this paper should be directed to the author(s). Other questions concerned with the availability, delivery, price, and so forth will receive prompt attention from:

Office of Standard Reference Materials
National Bureau of Standards
Washington, D.C. 20234

J. Paul Cali, Chief
Office of Standard Reference Materials

TABLE OF CONTENTS

	PAGE
1. Introduction	2
2. Theory of Operation of the NBS Measurement System (Model II)	4
A. System Components	4
1. Signal Amplitude Read Channel Components	4
2. Write Channel Components	5
3. Auxiliary Components and Systems	5
B. Description of System Operation	5
1. Signal Amplitude Read Channel Operation	5
2. Write Channel Operation	8
C. Switching System	10
1. Signal Amplitude Read System	10
2. Write System	11
3. Calibration and Operation of the Model II System	12
A. Dc Calibration Procedures	15
B. Ac Calibration Procedures	15
C. Master Gain Calibration and Operation of the Model II System	17
1. Output Voltage e_o (%) versus Write Current I_w Curves	18
2. ABC Chart Measurements	19
3. Candidate Tape Calibration Procedures	21
4. Additional System Checking and Calibrating Techniques	21

4.	Notes to Reference Tape Users	24
5.	Component List	28
6.	Acknowledgements	33

LIST OF FIGURES

<u>Figure No.</u>		PAGE
1.	NBS Model II Measurement System	34
2.	Signal Amplitude Read Channel Block Diagram	35
3.-7.	Signal Amplitude Read Channel Circuit Diagrams	36-40
8.	Write Channel Block Diagrams	41
9.-11.	Write Channel Circuit Diagrams	42-44
12.	Switching System for the Read Channel . . .	45
13.	Switching System for the Write Channel . .	46
14.	Front Panel Layout for the Model II System.	47
15.	e_o (%) versus I_w Curve	48
16.	ABC Chart Recording	49

CALIBRATION OF NBS SECONDARY STANDARD MAGNETIC TAPE
(COMPUTER AMPLITUDE REFERENCE) SRM 3200
USING THE REFERENCE TAPE AMPLITUDE MEASUREMENT "PROCESS A"
MODEL II

Sidney B. Geller

Information Processing Technology Division
Center for Computer Sciences and Technology
National Bureau of Standards
Washington, D.C. 20234

This publication describes the design, operation and calibration of the NBS signal amplitude measuring system (Process A - Model II) that is used for calibrating unrecorded Secondary Standard Magnetic Tapes (Computer Amplitude Reference) SRM 3200. This system supercedes the measurement system that was described in the NBS Special Publication 260-18 (November 1969). The signal level calibration is made with respect to a reference signal level derived from the NBS Master Standard Magnetic Tape (Computer Amplitude Reference) that is kept in repository at NBS. The techniques for measuring and recording the data that accompany each Secondary Standard Magnetic Tape in the form of strip chart recordings and saturation curves are described.

Key words: Average signal peak level; computer amplitude reference; magnetic tape; master standard; saturation curves; secondary standard; signal level calibration; standard reference materials; unrecorded reference.

1. Introduction

The characteristics of present day magnetic computer tapes are the result of long term research and development by the magnetic tape industry. Technological developments in related fields and transducer-tape interplay have stimulated continuing improvement of the tape media and their performance. This has often led to differences in tape characteristics and to marginal operation when tapes are interchanged between systems. The only tapes previously available for quality assurance purposes have been industry supplied standards.

At the request of industrial users of computer tape, Government procurement agencies, producers of magnetic computer tapes, and producers of tape handling equipment the National Bureau of Standards has developed a tape measurement system and is supplying unrecorded Secondary Standard Magnetic Tapes (Computer Amplitude Reference) through the NBS Office of Standard Reference Materials.

This material, which is designated as the NBS Standard Reference Material No. 3200 (SRM 3200), consists of a 600-foot or greater length of secondary reference tape accompanied by applicable test and calibration data, and a description of the equipment and procedures employed for measurement of the tape. At least 600 continuous feet on each tape must meet all of the requirements that are described on the accompanying SRM 3200 certificate. The remaining tape footage will also be calibrated but may or may not meet the certificate requirements. The calibration data charts will physically locate the 600 foot region of interest on each reel. The secondary tapes are 1/2 inch wide unrecorded magnetic computer tapes wound on 8-1/2 inch diameter precision reels.

Each SRM 3200 is calibrated in terms of a 100% signal level that is derived from the NBS Master Standard Magnetic

Tape (Computer Amplitude Reference) which is kept in repository at NBS. This signal level calibration is done at recording densities of 200, 800, 1600 and 3200 flux reversals per inch. Information in the form of signal output strip charts accompanies each secondary tape. These are recorded on the first read-while-write pass from 3 head tracks; one near each tape edge and one at the tape center and are referred to as ABC charts. A set of X-Y recorder curves relating the reproduce head output voltage to the write current on the first read-while-write pass at each bit density of both the NBS master and each secondary tape also accompanies the SRM 3200. These are referred to as e_o (%) versus I_w curves or X-Y curves.

Presently, the main criteria for the selection of unrecorded amplitude reference tapes for calibration as secondaries are signal amplitude uniformity and proximity of read-while-write output voltage to that of the master. The instantaneous track-to-track variation in the average signal peak amplitude is limited to a maximum of 3% among the outputs from the NBS test tracks 2, 5 and 8. The location of these tracks is defined in USASI Document X3.22-1967. The maximum variation in the longitudinal average signal peak amplitude along each test track is limited to 4% over the documented 600 foot length of tape. The value of the average signal peak amplitude measured from each test track is within 10% of the signal level derived from the NBS Master Standard Magnetic Tape (Computer Amplitude Reference.) These criteria are applied for peak signal recording on degaussed (fully ac erased) tape when measured on the NBS system in the manner described in this publication.

2. Theory of Operation of the NBS Measurement System (Model II)

A. System Components

Figure 1 shows the organization of the Model II system used for measuring and calibrating the unrecorded NBS Secondary Standard Magnetic Tapes (Computer Amplitude Reference) SRM 3200. The system consists of a write channel (NRZI mode), three identical signal amplitude read channels (Channels A, B and C), a supply voltage section that includes a precision voltage dividing network and a switching system for use in both the operation and the calibration of the system. Various readout instruments are also included in the system.

The following descriptive material lists the components that appear in each of the sections or channels. One of the figures that is given with each channel contains the block diagram of the channel functions and the other figures consist of the circuit realizations of the block functions. Note that within most of the individual blocks a figure number is inscribed which identifies the circuit diagram that corresponds to that block.

1. Signal Amplitude Read Channel Components (figures 2-7)
 - a. A slotted read-write head (IBM Assembly No. 5417960, Part No. 2510730 or equivalent), a line driver LD-1, a termination network TE-1B, and attenuator circuit AT-1 and a wideband preamplifier WPR-1 with internal and external gain potentiometers R_3 and R_4 and amplifier OA-1.
 - b. A peak level detect-sample-and-hold circuit PD-SH-1 that contains comparator IC-1, transistors T_6 through T_{14} , and diodes D_1 through D_4 .

- c. Level shifting, range setting and summing circuits containing operational amplifiers OA-2 through OA-5.
 - d. External 10-turn potentiometers R_5 for setting the "MASTER GAIN" of the system.
 - e. A passive R-C signal peak averaging circuit.
2. Write Channel Components (figures 8-11)
- a. A variable frequency square wave generator G-1 whose frequency ranges from at least 22.5 kHz to 360.0 kHz, a pulse counter, a binary counter circuit BC-1 and pulse level shifting circuits LS-1.
 - b. A slotted read-write head (IBM Assembly No. 5417960, Part No. 2510730 or equivalent), a write head current driver circuit WD-1 and a motorized write current amplitude control circuit CC-1.
3. Auxiliary Components and Systems
- a. Four precision voltage sources (± 6.0 , ± 14.0 , ± 14.0 , $+30.0$ volts) and a dividing network DV-1 for providing dc calibration voltages. Operational amplifiers OA-6 and OA-7. One precision digital voltage source.
 - b. A function switching system containing 9 wafer switch assemblies, 2 pushbutton switches, 1 lever and 1 toggle switch (figures 12-13).
 - c. A modified IBM-2401-VI Tape Transport.
 - d. Read-out devices: a 6-track ABC chart recorder, an X-Y recorder, a digital panel meter DPM-1 and a digital voltmeter DVM-1.
- B. Description of the System Operation
1. Signal Amplitude Read Channel Operation (figures 2-7)
- The signal amplitude measurements are performed at all bit densities on candidate tapes that

have been initially degaussed and then recorded with all "ones" in the NRZI mode.

- a. The signal which has been reproduced by a read-while-write operation from a candidate tape is passed through a unity gain, line driving amplifier LD-1 which is physically located at the read head. The line is terminated by TE-1B and network AT-1. AT-1 attenuates the incoming signals so that the inputs to the WPR-1 preamplifiers will fall within a reduced range of amplitudes for the different recording densities. AT-1 is adjusted with R_1 and R_2 . Typical values of output signal from LD-1 have been found to lie in the range of 12.0-14.0 mV p/p at 3200 frpi and 17.0-22.0 mV p/p between the densities of 1600 to 200 frpi. The WPR-1's are adjusted with R_3 to operate at gains of 470 with R_4 set at its mid-value of 500 ohms.
- b. The amplified signals from the WPR-1's are then fed into the peak-detect-sample-and-hold PD-SH-1 circuits via OA-1. PD-SH-1 converts the ac signals into dc levels that are equal to their peak values. 3.000 volts dc represents the 100% level for the measuring system and all output levels are described in terms of their value as a percentage of 3.000 volts.

The peak detect-sample-and-hold circuit PD-SH-1 in figure 5 operates as follows:

The hold capacitor C_1 is charged to the positive signal peak value through diode D_1 . Simultaneously, the output signal from OA-1 is fed into the high-speed comparator inte-

grated circuit IC-1. The output from IC-1 is a 4.0 volt p/p pulse train whose widths are determined by the zero cross-over points of the signal. This pulse train is fed into the two network branches that are tied to the output of IC-1 at terminal 7. The pulses are integrated by capacitor C_3 before driving the upper gating circuits consisting of T_6 , T_7 and T_8 . This integration stretches the signal peak voltage hold time across C_1 , and therefore produces a sampling time margin. The sampling is initiated when the IC-1 output pulse signal level falls from +4.0 volts towards ground and is differentiated at the input to T_{11} . The differentiated signal triggers the T_{12} - T_{13} current switching circuit and a strobe pulse is generated by T_{13} which drives the gate terminal of T_{14} (FET) during the stretched signal level interval. A dc level now appears across C_2 and is held there until another strobe pulse is initiated by the next signal cycle.

- c. The input circuit of OA-2 is adjusted by R_9 and R_{10} so that the dc levels from PD-SH-1 will track the incoming signal peak values.
- d. The output signal from C_2 is then fed into OA-3. The output from OA-3 is injected into the "MASTER GAIN" or "MG" branch of the final summing amplifier OA-4. The MG potentiometer R_5 is the principal calibration device of the system. The signal is offset by the OA-4 "% RANGE" branch voltage in order to attain the desired ABC chart percentage values. The output signal from OA-4 then is passed to the ABC and X-Y recording devices.

e. A passive R-C averaging circuit with a time constant of $R_A C_A = 0.30$ seconds is used to average the output signal from each OA-4. As seen in figure 6, $R_A = 100K\Omega$ and $C_A = 3.0 \mu\text{fd}$. The voltage across the capacitor C_A is applied to the ABC chart recorder track that is adjacent to the signal peak track that it is averaging. The upper track of each pair on the ABC chart is the average signal peak track. (See figure 16)

2. Write Channel Operation (figures 8-11)

The NBS signal amplitude read channel operates independently of the system from which the head-tape signal is derived, however the NBS write channel is designed to operate specifically with the IBM 2401-VI transport. This channel is not shown in detail because many different transports will be used with the SRM 3200 tapes in the field. Only the current control circuit CC-1, the binary counter circuit BC-1, the level shifter LS-1 and a simplified version of the write driver circuit WD-1 are shown (figures 9-11). WD-1 and the current source for WD-1 are both on the IBM 2401-VI "FHW" card. Additional level shifting beyond LS-1 is supplied by the "EPY" and "FAN" cards.

The following steps were taken to convert the IBM 2401-VI tape transport for continuous current and frequency control by the NBS system. These steps should be applied to any system for which similar control is desired:

a. Disable the internal bit rate generator and connect an external generator G-1. The pulse frequencies that are supplied by G-1 are as follows: 200 frpi - 22.5 kHz; 800 frpi -

90.0 kHz; 1600 frpi - 180.0 kHz; and 3200 frpi - 360.0 kHz.

- b. Since these frequencies produce double the desired bit rate they are used to trigger BC-1 which (1) halves the bit rate and (2) produces a constant amplitude square wave.
- c. The signal levels from BC-1 are then made compatible for driving the write head with level shifting circuits such as LS-1.
- d. Disable any step write current circuit if one exists.
- e. Disable or alter any circuits that are necessary in order to make it possible to record all "ones" in the NRZI mode.
- f. The current control circuit CC-1 consisting of T_{22} , T_{23} , and T_{24} (figure 11) is used to control the output from a continuously variable current source circuit over a range of 0.0 to 50.0 mA dc of write head current. The total write head current is controlled with the potentiometer R_{15} . R_{15} is operated in the "MANUAL" mode (in conjunction with vernier control R_{16}) when the ABC chart recordings are made and in the "AUTOMATIC" mode when producing the X-Y curves. R_{15} is motor driven through one turn in 10 seconds during automatic operation. The head current I_w is measured and displayed with the digital panel meter DPM-1.

Any existent circuits that impede the current source from attaining its full range of values should be disabled or removed.

- g. T_{25} and T_{26} form a constant current switch with matched circuit components so that equal values of write current will flow through each

winding of the write head during each half of the operating cycle. The switched head current is equal to the output from the current source and the switching rate is controlled by the level shifted pulse train that is applied to the base of T_{25} . The direction of current in the write head depends upon the instantaneous "on" and "off" states of T_{25} and T_{26} .

C. Switching System (figures 12-14)

The NBS Model II measuring system has a switching network that permits rapid dc, ac and "MASTER GAIN" calibration. However, these procedures could be performed with patch-cords or any other device that allows the user to cut into the circuitry.

The NBS measuring system contains 11 switches in the signal amplitude read section and 2 switches in the write section. The switches are shown in the simplified switching diagrams of figures 12 and 13. They are shown in their actual panel positions on the NBS Model II unit in figure 14. Figure 12 shows only the required switching sections for a single read channel. The other two read channels are controlled in an identical fashion by additional wafer sections that are stacked onto and are mechanically coupled to the same switch assemblies. The functions of the individual switches will now be described. Switch markings on the panel are in quotation marks:

1. Signal Amplitude Read System (See figure 12)

- Switch S1: "3200, 1600-200". Bit density switch.
Chooses AT-1 output line according to the operating bit density range.
- Switch S2: (Sections A, B, C): "OPERATE, SET CHART, AC CALIBRATE." Main function switch for the signal amplitude read channels.

- Switch S3: "Set X-Y." Pushbutton switch. Sets the 100% reference level on the X-Y recorder when depressed and the 0% level when released. The 100% level is equal to 5.000 volts dc.
- Switch S4: (Sections A to E): "ABC - X-Y." Chooses the measuring mode and the output recording device.
- Switch S5: "OPERATE, EXTERNAL INPUT, DC CALIBRATE." External high level signals or dc calibration volts can be injected into the system under the control of S5.
- Switch S6: "2-3-4-5": Routes "DC CALIBRATE" volts to S5 from DV-1.
- Switch S7: "OP, %, AC, MG: (Not shown in detail in figure 12.) S7 is used to both open and/or to cut into the individual inputs of OA-4 for calibration and system check purposes.
- Switches S8
and S9: These switches are used for metering purposes only. All supply voltages and the outputs from OA-3 and OA-4 are measured by a digital voltmeter (DVM-1) via S8 and S9.
- Switch S10A: "GROUND T_{13C}" Toggle switch on circuit card. Used during "DC CALIBRATE".
- Switch S10B: "GROUND DVM". Pushbutton switch. This is used to check the DVM or oscilloscope ground level.
2. Write System (See figure 13)
- Switch S11: "OFF, LOCAL, MAIN FRAME." Main write current control switch. Reduces write current to zero in "OFF" or gives control of the write current to the NBS measurement system in "LOCAL". S11 can also be wired to return

current control to the transport main frame if desired.

Switch S12: "AUTO-MANUAL." Lever Switch. Chooses the mode of write current control. The automatic mode is used for X-Y recording and the manual mode is used for setting the reference current level for ABC charts. S12 also controls the X-Y recorder pen drop circuit and activates the potentiometer motor during X-Y recording. Note that there are 4 SPDT sections on S12. The normally open sets of points are designated by "N.O."

3. Calibration and Operation of the Model II System

The calibration and operation of the read system is accomplished in the following sequence:

- A. Dc Calibration
- B. Ac Calibration
- C. "MASTER GAIN" Calibration and System Operation.

The calibration of the Model II system proceeds from the output of OA-4 back toward the input circuitry. The first adjustments are made on the output summing amplifier OA-4 which has the following input lines: (See figure 6)

- a. "MASTER GAIN" (MG) R_5
- b. "AC CALIBRATE" (AC) R_6
- c. "SET CHART" (SC) R_7
- d. "% RANGE" (%) R_8

R_6 , R_7 , and R_8 are adjusted so that the gain of OA-4 relative to dc inputs on these lines is equal to $G = 1.667$. This gain converts the input signal amplitudes to output values that yield a direct relationship between the chart divisions and the percentage value of the signal under test.

The functions of these OA-4 inputs and adjustments are as follows:

- a. The "MASTER GAIN" potentiometer R_5 adjustment sets the final gain of each read channel so that it will produce the desired reference output level as provided by the NBS master tape. The NBS secondary standard magnetic tapes are then calibrated with respect to this level. The "MG" input branch to OA-4 is functional during the normal "OPERATE" (S2) mode.
- b. The "AC CALIBRATE" input to OA-4 is used in the "AC CALIBRATE" (S2) mode of operation. This mode uses a simulating ac signal to test the stability and adjustment of the system.
- c. The "SET CHART" input to OA-4 is used in the "SET CHART" (S2) mode of operation. In this mode 3.000 volts dc is injected into OA-4 and produces the output voltage level which is used to set the X-Y and ABC recording devices into their 100% reference states prior to recording.
- d. The "%" input to OA-4 affects each of the preceding modes by providing a controlled offset voltage. This offset voltage is adjusted with the calibrated 10 turn potentiometer R_{12} so that the signal output from OA-4 will consist of a desired percentage of the total signal range. For example, a range consisting of from 75% to 125% of the total signal amplitude is charted on a strip chart recorder by offsetting the lower 75% of the output signal and then selecting that chart recorder range that will encompass the next 50% of the total signal level over its limits.

An NBS ABC chart recorder track has a useful width of 10 major linear divisions as shown in figure 16. When the recorder sensitivity is

set to 250mV/div then full chart deflection is obtained with 2.500 volts dc. If the chart centerline is chosen as the 100% reference level then 1.250 volts dc output from OA-4 is equal to 100%. Since 3.000 volts dc into OA-4 represents the 100% level for the system, it is necessary to offset this by inserting 2.250 volts dc onto the "%" line. This results in an OA-4 output equal to 0.750 volts times the OA-4 gain of $G = 1.667$ or 1.250 volts during the "SET CHART" (S2) mode of operation. The bottom of the chart represents the 75% signal level and the top of the chart represents the 125% signal level. The NBS system is designed so that the lowest percentage values on the 250 mV/div chart can be calculated from:

$$\text{Lowest \%} = \frac{\text{"\% RANGE" input voltage} \times 100}{3.00}$$

On the 250 mV/div scale setting the highest chart percentage is 50% above this lowest value.

NOTE: This same "%" offset capability can be used to compare relative signal peak values and to measure the distribution of incoming signal peaks on a high sensitivity range of an oscilloscope. This measurement, however, does not require prior peak detection and sample-and-holding of the signal, i.e., the signal is passed directly from WPR-1 to OA-4. When the oscilloscope sweep rate is set to display only one half or less (positive or negative) of one signal cycle per trace then a broad arched band of light appears on the screen. The broadness of the band is a function of the scope sensitivity and of the distribution of the signal peak amplitudes read from the tape. The intensity of the

light band varies across its height with the brightest level appearing at the amplitude related to the most prevalent signal peak value.

A. Dc Calibration Procedures (figures 4 to 6, 12)

1. The "AC", "SC" and "%" inputs of the OA-4's in figure 6 are set for gains of $G = 1.667$ by injecting 3.000 volts dc from the precision digital voltage source into each of these inputs via switch S7 and adjusting trimmers R_6 , R_7 , and R_8 for an output of 5.000 volts dc from OA-4 as measured on DVM-1. This can be done on an individual basis via S7 with all inputs held at zero volts except for the one being adjusted.
2. After the OA-4 inputs have been adjusted then the peak detect sample-and-hold PD-SH-1 system is dc calibrated as follows:
 - a. Open the input to OA-1 at point A of R_4 (via S_5) and set R_4 to its mid-point value of 500 Ω . R_4 is an external 10 turn potentiometer with a calibrated dial. (figure 4)
 - b. Short the collector of T_{13} to ground (via S10A in figure 5).
 - c. Inject 2.000, 3.000, 4.000 and 5.000 volts dc sequentially into R_4 from the precision voltage divider source DV-1 (figure 7). This is done with switch S5 and S6.
 - d. Adjust R_9 and R_{10} at the OA-2 inputs (figure 6) until the dc outputs from OA-3 track these voltages within an accuracy of at least 0.25%. This completes the dc calibration and all switches or connections are returned to normal.

B. Ac Calibration Procedures (figures 3, 4)

1. This is accomplished in two steps when the system is ac calibrated for the first time after the dc calibration has been completed:

Step (1) - An external sine wave signal is shunted around AT-1 and is injected directly into the connector to the input capacitors of each of the WPR-1 preamplifiers with S2 in "AC CAL" (figure 3). It has been found that an input signal amplitude of 12.7 mV p/p is a good value to use as the nominal operating signal level. The internal WPR-1 gain trimmers R_3 are then adjusted in each of the 3 read channels so that the output from each OA-3 is equal to 3.000 volts dc. This corresponds to an output of 6.0 volts peak to peak from WPR-1. The frequencies of the injected signals are 180 kHz, 90 kHz, 45 kHz, and 11.25 kHz for 3200, 1600, 800 and 200 frpi, respectively.

Step (2) - After each WPR-1 has been set for an equal gain of 470 the external sine wave signal is then injected into the input of attenuator AT-1 at point A (figure 3) with S2 in "OPERATE". For 3200 frpi the input signal level is set to 14.2 mV peak to peak at 180 kHz and the trimmer R_1 is adjusted so that the output from OA-3 is again 3.000 volts dc. The input signal is then set to 22.5 mV p/p at 45 kHz and the trimmer R_2 is set so that the output from OA-3 is again 3.000 volts dc. Trimmers R_1 and R_2 are now permanently secured and never re-adjusted. In operation switch S1 (figure 3) is used to activate the R_1 trimmer circuit at 3200 frpi and the R_2 trimmer circuit at 1600 to 200 frpi

so that the WPR-1's will be able to operate over a reduced range of gains for all densities. The ac calibration is now completed and if desired only step (2) need be performed for checking the dynamic response of each of the three read channels and the output recorders.

C. "MASTER GAIN" (MG) Calibration and Operation of the Model II System

After the dc and ac calibrations are completed the system is ready for its final working adjustment using either the NBS master or a working reference tape. This step is accomplished at each density by running either one of these reference tapes and adjusting the three external MG potentiometers R_5 . The sequence of operations are as follows:

1. Produce an uncalibrated e_o (%) versus I_w curve using the master or working reference tape and determine the reference write current level at the initial signal peak.
2. Produce an ABC strip chart recording of the signal outputs from 3 head tracks using the reference write current level. Adjust the MG potentiometers to achieve the correct percentage values on the ABC chart as determined by the master or working reference tape.
3. Now produce the calibrated e_o (%) versus I_w curves and ABC charts for the NBS master tape and for each candidate tape.
4. Record the MG numbers or voltages and make a "master template". Each one of these operations must be repeated for each of the 4 bit densities. The following is a detailed description of steps 1 to 4:

1. Output Voltage e_o (%) versus Write Current I_w Curves (figure 15)

(a) In order to determine the reference write current levels at which the ABC strip charts for the candidate tape are to be produced, it is first necessary to make an e_o (%) versus I_w curve for the master tape or a working reference tape at each operating density. This reference level is the "initial" saturation write current and is defined as the minimum write current level that produces the maximum value of output read head voltage as plotted on the X-Y chart. The output voltage e_o (%) is always obtained during a read-while-write pass on a previously bulk erased tape. The e_o (%) versus I_w curves are measured from the output of the center track (track #5) of the 9-track read head and are produced over a section of tape which lies approximately 100 feet past the beginning mark of the calibrated 600 foot section of the reference tape.

(b) The e_o (%) versus I_w curves are plotted on an X-Y recorder whose X axis is driven by a voltage that is derived from the voltage drop across the 10 ohm resistor in series with the center tap of the write head (figure 11). These voltage drops are converted by an X axis gain adjustment into chart abscissae values that represent the write head current in milliamperes. The range of the write current in the system is continuously controlled from 0 to 50.0 mA by CC-1 and the motorized potentiometer unit R_{15} . The write current is read from DPM-1.

(c) The Y axis of the X-Y recorder is driven directly by the output signal voltage from OA-4. The Y axis gain is calibrated so that 5.000 volts dc will

drive the recorder pen to the line that has been chosen as the 100% level on the e_o (%) versus I_w chart. These 5.000 volts dc are derived from OA-4 in the "SET CHART" (S2) - "X-Y" (S4) mode of operation by depressing pushbutton S3.

(d) The operating procedure is as follows:

- (1) The NBS master or working reference tape is threaded onto the tape transport.
- (2) The system is switched into "OPERATE" (S2) "X-Y" (S4).
- (3) The current control switch S11 is placed into "LOCAL".
- (4) S12 is depressed into "AUTO" and the tape transport is started.
- (5) The motorized potentiometer R_{15} varies the write current from zero to 50.0 mA and the e_o (%) versus I_w curve is plotted.
- (6) During step (5) the external "MASTER GAIN" potentiometer for the center channel (channel B-track #5) is adjusted to bring the e_o (%) signal peak value to within 5% of the 100% X-Y chart level that was set in step (c) above. This may require several passes over the same chart as the tape is running.

2. ABC Chart Measurements (See figure 16)

These measurements are made after the initial saturation write current level has been determined from the e_o (%) versus I_w chart as follows:

- (a) The system is switched into the "ABC" (S4) - "SET CHART" (S2) mode of operation and the ABC strip chart recorder tracks are adjusted or "set" to their 100% level. For example, the chart center line is used as the 100% level if the "% RANGE" voltage is set equal to 2.250 volts dc with R_{12} and the recorder sensitivity set to 250 mV/div.

- (b) After the ABC chart is "set", the write head current is adjusted to the initial saturation current level previously determined using the CC-1 write current control potentiometers R_{15} and R_{16} with S12 in the "MANUAL" position. The system is then switched into the "ABC" (S4) "OPERATE" (S2) mode of operation and the ABC chart recorder and tape transport are activated.
- (c) (1) The ABC chart speed is set at 1 mm/s.
(2) The IBM 2401 - VI tape transport speed is 112.5 in/s.
(3) Each major horizontal chart division (5 mm) represents the passage of 47 feet of tape.
(4) The 6 ABC tracks consist alternately of the signal peak outputs and the average of these signal peak outputs as derived from 3 head tracks (tracks #2, #5 and #8).
- (d) If the NBS master tape is being run on the transport, then the three external "MASTER GAIN" potentiometers R_5 are adjusted so that the signals on all of the ABC chart recorder tracks fall exactly at the pre-set 100% level. If a working reference tape is used instead of the master tape, then each MG potentiometer R_5 is set so that the signal level on each ABC track will fall at the predetermined relative percentage values for the working tape outputs. For example, for a particular working tape the MG potentiometers R_5 may have to be set to produce: track A = 98% level, track B = 95% level and track C = 97% level relative to the 100% master tape level. The system is now completely calibrated.

3. Candidate Tape Calibration Procedures

- (a) When the "MASTER GAIN" potentiometers have been adjusted as described above then calibrated e_o (%) versus I_w curves are produced for all of the candidate tapes and the master tape by repeating the procedures in Section 3, C, 1, d, but omitting step 6 in this section.
- (b) The reference current values that will now be used to produce the final ABC charts are marked on each of the calibrated X-Y curves that accompany the SRM 3200's as shown in figure 15. An e_o (%) versus I_w chart that was derived from the NBS master tape will also be marked and included in the package.

Since the system is completely calibrated the peak output voltage e_o (%) from the NBS master tape at each recording density will now fall at the 100% level on its X-Y chart and the peak voltage outputs from the candidate secondary tapes will appear directly in terms of their relative percentage values to the master tape. For example, if the peak output voltage e_o (%) for an NBS candidate secondary tape is reached at the 98% chart level, then that tape has been measured on the NBS calibration system as having a peak output voltage that is 2% less than the peak output voltage derived from the NBS master tape.

- (c) The steps in Section 3, C, 2, a, through 3, C, 2, c, are now repeated for all candidate secondary reference tapes at each bit density. These procedures will result in calibrated ABC charts for these tapes. The candidates are now completely calibrated.

4. Additional System Checking and Calibrating Techniques

Techniques have been developed for checking and calibrating the NBS Model II measurement system which do not

require the constant use of a working reference tape. In each instance the method assures that the overall system gain and the MG potentiometers R_5 are maintaining their original values.

(a) "MASTER GAIN" Numbers and Voltages

The "MASTER GAIN" potentiometers R_5 are 10-turn units with calibrated dials. After completing Section 3, C, 2, d, the numbers on these MG dials are recorded and can serve as future references. That is, if the system is dc and ac calibrated and the MG potentiometers R_5 are reset to these same dial numbers then the system is back in its original operating condition. These MG numbers are related only to the particular head that was used when they were derived. A more precise technique for resetting the MG potentiometers to their original values is achieved in the NBS system by injecting 3.000 volts dc into the calibrated "MG" inputs of the OA-4's with all of the other inputs at zero (switch S7 in "MG"). The output voltage from the OA-4's are then logged and the MG potentiometers can then be reset very precisely to these OA-4 output voltages when desired. This approach eliminates the effects of mechanical dial errors in the MG number method.

(b) Master Template Technique:

An alternate technique for testing the stability of the entire NBS measurement system as well as for recalibrating the system without the use of a reference tape is with a "master template". This template is produced as an ABC 6-track chart recording immediately after the system has been calibrated (after Section 3, C, 2, d). It is done by disconnecting the LD-1 line driver outputs and producing the ABC chart by injecting a sine wave

signal into the input of the calibrated system at AT-1. The frequencies and amplitudes of these signals are the same as those discussed in the Section 3, B. For example, at 3200 frpi a 180 kHz, 14.2 mV p/p signal is injected into AT-1. Since the injected sine wave signal consists of constant amplitude peaks the master template will consist of smooth lines at a fixed level on each ABC track. This template includes the effects of the entire measuring system on the injected signal. During an actual tape calibration run the system can be rechecked regularly by producing new ABC charts using the same injected sine wave signal and comparing the levels on the new charts to the levels on the original master templates. If necessary, amplifier gains can be adjusted with R_3 or R_4 to bring these levels into line with the master levels. A separate template is produced at each bit density for each calibrating head and the set of templates is stored with that head when it is removed from service.

When the response of the measuring system is recorded in this fashion, it is possible to observe changes in the head-tape output signal with time. These changes are due to variations in environmental and operating conditions as well as to the mutual physical effects of the heads and tapes on each other.

(c) Ac Calibration Mode:

This mode of calibration is similar to the master template mode with the exception that the reference sine wave signal is switched via S2 directly into the WPR-1's and the OA-4 input trimmers R_6 ("AC CAL") are set so that the 6-track chart recordings all fall at the 100% level in response to these

signals. The MG adjustment is assumed to be correct and no template is required. This mode offers a rapid system check during a candidate tape calibration run but is not as complete as the master template method. The sine wave generator can be permanently connected into an "AC CAL" input jack and the line drivers do not have to be disconnected in this mode.

4. Notes to Reference Tape Users

- A. Important: The NBS Secondary Standard Magnetic Tapes (Computer Amplitude Reference) SRM 3200 should be used sparingly so as to minimize physical changes to the tape and to assure continued performances as near to the supplied calibrations as possible.

It has been found that the best correlation with the NBS measurement system results can be produced under the following conditions:

- (1) The tape is bulk ac erased before writing.
- (2) The dc erase head on the tape transport is not energized during the measurement process.
- (3) A slotted read-write head (IBM Assembly No. 5417960 Part No. 2510730 or equivalent) is used as the transducer.
- (4) The curves are made during a first read-while-write pass.
- (5) The characteristics of the tape transport such as speed, tension and guidance should be similar to the IBM 2401-VI.

Departure from one or more of these conditions can result in variations from the calibrated results.

- B. The NBS Secondary Standard Magnetic Tape (Computer Amplitude Reference) SRM 3200 is packaged in lengths of approximately 900 to 1200 feet of tape per reel.

At least 600 continuous feet of tape within this length satisfy the requirements that are stated on the accompanying certificate. However, the full reel can be used for adjustment purposes because calibration data for the entire length of tape are included on the ABC charts. Originally the SRM 3200's were packaged in exact 600 foot lengths. The decision to change to the 900 to 1200 foot format resulted from experimental evidence which indicated that the longer tape lengths reduced the signal "rise" effect. It has been noted that many different tapes display a rise in signal amplitude as the tape is read from end to end, with the signal increasing most rapidly as the reel hub is approached. It is believed that the increase in signal amplitude is caused by effects of the pressure variation per unit length of tape upon the tape surface after it has been wound and stored. The longer tape length lowers this pressure gradient and the percentage signal amplitude variation over any continuous length of tape is also reduced.

Figure 16 shows 2 out of 3 channels on a typical ABC chart recording with the principal 600 foot section lying between the two right hand "marks". The length of tape between the "Beginning of Tape" (BOT) marker to the 600 foot starting "mark" is also shown on each ABC chart. The time in seconds that is required to reach this starting "mark" from the BOT mark is found from:

$$\text{Time (in seconds)} = \frac{\text{length from BOT to starting "mark" (feet)}}{\text{speed of transport (feet/second)}}$$

Note that the length of tape between each horizontal ABC chart division is approximately 47 feet, therefore in figure 16 the distance from the BOT mark to the starting "mark" is 376 feet. As an example, if the transport speed is 112.5 inches per second (9.38 ft/s) then the time required to reach the starting "mark" from the BOT marker is

$$T = \frac{376 \text{ feet}}{9.38 \text{ ft/s}} \approx 40 \text{ seconds}$$

It is anticipated that SRM 3200 users will devise other means for finding the starting "mark" after it has been located by them for the first time. For example, additional BOT and EOT ("End of Tape") markers may be added to the tape according to the operational design of each particular system. However, cutting the tape to different lengths is not recommended since it will alter the signal rise characteristics.

- C. e_o (%) versus I_w saturation curves for 3200, 1600, 800 and 200 frpi will accompany the NBS Secondary Standard Magnetic Tape (Computer Amplitude Reference) SRM 3200 from which they are derived. In addition, the four e_o (%) versus I_w saturation curves that were obtained from the NBS Master Standard Magnetic Tape (Computer Amplitude Reference) at these bit densities will also be included in the package. The user will therefore be able to use these curves in order to determine the relationships at different write current levels between the NBS master tape and the NBS secondary tapes. The user should note that every e_o (%) value on the NBS master tape X-Y curve can be assumed to be the 100% reference level and that the secondary tape outputs are then considered in

terms of their percentage relationship to these master levels at whatever write current has been chosen. NBS has chosen the initial saturation current at the e_0 (%) peak as the basic reference current level at which all of the ABC charts are produced. This level is marked on the X-Y curves as shown in figure 15. The ABC chart shown in figure 16 was produced at the current level that was marked for the tape T-1 in figure 15.

It has been found at 3200 frpi that most initial saturation write current levels lie between 13.0 to 16.0 mA and that between 200 and 1600 frpi most values lie between 26.0 to 30.0 mA. These results were obtained with a number of IBM slotted read-write heads described in Section 2, A, 1, a, and with groups of various industry tapes chosen at random.

D. ABC strip charts derived from 3 head tracks at each of the 4 bit densities accompany the NBS secondary tapes from which they were derived. Data from each read head are recorded on two adjacent pen tracks with the signal peak amplitude appearing on the lower track and the average peak amplitude of the signal appearing on the upper pen track. Figure 16 shows tracks B, \bar{B} , C and \bar{C} as they appear on a typical ABC strip chart recording. The bar over the track letter indicates the average peak value track.

- (1) Chart track A corresponds to the signal output from head track No. 2.
- (2) Chart track B corresponds to the signal output from head track No. 5.
- (3) Chart track C corresponds to the signal output from head track No. 8.

The head tracks are numbered in accordance

with USA Standard Recorded Magnetic Tape for Information Interchange (800 CPI, NRZI) - USASI X3.22-1967.

E. Construction Notes

- (1) Printed circuit layout figures for the plug-in cards that are used in the NBS Model II system will be made available upon request.
- (2) The muffin fans are important for maintaining the dc stability of the solid state devices and should be used. They are positioned to move the air through the side of the SDS card cage. The NBS laboratory is maintained at a temperature of $70^{\circ} \pm 1^{\circ}$ F.
- (3) Separate ± 14.0 volt supplies are used for the low signal level circuits in WPR-1 and for the high level signal circuits in PD-SH-1.
- (4) Coaxial leads are used in the low signal level input circuits and switches.
- (5) The NBS system is designed so that all printed circuit card adjustments are available from the front of the machine. This includes all internal trimmer resistors.
- (6) If the NBS circuit cards and the SDS Type MT-12 card cages are used it will be necessary to cut open the common pin No. 51 buss line on the SDS cage etched circuit plate.
- (7) The three read channels A, B and C do not interact, therefore, it is feasible to build a single channel read system if desired. Also, if only ABC charts are desired then it is not necessary to build the NBS write control system.

5. Component List

The mention of specific equipments or components in any portion of publication is not to be construed as an endorsement of these items by NBS to the exclusion of other equiv-

alent devices. There is considerable latitude in the choice of semi-conductor components, potentiometers, recording, reproducing and measuring devices. The following is a tabulation of the devices that are used in the NBS measurement system Model II.

Note: The marking of a component or heading with an asterisk indicates that only one each of these components or devices under the heading is used in the entire system. All other components unless otherwise indicated are used one each per channel, therefore, three of each are used in this system.

<u>Transistors</u>	<u>T(Numbers in Figures)</u>	<u>Type</u>
2N3646	7-10, (17-22)* 27, 28	NPN Switching
2N3638	6, 11, 12, 13, 15*, 16*	PNP Switching
2N916	1-3	NPN High Frequency Amplifier
2N3831	4, 5, 25, 26	NPN High Speed Switch
2N1700	23*, 24*	NPN Switching
2N4222A	14	N-Channel FET

Note: T_{15} to T_{18} and T_{25} to T_{28} were unmarked transistors that appeared on commercial circuit cards. They are replaceable with the types that are listed in the table.

<u>Diodes</u>	<u>D(Numbers in Figures)</u>	<u>Type</u>
1N276	1	Ge Switch
1N916	2, 3, 4, (5-10)*	Si Switch
Operational	OA	
<u>Amplifiers</u>	<u>(Numbers in Figs.)</u>	<u>Type</u>
PP45U	1-7	Philbrick Researches, Inc.
Integrated	IC	
<u>Circuits</u>	<u>(Number in Figs.)</u>	
μ A710C	1	Differential comparator, Fairchild semiconductor

<u>Adjustable Resistor</u>	<u>R(Number in Figures)</u>	<u>Type</u>
Trimmer Resistors (25 turns)	1, 2, 3, 6-10, 11*, 13*, 14*	Bourns Trimpot #3282P
Potentiometer (10 turns)	4, 5	Bourns #3501S-1
Potentiometer (10 turns)	12*	Beckman Instrument Helipot
Motorized Potentiometer (single turn)	15*	Dale Electronics, 4600 Series
Potentiometer (single turn)	16*	Bourns #3852

<u>Associated Devices*</u>	<u>Function</u>	<u>Type</u>
Digital Voltmeter (DVM-1)	Measure dc volts	Fairchild Model 7100A
6-Track Chart Recorder	ABC Charts	Clevite-Brush Mark 260
X-Y Recorder	e_o (%) vs. I_w Charts	Moseley-H.P Model 7004A
Digital Panel Meter (DPM-1)	Measure I_w	Analogic Model AN2510-1A
Electronic Voltmeter	Measure ac volts	Ballantine Labs Model 310A
Test Oscillator (sine wave)	AC calibrate signal	H.P. 650A
Square-wave generator G-1	Bit density generator	Tektronix Type 105
Pulse Counter	Measure bit density	Berkeley Model 5510
Magnetic Tape Eraser	Bulk eraser	GKI Model K80

<u>Switch Type*</u>	<u>S(Number in Figures)</u>	<u>No. of Wafer Sections</u>	<u>Poles per Wafer</u>	<u>Positions</u>
Wafer	S1	2	3	2
"	S2	4	3	3
"	S4	2	4	2
"	S5	2	3	3
"	S6	1	1	4
"	S7	4	3	5
"	S8	1	1	12
"	S9	1	1	8
"	S11	1	3	3
Pushbutton	S3, S10B			SPDT auto return Microswitch
Lever	S12			Switchcraft Lever-Lite Series 25000
Toggle	S10A			DPDT

Note: All of the wafers are made of steatite; for example Centralab type PA-7.

<u>Power Supplies*</u>	<u>Voltage</u>	<u>Type</u>
Dual Supplies	± 14.0 (2ea.), ± 6.0	Kepeco DTM 2x16-0.6
Single Supply	+28.0	Kepeco BKF 28-0.6
Digital Voltage Source	0.0-99.999	SRC Model 3517

<u>Miscellaneous</u>	<u>Type</u>
Card Cage*	SDS Type MT-12
Muffin Fans (3 per system)	Rotron 115 CFM, 115 vac.
10 turn dials (6 per system)	Bourns No. H-494-3
10 turn dials*	Beckman Instruments Duodial
Transformer TR-1*	Triad F-25X Filament Transformer

6. Acknowledgements

The assistance of Mr. N. G. Cleveland (IBM Research Associate, Boulder, Colorado) with the initial testing and development of the system, of Mr. P. A. Mantek (Information Processing Technology Division) with the conversion of the IBM tape transport to local current control and Mr. A. W. Ericson (Information Processing Technology Division) with the testing, construction and operation of the system is gratefully acknowledged. The assistance of Miss Sharon Michael (Information Processing Technology Division) in the preparation of the manuscript is also gratefully acknowledged.

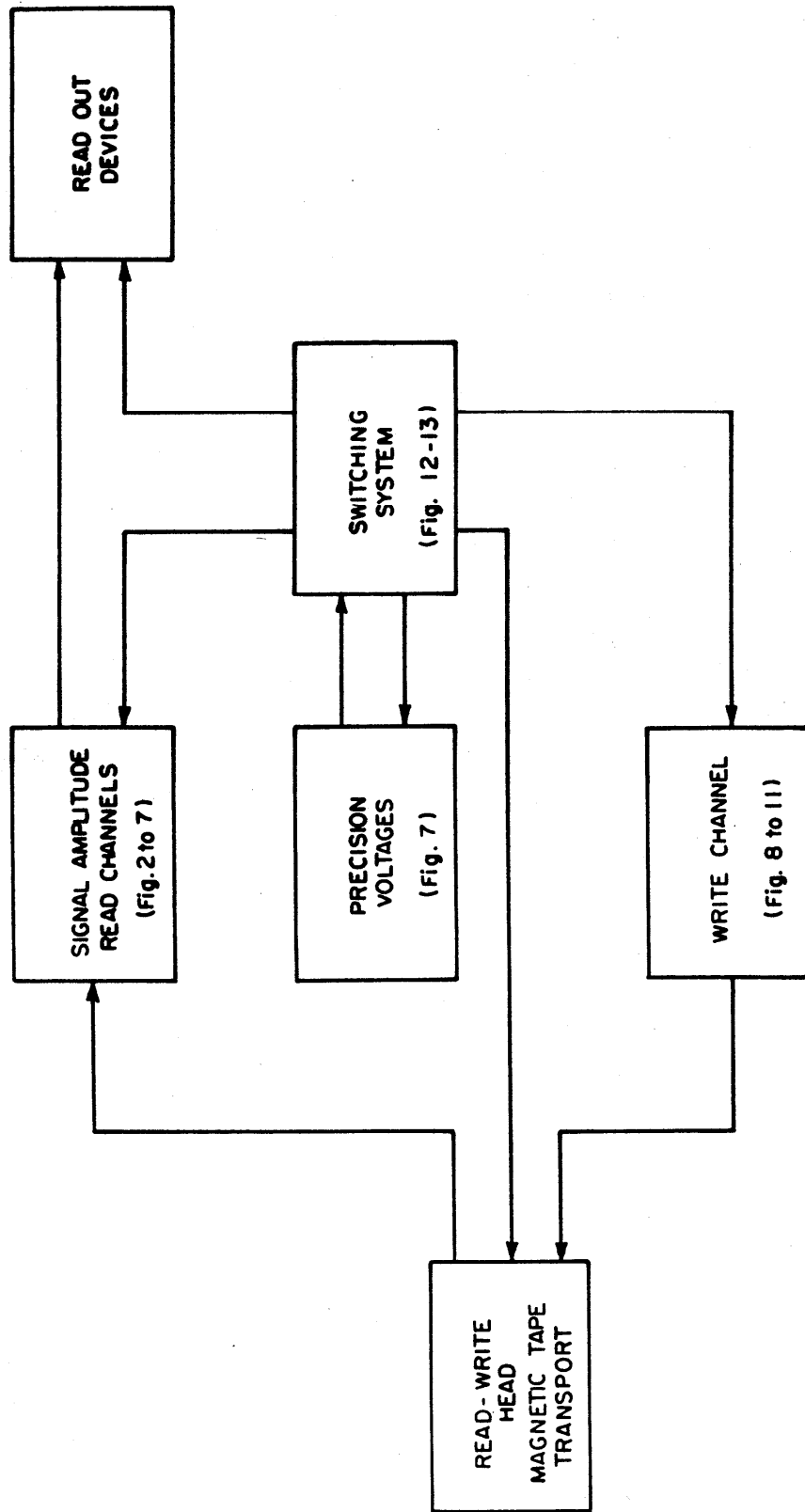

Figure 1. NBS Model II Measurement System

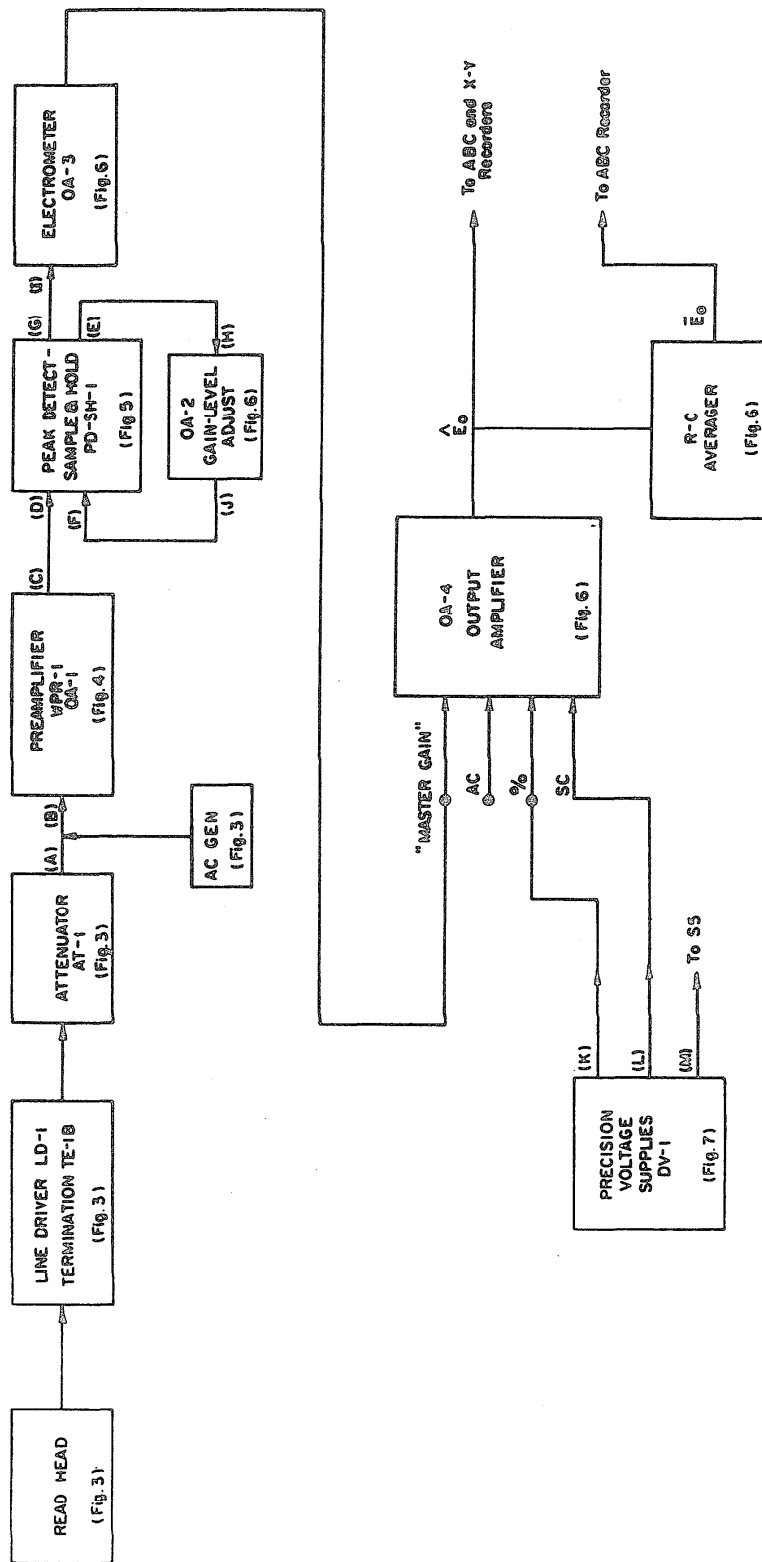

Figure 2. Signal Amplitude Read Channel Block Diagram

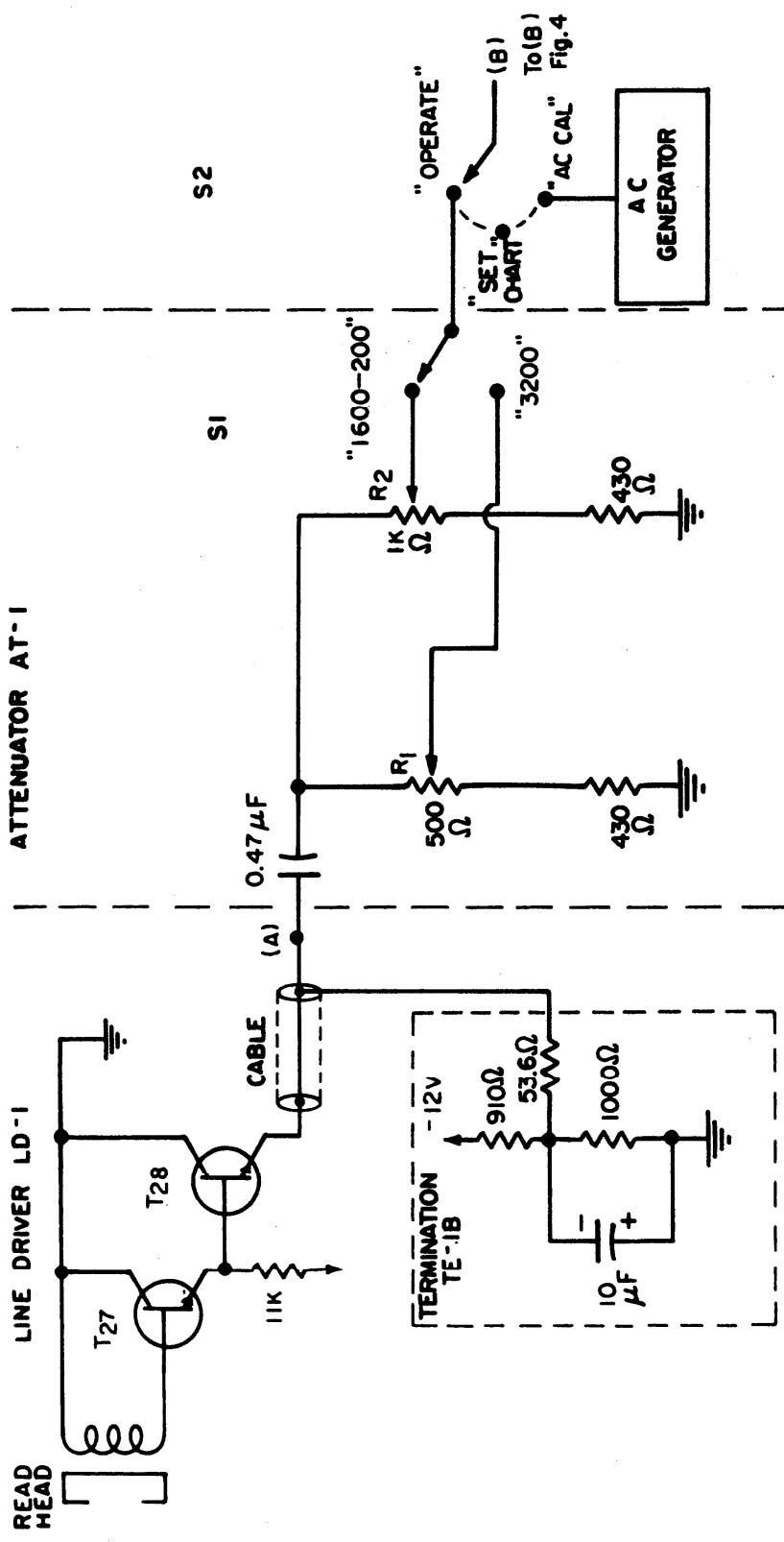

Figure 3. Signal Amplitude Read Channel Circuit Diagrams

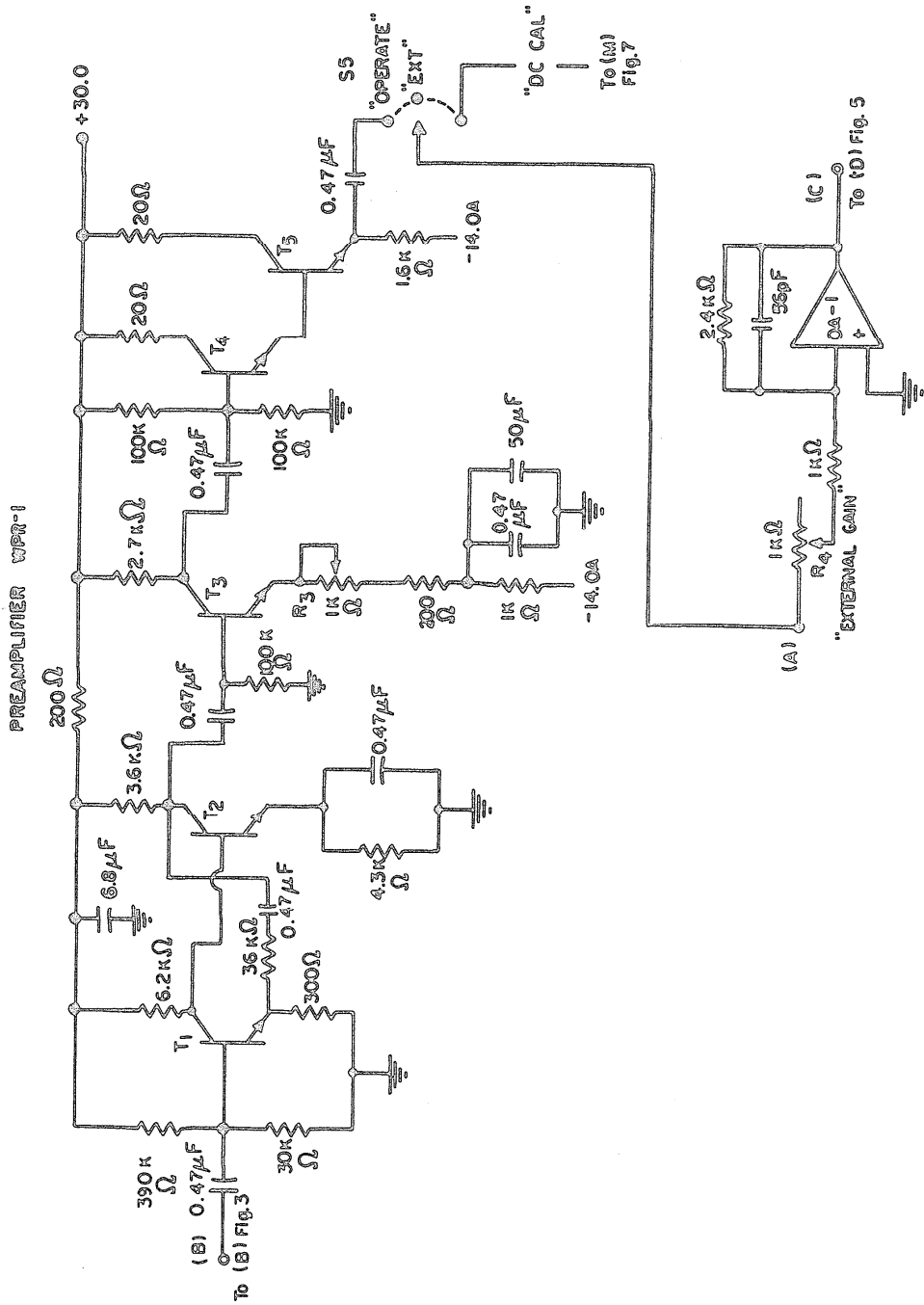

Figure 4. Signal Amplitude Read Channel Circuit Diagrams

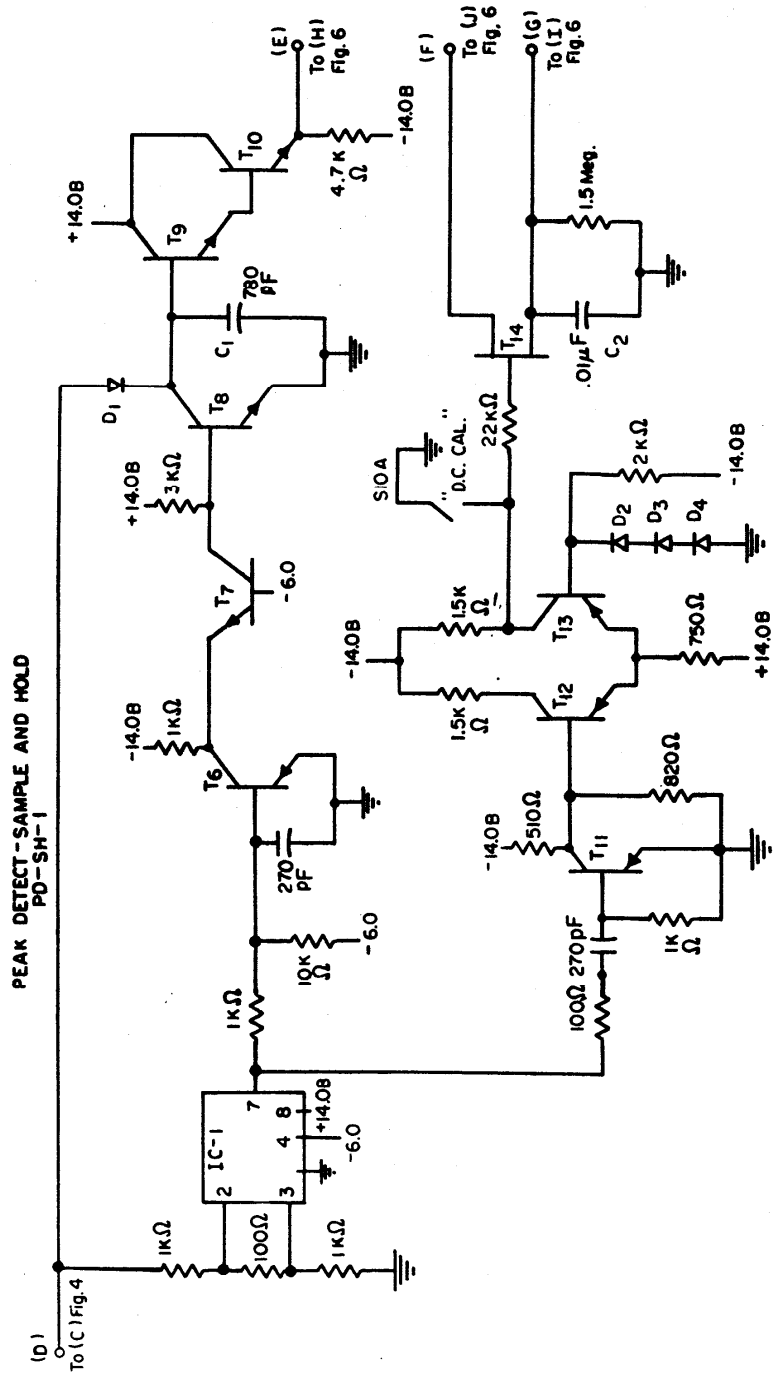

Figure 5. Signal Amplitude Read Channel Circuit Diagrams

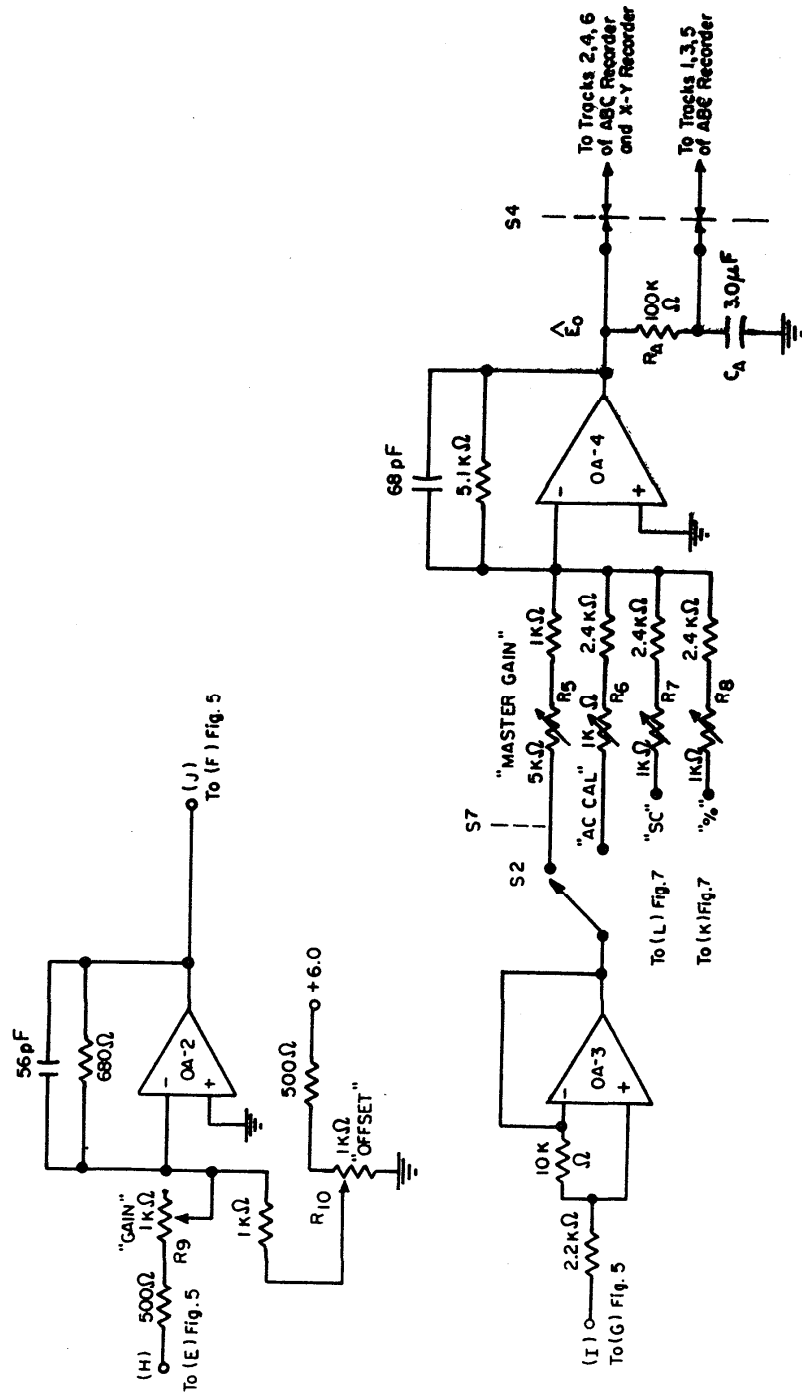

Figure 6. Signal Amplitude Read Channel Circuit Diagrams

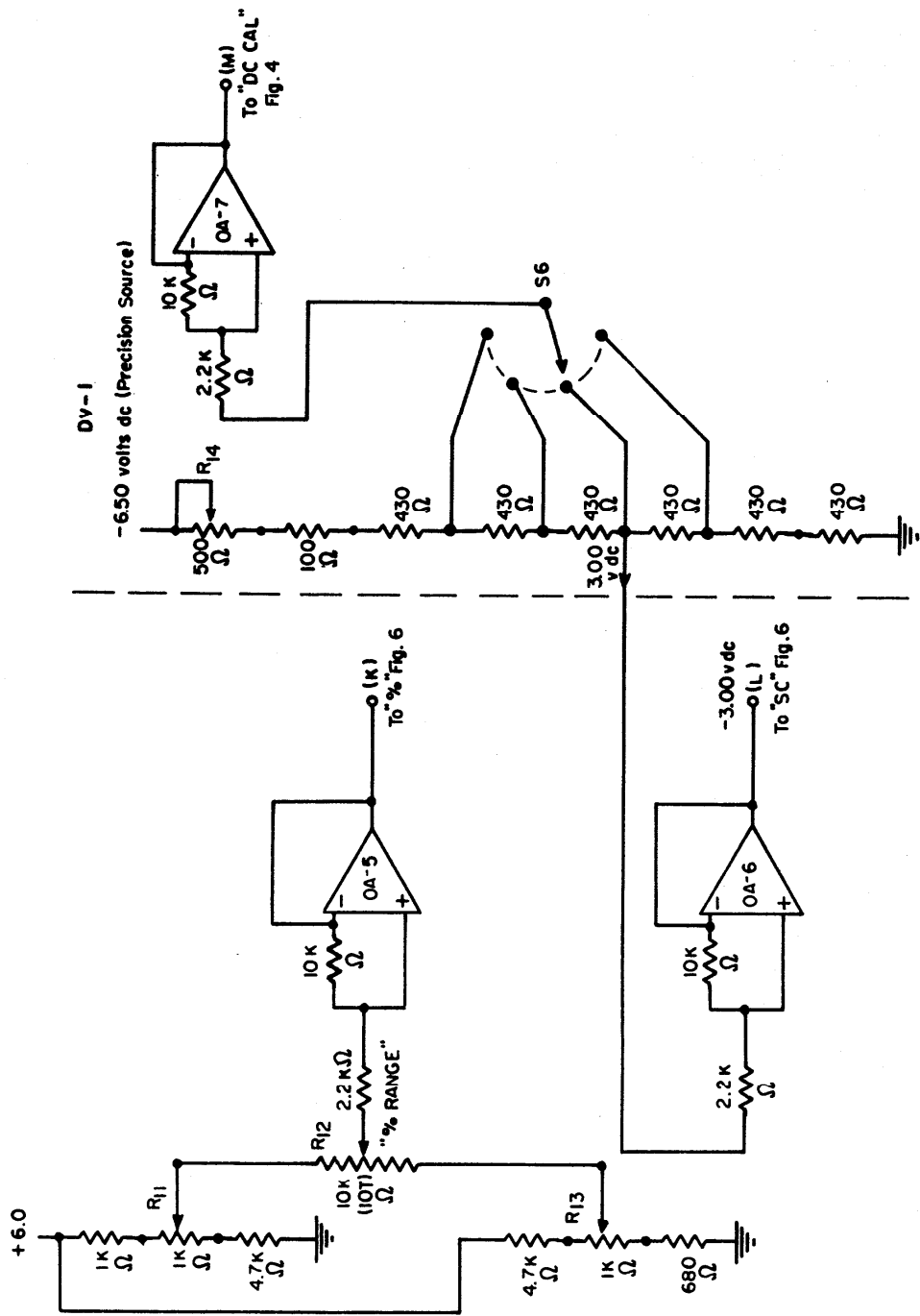
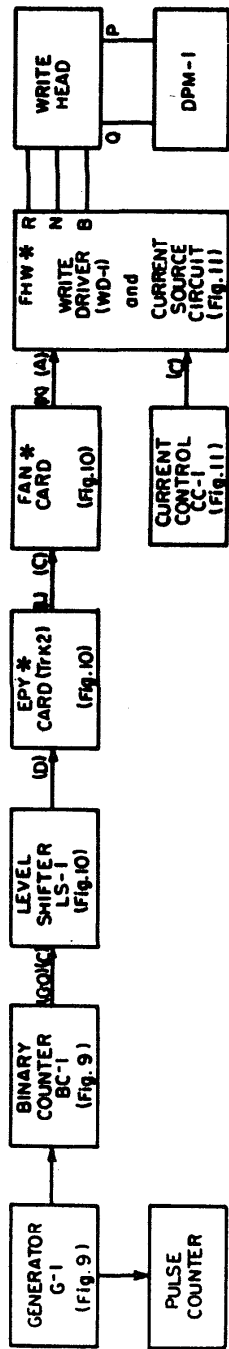

Figure 7. Signal Amplitude Read Channel Circuit Diagrams



* IBM 2401-VI System Notation

Figure 8. Write Channel Block Diagrams

BINARY COUNTER BC-1

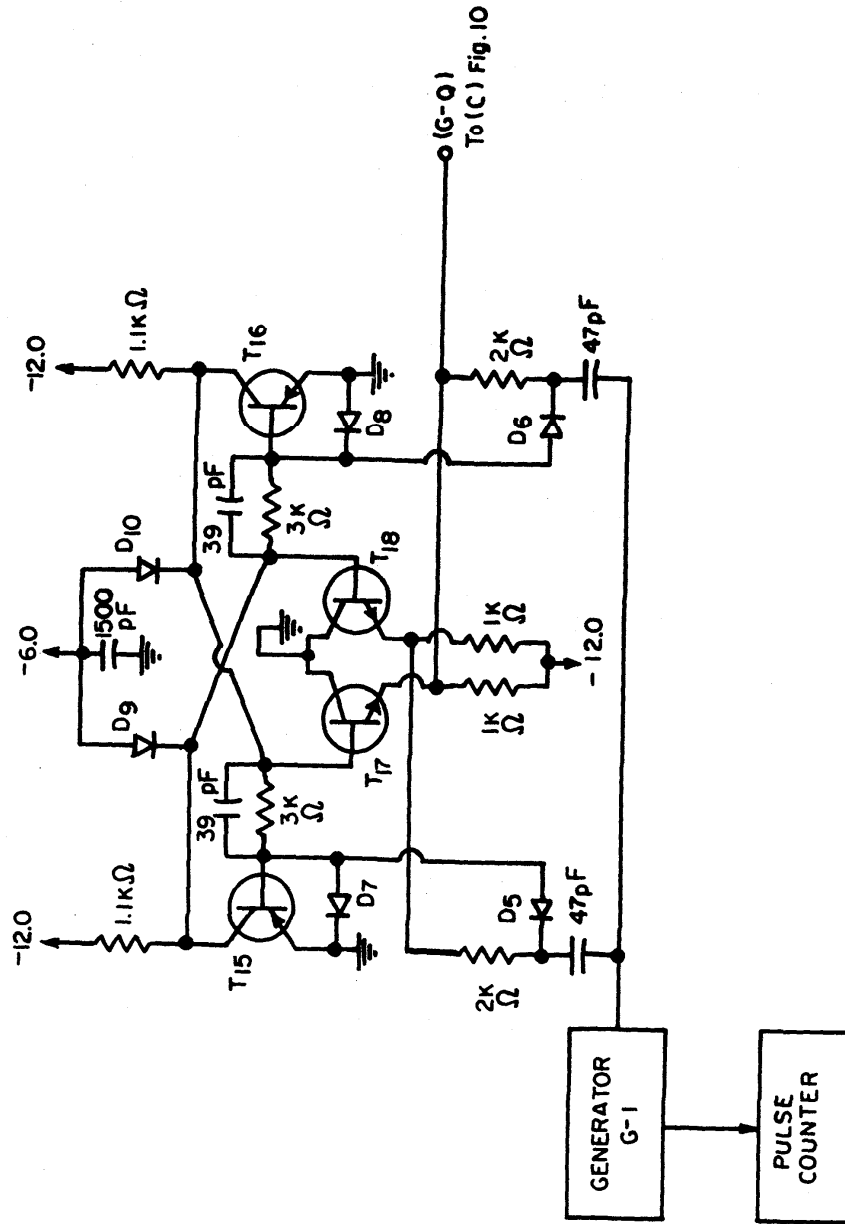

Figure 9. Write Channel Circuit Diagrams

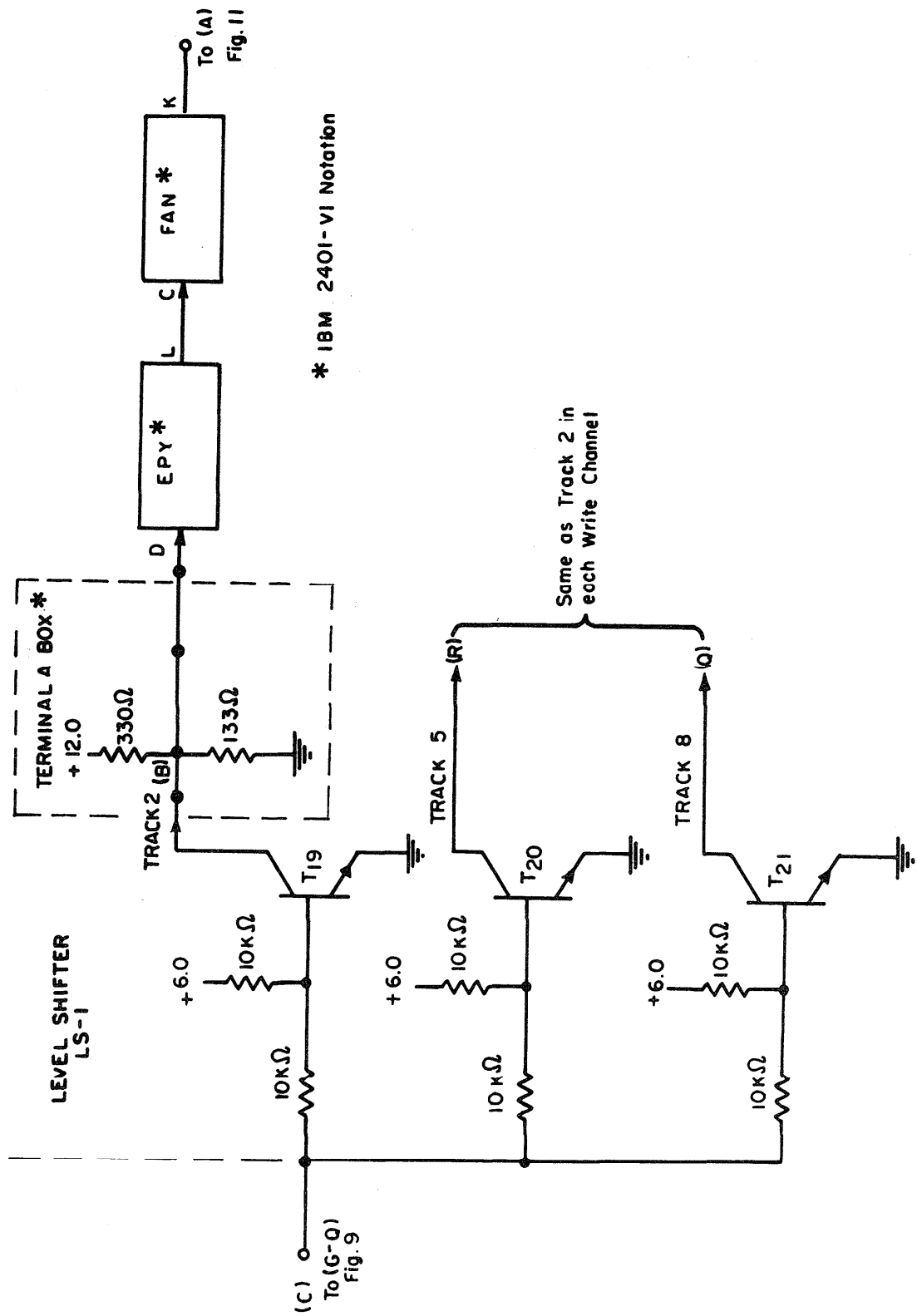

Figure 10. Write Channel Circuit Diagrams

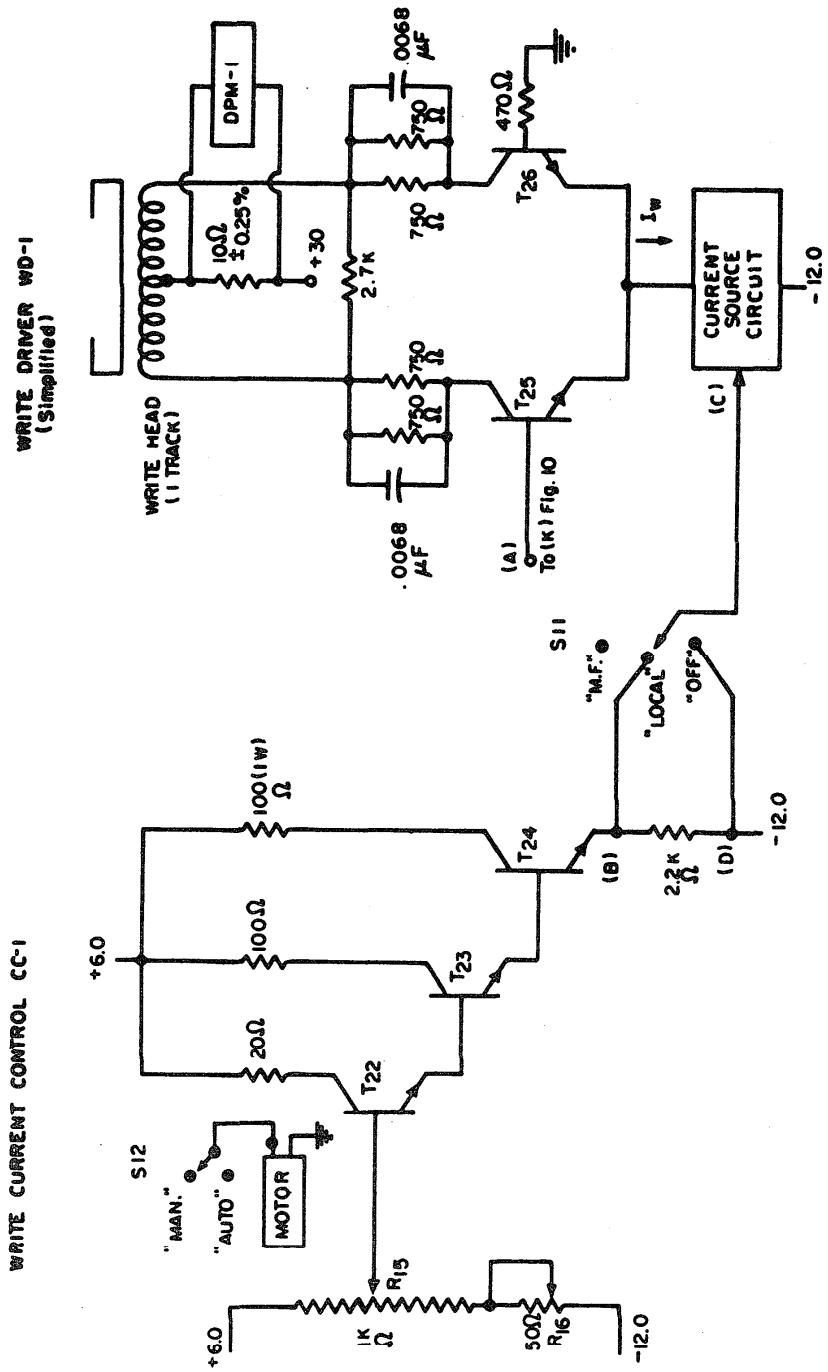
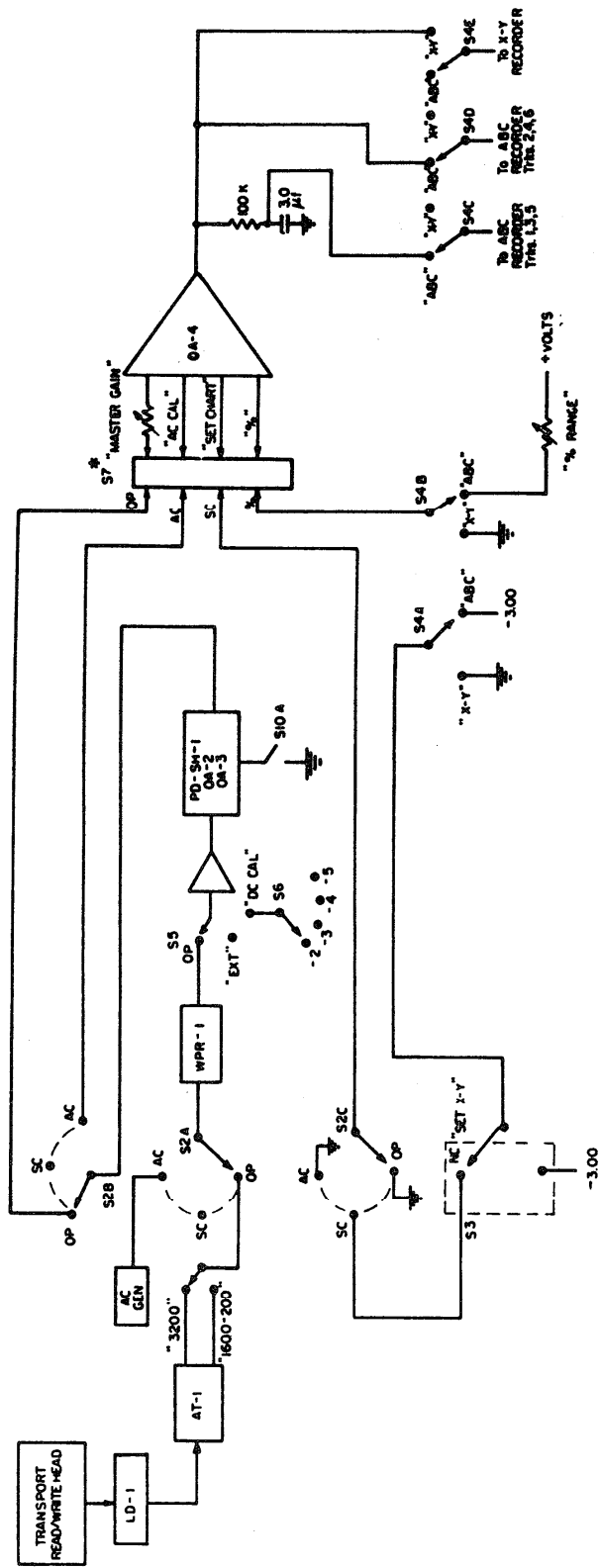

Figure 11. Write Channel Circuit Diagrams



* S7 Not shown in detail

Figure 12. Switching System for the Read Channel

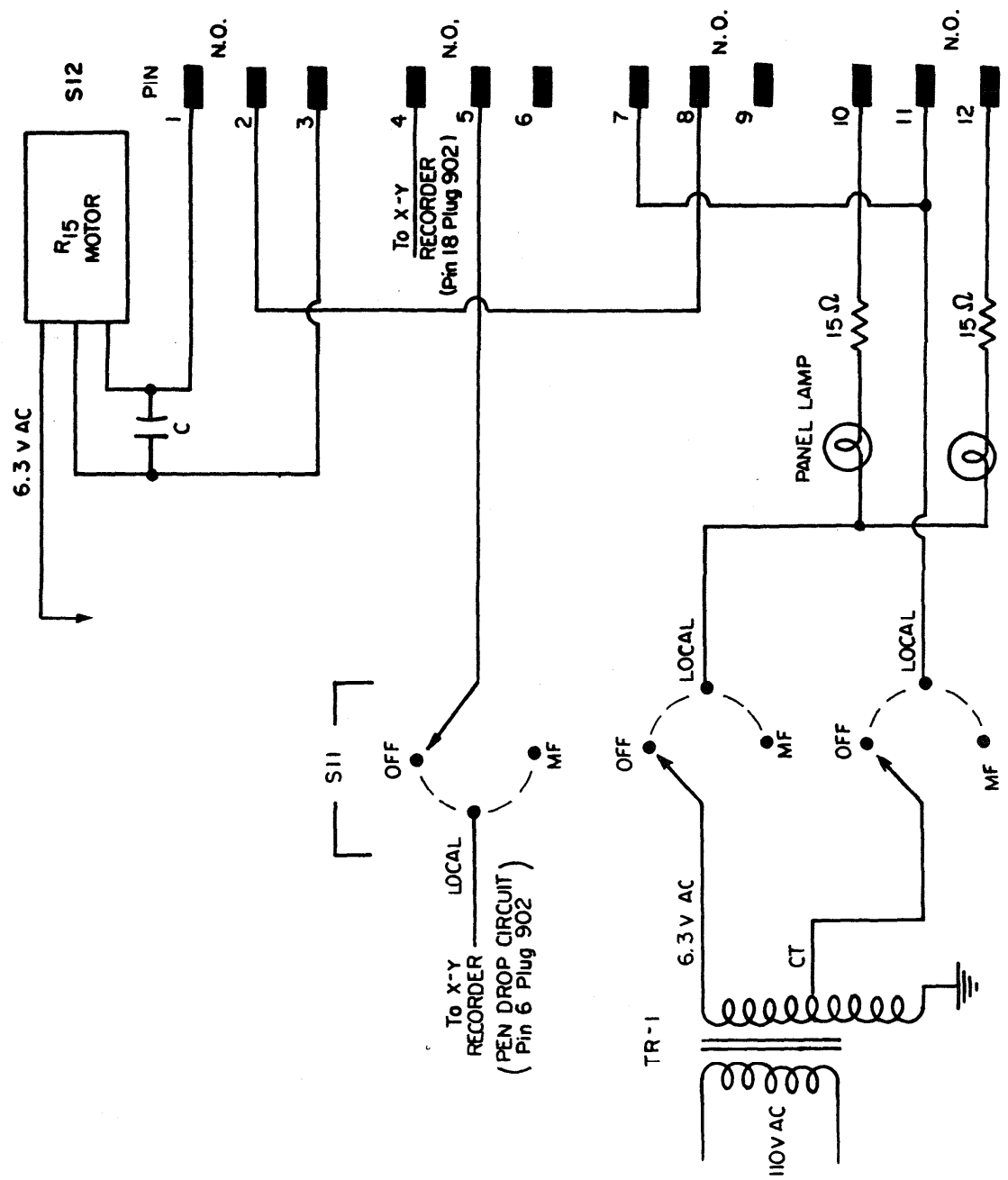

Figure 13. Switching System for the Write Channel

Figure 13. Switching System for the Write Channel

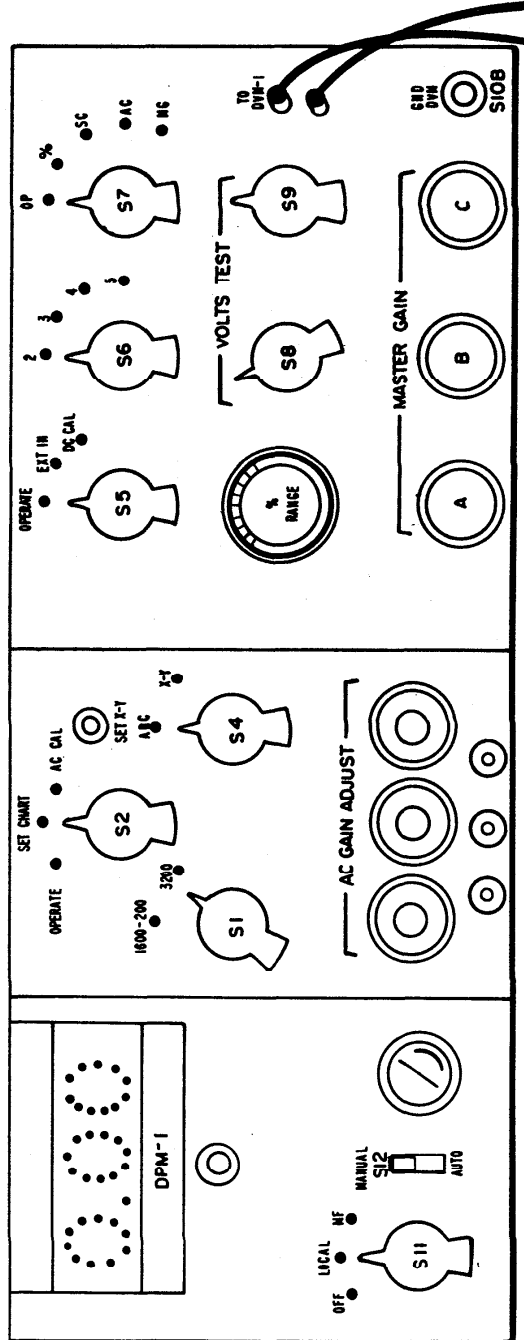

Figure 14. Front Panel Layout for the Model II System

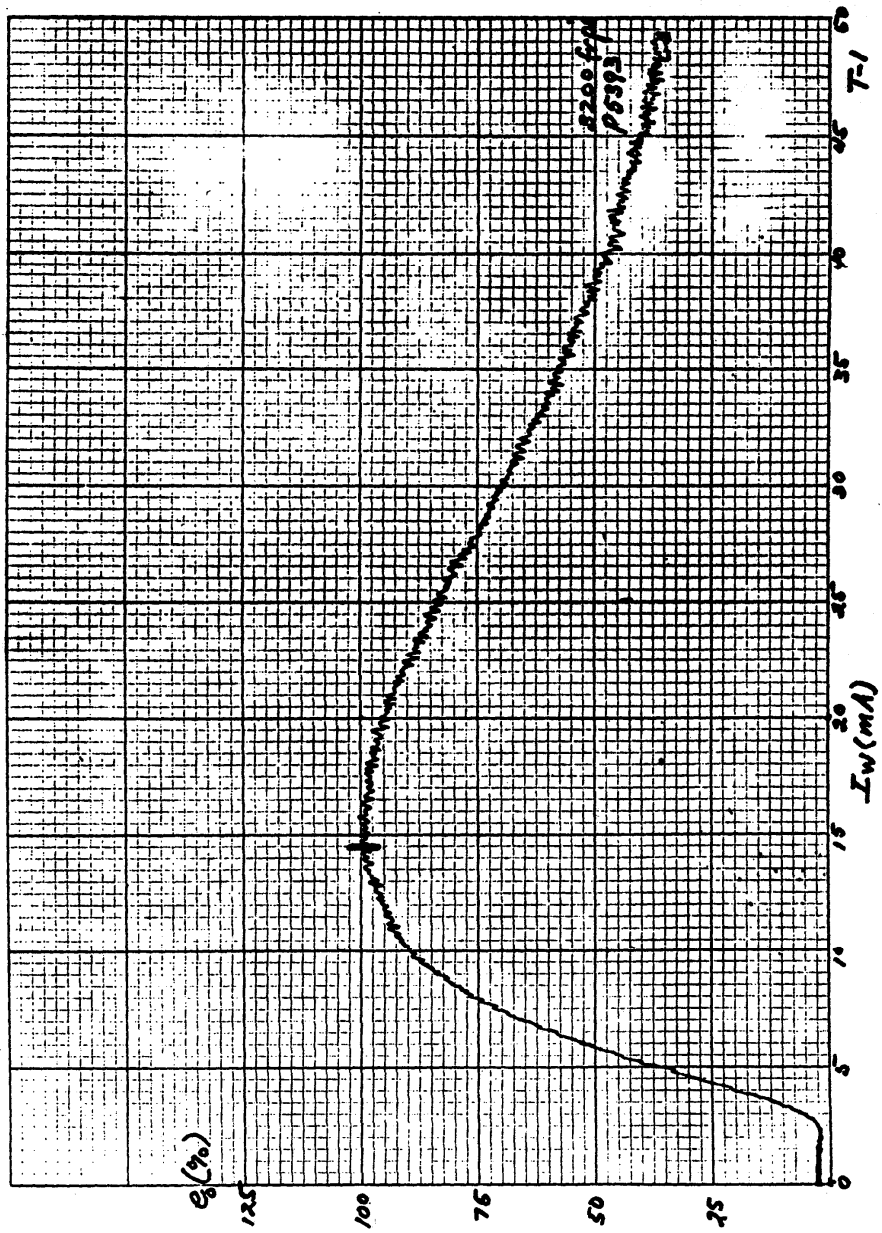

Figure 15. e_0 (%) versus I_w Curve

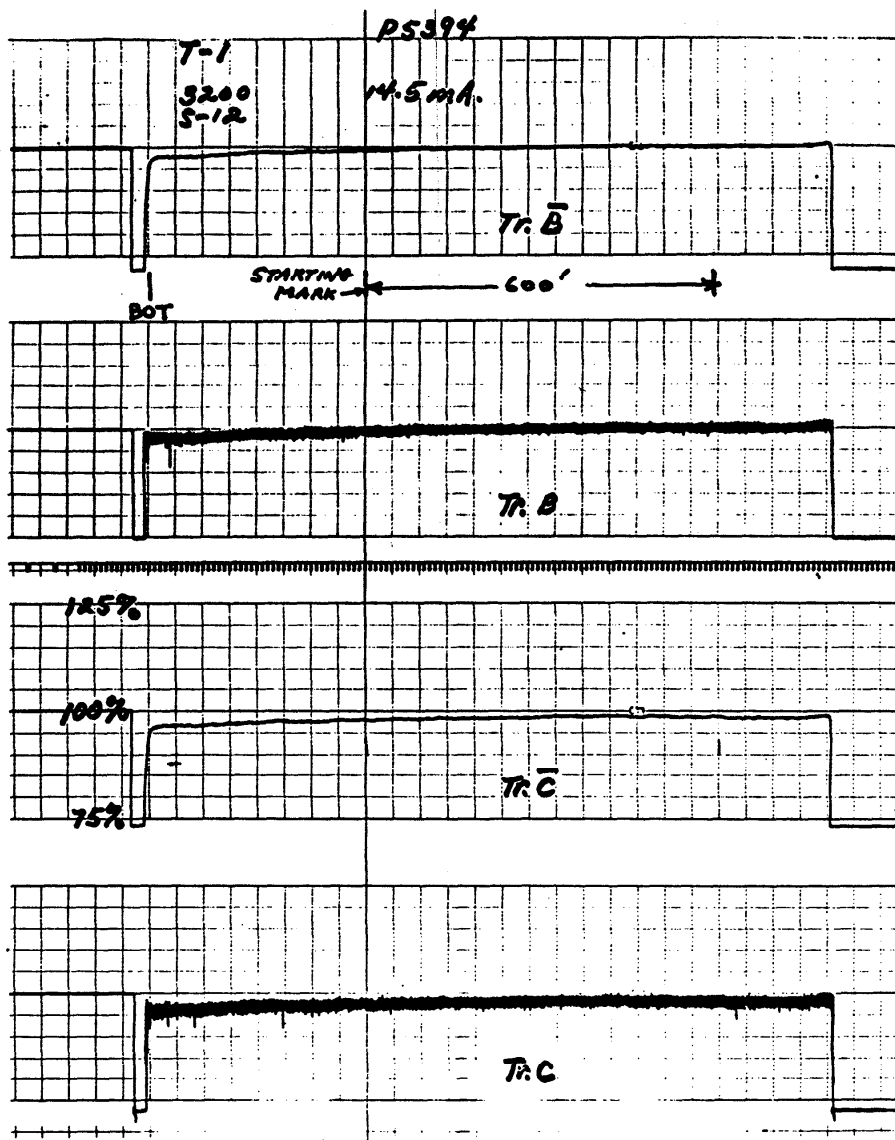

Figure 16. ABC Chart Recording