

JOINT
PUBLIC NOTICE

CHARLESTON DISTRICT, CORPS OF ENGINEERS
69A Hagood Avenue
Charleston, South Carolina 29403-5107
and the
S.C. DEPARTMENT OF HEALTH AND ENVIRONMENTAL CONTROL
OFFICE OF OCEAN AND COASTAL RESOURCE MANAGEMENT
1362 McMillan Avenue, Suite 400
Charleston, South Carolina 29405

REGULATORY DIVISION

Refer to: P/N #2007-239-2IM (Revised)

March 9, 2007

Pursuant to Section 10 of the Rivers and Harbors Act of 1899 (33 U.S.C. 403), Sections 401 and 404 of the Clean Water Act (33 U.S.C. 1344), and the South Carolina Coastal Zone Management Act (48-39-10 et.seq.) an application has been submitted to the Department of the Army and the S.C. Department of Health and Environmental Control by

LEWIS AND AMY WHITE FAMILY PARTNERSHIP, LP
6075 MOSSEY GROVE
AWENDAW, SOUTH CAROLINA 29492

for a permit to install a timber trunk in an existing dike that impounds water adjacent to waters connecting to the

ATLANTIC INTRACOASTAL WATERWAY (AIWW)

at a location at 6075 Mossey Grove, off of Bulls Island (Moore's Landing) Road, Charleston County, South Carolina (Latitude 32.94459, Longitude -79.66175)

In order to give all interested parties an opportunity to express their views

NOTICE

is hereby given that written statements regarding the proposed work will be received by both of the above mentioned offices until

12 O'CLOCK NOON, MONDAY, APRIL 9, 2007

from those interested in the activity and whose interests may be affected by the proposed work.

The proposed work consists of the construction of a timber trunk for outfall through an existing dike at an existing lake. The timber trunk will measure 6' x 2'. See attached drawings for the location and details of the project. The purpose of the proposed work, as stated by the applicant, is for the owner's private, recreational use.

NOTE: This revised public notice is being issued to replace an incorrect public notice issued February 23, 2007. Only comments received in response to this revised public notice will be considered in the decision making process.

NOTE: Plans depicting the work described in this notice are available and will be provided, upon receipt of a written request, to anyone that is interested in obtaining a copy of the plans for the specific project. The request must identify the project of interest by public notice number and a self-addressed stamped envelope must also be provided for mailing the drawings to you. Your request for drawings should be addressed to the

**U.S. Army Corps of Engineers
ATTN: REGULATORY DIVISION
69A Hagood Avenue
Charleston, South Carolina 29403-5107**

The District Engineer has concluded that the discharges associated with this project, both direct and indirect, should be reviewed by the South Carolina Department of Health and Environmental Control in accordance with provisions of Section 401 of the Clean Water Act. As such, this notice constitutes a request, on behalf of the applicant, for certification that this project will comply with applicable effluent limitations and water quality standards. The work shown on this application must also be certified as consistent with applicable provisions the Coastal Zone Management Program (15 CFR 930). The District Engineer will not process this application to a conclusion until such certifications are received. The applicant is hereby advised that supplemental information may be required by the State to facilitate the review.

This notice initiates the Essential Fish Habitat (EFH) consultation requirements of the Magnuson-Stevens Fishery Conservation and Management Act. Implementation of the proposed project would impact estuarine substrates and emergent wetlands utilized by various life stages of species comprising the red drum, shrimp, and snapper-grouper management complexes. Our initial determination is that the proposed action would not have a substantial individual or cumulative adverse impact on EFH or fisheries managed by the South Atlantic Fishery Management Council and the National Marine Fisheries Service (NMFS). Our final determination relative to project impacts and the need for mitigation measures is subject to review by and coordination with the NMFS.

The District Engineer has consulted the most recently available information and has made no determination of effect on any Federally endangered, threatened, or proposed species. This public notice serves as a request to the U.S. Fish and Wildlife Service and the National Marine Fisheries Service for any additional information they may have on whether any Federally listed or proposed to be listed endangered or threatened species and/or designated or proposed critical habitat may be present in the area which would be affected by the activity, pursuant to Section 7(c) of the Endangered Species Act of 1973 (as amended).

Pursuant to Section 106 of the National Historic Preservation Act (NHPA), this public notice also constitutes a request to Indian Tribes to notify the District Engineer of any historic properties of religious and cultural significance to them that may be affected by the proposed undertaking.

In accordance with the NHPA, the District Engineer has also consulted the latest published version of the National Register of Historic Places for the presence or absence of registered properties, or properties listed as being eligible for inclusion therein, and this worksite is not included as a registered property or property listed as being eligible for inclusion in the Register. To insure that other cultural resources that the District Engineer is not aware of are not overlooked, this public notice also serves as a request to the State Historic Preservation Office to provide any information it may have with regard to historic and cultural resources.

Any person may request, in writing, within the comment period specified in this notice, that a public hearing be held to consider this application. Requests for a public hearing shall state, with particularity, the reasons for holding a public hearing.

The decision whether to issue a permit will be based on an evaluation of the probable impact including cumulative impacts of the activity on the public interest and will include application of the guidelines promulgated by the Administrator, Environmental Protection Agency (EPA), under authority of Section 404(b) of the Clean Water Act and, as appropriate, the criteria established under authority of Section 102 of the Marine Protection, Research and Sanctuaries Act of 1972, as amended. That decision will reflect the national concern for both protection and utilization of important resources. The benefit which reasonably may be expected to accrue from the project must be balanced against its reasonably foreseeable detriments. All factors which may be relevant to the project will be considered including the cumulative effects thereof; among those are conservation, economics, aesthetics, general environmental concerns, wetlands, historic properties, fish and wildlife values, flood hazards, flood plain values, land use, navigation, shoreline erosion and accretion, recreation, water supply and conservation, water quality, energy needs, safety, food and fiber production and, in general, the needs and welfare of the people. A permit will be granted unless the District Engineer determines that it would be contrary to the public interest. In cases of conflicting property rights, the Corps of Engineers cannot undertake to adjudicate rival claims.

The Corps of Engineers is soliciting comments from the public; Federal, state, and local agencies and officials; Indian Tribes; and other interested parties in order to consider and evaluate the impacts of this activity. Any comments received will be considered by the Corps of Engineers to determine whether to issue, modify, condition or deny a permit for this project. To make this decision, comments are used to assess impacts on endangered species, historic properties, water quality, general environmental effects, and the other public interest factors listed above. Comments are used in the preparation of an Environmental Assessment and/or an Environmental Impact Statement pursuant to the National Environmental Policy Act. Comments are also used to determine the need for a public hearing and to determine the overall public interest of the activity.

If there are any questions concerning this public notice, please contact Christopher Mims at 843-329-8044 or toll free at 1-866-329-8187.

Tract	Acres	Owner
Tract A	64.2	Lance L. White
Tract B	64.2	Lance L. White
Tract C	64.2	Lance L. White
Tract D	64.2	Lance L. White
Tract E	30.3	Lance L. White
Tract F	30.3	Lance L. White
Tract G	64.2	Lance L. White
Tract H	33.3	Lance L. White
Tract I	27.8	Lance L. White

NOTE: ALL TRACTS ARE SUBJECT TO THE TERMS AND CONDITIONS OF THE DEED OF CONVEYANCE TO SAID TRACTS.

SOUTHERN KRAFT PULP & PAPER COMPANY

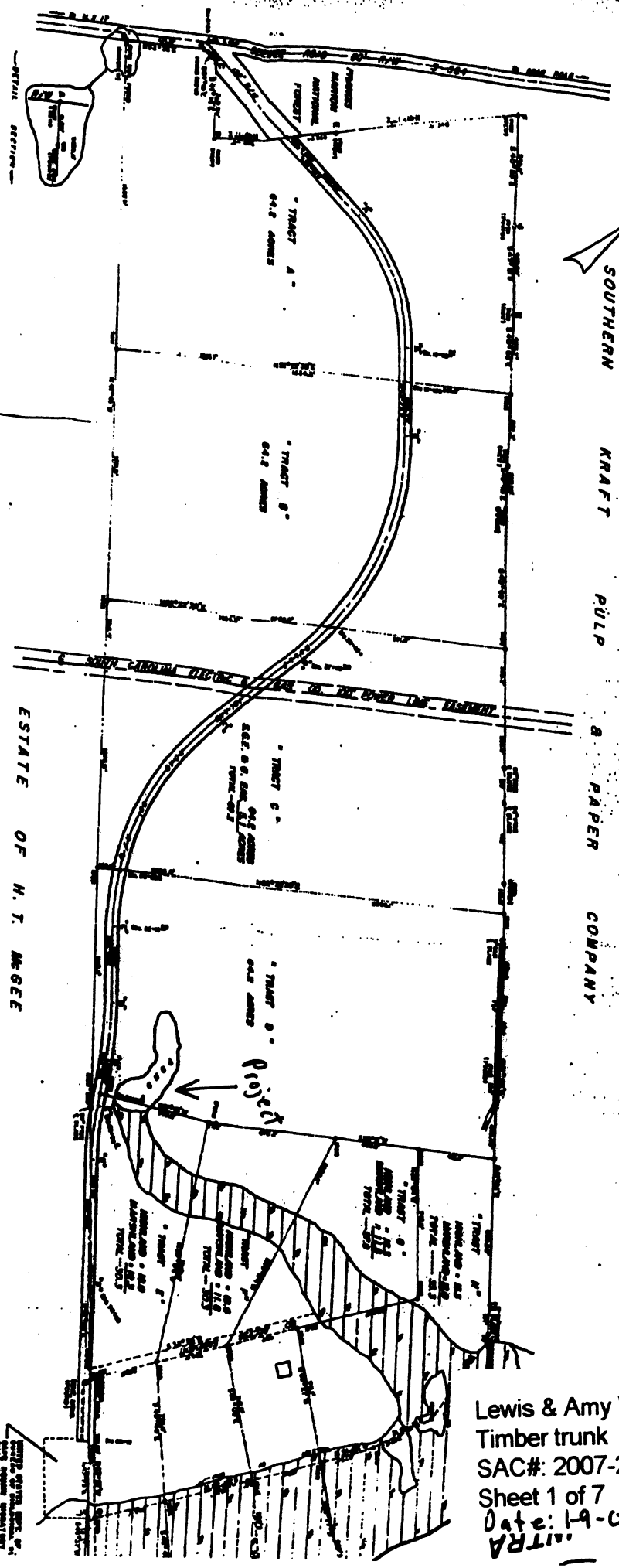

PLAT OF

ESTATE OF H. T. MCGEE

"THE GROVES PLANTATION", BEING LANDS OF THE ESTATE OF LOU S. WHITE SITUATE ON SEEWEE BAY IN ST. JAMES PARISH IN CHARLESTON COUNTY, SAID PROPERTY TO BE DIVIDED AS FOLLOWS:

- "TRACT A": CONTAINING 64.2 ACRES AND "TRACT E": CONTAINING 30.3 ACRES TO LANCE L. WHITE.
- "TRACT B": CONTAINING 64.2 ACRES AND "TRACT F": CONTAINING 30.3 ACRES TO JAMES L. WHITE.
- "TRACT C": CONTAINING 64.2 ACRES AND "TRACT H": CONTAINING 33.3 ACRES TO LEWIS C. WHITE.
- "TRACT D": CONTAINING 64.2 ACRES AND "TRACT I": CONTAINING 27.8 ACRES TO CHARLES F. WHITE.

SCALE: 1" = 400'

Lewis & Amy White Family
 Timber trunk
 SAC#: 2007-239-2IM
 Sheet 1 of 7
 20-6-1-100
 MIRA

IN WITNESS WHEREOF, I have hereunto set my hand and the seal of my office this 1st day of August, 1907.

Notary Public for the State of Louisiana

James E. Hill
Richard

Surveyed by James E. Hill
 and Richard
 on the 1st day of August, 1907.

NOTARY PUBLIC FOR THE STATE OF LOUISIANA
 JAMES E. HILL
 1907

NO.	DESCRIPTION	ACRES	DATE	BY
1
2
3
4
5
6
7
8
9
10

FRN KRAFT PULP & PAPER COMPANY

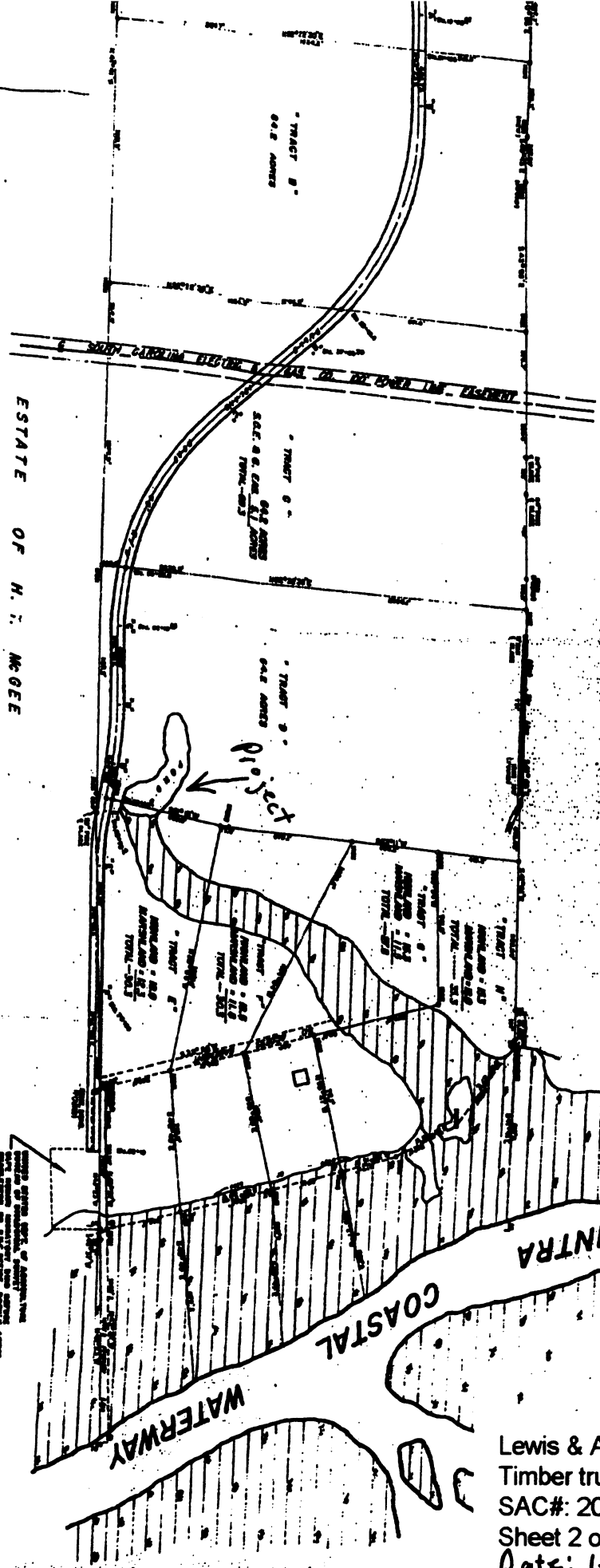

PLAT OF

ESTATE OF H. N. MCGEE

THE GROVE PLANTATION, BEING LANDS OF THE ESTATE OF LOU S. WHITE SITUATE ON SEEWEE BAY IN ST. JAMES SANTEE PARISH IN CHARLESTON COUNTY, SAID PROPERTY TO BE DIVIDED AS FOLLOWS:

- TRACT A: CONTAINING 64.2 ACRES AND TRACT E: CONTAINING 30.3 ACRES TO LANCE L. WHITE.
- TRACT B: CONTAINING 64.2 ACRES AND TRACT F: CONTAINING 30.3 ACRES TO JAMES L. WHITE.
- TRACT C: CONTAINING 69.3 ACRES AND TRACT H: CONTAINING 33.3 ACRES TO LEWIS C. WHITE.
- TRACT D: CONTAINING 64.2 ACRES AND TRACT G: CONTAINING 27.8 ACRES TO CHARLES F. WHITE.

MAY 1898

SCALE 1" = 400'

Surveyed and plotted by J. H. ...
 Witnessed by ...
 J. H. ...

WITNESSED THIS 18th day of May 1898
 J. H. ...

Lewis & Amy White Family
 Timber trunk
 SAC#: 2007-239-21M
 Sheet 2 of 7
 Date: 1-9-07



VICINITY MAP

3-D TopoQuads Copyright © 1999 DeLorme Yarmouth, ME 04096 Source Data: USGS 950 R Scale: 1 : 24,000 Detail: 13-3 Datum: WGS84

PURPOSE: TO CONSTRUCT A TIMBER TRUNK (6' x 2' ID)
ADJACENT PROPERTY OWNERS:

1. THOMAS SINGLETON
6063 MOSSEY GROVE
AWENDAW, S. C. 29429
2. CHARLES WHITE
6060 MOSSEY GROVE
AWENDAW, S. C. 29429
3. WANDO PROPERTIES, LLC
P. O. BOX 62709
CHARLESTON, S.C. 29419

Lewis & Amy White Family
Timber trunk
SAC#: 2007-239-2IM
Sheet 3 of 7

PROPOSED: TIMBER TRUNK (6' x 2' ID)
IN EXISTING LAKE

AT 6075 MOSSEY GROVE
TOWN OF AWENDAW, S. C.
CHARLESTON COUNTY, S.C.

APPLICATION BY:
LEWIS AND AMY WHITE FAMILY PARTNERSHIP, LP
6075 MOSSEY GROVE
AWENDAW, S. C. 29429

DATE: 1/09/07

LEWIS AND AMY WHITE
 FAMILY PARTNERSHIP, LP
 TMS 644-00-00-030

EXIST. POND

EXIST. DIKE

MARSH

WATER CONTROL
 STRUCTURE

Lewis & Amy White Family
 Timber trunk
 SAC#: 2007-239-21M
 Sheet 4 of 7

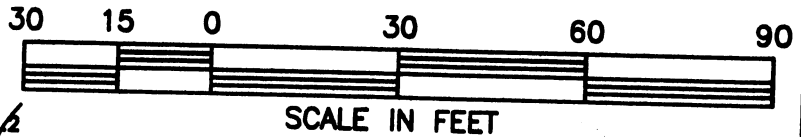
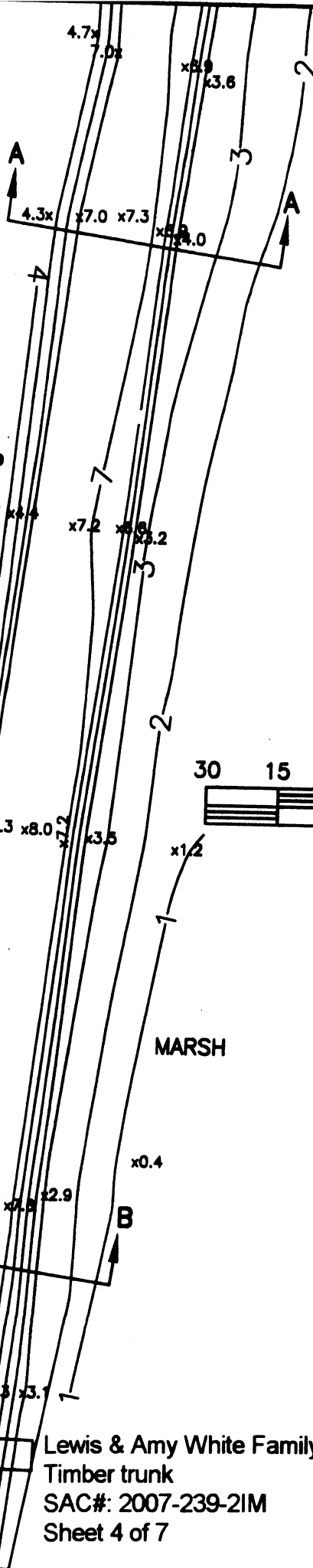

EXISTING LAKE PLAN

SCALE: 1" = 30'

DATUM: NGVD 29

PURPOSE: TO CONSTRUCT A TIMBER
 TRUNK (6' x 2' ID)

ADJACENT PROPERTY OWNERS:

1. THOMAS SINGLETON
 6063 MOSSEY GROVE
 AWENDAW, S. C. 29429
2. CHARLES WHITE
 6060 MOSSEY GROVE
 AWENDAW, S. C. 29429
3. WANDO PROPERTIES, LLC
 P. O. BOX 62709
 CHARLESTON, S.C. 29419

PROPOSED: TIMBER TRUNK (6' x 2' ID)

IN EXISTING LAKE

AT 6075 MOSSEY GROVE
 TOWN OF AWENDAW, S. C.
 CHARLESTON COUNTY, S.C.

APPLICATION BY:
 LEWIS AND AMY WHITE FAMILY PARTNERSHIP, LP
 6075 MOSSEY GROVE
 AWENDAW, S. C. 29429

DATE: 1/09/07

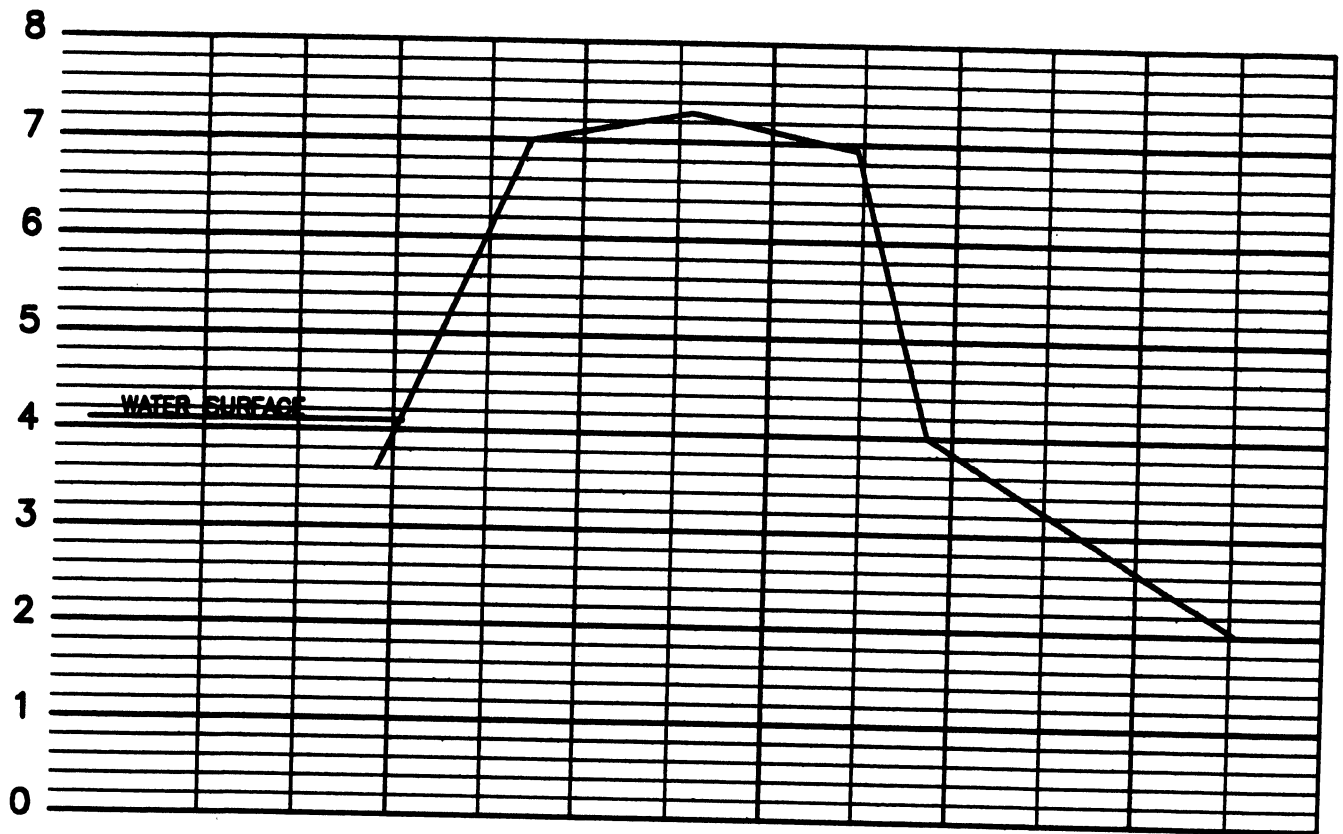

SECTION A-A

HORIZONTAL SCALE: 1" = 10'

VERTICAL SCALE 1" = 2'

DATUM: NGVD 29

PURPOSE: TO CONSTRUCT A TIMBER TRUNK (6' x 2' ID)
ADJACENT PROPERTY OWNERS:

1. THOMAS SINGLETON
6083 MOSSEY GROVE
AWENDAW, S. C. 29429
2. CHARLES WHITE
6080 MOSSEY GROVE
AWENDAW, S. C. 29429
3. WANDO PROPERTIES, LLC
P. O. BOX 62709
CHARLESTON, S.C. 29419

Lewis & Amy White Family
Timber trunk
SAC#: 2007-239-21M
Sheet 5 of 7

PROPOSED: TIMBER TRUNK (6' x 2' ID)
IN EXISTING LAKE

AT 6075 MOSSEY GROVE
TOWN OF AWENDAW, S. C.
CHARLESTON COUNTY, S.C.

APPLICATION BY:
LEWIS AND AMY WHITE FAMILY PARTNERSHIP, LP
6075 MOSSEY GROVE
AWENDAW S C 29429

DATE: 1/09/07

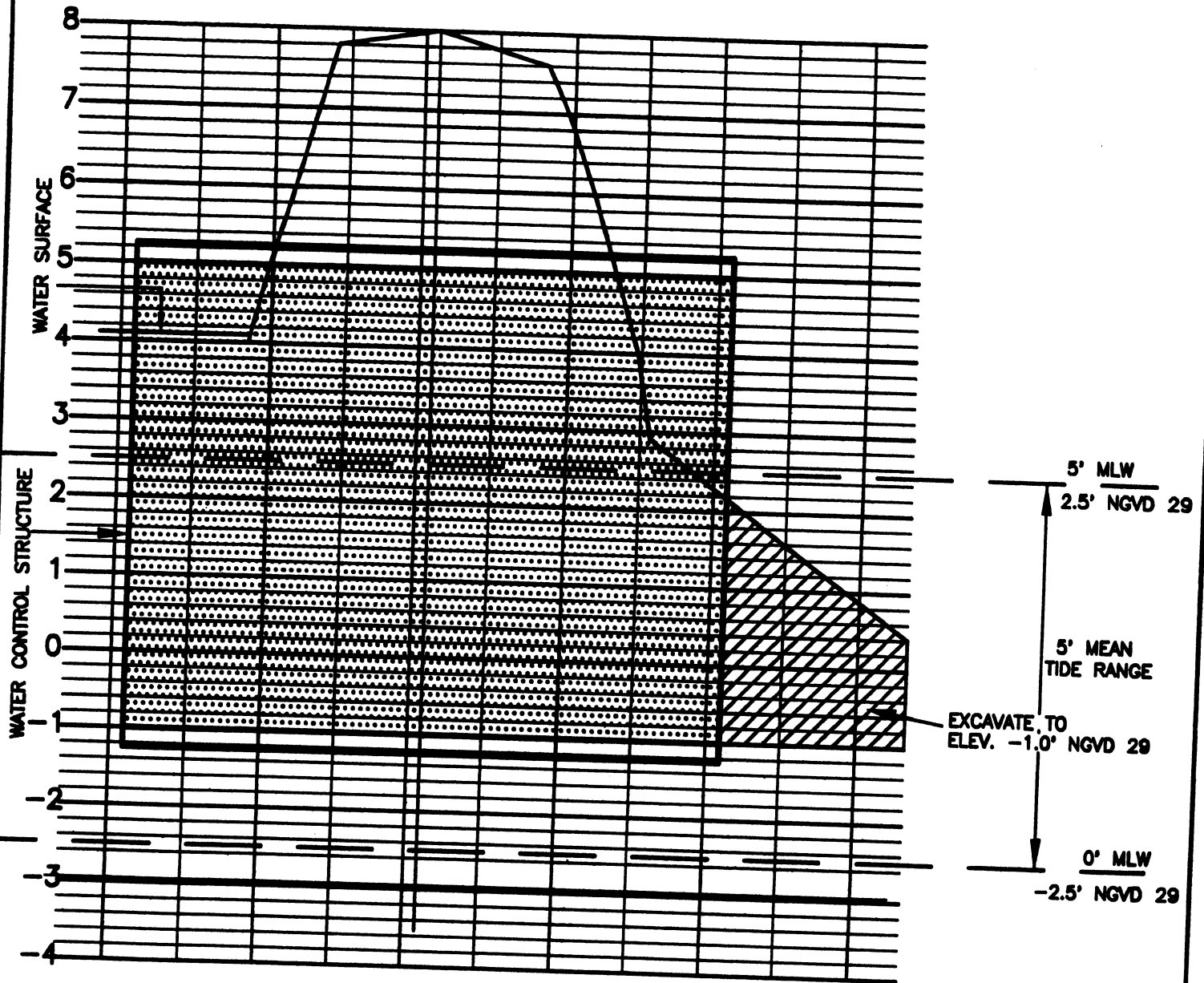

SECTION B-B

HORIZONTAL SCALE: 1" = 10'

VERTICAL SCALE 1" = 2'

DATUM: NGVD 29

NAIL IN 24" OAK
8.00' NGVD 29



PURPOSE: TO CONSTRUCT A TIMBER TRUNK (6' x 2' ID)
ADJACENT PROPERTY OWNERS:

1. THOMAS SINGLETON
8063 MOSSEY GROVE
AWENDAW, S. C. 29429
2. CHARLES WHITE
8060 MOSSEY GROVE
AWENDAW, S. C. 29429
3. WANDO PROPERTIES, LLC
P. O. BOX 62709
CHARLESTON, S.C. 29419

Lewis & Amy White Family
Timber trunk
SAC#: 2007-239-21M
Sheet 6 of 7

PROPOSED: TIMBER TRUNK (6' x 2' ID)
IN EXISTING LAKE

AT 6075 MOSSEY GROVE
TOWN OF AWENDAW, S. C.
CHARLESTON COUNTY, S.C.

APPLICATION BY:
LEWIS AND AMY WHITE FAMILY PARTNERSHIP, LP
6075 MOSSEY GROVE
AWENDAW, S. C. 29429

DATE: 1/09/07

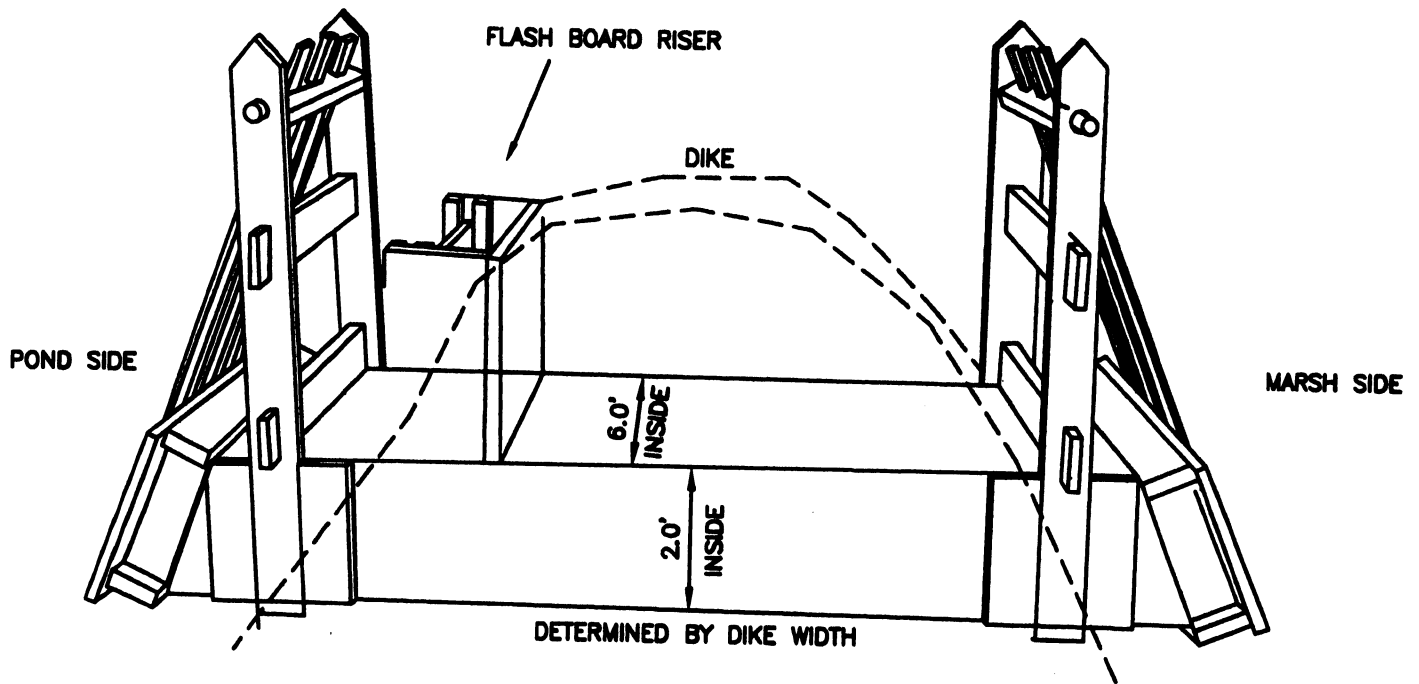

WATER CONTROL STRUCTURE DETAIL

NOT TO SCALE

PURPOSE: TO CONSTRUCT A TIMBER TRUNK (6' x 2' ID)
ADJACENT PROPERTY OWNERS:

1. THOMAS SINGLETON
 8083 MOSSEY GROVE
 AWENDAW, S. C. 29429
2. CHARLES WHITE
 6060 MOSSEY GROVE
 AWENDAW, S. C. 29429
3. WANDO PROPERTIES, LLC
 P. O. BOX 62709
 CHARLESTON, S.C. 29419

Lewis & Amy White Family
 Timber trunk
 SAC#: 2007-239-21M
 Sheet 7 of 7

PROPOSED: TIMBER TRUNK (6' x 2' ID)
 IN EXISTING LAKE

AT 6075 MOSSEY GROVE
 TOWN OF AWENDAW, S. C.
 CHARLESTON COUNTY, S.C.

APPLICATION BY:
 LEWIS AND AMY WHITE FAMILY PARTNERSHIP, LP
 6075 MOSSEY GROVE
 AWENDAW, S. C. 29429

DATE: 1/09/07