

## Chapter 5

# Construction Guidance

This chapter describes appropriate construction practices for the placement of plastic pipe that functions as an outlet works, spillway, siphon, or drainpipe in an embankment dam. Good construction practice is critical in accommodating the flexible nature of plastic pipe to avoid creating inherent deficiencies that would result in deformation or failure. Key construction issues are foundation preparation, the placement and compaction of earthfill, the selection of filter and drainage media, and the placement of filter and drainage systems.

For guidance on transportation, handling, and storage of plastic pipe, the reader should consult the manufacturer's recommendations and guidance provided in publications such as AWWA's *PE Pipe—Design and Installation* (2006) and *PVC Pipe—Design and Installation* (2002), and the PPI's *Handbook of Polyethylene PIPE* (2006), AWWA's, and Uni-Bell PVC Pipe Association's *Handbook of PVC Pipe Design and Construction* (2001).

### 5.1 Embankment Conduits

If conduits are located on foundations that are not uniform or homogenous, differential settlement can lead to problems within the conduit. If foundations consist of low strength or highly compressible materials, unacceptable deformations and lateral movements can damage the conduit. Zones of designed filter material have become the accepted method of preventing failures caused by uncontrolled flow of water through the embankment materials and foundation soils surrounding a conduit through an embankment dam. Plastic pipe that is used in the construction of new significant and high hazard potential embankment dams should be encased in properly shaped reinforced cast-in-place concrete to ensure quality compaction of earthfill against the conduit. Plastic pipe used in low hazard potential embankment dams is often not encased in reinforced cast-in-place concrete. However, use of a filter zone surrounding the conduit is a valuable defensive design measure, even for low hazard potential classification sites with favorable conditions. Some designs for low hazard potential embankment dams may not employ a filter zone around the conduit, but eliminating this valuable feature should be carefully considered and justified. Filter diaphragms should only be eliminated when extremely favorable soil conditions, good conduit construction materials and methods, reliable construction

practices, and favorable foundation conditions exist. For detailed construction guidance involving conduits, see FEMA's *Technical Manual: Conduits through Embankment Dams* (2005). Discussions within that reference include:

- Understanding the importance of excavation and foundation preparation for the installation of conduits. Special attention is needed for any excavations made transverse to the centerline or axis of the dam where the excavation backfill may be different in compressibility than the adjacent foundation materials.
- How the settlement of the dam near the conduit can create a hydraulic fracture mechanism.
- Recommendations for proper backfilling of embankment materials against the conduit. Problematic soils such as broadly graded soils and dispersive clays are defined, and the potential problems associated with them are included.
- The theory behind the concept for using filter zones to prevent erosion of earthen embankments near conduits caused by the uncontrolled flow of water through soils surrounding conduits that penetrate the dam.
- The type and configuration of the filter zone depends on site conditions and soils used in the embankment dam. Three basic designations for filter zones associated with conduits are discussed: filter diaphragms, filter collars, and chimney filters. Examples of typical designs used by the major design agencies are included.

### 5.2 Drainpipes and Filters

Construction of drainage systems consisting of drainpipes and filters is critical to the successful performance of embankment dams. Incorrect drainpipe and filter construction techniques can lead to contractor claims and unexpected performance during first filling, which can lead to embankment dam failure.

Corrugated plastic pipe is supplied in coils and straight tubes, depending on the pipe's wall thickness and stiffness. Manufacturers' recommendations should be followed for installation of plastic pipe. While axial bending or "snaking" may be permissible for less stiff products to accommodate directional changes in the alignment, it should not be allowed for products distributed as tubes. Some small changes in direction may be allowable for specially designed gasketed joints in PVC pipe, but this should be minimized to avoid the potential for joint leakage. Changes in directional alignment for tube products should always be accomplished using prefabricated fittings (figure 66), such as elbows or sweeping bends. See NRCS's

*Structural Design of Flexible Conduits*, chapter 52 (2005) or Uni-Bell's *Handbook of PVC Pipe* (2001), for additional guidance on longitudinal bending of plastic pipe.

At some sites, rodents, snakes, amphibians, and other animals may take up residence in drainpipes and other small outlets. This can be problematic if nests or blockages are built by the animals. To prevent animal entry into drainpipes, screens, bars, or flap gates can be installed at the downstream end. Caution should be used when installing screens, since they can become clogged with sediment or algae growth. Typically, clogging by algae growth is a function of the screen opening size where smaller openings lead to a greater chance of clogging.

Additionally, the design of the end protection should allow easy access by CCTV inspection equipment.



**Figure 66.**—Prefabricated 22.5-degree bend for profile wall corrugated HDPE pipe.

The following sections will address critical construction techniques for both drainpipe placement and earthwork associated with the filter zones. Discussion is also presented that addresses issues associated with filter processing and handling prior to placement.

The Ganado Dam case history in appendix B illustrates the importance of proper drainpipe installation.

### 5.2.1 Foundation preparation

While foundation preparation is important for drainpipe installations, it is not as critical as it is for embankment conduits. The major issue related to foundation preparation for drainpipes is the same as for conduits (e.g., settlement). The likelihood for differential settlement is greater than for uniform settlement due to the heterogeneous nature of most foundations. This differential settlement can lead to sags and joint separation, even in well constructed pipe laid to the correct grade during installation. For a detailed description of foundation preparation, see chapter 5 in FEMA's *Technical Manual: Conduits through Embankment Dams* (2005). Discussions in that reference, and variance, include:

- Proof rolling is recommended on soft foundations to help limit differential settlement and provide a uniform grade to lay the pipe on. Any offset in grade

produced by the proof rolling can be corrected during the placement of the filter material.

- Rock foundations can be excavated by ripping or blasting. If blasting is used, care should be taken not to damage the foundation by incorrect blasting techniques. Line drilling is the preferred excavation method in this instance. For drainpipe installations, cleaning and backfilling of joints and fractures is not required. The amount of cleanup required in rock foundations for drainpipe is limited to sufficient effort to produce a foundation that is readily mapped for foundation acceptance requirements. Removal of sharp edges and other rough surfaces is not required since these irregularities will be covered with filter material.
- Rock foundations in material that is subject to slaking should be cleaned of slaked material no more than 24 hours prior to filter placement. Protective slabs (mud slabs) are not required for drainpipe installations.
- Soil foundations should be free of organic material, such as roots and stumps, sod, topsoil, wood trash, or other foreign material. Other objectionable materials that may require removal include very low shear strength, highly compressible, and collapsible soils.
- Water control and removal are critical for both soil and rock foundations. As a minimum, the foundation should be free of water to enable the foundation mapping and acceptance to be performed. Placement of filter materials should not be made through standing water. Mud or other saturated soil should be removed prior to filter placement.

### 5.2.2 Placement around drainpipes

The following steps describe a common method for installation of drainpipe in a trapezoidal trench. Figure 67 shows a drainpipe being properly installed. Other methods have also been successfully used, but are not discussed in this manual. This installation method is for a two stage filter/drain system:

1. Excavate the trench as shown in figure 68.
2. Place the filter material on the trench invert and side slopes to the specified thickness and compact as shown in figure 69.
3. Place the drain material to a thickness of at least the crown of the pipe. In some instances, the entire thickness of drain material is placed as shown in figure 70.



**Figure 67.**—Trapezoidal side slopes used in drainpipe construction.

4. Excavate a small trench in the drain material to the invert elevation of the pipe as shown in figure 71.
5. Install the plastic pipe into the small trench, being careful to prevent debris or zone material from entering the pipe as shown in figure 72 (the use of temporary pipe caps is recommended). In inclement weather or other unsuitable situations, positive measures must be placed at the edges of the drain system to ensure that the materials are not contaminated. These may include for example, earthen berms, straw bales, and silt fences.
6. Place drain material around the pipe at select locations (approximately on 5-foot centers) as shown in figure 73. This material acts as an anchor so the pipe stays in place during the main backfilling. As an alternative, steel rods can be driven on either side of the pipe to anchor it. The drainpipe must be constantly monitored to ensure that its alignment remains as specified.
7. Place the remaining drain material over the pipe to the specified elevation as shown in figure 74, as this placement is made, ensure that drain material is placed in the haunch by hand labor using hand tools leaving no large voids or loose material. The drainpipe must be constantly monitored to ensure that its alignment remains as specified.
8. Place the remaining filter material to the specified grade with compaction as shown in figure 75. Note: Minimal compaction is needed for the preceding drain material placement. For guidance in compaction, see section 5.2.4.

9. Place the final miscellaneous fill or protective cap to the specified grade as shown on figure 76.

Figures 77, 78, and 79 show examples of filter and drain material placement around a drainpipe.

A number of poor practices are commonly encountered in pipe installation and should be avoided. These practices typically result in crown collapse or, in the worst case scenario, complete crushing of the pipe. They include, but are not limited to:

- Compaction of backfill using the backhoe bucket by “thumping” or setting the bucket on the backfill and lifting the end of the backhoe using the bucket.
- Wheel rolling either parallel or transverse to the pipe by any kind of construction equipment or vehicle.
- Haul roads or equipment crossing the pipe without sufficient cover. A minimum depth of 2 to 4 feet should be provided over the top of the pipe for H-20 highway truck loading (front axle load of 8,000 pounds and rear axle load of 52,000 pounds) in accordance with AASHTO standards (more depth may be required if recommended by the manufacturer). Construction equipment that exerts a loading on the top of the pipe larger than H-20 requires special consideration, and the contractor and dam owner should closely evaluate the proposed crossing method. See section 2.3 for additional guidance concerning loading from construction equipment.
- Not placing or fully compacting material under haunches of the pipe.

Placing material around plastic drainpipes can lead to damage and poor drainage when installed incorrectly. Manufacturers’ literature typically describes how to install pipe in vertically sided trenches (often using a trench box such as the “doghouse” shown in figure 80). However, vertically sided trenches should not be used for drainpipe construction in significant and high hazard potential dams; a trapezoidal section is preferred. Low hazard potential dams often utilize vertically sided trenches. Pipe installed in vertical trenches encounters arching that occurs in the fill above the pipe. This arching reduces load not only on the pipe, but also in the adjacent and overlying fill. Since arching is less likely to develop in a trapezoidal trench and load on the pipe is greater, pipe installation and backfill are critical in order to offer haunch support to the pipe so its maximum strength can be developed.

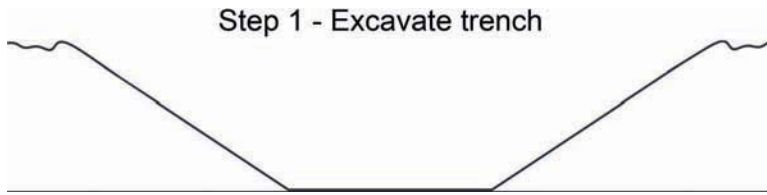

Figure 68.—Trench excavation.

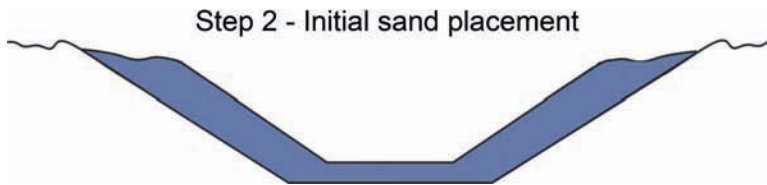

Figure 69.—Initial filter placement.

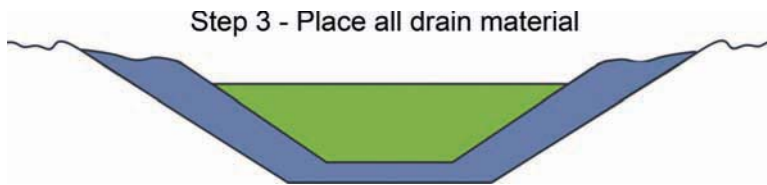

Figure 70.—Drain material placement.

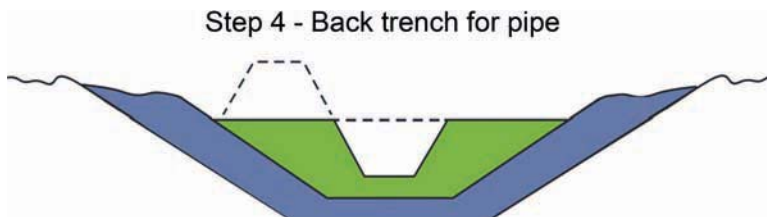

Figure 71.—Excavate for pipe.

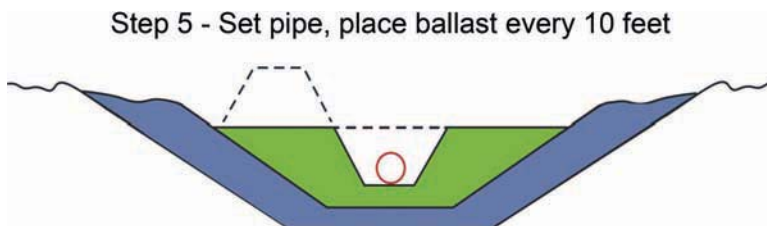

Figure 72.—Set pipe, place ballast.

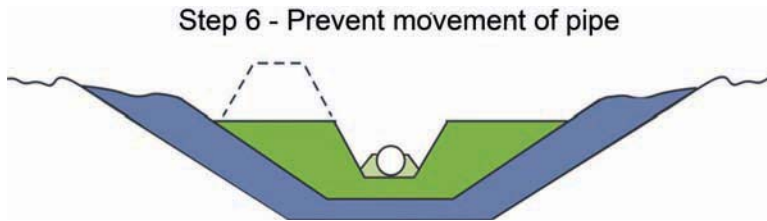

Figure 73.—Backfill haunch by hand.

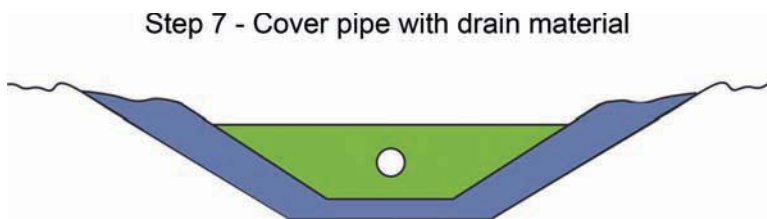

Figure 74.—Place remaining drain material.

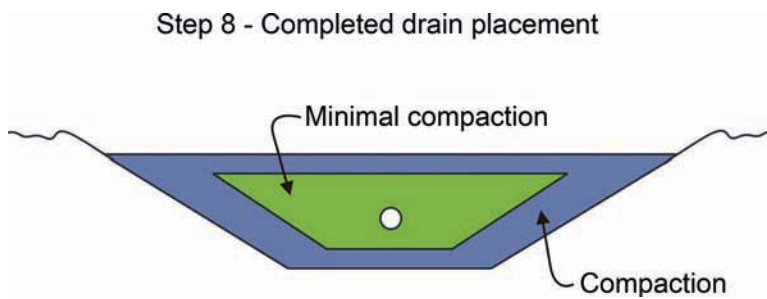

Figure 75.—Place remaining filter.

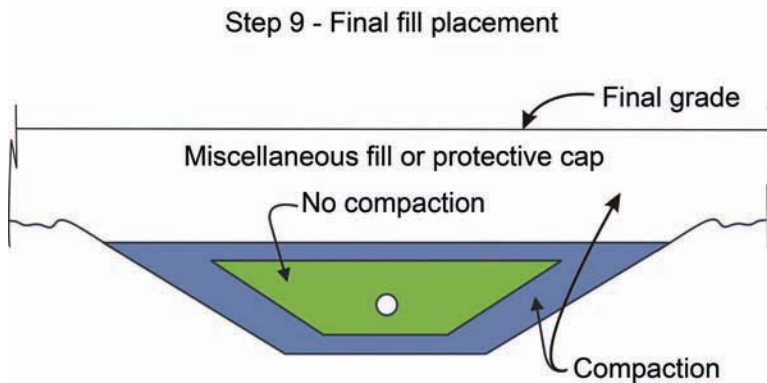

Figure 76.—Place the final miscellaneous fill or protective cap to the specified level.





Figure 77.—Initial filter placement in a trapezoidal trench.



Figure 78.—Drain material being placed over a drainpipe.



**Figure 79.**—Filter material being placed over drain material.



**Figure 80.**—A trench box or “doghouse” has been used to place material around drainpipes in vertically sided trenches in low hazard potential dams. Vertically sided trenches should not be used in significant and high hazard potential dam construction.

### 5.2.3 Segregation

Segregation during processing and placement is a common problem. Segregation may result in overly coarse filter/drain materials in contact with adjacent finer materials, which negates the effect of the filter. Incompatibility at the interface materials is the result. Many designers consider that segregation control during construction is the most important aspect of constructing a filter/drain. Segregation can have a significant bearing on the ultimate performance of the embankment dam. Figure 81 shows naturally occurring segregation.

A common cause of segregation is the manner in which material is handled. Material placed in a pile off a conveyor, or loaded from a chute, or from a hopper segregates because the larger particles roll to the sides of stockpiles or piles within the hauling unit. Material dumped from a truck, front loader, or other placing equipment almost always segregates, with the severity of the segregation corresponding to the height of the drop. When material is dumped on the fill, segregation occurs.

Segregation can be satisfactorily controlled in several ways. First, the designer should specify a uniformly graded filter or drain. Secondly, construction techniques to control segregation should be specified and enforced. Use of rock ladders, spreader boxes, and “elephant trunks” for loading hauling units, and hand working the placed materials help prevent segregation. If material is dumped, limiting the height of drop helps. Placing filter/drain material with belly dumps sometimes adequately limits segregation during placement. Limiting the width of the belly dump opening by chaining or other means can limit segregation. Using baffles in spreader boxes and other placing equipment can help reduce segregation. The personnel inspecting the filter/drain production, placement, and compaction should be apprised of the importance of limiting segregation.

### 5.2.4 Compaction methods for backfill and filter and drain materials around drainpipes

Compaction of filter and drain materials should be adequate to produce sufficient density to preclude liquefaction, limit consolidation, and provide adequate strength. However, excess compactive effort can cause particle breakdown and reduce permeability. Therefore, the amount of compactive effort should be limited to that required to produce the required strength and consolidation parameters, yet not cause excess particle breakage and unnecessarily high densities which both reduce permeability. Thought should be given to the number of passes specified instead of just using what has been used previously. If two passes will get the required density, then four passes are not justified because they will reduce permeability by causing more particle breakdown and increased density. Also, the roller operator should be made aware that it is undesirable to continue to roll after the required passes have



**Figure 81.**—Naturally occurring segregated soil. During deposition, the gravel sizes were segregated from the sand sizes. Poor construction practices can lead to similar segregation. The deposit is a broadly graded mixture of silt, sand, and gravel and is internally unstable. Note that silt has eroded into the gravel sizes and coated the particles.

been made. The idea often exists that, if two passes are necessary, three are better. This may not be the case, and the contractor and his operators should be aware so that additional passes are not made to ensure no failing densities or to fill in operator slack periods. When the specified density is not achieved during construction, typically the cause is insufficient water content in the fill (dry of optimum). A contractor may be resistant to applying water to the fill and instead will prefer to make many passes in an effort to achieve density. This will lead to material breakdown and the required density will still not be achieved. Vigilance should be exercised in assuring the contractor has the fill at sufficient water content prior to compaction (figure 82). For a pervious filter this may require that the application of water immediately precede the roller and in many cases the roller literally follows the water truck.

Most current equipment used for compaction of granular material used today possess vibratory capabilities where dynamic loading is used to achieve density. In addition to equipment compaction, granular materials can also be densified by flooding (i.e., applying sufficient water in order to achieve 100 percent saturation).

The recommended minimum density ranges from 50 to 75 percent relative density (the lower value can be used for small structures in areas of low seismic activity and the higher value used for large structures or structures in higher seismic active areas). Relative density can be determined in accordance with ASTM D 4254. Whenever grain-size limits for filters/drains are specified, the grain-size tests should be made on materials compacted to simulate as closely as possible the grain sizes and soil structure after particle breakdown caused by construction. Ring permeability tests



**Figure 82.**—Water being added to filter immediately preceding compaction. Note that this placement is occurring during a heavy rain, and wetting of the filter must continue.

made at various levels in test fills are one way to obtain realistic permeabilities representing vertical permeabilities of compacted filters and drains. Laboratory procedures that closely duplicate field placement and compaction methods can also provide reasonable values for levels of permeability to be expected in filters and drains. If proposed materials do not have sufficient permeability after compaction, changes in grain sizes should be made that will provide the required permeability.

Also, designers should consider changes in layer thickness or geometries of drains that will increase discharge capacity to the required levels, while providing the needed filter protection.

In-place density tests should be taken to verify the required density is being met. The sand cone density test, such as ASTM D 1556, will meet this need. Nuclear testing (ASTM D 2922) can also be used, although it may underestimate density in sand filters. This underestimation can lead to lift rejection and direction to the contractor to perform additional compaction. This additional compaction can lead to additional breakdown of the material, increasing its fines content. Opinions vary on the efficacy of these two test methods. The reader is directed to chapter 6 of FEMA's *Technical Manual: Conduits through Embankment Dams* (2005) for a more detailed explanation of density testing methods and their shortcomings.

### 5.2.5 Borrow sources

In general there are two potential sources for filter/drain material: undeveloped sources and existing commercial sources. For small dams it may be cost effective to

use commercial sources and for larger projects, more economical to develop a new source specifically for the job, if suitable undeveloped material exists near the job site. The availability and suitability of material must be factored into the design. For example, if suitable material is limited in quantity or expensive to obtain, it may be more economical to use thin or narrow zones (less than placement equipment width) and more intensive placement and inspection techniques to ensure construction of adequate filter/drain zones. On the other hand, if ample material is near the job site and can be economically developed, equipment width dimensions of filter/drain zones with less intensive placement and inspection techniques may be more cost effective. The designer must ensure that there is sufficient volume available to construct the work. Generally, it is prudent to have at least four times the volume of material available in borrow than is necessary to produce the final in-place volume of the filter/drain zones. For large jobs a sieve by sieve analysis should be made in order to find out which grain sizes are critical for a specific pit. If thinner zones are used, the dimensions must be checked for adequate hydraulic capacity, as discussed herein. Logical sources must be investigated and, for approved sources, appropriate information such as location, availability, ownership, drill logs, test pit logs, appropriate lab tests, and geotechnical considerations provided in the specifications. Figure 83 shows an example of a typical borrow area and processing plant.

### 5.2.6 Contamination

To avoid contamination of filter/drain zones with excess fines during construction, several techniques should be used. The zone should be maintained higher than the surrounding fill surface, and the fill should be placed to maintain drainage of surface water (and sediments) away from the filter/drain zones. This will prevent the flow of muddy water into the filter or drain. Traffic should be well controlled, with crossings limited to prepared roadways which will be removed entirely prior to placing of additional filter/drain materials (figures 84 and 85). Crossings should be

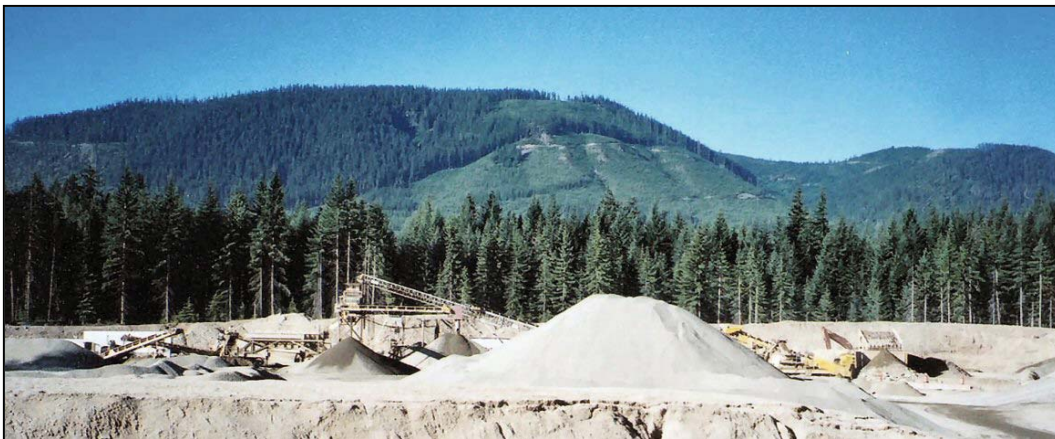

**Figure 83.**—Typical borrow area including processing plant. Produced material is in foreground and the plant is in the background.



**Figure 84.**—Roadway crossing over a filter. Photo courtesy of ASDSO (Hammer, 2003).



**Figure 85.**—Contaminated materials being excavated beneath a roadway crossing over a filter. Photo courtesy of ASDSO (Hammer, 2003).

staggered to remove any possibility of vertical transmissibility of the filter/drain zone being reduced. Durable materials should be specified, and compactive effort held to the minimum needed to obtain desired in-place density, to minimize particle breakdown during placement and compaction. Equipment for placement and compaction of filter/drain zones should be restricted to operation only on the filter/drain zones, or cleaned before moving onto the filter, to avoid unnecessary internal contamination. Commonly, equipment operators (spreading and compacting) will want to move off of the filter/drain zone when their operation is done for a particular lift. This will lead to cross contamination between zones and should be avoided. Operators should be instructed “once on the filter, stay on the filter.” In cold climates, construction seasons are often short. When the construction season is terminated, the surface of the filter/drain zones should be covered (in addition to surface drainage requirements) and the covering material removed completely before the resumption of placement in the subsequent season.

Contamination can also occur during loading, hauling, placing, and compaction because these processes tend to cause breakdown of the materials, sometimes to the extent of causing the gradation to be out of specification requirements. Specifically, trucks used to haul high fines content material may end up with that material stuck in corners of the truck box. When these trucks are then used to haul filter or drain material, this material can dislodge and end up in the filter. Truck boxes should be clean of such material before hauling filter or drain materials. Contamination can occur in the stockpile. Dust abatement control procedures and use of equipment around the stockpile that is maintained in a clean condition will reduce this problem. Reprocessing or not using the bottom foot or so of the stockpile may be necessary, since this is where the greatest contamination of the stockpile generally occurs. Generally, the concern is for an increase in the fines content, that is, material finer than a U.S. Standard, No. 200 sieve, because these fine materials can drastically reduce the filter permeability. However, breakdown of any particle size can be detrimental because this may alter the ability to filter or be filtered.

Generally, the percent fines after compaction should not exceed 5 percent to ensure that permeability is not decreased to an unacceptable degree when tested in accordance with ASTM C 117 and C 136. To achieve this, the material has to contain less than about 2 or 3 percent fines in the stockpile, depending on the durability of the particles. Durability requirements equal to those used for concrete aggregate as described in ASTM C 33 Class Designation 1N, are preferred, and will usually ensure that the material can withstand necessary processes to get them in place and compacted without excessive breakdown, and will also help ensure long-term durability during operation. Making the specifications requirement for filter material gradation in place after compaction is necessary. In some cases, such as in the case when material is preprocessed in a prior contract, after-compaction requirements are not desirable. In these cases, specifying clean material (less than 2 or 3 percent fines in the stockpile) and adequate durability becomes even more



important as well as thorough inspection to ensure the materials are not mishandled or over rolled.

### 5.2.7 Quality control and assurance

Individuals responsible for quality control and assurance should be experienced professional engineers with at least 2 years experience with design and construction of the type of drainpipe system being employed. Quality control and assurance should include the following:

For the subgrade:

- *Equipment.*—Visually inspect and verify soil processing, placement, and compaction equipment meet the requirements described in the specifications.
- *Weather conditions.*—Verify that soil placement, grading, or compaction does not occur during periods of freezing temperatures, if it is raining excessively, or if other detrimental weather conditions exist.
- *Subgrade preparation execution.* —
  1. *Subgrade preparation.*—(1) Ensure the elevation of the top surface of the subgrade is correct. (2) Verify the subgrade is smooth, free of voids, and composed of satisfactory materials. Also, verify the subgrade is compacted as specified. (3) Standard moisture and density tests are taken at the same location as the rapid tests so that results can be easily compared. Ensure that large equipment is turned off in the vicinity where sand cone tests are being performed.
  2. *Subgrade protection.*—(1) Ensure the contractor removes puddles and excess moisture from the soil surface prior to placement of additional soil, bedding, filter, or drain rock. (2) Look for areas of erosion after each rainfall. (3) Inspect for damage due to freezing and/or desiccation. (4) Ensure the contractor repairs damaged areas and reestablishes grades.
  3. *Subgrade repairs.*—If the subgrade does not conform to the specifications, the designer should assist in defining the extent of the area requiring repair. This should be done through the use of additional testing and visual inspection. Material from areas that are to be repaired should be removed and replaced. After repairs have been made, ensure retests are performed to check the repaired areas. In general, tests should be performed at the same frequency as the rest of the project. Additional testing should be performed in suspect areas.

For the bedding, filter, and drain materials:

- *Equipment.*—Verify equipment used to place and compact the materials are in accordance with the specifications and the pipe manufacturer’s recommendations.
- *Delivery, storage, and handling.*—The inspector shall be present during delivery, unloading, and stockpiling and should verify the following:
  1. Materials have not been segregated or mixed with deleterious materials during shipping, storage, and handling.
  2. Deliveries are properly recorded.
  3. The correct material type and gradation have been delivered.
  4. The materials are stockpiled with proper protection and handling.
  5. Materials that have been contaminated are rejected before placement.
- *Weather conditions.*—Verify weather conditions are acceptable for material placement.
- *Material properties.*—Verify that material is sampled and tested in accordance with the specifications and test results not meeting the requirements specified result in the rejection of applicable materials.
- *Installation execution.*—
  1. Oversize and deleterious material which could damage the performance of the system has been removed prior to placement.
  2. Drainpipes are not being damaged or moved out of alignment by placement equipment. Placement equipment should be observed from the front side as material is being spread over the plastic pipes.
  3. Excessive fines have not been generated as a result of handling and placement of the drainage materials.
  4. Wind-borne and water-borne fines do not contaminate the drainage system after placement.
  5. Erosion controls are placed such that drainage systems are not contaminated by fines.

6. Watch for ponds of water on top of the drainage system which may be an indication that an excessive amount of fines have contaminated the drainage materials.

For the drainpipe:

- *Equipment.*—Verify equipment used to place and cover pipe is in accordance with the specifications and the manufacturer’s recommendations.
- *Delivery, storage, and handling.*—The inspector should be present during delivery and unloading and should verify the following:
  1. Pipe and appurtenances are not damaged during shipping, storage, and handling.
  2. Deliveries are properly recorded.
  3. The correct material type, strength, and pipe sizes have been delivered.
  4. The size, number and location of pipe perforations are as specified.
  5. Pipes with gouges deeper than 10 percent of the wall thickness are rejected or repaired before use.
  6. Out-of-round pipe which cannot be properly joined together is rejected.
- *Weather conditions.*—Verify weather conditions are acceptable for pipe placement.
- *Material properties.*—Verify that pipe is sampled and tested in accordance with the approved manufacturer’s quality control manual and test results not meeting the requirements specified results in the rejection of applicable pipe.
- *Installation execution.*—
  1. *Pipe.*—Verify the following during pipe placement:
    - a. Pipe is carefully carried or pulled to the place of installation.
    - b. Defective or damaged pipe is not used.
    - c. Pipe is not laid when trench conditions or weather is unsuitable.
    - d. Pipe is not installed if standing or flowing water is present.
    - e. Pipe and accessories are carefully lowered into the trench.

- f. Pipe is placed at the lines and grades indicated in the plans and specifications. Verify the contractor does not lay pipe on blocks to produce the specified grade.
- g. Specified bedding is used and the bedding is graded to provide proper support of the pipe.
- h. The full length of each section of pipe rests solidly upon the pipe bedding layer with recesses excavated to accommodate couplings and joints.
- i. Compaction requirements are being met for bedding layers and haunch areas located around the pipe.
- j. Continually monitor the pipe for alignment and shape deformation during placement of “fill materials.” Correct immediately any problems identified.
- k. Partially perforated pipe is installed with the perforations facing down unless otherwise specified.
- l. Pipe and fittings are free of dirt, oil, or other contaminants.
- m. The interior of pipe and accessories are thoroughly cleaned of foreign matter before being lowered into the trench.
- n. Pinch bars and tongs for aligning or turning pipe are used only on the bare ends of pipe.
- o. Bell and spigot connections are seated properly with no foreign material introduced into the connection.
- p. If piping is butt fused, the fusion is allowed to set for the required cure time and within the recommended temperature range.
- q. All required leak tests are performed successfully prior to backfilling.
- r. When work is not in progress, open ends of pipes, fittings, and valves are securely plugged or capped so that no trench water, earth or other substance enters the pipe and fittings.
- s. The entire length of the drainage system is CCTV inspected initially when about 3 to 5 feet of fill is placed over the pipe and again prior to cleaning and completion.

## Chapter 6

# Inspection

Periodic inspection of the condition of plastic pipe is essential in detecting problems and evaluating its long-term safety and reliability. Periodic inspection may reveal trends that indicate more serious problems are developing. However, plastic pipe used in embankment conduits and drainpipes is often not inspected as part of an overall inspection of the embankment dam and appurtenant features. Generally, structural defects and deterioration develop progressively over time. A trained and experienced inspector can identify defects and potential problems before existing conditions in the dam and conduit become serious. On occasion, situations can arise suddenly that cause serious damage in a short period of time. Chapter 7 in FEMA's *Technical Manual: Conduits through Embankment Dams* (2005) provides guidance concerning modes of failure involving embankment conduits. This chapter will address the inspection of plastic pipe used in embankment conduits and drainpipes.

If changes are made in the field during construction and not accurately recorded, confusion may result during the inspection. Once plastic pipe is buried, it is difficult to find, making it difficult to service the pipe and more likely that unintentional damage will result from nearby digging. Accurate as-built construction drawings will facilitate the inspection process. Plastic pipe cannot be located using common metal pipe detection systems. Acoustical methods have been problematic when used on plastic pipes.

### 6.1 Embankment Conduits

For detailed guidance involving the inspection of embankment conduits, the reader is directed to chapter 9 in FEMA's *Technical Manual: Conduits through Embankment Dams* (2005). Discussions within this reference include:

- *Preparing for and performing an inspection.*—Good planning and preparation will ensure the successful outcome of an inspection. The inspection team should know what to look for and evaluate as the inspection progresses. The inspection team must keep proper documentation using written records and photographs. This documentation provides valuable information on changing conditions that could indicate a serious problem is developing. Confined space

precautions and proper ventilation must be considered for any man-entry in an embankment conduit.

- *Specialized inspections.*—Specialized inspection includes the use of a dive team, climbing team, remotely operated vehicle (ROV), or closed circuit television. Specialized inspection is required for embankment conduits that are inaccessible for man-entry.



**Figure 86.**—A butt fused, solid walled HDPE pipe joint in an outlet works slipliner as viewed using CCTV inspection equipment.

Figures 86 and 87 show examples of CCTV inspection of an HDPE sliplined outlet works conduit. Figure 88 shows CCTV inspection of a white HDPE pipe. Manufacturers are moving away from white HDPE pipe and are using gray or black pipe to provide better viewing of the interior of the pipe. Inspections have found that white reflected too much light, and gray or black provides a better picture.



**Figure 87.**—Looking upstream toward the control gate in an HDPE sliplined outlet works conduit using CCTV inspection equipment.



**Figure 88.**—CCTV inspection of a newly installed slipliner for an outlet works renovation.

## 6.2 Drainpipes

Before the 1990's, most drainpipes were too small in diameter to allow for adequate inspection and typically were not inspected. However, the use of CCTV equipment has allowed for inspection of many previously inaccessible drainpipes.

Unfortunately, in many existing dams, unless new access is provided, the drainpipes will likely remain uninspected, since older designs often have excessively long reaches of drainpipe or sharp bends. New drainpipe installations should always be designed to accommodate CCTV inspection equipment. The designer needs to consider the proper locations for inspection wells and cleanouts (figures 89 and 90). The reader is directed to chapter 9 in FEMA's *Technical Manual: Conduits through Embankment Dams* (2005) for a complete discussion of CCTV inspection.

The Bureau of Reclamation conducted a CCTV equipment performance study (Bureau of Reclamation, 2004) in order to assist their designers with the proper design of drainpipes to better accommodate CCTV equipment. This study evaluated the influence of drainpipe diameters, bends, invert slopes, and invert conditions on CCTV inspection equipment. The study was performed using varying configurations of profile wall corrugated HDPE drainpipe (figure 91).

The study was based on the assumption that a camera-crawler would travel up the pipe from a downstream location. Drainpipe designs that provide an upstream (upslope) access location from which the camera-crawler can enter allow for

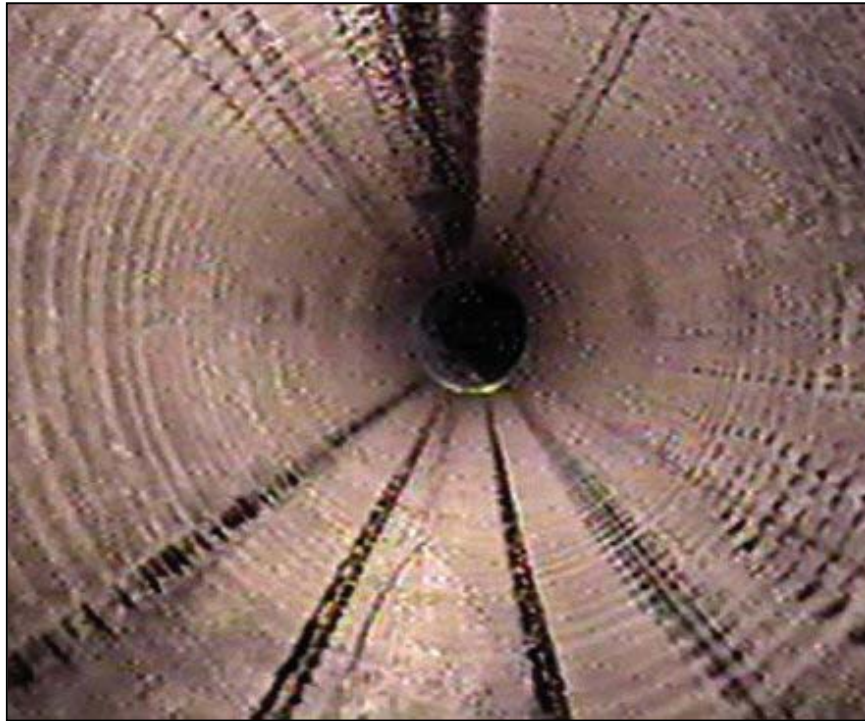

**Figure 89.**—Inspection well provides access to the drainpipe for CCTV inspection.



**Figure 90.**—Cleanout provides access to the drainpipe for CCTV inspection.





**Figure 91.**—Profile wall corrugated HDPE pipe has corrugated exterior and smooth interior surfaces.

improved cable tether pulling capacity, since the camera-crawler can move more easily downward (downslope) on a sloping decline. Sloping declines generally do not result in camera-crawler traction issues. For the camera-crawler backout process, the transport vehicle had a free-wheeling clutch mechanism on the track unit that allowed for high speed retrieval either manually or by a cable take up reel. Although not tested in this research program, an upstream access location would also benefit camera-crawler navigation around pipe bends and allow for the use of steeper invert slopes because the effect of cable drag would be lessened. Providing upstream access locations would be especially important where steeper invert slopes may be required, such as on abutments. The following summarizes the conclusions from the Bureau of Reclamation's study and provides recommendations concerning the layout of drainpipe systems to accommodate inspection using CCTV equipment:

- *Pipe diameters.*—The minimum recommended pipe diameter to successfully accommodate CCTV equipment is 8 inches. Although camera-crawlers are available for pipes smaller than 8 inches, they are very limited in cable tether pulling capacity and generally do not have sufficient traction for use in drainpipe inspection. In addition, the cameras typically only have a fixed lens, and the transport vehicle is not steerable. Camera-crawlers used in pipes with diameters between 8 and 12 inches generally have cameras with some pan, tilt, and zoom capabilities but generally are not steerable. Camera-crawlers used in

pipes with diameters of 15 inches or larger are steerable, have a greater cable tether pulling capacity, and have cameras that can provide a wider array of optical capabilities, including pan, tilt, and zoom. Where practical, the use of pipes with diameters 15 inches or larger is strongly encouraged. This allows for the use of more powerful and versatile camera-crawlers. The selection of larger pipe diameters allows for some accommodation of sediment accumulation on the pipe invert. Larger diameters also increase the likelihood of camera-crawlers getting past many types of obstructions that may exist in the pipe.

- *Pipe bends.*—The maximum recommended horizontal bend angle to successfully accommodate CCTV equipment is 22.5 degrees. In pipes with diameters of 8 and 10 inches, some camera-crawlers encounter difficulties navigating bends of 45 degrees or greater because the camera cannot clear the pipe crown as it travels through the bend, and drag friction on the tether cable reduces pulling capacity. Sweeping bends should always be used to facilitate camera-crawler navigation. For best practice in pipes of all diameters, a series of 22.5-degree bends is recommended. Each 22.5-degree bend should be connected to a minimum 5-foot length of pipe to allow the camera-crawler to navigate around the sweeping bend and provide adequate crown clearance.
- *Invert slope inclination.*—The maximum recommended invert slope inclination to successfully accommodate CCTV equipment is 5 degrees. The difference in invert slope inclination between flat and 10 degrees can reduce cable tether pulling capacity by as much as 70 percent depending upon the pipe diameter, degree of pipe bend, and the invert condition. Flat to 5-degree invert slopes would appear to be the most reasonable inclination. Slopes with inclinations greater than 10 degrees are not recommended, due to the significant loss of traction that occurs when camera-crawlers are pulling long cable tethers. If slopes greater than 5 degrees are required, upstream access locations should be provided within the pipe.
- *Distance between manholes or access entry locations (cleanouts).*—The maximum distance between manholes or access entry locations should be between 500 and 2,000 feet, but depends highly upon the pipe diameter, bends, invert slopes, and invert conditions. The designer needs to take these limitations into account when selecting the appropriate distance between manholes or access entry locations. In pipes with diameters of 8, 10, and 12 inches, the maximum distance should not exceed about 1,000 feet. This assumes that access is available on both ends of the pipe. If access will only be available on the downstream end of the pipe, then the maximum distance should be limited to about 500 feet. In pipes with diameters of 15 and 18 inches, the maximum distance should not exceed about 2,000 feet. This assumes that access is available on both ends of the pipe. If access will only be available on the downstream end of the pipe, then the maximum distance should be limited to about 1,000 feet.

The results of this study are also considered applicable for pipes constructed with PVC.

The primary cause of pipe failure is not always known. Reasons for failure could be singular or a combination of events. Failures observed are not indicative of all plastic pipe installations, but do assist in the understanding of drain reliability issues. The Bureau of Reclamation has been performing CCTV inspection of drainpipes as part of their dam safety program since about 1999. In performing these inspections a database has been developed to track the problems found within various types of drainpipe materials (Cooper, 2005). The results of these inspections show that early installations of single wall corrugated HDPE drainpipe experienced dimpling shape deformation, and/or failure in about half of all drainpipes inspected. Shape deformation ranged from minor to extensive. Figure 92 shows a single wall corrugated HDPE drainpipe experiencing buckling. Joint offsets and separations were observed in about 10 percent of all HDPE drainpipes inspected. Joint offsets and separations ranged from minor to extensive. Figure 93 shows a single wall corrugated HDPE drainpipe joint that has experienced an extensive separation and has allowed materials surrounding the drainpipe to enter through the separated joint.

HDPE is not the only type of plastic pipe that has experienced problems. Figures 94 and 95 show examples of PVC drainpipe that have failed. These pipes were damaged during construction.

The Davis Creek Dam case history in appendix B illustrates how CCTV can be utilized to inspect drainpipes.



**Figure 92.**—Single wall corrugated HDPE drainpipe experiencing failure due to buckling.



**Figure 93.**—This HDPE drainpipe has experienced joint separation allowing backfill materials to enter the drainpipe.

While the nature of plastic pipe minimizes the likelihood of plugging mechanisms (i.e., soluble encrustants, biofouling, etc.) developing within the pipe, they can still occur. For instance, calcite precipitates out of solution and forms deposits where ion concentrations in the seepage increase to the point where it exceeds the solutioning capacity of the water (Bureau of Reclamation, 2004, p. 173). This can occur at slots, perforations, and joints in the pipe. Figures 96 and 97 show examples of calcium carbonate that has precipitated out of solution as the mineral, calcite. Biofouling is the result of certain life process activities of bacteria. Bacterial growth can occur anaerobically (without oxygen) or aerobically (with oxygen). Plastic pipe lacks any nutrients in its composition, but fungi may still grow upon pipe surfaces, feeding upon nutrients that may settle or be deposited on the surface by seepage and serve as a physical support for the life cycle. Such surfaces are generally not attacked and may suffer only slight surface etching (PPI, 2000, p. 2). Bacterial growths can be soft and easily removed or can become hard and mineralized. Iron bacteria form the most common bacterial deposit (figure 98). Iron bacteria are often characterized by orange, red, brown, or black slime, unpleasant odor in water, and an oil-like film on water. Other microflora can exist in drainpipes, such as sulfate-reducing bacteria, sulfur-oxidizing bacteria, heterophic bacteria, and algae. Sampling and testing may be required to assist in planning the best course of action in dealing with plugging mechanisms.

Sediments are often encountered during a CCTV inspection (figure 99). Sediments may be transported by seepage flowing within the drainpipe and could be an indication of internal erosion occurring within the dam or foundation. Sampling and petrographic examination of the sediments may be required to assist in evaluating evidence of internal erosion.



**Figure 94.**—Slotted PVC pipe used for toe drain has experienced longitudinal cracking. The cracking occurred during construction.



**Figure 95.**—PVC pipe used for toe drain has experienced transverse cracking. The cracking occurred during construction.

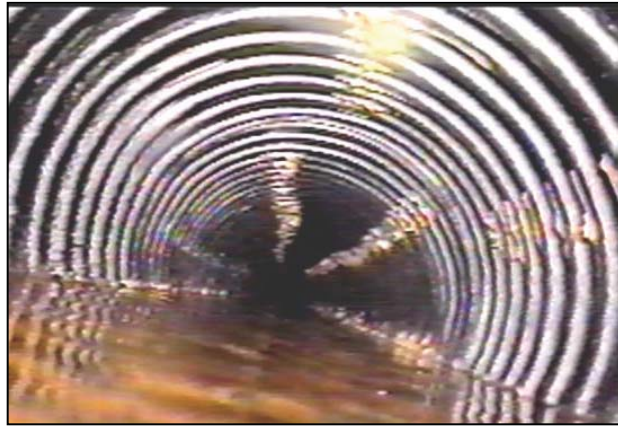

**Figure 96.**—Calcite deposits have blocked many of the slots in this HDPE drainpipe.



**Figure 97.**—Calcite deposits have formed at joints and perforations in this HDPE drainpipe.



**Figure 98.**—Iron bacteria have partially blocked the perforations in this HDPE drainpipe. Note that the only open perforation passing seepage is in the lower left corner of figure.



**Figure 99.**—Sediment deposit on the invert of a HDPE drainpipe.

HDPE drainpipe has been used in many drainpipes constructed or modified after about 1980. HDPE drainpipe, while lightweight and easily handled and installed, has experienced a significant number of shape deformation and failure instances. Many of the HDPE drainpipe failures may be related to stress cracking or improper installation of the pipe. Stress cracking is a failure mechanism which develops over time at stresses less than the yield strength. In the past, HDPE drainpipe resins have differed in the amount of SCR. Proper installation of HDPE drainpipe requires good compaction and quality control of the backfill to insure good support under the haunches. If the drainpipe is not well supported by the backfill, the drainpipe will deflect excessively and stresses will be concentrated at the crown, invert or springline. These stress concentrations can lead to premature failure. Other failures could be the result of isolated point loads from construction loading, such as equipment crossings.

The following guidelines are recommended for inspection of plastic drainpipe:

1. A preliminary CCTV inspection should be performed when 3 to 5 feet of backfill has been placed over the drainpipe. The purpose for this inspection would be to identify and repair any abnormalities, cracks, bulges, etc. early before construction is completed.
2. Another CCTV inspection should be performed when the final backfill loading over the drainpipe is completed. CCTV inspection should be performed prior to the contractor pulling the torpedo-shaped plug or pig through the drainpipe and prior to any cleaning. The purpose for this inspection would be to identify any abnormalities, cracks, bulges, etc. that may have developed since the preliminary inspection. CCTV inspection could replace the need for pulling the plug or pig through the drainpipe.

3. Subsequent periodic inspection should be performed based on the performance of the drainpipe, changes in the characteristics or quantity of the flow, or other events.

Cleaning can remove biofouling, mineral encrustation, roots, and soil deposits. Caution must be exercised in each step of the cleaning process to prevent damage. Before attempting to remove soil deposits, the engineer should consider if they are benign, like those that enter a pipe during the development of the filter (filter set), or if their removal could initiate more soil movement and make the condition worse. The fundamental guiding principle for any type of drainpipe cleaning should be “do no harm.”

After a newly installed drain system has been through first filling of the reservoir, sometimes soil material is seen in the pipe invert or in a downstream sediment trap during CCTV inspection. Concern may arise that this material could be from the foundation, but it is possible it could be from the filter and drain material itself. In order to address this concern, the method of filter and drain processing and construction quality will have to be determined. During material processing three methods can be used to produce a material of the desired gradation; crushing, dry screening, and washing. Details of the process used to produce the material in question will be needed to determine the likelihood that fine grain material exists within the filter and/or drain materials. Note that it is possible to produce filter and drain materials with small amounts of fines and still meet the specification requirements.

As an example, consider a borrow area material consisting of silt, sand, and gravel that will be used to produce a filter composed of sand and drain material composed of gravel. Upon entering the processing plant the material is dry screened separating the gravel from the silt and sand. The silt and sand go on to further processing to remove the silt, typically by using washers. This is the 'wet' side of the plant. Meanwhile, the gravel continues for additional dry screening until the final drain material gradation is achieved. This is the 'dry' side of the plant. Complications can arise on this side of the plant in that fine material, perhaps with some plasticity, can adhere to the gravel particles. For this reason drain material should be visually examined during construction for fines adhesion to the gravel particles. Experience indicates that sometimes a large amount of effort is needed to remove the fines contamination. This material can then show up in the drain system as described above. While this example describes one way fine grain material can show up in a drain, others can occur also. For this reason it should be expected that some finer material will flush out of newly constructed drain systems and plans should be made from the beginning of the job to clean the system after initial reservoir filling. This cleaning should occur after the reservoir has reached its maximum normal level so the drain system is wetted to the maximum extent.



No clear guidance exists on how to tell the difference between fines that flush out of a newly constructed drain system and material that may be coming from the foundation. However, material derived from the filter and drain materials should have a uniform appearance and should occur uniformly along pipe segments which have flow. The amount of material should also be modest, at the most, no more than one cup over a 100-foot drain length. The best indication though of the source of the material is re-examination in the second year. If no material is found in year two, then it most likely was from the filter/drain materials themselves.

Cleaning of drain systems is not yet routine (figure 100). Most drains have never been cleaned, and based on their performance, cleaning may not always be justified. CCTV inspection should precede any cleaning attempt, to ensure that cleaning will not degrade existing conditions. The proper method of cleaning a drainpipe varies according to the conditions within the pipe and the structural integrity of the pipe. Commercially available water-jet cleaning is most often used that utilizes high-pressure water spray from a nozzle. The orientation of individual jets on the nozzle of the cleaner can also be varied, depending on site conditions. In some cases, low pressure/high volume flow is best suited for sediment removal and high pressure/low volume flow is best suited for root or mineral encrustation removal. Sometimes both methods may be required at a particular site. The condition of the pipe is paramount for any cleaning attempted, and this may actually govern the cleaning method selected at a given site

Typically, it is difficult to ascertain how effective the cleaning has been, due to limited instrumentation and variations in drain flows caused by factors other than the reservoir, such as infiltration from precipitation. However, follow-up CCTV inspection after cleaning that used high pressure jet washing has shown that the biofouling and mineral encrustation was generally removed from the interior surface and some improvement of discharge from the drainpipe was often observed. No determination can usually be made as to the extent of the plugging mechanism remaining in the backfill materials surrounding the exterior of the pipe.

Any cleaning system used should always be proven effective in a similar situation and on similar pipe materials. If a new cleaning system is used, it should be tested on a piece of pipe similar to the drain to be cleaned to ensure the process will not damage the pipe.

The recommended process for drain cleaning generally includes the following six steps:

1. Record all pertinent information, including measuring drain outflows, reading all piezometers and observation wells, and walking the alignment of the drain to observe the preexisting conditions.
2. Perform an initial CCTV inspection to document existing conditions.



**Figure 100.**—Operator water jetting a drainpipe.

3. Test the cleaning system on the first short segment of pipe.
4. In cleaning the remainder of the pipe, use care to observe the entire process, including advancement rates, effluent, etc. Steps 2 through 4 may require an iterative process to ensure that cleaning procedures are not damaging previously uninspected portions of the drainpipe.
5. Reinspect the pipe using CCTV and record all other pertinent information again. This could be completed by the contractor doing the cleaning, if they have appropriate CCTV inspection equipment.
6. Document all information for use in future cleanings, if needed, and information beneficial to an evaluation of the cleaning by others. Disseminate copies of the cleaning report to the engineer and other appropriate parties.

For guidance on improving drainpipe access for inspection and cleaning activities, see section 4.3.4. For additional guidance on cleaning, see section 9.6 in FEMA's *Technical Manual: Conduits through Embankment Dams* (2005).

## Chapter 7

# Plastic Pipe Used in Tailings Disposal Facilities and Slurry Impoundments

The mining industry constructs dams for waste disposal, water supply, water treatment, and sediment control. Tailings dams are used for the disposal of “metal and nonmetal” mine waste or tailings. Slurry impoundments or coal waste impoundments are used for the disposal of fine waste from the processing (i.e. removing impurities) of coal. Tailings dams and slurry impoundments differ in many ways from traditional water storage embankment dams. For a discussion of the differences, see the *Introduction* of FEMA’s *Technical Manual: Conduits through Embankment Dams* (2005). This chapter will focus on the use of plastic pipes in tailings and slurry impoundments. Plastic pipe has been used since about 1980 in mining-industry dams for decant pipes, for internal-drain collector pipes, and for delivery pipes for slurry or tailings disposal. A decant pipe typically serves the functions of removing clarified water from the impoundment, controlling the normal water level, and drawing down the pool level following rainfall events.

The main reasons why plastic pipe has come into use, versus other types of pipe, in mine-waste disposal applications include its resistance to chemical attack, its capability to be constructed with watertight joints, its ease of construction, and its ability to tolerate deformation. More specifically, consider that:

- The drainage and the seepage from mine waste impoundments can cause chemical deterioration of pipe materials due to its acidity or alkalinity. Waste from the processing of materials such as coal and phosphate, for example, can be highly acidic.
- Some tailings dams are required to have impervious liners due to the acidity of the leachate. Plastic pipe has been used in these applications with a watertight seal provided by a boot at the point where the pipe penetrates the liner. In these cases, the potential for seepage along the pipe, and the development of a problem associated with such seepage is limited, provided careful attention is paid to design, construction, and monitoring. Some designers of tailings disposal facilities consider it best practice to avoid penetrations through embankments, whether the impoundment is lined or unlined, and use barge-mounted pumps to control the water level.

- When pressure-testing became more prevalent for decant pipes – such as in coal slurry impoundments – the fused joints of plastic pipe were able to meet the testing requirements.
- Designers have considered HDPE pipe to be beneficial for the type of foundation conditions and construction practices found at mining impoundments. The locations of these impoundments are limited to areas near the processing plants, meaning that designers need to deal with varied, and often times less than ideal, foundation conditions. Furthermore, decant pipes are extended as the impoundment is expanded and the pipes can become relatively long, sometimes exceeding 1,000 feet. Over such lengths, a flexible pipe can tolerate some differential movement due to varying foundation and installation conditions. Additionally, in the coal fields, many slurry impoundments have underground mining in their vicinity and the possibility of subsidence, or mining-induced ground movement, needs to be considered.

HDPE pipe has been the type of plastic pipe most commonly used for decant and internal drain conduits in mining applications. Decants are typically solid wall pipes in the range of 18 to 36 inches in diameter. SDR values are commonly in the range of 11 to 21.

Internal drains are used within tailings disposal facilities for various purposes such as to improve stability by lowering the phreatic surface; reduce the potential for the tailings to flow by promoting consolidation; lower the hydraulic head on an underliner to minimize seepage through the liner for environmental protection; and/or limit settlement after the surface of the tailings is capped and reclaimed. The collected seepage may be acidic, or for example, with gold tailings, contain cyanide from the processing of the gold ore. Profile wall corrugated HDPE pipe has been used for drainpipes in this type of application. The pipe has a corrugated wall on the exterior and smooth interior with slots in the recesses of the corrugations. This pipe is typically joined with snap couplings and surrounded by drainage aggregate. Pipe diameters in the 4- to 6-inch range are typically used for lateral drains that connect to main drains that may be 12 to 18 inches in diameter. The mains may be solid wall HDPE pipe. Numerous installations have been in operation for tens of years and are approaching 200 feet in height.

Another mining-industry application for corrugated plastic pipe is in the heap leaching process, where large piles of ore are leached with various chemical solutions to extract valuable minerals such as gold and copper. Perforated pipes installed under the heap collect the solution for processing of the metals. Heap leach pads can be over 300 feet high.

The design of tailings or slurry impoundments differs in many respects from the design for traditional embankment water dams. Basically, embankment dams are designed to store water, while tailings facilities are designed to form a basin for the

deposition of fine material. The tailings/slurry disposal facility designer can take advantage of this difference by, for example, minimizing the amount of free water that is stored and by using drainage to develop as “dry” a tailing/slurry deposit as is practical. Drier soils are inherently more stable than saturated soils.

The solids that settle out of suspension in a tailings/slurry impoundment can have a significant effect on seepage. Tailings or slurry is typically discharged from the upstream slope of the dam and the larger, sand-size particles tend to drop out near the discharge point. The finer particles settle out farther back in the impoundment, with the finest particles settling at the back end. A delta, which slopes back away from the dam, is formed by the settled material and a pool of free water accumulates at the back end of the reservoir. The effect of this typical configuration is that the free water must seep through the settled fines before seeping through the dam. Additionally, an objective in many tailings/slurry impoundment designs is to minimize the amount of free water. This is done both by site selection (i.e., minimizing the contributing watershed), diversion ditches, and the use of decants or pumping. If the impoundment is operated in a manner where ponded water can rise above the settled fines and contact the upstream slope of the dam for a period sufficient to develop steady-state seepage pressures, then the facility should be designed like a traditional water dam.

The characteristics of tailings/slurry impoundments sometimes allow designers to employ some differences in the design of tailings/slurry impoundments versus traditional embankment dams. In slurry impoundments, for example, plastic pipes that are not encased in concrete have been commonly used. Problems with seepage along the pipes has not been a significant occurrence in these impoundments, likely because of the effect of the settled fines in limiting seepage along the pipe combined with the long lengths of the decant pipes.

Another area where differences may be found, related to plastic pipe usage, is in the design of underdrains. For example, perforated or slotted plastic pipe is commonly used within underdrains, but the drainage aggregate used to surround the pipe may contain somewhat more than the recommended maximum of 5 percent minus No. 200 sieve material. This may be done, in cases where the seepage amounts and gradients are limited, to control the costs of installing drains to cover extensive areas. Where a less stringent requirement such as this is considered, however, tailings/slurry impoundment designers need to ensure that appropriate testing and analysis is performed—and construction and performance is carefully monitored—by engineers knowledgeable of the potential problems. Design alternatives must still ensure that filter criteria are met or critical exit gradients are not exceeded.

An important consideration in the design of underdrains for tailings/slurry impoundments is that the chemical characteristics of the seepage may affect the performance of the drainage system. Potential chemical reactions of the seepage

solution and the drain materials must be fully evaluated and thoroughly understood. The potential may exist for clogging, cementation, crystal growth, or biological growth to render the drains inoperable. There are many examples of drains that have failed by these mechanisms.

A unique situation with mine-waste disposal dams is that they are raised as needed to provide additional capacity. In some mine waste disposal impoundments, a decant pipe is initially constructed with inlets positioned at various intervals to handle the entire life of the facility (see figure 101).

The inlets are blocked off as the level of waste accumulates in the impoundment. More commonly, the decant pipe is extended as the dam is raised with new inlets being installed and the old inlets being blocked off. In some cases, the amount of fill over the pipe is limited by installing a completely new decant pipe at a higher elevation when the embankment is raised, and the lower decant pipe is abandoned by filling it with grout.

This method of construction, where mine waste dams are raised on a nearly continuous basis over the 20 or 30 year life of the facility, presents an opportunity to monitor the performance of conduits that is not available in traditional dams. That is, monitoring can be performed, and design assumptions can be verified, as the height of fill over the pipe is raised and well before the fill reaches a critical height. Additional research is proposed in chapter 8 (PM-4) to study this method of construction.

Designers have proposed fill heights in the range of 200 feet over plastic decant pipes in mine waste dams. Due to the limited experience with plastic pipe under high fills, and because of uncertainties in deflection analysis, such as appropriate  $E'$  values, the Mine Safety and Health Administration has generally only accepted designs for high fill heights contingent upon the mining company monitoring the pipe deflection at various amounts of cover and over time (figure 102). Based on the monitoring data, the value of  $E'$  is back-figured and an estimate is then made of the performance of the pipe under additional fill. Initial measurements are taken when the pipe is installed to establish baseline values. Subsequent deflection measurements start at a fill height where there is confidence that pipe performance will be adequate. Thereafter, the monitoring depends on how fast the fill level rises. Monitoring is done at predetermined increases in fill height and at predetermined time intervals, such as annually. Deflection monitoring has been accomplished by pulling devices, such as mechanical deflectometers (measures the vertical diameter of the pipe), sonar devices, and video cameras, through the pipe. Results of monitoring have shown, in some cases, that deflection was at or approaching the amount considered allowable (typically 7.5 percent). Once the allowable deflection is approached, or other signs of distress are evident, the decant pipe is replaced by another pipe. The new pipe is installed higher in the dam cross section, and the

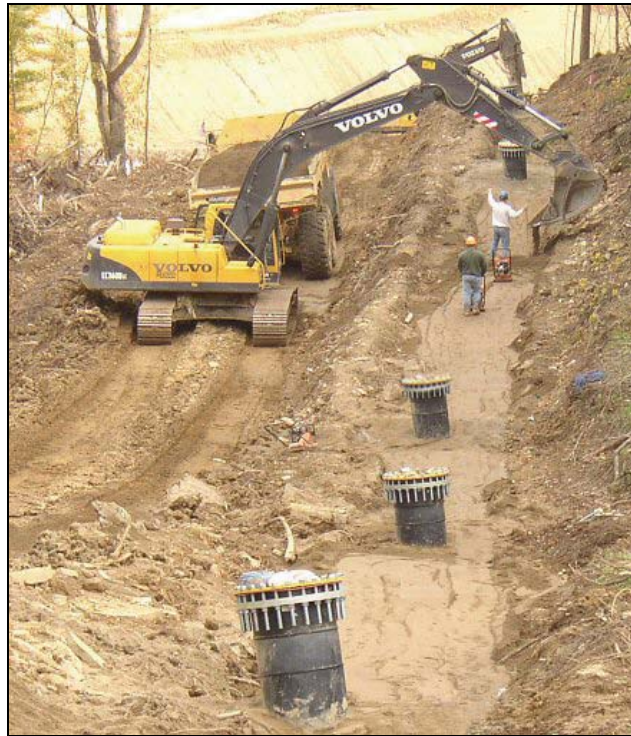

Figure 101.—Decant pipe with multilevel inlets.



Figure 102.—Deflection monitoring of a decant pipe.

original pipe is abandoned by being filled with grout. Designers have come to realize that it is costly to measure deflection every year and at certain fill levels, so they have moved toward installing new pipes at a higher elevations more frequently, so that the amount of fill on the active pipe, before it is grouted full, is limited.

Problems with the use of plastic pipe in mining dams are indicated by two of the case histories in appendix B. In the “Sediment Control Pond SP-4” case history, a 30-foot high dam failed during first filling due to seepage along a spillway pipe. This failure was attributed to inadequate compaction of the backfill and/or inadequate contact between the backfill and the pipe. In contrast to this failure, HDPE pipes have been used extensively as decants for coal slurry impoundments with no known failures from seepage along the pipe. In these applications the pipes have not been encased in concrete, but have typically been backfilled using hand-held equipment, such as pogo-sticks or rammers. The lack of problems with this type of construction may be due to a combination of factors which include: the impact of the lower-permeability settled slurry that acts to restrict seepage; the long length of the pipes - normally several hundred feet long; and the potential for the slurry fines to choke-off seepage paths along the pipe. The other problem, highlighted in the “Virginia Dam” case history in appendix B, involved a plastic pipe encased in concrete. In this case, the plastic pipe did not have adequate resistance to buckling and collapsed due to external hydrostatic pressure between the pipe and the concrete encasement.

Aside from the cases indicated above, the biggest performance concern with plastic pipe at slurry impoundments has been with pipe deflection. Excessive deflection or deformation has occurred in some cases and been attributed to soft or inadequately compacted areas in the backfill, or to stress concentrations from oversized rock in the backfill.

As stated elsewhere in this document, the “best practice” in installing a decant through a dam is to use a properly shaped reinforced cast-in-place concrete conduit through the impervious zone, so that the outside of the conduit can be battered to allow rubber-tired equipment to compact backfill directly against the conduit. This eliminates the problem with poor compaction in the haunch area. As indicated by Dr. Ernest Selig, “Apparently no amount of haunching effort can provide good soil support to the region about 20 degrees from the invert” (Selig, 1996, p. 6).

This “best practice,” however, creates a dilemma in the case of mine waste impoundments. As previously explained, there are benefits to having a conduit that can tolerate some deformation in these impoundments. Furthermore, tailings and slurry impoundments do not typically have an “impervious core” and the added cost of reinforced cast-in-place conduits is not as suitable for the shorter life of these conduits, as compared to traditional embankment dam conduits. And while the absence of significant problems does not rule out future problems, the record does provide some indication that alternatives to concrete encasement may be reasonable



in mine waste impoundment applications. The following recommendations are provided for installing conduits in tailings and slurry impoundments:

1. Although extensive problems have not been encountered with decant pipes through slurry impoundments, good conduit design and installation practices need to be followed. Slurry impoundment designers should recognize that the large body of evidence indicates adequate compaction cannot be achieved in the haunch area by conventional hand compaction methods. Using these methods, full contact between the pipe and the backfill cannot be ensured.
2. Decant pipes should be provided with an adequately designed seepage diaphragm and filter. The diaphragm should be extended far enough out from the pipe to intercept areas where cracks may occur due to hydraulic fracture or differential movement of backfill/embankment materials. See chapter 6 of FEMA's *Technical Manual: Conduits through Embankment Dams* (2005) for guidance on filter diaphragm design.
3. The seepage diaphragm should not be considered as an adequate defense, by itself, against problems with seepage along the pipe. The permeability of the backfill material and its level of compaction need to be sufficient to restrict seepage and reduce the hydraulic gradient along the pipe. The seepage diaphragm is intended to collect the limited seepage that occurs through well-compacted and suitable backfill and intercept particles that are being transported by water. The diaphragm could be overwhelmed and rendered ineffective by excessive seepage.
4. If the pipe is not to be encased in reinforced cast-in-place concrete, with battered sides that allow compaction by heavier equipment, then an alternate construction method, which provides for adequate backfill density in the haunch area, and full contact between the backfill and the pipe, needs to be specified.
5. Use of an alternate construction method should only be considered in slurry or tailings impoundments where it can be shown that the combination of hydraulic gradient and backfill material characteristics indicate adequate protection against internal erosion and piping. For example, slurry/tailings is typically discharged along the upstream face of the embankment resulting in the fine waste settling out and the free water collecting at the back end of the impoundment. However, if the slurry/tailings are discharged from the back end of the impoundment, free water would pond directly against the upstream slope of the dam. In this case, the seepage benefit from the settled fines would not be realized and the pipe should be designed as for a traditional embankment dam.

6. If the pipe is not encased in reinforced cast-in-place concrete, the installation options appear to be shaping the bedding, or the use of flowable fill. As indicated elsewhere in this document, many questions (see chapter 8, research items EM-3 through EM-8) need to be answered concerning the performance of flowable fill with respect to shrinkage, cracking, deformation properties, and stress concentrations at the pipe/backfill interface before it can be recommended for use.
7. Shaping the bedding to conform to at least the bottom one-third portion of the pipe is one technique that slurry impoundment designers have used to address the problem with compaction in the haunch area. However, the practice of shaping the bedding has concerns associated with it. Perfect contact between the shaped bedding and the pipe is not achievable. Designers have used a thin layer of expansive material, such as bentonite powder, to compensate for small irregularities between the shaped bedding and the pipe. An extreme level of care and attention to detail, with close supervision by a professional engineer knowledgeable of the potential problems, would be required. Further research (EM-7) is needed on this method, as proposed in chapter 8, before it can be recommended for use.
8. Specifications should include a detailed step-by-step procedure for installing the pipe and for achieving full contact between the conduit, bedding, and backfill. The type of equipment to be used to achieve the specified backfill densities should be specified. Construction related to critical piping installations should require full-time observation by experienced, qualified, and knowledgeable personnel.
9. Whatever pipe installation method is specified, quality control during construction should be the responsibility of a registered professional engineer who is familiar with the project specifications and the potential problems. The specifications should indicate how it will be determined that the required backfill moisture/density specifications have been met and that full contact between the conduit and the backfill has been achieved. The inspector should periodically remove a portion of the compacted backfill and making use of a knife, or whatever device is necessary, ensure that the adjacent backfill is in intimate contact with the conduit and that no voids are present, especially along the bottom half of the conduit. The engineer should be required to inspect and accept the conduit bedding and backfill installation before the embankment fill is placed over the conduit.
10. The designer(s) should always provide reasonable accommodations for inspection using CCTV in their designs.

As indicated elsewhere in this document, nonencased plastic embankment conduits are not recommended for traditional water-retention dams with significant or high

hazard potential. Designers of slurry tailings disposal facilities and impoundments should only specify nonencased plastic decant pipe where it can be shown, based on the conditions which are unique to slurry/tailings structures, that potential problems, such as with internal erosion along the pipe, are precluded.



## Chapter 8

# Research Needs

The National Dam Safety Program (NDSP), which was formally established by the Water Resources and Development Act of 1996, includes a program of technical and archival research. Research funding under the NDSP has addressed a cross section of issues and needs, all in support of ultimately making dams in the United States safer.

This chapter identifies research needs that are related to the performance of flexible plastic pipe within embankment and tailings/slurry impoundments. The authors considered these research needs to be good candidates for NDSP research funding.

### 8.1 Research Items

Research is needed in two categories: the performance of pipe material and the performance of embedment/encasement material.

#### 8.1.1 Pipe material (PM)

Research is needed for the performance of pipe material includes:

- *PM-1*.—Determine minimum pipe resins and grades needed for dam related applications using laboratory tests or a review of existing research.

A variety of formulations are used to produce the different kinds of plastic pipe. Even within a particular pipe category, such as HDPE, a number of resins are available. Some agencies require specific resins be used in the interest of obtaining sufficient pipe strength and resistance to aging. Currently there are no guidelines for chemical composition or grade for plastic pipe used in dams. A literature review would be done to determine standard practice and the associated issues with practitioners. At the completion of the literature review some laboratory testing may also be needed. Testing would focus on stress crack resistance, which in turn determines design life.

- *PM-2*.—Service life as it relates to the wear surface.

HDPE and PVC are reported to have better abrasion resistance than many other pipe materials. Manufacturers have conducted tests to measure pipe performance when subjected to abrasive forces. A literature review of research conducted by manufacturers is necessary to help determine the design life of plastic pipe that will be subjected to abrasion.

- *PM-3.*—Strain effects of perforations/slots on various types of pipe sections—solid wall, corrugated wall (single and profile wall).

Circular perforations and slots have the potential to weaken pipe. Laboratory tests would be used to assess how number, type, location and size of holes/slots affect strain under load in the pipe.

- *PM-4.*—The performance of plastic pipe under staged loading associated with the type of stage construction unique to mine-waste dams.

In tailings dams, the height of fill over a pipe may increase gradually over a period of 20 years or more. Testing should be performed, and field measurements collected and analyzed, to determine the affect on pipe performance of this type of staged construction. Issues include the allowable deflection, which is considered prudent under these conditions, and whether the short-term or long-term pipe modulus should be used in design.

- *PM-5.*—New and promising plastic pipe products.

Perform a market survey and technical evaluation of all new plastic pipe products currently available. Evaluate potential applications within embankment dams including the advantages and disadvantages associated with new each product.

- *PM-6.*—Evaluate the watertightness and long term suitability of new joining systems for PVC pipe in dam applications.

Newer joining systems have recently become available for PVC pipe. These newer joining systems include splined, heat fused, and mechanical joints. These types of joints are currently being used on water distribution and sewer installations, but have not been used in dam applications. Some manufacturers may have conducted tests for these new systems, and a literature search is needed. Additional laboratory testing may also be necessary.

### 8.1.2 Embedment/encasement material (EM)

Research is needed for the performance of embedment/encasement material includes:

- *EM-1.*—Investigate the interface bonding between plastic pipe and the encasement material.

A bond between encasement materials and plastic pipe cannot be achieved due to material differences. Designers use a downstream filter to control internal erosion of embankment soil along this interface. The use of materials such as chemical grout and bentonite that could be used to form a seal between the plastic pipe and the encasement material would be evaluated for cost effectiveness and functionality using laboratory testing.

- *EM-2.*—Investigate the effects of the heat of hydration on plastic pipe using laboratory testing.

Determine if heat of hydration from the curing of grout, concrete, or CLSM causes a significant rise in temperature which could cause the plastic pipe to expand.

- *EM-3.*—Quantify the Modulus of Soil Reaction for CLSM.

The soil structure interaction between a flexible pipe and CLSM backfill is not clearly understood. Since the strength of CLSM is somewhere between soil and concrete, the reaction is somewhere between flexible and rigid restraint, respectively. Design of flexible pipe, as described earlier in this document, requires that the designer know the strength and modulus of soil reaction for the backfill. Limited laboratory tests have been completed (Brewer, 1990) which have provided estimates of the Modulus of Soil Reaction for CLSM. Additional testing is necessary to better define the Modulus of Soil Reaction for a wider variety of CLSM mixes and materials.

- *EM-4.*—Quantify compressive strength for CLSM used as backfill in dam applications by literature review and laboratory testing.

CLSM is assumed to behave similar to a soil, allowing pipe deflection. The compressive strength of the CLSM will dictate the amount of pipe deflection. Laboratory testing is needed to determine recommended compressive strength for the use of CLSM as backfill in dam applications and changes with time as the CLSM ages. Full-scale laboratory tests would also be useful in evaluating the response of plastic pipe encased in CLSM exposed to large vertical loads.

- *EM-5.*—Evaluate the behavior of plastic pipe fully encased in CLSM.

A laboratory testing program would confirm the assumption that CLSM behaves like a soil. A testing program would confirm this assumption and explore additives, which could make CLSM more flexible.

- *EM-6.*—Evaluate the shrinkage, permeability, and cracking potential for different CLSM mixes.

A laboratory testing program would be used to measure the shrinkage, cracking potential, and erosion resistance for a variety of CLSM mix designs. The mix design would consist of evaluating a number of materials for improved performance of the mix. An example additive would be the use of nonshrink cement to see if shrinkage can be eliminated.

- *EM-7.*—Evaluate the response of plastic pipe partially encased with reinforced cast-in-place concrete (cradle) or CLSM.

Some designers are using plastic pipe partially encased by a cradle. There are concerns about the effect of stress concentrations in the pipe at the top of the cradle and the failure mechanism with deflection limited to the top half of the pipe. Full scale laboratory testing would be used to determine if CLSM and concrete could be used as cradle material.

- *EM-8.*—Investigate if CLSM should be placed in lifts so lateral support can develop.

Concerns exist that use of a single placement of CLSM can lead to pipe collapse, as lateral support has not developed prior to pipe being loaded vertically. There are also concerns with the placement of CLSM in lifts. In addition, the heat of hydration of the CLSM may heat the pipe, thus reducing its strength and potentially contributing to pipe collapse. Full scale laboratory testing would be used to evaluate CLSM placement methods.

- *EM-9.*—Evaluate the response of plastic pipe fully encased in nonreinforced concrete.

For the unreinforced concrete case, a laboratory testing program would determine if the plastic pipe does perform as a rigid pipe, as currently assumed, or is there some deflection. Testing would also determine if there is a minimum concrete strength at which the pipe behaves rigidly.

- *EM-10.*—Investigate the use of self-consolidating concrete (SCC). SCC is a high-performance concrete that can flow easily into tight and constricted spaces without segregating and without requiring vibration. Determine if SCC can be economically used as an encasement material to improve consolidation under the haunches of circular pipes.

- *EM-11.*—Investigate the use of the “cut-earth cradle” method for installing plastic pipe.



Obtaining adequate density in the haunch area of nonencased circular pipes is a problem. The cut-earth cradle method was developed in an attempt to address this concern. The cut-earth cradle method involves compacting the backfill to the level of the springline of the conduit and excavating a cradle through the compacted backfill to conform to the shape of the pipe. An expansive material, such as powdered bentonite is used to compensate for small irregularities in the contact between the backfill and the pipe. The effectiveness of this technique would be evaluated and limitations and guidelines for use in dam construction developed.

## References

The following references have been specifically cited in this document.

Advanced Drainage Systems, *Standard Pipe Perforations (4"-60" N-12 Pipe)*, Product Note 3.106, 2003.

American Association of State and Highway Transportation Officials, *LRFD Bridge Design Specifications*, Washington, DC, 2005.

American Concrete Institute, *Controlled Low-Strength Materials*, ACI 229R-99, 1999.

American Concrete Institute, *Cement and Concrete Terminology*, ACI 116R, Committee Report, 2000.

American Geological Institute, *Glossary of Geology*, 1987.

American Society of Civil Engineers, *Guidelines for Instrumentation and Measurements for Monitoring Dam Performance*, 2000.

American Water Works Association, *Concrete Pressure Pipe*, M9, 1995.

American Water Works Association, *Fiberglass Pipe Design Manual*, M45, 2000.

American Water Works Association, *PVC Pipe—Design and Installation*, M23, 2002.

American Water Works Association, *PE Pipe—Design and Installation*, M55, 2006.

Brewer, W.E., "The Design and Construction of Culverts Using Controlled Low Strength Material—Controlled Density Fill (CLSM-CDF) Backfill," *Proceedings of the First National Conference on Flexible Pipes*, 1990.

Brewer, W.E. and J.O. Hurd, "Controlled Low Strength Material—Controlled Density Fill (CLSM-CDF) as Backfill around Flexible Structures," *Proceedings of the Second Conference on Structural Performance of Pipes*, 1993.

Brinkgreve, R.B.J. and W. Broere, *Plaxis 3D Tunnel*, Version 2, Plaxis, 2004.

Bureau of Reclamation, *Air-Water Flow in Hydraulic Structures*, Engineering Monograph No. 41, 1980.

Bureau of Reclamation, *Results of the Carrant Creek Pipeline Impact Loading Study, Central Utah Project*, 1984.

- Bureau of Reclamation, *Design of Small Dams*, 1987a.
- Bureau of Reclamation, *Embankment Dams*, Design Standards No. 13, Chapter 8, “Seepage Analysis and Control,” 1987b.
- Bureau of Reclamation, *Earth Manual*, Part 2, 1989.
- Bureau of Reclamation, *Laboratory Pipe Box Test on Toe Drains at Lake Alice Dam and Enders Dam*, 1997.
- Bureau of Reclamation, *Design Summary—Ganado Dam*, 1998.
- Bureau of Reclamation, *Drainage for Dams and Associated Structures*, 2004.
- Bureau of Reclamation, *Wheatfields Design Summary*, 2006.
- Bureau of Reclamation, *Embankment Dams*, Design Standards No. 13, Chapter 5, “Protective Filters,” 2007.
- Burgon, Rex P., Steven L. Folkman, and A.P. Moser “A Parametric Study of the Influence of Profile Geometry on the Structural Performance of Buried Profile-Wall Pipe,” *Proceedings of Transportation Research Board Annual Meeting*, 2006.
- Chevron Phillips Chemical Company, *The Performance Pipe Engineering Manual*, 2002.
- Cooper, Chuck R., *Closed Circuit Television Inspection of Outlet Works and Spillway Conduits and Toe Drains*, ASDSO Annual Conference, 2005.
- Duncan, J.M., P. Byrne, K.S. Wong, and P. Mabry, *Strength, Stress-Strain and Bulk Modulus Parameters for Finite Element Analysis of Stress and Movements in Soil Masses*, Report No. UCB/GT/80-01, 1980.
- El-Sawy, Khaled and Ian Moore, *Parametric Study for Buckling of Liners: Effect of Liner*, ASCE, 1997.
- Federal Emergency Management Agency, *Federal Guidelines for Dam Safety: Hazard Potential Classification Systems for Dams*, FEMA 333, 1998.
- Federal Emergency Management Agency (FEMA), *Federal Guidelines for Dam Safety: Glossary of Terms*, FEMA 148, 2004.
- Federal Emergency Management Agency, *Technical Manual: Conduits through Embankment Dams*, FEMA 484, 2005.

- Hammer, David P., *Construction of Vertical and Inclined Sand Drains in Embankment Dams*, ASDSO Annual Conference, 2003.
- Hartley, James D., and James M. Duncan, "E' and Its Variation with Depth," *Journal of Transportation Engineering*, ASCE, 1987.
- Holtz, R.D. and W. D. Kovacs, *An Introduction to Geotechnical Engineering*, 1981.
- Howard, Amster K., "Modulus of Soil Reaction Values for Buried Flexible Pipe," *Journal of Geotechnical Engineering*, ASCE, Vol. 103, 1977.
- Howard, Amster K., *Pipeline Installation*, 1996.
- Howard, Amster, "The Reclamation E' Table, 25 Years Later," *Plastic Pipes XIII Conference Proceedings*, 2006.
- Hsuan, Y. Grace, J-Y Zhang, and W-K Wong, "Evaluate the Long-Term Stress Crack Resistance of Corrugated HDPE Pipes," *Plastic Pipes XIII Conference Proceedings*, 2006.
- Hsuan, Y. Grace and Timothy McGrath, *Protocol for Predicting Long-term Service of Corrugated High Density Polyethylene Pipes*, Prepared for the Florida Department of Transportation, Final Draft Report, 2005.
- Hulsmann, Thomas, and Reinhard E. Nowack, *70 Years of Experience with PVC Pipes*, 13<sup>th</sup> World Pipe Symposium, 2004.
- Janson, Lars-Eric, *Long-Term Studies of PVC and PE Pipes Subjected to Forced Constant Deflection*, Report No. 3, KP-Council, 1991.
- Jenkins, C.F. and A.E. Kroll, "External Hydrostatic Loading of Polyethylene Pipe," *Proceedings of the International Conference on Underground Plastic Pipe*, ASCE, pp. 527-541, 1981.
- Jeyapalan, Jey K. and Reynold Watkins, "Modulus of Soil Reaction (E') Values for Pipeline Design," *Journal of Transportation Engineering*, ASCE, Volume 130, Issue 1, January/February 2004, pp. 43-48.
- Kenney, T.C. and D. Lau, "Reply to Discussion of Kenney and Lau Article on Internal Stability of Granular Filters," *Canadian Geotechnical Journal*, Vol. 23, 1986, pp. 420-423.
- Laflaur, Jean, Hacek Mlynarek, and Andre Rollin, "Filtration of Broadly Graded Cohesionless Soils," *Journal of Geotechnical Engineering*, ASCE, Vol. 115, No. 12, December 1989, pp. 1747-1767.

- Lombardi, Tina, "Siphon—An Economic Lake Drain Option," *ASDSO Newsletter*, Vol. 11, No. 2, March 1996.
- McCook, Danny, *Things Your Mother Never Told You About Earth Dam Design*, ASDSO Annual Conference, 2002.
- McCook, Danny, *Supplemental Tests to Evaluate Suitability of Materials Proposed for Use in Critical Filter Zones*, ASDSO Annual Conference, 2005.
- Mendonca, Marcoa Barreto, Mauricio Ehrlich, and Magali Christie Cammarota, "The Formation of Ochre Biofilm in Geotextile Filters," *Geosynthetic Magazine*, 2006, pp. 34-42.
- Milligan, Victor, "Discussion of Kenney and Lau Article on Internal Stability of Granular Filters," *Canadian Geotechnical Journal*, Vol. 23, 1986, pp. 255-258.
- Mine Safety and Health Administration, *Investigation of Embankment Failure—Sediment Pond SP-4*, Report No. MW04-024, 2004.
- Moser, A.P., *Buried Pipe Design*, 2001.
- Musser, S.C., *CANDE-89 User Manual*, FHWA-RD-89-169, Federal Highway Administration, 1989.
- National Association of Women in Construction, *Construction Dictionary*, 1986.
- Natural Resources Conservation Service, "Hydraulics," *National Engineering Handbook*, Chapter 5 (NEH-5), 1956.
- Natural Resources Conservation Service, "Considerations for Embankment Dams," *Soil Mechanics Note No. 3*, 1971.
- Natural Resources Conservation Service, *Permeability of Selected Clean Sands and Gravels*, *Soil Mechanics Note No. 9*, 1984.
- Natural Resources Conservation Service, "Gradation Design of Sand and Gravel Filters," *National Engineering Handbook*, Part 633, Chapter 26, 1994.
- Natural Resources Conservation Service, "Structural Design of Flexible Conduits," *National Engineering Handbook*, Part 636 Chapter 52, 2005.
- Natural Resources Conservation Service, "Filter Diaphragms," *National Engineering Handbook*, Part 628, Chapter 45, 2007.

- Peck, R.B., W. E. Hansen, and T. H. Thornburn, *Foundation Engineering*, 1974.
- Performance Pipe, *Heat Fusion Joining Procedures and Qualification Guide*, 2006.
- Petroff, L.J., “Stress Relaxation Characteristics of the HDPE Pipe Soil System,” *Proceedings of Conference on Pipeline Design and Installation*, ASCE, 1990.
- Plastic Pipe Institute, *Resistance of Thermoplastic Piping Materials to Micro- and Macro-Biological Attack*, TR-11/2000, 2000.
- Plastic Pipe Institute, *Design Service Life of Corrugated HDPE Pipe*, TR-43, 2003.
- Plastic Pipe Institute, *Generic Butt Fusion Joining Procedure for Field Joining of Polyethylene Pipe*, TR-33/2005, 2005.
- Plastic Pipe Institute, *Handbook of Polyethylene Pipe*, 2006.
- Ripley, C.F., “Discussion of Kenney and Lau Article on Internal Stability of Granular Filters,” *Canadian Geotechnical Journal*, Vol. 23, 1986, pp. 414-418.
- Schluter, James C. and Theodore A. Capossela, “The Suitability of Spangler’s Iowa Formula for Predicting Deflection in All Pipes,” *Pipelines in the Constructed Environment*, ASCE, 1998.
- Selig, E.T., “Soil Parameters for Design of Buried Pipelines,” *Pipeline Infrastructure*, ASCE, 1988, pp. 99-116.
- Selig, E.T., *Installation Effects on Pipe Design*, Geotechnology in Infrastructure Improvement, ASCE, 1996.
- Sherard, James L., Lorn Dunnigan, and T.R. Talbot, “Basic Properties of Sand and Gravel Filters,” *Journal of Geotechnical Engineering*, ASCE Vol. 110, No. 6, June, 1984, p. 693.
- Smith, Greg and Reynold K. Watkins, “The Iowa Formula: Its Use and Misuse When Designing Flexible Pipe,” *Pipelines International Conference Proceedings*, ASCE 2004.
- Spangler, M.G., *The Structural Design of Flexible Pipe Culverts*, Iowa State College Bulletin No. 30, 1941.
- Spangler, Merlin G. and Richard L. Handy, *Soil Engineering*, 1982.
- Sugar Mill Community Association, Minutes of Board of Directors meetings: April 18, 2002; May 7, 2002; and January 14, 2003.

- U.S. Army Corps of Engineers, *Hydraulic Design of Reservoir Outlet Works*, EM 1110-2-1602, 1980.
- U.S. Army Corps of Engineers, *Laboratory Soils Testing*, EM 1110-2-1906, 1970 (original), 1986 (change 2).
- U.S. Army Corps of Engineers, *Seepage Analysis and Control for Dams*, EM 1110-2-1901, 1986 (original), 1993 (change 1).
- U.S. Army Corps of Engineers, *Long Term Structural Behavior of Pipeline Rehabilitation Systems*, 1994.
- U.S. Army Corps of Engineers, *Guidelines for Trenchless Technology: Cured-in-Place Pipe (CIPP), Fold-and-Formed Pipe (FFP), Mini-Horizontal Directional Drilling (Mini-HDD), and Microtunneling*, Construction Productivity Advancement Research (CPAR) Program Report No. CPAR-GL-95-2, Waterways Experiment Station, 1995.
- U.S. Army Corps of Engineers, *Technologies and Techniques for Drainage Pipe Maintenance and Repair: A Practical Guide to Technology Selection*, 2001.
- U.S. Army Corps of Engineers, *General Design and Construction Considerations For Earth and Rock-Fill Dams*, EM-1110-2-2300, 2004.
- Uni-Bell PVC Pipe Association, *Recommended Specification for Thermoplastic Pipe Joints, Pressure and Non-Pressure Applications*, UNI-B-95, 1995.
- Uni-Bell PVC Pipe Association, *Handbook of PVC Pipe-Design and Construction*, 2001.
- Vaughan, Peter and Hermosia Soares, "Design of Filters for Clay Cores of Dams," *Journal of the Geotechnical Engineering Division*, ASCE, Vol. 108, No. GT1, January 1982, pp. 17-31.
- Watkins, Reynold K., *Buried Pipe Encased in Concrete*, ASCE, 2004.
- Watkins, R.K. and M.G. Spangler, "Some Characteristics of the Modulus of Passive Resistance of Soil—A Study in Similitude," *Highway Research Board Proceedings*, Vol. 37, pp. 576-583, 1958.
- Webb, M.C., SSIS Marketing International, CandeCAD, 2005.
- Willoughby, David A., *Plastic Piping Handbook*, 2002.
- Wilson, Charles and Joseph Monroe, *Dam Surgery—Repairs to Sugar Mill Dam, Fulton County, Georgia*, ASDSO Southeast Regional Conference, 2004.

## Additional Reading

The following references have not been specifically cited within this document and are provided as suggested “additional reading.” These references are intended to assist the user with furthering their understanding of topics related to plastic pipe and its use in embankment dams. The user will find additional references related to conduits and embankment dams in FEMA’s *Technical Manual: Conduits through Embankment Dams* (2005).

Sound engineering judgment should always be applied when reviewing any of these references. While most of these references contain valuable information, a few may contain certain information that has become outdated in regards to design and construction aspects and/or philosophies. Users are cautioned to keep this mind when reviewing these references for design and construction purposes.

The user may want to periodically visit a particular agency or organization’s website for updates or revisions to these references.

Ackers, P. and A.R. Thomas, “Design and Operation of Air-Regulated Siphons for Reservoir and Head-Water Control,” *Proceedings of the Symposium on Design and Operation of Siphons and Siphon Spillways*, Paper No. A1, 1975, pp. A1-A20.

American Water Works Association, *Evaluation of Polyvinyl Chloride (PVC) Pipe Performance*, 1994.

Anderson, D. Wade, *Structural Design of Flexible Conduits*, ASDSO Annual Conference, 2004.

Babaeyan-Koopaei, E.M. Valentine, and D. Alan Ervine, “Case Study on Hydraulic Performance of Brent Reservoir Siphon Spillway,” *ASCE Journal of Hydraulic Engineering*, Vol. 128, No. 6, June 2002, pp. 562-567.

Beech, S.H. and E.Q. Clutton, “Interpretation of the Results of the Full Notch Creep Test and a Comparison With the Notched Pipe Test,” *Plastic Pipes XII Conference Proceedings*, 2004.

Boros, Stephen, “Development of an Accelerated SCG Cyclic Pressure Fatigue Test Method for Polyethylene (PE) Pipe and Correlation with Hydrostatic Stress Rupture Test Method ASTM D 1598,” *Plastic Pipes XIII Conference Proceedings*, 2006.

Bryant and Jewell, *Analysis of Siphon Lake Drain Performance for a Small Earthen Dam*, 1996 ASDSO Annual Conference, 1996.



- Bureau of Reclamation, *Design of Small Canal Structures*, Chapter 4, 1978.
- Bureau of Reclamation, *Water Conveyance Systems*, Design Standards No. 3, Chapter 11, "General Hydraulic Considerations," 1994.
- Bureau of Reclamation, *Method for Prediction of Flexible Pipe Deflections*, M-25, 1997.
- Bureau of Reclamation, *Clogging of Perforations in Plastic Pipe*, 2002.
- Burgon, Rex P., Steven L. Folkman, and A.P. Moser, "Comparing Measured and Computed Stiffness of HDPE Pipe," *Proceedings of Transportation Research Board Annual Meeting*, 2006.
- Burns, J.Q. and R.M. Richard, "Attenuation of Stresses for Buried Cylinders," *Proceedings of the Symposium on Soil Structure Interaction*, 1964, pp. 378-392.
- Corleto, Carlos and Eli Venecia, "Characterisation of Rapid Crack Propagation of PE Pipe Resins Using Dynamic Fracture Toughness," *Plastic Pipes XII Conference Proceedings*, 2004.
- Corrugated Plastic Pipe Association, *Hydraulic Considerations for Corrugated Polyethylene Pipe*, 1998.
- DesLauriers, Paul J. and David C. Rohlfiing, "Predicting Slow Crack Growth Resistance in Polyethylene Resins From Detailed Polymer Microstructure Obtained By SEC-FTIR," *Plastic Pipes XIII Conference Proceedings*, 2006.
- Fairfield, C.A., S.A. Campbell, and D.B. Reid, "Erosion Performance of Plastic Pipes," *Plastic Pipes XII Conference Proceedings*, 2004.
- Gumbel, John, *New Approach to Design of Circular Liner Pipe to Resist External Hydrostatic Pressure*, Symposium on Pipe Rehabilitation Design, 2001.
- Hammer, Greg, *If It Ain't Broke.....Or is It*, ASDSO Annual Conference, 2002.
- Horn, R., "Cut-Earth Cradle Method for Installing Conduits through Earth Dams," *The Journal of Dam Safety*, Vol. 3, Issue 3, ASDSO, 2005, pp. 16-26.
- Howard, Amster K., "Proposed Standard Practice for Installing Buried Pipe Using Flowable Fill," *The Design and Application of Controlled Low-Strength Materials (Flowable Fill)*, ASTM STP 1331, ASTM, 1998.

Hsuan, Y. Grace and Timothy McGrath, "Evaluation of Stress Crack Resistance of Corrugated High Density Polyethylene Pipes," *Plastic Pipes XII Conference Proceedings*, 2004.

Janson, Lars-Eric, "Investigation of the Long-Term Creep Modulus for Buried Polyethylene Pipes Subjected to Constant Deflection," *Advances in Underground Pipeline Engineering, Proceedings of the International Conference*, ASCE, 1989.

Janson, Lars-Eric, *Plastics Pipes for Water Supply and Sewage Disposal*, 1995.

Jeffrey, Jared D., A. P. Moser, Steven L. Folkman, "New Design Guidelines for Fatigue Failure in PVC Pipe," *Plastic Pipes XII Conference Proceedings*, 2004.

Krishnaswamy, Rajendra K., "Analysis of Ductile and Brittle Failures from Creep Rupture Testing of High-Density Polyethylene (HDPE) Pipes," *Plastic Pipes XIII Conference Proceedings*, 2006.

Krishnaswamy, R.K., P.S. Leever, M.J. Lamborn, A.M. Sukhadia, D.F. Register, and P.L. Maeger, "Rapid Crack Propagation (RCP) Failures in HDPE Pipes: Structure-Property Investigations," *Plastic Pipes XIII Conference Proceedings*, 2006.

Lamson Vylon Pipe, *Plastic Pipe Design Manual*, 2000.

Lemieux, Michele, and Laurence Siroky, *Use of Plastic Pipe in Dams: Variations in Design and Regulatory Perspective*, ASDSO Annual Conference, 2001.

Leumas, James K., *To Siphon or Not To Siphon: That is the Question (Among Others)—A Repair History of the Crossgate Dam*, ASDSO Annual Conference, 1998.

McCook, Danny, and James Talbot, *NRCS Filter Design Criteria—A Step By Step Approach*, ASDSO Southeast Regional Conference, 1995.

McCook, Danny, *The Filter Design Tightrope*, ASDSO Annual Conference, 2003.

McGrath, Timothy J., "Replacing E' with the Constrained Modulus in Flexible Pipe Design," *Pipelines in the Constructed Environment*, Pipeline Division Conference, ASCE, 1998.

McGrath, Timothy J., "Design of Profile Wall Thermoplastic Pipe for Compression," *Plastic Pipes XII Conference Proceedings*, 2004.

Meijering, Tiem, "Sustainable Municipal Pipes—The Performance of Plastics Pipes in Sewer Systems," *Plastic Pipes XIII Conference Proceedings*, 2006.

Milligan, Victor, "Some Uncertainties in Embankment Dam Engineering," *Journal of Geotechnical and Geoenvironmental Engineering*, ASCE Vol. 129, No. 9, September, 2003, pp. 785-797.

Morris, H.M., *Applied Hydraulics in Engineering*, pp 201-204, 1963.

Natural Resources Conservation Service, "Structural Design of Underground Conduits," *National Engineering Handbook*, Technical Release No. 5, 1958.

Natural Resources Conservation Service, *Hydraulics of Two-Way Covered Risers*, Technical Release 29 (TR-29), 1965.

Natural Resources Conservation Service, *Drop Inlet Entrance Losses*, Design Note 8 (DN-08), 1969.

Ng, Zena S. and Cindy Connolly, "Choosing PVC Resins for Formulation," *Plastic Pipes XIII Conference Proceedings*, 2006.

Pabst, Mark, *Ochoco Dam Drain Rehabilitation*, ASDSO Annual Conference, 1999.

Pabst, Mark, *Considerations for Filter Design*, USSD Annual Conference, 2007.

Phillips Drisco, *Pipe Design Manual*, "Table 9: Differential Pressure (Vacuum or External Fluid) Capability for Unsupported Pipe" and "Table 10: Multipliers for Temperature," 1998.

Plastic Pipe Institute, *The Complete Corrugated Polyethylene Pipe Design Manual and Installation Guide*, 2007.

Rahman, Shah and Wayne Bird, "PVC Pipe Joining: The Reiber System in North America," *Plastic Pipes XIII Conference Proceedings*, 2006.

Roth, Bruce L. and Mathew Snyder, *The Beneficial Use of Flowable Backfill Around Concrete Pipes*, ASDSO Annual Conference, 1992.

Sherard, J.L., *Sinkholes in Dams of Coarse, Broadly Graded Soils*, Thirteenth Congress on Large Dams, Question 49, R, 2, 1979.

Sherard, James L. and Lorn Dunnigan, "Discussion of Kenney and Lau Article on Internal Stability of Granular Filters," *Canadian Geotechnical Journal*, Vol. 23, 1986, pp. 418-420.

Thomas, Craig and Richard Horvath, *Installation and Operation of a Siphon System to Provide Water Supply Releases*, ASDSO Northeast Regional Conference, 2003, pp. 183-184.

U.S. Army Corps of Engineers, *Controlled Low Strength Material with Coal-Combustion Ash and Other Recycled Materials*, ETL 110-3-496, 1996.

U.S. Army Corps of Engineers, *Conduits, Culverts, and Pipes*, EM 1110-2-2902, 1997 (original), 1998 (change 1).

U.S. Department of Transportation, Federal Highway Administration, *Hydraulic Charts for the Selection of Highway Culverts*, HEC-5, 1965, Reprinted 1977.

Uni-Bell PVC Pipe Association, *Deflection—The Pipe/ Soil Mechanism*, UNI -TR-1-97, 1997.

Watkins, Reynold K., “Influence of Soil Characteristics on the Deformation of Embedded Flexible Pipe Conduits,” *Highway Research Board*, Bulletin 2231959, pp. 14-24, 1959.

Watkins, Reynold King and Loren Runar Anderson, *Structural Mechanics of Buried Pipes*, 2000.

Watkins, Reynold King, “Pipe and Soil Mechanics for Buried Corrugated HDPE Pipe,” *Plastic Pipes XII Conference Proceedings*, 2004.

Webb, M.C., T.J. McGrath, and Ernest T. Selig, “Field Test of Buried Pipe with CLSM Backfill,” *The Design and Application of Controlled Low-Strength Materials (Flowable Fill)*, ASTM STP 1331, ASTM, 1998.

Zhou, Zhiqiang Jimmy and Dane Chang, “Performance of Scratched HDPE Pressure Pipe,” *Plastic Pipes XIII Conference Proceedings*, 2006.

# Index

## A

AASHTO standards, xxvii, 9, 31, 32, 57, 67, 68, 104, 105, 132  
Abandonment/grouting of a drain system, 124-126  
Abbreviations, xviii  
Access, 1, 3, 5, 98, 101, 109, 111, 113, 122, 123, 124, 129, 149, 150, 151, 152, 160  
    improving, 122-124  
Aggregate, 80, 84, 85, 86, 116, 117, 120, 142, 162, 163  
Anchors, 95  
Arching action of a conduit, 38  
ASTM standards, xxviii-xxxii, 6, 8, 9, 10, 11, 12, 14, 15, 17, 20, 22, 26, 30, 31, 32, 53,  
    59, 67, 69, 70, 75, 84, 94, 107, 116, 117, 118, 120, 138, 139, 142  
AWWA standards, xxxiii, 6, 8, 17, 23, 32, 51, 53, 54, 60, 66, 69, 70, 71, 91, 94, 98,  
    127

## B

Backfill, 118-126, 30, 35, 40, 42, 43, 55, 57, 60, 64, 66, 79, 80, 82, 83, 86, 89, 101, 109,  
    118, 119, 120, 122, 128, 132, 134, 137, 157, 159, 166, 167, 168, 173, 175  
    compaction methods, 137-139  
    nonperforated drainpipe, 80, 118-120, 134  
    perforated drainpipe, 80, 118-120, 134  
Barrier condition, 119  
Bell and spigot joints, 15, 17, 18, 20, 23, 28, 29, 81, 93, 103  
Borrow sources, 139, 140, 158  
Buckling, *see* Wall buckling  
Buried conduits, classification, 34, 35, 40  
Butt fused HDPE pipe joints, 12, 13, 14, 15, 16, 24, 93, 94, 104, 146

## C

Calcite deposits, 154, 156  
Capacity, *see* Flow capacity  
Carrier pipe, 11, 14

- Cast-in-place, 25, 33, 53, 68, 73, 78, 79, 80, 81, 82, 83, 99, 109, 127, 166, 167, 168, 174
- CCTV inspection, 12, 26, 102, 111, 112, 113, 122, 124, 125, 129, 146, 148, 149, 150, 151, 152, 153, 154, 157, 158, 159, 160, 168
  - equipment, 102, 112, 122, 124, 129, 149, 160
- CIPP, 21-23, 29, 30, 53
- Classification of buried conduits, 2, 31, 34, 35, 39, 40, 53, 67, 99, 127
- Cleanouts, 101, 109-112, 149, 150, 152
- Closed circuit television, *see* CCTV inspection
- CLSM, 83, 84, 85, 86, 87, 88, 89, 90, 91, 95, 96, 173, 174
  - as an encasement material, 96, 83, 84, 85, 86, 87, 88, 89, 90, 91, 95, 96, 173, 174
  - design considerations, 86, 83, 84, 85, 86, 87, 88, 89, 90, 91, 95, 96, 173, 174
  - problems, 83, 84, 85, 86, 87, 88, 89, 90, 91, 95, 96, 173, 174
- Coefficient of thermal expansion, 25, 91, 92, 97
- Collapse of pipes, 49, 50, 60, 62, 75, 76, 79, 82, 83, 96, 132, 174
  - due to grout pumping pressure, 96-97
- Compaction of earthfill, 35, 37, 38, 40, 58, 83
  - methods for around drainpipes, 25, 27, 29, 89, 132, 137-139, 146
- Complete condition, 39, 40, 41
- Concrete, 2, 24, 25, 28, 30, 33, 35, 39, 50, 53, 57, 68, 73, 74, 75, 76, 78, 79, 80, 81, 82, 83, 84, 85, 88, 89, 90, 93, 94, 95, 96, 97, 99, 109, 116, 120, 127, 142, 163, 166, 167, 168, 173, 174
  - encasement, 2, 25, 33, 74, 78-83, 89, 93, 96, 166
  - reinforced cast-in-place concrete encasement, 2, 25, 33, 74, 78-83, 93, 166
  - reinforced concrete cradle, 81, 74, 80, 81, 83
  - unreinforced cast-in-place concrete encasement, 2, 25, 33, 74, 78-83, 93, 166
- Conduits
  - arching action, 38
  - buried, 33, 34, 39
  - embankment, 1, 2, 5, 6, 10, 11, 15, 17, 18, 20, 21, 22, 24, 25, 27, 28, 29, 30, 33, 35, 37, 38, 39, 40, 53, 60, 63, 69, 78, 79, 80, 83, 84, 93, 94, 97-100, 127-129, 147, 148, 168
  - embankment, construction, 97, 127, 128, 147
  - embankment, inspection, 97, 127, 147-149
- Construction, 1, 2, 5, 8, 16, 24, 25, 27, 29, 33, 34, 39, 40, 44, 50, 51, 55, 57, 64, 76, 78, 79, 82, 83, 84, 88, 89, 91, 92, 93, 94, 95, 98, 99, 102, 106, 113, 114, 119, 120, 123, 127, 128, 129, 132, 137, 138, 140, 142, 143, 147, 153, 157, 158, 161, 162, 163, 164, 166, 167, 168, 172
  - considerations, 92-97
  - drainpipe, 102, 131, 132
  - equipment, 50, 120, 132
  - guidance, 127-146
  - loading, 33, 50, 51, 157

- Containment pipe, 11, 12, 14, 24-26
  - dual-wall, 12, 24-26
- Contraction, 81, 91, 92, 95, 96, 97
- Controlled low strength material, *see* CLSM
- Corrugated HDPE pipe, 3, 9, 11, 12, 15, 17, 26, 27, 31, 32, 59, 61, 62, 64, 70, 72, 75, 102, 103, 104, 128, 151, 153, 162, 172
- Cover soil over plastic pipe, 6, 50, 51, 60, 66, 67, 68, 86, 95, 111, 112, 115, 120, 132, 145, 163, 164
- Cracking of PVC pipe, 31, 62, 84, 87, 89, 113, 157, 168, 174
- Cradle, *see* Concrete, reinforced concrete cradle
- Cured in place pipe, *see* CIPP

## D

### Dams

- construction, 8, 9, 10, 23, 85, 102, 136, 175
  - embankment, 1, 2, 3, 5-26, 30, 32, 33, 34, 35, 37, 39, 40, 44, 50, 53, 63, 64, 71, 74, 76, 78, 79, 83, 86, 98, 99, 101, 103, 121, 122, 127, 128, 137, 147, 161, 162, 163, 166, 167, 172
  - high hazard potential, 1, 17, 18, 25, 27, 33, 34, 63, 68, 78, 79, 80, 81, 83, 84, 86, 88, 99, 115, 127, 132, 136, 169
  - low hazard potential, 1, 17, 20, 23, 27, 28, 29, 33, 55, 60, 64, 79, 83, 85, 86, 94, 99, 114, 115, 127, 136
  - raise, 44, 45
  - size, 103
- Davis Creek Dam, 153
- Decant pipe, 6, 64, 161, 162, 163, 164, 165, 166, 167, 169
- Deflection of pipes, 30, 34, 36, 37, 40, 53, 54, 57, 58, 59, 60, 62, 63, 64, 65, 66, 67, 68, 69, 72, 73, 74, 76, 78, 79, 81, 83, 86, 87, 89, 90, 93, 164, 166, 172, 173, 174
- Deposition of soil, 138, 163
- Design
- considerations, 6, 53, 76, 78, 92-97
  - considerations for using CLSM, 86, 86
  - encased pipe, 90
  - flexible pipe, 53, 73, 91
  - hydraulic design of embankment conduits, 53, 97, 98
  - hydraulic design of drainpipes, 78, 102-109
  - life, 30-32
  - siphon, 49
  - structural design of drainpipes, 33, 54, 55, 74, 87, 92, 101, 102
  - values for the settlement ratio,  $r_{sd}$ , 43

- when to use flexible or encased plastic pipe design, 88-91
- zoning, 121, 122
- Drainpipe, 1, 2, 3, 5, 6, 17, 18, 26, 27, 28, 29, 30, 31, 33, 35, 36, 37, 38, 45, 50, 53, 63, 64, 69, 78, 80, 90, 94, 98, 101-115, 118, 119, 121, 122, 123, 124, 125, 127, 128, 129, 130, 131, 132, 135, 136, 137, 143, 144, 145, 147, 149-160, 162
  - construction, 102, 131, 132
  - diameter, 103
  - embedment, 119
  - HDPE, 153, 156, 157
  - inspection well, 110
  - nonperforated drainpipe, 119-120, 118, 119
  - perforated drainpipe, 120-121, 104, 118, 120
  - placement around, 130-137, 130
- Drains
  - drain system, 101, 113, 122, 124, 125, 126, 130, 131, 158, 159
  - materials, 80, 104, 105, 116, 117, 120, 130-140, 142, 144, 158, 159, 164
  - replacement, 118, 119
  - toe, 1, 26
- Dual-wall containment pipe, *see* Containment pipe, dual wall

## E

- Earthfill, *see* Backfill
- Embankment conduits, 1, 2, 5, 6, 11, 15, 17, 18, 20, 21, 22, 24, 25, 27, 28, 29, 30, 33, 35, 37, 38, 39, 40, 53, 60, 63, 69, 78, 79, 80, 83, 84, 93, 94, 96, 97-101, 127-129, 147, 148, 168
- Embedment materials, 68, 78, 79, 88, 96
  - comparison with encasement materials, 88, 89
  - considerations, 78-91
  - research needs, 172-175
  - soil as embedment material, 68, 78, 79, 88, 96
- Encased pipe, 74-76, 90
  - design, 76-78, 88-91
- Encasement materials, 3, 50, 51, 78-91, 95, 96, 97, 171, 172, 173, 174
  - comparison of, 90
  - comparison with embedment materials, 88, 89
  - reinforced cast-in-place concrete, 81-83, 90
  - research needs, 172-175
  - unreinforced cast-in-place concrete, 83, 90
- End restraint design, 92



Equipment, 12, 14, 24, 25, 26, 27, 28, 29, 30, 51, 84, 88, 111, 113, 120, 122, 132, 137, 138, 140, 142, 143, 144, 145, 149, 151, 152, 157, 166, 167, 168  
CCTV inspection, 102, 112, 122, 124, 129, 149, 160  
construction, 50, 120, 132  
Excavation, 37, 38, 82, 98, 122, 123, 128, 130, 131, 133  
contaminated materials, 141  
trench, 35, 82, 133  
Expansion, 81, 91, 92, 95, 96, 97  
External hydrostatic pressure, 33, 45, 50, 60, 61, 74, 76, 78, 79, 87, 96, 166  
Extrusion gun, 15  
Extrusion line, 9

## F

Factor of safety, 10, 31, 60, 70, 76, 77  
Failure, 1, 31, 46, 55, 58, 59, 73, 79, 93, 94, 101, 113, 124, 127, 128, 147, 153, 157, 166, 174  
modes, 58, 59, 101, 113  
Fill height, 41, 57, 63, 83, 164  
Fill material, 35, 37, 38, 40, 43, 146  
Filters, 34, 36, 64, 81, 83, 97, 99, 101, 104, 105, 106, 108, 113-121, 124, 127, 128, 129, 130, 131, 132, 133, 134, 135, 137, 138, 139, 140, 141, 142, 143, 144, 158, 159, 163, 167, 173  
gradation limits, 116-118  
material, 105, 106, 108, 114, 120, 127, 130, 131, 142  
placement, 130, 133, 135  
Flexible pipe, 30, 53-74, 79, 83, 91, 93, 102, 162, 173  
design, 53, 54, 58, 73, 76-78, 88-91  
failure modes, 59  
Flow capacity, 63, 103, 105, 118  
Flowable fill, *see* CLSM  
Foundations, 1, 2, 28, 34, 35, 36, 37, 40, 43, 44, 53, 64, 73, 93, 99, 101, 102, 103, 106, 108, 114, 116, 118, 119, 121, 122, 124, 127, 128, 129, 130, 154, 158, 159, 162  
preparation, 129, 130  
problems, 93

## G

Ganado Dam, 129

Gradation, 84, 106, 116, 117, 118, 119, 120, 142, 144, 158  
  filter gradation limits, 116-118  
Grout, 16, 24, 50, 61, 74, 79, 87-90, 92, 95, 96, 124, 164, 166, 173  
  abandonment/grouting of a drain system, 124-126  
  as encasement material, 96  
  pumping pressure, 96, 97

## H

Haunches, 25, 27, 29, 35, 79, 80, 81, 83, 86, 89, 132, 157, 174  
HDPE pipe, 9-17, 20, 24, 25, 26, 29, 31, 51, 73, 81, 94, 96, 103, 104, 148, 162, 166  
  calcite deposits, 156  
  dual-wall containment, 24, 25  
  iron bacteria blockage, 156  
  joints, 13, 14  
  single wall corrugated HDPE drainpipe, 60, 61, 153  
  slipliner, 24, 148  
  solid wall, 10, 16, 26, 31, 102, 104, 162  
  typical modulus of elasticity values, 54  
Heat fusion process, 19  
Historical perspective, 5, 6  
Hydraulic design, 53, 97, 98  
Hydraulic loading conditions, 1, 5, 33, 34, 45-50, 53, 86  
Hydrostatic inversion method, 22  
Hydrostatic pressure  
  external, 33, 45, 50, 60, 61, 74, 76, 78, 79, 87, 96, 166  
  internal, 33, 45-49, 59, 69-71, 74, 76, 78, 86

## I-L

Idealized cross sections, 115  
Incomplete condition, 38, 40, 41  
Inspection, 1, 2, 3, 12, 14, 26, 74, 101, 102, 109, 111, 112, 113, 121, 122, 123, 125,  
  140, 143, 147-160, 168  
  CCTV, 12, 26, 102, 111, 112, 113, 122, 124, 125, 129, 146, 148, 149, 150, 151, 152,  
  153, 154, 157, 158, 159, 160, 168  
  wells, 101, 109-112, 122, 149  
Installation, 1, 6, 9, 21, 22, 23, 24, 26, 28, 29, 30, 31, 32, 43, 51, 55, 64, 69, 78, 82, 91,  
  93, 94, 95, 98, 102, 103, 109, 114, 124, 127, 128, 129, 130, 132, 144, 145, 157, 162,  
  167, 168

---

Interior prism, 36, 37, 38, 39, 40, 88, 90  
Interior surfaces, 151  
Internal hydrostatic pressure, 45, 46, 49, 50, 60, 63, 65, 69-71, 73, 74, 75, 76, 78, 79  
Introduction, 1-3  
Iron bacteria, 115, 154, 156  
Joints  
    bell and spigot, 15, 17, 18, 20, 23, 28, 29, 81, 93, 103  
    butt fused, 14, 15, 16, 24, 94, 104, 146  
    restrained, 19, 20  
    separation, 129  
    snap, 17  
    splined, 19  
Leak testing, 94, 93  
Liner, CIPP, 21, 22, 23  
Load coefficient, 41, 42, 44, 45

## M

Marston load, 33, 34, 35, 39, 40, 41, 43, 44, 66, 78, 90  
    positive projecting conduits, 41-44  
Maximum perforation dimension, 118  
Meshes, two- and three-dimensional, 56  
Modes, failure, 58, 59, 101, 113  
Modified Iowa Equation, 62, 64, 65, 66, 67, 68, 86  
Modulus of elasticity, 29, 48, 50, 54, 60, 65, 72, 75, 92  
Modulus of soil reaction, 57, 60, 65, 66, 67, 68, 69, 79, 86, 87, 173

## N, O

Negative projecting conduit, 37, 38, 39, 82  
Nonperforated drainpipe, 118-120  
Outlet works, 1, 2, 5, 11, 22, 23, 24, 33, 36, 49, 98, 127, 148  
Outlet works slipliner, 23

### P

Perforated drainpipe, 104, 118, 120, 121

Perforations in pipe, 2, 103, 104, 105, 109, 114, 115, 145, 146, 154, 156, 172

    circular, 11, 104, 105

    slotted, 104, 163

Pipe, *see* Plastic pipe

Placement

    drain material, 115, 133

    filter, 130, 133, 135

    of a cast-in-place base slab for an inspection well, 110

    of fill, 85, 74, 130-137

    temperature, 95-97

Plastic pipe

    carrier, 11, 14

    CIPP, 21, 22, 23, 29, 30, 53

    collapse, 49, 50, 60, 62, 75, 76, 79, 82, 83, 96, 97, 132, 174

    common types used in embankment dams, 6-24

    common uses, 23-30

    corrugated, 9, 11, 12, 17, 26, 27, 31, 72, 103

    corrugated profile wall, 102

    corrugated single wall, 102

    decant, 6, 161, 162, 163, 164, 165, 167, 169

    design, 23, 51, 68, 74, 76-78, 81, 83, 87, 88, 89, 90, 91, 127

    drainpipes, 1, 2, 3, 5, 6, 26, 27, 28, 29, 33, 37, 38, 50, 53, 63, 64, 69, 78, 90, 94, 101,

        102, 104, 105, 108, 109, 111, 112, 113, 114, 115, 118, 122, 123, 128, 129, 132,

        136, 137, 147, 149, 153, 154, 157, 162

    dual-wall containment, 10, 11, 14, 24, 25, 26

    encased, 74-76, 90

    failure modes, 31, 58, 59, 101, 113, 124

    flexible, 30, 53-74, 79, 83, 91, 93, 102, 162, 173

    HDPE, 8, 9, 10, 12, 13, 14, 15, 16, 20, 24, 25, 26, 29, 31, 48, 51, 53, 54, 71, 73, 75,

        77, 81, 91, 94, 96, 97, 102, 103, 104, 148, 153, 156, 157, 162, 166, 171, 172

    in tailings disposal facilities and slurry impoundments, 161-170

    material, research needs, 78, 91, 171, 172

    minimum pipe stiffness, 77

    outlet works, 23

    PVC, 6, 7, 8, 15, 17, 18, 19, 20, 27, 28, 29, 32, 48, 53, 54, 69, 71, 73, 75, 77, 91, 94,

        95, 97, 98, 102, 103, 104, 127, 128, 153, 172

    rigid, 36, 53, 55, 73, 74, 102, 174

    solid wall, 8, 10, 11, 12, 15, 16, 17, 24, 25, 26, 31, 48, 54, 58, 61, 64, 65, 69, 72, 73,

        76, 77, 102, 103, 104, 162, 172

    thermoplastic, 7, 20-21, 29, 31, 53, 57, 95

- thermoset plastic, 7, 21-23, 53
  - when to use flexible or encased plastic pipe design, 88-91
- Pore pressure, 118, 119
- Positive projecting conduits, 36-44, 82, 90, 102
- Pressure
  - external hydrostatic, 45, 50, 74, 78, 87
  - grout pumping, 96, 97
  - internal hydrostatic, 45-49, 59, 69-71, 74, 76, 78
  - internal vacuum, 45, 49, 50, 60, 63, 65, 69, 73, 74, 75, 76, 78, 79
  - pore, 116, 118, 119
  - unconstrained collapse, 75, 76, 77
  - water pressure, 21, 23, 38, 86
- Prism
  - exterior, 36, 37, 38, 39, 40, 88, 90
  - interior, 10, 11, 12, 13, 16, 17, 24, 26, 28, 30, 36, 37, 38, 39, 40, 73, 81, 83, 87, 88, 90, 103, 113, 146, 148, 151, 159, 162
  - soil prism load, 36, 37, 39-42, 66, 90
- Problems, 32, 35, 55, 56, 57, 93, 95, 97, 113, 122, 127, 128, 146, 147, 153, 163, 166, 167, 168, 169
  - foundation, 93
  - with using CLSM, 86, 87
- Processing plant, 120, 140, 158, 162
- Profile wall corrugated HDPE pipe, 73, 104, 149, 151, 162
- Projecting, *see* Positive projecting conduit *or* Negative projecting conduit
- Projection ratio, 43, 44
- Pumping, grout, 96, 97
- PVC pipe, 6, 7, 8, 15, 17, 18, 19, 20, 27, 28, 29, 32, 48, 53, 54, 69, 71, 73, 75, 77, 91, 94, 95, 97, 98, 102, 103, 104, 127, 128, 153, 172
  - modulus of elasticity, 54
  - pressure pipe, 20
  - slotted, 105
  - solid wall, 17, 102

## R

- Reinforced cast-in-place concrete encasement, 81-83, 90
- Reinforced concrete cradle, 81, 90
- Renovation, 1, 2, 11, 20, 21, 24, 25, 30, 33, 98, 99, 112
  - drainpipes, 112-114
  - embankment conduits, 98-100
- Repair, 2, 15, 16, 94, 98, 99, 109, 113, 143, 157

Replacement, 1, 98, 99, 103, 113, 118, 119  
  drainpipes, 99, 112-114  
Research items, 171-175  
Research needs, 171-177  
Resin, 7, 21, 22, 23, 31, 32  
Rigid pipe, 73-74  
Roadway crossing, 141

## S

Sand, 68, 85, 108, 114, 116, 118, 119, 120, 121, 124, 138, 139, 143, 158, 163  
SDR, *see* Standard dimension ratio  
Sediment, 97, 103, 109, 111, 113, 122, 123, 124, 129, 152, 157, 158, 159, 161, 166  
  Sediment Control Pond SP-4 Dam, 97  
Seepage, 1, 35, 37, 40, 82, 83, 84, 87, 89, 97, 101, 102, 106, 107, 108, 113, 115, 118,  
  121, 124, 154, 156, 161, 162, 163, 166, 167  
Segregation, 85, 87, 137, 138  
Settlement ratio,  $r_{sd}$ , 43, 44  
Silt, 118, 119, 131, 138, 158  
Single wall corrugated HDPE pipe, 51, 59, 60, 61, 62, 76, 153  
  failure, 59, 61, 153  
  unconstrained collapse pressure vs. minimum pipe stiffness, 77  
Siphons, 1, 24, 27, 28, 33, 36, 49, 61, 63, 69, 78, 98, 127  
Slipliners, 15, 16, 68, 74, 79, 87, 88, 92, 94, 96, 114  
Slotted pipe, 2, 11, 12, 104, 105, 115, 116, 118, 154, 156, 162, 163, 172  
Slurry impoundments, 24, 161-171  
Snap joints, 17  
Soil  
  as embedment material, 79-80, 96  
  as embedment material, 96  
  loading, 11, 33, 34, 36, 37, 39-41, 44, 45, 54, 58, 63, 66, 74, 87, 88, 90  
  modulus of soil reaction,  $E'$ , 57, 60, 65, 66, 67, 68, 69, 79, 86, 87, 173  
  segregation, 138  
Solid wall pipe, 8, 10, 11, 12, 15, 16, 17, 24, 25, 26, 31, 48, 54, 58, 61, 64, 65, 69, 72,  
  73, 76, 77, 102, 103, 104, 162, 172  
  containment pipe, 24-26  
  HDPE, 10, 16, 26, 31, 102, 104, 162  
  PVC, 17, 102  
Spacers, 11, 95  
Spigot, *see* Bell and spigot joints  
Standard dimension ratio, 48, 49, 54, 65, 69, 70, 72, 75, 76, 77, 89, 162

## Standards

- AASHTO, xxv, 9, 31, 32, 57, 67, 68, 104, 105, 132
- ASTM, xxvi-xxx, 6, 8, 9, 10, 11, 12, 14, 15, 17, 20, 22, 26, 30, 31, 32, 53, 59, 67, 69, 70, 75, 84, 94, 107, 116, 117, 118, 120, 138, 139, 142
- AWWA, xxxi, 6, 8, 17, 23, 32, 51, 53, 54, 60, 66, 69, 70, 71, 91, 94, 98, 127
- Structural design, 33, 54, 55, 74, 78, 87, 92, 101, 102
- Sugar Mill Dam, 97
- Symbols, xxi-xxiv

**T**

- Temperature, 7, 12, 14, 20, 21, 70, 71, 91, 92, 95, 96, 97, 146, 173
  - placement, 95-97
  - reduction factors, 71
- Thermoplastic pipe, 7, 8, 9, 19, 20, 21, 29, 31, 53, 57, 95
- Thermoset plastic pipe, 7, 21, 22, 53
- Thrust blocks, 94, 95
- Toe drains, 1, 26
- Trapezoidal trenches, 130, 131, 132, 135
- Trenches, 35, 36, 37, 38, 39, 40, 41, 42, 44, 69, 82, 83, 86, 90, 96, 102, 114, 130, 131, 132, 135, 136, 145, 146
  - box, 132, 136
  - condition, 36, 37, 39, 41, 44, 90, 145
  - conduit, 35, 39-41, 90, 102
  - excavation., 35, 133
  - trapezoidal, 130, 132, 135
- Types of plastic pipe, 20-21

**U, V**

- Unconstrained collapse pressure, 75, 76, 77
- Unreinforced cast-in-place concrete encasement, 83, 90
- Upper Wheeler Reservoir Dam, 97
- Vacuum pressure, 33, 49, 50, 63, 86
- Venting, *see* Air venting
- Virginia Dam, 76, 166

## W-Z

Water filled liner, 23

Water jetting, 160

Websites, xxxii

Wells, *see* Inspection, wells

Wheatfields Dam, 11

Worster Dam, 24

Zoning, 114-116, 121

    design, 121, 122



# Glossary

The terms defined in this glossary use industry-accepted definitions whenever possible. The source of the definition is indicated in parentheses.

**Abrasion (ASTM, 2002):** A rubbing or wearing away.

**Additive (PPI, 2006):** A substance added in small amount for a special purpose such as to reduce friction, corrosion, etc.

**Allowable strain:** A change in pipe dimension relative to the original dimension that provides an adequate factor of safety against unacceptable performance or failure.

**Angle of friction (ASTM, 2002):** Angle whose tangent is the ratio between the maximum value of shear stress that resists slippage between two solid bodies at rest with respect to each other, and the normal stress across the contact surface.

**Anisotropy:** Exhibiting properties with different values when measured in different directions. For soils, typically the horizontal permeability is greater than the vertical permeability due to layering introduced during deposition.

**Antioxidant:** A plastic additive to extend the temperature range and service life.

**Arching:** The condition in which vertical pressures within backfill in a trench is reduced because of the transfer of stress at the backfill/excavation surface interface.

**Backfill (FEMA, 2005):** Soil or concrete used to fill excavations.

**Bead:** Small ridge formed around the circumference of a polyethylene pipe joint as the two pipe ends are brought together during the butt fusion process.

**Bell and spigot gasket joint:** See **Joint, bell and spigot gasket**.

**Biofouling:** An accumulation and growth of deposits or contamination linked to microbial activity.

**Borrow (AGI, 1987):** Earth material (sand, gravel, etc.) taken from one location (such as a borrow pit) to be used for fill at another location; e.g. embankment material obtained from a pit when there is insufficient excavated material nearby to

form the embankment. The implication is often present that the borrowed material has suitable or desirable physical properties.

**Branch saddle:** A fitting which is bonded to the exterior of a pipe to assist in transferring tensile loads in the pipe to a concrete thrust block.

**Branching:** The growth of a second chain of a polymer out of another one by replacement of a hydrogen atom on a monomer by a free-radical reaction, or by a condensation or other chemical reaction with a reactive group on a monomer.

**Breakdown:** Undesired alteration of soil gradation by mechanical action such as loading, pushing, and compacting.

**Broadly graded:** A soil consisting of a wide range of particle sizes where  $c_u \geq 5$ .

**Buckling:** See **Wall buckling**.

**Butt fusion (PPI, 2006):** A method of joining polyethylene pipe where two pipe ends are heated and rapidly brought together under pressure to form a homogeneous bond.

**Butt fusion joint:** See **Joint, butt fusion**.

**Camera-crawler (FEMA, 2005):** A video camera attached to a self-propelled transport vehicle (crawler). Typically, the camera-crawler is used for closed circuit television inspection of inaccessible conduits.

**Carbon black (PPI, 2006):** A black pigment produced by the incomplete burning of natural gas or oil, that possesses excellent ultraviolet protective properties.

**Carrier pipe:** The interior pipe of a dual containment pipe system.

**Cell classification:** A method used to classify thermoplastic compounds based on the material's composition and select properties.

**Centralizer:** Provides support to the carrier pipe within the containment pipe.

**Chimney filter:** See **Filter, chimney**.

**Closed circuit television (CCTV) (FEMA, 2005):** A method of inspection utilizing a closed circuit television camera system and appropriate transport and lighting equipment to view the interior surface of conduits.

**Coefficient of internal friction (ASTM, 2002):** The tangent of the angle of internal friction.

**Coefficient of thermal expansion (ACI, 2000):** Change in linear dimension per unit length or change in volume per unit volume per degree of temperature change.

**Colorant:** A plastic additive used to provide color.

**Complete condition:** A loading condition for an encased plastic pipe when the embankment height is less than or equal to the height of the plane of equal settlement. The frictional forces between the interior and exterior prisms extend to the top of the embankment.

**Compound:** A mixture of ingredients before the final processing into a completed product.

**Conduit (FEMA, 2004):** A closed channel to convey water through, around, or under an embankment dam.

**Containment pipe:** The outer pipe of a dual containment pipe system.

**Contamination:** The introduction of unwanted material into a dam, typically during construction, such as tracking core material onto a filter.

**Controlled low strength material (CLSM) (FEMA, 2005):** A self-compacting, cementitious material typically used as a replacement for compacted backfill around a conduit.

**Corrosion (ACI, 2000):** Disintegration or deterioration of a material by electrolysis or chemical attack.

**Corrugated metal pipe (CMP) (FEMA, 2005):** A galvanized light gauge metal pipe that is ribbed to improve its strength.

**Coupling agent:** A plastic additive to improve the properties of the plastic material.

**Coupling:** A mechanical device that serves to connect the ends of pipes.

**Crosslinking:** Chain-reaction polymerization which results in chemical links (bonds) between individual polymer chains.

**Cured-in-place pipe (CIPP) (ASTM, 2003):** A hollow cylinder consisting of a fabric tube with cured (cross-linked) thermosetting resin. Interior or exterior plastic coatings, or both, may be included. The CIPP is formed within an existing conduit and takes the shape of and fits tightly to the conduit.

**Dam (FEMA, 2005):** An artificial barrier that has the ability to impound water, wastewater, or any liquid-borne material, for the purpose of storage or control of water.

**Dam failure (FEMA, 2004):** A catastrophic type of failure characterized by the sudden, rapid, and uncontrolled release of impounded water or the likelihood of such an uncontrolled release. There are lesser degrees of failure, and any malfunction or abnormality outside the design assumptions and parameters that adversely affect an embankment dam's primary function of impounding water is properly considered a failure. These lesser degrees of failure can progressively lead to or heighten the risk of a catastrophic failure. They are, however, normally amenable to corrective action.

**Dam safety (FEMA, 2004):** Dam safety is the art and science of ensuring the integrity and viability of dams, such that they do not present unacceptable risks to the public, property, and the environment. Dam safety requires the collective application of engineering principles and experience, and a philosophy of risk management that recognizes that an embankment dam is a structure whose safe function is not explicitly determined by its original design and construction. Dam safety also includes all actions taken to identify or predict deficiencies and consequences related to failure, and to document and publicize any unacceptable risks, and reduce, eliminate, or remediate them to the extent reasonably possible.

**Decant:** A structure used in mining operations to draw water off a reservoir after the heavier materials have settled out.

**Deflection (FEMA, 2005):** The decrease in the vertical diameter of a pipe due to load, divided by the nominal diameter, expressed as a percent.

**Deformation (ACI, 2000):** A change in dimension or shape due to stress.

**Design (FEMA, 2005):** An iterative decisionmaking process that produces plans by which resources are converted into products or systems that meet human needs or solve problems.

**Designer (FEMA, 2005):** A registered engineer representing a firm, association, partnership, corporation, agency, or any combination of these who is responsible for the supervision or preparation of plans and specifications associated with an embankments dam and its appurtenances.

**Dimension ratio:** See **Standard dimension ratio**.

**Dimpling:** Localized instability (buckling) resulting in a wavy checkerboard appearance on the inner surface of a pipe wall.

**Double stage filter/drain:** A system consisting of a coarse drainage zone (gravel) surrounding the pipe and a filter (sand) zone surrounding the coarse element.

**Drainpipe:** A system of pipe within an embankment dam used to collect seepage from the foundation and embankment and convey it to a free outlet.

**Dual wall containment pipe:** A pipe system that provides a secondary containment pipe around the carrier pipe. Any leakage from the carrier pipe will be safely contained within the containment pipe.

**Durability (ACI, 2000):** The ability of a material to resist weathering, chemical attack, abrasion, and other conditions of service.

**Embankment dam (FEMA, 2005):** Any dam constructed of excavated natural materials, such as both earthfill and rockfill dams, or of industrial waste materials, such as tailings dams.

**End restraint:** A structural member designed to resist the anticipated expansion/contraction forces caused by temperature change in a plastic pipe.

**Engineer (FEMA, 2005):** A person trained and experienced in the profession of engineering; a person licensed to practice the profession by the appropriate authority.

**Environmental stress cracking (ASTM, 2001):** The development of cracks in a material that is subjected to stress or strain in the presence of specific chemicals.

**Extender:** A plastic additive used to reduce cost.

**External hydrostatic pressure:** Pressure on the outside of the pipe due to water surrounding the pipe in the voids or in the soil surrounding the pipe.

**Exterior prism:** The soil adjacent to the soil directly above the buried conduit (the interior prism).

**Extrusion joint:** See **Joint, extrusion**.

**Fibrous reinforcement:** A plastic additive used to improve the strength to weight ratio.

**Filler:** A plastic additive to improve properties of the resin.

**Filter (FEMA, 2005):** A zone of material designed and installed to provide drainage, yet prevent the movement of soil particles due to flowing water.

**Chimney (FEMA, 2005):** A chimney filter is a vertical or near vertical element in an embankment dam that is placed immediately downstream of the dam's core. In the case of a homogenous embankment dam, the chimney filter is typically placed in the central portion of the dam.

**Collar (FEMA, 2005):** A limited placement of filter material that completely surrounds a conduit for a specified length within the embankment dam. The filter collar is located near the conduit's downstream end. The filter collar is usually included in embankment dam rehabilitation only when a filter diaphragm cannot be constructed. A filter collar is different from a filter diaphragm, in that a filter diaphragm is usually located within the interior of the embankment dam.

**Diaphragm (FEMA, 2005):** A filter diaphragm is a zone of filter material constructed as a diaphragm surrounding a conduit through an embankment. The filter diaphragm protects the embankment near the conduit from internal erosion by intercepting potential cracks in the earthfill near and surrounding the conduit. A filter diaphragm is intermediate in size between a chimney filter and a filter collar. The filter diaphragm is placed on all sides of the conduit and extends a specified distance into the embankment.

**Filter collar:** See **Filter, collar**.

**Filter diaphragm:** See **Filter, diaphragm**.

**Filter material (NAWIC, 1986):** Granular material that has been graded to allow water to pass through it while retaining solid matter.

**First filling:** The initial filling of the reservoir behind a dam. Also, used to describe refilling of a reservoir after a modification has been made to a dam.

**Flanged joint:** See **Joint, flanged**.

**Flexible pipe:** A pipe that derives its load carrying capacity by deflecting at least 2 percent into the surrounding medium upon application of load.

**Fold-and-formed pipe (FFP):** A thermoset system where a plastic pipe manufactured in a folded shape of reduced cross-sectional area is pulled into an existing conduit and subsequently expanded to the internal shape by heat and pressure.

**Gasket:** A flexible material used to form a water-tight seal between two components.

**Geosynthetic (ASTM, 2004):** A planar product manufactured from polymeric material used with soil, rock, earth, or other geotechnical engineering related material as an integral part of a man-made project, structure or system.

**Gradation (ASTM, 2002):** The distribution of particles of granular material among standard sizes, usually expressed in terms of cumulative percentages larger or smaller than each of a series of sieve openings.

**Grout (FEMA, 2005):** A fluidized material that is injected into soil, rock, concrete, or other construction material to seal openings and to lower the permeability and/or provide additional structural strength. There are four major types of grouting materials: chemical, cement, clay, and bitumen.

**Haunch:** The area beneath a pipe between the springline and the invert.

**Hazard (FEMA, 2004):** A situation that creates the potential for adverse consequences such as loss of life, property damage, or other adverse impacts.

**Hazard potential (FEMA, 1998):** The adverse incremental consequences that result from the release of water or stored contents due to failure of the dam or misoperation of the dam or appurtenances. Impacts may be for a defined area downstream of a dam from flood waters released through spillways and outlet works of the dam or waters released by partial or complete failure of the dam. There may also be impacts for an area upstream of the dam from effects of backwater flooding or landslides around the reservoir perimeter.

- **Low (FEMA, 1998):** Embankment dams assigned the low hazard potential classification are those where failure or misoperation results in no probable loss of human life and low economic and/or environmental losses. Losses are principally limited to owners' property.
- **Significant (FEMA, 1998):** Embankment dams assigned the significant hazard potential classification are those dams where failure or misoperation results in no probable loss of human life but can cause economic loss, environmental damage, or disruption of lifeline facilities, or can impact other concerns. Significant hazard potential classification dams are often located in predominantly rural or agricultural areas, but could be located in areas with population and significant infrastructure.
- **High (FEMA, 1998):** Embankment dams assigned the high hazard potential classification are those where failure or misoperation will probably cause loss of human life.

**Hazard potential classification:** A system that categorizes dams according to the degree of adverse incremental consequences of a failure or misoperation of a dam.

The hazard potential classification does not reflect in any way on the current condition of the dam (i.e., safety, structural integrity, flood routing capacity).

**Heterogeneous:** Consisting of parts or aspects that are unrelated or unlike each other. In relation to earth materials, soils that consist of any combination of clays, silts, sands, gravels, cobbles, and boulders.

**High density polyethylene plastic (HDPE) (ASTM, 2001):** Those linear polyethylene plastics, having a standard density of 0.941 g/cm<sup>3</sup> or greater.

**High hazard potential:** See **Hazard potential, high**.

**Homogenous:** Consisting of a single material of uniform properties. In relation to earth dams, a design of uniform cross section.

**Hoop strain:** Strain in the pipe wall due to internal or external pressure.

**Hoop stress:** The tensile stress in the wall of the pipe in the circumferential orientation due to internal hydrostatic pressure.

**Hopper (NAWIC, 1986):** A storage bin or a funnel that is loaded from the top and discharges through a door or chute in the bottom.

**Hydraulic loading:** Loading on the pipe due to internal pressure, water hammer, internal vacuum pressure, or external hydrostatic pressure.

**Hydrostatic design basis (HDB) (ASTM, 2001):** One of a series of established stress values specified in ASTM D 2837 for a plastic compound obtained by categorizing the long-term hydrostatic strength determined in accordance with Test Method D 2837.

**Hydrostatic design stress (HDS) (ASTM, 2001):** The estimated maximum tensile stress the material is capable of withstanding continuously with a high degree of certainty that failure of the pipe will not occur. This stress is circumferential when internal hydrostatic water pressure is applied.

**Hydrostatic pressure:** The force per unit area due to water within the pipe (internal) or surrounding the pipe (external).

**Igneous (AGI, 1987):** Said of a rock or mineral that solidified from molten or partly molten material, i.e. from a magma; also, applied to processes leading to, related to, or resulting from the formation of such rocks.

**Inclination:** The degree of deviation from a horizontal.



**Incomplete condition:** A loading condition for an encased plastic pipe when the embankment height is greater than the height of the plane of equal settlement. The frictional forces between the interior and exterior prisms do not extend to the top of the embankment.

**Inspection (FEMA, 2005):** The review and assessment of the operation, maintenance, and condition of a structure.

**Inspector (FEMA, 2005):** The designated on-site representative responsible for inspection and acceptance, approval, or rejection of work performed as set forth in the contract specifications. The authorized person charged with the task of performing a physical examination and preparing documentation for inspection of the embankment dam and appurtenant structures.

**Interior prism:** The prism of soil directly above the buried conduit.

**Internal erosion (FEMA, 2005):** A general term used to describe all of the various erosional processes where water moves internally through or adjacent to the soil zones of embankment dams and foundation, except for the specific process referred to as “backward erosion piping.” The term “internal erosion” is used in this document in place of a variety of terms that have been used to describe various erosional processes, such as scour, suffosion, concentrated leak piping, and others. Note: For a complete discussion of internal erosion and backward erosion piping, see FEMA’s *Technical Manual: Conduits through Embankment Dams* (2005).

**Internal hydrostatic pressure:** Pressure inside the pipe (typically no more than the pressure due to the full reservoir).

**Internal vacuum pressure:** Negative internal pressure inside the pipe.

**Invert (FEMA, 2005):** The bottom or lowest point of the internal surface of the transverse cross section of a conduit.

**Joint (ASTM, 2001):** The location at which two sections of conduit or pipe and a fitting are connected together.

**Bell and spigot gasket (ASTM, 2001):** A connection between piping components consisting of a bell end on one component, an elastomeric gasket between the components, and a spigot end on the other component.

**Butt fusion (ASTM, 2001):** A joint in which the prepared ends of the joint components are heated and then placed in contact to form the joint.

**Extrusion (ASTM, 2001):** A joint formed by a process whereby heated or unheated plastic forced through a shaping orifice becomes one continuously formed piece.

**Flanged (ASTM, 2001):** A mechanical joint using pipe flanges, a gasket, and bolts.

**Mechanical (ASTM, 2001):** A connection between piping components employing physical force to develop a seal or produce alignment.

**Lean concrete:** Low strength concrete (low cement content) used for non-structural applications such as fill, or as a sub base for concrete pavements.

**Liquefaction (AGI, 1987):** In cohesionless soil, the transformation from a solid to a liquid state as a result of increased pore pressure and reduced effective stress.

**Load coefficient:** A coefficient used in calculating the soil load on buried conduits to account for the load transfer between the prism of soil directly above the pipe and the adjacent soil.

**Long-term modulus of elasticity:** A material property describing the stress/strain behavior of a material in the linearly elastic region after exposed to a long period of time (50 to 100 years).

**Low hazard potential:** See **Hazard potential, low**.

**Lubricant (ASTM, 2001):** A material used to reduce friction between two mating surfaces that are being joined by sliding contact.

**Marston load theory:** A theory on the magnitude of soil load on a buried conduit based on the construction method and relative settlements of the soil directly above the pipe, soil adjacent to the pipe, and soil adjacent to the soil directly above the pipe.

**Material quality:** Physical properties of soil related to strength, absorption, density, etc.

**Maximum dimension:** In relation to opening sizes in perforated pipe the diameter for circular holes and the length for slots.

**Maximum size aggregate (MSA):** The smallest sieve through which 100 percent of the aggregate sample particles pass.

**Mechanical joint:** See **Joint, mechanical**.

**Metamorphic (AGI, 1987):** Pertaining to the process of metamorphism or to its results.

**Metamorphism (AGI, 1987):** The mineralogical, chemical, and structural adjustment of solid rocks to physical and chemical conditions which have generally been imposed at depth below the surface zones of weathering and cementation, and which differ from the conditions under which the rocks in question originated.

**Miscellaneous fill:** Earthfill that does not serve a specific function such as drainage, filtering, or water barrier.

**Modulus of elasticity:** A material property describing the stress/strain behavior of a material in the linearly elastic region.

**Modulus of soil reaction (E'):** Measure of the stiffness of the material which surrounds the pipe.

**Multistage filter:** A filter consisting of more than one zone, such as a sand filter zone and gravel drain zone.

**Negative projecting conduit (Spangler and Handy, 1982):** A conduit installed in a relatively narrow and shallow trench with its top at an elevation below the natural ground surface and which is then covered with an embankment.

**Nuclear testing:** Of or relating to the nuclear density test as described in ASTM D 2922.

**Opening size:** The minimum dimension of a perforation in a pipe. For circular perforations it is the hole diameter, for slots, it is the slot width.

**Outlet works (FEMA, 2004):** A dam appurtenance that provides release of water (generally controlled) from a reservoir.

**Out-of-round:** The allowed difference between the maximum measured diameter and the minimum measured diameter (stated as an absolute deviation).

**Particle breakdown:** Undesired alteration of a soil grain by mechanical action such as loading, pushing, and compacting.

**Perforation:** A hole or pattern made by or as if by piercing, drilling, or sawing.

**Permeability (k):** The rate at which water passes through soil in accordance with Darcy's law.

**Pipe stiffness:** The inherent resistance of a flexible pipe to load.

**Plane of equal settlement:** A location above a pipe where the accumulated strain and settlement in the exterior prisms equal that of the interior prism. Above this plane, the interior and exterior prisms settle equally and no shear or friction forces are transferred between the prisms.

**Plastic (ASTM, 2001):** A material that contains as an essential ingredient one or more organic polymeric substances of large molecular weight, is solid in its finished state, and, at some stage in its manufacture or processing into finished articles, can be shaped by flow.

**Plastic pipe (ASTM, 2001):** A hollow cylinder of plastic material in which the wall thicknesses are usually small when compared to the diameter and in which the inside and outside walls are essentially concentric.

**Plasticity index:** Numerical difference between the liquid limit and the plastic limit.

**Poisson's ratio ( $\nu$ ) (ASTM, 2002):** Ratio between linear strain changes perpendicular to the direction of a given uniaxial stress change.

**Polyester (PPI, 2006):** Resin formed by condensation of polybasic and monobasic acids with polyhydric alcohols.

**Polyethylene (FEMA, 2005):** A polymer prepared by the polymerization of ethylene as the sole monomer.

**Polyvinyl chloride (PVC) (FEMA, 2005):** A polymer prepared by the polymerization of vinyl acetate as the sole monomer.

**Positive projecting conduit (Spangler and Handy, 1982):** A conduit installed in a bedding with its top projecting above the natural ground surface and which is then covered with an embankment.

**Preservative:** A plastic additive used to prevent bacterial attack.

**Pressure pipe (ASTM, 2001):** Pipe designed to resist continuous pressure exerted by the conveyed medium.

**Pressure rating (PR) (ASTM, 2001):** The estimated maximum water pressure the pipe is capable of withstanding continuously with a high degree of certainty that failure of the pipe will not occur.

**Profile pipe:** Pipe that has smooth interior and corrugated exterior surfaces.

**Projecting conduit:** A conduit covered by fill material such as embankment material.

**Projection condition:** A projecting conduit above which the exterior prisms settle more than the interior prism.

**Projection ratio ( $p$ ):** The ratio of the vertical height of the top of the conduit above the embankment subgrade to the outside conduit diameter.

**Proof rolling:** A process accomplished by the application of heavy construction or compaction equipment on an excavation invert in order to locate low density areas.

**Quality assurance (FEMA, 2005):** A planned system of activities that provides the owner and permitting agency assurance that the facility was constructed as specified in the design. Construction quality assurance includes inspections, verifications, audits, and evaluations of materials and workmanship necessary to determine and document the quality of the constructed facility. Quality assurance refers to measures taken by the construction quality assurance organization to assess if the installer or contractor is in compliance with the plans and specifications for a project. An example of quality assurance activity is verifications of quality control tests performed by the contractor using independent equipment and methods.

**Quality control (FEMA, 2005):** A planned system of inspections that is used to directly monitor and control the quality of a construction project. Construction quality control is normally performed by the contractor and is necessary to achieve quality in the constructed system. Construction quality control refers to measures taken by the contractor to determine compliance with the requirements for materials and workmanship as stated in the plans and specifications for the project. An example of quality control activity is the testing performed on compacted earthfill to measure the dry density and water content. By comparing measured values to the specifications for these values based on the design, the quality of the earthfill is controlled.

**Renovation (FEMA, 2005):** The repair or restoration of an existing structure, so it can serve its intended purpose.

**Repair (FEMA, 2005):** The reconstruction or restoration of any part of an existing structure for the purpose of its maintenance.

**Resin (ASTM, 2001):** A solid or pseudosolid organic material, often with high molecular weight, which exhibits a tendency to flow when subjected to stress, usually has a softening or melting range, and usually fractures conchoidally (shell-like fracture).

**Rigid pipe:** A pipe, typically reinforced concrete, designed to carry loads without support from the surrounding medium.

**Ring strain:** Strain in the pipe wall due to deflection or deformation from external loads.

**Rock ladder:** A device that lifts aggregate vertically by the use of buckets attached to a belt.

**Sand (ASTM, 2002):** Particles of rock that will pass the No. 4 (4.75- $\mu$ m) sieve and be retained on the No. 200 (0.075-mm) U.S. standard sieve.

**Sediment trap:** An area, such as a pool, behind a weir or flume where the inflow velocity is reduced sufficiently that any soil particles included in the flow will settle out.

**Sedimentary rock (AGI, 1987):** A rock resulting from the consolidation of loose sediment that has accumulated in layers; e.g. a clastic rock (such as conglomerate or tillite) consisting of mechanically formed fragments of older rock transported from its source and deposited in water or from air or ice; or a chemical rock (such as rock salt or gypsum) formed by precipitation from solution; or an organic rock (such as certain limestones) consisting of the remains or secretions of plants and animals.

**Seepage (ASTM, 2002):** The infiltration or percolation of water through rock or soil or from the surface.

**Seepage paths (ASCE, 2000):** The general path along which seepage follows.

**Segregation:** The process of separating coarser soil from finer soil, typically during construction activities.

**Service life (FEMA, 2005):** Expected useful life of a project, structure, or material.

**Settlement ratio (AWWA, 1995):** The relationship between the pipe deflection and the relative settlement between the prism of soil directly above the pipe and the adjacent soil.

**Short-term modulus of elasticity:** A material property describing the stress/strain behavior of a material in the linearly elastic region immediately upon a change in load.

**Significant hazard potential:** See **Hazard potential, significant**.

**Single stage filter/drain:** A system consisting of one zone of filter material, usually sand, surrounding a collector drainpipe.

**Siphon (FEMA, 2005):** An inverted u-shaped pipe or conduit, filled until atmospheric pressure is sufficient to force water from a reservoir over an embankment dam and out of the other end.

**Sliplining (FEMA, 2005):** The process of inserting a new, smaller-diameter lining or pipe into an existing larger-diameter conduit.

**Slot:** A long, narrow aperture or slit.

**Slow crack growth (PPI, 2006):** The slow extension the crack with time.

**Soil (ASTM, 2002):** Sediments or other unconsolidated accumulations of solid particles produced by the physical and chemical disintegration of rocks, and which may or may not contain organic matter.

**Soil prism theory:** The soil load on a buried pipe is weight of the soil directly above the pipe.

**Soil prism:** The soil directly above the pipe.

**Soil-cement:** Highly compacted mixture of soil/aggregate, portland cement, and water. Soil-cement differs from portland cement concrete pavement in several respects. One significant difference is the manner in which the aggregates or soil particles are held together. A portland cement concrete pavements mix contains sufficient paste (cement and water mixture) to coat the surface area of all aggregates and fill the void between aggregates. In soil-cement mixtures, the paste is insufficient to fill the aggregate voids and coat all particles, resulting in a cement matrix that binds nodules of uncemented material.

**Spillway (FEMA, 2004):** A structure, over or through which water is discharged from a reservoir. If the rate of flow is controlled by mechanical means, such as gates, it is considered a controlled spillway. If the geometry of the spillway is the only control, it is considered an uncontrolled spillway.

**Spreader box:** A device used in construction to deposit fill uniformly over the ground surface.

**Stabilizer:** A plastic additive to prevent degradation.

**Standard dimension ratio (SDR) (FEMA, 2005):** Ratio of the average specified outside diameter to the minimum specified wall thickness for outside diameter controlled plastic pipe. Also referred to as dimension ratio (DR).

**Standard inside dimension ratio (SIDR):** A specific ratio of the average specified inside diameter to the minimum specified wall thickness for inside diameter-controlled plastic pipe.

**Stockpile (NAWIC, 1986):** Material dug and piled for future use.

**Strain (ASTM, 2001):** The change per unit length in a linear dimension of a body, that accompanies a stress. Strain is a dimensionless quantity which may be measured in percent, in inches per inch, in millimeters per millimeter, etc.

**Stress crack resistance (SCR):** Resistance to cracking from tensile stresses; a failure that develops over time at stresses less than the yield strength. Stress cracking is a macro-brittle cracking phenomenon that occurs at a constant stress significantly less than the yield or break stress of the material. Stress cracking is initiated at an internal or external “defect” in the material such as an inclusion or scratch.

**Surge pressure (water hammer):** A surge in pressure caused by a sudden change in water velocity. Typical causes include the sudden starting or stopping of a pump, sudden valve movement, or air movement in a pipeline. The surge may damage or destroy pipelines and pumps if severe enough.

**Thermoplastic (ASTM, 2001):** A plastic that can be repeatedly softened by heating and hardened by cooling through a temperature range characteristic of the plastic, and that in the softened state can be shaped by flow into articles by molding or extrusion.

**Thermoset (ASTM, 2001):** A plastic that, when cured by application of heat or chemical means, changes into a substantially infusible and insoluble product.

**Tailings (FEMA, 2005):** The fine-grained waste materials from an ore-processing operation.

**Toe drain:** Typically a pipe used to collect water at the downstream toe of a dam.

**Trench condition:** A projecting conduit above which the interior prism settles more than the exterior prism.

**Trench conduit (Spangler and Handy, 1982):** A conduit installed in a relative narrow trench excavated in passive or undisturbed soil which is then covered with earth backfill.

**Undisturbed soil:** In situ or in place soil unaltered by human activity.

**Uniformly graded:** A soil consisting of a small range of particle sizes where  $c_u < 5$ .



**Void (FEMA, 2005):** A hole or cavity within the foundation or within the embankment materials surrounding a conduit.

**Wall buckling:** Collapse of the pipe due to excessive external pressure or internal vacuum pressure.

**Wall crushing:** Failure of the pipe wall due to excessive wall stress from loads on top of the pipe.

**Water content (ASTM, 2002):** The ratio of the mass of water contained in the pore spaces of soil or rock material, to the solid mass of particles in that material, expressed as a percentage.

**Water hammer:** See **Surge pressure**.

**Zoning:** The cross sectional area of an embankment divided into zones that serve different purposes such as core, shell, chimney filter, etc.

### References for Glossary

American Concrete Institute (ACI), *Cement and Concrete Terminology ACI 116 R*, Committee Report, 2000.

American Geological Institute (AGI), *Glossary of Geology*, 1987.

American Society of Civil Engineers (ASCE), *Guidelines for Instrumentation and Measurements for Monitoring Dam Performance*, 2000.

American Water Works Association (AWWA), *Concrete Pressure Pipe*, M9, 1995.

ASTM International\*, *Standard Terminology Relating to Plastic Piping Systems*, ASTM F 412, 2001.

ASTM International\*, *Standard Terminology Relating to Soil, Rock, and Contained Fluids*, ASTM D 653, 2002.

ASTM International\*, *Standard Practice for Rehabilitation of Existing Pipelines and Conduits by Pulled-in-Place Installation of Cured-in-Place Thermosetting Resin Pipe CIPP*, ASTM F 1743, 2003.

ASTM International\*, *Standard Terminology for Geosynthetics*, ASTM D 4439, 2004.

## Plastic Pipe Used in Embankment Dams

---

Federal Emergency Management Agency (FEMA), *Federal Guidelines for Dam Safety: Hazard Potential Classification Systems for Dams*, FEMA 333, 1998.

Federal Emergency Management Agency (FEMA), *Federal Guidelines for Dam Safety: Glossary of Terms*, FEMA 148, 2004.

Federal Emergency Management Agency (FEMA), *Technical Manual: Conduits through Embankment Dams*, FEMA 484, 2005.

National Association of Women in Construction (NAWIC), *Construction Dictionary*, 1986.

Plastic Pipe Institute (PPI), *Handbook of Polyethylene Pipe*, 2006.

Spangler, M.G. and R.L. Handy, *Soil Engineering*, 1982.

\* The ASTM definitions in this glossary were extracted, with permission, from ASTM standards, copyright ASTM International, 100 Barr Harbor Drive, West Conshohocken, PA 19428. A copy of the complete standard may be obtained from ASTM ([www.astm.org](http://www.astm.org)).

## Appendix A

### Example Calculations

#### Index

No.	Topic	Page
A-1	Flexible pipe design (for a drainpipe)	A-3
A-2	Encased pipe design (for an embankment conduit)	A-7
A-3	Siphon design	A-11
A-4	Toe drain design (filter and drain)	A-14



## A-1 Flexible pipe design (for a drainpipe)

### Description

A 12-inch diameter HDPE (ASTM D 3350 cell class 345464C) solid wall pipe will be used as a drainpipe (figure A-1). The maximum height (H) of fill over the pipe is 15 feet. The pipe will be embedded in a well graded sandy soil that is compacted to 50 percent relative density.

### Assumptions

The following assumptions are made for this example:

- The pipe is considered a projecting conduit within the footprint of an embankment dam and classified as a positive projecting conduit in a trench condition. Since the pipe is embedded in coarse grained soil rather than encased in grout or concrete, flexible pipe design will be used. The soil prism theory is used as recommended in section 2.1.1. Table 9 in section 3.5.6 describes the applicable soil load conditions.
- The total unit weight of soil ( $\gamma$ ) is 115 lb/ft<sup>3</sup> with an  $E'$  of 2,000 lb/in<sup>2</sup> (table 4, section 3.1.3, using 75% of this value is 1,500 lb/in<sup>2</sup>).
- The short-term modulus of elasticity ( $E$ ) of the HDPE is 140,000 lb/in<sup>2</sup> and the long-term modulus is 30,000 lb/in<sup>2</sup> (table 3, section 3.1). The modulus of elasticity and allowable compressive stress depend upon the type and classification of plastic.
- The pipe meets ASTM D 3035 and has an  $D_o = 12.75$  inches.
- The allowable long-term compressive stress ( $\sigma$ ) (1/2 the hydrostatic design basis of 1,600 lb/in<sup>2</sup>) of the HDPE (cell class 345464C) is 800 lb/in<sup>2</sup>.

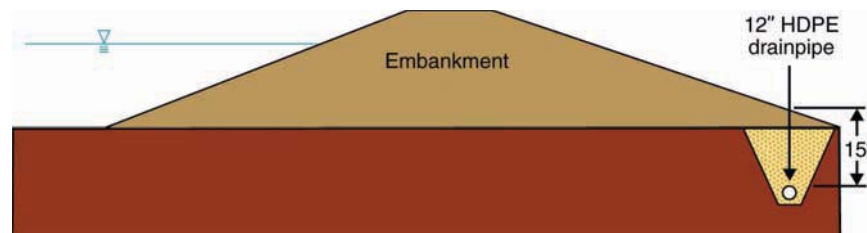

**Figure A-1.**—Cross section of an embankment dam and drainpipe (filter not shown).

### Calculations

Assume pressures from wheel ( $p_w$ ) and internal vacuum ( $p_v$ ) are zero.

#### Soil Load

The load due to overlying soil should be determined by the soil prism theory.

The soil load on the pipe by the soil prism theory is:

$$P_s = \gamma H = 115(15) = 1,725 \text{ lb/ft}^2 \quad (2-1)$$

#### Wall Crushing

The resistance to wall crushing of the plastic pipe is evaluated by:

$$T_{pw} = \frac{PD_o}{2} = \frac{(1725/144)(12.75)}{2} = 76.36 \text{ lb/in} \quad (3-1)$$

The required wall cross-sectional area is determined by:

$$A_{pw} = \frac{T_{pw}}{\sigma} = \frac{76.36}{800} = 0.095 \text{ in}^2/\text{in} \quad (3-2)$$

The area of a pipe wall may be computed as:

$$A_{pw} = \frac{(D_o - D_i)}{2} \text{ or } t \text{ (for solid wall pipe)} \quad (3-3)$$

where:

$$D_i = D_o - 2t$$

Solving for t:

$$t = 0.095 \text{ in}$$

So the minimum wall thickness,  $t$ , is 0.095 inches. The minimum wall thickness of a 12-inch HDPE pipe meeting ASTM D 3035 with an SDR of 26 (maximum recommended SDR) is 0.490 inches.

Wall Buckling

Plastic pipe embedded in soil may buckle due to excessive loads and deformations. The total soil load must be less than the allowable buckling pressure. The long-term modulus of elasticity is recommended since the soil load is a permanent load. The allowable buckling pressure may be determined from:

$$q_a = \frac{1}{FS} \left( 32R_w B' E' \frac{EI_{pw}}{D_o^3} \right)^{1/2} \quad (3-4)$$

$$B' = \frac{4(b^2 + D_o b)}{1.5(2b + D_o)^2} = \frac{4(15^2 + 12.75/12(15))}{1.5((2)(15) + 12.75/12)^2} = 0.665 \quad (3-6)$$

$$q_a = \frac{1}{2.5} \left( (32)(1)(0.665)(1500) \frac{(30,000) \left( \frac{0.490^3}{12} \right)}{12.75^3} \right)^{1/2} \quad (3-4)$$

$$= 22.8 \text{ lb/in}^2 = 3288 \text{ lb/ft}^2$$

The soil pressure of 1,725 lb/ft<sup>2</sup> is less than the allowable buckling pressure of 3,288 lb/ft<sup>2</sup> for a 12-inch diameter pipe with an SDR of 26.

Deflection

Since this pipe is a drainpipe for a filter, the recommended allowable deflection is 7.5% (see section 3.1.3). The deflection may be estimated from the following equation for solid wall pipe:

$$\begin{aligned}
 \frac{\% \Delta Y}{D} &= \frac{(D_L P_s + P_w + P_v) K (100)}{\left[ \left( \frac{2E}{3(SDR-1)^3} \right) + 0.061E' \right]} \\
 &= \frac{(1.5) \left( \frac{1725}{144} \right) + 0 + 0}{\left[ \left( \frac{(2)(140,000)}{3(26-1)^3} \right) + (0.061)(1500) \right]} (0.1)(100) \\
 &= 1.84\% < 7.5\%
 \end{aligned} \tag{3-8}$$

where:

$K = 0.1$  as recommended in section 3.1.3

Conclusion

A 12-inch diameter, HDPE with ASTM D 3350 cell class 345464C resin, and SDR of 26 is recommended for the drainpipe.



## A-2 Encased pipe design (for an embankment conduit)

### Description

An existing 20-foot high embankment dam has a 24-inch diameter CMP outlet works conduit (figure A-2). The conduit does not have a gate and is not considered a pressurized conduit. The foundation consists of stiff clay. The existing conduit will be sliplined with an HDPE (ASTM D 3350 cell class 345464C) pipe with an outside diameter,  $D_o$ , of 18-inches. The annulus between the existing conduit and the HDPE slipliner will be grouted. The liner pipe will be designed to withstand 18-feet of hydrostatic pressure.

### Assumptions

The following assumptions are made for this example:

- Since the annulus of the sliplined pipe will be grouted, the soil load will be assumed to act on the encased HDPE pipe. The grouted annulus is assumed to prevent deflection. Therefore, the HDPE liner will be considered a projecting conduit in the positive projecting condition.
- The CMP will continue to deteriorate and will not support the load.
- A solid wall HDPE pipe will be used as the slipliner pipe.
- The total unit weight of soil ( $\gamma$ ) is 110 lb/ft<sup>3</sup>.
- The short-term modulus of elasticity of the HDPE (cell class 345464C) is 140,000 lb/in<sup>2</sup> and the long-term modulus is 30,000 lb/in<sup>2</sup> (table 3, section 3.1).
- The allowable long-term compressive stress ( $\sigma$ ) (1/2 the hydrostatic design basis of 1,600 lb/in<sup>2</sup>) of the HDPE (cell class 345464C) is 800 lb/in<sup>2</sup>.

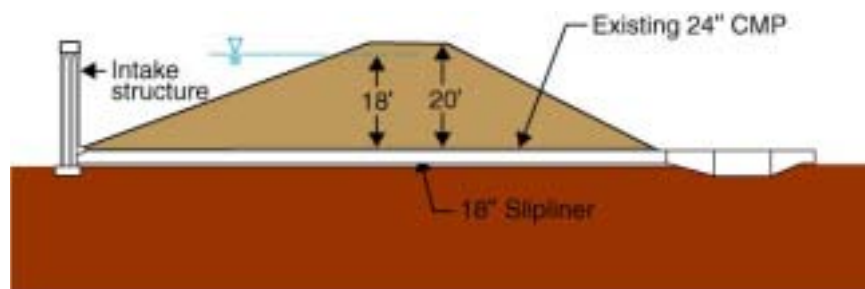

**Figure A-2.**—An 18-inch diameter solid wall HDPE slipliner installed in an existing 24-inch diameter CMP outlet works conduit.

## Plastic Pipe Used in Embankment Dams

---

- The settlement ratio ( $r_{sd}$ ) is assumed to be +0.5 since the fill around the pipe was a compacted earth fill (table 2, section 2.1.2).
- The projection ratio, p, is 1.0 (figure 35).

### Calculations

#### Soil Load

By prism method: The soil load on the pipe using the soil prism load is:

$$P_s = \gamma H = (110)(20) = 2,200 \text{ lb/ft}^2 \quad (2-1)$$

By Marston method: The Marston soil load for a positive projecting conduit in the projection condition may be determined from the following:

$$W_c = C_c \gamma D_o^2 \quad (2-2)$$

$C_c$  is determined from figure 30 for  $H/D_o = (20)/(18/12) = 13.3$ . The load is based on an incomplete condition with  $r_{sd} = +0.5$ . The value of  $C_c$  is approximately 20 from figure 36.

$$W_c = (20)(110) \left( \frac{18}{12} \right)^2 = 4,950 \text{ lb/ft}$$

The pressure on the top of the pipe may be determined by:

$$P_s = \frac{W_c}{D_o} = \frac{4950}{18/12} = 3,300 \text{ lb/ft}^2 \quad (2-6)$$

The Marston soil load is recommended for conduits encased in grout as shown in table 9 in section 3.5.6 and discussed in chapter 3.

#### Wall Crushing

The thrust in the pipe wall is

$$T_{pw} = \frac{PD_o}{2} = \frac{(3300/144)(18)}{2} = 206.25 \text{ lb/in} \quad (3-1)$$

The required wall cross-sectional area is:

$$A_{pw} = \frac{T_{pw}}{\sigma} = \frac{206.25}{800} = 0.2578 \text{ in}^2/\text{in} \quad (3-2)$$

The area of a pipe wall may be computed as:

$$A_{pw} = \frac{(D_o - D_i)}{2} \text{ or } t \text{ (for solid wall pipe)} \quad (3-3)$$

So the minimum wall thickness,  $t$ , is 0.2578 in.. The minimum wall thickness of an 18-inch HDPE pipe meeting ASTM D3035 is 0.554 inch with an SDR of 32.5.

### Wall Buckling

The external hydrostatic pressure on the pipe is

$$P_G = \gamma h_w = (62.4)(18) = 1,123 \text{ lb/ft}^2 \quad (2-16)$$

The long-term modulus of elasticity is recommended since the 18-feet of hydrostatic pressure act on the pipe throughout its design life.

The unconstrained buckling pressure of the pipe with an SDR of 32.5 is:

$$P_{CR} = \frac{2E}{(1-\nu^2)} \left( \frac{1}{SDR-1} \right)^3 = \frac{(2)(30000)}{(1-0.45^2)} \left( \frac{1}{32.5-1} \right)^3 = 2.41 \text{ lb/in}^2 = 2.41(144) = 346 \text{ lb/ft}^2 \quad (3-20)$$

where:

$$\nu = 0.45 \text{ for HDPE as recommended in section 3.3.2}$$

The unconstrained buckling pressure of a SDR 32.5 HDPE pipe is less than the external hydrostatic pressure of 1,123 lb/ft<sup>2</sup>.

Check the unconstrained buckling pressure of an SDR 17.

$$P_{CR} = \frac{(2)(30000)}{(1-0.45^2)} \left( \frac{1}{17-1} \right)^3 = 18.3 \text{ lb/in}^2 = 18.3(144) = 2,644 \text{ lb/ft}^2$$

## Plastic Pipe Used in Embankment Dams

---

A factor of safety of 2.0 is applied to the unconstrained buckling pressure.

$$\frac{P_{CR}}{1.5} = \frac{2,644}{1.5} = 1,763 \text{ lb/ft}^2 > 1,123 \text{ lb/ft}^2$$

### Conclusion

An 18-inch diameter, HDPE with cell class 345464C resin, and SDR of 17 is recommended.

### A-3 Siphon Design

The following assumptions are made for this example:

#### Description

A 10-inch diameter, solid wall, HDPE pipe will be installed as a siphon over the crest of an embankment dam (figure A-3). The siphon head ( $H$ ) is 14 feet. The siphon will provide additional drainage capacity and allow lowering of the reservoir.

#### Assumptions

- The siphon operates for short periods on an infrequent basis. The short-term modulus of elasticity will be used for the buckling analysis.
- The short-term modulus of elasticity ( $E$ ) of the HDPE is 140,000 lb/in<sup>2</sup> and the long-term modulus is 30,000 lb/in<sup>2</sup> (table 3, section 3.1). The modulus of elasticity and allowable compressive stress depend upon the type and classification of plastic.
- The allowable long-term compressive stress ( $\sigma$ ) (1/2 the hydrostatic design basis of 1,600 lb/in<sup>2</sup>) of the HDPE (cell class 345464C) is 800 lb/in<sup>2</sup>.
- The outside diameter of a HDPE pipe meeting ASTM D 3035 is 10.75 inches.
- The soil load will be determined by the soil prism theory.
- The internal vacuum pressure is 14 feet of head = 6 lb/in<sup>2</sup>.

$$P = \gamma H = \frac{(62.4)(14)}{144} = 6 \text{ lb/in}^2$$

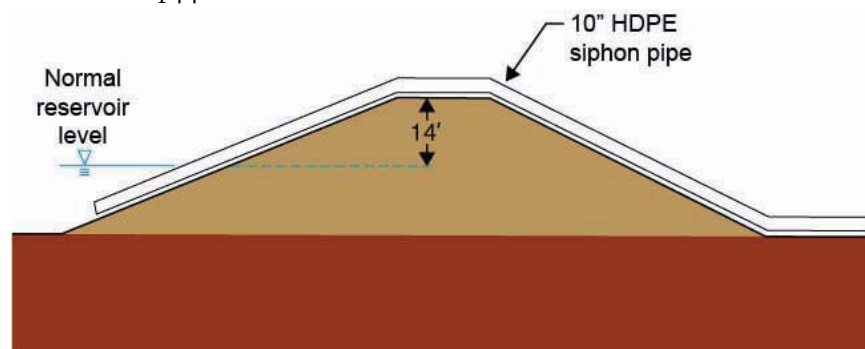

**Figure A-3.**—This figure illustrates a siphon extending over the crest of an embankment dam. Alternative siphon designs may want to consider the addition of earthen ramps over the siphon or embedment into the crest of the dam to facilitate vehicular traffic on the dam crest.

- The Poisson's ratio ( $\nu$ ) for HDPE = 0.45.

### Calculations

#### Soil Load

The pipe is on top of the embankment and does not have a soil load.

#### Wall Crushing

This is not an issue since there is not a soil load.

#### Deflection

Deflection is not determined since there is not a soil load.

#### Wall Buckling

The maximum SDR (minimum wall thickness) of a 10.75-inch HDPE pipe meeting ASTM D3035 is 32.5.

The unconstrained buckling pressure of the pipe with an SDR of 32.5 is:

$$P_{CR} = \frac{2E}{(1-\nu^2)} \left( \frac{1}{SDR-1} \right)^3 = \frac{2(140,000)}{(1-0.45^2)} \left( \frac{1}{32.5-1} \right)^3 = 11.2 \text{ lb/in}^2 \quad (3-20)$$

where:

$$\nu = 0.45 \text{ for HDPE as recommended in section 3.3.2}$$

A factor of safety of 1.5 is applied to the unconstrained buckling pressure.

$$\frac{P_{CR}}{1.5} = \frac{11.2}{1.5} = 7.5 \text{ lb/in}^2 > 6 \text{ lb/in}^2$$

The unconstrained buckling pressure of an SDR 32.5 HDPE pipe is greater than the internal vacuum pressure of 6 lb/in<sup>2</sup>.

#### Strain

Strain is not evaluated since there is not a soil load.

Conclusion

A 10-inch diameter, HDPE with cell class 345464C resin, and SDR of 32.5 is recommended.

#### A-4 Toe drain design (filter and drain)

##### Description

This example will illustrate the design of a toe drain system utilizing the guidelines presented in this document as well as judgment required by the designer beyond these guidelines. The example is derived from the case history of the Keechelus Dam modification completed in 2002 and includes a portion of the modified dam's entire drainage system. For brevity, filter materials at other toe drain locations are not included in this example. The filter used for the toe drain was designated Zone 2B and the drain material Zone 3. The foundation for the toe drain is an alluvial fan deposit in a glacial environment during the Quaternary (Qaf).

Zones 2B and 3 were designed in accordance with Bureau of Reclamation's *Embankment Dams*, Design Standards No. 13, Chapter. 5, "Protective Filters," 2007.

The gradation data of the base material (foundation), Qaf, was determined from laboratory testing on 17 samples obtained from drillholes and test pits. The statistics for the proportions of gravel, sand, and fines is shown on figure A-4. As a rule, grain size distribution for soils are not uniformly distributed due to the inherent heterogeneity of soil. Figure A-4 illustrates the simple statistics (minimum, maximum, mean, 1st std deviation) to indicate the nature of the material. The actual gradation curves for the 17 samples are shown on figure A-5.

##### Filter Design

The first step in sizing the filter is to mathematically regrade the base material (finer limit only) to the minus No. 4 sieve. The regraded limits are shown on figure A-5 in red. An outlier was identified and eliminated from the dataset as shown on the figure. The percent passing the No. 200 sieve is determined as 32.3% by using the finer side of the regraded curve. Based on the percent passing the No. 200 sieve, the base material is classified as "category 3" and protection against particle movement is controlled by:

$$D_{15}F \leq 0.7 \text{ mm} + \frac{(40 - a)(4D_{85}B - 0.7 \text{ mm})}{25}$$

where:

$D_{85}B$  = finer side of regraded gradation = 0.78 mm

$a$  = percentage of soil passing No. 200 sieve = 32.3%

$D_{15}F \leq 1.4$  mm (particle movement limit)

$D_{15}F \geq D_{15}B$  (permeability limit)

where:

$D_{15}B$ : coarser side of regraded = .05 mm



$$D_{15}F \geq (5)(0.05) = 0.25 \text{ mm}$$

$$0.25 \text{ mm} > 0.10 \text{ mm so } 0.25 \text{ mm controls}$$

$$D_{15}F \geq 0.25 \text{ mm (permeability limit)}$$

The  $D_{15}F$  limits for the range of acceptable filter gradations are 0.25 mm. to 1.4 mm. (i.e.,  $0.25 \text{ mm.} \leq D_{15}F \leq 1.4 \text{ mm}$ ), and are shown on figure A-6.

In order to maximize the permeability of the filter, the filter’s upper limit is set near the upper end of this range (the trial is shown on figure A-7).

The next step for sizing the filter is selecting the degree of uniformity of the gradation. Based on the trial  $D_{10}F$  of approximately 0.5 mm, the  $D_{85}F$  upper limit for segregation is 20 mm (as shown on Table 2, Bureau of Reclamation, 2007) and is indicated on figure A-6. Uniformity in this example is found by matching the coefficient of uniformity ( $c_u$ ) of “concrete sand,” as shown in table A-1. Since “concrete sand” (ASTM C 33, fine aggregate) has shown good performance in the field (does not segregate), it is used as a guide for this selection (this procedure is not in Bureau of Reclamation’s design standard).

**Table A-1.—Selection of coefficient of uniformity for Zone 2B**

Degree of Uniformity	“Concrete Sand”	Zone 2B
$D_{60} / D_{10}$	4.0	3.8 (1.63/0.425)

The third step is an estimation of the gradation limits (band width) for the filter. Since the  $D_{10}F$  at this stage of the design is less than 20 mm, no requirement is given for the width of the prescribed gradation range (limits of gradation). Again, recognizing that “concrete sand” is limited to ranges no greater than 35 points, this limit is set for this filter (this step is not in Bureau of Reclamation’s design standard). The trial gradation is given in table A-2 and plotted on figure A-7.

The permeability of this filter is checked against the foundation permeability later in this example.

Table A-2.—Gradation limits for Zone 2B

Sieve size	Percent passing, by weight
¾-inch	100
⅝-inch	90 - 100
No. 4	65 to 100
No. 8	40 to 75
No. 16	10 to 45
No. 30	0 to 15
No. 50	0 to 3
No. 100	0 to 2
No. 200	0 to 1

### Drain Design

A drain material will be used to surround the perforated drainpipe in the downstream toe drain (the envelope). This material is bounded by two surrounding materials; perforation size of the pipe and the  $D_{85}$  size of the filter. Since this is a two stage filter and it is assumed the drain material will be uniformly graded, the following relationship is used for the perforation constraint (also see section 4.1.2).

$$\frac{D_{85} \text{ of the filter nearest the pipe}}{\text{perforation opening of pipe drain}} > 2 \text{ uniformly graded}$$

Assuming a perforation width = 10 mm (HDPE 12-inch diameter, ADS N-12 pipe, circular perforation, ADS Product Note 3.106 (2003):

$$D_{85}E \geq (2)(10.0) = 20.0 \text{ mm,}$$

where:

$$D_{85}E \geq 20.0 \text{ mm (slot limit)}$$

$D_{85}E$ : finer side of envelope

Next, material size is determined against the base (filter). The first step in sizing the envelope against the filter is to determine the category of the filter. Since Zone 2B contains less than 15% fines as, shown on figure A-7, it is a “category 4 soil.” The envelope criteria is:

$$D_{15}E \leq D_{85}F \text{ (particle movement limit),}$$

where:

$$D_{85}F: \text{finer side of filter} = 3.4 \text{ mm}$$

$$D_{15}E \leq 13.6 \text{ mm (particle movement limit)}$$

$$D_{15}E \geq D_{15}F \text{ (permeability limit), but, not less than 0.10 mm.}$$

$$D_{15}E \geq (5)(0.6) \text{ mm,}$$

$$D_{15}E \geq 3.0 \text{ mm (permeability limit)}$$

$$D_{15}F: \text{finer side filter} = 0.6 \text{ mm}$$

The  $D_{15}E$  limits for the range of acceptable envelope gradations are 3.0 mm. to 13.6 mm (i.e.,  $3.0 \text{ mm} \leq D_{15}E \leq 13.6 \text{ mm}$ ), and  $D_{85}E$  limit is minimum 20.0 mm, for pipe perforation size. The limits are shown on figure A-7. The uniformity of the envelope ( $C_u = 2.80$ ) was slightly more uniform than the filter.

A summary plot of the selected filter and drain materials is shown on figure A-7. The gradation specification is given for the Zone 3 drain material in table A-3.

**Table A-3.—Gradation limits for Zone 3**

Sieve size	Percent passing, by weight
¾-inch	100
⅝-inch	90 - 100
No. 4	65 to 100
No. 8	40 to 75
No. 16	10 to 45
No. 30	0 to 15
No. 50	0 to 3
No. 100	0 to 2
No. 200	0 to 1

### Permeability Check

The permeability of the filter needs to be checked to see if its permeability is less than some material found in the foundation. Since this example consists of a relatively pervious foundation including highly pervious layers there is a concern that the filter could act as a barrier to these zones.

Examination of 17 gradations for the foundation materials range from GW–GM material at the upper bound, as shown in figure A-5, to SW-SM material near the midpoint of the gradation band. GW–GM materials are estimated to have a

permeability in the range of 10,000 to 1,000,000 ft/yr (Bureau of Reclamation, 1987a) and the SW-SM soils are in the range of 100 to 30,000 ft/yr. The finer side of the filter (figure A-7) classifies as an SP and its range of permeability is 50 to 150,000 ft/yr. This indicates that the permeability of the filter equals the foundation permeability somewhere between the mid point and upper limit of the gradations.

Assuming the four coarsest samples produce a permeability greater than 150,000 ft/yr, then about 25% (4/17) of the foundation would be blocked by the filter. An increase in pore pressure would then be expected until equilibrium is reached. Since 25% is a relatively small portion of the foundation, the filter is deemed adequate. Additionally, in this instance because of site topography, the toe drain was 10 to 18 feet deep. Due to this deep burial there was no concern about excessive uplift pressures

### **Borrow Area**

A local borrow site is available for use in producing filter and drain materials. Twelve test pits and three drillholes were used for characterization of this pit. The test pits ranged from 4.5 to 30 feet deep and the drillholes were about 40 feet deep. Laboratory analysis on forty-five samples (figure A-8) indicates that the material within the borrow site consists primarily of a Silty Sand (SM) to a Well Graded Gravel with Sand (GW)s. The percent of oversize material ranges from a trace to 30 percent cobbles and a trace to 20 percent boulders with maximum dimension of six feet. Simple statistics were produced on all samples (similar to figure A-4 described earlier) which results in the following categorization; gravel content varies from 0 to 76 percent, but generally ranges from 10 to 56 percent; sand content varies from 1 to 91 percent, but generally ranges from 31 to 76 percent, and fines content varies from 1 to 99 percent, but generally does not exceed 27 percent. The specific gradations of the borrow area (by grain size) are plotted on figure A-8.

Figure A-9 is a plot of the filter and drain materials (average) designed in the previous sections along with the average gradation of the borrow material. This plot is used to compare the available grain sizes against those that are required to produce the filter and drain. Note: "Oversize" material (material larger than 3-inches) has been removed from the data set. This is done because that material is not usable for the products in question. Additionally, a more detailed analysis was done for comparison of material demands from all produced materials against available material within the pit (not covered in this example). The demand is calculated by computing the weight required, per sieve, and deducting it from the available weight on a per sieve basis. Performing the analysis on a per sieve basis will illustrate which sieve (grain sizes) are used most and which are used least. Estimation can then be made on the amount of waste (from washing operations) and the amount of by-products produced (material that passes through the plant but is not used for any of the final products).

Figure A-9 illustrates that all grain sizes are available to produce the two required products. That is, no supplemental material will have to be brought in to complete the material. The figure also indicates that since the pit contains an average of 14% fines a washing operation will be required. Note that the 14% fines content is a product of scalping the sample to a minus 3-inch material and a number of samples that had very high fines content, as shown in figure A-8. At this site these samples were near the ground surface and were stripped prior to production. Examination of figure A-8 indicates that 7% fines (average) is a better indication of the actual amount of fines that would be expected during production.

Figure A-9 also indicates that a large amount of oversize material would be surplused (by products) from the screening operation. Once this was identified this material was specified for use as riprap, riprap bedding and slope protection. The more detailed analysis ('per sieve' analysis) also indicated that the medium sand sizes would be used most extensively. In order to reduce the total yardage that would have to be processed through the plant, a crushing operation was recommended.

### Reference

Bureau of Reclamation, *Design of Small Dams*, 1987a.

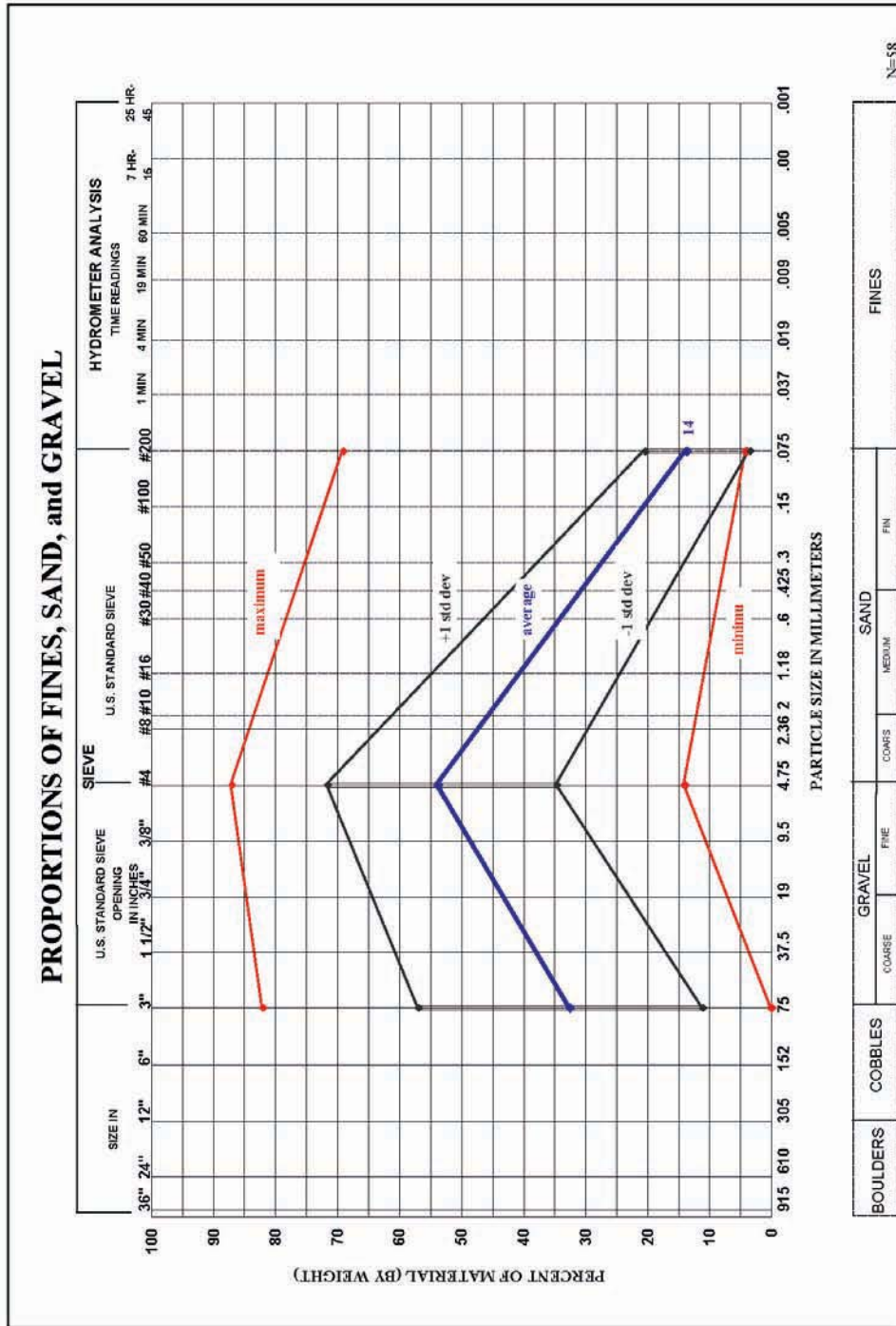

Figure A-4.—Proportion of fines, sand, and gravel for foundation soils.

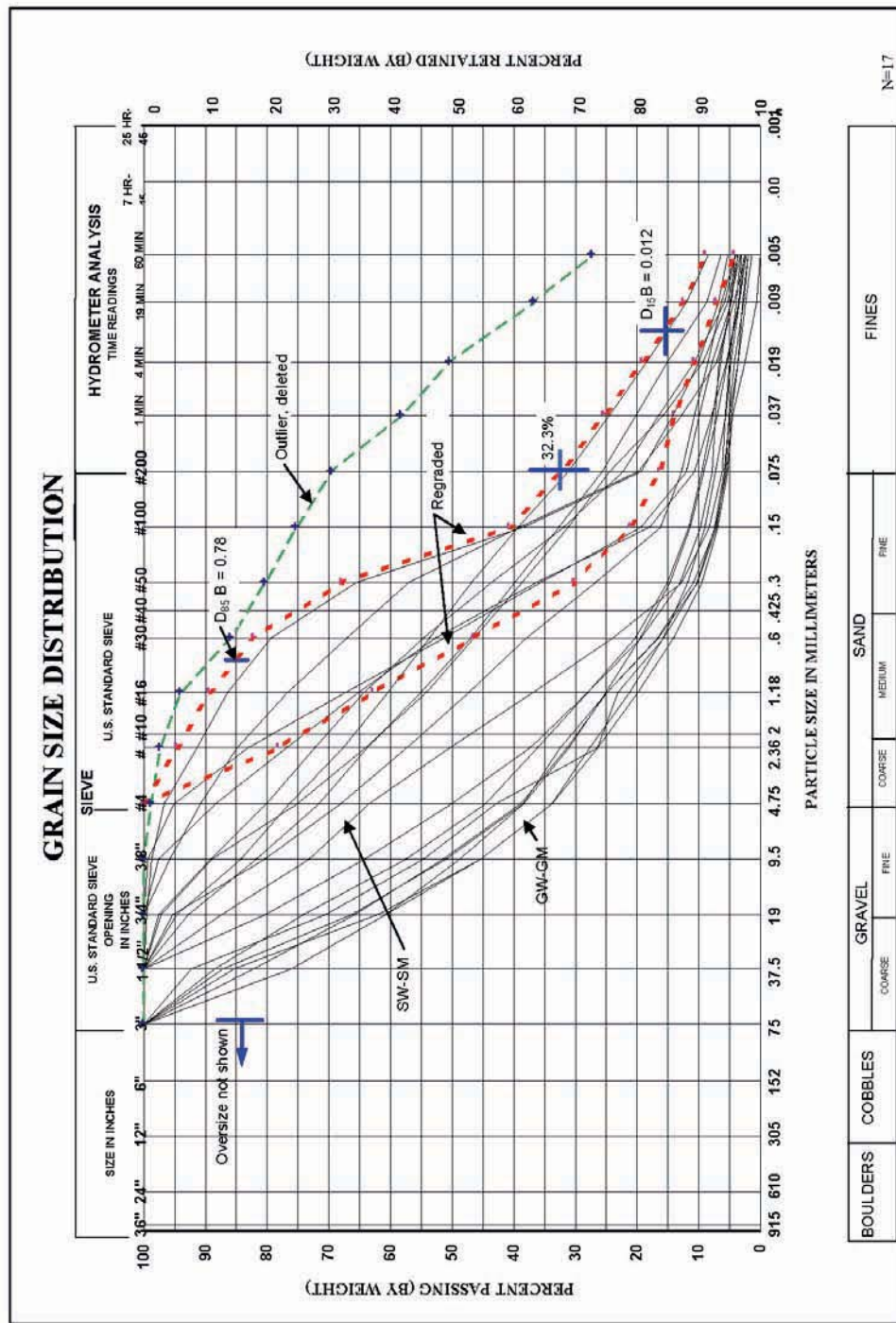

Figure A-5.—Individual gradations for foundation soil.

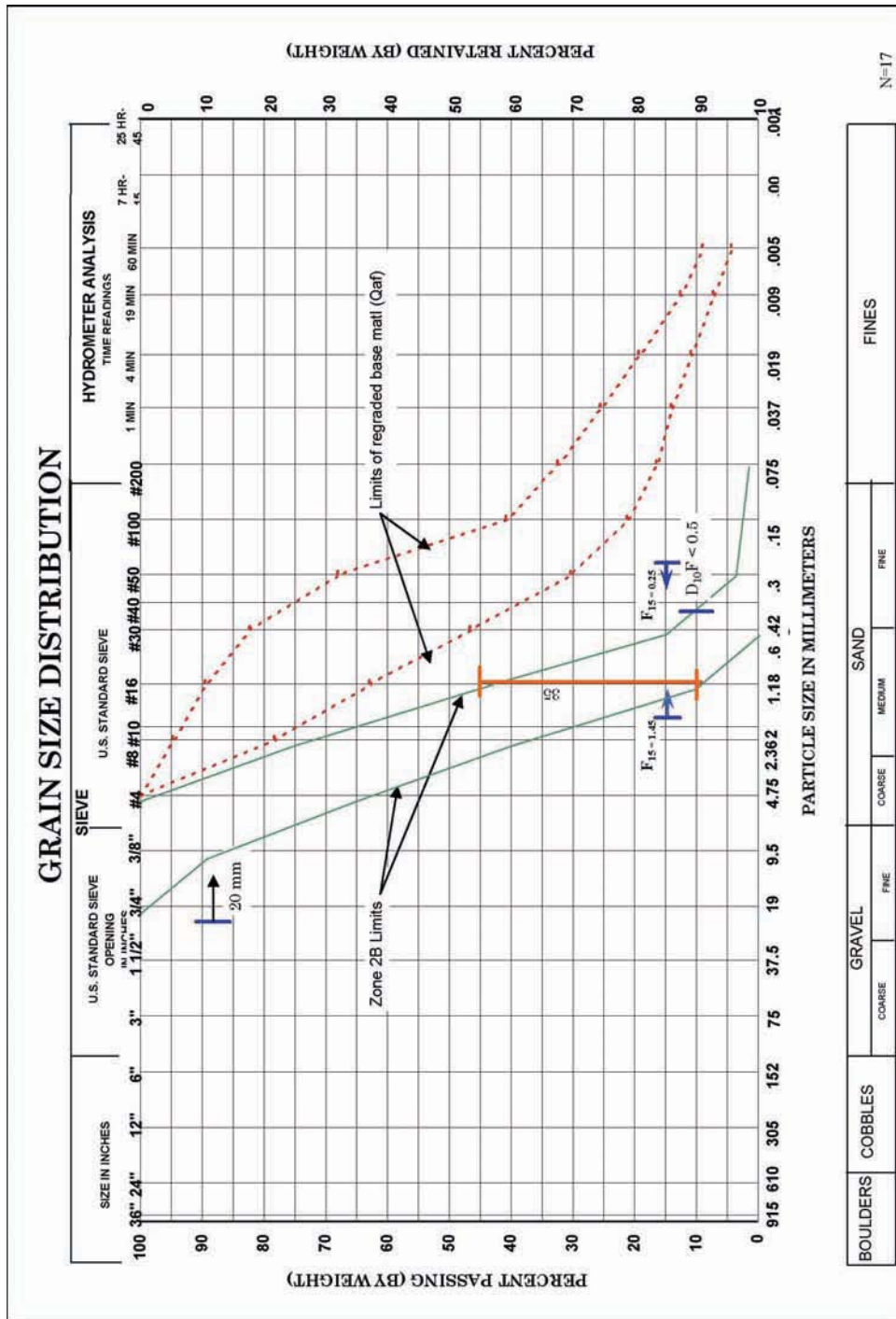

Figure A-6.—Design of filter material.



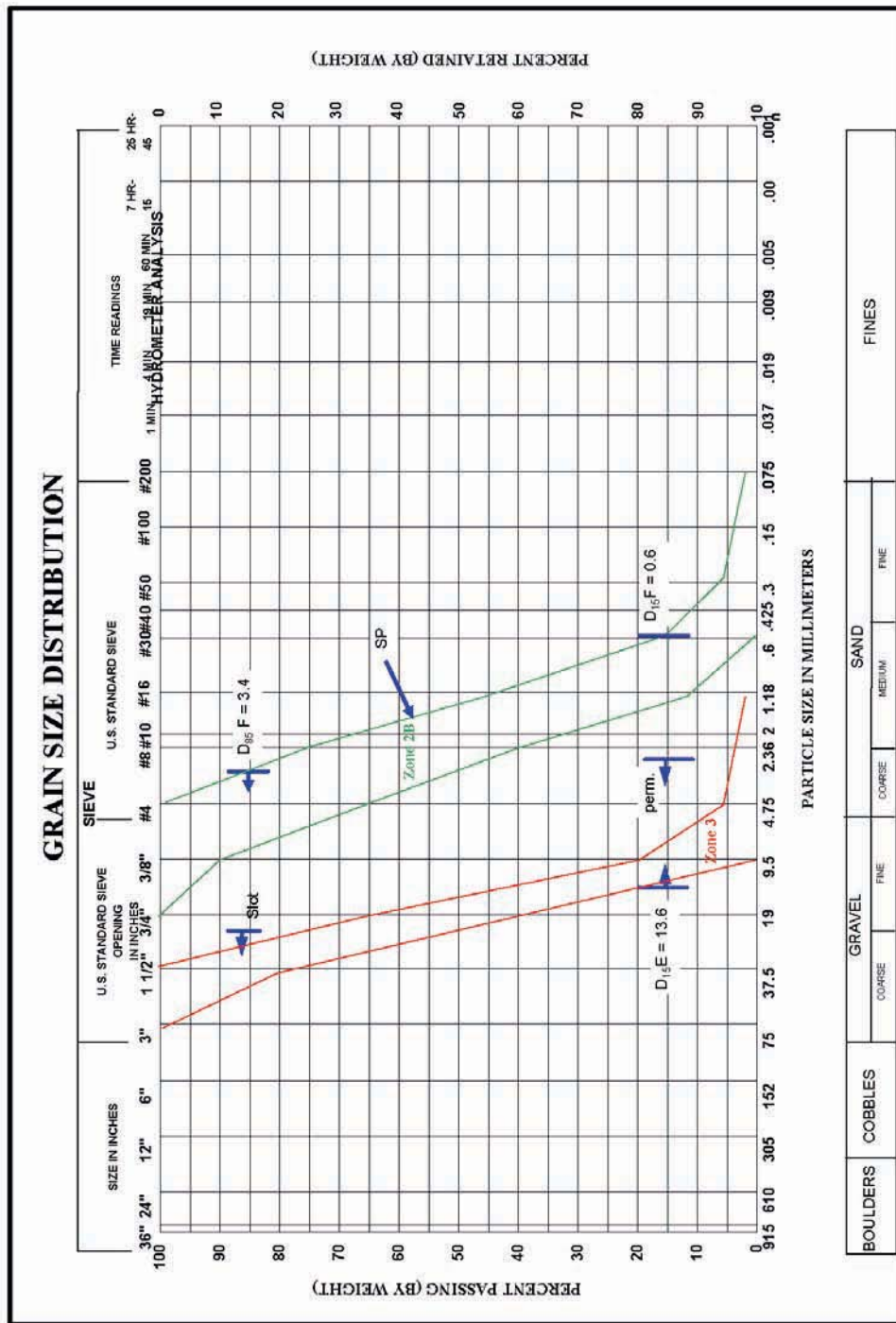

Figure A-7.—Design of drain material.

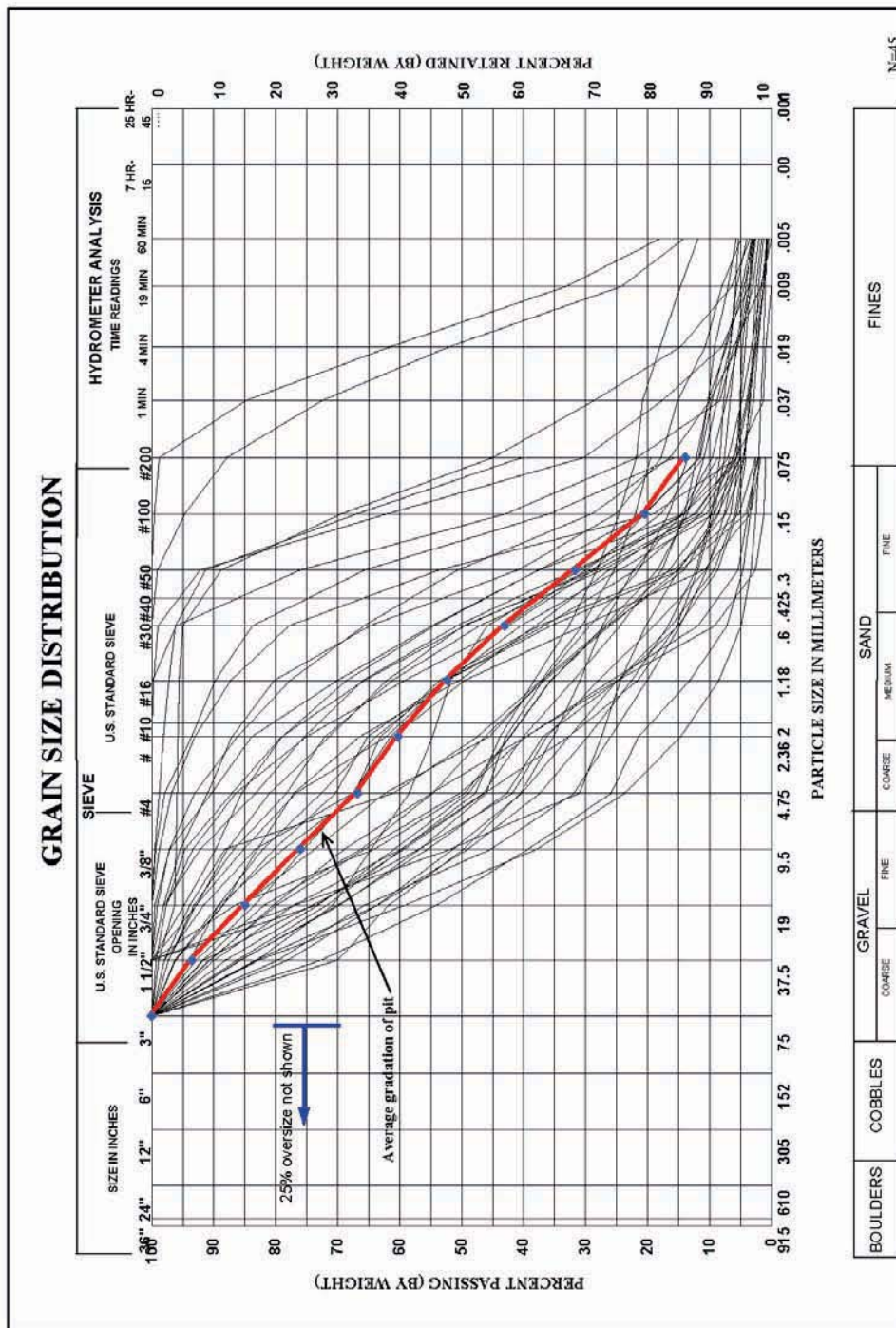

Figure A-8.—Individual gradations of borrow material.

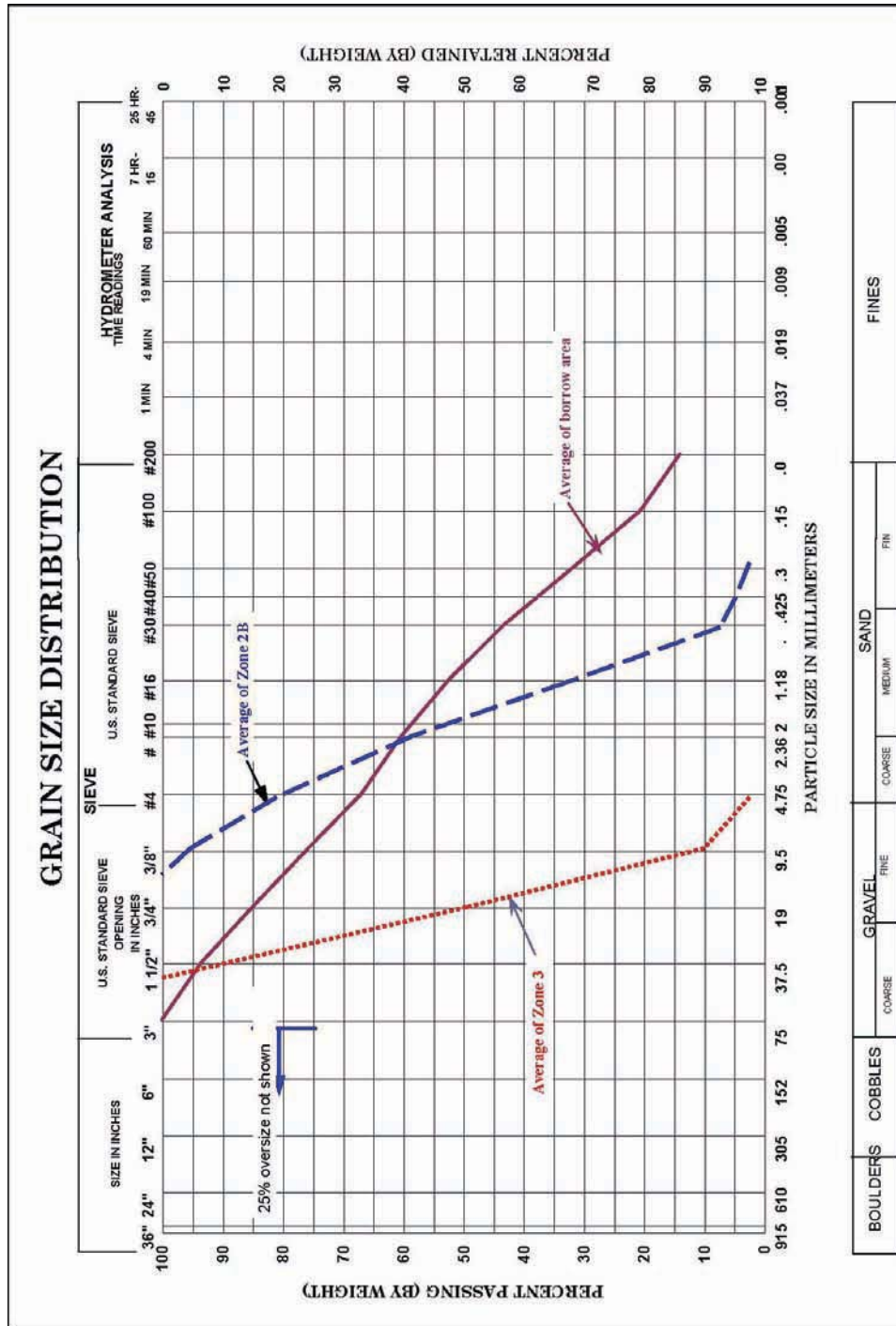

Figure A-9.—Average of filter, drain, and borrow materials.



# Appendix B

## Case Histories

### Index

Feature	Location	Topic	Page
Davis Creek Dam	Nebraska	CCTV inspection of a toe drain	3
Ganado Dam	Arizona	Toe drain installation in an embankment dam modification	7
Sediment Control Pond SP-4	Mississippi	A breach occurred due to excessive seepage along an HDPE pipe spillway	11
Sugar Mill Dam	Georgia	Poor construction practices lead to internal erosion along a siphon spillway	18
Upper Wheeler Reservoir Dam	Washington	Collapse of a HDPE pipe during grouting operation	22
Virginia Dam	Virginia	Collapse on a HDPE pipe encased in concrete due to external hydrostatic pressure	25
Wheatfields Dam	Arizona	Sliplining a deteriorating outlet works conduit using HDPE dual-wall containment pipe	29
Worster Dam	Colorado	Renovation of an existing outlet works using an HDPE slipliner grouted in place	35

Additional case histories involving plastic pipe used in dams are available in FEMA's *Technical Manual: Conduits through Embankment Dams* (2005).



**Project:** Davis Creek Dam

**Location:** Nebraska

**Summary:** CCTV inspection of a toe drain

Davis Creek Dam was completed in 1992 and is located about 6 miles southeast of North Loup in central Nebraska. The dam is a homogenous earthfill embankment with a structural height and crest length of approximately 110 feet and 3,000 feet, respectively. The toe drain system consists of two toe drains, one to the right of the outlet works centerline and another to the left of the outlet works centerline. The right and left toe drains consist, respectively, of approximately 1,200 feet of 8-inch-diameter and 1,440 feet of 12-inch-diameter perforated, corrugated polyethylene pipe. Flow from the right toe drain is measured by a V-notch weir, located about 30 feet to the right of the outlet works centerline in inspection well No. 7. Figure B-1 shows the toe drain layout. Flow from the left toe drain is measured by a V-notch weir located at the end of a weir box. The weir box is on the ground surface several hundred feet to the left of the outlet works centerline. The toe drains meet at the location of the toe drain outfall manhole, station 98+95, where they flow into the Jack Canyon drainpipe. The Jack Canyon drainpipe was constructed to carry toe drain discharges and surface runoff. The Jack Canyon drainpipe extends for about 1,100 feet and consists of 18-inch-diameter perforated, corrugated polyethylene drainpipe.

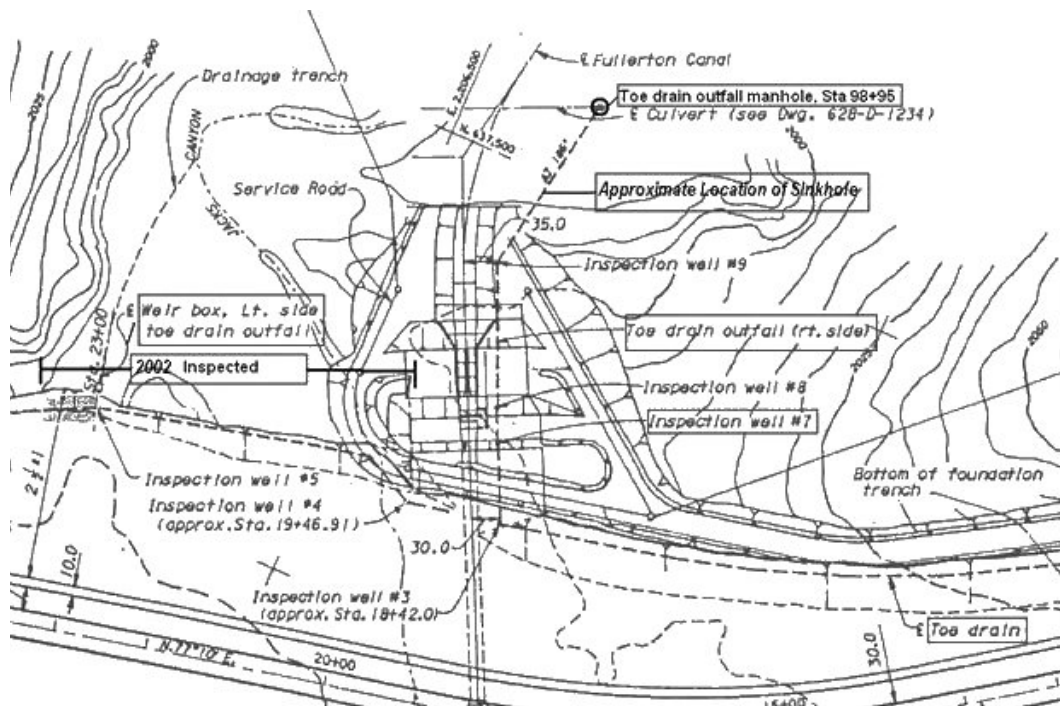

**Figure B-1.**—Locations of observation wells and cleaned reaches.

## Plastic Pipe Used in Embankment Dams

---

In the spring of 1994, a sinkhole 8 to 10 feet deep and approximately 20 feet wide developed above the 12-inch-diameter nonperforated, corrugated polyethylene outfall pipe. The sinkhole was located along the right outfall about midway between inspection well No. 9 and the Jack Canyon diversion drain culvert outlet transition. Drain rehabilitation in the fall of 1994 and the spring of 1995 consisted of replacing the 12-inch diameter outfall drainpipe with a 12-inch diameter perforated pipe placed within a gravel envelope.

In November of 2000, the Bureau of Reclamation performed a CCTV inspection of the toe drains at Davis Creek Dam as part of routine drain maintenance. Observations from the CCTV inspection showed areas of pipe buckling, other potentially damaged areas of pipe, and sediment deposition. Figure B-2 shows a typical amount of sediment deposition that was seen in the toe drain.

Based on CCTV inspection, selected reaches of the Davis Creek toe drains were cleaned using sewer cleaning equipment in January 2002. The reaches cleaned were located in the left toe drainpipe from stations 19+46.91 to 23+00 and from stations 23+00 to 26+00; however, care was taken not to wash out any of the materials from the locations where the pipe was damaged.

In February 2002, the Bureau of Reclamation inspected the cleaned reaches of pipe, including the short reach of the Davis Creek toe drain outfall replacement pipe and stations 98+95 to 99+12 of the Jack Canyon drain. The inspection of the left toe



**Figure B-2.**—The typical amount of sediment deposition observed in toe drain during the November 2000 inspection.



drain at Davis Creek was within the 12-inch-diameter pipe. The camera-crawler was inserted into the manhole at station 23+00, and proceeded downstream to station 19+46.91. The camera-crawler was then backed out and turned around in order to proceed upstream. The camera-crawler proceeded upstream to approximately station 23+25. Originally, it was intended to inspect the entire cleaned reach to station 26+00, but the camera-crawler was unable to proceed when it came across a section of buckled pipe that was previously reported during the 2000 inspection. Figure B-3 shows the results of drain cleaning and the pipe damage that halted the camera-crawler. This photograph was taken in the Davis Creek toe drain at approximately station 23+25. The fine materials previously seen on the pipe invert have been removed.

**Lessons learned:**

- In the short term, the cleaning was effective in removing most of the deposited sediments within the cleaned reaches. The long-term efficiency of the cleaning operation is unknown. No additional damage occurred inside the drainpipe because of the pressure jetting. Decreases in toe drain flows were not seen before cleaning, nor were higher flows seen immediately following cleaning. However, it should be noted that only a portion of the toe drain was cleaned. If the entire length were cleaned, the discharge rate might have increased. Also, it

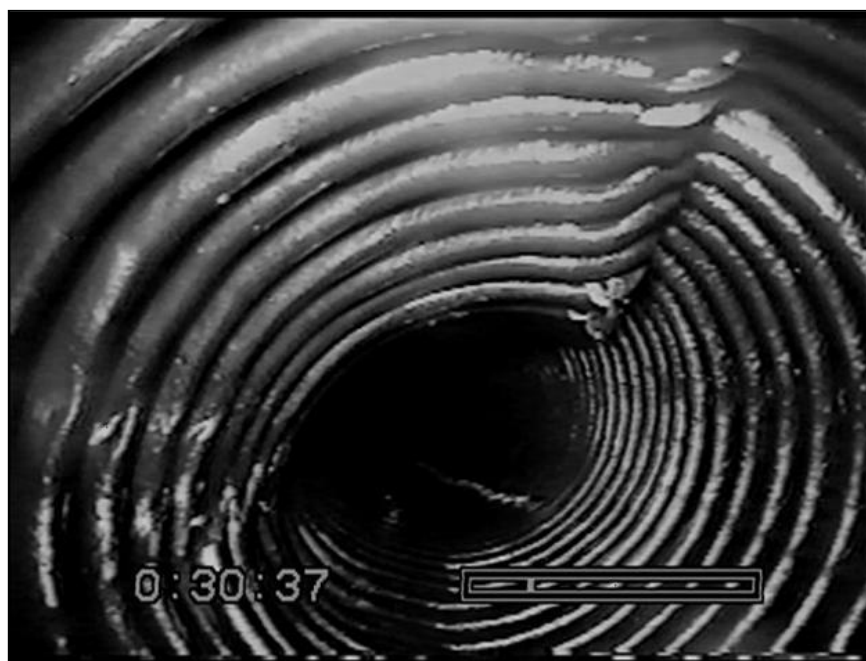

**Figure B-3.**—A buckled left toe drain pipe at approximately Sta. 23+25 stopped the camera-crawler. A cleaning removed fine materials from the pipe invert.

is possible that the sediments in the toe drain are not controlling toe drain flows.

- In a 1994 field examination, it was concluded that the sinkhole developed from material being transported into an open, collapsed pipe. The collapse of the pipe could have occurred either from equipment load during construction or from earth pressure on the outside of the pipe. A CCTV inspection immediately following or during construction would have been helpful in pinpointing the cause of the pipe failures. Even though the cause of the sinkhole could not be pinpointed, the CCTV inspections in 2000 and 2002 were helpful in viewing the condition of the drainpipe and supporting the conclusion from the 1994 exam. Both inspections noted some pipe failures that could facilitate the development of sinkholes.

### **Reference:**

Bureau of Reclamation, *Drainage for Dams and Associated Structures*, 2004.

**Project:** Ganado Dam

**Location:** Arizona

**Summary:** Toe drain installation in an embankment dam modification

Ganado Dam, originally constructed in the early 1900's, was raised 5.5 feet in 1943 for an approximate total height of 28 ft. Constructed of locally available dispersive soil on a dispersive foundation, numerous dam safety issues and poor performance led to the reservoir being drained in 1982.

The dispersive properties of the embankment and foundation led to a number of dam safety deficiencies including:

- Internal erosion initiated by seepage concentration through transverse cracks in the embankment.
- Erosion of dispersive material into porous regions of the dam foundation that can lead to piping.
- Erosion of dispersive material along structures that can lead to enlarged concentrated flow paths.
- Soil erosion and rilling of the downstream face of the embankment.

Most dispersive soils can be field identified by characteristic erosion features as shown on figures B-4 and B-5. This case history is an excellent example that even a low head structure was unable to store water due to the highly erosive nature of the soils.

The dam was rebuilt in its entirety, including embankment, outlet works, and spillway. Additionally, a toe drain system was added. Prior to draining the reservoir, seepage through and under the dam led to standing water downstream of the embankment. The redesign of the embankment included a cutoff trench in the foundation and the inclusion of chimney and blanket filters as shown in figure B-6. Since the foundation consisted of alternating clay, silt, and sand layers the intent was to include a cutoff of sufficient depth to engage at least several of the sand layers. This design feature minimized seepage and pore pressures in the downstream area of the dam.

The toe drain consisted of a 12-inch profile wall corrugated HDPE pipe surrounded by a two stage drainage system (gravel envelope surrounded by a sand filter). The cross section is shown in figure B-7. Profile wall corrugated pipe was selected due to its greater strength and smooth interior (single wall corrugated interior pipe can trap



**Figure B-4.**—Subsurface fissure located at the downstream toe of the dam east of the outlet works. The subsurface soil had a very high moisture content.



**Figure B-5.**—Erosional features typically associated with dispersive soils as seen at Ganado Dam. The common name for such features is “jughole.”

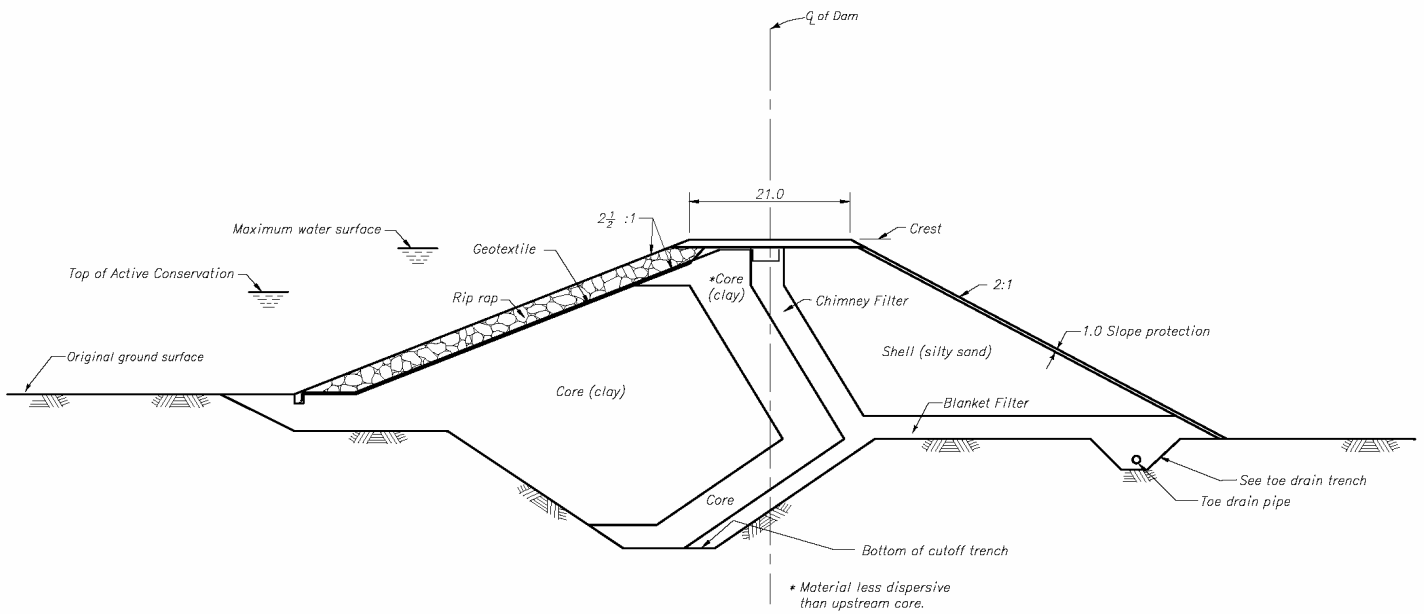

Figure B-6.—Modification cross showing embankment zones and toe drain system.

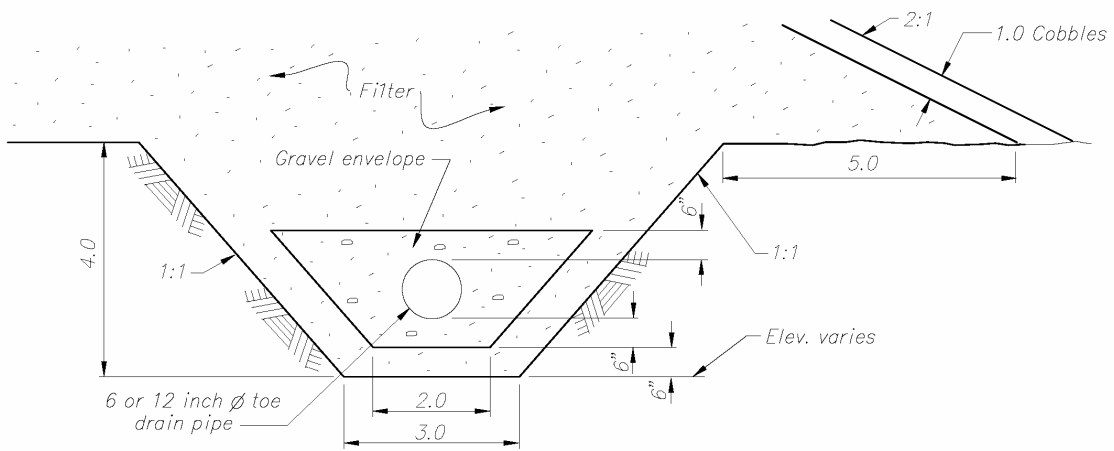

Figure B-7.—Cross section of toe drain.

## Plastic Pipe Used in Embankment Dams

---

sediment which may enter the pipe and is more difficult for CCTV examinations). The pipe diameter was selected at 12-inches as a minimum for camera crawler access since the predicted flows were expected to be quite small. Perforated pipe was used along the toe drain trench and nonperforated pipe was used for the outfalls. Clean outs and inspection wells were also included in the design for access to the toe drainpipe along with measurement devices and sediment traps. This arrangement allows for complete access to the toe drain system for monitoring and inspections.

### **Lessons learned:**

An effective foundation cutoff minimized the amount of seepage past the dam allowing a minimal toe drain installation. The available on-site sand source, although abundant in quantity, was composed mostly of No. 100 fine sand (locally known as blow sand). While acceptable as a filter, this was on the fine side of the criteria and was marginal in meeting the permeability requirement of the design standard. This was judged not an issue since the cutoff and very low permeability of the core rendered the cross section nearly impervious. In fact there is excellent seepage attenuation through the cross section and the toe drains are all dry.

As recommended in the Bureau of Reclamation's *Protective Filters* (2007) a filter compatibility test was performed. The design standard recommends that specific filter material be tested for specific sites when dispersive base soils are present. This check was done for the Ganado work and the prescribed filter was found to be adequate.

The profile wall corrugated HDPE pipe was easily installed and capable of withstanding construction installation loads.

### **Reference:**

Bureau of Reclamation, *Design Summary—Ganado Dam*, 1998.

Bureau of Reclamation, *Embankment Dams*, Design Standards No. 13, Chapter. 5, "Protective Filters," 2007.

**Project:** Sediment Control Pond SP-4 Dam

**Location:** Mississippi

**Summary:** A breach occurred due to internal erosion along an HDPE pipe spillway

Sediment Control Pond SP-4 Dam failed on February 13, 2004 when a 26-foot wide breach occurred at the location of the pond's spillway pipe. The failure occurred approximately 77 days after the facility began to impound water. Approximately 439 acre-feet of water were released as a result of the breach. No injuries or significant damage occurred.

The low hazard potential pond was constructed to control runoff and collect sediment from upstream mining operations. The earthen embankment had a crest width of 20 feet, maximum height of 29.5 feet, and an overall length of approximately 2,700 feet. The upstream and downstream slopes of the homogeneous embankment were sloped at 3 horizontal to 1 vertical. The embankment was constructed of clay and silty-clay soils. The PI values of soil used to backfill the pipe were in the range of 9 to 12. The majority of the embankment was constructed of CL soil with a PI in the range of 10 to 18.

The spillway pipe consisted of a drop inlet structure having a 60-inch diameter polymer-coated corrugated metal pipe riser and a 36-inch outside-diameter, SDR 17, HDPE conduit. Two slide gates on the side of the riser allowed for low level discharge. The length of the HDPE conduit was approximately 125 feet. Joints were butt fused. The pipe discharged into a plunge pool.

The pipe was installed by compacting fill to the bottom elevation of the pipe and then shaping the bedding by hand excavation, for a depth of approximately 6 inches, to conform to the shape of the pipe. The bedding was reportedly shaped until the workers achieved what they considered "reasonable contact." A transit and plywood template was used to maintain alignment and grade control. Workers reportedly rolled the pipe into and out of the cradle excavation several times to check if "full" contact was achieved between the pipe and the bedding. Backfill was then compacted in the haunch area in 6-inch lifts using powered hand-tampers. A walk-behind sheepsfoot roller was used to compact the remainder of the backfill to approximately 2 feet above the pipe. The fill was then raised above the pipe as the rest of the embankment was raised.

A seepage diaphragm was constructed approximately 25 feet downstream of the centerline of the embankment. The sand diaphragm was approximately 21 feet wide, 12 feet high, and 3 feet thick at the base (2 feet thick at the top). The diaphragm extended approximately 7 feet above the pipe, 10.5 feet to either side of the pipe's centerline, and less than 2 feet below the pipe. The pipe was located in the fill

portion of the dam. Approximately 8 feet of foundation soil had been removed and replaced with compacted fill. The diaphragm extended less than 1.5 feet into this replacement fill.

A sand filter zone extended downstream of the diaphragm as bedding for the spillway pipe and to act as a drainage outlet for seepage collected by the diaphragm. This bedding layer was approximately 6 feet wide and extended approximately 1 foot below the pipe. A 3-foot “gravel plug” was constructed at the downstream end of this sand layer. A woven geotextile separated the “gravel plug” from a layer of riprap that lined a plunge pool at the pipe outlet.

The embankment had been completed on November 28, 2003. During January 2004, the slide gates were opened on three occasions to release water from the reservoir. On January 20, 2004, a member of the pump crew noticed vibrations at the downstream end of the spillway pipe while treating the pond with a flocculent. Until February, the highest reported water level in the reservoir was only 4.5 feet above the invert of the transport section of the spillway pipe. However, on February 5, 2004, over 4 inches of rain fell in the area.

A routine embankment inspection was performed on February 13, 2004 at 3:30 p.m. At this time, the water level had risen to the point where it was 2.5 feet below the top of the riser pipe, and 9.5 feet below the crest of the dam. The corresponding head on the invert of the transport section was approximately 8.5 feet. This was the highest water level that the reservoir had experienced. Nothing unusual was noted during this inspection. No seepage was observed around the periphery of the decant pipe at that time.

The failure occurred 5 hours later (figures B-8, B-9, and B-10). Witnesses indicated that, just prior to the failure, they observed a stream of water, described as being about 10 inches in diameter, exiting at the downstream toe of the embankment adjacent to the spillway pipe. At the same time, a vortex was observed in the reservoir near the point where the pipe intersected the upstream slope. Failure of the embankment occurred approximately 20 minutes after the water flow was first observed. At the time of the failure, no water was flowing through the spillway pipe.

The following postfailure observations were made:

- The fused pipe joints were intact, and their workmanship appeared to be of high quality.
- The seepage diaphragm that had been constructed 25 feet downstream of the embankment centerline was completely washed away in the failure.





Figure B-8.—Looking upstream through the breach. Embankment was 18 feet high at breach.



Figure B-9.—Breach showing 36-inch diameter HDPE pipe and riser.



**Figure B-10.**—View looking downstream along the pipe. The breach was 26 feet wide.

- The pipe bedding and backfill soil was indicated to be nondispersive based on pinhole tests (ASTM D 4647), crumb tests (ASTM D 6572), and double hydrometer testing (ASTM D 4221).
- The conditions observed immediately prior to the failure indicated that a direct flow path was present along the outside of the pipe or through the pipe backfill. As indicated below, several explanations are possible for the presence of a preferential flow path:
  1. Apparently the procedures used in installing the pipe did not achieve adequate contact between the bedding/backfill and the pipe, and/or adequate compaction of the backfill immediately around the pipe. Based on the low permeability of the backfill when compacted to the specified density, voids or zones of poorly compacted material were likely present in portions of the haunch areas, allowing the flow path to develop as quickly as it did.
  2. Observations of the compacted fill surface that remained after the failure show the surface prepared for placement of the pipe was highly compacted and did not bond properly to subsequent lifts. Sheepsfoot roller impressions were visible in the lift surfaces remaining after the failure. This condition is favorable to hydraulic fracturing, which could also explain the internal erosion flow path.

3. The sand used to construct the filter diaphragm was much finer and more poorly graded than ASTM C 33 concrete sand. The gradation used for the filter diaphragm is shown in figure B-11 (plotted on the same graph with ASTM C 33 sand). The finer sand used to construct the diaphragm was probably more likely to crack and to sustain an open crack because it would likely have poor self-healing characteristics and a high potential to bulk during placement.
  4. The intent of filter diaphragms is to intercept any flow through preferential flow paths, and hydraulic fracture cracks. To effectively accomplish this, the diaphragm must extend well beyond the portion of the fill that could be affected by poor construction or hydraulic fracture. This filter diaphragm may not have been deep enough to encompass voids beneath the conduit or hydraulic fracture cracks at the contact between the conduit backfill and the remainder of the embankment. Current design criteria used by some agencies require the filter diaphragm to extend a distance equal to at least two times the outside diameter of the pipe below the pipe (NRCS, 2007). This would equal a distance of about 6 feet, but this diaphragm extended less than 2 feet below the conduit.
- Either the diaphragm or its outlet drain was overwhelmed by a large quantity of flow through defects under the haunches of the pipe, or flow bypassed the diaphragm. The head likely had reached a point where the gradient was sufficient to cause the uncontrolled flow along the pipe to carry away the embedment material, causing the soil above the pipe to collapse and erode, and the breach to develop.

**Lessons learned:**

- In the installation of a circular pipe, full contact between the pipe and the backfill is difficult to achieve, and compacting backfill in the haunch area is particularly difficult because the energy of backfill efforts can easily lift the pipe.
- If a pipe is not encased in concrete, then construction procedures, such as the shaping of the bedding for at least the lower third of the pipe diameter, must be used to ensure that full contact is achieved between the pipe and the surrounding soil and that the soil in the haunch area is adequately compacted.
- Filter diaphragms should have dimensions both horizontal and vertical that are extensive enough that flow in the vicinity of the conduit cannot circumvent the diaphragm, particularly under the diaphragm. The filter diaphragm did not extend deeply enough below the conduit according to current criteria used by many agencies.

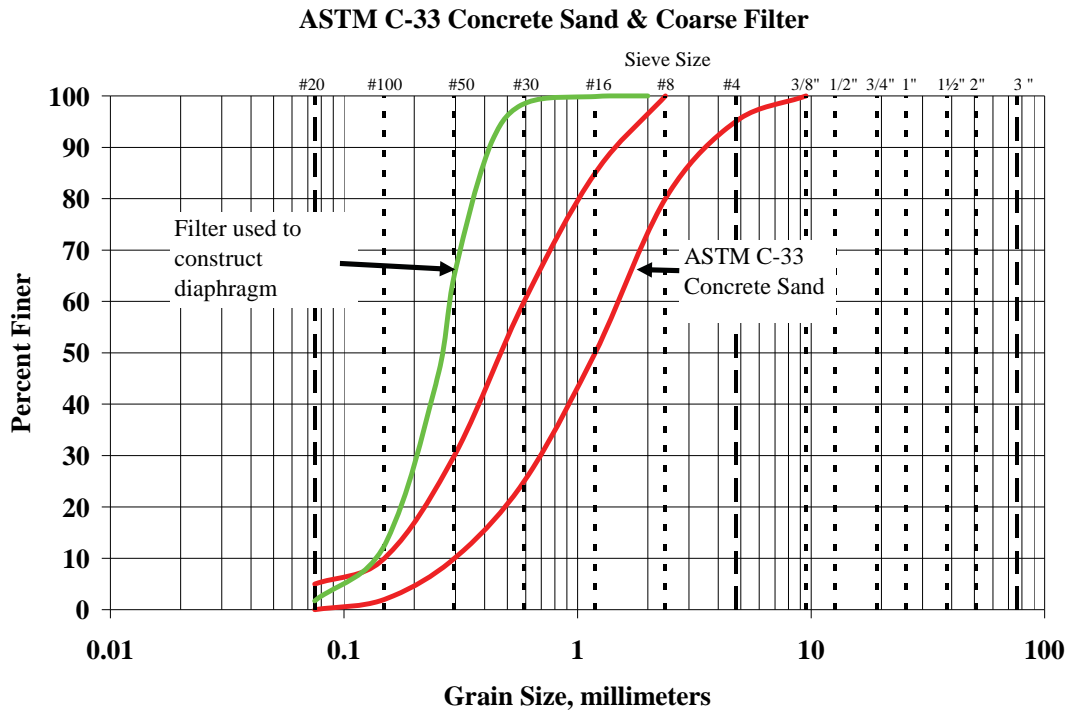

Figure B-11.—The gradation used for the filter diaphragm.

- The sand material used for the diaphragm was too fine and poorly graded to furnish properties considered desirable for filter diaphragms. Those properties are self-healing and a lack of bulking characteristics. ASTM C 33 concrete sand has been found to be an excellent filter for this purpose, but the filter used was significantly finer and more poorly graded than C 33 sand. The result was probably that the filter diaphragm could support an open crack and consequently could not fulfill the most important diaphragm function of collecting and filtering flow in the crack.
- The designer should monitor pipe installations to ensure that the specifications and the intent of the design are complied with, and that construction difficulties are adequately accounted for in the design requirements and construction specifications.
- The downstream area where the pipe exits the structure should be monitored closely for unusual quantities of seepage and evidence of internal erosion, especially during first filling of the reservoir.

**References:**

Mine Safety and Health Administration, *Investigation of Embankment Failure - Sediment Pond SP-4*, Report No. MW04-024, 2004.

Natural Resources Conservation Service, “Filter Diaphragms,” *National Engineering Handbook*, Part 628, Chapter 45, 2007.

**Project:** Sugar Mill Dam

**Location:** Georgia

**Summary:** Poor construction practices lead to internal erosion along a siphon spillway

Sugar Mill Dam is a residential subdivision that was developed in the early 1990's in north Fulton County, Georgia (Atlanta metropolitan area). A central amenity of the development was an existing lake impounded by an old earthen embankment with inadequate spillway capacity.

In addition to widening the earthen emergency spillway, five PVC siphon pipes (ranging from 6 to 24-inches in diameter) were installed in a trench excavated through the crest of the embankment and terminating in a new wall at the toe of the dam (figure B-12). The design called for the pipes to be bedded in concrete. Control valves were installed in the siphons at the top of the dam, inside of manhole structures.

In 2002, about ten years after construction of the siphon spillway system, the dam owner noted water flowing out of a hole in the embankment adjacent to the siphons, approximately 15 feet downstream of the valve manhole.



**Figure B-12.**—In the early 1990's the spillway capacity of the dam was increased by construction of a system of 5 PVC siphons embedded in concrete in a shallow trench through the dam.

The owner contacted the designer for guidance. An internal CCTV inspection of the siphons found no problems with the PVC pipes, and the designer recommended that a filter drain system be constructed to control the seepage along the pipes. However, this did not work and the seepage situation continued to get worse. In 2003, the owner attempted to operate the siphon spillways during a storm, and found that the manholes were full of water and that the seepage flow along the siphons had substantially increased.

The designer suspected that flow was occurring under the pipes and recommended exploratory “surgery” in an attempt to locate the source of the seepage. After removal of the backfill over the pipes (figure B-13), a small hole drilled through the concrete between the siphons (figure B-14) revealed no voids and additional excavation was required. After portions of the siphon pipes and concrete bedding were removed it was found that the original contractor had not achieved adequate placement of the concrete bedding, and there were extensive voids under the center of each siphon pipe. Constant flow through these voids had caused internal erosion of the underlying embankment soils.

These sections of the siphons were replaced with new PVC pipe and the bedding was replaced with a higher slump concrete than was used originally (figure B-15).



**Figure B-13.**—After about 10 years of operation, seepage was observed on the downstream slope of the dam in the vicinity of the siphons, and the overlying embankment material was excavated to expose the pipes to determine the source of the seepage.



Figure B-14.—A small hole drilled through the concrete bedding between the siphons did not encounter voids under the concrete, even though the designer suspected that seepage was occurring directly under the pipes.



Figure B-15.—After removal of portions of the PVC siphons, it was determined that the original concrete bedding had been improperly placed, resulting in voids under the centers of the pipes. Portions of the siphons were replaced, and the bedding was replaced with a high slump concrete.



**Lessons learned (adapted from Wilson and Monroe):**

- Internal erosion of soils is a real-life occurrence.
- Neglecting minor details during construction can result in development of failure mechanisms.
- Successive attempts were made to find the source of the seepage problem in a cost effective manner.
- Good communication between the contractor, owner, and designer can result in a cost effective solution to a major problem, saving dollars for the owner and improving the safety of the dam.

**References:**

Sugar Mill Community Association, Minutes of Board of Directors meetings: April 18, 2002; May 7, 2002; and January 14, 2003.

Wilson, Charles and Joseph Monroe, *Dam Surgery—Repairs to Sugar Mill Dam, Fulton County, Georgia*, ASDSO Southeast Regional Conference, 2004.

## Plastic Pipe Used in Embankment Dams

---

**Project:** Upper Wheeler Reservoir Dam

**Location:** Washington

**Summary:** Collapse of HDPE pipe during grouting operation

In 1992, construction on Upper Wheeler Reservoir Dam included sliplining an old concrete box conduit with an HDPE pipe. The project also included extending the outlet downstream. The problem arose while grouting the annular space between the original box conduit and the new HDPE pipe.

The grouting operation consisted of pumping grout in from the downstream end of the box conduit, forcing the grout upstream. The contractor was successful in only grouting the lower 120 feet of the existing box conduit. When they reached the halfway point, the sides of the old box conduit failed at the lower end, resulting in the loss of about 5-6 cubic yards of concrete. Because the contractor could no longer continue the grouting operation from the downstream end, the equipment was relocated to the upstream end of the conduit. At the time, no one was aware that the pipe had collapsed. The fact that they could not release any water was the ultimate “smoking gun.” Figure B-16 shows the grout tube in the original box conduit at the toe of the dam and the new outlet extension. Note: The State of Washington requires HDPE to be encased in concrete.



**Figure B-16.**—Looking upstream towards toe of dam: View of old box conduit and new downstream concrete encasement, during grout operation. Grout pipe is shown in top of photo.



**Figure B-17.**—Looking downstream from toe of dam after excavation of collapsed portion of HDPE pipe (located in original box conduit, upstream of new concrete encasement).

Calculations completed after the failure (figure B-17) showed that the HDPE pipe's resistance to external hydraulic pressures was much lower than the grouting pressures that were used. Due to the location of the grout pipe, high grout pressures were necessary to push the grout upstream.

**Lessons learned:**

- Get a specialty contractor experienced in grouting.
- Reviewers should get the specialty subcontractors documentation of the suitability of the grouting scheme and independently check their calculations of pipe stresses.

## Plastic Pipe Used in Embankment Dams

---

- If possible, the grouting of the downstream end of the pipe should be done using some form of slickline grout pipe inserted from the upstream end of the pipe.
- Avoid pumping grout up a pipe.
- If practical, use a low-density grout and fill the pipe to be encased with water during grouting.

### **Reference:**

State of Washington Department of Ecology.

**Project:** Virginia Dam

**Location:** Virginia

**Summary:** Collapse on a HDPE pipe encased in concrete due to external hydrostatic pressure

A plastic pipe that was encased in concrete collapsed during first filling of a slurry impoundment in 1996. The decant conduit consisted of a 48-inch diameter, SDR 32.5 HDPE pipe encased in unreinforced concrete. The encasement had been formed around the pipe during conduit construction and the concrete had been placed in several separate sections along the pipe. Blocks had been placed under the pipe to hold it in position during the concrete placement. The encasement was square and 72 inches on each side. The concrete thickness was 16 inches above the pipe, 8 inches below the pipe and 12 inches at the springline (figure B-18).

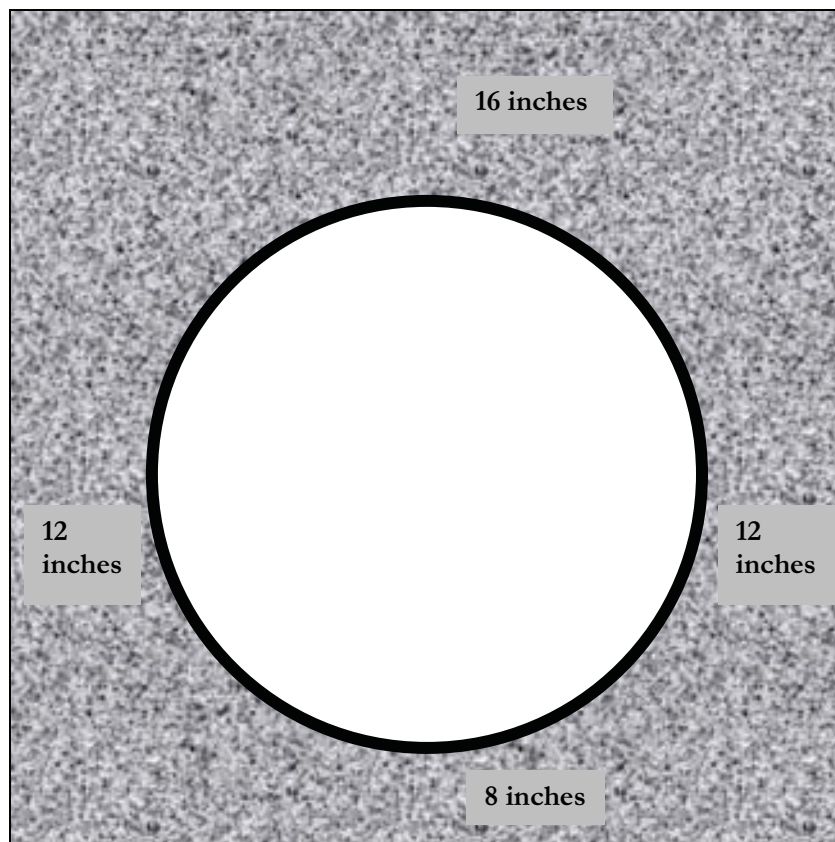

**Figure B-18.**—Position of 48-inch diameter, SDR 32.5 HDPE pipe in unreinforced concrete encasement.

Construction was completed in early May, 1996, and the reservoir began to fill in mid-May. No problems were evident up to and including an inspection of the pipe on May 27, 1996. On June 5, 1996, when the pool level had risen by approximately 50 feet, a discharge of approximately 300 gallons per minute was observed from the decant pipe, even though the pool was still three feet below the riser inlet elevation. Man-entry inspection of the pipe revealed that for a distance of approximately 25 feet, the bottom of the pipe had deformed upward, with the bottom of the pipe contacting the top of the pipe in one area. See figures B-19 and B-20. While inspecting the deformed area from the upstream end, running water could be heard entering the pipe farther downstream. Two days later, the pipe had deformed for a distance of approximately 250 linear feet. Eventually, the HDPE pipe became deformed along most of its encased length.

The plastic pipe had collapsed as a result of being subjected to hydrostatic pressure between the pipe and the concrete encasement. Possible entry points for the water included the joints between concrete placements, the contact area between the concrete and the blocks used to position the pipe, and cracks in the concrete. At the point where the collapse first occurred, the pipe was subjected to a potential head from the pool of approximately 81 feet, or a hydrostatic pressure of 35 lb/in<sup>2</sup>.

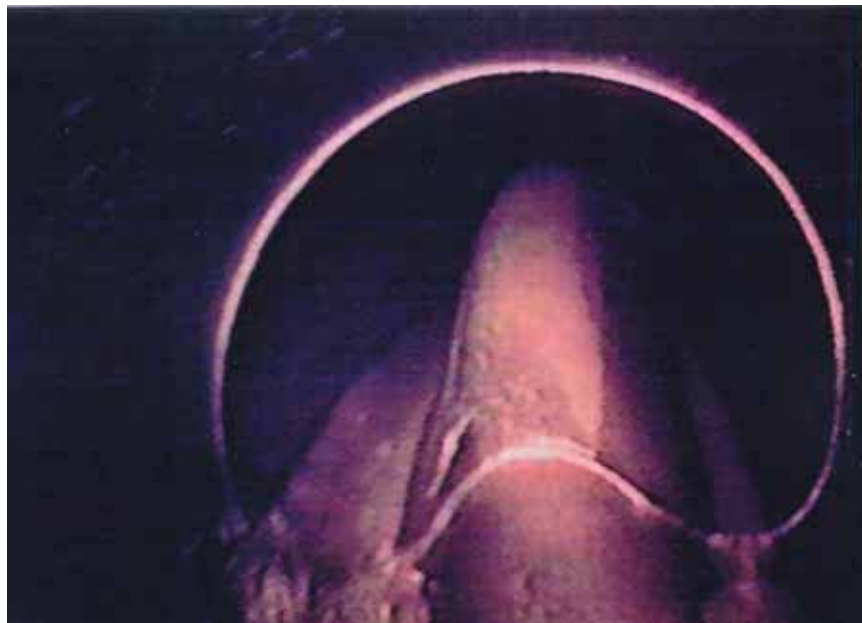

Figure B-19.—View of interior of deformed HDPE pipe from CCTV camera.

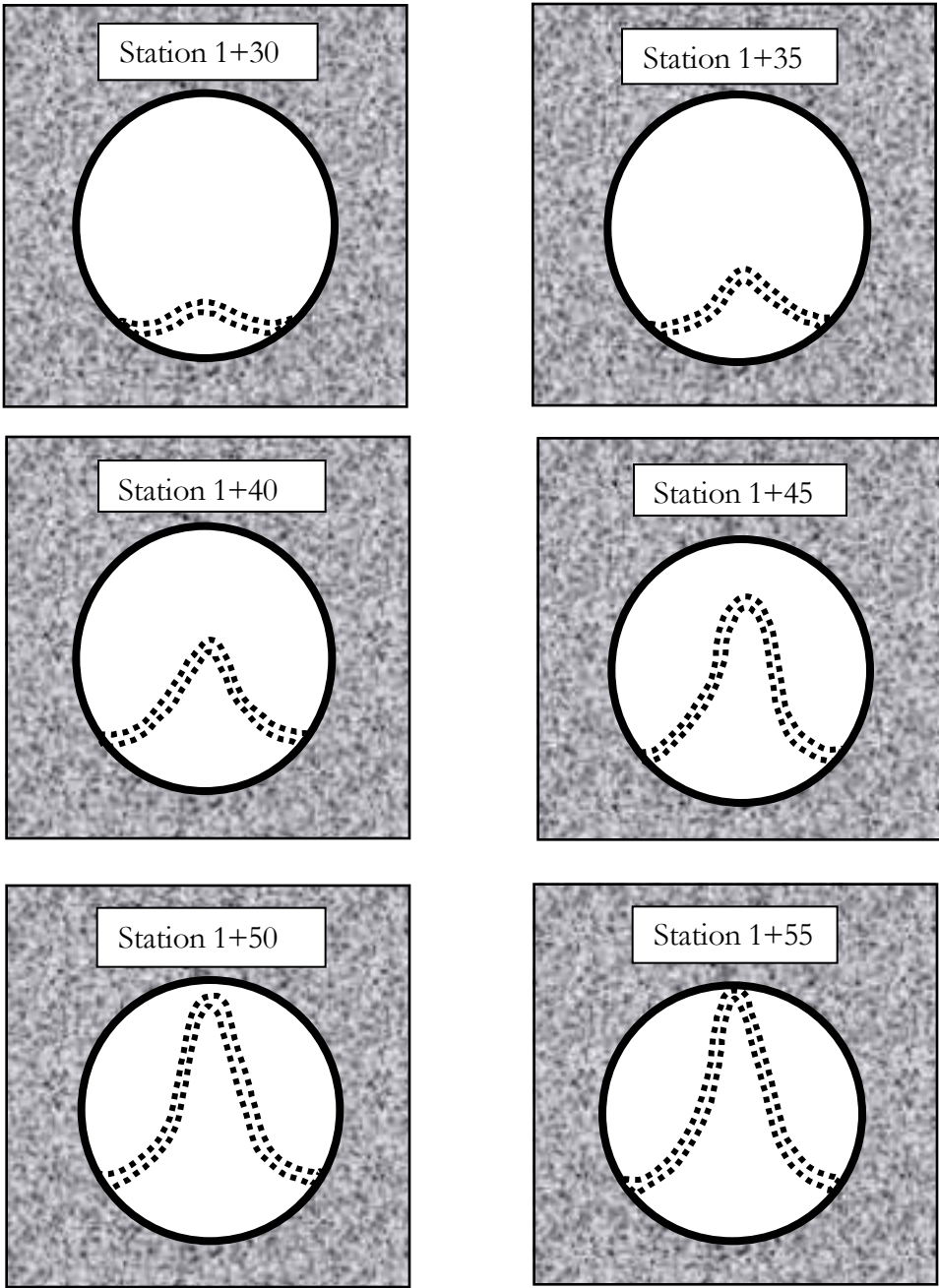

Figure B-20.—Approximate upward distortion of bottom of HDPE from outside hydrostatic pressure between the pipe and its concrete encasement.

Based on information supplied by HDPE pipe manufacturers, unrestrained SDR 32.5 pipe can collapse as a result of a short-duration external hydrostatic pressure of less than 7 lb/in<sup>2</sup>, and a long-duration hydrostatic pressure of less than 3 lb/in<sup>2</sup>. In a study by Jenkins and Kroll (1981), samples of SDR 32 polyethylene pipe which were encased in grout collapsed when subjected to short-term hydrostatic pressures, at the interface between the pipe and the grout, in the range of 32 to 34 lb/in<sup>2</sup>.

As a result of the problem with the pipe, the reservoir was lowered by pumping, an open channel spillway was excavated, and the conduit and annulus were filled with grout and abandoned.

### **Lesson learned:**

- Plastic pipe encased in concrete or grout must have sufficient strength to resist the external pressures to which it may be subjected. This includes pressures during the placement of the concrete or grout, as well as potential pressures from the reservoir. In this case, the concrete encasement had been evaluated for the earth loads, but the plastic pipe had not been designed to withstand hydrostatic pressure acting between the pipe and the encasement.
- Designs for encased pipes need to take into account that the pipe may become out-of-round or a flat spot may be created during the construction process. The floatation forces created during concrete pouring, for example, can cause deflection of the pipe and/or local deformation where the pipe is restrained. If a pipe is deflected or otherwise out of round, its resistance to collapse from outside hydrostatic pressure is reduced (Watkins, 2004).

### **Reference:**

Jenkins, C.F. and A.E. Kroll, "External Hydrostatic Loading Polyethylene Pipe," *Proceedings of the International Conference on Underground Plastic Pipe*, ASCE, pp. 527-541, 1981.

Watkins, Reynold King, *Buried Pipe Encased in Concrete*, ASCE, 2004.



**Project:** Wheatfields Dam

**Location:** Arizona

**Summary:** Sliplining a deteriorating outlet works conduit using HDPE dual-wall containment pipe

Wheatfields Dam is an earthfill embankment located on the Navajo Indian Reservation in Arizona. The dam is an offstream storage facility used for irrigation and recreational purposes. Wheatfields Lake has a storage capacity of 3,880 acre-feet at the top of active conservation, elevation 7,296.6. Wheatfields Dam impounds flows from a small drainage basin on an unnamed tributary of Wheatfields Creek and diverted flows from Wheatfields Creek via a diversion canal.

The embankment is homogenous earthfill consisting of silt, clay, gravel, and cobbles and was constructed to crest elevation 7,302.1 in 1963. The dam has a crest length of 1,600 feet and a maximum structural height of 66 feet, a 36-foot crest width, and upstream and downstream slopes of roughly 3H:1V. A highly traveled two-lane paved highway crosses over the crest of the dam.

Appurtenant structures at the dam include a spillway and an outlet works. The spillway is an unlined trapezoidal cut excavated through a shallow ridge at the north end of Wheatfields Lake. The outlet works is located in the central portion of the embankment. The outlet works foundation consists of Pleistocene age alluvial red silty clay. The outlet works has two intake structures for low-level and irrigation releases. The low-level intake structure consists of a trashracked concrete box with an inlet sill elevation of 7,261.0 and is controlled by a 24-inch diameter slide gate. The low-level intake structure connects to approximately 290 feet of 24-inch diameter CMP that extends downstream to an exit portal. The irrigation intake structure consists of a trashracked concrete box with an inlet sill at elevation 7,292.0 and is controlled by a 24-inch diameter slide gate. The irrigation intake structure connects to approximately 30 feet of 24-inch diameter CMP that extends vertically downward to a location where it merges with the low-level outlet works. The irrigation intake was abandoned after the sliplining of the CMP. The outlet works has a computed discharge capacity of 41 ft<sup>3</sup>/s (through the low-level intake only) when the reservoir water surface is at the spillway crest, elevation 7,296.6. The gate stem to the low-level gate is broken, making it inoperable. Figure B-21 shows the general configuration of the existing outlet works.

Modifications were required to the outlet works to address dam safety deficiencies and operational and maintenance issues. The primary deficiency involved separation of pipe joints and deterioration of the interior surface of the CMP. The existing condition of the conduit and the possibility of internal erosion of embankment materials either into or out of the conduit prompted concerns about increased risk

## Plastic Pipe Used in Embankment Dams

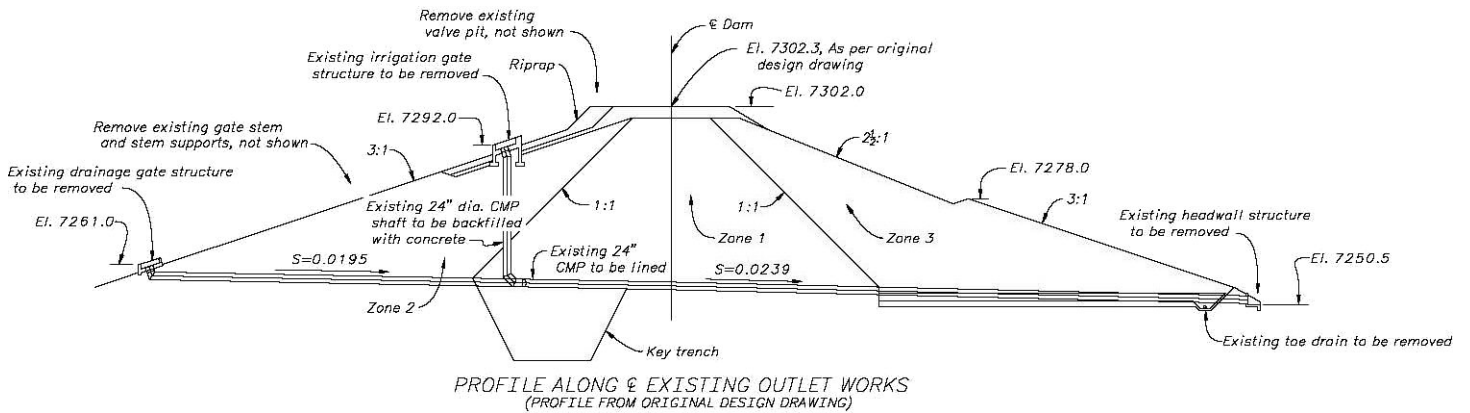

Figure B-21.—The profile of the existing outlet works prior to modifications.

for the development of a serious dam safety failure mode. As part of the modifications, new operational capabilities were added to supply pressurized flow to the outlet works to meet the need for future irrigation downstream from the dam.

After evaluation of a number of alternatives, sliplining of the outlet works conduit was selected as the best solution for eliminating the dam safety issues associated with the outlet works and accommodating future needs. Since the modified outlet works will have pressurized flow, it will be controlled by a rate-of-flow control valve located in a new downstream control structure during normal operations. For operations that require faster drawdown of the reservoir, the flow will be controlled by a ball valve located in the downstream control structure. The outlet works conduit will remain pressurized during the irrigation season. During the winter months, the upstream slide gate will be closed, and the liner will be drained. The ball valves will be left open in the winter to prevent freezing.

A dual-wall HDPE containment pipe was selected for sliplining. Dual-wall containment pipe provides structural integrity to the outlet works in addition to addressing potential internal erosion concerns by preventing seepage either into or out of the conduit. The potential for internal erosion along the outside of the CMP is addressed by using sufficient pressures during the grouting process to encourage grout travel through any existing small openings in the CMP and the construction of a downstream filter and drainage system.

A dual-wall HDPE containment pipe consisting of a 14-inch outside-diameter pipe in a 20-inch outside-diameter HDPE pipe was selected for sliplining and grouting into the existing 24-inch diameter CMP. In addition to sliplining, the upstream intake structure was removed and replaced, and a new downstream control structure was constructed. Figure B-22 shows the general configuration of the modified outlet works.

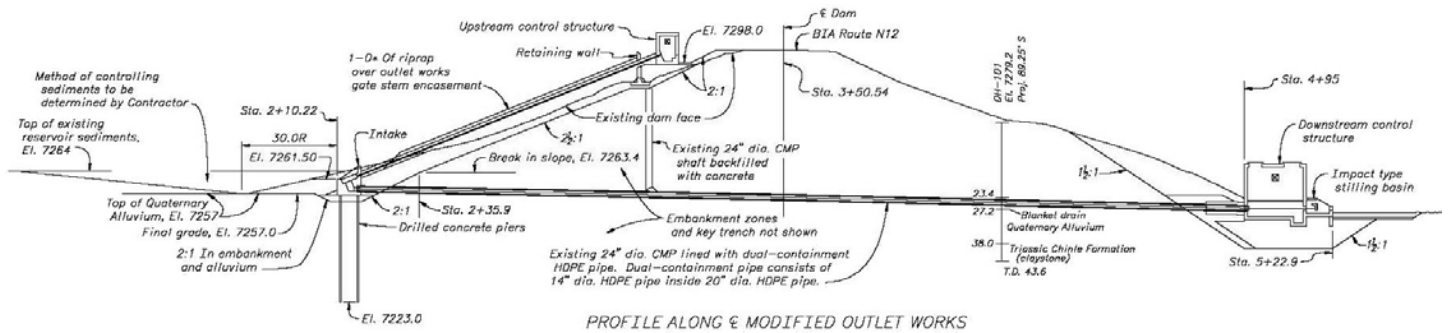

Figure B-22.—The profile of the modified outlet works.

The controlling hydraulic design factor of the modified outlet works was the maximum diameter of dual-wall containment pipe that could be inserted into the existing CMP. During initial design, the outside diameter of the HDPE lining was made about 10 percent smaller than the pipe to be lined. However, to facilitate installation and annular grouting, a dual-wall containment pipe consisting of a 14-inch outside-diameter carrier pipe (approximate inside diameter 12.9 inches) inside a 20-inch outside-diameter containment pipe (approximate inside diameter 18.5 inches) was selected. The inside dimensions of the existing CMP were carefully measured using a CCTV crawler-camera with a template attached to it to be sure there were no obstructions or deformations within the CMP that would prevent a 20-inch-diameter pipe from being installed.

The following loading conditions and methods of analysis were used for design of the slipliner:

- External loading equal to the maximum embankment load with no consideration given for the existing CMP and no internal pressure. Maximum embankment depth was assumed to be 50 feet. The HDPE pipe was analyzed for wall crushing, wall buckling, and ring deflection.
- Internal loading equal to the hydrostatic loading with the reservoir at the dam crest without side support from the surrounding embankment. Maximum hydraulic head rounded to 50 feet. Seventy percent of the strength of the internal 14-inch diameter pipe was used in the pressure calculations. This criterion was based on the manufacturer's recommendation for the dual-wall containment pipe. The strength is reduced because the fusion welds of the containment pipe cannot be inspected from the interior of the pipe. The welds will be visually inspected by CCTV before the pipe is grouted into the CMP.

The following material properties were used in design:

- Hydrostatic design stress = 800 lb/in<sup>2</sup>

- Standard dimension ratio = 26
- Linear thermal expansion coefficient =  $1.2 \times 10^{-4}$  in/in/°F
- Short term modulus of elasticity = 100,000 lb/in<sup>2</sup>
- Compressive yield strength = 1,500 lb/in<sup>2</sup>

Construction began in January 2005. The reservoir was drained prior to the start of construction. The existing outlet works conduit was pressure washed and the cleaning verified by CCTV inspection. During construction, it was decided to use two separate pipes to form the dual-wall containment pipe rather than using a fabricated prejoined system. A McElroy track-star 500 Series fusion welder was used to butt fusion weld the sections of HDPE pipe together. A John Deere 230LC excavator (figure B-23) and Case 580-super L backhoe were utilized for moving the HDPE pipe from the staging area and for placing the pipe onto the fusion machine. To facilitate butt fusion and avoid construction congestion, the 14-inch diameter pipe was joined together on the downstream side of the dam and the 20-inch diameter pipe was joined together on the upstream side of the dam. The ¾-inch diameter HDPE grout lines were attached to the exterior surface of the containment pipe using a Munsch MA-40-B hand extrusion welding gun. Spacers were placed on 8-foot centers to center the 14-inch diameter pipe within the 20-inch diameter pipe. Additional ¾-inch diameter pipe was extrusion welded onto the bottom quadrant of the containment pipe to act as centering skids.

The excavator was used for guiding the 20-inch diameter pipe into the CMP at the upstream end of the conduit (figure B-24), while the backhoe pulled the pipe using a specially designed steel pulling head attached to the pipe pulled from the downstream end. The installation process was reversed for pulling the 14-inch diameter pipe into the 20-inch diameter pipe. After installation of both pipes, water from the reservoir was used to separately fill each pipe for hydrostatic pressure testing.

Bulkheads were constructed at the upstream and downstream ends of the outlet works conduit for grouting of the annular space between the 20-inch diameter pipe and the existing 24-inch diameter CMP. A grouting subcontractor was used for the grouting operations. Two identical grout plants were made available onsite, with one plant serving as the backup in case it was needed. Grouting was performed through four ¾-inch diameter HDPE pipes extrusion welded to the crown of the 20-inch dual-wall containment pipe of different lengths. The four lengths are 25.5 feet, 60.5 feet, 90.5 feet, and 120.5 feet. One additional ¾-inch diameter HDPE pipe was also welded to the crown of the 20-inch dual-wall containment pipe and used as an air vent. An initial grout mix of 4,000 lb/in<sup>2</sup> with 0.6:1 w/c (water-cement ratio by volume) and super plasticizer was used. After grouting operations began, it was



Figure B-23.—HDPE pipe being unloaded at the site using a John Deere 230LC excavator.



Figure B-24.—Guiding the 20-inch pipe into the upstream end of the CMP.

determined that the grout mix could not be injected into the  $\frac{3}{4}$ -inch diameter grout pipe at the prescribed grout pressure of 5 lb/in<sup>2</sup>. The grout mix was changed to 0.8:1 w/c with the amount of superplasticizer increased and the pumping pressure slowly increased to 25 lb/in<sup>2</sup>. Additional modifications to grout mix and pumping pressure were required to maintain a constant injection rate. The entire grouting process took about 8 hours for injection of 340 bags of cement.

## Plastic Pipe Used in Embankment Dams

---

The modifications, including sliplining, construction of new upstream and downstream structures, and other toe drain modifications, were completed in September 2005. A CCTV inspection was performed after the completion of construction and showed no problems.

### **Lessons learned:**

The color of the installed HDPE dual-wall containment pipe was white. This was selected to improve inspection using CCTV equipment. However, it was later found that the white causes too much contrast and gray or black is better suited for CCTV inspection.

Grout pipes should be 1-inch diameter rather than  $\frac{3}{4}$ -inch diameter to facilitate grouting of the annulus.

### **References:**

Bureau of Reclamation, *Wheatfields Design Summary*, 2006.

**Project:** Worster Dam

**Location:** Colorado

**Summary:** Renovation of an existing outlet works using an HDPE slipliner grouted in place

Worster Dam and Reservoir, also known as Eaton Dam and Reservoir, are located in Larimer County northwest of Fort Collins, Colorado. The dam and reservoir is located on Sheep Creek, a tributary to the north fork of the Cache La Poudre River in a mountainous area about five miles south of the Colorado-Wyoming border.

Worster Dam is a concrete face rockfill dam constructed in the early 1900's. The exact year of construction is not known. The dam is about 72 feet in height with a crest width of about 12 feet and a crest length of over 700 feet. The impounded reservoir has a maximum storage capacity of about 3,750 acre-feet.

The outlet works consists of reinforced cast-in-place concrete arched pipe with a central gate chamber. The inlet conduit consists of a 36- to 38-inch wide and 37-inch high reinforced concrete arch. The inlet conduit then connects to a central gate chamber. The gate chamber is approximately 7 feet in height, approximately 3 to 6½ feet wide and about 10 feet long. Flow was controlled by two 36-inch diameter slide gates housed in the gate chamber. The gate stems extend vertically through the embankment with the operators located at the dam crest. The gate chamber discharges to a larger 48-inch by 48-inch reinforced concrete arch conduit and directly to the stream.

An evaluation of the existing outlet works was performed by Woodward-Clyde Consultants (heritage firm to URS Corporation). The evaluation found that the central gate chamber appeared to be in relatively good condition. However, the evaluation also found that the outlet works conduit upstream and downstream of the gate chamber was composed of extremely poor quality concrete. Areas of the inlet structure had exposed steel and the steel reinforcement was severely corroded. Furthermore, much of the cement paste had been dissolved by the aggressive water.

Renovation of the outlet works consisted of replacing the inlet structure and guard gate, demolishing the slide gates in the central chamber, and sliplining the outlet works with an HDPE pipe. The new HDPE outlet works conduit was designed to withstand the full reservoir for external water pressure (buckling) and internal reservoir pressure. The upstream portion of the outlet works conduit was lined with a 30-inch diameter SDR 17 HDPE pipe grouted with a 2,000 lb/in<sup>2</sup> cement grout. The downstream portion of the conduit was lined with 42-inch diameter SDR 17 HDPE pipe grouted in place. The 30-inch and 42-inch pipes were connected using an eccentric reducer. The upstream end of the inlet structure was connected to a

steel elbow using a Dresser coupling and a steel elbow with air vent was installed at the inlet with a 30-inch diameter reducing thimble.

The HDPE pipe was welded and assembled prior to installation. The conduit was then pushed/pulled into place using two Caterpillar D8 dozers. The integrity of the installed pipe was verified by pressure testing. Once a satisfactory condition was established, bulkheads were constructed at the upstream and downstream ends of the conduit. Grout discharge pipes of various lengths were installed on the downstream and upstream bulkheads and within the existing casing for the central grade chamber valve stems. In all, eight grout introduction points were established and utilized during the grouting process.

Flange ends were installed at the inlet and outlet, and the outlet pipe was filled with water. A pressure gauge was installed to monitor external grout pressures to verify that external pressures did not exceed the design pipe load.

The grout was slowly introduced at the downstream end. A combination of sand cement grout and neat cement grout with a superplasticizer were introduced at various times throughout the grouting process. The mix water was obtained from the reservoir. The mix water was near freezing because the source was a recent snowmelt. The cold grout resulted in constriction of the HDPE pipe. During the grouting process, the pipe water pressure began to increase. Grouting activities were suspended to allow the grout pressures to dissipate. Much to the surprise of the construction team, the water pressure continued to rise as the pipe continued to contract in response to the low grout temperature. Eventually the pressure became sufficiently high that the end couplings slipped, relieving the pressure. The internal water pressure returned to near zero pressure, the pressure remained stable, and grouting resumed. The temperature in the pipe stabilized and no further increases or decreases within the pipe pressure were observed. Once the grout was allowed to set up for 72 hours, the flanges were removed from the pipe and the outlet works was placed into service.

### **Lessons learned:**

The following lessons were applicable to the construction described above.

- Filling a pipe with water is an effective means to reduce risk of pipe collapse during grouting.
- Continuous monitoring of the internal pipe water pressure should occur.
- Plans should be made to consider and monitor the grout mix temperature. The subject project observed a contraction of the pipe due to the low water pressure. The opposite could occur in which the grout temperature may cause expansion of the HDPE pipe, resulting in a negative pressure in the pipe.



- All of the eight grout introduction points were utilized during the grouting process. The success of the grouting project was based on the ability to introduce grout at these eight locations and fewer locations would have resulted in a failure to establish a complete grout seal around the pipe.

**Reference:**

Christopher N. Hatton, P.E., Woodward-Clyde Consultants, 2005.

