

CHAPTER IV



OTHER FLOODPROOFING MEASURES (Emergency and Other Non-Permanent Actions)

A. EMERGENCY MEASURES

Emergency floodproofing includes techniques that can be initiated on relatively short notice using stored and/or natural materials to prevent flooding. Emergency methods that will be presented in this section include sandbag dikes, earthfill crib retaining walls and stop log barriers. The use of stop log barriers might be considered a contingent technique (Chapter III). However, the installation and the type of protection offered by these barriers is similar to that of the sandbag dikes and earthfill crib retaining walls. Therefore, all three techniques are presented in this section.

Although most of the construction activities related to emergency methods do not generally begin until a flood warning has been issued, emergency actions must be planned in advance. These plans must address material storage and maintenance, labor and equipment requirements for the installation of emergency barriers, and labor force training.

The primary advantage of an emergency method is the relatively low implementation cost. Natural materials such as sand, soil, and timber and the labor and equipment required to place these materials are all that is required. These methods are capable of providing an acceptable level of flood protection in areas characterized by low water velocities and shallow depths and, most importantly, where floodwaters rise so slowly that there is time to install emergency flood barriers. The availability of emergency floodproofing materials also provides flexibility in controlling unexpected circumstances such as overtopping of an existing levee by a flood that exceeds the design capacity of that levee.

The principal disadvantage of emergency measures is that sufficient advance warning is required to mobilize personnel and install emergency barriers. Most emergency floodproofing methods require an extensive labor force that must be available on relatively short notice. Other emergency measures depend on the availability of heavy machinery and trained operators. If the magnitude or rate of rise of a flood are misjudged, plans to protect a facility with emergency floodproofing techniques may fail.

Another disadvantage of some emergency methods is that a large amount of construction material must be stored on or near site to be protected. This represents a pronounced drawback for small sites and for sites where aesthetic values must be considered. Also, *emergency measures do not satisfy the minimum requirements for watertight floodproofing as set forth by the National Flood Insurance Program*. This is especially applicable to the protection of existing construction.

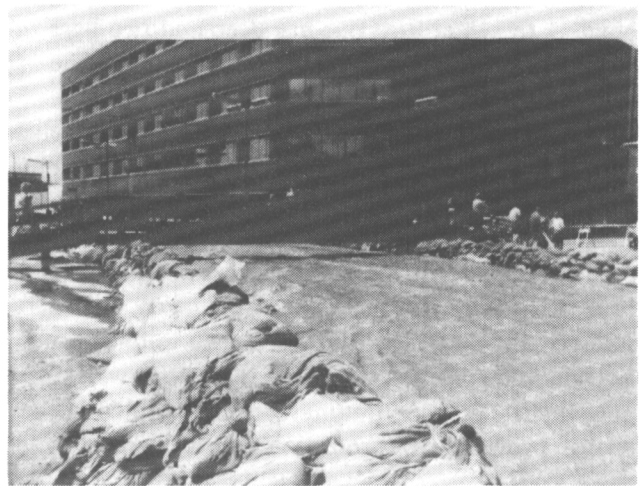

B. TYPES OF EMERGENCY MEASURES.

1. SANDBAG DIKES. A sandbag dike is the emergency flood protection method most frequently used. Sand is available at many locations and is relatively inexpensive. Sandbags may be fit to the irregularities of the area where they are placed. However, bags may be filled with soil if sand is not available. If soil fill will be required, excavating equipment (dozer, backhoe, etc.) should be available to remove sod, loosen the soil, and transport the material to the work site. Performing these tasks by hand requires much time and labor.

Bags should be strong enough to hold approximately one-third cubic yard of material and to withstand prolonged contact with water. Bags that are manufactured specifically for floodproofing are available in both burlap and plastic. Webbed polypropylene bags are often preferred because of their strength and resistance to wear. Feed bags and bags used for peat moss, bark mulch, etc. have also been effective when filled and placed in an appropriate manner.

For sandbagging to be effective, it is essential that required materials and equipment must be nearby in a location that will not be isolated from the site by floodwaters. In addition, an adequate work force must be available to fill and place the bags.

A recommended method for construction of a sandbag dike is shown in Figure IV-1. As shown, the first step involves removing the sod and excavating a bonding trench at least one bag deep and two bags wide. This will reduce seepage under the dike. The bags should be filled about one-half full. It is not necessary that the bags be tied. The bags in the trench and the first layer of bags should be placed parallel to the channel with bags in each line overlapping as shown in Figure IV-1. The second layer is placed perpendicular to the first, the third parallel to the first, and so on with each succeeding layer. For lateral stability, the dike should be about two to three times as wide at the base as it is high. If time allows, a polyethylene plastic sheet may be incorporated in the dike to provide extra protection against seepage.



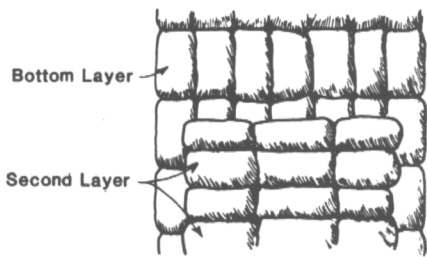
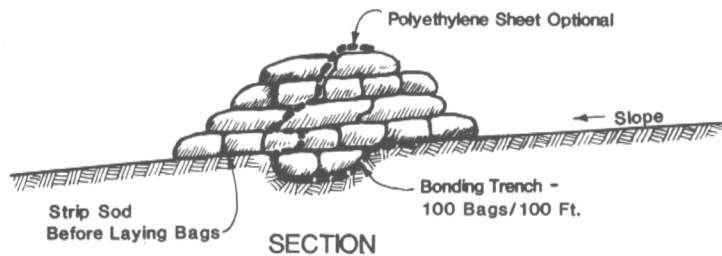

PLAN



METHOD OF LAPPING SACKS

Notes:

1. ALTERNATE DIRECTION OF SACKS.
I.E.: BOTTOM LAYER PLACED LENGTHWISE PARALLEL TO THE SLOPE; NEXT LAYER PLACED PERPENDICULAR TO FIRST, ETC.
2. LAP UNFILLED PORTION UNDER NEXT BAG.
3. TYING OR SEWING OF BAGS IS NOT NECESSARY
4. BAGS SHOULD BE APPROXIMATELY ONE-HALF TO TWO-THIRDS FULL.
5. TAMP THOROUGHLY IN PLACE.

MATERIALS REQUIRED FOR 100 LINEAR FEET		
Height Above Ground	Approx. Bags Required	Cu. Yds.
1 Ft.	600-800	10-13
2 Ft.	1400-2000	23-33
3 Ft.	2200-3400	37-57
4 Ft.	5300	88
5 Ft.	7600	137
6 Ft.	10000	167

Figure IV-1. Sandbag Dike Construction Techniques

Inflatable water hoses or mud-filled hoses may provide an alternative to sandbag dikes. With the mud-filled hose, a strong polyester hose of fixed dimension, with part of its skin perforated, is extended to any required length and filled with a mixture of mud or sand and water from the stream bottom by pumping through self-sealing inlets. Excess water is then drained through the perforation, leaving a compacted soil in the hose (Figure IV-2). The filling time depends on the soil content of the pumped mixture. For example, it is estimated that a wall 2.8 feet high and 1,000 feet long may be erected in three hours when four pumps (1,000 gpm each) are used to pump a mixture of 20% soil and 80% water into the hose. The height of the wall can be increased by laying additional hoses on top of each other.

Although water-filled hoses have been used in Europe for major structures, the application of mud and/or water-filled hoses as effective flood barriers for commercial structures in the U.S. has not been thoroughly demonstrated.

2. EARTHFILL CRIB RETAINING WALL.

Earthfill cribs or retaining walls may also provide effective emergency flood protection. An earthfill crib is formed by setting two lines of posts parallel to the

stream channel, nailing boards to the inside of each row, and bracing posts across from one another with a plank or wire (Figure IV-3). After the crib is formed, it is filled with soil which may be excavated near the site. Water resistance can be improved with the addition of a polyethylene plastic sheet as shown in Figure IV-3.

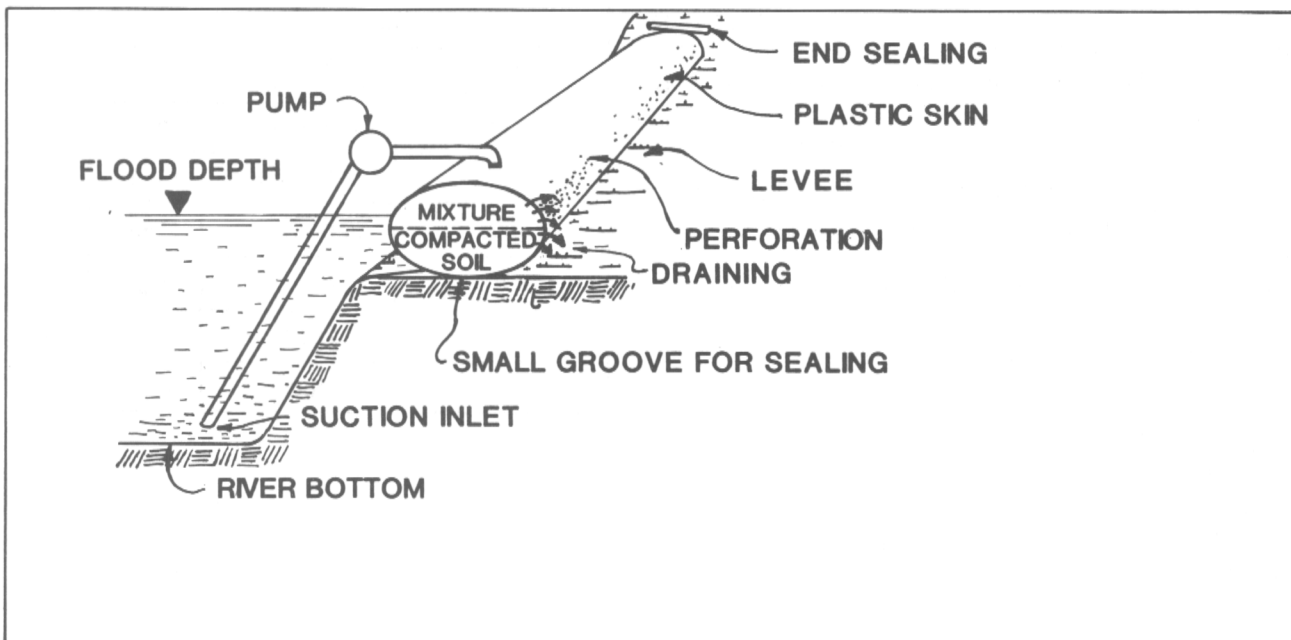

Figure IV-2. Mud Hose Profile

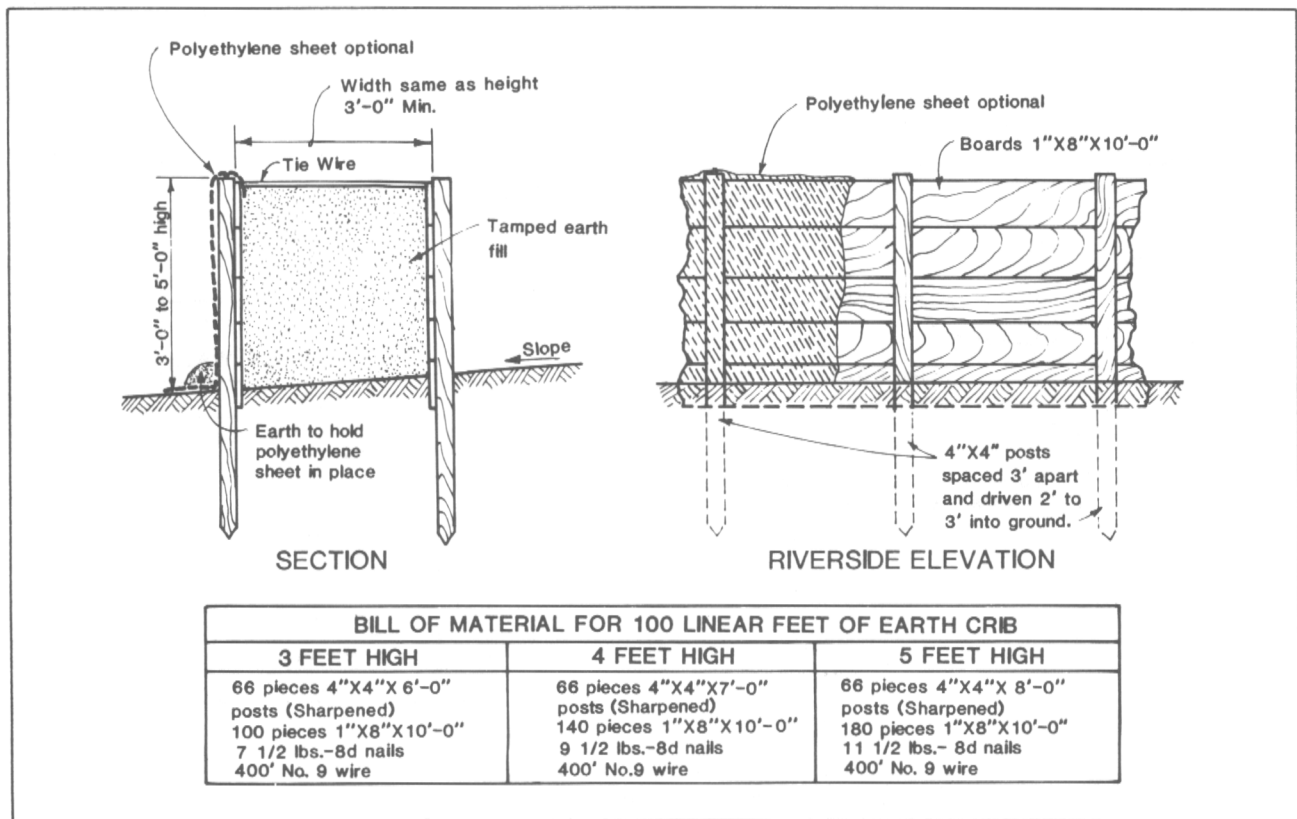

Figure IV-3. Earthfill Crib Retaining Wall

A variation of this procedure is the earth and timber retaining wall. For this technique, one row of posts is placed parallel to the stream channel, and planks are nailed on the side away from the water as shown in Figure IV-4. Sandbags or earth fill must be placed behind the wall. A polyethylene sheet may be used to reduce seepage. Post and boards must be available at the site as must be the required equipment and manpower to drive the posts or dig postholes and to move large quantities of soil or sand.

The use of these emergency retaining wall structures will not generally create a watertight barrier. Therefore, sump pumps should be available to remove leakage and stormwater behind the wall. Pumps with sufficient capacity for this purpose should be readily available and in good repair at all times. Enough fuel to operate the pumps for the duration of the flood should be stored at the site. Electric pumps should not be used because electrical service may be interrupted when flooding occurs.

3. STOP LOG BARRIERS. A stop log barrier is basically a temporary wall that is constructed by stacking small beams or planks on top of each other in such a manner as to prevent the passage of water through them. These logs or planks may be dropped into slots in concrete walls (Figure IV-5) or into freestanding metal channels.

Stop logs are normally made from treated lumber that is at least two inches thick (for instance, 2" x 12" planks). Tongue-and-groove lumber may be used to provide a better fit between adjacent planks. Any type of material may be used to fabricate the logs provided that: (1) it can be easily transported and installed; (2) the logs fit together to form a watertight seal; and, (3) the resulting plank wall and supporting framework are strong enough to withstand flood-induced loading.

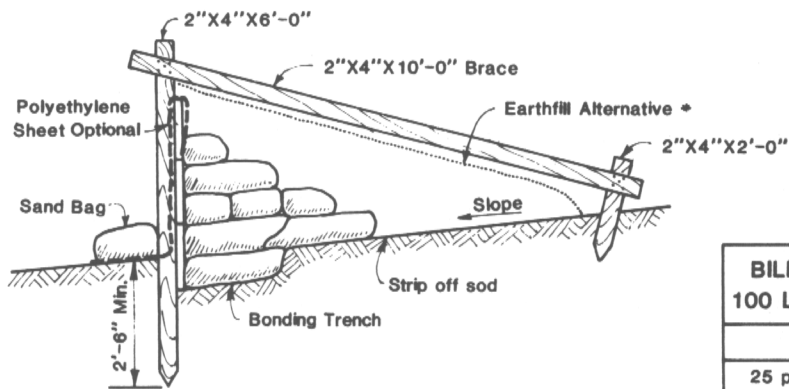

† Earth fill may be substituted for bags in times of emergency.

SECTION

BILL OF MATERIAL FOR 100 LINEAR FEET OF WALL	
LUMBER	
25 pieces	1" X 12" X 12'
17 pieces	2" X 4" X 10'
17 pieces	2" X 4" X 6'
17 pieces	2" X 4" X 2'
† (Sharpened)	
NAILS	
1 lb.	8d nails
2 lbs.	16d nails
SANDBAGS	
1100 bags	

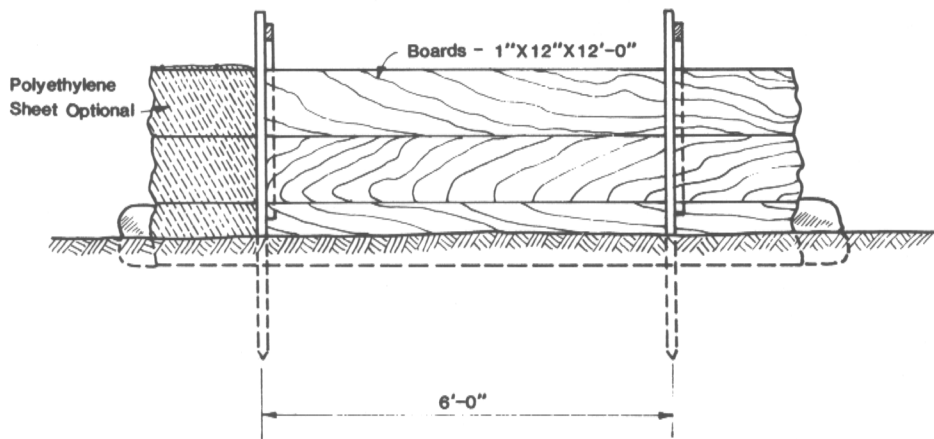

RIVERSIDE ELEVATION

Figure IV-4. Earth and Timber Retaining Wall

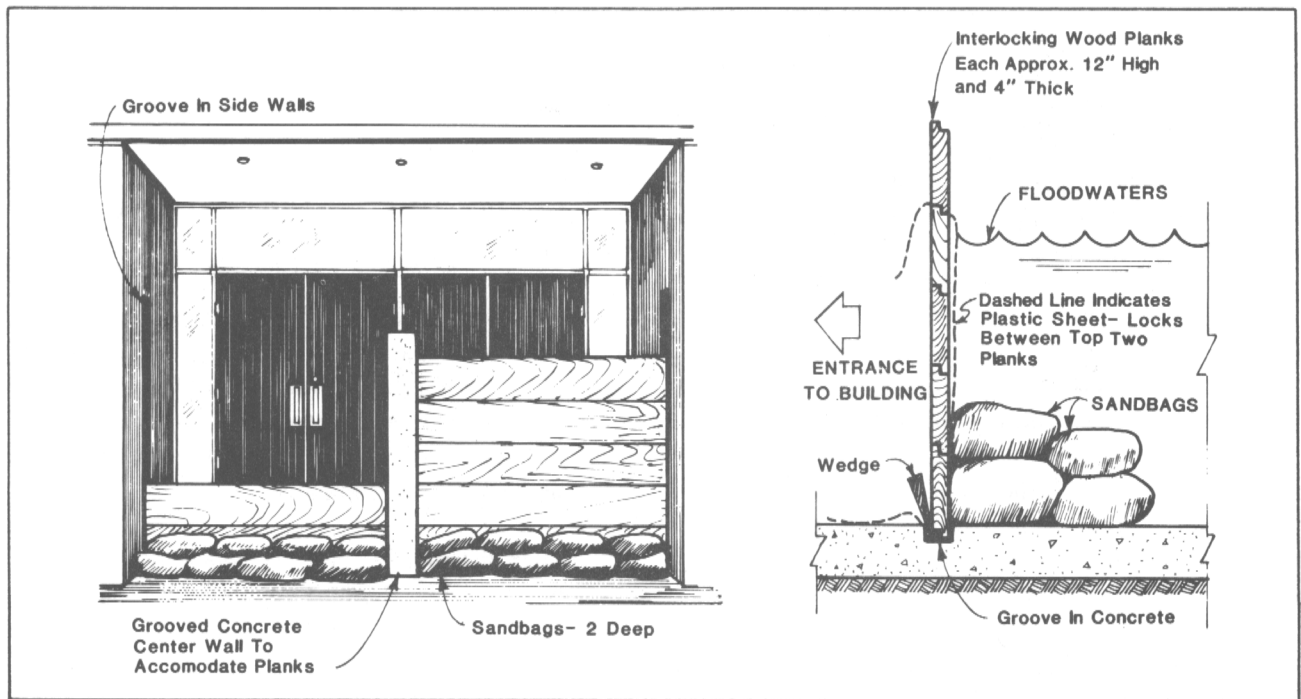

Figure IV-5. Typical Stop Log Barrier

Numerous methods may be used in conjunction with this type of barrier to reduce leakage. For example, polyethylene plastic sheets may be used as illustrated in Figure IV-5. The plastic is placed beneath the first plank and is held at the top by the top plank. For relatively heavy logs, the weight of the barrier may provide a suitable seal if a rubber gasket is placed under the bottom log or plank. It is recommended that a double layer of sandbags be placed at the base of the wall to help reduce seepage. As floodwaters rise, the resulting hydrostatic pressure will provide a reasonably watertight seal at the end of each log if the receiving slot is designed to include an appropriate sealing gasket. Swelling of the planks will tighten the seal. Because this type of flood barrier cannot generally provide a completely watertight seal, a permanent or portable pump should be available to discharge any leakage. Stop log barriers should be tested immediately when constructed to ensure that they are capable of providing an acceptable level of protection. General testing procedures are similar to those discussed in Chapter III for temporary flood shields.

C. FLOODPROOFING UTILITIES

Most of this manual is devoted to techniques that can be used to protect non-residential structures from flood damage. This section provides information concerning floodproofing of utilities that service the structure.

Elevation is the most effective way to prevent flood damage to exterior utilities. All incoming electrical power lines, transformers, and panels should be located at least one foot above the Design Flood elevation. Fuel tanks should also be elevated above the Design Flood level and be anchored (recommended safety factor of 1.5) to prevent flotation and associated damage. In addition, all fuel lines exposed to flooding should be equipped with automatic shut-off valves in case lines are broken.

Exhaust fans and louver outlets below the Design Flood level should be protected by flood shields (Figure IV-6) or enclosures or relocated above flood levels. At many non-residential facilities, utilities are located in a separate room or building adjacent to or near the main building. This utility room may be elevated, or constructed or modified to be watertight. Where flooding of a basement or utility room may occur (or is required for the safety of the structure), utility units may be protected and fuel tanks anchored.

Because sewer lines in most areas are highly susceptible to infiltration, they often become saturated during flooding events. In such cases floodwater may enter a facility through the sewer system and create internal flooding that is near or equal to exterior flood levels. To prevent this, backflow prevention valves should be placed on the building's sewer lines.

There are several alternatives for locating backflow devices. A main valve may be located where the sewer is strong enough to resist the flood-induced pressures and where all possible reverse flows can be stopped (Locations 'A' and 'B' in Figure IV-7). The valve should be selected to accommodate grit and other materials that could lodge in it. For pipe of

sufficient strength, separate valves may be installed on all basement fixtures and floor drains (Figure IV-7). Inflatable rubber plugs or mechanically expandable rubber plugs can also be used. Low pressure valves (20 pounds per square inch or less) may be installed in drain lines of fixtures that are below Design Flood levels. Sump pumps to handle any leakage should be provided. Alternative valve systems are shown in Figure IV-9.

Figure IV-8 presents another alternative for controlling sewer backup. All drainage and seepage is directed to a sump pump. The pump lifts drainage to an elevation above the Design Flood. By thus eliminating all gravity sewer drains, the problem of flooding backflow is eliminated.

Water distribution lines are usually not contaminated when flooding occurs unless the water plant itself is flooded. However, for those sites where wells are used for potable water, precautions should be taken to prevent contamination. The well should be equipped with a watertight casing that extends from one foot above the ground surface to at least 25 feet below the ground surface. Backflow prevention valves should be placed on the primary water service line at the well, and where it enters the building to prevent backflow of floodwater in case of a line break.

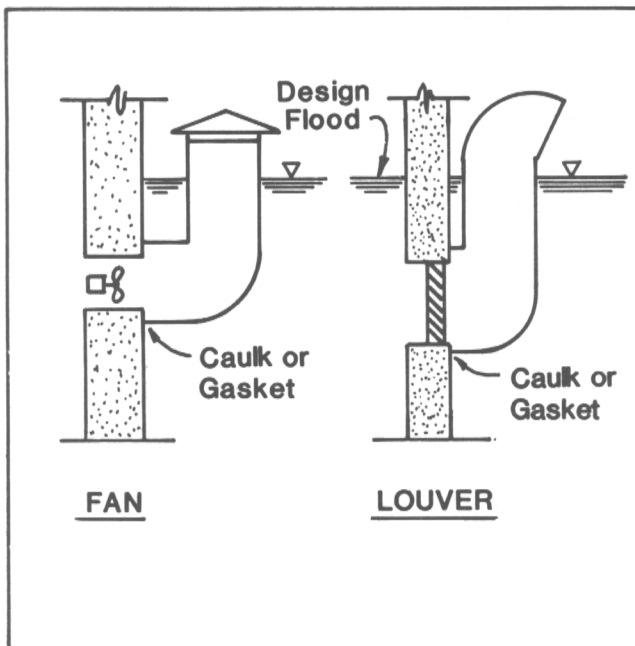

Figure IV-6. Floodshield for Exterior Openings

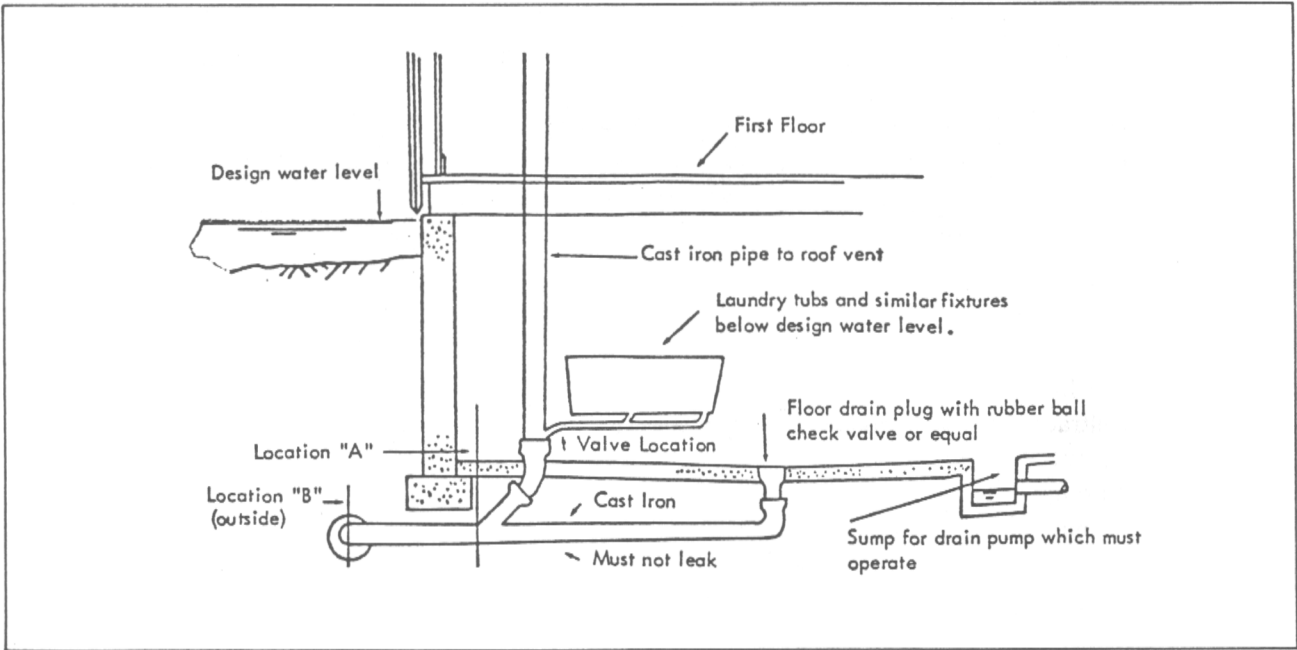

Figure IV-7. Alternative Locations for Cutoff Valves on Sewer Lines

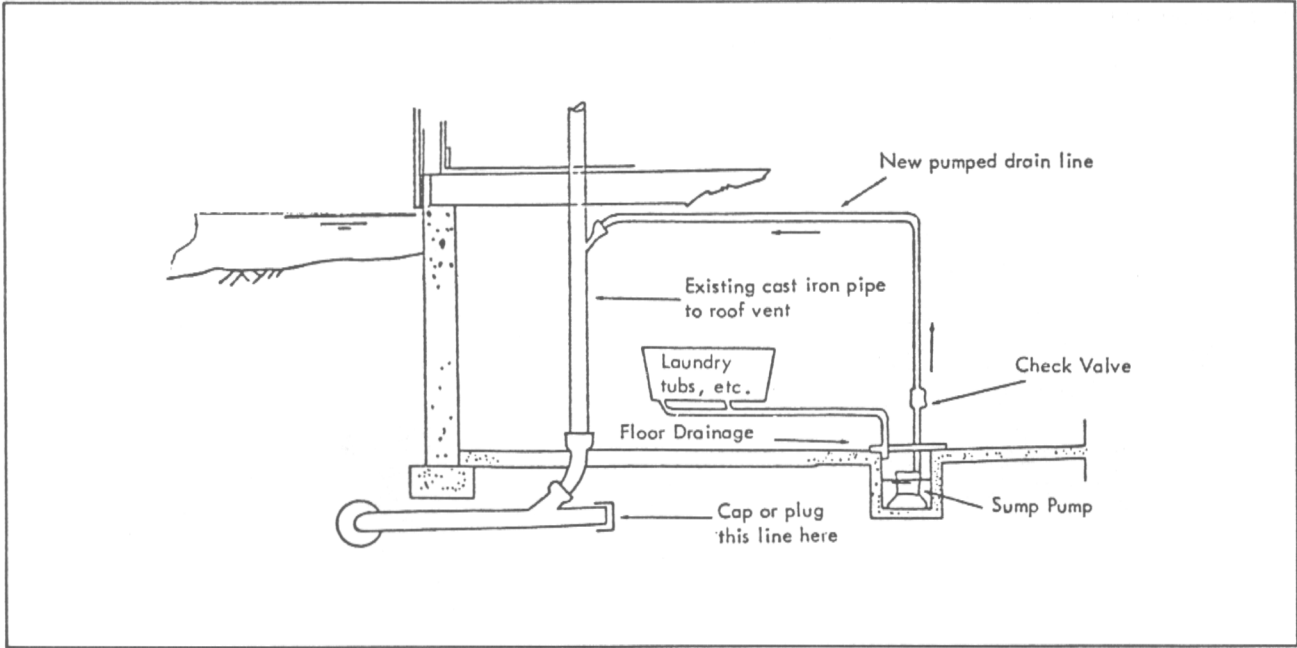
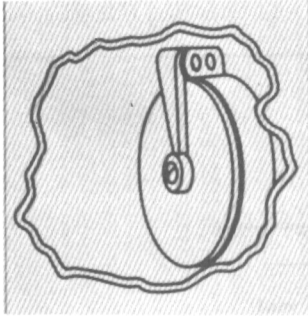
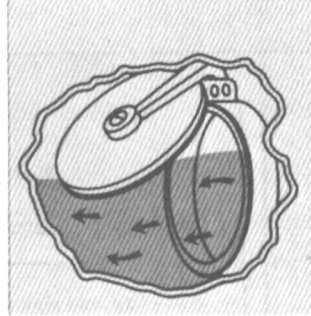

Figure IV-8. Elimination of Gravity Flow Basement Drains



Normal Position
Closed with No Flow



Flow Position
Variable Depending on
Discharge Flow

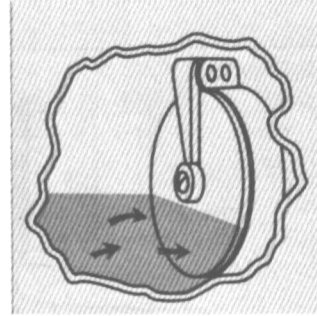

Backflow Position
Instant Closing with Backflow

OPERATION OF SWING-CHECK BACKWATER VALVE

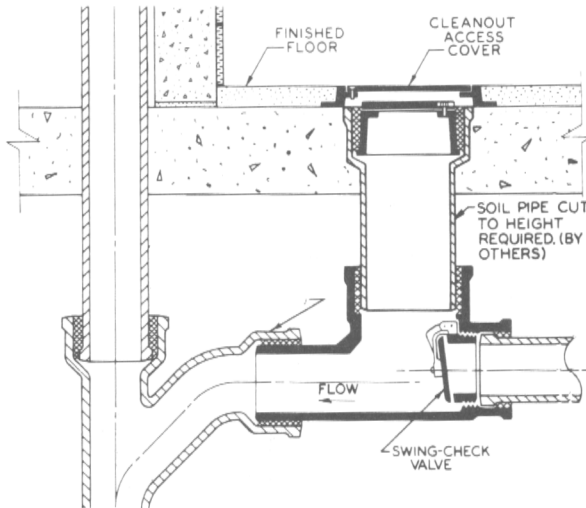

TYPICAL INSTALLATION OF SWING-CHECK VALVE

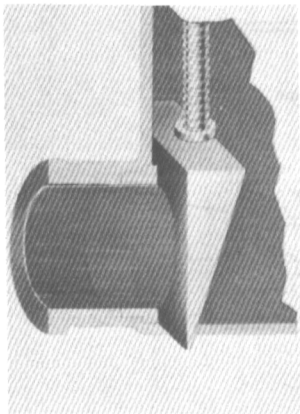

SHEAR-GATE VALVE

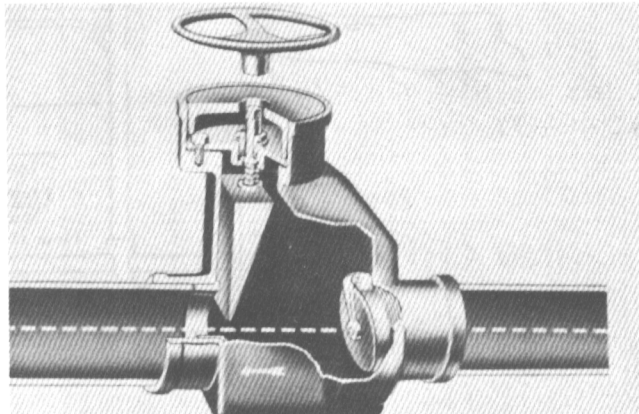

**TYPICAL INSTALLATION OF SHEAR-GATE
AND SWING-CHECK VALVE**

Figure IV-9. Sewage Backflow Prevention Devices

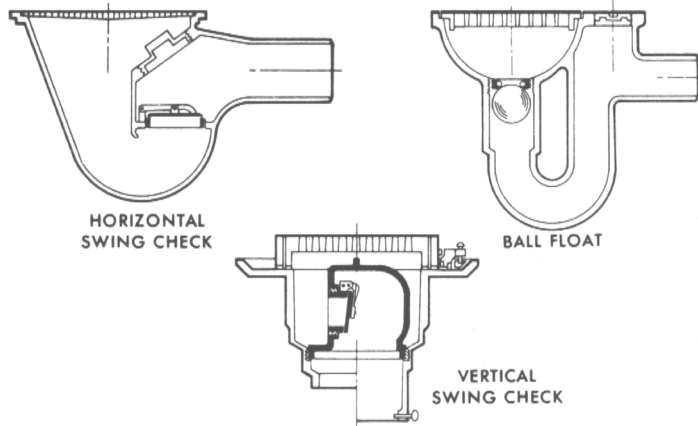

VARIOUS EXAMPLES OF BACKWATER VALVES

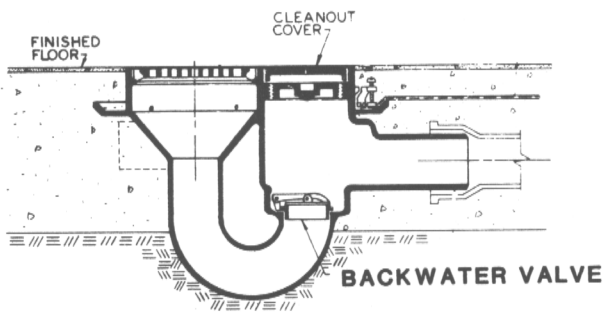

FLOOR DRAIN WITH INTEGRAL BACKWATER VALVE

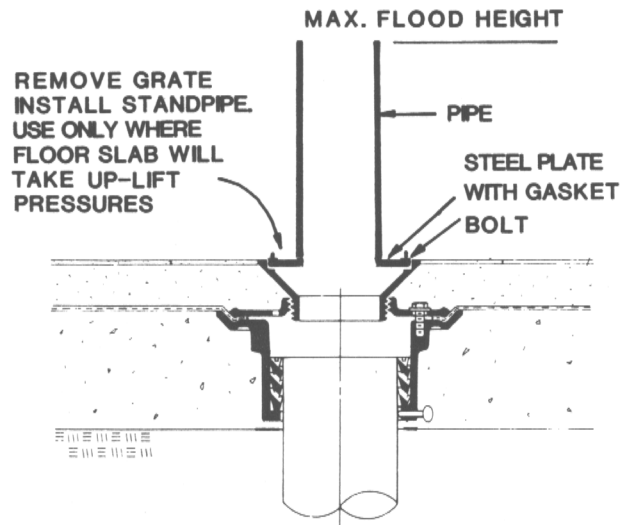

EXISTING BASEMENT DRAIN FLOOD-PROOFING

Figure IV-9. Sewage Backflow Prevention Devices (continued).

Heating or air conditioning units, or similar facilities that are located outside the structure, must also be floodproofed. Elevating the equipment is preferred, but if this is not feasible, a watertight closure system should be provided (see Figure IV-10). It is especially desirable to prevent air conditioning units from being damaged, because they can be used as dehumidifiers after the flood.

To complete the utility system floodproofing process, all openings below the Design Flood elevation where pipes, conduits, vents, or other fixtures pass through a floor or exterior wall must be sealed to prevent leakage. Penetrations can be pressure sealed in several ways: gel-like expansive sealants, elastomeric seals, molded sleeves, and neoprene seals. Figure IV-11 illustrates the use of a waterproof sleeve.

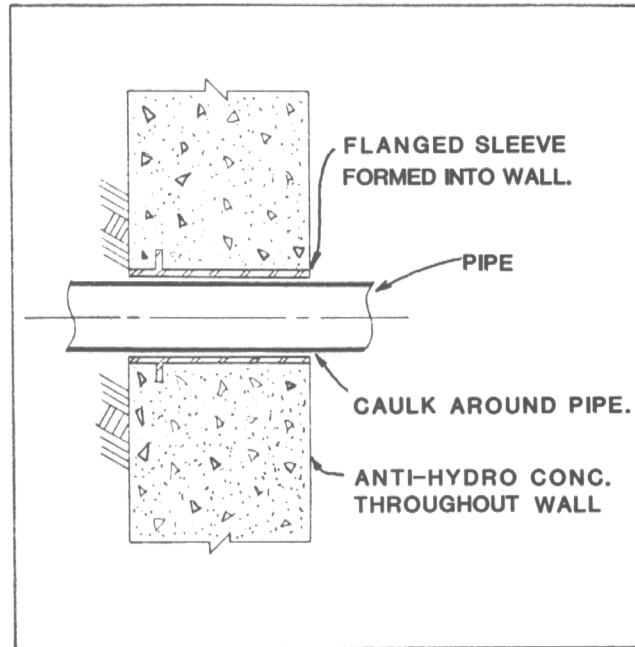

Figure IV-11. Waterproof Sleeve for Pipe Penetrations

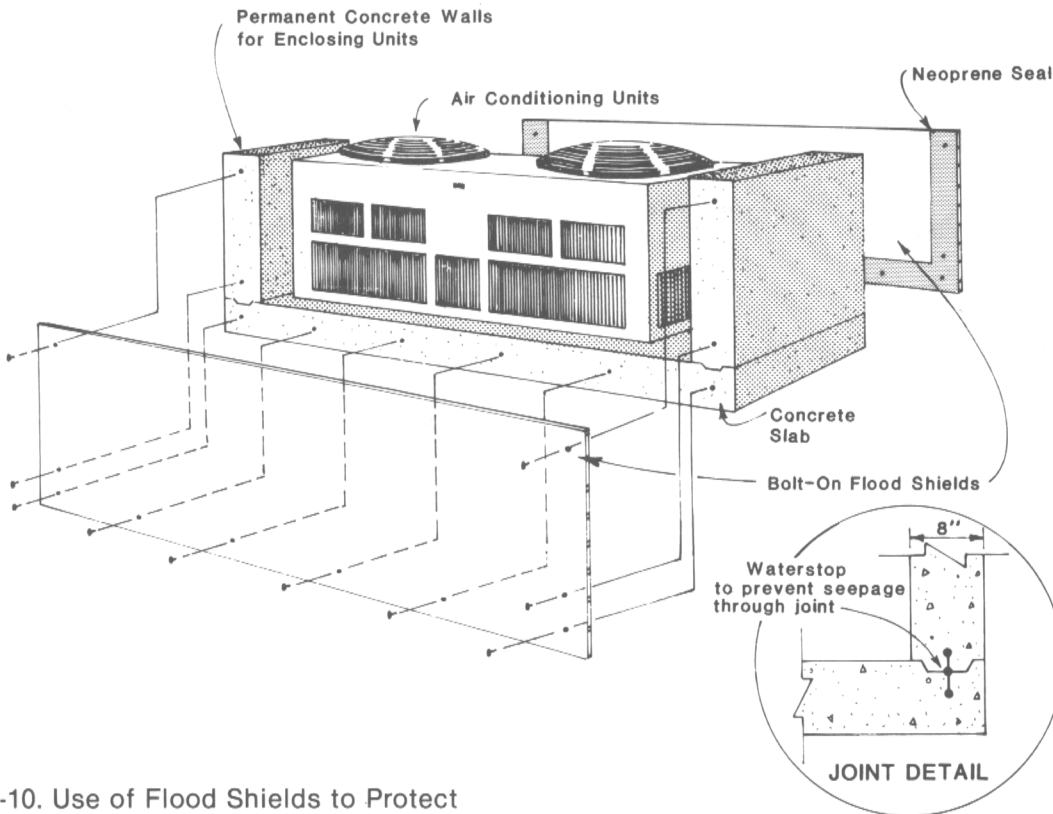

Figure IV-10. Use of Flood Shields to Protect Major Utility System Components

D. WET FLOODPROOFING TECHNIQUES

A properly designed and implemented floodproofing plan can virtually eliminate flood damage. A floodproofing plan may fail, however, for several reasons. Flood conditions may be more severe than planned for in the Design Flood. A flood may exceed the design level of floodproofing due to storm events greater than those associated with the Design Flood, or flood elevations may be raised above the Design Flood level by a stream or river that becomes blocked by debris or by man-made obstructions. Accidental damage to the structure or a critical component of the floodproofing system may occur. For example, floating debris may impose sufficient impact loads to bend a flood shield or crack a wall and allow water to enter the facility.

Failure may also occur if the plan is improperly implemented (i.e., if all floodproofing components are not properly installed). This could result from human error in evaluating flood conditions, from equipment failure or from lack of preparedness planning and training.

Finally, failure may occur due to a faulty floodproofing design. Examples of improper design decisions include the use of incorrect depth and velocity data, incorrect analysis of stability or strength, or failure to recognize and protect all openings below the flood level. As stated in Chapter 1, the scope of this manual is specifically limited to 'dry' floodproofing techniques. However, given the possibility of failure, some consideration must be given to damage reduction measures that can be used when water enters a structure. These measures are generally referred to as 'wet floodproofing'. In some instances, wet floodproofing may offer the only feasible alternative for dealing with flooding at existing structures. Wet floodproofing techniques are briefly discussed below. Additional wet floodproofing techniques are described in other sources (see Appendix A).

Utilities must be protected from interior flooding. All interior electrical lines and panels should be elevated above the Design Flood level. Electrical systems should be 'zoned', allowing selective cutoff.

Switches must be located in an area that will be accessible during a flood. Gas lines should be equipped with automatic shut-off valves to prevent leakage and resulting fire or explosion in case a line should break. The gas lines should be installed to allow positive drainage of water that may enter the system to an appropriate number of drainage plugs. Positive drainage to appropriate release points should also be provided for any ductwork that is below the Design Flood level. All heating, ventilating, and air conditioning equipment should be elevated above the Design Flood elevation; or, critical equipment may be enclosed in a watertight core as discussed in Chapter III.

In addition to actions that can be taken to protect the interior utilities, there are several measures that can be used to reduce damages throughout the facility. These techniques include the use of waterproof paints, finishes, flooring materials, and cabinetry. All critical records, files, documents, and computer facilities should be sited at a location that is well above the Design Flood elevation. To remove water from the building as quickly as possible after a flood, all floors should have a positive slope to a sump that can be used to pump water out of the structure as floodwaters begin to recede. However, to avoid damage to the structure, interior and exterior water levels should be kept approximately equal at all times.

A small percentage of equipment or stock may constitute a major portion of the flood damage that could occur. In this case, evacuation of this critical property would represent an important feature in reducing the risk of flood damage. If heavy equipment is to be removed, overhead hoists may be required to elevate the equipment above the floodwaters or to remove the equipment from the structure. For sites where smaller equipment or stock is to be removed, or where a hoist cannot be provided, aisles should be designed to accommodate fork lifts or similar transport equipment. The material to be evacuated should be on pallets or should be equipped with lifting eyes or bars. To facilitate the removal of manufacturing equipment, all electric lines, oil lines, etc. should be provided with quick disconnects. A safe, reliable form of transportation

must be provided between the floodproofed structure and a storage location well above the Design Flood elevation. Comprehensive guidance concerning wet floodproofing can be obtained from the Federal Emergency Management Agency's Technical Standards Bulletin 85-1, *Wet Floodproofing*.

E. COMBINATION OF FLOODPROOFING TECHNIQUES

A single floodproofing technique may be of limited effectiveness. However, when the techniques described in this chapter and Chapters III are combined to meet the requirements of a particular structure, they may lead to significant hazard reduction. Figure IV-12 shows how a variety of techniques may be applied to a single industrial structure.

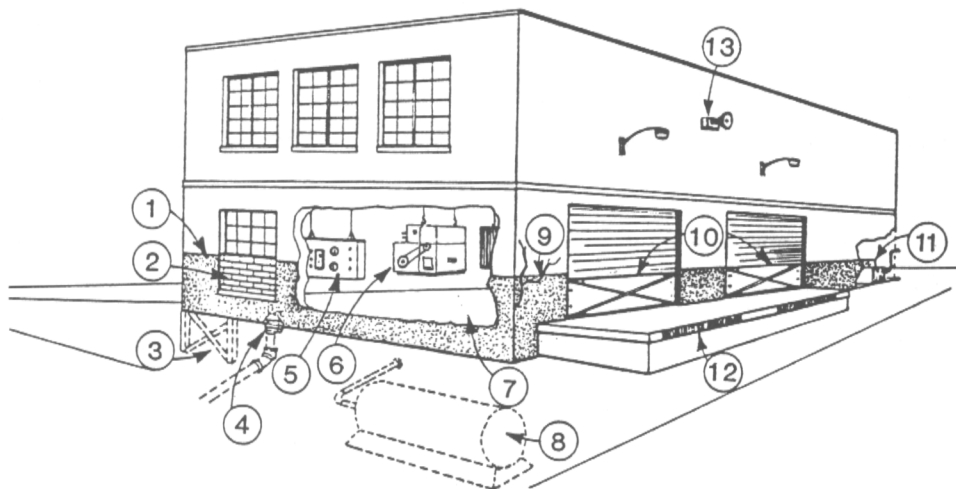

1. Waterproof coating to reduce seepage
2. Permanent closure of opening with masonry
3. Underpinning of structure to resist hydrostatic pressure
4. Valve on sewer line to prevent backflow
5. Instrument panel raised above expected flood level
6. Major equipment installed with quick-disconnects and elevated above flood level with overhead hoist
7. Floor has been reinforced to withstand uplift pressure
8. Underground storage tank properly anchored
9. Cracks sealed with hydraulic cement
10. Steel bulkheads for doorways
11. Sump pump and drain to eject seepage
12. Rescheduling has emptied the loading dock
13. Audible alarm installed as part of area-wide flood warning system

Figure IV-12. Combination of Floodproofing Techniques as Applied to Typical Industrial Structure

Adopted From: Introduction to Floodproofing by John Sheaffer, The Center for Urban Studies, 1967, University of Chicago