

Donald R. Drimer
EBJ3

FINAL REPORT

NASA-CR-179012

CORNEA OPTICAL TOPOGRAPHICAL SCAN SYSTEM (COTSS)

CONTRACT -- NAS8-34659

THIS REPORT WAS PREPARED

FOR

THE TECHNOLOGY UTILIZATION OFFICE
ATO1

SUBMITTED TO:

NATIONAL AERONAUTICS AND SPACE ADMINISTRATION
MARSHALL SPACE FLIGHT CENTER
MARSHALL SPACE FLIGHT CENTER, AL 35812

SUBMITTED BY:

ELECTRO-OPTICS CONSULTANTS, INC.
2512 GARTH ROAD
HUNTSVILLE, AL 35801

11 AUGUST 1986

N87-24184

Unclas
0079449

G3/74

(NASA-CR-179012) CORNEA OPTICAL
TOPOGRAPHICAL SCAN SYSTEM (COTSS) Final
Report (Electro-Optics Consultants) 39 p
Avail: NIS LC AC3/MF AC1 CSCL 20F

FINAL REPORT

**CORNEA OPTICAL TOPOGRAPHICAL
SCAN SYSTEM (COTSS)**

CONTRACT -- NAS8-34659

THIS REPORT WAS PREPARED

FOR

THE TECHNOLOGY UTILIZATION OFFICE
AT01

SUBMITTED TO:

NATIONAL AERONAUTICS AND SPACE ADMINISTRATION
MARSHALL SPACE FLIGHT CENTER
MARSHALL SPACE FLIGHT CENTER, AL 35812

SUBMITTED BY:

***ELECTRO-OPTICS CONSULTANTS, INC.
2512 GARTH ROAD
HUNTSVILLE, AL 35801***

11 AUGUST 1986

ABSTRACT

The Cornea Optical Topographical Scan System is an instrument designed for use by ophthalmologist to aid in performing surgical procedures such as radial keratotomy and to provide quick accurate data to aid in prescribing contact lens and eyeglasses. The Cornea Optical Topographical Scan System (COTSS) program was awarded to Electro-Optics Consultants (EOC) in October of 1983. A breadboard of the system was built and demonstrated in June of 1984. Additional refinements to the breadboard are needed to meet system requirements prior to proceeding with prototype development. This report gives the present status of the COTSS instrument and defines the areas in which system refinements are required.

TABLE OF CONTENTS

TITLE	PAGE
ABSTRACT	i
LIST OF FIGURES	iv
BACKGROUND	1
INTRODUCTION	1
OBJECTIVES AND REQUIREMENTS	1
PROGRAM HISTORY	3
COTSS FUNCTIONAL DESCRIPTION	4
COTSS OPERATIONAL PRINCIPAL	4
OPTICS	7
ELECTRONICS AND COMPUTER	7
DEMONSTRATION BREADBOARD DESCRIPTION	10
COLLECTING OPTICS	10
SCANNING	10
SIGNAL-TO-NOISE	10
INITIAL BREADBOARD IMPROVEMENTS	11
RESULTS AND RECOMMENDATIONS	12
ALIGNMENT SENSITIVITY	12
ANALOG SIGNAL PROCESSING	13
ELECTRONICALLY CONTROLLED MIRROR	13
DATA ACQUISITION	14
DATA COLLECTED	14
SYSTEM STUDIES	16
COLLECTING OPTICS DESIGN AND SENSIVITY ANALYSIS	16

BEAM ALIGNMENT	21
BEAM STEERING	24
TWO DIMENSIONAL SCANNER	26
CONCLUSIONS	29
APPENDIX A	30
RAY TRACE ANALYSIS	30

LISTS OF FIGURES

FIGURE NO.	TITLE	PAGE
1	COTSS OBJECTIVE & REQUIREMENTS	2
2	OPTICS PHOTO	5
3	COMPUTER PHOTO	5
4	COTSS SYSTEM DESCRIPTION	6
5	COTSS BREADBOARD OPTICS	8
6	COTSS BREADBOARD ELECTRONICS AND COMPUTER	9
7	SPATIAL DATA FROM SCANNING TEST LENS SURFACE	15
8	COTSS COLLECTOR LENS	18
9	SENSITIVITY ANALYSIS RESULTS	20
10	TABLE 1 & TABLE 2	23
11	QUAD DETECTOR FOR BEAM STEERING	25
12	BEAM STEERING SYSTEM	25
13	DUAL GALVO SCANNER	27
14	COTSS BREADBOARD	28

BACKGROUND

INTRODUCTION

New surgical techniques for the treatment of human eye cornea disorders depends on accurate measurements of the shape of the outer surface of the cornea. Radial keratotomy in which 8 to 16 radial cuts are made in the outer layer of the cornea to cause the surface to flatten and reduce myopia is an example. A very accurate mapping of the cornea is needed to establish the pattern of the cuts and to determine if the cornea is healing properly. In cornea transplants, the surgeon needs to have a quick measurement system to determine if the sutures are uniformly stretching the new cornea. Damage from trauma such as cuts, burns, and punctures also require quick diagnosis and an accurate measurement of the extent of damage to the eye. The fitting of contact lenses can also benefit from faster measurement techniques with greater accuracy. Instruments now in use by Ophthalmic surgeons will not provide the required accuracy or the high speed. Thus a need exists for an instrument that can provide the required accuracy and rapid display of the information thru real time data collection and data processing.

A breadboard of such an instrument has been developed and demonstrated. All technical requirements have not been met at this point. The following is a review of the development of the breadboard instrument and of its status.

OBJECTIVES AND REQUIREMENTS

The objective of the COTSS program is to demonstrate that an instrument with the capabilities described above can be built to meet the requirements of the medical community and still be practical for low cost, mass production. The more succinct technical requirements of the instrument are given in Figure 1. Also as indicated in Figure 1, it is planned to market the instrument for under \$30,000.

FIGURE 1

COTSS OBJECTIVE & REQUIREMENTS

ELECTRO-OPTICS CONSULTANTS

OBJECTIVE

- TO DEVELOP AN INSTRUMENT FOR RAPID ACCURATE MAPPING OF THE CORNEA SURFACE THAT CAN BE MARKETED FOR UNDER \$30,000.

INSTRUMENT REQUIREMENTS

- SCAN AREA - 12MM X 12MM
- DISPLACEMENT RESOLUTION - 100 MICRONS
- HEIGHT RESOLUTION - 1 MICRON
- SCAN TIME - 1 SECOND
- DISPLAY - CRT IN VARIABLE FORMAT

PROGRAM HISTORY

Electro-Optics Consultants was awarded a contract in October of 1983 to build and demonstrate a breadboard for the Cornea Optical Topographical Scan System (COTSS). A final design of the COTSS was agreed upon by NASA and EOC in November 1983. By March of 1984 the breadboard components had been procured and assembled. By June 1984 the breadboard had been "debugged" and system control software written for the computer. The breadboard was demonstrated at this time and the initial contract funding period ended. At this time the breadboard was not able to demonstrate that the system could meet all of the original technical requirements. During the latter part of 1984 and several months of 1985 EOC performed paper studies of the system, resulting in recommendations for improvements and modifications that will be required for the breadboard to meet the original technical requirements. Funds have not been available for continuation of the project since fall of 1985.

COTSS FUNCTIONAL DESCRIPTION

COTSS OPERATION PRINCIPAL

The COTSS instrument consists of three primary components: (1) an optics package containing a HeNe laser, modulator, scanner, lenses, mirrors, detectors, etc. (See Figure 2), (2) an electronics package that interfaces the optics package to the computer system, and (3) the computer system (See Figure 3) which controls the optics, acquires the data from the electronics, analyzes the data and displays it in a user oriented format. The interrelation of these components is shown schematically in Figure 4.

The instrument in its final configuration will contain the same components. The optics will be packaged into the portion of the instrument that is placed in front of the eye to be measured. The operator will give the instrument the command to collect and display data. The data collection time will be very short -- on the order of 1 second or less. Within a few seconds the topographical information will be displayed on the CRT. At this point it is envisioned and the operator can choose several options, e.g.

- Rotate the surface to view the topography from any angle desired
- Compute cornea contours and aid in prescribing eyeglasses or contact lens and give an estimate of the degree of correction these perscriptions will provide.
- Potentially provide data that can be used to determine *a priori* the results of a proposed surgical procedure as it relates to topography change and in turn to vision changes.

The system will have a special purpose computer with simplified controls to allow calibration, operation, etc. by a technician with minimum training.

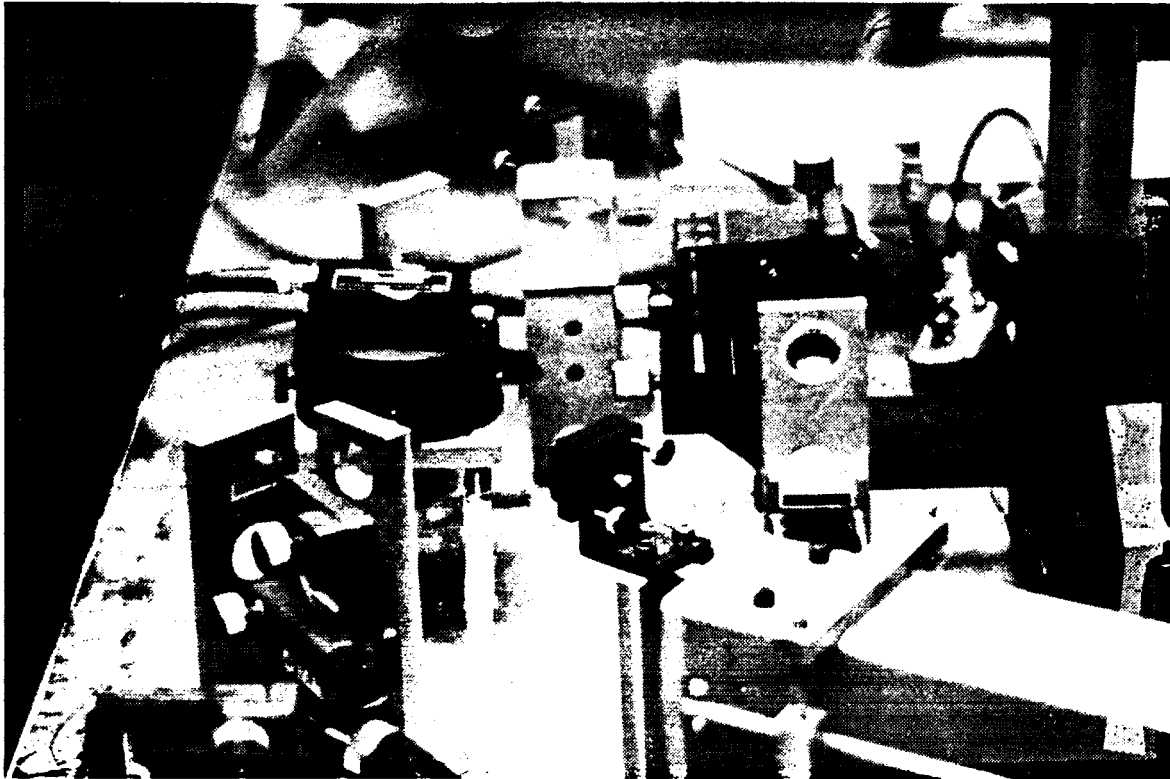

FIGURE 2: OPTICS PHOTO

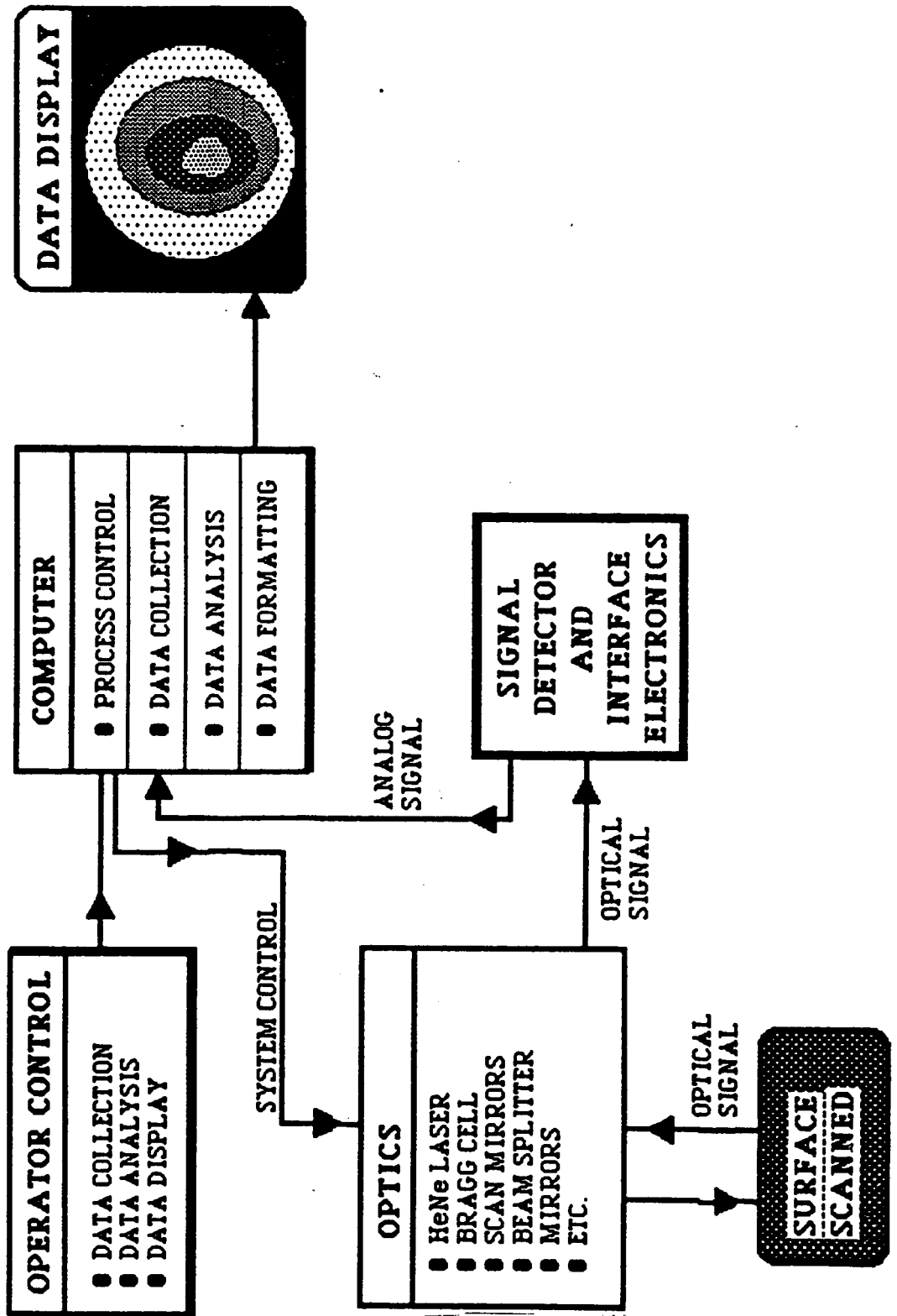

FIGURE 3: COMPUTER PHOTO

FIGURE 4

COTSS SYSTEM DESCRIPTION

ELECTRO-OPTICS CONSULTANTS



OPTICS

The optical system for COTSS is a real time phase interferometer (RTPI) concept (See Figure 5). A helium neon laser beam is split into an adjustable path reference beam and a measurement beam. The 40 MHz bragg cell modulation in the measurement beam provides a reference to determine slope change on the cornea. The beam is scanned across the cornea using a fast lens that matches the radius of curvature of the cornea surface. The two beams are recombined on the detector to provide data on the optical phase variation of the eye surface. Most RTPI systems are used to measure fractions of a wavelength. This system uses the doppler frequency shift to obtain a larger range and still provide resolution on the order of 1 micron.

ELECTRONICS AND COMPUTER

A Motorola 68000 based microprocessor system is used to control the hardware and record the cornea surface data (See Figure 6). A Bulova scan mirror system provides a reference to the computer to obtain the spot location on the eye. The signal from the photodetector is amplified and limited to reduce amplitude variations. A phase lock loop provides the doppler frequency to the computer which intergrates the signal to obtain the surface heights. The spatial data is displayed as contour plots.

FIGURE 5

COTSS BREADBOARD OPTICS

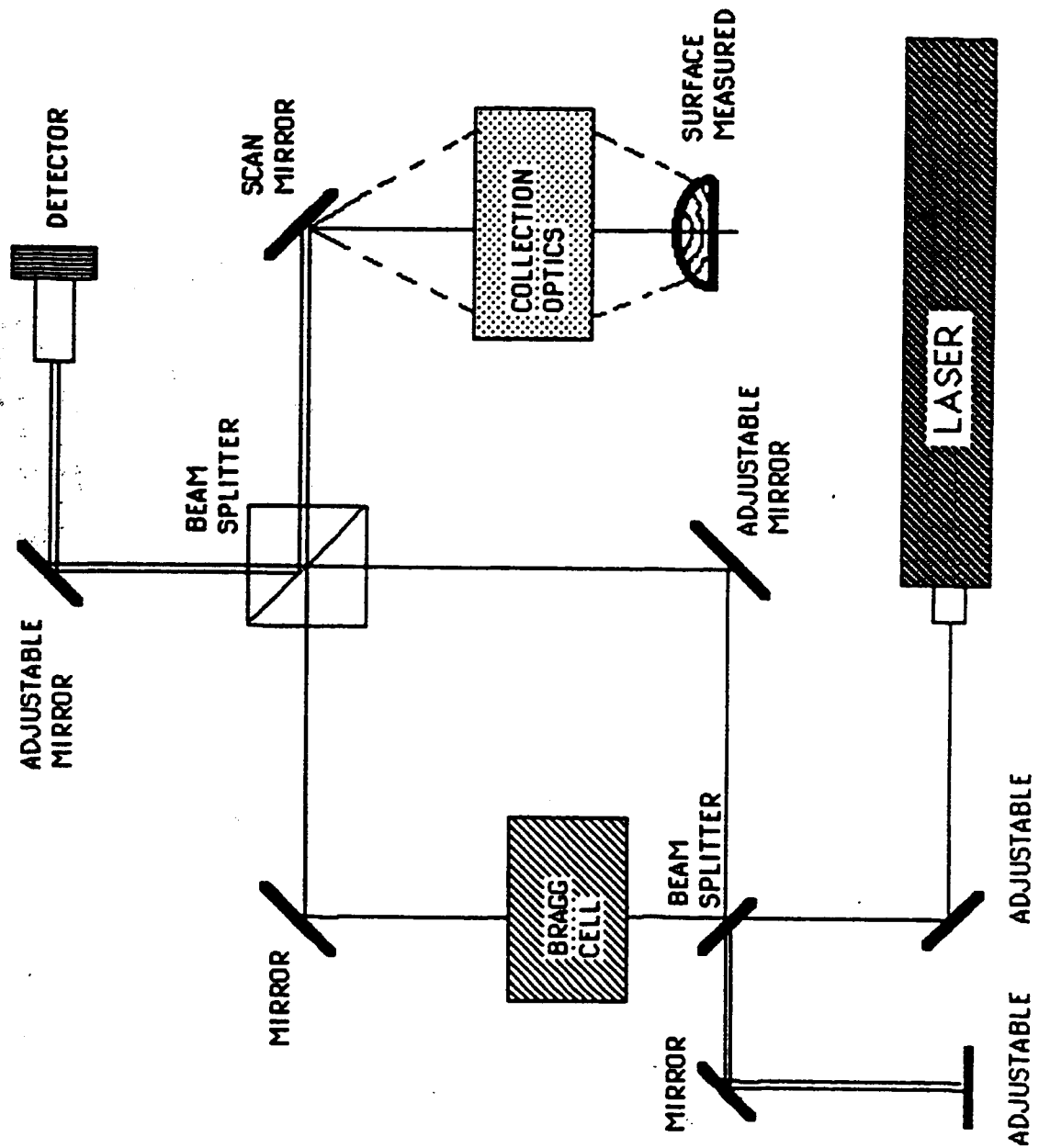
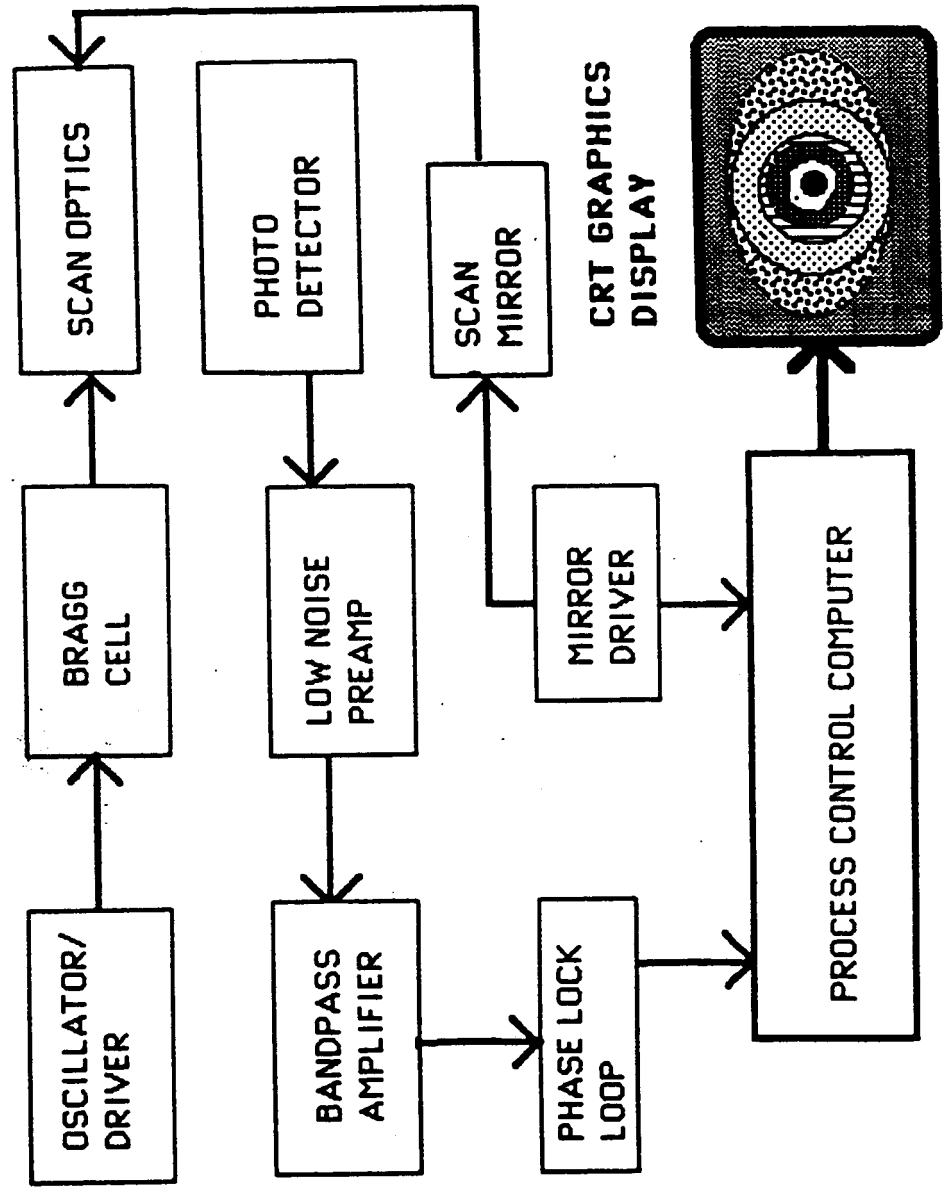

FIGURE 6

COTSS BREADBOARD ELECTRONICS AND COMPUTER



DEMONSTRATION BREADBOARD DESCRIPTION

Upon initial assembly and checkout of the breadboard, a series of problem areas were discovered. The following is a description of the problem areas followed by the steps that were taken to correct the problems prior to demonstrating the COTSS breadboard.

COLLECTING OPTICS

Early in the program it was recognized that collection of light reflected from the cornea would present some design problems because of the wide angle over which the light is reflected. In the time available a collection optic system was designed using graphic and simple analytic ray trace techniques. It was determined after experimentation that the collection optics design was not adequate to maintain reflected beam alignment

SCANNING

Scanning of the cornea was to be accomplished by the combination of a resonant mirror and image rotator. The image rotator mechanism could not maintain alignment of the beam reflected from the simulated cornea to the accuracy required. Thus it was not possible to do two axis scanning with the mechanism as initially configured because of signal drop out.

SIGNAL-TO-NOISE

Experimentation revealed that the signal to noise ratio of the hetrodyne beat signal was marginal and this problem combined with misalignments of the return beam caused appreciable drop in the signal amplitude and thus limited the accuracy of the instrument.

INITIAL BREADBOARD IMPROVEMENTS

At the time the above problems were identified funds were not available for new parts. Thus breadboard modifications were implemented using NASA in house parts. The breadboard modifications implemented were: use of a lower noise preamp for the heterodyne detector, use of a bandpass amplifier for further signal to noise ratio improvement and incorporation of a phase lock loop detector for improved detection threshold. The phase lock loop output voltage was digitized by an A/D Converter board in the process control computer. Beam position data (position on optic surface) were derived from digitizing the drive voltage to the scanning mirror. A standard camera lens was used for the collection optics for use with the simple lens being measured. The optical paths were reconfigured to improve the alignment of the return beam with the reference beam.

With the improved breadboard a one dimensional scan of a lens with less curvature than the cornea was performed to demonstrate fundamental data collection and processing.

RESULTS AND RECOMMENDATIONS

ALIGNMENT SENSITIVITY

Successfully collecting data with the COTSS system is dependent on proper optical alignment. The current optics layout is shown in figure 5. The lens used to simulate the cornea (test lens) is a simple biconvex of 2" focal length. The front surface of this lens is measured by COTSS along a line of approximately 1/4" in length across the front surface. This approximates measurement of the cornea surface. The camera lens serving as the collecting optic is positioned so that the center of curvature of the front surface and a point on the scan mirror along its axis of rotation are conjugates. These conditions ensure that the reflection from the surface will return along the path of the incident beam and produce a stationary spot on the detector. Deviations from this condition cause the spot to move across the face of the detector. This condition is also required for maintaining a nearly colinear path for the return beam and the reference beam. This is necessary for obtaining a strong beat signal from the heterodyne process. (The signal to noise ratio is approximately 20 to 1 at best alignment.) If the test lens is moved from the position of best alignment, the signal to noise ratio drops over portions of the scan. This is caused by misalignment of the return beam with the reference as well as by the spot moving off the active area of the diode. The test lens can be moved about 1/32" to the side of center before the signal drops below threshold. It can be moved about 1/8" along the optical axis without decreasing the signal to noise before the signal drops below threshold.

The cornea is an aspherical surface, therefore there will be some misalignment of the return beam. The misalignment due to the aspherical surface have an effect similar to translating the test lens as mentioned above. It should be possible to compensate for most of this misalignment by using a new collection lens design. There will be small perturbations that remain as a result of individual cornea curvature differences but these should remain small enough to allow proper operation of the instrument.

With the present knowledge of the alignment sensitivities discussed above, it appears that a new collection lens design is a key improvement to the COTSS instrument.

Additional techniques exist which can be implemented to allow the system to operate properly with larger misalignments. These are: improved analog signal processing, and the use of an electrically controlled mirror in the reference beam or return beam to maintain alignment during scan.

ANALOG SIGNAL PROCESSING

Analog signal processing can be used to improve the signal to noise ratio. This is accomplished by decreasing the bandwidth of the amplifier following the detector. The present amplifier has a much larger bandwidth than necessary. This is to accommodate the full range of frequencies produced by the doppler shift as the beam scans. The signal to noise can be improved by using a tunable narrow band filter which tracks the doppler frequency.

ELECTRONICALLY CONTROLLED MIRROR

The return beam can be held on the hetrodene detector by using a set of beam steering galvonometers inconjunction with a quad detector error sensor as shown in Figure 11 and 12. This is discussed in the section of Beam Steering.

DATA ACQUISITION

Another area that needed improvement is the data acquisition. The original technique used a phase comparator and counted cycles. The low signal to noise and signal dropout due to misalignment would not allow the counter technique to work. A phase lock loop technique was incorporated which provide a better resistant to signal dropout. The phase lock loop requires a high speed A/D to pass the information to the computer. The present A/D needs to be increased in rate to a 500 KHZ rate to meet the requirements of the phase lock loop technique. If the signal to noise is improved with the new optics and electronics the phase counting technique will be reinstated. If not a faster A/D will be incorporated.

DATA COLLECTED

Figure 7 is typical of the results obtained with the 1-D scan. The horizontal axis represents the scan across the test surface and the vertical axis represents the relative height of the test surface during the scan. The different curves were obtained by shifting the centerline of the test surface off the optical axis.

There is some lack of repeatability in the data. This results from dropouts of the phase lock loop at points of low signal to noise ratio. This has been reduced to some extent by careful alignment of the optical system. The sample rate of the A/D Converter is presently limiting the data to 12 samples per scan. This will be increased to 500 samples minimum per scan to allow for data smoothing to achieve 100 processed samples. A properly designed collection optics will improve the signal to noise ratio by improving beam alignment. These improvements coupled with improvement in the analog signal processing electronics will reduce the dropouts to a level required to achieve specified measurement accuracy.

ORIGINAL PAGE IS
OF POOR QUALITY

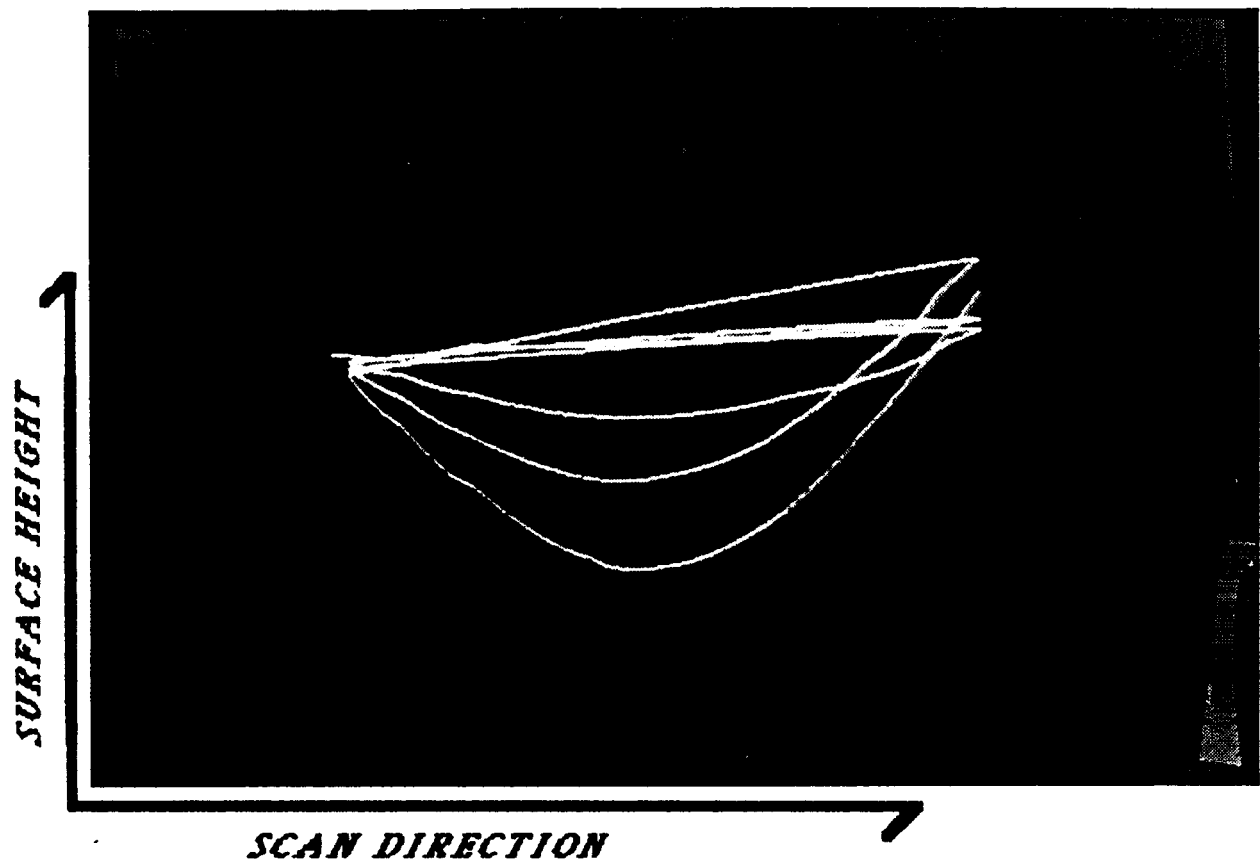

FIGURE 7: COTSS SPATIAL DATA FROM
SCANNING TEST LENS SURFACE

SYSTEM STUDIES

A number of areas have been discussed for improvement of the COTSS breadboard to get it to the point that it can meet the technical specifications spelled out previously. However, the following areas are considered to be the most crucial and cover most of the areas discussed previously.

- **Collecting Optics Design**
- **Beam Alignment**
- **Beam Steering**
- **Two Dimensional Scanning**

COLLECTING OPTICS DESIGN AND SENSITIVITY ANALYSIS

A small special purpose ray trace program was written. This program was written in a general manner in a three dimensional, right handed, rectangular coordinate system. (SEE APPENDIX FOR ANALYSIS) Rays are specified by a point and a direction vector. Optical surfaces are specified as a sphere of given radius and center. The program calculates the intersection point of the ray and spherical surface and then uses the law of refraction to determine the direction vector for the refracted ray. Management of the analysis is accomplished through use of Fortran subroutines called by a mainline program. The basic analysis is incorporated into "SUBROUTINE OPTIC". A second subroutine is written to accept the specifications for a lens element and use the analysis routine. This routine assumes the lens is located on and normal to the Z axis of the coordinate system. This subroutine is called "SUBROUTINE LENS". A third subroutine is written to find the minimum thickness of a lens from its height and two radius of curvature. This subroutine is called "SUBROUTINE THICK". The mainline program is written to prompt the user to enter the element number and parameters or analyze. The analysis traces 10 rays through the system and determines the point of intersection of each ray with the Z axis of the system.

The program accepts a distance in front of the lens from which all rays originate and generates 10 rays to cover the aperture of the first element. After tracing each ray through the lens system it prints the angle of each incident ray off the axis and the distance from the center of the last element to the intersection of the exit ray with the Z axis. The lens is evaluated in terms of longitudinal spherical aberration (L.S.A.) and angle error. The L. S. A. is expressed as a percentage variation of each ray focus from the first (low angle or paraxial) ray focus. The angle error is the angle that each ray makes with the normal to a sphere centered on the paraxial focus.

The lens design criteria for this application are: 1) the angle error must be as low as possible, 2) it must collect light over a very wide angle. The design approach was to cascade aplanats to produce a virtual image as far in front of the first element as possible and use this in conjunction with a focusing lens of very low L. S. A. The aplanats can be calculated theoretically and the virtual image can be moved to any distance required by adding more elements. The results obtained from the ray trace program indicate that the system becomes less tolerant to parameter variations as additional elements are added.

It was found that the most practical design consisted of 5 aplanats and a triplet focusing lens. Also it was possible to reduce the system aberration to below that of the triplet by changing the front elements slightly from true aplanats. The resulting 8 element lens system has a L. S. A. of less than .009% and an angle error of less than .004 degrees. The lens design is shown on the following page in Figure 8.

ORIGINAL PAGE IS
OF POOR QUALITY

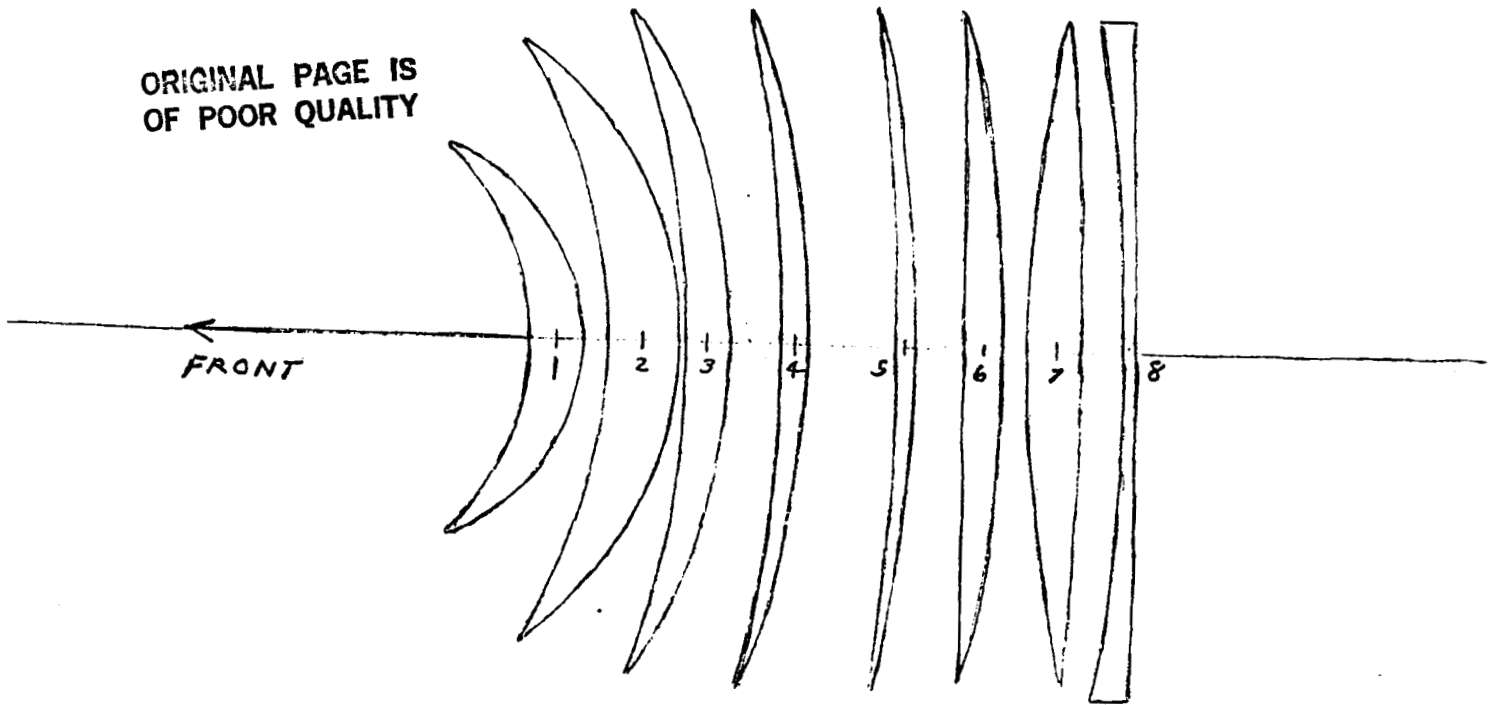

DIMENSIONS IN MM

ELEMENT NUMBER	DIAMETER	FRONT RADIUS	BACK RADIUS	THICKNESS	POSITION	REFRACTIVE INDEX
1	50.0	-38.8	27.0	7.7	0.00	1.52
2	80.0	-69.2	47.7	9.0	11.10	1.52
3	90.0	-126.0	78.0	6.0	20.15	1.52
4	90.0	-202.0	124.0	3.4	30.95	1.52
5	90.0	-323.0	196.0	2.1	45.00	1.52
6	90.0	-1040.0	198.0	6.2	55.00	1.62
7	90.0	280.0	407.0	6.1	65.00	1.52
8	90.0	-269.0	1200.0	2.0	75.00	1.62

FRONT FOCUS

40.0 mm

BACK FOCUS

492.2 mm

L. S. A.

0.2 mm

FIGURE 8: COTSS COLLECTOR LENS

To perform sensitivity analysis the program was modified by adding an option to trace the rays through the lens system and then back after reflection from a spherical surface. Two subroutines "OPTIC B" and "LENS B" were written to accomplish the reflection and retracing. When the retrace option is in effect the angle error is computed as the difference angle of the return ray from the incident ray. The analysis showed that the angle error would be less than .005 degrees for a range of radius of curvature from 5mm to 16mm as long as the lens system is focused on the center of curvature. This amount of error results in a fringe cycle length of 7.2mm so that with the 2mm detector the signal loss resulting from misalignment will be negligible.

For a nonspherical surface such as the cornea, different portions of the surface can be approximated by spherical surfaces of different radius. The sensitivity analysis is performed by selecting the mean radius as the locator for the focus of the optical system and then evaluating the performance of surfaces with a range of curvatures where the surfaces coincide along the axis. A range of curvatures from 11.6mm to 13.3mm were analyzed with the lens focus centered in a sphere of 12.5mm radius. The resulting analysis is presented in Figure 9.

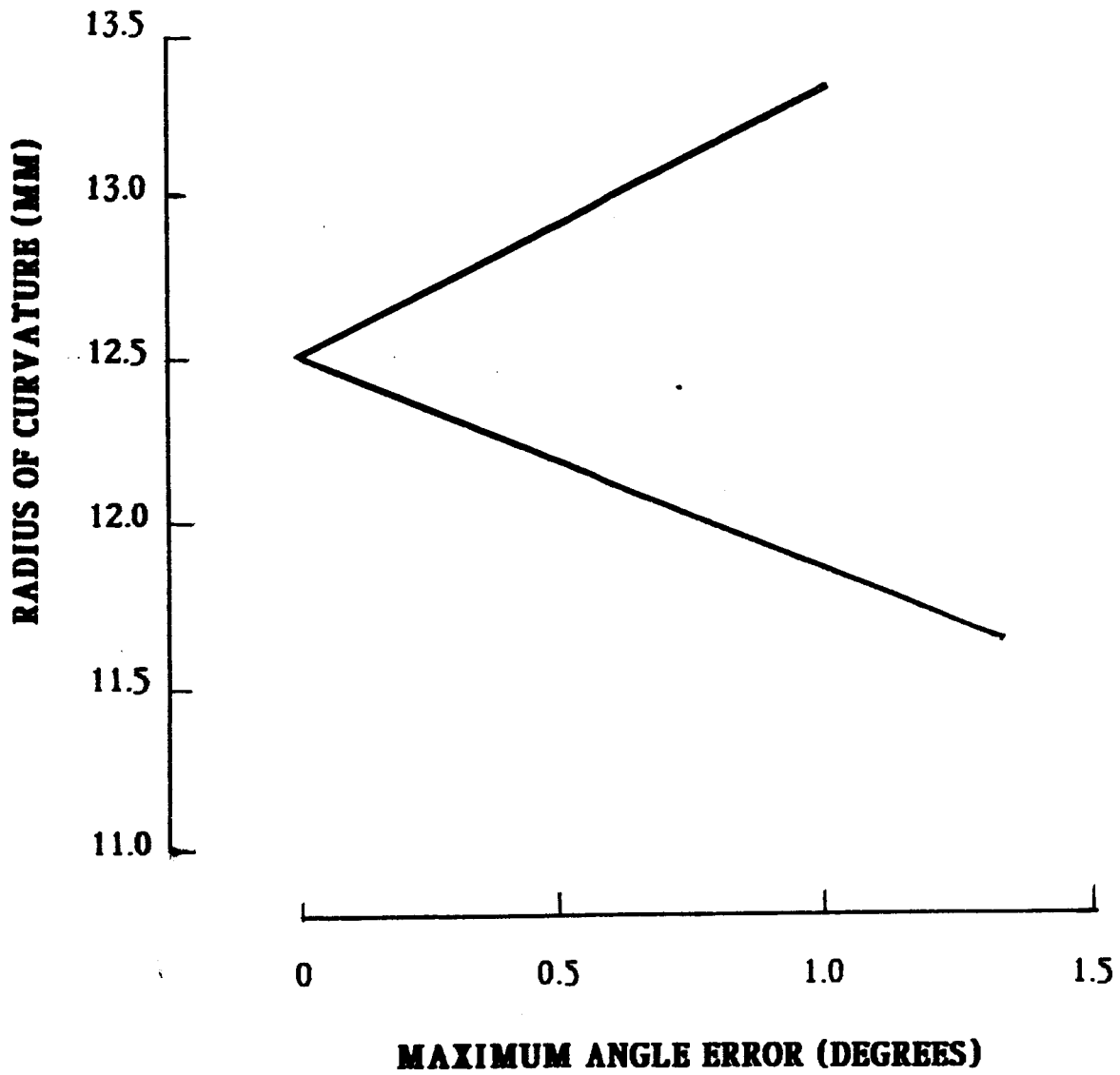

FIGURE 9. SENSITIVITY ANALYSIS RESULTS

BEAM ALIGNMENT

Ray trace analysis indicates that the return beam from the cornea will have to be steered with an auxiliary mechanism in order to keep it aligned with the reference beam. This alignment is necessary in order to maintain a strong heterodyne signal so that the signal-to-noise ratio can be high enough for accurate measurement at the desired scanning speed. A further analysis indicates that a simple bi-convex lens can be used to advantage as part of the beam steering system. This analysis is as follows. The ideal condition is for the return beam to retrace along the incident beam and return to the point of origin on the first of the two scanning galvo mirrors where it will exit along the same path as the beam entering the scanner regardless of the position in the scan. The aspheric curvature of the cornea causes a deviation from the incident beam as indicated in Figure 10.

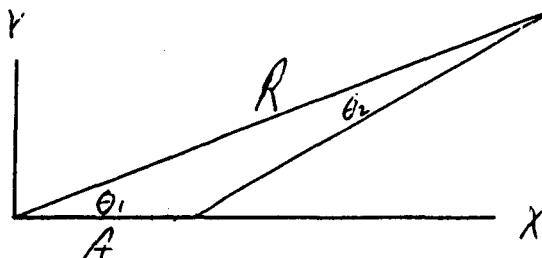

FIGURE 10

The ray trace program was used to determine θ_2 and A as a function of θ_1 for worst case cornea curvature. The distance R was then calculated using the formula:

$$R = \frac{A \sin(\theta_1 + \theta_2)}{\sin \theta_2}$$

The galvo scanner is located at the coordinate system origin and the beam will exit along the X axis if it returns to the origin. R represents the distance to an apparent point from which the divergent path appears to originate. The data resulting from this analysis is tabulated in Table 1.

The distance R was used as an on axis source point for the ray trace program with a simple bi-convex lens. A nominal focal plane was established and the height off axis of the lens output determined for each ray defined by θ and R from Table 1. The result is Table 2 for lens of 1.52 index and both radius of 150mm. Table 2 indicated that there is a maximum of approximately .2mm separation of beams at the focal plane. This separation allows the use of small mirror galvos for the beam steering and assures that the parallel beams exiting the beam steerer will stay within the 2mm square heterodyne detector.

The output of the beam steerer goes to a parabolic collimator which has a quadrature detector at its focal point. This detector provides the error signal for a servo loop that drives the beam steerer to hold the beam at the focal point of the parabola. This condition assures that the beams exit the beam steerer parallel.

TABLE 1			
		A	R
0.5214	0.03441	97.267	1029.34
1.0429	0.11076	98.059	1021.3
1.5643	0.17115	98.988	1003.57
2.0857	0.23788	100.71	983.45
2.6072	0.31379	102.86	957.08
3.1286	0.40246	105.71	926.88
3.65	0.50885	109.47	893.92
4.1715	0.64019	114.36	858.54
4.6929	0.80899	121.32	823.85
5.2143	1.0378	131.16	788.63

TABLE 2		
	R	H
1.0398	788.63	0.1
0.80899	823.85	0.027
0.64019	858.54	-0.032
0.50885	893.92	-0.0745
0.40246	926.88	-0.097
0.31379	957.08	-0.104
0.23788	983.45	-0.098
0.17115	1003.57	-0.08

BEAM STEERING

The previous sensitivity analysis shows a worst case angle error of 1.3 degrees for the returning beam. It will be necessary to compensate for this error by use of galvo driven or piezoelectric driven mirrors in the return beam so that it will be on the detector and aligned with the reference beam. The mirrors can be controlled by an analog servo loop using a 4 quadrant detector as an error sensor. This is illustrated below in Figure 11. The loop will ensure that the beam centroid remains centered on the detector.

Two servos are necessary because both angle and displacement must be corrected for. The first servo returns the beam to a fixed point and the second maintains a fixed direction. The beam steering system is illustrated below in Figure 12.

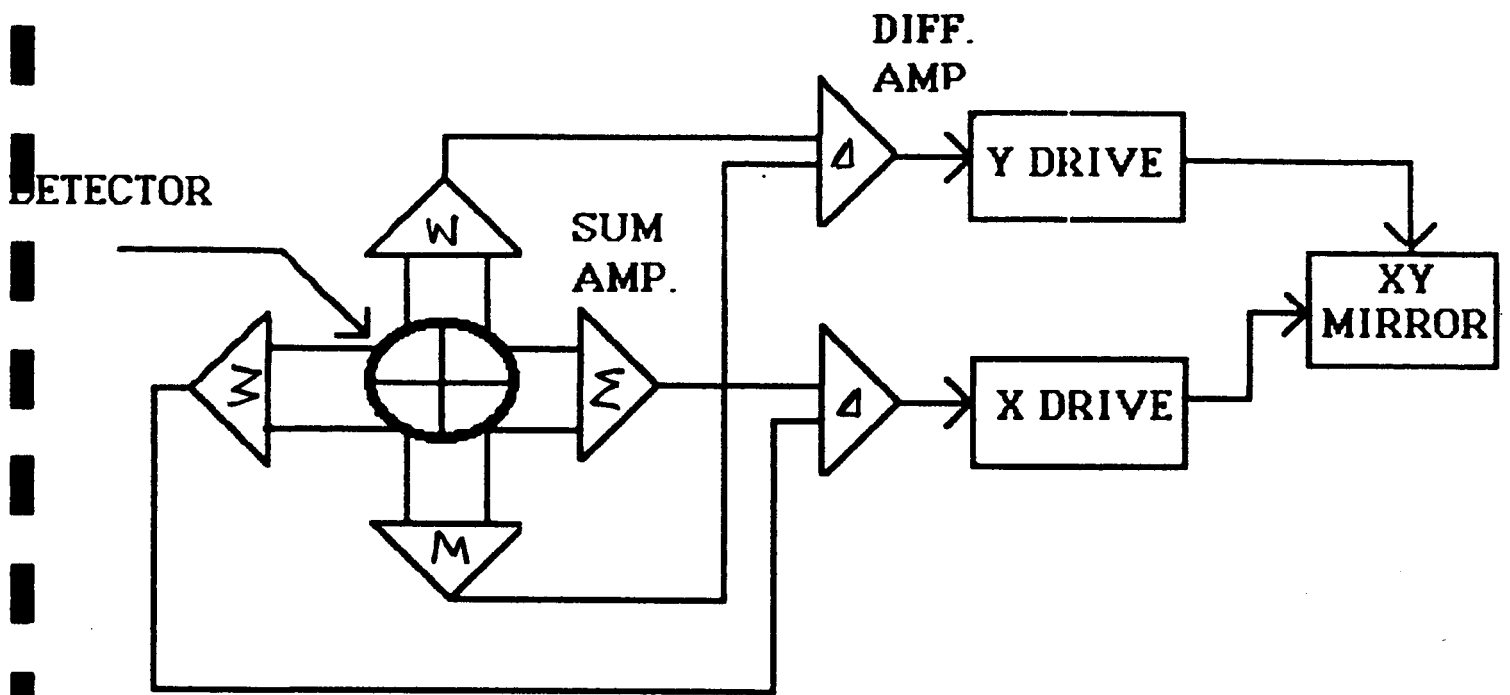

FIGURE 11: QUAD DETECTOR FOR BEAM STEERING

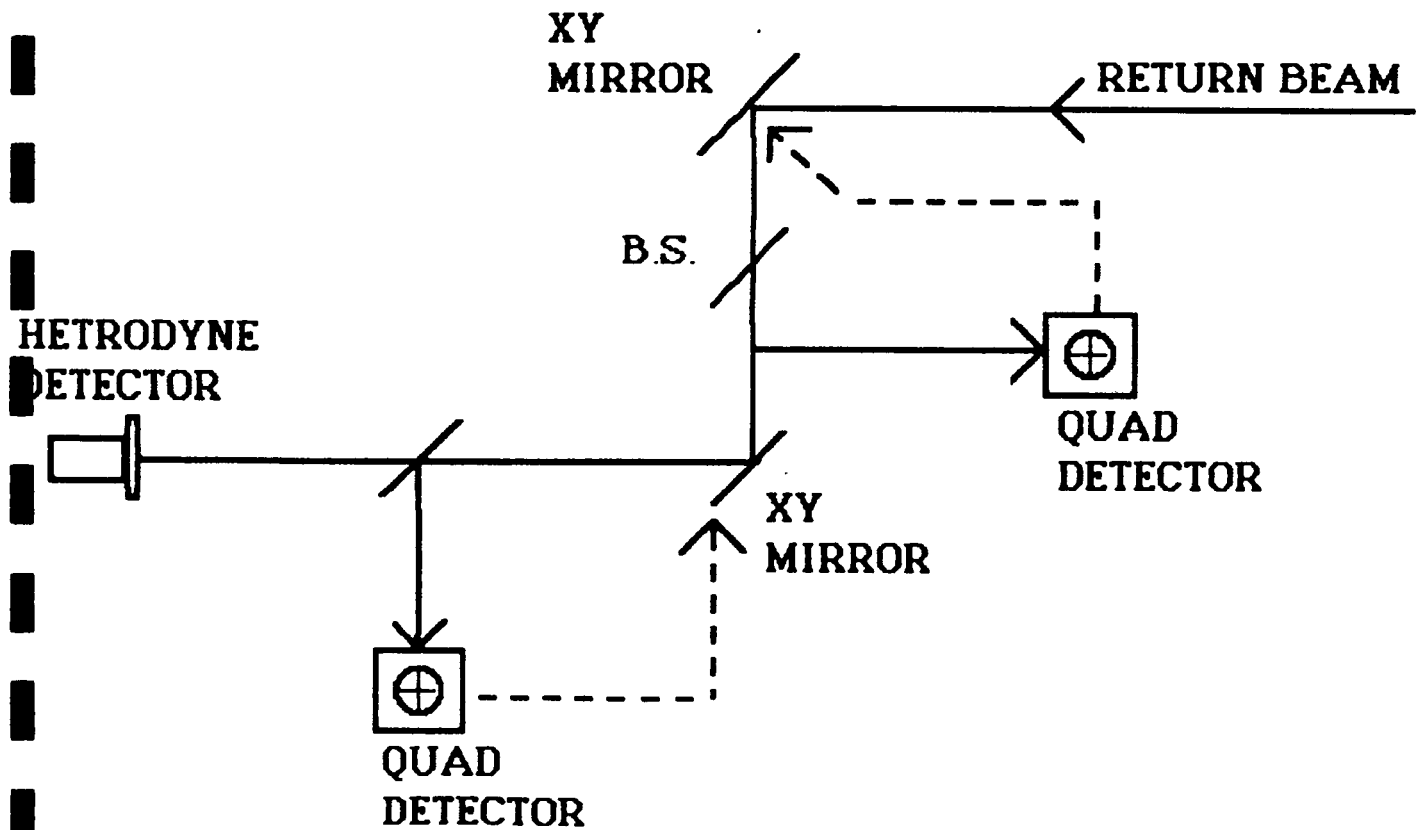

FIGURE 12: BEAM STEERING SYSTEM

TWO DIMENSIONAL SCANNER

The technique chosen is to use two galvanometer scanners in the arrangement of Figure 13. This seems to be the best available with off the shelf hardware. This design which has been chosen for the proof of principle breadboard will be limited to a 1 second frame scan time. It is limited by the use of the large galvo mirror for the fast axis scan. The small galvos which are used to correct the angle of the return beam have a .6ms step response and as such are adequate for a 1 ms line scan time. If a suitable scanner were to replace the fast axis galvo, the frame time could be reduced to .1 second. A possibility for future development is to use piezoelectric driven mirrors to replace the small galvos which correct the angle of the return beam. These are capable of 10ms. Also with .1 ms line time the polygon wheel could be used to obtain a .1 sec frame time. The use of .ms line time would require a redesign of the analog electronics to accommodate the increased signal bandwidth and an increase in laser power to maintain signal to noise ratio.

The proposed design for the 2-D scanning breadboard which will be used to demonstrate data collection from a surface typical of the cornea is shown in Figure 14.

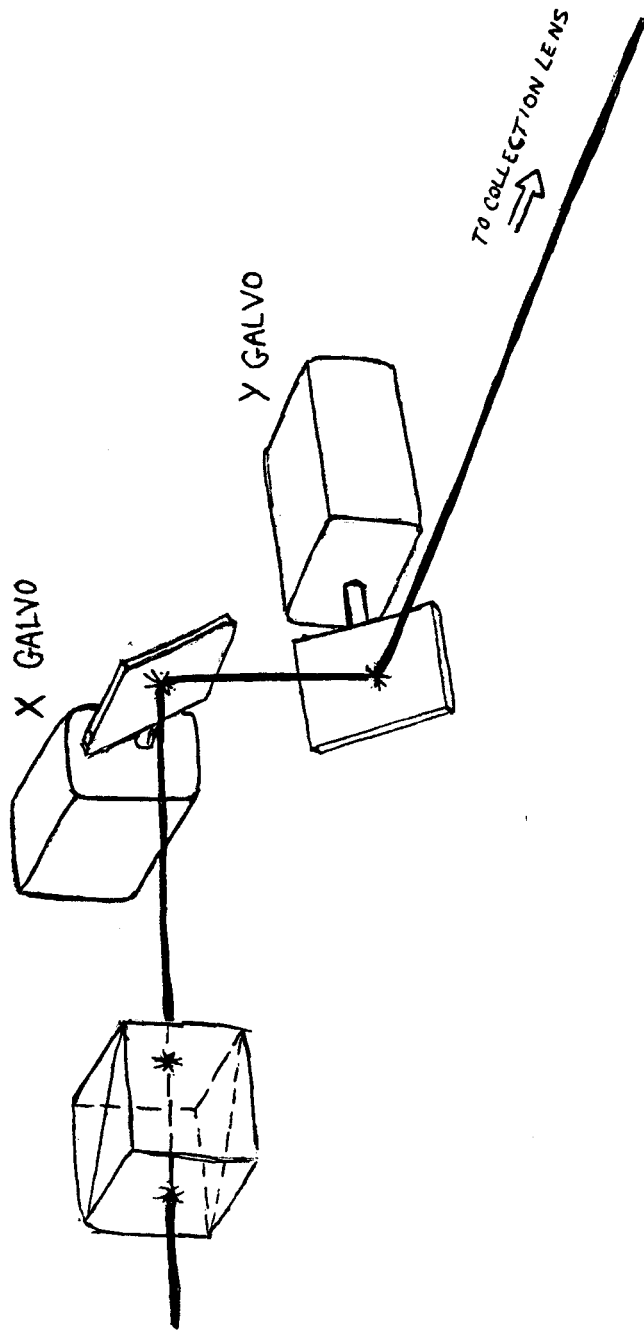

FIGURE 13: DUAL GALVO SCANNER

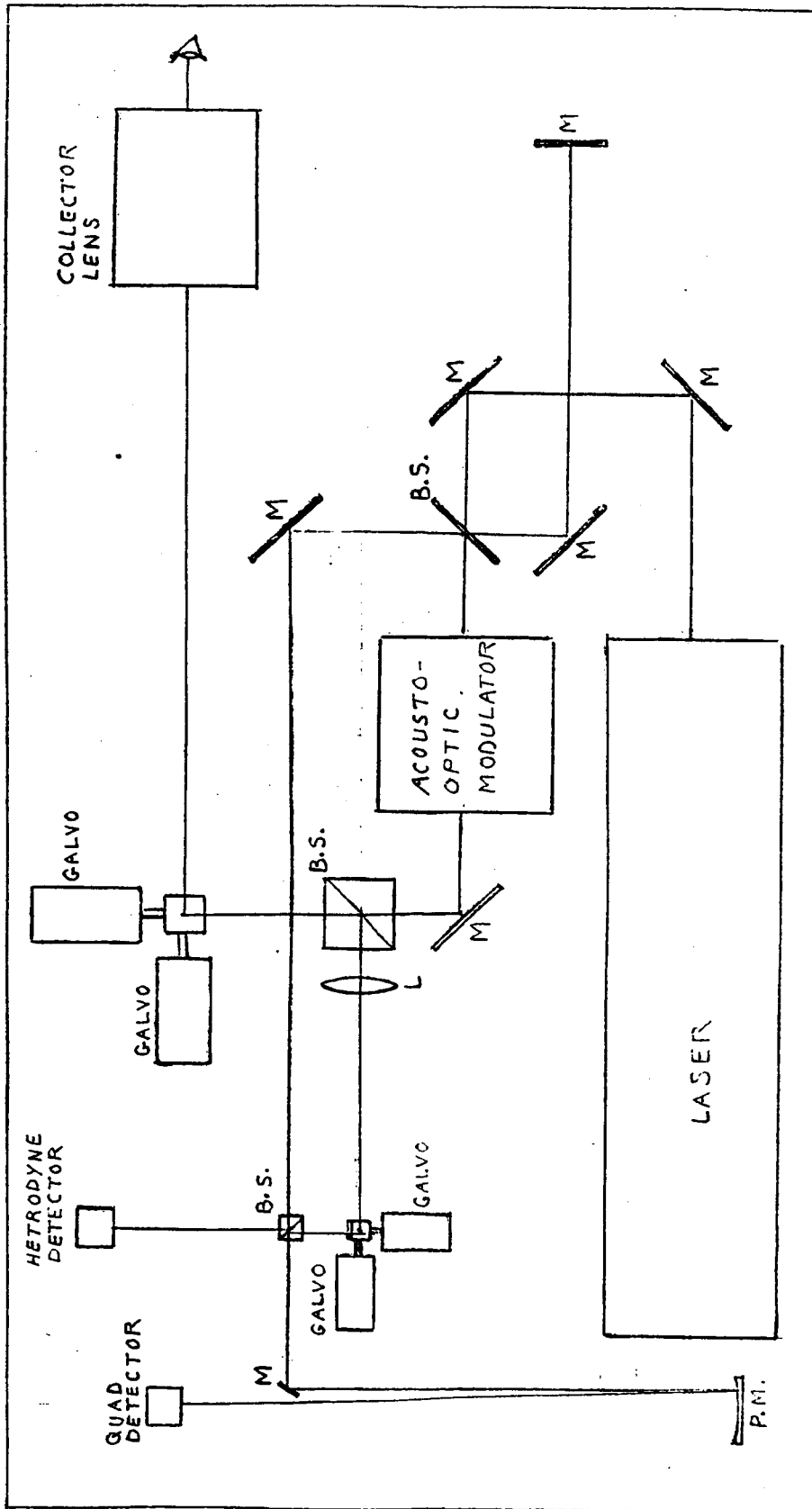

FIGURE 14: COTSS BREADBOARD

CONCLUSIONS

The COTSS has been demonstrated for a simple, one-dimensional scan. These results are documented in this report. Additional studies of the system have revealed techniques and modifications that must be implemented before the COTSS system can achieve all of the technical objectives that have been set forth. Based on these studies, the COTSS system still seems to be a viable system to meet the needs of the ophthalmic surgeon.

It is recommended that the required hardware be procured and the COTSS breadboard upgraded to demonstrate the two-dimensional scan capability. A list of hardware has been compiled that will be needed for these modifications. Also, shown in Figure 14 is a schematic layout of the breadboard with the modifications discussed in this report.

APPENDIX A RAY TRACE ANALYSIS

The following is a description of a computer algorithm which is used to analyze optical systems consisting of spherical surfaces. All vectors are referenced to the right hand cartesian coordinate system show.

A ray is described by the vector equation

$$\vec{R} = \vec{P} + S\vec{A}$$

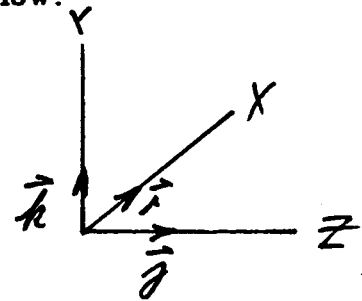

where: \vec{R} is position vector of any point along the ray:

\vec{P} is a constant specifying a given position on the ray such as the intersection of the ray with an optical surface.

\vec{A} is a unit vector in the direction of progress of the ray.

S is the scalar independent variable

An optical surface performs the function of transforming an incident ray into a departing ray in accordance with the law of reflection or refraction. This means that new vectors \vec{P} and \vec{A} are established at each surface. The vector \vec{P} is evaluated by solving the equation for the intersection of the incident ray with a sphere. The vector \vec{A} is computed by using the law of reflection or refraction as the case may be. Thus, the vector constants of the ray equation are evaluated at each encounter of a ray with an optical surface. This constitutes the algorithm. $P(I)$ and $A(I)$ are arrays in the Fortran program which are recomputed by SUBROUTINE OPTIC for each surface encountered.

The solution for the intersection of a ray with a spherical surface is obtained as follows.

\vec{Q} specifies the center of the sphere

R is the radius of the sphere

First the equation for the ray is transformed to a parallel coordinate system having its origin at the center of the sphere.

$$\vec{R}' = \vec{R} - \vec{Q} = \vec{P} + S\vec{A}$$

The equation for the sphere is:

$$X^2 + Y^2 + Z^2 = R^2$$

Expansion of the ray equation is:

$$X = X_p + SX_q$$

$$Y = Y_p + SY_q$$

$$Z = Z_p + SZ_q$$

so:

$$(X_p + SX_q)^2 + (Y_p + SY_q)^2 + (Z_p + SZ_q)^2 = R^2$$

or:

$$(X_q^2 + Y_q^2 + Z_q^2)S^2 + 2(X_qX_p + Y_qY_p + Z_qZ_p)S + (X_p^2 + Y_p^2 + Z_p^2 - R^2) = 0$$

This expression is solved for S using the quadratic equation. The variable S is then substituted into the ray equation to find X, Y, and Z.

Since the vector $\vec{P}' = x\hat{i} + y\hat{j} + z\hat{k}$ is referenced to a coordinate system whose origin is the center on the sphere, it is in the direction of the outward normal to the surface. Thus, the surface normal is:

$$\vec{U} = \vec{P}' / |\vec{P}'|$$

Finally, the position vector is transformed back to the original coordinate system by the equation:

$$\vec{P} = \vec{P}' + \vec{Q}$$

The direction of the departing ray is found using the law of reflection or refraction. These laws are illustrated below.

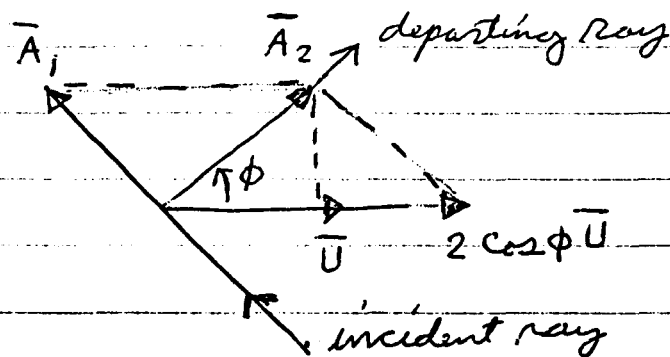

$$\bar{A}_2 = \bar{A}_1 + 2 \cos \phi \bar{U}$$

REFLECTION

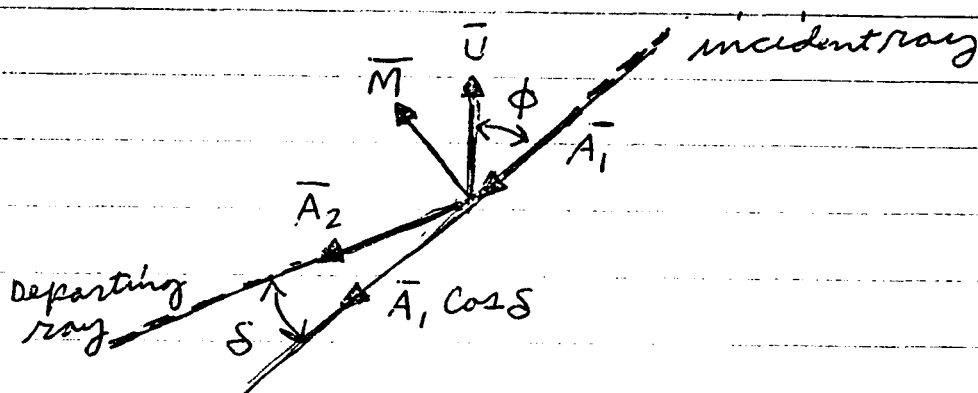

REFRACTION

In the refraction diagram above \bar{U} is the surface normal unit vector. \bar{A}_1 is the incident ray direction vector and \bar{A}_2 is the departing ray direction vector. Both \bar{A}_1 and \bar{A}_2 are unit vectors.

\bar{M} is a unit vector perpendicular to the incident ray. The angle "delta" is the difference between the angle of departure and the angle of incidence.

From the diagram:

$$\vec{U} = \vec{M} \sin \phi - \vec{A}, \cos \phi$$

so: $\vec{M} = (\vec{U} + \vec{A}, \cos \phi) / \sin \phi$

Then the departing ray direction vector is given by:

$$\begin{aligned} \vec{A}_2 &= \vec{A}, \cos \delta + \vec{M} \sin \delta \\ &= \vec{A}, \cos \delta + (\vec{U} + \vec{A}, \cos \phi) \sin \delta / \sin \phi \end{aligned}$$

or:

$$\vec{A}_2 = (\cos \delta + \cos \phi \sin \delta / \sin \phi) \vec{A}, + (\sin \delta / \sin \phi) \vec{U}$$

The angle functions appearing in this equation are evaluated as follows.

$$\begin{aligned} \cos \phi &= -\vec{A} \cdot \vec{U} \\ \sin \phi &= \sqrt{1 - \cos^2 \phi} \end{aligned}$$

From snells law:

$$\sin (\phi + \delta) = V \sin \phi$$

so:

$$\cos (\phi + \delta) = \sqrt{1 - \sin^2 (\phi + \delta)}$$

and:

$$\begin{aligned} \cos \delta &= \sin (\phi + \delta) \sin \phi + \cos (\phi + \delta) \cos \phi \\ \sin \delta &= \sin (\phi + \delta) \cos \phi - \cos (\phi + \delta) \sin \phi \end{aligned}$$

The equations which have been presented have been incorporated into the Fortran subroutine OPTIC.