

CEMP-RT Engineer Pamphlet 1110-1-11	Department of the Army U.S. Army Corps of Engineers Washington, DC 20314-1000	EP 1110-1-11 15 July 1992/ 30 September 1997
	Engineering and Design ASBESTOS ABATEMENT GUIDELINE DETAIL SHEETS	
	Distribution Restriction Statement Approved for public release; distribution is unlimited.	

CEMP-RT

Pamphlet
No. 1110-1-11

30 September 1997

Engineering and Design
ASBESTOS ABATEMENT GUIDELINE DETAIL SHEETS

1. This Change 1 to EP 1110-1-11, 15 Jul 92:
 - a. Lists additional OSHA and EPA references.
 - b. Incorporates the requirements of specific exposure and target risk activities established by OSHA.
 - c. Incorporates specific training requirements mandated by the Asbestos Hazard Reauthorization Act.

2. Substitute the attached pages as shown below:

Part	Remove page	Insert page
1	1 and 2	1 thru 2-a
1	5 and 6	5 and 6
1	27 and 28	27 and 28

3. File this change sheet in front of the publication for reference purposes.

FOR THE COMMANDER:



OTIS WILLIAMS
Colonel, Corps of Engineers
Chief of Staff

Errata Sheet

No.1

ENGINEERING AND DESIGN

Asbestos Abatement Guideline Detail Sheets

EP 1110-I-11, Change 1

30 September 1997

Page 2a: Replace page 2a with the enclosed page.

* and designed. Planners and designers shall ensure the appropriate requirements are considered in abatement specifications for individual projects.

c. *Asbestos Training.* When the Asbestos Hazardous Emergency Response Act (AHERA) was reauthorized as the Asbestos Hazard Reauthorization Act (ASHARA) it mandated specific training requirements for activities carried out in private and public buildings as well as schools. Specific training requirements for inspectors, management planners, project designers, contractors' supervisors and workers are found in the EPA Model Accreditation Program (MAP) in 40 CFR Part 763, Subpart E, Appendix C. EPA agreement states may have more stringent requirements. Ensure appropriate requirements are included where necessary for the type of asbestos related activity to be performed. *

d. *Building Occupancy.* According to Army policy, asbestos should be abated during periods when area occupancy is minimal or prohibited: however, project phasing or other critical factors may cause buildings to be occupied during abatement. If abatement must be scheduled while the building is occupied, the designer must investigate the following items before developing the contract specifications.

(1) The ability to install critical barriers that prevent access into and the exchange of air flow from the abatement-regulated work area to the occupied areas.

(2) The ability to install ventilation systems that will continuously maintain a negative pressure within the contained abatement work area and provide an air change rate of at least four or more air changes per hour within the abatement area, thereby augmenting pressure differential between the abatement area and the occupied area. Air exchange rates must be calculated for the regulated work area in order to



**US Army Corps
of Engineers**

**Office of the Chief
of Engineers**

CHANGE 1 INCORPORATED

ASBESTOS ABATEMENT GUIDELINE DETAIL SHEETS

**EP 1110-1-11
15 JULY 1992**

CEMP-RT

Pamphlet
No. 1110-1-11

Engineering and Design

15 July 1992

ABATEMENT DETAIL SHEETS

- 1. PURPOSE.** This pamphlet provides asbestos abatement Guideline Detail Sheets (Setup and Response Action) that will be used in conjunction with Corps of Engineers Guide Specification for Military Construction CEGS 02080, Asbestos Abatement.
- 2. APPLICABILITY.** This pamphlet applies to all HQUSACE/OCE elements and all U.S. Army Corps of Engineers commands (major subordinate commands, district commands, laboratories, and field operating activities) having civil works and/or military program responsibility.
- 3. CONTENTS.** This pamphlet is divided into three primary parts. Part 1, ASBESTOS ABATEMENT DETAIL SHEET INSTRUCTIONS, (pages 1-30) provides guidance to specifiers and designers on how to select, modify, and use the detail sheets in the preparation of asbestos abatement solicitations. Part 2, SETUP DETAILS, (pages 31-60) contains a series of detail drawing sheets with instructions that identify the proper containment and controls to be employed in support of individual abatement work tasks. One or more setup detail sheets are required for each defined abatement work task and are directly dependent upon the required response action detail sheet selected for that work task. Part 3, RESPONSE ACTION DETAILS, (pages 61-136) contains a series of detail drawing sheets with instructions that identify the abatement method to be employed (removal, encapsulation, encasement, enclosure, or repair) and the item to be abated (for example, removal of acoustical wall plastic on masonry). Only one response action detail sheet will be selected for each abatement work task. Each response action detail sheet refers to the appropriate setup detail sheets that are to be used to protect, contain, and control during the performance of the work task.
- 4. USE OF DETAIL SHEETS.** Asbestos abatement in CEGS 02080 entails the removal, encapsulation, encasement, enclosure, and repair of friable and nonfriable asbestos-containing materials. The series of detail drawing sheets *must* be used in conjunction with the CEGS 02080 in order to identify specific methods of abatement, containment, and control required during the performance of abatement work tasks. These detail sheets take into account all identifiable abatement work tasks that might be requested by Corps of Engineers' customers. Specifiers and designers must select the appropriate detail sheets and modify, as necessary, to fit the unique conditions of each defined abatement task, and then append the selected sheets to asbestos abatement solicitations for use by the Contractor.

FOR THE COMMANDER



MILTON HUNTER
Colonel, Corps of Engineers
Chief of Staff

Table of Contents

PART 1, ASBESTOS ABATEMENT DETAIL SHEET INSTRUCTIONS		Page
1. Purpose		1
2. Applicability		1
3. References		1
4. Explanation of Abbreviations.		1
5. Background: Guideline Development		1
6. Relative Hazard and Risk Assessment		2
7. Response Action Options		3
8. Abatement Decision Alternatives		4
9. Work Area Containment		5
10. Respiratory Protection		8
11. Guideline Application: Preparation of Contract Documents		8
12. Administrative Considerations		16
13. Containment Area Considerations		21
14. Response Action Selection		26
15. Abatement Design		28
16. Replacement Design		30
17. Cost Estimating		30
Figure 1. Notification of Demolition and Renovation Sample Format		17
Figure 2. Waste and Shipment Record Sample Format		22
Table 1. Recommended Respirator Selection for Protection Against Asbestos		9
Table 2. Asbestos Abatement Setup Details		10
Table 3. Response Action Details		11
Table 4. Response Action Detail Sheets By Abatement Method		13
Table 5. Final Air Clearance Requirements		20
 PART 2, SETUP DETAILS		
	Sheet	Page
Air lock	1	31
Installation of critical barrier and full containment area (for carpeted floors)	2	32
Installation of critical barrier and full containment area (for hard floor surfaces)	3	33
Installation of critical barrier and full containment area (for vinyl tile floors)	4	34
Single bulkhead containment area	5	35
Double bulkhead containment area	6	36
Mini-containment area	7	37
Ventilation of containment area and decontamination unit, using HEPA filters	8	38
Containers—double bagging	9A	39

Table of Contents—Continued

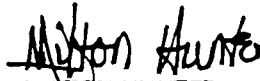
PART 2, SETUP DETAILS—Continued	Sheet	Page
Containers—leak-tight wrapping	9B	40
Containers—corrugated cardboard boxes	9C	41
Glove bag	10	42
Area warning signs and warning tape	11	43
Respiratory protection table	12	44
Protective clothing	13	45
Disposal container label	14	46
Decontamination unit signage	15	47
Preparation of full containment area for final clearance (for carpeted floors)	16	48
Preparation of full containment area for final clearance (for hard-surfaced floors)	17	49
Preparation of containment area for final clearance (for vinyl tile floors)	18	50
Certification of final cleaning and visual inspection	19	51
Load-out unit floor plan	20	52
Modified containment area	21	53
Decontamination unit floor plan	22	54
Decontamination unit piping details	23	55
Temporary equipment enclosure	24	56
Access tunnel	25	57
Asbestos power vacuum collection and removal system	26	58
Cleaning and storage	27	59
Structural critical barrier	28	60
PART 3, RESPONSE ACTION DETAILS	Sheet	Page
Bridging encapsulation of troweled wall plaster	29	61
Repair of troweled wall plaster on stud wall	30	62
Repair of troweled ceiling or wall plaster on masonry	31	63
Removal of troweled wall plaster on masonry	32	64
Removal of troweled wall plaster on stud wall	33	65
Bridging encapsulation of solid or acoustical ceiling plaster	34	66
Removal of troweled ceiling plaster on structural substrate	35	67
Removal of troweled ceiling plaster on hung ceiling	36	68
Enclosure of acoustical wall plaster on masonry wall	37	69
Bridging encapsulation of acoustical wall plaster	38	70
Penetrating encapsulation of acoustical wall and ceiling plaster	39	71
Combination encapsulation of acoustical wall and ceiling plaster	40	72

Table of Contents—Continued

PART 3, RESPONSE ACTION DETAILS—Continued	Sheet	Page
Repair of acoustical ceiling or wall plaster	41	73
Removal of acoustical wall plaster on masonry	42	74
Enclosure of acoustical ceiling plaster, spray-on fireproofing, and thermal insulation	43	75
Removal of acoustical ceiling plaster (nonasbestos substrate)	44	76
Removal of miscellaneous asbestos-containing materials	45	77
Removal of asbestos decorative paint on plaster	46	78
Removal of light curtain	47	79
Removal of interior asbestos cement, fiberboard, and drywall panels	48	80
Bridging encapsulation of asbestos cement wall, fiberboard, and drywall panels	49	81
Removal of asbestos-contaminated masonry for masonry chimney	50	82
Removal of asbestos-contaminated masonry wall or thermal insulation	51	83
Removal of suspended asbestos cement ceiling tile	52	84
Removal of asbestos cement architectural products	53	85
Removal of suspended acoustical ceiling tile	54	86
Removal of glued-on acoustical ceiling and wall tile	55	87
Repair of vinyl asbestos tile adhered to concrete floor system	56	88
Removal of vinyl asbestos tile adhered to concrete floor system by asbestos-containing adhesive	57	89
Removal of vinyl asbestos tile adhered to concrete floor system by asbestos-free adhesive	58	90
Removal of vinyl asbestos tile and chemical dissolution of asbestos-containing adhesives on concrete floor system	59	91
Repair of vinyl asbestos tile adhered to wood floor system by asbestos-containing adhesive	60	92
Removal of vinyl asbestos tile adhered to wood floor system by asbestos-containing adhesive	61	93
Removal of vinyl asbestos tile adhered to wood floor system by asbestos-free adhesive	62	94
Removal of sheet-flooring adhered to wood floor system	63	95
Removal of sheet-flooring adhered to concrete floor system by asbestos-containing adhesive	64	96
Removal of carpeting (asbestos-containing or -contaminated)	65	97
Encasement of fireproofing or thermal insulation of beams and decking	66	98
Encasement of fireproofing or thermal insulation on columns	67	99
Removal of fireproofing or thermal surface insulation	68	100
Encasement of acoustical ceiling insulation	69	101
Removal of acoustical ceiling insulation	70	102
Enclosing asbestos-contaminated soil	71	103
Penetrating encapsulation of asbestos-contaminated soil	72	104
Removal of asbestos-contaminated soil	73	105
Removal of built-up roofing and flashing	74	106

Table of Contents—Continued

PART 3, RESPONSE ACTION DETAILS—Continued	Sheet	Page
Removal of roof, shingles, and underlay	75	107
Bridging encapsulation of exterior asbestos stucco	76	108
Bridging encapsulation of interior asbestos stucco	77	109
Repair of interior asbestos stucco	78	110
Removal of exterior asbestos stucco	79	111
Repair of exterior asbestos stucco	80	112
Removal of asbestos cement siding	81	113
Removal of asbestos cement roofing	82	114
Removal of asbestos-containing walkway cover	83	115
Removal of asbestos-contaminated metal siding	84	116
Removal of asbestos cement sunscreen louvers	85	117
Repair of pipe and fitting insulation (using glove bag)	86	118
Removal of pipe insulation (using glove bag)	87	119
Removal of horizontal pipe insulation (using containment area)	88	120
Removal of pipe insulation (using mini-containment area)	89	121
Encasement of storage tank or boiler breeching	90	122
Bridging encapsulation of storage tank and boiler breeching	91	123
Repair of storage tank and boiler breeching	92	124
Removal of storage tank and boiler breeching insulation	93	125
Removal of pipe-fitting insulation (using glove bag)	94	126
Removal of asbestos-insulated electrical wiring	95	127
Removal of asbestos-insulated electrical fixture	96	128
Removal of boiler firebox insulation	97	129
Bridging encapsulation of boiler and piping gaskets	98	130
Removal of boiler and piping gaskets	99	131
Repair of duct insulation	100	132
Removal of duct insulation	101	133
Removal of asbestos cement pipe	102	134
Removal of asbestos cement ductwork	103	135
Removal of asbestos flex connector	104	136

Part 1, Asbestos Abatement Detail Sheet Instructions

1. PURPOSE. This engineer pamphlet (EP) provides the Setup and Response Detail Sheets that the designer must use in conjunction with CEGS 02080, Asbestos Abatement, when preparing asbestos abatement contract documents.

2. APPLICABILITY. This EP applies to all HQUSACE/OCE elements and all U.S. Army Corps of Engineers commands (major subordinate commands, district commands, laboratories, and field operating activities) having civil works and/or military program responsibility.

* **3. REFERENCES.** References which are cited in this engineering pamphlet and/or provide related guidance are listed below. *

- * a. 40 CFR Part 61, Subparts A and M.
- b. 29 CFR Part 1926.1101, Asbestos in Construction.
- c. 40 CFR 763, Asbestos.
- e. EPA Publication Asbestos/Demolition Decision Tree, 1994.
- f. EPA Publication No.340/1-90-018, Asbestos/NESHAP Regulated Asbestos Containing Materials Guidance, December 1990.
- g. EPA Publication No. 340/1-90-019, Asbestos/NESHAP Adequately Wet Guidance.
- h. EPA Publication No. 20-T-2003, Managing Asbestos in Place, July 1990.
- i. Corps of Engineers Guide Specifications (CEGS 02080), Asbestos Abatement.
- j. ENVR-EP Memorandum, dated 22 January 1992, subject: Policy Guidance on Interpretation of Revised EPA Asbestos Rule Affecting Demolition and Renovation of Buildings. (available from HQDA, Office of the Director of Environmental Protection).

Note: EPA documents available from U.S. Environmental Office Protection Agency, Small Business Ombudsman, 1230 C, 401 M St., S.W. Washington, DC 20460; 1-800-368-5888. *

4. EXPLANATION OF ABBREVIATIONS.
Abbreviations used in the EP are explained below.

- a. ACM.....asbestos-containing material.
- b. CEGS.....Corps of Engineers Guide Specifications
- c. CFR.....Code of Federal Regulations
- d. CO.....Contracting Officer
- e. COR.....Contracting Officer's Representative
- f. EP.....engineer pamphlet
- h. HEPA.....high efficiency particulate air
- I. NESHAP...National Emissions Standards for Hazardous Air Pollutants
- j. NIOSH.....National Institute of Occupational Safety and Health
- k. OSHA.....Occupational Safety and Health Administration
- l. PCM.....phase contrast microscopy
- m. TEM.....transmission electron microscopy

5. BACKGROUND: GUIDELINE DEVELOPMENT.

Historically, asbestos abatement, design has primarily used written specifications for detailing both the scope of work and abatement technologies. As a result, contract documents were lengthy and difficult to follow. Therefore, techniques were modified in order to:

- a. Reduce specification content by graphically depicting abatement techniques.

b. Present detail sheets of abatement techniques common to many response actions.

c. Provide as much information as possible on the detail sheets so that project specific variations can be developed by editing the sheets.

d. Provide a manageable process for guide specifications by covering several different abatement methods for both friable and nonfriable asbestos-containing material (ACM).

The detail sheets provided in this EP are the product of the combined practical experience of numerous professional design and management sources and must be used in conjunction with CEGS 02080.

6. RELATIVE HAZARD AND RISK ASSESSMENT.

The purpose of asbestos abatement is to protect building inhabitants, nearby receptors, and the environment from exposure to and contamination from asbestos fibers. Therefore, before establishing minimum control methods based on relative hazards, the designer must evaluate the potential for the release of asbestos fibers into the indoor and outdoor environment during abatement.

a. Friability.

(1) The most common hazard of assessment factor is the friability of ACM. The Environmental Protection Agency (EPA) through the National Emissions Standards for Hazardous Air Pollutants (NESHAP) for asbestos (40 CFR Part 61, Subparts A and M) and EPA Agreement-States implementing NESHAP require strictly controlled response actions for all friable ACM. 40 CFR Part 61, Subparts A and M, CEGS 02080; and ENVR-EP Memorandum, Policy Guidance on Interpretation of Revised EPA Asbestos Rule Affecting Demolition and Renovation of Buildings, provide detailed guidance relative to friability designation. Controlled removal of friable ACM is normally carried out using wet techniques. EPA Publication No. 340/1-90-019, Asbestos/NESHAP Adequately Wet Guidance, provides specific guidance regarding adequately wet requirements of the revised NESHAP standard.

*

*

* (2) In addition, NESHAP requires preconstruction surveys and assessments for planned demolition and/or renovation actions. Those surveys and assessments are particularly relevant to demolition and/or renovation actions. Those surveys and assessments are particularly relevant to demolition and/or renovation abatement projects involving nonfriable ACM. NESHAP defines two categories of nonfriable ACM. Category 1 nonfriable ACM includes resilient floor covering (including ACM floor tile), asphalt roofing materials, packing and gaskets. Category 2 nonfriable ACM includes all other nonfriable ACM, such as asbestos cement roofing tiles, siding, transite board, etc. If specific survey and assessment decision criteria in the NESHAP at 40 CFR Part 61, Subpart M, are met, categories 1 and 2 nonfriable ACM may be left in place during demolition projects.

(3) When planning customer abatement procedures that involve demolition and/or renovation of nonfriable ACM, the designer must consult with the following before including nonfriable ACM in or excluding nonfriable ACM from abatement documents:

(a) NESHAP asbestos standards.

(b) State and local requirements (both regulatory and local jurisdiction landfill).

(c) Army guidance on this subject (ENVR-EP Memorandum, Policy Guidance on Interpretation of New EPA Asbestos Rule Affecting Demolition and Renovation of Buildings).

(d) Installation guidance on this subject.

(e) Customer requirements.

* (f) OSHA Asbestos Standard 29 CFR Part 1926.1101. *

* *b. OSHA Construction.* OSHA in 29 CFR Part 1926.1101 has established specific exposure and target risk activities to include Categories I, II, III and IV tasks. Requirements in this OSHA regulation, to include state requirements which may be more stringent, will have a significant impact on the manner in which a project is planned *

* and designed. Planners and designers shall ensure the appropriate requirements are considered in abatement specifications for individual projects.

c. *Asbestos Training.* When the Asbestos Hazardous Emergency Response Act (AHERA) was reauthorized as the Asbestos Hazard Reauthorization Act (ASHARA) it mandated specific training requirements for activities carried out in private and public buildings as well as schools. Specific training requirements for inspectors, management planners, project designers, contractors' supervisors and workers are found in the EPA Model Accreditation Program (MAP) in 40 CFR Part 763, Subpart E, Appendix C. EPA agreement states may have more stringent requirements. Ensure appropriate requirements are included where necessary for the type of asbestos related activity to be performed. *

d. *Building Occupancy.* According to Army policy, asbestos should be abated during periods when area occupancy is minimal or prohibited: however, project phasing or other critical factors may cause buildings to be occupied during abatement. If abatement must be scheduled while the building is occupied, the designer must investigate the following items before developing the contract specifications.

(1) The ability to install critical barriers that prevent access into and the exchange of air flow from the abatement-regulated work area to the occupied areas.

(2) The ability to install ventilation systems that will continuously maintain a negative pressure within the contained abatement work area and provide an air change rate of at least four or more air changes per hour within the abatement area, thereby augmenting pressure differential between the abatement area and the occupied area. Air exchange rates must be calculated for the regulated work area in order to

ensure that air flows into the containment at all times.

(3) The re-examination of fire evacuation routes for compliance with local fire codes.

(4) The ability to safely access building service areas such as electrical panels, rest room facilities, and heating, ventilating, and air-conditioning systems.

(5) The ability to readjust building air-handling systems for isolation of airflow into/from the abatement area.

(6) The need for altered occupant travel paths and/or temporary facilities.

(7) The ability to provide security during and after daily abatement activities.

(8) The development, with the customer, of an occupant awareness program, including a description of the actual project work.

7. RESPONSE ACTION OPTIONS.

a. General. Asbestos abatement is achieved through the appropriate selection of the following five accepted techniques:

(1) Removal.

(2) Encapsulation (bridging, penetrating, and combination).

(3) Encasement.

(4) Enclosure.

(5) Repair.

The designer will consult with the customer and evaluate existing conditions of the ACM in order to identify all abatement work tasks and determine which abatement technique will be specified for each identified abatement task to be completed.

b. Removal.

(1) Of all available abatement techniques, removal offers the most satisfactory long-term solution. However, cost and the potential for spreading contamination during removal are major considerations. For information about the adverse effects of removal abatement projects, the

designer should review EPA Publication No. 20-T-2003, *Managing Asbestos In Place*, which describes in-place management versus removal.

(2) Many response action details for the removal of ACM are presented herein.

c. Encapsulation. The many types of encapsulants fall into two prime categories: bridging encapsulants and penetrating encapsulants. For friable ACM, either type has a narrow range of application possibilities as an abatement strategy, particularly interior ACM. Consequently, encapsulation should be limited to those situations where friable ACM is extremely difficult to reach or is relatively thin in depth. If encapsulation is used, the designer must ascertain that the friable ACM has sufficient strength to support itself with the added weight of the encapsulant. Furthermore, many encapsulants will reduce the effective fire rating; therefore, if the friable ACM is fire rated, critical selection of the encapsulant should include the effect on the fire rating. For nonfriable ACM, a broader spectrum of application exists; its use on durable and exterior building products is common.

(1) Bridging Encapsulants. Bridging encapsulants are characterized by their ability to span interstitial spaces and provide a superficial seal. Also, because of their high solids content, these encapsulants commonly provide high-temperature resistance as well. Bridging encapsulants are recommended for application on plaster, stucco, and wall paneling only. Bridging encapsulants are normally applied by airless-spray; although palm-grade encapsulant is trowel applied. Palm-grade bridging encapsulants, however, are recommended for application only on tank and boiler breeching or boiler and pipe gaskets.

(2) Penetrating Encapsulants.

(a) Penetrating encapsulants have a low solids content and reduce the natural surface tension of the asbestos fibers, thereby aiding absorption. They penetrate beyond the surface of the ACM and bind the asbestos fibers into a relatively hard mass. Silicon-based penetrating encapsulants develop extremely low surface

tension because of their chemical similarity to asbestos, but their use should be limited to encapsulating acoustical materials in place and asbestos-contaminated soils found in crawl spaces or pipe trenches.

(b) Lock down encapsulants are penetrating encapsulants designed to lock residual asbestos to the surface from which the ACM was removed and the polyethylene sheeting in the containment area. These encapsulants, however, dry into a clear, glossy surface that may interfere with the bonding of new, asbestos-free replacement materials.

(c) Removal encapsulants are a type of silicone-based penetrating encapsulant that do not have curing agents in their formulation, but instead keep the ACM wet—a characteristic particularly helpful in reducing ACM fiber release.

(3) *Combination encapsulants.* Combination encapsulation involves the sequential application of both a penetrating and then a bridging encapsulant. Repair of asbestos cement roofing panels or wall and ceiling plaster are the only recommended uses.

(4) *High-temperature encapsulant.* If encapsulants are to be used for a high-temperature application, such as a boiler gasket, a high-temperature encapsulant (2,000 °F, 1,100 °C,) should be specified. If a low-temperature encapsulant is used for a high-temperature application, it could result in toxic organic emissions and asbestos release. The manufacturer's data sheet can be used to confirm the temperature rating of the encapsulant.

d. *Encasement.* Encasement is an abatement technique involving a two-step process. First, the ACM is encapsulated by spraying a penetrating foam onto the ACM. Next, after the foam has cured, a plastic coating, which cures into a hard protective coating, is sprayed onto the foam. If encasement is chosen, the fire rating must be assessed and the ability of ACM to carry the additional weight of the foam and protective coating must be determined. If the ACM is unable to support the added weight, anchors can be installed or an analysis of the capability of the

protective coating to bridge between support points can be made. Encasement techniques are recommended only for *in situ* abatement of spray-on fireproofing and thermal insulation and for hot water storage tanks exposed to weather.

e. *Enclosure.* The enclosure of ACM involves constructing a permanent, airtight, impermeable barrier surrounding the ACM. Normally, studs are first installed around the ACM without disturbing it. Next, polyethylene is fastened to the studs, and all perimeter edges and points are sealed with duct tape. Finally, asbestos-free plaster board is attached to the studs. Enclosure should only be used when small amounts of ACM are involved or when access to the ACM is so restricted that a major component of the building would otherwise have to be demolished in order to complete the abatement.

f. *Repair.* This technique is used to re-establish the integrity of ACM that has deteriorated to a point where the potential for ACM release exists. Repair as an abatement action is principally directed toward small areas of nonfriable ACM. Friable ACM, however, can be repaired where removal is not an acceptable alternative. Furthermore, this technique can be used as a stop-gap measure for small, significantly damaged areas that are expected to be a part of a more permanent abatement action in the future.

8. ABATEMENT DECISION ALTERNATIVES.

Before asbestos abatement begins, the work area must be prepared in a manner that will protect human health and the environment. Since the disturbance of ACM generates airborne asbestos fibers that may remain suspended in the air for a long time and migrate to other areas of the building, work area preparations must be designed to contain fibers during the entire abatement process. Furthermore, the preparations protect interior finishes, equipment, fixtures, etc., from water damage or asbestos contamination, and also help reduce final cleaning procedures.

a. *Containment Alternatives.* The designer must decide the extent of the protection needed for a specific response action. The items to be considered are (1) the relative risk of the

alternatives, (2) the degree of protection necessary, and (3) the amount of protection the alternative provides. The five basic setup alternatives are listed in (1) through (5) below. The first four alternatives are primarily for interior abatement work; however, situations may occur where they could be applied to an exterior response action as well.

(1) Full-scale contaminant areas (sheets 2,3, and 4).

(2) Small-scale, short-duration abatement areas (sheet 10).

(3) Mini contaminant areas (sheets 5, 6, and 7).

(4) Modified contaminant areas (sheet 21).

(5) Exterior abatement areas. (These are not defined by a containment area sheet, but are identified on individual Response Action Detail (Sheets).

b. Alternative Requirements.

(1) Each containment alternative has many variations, since each abatement project presents its own unique requirements.

(2) One such requirement is abatement area sizing. Sizing is based upon site-specific data and requirements. For example, a large abatement area can be subdivided into small containment areas. As each containment area is completed, critical barriers can be installed over the access way of the completed containment area, thereby isolating it from the unabated areas. When abatement is complete, the air can be cleared for the entire abatement area, thereby minimizing cost. (For air clearance, however, the areas must be contiguous).

(3) Sizing may also be affected by economic analysis. For example, the construction of a bulkhead would probably shrink the size of the abatement area, thereby reducing the size of the high-efficiency particulate air (HEPA) filtered fan unit, the amount of plastic installed and disposed, and the decontamination time. Sizing may also be

affected by phasing considerations.

(4) In essence, area sizing and other requirements of an abatement area can vary widely; choosing the appropriate variation depends upon the good judgement of all parties involved.

9. WORK AREA CONTAINMENT. Airborne asbestos fibers are contained within the work area during abatement by the installation of polyethylene sheeting or strippable coatings on walls, floor, and/or ceiling.

a. Full-Scale Containment

(1) Basic. Full-scale containment is used for large projects involving significant fiber release caused by the quantity and/or friability of the ACM and if the environmental hazard and personal risk is high. (See sheets 2, 3, and 4). Full-scale containment involves the following items:

(a) The protection of all non-ACM surfaces in the work area.

(b) The blocking of all openings, penetrations, passage ways, and critical barriers into and out of the work area with polyethylene or rigid impermeable material.

(c) Material load-out units,

(d) Personnel decontamination units.

(e) HEPA-filtered air exhaust.

(f) High-level of personal protection.

(2) *Variations.* Under certain conditions, full scale containment may deviate from the items listed in paragraph (1) above. Take, for example, an abatement project response action requiring the removal of vinyl asbestos tile covering 6,000 square feet in a gymnasium. A comprehensive survey and assessment shows the floor tile is in poor condition and friable according to EPA NESHAP asbestos rule. The vinyl asbestos tile is very brittle (crumbling) and worn. Because of previous repairs, the floor looks like a patchwork quilt. The vinyl asbestos tile adhesive also contains asbestos. For this situation, both walls

and ceiling are to be protected, and all of the normal protection features are to be applied. Because the ceiling in the gymnasium is 30 feet high, the Contractor has quoted an alternative proposal in order to comply with all of the design provisions (including critical barriers), except the polyethylene will be installed on the walls up to a height of only 6 feet. The Contractor will use flooding for tile removal and an organic material for adhesive removal. This deviation is an acceptable and practical response action if upon completion, the Contractor cleans all wall and ceiling surfaces above the polyethylene, including lights, backboards, stage, seating, scoreboards, etc. Final air clearance will provide evidence of the Contractor's success.

* *b. Small-Scale, Short Duration Abatement (Rescinded)*

c. Mini-Containment.

(1) A mini-containment area provides an airtight enclosure around either a low-or high-hazard work area that is of limited size (see detail sheets 5,6, and 7). Mini-containment limits the spread of asbestos fibers to a small area rather than an entire room, and offers a quick and relatively inexpensive enclosure.

(2) The mini-containment area is constructed with a small compartment serving as an air lock that prevents the release of contaminated air to the "clean side." The abatement worker wears two sets of protective clothing. Before leaving the work area, the worker must vacuum the outer protective suit, remove it, and place it in a disposable bag. Then the worker steps into the air lock, where a clean bucket of water has been placed, and wet wipes the respirator and face and hands with a damp rag. Next the worker removes the respirator and places it in a clean plastic bag. Finally, wearing the inner suit, the worker proceeds to a shower located somewhere else. These personnel decontamination procedures generally, require the following items, as a minimum:

- (a) HEPA vacuum.
- (b) Critical barriers.
- (c) Full facepiece, negative pressure, air-purifying respirator.
- (d) Protective clothing.
- (e) Access to a shower or a three-stage decontamination unit.

(3) The mini-containment area can be applied to almost all interior response actions that are limited in scope. For example, a roof leak caused 4 square feet of wall plaster in a hallway to become crumbly and in need of repair. The plaster contains 5-percent chrysotile. The adjacent wall surfaces are painted and in good condition. In analyzing the needs of the response action, it was determined that only a mini-containment area was required. The damaged, friable plaster would be removed with a chisel, a brush, wet techniques, and a HEPA vacuum. It was estimated that removal of the damaged plaster and installation of new plaster would not exceed 4 hours (after installation of the mini-containment enclosure). After completing the response action work, the worker followed the predetermined personnel decontamination procedures at the enclosure.

d. Modified Containment Areas.

(1) Modified containment procedures are used only for low-hazard applications (see sheet 21). These procedures generally require the following items as a minimum:

- (a) HEPA vacuum
- (b) Local exhaust HEPA filtered ventilation unit.
- (c) Critical barriers.
- (d) Negative pressure, air-purifying respirator.
- (e) Protective clothing.
- (f) Access to a shower.

(2) Modified containment application is limited to response actions where nonfriable materials can be removed intact, for example, an asbestos cement tabletop or partition. Other projects that would qualify are easily contained

operations, such as glove bags. Furthermore, modified containment procedures can be applied to the encapsulation of small, low-hazard items such as flange and boiler gaskets, which are virtually nonfriable because of the relatively small surface area exposure and compressive containment.

(3) The removal of category 2 nonfriable asbestos-containing fiberboard or drywall panels also exemplifies the use of modified containment procedures. Critical barriers, along with a HEPA-filtered ventilation system that recirculates the air within the work area, are installed. Polyethylene sheeting is not placed on walls, since the wall material is to be removed, but the sheeting is placed on the floor beneath the work area. A respirator and protective clothing are required. Furthermore, an air lock is attached to the modified containment area (except for glove bag operations) where workers enter, exit, and conduct decontamination procedures as for the mini-containment area. Finally, all exposed workers should also take a shower immediately upon completion of abatement-related work activities.

e. Exterior Abatement Areas.

(1) Response actions to building exteriors commonly involve the noncontainment removal of category 1 and 2 nonfriable ACM, such as roofing and siding. If done carefully, the probability of any fiber release can be minimized, provided the material does not become friable, that is, crumbled, pulverized, or reduced to powder, during the removal. Simple breakage during removal does not mean that the abatement must be conducted under containment. If fiber release can be controlled by keeping the ACM nonfriable, then the need for a containment area and most of the associated work restrictions is unnecessary.

(2) When work occurs in an unconfined outdoor air space, access to the work area must be controlled. A boundary zone extending 30 to 40 feet beyond the work area must be delineated (see sheet 11). Furthermore, all workers should wear, as a minimum, a negative pressure, air-purifying respirator and breathable protective clothing. Workers should also shower immediately

after completion of work. The Contractor's asbestos hazard abatement plan will specify personal protection and decontamination facility requirements for exterior asbestos abatement actions.

f. Glove Bag Operations. The glove bag provides an airtight enclosure around the work area, enabling an abatement worker to remove or repair ACM within a contained area (see sheet 10). A glove bag provides safe removal of ACM without the expense of a full-scale room containment. When a glove bag is used, the immediate area must be isolated in order to restrict access, and critical barriers must be installed (see sheet 21). A HEPA-filtered vacuum unit supporting the glove bag operation is required. Also, the glove bag may be kept under negative pressure in order to prevent the spread of asbestos if the glove bag leaks. Finally, placing a (nonducted) HEPA-filtered exhaust system in the area of the glove bag operation can help control an accidental fiber release from spreading beyond the established work area.

10. RESPIRATORY PROTECTION.

a. Personal Air Monitoring. OSHA requires that the type of respirator used by the worker be determined by personal air monitoring that quantifies fiber content in the environment where the individual works. The fiber content is determined by collecting air samples in the worker's breathing zone. The samples are taken by a low-volume, battery-powered pump attached at the waist on the worker's belt and connected via polyethylene tubing to a filter cassette connected to the worker's clothing at the breathing zone. Constant air monitoring establishes a time-weighted average and ensures that worker exposure is kept below acceptable levels for a given respirator. The responsibility for personal air monitoring is the abatement Contractor's.

b. Respirator Types and Protection Factors.

(1) Detail Sheet 12 describes the respirator types required under various airborne asbestos fiber concentrations. Protection factors take into

consideration that any respirator functioning under negative air pressure depends solely upon the seal between the mask and the face. Since that seal is mechanical and likely to leak, the protection factor is appropriately lower for standard half-mask and full facepiece respirators than for powered air-purifying or pressure-demand supplied air respirators operating under positive pressure so that leakage is always outside the breathing zone.

(2) Under no circumstances are single-use disposable dust masks to be used. The minimum level of respiratory protection is the half-facepiece, negative pressure, air-purifying, dual cartridge (HEPA-filtered) respirator, regardless of the type of ACM. Table 1 indicates OSHA protection factors for various types of respirators. Maximum-use concentrations are based on a proposed OSHA standard of 0.1 fiber per cubic centimeter (i.e., $0.1 \times 10 = 1$ fiber/cc).

11. GUIDELINE APPLICATION: PREPARATION OF CONTRACT DOCUMENTS.

a. Guideline Detail Sheet and CEGS 02080 Development and Use. The detail sheets presented in this EP and the CEGS 02080 were developed as companion guidelines that must be used together. Furthermore, they must be adapted to fit the needs of specific projects.

(1) *Pictorial representations.* The detail sheets provide sketches of desired construction/abatement actions—particularly useful as a guide for Contractors and workers. Also, since information presented graphically does not have to be included as a part of the contract specification, pictorial representations may very well be "worth a thousand words." However, the sketches do not provide everything needed for contract documents for two reasons: First, graphic details must be generic enough for selective modifications or adaptation to project specific situations. Second, the number of detail sheets must be small enough so that designs can be selected reasonably quickly.

(2) *Details versus CEGS 02080.* There are many abatement requirements for which pictorial representations are inappropriate, from a practical

Table 1. Recommended Respirator Selection for Protection Against Asbestos

Respirator Type	OSHA Protection Factor	Maximum Use Concentration
Half facepiece, air-purifying, HEPA filter	10	1 fiber/cc
Full facepiece, air-purifying, HEPA filter	50	5 fibers/cc
Powered air-purifying, loose-fitting helmet or hood, HEPA filter	100	10 fibers/cc
Powered air-purifying, full facepiece, HEPA filter	100	10 fibers/cc
Supplied air, continuous flow, loose-fitting helmet or hood	100	10 fibers/cc
Supplied air, continuous flow, full facepiece, HEPA escape	100	10 fibers/cc
Full facepiece, supplied air, pressure demand, HEPA escape	1,000	100 fibers/cc
Full facepiece, supplied air, pressure demand, with auxiliary self-contained breathing apparatus, pressure demand or continuous flow	1,000	100 fibers/cc

point of view. The determination of what information would be presented either in the details or in CEGS 02080 was based upon the identification and selection of those abatement procedures that were worker related (instructive graphics) and those that were administrative in nature (written specifications). In combination, the guideline detail sheets and CEGS 02080 effectively respond to all applicable U.S. laws and regulations that can be enforced while the Contractor is under contract.

(3) *Project-specific adaptation.* Both the details and CEGS 02080 are generic and must be site adapted to meet project-specific requirements. Practical implementation of these guidelines will lead to the creation of project-specific details and specifications.

b. *Guideline Detail Sheet Organization.* The guideline detail sheets have been created using descriptive abatement instructions. Both the instructions and graphics contain enough data so that the detail can be modified for specific

projects by using manual deletion and editing techniques. The detail sheets are organized into two groups. The first group of 28 sheets, as shown in table 2, presents the techniques and information necessary to set up or prepare an abatement area for any response action. The remaining sheets, as shown in table 3, present specific response actions. The response action detail sheets are organized into three categories: interior architectural, exterior architectural, and mechanical/electrical applications. In addition, response action details have been segregated by abatement technique (removal, encapsulation, encasement, enclosure, repair) in table 4.

c. *CEGS 02080 Development and Use.*

(1) The information in CEGS 02080 is primarily technical in context but administrative in nature because CEGS 02080 was developed to support the detail sheets by providing other pertinent asbestos abatement information. Some worker-related abatement techniques, such as decontamination procedures, were made a

Table 2. Asbestos Abatement Setup Details

Setup Detail	Detail Number
Air lock	1
Installation of critical barrier/full containment area	2, 3, 4
Single bulkhead containment area	5
Double bulkhead containment area	6
Mini-containment area	7
Ventilation of containment area and containment unit, using HEPA filters	8
Double bagging, leak tight wrapping, paperboard boxes	9A, 9B, 9C
Glove bag	10
Area warning markers—signs and boundary warning tape	11A, 11B
Respiratory protection table	12
Protective clothing	13
Disposal container label	14
Decontamination unit signage	15
Full containment area—preparation for final clearance	16, 17, 18
Certification of final cleaning and visual inspection	19
Load-out unit floor plan	20
Modified containment area	21
Decontamination unit floor plan	22
Decontamination unit piping details	23
Temporary equipment enclosure	24
Access tunnel	25
Asbestos power vacuum collection/removal system	26
Furniture cleaning and storage	27
Structural critical barrier	28

Table 3. Response Action Details

ACM	RESPONSE ACTION DETAIL OPTION						
	Encasement	Enclosure	Encapsulation			Repair	Removal
			bridging	penetration	combination		
Interior Architectural							
Troweled wall plaster			29			30, 31	32, 33
Troweled ceiling plaster						31	35, 36
Acoustical wall plaster		37	38	39	40	41	42
Acoustical ceiling plaster	69	43	34	39	40	41	44
Miscellaneous materials							45
Decorative paint							46
Lightweight stage curtain							47
Cement wall panels			49				48
Fiberboard & drywall panels			49				48
Masonry wall							51
Cement ceiling tile							52
Cement products							53
Acoustical wall tile							55
Acoustical ceiling tile							54, 55
Vinyl floor tile on concrete						56	57, 58, 59
Vinyl floor tile on wood						60	61, 62
Sheet flooring (wood/cement)							63, 64
Carpeting							65
Fireproofing & thermal insulation	66, 67	43					51, 68
Ceiling insulation	69						70
Contaminated soil		71		72			73
Masonry chimney							50

Table 3. Response Action Details—Continued

ACM	RESPONSE ACTION DETAIL OPTION						
	Encasement	Enclosure	Encapsulation			Repair	Removal
			bridging	penetration	combination		
Exterior Architectural							
Built-up roofing & flashing						74	
Roof, shingles, & underlay						75	
Stucco			76, 77		78, 80	79	
Cement roofing and siding						81, 82	
Walkway roof/cover						83	
Metal siding						84	
Cement louvers						85	
Mechanical & Electrical							
Horizontal pipe insulation					86	87, 88, 89	
Vertical pipe insulation					86	87, 88, 89	
Tank & boiler breeching	90		91		92	93	
Pipe fittings						94	
Electrical wiring/fixture						95, 96	
Boiler firebox insulation						97	
Boiler & piping gaskets			98			99	
Duct insulation					100	101	
Cement piping						102	
Cement ductwork						103	
Flex connector						104	

Table 4. Response Action Detail Sheets By Abatement Method

Asbestos Abatement Method: Removal	Detail Sheet
Removal of troweled wall plaster on masonry	32
Removal of troweled wall plaster on stud wall	33
Removal of troweled ceiling plaster on structural substrate	35
Removal of troweled ceiling plaster on hung ceiling	36
Removal of acoustical wall plaster on masonry	42
Removal of acoustical ceiling plaster (nonasbestos substrate)	44
Removal of miscellaneous asbestos-containing materials	45
Removal of asbestos decorative paint on plaster.	46
Removal of light curtain	47
Removal of interior asbestos cement, fiberboard, and drywall panels	48
Removal of asbestos-contaminated masonry for masonry chimney	50
Removal of asbestos-contaminated masonry wall or thermal insulation	51
Removal of suspended asbestos cement ceiling tile	52
Removal of asbestos cement architectural products	53
Removal of suspended acoustical ceiling tile	54
Removal of glued-on acoustical ceiling and wall tile	55
Removal of vinyl asbestos tile adhered to concrete floor system by asbestos-containing adhesive	57
Removal of vinyl asbestos tile adhered to concrete floor system by asbestos-free adhesive	58
Removal of vinyl asbestos tile and chemical dissolution of asbestos-containing adhesives on concrete floor system	59
Removal of vinyl asbestos tile adhered to wood floor system by asbestos-containing adhesive	61
Removal of vinyl asbestos tile adhered to wood floor system by asbestos-free adhesive	62
Removal of sheet flooring adhered to wood floor system	63
Removal of asbestos-containing sheet flooring adhered to concrete floor system by asbestos containing adhesive	64
Removal of carpeting (asbestos-containing or contaminated)	65
Removal of fireproofing or thermal surface insulation	68
Removal of acoustical ceiling insulation	70
Removal of asbestos-contaminated soil	73
Removal of built-up roofing and flashing	74

Table 4. Response Action Detail Sheets By Abatement Method—Continued

Asbestos Abatement Method: Removal—Continued	Detail Sheet
Removal of roof, shingles, and underlay	75
Removal of exterior asbestos stucco	79
Removal of asbestos cement siding	81
Removal of asbestos cement roofing	82
Removal of asbestos-containing walkway cover	83
Removal of asbestos-contaminated metal siding	84
Removal of asbestos cement sunscreen louvers	85
Removal of horizontal pipe insulation (using full containment area)	88
Removal of pipe insulation (using glove bag)	87
Removal of pipe insulation (using mini-containment area)	89
Removal of storage tank and boiler breeching insulation	93
Removal of pipe-fitting insulation (using glove bag)	94
Removal of asbestos-insulated electrical wiring	95
Removal of asbestos-insulated electrical fixtures	96
Removal of boiler firebox insulation	97
Removal of boiler and piping gaskets	99
Removal of duct insulation	101
Removal of asbestos cement pipe	102
Removal of asbestos cement ductwork	103
Removal of asbestos flex connector	104
Asbestos Abatement Method: Encapsulation	Detail Sheet
Bridging encapsulation of troweled wall plaster	29
Bridging encapsulation of solid or acoustical ceiling plaster	34
Bridging encapsulation of acoustical wall plaster	38
Penetrating Encapsulation of acoustical wall and ceiling plaster	39
Combination Encapsulation of acoustical wall and ceiling plaster	40
Bridging encapsulation of asbestos cement wall, fiberboard, and drywall panels	49
Penetrating Encapsulation of asbestos-contaminated soil	72
Bridging encapsulation of exterior asbestos stucco	76

Table 4. Response Action Detail Sheets By Abatement Method—Continued

Asbestos Abatement Method: Encapsulation—Continued	Detail Sheet
Bridging encapsulation of interior asbestos stucco	77
Bridging encapsulation of storage tank and boiler breeching	91
Bridging encapsulation of boiler and piping gaskets	98
Asbestos Abatement Method: Encasement	Detail Sheet
Encasement of fireproofing or thermal insulation on beams and decking	66
Encasement of fireproofing or thermal insulation on columns	67
Encasement of acoustical ceiling insulation	69
Encasement of storage tank or boiler breeching	90
Asbestos Abatement Method: Enclosure	Detail Sheet
Enclosure of acoustical wall plaster on masonry wall	37
Enclosure of acoustical ceiling plaster, spray-on fireproofing, and thermal insulation	43
Enclosure of asbestos-contaminated soil	71
Asbestos Abatement Method: Repair	Detail Sheet
Repair of troweled wall plaster on stud wall	30
Repair of troweled ceiling or wall plaster on masonry	31
Repair of acoustical ceiling or wall plaster	41
Repair of vinyl asbestos tile adhered to concrete floor system by asbestos-containing adhesive	56
Repair of interior asbestos stucco	78
Repair of exterior asbestos stucco	80
Repair of vinyl asbestos tile adhered to wood floor system by asbestos-containing adhesive.	60
Repair of pipe and fitting insulation (using glove bag)	86
Repair of storage tank and boiler breeching	92
Repair of duct insulation	100

specific section, since they were common to all response actions and are an integral part of the worker-training curriculum (a fact that emphasizes that neither CEGS 02080 nor the detail sheets can be used as an independent entity).

(2) Like the guideline detail sheets, CEGS 02080 must be adapted to the requirements of a specific project, using deletion and editing techniques. Those techniques enhance the quality of the final product, since it is less likely that something may have been forgotten.

12. ADMINISTRATIVE CONSIDERATIONS.

Because improper abatement may result in a hazard to building occupants, careful planning and diligent implementation of a project is essential. For asbestos projects, the standard contractual relationship between the Contracting Officer's Representative (COR) and the Contractor remains the traditional construction overview practice. In addition, it is critical to foster cooperative onsite administration and coordination.

a. Contracting Officer's Representative (COR).

(1) The asbestos abatement contract requires the COR to take a more active role than the traditional construction or demolition contract allows. According to CEGS 02080, the COR is responsible for monitoring contract compliance, accepting the Contractor's final clearance (before clearance air sampling) via a thorough visual inspection, and normal inspection of workmanship and materials.

(2) Failure to properly control the asbestos abatement procedure can result in contamination outside the work area. Because of the critical value of onsite monitoring, the COR must be directly involved in the oversight of preabatement, abatement, and final clearance monitoring in order to ensure that the Contractor's performance meets quality standards. Should a hazardous situation arise (such as fiber counts exceeding established criteria or loss of containment area integrity), the COR will stop all work, investigate the causes, and establish if a contamination event has occurred. If contamination exists, work must be terminated until a sampling program is instituted to identify the source of contamination and the need for decontamination. The extent of contamination can be determined by establishing a thorough visual inspection and air-sampling strategy (phase contrast microscopy (PCM) or transmission electron microscopy (TEM)). Work will not recommence unless air samples prove negative or until the affected areas have been decontaminated and identified deficiencies corrected.

(3) The COR's responsibilities described above may be performed by a Contractor

(independent of the abatement Contractor) who is hired by the Contracting Officer (CO).

b. Contractor Prequalification. The most effective means of ensuring high standards in asbestos abatement is through prequalification of potential bidders. All potential bidders must have successfully completed abatement projects similar in size and complexity to the project being bid on. A preliminary assessment of the quality and type of abatement projects the potential bidders have completed will be helpful in assessing their depth of experience, quality of execution, and other factors. All prequalifications should be reviewed during the bidding stage by the CO and made a part of the bid analysis.

c. Preabatement Notification to EPA/State. Preabatement notification is a submittal requirement for the abatement. Per the revised NESHAP, each owner or operator of an ACM demolition and/or renovation site (covered by NESHAP) must, at least 10 working days before abatement begins, provide written notice of the intention to demolish or renovate. The revised NESHAP also requires a demolition/renovation notification in a format similar to figure 1. Check with the EPA region, the State, and the customer in order to determine who will submit the notification, the Contractor or the Government.

d. Oversight.

(1) *Contract enforcement.* Enforcement of the contract requirements by the COR encompasses both technical and administrative functions, including the following:

(a) Processing the Contractor's submittals as listed in the Contractor's submittal register.

(b) Visual inspecting and monitoring of the Contractor's work. Also, air sampling if specified in the contract.

(c) Reviewing all Contractor's progress reports and abatement daily log.

(d) Preparing the final abatement report.

(2) *Contract Submittals.* The Contractor's submittal register lists those items to be submitted to the CO (see CEGS 02080). There are four submittal categories: (1) those to be

NOTIFICATION OF DEMOLITION AND RENOVATION

Operator Project #	Postmark	Date Received	Notification #	
I. TYPE OF NOTIFICATION (O = Original R = Revised C = Cancelled) :				
II. FACILITY INFORMATION (Identify owner, removal contractor, and other operator)				
OWNER NAME:				
Address:				
City:	State:	Zip:		
Contact:	Tel:			
REMOVAL CONTRACTOR:				
Address:				
City:	State:	Zip:		
Contact:	Tel:			
OTHER OPERATOR:				
Address:				
City:	State:	Zip:		
Contact:	Tel:			
III. TYPE OF OPERATION (D = Demo O = Ordered Demo R = Renovation E = Emer. Renovation) :				
IV. IS ASBESTOS PRESENT? (Yes / No)				
V. FACILITY DESCRIPTION (Include building name, number and floor or room number)				
Bldg. Name:				
Address:				
City:	State:	County:		
Site Location:				
Building Size:	# of Floors:	Age in Years:		
Present Use:	Prior Use:			
VI. PROCEDURE, INCLUDING ANALYTICAL METHOD, IF APPROPRIATE, USED TO DETECT THE PRESENCE OF ASBESTOS MATERIAL:				
VII. APPROXIMATE AMOUNT OF ASBESTOS, INCLUDING:				
1. Regulated ACM To Be Removed	RACM To Be Removed	Nonfriable Asbestos Material Not To Be Removed		Indicate Unit of Measurement Below
2. Category I ACM Not Removed		Cat I	Cat II	UNIT
3. Category II ACM Not Removed				
Pipes				Ln Ft: Ln m:
Surface Area				Sq Ft: Sq m:
Vol. RACM Off Facility Component				Cu Ft: Cu m:
VIII. SCHEDULED DATES ASBESTOS REMOVAL (MM / DD / YY) Start: Complete:				
IX. SCHEDULED DATES DEMO / RENOVATION (MM / DD / YY) Start: Complete:				

Continued on page two

Figure 1. Notification of Demolition and Renovation Sample Format

NOTIFICATION OF DEMOLITION AND RENOVATION (continued)

X. DESCRIPTION OF PLANNED DEMOLITION OR RENOVATION WORK, AND METHOD(S) TO BE USED:		
XI. DESCRIPTION OF WORK PRACTICES AND ENGINEERING CONTROLS TO BE USED TO PREVENT EMISSIONS OF ASBESTOS AT THE DEMOLITION AND RENOVATION SITE:		
XII. WASTE TRANSPORTER #1		
Name:		
Address:		
City:	State:	Zip:
Contact Person:	Telephone:	
WASTE TRANSPORTER #2		
Name:		
Address:		
City:	State:	Zip:
Contact Person:	Telephone:	
XIII. WASTE DISPOSAL SITE		
Name:		
Location:		
City:	State:	Zip:
Telephone:		
XIV. IF DEMOLITION ORDERED BY A GOVERNMENT AGENCY, PLEASE IDENTIFY THE AGENCY BELOW:		
Name:	Title:	
Authority:		
Date of Order (MM / DD / YY):	Date Ordered to Begin (MM / DD / YY):	
XV. FOR EMERGENCY RENOVATIONS		
Date and Hour of Emergency (MM / DD / YY):		
Description of the Sudden, Unexpected Event:		
Explanation of how the event caused unsafe conditions or would cause equipment damage or an unreasonable financial burden:		
XVI. DESCRIPTION OF PROCEDURES TO BE FOLLOWED IN THE EVENT THAT UNEXPECTED ASBESTOS IS FOUND OR PREVIOUSLY NONFRIABLE ASBESTOS MATERIAL BECOMES CRUMBLED, PULVERIZED, OR REDUCED TO POWDER.		
XVII. I CERTIFY THAT AN INDIVIDUAL TRAINED IN THE PROVISIONS OF THIS REGULATION (40 CFR PART 61, SUBPART M) WILL BE ON-SITE DURING THE DEMOLITION OR RENOVATION AND EVIDENCE THAT THE REQUIRED TRAINING HAS BEEN ACCOMPLISHED BY THIS PERSON WILL BE AVAILABLE FOR INSPECTION DURING NORMAL BUSINESS HOURS. (Required 1 year after promulgation)		
_____		_____
(Signature of Owner / Operator)		(Date)
XVIII. I CERTIFY THAT THE ABOVE INFORMATION IS CORRECT.		
_____		_____
(Signature of Owner / Operator)		(Date)

Figure 1. Notification of Demolition and Renovation Sample Format—Continued

submitted with the proposal, (2) those requiring submittal before commencement of abatement work, (3) those submittals that continue throughout the progression of the abatement work, and (4) final submittals. Although various submittals may require no action and are only for the record (such as the medical examiner's report), the CO or COR should acknowledge receipt and acceptability of the documents submitted.

(3) *Contract compliance.* To determine compliance with the contract specifications regarding products and equipment may be a difficult task. The difficulty lies in the evaluation of an unfamiliar product for which there is no similar product. To aid in evaluating such products, manufacturer's data sheets and catalogues for the products and equipment are required submittal items per CEGS 02080.

(4) *Final report.* A final abatement report provides a means for documenting the project history for future reference. Included in that report are:

(a) Project Documents. Specifications and copy of as-built drawings.

(b) Contractor's Submittals.

(c) Daily Inspection Records.

(d) Final Air Clearance Reports.

(5) *Air-sampling compliance.* Monitoring of the abatement site includes National Institute of Occupational Safety and Health (NIOSH) method 7400 PCM air sampling of the ambient areas adjacent to but outside of the abatement area. The analysis of those samples will provide the assurance that all fiber releases have been contained within the abatement area and have not contaminated the adjacent building spaces. Confirmation of the PCM results by NIOSH method 7402 TEM is an option that the Contractor may employ (at the Contractor's own expense) in order to verify asbestos fiber concentrations.

e. *Air-sampling program.* A comprehensive air-sampling program combines (1) preabatement air testing, (2) daily air monitoring, and (3) final air

clearance in order to model or define environmental air quality at any given stage of the abatement process. For the three types of air samples, each has a different protocol and satisfies a unique purpose.

(1) *Preabatement.* Just before abatement begins, preabatement air tests are taken by the Contractor or COR, as specified in the contract. Those tests involve gathering air samples for analysis by NIOSH method 7400 PCM. If the PCM analysis identifies a fiber count in excess of 0.01 fibers/cc, then a sample from the same filter analyzed by NIOSH method 7402 TEM to confirm PCM results is conducted.

(2) *Abatement and Final Clearance.* CEGS 02080 requires the Contractor to implement an air-monitoring program meeting Federal and State requirements. Such an air-monitoring program is designed to define airborne fiber exposure levels of employees and guarantee good work practices, contaminant control, and an abated work area that meets final clearance airborne concentration limits. (See table 5 for final air clearance requirements). In addition, CEGS 02080 allows the CO the option of confirming good work practices by the Contractor and ensuring that contamination has not spread beyond the containment area. If the option is selected, during abatement activities, daily air samples would be taken for the COR by the Government (in-house or the contract industrial hygienist) in order to establish or confirm fiber counts inside and outside the containment area and at the discharge of each HEPA-filtered exhausting unit. The number of samples gathered each day depends upon how many containment areas are active, their size, and the activity occurring within.

f. *Packaging, Transportation, and Disposal.* Fugitive asbestos fiber emissions (fibers accidentally released from their containment) can occur at any stage during abatement; the packaging and handling of ACM in preparation for or in the actual transportation and disposal of ACM is no exception. If the methods and strategies discussed in paragraphs (1) through (4) below are properly applied, environmental protection can be assured.

Table 5. Final Air Clearance Requirements

NIOSH METHOD 7400, PCM ^a	
Location Sampled	Number of Samples
Inside abatement area	5 per first 1,500 square feet plus 1 per 1,500 additional square feet, but never less than 5 per abatement area
Each room in abatement area less than 1,500 square feet	1 ^b , but never less than 5 per abatement area
Field blank	2
Laboratory blank	1 ^b
TEM, EPA METHOD	
Location Sampled	Number of Samples
Inside abatement area	5 ^c
Outside abatement area	5
Field blank	2
Laboratory blank	1
^a PCM results can be confirmed by TEM NIOSH Method 7402 on a sample from the same filter. ^b Required by CEGS 02080. ^c Customer option upgrade. The mandatory method in EPA's 40 CFR Part 763 requires a minimum of 5 samples per abatement area and an equal number outside abatement area. Additional samples may be desirable when existing obstructions prevent proper characterization of the abatement area.	

(1) *Packaging.* The ACM must be properly prepared and packaged.

(a) Normally, before removal, the ACM should be thoroughly saturated with a penetrating encapsulant or with amended water before proceeding with packaging. Resaturation may be necessary if ACM is not packaged immediately after removal.

(b) Packaging techniques include double bagging, double wrapping, and packing in polyethylene-lined cardboard boxes, polyethylene, or fiberboard drums. The technique selected depends primarily on the ACM itself. Double bagging should be used for soft, rounded materials that are less likely to puncture the polyethylene. Double wrapping should be used for large, intact ACM that would not fit into a polyethylene bag, for example, carpeting,

suspended ceiling systems, partitions, and tabletops. Polyethylene-lined cardboard boxes should be used for sharp or pointed materials such as scrap metal, broken asbestos cement products, etc. Polyethylene-lined drums may be used for any ACM; however, their use is not recommended inside a containment area because of the decontamination and handling problems related to their size and weight. In addition, local regulators and disposal facilities may prohibit use of such containers.

(2) *Labels and licenses.* Before any container is released for shipment and disposal, it must be properly labeled, and the Contractor must have all necessary licenses and permits in hand.

(3) *Transport.*

(a) Waste must be transported in a polyethylene-lined truck or Dumpster that is

completely enclosed. The vehicle should be placarded to indicate the type of load. The vehicle should be loaded by abatement workers wearing respirators and protective clothing. Care must be taken not to rupture or tear the containers.

(b) The NESHAP requires a waste and shipment record similar to figure 2 in order to document that the waste has reached its intended destination. The form must be completed and signed by the Contractor, the transporter, and the disposal site operator. The data on the form should fully describe the ACM containers in the shipment, and the cargo should be confirmed by each signatory as the shipment is handed off.

(4) *Disposal.* The most common disposal practice is to bury the packaged waste in sanitary landfills approved for asbestos waste by State or local authority. Trench landfills are often used to minimize wind dispersion. If possible the trench should be sloped down from grade at one end so that the the truck can back into the trench. All waste will be unloaded and positioned in accordance with State and local landfill authority requirements. Positioning may be achieved by carefully sliding a load off a Dumpster or dump bed that extends to the ground or unloading by hand or mechanical forklift. Workers conducting this task should be wearing respirators and protective clothing. When the entire load is positioned, the waste is to be covered with a minimum of 6 inches of uncontaminated soil within 24 hours. The revised NESHAP standard governs specific requirements for landfill disposal; however, State and local criteria may be more stringent.

13. CONTAINMENT AREA CONSIDERATIONS.

Environmental and access control techniques protect the health of workers in a hazardous environment and the general public from incidental exposure. Discussed in paragraphs a through f below are the techniques used to control access to the environment within the containment area. These techniques are also intended to prevent uncontrolled fiber releases to the outside environment from within the containment area.

a. Access Control.

(1) *Barriers.* A work area can be delineated by a variety of barriers, from yellow warning tape to a chain link fence, depending upon the location, public access, relative security, etc. Perimeter warning tape must always be used in combination with any other selected barriers method (see sheet 11).

(2) *Signs.* In addition, warning signs (see sheet 11) must be installed at each entry point and at regular intervals along the established barrier.

(3) *Security guards.* Typically, a security guard needs to be considered only for full-scale abatement projects. If the abatement area can be made secure during nonworking hours, then only a daytime guard may be needed. If the nature of the abatement action requires constant monitoring to guarantee continuous operation of the negative exhaust system and/or the site cannot be secured, then a 24-hour security guard may be required.

b. *Work Area Isolation.* The degree of area isolation required is the prime factor of each abatement alternative (see paragraph 9 above). A work area is isolated by preventing the free interchange of air between clean and contaminated environments. In effect, an airtight chamber is created by overlapping polyethylene sheets and sealing all edges and seams to adjacent surfaces, using duct tape. Spray adhesives can be substituted for duct tape; however, they are more difficult to remove and may lift existing wall, floor, and ceiling finishes during removal. Spray adhesives are normally limited to joining and sealing polyethylene laps.

(1) *Critical barriers.* As a minimum, polyethylene critical barriers are installed over all windows, doors, and other openings or penetrations in the walls, floor, and ceiling. The prime purpose of any additional polyethylene is to protect nonabatement surfaces from contamination. Depending on required building usage factors during abatement activities, more rigid critical barriers may be necessary.

(2) *Airflow barrier (air lock).* Access into a work area is always through an airflow barrier consisting of three individual layers (panels) of

	1. Work site name and mailing address	Owner's name	Owner's telephone no.
	2. Operator's name and address		Operator's telephone no.
	3. Waste disposal site (WDS) name, mailing address, and physical site location		WDS phone no.
	4. Name, and address of responsible agency		
Generator	5. Description of materials	6. Containers No. Type	7. Total quantity m ³ (yd ³)
	SAMPLE		
	8. Special handling instructions and additional information		
9. OPERATOR'S CERTIFICATION: I hereby declare that the contents of this consignment are fully and accurately described above by proper shipping name and are classified, packed, marked, and labeled, and are in all respects in proper condition for transport by highway according to applicable international and government regulations.			
Printed/typed name & title		Signature	Month Day Year
Transporter	10. Transporter 1 (Acknowledgment of receipt of materials)		
	Printed/typed name & title	Signature	Month Day Year
	Address and telephone no.		
	11. Transporter 2 (Acknowledgment of receipt of materials)		
Printed/typed name & title		Signature	Month Day Year
Address and telephone no.			
Disposal Site	12. Discrepancy indication space		
	13. Waste disposal site owner or operator: Certification of receipt of asbestos materials covered by this manifest except as noted in item 12.		
	Printed/typed name & title	Signature	Month Day Year

(Continued)

Figure 2. Waste and Shipment Record Sample Format

INSTRUCTIONS

Waste Generator Section (Items 1-9)

1. Enter the name of the facility at which asbestos waste is generated and the address where the facility is located. In the appropriate spaces, also enter the name of the owner of the facility and the owner's phone number.
2. If a demolition or renovation, enter the name and address of the company and authorized agent responsible for performing the asbestos removal. In the appropriate spaces, also enter the phone number of the operator.
3. Enter the name, address, and physical site location of the waste disposal site (WDS) that will be receiving the asbestos materials. In the appropriate spaces, also enter the phone number of the WDS. Enter "on-site" if the waste will be disposed of on the generator's property.
4. Provide the name and address of the local, State, or EPA Regional office responsible for administering the asbestos NESHAP program.
5. Indicate the types of asbestos waste materials generated. If from a demolition or renovation, indicate the amount of asbestos that is
 - Friable asbestos material
 - Nonfriable asbestos material
6. Enter the number of containers used to transport the asbestos materials listed in item 5. Also enter one of the following container codes used in transporting each type of asbestos material (specify any other type of container used if not listed below):
 - DM - Metal drums, barrels
 - DP - Plastic drums, barrels
 - BA - 6 mil plastic bags or wrapping
7. Enter the quantities of each type of asbestos material removed in units of cubic meters (cubic yards).
8. Use this space to indicate special transportation, treatment, storage or disposal or Bill of Lading information. If an alternate waste disposal site is designated, note it here. Emergency response telephone numbers or similar information may be included here.
9. The authorized agent of the waste generator must read and then sign and date this certification. The date is the date of receipt by transporter.

SAMPLE

NOTE: The waste generator must retain a copy of this form.

(continued)

Figure 2. Waste and Shipment Record Sample Format—Continued

Transporter Section (Items 10 & 11)

10. & 11. Enter name, address, and telephone number of each transporter used, if applicable. Print or type the full name and title of person accepting responsibility and acknowledging receipt of materials as listed on this waste shipment record for transport. Enter date of receipt and signature.

NOTE: The transporter must retain a copy of this

Disposal Site Section (Items 12 & 13)

12. The authorized representative of the WDS must note in this space any discrepancy between waste described on this manifest and waste actually received as well as any improperly enclosed or contained waste. Any rejected materials should be listed and destination of those materials provided. A site that converts asbestos-containing waste material to nonasbestos material is considered a WDS.

13. The signature (by hand) of the authorized WDS agent indicates acceptance and agreement with statements on this manifest except as noted in item 12. The date is the date of signature and receipt of shipment.

NOTE: The WDS must retain a completed copy of this form. The WDS must also send a completed copy to the operator listed in item 2.

SAMPLE

Figure 2. Waste and Shipment Record Sample Format—Continued

polyethylene fastened at the top and on alternate sides. The middle layer is fastened on the opposite side to that of the two outer layers. When the HEPA-filtered fan unit is in operation, it creates a negative pressure inside the containment area, and the three access panels are drawn together by the airflow, creating an air lock by which airflow into the work area can be controlled. The following suggestions will help prevent deterioration of the access panels from frequent use and create a tighter air lock:

(a) Reinforce the free-moving edges with duct tape.

(b) Attach a rod weight to the bottom of the outer panel.

(c) Construct flaps from reinforced polyethylene.

(3) *Glove bags.* Glove bags also isolate a work area; however, their use is restricted (see paragraphs 9b(3) and 9f above).

c. Air-Exhausting System.

(1) The air-exhausting system must be installed in all full-scale containment areas before abatement work can begin because this is the system used to contain asbestos fibers within the work area. This system creates a negative pressure within the containment area as compared to the outside ambient area and a pressure gradient through air locks. Sequential air locks are found between the various compartments of the decontamination and load-out units. Negative pressure must be maintained. Then if a small tear or breach should occur in a critical barrier or access way, clean ambient air would flow into the

contaminated area; however, if no pressure differential existed, contaminated air could leak into the surrounding environment.

(2) The discharge of the air-exhausting system must be HEPA-filtered. HEPA filters retain at least 99.97 percent of 0.3 micron monodispersed aerosol before releasing air to the outside environment. The preferred point of air discharge is to the outside of the building. If that is impractical, filtered exhaust air may be discharged within the building, but as far away from the containment area as possible in order to guarantee airflow into the containment area. Flexible ductwork is commonly used to channel the airstream to its discharge point.

(3) As with any ventilation system, the entire system must be properly sized in order to provide the airflow needed to guarantee the desired pressure differential. Conventional practice is to specify a minimum ventilation rate of four air changes per hour. The number of exhaust units needed is determined by dividing the total airflow requirement by the rated capacity of the exhaust unit. The pressure difference between the outside and inside of the containment can be as low as 0.02 inches of water pressure. Although that pressure differential, if maintained, will guarantee airflow into the enclosure, caution must be exercised if the building itself is pressurized or if atmospheric or wind conditions alter or reverse the negative pressure gradient. Therefore, it is recommended that a minimum pressure differential be maintained in order to ensure that the negative pressure gradient is such that airflow into the enclosure would be guaranteed if the containment were breached.

d. Decontamination and Load-Out Units. Two types of decontamination units are usually required: (1) the personnel decontamination unit (see sheet 22) and (2) the material load-out unit (see sheet 20). A load-out unit does not need to be constructed if the volume of removed ACM is small or if there is no space to construct one. In such cases, the bagged ACM may be removed through the personnel decontamination unit. However, if the wrapped or containerized ACM is too large to carry through the personnel

decontamination unit, then a load-out unit must be provided. When properly constructed and used, the decontamination and load-out units will ensure that both airborne asbestos and loose asbestos debris remain within the work area and do not contaminate adjacent areas.

(1) *Personnel decontamination unit.* This unit is composed of at least three rooms: (1) the clean room, (2) the shower room, and (3) the equipment room. Upon entry, workers remove street clothes, put on protective clothing and respirators, and pass through the shower room and equipment room into the abatement work area. When exiting the work area, the workers shed their protective clothing in the work area, remove any additional clothing, shoes, etc., in the equipment room, and enter the shower room while wearing only their respirators. Street clothing is put on in the clean room. Prefabricated decontamination units are commonly used by experienced abatement Contractors.

(2) *Material load-out unit.* This unit is used for the removal of bagged or containerized ACM, and is composed of at least two rooms: (1) the wash room and (2) the holding room. Material flow is through the wash room where the exterior of the bags, etc., are wet wiped before temporarily storing in the holding room. When load-out activities are initiated, the bags, etc., are removed from the holding room onto an enclosed truck or other approved conveyance device. Workers are not to use the load-out unit for entry into or exit from the work area.

e. Personal Protection Program. The purpose of a personal protection program is to continuously evaluate asbestos fiber content in the abatement area so that the proper respirator is used and all other precautionary measures are taken to protect the workers. An effective personal protection program would include the following:

- (1) Respirator-fit testing.
- (2) Medical surveillance.
- (3) Respiratory selection criteria.

(4) Protective clothing, that is, disposable coveralls, boot covers, gloves, and hoods.

(5) Prescribed asbestos decontamination procedures for workers exiting the abatement area.

(6) Worker training.

(7) Appropriate practices to be used in the removal, handling, and disposal of asbestos.

The sections in CEGS 02080 dealing with respiratory protection and worker protection have been prepared using appropriate procedures. The objective of those procedures is to provide a safe level of protection to all parties involved, including workers, supervisors, inspectors, and visitors.

f. Cleaning and Decontamination Procedures. In order to protect the health of individuals who will reoccupy a building (including workers who will demolish the building), the cleaning and decontamination of an asbestos abatement work area is an essential part of all abatement projects, regardless of the type of containment used. The procedures for cleaning and decontamination involve a series of steps that should result in the complete removal of both visible and invisible asbestos fibers. All permanent surfaces (ceilings, walls, and floors) and all furnishings (lights, shelves, and miscellaneous equipment) are wet cleaned and/or HEPA vacuumed as many times as necessary to guarantee successful decontamination. A normal decontamination sequence requires three cleaning cycles, with a thorough visual inspection at the completion of the final cleaning cycle. If there is any discernible dust or debris found, the COR should require additional cleanings. After passing a final visual inspection, air samples are collected and analyzed for the presence of airborne asbestos fibers.

(1) Wet Removal Techniques.

(a) The EPA requires all ACM to be wetted before removal, unless conditions warrant an exception (see paragraph (2) below). Fiber release is minimized by the interstitial attraction that is developed from the wetting. Wetting techniques apply to both friable and nonfriable ACM, even though minimal penetration into the nonfriable ACM can be expected.

(b) Surfactants added to the water aid penetration and dispersal of the water used for

wetting. The surfactants reduce the surface tension of the ACM and prevent beading, thus promoting the interstitial attraction. There are two types of surfactants: (1) amended water and (2) removal encapsulant. Amended water is made from mixing a 1- to 3-percent solution of a inexpensive generic surfactant (such as 50-percent polyoxyethylene ester and 50-percent polyoxyethylene ether) in water. A removal encapsulant that contains an aqueous alkali silicate is more expensive than amended water, but because it has a similar chemical composition to asbestos, the asbestos, in particular amosite asbestos (the surface tension of amosite is higher than other forms of asbestos), is wetted more readily.

(c) When removing nonfriable ACM that breaks up under removal, such as plaster, stucco, or decorative paint, the ACM will be sprayed constantly. Low pressure, low velocity airless sprayers are used because they effectively atomize the wetting agent and reduce the possibility of fiber release from the impact zone.

(2) Dry Removal Techniques. Dry removal is considered extremely hazardous, since fiber release cannot be controlled; therefore, full containment must be employed. Because of the amount of fiber release caused by dry removal, supplied air respirators are recommended. Furthermore, because of the hazards associated with dry removal, the EPA requires that written approval be obtained before abatement begins. Dry removal would be used only in those situations where wet techniques would result in a greater hazard. Normally, dry techniques are used around electrical panels or thermally hot equipment that cannot be deactivated. When used, a local exhaust, HEPA-filtered ventilation and collection system will be placed as close as possible to the abatement activity.

14. RESPONSE ACTION SELECTION.

a. Options. The selection of the most appropriate response action depends upon the purpose of and the circumstances leading to the abatement, as determined during the site survey.

The following options are available to the designer when selecting the most appropriate abatement technique for specific situation:

- (1) Removal
- (2) Encapsulation.
- (3) Encasement.
- (4) Enclosure.
- (5) Repair.

Table 3 above lists the response action options for various ACM. Although all five options are available to the designer for the abatement of friable ACM, the last four are rarely used for demolition work.

b. Demolition and Renovation Factors.

(1) Demolition and renovation response actions are governed by the revised EPA NESHAP regulation and can entail either the repair or removal of both friable and nonfriable ACM. For example, if a building is being demolished and exterior nonfriable ACM is being removed before demolition, final clearance is not required. If the interior ACM is removed before demolition, final air sampling can be satisfied by PCM or as required by more stringent State or customer requirements. TEM sampling is not usually required. PCM air samples are required, however, since demolition workers would probably enter the building after abatement. For interior building renovations, final air clearance is also a requirement, since the space would be reoccupied for normal use. Normally if the ACM under the renovation is exterior, final air clearance would not be required, unless the penetration of airborne dust contaminated interior spaces.

(2) According to the revised NESHAP, category 1 and 2 nonfriable ACM may be left in place during demolition if specific conditions are met. See Army Environmental Office ENVR-EP Memorandum, Policy Guidance on Interpretation of Revised EPA Asbestos Rule Affecting Demolition and Renovation of Buildings.

(3) For demolition work, nonasbestos materials may have to be removed before ACM removal in order to reach the ACM or accommodate project phasing. Nonasbestos

demolition work performed before asbestos abatement should be under the supervision of an individual trained in asbestos abatement and with an awareness of ACM. That individual must be informed of the locations of the ACM and should be on the lookout for other hidden ACM that may become exposed as demolition proceeds.

c. Removal Factors. Complete systems, such as piping or mechanical equipment, may be removed with the ACM still attached. In such cases, glove bag procedures are used to remove the ACM where the pipe or equipment is to be cut or dismantled, leaving component sections as large as possible. Sections with the ACM still attached are wrapped and sealed according to established procedures. This method is feasible when systems are unsalvageable and the respective State does not require segregation of asbestos-contaminated waste before disposal. Removing systems with asbestos insulation intact will usually result in material and labor cost savings. However, the cost of transport and disposal of large components must be evaluated and weighed against the lower abatement cost.

d. Decontamination Factors.

(1) Cleaning the contaminated materials before disposal may be less expensive than preparing them for disposal as contaminated waste, although State regulations, labor rates, and cost of replacement materials for ACM will determine the relative economics of decontamination.

(2) It is possible to wash or HEPA vacuum asbestos-contaminated building materials and then dispose of the materials as nonasbestos waste. Some of the most common examples are carpeting, curtains, ductwork, and ceiling tile. However, it is recommended that laboratory tests be made to verify the success of decontamination.

e. Other Selection Factors. The selection of the most appropriate response action detail sheet should be made carefully, with full coordination with the customer. Furthermore, careful field observations of the situations leading to the response actions affect the selection of the most appropriate abatement detail. Also, a nonfriable

*

ACM that normally requires only a modified containment area should be inspected. Close inspection may reveal that the ACM is in poor condition and friable or would be damaged during removal to the point where it would be considered crumbled, pulverized, or reduced to powder. Then full-scale containment would be indicated. An example would be the removal of asbestos cement heat shields.

15. ABATEMENT DESIGN. Paragraph 14 above presented guidelines for evaluating the available alternatives and options. This paragraph further refines that process.

a. Gathering and Reviewing Data. The design of an abatement project starts with gathering and reviewing all related data and information so that construction documents can be prepared.

(1) General input. Data would include available videotapes, photographs, floor and site plans, and all other information that would aid in establishing the response actions and conceptualizing the abatement design.

(2) Military input. Data gathering would also include contacting the local military authorities to provide information about any changed conditions since the site survey was made.

(3) Customer input. Significant input into the design process can be provided by the local customer, particularly regarding detailed information on the ACM to be abated and scheduling requirements. The designer will take the necessary steps to coordinate with the customer in order to obtain any necessary information that could help prevent changes to the contract during abatement.

b. Guideline Application. Once the data is gathered and reviewed, the designer is ready to select the response action and corresponding setup details, edit the detail sheets and CEGS 02080, and review various factors.

(1) Selecting setup detail. Upon selection of the response action detail for the individual work task, use tables 2 through 5 above for identifying the appropriate setup details for each response

action. If more than one setup detail applies, the designer must analyze the project-related data to determine which alternative detail is the most applicable. For example, if the response actions of a room are for the removal of plaster on an exterior wall (sheet 47) and removal of vinyl asbestos floor tile (sheet 75), of the three alternative setup details that could apply, the most appropriate one would be sheet 4.

(2) Editing details and CEGS 02080 for a specific project.

(a) Both the graphics and the instructions of the details sheets may need to be edited to make them project specific. For instance, assuming the room has no furniture in it and the window wall is the exterior wall, the designer would delete the irregular lines on that wall, which designate polyethylene sheeting, along with any other features that do not exist, such as the register and exterior door. Instructions 1 and 2 for sheet 4 would be edited as noted below.

(Boldfaced indicates deletions.)

1. Establish work area so that unauthorized entry is prevented; see sheet 11. **Eliminate air flow into containment area by isolating all supply and return air ducts from mechanical system.** Lock doors and windows not required for access.

2. Install 6-mil polyethylene barriers over all windows, **doors,** wall openings, electrical outlets, etc. Secure with duct tape on all sides. **HEPA vacuum furniture, fixtures, and equipment and remove from or protect in containment area, as specified by the contract.**

Since no work is expected to be done on the ceiling, instruction 3 would be edited as follows:

3. Prepare area as follows: turn off electrical power **and remove light fixtures.** Protect ceiling as required. HEPA vacuum floor and walls.

As a final edit to sheet 4, the designer should transform the dashed lines representing duct tape to solid lines. Solid lines make the duct tape on the critical barriers visible rather than hidden.

(b) Any paragraph in CEGS 02080 containing brackets, regardless of the text within the brackets, will require editing. Also, the designer should review and edit every instruction on each detail sheet and every paragraph of each CEGS 02080 section, deleting all unrelated, superfluous data and modifying where necessary

to make both project specific. Final versions of the detail sheets supporting the abatement design drawings should be attached to the contract specification at table 1, Summary of Work Tasks.

(3) Review of Factors.

(a) Air rate factors. For sheets 5 and 6, the volume of the containment area must be calculated to verify the rate of exhaust air obtainable from a HEPA vacuum, which is normally 100 cfm or less. Should the size of the containment area exceed the capabilities of the HEPA vacuum, a small capacity HEPA-filtered fan unit would be required and the detail modified accordingly. The most effective way of installing the HEPA-filtered fan unit in a small area would be to cut a window in the polyethylene, slide the fan unit intake up to the window, and seal the polyethylene sheeting to the casing of the fan unit with duct tape. Most of the fan unit would remain outside the containment area and would not become contaminated.

(b) Mini-Containment limitation factors. Mini-containment areas (sheets 5, 6, and 7) should be limited to small-scale, short-duration work or to the removal of low-hazard items. However, that limitation does not apply if the air lock (sheet 1) is replaced with a decontamination/load-out unit. For example, when the abatement action involves only a portion of a large room or area, the use of a bulkhead becomes an economic consideration for several reasons: (1) only a small portion of the area is exposed to contamination, (2) less polyethylene is used, (3) less waste is generated, and (4) a smaller HEPA-filtered air-exhausting fan unit can be used.

(c) Structural critical barrier factors. The structural critical barrier (sheet 28) is a construction barrier that isolates the abatement area from nonwork areas and prevents air exchange between the two areas. This barrier also helps keep unauthorized persons out of the abatement area. Furthermore, this barrier can also serve as a volume-reducing bulkhead if used in conjunction with a decontamination unit elsewhere.

c. Abatement Drawing Creation.

(1) To create an abatement design, a series of two planimetric background drawings should be used. The first drawing would outline the abatement areas and would specify what response action detail sheets would apply for each abatement area. The second drawing would outline the abatement areas but would also superimpose the applicable setup detail sheets for each abatement area. For both drawings, construction-related notations that are an integral part of the abatement design must be added, for example, construction notes such as the following:

1. A construction barrier shall encircle the work area. It shall consist of yellow warning tape attached to posts at 9 feet on center and strung 3 feet above grade. Warning signage shall be attached to the tape at a 45 feet spacing (see detail sheet 14).

(2) The drawings should also include the following items:

(a) Location of the decontamination and load-out units.

(b) Pick-up points for electrical power and potable water.

(c) Route to be taken for disposal of the ACM, and the location of the disposal truck.

(d) Area for locating the HEPA-filtered fan unit and routing of the discharge air duct.

(3) For small, uncomplicated projects, the abatement area and response action plans may be combined in order to reduce the total number of sheets.

(4) A helpful technique for describing actual site conditions is the use of photographic sticky-back images that can be attached to a drawing in order to create a descriptive detail. With the addition of specific instructions, the photographic details can identify the ACM that will be removed, highlight the prospective site of the load-out unit, show how to discharge the HEPA-filtered exhaust air through a window, etc.

(5) If at any time during the abatement design process the designer identifies a building material that was not surveyed but is affected by the project, the designer should develop a bulk

sampling program and have the bulk samples gathered and forwarded to the designated project laboratory for analysis. However, if the quantity of material is limited and since all materials are assumed to be asbestos containing until proven otherwise, the designer could forego sampling, treat it as an ACM and include it with the other response actions.

16. REPLACEMENT DESIGN. This EP is directed toward abatement activities and does not include technical designs and specifications for the replacement or restoration of abated materials. It is expected that the development of designs and specifications for replacement will follow established procedures. To ensure that abated

ACM is replaced with asbestos-free substitutes, the Contractor must submit the manufacturer's guarantee or the manufacturer's material safety data sheet as evidence that the replacement materials are asbestos-free. If the same Contractor is providing and installing replacement materials, documentation that replacement products are asbestos free should be one of the items in the Contractor's submittal register.

17. COST ESTIMATING. Asbestos abatement and removal cost and pricing data may be obtained from the Corps of Engineers Computer-Aided Cost Engineering Support System, Division I. The data are to be site adapted as applicable.

Part 2, Setup Details

FRAME AIR-LOCK WITH VERTICAL STUDS SPACED A MAXIMUM OF 24 IN. ON CENTER EXCEPT AT 3'-0" OPENINGS. PROVIDE HORIZONTAL FRAMING MEMBERS AT TOP AND BOTTOM.

COVER WALLS AND ROOF FRAMING WITH PLYWOOD AND COVER WITH 2 LAYERS OF 6 MIL POLYETHYLENE. TAPE ALL JOINTS.

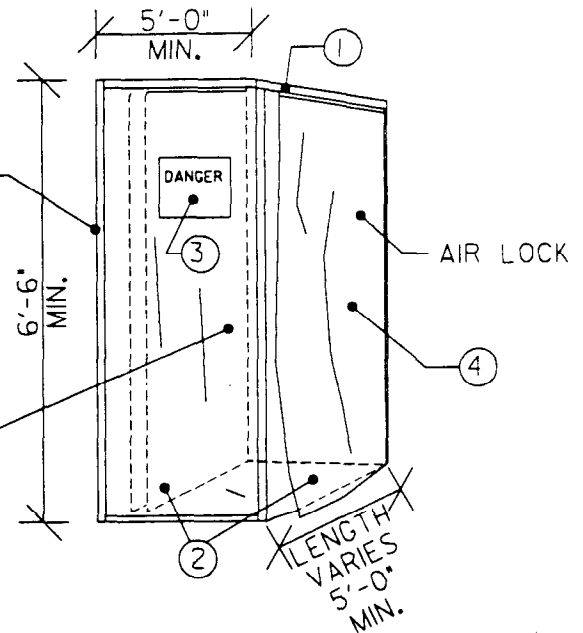

Air lock

1. Establish work area so that unauthorized entry is prevented; see sheet 11. Construct a wood frame. Install one layer of 6-mil polyethylene sheeting to structural members and two layers to the floor. Seal all edges of sheeting to wall, ceiling, and floor surfaces with duct tape.
2. Install triple flaps of 6-mil polyethylene sheeting at both doorways.
3. Install danger signs on each side of air lock area; see sheet 11.
4. Before leaving work area, remove outer suit. Place in a plastic bag; see sheet 9.

5. Enter air lock. Wet wipe respirator and wash hands with clean water from portable sprayer. Remove respirator, and place in a clean plastic bag. Proceed to shower, where inner suit may be removed.

Final clearance requirements. After abatement is completed, prepare area for final clearance. Contractor and Contracting Officer will certify visual inspection of work area on sheet 19, *Certification of Final Cleaning and Visual Inspection*. Contract designee(s) will conduct final air-clearance monitoring as required by the contract. Remove containment area upon instructions from the Contracting Officer, and treat as asbestos-contaminated material; see sheets 9 and 14.

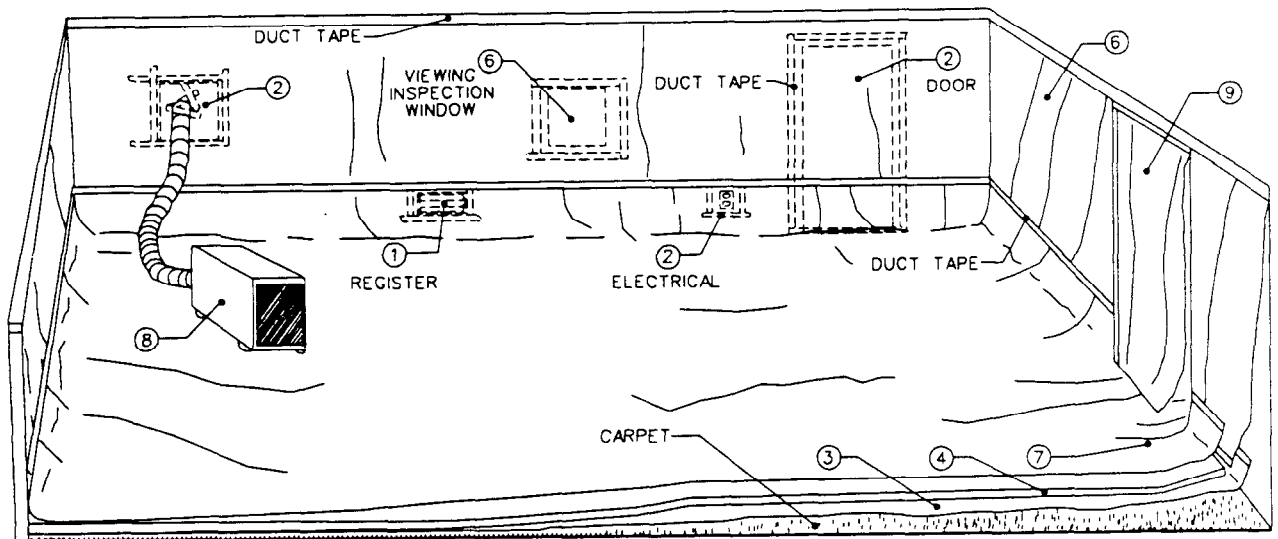

Installation of critical barrier and full containment area (for carpeted floors)

1. Establish work area so that unauthorized entry is prevented; see sheet 11. Eliminate airflow into containment area by isolating all supply and return air ducts from mechanical system. Lock doors and windows not required for access.
 2. Install 6-mil polyethylene critical barriers over all windows, doors, wall openings, electrical outlets, etc. Secure with duct tape on all sides. HEPA vacuum furniture, fixtures, and equipment and remove from or protect in containment area, as specified by the contract.
 3. Install first layer of 6-mil polyethylene on floor, extending the polyethylene 18 inches up wall. Secure with duct tape.
 4. Install 0.5-inch plywood in order to protect 6-mil polyethylene underlay.
 5. Prepare area as follows: turn off electrical power and remove light fixtures. Protect ceiling as required. HEPA vacuum plywood and walls.
 6. Protect wall surface with 6-mil polyethylene from floor to ceiling where walls are not to be abated. Install viewing inspection windows, where feasible.
 7. Place 6-mil polyethylene on top of plywood, extending polyethylene 18 inches up wall.
 8. Install HEPA filter unit and duct work; see sheet 8.
 9. Prepare door into decontamination or load-out unit. See sheet 22 for decontamination unit and sheet 20 for load-out unit. Doors that swing into the work area must be removed from hinges.
- Final clearance requirements.** After abatement has been completed, see sheet 16 for final clearance requirements.

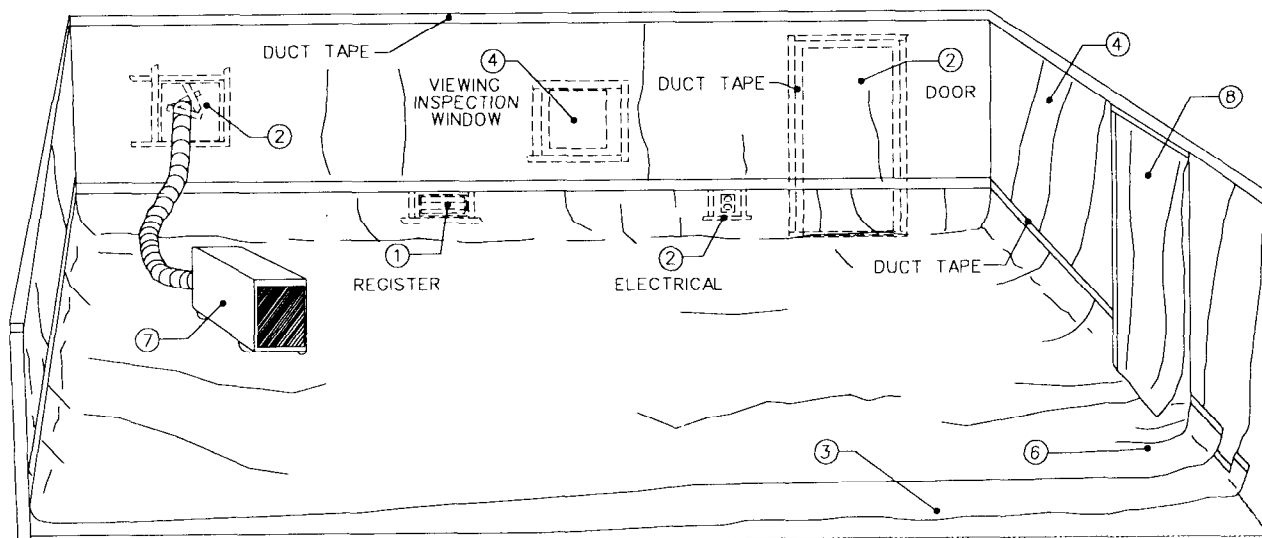

Installation of critical barrier and full containment area (for hard floor surfaces)

1. Establish work area so that unauthorized entry is prevented; see sheet 11. Eliminate airflow into containment area by isolation of all supply and return air ducts from mechanical system. Lock doors and windows not required for access.
2. Install 6-mil polyethylene critical barriers over all windows, doors, wall openings, electrical outlets, etc. Secure with duct tape on all sides. HEPA vacuum furniture, fixtures, and equipment and remove from or protect in containment area, as specified by the contract.
3. Install first layer of 6-mil polyethylene on floor, extending the polyethylene 18 inches up wall. Secure with duct tape.
4. Protect wall surface with 6-mil polyethylene from floor to ceiling. Install view inspection windows, where feasible.
5. Prepare area as follows: turn off electrical power and remove light fixtures. Protect ceiling as required. HEPA vacuum floor and walls.
6. Install top layer of 6-mil polyethylene.
7. Install HEPA filter unit and duct work; see sheet 8.
8. Prepare door into decontamination unit or load-out unit; see sheet 22 for decontamination unit and sheet 20 for load-out unit. Doors that swing into the work area must be removed from hinges.

Final clearance requirements. After abatement has been completed, see sheet 17 for final clearance requirements.

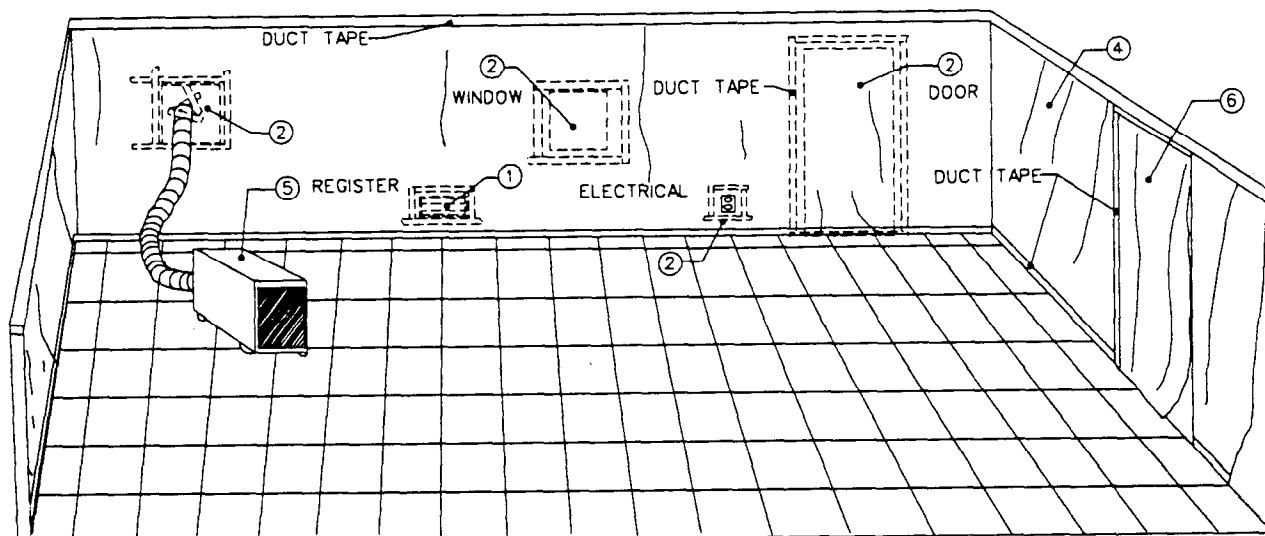

Installation of critical barrier and full containment area (for vinyl tile floors)

1. Establish work area so that unauthorized entry is prevented; see sheet 11. Eliminate airflow into containment area by isolating all supply and return air ducts from mechanical system. Lock doors and windows not required for access.

2. Install 6-mil polyethylene critical barriers over all windows, doors, wall openings, electrical outlets, etc. Secure with duct tape on all sides. HEPA vacuum furniture, fixtures, and equipment and remove from or protect in containment area, as specified by the contract.

3. Prepare area as follows: turn off electrical power and remove light fixtures. Protect ceiling as required. HEPA vacuum floors and walls.

4. Protect wall surface with 6-mil polyethylene from floor to ceiling. Install viewing inspection windows, where feasible.

5. Install HEPA filter unit and duct work; see sheet 8.

6. Prepare door into decontamination unit or load-out unit; see sheet 22 for decontamination unit and sheet 20 for load-out unit. Doors that swing into the work area must be removed from hinges.

Final clearance requirements. After abatement has been completed, see sheet 18 for final clearance requirements.

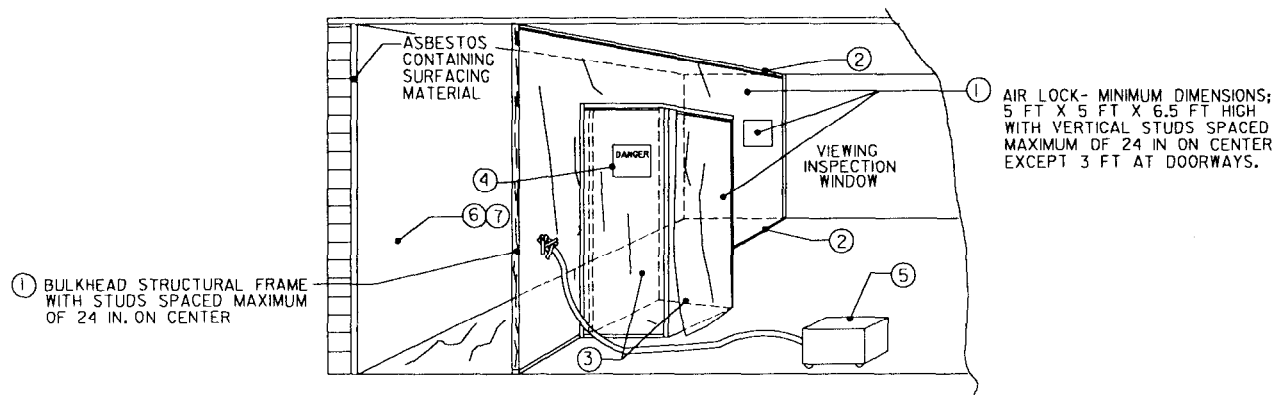

Single bulkhead containment area

1. Establish work area so that unauthorized entry is prevented; see sheet 11. Construct a structural frame for a bulkhead wall and an air lock. See sheet 1 for air lock requirements other than those identified in note 1 of this drawing. Bulkhead is to be parallel to the item requiring abatement. Attach structural frame to walls, floor, or ceiling as necessary for stability. Cover the frame with one layer and the floor with two layers of 6-mil polyethylene sheeting, sealing edges of polyethylene to walls, ceilings, and floor surfaces with duct tape. Install viewing inspection windows, where feasible.

2. Seal with duct tape all penetrations (typical) such as pipes, electrical conduit, or ducts.

3. Install triple 6-mil polyethylene flaps at both doorways. Place portable sprayer with clean water, disposable towels, and prelabeled disposal bag in air lock.

4. Install danger signs on outside of containment area; see sheet 11.

5. Install HEPA vacuum. Extend hose into mini-containment area for general vacuuming, negative air, and cleaning of disposable suit.

6. Accumulate all loose materials for disposal, and place in approved container; see Sheet 9. Apply labels; see sheet 14. Adequately wet clean all wall, floor, tool, and equipment surfaces.

7. Abatement worker must wear two disposable suits. Remove outer suit in work area and place in a plastic bag; see sheet 9. Enter air lock.

8. In air lock, wet wipe respirator and wash hands with clean water from portable sprayer. Remove respirator and place in clean plastic bag. Proceed to remote shower where inner suit may be removed.

Final clearance requirements. After abatement is completed, prepare area for final clearance. Contractor and Contracting Officer will certify visual inspection of work area on sheet 19, *Certification of Final Cleaning and Visual Inspection*. Contractor will apply lockdown encapsulant. Contract designee(s) will conduct final air-clearance monitoring as required by the contract. Remove containment area upon instructions from the Contracting Officer, and treat it as asbestos-contaminated material. Place in approved container; see sheet 9. Apply labels, see sheet 14. Dispose of as specified in the contract.

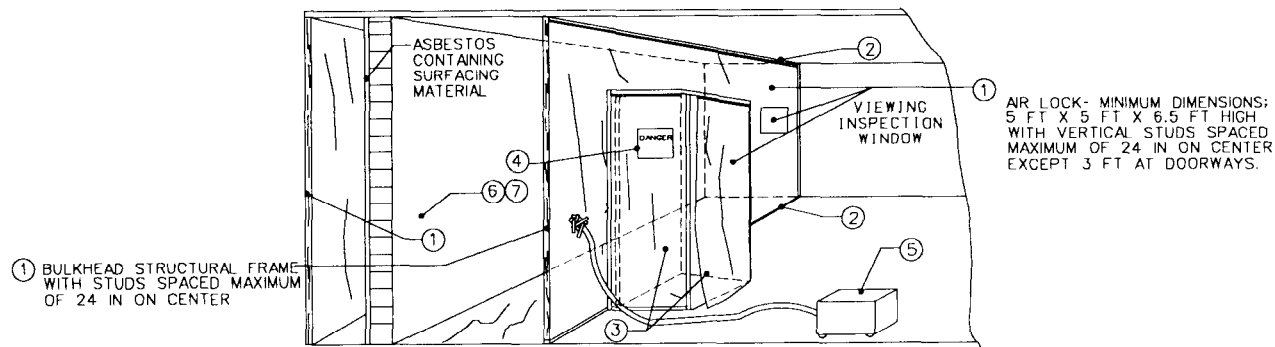

Double bulkhead containment area

1. Establish work area so that unauthorized entry is prevented; see sheet 11. Construct a structural frame for two bulkhead walls and an air lock. See sheet 1 for air lock requirements other than those identified in note 1 of this drawing. Bulkheads are to be parallel to the wall being removed. Attach structural frame to walls, floor, or ceiling as necessary for stability. Locate change room on the side opposite the asbestos-containing surface material. Cover the frame with one layer and the floor with two layers of 6-mil polyethylene sheeting and seal edges to walls, ceiling, and floor surfaces with duct tape. If a bulkhead is located outside the building, end walls and a roof will also be required. Install viewing inspection windows, where feasible.
2. Seal with duct tape all penetrations (typical) such as pipes, electrical conduit, or ducts.
3. Install triple 6-mil polyethylene flaps at doorways. Place portable sprayer with clean water, disposable towels, and prelabeled disposal bag in air lock.
4. Install danger signs on outside of containment area; see sheet 11.
5. Install HEPA vacuum; extend hose into mini-containment area for general vacuuming, negative air, and cleaning of disposable suit.

6. Accumulate all loose materials for disposal. Place in approved container; see sheet 9. Apply labels; see sheet 14. Adequately wet clean all wall, floor, tool, and equipment surfaces.

7. Abatement worker must wear two disposable suits. Remove outer suit in work area and place in a plastic bag; see sheet 9. Enter air lock.

8. In air lock, wet wipe respirator and wash hands with clean water from portable sprayer. Remove respirator and place in a clean plastic bag. Proceed to shower where inner suit may be removed.

9. After abatement is completed, prepare area for final clearance.

Final clearance requirements. After abatement is completed, prepare area for final clearance. Contractor and Contracting Officer will certify visual inspection of work area on sheet 19, *Certification of Final Cleaning and Visual Inspection*. Contractor will apply lockdown encapsulant. Contract designee(s) will conduct final air-clearance monitoring as required by the contract. Remove containment area upon instructions from the Contracting Officer, and treat it as asbestos-contaminated material. Place in approved container; see sheet 9. Apply labels; see sheet 14. Dispose of as specified in the contract.

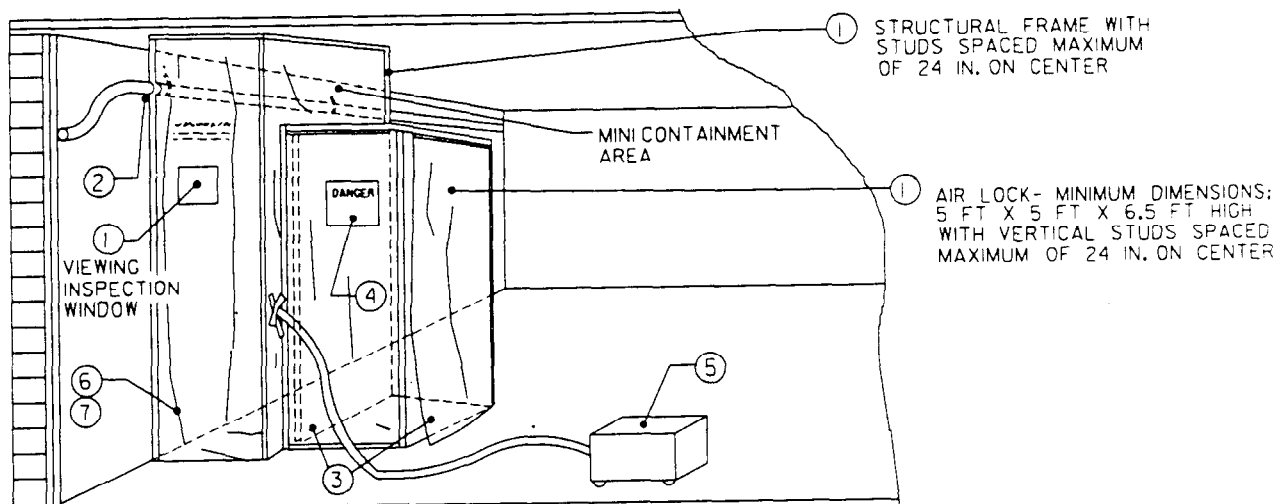

Mini-containment area

1. Establish work area so that unauthorized entry is prevented; see sheet 11. Construct a two-compartment wood frame around work area; install one layer 6-mil polyethylene sheeting to structural members and two layers 6-mil polyethylene sheeting to the floor. Seal all edges to wall, ceiling, and floor surfaces with duct tape. Install viewing inspection windows, where feasible.

2. Seal with duct tape all penetrations (typical) such as pipes, electrical conduit, or ducts.

3. Install triple 6-mil polyethylene flaps at both doorways. Place portable sprayer with clean water, disposable towels, and prelabeled disposal bag in air lock.

4. Install danger signs on outside of containment area. See sheet 11.

5. Install HEPA vacuum; extend hose into mini-containment area for general vacuuming, negative air, and cleaning of disposable suit.

6. Accumulate all loose materials for disposal. Place in approved container; see sheet 9. Apply labels; see

sheet 14. Adequately wet clean all wall, floor, tool, and equipment surfaces.

7. Abatement worker must wear two disposable suits. Remove outer suit in work area and place in a plastic bag; see sheet 9. Enter air lock.

8. In air lock, wet wipe respirator and wash hands with clean water. Remove respirator and place in a clean plastic bag. Proceed to remote shower unit where inner suit may be removed.

Final clearance requirements. After abatement is completed, prepare area for final clearance. Contractor and Contracting Officer will certify visual inspection of work area on sheet 19, *Certification of Final Cleaning and Visual Inspection*. Contractor will apply lockdown encapsulant. Contract designee(s) will conduct final air-clearance monitoring as required by the contract. Remove containment area upon instructions from the Contracting Officer, and treat it as asbestos-contaminated material. Place in approved container; see sheet 9. Apply labels, see sheet 14. Dispose of as specified in the contract.

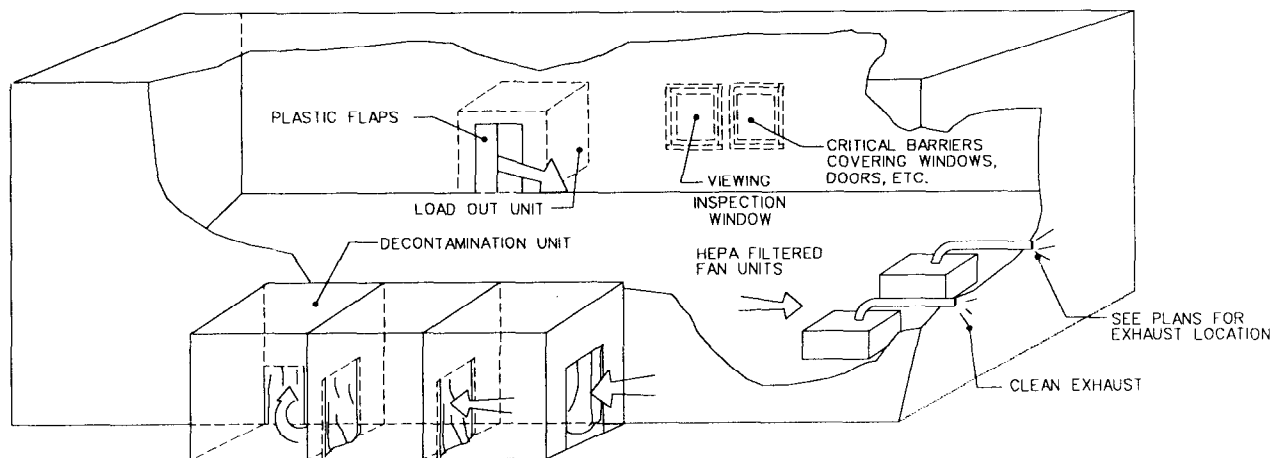

Ventilation of containment area and decontamination unit, using HEPA filters

1. Install a ventilation system in the containment area that draws the air supply through the decontamination and load-out units. See sheets 20 and 22.
2. Operate ventilation system 24 hours a day from start of abatement through final clearance.
3. Place at the decontamination unit entrance a pressure gauge that measures differential pressure between abatement and ambient areas. Gauge must be read hourly and logged or continuously recorded.
4. The ventilation system must create, as a minimum, a negative pressure of 0.02 inches of water inside the containment area (relative to the outside of the containment area) and must be sized for a minimum of four air changes per hour or more, as specified in the contractor's asbestos hazard abatement plan.
5. Locate HEPA filters in order to prevent dead air pockets.
6. Exhaust filtered air to outside of building, unless otherwise approved by the Contracting Officer.

Final clearance requirements. For final clearance, remove ventilation system upon instruction from the Contracting Officer and relocate to equipment room of decontamination unit. Thoroughly HEPA vacuum unit and ducting. Adequately wet clean all surfaces and wheels of unit(s). Collect all waste debris and unit filters, and treat as asbestos-contaminated material, placing in approved container; see sheet 9. Apply labels; see sheet 14. Dispose of waste as required by the contract. Wrap unit in one layer of 6-mil polyethylene sheeting, and seal with duct tape before removing from job location.

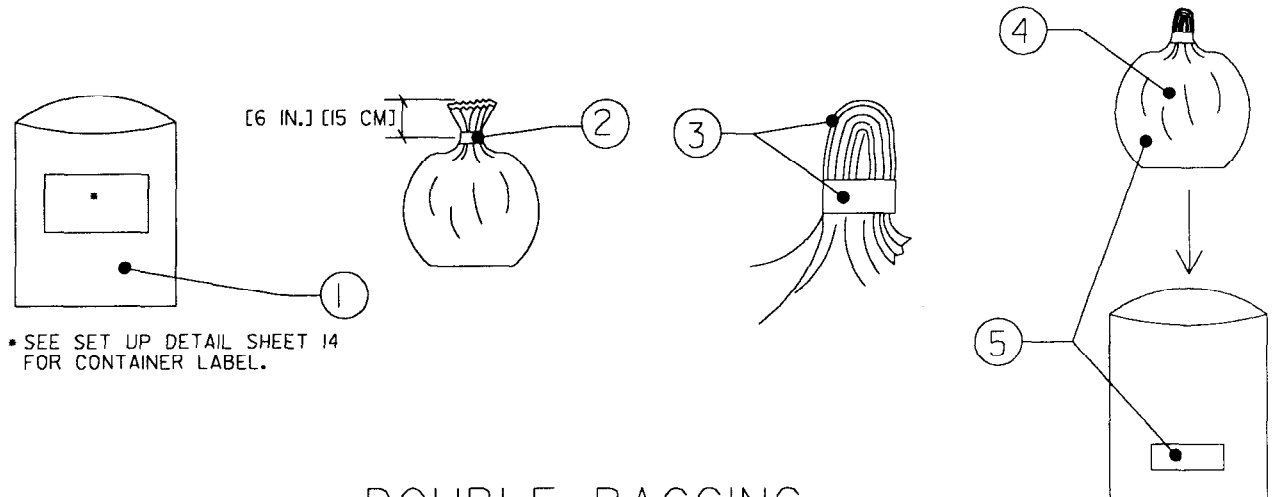

• SEE SET UP DETAIL SHEET 14 FOR CONTAINER LABEL.

DOUBLE BAGGING

Containers—double bagging

1. Place the still-wet asbestos-containing and asbestos-contaminated material into a prelabelled 6-mil polyethylene bag. Do not overfill. Do not use bag for asbestos-containing or asbestos-contaminated material that could puncture the bag. (See sheet 9C for packaging items that could puncture bags.)
2. Evacuate with HEPA vacuum, and seal collapsed bag by twisting top [6 in] [15 cm] closed and wrapping with a minimum of two layers of duct tape.
3. Twist top and fold over. Apply second wrap of duct tape.
4. Adequately wet clean outside of disposal bag by wet wiping, and take bag to the equipment and staging area.
5. Place bag inside a second prelabelled 6-mil polyethylene bag.
6. Seal outer bag by repeating steps 2 and 3 above. Take bag to load-out unit; see sheet 20.

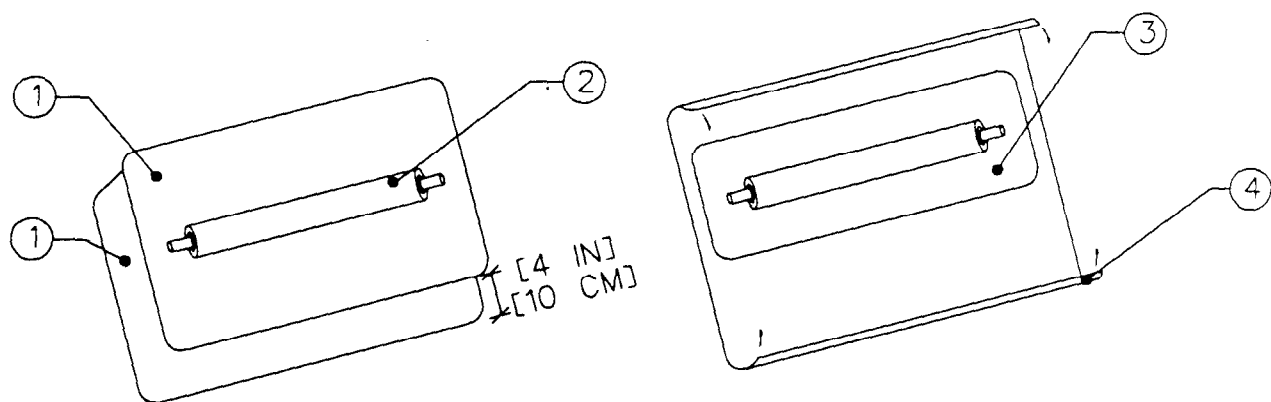

Containers—leak-tight wrapping

1. Place two layers of 6-mil polyethylene sheet on surface so that the bottom layer is offset [4 in] [10 cm] from the top layer.
2. Place the still-wet asbestos-containing or asbestos-contaminated material that is too large (boiler, vessel, pipe segment, etc.) to be placed in disposal bags on the top layer of polyethylene.
3. Wrap the top layer tightly around the contaminated material. Seal all edges of the top layer of sheeting with duct tape. Apply labels; see sheet 14.
4. Repeat procedure with bottom layer, including labeling. Take to load-out unit; see sheet 20.

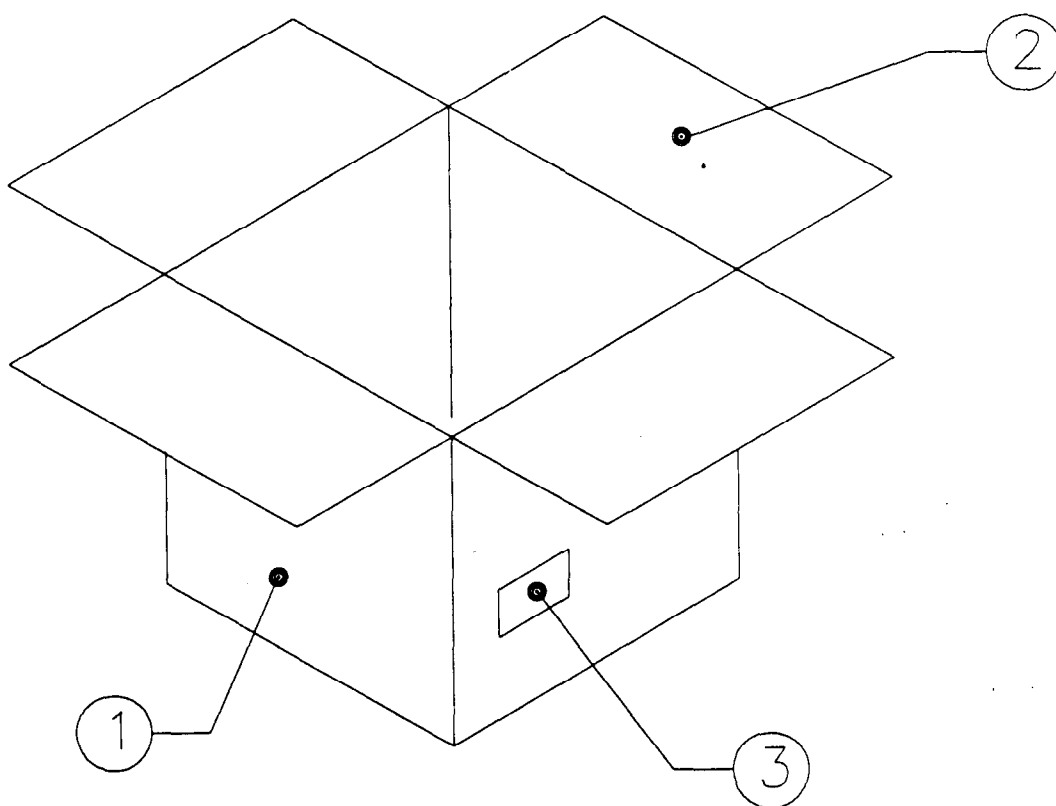

Containers—corrugated cardboard boxes

1. Place still-wet asbestos-containing or asbestos-contaminated material that could puncture disposal bags into heavy-duty corrugated cardboard boxes coated with plastic or wax that will retard deterioration from moisture.

2. Close flaps, and seal with duct tape.

3. Apply labels; see sheet 14. Place box into disposal bags; see sheet 9A. Take to load-out unit; see sheet 20.

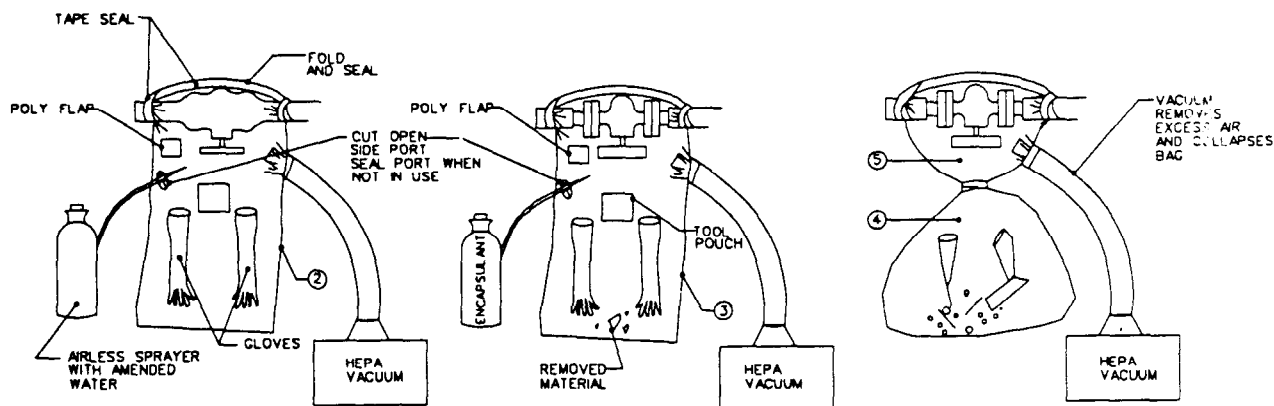

Glove bag

1. Construct modified containment area in accordance with sheet 21. NOTE: Inspect for structural integrity the insulation material adjacent to section being removed, since glove bag removal procedure is not appropriate if it will cause asbestos fiber release from adjacent asbestos-containing material.
2. Put tools and rags inside glove bag. Insulation adjacent to the asbestos-containing material being removed must be adequately wet cleaned and sprayed with an encapsulant before placing glove bag over the area to be removed. Install glove bag according to manufacturer's instructions. (NOTE: Negative-air glove bags may be used if first approved by Contracting Officer. Manufacturer procedures for negative-air glove bags will vary from procedures identified on this sheet.) Install HEPA filter vacuum cleaner with hose ducted into bag. Seal with duct tape. Smoke test for leaks. Soak insulation with amended water.
3. Remove insulation and clean exposed metal surfaces. Encapsulate exposed ends of insulation and metal surfaces. Adequately wet clean glove bag surfaces to below tool pouch.

4. Grasp tools in pouch and withdraw by pulling glove inside out. Twist glove above encased tools to create a constriction, and tape constricted area with duct tape. Cut through middle of taped area so that tools and glove bag will both remain sealed. Place encased tools into tool pouch of next glove bag or decontaminate by water immersion.

5. Evacuate glove bag, using HEPA vacuum. Twist bag to create a constriction below tool pouch. Wrap constricted area with duct tape. Cut bag [4 in] [10 cm] above constriction. Double bag cut off portion of bag; see sheet 9. Apply labels; see sheet 14. Cap and seal end of HEPA vacuum hose in order to prevent incidental fiber release.

6. Remove remaining portion of glove bag. Place in approved container; see sheet 9. Apply labels; see sheet 14. Dispose as asbestos-contaminated waste.

Final clearance requirements. For final clearance, Contractor and Contracting Officer will certify visual inspection of work area on sheet 19, *Certification of Final Cleaning and Visual Inspection*. Contract designee(s) will conduct final air-clearance monitoring as required by the contract.

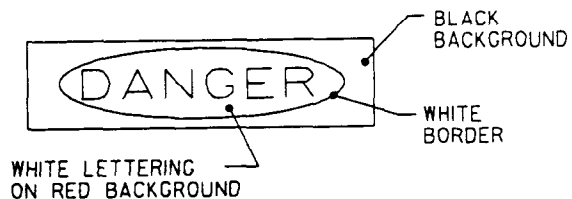
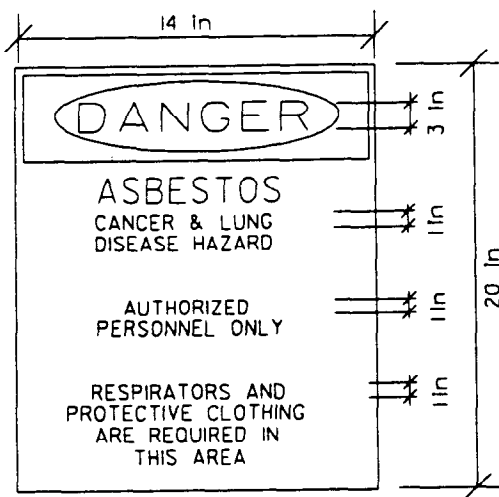







AREA WARNING SIGNS AND WARNING TAPE

DETAIL

Area warning signs and warning tape

1. Provide and install [4 mil] [0.10 mm] polyethylene warning tape at locations shown on the abatement area plan.
2. Warning tape is to be attached to wood or metal posts at [10 ft] [300 cm] on center. Tape must be [3 ft] [100 cm] from ground.
3. Attach both warning signs at each entrance of the work area and at [33 yd] [30 m] on center where security fencing is installed.
4. Warning signs must be in English and other languages required by the contract.
5. Install at eye level.

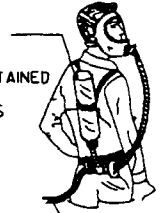
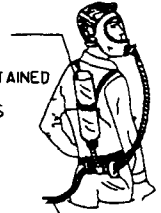
FIBER CONCENTRATION	MINIMUM REQUIRED RESPIRATOR	
NOT IN EXCESS OF 1 FIBER/CC	HALF-MASK AIR PURIFYING RESPIRATOR WITH HEPA FILTERS	
NOT IN EXCESS OF 5 FIBERS/CC	FULL FACEPIECE AIR-PURIFYING RESPIRATOR WITH HEPA FILTERS	HEPA FILTER 
NOT IN EXCESS OF 10 FIBERS/CC	LOOSE FITTING HELMET OR HOOD, POWERED AIR-PURIFYING RESPIRATOR WITH HEPA FILTERS	BATTERY-POWERED BLOWER WITH HEPA FILTER 
NOT IN EXCESS OF 10 FIBERS/CC	POWERED AIR-PURIFYING RESPIRATOR WITH FULL FACEPIECE AND HEPA FILTER	
NOT IN EXCESS OF 10 FIBERS/CC	LOOSE FITTING HELMET OR HOOD, SUPPLIED AIR RESPIRATOR OPERATED IN CONTINUOUS FLOW MODE WITH BACK-UP HEPA FILTER	
NOT IN EXCESS OF 10 FIBERS/CC	SUPPLIED AIR RESPIRATOR WITH FULL FACEPIECE OPERATED IN CONTINUOUS FLOW MODE WITH BACK-UP HEPA FILTER	AIR SUPPLY 
NOT IN EXCESS OF 100 FIBERS/CC	FULL FACEPIECE SUPPLIED AIR RESPIRATOR OPERATED IN PRESSURE-DEMAND MODE WITH BACK-UP HEPA FILTER	AIR SUPPLY 
GREATER THAN 100 FIBERS/CC OR UNKNOWN CONCENTRATION	FULL FACEPIECE SUPPLIED-AIR RESPIRATOR OPERATED IN PRESSURE-DEMAND MODE WITH AUXILIARY POSITIVE-PRESSURE SELF-CONTAINED BREATHING APPARATUS	AUXILIARY POSITIVE-PRESSURE SELF-CONTAINED BREATHING APPARATUS 
		AIR SUPPLY 

Respiratory protection table

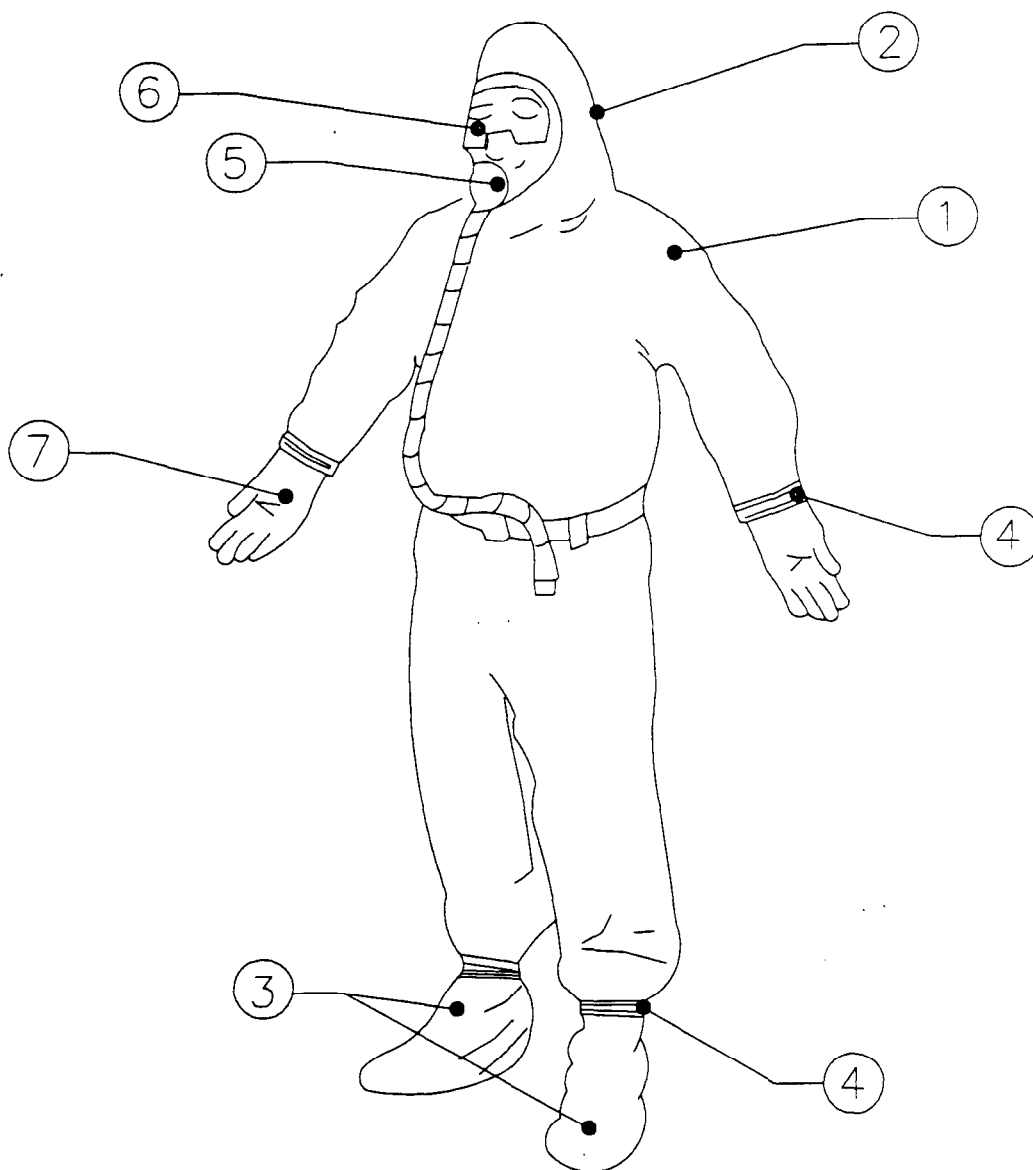

Protective clothing

1. Disposable or reusable full body suit with elastic around hood and shoe cover openings is required or as otherwise specified in the contract.
2. Hood shall be worn over respirator's head and neck straps.
3. Shoe covers shall be worn over work shoes.
4. Cuffs shall be taped with duct tape at wrists and ankles in order to prevent infiltration.
5. Cartridge-type air-purifying HEPA filter respirator is minimal requirement. Type shall be selected in accordance with sheet 12.
6. If eye protection is not integral with respirator, protection goggles are required.
7. Rubber work gloves are recommended to be worn alone or under outer work gloves provided for hand and operation safety.

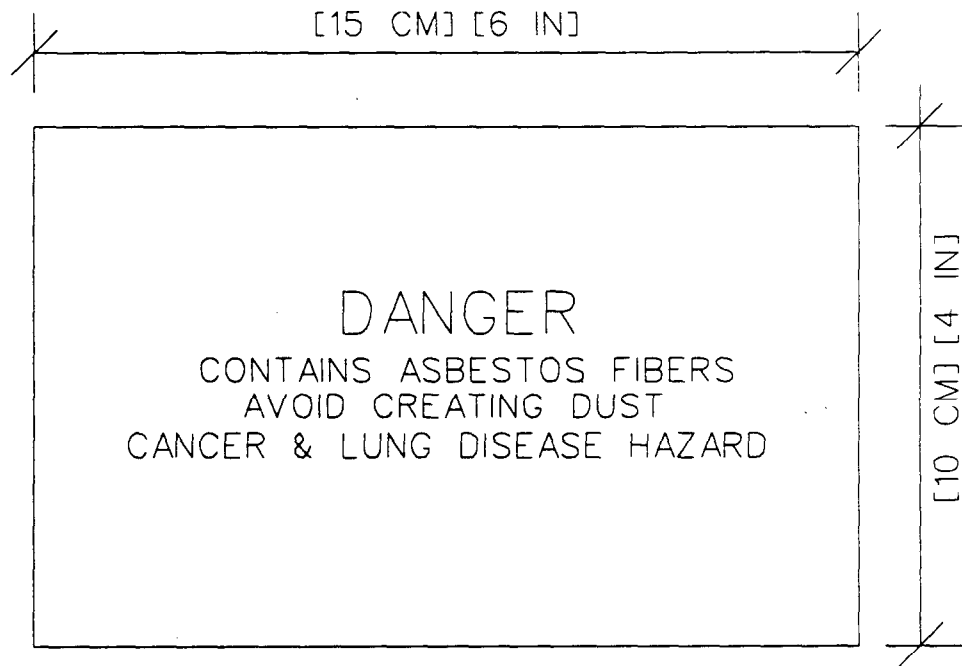

Disposal container label

Attach warning labels to each disposal container removed from abatement area.

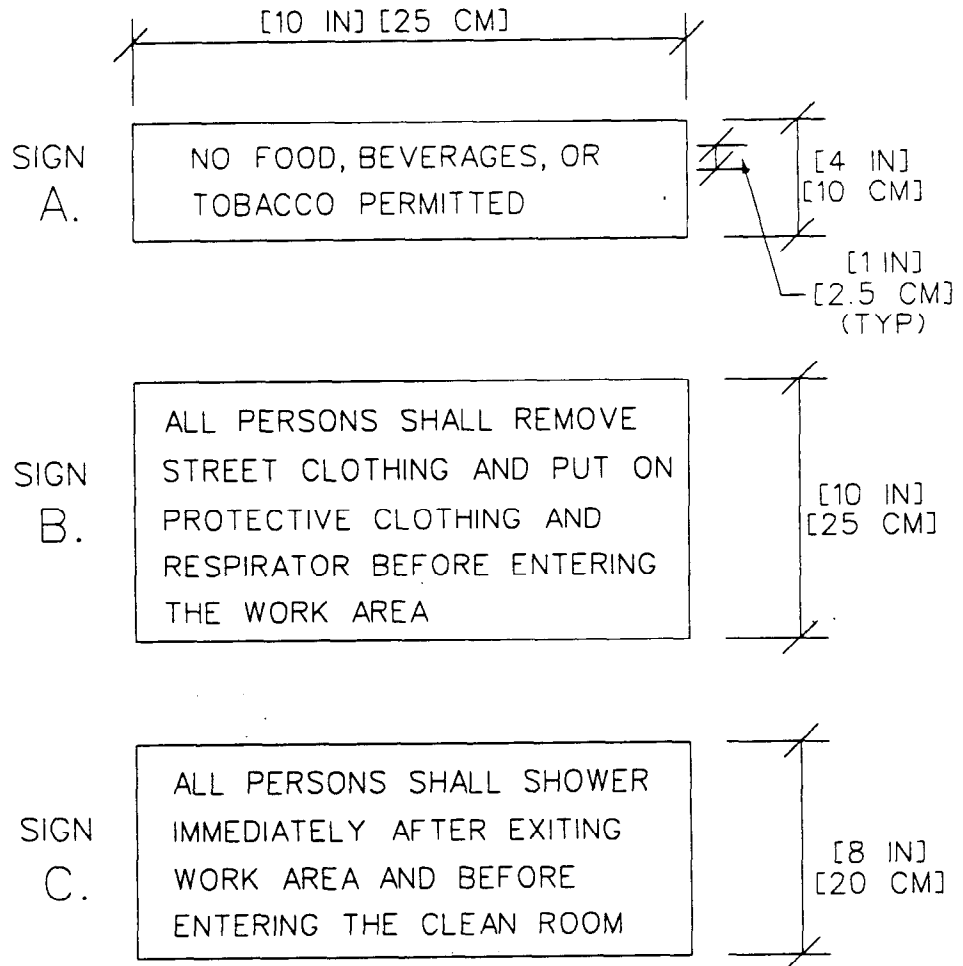

Decontamination unit signage

1. Provide signs in English and other languages required by the contract.
2. Install at eye level.

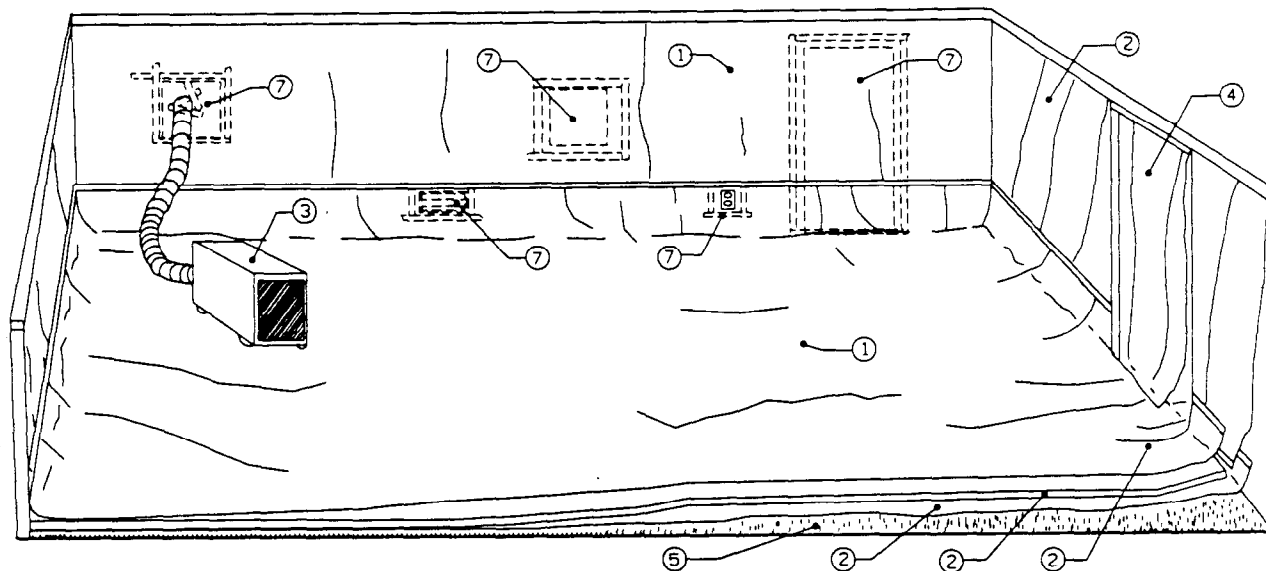

Preparation of full containment area for final clearance (for carpeted floors)

1. Accumulate all loose material for disposal. Place material in approved container; see sheet 9. Apply labels; see sheet 14. Adequately wet clean and HEPA vacuum all wall, floor, and equipment surfaces.
2. Contractor and contracting officer will certify visual inspection of work area on sheet 19, *Certification of Final Cleaning and Visual Inspection*.
3. Apply lockdown encapsulant.
4. Remove polyethylene from walls, floor, and plywood. HEPA vacuum plywood before removal. Critical barriers sealing all windows, doors, wall openings, electrical outlets, etc., are to remain. Remove any temporary equipment enclosures used; see sheet 24. Treat polyethylene as asbestos-contaminated material. Place in approved container; see sheet 9 for leak-tight wrapping. Apply labels; see sheet 14. NOTE: With approval from the Contracting Officer, uncontaminated plywood can be treated as ordinary construction waste; otherwise, treat as asbestos-contaminated material.
5. HEPA filter unit remains in place and operating.
6. Door into contamination unit or load-out room remains.
7. HEPA vacuum carpet.
8. Prepare area for final clearance.
9. Contractor and Contracting Officer will recertify visual inspection of work area on sheet 19, *Certification of Final Cleaning and Visual Inspection*.
10. Contract designee(s) will conduct final air-clearance monitoring as required by the contract.
11. Upon instruction from Contracting Officer, shut down HEPA filter ventilation system, detach duct work, move system to equipment room of decontamination unit, clear and dispose of waste; see sheet 8. Remove critical barrier and place in approved container; see sheet 9. Apply labels; see sheet 14. Dispose of waste as asbestos-contaminated material.

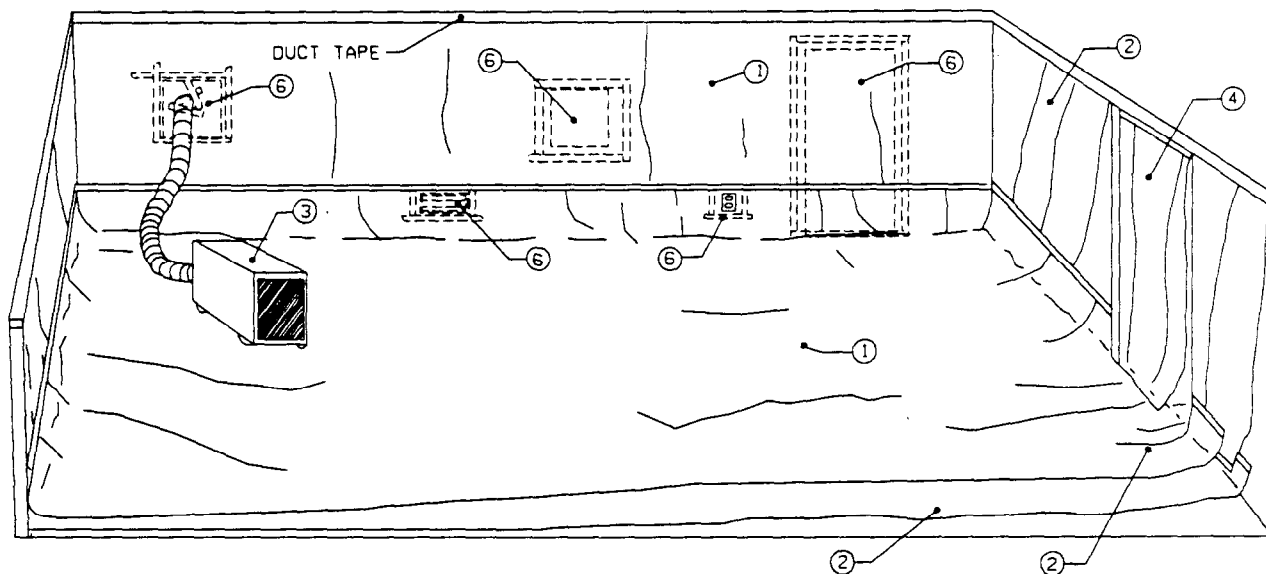

Preparation of full containment area for final clearance (for hard-surfaced floors)

1. Accumulate all loose material for disposal. Place in approved container; see sheet 9. Apply labels; see sheet 14. Adequately wet clean and HEPA vacuum all wall, floor, and equipment surfaces.
2. Contractor and contracting officer will certify visual inspection of work area on sheet 19, *Certification of Final Clearing and Visual Inspection*.
3. Apply lockdown encapsulant.
4. Remove polyethylene on walls and floor. Critical barriers sealing all windows, doors, wall openings, electrical outlets, etc., are to remain. Remove any temporary equipment enclosures used; see sheet 24. Treat polyethylene as asbestos-contaminated material. Place in approved container; see sheet 9 for leak-tight wrapping. Apply labels; see sheet 14.
5. HEPA filter unit remains in place and operating.
6. Door into decontamination unit or load-out room remains.
7. Prepare area for final clearance.
8. Contractor and Contracting Officer will recertify visual inspection of work area on sheet 19, *Certification of Final Clearing and Visual Inspection*.
9. Contract designee(s) will conduct final air-clearance monitoring as required by the contract.
10. Upon instruction from Contracting Officer, shut down HEPA filter ventilation system, detach duct work, move system to equipment room of decontamination unit, clear and dispose of waste; see sheet 8. Remove critical barrier and place in approved container; see sheet 9. Apply labels; see sheet 14. Dispose of waste as asbestos-contaminated material.

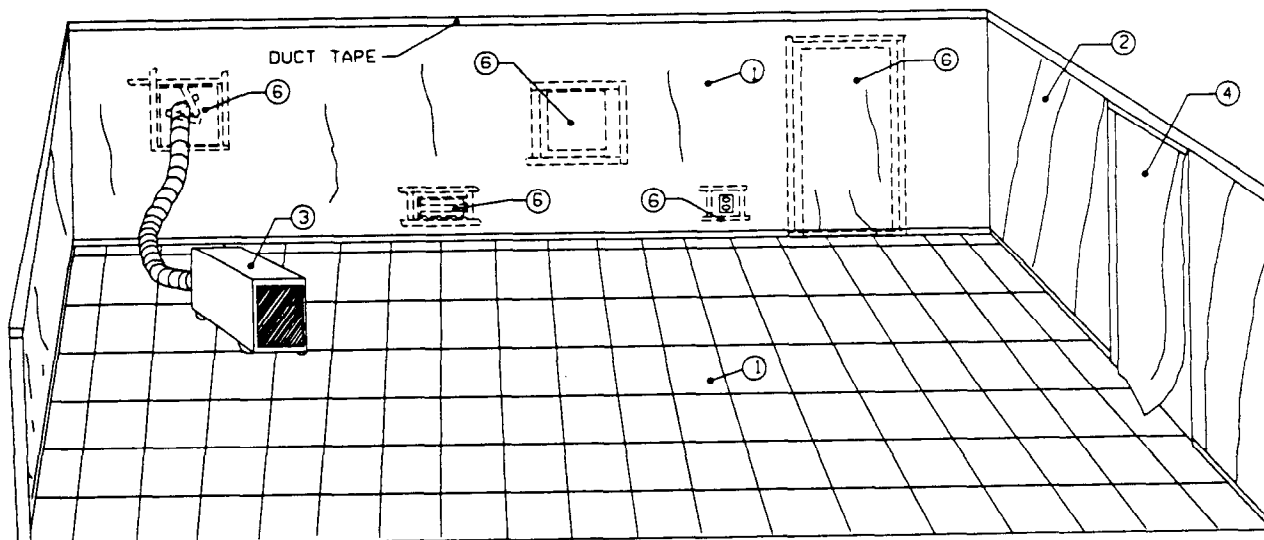

Preparation of containment area for final clearance (for vinyl tile floors)

1. Accumulate all loose material for disposal; see sheet 9. Apply labels; see sheet 14. Adequately wet clean all wall, floor, and equipment surfaces.
2. Contractor and contracting officer will certify visual inspection of work area on sheet 19, *Certification of Final Clearing and Visual Inspection*.
3. Apply lockdown encapsulant.
4. Remove polyethylene from walls. Critical barriers sealing all windows, doors, wall openings, electrical outlets, etc., are to remain. Remove any temporary equipment enclosures used; see sheet 24. Treat polyethylene as asbestos-contaminated material. Place in approved container; see sheet 9 for leak-tight wrapping. Apply labels; see sheet 14.
5. HEPA filter unit remains in place and operating.
6. Door into decontamination unit or load-out room remains.
7. Prepare area for final clearance.
8. Contractor and Contracting Officer will recertify visual inspection of work area on sheet 19, *Certification of Final Clearing and Visual Inspection*.
9. Contract designee(s) will conduct final air-clearance monitoring as required by the contract.
10. Upon instruction from Contracting Officer, shut down HEPA filter ventilation system, detach duct work, move system to equipment room of decontamination unit, clear and dispose of waste; see sheet 8. Remove critical barrier and place in approved container; see sheet 9. Apply labels; see sheet 14. Dispose of waste as asbestos-contaminated material.

Certification of Final Cleaning And Visual Inspection

Individual abatement task as identified in paragraph, Description of Work _____

In accordance with the cleaning and decontamination procedures specified in the Contractor's asbestos hazard abatement plan and this contract, the Contractor hereby certifies that he/she has thoroughly visually inspected the decontaminated regulated work area (all surfaces, including pipes, beams, ledges, walls, ceiling, floor, decontamination unit, etc.) in accordance with ASTM E1368, *Standard Practice for Visual Inspection of Asbestos Abatement Projects*, and has found no dust, debris, or asbestos-containing material residue.

BY: (Contractor's signature) _____ Date _____

Print name and title _____

(Contractor's Onsite Supervisor signature) _____ Date _____

Print name and title _____

(Contractor's Industrial Hygienist signature) _____ Date _____

Print name and title _____

Contracting Officer Acceptance or Rejection

The Contracting Officer hereby determines that the Contractor has performed final cleaning and visual inspection of the decontaminated regulated work area (all surfaces including pipes, beams, ledges, walls, ceiling, floor, decontamination unit, etc.) and by quality assurance inspection, finds the Contractor's final cleaning to be:

Acceptable

Unacceptable, Contractor instructed to reclean the regulated work area.

BY: Contracting Officer's Representative

Signature _____ Date _____

Print name and title _____

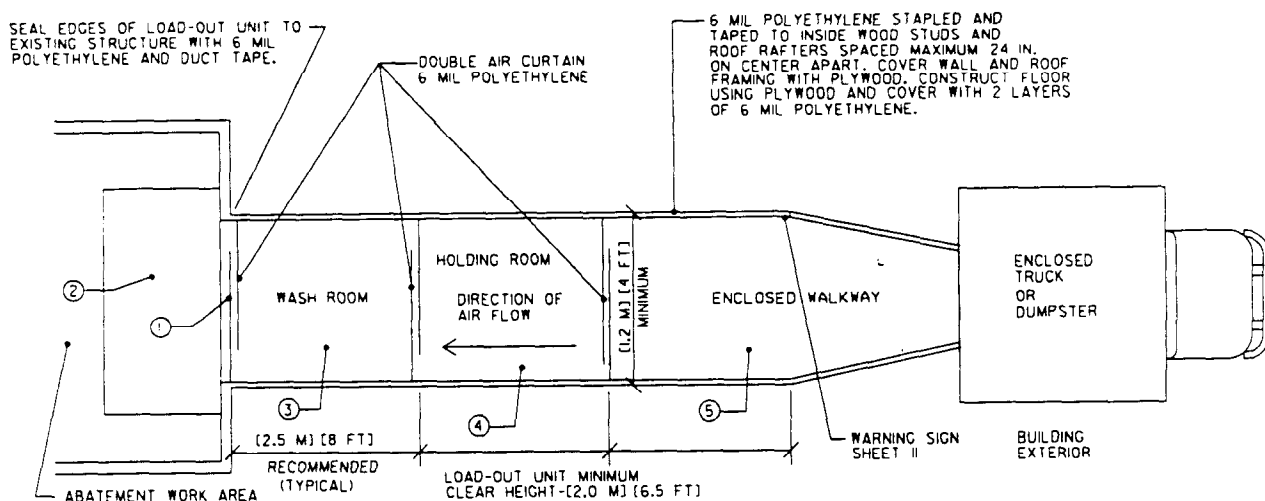

Load-out unit floor plan

1. Abatement worker is to enter and exit abatement work area only through decontamination unit.
2. Place additional 6-mil polyethylene sheeting on top of abatement area floor. Double bag asbestos-contaminated material in this area before removing.
3. Wet wipe bags, equipment, and containers, and take to holding room.
4. Stage clean bags, equipment, and containers in holding room until disposal worker removes them.
5. Disposal workers, wearing full protective clothing and appropriate respirator protection, carry decontaminated bags and containers through enclosed walkway and into enclosed truck or Dumpster.

Final clearance requirements. Before breaking down load-out unit, adequately wet clean and HEPA vacuum all surfaces and prepare area for final clearance. Contractor and Contracting Officer will certify visual inspection of work area on sheet 19, *Certification of Final Cleaning and Visual Inspection*. Contractor will apply lockdown encapsulant. Contract designee(s) will conduct final air-clearance monitoring as required by the contract. Breakdown load-out area upon instructions from Contracting Officer. Treat as asbestos-contaminated material. Place in approved container; see sheet 9. Apply labels; see sheet 14. Dispose of as required by the contract.

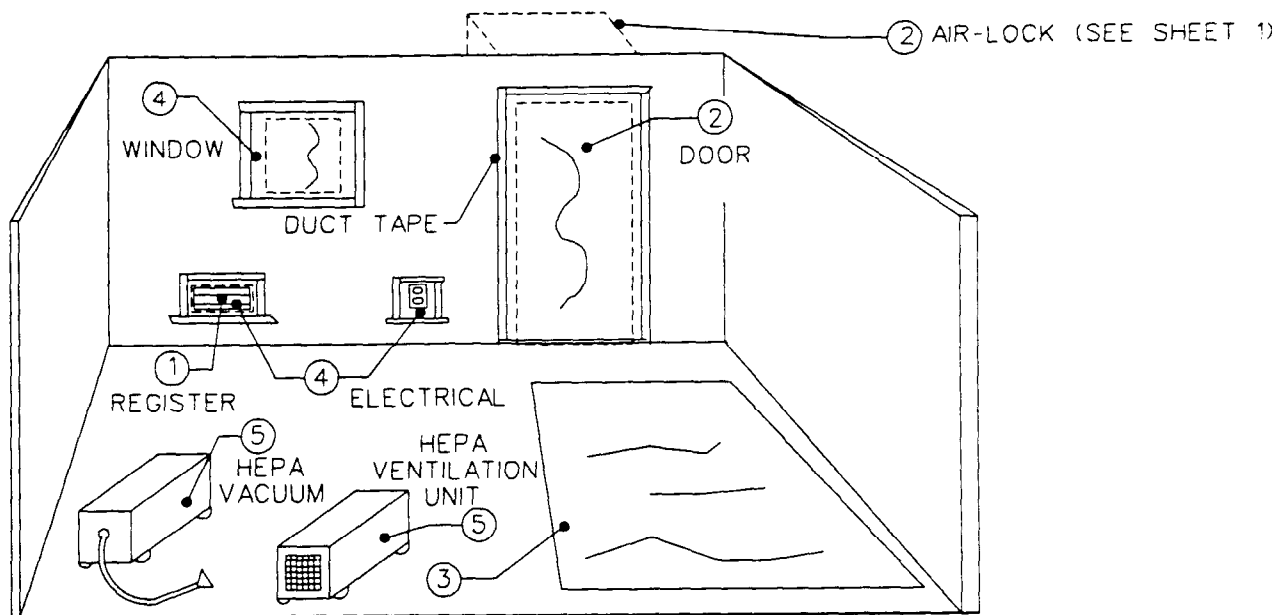

Modified containment area

1. Establish work area and prevent unauthorized entry; see sheet 11. Eliminate airflow into containment area by isolating all supply and return air ducts from mechanical system.
2. Install air lock at entrance to abatement area; see sheet 1. Air lock may be constructed either outside or inside of room. NOTE: Air lock is not required for glove bag operations.
3. Install 6-mil polyethylene sheet on floor under work area.
4. Install 6-mil polyethylene (critical barrier) over all windows, doors, wall openings, electrical outlets, etc. Provide airtight seal, using duct tape.
5. Provide a HEPA-filter vacuum cleaner and a HEPA-filter ventilation system in the work area; see sheet 8. The ventilation system does not have to be ducted to the outside of the structure. The ventilation system shall operate 24 hours a day from start of abatement through final air-clearance monitoring. The ventilation system shall be sized to recirculate the air a minimum of four air changes per hour. For glove bag operations, provide a single HEPA ventilation unit with a measured capture velocity at least 1,500 cfm.

6. Accumulate all loose material and polyethylene from floor. Place in approved container; see sheet 9. Apply labels; see sheet 14. HEPA vacuum and adequately wet clean all wall, floor, and equipment surfaces.

Final clearance requirements. Abatement worker must wear two disposable suits. Remove outer suit in the work area. Place suit in 6-mil disposal bag; see sheet 9. Enter air lock. In air lock, wet wipe respirator and wash hands with clean water from portable sprayer. Remove respirator and place in clean plastic bag. Proceed to remote shower where inner suit may be removed. Prepare work area and air lock for final clearance. Contractor and Contracting Officer will certify visual inspection of work area on sheet 19, *Certification of Final Cleaning and Visual Inspection*. Contract designee(s) will conduct final air-clearance monitoring as required by the contract. Upon instructions from the Contracting Officer, remove critical barriers and HEPA ventilation units; see sheet 8. Treat polyethylene as asbestos-contaminated material. Place in approved container; see sheet 9. Apply labels; see sheet 14. Dispose of as required by the contract.

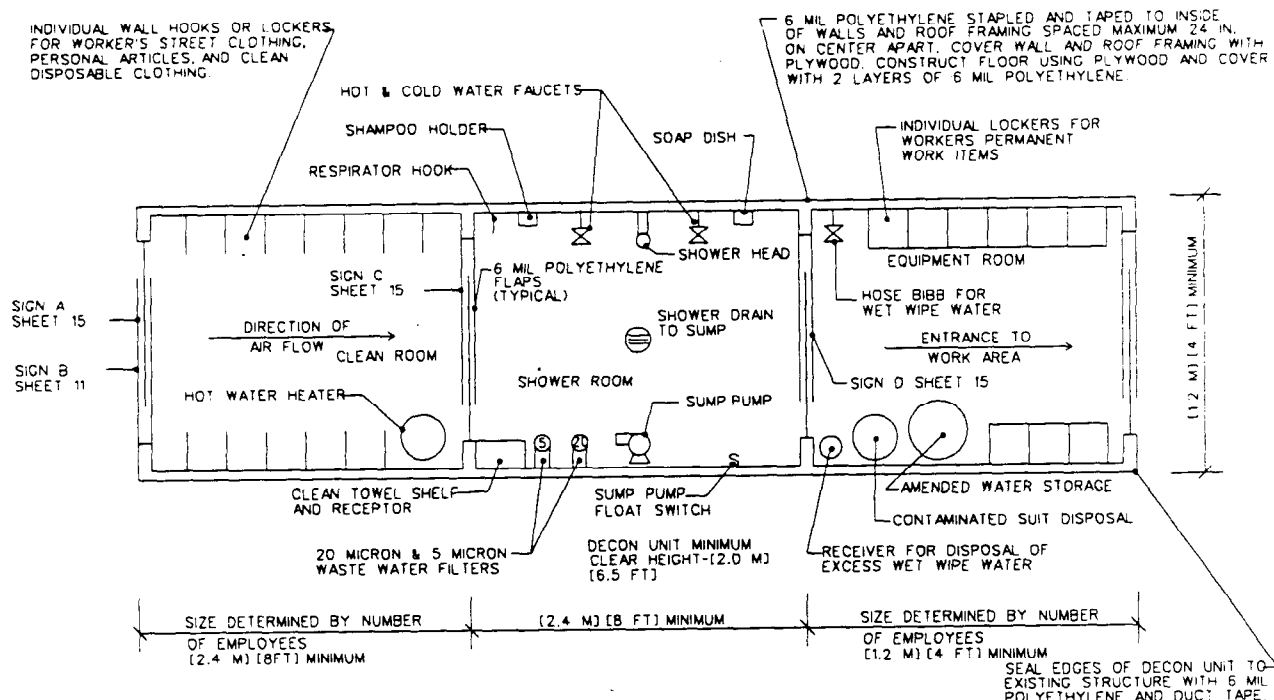

Decontamination unit floor plan

1. Establish work area so that unauthorized entry is prevented; see sheets 11 and 15. Before entering the work area, all personnel shall remove their street clothing in the clean room and put on protective clothing and respirator.

2. Whenever exiting the work area, all personnel shall:

- Vacuum clothing and shoes outside equipment room.
- Remove all clothing and equipment (except respirator) in equipment room.
- Store work shoes and equipment in locker.
- With respirator still on, shower thoroughly, including hair. Then remove respirator and finish shower.
- Proceed to clean room and put on street clothes.

3. See sheet 23 for minimum plumbing requirements, including wastewater filtration. Ensure that plumbing and specified filter size meet local requirements.

4. Twice daily, or more often if necessary, and before breaking down decontamination unit after abatement, adequately wet clean and HEPA vacuum all wall, floor, equipment, and other surfaces. Waste collected in shower room and equipment room shall be treated as asbestos-contaminated material. Place in approved container; see sheet 9. Apply labels; see sheet 14.

5. Prepare for final clearance.

Final clearance requirements. Contractor and Contracting Officer will certify visual inspection of work area on sheet 19, *Certification of Final Cleaning and Visual Inspection*. Contract designee(s) will conduct final air-clearance monitoring as required by the contract. If the unit is not a prefabricated decontamination unit, apply lockdown encapsulant before final air-clearance monitoring. After approval of final air clearance, break down and treat polyethylene as asbestos-contaminated material. Place in approved container; see sheet 9. Apply labels; see sheet 14. Dispose of as required by the contract.

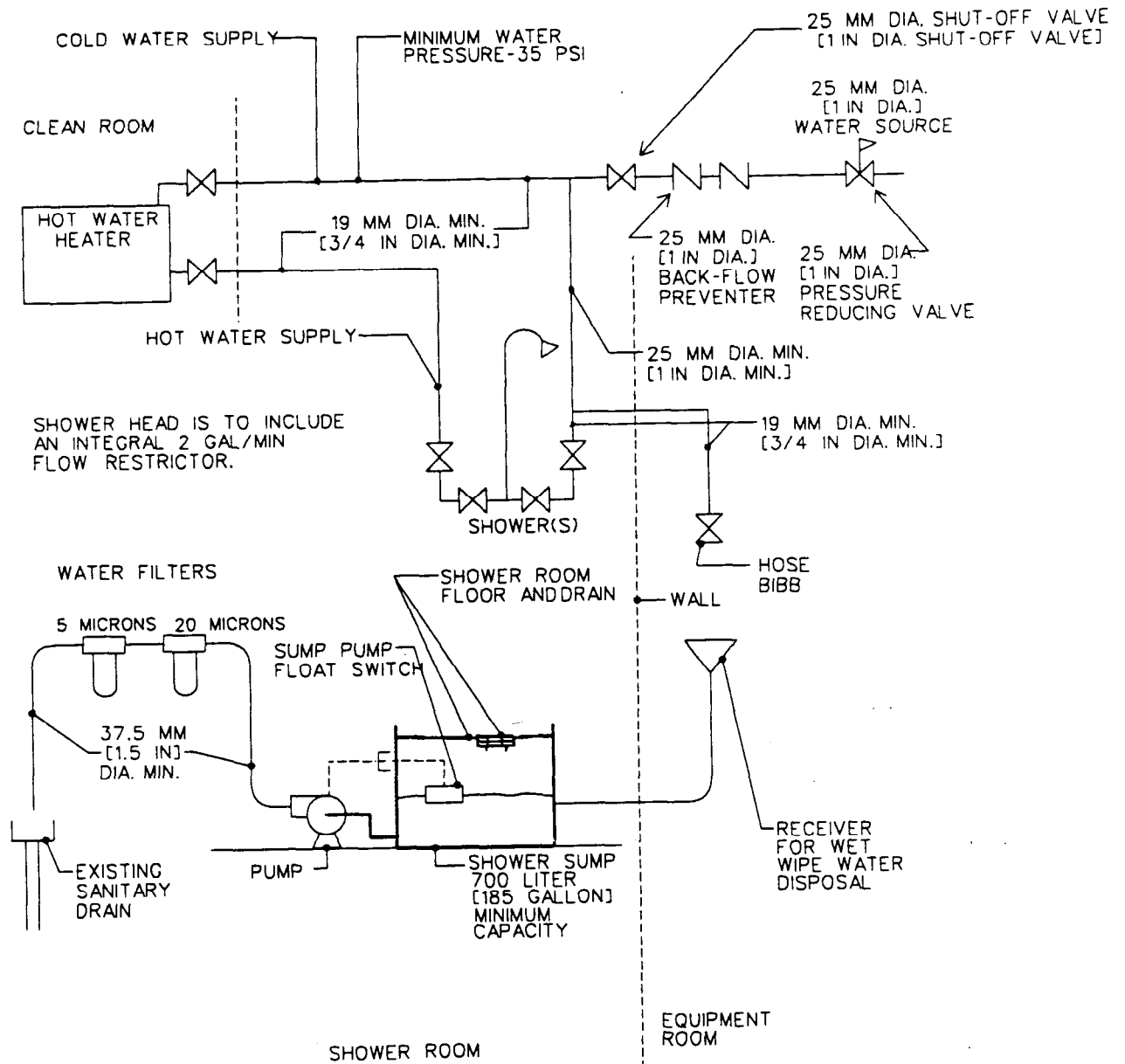

SIZE CAPACITY OF SUMP PUMP FOR TWICE THE EXPECTED WASTE WATER FLOW.

Decontamination unit piping details

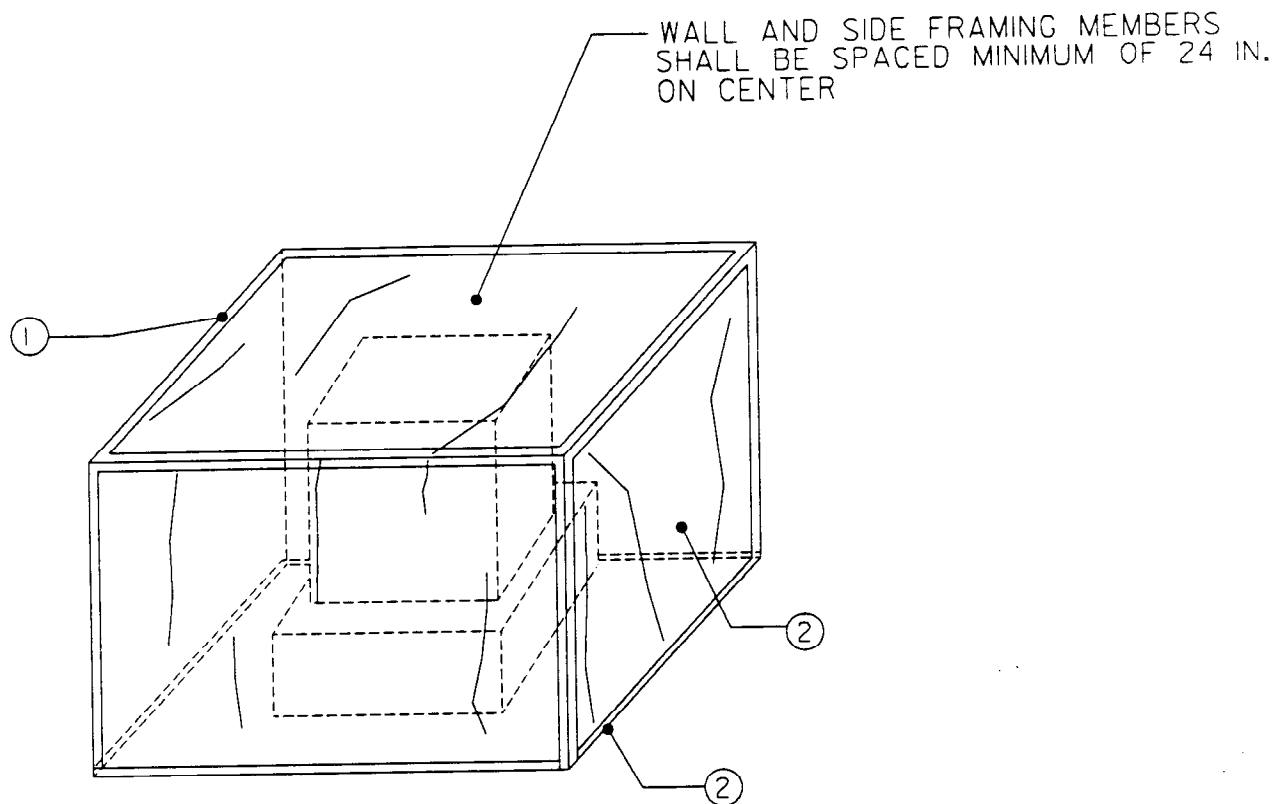

Temporary equipment enclosure

1. Construct wood frame of equipment enclosure; then cover all sides and the roof of frame with plywood.

2. Cover entire plywood equipment enclosure with 6-mil polyethylene. Seal seams and edges with duct tape, making the enclosure airtight and watertight.

Final clearance requirements. Upon completion of abatement work, remove temporary enclosure in accordance with the procedures listed on sheet 16, 17, or 18, and prepare for final clearance.

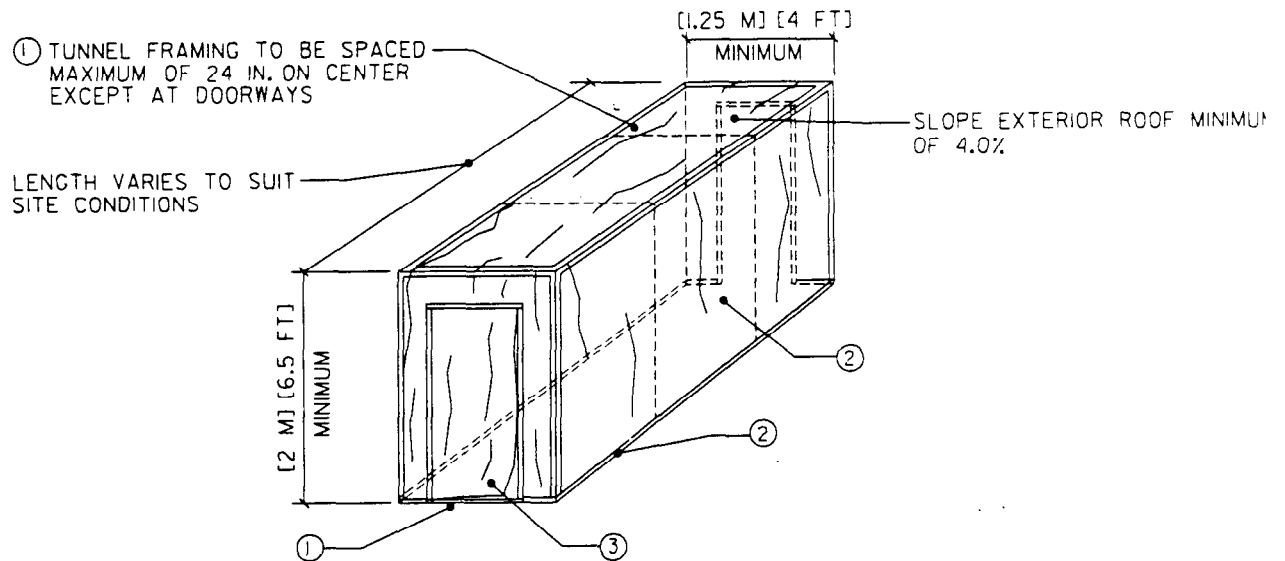

Access tunnel

1. Construct a wood frame tunnel; cover all sides and the roof of the frame with polyethylene. **NOTE:** Cover all sides and roof with plywood or reinforced polyethylene if access tunnel is located outside.

2. Cover entire tunnel with 6-mil polyethylene; seal seams and edges with duct tape, making the tunnel airtight and watertight.

3. Twice daily, or more frequently if necessary, adequately wet clean and HEPA vacuum all wall, floor, and equipment surfaces.

Final Clearance Requirements. Upon completion of abatement work, remove access tunnel in accordance with the procedures listed on sheet 16, 17, or 18, and prepare for final clearance.

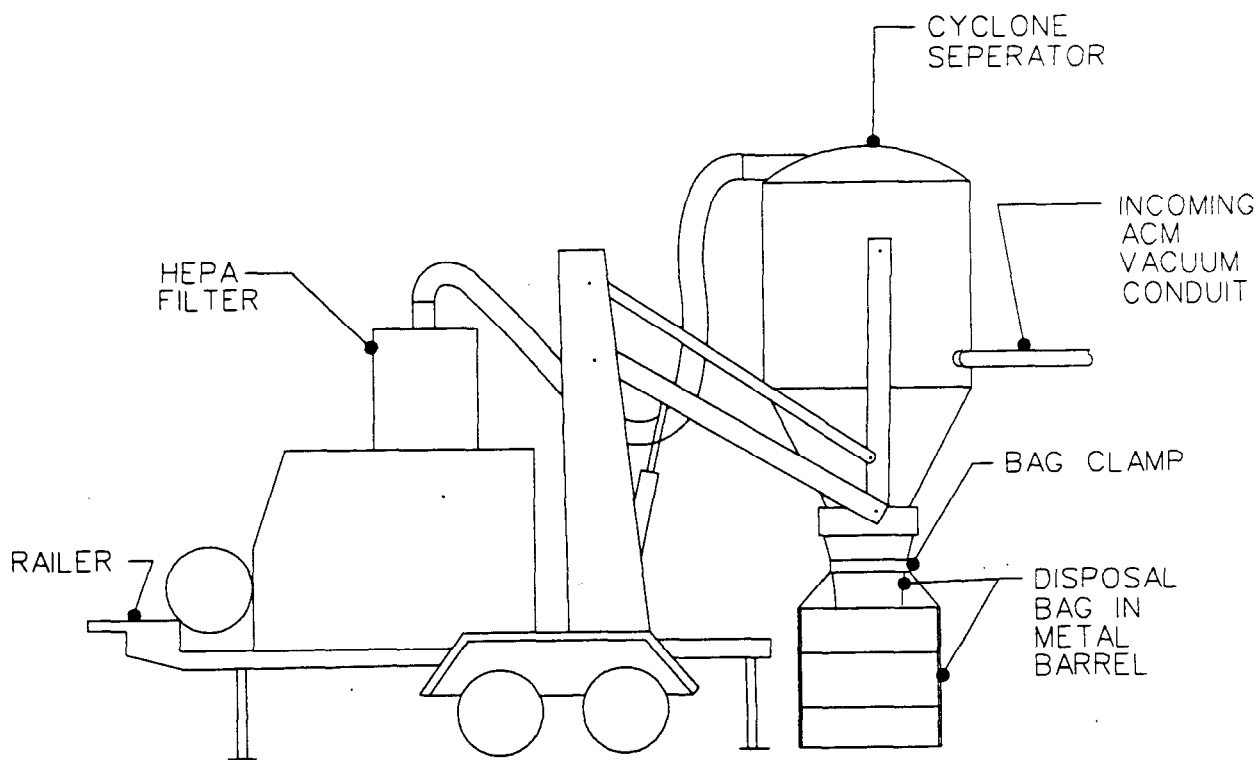

Asbestos power vacuum collection and removal system

An asbestos power vacuum collection and removal system is a completely self-contained, material-handling system used to transport large volumes of asbestos-containing material through a large-diameter vacuum conduit to a trailer or truck-mounted collector. The cyclone is designed to separate the wet asbestos-contaminated material

from the air stream and enable easy transfer to disposal containers. Asbestos-contaminated air is HEPA filtered before being discharged into the atmosphere. The contractor shall follow manufacturer-recommended operating and maintenance procedures in order to protect workers and environment.

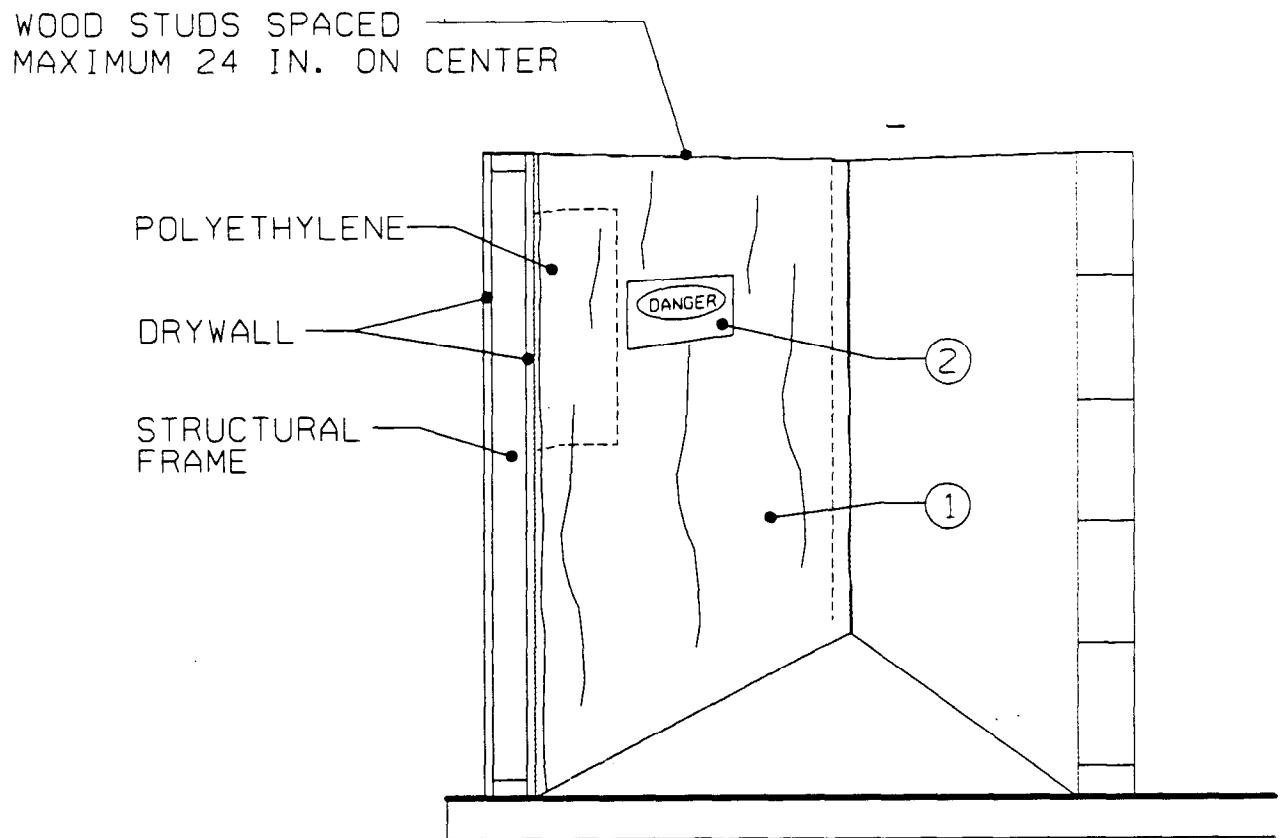

Structural critical barrier

1. The purpose of this critical barrier is to isolate the containment area from the remainder of the building. The barrier shall consist of fire-rated drywall mounted on both sides of a structural frame, with the face of the containment area covered by a 6-mil polyethylene sheet. Seal the edges of the polyethylene sheet to walls, ceiling, and floor with duct tape. Secure structural frame to adjacent walls as necessary for stability.

2. Install danger signs on side away from containment area. See sheet 11.

3. After final air-clearance monitoring and upon instructions from contracting officer, remove critical barrier and treat polyethylene sheet as asbestos-contaminated material; see sheets 9 and 14. If framing and drywall are asbestos-contaminated, treat as asbestos-contaminated material; see sheets 9 and 14.

Part 3, Response Action Details

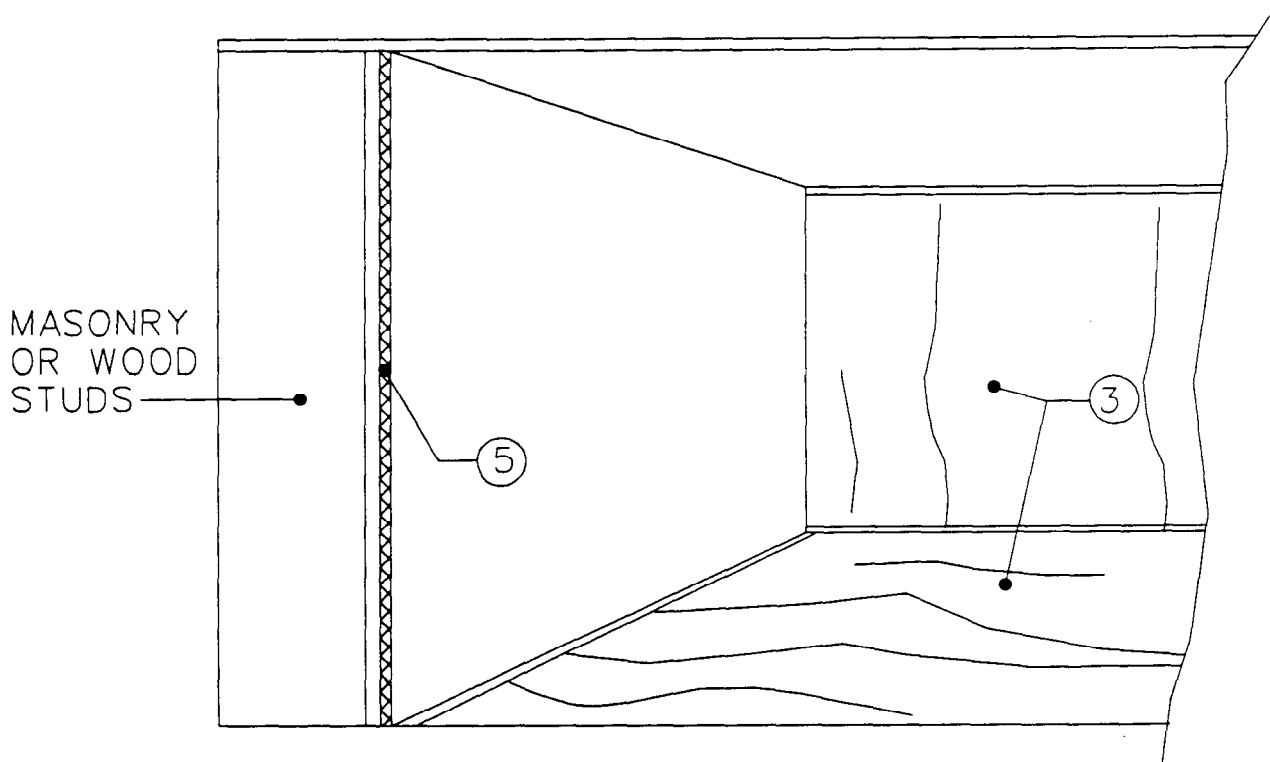

Bridging encapsulation of troweled wall plaster

1. Establish work area so that unauthorized entry is prevented; see sheet 11. Eliminate airflow into containment area by isolating all supply and return air ducts from mechanical system.
2. Install 6-mil polyethylene critical barriers over all windows, doors, wall openings, electrical outlets, etc. Secure with duct tape on all sides.
3. Install 6-mil polyethylene, protecting wall and floor surfaces. If only one wall is included, prepare bulkhead containment area as specified on sheet 5.
4. Install HEPA filter and ductwork; see sheet 8.
5. Apply tinted bridging encapsulant to surface by airless spray in accordance with manufacturer's recommendations.
6. Inspect and reapply encapsulant as necessary.
7. Remove polyethylene on walls, floor, and plywood. The critical barriers sealing all windows, doors, wall openings, electrical outlets, etc., are to remain. Treat polyethylene as asbestos-contaminated material; see sheet 9.
8. Prepare area for final clearance.
9. Carry out final clearance requirements as specified on sheet 5.

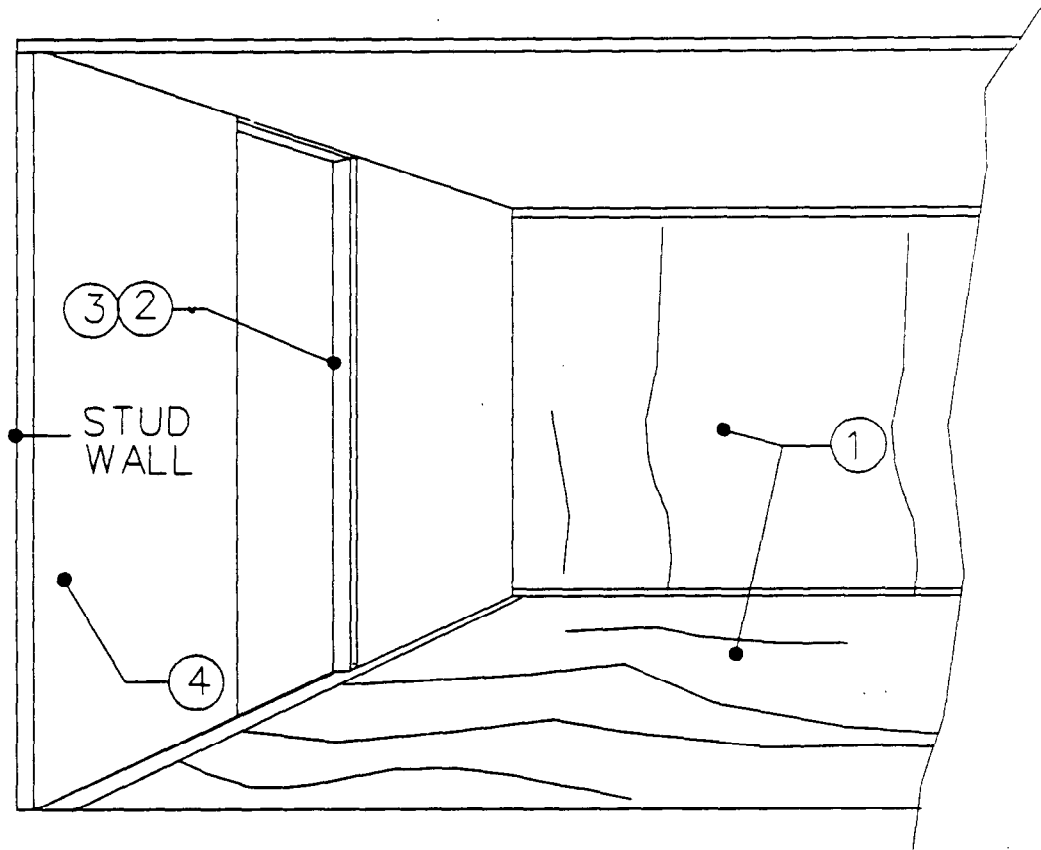

Repair of troweled wall plaster on stud wall

1. Prepare containment area as specified on applicable sheet 5, 6, or 7.
2. Adequately wet mist damaged plaster with amended water, initially and during removal procedures.
3. Remove damaged lath and plaster to nearest stud. Place in approved container; see sheet 9. Apply labels; see sheet 14.
4. Repair damaged area and install new rock lath. Trowel asbestos-free plaster on rock lath, matching adjacent surfaces. Apply tinted bridging encapsulant to repaired surface by airless spray in accordance with manufacturer's recommendations.
5. Inspect and reapply encapsulant as necessary.
6. Prepare area for final air clearance.
7. Carry out final clearance requirements specified on applicable sheet 5, 6, or 7.

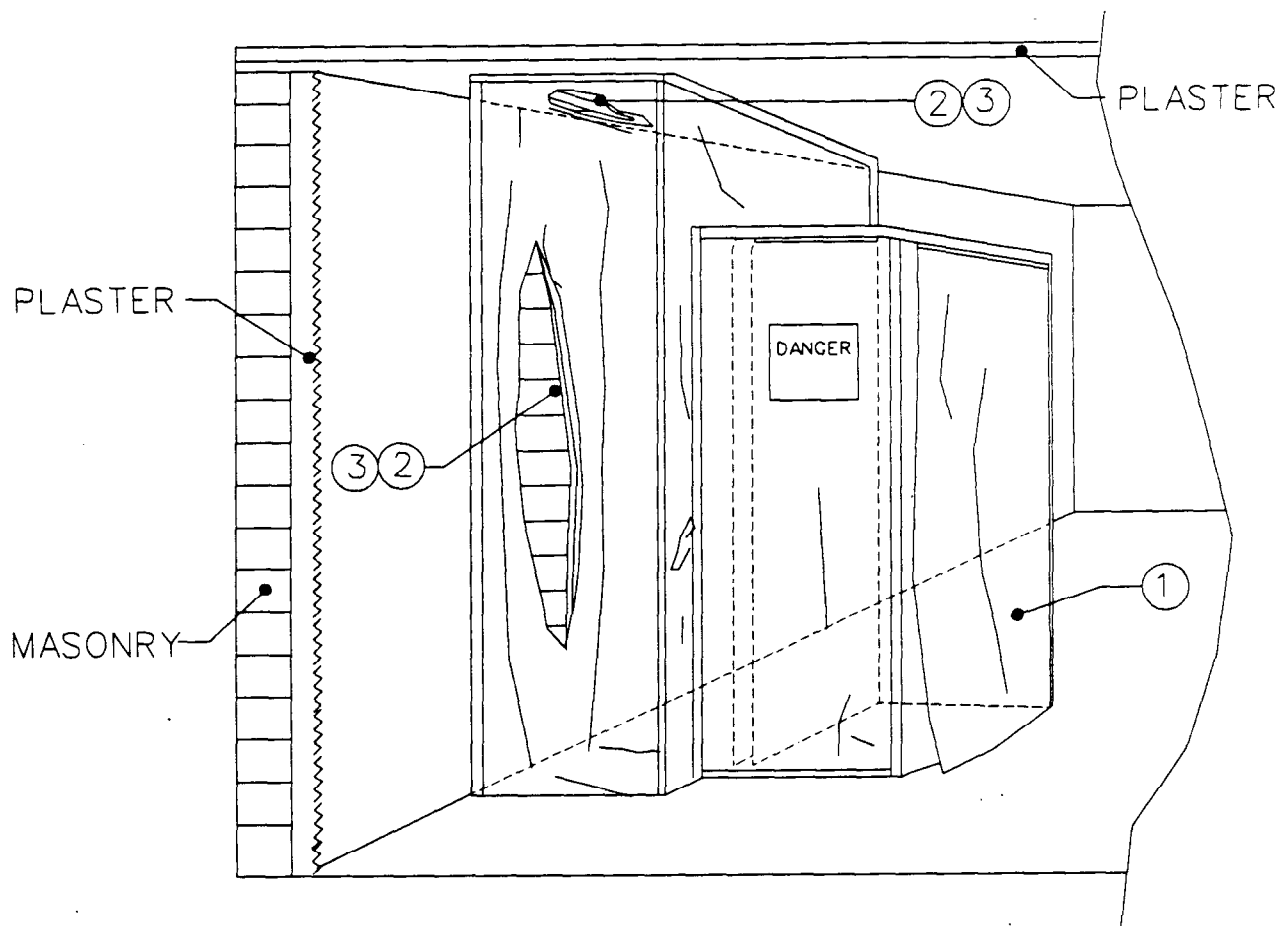

Repair of troweled ceiling or wall plaster on masonry

1. Prepare mini-containment area as specified on sheet 7.
2. Adequately wet mist damaged plaster with amended water, initially and during removal procedure.
3. Remove damaged material. Place in approved container; see sheet 9. Apply labels; see sheet 14.
4. Repair damaged area by troweling on asbestos-free plaster, and then damp sponge. Match adjacent surfaces.
5. Apply tinted penetrating encapsulant by airless spray to repaired surface in accordance with manufacturer's recommendations.
6. Inspect and reapply encapsulant as necessary.
7. Prepare area for final air clearance.
8. Carry out final clearance requirements specified on sheet 7.

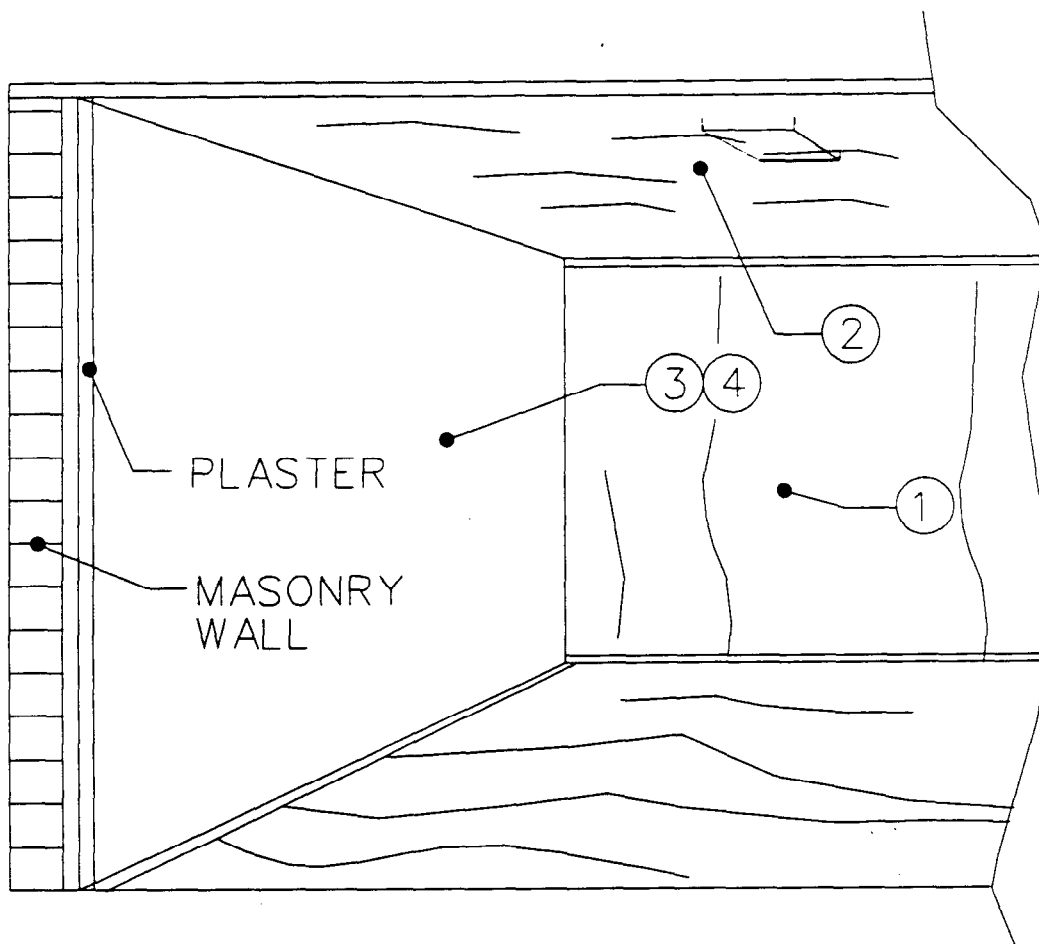

Removal of troweled wall plaster on masonry

1. Prepare containment area as specified on applicable sheet 2, 3, 4, or 5.
2. Prepare ceiling as follows:
 - Cover light fixture with 6-mil polyethylene.
 - Protect entire suspended ceiling system with 6-mil polyethylene.
3. Adequately wet mist surface of plaster with amended water, initially and during removal procedure.
4. Remove plaster on masonry. Brush, HEPA vacuum, and wet wipe surface in order to remove remaining
5. Apply tinted penetrating encapsulant by airless spray in accordance with manufacturer's recommendations.
6. Inspect and reapply encapsulant as necessary.
7. Prepare area for final air clearance.
8. Carry out final clearance requirements specified on applicable sheet 5, 16, 17, or 18.

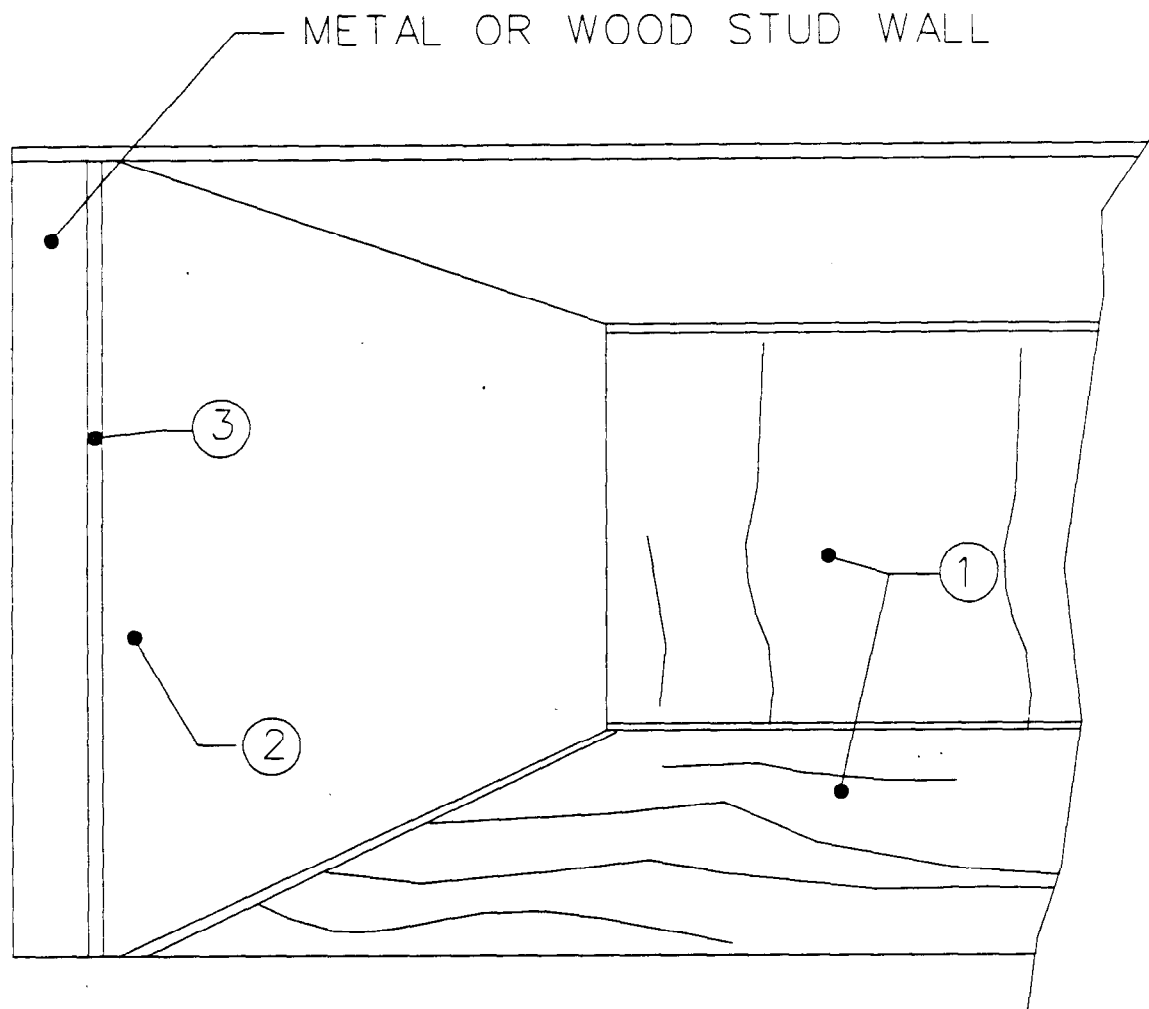

Removal of troweled wall plaster on stud wall

1. Prepare containment area as specified on applicable sheet 2, 3, 4, 5, or 6.
2. Adequately wet mist damaged plaster with amended water, initially and during removal procedure.
3. Remove plaster and lath from studs in manageable pieces. Stack the pieces onto two layers of 6-mil polyethylene. Wrap each polyethylene layer around the stack, sealing all joints and edges with duct tape; see sheet 9B for leak-tight wrapping. Apply labels; see
- sheet 14. Place smaller material in approved container; see sheet 9. Apply labels; see sheet 14.
4. Clean, HEPA vacuum, and adequately wet clean.
5. Apply tinted penetrating encapsulant. Inspect and reapply encapsulant as necessary.
6. Prepare area for final air clearance.
7. Carry out final clearance requirements as specified in the applicable sheet 5, 6, 16, 17, or 18.

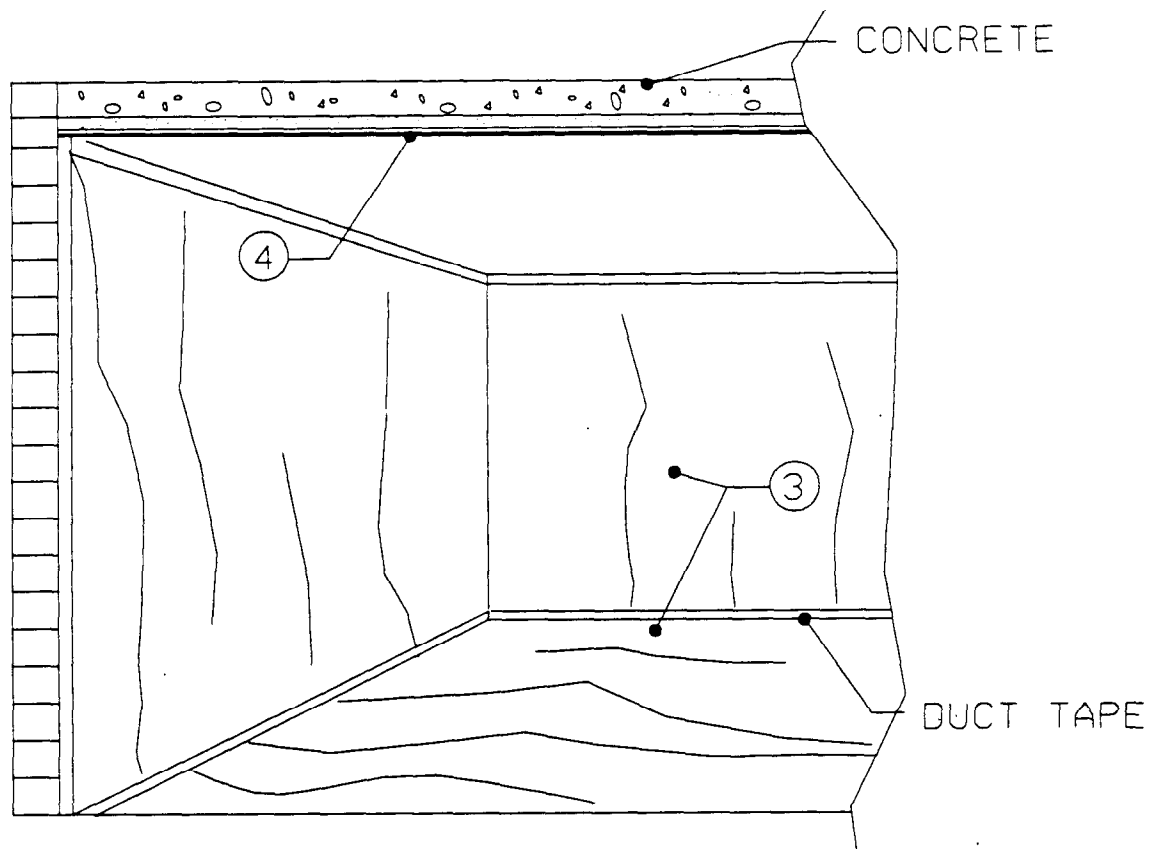

Bridging encapsulation of solid or acoustical ceiling plaster

1. Establish work area so that unauthorized entry is prevented; see sheet 11. Eliminate airflow into containment area by isolating all supply and return air ducts from mechanical system. Prepare containment area as specified on sheet 2, 3, or 4.
2. Install 6-mil polyethylene critical barriers over all windows, doors, wall openings, electrical outlets, etc. Secure with duct tape on all sides.
3. Install 6-mil polyethylene, protecting wall and floor surfaces, HEPA filter, and ductwork; see sheet 8.
4. Apply tinted bridging encapsulant to surface in accordance with manufacturer's recommendations.
5. Inspect and reapply encapsulant if necessary.
6. Remove polyethylene on walls, floor, and plywood. The critical barriers sealing all windows, doors, wall openings, electrical outlets, etc., are to remain. Treat polyethylene as asbestos-contaminated material; see sheet 9. Apply labels; see sheet 14.
7. Prepare for final air clearance.
8. Carry out final clearance requirements as specified in the applicable sheet 16, 17, or 18.

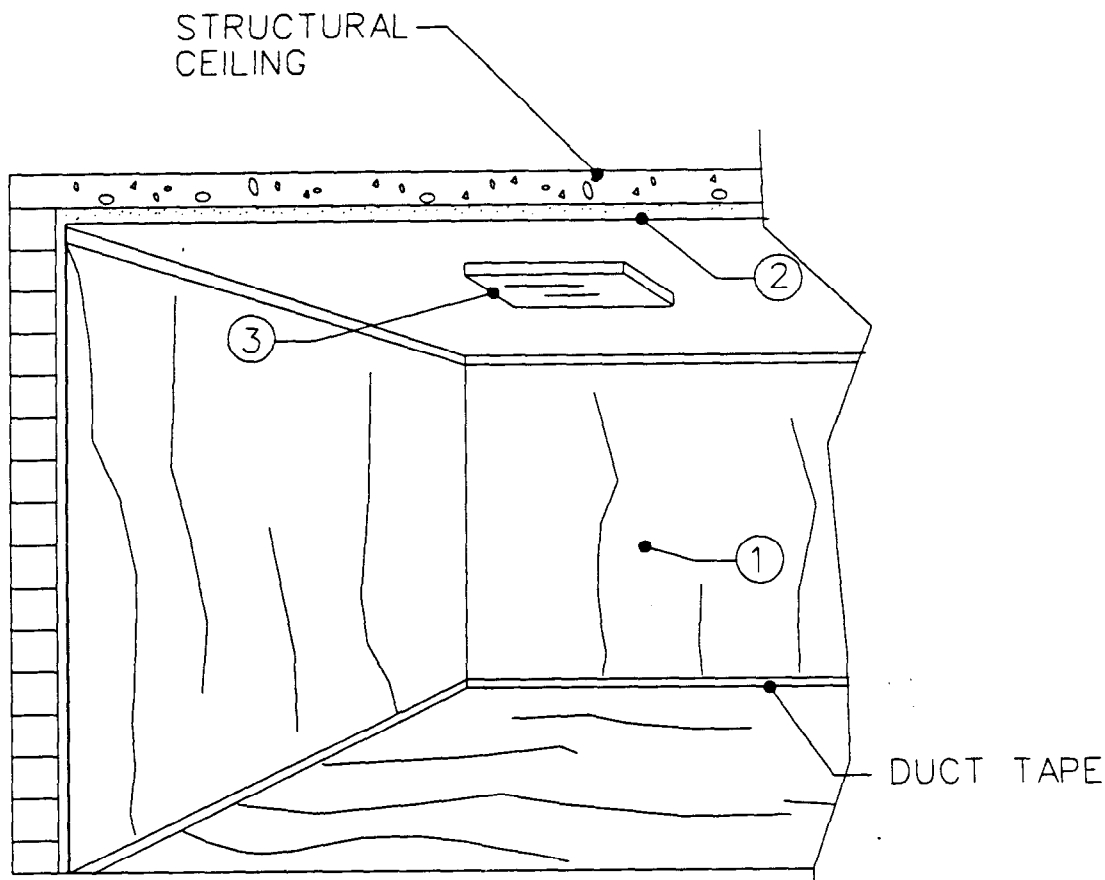

Removal of troweled ceiling plaster on structural substrate

1. Prepare containment area as specified on sheet 2, 3, or 4.
2. Adequately wet mist surface of plaster with amended water, initially and during removal procedure.
3. Remove all surface-mounted fixtures. Remove plaster on structural substrate. HEPA vacuum and wet wipe surface in order to remove remaining residue. Place removed asbestos-containing material in approved container, and seal leak-tight; see sheet 9. Apply labels; see sheet 14.
4. Inspect and reclean area as necessary.
5. Apply penetrating encapsulant. Tint encapsulant in order to visually verify full coverage. Inspect and reapply encapsulant as necessary.
6. Prepare area for final air clearance.
7. Carry out final clearance requirements as specified in applicable sheet 16, 17, or 18.

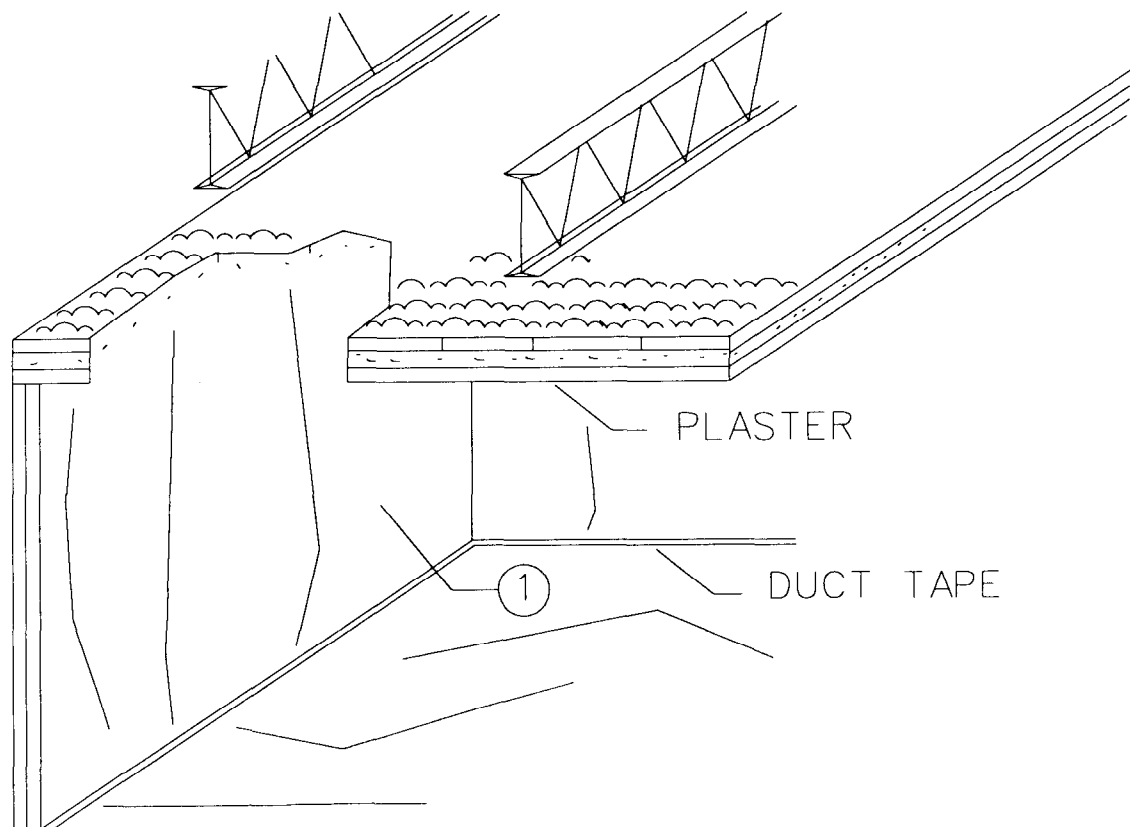

Removal of troweled ceiling plaster on hung ceiling

1. Prepare containment area as specified on applicable sheet 2, 3, or 4.
2. Access ceiling and wet mist top side of plaster with amended water, initially and during removal procedure.
3. Cut wire hangers in immediate area. Remove ceiling in manageable pieces. Stack the pieces onto two layers of 6-mil polyethylene. Wrap each polyethylene layer around the stack, sealing all joints and ends with duct tape see sheet 9B for leak-tight wrapping. Apply labels; see sheet 14. For smaller materials, place in approved container; see sheet 9A or 9C. Apply labels; see sheet 14.
4. HEPA vacuum entire area. Inspect and reclean area as necessary.
5. Apply penetrating encapsulant to exposed surfaces, including the underside of structural surfaces. Tint encapsulant in order to verify full coverage. Inspect and reapply encapsulant as necessary.
6. Prepare area for final air clearance.
7. Carry out final clearance requirements as specified in applicable sheet 16, 17, or 18.

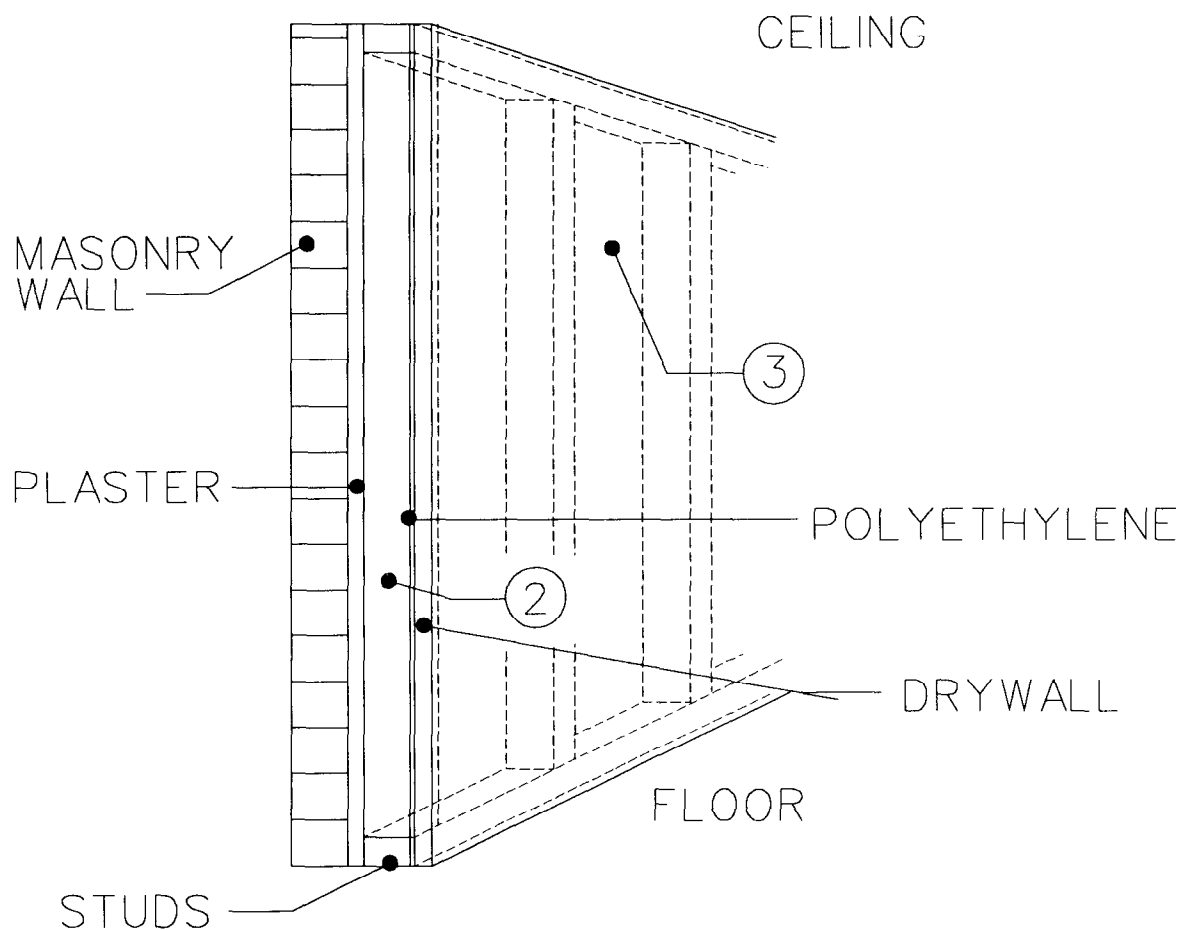

Enclosure of acoustical wall plaster on masonry wall

1. Establish work area and prevent unauthorized entry; see sheet 11. Prepare containment area as specified on sheet 5.
2. Carefully install floor, ceiling, and wall studs so that the wall plaster is not disturbed. Fasten 6-mil polyethylene to studs and seal edges with duct tape.
3. Attach asbestos-free drywall to studs. HEPA vacuum floor, walls, and ceiling.
4. After completion of abatement work, HEPA vacuum clothing and shoes.
5. Prepare area for final air clearance.
6. Carry out final clearance requirements specified on sheet 5.

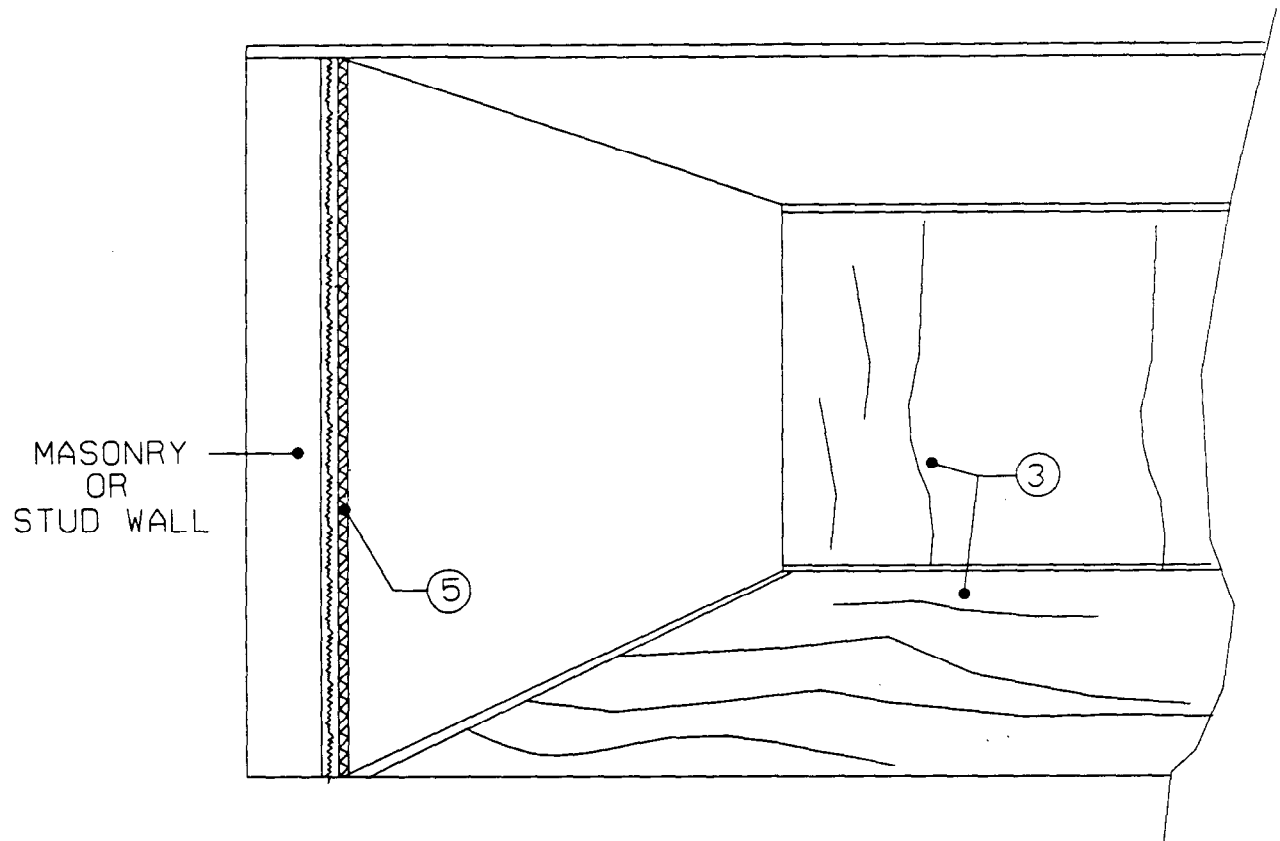

Bridging encapsulation of acoustical wall plaster

1. Establish work area and prevent unauthorized entry; see sheet 11. Eliminate airflow into containment area by isolating all supply and return air ducts from mechanical system.
2. Install 6-mil polyethylene critical barriers over all windows, doors, wall openings, electrical outlets, etc. Secure with duct tape on all sides.
3. Install 6-mil polyethylene, protecting wall and floor surfaces not to be encapsulated. If only one wall is included, prepare bulkhead containment area as specified on sheet 5.
4. Install HEPA filter unit and ductwork; see sheet 8.
5. Apply tinted bridging encapsulant to surface in accordance with manufacturer's recommendations.
6. Inspect and reapply encapsulant if necessary.
7. Remove polyethylene on walls, floor, and plywood. The critical barriers sealing all windows, doors, wall openings, electrical outlets, etc., are to remain. Treat polyethylene as asbestos-contaminated material; see sheet 9.
8. Prepare area for final air clearance.
9. Carry out final clearance requirements as specified on sheet 5.

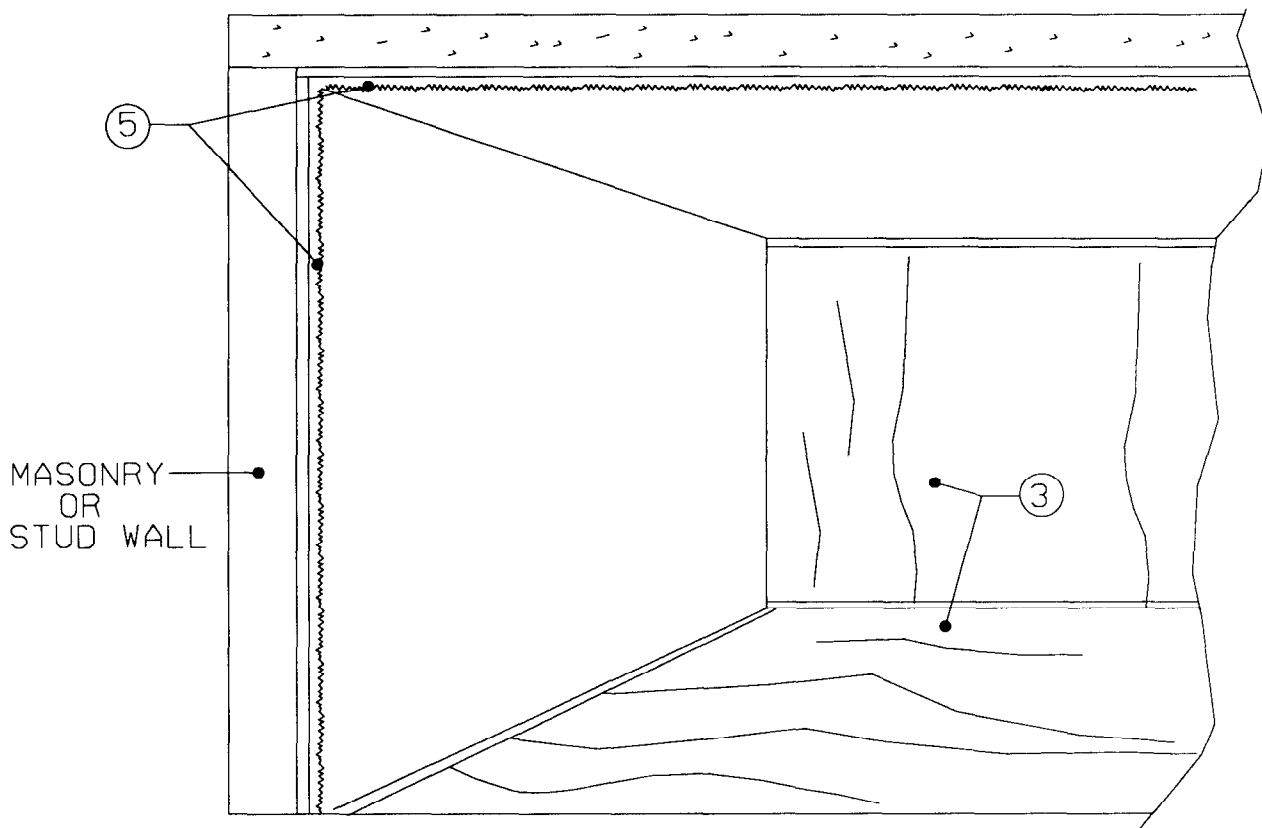

Penetrating encapsulation of acoustical wall and ceiling plaster

1. Prepare containment area as specified on applicable sheet 2, 3, 4, or 5. (If only one wall—and no ceiling—is to be abated, prepare bulkhead containment as specified on sheet 5.) Prevent unauthorized entry; see sheet 11. Eliminate airflow into containment area by isolating all supply and return air ducts from mechanical system.
2. Install 6-mil polyethylene critical barriers over all windows, doors, wall openings, electrical outlets, etc. Secure with duct tape on all sides.
3. Install 6-mil polyethylene on floor surfaces and all walls not to be encapsulated.
4. Install HEPA filter unit and ductwork; see sheet 8.
5. Apply tinted penetrating encapsulant to surface.
6. Inspect and reapply encapsulant as necessary.
7. Remove polyethylene on walls, floor, and plywood. The critical barriers sealing all windows, doors, wall openings, electrical outlets, etc., are to remain. Treat polyethylene as asbestos-contaminated material; see sheet 9.
8. Prepare for final air clearance.
9. Carry out final clearance requirements as specified on applicable sheet 5, 16, 17, or 18.

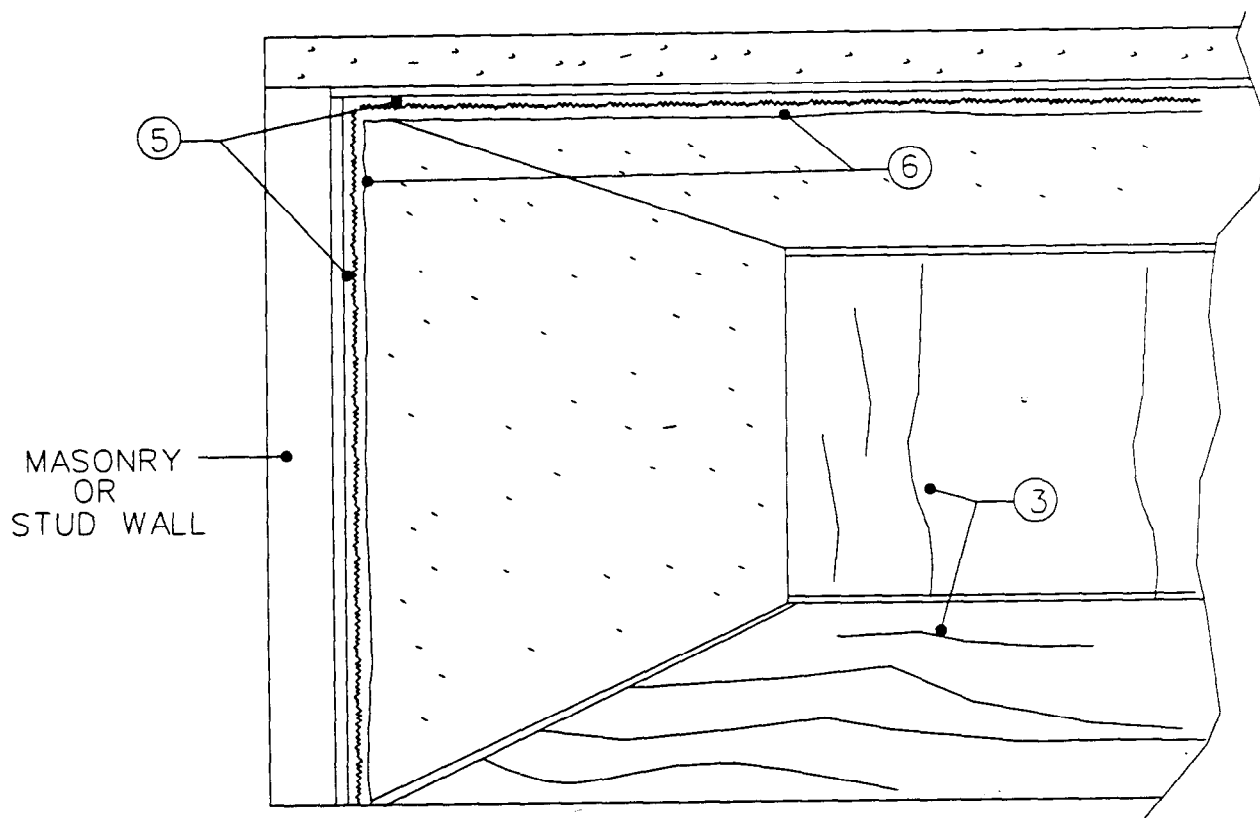

Combination encapsulation of acoustical wall and ceiling plaster

1. Prepare containment area as specified on applicable sheet 2, 3, 4, or 5. (If only one wall—and no ceiling—is to be abated, prepare bulkhead containment as specified on sheet 5.) Prevent unauthorized entry; see sheet 11. Eliminate airflow into containment area by isolating all supply and return air ducts from mechanical system.
2. Install 6-mil polyethylene critical barriers over all windows, doors, wall openings, electrical outlets, etc. Secure with duct tape on all sides.
3. Install polyethylene on floor surfaces and walls not to be encapsulated.
4. Install HEPA filter and ductwork; see sheet 8.
5. Apply tinted penetrating encapsulant to wall and ceiling surface.
6. Inspect and reapply encapsulant as necessary.
7. Apply tinted bridging encapsulant to surface of acoustical wall or ceiling plaster.
8. Inspect and reapply encapsulant as necessary.
9. Remove polyethylene on walls, floor, and plywood. The critical barriers sealing all windows, doors, wall openings, electrical outlets, etc., are to remain. Treat polyethylene as asbestos-contaminated material; see sheet 9.
10. Prepare area for final air clearance.
11. Carry out final clearance requirements as specified on applicable sheet 5, 16, 17, or 18.

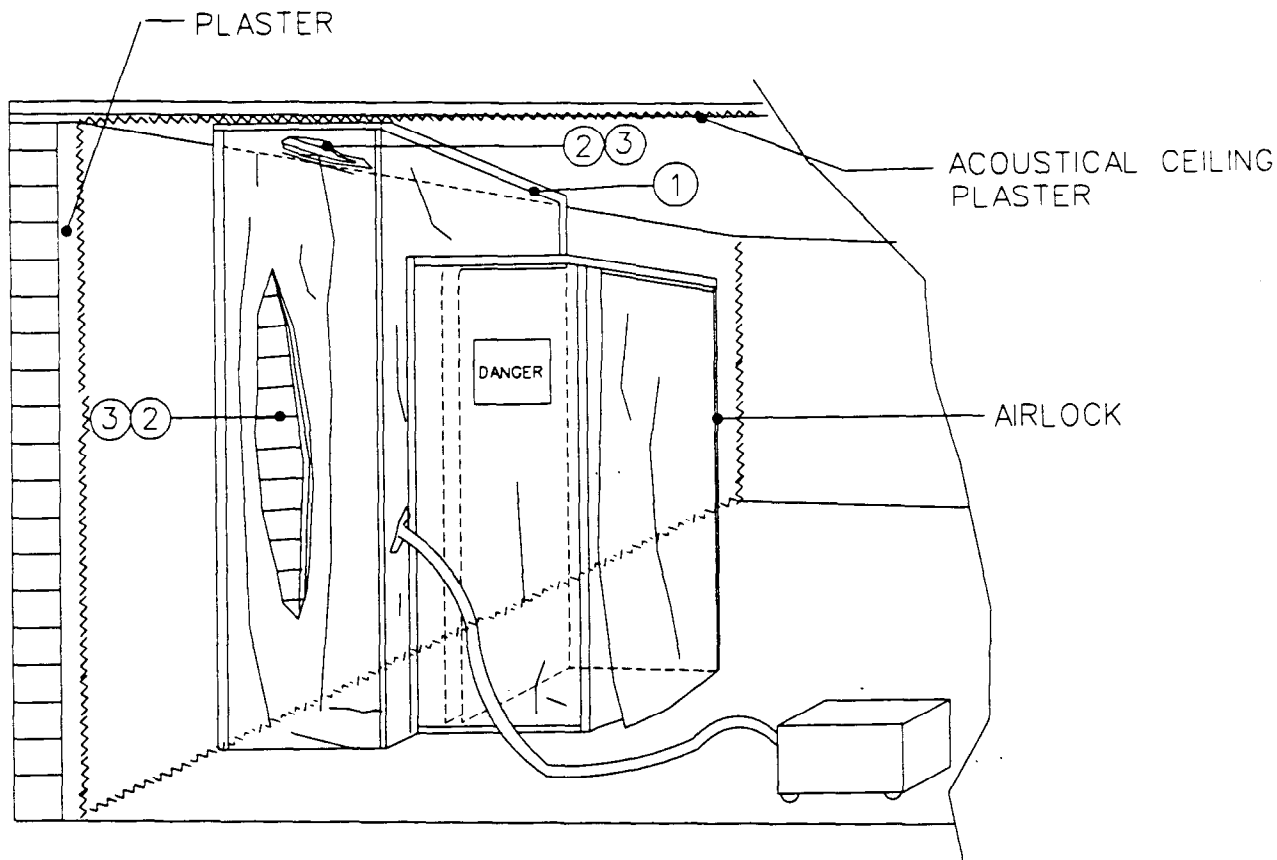

Repair of acoustical ceiling or wall plaster

1. Prepare mini-containment area as specified on sheet 7.
2. Adequately wet mist damaged plaster with amended water, initially and during removal procedure.
3. Remove damaged plaster down to the masonry, using chisel or other technique. Brush area to remove remaining residue. Place removed asbestos-containing material in approved containers; see sheet 9. Apply labels; see sheet 14.
4. Repair damaged area by troweling or otherwise applying new asbestos-free plaster to damaged areas, matching adjacent surfaces.
5. Apply tinted penetrating encapsulant to repaired surface.
6. Inspect and reapply encapsulant as necessary.
7. Prepare area for final air clearance.
8. Carry out final clearance requirements as specified on sheet 7.

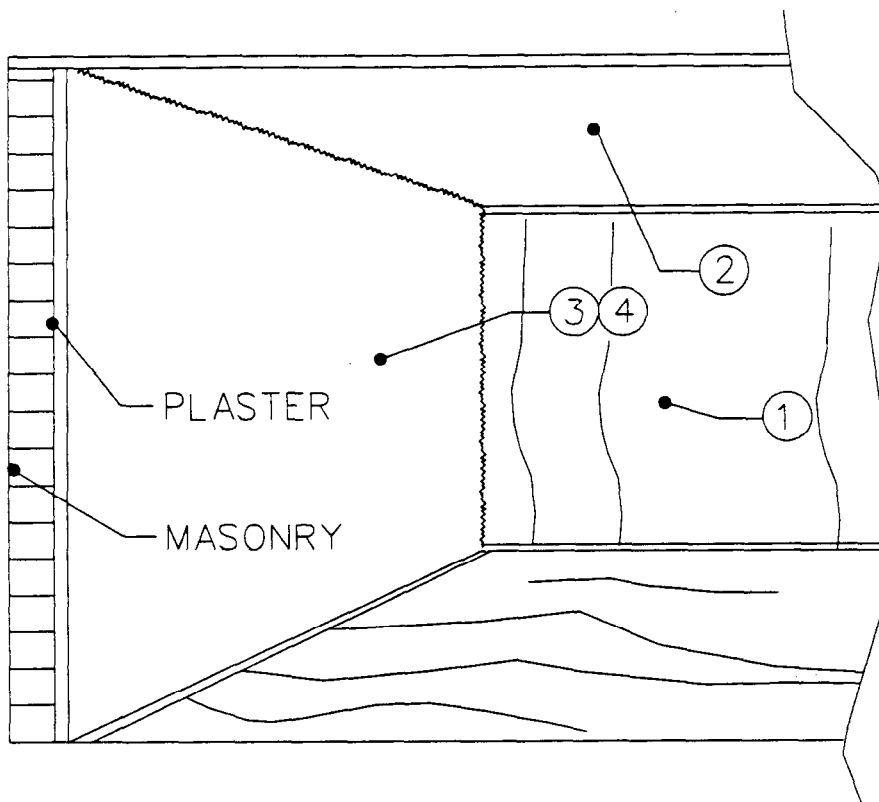

Removal of acoustical wall plaster on masonry

1. Prepare containment area as specified on applicable sheet 2, 3, 4, or 5.
2. Prepare ceiling as directed below:
 - Cover light fixture with 6-mil polyethylene.
 - Protect entire suspended ceiling system with 6-mil polyethylene.
3. Adequately wet mist surface of plaster with amended water, initially and during removal procedures.
4. Remove acoustical plaster from masonry wall by scraping or other technique. Brush, HEPA vacuum, and wet wipe surface in order to remove remaining dust and residue. Place in approved container; see sheet 9. Apply labels; see sheet 14.
5. Inspect and reclean as necessary. Apply tinted penetrating encapsulant.
6. Inspect and reapply encapsulant as necessary.
7. Prepare area for final air clearance.
8. Carry out final clearance requirements as specified on applicable sheet 5, 16, 17, or 18.

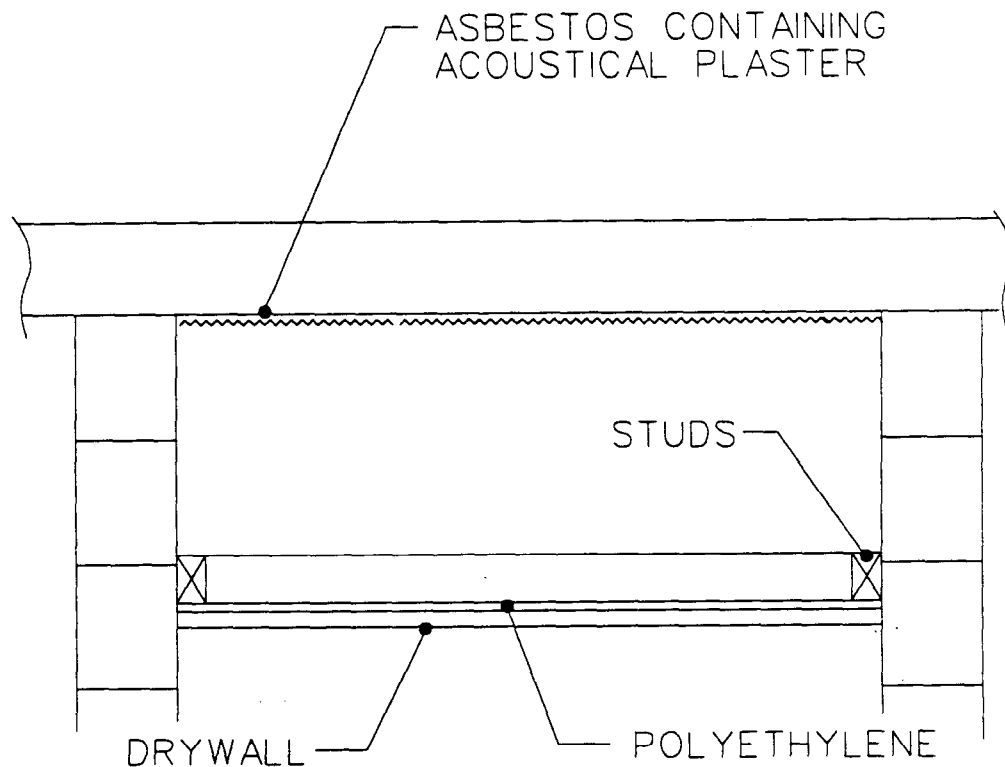

Enclosure of acoustical ceiling plaster, spray-on fireproofing, and thermal insulation

1. Establish work area so that unauthorized entry is prevented; see sheet 11. Prepare containment area as specified on sheet 21.
2. HEPA vacuum wall and floor surfaces. Anchor studs into adjacent walls, staple 6-mil polyethylene to studs, and seal edges with duct tape.
3. Attach asbestos-free drywall to studs. HEPA vacuum wall and floor surfaces.
4. After completion of abatement work, HEPA vacuum clothing and shoes.
5. Prepare area for final air clearance.
6. Carry out final clearance requirements as specified on sheet 21.

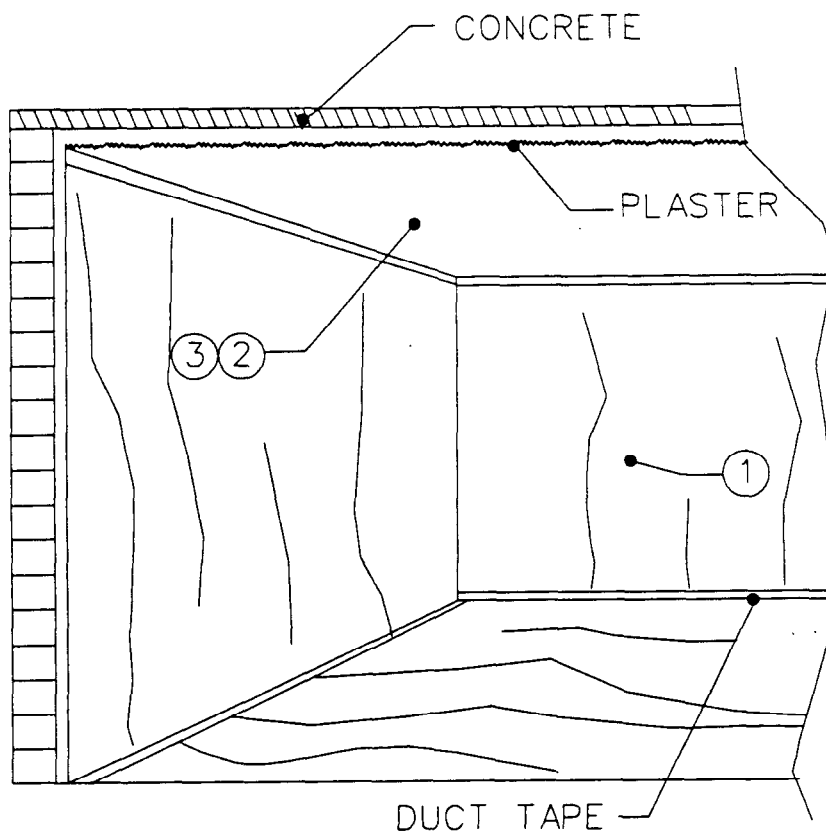

Removal of acoustical ceiling plaster (nonasbestos substrate)

1. Prepare containment area as specified on applicable sheet 2, 3, or 4.
2. Adequately wet mist surface of plaster with amended water, initially and during the removal procedure.
3. Remove acoustical plaster from masonry ceiling by scraping or other techniques. Brush, HEPA vacuum, and wet wipe surface in order to remove remaining dust and residue. Place in approved container; see sheet 9. Apply labels; see sheet 14.
4. Inspect and reclean area as necessary. Apply tinted penetrating encapsulant.
5. Inspect and reapply encapsulant as necessary.
6. Prepare area for final air clearance.
7. Carry out final clearance requirements as specified on applicable sheet 16, 17, or 18.

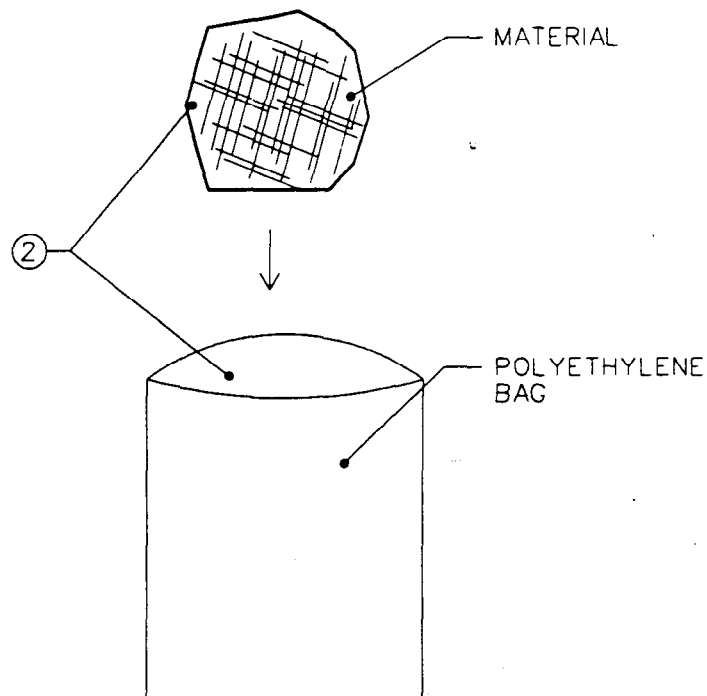

Removal of miscellaneous asbestos-containing materials

1. Establish work area so that unauthorized entry is prevented; see sheet 11. Prepare containment area as specified on sheet 21.
2. Adequately wet mist materials with amended water. Remove and place in approved container; see sheet 9. Apply labels; see sheet 14.
3. HEPA vacuum and wet wipe area in the immediate vicinity of removed materials.
4. Prepare area for final clearance.
5. Carry out final clearance requirements as specified on sheet 21.

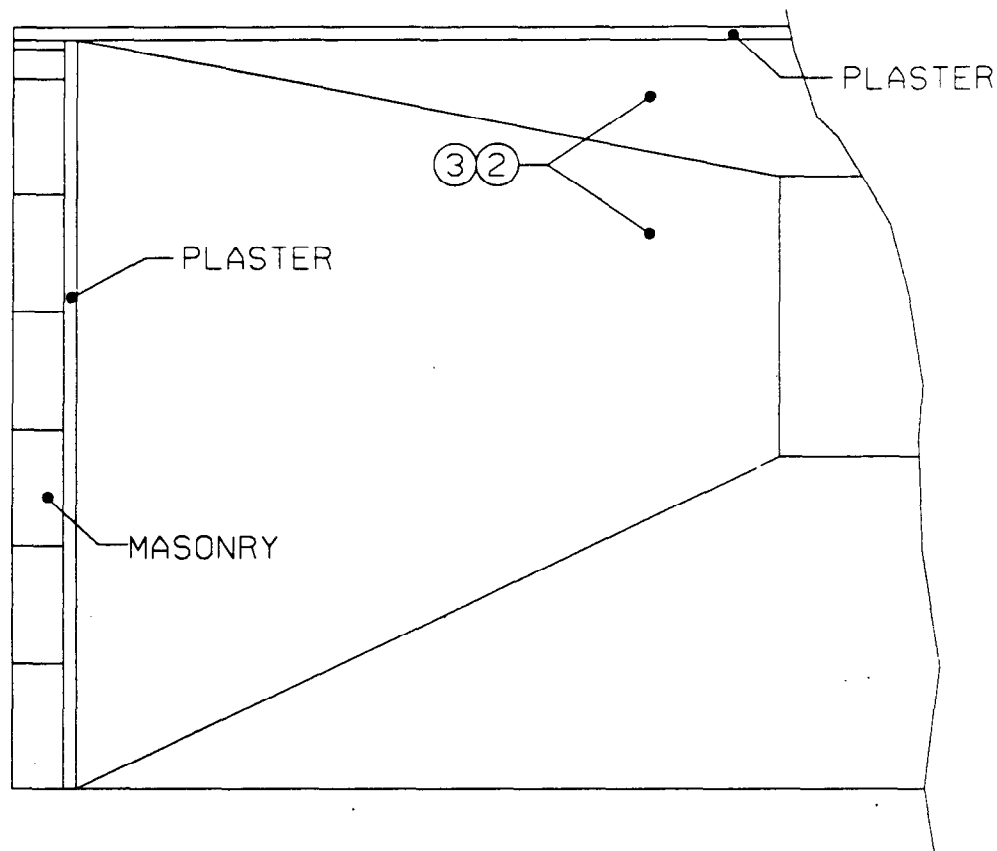

Removal of asbestos decorative paint on plaster

1. Prepare containment area as specified on applicable sheet 2, 3, 4, or 5.
2. Adequately wet mist surface of plaster with amended water, initially and during removal.
3. Remove all surface-mounted fixtures. Remove all decorative paint on plaster, using chisel and brush or other techniques. Brush, HEPA vacuum, and adequately wet clean surface in order to remove remaining dust and residue. Place in approved container; see sheet 9. Apply labels; see sheet 14.
4. Apply tinted penetrating encapsulant. Inspect and reapply as necessary.
5. Prepare area for final air clearance.
6. Carry out final clearance requirement as specified in applicable sheet 5, 16, 17, or 18.

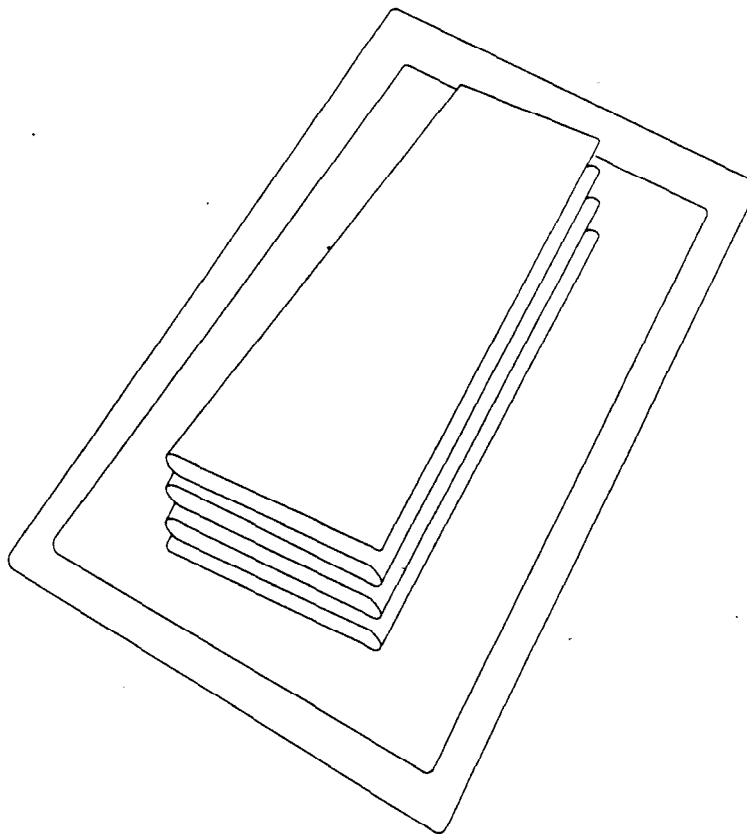

Removal of light curtain

1. Prepare modified containment area as specified on sheet 21.
2. While curtain is still hanging, spray a mist of removal encapsulant on both sides of curtain. Slowly and carefully lower curtain onto two layers of 6-mil polyethylene, folding the curtain in layers as it is lowered. Wrap top layer of polyethylene, creating a bundle. Seal bundle with duct tape; see sheet 9B. Apply labels; see sheet 14.
3. Wrap second layer of polyethylene around bundle and seal with duct tape; see sheet 9B. Apply labels; see sheet 14.
4. Prepare area for final air clearance.
5. Carry out clearance requirements as specified on sheet 21.

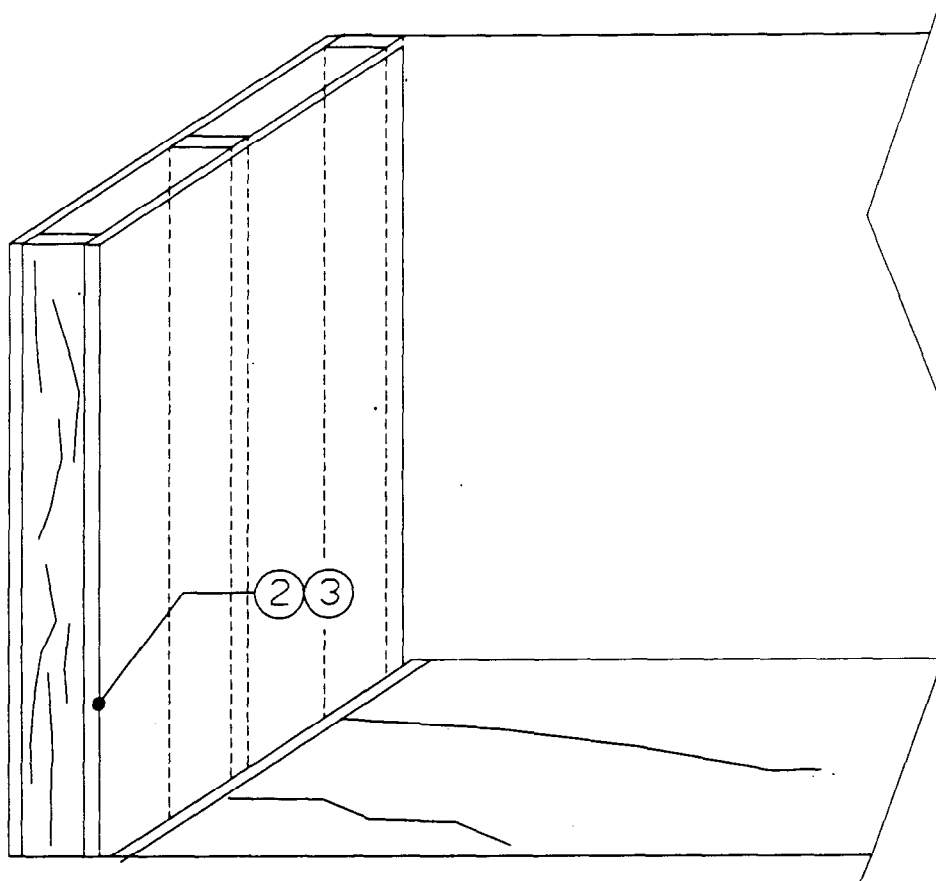

Removal of interior asbestos cement, fiberboard, and drywall panels

1. Prepare containment area as specified on applicable sheet 2, 3, 4, 5, or 6.
2. Adequately wet mist wall panels with amended water or removal encapsulant, initially and during removal.
3. Carefully remove all panels, minimizing breakage. Treat fasteners as asbestos-contaminated material. Take off any remaining residue on exposed structural surfaces and apply tinted penetrating encapsulant. Inspect and reapply encapsulant as necessary.
4. Separate, stack, and wrap all materials with two layers of 6-mil polyethylene. Seal the joints and ends of each layer with duct tape; see sheet 9B. Apply labels; see sheet 14. Place smaller material in approved container; see sheet 9B. Apply labels; see sheet 14.
5. Prepare area for final air clearance.
6. Carry out final clearance requirements as specified on applicable sheet 5, 6, 16, 17, or 18.

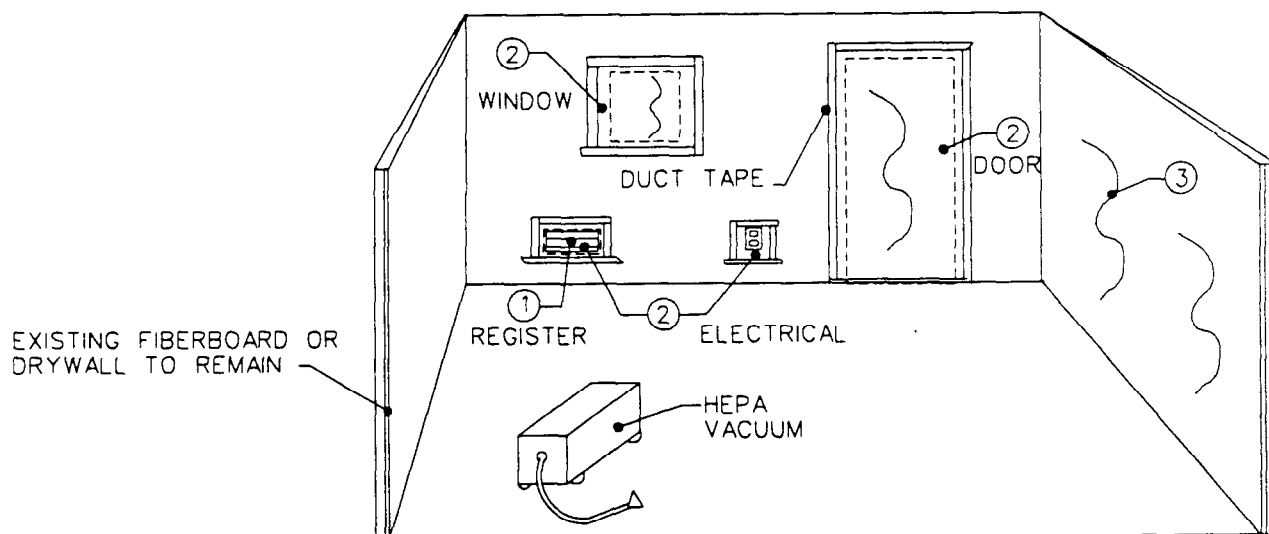

Bridging encapsulation of asbestos cement wall, fiberboard, and drywall panels

1. Prepare containment area as specified on applicable sheet 2, 3, 4, or 5. (If only one wall—and no ceiling—is to be abated, prepare bulkhead containment as specified on sheet 5.) Prevent unauthorized entry; see sheet 11. Eliminate airflow into containment area by isolating all supply and return air ducts from mechanical system.
2. Install 6-mil polyethylene critical barriers over all windows, doors, wall openings, electrical outlets, etc. Secure with duct tape on all sides.
3. Install 6-mil polyethylene, protecting wall and floor surfaces not to be encapsulated.
4. Install HEPA filter and ductwork, and locate unit to prevent dead air pockets; see sheet 8.
5. Apply tinted bridging encapsulant to surface.
6. Inspect and reapply encapsulant as necessary.
7. Remove polyethylene on walls, floor, and plywood. The critical barriers sealing all windows, doors, wall openings, electrical outlets, etc., are to remain. Treat polyethylene as asbestos-contaminated material; see sheets 9 and 14.
8. Prepare area for final air clearance.
9. Carry out final clearance requirements as specified on applicable sheet 5, 16, 17, and 18.

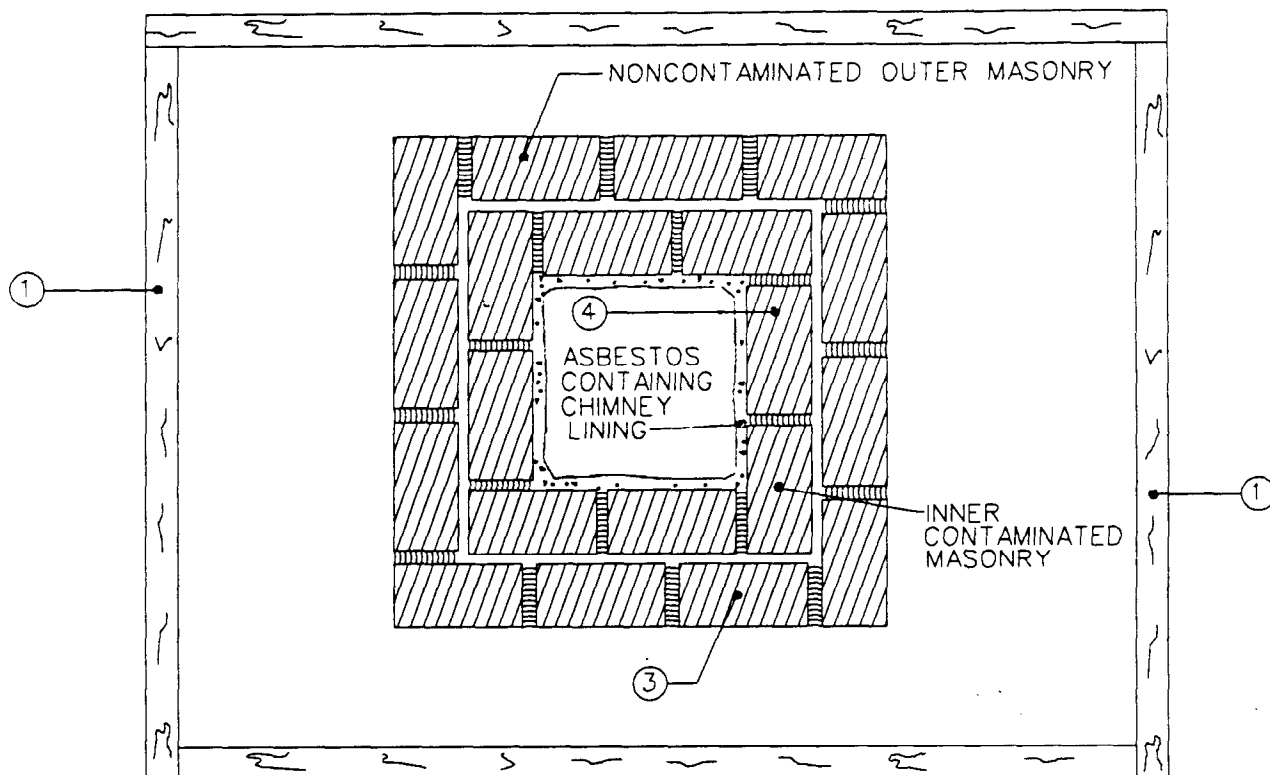

Removal of asbestos-contaminated masonry for masonry chimney

1. Prepare containment area as specified on sheet 3 (for interior applications) or sheet 7 (for exterior applications).
2. Adequately wet mist inner surface of chimney lining with amended water, initially and during removal procedures.
3. Demolish chimney by first separating outer masonry courses from the inner masonry courses, using a chisel. HEPA vacuum outer masonry and treat as ordinary construction waste.
4. Break the inner masonry and chimney lining apart. Place in a sealable rigid container; see sheet 9. Apply labels; see sheet 14.
5. Prepare area for final clearance.
6. Carry out final clearance requirements as specified on sheet 17 (interior applications) or sheet 7 (exterior applications).

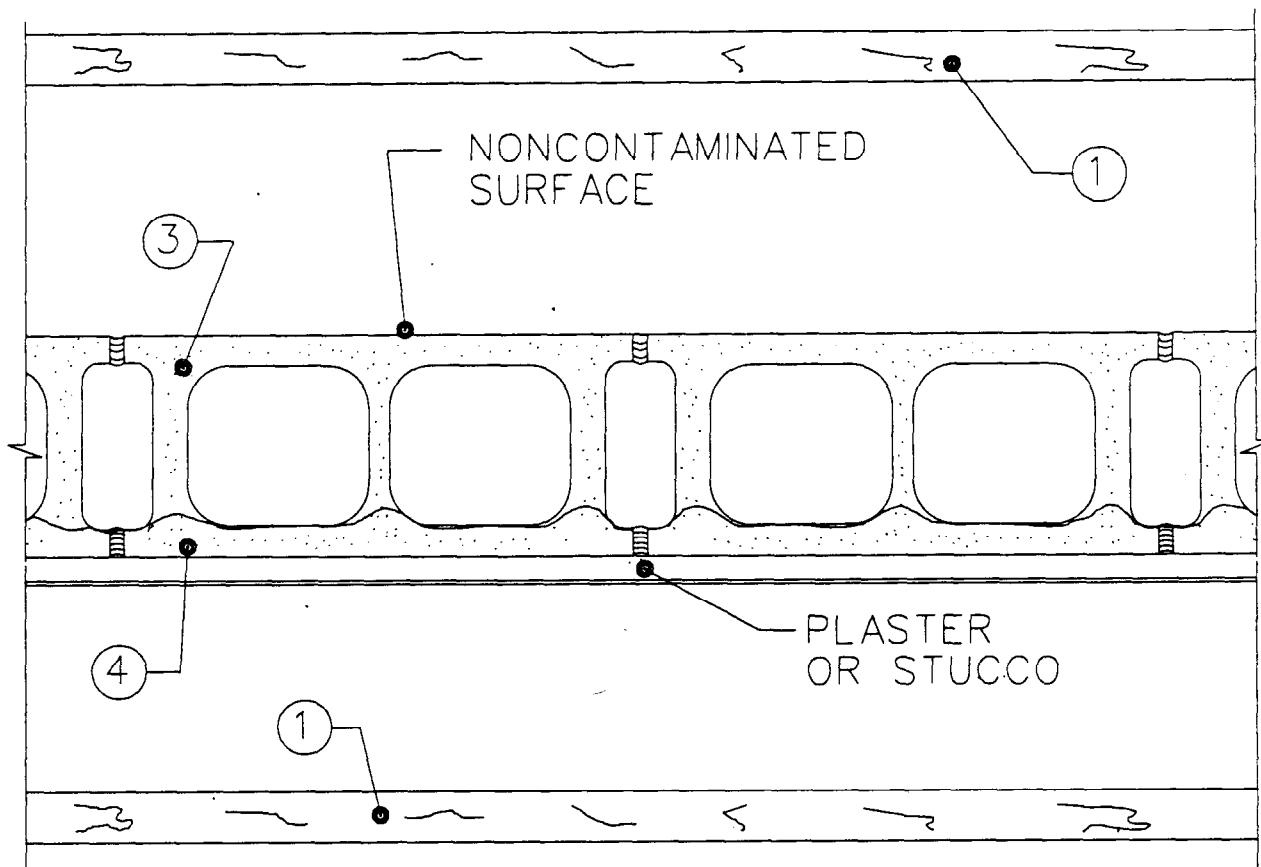

Removal of asbestos-contaminated masonry wall or thermal insulation

1. Prepare containment area as specified on sheet 6.
2. Adequately wet mist surface of plaster or stucco with amended water, initially and during removal procedure.
3. Demolish masonry wall.
4. Place contaminated masonry into a sealable rigid container; see sheet 9. Apply labels; see sheet 14.
5. Prepare area for final air clearance.
6. Carry out final clearance requirements as specified on sheet 6.

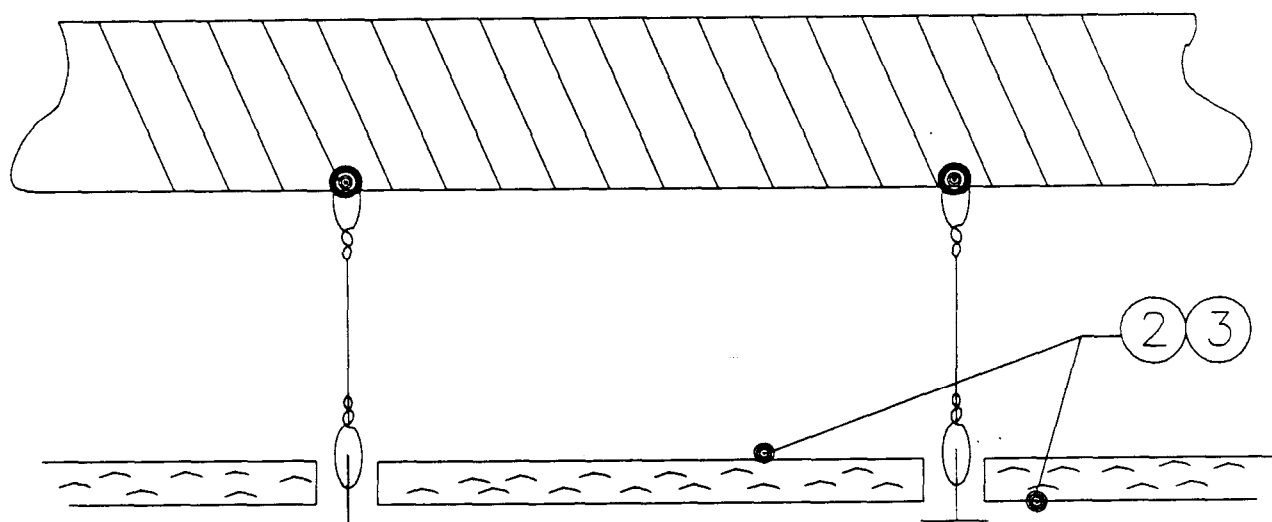

Removal of suspended asbestos cement ceiling tile

1. Prepare containment area as specified on sheet 21.
2. Adequately wet mist tile surfaces with amended water, initially and during removal.
3. HEPA vacuum while removing existing suspended ceiling system, including tile, splines, "T" bars, and wire hangers. Treat all materials as asbestos-contaminated waste. HEPA vacuum and wet wipe surfaces.
4. Separate and stack all materials, and wrap with two layers of 6-mil polyethylene. Seal the joints and ends of each layer with duct tape; see sheet 9B. Apply labels; see sheet 14. Place smaller material in approved container; see sheet 9B. Apply labels; see sheet 14.
5. Prepare area for final air clearance.
6. Carry out final clearance requirements as specified on sheet 21.

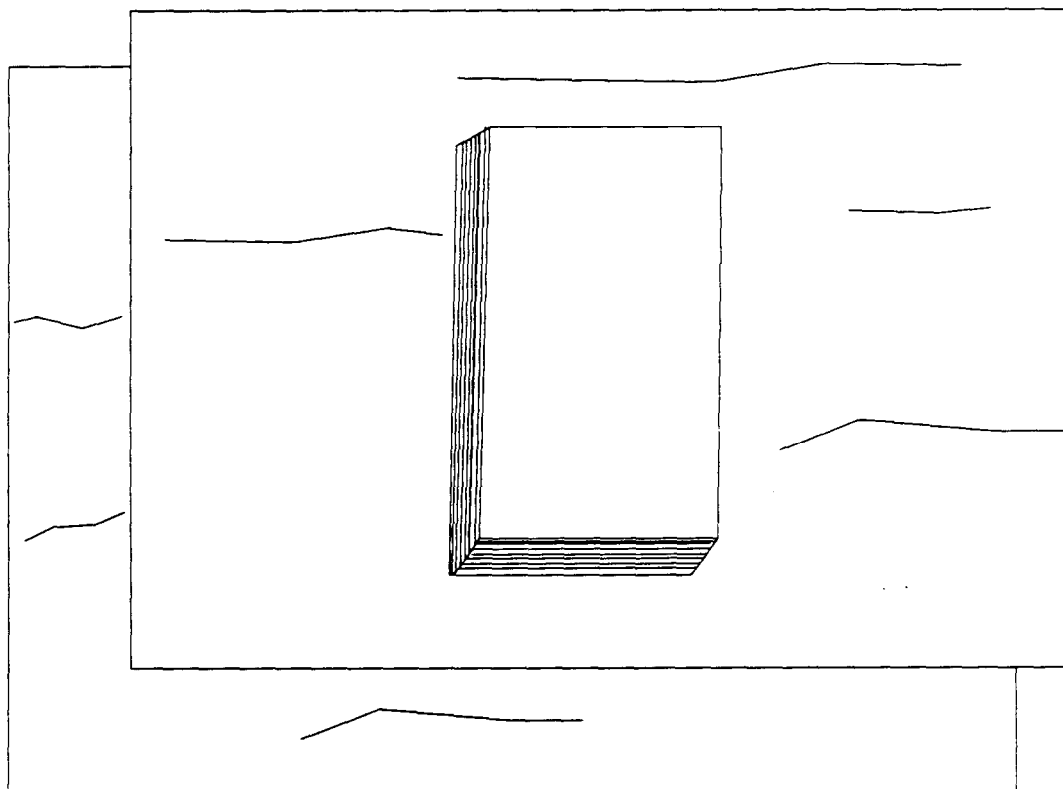

Removal of asbestos cement architectural products

1. Prepare modified containment area as specified on sheet 21.
2. Adequately mist a removal encapsulant on the top surface of the product. Remove product. HEPA vacuum and wet wipe surface area. Spread two layers of 6-mil polyethylene on floor beside the product. Wrap top layer of polyethylene around the product. Seal all joints and ends with duct tape; see sheet 9B. Apply labels; see sheet 14. Wrap again with second layer of polyethylene in the same manner; see sheet 9B. Apply labels; see sheet 14.
3. Prepare area for final clearance.
4. Carry out final clearance requirements as specified on sheet 21.

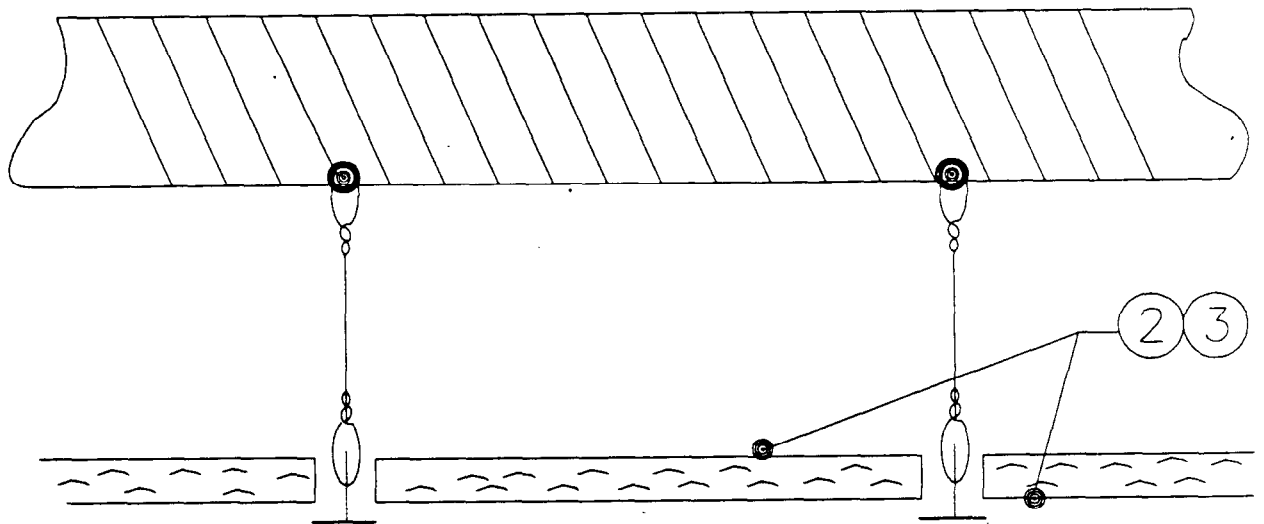

Removal of suspended acoustical ceiling tile

1. Prepare containment area as specified on applicable sheet 2, 3, or 4.
2. Adequately wet mist tile surfaces with amended water, initially and during removal procedures.
3. HEPA vacuum while removing existing suspended ceiling system, including tile, splines, "T" bars, and wire hangers. Treat all materials as asbestos-contaminated waste. HEPA vacuum and wet wipe surfaces.
4. Separate and stack all materials, and wrap with two layers of 6-mil polyethylene. Wrap top layer of polyethylene around the product. Seal the joints and ends of each layer with duct tape; see sheet 9B. Apply labels; see sheet 14. Wrap again with second layer of polyethylene in the same manner; see sheet 9B. Apply labels; see sheet 14.
5. Prepare area for final air clearance. (If the ceiling is being removed to gain access to other asbestos-containing materials, omit this step until abatement of all asbestos-containing materials is complete).
6. Carry out final clearance requirements specified on sheet 16, 17, or 18.

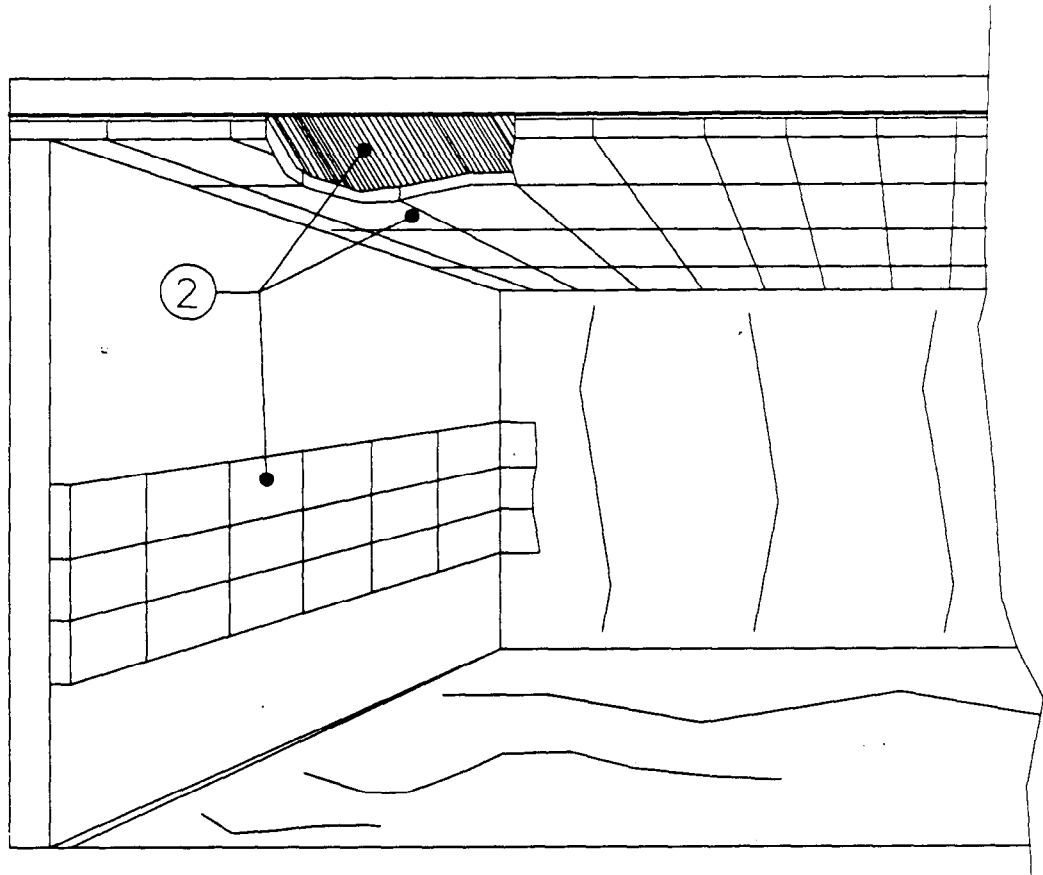

Removal of glued-on acoustical ceiling and wall tile

1. Prepare containment area as specified on applicable sheet 2, 3, or 4.
2. Adequately wet mist tile surfaces with amended water, initially and during removal procedures.
3. Remove glued-on tiles, and scrape off remaining glue.
4. Clean, HEPA vacuum, and adequately wet clean.
5. Separate and stack all materials, and wrap with two layers of 6-mil polyethylene. Wrap top layer of polyethylene around ACM. Seal the joints and ends of each layer with duct tape; see sheet 9B. Apply labels; see sheet 14. Wrap again with second layer of polyethylene in the same manner; see sheet 9B. Apply labels; see sheet 14. Place smaller material in approved container; see sheet 9B. Apply labels; see sheet 14.
6. Inspect and reclean area as necessary.
7. Apply tinted penetrating encapsulant. Inspect and reapply as necessary.
8. Prepare area for final clearance.
9. Carry out final clearance requirements specified on applicable sheet 16, 17, or 18.

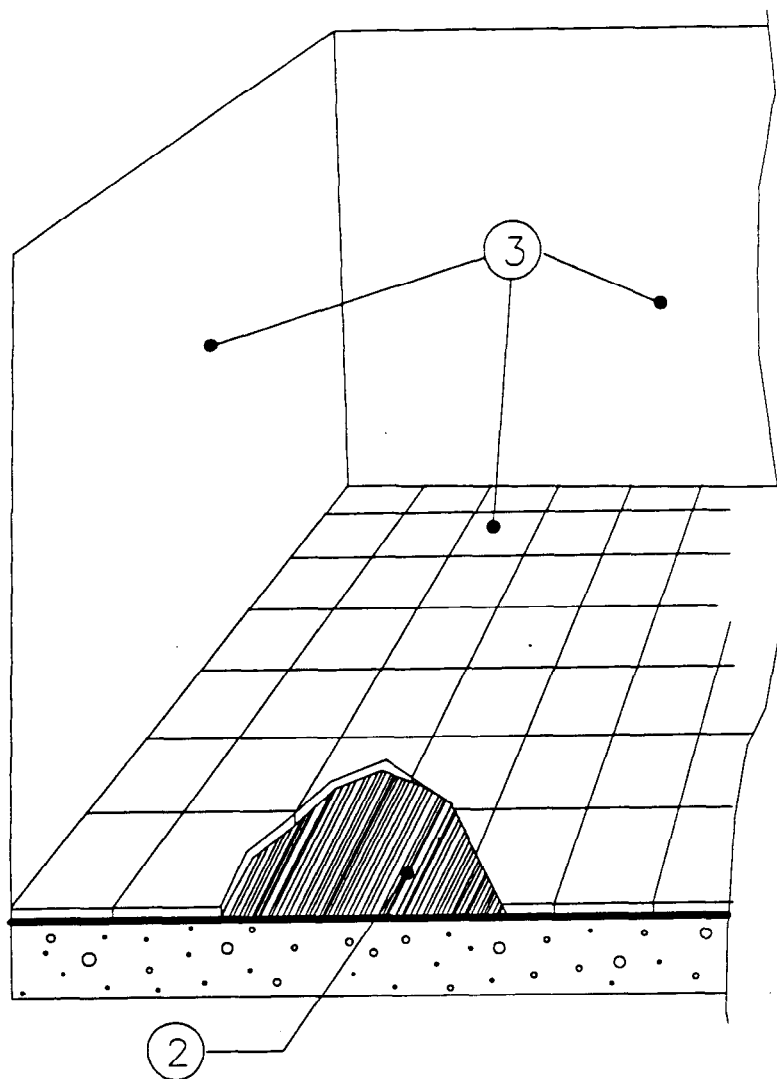

Repair of vinyl asbestos tile adhered to concrete floor system

1. Prepare work area; see sheet 21. Prevent unauthorized entry; see sheet 11.
2. Remove damaged asbestos tile. Place into an approved container; see sheet 9. Apply labels; see sheet 14.
3. HEPA vacuum and adequately wet clean.
4. Inspect.
5. Install new tile.
6. Prepare area for final clearance.
7. Carry out final clearance requirements specified on sheet 21.

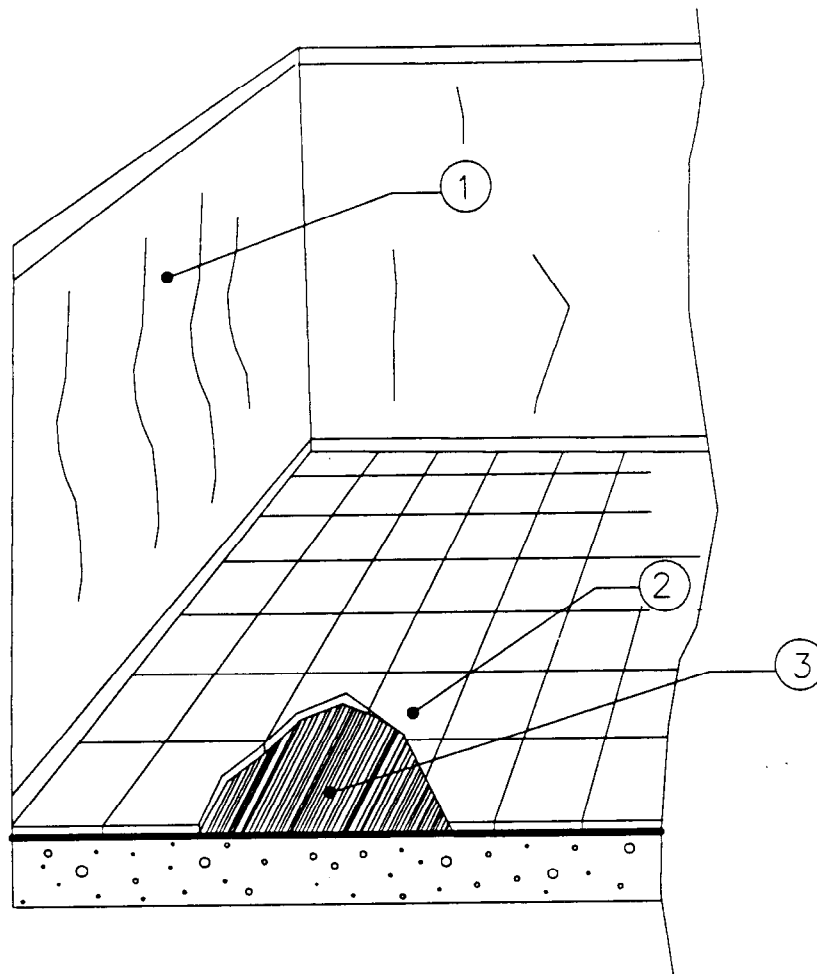

Removal of vinyl asbestos tile adhered to concrete floor system by asbestos-containing adhesive

1. Prepare containment area as specified on sheet 21.
NOTE: Where full containment area is required, follow instructions on sheet 4, except omit polyethylene on floor.

2. Lightly flood asbestos tile with amended water, and let soak for 48 hours. Remove asbestos tile and adhesive while they are wet in order to prevent asbestos fiber release. Place tile and adhesive into an

approved container; see sheet 9. Apply labels; see sheet 14.

3. Clean, HEPA vacuum, and wet wipe all surfaces.

4. Inspect and reclean area as necessary.

5. Prepare area for final air clearance.

6. Carry out final clearance requirements as specified on applicable sheet 18 or 21.

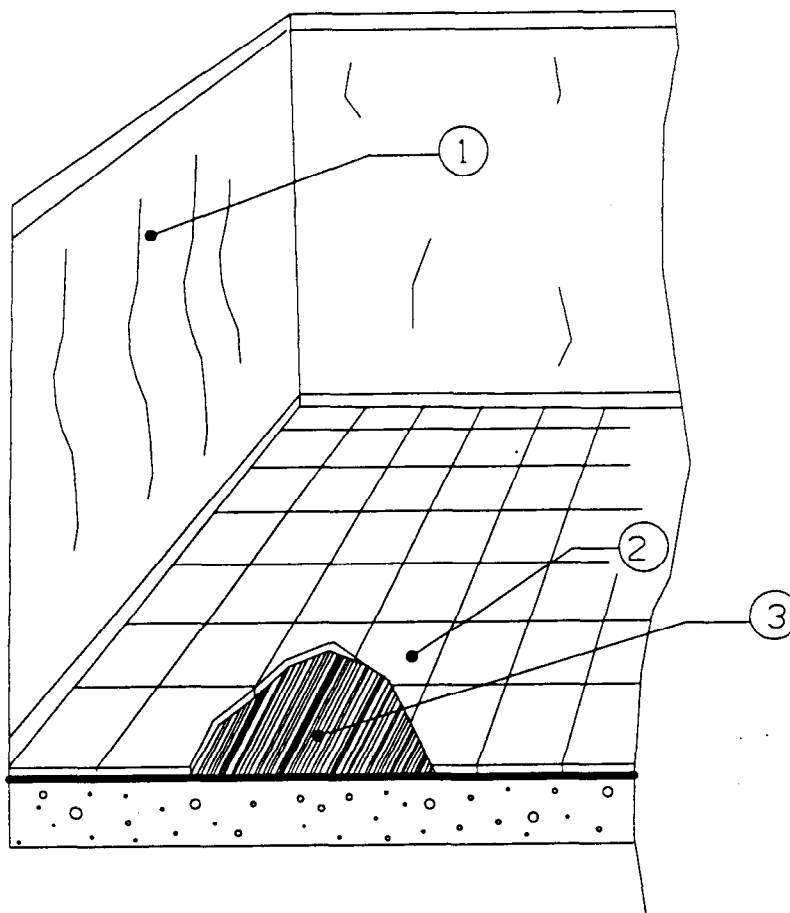

Removal of vinyl asbestos tile adhered to concrete floor system by asbestos-free adhesive

1. Prepare containment area as specified on sheet 21.
NOTE: Where full containment area is required, follow instructions on sheet 4, except omit polyethylene on floor.

2. Lightly flood asbestos tile, and soak for 48 hours. Remove asbestos tile and adhesive while they are wet in order to prevent asbestos fiber release. Place tile and adhesive into an approved container; see sheet 9. Apply labels; see sheet 14.

3. Clean, HEPA vacuum, and adequately wet clean all surfaces.

4. Inspect and reclean area as necessary.

5. Prepare area for final air clearance.

6. Carry out final clearance requirements as specified on applicable sheet 18 or 21.

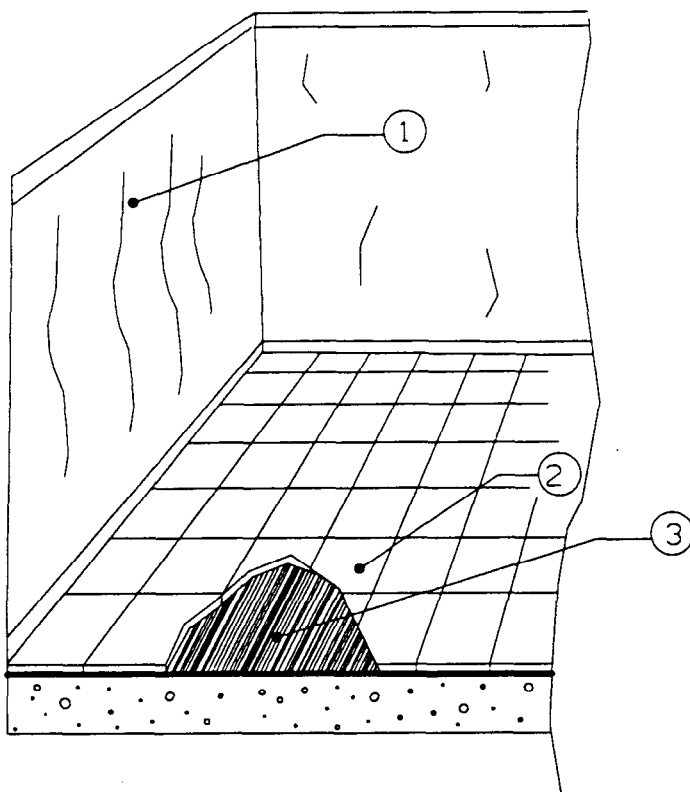

USE THIS DETAIL ONLY FOR
- SMALL SCALE PROJECTS
- GROUND FLOOR APPLICATIONS

Removal of vinyl asbestos tile and chemical dissolution of asbestos-containing adhesives on concrete floor system

1. Prepare containment area as specified on sheet 4.
2. Lightly flood asbestos tile, and soak for 48 hours. Remove asbestos tile and adhesive while they are wet in order to prevent asbestos fiber release. Place tile and adhesive into an approved container; see sheet 9. Apply labels; see sheet 14.
3. Before removing adhesive, increase ventilation rate to 10 air changes per hour. Air must be exhausted outside building.
4. Apply liquid adhesive remover. As soon as the adhesive is soft enough to scrape, remove and put into approved container; see sheet 9. Apply labels; see sheet 14.
5. Prepare area for final air clearance.
6. Carry out final clearance requirements as specified on sheet 18.

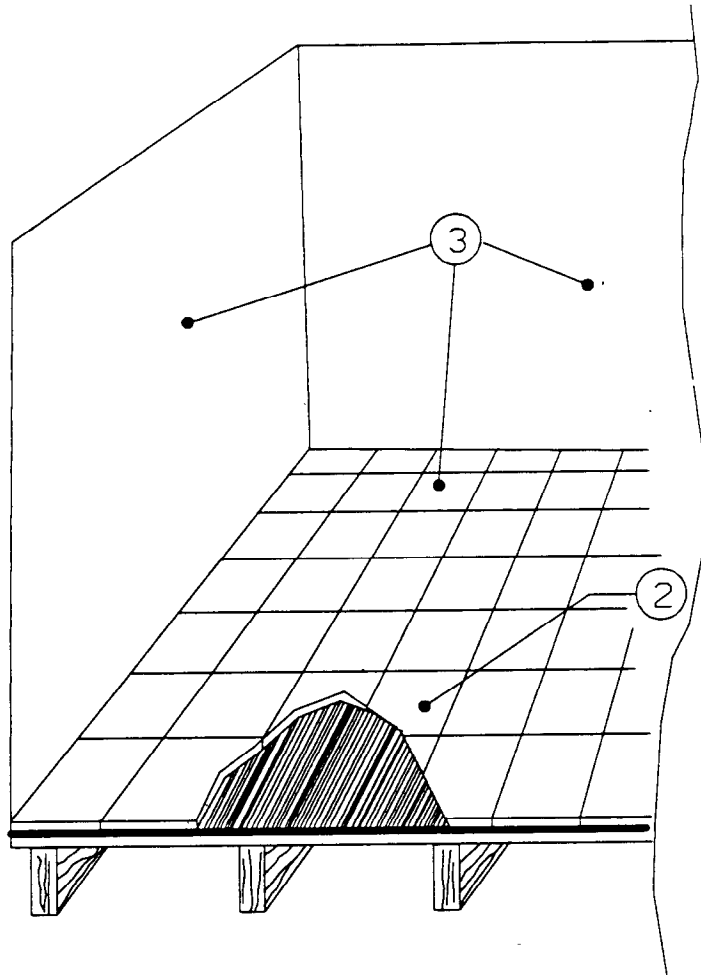

Repair of vinyl asbestos tile adhered to wood floor system by asbestos-containing adhesive

1. Prepare work area; see sheet 21. Prevent unauthorized entry; see sheet 11.
2. Adequately mist and remove damaged asbestos tile and adhesive. Place tile and adhesive into an approved container; see sheet 9. Apply labels; see sheet 14.
3. HEPA vacuum and wet wipe area.
4. Install new tile.
5. Inspect.
6. Prepare area for final clearance.
7. Carry out final clearance requirements specified on sheet 21.

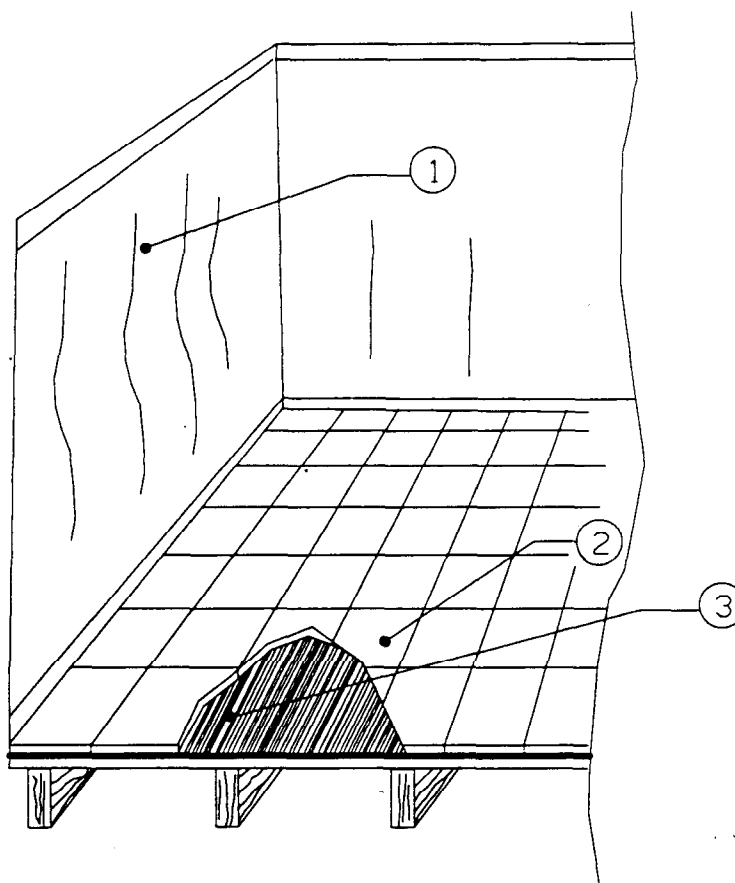

Removal of vinyl asbestos tile adhered to wood floor system by asbestos-containing adhesive

1. Prepare containment area as specified on sheet 21, except omit polyethylene on floor. **NOTE:** Where full containment is required, follow instructions on sheet 4.
 2. Where wood flooring is to remain, adequately wet and remove asbestos tile and adhesive in order to prevent asbestos fiber release. Place tile and adhesive into an approved container; see sheet 9. Apply labels; see sheet 14. **Note:** Where wood flooring is to be removed, adequately wet and remove existing wood flooring. Treat as asbestos-contaminated material. Spread a plastic sheet on the floor, and stack removed wood flooring onto two layers of 6-mil polyethylene.
 3. Clean, HEPA vacuum, and adequately wet clean all surfaces.
 4. Inspect and reclean area as necessary.
 5. Prepare area for final air clearance.
 6. Carry out final clearance requirements specified in applicable sheet 18 or 21.
- Wrap each polyethylene layer around the stack, sealing all joints and edges with duct tape; see sheet 9. Apply labels to stack; see sheet 14. Smaller material will be placed in approved container; see sheet 9. Apply labels; see sheet 14.

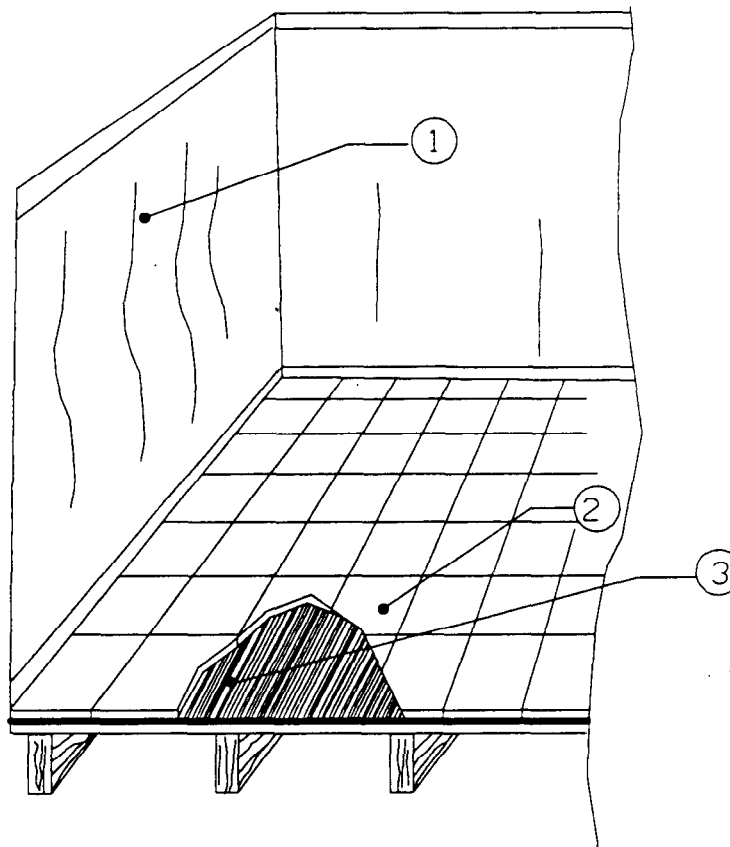

Removal of vinyl asbestos tile adhered to wood floor system by asbestos-free adhesive

1. Prepare containment area as specified on sheet 21.
NOTE: Where full containment is required, follow instructions on sheet 4, except omit polyethylene on floor.
2. Adequately wet and remove asbestos tile and adhesive while they are wet in order to prevent asbestos fiber release. Place tile and adhesive into an approved container; see sheet 9. Apply labels; see sheet 14.
3. Clean, HEPA vacuum, and wet wipe all surfaces.
4. Inspect and reclean area as necessary.
5. Prepare area for final air clearance.
6. Carry out final clearance requirements specified on applicable sheet 18 or 21.

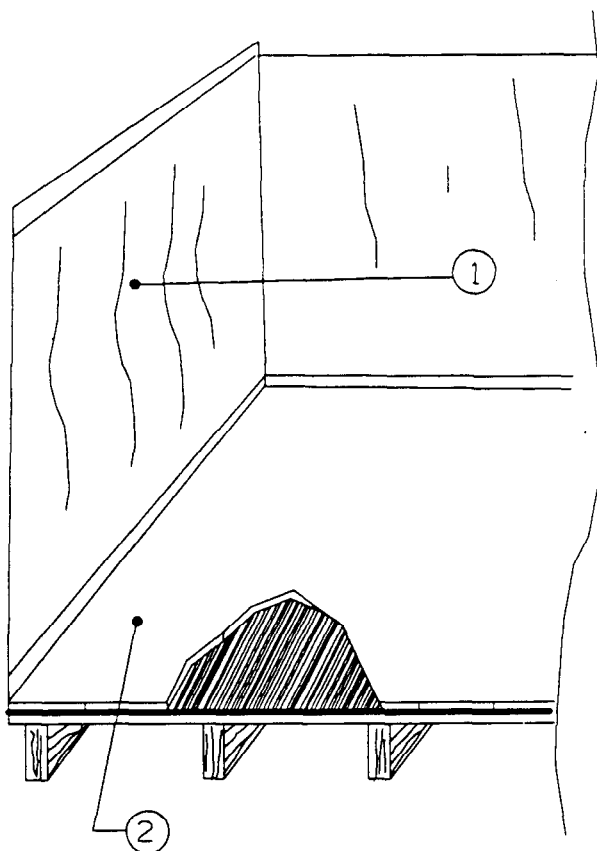

Removal of sheet-flooring adhered to wood floor system

1. Prepare containment area as specified on sheet 21.
NOTE: Where full containment is required, follow instructions on sheet 4, except omit polyethylene on floor.

2. Mist exposed surfaces with amended water just before sheet flooring is removed. Remove flooring in manageable pieces and place on two layers of 6-mil polyethylene. Wrap each layer of polyethylene around the stack, sealing all joints and edges with duct tape; see sheet 9. Apply labels; see sheet 14. Place smaller

material in approved container; see sheet 9. Apply labels; see sheet 14.

3. Clean, HEPA vacuum, and adequately wet clean all surfaces.

4. Inspect and reclean area as necessary.

5. Prepare area for final air clearance.

6. Carry out final clearance requirements as specified on applicable sheet 18 or 21.

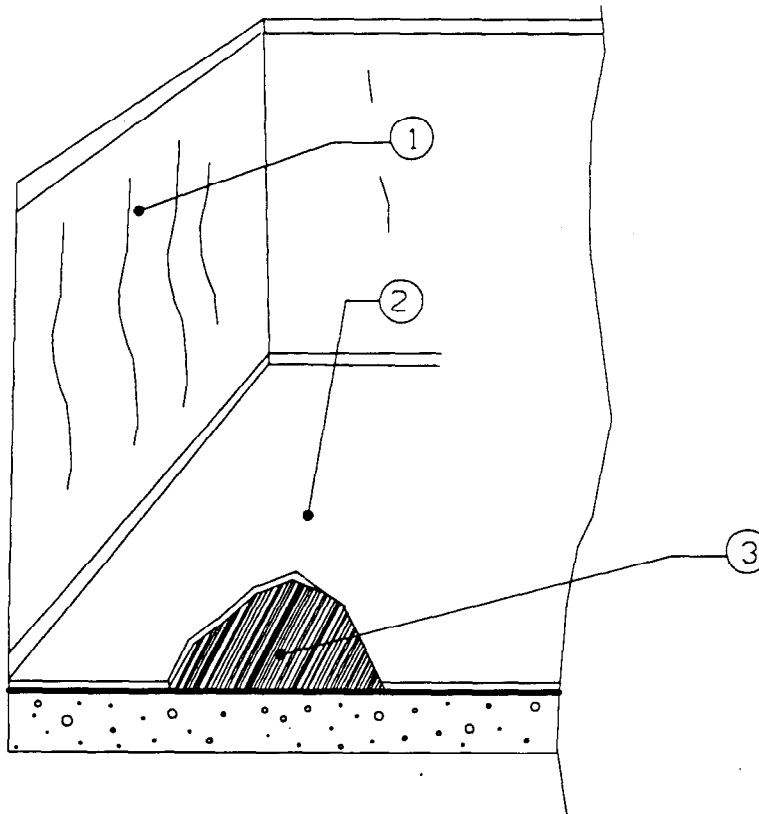

Removal of sheet-flooring adhered to concrete floor system by asbestos-containing adhesive

1. Prepare containment area as specified on sheet 21.
NOTE: Where full containment is required, follow instructions on sheet 4, except omit polyethylene on floor.
2. Mist exposed surfaces with amended water just before sheet flooring is removed. Remove flooring in manageable pieces and place on two layers of 6-mil polyethylene. Wrap each layer of polyethylene around the stack, sealing all joints and edges with duct tape; see sheet 9. Apply labels; see sheet 14. Place smaller material in approved container; see sheet 9. Apply labels; see sheet 14.
3. Remove remaining adhesive down to bare concrete. Place in approved container; see sheet 9. Apply labels; see sheet 14.
4. Clean, HEPA vacuum, and wet wipe all surfaces.
5. Inspect and reclean area as necessary.
6. Prepare area for final air clearance.
7. Carry out final clearance requirements specified on applicable sheet 18 or 21.

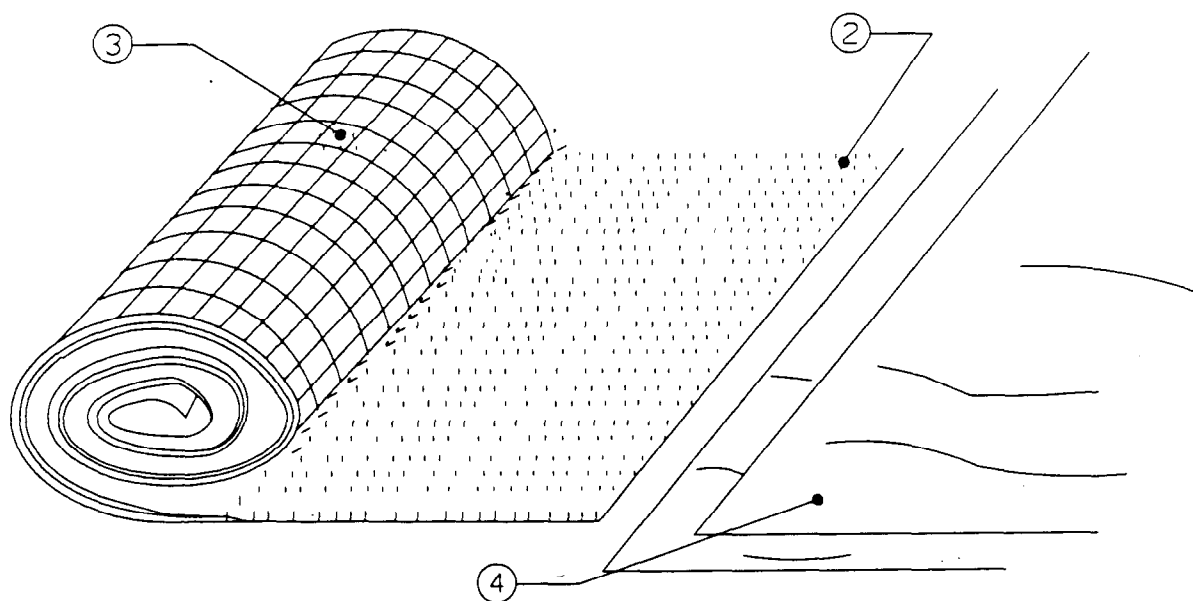

Removal of carpeting (asbestos-containing or -contaminated)

1. Prepare modified containment area as specified on sheet 21.
2. Adequately mist a removal encapsulant on the top surface of the carpet.
3. Carefully roll the carpet into a tight cylinder. As the carpet is being rolled, mist the newly exposed side.
4. Spread out two layers of 6-mil polyethylene on the floor beside the cylinder and carefully roll the carpet onto the polyethylene.
5. Wrap each layer of the polyethylene around the cylinder. Seal all joints and ends with duct tape; see sheet 9. Apply labels; see sheet 14.
6. Clean, HEPA vacuum, and adequately wet clean surfaces.
7. Prepare for final air clearance.
8. Carry out final clearance requirements as specified on sheet 21.

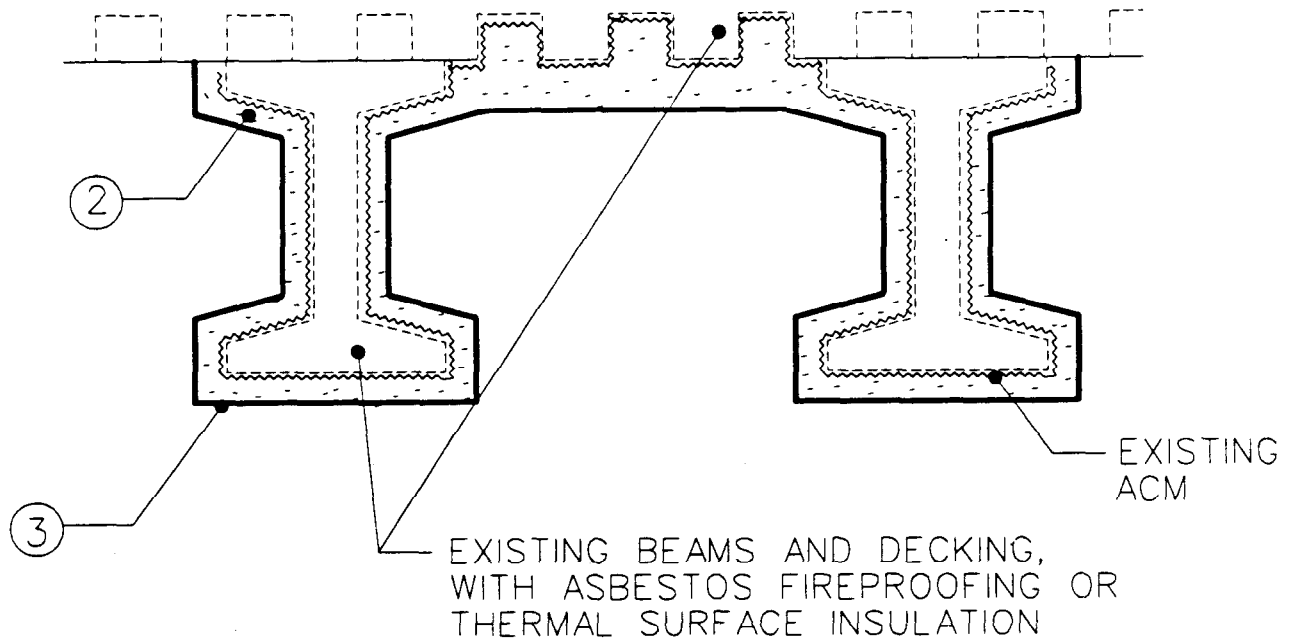

Encasement of fireproofing or thermal insulation of beams and decking

1. Prepare containment area as specified on applicable sheet 2, 3, or 4.
2. Apply foam sealer to existing asbestos fireproofing in accordance with manufacturer's recommendations.
3. Spray on polymer shell finish.
4. Inspect.
5. Prepare area for final clearance.
6. Carry out final clearance requirements specified on applicable sheet 16, 17, or 18.

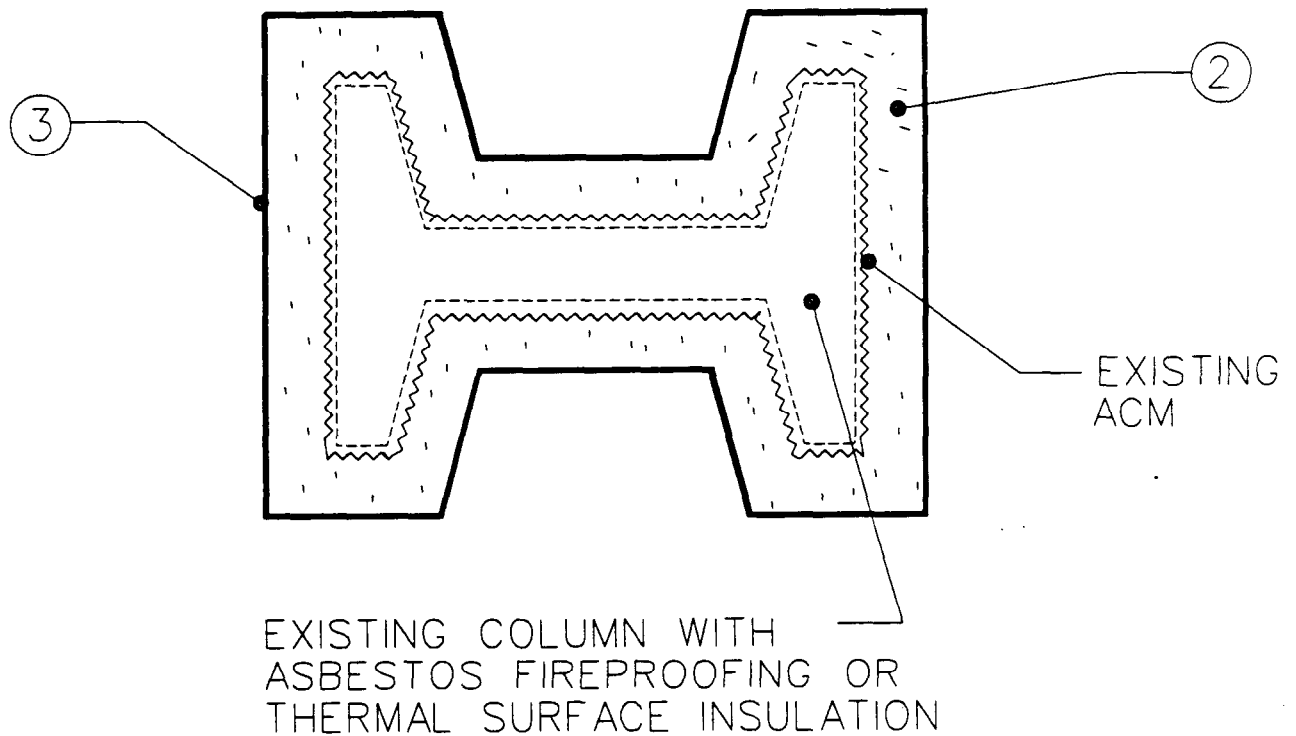

Encasement of fireproofing or thermal insulation on columns

1. Prepare containment area as specified on applicable sheet 2, 3, or 4.
2. Apply foam sealer to existing asbestos fireproofing in accordance with manufacturer's recommendations.
3. Inspect and reapply as necessary.
4. Spray on polymer shell finish.
5. Inspect and reapply polymer shell finish as necessary.
6. Prepare area for final air clearance.
7. Carry out final clearance requirements as specified on applicable sheet 16, 17, or 18.

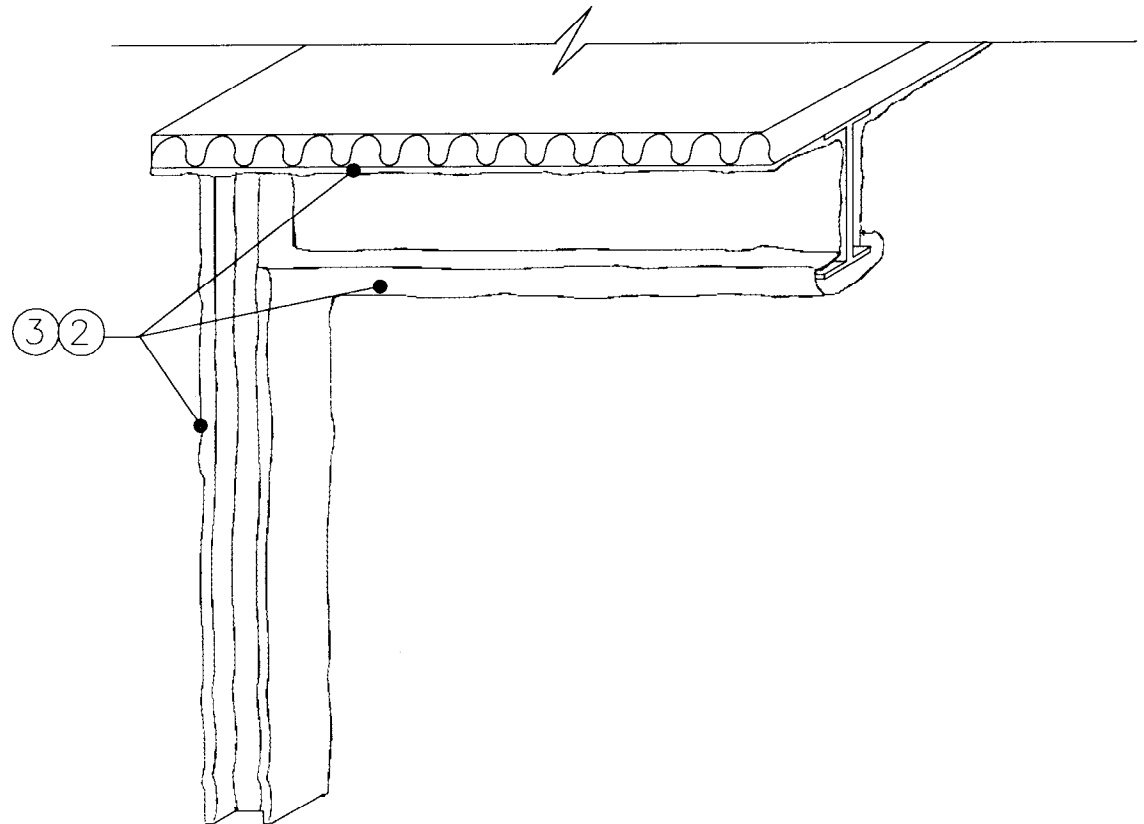

Removal of fireproofing or thermal surface insulation

1. Prepare containment area as specified on applicable sheet 2, 3, or 4.
2. Adequately wet mist surface of insulation/fireproofing with amended water, initially and during removal procedures.
3. Remove sprayed-on fireproofing from all structural members. Brush, HEPA vacuum, and wet wipe exposed steel surfaces in order to remove residual material. Place removed asbestos-containing material in approved containers; see sheet 9. Apply labels; see sheet 14.
4. Inspect and reclean area as necessary.
5. Apply tinted penetrating encapsulant. Inspect and reapply encapsulant as necessary.
6. Prepare area for final air clearance.
7. Carry out final clearance requirements as specified on applicable sheet 16, 17, or 18.

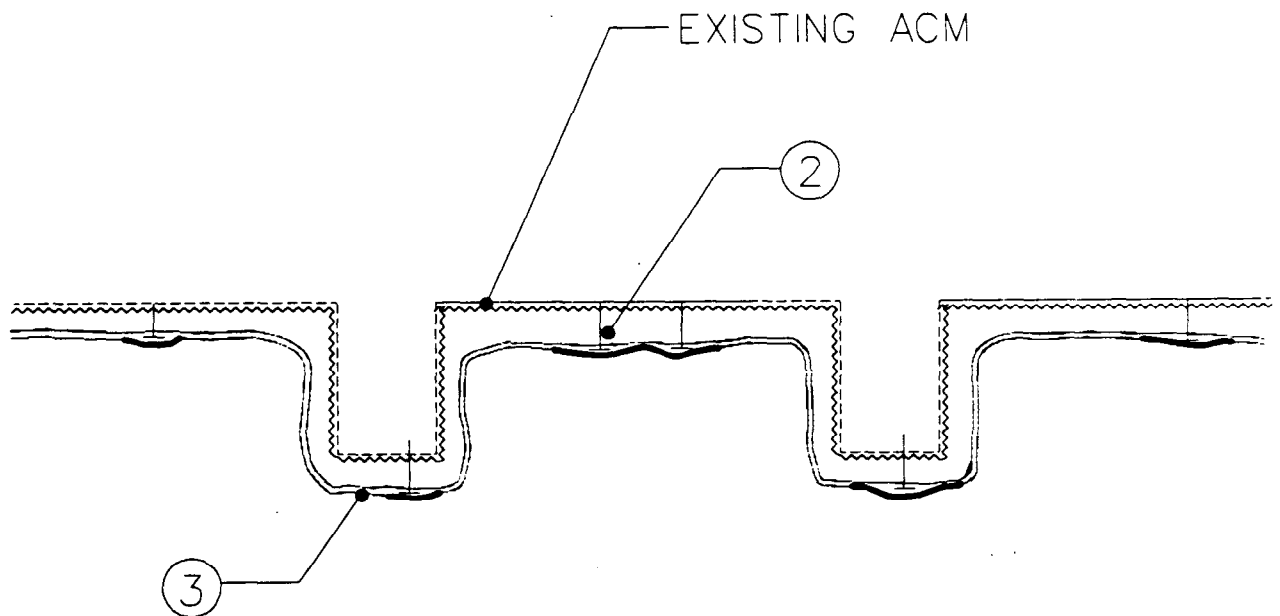

Encasement of acoustical ceiling insulation

1. Prepare containment area as specified on applicable sheet 2, 3, or 4.
2. Install encasement supports per manufacturer's recommendations. Apply foam sealer to existing acoustical ceiling insulation.
3. Inspect.
4. Spray on polymer shell finish.
5. Inspect.
6. Prepare area for final air clearance.
7. Carry out final clearance requirements as specified on applicable sheet 16, 17, or 18.

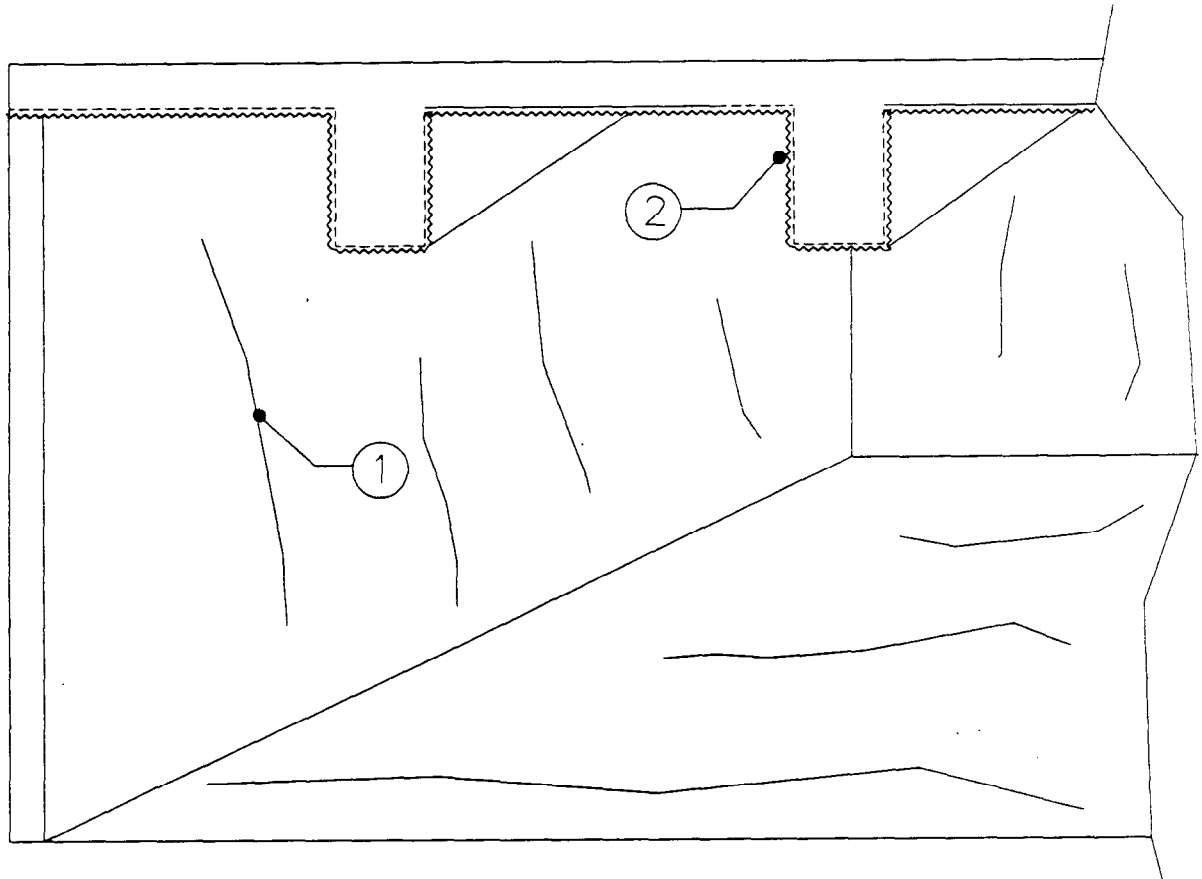

Removal of acoustical ceiling insulation

1. Prepare containment area as specified on applicable sheet 2, 3, or 4.
2. Adequately wet mist surface of acoustical ceiling insulation with amended water, initially and during abatement procedures.
3. Remove all surface-mounted fixtures. Remove insulation on structural substrate. Clean, HEPA vacuum, and adequately wet clean surface in order to remove remaining residue.
4. Inspect and reclean area as necessary.
5. Apply tinted penetrating encapsulant. Inspect and reapply encapsulant as necessary.
6. Prepare area for final air clearance.
7. Carry out final clearance requirements as specified on applicable sheet 16, 17, or 18.

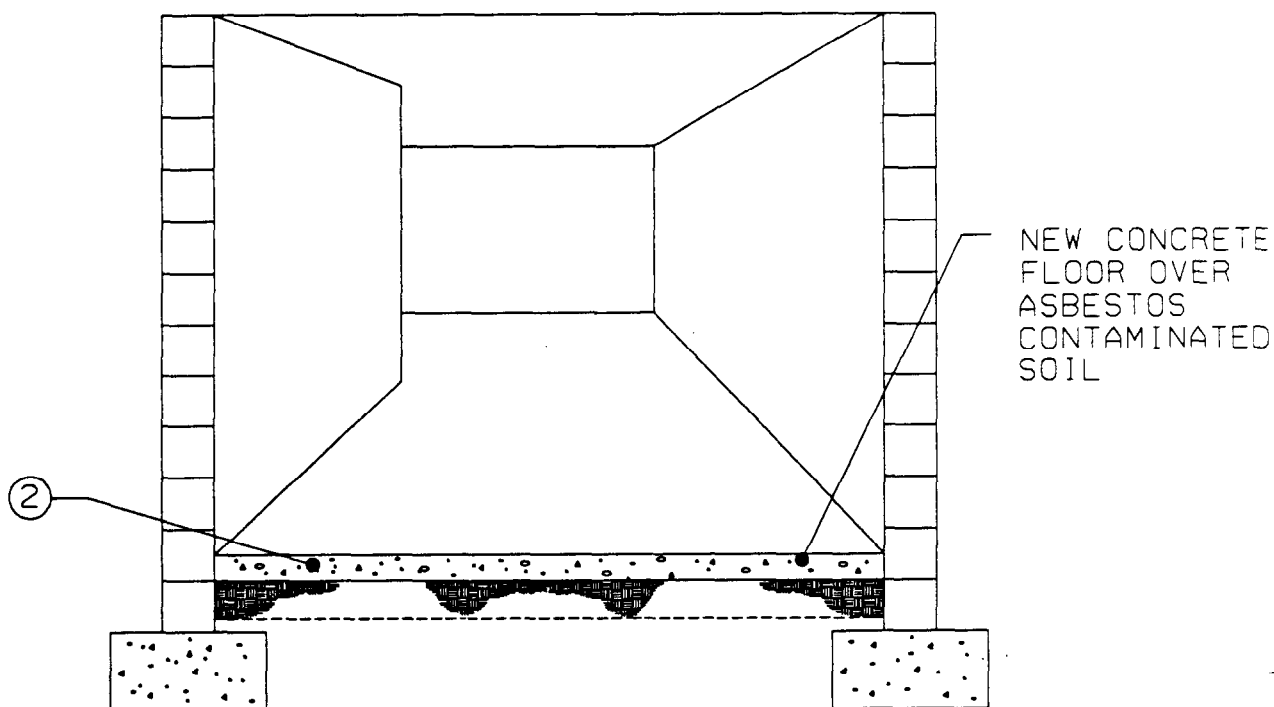

Enclosing asbestos-contaminated soil

1. Prepare mini-containment area as specified on sheet 7. Install HEPA-filtered air exhauster in a location that will provide air movement through work area. Adequately wet mist soil floor with amended water. Gather loose debris and place in approved container; see sheet 9. Apply labels; see sheet 14.
2. Place 6-mil polyethylene on top of soil floor, and cast a new 2-inch concrete floor.
3. Apply tinted penetrating encapsulant to wall and ceiling surfaces, using airless sprayer.
4. Prepare area for final clearance.
5. Carry out final clearance requirements as specified on sheet 7.

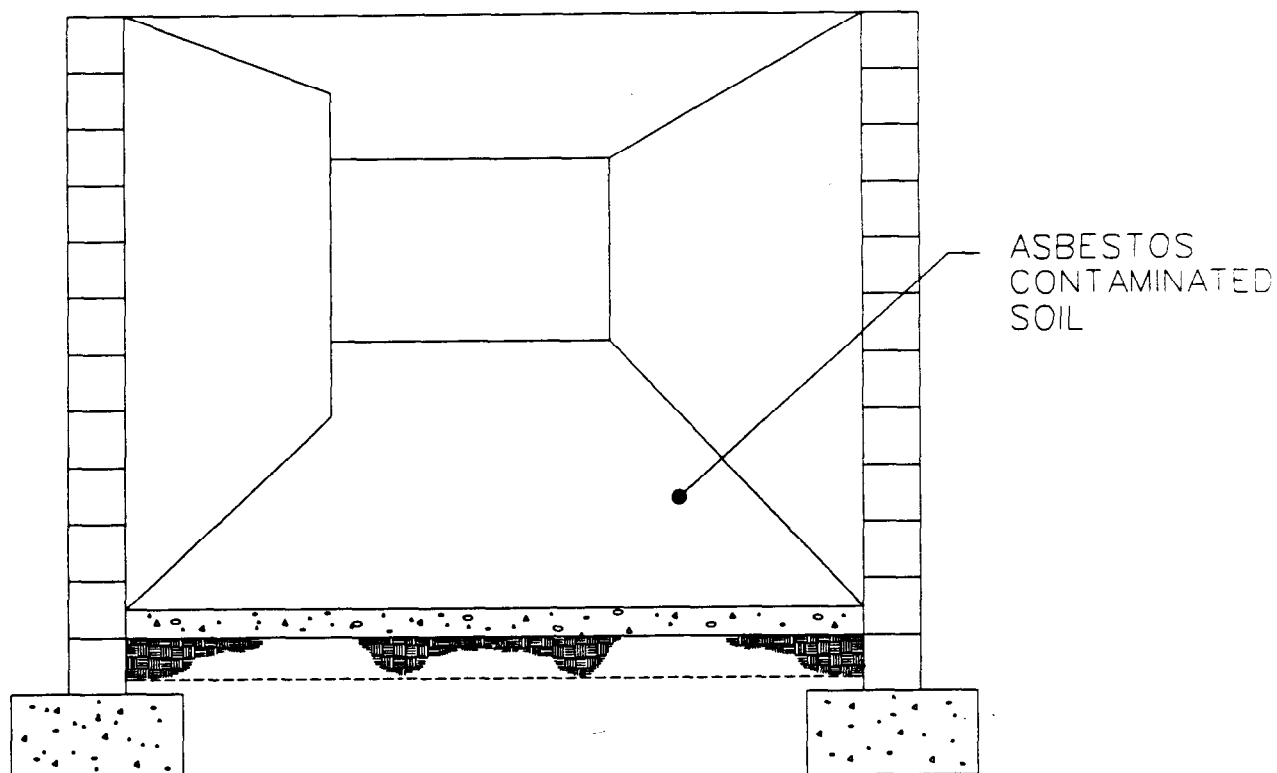

Penetrating encapsulation of asbestos-contaminated soil

1. Prepare mini-containment area as specified on sheet 7. Install HEPA-filtered air exhauster in a location that will provide air movement through work area. Adequately wet mist soil floor and debris with amended water. Gather loose debris and place in approved container; see sheet 9. Apply labels; see sheet 14.
2. Apply tinted penetrating encapsulant to walls and ceilings and the accepted soil encapsulation system to the soil.
3. Inspect and reapply encapsulant as necessary.
4. Prepare area for final clearance.
5. Carry out final clearance requirements as specified on sheet 7.

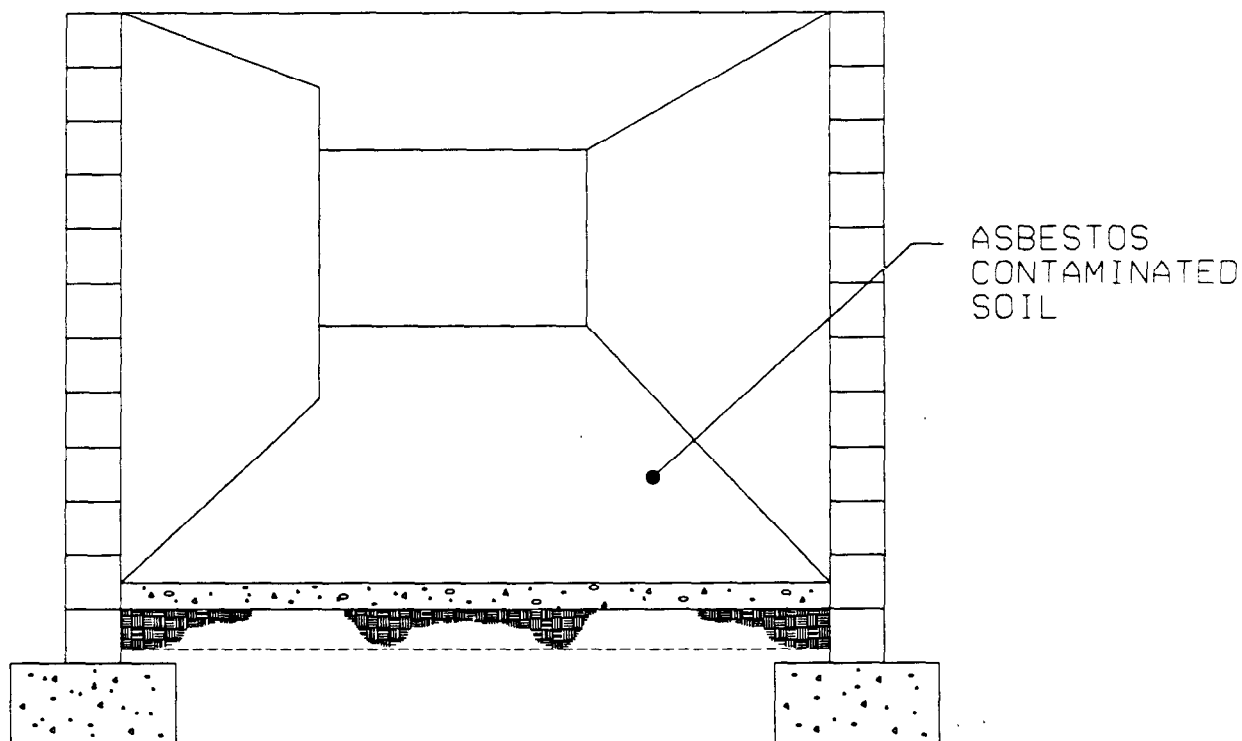

Removal of asbestos-contaminated soil

1. Prepare mini-containment area as specified on sheet 7. Install HEPA-filtered air exhauster in a location that will provide air movement through work area. Adequately wet mist soil floor and debris with amended water. Gather loose debris and place in approved container; see sheet 9. Apply labels, see sheet 14.
2. Gently loosen the top 2 inches of soil and remove, using an asbestos HEPA-filtered power vacuum collection and removal system; see sheet 26. Collect material into approved containers; see sheet 9. Apply labels; see sheet 14.
3. After all soil has been removed, use vacuum collection and removal system to vacuum walls and ceilings.
4. Inspect and reclean area as necessary.
5. Apply tinted penetrating encapsulant to wall and ceiling surfaces, and apply an approved soil encapsulation system to the soil. Inspect wall and ceiling and reapply encapsulant as necessary.
6. Prepare area for final clearance.
7. Carry out final clearance requirements as specified on sheet 7.

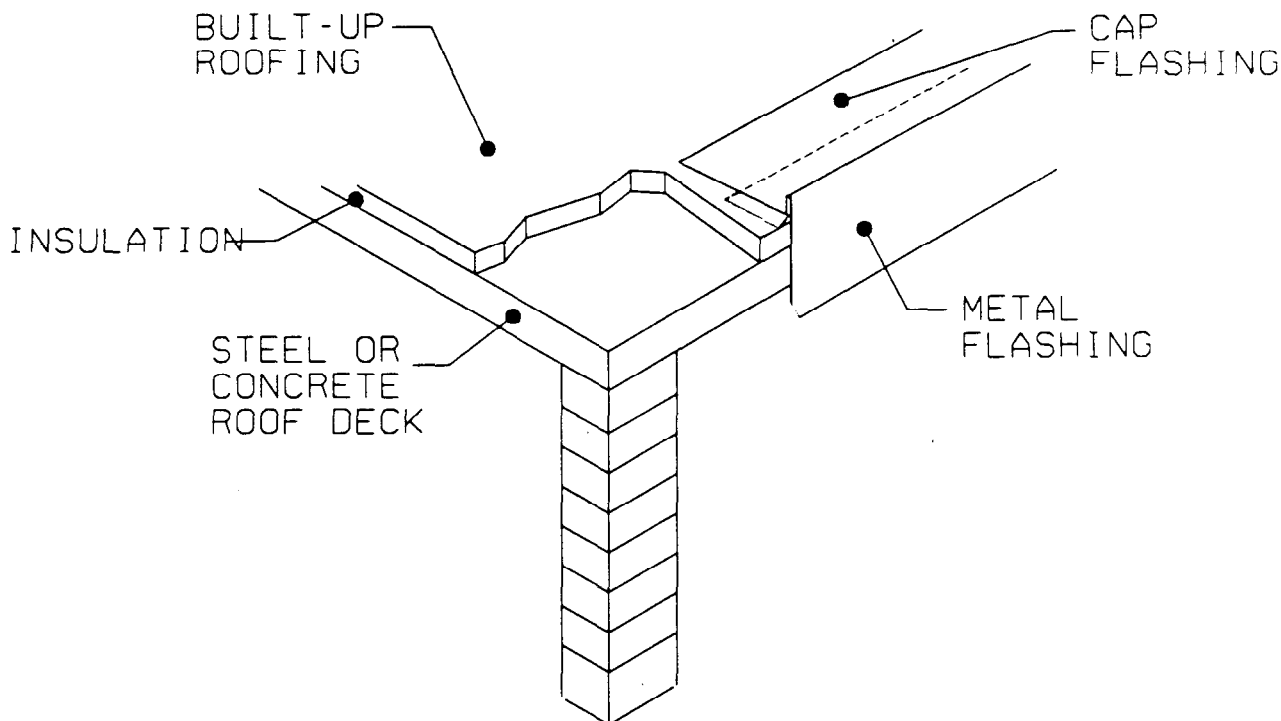

Removal of built-up roofing and flashing

1. No containment area is required. Establish boundaries of asbestos-regulated work area so that unauthorized entry is prevented; see sheet 11. Provide personal protection and decontamination facilities as specified in contractor's asbestos hazard abatement plan.
2. Remove accumulated debris.
3. Adequately wet mist flashing and built-up roofing, initially and during removal procedures. Remove flashing and built-up roofing.
4. Dispose of all materials by carefully sliding them down an enclosed chute into an enclosed Dumpster or truck that is lined with two layers of 6-mil polyethylene. When the Dumpster or truck is filled, fold the polyethylene edges over each other and seal with duct tape; see sheet 9 for leak-tight wrapping. Apply labels; see sheet 14.
5. Clean and HEPA vacuum roof.
6. Inspect and reclean area as necessary.
7. Apply tinted penetrating encapsulant to exposed roof deck, using an airless sprayer. Inspect and reapply encapsulant as necessary.
8. Prepare area for final clearance.
9. Contractor and contracting officer will certify visual inspection of work area on sheet 19, *Certification of Final Cleaning and Visual Inspection*.

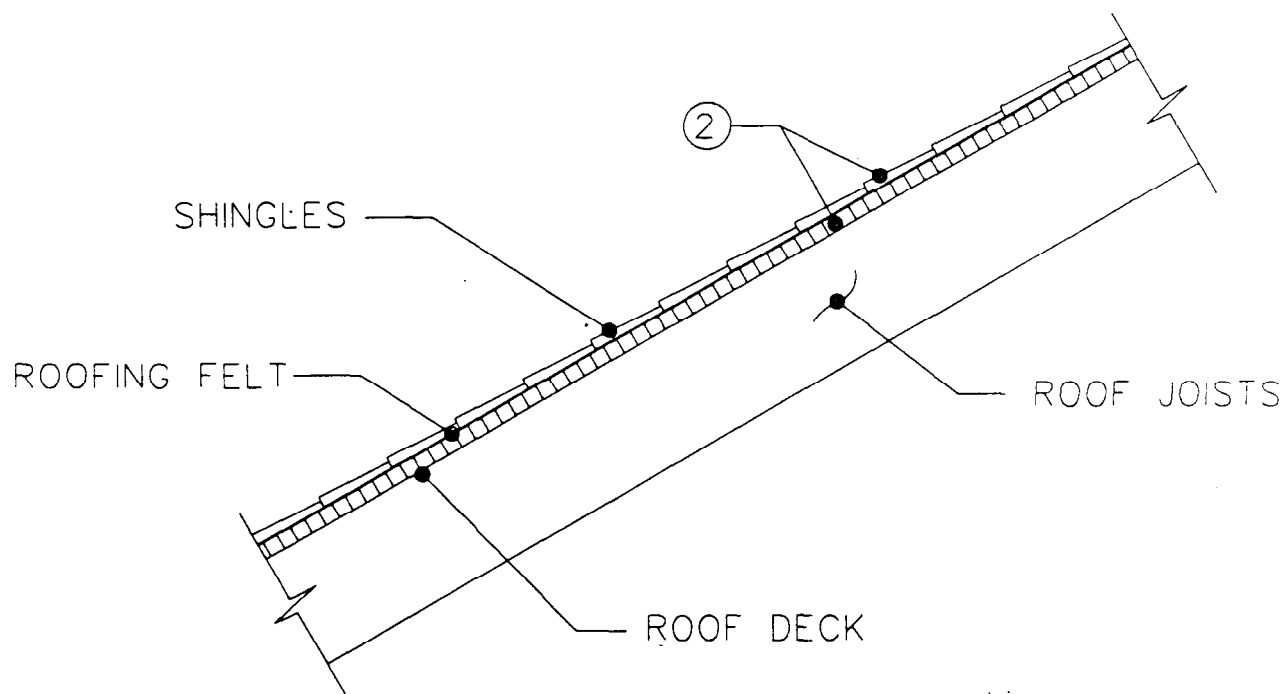

Removal of roof, shingles, and underlay

1. No containment area is required. Establish boundaries of asbestos-regulated work area so that unauthorized entry is prevented, and install warning signs; see sheet 11. Provide personal protection and decontamination facilities as specified in contractor's asbestos hazard abatement plan.
2. Remove shingles, roofing felt, nails, and debris, using wet removal technique.
3. Dispose of all materials by carefully sliding them down an enclosed chute into an enclosed Dumpster or truck that is lined with two layers of 6-mil polyethylene. When Dumpster or truck is filled, fold the polyethylene edges over each other and seal with duct tape; see sheet 9. Apply labels; see sheet 14.
4. Clean and HEPA vacuum roof.
5. Inspect and reclean area as necessary.
6. Apply tinted penetrating encapsulant to exposed roof deck, using an airless sprayer.
7. Prepare area for final clearance.
8. Contractor and contracting officer will certify visual inspection of work area on sheet 19, *Certification of Final Cleaning and Visual Inspection*.

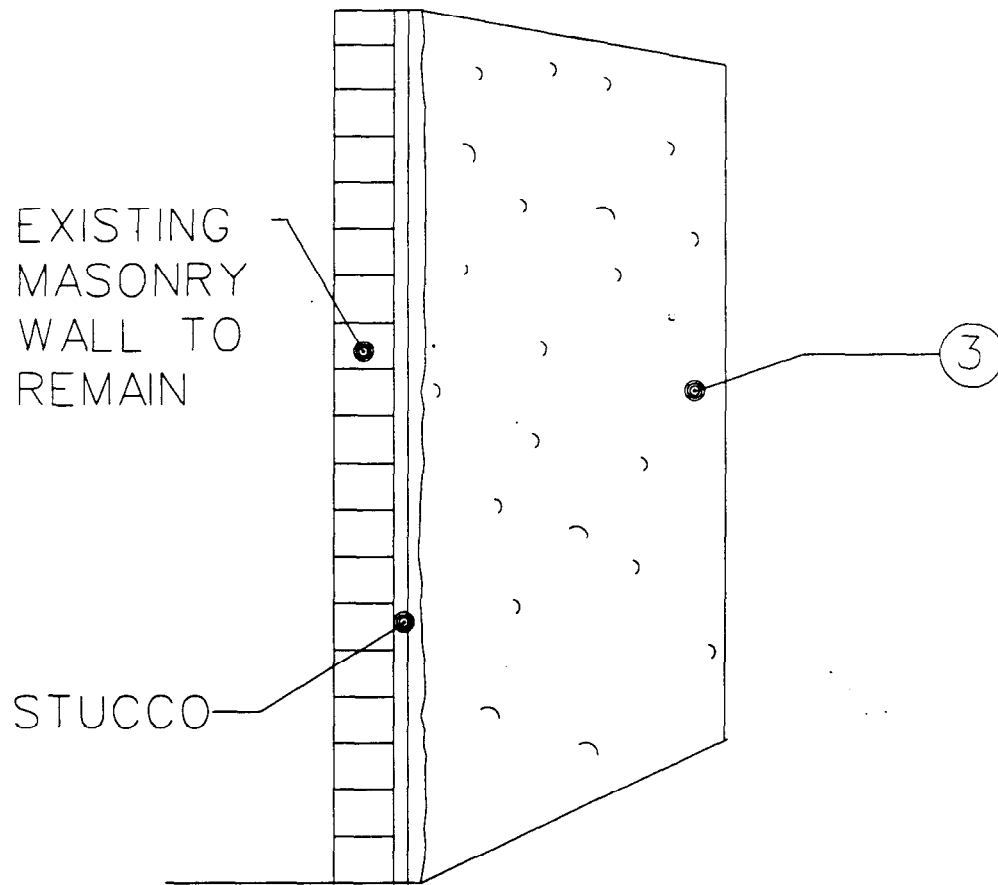

Bridging encapsulation of exterior asbestos stucco

1. Establish boundaries of asbestos-regulated work area so that unauthorized entry is prevented; see sheet 11. Provide personal protection and decontamination facilities as specified in contractor's asbestos hazard abatement plan.
2. Apply tinted bridging encapsulant to surface of stucco.
3. Inspect and reapply encapsulant as necessary.
4. Contractor and contracting officer will certify visual inspection of work area on sheet 19, *Certification of Final Cleaning and Visual Inspection*.

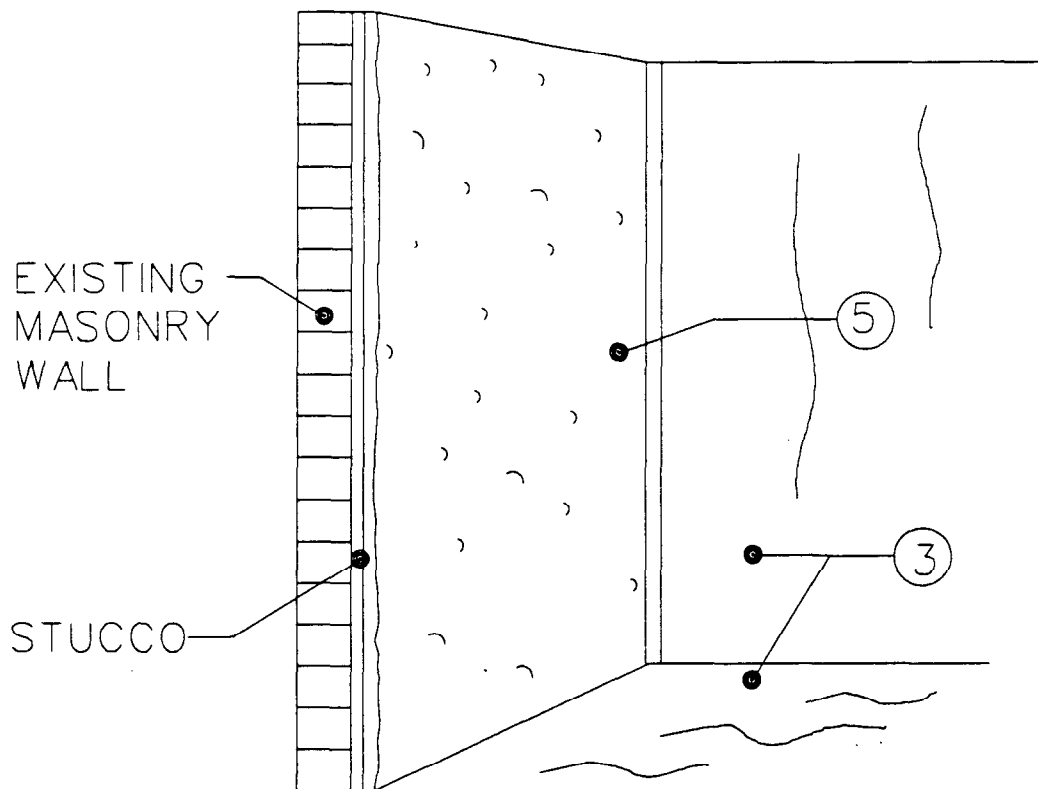

Bridging encapsulation of interior asbestos stucco

1. Prepare containment as specified on applicable sheet 2, 3, 4, or 5. (If only one wall—and no ceiling—is to be abated, prepare bulkhead containment area as specified on sheet 5.) Prevent unauthorized entry; see sheet 11. Eliminate airflow into containment area by isolating all supply and air ducts from mechanical system.
2. Install 6-mil polyethylene critical barriers over all windows, doors, wall openings, electrical outlets, etc. Secure with duct tape on all sides.
3. Install 6-mil polyethylene on floor surfaces and walls not to be encapsulated. If only one wall is included, prepare bulkhead containment area as specified on sheet 5.
4. Install HEPA filter unit and ductwork; see sheet 8.
5. Apply tinted bridging encapsulant to surface of asbestos stucco.
6. Inspect and reapply encapsulant as necessary.
7. Remove polyethylene on walls and floor. The critical barriers sealing all windows, doors, wall openings, electrical outlets, etc., are to remain. Treat polyethylene as asbestos-contaminated material; see sheet 9.
8. Prepare area for final air clearance.
9. Carry out final clearance requirements as specified on applicable sheet 5, 16, 17, or 18.

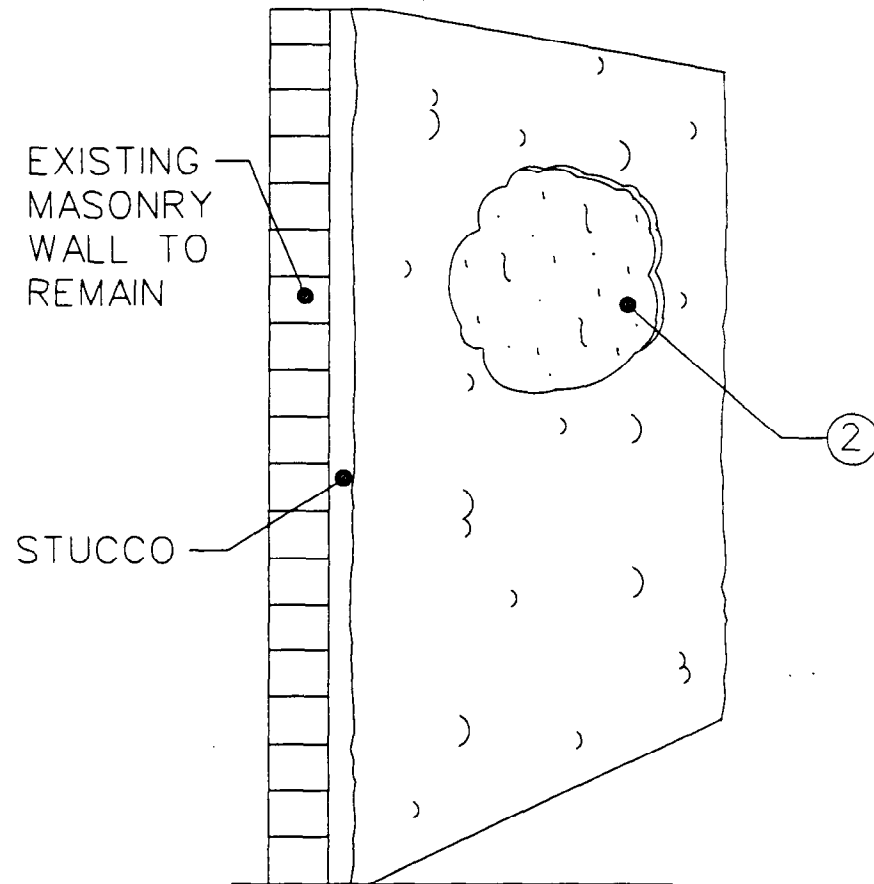

Repair of interior asbestos stucco

1. Prepare mini-containment area as specified on sheet 7.
2. Adequately wet mist stucco with amended water, initially and during removal procedure. Remove damaged stucco and place in approved container; see sheet 9. Apply labels; see sheet 14.
3. Apply tinted penetrating encapsulant. Inspect and reapply as necessary.
4. Apply new asbestos-free stucco to damaged area, matching adjacent stucco surfaces.
5. Inspect.
6. Prepare area for final air clearance.
7. Carry out final clearance requirements as specified on sheet 7.

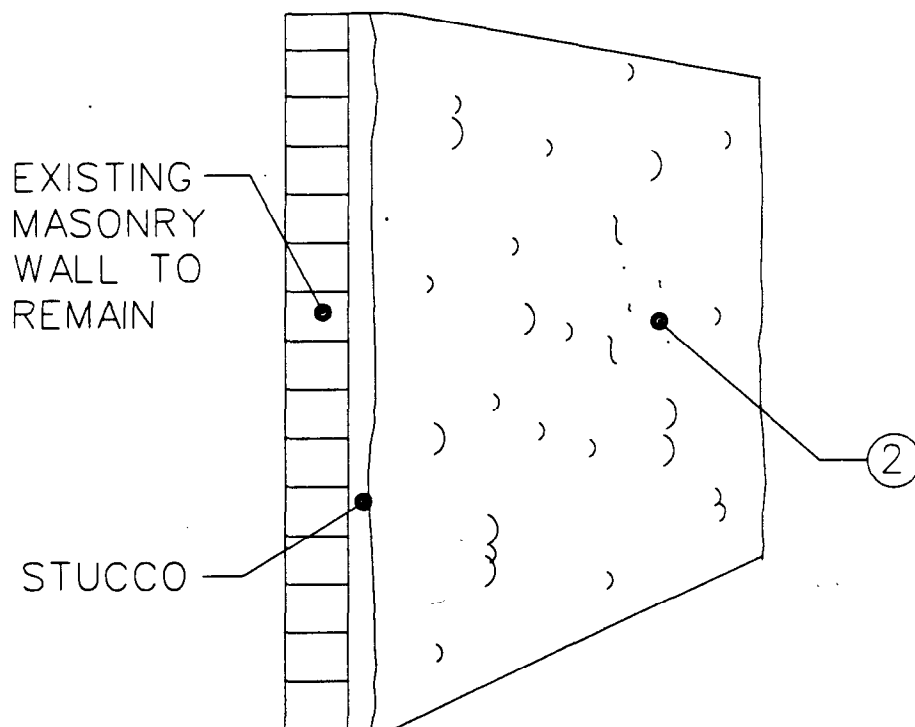

Removal of exterior asbestos stucco

1. Prepare containment area as specified in applicable sheet 5 or 7.
2. Remove stucco attached to masonry. Use adequate wet removal techniques, initially and during removal procedures. Brush, HEPA vacuum, and adequately wet clean area in order to remove residue.
3. Dispose of asbestos stucco in approved containers; see sheet 9. Apply labels; see sheet 14.
4. Inspect and reclean area as necessary.
5. Apply tinted penetrating encapsulant to exposed masonry.
6. Inspect and reapply encapsulant as necessary.
7. Prepare area for final clearance.
8. Carry out final clearance requirements as specified on applicable sheet 5 or 7.

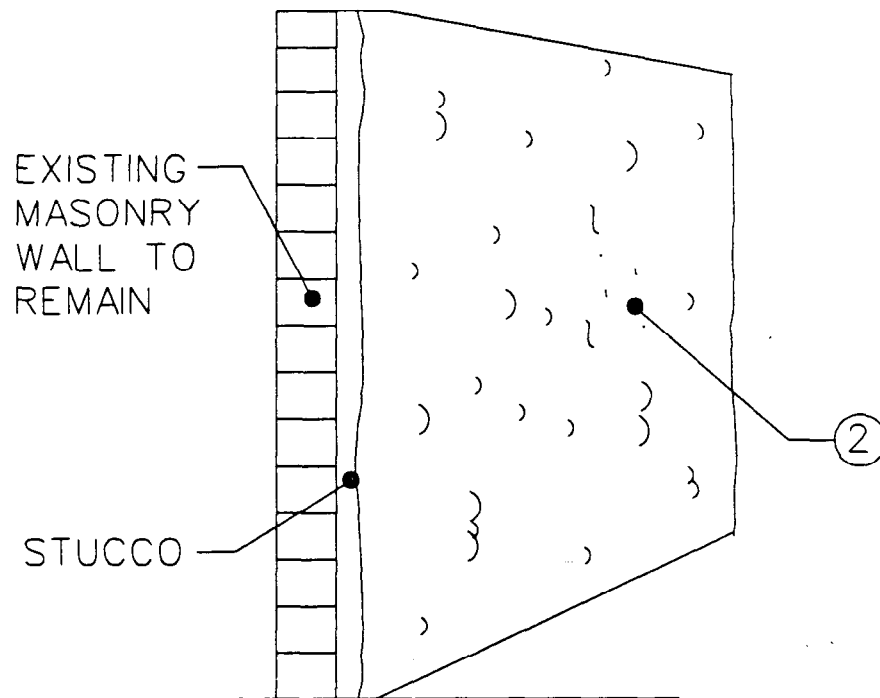

Repair of exterior asbestos stucco

1. No containment area is required. Establish boundaries of asbestos-regulated work area so that unauthorized entry is prevented; see sheet 11. Place two layers of polyethylene sheeting on the ground in order to collect debris.
2. Wet mist stucco with amended water, initially and during removal procedure. Carefully remove damaged stucco and place in approved containers; see sheet 9. Apply labels; see sheet 14.
3. Apply tinted penetrating encapsulant. Inspect and reapply as necessary.
4. Apply new asbestos-free stucco to damaged area, matching adjacent stucco surfaces.
5. Fold each layer of polyethylene sheeting inward, and seal all edges with duct tape; see sheet 9. Apply labels; see sheet 14. Treat as asbestos-contaminated material.
6. Prepare area for final clearance.
7. Contractor and contracting officer will certify visual inspection of work area on sheet 19, *Certification of Final Cleaning and Visual Inspection*.

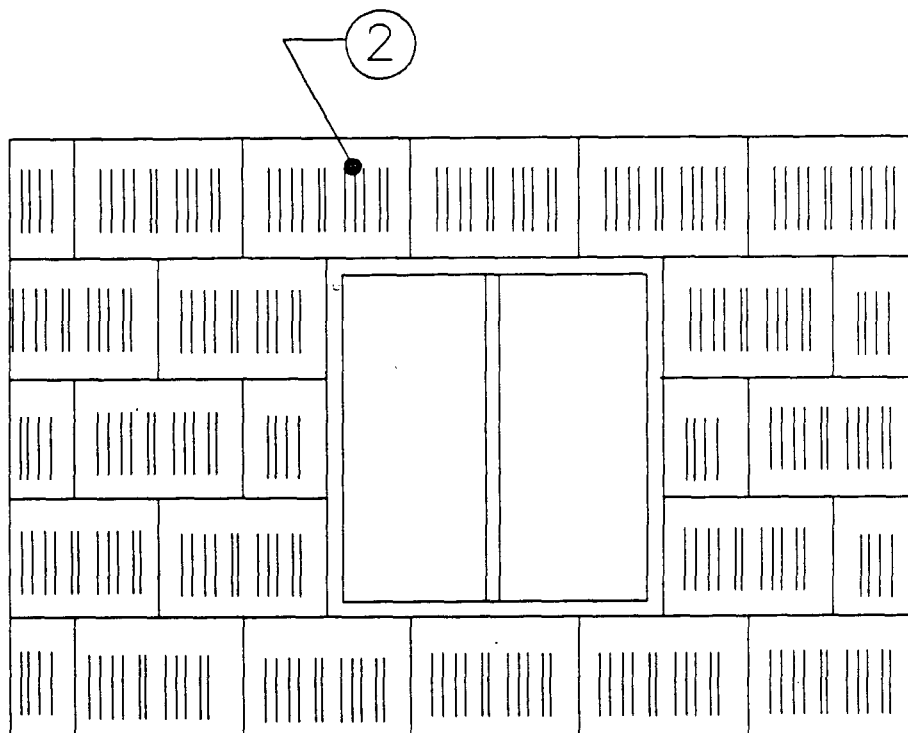

Removal of asbestos cement siding

1. No containment area is required. Establish boundaries of asbestos-regulated work area so that unauthorized entry is prevented; see sheet 11. Provide personal protection and decontamination facilities as specified in contractor's asbestos hazard abatement plan.
2. Wet mist siding with amended water, initially and during removal procedures.
3. Anchor 10-mil polyethylene sheeting below work area. Remove siding in a manner that will prevent crumbling, pulverizing, or reducing to powder during the removal procedure. NOTE: Normal breakage does not constitute crumbling, pulverizing, or reducing to powder.
4. Clean and HEPA vacuum all surfaces.
5. Inspect and reclean area as necessary.
6. Place all materials in Dumpster or other transport container lined with two layers of 6-mil polyethylene. Seal the joints and ends of each layer with duct tape; see sheet 9. Apply labels; see sheet 14. Other containers may be used; see sheet 9. Apply labels; see sheet 14.
7. Prepare area for final clearance.
8. Contractor and contracting officer will certify visual inspection of work area on sheet 19, *Certification of Final Cleaning and Visual Inspection*.

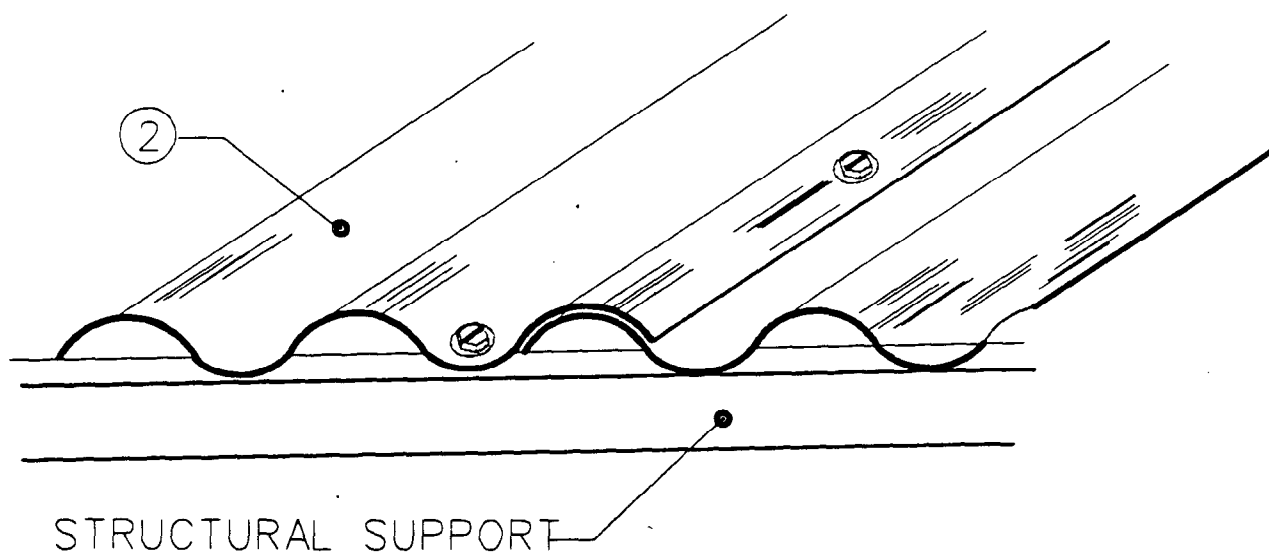

Removal of asbestos cement roofing

1. No containment area is required. Establish boundaries of asbestos-regulated work area so that unauthorized entry is prevented; see sheet 11. Provide personal protection and decontamination facilities as specified in contractor's asbestos hazard abatement plan.

2. Wet mist the top surface of the roofing with amended water, initially and during removal procedures. Carefully remove roofing in a manner that will prevent crumbling, pulverizing, or reducing to powder during the removal procedure. NOTE: Normal breakage does not constitute crumbling, pulverizing, or reducing to powder.

3. Place all materials in Dumpster or other transport container lined with two layers of 6-mil polyethylene. Seal the joints and ends of each layer with duct tape; see sheet 9. Apply labels; see sheet 14. Other containers may be used; see sheet 9. Apply labels; see sheet 14.

4. Prepare area for final clearance.

5. Contractor and contracting officer will certify visual inspection of work area on sheet 19, *Certification of Final Cleaning and Visual Inspection*.

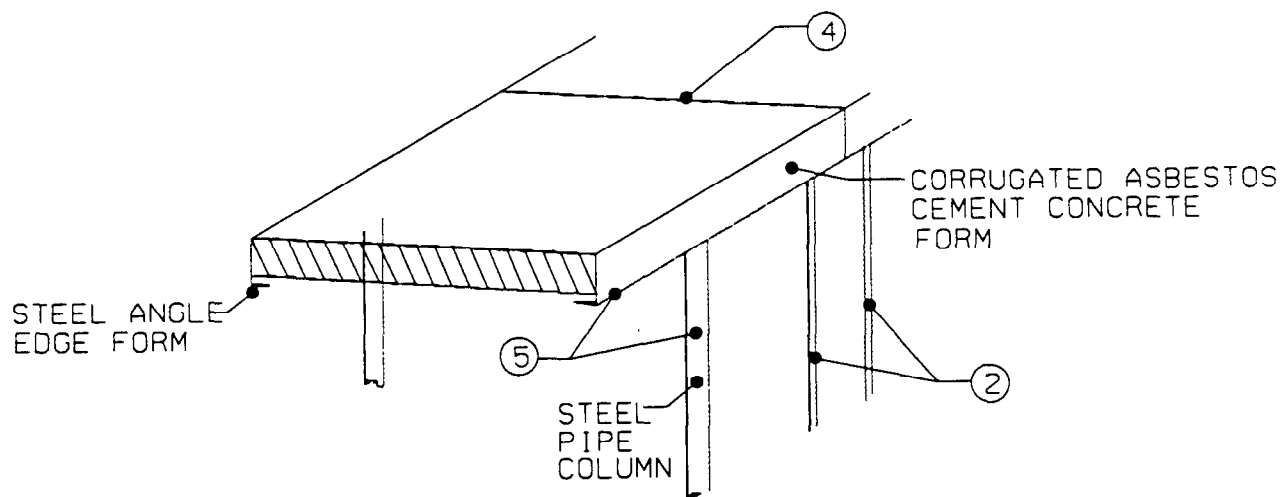

Removal of asbestos-containing walkway cover

1. No containment area is required. Establish boundaries of asbestos-regulated work area so that unauthorized entry is prevented; sheet 11. Provide personal protective equipment and decontamination facilities as specified in the contractor's asbestos hazard abatement plan.
2. Install temporary supports at midpoint between existing columns.
3. Support walkway-cover slab with forklift, crane, or other approved lifting device..
4. Saw cut through concrete no deeper than the concrete cover over the corrugated asbestos cement form.
5. Burn through steel side angles and pipe columns.
6. Lift slab and place on truck bed lined with two layers of 6-mil polyethylene sheeting. Seal the joints and ends of each layer with duct tape; see sheet 9. Apply labels; see sheet 14. Treat as asbestos-contaminated construction waste, keeping walkway-cover slab intact. Secure slab to truck bed and cover with tarp. Gather any loose debris lying on ground and place in approved container; see sheet 9. Apply labels; see sheet 14. Prepare area for final clearance.
7. Contractor and contracting officer will certify visual inspection of work area on sheet 19, *Certification of Final Cleaning and Visual Inspection*.

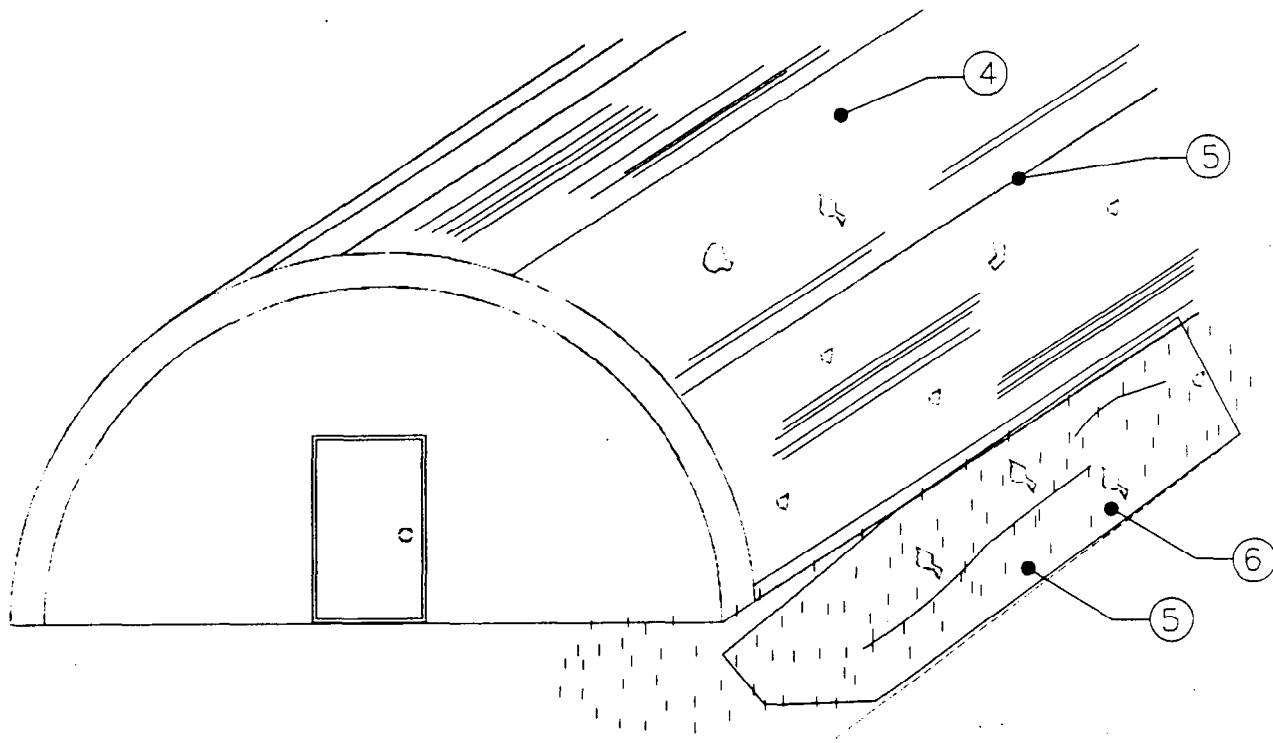

Removal of asbestos-contaminated metal siding

1. Demolish interior of Quonset hut, including wall surfaces, electrical services, etc. Treat as ordinary construction waste.

2. No containment area is required. Establish boundaries of work area so that unauthorized entry is prevented; see sheet 11. Provide personal protection and decontamination facilities as specified in the contractor's asbestos hazard abatement plan.

3. Anchor 10-mil polyethylene sheeting below work area. Adequately wet mist exterior siding and scrape off loose paint. Place paint chips and debris in approved container; see sheet 9. Apply labels; see sheet 14.

4. Apply tinted penetrating encapsulant to exterior surface of siding. Let dry.

5. From the inside of the Quonset hut, cut metal fasteners as close to metal siding as possible. With crow bar, carefully pry apart the abutting corrugated metal sheeting. Place disassembled sheets on a truck bed lined with two layers of 6-mil polyethylene sheeting. Seal the joints and ends of each layer with duct tape; see sheet 9. Apply labels; see sheet 14. Treat as asbestos-contaminated construction waste.

6. Gather contaminated 10-mil polyethylene sheeting and any loose debris lying on ground. Place in approved container; see sheet 9. Apply labels; see sheet 14.

7. Prepare area for final clearance.

8. Contractor and contracting officer will certify visual inspection of work area on sheet 19, *Certification of Final Cleaning and Visual Inspection*.

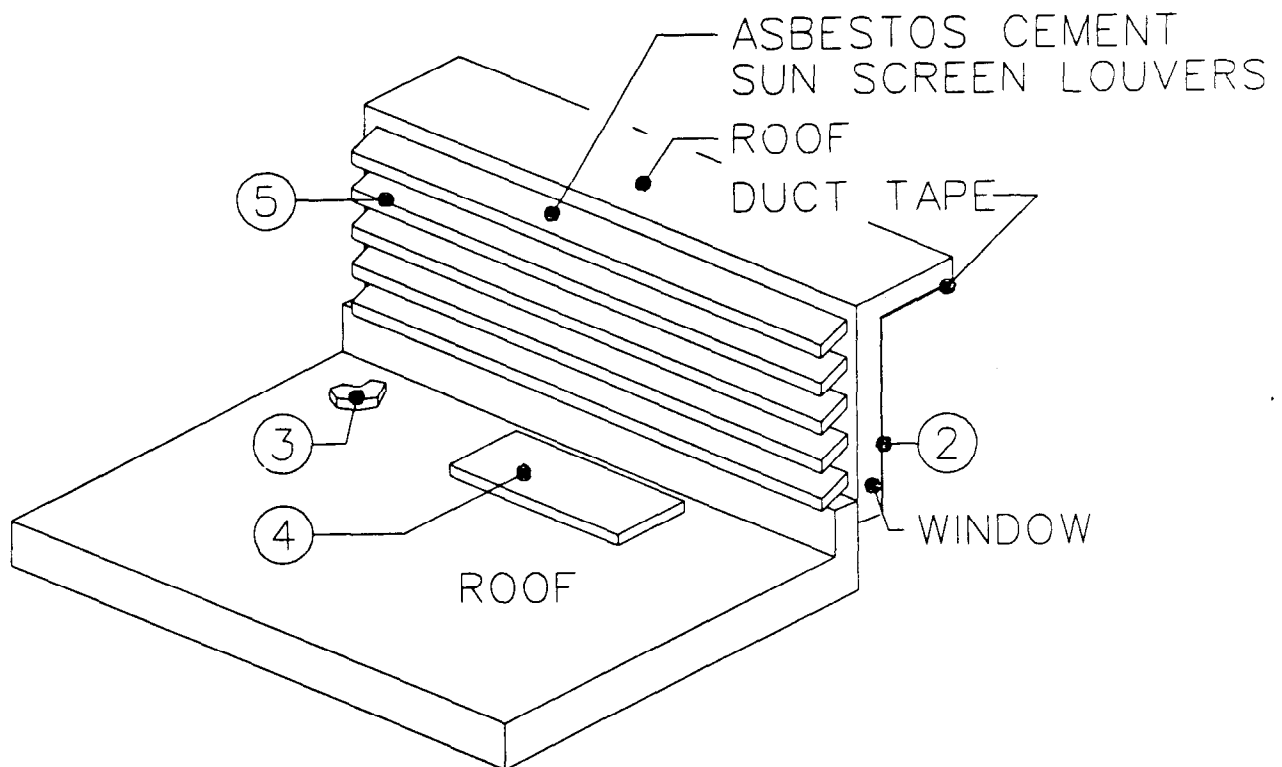

Removal of asbestos cement sunscreen louvers

1. No enclosed containment area is required. Establish boundaries of asbestos regulated work so that unauthorized entry is prevented; see sheet 11. Provide personal protection and decontamination facilities as specified in contractor's asbestos hazard abatement plan.
2. Install 6-mil polyethylene critical barrier over inside face of window and frame. Seal with duct tape. Anchor 10-mil polyethylene sheeting below work area.
3. Clean up roof debris from broken asbestos cement sunscreen louvers. Treat as asbestos-containing material. Place debris in approved containers; see sheet 9. Apply labels; see sheet 14.
4. Place [0.8-in] [20-mm] plywood sheets on roof or scaffolding adjacent to work area.
5. Adequately mist a removal encapsulant on all accessible louver surfaces, initially and during removal procedures. Gently remove each louver slat by disconnecting from supporting metal straps. If breakage occurs, place in approved containers per step 3 above. If slats can be removed intact, stack and wrap with two layers of 6-mil polyethylene. Seal the joints and ends with duct tape; see sheet 9. Apply labels; see sheet 14.
6. Mist the supporting straps with a removal encapsulant and remove. Treat as asbestos-contaminated waste. Dispose of per step 3 above.
7. HEPA vacuum roof, windows, jambs, and all adjacent surfaces as each work area is completed.
8. Prepare area for final clearance.
9. Contractor and contracting officer will certify visual inspection of work area on sheet 19, *Certification of Final Cleaning and Visual Inspection*.
10. Upon instructions from the contracting officer, remove all critical barriers and plywood. Treat as asbestos-contaminated waste per step 3 above.

NOTE: THIS SHEET CAN BE USED FOR
PIPE FITTINGS AND FOR VERTICAL
OR HORIZONTAL PIPING.

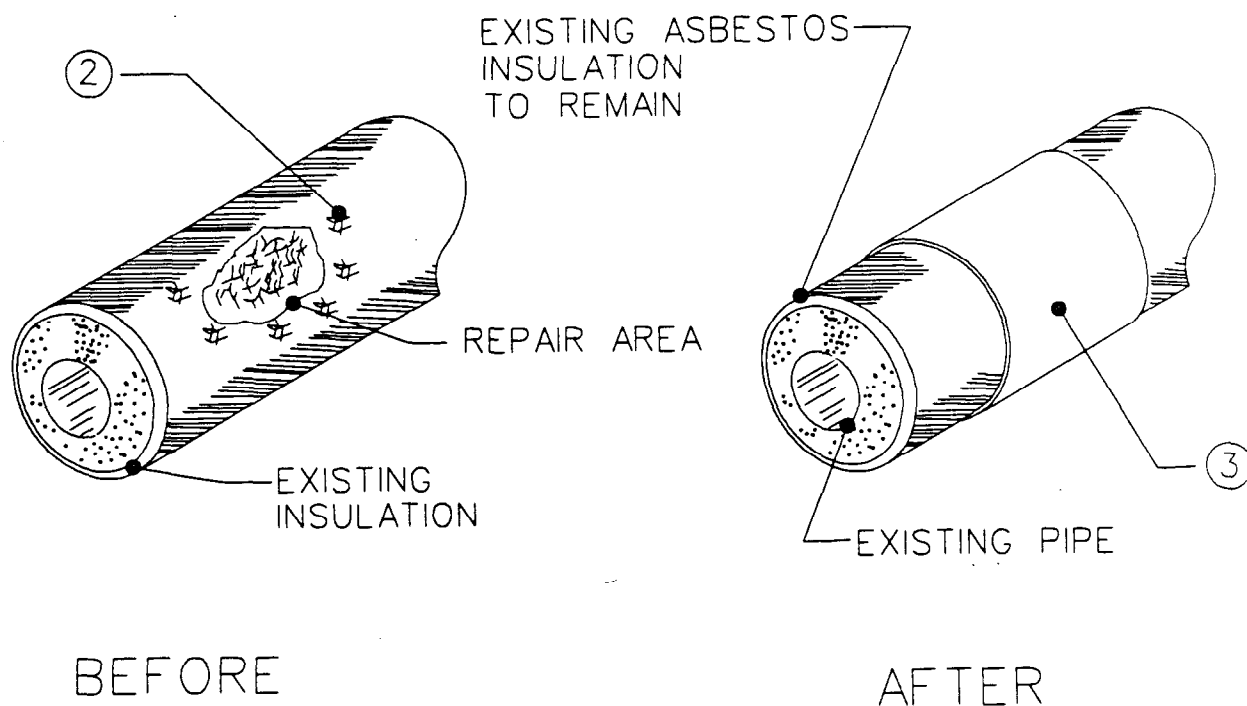

Repair of pipe and fitting insulation (using glove bag)

1. Install glove bag as specified on sheet 10. Prepare modified containment area as specified on sheet 21. Adequately wet mist insulation surface with amended water.

2. Remove any loose material in the repair area with a HEPA vacuum. Fill voids with mineral wool insulating cement.

3. Cover filled areas with a nonwoven fiberglass cloth saturated with a bridging encapsulant. Extend cloth a

minimum of 6 inches beyond edge of damaged areas. Allow area to dry for 24 hours. Coat area with a second layer of tinted bridging encapsulant.

4. Inspect and reapply encapsulant as necessary.

5. Prepare area for final clearance.

6. Carry out final clearance requirements specified on sheets 10 and 21.

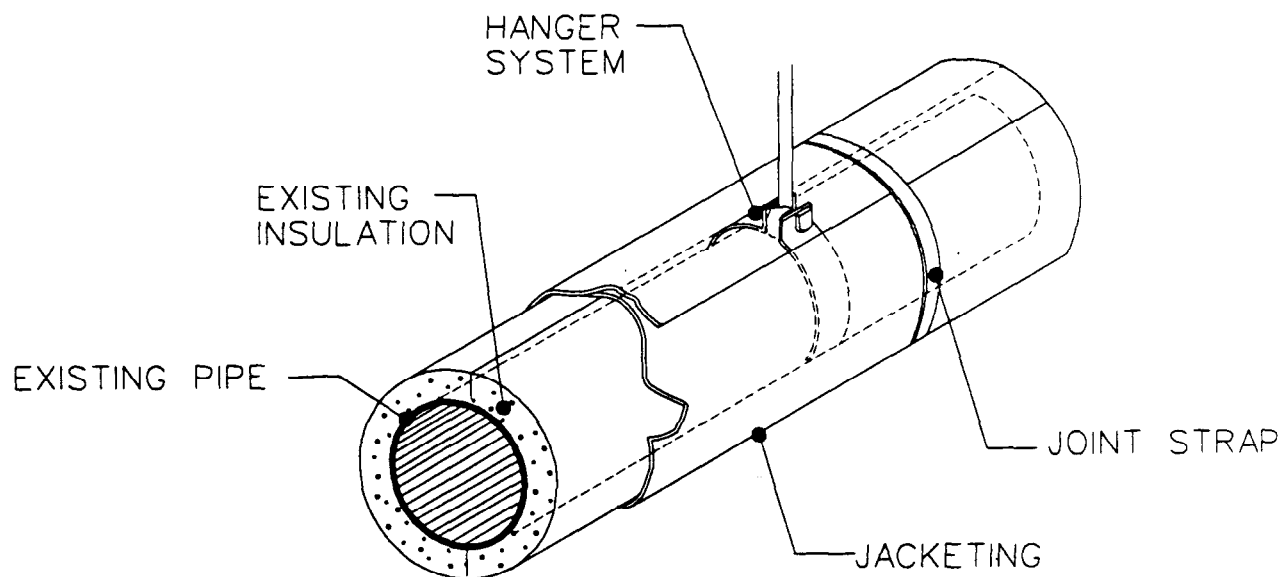

NOTE: THIS SHEET CAN BE USED FOR
VERTICAL OR HORIZONTAL PIPING.

Removal of pipe insulation (using glove bag)

1. Install glove bag as specified on sheet 10. Prepare modified containment area as specified on sheet 21. Adequately wet mist insulation surface with amended water, initially and during removal.
2. Remove jacketing and asbestos pipe insulation from pipe and hanger to within 2 inches of inside edges of glove bag.
3. Clean exposed surfaces by spraying with amended water and brushing.
4. Inspect and reclean as necessary.
5. Spray a tinted penetrating encapsulant on pipe and exposed ends of insulation.
6. Inspect piping and reapply encapsulant as necessary.
7. Prepare area for final air clearance.
8. Carry out final clearance requirements specified on sheets 10 and 21.

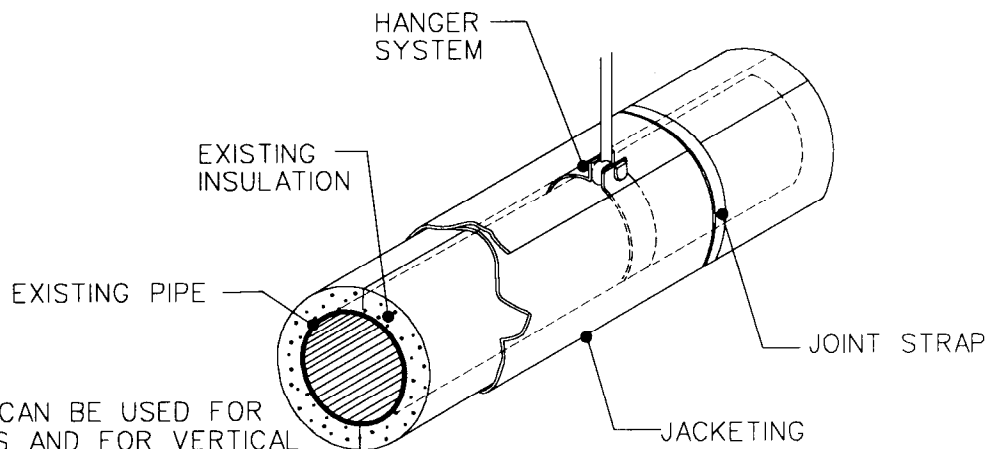

NOTE: THIS SHEET CAN BE USED FOR
PIPE FITTINGS AND FOR VERTICAL
OR HORIZONTAL PIPING.

Removal of horizontal pipe insulation (using containment area)

1. Prepare containment area as specified on applicable sheet 2, 3, or 4.
2. Adequately wet mist insulation surface with amended water, initially and during removal. Remove jacketing and insulation from pipe and hanger system.
3. Clean exposed surfaces by spraying with amended water and brushing.
4. Inspect and reclean as necessary.
5. Spray a tinted penetrating encapsulant on pipe and exposed ends of insulation.
6. Inspect piping and reapply encapsulant as necessary.
7. Prepare area for final air clearance.
8. Carry out final clearance requirements specified on applicable sheet 16, 17, or 18.

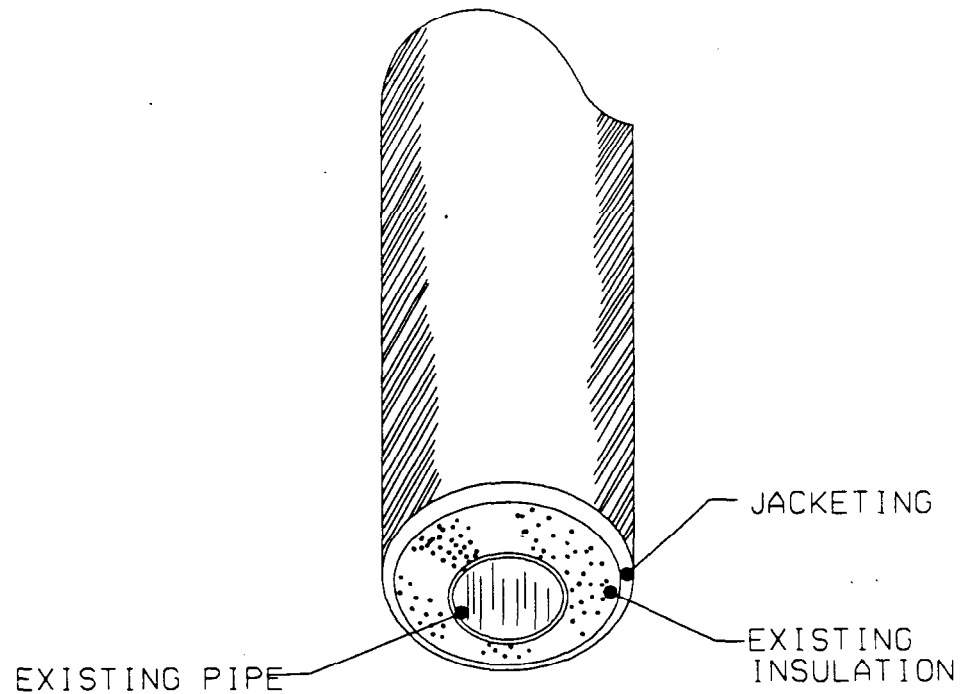

Removal of pipe insulation (using mini-containment area)

1. Prepare mini-containment area as specified on sheet 7.
2. Adequately wet mist insulation surface with amended water, initially and during removal. Remove jacketing and insulation from pipe and hanger system.
3. Clean exposed surfaces by spraying with amended water and brushing.
4. Inspect and reclean area as necessary.
5. Spray a tinted penetrating encapsulant on pipe and exposed ends of insulation. Inspect and reapply as necessary.
6. Prepare area for final clearance.
7. Carry out final clearance requirements specified on sheet 7.

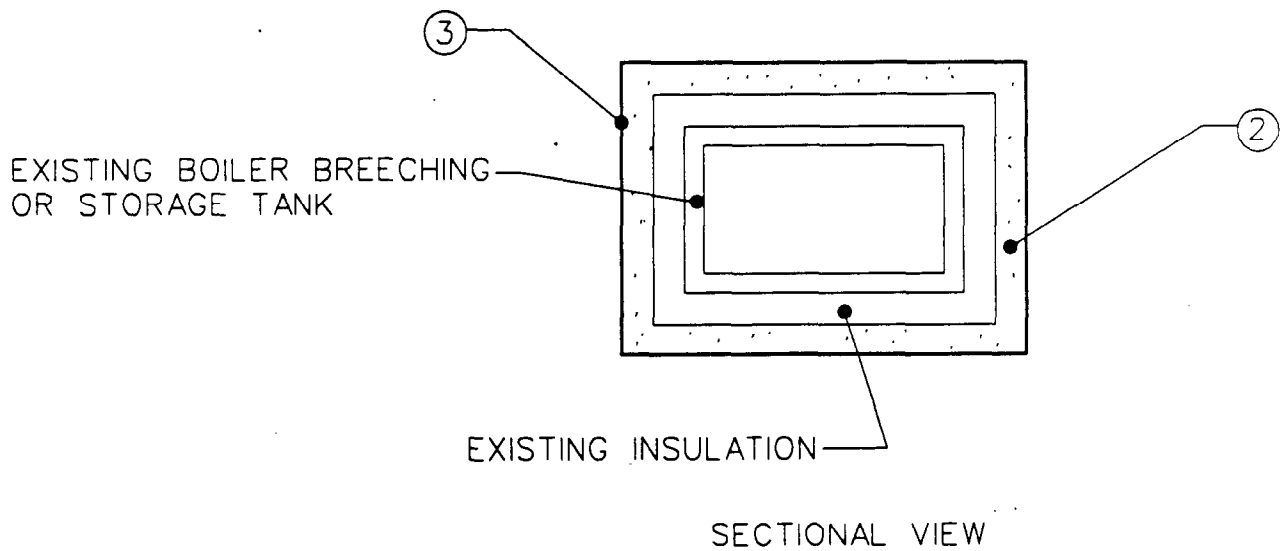

Encasement of storage tank or boiler breeching

1. Prepare modified containment area as specified on sheet 21. Install HEPA filter unit and ductwork; see sheet 8.
2. Apply foam sealer to existing insulation.
3. Inspect and reapply sealer as necessary.
4. Spray on polymer shell finish.
5. Inspect.
6. Prepare area for final air clearance.
7. Carry out final clearance requirements specified on sheet 21.

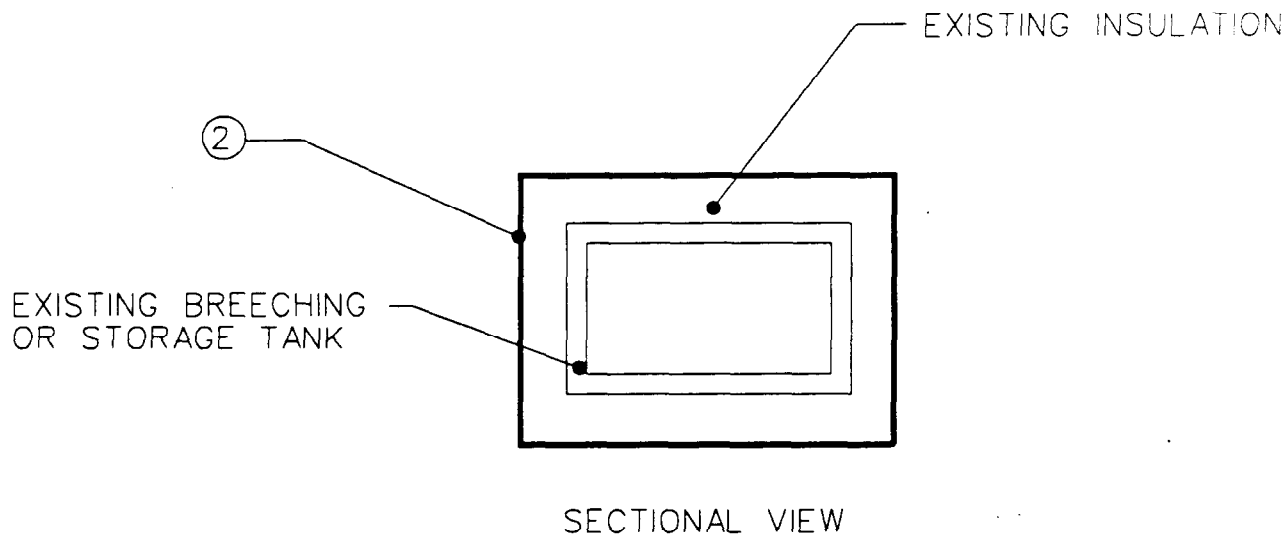

Bridging encapsulation of storage tank and boiler breeching

1. Prepare modified containment area as specified on sheet 21. Install HEPA filter unit and ductwork; see sheet 8.
2. Apply tinted bridging encapsulant to surface of insulation.
3. Inspect and reapply encapsulant as necessary.
4. Prepare area for final air clearance.
5. Carry out final clearance requirements as specified on sheet 21.

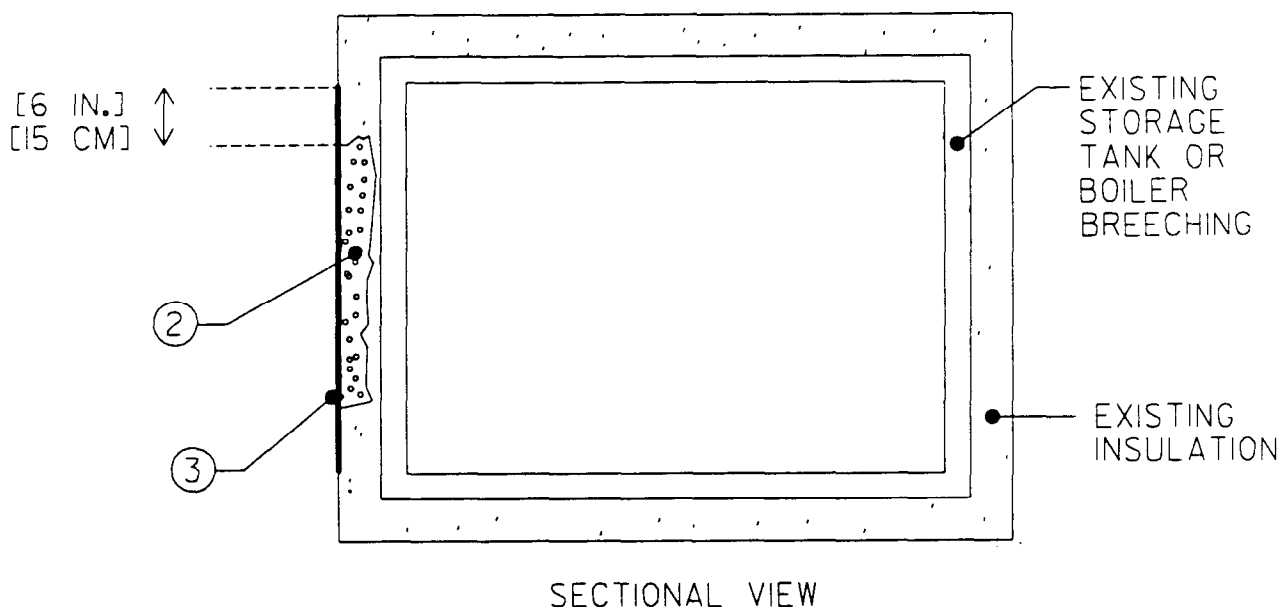

Repair of storage tank and boiler breeching

1. Prepare mini-containment area as specified on sheet 7. Adequately wet mist insulation with amended water.
2. Remove any loose material in the repair area with a HEPA vacuum. Fill voids with mineral wool insulating cement.
3. Cover filled areas with a nonwoven fiberglass cloth saturated with a bridging encapsulant. Extend cloth a minimum of [6 in] [15 cm] beyond the edge of damaged areas. Allow area to dry for 24 hours. Coat area with a second layer of tinted bridging encapsulant.
4. Inspect and reapply encapsulant as necessary.
5. Prepare area for final air clearance.
6. Carry out final clearance requirements specified on sheet 7.

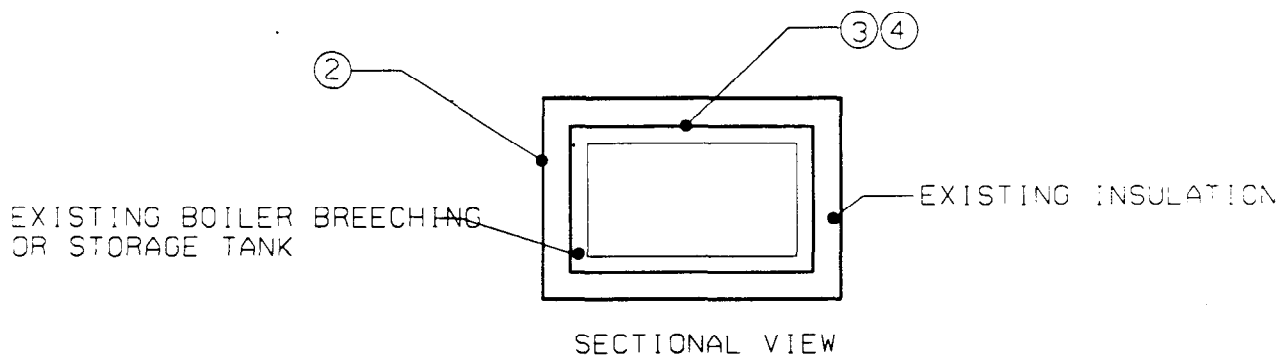

Removal of storage tank and boiler breeching insulation

1. Prepare containment areas as specified on applicable sheet 2, 3, or 4.
2. Adequately wet mist surface with amended water, initially and during removal. Remove insulation, including reinforcing fabric, mesh, steel bands or wire, and jacketing. Place in approved containers; see sheet 9. Apply labels; see sheet 14.
3. Clean exposed surfaces by spraying with amended water and brushing, HEPA vacuuming, and adequately wet cleaning all surfaces.
4. Inspect and reclean area as necessary.
5. Spray a tinted penetrating encapsulant. Inspect and reapply as necessary.
6. Prepare area for final air clearance.
7. Carry out final clearance requirements specified on applicable sheet 16, 17, or 18.

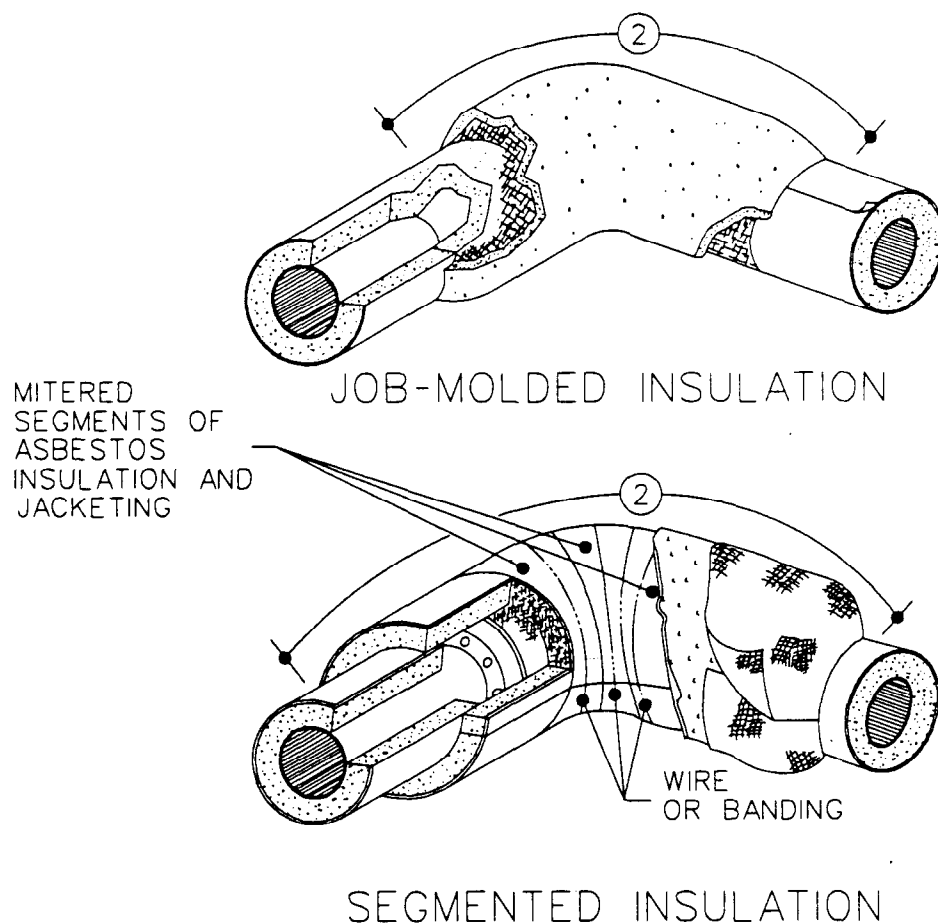

Removal of pipe-fitting insulation (using glove bag)

1. Install glove bag as specified on sheet 10. Prepare modified containment area as specified on sheet 21.
2. Adequately wet mist with amended water, initially and during removal procedure. Remove jacketing and asbestos-containing insulation from fittings and onto straight run of pipe until only asbestos-free insulation remains.
3. Clean exposed surfaces by spraying with amended water and brushing. HEPA vacuum and wet wipe all surfaces.
4. Inspect and reclean area as necessary.
5. Spray a tinted penetrating encapsulant on pipe and exposed ends of insulation.
6. Inspect and reapply penetrating encapsulant as necessary.
7. Prepare area for final air clearance.
8. Carry out final clearance requirements as specified on sheets 10 and 21.

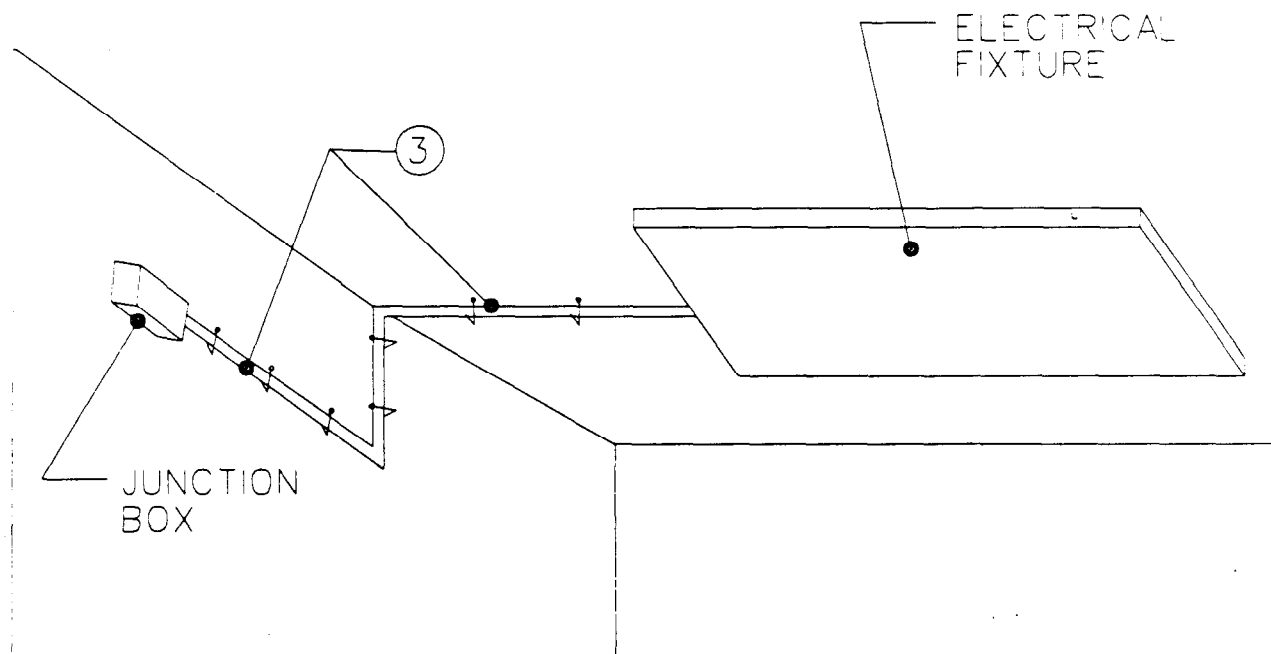

Removal of asbestos-insulated electrical wiring

1. Prepare modified containment area as specified on sheet 21.
2. Disconnect all electrical power to the area where electrical wiring is to be removed.
3. Adequately wet mist exposed asbestos insulation with removal encapsulant. Carefully remove wiring so as not to damage insulation. Coil wire and place in approved container; see sheet 9. Apply labels; see sheet 14.
4. Prepare area for final clearance.
5. Carry out final clearance requirements specified on sheet 21.

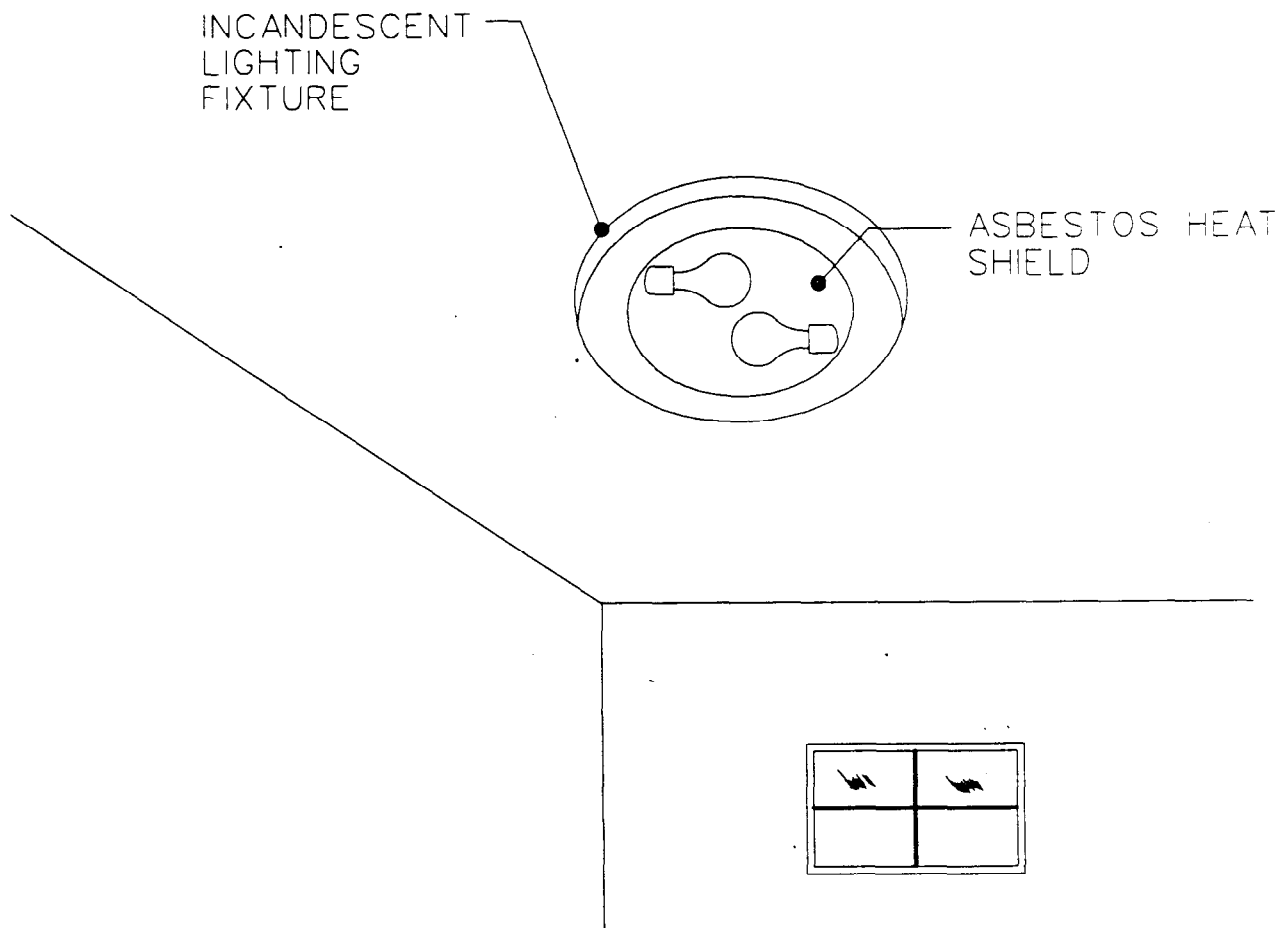

Removal of asbestos-insulated electrical fixture

1. Prepare modified containment area as specified on sheet 21.
 2. Disconnect all electrical power to the area where electrical fixture is to be removed.
 3. Adequately wet mist exposed asbestos heat shield with removal encapsulant. Carefully remove fixture so
 4. Prepare area for final clearance.
 5. Carry out final clearance requirements specified on sheet 21.
- as not to damage the heat shield. Place entire fixture in an approved container; see sheet 9. Apply labels; see sheet 14.

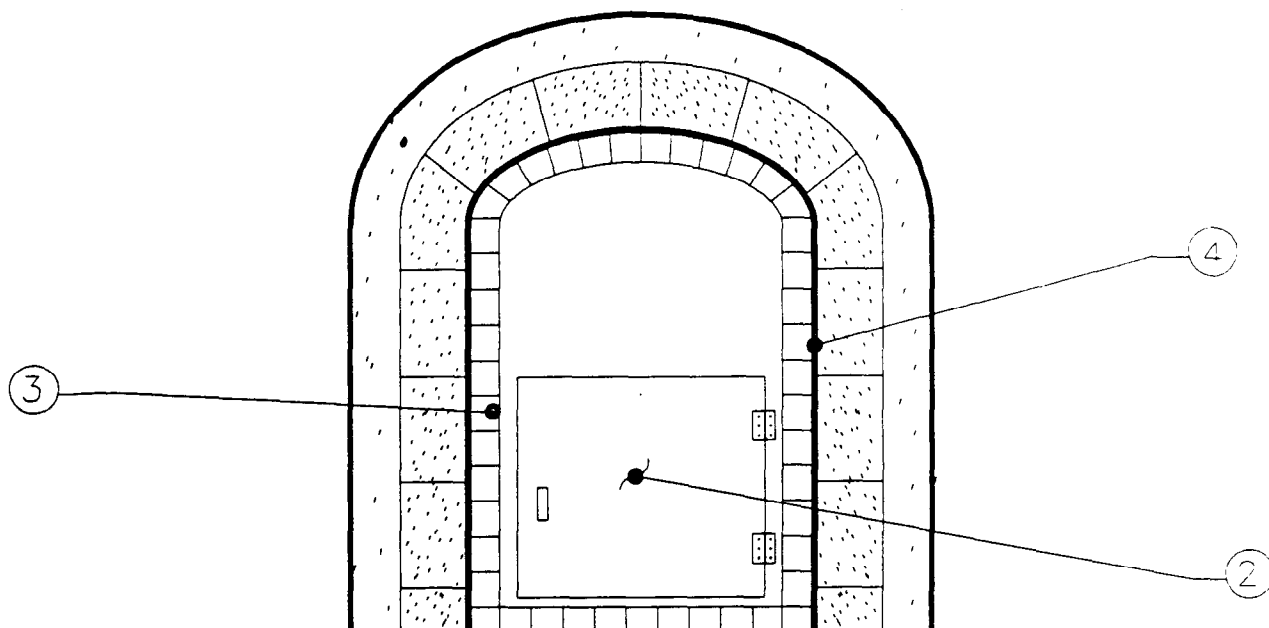

Removal of boiler firebox insulation

1. Prepare containment area as specified on applicable sheet 2, 3, or 4.
2. Isolate flue. Entry to boiler firebox is through firebox door.
3. Remove firebrick from firebox. Wet wipe each brick and spray with a removal encapsulant. Treat brick as uncontaminated waste, if authorized by the contracting officer; otherwise, treat as asbestos-contaminated waste. Place in approved container; see sheet 9. Apply labels; see sheet 14.
4. Adequately wet mist surface of exposed insulation with amended water. Remove asbestos-containing insulation behind the firebrick. Place in approved container; see sheet 9. Apply labels; see sheet 14.
5. Clean, HEPA vacuum, and adequately clean entire firebox.
6. Inspect and reclean area as necessary.
7. Apply a tinted penetrating encapsulant to entire firebox. Inspect and reapply as necessary.
8. Prepare area for final air clearance.
9. Carry out final clearance requirements specified on applicable sheet 16, 17, or 18.

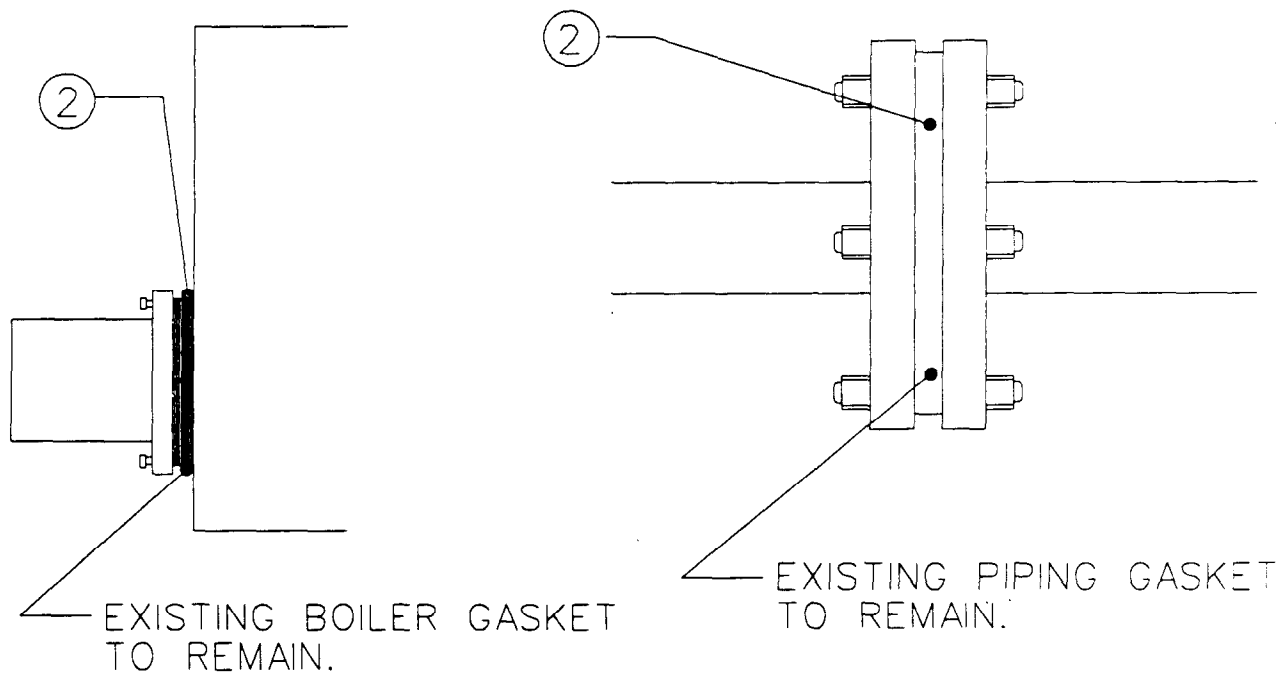

Bridging encapsulation of boiler and piping gaskets

1. Establish work area and prevent unauthorized entry; see sheet 11. Provide personal protection and decontamination facilities as specified in contractor's asbestos hazard abatement plan.
2. Apply tinted bridging encapsulant to exposed edge and surface of gasket by brushing to an acceptable thickness.
3. Inspect and reapply encapsulant as necessary.
4. Prepare area for final clearance.
5. Contractor and contracting officer will certify visual inspection of work area on sheet 19, *Certification of Final Cleaning and Visual Inspection*.

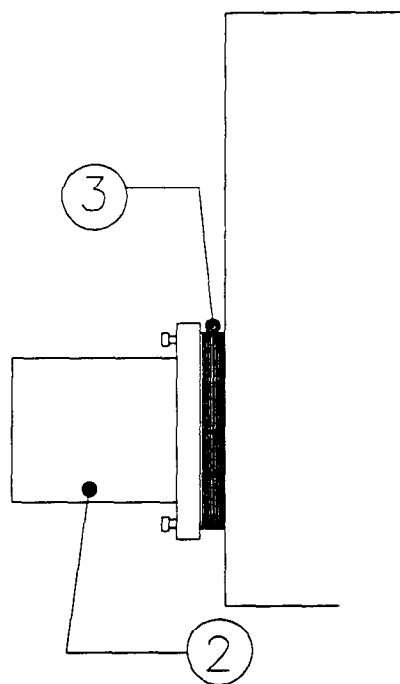

BURNER

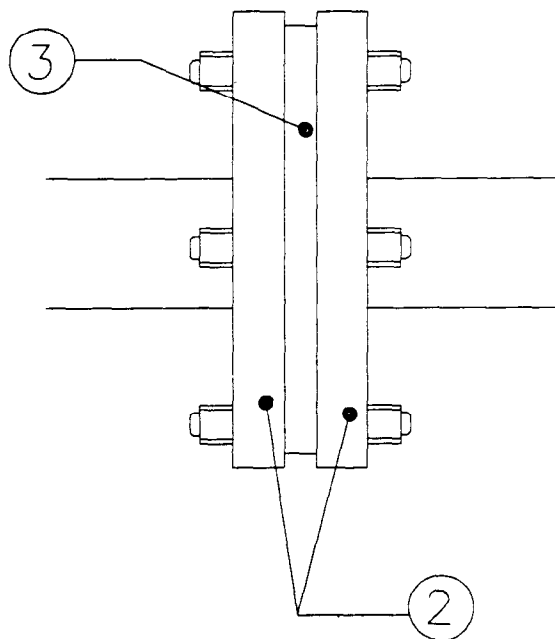

PIPING

Removal of boiler and piping gaskets

1. Prepare modified containment area as specified on sheet 21.
2. Adequately wet mist burner or piping before disassembling.
3. Adequately wet mist gasket surfaces with amended water, initially and during removal procedure. Remove boiler/piping gasket from flanges. Place gasket in approved container; see sheet 9. Apply labels; see sheet 14.
4. Clean, HEPA vacuum, and adequately wet clean surfaces.
5. Inspect and reclean as necessary.
6. Apply tinted penetrating encapsulant to flange surfaces. Inspect and reapply as necessary.
7. Prepare area for final clearance.
8. Carry out final clearance requirements as specified on sheet 21.

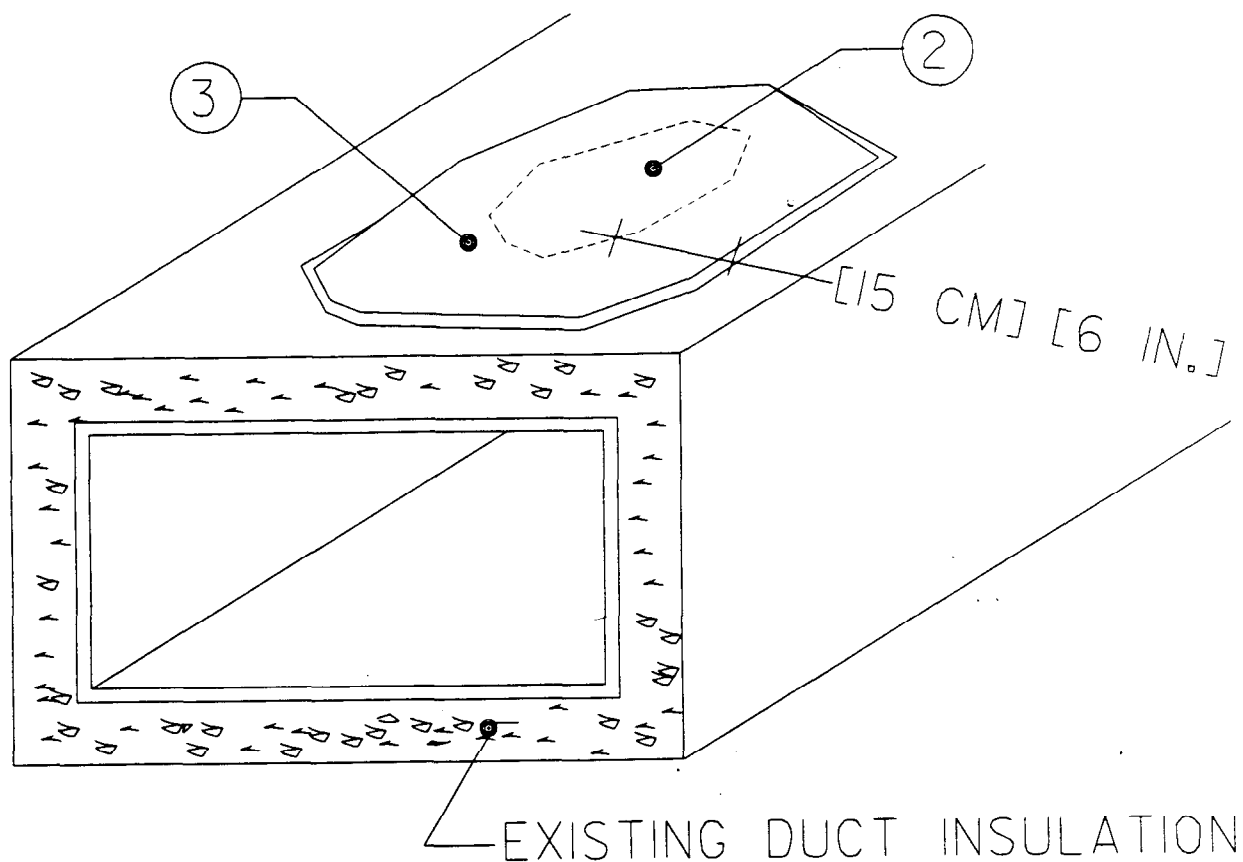

Repair of duct insulation

1. Install mini-containment area as specified on sheet 7.

2. Adequately wet mist area to be repaired. Remove any loose material with a HEPA vacuum. Fill voids with mineral insulating cement.

3. Cover filled areas with a nonwoven fiberglass cloth saturated with a bridging encapsulant. Extend cloth a minimum of [6 in] [15 cm] beyond the edge of

damaged areas. Allow area to dry for 24 hours. Coat area with a second layer of tinted bridging encapsulant.

4. Inspect and reapply encapsulant as necessary..

5. Prepare area for final air clearance.

6. Carry out final clearance requirements as specified on sheet 7.

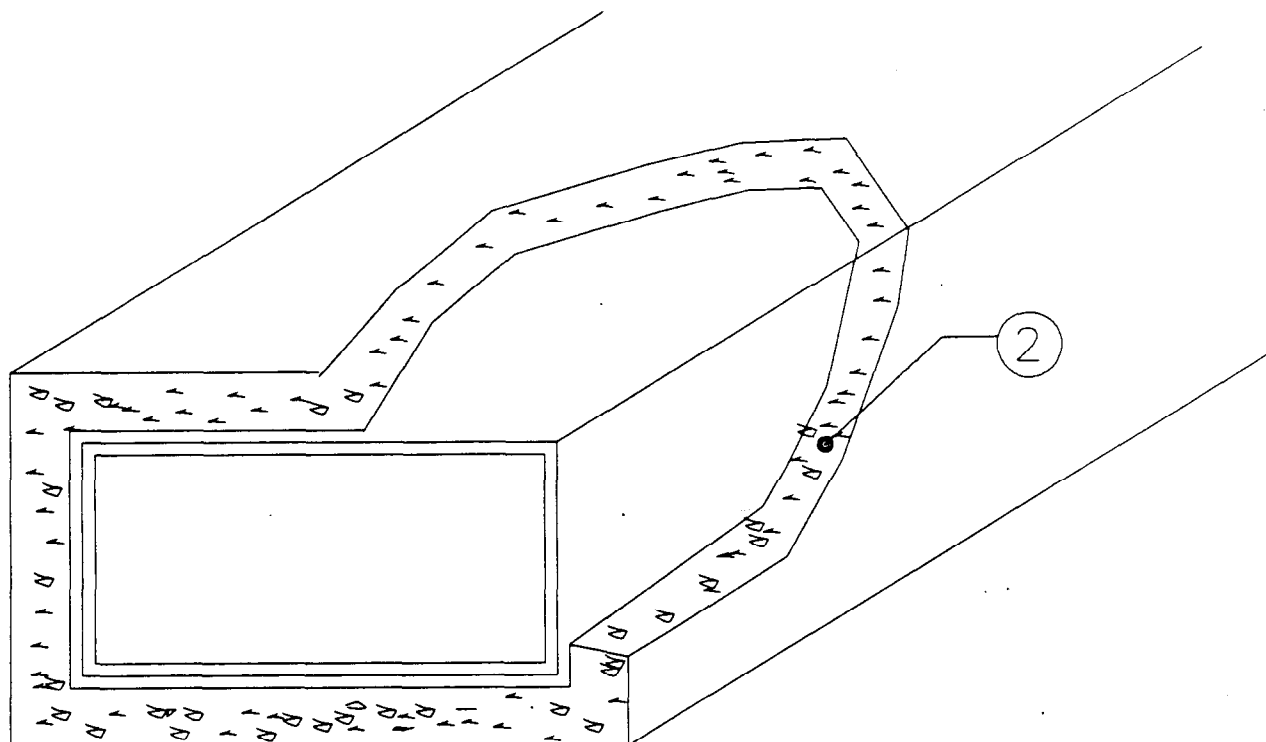

Removal of duct insulation

1. Prepare containment area as specified on applicable sheet 2, 3, or 4.
2. Adequately wet mist surface with amended water, initially and during removal procedure. Remove all asbestos insulation from duct. Place in approved container; see sheet 9. Apply labels; see sheet 14. Brush, HEPA vacuum, and wet wipe exposed duct surfaces to remove residual material.
3. Inspect and reclean area as necessary.
4. Apply tinted penetrating encapsulant. Inspect and reapply as necessary.
5. Prepare area for final air clearance.
6. Carry out final clearance requirements as specified on applicable sheet 16, 17, or 18.

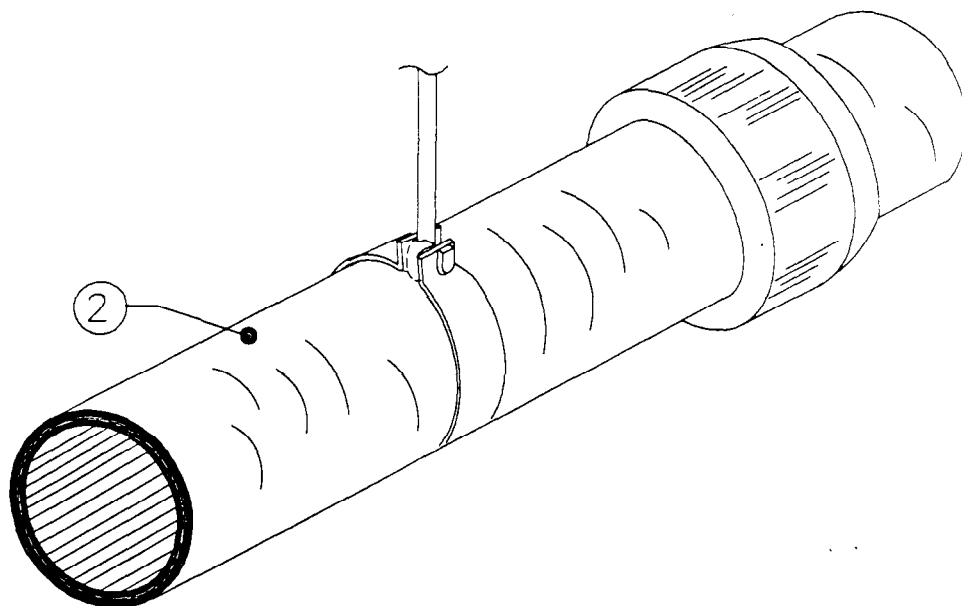

Removal of asbestos cement pipe

1. Prepare modified containment area as specified on sheet 21.
2. Adequately wet mist surface of pipe with amended water initially and during removal procedure. Remove existing asbestos cement pipe. Place each section on two layers of 6-mil polyethylene. Wrap each layer around pipe and seal ends and joints with duct tape; see sheet 9. Apply labels; see sheet 14.
3. Prepare area for final clearance.
4. Carry out final clearance requirements as specified on sheet 21.

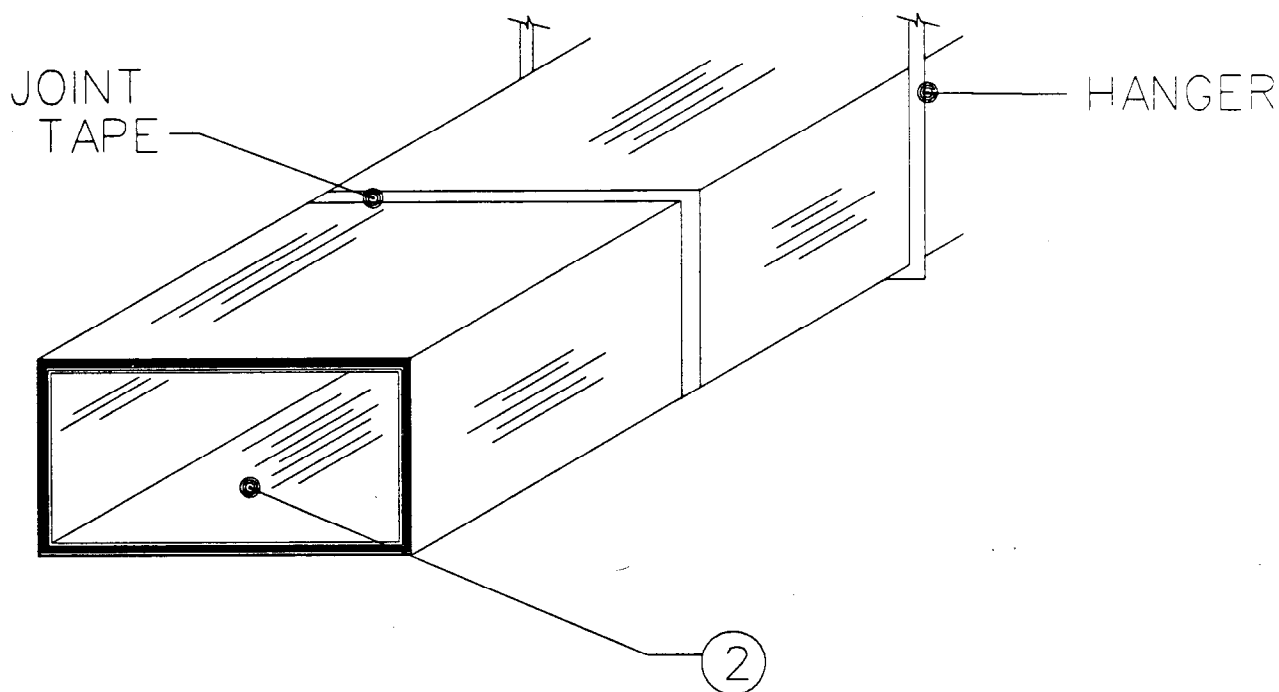

Removal of asbestos cement ductwork

1. Prepare modified containment area as specified on sheet 21.
2. Adequately wet-mist surface of ductwork with amended water, initially and during removal. Remove existing asbestos cement ductwork. Place each section on two layers of 6-mil polyethylene. Wrap

each layer around ductwork and seal ends and joints with duct tape; see sheet 9. Apply labels; see sheet 14. Place smaller material in approved containers; see sheet 9. Apply labels; see sheet 14.

3. Prepare area for final clearance.
4. Carry out final clearance as specified on sheet 21.

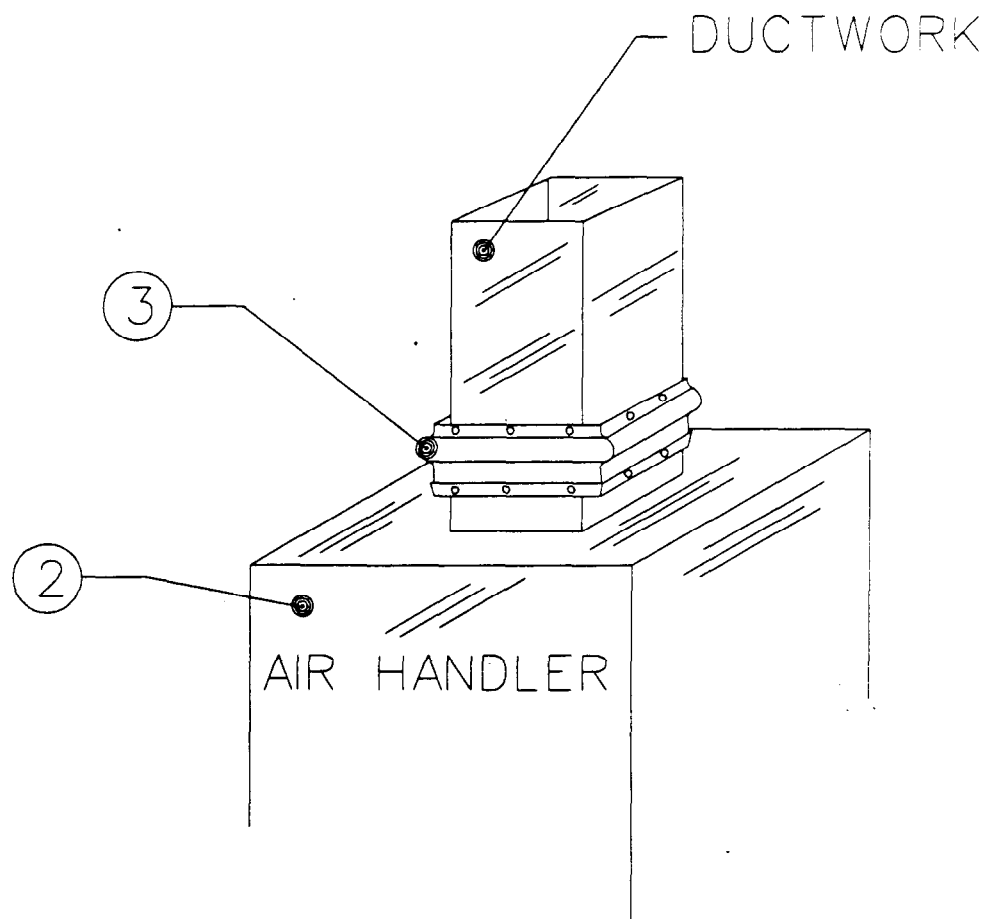

Removal of asbestos flex connector

1. Prepare modified containment area as specified on sheet 21.
2. Disconnect all electrical power to the air handler.
3. Adequately mist flex connector with removal encapsulant. Remove existing flex connector. Place in an approved container; see sheet 9. Apply labels; see sheet 14.
4. Clean, HEPA vacuum, and wet wipe area in the immediate vicinity of removed materials.
5. Inspect and reclean as necessary.
6. Prepare area for final clearance.
7. Carry out final clearance requirements as specified on sheet 21.