



United States Department of Commerce
Technology Administration
National Institute of Standards and Technology

NIST HANDBOOK 133
Third Edition, Supplement 4

**CHECKING THE
NET CONTENTS OF
PACKAGED GOODS**



**as adopted by the 79th National Conference
on Weights and Measures 1994**

The National Institute of Standards and Technology was established in 1988 by Congress to "assist industry in the development of technology . . . needed to improve product quality, to modernize manufacturing processes, to ensure product reliability . . . and to facilitate rapid commercialization . . . of products based on new scientific discoveries."

NIST, originally founded as the National Bureau of Standards in 1901, works to strengthen U.S. industry's competitiveness; advance science and engineering; and improve public health, safety, and the environment. One of the agency's basic functions is to develop, maintain, and retain custody of the national standards of measurement, and provide the means and methods for comparing standards used in science, engineering, manufacturing, commerce, industry, and education with the standards adopted or recognized by the Federal Government.

As an agency of the U.S. Commerce Department's Technology Administration, NIST conducts basic and applied research in the physical sciences and engineering and performs related services. The Institute does generic and precompetitive work on new and advanced technologies. NIST's research facilities are located at Gaithersburg, MD 20899, and at Boulder, CO 80303. Major technical operating units and their principal activities are listed below. For more information contact the Public Inquiries Desk, 301-975-3058.

Technology Services

- Manufacturing Technology Centers Program
- Standards Services
- Technology Commercialization
- Measurement Services
- Technology Evaluation and Assessment
- Information Services

Electronics and Electrical Engineering Laboratory

- Microelectronics
- Law Enforcement Standards
- Electricity
- Semiconductor Electronics
- Electromagnetic Fields¹
- Electromagnetic Technology¹

Chemical Science and Technology Laboratory

- Biotechnology
- Chemical Engineering¹
- Chemical Kinetics and Thermodynamics
- Inorganic Analytical Research
- Organic Analytical Research
- Process Measurements
- Surface and Microanalysis Science
- Thermophysics²

Physics Laboratory

- Electron and Optical Physics
- Atomic Physics
- Molecular Physics
- Radiometric Physics
- Quantum Metrology
- Ionizing Radiation
- Time and Frequency¹
- Quantum Physics¹

Manufacturing Engineering Laboratory

- Precision Engineering
- Automated Production Technology
- Robot Systems
- Factory Automation
- Fabrication Technology

Materials Science and Engineering Laboratory

- Intelligent Processing of Materials
- Ceramics
- Materials Reliability¹
- Polymers
- Metallurgy
- Reactor Radiation

Building and Fire Research Laboratory

- Structures
- Building Materials
- Building Environment
- Fire Science and Engineering
- Fire Measurement and Research

Computer Systems Laboratory

- Information Systems Engineering
- Systems and Software Technology
- Computer Security
- Systems and Network Architecture
- Advanced Systems

Computing and Applied Mathematics Laboratory

- Applied and Computational Mathematics²
- Statistical Engineering²
- Scientific Computing Environments²
- Computer Services²
- Computer Systems and Communications²
- Information Systems

¹At Boulder, CO 80303.

²Some elements at Boulder, CO 80303.

**NIST HANDBOOK 133
THIRD EDITION
SUPPLEMENT 4**

CHECKING THE NET CONTENTS OF PACKAGED GOODS

Editors:
Carroll S. Brickenkamp
Ken Butcher
Tom Coleman



U.S. DEPARTMENT OF COMMERCE, Ronald H. Brown, Secretary
Technology Administration, Mary L. Good, Under Secretary for Technology
National Institute of Standards and Technology, Arati Prabhakar, Director

Issued October 1994

National Institute of Standards and Technology Handbook 133, Third Edition, Supplement 4
Natl. Inst. Stand. Technol. Handb. 133, Third Ed., Suppl. 4, 50 pages (Oct. 1994)
CODEN: NIHAE2

U.S. GOVERNMENT PRINTING OFFICE
WASHINGTON: 1994

For sale by the U.S. Government Printing Office
Superintendent of Documents, Mail Stop: SSOP, Washington, DC 20402-9328
ISBN 0-16-045384-4

Foreword

This fourth supplement was prepared to inform users of changes to NIST Handbook 133 that were adopted at the 79th Annual Meeting of the NCWM and that will be soon be incorporated into a Fourth Edition of the handbook. These amendments will increase national uniformity, decrease paperwork, reduce inspection time by eliminating several calculations and steps in the lot compliance procedures, and lessen the cost of training inspection officials.

Food Safety and Inspection Service of the U.S. Department of Agriculture

The Food Safety and Inspection Service (FSIS) of the U.S. Department of Agriculture (USDA) adopted portions of the Third Edition of NIST Handbook 133 in 1992. NCWM adoption of these revisions shown in this supplement does not change the status of NIST Handbook 133 (Third Edition), tare procedures, or gray areas on meat and poultry products under the jurisdiction of the USDA. However, FSIS has indicated that it will propose adoption of the new Table 2-1 Category A Sampling Plans (as described in this supplement) for use at testing locations other than in the plant where the meat and poultry products are tested. FSIS has indicated that they will continue to require the use of Table 2-5 Sampling Plans of Category B and the Alternative Tare Procedures for in-plant inspections. Several editorial revisions to NIST Handbook 133 are shown in this supplement and will be made in the Fourth Edition. These editorial revisions will not change FSIS requirements for the in-plant testing of packages of meat and poultry products.

- Table 2-5. Sampling Plans for Category B has been editorially revised to include the Table 2-6. Initial Tare Sample Sizes for Alternative Tare Procedures. It has been renumbered as Table 2-2 in this supplement.
- Table 2-7. Total Number of Packages (n_t) to Be Opened for Tare Determination has been revised to include only the sample sizes for Category B (10 and 30) and the table has been renumbered as Table 2-4 in this supplement. It includes the following note "Use Only When Testing Meat and Poultry Products in Federally Inspected Plants."

FSIS adoption of the revised sampling plans described in this supplement will ensure that all food products are inspected at wholesale and retail locations using a single set of sampling plans that provide a high confidence level when declaring product nonconforming.

Brief Summary of Changes

The NCWM voted to:

- 1) Adopt a single set of sampling plans based on a 1980 net weight proposal of the Food and Drug Administration (FDA). The FDA sampling plans were modified by changing the sample sizes (e.g., they are based on a sample size of 12 instead of 10) and adding a sample correction factor for inspection lots of all sizes. The statistical correction factor (computed using the formula $[(2/\sqrt{n}) \times \text{sample standard deviation}]$) will provide a confidence limit (one-sided t-test) of approximately 97 percent that product found nonconforming is actually out of compliance with regulations. The sampling plan allows one package to exceed the individual package limits set by the Maximum Allowable Variations (MAV) in HB-133 when the sample size is 48 and the lot size is more than 3,200 packages.
- 2) Eliminate the finite population correction "f." The "f" factor corrects for the fact that sampling probabilities are based on the assumption that the population from which a sample is drawn is infinite in size; the "f" factor generally affects the results by less than 10 percent when the sample is less than 20 percent of the lot. The "f" factor assumes that what is available for inspection is the total inspection lot. Since many packages comprising a shipment or

delivery at retail may already have been sold, and the actual size of the shipment or delivery is difficult to determine, eliminating the finite population assumption will shift the benefit of the doubt to the favor of the packer.

3) Require that average tare weights be determined using the alternative tare procedures in HB-133 whether at point-of-pack or at the retail store level. The NCWM also voted to increase the initial tare sample size for glass and aerosol containers for lots containing more than 251 packages to ensure that the possible wide variability common to this type of packaging is better taken into account during the tare determination process.

These revisions to NIST (formerly National Bureau of Standards - NBS) Handbook 133, Third Edition, "Checking the Net Contents of Packaged Goods," were adopted by the National Conference on Weights and Measures on July 19, 1994.

1994 Changes

A list of changes that have been made to Handbook 133 and adopted by the Conference are listed on the next page as "Addendum - 1994"; the pages that follow also include editorial changes necessitated by the conversion to a 2-column format and the addition of metric units where appropriate. This supplement includes a summary of the revisions, a completely revised Core Method, and a complete update of Appendix B. Tables. Changes are included for **Section 3.5 Standard Pack Labeled by Weight: Core Method; Section 3.11 Aerosol Products, Section 3.18 Meat and Poultry from Federally Inspected Plants; and Appendix B. Tables** from the Third Edition. Please insert this entire publication in front of your copy of the Third Edition; the pages in this publication show the changes to corresponding sections in the Third Edition but may not be used as change pages because of differences resulting from the switch to a 2-column format.

National Institute of Standards and Technology

The National Institute of Standards and Technology (NIST) has a statutory responsibility for "cooperation with the States in securing uniformity of weights and measures laws and methods of inspection." In partial fulfillment of this responsibility, the Institute is pleased to publish these recommendations of the National Conference on Weights and Measures.

Addendum 1994		
Section	Action	Page
Entire Handbook	Additional detailed information on the following changes is available in the 79th Report of the Conference, Laws and Regulations Final Report. A Summary describing the following changes in detail may be obtained by contacting NIST Office of Weights and Measures, (301) 975-4004. Specific changes are listed below.	All Pages
2.11.4. Alternative Tare Procedures	Tare procedures revised to require that the "Alternative Tare Procedures" be followed in all inspections where gravimetric testing is used. See subsection 4 in § 3. Core Method for Checking the Net Contents of Packaged Goods.	3-7
3.5. Standard Pack Labeled by Weight: Core Method	Revised to incorporate adoption of the new sampling plans and tare procedures. This section can be used as the basis for inspections on a wide range of packaged goods.	3-7 - 3-10
3.11. Aerosol Packages	Edited entire subsection to eliminate references to aerosol foam test allowance	3-26 to 3-29
3.18. Meat and Poultry from Federally Inspected Plants	Edited section to reflect changes to the Category A sampling plans and updated addresses and telephone numbers of USDA regional offices.	3-43 to 3-50
Appendix A	Form A-2 was revised to incorporate new sample sizes, the revisions to the tare determination procedures, and Category A sampling plans	A-2
Appendix A	Form A-3 was revised to incorporate new sample sizes, the revisions to the tare determination procedures, and category A sampling plans	A-3
Appendix B	Tables were editorially revised (where appropriate) to place the values for metric units first and renumbered to reflect the elimination of several tables	B-1 to B-15
Appendix B	Table 1-1 was revised to include additional information on agencies responsible for net quantity of contents regulations.	B-1
Appendix B	Table 2-1 was deleted. Table 2-2. was replaced with a new table of Category A sampling plans and renumbered Table 2-1.	B-2
Appendix B	Table 2-3. "Values of $0.8598/\sqrt{n}$ and $2/\sqrt{n}$ for sample size n" was deleted.	B-3 to B-4
Appendix B	Table 2-4. "Values of 'f' for percent of lot sampled" was deleted.	B-4

Addendum 1994		
Section	Action	Page
Appendix B	Table 2-5. "Sampling Plans of Category B" revised to (1) indicate that it is for use only when testing products in a USDA meat and poultry plant, (2) the tare sample size for lots with 251 or more package was amended to reflect the initial tare sample size for this size lot from Table 2-6, and (3) was renumbered to Table 2-2.	B-5 to B-6
Appendix B	Table 2-6. "Initial Tare Sample Size for Alternative Tare Procedures" deleted.	B-7 to B-8
Appendix B	Table 2-7. Total Number of Packages (n_t) to be Opened for Tare Determination on pages B-3 and B-4 deleted and replaced with Table 2-3 and Table 2-4 listed below. Table 2-4 used only for meat and poultry products tested in the packaging plant and only includes the n_t values for sample sizes 10 and 30. The amended tables are: - Table 2-3. "Category A - Total Number of Packages (n_t) to be opened for Tare Determination." - Table 2-4. "Category B - Total Number of Packages (n_t) to be opened for Tare Determination."	B-9 to B-12
Appendix B	Table 3-2. "Test Allowance for Foam Aerosol Products" deleted.	B-13
Appendix C	Definitions for "Sample Correction Factor," "Sample Error Limit," and "Gravimetric Test Procedure" added.	C-1 to C-5
Appendix C	Definitions for "Corrected Average Tare," "Test Allowance," and "Foam Product Aerosol" deleted.	C-1 to C-5

NIST Handbook 133

Changes to Chapter 3 Methods of Test for Packages Labeled by Weight

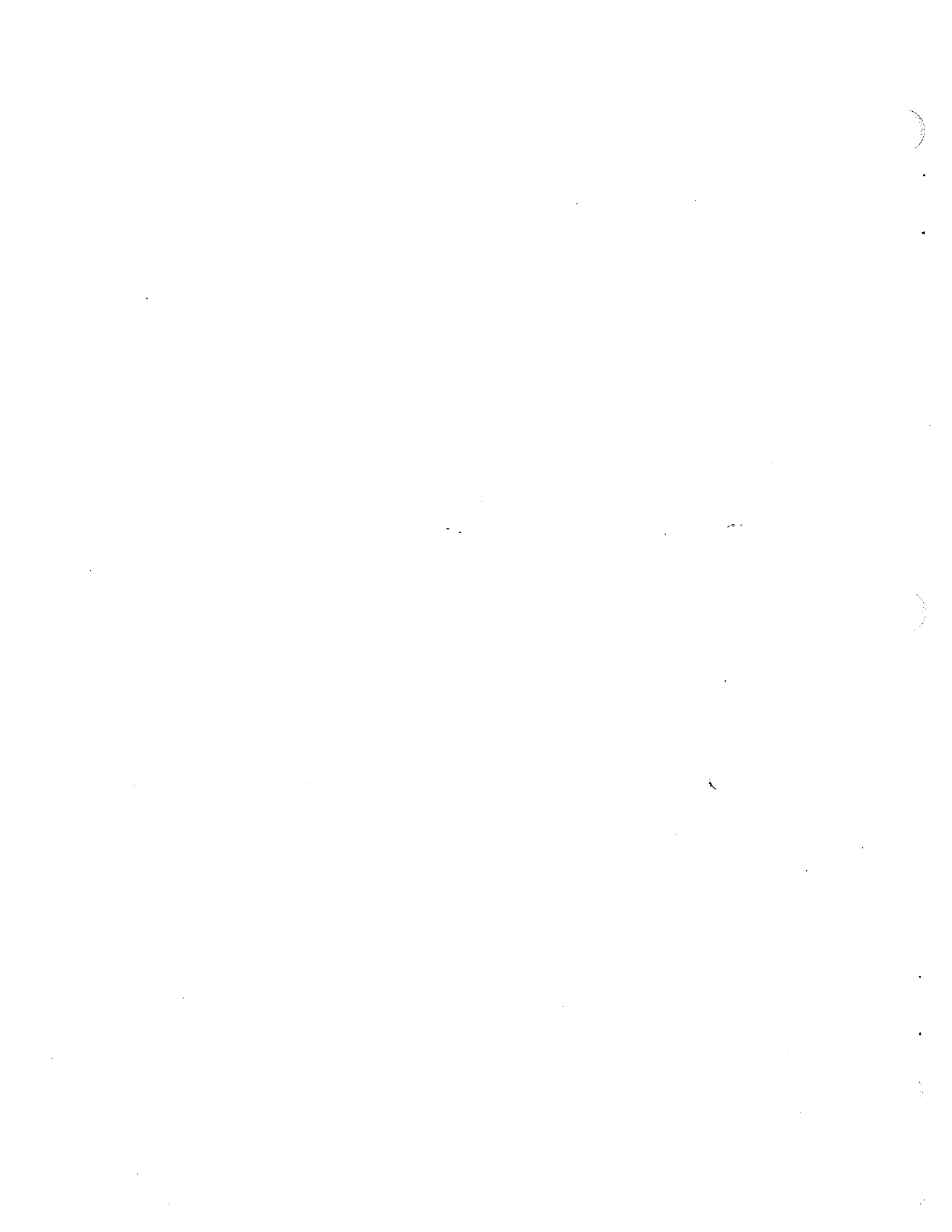

§ 3. Core Method for Checking the Net Contents of Packaged Goods

This outline guides inspectors in determining the net quantity of contents of packaged goods. Special and more detailed procedures, (e.g., testing liquids gravimetrically, random pack package testing) are not included below, but are built upon these procedures as appropriate. The following steps are applicable when testing any type of packaged commodity or product by weight or measure, as appropriate.

1. Selection of Sampling Plans

Use Table 2-1. Sampling Plans of Category A (page B-2) except when testing packages of meat and poultry products in a Federally-inspected plant; in the latter case, use Table 2-2. Sampling Plans for Category B (page B-2) as required under regulations by the USDA Food Safety and Inspection Service.

2. Inspection Information

Record the following information on the standard pack inspection report form (page A-2) identifying:

a. the product, packaging description, lot code, location of test, and other pertinent data, including:

b. the labeled net quantity of contents (record in box 1).

1) Record the labeled quantity in box 1 in the same units as the unit of measure. For example, if the labeled weight is "340 g (or 12 oz)," record 340 g in box 1 if using a unit of measure of 1 g, or record 0.75 lb (12 oz ÷ 16 oz) if using a unit of measure of 0.001 lb.

2) When the declaration of net quantity on the package includes both SI and inch-pound units, follow these guidelines:

Rounding rules permit packers to round declarations up or down based on their knowledge of their package filling targets and the accuracy of packaging equipment. Net quantity of contents enforcement shall always verify the larger of the declared values. Determine the larger of the values by converting the SI declaration to inch-pound units, or vice versa, using conversion factors that are accurate to at least 5 places. Compare the values and use the larger value in computing the nominal gross weight (see later steps).

For example if the net weight declared on a package is 1 lb, the SI equivalent (accurate to five significant digits) is 453.59 g. If the unit of measure is 0.001 lb and the packer has declared 454 g, then the labeled weight to

use to calculate the nominal gross weight is 1.0009 lb. If the packer has declared 453 g, then the 1 lb declaration is larger than the 453 g declaration. If using 1 g as the unit of measure, use 454 g when a "1 lb (454 g)" declaration is made, and use 453.59 g when a "1 lb (453 g)" declaration is given. **Inspectors should not round values in the calculations below until determining the nominal gross weight.**

c. the unit of measure* (record in box 2)

* **Note:** The unit of measure most often chosen is the size of the scale division. See discussion in Sections 2.5.1. and 2.5.2. on the unit of measure and dimensionless units.

d. the appropriate MAV value in box 3 for the type of package (weight, volume, etc.), the labeled net contents, and the unit of measure. Consider an example of bacon with the labeled weight of 1 lb and a scale to test the product with a scale division of 0.001 lb. Consulting Table 2-9, the column labeled "All Other Products" in the row "over 7 oz to 48 oz," and reading across, the "Lower Limit for Individual Weights" (in the lb column) is 0.062 lb.

Table	MAVs for Individual Packages	Page
2-5.	labeled by weight	B-5
2-6.	labeled by volume - liquid or dry	B-7
2-7.	labeled by count	B-9
2-8.	labeled by length, width, or area	B-10
2-9.	For USDA - Meat and Poultry	B-11

e. the MAV in dimensionless units (record in box 4); this value is obtained by dividing the MAV recorded in box 3 by the unit of measure recorded in box 2.

f. Count the number of packages comprising the inspection lot or estimate the size to within 5 percent and record the inspection lot size in box 5. Use this value to refer to Column 1 in Table 2.1 or Table 2-2. to determine the following information:

g. The sample size. Read across from Column 1 to find the value in Column 2 in Table 2-1 or 2-2. Record this number in box 6.

h. The initial tare sample size. See Column 5 - Initial Tare Sample Size (n_t) in Table 2-1, or Column 3 - Initial

Tare Sample Size (n_t) in Table 2-2. Record this number in box 7.

i. Number of Minus Package Errors Allowed to Exceed the MAV. See Column 4 in Table 2-1 or Table 2-2. Record this number in box 8.

3. Random Sample Selection

Randomly select a sample from the inspection lot (see Appendix E). Mark the first two (three or five) packages in the order the random numbers were first recorded. These first two (three, or five) packages are the initial tare sample.

4. Tare Procedures

a. Select the packages for the initial tare sample from the sample packages.

b. Determine and record the gross weight of each of the initial tare sample packages under the heading "Package 1," "Package 2," etc., block a. "Gross Wt" on the report form.

c. See Section 3.11.4. for instructions on emptying aerosol packages.) Except of aerosol or other pressurized packages, open the sample packages, empty, and clean them as appropriate for the packaging material.

d. Determine the tare weight for each package and record the value in block b. "Tare Wt" under the appropriate package column.

e. Subtract the individual tare weights from the gross weights (block a minus block b on the report form) to obtain the net weight for each package.

Net Weight = Gross Weight - Tare Weight

Record the net weight in block c "Net Wt" on the report form.

f. Determine and record the "range of net weights" for the initial tare sample (R_c) in box 9 on the report form. [The range is the difference between the largest net weight value and the smallest. See Appendix G for more complete instructions on determining the range.]

g. Determine and record the "range of tare weights" (called R_t) in box 10 on the report form.

h. Compute the ratio R_c/R_t by dividing the value in box 9 by the value in box 10. Record the resulting value in box 11. [R_c and R_t must both be in the same unit of measure or both in dimensionless units.]

i. Determine (and record in box 12) the total number of packages to be opened for the tare determination, n_t , from either Table 2-3. Category A - Total Number of Package (n_t) to be opened for tare determination (pages B-3 and B-4) or, when testing meat and poultry products in plants subject to USDA requirements, Table 2-4. Category B - Total Number of Package (n_t) to be opened for tare determination (page B-4).

Read down the first column (titled R_c/R_t) to find the range in which the computed R_c/R_t falls, then read across to the column headed with the appropriate sample size, n .

1) If the number of packages to open, n_t , is equal to the number already opened, no additional packages need to be selected and go to step j or

2) If n_t is greater than the number of packages already opened, compute the total number of additional packages to open (n_t minus the initial tare sample size) and go to step j.

3) If n_t is more than half the sample, tare is too variable to use an "average tare weight." Open every package in the sample and determine the net weight by subtracting each tare weight from each gross weight for each package. Determine each package error by subtracting the labeled net weight from the actual net weight of each package. Skip to step 6(b).

j. Determine the average tare weight using the tare weight values for all the packages opened and record the average tare weight in box 13.

5. Determine Nominal Gross Weight and Package Errors for Tare Sample

a. Compute the nominal gross weight, against which all the package gross weights will be compared to determine the package errors.

nominal gross weight = average tare + labeled weight

Add the average tare weight (recorded in box 13) to the labeled weight (recorded in box 1).

Note: Round the nominal gross weight to represent standard weights that can be placed on the package testing scale. For example, if 540.4 g is determined as the nominal gross weight, and the smallest weight used to test the packages is 1 g, round the nominal gross weight **down** to 540 g. Do not round up. If 1.2125 lb is determined as the nominal gross weight, and the smallest weight used in the test is 0.001 lb, round the nominal gross weight down to 1.212 lb.

b. Determine the package errors of the packages opened for tare by subtracting the nominal gross weight recorded in box 14 from the individual package gross weights recorded for each package ("Package 1," "Package 2," etc.) in block a "Gross Wt." Record the package error in block d under each column filled in for each package opened for tare. Either:

1) also copy the package error for these packages in the "Package Errors" portion of the report form, under the "-" column if the package error is minus, or under the "+" column if the package error is zero or plus. If you directly copy the package error, the error will be recorded in units of weight, either lb or g; or

2) convert the package error for these packages to dimensionless units. This allows the inspector to record the package errors as whole numbers without regard to decimal points and zeroes in front and unit of measure after the number.

Example: The scale reads to 0.001 lb. The unit of measure is therefore 0.001 lb. Flour packages of 2 lb labeled weight are being tested. The package error for the first package opened for tare is 0.008 lb. Instead of recording 0.008 lb in the plus column if the unit of measure has been recorded as 0.001 lb in box 2, record the first package error as "8" in the plus column. If the second package error as the scale reads is 0.060 lb, record the package error as "60" in the plus column, and so on.

Using the nominal gross weight rather than the actual net weight for each package to determine the package error ensures that it is the average tare weight that is used to determine the package error for every package in the sample, not just the unopened packages.

6. Test

a. Compare the unopened sample packages with the nominal gross weight (box 14). Place weights equal to the nominal gross weight on the scale and zero these weights out of the display. Place unopened packages individually on the scale. The scale will display the package error directly. For example, if the nominal gross weight is 1.212 lb and that weight has been zeroed out of the scale display, if a package weighing greater than 1.212 lb is placed on the scale, a plus package error will be displayed (the package is overpacked.) If a package weighing less than 1.212 lb is placed on the scale, say, 1.000 lb, the scale will display -0.212 lb, the minus package error for that package (the package is underfilled.)

Record the package errors for these packages in the "Package Errors" portion of the report form as described for the packages opened for tare either directly in units of weight (lb or g) or in dimensionless units.

b. Add the package errors for all the packages in the sample, taking care to subtract the minus package errors from the plus package errors. Record the total error in box 15.

7. Evaluation of Results

Note: If the product is subject to moisture loss, follow the procedures for correcting the MAV in 7 (g) Moisture Loss.

a. Compare each minus package error with the MAV recorded in box 3 (if using units of measure) or box 4 (if using dimensionless units). Circle the package errors that exceed the MAV. These are "unreasonable errors."

b. Record the number of unreasonable errors found in the sample in box 16. Compare that number with the number of unreasonable errors allowed (recorded in box 8.) If the number found exceeds the allowed number, the lot fails. Record this in box 17, whether the number of unreasonable errors found is less or more than allowed.

c. If the total error recorded in box 15 is a plus value and the number of unreasonable errors is equal to or less than the number allowed (recorded in box 17), the lot passes.

d. Determine the average error by dividing the total error recorded in box 15 by the sample size recorded in box 6. Record the average error in box 18 if using dimensionless units or in box 19 if using units of mass.

e. Compute the average error in terms of weight (if working in dimensionless units up to this time) by multiplying the average error in dimensionless units by the unit of measure and record the value in box 19.

1) If the average error is negative, the inspection lot fails under a Category B test. Record this in box 20.

2) If the average error is a negative value when testing under the Sampling Plans for Category A, compute the Sample Error Limit (SEL) as follows:

i. Compute the Sample Standard Deviation. Record this in box 21.

ii. Obtain the Sample Correction Factor from Column 3 of Table 2-1. Category A Sampling Plan and record this in box 22.

iii. Compute Sample Error Limit using the formula:

Sample Error Limit (box 23) = Sample Standard Deviation (box 21) x Sample Correction Factor (box 22)

f. Compliance Evaluation of the Average:

- 1) if the value of the Average Error (box 18) is smaller than the SEL (box 23), the inspection lot passes;
- 2) If the value of the average error (disregarding the sign) (box 18) is larger than the SEL (box 23), the inspection lot fails.

Note: If the product is subject to moisture loss the lot does not necessarily fail. Follow the procedures in g(4).

g. Moisture Loss

If applicable, calculate and record the moisture allowance:

- 1) Determine the value of the gray area (e.g., as listed in HB-133). Convert the percentage to the unit of measure.

Example:

Labeled net quantity of flour is 2 lb

Gray Area allowance is 3 percent (0.03)

Unit of Measure on the scale is 0.001 lb

Gray Area = 2 lb x .03 = 0.06 lb

Record this value in box 13a.

Compliance with the requirements for the Maximum Allowable Variation:

- 2) Go to box 3 and correct the MAV by adding the moisture loss allowed to the MAV.

Example: 2 lb package of flour. Gray Area added to the MAV = 0.06 lb (MAV for 2 lb) + 0.06 lb moisture allowance = 0.12 lb

- 3) Correct MAV in dimensionless units, by converting Gray Area to dimensionless units = 0.06 lb ÷ 0.001 lb = 60. Go to box 4 and add the Gray Area in dimensionless units to the MAV in dimensionless units.

Example: MAV = 60 (MAV for 2 lb/unit of measure = 0.001 lb) + 60 (Gray Area in dimensionless units) = 120. Minus package errors must exceed the MAV + gray area before they are declared "unreasonable errors."

If the number of unreasonable errors exceeds the allowed number (recorded in box 8), the inspection lot fails.

4) For compliance with the Average Error:

If the minus average error (box 18) is larger (disregarding the sign) than the SEL (box 23) and moisture loss is applicable, compare the difference between box 18 and box 23 with the moisture allowance recorded in box 13a. (Make sure that all the values are in units of weight or in dimensionless units before making this comparison.) If box 13a is larger than the difference between box 18 and 23, then the lot is considered to be in the gray area.

Example: Box 13a for 2 lb flour is 60 (dimensionless units); box 18 is 2 (dimensionless units); box 23 is .550 (dimensionless units). The difference between box 18 and box 23 is 1.450 (dimensionless units).

Since Box 13a is 60 (dimensionless units), 13a is larger than the difference between box 18 and box 23, further investigation is necessary before moisture loss can be ruled out as the reason for shortweight.

9. Continue with steps 7-11 of Section 3.5. (CORE METHOD) to determine lot conformance.

Note: Figure 3-8, The determination of tare for packages labeled by drained weight, has been deleted.

3.11 Aerosol Packages

The testing of aerosol packaged products is covered in the following sections. After a list of equipment (Section 3.11.1.) and a description of the assembly of a portable test stand used when emptying the containers (Section 3.11.2.); the details of the net contents determination are described in Sections 3.11.3. and 3.11.5. Methods for emptying the aerosol containers are given in Section 3.11.4.

3.11.1. Equipment

Scales and weights recommended in Section 3.1. are suitable for weight determinations.

Portable test stand with adjustable valve depressor; assembled from components available from a scientific supply company or hardware store. The components are:

- support stand, utility clamp, and 1 cm (0.5 in) carriage bolt (5 to 7 cm [2 to 3 in] long) and nut.
- gasoline can,
- two dishpans, sink or other appropriate receptacles, and

3.11.2. Preparation for Test

Assemble the stand and thread the carriage bolt into the nut and use the jaws of the utility clamp to grip the nut tightly. Mount the clamp on the rod of the support stand. [See Figure 3-9.] Adjust the height of the clamp to the height of the container under test and thread the carriage bolt to depress the aerosol valve until maximum flow of product is obtained.

Use the containers to collect the expelled product. Add the support plate and gasoline can to the stand for aerosol products such as paints and coatings (as shown in Figure 3-10). Adjust the support plate so that the orifice of the spray can is lined up with the intake of the gasoline can. Leave the vent on the gasoline can open and clear. The clamp and valve-depression adjustment is made in the same manner as with the other aerosol products.

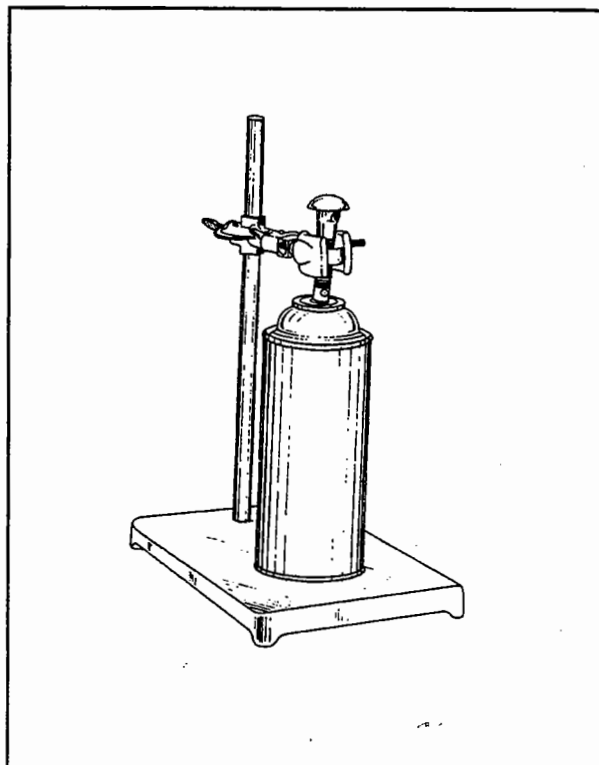

Figure 3-9. Portable test stand for all aerosol products except paints and coatings.

Unlike conventional packages, aerosol containers must not be opened. Instructions on the container specifically state:

Caution: Contents under pressure - do not puncture.

WARNING: The containers of packaged aerosol products are under pressure and should not be punctured, broken, or subjected to temperatures in excess of 49 °C (120 °F). The fumes and suspension of finely divided product may be toxic, irritating, and flammable.

Therefore, the exhausting procedure described in Section 3.11.4. should be conducted in a well ventilated area, in an exhaust hood, or outdoors, at least 15 m (50 ft) from any source of open flame or spark. Smoking should not be permitted in the test area.

Use the test stand equipped with the adjustable valve-button depressor for exhausting the container.

Place the test stand in a plastic dishpan with another dishpan in an inverted position over the test stand to minimize pollution with the sprayed product during the exhausting procedure. Use the gasoline can as a receiving vessel for paint and coating products. See Figure 3-10.

3.11.3. The Determination of Net Contents: Part 1

All aerosol packaged products (except refrigerated products) should be checked at a product temperature of 20 °C (68 °F). All products that must be refrigerated to maintain quality should be checked at a product temperature of 4 °C (40 °F). Lower temperatures will require applications of a correction because less product will be expelled at lower temperatures. For practicality, testing in a range of 20 °C to 27 °C (68 °F to 80 °F) range is suggested for non-refrigerated products and 4 °C to 7 °C (40 °F to 45 °F) for refrigerated aerosols. These temperature ranges are representative of the temperatures at which the products are normally used.

Regulations under the Fair Packaging and Labeling Act [Note 17, See page 3-27] require that, in the case of packages designed to deliver the product under pressure, "... the declaration shall state the net quantity of the contents that will be expelled when the instructions for use as shown on the container are followed."

Note 17: Regulations under the Fair Packaging and Labeling Act (PL 89-755) include 16CFR 500.25(a), 21CFR 701.13(g)(1), 21CFR 201.62(f), and 21CFR 101.105(g). Also see parallel requirements recommended by the National Conference on Weights and Measures in its Uniform Packaging and Labeling Regulation (Section 10.3) in NIST Handbook 130. Quotations above from 21CFR 101.105(g).

The procedure presented below may be used for checking aerosol net contents labeled by weight.

1. Fill out the heading of the standard pack report form (page A-2) and select the random sample. As explained in Appendix E.6.1., the random sample should be arranged in the order in which the random numbers were selected. This will be the order in which the packages will be opened for tare. Consult Table 2-1, page B-2, for the size of the initial tare sample.

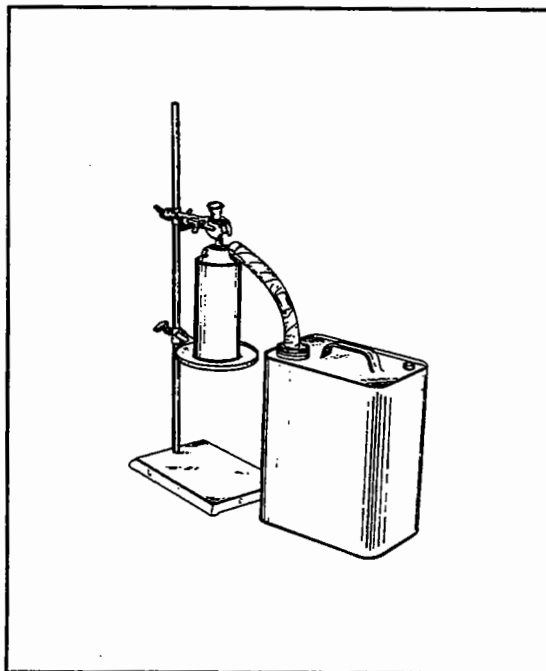

Figure 3-10. Portable test stand for aerosol paints and coatings.

2. Gross weigh each package in the initial tare sample and record this weight on the report form in the boxes labeled a. Follow Section 3.11.4. to empty the initial tare sample aerosol containers. After following Sections 3.11.4., go on to Section 3.11.5. for instructions on completing the procedure.

3.11.4. Exhausting the Aerosol Container

Follow the procedures below to empty aerosol containers and thereafter determine their tare.

Shaking Aerosol Containers

- Do not shake unless shaking is specified.
- If shaking is specified, shake according to directions on the container. If no directions are given as to how the can should be shaken, shake the container 5-times with a brisk wrist-twisting motion. If the container has a ball agitator, continue shaking procedure for one minute after the ball has shaken loose.

Place the selected container in the position specified in the instructions on the package, exhaust it by holding the valve wide open until visible spray is interrupted. Continue exhausting container for 30 seconds. If using portable test stand (see Figures 3-11 and 3-12), exhaust container following the above procedures. However, hold valve wide open for 30 minutes.

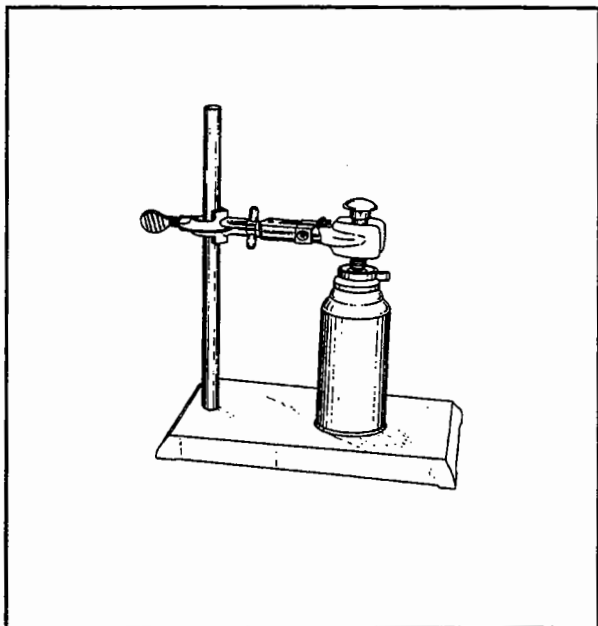

Figure 3-11. Portable test stand showing aerosol foam product ready to expel in upright position.

- If shaking during use is specified in the instructions, shake at periodic intervals (at least two or three times during expulsion of the product).

Exhausting Containers

With the container in the position specified on the package, exhaust the sample container by depressing the valve-actuator until visible spray is interrupted. As soon as spray is interrupted release the actuator. [A change in sound usually accompanies spray interruption.] Allow the container to warm to 20 °C to 27 °C (68 °F to 80 °F) before concluding the evacuation.

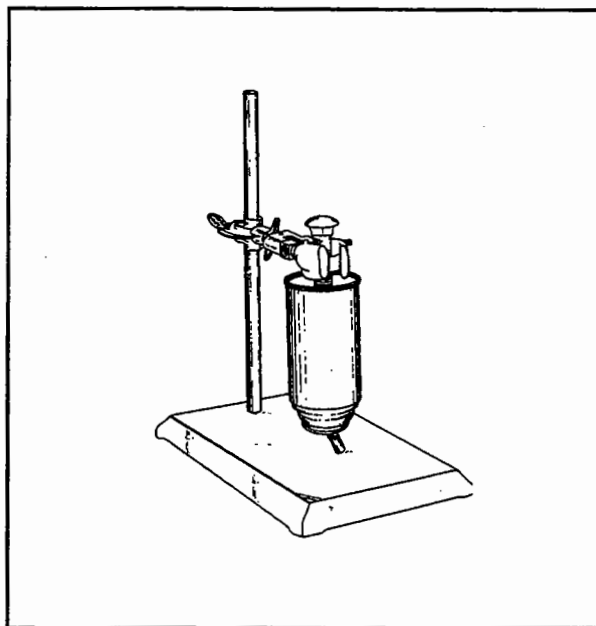

Figure 3-12. Portable test stand showing aerosol foam product ready to expel in inverted position.

Agitate the container with a swirling motion for 30 seconds. Hold the container at an angle of approximately 45 degrees from the upright position, with the valve-actuator depressed, and rotate the container to maintain a visible spray (again, note the sound change) as long as possible. [Rotating will ensure contact of the dip tube with any remaining product in the container.] Continue this procedure until no additional product or gas is expelled. Any undelivered product should be expelled as completely as possible by holding the container in the hand with the valve-actuator depressed and alternately inverting the container and then restoring to the original test position at approximately 10-second intervals until no additional product is delivered.

When exhausting containers with vapor tap valves (in which product continues to be expelled upon inversion of container), stop the exhausting procedure whenever the container becomes cold to the hand. Allow the container to return to test temperature of 20 °C to 27 °C (68 °F to 80°F) before continuing the test. A container with a metered valve cannot be emptied by holding the valve-actuator depressed since such a valve permits only a predetermined amount of product to be expelled each time the valve-actuator is depressed. Empty the container by alternately depressing and releasing the valve-actuator until no additional product or gas is expelled.

3.11.5. The Determination of Net Contents: Part 2

The following steps complete the procedures begun in 3.11.3:

3. Rinse the outside of the containers with a suitable solvent and dry the exteriors of the containers. If the valve-actuators are removable, remove for cleaning and drying, and then replace. Determine the tare weights of the initial tare sample and record on the report form in the boxes labeled b. Calculate the net weights for the initial tare sample and record in boxes labeled c. An individual package net weight is equal to:

package gross weight - package tare weight

4. Determine the range of net weights, R_c and record in box 9.

5. Determine the range of tare weights, R_t and record in box 10.

6. Compute R_c/R_t and record in box 11. From Table 2-3, pages B-3 and B-4, look up the total number of packages necessary for determining the tare; record n_t in box 12. If n_t is larger than the initial tare sample, select additional tare sample packages, as necessary, from remaining packages arranged in the order in which the random numbers were obtained. It may be necessary to empty all the packages in the sample.

7. Gross weigh, empty, and determine the tare for additional packages selected in box 7. Record these weights on a worksheet.

8. Follow core procedure to determine lot conformance.

- Desiccator and drying agent
- Analytical balance
- Drying dishes with covers
- Calibrated thermometer

b. Procedure

1. Set oven to $130\text{ }^{\circ}\text{C} \pm 3\text{ }^{\circ}\text{C}$. Let temperature stabilize.
2. Weigh at least three empty drying dishes and covers for each lot of flour being tested (that is, run a triplicate). Weigh covered dishes with about 2 g flour in each one.
3. Uncover dishes, place them in the oven.
4. Start timing for 1 hour for flour (2 hours for dry pet food) from the time the temperature returns to within $1\text{ }^{\circ}\text{C}$ of the specified temperature.
5. Cover the dishes, transfer them to a desiccator, and weigh after the dishes return to room temperature.

6. Compute the moisture content (MC) (percent) as follows:

$$\text{MC} = [(\text{SWBD} - \text{SWAD}) \div \text{SWBD}] \times 100$$

where: SWBD = sample weight before drying

SWAD = sample weight after drying

Do the calculation within the parentheses first. Then do the calculation within the brackets and multiply by 100.

7. Average the results on three dishes for each lot.
8. Exchange samples with packing plant in order to determine whether their laboratory results are equivalent to yours.

3.18. Meat and Poultry from Federally Inspected Plants

3.18.1. Background for Administrator and Inspector

These test procedures are for meat and poultry coming from Federally-inspected plants. If inspectors check packages at wholesale or retail, use Category A sampling plans from H-133, and either unused or dried used tare (see Section 3.18.3.5. for definition), there is no gray area; the sample is either in or out of compliance. If a jurisdiction uses wet tare (see Section 2.11. Tare, for definition), there is a "gray" or "no-decision" area. **The gray area is not a tolerance. If**

packages are found in the gray or no-decision area, they neither automatically pass nor fail the test. If lots are tested and found inside the gray area, they are not necessarily in compliance. The jurisdiction will have to do more work to determine the final status of the lot.

Jurisdictions wishing to perform wet tare tests upon products for which no gray area has yet been determined will need to permit "reasonable variations" until a gray area has been determined for that product. New gray area determinations will be printed in this Handbook and in the Federal Register. Contact the USDA Regional Office for a listing of the products that have gray areas, as well as the size of their gray area percentages. The size of the gray area is defined as a percentage of the labeled weight that extends downward from the labeled weight.

- a. **Enforcement action relative to the gray area.** - The overall objective is to test packages as closely as possible to a routine test. However, one difference will immediately be apparent.

Category A (Table 2-1) sampling procedures must be employed at retail or wholesale locations when testing packages put up in a Federally inspected plant (because a Category B test may have been run on the packages at the plant level).

Category B (Table 2-2) sampling procedures may be used when testing at the packaging plant.

- b. **"Dry Tare" Jurisdictions.** - For jurisdictions that normally utilize unused tare to test meat and poultry packaged at a retail store, it will be necessary to simulate unused tare for packages from Federally inspected plants by drying out absorbent materials (if any) comprising the used tare and to determine a "dried used tare." No additional information will be needed other than the results of a Category A test using "dried used tare" before taking enforcement action on lots.

- c. **"Wet Tare" Jurisdictions.** - For jurisdictions that normally use wet tare, if the package lots are found short weight with wet tare tests, but fall in the "gray area," it is necessary to collect additional information to determine whether or not the lot complies with net weight requirements.

If the package lots are found short weight using a Category A sampling plan and wet tare, it is first necessary to determine whether the lot is inside or outside the gray area. If the lot falls in the gray area,

additional information has to be collected before reaching a final determination whether the lot is in or out of compliance. Of course, nothing additional is needed for lots that fall outside the gray area. Appropriate enforcement should be taken on packages found short weight and outside the gray area.

A "hold" or a "stop sale" order should be put on packages found short weight, but inside the gray area, until their status can be determined. If this is not possible, the strongest legal remedy should be sought if the product cannot be held and subsequent tests or information indicates that the lot is out of compliance.

d. Which packages to consider as part of the lot being tested. - Ordinarily, an inspector taking a sample from retail will record lot codes, but will not select the lot for test by sorting the packages by lot code. He or she will simply select a sample from all packages of the same brand and style and size on the shelf or in the stock room. If short weight is found and the results are in the gray area (wet tare only), follow-up investigation requires sorting the lot codes at this point.

e. Category A sampling plans must be used for all tests conducted outside the Federally inspected plant. - See Section 3.18.3. for details. The discussion below is based on using these procedures and on recording the "package errors"--how much and in what direction the actual package weight differs from the labeled weight.

Thus, if a package labeled 2 lb actually weighs 2.010 lb, its package error is +0.010 lb. Similarly, the "average package error" is the difference between the average weight of the sampled packages and the labelled package weight. If the average of 10 package weights is 1.994 lb, the average package error is (1.994 - 2.000 lb) = - 0.006 lb.

f. Package lots must meet the average requirement and the individual requirement. - When checking packages not subject to possible moisture loss and using Category A sampling plans, two requirements must be met:

(1) The average net weight of the sample must equal or exceed the labeled net weight minus an adjustment factor called SEL, which represents the possible deviation between the sample average and the actual lot average. If a jurisdiction applies either unused or used dried tare to meat and poultry packages, this is sufficient to determine whether the average requirement has been met. See Figure 3-15.

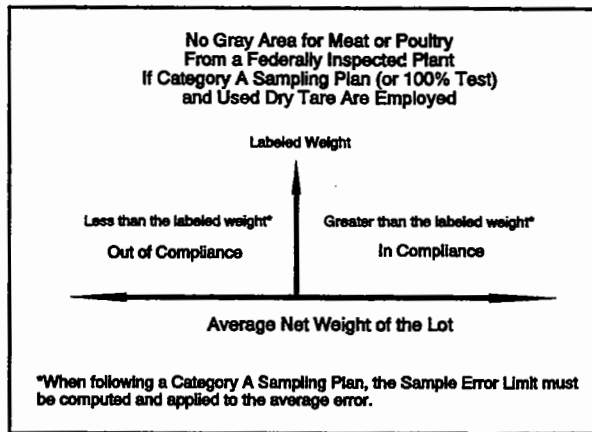

Figure 3-15.

If a jurisdiction uses wet tare, an amount defined by the gray area must be considered before determining noncompliance of the lot under test without further information or data collection. See Figure 3-16.

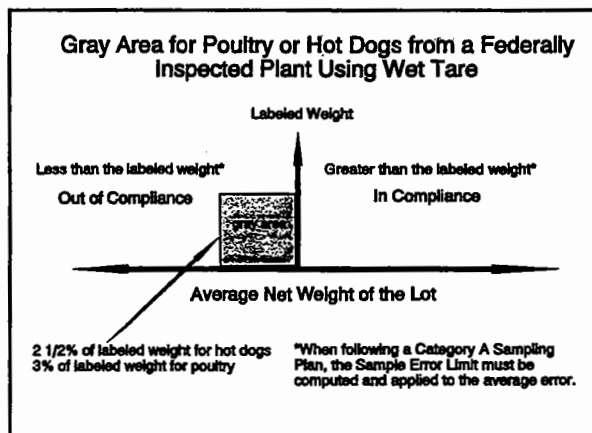

Figure 3-16.

The size of the gray area has been set at 3 percent of the average labeled weight for raw, fresh poultry, and 2-1/2 percent of the labeled weight for franks and hot dogs (whether made from meat or poultry).

(2) The number of packages that may fall below the MAV is specified in Category A sampling plans according to the sample size. Use Table 2-9 to look up the MAV for packages labeled by weight. USDA Meat and Poultry Inspection uses this set of MAV's for products under its supervision. Use Table 2-9 for all products coming from a Federally inspected plant.

The size of the gray area must be added to the individual package limits specified in Table 2-9 when the jurisdiction uses wet tare.

g. What to do when the lot is in the gray area ("Wet Tare" Jurisdictions Only). - Contact the USDA Regional Director or the Inspector-in-charge at the packaging plant (see Section 3.18.3.h.) to determine what information (either USDA's or the plant's) is available at the plant to clarify the status of the lot in question. General guidelines are given in Section 3.18.3.h. The jurisdiction also has the option of visiting the plant to collect its own data or, if the plant is located in another jurisdiction, asking the weights and measures officials in that jurisdiction to collect the necessary data. (Permission must be requested to test at the plant.)

3.18.2. Types of Products and Size of Gray Areas for Wet Tare Jurisdictions

a. Bacon. - The gray area is zero for bacon if there is no free-flowing liquid or absorbent materials in contact with the product and the package is cleaned of clinging material prior to tare weight determination; when there is no free-flowing liquid or absorbent materials in packaged bacon, wet tare and dried used tare are equivalent.

Whether you are following wet tare or dry tare procedures, wipe all packaging materials clean of fat and clinging moisture before weighing tare.

b. Fresh Sausage and Luncheon Meats. - Luncheon meats comprise any cooked sausage product, loaves, jellied products, cured products, and any sliced meat styled for placing on bread or similar products. This category of product does not include whole hams, briskets, roasts, turkeys, or chickens requiring further preparation to be made into ready-to-eat sliced product.

When there is no free-flowing liquid and no absorbent materials used in the package, there is zero gray area for fresh sausage or luncheon meats. Whether following wet tare or dry tare procedures, carefully clean and wipe all tare materials of fat and clinging moisture. Only when there is no free-flowing liquid inside the package and there are no absorbent materials in contact with the product, wet tare and dried used tare are equivalent.

c. Franks/Hot Dogs. - A gray area of 2-1/2 percent of the labeled weight is to be applied when wet tare tests are conducted.

d. Fresh Poultry. - For net weight determinations only, fresh poultry is defined as poultry above 3.3 °C (26 °F). This is product that yields or gives when pushed with a person's thumb. A gray area of 3 percent of the average labeled weight of the sample is to be applied to raw, fresh poultry in retail packages when wet tare tests are conducted.

3.18.3. Procedure for Tests Outside of the Plant

a. Field Equipment. - Use Scales and Weights recommended in Section 3.1.

b. Report Forms. - Use either the Standard Pack-Weight Only-Report Form (page A-2) or the Random Pack Report Form (page A-3). Record the official establishment number from the USDA logo in the space provided underneath name and address.

c. Selection of Lots. - Refer to Section 2.3. for defining and selecting the inspection lot. The lot codes are the packer's own identifying marks, not the universal product code (UPC). In many instances, the lot code may be represented by a "pull" or "sell by" date. Record the lot code on the report form.

d. Sample Size. - Select the sample according to the size of the inspection lot following a Category A sampling plan (Table 2-1, page B-2). Do not sort random-pack packages from lightest to heaviest as recommended in Section 3.8.1., step 2.

e. Tare. Select the tare sample.

(1) Unused or Dried Used Tare. - Unused tare material is rarely available at retail or wholesale locations for lots packaged at Federally-inspected plants. The tare weights printed on the shipping containers may not be accurate. Therefore, the inspector must reconstruct an unused tare weight by drying the used tare and weighing it. If the tare is composed of nonabsorbent materials, it can be cleaned and wiped in order to obtain a "dried used tare." The following technique should be followed to get "dried used tare" when absorbent materials are involved. Absorbed fats as well as absorbed water-based fluids must be dried out of these materials:

A fresh poultry package will be used as the example.

Shrink Wrap. - Open package shrink wrap, remove wrinkles from heat-seal area as much as possible, and wipe or pat dry with paper toweling or other suitable material. These procedures can be considered the

model for how to clean any nonabsorbent tare materials.

Tray. - If tray is foam or plastic, rinse tray and wipe or pat dry. If tray is paper or cardboard, pat dry between sheets of toweling and lay tray on heating element of prepack scale or heat in microwave oven to dry.

Depending on the power of the oven, total times between 2 and 5 minutes may be necessary. Frequent short bursts of power (30-second intervals), checking after each cycle, are better than a single 5-min run. (The trays can burn if the drying cycle is too long.) The tray should be cool and dry to the touch before final weighing.

Soaker Pad. - Many soaker pads are composed of plastic sheets laminated with fibrous paper tissue. Peel the plastic sheeting away from the tissue (if possible), press the tissue between sheets of paper toweling, then dry the tissue on the heating element of the scale or in a microwave as described above for a paper tray. Wipe or pat the plastic sheeting dry and weigh it with the cooled tissue pad, tray, shrink wrap, and label. Do not attempt to rinse soaker pads—they will often disintegrate if loaded with water.

Depending on the surface area of the microwave oven tray and the size of the soaker pads, do not load more than two to five tare pads in a microwave at one time and do not stack them. Stacking or loading too many pads at one time will take more oven time and power, increasing the possibility of burning or charring the pads.

(a) **What a package should weigh using unused or dried used tare.** - Add the average "dried" tare weight (ADTW) to the labeled net weight (LNW) to determine what the package is supposed to weigh—the "nominal gross weight" (NGW):

$$ADTW + LNW = NGW$$

(b) **Package errors using unused or dried used tare.** -Use the package checking scale to compare the gross weight of the packages in the sample (PGW) with the nominal gross weight (NGW). A package that weighs more than the nominal gross weight is overweight and has a "plus" package error (PE); a package that weighs less than this is underweight and has a "minus" package error.

$$PE = PGW - NGW$$

Go to Section 3.18.3.f. on the average requirement.

(c) **Packages opened for tare determination** may be rewrapped by the supermarket provided that the USDA logo does not appear on the package. The supermarket should contact the original packager if it intends to leave the brand name on the product when repackaging.

(2) **Wet Tare.**

(a) **When there is no free-flowing liquid or absorbent materials in contact with the product,** clean the tare materials of all clinging product and wipe dry. Weigh the wiped tare materials for the number of packages indicated in the sampling plan. Average the tare weights. Add the average tare weight (ATW) to the labeled net weight (LNW) to obtain the nominal gross weight (NGW):

$$ATW + LNW = NGW$$

Use the nominal gross weight (NGW) to compare with the gross weights of all the packages in the sample (PGW) to determine their package errors (PE):

$$PGW - NGW = PE$$

(b) **Determining the net weight when there is free flowing liquid or absorbent packaging materials in contact with the product.** - All free liquid is part of the wet tare. To avoid destroying too many packages:

(i) gross weigh two packages to be opened for tare, then

(ii) weigh solids inside;

(iii) get wet tare by subtracting solids weight from gross weight.

(iv) $AWTW + LNW = NGW$

where: $AWTW$ = Average wet tare weight
 LNW = Labeled net weight
 NGW = Nominal gross weight

Use the alternative tare procedure (Section 2.11.4.) to determine whether to open more packages (i.e., whether the tare is too variable).

Packages opened for a wet tare test may be rewrapped by the supermarket provided that the USDA logo does not go on the package. The supermarket should contact the original packager if it intends to leave the brand name on the product when repackaging.

(c) **Determining Package Errors.** - If individual package net weights are measured:

$$PE = PNW - LNW$$

where: PE = Package error
PNW = Package net weight
LNW = Labeled net weight

A package that weighs more than the labeled weight is overweight and has a "plus package error." A package that weighs less than the labeled weight is underweight and has a "minus package error."

If an average tare weight and nominal gross weight are determined:

$$PE = PGW - NGW$$

where: PE = Package error
PGW = Package gross weight
NGW = Nominal gross weight

f. The Average Requirement. - Compute the average error for the sample. Sum all individual package errors and divide by the number of packages in the sample. Record the average package error in box 18 on the standard pack or random pack report forms.

If the average error is zero or plus, the lot complies with the average requirement. If the average error is minus, first compute SEL. Record SEL on the report form, and continue with subsections (1), (2), or (3) below as appropriate.

(1) Unused or Dried Used Tare for Bacon, Sausage, Luncheon Meats with No Free-Flowing Liquid or Absorbent Materials. - If the average minus error is larger than SEL, the lot does not comply with the average requirement; enforcement action should be taken. Also, follow the process outlined in Section 3.18.3.g.

(2) Wet Tare - Fresh Poultry.

(a) Compute 3 percent of the average labeled weight.

$$\text{average labeled weight} \times 0.03 = \text{gray area}$$

(b) Record this in the comments section as "gray area."

(c) If SEL was computed, add the gray area to SEL, calculated and recorded on the random pack report form. Record in remarks section as "gray area + SEL."

(d) Compare value in box 19 with "gray area + SEL."

(e) If the value in box 19 is larger than the "gray area + SEL," the lot fails to comply. (Since box 19 will always have a minus value--or else you would not have calculated SEL--disregard the sign when comparing with gray area + SEL.) If the value in box 19 is between SEL and the gray area + SEL, go to Section 3.18.3.h. If the value in box 19 is less than SEL, the lot complies.

(3) Wet Tare - Hot Dogs or Franks.

(a) Compute 2 1/2 percent of the labeled net weight recorded in box 1 of the standard pack report form.

$$(\text{value in box 1}) \times 0.025 = \text{gray area (lb or oz)}$$

(b) Convert to dimensionless units by dividing by the unit of measure in box 2.

$$\begin{aligned} & \text{gray area (lb or oz)} \div \text{box 2} \\ & = \text{gray area (dimensionless units)} \end{aligned}$$

Record this in comments section as "gray area."

(c) Continue with (c), (d), and (e) as for Subsection (2), Wet Tare - Fresh Poultry.

g. The Individual Package Requirement. - Table 2-9 gives the limits for individual package errors for packages produced at Federally inspected plants. The number of individual minus package error permitted to be larger than the "lower limit for individual weights" (see the righthand column of this table) is given in Table 2-2 (page B-2). Convert this value (or values if a random pack lot falls between groups) to dimensionless units and record on the report form.

(1) Dried Used Tare or No Free-Flowing Liquid. When conducting a dried used tare test or testing bacon, sausage, or luncheon meats with no free-flowing liquid or absorbent tare materials, compare the value(s) from Table 2-9 (converted to dimensionless units) with the minus package errors. If the number of minus package errors that exceed the limits of Table 2-9 is more than allowed by the Category A plan being followed, the lot does not comply.

Wet Tare. - When conducting a wet tare test on hot dogs or fresh poultry, the size of the gray area must be added to Table 2-9 value(s) before counting the number of packages that exceed the MAV. In Section 3.18.3.f. the size of the gray area (in dimensionless units) was recorded in the comments area of the report form. The

values from Table 2-9 are recorded on the random and standard pack report form. Add the size of the gray area to the value(s) from Table 2-9 (converted to dimensionless units) before comparing with the minus package errors.

If the number of minus package errors that are greater than (Table 2-9 + the gray area) exceeds the number permitted in Category A plans, the lot does not comply. If minus package errors fall between the Table 2-9 value and (Table 2-9 + the gray area), they place the lot in the gray area if the number of these types of minus package errors exceeds the number permitted in Category A plans.

h. What to Do When the Lot Is in the Gray Area. - Although the following discussion is intended primarily for those jurisdictions using wet tare for meat and poultry, any jurisdiction is encouraged to follow these procedures when product from Federally-inspected plants fails to comply with net weight tests.

The "Meat and Poultry Inspection Directory" is available from the USDA Regional Offices listed at the end of this section. Meat and poultry packaging plants are listed by "establishment number." Use the establishment number on the package to look up the location and telephone number of the plant. A separate number is sometimes provided for the USDA Inspector-in-charge. If the establishment number is not listed in this directory (since new businesses, established after the directory was published, may not be listed in the directory), call the Regional Office to get the telephone number(s) of the plant and the appropriate USDA official for the plant in question.

Contact the appropriate USDA official to determine what information is available on the lot in question (see subsection (1) below). If a lot of hot dogs or fresh poultry has been tested using wet tare, any average package error that is minus and larger than SEL may place the lot in the gray area.

(1) Further Information. - Ask the USDA official:

(a) Whether the plant is operating under a "Total or Partial Quality Control Program" (TQC or PQC).

Some plants operate under a Federally approved "Total or Partial Quality Control Program." If such a program is in place, records on the lot in question will be maintained by the establishment, not by USDA. If the establishment is not operating under a TQC or PQC Program, USDA may or may not have tested the lot in question. The USDA official will be able to tell you what information is available, as compared with in-

formation that may be available from the plant personnel.

(b) What information is available from USDA concerning the particular lot in question.

- How many packages are tested at what time intervals?
- How many packages are produced in that time interval?
- What criteria are employed to decide when adjustments to the net weight are required?
- What were the net weight checks on the lot in question?
- What adjustments were made to the target weight?

If USDA has data on the specific lot in question or if there is an approved TQC or PQC program producing data on the lot, these data may serve to substantiate that the lot complied with net weight requirements when it left the plant. If data on the specific lot in question were not collected by USDA or under an approved QC program, the weights and measures test results are the only regulatory agency data on the lot. In this instance, the weights and measures authority should take whatever action is deemed appropriate; USDA has no data to dispute the weights and measures findings.

(c) What scale maintenance and testing program is in place in the plant.

(d) What tare verification system is in place in the plant, including how the tare is determined, how often it is monitored, how it is verified when new tare materials are delivered.

(e) What kind of net weight verification or testing (and how often) the USDA official conducts.

(f) Who are the establishment personnel to contact to review establishment-maintained records on the lot in question.

(2) Test Packages and Scales at the Packaging Plant. - Optionally, make arrangements to visit the plant or call the weights and measures jurisdiction where the plant is located. Discuss the net weight control program with plant quality control personnel, check their scales (if possible), and test packages. Even though it is not possible to test the lot in question at the plant, it may be possible to establish confidence

in plant process and weight control procedures. Note the type of scales used to monitor the fill weights of the packages. Ask to test the scales. (This may be disruptive during a production run.)

Test a sample of packages from the line or storage area using H-133 Category B sampling procedures plus the Table 2-9 values for individual packages. Since you are at the packaging plant and no distribution has occurred, there is no gray area to consider at this point. Due to the large number of packages in the lot when testing at the plant, the sample size will usually be 30 packages. Ask the USDA inspector to conduct a test using his procedures and equipment on the same lot.

(3) Other Optional Information That May Be Available from the Packer. - When testing at the packaging plant, this is the appropriate time (or it may be necessary to explore the issue by telephone) to get some optional information. The information below may be proprietary and not available to the inspector.

- How many packages are produced in a single production run? How much of the plant's production does each lot code represent (a single line's run, 8 hours/24 hours production, etc.)?
- What is the target weight for each label? How is this value set? (This will be considered confidential information.)
- What scales or other measuring equipment and procedures are used to measure or control the package net weights (checkweighers; line supervisor weighs a package every hour, etc.)?
- How quickly can adjustments be made to package fill targets that are found out of bounds?
- How often are the scales tested; who does the testing (yearly service call; quality control supervisor on a daily basis, etc.)?
- How does the plant determine the tare weight, how often does the plant change the tare weight, what does the plant do with tare information?
- (For example: actual tare unit used and changed whenever new shipment of tares sent; average weight to closest 0.01 lb is added to target weight; etc.)
- Does the packager report different tare weights to different areas of his market? (For example: wet tare values, unused tare values, something in between.) How are these determined?

- What variation in package weights from the labeled declaration does the line or plant normally encounter? (Ask them to show you or send copies of their records. These records are proprietary and may be available only for viewing.)

USDA Regional Offices	States or Territories
<p>Western Regional Office 620 Central Avenue, Bldg. 2C Alameda, CA 94501 510/273-7402 Fax (510) 273-7996</p>	<p>AK, AZ, CA, CO, HA, ID, MT, NV, OR, UT, WA, WY, ND, SD, AS, and GU</p>
<p>Southwestern Regional Office 1100 Commerce Street, Room 5-F41 Dallas, TX 75242 214/767-4508 Fax (214) 767-8175</p>	<p>AR, KA, LA, MO, NM, TX, and OK</p>
<p>North Central Regional Office 11338 Aurora Ave Des Moines, IA 50322 515/284-6300 Fax (515) 284-6307</p>	<p>IL, IN, IO, MI, MN, NE, WI, and OH</p>
<p>Southeastern Regional Office 1718 Peachtree Street, NW, Room 299-S Atlanta, GA 30309 404/347-3911 Fax (404) 347-2983</p>	<p>AL, FL, GA, KY, MS, NC, SC, TN, WV, PR, and VI</p>
<p>Northeastern Regional Office Mellon Independence Center 701 Market St. 2-B South Philadelphia, PA 19106-1515 215-597-4217 Fax (215) 597-4214</p>	<p>CT, ME, MD, MA, DA, NH, NJ, NY, PA, RI, VT, VA, and DC</p>

NIST Handbook 133

Changes to Appendix A Report Forms

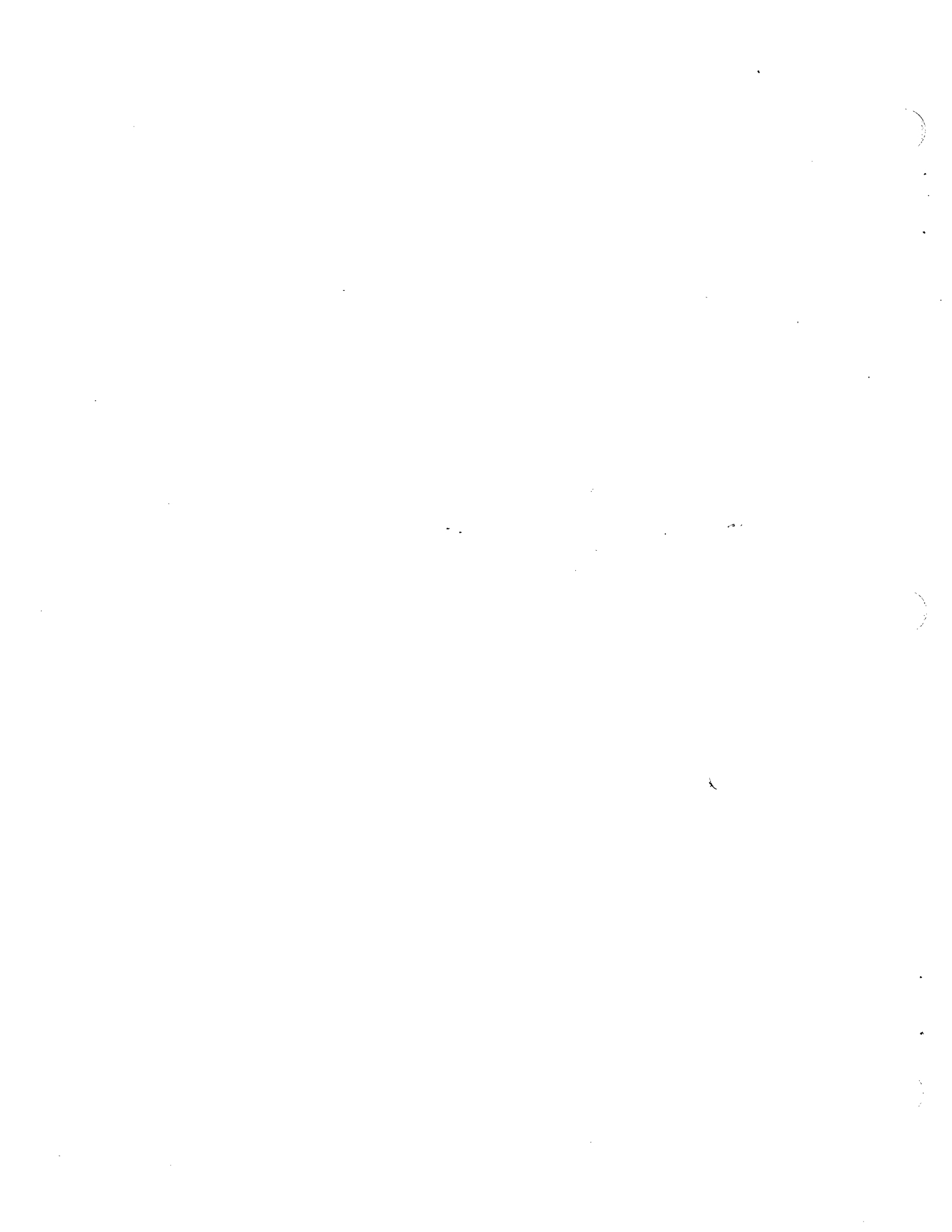

Date	Standard Pack Report Form			Report Number	
Location (Name, Address) <input type="checkbox"/> Retailer <input type="checkbox"/> Wholesaler <input type="checkbox"/> Packager	Product/Brand Identity		Manufacturer	Lot Code(s)	Container Description
	1. Labeled Quantity		2. Unit of Measure		3. MAV
					4. MAV (dimensionless units) (3 + 2 =)
5. Inspection Lot Size (N):	Package 1	Package 2	Package 3	Package 4	Package 5
	a. Gross Wt.	a. Gross Wt.	a. Gross Wt.	a. Gross Wt.	a. Gross Wt.
6. Sample Size (n): <input type="checkbox"/> A <input type="checkbox"/> B (p.B-2)	b. Tare Wt.	b. Tare Wt.	b. Tare Wt.	b. Tare Wt.	b. Tare Wt.
7. Initial Tare Sample Size (p.B-2):	c. Net Wt.	c. Net Wt.	c. Net Wt.	c. Net Wt.	c. Net Wt.
8. Allowed No. of Unreasonable Errors (p.B-2):	d. Package Error (a - 14)	d. Package Error (a - 14)	d. Package Error (a - 14)	d. Package Error (a - 14)	d. Package Error (a - 14)
9. R_c (see c.) Range of Net Wts	11. $R_c + R_t =$ (9 + 10) =	12. n_t (Table 2-3 or 2-4) Total number of tare (see B-3)	13. Average Tare <input type="checkbox"/> unused <input type="checkbox"/> used	13a. Tare Correction <input type="checkbox"/> Moisture <input type="checkbox"/> Vacuum Pack	14. Nominal Gross Wt. (1 + 13 - 13a =)
10. R_t (see b.) Range of Tare Wts					

Package Errors

-	+	-	+	-	+	-	+
1.		13.		25.		37.	
2.		14.		26.		38.	
3.		15.		27.		39.	
4.		16.		28.		40.	
5.		17.		29.		41.	
6.		18.		30.		42.	
7.		19.		31.		43.	
8.		20.		32.		44.	
9.		21.		33.		45.	
10.		22.		34.		46.	
11.		23.		35.		47.	
12.		24.		36.		48.	
Error -	Error +	Error -	Error +	Error -	Error +	Error -	Error +
15. Total Error	16. No. Unreasonable Minus Errors (Compare package error with 4)	17. Is 16 Greater than 8 <input type="checkbox"/> Yes: Lot Fails <input type="checkbox"/> No: Continue	18. Average Error (dimensionless units) (15 + 6 =)	19. Average Error (labeled units) (18 x 2 =)	20. Is 18 Zero or Plus? <input type="checkbox"/> No → Cat. B. Lot Fails Cat. A. go to 21 <input type="checkbox"/> Yes → Go to 25		
21. Compute Sample Standard Deviation	22. Sample Correction Factor from Column 3 in Table 2-1 (p. B-2)	23. Compute Sample Error Limit (SEL) 21 x 22 =	24. Disregarding the signs, is 18. larger than 23? <input type="checkbox"/> Yes → Lot Fails <input type="checkbox"/> No → Lot Passes		25 Disposition of Inspection Lot: <input type="checkbox"/> Approved <input type="checkbox"/> Rejected		

Comments

Acknowledged Receipt of Report

Official

Random Pack Report Form (Weight Only)

Date		Report Number		
Location of TEST (Name, Address) <input type="checkbox"/> Retailer <input type="checkbox"/> Wholesaler <input type="checkbox"/> Packager	Product/Brand Identity		Manufacturer	Lot Code(s)
	1. Labeled Quantity		2. Unit Of Measure	3. MAV
				4. MAV (dimensionless units) (3 + 2)
5. Inspection Lot Size (N):	Package 1	Package 2	Package 3	Package 4
	a. Gross wt.	a. Gross Wt.	a. Gross Wt.	a. Gross Wt.
6. Sample Size (n): <input type="checkbox"/> A (p.B-2) <input type="checkbox"/> B (p.B-2)	b. Tare Wt.	b. Tare Wt.	b. Tare Wt.	b. Tare Wt.
7. Tare Sample Size:	c. Net Wt.	c. Net Wt.	c. Net Wt.	c. Net Wt.
8. Allowed Number of Unreasonable Errors	d. Package Error (a - 14)	d. Package Error (a - 14)	d. Package Error (a - 14)	d. Package Error (a - 14)
9. R_c (see c.) Range of Net Weights	11. $R_c \div R_t =$ (9 \div 10 =)	12. n_t (Table 2-3, p. B-7 & 8)	13. Average Tare <input type="checkbox"/> unused <input type="checkbox"/> used	13a. Tare Correction <input type="checkbox"/> Moisture <input type="checkbox"/> Vacuum Pack
10. R_t (see b.) Range of Tare Weights			14. Nominal Gross Wt. (1 + 13 - 13a =)	

Product Description, Lot Code Unit Price	Money Error		Labeled Weight	Package Error		MAV (dimensionless)
	-	+		-	0/+	
1.						
2.						
3.						
4.						
5.						
6.						
7.						
8.						
9.						
10.						
11.						
12.						
13.						
14.						
15.						
16.						
17.						
18.						
19.						
20.						
21.						
22.						
23.						
24.						
Totals	-	+		-	+	

15. Total Error	16. No. Unreasonable Minus Errors (Compare package error with 4)	17. IS 16 Greater than 8 <input type="checkbox"/> YES: Lot Fails <input type="checkbox"/> NO: Continue	18. Average Error (dimensionless units) (15 + 6 =)	19. Average Error (labeled units) (18 x 2 =)	20. IS 18 Zero Or Plus? <input type="checkbox"/> NO -> Cat. B. Lot Fails <input type="checkbox"/> YES -> GO TO 25	Cat. A. go to 21
21. Compute Sample Standard Deviation	22. Sample Correction Factor Column 3 in 2-1	23. Compute Sample Error Limit (SEL) (21 x 22 =)	24. Disregarding the signs, is 18 larger than 23 (SEL)? <input type="checkbox"/> YES -> LOT FAILS <input type="checkbox"/> NO -> LOT PASSES		25. Disposition Of Inspection Lot: <input type="checkbox"/> APPROVED <input type="checkbox"/> REJECTED	

Comments

Acknowledged Receipt of Report

Official

NIST Handbook 133

Changes to Appendix B Tables

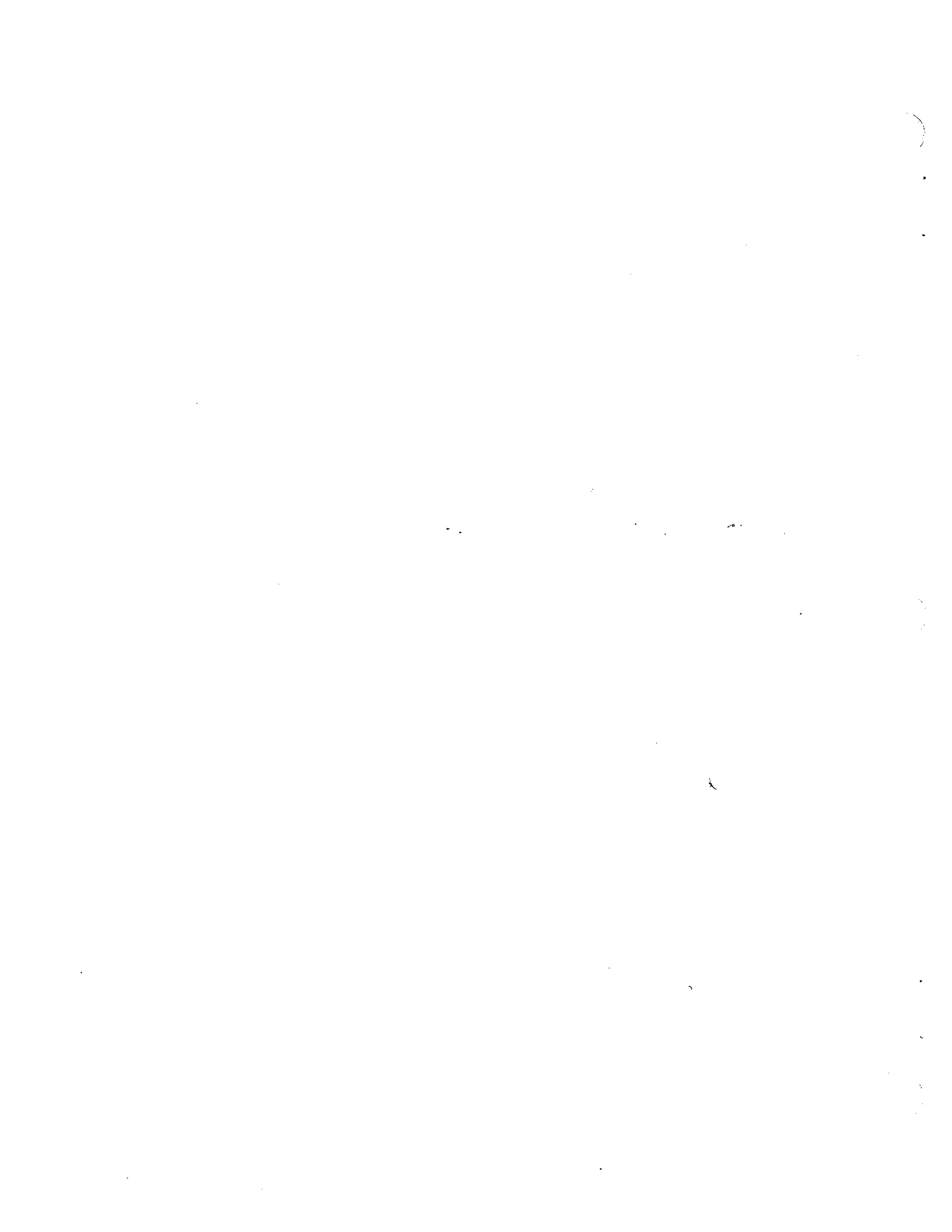

Appendix B Tables

Table of Contents

	<u>Page</u>
Table 1-1. Agencies Responsible for Package Regulations and Applicable Requirements	B-1
Table 2-1. Sampling Plans of Category A	B-2
Table 2-2. Sampling Plans of Category B. (use only for testing meat and poultry products in federally inspected plants)	B-2
Table 2-3. Category A - Total Number of Packages (n_t) to be opened for tare determination	B-3
Table 2-4. Category B - Total number of packages (n_t) to be opened for tare determination	B-4
Table 2-5. Maximum Allowable Variations (MAV's) for an individual package labeled by weight	B-5
Table 2-6. MAV's for an individual package labeled by volume- liquid or dry	B-6
Table 2-7. MAV's for an individual package labeled by count	B-7
Table 2-8. MAV's for an individual package labeled by length (width) or by area	B-8
Table 2-9. U.S. Department of Agriculture, meat and poultry, groups and lower limits for individual packages	B-9
Table 3-1. Recommended maximum units of measure to be used in recording package weights	B-10
Table 3-2. Boundaries of the gray area for different sizes of flour and dry pet food packages	B-11
Table 4-1. Weighing devices appropriate to use to check common consumer products labeled by liquid volume	B-12
Table 4-2. Recommended maximum units of measure to be used for recording the weights of packaged goods labeled by liquid volume	B-13
Table 4-3. Maximum permitted difference in weights of two equal quantities according to the type of scale used to weigh	B-14
Table 4-4. Thickness of paint can walls and labels.	B-15
Table 5-1. Sampling plans for packages labeled by low count.	B-15
Table 5-2. Sampling plans for packages given tolerances.	B-16
Standard Pack Report Form	A-2
Random Pack Report Form (Weight Only)	A-3

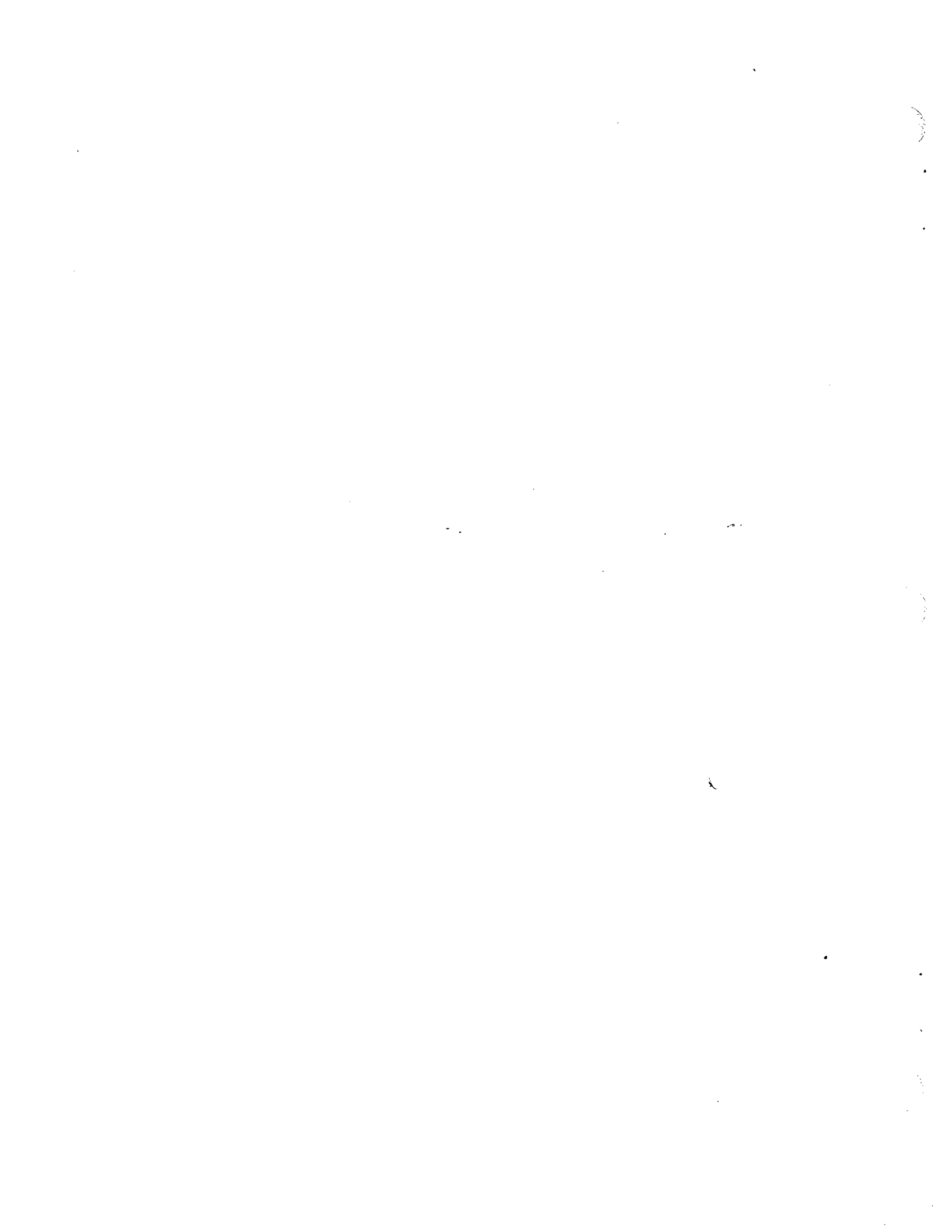

Table 1.1. Agencies Responsible for Package Regulations and Applicable Requirements

Commodity	Responsible Agency	NIST Handbook 133 Sampling Plan	Maximum Allowable Variations Table
Meat and Poultry	<p>U.S. Department of Agriculture/Food Safety and Inspection Service</p> <p>State and Local Weights and Measures</p>	<p>1. Use Table 2-1. Sampling Plans for Category A to test packages at other than the point-of-pack.</p> <p>2. Use Table 2-2. Sampling Plans for Category B to test packages in Federally Inspected meat and poultry plants</p>	<p>U.S. Department of Agriculture, Table 2-9. Meat and poultry, groups and lower limits for individual packages</p>
<p>Foods, drugs, and cosmetics subject to the Food, Drug, and Cosmetic Act including those packaged at the retail store level that have been in interstate commerce (e.g, seafood), or those made with ingredients that have been in interstate commerce</p>	<p>Food and Drug Administration</p> <p>State and Local Weights and Measures</p>	<p>Use Table 2-1. Sampling Plans for Category A</p>	<p>Table 2-5. MAV's for packages labeled by weight</p>
<p>Food products <u>not</u> subject to the Food, Drug, and Cosmetic Act, including meat and poultry products packaged at the retail store level.</p>	<p>State and Local Weights and Measures</p>		<p>Table 2-6. MAV's for packages labeled by liquid or dry volume</p> <p>Table 2-7. MAV's for packages labeled by count</p>
<p>Non-Food Products</p>	<p>Federal Trade Commission</p> <p>State and Local Weights and Measures</p>	<p>Use Table 2-1. Sampling Plans for Category A</p>	<p>Table 2-8. MAV's for packages labeled by length (width) or area</p>
<p>Alcohol and Tobacco Products</p> <p>Pesticides</p>	<p>Bureau of Alcohol, Tobacco, and Firearms</p> <p>Environmental Protection Agency</p> <p>State and Local Weights and Measures</p>		

Table 2-1. Sampling Plans for Category A

1	2	3	4	5	
Inspection Lot Size (N)	Sample Size (n)	Sample Correction Factor ($2/\sqrt{n}$)	Number of Minus Package Errors Allowed to Exceed the MAV	Initial Tare Sample Size ^a (n)	
1	1	MAV	0	Glass and Aerosol Packages	All Other Packages
2	2	1.414		2	2
3	3	1.155			
4	4	1.000			
5	5	0.8944			
6	6	0.8165			
7	7	0.7559			
8	8	0.7071			
9	9	0.6667			
10	10	0.6325			
11	11	0.6030			
12 to 250	12	0.5774	0		
251 to 3,200	24	0.4082	0		
More than 3,200	48	0.2887	1		

Sample Error Limit (SEL) = sample standard deviation x sample correction factor (column 3)

^a Tare Procedures. - Obtain the "initial tare sample" from the sample selected from the inspection lot. Keep the packages in the order in which their corresponding random numbers were obtained. The "initial tare sample" packages are the first 2, 3, or 5 packages (as appropriate for the sample size) of the sample. Used dried tare weights are determined by emptying, cleaning, drying (if necessary), and weighing all packaging materials. Determine the range of tare weights (R_t) and range of net weights (R_n). Compute R_n/R_t and look up this value in Table 2.3 or 2.4. Determine if additional packages must be opened and measured to determine an average tare. Determine package errors for the tare sample and for the rest of the sample by comparison with the nominal gross weight (unless all the packages in the sample are opened).

Table 2-2. Sampling Plans for Category B
Use Only for Testing Meat and Poultry Products in Federally Inspected Plants.

1	2	3	4
Inspection Lot Size (N)	Sample Size (n)	Initial Tare Sample Size ^a (n)	Number of minus package errors allowed to exceed the MAV's in Table 2-9. U.S. Department of Agriculture, Meat and Poultry, Groups and Lower Limits for Individual Packages
250 or less	10	2	0
251 or more	30	5	0

^a See note "a" to Table 2-1 above.

Table 2-3. Category A - Total number* of packages (n_t) to be opened for tare determination

Ratio R_c/R_t	number of packages in sample				
	$n = 12$	$n = 24$		$n = 48$	
	$n_t = 2$	$n_t = 2$	$n_t = 3$	$n_t = 2$	$n_t = 3$
≤ 0.2	12	24	24	48	48
0.21 - 0.40	12	23	23	46	46
0.41 - 0.60	11	22	22	44	44
0.61 - 0.80	10	21	21	41	41
0.81 - 1.00	10	19	19	38	38
1.01 - 1.20	9	18	18	35	35
1.21 - 1.40	8	16	16	32	32
1.41 - 1.60	7	15	15	29	29
1.61 - 1.80	7	13	13	27	27
1.81 - 2.00	6	12	12	24	24
2.01 - 2.20	5	11	11	22	22
2.21 - 2.40	5	10	10	20	20
2.41 - 2.60	4	9	9	18	18
2.61 - 2.80	4	8	8	16	16
2.81 - 3.00	4	7	7	15	15
3.01 - 3.20	3	7	7	13	13
3.21 - 3.40	3	6	6	12	12
3.41 - 3.60	3	6	6	11	11
3.61 - 3.80	3	5	5	10	10
3.81 - 4.00	2	5	5	10	10
4.01 - 4.20	2	4	4	9	9
4.21 - 4.40	2	4	4	8	8
4.41 - 4.60	2	4	4	8	8
4.61 - 4.80	2	4	4	7	7
4.81 - 5.00	2	3	3	7	7
5.01 - 5.20	2	3	3	6	6
5.21 - 5.40	2	3	3	6	6
5.41 - 5.60	2	3	3	5	5
5.61 - 5.80	2	3	3	5	5
5.81 - 6.00	2	2	3	5	5

* Including those already opened for initial tare determination.

Table 2-3. (continued). Category A - Total number* of packages (n_t) to be opened for tare determination

Ratio R_c/R_t	number of packages in sample				
	n = 12	n = 24		n = 48	
	$n_t = 2$	$n_t = 2$	$n_t = 3$	$n_t = 2$	$n_t = 3$
6.01 - 6.20	2	2	3	5	5
6.21 - 6.40	2	2	3	4	4
6.41 - 6.60	2	2	3	4	4
6.61 - 6.80	2	2	3	4	4
6.81 - 7.00	2	2	3	4	4
7.01 - 7.20	2	2	3	3	3
7.21 - 7.40	2	2	3	3	3
7.41 - 7.60	2	2	3	3	3
7.61 - 7.80	2	2	3	3	3
7.81 - 8.00	2	2	3	3	3
8.01 - 8.20	2	2	3	3	3
8.21 - 8.40	2	2	3	3	3
More than 8.40	2	2	3	2	3

Table 2-4. Category B - Total number* of packages (n_t) to be opened for tare determination (use only for testing meat and poultry products in federally inspected plants)

Ratio R_c/R_t	number of packages in sample	
	n = 10	n = 30
	$n_t = 2$	$n_t = 5$
≤ 0.2	10	30
0.21 - 0.40	10	29
0.41 - 0.60	10	28
0.61 - 0.80	9	26
0.81 - 1.00	8	24
1.01 - 1.20	8	23
1.21 - 1.40	7	21
1.41 - 1.60	7	19
1.61 - 1.80	6	17
1.81 - 2.00	5	15
2.01 - 2.20	5	14
2.21 - 2.40	5	13
2.41 - 2.60	4	12
2.61 - 2.80	4	11
2.81 - 3.00	4	10
3.01 - 3.20	3	9
3.21 - 3.40	3	8
3.41 - 3.60	3	8
3.61 - 3.80	3	7
3.81 - 4.40	2	6
More than 4.40	2	5

* Including those already opened for initial tare determination.

**Table 2-5. Maximum Allowable Variations (MAV's) for packages labeled by weight^a
(Use Table 2-9 for meat and poultry products subject to USDA requirements)**

SI		MAV
Labeled Weight ^b		grams (g)
≤ 36		10% of labeled quantity
> 36 ≤ 54		4
> 54 ≤ 82		5
> 82 ≤ 118		7
> 118 ≤ 154		9
> 154 ≤ 209		11
> 209 ≤ 263		13
> 263 ≤ 318		15
> 318 ≤ 381		16
> 381 ≤ 426		18
> 426 ≤ 490		20
> 490 ≤ 572		22
> 572 ≤ 635		24
> 635 ≤ 698		25
> 698 ≤ 771		27

Avoirdupois Units		
Labeled Weight ^b	MAV	Fractional Ounces (oz)
Pound (lb) or Ounce (oz)	Decimal Pound (lb)	
≤ 0.08 lb ≤ 1.28 oz	10% of labeled quantity	
> 0.08 lb ≤ 0.12 lb > 1.28 oz ≤ 1.92 oz	0.008	1/8
> 0.12 lb ≤ 0.18 lb > 1.92 oz ≤ 2.88 oz	0.012	3/16
> 0.18 lb ≤ 0.26 lb > 2.88 oz ≤ 4.16 oz	0.016	1/4
> 0.26 lb ≤ 0.34 lb > 4.16 oz ≤ 5.44 oz	0.020	5/16
> 0.34 lb ≤ 0.46 lb > 5.44 oz ≤ 7.36 oz	0.024	3/8
> 0.46 lb ≤ 0.58 lb > 7.36 oz ≤ 9.28 oz	0.028	7/16
> 0.58 lb ≤ 0.70 lb > 9.28 oz ≤ 11.20 oz	0.032	1/2
> 0.70 lb ≤ 0.84 lb > 11.20 oz ≤ 13.44 oz	0.036	9/16
> 0.84 lb ≤ 0.94 lb > 13.44 oz ≤ 15.04 oz	0.040	5/8
> 0.94 lb ≤ 1.08 lb > 15.04 oz ≤ 17.28 oz	0.044	11/16
> 1.08 lb ≤ 1.26 lb	0.048	3/4
> 1.26 lb ≤ 1.40 lb	0.052	13/16
> 1.40 lb ≤ 1.54 lb	0.056	7/8
> 1.54 lb ≤ 1.70 lb	0.060	15/16

^a Applies only to shortages in package weight (that is, the MAV is compared with minus package errors only)

^b > means "greater than"

≤ means "less than or equal to"

See Section 2.13 for polyethylene

**Table 2-5. (continued) Maximum Allowable Variations (MAV's) for packages labeled by weight^a
(Use Table 2-9 for meat and poultry products subject to USDA requirements)**

SI	
Labeled Weight	MAV
gram (g) or kilogram (kg)	gram (g)
> 771 ≤ 852	29
> 852 ≤ 971	32
> 971 ≤ 1.125	35
> 1.125 ≤ 1.350	40
> 1.350 ≤ 1.600	45
> 1.600 ≤ 1.800	50
> 1.800 ≤ 2.100	55
> 2.100 ≤ 2.640	65
> 2.640 ≤ 3.080	70
> 3.080 ≤ 3.800	80
> 3.800 ≤ 4.400	85
> 4.400 ≤ 5.200	100
> 5.200 ≤ 6.800	115
> 6.800 ≤ 8.20	130
> 8.20 ≤ 10.60	145
> 10.60 ≤ 14.30	170
> 14.30 ≤ 19.25	200
> 19.25 ≤ 24.70	230
> 24.70	2% of labeled quantity

Inch-Pound Units		
Labeled Weight	MAV	
Pound (lb)	Decimal Pound (lb)	Ounce (oz)
> 1.70 lb ≤ 1.88 lb	0.064	1
> 1.88 lb ≤ 2.14 lb	0.070	1 1/8
> 2.14 lb ≤ 2.48 lb	0.078	1 1/4
> 2.48 lb ≤ 2.76 lb	0.086	1 3/8
> 2.76 lb ≤ 3.20 lb	0.094	1 1/2
> 3.20 lb ≤ 3.90 lb	0.11	1 3/4
> 3.90 lb ≤ 4.70 lb	0.12	2
> 4.70 lb ≤ 5.80 lb	0.14	2 1/4
> 5.80 lb ≤ 6.80 lb	0.15	2 1/2
> 6.80 lb ≤ 7.90 lb	0.17	2 3/4
> 7.90 lb ≤ 9.40 lb	0.19	3
> 9.40 lb ≤ 11.70 lb	0.22	3 1/2
> 11.70 lb ≤ 14.30 lb	0.25	4
> 14.30 lb ≤ 17.70 lb	0.28	4 1/2
> 17.70 lb ≤ 23.20 lb	0.31	5
> 23.20 lb ≤ 31.60 lb	0.37	6
> 31.60 lb ≤ 42.40 lb	0.44	7
> 42.40 lb ≤ 54.40 lb	0.50	8
> 54.40 lb	2% of labeled quantity	

Table 2-6. Maximum Allowable Variations (MAV's) for packages labeled by liquid or dry volume^a
 (Use Table 2-9 for meat and poultry products subject to USDA requirements)

SI Units		Inch-Pound Units			
Labeled quantity (mL) ^d	Liquid and dry MAV (mL)	Labeled quantity ^d (fl oz)	Liquid MAV (fl oz)	Labeled quantity ^d (cu in)	Dry MAV (cu in)
≤ 3	0.5 ^c	≤ 0.50	^b	≤ 0.18	0.03
> 3 ≤ 8	1.0 ^c	> 0.50 ≤ 0.75	0.06	> 0.18 ≤ 0.49	0.06
> 8 ≤ 15	1.5 ^c	> 0.75 ≤ 2.25	0.13	> 0.49 ≤ 0.92	0.09
> 15 ≤ 22	2.0	> 2.25 ≤ 4.25	0.19	> 0.92 ≤ 1.35	0.11
> 22 ≤ 67	3.5	> 4.25 ≤ 5.75	0.25	> 1.35 ≤ 4.06	0.23
> 67 ≤ 126	5.5	> 5.75 ≤ 7.50	0.31	> 4.06 ≤ 7.67	0.34
> 126 ≤ 170	7.5	> 7.50 ≤ 11.75	0.38	> 7.67 ≤ 10.38	0.45
> 170 ≤ 222	9	> 11.75 ≤ 17.00	0.50	> 10.38 ≤ 13.54	0.56
> 222 ≤ 347	11	> 17.00 ≤ 21.00	0.63	> 13.54 ≤ 21.21	0.68
> 347 ≤ 503	15	> 21.00 ≤ 27.00	0.75	> 21.21 ≤ 30.68	0.90
> 503 ≤ 621	18	> 27.00 ≤ 31.00	0.88	> 30.68 ≤ 37.90	1.13
> 621 ≤ 798	22	> 31.00 ≤ 39.00	1.00	> 37.90 ≤ 48.73	1.35
		> 39.00 ≤ 55.00	1.25	> 48.73 ≤ 55.95	1.58
		> 55.00 ≤ 69.00	1.50	> 55.95 ≤ 70.38	1.80

Liquid Measure Equivalents:
 1 pint = 16 fl oz 1 quart = 32 fl oz
 1 gallon = 128 fl oz

^aApplies to shortages in package volume (that is, minus package errors). ^bConvert to SI units and use laboratory glassware. ^cUse laboratory glassware. ^d> means "greater than," ≤ means "less than or equal to."

Table 2-6. (continued). Maximum Allowable Variations (MAV's) for packages labeled by liquid or dry volume

Inch-Pound			
Labeled quantity (fl oz)	Liquid MAV (fl oz)	Labeled quantity (cu in)	Dry MAV (cu in)
> 69.00 ≤ 85.00	1.75	> 70.38 ≤ 99.26	2.26
> 85.00 ≤ 103.00	2.0	> 99.26 ≤ 124.5	2.71
> 103 ≤ 160 (1.25 gal)	2.5	> 124.5 ≤ 153.4	3.2
> 160 ≤ 185.6	3.0	> 153.4 ≤ 185.9	3.6
> 185.6 ≤ 240	3.5	> 185.9 ≤ 288.8	4.5
> 240 ≤ 272	4.0	> 288.8 ≤ 335.0	5.4
> 272 ≤ 344	4.5	> 335.0 ≤ 443.1	6.3
> 344 ≤ 392	5.0	> 443.1 ≤ 490.9	7.2
> 392 ≤ 560	6.0	> 490.9 ≤ 620.8	8.1
> 560 ≤ 640 (5 gal)	7.0	> 620.8 ≤ 707.4	9.0
> 640 ≤ 800	8.0	> 707.4 ≤ 1011	10.8
> 800 ≤ 904	9.0	> 1011 ≤ 1155	12.6
> 904	1% of Labeled Quantity	> 1155 ≤ 1444	14.4
		> 1444 ≤ 1631	16.2
		> 1631	1% of Labeled Volume

Dry Measure Equivalent:

1 Dry Pint = 33.6003125 cu in
 1 Dry Quart = 67.200625 cu in

1 Bushel = 2150.42 cu in
 1 cu ft = 1728 cu in

SI Units	
Labeled quantity (L)	Liquid and dry MAV (mL)
> 798 ≤ 917 mL	26
> 917 mL ≤ 1.153	30
> 1.153 ≤ 1.627	37
> 1.627 ≤ 2.041	44
> 2.041 ≤ 2.514	52
> 2.514 ≤ 3.046	59
> 3.046 ≤ 4.732	74
> 4.732 ≤ 5.489	89
> 5.489 ≤ 7.098	104
> 7.098 ≤ 8.044	118
> 8.044 ≤ 10.173	133
> 10.173 ≤ 11.593	148
> 11.593 ≤ 16.561	177
> 16.561 ≤ 18.927	207
> 18.927 ≤ 23.659	237
> 23.659 ≤ 26.734	266
> 26.734	1% of Labeled Quantity

See Section 2-13 for exception: bark mulch

Table 2-7. Maximum Allowable Variations (MAV's) for packages labeled by count^a

Labeled count	MAV
≤ 17 ^b	0
18 - 50 ^b	1
51 - 83	2
84 - 116	3
117 - 150	4
151 - 200	5
201 - 240	6
241 - 290	7
291 - 345	8
346 - 400	9
401 - 465	10
466 - 540	11
541 - 625	12
626 - 725	13
726 - 815	14
816 - 900	15
901 - 990	16
991 - 1075	17
1076 - 1165	18
1166 - 1250	19
1251 - 1333	20
≥ 1334	1.5% of labeled count rounded off to the nearest whole number

^aApplies only to shortages in package count (that is, minus package errors).

^bSee Section 5.2. for sampling plans to be used with these package sizes.

Table 2.8. Maximum Allowable Variations (MAV's) for packages labeled by length (width) or area^a

SI Units		
Length		Area
Labeled in meters	MAV in percent (%) of the labeled length	The MAV for packages labeled by area is 3% of the labeled quantity.
≤ ^b 1	3	
over 1 to 40	1.5	
over 40 to 85	2	
over 85 to 140	2.5	
over 140 to 300	3	
over 300 to 1000	4	
over 1000	5	

Inch-Pound Units of Measure		
Length		Area
Labeled in yards	MAV in percent (%) of the labeled length	The MAV for packages labeled by area is 3% of the labeled quantity
≤ ^b 1	3	
over 1 to 48	1.5	
over 48 to 96	2	
over 96 to 154	2.5	
over 154 to 330	3	
over 330 to 1100	4	
over 1100	5	

^a Applies only to shortages in package measure (that is, minus package errors).

^b ≤ means "less than or equal to."

See Section 2.13. for exceptions: textiles, polyethylene sheeting.

Table 2-9. U.S. Department of Agriculture, meat and poultry, groups and lower limits for individual packages

Group Name	Definition of Group		Lower Limit for Individual Weights (Use the limits according to the scale division being used)		
	Homogeneous, Fluid when Filled (e.g., baby food or containers of lard)	All Other Products			
A	less than 85 g (3 oz)	less than 85 g (3 oz)	10% of labeled quantity		
1	85 g (3 oz) to 453 g (16 oz)		g	oz	lb
			7.1	0.25 8/32 4/16 2/10 2/8 1/4	0.016
2	over 453 g (16 oz)	85 g (3 oz) to 198 g (7 oz)	14.2	0.50 16/32 8/16 5/10 4/8 2/4	0.031
3		over 198 g (7 oz) to 1.36 kg (48 oz)	28.3	1	0.062
4		over 1.36 kg (48 oz) to 4.53 kg (160 oz)	42.5	1.50 1-16/32 1-8/16 1-5/10 1-4/8 1-2/4	0.094
5		over 4.53 kg (160 oz)	1% of labeled quantity		

Table 3-1. Recommended maximum units of measure to be used in recording package weights

SI		Inch-Pound	
Labeled Quantity	Units of measure	Labeled Quantity	Units of measure
	(kg)		(oz avoird)
≤ 82 g	^a	≤ 1.92 oz (0.12 lb)	^a
> 82 g ≤ 250 g	0.001 ^b	> 1.92 oz (0.12 lb) ≤ 5.44 oz (0.34 lb)	1/32 ^b
> 250 g ≤ 900 g	0.002	> 5.44 oz (0.34 lb) ≤ 20 oz (1.25 lb)	1/16
> 900 g ≤ 2.5 kg	0.005	> 1.25 lb ≤ 4 lb	1/8
> 2.5 kg ≤ 30 kg	0.01	> 4 lb ≤ 8 lb	1/4
> 30 kg ≤ 60 kg	0.05	> 8 lb ≤ 25 lb	1/2
> 60 kg	0.1	> 25 lb ≤ 50 lb	1
		> 50 lb ≤ 150 lb	4
		> 150 lb	8
			0.002 ^b
			0.004
			0.008
			0.02
			0.02
			0.05
			0.2
			0.5

^aAn analytical or other high accuracy balance will be necessary for weighing packages in this category.

^bAn equal-arm package scale (or equivalent) must be used as a null-indicator for packages labeled from 82 to 250 g or from 1.92 to 5.44 oz to eliminate effects of possible tower errors. If an electronic balance is used, use class F1 standard weights to test the balance.

Table 3-2. Boundaries of the gray area for different sizes of flour and dry pet food^a packages

For packages labeled in SI units, the lot is in the gray area if:			
Column 1	Column 2	Column 3	Column 4
the labeled quantity is: ^b	the average package error is minus and is between zero and 3% of the labeled quantity:	and any individual package error is minus and is between the MAV from Table 2-5 and	MAV + 3% (Column 2 + 3)
500 g	15 g	22 g	37 g
1 kg	30 g	35 g	65 g
2 kg	60 g	55 g	115 g
5 kg	150 g	100 g	250 g
10 kg	300 g	145 g	445 g
25 kg	750 g	500 g	1.25 kg
50 kg	1.5 kg	1000 g	2.5 kg

For packages labeled in inch-pound units, the lot is in the gray area if:			
Column 1	Column 2	Column 3	Column 4
the labeled quantity is: ^b	the average package error is minus and is between zero and 3% of the labeled quantity	and any individual package error is minus and is between the MAV from Table 2-5 and	MAV + 3% (Column 2 + 3)
(lb)	(lb)	(lb)	(lb)
2	-0.06	-0.07	-0.13
5	-0.15	-0.14	-0.29
10	-0.30	-0.22	-0.52
20	-0.60	-0.31	-0.91
25	-0.75	-0.37	-1.12
50	-1.50	-0.50	-2.00
100	-3.00	-2.00	-5.00

^aDry pet food is defined as pet food packaged in paperboard boxes or kraft bags that has a moisture content of 13 percent or less at the time of pack. Moisture content information is declared in the nutrition and ingredient statement on the package.

^bIf a package size is not listed, apply 3 percent to the labeled net quantity.

Table 4-1. Weighing devices appropriate to use to check common consumer products labeled by liquid volume

Labeled Volume (SI Units)	Device	Labeled volume (Inch-pound Units)
≤ 126 mL	analytical or other high accuracy balance	≤ 4.25 fl oz
> 126 mL ≤ 1 L	small capacity scale or equal	> 4.25 fl oz ≤ 1 qt
> 1 L ≤ 12 L	large capacity scale or equal	> 1 qt ≤ 3 gal
> 12 L	commercial scale and substitution weighing	> 3 gal

Table 4-2. Recommended maximum units of measure to be used for recording the weights of packaged goods labeled by liquid volume

SI Units	
Labeled volume	Units of measure (g)
≤ 3 mL	0.01 ^a
> 126 mL ≤ 503 mL	0.1 ^a
> 503 mL ≤ 2.041 L	1.0 ^b
> 2.041 L ≤ 5.489 L	5.0
> 5.489 L ≤ 37.5 L	10.0

Inch-Pound		
Labeled volume	Units of measure	
	(oz av-oir)	(lb)
≤ 4.25 fl oz	a	a
> 4.25 fl oz ≤ 17 fl oz	1/32 ^b	0.002 ^b
> 17 fl oz ≤ 55 fl oz	1/16	0.004
> 55 fl oz ≤ 1.25 gal	1/8	0.01
> 1.25 gal ≤ 1.875 gal	1/4	0.02
> 1.875 gal ≤ 4.375 gal	1/2	0.02
> 4.375 gal ≤ 9 gal	1	0.05
> 9 gal ≤ 18 gal	2	0.1

^a Use analytical or other high accuracy balance.

^b Use package checking scale as null indicator.

Table 4-3. Maximum permitted difference in weights of two equal quantities according to the type of scale or balance used

Type of Scale or Balance	Grams	Pounds
Analytical or other high accuracy balance	0.05	0.0001
Small-capacity electronic scale ^a	1.0	0.002
Large-capacity electronic scale	2.0	0.004 0.005
Commercial scale up to and including 14 kg (30 lb)*	5.0	0.01
Commercial scale above 14 kg (30 lb) up to and including 100 lb	9.0	0.02

^aWhen using an electronic scale with a capacity different from the 5-lb or 20-lb equal-arm balance (some have capacities of 30 or 50 pounds), use the permitted difference in weight corresponding to the range of the equivalent equal-arm balance.

That is:

- for weights up to 5-lb permit 0.002 lb
- for weights between 5 and 20 pounds, permit 0.005 lb
- for weights between 20 and 30 pounds, permit 0.01 lb

Table 4-4. Thickness of paint can walls and labels

Wall Thickness			
SI Units		Inch-Pound Units	
Can Size	micrometer (μm)	Can Size	in
4 L	250	1 gal	0.010
2 L	250	1/2 gal	0.010
1 L	230	1 qt	0.009
500 mL	230	1 pt	0.008
250 mL	200		
Label thickness paper ^a (all can sizes)			
SI		Inch-Pound	
100 micrometer (μm)		0.004 inch	

^aThe thickness of labels lithographed directly on the container may be ignored.

Table 5-1. Sampling plans for packages labeled by low count^a

1	2	3	4
Lot size N	Sample size n	Tare sample size n _t	Number of packages allowed contain fewer than the labeled count
500 or less	10	2	1
501 - 5000	30	2	2
5001 or more	50	5	3

^a Labeled count is 50 or fewer units.

Table 5-2. Sampling plans for packages given tolerances

1	2	3	4
Lot size N	Sample size n	Tare sample size n _t	Number of package errors which may exceed allowable difference
500 or less	10	2	0
501 - 5000	30	2	1
5001 or more	50	5	2

NIST Handbook 133

Changes to Appendix C Glossary

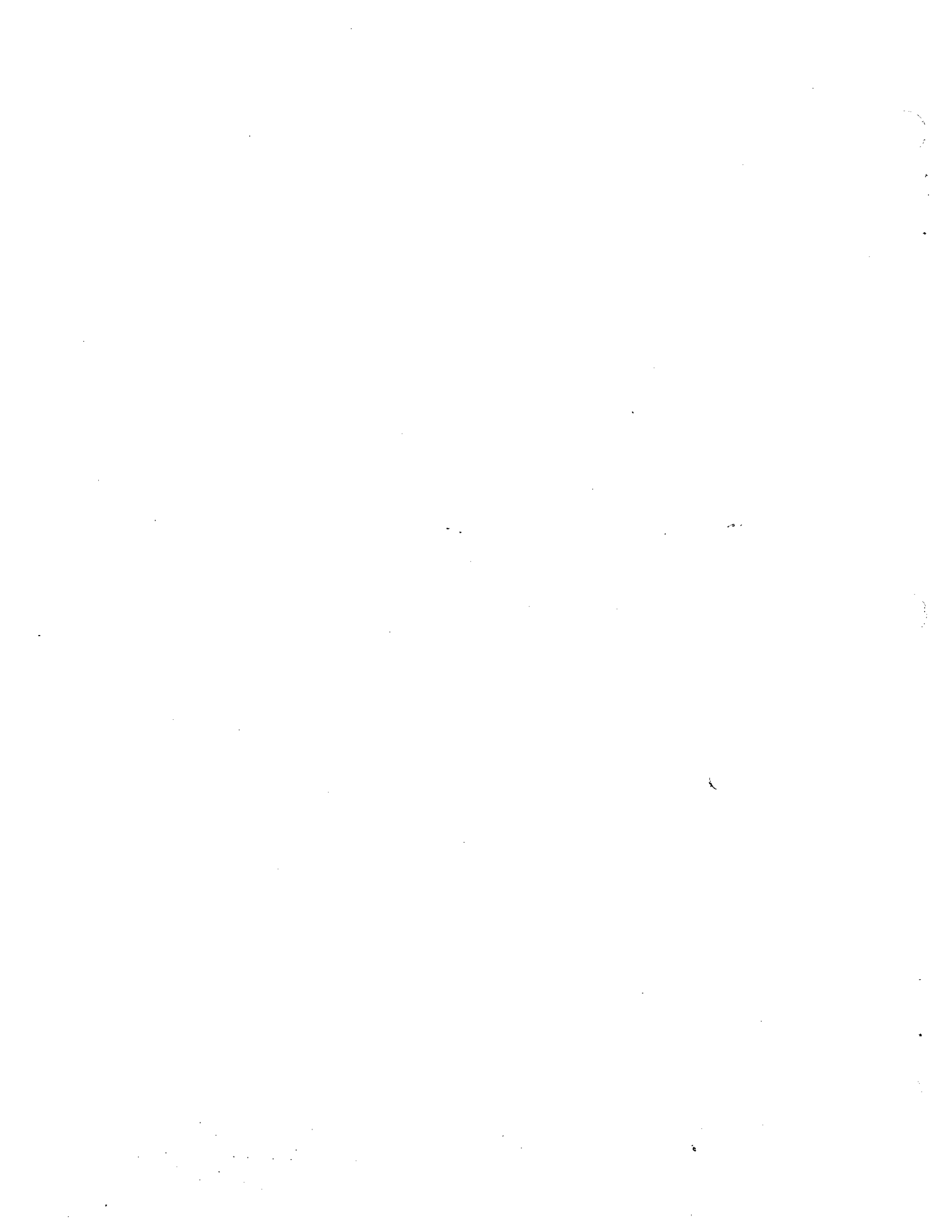

Appendix C Glossary

acceptance tolerance. The limit of inaccuracy for new, newly reconditioned, or adjusted equipment.

allowable difference. The amount by which the actual quantity in the package may differ from the declared quantity. Pressed and blown tumblers and stemware labeled by count and capacity are assigned an allowable difference in capacity. Also termed Tolerance.

analog scale. A weighing device in which weight values are indicated by means of "a series of graduations in combination with an indicator, or in which the most sensitive element of an indicating system moves continuously during the operation of the device."

audit testing. Preliminary tests designed to quickly potential noncompliance.

average. The sum of a number of individual measurement values divided by the number of values. For example, the sum of the individual weights of 12 packages divided by 12 would be the average weight of those packages.

average error. The sum of the individual package errors (defined) (considering their arithmetic sign) divided by the number of packages comprising the sample.

average requirement.

average tare. The sum of the weights of individual package containers (or wrappers, etc.) divided by the number of containers or wrappers weighed.

avoirdupois units. The inch-pound unit (defined) for weight commonly used in the United States of America, based on the pound of 16 ounces and the ounce of 16 drams.

berry baskets and boxes. ^[Note 1, See page C-1] Disposable containers in capacities of 1 dry quart or less for berries and small fruits.

Note 1: NIST Handbook 44

break point. That point at which a digital indicator changes its indication from one value to an adjacent value. [This is determined by adding test weights 0.1

of the value of the smallest indication until the break point is reached.]

category A (category B). A set of sampling plans provided in this handbook for use in checking packages that must meet the average requirement (defined).

checkweigher. A weighing device often used in packaging operations. It separates packages into weight groups according to the amount their actual weights differ (over or under) from the target or nominal weight.

combination quantity declarations. ^[Note 2, See page C-1] A package label that contains the count of items in the package as well as one or more of the following: weight, measure, or size.

Note 2: NIST Handbook 130, Uniform Method of Sale of Commodities Regulation.

compliance testing. The determination of conformance of packages with specified legal requirements.

decision criteria. The rules for deciding whether or not a lot is in conformance with package requirements based on the results of checking the packages in the sample.

delivery. A quantity of identically labeled product received at one time by a buyer.

dimensionless units. The integers in terms of which the official records package errors. The dimensionless units must be multiplied by the unit of measure (defined) to obtain package errors in terms of weight, length, etc.

disposable containers. A package container designed to be used only once.

division. ^[Note 1, See page C-1] (on a scale). The difference between two consecutively indicated values.

drained weight. The weight of solid or semisolid product representing the contents of a package obtained after a prescribed method for removal of the liquid has been employed.

dried used tare. Used tare (defined) that has been air-dried, or dried in some manner to simulate the unused tare weight.

dry measure. Rigid containers designed for general and repeated use in the volume measurement of particulate solids.

dry tare. Unused tare.

error. See PACKAGE ERROR.

fill weight. A supplemental statement of the weight of solids put into the package (usually canned food) but before further processing. It is not the same as a drained weight statement.

flush fill capacity. The capacity of a cup or container as defined by the volume contained by it when a flat plate (such as a slicker plate (defined)) rests on its rim.

gravimetric test procedure. An analytical procedure that involves measurement by mass or weight.

gray area. For packaged goods subject to moisture loss, when the average net weight of a sample is found between the labeled weight and the boundary of the gray area, the lot is said to be in a gray or no-decision area. Further information is required to determine lot compliance or noncompliance.

gross weight. The weight of the package including contents, packing material, labels, etc.

headspace. The container volume not occupied by product.

index of an indicator. That particular portion of an indicator (as, for example, on a weighing scale) that is directly utilized in making a reading (e.g., the tip of a movable pointer on a dial).

inch-pound units. Units based upon the yard, gallon, and the pound commonly used in the United States of America. Some of these units have the same name as similar units in the United Kingdom (British, English, or UK units), but are not necessarily equal to them.

initial tare sample. The first packages (either two or five) selected from the sample to be opened for tare determination in the tare procedure. Depending upon the variability of these individual tare weights as compared with the variability of the net contents, this

initial tare sample may be sufficient or more packages may be needed to determine the tare.

inspection lot. The collection of identically labeled (except for actual quantity in the case of random pack) packages available for inspection at one time. This collection will pass or fail as a whole based on the results of tests on a sample drawn from this collection.

label. ^[Note 3, See page C-2] "Any written, printed, or graphic matter affixed to, applied to, attached to, blown into, formed, molded into, embossed on, or appearing upon or adjacent to a consumer commodity or a package containing any consumer commodity, for purposes of branding, identifying, or giving any information with respect to the commodity or to the contents of the package, except that an inspector's tag or other nonpromotional matter affixed to or appearing upon a consumer commodity...(is)...not...a label."

Note 3: NIST Handbook 130, Uniform Packaging and Labeling Regulation.

location of test. The place where the package will be examined. Broadly defined as one of three general locations: (1) where the commodity was packaged, (2) a warehouse or storage location; or (3) a retail outlet.

lot. See INSPECTION LOT.

lot code. A series of identifying numbers and/or letters on the outside of a package designed to provide information such as the date and location of packaging, the expiration date, and so on.

lot size. The number of packages in the inspection lot (defined).

lubricating oil bottles. A rigid (inflexible) measure container (defined) for repeated use in "measurement of lubricating oil for direct delivery to the crankcase of a motor vehicle, whether or not the bottle is sealed with a cap or some other device."

MAV (maximum allowable variation). A deficiency in the weight, measure or count of an individual package beyond which the deficiency is considered to be an unreasonable error (defined). The number of packages with deficiencies greater than the MAV is controlled by the sampling procedure.

mean or arithmetic mean. See AVERAGE.

measure containers.^[Note 1, See page C-1] Containers whose capacities are used to determine quantity. They are of two basic types: (a) retail and (b) prepackaged. Retail containers are packaged at the time of retail sale and prepackaged containers are packaged in advance of sale. An example of a prepackaged measure container is an ice cream package.

metered valve. A push-button operated aerosol delivery device that meters a predetermined quantity of product when depressed and then shuts off automatically. No additional product will be expelled until the push button is released and depressed again to repeat the procedure.

milk bottles.^[Note 1, See page C-1] A container that is designed as a measure container (defined) for repeated use in the measurement and delivery of milk and other fluid dairy products at retail.

minus or plus errors. Negative or positive deviations from the labeled quantity of the actual package quantities as measured. [See package errors.]

mulch. Any product or material other than peat or peat moss for sale, or sold for primary use as a horticultural, above-ground dressing for decoration, moisture control, weed control, erosion control, temperature control, or other similar purposes.

moisture allowance. That variation in weight of a packaged product permitted in order to account for loss of weight due to loss of moisture during good package distribution practices.

net quantity or net contents. That quantity of packaged product remaining after all necessary deductions for tare (defined) have been made.

nominal.^[Note 1, See page C-1] Refers to "intended" ... as opposed to "actual."

nominal gross weight. The sum of the nominal tare weight (defined) plus the declared or labeled weight (or other labeled quantity converted to a weight basis).

nominal tare weight. The quantity designated as tare (defined) and used in the determination of the nominal gross weight. It may be an average tare value or a corrected average tare value.

null indicator. A device or portion of device used to indicate a "zero" or load-balanced condition.

observed value. A particular quantity determined as the result of an observation, test, or measurement.

packaged goods.^[Note 4, See page C-3] Product or commodity put up in any manner in advance of sale suitable for either wholesale or retail sale.

Note 4: 16 CFR §500.2(h).

package error. The difference between the actual net contents of an individual package as measured and the declared net contents on the package label; (-) minus for less than the label and (+) plus for more than the label.

petroleum products.^[Note 5, See page C-3] Gasoline, diesel fuel, kerosene, or any product (whether or not such a product is actually derived from naturally occurring hydrocarbon mixtures known as "petroleum") commonly used in powering, lubricating, or idling engines or other devices, or labeled as fuel to power camping stoves or lights. Sewing machine lubricant, camping fuels, and synthetic motor oil are "petroleum products" for the purposes of this regulation. Brake fluid, copier machine dispersant, antifreeze, cleaning solvents, and alcohol are not "petroleum products".

Note 5: NIST Handbook 130.

poise.^[Note 1, See page C-1] "A movable weight mounted upon or suspended from a weighbeam bar and used in combination with graduations, and frequently with notches, on the bar to indicate weight values."

plus errors. See MINUS OR PLUS ERRORS.

principal display panel or panels.^[Note 1, See page C-1] Indicates that part, or those parts, of a label that is, or are, so designed as to most likely be displayed, presented, shown, or examined under normal and customary conditions of display and purchase. Wherever a principal display panel appears more than once on a package, all requirements pertaining to the 'principal display panel' shall pertain to all such 'principal display panels'."

production lot. The total collection of packages defined by the packager, usually consisting of those packages produced within a given unit of time and coded identically.

pycnometer. A container of known volume used to contain material for weighing so that the weight of a known volume may be determined for the material.

random pack.^[Note 1, See page C-1] "The term 'random package' shall be construed to mean a package that is one of a lot, shipment, or delivery of packages of the same consumer commodity with varying weights; that is, packages of the same consumer commodity with no fixed pattern of weight."

random sampling. The process of selecting sample packages such that all packages under consideration have the same probability of being selected. An acceptable method of random selection is to use a table of random numbers.

range. The difference between the largest and the smallest of a set of measured values.

reasonable variation. An amount by which individual package net contents are allowed to vary from the labeled net contents. This term is found in most Federal and State laws and regulations governing packaged goods. Reasonable variations from the labeled declaration are recognized for (1) unavoidable deviations in good manufacturing practice, and (2) loss or gain of moisture in good distribution practice.

rounding. The process of omitting some of the end digits of a numerical value and adjusting the last retained digit so that the resulting number is as near as possible to the original number.

sample. A group of packages taken from a larger collection of packages and providing information that can be used as a basis for making a decision concerning the larger collection of packages or of the package production process. A sample provides a valid basis for decision only when it is a random sample (defined).

sample correction factor. The value $2/\sqrt{n}$, where 2 is an approximation of the Students' "t" value for a one sided test at the 3 percent confidence level and \sqrt{n} is the square root of the sample size.

sample error limit (SEL). Means a statistical value computed by multiplying the sample standard deviation times the sample correction factor from Column 3 of Table 2-1. Category A - Sampling Plans for the appropriate sample size. The SEL value allows for the uncertainty between the average error of the sample and the average error of the inspection lot with an approximately 97 percent level of confidence.

sample size. The number of packages in a sample.

sampling plan. A specific plan that states the number of packages to be checked and the associated decision criteria.

standard deviation. A measure to describe the scatter of the individual package contents around the mean contents.

scale tolerance. The official value fixing the limit of allowable error for commercial weighing equipment as defined in NIST Handbook 44.

seat (as in "seat diameter" or "seated capacity"). The projection or shoulder near the upper rim of a cup or container that is designed to serve as the support for a lid or cover.

seated capacity. The capacity of a cup, container, or bottle, as defined by the volume contained by them when the lid or a flat disc is inserted in the lid groove located inside and near the upper rim of the cup, container, or bottle.

SEL. See sample error limit.

sensitivity^[Note 1, See page C-1] (of a weighing device). The minimum change in the position of rest of the indicating element of the scale in response to an increase or decrease of the test-weight load on the scale.

shipment. A quantity of identically labeled product (except for lot code) sent at one time to a single location.

slicker plate. A flat plate, usually of glass or clear plastic composition used to determine the "level full" condition of a capacity (volumetric) measure.

standard pack. That type of package in which a commodity is put up with identical labels and only in certain specific quantity sizes. Examples of goods so packed are canned, boxed, bottled and bagged foods, and over-the-counter drugs.

substitution weighing. The use of a commercial scale as a "null indicator" (defined). The weight of the package or product is determined by using the official's test weights (defined), the commercial scale serving merely as an indicator for a "zero" or load balanced condition and not as an indicating device.

supplementary quantity declarations.^[Note 6, See page C-5] "The required quantity declaration may be supplemented by one or more declarations of weight,

measure, or count, such declaration appearing other than on a principal display panel. Such supplemental statement of quantity of contents shall not include any terms qualifying a unit of weight, measure, or count that tends to exaggerate the amount of commodity contained in the package (e.g., 'giant' quart, 'full' gallon, 'when packed,' 'minimum,' or words of similar import)."

Note 6: 16 CFR §500.20

survey testing. See audit testing.

tape rules. ^[Note 1, See page C-1] Flexible steel linear measures.

tare weight. The weight of a container, wrapper, or other material that is deducted from the gross weight to obtain the net weight.

tare sample. The packages or packaging material used to determine the average tare weight.

tare sample size. The number of packages or packaging material units used to determine the average tare weight.

test weights. Weights of known value used to check the accuracy of package quantities and scales (also used in substitution weighing).

tolerance. A value fixing the limit of allowed departure from the labeled contents; usually presented as a (+) and a (-) value.

unit of measure. An increment of weight, length, or volume chosen so that an inspector may record package errors in terms of small integers. [The package errors are actually the integers multiplied by the unit of measure.]

unreasonable errors. Minus package errors that exceed the MAV (defined). The number of unreasonable errors permitted in a sample is specified by the sampling plan.

unused tare. All packaging materials (including glue, labels, ties, etc.) that contain or enclose a product, including prizes, gifts, coupons, or decorations that are not part of the product. Unused tare is weighed before the product is introduced into the container.

used dried tare. See dried used tare.

used tare. All packaging materials that can be separated from the product, either readily (e.g., by shaking) or by washing, scraping, ambient air drying, or other techniques involving more than "normal" household recovery procedures, but not including laboratory procedures. Prizes, decorations, and the materials that are not part of the product are included in the used tare. See also "wet tare" and "dried used tare."

valve actuator (valve button). The push button located on the top of the aerosol package that controls the flow of product by means of a valve.

vapor tap valve. A push button aerosol delivery device that will expel product whether the container is in the upright or inverted position.

volumetric measures. Standard measuring flasks, graduates, cylinders, etc. for use in the measurement of volumes of liquids.

wet tare. Used tare (defined) when no effort is made to reconstruct unused tare weight by drying out the absorbent portion (if any) of the tare. Free-flowing liquid is part of the wet tare for meat or poultry products from Federally-inspected plants.

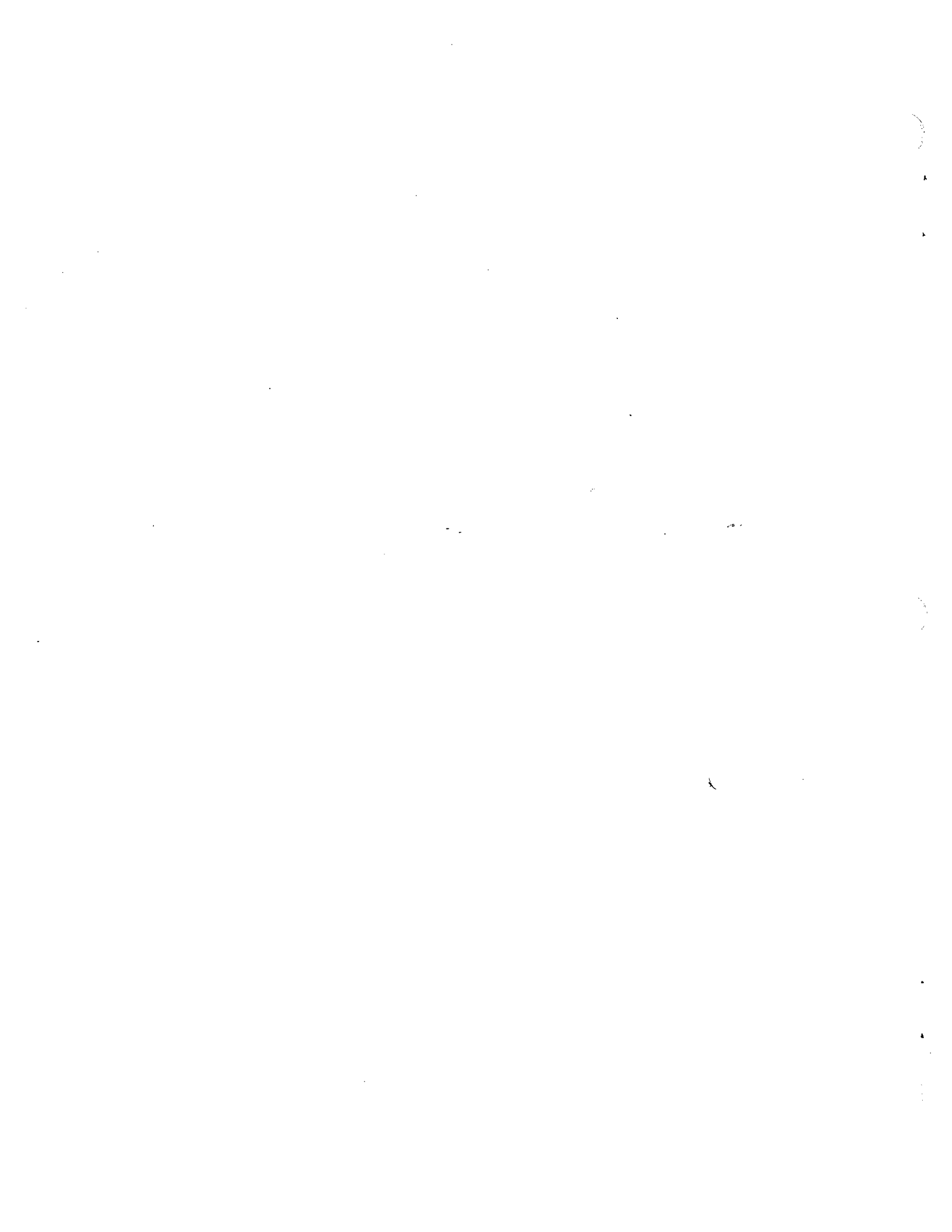

NIST Technical Publications

Periodical

Journal of Research of the National Institute of Standards and Technology—Reports NIST research and development in those disciplines of the physical and engineering sciences in which the Institute is active. These include physics, chemistry, engineering, mathematics, and computer sciences. Papers cover a broad range of subjects, with major emphasis on measurement methodology and the basic technology underlying standardization. Also included from time to time are survey articles on topics closely related to the Institute's technical and scientific programs. Issued six times a year.

Nonperiodicals

Monographs—Major contributions to the technical literature on various subjects related to the Institute's scientific and technical activities.

Handbooks—Recommended codes of engineering and industrial practice (including safety codes) developed in cooperation with interested industries, professional organizations, and regulatory bodies.

Special Publications—Include proceedings of conferences sponsored by NIST, NIST annual reports, and other special publications appropriate to this grouping such as wall charts, pocket cards, and bibliographies.

Applied Mathematics Series—Mathematical tables, manuals, and studies of special interest to physicists, engineers, chemists, biologists, mathematicians, computer programmers, and others engaged in scientific and technical work.

National Standard Reference Data Series—Provides quantitative data on the physical and chemical properties of materials, compiled from the world's literature and critically evaluated. Developed under a worldwide program coordinated by NIST under the authority of the National Standard Data Act (Public Law 90-396). NOTE: The Journal of Physical and Chemical Reference Data (JPCRD) is published bimonthly for NIST by the American Chemical Society (ACS) and the American Institute of Physics (AIP). Subscriptions, reprints, and supplements are available from ACS, 1155 Sixteenth St., NW, Washington, DC 20056.

Building Science Series—Disseminates technical information developed at the Institute on building materials, components, systems, and whole structures. The series presents research results, test methods, and performance criteria related to the structural and environmental functions and the durability and safety characteristics of building elements and systems.

Technical Notes—Studies or reports which are complete in themselves but restrictive in their treatment of a subject. Analogous to monographs but not so comprehensive in scope or definitive in treatment of the subject area. Often serve as a vehicle for final reports of work performed at NIST under the sponsorship of other government agencies.

Voluntary Product Standards—Developed under procedures published by the Department of Commerce in Part 10, Title 15, of the Code of Federal Regulations. The standards establish nationally recognized requirements for products, and provide all concerned interests with a basis for common understanding of the characteristics of the products. NIST administers this program in support of the efforts of private-sector standardizing organizations.

Consumer Information Series—Practical information, based on NIST research and experience, covering areas of interest to the consumer. Easily understandable language and illustrations provide useful background knowledge for shopping in today's technological marketplace.

Order the above NIST publications from: Superintendent of Documents, Government Printing Office, Washington, DC 20402.

Order the following NIST publications—FIPS and NISTIRs—from the National Technical Information Service, Springfield, VA 22161.

Federal Information Processing Standards Publications (FIPS PUB)—Publications in this series collectively constitute the Federal Information Processing Standards Register. The Register serves as the official source of information in the Federal Government regarding standards issued by NIST pursuant to the Federal Property and Administrative Services Act of 1949 as amended, Public Law 89-306 (79 Stat. 1127), and as implemented by Executive Order 11717 (38 FR 12315, dated May 11, 1973) and Part 6 of Title 15 CFR (Code of Federal Regulations).

NIST Interagency Reports (NISTIR)—A special series of interim or final reports on work performed by NIST for outside sponsors (both government and non-government). In general, initial distribution is handled by the sponsor; public distribution is by the National Technical Information Service, Springfield, VA 22161, in paper copy or microfiche form.

