

APPENDIX B

RULINGS AND ATF ARTICLES

Section 1.01 27 CFR 479.11²³⁴: MEANING OF TERMS

The AR15 auto sear is a machine gun as defined by 26 U.S.C. 5845(b)

Section 1.02 ATF Rul. 81-4

The Bureau of Alcohol, Tobacco and Firearms has examined an auto sear known by the various trade names including “AR15 Auto Sear,” “Drop In Auto Sear,” and “Auto Sear II,” which consists of a sear mounting body, sear, return spring, and pivot pin. The Bureau finds that the single addition of this auto sear to certain AR15 type semiautomatic rifles, manufactured with M16 internal components already installed, will convert such rifles into machine guns.

The National Firearms Act, 26 U.S.C. 5845(b) defines “machine gun” to include any combination of parts designed and intended for use in converting a weapon to shoot automatically more than one shot, without manual reloading, by a single function of the trigger.

Held: The auto sear known by various trade names including “AR15 Auto Sear,” “Drop In Auto Sear,” and “Auto Sear II,” is a combination of parts designed and intended for use in converting a weapon to shoot automatically more than one shot, without manual reloading, by a single function of the trigger. Consequently, the auto sear is a machine gun as defined by 26 U.S.C. 5845(b).

With respect to the machine gun classification of the auto sear under the National Firearms Act, pursuant to 26 U.S.C. 7805(b), this ruling will not be applied to auto sears manufactured before November 1, 1981. Accordingly, auto sears manufactured on or after November 1, 1981, will be subject to all of the provisions of the National Firearms Act and 27 C.F.R. Part 479.

Editor’s Note: Regardless of the date of manufacture of a drop in auto sear, possession of such a sear and certain M16 fire control parts is possession of a machine gun as defined by the NFA. Specifically, these parts are a combination of parts designed and intended for use in converting a weapon into a machine gun as defined in the NFA. (See “Important Information Concerning AR15-Type rifles” which follows)

IMPORTANT INFORMATION CONCERNING AR-15 TYPE RIFLES

ATF has encountered various AR-15 type rifles such as those manufactured by Colt, E.A. Company, SGW, Sendra and others which have been assembled with fire control components designed for use in M16 machine guns.

The vast majority of these rifles which have been assembled with an M16 bolt carrier, hammer, trigger, disconnect and selector will fire automatically merely by manipulation of the selector or removal of

²³⁴ The citations to 27 CFR part 179 have been rewritten as 27 CFR part 479 in conformance with the reorganization of title 27 CFR which became effective on January 24, 2003.

the disconnecter. Many of these rifles using less than the 5 M16 parts listed above will also shoot automatically by manipulation of the selector or removal of the disconnecter.

Any weapon which shoots automatically, more than 1 shot, without manual reloading, by a single function of the trigger, is a machine gun as defined in 26 U.S.C. 5845(b), the National Firearms Act (NFA). In addition, the definition of machine gun also includes any combination of parts from which a machine gun may be assembled, if such parts are in possession or under the control of a person. An AR-15 type assault rifle which fires more than one shot by a single function of the trigger is a machine gun under the NFA. Any machine gun is subject to the NFA and the possession of an unregistered machine gun could be the possessor to criminal prosecution.

Additionally, these rifles could pose a safety hazard in that they may fire automatically without the user being aware that the weapon will fire more than 1 shot with a single pull of the trigger.

In order to avoid violations of the NFA, M16, hammers, triggers, disconnectors, selectors and bolt carriers must not be used in assembly of AR-15 type semiautomatic rifles, unless the M16 parts have been modified to AR-15 Model SP1 configuration. Any AR-15 type rifles which have been assembled with M16 internal components should have those parts removed and replaced with AR-15 Model SP1 type parts which are available commercially. The M16 components also may be modified to AR-15 Model SP1 configuration.

It is important to note that any modification of the M16 parts should be attempted by fully qualified personnel only.

Should you have any questions concerning AR-15 type rifles with M16 parts, please contact your nearest ATF office. Our telephone numbers are listed in the “**United States Government**” section of your telephone directory under the “**United States Department of Justice.**”
Section 1.03

27 CFR 479.11: MEANING OF TERMS

- 1) **The KG-9 pistol is a machinegun as defined in the National Firearms Act.**

ATF Rul. 82-2

The Bureau of Alcohol, Tobacco and Firearms has examined a firearm identified as the KG-9 pistol. The KG-9 is a 9 millimeter caliber, semiautomatic firearm which is blowback operated and which fires from the open bolt position with the bolt incorporating a fixed firing pin. In addition, a component part of the weapon is a disconnecter which prevents more than one shot being fired with a single function of the trigger.

The disconnecter is designed in the KG-9 pistol in such a way that a simple modification to it, such as cutting, filing, or grinding, allows the pistol to operate automatically. Thus, this simple modification to the disconnecter together with the configuration of the above design features (blowback operation, firing from the open bolt position, and fixed firing pin) in the KG-9 permits the firearm to shoot automatically, more than one shot, without manual reloading, by a single function of the trigger. The above

combination of design features as employed in the KG-9 is normally not found in the typical sporting firearm.

The National Firearms Act, 26 U.S.C. 5845(b), defines a machine gun to include any weapon which shoots, is designed to shoot, or can be readily restored to shoot, automatically more than one shot, without manual reloading, by a single function of the trigger.

The “shoots automatically” definition covers weapons that will function automatically. The “readily restorable” definition defines weapons which previously could shoot automatically but will not in their present condition. The “designed” definition includes those weapons which have not previously functioned as machine guns but possess design features which facilitate full automatic fire by simple modification or elimination of existing component parts.

Held: The KG-9 pistol is designed to shoot automatically more than one shot, without manual reloading, by a single function of the trigger. Consequently, the KG-9 pistol is a machine gun as defined in section 5845(b) of the Act.

With respect to the machine gun classification of the KG-9 pistol under the National Firearms Act, pursuant to 26 U.S.C. § 7805(b), this ruling will not be applied to KG-9 pistols manufactured before January 19, 1982. Accordingly, KG-9 pistols manufactured on or after January 19, 1982, will be subject to all the provisions of the National Firearms Act and 27 C.F.R., Part 479.

Section 1.04 27 CFR 479.11: MEANING OF TERMS

The SM10 and SM11A1 pistols and SAC carbines are machineguns as defined in the National Firearms Act.

ATF Rul. 82-8

The Bureau of Alcohol, Tobacco and Firearms has reexamined firearms identified as SM10 pistols, SM11A1 pistols, and SAC carbines. The SM10 is a 9 millimeter or .45ACP caliber, semiautomatic firearm; the SM11A1 is a .380ACP caliber, semiautomatic firearm. And the SAC carbine is a 9 millimeter or .45ACP caliber, semiautomatic firearm. The weapons are blowback operated, fire from the open bolt position with the bolt incorporating a fixed firing pin, and the barrels of the pistols are threaded to accept a silencer. In addition, component parts of the weapons are a disconnecter and a trip which prevent more than one shot being fired with a single function of the trigger.

The disconnecter and trip are designed in the SM10 and SM11A1 pistols and in the SAC carbine (firearms) in such a way that a simple modification to them, such as cutting, filing, or grinding, allows the firearms to operate automatically. Thus, this simple modification to the disconnecter or trip together with the configuration of the above design features (blowback operation, firing from the open bolt position, and fixed firing pin) in the SM10 and SM11A1 pistols and in the SAC carbine, permits the firearms to shoot automatically, more than one shot, without manual reloading, by a single function of the trigger. The above combination of design features as employed in the SM10 and SM11A1 pistols and the SAC carbine are normally not found in the typical sporting firearm.

The National Firearms Act, 26 U.S.C. § 5845(b), defines a machine gun to include any weapon which shoots, is designed to shoot, or can be readily restored to shoot, automatically more than one shot, without manual reloading, by a single function of the trigger.

The “shoots automatically” definition covers weapons that will function automatically. The “readily restorable” definition defines weapons which previously could shoot automatically but will not in their present condition. The “designed” definition includes those weapons which have not previously functioned as machine guns but possess design features which facilitate full automatic fire by simple modification or elimination of existing component parts.

Held: The SM10 and SM11A1 pistols and the SAC carbine are designed to shoot automatically more than one shot, without manual reloading, by a single function of the trigger. Consequently, the SM10 and SM11A1 pistols and SAC carbines are machine guns as defined in Section 5845(b) of the Act.

With respect to the machine gun classification of the SM10 and SM11A1 pistols and SAC carbines, under the National Firearms Act, pursuant to 26 U.S.C. 7805(b), this ruling will not be applied to SM10 and SM11A1 pistols and SAC carbines manufactured or assembled before June, 21, 1982. Accordingly, SM10 and SM11A1 pistols and SAC carbines, manufactured or assembled on or after June 21, 1982, will be subject to all the provisions of the National Firearms Act and 27 C.F.R., Part 479.

27 CFR 479.11: MEANING OF TERMS

The YAC STEN MK II carbine is a machine gun as defined in the National Firearms Act.

ATF Rul. 83-5

The Bureau of Alcohol, Tobacco and Firearms has examined a firearm identified as YAC STEN MK II carbine. The YAC STEN MKII carbine is a 9 millimeter caliber, semiautomatic firearm which has identical design characteristics to the original selective fire STEN submachine gun designed by Reginald Vernon Shepherd and Harold John Turpin. The weapon is blowback operated and fires from the open bolt position with the bolt incorporating a fixed firing pin. In addition, a component part of the weapon is a trip lever (disconnecter) which has been modified to prevent more than one shot being fired with a single function of the trigger.

The trip lever (disconnecter) is designed in such a way that a simple modification to it, such as bending, breaking or cutting, allows the weapon to operate automatically. Thus, this simple modification to the trip lever (disconnecter) or trip together with STEN submachine gun design features and components in the YAC STEN MK II carbine, permits the firearm to shoot automatically, more than one shot, without manual reloading, by a single function of the trigger. The above combination of machine gun design features as employed in the YAC STEN MK II carbine are normally not found in the typical sporting firearm.

The National Firearms Act, 26 U.S.C. 5845(b), defines a machine gun to include any weapon which shoots, is designed to shoot, or can be readily restored to shoot, automatically more than one shot, without manual reloading, by a single function of the trigger.

The “shoots automatically” definition covers weapons that will function automatically. The “readily restorable” definition defines weapons which previously could shoot automatically but will not in their present condition. The “designed” definition includes those weapons which have not previously functioned as machine guns but possess specific machine gun design features which facilitate full automatic fire by simple modification or elimination of existing component parts.

Held: The YAC STEN MK II carbine is designed to shoot automatically more than one shot, without manual reloading, by a single function of the trigger. Consequently, the YAC STEN MK II semiautomatic carbine is a machine gun as defined in Section 5845(b) of the Act.

Section 1.05 27 CFR 479.111: IMPORTATION PROCEDURE

- a) **A National Firearms Act (NFA) firearm may not be imported for use as a sample for sales to law enforcement agencies if the firearm is a curio or relic unless it is established that the firearm is particularly suitable for use as a law enforcement weapon.**
- b)
- c) **ATF Rul. 85-2**

The Bureau of Alcohol, Tobacco and Firearms has approved a number of applications to import National Firearms Act (NFA) firearms for the use of registered importers to generate orders for such firearms from law enforcement agencies.

A review of the characteristics of the NFA firearms approved for importation as sales samples indicates that some of the firearms are not being imported for the purposes contemplated by the statute. Some of the NFA firearms imported are, in fact, curios or relics and are more suitable for use as collector’s items than law enforcement weapons.

Importations of NFA firearms are permitted by 26 U.S.C. 5844, which provides in pertinent part:

“No firearms shall be imported or brought into the United States or any territory under its control or jurisdiction unless the importer establishes, under regulations as may be prescribed by the Secretary, that the firearm to be imported or brought in is:

- (1) being imported or brought in for the use of the United States or any department., independent establishment, or agency thereof or any State or possession or any political subdivision thereof; or
- (2) ***
- (3) being imported or brought in solely for ... use as a sample by a registered importer or registered dealer;

except that, the Secretary may permit the conditional importation or bringing in of a firearm for examination and testing in connection with classifying the firearm.”

The sole purpose of the statute permitting the importation of NFA firearms as sales samples is to permit registered importers to generate orders for firearms from government agencies, on the basis of the sample.

The implementing regulation, 27 CFR Section 479.111, provides that the person importing or bringing a firearm into the United States or any territory under its control or jurisdiction has the burden of proof to affirmatively establish that the firearm is being imported or brought in for one of the authorized purposes. In addition, a detailed explanation of why the importation falls within one of the authorized purposes must be attached to the application to import. The mere statement that an NFA firearm is being imported as a sales sample for demonstration to law enforcement agencies does not meet the required burden of proof and is not a detailed explanation of why the importation falls within the import standards.

Held, an application to import a National Firearms Act firearm as a sample in connection with sales of such firearms to law enforcement agencies will not be approved if the firearm is determined to be a curio or relic unless it is established by specific information that the firearm is particularly suitable for use as a law enforcement weapon. For example, the importer must provide detailed information as to why a sales sample of a particular weapon is suitable for law enforcement purposes and the expected customers who would require a demonstration of the weapon. Information as to the availability of firearms to fill subsequent orders would help meet the burden of establishing use as a sales sample. Also, letters from law enforcement agencies expressing a need for a particular model or interest in seeing a demonstration of a particular firearm would be relevant.

Editor's Note:

The importation of machine guns for use as sales samples must also meet the requirements of 27 CFR 479.105(d).

26 U.S.C. § 5845(f)(2): DESTRUCTIVE DEVICE (Nonsporting shotgun having a bore of more than one-half inch in diameter)

The USAS-12 shotgun has a bore of more than one-half inch in diameter and is not generally recognized as particularly suitable for sporting purposes. Therefore, it is classified as a destructive device for purposes of the National Firearms Act, 26 U.S.C. Chapter 53.

Section 1.06 ATF Rul. 94-1

The Bureau of Alcohol, Tobacco and Firearms (ATF) has examined a firearm identified as the USAS-12 shotgun to determine whether it is a destructive device as that term is used in the National Firearms Act (NFA), 26 U.S.C. Chapter 53.

The USAS-12 is a 12 gauge, gas-operated, autoloading semiautomatic shotgun which is chambered for 12 gauge 2 ¾-inch ammunition. It has an 18 ¼-inch barrel, is approximately 38 inches long, and weighs 12.4 pounds unloaded and approximately 15 pounds with a loaded magazine, depending on the capacity of the magazine. The USAS-12 is equipped with a 12 round detachable box magazine, but a 28 round detachable drum magazine is also available. The shotgun is approximately 11 inches deep with a box magazine. There is an integral carrying handle on top of the receiver which houses a rifle –type aperture rear and adjustable post-type front sight. The USAS-12 has a separate combat-style pistol grip located on the bottom of the receiver, forward of the buttstock. An optional telescopic sight may be attached to the carrying handle. The barrel is located below the operating mechanism in such fashion that the barrel is in a straight line with the center of the buttstock.

Section 5845(f), Title 26 U.S.C., classifies certain weapons as “destructive devices” which are subject to the registration and tax provisions of the NFA. Section 5845(f)(2) provides the following:

(f) **Destructive Device** – The term “destructive device” means* * *

(2) any type of weapon by whatever name known which will, or which may be readily converted to, expel a projectile by the action of an explosive or other propellant, the barrel or barrels of which have a bore of more than one-half inch in diameter, except a shotgun or shotgun shell the Secretary or his delegate finds is generally recognized as particularly suitable for sporting purposes.

A “sporting purpose” test which is almost identical to that in section 5845(f)(2) appears in 18 U.S.C. § 925(d)(3). This provision of the Gun Control Act of 1968 (GCA) provides that the Secretary shall authorize a firearm to be imported into the United States if the firearm is “generally recognized as particularly suitable for or readily adaptable to sporting purposes.” With the exception of the “readily adaptable” language, this provision is identical to the sporting shotgun exception to the destructive device definition. The definition of “destructive device” in the GCA (18 U.S.C. § 921(a)(4)) is identical to that in the NFA.

In determining whether shotguns with a bore diameter of more than one-half inch in diameter are “generally recognized as particularly suitable for sporting purposes” and thus are not destructive devices under the NFA, we believe it is appropriate to use the same criteria used for evaluating shotguns under the “sporting purposes” test of section 925(d)(3). Congress used virtually identical language in describing the weapons subject to the two statutory schemes, and the language was added to the GCA and the NFA at the same time.

In connection with the determination of importability, ATF determined that the USAS-12 shotgun was not eligible for importation under the sporting purposes test in section 925(d)(3). In reaching this determination, ATF evaluated the weight, size, bulk, designed magazine capacity, configuration, and other characteristics of the USAS-12. It was determined that the weight of the USAS-12, 12.4 pounds, made it much heavier than traditional 12 gauge sporting shotguns, which made it awkward to carry for extended periods, as in hunting, and cumbersome to fire at multiple small moving targets, as in skeet and trap shooting. The width of the USAS-12 with drum magazine, approximately 6 inches, and the depth with box magazine, in excess of 11 inches, far exceed that of traditional sporting shotguns, which do not exceed 3 inches in width and 4 inches in depth. The large size and bulk of the USAS-12 made it extremely difficult to maneuver quickly enough to engage moving targets as is necessary in hunting, skeet, and trap shooting. The detachable box magazine with 12 cartridge capacity and the detachable drum magazine with 28 cartridge capacity were or a larger capacity than traditional repeating sporting shotguns, which generally contain tubular magazines with a capacity of 3 – 5 cartridges. Additionally, detachable magazines permit more rapid reloading than do tubular magazines. Finally, the combat-style pistol grip, the barrel-to-buttstock configuration, the bayonet lug, and the overall appearance and general shape of the weapon were radically different from traditional sporting shotguns and strikingly similar to shotguns designed specifically for or modified for combat and law enforcement use.

Section 7805(b), title 26 U.S.C., provides that the Secretary may prescribe the extent, if any, to which any ruling relating to the internal revenue laws shall be applied without retroactive effect. Accordingly, all rulings issued under the Internal Revenue Code are applied retroactively unless they specifically provide otherwise. Pursuant to section 7805(b), the Director, as the delegate of the Secretary, may prescribe the extent to which any ruling will apply without retroactive effect.

Held: The USAS-12 is a shotgun with a bore of more than one-half inch in diameter which is not particularly suitable for sporting purposes. The weight, size, bulk, designed magazine capacity, configuration, and other factors indicate that the USAS-12 is a semiautomatic version of a military type assault shotgun. Accordingly, the USAS-12 is a destructive device as that term is used in 26 U.S.C. § 5845(f)(2). Pursuant to section 7805(b), this ruling is applied prospectively effective March 1, 1994, with respect to the making, transfer, and special (occupational) taxes imposed by the NFA. All other provisions of the NFA apply retroactively effective March 1, 1994.

Section 1.07 26 U.S.C. § 5845(f)(2): DESTRUCTIVE DEVICE (Non-sporting shotgun having a bore of more than one-half inch in diameter)

Section 1.08

Section 1.09 The Striker-12/Streetsweeper shotgun has a bore of more than one-half inch in diameter and is not generally recognized as particularly suitable for sporting purposes. Therefore, it is classified as a destructive device for purposes of the National Firearms Act, 26 U.S.C. Chapter 53.

Section 1.10

Section 1.11 ATF Rul. 94-2

The Bureau of Alcohol, Tobacco and Firearms (ATF) has examined a firearm identified as the Striker-12/Streetsweeper shotgun to determine whether it is a destructive device as that term is used in the National Firearms Act (NFA), 26 U.S.C. Chapter 53.

The Striker-12 and Streetsweeper shotguns are virtually identical 12 - gauge shotguns with a spring-driven revolving magazine. The magazine has a 12 round capacity, The shotgun has a fixed stock or folding stock and may be fired with the folding stock collapsed. The shotgun with 18-inch barrel is 37 inches in length with the stock extended, and 26 .5 inches in length with the stock folded. The shotgun is 5.7 inches in width and weighs 9.24 pounds unloaded. The Striker/Streetsweeper has two pistol grips, one in the center of the firearm below the buttstock, and one on the forearm. The Striker/Streetsweeper was designed and developed in South Africa as a military, security, and anti-terrorist weapon. Various types of 12-gauge cartridges can be fired from the shotgun, and a rapid indexing procedure allows various types of ammunition to be loaded into the cylinder and selected for firing. All 12 rounds can be fired from the shotgun in 3 seconds or less.

Section 5845(f), Title 26 U.S.C., classifies certain weapons as “destructive devices” which are subject to the registration and tax provisions of the NFA. Section 5845(f)(2) provides as follows:

(f) Destructive Device – The term “destructive device” means* * *

(2) any type of weapon by whatever name known which will, or which may be readily converted to, expel a projectile by the action of an explosive or other propellant, the barrel or barrels of which have a bore of more than one-half inch in diameter, except a shotgun or shotgun shell the Secretary or his delegate finds is generally recognized as particularly suitable for sporting purposes.

A “sporting purpose” test which is almost identical to that in section 5845(f)(2) appears in 18 U.S.C. § 925(d)(3). This provision of the Gun Control Act of 1968 (GCA) provides that the Secretary shall authorize a firearm to be imported into the United States if the firearm is “generally recognized as

particularly suitable for or readily adaptable to sporting purposes.” With the exception of the “readily adaptable” language, this provision is identical to the sporting shotgun exception to the destructive device definition. The definition of “destructive device” in the GCA (18 U.S.C. § 921(a)(4)) is identical to that in the NFA.

In determining whether shotguns with a bore diameter of more than one-half inch in diameter are “generally recognized as particularly suitable for sporting purposes” and thus are not destructive devices under the NFA, we believe it is appropriate to use the same criteria used for evaluating shotguns under the “sporting purposes” test of section 925(d)(3). Congress used virtually identical language in describing the weapons subject to the two statutory schemes, and the language was added to the GCA and the NFA at the same time.

In 1984, ATF ruled that the Striker – 12 was not eligible for importation under section 925(d)(3) since it is not particularly suitable for or readily adaptable to sporting purposes. In making this determination, the 1984 letter-ruling notes that the Striker was being used in a number of “combat” shooting events. In a letter dated June 30, 1986, ATF again denied importation of the Striker – 12, on the basis that it did not meet the “sporting purposes” test of section 925(d)(3). This letter states that, “We believe the weapon to have been specifically designed for military and law enforcement uses.”

In evaluating the physical characteristics of the Striker – 12 /Streetsweeper, ATF concludes that the weight, bulk, designed magazine capacity, configuration, and other features indicate that it was designed primarily for military and law enforcement use and is not particularly suitable for sporting purposes.

The weight of the Striker – 12/Streetsweeper, 9.24 pounds unloaded, is on the high end for traditional 12-gauge sporting shotguns, which generally weigh between 7 and 10 pounds. Thus, the weight of the Striker – 12/Streetsweeper, makes it awkward to carry for extended periods, as in hunting, and cumbersome to fire at multiple small moving targets, as in skeet and trap shooting. The width of the Striker – 12/Streetsweeper, 5.7 inches, far exceeds that of traditional sporting shotguns, which do not exceed three inches in width or four inches in depth. The large size and bulk of the Striker – 12/Streetsweeper make it extremely difficult to maneuver quickly enough to engage moving targets as is necessary in hunting, skeet and trap shooting. The spring driven revolving magazine with 12 –cartridge capacity is a much larger capacity than traditional repeating shotguns, which generally contain tubular magazines with a capacity of 3 – 5 cartridges. The folding shoulder stock and the two pistol grips are not typical of sporting-type shotguns. Finally, the overall appearance and general shape of the weapon are radically different from traditional sporting shotguns and strikingly similar to shotguns designed specifically for or modified for combat and law enforcement use.

Section 7805(b), title 26 U.S.C., provides that the Secretary may prescribe the extent, if any, to which any ruling relating to the internal revenue laws shall be applied without retroactive effect. Accordingly, all rulings issued under the Internal Revenue Code are applied retroactively unless they specifically provide otherwise. Pursuant to section 7805(b), the Director, as the delegate of the Secretary, may prescribe the extent to which any ruling will apply without retroactive effect.

Held: The Striker – 12/Streetsweeper is a shotgun with a bore of more than one-half inch in diameter which is not particularly suitable for sporting purposes. The weight, size, bulk, designed magazine capacity, configuration, and other factors indicate that the Striker – 12/Streetsweeper is a military-type shotgun, as opposed to a shotgun particularly suitable for sporting purposes. Accordingly, the Striker – 12/Streetsweeper is a destructive device as that term is used in 26 U.S.C. § 5845(f)(2). Pursuant to

section 7805(b), this ruling is applied prospectively effective March 1, 1994, with respect to the making, transfer, and special (occupational) taxes imposed by the NFA. All other provisions of the NFA apply retroactively effective March 1, 1994.

**18 U.S.C. § 921(a)(4)
DESTRUCTIVE DEVICE**

**26 U.S.C. § 5845(f)(2):
DESTRUCTIVE DEVICE**

(Firearm having a bore of more than one-half inch in diameter)

37/38 mm gas/flare guns possessed with cartridges containing wood pellets, rubber pellets or balls, or bean bags are classified as destructive devices for purposes of the Gun Control Act, 18 U.S.C. Chapter 44, and the National Firearms Act, 26 U.S.C. Chapter 53.

ATF Rul. 95-3

The Bureau of Alcohol, Tobacco and Firearms (ATF) has examined various 37/38 mm gas/flare guns in combination with certain types of ammunition to determine whether these are destructive devices as defined in the Gun Control Act (GCA), 18 U.S.C. Chapter 44, and the National Firearms Act (NFA), 26 U.S.C. Chapter 53.

Section 5845(f), Title 26 U.S.C., classifies certain weapons as “destructive devices” which are subject to the registration and tax provisions of the NFA. Section 5845(f)(2) provides the following:

(f) Destructive Device – The term “destructive device” means* * *

(2) any type of weapon by whatever name known which will, or which may be readily converted to, expel a projectile by the action of an explosive or other propellant, the barrel or barrels of which have a bore of more than one-half inch in diameter, except a shotgun or shotgun shell the Secretary or his delegate finds is generally recognized as particularly suitable for sporting purposes: . . .”

Section 5845(f)(3) excludes from the term “destructive device” any device which is neither designed or redesigned for use as a weapon and any device, although originally designed for use as a weapon, which is redesigned for use as a signaling, pyrotechnic, Line throwing, safety, or similar device.

The definition of “destructive device” in the GCA (18 U.S.C. § 921(a)(4)) is identical to that in the NFA.

ATF has previously held that devices designed for expelling tear gas or pyrotechnic signals are not weapons and are exempt from the destructive device definition. However, ammunition designed to be used against individuals is available for these 37/38 mm devices. This “anti-personnel” ammunition consists of cartridges containing wood pellets, rubber pellets or balls, and bean bags.

When a gas/flare gun is possessed with “anti-personnel” type ammunition, it clearly becomes an instrument of offensive or defensive combat and is capable of use as a weapon. Since these gas/flare

guns have a bore diameter greater than one-half inch, fire a projectile by means or an explosive, and, when possessed with “anti-personnel” ammunition, are capable of use as weapons, the combination of the gas/flare gun and “anti-personnel” ammunition is a destructive as defined in the GCA and the NFA. As a result, registration as a destructive device is required. Any person possessing a gas/flare gun with which “anti-personnel” ammunition will be used must register the making of a destructive device prior to the acquisition of any “anti-personnel” ammunition. In addition, the gas/flare guns are classified as firearms as defined by the GCA when possessed with “anti-personnel” type ammunition.

Each gas/flare gun possessed with ant–personnel ammunition will be required to be identified as required by law and regulations (27 C.F.R. §§ 478.92and 479.102), including a serial number. Any person manufacturing the gas/flare gun and “anti-personnel” ammunition must, if selling them in combination, have the appropriate Federal firearms license as a manufacturer of destructive devices and must have paid the special (occupational) tax as a manufacturer of National Firearms Act firearms. Any person importing the gas/flare gun and the “anti-personnel” type ammunition must, if importing them in combination, have the appropriate Federal firearms license as an importer of destructive devices and must have paid the special (occupational) tax as an importer of National Firearms Act firearms.

Further, the “anti-personnel” ammunition to be used in the gas/flare launchers is ammunition for destructive devices for purposes of the GCA. Any person manufacturing the “anti-personnel” ammunition ,must have the appropriate Federal firearms license as a manufacturer of ammunition for destructive devices. Any person importing the “anti-personnel” ammunition must have the appropriate Federal firearms license as an importer of ammunition for destructive devices.

HELD: 37/38 mm gas/flare guns possessed with “anti-personnel” ammunition, consisting of cartridges containing wood pellets, rubber pellets or balls, or bean bags, are destructive devices as that term is used in 18 U.S.C. § 921(a)(4) and 26 U.S.C. 5845(f)(2).

26 USC 5844, 18 USC 922(o), 22 USC 2778: IMPORTATION OF BROWNING M1919 TYPE RECEIVERS FOR UNRESTRICTED COMMERCIAL SALE.

An ATF – approved method of destruction for the Browning M 1919 type machinegun will result in the severed portions of the receiver being importable for unrestricted commercial sale.

1) ATF Rul. 2003-1

The Bureau of Alcohol, Tobacco and Firearms (ATF) has received inquiries about modifications necessary to the receiver of a Browning M1919 type machinegun to make it importable under 26 U.S.C. 5844 and 18 U.S.C. 922(o) for unrestricted commercial sale.

The Browning M1919 is a machinegun as defined in 26 U.S.C. 5845(b). The receiver of a Browning M1919 is also a machinegun as defined. Various manufacturers made Browning M1919 style machineguns in caliber .30-06 and 7.62x51mm (.308). The M1919 is a recoil operated, belt-fed machinegun designed to be fired from a mount.

Section 5844 of title 26, United States Code, makes it unlawful to import any firearm into the United States, unless the firearm to be imported or brought in is: (1) being imported for use by the United States or any department, independent establishment, or agency thereof or any State or possession or any political subdivision thereof; or (2) the firearm is being imported for scientific or research purposes; or (3) it is being imported solely for testing or use as a model by a registered or dealer. Additionally, the Secretary may permit the conditional importation of a firearm for examination and testing in connection with classifying the firearm.

Section 922(o) of Title 18, United States Code, makes it unlawful for any person to transfer or possess a machinegun, except a transfer to or by the United States or any department or agency thereof or a State or department, agency or political subdivision thereof; or any lawful transfer or lawful possession of a machinegun lawfully possessed before May 19, 1986.

A review of the statutes above indicates that machinegun and machinegun receivers cannot be lawfully imported for unrestricted commercial sale. Accordingly. Machinegun receivers may be imported for commercial sale only if they are destroyed in a manner that will prevent their function and future use as a firearm. The resulting severed receiver portions would not be subject to the provisions of 26 U.S.C. 5844 or 18 U.S.C. 922(o); however, these articles would be subject the provisions of the Arms Export Control Act, 18 U.S.C. 925, 22 U.S.C. 2778, and implementing regulation at 27 CFR Part 47. It is important to note that these machinegun receivers must be destroyed and cannot be imported whether they are serviceable or unserviceable.

An ATF-approved method of destruction for a Browning M1919 type machinegun receiver requires three diagonal torch cuts that sever or pass through the following areas: (1) the trunion or barrel mounting block (corner to corner), (2) the center area of the bolt handle slot, and (3) the cover catch and back plate spline. All cutting must be done with a cutting torch having a tip of sufficient size to displace at least ¼ inch of material at each location. Each cut must completely sever the receiver in the designated areas and must be done with a diagonal torch cut. Using a bandsaw or a cut-off wheel to destroy the receiver does not ensure destruction of the weapon.

This method of destruction is illustrated in the diagram below.

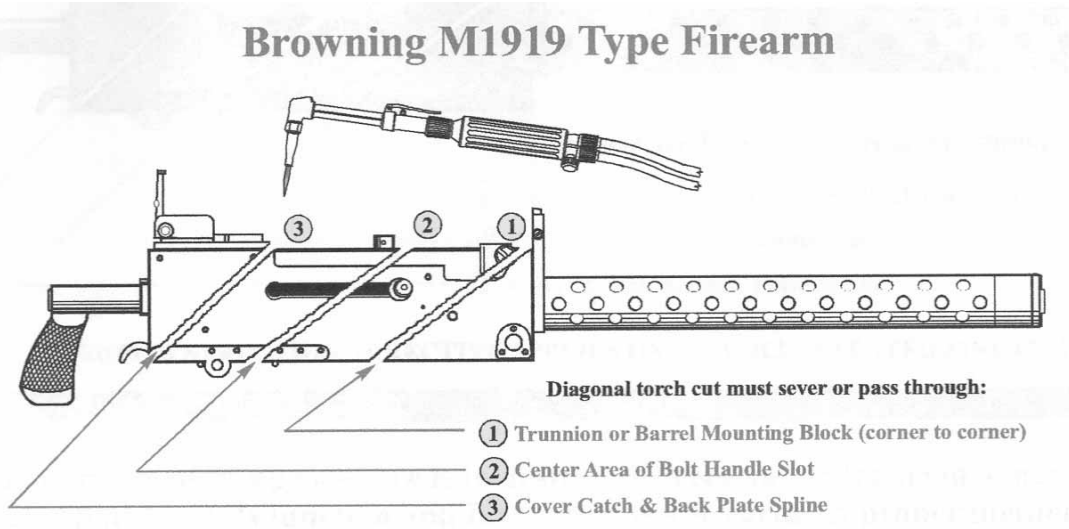

Alternative methods of destruction may also be acceptable. These alternative methods must be equivalent in degree to the approved method of destruction. Receivers that are not sufficiently modified cannot be approved for importation. To ensure compliance with the law, it is recommended that the importer submit in writing the alternative method of destruction to the ATF Firearms Technology Branch (FTB) for review and approval prior to importation.

Held, an ATF-approved method of destruction for a Browning M1919 type machinegun receiver will result in the severed portions of the receiver being importable for unrestricted commercial sale. The severed articles would not be subject to the provisions of 26 U.S.C. 5844 or 18 U.S.C. 922(o), but would continue to be subject to the provisions of the Arms Export Control Act, 22 U.S.C. 2778. Alternative methods of destruction may also be acceptable. It is recommended that such methods be reviewed and approved by the ATF Firearms Technology Branch prior to the weapon's importation.

Date signed: January 24, 2003

26 USC 5844, 18 USC 922(o), 22 USC 2778: IMPORTATION OF FN FAL TYPE RECEIVERS FOR UNRESTRICTED COMMERCIAL SALE.

An ATF – approved method of destruction for the FN FAL type machinegun will result in the severed portions of the receiver being importable for unrestricted commercial sale.

ATF Rul. 2003-2

The Bureau of Alcohol, Tobacco and Firearms (ATF) has received inquiries about modifications necessary to the receiver of an FN FAL type machinegun to make it importable under 26 U.S.C. 5844 and 18 U.S.C. 922(o) for unrestricted commercial sale.

The FN FAL is a machinegun as defined in 26 U.S.C. 5845(b). The receiver of an FAL is also a machinegun as defined. Various manufacturers made FAL style machineguns in caliber 7.62x51mm (.308). The FAL is a gas operated, shoulder fired, magazine fed, selective fire machinegun.

Section 5844 of title 26, United States Code, makes it unlawful to import any firearm into the United States, unless the firearm to be imported or brought in is: (1) being imported for use by the United States or any department, independent establishment, or agency thereof or any State or possession or any political subdivision thereof; or (2) the firearm is being imported for scientific or research purposes; or (3) it is being imported solely for testing or use as a model by a registered or dealer. Additionally, the Secretary may permit the conditional importation of a firearm for examination and testing in connection with classifying the firearm.

Section 922(o) of Title 18, United States Code, makes it unlawful for any person to transfer or possess a machinegun, except a transfer to or by the United States or any department or agency thereof or a State

or department, agency or political subdivision thereof; or any lawful transfer or lawful possession of a machinegun lawfully possessed before May 19, 1986.

A review of the statutes above indicates that machinegun and machinegun receivers cannot be lawfully imported for unrestricted commercial sale. Accordingly, Machinegun receivers may be imported for commercial sale only if they are destroyed in a manner that will prevent their function and future use as a firearm. The resulting severed receiver portions would not be subject to the provisions of 26 U.S.C. 5844 or 18 U.S.C. 922(o); however, these articles would be subject the provisions of the Arms Export Control Act, 18 U.S.C. 925, 22 U.S.C. 2778, and implementing regulation at 27 CFR Part 47. It is important to note that these machinegun receivers must be destroyed and cannot be imported whether they are serviceable or unserviceable.

An ATF-approved method of destruction for an FN FAL type machinegun receiver requires three diagonal torch cuts that sever or pass through the following areas: (1) the threaded portion of the receiver ring and magazine well opening at bottom, (2) the hinge pin, ejector block and bolt guide rails, and (3) the body locking lug and bolt guide rails. All cutting must be done with a cutting torch having a tip of sufficient size to displace at least ¼ inch of material at each location. Each cut must completely sever the receiver in the designated areas and must be done with a diagonal torch cut. Using a bandsaw or a cut-off wheel to destroy the receiver does not ensure destruction of the weapon.

This method of destruction is illustrated in the diagram below.

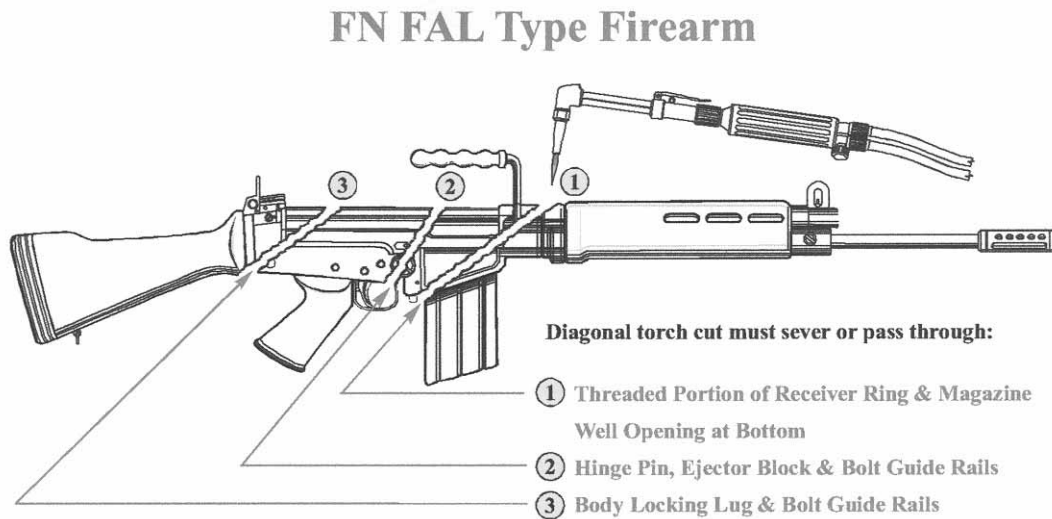

Alternative methods of destruction may also be acceptable. These alternative methods must be equivalent in degree to the approved method of destruction. Receivers that are not sufficiently modified cannot be approved for importation. To ensure compliance with the law, it is recommended that the importer submit in writing the alternative method of destruction to the ATF Firearms Technology Branch (FTB) for review and approval prior to importation.

Held, an ATF-approved method of destruction for an FN FAL type machinegun receiver will result in the severed portions of the receiver being importable for unrestricted commercial sale. The severed articles would not be subject to the provisions of 26 U.S.C. 5844 or 18 U.S.C. 922(o), but would continue to be subject to the provisions of the Arms Export Control Act, 22 U.S.C. 2778. Alternative

methods of destruction may also be acceptable. It is recommended that such methods be reviewed and approved by the ATF Firearms Technology Branch prior to the weapon's importation.

Date signed: January 24, 2003

26 USC 5844, 18 USC 922(o), 22 USC 2778: IMPORTATION OF HECKLER & KOCH G3 TYPE RECEIVERS FOR UNRESTRICTED COMMERCIAL SALE.

An ATF – approved method of destruction for the Heckler & Koch G3 type machinegun will result in the severed portions of the receiver being importable for unrestricted commercial sale.

ATF Rul. 2003-3

The Bureau of Alcohol, Tobacco and Firearms (ATF) has received inquiries about modifications necessary to the receiver of a Heckler & Koch G3 machinegun to make it importable under 26 U.S.C. 5844 and 18 U.S.C. 922(o) for unrestricted commercial sale.

The G3 is a machinegun as defined in 26 U.S.C. 5845(b). The receiver of a G3 is also a machinegun as defined. Various manufacturers made G3 style machineguns in caliber 7.62x51mm (.308). The G3 is a delayed blowback, shoulder fired, magazine fed, selective fire machinegun.

Section 5844 of title 26, United States Code, makes it unlawful to import any firearm into the United States, unless the firearm to be imported or brought in is: (1) being imported for use by the United States or any department, independent establishment, or agency thereof or any State or possession or any political subdivision thereof; or (2) the firearm is being imported for scientific or research purposes; or (3) it is being imported solely for testing or use as a model by a registered or dealer. Additionally, the Secretary may permit the conditional importation of a firearm for examination and testing in connection with classifying the firearm.

Section 922(o) of Title 18, United States Code, makes it unlawful for any person to transfer or possess a machinegun, except a transfer to or by the United States or any department or agency thereof or a State or department, agency or political subdivision thereof; or any lawful transfer or lawful possession of a machinegun lawfully possessed before May 19, 1986.

A review of the statutes above indicates that machinegun and machinegun receivers cannot be lawfully imported for unrestricted commercial sale. Accordingly, Machinegun receivers may be imported for commercial sale only if they are destroyed in a manner that will prevent their function and future use as a firearm. The resulting severed receiver portions would not be subject to the provisions of 26 U.S.C. 5844 or 18 U.S.C. 922(o); however, these articles would be subject the provisions of the Arms Export Control Act, 18 U.S.C. 925, 22 U.S.C. 2778, and implementing regulation at 27 CFR Part 47. It is important to note that these machinegun receivers must be destroyed and cannot be imported whether they are serviceable or unserviceable.

An ATF-approved method of destruction for a Heckler & Koch G3 type machinegun receiver requires four diagonal torch cuts that sever or pass through the following areas: (1) the chamber area, (2) the grip assembly locking pin hole, (3) the ejection port, and (4) the buttstock locking pin hole. All cutting must be done with a cutting torch having a tip of sufficient size to displace at least ¼ inch of material at each location. Each cut must completely sever the receiver in the designated areas and must be done with a diagonal torch cut. Using a bandsaw or a cut-off wheel to destroy the receiver does not ensure destruction of the weapon.

This method of destruction is illustrated in the diagram below.

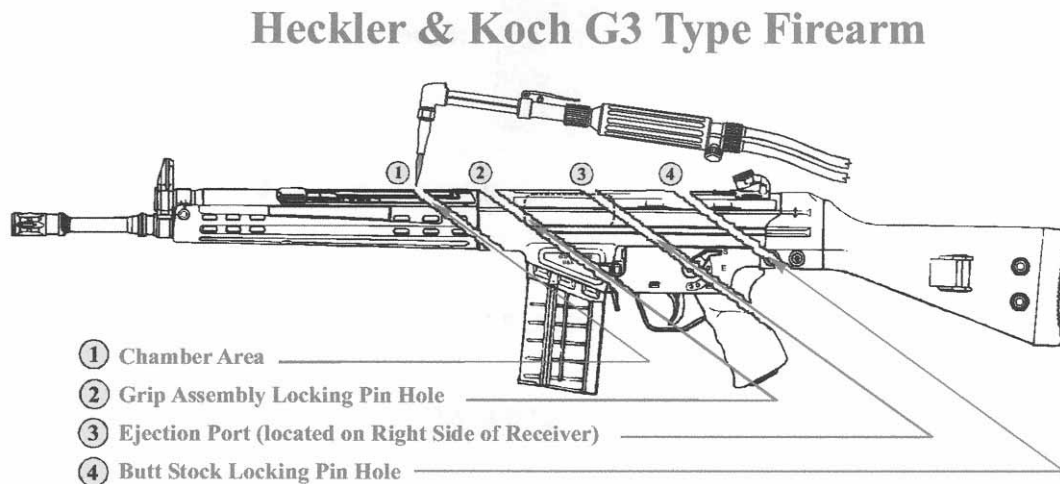

Alternative methods of destruction may also be acceptable. These alternative methods must be equivalent in degree to the approved method of destruction. Receivers that are not sufficiently modified cannot be approved for importation. To ensure compliance with the law, it is recommended that the importer submit in writing the alternative method of destruction to the ATF Firearms Technology Branch (FTB) for review and approval prior to importation.

Held, an ATF-approved method of destruction for a Heckler & Koch G3 type machinegun receiver will result in the severed portions of the receiver being importable for unrestricted commercial sale. The severed articles would not be subject to the provisions of 26 U.S.C. 5844 or 18 U.S.C. 922(o), but would continue to be subject to the provisions of the Arms Export Control Act, 22 U.S.C. 2778. Alternative methods of destruction may also be acceptable. It is recommended that such methods be reviewed and approved by the ATF Firearms Technology Branch prior to the weapon's importation.

Date signed: January 24, 2003

26 USC 5844, 18 USC 922(o), 22 USC 2778: IMPORTATION OF STEN TYPE RECEIVERS FOR UNRESTRICTED COMMERCIAL SALE.

An ATF – approved method of destruction for the Sten type machinegun will result in the severed portions of the receiver being importable for unrestricted commercial sale.

ATF Rul. 2003-4

The Bureau of Alcohol, Tobacco and Firearms (ATF) has received inquiries about modifications necessary to the receiver of a Sten type machinegun to make it importable under 26 U.S.C. 5844 and 18 U.S.C. 922(o) for unrestricted commercial sale.

The Sten is a machinegun as defined in 26 U.S.C. 5845(b). The receiver of a Sten is also a machinegun as defined. Various manufacturers made Sten style machineguns in caliber 9x19mm (9mm Luger). The Sten is a blowback-operated, shoulder fired, magazine fed, selective-fire submachinegun.

Section 5844 of title 26, United States Code, makes it unlawful to import any firearm into the United States, unless the firearm to be imported or brought in is: (1) being imported for use by the United States or any department, independent establishment, or agency thereof or any State or possession or any political subdivision thereof; or (2) the firearm is being imported for scientific or research purposes; or (3) it is being imported solely for testing or use as a model by a registered or dealer. Additionally, the Secretary may permit the conditional importation of a firearm for examination and testing in connection with classifying the firearm.

Section 922(o) of Title 18, United States Code, makes it unlawful for any person to transfer or possess a machinegun, except a transfer to or by the United States or any department or agency thereof or a State or department, agency or political subdivision thereof; or any lawful transfer or lawful possession of a machinegun lawfully possessed before May 19, 1986.

A review of the statutes above indicates that machinegun and machinegun receivers cannot be lawfully imported for unrestricted commercial sale. Accordingly, Machinegun receivers may be imported for commercial sale only if they are destroyed in a manner that will prevent their function and future use as a firearm. The resulting severed receiver portions would not be subject to the provisions of 26 U.S.C. 5844 or 18 U.S.C. 922(o); however, these articles would be subject the provisions of the Arms Export Control Act, 18 U.S.C. 925, 22 U.S.C. 2778, and implementing regulation at 27 CFR Part 47. It is important to note that these machinegun receivers must be destroyed and cannot be imported whether they are serviceable or unserviceable.

An ATF-approved method of destruction for a Sten type machinegun receiver requires three diagonal torch cuts that sever or pass through the following areas: (1) the threaded portion of the receiver/chamber area, (2) the return spring cap socket, and (3) the sear slot in the lower side of the receiver. All cutting must be done with a cutting torch having a tip of sufficient size to displace at least ¼ inch of material at each location. Each cut must completely sever the receiver in the designated areas and must be done with a diagonal torch cut. Using a bandsaw or a cut-off wheel to destroy the receiver does not ensure destruction of the weapon.

This method of destruction is illustrated in the diagram below.

Sten Type Firearm

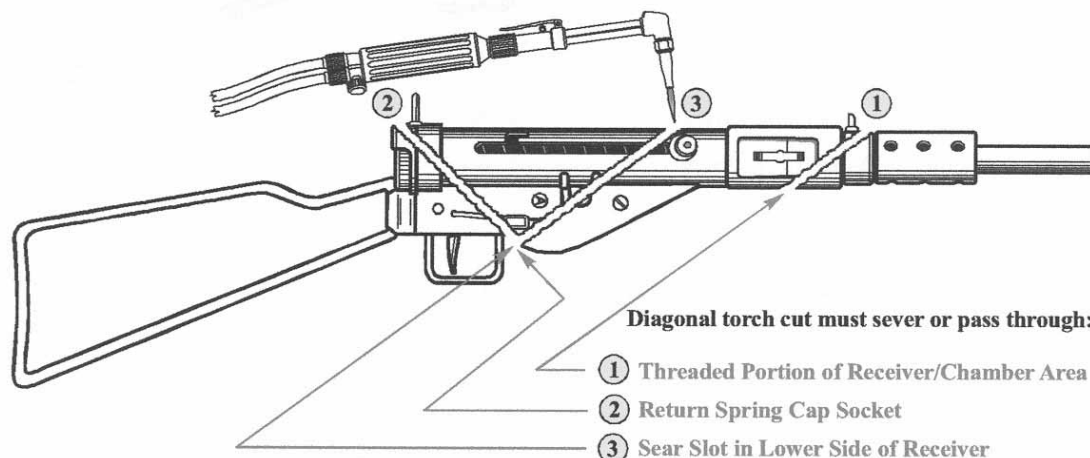

Alternative methods of destruction may also be acceptable. These alternative methods must be equivalent in degree to the approved method of destruction. Receivers that are not sufficiently modified cannot be approved for importation. To ensure compliance with the law, it is recommended that the importer submit in writing the alternative method of destruction to the ATF Firearms Technology Branch (FTB) for review and approval prior to importation.

Held, an ATF-approved method of destruction for a Sten type machinegun receiver will result in the severed portions of the receiver being importable for unrestricted commercial sale. The severed articles would not be subject to the provisions of 26 U.S.C. 5844 or 18 U.S.C. 922(o), but would continue to be subject to the provisions of the Arms Export Control Act, 22 U.S.C. 2778. Alternative methods of destruction may also be acceptable. It is recommended that such methods be reviewed and approved by the ATF Firearms Technology Branch prior to the weapon's importation.

Date signed: January 24, 2003

2) 26 U.S.C. 5812, 5841, 5844, 5861, 5872

27 CFR 479.11, 479.26, 479.105, 479.111, 479.112, 479.114 – 479.119: IMPORTATION OF FIREARMS SUBJECT TO THE NATIONAL FIREARMS ACT.

18 U.S.C. 921(a)(3), 922(i), 922(o), 923(e), 924(d), 925(d)(3)

27 CFR 478.11, 478.22, 478.111 – 478.113: IMPORTATION OF MACHINEGUNS, DESTRUCTIVE DEVICES, SHORT -BARREL SHOTGUNS, SHORT-BARREL RIFLES, FIREARMS SILENCERS, AND OTHER FIREARMS SUBJECT TO THE NATIONAL FIREARMS ACT.

22 U.S.C. 2778

27 CFR 447.11, 447.21: TEMPORARY IMPORTATION OF DEFENSE ARTICLES

The Bureau of Alcohol, Tobacco, Firearms and Explosives (ATF) has approved an alternate method or procedure for importers to use when temporarily importing firearms subject to the National Firearms Act, the Gun Control Act and the Arms Export Control Act for inspection, testing, calibration, repair, or incorporation into another defense article.

3) ATF Rul. 2004-2

The Bureau of Alcohol, Tobacco, Firearms and Explosives (ATF) has received numerous inquiries from importers who wish to temporarily import firearms subject to the Gun Control Act of 1968 (GCA), 18 U.S.C. Chapter 44, and the National Firearms Act (NFA), 26 U.S.C. Chapter 53, for inspection, testing, calibration, repair, or incorporation into another defense article. Importers advise ATF that they generally obtain a temporary import license, DSP-61, from the Department of State authorizing the importation or comply with one of the regulatory exemptions from licensing in 22 CFR 123.4. They ask whether such a license or exemption is sufficient to satisfy the requirements of the GCA and NFA.

- i) Statutory Background*
- ii)*
- iii) 1. The National Firearms Act*

The NFA imposes restrictions on certain firearms, including registration requirements, transfer approval requirements, and import restrictions. 26 U.S.C. 5812, 5841, 5844. The term “firearm” is defined in 26 U.S.C. 5845(a) to include machineguns, short-barrel shotguns, short-barrel rifles, silencers, destructive devices, and “any other weapons.” Section 5844 of the NFA provides that no firearm may be imported into the United States unless the importer establishes that the firearm to be imported is –

- (1) Being imported or brought in for the use of the United States or any department, independent establishment, or agency thereof or any State or possession or any political subdivision thereof; or
- (2) Being imported or brought in for scientific or research purposes; or
- (3) Being imported or brought in solely for testing or use as a model by a registered manufacturer or solely for use as a sample by a registered importer or registered dealer.

Regulations implementing the NFA in 27 CFR Part 479 require importers to obtain an ATF Form 6, Application and Permit for Importation of Firearms, Ammunition and Implements of War, prior to importing NFA firearms into the United States. 27 CFR 479.111. In addition, the regulations require importers to register the firearms they import by filing with the Director an accurate notice on Form 2, Notice of Firearms Manufactured or Imported, executed under the penalties of perjury, showing the importation of the firearm. 27 CFR 479.112. When an NFA firearm is to be exported from the United

States, the exporter must file with the Director an application on form 9, Application and Permit for Exportation of Firearms, to obtain authorization to export the firearm. 27 CFR 479.114-119.

Regulations in 27 CFR Part 479 indicate that NFA firearms may be imported for scientific or research purposes or for testing or use as a model by a registered manufacturer or as a sample by a registered importer or a registered dealer. 27 CFR 479.111(a). However, section 479.105(c), implementing section 922(o) of the GCA, clarifies that machineguns manufactured on or after May 19, 1986, may be imported only with a purchase order for transfer to a governmental entity, or as a dealer's sales sample pursuant to section 479.105(d).

The regulations in Part 479 give the Director the authority to approve an alternate method or procedure in lieu of a method or procedure specifically prescribed in the regulations when it is found that:

- (1) The alternate method or procedure is within the purpose of, and consistent with the effect intended by, the specifically prescribed method or procedure and that the alternate method or procedure is substantially equivalent to that specifically prescribed method or procedure; and
- (2) Good cause is shown for the use of the alternate method or procedure.
- (3) The alternate method or procedure will not be contrary to any provision of law and will not result in an increase in cost to the Government or hinder the effective administration of the GCA or regulations issued thereunder.

27 CFR 479.26

2. The Gun Control Act

Import provisions of the GCA, 18 U.S.C. 922(i) and 925(d)(3), generally prohibit the importation of firearms subject to the NFA, except for the use of governmental entities. 18 U.S.C. 925(a)(1). The term "firearm" is defined in section 921(a)(3) to include any weapon which will or is designed to or may be readily converted to expel a projectile by the action of an explosive; the frame or receiver of any such weapon; any firearm silencer; and any destructive device. In addition, section 922(o) of the GCA prohibits the transfer or possession of a machinegun manufactured on or after May 19, 1986, except for the official use of governmental entities.

Regulations implementing the GCA in 27 CFR part 478 require that persons importing firearms into the United States obtain an approved ATF Form 6, Application and Permit for Importation of Firearms, Ammunition and Implements of War, prior to bringing the firearm into the United States. 27 CFR 478.111-114. Regulations in Part 478 provide that the Director may approve an alternate method or procedure in lieu of a method or procedure specifically prescribed by the GCA and regulations when it is found that:

- (1) The alternate method or procedure is within the purpose of, and consistent with the effect intended by, the specifically prescribed method or procedure and that the alternate method or procedure is substantially equivalent to that specifically prescribed method or procedure; and

(2) Good cause is shown for the use of the alternate method or procedure.

(2) The alternate method or procedure will not be contrary to any provision of law and will not result in an increase in cost to the Government or hinder the effective administration of the GCA or regulations issued thereunder.

27 CFR 478.22

3. The Arms Export Control Act

The Arms Export Control Act (AECA), 22 U.S.C. 2778, gives the President the authority to control the export and import of defense articles and defense services in furtherance of world peace and the security and foreign policy of the United States. Authority to administer the permanent import provisions of the AECA was delegated to Attorney General, while the authority to administer the export and temporary import provisions of the AECA was delegated to the Secretary of State, Executive Order 11958 of January 18, 1977, as amended by Executive Order 13333 of January 23, 2003, 3 CFR Executive Order 13284.

The term “defense article” is defined in 27 CFR 447.11 as any item designated in sections 447.21 or 447.22. Section 447.21, the U.S. Munitions Import List, includes a number of defense articles that are also subject to the GCA and NFA. Category I, “Firearms,” includes nonautomatic and semiautomatic firearms to caliber .50 inclusive, combat shotguns, shotguns with barrels less than 18 inches in length, and firearms silencers and suppressors. All Category I firearms are subject to the GCA. “Combat shotguns” include the USAS-12 shotgun and the Striker-12/Streetsweeper shotgun, which have been classified as destructive devices under the GCA and NFA. In addition, all shotguns with barrels of less than 18 inches in length are subject to both the GCA and NFA. All rifles with barrels of less than 16 inches in length are subject to both the GCA and NFA, and silencers are subject to both the GCA and NFA.

Category II, “Artillery Projectors,” includes guns over .50, howitzers, mortars, and recoilless rifles. Firearms over .50 caliber have a bore of more than one-half inch in diameter and are “destructive devices” as defined in the GCA and NFA.

Category IV, “launch Vehicles, Guided Missiles, Ballistic Missiles, Rockets, torpedoes, Bombs and Mines,” includes rockets, bombs, grenades, torpedoes, and land and naval mines. All these articles are “destructive devices” as defined in the GCA and NFA.

Regulations of the Department of State implementing the AECA generally require a temporary import license, DSP-61, for the temporary import and subsequent export of unclassified defense articles, unless otherwise exempted. 22 CFR 123.3. Regulations in 22 CFR 123.4 provide an exemption from licensing if the item temporarily imported:

- (1) Is serviced (e.g., inspection, testing, calibration or repair, including overhaul, reconditioning and one-to-one replacement of any defective items, parts or components, but excluding any modification, enhancement, upgrade or other form of alteration or improvement that changes the basic performance of the item), and is subsequently returned to the country from which it was imported. Shipment may be made by the U.S. importer or a foreign government representative of the country from which the goods were imported; or

- (2) Is to be enhanced, upgraded or incorporated into another item which has already been authorized by the Office of Defense Trade Controls for permanent export; or
- (3) Is imported for the purpose of exhibition, demonstration or marketing in the United States and is subsequently returned to the country from which it was imported; or
- (4) Has been rejected for permanent import by the Department of the Treasury [after January 24, 2003, the Department of Justice] and is being returned to the country from which it was shipped; or
- (5) Is approved for such import under the U.S. Foreign Military Sales (FMS) program pursuant to an executed U.S. Department of Defense Letter of Offer and Acceptance (LOA).

Willful violations of the AECA are punishable by imprisonment for not more than 10 years, a fine of not more than \$1,000,000, or both. 22 U.S.C. 2778©. Articles imported in violation of the AECA are also subject to seizure and forfeiture. 18 U.S.C. 545.

Discussion

A temporary import license authorizing the temporary importation and subsequent export of a defense article by the Department of State satisfies all legal requirements under the AECA. Importers may also comply with AECA requirements if the importation meets one of the exemptions in 22 CFR 123.4. However, if the defense article is subject to the GCA and NFA, the importer must also comply with the requirements of those statutes. Neither the GCA nor NFA make a distinction between temporary importation and permanent importation, as is the case under the AECA. Regulations implementing the GCA and NFA make it clear that an “importation” occurs when firearms are brought into the territory of the United States. 27 CFR 478.11 and 479.11. Accordingly, any bringing of firearms into the territory of the United States is subject to the import provisions of the GCA and NFA. Issuance of a temporary import license by the Department of State, or exemption from licensing under regulations in 22 CFR Part 123, will not excuse compliance with the GCA and NFA.

The statutes and regulations outlined above do not address the importation of machineguns manufactured after May 19, 1986, for scientific or research purposes or for testing, repair, or for use as a model by a manufacturer or importer. Nor do the regulations address the importation of post-86 machineguns for repair, inspection, calibration, or incorporation into another defense article.

For other” defense articles” that are subject to the requirements of the GCA and NFA, such as silencers, destructive devices, and short-barrel weapons, ATF has the authority to approve the importation of such firearms for scientific or research purposes or for testing or use as a model or sample by a registered importer or a registered dealer. However, such importation must comply with all applicable provisions of the NFA, including filing of a Form 2, Notice of Firearms Manufactured or Imported, to effect registration. If such articles are subsequently exported, a Form 9, Application and Permit for Permanent Exportation of Firearms, must also be approved prior to exportation.

As with post-86 machineguns, neither the law nor regulation specifically address the importation of firearms subject to the NFA for purposes of repair, inspection, calibration, or for incorporation into another defense article.

ATF recognizes that inspection, repair, calibration, incorporation into another defense article, and reconditioning of machineguns, destructive devices, and other NFA firearms is often necessary for National defense. These defense articles are frequently sold to allies of the United States for their legitimate defense needs. Accordingly, ATF believes it is appropriate to recognize an alternate method that allows importers to temporarily import these firearms, subject to requirements to ensure the security of these defense articles while they are in the United States and accountability of the persons who import them.

Pursuant to 27 CFR 478.22 and 479.26, ATF hereby authorizes an alternate method or procedure for importers of defense articles to use for temporary importation of such articles for inspection, calibration, repair, or incorporation into another defense article when such articles are subject to the requirements of the NFA and GCA. The procedure requires that importers-

- (1) Be qualified under the GCA and NFA to import the type of firearms sought for importation;
- (2) Obtain a temporary import license, DSP-61, from the Department of State in accordance with 22CFR 123.3 OR qualify for a temporary import license exemption pursuant to 22 CFR 123.4;
- (3) Within 15 days of the release of the firearms from Customs custody, file an ATF Form 2, Notice of Firearms Manufactured or Imported, showing the importation of the firearms. The DSP-61 must be attached to the Form 2. If the importation is subject to a licensing exemption under 22 VFR 123.4, the importer must submit with the ATF Form 2 a statement, under penalty of perjury, attesting to the exemption and stating that the article will be exported within four years of its importation into the United States;
- (4) Maintain the defense articles in a secure place and manner to ensure that the articles are not diverted to criminal or terrorist use; and
- (5) Export the articles within 4 years of importation into the United States.

Importers who follow the procedures outlined above will be in compliance with the provisions of the GCA, NFA, and AECA administered and enforced by ATF. All other provisions of the law must be followed.

ATF finds that the procedure outlined above meets the legal requirements for an alternate method or procedure because there is a good cause to authorize the importation of defense articles for repair, inspection, calibration, or incorporation into another defense article. Because such defense articles are often provided to allies of the United States, it is imperative that the original manufacturers have a lawful method of importing such articles for repair and routing maintenance. The alternate method or procedure is consistent with the effect intended by the procedure set forth in the GCA and NFA, because the firearms must be registered and stored securely. Finally, the alternate method is consistent with the requirements of the GCA and NFA and will not result in any additional costs to ATF or the Department of State.

“Transfers” of NFA Weapons After Importation

ATF recognizes that temporarily imported NFA firearms are sometimes “transferred” from the importer to a contractor within the United States for inspection, testing, calibration, repair, or incorporation into another defense article. ATF has approved a procedure for authorizing the transportation or delivery of temporarily imported NFA firearms to licensed contractors for repair or manipulation, as noted above.

Conveyance of an NFA weapon to a licensee for purposes of inspection, testing, calibration, repair, or incorporation into another defense article is generally not considered to be a “transfer” under 26 U.S.C. 5845(j). ATF has taken the position that temporary custody by a licensee is not a transfer for purposes of the NFA since no sale, lease, or other disposal is intended by the owner. However, in order to document the transaction as a temporary conveyance and make clear that an actual “transfer” of a firearm has not taken place, ATF strongly recommends that the importer submit a Form 5, Application for Tax Exempt Transfer and Registration of Firearm, for approval prior to conveying a firearm for repair or manipulation. In the alternative, the importer should convey the weapon with a letter to the contractor, stating: (1) the weapon is being temporarily conveyed for inspection, testing, calibration, repair, or incorporation into another defense article; and (2) the approximate time period the weapon is to be in the contractor’s possession. The transferee must be properly licensed to engage in an NFA firearms business.

Held, pursuant to 27 CFR 478.22 and 479.26, the Bureau of Alcohol, Tobacco, Firearms and Explosives has approved an alternate method or procedure for importers to use when temporarily importing firearms subject to the Gun Control Act, National Firearms Act, and the Arms Export Control Act for inspection, testing, calibration, repair, or incorporation into another defense article. This procedure applies to all defense articles that are also subject to the NFA and GCA. The procedure requires that importers-

- (1) Be qualified under the GCA and NFA to import the type of firearms sought for importation;
- (2) Obtain a temporary import license, DSP-61, from the Department of State in accordance with 22CFR 123.3 OR qualify for a temporary import license exemption pursuant to 22 CFR 123.4;
- (3) Within 15 days of the release of the firearms from Customs custody, file an ATF Form 2, Notice of Firearms Manufactured or Imported, showing the importation of the firearms. The DSP-61 must be attached to the Form 2. If the importation is subject to a licensing exemption under 22 VFR 123.4, the importer must submit with the ATF Form 2 a statement, under penalty of perjury, attesting to the exemption and stating that the article will be exported within four years of its importation into the United States;
- (4) Maintain the defense articles in a secure place and manner to ensure that the articles are not diverted to criminal or terrorist use; and
- (5) Export the articles within 4 years of importation into the United States.

Held further, temporary conveyance of NFA weapons from the importer to a contractor within the United States for purposes of inspection, testing, calibration, repair, or incorporation into another defense article may be accomplished through advance approval of ATF Form 5, Application for Tax Exempt Transfer and Registration of Firearm, or with a letter from the importer to the contractor stating: (1) the weapon is being temporarily conveyed for inspection, testing, calibration, repair, or incorporation into another defense article; and (2) the approximate time period the weapon is to be in the contractor’s possession. The transferee must be properly licensed to engage in an NFA firearms business.

Date signed: April 7, 2004

26 U.S.C. 5845(B): DEFINITIONS (MACHINEGUN)

27 CFR 479.11: MEANING OF TERMS

The 7.62mm Aircraft Machine Gun, identified in the U.S. military inventory as the “m-134” (Army), “GAU-2B/A” (Air Force), and “GAU-17/A” (Navy), is a machinegun as defined by 26 U.S.C. 5845(b), Rev. Rul. 55-528 modified.

ATF Rul. 2004-5

The Bureau of Alcohol, Tobacco, firearms and Explosives (ATF) has examined the 7.62mm Aircraft Machine Gun, commonly referred to as a “Minigun.” The Minigun is a 36 pound, six barrel, electrically powered machinegun. It is in the U.S. military inventory and identified as the “M-134” (Army), “GAU 2B/A” (Air force), and “GAU 17/A” (Navy). It is a lightweight and extremely reliable weapon, capable of discharging up to 6,000 rounds per minute. It has been used on helicopters, fixed-wing aircraft, and wheeled vehicles. It is highly adaptable, being used with pintle mounts, turrets, pods, and internal installations.

The Minigun has six barrels and bolts which are mounted on a rotor. The firing sequence begins with the manual operation of a trigger. On an aircraft, the trigger is commonly found on the control column, or joy stick. Operation of the trigger causes an electric motor to turn the rotor. As the rotor turns, a stud on each bolt travels along an elliptical groove on the inside of the housing, which causes the bolts to move forward and rearward on tracks on the rotor. A triggering cam, or sear shoulder, trips the firing pin when the bolt has traveled forward through the full length of the bolt track. One complete revolution of the rotor discharges cartridges from all six barrels. The housing that surrounds the rotor, bolts and firing mechanism constitutes the frame or receiver of the firearm.

The National Firearms Act defines “machinegun” as “any weapon which shoots, is designed to shoot, or can be readily restored to shoot, automatically more than one shot, without manual reloading, by a single function of the trigger.” 26 U.S.C. 5845(b). The term also includes “the frame or receiver of any such weapon, any part designed and intended solely and exclusively, or combination of parts designed and intended, for use in converting a weapon into a machinegun, and any combination of parts from which a machinegun can be assembled if such parts are in the possession or under the control of a person.” *Id.*; see 18 U.S.C. 921(a)(23); 27 CFR 478.11, 479.11.

ATF and its predecessor agency, the Internal Revenue Service (IRS), have historically held that the original, crank-operated Gatling Gun, and replicas thereof, are not automatic firearms or machineguns as defined. See Rev. Rul. 55-528, 1955-2 C.B. 482. The original Gatling gun is a rapid-firing, hand-operated weapon. The rate of fire is regulated by the rapidity of the hand cranking movement, manually controlled by the operator. It is not a “machinegun” as that term is defined in 26 U.S.C. 5845(b) because it is not a weapon that fires automatically.

The Minigun is not a Gatling Gun. It was not produced under the 1862 – 1893 patents of the original Gatling Gun. While using a basic design concept of the Gatling Gun, the Minigun does not incorporate any of Gatling’s original components and its feed mechanisms are entirely different. Critically, the Minigun shoots more than one shot, without manual reloading, by a single function of the trigger, as prescribed by 26 U.S.C. 5845(b). See United States v. Fleischli, 305 F. 3d 643, 655-656 (7th Cir. 2002). See also Staples v. United States, 511 U.S. 600, 603 (1994) (automatic refers to a weapon that “once its trigger is depressed, the weapon will automatically continue to fire until its trigger is released or the ammunition is exhausted”); GEORGE C. NONTE, JR., FIREARMS ENCYCLOPEDIA 13 (Harper & Rowe 1973) (the term “automatic” is defined to include “any firearm in which a single pull and continuous pressure upon the trigger (or other firing device) will produce rapid discharge of successive shots so long as ammunition remains in the magazine or feed device in other words, a machinegun”); WEBSTER’S II NEW RIVERSIDE-UNIVERSITY DICTIONARY (1988) (defining automatically as

“acting or operating in a manner essentially independent of external influence or control”); JOHN B. QUICK, PH.D., DICTIONARY OF WEAPONS AND MILITARY TERMS 40 (McGraw-hill 1973) (defining automatic fire as “continuous fire from an automatic gun, lasting until pressure on the trigger is released”).

The term “trigger” is generally held to be the part of a firearm that is used to initiate the firing sequence. See United States v. Fleischli, 305 F.3d at 655-56 (and cases cited therein); see also ASSOCIATION OF FIREARMS AND TOOLMARK EXAMINERS (ATFE) GLOSSARY 185 (1st ed. 1980) (“that part of a firearm mechanism which is moved manually to cause the firearm to discharge”); WEBSTER’S II NEW RIVERSIDE-UNIVERSITY DICTIONARY (1988) (“lever pressed by the finger in discharging a firearm”).

Held, the 7.62mm Minigun is designed to shoot automatically more than one shot, without manual reloading, by a single function of the trigger. Consequently, the 7.62mm Minigun is a machinegun as defined in section 5845(b) of the National Firearms Act. See United States v. Fleischli, 305 F. 3d at 655-56. Similarly, the housing that surrounds the rotor is the frame or receiver of the Minigun, and thus is also a machinegun. *Id.*; see 18 U.S.C. 921(a)(23); 27 CFR 478.11, 479.11.

To the extent this ruling is inconsistent with Revenue Ruling 55-528 issued by the IRS, Revenue Ruling 55-528, 1955-2 C.B. 482 is hereby modified.

Date signed: August 18, 2004

Carl J. Truscott
Director



U.S. Department of Justice

Bureau of Alcohol, Tobacco,
Firearms and Explosives

January 31, 2006

www.atf.gov

901040:GS
5320Federal Firearms Licensees and National Firearms Act
Special (Occupational) Taxpayers

SUBJECT: Filing National Firearms Act Transaction Forms by Facsimile Transmission

This is to update information regarding the filing of certain National Firearms Act (NFA) forms by facsimile transmission as the functions of the NFA Branch have been relocated to Martinsburg, West Virginia from Washington, DC. Please note that the contact information for the NFA Branch is:

Bureau of Alcohol, Tobacco, Firearms and Explosives
NFA Branch
244 Needy Road
Martinsburg, WV 25401
Telephone: (304) 616-4500
Facsimile: (304) 616-4501

The Bureau of Alcohol, Tobacco, Firearms and Explosives (ATF) held in ATF Ruling 89-1, that certain forms required by ATF may be filed by facsimile transmission. This ruling and ATF Industry Circular 89-6 set forth the requirements and procedures.

The NFA Branch had determined that for forms filed under the NFA, the procedure would be available for ATF Form 2, Form 3, Form 9, and for Form 5 in situations where the application is not accompanied by fingerprint cards. The submission of NFA forms may only be done by Federal firearms licensees who have paid the special (occupational) tax to import, manufacture, or deal in NFA firearms.

If you choose to utilize the procedure, each person who will be filing forms on behalf of the licensee must first submit to us (in original) an affidavit declaring, under penalties of perjury, that certain conditions will be met. These conditions are detailed in the attached sample affidavit. The affidavit needs only to be submitted once. If you have previously filed an affidavit with us, there is no need to file another.

**AFFIDAVIT FOR FACSIMILE TRANSMITTAL OF
NFA NOTICE OR TRANSFER APPLICATION FORMS**

TO: Bureau of ATF
NFA Branch
244 Needy Road, Martinsburg, WV 25401

AFFIDAVIT

I, _____, doing business as _____
_____ hereby state:

1. In addition to those applications sent via U.S. mail, I will be filing ATF Forms (2, 3, 5 and/or 9) by facsimile transmission;
2. The signature appearing on the facsimile copies will be mine and is intended as the original signature;
3. I will be submitting the facsimile copies as originals for purposes of approval under the provisions of Title 27, Code of Federal Regulations, Part 479, and that the facsimile copies are to be treated as originals; and
4. I will personally transmit the copies via facsimile machine.

I declare under penalty of perjury under the laws of the United States that the above information is true and correct.

Signature	Date
Name	
Title	
Trade name	
Address	
Telephone	
FFL number	
EIN	

ATF Ruling 89-1

The Bureau of Alcohol, Tobacco and Firearms has been asked whether certain forms and other documents could optionally be transmitted to the Bureau by means of facsimile machines. These include various application forms, comments on notices of proposed rulemaking, reports, and other documents submitted to the Bureau.

Recent technology advances have made transmitting documents by facsimile machine practical and the use of facsimile machines has become widespread. The Bureau has acquired several facsimile machines and found them to be acceptable for transmitting many types of documents.

The statutes administered by the Bureau (including the Internal Revenue Code, the Federal Alcohol Administration Act, the Gun Control Act, Title XI of the Organized Crime Control Act of 1970, and the Arms Export Control Act) generally specify the information to be included on documents that are submitted to the Bureau. However, the form of the documents and the manner of filing are generally left to the Secretary of the Treasury to prescribe by regulation. The regulations issued pursuant to these statutes generally require that forms and other documents be submitted in original and signed by the applicant, licensee, or permittee.

The Bureau has concluded that if the person transmitting the form or document intends that it be treated as an original and it is filed via a facsimile machine at the person's direction, then the facsimile copy received by the Bureau would be for all intents and purposes the original.

In order to verify the authenticity of a signature on forms and other documents required to be signed under penalties of perjury, the Bureau will require that an affidavit executed by the person signing the facsimile documents be submitted to the Bureau prior to acceptance of any facsimile transmitted copies of such forms or documents.

The affidavit should declare, under penalties of perjury, that the affiant will be filing the appropriate forms or documents by facsimile machine, that the signature appearing on the facsimile copies will be that of the affiant, and is intended as the original signature.

The affidavit should also state that the affiant will be submitting the facsimile copies as originals for approval or other purposes under the appropriate regulations and that the affiant intends that the facsimile copies be treated as originals.

Finally, the affidavit should also state that the person signing the form or other document will personally transmit the copy via facsimile machine, or, if a designated agent is to do the transmittal, the name of the agent who will do the actual transmittal.

The affidavit would only have to be submitted one time to each Bureau office to which facsimile transmitted copies are to be sent, and would not have to be resubmitted unless a different official would be signing or transmitting the copies.

The Bureau concludes that only documents that are legible and of suitable size (8 1/2" X 11") may be submitted by facsimile transmission. The Bureau also concludes that facsimile transmitted copies would not be acceptable with respect to documents which are accompanied by such articles as samples, fingerprint cards, photographs, checks, and labels for alcoholic beverage containers.

The acceptance of facsimile transmitted copies at some Bureau offices may be restricted due to limited availability of facsimile machines, telephone lines or other reasons. If an ATF form may be submitted by facsimile transmission, the instructions on the form will so specify, and will also indicate the locations and telephone numbers where the transmissions may be sent. Instructions for facsimile transmitted copies of comments on a notice of proposed rulemaking will be provided in the notice itself.

Accordingly, the Bureau has determined that facsimile transmitted copies of forms and other documents may be accepted under certain conditions.

Held, forms and other documents submitted to the Bureau may be accepted when transmitted by facsimile

<http://www.ttb.gov/rulings/89-1.htm>

4/9/2007

machines under the following conditions:

1. The Bureau office to where the forms or other documents are to be submitted is suitably equipped with facsimile machines and telephone lines to receive the facsimile transmitted copies.
2. The forms or other documents are legible and of suitable size (8 1/2" X 11") for facsimile transmission.
3. The forms or other documents are transmitted in accordance with instructions provided on the form, notice of proposed rulemaking, or by other competent authority.
4. The forms or other documents are not accompanied by other articles such as samples, fingerprint cards, photographs, checks, and labels for alcoholic beverage containers.
5. Prior to accepting any facsimile transmitted copies of forms and other documents required to be signed under penalties of perjury, the Bureau must have received an acceptable affidavit executed by the person whose signature appears on the forms or documents. The affidavit must declare, under penalties of perjury, that
 - a. the affiant will be filing the appropriate forms or other documents by facsimile machine,
 - b. that the signature appearing on the facsimile copies will be that of the affiant, and is intended as the original signature,
 - c. the affiant will be submitting the facsimile copies as originals for purposes of approval or other purpose under the appropriate regulations and that the affiant intends that the facsimile copies be treated as originals, and
 - d. the person signing the forms or other documents will personally transmit the copies via facsimile machine, or, if a designated agent is to do the transmittal, the name of the agent who will do the actual transmittal.
6. The affidavit is required to be submitted only one time to each Bureau office to which facsimile transmitted copies are to be sent, and need not be resubmitted unless a different official will be signing or transmitting the forms.

Industry Circular

Number: 89-6

Date: September 27, 1989

Department of the Treasury
Bureau of Alcohol, Tobacco and Firearms
Washington, DC 20226



FACSIMILE TRANSMITTED COPIES OF FORMS AND OTHER DOCUMENTS

All Alcohol, Tobacco, Firearms and Explosives Licensees, Permittees, and Others Concerned:

PURPOSE. The purpose of this circular is to advise industry members that an ATF ruling will be published in a future issue of the Alcohol, Tobacco and Firearms Quarterly Bulletin. The ruling will read substantially as follows:

The Bureau of Alcohol, Tobacco and Firearms has been asked whether certain forms and other documents could optionally be transmitted to the Bureau by means of facsimile machines. These include various application forms, comments on notices of proposed rulemaking, reports, and other documents submitted to the Bureau.

Recent technological advances have made transmitting documents by facsimile machine practical and the use of facsimile machines has become widespread. The Bureau has acquired several facsimile machines and found them to be acceptable for transmitting many types of documents.

The statutes administered by the Bureau (including the Internal Revenue Code of 1986, the Federal Alcohol Administration Act, the Gun Control Act of 1968, Title XI of the Organized Crime Control Act of 1970, and the Arms Export Control Act) generally specify the information to be included on documents that are submitted to the Bureau. However, the form of the documents and the manner of filing are generally left to the Secretary of the Treasury to prescribe by regulation. The regulations issued pursuant to these statutes generally require that forms and other documents be submitted in original and signed by the applicant, licensee, or permittee.

The Bureau has concluded that if the person transmitting the form or document intends that it be treated as an original and it is filed via a facsimile machine at the person's direction, then the facsimile copy received by the Bureau would be for all intents and purposes the original.

In order to verify the authenticity of a signature on forms and other documents required to be signed under penalties of perjury, the Bureau will require that an affidavit executed by the person signing the forms or documents be submitted to the Bureau prior to acceptance of any facsimile transmitted copies of such forms or documents.

The affidavit should declare, under penalties of perjury, that the affiant will be filing the appropriate forms or documents by facsimile machine, that the signature appearing on the facsimile copies will be that of the affiant, and that the signature on the facsimile is intended as the original signature.

The affidavit should also state that the affiant will be submitting the facsimile copies as originals for approval or other purposes under the appropriate regulations and that the affiant intends that the facsimile copies be treated as originals.

Finally, the affidavit should also state that the person signing the form or other document will personally transmit the copy via facsimile machine, or, if a designated agent is to do the transmittal,

the name of the agent who will do the actual transmittal will be stated.

The affidavit would only have to be submitted one time to each Bureau office to which facsimile transmitted copies are to be sent, and would not have to be resubmitted unless a different official would be signing or transmitting the copies.

The Bureau concludes that only documents that are legible and of suitable size (8 1/2" X 11" or as specifically authorized by the receiving office) may be submitted by facsimile transmission. The Bureau also concludes that facsimile transmitted copies would not be acceptable with respect to fingerprint cards, bonds, photographs, checks, or labels for alcoholic beverage containers or the forms or documents required to be submitted with such items.

The acceptance of facsimile transmitted copies at some Bureau offices may be restricted due to limited availability of facsimile machines, telephone lines or other reasons. Instructions on the form or instructions otherwise provided will state whether a facsimile transmitted copy of a form or other document may be used.

The instructions will also indicate the locations and telephone numbers where the transmissions may be sent. Instructions for facsimile transmitted copies of comments on a notice of proposed rulemaking will be provided in the notice itself.

Accordingly, the Bureau has determined that facsimile transmitted copies of forms and other documents may be accepted under certain conditions.

Held: Forms and other documents submitted to the Bureau may be accepted when transmitted by facsimile machines under the following conditions:

1. The Bureau office to which the forms or other documents are to be submitted is suitably equipped with facsimile machines and telephone lines to receive the facsimile transmitted copies.
2. The forms or other documents are legible and of suitable size (8 1/2" X 11" or as specifically authorized by the receiving office) for facsimile transmission.
3. The forms or other documents are transmitted in accordance with instructions on the form, notice of proposed rulemaking, or otherwise provided.
4. The forms or other documents are not fingerprint cards, bonds, photographs, checks, or labels for alcoholic beverage containers and are not the forms or documents required to be submitted with such items.
5. Prior to accepting any facsimile transmitted copies of forms and other documents required to be signed under penalties of perjury, the Bureau must have received an affidavit executed by the person whose signature appears on the forms or documents. The affidavit must declare, under penalties of perjury, that:
 - a. the affiant will be filing the appropriate forms or other documents by facsimile machine,
 - b. the signature appearing on the facsimile copies will be that of the affiant, and is intended as the original signature,
 - c. the affiant will be submitting the facsimile copies as originals for purposes of approval or other purpose under the appropriate regulations and that the affiant intends that the facsimile copies be treated as originals, and
 - d. the person signing the forms or other documents will personally transmit the copies via facsimile machine, or, if a designated agent is to do the transmittal, the name of the agent who will do the actual transmittal.
6. The affidavit is required to be submitted only one time to each Bureau office to which facsimile transmitted copies are to be sent, and need not be resubmitted unless a different official will be

signing or transmitting the forms.

INQUIRIES. Inquiries concerning this circular should refer to its number and be addressed to the Associate Director (Compliance Operations), Bureau of Alcohol, Tobacco and Firearms, 1200 Pennsylvania Avenue, NW, Washington, DC 20226.



Acting Director