

---

August 1997

# DFAS TELECOMMUNICATIONS

## DFAS Has the Opportunity To Reduce Its Telecommunication Line Capacity



---

---

**Accounting and Information  
Management Division**

B-275892

August 1, 1997

Ms. Alice C. Maroni  
Acting Under Secretary of Defense (Comptroller)

Dear Ms. Maroni:

The Defense Finance and Accounting Service (DFAS) was established in January 1991 to streamline and standardize the Department of Defense's (DOD) finance and accounting policies, procedures, and systems. In May 1994, the Deputy Secretary of Defense announced plans to consolidate over 300 defense accounting offices (DAOS) into 5 large existing finance centers<sup>1</sup> and 21 new sites<sup>2</sup> called operating locations (OPLOCs). The success of this effort is dependent, in large part, on the OPLOCs' ability to obtain and process finance and accounting data from DOD's numerous and geographically dispersed military installations. DFAS is relying on the Defense Information Systems Agency (DISA) to provide the telecommunication services needed to transmit this critical information.

Due to the important role that telecommunication services have in DFAS' day-to-day accounting operations, as well as congressional interest in using information technology to maximize the efficiency and effectiveness of governmental operations, we reviewed the use of the 50 data communication lines that DFAS leases from DISA to connect its OPLOCs and finance centers and the DISA megacenters through one of DISA's common user data networks—the N-level (Unclassified-but-Sensitive) Internet Protocol Router Network (NIPRNET). Our primary objective was to determine whether these data communication lines are effectively managed.

---

**Results in Brief**

Our analysis of the usage data for the 50 leased data communication lines indicates that 29 lines may not be utilized in the most efficient, effective, and economical manner. This situation is due primarily to DFAS not performing a thorough analysis of its telecommunication requirements. To meet the tight time frames prescribed for the consolidation effort, DFAS did not consider critical factors such as frequency of use, peak usage periods, and the volume of information to be transmitted and received. Rather, the DFAS Deputy Director for Information Management decided that a start-up

---

<sup>1</sup>DOD's five large centers are located in Cleveland, Ohio; Columbus, Ohio; Denver, Colorado; Indianapolis, Indiana; and Kansas City, Missouri.

<sup>2</sup>As of May 1997, four sites had not yet been opened.

---

line of 512 kilobits (kbs) per second<sup>3</sup> would provide sufficient capacity for the workload requirements of each OPLOC. As the finance and accounting workload was transferred from the DAOS to the OPLOCs, operational problems, such as increased downtime and slow response times, began to surface. To resolve these problems, across-the-board line and equipment upgrades were made without knowing what specific changes were needed to remedy the problem at each location.

With the transfer of the DAOS to the OPLOCs virtually complete, DFAS can now thoroughly reassess and revalidate its existing telecommunication lines to determine if they are effectively utilized. Doing so would also enable DFAS to identify opportunities for reducing its lease cost. Such reassessments are important because they enable an agency to determine, based on empirical data, whether its telecommunication lines are properly sized, meet mission requirements, and are cost-effective.

---

## Background

As part of DOD's efforts to streamline and standardize finance and accounting activities, DFAS was given management control of the DOD's 5 large finance centers and many of the functions carried out at the 332 installation finance and accounting offices. In May 1994, the Deputy Secretary of Defense announced plans to consolidate DOD's finance and accounting operations into the 5 large finance centers and 21 OPLOCs. In previous work, we have questioned the overall need for DOD having 21 operating locations.<sup>4</sup>

While this is a massive effort in itself, it is also complicated by the scope of DOD's finance and accounting operations. For example, in fiscal year 1996, DOD disbursed \$266 billion related to 17 million invoices, 6 million payroll accounts, and 2 million travel vouchers, it also collected \$238 million from 116,000 debtors. As DOD's accounting agency, DFAS records these transactions in the Department's accounting records. DFAS also prepares reports for DOD managers and the DOD-wide and service-specific financial statements required by the Chief Financial Officers (CFO) Act and the Office of Management and Budget implementing directives.

Both DFAS and DISA have major responsibilities for ensuring the efficient and effective transmission of DOD's finance and accounting data. DFAS is

---

<sup>3</sup>One kilobit is one thousand bits; therefore, a 512 kilobit per second line can transmit 512,000 bits per second.

<sup>4</sup>DOD Infrastructure: DOD Is Opening Unneeded Finance and Accounting Offices ([GAO/NSIAD-96-113](#), April 24, 1996) and DOD Infrastructure: DOD's Planned Finance and Accounting Structure Is Not Well Justified ([GAO/NSIAD-95-127](#), September 18, 1995).

---

responsible for identifying its requirements by analyzing expected workloads and telecommunication performance parameters, such as transmission frequency, availability, and speed. As DOD's central manager for information technology and technical support, DISA is responsible for acquiring, operating, and maintaining the data communication lines needed to satisfy DFAS' day-to-day activities, as well as providing data processing services through its various megacenters. DFAS is leasing 50 data communication lines from DISA to transmit the finance and accounting data between its various accounting locations and DISA's megacenters through the NIPRNET. Figure 1 illustrates this connectivity and the transmission of the data. Our review focused on the use of the communication lines used to connect DFAS' finance centers, OPLOCS, and DISA megacenters through DISA's NIPRNET.

Figure 1: Flow of Finance and Accounting Data Between DFAS' OPLOCs and Finance Centers and DISA's Megacenters Through NIPRNET

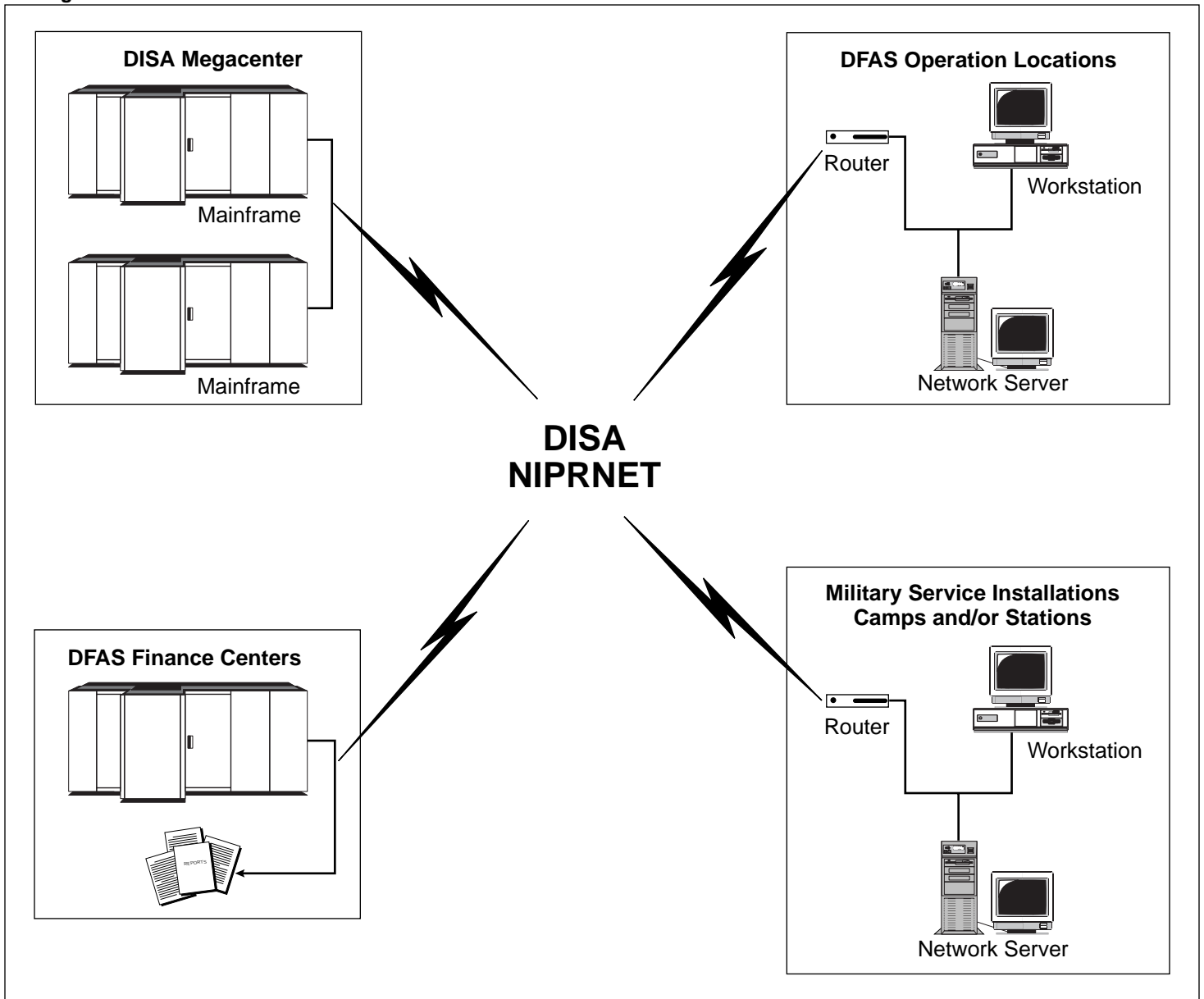

## Scope and Methodology

To determine whether DFAS is effectively managing the telecommunication lines it is leasing from DISA to support the consolidation of DOD's accounting and finance operations, we reviewed DOD directives and instructions to determine the specific roles and responsibilities of DFAS and

---

DISA in the procurement and management of data communication services. We met with DFAS and DISA officials involved in the consolidation effort to obtain an understanding of the importance of data communications to the success of consolidated DOD accounting and finance operations and identify specific criteria used to select communication lines connecting DFAS' OPLOCS and finance centers, and DISA's megacenters with the NIPRNET.

We extracted and analyzed data from two DISA computerized databases and reconciled any inconsistencies found to identify and assess DFAS' use of its leased telecommunication lines for the 4 months ending January 31, 1997. Our analyses of the Defense Information Services Database and the World-Wide On-Line System identified 50 data communication lines used by DFAS to transmit finance and accounting data between the OPLOCS, finance centers, and megacenters through the NIPRNET. Further, we compared data from the two DISA databases with service request documentation used to initiate the telecommunication services to cross-check data accuracy and completeness. We evaluated line use data sampled every hour by DISA's regional control centers detailing the daily use of the 50 DFAS lines from October 1, 1996, through January 31, 1997. We determined the maximum usage level by adding the highest individual levels of utilization in receiving and sending data experienced during the 4-month period. We compared our calculated rate of utilization with the line currently in place. We discussed our approach with DISA and DFAS officials responsible for ensuring efficient use of DOD telecommunication resources.

We performed our work at DFAS and DISA headquarters offices, Washington, D.C.; DFAS Center, Denver, Colorado; DFAS Center and Financial Service Organization, Indianapolis, Indiana; DFAS OPLOCS in Limestone, Maine; Oakland, California; and Seaside, California; DISA Regional Control Center, Columbus, Ohio; DISA Defense Information Technology Contracting Organization and the Defense Information System Network Service Center, Scott Air Force Base, Illinois; and the Defense Megacenter, Denver, Colorado. We also contacted and obtained information from the DISA Regional Control Center in Oahu, Hawaii. Our work was performed from July 1996 through May 1997 in accordance with generally accepted government auditing standards.

We requested written comments on a draft of the report from the Secretary of Defense or his designee. The Deputy Chief Financial Officer provided written comments, which are discussed in the "Agency Comments and Our Evaluation" section and reprinted in appendix II.

---

## Determining Requirements Is Key to Properly Sizing Telecommunication Lines

DFAS did not adequately identify its telecommunication requirements before the OPLOCS began operations. As a result, many of DFAS' telecommunication lines may have excess capacity. Our analysis of utilization data, which is one element that should be considered in properly sizing lines, disclosed that 29 lines may have larger capacity than required. Leasing more capacity than is needed to meet day-to-day operational requirements could result in DFAS incurring unnecessary lease cost.

Defining and validating requirements through analysis of expected workload and performance parameters is an essential first step in the telecommunication selection and acquisition process.<sup>5</sup> Such definitions form the basis for identifying and evaluating alternative approaches and selecting and acquiring an appropriate technical solution based on those alternatives. Defining requirements necessitates the collection and identification of such elements as (1) the location, type, and number of users, (2) the nature of the interfacing computer applications and equipment, (3) the frequency of use and the transmission speed, (4) peak usage periods, and (5) the volume of data to be transmitted and received. The next step involves identifying and evaluating viable technical alternatives for meeting those requirements. Critical factors evaluated within this step include such elements as the compatibility with existing networks and equipment, technical feasibility, maintainability, cost, and the ability to meet the defined requirements.<sup>6</sup>

DFAS did not perform a thorough analysis of its site specific requirements before the OPLOCS began operations because of the tight time frames prescribed for bringing the OPLOCS on-line and transferring the accounting responsibility and workload from the consolidated DAOS. In response to DFAS' request, DISA developed a project implementation plan<sup>7</sup> dated February 1995 that addressed the connectivity requirements for consolidating the 332 DAOS into the 21 OPLOCS. The plan identified various alternatives for addressing DFAS connectivity requirements. The plan cautioned that the implementation requirements might need to be revised based on analyses of actual site workload demands and results as the

---

<sup>5</sup>Defense Communications: Management Problems Jeopardize DISN Implementation (GAO/AIMD-95-136, July 13, 1995).

<sup>6</sup>These requirement definitions and critical factors were developed by the Institute of Internal Auditors Research Foundation, Systems Auditability and Control, December 1991, Module 8, "Telecommunications."

<sup>7</sup>DFAS/DAO Consolidation Information Management Service, Project Implementation Plan, February 1995.



---

consolidation progressed. Based on a decision by the DFAS Deputy Director for Information Management, all alternatives assumed the use of 512 kbs lines for the initial network configuration.

As the finance and accounting functions were transferred from the DAOS to the OPLOCS, the data traffic was greater than anticipated, and transmission of the finance and accounting data was unexpectedly slow. This problem was compounded by the shared use of military owned communication equipment at four DISA megacenters. Together, these two problems caused major breakdowns in DFAS' day-to-day operations. For example, DFAS experienced periods each month when the OPLOCS and finance centers could not receive or send data. When data could be transmitted, the system responses to user inquiries were often very slow.

To resolve these problems, DFAS and DISA implemented several corrective actions. DFAS upgraded its telecommunication lines between the OPLOCS and the NIPRNET. DISA also upgraded the lines between its megacenters and procured dedicated communication equipment for DFAS. These actions, which addressed serious problems, were taken across the board without determining the specific line capacity required at each site.

Since DFAS had not developed site-specific requirements, we used utilization data to identify lines that may be potentially underutilized. Our analysis of the usage data for the 50 lines, which we have provided to and discussed with DFAS, disclosed that 29 lines may not be utilized in the most economical manner, resulting in DFAS incurring unnecessary lease cost. For each line we were conservative in establishing a maximum possible peak usage by combining the sum of the highest peak sent and highest peak received.<sup>8</sup> Figure 2 shows the 29 DFAS lines that may be underutilized.

---

<sup>8</sup>The maximum possible peak was determined by adding the highest peak received and the highest peak sent. These levels of utilization could have occurred on different days and at different hours during the 4-month measured period.

Figure 2: Utilization Rate for 29 DFAS Lines

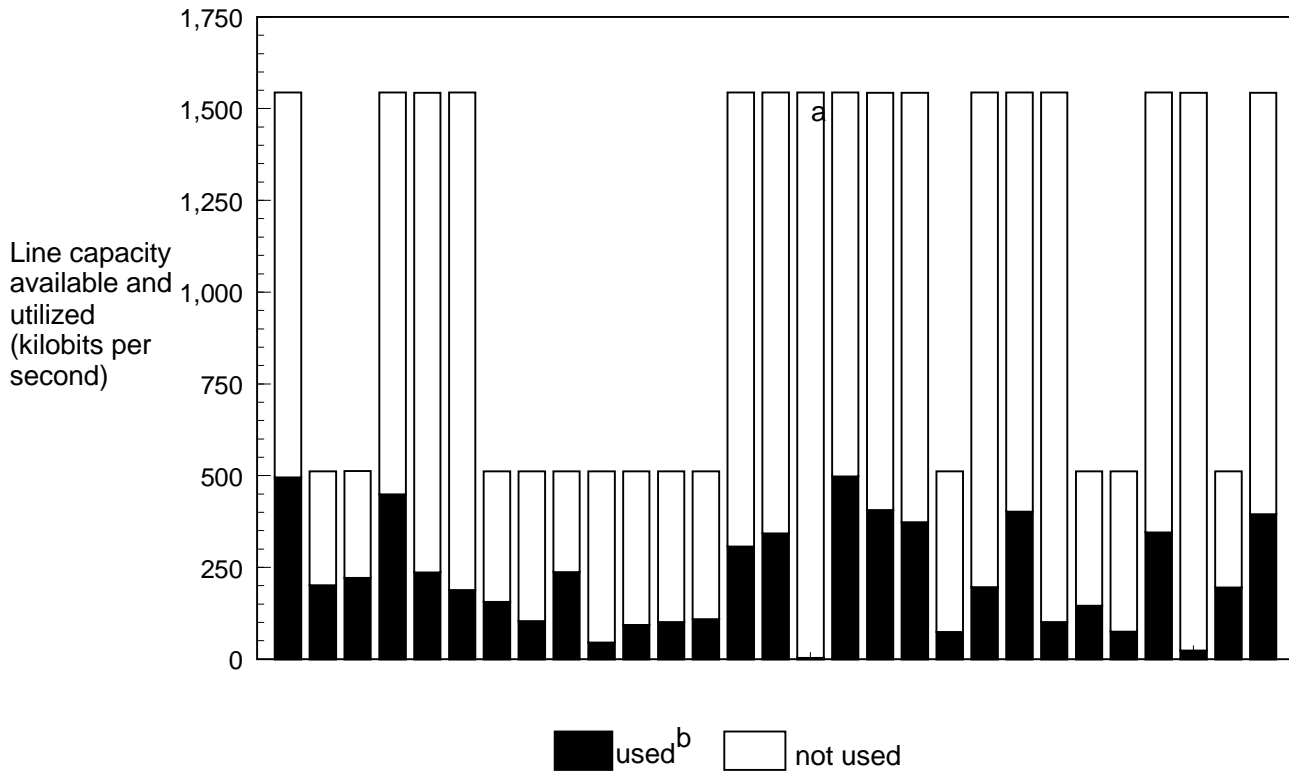

<sup>a</sup>The utilization on this line was four kilobits.

<sup>b</sup>The amount used represents the sum of the highest peak sent and the highest peak received.

Additional utilization detail is provided in appendix I. While usage data alone is not sufficient to determine required line capacity, it is a significant consideration that DFAS should include in its review and revalidation effort, as discussed in the following section.

---

## Reassessment of DFAS' Telecommunication Requirements Is Needed

DOD requires<sup>9</sup> that agencies biennially review and revalidate their requirements for telecommunication equipment and services to ensure that they acquire and use such services in the most efficient and economical manner. Such reassessments are important because they enable an agency to determine, based on empirical data, whether its telecommunication lines are properly sized, meet mission requirements, and are cost-effective.

As of March 1997, this type of thorough reassessment had not been performed on the 50 data communication lines. DFAS officials informed us that they had not reassessed the lines because they were managed by DISA during fiscal year 1996. Although DISA performed an assessment in early 1996, this effort was somewhat limited. For example, DISA did not obtain utilization data or reassess the validity of the users' prescribed performance parameters, such as transmission speed.

With the transfer of the finance and accounting operations for 307 of the 332 DAOS to be completed by the end of this fiscal year, DFAS' operations have been largely stabilized, thus affording DFAS an opportunity to reassess its data communication requirements. Such a reassessment would enable DFAS to refine its requirements and establish what needs to be done to reduce the cost of operations without hindering operational effectiveness. Since DFAS has not yet performed any detailed analyses, it would be prudent to conduct a full-scale assessment, which would include tasks similar to those normally performed when a requirement is originally defined and validated, as discussed previously. If performed properly, this assessment would enable DFAS to ensure that its data communication lines satisfy mission requirements cost-effectively.

---

## Conclusions

In the absence of a thorough analysis of DFAS' requirements, our evaluation of utilization data indicates that many of its telecommunication lines may have excess capacity. Until DFAS completes such an analysis, it runs the risk of paying for excess capacity.

---

## Recommendation

To ensure that the long-term telecommunication needs of DFAS are properly defined and cost-effective, we recommend that the Director of DFAS follow existing DOD policy and reassess DFAS' telecommunication requirements, at a minimum considering such factors as workload

---

<sup>9</sup>Defense Directive 4640.13, Management of Base and Long-Haul Telecommunications Equipment and Services, December 5, 1991, and Defense Instruction 4640.14, Base and Long-Haul Telecommunication Equipment and Services, December 6, 1991.

---

capacity, utilization statistics of its telecommunication assets, response time, and cost-benefit analyses supporting the use of the telecommunication resources.

---

## Agency Comments and Our Evaluation

In written comments on a draft of this report, DOD's Deputy CFO agreed with our recommendation that DFAS reassess its telecommunication requirements, stating that DFAS will perform such a reassessment in September and October 1997.

However, DOD did not concur with our findings and conclusions. The Deputy CFO stated that our analysis did not take into consideration DFAS' mission and future requirements and, therefore, should not be used as a basis to downsize DFAS' telecommunication lines. Our report does not identify specific telecommunication lines that should be downsized. Rather, it points out that utilization data is one factor that needs to be considered in determining if telecommunication lines are being utilized in the most efficient, effective, and economical manner. As discussed in the report, our analysis of the utilization data disclosed that 29 lines may have larger capacity than required. Therefore, based on our analysis, and the fact that DFAS has not determined site specific requirements, we recommended that DFAS reassess its telecommunication requirements which, as noted above, the Department agreed with.

---

We are sending copies of this report to the Chairmen and Ranking Minority Members of the Senate and House Committees on Appropriations, the Senate Committee on Armed Services, the Senate Committee on Governmental Affairs, the House Committee on National Security, and the House Committee on Government Reform and Oversight; the Secretary of Defense; the Director, Defense Information Systems Agency; the Acting Director, the Defense Finance and Accounting Service; and the Director of the Office of Management and Budget. Copies will be made available to others on request.

---

Within 60 days of the date of this report, we would appreciate receiving a written statement on actions taken to address our recommendation.

If you have any questions about the report, please call me at (202) 512-6240. Major contributors to this report are listed in appendix III.

Sincerely yours,

A handwritten signature in black ink, appearing to read "J. Brock, Jr.", with a stylized, cursive flourish extending to the right.

Jack L. Brock, Jr.  
Director, Defense Information  
and Financial Management Systems

---

# Contents

---

Letter	1
Appendix I Detailed Usage Data for DFAS' 50 Telecommunication Lines	14
Appendix II Comments From the Department of Defense	16
Appendix III Major Contributors to This Report	19
Figures	
Figure 1: Flow of Finance and Accounting Data Between DFAS' OPLOCs and Finance Centers and DISA's Megacenters Through NIPRNET	4
Figure 2: Utilization Rate for 29 DFAS Lines	8

---

## Abbreviations

CFO	Chief Financial Officer
DAO	Defense Accounting Office
DFAS	Defense Finance and Accounting Service
DISA	Defense Information Systems Agency
DOD	Department of Defense
kbs	kilobits per second
NIPRNET	N-level (Unclassified-but-Sensitive) Internet Protocol Router Network
OPLOC	Operating Location

---

---

# Detailed Usage Data for DFAS' 50 Telecommunication Lines

The following table shows the DFAS OPLOCS' and centers' peak use for receiving and sending information from October 1, 1996, through January 31, 1997, over leased telecommunication lines connected to the NIPRNET. The maximum peak method sums the highest peak sent and highest peak received experienced during the measurement period.

Line number	From location	To location	Current line size (kbs)	Peak use received (Percent)	Peak use sent (Percent)	Max peak use (Percent)	Used line capacity (kbs)
71SK	Dayton	Wright-Patterson	1544	15.7	16.4	32.1	496
71QR	Ft. Sill	Tinker AFB	512	17.4	22.0	39.4	202
71SH	Rock Island	Rock Island	1544	28.8	13.2	42.0	649
71LF	Dayton	Dayton	512	4.7	38.5	43.2	222
71ST	Pensacola	Jacksonville	1544	19.1	10.0	29.1	450
71SP	San Bernardino	North Island	1544	5.7	9.6	15.3	237
71SJ	Norfolk	Hampton Roads	1544	10.2	2.0	12.2	189
718Y	San Antonio	Tinker AFB	512	10.0	20.6	30.6	157
7LKR	Charleston	Charleston	512	10.1	10.1	20.2	104
7LLA	Norfolk	Hampton Roads	512	12.2	38.3	50.5	259
7LKY	Offutt AFB	Tinker AFB	512	21.6	24.7	46.3	238
7LKZ	Rock Island	Chicago O'Hare	512	0.0	8.8	8.8	46
7LKU	Oakland	Oakland	512	2.4	15.9	18.3	94
71QY	Oakland	Oakland	512	1.1	18.7	19.8	102
71QX	St. Louis	St. Louis	512	6.2	15.1	21.3	110
71SG	Offutt AFB	Denver	1544	6.2	13.7	19.9	308
7LPT	Limestone	Boston	512	11.5	40.0	51.5	264
71SN	Limestone	Mechanicsburg	1544	6.8	15.4	22.2	343
7139	Kansas City	Kansas City	1544	0.1	0.1	0.2	4
7136	Kansas City	St. Louis	1544	8.3	24.0	32.3	499
71SR	Charleston	Charleston	1544	10.9	15.4	26.3	407
71SQ	Orlando	Jacksonville	1544	16.1	18.6	34.7	536
71SM	Oakland	Oakland	1544	7.2	17.0	24.2	374
71SL	Griffiss	Mechanicsburg	1544	11.8	22.7	34.5	533
71K6	Pensacola	Pensacola	512	2.9	11.6	14.5	75
7181	Seaside	McClellan AFB	1544	4.6	8.1	12.7	197
718X	San Antonio	Kelly AFB	1544	17.6	8.5	26.1	403
715H	St. Louis	St. Louis	1544	2.5	4.1	6.6	102
71SF	San Diego	North Island	1544	12.5	28.0	40.5	626
71K7	San Bernardino	North Island	512	25.8	56.4	82.2	421
71QQ	Pensacola	Jacksonville	512	1.4	27.0	28.4	146

(continued)



**Appendix I  
Detailed Usage Data for DFAS' 50  
Telecommunication Lines**

<b>Line number</b>	<b>From location</b>	<b>To location</b>	<b>Current line size (kbs)</b>	<b>Peak use received (Percent)</b>	<b>Peak use sent (Percent)</b>	<b>Max peak use (Percent)</b>	<b>Used line capacity (kbs)</b>
7LKX	San Diego	North Island	512	4.2	10.6	14.6	76
7LLB	Griffiss	Mechanicsburg	512	31.0	30.9	61.9	317
715N	Columbus	Wright-Patterson	1544	16.5	37.7	54.2	837
715M	Columbus	Columbus	1544	32.3	45.7	78.0	1205
71SS	Ft. Ben Harrison	Columbus	1544	41.8	55.9	97.7	1509
71OZ	Ft. Ben Harrison	Ft. Ben Harrison	512	74.0	5.9	79.9	410
72E8	Cleveland	Columbus	1544	35.0	26.5	61.5	950
71RT	Arlington	Richmond	1544	10.0	12.4	22.4	346
7191	Bratenahl	Columbus	1544	7.8	63.8	71.6	1106
7190	Bratenahl	Wright-Patterson	1544	45.9	21.3	67.2	1038
715L	Denver	Denver	10000	4.9	6.6	11.5	1150
715K	Denver	Ft. Huachuca	1544	0.2	1.3	1.5	24
7LMH	Orlando	Pensacola	512	14.2	24.0	38.2	196
7MLU	Cleveland	Cleveland	10000	14.4	14.8	29.2	2920
7WYC	Lowry	Lowry	10000	13.1	5.9	19.0	1900
71WV	San Diego	San Diego	19	42.4	89.4	131.8	26
719Z	Saufley Field	Pensacola	512	68.4	19.0	87.4	448
XD6K	Hickam	Ford Island <sup>a</sup>	1344	26.1	18.6	44.7	601
XD7U	Ft. Shafter	Ford Island <sup>a</sup>	1544	14.9	10.7	25.6	396

Legend  
kbs=Kilobits per second.

<sup>a</sup>Usage data for telecommunication lines of XD6K and XD7U covered October 1, 1996, through December 31, 1996, and January 20, 1997, through January 31, 1997.

Source: Defense Information Services Database and the World-Wide On-Line System

# Comments From the Department of Defense



COMPTROLLER

OFFICE OF THE UNDER SECRETARY OF DEFENSE  
1100 DEFENSE PENTAGON  
WASHINGTON, DC 20301-1100



JUL 30 1997

Mr. Gene L. Dodaro  
Assistant Comptroller General  
Accounting and Information Management Division  
United States General Accounting Office  
Washington, DC 20548

Dear Mr. Dodaro:

This is the Department of Defense (DoD) response to the General Accounting Office Draft Report, "DFAS TELECOMMUNICATIONS: DFAS Can Reduce Its Telecommunications Line Capacity," dated June 6, 1997 (GAO Code 511358), OSD Case 1379.

Subsequent to the release of the June 6, 1997, draft report, your office provided a revised draft report to the Department for comment. Based on that revised draft report the DoD concurs with the recommendation. However, the Department does not concur with the finding and conclusion in the draft report. Enclosed are the Department's specific comments.

The Department appreciates the opportunity to comment on the subject draft report.

Nelson Toye  
Deputy Chief Financial Officer

Enclosure

**GAO DRAFT REPORT—DATED JUNE 6, 1997**  
**(GAO CODE 511358) OSD CASE 1379**

**“DFAS TELECOMMUNICATIONS: DFAS CAN REDUCE ITS**  
**TELECOMMUNICATIONS LINE CAPACITY”**

**DEPARTMENT OF DEFENSE COMMENTS OF THE GAO RECOMMENDATION**  
**AND FINDING AND CONCLUSION**

**Recommendation.** To ensure that the long-term telecommunications needs of DFAS are properly defined and cost-effective. We also recommend that the Director of DFAS follow existing DoD policy and reassess its telecommunication requirements, at a minimum considering such factors as workload capacity, utilization statistics of its telecommunication assets, response time, and cost-benefit analyses supporting the use of the telecommunication assets, response time and cost-benefit analyses supporting the use of the telecommunication resources.

**DoD Response.** Concur.

The Department plans to conduct a revalidation study beginning September 1997, and will continue through the end of October 1997.

**FINDING AND CONCLUSION**

The GAO rationale for downsizing the telecommunication lines failed to include the mission and future requirements of DFAS. In addition, the methodology does not conform to engineering standards used to determine user capacity requirements based on a known mission requirement. The Department disagrees with the data gathered to support the GAO analysis for the following reasons:

**Technical.** The analysis of data gathered is too simplistic. Peak traffic, response time, traffic destination, frequency of transmission, and reliability are some of the factors that need to be considered to size an access circuit. Other than peak traffic, none of these parameters were evaluated in the audit. In the case of peak traffic, it was evaluated based on a 4-month time period determined by GAO without benefit of an analysis of the mission requirement.

**Mission.** The GAO report did not take into consideration that the DFAS data network includes backup circuits. These circuits were installed for contingency of operation (COOP) and should not be viewed as daily operational circuits. The current DFAS telecommunications plan is to use these circuits in the event that an operational circuit fails. These back-up (coop) circuits assure the Department of continued operational capability. The 512KBPS trunks are designed to take over in the event that a main circuit fails. The 512 KBS circuits examined by GAO deliberately provide for redundancy and are, by design, not fully utilized. This backup is needed so that DFAS can meet the provisions of the timely payment act, and other mandates for timeliness. GAO was informed of this when they visited the Columbus Regional Control Center. These circuits should

---

**Appendix II**  
**Comments From the Department of Defense**

---

not have been included in the study. Thirteen of the circuits identified for downsizing are 512 Kbps circuits. The current DISA charge is half the normal monthly access charge for these circuits. As an example, the Rock Island Circuit 71SH is used as the main circuit (1.544 MBPS) and will remain at that speed. The backup circuit is 7LKZ (512 KBPS). The GAO audit recommends downsizing this circuit to 64 KBPS. If this recommendation were implemented the Rock Island backup circuit would only have 10 percent of the needed capacity required to continue operations of the main NIPRNET circuit (64 KBPS capacity to replace the peak work load of 649 KBPS) as documented in the audit. This disparity exists in the backup circuit capacity at the other sites.

**Future Requirements.** The GAO audit fails to take into consideration the future mission and technical requirements of DFAS. Since January 1997, DFAS has been expanding WEB based business applications at a rapid pace. Projects such as the Vendor Pay WEB site, Electronic Document Access for viewing contracts, On Line Report Viewing (OLRV) which eliminates printing mainframe reports, have greatly increased the utilization on DFAS' DISN access circuits. In addition the DISN itself is in transition as it bundles circuit requirements, and transitions to a common user SONET based backbone. These recent changes in bandwidth requirements justify current capacity levels, and will in the foreseeable future necessitate expansion of the capacity addressed by GAO in this audit. As a result, any short term gains from reductions in capacity ultimately may lead to increased costs to the government because of the need to increase capacity in the near future.

# Major Contributors to This Report

---

**Accounting and  
Information  
Management Division,  
Washington, D.C.**

John S. Reifsnyder, Project Director (703) 695-7510  
Darby W. Smith, Assistant Director  
William D. Hadesty, Technical Advisor  
Madhav S. Panwar, Technical Advisor  
Cristina Chaplain, Communications Analyst

---

**Chicago/Dayton Field  
Office**

Phillip E. Rutar, Project Manager  
Sanford F. Reigle, Senior Information Systems Analyst

---

**Denver Regional  
Office**

Peggy A. Hegg, Senior Information Systems Analyst

---

## Ordering Information

The first copy of each GAO report and testimony is free. Additional copies are \$2 each. Orders should be sent to the following address, accompanied by a check or money order made out to the Superintendent of Documents, when necessary. VISA and MasterCard credit cards are accepted, also. Orders for 100 or more copies to be mailed to a single address are discounted 25 percent.

### Orders by mail:

U.S. General Accounting Office  
P.O. Box 6015  
Gaithersburg, MD 20884-6015

### or visit:

Room 1100  
700 4th St. NW (corner of 4th and G Sts. NW)  
U.S. General Accounting Office  
Washington, DC

Orders may also be placed by calling (202) 512-6000 or by using fax number (301) 258-4066, or TDD (301) 413-0006.

Each day, GAO issues a list of newly available reports and testimony. To receive facsimile copies of the daily list or any list from the past 30 days, please call (202) 512-6000 using a touchtone phone. A recorded menu will provide information on how to obtain these lists.

For information on how to access GAO reports on the INTERNET, send an e-mail message with "info" in the body to:

[info@www.gao.gov](mailto:info@www.gao.gov)

or visit GAO's World Wide Web Home Page at:

<http://www.gao.gov>

---

**United States  
General Accounting Office  
Washington, D.C. 20548-0001**

**Bulk Rate  
Postage & Fees Paid  
GAO  
Permit No. G100**

**Official Business  
Penalty for Private Use \$300**

**Address Correction Requested**

---

