

DMH 0360

DATE OF REGISTRATION/PUBLICATION  
 10 30 07  
 Month Day Year

**DO NOT WRITE ABOVE THIS LINE. IF YOU NEED MORE SPACE, USE A SEPARATE CONTINUATION SHEET. (Form D-VH/CON)**

**1**  
**TITLE**  
 Please give the make and model of the vessel that embodies the design.  
 Hydra-Sports 35 VX

**2**  
**DESIGN**  
 (a) What is the type or style of the design for which registration is sought?  
 Fishing boat  
 (b) Provide a brief general statement setting forth the salient features of the design.  
 The features relate to the design of the deck and the configuration of the hull.

Check here if this is a single design.  
 Check here if registering more than one design. Use Form D-VH/CON for additional designs.

(c) If this design is derived from an earlier design, describe how that design has been revised, adapted, or rearranged.

**3**  
**DESIGNER(S)**  
 Provide the name and address of the designer(s). The name of the employer may be given instead of the designer(s) if, (1) the design was made within the regular scope of employment of the designer(s) and (2) the individual authorship of the design is difficult or impossible to ascribe.  
 Please check here if those conditions are satisfied and you are providing the employer's name.

Name: Hydra-Sports Boats  
 Address: 1651 Whitfield Avenue  
 Sarasota, Florida 34243

**4**  
**OWNER, IF NOT DESIGNER(S)**  
 If the owner is different from the designer(s) or employer named above, provide the name and address of the owner:  
 Name:  
 Address:

**5**  
**PRIORITY CLAIM**  
 (a) Was an application for registration of this design identified in an application filed in a foreign country that extends to designs of owners who are citizens of the United States, or to persons filing applications in the United States, similar protection to that afforded in 17 U.S.C. chapter 13?  
 Yes  No  
 (b) If yes, identify the country and date of application:  
 Country:  
 Date of application:  
 Serial No:

**6**  
**DATE MADE PUBLIC**  
 Was this design made public before the date of application?  Yes  No  
 If yes, on what date? July 16 2007  
 Month Day Year

DO NOT WRITE HERE OFFICE USE ONLY  
 APPLICATION RECEIVED SEP 27 2007  
 DESIGN COPIES RECEIVED SEP 27 2007  
 FUNDS RECEIVED

CHECKED BY \_\_\_\_\_

CORRESPONDENCE

 YesFOR  
COPYRIGHT  
OFFICE  
USE  
ONLY**DO NOT WRITE ABOVE THIS LINE. IF YOU NEED MORE SPACE, USE A SEPARATE CONTINUATION SHEET. (Form D-VH/CON)**

Please provide the name and address of the person to whom correspondence regarding this application may be directed:

Name: Alpaslan SapmazAddress: 3200 IDS Center, 80 South Eighth Street, Minneapolis, Minnesota 55402Email address asapmaz@merchant-gould.comFAX number 612-332-9081Daytime phone: ( 612 ) 766-6093

Give the name and account number if the registration fee is to be charged to a Deposit Account established in the Copyright Office:

Name of Account: \_\_\_\_\_

Account number: \_\_\_\_\_

**DECLARATION:** The undersigned, as the applicant or the applicant's duly appointed agent or representative, being hereby warned that willful false statements are punishable by fine or imprisonment, or both, under 18 U.S.C. §1001, and that such willful false statements may jeopardize the validity of this application or any resulting registration, hereby declares to the best of his or her knowledge and belief:

- (1) that the design has been fixed in a useful article;
- (2) that the design is original and was created by the designer(s), or employer if applicable, named in the application;
- (3) that those aspects of the design for which registration is sought are not protected by a design patent;
- (4) that the design has not previously been registered on behalf of the applicant or applicant's predecessor in title; and
- (5) that the applicant is the person entitled to protection and to registration under chapter 13 of title 17, United States Code.

Complete if applicable:

The design has been made public with a design notice as prescribed by 17 U.S.C. §1306.

Following is the exact form of the design notice:

Protected Design, Hydra-Sports Boats 2007

Where on the useful article is the design notice located?

Transom

If the undersigned is not the applicant he or she is properly authorized to execute this application on behalf of the applicant.

Signature

Alpaslan Sapmaz

Print or type name

612-766-6093

Telephone number

612-332-9081

FAX number

Date

Attorney

Position or Title

asapmaz@merchant-gould.com

Email address

9/20/07**Copyright Office fees are subject to change. For current fees, check the Copyright Office website at [www.copyright.gov](http://www.copyright.gov), write the Copyright Office, or call (202) 707-3000.**Certificate  
will be  
mailed in  
window  
envelope  
to this  
address:

Name ▼	Alpaslan Sapmaz
Number/Street/Apt ▼	3200 IDS Center, 80 South Eighth Street
City/State/ZIP ▼	Minneapolis, Minnesota 55402

**YOU MUST:**

- Complete all necessary spaces
- Sign your application in space 9

**SEND ALL 3 ELEMENTS  
IN THE SAME PACKAGE:**

1. Application form
2. Nonrefundable filing fee in check or money order payable to Register of Copyrights
3. Design material

**MAIL TO:**

Dept. D-VH  
Vessel Hull Registration  
P.O. Box 71380  
Washington, D.C. 20024-1380

17 U.S.C. §1327. Penalty for false representation. "Whoever knowingly makes a false representation materially affecting the rights obtainable under this chapter for the purpose of obtaining registration of a design under this chapter shall pay a penalty of not less than \$500 and not more than \$1,000, and any rights or privileges that individual may have in the design under this chapter shall be forfeited."

FIG. 1

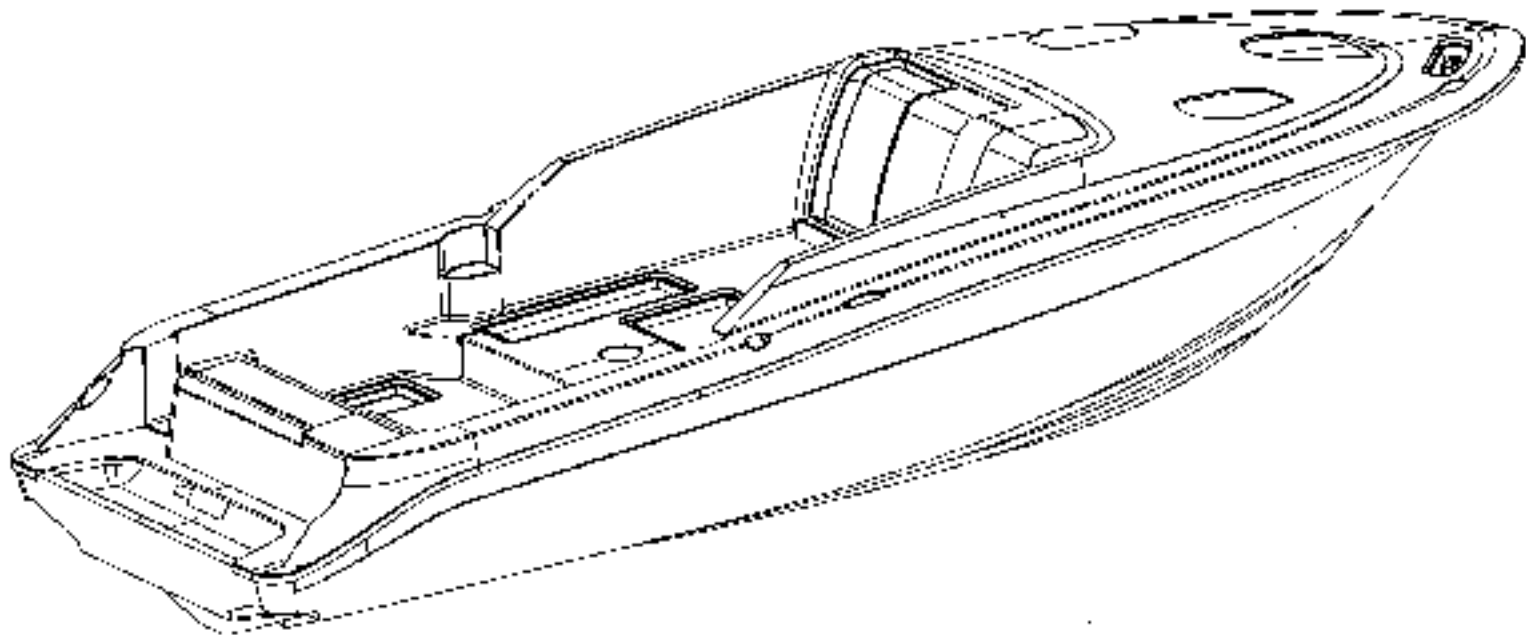

FIG. 2

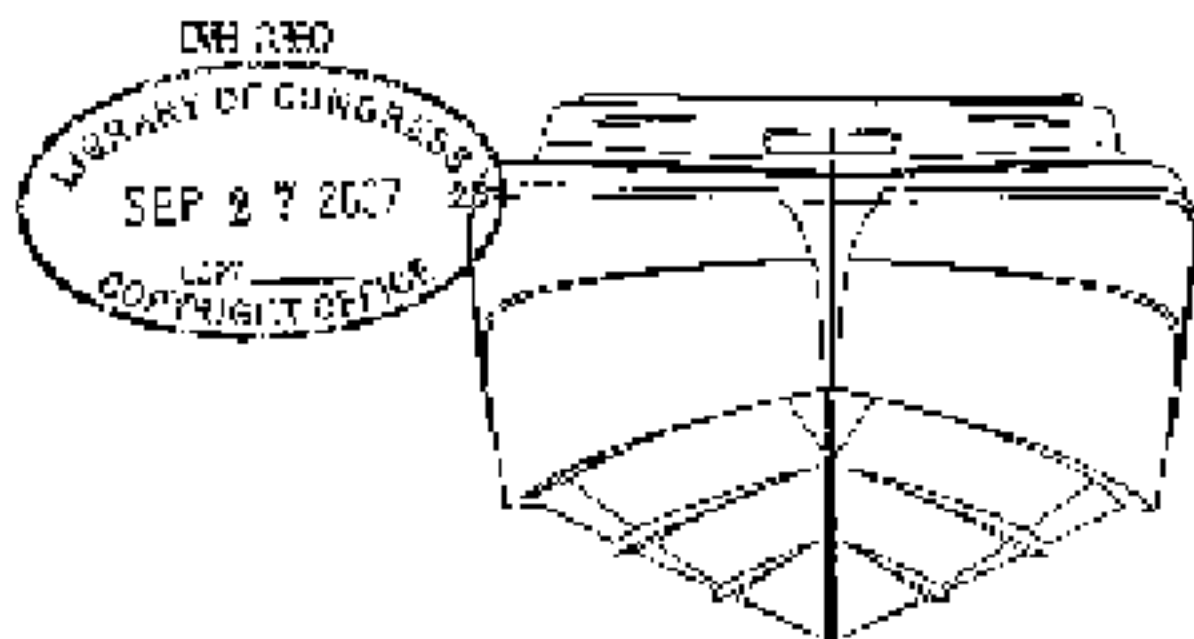

FIG. 3

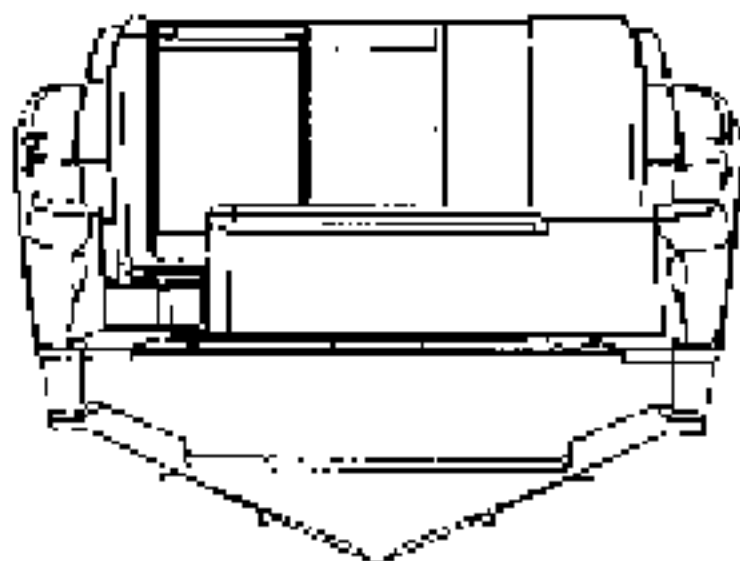

FIG. 4

DW 0380

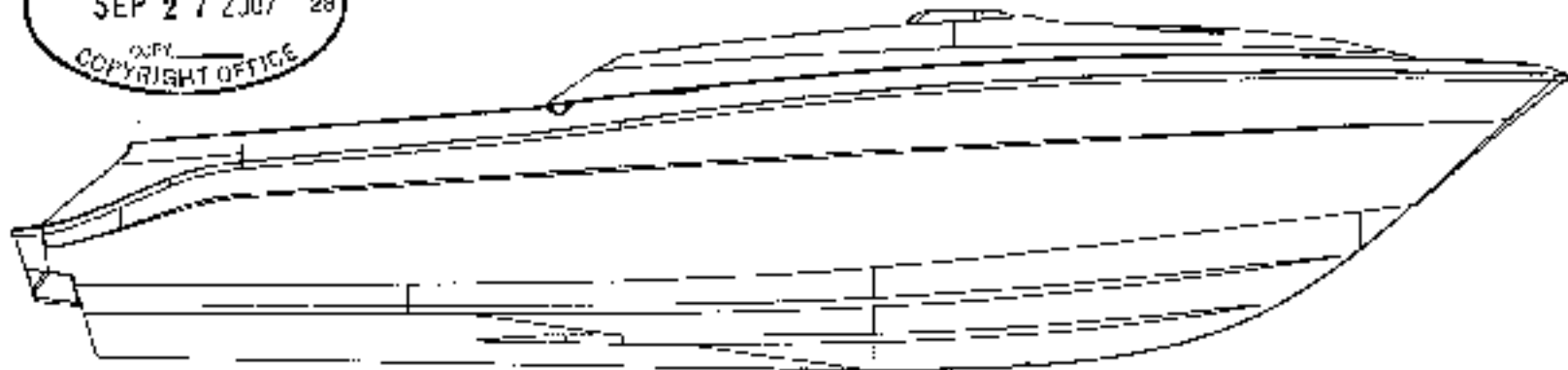
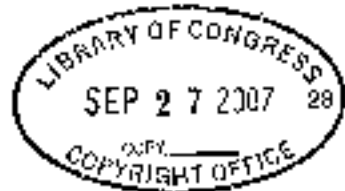

FIG. 5

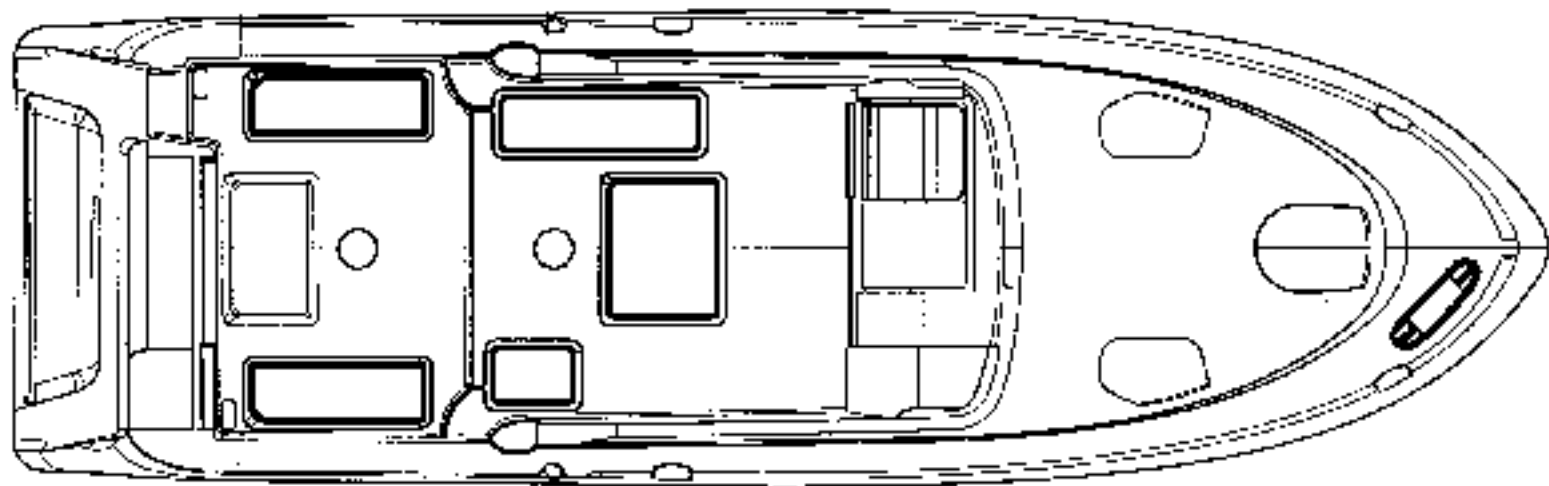

FIG. 6

DAH 0360

