

**Chapter 10—****S**ecuring Horses and Mules

After riders unload their stock at a recreation site, keeping them there can be a challenge. Stock may escape when a handler accidentally leaves a corral gate open, when a mule opens a gate or unties itself, or when a rider falls off and the horse runs away. A combination of continuous perimeter fences, road barriers, and trail barriers is vital. Inside the recreation site additional confinement methods are used. Corrals and highlines secure stock at camp units, especially overnight. Hitch rails serve short-term needs. Arenas and round pens provide space for exercising and training horses and mules.

Importance of Perimeter Fences

When a horse or mule gets loose, it may remain calm or it may run wildly about. Other stock nearby may get nervous if they see or hear a loose animal running because they assume it is running from a predator. Powerful instincts kick in, and the stock nearby may try to join the freed animal and flee the perceived threat. An unbroken barrier around the recreation site makes it easier to catch escaped stock and prevents them from running headlong onto a busy road. Perimeter fences also keep large wildlife

or domestic animals, such as cattle, out of the site. These uninvited animals are nuisances and can hurt recreationists. Combine perimeter fences with a barrier at the site entrance.

If the terrain is varied, locate perimeter fences on the highest point of the landscape. Horses and mules watch the horizon and are more likely to see the fences there. They may not notice fences in drainages or hollows.

Fence Materials and Construction

The materials used to build perimeter fences and horse enclosures, such as corrals, arenas, and round pens, are often the same. Slight variations exist in construction details. For maximum security, perimeter fences should not be one side of a corral, arena, or round pen. When choosing materials for perimeter fences and horse enclosures, the primary consideration is safety. Materials must be durable, suitable for the application, and appropriate for the level of development. The goal is to choose horse-friendly, nontoxic materials that discourage chewing and scratching.

The cornerposts of perimeter fences need to be larger diameter than the lineposts, because cornerposts receive more stress. The recommended distance between perimeter fenceposts is 8 to 12 feet (2.4 to

**Scratching an Itch****Horse Sense**

Horses and mules like to rub against fences, structures, and trees to relieve the discomfort caused by insect bites, dried sweat, or shedding hair. They can cause substantial damage when scratching their itch.

3.6 meters). Set all posts in concrete and bury them an appropriate depth for local soil conditions. The higher the fence, the deeper the posts must be buried. Set cornerposts and gateposts deeper than lineposts. Regardless of the fence style selected, the bottom rail or strand should be no less than 1 foot (0.3 meter) from the ground, high enough to allow mowing or raking, yet low enough to prevent small stock from rolling under the fence. Corrals, arenas, and round pens should be 5 to 6 feet (1.5 to 1.8 meters) high. The recommended height for perimeter fences is between 4.5 and 5 feet (54 and 60 inches or 1,372 and 1,524 millimeters).

Avoid making square or rectangular enclosures that hold more than one animal, because they can be unsafe. Horses and mules that are being pursued are less likely to be trapped by more aggressive stock when enclosures are oval or have angled sections instead of 90-degree corners.



10

Post-and-Rail Construction

Post-and-rail construction is suitable for perimeter fences and horse enclosures. One style places the rails in line with the posts, and the other mounts the rails on the sides of posts. Of the two styles, inline construction generally is stronger, cleaner, and looks more professional (figure 10–1). Placing steel rails in line requires more welding and is more costly. Saddle-welded joints are preferred because they are stronger than surface- or butt-welded joints. Mounting steel rails on the sides of posts usually is more economical because it requires less labor. However, the fence appears bulky and may have weak joints at the cornerposts (figure 10–2). Rails on the inside don't pop off as easily if an animal runs into or pushes against them.

Some post-and-rail fences made of wood and vinyl have inline rails. The rails measure up to 16 feet (4.9 meters) long and are set in holes drilled through the posts (figure 10–3). Many traditional wood fences have rails attached securely to the sides of the posts on the inside of the horse enclosure.

Post-and-rail perimeter fences and horse enclosures may have three to five rails. Riders debate the required number of rails needed in corral fences. Some feel that the more rails in a corral fence, the better it is. They recommend using four or five rails, saying that the fence appears more solid to a horse

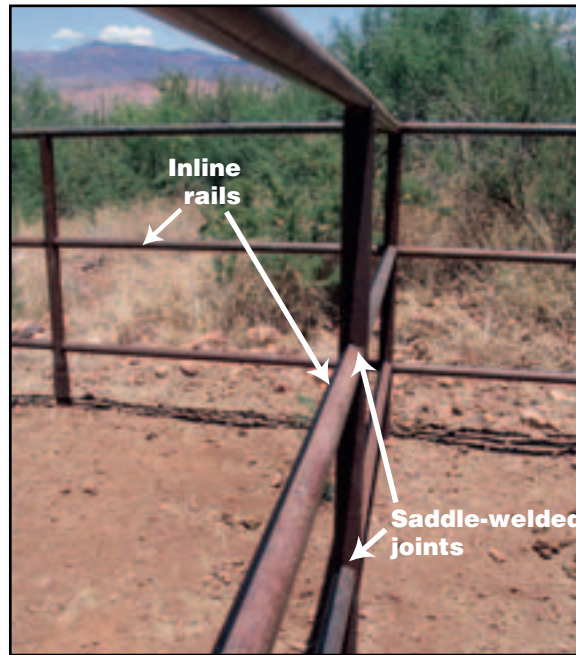

Figure 10–1—Welded inline rails generally are stronger than side-mounted rails. Saddle-welded joints are preferred.

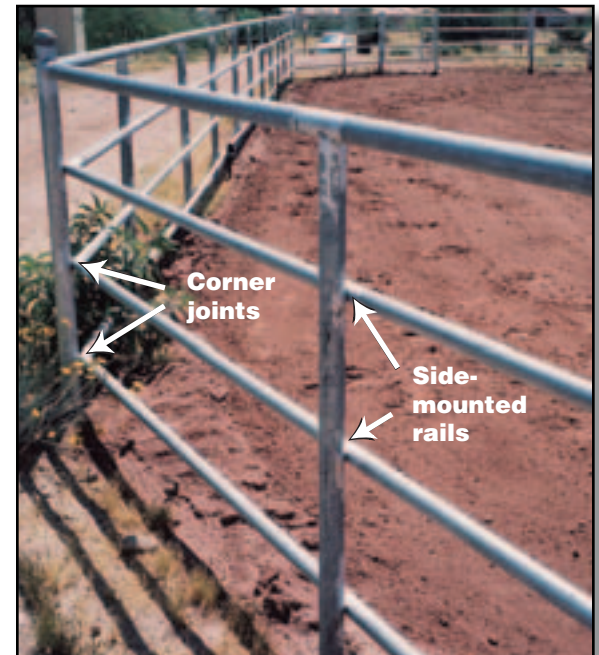

Figure 10–2—Steel fence rails mounted on the sides of posts are more economical, but they may have weak corner joints.

or mule, reducing any temptation to run through it. Other riders say the more rails, the easier it is for an animal to trap a leg or hoof. These riders prefer three rails. When deciding how many rails are needed, seek input from riders who will use the enclosures. Regardless of the number of rails, fences must be free from sharp corners or protruding hardware. This is critical—horses, mules, and people get hurt when they rub against sharp objects.



Figure 10–3—Some rustic wood fences have inline rails that pass through holes in the posts.



Steel Post-and-Rail Fences

Fences made of steel posts and steel rails are suitable for most perimeter fences and horse enclosures. While steel post-and-rail fences cost more initially than fences made from other materials, steel fences are the most durable and will please riders. The horizontal rails usually are made from schedule 40 pipe that is at least 1 $\frac{7}{8}$ inches (about 47.6 millimeters) in diameter. Posts usually are schedule 40 pipe that is 2 $\frac{3}{8}$ inches (about 60.3 millimeters) in diameter.

Galvanized finishes reduce maintenance, but they may be too shiny for some settings. Black pipe is sometimes used because it rusts, allowing it to blend with less developed settings. However, rusted pipe tends to leave red particles behind when stock rub against it, something riders don't appreciate. If steel fences are painted, use an earth-toned enamel product that blends with the environment. Some stock chew on anything, including steel rails. If the steel rail is painted, chewing can make it unsightly.

Caps on posts keep rainwater from settling at the bottom and rusting through or weakening the posts. Caps on exposed pipe ends keep out bees and wasps.

Wood Post-and-Rail Fences

Wood post-and-rail fences blend well with the natural environment. However, most stock chew on wood fences (figure 10–4). Not only do chewed rails have to be replaced or maintained frequently, ingested wood slivers may be hazardous to stock. Wood rails can be treated with a solution that discourages chewing, but the solution is costly. Stock can easily damage wood fences or panels when they kick, especially if the rails are weak (figure 10–5). Wood post-and-rail fences need to be checked frequently for damage and decay.



Figure 10–4—Hungry or bored stock often chew on inappropriate items, causing considerable damage.



Figure 10–5—Riders repair corrals with whatever materials are available—in this case, baling twine and wire. Schedule regular inspections and maintenance so riders don't have to make repairs themselves.



Preserving Wood

Resource Roundup

For an overview of wood preservatives, treatment processes, alternatives, and guidelines, refer to *Preservative-Treated Wood and Alternative Products in the Forest Service* (Groenier and Lebow 2006) at <http://www.fs.fed.us/t-d/pubs/htmlpubs/htm06772809>. This site requires a username and password. (Username: t-d, Password: t-d)



10

The American Youth Horse Council (1993) lists decay-resistant woods that are suitable for horse enclosures. Osage orange, western red cedar, western juniper, and black locust make good post materials without pressure treatments. Painting or staining wood fences may help them last longer. Waterborne treatments usually are safer for stock than oil-based treatments. Surface treatments require regular reapplication and are not as effective as pressure treatments. Although pressure-treated posts and rails last longer than untreated posts, avoid posts and rails treated with chromated copper arsenate (CCA), pentachlorophenol (penta), and creosote, because these substances may be harmful or toxic to stock.



Figure 10-6—Sizable rails, attached to the inside of posts, define a classic wood corral.

Wood is most appropriate for perimeter fences, arenas, and round pens where horses and mules don't spend a lot of time. Stock spend more time in corrals and have more opportunity to chew or damage wood. Wood is still the most popular material for corrals in some areas of the country. Figure 10-6 shows a sturdy wood corral with round rails.

Vinyl Post-and-Rail Fences

Molded vinyl materials (figure 10-7) are suitable for perimeter fences, arenas, and round pens because they are durable. Some synthetic fence materials that have a steel wire bonded inside are light, but are still strong enough for gates. When correctly installed, vinyl fences generally need little maintenance. Most synthetic materials have ultraviolet stabilizers and antifungicidal agents that aren't toxic to stock and stock don't find vinyl appealing to chew on. Vinyl has no sharp edges, so most stock don't get satisfaction from rubbing against it. Synthetic fence materials are available in many colors, including colors that harmonize with the surrounding environment—dark green, brown, and black. Vinyl and similar synthetic materials don't blend well in areas with a low level of development—they are more suited to highly developed areas. A disadvantage of vinyl fence panels is their high initial cost.



Figure 10-7—When they are installed correctly, vinyl post-and-rail fences are strong, durable, require little maintenance, and have no sharp edges to injure stock.

Premanufactured Tubular Panels

Equestrians commonly use premanufactured metal panels to construct horse enclosures at home. The lightweight, inexpensive panels are a popular substitute for steel pipe in corrals, arenas, and round pens. It is easy to construct temporary enclosures like the one shown in figure 10-8. An advantage of these panels is their somewhat forgiving nature. Horses and mules are less likely to be injured if they kick or collide with a panel than with a permanent fence.

The safest tubular fence panels are connected with hinged rods, but these panels are difficult to install on uneven terrain. Panels with loose pin connectors



are easier to install on uneven surfaces, but stock may be able to catch a leg or tail in the gap between panels (see figure 10–62). Panels with rounded corners may appear safer for stock but they are actually more dangerous. If an animal rears higher than the rail, the rounded corner can funnel the animal's hoof or head into the gap between panels. A square corner with edges that have been ground smooth is better. Other fasteners include bolt clamps and rubber connectors to secure the panels solidly. Stock can rub on the protruding fasteners, which may give way, releasing the panel and freeing the horses.

If the recreation site budget does not cover steel pipe, vinyl, or wood for enclosures, consider using tubular fence panels—but use them with caution. Occasionally an agitated animal will knock the panels down and escape. Sometimes riders tie stock to panels when preparing for a ride. The unsecured panel



Figure 10–8—Building a corral is quick and easy with premanufactured metal panels.

may move if something spooks the tied animal and it pulls back. Frightened by the panel's unexpected movement, the animal may run off, dragging the panel behind it. There are several solutions:

- ☆ Install permanent posts in corrals, arenas, and round pens.
- ☆ Place hitch rails near horse areas, arenas, or round pens.

Wire Fences

A horse or mule is more likely to challenge materials it can lean over or push through. Because wire fence materials stretch, they are not suitable for corrals, arenas, round pens, or gates. Horses also can get their feet or heads caught in the wires. If they are constructed properly, wire fences may be used to secure a site perimeter. Smooth wire fences with four strands are generally adequate to discourage fleeing stock. Fences with five or six strands are even more secure.

A leaning or running animal can loosen wire fences—install materials on the inside of the posts for maximum strength. Avoid using T-posts for wire and wire-mesh fences, because stock may impale themselves on the posts. Pressure-treated wood is a sturdier—and safer—solution.

High-tensile, smooth wire of at least 12.5 gauge can be used instead of barbed wire. High-tensile wire coated with vinyl or plastic is safer—although it

costs more than uncoated high-tensile wire. Coated, smooth wire costs less than post-and-rail construction and does not rust, stretch, or fade. When installed properly, coated wire provides an effective perimeter fence. Coated smooth wire is strong, somewhat flexible, and easier for stock to see than uncoated smooth wire. If stock do run into coated wire, they have less chance of injury than with barbed wire. When using smooth wire for a perimeter fence, consider adding a steel, wood, or vinyl top rail so that stock can see it easily. Using smooth wire instead of barbed wire doesn't eliminate the possibility that stock might get tangled in the strands.



Barbed Response

Horse Sense

In some areas, perimeter fences keep cattle out of the recreation site while keeping stock inside. The traditional cattle fence incorporates multiple strands of barbed wire, an unsafe practice for horse fences. When horses and mules catch a leg or hoof in fences, they often struggle vigorously to free themselves and sustain serious injuries. Barbed wire is generally not recommended for horse fences—many alternatives are safer. When barbed wire must be used, a compromise is to use smooth wire or wire mesh for the bottom of the fence, and a single strand of barbed wire at the top (figure 10–9). Do not use barbed wire for interior fences.



Figure 10-9—Barbed wire discourages cattle from leaning over and breaking down a fence, but can be dangerous for horses and mules. Choose an alternative fencing material in recreation sites.

Wire Mesh Fences

Wire mesh is made of woven wire or welded wire and is commonly used for horse fences. The bottom portion of the pasture fence in figure 10-9 is constructed of wire mesh. Woven wire is a better choice than welded wire, because aging welds can burst, resulting in sharp projecting ends. Although wire mesh is the least expensive fence material, it is not safe for use on horse corrals. When some horses and mules are kept in wire mesh enclosures, they try to climb or step on the wire grids. They can easily catch a hoof or horseshoe in the wire. Wire mesh is suitable for perimeter fences, arenas, and round pens because horses are not loose there for long.

Wire mesh stretches when a horse hits it, distributing the impact over a wide area and reducing injuries and damage. The mesh should be attached to a post-and-rail fence made of wood or steel (figure 10-10). As with all enclosures, secure the boards and wire to the inside of posts. For horse fences, V-mesh woven wire, a more costly variation, generally is safer than rectangular woven wire. Table 10-1 lists suggested materials for horse fences and gates. Table 10-2 compares characteristics of materials suitable for fences in equestrian recreation sites.



Figure 10-10—Attaching wire mesh to post-and-rail fences makes the fence more resilient. Stock also can see it better.

Table 10-1—Suggested materials for horse fences, enclosures, and gates.

Material	Perimeter fences	Corrals	Arenas and round pens	Gates	Appropriate level of development
Steel post and rail	X	X	X	X	Low, moderate, high
Vinyl post and rail	X		X	X	High
Wood post and rail	X	X	X		Low, moderate, high
Square, woven wire mesh	X		X	X	Low, moderate, high
Tubular panels		X	X	X	Low, moderate, high
Coated, smooth wire	X				Low, moderate, high



Table 10–2—Characteristics of fence and panel materials for equestrian recreation sites.

Material	Sturdy	Economical	Safe for horses	Low maintenance	Long lifespan
Steel (unpainted)	Excellent	Poor	Excellent	Excellent	Excellent
Wood	Fair	Good	Poor	Poor	Poor
Vinyl	Excellent	Poor	Excellent	Excellent	Excellent
Portable panels	Poor	Excellent	Poor	Good	Poor
Square, woven wire mesh	Fair	Excellent	Poor	Fair	Fair
Coated, smooth wire	Fair	Good to excellent	Fair to good	Fair	Fair to good

Cattle Guards, Gates, and Latches

Perimeter fencing by itself is not enough. To complete the continuous barrier around the recreation site, install gates at trail access points and roads. Within the recreation site, provide appropriate gates and latches for corrals, arenas, and round pens. Often a cattle guard is required by land management agencies, but most riders do not like them.

Cattle Guards

Many agencies require cattle guards on access roads to keep cattle out of recreation sites. Cattle guards are dangerous for horses and mules—whether they are loose or under saddle. They may try to walk or jump over the cattle guard or walk around its ends. They can trap a hoof or leg in the cattle guard, severely injuring themselves. Figure 10–11 shows a cattle guard that has objects and barbed wire in the angled side wings, creating hazards for all users. If a cattle guard is required, install a vehicle gate between the recreation site and the cattle guard to contain loose stock. If a gate is not feasible, consider painting bold, white parallel stripes on the pavement between the recreation site and the cattle guard. Some horses and mules are reluctant to cross these highly visible markings, and the sight may temporarily distract a fleeing animal. Cattle guards generally are subject to the MUTCD or the governing agency’s sign requirements.



Electric Solutions

Many riders travel with portable electric corral kits that include posts, fasteners, stakes, a gate, synthetic wire, a tester, and a battery-operated fence charger. Horses and mules are very sensitive to small electrical shocks. One shock is usually enough to convince stock to stay away. When stock have been conditioned to electric fences, they generally don’t test or challenge them, but

Horse Sense

if a horse or mule perceives a real or imagined predator, an electric fence will do little to deter the animal’s flight. Animals, people, or property can be hurt. Other domesticated animals and wildlife may not respect electric fences, whether they are set up with single or double strands. This guidebook recommends using other fence options for equestrian recreation sites.

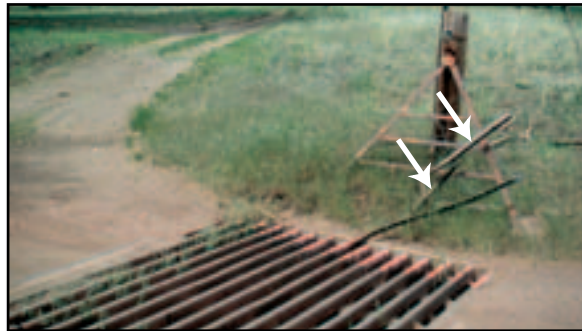

Figure 10-11—Some stock attempt to go around cattle guards. Pieces of wood stuck in the wings of this cattle guard discourage passage, but are safety hazards for all users. Find another solution. Cattle guards must be marked according to the MUTCD standards.

Road Gates

A gate provides a safe barrier that will be respected by loose stock. Provide gates at entrances to campgrounds and trailheads and at each loop road. Even though the loops may not be fenced, gates can help if access must be restricted for any reason, including maintenance and renovation. Entrance

road gates should remain closed except when a rider opens and closes them for vehicle access. Plan for turnaround areas when placing gates, so gate closures do not create dead ends. Figure 10-12 shows the perimeter fence and gates in a campground with loops and turnarounds.

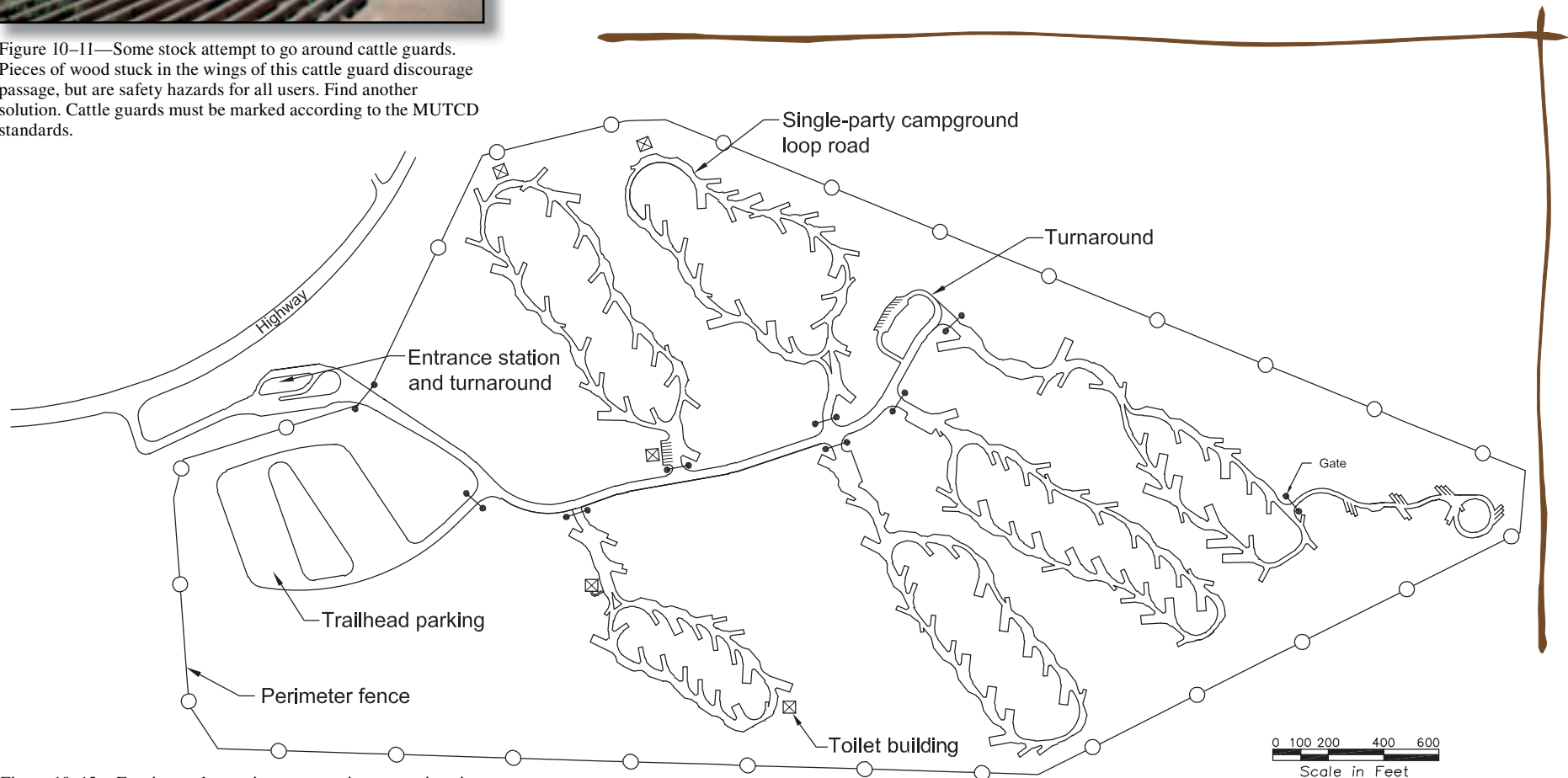

Figure 10-12—Fencing and gates in an equestrian recreation site.



Road gates commonly range from 16 to 20 feet (4.9 to 6.1 meters) wide. Two-lane roads normally have two gates. Figure 10–13 shows a gate suitable for an area with a high level of development. A standard gate is preferred in areas with low to moderate development (figure 10–14). A farm gate is more appropriate for areas with low development (figure 10–15).

When trails or attractions are outside the recreation site, provide a smaller trail gate beside the road gate. The additional gate is necessary when a cattle guard blocks the exit (figure 10–16). Trail gates are easier for riders to open and close than large road gates.



Figure 10–14—A gate commonly used by the Forest Service in recreation sites.



Figure 10–15—Farm gates are used in some areas for horse trails.



Figure 10–13—This pair of gates is suitable for a recreation site with a high level of development.

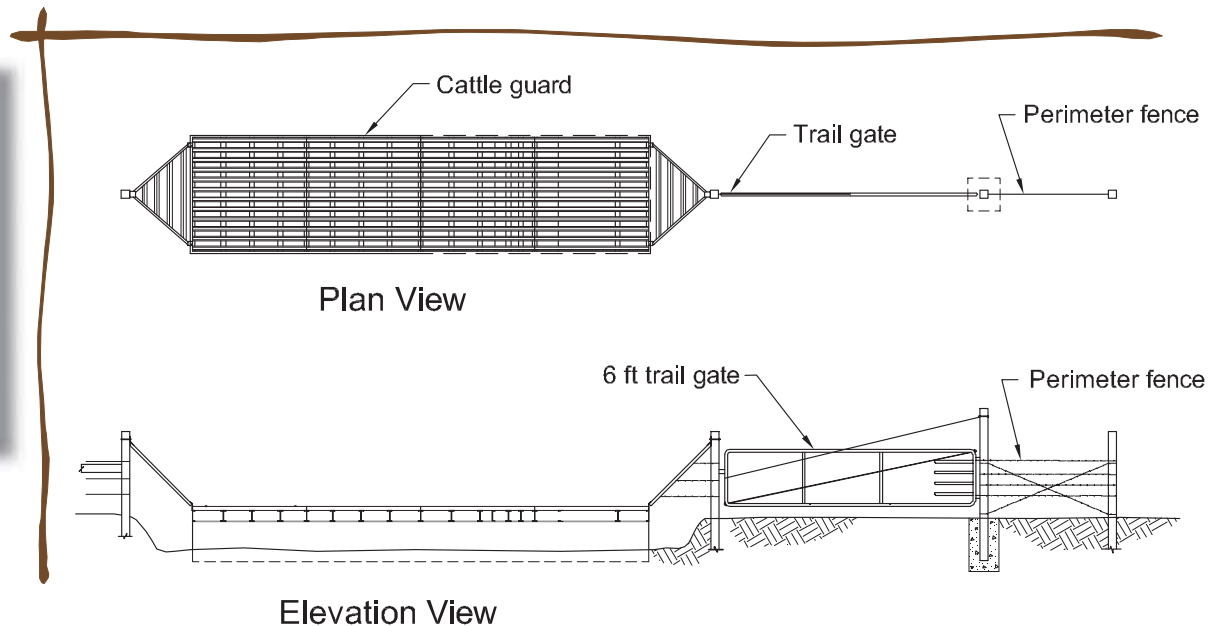

Figure 10–16—A cattle guard with an adjacent trail gate.



Stepover Gates

A road gate can have a low section—or stepover—that keeps wheeled vehicles out, but allows pedestrians and equestrians to pass (figure 10–17). Gates with stepover bars are not effective perimeter closures because a loose horse or mule may walk or jump over the bars, as might wildlife or cattle.

Trail stepover gates have a horizontal bar or other device placed across the tread to deter unauthorized use. Figure 10–18 shows a rural trail with a narrow V-gate and a stepover bar. Land managers commonly use stepover gates to discourage motor vehicles on nonmotorized trails. Stepover gates are not foolproof. While it is difficult to get an off-highway vehicle (OHV) across them, it is easy to lift motorbikes over them. Recreationists sometimes fill the gap between the ground and the bar with soil, creating a ramp for motor vehicles. One challenge facing land management agencies is designing a stepover gate that allows a person with disabilities to pass through the barrier while excluding OHVs.

Many horses and mules routinely use stepover gates; others are hesitant to do so. Wrapping the bar with cushioning material will dampen the noise when an animal’s hoofs contact the bar. The preferred height for the stepover bar is 12 inches (305 millimeters). The maximum is 16 inches (406 millimeters). When a bar is too high, stock may jump over it, unseating inexperienced riders. On horse trails where riders

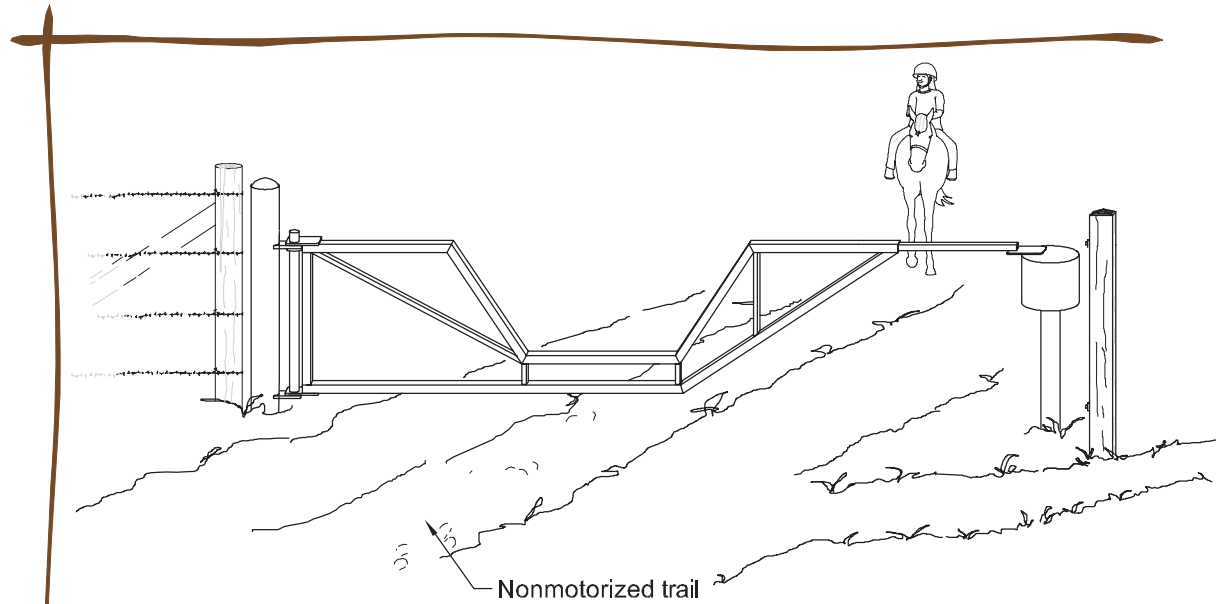

Note:

1. When a need has been appropriately determined, use standard object markers (Type II and III) to mark hazards, such as gates, within or adjacent to the trail.
2. When a need has been appropriately determined, traffic control devices, such as retroreflective signs, may be used on roads and trails open to motorized or mechanized traffic.
3. Retroreflective signs may be considered for added emphasis on trails that are closed to motorized and mechanized traffic.
4. All traffic control devices must meet the MUTCD or governing agency standards.
5. Signs are not shown for clarity.

Figure 10–17—This prototype road closure gate allows trail stock and pedestrians to pass, while restricting many motor vehicles. This trail gate is not accessible to people with disabilities because the bar across the opening is higher than 2 inches. See *Chapter 12—Providing Signs and Public Information* for sign details.



Figure 10-18—Riders, pedestrians, and mountain bikers can pass through this relatively narrow V-gate on a rural trail, but ATVs are restricted. The gate is not accessible to people with disabilities because it is narrower than the minimum width required for passage of a wheelchair—32 inches—and the bar across the opening is higher than 2 inches.

have limited experience, a bar lower than 12 inches (305 millimeters) may be appropriate. Tread surfaces on both sides of stepover gates wear down or become compacted over time, leaving the bar higher from the ground (figure 10-19). Short stepover bars



Figure 10-19—As heavy traffic wears the tread down, negotiating stepovers may become more difficult for all users. This trail gate is not accessible to people with disabilities because the bar across the opening is higher than 2 inches.

accommodate trail compaction, but may allow unauthorized trail users to pass. Higher stepover bars may require frequent maintenance because of tread

wear. To reduce tread wear at a stepover gate, install a concrete pad below grade and cover it with tread surface material (figure 10-20).

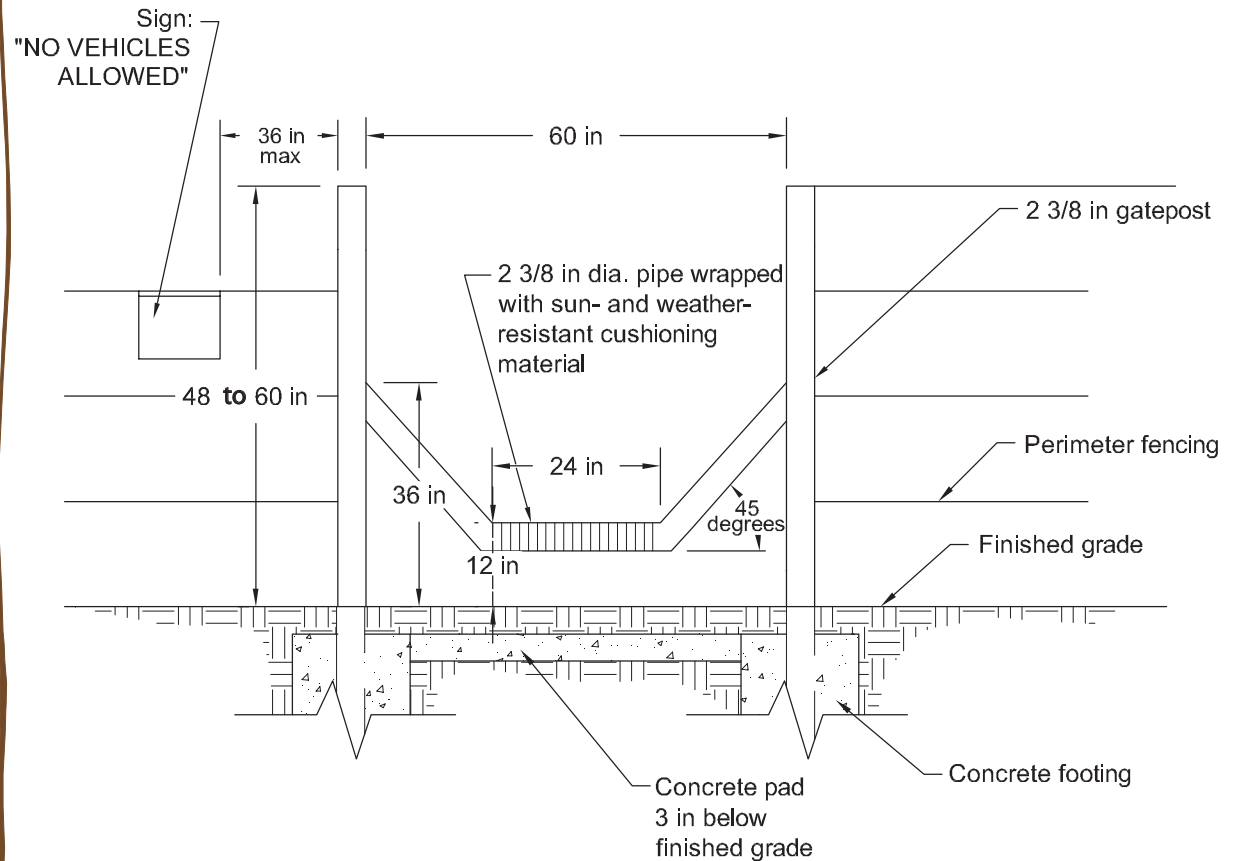

Figure 10-20—A stepover gate for nonmotorized trail users. This trail gate is not accessible to people with disabilities because the bar across the opening is higher than 2 inches.



10

Trail and Corral Gates

Gates must be wide enough to allow riders, stock, and loads to pass through without rubbing. The minimum width for trail gates is 5 feet (1.5 meters), and the minimum width for corral gates is 4 feet (1.2 meters). A 6-foot- (1.8-meter-) wide gate is easier to use when riders are leading stock (figure 10–21). Standard, prefabricated gates are available in 4 and 6 feet widths, while 5-foot gates generally must be custom built. Trails often have standard 6-foot prefabricated gates because they cost less than 5-foot custom gates.



Figure 10–21—The bulky loads carried by packstock require relatively wide gate openings.

Gates for Arenas and Round Pens

The minimum recommended gate width for arenas and round pens is 12 feet (3.6 meters) to allow access by maintenance vehicles. Large gates may be awkward for riders to open and close when they are leading an animal. To avoid installing a single, heavy gate consider installing two, 6-foot (1.8-meter) gates, or a 12-foot gate for vehicles with an adjacent 6-foot gate for riders (figure 10–22).



Figure 10–22—This arena can be accessed through a large or a small gate.

Gate Designs

Stock perceive narrow gates, or those that don't swing completely open, as tight spaces and may move too quickly through them for safe passage. Gates that swing freely in and out of the enclosure are the best. Gates should be easy to open and close with one hand—riders should not have to pick up a gate end and carry it. Once opened, gates should stay open long enough to lead an animal through them. A gate that unexpectedly swings closed against an animal can startle it. Self-closing gates that close too quickly can snag packs, loads, and reins in the closing device. Many riders dismount, hold the self-closing gate open with one hand, and awkwardly maneuver the animal through with the other hand. Sometimes, another rider dismounts and holds the gate open as others pass. To remedy such problems, install a large hook and an eye bolt to hold the gate open.

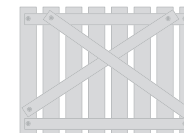



Gate Materials

Construct gates from smooth fence materials, such as steel, to discourage stock from rubbing against them and straining the hinges. The ideal gate is strong and lightweight—heavy gates frequently sag (figure 10–23) over time. Gates made of wood rails or lumber are heavy, especially if they span more than 5 feet (1.5 meters). Wood gates longer than 5 feet will require frequent maintenance. A premanufactured gate made of steel tubing is a sturdier option that will require less maintenance (figure 10–24). Prefabricated farm gates made with formed flat steel or standard aluminum livestock gates are not safe for horses and mules. When a horse gets a leg caught in a gate made with these materials, the rolled edges can open, injuring the animal as it tries to pull free. The lightest gate material is chain (figure 10–25). When gates are made of wire mesh, a structural frame of steel or vinyl is recommended for stability and ease of use.



Figure 10–23—Wood corral gates are heavy and can sag over time. This corral has rails attached to the outside of posts. A horse could pop the rails loose by leaning against them.



Figure 10–24—Premanufactured tubular steel gates are lighter and less likely to sag than wood gates.



Figure 10–25—Chain gates are simple and effective. Some riders do not like them because a horse or mule may get its head or hoof caught in the large openings.

Gate Safety

A safe gate doesn't have sharp edges or protrusions that can cut stock. Figure 10–26 shows an attempt to repair a damaged gate with baling twine, unacceptable for recreation sites. Grind smooth or round all gate corners. Otherwise, curious or playful stock may hurt themselves. Although most tubular steel gates have safe, rounded bottom corners, some have sharp ends on the vertical tubes that can cause serious injury if an animal catches a hoof or leg under the gate. Maintain gates regularly.



Figure 10–26—Baling twine provides a temporary—and possibly unsafe—field fix for a broken gate. Schedule regular inspection and maintenance for gates and fences in recreation sites.





Gateposts can support a heavy swinging gate if the posts are set in concrete. Minimize the gaps between the gate and the gateposts, so swished tails won't get caught. Gates should fit closely to the posts, with clearance only for hinges. Make sure the upper hinge pin on horse gates made from pipe or tube is placed correctly. If the pin is set too low, stock can rear up and catch a front leg or hoof between the gate and the gatepost. Minimize the hazard by placing the upper hinge pin as high as possible on the gatepost. Avoid gates made from portable fence panels that have a bottom rail at ground level. When the ground erodes away from the base of the rail, stock can trip or wedge a hoof between the tube and the ground. If these gates must be used, they require regular maintenance.

Accessible Gates

Accessible shared-use trails must have gates that meet ADA/ABAAG requirements. Because gates that can be opened from horseback may not meet pedestrian accessibility requirements, consider installing two separate gates, one for riders and one for other trail users, including people in wheelchairs. Figure 10–27 shows a horse-friendly road gate

combined with an accessible kissing gate. This gate and the gates in the following examples don't have latches. These gates would be suitable for trail installations, perimeter fences, and places where stock don't spend a lot of time. Gates without latches are not suitable for areas where horses and mules are confined, because they would figure out how to escape. The tread through accessible gates must meet the requirements for firmness and stability.

In 2006, MTDC developed a prototype equestrian kissing gate without a latch that is accessible to people in wheelchairs. Kissing gates, a half-round or V-shaped fence with a hinged gate, are used in the United Kingdom to confine livestock while allowing people to pass. The gate opens by pushing from either side, and closes when it hits the fence on either side. When the gate is pushed partially open, a gap allows a single person to pass through. The prototype MTDC gate combines a horse stile with a traditional kissing gate design (figure 10–28). This gate is appropriate where motor vehicle use is not allowed, because the gate combination restricts the passage of most OHVs and motorcycles.

In Utah, the Bureau of Land Management and the Forest Service use a dual-purpose V-gate (figure 10–29) that has an opening at the bottom wide enough to allow wheelchair access. The opening flares at the top to allow loaded packstock to pass. The gate blocks use by OHVs with four wheels, but doesn't restrict smaller vehicles, such as bicycles or motorcycles.

Figures 10–30 and 10–31 show another gate that discourages motor vehicles while allowing access for stock and wheelchairs. It is a modified *chicane*—double bend—design that incorporates an L-shaped leg off the main rail fence. To be accessible, the dimensions at the right turn must allow a 60-inch (1524-millimeter) turning radius for a wheelchair, which may permit passage by some small OHVs.



Resource Roundup

Accessible Horse Gates

For more information on the accessible gates developed by MTDC, refer to *Accessible Gates for Trails and Roads* (Groenier 2006) at <http://www.fs.fed.us/t-d/pubs/htmlpubs/htm06232340>. This site requires a username and password. (Username: t-d, Password: t-d)

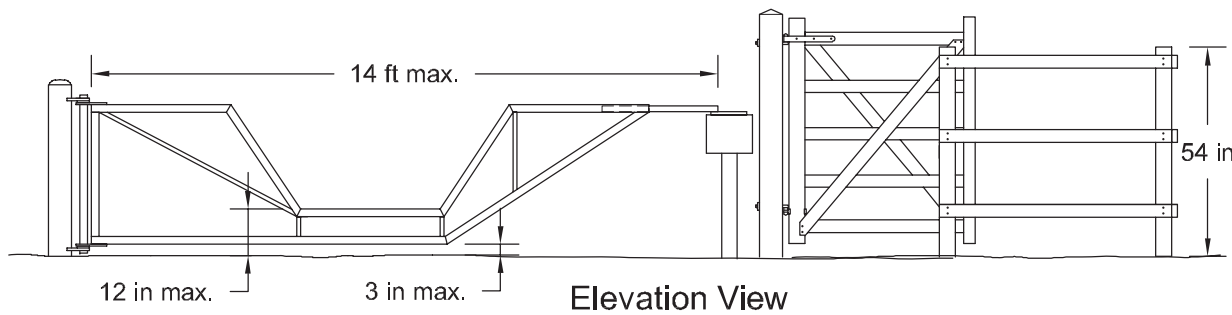
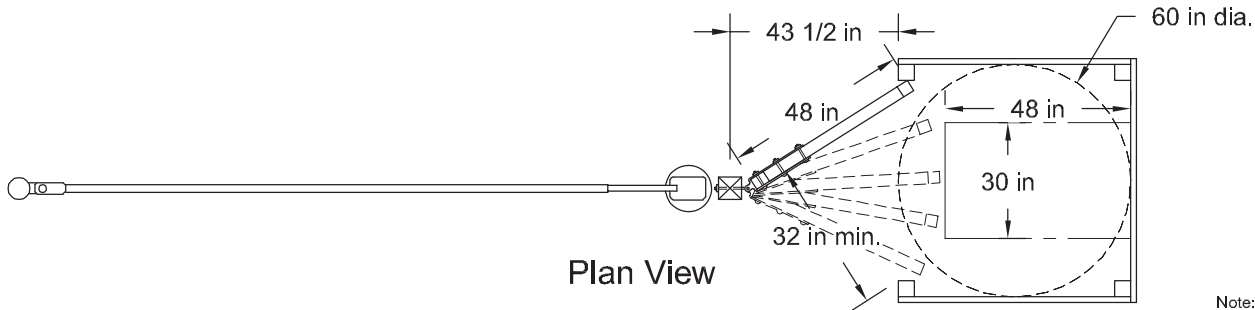
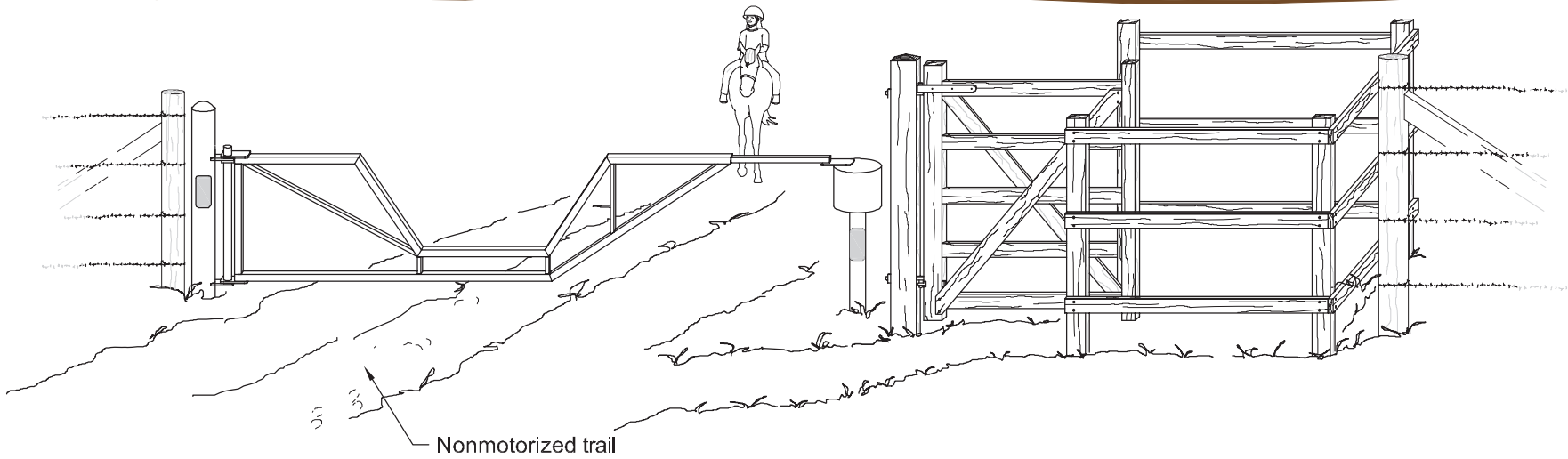

Note:

1. When a need has been appropriately determined, use standard object markers (Type II and III) to mark hazards, such as gates, within or adjacent to the trail.
2. When a need has been appropriately determined, traffic control devices, such as retroreflective signs, may be used on roads and trails open to motorized or mechanized traffic.
3. Retroreflective signs may be considered for added emphasis on trails that are closed to motorized and mechanized traffic.
4. All traffic control devices must meet the MUTCD or governing agency standards.
5. Signs are not shown for clarity.

Figure 10-27—This prototype road closure gate has a kissing gate alongside. The combination would allow stock, pedestrians, and people who use wheelchairs to pass, while still restricting many motor vehicles.

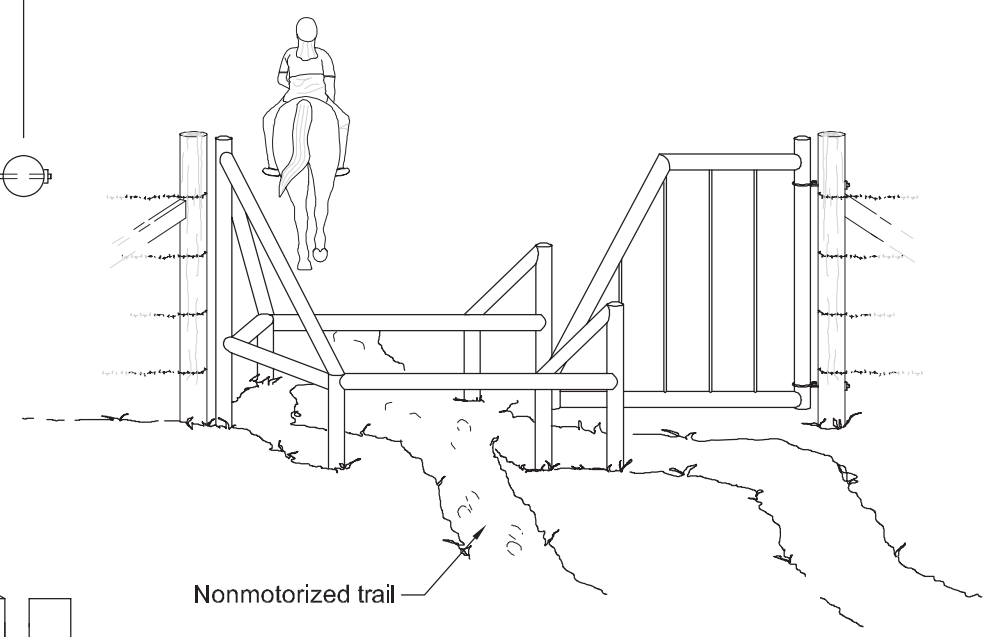
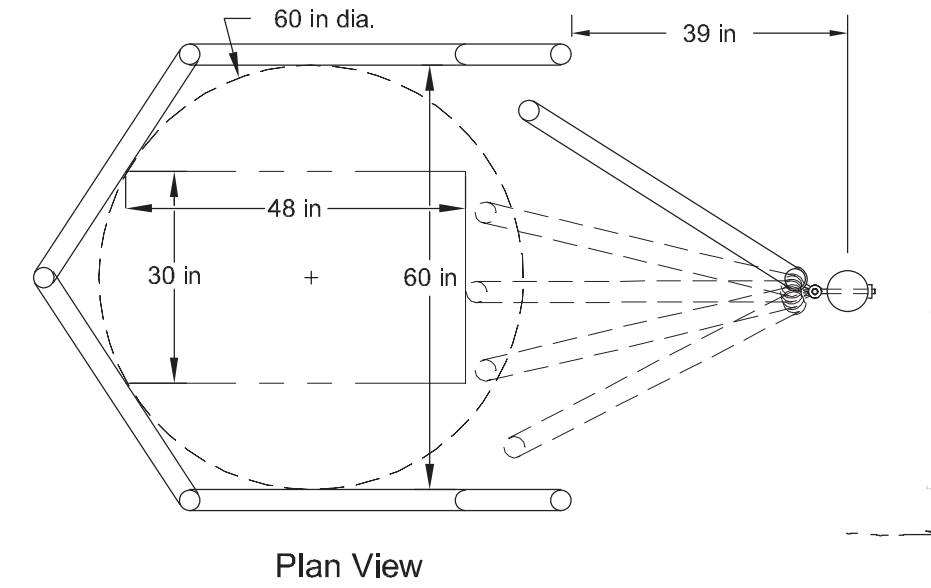

Nonmotorized trail

- Note:
1. When a need has been appropriately determined, use standard object markers (Type II and III) to mark hazards, such as gates, within or adjacent to the trail.
 2. When a need has been appropriately determined, traffic control devices, such as retroreflective signs, may be used on roads and trails open to motorized or mechanized traffic.
 3. Retroreflective signs may be considered for added emphasis on trails that are closed to motorized and mechanized traffic.
 4. All traffic control devices must meet the MUTCD or governing agency standards.
 5. Signs are not shown for clarity.

Figure 10-28—A combination horse stile and accessible kissing gate.

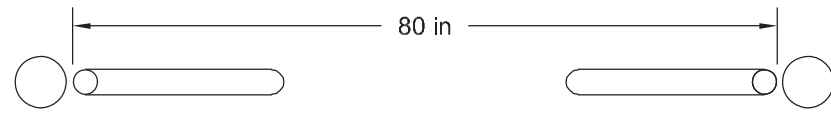

Plan View

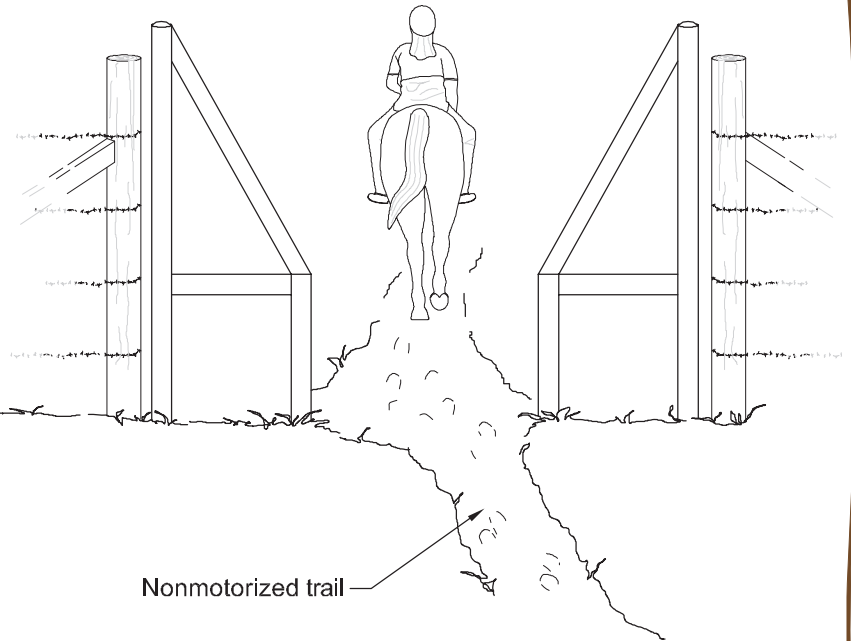

Nonmotorized trail

Note:

1. When a need has been appropriately determined, use standard object markers (Type II and III) to mark hazards, such as gates, within or adjacent to the trail.
2. When a need has been appropriately determined, traffic control devices, such as retroreflective signs, may be used on roads and trails open to motorized or mechanized traffic.
3. Retroreflective signs may be considered for added emphasis on trails that are closed to motorized and mechanized traffic.
4. All traffic control devices must meet the MUTCD or governing agency standards.
5. Signs are not shown for clarity.

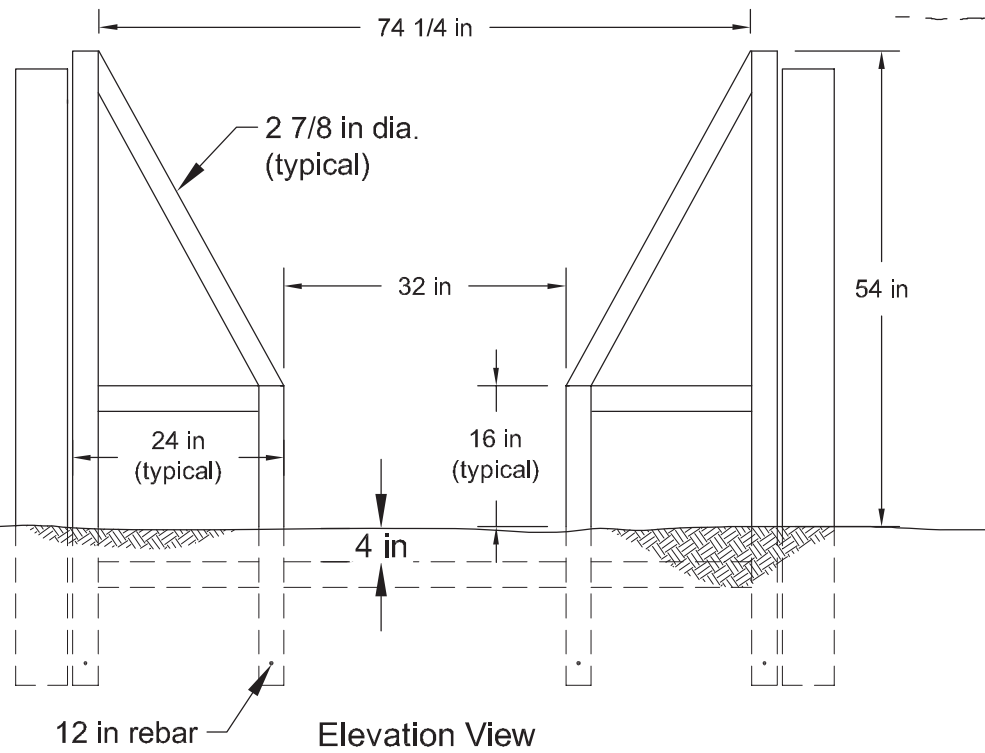

Elevation View

Figure 10-29—A V-gate for stock and pedestrians.



Figure 10-30—Chicanes use tight turns to prevent unauthorized use. The entrance to this modified chicane is immediately left of the signs.



Figure 10-31—The dogleg design of a chicane restricts some trail users.



Gate Latches

When it comes to latches and gates, one size does not fit all equestrian situations. Gates along trails should have latches that can be opened from horseback. Corral gates and latches should open easily from ground level because riders generally dismount before leading stock into corrals. Arena gates are a slightly different situation. Many riders prefer to ride into arenas, and they appreciate latches that can be opened from horseback.

Suitable equestrian gate latches must be *horseproof*—strong enough to give an equestrian peace of mind and complex enough to withstand exploration by a mule’s prehensile lips. The latch and gate should be easy to operate with one hand because riders need the other hand to control their mount. A bored or lonesome animal may spend hours methodically moving a latch back and forth with its teeth or lips until the device breaks or releases. If a 2-year-old child can open a latch, a determined horse or mule probably can open it. To deter curious stock, choose horseproof hardware or shield the latch with an overhanging cover. Horseproof latches are optional on gates where stock are not confined for long periods, such as a trail gate designed to restrict motor vehicles while allowing pedestrians and riders to pass.

Premanufactured metal gates commonly include a slotted steel plate and a length of chain welded on the gate panel. The chain wraps around the gatepost and

slips into the slot (figure 10-32). Opening the gate is relatively easy with one hand, but closing it requires two hands to wrap the chain around the gatepost. This style is common in ranch country, but many horses and mules can open such gates. To prevent stock from escaping, wrap the chain around the post and use a strong snap to secure the chain.

The most secure latches generally are made of metal, and many are lockable. Horse-resistant latches may employ a sliding male hook or bar that fits into a female opening or sleeve. Some include a metal chain secured with a pressure snap that stock can’t operate.

Mounted riders generally can open gates equipped with double-piston, pull-rod, or spring-lever latches without dismounting. Place latches used by mounted riders about 5 to 6 feet (1.5 to 1.8 meters) above the tread.



Figure 10-32—Premanufactured gates often come with a slot latch and chain to wrap around the gatepost. Attaching a sturdy snap that can be hooked back into the wrapped chain prevents most curious horses and mules from letting themselves out.



Latching the Gate

Some effective and easy-to-use latches for horse gates include:

- ☆ Figure 10-33 is a lockable latch that comes with a self-latching strike plate. It is almost impossible for a horse or mule to open this latch.
- ☆ Figure 10-34 is a latch that opens easily with one hand from horseback or from the ground. It is rustproof, frostproof, and is difficult for stock to open.
- ☆ Figure 10-35 is a latch that opens with one hand from horseback or from the ground. When the latch is open, it allows the gate to swing both ways. When the latch is closed, it supports the gate. This latch is designed for gates with tubes that have an outside diameter of 1 $\frac{5}{8}$ to 2 inches (about 42 to 51 millimeters).
- ☆ Figure 10-36 is a self-latching unit that mounts on the post rather than on the gate. It is operated from horseback or from the ground. The gate can be pulled or pushed open by pressing down on the rod. Lifting the rod up and giving it a half turn locks the latch in place, foiling curious stock.
- ☆ Figures 10-37, 10-38, and 10-39 show some handmade latches that can be operated from horseback.



Figure 10-33— This galvanized latch is horse resistant.



Figure 10-34— This galvanized latch is easy to open with one hand, even from horseback. —*Courtesy of Ramm Fence Systems, Inc.*



Figure 10-35— This latch allows the gate to swing both ways, can be opened from horseback, and supports the closed gate. —*Courtesy of Co-Line Welding, Inc.*



Figure 10-36— Pushing down on this adjustable latch while pushing or pulling opens the gate. —*Courtesy of HiQual Manufacturing.*



Figure 10-37— This rustic wood gate opener has a lever that can be operated from horseback.



Figure 10-38— Pull-rod latches allow riders to open gates without dismounting.



Figure 10-39— A spring-lever latch must be placed appropriately to be used from horseback.



Accessible Latches

Gates and latches designed to accommodate all riders, including riders who have disabilities, add tremendously to overall trail accessibility. To be accessible, latches must

comply with the ADA/ABAAG requirements—operating mechanisms must be operable with one hand without pinching, tight grasping, or twisting the wrist and cannot require more than 5 pounds (2.3 kilograms) of force to operate.



Prototype Latch

In 2006, Hamilton Hinge Co. worked with MTDC to develop a prototype gate latch that keeps stock in and also provides access for people with disabilities (figure 10–40). The gate swings both directions and can be reached from a wheelchair. Dexterous riders can open the gate from horseback with their foot. Figure 10–41 shows a guard ring that can be added to discourage animal exploration. Because some clever mules and horses may be able to open this latch, avoid using it on corrals or other areas where stock are confined for long periods. This latch is best suited to trail or perimeter gates where stock have little opportunity to investigate the mechanism. For more information, refer to *Accessible Gate Latch* (Groenier 2006) at <http://www.fs.fed.us/t-d/pubs/htmlpubs/htm06232331>. This site requires a username and password. (Username: t-d, Password: t-d)

Resource Roundup

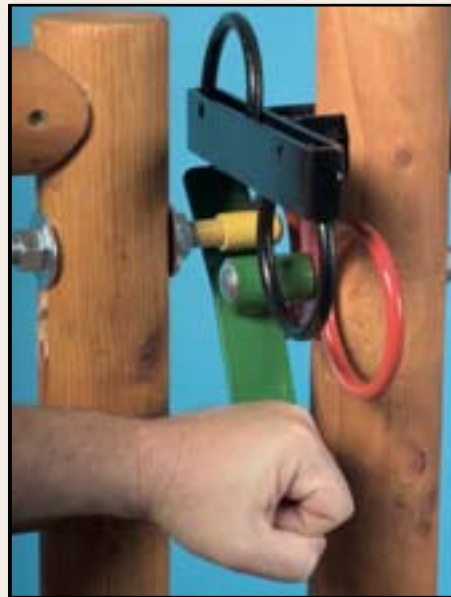

Figure 10–40—Depressing the plate while pushing the gate releases this prototype accessible latch. Some riders can open the gate from horseback using their foot to depress the plate.

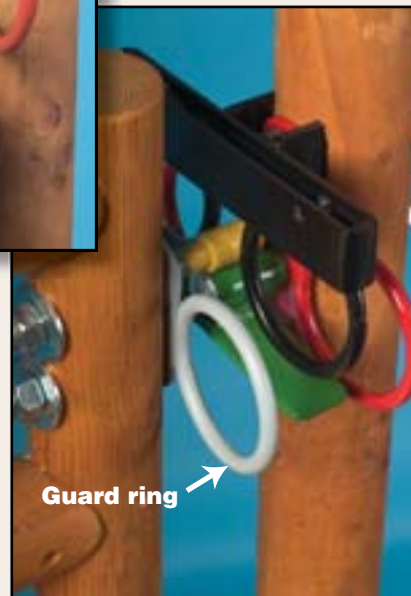

Figure 10–41—Adding guard rings on the gate frame confounds most escape attempts by stock. Because some clever horses and mules still may be able to open this latch, it is best suited for gates inside an area that also has a perimeter fence.

Tethering Devices and Enclosures

The most common methods for securing stock within a facility and at camp units are tying them to something solid or placing them in an enclosure. The most suitable method depends on the length of time the horse or mule is confined and the individual animal’s personality. Preferences vary widely among riders.

Riders use the terms *hitching* or *tethering* to describe tying their stock. Preferred tether anchors in recreation sites include highlines, tie loops on horse trailers, and hitch rails. The most common horse enclosure in a developed recreation site is a corral, which is suitable for overnight use. Two other enclosures—arenas and round pens—are used for exercising or training horses. Generally, they are not used for confining stock at recreation sites.



No method of tethering or confining a horse or mule is absolutely secure. Anytime an animal is tied to something or confined, there is risk of escape or injury. Inadequately anchored objects may be pulled out of the ground or broken. An animal may work a knot loose, or it may get a leg or head caught in a rope and injure itself. When a horse or mule is confined, it may push through a barrier, worry a latch and open the gate, or get a leg caught in the rails or wires. All confinement options have advantages and disadvantages. To minimize problems and hazards, design facilities so stock can be monitored easily.

Hitch Rails

Hitch rails—also called *hitching rails* or *tethering rails*—allow riders to secure horses or mules for relatively short periods. Riders tie the lead rope around the hitch rail to restrain the animal. Riders appreciate hitch rails near toilet buildings and information stations. Another good place to install hitch rails is near water hydrants. Doing so minimizes the distance handlers have to carry water buckets for stock. Allow at least 25 feet (7.6 meters) between the hitch rail and the hydrant to keep animal waste away from the water source.

Install hitch rails at trail access points so riders can tie their stock up before and after outings. Hitch rails midway on trails longer than 8 miles (12.9 kilometers) allow riders to secure their stock during short breaks.

Hitch rails are not needed:

- ☆ In trailhead parking areas if parking spaces are large enough to accommodate stock tied to trailers
- ☆ At camp units with permanent corrals

Provide hitch rails if portable panels are used for enclosures, because portable panels are not strong enough for tethering stock.

Hitch rails commonly are constructed of wood or steel. Wood rails are suitable for low and moderate levels of development—however, stock may chew on them, causing damage (figure 10–42). Common steel hitch rails range from 4 to 10 feet (1.2 to 3 meters) long. A hitch rail that is 4 feet long generally has space for one animal tied on each side. A hitch rail that is 10 feet long accommodates three



Figure 10–42—Because stock chew on wood hitch rails, the crossmembers eventually weaken.

animals—two animals on one side (one animal near each end of the rail) and the third animal tied to the opposite side in the middle of the rail. This allows a comfortable distance between the three animals. However, because stock can touch noses, it is best that the animals know each other and get along well. The extra-long hitch rail shown in figure 10–43 is frequently full during hunting season.



Figure 10–43—Hitch rails come in a variety of lengths to accommodate the number of stock expected. This unusually long hitch rail is at a trailhead that is heavily used during hunting season.



The recommended height for hitch rails is 42 inches (1,067 millimeters). This height is good for both riders and stock when lead ropes are tied properly. To avoid injuries, round the corners of hitch rails (figures 10–44 and 10–45). Properly designed hitch rails don't allow a lead rope to slide from the horizontal rail down the upright posts. If this happens, the animal could easily step over the rope and tangle its front legs, a setup for panic and injuries. Crossmembers may be installed at each end of the rail (figure 10–46) to keep the rope from sliding down or tie rings could be installed on the rail. When lead ropes are tied to the rings, they can't slide along the length of the rail. Lead ropes tied to the long, overhanging ends of the hitch rail shown in figure 10–47 may slide off, releasing the stock.

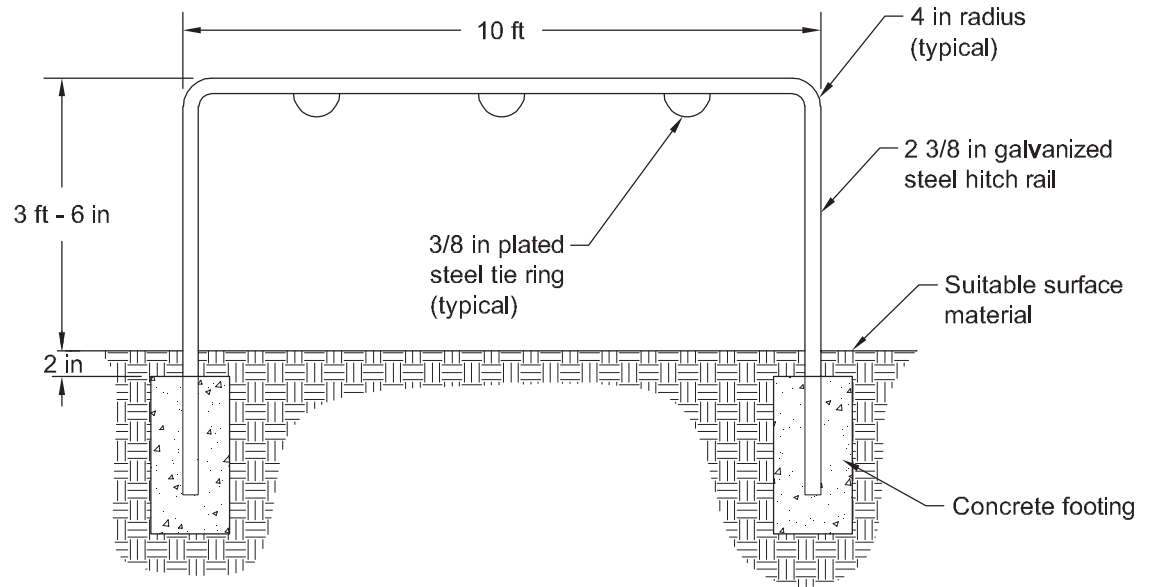

Figure 10–44—A hitch rail.

For safety, provide a level area around hitch rails that is free of vegetation or other obstacles (figure 10–48). See figure 10–46 for an example of a well-designed hitch rail that is not popular because a raised curb, large rocks, and encroaching vegetation prevent stock from being tethered on one side. Riders do not use the hitch rail shown in figure 10–49 because the ground is uneven, and the signs, bollards, and rocks nearby are dangerous for horses and mules. Figure 10–50 shows a hitch rail with a suitable cleared area. Because hitch rails may be in high traffic areas, it is wise to add suitable surface material such as aggregate.



Figure 10–45—Welded steel loops prevent lead ropes from sliding along this hitch rail.



Figure 10–46—The braces in the corners of this hitch rail confine lead ropes to the horizontal bar and make it a good design choice. However, this site would be more horse friendly without the raised curb, large loose rocks, and encroaching vegetation.

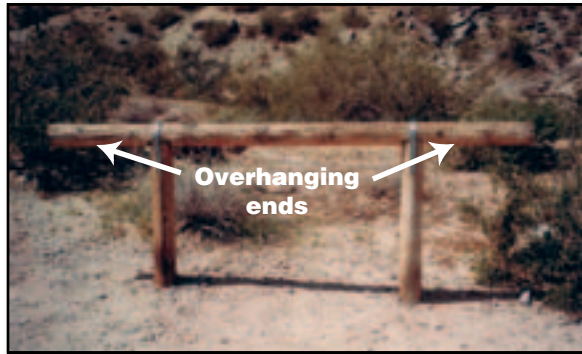

Figure 10-47—Because the overhanging ends on this hitchrail are so long, some riders may tie stock there. Lead ropes could slide off the open ends, leaving stock loose.



Figure 10-49—Signs, bollards, and an uneven surface would make these hitch rails unpopular with many riders.



Figure 10-50—Areas near toilet buildings are excellent places to install hitch rails. Provide plenty of clear space around the hitch rails. This rest area also includes a horse trough nearby, a welcome amenity.

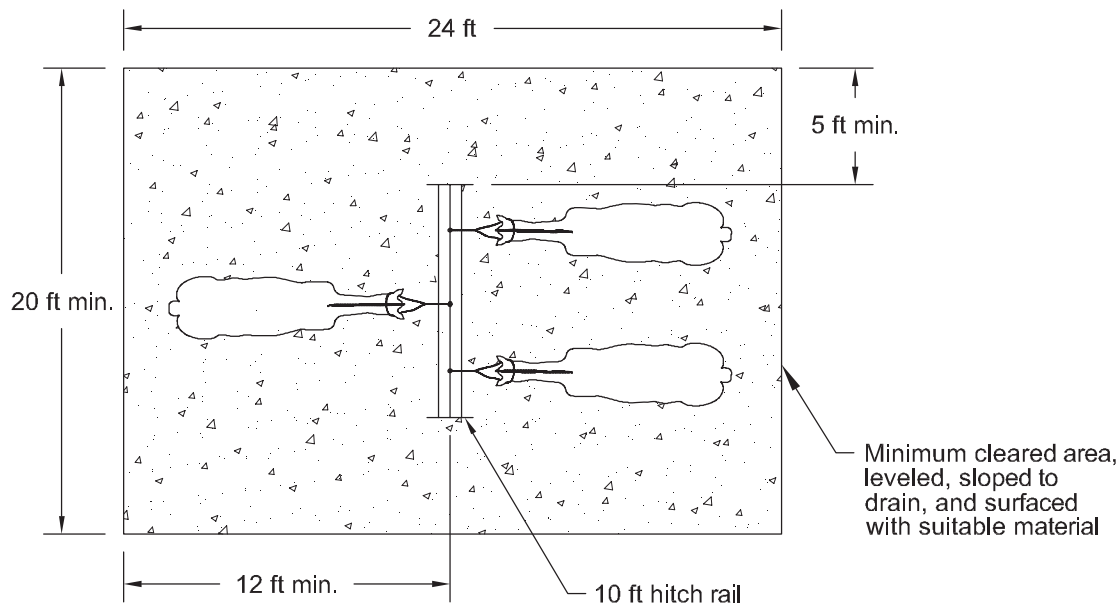

Figure 10-48—The minimum wearing surface recommended at a hitch rail.

Hitching Posts

A *hitching post* is a variation of a hitch rail that has a single, solid upright with a ring attached near the top (figure 10-51). Riders tie the lead rope to the ring. While hitching posts save space, they have several drawbacks—they only accommodate one horse or mule at a time, and the animal can circle the post, wrapping the lead rope. Use other tethering devices in recreation sites.



Figure 10-51—Stock tied to hitching posts tend to move in circles, wrapping the lead rope, restricting their movement, and possibly injuring themselves.



10

Trailer Ties

Some riders prefer tying stock to the side or end of a horse trailer in such a way that the animals can eat, drink, and lie down (figure 10–52). When animals are nearby, riders who sleep in the horse trailer or towing vehicle can keep an eye on their stock. Access to equipment, feed, and supplies is also convenient. To allow riders to tie their stock to trailers, design extra length and width into parking pads and parking spaces. Consult *Chapter 8—Designing Roads and Parking Areas* and *Chapter 9—Designing Camp and Picnic Units* for more information.

Stock tied to a trailer can only move sideways 180 or 270 degrees. They can untie themselves, catch their heads or a leg in the lead rope or under the trailer, or injure themselves on sharp, protruding objects. Stock tied to trailers require close monitoring.



Figure 10–52—Riders frequently anchor highlines to their horse trailers. —*Courtesy of Kandee Haertel.*

Highline Ties

Some riders prefer tethering stock to a *highline*, also called a *tethering line* or *picket line*. A highline is a rope stretched taut between two secure uprights above the animal’s head. The stretched rope has tie loops spaced for securing stock with lead ropes. Sturdy trees often are used as anchors for highlines (figure 10–53). When trees are not available, posts



Figure 10–53—A highline allows stock substantial freedom of movement. Care must be taken to protect surrounding vegetation and ground surfaces. —*Courtesy of Kandee Haertel.*

set in concrete may serve as uprights (figure 10–54). Riders sometimes park their horse trailers parallel to each other and stretch a rope between them. This is feasible only in locations with double-party or several-party parking pads or group parking areas. Many riders prefer highlines because their stock can move 360 degrees. Highlines are easy to carry and



Figure 10–54—To be effective, highlines must be stretched taut. A hand winch helps to apply enough tension.

install, and they are an option for stock that shouldn’t be confined in corrals.

Highlines require a cleared area of at least 32 feet (9.8 meters) wide by 24 feet (7.3 meters) deep to accommodate two animals (figure 10–55). Plan the location of the cleared areas to avoid sensitive soils. Refer to *Chapter 13—Reducing Environmental and Health Concerns* for more information on soils. Protect the vegetation, too—hungry or curious stock may devour edibles within 12 feet (3.7 meters) above the cleared space and within 7 feet (2.1 meters) to the side. Trees or branches anchoring highlines should be at least 1 foot (0.3 meter) in diameter. Permanent posts with sturdy tie hooks can be installed for highlines. Securely weld or bolt the tie hooks to the posts.

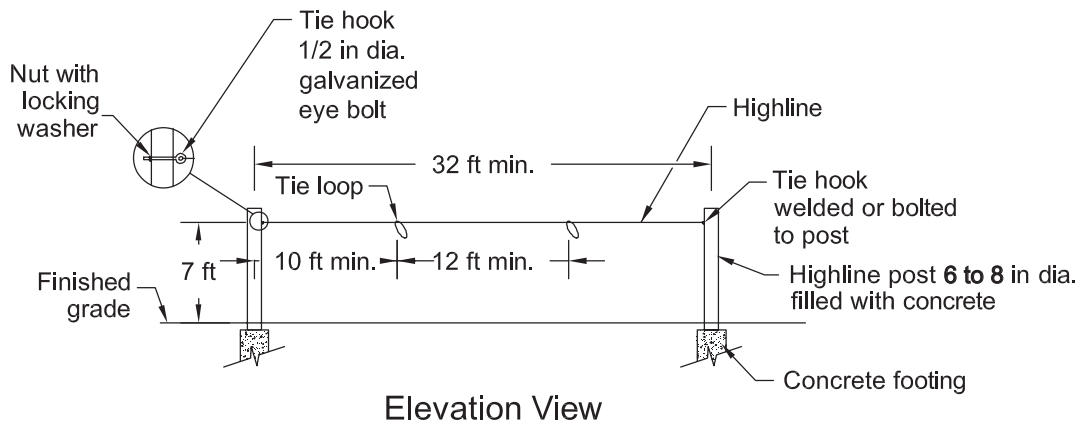
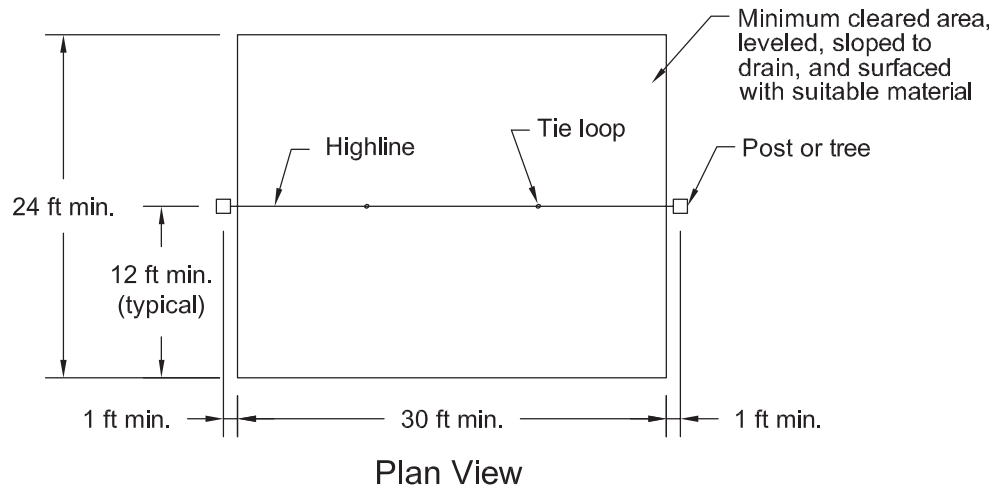

In areas that are not prone to vandalism, managers may provide ropes for highlines. However, most riders prefer to bring their own ropes. Install a highline by stretching a suitable rope tightly between the trees or posts, about 7 feet (2.1 meters) above the ground (figure 10–56). Suitable ropes include a 1/2-inch (12.7-millimeter) multifilament polyester-plus-hemp rope or 3/8-inch (9.5-millimeter) poly Dacron rope. Using 2-inch- (51-millimeter-) wide, flat tree-saver straps (figure 10–57), or an equally wide padded rope, helps prevent damage to trees. Fixed tie loops should be at least 12 feet (3.6 meters) apart. The outside loops should be at least 10 feet (3 meters) from trees or posts. At this distance, the animal's heavy front quarters are away from the tree, minimizing soil compaction on tree roots. Do not use metal cables and connectors with metal uprights, as they can be targets for lightning strikes.



Resource Roundup

Don't Fence Me In

Learn more about tree-saver straps, animal hobbles, pickets, and other time-honored equipment in *Techniques and Equipment for Wilderness Travel with Stock* (Stoner and others 1993), available at <http://www.fs.fed.us/t-d/pubs/htmlpubs/htm93232839>. This Web site requires a username and password. (Username: t-d, Password: t-d)

Figure 10–55—A horse area with a highline suitable for two animals.



10

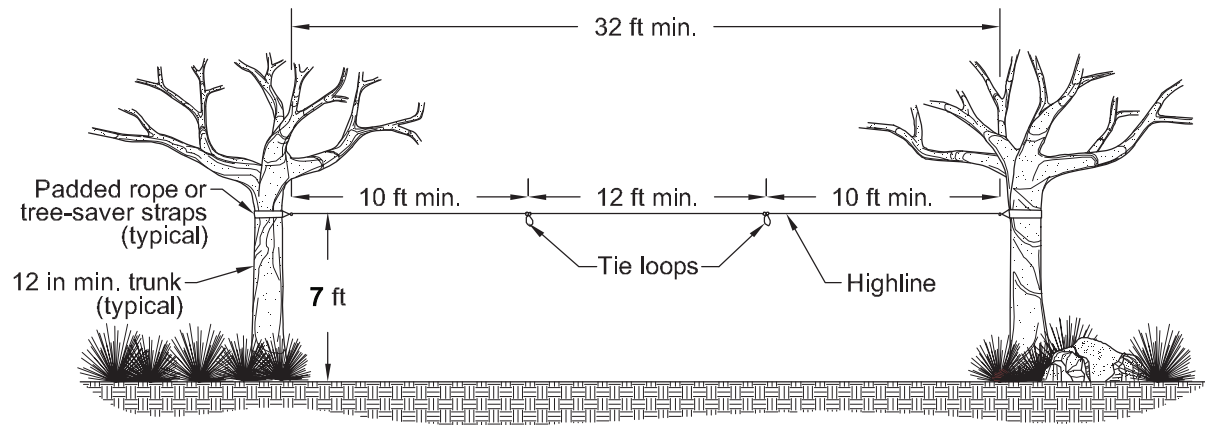
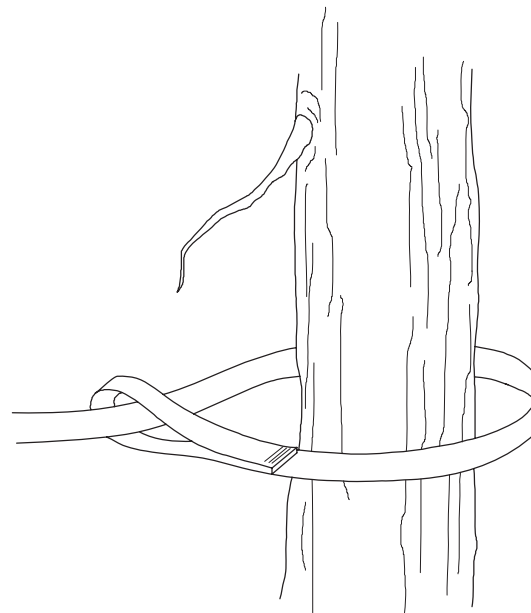
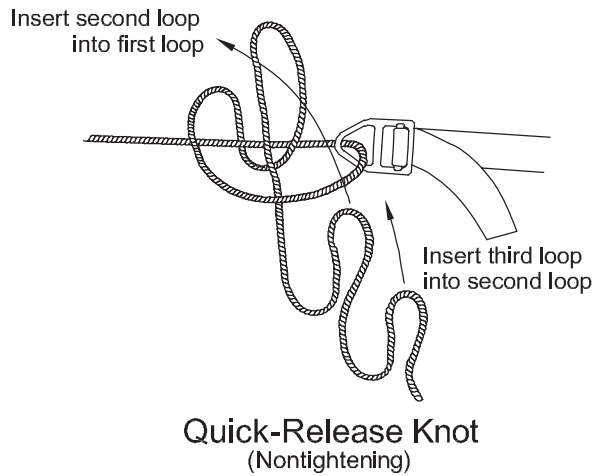

Figure 10-56—A highline attached to trees.



Flat Strap

Figure 10-57—Highlines can be quickly set up using tree-saver straps and a rope.



Corrals

Some campers like the security of keeping their stock in corrals, especially riders who have a corral at home. Stock have maximum freedom of movement in corrals, and riders don't have to monitor their stock as frequently. Of all the options presented in this chapter, well-designed corrals that include suitable gates and latches are usually the best choice for recreation sites,

Most stock want to roll on their backs after a workout. If they don't have adequate space to roll in corrals, they can *cast* a leg or hoof—get it stuck—in the rails. A 12- by 12-foot (3.6- by 3.6-meter) corral is the minimum a larger animal needs to roll, move, and turn around. It also provides enough space for a horse or mule to escape an aggressive animal in an adjoining corral. Where space allows, a 12- by 16-foot (3.6- by 4.9-meter) corral is preferred. Locate corral posts at every corner and midway on each side (figure 10–58). Place posts every 6 feet (1.8 meters) in 12-foot corrals, and every 8 feet (2.4 meters) in 16-foot corrals.

The greatest cost and space efficiencies are achieved when two 12- by 12-foot (3.6- by 3.6-meter) or two 12- by 16-foot (3.6- by 4.9-meter) corrals share a side, forming a *corral set* (figures 10–59 and 10–60). A drawback to corral sets is that the adjoining enclosures can only be used for compatible stock. Horses or mules that fight, kick, and bite should not

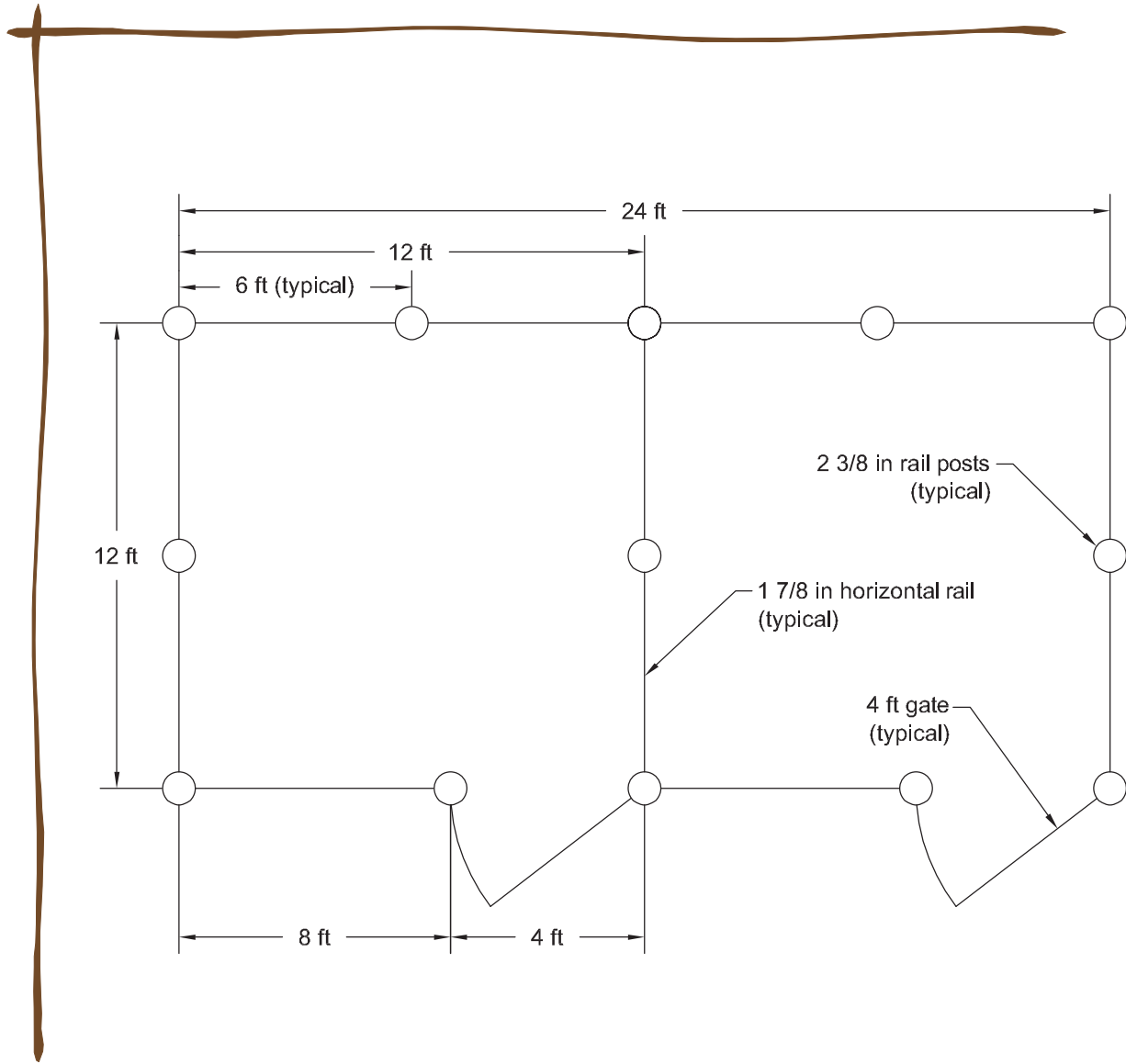

Figure 10–58—Dimensions for a single corral set. A single corral set holds two animals.

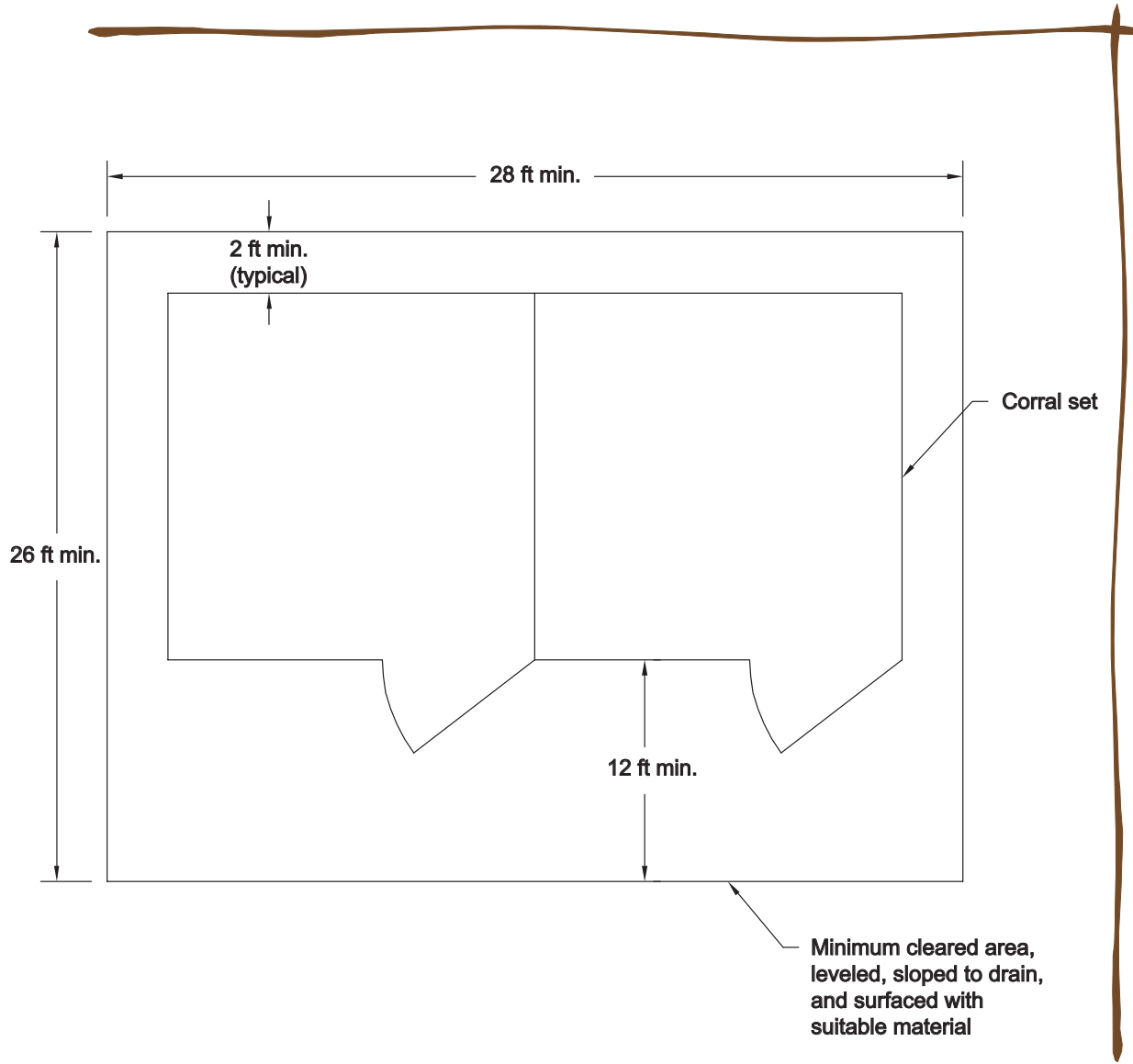

Figure 10-60—Two horses relax in a single corral set. Water buckets are tied to the lower rail. —*Courtesy of Janet Grove.*

be confined adjacent to other stock. It is the rider's responsibility to minimize aggression between stock. This may mean segregating aggressive horses or mules by tying some to the horse trailer. To avoid aggressive horse behavior, build no more than two adjoining corrals in a set. Construct multiple corral sets instead of additional adjoining corrals. Corral sets should be located far enough apart that penned stock can't reach each other.

Figure 10-59—The area required for a single corral set.



A single-party camp unit usually includes one corral set. Two corral sets are installed for a double-party camp unit, and three to four are supplied for a several-party camp unit. The number of corrals to include in a group unit depends on the anticipated use and the available space. If there are more than two corral sets, arrange them in a row. Separate corral sets by 10 to 12 feet (3 to 3.6 meters). If space is not available for multiple corral sets in a row, arrange them as shown in figure 10-61. Stock may be uncomfortable walking down the center aisle when there are unfamiliar stock on both sides, so don't install corral gates facing the aisle.

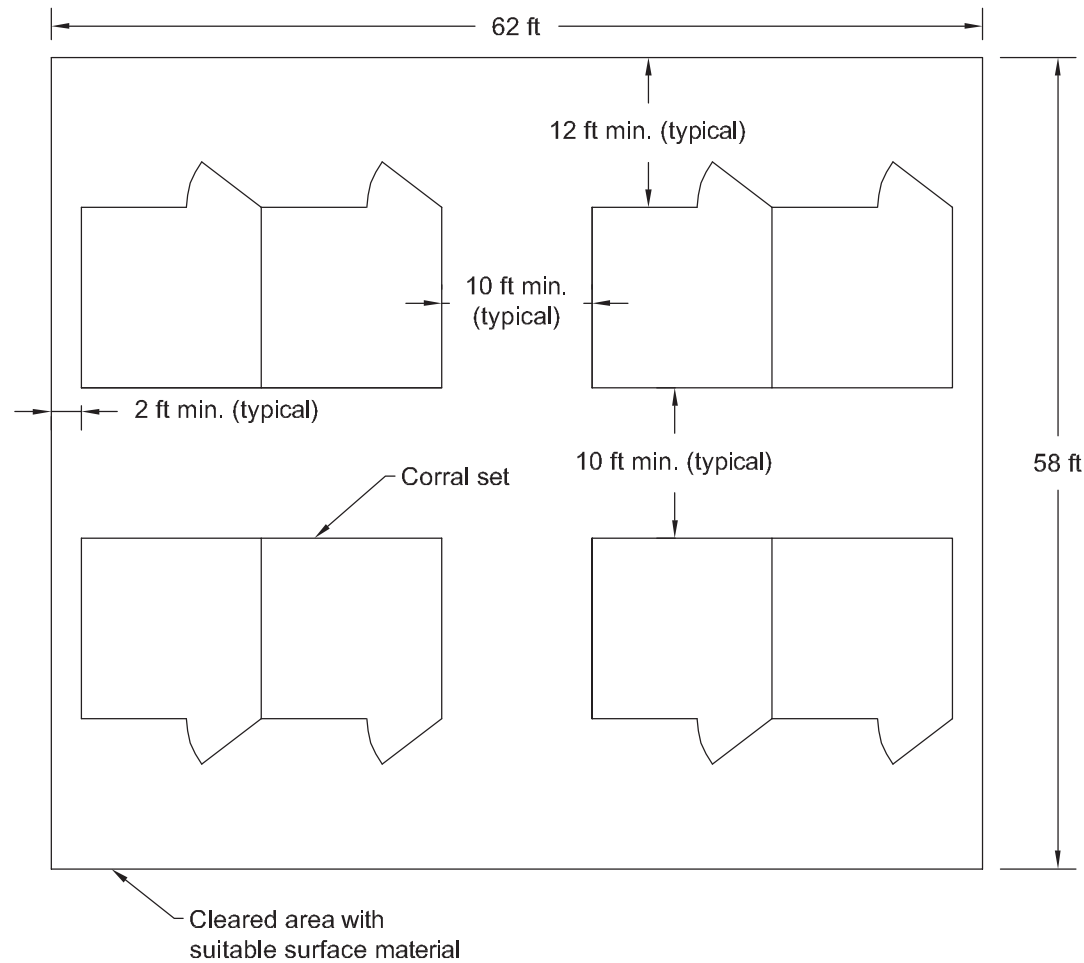

Figure 10-61—Corral placement for a horse area with four corral sets that are not placed in a row. Four corral sets hold eight animals.



Related Facilities—Arenas and Round Pens

Riders frequently use round pens (figure 10–62) to exercise a high-strung animal before a ride, and to cool an animal down afterward. Round pens also offer a safe place for stock to roll. Round pens are appropriate for areas with high levels of development but are not essential at trailheads or in campgrounds.

Arenas are spacious fenced areas that provide a comfortable setting to train or exercise stock, teach riding lessons, or hold group events (figure 10–63). In many cities, recreationists use a trailhead much like a community park, and an arena may be appropriate.



Figure 10–62—A round pen is convenient for exercising stock before and after a ride. When setting up portable panels, connectors need to hold the panels close together. Install the connectors carefully—a large gap could trap a horse’s leg.



Figure 10–63—Group events and equestrian training sessions often are held in outdoor arenas.



Figure 10–64—It is more comfortable to exercise an animal in a round enclosure.

Size and Location

The minimum diameter for round pens that allow riding is 60 feet (18.2 meters). If the pen is smaller, it impedes the natural movements of a horse or mule moving faster than a walk. Suggested dimensions for a multipurpose arena are 100 by 200 feet (30.5 by 61 meters). Round all arena corners (figure 10–64). This allows smooth riding when riders are working their stock, and just as with perimeter fences, prevents stock from being trapped in corners. Because activities in arenas and round pens are likely to excite nearby stock, locate these facilities in isolated but convenient locations. Choose sites with dry, well-drained soil.

Grade

Arenas and round pens must be reasonably level with enough slope to allow drainage. Crown the subgrade in the center and incorporate a 1-percent slope from the centerline to all sides. If the surface is not crowned, slope it 2 percent from one side to the other. For an arena or round pen to be functional year-round, regular maintenance is required. The surface needs to be dragged weekly, monthly, or quarterly, depending on frequency of use. The surface—or *footing material*—should be replaced every 5 to 10 years.



Dust Prevention

Activity in arenas and round pens can create dust that is unhealthy for stock, riders, and other people in the area. When water is available, a sprinkler system can effectively control dust. Install sprinkler heads that meet plumbing pressure requirements and provide complete and even coverage (figure 10–65). For the safety of arena users, install sprinkler heads where arena users or stock won't trip over or run into them. Common placements include the top rail or ground level adjacent to posts. For convenience and efficiency, allow users to control the sprinklers with a timer. Alternatives to plumbed sprinklers include portable water sprayers and dust abatement products.



Resource Roundup

Best Hoof Forward

The ideal surface for arenas and round pens provides a cushion, is dust-free, and doesn't abrade horses' hoofs. Existing soil and slope characteristics should be evaluated, and a mix of footing materials applied over a base. The most suitable base and footing materials depend on the planned activities—for example, rodeo or jumping activities require different materials than cart driving or miniature horse activities. The *Equine Arena Handbook* (Malmgren 1999) applies soil science to footing materials. *Underfoot* (United States Dressage Federation 2007) addresses construction and maintenance of arenas.



Figure 10–65—Sprinkler heads can be placed on the top fence rail. Another popular location is at ground level. Regardless of the location, the sprinkler heads should be placed so they are not hazardous to riders or stock.

Lighting

In areas with high levels of development, lighting may be appropriate for arenas and round pens. To minimize light pollution and maximize energy efficiency, install a timer that allows users to control the lights when needed. Properly selected fixtures reduce environmental impacts and minimize the spread of light into surrounding areas. For best results, have a lighting consultant or engineer design the system.





10

