



# Chapter 4— Designing Trail Elements

Safe shared-use trails follow engineering principles that are similar to those used for highways, including adequate sight distance and alignment. With careful design, safe trails don't have to be minihighways—they can adhere to professional standards and still be esthetically pleasing. A single trail corridor can include many design considerations, requiring flexibility on the part of designers. Because each situation is unique, appropriate solutions require sound judgment by the designer, adherence to applicable legal requirements, and sensitivity to local conditions, preferences, and needs.

## Trail Terms

It is helpful to understand trail structure and the terms that describe it. Figure 4-1 illustrates some common trail corridor terms.



### Building Lightly

#### Resource Roundup

The Student Conservation Association (SCA) uses *Lightly on the Land: The SCA Trail Building and Maintenance Manual* (Birkby 2006) as a field guide for trail construction. The manual covers basic techniques, from building with timbers to rock construction and environmental reconstruction.

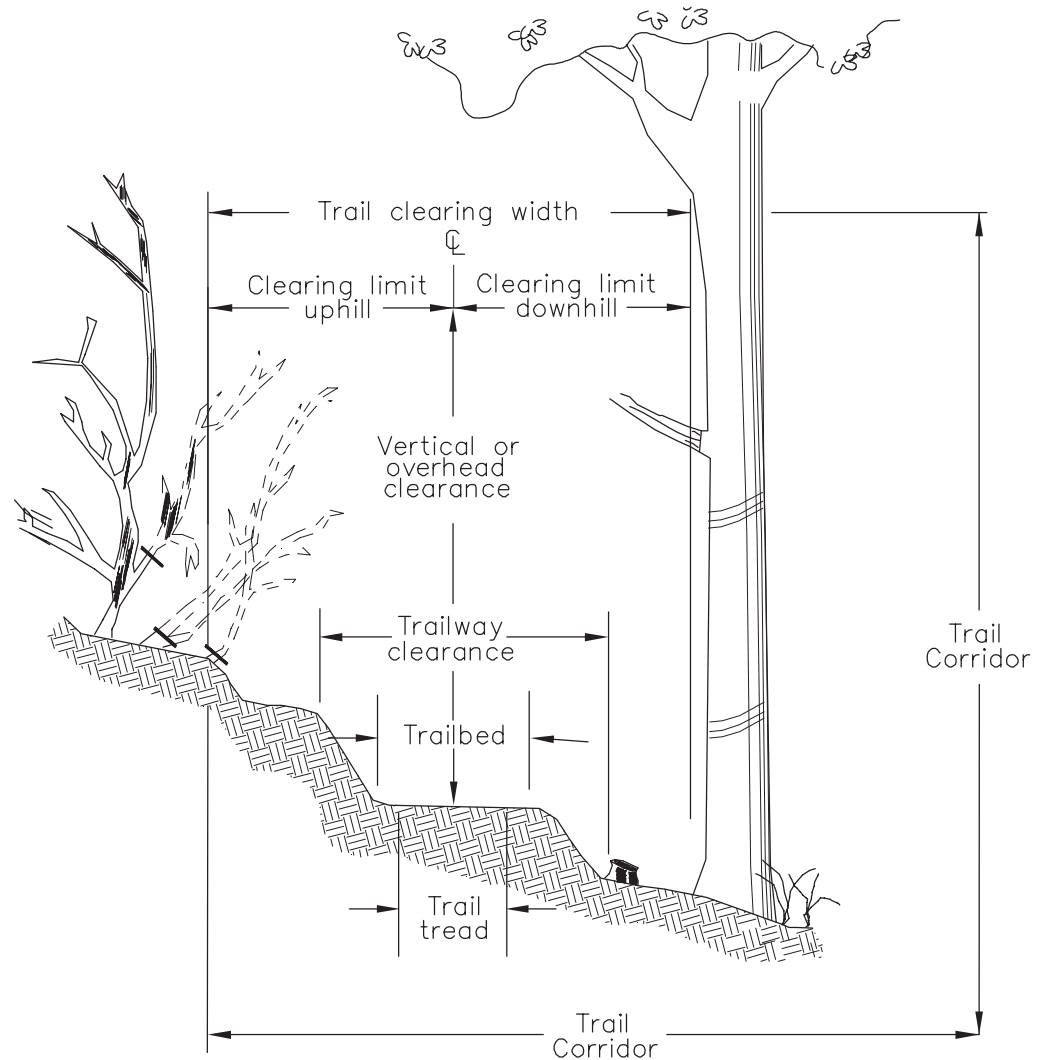

Figure 4-1—Common trail terms. Agency specifications may vary.





### Trail Words

When speaking about trails, it is helpful to use common terminology. This guidebook uses the following definitions:

- ☆ *Transportation corridor*—The larger alignment of a trail, which may include other modes of transportation; for example, a multimodal transportation corridor between two attractions that has separate trails for stock and bicycles and a road for motor vehicles.
- ☆ *Trail corridor*—The zone that includes the trail tread and areas immediately above and to each side. The edges of single-tread trail corridors generally are the same as the trail’s clearing width plus its vertical clearance. Multiple-tread trail corridors include the trail clearing width and vertical clearance for all the treads. Sometimes trail corridors include more land than is needed to accommodate the trail tread and clearance.

### Lingo Lasso

- ☆ *Trail tread or tread*—The travel surface of the trail.
- ☆ *Trailbed*—The tread plus base materials.
- ☆ *Trail clearing width*—The space to each side of the trail tread that is cleared for trail users. Usually, there is an uphill and a downhill clearing width.
- ☆ *Trail vertical or trail overhead clearance*—The space over the trail tread that is clear of obstructions. For riders, this clearance is sometimes referred to as vertical shy distance.
- ☆ *Trail clearing limit*—The area over and beside a trail tread that is cleared of trees, limbs, and other obstructions; often the edges of the trail corridor.
- ☆ *Trailway clearance*—The trailbed plus the area to either side that is needed to accommodate construction cuts and fills.

### Trail Length

A single trail system can give trail users choices, including scenic variety, different trail lengths, or more than one challenge level. Trails with loops let trail users travel new ground the entire way.

Loop trails allow more miles of trail in smaller areas and avoid the extra traffic of out-and-back—or *linear*—trails. Elongated loops with cross trails (figure 4–2) allow trail users to select their own trails. An interesting variation contains stacked loop trails, which resemble the links in a chain. A common approach is designing the closest loop to appeal to the greatest number of trail users and to be the easiest to travel. Succeeding loops provide additional length or more challenge.

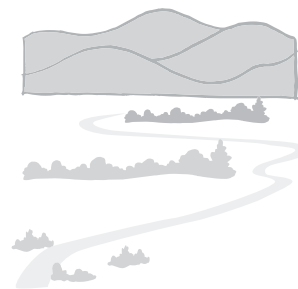



Trail users' travel speeds differ, and it is important to vary the trail length. Design horse trails no shorter than 5 miles (8 kilometers)—preferably longer. It takes 1 to 2 hours for most equestrians to ride an average 5-mile trail. The length of many day-use trails ranges from 5 to 25 miles (8 to 40.2 kilometers). The best trail systems include a variety of routes that allow rides of 2 to 3 hours, a half-day,

and a full day or more. Provide reasonable access to stock water. When practical, the Forest Service (1991) recommends providing water at intervals of no more than 10 miles (16.1 kilometers) and informing visitors if water is not available within this distance. In areas that experience very hot weather, consider locating water sources at 5- to 6-mile (8- to 9.7-kilometer) intervals.



Trail Talk

**Making the Loop**

The Pennsylvania Trails Program (1980) suggests day-use loop trails of 15 to 20 miles (24.1 to 32.2 kilometers) for riders, with an inner loop of 7 to 10 miles (11.3 to 16.1 kilometers) for half-day trips. They recommend providing vehicle access points with adequate parking near overnight stops to allow riders to bring in food and water for stock. The authors note that pedestrians may find all-day equestrian loop trails too long.

Baughman and Serres (2006) recommend horse trails with multiple or single loops that include a variety of scenery and terrain, and an open gathering area. They also recommend trail lengths of 5 to 25 miles (8 to 40.2 kilometers).

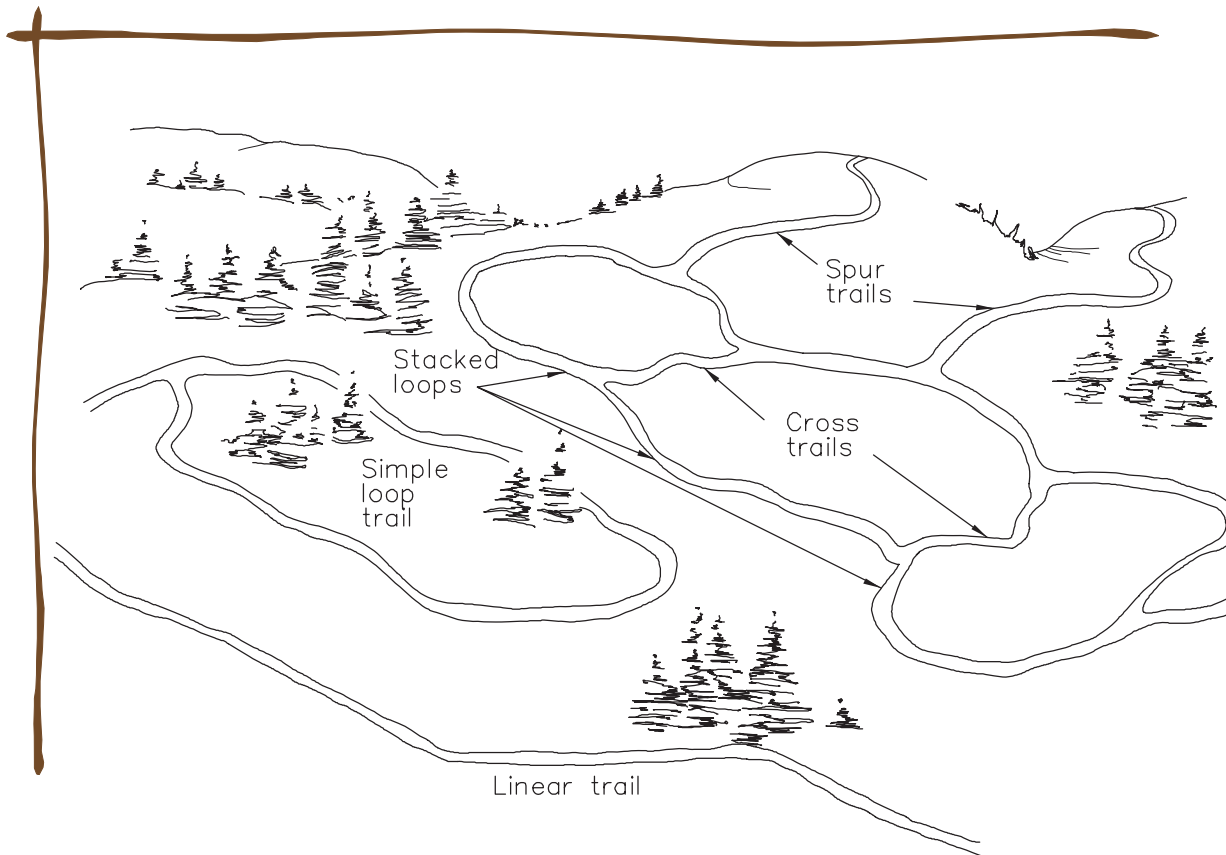

Figure 4-2—Linear, loop, spur, and cross trails. —Adapted with permission of University of Minnesota Extension.



Calculating trail distances and trip times is easier if you know the average speed of a trail animal. Horses and mules have different gaits and speeds, depending on breed, training, and physical condition. The speed also depends on the animal's size, trail conditions, topography, size of the riding group, and experience level of the rider.

Most recreation trail users ride their animals at a walk on trails, or combine a walking gait with periods of trotting or cantering, averaging between 4 and 6 miles per hour (6.4 and 9.7 kilometers per hour). Keep in mind that many riders stop along the trail to socialize or enjoy the setting, slowing their average time. Some riders train for *endurance rides* (figure 4-3)—fast athletic events that cover 50 or 100 miles (80.5 or 161 kilometers).

### Trail Sight Distance

Mounted riders can see farther than trail users on the ground. This added height helps others see the rider. Near the crest of a hill, a trail user should see the head of another trail user on the other side of the hill before reaching the hill's crest. Riders training for endurance races and other trail users that travel at increased speeds require plenty of sight distance to avoid collisions. Downhill travelers need more stopping distance than uphill travelers. Curves in the trail reduce the sight distance; in such cases, trim vegetation along the curve. Design trail curves for appropriate speeds and sight distance to prevent conflicts, considering individual site conditions. The large group of riders shown in figure 4-4 requires a long sight distance to give them time to react.



#### Horse Sense

##### Speeding By

The average speeds of the most common horse gaits on relatively flat ground are:

- ☆ Walk—About 2.5 to 4 miles per hour (4 to 6.4 kilometers per hour), about as fast as a person walks
- ☆ Trot—About 8 miles per hour (12.9 kilometers per hour)
- ☆ Canter or Lope—About 12 miles per hour (19.3 kilometers per hour)
- ☆ Full Gallop—About 20 to 30 miles per hour (32.2 to 48.2 kilometers per hour)



Figure 4-3—Endurance races are long-distance rides with strict veterinary controls.



Figure 4-4—A large equestrian group needs a relatively long sight distance to avoid conflicts with other trail users.





**Lingo Lasso**

**Sight Distance**

People sometimes confuse the terms *sight distance*, *sight line distance*, and *sight stopping distance*. Sight distance and sight line distance—or *sight line*—usually refer to how far a person can see along an unobstructed line of sight. Sight stopping distance usually takes into consideration the time it takes a traveler to see something, react to it, and stop safely.

Sight distance in areas with low development is most critical when trail users encounter approaching bicyclists or riders (figure 4–5). It is often customary for other trail users to yield to horses and mules. To do so, trail users need adequate warning and space. When two horses meet, passing is difficult.



Figure 4–5—Horses and mules need more maneuvering space than people. Usually other trail users yield to riders, and individual riders yield to packstrings.

Frequently, horses heading uphill take precedence. In some areas, time is used to separate trail users. For example, on the Holland Lake Trail to the Bob Marshall Wilderness in Montana, incoming traffic

has the right-of-way until noon, when the preference switches to outbound trail users. Local custom often determines who has the right-of-way. There are no fixed rules that apply nationwide.



**View from the Saddle**

**Trail Talk**

There are different ways to determine sight distance on trails.

- ☆ For trails on small properties, Melvin Baughman and Terry Serres (2006) recommend a minimum sight distance of 50 feet (15.2 meters) with 100 feet (30.5 meters) preferred. Provide 100 feet of sight distance at road crossings.
- ☆ On horse trails in Pinellas Park, FL, Orth-Rodgers and Associates (2002) recommend sight distance of 100 feet (30.5 meters) forward and backward.
- ☆ On roads and some trails, especially trails that intersect with motorized traffic, sight and stopping sight distances are subject to guidelines established by AASHTO. Many

agencies incorporate AASHTO guidelines into their own standards, sometimes by reference. AASHTO publishes numerous guidebooks that cover highways, roads, roadsides, bridges, bicycle and pedestrian trails, and other related subjects. Some AASHTO publications are listed in *Appendix C—Helpful Resources*.

- ☆ In the United Kingdom, The Highways Agency (2005b) calculates stopping sight distance using rider eye heights, 4.9 to 8.9 feet (1.5 to 2.7 meters) off the ground. This range allows children on ponies as well as adults on larger stock to see, react, and stop in time. Distance calculations must include additional traffic factors, such as the speed of other trail users.





### Trail Clearance

Vegetation that encroaches on tread width and overhead clearance is more than a nuisance for trail users—it can entangle users and gear. Trim or remove vegetation and other obstacles—such as boulders—from this area (see figure 4–1) so trail users can more easily avoid plants that have prickly seeds, thorns, and pointed branches. Periodically providing larger cleared areas for turnouts gives trail users room to move off the tread for breaks or to allow others to pass. Keep in mind that the weight of leaves can cause deciduous tree branches to bend 1 to 2 feet (0.3 to 0.6 meter) in summer and snow can cause evergreen trees to bend in winter, reducing the overhead clearance (Baughman and Serres 2006).

### Horizontal Clearance

Trail clearance varies by trail use and setting. Table 4–1 shows a general range for clearing widths and overhead clearance on single-track horse trails. Tread width is discussed later in this chapter. Appropriate clearing width depends on the site. For example, on shared-use bicycle/pedestrian trails, AASHTO (1999) recommends at least 2 feet (0.6 meter) of graded width on each side of the tread. A distance of 3 feet (0.9 meter) is preferred from trees, poles, walls, fences, guardrails, and other obstructions. On Forest Service pack and saddle trails in the Northern Rockies, the trail clearing width is 8 feet (2.4 meters) and the trail vertical clearance is 10 feet (3 meters).

Table 4–1—Suggested widths and clearance for a standard, single-track horse trail. Agency specifications may vary.

Trail element	Low development (feet)	Moderate development (feet)	High development (feet)
Tread width	1.5 to 2	3 to 6	8 to 12
Clearing width (horizontal)	5.5 to 8 (Tread plus 2 to 3 feet to each side)	9 to 12 (Tread plus 3 feet to each side)	14 to 18 (Tread plus 3 feet to each side)
Overhead clearance (vertical)	10	10 to 12	10 to 12

Baughman and Serres (2006) of the University of Minnesota Extension recommend a clearing width of 8 feet (2.4 meters) on one-way trails or trails with light use. They recommend a clearing width of 12 feet (3.6 meters) on two-way trails or trails with heavy use.

On level terrain, trails are cleared an equal distance on either side of the tread centerline. Using the previous Forest Service trail example with a 2-foot (0.6-meter) tread, the clearing width would be 3 feet (0.9 meter) on either side of the tread, for a total cleared width of 8 feet (2.4 meters). It is unnecessary to remove all the vegetation from the side of the trail. Instead, consider leaving vegetation or objects less than 30 inches (762 millimeters) tall. The cleared area—also called *load clearance* (see figure 3–11)—accommodates items tied to saddles, such as picnic

articles, sporting gear, or very full saddlebags, but it’s also useful when two trail users must pass on a narrow trail. The concept applies to urban and rural areas if the trail does not already have substantial shoulders or horizontal clearance. Consult the land management agency’s guidelines.

On moderate to steep side slopes, extensive travel along the lower—or *outer*—edge of the tread can cause the tread to fail. A log cut nearly flush with the trail’s downhill trail edge will encourage travelers to move toward the center of the tread. Rocks, limbed trees, and other natural materials near the lower edge of the tread also help guide traffic back to the center. Obstacles left as guide material on either side of a trail can interfere with loads and can catch a rider’s legs or stirrups. Be sure to leave load clearance as described previously. Experienced trail stock may adjust their position on a trail tread to avoid contact with encroaching objects—less experienced stock may not.

To compensate for guide material left near the downhill edge of the trail, cut and remove material



for a greater distance from the centerline on the uphill side. When slopes are steeper than 50 percent, consider providing additional horizontal clearance for logs or protruding branches. For example, on the 2-foot (0.6-meter) wide Forest Service trail cited earlier, extend the clearance 6.5 feet (2 meters) from the centerline. This would mean clearing 5.5 feet (1.7 meters) beyond the edge of the tread. This added clearance is particularly necessary for packstock because a horse may shy away from any object near its head. Widen trails cut through solid rock on steep hillsides to provide load clearance. Also, widen the trail base along a precipice or other hazardous area. Using a 2-foot (0.6-meter) Forest Service trail as an example, hazardous trail segments would be widened to 4 or 5 feet (1.2 or 1.5 meters) for safety. Wider treads also provide safe passing areas. Planning this flexible clearance takes some thought and may be difficult for inexperienced trail construction crews. Meander the clearing edges so the trail looks natural.

### Vertical Clearance

Low vertical clearance is a potential safety hazard for riders when stock need maneuvering space. Vertical clearance for physical barriers, including bridges, underpasses, and vegetation, should extend at least 10 feet (3 meters) above the tread. Vertical clearance of 12 feet (3.6 meters) is recommended. Increasing the vertical clearance, especially on engineered structures, can be quite costly, and designers must exercise good engineering judgment.

### Vegetation Clearance

Cut tree and shrub branches back to the tree trunk or to the vegetation's stem. Don't cut all vegetation back exactly the same distance. In some cases, some slightly encroaching vegetation may help slow trail users down. During construction of new trails, minimize plant disturbance. Using the least obtrusive tool to do the job helps accomplish this goal. When highly valued or rare plants cannot be trimmed and must be removed, consider relocating them. On public lands, follow guidelines for sensitive plant species that require extra protection.

It is important to know which vegetation is toxic to stock to avoid routing trails nearby. If toxic plants can't be avoided, the next best choice is to remove them. If toxic plants can't be removed, use signs that identify toxic plants adjacent to trails, especially in highly developed or high-use areas.



#### Native Plants

#### Resource Roundup

*Roadside Use of Native Plants* (Kartesz and others 2000) addresses preserving and restoring native plants. The State-by-State section lists native, endangered, and noxious plants. Additional resources also are included. The document is available at <http://www.fhwa.dot.gov/environment/rdsduse>.

### Trail Tread

Tread is the actual travel surface of the trail, where the hoof meets the surface. Tread is constructed and maintained to support the designed trail use and may or may not be paved. Most trail construction involves establishing solid, obstacle-free tread that stays in place. A good job of locating, constructing, and maintaining tread discourages trail users from creating their own paths.

### Tread Width

No national standards establish the width of shared-use trails. Determining the best trail width is site-specific and depends on many factors, including the types of trail users and their needs, the level of development, the setting, land availability, jurisdictional requirements, safety, potential conflicts, local expectations, and maintenance concerns.

To accommodate their natural stride, horses and mules require a tread that's at least 1.5 to 2 feet (0.5 to 0.6 meter) wide. The trail animal and rider require about 4 feet (1.2 meters) of unobstructed width, and packstock with loads require a minimum unobstructed width of 5 feet (1.5 meters). If stock frequently carry bulky items, the suggested minimum clearing width is 6 feet (1.8 meters).



Tread width also varies by the number of incorporated lanes—or *tracks*. A single-track tread forces trail users to travel single file. They must move off or to the side of the trail when meeting or passing others. A double-track tread allows trail users to travel two abreast or easily accommodates passing. Single-track treads vary from 1.5 feet (0.5 meter) wide in wildland areas to 8 feet (2.4 meters) or wider in urban areas. Double-track treads are often 5 to 6 feet (1.5 to 1.8 meters) wide if there is plenty of clearance on each side to allow passing. This is a common configuration for moderately developed trails in rural settings. In highly developed areas, double-track treads frequently are 8 to 12 feet (2.4 to 3.6 meters) wide to meet the needs of all trail users. Trails should be wider in areas with heavy shared use.

4



Trail Talk

**Flexible Tread Width**

On single-track trails with low, but steady use, the Pennsylvania Trails Program (1980) recommends a minimum tread width of 2 feet (0.6 meter) for stable soils and 3 feet (0.9 meter) for poorer soils. Where there are frequent encounters between stock and other trail users coming from opposite directions, the minimum suggested tread width is 6 feet (1.8 meters). In areas with steep dropoffs or other hazards, the recommended width is 8 feet (2.4 meters), which allows stock to pass each other safely.

In areas with low development, trail users usually have fewer encounters with other users, and the trail tread can be narrower. To allow proper use and to reduce animal impacts, horse trails with low levels of development require at least 1.5 to 2 feet (0.5 to 0.6 meter) of tread width. Narrower trails force stock, particularly packstock, to step off the tread. The outer edges of a wildland trail generally receive the greatest impacts from packstock and wildlife. The suggested tread width for horse trails is summarized in Table 4–2. Narrow single-track treads require trail users to move to the side when others pass. Design cleared areas or wide spots to accommodate this practice. Double-track treads may need additional width near walls, fences, or other obstacles. Highly developed trails often have to be wider to accommodate higher traffic volumes and multiple trail user groups. The preferred tread width on shared-use trails depends on who is doing the sharing. The guidelines in table 4–2 apply to most nonmotorized shared-use situations

except those involving bicycles—which require additional considerations.

Not all equestrians are found in the saddle—some drive single animals or teams pulling carriages, wagons, carts, sleighs, or other conveyances. Stock that pull carts require tread width that accommodates the vehicles. Single-horse runabout carts (figure 4–6) require a tread width of 4 to 5 feet (1.2 to 1.5 meters), and those pulled by teams of two or more animals require even more. Figure 4–7 shows common dimensions for a runabout cart pulled by a single, standard-sized driving horse. Four-wheeled conveyances pulled by a team of animals are longer and wider than single-horse runabout carts. Other trail users passing in either direction require adequate space to go around. The minimum preferred tread width for a team of animals is 12 feet (3.6 meters). Consult carriage manufacturers or local equestrians for more details.

Table 4–2—Suggested tread width on shared-use horse trails with no bicyclists. Agency specifications may vary.

Number of tracks	Low development (feet)	Moderate development (feet)	High development (feet)
Single-track tread	1.5 to 2	3 to 4	6 to 8
Double-track tread	Usually is a converted vehicle trail	5 to 6	8 to 12



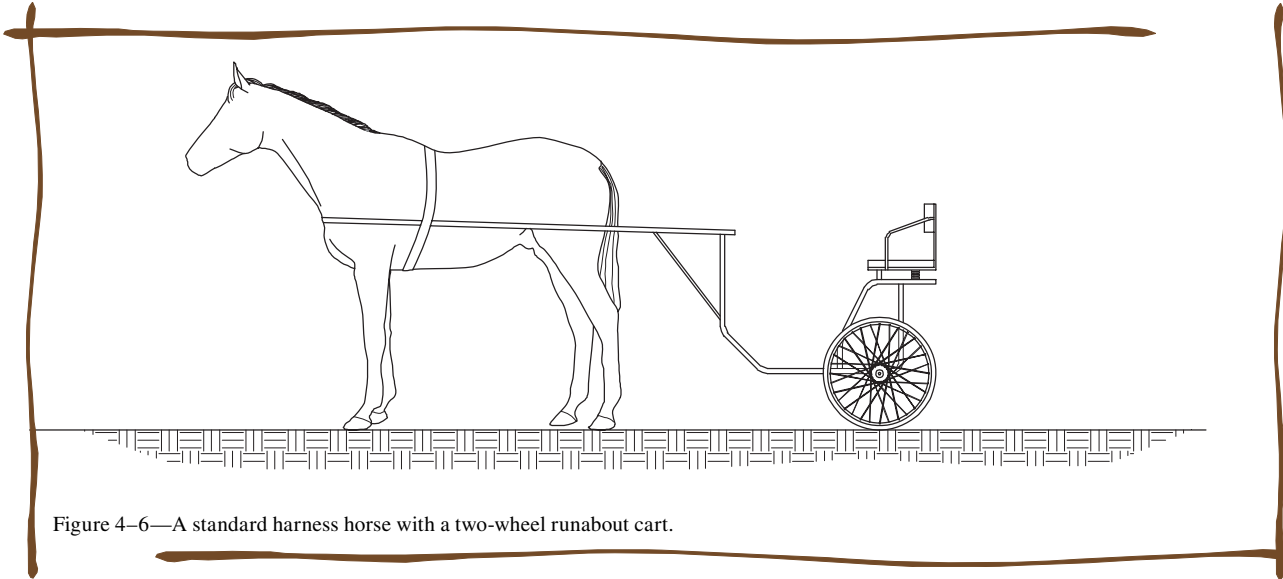

Figure 4-6—A standard harness horse with a two-wheel runabout cart.

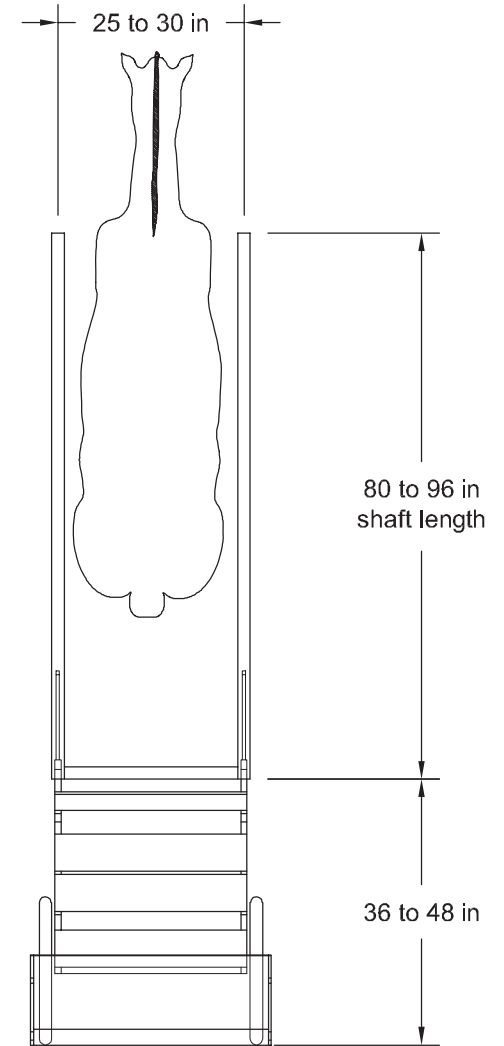
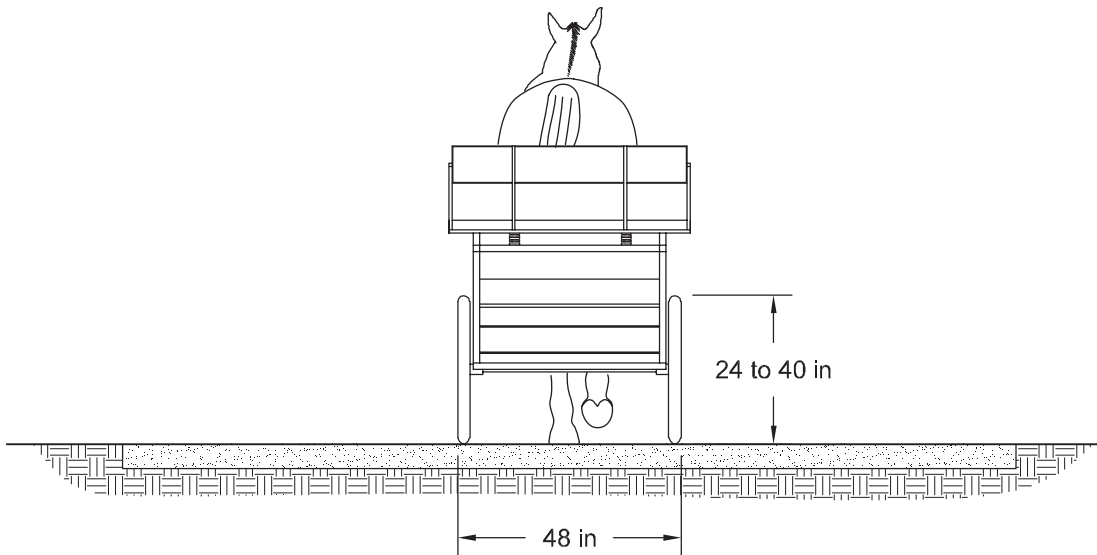

Figure 4-7—Some common dimensions for a single-horse runabout cart.



## Tread Surface

The choice of tread surface treatment affects the speed at which horses and mules can travel. For example, fine aggregate and dry woodchips provide relatively good traction and are conducive to safe cantering. Hard surfaces, such as large flat rocks, offer poor traction, and for safety reasons, limit travel to a walk. Consult *Chapter 6—Choosing Horse-Friendly Surface Materials* for more information.

## Tread Obstacles

Tread obstacles, including tree roots, waterbars, holes, or projecting objects, present tripping hazards and should be removed. Whenever possible, construct edges flush on either side of the trail tread without rocks, curbs, or other delineating materials. Stock may encounter curbs and other low objects, especially in highly developed areas. Most horses and mules navigate them successfully, but it is better to avoid them when possible. If curb cuts and grades are designed to meet accessibility guidelines and are at least as wide as the trail tread, the curbs usually are passable.

## Alignment

Alignment is a major consideration when locating trails. Alignment—horizontal and vertical—affects trail users' satisfaction and the trail's longevity. Alignment also affects sight distance and the speed at which trail users travel. The ideal trail matches the route to the ground, following the contours of the land

and providing the best view (figure 4–8). The most enjoyable trails take advantage of natural features, such as drainages, winding around trees and rocks.



Figure 4–8—Elevation on contour trails remains relatively constant. Trail users appreciate contour trails because they are easier to travel and frequently offer great views.

*Horizontal alignment* is the way the trail looks from above, as on a map. The best horizontal alignment includes simple curves rather than straight sections with sharp turns. *Vertical alignment* is the way the trail climbs and descends slopes. The vertical alignment determines not only how steep the trail is, but also how it channels water. Erosion from runoff is one of the most destructive forces affecting a trail. For information regarding trail alignment, refer to *Appendix B—Trail Libraries, Trail Organizations, and Funding Resources* and *Appendix C—Helpful Resources*.

## Grade

Steepness—or *grade*—determines how challenging a trail is. In the English measurement system, grade is the amount of rise in 100 feet (30.5 meters) expressed as a percentage. A trail that climbs 5 feet (1.5 meters) over a distance of 100 feet has a 5-percent grade. Grade directly affects how a trail needs to be designed, constructed, and maintained to establish and retain solid tread.

Generally it is easier for stock to maintain their balance when they are traveling uphill rather than downhill. This is because most of their weight is over the forelegs. Descents require stock to shift more weight to their forelegs. Table 4–3 shows suggested design grades for horse trails. Surface water runoff can be controlled on all of the grades listed in the table. On grades nearing 50 percent, erosion cannot be controlled.

The best contour trails have grades, slopes, and turns that are comfortable for all trail users, not just horses and mules. Following contours helps reduce erosion and minimize trail maintenance. Keep trail segments between slope breaks—or *running grades*—as short as possible. Do so by following land contours, as opposed to cutting across or going straight up and down contours. Incorporate periodic short grade reversals as needed to remove surface water from the trail. Because water gains speed as it runs downhill, the potential for erosion increases greatly as the running grade becomes longer.



Table 4-3—Suggested design grades for horse trails. Agency specifications may vary.

Length of pitch	Low level of development**	Moderate level of development**	High level of development**
<b>Target range* (Over at least 90 percent of trail)</b>	Less than or equal to 12-percent grade	Less than or equal to 10-percent grade	Less than or equal to 5-percent grade
<b>Steep exceptions*</b>	20-percent grade for no more than 200 feet	15-percent grade for no more than 200 feet	5- to 8-percent grade for 800 to 1,500 feet  8- to 10-percent grade for 500 to 800 feet  10-percent grade for no more than 500 feet

\* May not meet accessibility requirements.

\*\* Base any grade variances on soils, hydrological conditions, use levels, and other factors contributing to surface stability and erosion potential.

Horses and mules easily can master steady grades steeper than 10 percent—even 20 percent. However, as the grade increases, so does the potential for runoff to harm the trail’s surface. In areas where grades are steeper than 10 percent, consider using one or more switchbacks to gain elevation (figure 4-9). Refer to *Trail Switchbacks* in this chapter for more information.

On running grades steeper than 5 percent, add 6 to 12 inches (152 to 305 millimeters) of extra tread width as a safety margin where possible. This helps a trail animal regain its footing if it accidentally steps off the downhill side of the trail. Benches or trail sections that are at least 100 feet (30.5 meters) long without a running grade can serve as resting areas for stock that are out of condition, large groups, and packstock. The larger, relatively flat area means an entire group can rest together at one time.



### Making the Grade

#### Trail Talk

In the United Kingdom, equestrian routes are available to bicyclists, and are subject to bicycle grade recommendations of 3 to 5 percent, with occasional steeper pitches. The preferred maximum grade on routes limited to equestrian use is 20 percent (The Highways Agency 2005b). The British Horse Society (2005b), an advocacy group, recommends a maximum grade of 8.3 percent for routes that include equestrians.

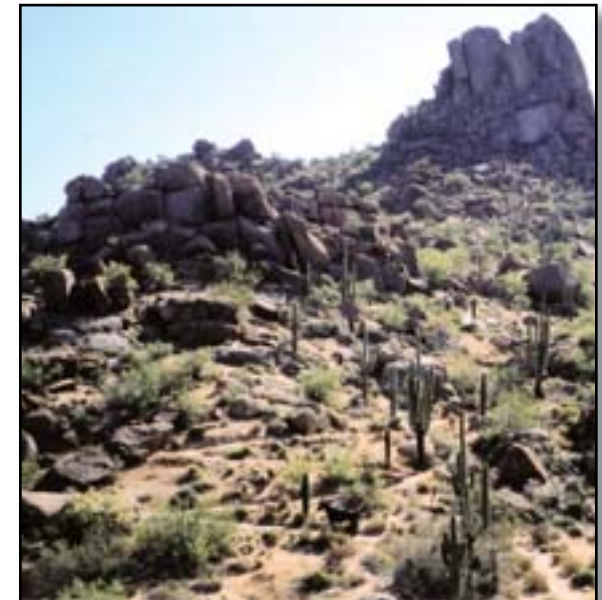

Figure 4-9—A trail with segments separated by switchbacks is easier to travel than a single, steep trail.



### Steps

In areas where grades exceed 10 percent, trail steps are common (figure 4–10). Most horses and mules navigate steps successfully, but steps sized for humans may present difficulties for stock. Some stock hesitate at steps, and some riders don't like the jostling that occurs when they're forced to navigate steps on horseback. Figure 4–11 shows a ford that incorporates a step up to the trail. The landing is too small, causing some stock to balk. Soils at the approach and landing areas of steps or staircases may erode quickly, leaving a gap that can catch an animal's hoof. Stock can negotiate steps with risers that are 16 inches (406 millimeters) high or higher, but many riders prefer steps with risers that are no higher than 12 inches (305 millimeters).

4



Figure 4–10—Experienced trail stock readily travel these steps to a bridge crossing. The risers are 8 to 12 inches tall, and the landings are 6 to 8 feet deep. The trail tread is about 3 feet wide. Trees and rocks along the sides direct stock onto the bridge.



Figure 4–11—After fording the irrigation ditch, stock must step up about 12 inches. Because the landing is only 4 feet square, some untrained stock balk at the step.



### Stepping Up

#### Trail Talk

Steps on horse trails should be used with caution.

☆ In the United Kingdom, neither The Highways Agency (2005b) nor the British Horse Society (2005b) recommends steps for equestrian routes. In cases where steps are unavoidable, the British Horse Society recommends a step length of 9.5 feet (2.9 meters) to allow stock to stand with all four feet on a single step. The recommended height for risers is 5.9 inches (150 millimeters). The step may slope slightly downward to make use of limited space.

☆ The Student Conservation Association avoids building steps on trails used by stock (Birkby 2006). When there is no alternative, they require landings at least 4 feet (1.2 meters) deep, but prefer them to be 5 feet (1.5 meters) deep. Stones form the front and sides of the step—the *crib*. For crib fill, SCA uses crushed rock or other durable material that is not easily kicked loose or eroded by hoofs. SCA also recommends using visual barriers alongside steps to encourage stock to stay on the tread. Sometimes, rocks placed randomly alongside the trail serve this purpose.



### Outslopes

Flowing water follows the path of least resistance, which may be directly down a poorly constructed trail. An *outslope*—also known as a cross slope—helps shed water from the trail (figure 4–12). Grading with an outslope leaves the outside edges of a hillside trail slightly lower than the inside edge. Table 4–4 shows suggested slope ranges for outslopes for horse trails.

Table 4–4—Suggested slope range for outslopes on horse trails. Agency specifications may vary.

Low development (percent)	Moderate development (percent)	High development (percent)
5 to 10	5	2 to 5

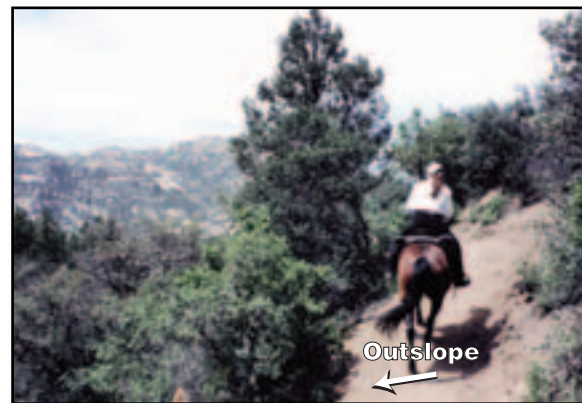

Figure 4–12—An outsloped section of trail directs water off the tread, reducing erosion damage.

### Grades, Outslopes, and Drift

Over time, trails tend to drift downhill as trail users step to the tread’s outside edge and wear it away. As running grades increase and outslopes become extreme, stock may find it difficult to maintain their balance and stay in the center of the tread. To protect the edges of the trail, make trails wider as the outslope becomes steeper. When trails have outslopes of 4 to 5 percent, widening the trail an additional 6 to 12 inches (152 to 305 millimeters) helps stock stay in the center. An alternative is to create wide spots where obstacles might force riders and packstock to the outer edge of a trail. Berms sometimes build up on the edges of trails, preventing water from flowing off the tread. Proper maintenance removes these berms, preventing erosion.

### Slopes With Hard Surfaces

Trail animals can slip on smooth, hard surfaces, especially if they are outsloped. Where trails intersect solid rock ledges, asphalt, concrete, or other hard surfaces, keep the outslope to 5 percent or less to reduce the possibility of slipping. Add texture to hard surfaces at trail crossings. Evaluate surface treatments carefully where trails make a transition to pavement—loose material may end up on the hard surface and reduce traction further. Consult *Chapter 6—Choosing Horse-Friendly Surface Materials* for additional information.

### Trailbed Construction

On hillsides, excavate the trailbed into the hill to provide a slightly outsloped travel path. Figure 4–13 shows cross sections of a trail with a relatively flat trailbed, full-bench construction, ¾-bench construction, and a balanced section. Full-bench construction is preferred because it produces a more durable trail that requires less maintenance. During full-bench construction, excavated soil from the hill is cast as far as possible from the trail since it is not needed for fill (figure 4–14). Partial-bench construction incorporates part of the cut material in a process known as *sliver fill*. Because it is difficult to compact the fill evenly, the trail may be prone to failure, especially on the downhill side. If a slope needs to be filled, reinforce it with retaining walls or use step cuts and fills (see figure 4–13) to key the fill material into the slope.

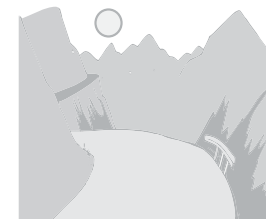

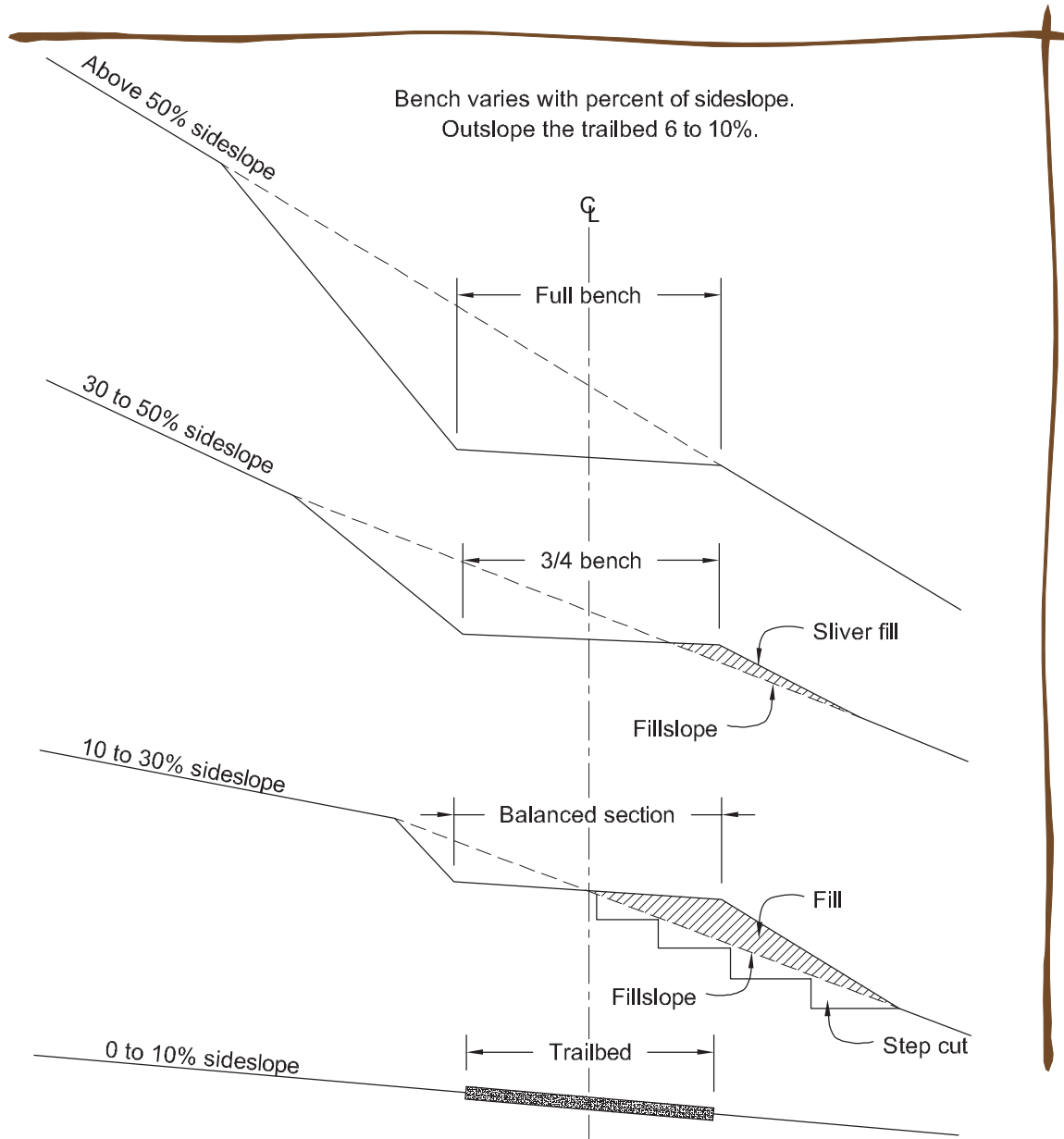

Figure 4-14—When constructing hillside trails in steep terrain, excavated soil is cast downhill.

### Trail Drainage

Proper drainage is vital trails because it reduces erosion from runoff and boggy conditions from water pooling in flat areas. Poor drainage increases tread damage by all trail users. Figure 4-15 shows an advanced case of poor trail drainage on a popular shared-use trail. For further information on trail drainage, refer to *Appendix B—Trail Libraries, Trail Organizations, and Funding Resources*.



Figure 4-15—Running or standing water can cause extensive damage.

Figure 4-13—Trail typical cross sections. Full bench construction gives the fewest problems, especially on steep slopes.



### Crowned Tread

One way to avoid water damage on relatively flat or level ground is to *crown* the tread—keep it higher in the center than on the edges. Usually, treads are crowned 2 to 5 percent. Soil composition, texture, type, and the trail’s use determine how often crowned tread needs to be maintained. Tread quickly becomes trenched on trails that are not maintained or that have significant traffic. Turnpikes are structures with a crowned tread that are sometimes used when trails cross boggy areas. Don’t crown short sections of trail paved with asphalt or cement.

### Waterbars

Although waterbars are common on trails, they often work poorly and require substantial maintenance. In theory, water running down the trail is deflected by the waterbar and runs off the trail’s lower edge. In reality, waterbars fill in with soil, wash out, dislodge, or deteriorate over time. In the process, the anchors holding waterbars in place may become exposed, creating a significant tripping hazard. Wildlife often go around waterbars, which also is the natural inclination for horses and mules. These unwelcome detours widen treads. When waterbars on horse trails are unavoidable, construct them of rock or wood.

Rock—or *armored*—waterbars are occasionally used where the trail grade is less than 5 percent (figure 4–16). On steeper grades—15 to 20 percent—waterbars are likely to clog if the waterbar is set at an angle of

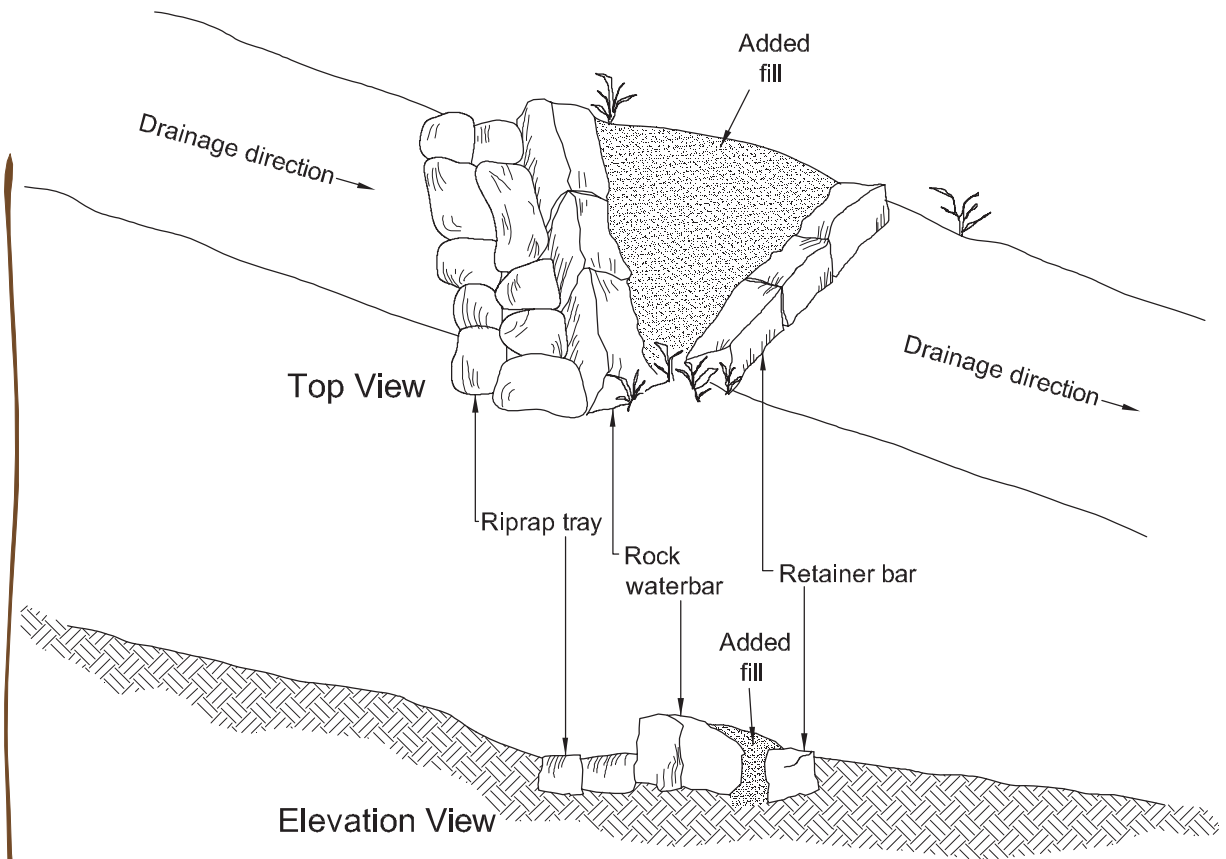

Figure 4–16—A reinforced or armored waterbar.

less than 45 degrees to the trail. When grades are steeper than 20 percent, waterbars are ineffective.

At such steep grades, there is a fine line between clogging the waterbar and eroding it away.



### Grade Reversals, Knicks, and Rolling Grade Dips

Grade reversals are used on new outsloped trails to shed water from the tread. In a grade reversal, the vertical tread alignment levels out and then drops subtly for 10 to 50 linear feet (3 to 15.2 meters) before rising again. Water flows down the drop, running off at the low spot before the water gains significant momentum or volume. Contour trails with grade reversals are often referred to as rolling contour trails. Retrofitting trails generally incorporate knicks or rolling grade dips. A knick is appropriate for draining puddles on relatively flat ground. A knick (figure 4-17) consists of a subtle, semicircular depression in the trail, about 5 to 10 feet (1.5 to 3 meters) long. The depression is angled about 15 percent so water runs off the edge of the trail. A rolling grade dip (figure 4-18) is similar to a knick. A rolling grade dip has an outsloped depression with a ramp built from the removed soil. The ramp is outsloped like normal tread, up to 5 percent. Rolling grade dips are 15 to 30 feet (4.6 to 9.1 meters) long and are more suitable than knicks for relatively steep trails. Stock tolerate grade reversals, knicks, and rolling grade dips well. Grade reversals, knicks, and rolling grade dips are preferred over waterbars in nearly all situations.

4



Figure 4-17—A trail knick directs water off relatively flat areas.

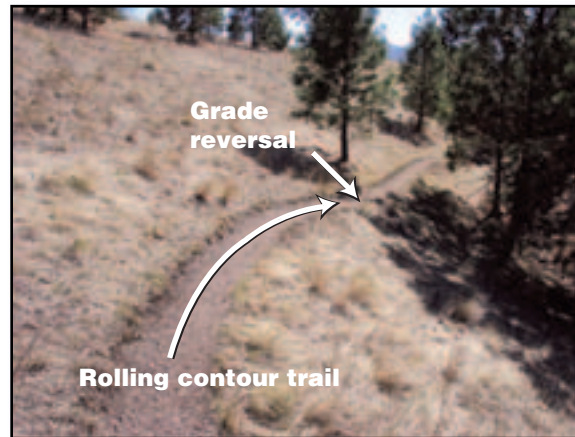

Figure 4-18—A trail with a grade reversal handles water more effectively than a trail with a waterbar. A grade reversal also requires less maintenance.



#### Trail Talk

#### Grade Dip or Waterbar?

For existing trails with water issues, Woody Hesselbarth, Brian Vachowski, and Mary Ann Davies (2007) encourage the use of rolling grade dips or knicks instead of waterbars. This is “...because by design, water hits the waterbar and is turned. The water slows down and sediment drops in the drain. Waterbars commonly fail when sediment fills the drain. Water tops the waterbar and continues down the tread. The waterbar becomes useless. You can build a rolling grade dip quicker than you can install a waterbar, and a rolling grade dip works better.”

#### Culverts

Where running water crosses the trail, culverts may be needed. Construct culverts of rock (figure 4-19), treated timbers, plastic, concrete, or metal, and surface them with at least 6 inches (152 millimeters) of suitable tread material. Bare culverts are slippery and have other undesirable features. The hollow sound of horseshoes hitting a bare culvert and the metal’s bright reflections or odd contrast can spook stock. Consider using tapered end sections (figure 4-20), painting the culvert ends, or screening the edges with rock or timber for safety and esthetics. The tread surface over culverts has a tendency to erode and needs to be replaced regularly.



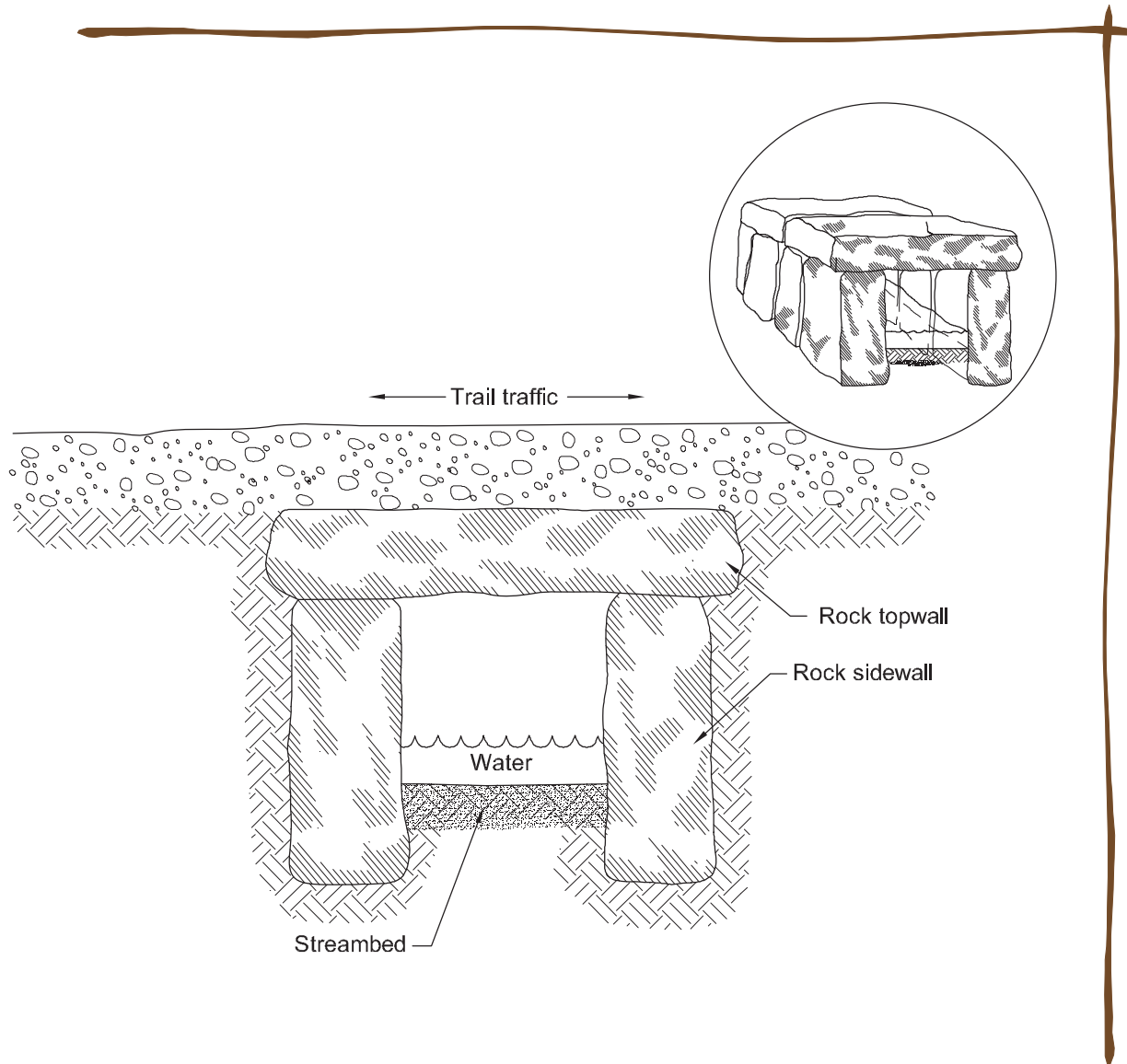

Figure 4-19—A rock culvert. Stones may also be laid along the bottom of the culvert.



Figure 4-20—This trail culvert has a flared end piece that is partially concealed with rock. It is attractive, durable, conforms to the slope, and improves waterflow. Culverts with flared or covered ends are more horse-friendly than exposed culverts because they look more natural and there is no exposed metal to make noise when a horse steps on it. —*Courtesy of Kandee Haertel.*

### Grates

Any grates should be strong enough to support the weight of stock safely. Grate patterns should not catch horseshoes. Small grates placed to the side of the tread are better than grates that encroach on the center of the trail. Long, narrow grates are more likely to be accepted by stock than large square ones. Horses and mules often avoid grates because their surface does not appear solid and they make noise when stock step on them.





### Curves, Turns, Passing Areas, and Switchbacks

The large size of stock and their loads requires plenty of maneuvering space. While curves and switchbacks designed to accommodate riders are usable by many recreationists, the design parameters are slightly different than those for other users, such as bicyclists. Refer to *Chapter 1—Understanding Horses and Mules* for the design dimensions of horses.

#### Curves and Turns

On trail curves and turns, the minimum comfortable radius is 5 feet (1.5 meters). When turns are any tighter, stock may stumble over their own legs. Turns with a radius of 6 to 8 feet (1.8 to 2.4 meters) are more comfortable for both animal and rider.

Table 4–5 shows the minimum suggested turning radius on horse trails with different levels of development. Wider turns are preferred. In addition to handling increased traffic volume and being more comfortable, wider turns may better suit tread width, site conditions, and trail users' experience levels. Allow additional clearance for packstock equipped with side panniers or for stock that are pulling carts.

Table 4–5—Minimum suggested turning radius for horse trails, depending on site conditions. Agency specifications may vary.

Low development (feet)	Moderate development (feet)	High development (feet)
5 to 6	6 to 8	8 to 10

#### Passing Areas

When trails are in steep terrain, other trail users can find it challenging to move aside for stock. Incorporate passing areas on narrow trails, particularly those on steep hillsides. A space 5 feet (1.5 meters) wide by 10 feet (3 meters) long will allow a single trail animal to pull off the tread. Locate passing areas in natural openings if possible. Larger passing areas, where large groups or packstrings may move off the trail while another group goes by, are sometimes needed. Plan these areas to handle the expected traffic volume and group sizes.

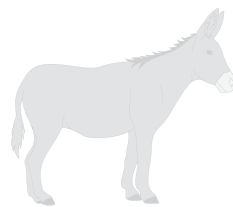

#### Switchbacks

Switchbacks reduce the grade on a trail by incorporating sharp turns on one or more trail segments. Several switchbacks may be needed to traverse a steep area effectively. Switchbacks consist of an upper and lower approach, guide structures, a landing—or turn platform—and a drain for the upper approach and landing. Figure 4–21 illustrates suggested guidelines for trail switchbacks on horse trails.

#### Trail Talk



#### Rounding the Curve

The Pennsylvania Trail Program (1980) recommends switchback landings no narrower than 8 feet (2.4 meters) on its trails. On horse trails, the Pitkin County, CO, Open Space and Trails Program (Parker 1994) specifies a minimum switchback radius of 10 feet (3 meters) and a minimum trail curve radius of 12 feet (3.6 meters) elsewhere.

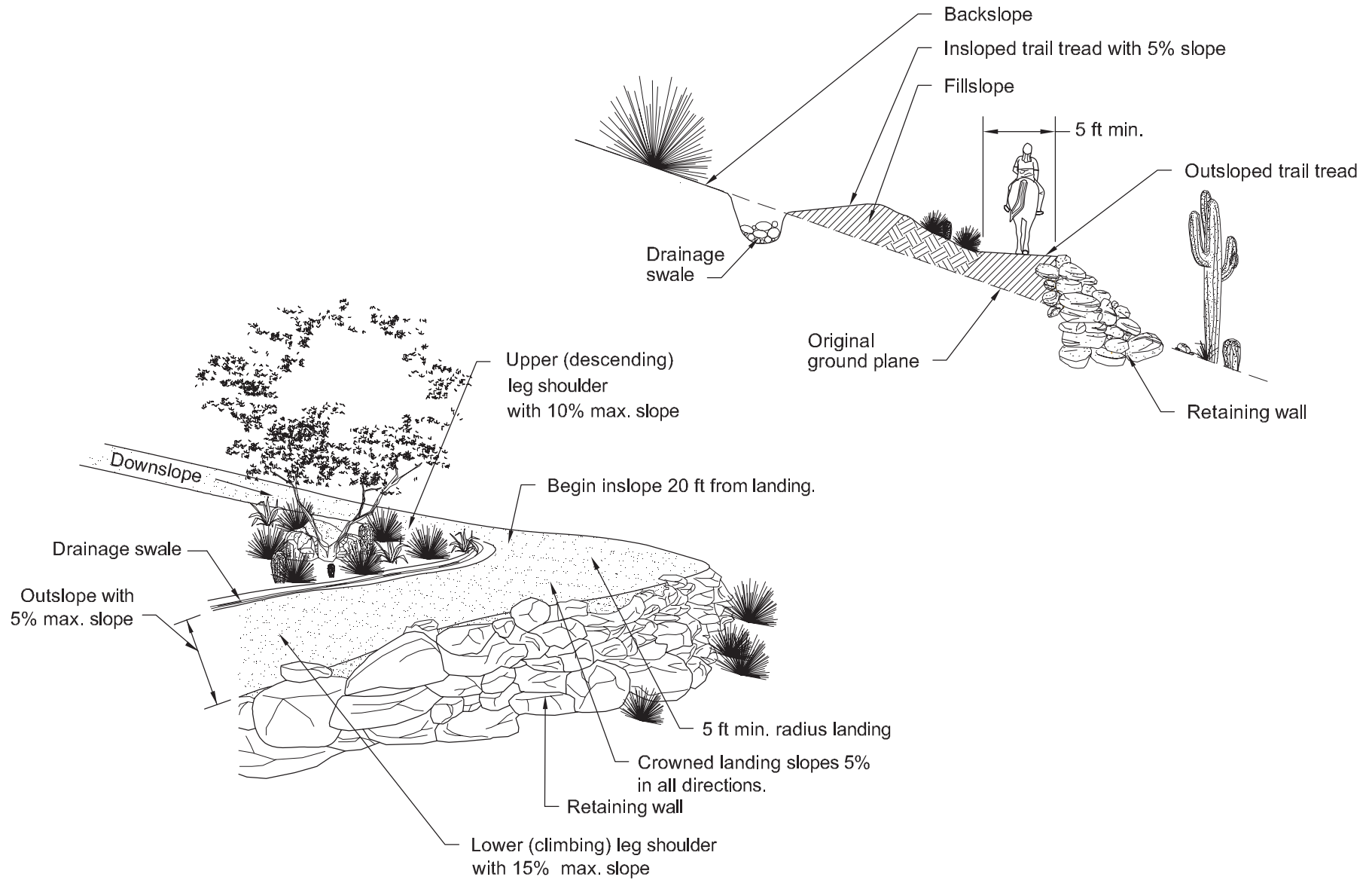

Figure 4-21—A switchback with a retaining wall.



### Shortcuts

Inexperienced or inattentive riders frequently cut across switchbacks. Packstock do too, but for a different reason. As the lead horse or mule completes its turn, the towrope tightens and prevents the following animal from making a wide turn. The effect continues down the line as each animal follows the one ahead. If the packstring is traveling too fast, stock cut the curve of the switchback.

Design trail switchbacks with as long a curve radius as possible, generally with a radius of at least 5 feet (1.5 meters). To discourage shortcutting, design grades of 10 percent or steeper for 100 feet (30.5 meters) leading to and away from switchbacks. Consider using a boulder or log barrier for 15 to 30 feet (4.6 to 9.1 meters) back

### Trail Talk

from the turning point, on the inside of the curve. Placing natural barriers at the inside of the curve is another approach to prevent shortcutting (figure 4–22).



Figure 4–22—This newly reconstructed switchback includes a landing reinforced with a retaining wall. A boulder placed at the inside of the turn prevents shortcutting.

### Climbing Turns

Where appropriate, climbing turns are an alternative to switchbacks and are easier for packstock to negotiate. A climbing turn (figure 4–23) follows the natural slope. When the tread turns, it climbs at the same rate as the slope. The advantage of climbing turns is that a larger radius turn is easier to construct. Construction is much less expensive because less excavation is required and fill is not needed. The minimum suggested radius for a climbing turn is 20 feet (6.1 meters). Climbing turns work best when built on slopes of 15 percent or less. In steeper areas, switchbacks are a better choice.



Figure 4–23—Several stumps discourage trail users from cutting across this climbing turn.

