



## ATV Utility and Gravel Trailer

*Brian Vachowski, Project Leader*

### ATV Utility and Gravel Trailer

The Missoula Technology and Development Center (MTDC) has construction drawings available for a rugged, steel trailer designed to be pulled behind an all-terrain vehicle (ATV) (Figure 1). The trailer has been used on the Palouse Ranger District, Clearwater National Forest, over the past several years. It has proven invaluable for hauling gravel and supplies for trail work on their ATV trail system. It should be equally well suited for other project work like hauling supplies on fires, for fencing projects, or wherever an ATV is a safe and appropriate tool to help get the job done.

The trailer is quite versatile. Special features include an easily detachable dump bed that pivots, an adjustable tailgate for spreading gravel, bunk supports for carrying longer items like posts, and a removable bed that allows long timbers to be secured to the axle and dragged behind the ATV. Local metal fabrication shops should be able to construct the trailer from the available plans.

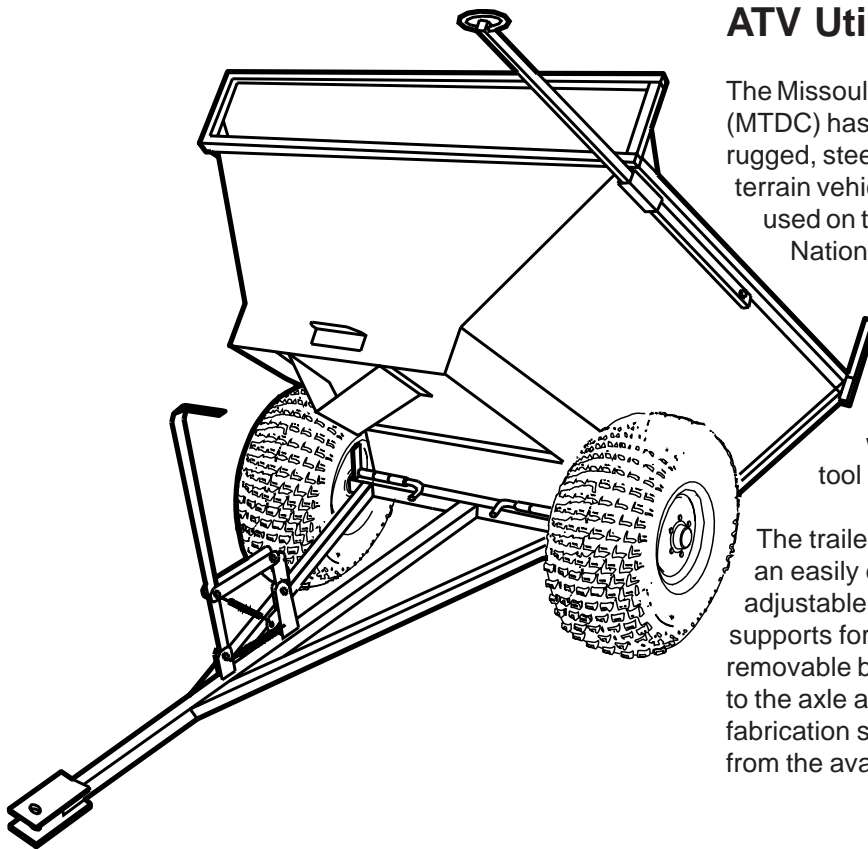

Figure 1—This sturdy ATV trailer features a dump bed and adjustable tailgate.

### Acknowledgments

Thanks to the following people who played key roles in this project:

**Mike Peterson**—Intermountain Research Station, Moscow, ID

**Debra O'Rourke**—MTDC

**Neal Maier**—MTDC

**Dick Karsky**—MTDC

### Features of the Trailer

Mike Peterson, formerly with the Palouse Ranger District and now at the Intermountain Research Station in Moscow, ID, designed the trailer. It was fabricated at a shop in Palouse, WA. MTDC drafted the plans for the trailer as it was built, did some validation testing, and made a few minor design changes.

Other ATV trailers are commercially available. Most are not as sturdy—or as expensive—as this one. MTDC did not evaluate any other trailers.



## Specifications for the ATV Utility and Gravel Trailer

Empty trailer weight	(114.75 kg) 255 pounds
Maximum recommended load capacity	800 pounds (360 kg)*
Bed length	48 inches (1219 mm)
Overall length	77 <sup>1</sup> / <sub>2</sub> inches (1969 mm)
Bed width	47 <sup>3</sup> / <sub>4</sub> inches (1213 mm)
Overall width	48 inches (1219 mm)
Height	42 inches (1067 mm)
Tires	22 x 11.00-8 ATV tires (inflated to 10 PSI {68.9 KPa} when loaded)
Hitch type	Pin

\* The trailer will physically hold nearly 1900 pounds (855 kg) of gravel, but it is not safe to operate with that much weight.

## Limited Testing

Experienced ATV operators on the district trail crew have used the trailer safely for several years. In limited validation testing, we determined that when the trailer was three-quarters full of gravel (weighing about 1160 pounds or 522 kg), the ATV could not pull the load up slopes without spinning out, the tires were overloaded, and the ATV did not handle well. Therefore, for actual field testing, we reduced the load of gravel to 800 pounds (360 kg) (Figure 2). This is the amount we recommend as a maximum capacity.



Figure 2—This maximum recommended load of 800 pounds of gravel fills the trailer less than half full.

Our test ATV was a 1996 Polaris Magnum 425 four-wheel drive. We loaded the trailer with 800 pounds (360 kg) of gravel, and added five posts (Figure 3) to test it with an overloaded, back-heavy load. The combination handled well up and down the 5 to 10% grades of a typical ATV trail. The ATV had a tendency to lose traction and spin out unless four-wheel drive was engaged. Starting from a stop, the ATV could not pull the trailer out of a short pitch of approximately 25% grade, but did just barely make it after we unloaded the posts.



Figure 3—Posts and gravel used for validation testing.

The trailer handled well on sideslopes that the ATV could handle comfortably and safely.

The manufacturer's recommended tire pressure is 5 pounds per square inch (PSI) (34.5 KPa). We inflated the trailer tires to 10 PSI (68.9 KPa) to keep them from flattening under the 800-pound (360-kg) load. Increased risk of sidewall punctures and abrasion damage would be expected with this increased pressure.

The dump body releases easily and can be raised with little effort (Figure 4). The whole dump bed can be easily removed by pulling two pins (Figure 5). That way, the axle can support one end of long timbers that can be dragged to remote construction sites.

Opening only the bottom 3 inches (76 mm) of the two-part tailgate worked great for laying gravel in a continuous line (Figure 6). The flow rate is controlled by the speed of the ATV and by chain adjusters on the tailgate. The trailer we tested did not have chain adjusters, but we added them to the construction drawings. Once the trailer was unlatched and lifted, it



Figure 4—It takes very little effort to operate the dump body.



Figure 5—Pull two pins to remove the box.



Figure 6—Gravel flow was uniform and adjustable.

remained in the dump position until empty.

When the entire tailgate was unbolted and lifted (Figure 7), it stayed in the raised position so material could be shoveled out. The entire tailgate can be easily removed to haul longer materials in the bed.



Figure 7—The entire tailgate can be lifted as shown or removed altogether.

## Safe ATV and Trailer Operation

Forest Service employees who operate ATV's on official business must attend a standardized ATV training course, pass the course and a field operations evaluation, and be certified as successfully completing a training curriculum as recommended by the Consumer Product Safety Commission (Hoshide and others, 1993).

ATV operators who tow trailers need to recognize that some handling characteristics of the ATV may be compromised. An ATV with a loaded trailer can easily "rear up" when driving uphill. Also, steering ability going uphill is reduced. Going downhill, the force of an overloaded trailer can lift the rear wheels of an ATV off the ground, resulting in a side skid or rollover.

Proper training, prudent operation, and common sense are critical. With a trailer, an ATV is more difficult to control. Go slower, do not drive on steep slopes, and make sure the trailer is not overloaded. Keep weight forward and as low as possible in the trailer, and consider how the center of gravity will affect vehicle

and trailer stability on slopes you will be negotiating. Complete a job hazard analysis that relates to the specific project, ATV, trailer, terrain, and operator skill level.

Nordfjell (1995) cites the development of a new ATV trailer hitch, called the Garphitch, which moves the vertical force of the trailer in front of the rear axle instead of behind it (Figure 8). This reduces many of the problems mentioned above. The Garphitch, developed in Sweden, is not yet widely available in the United States, and MTDC has not evaluated it.

## Construction Drawings Available

For a complete set of construction drawings, contact MTDC and ask for Drawing No. MTDC-928, ATV Utility Trailer. Most metal fabrication shops should be able to construct the trailer using the drawings.

The prototype trailer cost \$855 to build in 1995.

## Sources

### Construction Drawings

USDA Forest Service-MTDC  
5785 Hwy. 10 West  
Missoula, MT 59808-9361  
Ph: (406) 329-3900  
DG: MTDC:R01A

### Fabrication of Prototype

Palouse Welding and Machine Shop  
605 East Main  
P.O. Box 187  
Palouse, WA 99161-0187  
Ph: (509) 878-1551

## References

Hoshide, Gary; Dolfay, Michael; Horton, Phil; Lockwood, Cam. 1993. ATV operator training. Tech Tip 9467-2304-MTDC. Missoula, MT: U.S. Department of Agriculture, Forest Service, Missoula Technology and Development Center. 4 p.

Nordfjell, Tomas, 1995. ATVs in forestry: Risk of accidents, ergonomic problems and possible solutions. Garpenberg, Sweden. Res. Notes 283. Swedish University of Agricultural Sciences, Department of Operational Efficiency. 53 p.

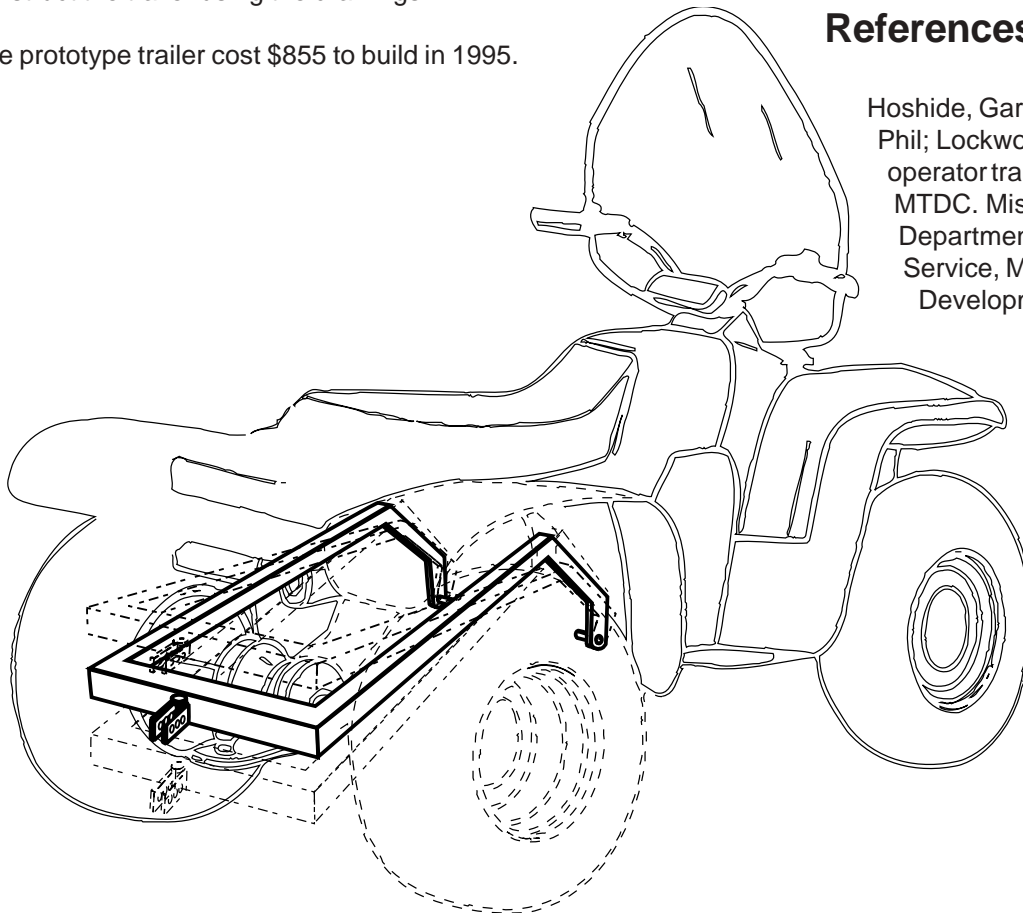

Figure 8—The Swedish Garphitch may provide safer handling characteristics for ATVs towing trailers.



The United States Department of Agriculture (USDA) prohibits discrimination in its programs on the basis of race, color, national origin, sex, religion, age, disability, political beliefs, and marital or familial status. (Not all prohibited bases apply to all programs.) Persons with disabilities who require alternative means of communication of program information (braille, large print, audiotape, etc.) should contact the USDA Office of Communications at (202) 720-2791. To file a complaint, write the Secretary of Agriculture, U.S. Department of Agriculture, Washington, D.C. 20250, or call 1-800-245-6340

(voice) or (202) 720-1127 (TDD). USDA is an equal employment opportunity employer. The USDA Forest Service has developed this information for the guidance of its employees, its contractors, and its cooperating Federal and State agencies, and is not responsible for the interpretation or use of this information by anyone except its own employees. The use of trade, firm, or corporation names in this publication is for the information and convenience of the reader, and does not constitute an endorsement by the Department of any product or service to the exclusion of others that may be suitable.