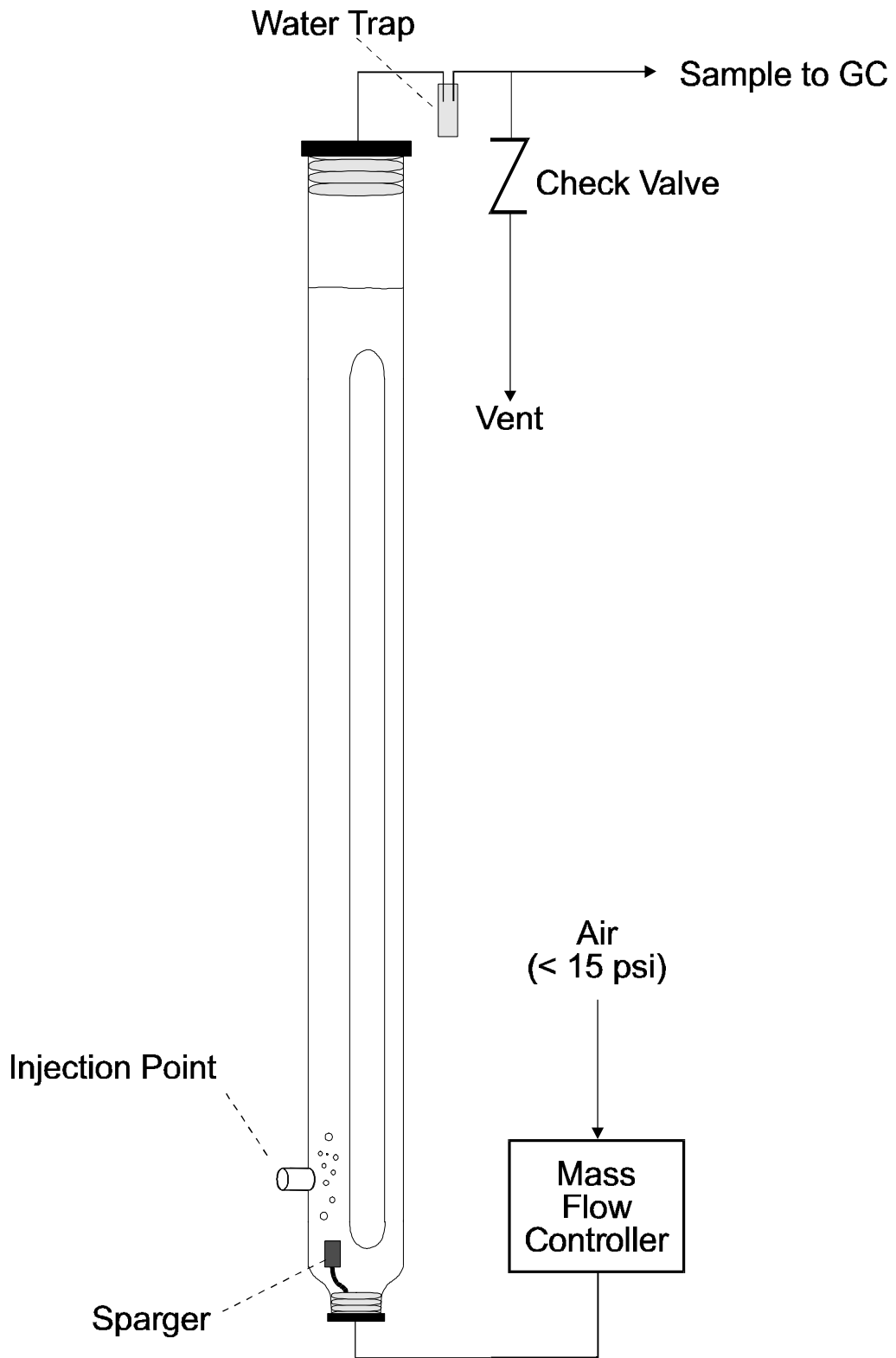
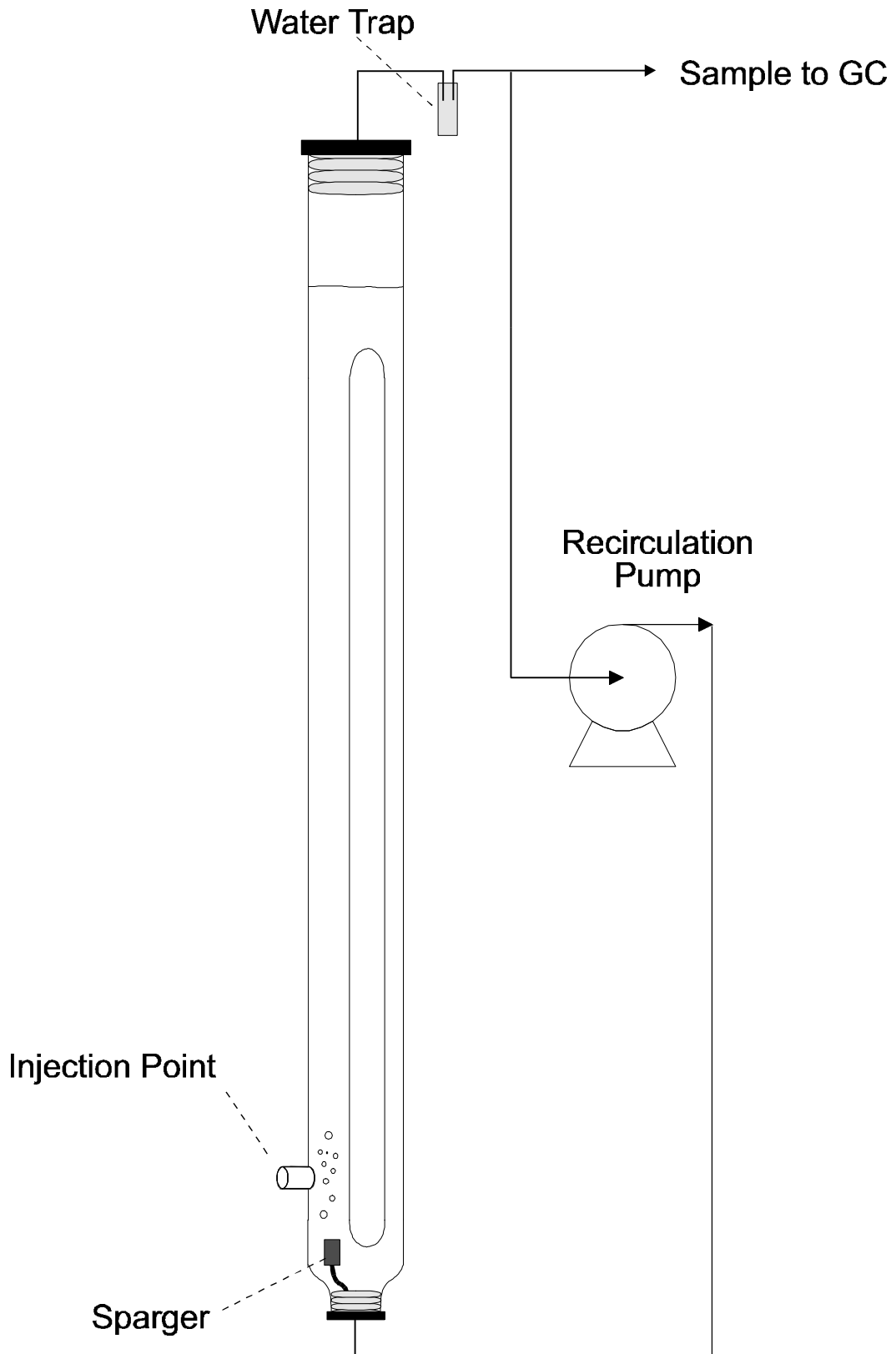

**Figure 2. Example Aerated Draft Tube Reactor**



**Figure 3. Example Sealed Draft Tube Reactor**



Form I			
<b>DATA FORM FOR THE ESTIMATION OF THE EPA METHOD 304B FIRST ORDER BIORATE CONSTANT</b>			
NAME OF THE FACILITY for site specific biorate determination			Example
COMPOUND for site specific biorate determination			<i>METHANOL</i>
INLET CONCENTRATION used in EPA METHOD 304B	1		78
EXIT CONCENTRATION measured by EPA METHOD 304B	2		6
BIOMASS (g/L) This is the dried solids that are obtained from the mixed liquor suspended solids in the bench scale bioreactor.	3		0.075
TEMPERATURE OF BIOREACTOR (deg. C)	4		35
VOLUME of EPA METHOD 304B bench scale bioreactor (L)	5		6
FLOW RATE of waste treated in the bench scale bioreactor (L/hr)	6		0.146
<b>CALCULATIONS FROM EPA METHOD 304B DATA MEASUREMENTS</b>			
RESIDENCE TIME (hr) Divide the number on line 5 by the number on line 6 and enter the results here.	7		41.10
Concentration Decrease (g/m <sup>3</sup> ). Subtract the number on line 2 from the number on line 1 and enter the results here.	8		72.00
BIORATE (g/m <sup>3</sup> -hr). Divide the number on line 8 by the number on line 7 and enter the results here.	9		1.75
Product of concentration and biomass. Multiply the number on line 2 by the number on line 3 and enter the results here.	10		0.45
BIORATE K1 (L/g bio-hr) Divide the number on line 9 by the number on line 10 and enter the results here.	11		3.89
Temperature adjustment. Subtract 25 deg. C from the number on line 4 and enter the results here.	12		10
Temperature adjustment factor. 1.046 is the default temperature adjustment factor. Enter the temperature adjustment factor here.	13		1.046
Biorate temperature ratio. Raise the number on line 13 to the power of the number on line 12.	14		1.567
BIORATE K1 at 25 deg. C (L/g MLVSS-hr) Divide the number on line 11 by the number on line 14 and enter the results here.	15		2.48

Note: With Monod kinetics, use  $K_{max}=1000$  to convert the Monod kinetics to first order. If a different temperature adjustment factor than the default is entered on line 13, make sure that the adjustment factor used in the calculations agrees with the value entered on line 13.

Form II

**PROCEDURES FORM FOR THE  
ESTIMATION OF THE KL FROM UNIT SPECIFICATIONS**

NAME OF THE FACILITY for site specific biorate determination		
NAME OF UNIT for site specific biorate determination		
NAME OF COMPOUND		
HENRY'S LAW constant for the compound (mole fraction in gas per mole fraction in water at 25 degrees Celsius)		
IDENTIFY THE TYPE OF UNIT (check one box below)		
	Quiescent impoundment	1
	Surface agitated impoundment	2
	Surface agitated impoundment with submerged air	3
	Unit agitated by submerged aeration gas	4
	EPA Method 304A, Covered unit, UNOX system, or bench scale reactor	5
PROCEDURES BASED UPON THE TYPE OF UNIT		
UNIT	PROCEDURE TO FOLLOW	
1	Use the quiescent impoundment model to determine KL. Use Kq as KL as determined from Form VII.	
2	Use the quiescent impoundment model to determine KL for the quiescent zone, Form VII. Use the aerated impoundment model to determine KL for the agitated surface, Form VIII.	
3	Use the quiescent impoundment model to determine Kq for the quiescent zone, Form VII. Use the aerated impoundment model to determine KL for the agitated surface, Form VIII. The total system KL is the sum of the KL from Form VIII and the equivalent KL from Form V. Use the submerged air rate as the vent rate in form V.	
4	Use the aerated impoundment model to determine KL if the surface is agitated. Use the quiescent impoundment model if the surface is not agitated. KL includes the effect of volatilization in the air discharge. See section 5.6.1 in AIR EMISSIONS MODELS FOR WASTE AND WASTEWATER (EPA-453/R-94-080A). The total system KL is the sum of the KL from Form VIII and the equivalent KL from Form V. Use the submerged air rate as the vent rate in Form V.	
5	KL for the surface is assumed to be equal zero. Determine equivalent KL based upon air discharge. Use Form V for EPA Method 304A or if the concentration in the vent is not measured. Use Form V-A if the concentration in the vent is measured.	
Estimate of KL obtained from above procedures (m/s)		6

Form II-A

**PROCEDURES FORM FOR THE  
ESTIMATION OF THE KL FROM WATER 7**

NAME OF THE FACILITY for site specific biorate determination		
NAME OF UNIT for site specific biorate determination		
NAME OF COMPOUND		
HENRY'S LAW COMPOUND		
IDENTIFY THE TYPE OF UNIT		(check one box below)
	Quiescent impoundment	1
	Surface agitated impoundment	2
	Surface agitated impoundment with submerged air	3
	Unit agitated by submerged aeration gas	4
	Covered unit, UNOX system, bench scale reactor	5
<b>PROCEDURES BASED UPON THE TYPE OF UNIT</b>		
unit	procedure to follow	
1	Use the quiescent impoundment model to determine KL.	
2	Use the aerated impoundment model to determine KL for the combined agitated surfaces and quiescent surfaces.	
3	Use the aerated impoundment model to determine KL for the combined agitated surfaces and quiescent surfaces.	
4	Use the aerated impoundment model to determine KL if the surface is agitated. Use the quiescent impoundment model if the surface is not agitated. KL includes the effect of volatilization in the air discharge. See section 5.6.1 in AIR EMISSIONS MODELS FOR WASTE AND WASTEWATER (EPA-453/R-94-080A).	
5	KL for the surface is assumed to equal zero. Select the covered unit option with the aerated impoundment model.	

Form III <b>DATA FORM FOR THE ESTIMATION OF THE COMPOUND FRACTION BIODEGRADED AND AIR EMISSIONS</b>			
NAME OF THE FACILITY for site specific biorate determination			example
COMPOUND for site specific biorate determination			<i>methanol</i>
ESTIMATE OF K1 from Form I line 11, Form V line 15, Form V-A line 15, Form IV line 14, Form VI line 13, or Form XII line 9. (L/g MLVSS-hr)	1		3.89
BIOMASS (g/L) This is the dried solids that are obtained from the mixed liquor suspended solids in the full-scale bioreactor.	2		2.4
VOLUME of full-scale system (cubic meters)	3		2700
AREA of the liquid surface of the full-scale system (square meters)	4		1500
ESTIMATE OF KL from Form II or Form IV (m/s)	5		0.0000036
FLOW RATE of waste treated in full-scale bioreactor (m <sup>3</sup> /s)	6		0.1565
<b>CALCULATIONS FROM ESTIMATES OF K1 AND KL</b>			
BIORATE (m <sup>3</sup> /s) Multiply the numbers on lines 1, 2, and 3 together and divide the results by 3600. Enter the results here.	7		7.0020000
AIR STRIPPING (m <sup>3</sup> /s). Multiply the numbers on lines 4 and 5 together. Enter the results here.	8		0.0054000
EFFLUENT DISCHARGE (m <sup>3</sup> /s). Enter the number on line 6 here.	9		0.1565000
TOTAL of the three loss mechanisms. Add the numbers on lines 7, 8, and 9. Enter the results here.	10		7.1639000
Fraction biodegraded: Divide the number on line 7 by the number on line 10 and enter the results here.	11		0.9774006
Fraction air emissions: Divide the number on line 8 by the number on line 10 and enter the results here.	12		0.0007538
Fraction remaining in unit effluent: Divide the number on line 9 by the number on line 10 and enter the results here.	13		0.0218456
Total: add the numbers on lines 11, 12, and 13. The sum should equal 1.0	14		1.0000000

Form IV <b>DATA FORM FOR THE ESTIMATION OF K1 AND KL</b> <b>FROM FULL SCALE UNIT DATA WITH AND WITHOUT BIODEGRADATION</b>			
NAME OF THE FACILITY for site specific biorate determination			example
COMPOUND for site specific biorate determination			<i>methanol</i>
BIOMASS (g/L) This is the dried solids that are obtained from the mixed liquor suspended solids in the full-scale bioreactor.	1		2.4
VOLUME of full-scale system (cubic meters)	2		2700
AREA of the liquid surface of the full-scale system (square meters)	3		1500
INLET CONCENTRATION of compound (g/m <sup>3</sup> or ppmw)	4		133.5
EXIT CONCENTRATION of compound (g/m <sup>3</sup> or ppmw)	5		10.57
EXIT CONCENTRATION (NO BIODEGRADATION) of compound (g/m <sup>3</sup> or ppmw)	6		133
FLOW RATE of waste treated in the full-scale bioreactor (m <sup>3</sup> /s)	7		0.1565
ESTIMATES OF K1 AND KL FROM FIELD DATA WITH AND WITHOUT BIODEGRADATION			
REMOVAL WITH BIODEGRADATION (g/s) Subtract the number on line 5 from the number on line 4 and multiply the results by the number on line 7. Enter the results here.	8		19.238545
REMOVAL WITHOUT BIODEGRADATION (g/s) Subtract the number on line 6 from the number on line 4 and multiply the results by the number on line 7. Enter the results here.	9		0.078250
KL A ESTIMATE (m <sup>3</sup> /s) Divide the number on line 9 by the number on line 6. Enter the results here.	10		0.000588
K1 B V + KL A ESTIMATE (m <sup>3</sup> /s) Divide the number on line 8 by the number on line 5. Enter the results here.	11		1.820108
K1 B V ESTIMATE (m <sup>3</sup> /s) Subtract the number on line 10 from the number on line 11. Enter the results here.	12		1.819520
Product of B and V. Multiply the number on line 1 by the number on line 2 and enter the results here.	13		6480
K1 ESTIMATE (L/gMLVSS-hr) Divide the number on line 12 by the number on line 13 and multiply by 3600 s/hr. Enter the results here.	14		1.010844
KL ESTIMATE (m/s) Divide the number on line 10 by the number on line 3. Enter the results here.	15		0.0000004



**Form V DATA FORM FOR THE ESTIMATION OF K1 FOR EPA METHOD 304A  
OR FROM A COVERED, VENTED BIODEGRADATION UNIT.**

NAME OF THE FACILITY for site specific biorate determination			example
COMPOUND for site specific biorate determination			<i>methanol</i>
BIOMASS (g/L) This is the dried solids that are obtained from the mixed liquor suspended solids in the unit.	1		0.075
VENT RATE of total gas leaving the unit (G, m <sup>3</sup> /s)	2		.1
TEMPERATURE of the liquid in the unit (deg. C)	3		25
INLET CONCENTRATION of compound (g/m <sup>3</sup> or ppmw)	4		100
EXIT CONCENTRATION of compound (g/m <sup>3</sup> or ppmw)	5		5
ESTIMATE OF Henry's law constant (H, g/m <sup>3</sup> in gas / g/m <sup>3</sup> in liquid). Obtained from Form IX	6		0.00021
AREA OF REACTOR (m <sup>2</sup> )	7		3400
VOLUME OF REACTOR (m <sup>3</sup> )	8		10000
FLOW RATE of waste treated in the unit (m <sup>3</sup> /s)	9		0.146
<b>CALCULATION OF THE ESTIMATE OF K1</b>			
TOTAL REMOVAL (g/s) Subtract the number on line 5 from the number on line 4 and multiply the result by the number on line 9. Enter the results here.	10		13.870000
[H G] ESTIMATE (m <sup>3</sup> /s) Multiply the number on line 2 by the number on line 6. Enter the results here.	11		0.075600
[K1 B V + H G] (m <sup>3</sup> /s) Divide the number on line 10 by the number on line 5. Enter the results here.	12		2.774000
[K1 B V] ESTIMATE (m <sup>3</sup> /s) Subtract the number on line 11 from the number on line 12. Enter the results here.	13		2.698400
If the number on line 11 is greater than the number on line 13, this procedure cannot be used to demonstrate that the compound is biodegradable. Do not complete lines 14 and 15.			
Product of B and V. Multiply the number on line 1 by the number on line 8 and enter the results here.	14		750.000000
K1 ESTIMATE (L/g MLVSS-hr) Divide the number on line 13 by the number on line 14 and multiply by 3600 s/hr. Enter the results here.	15		12.952320
EQUIVALENT KL. Divide the number on line 11 by the number on line 7. Enter the results on line 16.	16		0.00002224

This form may be used to estimate the Equivalent KL with input data for lines 2, 6, and 7.

Form V-A DATA FORM FOR THE CALCULATION OF K1 FROM A COVERED, VENTED BIODEGRADATION UNIT. THE VENT CONCENTRATION IS MEASURED.			
NAME OF THE FACILITY for site specific biorate determination			example
COMPOUND for site specific biorate determination			<i>methanol</i>
BIOMASS (g/L) This is the dried solids that are obtained from the mixed liquor suspended solids in the unit.	1		0.075
VENT RATE of total gas leaving the unit (G, m <sup>3</sup> /s)	2		.1
TEMPERATURE of the liquid in the unit (deg. C)	3		25
INLET CONCENTRATION of compound (C <sub>i</sub> , g/m <sup>3</sup> or ppmw)	4		100
EXIT CONCENTRATION of compound (C <sub>e</sub> , g/m <sup>3</sup> or ppmw)	5		5
VENT CONCENTRATION of compound (C <sub>v</sub> , g/m <sup>3</sup> )	6		0.001
AREA OF REACTOR SURFACE (m <sup>2</sup> )	7		3400
VOLUME OF REACTOR (m <sup>3</sup> )	8		10000
FLOW RATE of waste treated in the unit (m <sup>3</sup> /s)	9		0.146
<b>CALCULATION OF THE ESTIMATE OF K1</b>			
TOTAL REMOVAL (g/s) Subtract the number on line 5 from the number on line 4 and multiply the results by the number on line 9. Enter the results here.	10		13.87
[ G C <sub>v</sub> /C <sub>e</sub> ] ESTIMATE (m <sup>3</sup> /s) Multiply the number on line 2 by the number on line 6 and divide by the number on line 5. Enter the results here.	11		0.000020
[K1 B V + G C <sub>v</sub> /C <sub>e</sub> ] (m <sup>3</sup> /s) Divide the number on line 10 by the number on line 5. Enter the results here.	12		2.77
[K1 B V] ESTIMATE (m <sup>3</sup> /s) Subtract the number on line 11 from the number on line 12. Enter the results here.	13		2.77
If the number on line 11 is greater than the number on line 13, this procedure cannot be used to demonstrate that the compound is biodegradable. Do not complete lines 14 and 15.			
Product of B and V. Multiply the number on line 1 by the number on line 8 and enter the results here.	14		750.00
K1 ESTIMATE (L/g MLVSS-hr) Divide the number on line 13 by the number on line 14 and multiply by 3600 s/hr. Enter the results here.	15		13.30
EQUIVALENT KL. Divide the number on line 11 by the number on line 7. Enter the results here.	16		5.9e-09

This form may be used to calculate the Equivalent KL with input data for lines 2, 5, 6, and 7.

Form V-B DATA FORM FOR THE CALCULATION OF EQUIVALENT KL  
FROM A VENTED BIODEGRADATION UNIT WITH AN AIR SUPPORTED COVER.  
THE VENT CONCENTRATION IS MEASURED.

NAME OF THE FACILITY for site specific biorate determination		example
COMPOUND for site specific biorate determination		<i>methanol</i>
Vent rate of total gas entering the cover (m <sup>3</sup> /s)	1	120
Vent rate of total gas leaving the cover transferred to a control device (m <sup>3</sup> /s)	2	100
TEMPERATURE of the liquid in the unit (deg. C)	3	25
Area of air supported cover (m <sup>2</sup> )	4	1950
Permeability through the cover (cm/s)	5	5E-6
VENT CONCENTRATION of compound (g/m <sup>3</sup> )	6	0.0022
EXIT CONCENTRATION of compound (g/m <sup>3</sup> or ppmw)	7	10.57
AREA OF REACTOR SURFACE (m <sup>2</sup> )	8	1500
Performance of vent control device (% control)	9	95
CALCULATION OF THE ESTIMATE OF EQUIVALENT KL		
Loss of forced air in the cover due to leakage. (m <sup>3</sup> /s) Subtract the number on line 2 from the number on line 1. Enter the results here.	10	20
Loss of compound in forced air (g/s) Multiply the number on line 10 by the number on line 6. Enter the results here.	11	0.044
Loss of compound by permeation through cover (g/s). Line 4 times line 5, line 6, and 100. Enter the results here.	12	0.002
Loss of compound by permeation through vent (g/s). Line 2 times line 6. Enter the results here.	13	0.22
Treatment of compound in control device (g/s). Line 13 times line 6, divided by 100. Enter the results here..	14	0.209
Total removal from air phase (g/s). Sum of 11, 12, and 13.	15	0.26615
Total treatment effectiveness (%) Line 13 divided by 14 times 100.	16	1.05263
[G Cv/Ce] ESTIMATE (m <sup>3</sup> /s) Divide line 15 by line 7.	17	0.0252
EQUIVALENT KL. Divide the number on line 17 by line 8.	18	1.68e-05

The permeability is the ratio of the flux (g/cm<sup>2</sup>) to the gas concentration (g/cm<sup>3</sup>).

If the gas is generated by the unit, the gas entering the cover may be estimated from an estimate of the cover leak rate and the total gas transferred to the control device.

Form VI DATA FORM FOR THE ESTIMATION OF K1 FROM FULL SCALE UNIT DATA WITH BIODEGRADATION			
NAME OF THE FACILITY for site specific biorate determination			example
COMPOUND for site specific biorate determination			<i>methanol</i>
BIOMASS (g/L) This is the dried solids that are obtained from the mixed liquor suspended solids in the full-scale bioreactor.	1		0.075
VOLUME of full-scale system (cubic meters)	2		100000
AREA of the liquid surface of the full-scale system (square meters)	3		10000
INLET CONCENTRATION of compound (g/m <sup>3</sup> or ppmw)	4		100
EXIT CONCENTRATION of compound (g/m <sup>3</sup> or ppmw)	5		5
ESTIMATE OF KL from Form II (m/s)	6		0.00001
FLOW RATE of waste treated in the full-scale bioreactor (m <sup>3</sup> /s)	7		0.146
CALCULATION OF THE ESTIMATE OF K1 FROM FIELD DATA			
REMOVAL WITH BIODEGRADATION (g/s) Subtract the number on line 5 from the number on line 4 and multiply the results by the number on line 7. Enter the results here.	8		13.87
[KL A] ESTIMATE (m <sup>3</sup> /s) Multiply the number on line 3 by the number on line 6. Enter the results here.	9		0.10
[K1 B V + KL A] (m <sup>3</sup> /s) Divide the number on line 8 by the number on line 5. Enter the results here.	10		2.774
[K1 B V] ESTIMATE (m <sup>3</sup> /s) Subtract the number on line 9 from the number on line 10. Enter the results here.	11		2.674
Product of B and V. Multiply the number on line 1 by the number on line 2 and enter the results here.	12		7500
K1 ESTIMATE (L/g MLVSS-hr) Divide the number on line 11 by the number on line 12 and multiply by 3600 s/hr. Enter the results here.	13		1.28352

**FORM VII**

**DATA FORM FOR CALCULATING THE  
MASS TRANSFER COEFFICIENT FOR A QUIESCENT SURFACE IMPOUNDMENT**

Facility Name: \_\_\_\_\_

Waste Stream Compound: \_\_\_\_\_

Enter the following:

- F - Impoundment fetch (m) \_\_\_\_\_
- D - Impoundment depth (m) \_\_\_\_\_
- $U_{10}$  - Windspeed 10 m above liquid surface (m/s) \_\_\_\_\_
- $D_w$  - Diffusivity of compound in water (cm<sup>2</sup>/s) \_\_\_\_\_
- $D_{ether}$  - Diffusivity of ether in water (cm<sup>2</sup>/s) \_\_\_\_\_
- $\mu_G$  - Viscosity of air, (g/cm-s) \_\_\_\_\_
- $\rho_G$  - Density of air, (g/cm<sup>3</sup>) \_\_\_\_\_
- $D_a$  - Diffusivity of compound in air, (cm<sup>2</sup>/s) \_\_\_\_\_
- A - Area of impoundment, (m<sup>2</sup>) \_\_\_\_\_
- H - Henry's law constant, (atm-m<sup>3</sup>/g mol) \_\_\_\_\_
- R - Universal gas constant, (atm-m<sup>3</sup>/g mol. °K) \_\_\_\_\_
- $\mu_L$  - Viscosity of water, (g/cm-s) \_\_\_\_\_
- $\rho_L$  - Density of liquid, (g/cm<sup>3</sup>) \_\_\_\_\_
- T - Impoundment temperature, (°C) \_\_\_\_\_

Calculate the following:

Calculate F/D: \_\_\_\_\_

A. Calculate the liquid phase mass transfer coefficient,  $k_L$ , using one of the following procedures, (m/s)

1. Where  $F/D < 14$  and  $U_{10} > 3.25$  m/s, use the following procedure from MacKay and Yeun:<sup>1</sup>

Calculate the Schmidt number on the liquid side,  $Sc_L$ , as follows:

$$Sc_L = \mu_L / \rho_L D_w \quad \underline{\hspace{10em}}$$

Calculate the friction velocity,  $U^*$ , as follows, (m/s):

$$U^* = 0.01 \times U_{10} (6.1 + 0.63 U_{10})^{0.5} \quad \underline{\hspace{10em}}$$

Where  $U^*$  is  $> 0.3$ , calculate  $k_L$  as follows:

$$k_L = (1.0 \times 10^{-6}) + (34.1 \times 10^{-4}) U^* \times Sc_L^{-0.5}$$

Where  $U^*$  is  $< 0.3$ , calculate  $k_L$  as follows:

$$k_L = (1.0 \times 10^{-6}) + (144 \times 10^{-4}) (U^*)^{2.2} \times Sc_L^{-0.5}$$

2. For all other values of F/D and  $U_{10}$ , calculate  $k_L$  using the following procedure from

---

<sup>1</sup>Mackay, D., and A. Yeun. Mass Transfer Coefficient Correlations for Volatilization of Organic Solutes from Water. Environmental Science and Technology. 17:211-217. 1983.

Springer:<sup>2</sup> \_\_\_\_\_

Where  $U_{10}$  is  $< 3.25$  m/s, calculate  $k_L$  as follows:

$$k_L = 2.78 \times 10^{-6} (D_w/D_{\text{ether}})^{2/3}$$

Where  $U_{10}$  is  $> 3.25$  and  $14 < F/D < 51.2$ , Calculate  $k_L$  as follows:

$$k_L = [2.605 \times 10^{-9}(F/D) + 1.277 \times 10^{-7}] U_{10}^2 (D_w/D_{\text{ether}})^{2/3}$$

Where  $U_{10} > 3.25$  m/s and  $F/D > 51.2$ , calculate  $k_L$  as follows:

$$k_L = (2.611 \times 10^{-7}) U_{10}^2 (D_w/D_{\text{ether}})^{2/3}$$

- B. Calculate the gas phase mass transfer coefficient,  $k_G$ , using the following procedure from MacKay and Matsasugu, (m/s):<sup>3</sup>

Calculate the Schmidt number on the gas side,  $Sc_G$ , as follows:  $Sc_G = \mu_G/\rho_G D_a$  \_\_\_\_\_

Calculate the effective diameter of the impoundment,  $d_e$ , as follows, (m):

$$d_e = (4A/\pi)^{0.5}$$
 \_\_\_\_\_

Calculate  $k_G$  as follows, (m/s):  $k_G = 4.82 \times 10^{-3} U_{10}^{0.78} Sc_G^{-0.67} d_e^{-0.11}$  \_\_\_\_\_

- C. Calculate the partition coefficient,  $Keq$ , as follows:  $Keq = H/[R(T+273)]$  \_\_\_\_\_

- D. Calculate the overall mass transfer coefficient,  $K_q$ , as follows, (m/s):

$$1/K_q = 1/k_L + 1/Keq-k_G$$
 \_\_\_\_\_

Where the total impoundment surface is quiescent:

$$KL = K_q$$

Where a portion of the impoundment surface is turbulent, continue with Form VIII.

---

<sup>2</sup>Springer, C., P. D. Lunney, and K. T. Valsaraj. Emission of Hazardous Chemicals from Surface and Near Surface Impoundments to Air. U.S. Environmental Protection Agency, Solid and Hazardous Waste Research Division. Cincinnati, OH. Project Number 808161-02. December 1984.

<sup>3</sup>Hwang, S. T. Toxic Emissions from Land Disposal Facilities. Environmental Progress. 1:46-52. February 1982.

**FORM VIII**

**DATA FORM FOR CALCULATING THE  
MASS TRANSFER COEFFICIENT FOR AN AERATED SURFACE IMPOUNDMENT**

Facility Name: \_\_\_\_\_

Waste Stream Compound: \_\_\_\_\_

Enter the following:

- J - Oxygen transfer rating of surface aerator, (lb O<sub>2</sub>/hr-hp) \_\_\_\_\_
- POWR - Total power to aerators, (hp) \_\_\_\_\_
- T - Water temperature, (°C) \_\_\_\_\_
- O<sub>t</sub> - Oxygen transfer correction factor \_\_\_\_\_
- MW<sub>L</sub> - Molecular weight of liquid \_\_\_\_\_
- A<sub>t</sub> - Turbulent surface area of impoundment, (ft<sup>2</sup>) \_\_\_\_\_  
(If unknown, use values from Table 1)
- A - Total surface area of impoundment, (ft<sup>2</sup>) \_\_\_\_\_
- ρ<sub>L</sub> - Density of liquid, (lb/ft<sup>3</sup>) \_\_\_\_\_
- D<sub>w</sub> - Diffusivity of constituent in water, (cm<sup>2</sup>/s) \_\_\_\_\_
- D<sub>O<sub>2</sub>,w</sub> - Diffusivity of oxygen in water, (cm<sup>2</sup>/s) \_\_\_\_\_
  
- d - Impeller diameter, (cm) \_\_\_\_\_
- w - Rotational speed of impeller, (rad/s) \_\_\_\_\_
- ρ<sub>a</sub> - Density of air, (gm/cm<sup>3</sup>) \_\_\_\_\_
- N - Number of aerators \_\_\_\_\_
- g<sub>c</sub> - Gravitation constant, (lb<sub>m</sub>-ft/s<sup>2</sup>/lb<sub>f</sub>) \_\_\_\_\_
- d\* - Impeller diameter, (ft) \_\_\_\_\_
- D<sub>a</sub> - Diffusivity of constituent in air, (cm<sup>2</sup>/s) \_\_\_\_\_
- MW<sub>a</sub> - Molecular weight of air \_\_\_\_\_
- R - Universal gas constant, (atm-m<sup>3</sup>/g mol. °C) \_\_\_\_\_
- H = Henry's law constant, (atm-m<sup>3</sup>/g mol) \_\_\_\_\_

Calculate the following:

- A. Calculate the liquid phase mass transfer coefficient, k<sub>L</sub>, using the following Equation from Thibodeaux:<sup>4,5</sup>

$$k_L = [8.22 \times 10^{-9} J (POWR)(1.024)^{T-20} O_t 10^6 MW_L / (V a_v \rho_L)] (D_w / D_{O_2,w})^{0.5}, (m/s)$$

\_\_\_\_\_

- B. Calculate the gas phase mass transfer coefficient, k<sub>G</sub>, using the following procedure from
- \_\_\_\_\_

<sup>4</sup>GCA Corporation. Emissions Data and Model Review for Wastewater Treatment Operations. Draft Technical Note. Prepared for U.S. Environmental Protection Agency. Contract No. 68-01-6871, Assignment 49. August 1985. p. 4-2.

<sup>5</sup>Hwang, S. T. Toxic Emissions from Land Disposal Facilities. Environmental Progress. 1:46-52. February 1982.

Reinhardt:<sup>6,7</sup>

Calculate the viscosity of air,  $\mu_a$ , as follows, (g/cm.s):

$$\mu_a = 4.568 \times 10^{-7} T + 1.7209 \times 10^{-4}$$

\_\_\_\_\_

Calculate the Reynold's number as follows:

$$R_e = d^2 w \rho_a / \mu_a$$

\_\_\_\_\_

Calculate power to impeller,  $P_I$ , as follows, (ft.lb<sub>f</sub>/s):

$$P_I = 0.85 (\text{POWR}) 550/N$$

\_\_\_\_\_

Calculate the power number,  $p$ , as follows:

$$p = P_I g_c / (\rho_L d^{*5} w^3)$$

\_\_\_\_\_

Calculate the Schmidt number,  $Sc_G$ , as follows:

$$Sc_G = \mu_a / \rho_a D_a$$

\_\_\_\_\_

Calculate the Fronde number,  $F_r$ , as follows:

$$F_r = d^* w^2 / g_c$$

\_\_\_\_\_

Calculate  $k_G$  as follows:

$$k_G = 1.35 \times 10^{-7} R_e^{1.42} p^{0.4} Sc_G^{0.5} F_r^{-0.21} D_a MW_a / d, (\text{m/s})$$

\_\_\_\_\_

C. Calculate the partition coefficient,  $Keq$ , as follows:

$$Keq = H/[R(T+273)]$$

\_\_\_\_\_

D. Calculate the overall turbulent mass transfer coefficient,  $K_t$ , as follows, (m/s):

$$1/K_t = 1/k_L + 1/Keq.k_G$$

\_\_\_\_\_

E. Calculate the quiescent mass transfer coefficient,  $K_q$ , for the impoundment using Form VII.

\_\_\_\_\_

F. Calculate the overall mass transfer coefficient,  $KL$ , for the impoundment as follows:

$$KL = \frac{K_q (A - A_t) + K_t A_t}{A}$$

\_\_\_\_\_

---

<sup>6</sup>GCA Corporation. Emissions Data and Model Review for Wastewater Treatment Operations. Draft Technical Note. Prepared for U.S. Environmental Protection Agency. Contract No. 68-01-6871, Assignment 49. August 1985. p. 4-3.

<sup>7</sup>Reinhardt, J. R. Gas-Side Mass-Transfer Coefficient and Interfacial Phenomena of Flat-Bladed Surface Agitators. Ph.D. dissertation, University of Arkansas, Fayetteville, Ar. 1977. p. 48.



**Table 1. Turbulent Areas and Volumes for Surface Agitators<sup>a</sup>**

$\omega$ , Motor horsepower, hp	$A_t$ , Turbulent area,		Effective depth, ft	$V$ , Agitated volume, ft <sup>3</sup>	$a_v$ , Area per volume ft <sup>2</sup> /ft <sup>3</sup>
	ft <sup>2</sup>	m <sup>2</sup>			
5	177	16.4	10	1,767	0.100
7.5	201	18.7	10	2,010	0.100
10	227	21	10.5	2,383	0.0952
15	284	26.4	11	3,119	0.0909
20	346	32.1	11.5	3,983	0.0870
25	415	38.6	12	4,986	0.0833
30	491	45.7	12	5,890	0.0833
40	661	61.4	13	8,587	0.0769
50	855	79.5	14	11,970	0.0714
60	1,075	100	15	16,130	0.0666
75	1,452	135	16	23,240	0.0625
100	2,206	205	18	39,710	0.0555

<sup>a</sup>Data for a high speed (1,200 rpm) aerator with 60 cm propeller diameter (d).

**Form IX DATA FORM FOR THE ESTIMATION OF THE HENRY'S LAW  
CONSTANT FOR A COMPOUND IN THE BIOLOGICAL TREATMENT UNIT**

NAME OF THE FACILITY for site specific biorate determination			example
COMPOUND for site specific biorate determination			<i>methanol</i>
LISTED HENRY'S LAW VALUE AT 25 degrees Celsius. (ratio of mol fraction in gas to mole fraction in water)	1		.2885
TEMPERATURE of the liquid in the unit (deg.C)	2		25
<b>CALCULATION OF K</b>			
Temperature adjusted Henry's law value (equals the value on line 1 if the temperature on line 2 is 25)	3		0.2885
Discuss basis of temperature adjustment			
Temperature in degrees Kelvin. Add 273.16 to the number on line 2. Enter the results here.	4		298.1600
Temperature ratio. Divide 273.16 by the number on line 4. Enter the results here.	5		0.9162
Henry's Law adjustment factor. Multiply the number on line 5 by 0.804 and enter the results here.	6		0.7366
Henry's Law value (g/m <sup>3</sup> gas per g/m <sup>3</sup> liquid) Multiply the number on line 3 by the number on line 6 and divide the results by 1000. Enter the results here and on Form V line 6.	7		0.000213
Henry's Law value (atm m <sup>3</sup> per mol ) Divide the number on line 3 by 55555 and enter the results here.	8		0.000005

Form X DATA FORM FOR THE CALCULATION OF THE HENRY'S LAW CONSTANT FOR A COMPOUND IN A SEALED BATCH TEST					
NAME OF THE FACILITY for site specific biorate determination					example
COMPOUND for site specific biorate determination					<i>methanol</i>
REACTOR HEADSPACE VOLUME, (L)			1		1
REACTOR LIQUID VOLUME (L)			2		10
TEMPERATURE of the liquid in the unit (deg.C)			3		25
Wastewater compounds are biodegraded by biomass in a sealed batch test. For the compound listed above, a data set of liquid and gas concentrations is measured at four different times during the sealed batch test. The data are entered below, and the ratio of the concentrations for each data set is entered in column E.					
A	B	C	D	E	
Data set	Time (hr)	Liquid Conc. (mg/L)	Gas Conc. (mg/L)	$K_{eq}$ D/C	.000213
1					
2					
3					
4					
Temperature in degrees Kelvin. Add 273.16 to the number on line 3. Enter the results here			4		298.16
Molar ratio. Multiply the number on line 4 by 4.555. Enter the results on line 5.			5		1,358.12
Henry's law value (mg/L gas per mg/L liquid). Enter the average value in column E above on line 6.			6		0.000213
Henry's law value (mole fraction gas per mole fraction liquid) Multiply the number on line 6 by the number on line 5. Enter the results on line 7.			7		0.28928
Expected Henry's law value. Enter the number from Form IX line 3.			8		0.288500
Precision: Discuss any variability of the numbers in column E. Accuracy: Discuss any difference between the numbers on line 7 and line 8. Identify which value will be used for evaluating the biodegradation rate data. Divide the Henry's law value by the number on line 5 and enter the results on line 9.					
$K_{eq}$ value (mg/L gas per mg/L liquid)			9		0.000213
HEADSPACE CORRECTION FACTOR. Divide the number on line 2 by the sum of the number on line 2 and the product of the numbers on line 9 and line 1. Enter the result on line 10.			10		0.999979
The headspace correction factor should equal approximately 1 if the headspace is relatively small. Reducing the headspace volume may improve the test data quality if the headspace correction factor is substantially less than one.					

Form XI DATA FORM FOR THE CALCULATION OF THE HENRY'S LAW CONSTANT AND THE STRIPPING CONSTANT FOR A COMPOUND IN AN AERATED BATCH TEST				
NAME OF THE FACILITY for site specific biorate determination				example
COMPOUND for site specific biorate determination				<i>methanol</i>
Concentration basis (liquid or gas)				gas
TEMPERATURE of the liquid in the unit (deg.C)		1		25
GAS FLOW RATE (L/hr)		2		1
LIQUID VOLUME (L)		3		10
Co concentration measurement at time=0 (mg/L)		4		
A	B	C	D	E
data point	time (hr)	Concentration, C (mg/L)	C/Co	-ln(C/Co)
1				
2				
3				
4				
5				
<p>CALCULATIONS. Use additional lines as needed in an expansion of the above table. Plot the values in column E (y axis) vs the data in column B (x axis). Reject outliers. Curve fit with a straight line. Calculate the slope and enter the slope on line 7. Attach the plot and table to this form.</p>				
Temperature in degrees Kelvin. Add 273.16 to the number on line 1. Enter the results here		5		298.16
MOLAR RATIO. Multiply the number on line 5 by 4.555. Enter the results on line 6.		6		1,358.12
Slope of the plot of -ln(C/Co) vs time (per hour)		7		
Calculated $K_{eq}$ value (mg/L gas per mg/L liquid). Divide the number on line 7 by the number on line 2 and multiply the results by the number on line 3. Enter the results on line 8.		8		25.00000 0
Expected $K_{eq}$ value. Divide the number from Form IX line 3 by the number on line 6 and enter the results on line 9.		9		0.000212
<p>Discuss any differences between the numbers on line 8 and line 9. Identify which value will be used for the evaluation of the stripping constant (line 10). Problems can sometimes be resolved by system redesign, changing the bubble size, or confirming the experimental value of <math>K_{eq}</math> by using Form X.</p>				
$K_{eq}$ value (mg/L gas per mg/L liquid)		10		0.000000
STRIPPING CONSTANT(per hour). Divide the number on line 10 by number on line 3 and multiply by the number on line 2. Enter the final result on line 11.		11		0.002130
The headspace correction factor equals one for an aerated batch test.				

Form XII <b>DATA FORM FOR THE CALCULATION OF BATCH RATES AND THE DETERMINATION OF THE MONOD CONSTANTS</b>						
Complete this table with measured liquid concentrations from the batch test. If headspace concentrations were measured and equilibrium has been verified, convert them to liquid concentrations by using $K_{sq}$ . If the data are scattered, plot the concentration vs. time data, and fit the data with a curve based on Equation Appendix C-4 for the Aerated Batch test or Equation Appendix C-6 for the Sealed Batch test. Complete this form with concentrations obtained from that fitted curve. If the curve fitting approach is used, attach a plot of the data and the associated fitted curve to this form. Note: If the initial results appear to be anomalous, do not use the initial results.						
COMPOUND for site specific biorate determination						Methanol
Stripping rate constant (/hr) Form XI, line 11					1	1
Enter the batch test Biomass concentration (g/L) on line 2.					2	.25
Headspace correction factor. For a Sealed Batch test use Form X line 10 or 1.00 for an Aerated Batch test.					3	1
A	B	C	D	E	F	G
concentration S (mg/L)	time (hr)	Rate for interval (mg/L-hr) $(a_i - a_{i+1}) /$ $(b_{i+1} - b_i)$	Log Mean S for interval (mg/L) $(a_i - a_{i+1}) /$ $\ln(a_i / a_{i+1})$	Ratio of rate to S (/hr) (C/D)	Adjusted rate (/hr) (E-line 1)	Reciprocal of adj. rate (hr) (1/F)
1.						
2.						
3.						
4.						
5.						
6.						
7.						
8.						
9.						
Continue table on attached sheet as needed. Plot values in column G on y axis, values in column D on x axis. Extrapolate the trend of data points to the y intercept (S=0). Attach the plot to the form.						
Slope of line near intercept (hr-L/mg)					4	.571
Y intercept from plot (hr)					5	1.1428
First order rate constant K1 (or $Q_m/K_s$ , L/g-hr). The number 1.00 divided by the products of the values on line 5, line 2, and line 3.					6	??
Zero order rate constant ( $Q_m$ , /hr). The number 1.00 divided by the products of the values on line 4, line 2, and line 3.					7	ERR
Concentration applicable to full-scale unit. Enter on line 8.					8	
Effective biorate K1 ESTIMATE (L/g MLVSS-hr)*					9	
*Match the concentration on line 8 to the values in Column D and look up the equivalent rate in Column F. Divide the result with both the biomass concentration (line 2) and the headspace correction factor (line 3). Enter this value on line 9. Do not use this method to estimate K1 for line 9 if the data quality is poor in Column F. The number on line 9 is multiplied by the biomass and the system concentration to estimate the full scale biorate. Alternatively, the Monod model parameters may be used.						

**Form XI-A DATA FORM FOR THE CALCULATION OF BATCH RATES  
AND THE DETERMINATION OF THE MONOD CONSTANTS I**

Complete this table with measured liquid concentrations from the batch test. If the data is scattered, plot the concentration vs. time, add a curve that represents the data and complete this table with concentrations obtained from the curve. If the concentration data are plotted, attach that plot to this form. Note: If the initial results appear to be anomalous, do not use the initial results.

COMPOUND for site specific biorate determination						Methanol
A	B	C	D	E	F	G
concentration S (mg/L)	time (min)	Change in concentration	Change in time	Rate for interval (mg/L-hr) 60 C/D	Avg. S for interval (mg/L)	Ratio of rate to S (/hr) E/F
1.						
2.		1-2	2-1			
3.		2-3	3-2			
4.		3-4	4-3			
5.		4-5	5-4			
6.		5-6	6-5			
7.		6-7	7-6			
8.		7-8	8-7			
9.		8-9	9-8			

Continue table on attached sheet as needed. Plot values in column G on y axis, values in column F on x axis. Extrapolate the trend of data points to the y intercept (S=0). Attach the plot to the form.

First order rate constant (per hour). Enter the Y intercept (ratio of rate to S) on line 1.	1		
Stripping rate constant (/hr) Form X, line 11	2		
Headspace correction factor. From Form XI-B line 14	3		
First order biodegradation rate constant (QmX/Ks). Subtract the number on line 2 from the number on line 1 and divide by the number on line 3. Enter the results on line 4.	4		
Enter the batch test Biomass concentration (g/L) on line 5.	5		
Monod K1 (Qm/Ks, L/g-hr). Divide the number on line 4 by the number on line 5 and enter the results on line 6.	6		
Concentration applicable to full-scale unit. Enter on line 7.	7		
Effective biorate K1 ESTIMATE (L/g MLVSS-hr)*	8		

\*Match the concentration on line 7 to the values in Column F and look up the equivalent rate in Column G. Subtract the value on line 2 and divide the result with both the value on line 5 and the value on line 3. Enter this value on line 8. Do not use this method to estimate K1 if the data quality is poor.

**Form XI-B DATA FORM FOR THE CALCULATION OF BATCH RATES  
AND THE DETERMINATION OF THE MONOD CONSTANTS II**

The Monod constants can be used with computer programs to estimate the biorates. The constants may be obtained from Form XI-A line 6 and line 10 of this form. Complete this table using values calculated from Form XI-A. If line 8 could be completed on Form XI-A, this form is not needed to estimate  $F_{bio}$  on Form III.

COMPOUND for site specific biorate determination					Methanol
Batch test biomass concentration (g/L)				1	
First order biorate constant (1/hr). Form XI-A, line 3				2	
Stripping rate constant (/hr) Form X, line 11				3	
A	B	C	D	E	F
Ratio of rate to concentration (/hr)	Avg. C (mg/L)	Adjusted rate A - line 3	C times B	line 1-C/line2	$Q_m$ mg/g-hr D/E
4.					
5.					
6.					
7.					
8.					
9.					
Average value of $Q_m$ (mg/g-hr)				10	

Discuss any differences in the values of  $Q_m$  obtained for the different data points. Reject outliers or questionable values before calculating the average value for line 10.

Volume of headspace in closed reactor (L)	11	
Volume of liquid in reactor (L)	12	
Henry's law value. Enter the value from Form X line 8 on line 13	13	
Headspace correction factor. Divide the number on line 12 by the sum of the number on line 12 and the product of the number on line 11 and line 13. Enter the result on line 14 and on Form XI-A line 3.	14	

The headspace correction factor on line 14 will equal 1 if the headspace is vented from the reactor.