

Report No. FHWA-RD-75-129

LATERAL SUPPORT SYSTEMS AND UNDERPINNING

Vol. II. Design Fundamentals

D. T. Goldberg, W. E. Jaworski, and M. D. Gordon



April 1976

Final Report

This document is available to the public
through the National Technical Information
Service, Springfield, Virginia 22161

Prepared for

FEDERAL HIGHWAY ADMINISTRATION

Offices of Research & Development

Washington, D.C. 20590

NOTICE

This document is disseminated under the sponsorship of the Department of Transportation in the interest of information exchange. The United States Government assumes no liability for its contents or use.

The contents of this report reflect the views of Goldberg-Zoino and Associates, Inc., who are responsible for the facts and the accuracy of the data presented herein. The contents do not necessarily reflect the official views or policy of the Department of Transportation. This report does not constitute a standard, specification, or regulation.

The United States Government does not endorse products or manufacturers. Trade or manufacturers' names appear herein only because they are considered essential to the object of this document.

FHWA DISTRIBUTION

Sufficient copies of this report are being distributed by FHWA Bulletin to provide two copies to each regional office, one copy to each division office, and two copies to each State highway department. Direct distribution is being made to the division offices.

1. Report No. FHWA-RD-75-129		2. Government Accession No.		3. Recipient's Catalog No.	
4. Title and Subtitle LATERAL SUPPORT SYSTEMS AND UNDERPINNING Volume II. Design Fundamentals				5. Report Date April 1, 1976	
				6. Performing Organization Code	
7. Author(s) Donald T. Goldberg, Walter E. Jaworski, and M Daniel Gordon				8. Performing Organization Report No. 1363	
9. Performing Organization Name and Address Goldberg-Zoino & Associates, Inc. 30 Tower Road Newton Upper Falls, Massachusetts 02164				10. Work Unit No. (TRAIS) FCP 35 B 104-2	
				11. Contract or Grant No. DOT-FH-11-8499	
12. Sponsoring Agency Name and Address Offices of Research and Development FHWA U. S. Department of Transportation Washington, D. C. 20590				13. Type of Report and Period Covered Final report	
				14. Sponsoring Agency Code S0514	
15. Supplementary Note. Contract manager for this study: J. R. Sallberg (HRS-11)					
16. Abstract This report provides current information and design guidelines on cut-and-cover tunneling for practicing engineers. The main emphasis is on the geotechnical aspects of engineering. Included in this volume is a state-of-the-art summary of displacements and lateral pressure. Other topics are basic concepts of soil mechanics, ground water in open cut, passive resistance, design aspects of lateral earth pressure, stability analysis of sheeted excavations, bearing capacity of deep foundations, and construction monitoring. Detailed explanations of design methods and literature citations are included. Other reports prepared as part of the study are FHWA-RD-75-128, Volume I, Design and Construction; FHWA-RD-75-130, Volume III, Construction Methods; and FHWA-RD-75-131, Concepts for Improved Lateral Support Systems.					
17. Key Words Bracing, Ground Support, Excavation, Underpinning, Cut-and-Cover Construction.				18. Distribution Statement No restrictions. This document is available to the public from the National Technical Information Service, Springfield, Virginia 22161.	
19. Security Classif. (of this report) Unclassified		20. Security Classif. (of this page) Unclassified		21. No. of Pages 249	22. Price

PREFACE

Volumes II and III of this three volume set present the current state-of-the-art on the engineering aspects of the design and construction of ground support walls and the closely related techniques of underpinning, ground freezing, and grouting. So that the reader will understand the rationale behind the subject matter, the text contains detailed discussions, especially in areas of controversial or technically new issues. On the other hand Volume I, a summary of Volumes II and III, is free from the detailed discussions embodied in the latter two. Its purpose is to provide a ready reference manual.

Overall, the primary intent is to provide information and guidelines to practicing engineers, in particular those engineers with an advanced background in the disciplines of Soil Mechanics and Foundation Engineering.

Volume II incorporates design fundamentals, primarily those of a geotechnical nature. It places considerable emphasis upon displacements of adjacent ground and adjacent structures and considers those parameters which are primary contributors to excessive displacements.

Volume III is directed toward the essential design and construction criteria associated with each of the following techniques: (a) Support Walls - soldier pile walls, sheet pile walls, concrete diaphragm walls; (b) Support Methods - internal bracing and tieback anchorages; (c) Underpinning; (d) Grouting; (e) Ground Freezing. Also, it presents an overview of these construction methods with regard to selection, performance, and relative cost. Throughout, an attempt has been made to provide a balance between the practical engineering considerations of construction and appropriate corresponding considerations of engineering fundamentals.

These publications are produced under the sponsorship of the Department of Transportation research program, a long range plan to advance the technology of bored and cut-and-cover tunnels, in particular those constructed in the urban environment.

Part of this program involves a synthesis and evaluation of existing knowledge and part involves a Research and Development effort. These volumes fall under the category of the former, "State of the Art", aspect of the **program** from which it is hoped that progress through development of bold innovative approaches will emanate.

ACKNOWLEDGEMENTS

The authors acknowledge with gratitude: The assistance of Melvin Febesh of Urban Foundation Company, New York, who contributed so heavily to the underpinning chapter and whose insight and construction experience assured proper direction to the effort.

The contributions of Dr. James P. Gould, of Mueser, Rutledge, Wentworth and Johnston, New York, through his review of the chapters in Volume I dealing with displacements, earth pressure, and design aspects of land cofferdams. Thanks also to:

To Mr. John Shuster of Terrafreeze Corporation, Bethesda, Maryland for the review and contributions for the section on the techniques of ground freezing.

To **Mr. John** Jones of **Schnabel** Foundation, Co., Washington, D. C. for his review and comments on Volume III, "Construction Methods".

To Mr. D. Maishman of Foraky, Ltd., Great Britain for allowing the authors the opportunity to review his yet unpublished manuscript on ground freezing.

To those many engineers, manufacturers, and contractors who graciously **provided** comments, data, and photographs.

To Mr. John Dunicliff of Soil & Rock Instrumentation, Inc., of Newton Upper Falls, Massachusetts for the chapter on Construction Monitoring.

To those individuals associated with Goldberg-Zoino & Associates, Inc. who contributed greatly to the various chapters in these manuals: Dr. Stephen A. **Alsup** on Ground Freezing; Mr. Peter Riordan on Bearing Capacity; Mr. Jackson Ho for the outstanding effort on computer work; the efforts of Ms. Andrea Wizer and Mrs. Joan Jennings for their patience and endurance in the typing of these manuscripts.

To Mr. Gardner L. Hayward, Jr. for a job well done **on** the drafting of the figures.

And finally, to Mr. J. R. Sallberg, contract manager for the Department of Transportation and Federal Highway Administration, for his patience, support, and welcome criticisms throughout the program.

TABLE OF CONTENTS

INTRODUCTORY SECTION

	<u>Page Number</u>
TITLE PAGE	i
PREFACE	ii
ACKNOWLEDGEMENTS	iv
TABLE OF CONTENTS	v
CONVERSION FACTORS	viii
SYMBOLS	x

TEXT

	<u>Page Number</u>
CHAPTER 1 INTRODUCTION	1
1.10 Purpose and Scope	1
1.20 Organization and Usage	1
CHAPTER 2 DISPLACEMENTS	5
2.10 General	5
2.20 Characteristics of Wall Deformation	6
2.30 Magnitude of Displacements	12
2.40 Parametric Studies	27
2.50 Distribution of Deformations	30
2.60 Lateral Deformations in Adjacent Soil	39
Mass	
2.70 Effect of Construction Procedures	42
2.80 Estimating Settlements	43
2.90 Summary	43
Appendix A	45
CHAPTER 3 BASIC CONCEPTS OF SOIL MECHANICS	51
3.10 General	51
3.20 Effective Stress	51
3.30 Soil Unit Weights	52
3.40 Shear Strength of Soils	53
CHAPTER 4 GROUND WATER IN OPEN CUTS	62
4.10 Ground Water Cutoff	62
4.20 Seepage Pattern to Excavation Face	64
4.30 Ground Water Recharge	66

TABLE OF CONTENTS (con't)

		<u>Page Number</u>
CHAPTER 5	LATERAL EARTH PRESSURE	67
	5.10 Basic Considerations	67
	5.20 Internally Braced Cofferdams	72
	5.30 Tiebacks	83
	5.40 Surcharge Loading	87
CHAPTER 6	PASSIVE RESISTANCE BELOW BASE OF EXCAVATION	96
	6.10 General	96
	6.20 Soil Parameters	96
	6.30 Analysis of Passive Resistance	99
	6.40 Over cut Design Details	102
	6.50 Berms	102
CHAPTER 7	DESIGN ASPECTS OF LATERAL PRESSURE	103
	7.10 Load on Support Levels	103
	7.20 Analysis of Wales and Support Walls	103
	7.30 Bracing and Tiebacks	110
	7.40 Depth of Penetration Below Cut	110
	7.50 Example Problems	112
	7.60 Finite Element Analysis of Braced Excavations	115
CHAPTER 8	STABILITY ANALYSIS OF SHEETED EXCAVATIONS	133
	8.10 General	133
	8.20 Bottom Heave	133
	8.30 Local Failure	136
	8.40 Deep Seated Failures	138
CHAPTER 9	BEARING PRESSURE OF DEEP FOUNDATIONS	145
	9.10 General	145
	9.20 Presumptive Bearing Value	145
	9.30 Bearing Values Based on Shear Failure	145
	9.40 Bearing Values Based on Settlement	150

TABLE OF CONTENTS (con't)

	<u>Page Number</u>
CHAPTER 10 CONSTRUCTION MONITORING	168
10.10 Introduction	168
10.20 Planned Construction Monitoring Programs	169
10.30 Parameters to be Measured	169
10.40 Example s	174
10.50 Recommended Methods of Measurement	177
lo. 60 Contracting for Instrumentation	180
10.70 The Key to Successful Construction Monitoring	182
 BIBLIOGRAPHY	 183

LIST OF CONVERSIONS

The list of conversions is designed to aid in converting from British units of measure to metric units. This section has been divided into two parts; general notation and arithmetic conversion.

General Notation

BTU	British Thermal Unit
cm	centimeter
cm²	square centimeter
cm³, cc	cubic centimeter
cfs	cubic feet per second
ft	feet
ft²	square feet
ft³	cubic feet
fps	feet per second
gal	gallon
gpm	gallons per minute
g, gr	grams
hr	hour
in	inches
in²	square inches
in³	cubic inches
k	kilo (thousand)
kg	kilogram
m	meters
m²	square meters
m³	cubic meters
min	minute

mm	millimeter s
mm ²	square millimeter g
mm ³	cubic millimeters
ml	milliliters
N	Newton
lbs	pounds
pcf	pounds per cubic foot
plf	pounds per lineal foot
psf	pounds per square foot
psi	pounds per square inch
sec	second

Conversions

British Units

1 BTU

1 in

1 in²

1 in³

1 ft

1 ft²

1 ft³

1 pcf (lbs/ft³)

1 psf (lbs/ft²)

1 ksf (kips/ft²)

1 psi (lbs/in²)

1 lb

Lin- lb

Metric Units

0.2520 kg = calories

107.5 kg = meters

2.540 cm = 25.4 mm

6,452 cm²

16.103 cm³

30.48 cm = 0.3048 m

929 cm² = 0.0929 m²

28,317 cm³ = 0.0283 m³

16.02 kg/m³ = 0.01602 g/cm³

4,883 kg/m² = 47.9 N/m²

4.45 N

0.1127 N-m

List Of Symbols

The following list of symbols has been prepared to aid the interpretation of symbol use in the text. This list identifies only the major symbols used in the text and their general meaning. Each symbol (with subscripts) is defined in the text for its particular usage. This list is not a complete list of all symbols or all symbol usage in the text but is a summary of major symbols and their usage.

<u>Symb 1</u>	<u>Represents</u>	<u>Reference</u>
A	general symbol for area	
B, b	general symbols for width	
c	cohesion intercept	
C	heat capacity	Volume I, Chapter 16 Volume III, Chapter 9
D, d	general symbols for distance and diameter	
E	general symbol for modulus	
f	general symbol for stress	
F. S.	factor of safety	
H	depth of excavation: also general symbol for height	
K	general symbol for coefficient of lateral earth pressure	
K_o	coefficient of lateral earth pressure at rest	
K_a	coefficient of active earth pressure	
K_p	coefficient of passive earth pressure	
K	thermal conductivity	Volume I, Chapter 16 Volume III, Chapter 9
L, l	general symbols for length or distance	
N	general, symbol for stability number or standard penetration resistance	
OCR	over consolidation ratio	

<u>Symbol</u>	<u>Represents</u>	<u>Reference</u>
P	general symbol for load or force	
p	general symbol for pressure	
pH	negative logarithm of effective hydrogen ion concentration	
R, r	general symbols for radius	
S, s	general symbols for shear resistance or shear strength	
S_u	undrained shear strength	
u	pore pressure	
W	general symbol for weight	
w	general symbol for water content	
δ	general symbol for displacement or movement; also angle of wall friction	
$\delta_{v(max)}$	vertical displacement (maximum)	
$\delta_{h(max)}$	horizontal displacement (maximum)	
ϵ	general symbol for strain	
γ	general symbol for unit weight; total unit weight of soil unless otherwise specified	
γ_d	dry unit weight of soil	
γ_m	total unit weight of soil	
γ_{sub}	bouyant unit weight of soil	
γ_w	unit weight of water	
μ	Poisson's Ratio	
ν	Poisson's Ratio	
ϕ	general symbol for friction angle of soil	

<u>Symbol</u>	<u>Represents</u>	<u>Reference</u>
ρ	general symbol for settlement	
σ	general symbol for stress	
σ_v ($\bar{\sigma}_v$)	total vertical stress (effective vertical stress)	
σ_h ($\bar{\sigma}_h$)	total horizontal stress (effective horizontal stress)	
$\bar{\sigma}_{vm}$	maximum past vertical consolidation pressure (effective stress)	
τ	general symbol for shear stress or shear resistance	

Note: Line over symbols indicates effective stress parameters are to be used. (e. g. $\bar{\sigma}_v$ = vertical effective stress).

CHAPTER 1 - INTRODUCTION

1.10 PURPOSE AND SCOPE

This report, Volume II, discusses the general design aspects of cut-and-cover tunneling, in particular those factors affecting the design of the ground support wall, such as earth pressure, Lateral resistance , ground water, and bearing capacity. In addition, considerable emphasis is placed on displacements of adjacent ground and adjacent structures.

The intent of Volume II is to provide the basic theoretical elements and design framework with which to approach the engineering of deep excavations and underpinning. Because emphasis is upon geotechnical considerations, comments on structural factors are included only when closely related. Legal and contractual relationships are not discussed.

1.20 ORGANIZATION AND USAGE

Including this introductory chapter, there are 10 chapters in this volume, With the exceptions of Chapters 3 and 10, each of the remaining chapters discusses analytical procedures or a particular aspect of design. Chapter 3 presents basic soil behavior concepts for reference, and Chapter 10 is an overview of construction monitoring as related to deep excavations and tunnels. Each of the remaining chapters is discussed briefly below.

1.21 Displacements - Chapter 2

The displacements occurring in the structures and soil mass adjacent to an excavation will have an effect on the choice of wall and the remedial or preventive measures required to protect the structures. The greater the amount of movement, the greater will be the protective measures required. An analysis of the performance data recorded at approximately 60 excavations revealed several important relationships between wall type, support type, soil type, and movements .

In sands and gravels and very stiff to hard clays, the wall type did not markedly affect performance. However, in softer cohesive soils the stiffer support systems (concrete diaphragm walls) limited movements to a much greater extent than did the more

flexible soldier pile or steel sheet pile walls. Some preliminary conclusions can be drawn from the displacement data analyzed which may be used as an aid in predicting movements behind a wall.

By improving the displacement prediction techniques for movements adjacent to an excavation, the engineer will be in a better position to evaluate the many factors involved in the decision to underpin structures. If displacements can be reliably predicted, particularly with distance behind excavations, the effect that the movements will have on structures can be evaluated, and the costs of repair can be compared to the costs of alternative procedures.

1.22 Basic Soil Parameters - Chapter 3

This chapter is a brief review of the basic soil parameters and soil behavior that affect lateral support wall design. Of particular interest are the differences in strength behavior between cohesionless and cohesive soils. In cohesive soils, it is important to identify the situations where undrained strength or drained strength is the critical controlling parameter. The chapter is not intended to be a complete review of soil properties and soil behavior; rather, it is intended to provide a general overview of factors affecting wall design.

1.23 Ground Water - Chapter 4

In many excavations, ground water control is often the most difficult aspect of wall construction. Lowered ground water levels may cause consolidation settlements in soil profiles where compressible soils are present. Ground water flow into the excavation may result in running soils and creation of voids behind a wall. This chapter summarizes the basic concerns in ground water as it relates to cut-and-cover tunneling; however, it does not provide specific details on design of dewatering systems.

1.24 Lateral Earth Pressure - Chapter 5

Lateral earth, water, and surcharge pressures on a wall represent the driving forces that must be resisted by the passive resistance of the soil below the base of the excavation and by the support members (internal bracing or tiebacks). This chapter reviews the established state-of-the-art, advances some new

concepts, and presents recommended design earth pressure distributions for internally braced and tied-back walls. Lateral pressures caused by surcharge are also discussed.

1.25 Passive Resistance - Chapter 6

The passive resistance mobilized in the soil below the cut may play a role in maintaining the stability of the wall and in controlling the amount of lateral deflection. Design parameters for passive pressures are presented, and specific design criteria are discussed,

1.26 Design Aspects of Lateral Pressure - Chapter 7

This chapter discusses the techniques used to evaluate strut loads, wale loads, and presents some typical design problems incorporating the principles advanced in the previous chapters. Specific design recommendations are made for allowable stresses in steel members, determination of passive resistance, and methods of analyzing loads in structural members. Recommendations are made relative to overcut, depth of embedment, and temporary overstressing.

1.27 Stability - Chapter 8

The base stability of excavations must always be examined, particularly in softer soil profiles. Methods of evaluating overall stability as well as shear strains inherent in localized zones of excessive shear, are also discussed.

1.28 Bearing Capacity of Deep Foundations - Chapter 9

This chapter is most useful in the design of underpinning members. However, this section may also be applicable to tied-back walls where the vertical load induced in the wall by the vertical component of tieback load can be significant. Design criteria and design charts are presented for analysis of failure load and settlement under various loading conditions.

1.29 Construction Monitoring - Chapter 10

Chapter 10 describes the basic considerations and reasons for monitoring the performance of a lateral support wall.

The reasons may be to verify design assumptions, assure structure stability, observe performance for possible legal litigations, or to advance the state-of-the-art. The general procedure to be followed in planning a monitoring scheme is outlined.

2.10 GENERAL

2.11 Purpose and Scope

The purpose of this section is to provide insight into displacements occurring adjacent to deep excavations ■ specifically, into those factors influencing displacements and into the manner in which displacements occur.

This section describes the basic performance of excavations in terms of the magnitude and pattern of soil and wall movements, Empirical plots are derived from the measured performance and presented. In addition, finite element analyses have been used to help assess qualitatively the relative influence of the aforementioned parameters. Together, the empirical studies of performance data and accompanying computer analyses have provided new insight into the understanding and prediction of displacement.

Several other empirical analyses of the performance of laterally supported cuts have been performed. Peck (1969) and D'Appolonia (1971) are perhaps the most widely known, and their work has been most valuable in the preparation of this section. This present investigation incorporates data from the more recent cases, including many with tiebacks and concrete diaphragm walls.

2.12 Significance of Displacements

While the magnitude of settlement is a useful indicator of potential damage to structures, the amount of settlement change with horizontal distance (settlement profile) is actually of greater significance. This fundamental concept is related to the concept of differential settlement, as opposed to gross settlement.

Horizontal displacements have proven to be a source of severe damage (Gould, 1975). Therefore,, attention to the threat of settlement should not cause us to overlook what may even be a greater source of damage, Indeed, horizontal displacements are often of greater concern than are vertical displacements in the presence of underpinned structures (Febesh, 1975).

2.13 Relationship to Underpinning

Historically, the decision whether or not to underpin has been a subjective judgement based upon experience - experience which reflects local soil conditions, contractors' practices, attitudes of engineers, and jurisdictional authorities. Rarely, if ever, have engineers attempted to base a decision concerning underpinning on a quantitative evaluation of displacements. Rather, structures within certain preestablished influence zones would be underpinned. Alternatively, if the cost of underpinning was disproportionate in relation to the value of the structure and there was no danger of collapse, one might accept the inherent risk of not underpinning and make necessary repairs afterwards.

Fundamentally, the amount and distribution of the movements in a soil mass adjacent to an excavation is governed primarily by soil type, stiffness of support wall, and construction procedures. A better understanding of how these parameters control displacement will lead to a more rational assessment of effects on adjacent buildings and to the development of improved techniques to minimize displacements. Ultimately, these efforts will contribute to the decisions concerning **methods** of support and underpinning of structures.

2.20 CHARACTERISTICS OF WALL DEFORMATION

2.21 General Mode of Deformations

Figure 1 shows the possible range of deformations for perfectly rigid walls and for walls displaying flexure. Basically the range of behavior includes translation and either rotation about the base or rotation about the top. In addition, wall deformation will include some bulging as a result of flexure -- the amount of bulging depending upon the stiffness of the wall support system.

2.22 Internally Braced Walls

The upper portion of internally braced walls is restrained from undergoing large horizontal movement especially when braces are prestressed and are installed at or close to the surface. This produces the typical deformation mode as shown in Figure 2a. The degree of rotation will depend upon the toe restraint below the bottom of the excavation.

(a) INFINITELY RIGID WALLS

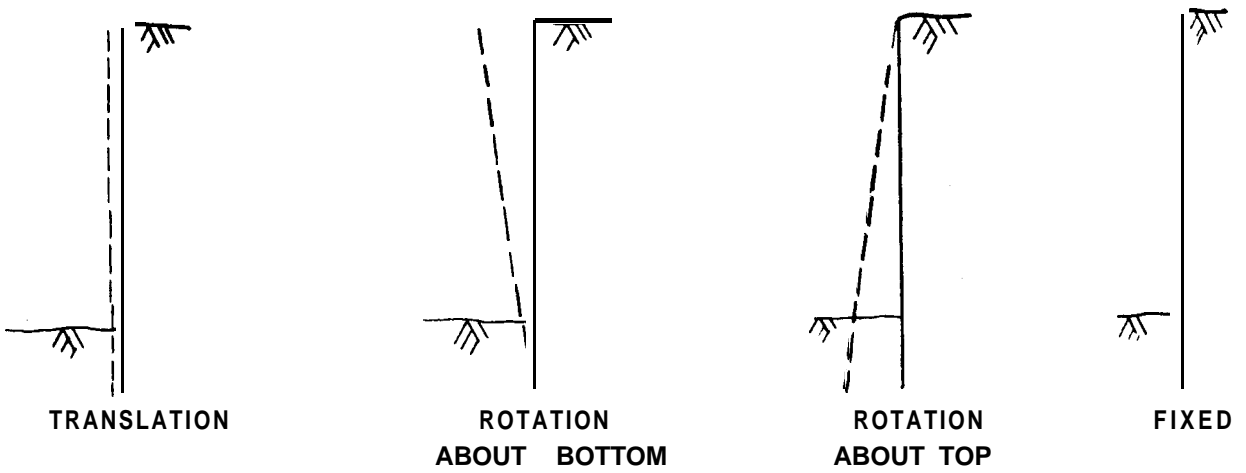

(b) WALLS DISPLAYING FLEXURE

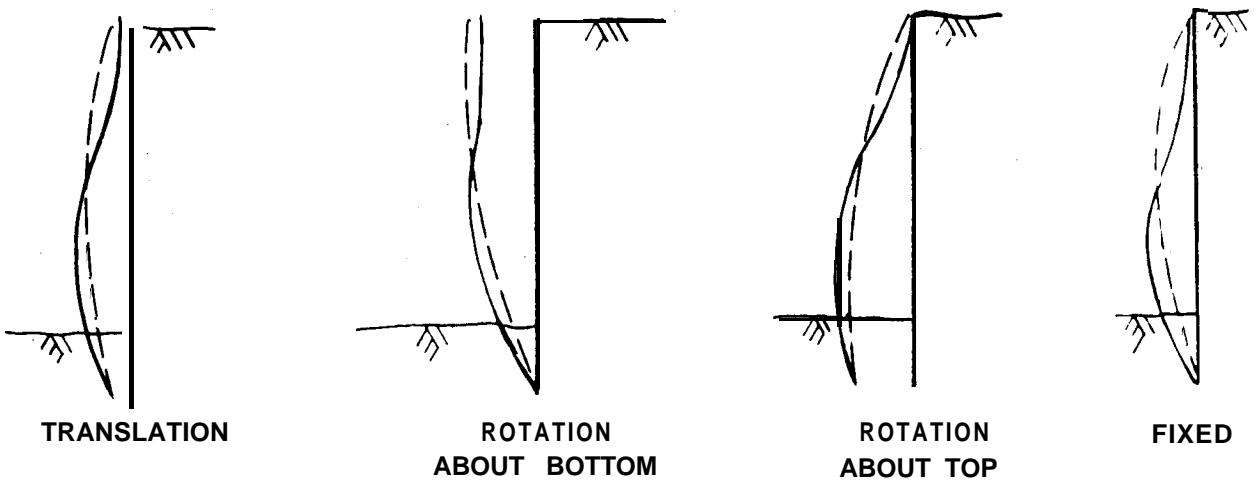
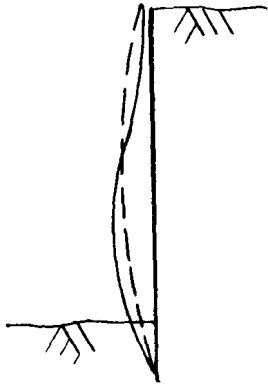
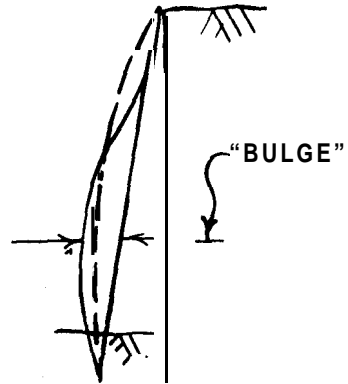

Figure 1. General deformation modes.

(a) TYPICAL FOR INTERNAL BRACING



**FIXED OR SLIGHT
TRANSLATION**



**ROTATION
ABOUT TOP**

(b) TYPICAL FOR TIEBACKS

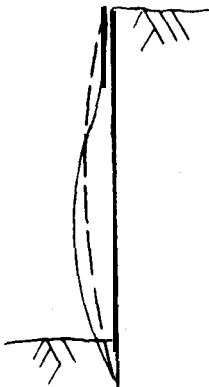

**FIXED OR SLIGHT
TRANSLATION**

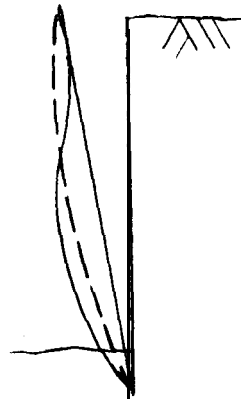

**ROTATION
ABOUT BOTTOM**

Figure 2. Typical deformation of tied-back and internally braced walls.

2. 23 Tied-Back Walls

If the top of the tied-back wall remains fixed, then the deformation mode is similar to that of an internally braced wall (see Figure 2b, left panel). On the other hand, settlement of the wall, partial yielding of the ties, gross movement of the soil mass, or shear deformation of the soil mass may result in inward movement of the top and rotation about the bottom as shown in Figure 2b, right panel.

Nendza and Klein (1974) attributed the deformation mode of Figure 2b, right panel, to a combination of shear deformation, which contributed to inward movement of the top, and flexure, which contributed to the bulging effect.

If the soil mass embodied by the tiebacks deforms somewhat as a unit, the pattern would be similar to that shown in Figure 3. Here, the top moves inward toward the excavation and the earth mass mobilizes internal shear. Such a concept was originally proposed by Terzaghi (1945) in connection with earth-filled cellular or **double-walled** cofferdams. Such a deformation mode is not true for all situations, but is very likely in cases of an unyielding base and with the bottom of the wall restrained from outward movement.

Overall, the deformation mode of a tied-back wall is complex in that various factors develop in different ways. For example:

1. High prestressing pulls the **top** of the wall into the soil, thus leading to a deformation mode of outward rotation about the **bottom**. In sensitive clays, this condition could induce consolidation (McRostie, et al, 1972).
2. Lateral translation of the **entire** soil mass occurs from shear strains within a weak underlying cohesive layer or from general lateral strain following relief of large residual horizontal stress in highly overconsolidated clay or soft shales. Observations show this may continue even after reaching full depth. (Burland, 1974; St. John, 1974; Breth and Romberg, 1972; Romberg, 1973).
3. Very stiff walls, such as diaphragm walls, will display less bulging from flexure. Therefore, horizontal movement at the top due to movement of the soil monolith will be large compared to the effect of flexure and therefore will assume relatively more importance.

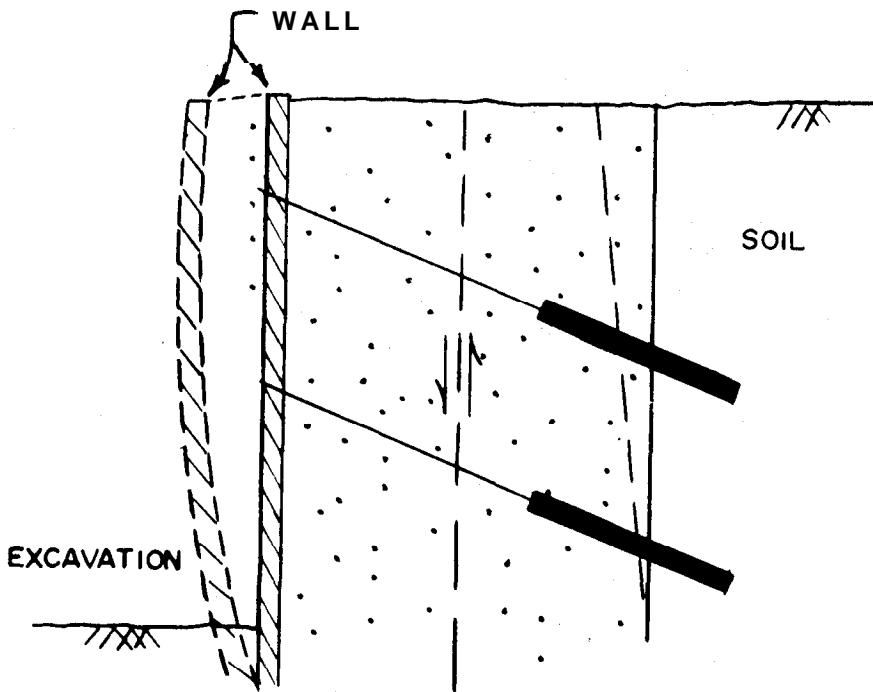

Figure 3. Internal shear development, horizontal shift at top relative to bottom,

2. 24 Comparison of Braced Walls with Tied-Back Walls

Overall, there are insufficient data to quantitatively compare deformations of internally braced walls with tied-back walls. Performance is highly dependent on construction methods and variables are many. In competent soils (e. g. granular deposits, dense cohesive sands, very stiff or hard clays, etc.) performance data suggest that tied-back walls display about the same deformation as internally braced walls.

Although the observational data demonstrate little difference between displacements with bracing or tiebacks, from a purely qualitative aspect, a number of factors suggest a superior performance should be attained with tiebacks in competent soils:

1. In granular soils in which soil modulus increases with stress level, the prestressed soil mass engaged by the tiebacks is made more rigid and therefore less deformable.

2. Tiebacks are typically prestressed to about 125 percent of the design load and then locked-off between 75 percent and 100 percent of the design load. **Prestress**ing in this manner prestrains and stiffens the soil monolith. Further, the process pulls the wall back toward the soil to remove any "slack" in the contact zone.

3. Internal bracing, if prestressed, is usually prestressed to about 50 percent of the design load. Typically, the bracing **gains** in load as the excavation deepens. In contrast, tiebacks, being **locked-off** at higher loads, typically maintain the load or experience a slight **loss** of load with time. In the case of internal bracing elastic shortening of the strut continues after installation of the member.

4. Temperature strains are more important with bracing than with tiebacks because the latter are insulated in the ground. Temperature drop **may** cause a drop in load and/or contraction of the member. If load remains constant, a 35-degree Fahrenheit temperature drop from time of installation would cause a 75 foot member to shorten by about **0.2** inches.

5. Frequently, internal bracing is removed then **rebraced** to facilitate construction, whereas tiebacks do not have to be removed.

Obviously, the flexure occurring with strut **removal** is affected by wall stiffness, span distance, and concurrent backfill and compaction. Past experience has shown strut removal to contribute significantly to settlement of adjacent ground. The settlement is the result of lateral wall deformation during the process of removing the support.

6. Contractors commonly overexcavate below bracing levels to facilitate removal of materials. This induces greater movements, especially in weak soils.' **With tiebacks** the contractor maintains the excavation at or slightly above the tieback level.

2.30 MAGNITUDE OF DISPLACEMENTS

2.3.1 Reported Horizontal and Vertical Displacements

Displacement of the soil retained by and adjacent to an excavation is a function of several factors including wall stiffness, **construction** technique, etc. Because of the inherent complexities of an actual installation, it is difficult to isolate all variables and analyze each separately on the basis of empirical data. However, some indication of the effect of some variables can be obtained by simplifying the primary characteristics of a cofferdam (soil type wall and bracing type) and summarizing and comparing them with the results of field measurements.

Figures 4 and 5 are an extension of a similar plot presented by **D'Appolonia** (1971). The figures show normalized vertical and horizontal displacements (ratio of the maximum displacements to the height of the cut) versus three general categories of soil type and support type. References for this data are summarized in Table 1. Diaphragm walls are distinguished from the relatively more flexible soldier pile or sheet pile walls by symbol.

Vertical and horizontal displacements in the ground outside the excavation arise from:

1. Horizontal and vertical displacement of the wall -- in general, these are rotation, translation, and flexure,
2. Movement of soil -- for example, loss of soil through lagging, overcutting and improperly backpacking of lagging, spalling of

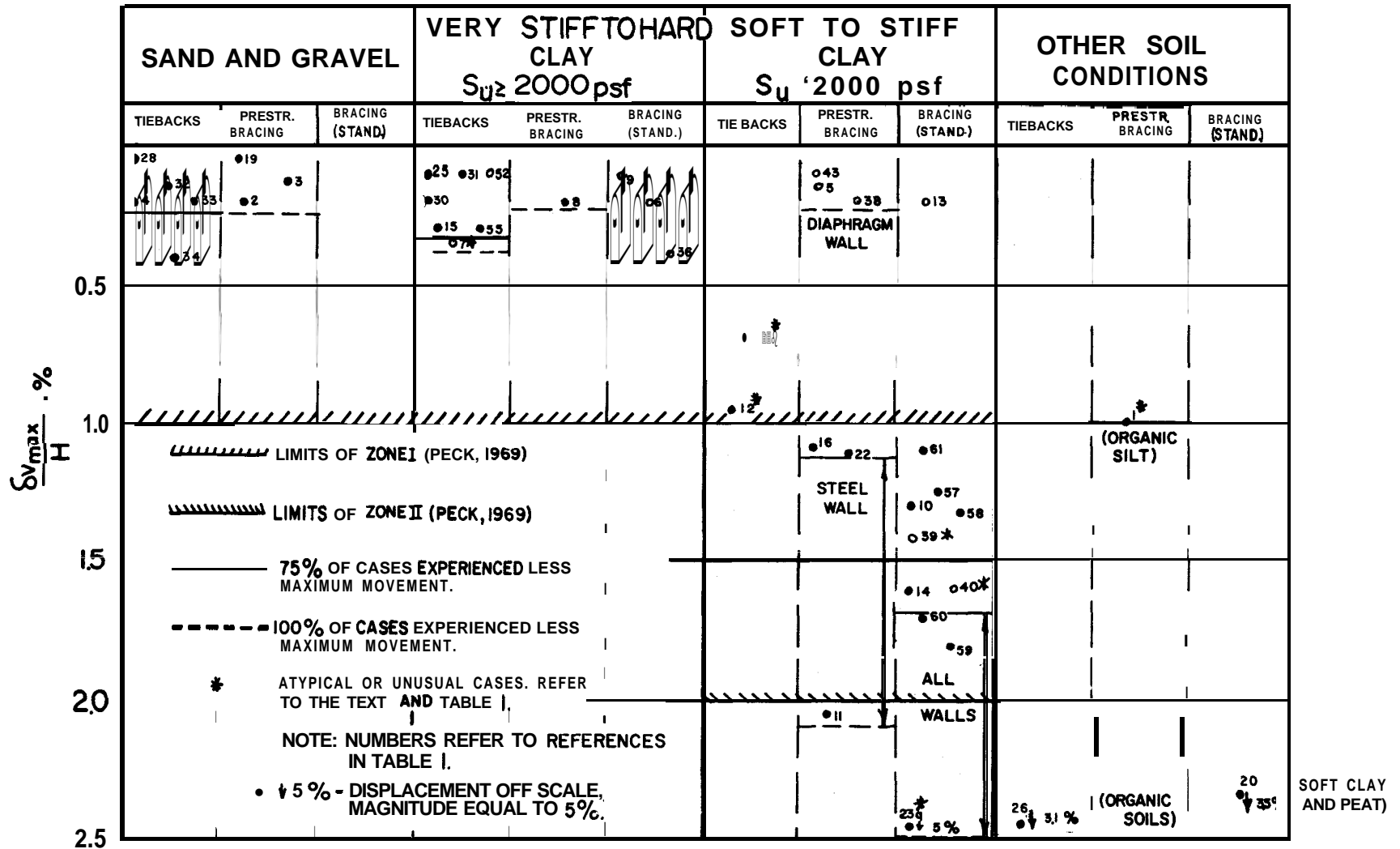

Figure 4. Normalized vertical movements,

⊙ = DIAPHRAGM WALL
● = SOLDIER PILE OR STEEL SHEETING

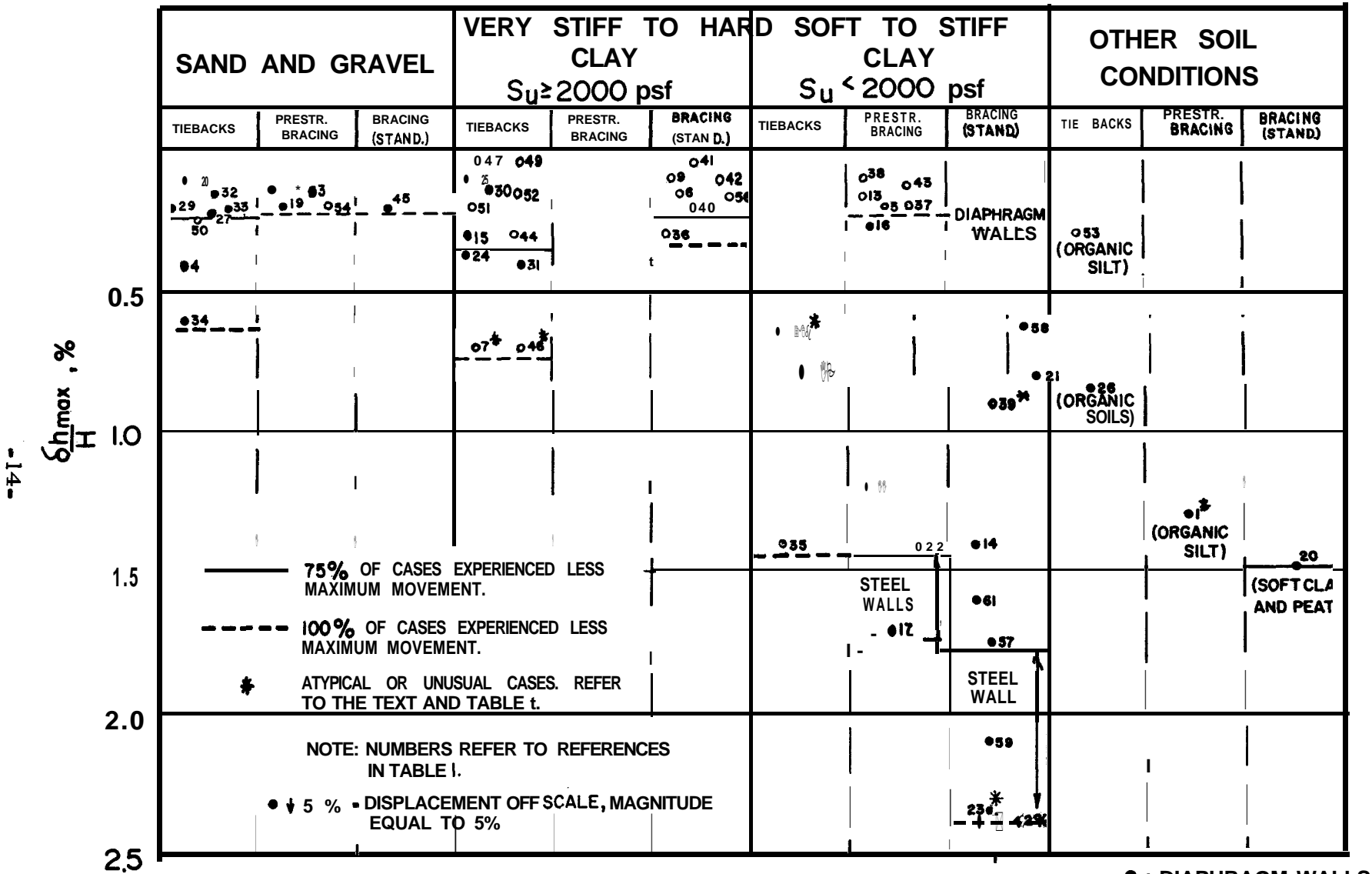

Figure 5. Normalized horizontal movements.

○ = DIAPHRAGM WALLS
 . = SOLDIER PILES OR STEEL SHEETING

Table 1. Summary of references on displacement,

Ref. #	Author(s)	Wall Type	Bracing Type	Soil Type	Depth of Cut	$\delta_{v,max}$	$\delta_{h,max}$	Comments
1	Lambe, Wolfskill, & Wong (1970)	SSP	Struts (Prestressed)	Fill, Organic Silt, till, rock	58' (17.7m)	7" (17.8cm)	9" (22.9cm)	Consolidation settlements significant. Settlements of 3" (7.6cm) up to 70' (21.3m) from excavation.
2	O'Rourke and Cording (1974) (G St. Excavation)	SP	Struts (Prestressed)	Dense Sand and gravel, Stiff clay	60' (18.3m)	1.5" (3.8cm)	9" (2.3cm)	Removal of struts increased settlement from 0.9" (2.3cm) to 1.5" (3.8cm).
3	O'Rourke and Cording (1974) (7th & G Streets)	SP	struts (Prestressed)	Dense Sand and gravel, Stiff clay	82' (25m)	1.5" (3.8cm)	1.25" (3.2cm)	Some time-dependent consolidation settlements.
4	O'Rourke and Cording (1974) and Ware, Mirsky, and Leuniz (1973) (4th & G Streets)	SP	Tiebacks	Dense Sand and gravel, Stiff clay	40' (12.2m)	.7" (1.8cm)	2" (5.1cm)	Street settlements small while soldier piles settled due to down-drag from tiebacks. Soldier piles settled 2" (5.1cm) maximum.
5	Lambe, Wolfskill and Jaworski (1972)	DW	struts (Prestressed)	Fill, hard to medium clay, till	50' (15.2m)	1" (2.5cm)	1.2" (3.0cm)	Minor consolidation settlements. School located 5' (1.5m) from wall.
6	Burland (1974) and St. John (1974) (New Palace Car Park)	DW	Struts (Slabs poured as excavation proceeded)	Gravel and very stiff clay	52' (15.9m)	.6" (1.5cm)	1" (2.5cm)	
7	Burland (1974) and St. John (1974) (Neasden Under-	DW	Tiebacks	Very Stiff clay	26' (7.9m)	1.1" (2.8cm)	2.2" (5.6cm)	Much of the wall movement was pure translation and continued with time. Extremely small vertical settlements except directly behind the wall.
8	O'Rourke and Cording (1974) (11th & G Streets)	SP	struts (Prestressed)	Dense Sand and gravel and stiff clay	--	2%	--	Did not report depth of excavation or amount of settlement.
9	Burland (1974) and St. John (1974) (London YMCA)	DW	Slabs and Tiebacks	Gravel and very stiff clay	52' (15.9m)	.5" (1.3cm)	.6" (1.5cm)	
10	N.G.I. (1962) (Oslo Technical School)	SSP	Struts	Soft to medium clay	19.5' (5.9m)	3" (7.6cm)	--	Consolidation settlements due to lowering of head in underlying sand.
11	N. G. I. (1962) (Waterland #2)	SSP	struts (Prestressed)	Soft to medium clay	36' (11m)	8.9" (22.6cm)	5.1" (13cm)	Nearby <u>underpinned</u> structure settled significantly.
12	McRostie, Burn and Mitchell (1972)	SSP	Tiebacks	Medium to stiff Clay	40' (12.2m)	4.5" (11.4cm)	-4" (-10.2cm)	Excessive tieback prestressing pulled wall away from excavation. Sensitive clay consolidated due to shearing stresses.
13	DiBiagio and Roti (1972)	DW	Floor slabs used to support wall	Medium clay	62' (18.9m)	1.6" (4.1cm)	1-1.2" (2.5-3.0cm)	Structure < 2" (0.6cm) from wall. All settlement appeared to be due to lateral wall deflection.

See Sheer 5 for notes.

Sheet | of 5

Table 1. Summary of references on displacement. (Continued.)

Ref. #	Author(s)	Wall Type	Bracing Type	Soil Type	Depth of Cut	$\sigma_{v\max}$	$\sigma_{h\max}$	Comments
14	N. G. I. (1962) (Grønland #2)	SSP	struts	Soft to medium clay	37' (11.3m)	7" (17.8cm)	6.3" (16.0cm)	Part of excavation performed under water.
15	Shannon and Strazer (1970)	SP	Tiebacks	Very stiff clay and sand	78' (23.8m)	3" (7.6cm)	3" (7.6cm)	Maximum settlement measured at wall. Settlement may be due to downward force exerted by tiebacks.
16	Swatek, Asrow, and Seitz (1972)	SSP	struts (Prestressed)	Soft to stiff clay	70' (21.4m)	9" (22.9cm)	2.3" (5.8cm)	Large settlement attributed to localized heavy truck traffic. Typically settlements < 5" (12.7cm).
17	Rodriquez and Flamand (1969)	SSP	struts (Prestressed)	Soft to medium clay	37' (11.3m)	--	7.9" (20.1cm)	Staged construction to minimize movements. Dewatered to prevent bottom heave.
18	Scott, Wilson and Bauer (1972)	SSP	struts	Dense fine sands	50' (15.3m)	--	8" (20.3cm)	Poor performance attributed to poor construction techniques and dewatering problems. Nearby structures damaged.
19	Chapman, Cording and Schnabel (1972)	SP	Struts and Rakers (Prestressed)	Sand and gravel and stiff clay	45' (13.8m)	.25" (0.64cm)	1" (2.5cm)	Running soil encountered in one section.
20	Boutsma and Horvat (1969)	SSP	struts	Soft clay and soft peat	33' (10.1m)	14" (35.6cm)	6" (15.2cm)	Some settlement due to extensive dewatering for long time period. Affected structures 600' from excavation. Liquefaction of back-fill during extraction.
21	Insley (1972)	SP	Rakers	Soft to medium clay	25' (7.6m)	--	2.5" (6.4cm)	One section tested to failure.
22	Tait and Taylor (1974)	SSP	Struts and Rakers (Prestressed)	Soft to medium clay	45' (13.8m)	6" (15.2cm)	7.5" (19.1cm)	Larger movements attributed to lack of firm bottom for wall. Utility lines damaged; no major damage to adjacent structures.
23a	Hansbo, Hofman, and Mosesson (1973)	SSP	Rakers	Soft clay	23' (7.0m)	13.8" (35.1cm)	11.8" (29.9cm)	Poor sheet pile interlocking. Long time between excavation of center portion and bracing. Disturbance during pile driving for foundation.
23b	Hansbo, Hofman, and Mosesson (1973)	SSP	Tiebacks and Rakers	Soft clay	23' (7.0m)	2" (5.1cm)	2" (5.1cm)	Improved construction techniques.
24	Prasad, Freeman, and Klajnerman (1972)	SP	Tiebacks	Very stiff clay	45' (13.8m)	--	-2" (-5.1cm)	Top of wall moved away from excavation. Maximum movement at top.
25	Mansur and Alizadeh (1970)	SP	Tiebacks	Very stiff to hard clay	45' (13.8m)	.5" (1.3cm)	.5" (1.3cm)	
26	Sandqvist (1972)	SSP	Tiebacks	Sand and silt with organic soils	19.5' (5.9m)	7.9" (20.1cm)	2" (5.1cm)	Settlement in organics due to lowered ground water level. Pile driving also caused settlement.

See Sheet 5 for notes.

Sheet 2 of 5

Table 1. Summary of references on displacement. (Continued.)

Ref. #	Author(s)	Wall Type	Bracing Type	Soil Type	Depth of cut	σ_v max	σ_h max	Comments
27	Sigourney (1971)	SP	Tiebacks	Clayey sand and hard clay	20-26' (6.1-7.9m)	--	.5" (1.3cm)	
28	Goettle, Flaig, Miller, and Schaefer (1974)	SP	Tiebacks	Dense sand and gravel	23' (7.0m)	.25" (0.64cm)	.25" (0.64cm)	Structure with footings only 2' (0.62m) from wall was undamaged.
29	Sigourney (1971)	SP	Tiebacks	Very dense silty sand and gravel	35.43' (10.7-13.2m)	--	.1" (0.25cm)	
30	Clough, Weber, and Lamont (1972)	SP	Tiebacks	Vary stiff clay	64' (19.6m)	1.25" (3.2cm)	1" (2.5cm)	Top of wall moved away from excavation.
31	Nelson (1973)	SP	Tiebacks	Sandy overburden, hard clay shales	90' (27.5m)	1" (2.5cm)	4" (10.2cm)	Cracking in street indicated potential stability failure (σ_h max [15.2cm]) Maljian & Van Beveren (1974).
32	Liu and Dugan (1972)	SP	Tiebacks	Dense sand and gravel, very stiff clay	55' (16.8m)	8" (20cm)	1" (2.5cm)	Tops of soldier piles pulled away from excavation during prestressing.
33	Larson, Willette, Hall, and Gnaedinger (1972)	SP	Tiebacks	Dense sand	50' (15.2m)	1" (2.5cm)	1" (2.5cm)	
34	Dietrich, Chase, and Teul (1971)	SP	Tiebacks	Silty sand	23-54' (7-16.5m)	2.5" (6.3cm)	1.8" (4.6cm)	Lateral movements measured at top of wall.
35	Cunningham and Fernandez (1972)	DW	Tiebacks	Medium clay under dense sand	23' (7.0m)	--	4" (10.2cm)	Tiebacks anchored to deadman.
36	Cole and Burland (1972)	DW	Rakers	Very stiff clay	60' (18.4m)	1.5" (3.8cm)	2.5" (6.3cm)	Most movements occurred while earth berm supported wall. Excavation in heavily overconsolidated clay.
37	Tait and Taylor (1974)	DW	Tiebacks, prestressed struts and rakers	Medium and soft clay	45' (13.8m)	--	9" (2.3cm)	Minor settlements of nearby structures
38	Armento (1973)	DW	struts (Prestressed)	Sand and soft to medium	70' (21.4m)	1.7" (4.3cm)	1" (2.5cm)	Some settlement may have been caused by other excavations in
39	Cunningham and Fernandez (1972)	DW	Struts	Soft and medium clay	32' (9.8m)	5.5" (13.9cm)	3.5" (8.9cm)	Underpinning of nearby footings required after 5.5" (13.9cm) of settlement. 50.70% of movement during caisson construction.
40	Tan (1973)	DW	Basement slab as support	Soft clay	43' (13.2m)	6" (15.2cm)	--	Settlement estimated on basis of substantial damage to structure 40' (12.2m) from excavation.

See Sheet 5 for notes.

Sheet 3 of 5

Table 1. Summary of references on displacement. (Continued.)

Ref. #	Author(s)	Wall Type	Bracing Type	Soil Type	Depth of Cut	σ_v max	σ_h max	Comments
41	Breth and Wanoscheck (1969)	DW	struts	Hard clay and limestone	60' (18.4m)	--	.4" (1.0cm)	
42	Huder (1969)	DW	Basement slabs as support	Slightly plastic silt and clay	65' (19.9m)	--	1.4" (3.6cm)	
43	Thon and Harlan (1971)	DW	struts (Prestressed)	Soft to medium clay	78' (23.8m)	1"	1.2" (3.0cm)	
44	Barla and Mascardi (1974)	SW	Tie backs	Stiff clay	85' (25.9m)	--	2.6" (6.6cm)	Cracking in nearby structures.
45	Heeb, Schurr, Bone, Henke, and Muller	SP	struts	Sand	40' (12.2m)	--	.8" (2.0cm)	
46	Breth and Romberg (1972), Romberg (1973)	SP	Tiebacks	Stiff clay and sand	68' (20.8m)	--	5.9" (14.9cm)	Lateral movement of entire soil block.
47	Schwarz (1972) and Andra, Kunzl, and Rojek (1973)	SW	Tie backs	Clayey marl (stiff clay)	97.5' (29.8m)	.2"	.6" (1.5cm)	Many levels of tiebacks at very close spacing.
48	Corbett, Davies, and Langford (1974)	DW	Rakers	Very stiff clay; upper sand and gravel	--	--	.2" (0.51cm)	Construction delayed after hole opened.
49	Hodgson (1974)	DW	Tiebacks and struts	Fill, gravel very stiff clay	26' (7.9m)	--	.12" (0.3cm)	Special construction procedure used.
50	Corbett and Stroud (1974)	SP	Tiebacks	Fill, sand and marl	51' (15.6m)	--	.8" (2.0cm)	Heave observed 18m from wall.
51	Littlejohn and MacFarlane (1974)	DW	Tiebacks	Gravel and very stiff clay	18' (5.5m)	--	.8" (2.0cm)	
52	Littlejohn and MacFarlane (1974)	DW	Tiebacks	Gravel and very stiff clay	47' (14.4m)	.9"	.9" (2.3cm)	
53	Saxena (1974)	DW	Tiebacks	Organic Silt and sand	55' (16.8m)	--	2.7" (6.9cm)	Tops of some wall sections moved toward sail by same amount.
54	Ware (1974) Personal communication	DW	struts (Prestressed)	Sand and gravel and stiff clay	62' (18.9m)	--	1.25" (3.2cm)	
55	Goldberg-Zoino & Assoc. Files	SP	Tiebacks	Fill, organic sand, stiff clay, till	45' (13.8m)	1.5" (3.8cm)	1" (2.5cm)	Vertical settlements due to lagging installation. Most horizontal movement away from excavation.
56	Burland (1974) and St. John (1974)	DW	Cantilever Wall	Very stiff clay	Small (7% settlements)	--	.5" (1.3cm)	

See Sheet 5 for notes.

Sheet 4 of 5

Table 1. Summary of references on displacement. (Continued.)

Ref. #	Author(s)	Wall Type	Bracing Type	Soil Type	Depth of Cut	$\delta_{v,max}$	$\delta_{h,max}$	Comments
57	N.G.I. (1962) Telecommunications Center	SSP	struts (Prestressed)	Medium and soft clay	26' (7.9m)	3.9" (9.9cm)	5.5" (13.9cm)	Significant movements after strut removal,
58	N.G.I. (1962) Enerhaugen South	SSP	struts (Prestressed)	Medium and soft clay	26' (7.9m)	4.2" (10.7cm)	2" (5.1cm)	Lateral deflections probably more than shown.
59	N.G.I. (1962) Vaterland #1	SSP	struts	Medium and soft clay	36' (11.0m)	7.9" (20.1cm)	9" (22.9cm)	
60	N.G.I. (1962) Grønland #1	SSP	Slabs as support	Medium to soft clay	37' (11.3m)	7.5" (19.0cm)	--	Air pressure and upside down construction used.
61	N.G.I. (1962) Vaterland #3	SSP	struts	Medium and soft clay	30' (9.2m)	3.9" (9.9cm)	5.9" (14.9cm)	
62	Maljian and Van Beveren (1974)	SP	Tiebacks	Stiff to very stiff clay and cohesive sand and silt	110' (33.6m)	3" (7.6cm)	2" (5.1cm)	Maximum vertical settlement atypical for the site-usually lateral movement greater than vertical.
63	Jennings (cases reported by Littlejohn and MacFarland [1974]) South Africa		Tiebacks	Firm	48' (14.7m)	--	3" (7.6cm)	Damage to utilities in street and building across street.
				Fissured	48' (14.7m)	--	1.5" (3.8cm)	Acceptable movements
				Clay	74' (22.6m)	--	1.5" (3.8cm)	
				Very stiff fissured clay	48' (14.7m)	--	.75" (1.9cm)	
				Soft jointed rock	59' (18.0m)	--	1" (2.5cm)	

Sheet 5 of 5

Notes:

1. SSP = Steel sheet piling
 SP = Soldier pile wall
 DW = Diaphragm wall
 SW = Secant wall
2. δ_h and δ_v are maximum horizontal and vertical displacements.
3. Reference # represents references listed by author in Bibliography.

slurry trench walls, voids created from pulling of sheeting, etc. (See Volume III, Construction-Methods, for a more detailed discussion of various construction techniques.)

3. Consolidation of soil -- for example, densification of loose granular soils from vibration, or consolidation of soft cohesive soils from lowering of ground water outside the excavation.

4. Base instability or near instability -- excessive shear strains caused by the imbalance created by removal of load contribute to base heave and/or plastic conditions in soil.

5. Stress relief from excavation -- this reduces vertical stress below the base and relieves the K_0 horizontal stress (earth pressure at rest). In turn, the possible displacement modes are base heave, shear strains, and lateral strains.

The tabulated performance data indicates the following:

1. Sand and Gravel; Very Stiff to Hard Clay

Seventy-five percent of the excavations in this material experienced horizontal movements less than 0.35 percent of the excavation depth. On the average the clays experienced approximately 30 percent greater movement (0.35 percent vs. 0.25 percent of H) than the sands and gravels. Generally, the performance is not significantly affected by support method or by wall type. Sheet piling, however, is uncommon to these soil types due to difficulty in installation. One probable reason for little apparent difference between wall type and support method is the fact that the measured displacements are small (typically less than 0.10 feet for a 50-foot excavation). Many construction factors can contribute to displacements of similar magnitude and therefore would mask the variation in displacement caused by wall support type.

Two anomalous cases (no. 7 and no. 46, Table 1) reveal a potential source of extraordinary lateral movement of a tied-back wall retaining a predominately very stiff or hard clay (see previous discussion in Section 2.23 on tied-back walls). The mechanism causing this movement still is not clearly defined. However, the practical implications are to approach similar cases with caution. Ward (1972) cites horizontal strains as two to three times as large as vertical strains in overconsolidated London clay.

2. Soft to Stiff Clay

Wide variations for both horizontal and vertical displacements are evident. Sixty-five percent of the cases experienced horizontal displacements which exceed 1 percent for steel sheet pile or soldier pile walls, whether prestressed or not. The data suggest prestressing of these walls makes only minor difference.

The largest benefit is derived from concrete diaphragm walls with prestressed bracing. Indeed, both horizontal and vertical displacements are no different from those typical for sands and very stiff to hard clay, being about 0.25 percent or less.

A unique case is included in Table 1. In this case the wall was tied-back in a stratum stronger than the clay. The case reports on the performance of tiebacks (McRostie, et al - no. 12) anchored in underlying bedrock. The soil was a sensitive clay which experienced significant consolidation settlements due to excessive prestressing (McRostie, et al, 1972).

Another major cause of settlements in cohesive soils is due to lowering of the ground water table. These settlements can often be quite severe (Lambe, Wolfskill, and Wong, 1970; Boutsma and Horvat, 1969; NGI, 1962; Sandqvist, 1972).

2.32 Effect of Wall Stiffness on Lateral Displacements in Clay

Wall stiffness refers not only to the structural elements comprising the wall but includes the vertical spacing between the support members. The measure of wall stiffness is defined as the inverse of Rowe's flexibility number for walls $\frac{EI}{L^4}$

where:

E = modulus of elasticity of wall

I = moment of inertia. per foot of wall

L = vertical distance between support levels or between support level and excavation base

Concrete walls generally have a much higher EI value than soldier pile or sheet pile walls, and with comparable wale **spacing, are** much stiffer. On the other hand, soldier piles or sheet pile walls with closely spaced support levels may be stiffer than concrete walls with widely spaced support **levels** .

Figures 4 and 5 indicate that diaphragm walls reduce the magnitude of the movements in soft to stiff clay significantly below the magnitude of the movements for the more flexible sheet pile or soldier pile walls. In an attempt to further refine the effect of wall stiffness on displacements in cohesive soils, a plot of observed displacements versus corresponding stability number

($N = \frac{\gamma H^*}{S_u}$) and stiffness factor ($\frac{EI}{LA}$) is **developed** on Figure 6. The **stability** number, which **considers** both overburden stress (γH) and the undrained shear strength (S_u), is a **measure** of the relative strength or deformability of the soil.

1. The maximum lateral displacement rather than the vertical has been plotted, since consolidation settlements would introduce a secondary variable.

2. 'The maximum value of N was calculated on the basis of the available strength data.' H was taken as the depth of excavation to the lower Limit of an intermediate clay stratum where it intersected the **wall**,

3. The wall-support stiffness was based on the span distance, L, occurring where the "stability number, N, is a maximum. If N was a maximum at an intermediate excavation depth, L was calculated as the wale spacing plus 2 feet (for overcut). If N was a maximum at the excavation base, the span L was calculated from the lowest strut to the excavation base.

The data plotted in Figure 6 demonstrate what is intuitively obvious -- namely, deformations are functions of soil strength and wall stiffness. The contour lines of maximum lateral wall movement show this trend clearly. These data allow one to qualitatively

*Ratio of overburden stress to undrained shear strength.

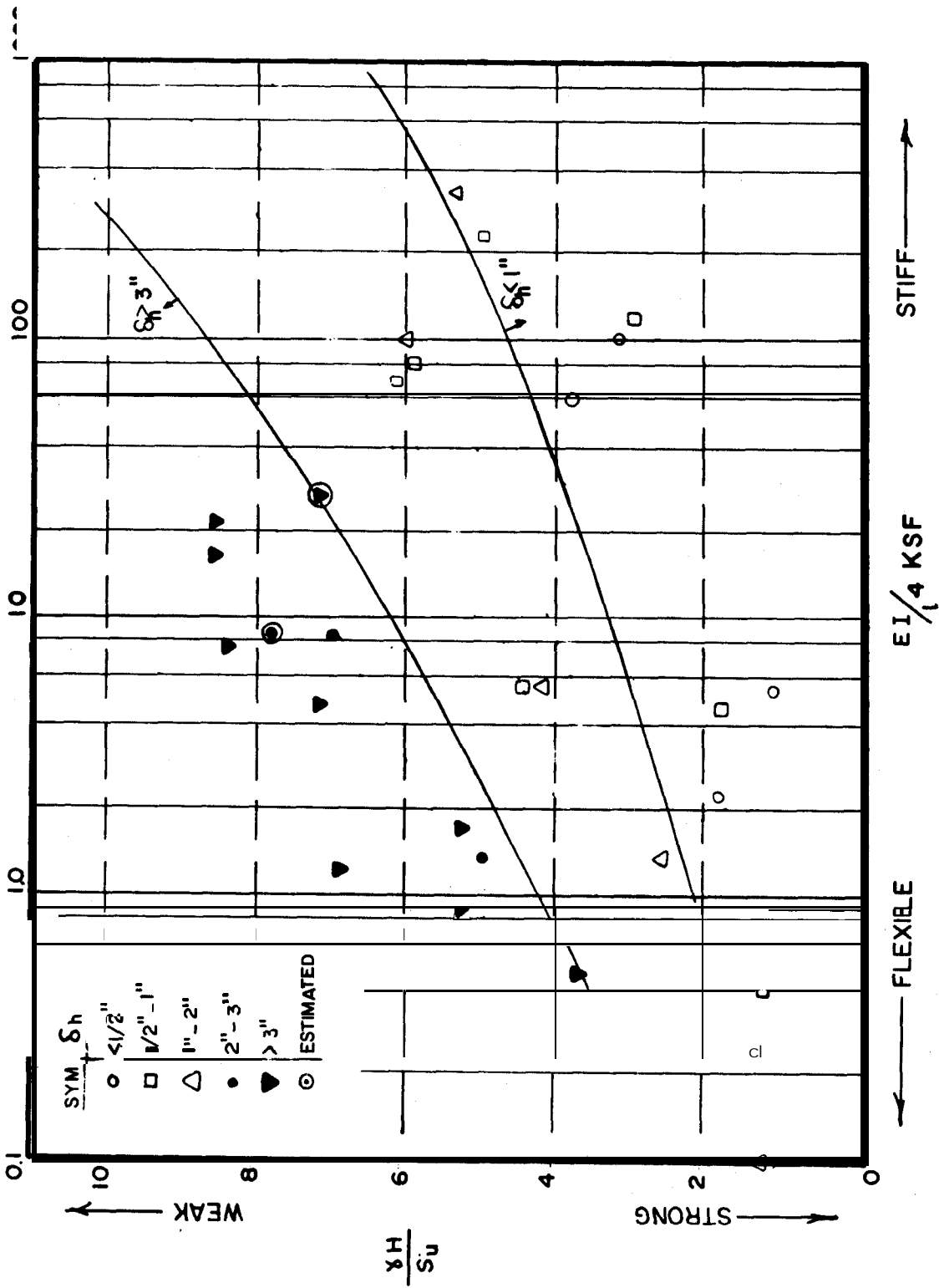

Figure 6. Effect of wall stiffness and soil strength on lateral wall deflection.

examine the relative change in anticipated lateral displacement for a given change in wall stiffness and/or stability number of the soil.

As an **example**, consider a soil with stability number of 6. Assume we are evaluating PZ-38 sheeting versus a 30-inch thick concrete diaphragm wall, both with **8-foot** spans between wale **levels**. For an intermediate construction condition 2 feet is added to the span distance for overexcavation yielding a length, **L=10** feet.

The stiffness factor of the steel sheeting (PZ-38) is:

$$\frac{EI}{L^4} = \frac{(30 \times 10^6) (281)}{(120)^4} = 40.7 \text{ psi} = 5.86 \text{ ksf}$$

Correspondingly, the stiffness factor of a 30-inch concrete wall is:

$$\frac{EI}{L^4} = \frac{(3 \times 10^6) \times 1/12 (12 \times 303)}{(120)^4} = 391 \text{ psi} = 56.3 \text{ ksf}$$

The data in the figure show that the expected maximum lateral displacement for the PZ-38 is **approximately** 3 inches, whereas that for the stiffer diaphragm wall is approximately 1.5 inches.

2.33 Wall Movement Versus Settlement

2.33.1 Comparison for all Cases

Figure 7 compares observed maximum horizontal and vertical displacements for all types of soils, support systems, and wall types. The absolute magnitude is shown in panel (a) and the frequency distribution of the ratio of the movements in panel (b). The figure shows that practically all the vertical displacements fall within a range of 1/2 to 1-1/2 times the horizontal displacements, with most of them lying in the range of 2/3 to 1-1/3 times the horizontal movement.

2.33.2 Soft to Medium Clay

Figure 8 compares displacements for soft to medium clays. The average curve shows that the vertical displacements are generally well in excess of the horizontal displacements and that the disparity increases with the magnitude of the displacements.

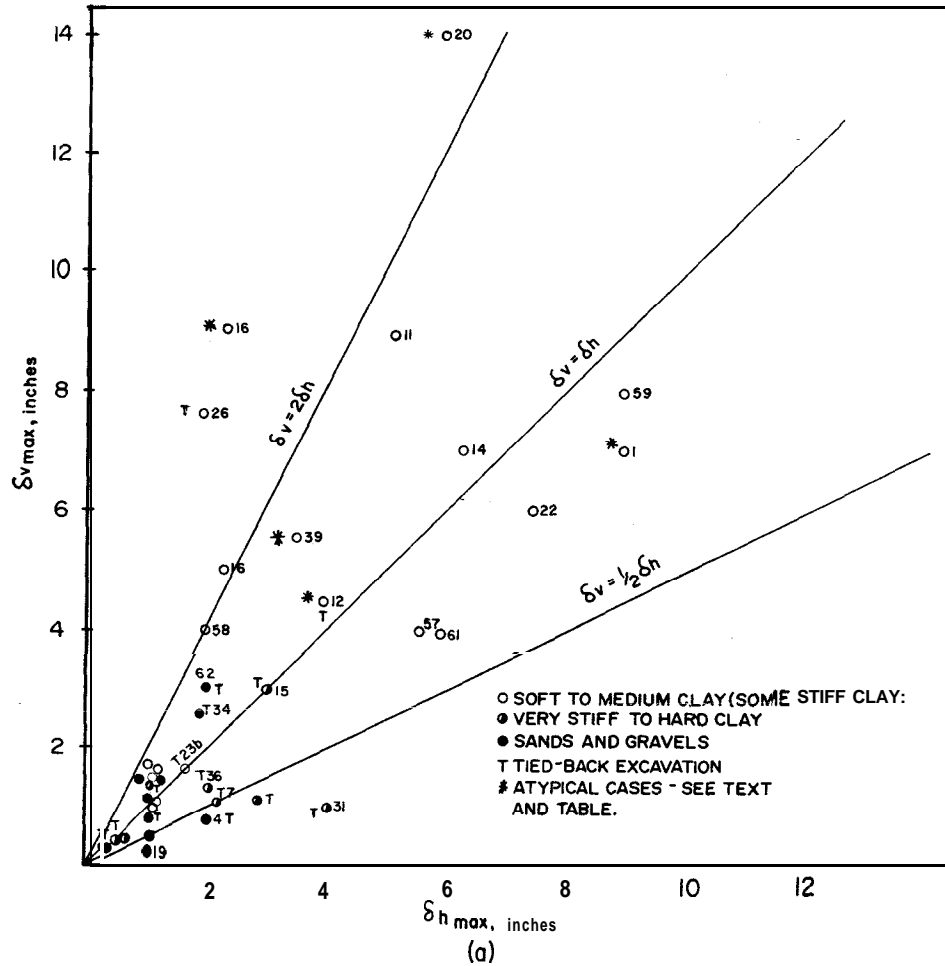

MAXIMUM VERTICAL AND HORIZONTAL DEFORMATIONS

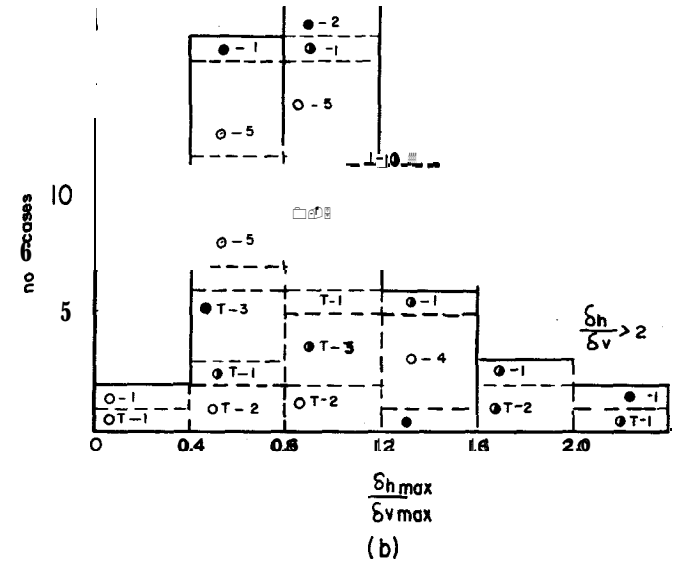

FREQUENCY DISTRIBUTION OF RATIO OF MOVEMENTS

NOTE: NUMBERS REFER TO CASE STUDIES LISTED IN TABLE I.

Figure 7. Comparison of maximum vertical and horizontal displacements.

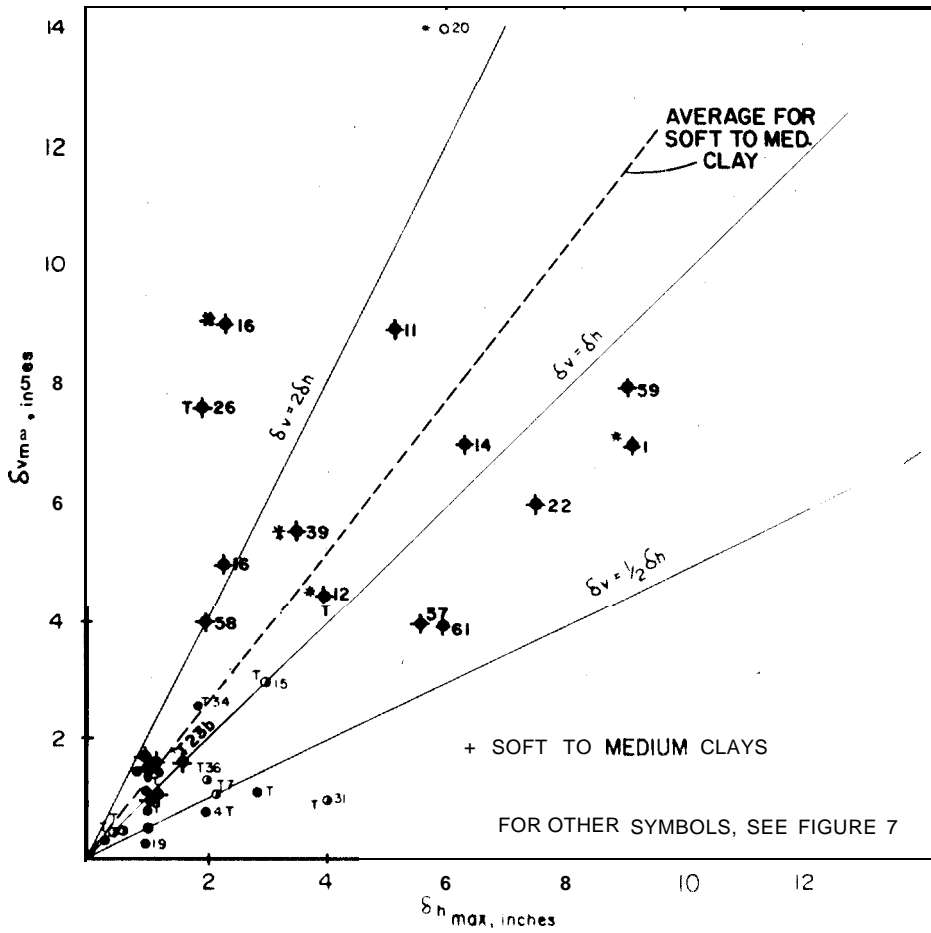

NOTE: NUMBERS REFER TO CASE STUDIES LISTED IN TABLE I.

Figure 8. Comparison of vertical and horizontal displacements for soft to medium clays,

This difference is believed to be directly attributable to consolidation settlements which are usually the result of changes in water levels adjacent to the excavation. This situation becomes more acute where deep deposits of soft clay underlie the excavation.

2.33.3 Very Stiff to Hard Clays

Figure 9 compares the displacements of these As mentioned in a previous discussion (Section 2.31), comparatively large lateral displacements have been reported in **several** tie-back projects. Notable among these are cases no. 7 (**Burland** and St. John), no. 31 (Nelson), and no. 46 (Breth and Romberg),

2.40 PARAMETRIC STUDIES

Finite element studies are useful in providing qualitative information on the behavior of cofferdams. Several studies of this type have been undertaken for evaluating the primary parameters affecting bracing loads and deformations (Wong, 1971; Palmer and Kenney, 1972; Jaworski, 1973; Clough and Tsui, 1974).

The results of a finite element study for evaluating the effect of wall stiffness on reducing deformations in various soil conditions is shown in Figure 10. Also shown for comparison are the lines defining deformation limits from Figure 6.

The finite element computer program used to develop these data considered only cohesive soils and internally braced excavations. A brief description of the program, its capabilities, and the soil properties used in the analysis is appended to this section.

Briefly, the conditions assumed in developing Figure 10 are:

1. The excavation was 60 feet deep, with a wall penetration of 30 feet. The wall was supported by five strut levels with approximately a 10 foot vertical span between each level.
2. Three wall stiffnesses were analyzed. The $\frac{EI}{L^4}$ ratios were 1.00, 5.8, and 230.

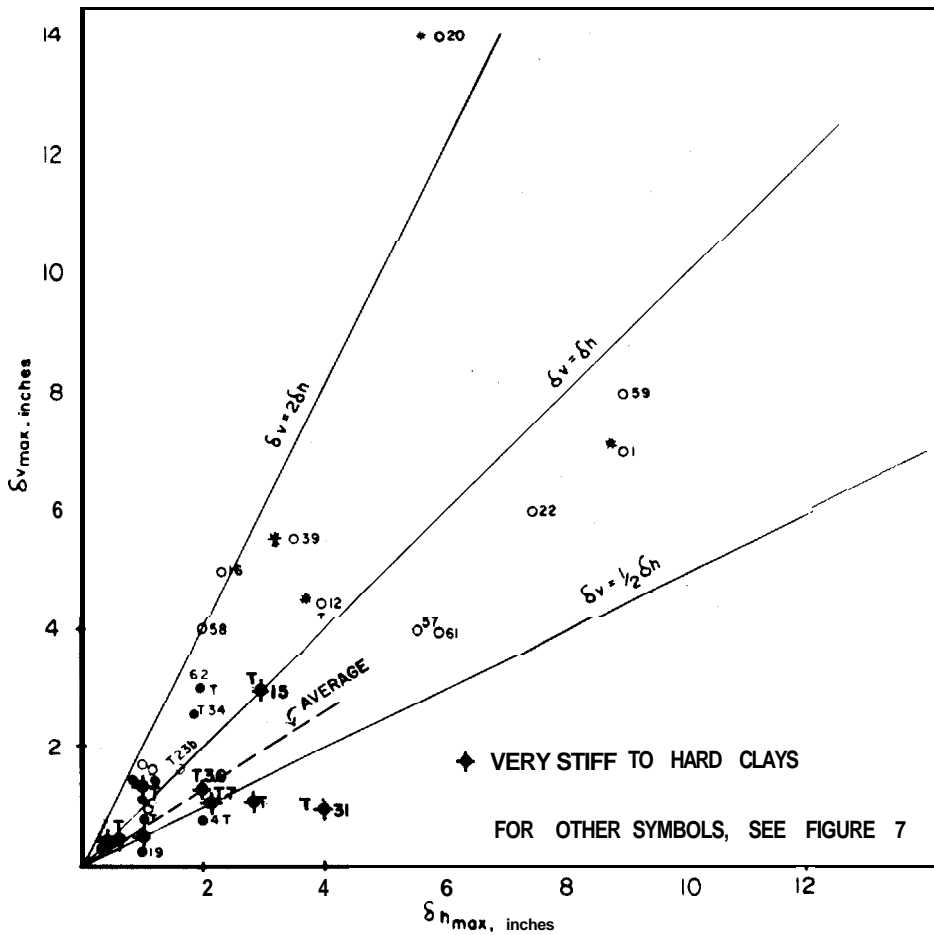

NOTE: NUMBERS REFER TO CASE STUDIES LISTED IN TABLE I.

Figure 9. Comparison of vertical and horizontal displacements for very stiff to hard clays.

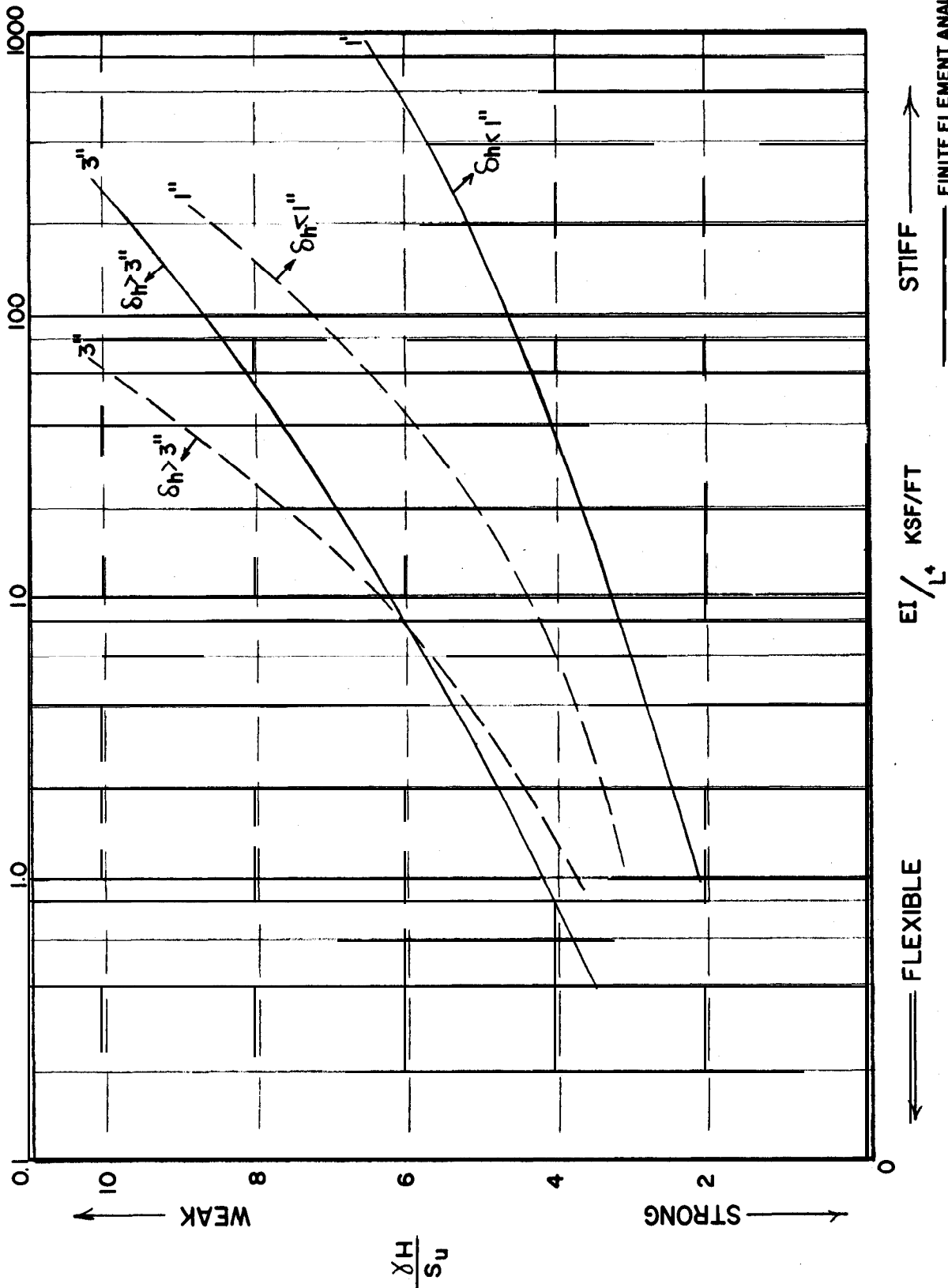

Figure 10. Comparison of lateral movements from finite element analysis and observed movements.

3. A uniform soil profile was assumed in which the shear strengths were varied to obtain different stability numbers (N). The value of N used to develop this plot was based on the shear strength of the soil at the base of the 60 foot deep excavation,
4. The finite element analysis models ideal conditions. It does not account for variations in construction procedure (such as overexcavation for a strut level) or anticipated construction events which are reflected in Figure 6.

Figure 10 shows the predicted lateral displacements are less than the **observed** values for a given condition. This difference is related to the inherent movements which are a function of the construction process. Nonetheless, the theoretical results show a trend similar to that described by the field observations; that is, the stiffer walls result in lower movements for a given soil condition.

The results of the finite **element** analyses should not be taken in the quantitative sense. The intent is that such analysis should be used as a guide in the design and in the consideration of various options for a bracing system.

2. 50 DISTRIBUTION OF DEFORMATIONS

In addition to knowing what the maximum lateral and vertical displacements will be for a cut, it is also important to know the influence zone of these deformations adjacent to an excavation. Primarily, this is related to the distortion the deformations may impart to a structure, for if it is anticipated that differential displacements will result in structural distress, then alternate procedures should be considered.

Currently many engineers rely on judgement and experience in predicting **deformation** patterns adjacent to sheeted excavations. It is the intent of this section to provide some information to aid the engineer in evaluating what deformation patterns might be expected adjacent to a cofferdam.

2. 51 Vertical Deformations

Peck (1969) suggested envelopes for the zone of influence of settlements behind an excavation based on field measurements. The envelope showed that significant vertical movements may occur up to a

distance of twice the excavation height from the excavation face depending on workmanship and soil profile. **A refinement of this plot** was undertaken to provide more information on settlement patterns adjacent to cofferdams. This was accomplished through a series of normalized plots of vertical deformations versus distance from the excavation face for three general soil classifications.

Figure 11 illustrates how the observed maximum settlement patterns behind a wall varied with the soil conditions. The pattern of movements indicates that maximum movements occur immediately adjacent to the excavation. Also, one might expect significant movements a distance from the cut equal to twice the depth of the cut. At present, there are insufficient data to define any significant difference in settlement pattern based on soil type or support wall.

Comparing the settlement patterns of sand versus cohesive soil, the sands show essentially no settlement beyond twice the depth of the excavation whereas the cohesive soils do. This is most likely caused by the consolidation in the more compressible soils from lowering of the ground water table. A factor to consider when viewing these results is that when settlements are small consolidation can be a large percentage of the total settlement; hence, in dimensionless plots the total settlement may appear to extend over a greater zone than is attributable to lateral movement or shear strain alone. This is evident in the data presented by **Lambe, Wolfskill, and Jaworski (1972)**. The measured settlements due to drops in ground water table appear significant even though the settlements were small (less than 1 inch). On the other hand, when the maximum settlements are large (NGI, 1962 Oslo Technical School), consolidation settlements do not appear as significant. The data is further influenced by variations in the surface elevation caused by ground water fluctuations, **freeze-thaw** cycles, and other factors which will also be a greater percentage of the maximum observed movement in those cases where $\sigma'_{v \max}$ is small.

Reviewing Figure 11, it appears that both soft clays and the granular soils experience a significant angular distortion outside a distance equal to the excavation depth ($D/H = 1$). The average lines of settlement ratio versus normalized distance, shown as dashed lines on the figure, may be used as a basis of comparison of this distortion. On the other hand, the stiffer **clays ($S_u > 2000$ psf)** seem to experience more gentle distortion slope, even though the zone of influence

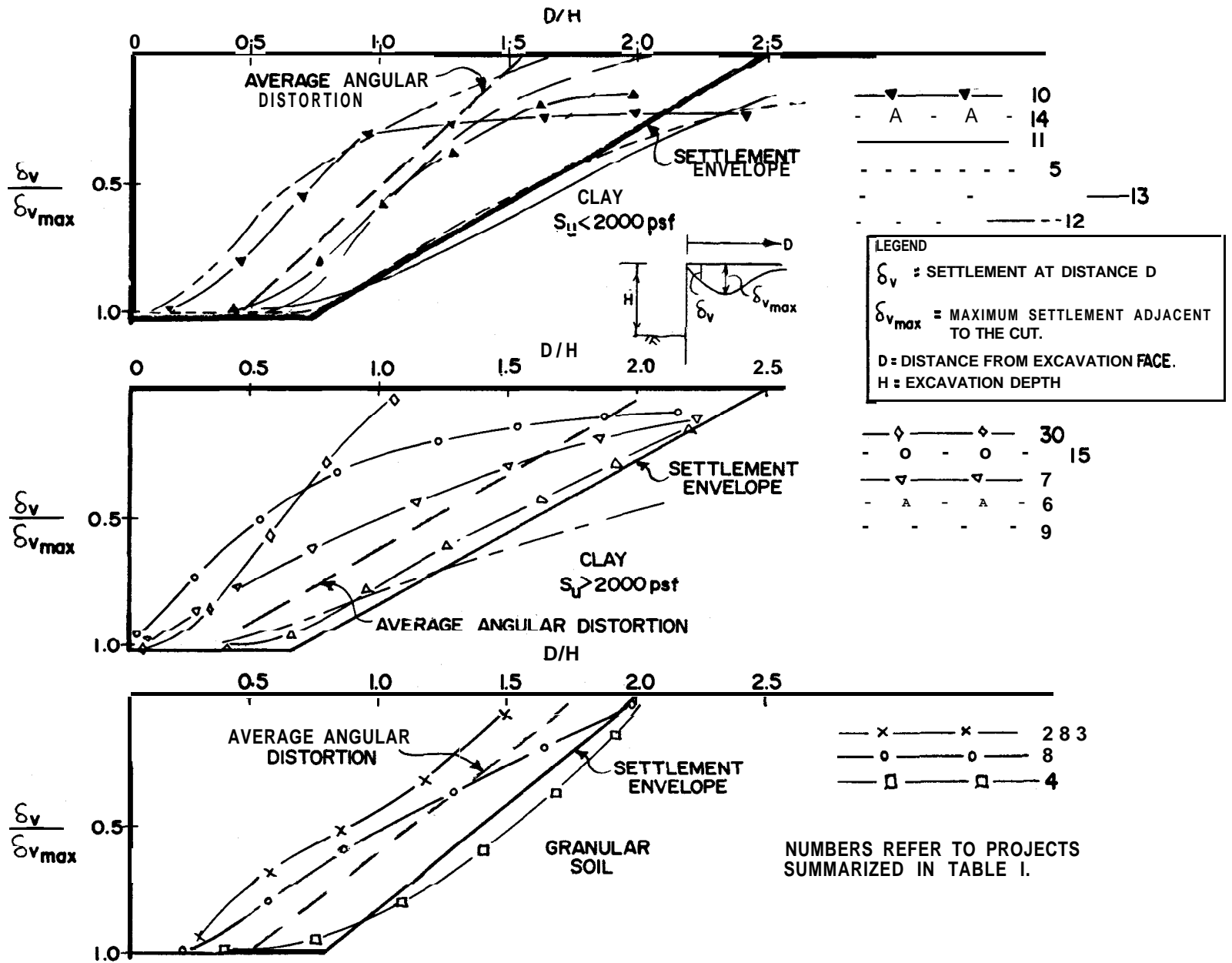

Figure 11. Normalized settlements adjacent to a wall.

extends farther back from the excavation face. Of course these figures do not show the absolute value of angular distortion. This is determined by estimating $\delta_{v \max}$ from Figure 4, based on excavation depth and method of wall support. Then the angular distortion is related to the differential settlement by:

$$\alpha = \alpha_n \times \delta_{v \max}$$

where:

α = differential settlement over distance D

α_n = normalized differential settlement from Figure 11

$\delta_{v \max}$ = maximum settlement from Figure 4.

2. 52 Parametric Study on Zone of Influence

Finite element studies were performed on several of the deformation modes shown in Figure 1. The analyses were aimed at obtaining some qualitative information on the settlement profile one might expect adjacent to the excavation. The analytical approach used was to **apply** incrementally a specified mode of horizontal wall displacement to a soil profile and, using the finite element program BRACE II, determine the induced settlement profile. The results of this analysis portray only those constant volume settlements associated with the wall displacement and ignore settlements associated with consolidation of the soil.

Figures 12 through 14 show the wall deformations assumed and the corresponding settlement **profiles** predicted by the finite element program. The results are reported in dimensionless form. The basic patterns of deformation used were: tilting about the base, rotation about the top, symmetrical bulging, a combination of bulging with tilting, rotation and lateral translations.

The patterns, although ideal, typify the more common modes of deformations experienced in braced and tied-back walls. In those cases where bulging of the wall was used to represent the **flexural** deformation of the wall, the bulging was assumed to be **symmetrical** around a depth equal to two-thirds of the excavation depth.

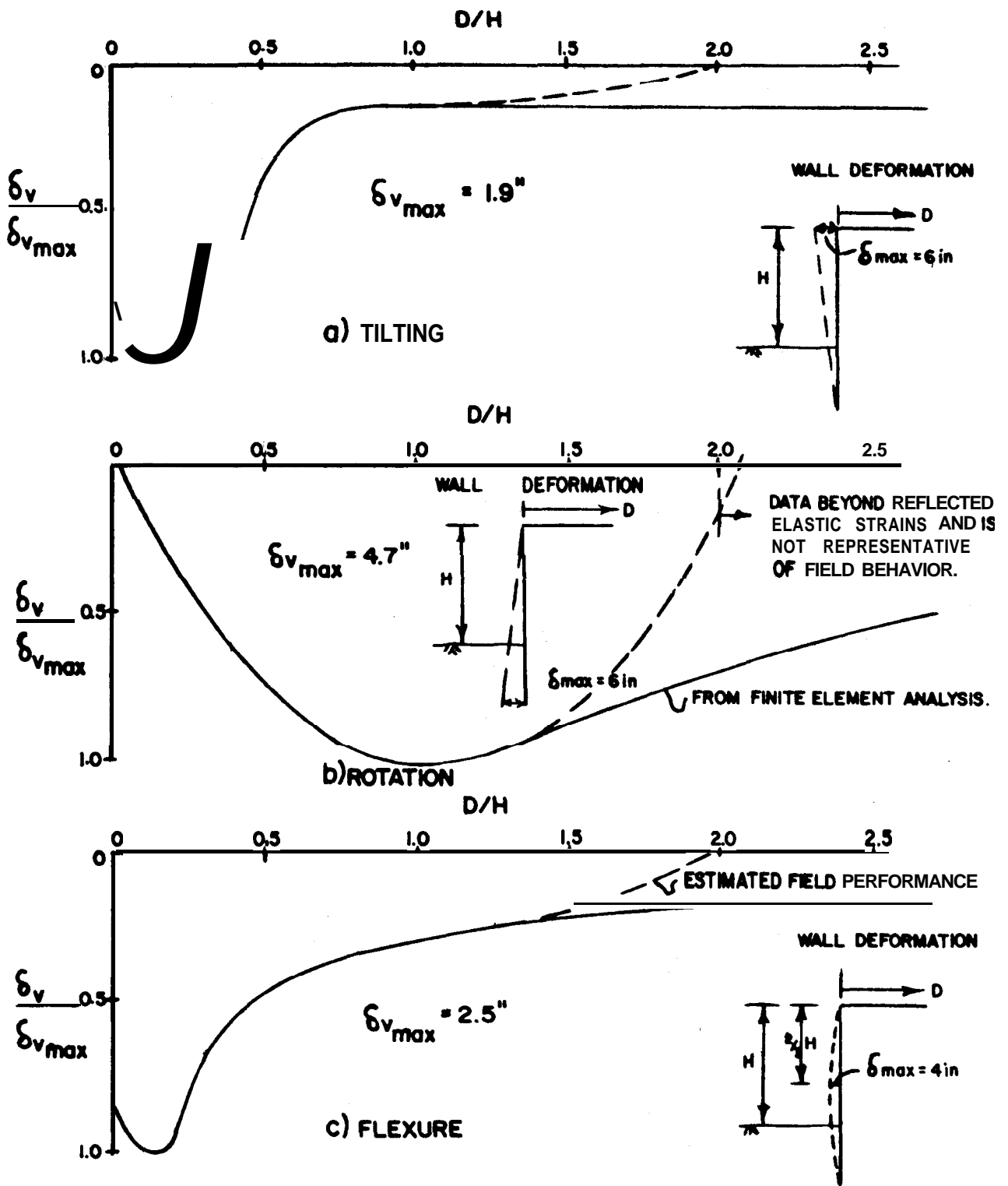

Figure 12. Finite element prediction of surface settlement profiles for normally consolidated clays,

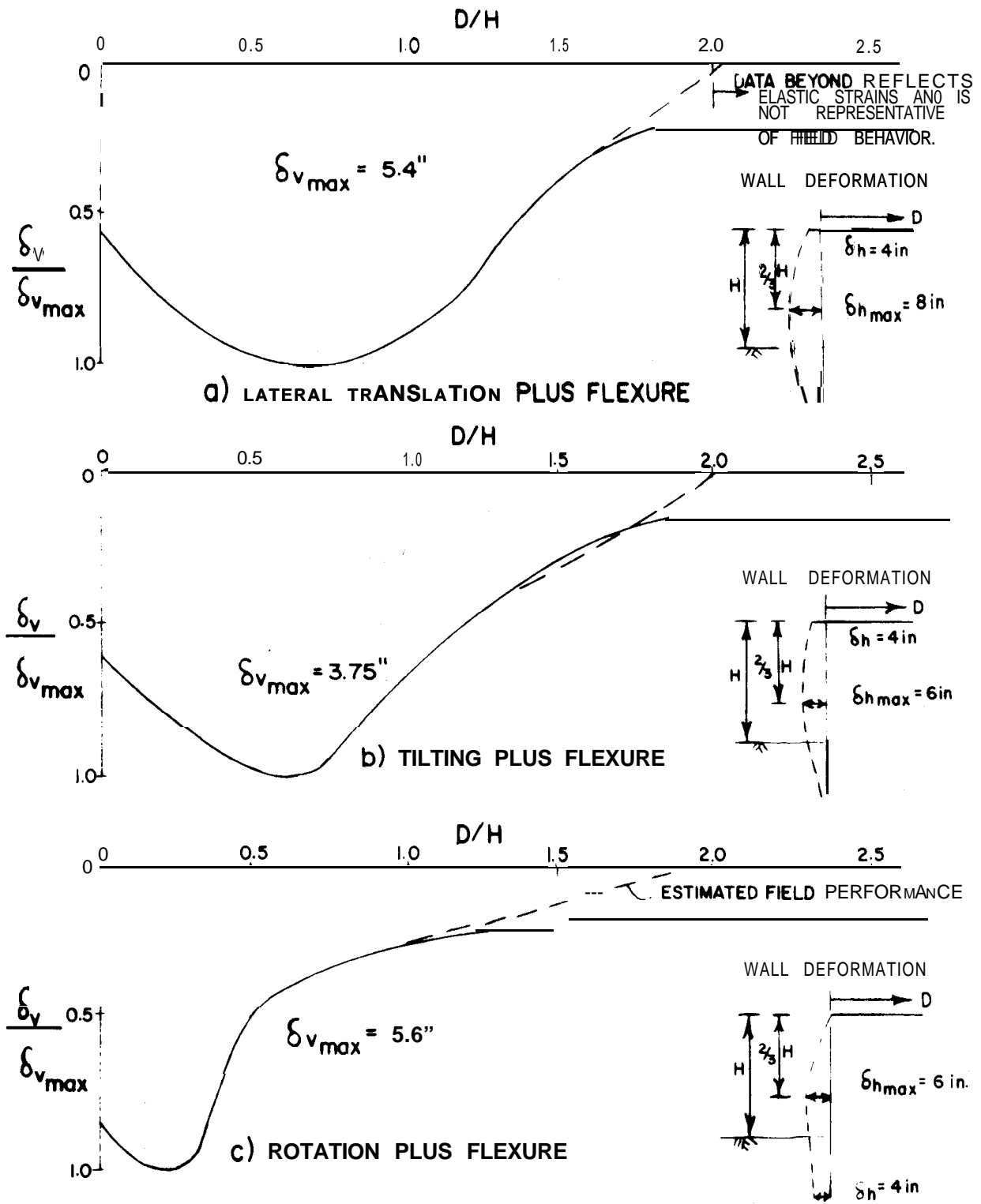

Figure 13. Finite element prediction of surface settlement profiles for normally consolidated clays,

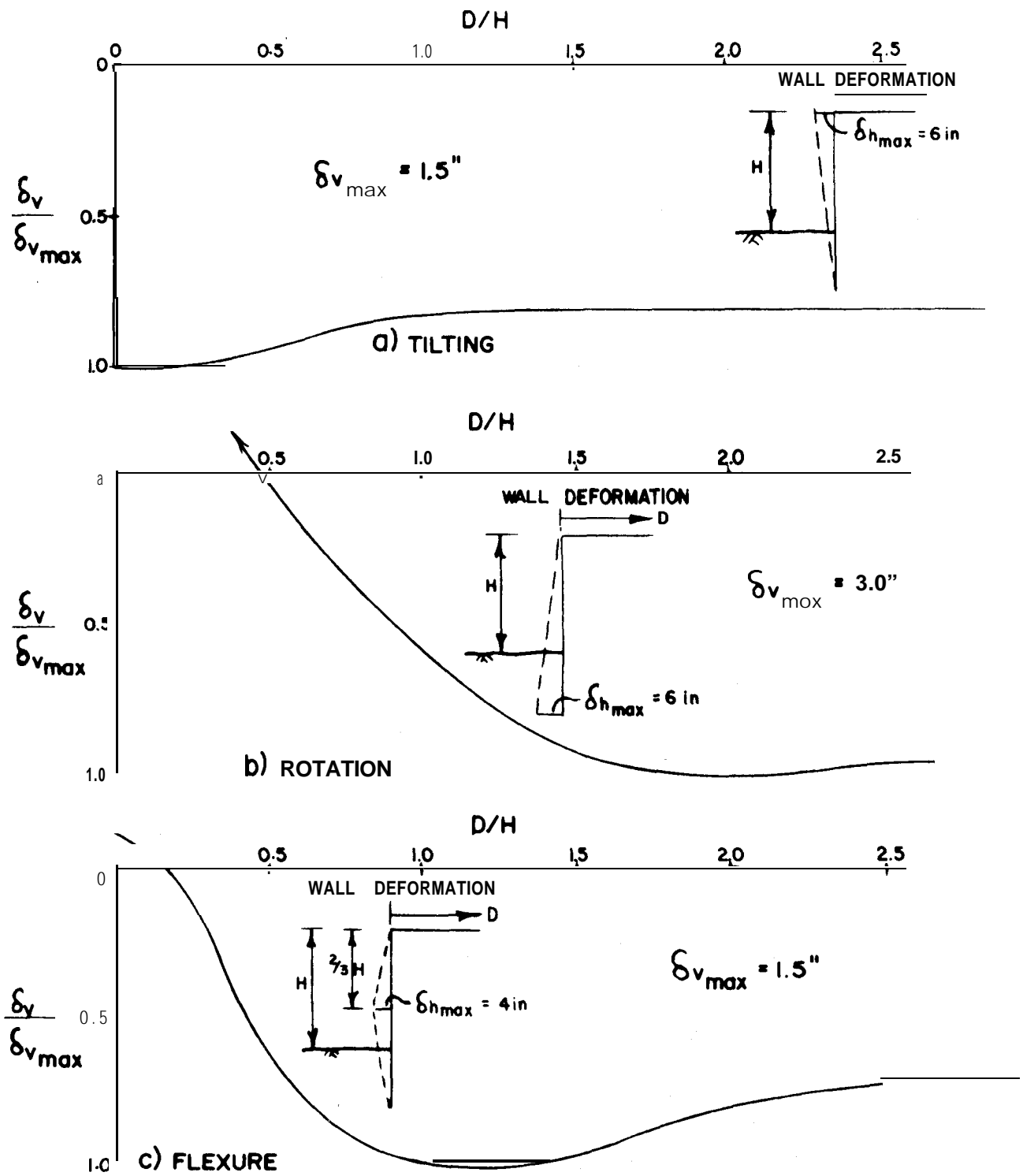

Figure 14. Finite element prediction of surface settlement profiles in elastic medium,

Two soil conditions were analyzed:

- (a) Normally consolidated clay with both the soil strength and soil modulus increasing with depth as a function of the effective overburden stress.
- (b) **Elastic** medium where the soil was assigned a constant modulus with depth. The elastic cases were analyzed primarily to provide background information to evaluate the extent to which the elastic strains influence the results from the yielding soil profiles of normally consolidated clay.

In addition, the elastic cases provide some insight into the settlement patterns for cohesive soil profiles where the stability number is less than 4. The parameters for the cases studied are summarized in Table 3 in the appendix to this section,

Figure 12 illustrates settlement profiles for ideal tilting, rotation, and bulging. The first two conditions may be considered representative of rigid wall behavior, whereas the bulging cases represent deformations associated with a flexible **wall**.

The results indicate that for tilting and flexure the settlements are concentrated within a distance **one-half the excavation depth**. Settlements beyond this distance are elastic and probably not representative of actual field conditions. For both cases, the severe angular distortion occurs within this zone as expressed by the slope of the settlement profile. On the other **hand, when rotation is the predominant mode of deformation**, significant deformations may occur at distances up to 1.5 the excavation depth from the excavation face. This should be expected since the maximum lateral deformation is deep. The **over-stressed** zone of soil is also deep, hence leading to a greater zone of **influence**. However, the settlement profile for this latter case suggests a less severe angular distortion along the ground surface.

Figure 13 shows the settlement profiles for wall deformations which are a combination of rigid wall displacement plus **flexural deformations (example, tilting plus flexure shown in Figure 13b)**. The results show the zone of influence is greatly affected by the nature and volume encompassed by the horizontal wall movement. This behavior agrees with the measured field performance of braced excavations (Flaate 1966). The data also indicate that as the zone of influence

increases from the excavation face, the settlement profile will have a gentler slope. Hence, even though the area affected increases, the actual danger to a structure may not be as severe since the angular distortion is less.

Figure 14 shows the settlement pattern which results when the soil is assumed to behave elastically. For all three wall deformations the vertical displacements become essentially horizontal beyond the distance twice the excavation depth. Comparing Figures 12 and 13, the same trend of constant displacement occurs on the latter two figures beyond this same distance, thus suggesting these **deformations** are related to elastic strains. The elastic strains are transmitted to this outer zone by tensile stresses which are not capable of developing in soils. This idiosyncrasy of finite element analyses leads to behavioral trends which are not in keeping with field observations. Consequently, the settlements shown on Figures 12 and 13 beyond a distance of twice the excavation depth should be discounted as not representative of field **conditions**.

A comparison of Figure 13 with the field measurements summarized on Figure 11 shows some interesting trends. First, the finite element predictions give zones of influence and distribution of settlements similar to those recorded in the field. **Considering** the deformations beyond a distance $2.0 D/H$ from the excavation as primarily elastic in origin, the finite element analysis gave a zone of influence which ranged between $0.5H$ and $2.0H$ from the excavation face. Correspondingly, the field measurements show a greater zone since their results do contain some consolidation settlements not accounted for in a finite element analysis. Nonetheless, it appears that the finite element programs can be used to give qualitative information on settlement profiles.

The effect wall movement has on the zone of influence is another significant trend. Figure 12 and Figure 13 both show the importance of minimizing movement below the excavation base which is often associated with base instability or local overstressing adjacent to the wall. (Chapter 8 discusses both types of instability in detail). For **all** cases it appears that the deeper the maximum movement is seated, the greater the zone of influence will extend from the excavation face.

2.60 LATERAL DEFORMATIONS IN ADJACENT SOIL MASS

Lateral movements of a structure have been observed to be more damaging than vertical movements. Therefore, one should attempt to evaluate the extent of lateral movement which may occur as the result of constructing a temporary retaining structure. These movements are most prevalent in heavily overconsolidated clays which have large residual horizontal stresses which are released as a result of the excavation.

Intuitively, one would think that the lateral movements would be a maximum at the face of the wall and decrease with distance from the wall. Also, the deflected wall shape would have some bearing on the distribution of lateral displacements in the soil mass. Unfortunately, very few measurements are available showing the distribution of lateral deflection behind a wall.

A few normalized contour plots of horizontal deformation are presented in Figures 15 and 16. The measurements were made in heavily overconsolidated clays where tied-back walls were used to support the excavation. The observations show that the lateral movements were time dependent. In another similar case, (Burland, 1974 and St. John, 1974) where only the Lateral movements at the surface were monitored, the measured horizontal movements were 20 per cent of the **maximum** movement of 0.5 inches at a distance $1.5H$ from the excavation.

The aforementioned field data suggest two trends. First, the pattern of the lateral movement follows closely with the deflected shape of the sheeting. Second, the lateral movements can extend a substantial distance from the excavation face as illustrated by the data from **Burland** (1974) and St. John (1974).

Another factor to consider with respect to tied-back walls in heavily overconsolidated clays is that the entire soil mass embodied within the tiebacks may move laterally (Burland, 1974; St. John, 1974; Breth and Romberg, 1972; and Romberg, 1973). Hence, in these types of soils the tied-back excavation may not be as successful in limiting wall movements as they would be in other soil types.

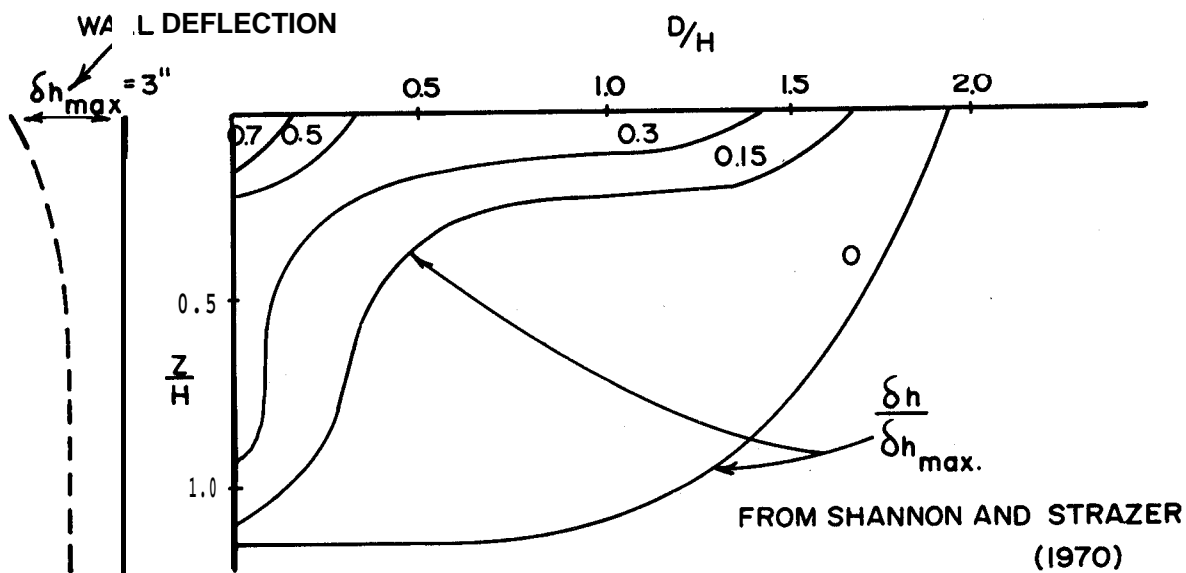

D/H — NORMALIZED DISTANCE FROM CUT.

Z/H — NORMALIZED DEPTH OF CUT.

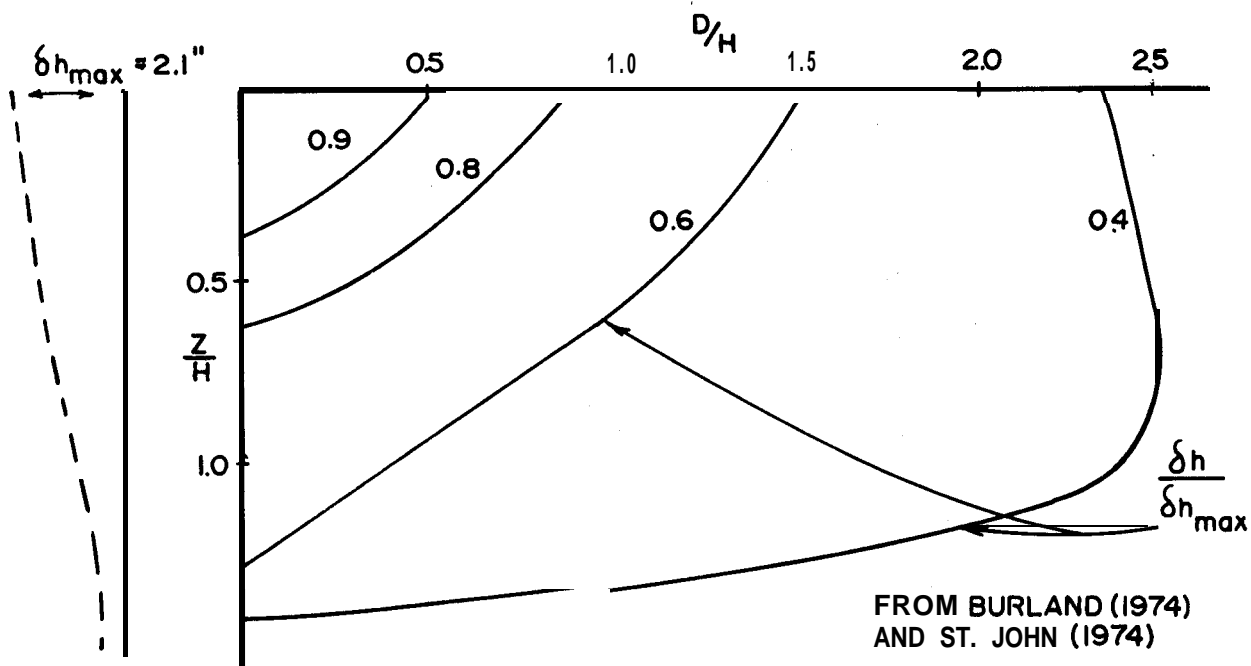

Figure 15. Normalized lateral movement for tied-back excavation in heavily overconsolidated clays.

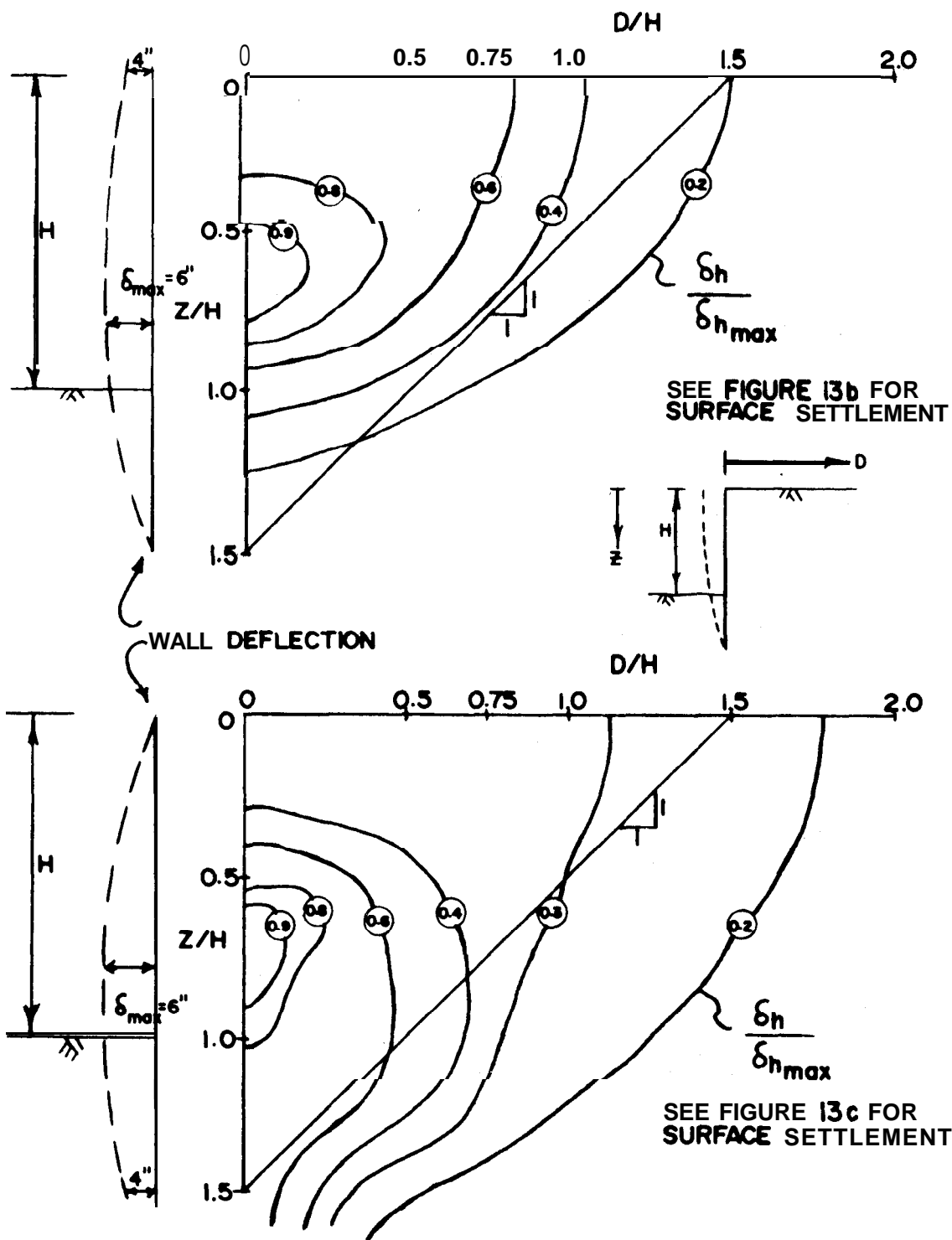

Figure 16. Normalized Lateral movements from finite element analysis for normally consolidated clays.

There are **little** data available regarding the distribution of horizontal displacements for excavations in a normally consolidated clay for comparison with the observed data for the heavily **over-**consolidated clays. Therefore, the results of the finite element studies used to develop Figure 13 were reduced to provide some insight as to the distribution which might be expected for ideal conditions. These results are shown in Figure 16. In contrast to the data from **Burland** (1974) and St. John (1974) for heavily over consolidated clays, the finite element analysis indicates that in this normally consolidated soil the **zone** of significant movement is confined to an area described by a 1 on 1 slope from the base of the sheeting. As expected, it is within the theoretical yield zone. The movements are largely controlled by the sheeting displacement. The zone of significant movements increases with depth in the same pattern as the sheeting movements.

2.70 EFFECT OF CONSTRUCTION PROCEDURES

It is well known that construction procedures can have a significant effect on the performance of excavations.

Lowering of the ground water level either by pumping or by seepage into the excavation can result in significant settlements. These settlements could be associated with consolidation of the soil **or**, in the case of granular soils, the piping of soil into the excavation.

Poor installation techniques for tiebacks or struts can lead to surface settlements. Tiebacks should be carefully drilled to minimize the soil removed from holes. Also, any voids remaining after the tieback is installed should be filled with grout. Struts, rakers, and wales should be tightly wedged and preloaded to prevent movement of the wall. In addition, hard wood or steel wedges should be used for shimming to reduce movements caused by crushing. Earth beams when used to provide temporary support before installing a strut have been observed to be of little value in preventing wall **movement**. Cole and **Burland** (1972) and Hansbo, Hofmann, and **Mosesson** (1973) report cases where earth berms did little to restrict wall movement.

Even though the entire support system may be in place, the sides of the excavation may continue to creep inward with time. This problem appears to be particularly acute in tied-back walls in very stiff to hard

clays. There is also some evidence to indicate that lagging in soldier pile walls tends to pick up more load with time in all soils. Excessive bulging or even failure of some lagging has been observed,

2.80 ESTIMATING SETTLEMENTS

The data presented in the section may be used to obtain rough estimates of the ground movements which might occur adjacent to a support wall. The reason for making this estimate is to provide some additional input to aid in the decision of whether or not to underpin adjacent structures or utilities.

Settlements may be estimated using both Figure 4 and Figure 11. Once the soil type and excavation geometry are defined, an estimate of the maximum settlement may be made from Figure 4. Figure 11 provides a means of estimating the angular distortion and zone of influence of the ground movements. In the case of cohesive soils, Figure 5 may be used to estimate the wall stiffness necessary to limit the settlements.

2.90 SUMMARY

A review of available field measurements shows that wall and soil movement at the site of a temporary cut are influenced by the soil conditions, wall stiffness, vertical support spacing, prestressing, and construction procedures. For any given wall any one of these may be the most important factor. However, for situations where good construction procedures and typical wall types are used, Figures 4 and 5 indicate **that the magnitude of maximum vertical and horizontal deflection** is dependent on wall stiffness and method of support in soft to stiff clays, but independent of these factors for walls in sands and gravels or in very stiff clays.

In clays with an undrained shear strength of less than 2000 psf, flexible walls (soldier piles and lagging or steel sheeting) commonly experience vertical settlements in excess of 1.0 percent of the excavation depth. The magnitude of the settlements can be reduced to less than 0.75 percent of the excavation depth by strictly controlled construction procedures (Hansbo, **Hofmann**, and **Mosesson**, 1973). Where stiff support wall systems (such as diaphragm walls) are used in these soils, the settlements were less than 0.3 percent of the excavation depths.

The maximum settlements for all wall types in sands and gravels is typically less than 0.25 percent of the excavation depth. For cuts in very stiff clays, the maximum settlements may be slightly larger although most of the maximum movements are still less than 0.25 percent of the height of the cut.

Concerning lateral wall deformations, the maximum for walls in sands and gravels is typically less than 0.2 percent of the cut height. However, the lateral wall movements in very stiff clays are somewhat larger, reflecting the tendency for these soils to creep laterally with time. This behavior is most prevalent in situations where tiebacks were used in very stiff clays. For the very stiff clays, the maximum lateral movements for internally braced cuts are about 0.2 percent of cut height while maximum lateral movements for tied-back walls are generally less than 0.4 percent of cut height.

In general, Figure 4 shows that the stiffness of the wall-support system aids in controlling movements in virtually all soil types, although the effect is much less marked in sands, gravels, and very stiff clays.

Figure 11 shows how the vertical surface deformations vary with distance behind a cut. This data indicates that maximum settlements can occur at distances equal to the excavation depth from the support wall. To date, settlement profiles versus depth have not been measured. Also, it is not known to what extent adjacent structures affect the observed settlement profiles. In two cases (**Lambe**, Wolfskill, and Jaworski, 1972; **DiBiagio** and **Roti**, 1972), the settlement profiles were determined from the settlement of structures on shallow foundations. These settlement patterns are very similar to those for other cases.

APPENDIX A to CHAPTER 2

A. 10 INTRODUCTION

Finite element analyses of complex engineering problems are becoming more common each day in the engineering world. These analyses are often conducted to gain insight into the parameters which control the performance of a structure. As part of the development of this manual, computer analyses of braced excavations were made using the finite element program known as BRACE II (Jaworski, 1973). A brief description of this program's capabilities along with the details of the computer runs used to develop the data in this manual are presented in this appendix.

A. 20 BRACE II - FINITE ELEMENT PROGRAM

A. 21 General

The computer program, BRACE II, was developed expressly for the purpose of analyzing internally braced excavations. The program simulates the construction process for a braced excavation in an isotropic, **bilinearly-elastic** material by performing a total stress analysis. It models sequentially the events of excavation and installation of struts. It can also consider such effects as prestressing of struts or additional movements at the strut levels after installation. Additional capabilities of the program include the facilities for handling anisotropic, **bilinearly-elastic** materials and the overstressing of the sheeting piling.

A. 22 Program Description

The use of the finite element technique in analyzing complex engineering problems is well described in the literature (Zienkiewicz, 1967). Briefly, this technique models a problem by an assemblage of discrete triangular to quadrilateral elements. The forces (\underline{Q}) at the nodes of these elements is related to the node displacements (\underline{U}) and the global stiffness (\underline{K}) of the element assemblage. A system of **linear** equations results which can be described by the equation:

$$\underline{K} \underline{U} = \underline{Q}$$

This system of equations is solved to obtain nodal displacements. These displacements are then used to determine individual element strains and stresses.

This technique was used in the development of a computer program, BRACE II, for analyzing the behavior of braced excavations. This current program is a second generation of the original program, BRACE, developed by Wong (1971). The program **models** soil by discrete elements with bilinearly-elastic stress/strain properties. Within each element the strain is assumed constant. The retaining wall for the excavation is simulated by one-dimensional linearly elastic bar elements. The program simulates a specified excavation and bracing-construction sequence by applying the load relief due to an excavation stage or by applying a force at a node as a strut is prestressed. The loads from a particular construction operation are applied incrementally. For each load increment a specified modulus is used until the yield strength of the soil is attained. Thereafter, a reduced modulus is used for each additional load increment.

Additional capabilities of BRACE II are: The retaining wall is allowed to develop a plastic hinge when a specified yield moment is exceeded; the soil behind the wall is allowed to slip unrestrained relative to the sheeting. Both capabilities are important in the analysis of braced excavations. In braced excavations in soft clay with large **strut** spacings, the sheeting may become overstressed and large movements will result. In cases where a concrete slurry wall is installed, a **bento-**nite clay cake remains between the concrete and the soil. Since this clay has essentially no shear strength, restraint of slippage between the soil and concrete wall may **be** considered non-existent.

If, during a given excavation stage, the yield moment of the sheeting is exceeded at a bar element node, that node is made a plastic hinge for all additional incremental loads. Unrestrained **slippage** between the soil and the sheeting is **modelled** by setting the axial stiffness of the sheeting to zero.

The anisotropic variation of modulus of the soil is simulated based on the methods proposed by Christian (1971). He recommends the following approximate relation to account for the effect of stress reorientation on the undrained **modulus**:

$$E_{\theta} = E_{uh} - (E_{uh} - E_{uv}) \cos^4 \theta$$

where E_{uh} and E_{uv} are the undrained modulus for tests with the major principle **stress** applied to the soil in the vertical and horizontal directions respective **y**; θ is the orientation of the major **pri-**nciple stress from the **verticl** plane; and E_{θ} is the **modulus** used to compute the deformations of the soil.

To account for anisotropic shear strength properties the following yield criterion recommended by Davis and Christian (1971) was used:

$$\left(\frac{\sigma_x - \sigma_y}{2} - \frac{s_{uv} - s_{uh}}{2} \right)^2 + \tau_{xy}^2 \frac{a^2}{b^2} = a^2$$

where:

$$\frac{b}{a} = \sqrt{\frac{s_{u45}}{s_{uv} s_{uh}}}$$

$\sigma_x, \sigma_y, \tau_{xy}$ = conventional total stress components in the x, y plane

s_{u45} = shear strength of a soil sample oriented at 45 degrees from the vertical

s_{uv}, s_{uh} = shear strength for compression in the vertical and horizontal directions

A.23 Summary of Parametric Studies

The details of the parametric studies used to generate the data in Chapter 2 and Chapter 7 are summarized in Tables 2 and 3. The tables show the sheeting stiffness and corresponding soil parameters used in each analysis. The soil parameters were selected based on synthesized data presented by Ladd, et al (1971) and Ladd and Vallaroy (1965). The soil parameters used in the analysis are not exactly those reported by Ladd, et al (1971), rather they reflect values which give stability conditions which would yield a broad spectrum of excavation performance.

The finite element grid used to model this excavation is shown in Figure 17. The soil mass was restrained against both vertical and horizontal deformations along the bedrock base (150 foot base) and at a distance of 250 feet from the excavation face. Excavation stages consisted of excavating approximately 3 feet below strut level. The struts were **installed** without **prestressing; but, once the strut was installed, no further lateral movement was permitted at the strut level.**

Table 2. Summary of case studies for analysis of strut loads and sheeting deformations.

Case	Soil Profile	Wall Type	Depth of cut (ft)	Penetration (ft)	$\frac{EI}{L^4}$ @ base	$\frac{\gamma H}{S_u}$ @ base	SOILS					
							Type	K_0	S_{uv}	S_{uh}	E_{uv}	E_{uh}
CASE I	Uniform	PZ-38 Steel	60	29	5. a3	6. a2	Soft Uniform	0.5	0.28 $\bar{\sigma}_v$	0.15 $\bar{\sigma}_v$	200 $\bar{\sigma}_v$	120 $\bar{\sigma}_v$
	Uniform	PZ-38 Steel	60	29	5. a3	4. 78	Medium Uniform	0. 6	0.406"	0.250,	290 $\bar{\sigma}_v$	180 $\bar{\sigma}_v$
	Uniform	26.5" Diaphragm Wall	60	29	38.40	6. a2	Soft Uniform	0.5	0.28 $\bar{\sigma}_v$	0.156 $\bar{\sigma}_v$	200 $\bar{\sigma}_v$	120 $\bar{\sigma}_v$
	Uniform	26.5" Diaphragm Wall	60	29	38.40	4. 78	Medium Uniform	0. 6	0.406 $\bar{\sigma}_v$	0.25 $\bar{\sigma}_v$	290 $\bar{\sigma}_v$	180 $\bar{\sigma}_v$
	Uniform	48" Diaphragm Wall	60	29	228.96	6. a2	Soft Uniform	0.5	0.28 $\bar{\sigma}_v$	0.15 $\bar{\sigma}_v$	200 $\bar{\sigma}_v$	120 $\bar{\sigma}_v$
	Uniform	48" Diaphragm Wall	60	29	228.96	4. 78	Medium Uniform	0. 6	0.40 $\bar{\sigma}_v$	0.25 $\bar{\sigma}_v$	290 $\bar{\sigma}_v$	180 $\bar{\sigma}_v$
CASE II	Uniform	PZ-38 Steel	60	10	5. a3	2. 25	Stiff Uniform	1.0	3,200 psf	3,200 psf	3,000,000 psf	3,000,000 psf
	Soft Over Stiff	PZ-38 Steel	60	29	5. a3	2.25	Soft	0.5	800	540	800,000	500,000
	Soft Over Stiff	PZ-38 Steel	60	10	5. a3	2.25	Stiff	1.0	3,200	3,200	3,000,000	2,500,000
	Over Stiff	Steel	60	10	5. a3	2.25	Soft	0.5	800	540	800,000	500,000
	Over Stiff	48" Diaphragm Wall	60	29	228.96	2.25	Stiff	1.0	3,200	3,200	3,000,000	2,500,000
	Over Stiff	PZ-38 Steel	60	29	228.96	2.25	Soft	0.5	800	540	800,000	500,000
CASE III	Over Soft	Steel	60	29	5. a3	6. 37	Stiff	1.0	3,200	3,200	3,000,000	2,500,000
	Soft Over Stiff	48" Diaphragm Wall	60	29	228.96	6.37	Soft	0.5	0.3 $\bar{\sigma}_v$	0.2 $\bar{\sigma}_v$	360 $\bar{\sigma}_v$	216 $\bar{\sigma}_v$
	Soft Over Stiff	48" Diaphragm Wall	60	29	228.96	6.37	Stiff	1.0	3,200	3,200	3,000,000	2,500,000
	Soft Over Stiff	PZ-38 Steel	32.5	17.5	1. 52	4. 30	Soft	0.5	0.38"	0.2 $\bar{\sigma}_v$	360 $\bar{\sigma}_v$	216%
	Soft Over Stiff	PZ-38 Steel	32.5	17.5	1. 52	4. 30	Stiff	1.0	2,000	2,000	2,400,000	2,400,000
	Soft Over Stiff	48" Diaphragm Wall	32.5	17.5	59.60	4.30	Soft	0.5	0.38"	0.2 $\bar{\sigma}_v$	360 $\bar{\sigma}_v$	216 $\bar{\sigma}_v$
Soft Over Stiff	48" Diaphragm Wall	32.5	17.5	59.60	4.30	Stiff	1.0	2,000	2,000	2,400,000	2,400,000	
Soft Over Stiff	48" Diaphragm Wall	32.5	17.5	59.60	4.30	Soft	0.5	0.3 $\bar{\sigma}_v$	0.2 $\bar{\sigma}_v$	360 $\bar{\sigma}_v$	216 $\bar{\sigma}_v$	

Notes: For all cases $\gamma_{sat} = 120$ pcf
 GWT = 5.0 ft. below GL
 Vertical strut spacing = 10'

Table 3. Summary of case studies for analysis of zone of influence of deformations.

Type of Movement	Maximum Lateral Movement	K_o	S_{uv}	S_{uh}	E_{uv}	E_{uh}
Top tilt	6"	1.0	$0.3\bar{\sigma}_v$	$0.2\bar{\sigma}_v$	$300\bar{\sigma}_v$	$200\bar{\sigma}_v$
Rotation about top	6"	1.0	$0.3\bar{\sigma}_v$	$0.2\bar{\sigma}_v$	$300\bar{\sigma}_v$	$200\bar{\sigma}_v$
Flexure	4"	1.0	$0.3\bar{\sigma}_v$	$0.2\bar{\sigma}_v$	$300\bar{\sigma}_v$	$200\bar{\sigma}_v$
Top tilt and flexure	6"	1.0	$0.3\bar{\sigma}_v$	$0.2\bar{\sigma}_v$	$300\bar{\sigma}_v$	$200\bar{\sigma}_v$
Rotation and bulge	6"	1.0	$0.3\bar{\sigma}_v$	$0.2\bar{\sigma}_v$	$300\bar{\sigma}_v$	$200\bar{\sigma}_v$
Lateral shift and flexure	8"	1.0	$0.3\bar{\sigma}_v$	$0.2\bar{\sigma}_v$	$300\bar{\sigma}_v$	$200\bar{\sigma}_v$
Top tilt	6"	1.0	elastic	elastic	3,000,000	2,500,000
Rotation	6"	1.0	elastic	elastic	3,000,000	2,500,000
Flexure	4"	1.0	elastic	elastic	3,000,000	2,500,000

Notes: For all cases:
 $\gamma = 0.01$ psf
 gwt = 150' below G. L.
 depth of cut = 60'
 depth of penetration = 29'
 Poisson's ratio = $\nu_{hh} = \nu_{vh} = 0.499$

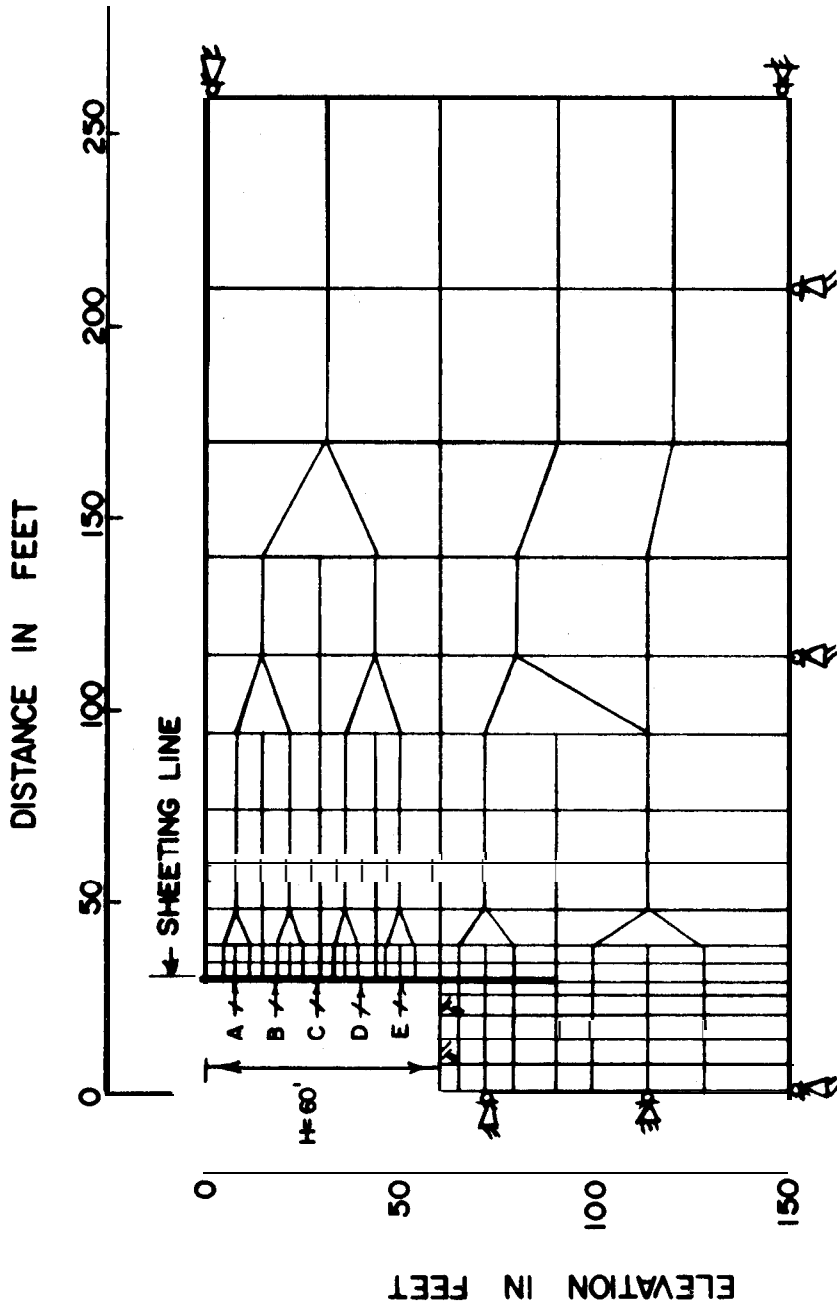

Figure 17. Finite element grid used in BRACE II analysis.

CHAPTER 3 - BASIC CONCEPTS OF SOIL MECHANICS

3.10 GENERAL

This chapter briefly summarizes typical properties and stress behavior of various soil types. Emphasis is placed upon basic concepts controlling behavior, particularly as related to the strength properties. This discussion should not be construed as a substitute for more comprehensive treatment given in soil mechanics texts, nor should the data concerning typical soil parameters obviate the need for soil testing. Rather, the data are given only as guidelines.

Soils may be classified under two broad categories, cohesive and cohesionless soils. In the cohesive category are clays which have low permeability and hence drain slowly. Most sands and gravels are classified as cohesionless. Silts and cohesive sands are an intermediate type whose engineering properties, especially strength, are largely controlled by their rate of drainage. Because of the general relationship between permeability and plasticity, the latter is a useful index for classification of these intermediate soils.

3.20 EFFECTIVE STRESS

Soil behavior is controlled largely by the effective stress in the soil. Effective stress is defined as follows:

$$\bar{\sigma} = \sigma - u$$

where:

$\bar{\sigma}$ = effective stress

σ = total stress

u = pore water pressure

Where $\bar{\sigma}_v$ is the vertical effective stress and $\bar{\sigma}_h$ is the horizontal effective stress, the in situ horizontal and vertical effective stresses are related by the at-rest coefficient of stress, K , defined as the ratio of the initial horizontal to the vertical effective stresses.

$$K_o = \frac{\sigma_h}{\sigma_v}$$

Soil strength parameters are governed by effective stresses which make the evaluation of pore pressure an important consideration in any engineering analysis.

Changes in pore water pressure generated by shear strain will dissipate immediately in cohesionless soil. Thus, the pore water pressure is controlled simply by the depth below the hydrostatic water level.

With cohesive soil, pore water pressure dissipates very slowly, in perhaps months or years. Moreover, one cannot accurately predict changes in pore water pressure caused by shear strain. As a corollary one cannot, with confidence, predict effective stress conditions in cohesive soil before the start of construction. On the other hand, pore water pressure measurements during construction do provide a basis for computing effective stress.

3.30 SOIL UNIT WEIGHTS

The effective stresses in a soil mass depend upon the total unit weight of the soil (γ_m), stress due to surcharge, and the pore pressures within the soil mass (often controlled by the water table). The unit weight of soil is a function of its specific gravity, void ratio, and water content.

The following table gives a range of unit weights for various soils for use in analysis.

Typical Values of Unit Weight

Soil Type	Moist Unit Weight (above water table) γ , pcf	Saturated Unit Weight* (below water table) γ_{sat} , pcf
Poorly graded sands	105 - 115	115 - 125
Clean well graded sand	115 - 125	120 - 130
Silty or clayey sands	120 - 130	125 - 135

Soil Type	Moist Unit Weight (above water table) γ , pcf	Saturated Unit Weight* (below water table) γ sat, pcf
Silty or clayey sands and gravels	125 - 135	130 - 145
Soft to medium clay	100 - 115	100 - 115
Stiff to very stiff clay	110 - 125	110 - 125
Organic silt or clay	90 - 100	90 - 100

"Submerged unit weights = $\gamma_{sat} - \gamma_w = \gamma_{sub}$

3.40 SHEAR STRENGTH OF SOILS

3.41 General

Coulomb has defined soil shear strength in the general form of the effective strength parameters \bar{c} and $\bar{\phi}$, where \bar{c} is the cohesion intercept and $\bar{\phi}$ is the angle of internal friction as determined in laboratory tests. The shear strength of a soil is:

$$\tau_{ff} = \bar{c} + \bar{\sigma}_{ff} \tan \bar{\phi}$$

where:

τ_{ff} = shear stress on the failure plane at failure

$\bar{\sigma}_{ff}$ = effective normal stress on the failure plane at failure

Figure 18 illustrates the failure envelope.

3.42 Cohesionless Soils

In cohesionless soils (sands and gravels) the cohesion intercept, \bar{c} , is zero. Therefore, the shear strength can be expressed as:

$$\tau_{ff} = \bar{\sigma}_{ff} \tan \bar{\phi}$$

Figure 19 illustrates the failure envelope for a typical cohesionless soil.

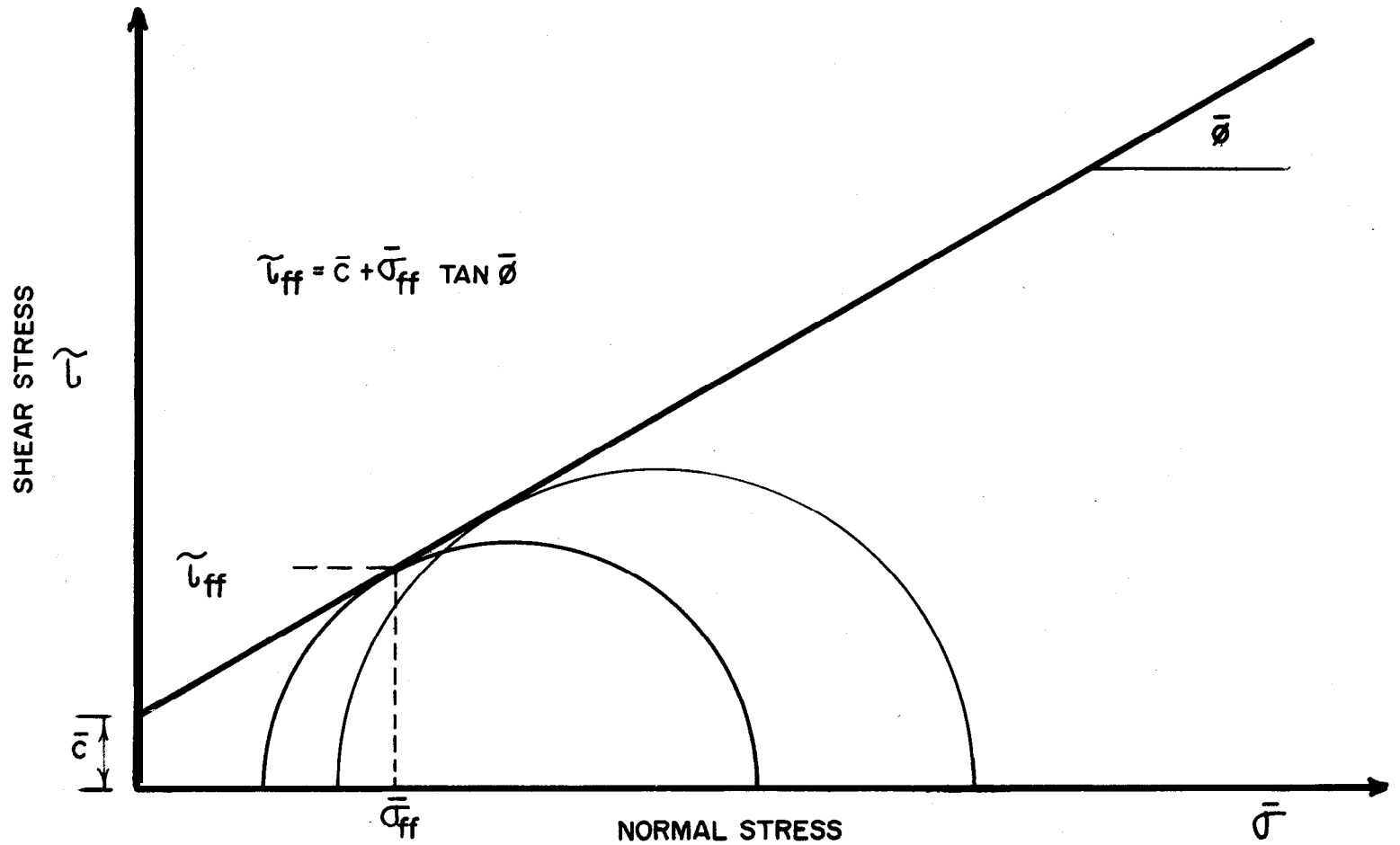

Figure 18. Failure envelope for soil, general Mohr-Coulomb failure criterion.

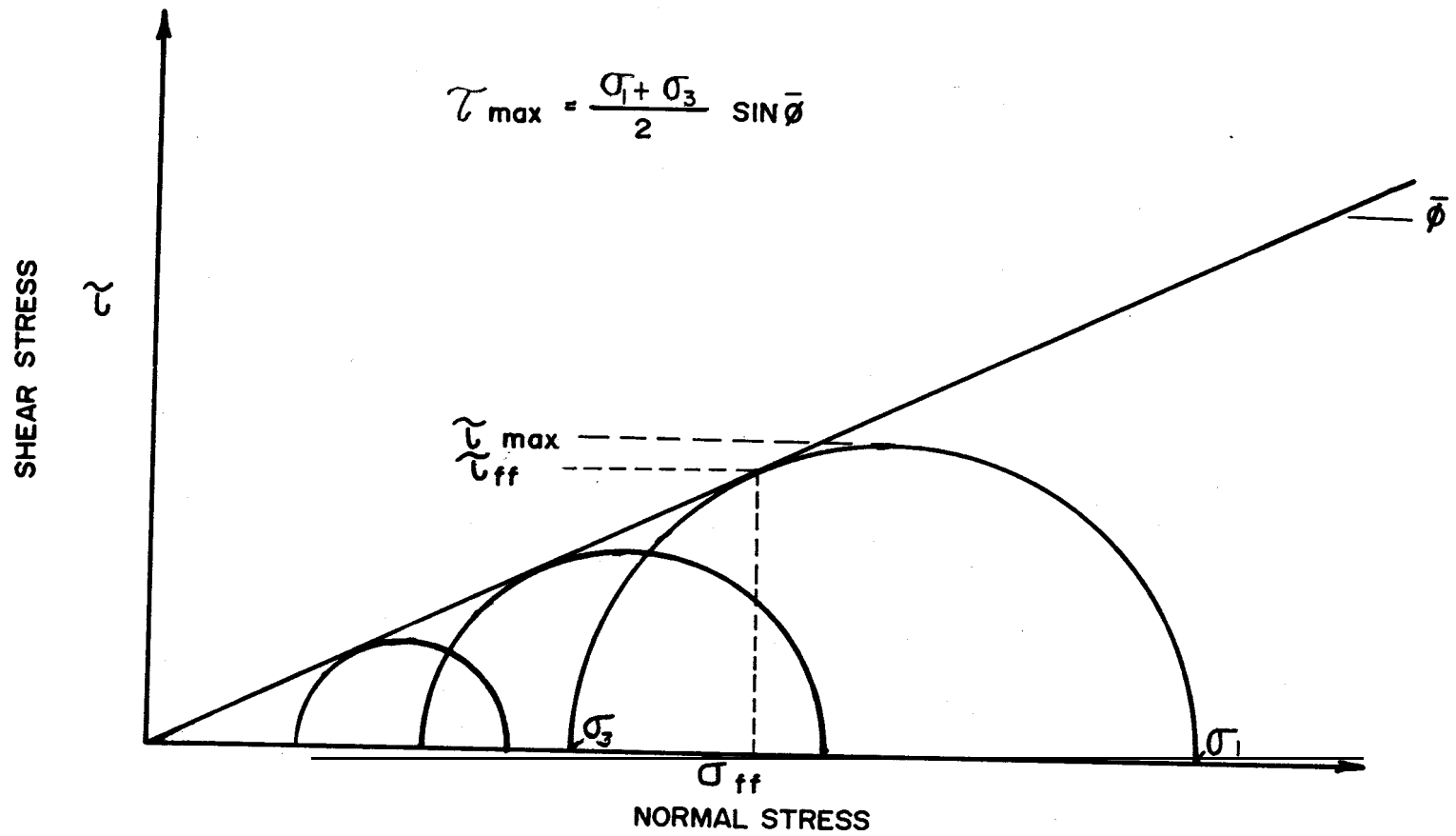

Figure 19. Strength envelope for cohesionless soils (based on effective stress).

As mentioned previously, sands and gravels are free draining and therefore, pore pressure changes generated by loading or shear strains dissipate quickly. Therefore, the shear strength of the soil is related to the loading condition and the $\bar{\phi}$ value. For all practical purposes, the pore pressure remains unchanged during the loading.

The value of the angle of internal friction is determined from laboratory tests such as drained triaxial tests, direct shear tests, or from empirical correlations. A crude guide for making an initial estimate of $\bar{\phi}$ is the standard penetration test during sampling in the bore hole. Peck, Hanson, and Thornburn (1974), for example, relate $\bar{\phi}$ values for sands and gravels to the standard penetration resistance (N), as shown in the following table:

$\bar{\phi}$ vs N for Cohesionless Soil

<u>Relative Density</u>	<u>$\bar{\phi}$</u>	<u>N*</u> (blows/ft)
Loose	$28^{\circ} - 30^{\circ}$	5 - 10
Medium	$30^{\circ} - 36^{\circ}$	10 - 30
Dense	$36^{\circ} - 41^{\circ}$	30 - 50
Very dense	$41^{\circ} - 44^{\circ} +$	>50

* N, standard penetration resistance, is dependent on soil density, gradation, drilling procedures, sampling procedures, and depth below surface.

3.43 Cohesive Soils

Unlike cohesionless soils, which drain quickly, the strength of cohesive soils is related to the changes in pore pressure that occur during shear. The general expression for soil strength, $\tau_{ff} = \bar{c} + \bar{\sigma}_{ff} \tan \bar{\phi}$, is applicable to these soils; however, the evaluation of $\bar{\sigma}_{ff} = \bar{\sigma}_{ff} - u$ can only be made with knowledge of the pore pressure, u. As stated previously, the current state-of-the-art does not provide a sufficiently accurate means to predict pore pressure, but it can be measured in situ.

Figure 20 illustrates the differences in the strength envelopes for normally consolidated and over consolidated clay. Note that the cohesion intercept (\bar{c}) is observed in overconsolidated clays, but not in normally consolidated clays.

Figure 20. Strength envelopes for clay (based on effective stress).

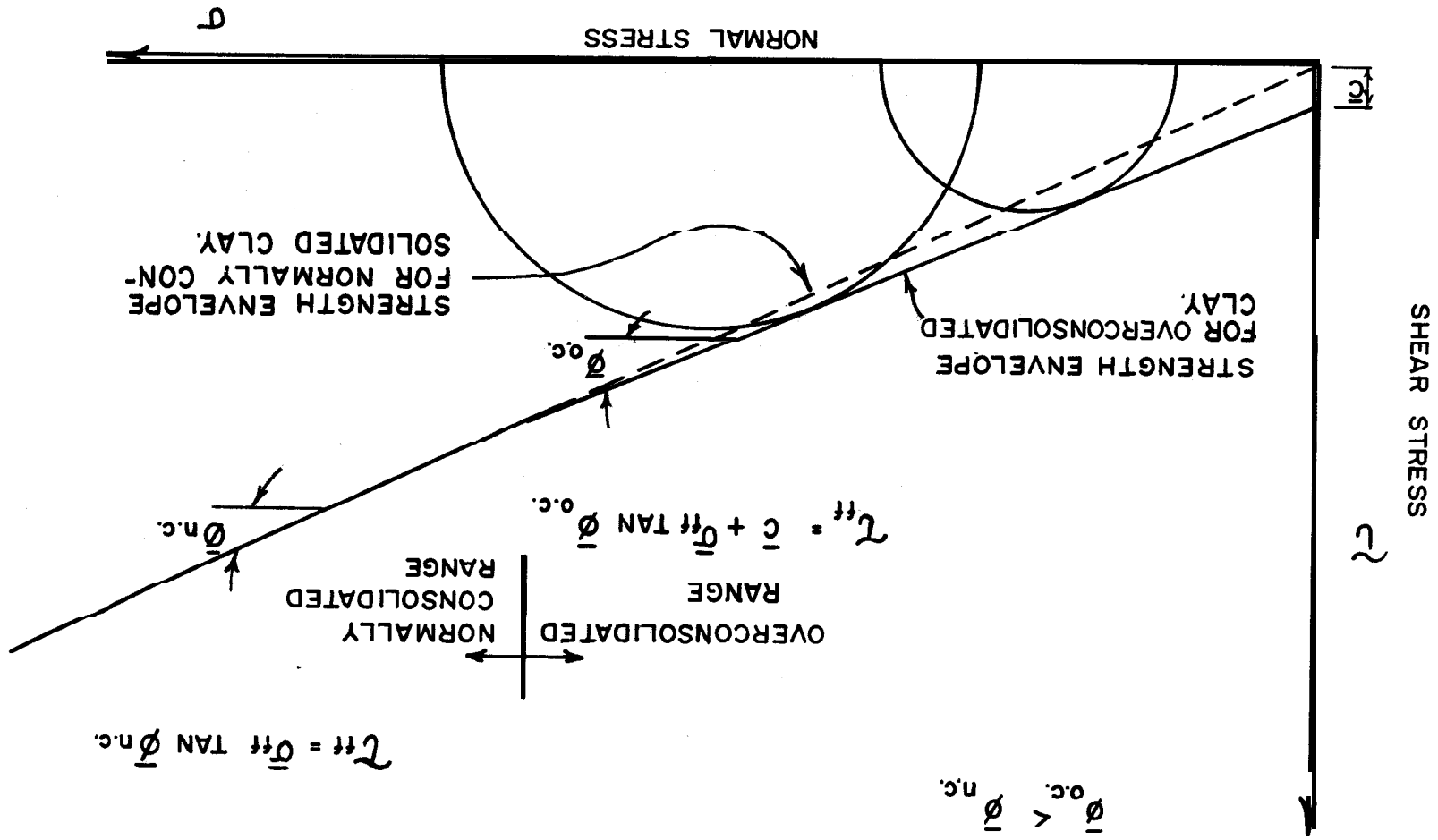

3.43.1 Undrained Strength

Cohesive soils are not normally permeable enough to allow significant drainage during shear, and excess pore pressures do not dissipate quickly. Therefore, to be on the safe side during initial application of Load, the shear strength should be based on undrained strength of the soil at natural water content. For most loading conditions, normally consolidated soils will experience a pore pressure increase (positive). Over consolidated soils experience either a smaller pore pressure increase or may even experience a pore pressure decrease depending on the degree of overconsolidation.

When the change in pore pressure is positive, the effective stress in the soil is lowered; therefore, the shear strength is less than that which would be obtained using effective strength parameters based on static water table conditions. With time, as pore pressure dissipates, the effective stress, and therefore shear strength; increases.

When pore pressure decreases as a result of shear strain, as is characteristic of overconsolidated soils, the effective stress increases. Therefore, the shear strength is greater than that which would be computed using effective strength parameters based on the static water table conditions. With time, the pore pressure becomes increasingly positive (approaching the static water table condition), the effective stress decreases, and the strength becomes less.

Figure 21 shows two strength relationships. One is a drained strength envelope in terms of effective stress. The other is a plot of consolidation pressure vs. undrained strength. The plots in the figure show cases where the undrained strength is greater than the drained strength and, conversely, where it is Less.

Cohesive soils at their natural water content exhibit a unique shear strength for all undrained loadings (and unloadings) regardless of the total confining pressures. This value of shear strength is referred to as the undrained shear strength, S_u , of the soil. It is approximately equal to (and usually taken as) one half the

compressive strength, $\frac{\bar{\sigma}_1 + \bar{\sigma}_3}{2}$, as determined in a compression test. The undrained strength at natural water content can also be determined by a vane shear device, either in situ or in the laboratory.

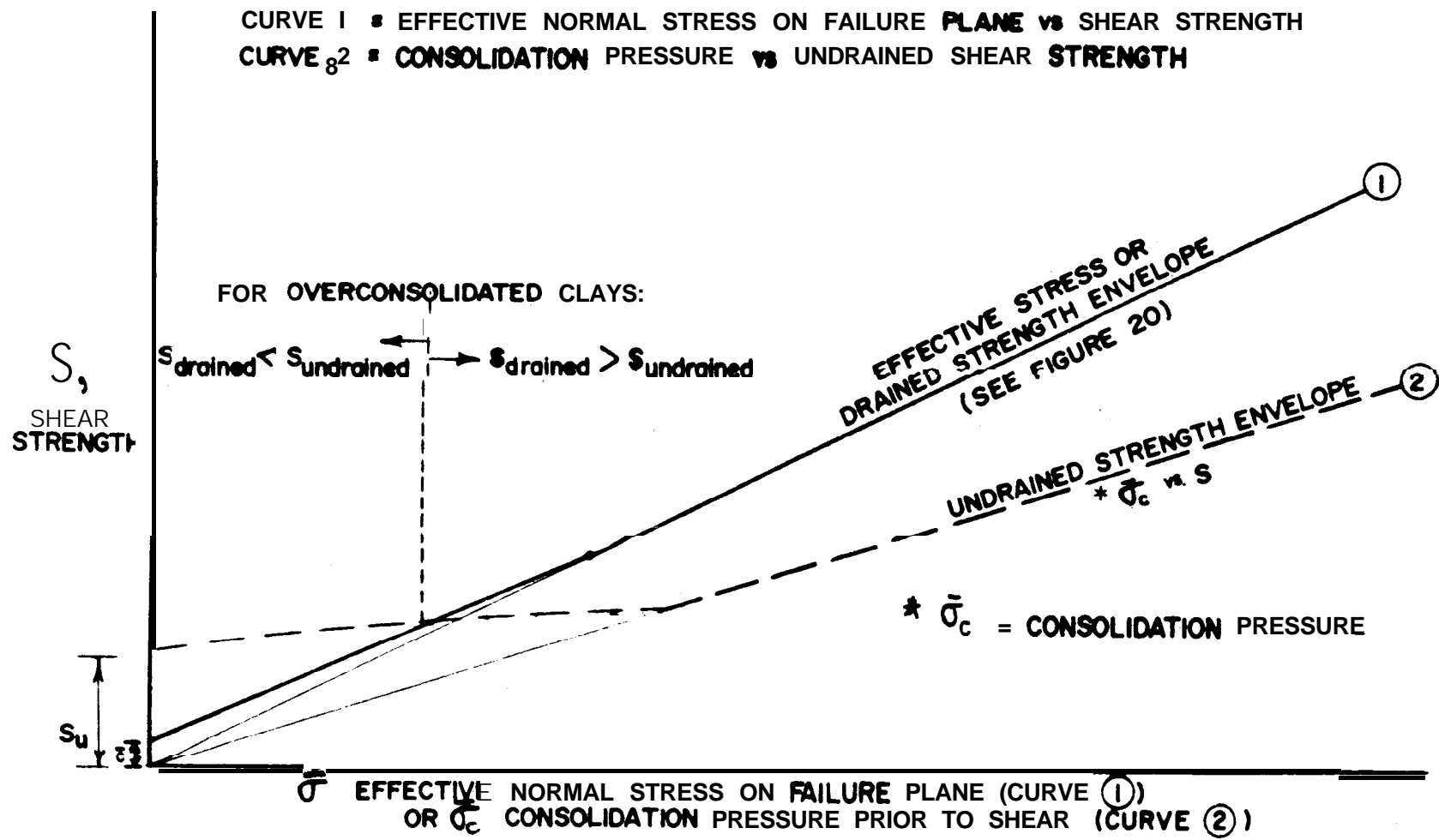

Figure 21. Comparison of drained and undrained strengths.

3.43.2 Drained Strength

Ultimately the excess pore pressures generated by shear strain in a cohesive soil will drain, thus resulting in zero excess pore pressures and a return to hydrostatic conditions. Drained and undrained strengths present the limiting strength conditions for a cohesive soil. Because one does not necessarily know what the pore pressure conditions are, it is important to recognize which is the more conservative for a particular case. At low confining pressures (with respect to the degree of over-consolidation) the drained strengths control. On the other hand, the undrained strengths are more critical at higher confining pressures. A comparison of undrained and drained strengths is made in Figure 21.

3.43.3 Intermediate Cases

During drainage the strength lies between the drained and undrained strengths and is a function of the pore pressure dissipation, i. e. it is related to the effective stresses at any given instant.

3.43.4 Cohesive Soil Strength During Excavation

Consider the case of an element of cohesive soil located at a depth inside an excavation. Initially, the shear strength of the soil will be equal to the in situ undrained shear strength, S_u , Assuming an immediate unloading of the soil element (due to excavation), the soil element will experience a reduction in pore pressure, maintain a constant effective stress, and therefore, a constant strength value (except for minor changes due to loading conditions). However, as these negative excess pore pressures dissipate, the strength of the soil will decrease until the ultimate drained conditions are achieved.

This factor is particularly important for overconsolidated cohesive soils with high undrained strengths. Accordingly, upon initial excavation, the undrained shear strength at natural water content should be assumed. But if the excavation is open sufficiently long for excess pore pressure to dissipate, the drained strength should be the basis for an analysis of this long term case. See Chapter 6 for further discussion on the relationship to passive pressure.

3.43.5 Consistency

Cohesive soils are described in terms of their consistency, which in turn is directly related to their undrained strength, Standard penetration resistance may also be used as a rough measure of consistency for insensitive cohesive soils. See following table:

<u>Consistency of Cohesive Soil</u>	<u>N* (blows /ft)</u>	<u>Undrained shear strength psf</u>
Very soft	< 2	< 250
Soft	2 - 4	250 - 500
Medium	4 - 8	500 - 1000
Stiff	8 - 15	1000 - 2000
Very stiff	15 - 30	2000 - 4000
Hard	> 30	> 4000

N* - Standard penetration resistance

3.43.6 Heavily Over consolidated Clay

For heavily overconsolidated clays with fissures and subject to strength deterioration with time, \bar{c} should be set equal to zero in the calculation of passive resistance.

It is also possible that in heavily over consolidated clays, where $\bar{\sigma}_h > \bar{\sigma}_v$, a passive failure may occur in the soil due to the release of vertical soil pressure. These passive failures have been observed as base heave in excavations in heavily overconsolidated clays. In these soils, a detailed analysis of the effective stresses in the soil with excavation depth is required. Careful analysis of the in situ stress system is required for all clays.

Further discussion relative to strengths of highly over consolidated clays is made in Chapter 8 (Stability Analysis).

CHAPTER 4 - GROUND WATER IN OPEN CUTS

4.10 GROUND WATER CUTOFF

4.11 General

Cutoff walls are used for the following purposes:

1. To avoid or to minimize dewatering of the excavation.
2. To lessen or to prevent lowering of ground water level outside of the excavation because of possible settlement and damage to adjacent structures.
3. Because it is otherwise impractical to place lagging in soils that are extremely difficult to dewater in advance of excavation (such as silts and/or dilatant clayey sands).
4. To cut off pervious water bearing strata within or just below the bottom of the excavation: thus, protecting against the possibility of a "blow" condition or other source of ground loss.

4.12 Soldier File Wall

A soldier pile and lagging wall is not watertight. In order to control ground water; dewatering, grouting, or freezing must be performed. While excavating in "running" soils it is essential to maintain the ground water level below the working face to prevent inflow and subsequent ground loss.

4.13 Interlocked Sheet piling

The permeability of interlocked steel sheet piling has been studied both experimentally and by observations of actual installations. The results of these studies are quite variable, but as an approximation the seepage through intact interlocks may be assumed to be in the order of 0.01 gallons per minute per square foot of wall under a 1 foot differential head (Fruco & Associates, 1966). Sherard, et al (1963) suggest that flow through intact steel sheet piling is equivalent to about 30 to 40 feet of soil (probably relatively pervious granular soils), under the same hydraulic head.

Clearly, the effectiveness of an interlocked steel sheet pile cutoff wall depends upon the permeability of the soil in which the sheeting is driven. If the steel sheet pile wall remains intact and penetrates into an underlying impervious stratum, the effectiveness will be very significant in pervious sands and gravel. On the other hand, in granular soils of low permeability, such as silty or clayey sands, the interlocked sheeting will have little effect on the relatively low flow into the excavation. In all cases, however, sheeting effectively cuts off flow in pervious layers that are interbedded within a parent stratum of impervious soil.

With regard to maintaining ground water level outside of the excavation, interlocked sheeting is effective in pervious granular soils. For relatively impervious soils (such as clayey sands, silts, and clays) the sheet piling is essentially equivalent to the permeability of the soil, and therefore will have little or no effect on the seepage pattern toward the excavation or on lowering of piezometric levels.

The above discussion applies only to intact sheeting. The presence of boulders, difficult driving conditions, or obstructions can lead to ripping of the sheeting and/or jumping out of interlocks which will seriously impair if not destroy the effectiveness of the cut-off wall.

Another common problem is when the effectiveness of a cutoff in pervious soil depends upon achieving a tight seal on rock. This situation may be especially acute when rock occurs within the depth of excavation. Settlement may result from ground loss due to water inflow or from lowering of ground water levels and thus induce consolidation of compressible soils.

In a case in Boston (Lambe, et al, 1970), the lowering of piezometric head in a sand and gravel deposit below organic silt contributed to consolidation of the organic silt contributed to consolidation of the organics and settlement of the adjacent ground. Interlocked sheet piling could not completely cut off water in a deposit of pervious sand and gravel over bedrock near the bottom of the excavation. A similar case was reported in Oslo (Hutchinson, 1964).

4.14 Concrete Diaphragm Walls

For all practical purposes, a well-constructed concrete diaphragm wall is essentially impermeable, It will effectively cut off flow and prevent ground water lowering outside the excavation provided that there is penetration into an underlying impervious formation. Nevertheless, lowering of ground water may be caused by several poor construction procedures, such as: (a) leaky joints,(b) water loss through drill holes made for tieback installations, (c) inadequate seal on bedrock, especially within the excavation.

4.20 SEEPAGE PATTERN TO EXCAVATION FACE

As mentioned previously, interlocked steel sheeting has relatively little influence on the seepage pattern in impervious soils. As a result, when cuts are made below ground water there will be flow to the face of the excavation. In clays, such a flow will be so small that it may not even be noticeable.

An example of a flow net for this type of situation is shown in Figure 22. During the initial process of excavation, deformation in the soil will generate shear strains and cause pore pressure changes. Eventually, these pore pressures will be dissipated, and a steady state seepage pattern will develop as shown in the figure.

The equipotential lines shown in the figure demonstrate the changes in hydrostatic stress. Such changes in hydrostatic stress lead to a time-dependent equivalent change in effective stress and consolidation of the soil, In precompressed cohesive soils, the amount of consolidation will be negligible; however, in soft normally consolidated clays or organic soils the associated amount of consolidation can be significant and will contribute to displacements behind the excavation.

The foregoing case is important because it illustrates that steel sheeting may not be effective in preventing consolidation of normally consolidated soils within depth of the cut. Soil compressibility and rate of consolidation must be considered.

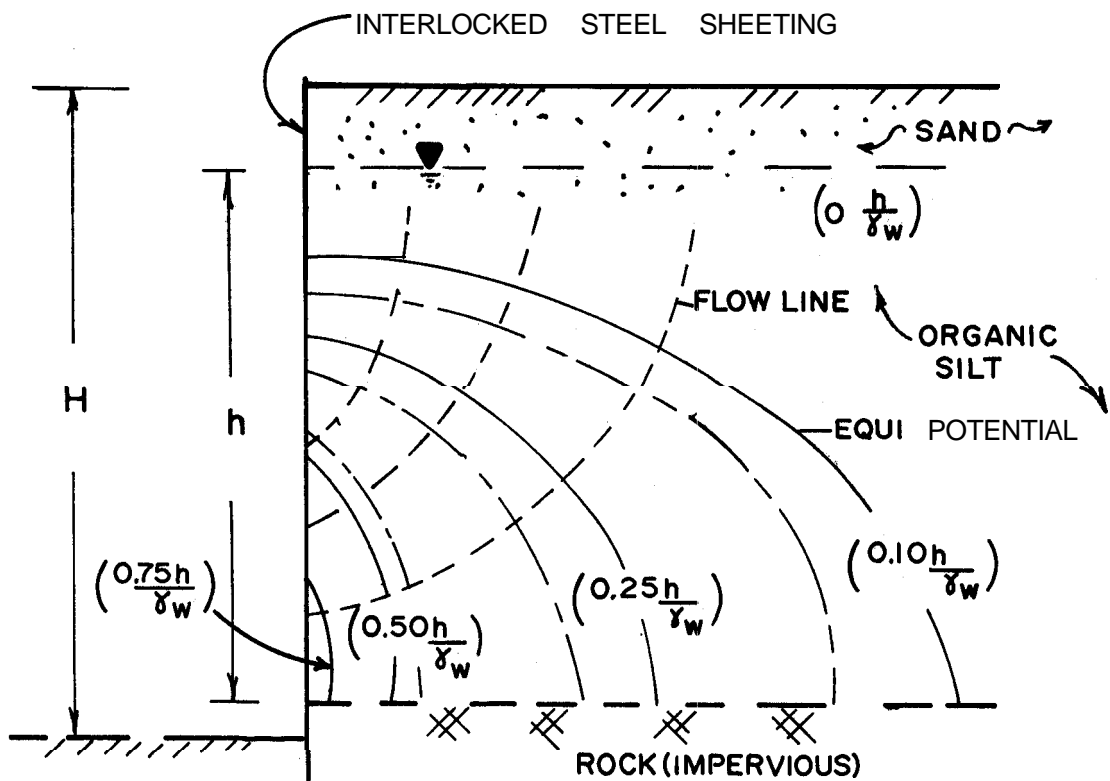

$(0.50\frac{h}{\gamma_w})$ INDICATES CHANGE IN TOTAL HEAD FROM INITIAL CONDITION TO STEADY STATE SEEPAGE CONDITION.

Figure 22. Change in pressure head for cut in impervious soil.

4.30 GROUND WATER RECHARGE

Lowering of ground water is accompanied by a corresponding decrease in hydrostatic pressure and an increase in effective stress. Such an increase in effective stress may possibly be accompanied by consolidation of compressible soils and settlement of surrounding buildings .

Compressibility of cohesive soils is time-dependent; compressibility of loose sand or non-plastic silt is immediate. Recharging of ground water can be accomplished through trenches, pits, or wells, in communication with pervious strata adjacent to the excavation. Most commonly, recharge wells are used in conjunction with excavations made in urban situations. Examples of recharge wells to maintain the ground water level outside of the excavation and to prevent settlement have been reported by Parsons (1959) and by Ball (1962).

One of the most difficult technical considerations in developing recharge wells is the problem of avoiding plugging of the well screen and surrounding soil. Contamination may develop from suspended particles, from corrosion, or by microorganisms which grow on the well screen. In addition, the recirculated water contains dissolved air which expands and plugs the soil pores after diffusion back into the soils, thus reducing the permeability of the soil.

Measures taken to counteract such contamination are to filter and chlorinate the water or to use cathodic protection to prevent corrosion.

A final consideration is to prevent buildup of excessive hydrostatic pressure by diffusion near the recharge well. Such a condition, especially in loose granular soils, can lead to loss of effective stress and settlement of adjacent foundations.

CHAPTER 5 - LATERAL EARTH PRESSURE

5.10 BASIC CONSIDERATIONS

The following discussion presents fundamentals concerning magnitude and distribution of lateral earth pressure when influenced solely by conditions within the depth of excavation. The influence of surcharge loadings are covered in Section 5.40.

In the case of excavations underlain by weak strata, the lateral pressure may be greatly increased as a result of shear deformations generated by marginal safety against base instability. These situations are addressed empirically in Section 5.22.

5.11 Earth Pressure at Rest

The ratio of the geostatic horizontal stress to vertical stress of a natural soil formation is defined as:

$$K_0 = \frac{\bar{\sigma}_h}{\bar{\sigma}_v}$$

w h e r e :

K_0 = coefficient of earth pressure at rest

$\bar{\sigma}_h$ = horizontal effective stress

$\bar{\sigma}_v$ = vertical effective stress

For granular soils Terzaghi and Peck (1968) suggest K_0 values of 0.5 for loose deposits and 0.4 for dense soils. Generally K_0 can be estimated for normally loaded soil deposits as:

$$K_o = 1 - \sin \bar{\phi}$$

where:

K_o = coefficient of earth pressure at rest

$\bar{\phi}$ = angle of internal friction in terms of effective stress

For cohesive soils, K is primarily dependent on the over consolidation ratio ($OCR = \bar{\sigma}_{vm} / \bar{\sigma}_v$) as shown on Figure 23. Normally consolidated clays **typically** have K_o values of 0.5 to 0.6; lightly over consolidated clays ($OCR \leq 4$) **have** K_o values up to 1; for heavily over consolidated clays ($OCR > 4$) K_o **may** range up to a value of 2.

5.12 Active Earth Pressures

5.12.1 Mobilization

Lateral displacement (as shown in Figure 24) transforms the state of stress in the ground from the at-rest condition to the active condition. The mechanics of this process are the mobilization of full shear-resistance within the soil **mass** - a state of stress referred to as "plastic equilibrium".

In their state-of-the-art report given at Madrid in 1972, Bjerrum, Frimann-Claussen, and Duncan summarized previous work concerning the amount of lateral displacement sufficient for mobilization of active earth pressure. They reported that lateral displacement of 0.1 percent of the wall height **was** sufficient to mobilize fully the active earth pressure of sands; whereas full active earth pressure develops in soft clays with displacements of 0.1 percent to 0.2 percent of the wall height.

5.12.2 Distribution

Figure 24 shows the active earth pressure distribution associated with displacement modes. The fully active state stems from lateral translation, by rotation about the bottom, or a combination of both. The earth pressure distribution is triangular and the resultant occurs at the third height of the wall.

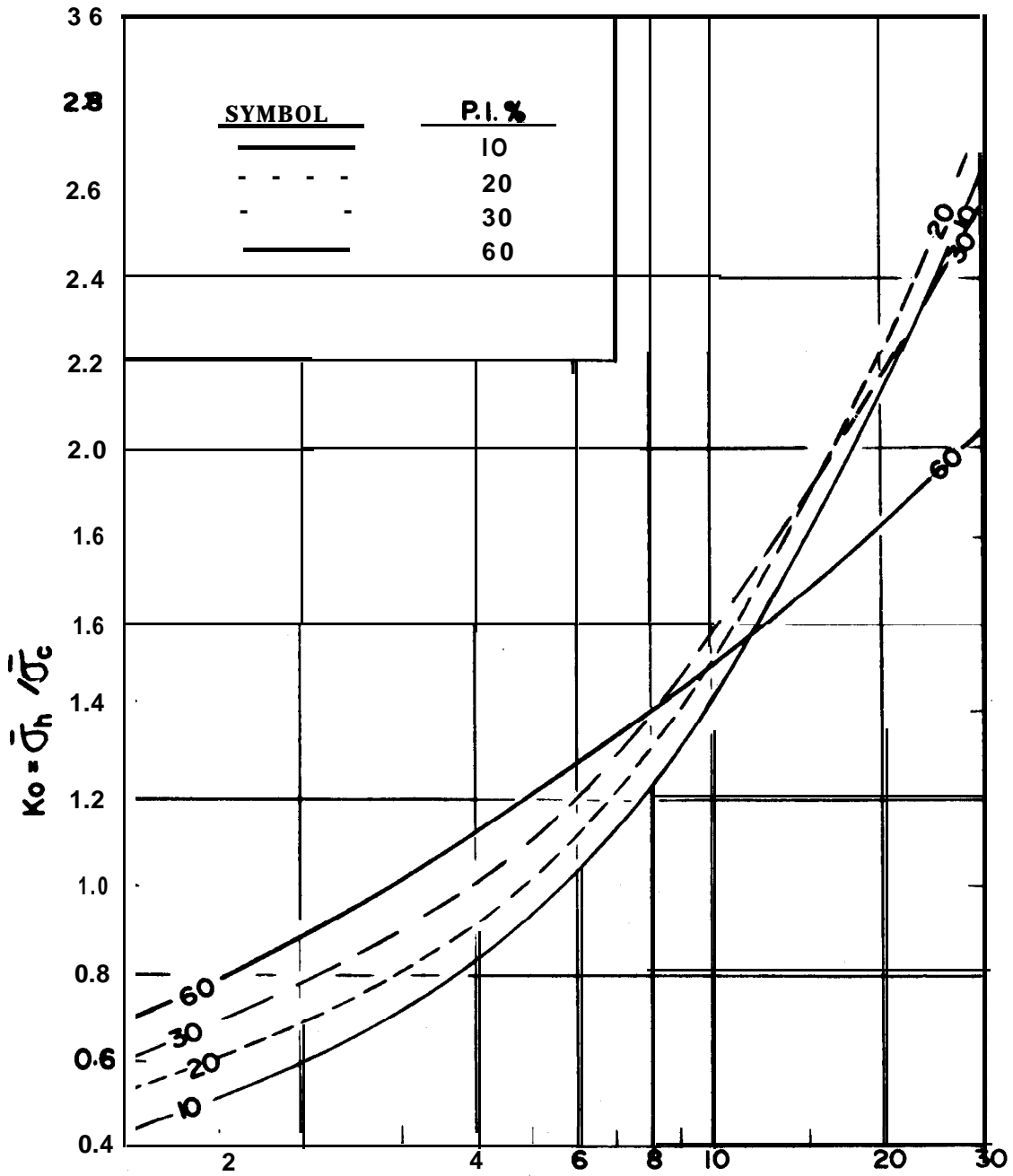

NOTE: BROOKER & IRELAND(1965); DATA REDRAWN FROM THEIR FIGURE II.
 $LOG\ OCR = \bar{\sigma}_{vm} / \bar{\sigma}_v$

Figure 23. K_o versus OCR for soils of varying plasticity, from Ladd (1968).

(a) FULLY ACTIVE

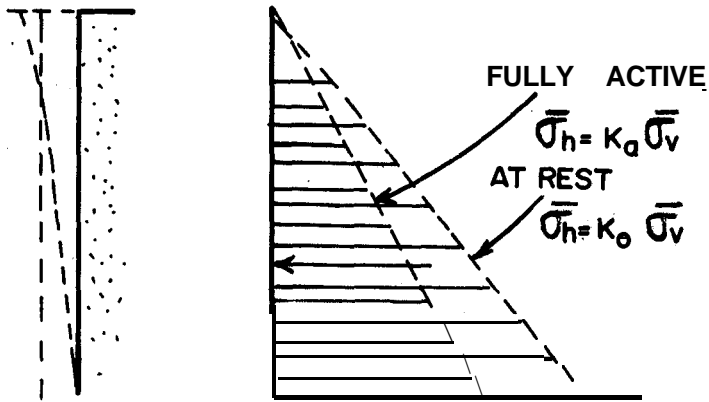

(b) ARCHING ACTIVE

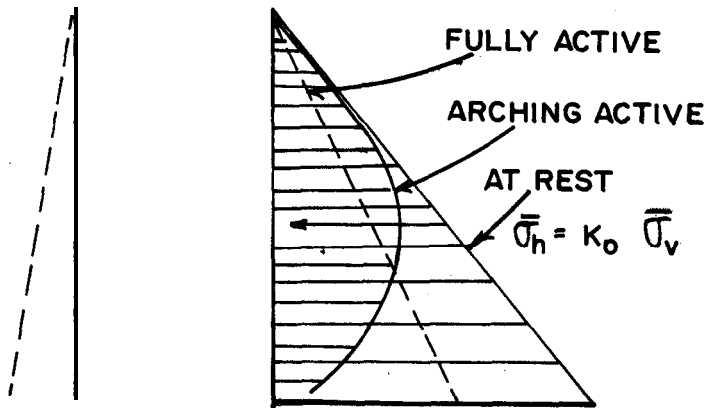

Figure 24. Earth pressure distributions for active and arching active conditions.

For a rigid retaining wall, the arching active case occurs by rotation about the top (Taylor, 1948). The resulting earth pressure distribution is parabolic in shape: it exceeds active near the top but is less than active near the bottom of the wall. On a more flexible cofferdam wall the pressure distribution may be highly irregular due to the sequence of excavation and bracing or variation in the tightness of braces, both of which affect load concentration.

5.12. 3 Coefficients

The direction and magnitude of active pressure depends upon whether or not there is wall friction. The particular case of horizontal surface and zero wall friction is the Rankine fully active condition, shown in Figure 24a. For this case, the active stress acts horizontally on a vertical wall. The Rankine coefficient of active earth pressure, K_a , is the ratio of the effective stresses.

$$\frac{\bar{\sigma}_h}{\bar{\sigma}_v} = \frac{\bar{\sigma}_a}{\bar{\sigma}_v} = K_a$$

For sands, $K_a = \tan^2 (45^\circ - \bar{\phi}/2)$

For cohesive soils,

General case ($\bar{\phi}$, \bar{c}):

$$K_a = \tan^2 (45^\circ - \bar{\phi}/2) - \frac{2\bar{c}}{H} \tan(45^\circ - \bar{\phi}/2)$$

Special case ($\bar{\phi} = 0$, $c = S_u$):

$$K_a = \frac{2S_u}{H}$$

where:

K_a = coefficient of active pressure

$\bar{\phi}$, \bar{c} = friction angle and cohesion intercept

$\bar{\sigma}_v$ = vertical effective stress

σ_h = horizontal effective stress

$\bar{\sigma}_a$ = active earth pressure (horizontal)

S_u = undrained shear strength ($\phi = 0$ case)

According to the Rankine expression, the pressure distribution for cohesive soils is theoretically in tension in the upper part of the wall as shown on Figure 25a. Frequently, adhesion simply does not (or cannot) develop and therefore tension cannot occur. However, the net total lateral force on the wall is equivalent to that described by subtracting the "negative" pressure at the top from the positive pressure at the bottom. Assuming that this net force increases linearly with depth of wall, it can be represented by a net pressure diagram with a triangular distribution of the same force magnitude as shown on Figure 25b. The ordinate at the base of the wall is:

$$\bar{\sigma}_a = \gamma H - 4S_u$$

This procedure was described by Terzaghi and Peck (1968) as a means of comparing measured lateral forces with computed forces acting on braced cofferdam walls. While the method is reasonable for short term conditions, it is probably unrealistic to assume that undrained strength is mobilized over long periods of time. Clearly, such an approach is unconservative with very stiff or hard clays. In such cases and given the time for dissipation of pore pressure generated by shear strain, one should examine pressures based upon the effective strength angle, $\bar{\phi}$.

5.20 INTERNALLY BRACED COFFERDAMS

5.21 General

Initially the internal bracing is set near or at the top, thus restraining inward displacement. With each stage of excavation and bracing there will be progressive inward displacement below previously placed braces. The net displacement profile typically takes the form shown in Figure 26 (after Bjerrum, et al, 1972).

(a) RANKINE ACTIVE PRESSURE: DISTRIBUTION IN COHESIVE SOILS

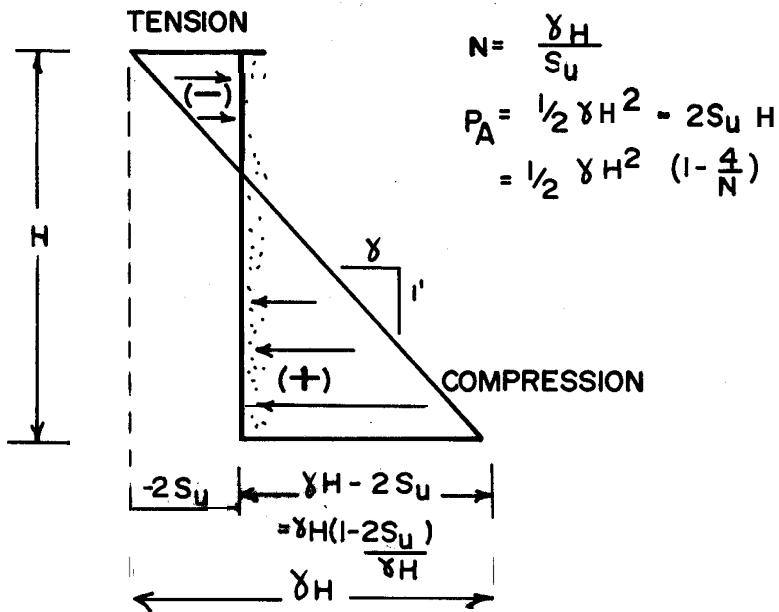

(b) TRIANGULAR PRESSURE DISTRIBUTION EQUIVALENT TO NET RANKINE FORCE

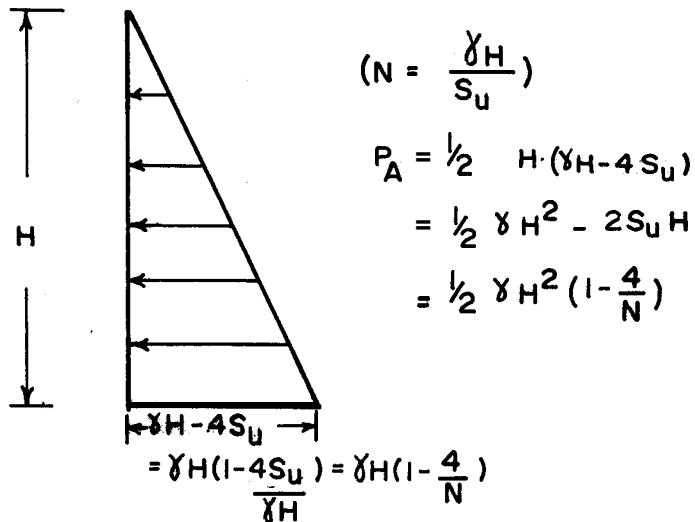

Figure 25. Earth pressure distribution for cohesive soil ($\phi = 0$).

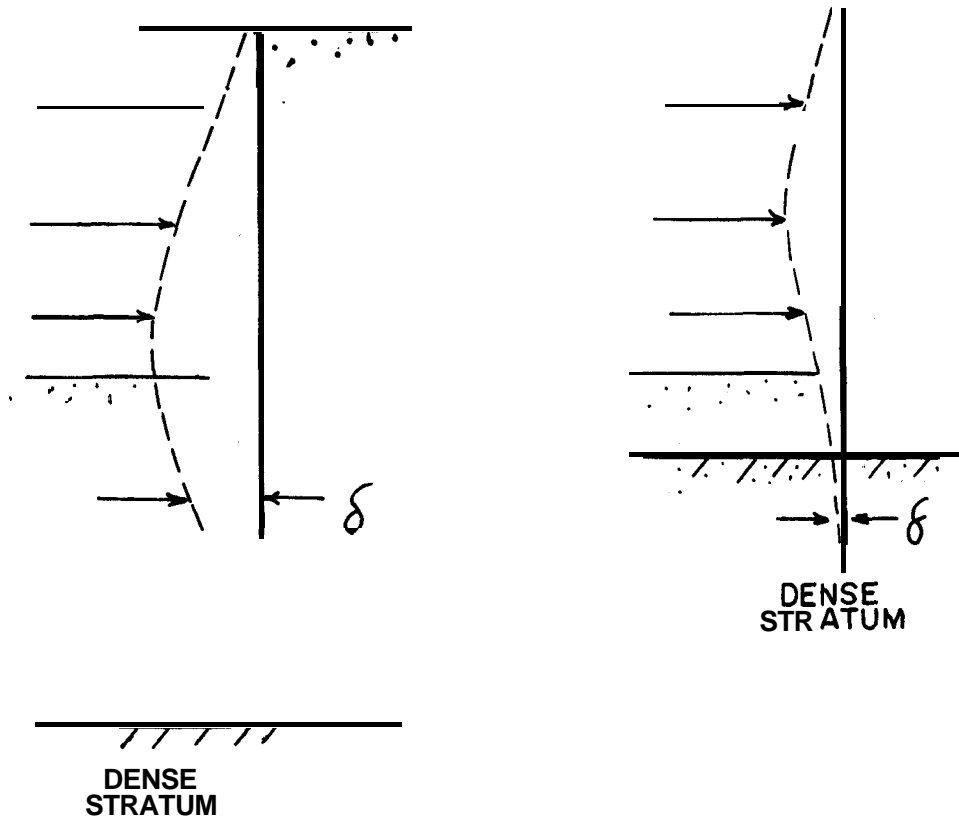

Figure 26. Mode of deformation of internally braced cofferdam (after Bjerrum, et al, 1972).

Characteristically, there will always be some inward rotation about the top, at least in the upper portion of the cut. The degree of bulging and displacement **below** the cut depends upon several factors - the distance between braces, the stiffness of the wall, and the stiffness of soils near the base of the wall. **In general**, the resulting deformation pattern most closely **resembles the arching** active condition. Therefore,- a parabolic, rather than triangular, pressure distribution is most Likely to act on the wall.

The Load concentrated on individual levels of lateral support is greatly affected by the construction procedure itself, environmental **l** changes, and design considerations.

Several factors that can affect the load in a strut are:

For bracing:

- a. The tightness and consistency of the contact between struts, wales, and wall.
- b. Whether or not prestressing was employed.
- c. Temperature of braces during and following their **install-
ation**. (Bracing loads may be significantly affected by temperature changes; especially in excavations which are not decked over.)
- d. Excavation distance between levels of support. (The relative consistency of Loads is directly affected by the variation in vertical distance between Levels of support. For example, if the upper 2 wale levels were spaced 10 feet apart and the third wale level were **15** to 20 feet below the second, the load on level 2 would-be relatively higher.)

For bracing or tiebacks:

- e. Weak soils below depth of excavation. (For example, soft clay underlying the bottom of a deep cut would cause relatively high loads in the lower strut levels because of Lack of passive resistance below the excavation base. This occurs even though soils within the depth of cut are highly competent. Another example-of increased load on bottom struts would be an upward seepage gradient causing a loss of

passive resistance in front of the cofferdam wall.)

f. A stratum of weak cohesive soils within the depth of excavation. (Such a condition may selectively increase Loading on a particular wale Level unfavorably positioned in relation to the bracing sequence and the weak stratum.)

g. Concentrated construction surcharge.

h. Frost action causing additional lateral thrust on wall.

i. Erratic ground water conditions - perhaps Locally perched zones combined with seepage.

Because of the number of variables affecting the distribution of Load on ground support walls, design procedures are Largely dependent upon empirical studies and correlations. The design procedures summarized in the two state-of-the-art reports by Peck (1969) and Bjerrum, Frimann-Clausen, and Duncan (1972) are based upon data primarily from internally braced, relatively flexible walls.

Figure 27 shows the conventional procedure for analyzing empirical load data. The approach has been to develop an apparent earth pressure diagram by distributing the maximum measured strut Loads during construction over an area described as midway between the upper and Lower adjacent spans of the particular strut Load measurement. The resulting apparent earth pressure diagrams are used to develop an envelope encompassing the maximum distributed pressures. This design envelope then represents the maximum strut Load that can be anticipated at any stage of construction.

5.22 Design Earth Pressure Diagram

Apparent earth pressure diagrams suggested by Terzaghi and Peck (1968) for design of braced walls are shown on Figure 28. Strut Loads for a given Level are determined by reversing the procedure used for development of the diagram. A strut is designed to support a load described by the area between the midpoints of the adjacent upper and Lower support Levels.

The following discussion does not include the effect of surcharge (see Section 5.40).

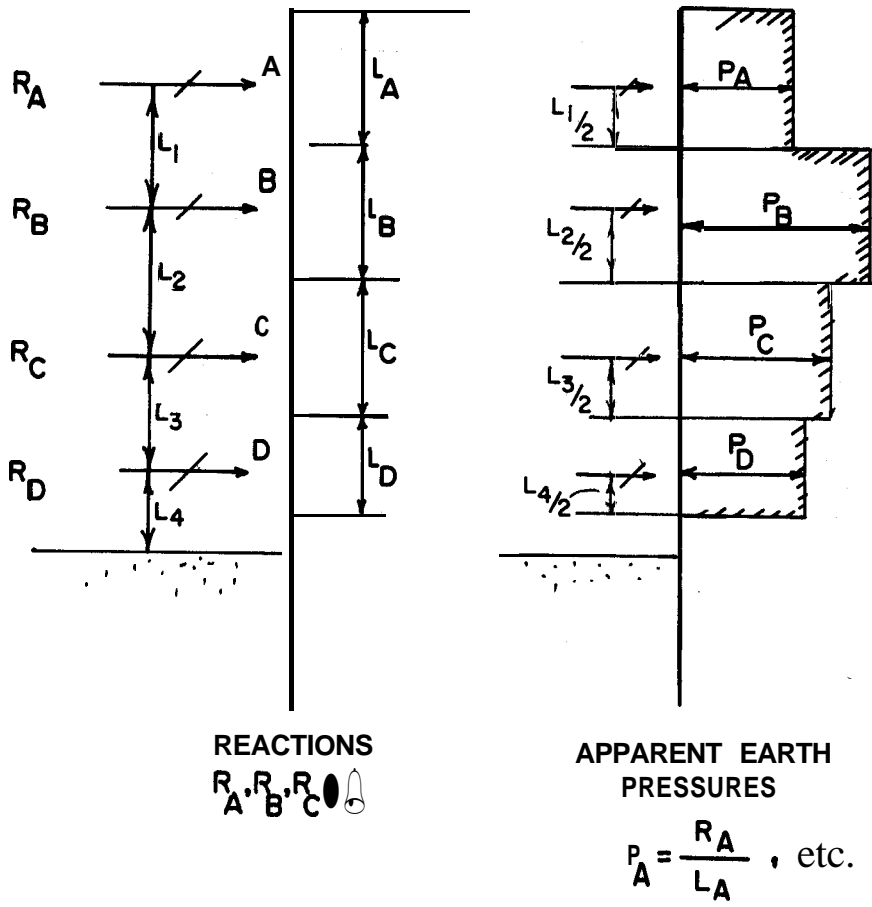
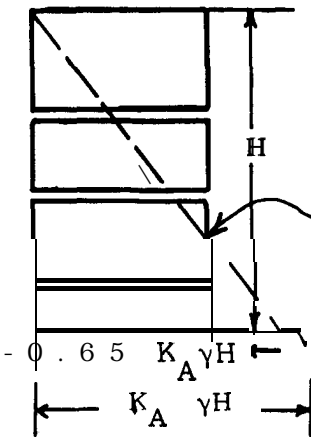

Figure 27. Conventional procedure for development of earth pressure diagram,

PRESSURE DISTRIBUTION

TOTAL FORCE



a) Sands

$$K_A = \tan^2(45 - \phi/2)$$

Rankine Active

$$P_t = \text{Trapezoid}$$

$$P_A = \text{Rankine}$$

$$P_t = .65 K_A \gamma H^2$$

$$P_A = .50 K_A \gamma H^2$$

$$\frac{P_t}{P_A} = 1.30$$

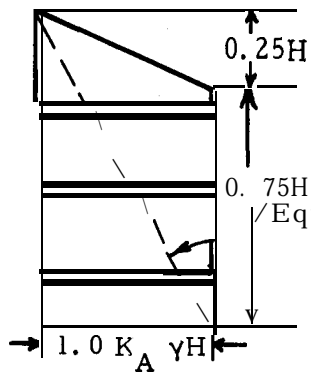

b) Soft to Medium Clays
($N > 6$)

For clays, base the selection

$$\text{on } N = \frac{\gamma H}{S_u}$$

Equivalent Rankine Active

$$K_A = 1 - m \frac{4S_u}{\gamma H} = 1 - \frac{4}{N}$$

$m = 1.0$ except

where cut is underlain by deep soft normally consolidated clay

$$m = 1.0$$

$$P_t = .875 \gamma H^2 (1 - \frac{4}{N})$$

$$P_A = .50 \gamma H^2 (1 - \frac{4}{N})$$

$$\frac{P_t}{P_A} = 1.75$$

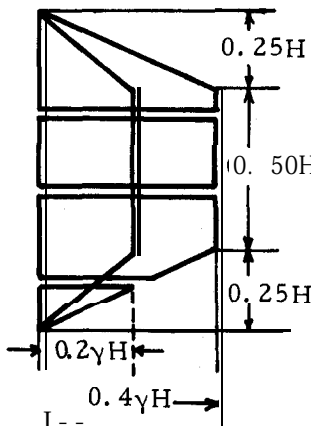

c) Stiff-Clays

For $N < 4$

For $4 < N < 6$, use the larger of diagrams (b) and (c).

$$P_t = .15 \gamma H^2 \text{ to } .30 \gamma H^2$$

$$\frac{P_t}{N} = 4, P_A = 0$$

$$N < 4, P_A < 0$$

NOTE: Equivalent Rankine Active = 0

Figure 28. Design earth pressure diagram for internally braced flexible walls (sands, soft to medium clays, stiff fissured clays), from Terzaghi and Peck (1968).

5.22.1 Sands

This diagram, which was developed from dewatered sites applies to cohesionless soils. If the soils outside the excavations remain submerged, then the earth pressure should be computed using the bouyant unit weight of the soil. Hydrostatic pressures are treated separately and added to the effect of the earth pressure.

5.22.2 Soft to Medium Clays

The recommended earth pressure diagram for these soils is shown in Figure 28b. The selection of an appropriate design diagram is dependent upon the stability number, $(N = \gamma H / S_u)$. The earth pressure computation for clays is based upon the total weight of soil, assuming undrained behavior. This follows from the fact that the data were empirically developed on the basis of total unit weights and the soils' initial shear strength.

Where the stability number (N) exceeds 5 or 6, shear deformation becomes significant. Note, by inspection of the empirical diagram for sands and for soft clays, that the latter is significantly greater than the equivalent Rankine pressure which is shown for comparison. The value of 'm' used in the determination, of the ordinate for earth pressure applies to situations where the cut is underlain by a deep deposit of soft clay. Its value can only be determined by empirical means from measurements and performance of an actual excavation. Experience thus far, reported by Peck (1969) from cases in Mexico City and Oslo, Norway, lead to the conclusion that the value of 'm' is in the order of 0.4 for sensitive clays. For insensitive clays the value of 'm' may be taken as 1.0.

5.22. 3 Stiff Clays

The recommended apparent earth pressure diagram for stiff clays is used when the stability number, N, is less than 4. This empirical diagram is independent of the value of shear strength, rather the lateral earth pressure is a function of the gravity forces only. Strains associated with excavations for cut and cover tunneling in these relatively strong soils are small, and the shear strength of the soil is only partially mobilized. However, the movement is sufficient to drop the lateral earth pressure below the K_o values (Gould, 1970).

5.22.4 Heavily Overconsolidated Very Stiff Fissured Clays

Several cases have been reported which suggest that stress relief from excavation leads to lateral deformation of these soils toward the excavation. The mechanism probably includes both elastic strain and volumetric expansion. The elastic deformations occur during the excavation process whereas the swelling is time dependent and is a result of the development of negative pore pressures caused by stress relief. Soil behavior would suggest that the deformations should increase with increasing overconsolidation ratio, increasing plasticity of clay, depth below the water table, and intensity of fissuring in the soil. For strutted excavations, this condition may lead to build up of strut load with time.

Pending the reporting of more field experience, design criteria for cases involving potentially, laterally expansive soils are as yet undeveloped. Therefore, a laboratory test program (possibly stress-path triaxial) should be undertaken to aid in evaluating the magnitude of the problem. Prototype test sections with construction monitoring are also recommended.

5.22.5 Dense Cohesive Sand; Very Stiff, Sandy Clay

Recent papers concerning measurements of loads in dense cohesive sands and sandy clays have been reported by Armento (1972), Liu and Dugan (1972), O'Rourke and Cording (1974) and by Chapman, et al (1972). Several cases involved cohesionless soils (either fill or natural deposits of sand) within the upper portions of the excavations. Others included interbedded strata of stiff clay. In all cases, the soils near or below the bottom of the excavation were extremely dense and highly over consolidated.

The cases reported that the following factors affect the load distribution:

- a. Cohesionless soils within the upper portion of the cut.
- b. The construction procedure.
- c. The depth of the excavation and bracing sequence.

Chapman, et al (1972) report that for a number of cases studied in Washington, the ordinate of the apparent pressure diagram increased from $0.15 \gamma H$ for 30-foot cuts to $0.23 \gamma H$ for 60-foot deep cuts. They attribute the low pressures at shallow depth to the relative importance of soil cohesion. O'Rourke and Cording (1974) in their report to the Washington Metro also noted an increase in the ordinate of the apparent pressure diagram with depth.

Recommended design diagrams for dense cohesive sands and very stiff sandy clays are shown in Figure 29. The minimum pressure line is associated with cuts having reasonably consistent spacing between wale levels, relatively uniform soil conditions, and depths less than about 30 or 40 feet. The maximum pressure line is recommended to cover uncertainty regarding the effect of weak strata within the depth of cuts, the contingencies arising from construction (for example, over-excavation below support level or ineffective toe berms), and cuts in excess of 60 or 70 feet deep.

Cohesive soils near the top of the cut will justify pressure reduction as shown in Figure 29a. Absence of cohesive soils near the top of cut will require the higher pressures associated with Figure 29b.

5.22.6 Stratified Soils

The aforementioned cases are for readily idealized soil profiles. Actual soil conditions may have a stratigraphy which does not conveniently match these simplified cases. Moreover, an irregular ground surface or surcharge may complicate the analysis.

Under such circumstances, one approach is to determine the Lateral thrust either on the basis of classic active earth pressure or on the basis of trial planar sliding surfaces and wedge stability analysis. In this latter case the most critical wedge is used to determine the Lateral thrust (see Chapter 8). In such cases, hydrostatic forces are treated separately.

Once the lateral thrust is determined, it should be increased by the most appropriate value of P_t/P_A (ratio of force from the empirical diagram to the force determined from the analysis from active earth pressure or wedge equilibrium). The designer must choose the most appropriate ratio based upon a comparison of the actual case to one of the simplified cases presented in this section.

The final question is one of pressure distribution. Again, at least initially, this is a question of the designer's judgement by com-

(a) RELATIVELY UNIFORM CONDITIONS

$$P_t = 0.112\gamma H^2 \text{ TO } 0.188\gamma H^2$$

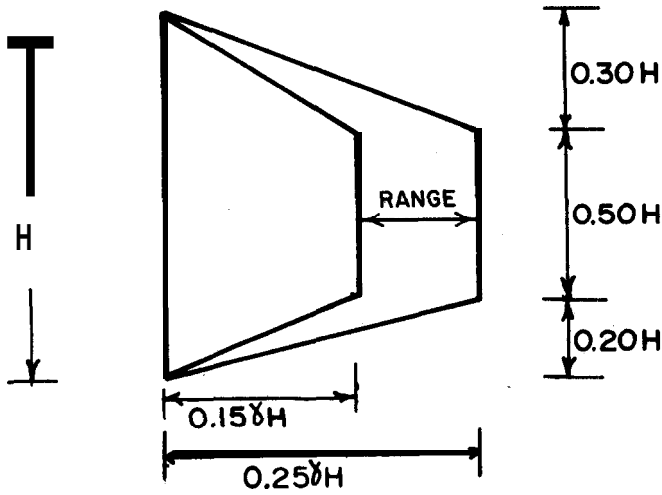

(b) UPPER THIRD OF CUT DOMINATED BY COHESIONLESS SOIL

$$P_t = 0.135\gamma H^2 \text{ TO } 0.225\gamma H^2$$

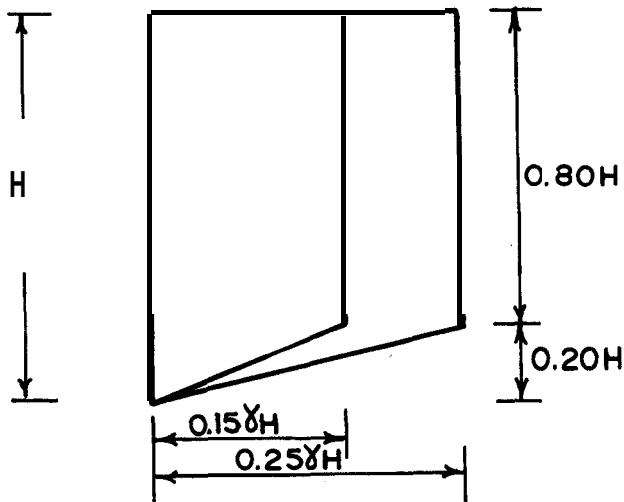

Figure 29. Proposed pressure diagram for internally braced flexible walls (dense cohesive sands, very stiff sandy clays).

parison with the simplified cases. Serious questions may need field measurements to provide data input during construction.

5. 30 TIEBACKS

5. 31 Background

Many practitioners have successfully applied the empirical rules developed for internally braced walls to tiebacks; others make variations for tied-back installations. In any event, at the present time there are no empirical methods for tied-back walls that have been accepted as universally as **Peck's** rules for internally braced flexible walls.

In a series of model tests, Hanna and Matallana(1970) studied the effect of prestressing a **wall** to different design pressures and distributions. They observed with excavation that triangular distributions tended to redistribute Load to an apparent trapezoidal distribution. In addition, when ties were prestressed to loads corresponding to a trapezoidal distribution, there was Less Load redistribution and the movements were less than for the cases with triangular distributions. One problem with Hanna and **Matallana's** work was the Location of the ties. They were connected to a rigid wall of the experimental setup rather than embedded in the soil mass.

Apparently the tieback prestress has a significant effect upon the pressure distribution. Clough (1972) found, after studying several tied-back cases, that the pressure distribution suggested a parabolic shape; moreover, this was borne **out** by finite element analyses.

5. 32 Comparison Between Bracing and Tiebacks

Tied-back installations differ from internal bracing in their deformation mode, in the mechanics of stress conditions in the soil, and in various construction aspects.

a. Deformations associated with tiebacks and bracing are discussed in Chapter 2. Internally braced walls are restrained at the top and tend to move inward with depth by rotation about the top, whereas tied-back walls are more free to move inward at the top. Thus, the deformation mode often develops as inward rotation about the bottom. This latter mode is theoretically compatible with the "**fully**" active state and linear pressure increase with depth.

b. Temperature: Bracing loads may be significantly affected by temperature increase, especially by direct sunlight - to the extent that some projects require remedial measures to reduce thermal effects. Tiebacks are not subject to severe temperature changes since they are insulated in the ground. Thermal effects are more pronounced in prestressed struts when the strut is essentially between two unyielding supports.

c. Preload: Tiebacks are **typically** Locked off at 75 percent or more of the design Load. Observations suggest that tiebacks will either maintain their load or experience a slight load Loss with time. On the other hand, struts are generally **preloaded** to 50 percent or Less of the design Load and **will** gain Load as the excavation proceeds. (A greater preload in struts may risk excessive Load, especially from temperature rise.) These observations suggest that prescribed preloads for tiebacks are greater than the earth pressure wishes to impose. In effect, the tieback **lockoff** Load predetermines earth pressure rather than vice versa.

d. Mechanics: Tiebacks do not act by themselves, but in consort with the earth mass within which they are embedded. This behavior tends to dampen out Local variations in a given soil stratum and thus Leads to more uniform loading on the wall.

e. Load Variation: Overall, Load variation with tiebacks is Less than **with** bracing. Production testing of each tie above design Load, locking-off at 75 percent or greater of design Load, insulating from temperature effects, and engaging of an earth mass between the **wall** -- all tend to Lessen the variation in Load between individual tiebacks.

5. 33 Recommendations for Tiebacks

The following discussion does not include the effect of surcharge (see Section 5.40)

Because of the reasons cited above, the Load variation on individual tiebacks is believed to be Less than that on internal bracing. Thus, it follows that the design pressure envelope for tiebacks need not be as conservative as that for internal bracing. This does not mean that the resultant horizontal force on a section is Less with tiebacks. The actual resultant Lateral force must be differentiated from the empirical design envelope which is greater 'because it assures that no one tieback level is overstressed. Paradoxically, if one were to compare the actual forces on a given **cross**-section, the force on conventionally

installed tiebacks would probably exceed the force on a braced wall. This is because of the prestressing of tiebacks.

Only limited documentation is available to quantify conclusions concerning the relative magnitudes of appropriate pressure envelopes for tiebacks and bracing. Accordingly, there is no present justification for significantly changing the pressure diagrams for tied-back walls from those used for internally braced walls. The following recommendations for tied-back walls yield similar total forces, but the pressures are distributed somewhat differently than for internally braced walls.

The soil classifications are the same as for internally braced walls shown in Figures 28 and 29 namely; sands, soft to medium clays, stiff clays, and dense cohesive sands or very stiff sandy clays. A triangular pressure distribution, increasing linearly with depth, is recommended for soft to medium clay; a uniform pressure distribution is recommended for all other cases.

a. Sands: Where deformations are critical, and it is intended to prestress to LOO percent of design Load, compute force using K_o . For dense sands $K_o = 0.4$; for Loose sands $K_o = 0.5$. Thus, the uniform ordinate will vary from:

$$\text{Uniform Pressure, } p = 0.20 \gamma H \text{ to } 0.25 \gamma H$$

$$\text{Force, } P_t = 0.20 \gamma H^2 \text{ to } 0.25 \gamma H^2$$

Where deformations are not critical, use $K_{avg} = \frac{K_o + K_a}{2}$, that is

a coefficient midway between active and at rest. A similar procedure was used by Hanna and Matallana (1970).

Typical range is:

Loose sand:

$$K_a = 0.33; K_o = 0.50$$

$$K_{avg} = 0.42$$

$$\text{Force, } P_t = L/2 \times 0.42 \gamma H^2 = 0.21 \gamma H^2$$

$$\text{Uniform Pressure, } p = 0.21 \gamma H$$

Dense sand:

$$K_a = 0.24; K_o = 0.40$$

$$K_{avg} = 0.32$$

$$\text{Force, } P_t = L/2 \times 0.32 \gamma H^2 = 0.16 \gamma H^2$$

$$\text{Uniform Pressure, } p = 0.16 \gamma H$$

b. Stiff to Very Stiff Clays: Use a uniform pressure ordinate of $0.15\gamma H$ to $0.30\gamma H$ to produce the same force magnitude as that for braced excavations. The higher value is associated with a stability number of about 4. The lower number is associated with very stiff clays where the stability number is less than 4. The force varies as follows:

$$\text{Stiff Clays, } P_t = 0.30 \gamma H^2$$

$$\text{Very stiff clays, } P_t = 0.15 \gamma H^2$$

c. Cohesive Sand, Very Stiff Sandy Clays: Compute the total force associated with the diagram for braced excavations (Figure 28) and distribute the force uniformly with depth. For relatively uniform conditions use:

$$\text{Force, } P_t = 0.112 \gamma H^2 \text{ to } 0.188 \gamma H^2$$

$$\text{Uniform Pressure, } p = 0.112 \gamma H \text{ to } 0.188 \gamma H$$

Where the upper third of the cut is dominated by cohesionless soil use:

$$\text{Force, } P_t = 0.135 \gamma H^2 \text{ to } 0.225 \gamma H^2$$

$$\text{Uniform Pressure, } p = 0.135 \gamma H \text{ to } 0.225 \gamma H$$

d. Soft Clays: It is unlikely that tiebacks would be used unless they could be embedded in an underlying denser stratum of soil or in rock. The walls should be designed with a triangular earth pressure diagram assuming at-rest conditions and a K_o value between 0.5 and 0.6.

$$\text{Force, } P_t = 0.25 \gamma H^2 \text{ to } 0.30 \gamma H^2$$

In normally consolidated sensitive clays, excessive prestressing should be avoided because of the potential for induced consolidation (see McRostie, et al, 1972).

e. Stratified Soils: As with braced excavations an approach based upon active earth pressure or wedge equilibrium should be investigated. Section 5.22.6 generally describes a procedure for increasing the computed force in the same proportion as that of the most closely related simplified soil profile that exceeds active earth pressure. Use the force distribution most closely related to the simplified case.

5. 34 Effect of Wall Stiffness on Load Distribution

Theoretical analyses of the effects of wall stiffness on tie-back loads (Egger, 1972; **Clough** and Tsui, 1974) and model tests (James and Jack, 1974) indicate that wall stiffness does affect anchor and wall load distribution.

Finite element analyses have shown that a more uniform load distribution occurs for a stiff wall than for a flexible wall. In the more flexible walls the pressure distribution concentrates at the wale level due to arching. The difference between the load distribution for stiff versus flexible walls is greater with increased spacing between the wale levels. Clough and Tsui (1974) suggest that for typical spacing of tiebacks there is a relatively minor load distribution difference for the different wall types. Therefore, there appears to be no present **justification** for drawing a distinction in **pressure** distribution on the basis of wall stiffness.

5.40 SURCHARGE LOADING

5. 41 General Background

Surcharge near excavations may be the result of many different types of loading conditions including footing structures, storage of construction materials, or traffic. The Lateral pressure caused by a surcharge Load on a retaining wall has been investigated for a variety of different loading and soil conditions (Spangler, **1940**; **Newmark**, 1942; Ter **zaghi**, **1954b**). This pressure is in addition to the normal earth and water pressure.

5. 42 Theoretical Considerations

The four basic Loading conditions for which **solutions of** the lateral stresses in an elastic medium are readily available are:

1. Point loading
2. Uniform line Loading

3. Irregular area Loading

4. Uniform area Loading

Typically, the stresses within a soil mass due to surcharge loadings are computed on the basis of elastic half-space theory; When the wall is represented as a rigid boundary, it is necessary, to double all stresses obtained from half-space theory at the face of the wall in order to maintain compatible boundary conditions.

When lateral strains of the same magnitude as those in an elastic half-space do occur, it is not necessary to double the stress. In general, the true value of lateral pressure due to surcharges will be somewhere between these two cases. Since the assumption of an unyielding rigid boundary is conservative, uniform application of this rule should be questioned, and judgements made as to the appropriateness of the assumption for a given job condition (Gould, 1975).

5.43 Practical Considerations

With regard to surcharge loading from construction operations, it is common to take a distributed surface surcharge on the order of 300 psf to cover storage of construction materials and general equipment. Usually, this surcharge should be considered within a rather limited work area on the order of 20 feet to 30 feet from the cofferdam wall.

A second major consideration is the question of concentrated loads from heavy equipment (concrete trucks, cranes, etc.). Lateral thrust from such equipment would be easily covered within the 300 psf surcharge, provided that the equipment were more than approximately 20 feet from the wall. On the other hand, such equipment within a few feet of the wall may create a concentrated surcharge loading which would be of far greater significance than a uniform surcharge Loading. This must be accounted for separately. It may necessitate the designation of specific areas rather than designing the entire cofferdam for such Loading.

5.44 Point Load

While it is impossible to have a perfect point loading situation, the computed stress for an area Load or a point load is essentially the same when the distance to the wall is large compared to the size loaded area. The difference is small if a point load is assumed when the distance is greater than twice the average dimension of the Loaded area. There are several practical cases for which point loadings may

be as **sumed**. An isolated footing for a **structure** or a heavy object resting on a small base may be cases that can best be analyzed as point Loadings .

In the work of **Spangler** and Gerber, summarized by Terzaghi (1954b), it was shown that there is little change in the magnitude or distribution of Lateral stress from that determined by elastic theory **until** the point Load is located at a distance x Less than $0.4 H$ from the wall. This Leads to the following equations **for evaluating** the effects of a point Load on a rigid wall.

For $m < 0.4$:

$$\sigma_h = \frac{0.28 n^2 Q_p}{(0.16 t n^2)^3 H^2}$$

where:

σ_h = horizontal stress at a depth, $z = nH$

Q_p = magnitude of point Load

H = height of cut

$n = \frac{z}{H} = \frac{\text{depth to point on wall}}{\text{depth of cut}}$

$m = \frac{x}{H} = \frac{\text{distance of point Load from wall}}{\text{depth of cut}}$

For $m > 0.4$:

$$\sigma_h = \frac{1.77 m^2 n^2 Q_p}{(m^2 t n^2)^3 H^2}$$

Figure 30a presents solutions to these equations for selected values of m . The equation for $m < 0.4$ has been derived from measured lateral pressures and does not correspond to results from elastic theory. For $m > 0.4$, the equation gives values twice that of elastic theory to account for the wall as a non-yielding reflective boundary.

Figure 30c shows how the Lateral stress for a point Load varies along the Length of the wall. The calculation of σ_h gives the horizontal stress on a vertical plane lying perpendicular to the wall and through the point Load. The horizontal stresses along the wall vary as $\sigma_h' = \sigma_h \cos 2(1.1\theta)$.

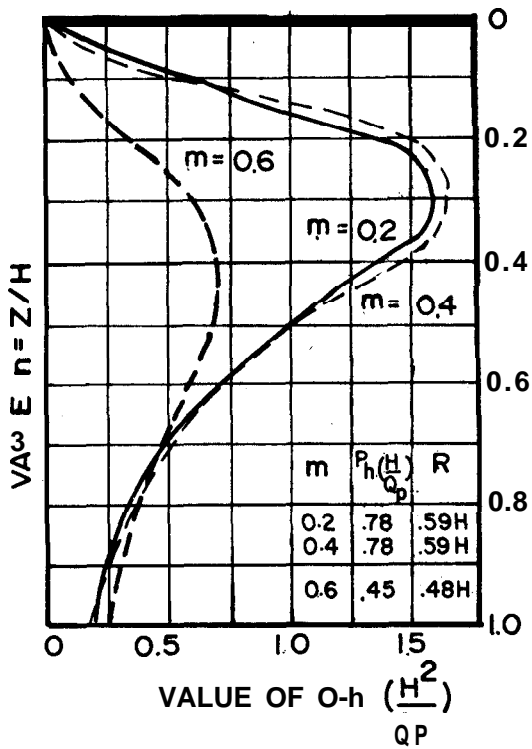

(a)

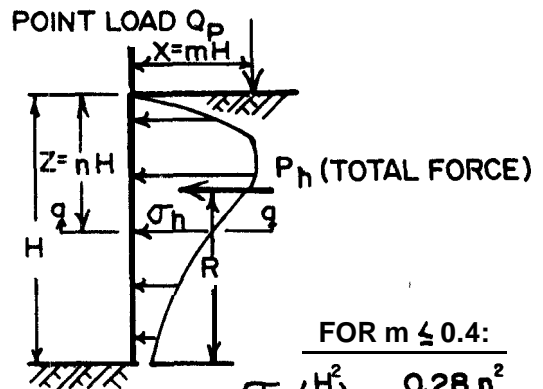

(b)

$$\text{FOR } m \leq 0.4: \quad \sigma_h \left(\frac{H^2}{Q_p} \right) = \frac{0.28 n^2}{(0.16 + n^2)^3}$$

$$\text{FOR } m > 0.4: \quad \sigma_h \left(\frac{H^2}{Q_p} \right) = \frac{1.77 m^2 n^2}{(m^2 + n^2)^3}$$

NOTE:

$$m = \frac{X}{H}$$

$$n = \frac{Z}{H}$$

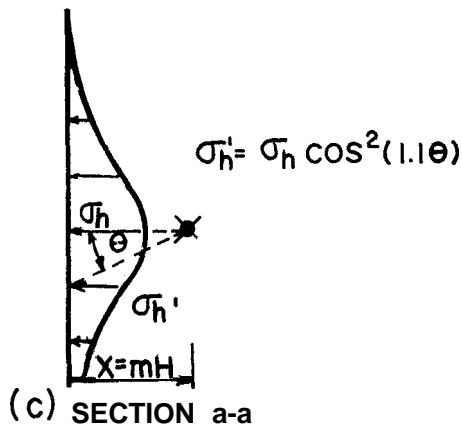

(c) SECTION a-a

Figure 30. Lateral stresses on the face of an unyielding wall from a point loading (NAVFAC, 1971 and Terzaghi, 1954b).

5.45 Line Load

Terzaghi (1954b) also synthesized previous works on the effect of line load on rigid walls. Figure 31 presents simplified equations for evaluating horizontal stresses for a line load which is parallel to the direction of the wall and located a distance, x , from the wall. In practice, such a situation may arise if a continuous strip footing runs parallel to an excavation. Again, these equations are for a non-yielding wall.

As for the case of the point loading, where $m < 0.4$, the horizontal pressures predicted by elastic theory are too high. Hence, the equations given have been modified to correspond to measured lateral pressures. Where the load is located a distance less than $0.4 H$ from the wall, there is little change in the magnitude and distribution of lateral pressures from that computed at a distance x equal to $0.4 H$ (see Figure 31). The variation in the location of the resultant, P_h , is also small until $x > 0.4H$. The equations presented in this section have been adjusted to represent the boundary conditions of a rigid wall.

5.46 Irregular Area Loading

In some instances it may be unrealistic to assume a surcharge loading of infinite extent behind a wall. Theoretical solutions for area loading of limited (and irregular) dimensions have been developed for elastic half-spaces. Newmark (1942) presents an influence chart for use in determining the horizontal stress on a vertical plane. Although the chart was developed on the basis of Poisson's ratio $\nu = 0.5$, Newmark (1942) does give a method of converting these values to soils with other values of Poisson's ratio. The values of horizontal stress derived from Newmark's (1942) chart are for an elastic half-space. If the wall is assumed to be rigid, the values from the chart should be doubled.

Figure 32 shows an influence chart for evaluating the lateral stresses acting on a rigid wall from a rectangular loading (Sandhu, 1974). These charts assume a Poisson's ratio of 0.5 for the soil mass. Using the influence charts for point loadings, the lateral stress due to an irregular surcharge loading can be more easily calculated.

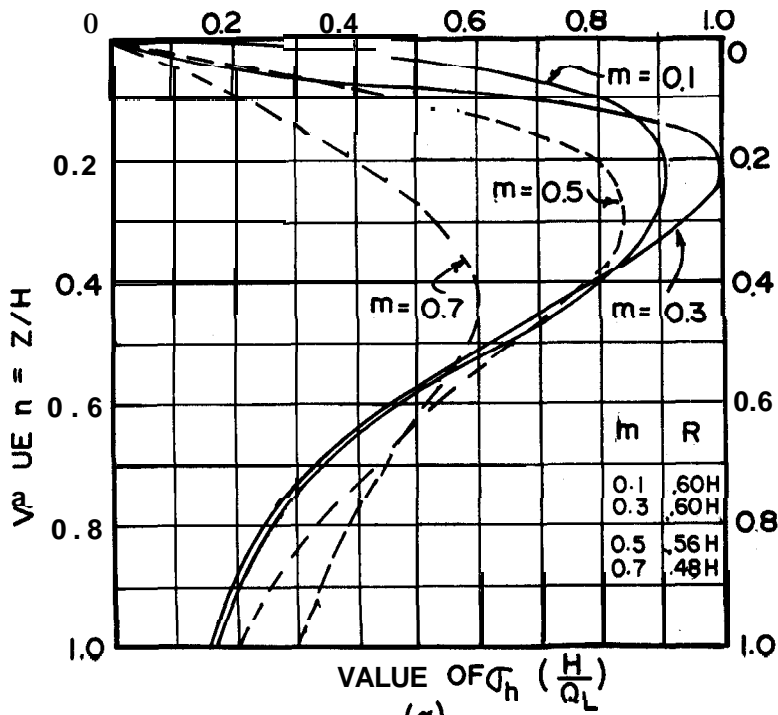

LINE LOAD Q_L

(d)

FOR $m \leq 0.4$:

$$\sigma_h \left(\frac{H}{Q_L} \right) = \frac{0.20n}{(0.16+n^2)^2}$$

$$P_h = 0.55 Q_L$$

FOR $m > 0.4$:

$$\sigma_h \left(\frac{H}{Q_L} \right) = \frac{1.28m^2n}{(m^2+n^2)^2}$$

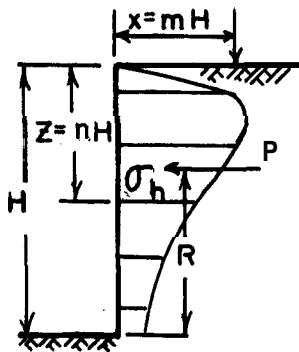

RESULTANT

$$P_h = \frac{0.64 Q_L}{(m^2 + 1)}$$

Figure 31. Lateral stresses acting on an unyielding wall from a uniform line loading (NAVFAC, 1971 and Terzaghi, 1954b).

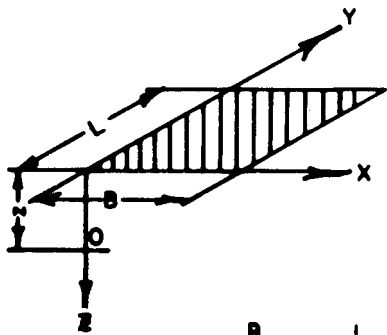

$$m = \frac{B}{z}, \quad n = \frac{L}{z}, \quad p = q \times I_p$$

$$\mu = 0.5$$

Q = SURCHARGE

L = LENGTH PARALLEL TO WALL

B = LENGTH PERPENDICULAR TO WALL

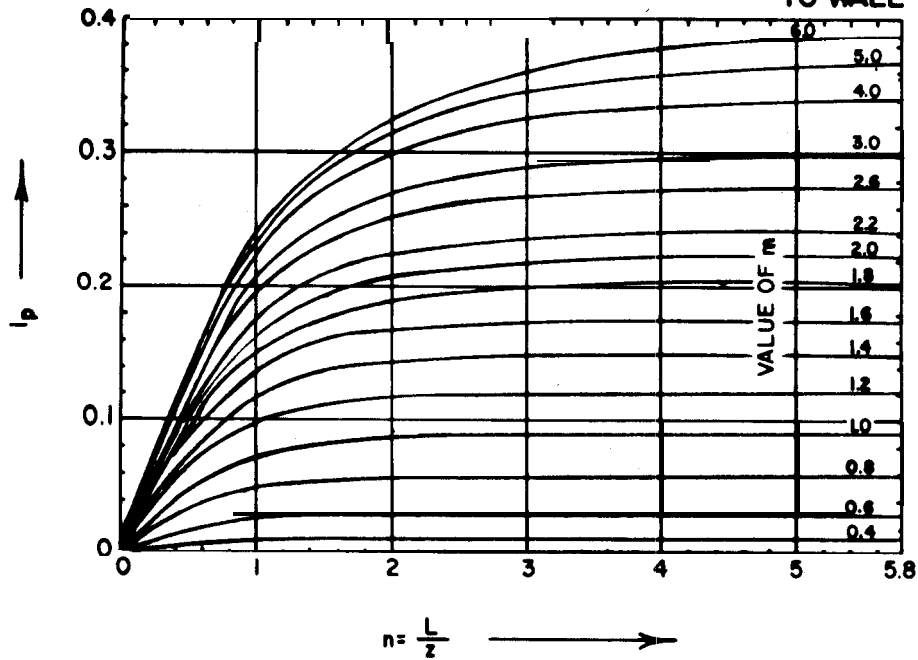

Figure 32. Lateral stresses on an unyielding wall due to irregular surface loading (Sandhu, 1974).

5.47 Uniform Area Loading

Intensity and distribution of Loading was discussed in Section 5.43. One approach is to treat the surcharge as a stress in an elastic medium. The solution for lateral stresses on a rigid wall are presented in Figure 32. An example of the stress effect with depth is shown in Figure 33. Note that the stress influence below a depth of about $1.5B$ is negligible.

A second approach is to apply an earth pressure coefficient, K , to the surcharge loading and to consider the surcharge effective within some portion of the cut. The magnitude of this coefficient will range from K_a (active earth pressure) to K_o (earth pressure at rest).

In evaluating which of the above approaches to use, one should first establish whether or not there are significant design implications between the various methods. If there are then one must apply judgement concerning the relative rigidity of the wall (see Section 5.42). Moreover if the surcharge exists during the excavation process, then the appropriate coefficient is closer to K_a . If the surcharge is applied after excavation and bracing against a relatively unyielding wall, then one should use K_o or Figure 32.

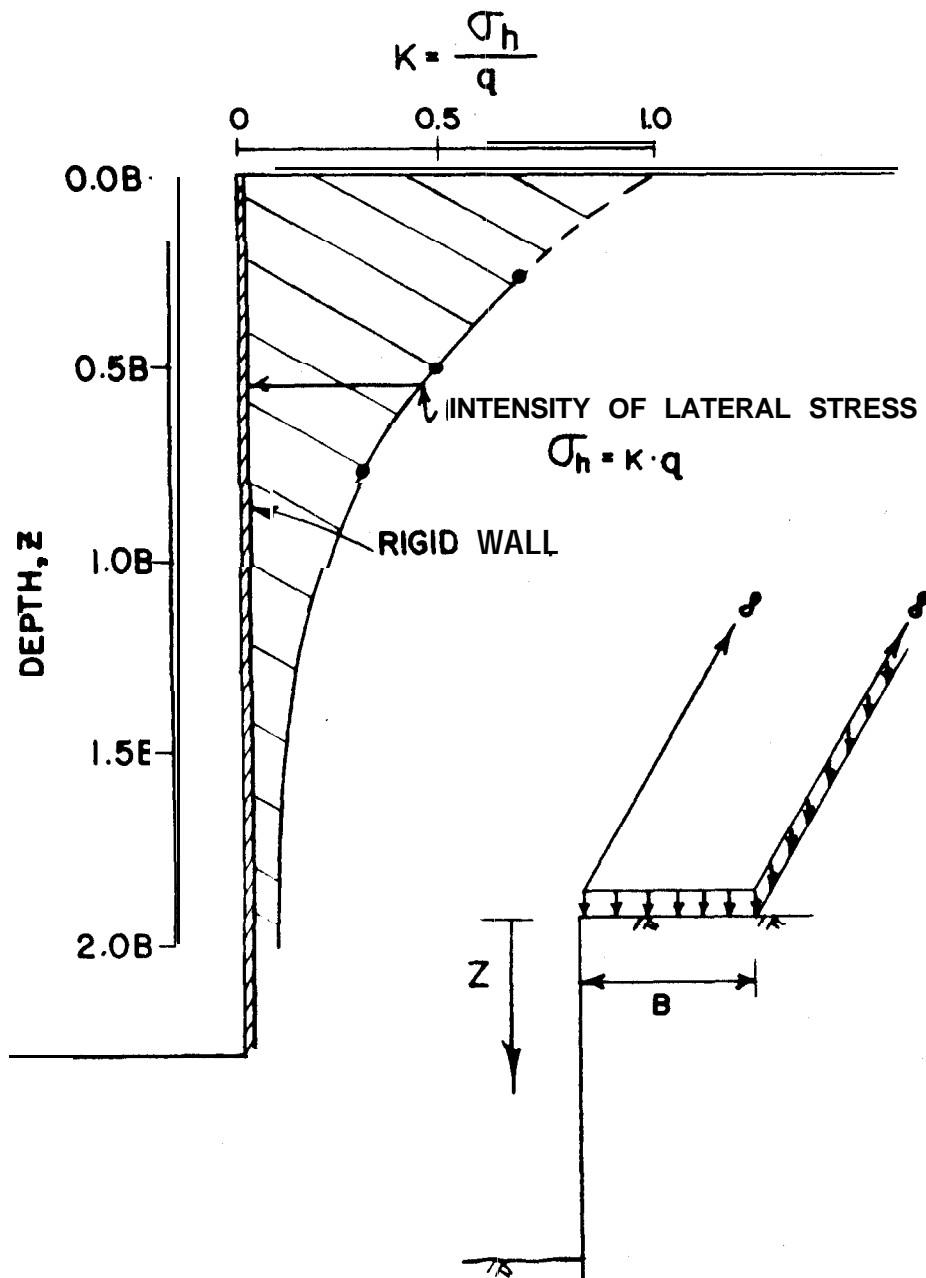

Figure 33. Lateral stress on rigid wall from surcharge of width B and infinitely long (solution from Sandhu, 1974).

CHAPTER 6 - PASSIVE RESISTANCE BELOW BASE OF EXCAVATION

6.10 GENERAL

The design process frequently requires that the soils below the base of an excavation provide passive resistance for force equilibrium or to limit movement. The performance of the wall will depend upon the spacing of the support Levels since the greater the spacing, the greater the required passive resistance (and movement) below the Lowermost support level. Figure 34 illustrates the case of a wall in which the passive resistance of the soil is insufficient to limit excessive wall movements.

This section will describe the selection of soil parameters and methods used to evaluate passive resistance. This section will not consider the depths of penetration required to maintain overall stability of the earth mass or to limit displacements.

6.20 SOIL PARAMETERS

This section summarizes the soil properties relevant to the calculation of the passive pressures. Chapter 3 of this volume presented the basic concepts in more detail.

6.21 Granular Soil

Granular soils are free draining and cannot sustain positive or negative pore pressures generated by strain or Load changes for even a short period of time. Therefore, analyses of the stability of granular soils is performed on the basis of drained strength parameters and effective stresses in the ground referenced to the static water level. The appropriate soil strength parameter for the soil is the angle of internal friction, ϕ , for the soil. For design, granular soils are assumed to have no cohesive strength component.

6.22 Cohesive Soil

Passive stress conditions occur with excavation below the Last placed support Level. Because of the load decrease from excavation, soils in the passive zone just below the excavation will initially experience a pore pressure decrease. As a result, a gradient is set up which causes water to flow into the voids of the soil. This causes excess pore pressure to rise (i.e. become Less

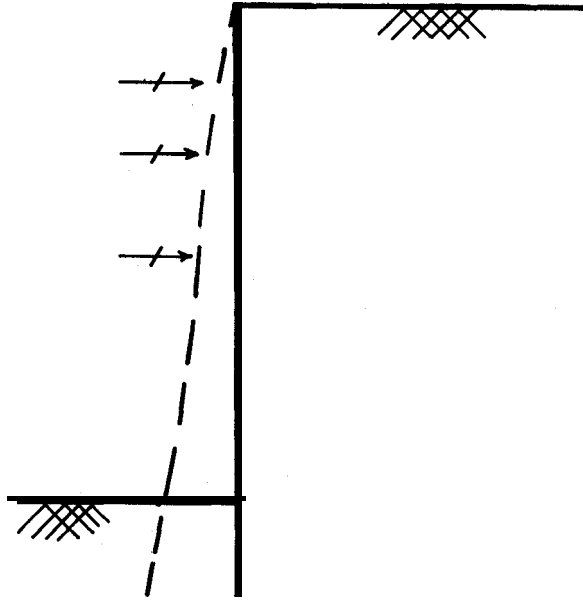

Figure 34. Movement at wall base due to insufficient passive resistance.

negative.) This may be accompanied by heave caused by swelling of the soil.

Limiting case strength parameters for passive pressure computation are:

a. Immediate Condition: Pore pressures generated by unloading and strain do not have time to dissipate. Moreover, pore pressure cannot be reliably predicted. Use undrained strength of soil at natural water content, S_u . Conventionally, this is determined from vane shear, unconfined compression, or unconsolidated undrained compression tests.

b. Ultimate Condition: Pore pressures generated by unloading and strain are dissipated by drainage. Effective stresses can be computed on the basis of static water levels. Use strength parameters from the effective stress envelope, \bar{c} and $\bar{\phi}$.

Specific cases obviously require soil testing and analysis in the light of soil properties, boundary conditions, and construction time. General recommendations for strength relationships are to use undrained strength parameters for the "during excavation" stage, that is, during the period of sequentially excavating and installing braces or tiebacks. For the fixed depth conditions, pore pressures will generally have sufficient time to dissipate, and therefore, effective stress parameters will apply for this limiting case condition. With in-situ pore pressure measurements during construction, the passive force can be assessed in terms of effective stress strength parameters based upon the computed effective stress conditions.

As was pointed out in Chapter 3, the undrained strength at natural water content may be greater than the drained strength of over consolidated soils. Therefore, indiscriminate use of undrained strength without regard for pore pressure dissipation may be on the unsafe side.

Two factors that affect strength loss with pore pressure dissipation are the proximity of the soil element to the bottom of the excavation and the amount of unloading. Typically, the drained strength of cohesive soils in the passive zone of deep cuts will be the controlling strength.

6.30 ANALYSIS OF PASSIVE RESISTANCE

Several articles and texts address the problem of passive pressures that can develop behind a continuous wall (Terzaghi, 1954b; NAVFAC, 1971). In cohesionless soil wall friction modifies both the direction and magnitude of the passive resistance. Typically, the resultant of the passive pressure acts at an angle δ equal to 1/2 to 2/3 of the angle of internal friction. The following table (from Terzaghi, 1954b) summarizes values of K_p for various values of ϕ and δ .

Values of Passive Earth Pressure Coefficient
as a Function of ϕ and δ

ϕ	$\delta = 0$	$\delta = \phi/2$	$\delta = 2/3 \phi$
25°	2.46	3.00	3.20
30°	3.00	4.20	4.80
35°	3.70	6.50	7.30
40°	4.60	9.20	11.00

The passive pressure for drained loading or in terms of effective stress at depth, z , will be:

$$\bar{\sigma}_p = \bar{\sigma}_v \tan^2 (45^\circ + \bar{\phi}/2) + 2\bar{c} \tan (45^\circ + \bar{\phi}/2) \quad \text{Eq. 6.30.1}$$

where :

$\bar{\sigma}_p$ = passive pressure (effective stress)

$\bar{\sigma}_v$ = vertical effective stress = $\gamma_z - u$

$\bar{\phi}$ = angle of internal friction (effective stress envelope)

\bar{c} = cohesion intercept

For this drained condition, in which by definition there is no excess pore pressure, the total lateral stress at any depth, z , will be:

$$\sigma_h = \bar{\sigma}_p + \gamma_w z \quad \text{Eq. 6.30.2}$$

where:

σ_h = lateral stress

γ_w = unit weight of water

The passive resistance of cohesive soils in an undrained condition should be evaluated on the basis of the undrained shear strength, S_u , and the in situ total vertical stress, σ_v . For a continuous wall, the passive pressure at a given depth will equal:

$$\begin{aligned}\sigma_p &= \sigma_v + 2 S_u \\ &= \gamma_{zt} + 2 S_u\end{aligned}\quad \text{Eq. 6.30.3}$$

where:

$$\sigma_v = \text{total vertical stress} = \gamma z$$

$$S_u = \text{undrained shear strength of the soil}$$

In this case, the water pressure is not added because pore pressure effects are already accounted for in the determination of undrained shear strength, S_u . Therefore, the total lateral stress at any depth, z , will be:

$$\sigma_h = \sigma_p = \gamma z + 2 S_u \quad \text{Eq. 6.30.4}$$

Soldier pile walls are not continuous walls, therefore the passive earth pressure coefficients must be modified from those used for continuous walls, Broms (1965) showed that the passive resistance of laterally loaded piles based upon pile width and on K_p values for continuous walls was too conservative. His study showed that soil arching and non-plane strain conditions increase the capacity of individual piles. Indeed, the process is probably closely related to lateral bearing capacity. Broms' recommendations are given in the charts shown in Figure 35. It should be noted that for cohesive soils the lateral resistance of the soil should be neglected to a depth of 1.5 pile diameters. In cohesionless soils where the depth of penetration is greater than one pile diameter, soil arching causes an effective increase of 3.0 in the value of K_p .

A factor of safety of 1.5 is recommended for use in passive pressure calculations.

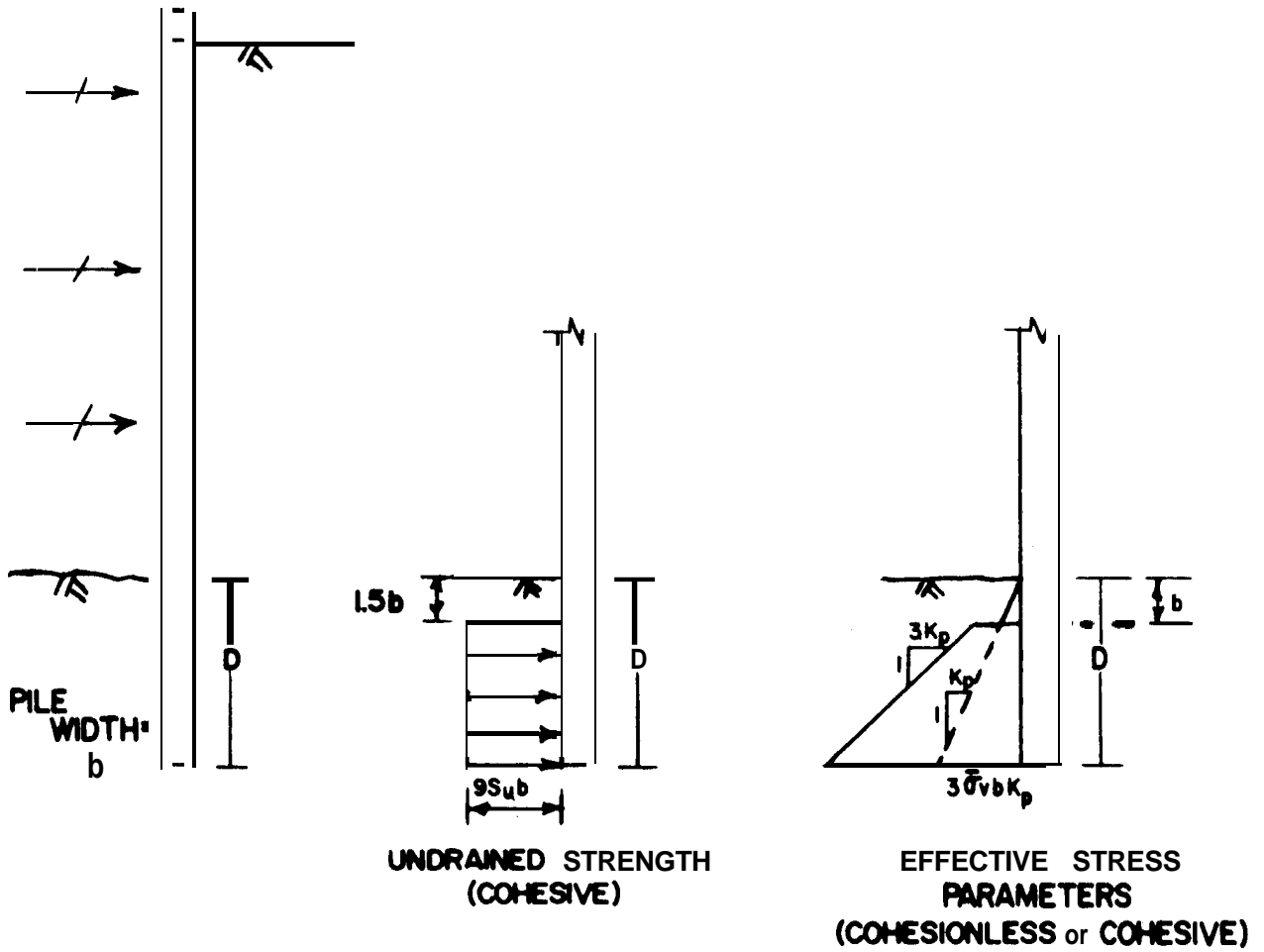

Figure 35. Passive pressure for soldier piles
(after Broms, 1965). (Modified.)

6.40 OVERCUT DESIGN DETAILS

Over-excavation below the required support level depth is common either to obtain working room or to muck up the bottom, During intermediate excavation phases, assume a minimum of two feet of overcut before strut placement. At final depth, assume a minimum of one foot of over cut.

6.50 BERMS

Lateral resistance of berms will, of course, be lower than the case of a horizontal plate at the top elevation of the berm. One method of analysis is by wedge or logarithmic spiral force equilibrium of trial failure surfaces. Another procedure is to replace the berm with an equivalent sloping plane and assign the appropriate passive coefficient (Terzaghi and Peck, 1968; NAVFAC, 1971).

CHAPTER 7 - DESIGN ASPECTS OF LATERAL PRESSURE

The analysis of forces acting on a support wall, the related sizing of members, and the determination of wall penetration below the bottom of the excavation is related primarily to the wall stiffness and the type of wall. The wall stiffness is related to the ratio $\frac{EI}{L^4}$.

For example, steel sheet piling and soldier pile walls with a typical wale spacing of eight feet or more and **generally greater** horizontal distance between support members are considered to be "flexible" walls. Design earth pressure diagrams should be determined in **accordance** with **Chapter 5**.

7. 10 LOAD ON SUPPORT LEVELS

Commonly, wale loads are determined by area proportioning from the pressure diagrams developed from field measurements. This method for evaluating wale loads merely consists of reversing the procedure for developing the apparent earth pressure diagrams shown in Figure 28. This procedure is illustrated in Figure 36.

7. 20 ANALYSIS OF WALES AND SUPPORT WALLS

7. 21 General

Deflection of structural members supporting soil causes arching of earth resulting in a reduction of pressure near the center of spans and a concentration of pressure at the supports. Hence, the actual bending moments in wall elements and wales is less than that which would be computed assuming a uniform loading on these **flexural** members.

Several approaches have been used to determine moments in support members. Armento (1972), for example, used 80 percent of the uniform apparent pressure and computed moments assuming hinges at support levels. Peck, Hanson, and Thornburn (1974) propose using $\frac{2}{3}$ of the apparent pressure and assuming continuity over supports in computing moments.

The approach used herein, for moment computation in wales and support walls, is to use 80 percent of the loading diagram. For evaluation of loads in internal bracing and tiebacks, the full loading

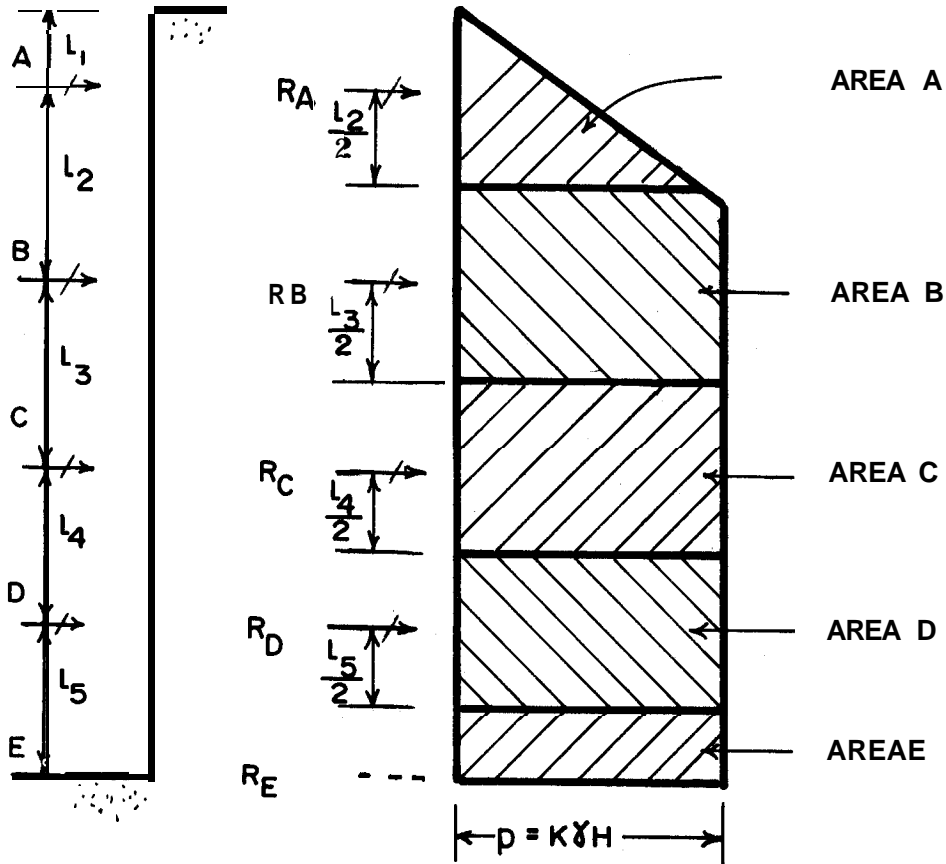

STRUT LOAD PER LINEAL FOOT OF WALL IS EQUAL TO DESIGNATED AREA

EXAMPLE: $R_C = p \left(\frac{L_4}{2} + \frac{L_3}{2} \right)$

Figure 36, Load determination from apparent earth pressure diagram.

diagram (100 percent) is used. This recommendation is linked to a number of other associated design recommendations -- the pressure diagram itself, methods for moment computation, preload practice, allowable stress, etc.

Where rigid walls support the earth, such as diaphragm walls with $\frac{EI}{L^4}$ greater than 50 ksf/ft, arching will be minimal; therefore, structural design of the wall as well as other elements should be based on the full pressure diagram,

7.22 Continuous Members

The following expression should be used for computing moments over continuous members with uniformly applied loads:

$$M = C w l^2$$

where:

M = moment

C = moment coefficient

w = distributed load on span

l = span length

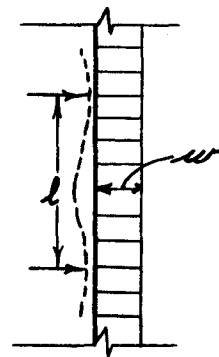

Hinged ends would have a coefficient, C = +0.125, with a maximum positive moment in the center of the span. Fixity at each support (no rotation) results in a maximum negative moment at the support and a moment coefficient, C = 0.087. Since construction methods greatly influence the position of the elastic line of members (especially vertical members), there is no practical way that the moment can be precisely analyzed. Therefore, a coefficient of C = 0.10 is recommended for continuous members supporting a uniform distributed load.

7.23 Discontinuous Walls

The moment in the wale will depend on the splice detail. For splices which occur at a strut and tie the wale with a steel strap,

to transfer shear but not moment, zero moment should be assumed at that point.

Wales supporting uniform load with moment splices over less than three spans, should not be considered continuous. Three spans or more should be considered continuous using a moment coefficient, $C = 0.10$.

The moment in wales supporting concentrated load (as from soldier piles or tiebacks) should be calculated on the basis of statics. Assume full continuity where moment splices are used; assume zero moment in other splices.

7. 24 Member Connections

It is common to design splices for the full structural capacity of the member (both shear and moment). This is often done with a combination of fully penetrating butt welds and cover plates.

Figures 37, 38, and 39 show some typical details for splices and wale to strut connections. For splices that are butt welded it is often assumed that the butt weld is only 50 percent to 75 percent effective since the beveled edges at the splice are field cut. Hence, the cover plates are designed to carry 25 percent to 50 percent of the member capacity. In designing a strut to wale connection, stiffness must be provided to prevent web crippling. Also, if raked struts are used, a knee brace is required at the strut to prevent buckling of the wale from the vertical component of load.

7. 25 Lagging

Arching of soil to the soldier piles results in substantial reduction of loads on lagging between soldier piles. This reduction depends on soil type and construction procedure, and it is not possible to predict by rational analysis. Therefore, the determination of lagging size is largely based on the past experience of the construction industry. The soldier pile section in Volume III (Construction Manual) summarizes recommended lagging sizes versus soil type and excavation depth.

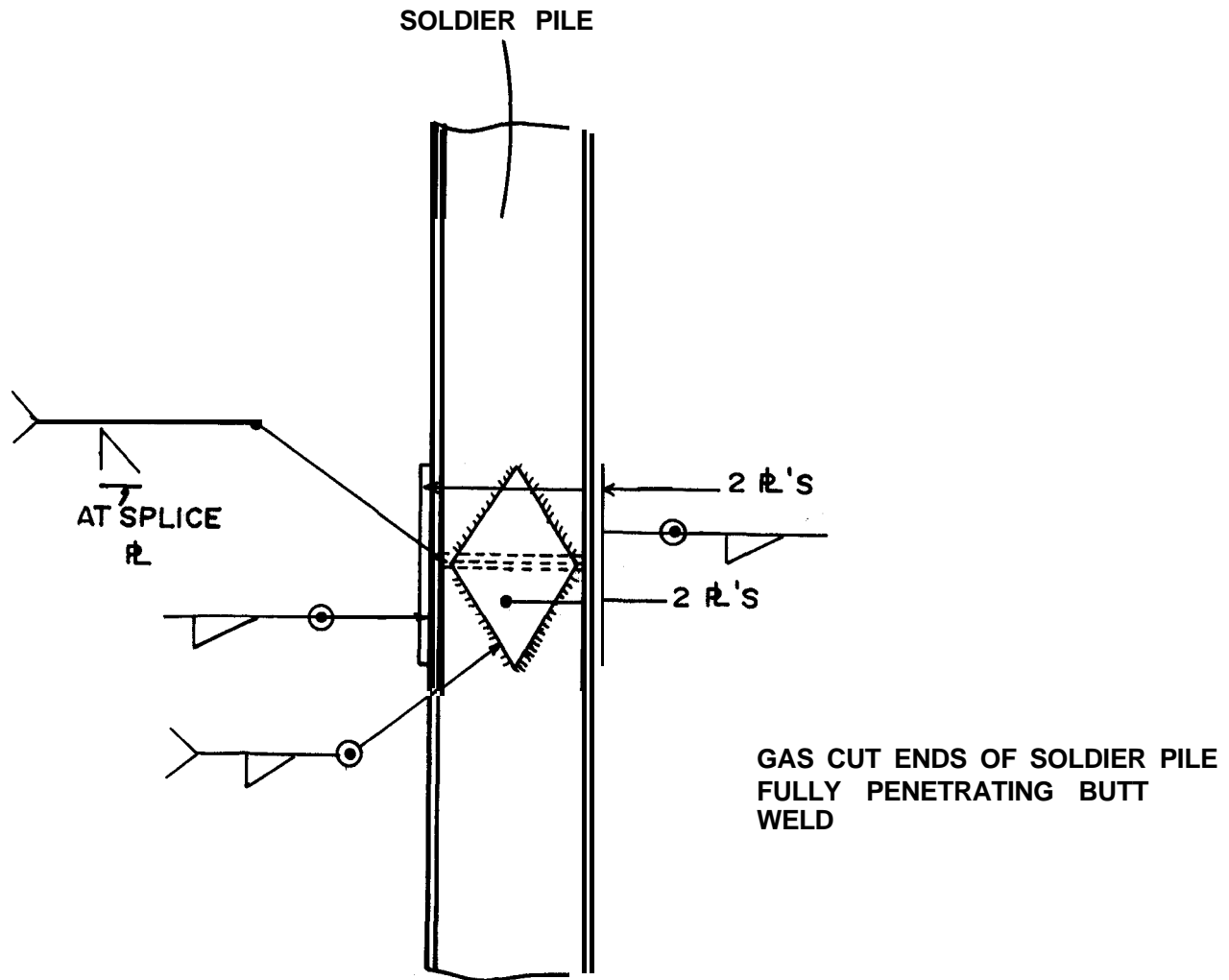

Figure 37. Typical splice with butt welding.

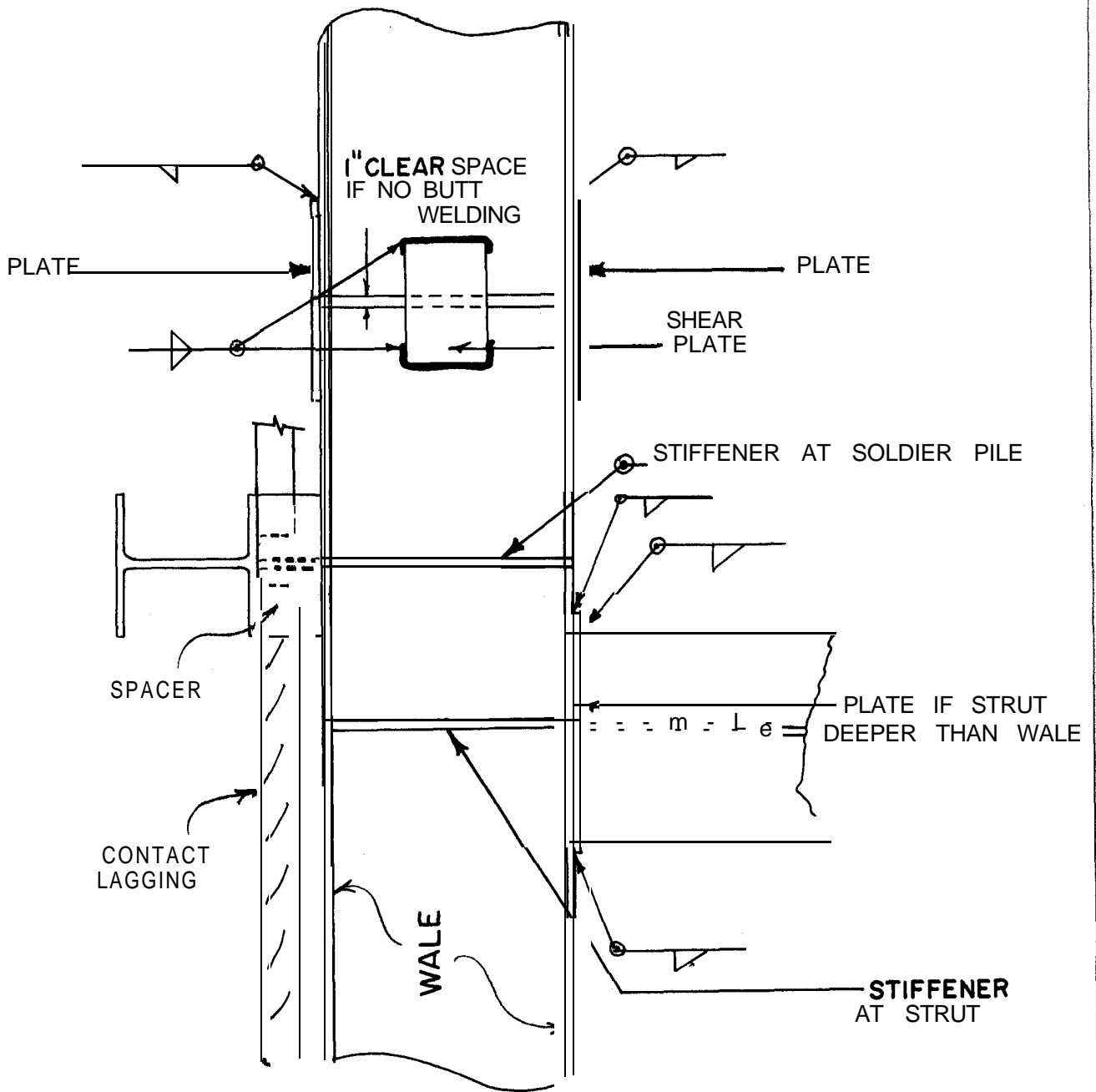

Figure 38. Plan view of typical wale splice and strut connection.

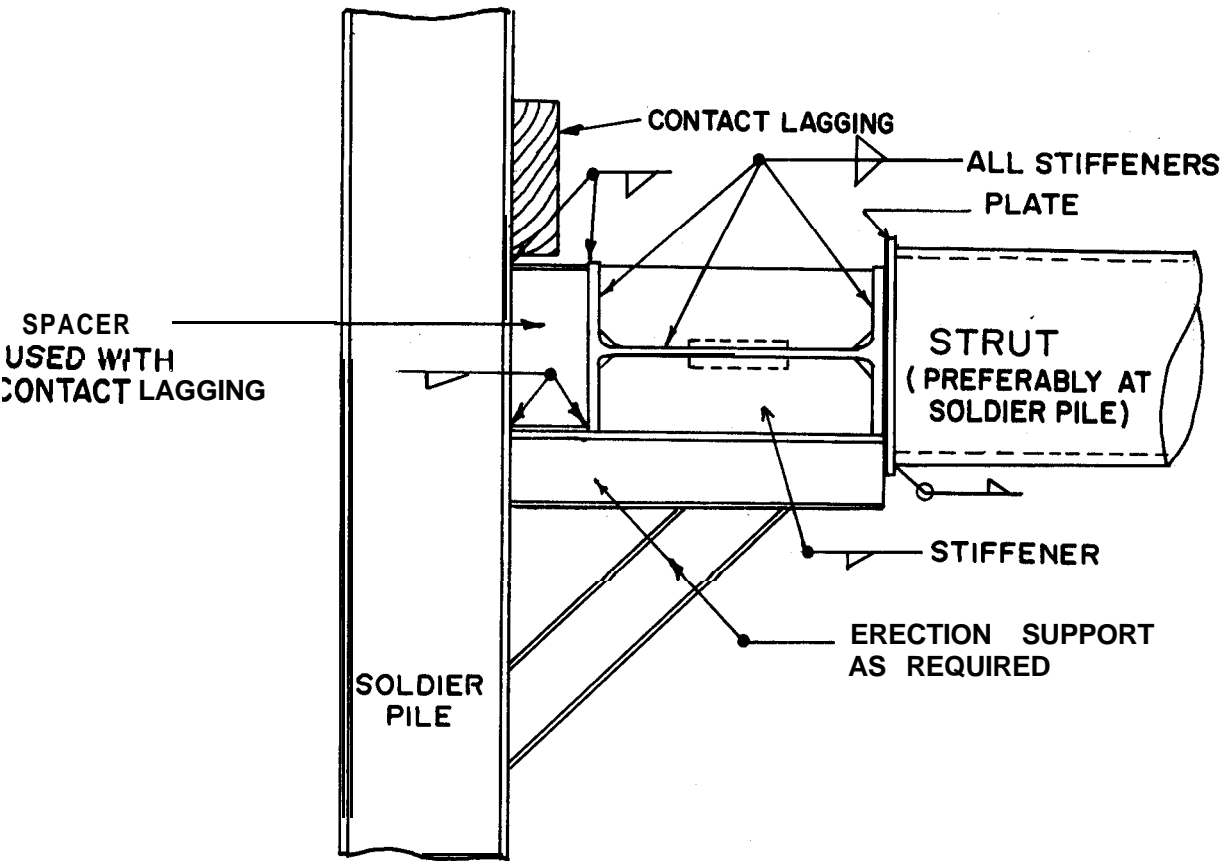

Figure 39. Typical strut -wale- soldier pile connections (elevation view).

7.30 BRACING AND TIEBACKS

Bracing and tieback loads must be determined for the most critical construction condition. This may be an intermediate depth of cut or at full depth.

For bracing, the allowable axial loads are governed by the **member's** slenderness ratio. Posting and lacing may be necessary to cut down on unsupported length to provide economical bracing members. Pipe sections may be utilized because of their efficiency as column members. Wide flange sections with vertical webs are also efficient, but this orientation may complicate wale connections.

For bracing:

- a. At final depth, use allowable stresses by **AISC** Code.
- b. For temporary conditions at intermediate depth of excavation use **AISC** t 20 percent.

For tiebacks, use the stress values stated in Volume III, Chapter 6 (Tiebacks).

7. 40 DEPTH OF PENETRATION BELOW CUT

7. 41 Lateral Resistance

When design pressure diagrams are used, a reaction at the base of the cut is assumed to **exist** which is equal to the lowest area shown in Figure 36. This reaction is provided by the passive resistance of the soil beneath the cut. The magnitude of the passive resistance is analyzed for continuous walls using the modified Coulomb earth pressure coefficients given in Section 6. 30. Passive resistance for soldier piles reflects an added resistance due to soil arching as explained in **Chapter 6**.

Figure 40 illustrates the method for determining the depth of penetration in competent soils that are capable of developing adequate passive resistance. Soils satisfying this condition are medium-dense to dense granular soils and stiff to hard clays. The general method of analysis is:

- a. Compute the equivalent reaction at the base of the cut (R_E).

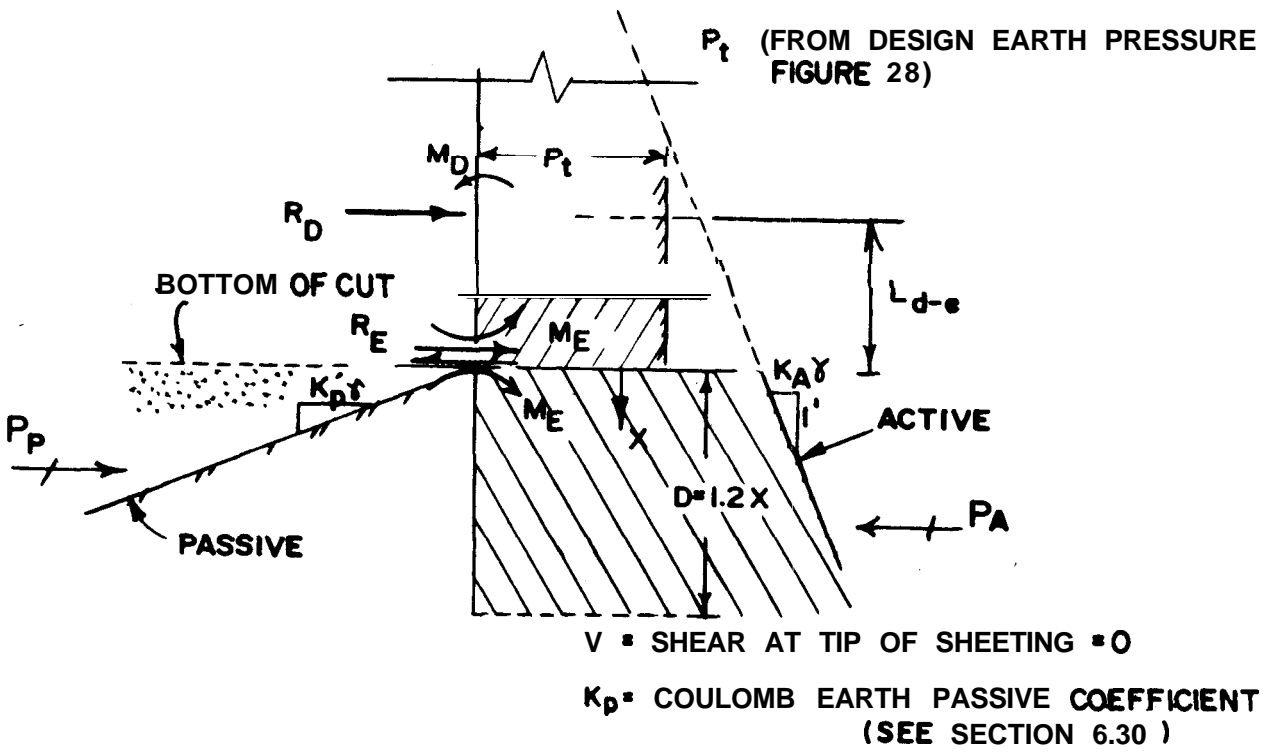

1. Compute $R_E = 0.5 p_t L_{d-e}$
2. Compute depth x such that: $P_p = R_E + P_A$
Use minimum F. S. = 1.5 for passive coefficient, $K'_p = \frac{K_p}{1.5}$
3. Check $M_{\max} \leq \text{yield moment of sheeting}$
4. Drive to depth $D = 1.2x$

Figure 40. Procedure for determining depth of penetration in relatively uniform competent soil conditions.

b. Determine the depth required to satisfy force equilibrium on the horizontal plane.

c. Check the maximum moment at or below RD against overstressing of the support wall.

d. Drive sheeting to a depth 20 percent greater than that required for force equilibrium.

In cases where the soils below the base of the cut are very loose to loose granular soils or soft to medium clays, the sheeting should penetrate to only a minimal depth of approximately 20 percent of the excavation depth and be designed as a cantilever below RD.

The reason is that in loose granular soils the sheeting must experience large lateral deformation **before** building significant passive resistance. It is probable the sheeting will be overstressed before this deformation is attained. Hence, the sheeting will either act as a cantilever, or if it is driven to great depths it will act as a simple beam with a substantial span. In either case, the sheeting would most likely be overstressed at the lowest strut level. If the cut is underlain by soft to medium clays, the net pressure on the sheeting often is in the active state, hence there is theoretically a net active pressure. This situation can arise in deep cuts even when the base of the cut is stable as illustrated in Figure 41.

7.42 Bearing Capacity Considerations

Load capacity must be evaluated when there is a downward component of load, as is the case for inclined tiebacks. This may be accomplished using pile driving formulas or by the empirical and semi-empirical methods outlined in Chapter 9.

7.50 EXAMPLE PROBLEMS

7.51 Introduction

Three example problems are analyzed to illustrate methods of evaluating the depth of penetration required for sheeting stability and to show the effect soil stratification can have on the variation in strut load. The three examples, shown at the end of this chapter, consider the following three conditions:

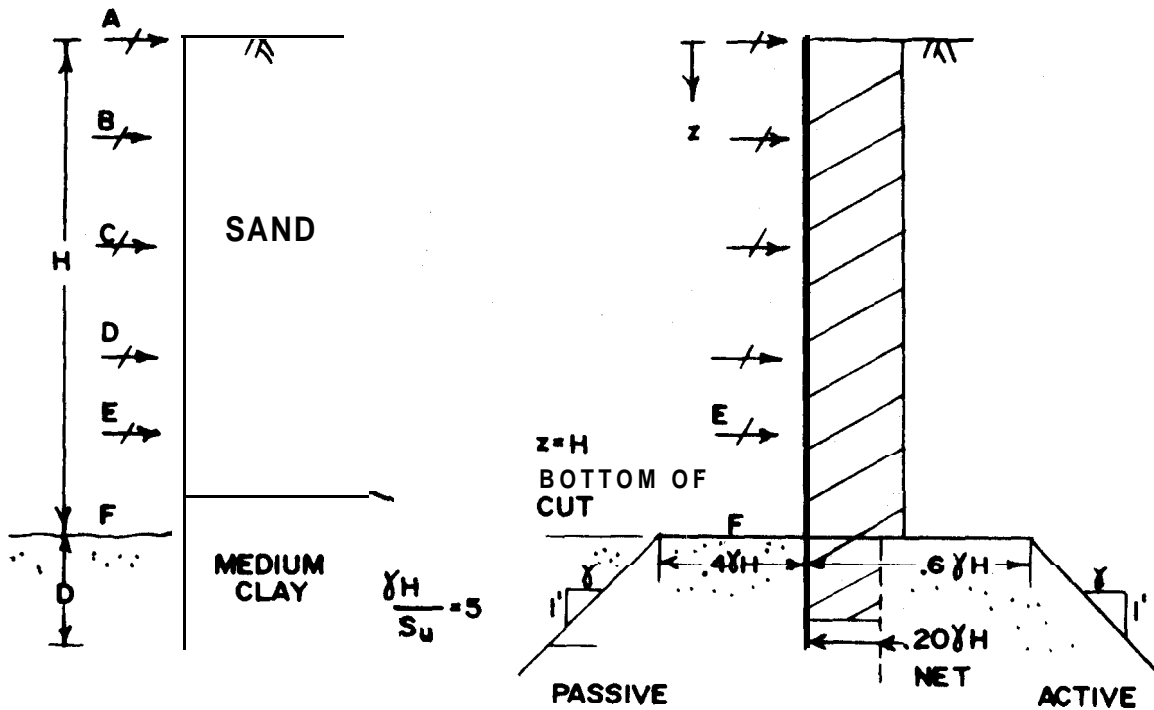

$$s_u = \frac{\gamma H}{5} = 0.20\gamma H$$

$$\text{RANKINE ACTIVE} = \gamma H - 2(0.20\gamma H) = 0.60\gamma H \text{ AT } z = H$$

$$\text{RANKINE PASSIVE} \text{ AT } z = H = 0 + 2(0.20\gamma H) = 0.40\gamma H$$

1. Theoretical passive resistance is not available below bottom of cut to develop horizontal reaction. In fact, the net force below cut is theoretically toward excavation, based on active and passive pressure.
2. Use nominal penetration of 0.2 H or 5 feet whichever is **greater**, or penetration to cut off pervious layers.
3. **Check base stability (see Chapter 6),**
4. **Design for cantilever condition below E.**

Figure 41. Method for analyzing sheeting with weak under lying layer.

Case I. Homogeneous soil profile.

Case II. "Soft" soil stratum to base of excavation underlain by a dense stratum.

Case III. A soft layer underlying a more competent soil.

Above the base of the excavation an empirical design pressure diagram is used as shown in Chapter 5. Below the base level Rankine active and passive pressures are used.

It is recognized that when using Peck's design envelopes the largest strut load for any condition is taken into consideration. However, a review of the development shows that in a few cases, strut loads gave apparent pressures which were greater than the design envelopes. The intent of this exercise is to illustrate a means by which a designer may estimate the magnitude of a strut load for unique conditions as well as providing a basis for judging whether or not to increase the design load on a given strut over that predicted by the design envelope. In addition, the analytical approaches will aid in the evaluation and understanding of observed strut loads obtained from instrumentation programs.

i. 52 Results of Analysis

Case I is the analysis of a homogeneous soil profile which provides **a basis** for comparison of required penetration depth and strut load variations. It represents, most ideally, the conditions where the design envelope is appropriate. The method for analyzing soldier piles set in concrete-filled, pre-augered holes is also presented.

Case II analyzes the effect of a weak soil overlying a more competent one. It illustrates how the load in the second lowest strut can exceed that of the lowest strut.

As the excavation proceeds below level D to level E, little passive resistance is provided to the retaining wall; hence, the wall deflects inward. Effectively, the wall spans from level D to the excavation base with full active pressure applied and no passive resistance. The deformation of the sheeting is such that, during this excavation stage, it resists essentially the same load over the span D to F whether or not strut level **E** is installed. This would be particularly true in the stiffer diaphragm walls. The effect of this

large unsupported length is twofold:

a. Since the sheeting has already assumed an elastic line such that it resists the full active load, little load is transferred to strut level E. Hence, strut level D effectively takes a disproportionate share of the load.

b. The moment in the sheeting is greatly increased by the long unsupported length. **As** expected, the required depth of penetration for the sheeting will be significantly less than for Case I.

Case III depicts a method for evaluating the maximum strut load when a relatively weak soil layer starts immediately beneath the base of the excavation. Since little **passive** resistance can be expected from the weak layer the sheeting acts as a cantilever member; thus, a large load is developed in the lowest strut. For these conditions, where the base is stable against bottom heave, little is gained from driving the sheeting to any depth below the bottom of the cut. Therefore, a minimum penetration is recommended of five feet or 20 percent of the excavation depth, whichever is greater. In situations where the base is unstable, consideration may be given to deeper penetration and **stiffer** sheeting to prevent bottom heave.

7.60 FINITE ELEMENT ANALYSIS OF BRACED EXCAVATIONS

7.61 Introduction

In recent years several computer programs, based on the finite element methods of analysis, have been developed to analyze braced excavations (**Wong**, 1971; Palmer and Kenney, 1972; Jaworski, 1973; Clough and Tsui, 1974). Currently, the primary use of these programs is to provide insight into the behavioral trends of braced cuts. Using computer programs parametric studies can be conducted to evaluate, at least in a qualitative manner, the effect of wale spacing, sheeting stiffness, and soil stratification on strut loads and sheeting deformation. Further, these studies may be used to provide guidelines for engineering judgement and for obtaining some qualitative **verification** of design assumptions.

7.62 Case Studies

To illustrate how the finite element programs can be

used as an aid to the design engineer, the program BRACE II (see appendix to Chapter 2 for description) was used to analyze three different soil profiles. These profiles are similar in concept to those described in Section 7.50, except that cohesive soils are assumed due to program limitations.

As was the intent of the design examples of Section 7.50, the results of these analyses are used to give some insight into the effect soil stratification and sheeting stiffness may have on the variation of strut load and sheeting forces.

Specifically, four soil conditions were analyzed:

Case 1a. Homogeneous soil profile of soft, normally consolidated clays.

Case 1b. Homogeneous soil profile of medium-stiff clay.

Case 2. A soft soil stratum above the base of the excavation underlain by a stiff stratum.

Case 3. A soft soil layer underlying a more competent stiff soil.

For all cases, the ground water table was taken at a five foot depth, and undrained soil parameters were assumed for both the shear strength (S_u) and deformation modulus (E_u). For soft and medium soils, these parameters increased linearly with depth within a stratum as a function of the vertical effective stress ($\bar{\sigma}_v$). For the stiff soils, the strength and modulus were considered constant with depth. The soil parameters used in the analysis are summarized as follows:

Soil Type	K_o	Saturated Unit Weight (pcf)	Shear* Strength (S_u)	Soil* Modulus (E_u)
Soft	0.5	120	$0.28\bar{\sigma}_v$	$200\bar{\sigma}_v$
Medium-Stiff	0.6	120	$0.40\bar{\sigma}_v$	$290\bar{\sigma}_v$
Stiff	1.0	120	3200	3×10^6 psf

* The parameters for the soft **and** medium-stiff cohesive soils are from Ladd, et al(1971). These **parameters** are normalized against the vertical effective stress on the soil, i. e. they are directly related to the effective overburden pressure $\bar{\sigma}_v$. Hence, the strength and modulus increase linearly with $\bar{\sigma}_v$ and therefore with depth in a soil stratum.

For the purpose of providing a basis of comparison, the cofferdam geometry was the same for all (cases:

Strut spacing (L) - 10' c/c
 Depth of excavation (H) - 60'
 Width of Excavation - 60'
 Sheet piling penetration - 30'

Also, two wall types were considered in order to provide some information on the effect of wall stiffness. The wall types were a steel sheet pile wall (PZ-38) and a 4 foot thick concrete diaphragm wall.

7. 63 Distribution of Earth Pressures

Figures 42 and 43 show **normalized** apparent earth pressure diagrams predicted by the finite element **analysis** for the four soil conditions outlined in Section 7. 62. These apparent earth pressures were obtained in the same manner as shown on Figure 27 for apparent earth pressures from field measurements. The pressures are normalized by taking the ratio of the predicted apparent pressure at a strut level (P) to the maximum apparent pressure (P_{max}), both computed from the finite **element** analysis. The diagrams were developed using the maximum strut load computed in any strut level and during any stage of excavation.

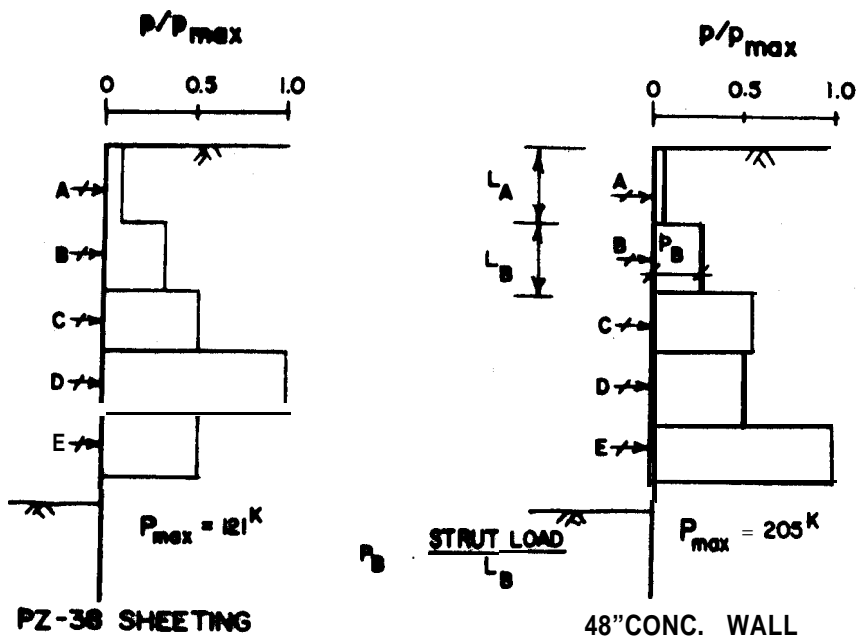

N = 6.8 AT BASE OF CUT

CASE 1a - HOMOGENIOUS SOFT CLAY

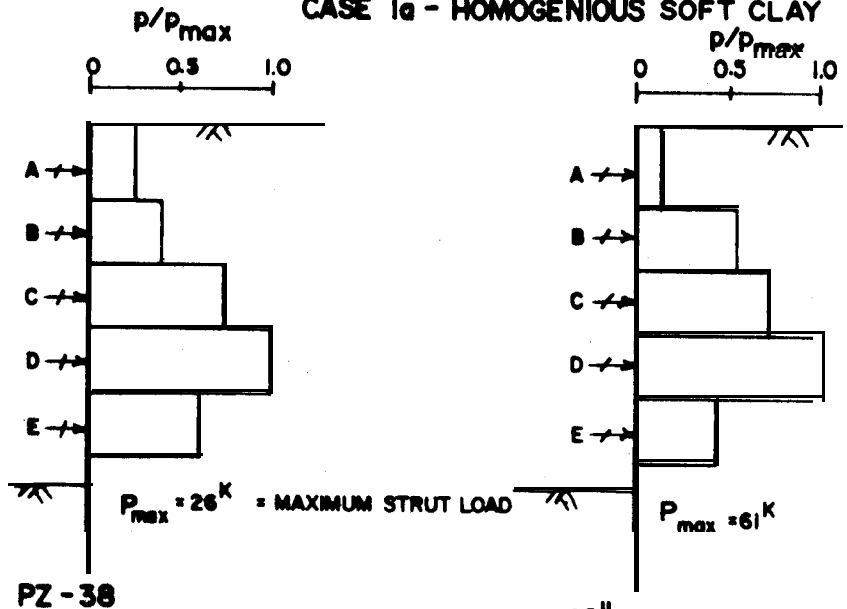

N = 4.8 AT BASE OF CUT

CASE 1b- HOMOGENIOUS MEDIUM-STIFF CLAY

Figure 42. Normalized apparent earth pressure diagrams predicted by finite element analysis.

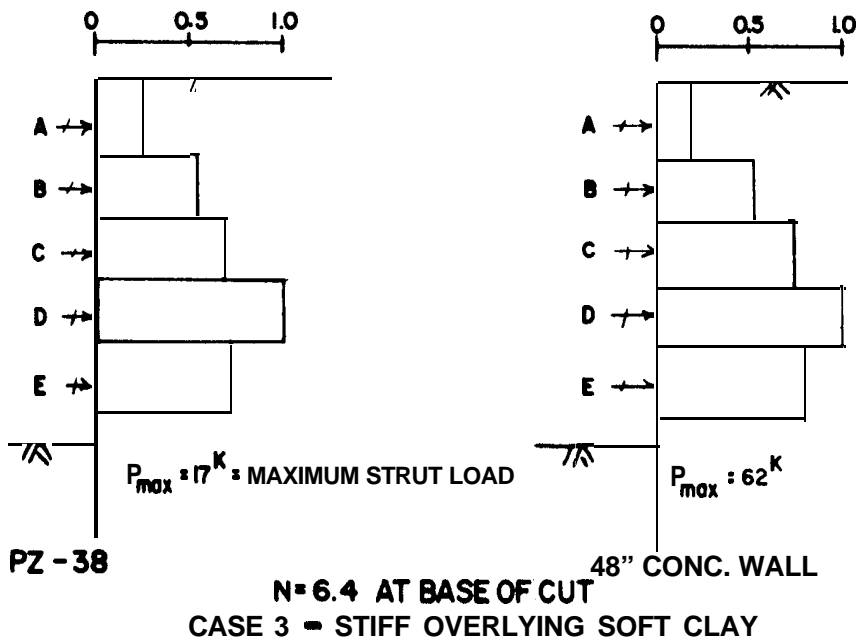
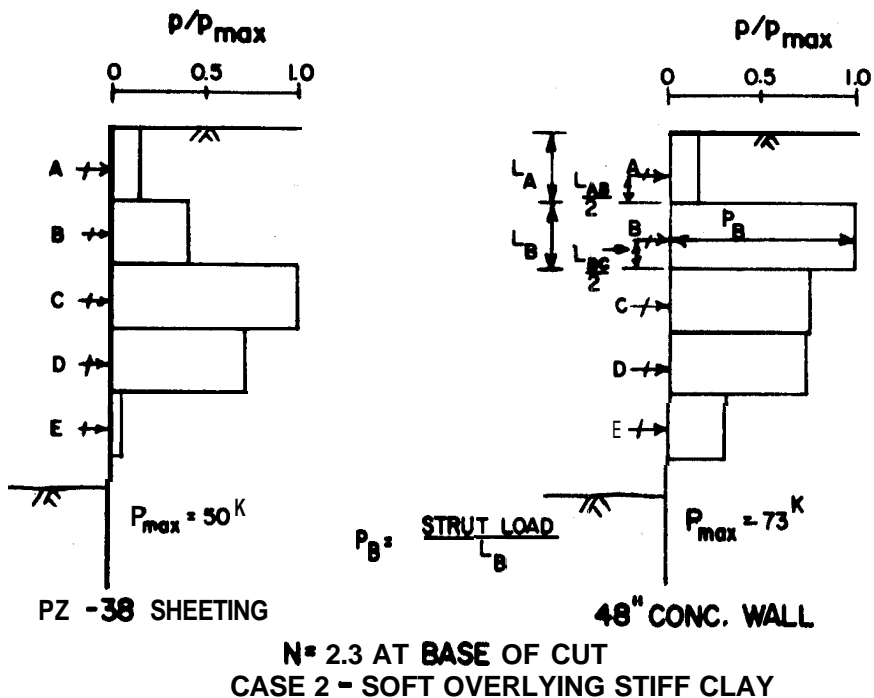

Figure 43. Normalized apparent earth pressure diagrams predicted by finite element' analysis,

Comparing Case 1a with Case 1b in Figure 42, the analysis shows that **walls** in the soft clay should be expected to experience relatively higher pressures near the base of the cut than the wall in the **medium-** stiff clay. This trend is **more** obvious for the stiffer concrete walls. **In** addition, the predicted earth pressures in the soft soil may be much higher, as shown by the maximum strut loads. The apparent reason for this behavior is the lack of lateral support **below** the base of the excavations; hence, an inward rotation around the lowest strut. The stability number of $N = 6.8$ in Case 1a results in a factor of safety of less than 1. Hence, a bottom heave failure occurred which resulted in the Loss of passive resistance below the excavation Level. On the other hand, the stability number for Case 1b is low ($N \approx 4.8$), resulting in a stable bottom. With increasing wall stiffness less curved deformation is expected, and the potential for unloading the second lowest strut and overloading of the lowest strut is increased. As Case 1b shows, this behavior becomes less pronounced as the soil becomes stiffer. One possible remedy for reducing this effect in soft soils would be to prestress the second lowest strut and lock in a high residual compressive force.

On Figure 43, Case 2 (soft clay overlying stiff clay) shows opposite effect to that experienced in the homogeneous soil mass. This stiffer layer provides an adequate reaction for the wall, restricting its inward deflection in the overlying soft clay. This leads to a larger strut load in the second to last strut and a reduction in the load received by the lowest strut. This results because the wall has already deflected inward close to its maximum amount before the last strut is installed and final excavation completed. Therefore, this last excavation stage results in little load transfer to the lowest strut.

For Case 3, where the soils within the depth of cut are stiff, stability number $N < 4$, and soft soils exist immediately below the base of the excavation, the results show that the strut loads are greatest in the second lowest strut. This occurs for the same reasons given for Case 1a, that is, lack of support below the excavation base. For this soil profile, the pattern of pressure distribution appears independent of wall rigidity since both give essentially the same normalized pressure diagram.

7.64 Magnitude of Strut Loads

Figure 44 shows the magnitudes of the predicted loads for Cases 2 and 3. In both cases, the diaphragm wall receives much greater apparent pressures, on the order of 2 to 4 times that of the more flexible PZ-38 steel sheeting,

The higher apparent pressures in the concrete wall are attributed to smaller lateral deformations, hence, less mobilization of shear strength in the soil adjacent to the wall. The stiffer wall tends to retain a large portion of the initial stresses, consequently its loading is more dependent on the K_0 value of the supported stratum.

This behavior is particularly acute in the heavily overconsolidated soils such as those assumed for Case 3. Considering the pressure diagrams for this case, the steel sheeting experienced a greater inward movement. Therefore, the high undrained shear strength of the soil was mobilized resulting in relatively low apparent pressures compared to those for the concrete wall which experienced little inward movement.

There is scant field evidence to support this trend. Observations of tied-back walls in heavily overconsolidated clays show that the walls move laterally with time. The movement may be associated with the stress relief and subsequent lateral swelling of the soil. This swelling is time dependent and could result in the build up of strut loads somewhere between the Rankine active stress and the initial horizontal stresses in the clay. Inward bulging of lagging was observed in an internally braced cut made in overconsolidated soil in the Washington, D. C. area. The severity of the bulging increased with time suggesting a load build up on the lagging and hence, an increase of load in the support system. In any case, when over consolidated soils are present, one should be aware that loads may build up on the support system with time causing overloading, especially if a relatively rigid wall is used which restricts the lateral swelling of the soil.

7.65 Structural Behavior

Table 4 compares the predicted location of zero moment and zero shear versus the sheeting stiffness for the three cases described in Section 7.61. For all conditions analyzed

APPARENT LATERAL PRESSURE (psf)

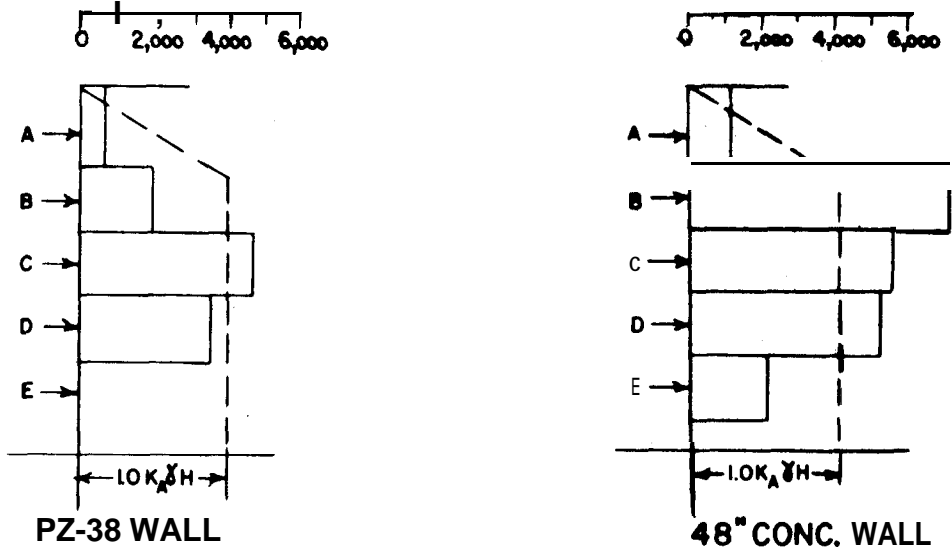

AT BOTTOM OF CUT: $N = 2.3$

CASE 2 (SOFT OVERLYING STIFF CLAY)

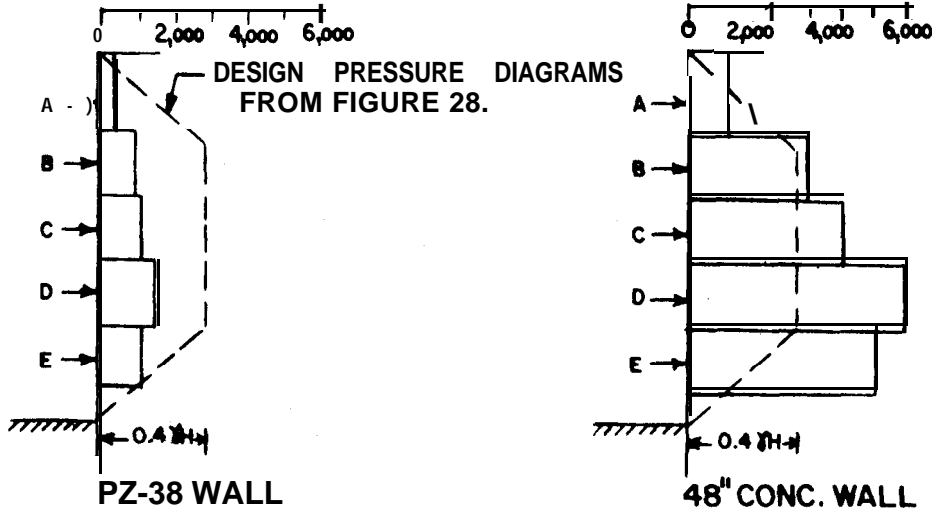

AT BOTTOM OF CUT: $N = 6.4$

CASE 3 (STIFF OVERLYING SOFT CLAY)

(SEE SECTION 7.64 FOR DISCUSSION)

Figure 44, Comparison of predicted apparent earth pressures from finite element analysis on stratified soils.

Table 4. Summary of structural behavior for braced walls from finite element analysis.

Case	Wall Type	$N = \frac{\gamma H^{(1)}}{S_u}$		Wall Stiffness ⁽⁴⁾ $\frac{EI}{L^4}$ (ksf)	Location of Zero Moment		Depth Below Base to Zero Shear
		At Base ⁽²⁾	Within Depth of Cut ⁽³⁾		Above Base ⁽⁴⁾	Below Base	
Uniform Soil	PZ-38 Steel	6.8	11.8	5.8	9 ft.	>30 ft.	30 ft.
	PZ-38 Steel	4.8	8.2	5.8	>10 ft.	13 ft.	19 ft.
	4' Diaphragm Wall	4.8	8.2	229.0	>10 ft.	13 ft.	19 ft.
	4' Diaphragm Wall	6.8	11.8	229.0	>10 ft.	>30 ft.	>30 ft.
2 Stiff Soil Below Base of cut	PZ-38	2.3	9.0	5.8	2 ft.	>30 ft.	2 ft.
	PZ-38 ⁽⁵⁾	2.3	9.0	5.8	3 ft.	>10 ft.	4 ft.
	4' Diaphragm Wall	2.3	9.0	229.0	>10 ft.	2 ft.	7 ft.
3 Soft Soil Below Base of Cut	PZ-38	6.4	2.2	5.8	7 ft.	11 ft.	19 ft.
	4' Wall Diaphragm	6.4	2.2	229.0	10 ft.	17 ft.	19 ft.

(1) All excavations 60 ft. deep; wall penetration 30 ft. below base of excavation.

(2) Based on S_u at base of excavation.

(3) Based on average S_u within the depth of the excavation

(4) Strut spacing 10 ft. c/c; lowest strut 10 ft. above base of excavation.

(5) Assumed depth of penetration below base was 10 ft.

except one; the sheeting penetration was assumed to be 30 feet, The exception was for Case 2 where, for one analysis, the PZ-38 sheeting penetration was assumed to be 10 feet to provide a comparison of the effect of sheeting penetration in stiff soils.

It is important to recognize that the finite element method is for analysis of a soil condition; therefore, the 30 foot depth of penetration was chosen to provide information on the effective depth of sheeting.

7.66 Implications of Finite Element Analysis

A comparison of the behavioral trends predicted by the finite element method (FEM) with the results of the simplified analytical method (SAM) described in Section 7.50 shows the benefits of performing finite element studies. Even though such a comparison is not theoretically justified since two different soil types are considered, the results from the FEM are indicative, in a general sense at least, of the type of behavioral pattern one might expect for the soil profiles considered,

For example, Figures 42 and 43 indicate that sheeting stiffness has little effect on the apparent normalized earth pressure diagrams. Figure 44, however, suggests that sheeting stiffness has a marked effect on the magnitude of the loads, The stiffer sheeting gives higher apparent earth pressures. This trend stems from the reduction in ground movement achieved by the stiffer wall versus the movements associated with the more flexible steel sheeting. This behavior is not inherently considered in the SAM. For this latter method, one must rely on engineering judgment to account for the effects of sheeting stiffness on strut loads.

Regarding Case 2, the SAM approach predicts higher strut loads on the second from the bottom strut and low strut loads at the lowest strut. The finite element analysis indicates a similar trend, i. e. , the predominance of load is in the upper strut levels. However, with the FEM the greatest loads are higher. For example, the maximum load is in strut B.

7. 67 The Use of the Finite Element Method in Design

The finite element method is a more realistic mathematical modeling of the complex soil profile and the soil-structure system, thus making it a powerful tool in the analysis of supported excavations. However, this method should be used cautiously. The computer programs are developed by making various assumptions concerning soil behavior. Naturally, these assumptions have a large effect on the accuracy of the results. The results are only as good as the input, particularly the soil parameters assumed. Therefore, these programs should be used only by experienced individuals who are aware of the assumptions used in the program development and how the assumptions could possibly effect the results. Finally, when making a finite element analysis, the results should be carefully evaluated for consistency and behavioral trends. The results may appear correct, but because of inappropriate input or misapplication of the program, the analysis may be giving erroneous-results.

It is recommended that until substantially more experience is gained with the FEM as a design tool it be used primarily as an aid to guide engineering judgement.

GENERAL OVERVIEW OF EXAMPLES

Granular Soils Within Depth of Cut

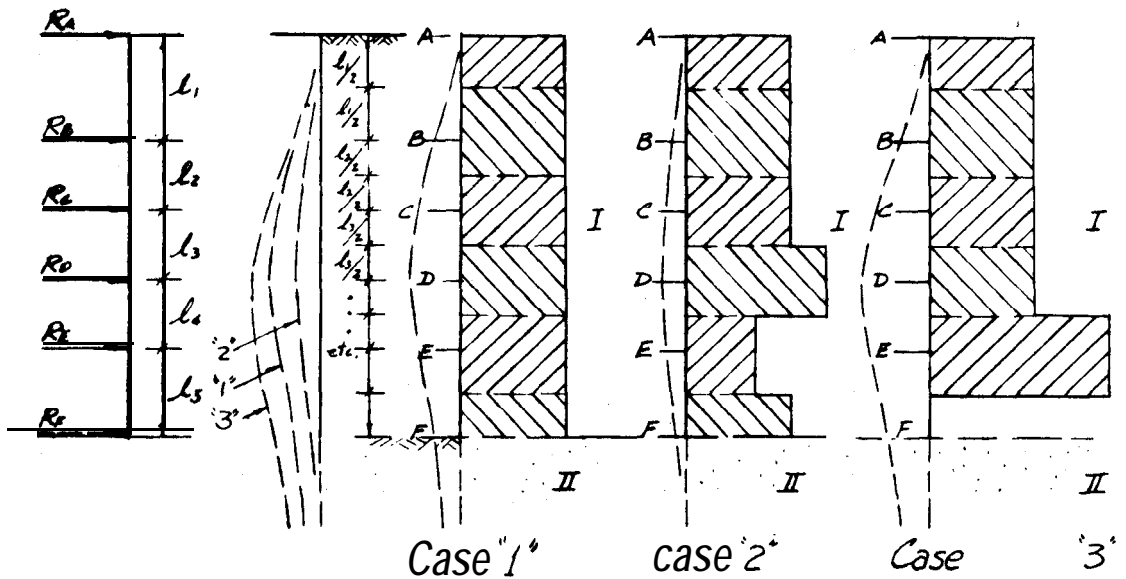

Case 1* Uniform soil throughout

Case 2* Stratum II much denser and unyielding

Case 3* Stratum II weaker and more yielding than Stratum I.

BASIC APPROACH FOR DETERMINATION OF STRUT LOAD

With reasonably uniform spacing between levels of support:

Case 1* Apportion load by area distribution

Case 2* Same as Case 1* except, analyse condition of support set at D and excavate to E. Assume concentrated reaction at F and at D. Neglect passive force in span EF.

Decrease force at E by the same amount that force at D is increased above Case 1

Case 3 Same as Case 1 except, assume $R_F = 0$. Therefore reaction at E takes all pressure between E and F. Examine cantilever moment at E.

ANALYSIS OF CASE 1

Uniform medium dense sand throughout

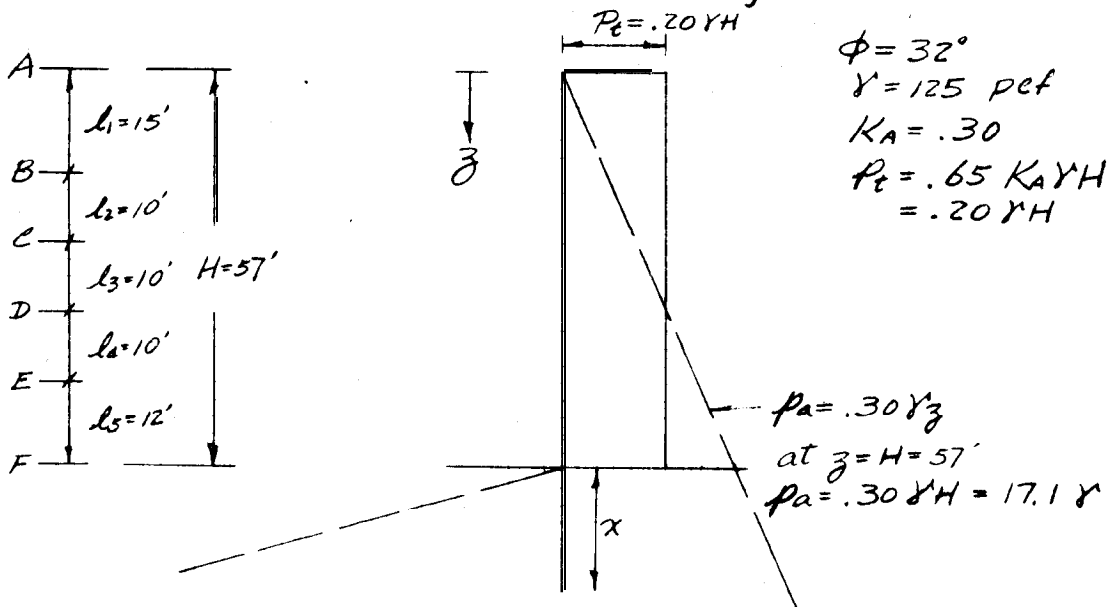

$$R_A = (7.5)(.20 \gamma H) = 1.5 \gamma H$$

$$R_B = \left(\frac{15}{2} + \frac{10}{2}\right)(.20 \gamma H) = 2.5 \gamma H$$

$$R_C = \left(\frac{10}{2} + \frac{10}{2}\right)(.20 \gamma H) = 2.0 \gamma H$$

$$R_D = \quad \quad \quad = 2.0 \gamma H$$

$$R_E = \left(\frac{10}{2} + \frac{12}{2}\right)(.20 \gamma H) = 2.2 \gamma H$$

$$R_F = (6.0)(.20 \gamma H) = 1.2 \gamma H$$

Depth of penetration for Continuous Wall

Follow procedure in Figure 40.

$$\text{Let } \delta = \frac{\phi}{2} = 16^\circ \quad \therefore K_p = 5.5$$

$$\text{Use F.S.} = 1.5 \quad \therefore K_p' = \frac{5.5}{1.5} = 3.7$$

$$P_p = \frac{1}{2} \gamma x^2 (3.7) = 1.85 \gamma x^2$$

$$P_a = 17.1 \gamma x + \frac{1}{2} \gamma x^2 (1.30) = .15 \gamma x^2 + 17.1 \gamma x$$

$$R_F = 1.2 \gamma H = 68.4 \gamma$$

$$\Sigma H = 0$$

$$68.4 \gamma + .15 \gamma x^2 + 17.1 \gamma x - 1.85 \gamma x^2 = 0$$

$$1.7 x^2 - 17.1 x - 68.4 = 0$$

$$x = 13' \quad D = 1.2 \times 13 = 15.6'$$

Say 16'

Depth of penetration for Soldier Pile

Assume soldier piles predrilled and encased in concrete, pile diameter $d = 2.5'$, For depth of 2.5' consider passive resistance reacts only on the width of soldier pile.

$$K_p' = 3.7$$

$$(P_p)_u = \frac{1}{2} \times 9.25 \gamma (2.5)^2 = 29.0 \gamma$$

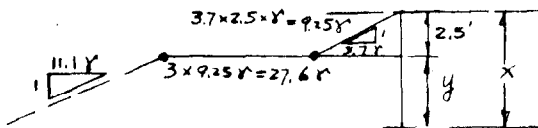

Below 2.5' K_p acts on 3 x width of pile diameter

$$3 K_p' = 3 \times 3.7 = 11.1$$

$$(P_p)_L = (27.6 \gamma y + \frac{11.1}{2} \gamma y^2) \times 2.5$$

$$= 13.9 \gamma y^2 + 69.0 \gamma y$$

Let soldier piles be at 8.0' o.c.

$$\therefore R_F = 8 \times 68.4 \gamma = 547 \gamma$$

$$P_A = 8 \times (.15 \gamma x^2 + 17.1 \gamma x) = 1.2 \gamma x^2 + 136.8 \gamma x$$

$$P_p = 13.9 \gamma y^2 + 69.0 \gamma y + 29.0 \gamma$$

$$x = 2.5 + y$$

$$\text{Try } x = 13', y = 10.5'$$

$$R_F + P_A - P_p = 0$$

$$\begin{array}{r} 547 \gamma + 202.8 \gamma - 1532.5 \gamma \\ \underline{1778.4 \gamma} \quad \underline{724.5 \gamma} \\ 1981.2 \gamma \quad \underline{270 \gamma} \\ \hline 2286 \gamma \end{array} = +2422$$

Try $x = 15'$, $y = 12.5'$

$$R_F + P_A - P_D = 0$$

$$547 \gamma + \frac{270 \gamma}{2052 \gamma} - \frac{2171.9 \gamma}{862.5 \gamma} = -194.4$$

$$\frac{2322 \gamma}{3063.4 \gamma}$$

Say $x = 14.0'$

$$D = 1.2x = 16.8' \quad \underline{\text{say } 17.0'}$$

ANALYSIS OF CASE "2"

Let stratum I be medium dense sand

stratum II be glacial till (very dense clayey sand some gravel) $\phi = 40^\circ$

Reactions:

$$R_A = 1.5 \gamma H \quad (\text{same as before})$$

$$R_B = 2.5 \gamma H \quad (\quad = \quad)$$

$$R_C = 2.0 \gamma H \quad (\quad = \quad)$$

R_D Examine condition of support at D and excavate to E

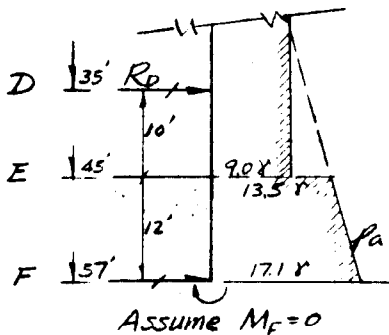

@ 45°

$$P_L = 45 \times 2.0 \gamma = 9.0 \gamma$$

$$P_A = 45 \times 3.0 \gamma = 13.5 \gamma$$

@ 57°

$$P_A = 57 \times 3.0 \gamma = 17.1 \gamma$$

$$\sum M_F = 0 \quad (R_D)_L = \frac{1}{22} [(9.0)(10)(17) + (13.5)(12)(16) + (3.6) \left(\frac{12}{2}\right) (4)] \gamma$$

$$= 117.7 \gamma$$

$$= 2.06 \gamma H$$

$$(R_D)_U = 1.0 \gamma H$$

$$\therefore R_D = (R_D)_U + (R_D)_L = 3.06 \gamma H$$

$$R_E = (2.0 \gamma H + 2.2 \gamma H) - (3.06 \gamma H) = 1.14 \gamma H$$

$$R_F = 1.20 \gamma H \quad (\text{same as before})$$

Depth of penetration for Continuous Wall

Follow procedure outlined in Figure 40.

(a) Check Temporary condition of brace at R_D and excavate to E

$$\begin{aligned} R_F &= -(R_D)_L + (9.0)(10) \gamma_I + (13.5)(12) \gamma_I + (3.6) \frac{(12)}{2} \gamma_I \\ &= -117 \gamma_I + 90 \gamma_I + 162 \gamma_I + 22 \gamma_I \\ &= 157 \gamma_I = (157)(125) = 19,600 \text{ lb.} \end{aligned}$$

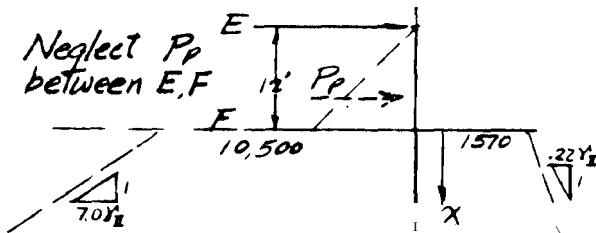

I	sand:	$\phi = 32^\circ$	$\gamma_I = 125$
		$\delta = \frac{\phi}{2}$	
		$K_A = .22$	$K_p = 5.5$
II	Glacial Till	$\phi = 40^\circ$	$\gamma_{II} = 140$
		$\delta = 25^\circ$	
		$K_A = .22$	$K_p = 10.5$

@ F

On active side $z = 57'$

$$P_a = (157 \times 125) (.22) = 1570 \text{ psf}$$

$$K_A \gamma_{II} = .22 \times 140 = 30.8$$

On passive side $z = 12'$

$$K_p' = \frac{K_p}{F.S. = 1.5} = \frac{10.5}{1.5} = 7.0$$

$$P_p = 7.0 \times 12 \times 125 = 10500$$

$$K_p' \gamma_{II} = 7.0 \times 140 = 980$$

$$\Sigma H = 0 \quad (10,500 - 1,570) x + (980 - 30.8) \frac{x^2}{2} = 19,600$$

$$474.6 x^2 + 8930 x - 19600 = 0$$

$$x^2 + 18.8 x - 41.3 = 0$$

$$x = 2'$$

(b) Check full depth condition with brace at R_E and excavate to F

$$R_F = 1.20 \gamma_I H = 1.2 \times 125 \times 57 = 8550$$

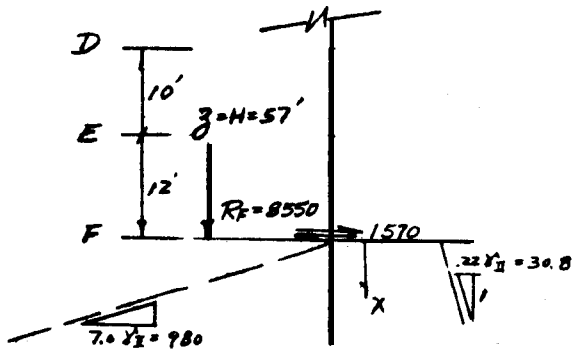

$$\Sigma H = 0$$

$$1570x + \frac{30x^2}{2} - \frac{980x^2}{2} + 8550 = 0$$

$$475x^2 - 1570x - 8550 = 0$$

$$x^2 - 3.3x - 18.0 = 0$$

$$x \approx 6'$$

$$D = 1.2 \times 6 = 7.2'$$

Say 8.0'

Note:

1. Full depth condition controls
2. $D = 8.0'$ Case "2"
- $D = 16.0'$ Case "1"

ANALYSIS OF CASE "3"

Let stratum I be medium dense sand

stratum II be loose stratified fine sand & silt

$\phi = 25^\circ$ $\gamma_s = 110$ ground water cannot be lowered below top of silty soil

Analyze by procedure outline in Figure 41.

If limiting case condition of $R_F = 0$ is used, then theoretically no penetration is required below point F. Nominal penetration of $0.2H$ (or $\sim 5'$) should be used.

Reactions

$$R_A = 1.5 \gamma H \quad (\text{Same as before})$$

$$R_B = 2.5 \gamma H \quad (\quad \quad)$$

$$R_C = 2.0 \gamma H \quad (\quad \quad)$$

$$R_D = 2.0 \gamma H \quad (\quad \quad)$$

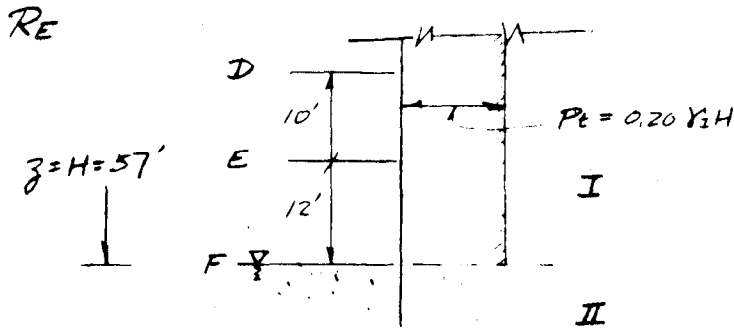

Assume $R_F = 0$

$$R_E = .20 \gamma H \left(\frac{10}{2} + 12 \right) = 3.40 \gamma H$$

$$R_F = 0$$

Must check cantilever moment at E provide nominal say 5' penetration, below F

SUMMARY AND COMPARISON OF THREE CASES

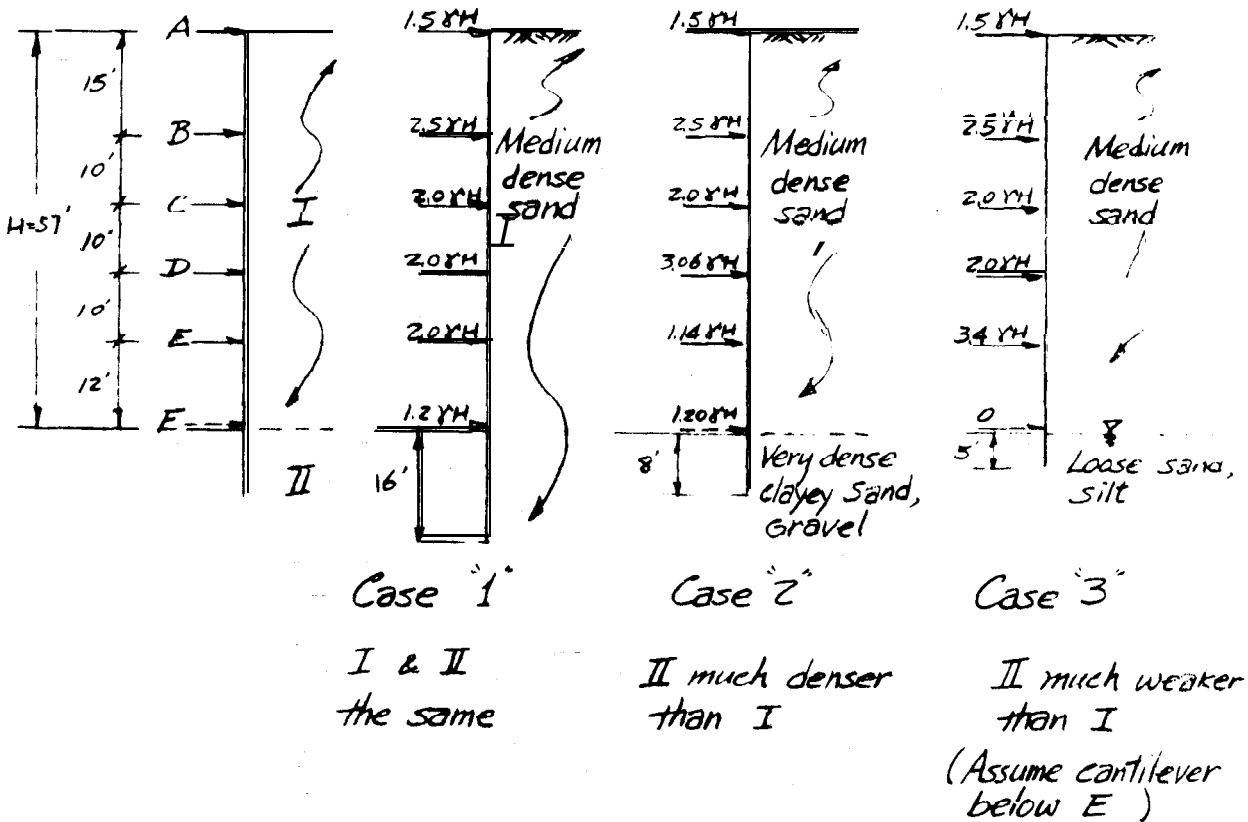

CHAPTER 8 - STABILITY ANALYSIS OF SHEETED EXCAVATIONS

8.10 GENERAL

There are three primary modes of instability of concern in sheeted excavations in clay:

- a. Bottom heave (Figure 45a).
- b. Deep seated failures (Figures 45b and 45c)
- c. Local failures immediately adjacent to the support wall.

Of these modes, b). and c). are related to the overall stability of the excavations. They often will dictate the procedures to be used in constructing a cofferdam. These conditions of instability may also result in heavier strut loading than predicted by the method described in Chapter 5. An example of the potential for increased loading if bottom heave occurs is described in Section 7. 50.

Local failures (mode c) are of concern where it is necessary to limit inward sheeting deformations. Failures of this type occur below the excavation level immediately adjacent to the sheeting, resulting in partial loss of lateral support.. This loss of support creates a large unsupported length and can lead to excessive inward deflections of the sheeting.

8.20 BOTTOM HEAVE

Bottom heave is a problem primarily in soft to medium clays where the strength of the soil is nearly constant with depth below the base of the excavation. The failure is analogous to a bearing capacity failure, should be analyzed (Bjerrum and Eide, 1956) using the stability chart given in Figure 46. The factor of safety against a bottom heave is determined as:

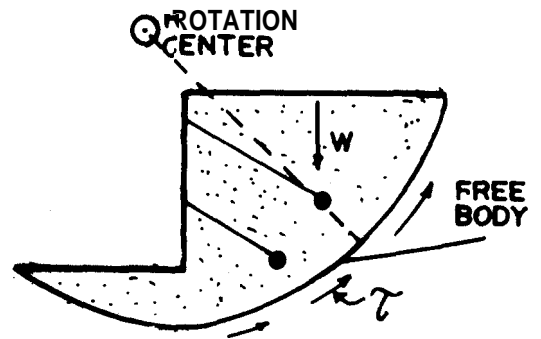
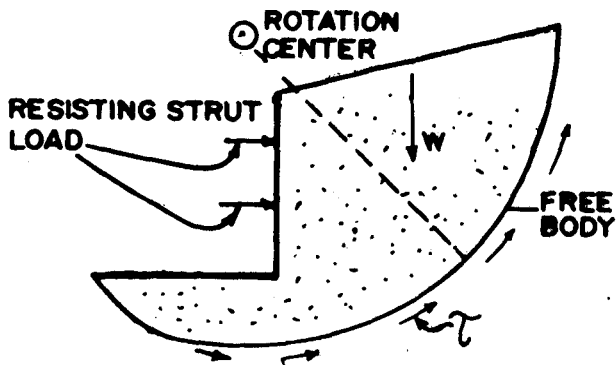
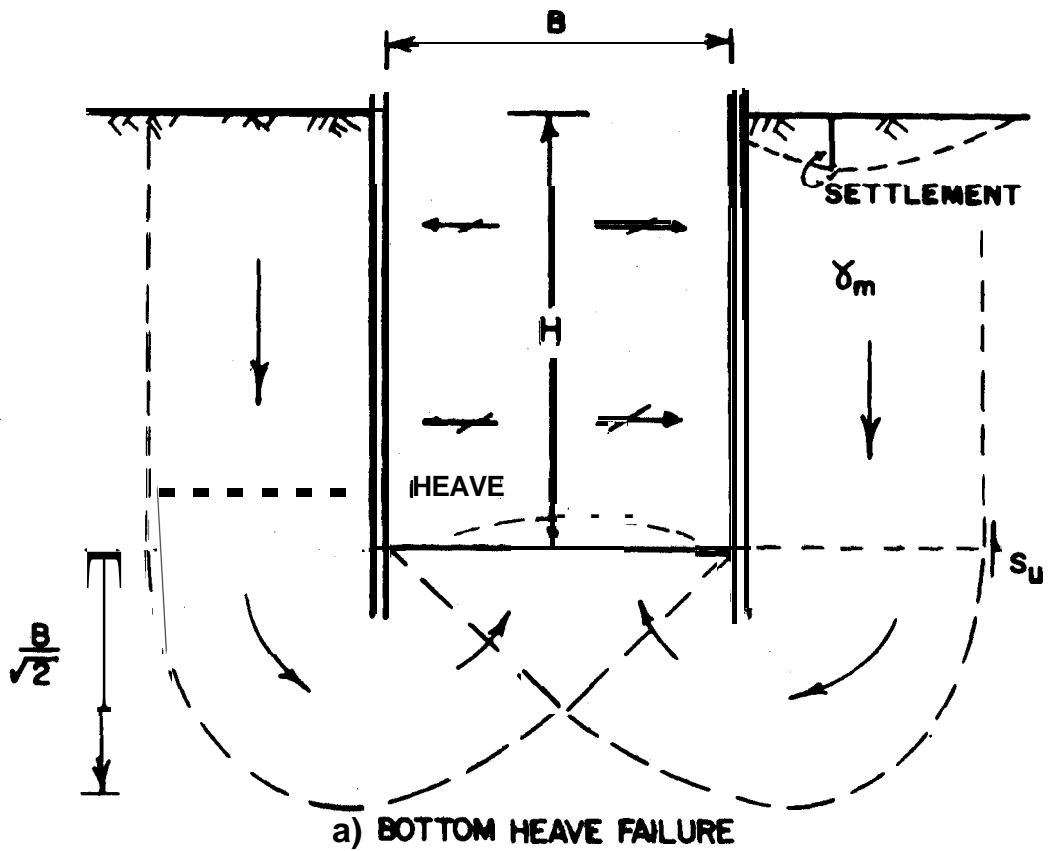
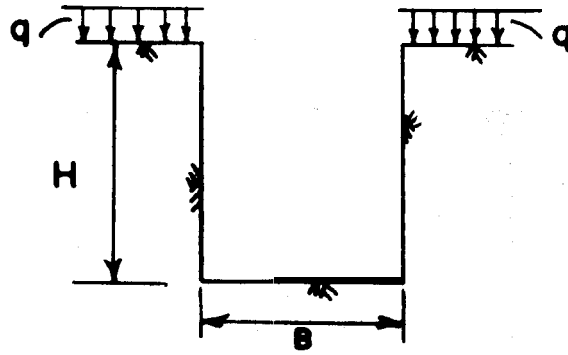

Figure 45. Potential failure surfaces.



$$H_{max.} = \frac{(S_u N_{cb} - q)}{\gamma_m}$$

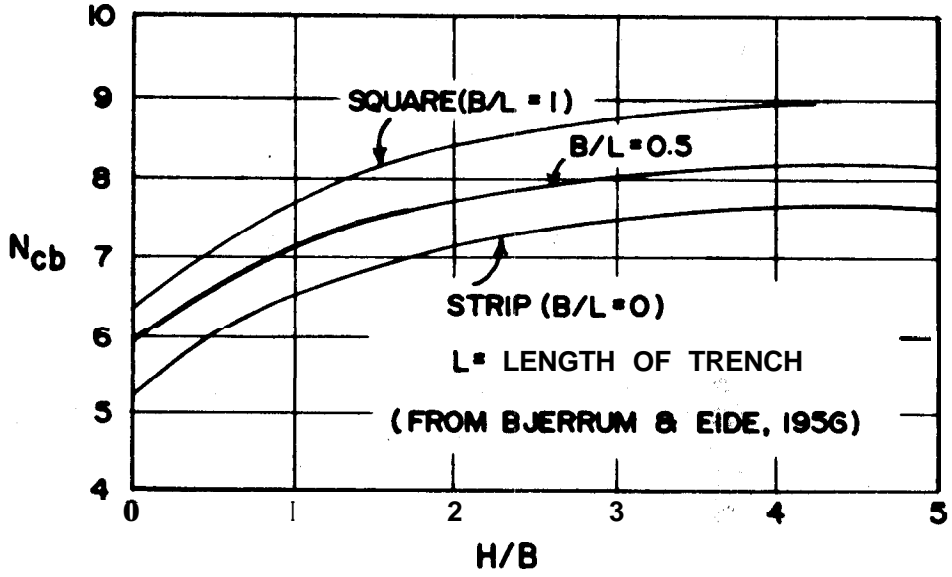

Figure 46. Bearing capacity factors for bottom stability analysis,

$$F. S = N_{cb} \left(\frac{S_u}{\gamma H + q} \right) = \frac{N_{cb}}{N}$$

where:

$$N = \text{stability number} = \frac{\gamma H + q}{S_u}$$

N_{cb} = bearing capacity factor from Figure 46

S_u = the undrained shear strength of the clay

γ = total unit weight of the soil

q = uniform surcharge loading on the area adjacent to the excavation

Where the soil is stratified within the depth of excavation and below, a weighted average of undrained strength should be used for S_u . This average should be taken over a zone described between $B/\sqrt{2}$ below the excavation base and $2.5B$ above the base.

8.30 LOCAL FAILURE

When braced excavations reach a certain depth in clay soils, the lateral pressures on the retaining wall coupled with the stress relief from the excavations can be of sufficient magnitude to cause local yielding of the soil immediately adjacent to the inside of the sheeting. This localized overstressing results in loss of passive resistance which in turn leads to uncontrolled inward movements of the sheeting. As the excavation proceeds, these inward movements become additive, resulting in large inward movements and a corresponding loss of ground adjacent to the excavation. D'Appolonia (1971), Jaworski (1973), and O'Rourke and Cording (1974a) all show data which indicate these uncontrolled movements can account for up to 50 percent of the loss of ground.

Figures 47a and 47b can be used to estimate when local failure is imminent in cohesive soils where flexible sheeting is used. The failure is related to the shear strength (S_u) and to the initial state of stress in the ground. Figure 47a shows the factor of safety against bottom heave necessary to prevent local yield as a function of excavation geometry and the shear stress ratio. The shear stress ratio (f) is a convenient dimensionless parameter which defines the initial state of

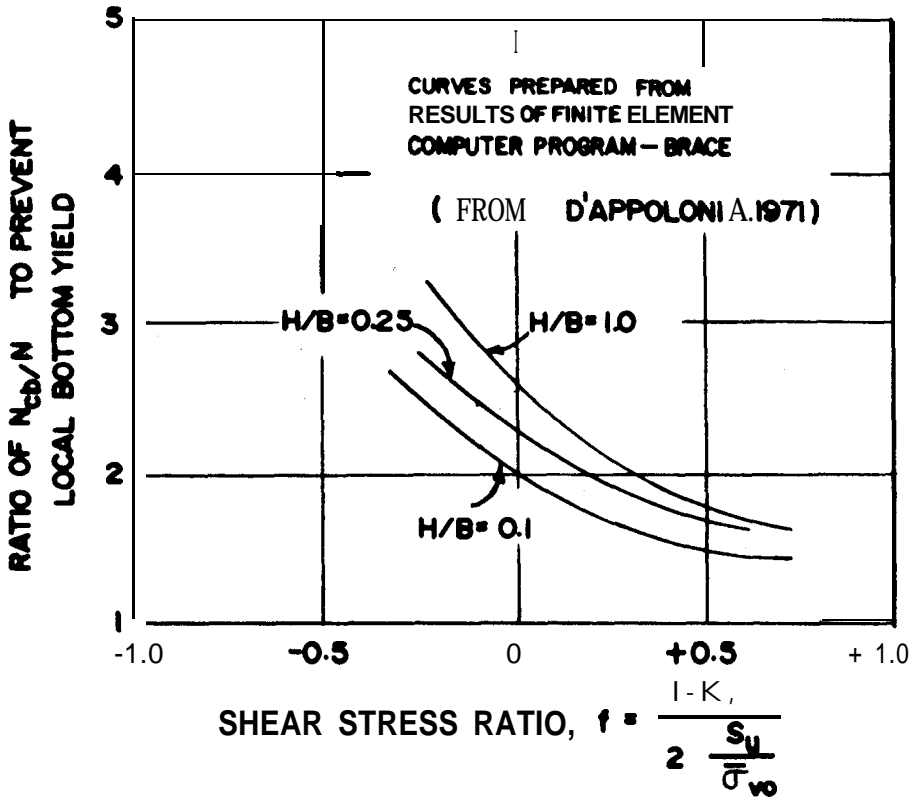

Figure 47a. Factor of safety required to prevent local yield below bottom of excavation in clay.

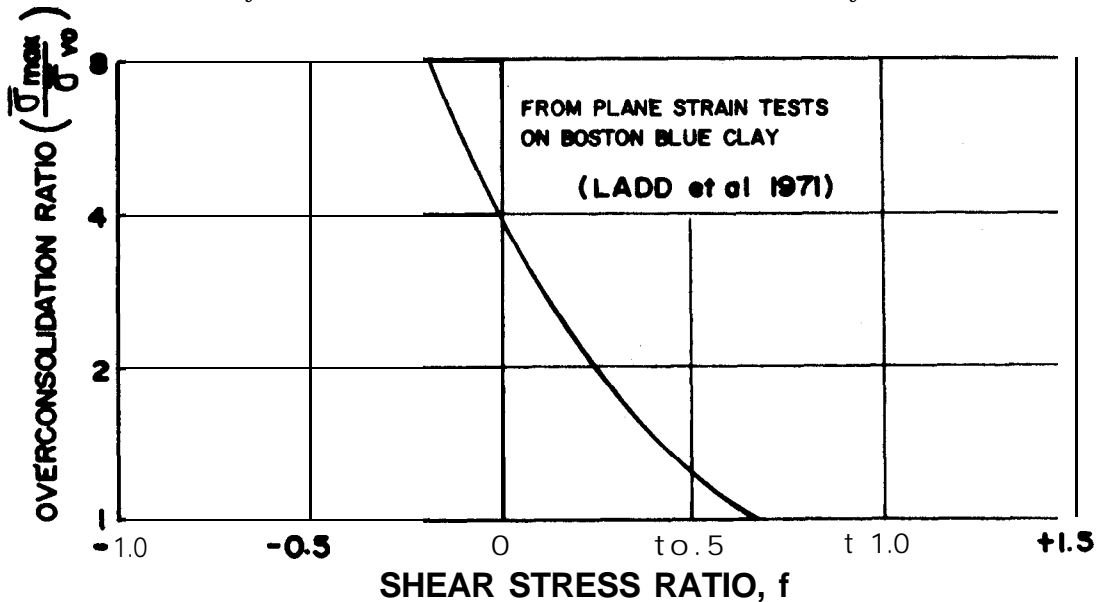

Figure 47b. Shear stress ratio vs. over consolidation ratio.

stress in the ground and the strength of the soil. Figure 47b gives the variation of the ratio (f) versus over consolidation ratio for Boston Blue Clay.

The depth at which local failures begin to develop is related to the shear strength of the soil and the initial state of stress in the ground. The potential for local yielding is most prominent in the over consolidated soils. The reason for this is the high value of K_o , ($\bar{\sigma}_{ho}/\bar{\sigma}_{vo}$), which is close to or can exceed 1. The failure at the base of the excavation is one of extension; that is, the shear stress (or deviator, stress) is increased by a decrease in the vertical stress. It follows that the higher the K_o value the closer the soil is to a failure condition. Hence, it takes less stress relief to cause overstressing of the soil.

Figure 47a shows that where the depth to width ratio of an excavation is 1 and the OCR is 6, a F.S. ≈ 3 may be necessary to prevent local yielding. On the other hand, for the same excavation in the softer normally consolidated soils (OCR = 1), a F. S. ≈ 1.5 is sufficient to limit local yielding. This lower factor of safety is associated with the low K_o value ($K_o \approx 0.5$) in normally consolidated soils. Thus, they can experience much Larger stress release before failure.

Figure 48 shows when Local yielding starts in normally consolidated clays as a function of sheeting stiffness (K) and excavation geometry (H/B). These data were developed using a finite element program (see Appendix to Chapter 2). The results indicate that for a given excavation geometry (up to $H/B \approx 1.0$) stiffening the sheeting reduces the factor of safety required to prevent local failure. This trend is related to the ability of the stiffer sheeting to act as a cantilever wall while minimizing inward movement.

8.40 DEEP SEATED FAILURES

8.41 Internally Braced Excavations

8.41.1 Circular Arc Analysis

In situations where internally braced excavations are either underlain by weak soils or the ground adjacent to the excavation slopes upward, the overall stability of the excavation should be analyzed.

One approach to analyze the stability is by the classical circular arc analysis as illustrated in Figure 49. It consists of assuming a series of centers of rotation and failure surfaces to find

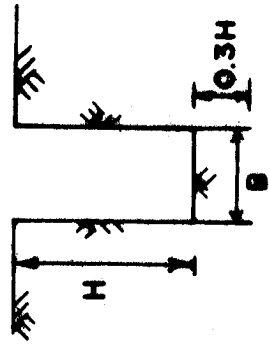
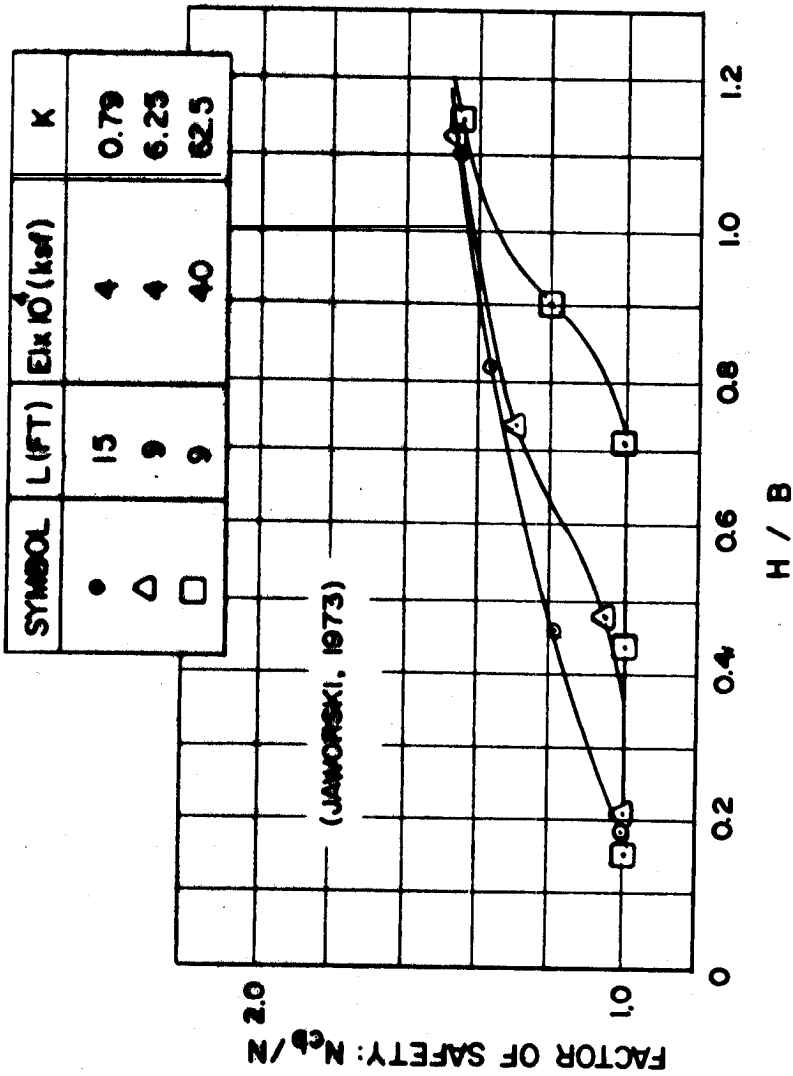

$$K = \frac{EI}{L^3}$$

L = STRUT SPACING

N_{cb} = BEARING CAPACITY NO.

$$N = \frac{\delta H}{S_u}$$

$$f = 0.75 = \left(\frac{1 - K_0}{2} \frac{S_u}{\bar{\sigma}_{v0}} \right)$$

Figure 48. Effect of sheeting stiffness on factor of safety at which first yield occurs in normally consolidated clay.

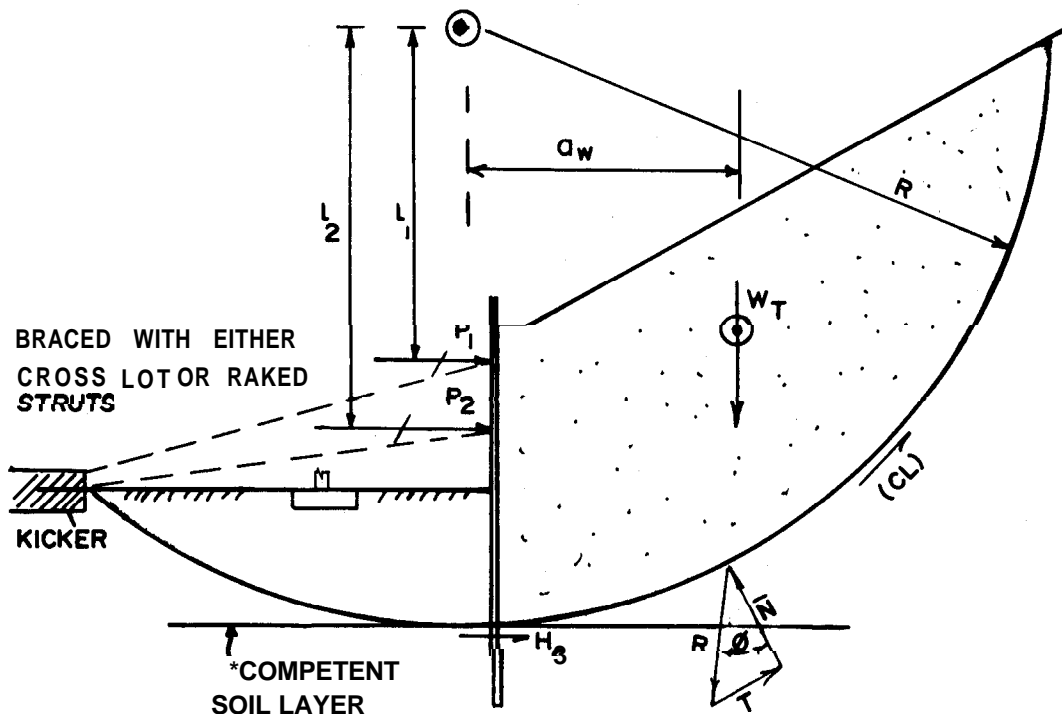

Consider overall stability:

Moments around center of rotation

Forces to consider:

- 1) Weight of driving mass (WT)
- 2) Resisting strut loads (P₁, P₂) (Horizontal component of support load.)
- 3) Resisting shear capacity of wall (H_s) from **competent** soilkyer.
- 4) Shear strength of soil, frictional component (T) and Cohesion, (c)

Note: If rakers used, kicker must be located outside failure mass for P₁ and P₂ to be considered in analysis.

$$\text{Safety Factor} = \frac{\Sigma M_R}{\Sigma M_D} = \frac{(\bar{N} \tan \phi \bar{t}_{CL}) R}{W_T a_w \cdot P_1 l_1 \cdot P_2 l_2 \cdot H_s R}$$

Figure 49. Stability of internally braced cut (circular arc method).

the minimum factor of safety against a rotational failure. The conditions shown are for the case of a homogeneous soil where the driving forces are the total weight of the soil **mass** plus any surcharge loads. Resisting forces consist of the strut loads (PL, P), the shear strength along the failure arc, and the shear capacity of the sheeting below the failure arc. If the soil is **stratified, then** the stability analysis should be made using the classical "Method of Slices".

The analysis will determine the hypothetical failure surface bounding the failed soil mass. If rakers support the wall, care must be taken to insure their kicker support is outside the failure zone. Otherwise, the thrust forces from the rakers should not be considered in the analysis.

The sum of the strut forces necessary to maintain a stable excavation should be compared to those predicted from **the** Lateral earth pressure diagram as outlined in Section 7. 50. The greater of the two total Loads should be used to **establish** the ordinate of the design earth pressure diagram.

In the cases where the retaining wall extends through a weak Layer into a highly competent soil, the **structural** resistance of the retaining wall (H_s) should be considered in the analysis. The shear resistance should be taken equal to the passive force determined in accordance with Chapter 6.

8.41.2 Wedge Stability Analysis

An alternate means of evaluating the overall stability of an internally braced excavation is to make a wedge stability analysis. It is often a simple method for analyzing a stratified soil deposit for the maximum loads which might occur in a support system.

Figure 50 shows this method of analysis for an internally braced excavation. The analysis illustrated is general, with no assumption for either failure surface or direction of active and passive Loads. However, this Leads to a tedious analysis. A simple alternative for analyzing this condition is to assume Rankine conditions for failure surfaces and direction of Load. **Although** this Latter approach does not yield theoretically correct answers, the results will be adequate for most problems.

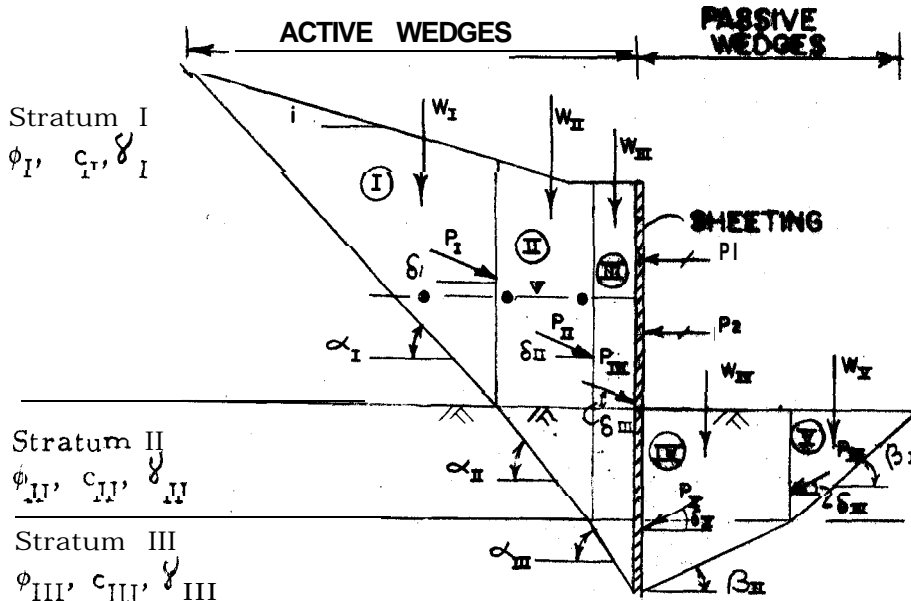

For general solution vary α , β , and δ angles to obtain minimum value for factor of safety.

Method of Analysis:

1. Assume α, β, δ angles.
2. Sequentially analyze the active and passive segment for loads P_{III} and P_V . Include water pressure.
3. Sum forces in horizontal direction for factor of safety

$$\text{i.e. F.S.} = \frac{P_1 + P_2}{P_{III} - P_v}$$

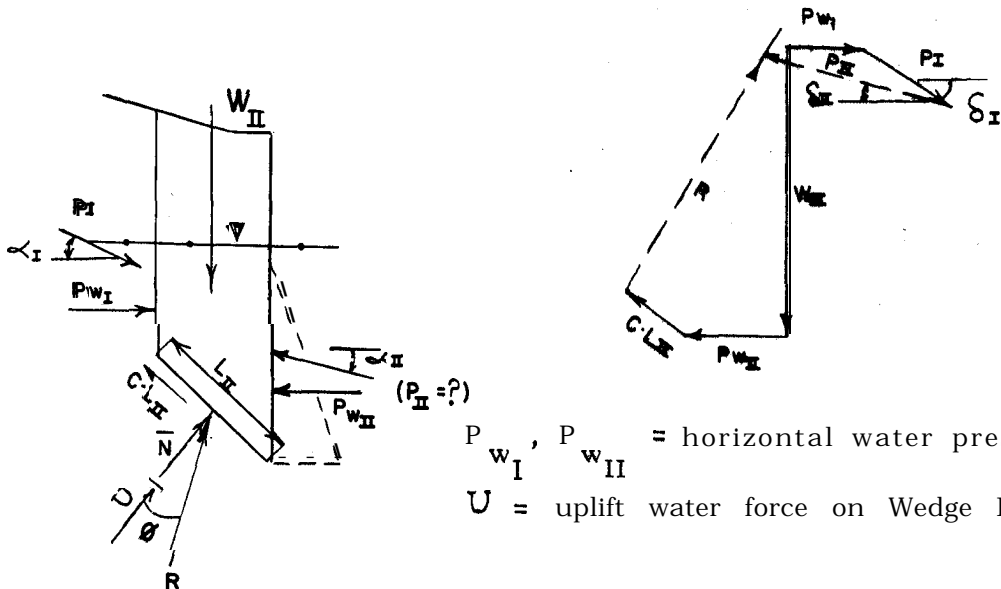

P_{WI}, P_{WH} = horizontal water pressure
 U = uplift water force on Wedge II

Typical Analysis of Wedge (Wedge II)

Figure 50. Wedge stability analysis for braced cut.

Detailed procedures for analyzing the stability of tied-back walls by a variety of methods employing trial planar surfaces and wedges are presented in Volume III. By and Large, these methods placed emphasis upon the failure surface passing through the zone of tiebacks. This technique may be used as a design tool for establishing the appropriate Length of tiebacks.

This section makes a simplified presentation of the circular arc method below as a means to examine overall stability for a failure surface passing beyond, or nominally through, the tieback zone. This concept is particularly appropriate when weak soils occur near or below the excavation base.

The analysis is quite similar to that used for internally braced excavations. Figure 51 illustrates the general approach for an assumed circular failure surface. The analysis must consider the position of the anchor relative to the failure surface. The example illustrated shows the surface cutting through the lowest anchor. The resisting force contributed by this anchor is a function of the amount of anchor outside the failed mass. If the failure surface passed before the anchor zone, then the tension force may be assumed to be the **full** design force in the tieback, T_c . For the surface shown, the failure plane passes through the **anchor** zone, therefore, it is necessary to make an assumption concerning tension force remaining in the tieback.' With ties having essentially uniform resistance in the anchor zone the load variation will be linear. Thus, the value of T to be used in the analysis may be taken as:

$$T = \frac{y}{x + y} T_c$$

where T_c is the total force in the anchor. In cases where ties are anchored in rock or belled anchors in highly competent soils are used, the full tension force may be assumed since the failure surfaces will not cut through these strata.

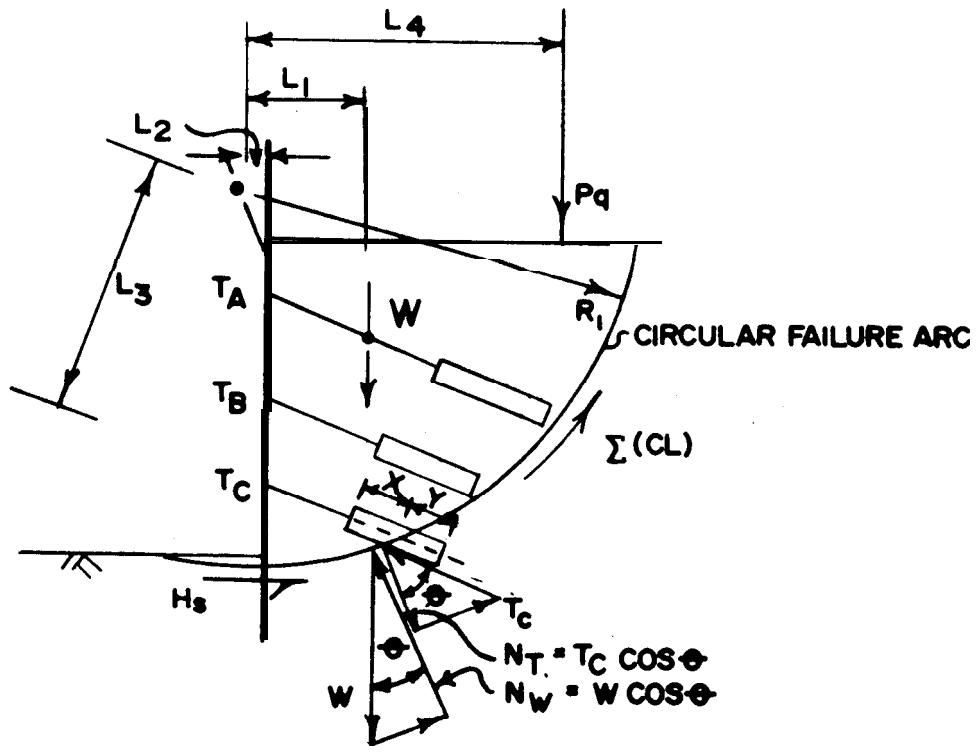

Take moments about center of rotation.

$$\Sigma M_0 = W l_1 + P_q l_4 - (T_C l_3 + H_s R_1)$$

$$\Sigma M_R = (W \cos \theta \tan \phi + cL) Rl + T_C \cos \theta \tan \phi$$

Safety Factor:

$$F. S. = \frac{\Sigma M_R}{\Sigma M_0}$$

Figure 51. Stability of tied-back excavation,

CHAPTER 9 • BEARING PRESSURE OF DEEP FOUNDATIONS

9.10 GENERAL

This section is directed toward those basic considerations used to establish bearing values for elements used in connection with cut and cover operations. These principles would be applied for underpinning units or for walls and soldier piles subjected to a vertical component of load.

Typically, the bearing stratum is deep -- that is, it lies at great depth relative to the width of the bearing area. Accordingly, those design rules developed for "shallow foundations" such as are presented in Terzaghi and Peck (1968) will be overly conservative.

Fundamentally, allowable bearing value must recognize two governing criteria -- first, adequate safety against shear failure of the foundation and second, a limitation of settlement. Usually, it is shear which controls for clays and settlement which controls for sands. The following discussion presents those basic tools required to assess the above stated criteria.

9.20 PRESUMPTIVE BEARING VALUE

Table 5 presents a summary of the range of allowable bearing values for building foundations resting on a variety of soil types. This tabulation is not intended to represent a recommendation for design; rather its purpose is to convey a means to assess the relative competency of different materials and to provide a crude initial guide. Because the values typically apply to shallow foundations, acceptable values for deep foundations will be somewhat higher.

9.30 BEARING VALUES BASED ON SHEAR FAILURE

9.31 General

The following represents a summary of theoretical procedures for calculating net ultimate bearing capacity using shear strength parameters, ϕ , for cohesionless soil, and undrained shear strength, S_u , of cohesive soils. A factor of safety of 2 to 3 should be applied depending upon risk and the confidence level in data.

Table 5. Abstract of presumptive bearing capacity, ksf.

	A Mass. State Code (1974)	B New York City (1968)	C Atlanta (1950)	D National Board of Fire Under- writers (1955)	E BOCA (1970)
Glacial Till*	20	--	--	--	--
Hardpan*	--	16 - 24	20	20	20
Gravel, well-graded sand and gravel*	10	8 - 20	8 - 12¹	8 - 12¹	8 - 12¹
Coarse sand*	6	6 - 12²	--	6 - 8¹	6 - 8¹
Medium sand*	4	--	--	--	4 (loose)
Fine sand	2 - 4	4 - 8³	--	4 - 6¹	--
Hard clay	10	10	--	--	--
Stiff clay	--	--	4	5	--
Medium clay	2	4	--	5	--

* Massachusetts and New York Code allow 5 percent increase in bearing value per foot of additional embedment, but not more than twice tabulated value.

1 - Range reflects compactness, gradation, and/or silt content

2 - $0.1 \times N$, but not less than 6 ksf nor more than 12 ksf (where N = no. of blows in SPT)

3 - $0.1 \times N$, but not less than 4 ksf nor more than 8 ksf (where N = no. of blows in SPT)

9. 32 Sand

For deep piers, in sand, the end bearing load capacity is generally expressed as:

$$q_u = N_q \bar{\sigma}_v$$

where:

N_q = dimensionless bearing capacity factor that is a function of the shear strength parameter, ϕ , of the bearing material and shape of the loaded area

$\bar{\sigma}_v$ = effective stress in the soil at the bearing surface

q_u = ultimate bearing capacity (load per unit area)

Values of N_q vary depending upon assumptions made in the derivation. Vesic (1965) presents ranges for the values as shown in Figure 52. The lower curves represent modes of failure in which the shear strength of the soil is developed below the footing. Higher values of N_q will be obtained by assuming that the failure surface extends above the plane of bearing, thus engaging shear resistance above that level,

As a practical matter, because of the high bearing capacity of sand there is little penalty in adopting a conservative value. For example, consider an extended underpinning pier bearing at a depth of 20 feet on a sand with $\phi = 35^\circ$. Assuming a unit weight of 125 psf, the effective stress would be:

$$\bar{\sigma}_v = 20 \times 125 = 2500 \text{ psf}$$

$$N_q = 58 \text{ (Vesic)}$$

$$= 75 \text{ (Berezantsev)}$$

$$= 110 \text{ (Brinch Hansen, 1961)}$$

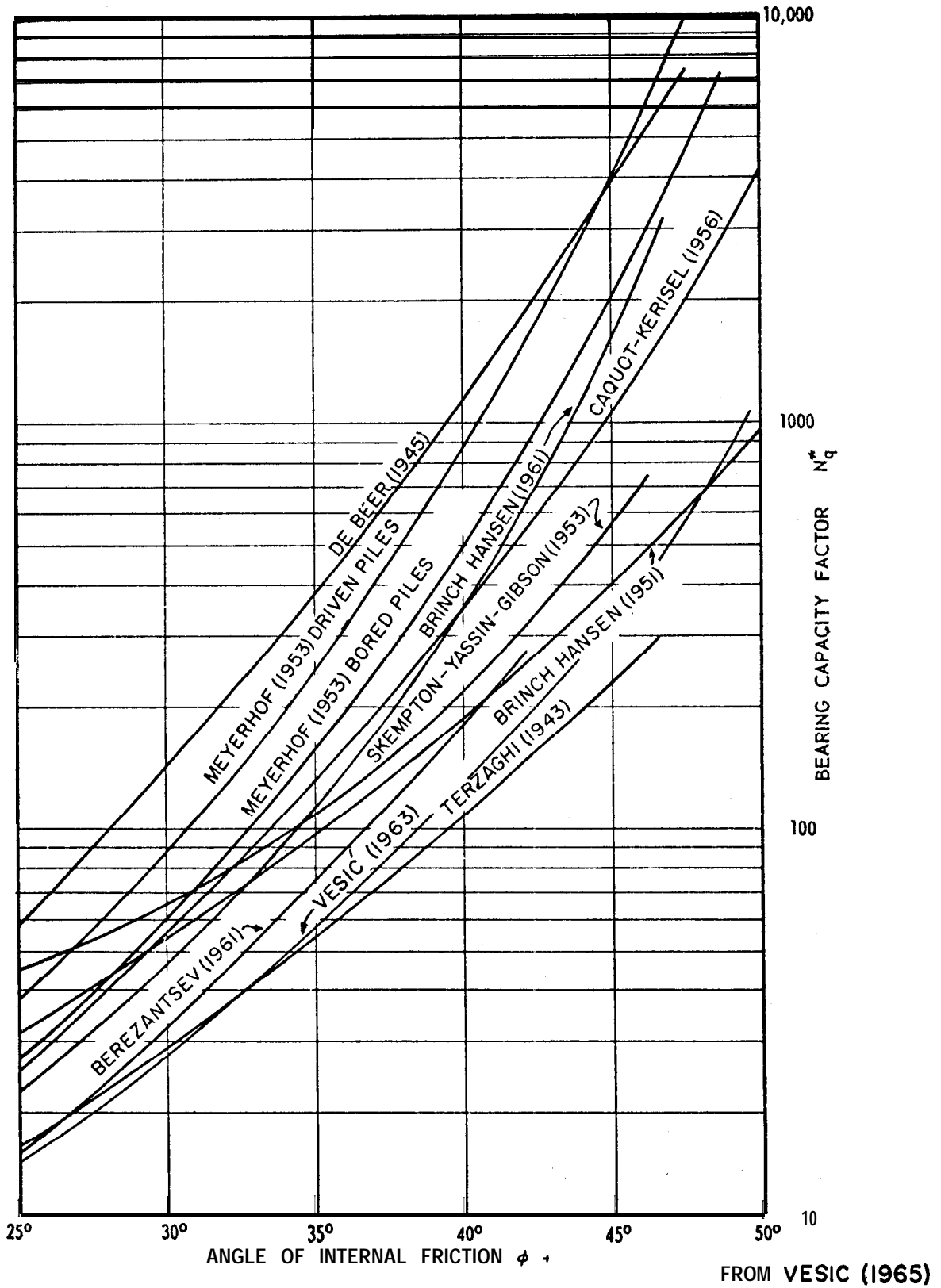

Figure 52. Bearing capacity factors for deep circular foundations.

Thus, the ultimate bearing pressure will range from:

$$\begin{aligned} \text{Vesic: } q_u &= 58 \times 2500 = 145,000 \text{ psf} \\ \text{Berezantsev: } q_u &= 75 \times 2500 = 187,500 \text{ psf} \\ \text{Brinch Hansen: } q_u &= 110 \times 2500 = 275,000 \text{ psf} \end{aligned}$$

Obviously, all values are quite acceptable. Accordingly, there is little to be gained in most applications by debating the appropriate value of N_q . In general, a safety factor of 3 is applied to these ultimate values. As stated above the settlement limitation usually controls in granular soils.

9.33 Clay

In clays the undrained strength, S_u , rather than drained strength will control the bearing capacity of a foundation element. Skempton (1951) presented bearing capacity factors N_c for net ultimate bearing capacity in clays. In this case, "net" means pressure in excess of the effective overburden stress of the bearing level.

$$q_u = N_c S_u$$

where:

$$\begin{aligned} q_u & \text{ net ultimate bearing capacity (load per} \\ & \text{unit area)} \\ N_c & = \text{dimensionless bearing capacity factor} \\ & \text{that is a function of the shape of the loaded area} \\ S_u & \text{undrained shear strength of soil} \end{aligned}$$

For deep foundations (at depth greater than 4 to 5 times the breadth of the Loaded area) values of N_c are as follows:

$$\begin{aligned} \text{Circle: } N_c &= 9 \\ \text{Strip: } N_c &= 7.5 \\ \text{Rectangle: } N_c &= 7.5 (1 \pm 0.2 B/L) \end{aligned}$$

$$\begin{aligned} \text{where: } B &= \text{breadth and} \\ L &= \text{length} \end{aligned}$$

Note that for clays, the net ultimate bearing pressure is independent of depth (and therefore overburden stress). It is a function only of the shape of the loaded area and undrained shear strength of the soil.

In addition to the load bearing capacity at the base, the side friction may be determined on the basis of the embedded area and

adhesion along the shaft. In soft clays, the adhesion is equal to or only slightly less than the undrained shear strength. However, in stiff to hard clays the adhesion is typically less than one-half the undrained strength. Tomlinson (1969) presents a summary of data for adhesion in both driven and bored piles.

Much of the data on shaft adhesion was developed on bored piles in London clay. The practice is to apply a reduction factor, α , to the undrained strength to estimate adhesion. Thus:

$$S_{\text{eff}} = \alpha S_u$$

where :

α = reduction factor

S_u = undrained shear strength, psf

S_{eff} = adhesion along shaft, psf

Figure 53 (after Peck, et al, 1974) shows that α decreases as the shear strength of clay increases. In general, shaft adhesion is counted on for load support in very stiff to hard clay. In this range, α varies from about 0.3 to 0.5. For stiffer clays, the average developed adhesion, αS_u , shows little variation with increasing shear strength. It varies from only about 1 tsf to 1.3 tsf.

In areas where there is little prior data, Skempton recommends a maximum adhesion of 1 tsf (Tomlinson, 1969) when using the chart. The total capacity of the shaft is equal to:

$$Q_{\text{shaft}} = \alpha S_u A$$

where:

A = shaft area

Again, a safety factor of between 2 and 3 should be used.

9.40 BEARING VALUES BASED ON SETTLEMENT

9.41 General

The following presents the recommended procedures for estimating the settlements of deep foundations.

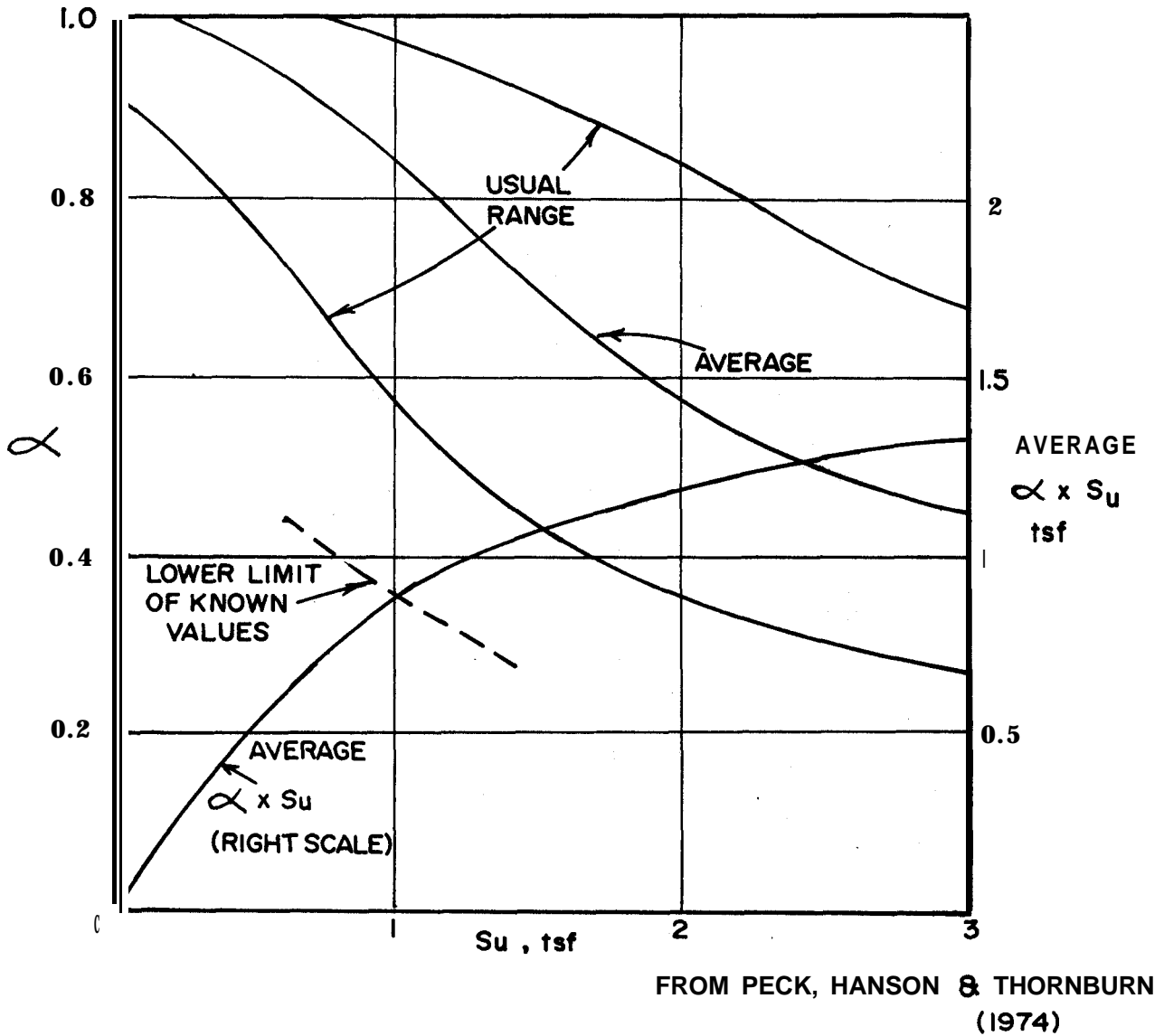

Figure 53. Reduction factor in S from observed capacity of friction piles.

9.42. 1 Surface Loading

Theoretical procedures for determination of settlements have been developed by Fox (1948) for square and rectangular bearing areas and by Woodward, et al (1972) for round bearing areas. These are based on integration of the Mindlin solution for a point load within an elastic half space. At a depth equal to zero, the Mindlin solution is identical to the familiar Boussinesq solution. These solutions all have the general form.

$$\rho = q \frac{BI_p}{E} (1 - \nu)^2 \quad \text{Eq. 9.42. 1}$$

where:

ρ = settlement

q = distributed load

B = least dimension of foundation unit

E = modulus of deformation

ν = Poisson's Ratio

I_p = influence factor which depends on rigidity of footing, shape of footing, and depth of footing

A simplified method for determining settlement at the surface is based upon a coefficient of **subgrade** reaction defined as follows:

$$k = \frac{q}{\rho} \quad \text{Eq. 9.42. 2}$$

And thus, the settlement is computed as follows:

$$\rho = \frac{q}{k} \quad \text{Eq. 9. 42. 3}$$

where:

ρ and q are defined as above

k = coefficient of **subgrade** reaction in general units of pressure per unit deflection

The value of the coefficient of **subgrade** reaction is commonly determined by plate loading tests or by correlation with in situ soil indices such as relative density and standard penetration resistance. By comparison of Eq. 9.42.1 and 9.42.3, the coefficient of **subgrade** reaction is related to the theoretical settlement as follows:

$$k = \frac{E}{B(1 - \nu)^2} \frac{1}{I_p} \quad \text{Eq. 9.42.4}$$

For a constant footing shape and depth and constant material properties, the coefficient of **subgrade** reaction for a footing of size B is therefore related to a footing of size B' by the following relationship:

$$k_{B'} = k_B \left(\frac{B}{B'} \right) \quad \text{Eq. 9.42.5}$$

It is common to express the coefficient of **subgrade** reaction in terms of the value for a 1 foot square plate (k_1) as this is the size for conventional plate loading tests. Therefore,

$$k_B = \frac{k_1}{B}$$

Typical values for k_1 are shown in Figure 54.

9.42.2 Rectangular Footings

Influence values for other than square footings can be determined from elastic theory. These values however, become very large for long narrow footings and in fact approach infinity (k approaches zero) for an infinitely long footing. These results directly follow from the fact that the Boussinesq solution does not approach the actual plane strain conditions when integrated to infinite limits. Therefore, the elastic solution is unrealistic for long footings. To solve the problem, Terzaghi (1955) has proposed the following empirical relationship for rectangular footings:

$$k_{L \times B} = k_B \frac{(1 + 0.5 B/L)}{1.5} \quad \text{Eq. 9.42.6}$$

where:

$k_{L \times B}$ = coefficient of **subgrade** reaction for footings of Length, L, and width, B

k_B = coefficient of **subgrade** reaction for square footing of dimension, B

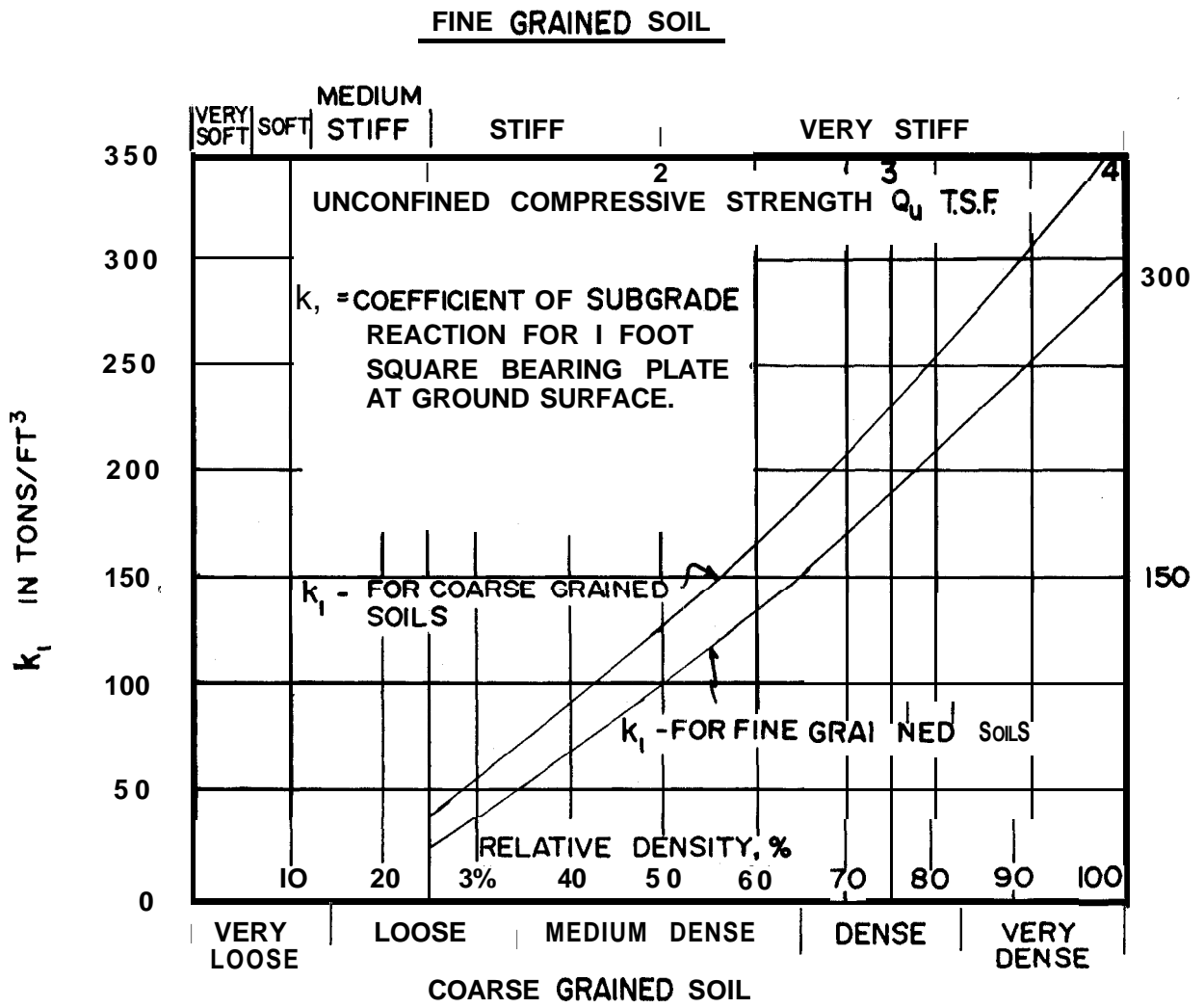

Figure 54. Coefficient of subgrade reaction vs. in situ soil indices (NAVFAC, 1971).

This relation suggests that the **subgrade** modulus for an infinitely Long footing approaches a value equal to $2/3$ of that for a square footing.

Both the elastic theory and **Terzaghi's** empirical relationship are plotted in Figure 55. The recommended procedure is the Terzaghi relationship especially for Larger values of L/B.

9.42.3 Effect of Depth

For a footing with constant Loading, shape, and material properties, the **subgrade** modulus of that footing is inversely proportional to the influence factor (see Eq. 9.42.4). Thus, when the influence factor varies with depth, the ratio of **subgrade modulus** at the surface to the **subgrade** modulus at depth may be computed as follows:

$$\frac{k_B^S}{k_B^D} = \frac{I_\rho^D}{I_\rho^S} \quad \text{Eq. 9.42.7}$$

where:

k_B^S = coefficient of **subgrade** reaction for a footing (breadth B) at the surface.

k_B^D = coefficient of **subgrade** reaction for a footing (breadth B) at depth, D.

I_ρ^D = influence factor for footing at depth D.

I_ρ^S = influence factor for footing at surface.

Elastic theory demonstrates a variation of influence factor, I_ρ with depth. On this basis, the depth factor FD has been plotted in **Figure 56** for circular and rectangular footings. Note that this figure is for the special case of constant modulus of deformation.

Also shown on this figure is a plot of depth factor for a circular shaft which relies on 100 percent side friction and no end bearing. It can be seen that the depth factor is Less for this case than for the case of 100 percent end bearing for depth ratios.

$\left(\frac{D}{\sqrt{L \times B}}\right)$ greater than approximately 1.25. For **all** cases,

the effect of depth is to increase the **subgrade** modulus and thus to reduce settlement.

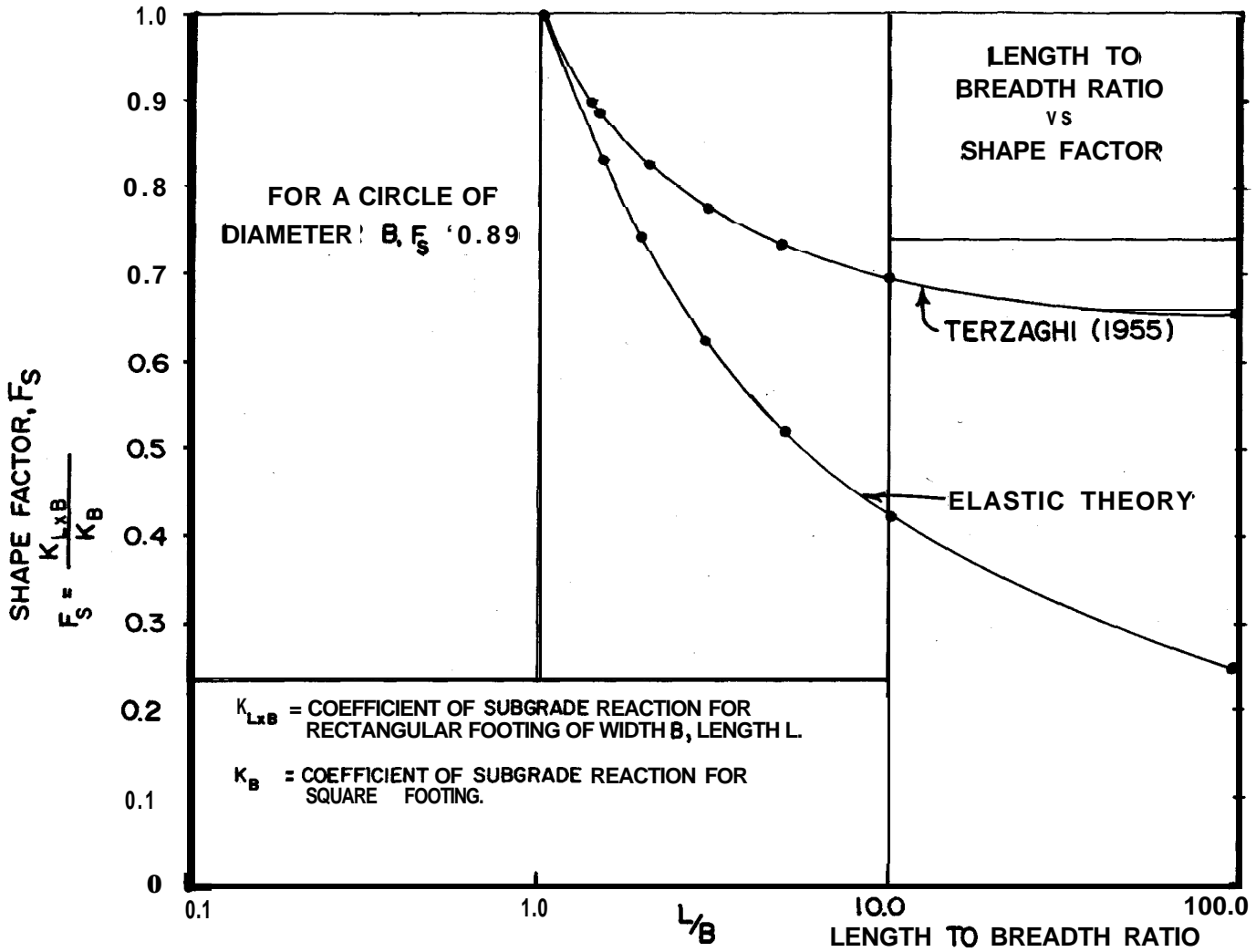

Figure 55. Shape factor for rectangular footings.

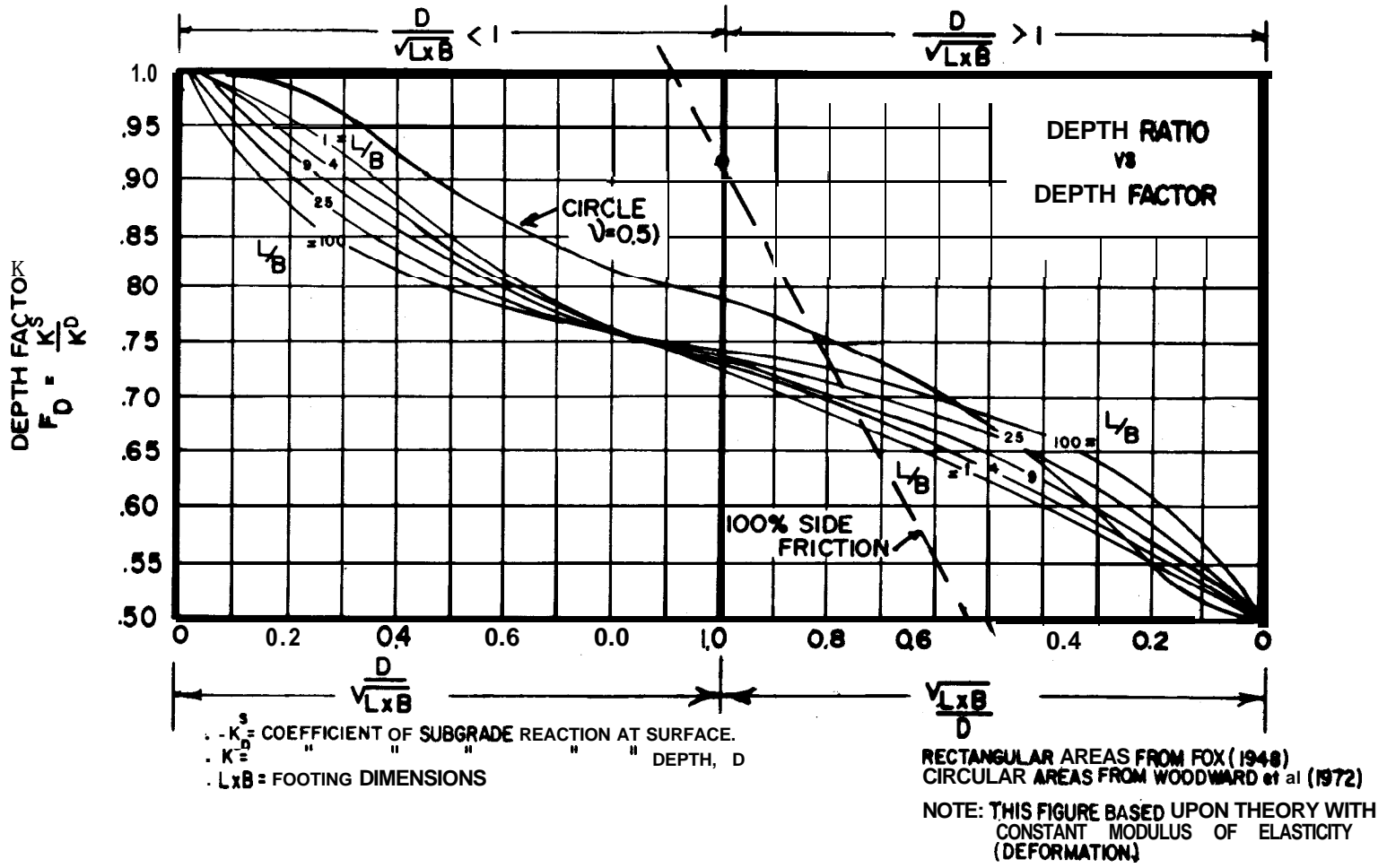

Figure 56. Influence of depth on coefficient of subgrade reaction (based on modulus of deformation that is constant with depth).

9.43.1 r f a c e

In the case where the modulus of deformation increases linearly with depth, it can be seen that the coefficient of **subgrade** reaction will vary in direct proportion to the increase in modulus. This effect comes into play in two ways: first, for larger size footings a larger area is loaded and consequently a greater depth of stress influence is created; and second, for footings at depth, the deformation modulus E , will not be the same as at the surface, thereby invalidating the relationships in the preceding section.

For the former case, Terzaghi (1955) has proposed the following empirical relationship to convert the coefficient of **subgrade** reaction for a 1 foot square area to an area $B \times B$ square.

$$k_B = k_1 \left[\frac{B + 1}{2B} \right]^2 \quad \text{Eq. 9.43. 1}$$

9.43.2 Rectangular Footings

Once k_B is determined, $k_{L \times B}$ at the surface can be obtained from Figure 55.

9.43.3 Depth Effects

The special case of constant modulus of deformation was discussed in Section 9.42. 3. In addition, Taylor (1948) has proposed an embedment correction to account for the increase in modulus of deformation with depth as follows:

$$k_B^D = k_B^S (1 + 2 D/B) \quad \text{Eq. 9.43.2}$$

Where: D = depth of footing
 B = least breadth of footing

In using this relationship, care must be taken to assure that the value of k_1 used to determine k_B does represent the material at the surface. If the value of k_1 is determined from correlation with indices such as standard penetration resistance or relative density at the bearing level., the correction for increase in modulus would not be made.

A second method of evaluating the effect of increasing modulus of deformation is to consider the coefficient of **subgrade** reaction to be directly proportional to the initial tangent modulus E_{it} . Janbu (1963) shows that E_{it} for granular soils is **proportional** to a power function of stress Level. Specifically:

$$E_{it} \sim (\bar{\sigma}_3)^n \quad \text{Eq. 9.43. 3}$$

where:

$\bar{\sigma}_3$ = lateral stress (assumed to be effective Lateral stress)

$n = 0.3$ for gravels, 0.5 for sands

Accordingly, it follows that:

$$\frac{k_B^S}{k_B^D} = \left[\frac{\bar{\sigma}_3^S}{\bar{\sigma}_3^D} \right]^n = F_{DG} \quad \text{Eq. 9.43.4}$$

where: F_{DC} is defined as the depth factor for granular soil.

In normally consolidated deposits, $\bar{\sigma}_3$ is **proportional** to the overburden stress and therefore to the depth. The following equation results:

$$\frac{k_B^S}{k_B^D} \left[\frac{z^S}{z^D} \right]^n = F_{DG} \quad \text{Eq. 9.43.5}$$

The recommended **value** of 'z' to be used in this expression is:

$$z = D_F \text{ t } 0.75B \quad \text{Eq. 9.43.6}$$

where :

D_F = depth of footing from average ground surface

The results of both methods for determining depth effects in soils with varying modulus of deformation are presented in Figure 57. Note that a Limitation of $F_{DG} = 0.5$ has been set on the Taylor expression. The relationships shown in the figure are typically

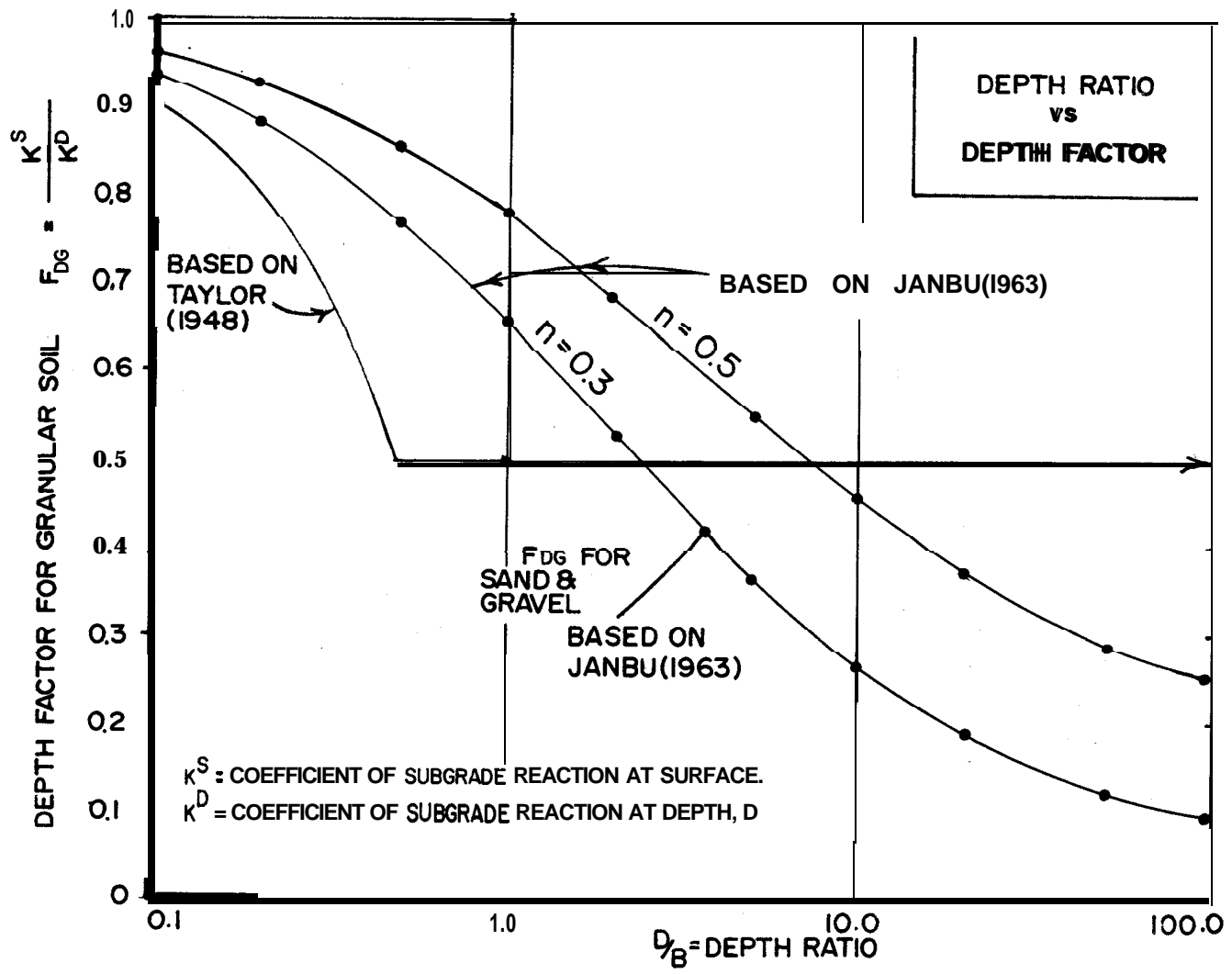

Figure 57. Influence of depth on coefficient of subgrade reaction for granular soils (based on modulus of deformation that increases with depth).

applicable to granular soils because their modulus of deformation is a function of stress level, and therefore, depth. Such soils rarely exhibit "over consolidated" behavior; however, they would only be applicable to cases where the determination of the basic value of subgrade modulus did not already include the effects of increasing modulus with depth. For instance, if k were based on the average standard penetration resistance in the zone of significant stress increase beneath the proposed footing, no correction for increasing modulus with depth would be made ($F_{DG} = 1$). On the other hand, if k were based on a plate loading test at the surface, the value of F_{DG} as determined from Figure 57 should be used.

9. 43. 4 Water Table Effects

The presence of ground water in granular soils will effect the modulus of deformation by reducing the Lateral effective stress. The effect of the ground water table can be estimated by considering equation 9.43.4 and computing the lateral effective stress at midpoint of the zone of significant stress increase. If the water table is below a depth of $1.5B$ beneath the base of the footing, then no water table correction would be necessary and Figure 57 could be used directly. If the water table is at or above the base of the footing, then F_{DG} would be computed using effective stress values at the average depth of significant stress increase substituted into Eq. 9.43.4. Where the water table lies between these limits, a pro-rated correction should be made.

The effects of the water table would only be considered where the water table effects have not been considered in determining the basic value of the subgrade modulus. For instance, if k is based on a plate loading test at the surface, with the water table also at the surface, Figure 57 could be used directly since water table effects would be accounted for in the value of k ; however, if the footing and water table were at some depth D greater than the influence area of the loading test, F_{DC} would be computed as described above. Conversely, if the value of k were based on the average standard penetration resistance in the zone of significant stress increase, no adjustment to k would be necessary, either for water table effects or the increase in modulus with depth.

9.44 Recommended Procedure for Determination of Settlements of Deep Foundations

9.44.1 Clays

Assume that modulus of deformation is constant with depth. Compute settlement for Eq. 9.42.2.

$$\rho = q/k$$

where:

q = load in tsf

k = coefficient of subgrade reaction in tsf/ft

ρ = settlement in feet

Determine k by first determining k_1 at the surface of the soil from Figure 54 or from plate load test.

Modify k , as follows, to account for size, shape and depth:

$$k = \frac{k_1}{B} \left[\frac{F_S}{F_D} \right]$$

where:

F_S = shape factor from Figure 55

F_D = depth factor from Figure 56

B = least dimension of bearing area in feet

9.44.2 Sands

Assume modulus of deformation increases with depth. Compute settlement from Eq. 9.42.2 as above. Determine k by first determining k_1 as above. Modify k_1 as follows to account for size, shape and depth:

$$k = \frac{k_1 \times F_S}{F_D \times F_{DG}} \left[\frac{B + 1}{2B} \right]^2$$

where:

F_S , F_D , and B as defined above

F_{DG} = depth factor for granular soil from Figure 57

9.45 Example Problems

9.45.1 Problem Number 1

Determine the average settlement of a continuous footing for underpinning; 4 feet wide at a depth of 30 feet in sand. The water table is at a depth of 50 feet **and the** average load per **linear** foot of footing is 20 kips. The **subgrade** modulus of 200 **tons/ft³** was determined from a plate **loading** test at the surface prior to excavation. The unit weight is **125pcf**.

a) Make correction for footing **size** and shape:

(1) Find k_4 (coefficient for 4' x 4' footing)

$$k_B = k_1 \left[\frac{B + 1}{2B} \right]^2$$
$$k_4 = 200 \left[\frac{4 + 1}{8} \right]^2 = 78 \text{ tons/ft}^3$$

(2) **Find** shape factor for an **infinitely** long footing 4 feet wide. See Figure 55.

$$F_S = 2/3 \text{ (Tereaghi curve)}$$

b) Make correction for footing depth.

(1) Find depth factor, based upon elastic theory and constant modulus. See Figure 56.

$$F_o = 1.0 \text{ for } L = \infty \quad \text{b y } \text{depth}$$

(2) Find depth factor due to increasing modulus with depth. See Figure 57.

$$D/B = 30/4 = 7.5$$

from Figure 57

$$F_{DG} = 0.5 \text{ (both Taylor and Janbu criteria)}$$

- c) Find corrected coefficient of **subgrade** reaction.

$$\begin{aligned} k &= 78 \times \frac{F_S}{F_D \times F_{DG}} \\ &= 78 \times \frac{2}{3} \times \frac{1}{0.5 \times 1.0} \\ &= 104 \text{ tons/ft}^3 \end{aligned}$$

- d) Settlement Computation

$$\begin{aligned} \rho &= q/k \\ q &= \frac{20k/ft}{4ft} = 5 \text{ ksf} \\ k &= 104 \text{ tons /ft}^3 = 208 \text{ k/ft}^3 \\ P &= \frac{5}{208} = 0.024' = 0.288''; \text{ say } \sim 0.3'' \end{aligned}$$

9.45.2 Problem Number 2

Determine the settlement of a 3 foot square footing for an underpinning unit at a depth of 5' in stiff clay. The unconfined compressive strength of the clay was 1.5 tsf, and the footing load is 45 k.

- a) Determination of k_1

From Figure 54 for fine **grained** soils:

$$k_1 = 60 \text{ tons/ft}^3$$

- b) Make correction for size

$$k_3 = k_1 (l/B) = 60/3 = 20 \text{ tons/ft}^3$$

c) Make correction for depth

1) Find depth factor based upon elastic theory and constant modulus. See Figure 56.

$$F_D = \frac{5'}{3' \sqrt{B'}} = 1.67$$

d) Find corrected coefficient of **subgrade** reaction

$$k = 20 \times \frac{1}{F_D} = \frac{20}{0.64} = 31 \text{ tons /ft.}^3$$

e) Settlement Computation

$$\rho = q/k$$

$$q = \frac{45 \text{ k}}{9 \text{ ft.}^2} = 5 \text{ ksf}$$

$$k = 31 \text{ tons /ft.}^3 = 62 \text{ k /ft.}^3$$

$$\rho = \frac{5}{62} = 0.08' = 1.0''$$

9.45.3 Problem Number 3

Same as problem number 1 except that the water table is at 5 feet. The only difference will be the determination of F_{DG} .

a) Make corrections for footing size and shape

$$k_4 = 78 \text{ tons /ft.}^3 \text{ and } F_S = 2/3 \text{ (from example 1)}$$

b) Find depth factor (F_{DG}) due to increasing modulus with depth. In this case F_{DG} must be determined by Eq. 9.43.4, since the original estimate of **subgrade** modulus did not include the effects of the water table. **Let** K_o = at rest earth pressure coefficient.

Under a 4 foot wide load at the surface

$$\bar{\sigma}_3 = 125 (0.75 \times 4) K_o = 375 K_o$$

Under a 4 foot wide load at 30 feet with the water table at 10 feet.

$$\sigma_3 = \left[(125 \times 5) + (25 \times 62.6) \right] K_o = 2190 K_o$$

$$\frac{\bar{\sigma}_3^S}{\bar{\sigma}_3^D} = \frac{375}{2190} = 0.17$$

$$F_{DG} = \left[\frac{\bar{\sigma}_3^S}{\bar{\sigma}_3^D} \right]^n = (0.17)^{0.3} = 0.59$$

c) Find depth factor based on elastic theory and constant modulus.

$$F_D = 1.0 \text{ from Example 1.}$$

d) Find corrected coefficient of subgrade reaction

$$k = 78 \frac{F_s}{F_{DG} \times F_D} = 78 \times \frac{1}{0.57 \times 1.0}$$

$$91 \text{ tons/ft.}^3 = 182 \text{ k/ft.}^3$$

e) Settlement computation

$$\rho = q/k = \frac{5}{182} = 0.027' = 0.324''; \text{ say } \sim 0.3''$$

9.45.4 Problem Number 4

Determine the settlement of a 5 x 5 footing at a depth of 10 feet in sand and gravel. The load is 80 tons and the coefficient of subgrade reaction is estimated to be 100 tons/ft³ for a 1 square foot footing on the basis of the standard penetration resistance between 10 feet and 17.5 feet. The water table is at 10 feet.

a) Correct for size effects

$$k_5 = k_1 \left(\frac{B+1}{2B} \right)^2 = 100 \left(\frac{6}{10} \right)^2 = 36 \text{ tons/ft.}^3$$

where: k_5 = coefficient of subgrade modulus for 5' x 5' footing at surface.

b) Shape effect - None required for square footing.

$$F_s = 1.0$$

c) Make corrections for depth effects

1) Consider elastic theory and constant modulus.
See Figure 56

$$D/B = 5/10 = 0.5$$

$$F_D = 0.85$$

2) Consider the effect of increasing modulus with depth.

No correction for increasing modulus or water table effects since k was based on data from the zone of influence of proposed footing. $F_{DG} = 1.0$

d) Find corrected coefficient of subgrade reaction

$$k = 36 \times \frac{F_s}{F_D \times F_{DG}} = 36 \times \frac{1.0}{0.85 \times 1.0}$$

$$k = 42 \text{ tons/ft.}^3$$

e) Settlement computation

$$\rho = q/k$$

$$q = \frac{80 \text{ tons}}{5 \times 5} = 3.2 \text{ tons/ft.}^2$$

$$\rho = \frac{3.2}{42} = 0.076' = 1.1''$$

CHAPTER 10 - CONSTRUCTION MONITORING

10. 10 INTRODUCTION

Geotechnical engineering, by its nature, involves contingencies from unforeseen conditions that are encountered during **construction**. Bold innovative designs may justify experimental test sections and then continuing re-assessment and verification during actual construction.

The preceding chapters in this volume are addressed to engineering during the design phase. Geotechnical engineering must extend beyond design into construction, and therefore it is essential that data be obtained for re-evaluation of design assumptions and implementation of appropriate modifications.

10. 11 General

This chapter presents an overview of the purpose of construction monitoring, what is measured, and how the task is planned and executed. Emphasis is placed on open cut deep excavations and adjacent structures. Construction monitoring case histories were reviewed by Schmidt and Dunnicliff (1974), who also describe construction monitoring of soft ground tunnels.

10. 12 Reasons for Construction Monitoring

If a construction monitoring program is performed for the right reasons, planned properly, and executed by diligent engineers, it can make a large contribution towards increasing safety, reducing cost, and reducing the impacts of construction on the environs. Some valid reasons for monitoring are:

- | | |
|-------------|---|
| Diagnostic: | To verify adequacy of design |
| | To verify suitability of construction techniques |
| | To diagnose the specific nature of an adverse event |
| | To verify continued satisfactory performance |
| Predictive: | To permit a prediction of behavior later on at the same job |

Legal: To establish a bank of data for possible use in litigation
Research: To advance the state-of-the-art by providing better future design data

10.20 PLANNING CONSTRUCTION MONITORING PROGRAMS

Many construction monitoring programs fail to achieve their purpose because the engineer does not approach the program design in a logical sequence. There is a tendency **among** engineers to select an instrument, make some measurements, and then wonder what to do with the data (Peck, 1970). The essential elements required for successful planning to a construction monitoring program are presented in Table 6. This table is not a substitute for an experienced engineer, but if used as a guide by such a man it will help to minimize the the possibility of a monitoring program failing in its purpose.

10.30 PARAMETERS TO BE MEASURED

10.3 1 General

The most important parameters to be measured, irrespective of wall or support type, are load, pore water pressure (or ground water level), and horizontal and vertical displacement.

Temperature measurements have special application to excavations supported by internal bracing because of the influence that temperature may have on bracing load. In general, direct earth pressure measurements have been unreliable except where backfill has been placed carefully against an instrumented structure, which is generally not possible with a deep excavation. It is preferred to determine earth loading from load measurements in supports.

10. 32 Instruments

Types of instruments suitable for measuring the above parameters together with advantages and limitations are given in Table 7. Less suitable instruments, although available and occasionally used, have not been included in this table. Schematic diagrams illustrating instrument operation principles are given by Dunnicliff (1970, 1971, 1972).

Table 6. Steps for planning construction monitoring programs.

1. Define the Problem

Project type
Soil conditions
Ground water conditions
Status of nearby structures

2. Define the Purpose of the Instrumentation

Diagnostic: To verify adequacy of design
To verify suitability of construction techniques
To diagnose the specific nature of an adverse event
To verify continued satisfactory performance

Predictive: To permit a prediction of behavior later on at the same job

Legal: To establish a bank of data for possible use in litigation
To demonstrate a contractor's compliance with contract requirements

Research: To advance the state-of-the-art by providing better future design data

3. Select Monitoring Parameters

Load or stress
Pore water pressure
Earth pressure
Settlement or heave (surface or subsurface)
Horizontal movement (surface or subsurface)
Tilt
Temperature

4. Make Predictions of Behavior and Define Specific Instrumentation Needs

Range
Accuracy
Duration of readings
Frequency of readings
Data evaluation schedule

5. Decide Who Will Do What

Who will procure the instruments?
Who will install the instruments?
Who will monitor the instruments?
Who will maintain the instruments?
Who will process the data?
Who will analyse the data?
Who will decide on implementation?
Who will implement?

6. Select Instruments, Components, and System

General Criteria
Select each part of the system with equal care
Will it achieve objective?
Maximum simplicity
Maximum durability in installed environment
Minimum susceptibility to vandalism
Appropriate accuracy, range, longevity
Good past performance record

6. General Criteria (continued)

Minimum cost (to furnish, install, read, process)
Maximum environmental stability
Calibration can be verified after installation
Consistent with skills of available personnel as in 5. above
Minimum interference to construction while installing and reading
Minimum falsification of measured parameter

Selection

Refer to Table 7 and Section 10.40

7. Determine What Factors May Influence Measured Data (to permit an analysis of cause and effect)

Detailed record of all construction particulars, progress and other data
Incidence of any observed distress or unusual event
Environmental factors which may, in themselves, affect monitored data, e.g. temperature, nearby construction activities

8. Plan Procedures for Ensuring Reading Correctness

Consider necessary redundancy
Consider duplicate measuring system
Plan how instruments will be calibrated and corrected for environmental effects
Consider possibility of feature to check-calibrate in place

9. Determine a Numerical Value of Deviation from Anticipated Performance at which the Engineer Should:

Be concerned
Press the panic button

10. Plan Instrument Layout

How many?
Where?

11. Write Instrument Procurement Specifications

12. Plan Installation

Write installation specifications
Prepare field data sheet for recording details of installation
Examine every detail of the planned installation procedure and think through alternative methods in the event problems arise
Make detailed list of all materials and tools required

13. Plan Procedures Subsequent to Installation

Plan monitoring arrangements
Prepare field data sheets
Plan maintenance arrangements
Plan data processing arrangements
Plan analytical procedures
Plan remedial measures (in the event data indicates adverse event) or other methods of implementation, and forewarn all concerned parties

Table 7. Types of available instruments.

Parameter	Instrument	Advantages	Limitations
Surface movement of buildings and adjacent ground (horizontal and vertical).	Optical survey for settlement using settlement reference points.	Simple and direct.	Care required to prevent pin disturbance. Requires reliable benchmark.
	Optical survey for horizontal movement, using offsets from <u>line of transit.</u>	Simple and direct.	Requires immovable reference stations.
	Crack opening using portable mechanical gage.	Simple, inexpensive and direct.	Care required to prevent disturbance to reference points.
	Hose level for settlement within buildings.	Precise. Can monitor <u>many points.</u>	Requires skill to read. Manpower reading costs high.
	Tilt using "tidal quality resolution" tiltmeters.	Very precise, hence give useful data in short monitoring <u>period.</u>	Expensive and complex.
Subsurface settlement of adjacent ground.	Single or multi-point rod extensometer with <u>mechanical</u> readout.	Simple and reliable.	Rods can hang up within surrounding sleeves if many anchors in one hole, thereby falsifying readings. Requires manual access to read (may create traffic interference and danger to reading personnel).
	Magnet/reed switch vertical pipe gage.	Anchors follow pattern of settlement without falsification. Simple and reliable.	Requires manual access to read (may create traffic interference and danger to reading personnel).
	Single or multi-point embedded rod extensometer with <u>electrical</u> readout.	Can be read remotely, without traffic interference.	Rods can hang up. More prone to malfunction, damage and vandalism than mechanical <u>readout.</u>
Subsurface horizontal movement of adjacent ground.	Horizontal or inclined extensometer.	Only few required to locate zone of no displacement.	Expensive. Must relate to datum for absolute movements.
	Inclinometer.	No embedded electrical parts. Gives full full depth profile of movement.	Expensive but usually cheaper than extensometers. Many required to locate zone of no displacement. Must relate to <u>immovable reference station.</u>
Movement of soldier piles, sheet piles, walers and diaphragm walls (horizontal and vertical).	Optical survey.	Simple and direct.	Requires reliable benchmark and immovable reference stations. No readings possible at depth until member exposed.
	Inclinometer installed on pile or in wall.	Readings at all depths available immediately after pile or wall installation.	Not suitable for driven piles. For soldier piles, must install inclinometer casing inside pipe for protection during pile installation. Best to weld pipe and install casing after pile is in place.

Table 7. Types of available instruments. (Continued).

Parameters	Instrument	Advantages	Limitations
Movement of tieback anchors.	During proof test: Dial gage, mounted on survey tripod.	Simple and direct.	
	After proof test: Sleeved unstressed telltale rod attached to anchor.	Simple and direct.	Measures only relative movement of soldier pile and anchor. Must relate to datum for good understanding of anchor load test.
Bottom heave of excavation.	Anchor embedded in borehole below eventual bottom Elevation read with probing	Simple. Inexpensive.	Requires survey crew. Risk of boring caving during excavation.
	Single or multi-point embedded rod extensometer with electrical readout.	Precise. Can connect several sensors at different elevations to one anchor. Can become settlement gage.	Risk of electrical failure and damage during excavation. Bottom anchor must be deep enough to serve as benchmark.
Load and stress in struts, soldier piles, sheet piles, walers and diaphragm walls.	Mechanical strain gage.	Inexpensive. Simple. Easy to install. Minimum damage potential.	Access problems. Many temperature corrections required. Limited accuracy. Readings are subjective.
	Vibrating wire strain gage.	Remote readout. Readout can be automated. Potential for accuracy and reliability. Frequency signal permits data transmission over long distances. Gages can be re-used.	Expensive. Sensitive to temperature, construction damage. Requires substantial skill to install. Risk of zero drift. Risk of corrosion if not hermetically sealed.
	Electrical resistance strain gage.	Inexpensive. Remote readout. Readout can be automated. Potential for accuracy and reliability. Most limitations listed opposite can be overcome if proper techniques are used.	Sensitive to temperature, moisture, cable length change in connections, construction damage. Requires substantial skill to install. Risk of zero drift.
Load in tieback anchors.	Telltale load cell.	Inexpensive. Simple. Calibrated in-place.	Access problems. Cannot be used with all proprietary anchor systems.
	Mechanical load cell.	Direct reading. Accurate and reliable. Rugged and durable.	Expensive. Access problems.
	Electrical resistance strain gage load cell.	Remote readout. Readout can be automated.	Expensive. Sensitive to temperature, moisture, cable length, change in connections. Risk of zero drift.
	Vibrating wire strain gage load cell.	Remote readout. Readout can be automated. Frequency signal permits data transmission over long distances.	Expensive. Sensitive to temperature. Risk of zero drift.
	Photelastic load cell.	Inexpensive.	Limited capacity. Access problems. Requires skill to read.

Table 7. Types of available instruments. (Continued).

Parameter	Instrument	Advantages	Limitations
Earth pressure on sheet piles and diaphragm walls.	Hydraulic, pneumatic or electrical interface stress cell.	Direct method.	Few successful case records.
	Backfiguring from strut load measurements.	As for strain gages above.	As for strain gages above.
Groundwater or piezometric level.	Standpipe piezometer or wellpoint.	Simple. Reliable. Long experience record. No elaborate terminal point needed. Heavy liquid version available for reducing response time and overcoming freezing problems.	Slow response time. Tubing must be raised nearly vertical. May create traffic interference and danger to reading personnel. Freezing problems.
	Pneumatic piezometer.	Level of terminal independent of tip level. Rapid response.	Must prevent humid air from entering tubing.
	Vibrating wire strain gage or semi-conductor pressure transducer piezometer. Suitable for automatic readout.	Level of terminal independent of tip level. Rapid response. High sensitivity.	Expensive. Temperature correction may be required. Errors due to zero drift could arise (although most manufacturers have overcome major problems).
Temperature	Thermistor	Precise	Delicate, hence susceptible to damage. Sensitive to cable length.
	Thermocouple	Robust. Insensitive to cable length. Available in portable version as "surface pyrometer"	Less precise than thermistor, but premium grade can give $\pm 1^\circ$ F.

10. 33 Related Parameters

To permit a cause and effect analysis, a complete record of other relevant parameters should be monitored:

- a. A record of depth of excavation versus time, at close stations.
- b. Time of installation of all wales, struts, and ties, with preload records if any, and depth of excavation below strut or tie at time of installation.
- c. **Incidences** of extraordinary ground losses, ground water behavior, observed distress, or any other unusual event.
- d. Complete as-built construction plans and records, including records of any pile driving.
- e. Environmental factors which may, in themselves, affect monitored data, e. g. temperature, nearby construction activities.

10.40 EXAMPLES

Two somewhat overly simplified situations are demonstrated in the accompanying Figures 58 and 59.

Figure 58 is at a test section well removed from adjacent structures that might be damaged by displacements caused **by** the excavation. The objective of the test section is to determine the magnitude and influence zone of displacements. Note that vertical and horizontal displacements can be measured at and below the surface.

Figure 59 is an example of monitoring performed for a building close to the excavation. Horizontal and vertical displacements are measured at and below the surface; also, settlement points are established around the building. Concern over possible consolidation requires monitoring of piezometric levels above and below the clay.

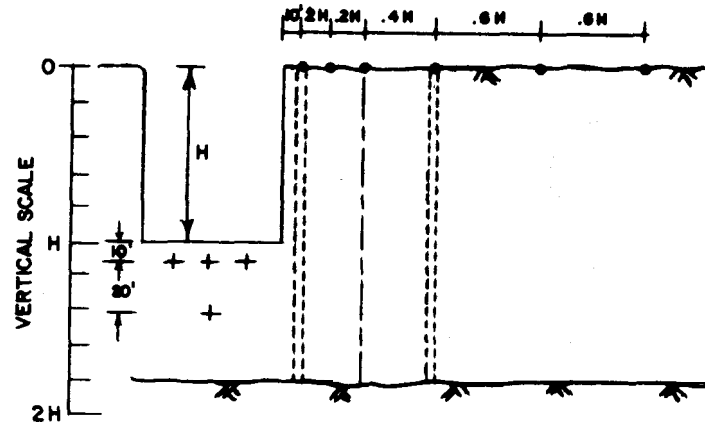
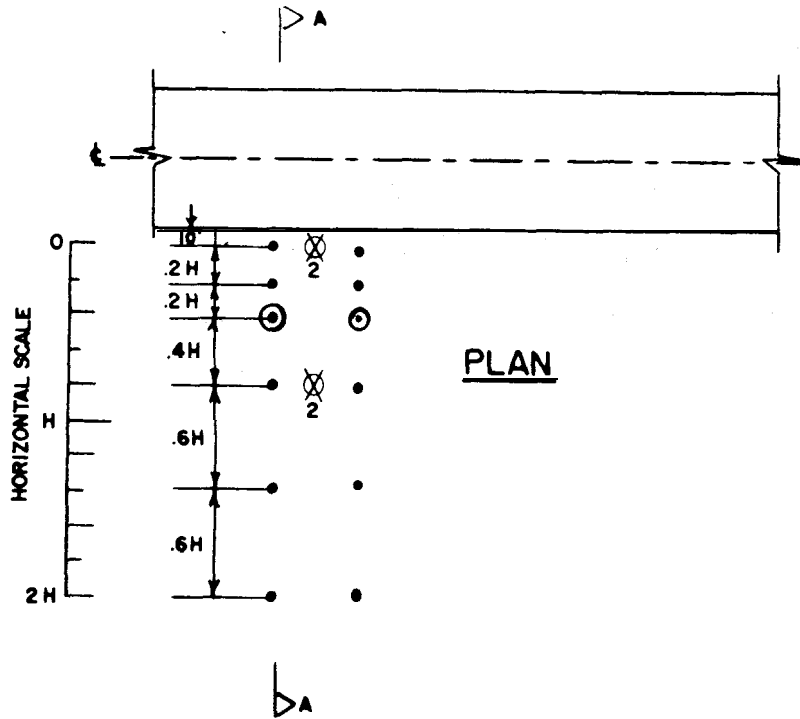

LEGEND

1. $\odot f_v$ - multi-point subsurface settlement system (e. g. magnet/reed switch gage)
2. $\otimes f_v, f_h$ - multi-point subsurface settlement and horizontal movement system (e. g. inclinometer with magnet/reed switch gage)
3. f_v - surface settlement point
4. $+ f_v$ - heavepoint (use when underlain by cohesive soil; otherwise optional)

Figure 58. Example of instrumentation for measurement of displacement at test section.

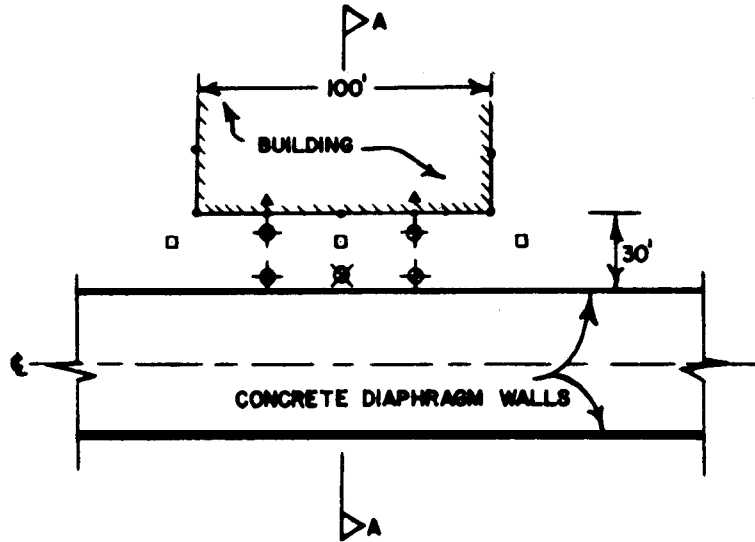

PLAN

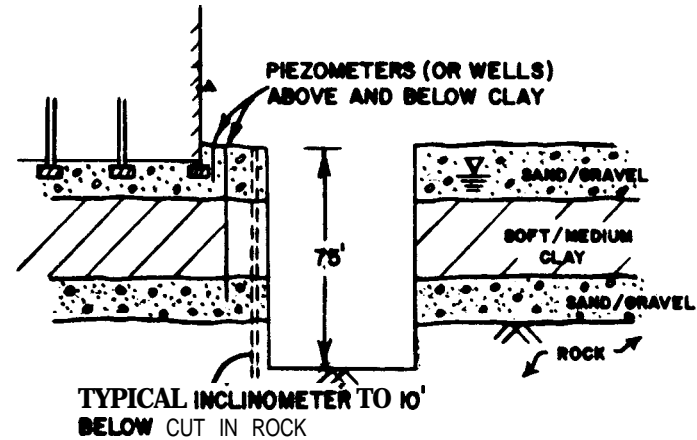

SECTION A-A

LEGEND

1. \odot δ_v - settlement point at surface
2. \oplus δ_h - inclinometer (for measurement of subsurface horizontal movements)
3. \otimes δ_h, δ_v - inclinometer with multi-point subsurface settlement system
4. \square - piezometer
5. \odot - tilt meter on building
6. Monitor horizontal movements at the face of the diaphragm wall by optical survey. Monitor settlement of diaphragm wall by optical survey.

Figure 59. Example of instrumentation adjacent to building and diaphragm wall.

10. 50 RECOMMENDED METHODS OF MEASUREMENT

10.51 General

The **selection** of the measurement method depends upon case specific factors, and no general rules can be made. However, Table 7 provides basic information to assist in the selection process. The most difficult task, and the task with the poorest success record, is measurement of load in supporting members. The following sections therefore provide more detailed guidelines to assist in selecting a method for monitoring load in braced and tied-back excavations.

10. 52 Strut Loads

10. 52. 1 Instrument Type

For monitoring strut loads, strain gages are preferred rather than load cells, primarily because inclusion of a load cell will tend to create non-typical loading conditions and will interfere with the contractor's work. Strain gages permit measurement of bending stresses, whereas a load cell does not.

Since the most expensive feature of an instrumentation program is often the disruption to construction activities, remote readout is a desirable feature, and vibrating wire and electrical resistance strain gages are the preferred instruments. Selection between the two gage types should be based on the experience and skills of available personnel, rather than on any quality inherent to one or the other type.

In general, a backup system should be established, using mechanical strain gages, although of course, their use is limited by access restrictions. Each gage is discussed below, and advantages and limitations are summarized in Table 7. In general, an accuracy of no better than ± 10 percent of design load can be attained, and this accuracy is usually adequate.

10. 52. 2 Vibrating Wire Strain Gages

O'Rourke and Cording (1974b) provide a detailed and up-to-date technical guide in use of vibrating wire gages. Gages that are perfectly temperature compensated (equal thermal coefficients for gage and structural member) will provide optimum accuracy, and the vibrating wire itself should be as close as possible to the surface of the strut.

The problem of **thermal** response, in particular caused by temperature **differential** between gage and strut, and the problem of zero drift remain the most severe. Estimates of long term zero drift are necessary to judge the reliability of measurement. **Individual** gages set to different frequencies should be mounted on unloaded sections of strut steel and monitored throughout the life of the project. No-load gage readings should be taken after strut removal and then compared with the initial no-load readings taken before strut **installation**. Temperatures should be measured at the time of each recording, and readings should be appropriately corrected on the basis of temperature changes between the initial and subsequent values.

10. 52.3 Electrical Resistance Strain Gages

Electrical resistance (**SR4**) strain gages have been used very successfully to monitor strain in laboratories, but their use in field measurements has often yielded poor results, Largely because of the **inexperience** of personnel undertaking the monitoring program. Since an electrical property of the wire rather than a mechanical property is being measured, it is important that these personnel have experience in field electronics, and such personnel are rare among geotechnical firms.

Dunncliff (1975) elaborates on key factors: gage selection and installation; sensor configuration; wiring; amplification and readout equipment. The task requires attention to many minute details, and wherever possible the gage installation work should be performed in a controlled labor environment prior to installation of the structural member.

When using electrical resistance gages zero drift tests should be made, as described above for vibrating wire gages.

Weldable gages have not yet been used on a widespread basis, perhaps because they are more costly than bonded gages, but the ease of installation and hermetic insulation of the gages are great advantages. Their sensitivity, although less than that of bonded gages, will normally be adequate.

10. 52.4 Mechanical Strain Gages

Although less accurate than the gages discussed above, use of mechanical gages provides valuable backup data provided three rules are adhered to. First, the Demec rather than the **Whittemore** type should be used (Schmidt and Dunncliff, 1974). Second,

gage points must be rigidly **attached** to the structural member, by drilling into the member or by welding. Third, proper temperature correction procedures must be used, taking into account thermal coefficients of strut, gage, and gage reference bar.

10. 52. 5 Temperature Correction

Strain-gages are used to measure strain, which then has to be converted to stress and load by using a value for modulus. However, temperature change also causes strain, and any such strain must be subtracted from measured strain before the conversion to stress is made. In the absence of complete temperature compensation (possible using resistance gages, approachable using certain vibrating wire gages, impossible using mechanical gages) temperature must be measured and thermal strain accounted for. Temperature variations always contribute to inaccuracy, and any effort to **minimize** temperature variation is worthwhile.

10.53 Tieback Loads

Load cells have been more commonly used to monitor tieback loads than have strain gages. Strain gages are inapplicable for use on stranded wire tendons since no convenient method is available for attaching the gages. Furthermore, a single load cell with a central hole can surround an entire group of tendons. It is possible to attach strain gages to steel rods, although the rate of gage attrition is generally high. Advantages and limitations of the five basic types of load cell are given in Table 7. Portable 'calibrated' hydraulic jacks have also been used, but measurement error may be up to 30 percent.

Selection of cell type depends on the factors given in Table 6, on past personal experience of the engineers executing the monitoring program, and load cell availability. Dunicliff (1975) describes an inexpensive home-made "telltale load **cell**" capable of monitoring 150 kip loads with an accuracy of **±5 kips**, and in view of its simplicity and economy, it **seems** logical to use this method wherever feasible.

A backup system is desirable, although less necessary than for strut load monitoring. This can be done in one of two ways, although neither way is always practical. First, one or more Load cells, on a special test frame or rod, can be retained on the site in

a loaded condition. Readings can be examined for drift, and the cells can be checked periodically by calibrating in the normal way. Second, it may be possible to check and calibrate selected cells in place by pulling a tie to unload the cell and then releasing the tie. For this test, it is necessary to connect a calibrated load cell, in addition to the stressing jack, in series with the cell under test.

10.60 CONTRACTING FOR INSTRUMENTATION

Table 8 presents the three basic contracting methods for furnishing and installing instrumentation.

Sophisticated instrumentation should not be included as a bid item in the prime contract, as the task requires professional skill and dedication, usually unobtainable if the prime contractor shops between 'specialist' subcontractors. A separate contract between owner and a specialist firm is suitable for sophisticated instrumentation provided the specialist and prime contractor's work areas do not overlap. If sophisticated instrumentation is to be installed within the prime contractor's work area the only viable method is use of a cost plus item in the prime contract. The essential elements of this procedure are:

- a. Work which is within the capability of the average prime contractor is bid in the normal way.
- b. The prime contract specification defines the nature of special instrumentation work. This work is included in the bid schedule as an allowance item, with an estimate of cost, and the prime contract bidder bids a markup, carrying forward the marked up total to the amount column. The estimate is not an upset.
- c. The owner selects an instrumentation specialist firm, using normal professional procedures for engagement of engineering services, and agrees on a basis of payment for the firm's services.
- d. The owner instructs the prime contractor to enter into a subcontract with the specialist firm and to pay the firm in accordance with the agreed basis. The contractor is reimbursed by the owner at cost plus the bid markup.

This procedure requires a clear and thorough prime contract specification. It also requires close coordination, cooperation, and trust between owner and specialist to ensure that **all** expenditures are necessary,

Table 8. Contracting for instrumentation.

Type of Instrumentation	Location of Instrurrients	Example	Contract for Furnish and Install		
			Bid Item in Prime Contract	Separate Contract With Specialists	cost Plus Item in Prime Contract
Simple	Outside or within contractor's work area.	Wellpoint s Optical survey	Suitable	Not necessary	Not necessary
Sophisticated	Outside contrac- tor's work area	Inclinometer with top on sidewalk	Not suitable	Suitable	Suitable
	Within contrac - tor's work area	Strain gages on struts Load cells on tiebacks	Not suitable	Not suitable	Suitable

thereby keeping costs to a minimum. If handled properly, it results in cooperation, flexibility to accommodate changes as the work proceeds, and a successful monitoring program at minimum cost to the owner.

10.70 THE KEY TO SUCCESSFUL CONSTRUCTION MONITORING

The key to successful construction monitoring may be stated as:

- a. Have a valid reason for monitoring, and perform complete and **logical** planning (Table 6).
- b. Select the most appropriate parameters and instruments (Table 7).
- c. Establish workable contractual arrangements with experienced personnel who have a full understanding of the monitoring objective, and who have the patience and desire to ensure the success of the program (Table 8).
- d. Achieve cooperation between all parties in the field. Cooperation can best be gained by explaining to the contractor's personnel the purpose of the program, gaining his respect by performing top quality work, then throughout the program being responsive to the effects of the program on him/her and working with him/her to minimize any adverse effects.
- e. Observe and record all relevant construction data (Section 10.33).
- f. Make use of the data in the way intended.

BIBLIOGRAPHY

Abbreviations:

ASCE	American Society of Civil Engineers
ICSMFE	International Conference on Soil Mechanics and Foundation Engineering
ECSMFE	European Conference on <i>Soil</i> Mechanics and Foundation Engineering
JSMFD	Journal Soil Mechanics and Foundation Division
GTED	Journal Geotechnical Engineering Division
SGDMEP	Symposium on Grouts and Drilling Muds in Engineering Practice

BIBLIOGRAPHY

- ADLER, F., Vereinfachte Längenberechnung Für Erkander (Simplified Method for Length Calculations of Tie-Backs), Schweizerische Bauzeitung, Vol. 91, No. 5, pp. 103-105, 1973.
- AMERICAN Institute of Timber Construction, Timber Construction Manual, Second Edition, Wiley, 1974,
- AMERICAN Petroleum Institute, Oil Well Drilling Fluid Materials, API Specification 13A, Sixth Edition, January 1974.
- AMERICAN Petroleum Institute, Standard Procedure for Testing Drilling Fluids, API RP 13B, Fifth Edition, February 1974.
- AMERICAN Society of Civil Engineers, JSMFD, Proceedings, Chemical Grouting, Vol. 83, SM4, Paper No. 1426, pp. 1-106, November 1957.
- AMERICAN Society of Civil Engineers, JSMFD, Proceedings, Bibliography on Chemical Grouting, Vol. 92, SM6, pp. 39-66, November 1966.
- ANDERSEN, Paul, Earth Anchors and Tieback Installations, 18th Annual Soil Mechanics and Foundation Engineering Conference, University of Minnesota, March 26, 1970.
- ANDRÁ, W., Kunzl, W. and Rojek, R., Bohrpfahlwand Für die Allianz-Neubauten in Stuttgart - Entwurf und Messungen (Secant Wall for the New Allianz Insurance Building in Stuttgart - Design and Measurements), Bie Bautechnik, Vol. 50, No. 8, pp. 258-264, 1973.
- ARMENTO, William, Design and Construction of Deep Retained Excavations, ASCE /SEAONC, Continuing Education Seminars, November 1970.
- ARMENTO, W. J., Criteria for Lateral Pressures for Braced Cuts, ASCE Specialty Conference on Performance of Earth and Earth Supported Structures, Purdue University, pp. 1283-1302, June 1972,
- ARMENTO, W. J., Coffer dam for BARTD Embarcadero Subway Station, ASCE, JSMFD, Vol. 99, SM10, pp. 727-744, 1973.

- BACHY Enterprise, Brochure on Firm Capability,; France 1970.**
- BADAPPANAVAR, M. G., Chemical Grouting in Pervious and Rock Foundations*, Journal of the Institute of Civil Engineers (India), Vol. 54, Part C13, pp. 110-115, 1974.**
- BALL, Donald G., Prudential Center Foundations, Journal of Boston Society of Civil Engineers, July 1962.**
- BARES, F. A., Use of Pali Radice in the Solution of Difficult Foundation Problems, ASCE/ The Engineering Institute of Canada/ Roads & Transportation Association of Canada, Joint Transportation Meeting, Montreal, July 1974.**
- BARES, F. A., Use of Pali Radice (Root Piles), Open Cut Seminar, Metropolitan Section, ASCE, New York, February 1975.**
- BARES, F. A., Personal Communication, 1975**
- BARLA, G., and Mascardi, C. , High Anchored Wall in Genoa, Conference on Diaphragm Walls and Anchorages, Institution of Civil Engineers, London, pp. 101-106, September 1974**
- BARTHEL, H., Verbesserung der Gebirgsfestigkeit durch Chemische Injektionen (Improvement of Rock Mass Strength by Chemical Injections), Bergbau-Wissenschaft, Vol. 17, No. 8, pp. 281, 285, 1970.**
- BASSETT, Discussion, Conference Organized by Institution of Civil Engineers, London, 1970.**
- BASTIAN, S., and Grueno, M., Erweiterung des Bereiches der Zementiverungsarbeiten auf Grund von Neuen Eigenschaften der Zement Suspensionen (Increasing the Range of Soils Suitable for Cement Injection Through New Properties of the Cement Suspension), Bergbau-Wissenschaft, Vol. 17, No 8, p. 303, 1970.**
- BAUER, M., Personal Communication, 1974.**
- BAUER Schrobhausen, Company Catalogue**
- BAUERNFEIND, P. and Hilmer, K., Neue Erkenntnisse aus Sohldruck-und Erddruck-Messungen bei der U-Bahn Nurnberg (New Information from Earth Pressure Measurements on the Subway Tunnel in Nurenberg) Die Bautechnik, Vol. 51, No. 8, pp. 523-259, 1974.**

- DEHRENDT, J., Die Schlitzwandbauweise beim U-Bahnbau in Köln
(The Slurry Trench Wall Construction at the Subway in Cologne)
Der Bauingenieur, Vol. 45, No. 4, pp. 121-126, 1970.
- BETHEL, R., Underpinning a Landmark, Civil Engineering, ASCE,
Vol. 38, No. 8, pp. 67-68, August 1968.
- BJERRUM, L., and Eide, O., Stability of Struttred Excavations in Clay,
Geotechnique, Vol. 6, pp. 32-47, 1956.
- BJERRUM, L., Frimann-Clausen, C. J., and Duncan, J. M., Earth
Pressures on Flexible Structures - A State-of-the-Art Report,
General Report, 5th ECSMFE, Madrid, pp. 169-196, April 1972.
- BJERRUM, L., and Johannessen, I. J., Reduction of Negative Skin
Friction on Steel Piles to Rock, 7th ICSMFE, Vol. 2, pp. 27-34,
1969.
- BOGUTH, K., Vibrationsprobleme beim Rammen und Ziehen (Vibration
Problems by Driving and Retrieval), Tiefbau, Vol. 15, No. 4,
pp. 345-347, 1973.
- BONARES, R., Baugrubensicherung und Sohlplatte des Bfg-Hochhauses
in Frankfurt (Excavation Support and Base Slab for the "Bank of
Gemeinwirtschaft" in Frankfurt), Der Bauingenieur, Vol. 49, No. 6,
pp. 214-218, 1974.
- BONZEL, J. and Dahms, J., Über den Einfluss des Zements und der
Eigenschaften der Zementsuspensionen auf die Injizierbarkeit in
Lockergesteinsboden (The Influence of the Cement and the Suspension
Characteristics on the Groutability of Soils), Beton Herstellung und
Verwendung, vol. 22, No. 4, pp. 156-166, 1972.
- BOOTH, W. S., Tiebacks in Soil for Unobstructed Deep Excavation,
Civil Engineering, ASCE, pp. 46-49, September 1966.
- BOTTKE, H., Geologische und Sedimentpetrographische Grundlagen
der Stabilisierung und Verfestigung von Lockergesteinen (Geological
and Sediment-Petrographical Principles for the Stabilization and
Consolidation of Loose Soils), Bergbau-Wissenschaft, Vol. 17,
No. 8, pp. 278-281, 1972.

- BOUTSMA, K., and Horvat, E., Soil Mechanical Aspects of the Metro Construction in Rotterdam, Proc., 7th ICSMFE, Mexico City, Vol. 2, pp. 417-422, **1969**.
- BRAIN, M. G., Tunnel Interface Crossing Solved by Specialized Consolidation, Ground Engineering, Vol. 5, No. 5, September 1972.
- BRANDL, H., Bemessungsdiagramme für einfach verankerte Spundwände (Dimensioning Diagrams for Simply Anchored Sheet Pile Walls), Oesterreichische Ingenieur-Zeitschrift, Vol. 15, No. 6, pp. **161-169**, **1972**.
- BRAUN, B., Arbeiten in Hamburg, (Work in Hamburg), Unser Betrieb, No. 3, **Deilmann-Haniel**, Dortmund-Kurl, **1969**.
- BRAUN, B., Die bisher groesste, allein durch Bodenvereisung gesicherte Baugrube der Welt, (The Largest Present Day Safe Excavation in the World Wholly Supported by Frozen Ground), Unser Betrieb, No. 6, **Deilmann-Haniel**, Dortmund-Kurl, 1970.
- BRAUN, B., Ground Freezing for Tunneling in Water-Bearing Soil at Dortmund, Germany, Tunnels and Tunneling, Vol. 4, No. 1, pp. 27-32, January 1972.
- BRAUN, B. and Macchi A., Ground Freezing Techniques at Salerno, Tunnels and Tunneling, **vol. 6, No. 2**, pp. 81-85, 87, **89**, March - April 1974.
- BRAUN, W. M., The Art of Tunneling in Vienna, Tunnels and Tunneling, Vol. 6, pp. 29-32, May, 1974.
- BRETH, H. and Romberg, W., Messungen an einer verankerten Wand (Measurements on a Tied-Back Wall), **Mitteilungen der Versuchsanstalt für Bodenmech und Grundbau der Technische Hochschule** Damstadt, No. 11, 1972-73.
- BRETH, H. and Wanoschek, H. R., Steifenkraftmessungen in einer durch Pfahlwände gesicherten Tiefbahngrube im Frankfurter Ton (Strut Load Measurements in a Subway Excavation in Frankfurt Clay Supported by Secant Walls), Der Bauingenieur, Vol. 44, No. 7, pp. 240-243, 1969.
- BRISKE, R., Anwendung von Druckumlagerungen bei Baugrubenumschliessungen (The Use of Pressure Redistribution in Supported Excavations), Die Bautechnik, Vol. 35, No. 6 and 7, pp. 242-244 and 279-281, 1958.

- BRISKE, R., Erddruckumlagerungen bei abgesteiften Trägerbohlwänden (Earth Pressure Redistribution at Struttet Soldier Pile Walls), Die Bautechnik, Vol. 48, No. 8, pp. 254-259, 1971.
- BRISKE, R. and Pirlet, E., Messungen über die Beanspruchung des Baugrubenverbaues der Kölner U-Bahn (Strain Measurements on the Excavation Wall in the Cologne Subway), Die Bautechnik, Vol. 45, No. 9, pp. 290-299, 1968.
- BROMS, B. B., Design of Laterally Loaded Piles, ASCE, JSMFD, Vol. 91, SM3, pp. 79-99, 1965.
- BROMS, B., Swedish Tieback Systems for Sheet Pile Wafts, Swedish Geotechnical Institute, Report No. 32, Reprinted from Proceedings of Third Budapest Conference on Soil Mechanics and Foundation Engineering, Budapest, Vol. 1, 13 pages, 1968.
- BROMS, B. B., and Bennemark, H., Stability of Clay at Vertical Openings, ASCE, JSMFD, Vol. 93, SM 1, pp. 71-94, 1967.
- BROMS, B. B. and Bennemark, H., Stability of Cohesive Soils Behind Vertical Openings in Sheet Pile Walls. Contributions to the 3rd Budapest Conference on Soil Mechanics and Foundation Engineering, Budapest, 1968.
- BROMS, B. B., Bjerke, H., Extrusion of Soft Clay Through a Retaining Wall, Canadian Geotechnical Journal, Vol. 10, No. 1, pp. 103-109, 1973.
- BROOKER, E. W., and Ireland, H. O., Earth Pressures at Rest Related to Stress History, Canadian Geotechnical Journal, vol. 2, No. 1, pp. 1-15, 1965.
- BROWN, D. R., and Warner J., Compaction Grouting, ASCE, JSMFD, Vol. 99, SM8, pp. 589-601, August 1973.
- BURLAND, J. B., Recent Research on Excavations and Diaphragm Walls, Paper presented at BRS Symposium, 1974.
- _____, Grouts and Drilling Muds. in Engineering Practice, Butterworths, London, 1963.
- BÜTTNER, J. H., Herstellung von Injektionssohlen zur Abdichtung von Baugruben (Construction of Horizontal Grouted Surfaces for Waterproofing of Excavations), Tiefbau, Vol. 15, No. 5, pp. 450-455, 1973.

BÜTTNER, J. H., Neue Technik zur Herstellung dünner horizontaler Injektionssohlen (New Method for Placing Thin Horizontal Grouting Shells), Die Bautechnik, Vol. 51, No. 2, pp. 62-65, 1974.

- CARSON, A. B., Foundation Construction, McGraw Hill, New York, pp. 116-147, 1965.
- CASHMAN, P. M. and Haws, E. T., Control of Groundwater by Water Lowering, Proceedings of a Conference Organized by the Institution of Civil Engineers in London, London, pp. 23-32, 1970.
- CHAPMAN, K. R., Cording, E. J., and Schnabel, H. Jr., Performance of a Braced Excavation in Granular and Cohesive Soils, ASCE Specialty Conference on Performance of Earth and Earth-Supported Structures, Purdue University, Vol. III, pp. 271-293, 1972.
- CHARGE, J., The Raising of the Old Wellington Inn and S'inclairs Oyster Bar, The Structural Engineer, Vol. 50, No. 12, pp. 483-494, December 1972.
- CHEN, W. F. and Rosenfarb, J. L., Limit Analysis Solutions of Earth Pressure Problems, Soils and Foundations, Vol. 13, No. 4, pp. 45-60, December 1973.
- CHRISTIAN, J. T., Personal Communication, 1971.
- CHRISTIAN, J. T. and Wong, I. H., Errors in Simulating Excavation in Elastic Media by Finite Elements, Soils and Foundations, Vol. 13, No. 1, pp. 1-10, March 1973.
- CLOUGH, G. W., Performance of Tie-Back Support Systems, ASCE Specialty Conference on Performance of Earth and Earth-Supported Structures, Purdue University, Vol. III, pp. 259-264, June 1972.
- CLOUGH, G. W., Deep Excavations and Retaining Structures, Paper to be Presented at Lehigh Conference on Foundations for Tall Buildings, August 1975.
- CLOUGH, G. W. and Tsui, Y., Performance of Tied-Back Walls in Clay, ASCE, JGED, Vol. 100, GT 12, pp. 1259-1273, 1974.
- CLOUGH, G. W., Weber, P. R., and Lamont, J. Jr., Design and Observation of a Tied-Back Wall, ASCE Specialty Conference on Performance of Earth and Earth-Supported Structures, Purdue University, Vol. I, Part 2, pp. 1367-1389, June 1972.

- COLAS DES FRANCS, E., Prefasif Prefabricated Diaphragm Walls, Conference on Diaphragm Walls and Anchorages, Institution of Civil Engineers, London, pp. 63-70, September 1974.
- COLE, K. W. and Burland, J. B., Observation of Retaining Wall Movements Associated with a Large Excavation, 5th ECSMFE, Madrid, Vol. I, pp. 445-453, April 1972.
- CONSEDINE, R. L., Hi-Rise Costs Cut by Excavating After Subgrade Walls in Place, Engineering Contract Record, Vol. 85, No. 9, pp. 48-49, 1972.
- CONSEDINE, R. L., Slurry Trench Method Used for Olympic Stadium Retaining Walls, Engineering Contract Record, Vol. 86, No. 8, pp. 72-73, 1973.
- CONSTRUCTION Methods, Long, Buried Tiebacks Leave Cofferdam Unobstructed, pp. 130-135, May 1966.
- CONSULTING Engineer, The, Ground Anchors, Panel Presentation on Ground Anchors, pp. 1-39, May 1970.
- CORBETT, B. O., Davies, R. V., and Langford, A. D., A Load Bearing Diaphragm Wall at Kensington and Chelsea Town Hall, London, Conference on Diaphragm Walls and Anchorages, Institution of Civil Engineers, London, pp. 1-10, September 1974.
- CORBETT, B. O. and Stroud, M. A., Temporary Retaining Wall Constructed by Berlinoise System at Centre Beaubourg, Paris, Conference on Diaphragm Walls and Anchorages, Institution of Civil Engineers, London, pp. 77-83, September 1974.
- COYLE, H. M., Bartoskewitz, R. E., Milberger, L. J., and Butler, H. D., Field Measurement of Lateral Earth Pressures on a Cantilever Retaining Wall, Paper prepared for presentation at the 53rd Annual Meeting of the Highway Research Board, January 1974.
- CUNNINGHAM, J. A. and Fernandez, J. I., Performance of Two Slurry Wall Systems in Chicago, ASCE Specialty Conference on Performance of Earth and Earth-Supported Structures, Purdue University, Vol. I, Part 2, pp. 1425-1449, June 1972.

CZARNOTA-BOJARSKI, R. and Rymysza, B., Influence of Neighboring Structures on Deep Foundations, 8th ICSMFE, Moscow, Vol. 2.1, pp. 61-66, August 1973.

- D'APPOLONIA, D. J. , Effects of Foundation Construction on Nearby Structures, Proceedings of the 4th Panamerican Conference on Soil Mechanics and Foundation Engineering, Vol. I, pp. 189-236, 1971.**
- D'APPOLONIA, D. J., D'Appolonia, E., and Namy, E., Proceedings of Workshop on Cut and Cover Tunneling: Precast and Cast-in Place Diaphragm Walls Using Slurry Trench Techniques, Report prepared for FHA Office of Research and Development, Report No. FHWA-RD-74-57, Washington D. C., January 1974.**
- DARRAGH, R.. D., Design and Construction of Deep Retained Excavations, ASCE/SEAONC Continuing Education Seminars, Lecture dated November 23, 1970.**
- DAVIS, E. H., and Christian, J. T. ; Bearing Capacity of Anisotropic Cohesive Soil; ASCE JSMFD, Vol. 97, No. SM5, pp. 753-769, 1971.**
- DEILMANN-HANIEL, GmbH, Soil Stabilization by Freezing, Undated Procedures, Dortmund-Assein, Germany.**
- DEMPSEY, J. A. and Moller K., Grouting in Ground Engineering, Proceedings Conference on Ground Engineering - London, Paper 1, pp. 3-10, 1970.**
- DEUTSCHE Normen, DIN 1054 (German Codes, DIN 1054), Beuth-Vertrieb, GmbH, Berlin 30, November 1969.**
- DEUTSCHE Normen, DIN 4014 Bohrpfahle (German Codes, DIN 4014, Angered Piles) Beuth-Vertrieb, GmbH, Berlin 30, November 1969.**
- DEUTSCHE Normen, DIN 4017, Baugrund (German Codes, DIN 4017, Foundations), Beuth-Vertrieb, GmbH, Berlin, March 1965.**
- DEUTSCHE, Normen, DIN 4026, Rammfahle (German Codes, DIN 4026, Driven Piles) Beuth-Vertrieb GmbH, Berlin 30, July 1968.**
- DEUTSCHE Normen, DIN 4033 (German Codes, DIN 4033) Beuth-Vertrieb GmbH, Berlin 30.**
- DEUTSCHE Normen, DIN 4123, Gebaudesicherung im Bereich von Ausschachtungen, Gründungen und Unterfangungen (German Codes DIN 4123, Underpinning of Buildings Near Excavations and Foundation Pits), Beuth-Vertrieb GmbH, Berlin 30, May 1972.**
- DEUTSCHE Normen, DIN 4124, Baugruben und Graben (German Codes, DIN 4124, Excavations and Pits), Beuth-Vertrieb GmbH, Berlin 30, January 1972.**

DEUTSCHE Normen, DIN 4125, Verpressanker für vorübergehende Zwecke in Lockergestein (German Codes, DIN '4125, Grouted Temporary Soil Tie-Backs), Beuth-Vertrieb GmbH, Berlin 30, 1972.

DEUTSCHE , Stahlbau-Verband, Stahlbau. Vorschriften. Normen. Profile. (Steel Construction Rules, Codes, Profiles). Deutscher Stahlbau-Verband, Cologne, 1974.

DIBIAGIO, E. and Myrvoll, F., Full Scale Field Tests of a Subway Trench Excavation in Soft Clay, 5th ECSMFE, Madrid, Vol. I, pp. 461-471, April 1972.

DIBIAGIO, E. and Roti, J. A., Earth Pressure Measurements on a Braced Slurry Trench Wall in Soft Clay, 5th ECSMFE, Madrid, Vol. I, pp. 473-483, 1972.

DIDLAUKIES, J., Vorschactebau mit Hilfe des Gefrierfahrens am Beispiel des Schactes Kurl 4, Unser Betrieb, No. 8, Deilmann-Haniel, Dortmund-Kurl., West Germany, 1971.

DIETRICH, M., Chase, B., and Teul, W., Tieback System Permits Uncluttered Excavation, Foundation Facts, Vol. VII, No. 1, pp. 3-7, 1971.

DONOLO, Louis, Mur de Soutenement Special, L'Ingenieur, Montreal, November 1971.

DROSSEL, M. R., Drill Steel Tubes Act as Temporary Tieback Casing, Construction Methods and Equipment, Vol. 55, No. 8, pp. 50-51, August 1973.

DUMONT-VILLARES, A., The Underpinning of the 26-Story Companhia Paulista De Seguras, Building, São Paulo, Brazil, Geotechnique, Vol. 6, pp. 1-14, March 1956.

DUNCAN, J. M., Use of the Finite Element Method in Analysis of Soil Structure Interaction, ASCE Specialty Conference on Performance of Earth and Earth Supported Structures, Purdue University, Vol. III, pp. 265-269, June 1972.

DUNNICLIFF, C. J. , Equipment and Methods for Measurement of Displacements and Settlement, Lecture Notes, Met Section ASCE, Seminar on Field observations in Foundation Design and Construction, New York, April. (Reprinted in Highway Focus, U. S. Department of Transportation, F.H. W.A., Vol. 4, No. 2, June 1972, pp. 105-137), 1970.

DUNNICLIFF, C. J., Equipment for Field Deformation Measurements, Proc. 4th Panamerican Conf. on Soil Mechanics and Foundation Engineering, San Juan, Vol. 2, pp. 319-332, 1971.

DUNNICLIFF, C. J., Schematic Arrangements of Various Types of Soil Mechanics and Rock Mechanics Measuring Instruments, Highway Focus, U. S. Department of Transportation, F. H. W.A., Vol. 4, No. 2, June, pp. 139-143, 1972.

DUNNICLIFF, C. J., Instrumentation of Open Cut Construction, Lecture Notes, Met. Section ASCE, Seminar on Open Cut Construction, New York, February, 1975.

DUNNICLIFF; C. J., and Schmidt, B.. An Engineering Approach to Monitoring the Performance of Soft Ground Tunnels During Construction, Proc. Rapid Excavation and Tunneling Conference, San Francisco, Vol.' 1, pp. 377-396, 1974.

DUNS, C. S. and Butterfield, R., Flexible Buried Cylinders, Part I, Static Response, Part II, Dynamic Response, and Part III, Buckling Behavior, International Journal of Rock Mechanics and Mining Sciences, Volume 8, No. 6, November, 1971.

ECI Sotetanche, Brochure of Firm Capabilities, 1971.

EDELING, H. and Schulz, W., Die neue Osterreichische Tunnelbauweise (The New Austrian Tunnel Driving Method, Der Bauingenieur, Vol. 47, No. 10, 11 pages, 1972.

EDER., P. and Rummeli, H., Die erste vorfabrizierte Schlitzwand in der Schweiz (The First Precast Slurry Trench Wall in Switzerland), Schweizerisch Bauzeitung, Vol. 91, No. 28, pp. 689-691, 1973.

EGGER, P., Die Grundung der Kraftwerkserweiterung Bordeaux-Ambes (Foundations for the Extension of the Bourdeaux - Ambes Power Station), Osterreichische Ingenieur - Zeitschrift, Vol. 15, No. 7, pp. 203-209, 1972 a.

EGGER, P. Influence of Wall Stiffness and Anchor Prestressing on Earth Pressure Distribution, 5th ECSMFE, Madrid, Vol. I, pp. 259-264, April 1972b.

EIDE, O., Aas, G., and Josang, T., Special Application of Cast-in-Place Walls for Tunnels in Soft Clay in Oslo, 5th ECSMFE, Madrid, Vol. 1, pp. 485-498, 1972.

ELLINGER, M., Die Untergrundbahnbau in Wien (The Vienna Subway), Osterreichische Ingenieur - Zeitschrift, Vol. 15, No. 9, pp. 257-262, 1972.

ELSON, W. K., An Experimental Investigation of Slurry Trenches, Geotechnique, Vol. 18, No. 1, pp. 37-49, 1968.

ENDO, K., Artificial Soil Freezing Method for Subway Construction, Civil Engineering in Japan, Vol. 8, pp. 103-117, 1969.

ENDO, K., Problem Factors and Execution of Under ground Excavation Methods for Bad and Soft Ground, Proceedings of Sixth National Tunnel Symposium, Tokyo, Japan, September 14-16, 1970.

, Unbraced Walls Hold Up a Street, Engineering News Record p. 43, November 8, 1962

Soil-Anchored Tiebacks Aid Deep Excavation. Engineering News Record, pp. 34-35, August 10, 1967.

_____, Foundation for Tallest Towers: Water Out, Trains In, Engineering News Record, pp. 30-32, October 31, 1968.

_____, Swedes Quick Freeze 39 Ft. Tunnel Section, Engineering News Record, P. 13, October 29, 1970.

_____, Massive Underpinning Job Paves Way for Construction of D. C. Subway, Engineering News Record, p. 37, February 4, 1971a.

_____, Brussels Subway Work Runs Obstacle Course, Engineering News Record, pp. 17-18, August 5, 1971b.

_____, Grout, Slurry Protect Neighboring Foundations, Engineering News Record, March 9, 1972a.

_____, Small-Diameter Piles Protect Tunnel, Buildings, Engineering News Record, pp. 22-23, April 20, 1972b.

_____, Europes Tallest Building Encases an Operating Subwgy, Engineering News Record, pp. 22-23, July 15, 1972c.

_____, Deep Excavation in Bad Geology Secured by 60 Miles of Tiebacks, Engineering News Record, p. 31, January 11, 1973a.

_____, Special Formwork Casts Two-Level Arch Station Under Street, Engineering News Record, pp. 20-21, July 26, 1973b.

_____, Tiebacks Driven In Place Keep Excavation Open, Engineering News Record, p. 25, August 9, 1973c.

_____, Rio Subway Builders Beat High Water Table, Engineering News Record, Vol. 192, No. 20, p. 54, 1974a.

_____, New Underpinning System Solves Explosive Problem, Engineering News Record, p. 21, July 21, 1974b.

ERLER, K., Keilformige Zupanker im Baugrund bei Senkrecht- und Schragzug (Wedge Shaped Tie-Backs in Soil. by Vertical and Oblique Pull), Bauplanung - Bautechnik, Vol. 27, No. 12, pp. 586-591, 1973.

ETHERIDGE, D. C., Tie-Backs Unclutter Deep Foundation, Construction Methods, pp. 66-71, September 1966.

FEBESH, M., Earth Tie Backs, Draft of Paper Presented at New York Metropolitan Section, ASCE, undated.

FEBESH, M., Personal Communication, 1975.

FEDDERSEN, J., Verpressanker im Lockergestein (Pressure Grouted Tie Backs in Soil), Der Bauingenieur, Vol. 49, No. 8, pp. 302-310, 1974.

FEDERATION of Piling Specialists, Specification for Cast-in-Place Concrete Diaphragm Walling, Ground Engineering, Vol. 6, No. 4, July 1973.

FENOUX, G. Y., La Mise en Precontrainte Des Tirants (Prestressing of Anchor Rods), Travaux, No. 449-450, pp. 33-43, August-September 1972.

FENOUX, G. Y., La Paroi Préfabriquée, Ses Applications (The Precast Wall, Its Application), Annales de L'Institut Technique du Batiment et des Travaux Publics, No. 313, pp. 198-219, January 1974.

FENOUX, G. Y. and Milanise, S., Applications Récentes de La Paroi Préfabriquée Panazol (Recent Applications of the Precast "Panazol" Wall), Travaux, pp. 24-31, December 1971.

FERNANDEZ-RENAU, L. F., Discussion of Slurry Trench Analysis, 5th ECSMFE, Madrid, Vol. 2 pp. 366-373, 1972.

FREI, R. and Graf, W., Schlitzwände mit Vorfabrizierten Betonteilen (Slurry Trench Walls with Precast Concrete Elements), Schweizerische Bauzeitung, vol. 91, No. 28, pp. 691-692, 1973.

FLAATE, K. S., Stresses and Movements in Connection with Braced Cuts in Sand and Clay, Ph. D. Thesis, University of Illinois, Urbana, Illinois, (1966).

FLATAU, A. S., Brockett, R. W., and Brown, J.V., Grouts and Grouting, A Survey of Materials and Practice, Civil Engineering and public Works Review, Vol. 68, No. 804, July 1974.

FLEMING, W. G. K. ; Fuchsberger, M. ; Kipps, O. ; and Sliwinski, Z. ;
Diaphragm Wall Specification, Conference on Diaphragm Walls
and Anchorages, Institution of Civil Engineers, London, pp. 57-61,
September 19 74.

FOLLENFANT, H. G., The Victoria Line, Proceedings Institute of
Civil Engineers, Supplemental Paper 7270S, pp. 335-478, 1969.

FONDEDILE, The Pali Radice for Underpinning, Company Brochure,
England.

FORAKY, Execution d'une Congelation de Sol Pour Creas'ement d'un
Collecteur Souterrain a Watterlos (Nord), Brussels, Belgium,
Undated Company Brochure.

FOREST, K. , Der Verbau von Leitungsgraben mit Verbauteilen aus
Stahl (Soil Support with Steel Profiles for Utility Excavations,
Schriftenreihe der Tiefbau-Berufsgenossenschaft, No. 6, 1970.

FOSTER Company, L. B., Vibrating Pile Driving/Extracting Informa-
tion Booklet, Company Brochure, Pittsburgh, Pennsylvania, 1971.

FOX, E. N., The Mean Elastic Settlement of a Uniformly Loaded Area
at a Depth Below the Ground Surface, 2nd ICSMFE, Vol. 1, p. 129, 1948.

FRANKE, E., Zur Frage der Standsicherheit von Bentonit-Schlitz-
wanden (The Question of Stability in Bentonite-Filled Slurry Trenches).
Die Bautechnik, Vol. 40, No. 12, pp. 408-411, 1963.

FRUCO & Associates, Dewatering and Ground Water Control, for Deep
Excavations, Report prepared for Waterways Experiment Station,
U. S. Corps of Engineers, January 1966.

FUCHSBERGER, M., Some Practical Aspects of Diaphragm Wall
Construction, Conference on Diaphragm Walls and Anchorages,
Institution of Civil Engineers, London, pp. 57-62, September 1974.

FUJII, T., The Practical Application of Thermal and Freezing Methods
to Soils Stabilization, Proceedings of the First Australia-New Zealand
Conference on Geomechanics, Melbourne, pp. 337-343, 1971.

- GAIL, C. P., Tunnel Driven Using Subsurface Freezing, Civil Engineering, ASCE, Vol. 42, No. 5, pp. 37-40, May 1972.
- GAIL, C. P., Subsurface Freezing As An Aid to Soft Ground Tunnel Construction, Paper presented at University of Wisconsin - Extension Professional Development Seminar on "Soft Ground Tunneling", April 24-25, 1973.
- GALLER, S., Slurry Wall Technique Expedites Subway Construction, Public Works, Vol. 104, No. 8, pp. 72-73, 1973.
- GEDDES, W. G. N. ; Rock, G. ; and Scrimgeor, J. ; The Backwater Dam, Proceedings of the Institution of Civil Engineers, London, Vol. 51, pp. 433-464, March 1972.
- GEFFRIAUD, J. P., Controle de la Tension des Tirants Precontraints Definitifs D'ancrage de la Paroi Moulee du Musee Archeologique de Fourviere a Lyon (Stress Checking of Prestressed Tie Rods of the Diaphragm Wall of the Fourviere Archeological Museum at Lyon), Travaux, No. 449-450, pp. 44-54, August-September 1972.
- GENERAL Under ground Structures, Inc. , Construction Freezing, Undated Company Brochure, Wheatridge, Colorado, 21 pages.
- GERBER, E., Untersuchungen über die Druckverteilung in örtlich belasteten Sand, Zinich, Switzerland, 1929.
- GIRNAU, G., Probleme und Entwicklungstendenzen beim unterirdischen Bahnbau in der Bundesrepublik (Problems and Developments in Subway Construction in Germany), Strasse Brücke Tunnel, Vol. 21, No. 6, pp. 141-150, 1969.
- GLOSSOP, R., The Rise of Geotechnology and its Influence on Engineering Practice, Geotechnique, Vol. 18, No. 2, pp. 105-150, June 1968.
- GOETTLE, R. ; Flaig, J. J. ; Miller, A. J. ; Schaefer, S. E. ; Deep Excavation and Buildings Supported by Tie-Back System, Accompanying Inland Ryerson Catalog entitled "Prestressed Soil and Rock Anchor Systems", August 1974.
- GOLDBERG-Zoino & Associates, Inc. , Job Files
- GOLDER, H. Q; Gould, J. P. ; Lambe, T. W. ; Tschebotauioff, G. P. ; and Wilson, S. D. ; Predicted Performance of Braced Excavations, ASCE, JSMFD, Vol.. 96, SM 3, pp. 801-815, 1970.

GOLDFINGER, H., Permanent Steel Used as Subway Shoring, Civil Engineering, ASCE, Vol.. 30, No. 3, pp. 47-49, March 1960.

GOULD, J. P., Design of Temporary Retaining Structures for the Washington Subway System, ASCE Specialty Conference on Earth and Earth-Supported Structures, Purdue University, Vol. III, pp. 251-253, 1972.

GOULD, J. P. , Personal Communication, 1975.

GOUVENOT, D., Essais en France et a L'etranger sur le Frottement Lateral en Fondation: Amelioration par Injection, (French & Foreign Works on Lateral Contact in Foundations: Improvement by Grouting), Travaux, pp. 64-72, November 1973.

GRAF, E. D., Compaction Grouting Technique and Observations, ASCE, JSMFD, Vol. 95, No. SM 5, pp. 1151-1158, September 1969.

GREENWOOD, D. A. , Baugrundverbesserung dur ch Tiefenverdichtung (Improvement of Foundation Soil by Deep Compaction), Baumaschine und Bautechnik, Vol. 19, No. 9, pp. 367-375, 1972.

GRINERØD, M., , Boreslam pa Norsk Kontinentalsokkel (Drilling Mud on the Norweigan Continental Shelf), Teknisk Ukeblad, Vol. 121, No. 34, pp. 37-42, 1974.

GRUNDBAU- Taschenbuch Band I (Foundation Engineering Handbook, Volume I) 2nd Edition, Berlin Munich, Wilh. Ernst' & Sohn, 1966.

- HAFFEN, M., Unterirdische Bauwerke in Kohäsionsarmen, kornigen Boden, Vorbehandlung zur Abdichtung und Verfestigung mittels Injektionen (Underground Structures in Low-Cohesion, Granular Soils, Injection Treatment for Sealing and Compaction), *Bergbau-Wissenschaft*, Vol. 17, No. 8, pp. 290-294, 1970.
- HAFFEN, M., Der Stand der Schlitzwandtechnik (The State of Slurry Trench Wall Technology), *Osterreichische Ingenieur - Zeitschrift*, Vol. 16, No. 10, pp. 321-330, 1973.
- HAFFEN, M. and Janin, J., Grouting Cohesionless Water -Bearing Soils in City Tunnels, *Proceedings, North American Rapid Excavation and Tunneling Conference*, Vol. 2, June 5-7; 1972.
- HAGERTY, D. J., Noise, Pile Driving and OSHA, Paper presented at Piletalk Seminar on Current Practices in Pile Design and Installation. 1974.
- HALLIBURTON Services, Grouting in Soils, Vol. I, A State-of-the-Art Report FHWA-RD-76-26; Vol. II, Design and Operations Manual FHWA-RD-76-27, 1976.
- HANKE, W. K., Die U-Bahn - Tunnel unter dem Munchener Rathaus (The Subway Tunnel Below the Munich City Hall), *Der Bauingenieur*, Vol. 44, No. 2, pp. 46-51, 1969.
- HANNA, T. H., Design and Behavior of Tie-Back Retaining Walls, *Acta Technica Academiæ Scientiarum Hungaricæ Tomus*, Vol. 63, pp. 423-431, 1968a.
- HANNA, T. H., Ground Anchors in Civil Engineering, *Ground Engineering*, Vol. 1, No. 5, pp. 38-41, 1968b.
- HANNA, T. H., Ground Anchor s in Civil Engineering, *Institution of Civil Engineers, Northern Ireland Association*, 26 pages, February 9, 1970.
- HANNA, T. H., The Influence of Anchor Inclination on Pull-Out Resistance of Clays, *Canadian Geotechnical Journal*, Vol. 10, No. 4, pp. 664-669, 1973a.
- HANNA, T. H., Anchored Inclined Walls; A Study of Behavior, *Ground Engineering*, Vol. 6, No. 6, pp. 24-33, November 1973 b.

HANNA, T. H., Foundation Instrumentation, Trans Tech **Publications**, Cleveland, 1973c

HANNA, T. H., Personal Communication, 1975.

HANNA, T. H. and Kur di, I. I., Studies on Anchored Flexible Retaining Walls in Sand, ASCE, JGED, GT 10, pp. 1107-1 122, October 1974.

HANNA, T. H. and Littlejohn, G. S., Design and Construction Considerations Associated with Retaining Walls Supported by Prestressed Tie-Backs, The Consulting Engineer, Part 1, May 1969, Part 2, June 1969.

HANNA, T. H. and Matallana, G. A., The Behavior of Tied-Back Retaining Walls, Canadian Geotechnical Journal, Vol. 7, No. 7, pp. 372-396, 1970.

HANNA, T. H. and Seeton, J. E., Observations on a Tied-Back Soldier Pile and Timber Lagging Wall, Ontario Hydro Research Quarterly, Vol. 19, No. 2 pp. 22-28, 1967.

HANSBO, S., Hofmann, E. and Mosesson, J., Östra Nordstaden, Gothenburg, Experiences Concerning a Difficult Foundation Problem and Its Unorthodox Solution, 8th ICSMFE, Moscow, Vol. 22, pp. 105-110, 1973.

HARMS, H. and Berg, R., Die Baugrubenaussteifung beim Bau von Untergrundbahnen nach der Berliner Bauweise (The Bracing in Open Cuts for Subway Constructions with the Berlin Method), Die Bautechnik, Vol. 34, No. 1, pp. 16-20, 1957.

HASHEMI, H. T. and Sliepcevich, C. M., Effect of Seepage Stream on Artificial Soil Freezing, ASCE, JSMFD, Vol. 99, SM 3, pp. 267-287, March 1973.

HEATON, E., Grouting, Theory of Grouting, Mining in Canada, February 1968.

HEATON, E., Grouting, Methods and Procedures, Mining in Canada, March 1968.

- HEATON, E., Grouting, Properties of Chemical Grouts and Pumping Systems, Mining in Canada, June 1968.
- HEATON, E. , Grouting, Pumping Equipment Specifications, Mining in Canada, November 1968.
- HEATON, E., Grouting, Estimating Chemical Quantities and Grouting Systems, Mining in Canada, December 1968.
- HEATON, E., Grouting, Examples of Chemical Grout Technology, Mining in Canada, March 1969.
- HEEB, A., Schurr, E., Bonz, M., Henke, K. F., and Muller, H., Erddruckmessungen am Baugrubenverbau für Stuttgarter Verkehrsbauwerke (Earth Pressure Measurements on Sheeted Excavations during Construction of the Stuttgart Subway), 'Die Bautechnik, Vol. 43, No. 6, pp. 208-216, 1966.
- HENKE, K. F. and Bonz, M., Steifenkraftmessungen beim U-Bahn-Bau in Stuttgart (Strut Load Measurements during the Subway Construction in Stuttgart), Strasse **Brücke** Tunnel, Vol. 24, No. 12, pp. 318-321, 1972.
- HENKEL, D. J., Geotechnical Considerations of Lateral Stresses, ASCE Specialty Conference on Lateral Stresses in the Ground and Design of Earth - Retaining Structures, Cornell University, pp. 1-49, June 1970.
- HENNING, D., Warmetechnische Verfestigung bindiger Lockergesteine (Thermic Compaction of Cohesive Loose Soils), **Bergbau-Wissenschaft**, Vol. 17, No. 8, pp. 311-314, 1970.
- _____, Ruhr schnellwegtunnel im Essen (The Ruhr Highway Tunnel in Essen), Hochtief-Nachrichten, 1970.
- HODGSON, F. T., Design and Construction of a Diaphragm Wall at Victoria Street, London, Conference on Diaphragm Walls and Anchorages, Institution of Civil Engineers, London, pp. 45-50, September 1974.

- HOFFMANN, M., Bangrubenums chliessungen mit ruckwartiger Verankerung (Excavation Walls with Tie-Backs), **Der Bauingenieur**, Vol. 46, No. 10, pp. 374-377, 1971.
- HOLZMANN, A. G., Technische Berichte, U-Bahn-Bau (Subway Construction), April 1967.
- HOUK, I. I., Arch Dams, published in **Section 3 of the second** edition of the Handbook of Applied **Hydraulics**, C. V. Davis, Editor in **Chief**, McGraw Hill, 1952
- HUDER, J., Deep Braced Excavation with High Ground Water Level., 7th ICSMFE, Mexico, Vol. 2, pp. 443-448, 1969.
- HUDER, J., Stability of Bentonite Slurry Trenches; Some Experience in Swiss Practice, 5th ECSMFE, **Madrid**, Vol. 1, pp. 517-522, 1972.
- HUNT, Hal W., Design and Installation of Pile Foundations, Associated Pile & Fitting Corp., Clifton, New Jersey, 1974,
- HURTADO, J., Parois prkfabriquees scellees dans les sol, (Precast Concrete Walls Sealed in the Soil), **Annales de L'Institut Technique du Batiment et des Travaux Publics**, No. 299, pp. 34-48, November 1972.
- HUTCHINSON, J. N., Settlements in Soft Clay Around a Pumped Excavation in Oslo, Norwegian **Geotechnical** Institute, Oslo, Publication No, 58, pp. 1-8, 1964.
- HUTCHINSON, M. T.; Daw, G. P.; **Shotton, P. G.**; and James, A.N.; The Properties of Bentonite Slurries used in Diaphragm Walling and Their Control, Conference on Diaphragm Walls and Anchorages, Institution of Civil Engineers, pp. 27-34, September 1974.

- ICOS Corporation, The ICOS Company in the Underground Works,
Company Brochure, 1968.
- IKUTA, Y., Diaphragm Walling in Japan, Ground Engineering,
pp. 39-44, 1974.
- INGLES, O. G., and Metcalf, J. B., Soil Stabilization, Principles
and Practice, Wiley, New York, 1975.
- INGLES, O. G. and Metcalf, J. B., Soil Stabilization, Halsted Press,
1973.
- INLAND • Ryerson, Catalog on Soil and Rock Anchors, March, 1974.
- INSLEY, A., A Deep Excavation and a Raft Foundation in Soft Clay,
Canadian Geotechnical Journal, Vol. 9, No. 3, pp. 237-248, 1972.
- _____, Contributions to Soil Anchors, Proceedings
of a Conference Organized by the Institution of Civil Engineers in
London, pp. 84-94, June 1970.
- _____, Contributions to Lateral Support Systems,
Proceedings of a Conference Organized by the Institution of Civil
Engineers in London, London, pp. 97-101, June 1970.
- ISCHY, E. and Glossop, R., An Introduction to Alluvial Grouting,
Proceedings Institution of Civil Engineers, Vol. 21, pp. 449-474,
March 1962.

- JACKSON, R. H., Freeze Watts Key to Deep Excavation, Western Construction (reprint), April 1969.
- JACKSON, W. T.; Perez, J. V.; and Lacroix, Y.; Foundation Construction and Performance for a 34-Story Building in St. Louis, Geotechnique, Vol. 24, No. 1, pp. 63-90, 1974.
- JAMES, E. L., and Phillips, S. H. E., Movement of a Tied Diaphragm Retaining Wall During Excavation, Ground Engineering, July 1974.
- JAMES, E. L., and Jack, B. J., A Design Study of Diaphragm Walls, Conference on Diaphragm Walls and Anchorages, Institution of Civil Engineers, London, pp. 35-44, September 1974.
- JANBU, N., Soil Compressibility As Determined by Oedometer and Triaxial Tests, ECSMFE, Weisbaden, Vol. 1, 1963.
- JANIN, J. J. and LeSciellour, G. F., Chemical Grouting for Paris Rapid Transit Tunnels, ASCE, Journal of the Construction Division, Vol. 96, CO 1, pp. 61-74, June 1970.
- JAWORSKI, W. E., An Evaluation of the Performance of a Braced Excavation, Massachusetts Institute of Technology, June 1973.
- JELINEK, R. , Constructive Problems and Case Histories, 5th ECSMFE, Madrid, pp. 295 -310, April 1972.
- JENNE, G., Wirtschaftliche Spundwandberechnung (Economical Designing of Steel Walls), Die Bautechnik, Vol. 49, No. 8, pp. 260-264. 1972.
- JESKE, T. and Przeddecki, T., The Rankine Pressure Theory in the Light of Kinematics of Granular Medium, 8th ICSMFE, Moscow, pp. 149-154, August 1973.
- JESSBERGER, H. L., and Nussbaumer, M., Einfluss von Zeit und Temperatur auf die Bemessung von Konstruktionen aus geforenem Lockergestein (Influence of Time and Temperature on the Dimensioning of Frozen Soil Structures), Bergbau-Wissenschaft, Vol. 17, No. 8, pp. 299-303, 1970.

JESSBERGER, H, L, and Nussbaumer, M., Anwendung des Gefrier-
verfahrens (Application of Artificial Soil Freezing, Die Bautechnik,
Vol. 50, No. 12, pp. 414-420, 1973.

JOAS, H., Weber, J., and Heine, E., Die Sicherung von Gebäuden
und sonstigen Anlagen beim Münchener U-Bahn-Bau (The Under-
pinning of Buildings and Other Structures during the Subway
Construction in Munich), Die Bautechnik, Vol. 48, No. 2, pp. 37-
42, 1971.

JORGE, G. R., Le Tirant IRP Reinjectable Special pour Terrains
Meubles, Karstiques ou a Faibles Caracteristiques Géotechniques,
7th IGSMFE, Mexico (Abstracted translation by ECI Solelanche,
Pittsburgh, PA), 1969.

JUMIKIS, A. R. , Thermal Soil Mechanics, Rutgers University Press,
New Jersey, 267 pages, 1966.

- KAMENSKII, R. M.** Thermal Engineering Calculations of the Frozen Soil Watertight Cutoff Dams, Taking into Account the Mutual Influence of the Freezing Columns, published in Russian in *Gidrotekhnicheskoi Stroitel'stvo*, No. 4., pp. 38-42, April, 1971.
- KANY, M.**, Empfehlungen zur Berechnung und Konstruktion von Tunnelbauten (Recommendation for Design and Construction of Tunnels), *Die Bautechnik*, Vol. 51, No. 8, pp. 276-280, 1974.
- KAPP, M. S.**, Tall Towers Will Sit on Deep Foundations, *Engineering News Record*, pp. 36-38, July 9, 1964.
- KAPP, M. S.**, Slurry Wall Construction for Basement Wall of World Trade Center, *Civil Engineering*, Vol. 39, No. 4, pp. 36-40, April 1969.
- KÄRCHER, K.**, Erdwiederstand bei Bohlwänden in bindigen Böden (Earth Pressure on Soldier Pile Walls in Cohesive Soils), *Die Bautechnik*, Vol. 49, No. 8, pp. 264-268, 1972.
- KAROL, R. H.**, Chemical Grouting Technology, ASCE, JSMFD, Vol. 94, SM 1, pp. 175-204, 1968.
- KASTNER, R. and Lareal, P.**, Experimental Excavation of Length 50m Supported by Strutted Cast Diaphragm Walls: An Analysis of Stress Distribution in the Struts, *Conference on Diaphragm Walls and Anchorages*, Institution of Civil Engineers, London, pp. 17-20, 1974.
- KEUTE, H., and Schurrer, V.**, Bemessungshilfen und Ankerlängenbestimmung für Baugrubensicherungen mit Hilfe von Diagrammen (Design Diagrams for Tie-Back Length and Excavation Support), *Die Bautechnik*, Vol. 51, No. 5, pp. 155-160, 1974.
- KERSTEN, M. S.** Final Report, Laboratory Research for the Determination of the Thermal Properties of Soils, Engineering Experiment Station, University of Minnesota, 1949.
- KEZDI, A.**, Stability of Rigid Structures, General Report, 5th ECSMFE, Madrid, pp. 105-130, April 1972.

- KIENBERGER, H., Diaphragm Walls as Load Bearing Foundations, Conference on Diaphragm Walls and Anchorages, Institution of Civil Engineers, London, pp. 19-22, September, 1974.
- KJAERNSLI, B., Empirisk regel for bestemmelse av avstivingskrefter i utgravninger i Oslo-leire (Empirical Rules for Determination of Strut Loads in Excavations in Oslo Clay), N. G. I. - Report No. 83, Oslo, pp. 1-10, 1970.
- KLEIN, K., Lateral Pressure of Clayey Soils on Structures, Discussion in Specialty Session 5, Vol. 4. 3, 8th ICSMFE, p. 232, Moscow, 1973.
- KLOPP, R., Verwendung vorgespannter Felsanker in geklüftetem Gebirge aus ingenieurgeologischer Sicht (The Application of Prestressed Anchors in Jointed Rock), Der Bauingenieur, Vol. 45, No. 9, pp. 328-331, 1970.
- KNAUPE, W., Hydraulischer Grundbruch an Baugrubenumschliessungen in Schichtweise gelagerten Baugrund (Hydraulic Ground Failure in Excavations in Layered Soils), Bauplanung, Bautechnik, Vol. 26, No. 9, pp. 428-431, 1972.
- KNAUPE, W., Aushub umschlossener Baugruben im Schichtweise gelagerten Baugrund bei Wasserandrang (Excavations in Layered Soils with High Ground Water Table), Bauplanung-Bautechnik, Vol. 27, No. 10, pp. 500-504, 1973.
- KOTULLA, B., Konstruktive Probleme bei der Sicherung von Bauwerken im Bereich tiefer Baugruben (Constructional Problems by the Support of Buildings Adjacent to Deep Excavations), Tiefbau, Vol. 15, No. 9, pp. 784-788, 1973.
- KRAMER, J., Wasserhaltung bei tiefen Baugruben im Ruhrgebiet (Groundwater Control in Deep Excavations in the Ruhr Area), Tiefbau, Vol. 15, No. 5, pp. 526-530, 1973.
- KRANICH, W. and Musfeldt, T., Das Einpressen ganzer Bauwerke unter Eisenbahngleisen (The Jacking of Complete Structures Through Railway Embankments), Beton-und Stahlbetonbau, Vol. 67, No. 12, pp. 265-271, 1972.

KRANZ, E., Über die Verankerung von Spundwänden, 2 Auflage, Mitteilungen aus dem Gebiete des Wasserbaues und der Baugrundforschung, Heft 11, Berlin: 'Wilh, Ernst & Sohn, 1953.

KRIMMER, H., Technische Entwicklung der Baugrubenwände beim Frankfurter U-Bahn-Bau (Technical Development of the Excavation Support for the Subway Construction in Frankfurt), Baumaschine und Bautechnik, Vol. 19, No. 4, pp. 136-144, 1972.

KRIZEK, R. J., and Corotis, R. B., Probabilistic Approach to Heave of Soft Clay Around Sheetpile Walls, 8th ICSMFE, Moscow, Vol. 1.3, pp. 143-150, 1973.

KUTZNER, C., Über die mechanischen Eigenschaften der mit Silikatgelen injizierten Erdstoffe (The Mechanical Properties of Soils Injected with Silicate or Grout), Die Bautechnik, Vol. 45, No. 3, 12 pages, 1968.

KUTZNER, C., and Ruppel, G., Chemische Bodenverfestigung zur Unterfahrung des Hauptbahnhofes beim U-Bahnbau in Köln (Chemical Soil Stabilization as Underpinning of the Main Railway Station in Cologne for Subway Construction), Strasse Brücke Tunnel, Vol. 22, No. 8, pp. 202-205, 1970.

- LACKNER, E., Technischer Jahresbericht 1971 des Ausschusses "Uferneimfassungen" (Annual Report 1971 of the German Committee for Quay and Shore Walls), Die Bautechnik, Vol. 48, No. 12, pp. 409-420, 1971.
- LACKNER, E., Tochnischer Jahresbericht 1972 des Ausschusses "Uferneimfassungen" (Annual Report 1972 of the German Committee for Quay and Shore Walls), Die Bautechnik, Vol. 49, No. 12, pp. 405-420, 1972.
- LACKNER, E. Technischer Jahresbericht 1973 des Ausschusses "Uferneimfassungen" (Annual Report 1973 of the German Committee for Quay and Shore Walls), Die Bautechnik, Vol. 50, No. 12, pp. 397-414, 1973.
- LA CROIX, Y. and Jackson, W., Design and Construction of Supported Temporary Excavations in Urban Environment, 3rd Ohio Soil Seminar, October 1972.
- LADD, C. C., Strength Parameters and Stress-Strain Behavior of Saturated Clays, Research Report R71-23, Soils Publication 278, Massachusetts Institute of Technology, 1971.
- LADD, C.C.; Bover, R.B.; Edgers, L.; and Rixner, J. J.; Consolidated Undrained Plane Strain Shear Tests on Boston Blue Clay, Research in Earth Physics, Phase Report 15, M.I. T. Department of Civil Engineering, Research Report R71-13, 243 p., 1971.
- LADD, C. C., and Varallyay, J; The Influence of Stress System on the Behavior of Saturated Clays During Undrained Shear, M. I. T. Department of Civil Engineering, Research Report R65-11, 263 p., 1965.
- LAMB, B., Massive Concreting Follows Earth-Anchoring, Construction Methods and Equipment, Vol. 55, No. 2, pp. 64-67, 1973.
- LAMBE, T. W., Soil Stabilization, Foundation Engineering, Chapter 4, G. A. Leonards, Ed., McGraw-Hill Book Co., pp. 351-437, 1962.

LAMBE, T. W., Predicting Performance of Braced Excavations, ASCE Specialty Conference on Performance of Earth and Earth-Supported Structures, Purdue University, Vol. III, pp. 255 -256, 1972.

LAMBE, T. W., Wolfskill, L. A., and Jaworski, W. E., The Performance of a Subway Excavation, ASCE Specialty Conference on the Performance of Earth and Earth-Supported Structures, Purdue University, Vol. I, Part 2, pp. 1403-1424, 1972.

LAMBE, T. W., Wolfskill, L. A., and Wong, I. H., Measured Performance of Braced Excavation, ASCE, JSMFD, Vol. 96, SM3, pp. 817-836, 1970.

LARNACH, W. J., The Behavior of Grouped Inclined Anchors in Sand, Ground Engineering, Vol. 6, No. 6, pp. 34-41, November 1973.

LARSON, M. L. , Willette, W. R.; Hall, H. C. ; and Gnaedinger, J. P. ; A Case Study of a Soil Anchor Tie-Back System, ASCE Specialty Conference on Performance of Earth and Earth-Supported Structures, Purdue University, Vol. I, Part 2, pp. 1341-1366, 1972.

LAUNINGER, K. and Song, F., Stützmauern. Beispiele mit Anwendung von Pressbetonbohrpfählen und rückwärtigen Verankerungen (Retaining Walls. Examples of the Use of Bored Concrete Piles with Tie-Backs), Beton-und Stahlbetonbau, Vol. 69, No. 4, pp. 88-92, 1974.

LEISER, A. , and Schmaus, W. , A bfangung Nochbelas teter Stützen und Umbau der Gründung bei einer Stahlbetonskelettkonstruktion (Underpinning of Heavy Loaded Columns and Reconstruction of the Foundations for a Reinforced Concrete Skeleton Building), Beton-und Stahlbetonbau, Vol. 64, No. 10, pp. 225-229, 1969.

LEONARD, M. W., and Moller, K., Grouting for Support with Particular Reference to the Use of Some Chemical Grouts, Grouts and Drilling Muds in Engineering Practice, Butterworths, London, 1963.

- LEONARD, M. S. M., Precast Diaphragm Walls Used for the A13 Motorway, Paris, Conference on Diaphragm Walls and Anchorages, Institution of Civil Engineers, London, pp. '71-75, September 1974.**
- LEONARDS, G. A., Foundation Engineering, McGraw-Hill. Book Company, Inc. , 1962.**
- LINELL, K. A., Hennion, F.B., and Lobacz, E. F., Corps of Engineers' Pavement Design in Areas of Seasonal Frost, H. R. B. Research Record, No. 33, 1963.**
- LITTLEJOHN, G. S., Soil Anchors, Proceedings of a Conference Organized by the Institution of Civil Engineers in London, pp. 33 -44, June 1970a.**
- LITTLEJOHN, G. S. , Discussion of Soil Anchors, Proceedings of a Conference Organized by the Institution of Civil Engineers in London, pp. 70-71, 1970b.**
- LITTLEJOHN, G. S. , Ground Anchors Today - A Foreword, Ground Engineering, Vol. 6, No. 6, pp. 20-23, November, 1973.**
- LITTLEJOHN, G. S., Rock Anchors - Some Design Considerations, Draft of Report on Rock Anchors, 1974.**
- LITTLEJOHN, G. S. ; Acceptable Water Flows for Rock Anchor Grouting, Geotechnics Research Group, Department of Engineering, University of Aberdeen, 1974.**
- LITTLEJOHN, G. S. and Bruce, D.A., Rock Anchors-State-of-the-Art, Part I: Design, Ground Engineering, Vol. 8, No. 3, May, pp. 25-33, 1975.**
- LITTLEJOHN, G. S. ; Jack, B. J. ; and Sluvinski, Z., Anchored Diaphragm Walls in Sand, Reprinted articles from Ground Engineering, September to November 1971, January 1972.**
- LITTLEJOHN, G. S. and MacFarlane, I. M., A Case History Study of Multi-Tied Diaphragm Walls, Conference on Diaphragm Walls and Anchorages, Institution of Civil Engineers, London, pp. 91-100, September 1974.**
- LIU, T. K. and Dugan, J. P. Jr., An Instrumented Tied-Back Deep Excavation, ASCE Specialty Conference on Earth and Earth-Supported Structures, Purdue University, Vol. I, Part II, pp. 1323-1339, June 1972.**

- LIVER, N. L., Tension Piles and Diagonal Tiebacks, ASCE, Journal of the Sanitary Engineering Division, pp. 107-120, July 1969.
- LIZZI, I. F., Special Patented System of Underpinning and. More Generally, Subsoil Strengthening by Means of "Pali Radice" (Root Piles) with Special Reference to Problems Arising from the. Construction of Subways in Built-Up Areas, Illustrated Text of Lecture on Root Piles, Fondedile Corp, 1974.
- LIZZI, F., Reticolo Di Pali Radice, Italian Geotechnical Association Meeting BARI, October 1970.
- LOCHTE, J., Möglichkeiten zur Anwendung des Injektionsverfahrens bei gering durchlässigen Lockergesteinen (Application Possibilities of the Injection Method in Low-Permeability Soils), Berbau-Wissenschaft, Vol. 17, No. 8, pp. 295-299.
- LOERS, G., Neue Erkenntnisse bei der Herstellung und Aus bildung von Schlitzwänden (New Facts for the Construction and Design of Slurry Walls), Tiefbau, Vol. 15, No. 5, pp. 445 -449, 1973.
- LOGEAIS, L. and Graux, D., Les tirants d'ancrage, (Tie-Backs), Annales de L'Institut Technique du Batiment et des Travaux Publics, No. 3 12, pp. 126- 146, December 1973.
- LORENZ, H., Utilization of a Thixotropic Fluid in Trench Cutting and the Sinking of Caissons, SDGMEP, Butterworth, London, pp. 202-205, 1963.
- LOVENBURY, H. T., and Vaughan, P. R., Discussion to the Proceedings, 5th ECSMFE, Madrid, Vol. 2, p. 339, 1972.

MALJIAN, P. A., and Van Beveren, J. L., Tied-Back Deep Excavations in Los Angeles Area, ASCE, Journal of the Construction Division, CO 3, pp. 337-356, September 1974.

MAIDL, B. and Nellessen, H. G., Bewehrungsstösse im Tunnelbau unter Berücksichtigung der neuen DIN 1045 (Reinforcement in Tunnel Construction as a Result of the New DIN 1045), Die Bau-technik, Vol. 50, No. 11, pp. 361-370, 1973.

MAISHMAN, D., Ground Freezing, Methods of Treatment of Unstable Ground (in press), Butterworth and Co, 1975.

MAJTENYI, S. I., Personal Communication, 1975.

MANSUR, C. I., and Alizadeh, M., Tie-Backs in Clay to Support Sheeted Excavation, ASCE, JSMFD, Vol. 96, SM 2, pp. 495-509, 1970.

MARGOLIN, V. M., and D'Yakonov, V. P., Stability of Vertical Walls of Trenches Under Hydrostatic Heads, Soil Mechanics and Foundation Engineering, Vol. 10, No. 1, pp. 60-62, 1973.

MARKER, H., Die Anwendung der Schlitzwandbauweise (The use of Slurry Walls), Schweizerische Bauzeitung, Vol. 88, No. 33, pp. 735-740, 1970.

MARSAK, S. A., Herstellung eines Wassertunnels im Gefrierverfahren, Hidrotechniceskoe stroitel stvo (Wassertechnisches Bauwesen), Volume 35, No. 6.

MARTIN, A., Vorgespannte Schlitzwände ffr die Zeltdachyankerung der Olympia - Sports&ten in Munchen (Prestressed Diaphragm Walls for Anchoring the Tent-Roof over the Olympia Stadiums in Munich), Baumaschine und Bautechnik, Vol. 18, No. 10, pp. 415-419, 1971.

Massachusetts Institute of Technology, "Grouting Applications in Civil Engineering", Department of Civil Engineering, Prepared for Oak Ridge National Laboratory, Contract: ORNL-Sub-3960-1, December 1974.

**Massachusetts Institute of Technology, Project Report, M. I. T.
Test Section Instrumentation - Massachusetts Bay Transportation
Authority Haymarket - North Extension, Soil Mechanics Division,
Project Mass. MTD-2, 1972.**

**MAZURKIEWICZ, B. K., The Rupture Figure for a Double Wall
Cofferdam, ASCE Specialty Conference on Performance of Earth
and Earth-Supported Structure, Purdue University, pp. 1271-1281,
June 1972.**

**McROSTIE, G. C.; Burn, K. N. ; and Mitchell, R. J. ; The Perform-
ance of Tied-Back Sheet Piling in Clay, Canadian Geotechnical
Journal, Vol. 9, No. 2, pp. 206-218, 1972.**

**MEAD, H. T., Complex Earth Holding System Prepares for Deep
Excavation in Congested Area, World Construction, Vol. 27, No. 5,
pp. 18-22, 1974.**

**MEISSNER, H., Zur Verankerung von Wänden, die Geländesprünge
verformungsarm abstützen sollen (Design of Tie-Backs to Obtain
Minimum Wall Deformation), Der Bauingenieur, Vol. 45, No. 9,
pp. 337-339, 1970.**

**MERGENTIME, C. E., Underpinning Massive Structures, Civil
Engineering, Vol. 42, No. 3, pp. 40-41, March 1972.**

**MEYERHOF, G. G., Stability of Slurry Trench Cuts in Saturated Clay,
ASCE Specialty Conference on Performance of Earth and Earth-
Supported Structures, Purdue University, Vol. I, Part 2,
pp. 1451 - 1466, 1972.**

**Milan Polytechnic, Report on the Measurements Taken on a Portion
of Reticulated "Pali Radice" Retaining Wall, on Behalf of the
Metropolitan Transit Authority of Milan, Institute of Geodesy,
Topography and Photogrammetry.**

**MITCHELL, J. K., Fundamental Aspects of Thixotropy in Soils,
ASCE, JSMFD, Vol. 86, SM 3, pp. 19-53, 1960.**

- MITCHELL, J. K., In Place Treatment of Foundation Soils, Paper presented at specialty Conference: Placement and Improvement of Soil to Support Structures, MIT, Cambridge, Mass., August 26-28, also ASCE JSMFD, Vol. 96, SM1, 1970.
- MITCHELL, J. M., Some Experiences with Ground Anchors in London, Conference on Diaphragm Walls and Anchorages, Institution of Civil Engineers, London, pp. 1 - 11, September 1974.
- MÖBIUS, C. H. , and Günther, T. H., Modellver suche zur Standfestigkeit flüssigkeitgestützter Erdwände (Model Tests to Determine Stability of Slurry Trenches), Die Bautechnik, Vol. 50, No. 5, pp. 156-160, 1973.
- MOLLER, K., Grouting Now, Consulting Engineer, London, Vol. 36, No. 8, pp. 44 - 49, 1972.
- MORGENSTERN, N. and Amir-Tahmasseb, A., The Stability of a Slurry Trench in Cohesionless Soils, Geotechnique, Vol. 15, No. 4, pp. 387-395, 1965.
- MORONEY, N., Recharge Wells and Pit Underpinning Overcome Settlement Caused by Dessication, Civil Engineering, ASCE, Vol. 31, No. 1, January 1961.
- MÜLLER, D. and Krense, P., Rammversuche mit Verschiedenen Stahlspundbohlen in einem Ton-und Geschiebemergel (Driving Tests With Various Steel Sheetings in Clayey Marl with Obstructions), Die Bautechnik, Vol. 49, No. 11, pp. 370-374, 1972.
- MÜLLER-Haude, H. Ch., and von Scheibner, D., Neue Bodendruckmessungen an Baugruben und Tunnelbauten der Berliner U-Bahn (New Earth Pressure Measurements on Support Walls and Tunnel Structures at the Berlin Subway), Die Bautechnik, Vol. 42, No. 9 and 11, pp. 293-298 and 380-385, 1965.
- MULLER-Kirchenbauer, H., Erddruckmessungen an einem hohen Brückenwiederlager (Earth Pressure Measurements on a High Bridge Abutment), Baumaschine und Bautechnik, Vol. 20, No. 5, pp. 169-173, 1973.

MULLER-KIRCHENBAUER, H., Stability of Slurry Trenches, 5th ECSMFE, Madrid, Vol. 1, pp. 543-553, 1972.

MÜLLER-KIRCHENBAUER, H., Einflüsse der Filtratbildung auf die Stabilität von Schlitzwänden (The Influence of Filter Cakes on the Stability of Slurry Trenches), Vorträge der Baugrundtagung 1972 in Stuttgart, pp. 843-860, Deutsche Gesellschaft für Erd-und Grundbau e.v. Essen 1973.

MURPHY, D. J. ; Clough, G. W.; and Woolworth, R.S. ; Temporary Excavation in Varved Clay, ASCE, JGED, Vol. 101 GT 3, March, pp. 279-295, 1975.

MYRVOLL, F., Feltforsøk ved utførelse av tverrlissegrøft 41 ved fellestunnelen i Studenterlunden (Field Test by the Construction of the Transverse Slurry Trench 41 for the Studenterlund Tunnel), NGI Internal Report 71075-1, September 25, 1973.

MYRVOLL, F., Malinger og observasjoner utført under arbeidet med tverrlissegrøft 42 i Studenterlunden (Measurements and Observations Made During the Work with Transverse Slurry Trench 42 in Studenterlunden, Oslo), NGI Internal Report No. 71075-2, March 25, 1974.

MYRVOLL, F., and Karlsrud, K., Skjærforsøk i full målestokk på bløt leire i Studenterlunden, Oslo (Full Scale Shear Test on Soft Clay in Studenterlunden, Oslo), NGI Publication 102, pp. 31-38, 1974.

- NASH, J. K. T. L. , and Jones, G. K. , The Support of Trenches Using Fluid Mud, SMDMEP, Butterworths, London, pp. 177-180, 1963.**
- NAVARRO, H., Les tirants en terrain meuble, type T. M. (Anchoring Rods of T. M. Type for Loose Soil), Travaux, No. 451, pp. 15-21, October, 1972.
- NAVFAC DM-7, Design Manual - Soil Mechanics, Foundations and Earth Structures, Department of the Navy, Naval Facilities Engineering Command, Washington, D. C. , 197 1.
- NEELANDS, P. J., and James, A. N., Formulation and Selection of Chemical Grouts with Typical Examples of Field Use, Grouts and Drilling Muds in Engineering Practice, Butterworths, London, pp. 150-155, 1963.
- NEELY, W. J., and Montague-Jones, M., Pullout Capacity of Straight-Shafted and Underreamed Ground Anchors, Die Siviele Ingenieur, South **Aftica**, Vol. 16, pp. 131-134, April, 1974.
- NELSON, J. C., Earth Tiebacks Support Excavation 112 Feet Deep, Civil Engineering, Vol. 43, No. 11, pp. 40-44, November, 1973.
- NENDZA, H., Sicherung tiefer Baugruben neben Bauwerken (Lateral Support of Deep Excavations Adjacent to Buildings), Tiefbau, Vol. 15, No. 8, pp. 698-702, 1973.
- NENDZA, H. , and Klein, K. , Bodenverformung beim Aushub tiefer Baugruben (Soil Deformation by Deep Excavations), Strasse **Brücke** Tunnel, Vol. 26, No. 9, pp. 23 1-239, 1974.
- NEUMANN, H. , and Wilkins, L. S., Soil Solidification by Chemical Injection, Civil Engineering and Public Works Review, pp. 635-636, June, 1972.
- NEWMARK, N. M., Influence Charts for Computation of Stresses in Elastic Foundation, University of Illinois Bulletin, Vol. 40, No. 12, 1942.
- NICHOLSON Anchorage Co., Nicholson Ground Anchors, Company Catalogue, 1974.

NORTH-LEWIS, J. P. and Lyons, G. H. S., Continuous Bored Piles,
Conference on Diaphragm Walls and Anchorages, Institution of
Civil Engineers, London, pp. 43-48, 1974.

NORWEGIAN Geotechnical Institute, Measurements at a Strutted
Excavation, Report Nos, 2-9.

NORWEGIAN Geotechnical Institute, Measurements at a Strutted
Excavation, Oslo Subway, Gronland 2, km 1, 692, Oslo, 111 pages.

- OOSTERBAAN, M. D., and Gifford, D. G. , A Case Study of the Bauer Earth Anchor, ASCE Specialty Conference on Performance of Earth and Earth-Supported Structures, Purdue University, Vol. 1, Part 2, pp. 1391-1401, 1972.
- O'ROURKE, T. D., and Cording, E. J. , Observed Loads and Displacements for a Deep Subway Excavation, Proceedings Rapid Excavation and Tunneling Conference, San Francisco, Vol. 2, p. 1305, 1974a.
- O'ROURKE, T. D. , and Cording, E. J. , Measurement of Strut Loads by Means of Vibrating Wire Gages, Proceedings Symposium on Performance Monitoring for Geotechnical Construction, ASTM, STP 584, pp. 58-'77, 1974b.
- OSTERBY, N. P. , The Lowry Hill Tunnel Freeze Wall, Paper presented at the Highway Research Board meeting, January, 1971.
- OSTERMAYER, H. , Discussion on Ground Anchors, 5th ECSMFE, Madrid, Vol. II, pp. 334-336, April, 1972.
- OSTERMAYER, H. , Construction, Carryinp Behavior and Creep Characteristics of Ground Anchors, Conference on Diaphragm Walls and Anchorages, Institution of Civil Engineers, London, pp. 1-12, September, 1974.

- PALMER, J. H. , and Kenney, T. C., Analytical Study of a Braced Excavation in Weak Clay, Canadian Geotechnical Journal, Vol. 9, No. 2, pp. 145-164, 1972.
- PARSONS Associates, Report on Underpinning with Root Piles, Non-published Technical Report prepared for Washington Metropolitan Area Transit Authority,
- PARSONS, J. D., Foundation Installation Requiring Recharging of Ground Water, Journal of the Construction Division, ASCE, September, 1959
- PASSARO, Aldo, St. Lucia Tunnel - Salerno Underpinning by Reticulated Root Piles, Report to Italian State Railway System.
- PATERSON, A. C. , Underpinning, Proceedings, Conference on Ground Engineering organized by the Institution of Civil Engineers, London, Paper No. 5, pp. 45-54, 1970.
- PAVLOW, Fred, Design and Construction of Deep Retained Excavations, ASCE/SEAONC Continuing Education Seminars, Lecture dated November 23, 1970.
- PECK, R. B. , Deep Excavations and Tunneling in Soft Ground, State-of-the-Art Report, 7th ICSMFE, Mexico City, State-of -the -Art Volume, pp. 225-290, 1969.
- PECK, R. B., Observation and Instrumentation, Some Elementary Considerations, Lecture Notes, Met. Section ASCE, Seminar on **Field** Observations in Foundation Design and Construction, New York, April, 1970. (Reprinted in Highway Focus, U. S. Dept. of Transportation, F.H.W.A., Vol. 4, No. 2, pp. 1-5, June, 1972.)
- PECK, R. B., Hanson, W. E., and Thornburn, T. H., Foundation Engineering, Second Edition, Wiley, New York, 1974.
- PEER, G., Concrete Caissons Shore Highway Wall, Reprint from Heavy Construction News, May 29, 1972.
- PEER, G. A. , Montreal Job has Two Types of Shoring, Reprint from Heavy Construction News, January 22, 1973.
- PETERSEN, G., and Schmidt, H., Untersuchungen über die Standsicherheit verankerter Baugrubenwände an Beispielen des Hamburger Schnellbahntunnelbaues (Stability Analysis of Anchored Walls for the Subway in Hamburg), Strasse Brücke Tunnel, Vol. 23, No. 9, pp. 225-233, 1971.

- PETERSEN, G. , and Schmidt, H. , Zur Berechnung von Baugrubenwände nach dem Traglastverfahren (Design of Support Walls by the Method of Load Capacity), Die Bautechnik, Vol. 50, No. 3, pp. 85-91, 1973.
- PETERSON, C. R. , Force Reduction in Excavation Devices, ASCE, Journal of the Construction Division, Vol. 99, No. CO1, pp. 21-33, 1973.
- PIASKOWSKI, A. , and Kowalewski, Z. , Thixotropic Properties of Suspensions of Soils with Different Grain Sizes and of Various Mineralogical Types, 5th ICSMFE, Vol. 1, pp. 293 -296, 1961.
- PIASKOWSKI, A., and Kowalewski, Z. , Application of Thixotropic Clay Suspension for Stability of Vertical Sides of Deep Trenches Without Strutting, 6th ICSMFE, Canada, Vol. II, pp. 526-529, 1965.
- PILARSKI, L., Precast- Walls Drop Into Place in Six Easy Steps, Construction Methods and Equipment, Vol. 56, No. 7, p. 71, 1974.
- PLAISTED, A. C., Application of Chemical Grouts to Ground Consolidation, Ground Engineering, Vol. 7, No. 4, pp. 42-44, July, 1974.
- POTEVIN, G. , La Congelation des Terrains Dans les Travaux Publics, Industrie Minerale, April, 1972.
- PRASAD, G. D., Freeman, C. F., and Klajnerman, D., Deep Excavations for the Manufacturers Life Centre, Toronto, Canadian Geotechnical Journal, Vol. 9, No. 2, pp. 137-144, 1972.
- PREGL, O., Ein allgemeiner Extremwertverfahren zur Bestimmung der Erdrucke s und der Erddruckverteilung auf Abstützung (A General Maximum Value Method to Calculate Earth Pressure and Pressure Distribution on Lateral Support Walls), Der Bauingenieur, Vol. 45, No. 9, pp. 332 -336, 1970.
- PRENTIS, E. A. , and White, L., Underpinning, Columbia University Press, 374 pp., 1950.

PROCHAZKA, J., Berechnung unveranketer Spundwände bei trapez-
förmiger Verteilung des Erddruckes (Design of Unsupported Steel
Sheet Piling with Trapezoid Shaped Earth Pressure), Die Bautechnik,
'Vol. 48, No. 5, pp. 153-160, 1971.

PULLER, M. J., Slurry Trench Stability Theoretical and Practical
Aspects, Ground Engineering, pp. 34-38, September, 1974,

- RANK, D., and Nussbaumer, W., Bodenverfestigungsversuch bei der Schwedenbrücke in Wien - eine neue Anwendung von Radionukliden in der Bauwirtschaft (Earth Stabilization Test by the Swedish Bridge in Vienna, A New Way of Using Nuclear Dye in the Construction Business), Oesterreichische Ingenieur-Zeitschrift, Vol. 16, No. 10, pp. 331-338, 1973.
- RANKE, A., and Ostermayer, H., Beitrag zur Stabilitäts - Untersuchung mehrfach verankerter Baugrubenumschliessungen (A contribution to the Stability Calculations of Multiple Tied-Back Walls), Die Bautechnik, Vol. 45, No. 10, pp. 341-349, 1968.
- RAPPERT, D., Beeinflussung von Bauwerken durch Unterfahrungen (The Influence of Tunnel Constructions on Buildings Above the Tunnel), Holzmann-Nachrichten, 1970.
- RICHARDS, R., Jr., and Agrawal, J. S., Stresses on Shallow Circular Pipe by Transformed Section, ASCE, GTED, Volume 100, GT6, June, 1974.
- RODRIGUE Z, J. M. , and Flamand, C. L. , Strut Loads Recorded in a Deep Excavation in Clay, Proceedings, 7th ICSMFE, Mexico City, Vol. 2, pp. 459-467, 1969.
- ROGERS, Walter F., Composition and Properties of Oil Well Drilling Fluids, Gulf Publishing Co. , 1963.
- ROTH, B., Rückwärtige Verankerung an Baugrubenwänden, Teil II, (Tied-Back Excavation Walls, Part II), Vortragsveröffentlichungen, Haus der Technik, Essen, No. 241, 1970.
- ROMBERG, W., Messungen an einer verankerten Baugrubenwand (Measurements on a Tied-Back Excavation Wall), Mitteilungen der Versuchsanstalt für Bodenmechanik und Grundbau der Technischen Hochschule Darmstadt, No. 12, December, 1973.
- RUFFANI, E. , Baugrubensicherung für eine extrem tiefe Pressengrube (Bracing of an Extremely Deep Structural Excavation), Bauplanung - Bautechnik, Vol. 26, No. 9, pp. 418-421, 1973.
- RUFFERT, G., Betonspritzverfahren zum Schutz unterirdischer Bauten (Shotcrete for Protection of Subsurface Constructions), Tiefbau, Vol. 15, No. 3, pp. 213-216, 1973.
- RUPPEL, G. , Ausführung von Injektionen in Lockergesteinen (Injection Technique in Cohesionless Soil), Bergbau-Wissenschaft, Vol. 17, No. 8, pp. 285-290, 1970.

- SABZEVARI, A., and Ghahramani, A., Theoretical Investigations of the Passive Progressive Failure in an Earth Pressure Problem, Soils and Foundations, Vol. 13, No. 2, pp. 1-18, June 1973.
- SADLIER, N. A., and Dominioni, G. G. , Underground Structural Concrete Walls, SGDMEF, Butterworths, London, pp. 189-195, 1963.
- SALAS, J. A. J., Ureil, S. , and Serrano, A. A., Behavior Under Horizontal Forces of Two Cast-in-Place Diaphragm Walls in Loose Layered Soil, Proceedings 5th ECSMFE, Madrid, Supplement B. , pp. 79-89, 1972.
- SANDHU, B.S. ,Earth Fressure on Walls Due to Surcharge, Civil Engineering, ASCE, Vol. 44, No. 12, pp. 68-70, December, 1974.
- SANDQVIST,G., Back-Tied Sheet Pile Wall in Friction Soil. Defor - mations and Drag Forces Due to Piling and Freezing, 5th ECSMFE, Madrid, Vol. I, pp. 293 -298, April, 1972.
- SANGER, F. J., Ground Freezing in Construction, ASCE, JSMFD, Vol. 94, SM 1, pp. 131-158, 1968.
- SAXENA, S. K. , Measured Performance of a Rigid Concrete Wall at the World Trade Center, Conference on Diaphragm Walls and Anchorages, Institution of Civil Engineers, London, pp. 85-90, September, 1974.
- SCHEUCH, G. , Die Gründung des Fariser Turmhochhauses Maine-Montparnasse (The Foundation of the Paris Skyscraper Maine-Montparna sse), Tiefbau, Vol. 14, No. 12, pp. 1151-1152, 1972.
- SCHEUCH, G. , U-Bahn Bau in Hannover (Subway Construction in Hanover), Tiefau, Vol. 15, No. 5, pp. 540-542, 1973.
- SCHMID, W. E. , and Prieto, L. A., Earth Anchors. Stress Distri- bution Analysis and Design, 5th ECSMFE, Madrid, Vol. 1, pp. 25-31, April, 1972.
- SCHMIDT, B., and Dunicliff, C. J. , Construction Monitoring of Soft Ground Rapid Transit Tunnels. A Definition of Needs and Potential Developments, Report on Contract DOT/TSC 661, Rail Program Branch of the Urban Mass Transportation Administration, Office of Research, Development and Demonstrations, 1974.

- SCHMIDT, H. , Zur Ermittlung der kritischen tiefen Gleitfuge von mehrfach verankerten hohen Baugrubenwänden (Construction of The Critical Deep Failure Surface by High Support Walls with Several Anchorages), Die Bautechnik, Vol. 51, No. 6, pp. 210-212, 1974.
- SCHMITT, G. P., Ein Beitrag zur Klärung des Tragverhaltens einfach verankerter Baugrubenwände (A Contribution to the Understanding of Soil-Structure Interaction by Single Tied-Back Walls), Mitteilungsheft 14 der Versuchsanstalt für Bodenmechanik und Grundbau der Technischen Hochschule Darmstadt, 1974.
- SCHMITZ, H., and Schmaus, W., Tieflegung der Bundesbahn in Bonn (Subsurface Reconstruction of the Railway System in Bonn), Strasse **Brücke** Tunnel, Vol. 25, No. 7, 9 pages, 1973.
- SCHNABEL, H., Jr., Procedure for Testing Earth Tiebacks, ASCE National Structural Engineering Meeting, Cincinnati, Ohio, April 22-26, 1974.
- SCHNEEBELI, P. G., La Stabilité Des Tranchées Profondes Forées en Présence De Boue (The Stability of Deep Trenches Excavated in a Slurry), La Houille Blanche, No. 7, pp. 815-820, 1964.
- _____, Durchpressungen (Horizontal Pile Jacking) Schriftenreihe der Tiefbau-Berufsgenossenschaft, No. 8, 1972.
- SCHULTZ, E. W., Die Anwendung der Spritzbetonbauweise beim Bau der Frankfurter S-Bahn (The Use of Shotcrete in the Construction of the Frankfurt Subway), Der Eisenbahningenieur, Vol. 24, No. 6, pp. 177-181, 1973.
- SCHWARZ, H., Permanentverankerung einer 30 m hohen Stützwand im Stuttgarter Tonmergel durch korrosionsgeschützte Injektionsanker, System Duplex (Permanent Anchoring of a 30 m High Secant Wall in the Stuttgart Clayey Marl by Means of the Duplex System of Corrosion Protected Injection Tiebacks), Die Bautechnik, Vol. 49, No. 9, pp. 305-312, 1972.
- SCOTT, J. D., Wilson, N. E., and Bauer, G. D., Analysis and Performance of a Braced Cut in Sand with Large Deformations, Canadian Geotechnical Journal, Vol. 9, No. 4, pp. 384-406, 1972.
- SEELING, R., Die Schlitzwandbauweise (Diaphragm Wall Construction), Baumaschine und Bautechnik, Vol. 18, No. 2, pp. 55-63, 1971.
- SEELING, R. , Rückwärtige Verankerungen für Baugrubenumschließungen (Tieback Systems for Excavation Pits), Baumaschine und Bautechnik, Vol. 20, No. 1, pp. 3-7, 1973.

- SEEWIG, K., and Schebetz, F., Horizontale Baugrundvereisung unter Bundesbahngleisen, Der Eisenbahn-Ingenieur, Vol. 20, No. 11., 1969.
- SENING, G., and Klotschke, G., Die Unterfahrung des Hauptbahnhofes beim U-Bahnbau in Köln (The Subway Tunnel Construction Below the Main Railway Station in Cologne), Strasse Brücke Tunnel., Vol. 22, No. 8, pp. 197-202, 1970.
- SHANNON, W. L., and Straier, R. J., Tied-Back Excavation Wall for Seattle First National Bank, Civil Engineering, ASCE Vol. 40, pp. 62-64, March 1970.
- SHERARD, Woodward, Gizienski, and Clevenger, Earth and Earth-Rock Dams, Wiley, 1963.
- SHUSTER, J. A., Controlled Freezing for Temporary Ground Support, Proceedings, North American Rapid Excavation and Tunneling Conference, Vol. 2, Chicago, June 5-7, 1972.
- SHUSTER, J. A., Personal Communication, 1975.
- SIGOURNEY, J. W., Tieback Installations by Schnabel Foundation Co., Conference on Design and Construction of Earth and Rock Tiebacks. George Washington University, February 3, 1971.
- SKEMPTON, A. W., The Bearing Capacity of Clays, Bldg. Research Congress, England, 1951.
- SKEMPTON, A. W., and Cattin P., A Full-Scale Alluvial Grouting Test at the Site of the Mangla Dam, Grouts and Drilling Muds in Engineering Practice, Butterworths, London, pp. 131-141, 1963.
- SLIWINSKI, Z. J., Permeability of Concrete Diaphragm Walls, Ground Engineering, Vol. 7, No. 4, p. 21, July 1974.
- SLIWINSKI, Z., and Fleming, W. G. K., Practical Considerations Affecting the Construction of Diaphragm Walls, Conference on Diaphragm Walls and Anchorages, Institution of Civil Engineers London, pp. 1-10, September 1974,
- SOOS, P. von, Anchors for Carrying Heavy Tensile Loads into the Soil, 5th ECSMFE, Madrid, Vol. 1, pp. 555-563, 1972.
- SPANGLER, M. G., Horizontal Pressures on Retaining Walls Due to Concentrated Surface Loads, Bulletin No. 140, Iowa Engineering Experiment Station, 1940.

- STAVROPOULOS, D., Ein Beitrag zur Frage der Verankerung von Stütswänden durch Injektionsanker (A Contribution to the Problem of Anchoring Support Walls with Tie-Backs), Die Bautechnik, Vol. 49, No. 8, pp. 253-260, 1972.
- ST. JOHN, H. D., Personal Communication, 1974.
- STOSS, K., Die Abteufen kleiner Gefrierschachte mit mobilen Grosslochbohranlagen, Gluckauf, Vol. 197, No. 20 (reprint), 1971.
- STROH, D. Berechnung verankerter Baugruben nach der Finite Element Methode (Design of Anchored Walls with the Finite Element Method), Mitteilungsheft 13 der Versuchsanstalt für Bodenmechanik und Grundbau der Technischen Hochschule Darmstadt, 1974.
- SVERDRUP and Parcel and Associates, Cut-and-Cover Tunneling Techniques, National Technical Information Service, Report No. FHWA -RD-73-40, Springfield, Virginia, 1973.
- SWATEK, E.P., Asrow, S.P., and Seitz, A.M., Performance of Bracing for Deep Chicago Excavation, ASCE Specialty Conference on Performance of Earth and Earth-Supported Structures, Purdue University, Vol. 1, Part 2, pp. 1303-1322, June 1972.
- SZÉCHY, K., Some Practical Comments to the Slurry Trench Method, 5th ECSMFE, Madrid, Vol. 2, pp. 319-323, 1972.
- SZECHY, K., Über die Stabilität von Schlammchlitzten (The Stability of Slurry Trenches) *Acta Technica Academiae Scientiarum Hungaricae*, Tomus 75 (1-4), pp. 371-381, 1973.

- TAIT, R. G. , and Taylor, H. T. , Design Construction and Performance of Rigid and Flexible Bracing Systems for Deep Excavations in San Francisco Bay Mud, ASCE National Meeting on Water Resources Engineering, Los Angeles, Preprint No. 2162, 25 pages, January 21-25, 1974.
- TAMARO, G., Concrete and Slurry Walls Using Slurry Trench Construction, Lecture Notes at 20th Annual Soil Mechanics and Foundation Engineering Conference, University of Minnesota, March 23, 1972.
- TAMARO, G., Slurry Walls, Open Cut Construction Seminar, Metropolitan Section, ASCE, New York, 1974.
- TAN, S.B., Settlements Due to Deep Foundation Construction, 8th ICSMFE, Moscow, Vol. 22, pp. 221-226, August 1973.
- TAYLOR, D. W., Fundamentals of Soil Mechanics, John Wiley and Sons, New York, 1948.
- TSCHEBOTARRIOFF, G. P., Foundations Retaining and Earth Structures 2nd Ed., McGraw Hill, 1973.
- TENG, W. C., Foundation Design, Prentiss-Hall, pp. 418-419, 1962.
- TERZAGHI, K., Stability and Stiffness of Cellular Cofferdams, TRANS. ASCE, Vol. 110, pp. 1083-1202, 1945.
- TERZAGHI, K., Theoretical Soil Mechanics, John Wiley & Sons, New York, Seventh Printing, 510 pages, 1954a.
- TERZAGHI, K., Anchored Bulkheads, Transactions, ASCE, Vol. 119 Paper 2720, pp. 1243-1324, 1954b.
- TERZAGHI, K., Evaluation of Coefficient of Subgrade Reaction, Geo technique, Vol. 4, pp. 279, London 1955.
- TERZAGHI, K., and Peck, R. B., Soil Mechanics in Engineering Practice, Wiley, 1968.
- THON, J. G., and Harlan, R. C., Slurry Walls for BART Civic Center Subway Station, ASCE, JSMFD, Vol. 97, SM 9, pp. 1317-1333, 1971.

- _____ U-Bahn-Barr in **Numberg** (Subway Construction in Number g), Tiefban, Vol. 15, No. 12, pp. 1051 - 1055.
- TOMLINSON, M. J., Foundation Design and Construction, 2nd Ed., Wiley Inters **cience**, Division of Wiley, New York, **1969**.
- TOMLINSON, M. J., Lateral Support of Deep Excavations, **Proc.** of Conference Organized by the Institution of Civil **Engineers** in London, pp. 55-64, June 1970.
- TOMLINSON, M. J., Discussion of Lateral Support Systems, **Proc.** Conference Organized by Institution of Civil **Engineers** in London, pp. 72, 74, June 1970.
- TROW, **W.A.**, Temporary and Permanent Earth Anchors: Three Monitored Installations, Canadian **Geotechnical Journal**, Vol. 11, No. 2, pp. 257-268, 1974.
- TSYTOVICH, N. A., (Translated from Russian by L. Diashevskaja), Bases and Foundations on Frozen Soils, Highway Research Board Special Report No. 58, National Academy of Sciences - National Research Council Publication 804, Washington, D. **C.**, 1960.

- VIALOV, S. S. , The Strength and Creep of Frozen Soils and Calculations for Ice Soil Retaining Structures, Translation 76, U. S. Army Corps of Engineers, Cold Regions Research and Engineering Laboratory, September 1965 (original article published in 1962 in Russian),
- VEDER, C., An Investigation on the Electrical Phenomena at the Area of Contact Between Bentonite Mud and Cohesionless Material, 5th ICSMFE, Vol. 3, pp. 146-149, 1961.
- VEDER, C., Excavation of Trenches in the Presence of Bentonite Suspensions for the Construction of Impermeable Load-Bearing Diaphragms, SGDMEP, Butterworth, London, pp. 181-188, 1963.
- VEDER, C., Behavior of Concrete Poured Under Bentonite Suspensions, 7th ICSMFE, Mexico, Vol. 2, pp. 483-486, 1969.
- VEDER, C., Oral Discussion Conference on Diaphragm Walls and Anchorages, Institution of Civil Engineers, London, 1974.
- VESIC, A. S. , Ultimate Loads and Settlements of Deep Foundations in Sand, Bearing Capacity and Settlement of Foundations, Proceedings of a Symposium **held** at Duke University, pp. 53-68, April, 1965. (Published 1967).

- WAKABAYASHI, J., Water and Air Inject Instant Slurry Wall, Construction Methods and Equipment, Vol. 56, No. 7, pp. 64-65, 1974.
- WANOSCHEK, R., and Breth, H., Auswirkung von Hauslasten auf die Belastung ausgesteifter Baugrubenwände (The Effect of Building Loads on Lateral Earth Pressure in Braced Excavations), Strasse **Brücke** Tunnel, Vol. 24, No. 8, pp. 197-200, 1972.
- WARD, W.H., Performance of Braced Excavations in London Clay, ASCE Specialty Conference on Performance of Earth and Earth-Supported Structures, Purdue University, Vol. III, pp. 257-258, June 1972.
- WARE, K. R., Underpinning Methods and Related Movements, RETC Conference - San Francisco, Vol. II, 1974.
- WARE, K. R., Personal Communication, 1974.
- WARE, K.R., Mirsky, M., and Leuniz, W.E., Tieback Wall Construction Results and Controls, ASCE, JSMFD, Vol. 99, SM 12, pp. 1135-**1152, 1973.**
- WARNER, J., Strength Properties of Chemically Solidified Soils, ASCE, JSMFD, Vol. 98, SM 11, pp. 1163-1185, November 1972.
- WARNER, J., and Brown, D. R., Planning and Performing Compaction Grouting, ASCE, JGED, Vol. 100, CT 6, pp. 653-666, 1974.
- WEBSTER, L. , How to Get a Clear Excavation by Using a New Shoring Method, Engineering and Contract Record, Vol. 85, No. 2, pp. 62-65, February 1972.
- WEINHOLD, H., and Kleinlein, H., Berechnung and Ausführung einer schragen Bohrpfahlwand (Design and Construction of an Inclined Secant Wall), Der Bauingenieur, Vol. 44, No. 7, pp. 233-239, 1969.
- WEISS, F. , Schlitzwand Bauweise (Slurry Trench Construction), Schriftenreihe der Tiefbau-Berogossenschaft, No. 7, 1971.
- WEISSENBACH, A., Berechnung von mehrfach gestützten Baugrubenspundwänden and Tragerbohlwänden nach dem Traglastverfahren (Design of Multiple Supported Soldier Pile and Steel Sheet Piling Walls with the "Carrying Load Method"), Strasse **Brücke** Tunnel, Vol. 21 Nos. **1, 2, 3**, and 4, pp. 17-23, 38-42, 67-74, 130-136, **1969.**

- WEISSENBACH, A., Empfehlungen des Arbeitskreises "Baugruben" der Deutschen Gesellschaft für Erd- und Grundbau e. V. (Recommendations from the German Committee for Excavations), Die Bautechnik, Vol. 47, No. 7, p. 223, 1970.
- WEISSENBACH, A., Empfehlungen des Arbeitskreises "Baugruben" der Deutschen Gesellschaft für Erd- und Grundbau e. V. (Recommendations from the German Committee for Excavations), Die Bautechnik, Vol. 49, No. 6 and 7, pp. 192-204 and 229-239, 1972.
- WEISSENBACH, A., Lastannahmen für Bauten, Kenngrößen des Bodens (Building Loads and Soil Parameters), Die Bautechnik, Vol. 51, No. 6, pp. 201-206, 1974(a).
- WEISSENBACH, A., Empfehlungen des Arbeitskreises "Baugruben" der Deutschen Gesellschaft für Erd- und Grundbau e. V. (Recommendations of the German Committee for Excavations), Die Bautechnik, Vol. 51, No. 7, pp. 228-232, 1974 (b).
- WELZIEN, K., and Wyleciol, H., Untersuchungen zur Beurteilung der Wasserdurchlässigkeit von Schlitzwänden (Investigations to Determine the Permeability of Diaphragm Walls), Bauplanung-Bautechnik, Vol. 27, No. 4, pp. 189-190, 1973.
- WHITE, E. E., Underpinning, Foundation Engineering, ed. G. A. Leonards, McGraw-Hill, pp. 826 - 893, 1962.
- WHITE, E. E., Sheeting and Bracing Systems for Deep Excavations, World Construction, Vol. 26, No. 1, pp. 20 - 24, January 1973.
- WHITE, R. E., Caissons and Cofferdams, Article in Foundation Engineering, Leonards, McGraw-Hill, 1962.
- WHITE, R. E., Anchored Walls Adjacent to Vertical Rock Cuts, Conference on Diaphragm Walls and Anchorages, Institution of Civil Engineers, London, pp. 35-42, 1974 (a).
- WHITE, R. E., Discussion of Tieback Wall Construction - Results and Controls, Proceedings, ASCE JGED, No. 10, pp. 1167-1168, 1974(b).

- WILDFENER, F., Konsolidierung bei nicht standfestem Boden durch Injektion (Consolidation of Unstable Soil with Grouting), Der Mensch und die Technik, March 8, 1973.
- WÖHLBIER, H., Verbesserung der Gebirgsfestigkeit (Improving Soil Stability), Bergbau-Wissenschaft, Vol. 17, No. 8, pp. 276-277, 1970.
- WONG, I. H., Analysis of Braced Excavations, Sc. D. Thesis, Massachusetts Institute of Technology, 1971.
- WOODWARD, R. J. , GARDNER, W. S. , and GREER, D. M. , Drilled Pier Foundations, McGraw-Hill, 287 p. 1972.
- WOODWARD-MOORHOUSE & ASSOC., INC., Sheetpile Interlock Seepage Study for AISI, undated.
- _____ , Quieter Sheet Pile Driving, World Construction Vol. 22, No. 4, p. 28, 1974.
- WOSSER, T. D., and DARRAGH, R. D., Tiebacks for Bank of America Building Excavation Wall, Civil Engineering, Vol. 40, No. 3, pp. 65-67, 1970.
- WROTH, C. P., General Theories of Earth Pressures and Deformations, General Report, 5th ECSMFE, Madrid, Vol. II, pp. 33-52, April 1972.
- XANTHAKOS, P. P., Underground Construction in Fluid Trenches, University of Illinois at Chicago Circle, 1974.
- YOKOYAMA, H., Excavation Work of a Large Scale in a Soft Layer at the Tokyo Underground Station, Proc. of the 6th National Tunnel Symposium, Tokyo, pp. 6-1 --6-29, September 14-16, 1970.
- ZELGER, C., Messungen der Kräfte in Baugrubenaussteifungen der Münchener U-Bahn (Load Measurements on the Support Walls for the Munich Subway), Die Bautechnik, Vol. 50, No. 1, pp. 2-7, 1973.
- ZIENKIEWICZ, O. C., and Cheung, Y.K., The Finite Element Method in Structural and Continuum Methods, McGraw-Hill Publishing Company, Ltd., London, 1967.
- ZIMMERMANN, H., Kreuzungsbauwerk Nord-Süd-Fahrt/Eigelstein in Köln (Crossing Construction for North-South Highway in Cologne), Strasse Brücke Tunnel, Vol. 21, No. 5 and 6, pp. 113-120 and 151-156, 1969.