

ASHTABULA RIVER PARTNERSHIP

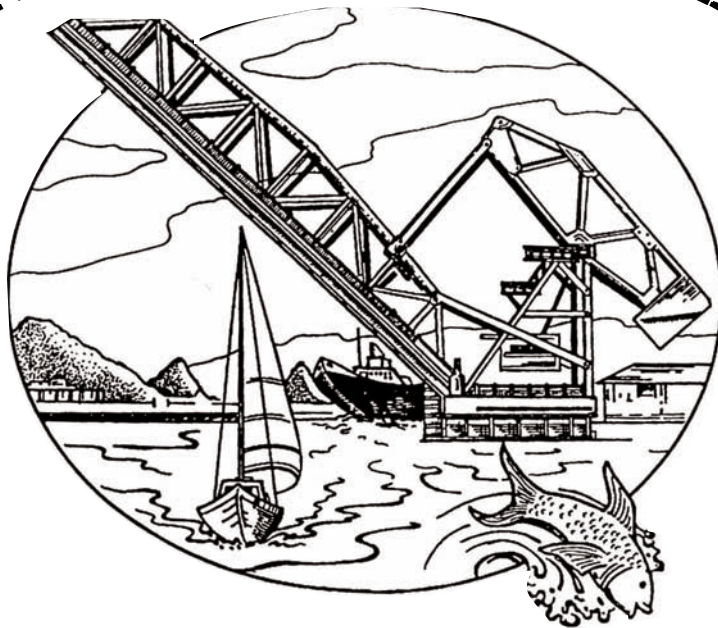

Part of the Solution
Ashtabula River & Harbor • Ashtabula, Ohio
Final

Comprehensive Management Plan

Volume 1 of 2 • Main Report
and Environmental Impact Statement
June 2001

Remedial Actions for Environmental Enhancement and General Navigation, Dredging &
Disposal of Contaminated Sediments



OhioEPA



**US Army Corps
of Engineers®**
Buffalo District



ACKNOWLEDGEMENTS

On behalf of the Ashtabula River Partnership, we gratefully acknowledge and commend the selfless and dedicated work of local citizens and community leaders and, as importantly, we commend the following agencies: the Ohio Environmental Protection Agency, the U.S. Army Corps of Engineers, the U.S. Environmental Protection Agency, and the U.S. Fish & Wildlife Service. Without the support of these agencies and the substantial assistance of their various representatives, the Ashtabula River Partnership project would not have come to pass.

N.F. Brewer
Co-Chair
Coordinating Committee

Fred C. Leitert
Co-Chair
Coordinating Committee

EXECUTIVE SUMMARY

Ashtabula River Partnership Comprehensive Management Plan

The Comprehensive Management Plan (CMP) is a feasibility-level planning document for a one-time cleanup of contaminated sediments in the lower Ashtabula River and Harbor. The CMP was developed by the Ashtabula River Partnership (ARP); an organization made up of the members of the diverse community interested in the Ashtabula River and Harbor sediment remediation and ecological restoration. The Partnership was established in 1994 with a stated purpose of exploring how to effectively remediate the contaminated sediments in the Ashtabula River and Harbor. The Partnership includes over 50 official partners, including the United States Environmental Protection Agency (USEPA), the United States Army Corps of Engineers (USACE), the Ohio Environmental Protection Agency (OEPA), the United States Fish and Wildlife Service (USFWS), as well as many other Federal, State, and local affiliates. The USACE, Buffalo District, working as a partner and at the direction of the Partnership, has taken the lead as the Project Manager in the preparation of the CMP and Environmental Impact Statement (EIS).

The lower Ashtabula River and Harbor was designated a Great Lakes Area of Concern (AOC) in 1985 by the International Joint Commission (IJC). The lower Ashtabula River is defined as the two-mile reach extending from the upper limit of the Federal navigation channel to the mouth. Beneficial use impairments include:

1. Restriction on fish and wildlife consumption.
2. Degradation of fish and wildlife populations.
3. Fish tumors and other deformities.
4. Degradation of benthos.
5. Restrictions on dredging activities.
6. Loss of fish and wildlife habitat.

Contaminants contribute to these beneficial use impairments.

Primary contaminants of concern in the lower Ashtabula River include numerous chlorinated organic compounds, in particular polychlorinated biphenyls (PCBs); polyaromatic hydrocarbons (PAH); heavy metals such as cadmium, mercury, lead, and zinc; and low level radionuclides (RAD) such as uranium, radium, and thorium. These contaminants have been detected in Ashtabula River sediments, water, and fish.

The consequences of accumulated contaminants are many, including restrictions on dredging and disposal; reduced commercial shipping; recreational boating; habitat loss; and impacts on biota, including the consumption of fish. The disposal of dredged sediments with PCBs equal to or in excess of 50 mg/kg is regulated under the Toxic Substances Control Act (TSCA) and cannot be open lake disposed. The remaining sediments, with elevated levels of contaminants also cannot be disposed of at open lake disposal sites. A total of more than 1,000,000 cubic yards of minor to heavily contaminated sediments are situated in the lower Ashtabula River. The estimated mass of PCBs in the river sediment

is appreciable, approximately 11,018 kilograms. The largest concentration of contaminated sediments has collected within the Federally authorized channels.

Contaminated sediments continue to migrate slowly downstream into the Lower River, Outer Harbor, and Lake Erie. Storm events may greatly accelerate this process causing scouring and the resuspension of sediments and associated contaminants, which may periodically compromise water quality standards. Navigation channel maintenance has been limited in the lower Ashtabula River, due to the lack of an appropriate disposal site for these contaminated sediments. Dredging and vessel activities have caused resuspension of sediments, suffocating bottom organisms and disrupting fish habitat. Storm events may greatly accelerate this process causing scouring and the resuspension of sediments and associated contaminants, which may compromise water quality standards in Lake Erie. The estimated mass of PCBs in the river sediment is appreciable, approximately 11,018 kilograms. Finally, structural developments (i.e., bulkheads and docks) have essentially eliminated shallow aquatic habitats, which provide habitat for aquatic life.

The Ohio Environmental Protection Agency (OEPA) is coordinating a Remedial Action Plan (RAP) for the Ashtabula AOC. The overall goals of a RAP are to restore all beneficial uses to an AOC, prohibit the discharge of toxic substances in toxic amounts, and virtually eliminate the discharge of persistent toxic substances. Many of the identified impairments of beneficial uses in the Ashtabula River AOC are directly related to contaminated sediment, more specifically to the PCB, RAD, and PAH mass associated with the contaminated sediment. Removal and remediation of the PCB, RAD, and PAH mass is critical to comprehensive restoration of the area's ecological integrity.

The CMP recognizes the beneficial use impairments of the Ashtabula River AOC, and addresses the goals of the ARP through:

1. environmental remediation of the lower river; and
2. Maintenance of relatively uncontaminated outer harbor navigation shipping channels by dredging and open-lake disposal.

The CMP sets forth a Recommended Environmental Dredging Plan that would address contaminated sediment removal and disposal. The Recommended Environmental Dredging Plan also includes recommendations for supplemental aquatic ecosystem restoration measures. It is expected that the project will accomplish project incremental goals/objectives and work towards remediation of the six beneficial use impairments identified in the Ashtabula River AOC, thus attaining the goals of the Partnership.

The contaminants in the Ashtabula River and Harbor sediments originate primarily from unregulated discharges in the Fields Brook watershed. Fields Brook has been placed on the USEPA National Priorities List of uncontrolled hazardous waste sites (Superfund), and is being remediated by the USEPA under the Comprehensive Environmental Response Compensation and Liability Act (CERCLA). Ashtabula River contaminated sediment removal is proposed under other legislation, including Corps of Engineers authorities, particularly Environmental Dredging (Section 312 of the Water Resources Development Act of WRDA 1990, as amended by Section 205 of WRDA 1996 and Section 224,

WRDA 1999), following a Federal Planning and National Environmental Policy Act (NEPA) based approach. The Partnership project will expedite the remediation, address the commercial navigation goals which would not be addressed under CERCLA, and avoid litigation costs often associated with CERCLA.

The Lake Erie/Ashtabula River Area of Concern has been identified as a priority area for re-mediation in Section 205 of the Water Resources Development Act (WRDA) of 1996 and in the U.S. Army Corps of Engineers PGL No. 49 section 5.c. The Ashtabula River Partnership first assessed the Ashtabula River Partnership Lower Ashtabula River Remediation Project with regard to Section 312 (b) of WRDA 1990, Environmental Dredging, as Amended by Section 205 and 206 of WRDA 1996, as promulgated by Corps of Engineers Policy Guidance Letter No. 49 and EC 1105-2-210. Also, Section 224 WRDA 1999.

Justification for dredging under the 312(b) and 206 authorities must include a habitat assessment procedure (HAP) analyses. In this case a HAP developed by the State of Ohio Environmental Protection Agency was utilized. Essentially, the HAP analyses utilizes comparative biological field survey data and developed indices to identify problems and to compare existing environments and remedial alternatives. The Ohio Habitat Assessment Procedure (HAP) and assessment/evaluation is presented and discussed in more detail in EIS APPENDIX EA- J SECTION 312(b) AND 206 ECOLOGICAL RESTORATION/ PRESERVATION ANALYSES.

The 312(b) and 206 assessment/evaluation found the project to be justified under the authority. Both ecological and economic benefits exceed associated project costs. Review per Criteria for Decision Making for Ecological Restoration/Preservation found the project to be: Total and Incrementally Cost Effective, Acceptable to the Ashtabula River Partnership, Complete, Efficient, Effective, developed and to be implemented in a Partnership Context, and Reasonable in Cost.

Subsequently, the commercial channel reach in the project area down stream of the 5th Street Bridge was examined from an operations and maintenance and 312(a) authorities perspective. The O&M and 312(a) authorities were found to be applicable to that channel area. Both ecological and economic benefits exceed associated project costs.

The “Project Area” and associated problems were assessed from an ecological perspective for this study. Problems including contaminants, lack of physical habitat, dredging, and vessel traffic were identified for different areas in the river, and goals and objectives were developed.

In addition to considering the No Action scenario, the Ashtabula River Partnership considered a wide array of alternatives during Plan Formulation including potentially capping, dredging, dewatering/transfer, treatment technologies, transportation, and disposal of TSCA and Non-TSCA dredged sediment and supplemental aquatic ecosystem restoration. Alternatives were assessed and evaluated for environmental and social acceptability, for engineering and economic feasibility, and for best meeting the project objectives.

The assessment identified the Deep Dredge scenario as the optimized and “Recommended Environmental Dredging Plan” for contaminated sediment removal. The Deep Dredge scenario removes

the amount of contaminated sediment consistent with the ARP's goals, moderates costs and adverse impacts, and meets incremental ecological restoration goals for the river. The assessment also identified measures for aquatic ecosystem restoration. These latter measures would be undertaken separately as an independent project under the Section 206 authority.

The Recommended Environmental Dredging Plan involves:

1. dredging (environmentally/low turbidity) of approximately 696,000 cubic yards of contaminated sediments, including up to 150,000 cubic yards that would be handled and disposed of in accordance with Toxic Substances Control Act (TSCA) regulations based upon available dredging technology, marine equipment and levels of PCB contamination;
2. developing and utilizing a transfer/dewatering facility on Norfolk Southern Railroad property located between Slip 5A (a.k.a. the Conrail Slip) and the Ashtabula River;
3. transport of the dewatered dredged sediment to a developed upland landfill at the State Road disposal site; and
4. Disposing of the sediment, as appropriate, in the developed upland landfill facilities at the State Road disposal site.

Dredging would be performed by a marine operation utilizing a derrick boat to excavate contaminated sediments with an environmental or enclosed clamshell bucket, or other low turbidity dredge technology. The sediments would be loaded into dredge scows/barges and transported to a transfer/dewatering site. The use of this special clamshell bucket in combination with silt curtains placed around the excavation would minimize the dispersion of resuspended sediments. Environmental protection measures were incorporated into the Recommended Environmental Dredging Plan and will be further addressed in the detailed project design, construction, operation, and maintenance plans to meet Federal, State, and local regulations.

The Recommended Environmental Dredging Plan includes a shoreline transfer/dewatering facility at the 1993 Interim Dredging and Disposal project Interim Confined Disposal Facility (CDF) site (Interim CDF) located between Slip 5A (a.k.a. the Conrail Slip) and the Ashtabula River on Norfolk Southern property. The area estimated for the transfer/dewatering facility is between 5 - 10 acres in size. All the dredged sediment would be transported by scow/barge to the transfer/dewatering facility staging area. Sediments would be allowed to settle out (initially in barges) and the water decanted to the facility. The sediments would be off-loaded, dewatered to meet the legal requirements for containment of no free liquid prior to being final landfilled, and loaded into trucks for transport to the final disposal facility. The transfer/dewatering facility would initially employ the use of passive technologies for sediment dewatering, and collection and treatment of decant and elutriate water to meet state water quality discharge requirements. The Recommended Environmental Dredging Plan subsequently includes the use of multi-media filtration and carbon column treatment methods to treat decant and elutriate water. When project remedial actions are completed, the transfer/dewatering site would be razed, contaminated sediments transported to the upland landfill disposal site for final containment and the transfer/dewatering site restored for future planned uses. The Non-TSCA sediments presently stored in

the Interim CDF would be disposed of at the Ashtabula River Partnership's Non-TSCA upland landfill disposal facility.

The Recommended Environmental Dredging Plan includes the use of the former RMI Sodium Plant site (State Road site) as the upland landfill disposal site for the project. The State Road site has been disturbed by past development and recent demolitions, is of little value to fish and wildlife, and contains a small wetland within the northeast corner of the site that would be avoided. The Fields Brook Superfund remediation project material is being disposed of at the State Road site. There is sufficient site capacity for the Ashtabula River Partnership dredged elevated PCB and RAD material to be disposed of in a new landfill facility adjacent to the Fields Brook disposal facility. There is also sufficient capacity for the dredged Non-TSCA ARP dredged contaminated material to be disposed of in a new landfill facility adjacent to the Fields Brook disposal facility. Assessment/evaluation determined that this is the overall preferred disposal alternative and accordingly is the Recommended Environmental Dredging Plan for the project disposal component. The upland landfill disposal facilities at the State Road site would also include leachate collection, treatment, and monitoring facilities, closure, and post closure monitoring measures.

An alternative plan for contaminated sediment disposal would be the use of existing disposal facilities to dispose of TSCA and/or Non-TSCA classified sediments. An existing permitted TSCA landfill facility does not currently exist, but such an alternative would be evaluated if it became available and economically justified. The ARP would like to reserve the option whereby the ARP and/or project contractor could dispose of the Non-TSCA dredged sediments in appropriate existing environmentally acceptable disposal facilities, if demonstrated to be substantially more cost-effective. Specifically, dewatered Non-TSCA dredged sediments would be transported to, and disposal of, in an existing solid waste disposal facility that could accept the material under a current or modified permit.

The recommendations set forth in the CMP for aquatic ecosystem restoration will not be addressed in the design document for the environmental dredging project. The ARP's environmental dredging project addresses contaminated sediment removal only. It is the intent of the ARP to undertake the recommended aquatic ecosystem restoration measures as an independent project under the Section 206 (or similar) authority. Presuming funds are available, it is the further intent of the ARP to complete the planning and design of the aquatic ecosystem restoration measures concurrent with the design and implementation of environmental dredging so that when dredging is complete, the aquatic habitat restoration measures would be implemented in the target areas.

Construction of the ARP project facilities and operations for implementation of environmental dredging will likely occur over a five-year time frame to include in the first two years contractor mobilization, construction of project facilities (i.e., transfer/dewatering facilities and landfill disposal facilities) and three years for dredging and disposal operations. Dredging would start at the upper turning basin and proceed downstream to just past the U.S. Coast Guard Station. Dredging would likely occur from upstream to downstream, if possible, to recapture any resuspended sediments and associated contaminants. Aquatic ecosystem restoration, as it is related to this project, will be undertaken as a separate project under the Section 206 (or similar) authority, assuming the availability of Section 206 funds and a Non-Federal sponsor, concurrent with the design and implementation of environmental dredging. Construction of this project would follow completion of the remediation of Fields Brook.

Dredging the Ashtabula River sediments may have short-term negative environmental effects on the river and, to a lesser extent, Ashtabula Harbor and Lake Erie. However, the long-term beneficial impacts far outweigh the adverse effects, most notably the environmental remediation and continuation of commercial shipping and recreational boating. Dredging the sediments from the river would remove those contaminants associated with the sediments in the Ashtabula River aquatic ecosystem. Further, dredging sediments from the river would eliminate the ability of these contaminants to be resuspended and transported downstream and into Lake Erie. Dredged sediments from operations and maintenance dredging, that is suitable for open-lake disposal, and/or shoreline excavated sediment discharged into the initially dredged Project Area, would provide an immediate clean cover and expedite ecological recovery. Future sediment deposits would be essentially clean and able to support a better variety of benthic organisms, enabling the river to achieve a higher diversity of aquatic species.

It is expected that within several years of project implementation sediment and benthos quality will be improved markedly; and, that within another few years the area fishery will be improved markedly. Species listed as sensitive can all be expected to increase in numbers after sediment removal and a consequent influx of clean sediment from upstream areas. Species presently not found in the Ashtabula but found in the Grand and Conneaut will return to the Ashtabula. The sensitive species that are absent from the Ashtabula represent all trophic levels of the fish community. The removal of contaminated sediments will prepare the Ashtabula for the entrance of species such as lake sturgeon, mooneye, muskellunge, pugnose minnow, black-chin shiner, blacknose shiner, pugnose shiner, longnose sucker, lake chubsucker, creek chub-sucker, tadpole madtom, banded killifish, burbot and sand darter into the system.

The total estimated Project Cost, with contingencies, is \$47,615,000¹. The project is estimated to be cost-shared \$32,772,000 Federal and \$14,843,000 Non-Federal, based on project outputs (commercial navigation and environmental restoration), and in accordance with the authorities addressed in the CMP. The Ashtabula City Port Authority has been identified as the project's local sponsor and will provide all the necessary items of local cooperation, including real estate requirements and the collection and distribution from local and private sources of the Non-Federal share of overall project costs. The State of Ohio has pledged \$7,000,000 toward the project. The present worth of the proposed project costs is \$51,319,900. An evaluation of the benefits of completing the ARP Project results in a favorable benefit-cost ratio of 2.66.

In conclusion, this Comprehensive Management Plan for the Ashtabula River is a tangible reflection of the progress of the Partnership toward the ultimate goal of removing contaminated sediments from the lower Ashtabula River and Harbor. This document provides the basis for the first of two public reviews of the CMP. It is our goal to continue the successful Partnership process. We expect that we will evaluate additional options, and ultimately enhance the project and reduce spending, while satisfying regulatory requirements.

¹ Included in these costs were expenditures over the 50-year life of the project for: Disposal Site Post Construction Monitoring (\$1,301,300) and Annual Maintenance Expenditures at the Disposal Site (\$1,307,900).

Summary of Derivation of Average Annual Costs-Recommended Plan-October 2000 Prices

Total Project Construction Costs and First Costs

Construction Costs	
Dredging Costs	\$11,460,200
Dewatering Costs	\$ 4,895,600
Landfill Costs-TSCA	\$ 2,834,700
Landfill Costs- Non TSCA Sampling & Analysis	\$10,319,800
During Dredging & At The Transfer Facility	\$ 816,600
At The Disposal facility- After Construction	\$ 173,100
Construction Contingencies	\$ 6,702,100

Total Construction Costs \$37,202,100

Study Costs And Engineering And Design During Construction	\$ 4,876,200
Construction Management	\$ 2,555,100
Real Estate- Section 312, O&M	\$ 372,400

First Costs¹ \$45,005,800

Investment Costs

Project First Costs To Be Average Annualized	\$45,005,800
Interest During Construction ²	\$ 5,531,600

Investment Costs To Be Average Annualized	\$50,537,400

Average Annual Costs

Interest And Amortization (.06678897) Disposal Site	\$ 3,375,400
Post Construction Monitoring ³	\$ 26,000
Annual Maintenance ⁴	\$ 26,200

Average Annual Costs ⁵	\$ 3,427,600
Present Worth Factor for 6.375%	14.97253
Present Worth Of Average Annual Costs	\$51,319,853
Rounded PW of Average Annual Costs	\$51,319,900

-
- (1) Project First Costs provided by Cost Estimating came to \$47,615,000. Included in these costs were expenditures over the 50-year life of the project for Disposal Site Post Construction Monitoring (\$1,301,300) and Annual Maintenance Expenditures at the Disposal Site (\$1,307,900). These types of costs are normally presented as average annual costs. Consequently, these expenditures were subtracted from the \$47,615,000 to arrive at a construction cost of \$45,005,800. These Post Construction Disposal Site Monitoring Costs (\$1,301,300) and Post Construction Disposal Site Maintenance Costs (\$1,307,900) were converted to average annual dollars and are reflected in Disposal Site Average Annual Costs.
 - (2) Construction Costs used to develop Interest During Construction (\$44,633,400) were computed by subtracting from Total First Costs (\$45,005,800), the projects Real Estate costs (\$372,400). IDC was based on 16 different construction cost components, a four year construction period and monthly compounding using a 6.375 percent annual interest rate.
 - (3) Disposal Site Post Construction Monitoring costs for a 50 year evaluation period were \$1,301,300. These costs were converted to an average annual dollar value. This average annual value came to \$26,000. This average annual value reflects a 6.375 percent annual interest rate, a 50 year project life and October 2000 price levels.
 - (4) Disposal Site Maintenance costs for the 50 year evaluation period were \$1,307,900. These costs were converted to an average annual dollar value. This average annual value came to \$26,200. This average annual value reflects a 6.375 percent annual interest rate, a 50 year project life and October 2000 price levels.
 - (5) Average Annual Costs reflect a 6.375 annual interest rate, a 50-year project life and October 2000 price levels.

TABLE OF CONTENTS

	<u>Page</u>
1.0 INTRODUCTION	1
1.1 <u>Ashtabula River Partnership (ARP) Project Planning Study</u>	1
1.1.1 ARP Project and Planning Study Purpose.....	1
1.1.2 ARP Project Area Scope and Demarcation.....	1
1.1.3 Ashtabula River and Harbor Setting.....	5
1.1.3.1 Ashtabula River Federal Navigation Project.....	5
1.2 <u>USACE Authorities, Involvement and Determination of Federal Interest</u>	6
1.2.1 Ashtabula Harbor Federal Navigation Project Authorization.....	6
1.2.2 Section 312(a), Section 1, and Section 101 Commercial Navigation Dredging	7
1.2.3 Section 312(b) Environmental Dredging.....	8
1.2.4 Application of Authorities to the ARP Project.....	9
1.2.5 Other Considered Authorities.....	9
1.3 <u>Planning Study Reports and Guidance</u>	10
1.3.1 Initial Appraisal Report.....	10
1.3.2 Project Specific Guidance.....	11
1.3.3 Comprehensive Management Plan and Environmental Impact Statement....	11
1.3.3.1 Economic and Cost Evaluation Methodology.....	12
1.3.3.2 Comprehensive Management Plan Variables.....	13
2.0 ASHTABULA RIVER PARTERNSHIP (ARP)	13
2.1 <u>Ashtabula River Remedial Action Plan (RAP) Advisory Council</u>	13
2.2 <u>ARP Formation and Organizational Structure</u>	14
2.3 <u>ARP Goals</u>	16
2.3.1 Environmental Remediation.....	16
2.3.2 Uncontaminated Outer Harbor.....	16
2.4 <u>Public Involvement</u>	17
2.4.1 Coordination of CMP/EIS Documents.....	18

TABLE OF CONTENTS (cont.)

	<u>Page</u>
3.0 PROBLEM IDENTIFICATION	19
3.1 <u>Study Area Profile</u>	19
3.1.1 Significant Resources.....	19
3.1.2 Overview of Physical and Natural Resources.....	19
3.1.3 Overview of Cultural and Human Resources.....	23
3.2 <u>Ashtabula River Area of Concern Beneficial Use Impairments</u>	25
3.3 <u>Sediment Conditions</u>	27
3.3.1 Effects of Contaminant Migration.....	30
3.4 <u>Ecosystem Based ARP Project Area Evaluations and Existing Conditions</u>	31
3.5 <u>Identified Problems and ARP Project Objectives</u>	38
3.5.1 Problems Associated with Contaminated Sediment.....	38
3.5.2 Comprehensive Problem Identification.....	40
3.5.3 ARP Project Objectives.....	41
4.0 PLAN FORMULATION & ALTERNATIVE PLAN EVALUATION	44
4.1 <u>Overview of the ARP Plan Formulation Process</u>	44
4.2 <u>Project Alternatives Evaluation</u>	47
4.3 <u>Preliminary Considered Alternatives</u>	48
4.3.1 No Action Alternative (Without Project Conditions).....	48
4.3.2 In-River Shear Cap Alternative.....	48
4.4 <u>Project Component Alternatives Assessment</u>	49
4.4.1 Dredging Technology Alternatives.....	49
4.4.1.1 Environmental Control Alternatives.....	50
4.4.2 Sediment Dredging Alternatives Formulation and Assessment.....	52
4.4.2.1 Extent of Sediment Contamination.....	52
4.4.2.1.1 Radionuclides.....	55
4.4.2.2 Estimated Contaminated Sediment Removal Volumes.....	58
4.4.2.3 Dredging Alternatives Formulation and Assessment.....	62
4.4.2.4 Dredging Alternatives Risk Assessment.....	70

TABLE OF CONTENTS (cont.)

	<u>Page</u>
4.4.2.4.1 Radiological Risk Assessment.....	73
4.4.2.5 Recontamination Assessment.....	74
4.4.2.6 Dredging Alternatives Assessment: Summary and Recommendation.....	74
4.4.3 Transfer/Dewatering Alternatives.....	75
4.4.3.1 Sediment Dewatering Alternatives.....	75
4.4.3.2 Alternative Treatment Technologies.....	76
4.4.3.2.1 TSCA Sediment Treatment Alternatives.....	76
4.4.3.2.2 Decant Water Treatment Alternatives.....	77
4.4.3.3 Transfer/Dewatering Facility Siting Alternatives.....	77
4.4.4 Disposal Facility Alternatives.....	78
4.4.4.1 Disposal Facility Siting Alternatives.....	78
4.5 <u>Alternatives for Aquatic Ecosystem Restoration</u>	84
4.5.1 Aquatic Ecosystem Restoration Alternatives Assessment and Recommendation.....	84
4.5.2 Alternative Long-term Dredging Scenarios for Aquatic Ecosystem Restoration.....	94
4.6 <u>Comparative Impacts of Selected Project Component Alternatives</u>	96
4.7 <u>Recommended Environmental Dredging Plan Components</u>	96
4.7.1 Related Project Component Recommendations.....	107
5.0 THE RECOMMENDED ENVIRONMENTAL DREDGING PLAN	109
5.1 <u>Recommended Environmental Dredging Plan Description</u>	109
5.1.1 Recommended Environmental Dredging Plan Component Descriptions.....	110
5.1.1.1 Dredging Component: Deep Dredge.....	110
5.1.1.2 Transfer/Dewatering Component: Shoreline Norfolk Southern Site.....	112
5.1.1.3 Disposal Facilities Component: State Road Site.....	118
5.1.1.3.1 Alternative Disposal Site Options.....	122
5.2 <u>Related Aquatic Ecosystem Restoration Measures</u>	126

TABLE OF CONTENTS (cont.)

	<u>Page</u>
5.2.1 Environmental Assessment Area 2 (EAA 2).....	126
5.2.2 Environmental Assessment Area 3 (EAA 3).....	126
5.2.3 Alternative Long-term Dredging Scenarios.....	127
5.3 <u>Summation of Recommended Environmental Dredging Plan Cumulative Effects Assessment</u>	127
5.4 <u>Post Project Continued Harbor Operation and Maintenance Dredging and Disposal</u>	129
5.5 <u>Ashtabula Harbor Long Term Management Plan</u>	129
5.6 <u>Summary of Economic Costs; Benefits; Cost Share; and the Basis for Selection of the Recommended Environmental Dredging Plan</u>	130
5.6.1 Overview of ARP Project Economic Analysis.....	130
5.6.2 Overview of ARP Project Ecosystem Based Analysis.....	131
5.6.3 Recommended Environmental Dredging Plan Costs.....	132
5.6.4 Recommended Environmental Dredging Plan Costs by Authority.....	136
5.6.5 Benefit to Cost Ratios.....	137
5.6.6 Basis for Selection of the Recommended Environmental Dredging Plan.....	144
5.6.6.1 Upstream of the 5 th Street Bridge.....	144
5.6.6.2 Downstream of the 5 th Street Bridge.....	145
6.0 LANDFILL DESIGN SUMMARY	148
6.1 Landfill Design Considerations.....	151
7.0 CONSTRUCTION SEQUENCE AND PROJECT IMPLEMENTATION	154
7.1 <u>Dredging</u>	154
7.2 <u>Transfer/Dewatering Facility</u>	154
7.3 <u>Construction of Upland Landfill Disposal Facility</u>	155
7.4 <u>Sediment Landfill Disposal</u>	156
7.5 <u>Landfill Closure</u>	156

TABLE OF CONTENTS (cont.)

	<u>Page</u>
8.0 FINANCIAL VIABILITY OF THE NON-FEDERAL COST SHARE SPONSOR.....	156
8.1 <u>Letter of Intent</u>	157
9.0 BENEFIT EVALUATION.....	157
9.1 <u>Benefits Definition</u>	157
9.2 <u>The “Without Project” and The “With Project” Conditions Descriptions</u>	158
9.3 <u>Benefits Associated with the One-time Cleanup of Contaminated Sediments</u>	159
9.3.1 Environmental Indicators.....	159
9.3.2 Section 312(b) Ecosystem Restoration Benefits.....	160
9.3.3 Related (Section 206) Aquatic Ecosystem Restoration Measures.....	163
9.3.4 The Recommended Environmental Dredging Plan and Corresponding Section 312(b) Benefits.....	163
9.3.5 Further Information on the Section 312(b) Evaluation.....	165
9.4 <u>Project Authorities Used to Implement the Recommended Environmental Dredging Plan And Their Associates River Areas</u>	165
9.5 <u>Recommended Environmental Dredging Plan Benefits Associated with the One-Time Cleanup of Contaminated Sediments Upstream of the 5th Street Bridge</u>	166
9.6 <u>Recommended Environmental Dredging Plan Benefits Associated with the One-time Cleanup of Contaminated Sediments Downstream of the 5th Street Bridge</u>	166
9.6.1 Commercial Navigation Benefits.....	167
9.6.1.1 Description of the “Without Project” and “With Project” Conditions.....	167
9.6.1.2 Other Economic Data.....	168
9.6.1.3 “Without Project” Conditions Average Annual Total Commercial Navigation Transportation Costs.....	168
9.6.1.4 “With Project” Conditions Average Annual Total Commercial Navigation Transportation Costs.....	170

TABLE OF CONTENTS (cont.)

	<u>Page</u>
9.6.1.5 Average Annual Commercial Navigation Transportation Benefits.....	173
9.6.2 Section 312(a) Benefits.....	175
9.6.2.1 Description of Two Alternatives “Future Maintenance” Conditions.....	175
9.6.2.2 “Normal Maintenance-Contaminated Sediment Present” Operation and Maintenance Costs.....	178
9.6.2.3 “Normal Maintenance-Contaminated Sediment Removed” Operation and Maintenance Costs.....	180
9.6.2.4 Section 312(a) Benefits Summary.....	180
9.7 <u>Recommended Environmental Dredging Plan Benefits Associated with Related Aquatic Ecosystem Restoration Measures</u>	182
9.8 <u>Summary of Benefits Associated with the Ashtabula River Cleanup Plans</u>	182
9.8.1 Introduction.....	182
9.8.2 Benefit Category Evaluation Summary.....	183
9.8.3 The Present Worth Value of Benefits by Benefit Category.....	184
9.8.3.1 Commercial Navigation (Reduction in Transport Costs).....	184
9.8.3.2 Boating (Consumer Surplus).....	185
9.8.3.3 Fishing (Consumer Surplus).....	186
9.8.3.4 Passive Use Values (Consumer Surplus).....	187
9.8.3.5 Change in Property Values.....	188
9.8.3.6 Risk Reduction to Lake Erie Walleye Fishery.....	189
9.8.3.7 Local Economic Impacts.....	189
9.8.3.8 Boating (Impact of Expenditures on Output).....	190
9.8.3.9 Fishing (Impact of Expenditures on Output).....	191
10.0 LOCAL COPPERATION AND REAL ESTATE REQUIREMENTS	192
10.1 <u>Local Sponsor and Items of Local Cooperation</u>	192
10.2 <u>Local Sponsorship Agreement</u>	196
10.3 <u>Real Estate Acquisitions</u>	197

TABLE OF CONTENTS (cont.)

	<u>Page</u>
11.0 PROJECT DISCUSSION AND RATIONALE FOR FEDERAL COST-SHARE SUPPORT.....	198
11.1 <u>Project Review</u>	198
11.2 <u>Justification of Cost Share Formula</u>	199
11.2.1 Ashtabula River - Downstream of the 5 th Street Bridge.....	200
11.2.2 Ashtabula River – Upstream of the 5 th Street Bridge.....	200
11.2.3 Aquatic Ecosystem Restoration	200
11.3 <u>Cost Sharing Breakdown by Components</u>	201
12.0 CONCLUSIONS AND RECOMMENDATIONS.....	203

LIST OF FIGURES

<u>Figure</u>	<u>Title</u>	<u>Page</u>
1-1	Ashtabula Harbor	2
1-2	Ashtabula River Downstream of the 5 th Street Bridge	3
1-3	Recreational Boating Facilities on the Ashtabula River	4
<hr/>		
2-1	Ashtabula River Project Timeline	15
<hr/>		
3-1	Ashtabula River: Project Sediment Dredging Areas Map	20
3-2	Ashtabula River Channel Cross Section at Station 170+00 Showing Location and Concentration of PCBs in Sediment.	29
3-3	Ecological Assessment Areas (EAA 1-4) in Lower Ashtabula River and Harbor.	33
3-4	Bar Graph of Day and Night IBI Values for the Ashtabula River and Conneaut Creek Study	35
3-5	Bar Graph of Day and Night Mimb Values for the Ashtabula River and Conneaut Creek Study	36
<hr/>		
4-1	Dredge Types	51
4-2	Sediment Sampling Locations	53
4-3	Ashtabula River PCB sample Locations	54
4-4	Map of 1999 Radiological Sampling Locations	56
4-5	Plan View of 50 ppm PCB Plum Generated from IDW Interpolation with Quadratic Nodal Functions	59
4-6	Side View of 50 ppm PCB Plum Generated from IDW Interpolation with Quadratic Nodal Functions	60
4-7	Oblique View of 50 ppm PCB Plum Generated from IDW Interpolation with Quadratic Nodal Functions	61
4-8	Ashtabula River: 1990 and 1992 PAH Samples	63
4-9	Ashtabula River: Project Sediment Dredging Areas Map	64
4-10	Considered Alternative Transfer/Dewatering and Disposal Sites	79
4-11	Considered Alternative Transfer/Dewatering Sites	80
4-12	Ecological Restoration Plan (EAA 2 and EAA 3)	85

LIST OF FIGURES (cont.)

<u>Figure</u>	<u>Title</u>	<u>Page</u>
4-13	EAA 3: Plan 2 Aquatic Fishery Shelf - Hung	86
4-14	EAA 2: Plan 1 Area	87
4-15	EAA 2: Plan 2 Area	87
4-16	EAA 2: Plan 3 Area	88
4-17	EAA 2: Plan 4 Area	88
4-18	EAA 3: Plan 1 Aquatic Shelf Cut (Embankment Cutback)	89
4-19	EAA 3: Plan 3 Aquatic Fishery Diversion By-Pass Cut	89
4-20	Comparison of Relative Habitat Quality of the Ashtabula River Lacustrary Areas	91
4-21	Macroinvertebrate Community Status in the Ashtabula River Lacustrary as Measured by the Invertebrate Community Index (ICI)	92
4-22	Fish Community Status of the Lower Ashtabula River Lacustrary As Measured by the Index of Biotic Integrity (IBI)	93
4-23	Alternative Long-term Dredging Measures: Reduce Depth	95
4-24	Alternative Long-term Dredging Measures: Reduce Width	95
4-25	Remaining Alternative Components Option(s) Assessment/Evaluation/Selection (Site Vicinities)	97
<hr/>		
5-1	Ashtabula River Sediment Dredging Areas	111
5-2	Dredging Transfer/Dewatering and Disposal Sites	113
5-3	Shoreline Transfer/Dewatering Site at Norfolk Southern Property	114
5-4	Typical Transfer/Dewatering Site Facilities Operational Systems Layout	115
5-4a	Typical Transfer/Dewatering Site Barge Operation	116
5-4b	Typical Transfer/Dewatering Facility Water Treatment Train Diagram	117
5-5	State Road Disposal Facility Site Location	119
5-5a	State Road Site: Ecological Communities	120
5-5b	State Road Disposal Site Conceptual Facilities Lay out	121

LIST OF FIGURES (cont.)

<u>Figure</u>	<u>Title</u>	<u>Page</u>
5-5c	Conceptual Plan View of Landfill Disposal Facility Layout for Ashtabula River Dredged Sediments	123
5-5d	Conceptual Cross-Section of TSCA Landfill Disposal Facility	124
5-5e	Conceptual Cross-Section of Non-TSCA Landfill Disposal Facility	125
<hr/>		
6-1	Ashtabula River Sediment TCLP Concentrations Compared to Regulatory Levels for Residual Waste	152

LIST OF TABLES

<u>Table</u>	<u>Title</u>	<u>Page</u>
3-1	Pollutants Identified in the Ashtabula River Area of Concern	28
3-2	Sediment Quality Clean-Up Ratings Based on Available Information	42
<hr/>		
4-1	Measured Costs Associated with Dredging for PCB Contaminant Removal (1997 preliminary comparative cost estimates)	65
4-2	Post Dredging Surface Area Weighted PCB Sediment Concentrations for Ashtabula River Dredging Alternative Scenarios	66
4-3	Comparison of Sediment Volume and PCB Mass Removal for Ashtabula River Alternative Dredging Scenarios	67
4-4	Linear Feet of Sheet Piling Affected in the Each Alternative Dredging Scenario	68
4-5	Alternative Dredging Scenarios for Contaminant Removal and Ecological Restoration and Preservation	71
4-6	Alternative Transfer/Dewatering Sites Assessment and Evaluation Matrix	81
4-7	Alternative Disposal Sites Assessment and Evaluation Matrix	83
4-8	Comparative Assessment of Potential Alternative Ecological Restoration and Preservation Measures (EAA 2 and EAA3) for the Ashtabula River	90
4-9	Remaining Alternative Component Option(s) Assessment/Evaluation (General Description)	98
4-10	Remaining Alternative Component Option(s) Assessment/Evaluation (Comparative Costs)	99
4-11	Remaining Alternative Component Option(s) Assessment/Evaluation (Env. Assessment Matrix)	100
4-12	Remaining Alternative Component Option(s) Assessment/Evaluation (Selection Matrices)	104
4-13	Comparative Impacts of Final Considered Alternatives	105

LIST OF TABLES (cont.)

<u>Table</u>	<u>Title</u>	<u>Page</u>
4-14	Summary Table of Environmental Protection Statutes and Other Environmental Requirements	108
<hr/>		
5-1	Derivation of Average Annual Costs associated with the Recommended Environmental Dredging Plan (October 2000 Prices).	135
5-2	Recommended Environmental Dredging Plan: Average Annual Project Costs by Area and by Authority.	139
5-3	Present Worth of Outputs by Plan.	140
5-4	Recommended Environmental Dredging Plan: Overall Project Viability	141
5-5	Benefit to Cost Ratio for all Work Located Down Stream of the 5 th Street Bridge	142
5-6	Benefit to Cost Ratio for all Work Located Down Stream of the 5 th Street Bridge and Within the Federal Channel	142
5-7	Benefit to Cost Ratio for 312(a) Work Located Down Stream of the 5 th Street Bridge	142
5-8	Recommended Environmental Dredging Plan: Proposed Project Conceptual Cost Shares	143
5-9	<u>Total ARP Project Average Annual Benefits: October 1997 and 2000 Price Level Comparison of 1997 “Original” Project Alternatives and 2000 “Updated” Project Alternatives.</u>	147
<hr/>		
6-1	Landfill Base and Leachate Collection Components for TSCA and Non-TSCA Cells	149
6-2	Conceptual Landfill Design Parameters Common to TSCA and Non-TSCA Cells	150
6-3	TCLP Results From Ashtabula River Sediments Compared to Residual Waste Landfill Standards	153
<hr/>		
9-1	Comparison of Considered Project Alternatives and Attainment of Ecological Benefits	162

LIST OF TABLES (cont.)

<u>Table</u>	<u>Title</u>	<u>Page</u>
9-2	Total Average Annual “Without Project” Condition for Commercial Navigation	171
9-3	Total Average Annual “With Project” Condition for Commercial Navigation	172
9-4	Total Average Annual Commercial Navigation Benefits	174
9-5	Benefits and Costs Associated with the Restoration of the Ashtabula River Below the 5 th Street Bridge	175
9-6	“Normal Maintenance – Contaminated Sediments Present” (NMCSP) Future Scenario: Sediment Volumes and Method of Sediment Disposal by Year	176
9-7	Average Annual Operation and Maintenance Costs Under “Normal Maintenance – Contaminated Sediments <u>Present</u> ” Future Scenario	179
9-8	Average Annual Operation and Maintenance Costs Under “Normal Maintenance – Contaminated Sediments <u>Removed</u> ” Future Scenario	181
9-9	Section 312(a) Benefits	182
9-10	Benefits and Costs Associated with Section 312(a)	182
<hr/>		
11-1	Breakdown of Federal and Non-Federal Cost Sharing of Project Features	202

VOLUME II: TECHNICAL APPENDICES

<u>Appendix</u>	<u>Title</u>
A	Ashtabula River Partnership Structure
B	Federal Project Authorizations and Past Studies
C	Ashtabula River Sediment Sampling and Analysis of Extent of Contamination
D	Ashtabula River Sediment Sampling and Analysis of Extent of Radionuclide Contamination
E	Dredging Scenarios and Sediment Volume Estimates
F	Environmental Risk Assessment and Management Considerations for Dredging the Ashtabula River and Harbor
G	Radiological Risk Assessments for Ashtabula River, Ashtabula, Ohio
H	Ashtabula River Recontamination Assessment
I	Dredging Alternatives and Selection
J	Sediment Dewatering Alternatives and Selection
K	Environmental Monitoring
L	Screening of Treatment Technologies and Cost Comparison of Potentially Feasible Alternatives
M	Geotechnical Engineering
N	HTRW Evaluation of Potential Landfill Sites
O	Conceptual Dewatering Facility Design
P	Landfill Design Criteria
Q	Coastal Engineering Design
R	Project Cost Estimates

VOLUME II: TECHNICAL APPENDICES (cont.)

<u>Appendix</u>	<u>Title</u>
S	Economic Evaluation
T	Real Estate Requirements
U	Cost Sharing and Non-Federal Responsibilities
V	Environmental Justice

1.0 INTRODUCTION

1.1 Ashtabula River Partnership (ARP) Project Planning Study

1.1.1 ARP Project and Planning Study Purpose

The purpose of the Ashtabula River Partnership (ARP) project is the removal of lower Ashtabula River (River) contaminated sediments, the environmentally acceptable disposal of the contaminated sediments, and the restoration and possible enhancement of lost beneficial uses due to the contaminated sediments. The ARP's feasibility-level planning study is necessary and required to support and document project planning and plan formulation; alternatives assessment/evaluation; and the justification for selection of a recommended plan for the one-time cleanup of contaminated sediments in the lower Ashtabula River.

1.1.2 ARP Project Area Scope and Demarcation

The Ashtabula River Partnership "Project Area" encompasses the lower two miles of the Ashtabula River. Specifically, the ARP defined the geographic scope of the Project Area to extend from the upstream limit of the Federal Navigation Channel (Station 207+00) downstream to Station 120+00. Figure 1-1 depicts Stations 120+00 and 207+00, the Ashtabula Harbor features, and the location of the Federally maintained navigational channel and harbor "Areas" (Areas A-G). The lower River is defined as the lower two miles of the River extending from Station 207+00 downstream to the mouth of the River at Station 100+00 (approximately 0.36 miles [1900 feet] downstream of the 5th Street Bridge).

The designation of the lower limit of the Project Area was based upon historical Corps of Engineers established dredging limits for commercial navigation and bioassay and toxicity testing of River sediments. The upstream Project Area limit was based upon PCB levels in River sediments and the requirement to maintain a channel depth sufficient for recreational navigation. It should be noted that the demarcation between commercial navigation and recreational navigation is the downstream face of the 5th Street Bridge, which is at Sta. 139+00.

For this planning study the ARP Project Area is divided into two segments delineated by the 5th Street Bridge. These areas are hereafter referred to in the CMP as follows (see Figure 1-1):

1. Downstream (or north) of the 5th Street Bridge: The portion of the Ashtabula River Project Area extending northward to Station 120+00 that has been regularly maintained as a Federal navigation channel.
2. Upstream (or south) of the 5th Street Bridge: The Ashtabula River Project Area extending from the 5th Street Bridge southward past the Upper Turning Basin to the upper limit of the authorized Federal channel.

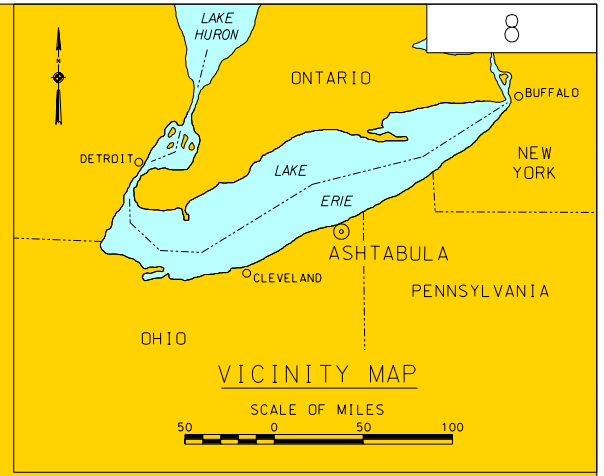
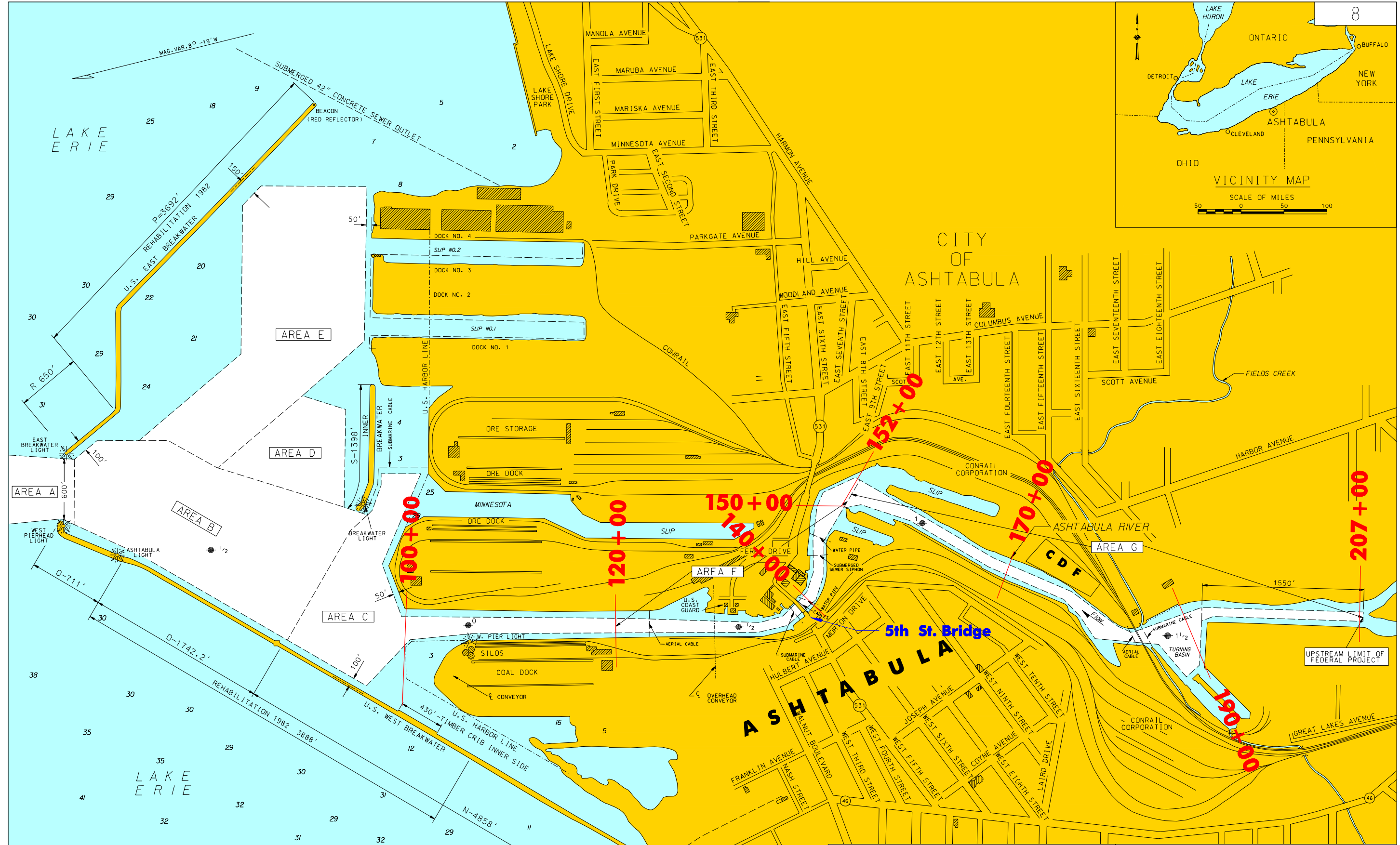

Project depths and soundings are referred to Low Water Datum, elevation 569.2 feet above Mean Water Level at Rimouski, Quebec (IGLD 1985) (International Great Lakes Datum 1985)

Aerial Cables have 120' clearance at Low Water Datum

● 1/2 Indicates miles above West Pier Light near outer end of Conrail Corp Ore Dock

4 Indicates sounding

(41) Indicates State Route

PROJECT DEPTHS

AREA	IN SOFT MATERIAL	IN HARD MATERIAL
A	29'	30'
B	28'	29'
C	27'	28'
D	22'	23'
E	28'	29'
F	18'	-
G	16'	-

Figure 1-1
ASHTABULA HARBOR

SCALE OF FEET

U.S. ARMY ENGINEER DISTRICT BUFFALO
MAY 2000

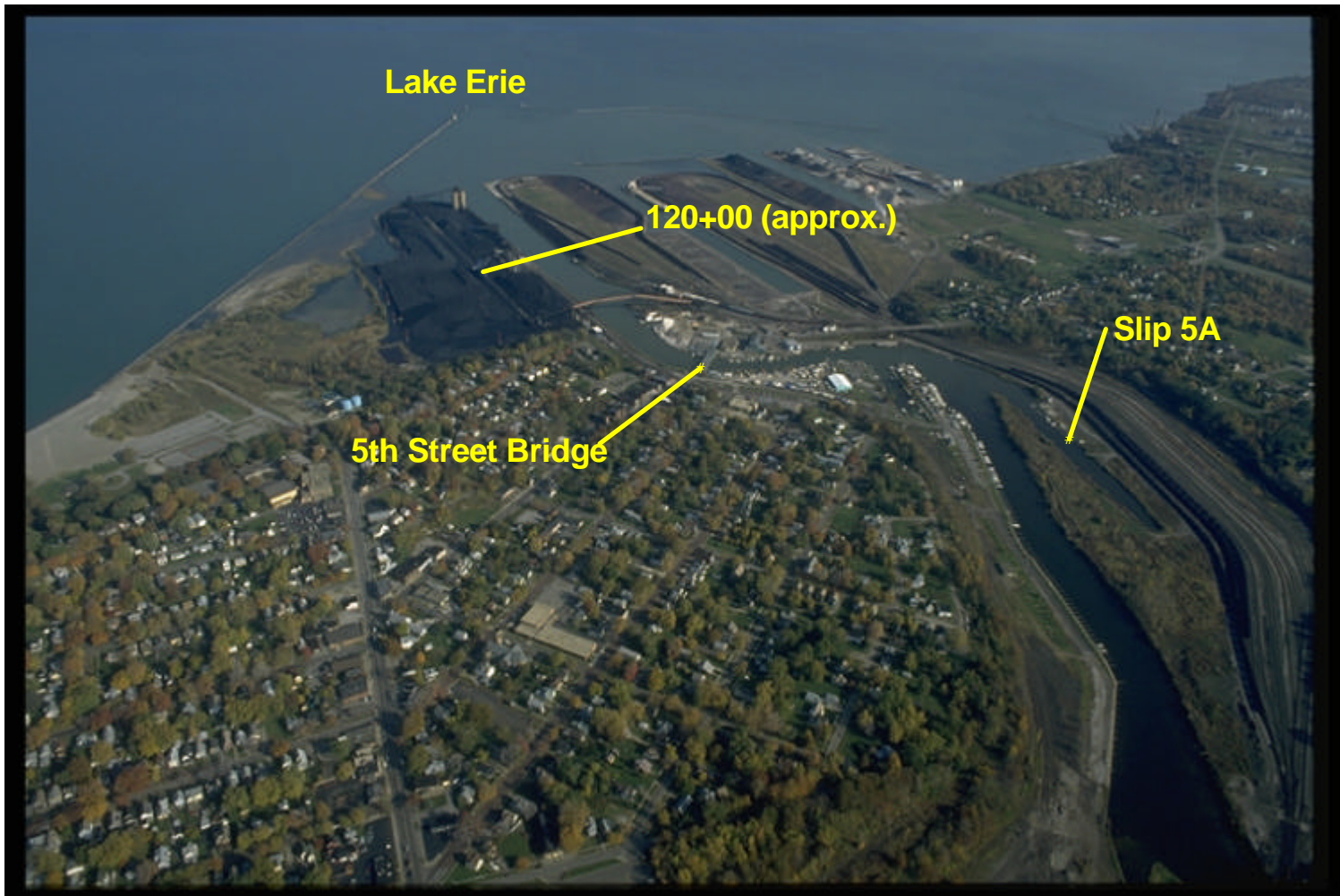

**Figure 1-2: 1992 Aerial Photograph
of the Lower Ashtabula River and Harbor**



Figure 1-3: 1992 Aerial Photograph Showing the Ashtabula River Upstream of the 5th Street Bridge.

1.1.3 Ashtabula River and Harbor Setting

The Ashtabula River lies in extreme northeast Ohio, flowing into Lake Erie's central basin at the City of Ashtabula. Its drainage basin covers an area of 137 square miles, with 8.9 square miles in western Pennsylvania. Major tributaries include Fields Brook, Hubbard Run, and Ashtabula Creek. The City of Ashtabula, with an estimated population of 21,633 (1990 Census), is the only significant urban center in the watershed, the rest of the drainage basin being predominantly rural and agricultural.

Ashtabula Harbor is located at the mouth of the Ashtabula River on the south shore of Lake Erie. It is a significant Great Lakes and St. Lawrence Seaway harbor. It is situated among the significant water and ecological resources of the Great Lakes, Lake Erie, and the Ashtabula River Watershed. Commodities such as iron ore, coal, other bulk commodities, and general cargo transit the harbor. Several marina developments docking hundreds of recreational vessels are situated along the lower river and harbor. The reach of the Ashtabula River downstream of the 5th Street Bridge (see Figure 1-2) is used primarily for deep draft commercial navigation. Upstream of the 5th Street Bridge (see Figure 1-3), bulk commodity movements are no longer a principal activity and the River in this reach is used primarily for recreational activities. Commercial activities downstream of the 5th Street Bridge include:

- A. Norfolk Southern (formerly Conrail) rail lines - on the east side of the river from the river mouth (approximately River Sta. 101+00 to Station 124+80);
- B. Norfolk Southern (Conrail) docks/marina - Station 124+80 to Station. 131+25;
- C. The U. S. Coast Guard Station - Station 131+25 to Station 132+65;
- D. The R. W. Sidley stone docks - Station 132+65 to Station 137+50; and
- E. River Marine fishing and bait shop - Station 137+50 to Station 139+00 (downstream face of the 5th Street Bridge).

Along the entire west-side of the River from the River mouth (Sta. 101+00) to Sta. 135+70 are the Norfolk Southern (Conrail) coal docks. Station 137+50 to Station 139+00 is City of Ashtabula property, which the transient dock spans from Station 137+60 to the 5th Street Bridge. Upstream of the 5th Street Bridge limited commercial activities associated with storage and repair of tugs and barges, commercial fishing and charter boats have also been observed.

1.1.3.1 Ashtabula River Federal Navigation Project

The Federal navigation project (see Figure 1-1) consists of two converging breakwaters protecting an Outer Harbor area in Lake Erie of about 0.3 square miles, and an Interior Harbor in the lower Ashtabula River. The Outer Harbor includes a system of channels with turning basins and encompasses about 185 acres. The Interior Harbor consists of a channel and a turning basin and extends upstream to approximately River Mile (RM) 1.8.

Commercial navigation dredging of the Ashtabula River is limited. Regular maintenance dredging of the Federal navigational channel occurs only from Station 100+00 upstream to Station 120+00. This is the only reach of the River where sediments are suitable for open lake disposal. Although the River from the 5th Street Bridge downstream to Station 120+00 is used for deep draft commercial navigation, this reach of the River has not been dredged since 1976 because dredged river sediments are unsuitable for open lake disposal and an environmentally safe disposal facility is currently unavailable.

1.2 USACE Authorities, Involvement and Determination of Federal Interest

Based on Buffalo District recommendations, the ARP pursued the Ashtabula River project primarily under the authority of Section 312 of the Water Resources Development Act (WRDA) 1990, Environmental Dredging, as amended by Section 205 of WRDA 1996 and Section 224 of WRDA 1999, as promulgated by Corps of Engineers Policy Guidance Letter (PGL) No. 49, and in accordance with Engineer Circular (EC) 1105-2-210. Further, the Lake Erie/Ashtabula River Area Of Concern (AOC) was identified as a priority area for remediation in Section 205 of WRDA 1996 and in the U.S. Army Corps of Engineers PGL No. 49 Section 5.c.

1.2.1 Ashtabula Harbor Federal Navigation Project Authorization

The U.S. Army Corps of Engineers is authorized by Congress (under the U.S. Rivers and Harbors Acts and Water Resources Development Acts) to operate and maintain more than 125 navigation projects around the Great Lakes. The lower two miles of the Ashtabula River is the site of a designated Federal navigation channel.

Project features that must be maintained include Federal navigation channels in rivers and harbors. To maintain Federal navigation channels at authorized depths, the USACE dredges bottom sediments that accumulate in the channels. The depths and widths to which navigation channels are maintained are prescribed in the Congressional authorizations for each project. Dredging beyond authorized Federal navigation channel limits must be done in accordance with all applicable laws and regulations.

The Ashtabula Harbor Federal navigation project, as currently maintained, is authorized by:

- a) Section 103 of the Rivers and Harbor Act of 1965 (Area E, House Document Numbered 269, Eighty-ninth Congress);
- b) Section 101 of the Rivers and Harbor Act of 1960 (Areas A, B, C, and D, House Document Numbered 148, Eighty-sixth Congress);
- c) Section 2 of the Rivers and Harbors Act of 1945 (That portion of Area G above the Turning Basin, House Document Numbered 321, Seventy-seventh Congress);
and
- d) Section 1 of the Rivers and Harbors Act of 1937 (Areas F and G, House Document Numbered 78, Seventy-fourth Congress).

The original authorization language for the River channels is as follows:

Area C (River entrance channel): “A navigation channel extending from inside the inner breakwater to Conrail’s Minnesota slip and also to a point 2,000 feet upstream from the mouth of the Ashtabula River. This area is 27 feet in soft material and 28 feet in hard material, Area C; and

Areas F and G (River channels): “A channel in the Ashtabula River upstream of the terminus of the lower 27 foot deep channel (Area C), to a depth of 18 feet to the upper car ferry slip, Area F, continuing with a channel 16 feet deep to a point 1,550 feet upstream the turning basin (Area G).”

1.2.2 Section 312(a), Section 1, and Section 101 Based Commercial Navigation Dredging

Section 312 of the WRDA 1990, as amended, entitled: “Environmental Dredging,” authorizes the Secretary of the Army to remove contaminated sediments from the navigable waters of the United States.

In the Project Area downstream of the 5th Street Bridge used for deep draft commercial navigation, Section 1 of the River and Harbors Act of 1937, Section 101 of WRDA 1986, and Section 312(a) WRDA 1990, as amended, were found to be applicable.

Section 1 of the Rivers And Harbor act of 1937 authorizes the dredging of sediment located inside the Federal channels downstream of the 5th Street Bridge at 100% Federal cost, to insure continued usage of the channels for commercial navigation purposes.

Section 101 of WRDA 1986 allows Federal cost sharing of confined disposal facilities (CDFs) required for the containment of dredged sediments removed from Federal navigation channels when the sediments are found to be unsuitable for open lake disposal. In the event that open lake disposal is allowed, 100% of the costs associated with dredging operations are Federal and there are no Non-Federal costs associated with dredging operations. Benefits associated with this dredging are essentially commercial navigation transportation cost increases avoided.

Section 312(a), WRDA 1990, as amended by Section 205, WRDA 1996 and Section 224, WRDA 1999, authorizes dredging contaminated sediments outside the limits of the authorized Federal navigation channel downstream of the 5th Street Bridge. Section 312(a) may be considered if dredging costs are economically justified based on savings in future operation and maintenance costs. A summary of benefits associated with dredging downstream of the 5th St. Bridge is presented in Section 9, “Benefit Evaluation.”

Substantiation for use of the Section 312(a) authority for dredging accumulated sediments outside and adjacent to the Federal navigation project has been made. The substantiation is based upon the documented potential for impacts to the commercial portion of the Ashtabula Harbor due to migration and mixing of the contaminated sediment (see CMP Sub-section 3.2.1 “Effects of Sediment Migration”) presently outside and adjacent to a Federal navigation project downstream of the 5th Street Bridge. Specifically, the migration, mechanical displacement, and

agitation of contaminated sediments would induce the PCBs and PAHs to move into the channel, berth, and berth approach areas. Consequently, maintenance of shallow, shoaled-in areas would require higher life-cycle maintenance.

1.2.3 Section 312(b) Based Environmental Dredging

Section 312(b) of WRDA 1990, as amended by Section 205 WRDA 1996 and Section 224 WRDA 1999, provides dredging authority for removal of contaminated sediments from navigable waterways. Section 312(b) applies to all United States navigable waterways regardless of the existence of a Federal navigational project and authorizes dredging of contaminated sediments for environmental enhancement and water quality improvement if such removal is requested by a Non-Federal sponsor and justification is demonstrated in accordance with EC 1105-2-210. Per Corps Policy Guidance Letter No. 49 and EC 1105-2-210, the Corps of Engineers may appropriately consider ecological restoration measures if the measures pertain to traditional water and associated land resources, and measures are associated with restoration of ecological structure and function (i.e., hydrology and substrate) disrupted by and/or disruption is facilitated by Corps harbor development and/or activities.

The Non-Federal sponsor must demonstrate the ability to meet the responsibilities associated with serving as the Non-Federal sponsor as delineated in Section 221 of the Rivers, Harbors, and Flood Control Act of 1970, as amended. The Non-Federal sponsor is required to contribute (cost-share) 35% of the project cost for planning engineering design and construction, which includes dredging operations and disposal facilities. The Non-Federal Sponsor must also meet real estate requirements. The Federal cost-share for Section 312(b) based projects is 65%.

An ecosystem-based analysis (“Section 312(b) *and* Section 206 Ecological Restoration/Preservation Analyses”) was undertaken by the ARP to determine the justification for the use of the 312(b) authority for removal of contaminated sediments throughout the entire ARP Project Area. This evaluation is included as Appendix EA-J to the EIS. Measurement of ecosystem restoration outputs followed procedures developed by the OEPA. Project Guidance Memorandum dated April 17, 1998, states that the OEPA methodology is appropriate and consistent with the intent of “Ecosystem Restoration in the Civil Works Program” (EC 1105-2-210) to measure the quality and/or quantity of the habitat-related outputs.

The “Section 312(b) *and* Section 206 Ecological Restoration/Preservation Analyses” established justification for the use of the Section 312(b) authority for removal and disposal of contaminated sediments throughout the entire ARP Project Area (both upstream and downstream of the 5th Street Bridge).

In addition to the 312(b) Analysis, Corps of Engineers involvement was recommended based upon the determination that benefits exceed costs. This determination was based on the following tasks, as outlined in “Ecosystem Restoration in the Civil Works Program” (EC 1105-2-210):

- a. establish the importance and value of the ecosystem and the study objectives;
- b. estimate costs and benefits in monetary and non-monetary terms; and

- c. Evaluate alternatives via application of cost effectiveness and incremental cost analysis.

Within the Project Area both ecological and economic total and incremental benefits were determined to exceed associated project costs. In addition, substantial ecological and economic benefits could also be realized for the Outer Harbor, Lake Erie, and the immediate Great Lakes areas (primarily from prevention of outflow of contaminants).

Although the “Section 312(b) *and* Section 206 Ecological Restoration/Preservation Analyses” established justification for the entire ARP Project Area (both upstream and downstream of the 5th Street Bridge), the “Section 312(b) *and* Section 206 Ecological Restoration/Preservation Analyses” also found that:

1. from the 5th Street Bridge upstream through the Upper Harbor area dredging would facilitate substantial ecological and more moderate economic benefits; and
2. From the 5th Street Bridge downstream to the mouth of the River dredging would facilitate substantial economic and more moderate ecological benefits.

1.2.4 Application of Authorities to the ARP Project

Based upon the findings of the 312(b) Analysis, rather than proceeding with the project entirely under the 312(b) authority, the ARP investigated whether a number of different authorities could be used to accomplish various components of the cleanup in the two Project Area Segments. Subsequently, the ARP recommended the following comprehensive application of authorities to the ARP Project Area Segments.

1. the Section 312(b) authority would be used to remove and dispose of all polluted sediments in Project Area upstream of the 5th Street Bridge; and
2. The Section 1, Section 101, and Section 312(a) authorities would be used to remove and dispose of all polluted sediments in the Project Area downstream of the 5th Street Bridge.

The application of the study authorities was based upon the Ashtabula River’s predominant usage and current existing environmental ecosystems. Further information can be found in Appendix B, “Federal Project Authorizations and Past Studies”.

1.2.5 Other Considered Authorities

Section 206 of WRDA 1996, as amended, is a general continuing authority authorizing the Corps of Engineers to restore degraded ecosystem structure, function and dynamic processes to a less degraded, more natural condition. Engineering studies should consider innovative solutions and do not need to have the same design considerations as traditional Corps projects. Restoration of aquatic ecosystem structures and function, usually includes manipulation of surface elevations and hydrology in and along bodies of water, including wetland and riparian areas. No

relationship to a Federal project is required. A traditional cost-benefit ratio is not required but a study must be able to quantify and qualify how the project will improve the environment.

The ARP determined that the Section 206 authority would be investigated for accomplishing aquatic ecosystem restoration throughout the ARP Project Area. Accordingly, under the provisions of this authority, alternatives for aquatic ecosystem restoration were developed during Plan Formulation. These alternatives were developed to provide comprehensive plan options for future structural and functional restoration of the Ashtabula River and included in the “Section 312(b) and Section 206 Ecological Restoration/Preservation Analyses” to derive a complete tabulation of economic and environmental benefits associated with related project features and sub-features. The ARP intends undertake the planning and design of aquatic ecosystem restoration measures on the Ashtabula River as a separate project.

1.3 Planning Study Reports and Guidance

1.3.1 Initial Appraisal Report

An Initial Appraisal report, dated November 1994, was prepared in accordance with CECW-PA/CECW-OD Memorandum, dated 17 March 1992, SUBJECT: Policy Guidance Letter No. 35, Section 312 of WRDA 1990, Environmental Dredging. The Initial Appraisal report attempted to address the potential savings to future operation and maintenance costs when environmental dredging is implemented. In addition, the Initial Appraisal report briefly analyzed non-dredging alternatives but these were deleted from further consideration due to the impairments to navigation and impacts to future economic growth of area businesses.

USACE, North Central Division (CENCD) memorandum, dated 27 January 1995, and in-house discussions of the findings of the Initial Appraisal report determined that the sole use of the Section 312 Environmental Dredging authority is not an appropriate vehicle for accomplishing a comprehensive plan for remedial actions at Ashtabula. CENCD verified the Corps of Engineers' participation in the ARP project and directed the Buffalo District to prepare a comprehensive plan, using a combination of funding authorities and sources to address contaminated sediment dredging and disposal remedial actions. CENCD approved the study's cost sharing by 3rd Endorsement, dated 20 June 1995 and the project was defined as follows:

PROJECT: THE DEVELOPMENT OF A COMPREHENSIVE MANAGEMENT PLAN AND ENVIRONMENTAL IMPACT STATEMENT for the Ashtabula River Partnership goal(s)/efforts for complete sediment remediation. Presently, the area of concern is that portion of the river commencing from River Station 120+00 to the upstream limit of the Federal navigation channel, which includes the entire width of the river. This includes removal and treatment/disposal of contaminated sediments within and adjacent to the Federal navigation channel.

Accordingly, the Buffalo District, using funds made available from USEPA, OEPA, and the General Operations and Maintenance (O&M) program, took the lead in the preparation of the ARP's Comprehensive Management Plan (CMP) and Environmental Impact Statement (EIS) for the ARP project.

1.3.2 Project Specific Guidance

Subsequent to the Initial Appraisal report, two primary guidance documents from USACE Headquarters provided project specific procedures for the ARP project planning study:

- a) Project Guidance Letter (PGL) No. 49 dated 28 January 1998; and
- b) Policy Guidance Memorandum (PGM) dated 17 April 1998 (and Supplement No. 1 thereto dated 21 April 1999).

In accordance with paragraphs 4.d. and 6.e. of PGL No. 49, procedures for removal and remediation of contaminated sediments under both Sections 312(a) and 312(b) of WRDA 1990, as amended, require “a feasibility level decision document”. The Ashtabula River Partnership’s CMP/EIS have been prepared in accordance with this guidance and Engineering Regulation ER 1105-2-100 feasibility report content guidelines. Accordingly, the CMP/EIS together with the Technical Appendices constitute a feasibility-level planning decision document.

1.3.3 Comprehensive Management Plan & Environmental Impact Statement

The Comprehensive Management Plan and Environmental Impact Statement is the ARP’s feasibility-level planning document for the one-time cleanup of contaminated sediments in the lower Ashtabula River. It describes the problems pertaining to contaminated sediments and disrupted habitats that have led to this proposed cleanup effort, and the unique partnership of Federal and Non-Federal parties that collaborated during the planning study process.

The CMP documents the remediation plan and long-term harbor dredging and disposal management plan for sediments in the lower (navigable) Ashtabula River and Harbor to alleviate impairments to beneficial uses. The CMP was developed by the ARP and addresses the ARP’s goals:

- 1) environmental remediation of the lower river; and
- 2) Maintenance of an uncontaminated outer harbor shipping channel by dredging and open-lake disposal.

In 1995 the ARP appointed the Buffalo District Project Manager and preparer of the planning study reports. Accordingly, the Buffalo District prepared the CMP/EIS developed by the Ashtabula River Partnership, which includes the OEPA, USEPA, and the USACE as partners. The Buffalo District is only one of the ARP’s partners and was dependent upon full ARP involvement/commitment to fulfill its project management tasks.

The CMP/EIS is comprised of two volumes. Volume I includes the CMP main text document and the EIS and associated EIS technical appendices. Volume II contains the CMP Technical Appendices.

The CMP includes items such as USACE authorities and involvement; problem identification; plan formulation; the recommended plan; landfill site selection and design summary; construction and project implementation; cost/benefit evaluation; rationale for Federal participation and cost-share support; and Federal and Non-Federal roles and cost-share requirements.

The Technical Appendices consist of the technical studies and investigations undertaken or referenced during plan formulation, alternatives evaluation, and selection of the recommended plan. There are 22 Technical Appendices, containing detailed information on various components of the CMP, including river sediment sampling data, information on dredging alternatives and selection, and conceptual landfill design.

The EIS is required under National Environmental Policy Act (NEPA) laws and regulations, and its format follows USACE regulations in addressing project environmental issues and problems.

Together, the CMP/EIS and Technical Appendices document and support the process, findings and recommendations of the ARP project planning study. Including, among other data and information, the following planning activities:

1. Field investigations, such as additional sediment sampling, testing, and field surveys, to ascertain the extent of contamination in the river area to determine the volumes of TSCA and Non-TSCA materials that required removal. The use of the volumes to determine the overall size and makeup of the disposal facility.
2. The formulation of alternatives for each project component (plan formulation). Specifically, dredging, transfer/dewatering, and disposal. The assessment of formulated project component alternatives and recommendation of a final proposed project plan.
3. Economic and environmentally based analysis of project alternatives and the justification for Federal involvement in the total cleanup.
4. All economic/environmental impacts to the area.
5. Project liabilities and responsibilities associated with the overall project (i.e.; resources that should be made available for the overall study, monitoring, insurance in the case of project failure, etc.).
6. Project cost-sharing dependent upon the project implementation costs and the agency authorities/responsibilities.

1.3.3.1 Economic and Cost Evaluation Methodology

The CMP can be divided into two principal parts: Plan Formulation and the Recommended Plan. Each part has associated cost-benefit analysis. For the CMP, the Costs and Benefits associated

with the “ARP Recommended Environmental Dredging Plan” were evaluated and adjusted to reflect October 2000 price levels, a 6.375% annual Federal Discount Rate and vessel movements and commodities. Tonnages reflect existing traffic patterns/conditions based on commercial navigation traffic using the Ashtabula Harbor from 1994 to 1998.

The Plan Formulation for this project is complete, and was an iterative process that took place over a five-year period from 1994 through 2000. Plan Formulation had its own cost-benefit evaluation matrix that was comprised of a number of different price levels and interest rate bases, which were consistent within themselves. Accordingly, the costs and benefits presented in the text, tables and figures in this report reflect the information used at that chronological point in the analysis.

The cost estimate in this report was prepared using the Micro Computer-Aided Cost Estimating System (MCACES) software, which was developed by Building Systems Design Inc., of Atlanta, GA. The MCACES software system includes a project database and supporting databases including the unit price book, crews, labor rates, and equipment ownership schedule costs. All the databases work in conjunction with each other to produce a detailed cost estimate.

The cost estimate is based upon all the construction features associated with the current FY01 level of design for the Recommended Environmental Dredging Plan, which includes changes to the disposal site and water treatment technologies at the dewatering facility. The cost estimate for the Recommended Environmental Dredging Plan is in accordance with the policy, guidance and procedures described in the Department of the Army’s Engineering Regulation (ER) 1110-2-1302.

1.3.3.2 Comprehensive Management Plan Variables

Plan Formulation and project component alternatives assessment is an iterative process that was conducted by the ARP from approximately 1994 through 2000. Although developed quantities of dredged sediment are comparable for a time, they may change as the alternatives are refined and more accurate data becomes available. Accordingly, quantities such as considered dredged quantities, acreage, costs etc. discussed in the CMP may vary and reflect comparative values used for alternatives assessment and evaluation at the time as compared to those reflected for the final developed Recommended Environmental Dredging Plan. Present considered values are those reflected for and in the ARP Recommended Environmental Dredging Plan.

2.0 ASHTABULA RIVER PARTNERSHIP

2.1 Ashtabula River Remedial Action Plan (RAP) Advisory Council

After the Ashtabula River was designated an Area Of Concern (AOC) in 1985 by the International Joint Commission (see Figure 2-1), an early step was the development and implementation of a Remedial Action Plan (RAP), as required under the 1978 Great Lakes Water Quality Agreement (GLWQA). The Ashtabula River Remedial Action Plan Advisory Council was established in 1988 with volunteer members representing local, Federal, and state government agencies, industry, business, special interest groups, Ohio Sea Grant and unaffiliated

citizens. The Ohio Environmental Protection Agency (OEPA) served as the secretariat for the group and produced the Stage 1 Report (problem identification) and newsletters. However, as with RAP groups throughout the Great Lakes, it was hindered at Stage 2, which describes the selection of remedial measures.

2.2 ARP Formation and Organizational Structure

In November 1993 a coordination effort was initiated with the U.S. Environmental Protection Agency (USEPA), Ohio Environmental Protection Agency (OEPA), and the U.S. Army Corps of Engineers (USACE) for the cleanup of contaminated river sediments in the Ashtabula River in Ashtabula, Ohio. This action was taken in lieu of Superfund action. A USEPA public meeting in January 1994 on the Fields Brook Superfund site provided the Ashtabula River Advisory Remedial Action Plan (RAP) Council with an introduction to the concept of a “partnership”.

In 1994, the USEPA and the local congressional office described a possible alternative to Superfund involvement at the Ashtabula River. If a partnership of public and private interests were formed, similar to the efforts conducted for the Indiana Harbor and Canal project in East Chicago, Indiana, and if that partnership made a schedule, set milestones, and demonstrated continuous progress toward remediation of the Ashtabula River, USEPA was willing to suspend Superfund designation.

In a subsequent meeting held in Ashtabula during July 1994, government and the private sector were formally introduced to the “partnership” concept and the prospects of a charter. That same year, as an alternative to the impending designation of the Ashtabula River as an extension of the Fields Brook Superfund site, the Ashtabula River RAP Advisory Council voted to support creation of the Ashtabula River Partnership (ARP) (see Figure 2-1). The ARP was a more comprehensive, structured attempt to get the river dredged with over 50 official partners, including USEPA; USACE; OEPA; USFWS; and as many local affiliates.

On July 7, 1994, the Ashtabula River Partnership began with a ceremonial signing of its charter by the charter members. The ARP Charter designates the ARP goal, delineates the Area of Concern (AOC), the requirement to establish and volunteer resources, and an overall project schedule. The ARP Charter was signed by representatives from Federal and State Governments (USACE, USEPA, OEPA), local government (City and County of Ashtabula), and private industry.

The ARP's stated purpose is "to look beyond traditional approaches to determine a comprehensive solution for the impairment of beneficial uses posed by the contaminated sediments not suitable for open-lake disposal." More information about the ARP can be found in Appendix A.

In July, 1994, a managing committee and several standing committees were established to support the various activities of the ARP. These committees were originated to develop and accomplish various ARP objectives. Initial ARP committees included the: Coordinating Committee; Outreach Committee; Project Committee; Siting Committee; and Resources

Figure 2-1: Ashtabula River Project Timeline.

1994	
January	"Partnership" Concept Proposed for project.
July	Ashtabula River Partnership (ARP) Formed and Charter Signed.
August	Initial ARP Organizational Meeting.
November	USEPA Provides Support for Others (SFO) Funding for CMP/EIS preparation.
1995	
March	Approval of ARP By-laws.
May	OEPA/Corps of Engineers Execute Section 401 Planning Assistance Agreement.
June	ARP Project Supplemental Scoping Letters.
*	Plan Formulation Initiated: Project Component Alternatives Formulation
June	Initiated preparation of Preliminary Draft Comprehensive Management Plan (CMP), Technical Appendices & Environmental Impact Statement (EIS) and Appendices. USACE (Buffalo District) Designated Project Manager.
July	ARP Coordinator Hired.
August	Speakers Bureau Formed.
December	Three Potential CDF Sites Announced.
1996	
January	Notice of Intent to Prepare an Environmental Impact Statement.
*	ARP Project Technical Studies Undertaken.
*	Plan Formulation: Alternatives Evaluation and Assessment.
December	Ashtabula River Foundation (ARF) Formed.
1997	
*	Plan Formulation: Continued Alternatives Assessment/Selection of Preferred (Recommended) Project Component Alternatives. Disposal Facility Site Evaluation Report Completed and "Site 7" Selected.
April	First Preliminary Draft Comprehensive Management Plan (CMP) and Environmental Impact Statement (EIS) and Appendices to the Partnership.
September	Preliminary Draft Comprehensive Management Plan (CMP) and Environmental Impact Statement (EIS) and Appendices to the Partnership.
December	U.S. Army Corps of Engineers HQUSACE Review Conference.
December	ARP Decides not to Release the Draft CMP/EIS Reports Based on USACEHQ Recommendation.
1998	
January	Section 312(b) Authority Project Sub-Committee Formed and 312(b) Analysis Work Initiated.
May	Preliminary Draft 312(b) Authority Report Presented to the ARP.
May	Project Authority Conference at USACE Division HQ in Cincinnati, Ohio.
October	Revised Preliminary Draft Comprehensive Management Plan (CMP), Technical Appendices, and Environmental Impact Statement (EIS) and Appendices submitted to the Ashtabula River Partnership.
1999	
*	Revisions to Draft Comprehensive Management Plan (CMP) and Environmental Impact Statement (EIS) and Appendices.
July	Revised Draft Comprehensive Management Plan (CMP), Technical Appendices, and Environmental Impact Statement (EIS) and Appendices submitted to the Ashtabula River Partnership.
August	Draft Comprehensive Management Plan (CMP), Technical Appendices, and Environmental Impact Statement (EIS) and Appendices submitted to the Public.
October	Public Information Meeting Conducted (Positive Feedback Received).
2000	
*	Advance Preliminary Design and Value Engineering Review.
July	Plan Formulation: Assessment/Evaluation of the State Road (RMI) Sites as an Alternative Disposal Site to Sites 5 and 7.
August	At Annual Meeting, ARP Overall Membership Informed of RMI Site to be Recommended for Disposal Facility.
*	Supplemental Radionuclide Sampling and Analyses Conducted on the Ashtabula River.
*	Response to Comments on the Draft CMP/EIS Reports and Revised Reports.
2001	
February	Preliminary Final Comprehensive Management Plan (CM), Technical Appendices, and Environmental Impact Statement (EIS) and Appendices sent to the USACE, Chicago District for Independent Technical Review and to the Ashtabula River Partnership.
April	ITR Comment/Response Period Complete and Resolution Telephone Conference Held with Chicago District.
May	Second ITR Teleconference Held with Chicago District to Address Supplemental ITR Comments and Issuance of the ITR Certification.

* = Event(s) occurring throughout the year shown.

Committee. The committees had oversight over plan formulation and the organization and preparation of associated planning study reports and technical appendices. The committees devoted resources to accomplish their respective studies and plan formulation tasks. The ARP committee plan formulation efforts were augmented with available resources (funding, personnel, and equipment) from the USACE, OEPA, and the USEPA.

A local ARP office was set up, and a local coordinator hired. The nonprofit Ashtabula River Foundation, a separate organization, was created with one of its primary purposes to assist in support of the ARP. While the ARP proceeds in its intense effort to dredge the river, the Ashtabula River RAP Advisory Council continues to look at other issues in the AOC as well, such as habitat enhancement and restoration.

2.3 Ashtabula River Partnership Goals

The Ashtabula River Partnership, comprised of private citizens, government officials, and business and industry leaders, is dedicated to exploring how to effectively remediate the contaminated sediments in the Ashtabula River and Harbor. The goal is to look beyond traditional approaches to determine a comprehensive solution for remediation of the contaminated sediments not suitable for open-lake disposal. Successful remediation of contaminated sediments in the Ashtabula River and Harbor will ultimately enhance economic, environmental, and social development opportunities in the Ashtabula, Ohio region.

The Ashtabula River Partnership has defined the following goals, which have focused the project and guided the CMP development process:

1. environmental remediation of the lower river; and
2. Maintenance of an uncontaminated outer harbor shipping channel by dredging and open-lake disposal.

2.3.1 Environmental Remediation

The ARP's first goal is to address potentially unacceptable risks to human health and the environment, and to address the impairment of beneficial uses caused by contaminated sediment and habitat degradation. This includes long-term contaminant risk reduction to human health and the environment, including complete removal of the fish advisory. Also included is the restoration of ecological habitat, fish and benthic communities, and wildlife populations (e.g. fish-eating birds and mammals). More specific detail on this goal can be found in CMP Sub-section 3.5.3, "ARP Project Objectives."

2.2.2 Uncontaminated Outer Harbor

The ARP has set as its second goal a one-time cleanup of the river and the contaminated sections of the harbor, to an extent that will prevent the future contamination of the harbor so that future dredging can be open-lake disposed.

Commercial shipping traffic continues in the river downstream of the 5th Street Bridge, and in the Outer Harbor. The USACE dredges approximately 100,000 to 150,000 cubic yards of sediment from the shipping channels once every 2 years and disposes of it in the open lake. Prior to each dredging operation, USACE samples and characterizes the sediment. As a result of each recent dredging campaign, an increasingly larger area immediately downstream of the 5th Street Bridge was found to be unsuitable for open-lake disposal due to the slow downstream migration of contaminants located upstream of the 5th Street Bridge.

Typically, USACE deals with storage of contaminated sediments in other harbors by building a Confined Disposal Facility (CDF). Under current USACE authorities, a portion of the cost must be borne by a local governmental entity, commonly referred to as the Non-Federal sponsor. When one CDF is filled, another is built as necessary, and so on. In 1992, USACE prepared a Letter Report addressing the construction of a CDF in Ashtabula, but cost shares were undetermined and no local sponsor was identified. As a result, the project was deferred.

The ARP was founded, at least in part, on the concept that it is better to build a single confined disposal facility for the removal and containment of the contaminated sediment from the lower river and adjacent areas, than to fill multiple CDFs with diluted harbor sediment, with each CDF requiring long-term maintenance.

2.4 Public Involvement

This section briefly describes the ARP's public involvement program, required coordination, statement recipients, and public views and responses.

The Ashtabula River Partnership is lead by a Coordinator and various committees to develop and accomplish various goals and objectives. One such committee, the Outreach Committee is responsible for developing and implementing both internal and external outreach communications strategies and public involvement program.

Generally, committees meet monthly, while committee task groups often meet more frequently. Full partnership meetings are held quarterly and are open to the press and public. A Critical Path Method (CPM) work plan was developed for this project in accordance with Federal Planning and National Environmental Policy Act guidelines. It incorporates various milestones and decision points in conjunction with these milestones, the Outreach Committee coordinated numerous public workshops and meetings and/or news conferences to communicate project status with the public.

The Outreach Committee's work is extensive and the Public Involvement Program includes a proactive government and media relations program assuring that two-way feedback with constituents occurs. Study activities were extensively coordinated with government agencies, interest groups, and the public. Public Involvement Program activities include: scoping correspondence; surveys; educational outreach sessions; public workshops and meetings; and formal draft and final report review procedures. A speaker's bureau was formed from which the Coordinator, Committee Chairpersons, and members of the ARP make presentations about the ARP and project to various local, regional, national, and even international interest groups.

The Public Involvement Program serves to facilitate the project planning process by:

- a. outlining existing and anticipated future environmental conditions;
- b. identifying specific problems, needs, and objectives (goals);
- c. developing alternative solution plans; and
- d. Assessing alternative solution plans to identify a recommended environmental dredging plan.

2.4.1 Coordination of CMP/EIS Documents

The Comprehensive Management Plan and Environmental Impact Statement will be coordinated in accordance with Federal Planning and National Environmental Policy Act (NEPA) guidelines. The ARP project planning study has been and is being conducted to comply with the various Federal and state environmental statutes and executive orders and associated review procedures. An EIS is necessary for this project because the project is a major Federal action that will significantly affect the human environment.

The following activities were conducted to address required planning and NEPA coordination and compliance. In January of 1994, an initial scoping meeting was held locally involving key Federal and State agencies and local interests. Subsequent meetings followed. In June 1995, supplemental scoping letters were coordinated with agencies and others known to have an interest in the study. A Notice of Intent to prepare a draft Environmental Impact Statement (DEIS) was prepared for the Ashtabula River Partnership by the Buffalo District and published in the Federal Register on January 24, 1996. Notice was made in the Federal Register and in September 1999 the Draft EIS was coordinated for a 45-day review period with Federal, state, local, and public interests.

Notice will be made and the Final EIS and CMP will be coordinated for a 30-day review period. If the proposed project is approved, a Record of Decision will be signed and coordinated. Subsequent preparation of final plans and specifications, and construction would follow.

This CMP is in compliance with key Federal and State environmental statutes and regulations. Federal, State, and local laws and regulations will be complied with for handling and disposal of the various levels of contaminated dredged sediment, the most critical pertaining to those regulated per TSCA for sediments with PCBs equal to or in excess of 50 mg/kg. Relevant Federal, State and local regulations are discussed in detail in Section 6 of the EIS, and referenced in Section 6 of the EIS, and summarized in Table 4-14 in this report.

Numerous representatives, agencies, and interest groups have been and/or are being coordinated with pertaining to this study. A full list can be found in Section 6 of the EIS. The views of the local sponsors and concerned resource agencies played a major role in the assessment and selection of the proposed ARP project alternatives. The EIS lists key planning, regulatory

agencies and public interest groups including their issues expressed by these parties during this study.

3.0 PROBLEM IDENTIFICATION

3.1 Study Area Profile

The ARP Project Area is shown in Figure 3-1. The following information provides an overview of the Ashtabula River Partnership (ARP) Project Area significant resources, physical, biological, and cultural setting. Sediment conditions are specifically discussed in Section 3.3 of this report. This summary is based upon detailed data and information set forth in text, tables, and figures in Section 3.0 of the EIS (“Environmental Setting and Affected Environment”), which should be referenced accordingly.

3.1.1 Significant Resources

The significant resources identified within the Project Area during the environmental evaluation are geology; water quality; sediment quality; benthos; fisheries; wildlife; threatened & endangered species; wetlands; community and regional growth; business, industry, employment, income; public facilities and services; recreation; property value; tax revenue; noise; and aesthetics. Air quality and cultural resources were found not to be significant resources. Section 3.0 of the EIS provides greater detail for each of these parameters.

3.1.2 Overview of Physical and Biological Resources

The Ashtabula River basin, (not including Conneaut Creek and Lake Erie tributaries), drains an area of 137.14 square miles or 87,770 square acres. The Ashtabula River main-stem originates in eastern Ashtabula County and flows in a northwesterly direction, to the City of Ashtabula, where it discharges to Lake Erie. The main-stem is 39.7 river miles in length (including West Branch). The Ashtabula River main-stem falls an average gradient of 11.6 feet per mile (from an elevation of 1033 to 573 feet above mean sea level). Principal tributaries to the Ashtabula River include Ashtabula Creek, Fields Brook, and Hubbard Run. No significant surface water impoundments are located within the Ashtabula River watershed.

The Ashtabula River watershed is situated within the gently rolling dissected glacial plateau of the Erie/Ontario Lake Plain ecoregion. During the Pleistocene era varying thickness of glacial drift were deposited over Devonian shales. The majority of this watershed exists in ground moraines and end moraines. Sediments deposited by former beach ridges arranged parallel to the existing Lake Erie shoreline are composed of sand, gravel, and cobble. The preglacial valleys within the underlying bedrock shale were buried by glacial clays, sands, and gravels down to depths of 200 feet from ground surface. The watershed is primarily woodland and agricultural in the upper basin, and primarily developed and industrial in the lower basin (reference EIS Section 3.19).

Upland land use in the watershed is predominantly rural and agricultural, with the City of Ashtabula the only significant urbanized area (EIS Figures 3.1, 3.3 and 3.16). Several park

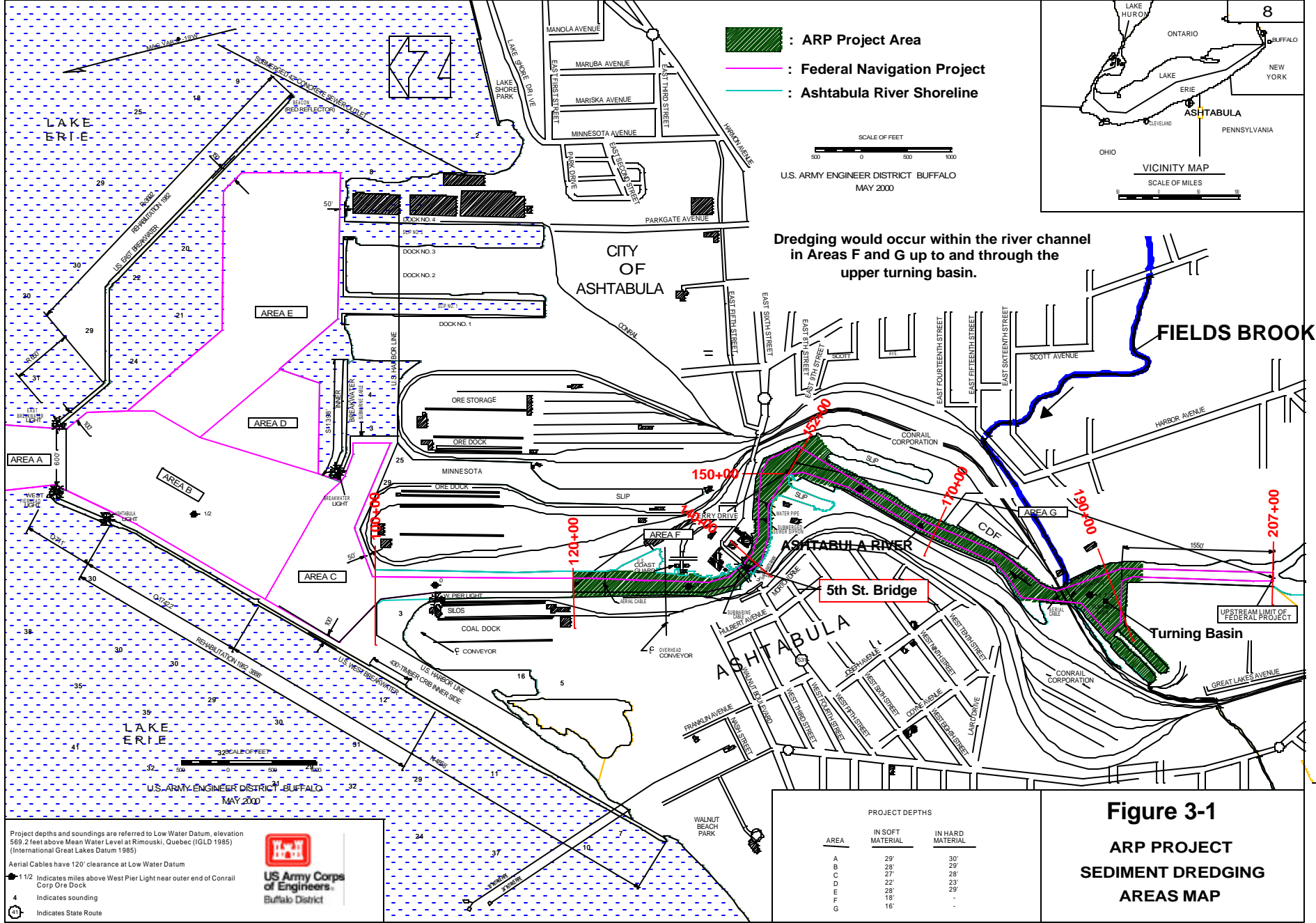

Project depths and soundings are referred to Low Water Datum, elevation 569.2 feet above Mean Water Level at Rimouski, Quebec (IGLD 1985) (International Great Lakes Datum 1985)

Aerial Cables have 120' clearance at Low Water Datum

1/12 Indicates miles above West Pier Light near outer end of Conrail Corp Ore Dock

4 Indicates sounding

43 Indicates State Route



areas are located just upstream of the harbor area. Undisturbed shorelines exist upstream from RM 2.0 where, the benefits of conservation farming practices paired with intact riparian vegetation and low density development are manifest, especially in the middle reaches.

Ashtabula Harbor is located at the mouth of the Ashtabula River on the south shore of Lake Erie Ashtabula County, Ohio (see Figures 1-1 and 3-1). It is a significant Great Lakes and St. Lawrence Seaway harbor. The existing Federal navigation project consists of a breakwater protected Outer Harbor in Lake Erie and an interior harbor in the Ashtabula River. The Outer Harbor includes a system of channels with turning basins and encompasses about 185 acres. The Interior Harbor consists of a channel and a turning basin and extends upstream to approximately RM 1.8.

The mainstem of the Ashtabula and conjoining tributaries have been designated warmwater habitat (WWH), which defines the “typical” warm-water assemblages of aquatic organisms for Ohio rivers and streams (reference EIS Figure 3.3). The current non-aquatic life use designations for the Ashtabula River system are agricultural and industrial water supply and primary contact recreation. Lake Erie is designated as being exceptional warmwater habitat, State resource water, a source of public- agricultural-industrial water supply and use for recreational bathing.

Concentrations of phosphorus and oxidized nitrogen (nitrate-nitrite), measured in 1996 water quality grab samples collected from the Ashtabula River upper watershed (RM 2.5 to 27.2) were at or near detection levels in most samples (see EIS Figure 3.4) reflecting the lack of point sources and relatively low intensity land use within the watershed. Ammonia nitrogen levels, while generally low, were elevated in several samples, especially from those collected at RM 19.1 and RM 2.5. The highest ammonia-nitrogen levels were recorded during rain event sampling (see EIS Figure 3.4) and likely represent runoff from livestock waste in the upper and middle reaches, and unsewered inputs in the lower reach (i.e., RM 2.5). Similarly, fecal coliform bacterial levels were also elevated in rain event samples. Correspondingly, chemical oxygen demand was higher in the headwater reaches compared with downstream. Other parameters indicative of organic enrichment (i.e., TKN and TDS) were not elevated suggesting the enrichment was not acute.

Concentrations of water column metals in the Ashtabula River were low and well within the WWH water quality criteria. Arsenic, lead, copper and zinc were detected at concentrations very close to their analytical detection limits. Table 3.1 in the EIS provides a summary of some past water quality standards violations measured in the Ashtabula River Area of Concern. Presently, pollutants in the water column are less prevalent and violations of water quality standards are infrequent and localized due to current discharge controls and some cover of contaminated sediments with cleaner sediments. The primary problem pertaining to contaminants and water quality is that associated with the resuspension of sediments and associated contaminants. EIS Table 3.2 presents some Ohio EPA Water Quality Standards for Lake Erie for some contaminants of concern.

Dissolved oxygen (DO) levels have been a problem in the lower river during the low flow period of June through September. Corps of Engineers’ sediment analysis over the years indicates

sediments are moderately contaminated with oxygen demanding materials. Dissolved oxygen concentrations in the lower river, however, are strongly influenced by harbor morphology; low flow; meteorological conditions; and lake-levels. Accordingly, low DO levels not related solely to chemically degraded water quality. However, low DO levels are an aquatic problem whether related to pollution or alteration of the natural river morphology (reference EIS Figure 3.4).

Vegetation on the open upland banks, roadsides and railroad yards of the Ashtabula River are non-indigenous and invasive species. The only assemblage of high quality natural forest is on the east valley wall of the Ashtabula River just south of the mouth of Fields Brook. Undeveloped sections of the valley walls and Ashtabula River flats on both sides of the River are second growth woody thickets dominated by a mixture of native and non-native trees (see EIS for plant species descriptions).

The U.S. Fish and Wildlife Service's draft "National Wetlands Inventory Map" for Ashtabula identifies the Ashtabula Harbor area protected by the stone breakwaters as littoral, limnetic permanent open water zone. The immediate shallow water margins along the existing stone breakwaters in the harbor are classified as being lacustrine, littoral rocky shore zones artificially created. (see EIS Figure 3.19). Palustrine emergent wetland referred to as the "Ashtabula River Wetland" located inside the Harbor's west breakwater approximately 1.5 miles southwest of the existing west breakwater entrance channel light.

Palustrine Sand Plain community plants exist along the shore east at the break-wall. The sand dunes are dominated by beach grass east of the Ashtabula River mouth and are the finest beach grass dunes in Ohio. The dunes support rare plants and a number of other rare plant species, per ODNR's current Natural Heritage database, thrive throughout the Ashtabula River watershed.

Much cover is provided by the growth of aquatic plants in waters shallower than twelve feet. Downed trees and boulders in the water also provide cover for fish and invertebrates. Presently the Ashtabula River Project Area downstream of Fields Brook at RM 1.3 has abundant aquatic plant growth, logs and woody debris, and boulders. Habitat quality at this site is high and provides abundant cover for diverse communities of organisms.

Upstream of the Ashtabula River Area of Concern, the River is fully attaining the WWH status (EIS Figures 3.1, 3.3 and 3.20). The positive warm water habitat attributes encountered in the lotic Ashtabula River is largely ascribed to a lack of channelization, wide mature riparian areas, and small acreage farms using conservative practices in the basin. Variable substrate conditions provided habitat complexity, especially in the upper watershed. Although the physical habitat is very good, extremely low or intermittent flows occur every summer in the Ashtabula River (USGS reference) limiting the amount of habitat available to aquatic fauna.

In the Project Area in the turning basin, including the area near the mouth of Fields Brook, the biological community does not meet WWH standards and is impacted by discharge from Fields Brook as well as habitat destruction and extensive recreational boat traffic. The lower 0.7 miles of the river have been lined with vertical sheet piling, railroad ties and concrete docks for commercial activities. This area is frequently deep dredged. In addition, there is a PAH problem in the area. These conditions have severely altered the natural habitat, resulting in an adversely

impacted biological community within the AOC. This effect appears to be localized as fish population and diversity recover in the outer harbor where habitat conditions improve and the impacts from Fields Brook discharges have dissipated. Typical fish species include: rosyface shiner, black red-horse, rainbow darter, central stoneroller, rockbass, mimic shiner, and bluntnose minnow. There is a high relative abundance of mimic shiner and bigeye chub, species

requiring clear, silt free habitats to thrive. Note: The bigeye chub, a rare species in Ohio and an indicator of exceptional water quality, flourishes throughout the upper watershed beginning at the upstream limit of the AOC at RM 2.0.

The macroinvertebrate community is in good condition in the vicinity of RM 2.5 to RM 2.3 based on sampling conducted at three sites in 1995 and 1996 (EIS Figures 3.1, 3.3 and 3.17). The good ranking was made using Ohio EPA's Invertebrate Community Index (ICI), a measure of stream ecological health that is based on macroinvertebrate species richness, composition, abundance, condition, and food web composition. The macroinvertebrate community is impacted by altered habitat and is in poor condition in the Ashtabula River between RM 1.9 (upstream of Fields Brook) and the mouth of the river.

A fish consumption advisory for the lower two miles of the river and harbor was issued in 1983 by the Department of Health and Ohio EPA citing PCB concentrations ranging from 2.4 to 58.3 mg/kg in the edible portion (skin-on fillet). There are no criteria for the other organic chemicals listed in the advisory, but the presence of so many different chemicals is a concern. In 1997, the fish consumption advisory was revised based on decreased levels of PCBs more recently measured in fish. The current fish advisory is less stringent. It places specific limits on the amounts of smallmouth bass, largemouth bass, walleye, channel catfish, and common carp that can be safely consumed.

Two hundred sixty-eight species of birds have been recorded from the Ashtabula River and Ashtabula Harbor. Breeding birds of the upper Ashtabula River are typical for northeast Ohio (see EIS Sections 3.97 through 3.104 for species descriptions). Lake Erie's south shore is an extremely important flyway for migrating small birds, raptors, and water birds. Birds also use waterways such as the Ashtabula River as migration corridors. Large numbers of water birds move along the Lake Erie shoreline and readily use Ashtabula Harbor for resting, feeding, and for shelter in storms.

The Ashtabula area supports many other species of wildlife including deer; squirrel; cottontail rabbit; opossum; skunk; raccoon; mice; a variety of reptiles and amphibians; and other small mammals. The small amount of natural shoreline remaining in the harbor area supports some reptiles, amphibians, birds, and mammals. Most are limited to the adjacent wetland and park areas. Also, a small beaver community inhabits the AOC. Critical mammalian habitat is limited to a few scattered areas left to natural growth and the Ashtabula River wetland.

The Ohio Department of Natural Resources Division of Natural Areas & Preserves currently lists ermine as an animal of special interest found in the Ashtabula River watershed and mink may be readily observed feeding in areas immediately adjacent to Ashtabula Harbor. The ARP project lies within the range of the Indiana bat, bald eagle, and piping plover, Federally listed endangered species.

3.1.3 Overview of Cultural and Human Resources

Many years ago, large conical mounds in which human skeletons were found, and evidences of burial grounds, were discovered along the banks of the Ashtabula River several miles from Lake Erie. These mounds have long since been destroyed. In 1887, a 150-foot schooner, the JOY, sank off Ashtabula, carrying millstones and ore. Currently, many large sections of this vessel are lying on the bottom in about 15 feet of water, approximately 100 feet southeast of the east end of the east breakwater at Ashtabula Harbor. National Register Properties listed on the National Register of Historic Places include the Ashtabula Harbor Light(s) (U.S. Coast Guard Lighthouses and Light Stations on the Great Lakes) located on the harbor breakwaters and the Colonel William Hubbard House on the northwest corner of Lake Avenue and Walnut Boulevard in Ashtabula. The vicinity location of the archaeological sites, the sunken vessel, and the historic properties are all shown on EIS Figure 3.27.

The Ohio State Historic Preservation Office indicated, based on a brief check of cultural resource records, that aquatic and terrestrial sites in the Ashtabula area may be archaeologically or historically sensitive and appropriate archaeological surveys should be conducted for sites finally considered. The Ashtabula River Project Area has been previously significantly disturbed by channel dredging and shoreline disturbances. Accordingly no significant cultural resource items would be expected to be located in these areas (reference Figures 3.9 and 3.28 item a).

The Ashtabula Harbor vicinity is composed of a variety of land uses, which include: industrial; commercial; residential; park; public use; and marina (reference EIS Figures 3.22 and 3.23). Commodities handled through the Port of Ashtabula include coal (exported), iron ore, sand, gravel, stone and limestone (imported). Conrail's coal dock is the only exporter of coal in the Ashtabula Port. Coal is brought to the dock via rail from West Virginia and Pennsylvania coal fields for shipping. Principal customers are electric generating utilities in Canada. The largest customer is Ontario Hydro in Toronto. Recent new business includes the European market. Lake vessels are loaded at the Port of Ashtabula and off-loaded into large ocean vessels on the St. Lawrence River for movement to Europe. Competition for coal movement comes from the port of Toledo, Sandusky and Conneaut in Ohio and from the Chicago, Illinois and Erie, Pennsylvania ports. Maintenance of harbor facilities is important in facilitating these activities. Hundreds of people are employed in these activities.

The Ashtabula Harbor vicinity includes recreational park; trail; fishing; recreational boating; and tourist areas (EIS Figures 3.20 through 3.23 depict the Ashtabula Harbor area including many water oriented recreational facilities.). Recreational boating is the most visible form of recreation in the Ashtabula Harbor area. The majority of recreational navigation facilities in Ashtabula are located along the Ashtabula River upstream of the Fifth Street bridge. Boaters presently using the Ashtabula Harbor Area marina/yacht club services come from all over northeast Ohio, including Ashtabula, Trumbull, Mahoning, Geauga, and Lake Counties, and from northern Pennsylvania as well. The Ashtabula Harbor boasts eleven marinas and yacht clubs located along the Ashtabula Riverfront. Other Harbor related activities include fish charters. Six marina/yacht clubs currently have fishing charter services operating out of their facilities.

A survey was undertaken in October 1992 to determine the existing facilities, needs, and concerns of the marina community. The most frequent comment noted is the shallowness of the Ashtabula River. Other comments include the need to clean up the Ashtabula River, the lack of transient dockage and pump-out facilities, the lack of promotion/advertisement of the Harbor area, and the need for more support from the City and County to make the Harbor area a viable recreational area.

Relative to continued Ashtabula River Harbor operation and maintenance, most interests agree that the Ashtabula Harbor should be maintained to facilitate industry/commerce and recreation and associated community economic and social well-being, and that dredged material should be appropriately disposed.

3.2 Ashtabula River Area of Concern Beneficial Use Impairments

In 1985, when the International Joint Commission (IJC) designated the Ashtabula River as one of 42 Areas of concern, they recognized 6 out of 14 potential impairments of beneficial uses (i.e., changes in chemical, physical, or biological integrity of the ecosystem) as listed under the GLWQA. A comprehensive report titled the Ashtabula River Stage 1 Investigation Report, published in December 1991, described in detail six beneficial use impairments associated with the Ashtabula River AOC:

1. *Restrictions on Fish and Wildlife Consumption.* An advisory was issued in 1983 by the Ohio Department of Health and Ohio EPA recommending that no fish caught in the lower two miles of the Ashtabula River be eaten. The advisory was based on the results of fish tissue sampling from 1978 to 1981. Forty-five organic chemicals had been detected in fish tissue. Those of greatest concern included PCBs, hexachlorobenzene, hexachlorobutadiene, pentachlorobenzene, tetrachloroethane and octachlorostyrene.

In 1997, the Ohio Department of Health revised the fish advisory to restricted consumption of some species, based upon more recent fish tissue samples. Contaminant levels decreased significantly by 1990. This decrease is primarily associated with improved source discharge control. PCB levels in fish tissue, however, appear to have increased slightly in 1994. Residual PCB contaminants in sediments provide a continuing source of PCBs, and contaminant levels remain above safe thresholds. It should be noted that the 1990 and 1997 fish tissue samplings were not large enough to be definitive, and that there remains a high incidence of external anomalies in the fish population. Until these anomalies disappear or are explained, it is unlikely that the fish advisories will be withdrawn.

2. *Degradation of Fish and Wildlife Populations.* The Ashtabula River AOC is classified as Warm water Habitat (WWH) in the Ohio Water Quality Standards. Upstream from the AOC, the river is fully attaining the WWH status. In the upper turning basin, including the area near the mouth of Fields Brook, the biological community does not meet WWH standards and is impacted by contaminated

sediments, as well as habitat destruction and extensive recreational boat traffic. The lower 0.7 mile of the river has been lined with vertical sheet piling, railroad ties, and concrete docks for commercial activities. This area is frequently deep dredged. There are elevated PAH concentrations in the sediments in this area. These conditions have severely altered the natural habitat, resulting in the poorest biological community in the AOC. The 1991 RAP report also indicated that, if not for the contaminant problem, the Ashtabula River would be a prime site for salmonid stocking considerations.

3. *Fish Tumors or Other Deformities.* Local fishermen and surveys have reported the presence of tumors and lesions on fish. A community of brown bullhead in the area inside the west break wall was found to have a high incidence of lip and skin tumors and pre-cancerous conditions. Tumors in brown bullhead are associated with PAHs as found in coal tars, and coal dust has been observed on the river bottom, originating from a coal handling facility on the west bank of the river. Some PAHs have also been found to cause non-cancer adverse health effects in humans, including difficulty in reproduction, decreased body weight, immunosuppression, and harmful effects to the skin.

PCBs build up in the environment and cause a number of harmful effects, potentially including cancer and non-cancer adverse effects. Non-carcinogenic health effects such as reproductive impairment, neurotoxicity, developmental toxicity, endocrine disruption, and immunosuppression have also been associated with exposure to PCBs. PCBs are a particular concern to aquatic food chains because of the process known as biomagnification where contaminant concentrations increase at each step in the food chain. Because of the concentrations of PCBs detected in fish, and the ability of PCBs to biomagnify up the food web, fish eating birds and mammals have the highest potential to experience any associated toxicological effects.

4. *Degradation of Benthos.* The macroinvertebrate community exhibits similar WWH attainment status as the fish community. Biological indices are high in upstream, flowing sections of the river, but decreased downstream from Fields Brook. Again, the major impacts appears to be habitat related, and affected by the heavy commercial and recreational use of the river. Chemical impact was recorded near and downstream of the confluence of Fields Brook and in the commercial channel area and outer harbor. The macroinvertebrate community in the near shore area is indicative of moderate organic enrichment, and similar to the community found throughout the southern central basin near shore. The harbor is more contaminated and there is a noticeable gradient of decreasing pollution in an offshore direction.
5. *Restrictions on Dredging Activities.* Navigation channel maintenance has been limited in the lower Ashtabula River. Deep dredge commercial navigation channels (-18 and -16 feet LWD) have not been maintained in the problem area from Station 120 to the turning basin just upstream of the 5th Street Bridge since

1976, and from the turning basin just upstream of the 5th Street Bridge to the upstream Federal channel limits since 1962 due to contaminated sediments which require confined disposal. Appropriate disposal facilities for contaminated sediments are required, but are presently unavailable. Contaminated sediments in the lower Ashtabula River continue to migrate toward the outer harbor and lake.

6. *Loss of Fish and Wildlife Habitat.* The results of several Ohio EPA surveys indicate that, in addition to contaminants, non-attainment of WWH status at the river mouth is largely due to lack of habitat (Ohio EPA 1990c). Few protected aquatic shallow areas exist. Much of the river shoreline has been developed for marinas. The lower section of the river has been completely bulkheaded for commercial docking facilities and activities and is the site of the poorest biological community. Heavy recreational boat traffic and commercial vessel traffic continually resuspend bottom sediment, covering macro invertebrates on the river bottom.

3.3 Sediment Conditions

Over the years, run-off from urban and primarily industrial developments (most of the latter are located along Fields Brook) have resulted in contamination of water and sediments in adjacent streams (i.e., Fields Brook) and the lower Ashtabula River (see Figure 3-1). Primary contaminants of concern in the lower Ashtabula River include numerous chlorinated organic compounds, especially polychlorinated biphenyls (PCBs) and polyaromatic hydrocarbons (PAH), heavy metals such as cadmium, mercury, lead, and zinc, and other organics such as hexachlorobenzene and hexachlorobutadiene. Radionuclides, such as uranium, radium and thorium, have also been identified as contaminants of concern in the lower Ashtabula River. Low levels of these radionuclides have been detected in Ashtabula River sediments as described in Technical Appendix D, "Ashtabula River Sediment Sampling and Analysis of Extent of Radionuclide Contamination". Table 3-2 gives a more complete list of pollutants identified in the Ashtabula River AOC. Figure 3-2 shows a typical cross-section of the Ashtabula River channel at Station 170+00, indicating the location of PCB-contaminated sediments. Analyses and results of sediment sampling can be found in Technical Appendix C.

Harbor structural developments and accumulated contaminants have caused significant problems pertaining to the ecology, benthic and fishery habitat and harbor operations and maintenance dredging. Structural developments (i.e., channelization and bulkheading) have essentially eliminated physical aquatic habitats including shallow areas. Dredging and vessel activities have caused resuspension of sediments, resulting in suffocation of bottom organisms and disruption of fish habitat. Most of the contaminated sediments have collected within the Federal authorized channels. Storm events cause scour and the resuspension of sediments and associated contaminants, which may potentially compromise water quality standards. Contaminated sediments continue to migrate downstream into the River below Fields Brook, the Outer Harbor, and eventually Lake Erie. Navigation channel maintenance has been limited in the lower Ashtabula River, since there are concerns about dredging and appropriate disposal of contaminated sediments.

Table 3-1: Pollutants Identified in the Ashtabula River Area of Concern.

PARAMETER	PRIORITY POLLUTANT	CARCINOGEN	PERSISTANT TOXIC*	WATER				SEDIMENT				FISH
				OUTER HARBOR	ASHTABULA RIVER	FIELDS BROOK	LAKE ERIE	OUTER HARBOR	ASHTABULA RIVER	FIELDS BROOK	LAKE ERIE	
Inorganics												
Aluminum	N	N	N	X	X	X	-	X	X	X	X	-
Arsenic	Y	Y	Y	-	-	-	X	X	X	X	X	X
Barium	N	N	N	X	X	X	X	X	X	X	X	-
Beryllium	Y	Y	-	-	-	-	-	-	X	X	X	X
Cadmium	Y	N	Y	X	X	X	X	X	X	X	X	-
Chromium	Y	N	Y	X	X	X	X	X	X	X	X	X
Copper	Y	N	Y	X	X	X	-	X	X	X	X	X
Cyanide	Y	N	N	-	X	-	-	X	X	X	X	-
Iron	N	N	Y	X	X	X	X	X	X	X	X	X
Lead	Y	N	Y	X	X	X	X	X	X	X	X	X
Manganese	N	N	N	X	X	X	-	X	X	X	X	X
Mercury	Y	N	Y	X	-	-	X	X	X	X	X	-
Nickel	Y	N	Y	X	-	-	X	X	X	X	X	-
Nitrogen (Ammonia)	N	N	N	X	X	X	X	X	-	-	X	-
Nitrate + Nitrite	N	N	N	X	X	X	X	X	-	-	X	-
Phosphorus	N	N	N	X	X	X	X	X	-	-	X	-
Oil and Grease	N	N	N	-	-	-	-	X	X	X	X	-
Silver	Y	N	-	-	-	-	-	-	X	X	X	X
Zinc	Y	N	Y	X	X	X	X	X	X	X	X	X
Total Dissolved Solids	N	N	Y	X	X	X	X	-	-	-	-	-
Phenols	Y	N	-	-	-	-	-	X	X	-	X	-
Organics												
Aldrin + Dieldrin	Y	Y	Y	X	X	-	X	-	X	-	-	-
PCBs	Y	Y	Y	-	-	-	X	X	X	X	X	X
PAHs												
Acenaphthene	Y	Y	-	-	-	-	-	X	-	-	-	-
Anthracene	Y	Y	-	-	-	-	-	X	X	-	X	-
Benzo(a)anthracene	Y	Y	-	-	-	-	-	X	X	-	X	-
Benzo(a)pyrene	Y	Y	-	-	-	-	-	X	X	-	X	-
Benzo(b)fluoranthene	Y	Y	-	-	-	-	-	X	X	-	X	-
Chrysene	Y	Y	-	-	-	-	-	X	X	-	X	-
Fluoranthene	Y	Y	-	-	-	-	-	X	X	-	X	-
Fluorene	Y	Y	-	-	-	-	-	X	X	-	X	-
Naphthalene	Y	Y	-	-	-	X	-	X	X	-	X	-
Phenanthrene	Y	Y	-	-	-	-	-	X	X	-	X	-
Pyrene	Y	Y	-	-	-	-	-	X	X	-	X	-
2-chloronaphthalene	-	-	-	-	-	-	-	-	X	-	-	-
Benzo(k)fluoranthene	Y	Y	-	-	-	-	-	-	X	-	-	-
Other Organics												
Acetone	N	N	-	-	-	-	-	-	X	X	-	-
Benzene	Y	Y	-	-	-	-	-	-	-	X	-	-
Bis(2-ethylhexyl) phthalate	Y	N	Y	-	-	-	-	X	X	X	X	-
2-butanone	N	N	-	-	-	-	-	-	-	X	-	-
Butylbenzyl phthalate	Y	N	Y	-	-	-	-	-	X	X	-	-
Chlorobenzene	Y	N	-	-	-	-	X	-	X	-	-	-
Chloroform	Y	Y	-	-	-	X	-	-	-	X	-	-
1,1-dichloroethene	Y	Y	-	-	-	-	-	-	-	X	-	-
Diethyl phthalate	Y	N	Y	-	-	X	-	-	-	X	-	-
Dimethyl phthalate	Y	N	Y	-	-	-	-	-	-	X	-	-
DI-n-butyl phthalate	Y	N	Y	-	-	-	-	-	X	X	-	-
Ethylbenzene	Y	N	-	-	-	-	-	-	X	X	-	-
Fluorotrichloromethane	N	N	-	-	-	-	-	-	-	X	-	-
Hexachlorobenzene	Y	Y	-	-	-	X	X	-	X	X	-	X
Hexachlorobutadiene	Y	Y	-	-	-	X	-	-	X	X	-	X
Hexachloroethane	Y	Y	-	-	-	-	-	-	X	X	-	X
Methylene chloride	Y	Y	-	-	X	X	-	X	X	X	X	-
1,2-Dichlorobenzene	Y	N	-	-	-	X	X	-	-	-	-	-
1,3-Dichlorobenzene	Y	N	-	-	-	X	X	-	X	-	-	-
1,4-Dichlorobenzene	Y	N	-	-	-	X	X	-	X	-	-	-
n-nitrosodiphenylamine	Y	Y	-	-	-	X	-	-	-	-	-	-
Carbon tetrachloride	Y	Y	-	-	-	X	X	-	-	-	-	-
Octachlorostyrene	N	N	-	-	-	-	-	-	X	-	-	X
Xylene	N	N	-	-	-	-	-	-	X	-	X	-
Pentachlorobenzene	N	N	-	-	-	-	X	-	-	-	-	X
1,1,1,2-tetrachloroethane	N	N	-	-	-	-	-	-	X	-	-	-
1,1,2,2-tetrachloroethane	Y	Y	-	X	X	X	-	-	-	X	-	-
Tetrachloroethene	Y	Y	-	X	X	X	-	-	X	X	-	X
1,2-transdichloroethene	N	N	-	-	-	X	-	-	-	X	-	-
1,1,2-trichloroethane	Y	Y	-	-	-	X	-	-	-	X	-	-
1,1,1-trichloroethane	Y	N	-	-	-	-	-	-	-	X	-	-
Trichloroethene	Y	N	-	X	X	X	-	-	X	X	-	X
Toluene	Y	N	-	-	-	-	-	-	X	X	-	-
Vinyl chloride	Y	Y	-	-	-	-	-	-	-	X	-	-
1,2,4-trichlorobenzene	N	N	-	-	-	-	X	-	X	-	-	-
1,2-dichloroethane	Y	Y	-	-	-	X	-	-	-	-	-	-
1,3,5-trichlorobenzene	N	Y	-	-	-	-	X	-	-	-	-	-
1,2,3,4-tetrachlorobenzene	N	Y	-	-	-	-	Y	-	-	-	-	-

* As Identified in the Great Lakes Water Quality Agreement
 Y - Yes
 N - No
 X - Pollutant detected in medium
 n.a. - Pollutant not present or not tested

This table was compiled from the results of a number of studies conducted in the area since 1975. This table documents only positive identification of pollutants.

Figure 3-2: Ashtabula River Channel Cross Section at Station 170+00 Showing Location and Concentration of PCBs in Sediment.

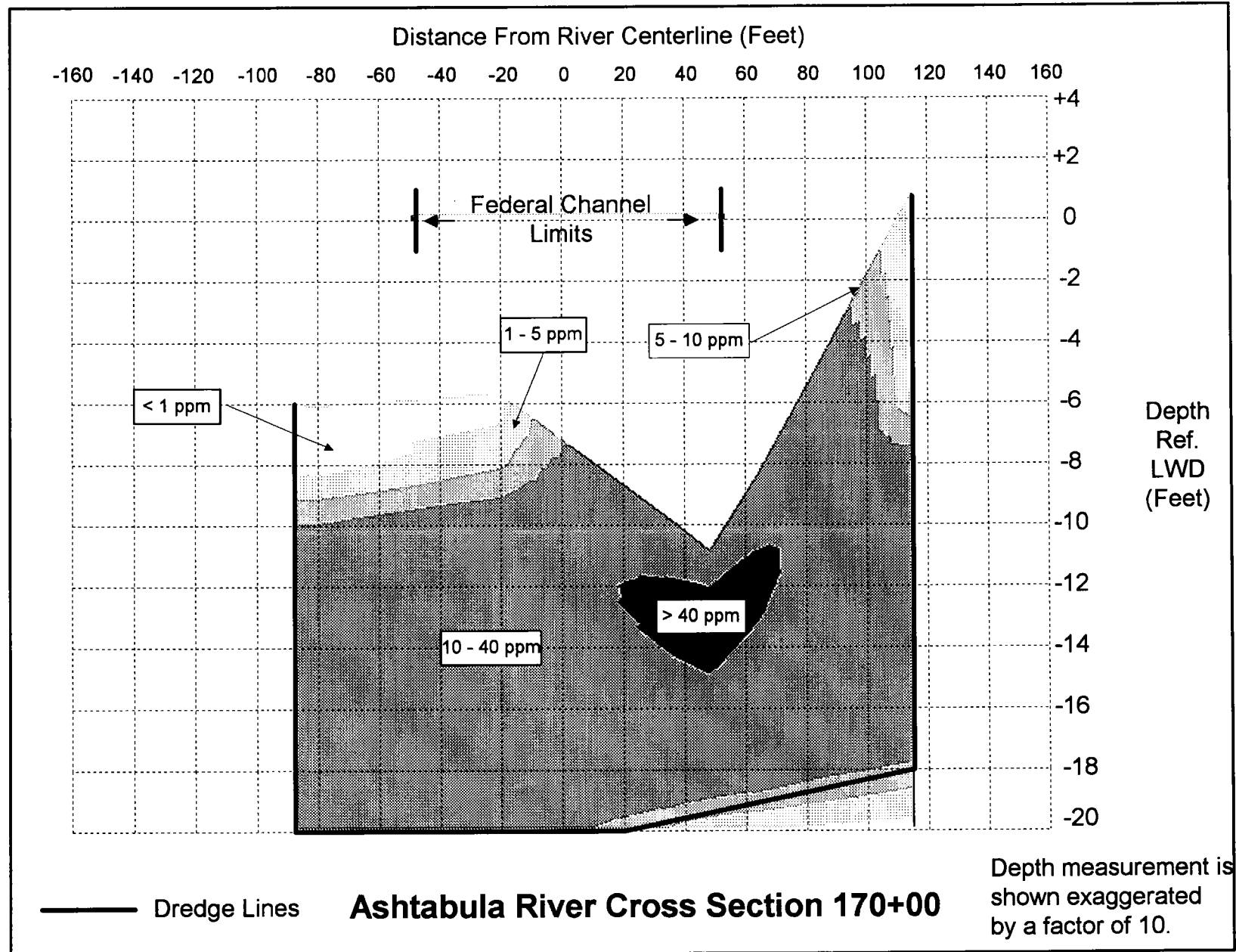

One issue that required noteworthy discussion and negotiation with regulatory agencies was how to determine the volume of TSCA contaminated sediments based on numerical model results. Sediment volumes were initially calculated for the project using the Department of Defense (DOD) program, Groundwater Modeling System (GMS). GMS provided a comprehensive graphical environment of numerical modeling, site characterization, model conceptualization, mesh and grid generation, geostatics and sophisticated tools for graphical visualization. The estimated volume of sediments with PCB contamination greater than or equal to 50 mg/kg (ppm) is approximately 29,000 cubic yards (CY). It was ultimately agreed that the threshold of 40 mg/kg (ppm) (rather than 50 mg/kg) for TSCA would be used for the modeled data due to the inherent uncertainty associated with the interpolation process in the numerical model. To determine the actual volume of sediment that would be dredged to remove TSCA-classified sediments, dredging cut lines were drawn around the contaminated areas and incorporated into the GMS. These cut lines were drawn based on the accuracy and limitations associated with marine dredging equipment. The surface area of each TSCA area, based on the dredging cut lines was then calculated and multiplied by an average depth of contamination to arrive at the actual volume of 150,000 cubic yards of sediment to be removed to dredge the TSCA-classified sediments.

Sediments with PCBs equal to or in excess of 50 mg/kg are regulated under the Toxic Substances Control Act (TSCA) and must be appropriately handled and disposed. Other sediments with elevated levels of contaminants may not be disposed of at open lake disposal sites and must be appropriately disposed of by alternate disposal methods. Appropriate disposal facilities for contaminated sediments are required, but are presently unavailable.

3.3.1 Effects of Contaminant Migration

A study was commissioned by the USEPA to determine if the contaminated river sediments have the potential to move. At the request of the USEPA, Region V office a sediment transport model was conducted by U.S. Army Corps of Engineers Waterways Experiment Station (WES), which involved numerical modeling and field data collection and analysis. The field data collection and analyses provided the parameters (i.e., sediment erodability) that were used to develop the model. The results of the numerical modeling indicated that the maximum computed depth of scour for the 100 year return period flood event with the Lake Erie stage held at the low water datum was generally less than 1 meter throughout the area of interest and less than 0.6 meters in the upper turning basin. WES determined the volume, extent, and surface area weighted estimates of PCB-laden sediment in the Ashtabula River, assuming that a 100 year event scoured to the calculated depths that resulted from the numerical modeling. The PCB concentrations for the scoured sediment ranged from 0.04 to over 50 ppm. The Department of Defense Groundwater Modeling System (GMS) was used to accomplish this task. The results indicated a total scour volume of 63,100 cubic yards of river sediment, of which 2,300 cubic yards contain PCBs > 50 ppm. Furthermore, for the short term case (immediately after dredging) the angle of repose for Ashtabula River sediments is anticipated to be between 1V:2H and 1V:3H, and for the long term case the natural angle of repose for Ashtabula River sediments is anticipated to be between 1V:6H and 1V:8H. Due to the mixing of river sediments during sediment transport, it is reasonable to anticipate that PCB-contaminated sediments exist in the cross sectional area between the short and long term cases, and it is fully anticipated that this sediment will slough

off into the Federal channel at some time in the near future and will impact on future disposal operations and options.

The transport of the PCB-contaminated sediments has been documented in the area of the Ashtabula River between Station 120+00 and the 5th Street Bridge based on sediment testing (bulk chemistry) performed to determine the suitability of dredged sediment for open lake disposal. The last recorded dredging performed on Area "F" (authorized depth of -18 ft LWD) downstream of the bridge was 1976, and further dredging and open lake disposal was prevented due to the high levels of PCBs present in the sediments. The area of commerce between the mouth of the river and bridge involves the transshipment of materials (coal and stone) that do not contain PCBs (which are not naturally occurring), therefore the contamination is due to the downstream migration of contaminated sediments. It should be noted that the sediments downstream of the 5th Street Bridge are contaminated with both PCBs and PAHs, but the PCBs are the contaminant of concern and are the driving contamination of concern for determining sediment suitability for open-lake disposal. It was the bulk chemistry testing performed in the past and the fact that the levels of PCB contamination precluded dredging due to lack of suitability of the sediment for open lake disposal that had eventually led to the discontinuance of dredging in the area from Station 120+00 to the 5th Street Bridge, since there is no existing disposal facility available for Ashtabula.

3.4 Ecosystem Based ARP Project Area Evaluations and Existing Conditions

The Ashtabula River Partnership conducted an evaluation of the aquatic ecology of the Project Area of the Ashtabula River to facilitate the formulation of project alternatives that would compliment environmental dredging and contribute to the comprehensive restoration of the Project Area ecology. The evaluation included the use of the Ohio Habitat Assessment Procedure (OHAP) and associated indices. Indicators include such items as: water quality, Qualitative Habitat Evaluation Index (QHEI), Invertebrate Community Index (ICI), the fishery Index of Biological Integrity (IBI), percent of fish with external anomalies, and the return of endangered species.

The procedure and evaluation utilized biological survey data from creeks and rivers similar to the Ashtabula River but without contaminants, bulkheading, or significant vessel traffic. Data primarily from Conneaut Creek and the Grand River were used. This comparison provides information on what Ashtabula River ecological conditions would be with implementation of various measures for removal of contaminated sediments and habitat restoration. Restoration opportunities were particularly evident in the area between the 5th Street Bridge and the upper turning basin.

The evaluation identified considerable improvements in physical, benthic, and fishery habitat with extensive contaminant removal and even more with habitat restoration. Restoration of more than 20 acres of aquatic and fishery habitat, resulting in increases of tens of quality fish species and hundreds of fish per kilometer could be expected. This was further related to human and economic values. This evaluation was incorporated into the overall planning process and is discussed further in the corresponding section of this report.

Ohio EPA has classified the Ashtabula River estuary system as a warm water habitat (WWH), which defines the “typical” warm water assemblages of aquatic organisms for Ohio rivers and streams. The river system can be divided into four “Ecological Assessment Areas” (EAA). These include: the Outer Harbor area (EAA 4), the lower river from the mouth upstream to the 5th Street Bridge (EAA 3), the lower river from the 5th Street Bridge upstream through the Upper Turning Basin (EAA 2), and the watershed area upstream of the developed harbor area (EAA 1). Figure 3-3 shows the locations of these areas.

EAA 1 is fully attaining the warm water habitat status. Riffle and channel substrates are unembedded and generally silt free. Glacial till and fractured bedrock provide a variety of substrate sizes and habitat complexity. Although the physical habitat is very good, extremely low or intermittent flows occur every summer. This limits the amount of habitat available to aquatic fauna. Typical fish species in EAA 1 include rosyface shiner, black redhorse, rainbow darter, central stoneroller, rock bass, mimic shiner, and bluntnose minnow. There is a relatively high abundance of mimic shiner and bigeye chub, species requiring clear, silt free habitats to thrive. The bigeye chub, a rare species in Ohio and an indicator of exceptional water quality, flourishes throughout the upper watershed.

The biological community in EAA 2 and 3 does not meet warm water habitat standards. EAA 2 is impacted by Fields Brook contaminated sediment and extensive recreational development and traffic. EAA 3, the lower 0.7 miles of the river, has been lined with vertical sheet piling, railroad ties and concrete docks to service commercial activities. This area is frequently deep dredged. In addition, there is a PAH problem in this area. These conditions have severely altered the natural habitat, resulting in an adversely impacted biological community. This effect appears to be localized as fish population and diversity recover in the outer harbor where habitat conditions improve and the impacts from Fields Brook discharges have dissipated.

The fish community in the Outer Harbor (EAA 4) achieves partial to full warm water habitat standards with respect to diversity and abundance. The outer harbor area supports a diverse fish community of river and lake species particularly in a vegetated area protected by the inner breakwall. Protected areas of the harbor usually contain relatively large numbers of yellow perch, white bass, pumpkinseed, white crappie, goldfish and emerald shiner. More open water areas contain lower densities of gizzard shad, yellow perch, carp, goldfish, brown bullhead and emerald shiner. The banded killfish, an Ohio endangered species, has been recorded here. Much of the near-shore provides nursery and spawning grounds for the local fish community. The breakwall and gravel bars near the CEI power plant provide spawning grounds for rainbow smelt, carp, spottail shiner, shiner species, logperch, walleye and fresh water drum. The outer harbor breakwalls and the breakwalls lakeward of Lakeshore Park provide spawning sites for alewife, gizzard shad, small mouth bass, rainbow smelt, brown bull head and Johnny darter. The deeper near-shore waters provide spawning grounds for burbot, mottled sculpin and yellow perch.

Various lake and stream species of fish migrate to and from the lower Ashtabula River when warm water conditions are favorable. Spawning migration runs for walleye and small mouth bass occur in the spring. Species composition is typical of the warm water fish community in Lake

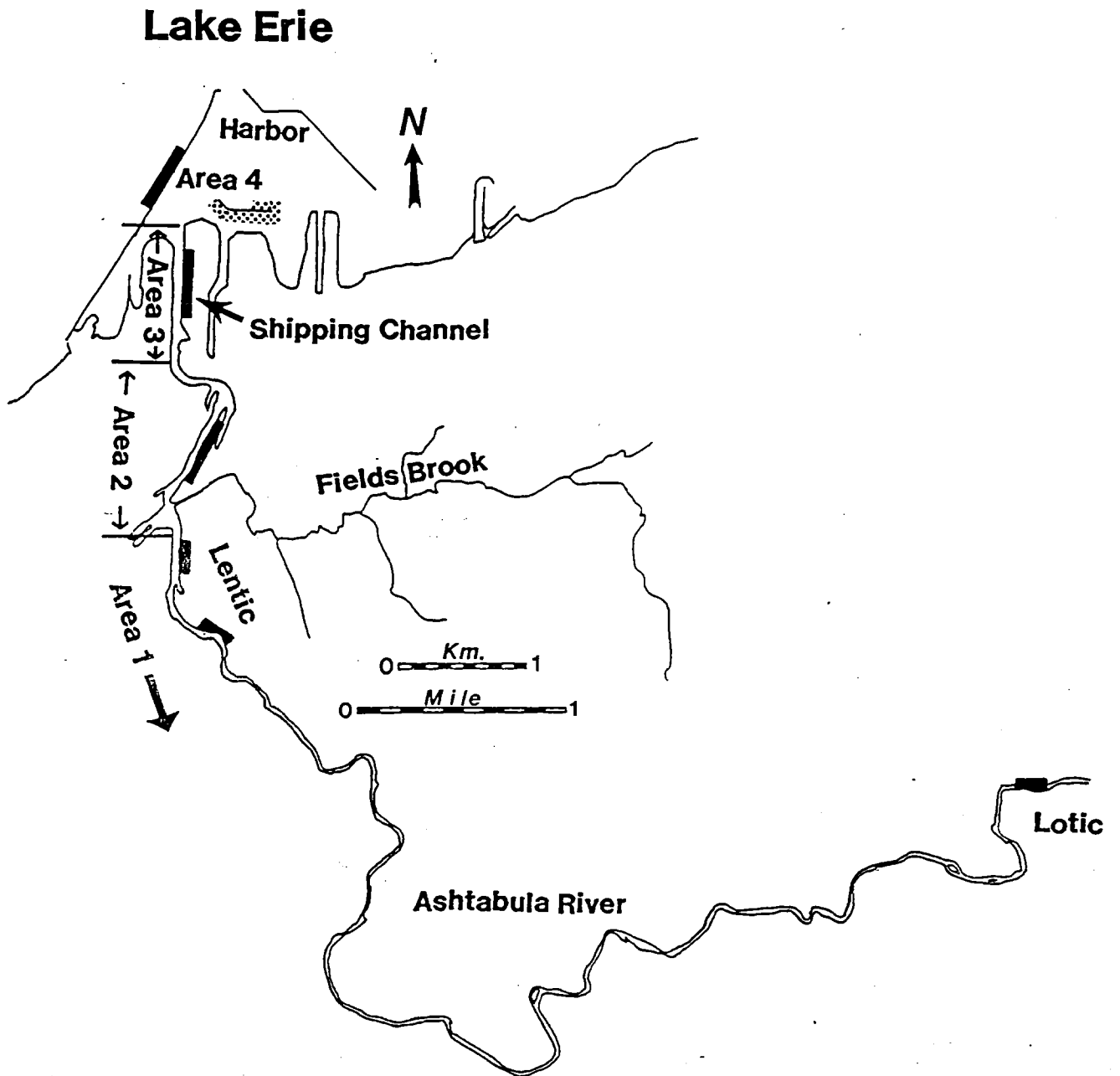

Figure 3-3: Ecological Assessment Areas (EAA 1-4) in Lower Ashtabula River and Harbor.

Erie river mouths. Cold water species such as the Steelhead trout also move up the Ashtabula River on a limited basis. If not for the contaminant problem, the Ashtabula River could be a prime site for salmonid stocking. The evaluation area extends basically from the outer harbor upstream for approximately two miles. This section of the river was evaluated with respect to usage and environmental and ecosystem development. Based upon the location of contaminated sediments, river usage, channel depths and potential for environmental restoration, the harbor/river study area fell into two distinct areas: downstream of the 5th Street Bridge and upstream of the 5th Street Bridge. These two areas corresponded to Ohio EPA's EAA 3 and EAA 2. Ohio EPA has identified these two areas as being biologically distinct in their 1992 and 1997 reports on the biological status of the lower Ashtabula River and Harbor. A discussion of the river usage and existing ecosystems located in EAAs 2 and 3 follows.

EAA 3 Ashtabula River channels located downstream of the 5th Street Bridge is used predominately to serve commercial navigation purposes. Maintained channel depths in this area are tied to the drafts of commercial vessels that service deep draft lake freighter docks. The authorized depths in the outer harbor and along the first 2,000 feet of the river vary from 30 to 27 feet LWD. The remainder of the river up to the 5th Street Bridge is maintained to 18 feet LWD. This section of the river is also utilized by recreational boat traffic to access slips upstream of the 5th Street Bridge. Consequently, the river located downstream of the 5th Street Bridge can be characterized as servicing deep draft commercial navigation and providing an access route for recreational craft to slips located upstream of the 5th Street Bridge.

Maintenance of channel depths of at least 27 feet LWD for commercial navigation purposes, continual usage of the channels by commercial Great Lakes self unloading vessels that draft up to 26 feet, and sheet piling of the river banks at commercial dock locations has severely disrupted the potential of the affected stream segments to support fish communities. The stream evaluation classification for this area is "very poor", the lowest Ohio EPA stream evaluation possible. Continual turbidity of the water column by Great Lakes vessels as well as periodic dredging of the channel bottoms in this area has created a highly stressful environment that inhibits the development of any type of ecosystem. Heavy commercial vessel traffic continually resuspends bottom sediment, covering macroinvertebrate on the river bottom. Although the habitat quality for supporting fish communities is very poor in the ship channels, fish migration through the area is not totally impeded. For fish populations, the area serves as a conduit between the lake and a more fertile aquatic environment located upstream of the 5th Street Bridge (See Figures 3-4 and 3-5).

The implementation of any improvement plans will be limited and will not substantially alter the habitat found in EAA 3. This area will continue to be bulkheaded, undergo periodic dredging to maintain channel depths of 27 to 28 feet LWD, and receive heavy traffic from commercial navigation vessels that will continually resuspend bottom sediments.

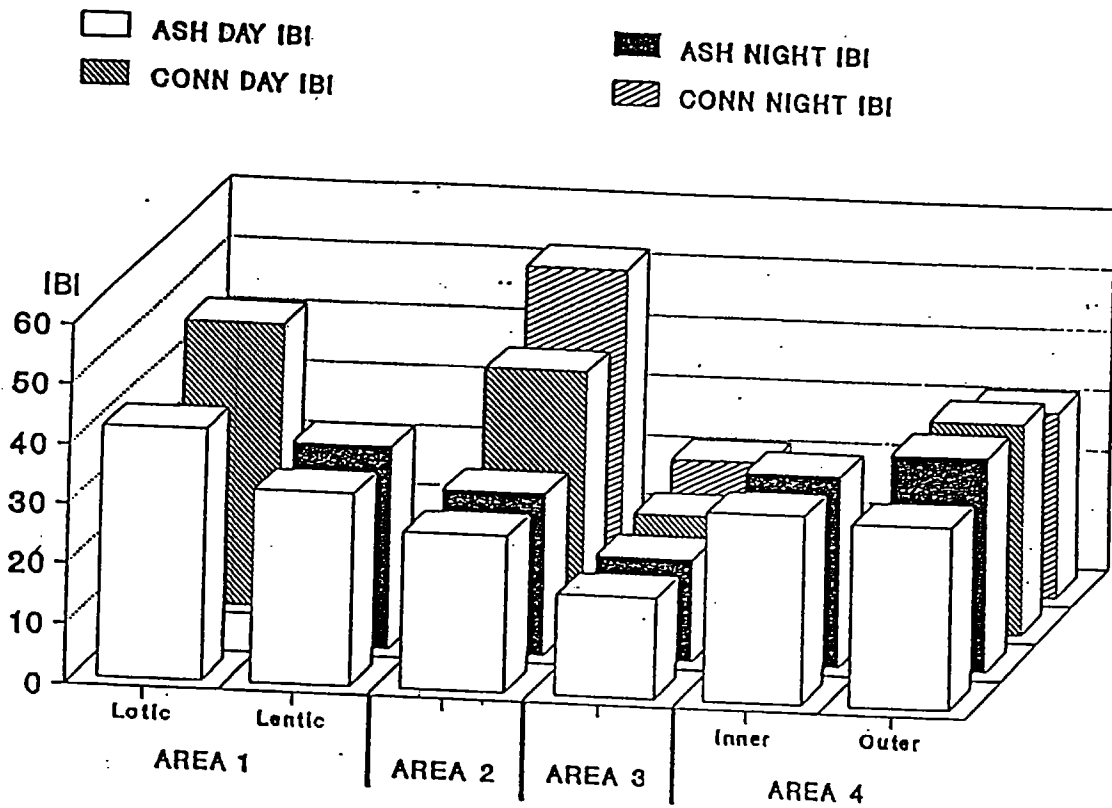

IBI= Index Of Biotic Integrity
 IBI greater than 32=Attaining warm water habitat values

Figure 3-4: Bar Graph of Day and Night IBI Values for the Ashtabula River and Conneaut Creek Study.

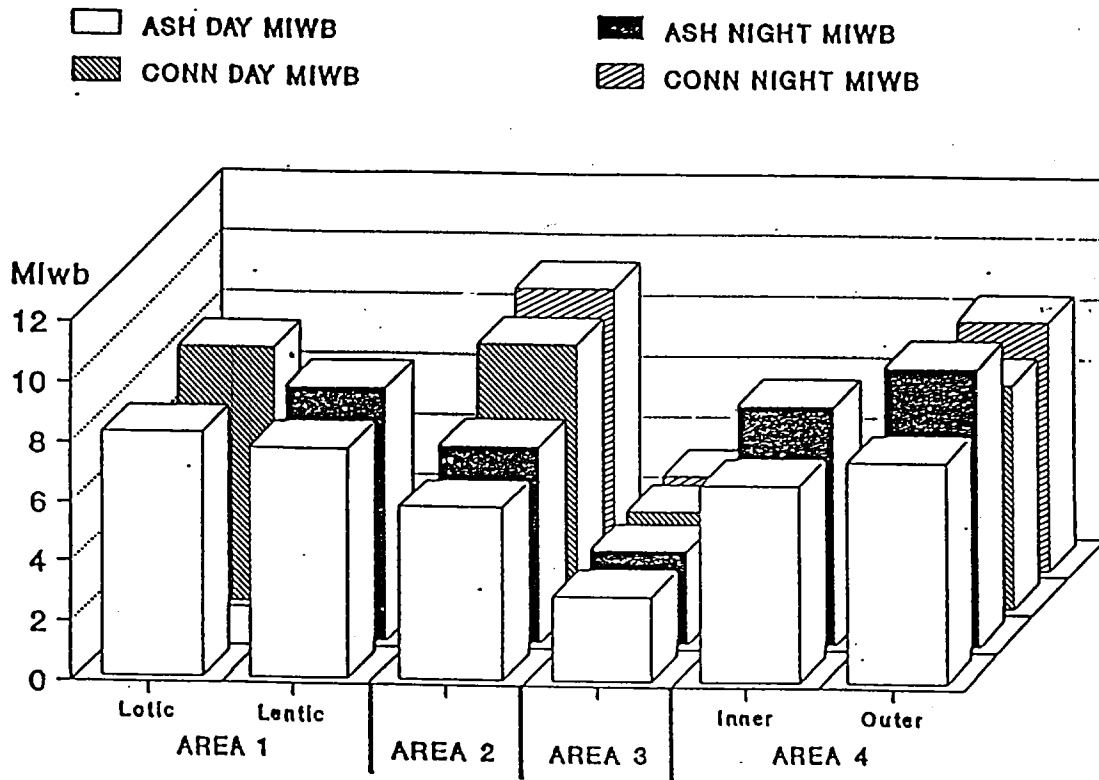

MIwb= Modified Index Of Well Being
 MIwb greater than 7.5=Attaining warm water habitat values

Figure 3-5: Bar Graph of Day and Night Mimb Values for the Ashtabula River and Conneaut Creek Study.

The usage and environmental composition of the Ashtabula River in EAA 2, located upstream of the 5th Street Bridge differs markedly from that located downstream of the 5th Street Bridge. The navigable extent of the river extends over 6,800 feet upstream from the 5th Street Bridge. The channel depths in this section of the river are markedly shallower than downstream of the 5th Street Bridge. Dredging in the Federal channel in this area has been restricted since the early 1960's. Channel depths upstream of the 5th Street Bridge vary from 0 to 10 feet below LWD. There are no active commercial docks located in this area of the river. The river essentially services recreational boating traffic as well as charter fishing craft. These vessels draft from 2 to 7 feet. There are over 1,000 recreational boating slips located upstream of the 5th Street Bridge, as well as over 50 charter boat operators. These recreational boating slips are concentrated in eleven marinas and/ or yacht clubs located upstream of the 5th Street Bridge. Marina development is located on approximately 50% of the total river shoreline available in this area, with the west bank sustaining the bulk of total dockage.

EAA 2 has a high habitat quality area located at River Mile 1.3 (downstream of Fields Brook). This area provides much cover from the growth of aquatic plants in waters shallower than 12 feet. The plant growth, logs, woody debris and boulders in the water provide abundant cover for communities of organisms. Although the quality of physical habitat is high, this area has low biological scores. It has been concluded from the "Section 312(b) and Section 206 Ecological Restoration/Preservation Analyses" (EIS, Appendix "EA-J") that contaminated sediments are the greatest cause of lower fish community scores at this site. The low abundance of vegetation loving species and the low species diversity in EAA 2 is a consequence of contaminated sediments.

EAA 2 is where over 80% of the contaminated sediments to be dredged under the Recommended Environmental Dredging Plan are located. Once these contaminated sediments are removed, these areas will be available for ecological restoration. Approximately 20+ acres of river environment would achieve benthic habitat restoration, most of which is located in EAA 2. The fish community that can be expected in boat traffic areas without contaminated sediments is mirrored on Conneaut Creek and on the Grand River near its mouth (River Mile 0.6). Comparison of fish communities at this Grand River site to fish communities in EAA 2 reveal twenty-one species were more abundant in the Grand River, i.e. yellow perch and large mouth bass. EAA 2 fish communities should approach Grand River communities with respect to abundance and diversity after remediation. If spawning areas were rehabilitated in EAA 2, habitat would be available for juvenile fish in the harbor. The Ashtabula Harbor area has the potential to serve as a nursery for fish produced in the lacustrary portion of the system.

The Ashtabula River fish community in areas of contaminated sediments has a high potential for recovery after sediment removal. EAA 2 would realize the large majority of these improvements since over 80 percent of the contaminated sediments are located in EAA 2 and most of the 20 acres of rehabilitated benthic habitat are located in EAA 2. Endangered species, top carnivores (game fish), species diversity, pollution sensitive species, number of individuals and incidence of external anomalies would all show improvement with removal of contaminated sediment.

The recovery of the Ashtabula lacustrary fish community is expected to influence fish communities in surrounding areas both upstream and in the lake. Species such as northern pike

and muskellunge moderate fish communities through predation and drive community structure towards greater ecological integrity. Greater ecological integrity results in even higher numbers of top carnivores, endangered species, and sensitive species. Historically, the muskie and northern pike were very abundant and commercially important. The destruction of lacustrine habitats throughout Lake Erie has resulted in drastic reductions of the two species populations and the positive influences they had on the Lakes ecosystem. The restoration of the Ashtabula lacustrine will allow it to resume its historic contribution to top carnivore populations (including northern pike and muskellunge).

Given the amount of ecosystem extant upstream of the 5th Street Bridge, and its potential for improvement, Section 312(b) was determined to be an appropriate vehicle to accomplish cleanup in this area. Section 312(b) costs have been compared and justified based on Environmental Restoration and Water Quality Outputs generated by the project, as required by Section 312(b).

Based upon river usage and ecosystem presence, the ARP recommends the use of Section 312(b), WRDA 90, as amended, to accomplish the cleanup located upstream of the 5th Street Bridge and WRDA 1986 Section 101 (General O&M) and Section 312(a) to cleanup the river located downstream of the 5th Street Bridge.

Section 3 of the EIS discusses in greater detail the physical, environmental, socioeconomic and cultural resources aspects of the project setting. Appendix EA-J of the EIS (Section 312(b) *and Section 206 Ecological Restoration Analysis*) provides an assessment of the environmental restoration and water quality improvements used to justify the costs associated with the Section 312(b) work. Environmental restoration and water quality improvements generated by the Recommended Environmental Dredging Plan will be discussed further in Section 4, “Plan Formulation”, Section 5, “Recommended Environmental Dredging Plan” and in Section 9, “Benefit Evaluation.”

3.5 Identified Problems and ARP Project Objectives

3.5.1 Problems Associated with Contaminated Sediment

Primary contaminants of concern in the lower Ashtabula River include numerous chlorinated organic compounds, especially polychlorinated biphenyls (PCBs); polyaromatic hydrocarbons (PAH); heavy metals such as cadmium, mercury, lead, and zinc; hexachlorobenzene; and hexachlorobutadiene. These contaminants have been detected in Ashtabula River sediments, water, and fish, as described in Technical Appendix C, “Ashtabula River Sediment Sampling and Analysis of Extent of Contamination”.

Radionuclides (RAD), such as uranium, radium and thorium, have also been identified as contaminants of concern in the lower Ashtabula River. Low levels of these radionuclides have been detected in Ashtabula River sediments as described in Technical Appendix D, “Ashtabula River Sediment Sampling and Analysis of Extent of Radionuclide Contamination”. The risks associated with radionuclides are further discussed in Technical Appendix G “Radiological Risk Assessment”.

Of particular concern is the extensive PCB contamination in the river sediments. PCBs bioaccumulate and cause a number of harmful effects, which potentially include both cancer and non-cancer adverse effects and ecological effects due to biomagnification. The risks associated with PCBs and the other identified contaminants are further discussed in Technical Appendix F, “Environmental Risk Assessment and Management Considerations for Dredging the Ashtabula River and Harbor”.

The consequences of these accumulated contaminants are many, including restrictions on fish consumption, reduced commercial shipping and recreational boating due to lack of suitable disposal facilities for dredged sediments, habitat loss, and impacts on biota. Dredged sediments with PCBs equal to or in excess of 50 mg/kg are regulated under the Toxic Substances Control Act (TSCA) and must be appropriately handled. Other sediments with elevated levels of contaminants may not be disposed of at open lake disposal sites and must be appropriately disposed of by alternate disposal methods. A total of more than 1,000,000 cubic yards of minor to heavily contaminated sediments are situated in the lower Ashtabula River.

Most of the contaminated sediments have collected within the Federally authorized navigation channels. Storm events may cause scour and the resuspension of sediments and associated contaminants, which may potentially compromise water quality standards. Contaminated sediments continue to migrate slowly downstream into the Lower River, Outer Harbor, and Lake Erie. Navigation channel maintenance has been limited in the lower Ashtabula River, due to concerns about dredging and lack of suitable disposal facilities for contaminated sediments.

The contaminants in the Ashtabula River and Harbor sediments are thought to have originated primarily from unregulated discharges in the Fields Brook watershed. Fields Brook has been placed on the USEPA National Priorities List of uncontrolled hazardous waste sites (Superfund), and is being remediated under the Comprehensive Environmental Response Compensation and Liability Act (CERCLA).

In the absence of a formal CERCLA action, remediation of the contaminated sediments in the Ashtabula River is proposed under other authorities, including U.S. Army Corps of Engineers Environmental Dredging Legislation (Section 312 of WRDA 1990, as amended by Section 205 of WRDA 1996 and Section 224 of WRDA 1999), following a NEPA-based approach. It is expected that an ARP project would expedite the remediation, address the commercial navigation goals which would not be addressed under CERCLA, and avoid litigation costs often associated with CERCLA.

Six impairments of beneficial uses are associated with the Ashtabula River AOC many of are directly related to contaminated sediment, more specifically to the PCB and PAH mass associated with the contaminated sediment. Removal and remediation of the PCB and PAH mass is critical to comprehensive restoration of the ecological integrity of the area.

3.5.2 Comprehensive Problem Identification

The ARP Project Area (see Figure 1-1) was assessed from an ecological perspective for this study. Primary problems that exist in the Ashtabula River from the mouth upstream to the 5th Street Bridge are those associated with commercial harbor development bulkheading, dredging,

the use of the commercial navigation channel, and contaminants in the sediments. In this segment of the river, sediment contamination consists of primarily PAHs, which are likely associated with the coal dock developments in the immediate area but also other contaminated sediments migrating in from upstream.

Upstream of the 5th Street Bridge, to the end of the Federal navigation channel at Station 207+00, problems are those associated with recreational harbor development bulkheading, dredging and use of the recreational navigation channel, and contaminants in the sediments. The sediment contaminants are comprised primarily of PCBs (some equal to or in excess of 50 mg/kg or TSCA) sediment, and low level radionuclides.

Throughout the Project Area, benthic and fishery habitat has been significantly degraded in areas as compared to quality warm water habitat criteria. Structural developments have essentially eliminated shallow areas, which provide habitat for aquatic life. Dredging and vessel activities have caused resuspension of sediments, suffocating bottom organisms and disrupting fish habitat.

The watershed area upstream of the developed harbor area is in relatively good condition.

Based on this assessment, three common problem matters can be identified for Project Area:

- a. contaminated sediments;
- b. loss of protected riparian aquatic shallows; and
- c. Dredging and commercial and recreational vessel traffic.

Under the 1978 GLWQA, the overall goals of a RAP are to restore all beneficial uses to an AOC, prohibit the discharge of toxic substances in toxic amounts, and virtually eliminate the discharge of persistent toxic substances. Many of the beneficial use impairments in the Ashtabula River AOC are directly related to contaminated sediment, more specifically to the PCB and PAH mass associated with the contaminated sediment. Removal and remediation of the PCB and PAH mass is critical to comprehensive restoration of the ecological integrity of the area. Some of the beneficial use impairments are related to loss of protected aquatic riparian shallow areas and lower river activities. Cleanup of the Ashtabula River via the Ashtabula River Partnership should eliminate all of the use impairments assigned to the lower river. The Lake Erie/Ashtabula River Area of Concern has been identified as a priority area for remediation in Section 205 of WRDA 96 and in the U.S. Army Corps of Engineers PGL No. 49 section 5.c.

It is understood that commercial and recreational facilities and activities will remain. It is also understood that discharge sources of pollutants have been remediated and Fields Brook is presently being remediated by separate authority and will be remediated prior to implementation

of the Ashtabula River Partnership project. Best management practices will be in effect by the coal and Fields Brook industries.

3.5.3 ARP Project Objectives

Considering the three identified common problem matters, and the goals of the RAP, the ARP developed more specific objectives (Plans) to address contaminated sediments and the loss of aquatic habitat that could also be applied to restore beneficial uses on the lower Ashtabula River.

1. Regarding contaminated sediments: Develop an optimized dredging contaminant removal plan for the problem areas that will:
 - Plan A1. leave surface sediment PCB and PAH concentrations no worse than existing conditions initially;
 - Plan A2. remove all TSCA and scour-risk PCB and PAH mass; and
 - Plan A3. Set targeted long-term surface sediment concentrations for PCBs and PAHs of equal to or less than 0.35 ppm and 10-20 ppm respectively. These targets consider siltation or placement cover of relatively clean sediment. This is based on reference studies, as listed in Table 3-3.

2. Regarding aquatic habitat loss: Develop an optimized aquatic ecosystem restoration plan for the problem areas that will:
 - Plan B. Replace protected aquatic shallow areas, as possible, for lengths along the river problem areas. These developments would include measures such as a shoreline aquatic shelf cut or provision and miscellaneous improvements such as soil cover, aquatic and terrestrial plantings, placement of stone and gravel, and placement of cover structures. This would provide missing habitat for fisheries and benthos for passage, cover, feeding, and possibly spawning. The objective would be to reach a quality warm water habitat condition along the problem reaches.

Focus has been on the main contaminants of concern in the Ashtabula River Area of Concern (AOC) due to their level and extent of contamination. Specifically, the focus is on PCBs and to a lesser extent PAHs. It is assumed that by focusing on PCBs and PAHs, the other contaminants of concern will be addressed due to co-location of contaminants. A more complete list of pollutants identified in the Ashtabula River AOC is presented in Table 3-3.

The developed dredging contaminated sediment removal and aquatic ecosystem restoration plans would be applied to restore beneficial uses, as follows:

1. Remediate Restriction on Fish and Wildlife Consumption: Apply Plan A.
2. Remediate Degradation of Fish and Wildlife Populations: Apply Plans A and B.
3. Remediate Fish Tumors and Other Deformities: Apply Plan A.

Table 3-2: Sediment Quality Clean-Up Ratings Based on Available Information.

<u>PCBs ppm</u>	<u>Rating</u>	<u>Comment</u>	<u>Reference</u>
0 - .023	Exceptional	No noticable effects to Ashtabula (Potential) benthos and fishery.	1,4
.023 - .3	Excellent	Negligible effects to Ashtabula (potential) benthos and fishery. Comparative to that for Lake Reference Sites.	1,2,3,4
.3 - 1	Very Good	Very minor effects to Ashtabula (Potential) benthos and fishery.	1,2,3
1 - 3	Good	Minor effects to Ashtabula (potential) benthos and fishery.	1,2
3 - 10	Fair	Noticable effects to Ashtabula (potential) Benthos and Fishery.	1,2
<u>PAHs ppm</u>			
0 - 4	Excellent	Negligible effects to Ashtabula (potential) benthos and fishery. Comparative to that for Lake Reference Sites.	1,2,4
4 - 10	Very Good	Very minor effects to Ashtabula (Potential) benthos and fishery.	1
10 - 20	Good	Minor effects to Ashtabula (potential) benthos and fishery.	1

REFERENCES

- 1) Ashtabula River Partnership, Environmental Risk Assessment and Management Considerations for Dredging the Ashtabula River and Harbor, Ohio, 1997, Ashtabula River Partnership.
- 2) Pickard, S. W., (DRAFT) Development of Polychlorinated Biphenyl (PCB) Sediment Cleanup Guidelines for Ashtabula Harbor (Upper River), Ohio. U.S. Army Corps of Engineers.
- 3) U.S. EPA, Assessment and Remediation of Contaminated Sediments (ARCS) Program, Calculation and Evaluation of Sediment Effect Concentrations for the Amphipod (Hyalella Azteca) and the Midge (Chironomus Riparius), 1996, U.S. EPA.
- 4) U.S. EPA, Ecotox Thresholds, Eco Update, Office of Emergency and Remedial Response, Publication 9345.0-12FSI, EPA 540/F-95/038.

4. Remediate Degradation of Benthos: Apply Plans A and B.
5. Remediate Restrictions on Dredging Activities: Apply Plan A.
6. Remediate Loss of Fish and Wildlife Habitat: Apply Plan A and B.

Cleanup of the Ashtabula River with contaminant removal and follow-up restoration of riparian shallow areas is expected to eliminate all of the use impairments assigned to the lower river.

4.0 PLAN FORMULATION

This section sets forth the considered ARP project alternatives and describes the assessment and evaluation of the most feasible alternatives for contaminated sediment removal that resulted in the selection of the Recommended Environmental Dredging Plan. The ARP's project is comprised of the following individual components that together constitute the overall sediment removal project.

1. Dredging (environmental);
2. Transfer/Dewatering;
3. Disposal of TSCA and Non-TSCA dredged sediment.

Although the ARP project specifically focuses on contaminated sediment removal, the ARP's comprehensive plan for environmental restoration of the lower Ashtabula River includes measures for physical habitat restoration. Accordingly, alternatives for aquatic ecosystem restoration were also assessed and evaluated during Plan Formulation and are included in this CMP as a means of setting forth a complete framework for future overall environmental and ecological restoration in the Ashtabula River Project Area.

4.1 Overview of the ARP Project Plan Formulation Process

The ARP project consists of several components comprised of dredging; developing a land based transfer and dewatering facility; developing a suitable upland disposal facility; transport of dewatered dredged material for disposal; and monitoring of the project operations/facilities during and after implementation. Plan formulation was a total progressive partnership effort undertaken from 1994 through 2000 by the ARP Committees and partners. Committees met monthly, and more frequently as necessary, to address the tasks required to formulate and evaluate alternatives to attain the goals of the ARP project.

As early as 1994 the ARP Committees conducted initial assessments of dredging alternatives. There were several sequences of assessments and evaluations based on assessment parameters including:

- disposal facility siting;
- costs and economic benefits;
- practicality;
- ecological improvement;
- quantities dredged;
- shoreline bulkhead affected;
- PCB/ RAD/PAH mass removed;
- initial remaining PCB/RAD/PAH surface concentrations;
- beneficial uses addressed; and
- Scour release potential.

Other assessment parameters included:

- PCB bio-accumulation in fish tissue and advisories;
- water quality (turbidity);
- benthic habitat chemically restored;

- benthic habitat and scour protection area chemically restored; and
- aquatic/fishery shallows initially impacted.

The ARP established the project area “Without Project Condition” and considered the “No Action” alternative. The ARP formulated and assessed a wide array of alternatives pertaining to dredging, transfer/dewatering, treatment technologies for dredged sediment, transportation to the disposal site, and design options for TSCA and Non-TSCA dredged material disposal. The “No Action” conditions served as the basis of comparison for the assessment of the formulated project alternatives. With “No Action”, “Without Project Conditions” would be expected to persist for some time.

Alternatives for each project component were assessed by the ARP for engineering and economic feasibility, environmental and social acceptability, and/or for best meeting the project planning objectives. A number of technical studies were initiated in this regard between 1994 and 1997 and are documented in the CMP, Technical Appendices and EIS Appendices.

In addition to an initially considered Bank-to-Bank-to-Bedrock dredging plan, the ARP formulated and assessed several other dredging alternatives upstream of the 5th Street Bridge consisting of:

- a) Shallow Dredge leaving in place a small amount of elevated PCB contaminated sediments; sediments with lower contaminant levels; sediments at lower elevations (greater depth); and virgin sediments that would be extensively covered by new clean sediments;
- b) Deep Dredge involving more extensive dredging removing all of the elevated PCB contaminated sediments; but, leaving some lower level contaminated sediments and virgin sediments that would be extensively covered by new clean sediments; and
- c) Bank to Bank to Bedrock Dredge involving extensive dredging to remove all of the elevated PCB contaminated sediments and all of the contaminated sediments that would, in time, be replaced by new clean sediments.

Dredging would also include removal of approximately 115,000 cubic yards of primarily PAH contaminated sediments downstream of the 5th Street Bridge.

The ARP assessed these dredging alternatives for engineering feasibility and effectiveness at removing the necessary volume of material to meet Ashtabula River clean-up goals, cost effectiveness, and environmental acceptability. Assessment relied upon technical data and criteria particular to each reach, including contamination levels; location of contaminated sediments; shoreline structural stability; dredging technology; channel limits; future sedimentation; and scour. Cross sections identifying contamination levels and location of contaminated sediments were available and evaluated for every one hundred feet of the project area.

The assessment identified the Deep Dredge scenario as the optimized plan and recommended plan component. It delineates the amount of contaminated material that needs to be removed, moderating costs and meets ARP project River ecological clean-up goals.

Initially, 4 vicinity and 11 specific alternative dewatering sites were assessed for development of dredged material transfer and dewatering facilities. Assessment parameters included: costs; availability; capacity; ease of access and transport, engineering, environmental, community, and other resource considerations. Dredging and disposal site considerations were also included. An Ashtabula River shoreline was identified.

Numerous alternative dewatering technologies were assessed including passive dewatering technologies and active evaporation technologies. These were assessed in light of the scope of the project and economic, engineering, and environmental efficiencies. The assessment revealed that the Ashtabula River sediments should be dewatered using essentially passive dewatering technologies, regardless of whether the sediments are dredged mechanically or hydraulically.

A number of alternative contaminated sediment treatment and disposal alternatives were formulated and assessed. The assessments concluded that treatment and disposal of the residual material is considerably more expensive than dewatering and disposal of the dewatered dredged material.

There were 36 alternative dredged material disposal sites initially assessed for development of TSCA and Non-TSCA disposal facilities, including use of existing disposal facilities (as appropriate). Potential disposal sites were initially identified primarily via previous studies, committee member knowledge of potential available areas, and by identifying non-wetland land areas verified on U.S. Fish and Wildlife Service National Wetlands Inventory Maps. Assessment parameters were developed per various Federal, State, and Local siting criteria and considerations. Each alternative site was assessed considering planning objectives and engineering, economic, and environmental parameters.

Comparative costs and potential impact assessments were summarized and ARP discussions ensued that essentially eliminated many alternatives due to environmental and cost considerations. Initially, the use of existing disposal facilities was considered economical, but subsequently it was determined that an existing facility can not be utilized because according to State of Ohio regulations RAD material can not be co-mingled with other disposed material. Consequently, dredged River sediments must have separate disposal facilities.

It was decided that an upland confined disposal facility would be better suited for disposal of the contaminated dredged material involved in this project. The 36 sites were narrowed down to 5 and then 2 upland sites (Sites 5 and 7). More detailed geotechnical and environmental studies were conducted on Sites 5 and 7 and the results indicated that either Site 5 or Site 7 would be geotechnically suited for development of upland disposal facilities. Based on problems with existing fill material at Site 5, and greater environmental impacts (i.e., wetlands and low level contamination), it was subsequently determined that an upland disposal facility would be constructed at Site 7. Wetland impacts at Site 7 would be mitigated under Clean Water Act Section 401 and 404 guidance.

In February 1997 the final array of project component alternatives and potential combinations were assessed and evaluated in greater detail. Based on ARP evaluation and discussion and initial Recommended Plan was selected and the Preliminary Draft CMP, Technical Appendices, and EIS were prepared. The Preliminary Draft CMP/EIS report was submitted to USACE Division and Headquarters in September of 1997 and a USACE Headquarters review conference was held in December. USACE Headquarters subsequently set forth two directives:

1. the entire ARP Project Area should be examined for justification under Section 312(b); and
2. The Project Area downstream of the 5th Street Bridge should be evaluated under O&M and Section 312(a) authorities.

In response to the USACE Headquarters guidance, a “Section 312(b) Project Sub-Committee” was formed and from December 1997 through May of 1998 the entire ARP Project Area was reviewed under the Section 312(b) authority for environmental dredging. A project authorities conference was held at USACE Headquarters in May 1998 and revisions to the CMP and EIS were made accordingly. In 1999 the CMP and EIS revisions were complete and in September of that year the preliminary draft CMP/EIS was submitted to the public for comment.

In 2000, subsequent to the release of the draft CMP and EIS reports, the ARP identified the former RMI Sodium Plant site (State Road site) as a preferred disposal site over Site 7. The State Road site has been disturbed by past plant development, it is feasible from an engineering and economic perspective, is of little value to fish and wildlife, and contains only minor (0.02± acre) wetlands. The Fields Brook Superfund remediation project material is being disposed of on part of this property and there is room for the Ashtabula River Partnership dredged TSCA-classified and RAD material to be disposed of in a developed facility adjacent to the Fields Brook project disposal facility. There is also enough room for the remaining Ashtabula River Partnership dredged Non-TSCA material to be disposed of in a developed facility nearby the TSCA/RAD disposal facilities. Consequently, the State Road site replaced Site 7 in the Recommended Plan.

4.2 Project Alternatives Evaluation

During the planning process the ARP formulated and evaluated an array of potential project alternatives for each of the above listed project components. The ARP also developed a series of alternative scenarios based on the project components. These alternatives and alternative scenarios were assessed and evaluated to select a “Recommended Environmental Dredging Plan”. The alternatives related to aquatic ecosystem restoration were also assessed, and measures were recommended for the Project Area in this regard.

Alternatives were considered for each project component in various potential combinations and progressively evaluated by work groups within the Ashtabula River Partnership for engineering and economic feasibility, environmental and social acceptability, and/or for best meeting the project planning objectives. All alternatives were evaluated assuming that cleanup took place solely under the Section 312(b) authority. Accordingly, the ARP formed a Section 312(b) Sub-Committee to accomplish this task. Alternatives evaluated by the Sub-Committee include:

- a. “No Action”.
- b. In-River Shear Cap .
- c. Shallow Dredging, Deep Dredging, Bank-to-Bank-to-Bedrock Dredging.
- d. Aquatic Habitat Restoration.

The No Action (Without Project Condition) and In-River Shear Cap alternatives were preliminarily evaluated by the ARP and later removed from further consideration. later However, the No Action alternative was used to evaluate the later project alternatives (Shallow Dredging, Deep Dredging, Bank-to-Bank-to-Bedrock Dredging; and Aquatic Habitat Restoration) for each project component.

4.3. Preliminary Considered Alternatives

4.3.1 No Action Alternative (“Without Project Conditions”)

The No Action alternative means that the ARP would take no action to implement a sediment removal project on the Ashtabula River based on final findings of this study. Without a project, Without Project Conditions would be assumed and serve as a basis for the comparison of other project alternatives.

Under the No Action alternative contaminated sediments would continue to migrate downstream, the river channel will shoal in, maintenance dredging of the navigation channels will eventually cease because there is no disposal facility to confine these sediments, and commercial shipping would eventually end in Ashtabula.

If the ARP project were not implemented, remediation efforts would likely be piecemeal and not fully or comprehensively address the problems. Existing problems and conditions would likely persist well into the future. A Superfund contaminant remediation level action would likely occur in the more distant future, but would probably not be remediated to the extent of the ARP project. Migration of residual contaminated sediments into the harbor navigation channels would likely continue, and the potential for a major storm event washout would persist. To maintain harbor navigation channels and dispose of contaminated dredgings, the Corps of Engineers and local sponsors would likely still need to consider development and use of an in-lake confined disposal facility (CDF), which is opposed by U.S. Fish and Wildlife and other natural resource agencies. An alternative would be development and use of a dewatering and upland confined disposal facility, or use of an existing upland confined disposal facility. Other ecological restoration programs may enable some limited ecological restoration measures. Total time and costs expended would be substantially higher. Fewer immediate and long-term environmental benefits would be realized.

4.3.2 In-River Shear Cap Alternative

A river capping alternative, that was considered in prior studies, involved maintaining the Federal navigation channel in the Ashtabula River, upstream of the 5th Street Bridge, at a depth of -6 feet Low Water Datum (LWD) and a limited dredging and in place containment scheme to

prevent TSCA classified sediments from migrating into the Federal navigation channel in the lower portion of the Ashtabula River and Harbor.

Under this alternative, sheetpile would be placed and sediments would be dredged to about four feet below desirable channel depths. Dredged sediments would be replaced with a non-permeable barrier and about three feet of riprap and/or clean sediment material. Initial material dredged (about 5,000 cubic yards of TSCA material and about 100,000 cubic yards of Non-TSCA material) would be disposed of in the most efficient method discussed in the following sections. This alternative would provide several feet of In-River Shear Cap containing deeper existing contaminated sediments in-place, even during severe storm flows.

This alternative was not favorable from the perspective of the Ashtabula River RAP and ARP goal of a "total" river cleanup. The recommended Ashtabula River Partnership Plan is to be accomplished via several U.S. Army Corps of Engineers dredging authorities. Thus, dredging to remove contaminants was a primary consideration that could be implemented with Corps authority and funding. A dredging and capping plan presents considerable problems in this regard with placement of the cap in the Federal channel. The Federal channel would likely need to be deauthorized by Congress and the capping paid for by entities other than the Corps. Accordingly, this alternative was deleted from further consideration due to the impairments to navigation and future economic expansion.

4.4 Project Component Alternatives Assessment

4.4.1 Dredging Technology Alternatives

Dredging (Environmentally) pertains primarily to dredging with equipment that will minimize turbidity and the resuspension of contaminated sediments. Criteria for selecting the dredging equipment to accomplish this removal action were identified. More than twenty dredge types, including mechanical, hydraulic, and special purpose dredges were listed, characterized, and evaluated using the selection criteria. Several options appear acceptable, including the closed bucket clamshell, cutterhead, and horizontal auger dredge. Environmental control measures including operations controls, oil boom, and silt curtains were also evaluated for use in conjunction with the most appropriate dredging technology. Dredging technology considerations are discussed in significant detail in Appendix I, "Dredging Alternatives and Selection".

The first identified dredging alternative involves the use of a closed bucket clamshell (see Figure 4-1), a mechanical dredge, to remove the targeted volume of contaminated sediments. This dredge is capable of high production rates, is able to remove both sediments and debris, and can navigate the Ashtabula River. The use of a closed bucket clamshell (readily available within the Great Lakes region), as well as restrictions on the dredging operation and the use of turbidity barriers and oil booms, would help to reduce adverse environmental effects caused by this dredging.

The second identified dredging alternative involves use of a cutterhead dredge (a hydraulic dredge) to excavate the Ashtabula River sediments. This dredge is the most commonly used dredging equipment and is versatile, and capable of dredging clays, silts, sands, gravels, etc. The

cutterhead dredge is also able to dredge while generating reduced amounts of turbidity. As with the closed bucket, restrictions placed on dredging operations and the use of turbidity barriers and oil booms will help to further reduce adverse environmental impacts caused by this dredge.

The third identified dredging alternative involves the use of both mechanical and special purpose dredging equipment. A closed bucket clamshell dredge would be used first to remove the majority of the targeted volume of contaminated sediments. To excavate the last of the sediment intended for removal, without performing significant over-dredging, a special purpose dredge with greater vertical control than the closed bucket would complete the dredging operation. Two special purpose dredges that have greater vertical control and generate relatively low amounts of turbidity include the horizontal auger dredge and the matchbox suction head dredge.

It was determined that the special purpose dredging equipment would dredge excessive amounts of water that would require treatment. The increased water treatment and delays in dewatering the dredged sediment for upland disposal would significantly affect project costs and implementation. Therefore, the enclosed clamshell bucket was selected as the dredging technology (equipment) component of the project.

4.4.1.1 Environmental Control Alternatives

Primary mechanisms of contaminant loss associated with each dredging technology were identified. Subsequently, an array of potential environmental control measures were identified and evaluated for applicability to the project conditions that would minimize primary mechanisms of contaminant losses. Regardless of the technology selected, water quality controls, dredging operation controls, and/or environmental controls will be placed on the dredging operation to limit adverse impacts of this sediment removal action.

Water quality control alternatives include placing limits on the amount of turbidity or concentrations of PCBs or other contaminants allowed in the water column outside the immediate dredging area. Dredge operation controls could include limiting the bucket cycle time, prohibiting nighttime dredging operations, and allowing barges to be only partially filled. Environmental controls that will be used around the dredging operation include oil booms and adsorbents to capture oil film released by the dredging action. Silt curtains will also be used if it is determined during detailed project design that such measures, especially during dredging of the TSCA sediment, are necessary limit the spread of resuspended sediments and associated contaminants. In addition, watertight barges will be required for transporting sediments. Cover of TSCA sediments may also be required. While it is virtually impossible to completely eliminate the adverse environmental impacts of this dredging action, controls such as these can greatly reduce impacts. The specific array of environmental control measures for the ARP project will be determined during detailed design.

Figure 4-1: Dredge Types

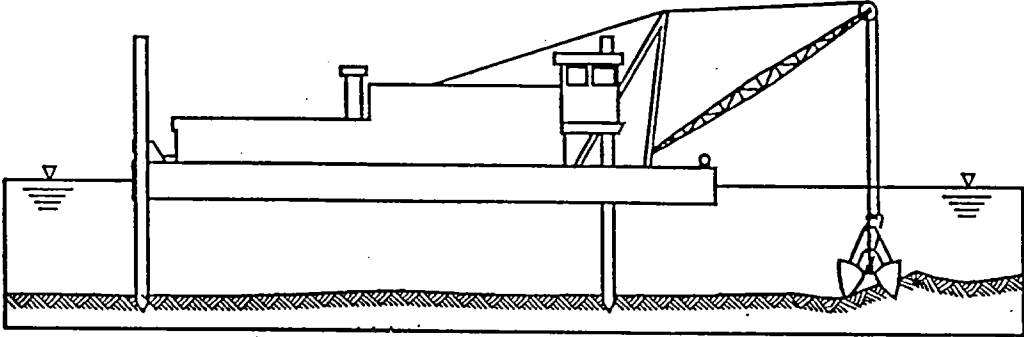

Clamshell dredge

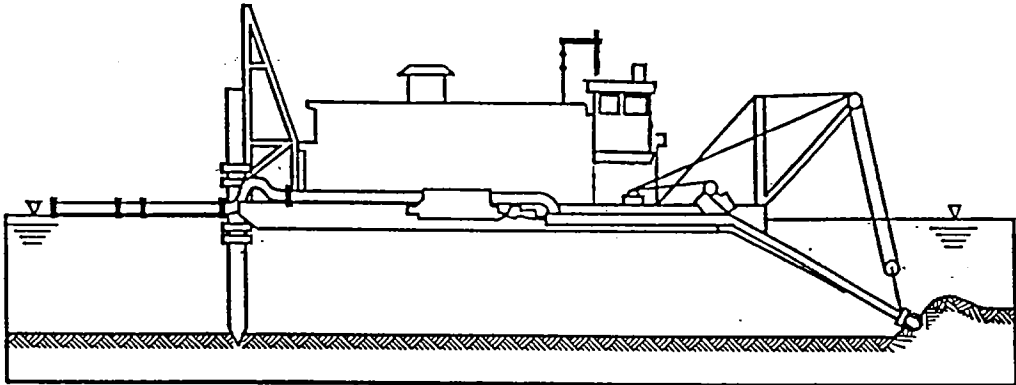

Cutterhead pipeline dredge

4.4.2 Sediment Dredging Alternatives Formulation and Assessment

4.4.2.1 Extent of Sediment Contamination

In 1989-90, sediment core samples were collected from the Ashtabula River from the mouth upstream to the Federal navigation channel's project limit. Bulk chemical and physical (particle size) analyses of these samples were completed by Woodward Clyde, Inc to evaluate the distribution of various contaminants with respect to area and depth. The results of these analyses are included in Technical Appendix C. Additional data were collected in 1995-1996 to fill in data gaps and more clearly define the level and location of PCB contamination in the river. All sampling sites are depicted on Figures 4-2 and 4-3.

The most recent U.S. Army Corps of Engineers, Buffalo District Operations and Maintenance Dredging Program sediment sampling and bulk physical and chemical analysis for Ashtabula Harbor occurred in 2000. Sediment samples were taken from the Outer Harbor (western portion) and lower Ashtabula River federal navigation channels and Lake Erie reference areas (several miles northwest of the harbor). More detail on the 2000 sediment sampling and testing results is provided in Section 2.0 of the EIS.

Particle size analysis indicated that the sediments are composed primarily of silts and fine sands. Inorganic and organic analyses indicated that most Ashtabula River core sediments are generally considered contaminated and not suitable for unrestricted open-lake disposal. The sediments were assigned this pollution classification because of a number of elevated inorganic parameters including Arsenic, Barium, Cadmium, Chromium, Cyanide, Lead, Mercury, and Zinc. Most of the other inorganic parameters were found at levels considered characteristic of sediments ranging from "clean" to moderate levels of contamination. Organic analysis showed appreciable levels of dichlorobenzenes, trichlorobenzenes, and hexachlorobenzenes in most of the sediment samples and some showed very low levels of Polynuclear Aromatic Hydrocarbons (PAHs).

Dry weight concentrations of Polychlorinated Biphenyls (PCBs) in sediment samples collected downstream of the 5th Street Bridge above -18 feet LWD (Low Water Datum), or authorized project depth, were measured at generally low levels. Sediment PCB concentrations in this reach were all <5 ppm (parts per million) and most were <1 ppm, with the exception of one area just downstream of the 5th Street Bridge, with a PCB concentration of 16 ppm at -18 feet LWD. Upstream PCB concentrations were also generally low in sediment samples collected above -6 feet LWD. While most Ashtabula River surface sediment showed relatively low levels of PCBs, some samples in the vicinity of the mouth of Fields Brook (mostly in the River Turning Basin) indicate higher levels of PCB's at or below -6 or -8 feet LWD. Some of these deeper sediment samples contain PCB levels equal to or in excess of 50 ppm. Per the Toxic Substances Control Act, 1976, dredged sediment with PCB concentrations equal to or greater than 50 parts per million must be handled in accordance with guidelines set forth by the Act.

The maximum PCB concentration detected in 1989-90 was 660 mg/kg, and the maximum PCB concentration detected in 1995-96 was 160 mg/kg in 1995-96. The average PCB concentration (for samples with detections) for 1989-90 was 18.2 mg/kg and 15.7 mg/kg for 1995-96. The

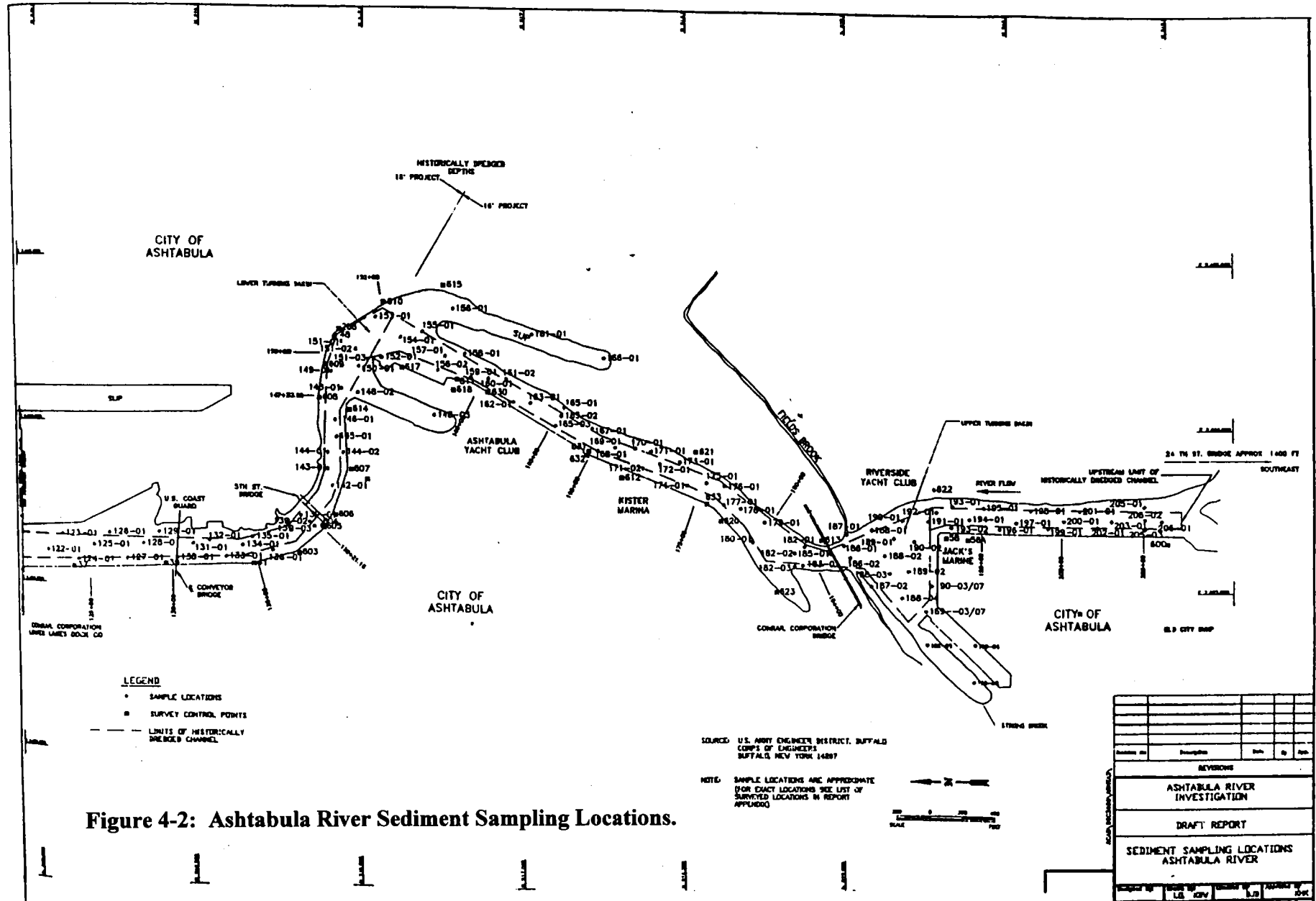

Figure 4-2: Ashtabula River Sediment Sampling Locations.

REVISIONS				
Revision No.	Description	Date	By	App.
ASHTABULA RIVER INVESTIGATION				
DRAFT REPORT				
SEDIMENT SAMPLING LOCATIONS ASHTABULA RIVER				
Project No.	Sheet No.	Scale	Project No.	Date
Date: FEBRUARY 1978 Project No.: 02-3077-200 Sheet No.: 1.3.3 Woodward-Clyde Consultants				

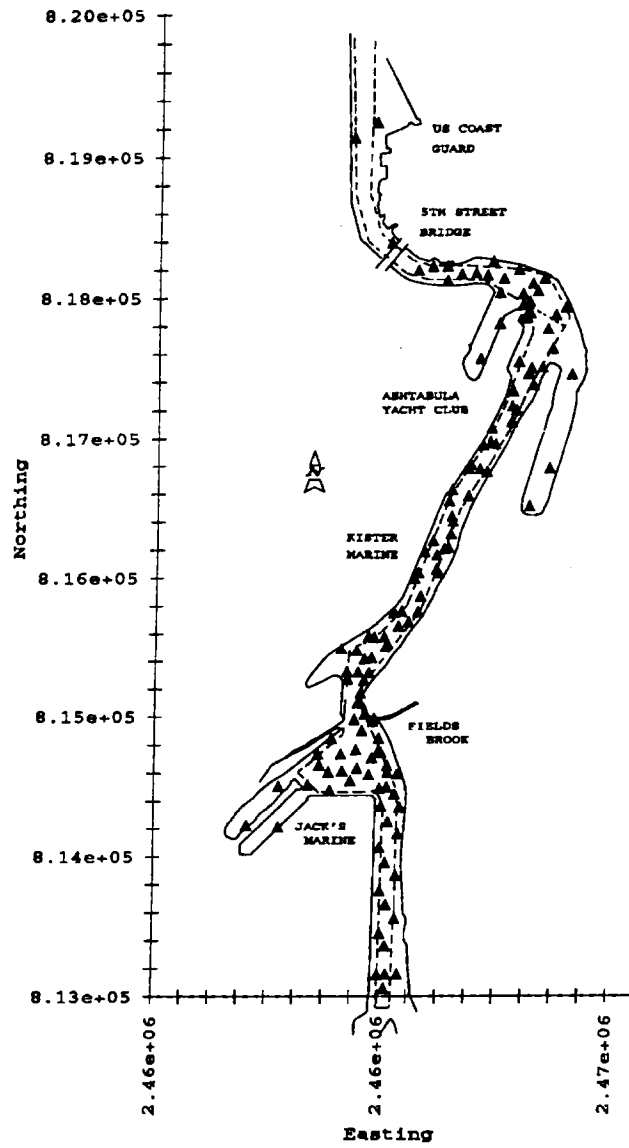

Figure 4-3: Ashtabula River PCB Sample Locations.

sampling locations closest to Fields Brook contain the highest concentrations, with decreasing levels in the downstream direction.

For PAHs, the most relevant sediment chemistry data for the lower river is from 1990 and 1992. The highest concentrations of PAH's (100 - 400 ppm) were found in the vicinity of the Ashtabula Yacht Club inlet and the 5th Street Bridge, and high concentrations (50 - 100 ppm) were found in sections of the Lower River and Outer Harbor downstream of the 5th Street Bridge (see Figure 4-8). PAHs may be linked to poor mortality rates in bioassays conducted on harbor sediment samples from the area downstream of the 5th Street Bridge.

PCBs are the primary contaminant of concern within the reach from the Upper Turning Basin downstream to the 5th Street Bridge. PAHs are the primary contaminant of concern within the reach from the 5th Street Bridge to Station 120. The focus in remediation is on PCBs, and to a lesser extent PAHs. It is assumed that by focusing on PCBs and PAHs, the other contaminants of concern will be addressed, due to co-location of contaminants. The contaminants that have been detected in Ashtabula River sediment, surface water, and fish are summarized in Table 3-3 (from Ohio EPA, Stage 1 Report, 1991).

4.4.2.1.1 Radionuclides

The U. S. Environmental Protection Agency, (USEPA) Great Lakes National Program Office (GLNPO) and the ARP had concerns regarding radionuclide contamination within the river sediments. This prompted the ARP to initiate a review analytical data for radionuclides that the USEPA collected at 12 sediment-sampling locations in late 1990 (see Figure 4-4). The 12 sites were identified as "hot spot" areas with numerous chemical contaminants, based on a comprehensive Ashtabula River sediment study completed in early 1990. That sampling was done to determine whether river sediments contained high levels of radioactive material. The highest concentrations of radionuclides were found at depths in sediment of 4 to 15 feet, in the area of the upper turning basin. The concentrations of total uranium (U-234+U-235+U-238) detected in the sampling ranged from 2.4 to 22.3 picocuries per gram (pCi/g), with an average value of 10.1 pCi/g. The concentrations of total radium (Ra-226+Ra-228) detected in the sampling ranged from 2.6 to 20.6 pCi/g, with an average value of 10.8 pCi/g. In October 1990, USEPA issued a press release about the sample results, stating "these values, are well below the 30 pCi/g guideline limit set by the Nuclear Regulatory Commission, for unrestricted use of cleaned-up land. Based on the results of this sampling, EPA sees no need to employ special precautions for radionuclides during the dredging and disposal of these river sediments".

In August 1992, the Ohio General assembly enacted Senate Bill 130, which required that Low-Level Radioactive Waste not be disposed of without a license issued by the Nuclear Regulatory Commission and / or the Director of the Ohio Department of Health. The Ohio Department of Health, Bureau of Radiation Protection (ODH/BRP), as the State of Ohio Radiation Control Agency, and as a member of the Ashtabula River Partnership, is reviewing the conceptual, and subsequent detailed versions, of the design plans for dredging, transfer/dewatering and disposal of river sediments to provide assurance that the river cleanup project is consistent with State requirements and will be protective of public health.

Figure 4-4: 1999 Ashtabula River Radiological Sampling Locations.

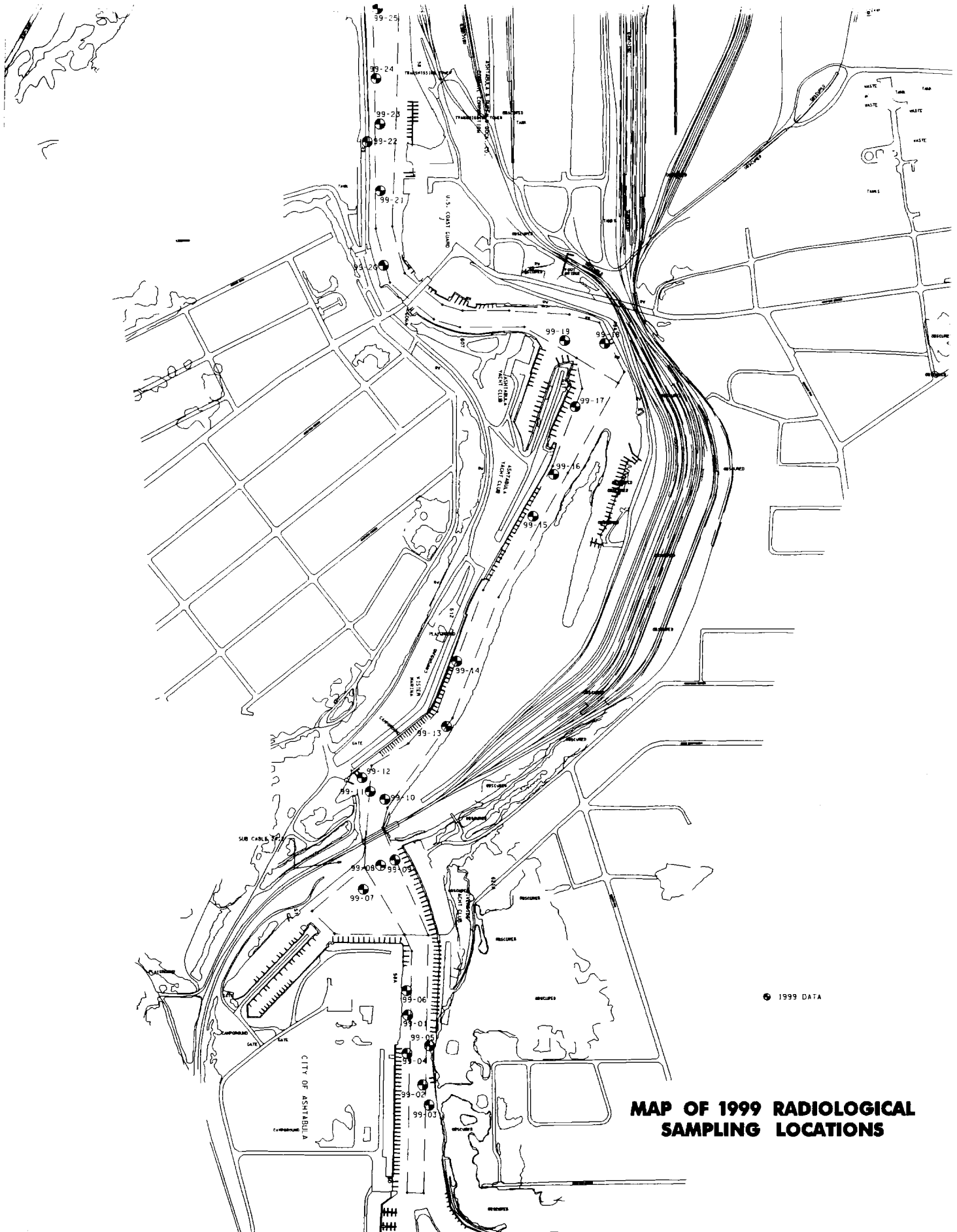

In early 1998, after a review of the analytical data from Ashtabula river sediments collected, beginning in 1996, by Michael E. Ketterer, then a chemistry professor at John Carroll University, and a re-review of their own 1990 analytical data, the USEPA decided to add radioactivity as an analysis parameter for the planned sediment sampling later that year. In May 1998, the USEPA collected eight sediment samples from six depositional areas in the lower river. This scoping survey was done for several reasons. Historically, sediment sampling analysis had been focused primarily on uranium. Several radionuclides are naturally occurring substances found in coal and titanium ore, which is processed in the area. Additional analysis was necessary to determine the extent of the presence of other radionuclides within river sediments. Additionally, the USEPA was reviewing risk based cleanup goals for Fields Brook (an Ashtabula River tributary and USEPA Superfund site) and required additional verification sampling/analysis. The highest concentrations of radionuclides were found at depths in sediment of 4 to 15 feet, in the area of the confluence of Fields Brook. The concentrations of total uranium detected in the sampling ranged from 1.6 to 64.7 pCi/g, with an average value of 11.9 pCi/g. The concentrations of total radium detected in the sampling ranged from 1.0 to 17.3 pCi/g, with an average value of 4.1 pCi/g. The maximum total uranium concentration is about twice that being applied to a commercial cleanup on Fields Brook. The maximum total radium concentration is about 30% more than the commercial cleanup criterion and about 3 times the residential cleanup criterion for Fields Brook. From this data, it became evident to the ARP that radionuclides were part of the contaminants of concern for the Ashtabula River clean up.

On May 18, 1999, the ODH/BRP issued an opinion letter to the ARP regarding the ARP's remedial action design. The ODH/BRP opinion letter stated: "...that based on the review of the ARP draft CMP/EIS and given the presently known radionuclide concentrations within the sediments of the Ashtabula river, the Recommended Environmental Dredging Plan for disposal of the sediments is consistent with State requirements". Ohio Revised Code Title 37 – Chapter 48 and the rules promulgated there under delineate the regulatory authority under which the ODH/BRP performed its review. During its consideration of this matter, ODH/BRP staff reviewed the criteria in 10 CFR 61 as delineated in Ohio Administrative Code (OAC) 3701-39-021. The ODH/BRP takes the position that the dredging and disposal of low-level radioactive sediments from the Ashtabula River does not require a 10 CFR 61 as delineated in OAC 3701-39-021 disposal action. The ODH/BRP has and will continue to implement the State of Ohio's regulations consistent with a 10CFR 20.2002 as delineated in OAC 3701-39-021 on-site remediation and disposal action.

During the week of August 23-29, 1999, a radiological characterization of the sediments in the Ashtabula River was conducted by members of the Radiation staff of the USEPA's Superfund Division (USEPA-SD) and personnel from the ODH/BRP. The USEPA's Research Vessel "Mudpuppy" was used to collect 106 sediment samples. USEPA's National Air and Radiation Environmental Lab (NAREL) performed radiological analysis of the samples. The highest concentrations of radionuclides were found at depths in sediment of 4 to 15 feet, in the area of the upper turning basin. The concentrations of total uranium detected in the sampling ranged from 0.98 to 109.99 pCi/g, with an average value of 6.95 pCi/g. The concentrations of total radium detected in the sampling ranged from 1.8 to 16.1 pCi/g, with an average value of 4.2 pCi/g. This information was used towards the determination of specific project objectives. Those objectives included, determining if the Non-TSCA area sediments differ statistically from

upstream background sediments, and obtaining an adequate amount of data to perform radiological risk assessments.

Statistical evaluation of the Non-TSCA area sediment sample data was performed by USEPA Region 5 statisticians under direction of USEPA-SD and ODH/BRP Radiation staff. The statistical procedures used to compare background to sediment sample site concentrations were the parametric two-sample T test and the non-parametric Mann-Whitney U and the Wilcoxon Rank Sum tests. Both parametric and non-parametric procedures were used because environmental data rarely adheres to a normal data distribution. The results showed that there is a statistical difference between the unaffected background sediments, i.e., upstream of the confluence of Fields Brook, and the downstream, Non-TSCA area sediments. The details of the USEPA statistical analysis and risk assessment can be found in Technical Appendix D, “Ashtabula River Sediment Sampling and Analysis of Extent of Radionuclide Contamination” and in Technical Appendix G “Radiological Risk Assessment”.

On June 12, 2000 the ODH/BRP, in response to a ARP letter of request, clarified its regulatory position on the disposal of Ashtabula river sediments. The ODH/BRP has classified the river sediments: as radioactive material in accordance with the definition set forth in Ohio Revised Code 3748.01(O); as source material in accordance 10 CFR 40.4 as delineated in OAC 3701-39-021; and as low-level radioactive waste as defined in RC 3748.01(L). It is the understanding of the ODH/BRP that the sediments are not regulated pursuant to 40 CFR 240 and therefore are not classified as mixed wastes. The ODH/BRP continues to assert that the sediments can be placed in a properly designed cell as described in the CMP/EIS “Recommended Environmental Dredging Plan”.

4.4.2.2 Estimated Contaminated Sediment Removal Volumes

The U.S. Army Corps of Engineers Waterway Experiment Station (WES) conducted a three-dimensional analysis (Groundwater Modeling System, or GMS) to determine the extent and volume of contaminated sediments using the results of the sediment sampling events. Figures 4-2 and 4-3 depict PCB sample locations, Figure 4-5 shows a plan view of the 50 ppm PCB Plume, Figure 4-6 shows a side view of the 50 ppm PCB Plume, and Figure 4-7 shows an oblique view of the 50 ppm PCB plume. Table 4-2 depicts surface area weighted sediment concentrations (PCBs) and Table 4-3 presents the volumes of contaminated sediment (PCBs) above each of the given threshold values. As noted previously, those sediments with PCB concentrations equal to or greater than 50 parts per million (ppm) must be handled/addressed in accordance with guidelines set forth by the Toxic Substances Control Act, 1976.

The core sediment sampling results indicate that there are approximately 1,150,000 cubic yards of sediment in the river that would not be suitable for open-lake disposal. Approximately 150,000 cubic yards (bulked, includes a number of dredging considerations) of this volume is significantly PCB contaminated and would be handled as TSCA sediment, and would need to be appropriately dredged, dewatered, and disposed of.

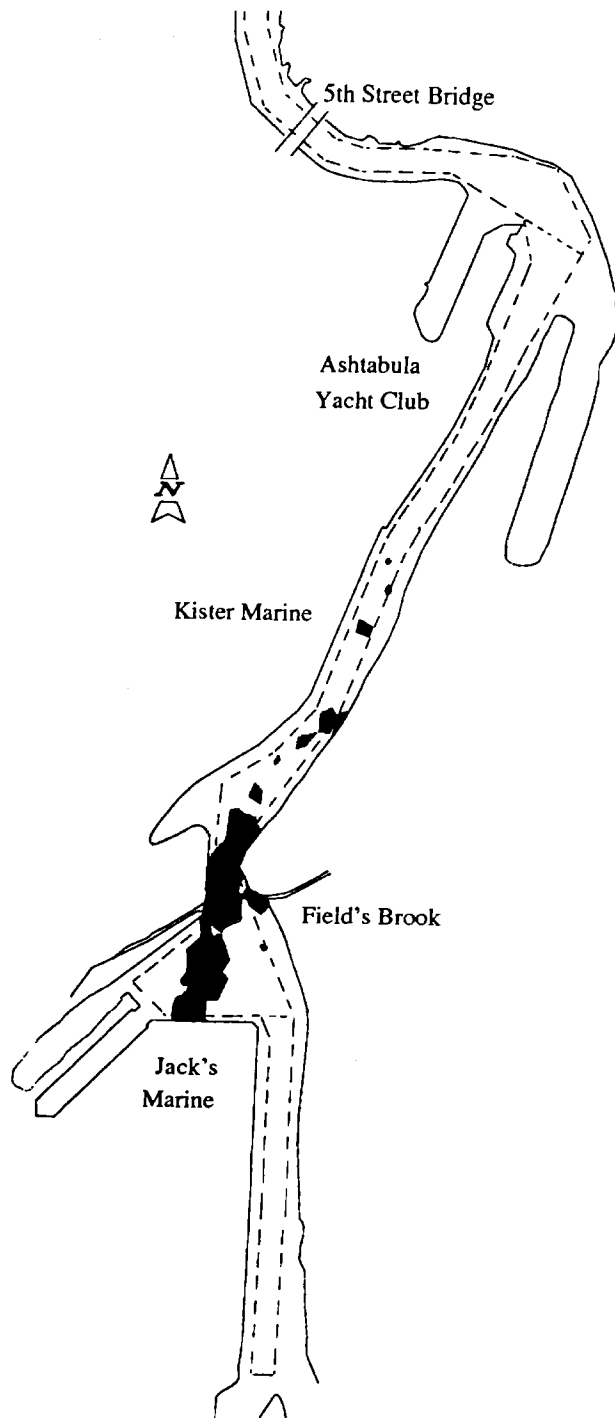

Figure 4-5: Plan View of 50 ppm PCB Plume Generated from IDW Interpolation with Quadratic Nodal Functions.

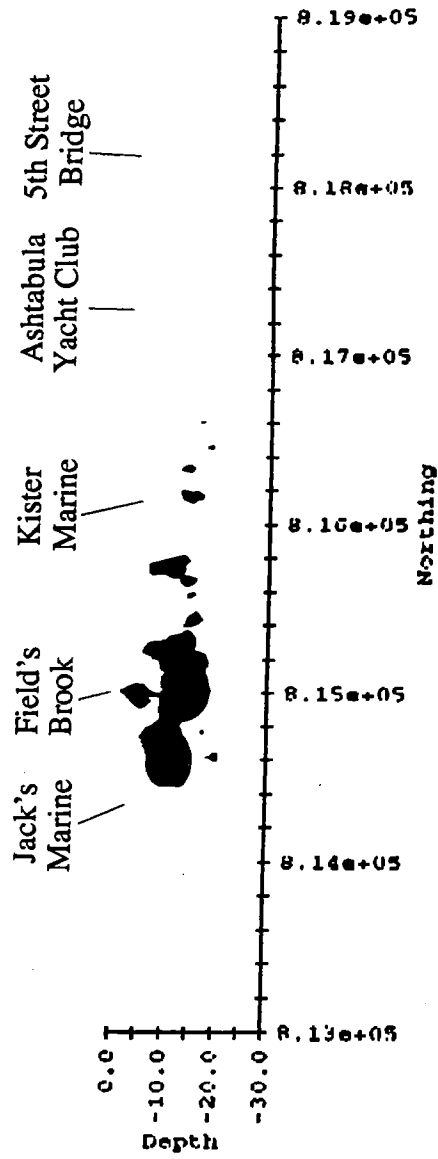

Figure 4-6: Side View of 50 ppm PCB Plume Generated from IDW Interpolation with Quadratic Nodal Functions.

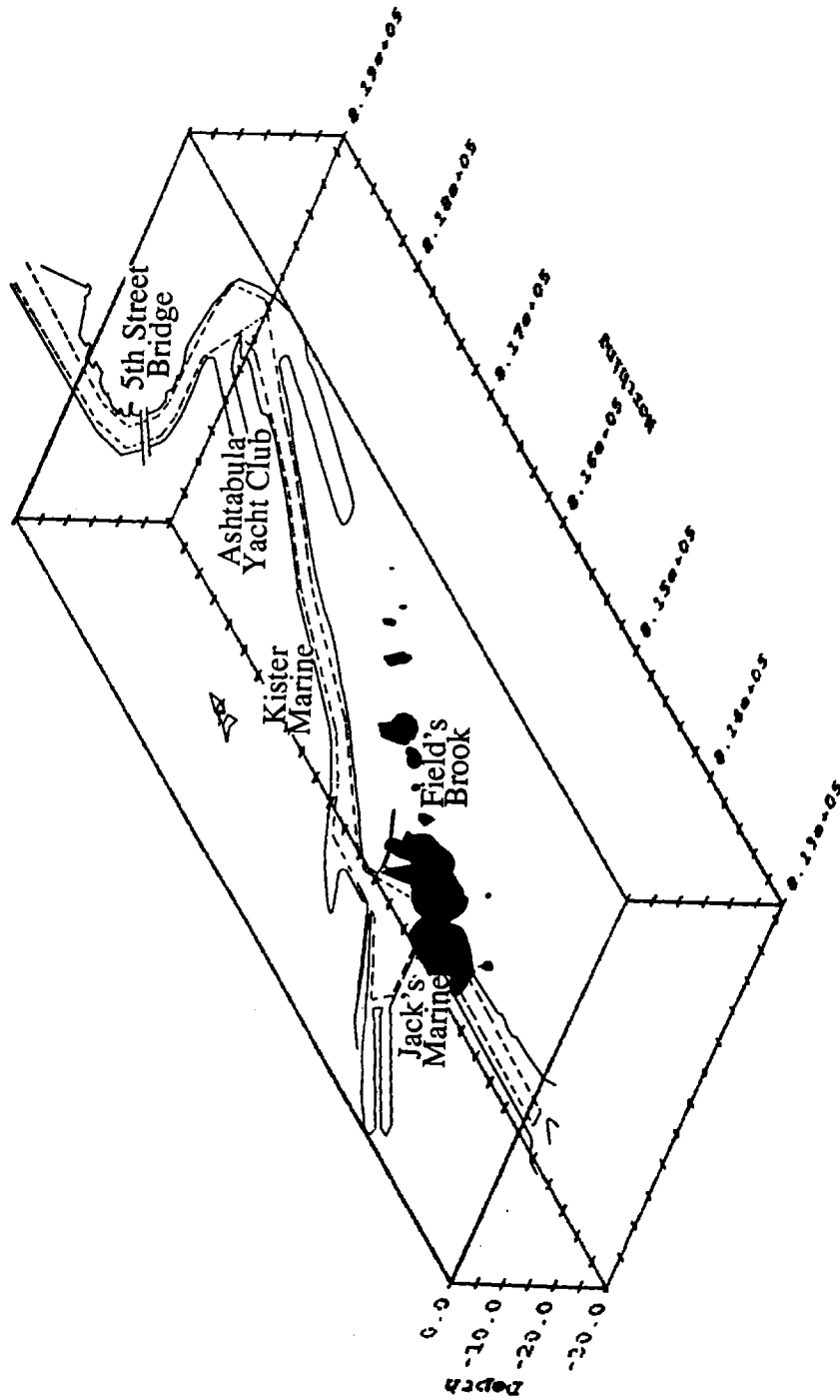

Figure 4-7: Oblique View of 50 ppm PCB Plume Generated from IDW Interpolation with Quadratic Nodal Functions.

The volume of sediments that are TSCA-classified (PCB concentrations equal to or greater than 50 mg/kg (ppm)) is estimated at 28,700 cubic yards. The regulatory agencies (USEPA, OEPA, and USACE, Buffalo District) have agreed that setting a limit of 40 mg/kg for TSCA waste would be prudent, given to the uncertainty associated with the modeling process. The estimated volume of sediments with PCBs greater than 40 mg/kg is estimated at 49,400 cubic yards. The

area and extent of the sediment within the 40 mg/kg contour of the GMS model, would be the minimum amount of sediment that needs to be dredged as TSCA material. Based on further engineering analysis of possible dredging techniques available, it had been determined the most feasible dredging plan would remove an estimated 150,000 cubic yards of contaminated sediments which would be handled as if they were TSCA-classified sediments.

In the project reach from the 5th Street Bridge downstream to station 120+00 located about half way down to the Lake, PAH contamination is considered to be the primary contaminant of concern (see Figure 4-8). Considering this, it was determined that dredging and disposal of approximately 115,000 cubic yards of sediment from this reach would address this problem. Upstream of (south of) the 5th Street Bridge to the limit of the Federal Navigation Channel (Station 213+36) PCBs and commingled RADs are considered to be the primary contaminants of concern. It was determined that dredging and disposal of approximately 581,000 cubic yards of sediment from this reach would address this problem.

Figure 4-9 depicts the contaminated sediment dredging areas. Table 4-1 presents Dredging for Contaminant Removal Measures (Costs). Table 4-2 presents a comparison of initial and Post-Dredging Surface Area Weighted Sediment Concentrations for Ashtabula River Dredging Scenarios. Table 4-3 presents a Comparison of Sediment Volume and PCB Mass Removal for Ashtabula Dredging Scenarios. Table 4-4 presents the Linear Feet of Sheet Piling Affected in Different Dredging Scenarios.

4.4.2.3 Dredging Alternatives Formulation and Assessment

Based on the location and extent of contaminated sediments, and the estimated removal volumes, dredging alternatives were formulated using the following general guidelines.

- a. Develop cross sections of the river every 100 feet.
- b. Interpolate PCB Sampling data to cross-section.
- c. Plot isoconcentration lines.
- d. Evaluate cross sections and develop dredging alternatives.
- e. Develop a post-dredging surface in GMS based on dredging cut lines.

Appendix E, “Dredging Scenarios and Sediment Volume Estimates” includes detail on the formulation process. Alternatives formulation resulted in the following final three dredging alternative plans.

1. Shallow Dredging
2. Deep Dredging
3. Bank-to-Bank-to-Bedrock Dredging

Ashtabula River: 1990 and 1992 PAH Samples

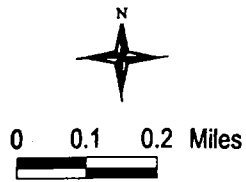
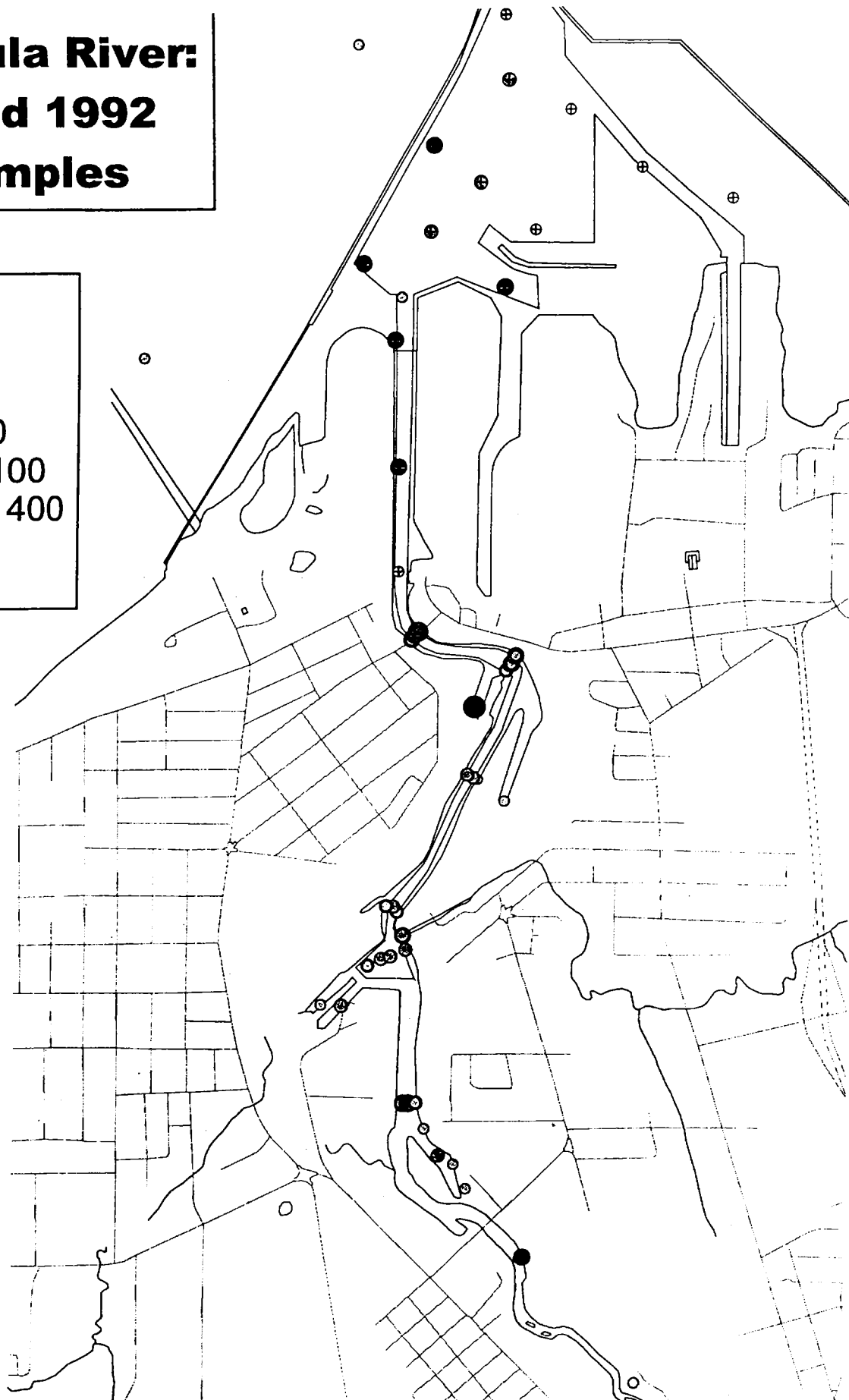
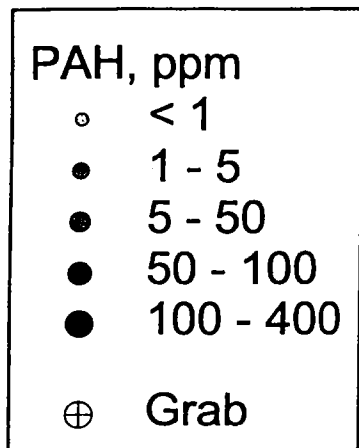
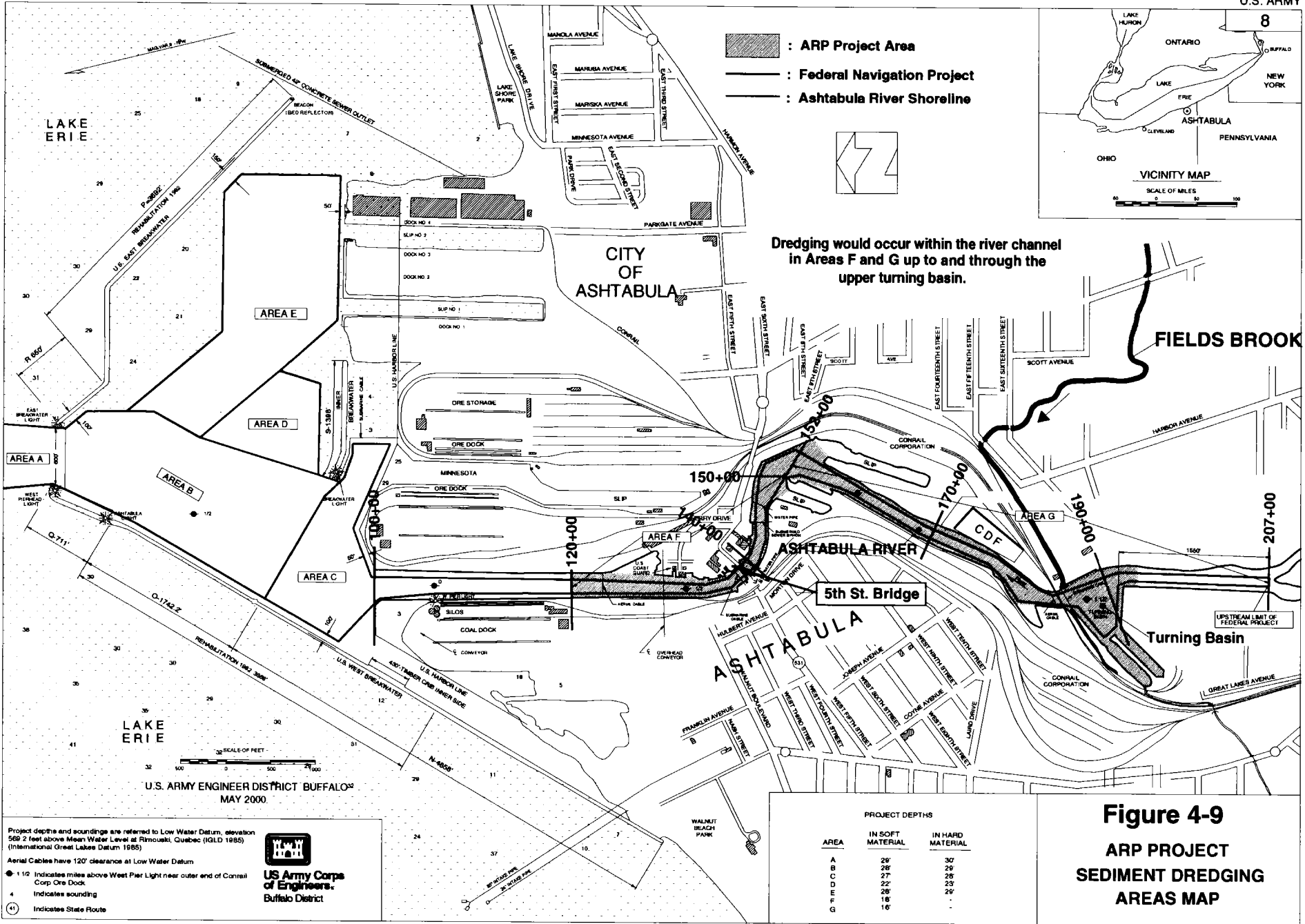

Figure 4-8: Ashtabula River: 1990 and 1992 PAH Samples.



Project depths and soundings are referred to Low Water Datum, elevation 569.2 feet above Mean Water Level at Rimouki, Quebec (IGLD 1985) (International Great Lakes Datum 1985)

- Aerial Cables have 120' clearance at Low Water Datum
- 1/12 Indicates miles above West Pier Light near outer end of Conrail Corp Ore Dock
- 4 Indicates sounding
- 41 Indicates State Route



Table 4-1: Measured Costs Associated with Dredging for PCB Contaminant Removal.
 (1997 Preliminary Comparative Cost Estimates. September 1996 Price Levels.)

Item	<u>Dredging for Contaminant Removal</u>		
	<u>Bank to Bank To Bedrock</u>	<u>Deep Dredge</u>	<u>Shallow Dredge</u>
Construction			
First Cost \$			
Dredge :	30,448,750	20,153,500	17,742,000
Disposal:	35,051,250	29,746,500	27,758,000
Total :	65,500,000	49,900,000	45,500,000
Study			
E&D			
S&A			
RE			
Project Cost:	72,900,000	56,500,000	51,800,000

Note: The material proposed to be dredged downstream of the Fifth Street Bridge (115,000 CY) constitutes about 17% of the total material to be dredged (696,000 CY) for the Deep Dredge Plan.

Table 4-2: Post Dredging Surface Area Weighted PCB Sediment Concentrations for Ashtabula River Dredging Alternative Scenarios.

Initial Conditions

Concentration Range (ppm)	Average Concentration (ppm)	Surface Area in Range (sf)	Percent of Total Surface Area	Surface Area Weighted Concentration (ppm)
> 50	75	5,019	0%	0.18
40-50	45	12,983	1%	0.28
30-40	35	60,075	3%	1.00
20-30	25	125,701	6%	1.50
10-20	15	204,444	10%	1.46
5-10	7.5	286,404	14%	1.02
1-5	3	434,456	21%	0.62
0-1	0.5	969,437	46%	0.23
Total		2,098,519	100%	6.29

Calculations on left hand side assume that sediments > 10 ppm at bedrock interface are redredged with a specialty dredge.

Calculations on right hand side assume that sediments > 10 ppm at bedrock interface are left in place.

Bank to Bank to Bedrock Dredging

Concentration Range (ppm)	Average Concentration (ppm)	Surface Area in Range (sf)	Percent of Total Surface Area	Surface Area Weighted Concentration (ppm)
5-10	7.5	601,654	29%	2.15
5	5	633,045	30%	1.51
1 - 5	3	214,392	10%	0.31
0.5 - 1.0	0.75	40,937	2%	0.01
0 - 0.5	0.25	608,491	29%	0.07
Total		2,098,519	100%	4.05

Concentration Range (ppm)	Average Concentration (ppm)	Surface Area in Range (sf)	Percent of Total Surface Area	Surface Area Weighted Concentration (ppm)
5-10	7.5	601,654	29%	2.15
>10	20	633,045	30%	6.03
1 - 5	3	214,392	10%	0.31
0.5 - 1.0	0.75	40,937	2%	0.01
0 - 0.5	0.25	608,491	29%	0.07
Total		2,098,519	100%	8.58

Deep Dredging

Concentration Range (ppm)	Average Concentration (ppm)	Surface Area in Range (sf)	Percent of Total Surface Area	Surface Area Weighted Concentration (ppm)
5-10	7.5	526,580	25%	1.88
5	5	542,260	26%	1.29
1 - 5	3	218,476	10%	0.31
0.5 - 1.0	0.75	49,106	2%	0.02
0 - 0.5	0.25	762,097	36%	0.09
Total		2,098,519	100%	3.59

Concentration Range (ppm)	Average Concentration (ppm)	Surface Area in Range (sf)	Percent of Total Surface Area	Surface Area Weighted Concentration (ppm)
5-10	7.5	526,580	25%	1.88
>10	20	542,260	26%	5.17
1 - 5	3	218,476	10%	0.31
0.5 - 1.0	0.75	49,106	2%	0.02
0 - 0.5	0.25	762,097	36%	0.09
Total		2,098,519	100%	7.47

Shallow Dredging

Concentration Range (ppm)	Average Concentration (ppm)	Surface Area in Range (sf)	Percent of Total Surface Area	Surface Area Weighted Concentration (ppm)
5-10	7.5	436,364	21%	1.56
5	5	432,642	21%	1.03
1 - 5	3	321,960	15%	0.46
0.5 - 1.0	0.75	71,944	3%	0.03
0 - 0.5	0.25	835,609	40%	0.10
Total		2,098,519	100%	3.18

Concentration Range (ppm)	Average Concentration (ppm)	Surface Area in Range (sf)	Percent of Total Surface Area	Surface Area Weighted Concentration (ppm)
5-10	7.5	436,364	21%	1.56
>10	20	432,642	21%	4.12
1 - 5	3	321,960	15%	0.46
0.5 - 1.0	0.75	71,944	3%	0.03
0 - 0.5	0.25	835,609	40%	0.10
Total		2,098,519	100%	6.27

Table 4-3: Comparison of Sediment Volume and PCB Mass Removal for Ashtabula River Alternative Dredging Scenarios.

Initial Conditions					
Threshold Value	Cubic Feet Between Threshold Values	Cubic Yards Between Threshold Values	Cumulative Volume Removed (CY)	Mass Between Threshold Values (kg)	Cumulative Mass (kg)
50 ppm	775,980	28,740	28,740	1735	1735
40 ppm	557,150	20,635	49,375	801	2,537
30 ppm	1,346,300	49,863	99,238	1505	4,042
20 ppm	2,788,900	103,293	202,531	2228	6,270
10 ppm	4,838,500	179,204	381,734	2320	8,589
5 ppm	4,922,400	182,311	564,046	1180	9,769
1 ppm	4,987,100	184,707	748,753	1196	10,964
0.5 ppm	1,144,200	42,378	791,131	27	10,992
0.1 ppm	1,259,800	46,659	837,790	12	11,004
0	8,223,300	304,567	1,142,357	14	11,018

Bank to Bank to Bedrock					
Threshold Value	Cubic Feet Between Threshold Values	Cubic Yards Between Threshold Values	Cumulative Volume Removed (CY)	Mass Between Threshold Values (kg)	Cumulative Mass Removed (kg)
50 ppm	775,848	28,735	28,735.11	1735	1735
40 ppm	555,638	20,579	49,314	799	2,534
30 ppm	1,337,337	49,531	98,845	1495	4,029
20 ppm	2,723,117	100,856	199,701	2175	6,205
10 ppm	4,595,420	170,201	369,902	2203	8,408
5 ppm	4,687,910	173,626	543,529	1124	9,531
1 ppm	4,858,800	179,956	723,484	1165	10,696
0.5 ppm	1,130,614	41,875	765,359	27	10,723
0.1 ppm	1,243,234	46,046	811,404	12	10,735
0	5,247,400	194,348	1,005,753	9	10,744
PCB Mass Removal =					98%

Deep Dredging					
Threshold Value	Cubic Feet Between Threshold Values	Cubic Yards Between Threshold Values	Cumulative Volume Removed (CY)	Mass Between Threshold Values (kg)	Cumulative Mass (kg)
50 ppm	775,836	28,735	28,734.67	1735	1735
40 ppm	554,569	20,540	49,274	797	2,532
30 ppm	1,334,065	49,410	98,684	1492	4,024
20 ppm	2,723,697	100,878	199,562	2176	6,200
10 ppm	4,025,860	149,106	348,668	1930	8,130
5 ppm	2,229,700	82,581	431,249	534	8,664
1 ppm	1,627,100	60,263	491,512	390	9,054
0.5 ppm	370,390	13,718	505,230	9	9,063
0.1 ppm	130,500	4,833	510,064	1	9,064
0	1,119,300	41,456	551,519	2	9,066
PCB Mass Removal =					82%

Shallow Dredging					
Threshold Value	Cubic Feet Between Threshold Values	Cubic Yards Between Threshold Values	Cumulative Volume Removed (CY)	Mass Between Threshold Values (kg)	Cumulative Mass (kg)
50 ppm	771,751	28,583	28,583	1726	1726
40 ppm	524,962	19,443	48,026	755	2,481
30 ppm	1,297,562	48,058	96,084	1451	3,932
20 ppm	2,698,220	99,934	196,018	2155	6,087
10 ppm	3,290,500	121,870	317,889	1577	7,664
5 ppm	1,201,300	44,493	362,381	288	7,952
1 ppm	1,081,400	40,052	402,433	259	8,212
0.5 ppm	318,350	11,791	414,224	8	8,219
0.1 ppm	15,100	559	414,783	0	8,219
0	1,173,800	43,474	458,257	2	8,221
PCB Mass Removal =					75%

Table 4-4: Linear Feet of Sheet Piling Affected in Each Alternative Dredging Scenario

Shallow Dredge Option					Deep Dredge Option					Bank-to-Bank-to-Bedrock
Left Bank Station No.	Feet Impacted	Right Bank Station No.	Feet Impacted	Total Feet Impacted	Left Bank Station No.	Feet Impacted	Right Bank Station No.	Feet Impacted	Total Feet Impacted	Total Feet Impacted
192	100	189	100	200	194	100	189	100	200	
191	100	188	100	200	193	100	188	100	200	
190	100	187	100	200	192	100	187	100	200	
189	100	186	100	200	191	100	186	100	200	
187	100	185	100	200	190	100	185	100	200	
186	100	184	100	200	189	100	184	100	200	
185	100	183	100	200	187	100	183	100	200	
184	100	182	100	200	186	100	182	100	200	
183	100	181	100	200	185	100	181	100	200	
179	100	180	100	200	184	100	180	100	200	
178	100	179	100	200	183	100	179	100	200	
177	100	178	100	200	179	100	178	100	200	
176	100	177	100	200	178	100	177	100	200	
175	100	176	100	200	177	100	176	100	200	
174	100	175	100	200	176	100	175	100	200	
173	100	174	100	200	175	100	174	100	200	
172	100	173	100	200	174	100	173	100	200	
171	100	172	100	200	173	100	172	100	200	
170	100	171	100	200	172	100	171	100	200	
169	100	170	100	200	171	100	170	100	200	
168	100	169	100	200	170	100	169	100	200	
167	100	168	100	200	169	100	168	100	200	
166	100	167	100	200	168	100	167	100	200	
165	100	166	100	200	167	100	166	100	200	
164	100	165	100	200	166	100	165	100	200	
163	100	164	100	200	165	100	164	100	200	
162	100	163	100	200	164	100	163	100	200	
161	100	162	100	200	163	100	162	100	200	
		161	100	100	162	100	161	100	200	
					161	100	159	100	200	
					159	100	158	100	200	
					158	100	157	100	200	
					157	100	156	100	200	
					156	100	152	100	200	
					154	100			100	
					153	100			100	
					152	100			100	
					150	100			100	
					149	100			100	
					148	100			100	
	2800		2900	5,700		4,100		3,400	7,500	21,000

The three dredging alternative plans were assessed to determine their effectiveness at achieving target sediment removal volumes, attaining project goals and meeting costs. The evaluation is described in detail in Technical Appendix E, “Dredging Scenarios and Sediment Volume Estimates.” The assessment included the application of the following general guidelines.

- a. determine post dredging surface weighted PCB concentrations for each scenario;
- b. determine sediment volume removed for each scenario;
- c. determine PCB mass removed for each scenario;
- d. determine linear feet of bank affected for each scenario; and
- e. Assess scenarios, considering cost and environmental items.

The assessment process provided the following specific information for each dredging alternative under consideration:

- 1) Bank to Bank to Bedrock Dredging-
Would involve extensive dredging and removal of all of the sediments in the lower river, to the maximum extent possible. New clean sediments would in time replace all of the contaminated sediments. This would be very costly, would present more shoreline structural stability concerns, and was determined to be considerably more extensive than required to meet the project goals and objectives.
- 2) Deep Dredging-
Would involve more extensive dredging removing all of the TSCA PCB-contaminated sediments but leaving some lower level contaminated sediments and virgin sediments that would be extensively covered by new clean sediments (removal of 82% of total estimated PCB mass), and
- 3) Shallow Dredging-
Would leave a small amount of TSCA PCB contaminated sediments, some lower level contaminated sediments, and virgin sediments that would be extensively covered by new clean sediments (removal of 75% of total estimated PCB mass),

Comparison of Estimated Sediment Dredging Volumes (cu. yds.)
by Alternative and Location

Dredge Alternative	Upstream of the 5 th Street Bridge	Down Stream of the 5 th Street Bridge	Overdredging ¹ (if used)	Total with Overdredging
Bank-to-Bank-to-Bedrock	1,010,000	115,000	25,000	1,150,00
Deep Dredge	560,000	115,000	21,000	696,000
Shallow Dredge	460,000	115,000	17,000	592,000

(1) All overdredging is upstream of the 5th Street Bridge.

Comparison of Estimated TSCA and Non-TSCA Sediment Volumes (cu. yds.) by
Alternative and Sediment Classification

Dredge Alternative	Total TSCA ¹	Total Non-TSCA ²
Bank-to-Bank-to-Bedrock	150,000	1,000,000
Deep Dredge	150,000	546,000
Shallow Dredge	150,000	442,000

(1) All TSCA sediment is located upstream of the 5th Street Bridge.

(2) Includes overdredged material.

The Bank-to-Bank-to-Bedrock alternative is the most protective and conservative in terms of PCB mass reduction, addressing most use impairments, and reducing scour potential. It attempts to remove practically all of the PCBs in this system. However, the Bank-to-Bank to-Bedrock alternative also has extremely high implementation costs and concerns regarding river bank stability. The Deep Dredging alternative provides a similar degree of protectiveness and accomplishes much of what the Bank-to-Bank-to-Bedrock does at a significantly lower cost. Deep Dredging removes all TSCA sediment and a significant PCB mass (82%), substantially reducing any future scouring and potential release of elevated levels of contaminants. This large PCB mass removal gives greater assurance of open-water disposal for future dredging. In addition, Deep Dredging will likely facilitate river bank stability, help sustain habitat diversity, and result in less impact to ecological communities along the channel edges, compared to Bank-to-Bank to-Bedrock dredging. Given the high costs and logistical issues inherent with Bank-to-Bank to-Bedrock, and the positive anticipated results of the Deep Dredging Alternative, the Deep Dredging alternative is the recommended sediment dredging alternative for the ARP project.

4.4.2.4 Dredging Alternatives Risk Assessment

Dredging alternatives were assessed and evaluated from a human and ecological risk perspective as described in Technical Appendix F, “Environmental Risk Assessment and Management Considerations for Dredging the Ashtabula River and Harbor”, and EIS Appendix EA-C, “Environmental Risk Management Considerations for the Ashtabula River and Harbor.” Generally, a risk assessment consists of a qualitative and/or quantitative evaluation of the actual or potential impacts of contaminants on humans, animals, and plants.

To assess the proposed dredging alternatives from a risk perspective, a weight of evidence approach that considers several factors, not just risk, was employed. An Alternatives Matrix (see Table 4-5), comprised of the three dredging alternatives, was developed and considers the following factors: 1) PCB mass removed; 2) surficial PCB sediment concentration after dredging; 3) beneficial uses addressed; and 4) scour and release potential.

The findings of the Risk Assessment indicate that if either the Bank-to-Bank-to-Bedrock or Deep Dredging alternatives are implemented, and the majority of PCB mass is removed, long-term protectiveness is expected to be achieved. The GMS model indicates that after dredging, surface area weighted PCB sediment concentrations will approximate current surficial concentrations. Ongoing sedimentation in the Ashtabula River (assumed for this study to be 0.5 feet per year)

Table 4-5: Alternative Dredging Scenarios for Contaminant Removal and Ecological Restoration and Preservation.

Dredging Ecological Restoration/Preservation Scenarios for Contaminant Removal and Assessment/Evaluation Items

Item	Dredging for Contaminant Removal		
	Bank to Bank To Bedrock	Deep Dredge	Shallow Dredge
Construction First Cost \$			
Dredge :	30,448,750	20,153,500	17,742,000
Disposal:	35,051,250	29,746,500	27,758,000
Total :	65,500,000	49,900,000	45,500,000
Study E&D S&A RE			
Project Cost: (Present Worth)	72,900,000	56,500,000 (62,038,800)	51,800,000
Project Economic Benefits (Present Worth)			
NED :	65,347,100	65,616,200	23,813,100
Regional :		113,268,100	
Total :	176,235,500	(178,884,300)	36,086,000
(1997)(Sept 1996 Price Levels)			
Practicality*	Poor	Good	Good
Ecological Improvement Rank	2	1	3
Dredged (CY)	1,150,000	696,000	592,000
TSCA (CY) Material Removed	All 150,000	All 150,000	Most 149,500

Item	Dredging for Contaminant Removal		
	Bank to Bank To Bedrock	Deep Dredge	Shallow Dredge
Shoreline Bulkhead Affected	21,000 (Ft)	7,500 (Ft)	5,700 (Ft)
PCB Mass Removed	98%	82%	75%
PCB ppm Surface Concentrate Initial(6.29)	8.58	7.47	6.27
Beneficial Uses Addressed			
-Open Lake Disposal	Excellent	Good	No Dif.
-Recreation/ Commercial Shipping	Excellent	Excellent	Good
-Fish Advisory Lifted	Excellent	Good	No Dif.
-Long-term Risk Reduction	Excellent	Good	No Dif.
-Habitat Quality	Good	Excellent	Good
<i>Scale: (Poor, Low, No Difference, Good, Excellent)(Reference the Risk Assessment)</i>			
Scour Release Potential (& to Lake)	Low	Low	Medium

Scale: (Low, Medium, High)(Reference the Risk Assessment)

Table 4-5: Alternative Dredging Scenarios for Contaminant Removal and Ecological Restoration and Preservation (cont.).

Item	Dredging for Contaminant Removal		
	Bank to Bank To Bedrock	Deep Dredge	Shallow Dredge
Water Quality Turbidity	Low	Low	Medium
Benthic Habitat Chemically Restored (3' Deep)	~ 20 Acres ~ 100,000 (CY)	~ 20 Acres ~ 100,000 (CY)	< 20 Acres < 100,000 (CY)
Benthic Habitat & Scour Protection Restored (6' Deep)	~ 20 Acres ~ 200,000 (CY)	~ 20 Acres ~ 200,000 (CY)	< 20 Acres < 200,000 (CY)
Aquatic/Fishery Shallows (Acres) Initially Impacted	~ 10.5	~ .33	~ .33
Physical Habitat Improvement (HAP QHEI up to)	NA	NA	NA
Fishery Improvement (HAP IBI up to)	Good +12	Good +12	Fair +10
Macroinvertebrate Improvement (HAP ICI up to)	Good +20	Good +20	Fair +18
Anomally Reduction (HAP)	Good	Good	Fair

Item	Dredging for Contaminant Removal		
	Bank to Bank To Bedrock	Deep Dredge	Shallow Dredge
Accomplishment of Sediment Contaminant Reduction Objective	Good	Good	Poor
Accomplishment of Total Ecological Restoration Objective	Good	Good	Poor

Notes:

* Cost, volume, and bulkheading concerns.

General Scales: (Good, Fair, Poor) (Low, Medium, High)

Scale: (Poor, Low, No Difference, Good, Excellent) (Reference the Risk Assessment)

EAA - Ecological Assessment Area

EAA 3 - Mouth of River to Fifth Street Bridge

EAA 2 - Fifth Street Bridge through Upper Turning Basin

(HAP QHEI) - Habitat Assessment Procedures Qualitative Habitat Evaluation Index

(HAP IBI) - Habitat Assessment Procedure Index of Biotic Integrity

(HAP ICI) - Habitat Assessment Procedure Invertebrate Community Index

NA - Not Applicable

will gradually cover any low level residual contaminants left behind. Since 1983, significant reductions in the concentration of PCBs in fish have occurred due in part to cleaner sediments burying contaminated sediments, and also due to regulation of discharges. After cleanup, it is expected the fish consumption advisory will eventually be lifted and long-term protection will be achieved because the majority of the PCB mass will be removed. To maintain navigable depths for recreational purposes, future dredging in the lower river will likely be conducted to no more than 8 feet depth. Therefore, an adequate buffer will exist between the residual contamination left behind and the amount of clean sediment that will gradually cover it to help ensure long-term protection of human health and the environment.

4.4.2.4.1 Radiological Risk Assessment

Risk assessments were made by the U.S. Environmental Protection Agency (USEPA) Region 5 involving inadvertent and unknowing use of Ashtabula River sediments (see Appendix G). The first risk assessment was based upon a resident-farmer applying these sediments, left below the cutline for chemical removal, to their property and growing foodstuffs there. There were potentials for external exposure, plant ingestion, soil ingestion and dust inhalation (including radon + decay products) risks. The second risk assessment was based upon a worker being exposed as they dredged the chemically contaminated sediments or as they unknowingly dredged sediments above the cutline. There were potentials for external exposure and soil ingestion risks.

The results for the Resident-Farmer showed that the total risk from all pathways to a resident (born on the property and living there for 30 years) was about 1×10^{-4} . The risk was about equally apportioned between external exposure, plant ingestion and inhalation of radon + decay products. The greatest impact was on the older age groups; older child (6 - 12 years), teenager (13 - 19 years) and adult (20 - 30 years) who had longer exposure periods. The other age groups [baby (0 - 1 year), older baby (1 - 2 years), young child (3 - 5 years)] were lesser impacted. 1×10^{-4} is at the upper bound of the acceptable risk range for lifetime cancer risk found in USEPA's guiding document, the National Oil and Hazardous Substances Pollution Contingency Plan (NCP).

The sediment concentrations that led to this risk were found in the Uranium, Thorium and Actinium Decay Series. In no case were any concentrations more than twice background levels for the river and in most cases these were 50% or less over background. The levels measured here are one picocurie per gram (pCi/g) or less background and less than 0.5 pCi/g additional in the sediments.

Thus, even though the 30-year risk is at the upper end of the NCP risk range, the small deviation from background radiation sediment levels does not warrant further dredging of the river.

For the Worker-Dredger the total risk for 2 year plus 4 month excavation project is about 5×10^{-5} . This risk is within the 10^{-6} to 10^{-4} risk range in the NCP.

The maximum levels found in these sediments reach about 45 pCi/g uranium-238 + decay products (over background) and about 57 pCi/g uranium-234 (over background) and. These

concentrations diverge substantially from background and warrant a health and safety plan and worker protection. However, during the chemical cleanup workers will be under such a plan and will be wearing protective clothing. Thus, if the health and safety plan specifically deals with radiation and the worker is monitored for radiation (e.g., dosimeter, radiation frisking, etc.) this should be adequate.

In the case of an unknowing Worker-Dredger, the high radioactive concentrations should be a matter of concern even if the risks are still within the NCP risk range. In radiation public health, the philosophy of ALARA (radiation exposures should be As Low As Reasonably Achievable) is always applied. Removal of these contaminated sediments is a prudent action that would prevent inadvertent exposure of a worker-dredger and keep their potential doses ALARA.

4.4.2.5 Recontamination Assessment

An Ashtabula River Recontamination Assessment was conducted for the study. It considered the Fields Brook remediation scenario, as well as low, average, and high flow events from Fields Brook and the Ashtabula River. Based upon the results of the Recontamination Assessment, the low level of PCB that is deposited into the Ashtabula River from Fields Brook is less than 2 parts per billion (ppb) under all of the scenarios that were modeled. This presents a negligible recontamination scenario. Appendix H, "Ashtabula River Recontamination Assessment" provides details on this assessment.

4.4.2.6 Dredging Alternatives Assessment: Summary and Recommendation

The ARP formulated three incremental dredging alternative scenarios: Shallow Dredge, Deep Dredge and Bank-to-Bank-to-Bedrock Dredge. These alternatives were assessed and evaluated to determine which alternative would best achieve the established contaminated sediment removal goals and objectives of the ARP project.

Initial assessment output measures included:

1. Costs, Economic Benefits.
2. Practicality, Ecological Improvement (Rank).
3. Quantities Dredged.
4. TSCA (PCB) Sediment Removed.
5. Shoreline Bulkhead Affected.
6. PAH/PCB Mass Removed.
7. Initial PAH/PCB Surface Concentrations.
8. Beneficial Uses Addressed.
9. Scour Release Potential (including to Lake Erie).

Other assessment output measures included items such as: PCB Bio-accumulation in Fish Tissue and Advisories, Water Quality (Turbidity), Benthic Habitat Chemically Restored, Benthic Habitat and Scour Protection Area Chemically Restored, Aquatic Shallows Initially Impacted, Ohio Habitat Assessment Procedures (HAP) Biological Indices (Qualitative Habitat Evaluation Index QHEI, Fishery Index of Biotic Integrity IBI (incl. T&E Species), Macroinvertebrate

Invertebrate Community Index ICI, Anomaly Reductions) Improvements, Accomplishment of Sediment Contaminant Reduction Objective and Accomplishment of Total Ecological Restoration Objective. See Table 4-5 for more detail.

The assessment of the three dredging alternatives resulted in the identification of the Deep Dredge alternative as the optimized and recommended alternative for the dredging component of the project. It removes the amount of contaminated sediment consistent with the ARP's goals, moderates costs and adverse impacts, and meets river environmental cleanup and goals and objectives.

The selected Deep Dredge alternative would be implemented in the Project Area to remove a total of 696,000 cubic yards of contaminated sediments. Sediment removal by river segment would be as follows:

Downstream of the 5th Street Bridge - Dredging would remove approximately 115,000 cubic yards of contaminated sediment. Dredging would address PAH contamination, which was considered to be the primary contaminant of concern in this area.

Upstream (south) of the 5th Street Bridge - Dredging would remove approximately 581,000 cubic yards of contaminated sediments which includes up to 150,000 cubic yards of significantly PCB contaminated sediment, which will be handled and disposed of in accordance with TSCA regulations.

Dredging of clean sediment from the river channel upstream of the Upper Turning Basin (and possibly from the Outer Harbor), may be possible to complete as part of the Corps' normal O & M program. This sediment could be deposited as cover into the Deep Dredge Area for at least one cycle of the operations and maintenance dredging program. This could expedite the formation of a clean sediment cover for benthic recovery at no additional O&M cost and possibly savings.

4.4.3 Transfer/Dewatering Alternatives

4.4.3.1 Sediment Dewatering Alternatives

Sediments will require dewatering to accommodate transport, and to meet the legal requirements of containment of no free liquid prior to being final landfilled. Numerous dewatering technologies were reviewed, including passive dewatering technologies (i.e., primary settling, solar evaporation, surface drainage, subsurface drainage, wick drains), mechanical dewatering technologies (i.e., belt filter press, centrifugation, gravity thickeners, chamber filtration, vacuum filtration), and active evaporation technologies. These were evaluated in light of the scope of the project (sediment volumes and quality) and economic, engineering, and environmental efficiencies.

Based on this evaluation the ARP recommended that the dredged sediments be dewatered using passive dewatering technologies, regardless of whether the sediments are dredged mechanically or hydraulically. Several available technologies could be used in conjunction with one to

optimize the dewatering process. Advantages of passive dewatering include the ability to dewater large quantities of sediment at low cost. Disadvantages include the large land area required, and the time required to achieve dewatering. The recommended transfer/dewatering facility site would be of sufficient size to accommodate sediment volume and dewatering requirements using passive technologies. The sediment dewatering assessment is presented in detail in Appendix J, “Sediment Dewatering Alternatives and Selection.”

4.4.3.2 Alternative Treatment Technologies

4.4.3.2.1 TSCA Sediment Treatment Alternatives

Suitable disposal of dredged PCB (TSCA) contaminated sediment can be accomplished in one of three ways:

- a. Disposal of the dredged, dewatered TSCA sediment in an existing TSCA approved landfill (Option 1)
- b. Treatment of the dredged, dewatered TSCA sediment to achieve lower PCB concentrations, followed by disposal of the treated residue in a solid waste landfill (Option 2)
- c. Disposal of the dredged, dewatered TSCA sediment to in a appropriately designed new TSCA approved upland landfill (Option 3)

Option 1 can only be used for disposal of the TSCA sediment if an approved facility is available to accept TSCA sediment co-mingled with low level RAD waste sediments. Option 2 requires treatment of the dredged TSCA sediment and is contingent upon the availability of proven, technically feasible and cost effective treatment technologies for removing PCBs from dredged sediment. A technology screening and cost estimate was performed to assess the feasibility of Option 2 for facilitating optimal disposal of dredged TSCA sediment. The Treatment Technologies assessment is presented in considerable detail in Technical Appendix L, “Screening of Treatment Technologies and Cost Comparison of Potentially Feasible Alternatives.”

To assess the technical feasibility of treating PCB contaminated sediments, a suite of alternative treatment technologies were considered that are potentially capable of removing organic compounds from a solid matrix. These technologies were retained for further consideration if they have previously been demonstrated to successfully remove organic materials from or immobilize organic materials within a solid material on a commercial scale. Technologies that have been demonstrated only on a bench scale were eliminated from consideration, as were processes that appear attractive on a pilot scale but are commercially unavailable as full-scale equipment.

Preliminary cost estimates were prepared for the remaining alternative treatment technologies, which compared the treatment alternative and the associated disposal against the disposal of untreated sediments. Based upon this analyses, incineration followed by land disposal of the residue would cost \$270/ CY and thermal desorption followed by land disposal of the residue would cost \$290/CY, exclusive of costs for dredging, temporary storage, debris removal, dewatering, and treatment of removed water. These costs must be added to the above costs to

obtain total costs of treatment and disposal. These costs compare to \$196/CY for burial of untreated sediment in a TSCA landfill. Based upon these preliminary costs, landfill disposal of untreated sediment was determined to be more cost effective than burial of sediment treated to a lower contamination level.

4.4.3.2.2 Decant Water Treatment Alternatives

After initial settling, the decant water (supernatant) released from the dredged sediment during dewatering will be treated at the transfer/dewatering facility prior to release back into the Ashtabula River. Treatment alternatives were assessed in this regard and it was determined that the use of the treatment process presently being used at the Field Brook remediation project would be the recommended alternative for this project. This alternative consists of the use of flocculent polymers, multi-media filtration and activated carbon polishing to meet Ohio EPA State Water Quality Standards. Appendix M “Dewatering Facility and Water Treatment Technology” contains an outline of the proposed treatment processes in this regard.

4.4.3.3 Transfer/Dewatering Facility Alternatives

The ARP project involves the dredging of contaminated sediments and the placement of both TSCA and Non-TSCA dredged sediment into barges for transport to a transfer/dewatering facility. The transfer/dewatering facility would function as the focal point of sediment off-loading, dewatering and transport of the dewatered sediment to an upland landfill disposal facility. To accommodate this process, alternative transport methods were assessed as well as alternative sites for the transfer/dewatering facility to select a recommended alternative for each. Alternatives considered for transport of the dewatered dredged sediment to the disposal site included barge, pipe, truck, and/or rail, as appropriate. Generally, it was expected that if the material were to be piped to a disposal site, it would need to be piped as slurry and dewatered at the disposal site. If it were to be trucked or railed to a disposal site, it would need to be primarily dewatered at a developed harbor-front transfer site to avoid transport of more voluminous and less manageable slurry material. Two general transfer/dewatering facility scenarios were therefore considered based on these transport alternatives:

1. a barge pump-out setup where the dewatering facilities (several acres of settling basin/filtration/treatment facilities) would be located at the upland landfill disposal site; and
2. A harbor-front setup where the transfer/dewatering facility would be located at the harbor front with transport of resulting dewatered sediment by truck or rail to the upland disposal site. If an in-lake CDF were to be utilized for disposal of dredged sediment (Non-TSCA), it would be barged and pumped or mechanically discharged into the CDF facility.

For the in-lake and pumping alternative, a preliminary coastal design for an offshore wave attenuation structure was prepared to provide shelter for scows, tugs, barges and pump-out facilities during unloading operations. This design can be found in Appendix Q, “Coastal Engineering Design.” The proposed design involves a rubble mound breakwater to be placed

parallel to shore, east of Ashtabula Harbor and offshore from the proposed upland disposal site. Alternative designs were also considered.

Initially, four vicinity and eleven specific sites were assessed and evaluated (see Figures 4-10 and 4-11) as potential sites for development of dredged sediment transfer/dewatering facilities. General assessment parameters included associated costs, availability, capacity, ease of access and transport, as well as engineering, environmental, community, and cultural resources considerations. Dredging and disposal site considerations were also included. As a result of the assessment of the alternative transfer methods and potential transfer/dewatering sites, truck transport to the disposal facility has been selected as the recommended method of dewatered TSCA and Non-TSCA sediment transport. Also, a shoreline transfer/dewatering facility site was identified along the eastern shore of the Ashtabula River and is the recommended alternative for this component of the project. See Figures 4-10 and 4-11 and Table 4-6 for more details.

4.4.4 Disposal Facility Alternatives

4.4.4.1 Disposal Facility Siting Alternatives

The ARP Siting Committee was formed and tasked with identifying alternative transfer and disposal sites for project dredged sediment. Alternative facilities for disposal of both TSCA and Non-TSCA sediment were assessed. Sediment disposal options for TSCA sediment included:

1. use of an existing regional TSCA permitted landfill disposal site; and
2. Construction of a new upland landfill disposal (TSCA cell) site.

When bulking, dewatering and settling of dredged sediments are considered, along with the disposal of 30,000 cu. yds. of sediment from the 1993 Interim Dredge CDF, the estimated required capacity of the disposal landfill facilities is summarized as follows.

Dredge Alternative	Total TSCA	Total Non-TSCA
Bank-to-Bank-to-Bedrock	100,000	700,000
Deep Dredge	100,000	400,000
Shallow Dredge	100,000	350,000

An application to U.S. EPA was also pursued that would permit the disposal of PCB contaminated sediments (with a concentration at or above 50 ppm) in existing Best Available Technology solid waste disposal facilities. Alternatives for sediment disposal options for Non-TSCA sediment that were evaluated included:

1. use of an existing area Non-TSCA permitted landfill disposal site;
2. construction of a new upland landfill disposal (Non-TSCA) site; and
3. Construction of a new in-lake CDF disposal site (Site P).

Figure 4-10: Considered Alternative Transfer/Dewatering and Disposal Sites.

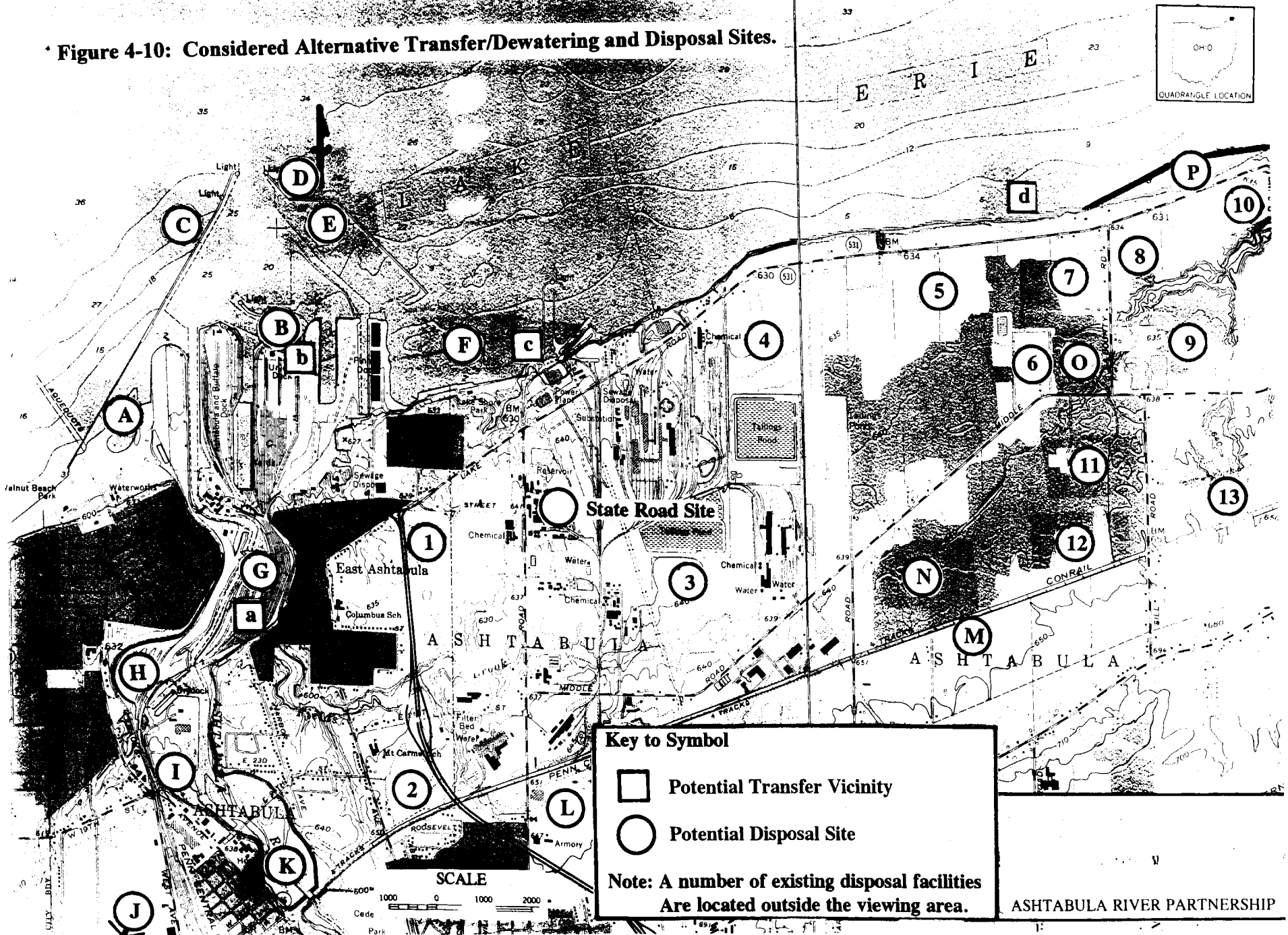

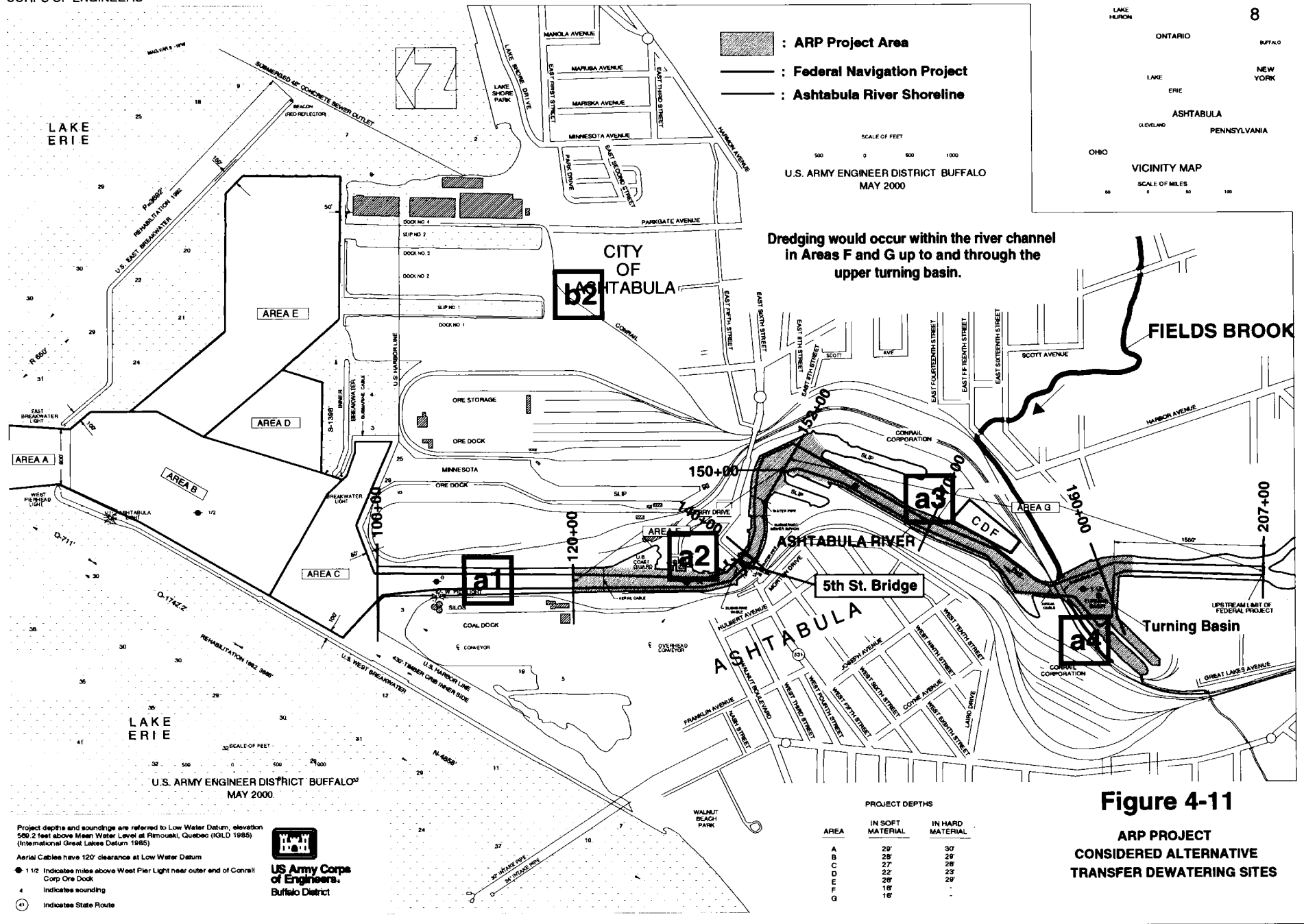

Table 4-6: Alternative Transfer/Dewatering Sites Assessment and Evaluation Matrix.

Ashtabula River Partnership

11/15/96

Transfer Sites General Assessment/Evaluation (Problem Areas)

General Evaluation Parameters	Sites										
	a1	a2	a3	a4	b1	b2	c1	c2	d1	d2	d3
Cost											
Available	●				●	●		●			
Capacity	0	0		0	0		0	0			
Ease of Access & Transport	0			0	0						
Engineering	0	0		0	0	0	0	0	0	0	0
Environment (Natural)				0			0		0	0	0
Community (Social)	0	0	0	0	0		0				
Cultural Resources				0			0		0	0	0

Key

- - Major concern essentially contributing to the elimination of the site from further consideration
- 0 - Potential concern

Sites (See Maps)

a.

- a1. Conrail Docks
- a2. Sidley Docks
- a3. Conrail Interim CDF Site
- a4. Jack's Marine

c.

- c1. Lake Shore Park
(Tandem Barge)
- c2. CEI Power Plant

b.

- b1. Conrail Docks
- b2. Pinney Docks

d.

- d1. Pumpout to Site 5
- d2. Pumpout to Site 7
- d3. Pumpout to CDF Site P

Initially, 36 alternative sites were assessed as potential sites for development of disposal facilities. Potential disposal sites were initially identified primarily via previous studies, committee member knowledge of potential available areas, and by identifying non-wetland areas as depicted by the U.S. Fish and Wildlife Service National Wetlands Inventory Map.

Assessment parameters were developed which included engineering, economic and environmental concerns. Sites and alternative scenarios were further assessed per various planning objectives and associated engineering, economic, and environmental (physical, natural, human, community, social, cultural resources) parameters.

The 36 sites were narrowed down to five and then to two upland sites (Sites 5 and 7). The in lake site/CDF facility (Site P) was considered but deleted from further consideration due to inherent environmental problems associated with the level of contamination in the river sediments. For this reason, it could be utilized only for disposal of Non-TSCA dredged sediment. Use of existing disposal facilities (as appropriate) was also considered. See Figure 4-10 and Table 4-7 for more details.

Initially, Sites 5 and 7 were selected as the recommended disposal sites for the project. Accordingly, more detailed geotechnical and environmental studies were conducted on these sites and the results of these indicated that either Site 5 or Site 7 would be geotechnically suited for development of upland disposal facilities. However, there would be problems with existing fill material at Site 5 and that a full scale development would have greater environmental impacts, particularly to wetlands, at Site 5 than at Site 7.

In the year subsequent to the August 1999 draft CMP, the ARP assessed and evaluated a number of additional alternative disposal facilities and identified the former RMI Sodium Plant site (State Road site) as an improved alternative disposal site over Sites 5 and 7 (see Figure 4-10).

The State Road site has been disturbed by past development and recent demolitions and is of little value to fish and wildlife and contains only minor wetlands (0.02± acre) at the eastern boundary and northeast corner. The Fields Brook remediation project material is being disposed of in part of this property. There is room for the TSCA dredged sediment to be disposed of in a developed facility adjacent to the Fields Brook remediation project disposal facility. There is also enough room for the ARP dredged Non-TSCA sediment to be disposed of in a developed facility adjacent to the Fields Brook remediation project disposal facility. Assessment/evaluation indicates that this is the overall preferred disposal alternative and is now the recommended disposal component for the project.

More detail on landfill siting and design criteria is provided in Sections 5.0 and 6.0 of this document and in Appendix P, "Landfill Design Criteria". The "HTRW Evaluation of Potential Landfill (disposal) Sites" is included in Appendix N and the geotechnical evaluation of Sites 5 and 7 and the State Road site is found in Appendix O, "Geotechnical Engineering."

Table 4-7: Alternative Disposal Sites Assessment and Evaluation Matrix.

ASSESSMENT/EVALUATION MATRIX ASSESS/EVAL PARAMETERS, CONSIDERED SITES, AREAS OF CONCERN													
ASSESSMENT/EVALUATION PARAMETERS	CONSIDERED SITES				NonTSCA Landfill				TSCA Landfill				
	1	2	3	4	5	6	7	8					
ECONOMICS													
Federal Cost													
Non Federal Cost													
Total Cost													
Benefits													
Net Benefits													
Average Annual Benefits													
Average Annual Costs													
B/C													
GENERAL & PRELIMINARY ENGINEERING													
Boundary (Ashtabula C/T,N of RR)						0	0	0	0				
Distance (Fav Miles From Harbor)						0	0	0	0				
Site Capacity (TSCA -15A, Total -30A)			0		?	?	?						
Availability (TBD)	•	?	?	•	?	?	?	?					
Transportation Facilities (Pipe, Truck, Rail)													
Location and Community Acceptability (Land Use, Safety, etc Perceptions)													
Soils/Geology & Design Material Friendly (TBD) Likely	?	?	?	?									
Location Restrictions (3745-27)	?	?	?	?	0	?	?	?	?				
Generally Solid Waste Material Shall Not Be Placed (some exceptions):													
1. within partially excavated sand/gravel pit													
2. within limestone/sandstone quarry													
3. within National/State park or recreation area													
4. within public water supply (5 year area soils migration limit)													
5. above sole source aquifer													
6. within 1000 feet of Federal/State Significant Natural/Historic Resource Area													
7. above underground mine													
8. above unconsolidated aquifer or within 1000 feet of associated water supply well (>100g/min/24hr)													
9. within 1000 feet of a water supply well/spring													
10. within 200 feet of the facility property line													
11. within 1000 feet of a domicile													
12. within 200 feet of a stream, lake, or wetland													
13. within 15 feet of the uppermost aquifer and the bottom of the clay liner													
14. within 10,000 feet of a jetport													
15. within 5,000 feet of a port													
16. within a regulatory floodplain (100 year flood)													
17. within 200 feet of a (holocene) fault													
18. within a significant seismic impact zone													
19. within an unstable area													
20. within 2000 feet of any Residence, school, hospital, jail, or prison (pertains to TSCA material)													
21. within any naturally occurring wetlands (TSCA)													
22. within any flood hazardous area, if the applicant cannot show that the facility will be designed, constructed, operated, and maintained to prevent washout by a 100 year flood or that procedures will be in effect to remove the waste before flood waters can reach it (TSCA)													
Safety (TBD)	?	?	?	?									

ASSESSMENT/EVALUATION MATRIX (Continued) ASSESS/EVAL PARAMETERS, CONSIDERED SITES, AREAS OF CONCERN													
EVALUATION/ASSESSMENT PARAMETERS	CONSIDERED SITES				NonTSCA Landfill				TSCA Landfill				
	1	2	3	4	5	6	7	8					
ENVIRONMENTAL													
NATURAL RESOURCES													
Air Quality													
Water Quality	?	?	?										
Sediment Quality		0					0	0	0				
Benthos							0						
Aquatic Vegetation							0						
Fisheries							0						
Wetlands	0	0	0	0									
Riparian							0	0					
Terrestrial Vegetation	0	0	0	0									
Wildlife	0	0	0	0									
Threatened Endangered	?	?	?	?									
HUMAN (MANMADE) RESOURCES													
Community and Regional Growth		?	?	?	?								
Displacement of People													
Displacement of Farms													
Business/Industry Employment/Income	?	?	?	?									
Public Facilities and Services													
Recreational Resources													
Property Value and Tax Revenue	0	0	0	0									
Noise and Aesthetics													
Community Cohesion		?	?	?	?								
CULTURAL RESOURCES													
Archeological	?	?	?	?									
Historical	?	?	?	?									

KEY

- Major concern which essentially contributed to the elimination of the site from further consideration.
- 0 Potential Parameter of Concern
- ? Parameter could be of some concern, but not enough current information to be sure.

Parameter probably not of significant concern based on current information

4.5 Aquatic Ecosystem Restoration Alternatives

The Ashtabula River system was divided into four Ecological Assessment Areas (EAA 1 through EAA 4) (see Figure 3-3). The initial evaluation of these areas arrived at the determination that EAA 2 and EAA 3 possess the greatest potential for aquatic ecosystem restoration. Alternatives for aquatic ecosystem restoration were developed in these areas to address the lack of physical fish and wildlife habitat (i.e., fishery shallows and vegetated littoral shoreline habitats) in the lower river.

EAA 2 is defined as from the 5th Street Bridge through the upper navigation channels and EAA 3 is defined as the reach from the mouth of the river to the 5th Street Bridge.

Alternative measures considered for EAA 2 and EAA 3 included acquisition of river shoreline property and construction of aquatic fishery shelves and vegetated shallows. These alternatives would include a mix of aquatic and shoreline plantings, stone and gravel bottom areas, and cover structures. The areas would be interfaced with the lake/river regime and would provide fish passage, cover, and habitat for feeding and spawning. See Figures 4-12 through 4-19 for illustration of these alternative measures.

There are limited alternative measures available that could be applied to EAA 3 since the area continues to be utilized for commercial shipping and docking and transfer of primarily coal, ore, and limestone. A long-term alternative of moderate cost and some benefit would be the construction of a man-made aquatic habitat shelf along the channel reach in EAA 3. The fishery shelf in this location would function primarily to facilitate movement of fisheries through the reach.

4.5.1 Aquatic Ecosystem Restoration Alternatives Assessment and Recommendation

Four aquatic ecosystem restoration alternatives were developed and assessed for EAA 2 and three aquatic ecosystem restoration alternatives were formulated assessed for EAA 3 (see Figures 4-12 through 4-19) Considering the developed aquatic ecosystem restoration goals and objectives, primary assessment output measures included: Costs, Economic Benefits, Practicality, Ecological Improvement (Rank), Shoreline Improvement (Acres), Shallows Improvement (Acres), Fishery Passage Length, Ohio Habitat Assessment Procedures (HAP) Biological Indices (Qualitative Habitat Evaluation Index QHEI, Fishery Index of Biotic Integrity IBI (including Threatened and Endangered Species), Macroinvertebrate Invertebrate Community Index ICI) Improvements, and Accomplishment of Supplemental Ecological Restoration Objective.

Table 4-8, which follows, shows the comparative assessment of aquatic ecosystem restoration alternatives and Figure 4-20 through Figure 4-22 depict existing and expected ecological indices (OHAP: QHEI, ICI, IBI) improvements along reaches of the lower river with implementation of dredging alternatives and some comparative alternatives data. These are discussed in more detail in Section 4, “Environmental Effects” and Appendices of the Environmental Impact Statement.

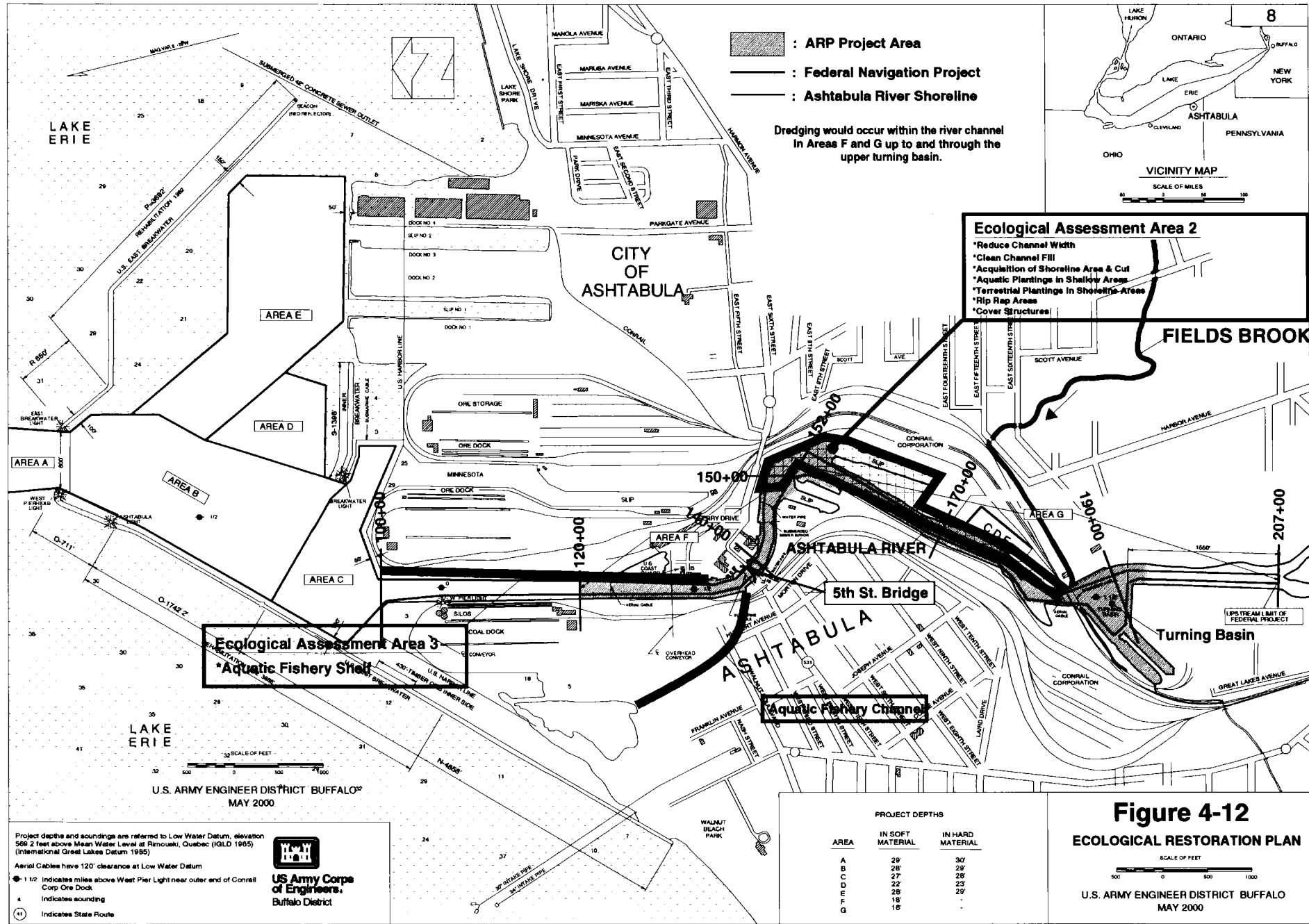

- : ARP Project Area
- : Federal Navigation Project
- : Ashtabula River Shoreline

Dredging would occur within the river channel in Areas F and G up to and through the upper turning basin.

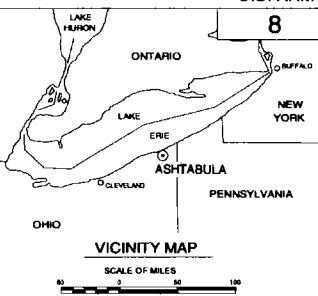

Ecological Assessment Area 2

- *Reduce Channel Width
- *Clean Channel Fill
- *Acquisition of Shoreline Area & Cut
- *Aquatic Plantings in Shallow Areas
- *Terrestrial Plantings in Shoreline Areas
- *Rip Rap Areas
- *Cover Structures

Ecological Assessment Area 3

- *Aquatic Fishery Shelf

Aquatic Fishery Channel

AREA	PROJECT DEPTHS	
	IN SOFT MATERIAL	IN HARD MATERIAL
A	28'	30'
B	28'	28'
C	27'	28'
D	22'	23'
E	28'	28'
F	18'	
G	18'	

Figure 4-12
ECOLOGICAL RESTORATION PLAN

SCALE OF FEET
 0 500 1000

U.S. ARMY ENGINEER DISTRICT BUFFALO
 MAY 2000

Project depths and soundings are referred to Low Water Datum, elevation 569.2 feet above Mean Water Level at Rimouki, Quebec (IGLD 1985) (International Great Lakes Datum 1985)

Aerial Cables have 120' clearance at Low Water Datum

● 1/2 Indicates miles above West Pier Light near outer end of Conrail Corp Ore Dock

4 Indicates sounding

④ Indicates State Route



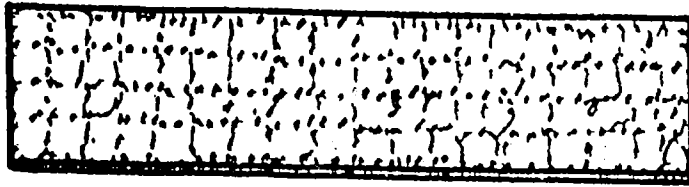

Plan View

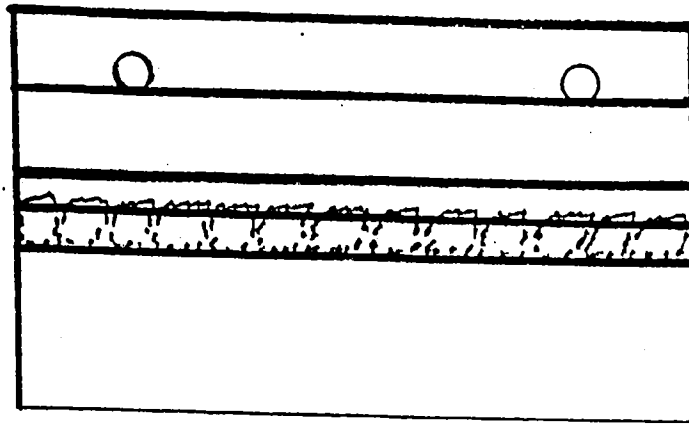

Elevation

FISHERY SHELF

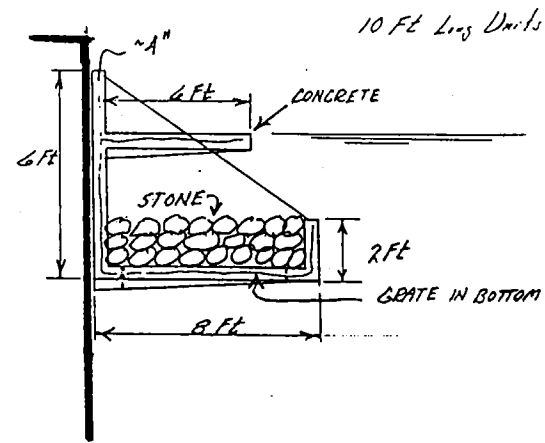

Cross-Section

Figure 4-13: EAA 3: Plan 2 - Aquatic Fishery Shelf - Hung.

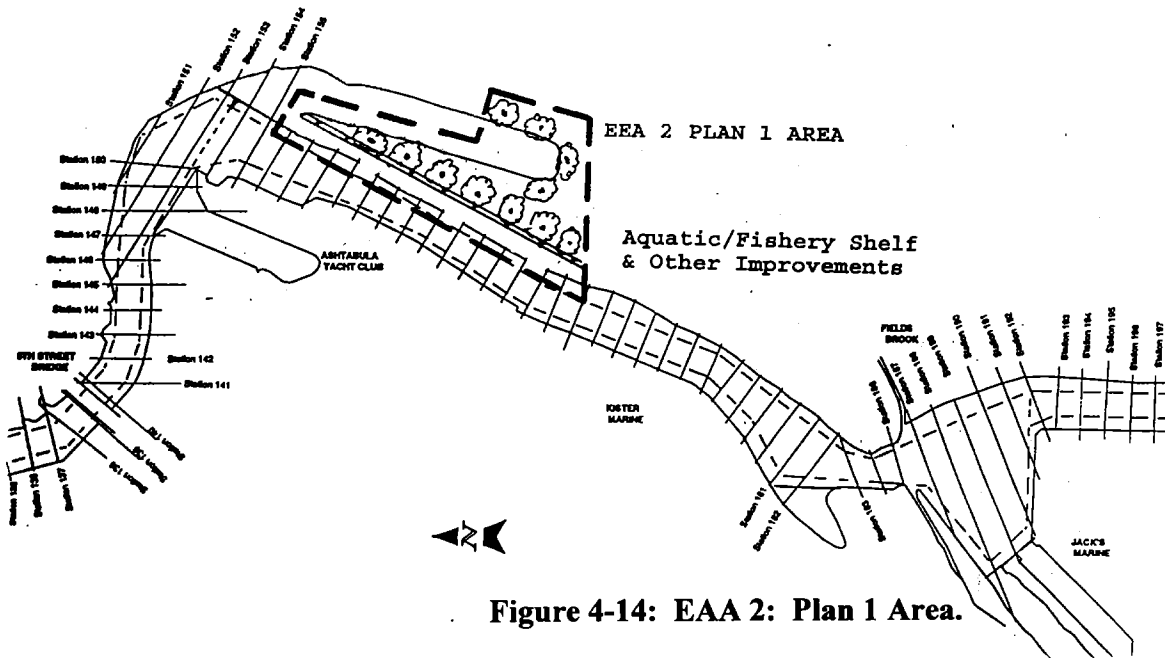

Figure 4-14: EAA 2: Plan 1 Area.

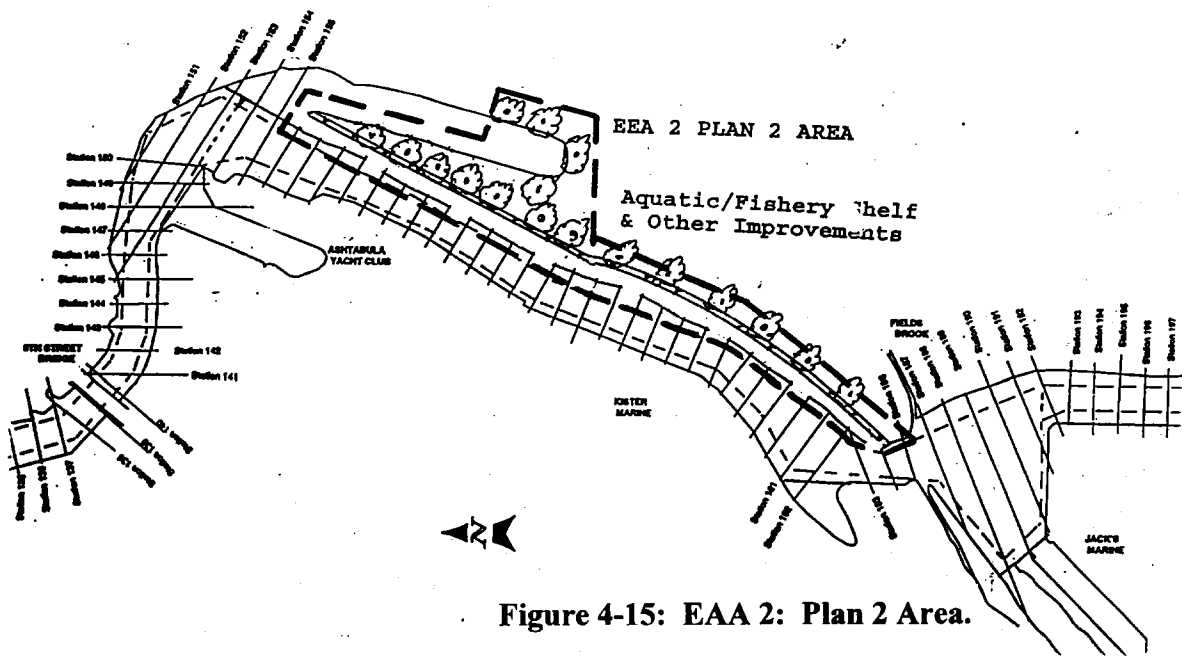

Figure 4-15: EAA 2: Plan 2 Area.

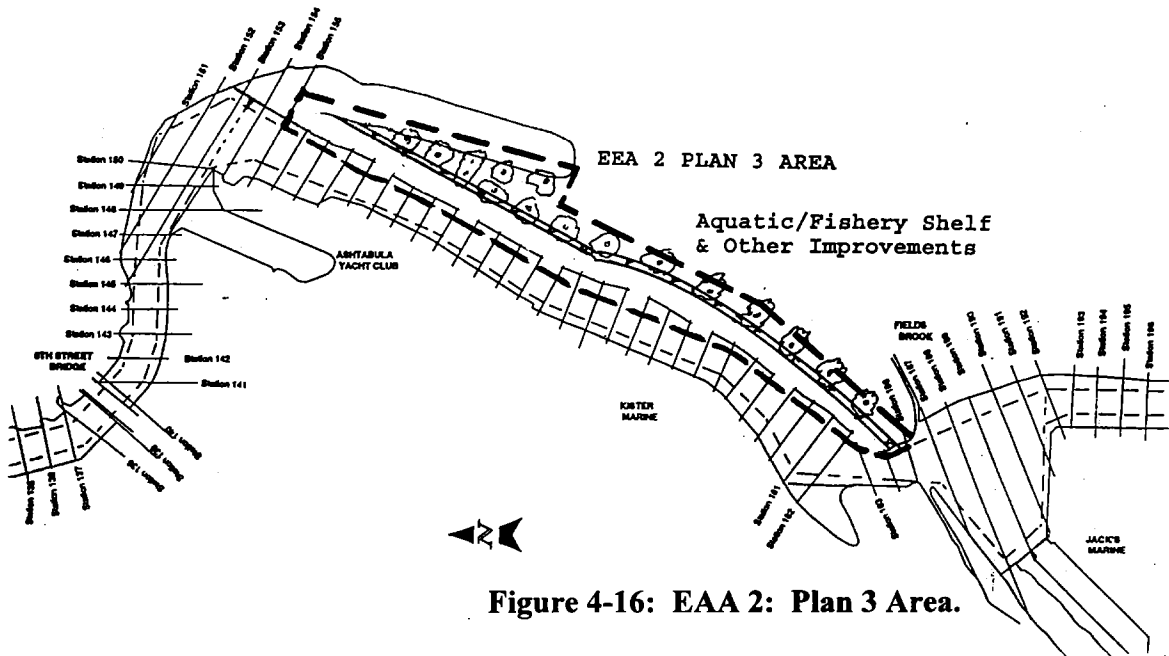

Figure 4-16: EAA 2: Plan 3 Area.

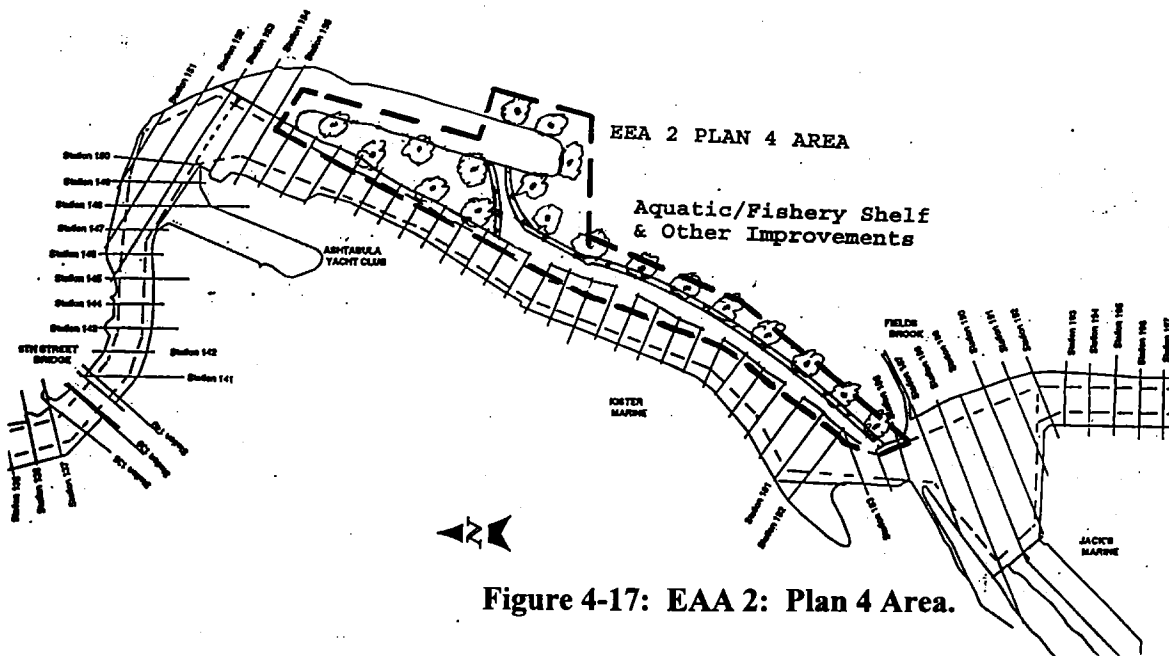
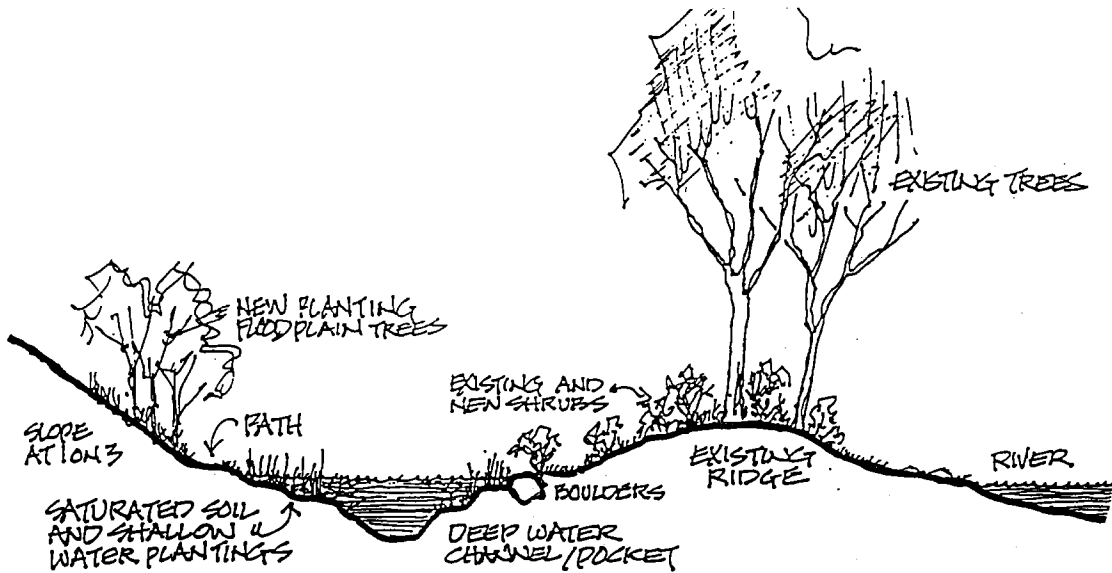
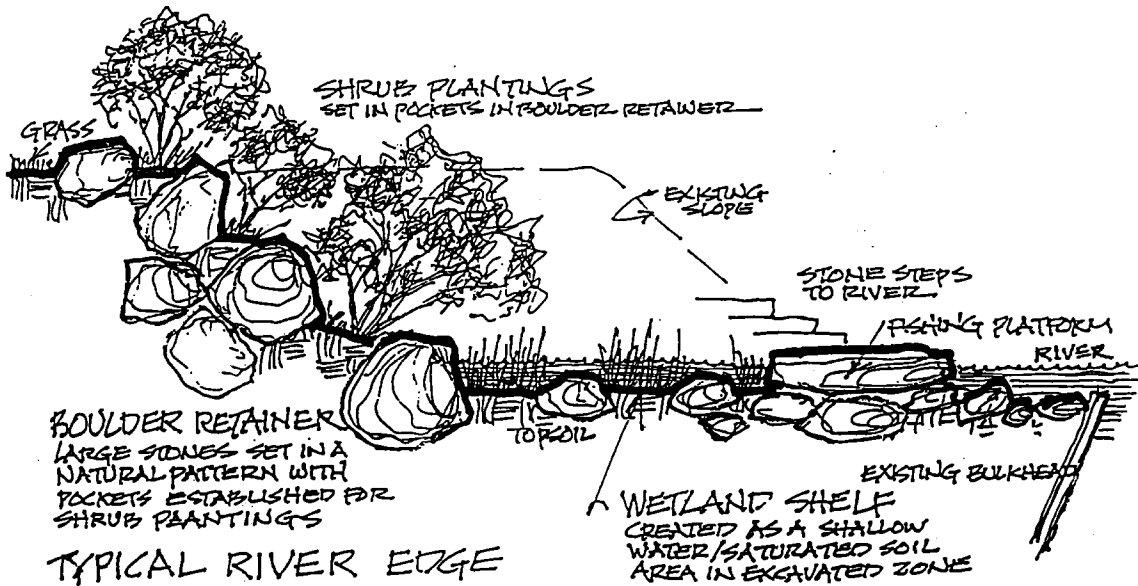

Figure 4-17: EAA 2: Plan 4 Area.



Source: Buffalo River Remedial Action Plan
 (Sterns and Wheler) (Integrated Site, Inc.)

Figure 4-18: EAA 3: Plan 1 Aquatic Shelf Cut (Embankment Cutback).



Source: Buffalo River Remedial Action Plan
 (Sterns and Wheler) (Integrated Site, Inc.)

Figure 4-19: EAA 3: Plan 3 - Aquatic Fishery Diversion Channel (By-Pass Cut).

Table 4-8: Comparative Assessment of Potential Alternative Ecological Restoration and Preservation Measures (EAA 2 and EAA3) for the Ashtabula River.

Summary Assessment Items Item	(Ecological Assessment Area 3 Plans)			(Ecological Assessment Area 2 Plans)			
	Plan 1	Plan 2	Plan 3	Plan 1	Plan 2	Plan 3	Plan 4
	Aquatic/Fishery Shelf Cut	Aquatic/Fishery Shelf Hung	Aquatic/Fishery By-Pass Cut	Conrail Slip & Aquatic/Fishery Shelf Cut	Conrail Slip & Aquatic/Fishery Shelf Extended	Aquatic/Fishery Shelf Cut	Conrail Slip & Aquatic/Fishery Shelf Cut
Construction First Cost (+12.5%)	\$ 400,662	\$ 313,111	\$ 787,313	\$ 1,250,004	\$ 1,537,136	\$ 400,662	\$ 447,237
Project Cost: (Present Worth)	\$ 450,745	\$ 352,250	\$ 885,727	\$ 1,406,255	\$ 1,729,279	\$ 450,745	\$ 503,142
Project Economic Benefits (Present Worth)							
NED :		302,508					\$ 817,892
Regional :		280,962					\$ 759,638
Total :	(+/-)	\$ 583,470	(+/-)	(+/-)	(+/-)	(+/-)	\$1,577,530
Practicality*	Poor	Fair	Poor	Good	Good	Good	Good
Ecological Improvement Rank	1	3	2	2	1	4	3
Shoreline Improvement (Acres)	0.7	0.5	1.5	3.5	4.0	0.7	0.7+Acq.
Shallows Improvement (Acres)	0.7	0.1	1.5	2.5	3.0	0.7	0.7+Acq.
Fishery Passage Length	Good	Good	Good	Poor	Good	Good	Good
Physical Habitat Improvement (HAP QHEI up to)	Fair +5	Fair +4	Fair +5	Good +8	Good +9	Good +7	Good +8
Fishery Improvement (HAP IBI up to)	Fair +4	Fair +3	Fair +4	Good +11	Good +12	Good +10	Good +11
Macroinvertebrate Improvement (HAP ICI up to)	Fair +4	Poor +2	Fair +4	Good +13	Good +14	Good +12	Good +13
Supplemental Accomplishment of Ecological Restoration Objective	Fair	Fair	Fair	Good	Good	Good	Good

Notes:

* Commercial shipping activities pertaining to coal transshipment and storage. Coal dust problem.

* Recreational boating channel area. Available shoreline area.

General Scale: (Good, Fair, Poor)(Aqu. = Acquisition)

(HAP QHEI) - Habitat Assessment Procedure Qualitative Habitat Evaluation Index

(HAP IBI) - Habitat Assessment Procedure Index of Biotic Integrity

(HAP ICI) - Habitat Assessment Procedure Invertebrate Community Index

Figure 4-20: Comparison of Relative Habitat Quality of the Ashtabula River Lacustrary Areas.

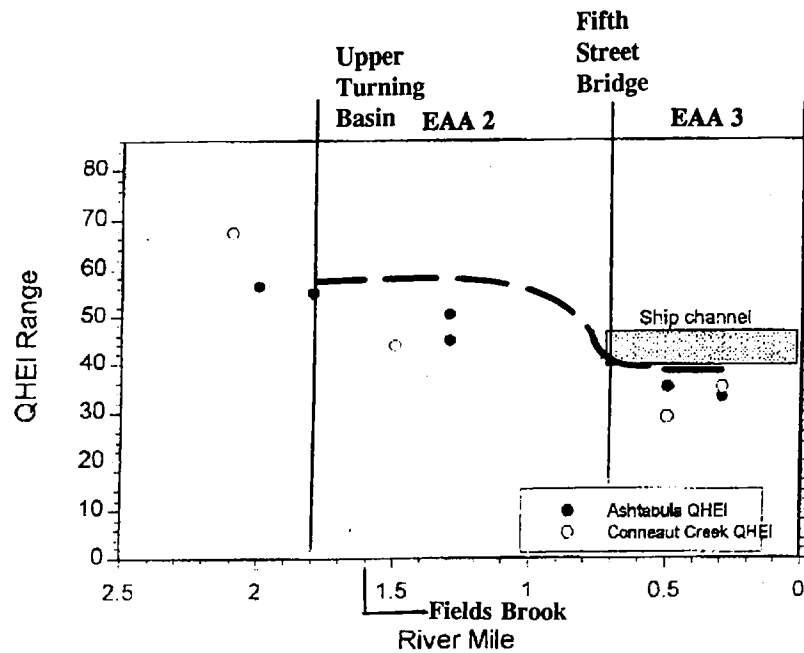

FIGURE 4.1

A comparison of relative habitat quality of the Ashtabula and Conneaut lacustrary areas.

HQEI - Qualitative Habitat Evaluation Index (Physical)

IMPROVEMENT MEASURES

Dredging/Aquatic/Fishery Shallows (* Recommended Plan)
(Plans Ecological Improvements Rank)

	Cost	IBI Score	Cost/Unit
Ecological Assessment Area (EAA) 3			
Plan 1 - Aquatic/Fishery Shelf Cut	\$ 450,745	+5	\$ 90,149
Plan 3 - Aquatic/Fishery Diversion/By-Pass Cut	\$ 885,727	+5	\$ 177,145
* Plan 2 - Aquatic/Fishery Shelf Hung	\$ 352,250	+4	\$ 88,063
Ecological Assessment Area (EAA) 2			
Plan 2 - Conrail Slip and Aquatic/Fishery Shelf Cut Extended	\$ 1,729,279	+9	\$ 192,142
Plan 1 - Conrail Slip and Aquatic/Fishery Shelf Cut	\$ 1,406,255	+8	\$ 127,841
* Plan 4 - Acquire Conrail Slip and Aquatic/Fishery Shelf Cut	\$ 503,142	+8	\$ 62,893
Plan 3 - Aquatic/Fishery Shelf Cut	\$ 450,745	+7	\$ 64,392

Figure 4-21: Macroinvertebrate Community Status in the Ashtabula River Lacustuary as Measured by the Invertebrate Community Index (ICI).

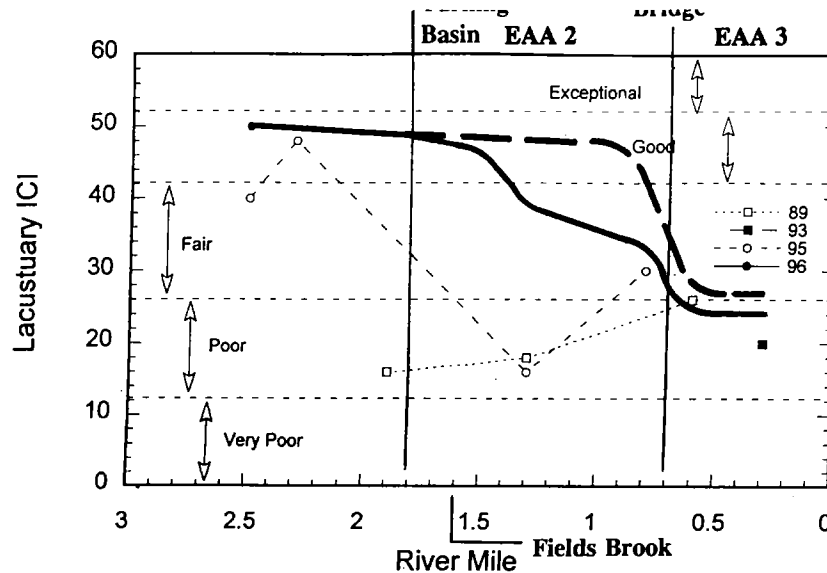

Macroinvertebrate community status in the Ashtabula River lacustuary as measured by the Invertebrate Community Index (ICI).

ICI - Invertebrate Community Index

IMPROVEMENT MEASURES

Dredging/Aquatic/Fishery Shallows (* Recommended Plan)
(Plans Ecological Improvements Rank)

Ecological Assessment Area (EAA) 3

	Cost	ICI Score	Cost/Unit
Plan 1 - Aquatic/Fishery Shelf Cut	\$ 450,745	+4	\$ 112,686
Plan 3 - Aquatic/Fishery Diversion/By-Pass Cut	\$ 885,727	+4	\$ 221,432
* Plan 2 - Aquatic/Fishery Shelf Hung	\$ 352,250	+2	\$ 176,125

Ecological Assessment Area (EAA) 2

Plan 2 - Conrail Slip and Aquatic/Fishery Shelf Cut Extended	\$ 1,729,279	+14	\$ 123,520
Plan 1 - Conrail Slip and Aquatic/Fishery Shelf Cut	\$ 1,406,255	+13	\$ 108,174
* Plan 4 - Acquire Conrail Slip and Aquatic/Fishery Shelf Cut	\$ 503,142	+13	\$ 38,703
Plan 3 - Aquatic/Fishery Shelf Cut	\$ 450,745	+12	\$ 37,562

Dredging/Contaminant Removal (* Recommended Plan)
(Plans Ecological Improvements Rank)

Ecological Assessment Area (EAA3)

	Cost	IBI Score	Cost/Unit
* Deep Dredge	\$ 9,605,000	+3	\$ 3,201,667
Bank to Bank	\$ 9,605,000	+3	\$ 3,201,667
Shallow Dredge	\$ 9,605,000	+2	\$ 4,802,500

Ecological Assessment Area (EAA2)

* Deep Dredge	\$ 46,895,000	+20	\$ 2,344,750
Bank to Bank	\$ 63,295,000	+20	\$ 3,164,750
Shallow Dredge	\$ 42,195,000	+18	\$ 2,344,167

Figure 4-22: Fish Community Status of the Lower Ashtabula River Lacustuary As Measured by the Index of Biotic Integrity (IBI).

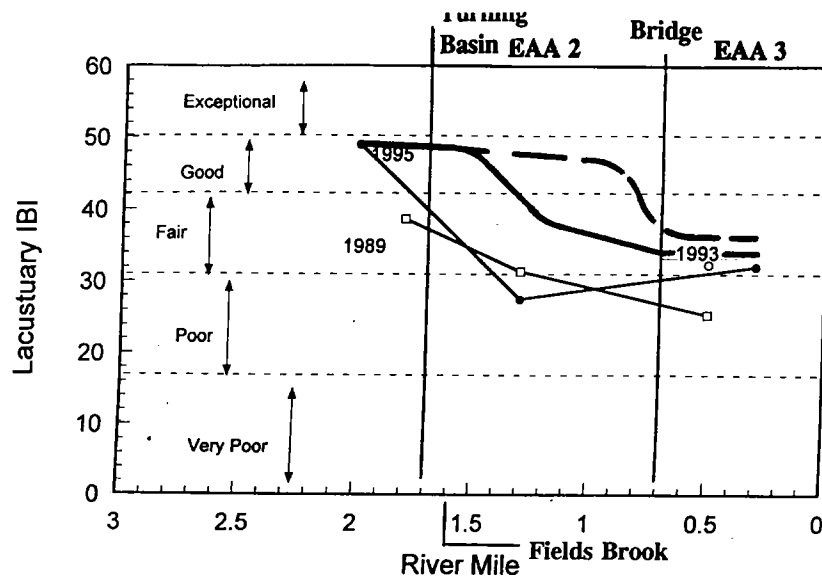

Fish community status of the Ashtabula River lacustuary as measured by the Index of Biotic Integrity (IBI).

IBI - Index of Biotic Integrity (Fishery)

IMPROVEMENT MEASURES

Dredging/Aquatic/Fishery Shallows (* Recommended Plan)
(Plans Ecological Improvements Rank)

	Cost	IBI Score	Cost/Unit
Ecological Assessment Area (EAA) 3			
Plan 1 - Aquatic/Fishery Shelf Cut	\$ 450,745	+4	\$ 112,686
Plan 3 - Aquatic/Fishery Diversion/By-Pass Cut	\$ 885,727	+4	\$ 221,432
* Plan 2 - Aquatic/Fishery Shelf Hung	\$ 352,250	+3	\$ 117,417
Ecological Assessment Area (EAA) 2			
Plan 2 - Conrail Slip and Aquatic/Fishery Shelf Cut Extended	\$ 1,729,279	+12	\$ 144,107
Plan 1 - Conrail Slip and Aquatic/Fishery Shelf Cut	\$ 1,406,255	+11	\$ 127,841
* Plan 4 - Acquire Conrail Slip and Aquatic/Fishery Shelf Cut	\$ 503,142	+11	\$ 45,740
Plan 3 - Aquatic/Fishery Shelf Cut	\$ 450,745	+10	\$ 45,075

Dredging/Contaminant Removal (* Recommended Plan)
(Plans Ecological Improvements Rank)

	Cost	IBI Score	Cost/Unit
Ecological Assessment Area (EAA3)			
* Deep Dredge	\$ 9,605,000	+3	\$ 3,201,667
Bank to Bank	\$ 9,605,000	+3	\$ 3,201,667
Shallow Dredge	\$ 9,605,000	+2	\$ 4,802,500
Ecological Assessment Area (EAA2)			
* Deep Dredge	\$ 46,895,000	+12	\$ 3,907,917
Bank to Bank	\$ 63,295,000	+12	\$ 5,274,583
Shallow Dredge	\$ 42,195,000	+10	\$ 4,219,500

In EAA 2 the alternatives assessment identified Plan 4, consisting of the acquisition of the Conrail Slip (Slip 5A) and the modification of river shoreline to establish vegetated shallows for fisheries, as the selected plan for this area. Plan 4 is called the “Acquire Conrail Slip (Slip 5A) Aquatic Fishery Shelf Cut Plan”. For EAA 3 the assessment identified Plan 2, “Aquatic Fishery Shelf Plan” comprised of the construction of a man-made aquatic habitat shelf along the channel reach in EAA 3, as the selected alternative for this area. The fishery shelf in EAA 3 would function primarily to facilitate movement of fisheries through the river reach to upstream areas.

These selected alternatives constitute the recommended related aquatic ecosystem restoration measures for the ARP Project Area. These alternatives would, as much as possible, mitigate for the historic loss of aquatic fishery shallows due to structural (i.e. bulkheading, channelization), and activity based impacts to the physical habitats on the lower Ashtabula River. These are practical optimized plans of moderate cost, that would provide protected aquatic habitat (i.e., fishery shallows) of substantial length which would accomplish project goals and objectives. The areas would be interfaced with the lake/river regime and would provide passage, cover, feeding, and spawning habitat. A more detailed description of the Recommended aquatic ecosystem restoration measures related to the ARP’s Recommended Environmental Dredging Plan are presented in Section 5.0.

4.5.2 Alternative Long-term Dredging Scenarios for Aquatic Ecosystem Restoration

Alternative long-term dredging measures that may be recommended to facilitate the recovery of aquatic ecosystem conditions in the Ashtabula River include:

1. Continue long-term channel maintenance dredging upstream of the 5th Street Bridge to recreational navigation depths as is being done at present (see Figure 4-23). This will provide aquatic shallow areas along the lower River shoreline in the distant future at no cost.
2. Decrease the width of the maintained recreational navigation channel to the west upstream of the 5th Street Bridge between the Conrail slip and the Upper Turning Basin about eight feet or more, as possible (see Figure 4-24). This will provide additional aquatic shallow area along the east embankment in the distant future at no cost and likely savings. A fuller description of these components for the Recommended Environmental Dredging Plan are presented in Section 5.0

That portion of the CMP addressing aquatic ecosystem restoration will not be prepared or implemented in subsequent reports (i.e., detailed design and plans and specifications) for the ARP environmental dredging project, which is to address sediment remediation. Rather, it is the intent of the ARP to undertake the recommended aquatic ecosystem restoration measures as a separate project under the Section 206 authority. The planning and design of these measures would be completed, assuming Section 206 funding is available and the presence of a Non-Federal sponsor, concurrent with the design and implementation of environmental dredging, so that when dredging is complete the habitat restoration measures can be implemented in the target areas.

Figure 4-23: Alternative Long-term Dredging Measures: Reduce Depth.

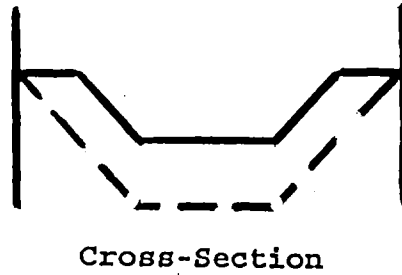
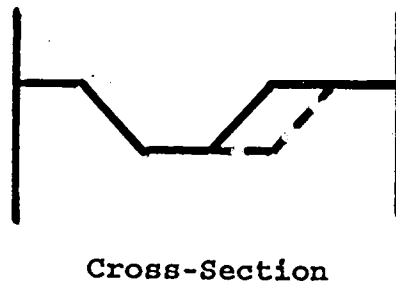

Figure 4-24: Alternative Long-term Dredging Measures: Reduce Width.



4.6 Comparative Impacts of Selected Project Component Alternatives

Remaining Plans and Component Alternatives were subsequently assessed/evaluated in greater detail (1997). Impact trade-off discussions ensued. Development of pumpout/pipeline facilities and use of existing disposal facilities were essentially eliminated due to substantially higher costs. Of considerable discussion was the option of developing an in-lake diked confined disposal facility at Site P for the disposal of Non-TSCA material. Although this option presented some potential project cost savings and reduced transportation impacts, it also presented considerable environmental concerns including those pertaining to: water quality, fish and wildlife, long-term O&M and contaminated sediment containment, coastal processes, the Coastal Zone Management Program, and public perception. It was decided that an upland confined disposal facility would be better suited for disposal of the contaminated dredged material involved in this project, and the Site P development option was eliminated from further consideration. Based on this assessment/evaluation of Plan Component Alternatives a recommended plan was formulated.

Figure 4-25 shows the locations of the recommended transfer/dewatering facility site and the upland landfill disposal sites. Tables 4-9 through 4-13 present the general description of the component alternatives, the comparative costs, environmental assessments, and the selection matrices.

4.7 Recommended Environmental Dredging Plan Components

Based upon the Plan Formulation assessment and evaluation process, project alternative components were selected and a “Recommended Environmental Dredging Plan ” was formulated. The selected individual project component alternatives that together constitute the ARP project are summarized as follows:

1. Dredging:
 - a) Enclosed clamshell bucket technology.
 - b) Deep-Dredge alternative.
2. Transfer/Dewatering:
 - a) Barge transfer of dredged sediment to dewatering site.
 - b) River shoreline transfer/dewatering facility at the Norfolk Southern site.
 - c) Passive sediment dewatering technology.
 - d) Multi-media carbon filtration treatment of decant water.
 - e) Truck transport of dewatered sediment to disposal facility.
3. Disposal:
 - a) New upland TSCA and Non-TSCA landfill at the State Road site.

Figure 4-25: Remaining Alternative Components Option(s) Assessment/Evaluation/Selection (Site Vicinities).

**REMAINING ALTERNATIVE COMPONENTS OPTION(S) -
ASSESSMENT/EVALUATION/SELECTION**

SITE VICINITIES

Source: USGS Quad.
Ashtabula N.

Source: USGS Quad.
N. Kingsville

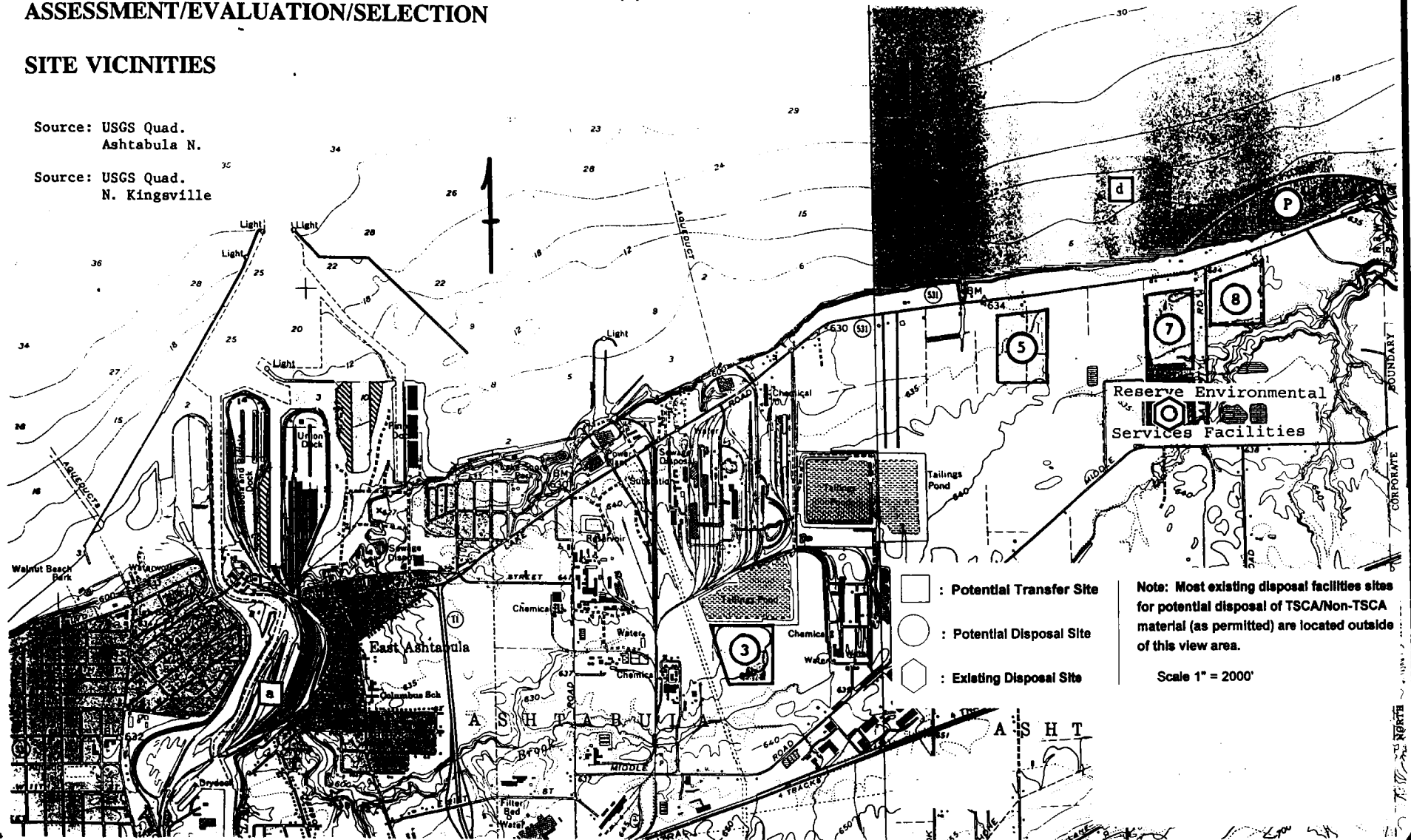

Table 4-9: Remaining Alternative Component Option(s) Assessment/Evaluation/Selection.

GENERAL DESCRIPTIONS

DREDGING (ENVIRONMENTALLY)

Dredging (Environmentally) pertains primarily to dredging with equipment that will minimize turbidity and the resuspension of contaminated sediments. A number of alternative mechanical, hydraulic, and special dredging methods have been assessed/evaluated and several options appear acceptable, including: the closed bucket clamshell, cutterhead, and horizontal auger dredge, respectively. Measures such as operations controls, an oil boom, and silt curtains would also be incorporated, as appropriate. It is expected that approximately 80,000 cubic yards of TSCA material (> 50 ppm PCBs) [subsequently revised to 150,000 cubic yards of which is significantly PCB contaminated and would be handled as TSCA material] and 1,130,000 cubic yards [subsequently revised to 546,000 cubic yards] of Non-TSCA material will be dredged from the Ashtabula River. Approximately 70,000 cubic yards [subsequently revised to 30,000 cubic yards] of Non-TSCA material is expected to be excavated from the 1993 Interim Disposal Site and disposed of in a Non-TSCA disposal facility.

TRANSFER/DEWATER/TRANSFER

A. Harbor Area Barge Operation. This option would involve the use of water tight barges in the harbor vicinity as settling basins for dredged material. Sediments would be allowed to settle out from the dredged material. Remaining water/slurry would be pumped out into a series of water tight barge settling basins and finally filtered (until the water meets water quality discharge standards) and discharged into the river or lake. Consolidated sediments would be unloaded and transported (most likely by truck) to an appropriate disposal facility.

B. Harbor Area Shore Operation. This option would involve construction of impermeable earthen diked settling basins along the harbor area shoreline (ie Conrail Interim Diked Disposal Area 1993) as settling basins for dredged material. Dredged material would be transferred from the barges and placed into the initial settling basin. Sediments would be allowed to settle out from the dredged material. Remaining water/slurry would be pumped/drained into a secondary settling basin and finally filtered (until the water meets water quality discharge standards) and discharged into the river or lake. Consolidated sediments would be transferred and transported (most likely by truck) to an appropriate disposal facility.

C. Off-Shore Pump/Pipe Operation. This option would involve construction of an off-shore pump/pipe operation facility located along the lake shoreline several miles east of the harbor. The facility would likely include a wave protection breakwater and/or platform to protect pumpout operations from wave action, a pumpout platform/facility, piling (about 2000 feet long) from the pumpout platform/facility up the shoreline embankment to a developed upland dewatering and disposal facility (ie. at Site 7), and lift pumps to pump dredged material slurry up the embankment. Dredged material would be barged to the pumpout platform/facility, pumped out, and pumped/piped to the upland dewatering and disposal facility. Sediments would be allowed to settle out from the dredged material utilizing a dewatering facility similar to that described in B. or possibly utilizing the disposal facility cells. Water would finally be filtered (until the water meets water quality discharge standards) and discharged (probably by pipeline along the same pumpout pipeline alignment) into the lake. Consolidated sediments would be transferred to or left in the appropriate disposal cells.

TREATMENT TECHNOLOGIES

A number of alternative PCB contaminated sediment treatment and disposal measures were assessed/evaluated. The conclusion is that treatment and disposal of the residual material is considerably more expensive than dewatering and appropriate disposal of the dewatered dredged material.

SEDIMENT DISPOSAL OPTIONS - TSCA

A. Existing Regional TSCA Permitted CDF Disposal Site. This option would involve transporting (by rail or truck) the consolidated dredged TSCA material to an existing regional TSCA permitted CDF disposal facility and disposing of the material at the facility (for a fee). The facility would have an impermeable lining, a leachate collection system and water filtration/treatment system in order to meet water quality discharge standards. The facility would be capped at some time in the future after it is filled. The closest regional TSCA permitted CDF disposal facility is located in Model City, New York.

B. New Upland CDF Disposal (TSCA Cell) Site (Site 7). This option would involve construction of a new upland TSCA designed/permitted disposal facility (cell), probably at recommended Site 7. The facility would have two impermeable linings, a leachate collection system and water filtration/treatment system in order to meet water quality discharge standards. Consolidated dredged TSCA material would be transported/transferred (most likely by truck or pipeline) to the site and appropriately disposed of in the facility. The facility would be capped after it is filled.

C. TSCA Alternative Disposal Option. [Subsequently revised to: An application to U.S. EPA on behalf of the Ashtabula River Partnership is being pursued that would permit the disposal of PCB contaminated sediments with a concentration at or above 50 ppm in existing Best Available Technology solid waste disposal facilities.] Consolidated dredged TSCA material would be transported/transferred (most likely by truck or pipeline) to a site and appropriately disposed of in the facility. The facility would be capped after it is filled. (Note: Somewhat revised from original).

SEDIMENT DISPOSAL OPTIONS - NON TSCA

A. Existing Area Non-TSCA Permitted CDF Disposal Site. This option would involve transporting (most likely by truck) the consolidated dredged Non-TSCA material to an existing area Non-TSCA permitted disposal facility and disposing of the material at the facility (for a fee). The facility would have an impermeable lining, a leachate collection system and water filtration/treatment system in order to meet water quality discharge standards. The facility would be capped at some time in the future after it is filled. Several such facilities are located in the area and region.

B. New Upland CDF Disposal (Non-TSCA Cell) Site (Site 7). This option would involve construction of a new upland Non-TSCA designed/permitted CDF disposal facility (cell), probably at recommended Site 7. The facility would have an impermeable lining, a leachate collection system and water filtration/treatment system in order to meet water quality discharge standards. Consolidated dredged Non-TSCA material would be transported/transferred (most likely by truck or pipeline) to the site, and appropriately disposed of into the facility. The facility would be capped after it is filled.

C. New In-Lake CDF Disposal Site (Site P). This option would involve construction of a new in-lake Non-TSCA designed/permitted CDF disposal facility (diked CDF cell), probably at recommended Site P. Containment dike walls would include interior filter or impermeable lining material. Dredged Non-TSCA material would be barged directly to the site, and discharged directly into the facility. Water would be displaced and filtered through the containment dike filter material and/or settled and filtered at the facility discharge weir in order to meet water quality discharge standards.

SAMPLING AND ANALYSIS

Sampling and analysis measures would be incorporated for project short and long-term dredging, transfer, and CDF disposal facilities activities, as appropriate. Generally, existing, project construction and operations, and post project conditions would be profiled/monitored.

**Table 4-10: Remaining Alternative Component Option(s)
Assessment/Evaluation/Selection.**

COMPARATIVE COSTS

ASHTABULA RIVER PARTNERSHIP

WORK ITEM	Quantity	UNIT COST	ITEM COST
DREDGING			
Mob/Demob		LS	\$580,000
Dredging	1,210,000	CY	\$16.00 \$19,360,000
Total			\$19,940,000
TRANSFER/DEWATER/TRANSFER			
A. (Barge Operation)			
-Mob Equipment & Assemble Plant		LS	423,000
-Operation	1,210,000	CY	\$2.60 \$3,146,000
-Transfer Operation	1,210,000	CY	\$2.30 \$2,783,000
-TSCA Liability			50,000
-Mitigation (Roads)			200,000
Total			\$6,602,000
	*(If Site P, 80,000 CY) (*6)		(1,065,000)
B. (Interim CDF)			
-Construction		LS	\$2,180,000
-Operation	1,210,000	CY	\$2.55 \$3,085,500
-TSCA Liability		LS	50,000
-Mitigation			50,000
*Wetland			200,000
*Roads			200,000
Total			\$5,565,500
	*(If Site P, 80,000 CY) (*3)		(2,684,000)
C. (Off-Shore Pump/Pipe) (Dewater Facilities)			
-Construction			
*Pump/Pipe/Breakwater		LS	\$6,000,000
*Dewatering Facility		LS	\$2,180,000
-Operation	1,210,000	CY	\$6.30 \$7,623,000
(Minus Trans See Sediment Disposal Options)			\$2.65 -\$3,206,500
-TSCA Liability			50,000
-Mitigation (Wetlands)			50,000
Total			\$12,696,500
	*(If Site P, 80,000 CY) (*4)		(8,572,000)
SEDIMENT DISPOSAL OPTIONS - TSCA			
A. (Commercial Options)			
Model City, NY Total (common carrier)			
-Transport and Disposal	120,000	TN	\$150 \$18,000,000
-TSCA Liability			?
Total			\$18,000,000
ECDC Landfill, Utah Total (Rail)			
-Transport and Disposal	120,000	TN	\$115 \$13,800,000
-TSCA Liability			?
Total			\$13,800,000

WORK ITEM	Quantity	UNIT COST	COST
B. (New Upland CDF Site 7)			
-Construction		LS	\$3,000,000
-Mitigation (Wetlands)			50,000
-Transport Sediments to CDF	80,000	CY	\$2.65 \$212,000
-CDF Operation	80,000	CY	\$1.60 \$128,000
-TSCA Liability			2,000,000
-O&M			2,000,000
Total			\$7,390,000
C. (TSCA Alternative Disposal Option)			
(See B.) Total			< \$7,390,000
(ie. Existing Facility) Total	120,000	TN	30.00 \$3,600,000 +
(Plus TSCA Fee +)	120,000	TN	23.00 > \$2,760,000 +
SEDIMENT DISPOSAL OPTIONS - NON TSCA			
A. (Commercial Options)			
(ie. Existing Facility) Total	1,695,000	TN	30.00 \$50,850,000
			23.00 \$38,985,000
B. (New Upland CDF Site 7)			
-Construction		LS	\$11,800,000
-Mitigation (Wetlands)			300,000
-Transport Sediments to CDF	1,130,000	CY	\$2.65 \$2,994,500
-CDF Operation	1,130,000	CY	\$1.60 \$1,808,000
-O&M (25%C)			3,025,000
Total			\$19,927,500
C.* (New In-Lake CDF Site P)			
-Construction (Incl Breakwater)		LS	\$13,000,000
-Mitigation			100,000
-Transport Sediments to CDF	1,130,000	CY	\$1.25 \$1,412,500
-CDF Operation	1,130,000	CY	\$2.00 \$2,260,000
-O&M (25%C)			3,275,000
Total			\$20,047,500
SAMPLING AND ANALYSIS			
A. (Dredging)		LS	\$271,000
B. (Transfer Facility)		LS	\$131,000
C. (Disposal Facility CDFs)		LS	\$2,276,500
CONSTRUCTION COST			
25% CONTINGENCY			
TOTAL PROJECT COST			LS=Lump Sum
			CY=Cubic Yard
NOTE: 1. Assumes 1 CY = 1.5 Ton. 2. *(If Site P CDF) TN=Tons			

Table 4-11: Remaining Alternative Component Option(s) Assessment/Evaluation.

ENVIRONMENTAL ASSESSMENT MATRIX

Table Comparative Impacts of Considered Alternatives

Evaluation Parameters	Considered Alternatives		Transfer/Dewater Harbor Shoreline	Transfer/Dewater Harbor Barge	Transfer/Dewater Pump/Pipe Upland
	No Action (Without Project)	Channel Dredging			
Physical/Natural					
Air Quality	ST:Not Significant LT:Not Significant	ST:Minor Adverse LT:Not Significant	ST:Minor Adverse LT:Not Significant	ST:Minor Adverse LT:Not Significant	ST:Minor Adverse LT:Not Significant
	Migration of contaminated sediments down stream. Dredging/harbor activity limited.	Construction equipment fumes. Some initial dredged material volatilization.	Construction equipment fumes. Some dredged material volatilization.	Construction equipment fumes. Some dredged material volatilization.	Construction equipment fumes. Some dredged material volatilization.
Water Quality	ST:Minor Adverse LT:Moderate Adverse	ST:Moderate Adverse LT:Moderate Beneficial	ST:Minor Adverse LT:Not Significant	ST:Minor Adverse LT:Not Significant	ST:Minor Adverse LT:Not Significant
	Migration of contaminated sediments down stream. Dredging and disposal increasing ly limited.	Dredging turbidity within the mixing zone. Removal of contaminated sediment from the river.	Construction runoff. Treated discharges.	Construction runoff. Treated discharges.	Construction runoff. Treated discharges.
Sediment Quality	ST:Moderate Adverse LT:Major Adverse	ST:Moderate Beneficial LT:Major Beneficial	ST:Minor Adverse LT:Not Significant	ST:Minor Adverse LT:Not Significant	ST:Minor Adverse LT:Not Significant
	Migration of contaminated sediments down stream. Dredging and disposal increasing ly limited.	Dredging turbidity within the mixing zone. Removal of contaminated sediment from the river.	Construction runoff. Transfer processing. Treated discharges.	Construction runoff. Transfer processing. Treated discharges.	Construction runoff. Transfer processing. Treated discharges.
Benthos	ST:Moderate Adverse LT:Major Adverse	ST:Minor Adverse LT:Moderate Beneficial	ST:Not Significant LT:Not Significant	ST:Not Significant LT:Not Significant	ST:Not Significant LT:Not Significant
	Migration of contaminated sediments down stream. Dredging and disposal restricted.	Dredging excavation of benthos. Recolonization in cleaner sediments.			
Fisheries	ST:Minor Adverse LT:Moderate Adverse	ST:Minor Adverse LT:Moderate Beneficial	ST:Not Significant LT:Not Significant	ST:Not Significant LT:Not Significant	ST:Minor Adverse LT:Not Significant
	Migration of contaminated sediments down stream. Dredging and disposal restricted. Wider contamination.	Dredging turbidity within the mixing zone. Removal of contaminated sediment from the river.	Transfer operation.	Transfer operation.	Breakwater, mooring pipeline construction. Transfer operations.
Vegetation	ST:Minor Adverse LT:Adverse	ST:Minor Adverse LT:Moderate Beneficial	ST:Minor Adverse LT:Not Significant	ST:Not Significant LT:Not Significant	ST:Minor Adverse LT:Not Significant
	Migration of contaminated sediments down stream. Dredging and disposal limited.	Dredging excavation of vegetation. Recolonization in cleaner sediments.	Clear and grub about 5 acres of low value vegetation. Grass/legume slope cover. Restoration.	Use existing docking facilities.	Clear and grub about 5 acres of wooded vegetation. Grass legume slope cover.
Wildlife	ST:Minor Adverse LT:Moderate Adverse	ST:Minor Adverse LT:Moderate Beneficial	ST:Not Significant LT:Not Significant	ST:Not Significant LT:Not Significant	ST:Minor Adverse LT:Not Significant
	Migration of contaminated sediments down stream. Dredging and disposal limited.	Dredging disruptions. Removal of contaminated sediments from the river.	Clear and grub about 5 acres of low value habitat. Grass/legume slope cover. Restore.	Use existing docking facilities.	Clear and grub about 5 acres of wooded habitat. Grass/legume slope cover.
Threatened and Endangered Species	ST:Not Significant LT:Not Significant	ST:Not Significant LT:Not Significant	ST:Not Significant LT:Not Significant	ST:Not Significant LT:Not Significant	ST:Not Significant LT:Not Significant
	Transient species.	Transient species.	Transient species only, no residents.	Transient species only.	Transient species only, no residents.
Wetlands	ST:Minor Adverse LT:Moderate Adverse	ST:Not Significant LT:Not Significant	ST:Minor Adverse LT:Not Significant	ST:Not Significant LT:Not Significant	ST:Minor Adverse LT:Not Significant
	Migration of contaminated sediments down stream. Contamination. Mitigation plan.	Small riparian areas may be impacted. Mitigation plan.	Small riparian area construction impact. Mitigation plan.	Use existing docking facilities.	A small area of wooded wetland may be impacted by construction. Mitigation plan
General Soils Geology and Ground Water	ST:Minor Adverse LT:Minor Adverse	ST:Minor Adverse LT:Moderate Beneficial	ST:Minor Adverse LT:Not Significant	ST:Not Significant LT:Not Significant	ST:Minor Adverse LT:Minor Adverse
	Migration of contaminated sediments down stream. Dredging and Disposal limited.	Dredging turbidity and excavation of sediments. Removal of contaminated sediment from the river.	Construction disruption. Facility operations. Restoration.	Use existing docking facilities.	Construction disruption. Facility operations. Retained.

Table 4-11: Remaining Alternative Component Option(s) Assessment/Evaluation (cont.).

ENVIRONMENTAL ASSESSMENT MATRIX (CONTINUED)

Table Comparative Impacts of Considered Alternatives

Evaluation Parameters	Considered Alternatives			Transfer/Dewater Harbor Shoreline	Transfer/Dewater Harbor Barge	Transfer/Dewater Pump/Pipe Upland
	No Action (Without Project)	Channel Dredging				
<u>Human (Man-Made)</u>						
Community and Regional Growth	ST: Moderate Adverse LT: Major Adverse Migration of contaminated sediments down stream. Dredging and disposal restricted. Harbor activity restricted. Associated adverse impacts to the community.	ST: Minor Adverse LT: Major Beneficial Construction, dredging, and disposal operations disruptions. Removal of contaminated sediments from the harbor. CDF containment. Harbor O&M.	ST: Minor Adverse LT: Moderate Beneficial Construction, facilities operations, transport disruption. Harbor dredged. Cleaner river sediments. Area restoration.	ST: Minor Adverse LT: Moderate Beneficial Facilities operations, transport disruption. Harbor dredged. Cleaner river sediments. Existing docking facilities.	ST: Minor Adverse LT: Moderate Beneficial Construction, facilities operations, transport disruption. Harbor dredged. Cleaner river sediments. Facility retained.	ST: Minor Adverse LT: Moderate Beneficial
Displacement of People	ST: Minor Adverse LT: Moderate Adverse Harbor activity restricted. Possible loss of businesses.	ST: Not Significant LT: Not Significant No displacement of residences or developments.	ST: Not Significant LT: Not Significant No displacement of residences or developments.	ST: Not Significant LT: Not Significant No displacement of residences or developments.	ST: Not Significant LT: Not Significant No displacement of residences or developments.	ST: Not Significant LT: Not Significant
Displacement of Farms	ST: Not Significant LT: Not Significant	ST: Not Significant LT: Not Significant	ST: Not Significant LT: Not Significant No farmland.	ST: Not Significant LT: Not Significant Existing facilities.	ST: Minor Adverse LT: Not Significant Abandoned farmland. Zoned industrial.	ST: Minor Adverse LT: Not Significant
Business/Industry Employment/Income	ST: Moderate Adverse LT: Major Adverse Migration of contaminated sediments down stream. Dredging and disposal restricted. Harbor activity restricted. Possible loss of businesses.	ST: Minor Adverse LT: Major Beneficial Construction, dredging, and disposal operations needs. Removal of contaminated sediments from the harbor. CDF containment. Harbor O&M	ST: Minor Beneficial LT: Minor Beneficial Construction, facilities operation work, disruption. Costs. Harbor dredged. Area restoration.	ST: Minor Beneficial LT: Minor Beneficial Use existing facilities. Facilities operation work, disruption. Costs. Harbor dredged.	ST: Minor Beneficial LT: Minor Beneficial Construction, facilities operation work. Costs. Harbor dredged. Available facilities.	ST: Minor Beneficial LT: Minor Beneficial
Public Facilities and Services	ST: Moderate Adverse LT: Major Adverse Migration of contaminated sediments down stream. Dredging and disposal restricted. Harbor activity restricted. Possible loss of businesses.	ST: Minor Adverse LT: Moderate Beneficial Construction, dredging, and disposal operations needs. Removal of contaminated sediments from the harbor. CDF containment. Harbor O&M	ST: Minor Adverse LT: Not Significant Construction and facilities operation needs. Transport impacts. Area restoration.	ST: Minor Adverse LT: Not Significant Use existing docking facilities. Facilities operation needs. Transport impacts. Harbor dredged.	ST: Minor Adverse LT: Minor Beneficial Construction and facilities operation needs. Constructed pipeline. Harbor dredged. Available facilities.	ST: Minor Adverse LT: Minor Beneficial
Recreation	ST: Moderate Adverse LT: Major Adverse Migration of contaminated sediments down stream. Dredging and disposal restricted. Contamination wider. Possible loss marina activity/businesses.	ST: Minor Adverse LT: Major Beneficial Construction, dredging, and disposal operations disruptions. Removal of contaminants from the harbor. CDF containment. Harbor O&M.	ST: Minor Adverse LT: Minor Beneficial Construction and facilities operation disruptions. Harbor dredged. Cleaner river sediments. Area restoration.	ST: Minor Adverse LT: Minor Beneficial Construction and facilities operation disruptions. Harbor dredged. Cleaner river sediments. Existing facility.	ST: Minor Adverse LT: Minor Beneficial Construction and facilities operation disruptions. Harbor dredged. Cleaner river sediments. Facility retained.	ST: Minor Adverse LT: Minor Beneficial
Property Value and Tax Revenue	ST: Moderate Adverse LT: Major Adverse Migration of contaminated sediments down stream. Dredging and disposal restricted. Harbor activity restricted. Possible loss of business/tax	ST: Minor Adverse LT: Minor Beneficial Construction, dredging, and disposal operations and costs. Removal of contaminated sediments from the harbor. CDF containment. Harbor O&M.	ST: Minor Adverse LT: Minor Beneficial Construction and facilities operation and costs. Use interim disposal area. Area restoration.	ST: Not Significant LT: Not Significant Use existing docking facilities. Facilities operation and costs.	ST: Minor Adverse LT: Minor Adverse Construction and facilities operation and costs. Use wooded upland area. Retain facility.	ST: Minor Adverse LT: Minor Adverse
Noise and Aesthetics	ST: Minor Adverse LT: Moderate Adverse Migration of contaminated sediments down stream. Dredging and disposal restricted. Harbor activity restricted. Possible loss of business and delapidations.	ST: Moderate Adverse LT: Minor Beneficial Construction, dredging, and disposal operations disruptions. Removal of contaminated sediments from the harbor. CDF containment. Harbor O&M.	ST: Moderate Adverse LT: Not Significant Construction and facilities operation disruptions. Transport disruptions. Area restoration.	ST: Moderate Adverse LT: Not Significant Use existing docking facilities. Facilities operation disruptions. Transport disruptions.	ST: Minor Adverse LT: Minor Adverse Construction and facilities operation disruptions. Transport disruptions. Facility retained.	ST: Minor Adverse LT: Minor Adverse
Community Cohesion	ST: Moderate Adverse LT: Major Adverse Migration of contaminated sediments down stream. Dredging and disposal restricted. Harbor activities restricted. Associated adverse impacts to the community.	ST: Minor Adverse LT: Moderate Beneficial Construction, dredging, and disposal operations disruptions. Removal of contaminated sediments from the harbor. CDF containment. Harbor O&M	ST: Minor Adverse LT: Moderate Beneficial Construction, facilities operations, transport disruption. Harbor dredged. Cleaner river sediments. Area restoration.	ST: Minor Adverse LT: Moderate Beneficial Facilities operation, transport disruption. Harbor dredged. Cleaner river sediments. Existing docking facilities.	ST: Minor Adverse LT: Moderate Beneficial Construction, facilities operations, transport disruption. Harbor dredged. Cleaner river sediments. Facility retained.	ST: Minor Adverse LT: Moderate Beneficial
Cultural Resources	ST: Not Significant LT: Not Significant None identified in the dredging areas.	ST: Not Significant LT: Not Significant None identified in the dredging areas.	ST: Not Significant LT: Not Significant None identified in the interim disposal site area.	ST: Not Significant LT: Not Significant Use existing docking facility.	ST: Not Significant LT: Not Significant None identified in the Sites 5 and 7 vicinities.	ST: Not Significant LT: Not Significant

Table 4-11: Remaining Alternative Component Option(s) Assessment/Evaluation (cont.).

ENVIRONMENTAL ASSESSMENT MATRIX (CONTINUED)

Table Comparative Impacts of Considered Alternatives

Evaluation Parameters	Considered Alternatives					
	Treatment Technologies	Upland CDF Development Site 5	Upland CDF Development Site 7	In-Lake Diked CDF Site P (Non-TSCA)	Existing Landfill (Non-TSCA)	Existing Landfill (TSCA Permitted)
Physical/Natural						
Air Quality	ST: LT:	ST:Minor Adverse LT:Not Significant	ST:Minor Adverse LT:Not Significant	ST:Minor Adverse LT:Not Significant	ST:Minor Adverse LT:Not Significant	ST:Minor Adverse LT:Not Significant
Water Quality	ST: LT:	Construction equipment fumes. Some initial dredged material volatilization. ST:Minor Adverse LT:Minor Adverse	Construction equipment fumes. Some initial dredged material volatilization. ST:Minor Adverse LT:Minor Adverse	Construction equipment fumes. Some initial dredged material volatilization. ST:Moderate Adverse LT:Minor Adverse	Transport equipment fumes. Some initial dredged material volatilization. ST:Minor Adverse LT:Minor Adverse	Transport equipment fumes. Some initial dredged material volatilization. ST:Minor Adverse LT:Minor Adverse
Sediment Quality	ST: LT:	Construction runoff. Confined disposal of contaminated material. ST:Minor Adverse LT:Minor Adverse	Construction runoff. Confined disposal of contaminated material. ST:Minor Adverse LT:Minor Adverse	Discharge to CDF. Confined disposal of contaminated material. ST:Minor Adverse LT:Minor Adverse	Placement in CDF. Confined disposal of contaminated material. ST:Minor Adverse LT:Minor Adverse	Placement in CDF. Confined disposal of contaminated material. ST:Minor Adverse LT:Minor Adverse
Benthos	ST: LT:	ST:Not Significant LT:Not Significant	ST:Not Significant LT:Not Significant	ST:Minor Adverse LT:Minor Beneficial	ST:Not Significant LT:Not Significant	ST:Not Significant LT:Not Significant
Fisheries	ST: LT:	ST:Not Significant LT:Not Significant	ST:Not Significant LT:Not Significant	Dike placement and discharge cover of benthos. Stone dike habitat. ST:Moderate Adverse LT:Minor Adverse	ST:Not Significant LT:Not Significant	ST:Not Significant LT:Not Significant
Vegetation	ST: LT:	ST:Moderate Adverse LT:Moderate Adverse	ST:Major Adverse LT:Moderate Adverse	Dike placement and discharge cover of habitat (Incl GMB spawn). (~40 acres) Stone dike habitat. ST:Minor Adverse LT:Minor Adverse	ST:Not Significant LT:Not Significant	ST:Not Significant LT:Not Significant
Wildlife	ST: LT:	Clear and grub about 45 acres of mix value vegetation. Grass/legume slope cover. ST:Moderate Adverse LT:Moderate Adverse	Clear and grub about 45 acres of high value vegetation. Grass/legume slope cover. ST:Moderate Adverse LT:Moderate Adverse	Dike placement and discharge cover of habitat. Emergent upland veg. (~40 A). ST:Minor Adverse LT:Minor Beneficial	Existing development ST:Not Significant LT:Minor Beneficial	Existing development ST:Not Significant LT:Minor Beneficial
Threatened and Endangered Species	ST: LT:	Clear and grub about 45 acres of mix value habitat. Grass/legume slope cover. ST:Not Significant LT:Not Significant	Clear and grub about 45 acres of high value habitat. Grass/legume slope cover. ST:Not Significant LT:Not Significant	Dike placement and discharge cover of habitat. Emergent upland hab. (~40 A). ST:Not Significant LT:Not Significant	Existing development ST:Not Significant LT:Not Significant	Existing development ST:Not Significant LT:Not Significant
Wetlands	ST: LT:	Transient species only, no residents. ST:Moderate Adverse LT:Minor Adverse	Transient species only, no residents. ST:Moderate Adverse LT:Minor Adverse	Transient species only, no residents. ST:Not Significant LT:Not Significant	Existing development ST:Not Significant LT:Not Significant	Existing development ST:Not Significant LT:Not Significant
General Soils Geology and Ground Water	ST: LT:	Loss of about 30 acre of mixed wetland. Adj/bank mitigation. ST:Moderate Adverse LT:Minor Adverse	Loss of about 11 acre of wooded wetland. Adj/bank mitigation. ST:Moderate Adverse LT:Minor Adverse	None identified in the CDF area. ST:Not Significant LT:Not Significant	Existing development ST:Not Significant LT:Not Significant	Existing development ST:Not Significant LT:Not Significant
		Construction disruption. CDF construction. Containment of contaminated sediment	Construction disruption. CDF construction. Containment of contaminated sediment	Stone diked CDF. Disposal discharge. Containment of contaminated sediments.	Existing development Containment of contaminated sediments.	Existing development Containment of contaminated sediments.

Table 4-11: Remaining Alternative Component Option(s) Assessment/Evaluation (cont.).

ENVIRONMENTAL ASSESSMENT MATRIX (CONTINUED)

Table Comparative Impacts of Considered Alternatives

Evaluation Parameters	Considered Alternatives					
	Treatment Technologies	Upland CDF Development Site 5	Upland CDF Development Site 7	In-Lake Diked CDF Site P (Non-TSCA)	Existing Landfill (Non-TSCA)	Existing Landfill (TSCA Permitted)
<u>Human (Man-Made)</u>						
Community and Regional Growth	ST: LT:	ST:Minor Adverse LT:ModerateBeneficial	ST:Minor Adverse LT:ModerateBeneficial	ST:Minor Adverse LT:ModerateBeneficial	ST:Minor Adverse LT:ModerateBeneficial	ST:Minor Adverse LT:ModerateBeneficial
Displacement of People	ST: LT:	ST:Not Significant LT:Not Significant	ST:Not Significant LT:Not Significant	ST:Not Significant LT:Not Significant	ST:Not Significant LT:Not Significant	ST:Not Significant LT:Not Significant
Displacement of Farms	ST: LT:	ST:Minor Adverse LT:Not Significant	ST:Minor Adverse LT:Not Significant	ST:Not Significant LT:Not Significant	ST:Not Significant LT:Not Significant	ST:Not Significant LT:Not Significant
Business/Industry Employment/Income	ST: LT:	ST:Minor Beneficial LT:ModerateBeneficial	ST:Minor Beneficial LT:ModerateBeneficial	ST:Minor Beneficial LT:ModerateBeneficial	ST:Minor Beneficial LT:ModerateBeneficial	ST:Minor Beneficial LT:ModerateBeneficial
Public Facilities and Services	ST: LT:	ST:Minor Adverse LT:ModerateBeneficial	ST:Minor Adverse LT:ModerateBeneficial	ST:Minor Adverse LT:ModerateBeneficial	ST:Minor Adverse LT:ModerateBeneficial	ST:Minor Adverse LT:ModerateBeneficial
Recreation	ST: LT:	ST:Minor Adverse LT:Minor Adverse	ST:Minor Adverse LT:Minor Adverse	ST:Not Significant LT:Minor Beneficial	ST:Not Significant LT:Not Significant	ST:Not Significant LT:Not Significant
Property Value and Tax Revenue	ST: LT:	ST:Minor Adverse LT:Not Significant	ST:Minor Adverse LT:Minor Adverse	ST:Minor Adverse LT:Minor Beneficial	ST:Minor Adverse LT:Not Significant	ST:Minor Adverse LT:Not Significant
Noise and Aesthetics	ST: LT:	ST:Minor Adverse LT:Minor Adverse	ST:Moderate Adverse LT:Minor Adverse	ST:Minor Adverse LT:Minor Beneficial	ST:Minor Adverse LT:Not Significant	ST:Minor Adverse LT:Not Significant
Community Cohesion	ST: LT:	ST:Minor Adverse LT:Minor Adverse	ST:Minor Adverse LT:Minor Adverse	ST:Minor Adverse LT:Minor Adverse	ST:Minor Adverse LT:Minor Adverse	ST:Minor Adverse LT:Minor Adverse
<u>Cultural Resources</u>	ST: LT:	ST:Not Significant LT:Not Significant	ST:Not Significant LT:Not Significant	ST:Not Significant LT:Not Significant	ST:Not Significant LT:Not Significant	ST:Not Significant LT:Not Significant

Table 4-12: Remaining Alternative Component Option(s) Assessment/Evaluation.

ASSESSMENT/EVALUATION/SELECTION MATRICES REMAINING ALTERNATIVE COMPONENTS (OPTIONS)	SOME TRADE-OFF CONCERNS ●						
	Least Cost	Cost Mil \$	Transport Through Community	Wear & Tear on Roads	New Site Develop Impacts	Assumed Disposal Liability	No LTMP Tran/Dewat Site
*DREDGING ENVIRONMENTALLY (LOW TURBIDITY & SILT CURTAIN)	*	19.9					
*TRANSFER / DEWATER / TRANSPORT							
A. Harbor Area Barge Operation (Site P)	**	6.6 (1.0)	●	●			
B. Harbor Area Shore Operation (ie. Conrall Interim Site) (Site P)	*	5.6 (2.7)	●	●	●		●
C. Off-Shore Pump/Pipe Operation (Site P)		12.7 (8.6)			●		
*SEDIMENT DISPOSAL OPTIONS - TSCA							
A. New Upland CDF Disposal (TSCA Cell)(Site 7)	**	7.4	●	●	●	●	
B. Existing Regional TSCA Permitted CDF Disposal Site		18.0 13.8	●	●			
C. TSCA Alternative Disposal Option (Existing or New CDF Disposal Site) (Pending Approval)	*	3.6 + 2.8 + <7.4	●	●			
*SEDIMENT DISPOSAL OPTIONS - NON TSCA							
A. New Upland CDF Disposal (Non-TSCA Cell)(Site 7)	*	19.9	●	●	●	●	
B. Existing Area Non-TSCA Permitted CDF Disposal Site		50.9 39.0	●	●			
C. New In-Lake CDF Disposal Site (Site P)	**	20.0			●	●	
SAMPLING AND ANALYSIS (As Required)							
A. (Dredging)		.3					
B. (Transfer Facility)	*	.1					
C. (Disposal Facility CDFs)		2.3					

Note: * Least Cost, ** Second Least Cost, ● Some Trade-off Concerns.

Table 4-13: Comparative Impacts of Final Considered Alternatives.

Costs/Benefits	Final Considered Alternative Plans		
	No Action (Without Project Conditions)	Proposed Upland State Road Site Plan	Alternative Disposal Plan
Federal Cost		\$ 31,011,000	
Non-Federal Cost		\$ 13,994,800	
Total First Cost	NA	\$ 45,005,800	NC
Benefits (PW)		\$136,701,000	
Costs (PW)		\$51,319,900	
B/C		2.66	

(1) All benefits and Costs reflect a 50 year project life, a 6.375% annual interest rate and October 2000 prices.
 (2) Reference the Feasibility Report and Technical Appendices: Cost Estimating, Cost Sharing, and Economic Analyses for Details.
 (NA)=Not Applicable, (NC)=Not Calculated, (PW)=Present Worth.

Environmental Assessment - Comparative Impacts of Final Considered Alternatives
 ST: = Short Term (i.e., Construction), LT: = Long Term

Evaluation Parameters	Considered Alternatives					
	No Action (Without Project)	Channel Dredging	Transfer/Dewater Harbor Shoreline	Transfer/Dewater Harbor Barge	Upland CDF Development	Existing Landfill (Permitted)
Physical/Natural						
Air Quality	ST: Not Significant LT: Not Significant Migration of contaminated sediments downstream. Dredged/harbor activity limited.	ST: Minor Adverse LT: Not Significant Construction equipment fumes. Some initial dredged material volatilization.	ST: Minor Adverse LT: Not Significant Construction equipment fumes. Some dredged material volatilization.	ST: Minor Adverse LT: Not Significant Construction equipment fumes. Some dredged material volatilization.	ST: Minor Adverse LT: Not Significant Construction equipment fumes. Some initial dredged material volatilization.	ST: Minor Adverse LT: Not Significant Transport equipment fumes. Some initial dredged material volatilization.
Water Quality	ST: Minor Adverse LT: Moderate Adverse Migration of contaminated sediments downstream. Dredging and disposal increasingly limited.	ST: Moderate Adverse LT: Moderate Beneficial Dredging turbidity within the mixing zone. Removal of contaminated sediment from the river.	ST: Minor Adverse LT: Not Significant Construction runoff. Treated discharges.	ST: Minor Adverse LT: Not Significant Construction runoff. Treated discharges.	ST: Minor Adverse LT: Minor Adverse Construction runoff. Treated discharges.	ST: Minor Adverse LT: Minor Adverse Transport runoff. Treated discharges.
Sediment Quality	ST: Moderate Adverse LT: Major Adverse Migration of contaminated sediments downstream. Dredging and disposal increasingly limited.	ST: Moderate Beneficial LT: Major Beneficial Dredging turbidity within the mixing zone. Removal of contaminated sediment from the river.	ST: Minor Adverse LT: Not Significant Construction runoff. Transfer processing. Treated discharges.	ST: Minor Adverse LT: Not Significant Construction runoff. Transfer processing. Treated discharges.	ST: Minor Adverse LT: Minor Adverse Construction runoff. Confined disposal of contaminated material.	ST: Minor Adverse LT: Minor Adverse Placement in CDF. Confined disposal of contaminated material.
Benthos	ST: Moderate Adverse LT: Major Adverse Migration of contaminated sediments downstream. Dredging and disposal restricted.	ST: Minor Adverse LT: Moderate Beneficial Dredging excavation of benthos. Recolonization in cleaner sediments.	ST: Not Significant LT: Not Significant	ST: Not Significant LT: Not Significant	ST: Not Significant LT: Not Significant	ST: Not Significant LT: Not Significant
Fisheries	ST: Minor Adverse LT: Moderate Adverse Migration of contaminated sediments downstream. Dredging and disposal restricted. Wider contamination.	ST: Minor Adverse LT: Moderate Beneficial Dredging turbidity within the mixing zone. Removal of contaminated sediment from the river.	ST: Not Significant LT: Not Significant Transfer operation.	ST: Not Significant LT: Not Significant Transfer operation.	ST: Not Significant LT: Not Significant	ST: Not Significant LT: Not Significant
Vegetation	ST: Minor Adverse LT: Minor Adverse Migration of contaminated sediments downstream. Dredging and disposal limited.	ST: Minor Adverse LT: Moderate Beneficial Dredging excavation of vegetation. Recolonization in cleaner sediments.	ST: Minor Adverse LT: Not Significant Clear and grub about 5 acres of low value vegetation. Grass/legume slope cover. Restoration.	ST: Not Significant LT: Not Significant Use existing docking facilities.	ST: Minor Adverse LT: Not Significant Clear and grub about 32 acres of low value vegetation. Grass/legume slope cover. Restoration.	ST: Not Significant LT: Not Significant Existing development.
Wildlife	ST: Minor Adverse LT: Moderate Adverse Migration of contaminated sediments downstream. Dredging and disposal limited.	ST: Minor Adverse LT: Moderate Beneficial Dredging disruptions. Removal of contaminated sediments from the river.	ST: Not Significant LT: Not Significant Clear and grub about 5 acres of low value habitat. Grass/legume slope cover. Restore.	ST: Not Significant LT: Not Significant Use existing docking facilities.	ST: Not Significant LT: Not Significant Clear and grub about 32 acres of low value habitat. Grass/legume slope cover. Restore.	ST: Not Significant LT: Minor Beneficial Existing development. Eventual fill cover.
Threatened and Endangered Species	ST: Not Significant LT: Not Significant Transient species	ST: Not Significant LT: Not Significant Transient species.	ST: Not Significant LT: Not Significant Transient species only, no residents.	ST: Not Significant LT: Not Significant Transient species only.	ST: Not Significant LT: Not Significant Transient species only, no residents.	ST: Not Significant LT: Not Significant Existing development.
Wetlands	ST: Minor Adverse LT: Moderate Adverse Migration of contaminated sediments downstream. Contamination	ST: Not Significant LT: Not Significant Small riparian areas may be impacted.	ST: Minor Adverse LT: Not Significant Small riparian area construction impact	ST: Not Significant LT: Not Significant Use existing docking facilities.	ST: Minor Adverse LT: Not Significant Small riparian area construction impact.	ST: Not Significant LT: Not Significant Existing development.
General Soils Geology and Ground Water	ST: Minor Adverse LT: Minor Adverse Migration of contaminated sediments downstream. Dredging and disposal limited.	ST: Minor Adverse LT: Moderate Beneficial Dredging turbidity and excavation of sediments. Removal of contaminated sediment from the river.	ST: Minor Adverse LT: Not Significant Construction disruption. Facility operations. Restoration.	ST: Not Significant LT: Not Significant Use existing docking facilities.	ST: Moderate Adverse LT: Minor Adverse Construction disruption. CDF construction. Containment of contaminated sediment.	ST: Not Significant LT: Not Significant Existing development. Containment of contaminated sediments.

Table 4-13: Comparative Impacts of Final Considered Alternatives (cont.).

Evaluation Parameters	Considered Alternatives					
	No Action (Without Project)	Channel Dredging	Transfer/Dewater Harbor Shoreline	Transfer/Dewater Harbor Barge	Upland CDF Development	Existing Landfill (Permitted)
Human (Man-Made)						
Community and Regional Growth	ST: Moderate Adverse LT: Major Adverse Migration of contaminated sediments downstream. Dredging and disposal restricted. Harbor activity restricted. Associated adverse impacts to the community.	ST: Minor Adverse LT: Major Beneficial Construction, dredging, and disposal operations disruptions. Removal of contaminated sediments from the harbor. CDF containment. Harbor O&M.	ST: Minor Adverse LT: Moderate Beneficial Construction, facilities operations, transport disruption. Harbor dredged. Cleaner river sediments. Area restoration.	ST: Minor Adverse LT: Moderate Beneficial Facilities operations transport disruption. Harbor dredged. Cleaner river sediments. Existing docking facilities.	ST: Minor Adverse LT: Moderate Beneficial Construction, dredging, and disposal operations disruptions. Local CDF containment of contaminated sediments. Some O&M disposal capacity. Use lower value land.	ST: Minor Adverse LT: Moderate Beneficial Construction, transfer, transport disruptions. Regional upland CDF disposal of TSCA contaminated sediments. Existing facility.
Displacement of People	ST: Minor Adverse LT: Moderate Adverse Harbor activity restricted. Possible loss of businesses.	ST: Not Significant LT: Not Significant No displacement of residences or developments.	ST: Not Significant LT: Not Significant No displacement of residences or developments.	ST: Not Significant LT: Not Significant No displacement of residences or developments.	ST: Not Significant LT: Not Significant No displacement of residences or developments.	ST: Not Significant LT: Not Significant Existing facility.
Displacement of Farms	ST: Not Significant LT: Not Significant	ST: Not Significant LT: Not Significant	ST: Not Significant LT: Not Significant No farmland.	ST: Not Significant LT: Not Significant	ST: Not Significant LT: Not Significant No farmland	ST: Not Significant LT: Not Significant Existing facility.
Business/Industry Employment/Income	ST: Moderate Adverse LT: Major Adverse Migration of contaminated sediments downstream. Dredging and disposal restricted. Harbor activity restricted. Possible loss of businesses.	ST: Minor Adverse LT: Major Beneficial Construction, dredging, and disposal operations and costs. Removal of contaminated sediments from the harbor. CDF containment. Harbor O&M.	ST: Minor Beneficial LT: Minor Beneficial Construction, facilities operation work, disruption. Costs. Harbor dredged. Area restoration.	ST: Minor Beneficial LT: Minor Beneficial Use existing facilities. Facilities operation work, disruption. Costs. Harbor dredged.	ST: Minor Beneficial LT: Moderate Beneficial Construction, dredging, and disposal operations. Costs. Removal of contaminated sediments from the harbor. CDF containment. Harbor O&M.	ST: Minor Beneficial LT: Moderate Beneficial Construction, transfer, transport, disposal operations. Cost. Regional up-land CDF Containment of TSCA contaminated sediment. Existing facility.
Public Facilities and Services	ST: Moderate Adverse LT: Major Adverse Migration of contaminated sediments downstream. Dredging and disposal restricted. Harbor activity restricted. Possible loss of businesses.	ST: Minor Adverse LT: Moderate Beneficial Construction, dredging, and disposal operations needs. Removal of contaminated sediments from the harbor. CDF containment. Harbor O&M.	ST: Minor Adverse LT: Not Significant Construction and facilities operation needs. Transport impacts. Harbor dredged. Area restoration.	ST: Minor Adverse LT: Not Significant Use existing facilities. Facilities operation work, disruption. Costs. Harbor dredged.	ST: Minor Adverse LT: Moderate Beneficial Construction, dredging, and disposal operations needs. Local CDF containment facility. Some O&M disposal capacity. Serves harbor O&M.	ST: Minor Adverse LT: Moderate Beneficial Construction, transfer, transport, disposal operation needs. Regional up-land TSCA facility. Existing facility.
Recreation	ST: Moderate Adverse LT: Major Adverse Migration of contaminated sediments downstream. Dredging and disposal restricted. Contamination wider. Possible loss marina activity/businesses.	ST: Minor Adverse LT: Major Beneficial Construction, dredging, and disposal operations disruptions. Removal of contaminants from the harbor. CDF containment. Harbor O&M.	ST: Minor Adverse LT: Minor Beneficial Construction and facilities operation disruptions. Harbor dredged. Cleaner river sediments. Area restoration.	ST: Minor Adverse LT: Minor Beneficial Construction and facilities operation disruptions. Harbor dredged. Cleaner river sediments. Existing facility.	ST: Minor Adverse LT: Minor Adverse Construction and disposal operations disruptions. Local DCF containment of contaminated sediments. Grass/legume cover. Use lower value land.	ST: Not Significant LT: Not Significant Existing facility.
Property Value and Tax Revenue	ST: Moderate Adverse LT: Major Adverse Migration of contaminated sediments downstream. Dredging and disposal restricted. Harbor activity restricted. Possible loss of business/tax.	ST: Minor Adverse LT: Minor Beneficial Construction, dredging, and disposal operations and costs. Removal of contaminated sediments from the harbor. CDF containment. Harbor O&M.	ST: Minor Adverse LT: Minor Beneficial Construction and facilities operation and costs. Use interim disposal area. Area restoration.	ST: Not Significant LT: Not Significant Use existing docking facilities. Facilities operation and costs.	ST: Minor Adverse LT: Minor Adverse Construction and disposal operations and costs. Local CDF containment of contaminated sediments. Grass/legume cover. Use lower value land.	ST: Minor Adverse LT: Not Significant Construction, transfer, transport, and disposal operations and costs. Regional TSCA upland CDF. Existing facility.
Noise and Aesthetics	ST: Minor Adverse LT: Moderate Adverse Migration of contaminated sediments downstream. Dredging and disposal restricted. Harbor activity restricted. Possible loss of business and delapidations	ST: Moderate Adverse LT: Minor Beneficial Construction, dredging, and disposal operations disruptions. Removal of contaminated sediments from the harbor. CDF containment. Harbor O&M.	ST: Moderate Adverse LT: Not Significant Construction and facilities operation disruptions. Transport disruptions. Area restoration.	ST: Moderate Adverse LT: Not Significant Use existing docking facilities. Facilities operation disruptions. Transport disruptions.	ST: Moderate Adverse LT: Minor Adverse Construction and disposal operations disruptions. Local CDF containment of contaminated sediments. Grass/legume cover. Use lower value land.	ST: Minor Adverse LT: Not Significant Construction, transfer, transport, and disposal operations disruptions. Regional TSCA upland facility. Existing facility.
Community Cohesion	ST: Moderate Adverse LT: Major Adverse Migration of contaminated sediments downstream. Dredging and disposal restricted. Harbor activities restricted. Associated adverse impacts to the community.	ST: Minor Adverse LT: Moderate Beneficial Construction, dredging, and disposal operations disruptions. Removal of contaminated sediments from the harbor. CDF containment. Harbor O&M.	ST: Minor Adverse LT: Moderate Beneficial Construction, facilities operations, transport disruption. Harbor dredged. Cleaner river sediments. Area restoration.	ST: Minor Adverse LT: Moderate Beneficial Facilities operation transport disruption. Harbor dredged. Cleaner river sediments. Existing docking facilities.	ST: Minor Adverse LT: Minor Adverse Construction and disposal operations disruptions. Local CDF containment of contaminated sediments. Use lower value land.	ST: Minor Adverse LT: Minor Adverse Construction, transfer, transport, and disposal operations disruptions. Regional TSCA upland facility. Existing facility.
Cultural Resources	ST: Not Significant LT: Not Significant None identified in the dredging areas.	ST: Not Significant LT: Not Significant None identified in the dredging areas.	ST: Not Significant LT: Not Significant None identified in the interim disposal site area.	ST: Not Significant LT: Not Significant Use existing docking facility	ST: Not Significant LT: Not Significant None identified in the site area.	ST: Not Significant LT: Not Significant Existing facility.

4.7.1 Related Project Component Recommendations

The assessment of the related aquatic ecosystem restoration alternatives resulted in the selection and recommendation of the following measures for later implementation, as a separate independent project, in the Project Area after completion of environmental dredging.

1. Aquatic Ecosystem Restoration:
 - a) EAA 2 “Acquire Conrail Slip (Slip 5A) Aquatic Fishery Shelf Cut Plan” (Plan 4)
 - b) EAA 3: “Aquatic Fishery Shelf Plan” (Plan 2).

The following section of the CMP (Section 5.0) describes in detail the ARP’s Recommended Environmental Dredging Plan based on the results of Plan Formulation and recommended project component alternatives including tables and figures.

Summary Table 4-14, which follows, indicates the relationship of final plans considered in detail to Federal and state Environmental Protection Statutes, Executive Orders, and Memoranda. For more detail, see Section 6.0 of the EIS, “Public Involvement” (Required Coordination) and associated Appendices.

Federal Statutes	Plan Compliance	
	Upland State Road Site	Alternative Disposal
*Historical and Archaeological Data Preservation Act, 16 USC 649, et seq.	N/A	N/A
*National Historic Preservation Act, 16 USC 470 et seq.	Full	Full
*Clean Air Act, 42 USC 7401 et seq.	Full	Full
*Clean Water Act (Water Pollution Control Act) 33 USC 1251 et seq.	Full	Full
*National Environmental Policy Act, 42 USC 4321 et seq.	Full	Full
*Fish and Wildlife Coordination Act, 16 USC 661 et seq.	Full	Full
*Endangered Species Act, 16 USC 1531 et seq.	Full	Full
*Estuary Protection Act, 16 USC 1221 et seq.	N/A	N/A
*Marine Protection Research and Sanctuaries Act, 16 USC 1401, et seq.	N/A	N/A
*Rivers and Harbors Act, 33 USC 401 et seq.	Full	Full
*Water Resources Development Act(s)	Full	Full
*Water Resources Planning Act, 42 USC 1962 et seq.	Full	Full
*Federal Water Project Recreation Act, 16 USC 4601-12 et seq.	Full	Full
*Land and Water Conservation Fund Act, 16 USC 4601-4	Full	Full
*Wild and Scenic Rivers Act, 16 USC 1271 et seq.	Full	Full
*Coastal Zone Management Act, 16 USC 1451 et seq.	Full	Full
*Watershed Protection and Flood Prevention Act, 16 USC 1001 et seq.	Full	Full
*Farmland Protection Policy Act, 7 USC 4201 et seq.	Full	Full
Hazardous, Toxic, Radioactive Waste (HTRW) (Legislation/Regulations)		
*Resource Conservation and Recovery Act (RCRA), 1976, 42 USC 6901 et seq.	Full	Full
*Hazardous and Solid Waste Amendments (HSWA), 1984.	Full	Full
*Comprehensive Environmental Response, Compensation, and Liabilities Act (CERCLA or SUPERFUND), 1980, 42 USC 9601 et seq.	Full	Full
*Superfund Amendments and Reauthorization Act (SARA) 1986.	Full	Full
*Toxic Substance Control Act (TSCA), 1976, 15 USC 2601.	Full	Full
*Pollution Prevention Act, 1990, 42 USC 13101 et seq.	Full	Full

Executive Orders, Memoranda, etc.

*Protection and Enhancement of Environmental Quality (EO 11514).	Full	Full
*Protection and Enhancement of the Cultural Environment (EO 11591).	Full	Full
*Flood Plain Management (EO 11988).	Full	Full
*Protection of Wetlands (EO 11990).	Full	Full
*Environmental Effects Abroad of Major Federal Actions (EO 12114).	Full	Full
*Analysis of Impacts on Prime and Unique Farmlands (CEQ Memorandum, 30 August 76).	Full	Full
*Federal Compliance with Pollution Control Standards (EO 12088).	Full	Full
*Superfund Implementation (EO 12580).	Full	Full
*Federal Compliance with Right to Know laws and Pollution Prevention Requirements (EO 128856).	Full	Full
*Environmental Justice	Full	Full

Ohio State Environmental Protection

*Ohio State Administrative Code		
Title 3745 - Environmental Protection Agency	Full	Full
-Clean Water Act 401 Certification	Full	Full
-State Pollution Discharge Elimination System	Full	Full
-Permit to Install	Full	Full
-Solid Waste Disposal Regulations	Full	Full
*Ohio Revised Code		
-Hazardous Waste and Solid Waste Laws	Full	Full
-Water Pollution Control Laws	Full	Full
*Ohio Department of Health (RAD)	Full	Full
*State Coastal Management Program Consistency Determination	Full	Full

Local Land Use Plans

*Ashtabula County Solid Waste Disposal Facility (Siting Criteria)	Full	Full
*Town of Ashtabula Local Land Use Plans	Full	Full

Compliance categories used in this table were assigned based on the following definitions:

- Full Compliance** - All requirements of the statute, EO, or other policy and related regulations have been met for this stage of the study.
- Partial Compliance** - Some requirements of the statute, EO, or other policy and related regulations, which are normally met by this stage of the study, remain to be met.
- Non compliance** - None of the requirements of the statute, or EO, or other policy and related regulations have been met.
- N/A** - The statute, EO, or other policy and related regulations are not applicable for this study.

Table 4-14: Summary Table of Environmental Protection Statutes and Other Environmental Requirements.

5.0 THE RECOMMENDED ENVIRONMENTAL DREDGING PLAN

5.1 Recommended Environmental Dredging Plan Description

Based upon the results of Plan Formulation, the ARP has selected an alternative for each project component. The selected alternatives constitute the Recommended Environmental Dredging Plan for the ARP project. The Recommended Environmental Dredging Plan is comprised of the following components.

1. Dredging (contaminated sediment removal):
 - a) Enclosed clamshell bucket technology.
 - b) Deep-Dredge alternative.

2. Transfer/Dewatering:
 - a) Barge transfer of dredged sediment to dewatering site.
 - b) River shoreline transfer/dewatering facility at the Norfolk Southern site.
 - c) Passive sediment dewatering technology.
 - d) Multi-media carbon filtration treatment of supernatant.
 - e) Truck transport of dewatered sediment to disposal facility.

3. Disposal:
 - a) New upland TSCA and Non-TSCA landfill at the State Road site.

The selected related aquatic ecosystem restoration measures (not part of the Recommended Environmental Dredging Plan) are as follows. These measures would be implemented as a separate independent project under Section 206 Authority, assuming Section 206 funding is available and the presence of a Non-Federal sponsor, concurrent with the design and implementation of environmental dredging.

1. Aquatic Ecosystem Restoration:
 - a) EAA 2 “Acquire Conrail Slip (Slip 5A) Aquatic Fishery Shelf Cut Plan” (Plan 4)
 - b) EAA 3: “Aquatic Fishery Shelf Plan” (Plan 2).

The Recommended Environmental Dredging Plan involves the use of enclosed clamshell bucket technology to implement the Deep Dredge alternative to remove a total of 696,000 cubic yards of contaminated sediment from the Project Area. Sediment removal by river segment would be as follows:

Downstream of the 5th Street Bridge - Dredging would remove approximately 115,000 cubic yards of contaminated sediment. Dredging would address PAH

contamination, which was considered to be the primary contaminant of concern in this area.

Upstream (south) of the 5th Street Bridge - Dredging would remove approximately 581,000 cubic yards of contaminated sediments which includes up to 150,000 cubic yards of significantly PCB contaminated sediment, which will be handled and disposed of in accordance with TSCA regulations.

Dredged sediment would be placed in barges and transported to the recommended shoreline transfer/dewatering facility on the Ashtabula River. At the transfer/dewatering facility passive sediment dewatering methods and multi-media carbon filtration treatment technology would be used to treat the decant (supernatant) water. Once the sediment is sufficiently dewatered, (passes the paint filter test), trucks would be used to transport the dewatered sediment to the disposal site at State Road, where TSCA and Non-TSCA landfill cells would be created for the project.

The implementation of the recommended related aquatic ecosystem restoration measures would restore aquatic habitat in EAA 2 and EAA 3 along the river shoreline subsequent to the completion of the ARP project. See Figure 5-1 through 5-15 for more detail.

5.1.1 Recommended Environmental Dredging Plan Component Descriptions

5.1.1.1 Dredging Component: Deep Dredge

Figure 5-1 shows the ARP Ashtabula River contaminated sediment removal Project Area upstream and downstream of the 5th Street Bridge. The selected dredging alternative of the Recommended Environmental Dredging Plan for contaminated sediment removal is Deep Dredge. This alternative removes the amount of contaminated sediment consistent with Ashtabula River Partnership goals, has moderate costs, minimizes adverse impacts, and meets river ecological cleanup restoration goals and objectives. The Recommended Environmental Dredging Plan calls for removal and disposal of approximately 696,000 cubic yards of sediments. Approximately 581,000 cubic yards of contaminated sediments are located upstream of the 5th Street Bridge of which as much as 150,000 cubic yards is significantly PCB contaminated and would be handled and disposed of in accordance with Toxic Substances Control Act (TSCA) regulations. The remaining 115,000 cubic yards of contaminated sediments are located downstream of the 5th Street Bridge to station 120+00 where PAH contamination is considered to be the primary contaminant of concern (see Figure 5-1).

Dredging, particularly of TSCA sediment, would be accomplished in a manner that would minimize turbidity and resuspension of sediments and associated contaminants. Figure 4-1 in Section 4.0 illustrates typical dredge types. Dredged sediment would be placed in watertight barges for transport on the river to the transfer/dewatering facility. Cover of the TSCA sediment during transport would be considered. Applicable environmental controls including water quality controls and dredging operation controls would be in effect on the dredging operations to limit adverse impacts. Water quality controls include placing limits on the amount of turbidity or concentrations of PCB's and other contaminants allowed in the water column outside the immediate dredging area. Dredging operation controls include limiting the bucket cycle time,

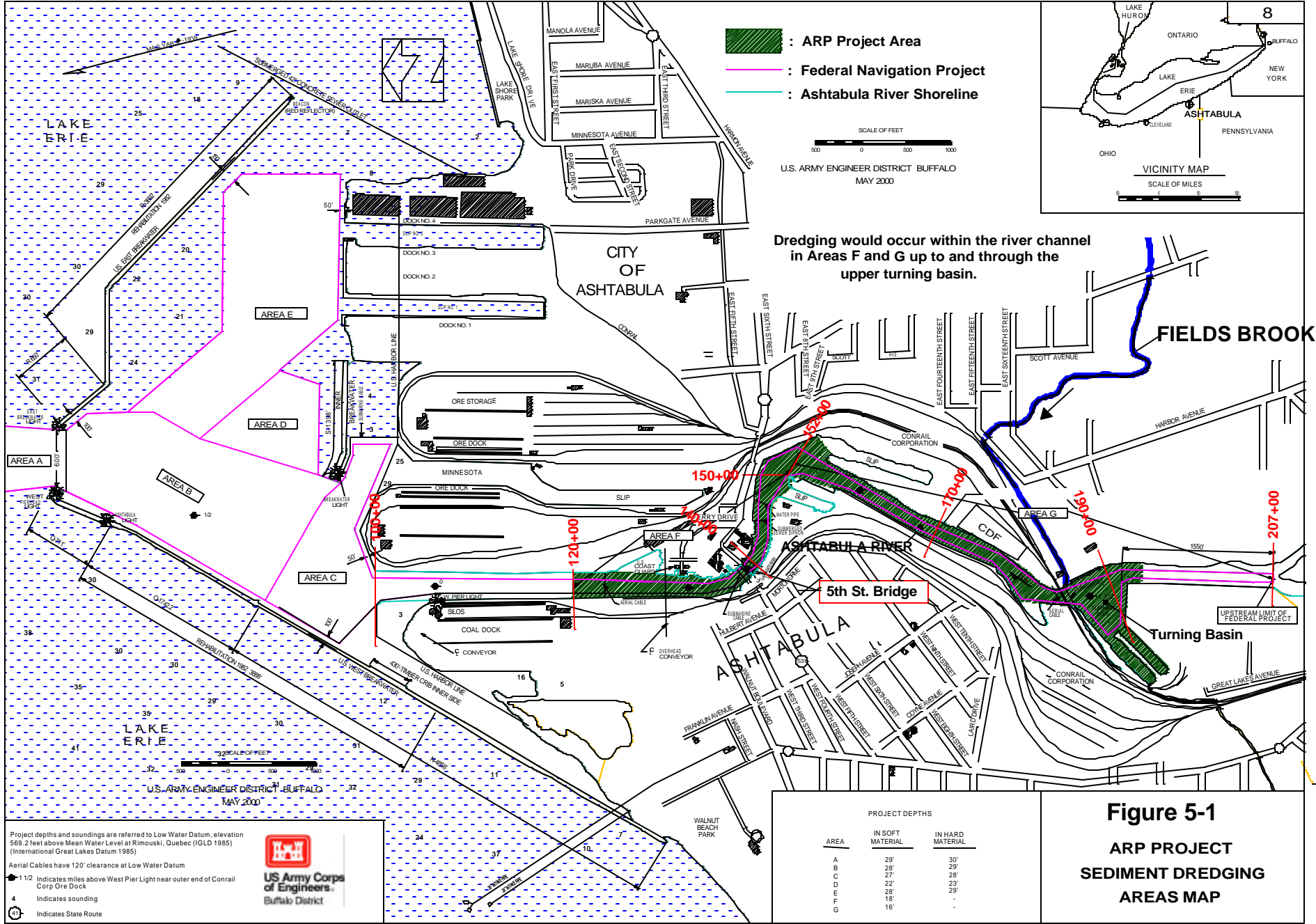

Project depths and soundings are referred to Low Water Datum, elevation 569.2 feet above Mean Water Level at Rimouski, Quebec (IGLD 1985) (International Great Lakes Datum 1985)

Aerial Cables have 120' clearance at Low Water Datum

1/2 Indicates miles above West Pier Light near outer end of Conrail Corp Ore Dock

4 Indicates sounding

43 Indicates State Route



prohibiting nighttime dredging operations, and allowing barges to be only partially filled. Environmental controls that would be used during the dredging operation include oil booms and absorbents to capture oil film released from the dredging action. Silt curtains would also be used if a determination is made during detailed project design that such measures, especially during dredging of the TSCA sediment, are necessary to limit the spread of resuspended sediments and associated contaminants.

5.1.1.2 Transfer/Dewatering Component: Shoreline Norfolk Southern Site

The Recommended Environmental Dredging Plan includes the development of a transfer/dewatering facility along the east bank of the Ashtabula River shoreline on property presently held by Norfolk Southern (see Figures 5-2 and 5-3). This facility would require from five to ten acres and would include a barge mooring area, dredged sediment holding/settling basins and treatment and support facilities. Figure 5-4 shows a conceptual representation of the transfer/dewatering facility site layout. Included in this representation is the barge shoreline mooring area, vehicle loading areas and access roads, ditching, dredged sediment settling basins and storage facilities, the water filtration system staging area, and decontamination pad. Figure 5-4a illustrates a typical plan view and plan profile representation of the conceptual barge shoreline tie-up, barge settling basin and pump-out configuration, and Figure 5-4b illustrates the conceptual transfer/dewatering facility water treatment train diagram.

The dewatering of dredged sediment will be a multi-step process. The first step in dewatering would involve the use of watertight barges as primary settling basins for dredged material. The second step involves transfer of consolidated sediments from the watertight barges to impermeable lined earthen holding and settling basins constructed within the shoreline transfer/dewatering facility (see Figures 5-4 and 5-4a). Dredged contaminated sediments will settle over a period of one to two days, first in the barges and then on shore in settling basins. Most contaminants are tightly bound to sediment particles and will settle out along with the sediments.

In barges, the water/slurry (supernatant) on the surface of the dredged sediment will be pumped to an on-site water treatment system for processing. In the settling basins, supernatant will drain out of the sediments during this process to a sump. The water/slurry will be pumped out of the sump into a secondary settling basin and allowed to settle. The sediments will be worked across the surface of the holding basin, to the inland side for loading into trucks. Excess water will drain out of the sediments during this process and flow to a sump.

All supernatant will be processed through an on-site water treatment system comprised of a series of portable truck mounted units that includes flocculation, multi-media filtration, and carbon treatment (see Figure 5-4b) components. Supernatant will be processed through the treatment train until attaining the State water quality standards for discharge into the Ashtabula River.

Figure 5-2: Selected Transfer/Dewatering and Disposal Sites.

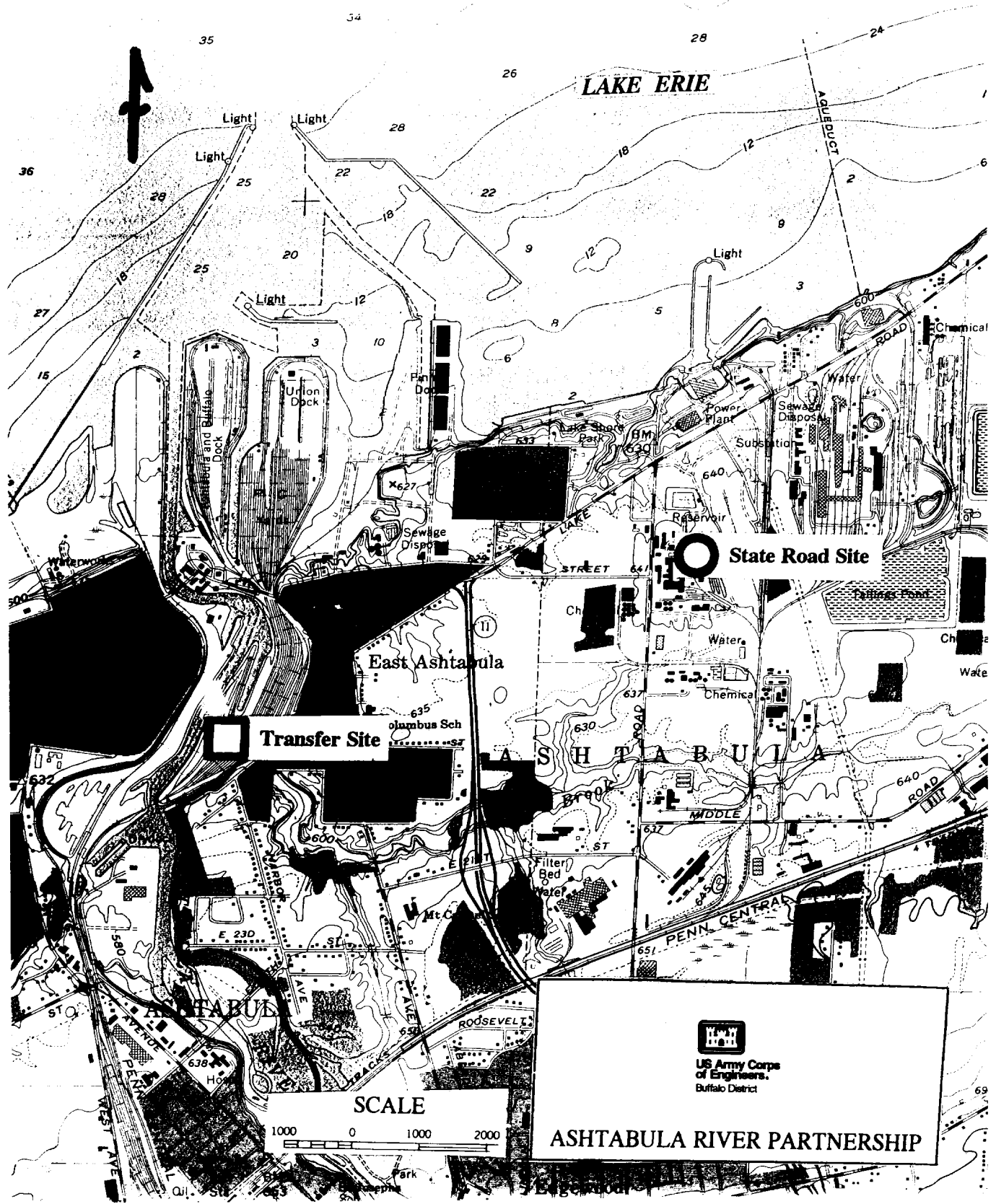

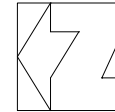
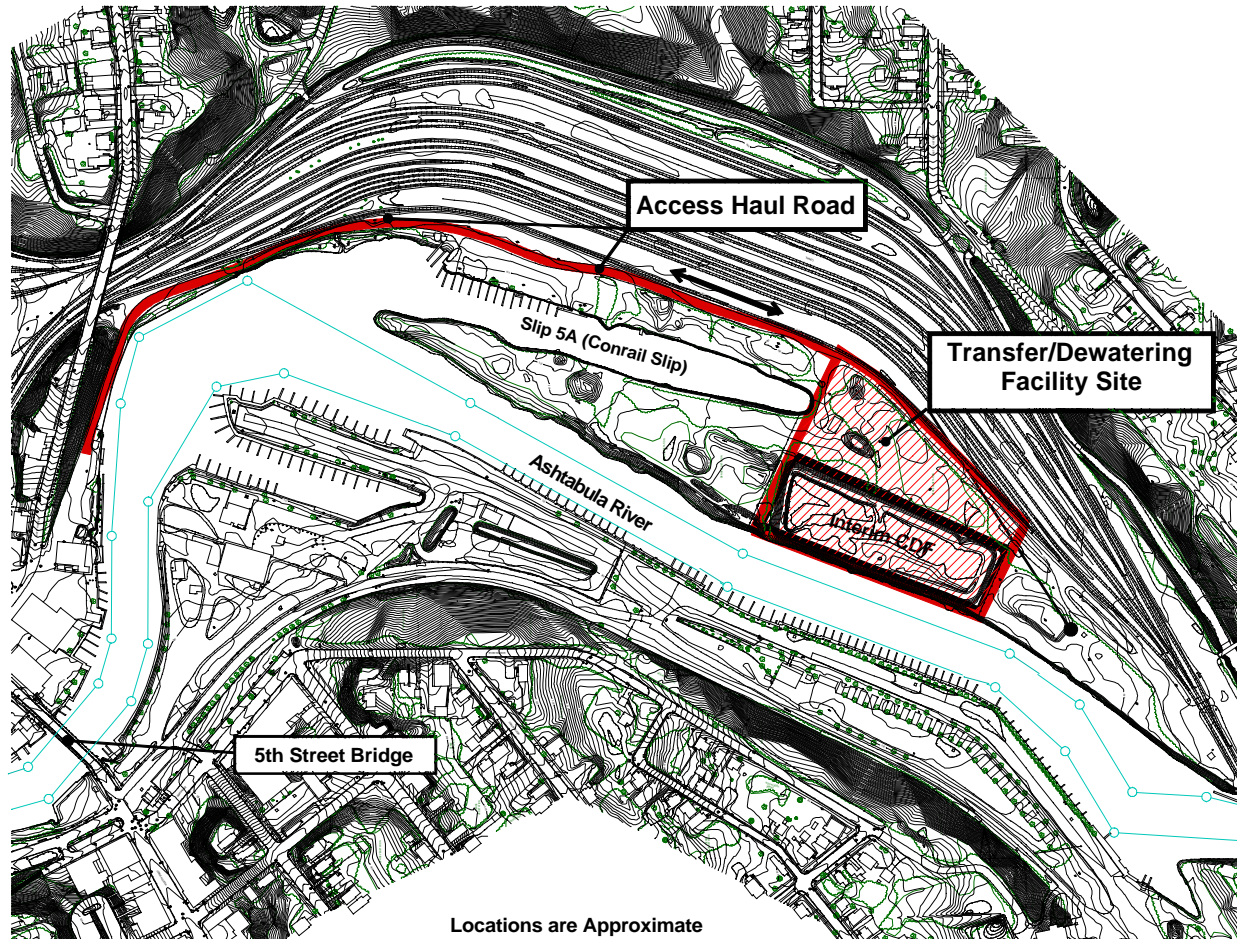

Map Not To Scale



-  : Transfer/Dewatering Facility Site
-  : Access Haul Road
-  : Federal Authorized Channel

Figure 5-3

ARP PROJECT
SHORELINE TRANSFER/DEWATERING
FACILITY SITE



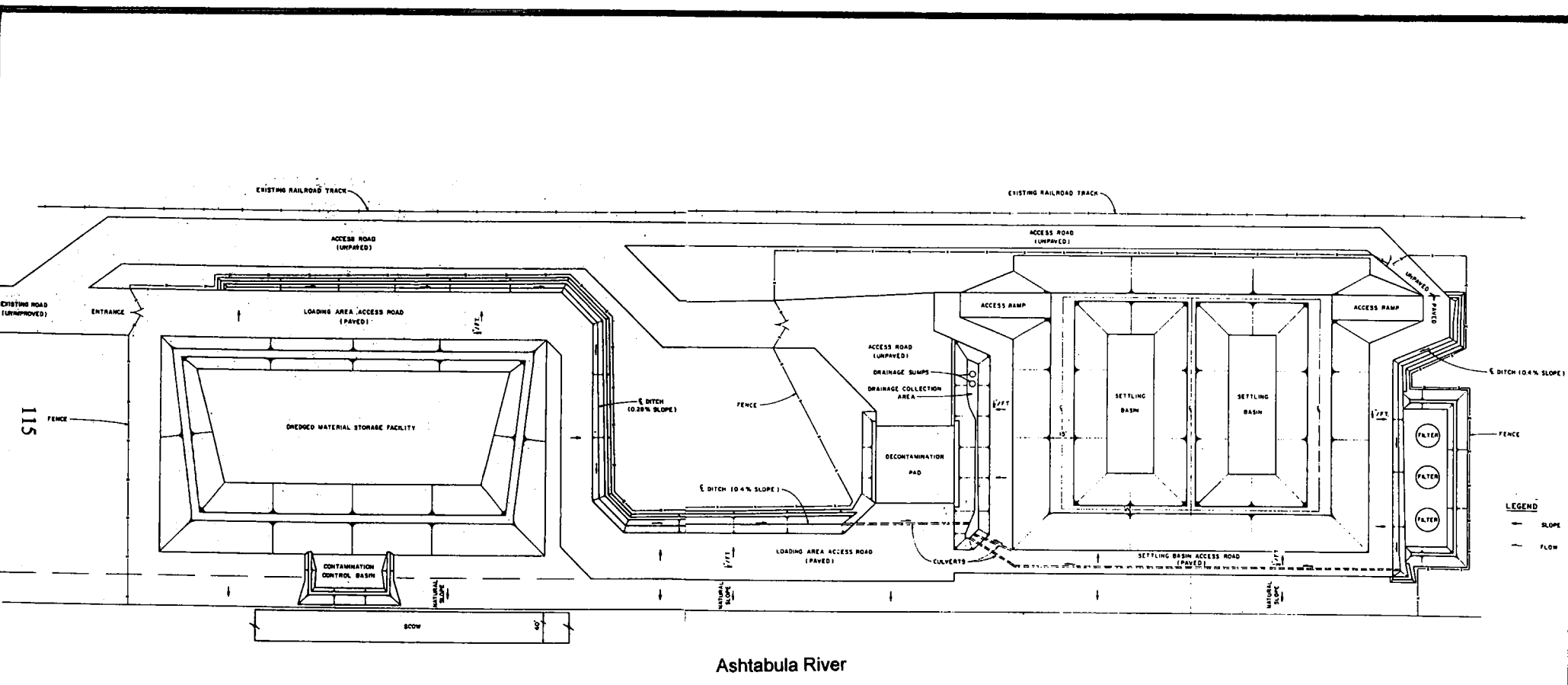
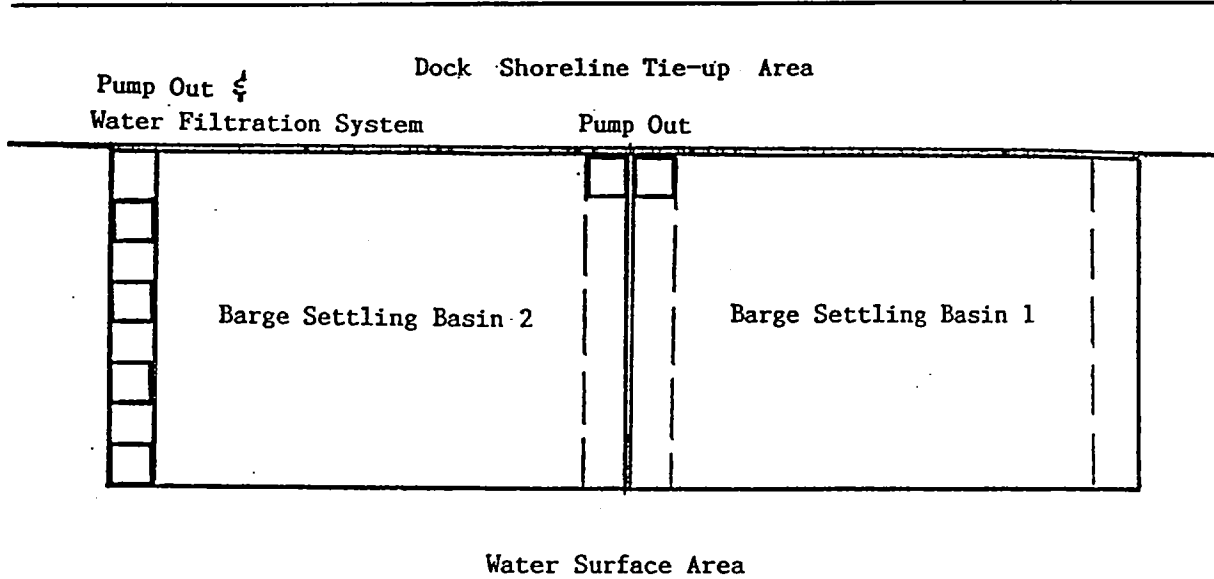

Figure 5-4: Conceptual (Typical) Transfer/Dewatering Site Facilities Operational Systems Layout.

Figure 5-4a: Typical Transfer/Dewatering Site Barge Operation.

TANDEM BARGE SETTLING/FILTRATION SYSTEM
(PLAN VIEW)



TANDEM BARGE SETTLING/FILTRATION SYSTEM
(ELEVATION)

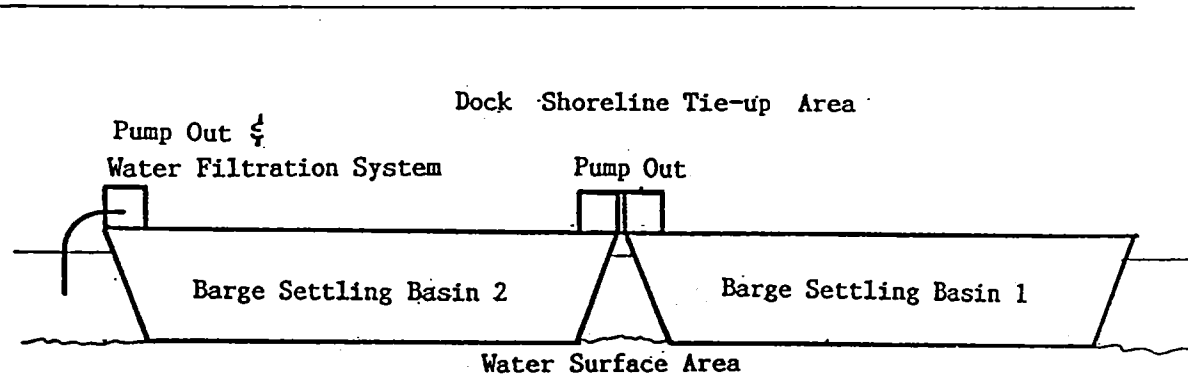

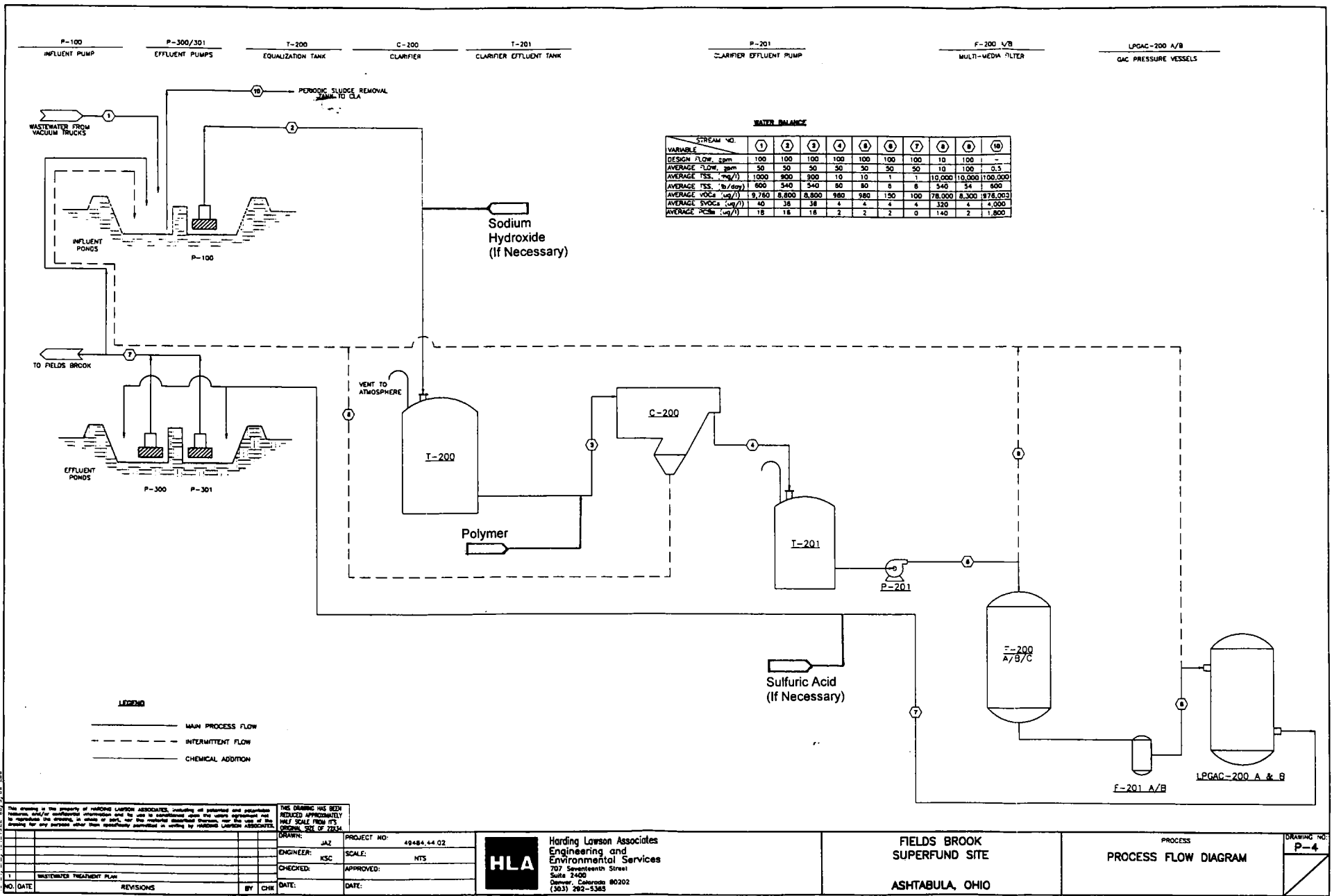

Figure 5-4b: Typical Transfer/Dewatering Facility Water Treatment Train Diagram.

117



Harding Lawson Associates
Engineering and
Environmental Services
707 Seventeenth Street
Suite 2400
Denver, Colorado 80202
(303) 292-5385

FIELDS BROOK
SUPERFUND SITE
ASHTABULA, OHIO

PROCESS
PROCESS FLOW DIAGRAM

DRAWING NO.
P-4

Consolidated sediments, having met the paint filter test, will be loaded into sealed trucks and transported to the final disposal facility, a landfill located on the State Road site. Transportation would be conducted in accordance with regulations pertaining to the transport of TSCA and contaminated dredged Non-TSCA sediment. Access and egress to this facility will necessitate use of the railroad's roadway paralleling the river and the tracks. At the start of construction the roadway will be properly surfaced and the maintained throughout the environmental dredging project. The Transfer/dewatering facility will include an equipment decontamination station, storage area(s), loading areas for the trucks, and a work trailer for on-site personnel.

Safety and security features will include but not limited to: surrounding fencing, gates and locks, appropriate lighting, protective barricades for power poles and flagmen stationed at strategic locations. Monitoring equipment will be installed on-site and air quality standards met at all times. Upon completion of the project after all dredging has been completed, the entire transfer/dewatering facility will be dismantled and construction related structures, equipment and supplies will be hauled off-site. All materials, soils, liners, etc. which came in contact with dredged sediments will be removed from the site and disposed of in the permanent landfill. The transfer/dewatering site will then be restored to its pre-existing condition, topsoil added as required and the area will be seeded with an appropriate mix of grasses and ground cover. Dredged debris items (i.e., tree stumps, tires) would be stockpiled, transported and appropriately disposed of at the landfill. Debris associated with the TSCA-regulated sediment would be considered contaminated and disposed as TSCA sediment.

5.1.1.3 Disposal Facilities Component: State Road Site

The final upland TSCA and Non-TSCA sediment disposal facility would utilize the State Road site (see Figures 5-2 and 5-5). Development of the disposal facilities at the State Road site would require about 33± acres. The State Road site is presently a brownfield site that supports primarily upland open field, patchy herbaceous re-growth and common reed, which is consistent with urban industrial sites. (see Figure 5-5a).

A portion of the disposal facility would be built according to TSCA disposal standards to receive the 150,000 cubic yards of TSCA classified sediment. The remainder of the disposal facility would be used to store the Non-TSCA sediment. There is sufficient capacity for the Ashtabula River elevated PCB and RAD dredged material to be disposed of in an existing facility adjacent to the Fields Brook remediation project disposal facility. There is also enough room for the ARP dredged contaminated dredged sediments to be disposed of in a new landfill that could be developed adjacent to the Fields Brook remediation project disposal facility at the State Road site. Assessment/evaluation indicates that this is the overall preferred disposal alternative and is the recommended project disposal component plan (see Figure 5-5b).





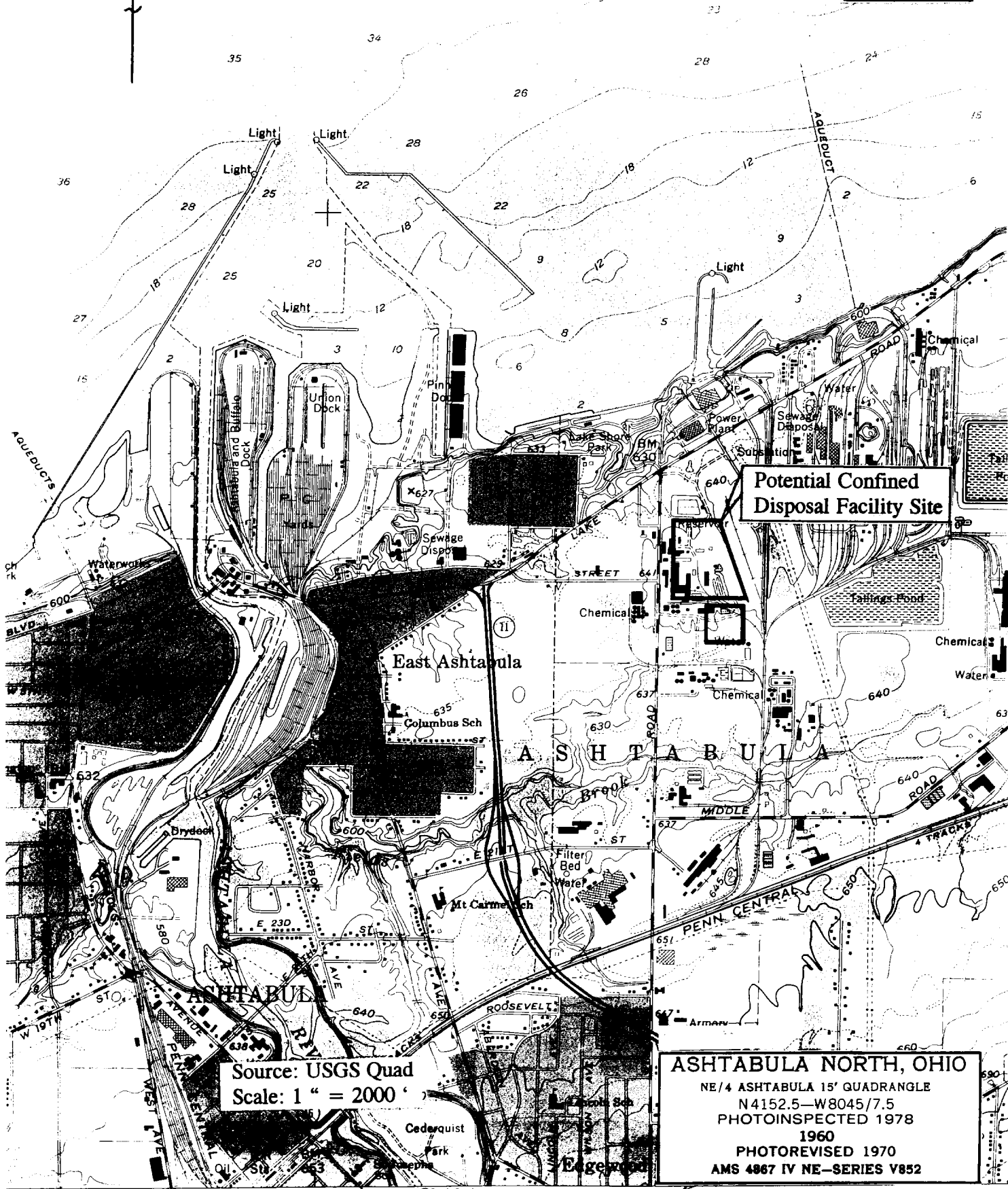

The regulations developed by the U.S. Environmental Protection Agency to implement TSCA remediation are found at Title 40 CFR Part 761. The main portion of the Toxic Substances Control Act applicable to the design and operation of a TSCA landfill is subpart D of 40 CFR Part 761. Developed upland TSCA disposal facilities would be designed in accordance these regulations.

Figure 5-5: State Road Disposal Facility Site Location.



Source: USGS Quad
Scale: 1" = 2000'

ASHTABULA NORTH, OHIO
NE/4 ASHTABULA 15' QUADRANGLE
N4152.5—W8045/7.5
PHOTOINSPECTED 1978
1960
PHOTOREVISED 1970
AMS 4867 IV NE—SERIES V852

-  : Buildings, Bare Urban Land, Demolition Rubble and Patchy Upland Herbaceous Vegetation
-  : Lagoons
-  : Upland Field
-  : Wetland
-  : Site Investigation Boundary
-  : Monotypic Common Reed Growth
-  : Maintained Grasses

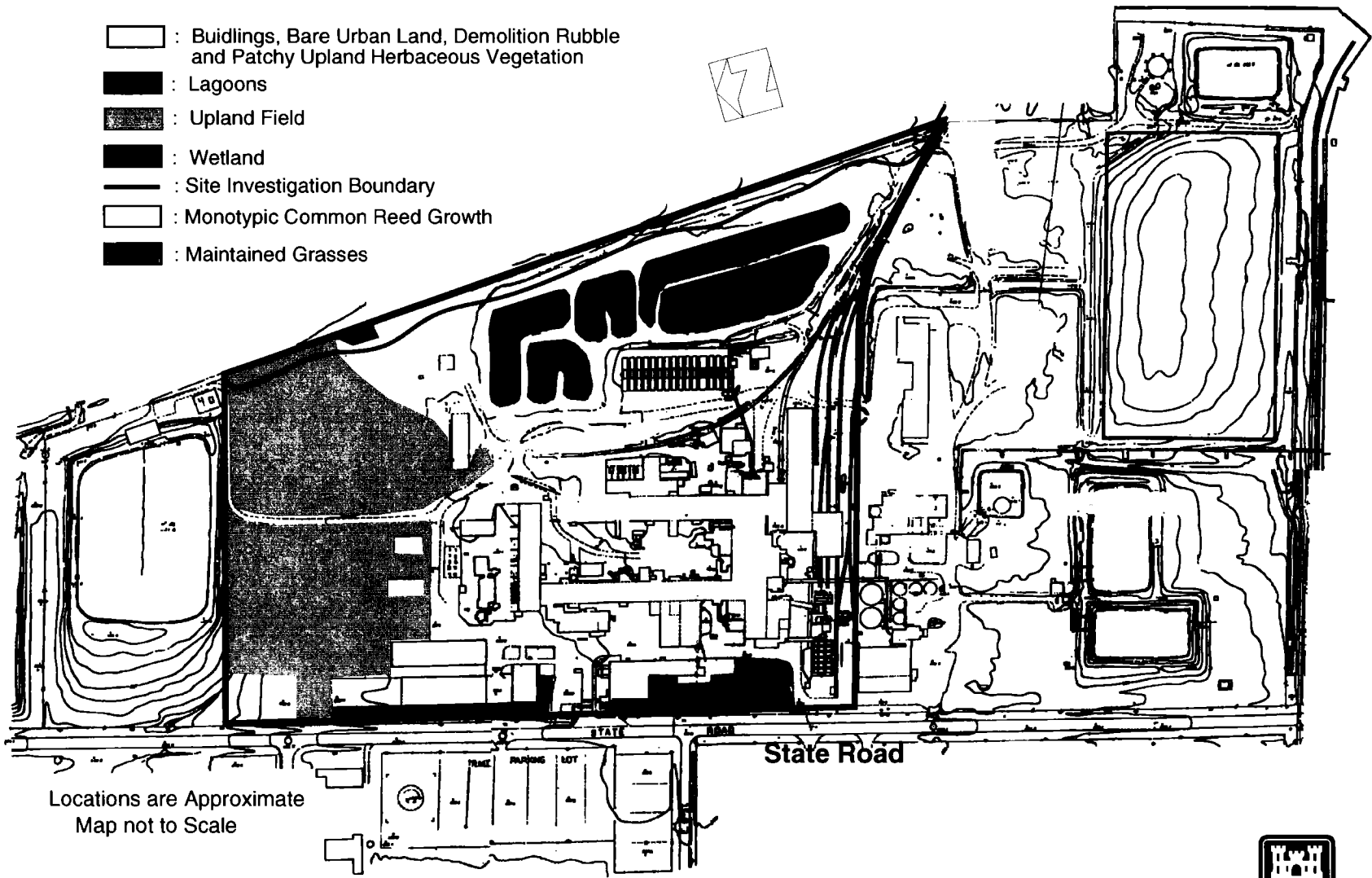

Locations are Approximate
Map not to Scale

**Figure 5-5a: State Road ARP Project Upland TSCA & Non-TSCA Disposal Site
Ecological Communities**



US Army Corps
of Engineers.
Buffalo District

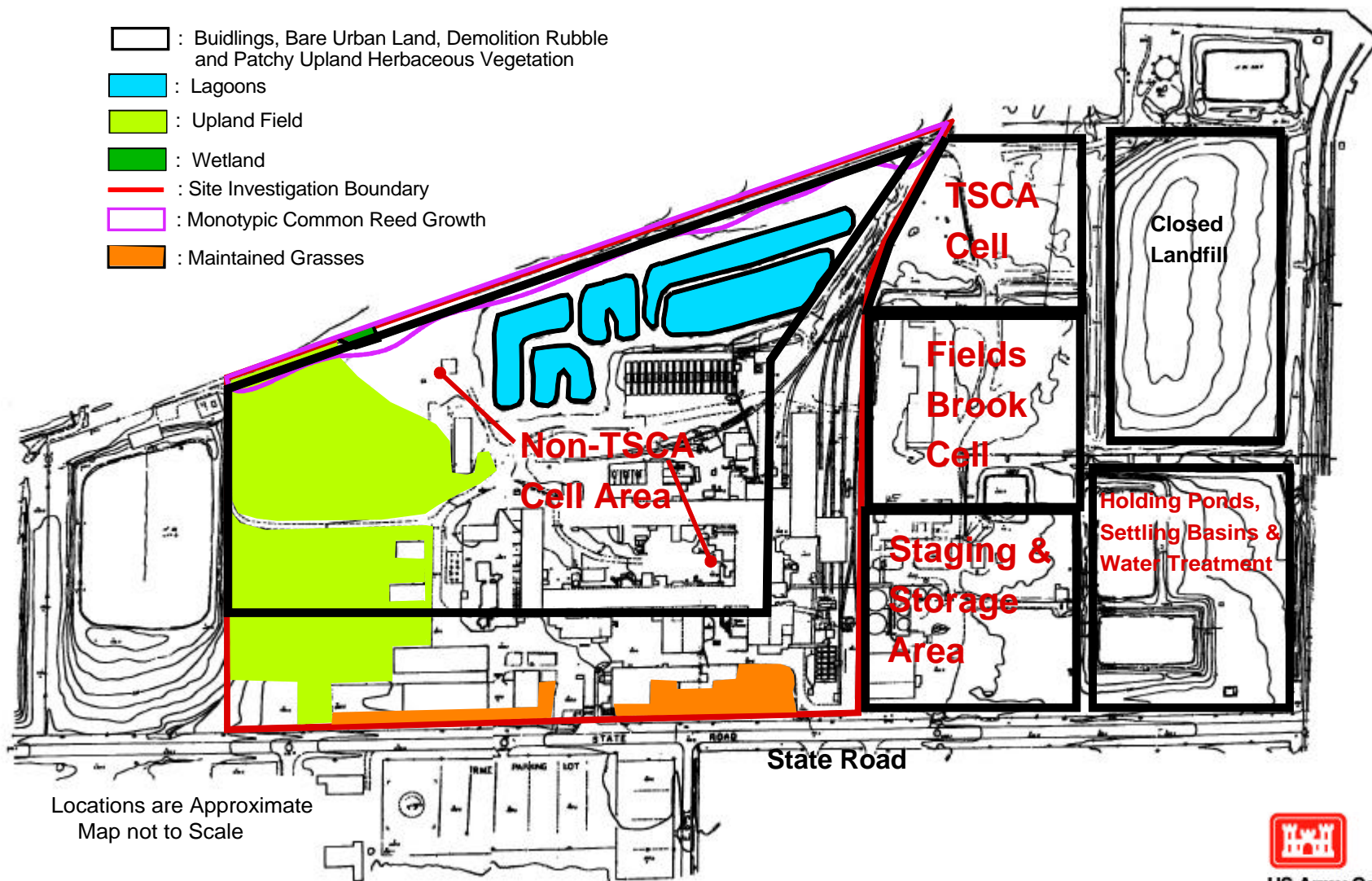

**Figure 5-5b: State Road ARP Project Upland TSCA & Non-TSCA Disposal Site
Conceptual Site Layout**



US Army Corps
of Engineers
Buffalo District

A conceptual Non-TSCA disposal facility plan has been designed with reference to Ohio's Revised Code Chapter 6111 Water Pollution Control Laws 6111.45 Approval of Plans for Disposal of Waste, Department of Surface Waters 0400-028 Policy-Industrial Other Waste, and Ohio's Solid Waste Best Available Technologies (BAT) Rules (RCRA Subtitle D) effective July 1, 1994.

On May 18, 1999 the Ohio Department of Health, Bureau of Radiation Protection (ODH), as the State of Ohio Radiation Control Agency, issued a letter to the Ashtabula River Partnership stating: "It is the opinion of the ODH that based on a review of the ARP draft CMP/EIS and given the presently known radionuclide concentrations within the sediments of the Ashtabula River, the recommended plan for disposal of the sediments is consistent with state requirements."

The Ohio Revised Code Title 37 – Chapter 48 and the rules promulgated thereunder delineate the regulatory authority under which ODH performed its review. During consideration of the disposal matter, ODH staff reviewed the criteria in 10 CFR 61 as delineated in OAC 3701-39-021. ODH determined that the dredging and disposal of low-level radioactive sediments from the Ashtabula River does not require a 10 CFR 61, as delineated in OAC 3701-39-021, disposal action. ODH has and will continue to implement the State of Ohio's regulations consistent with a 10 CFR 20.2002, as delineated in OAC 3701-39-021, on-site remediation and disposal action.

The facility would require impermeable synthetic and clay linings, a leachate collection system and a water filtration/treatment system to meet water quality discharge standards. The primary difference between the TSCA cell and the Non-TSCA cell is that the TSCA cell includes a double liner with double leachate collection and leak detection monitoring. The facility would be capped with a clay and synthetic liner after it is filled and would include closure and post closure monitoring measures. See Figures 5-5c, 5-5d and 5-5e for more detail. Gradual and long-term vegetation replacement would likely be with grasses or legumes on disposal facility slopes.

5.1.1.3.1 Alternative Disposal Site Options

The planning assessment indicated that construction of upland landfill disposal facilities and the disposal of dredged sediment at the State Road site is the best available alternative for the Recommended Environmental Dredging Plan. This finding is due primarily to estimated significant cost savings and greatly reduced environmental impacts compared to Site 7.

As an alternative to the State Road site, the ARP and/or project contractor would reserve the option to dispose of the Non-TSCA dredged sediment in existing approved (at the time of project implementation) disposal facilities (those that would and could accept the material under current or modified permit). This option would be used if demonstrated to be substantially more cost effective while remaining environmentally acceptable. Environmental impacts have been generically assessed for the "Alternative Disposal Option" and assessed as somewhat more environmentally acceptable. The Non-TSCA alternative disposal option would include transport

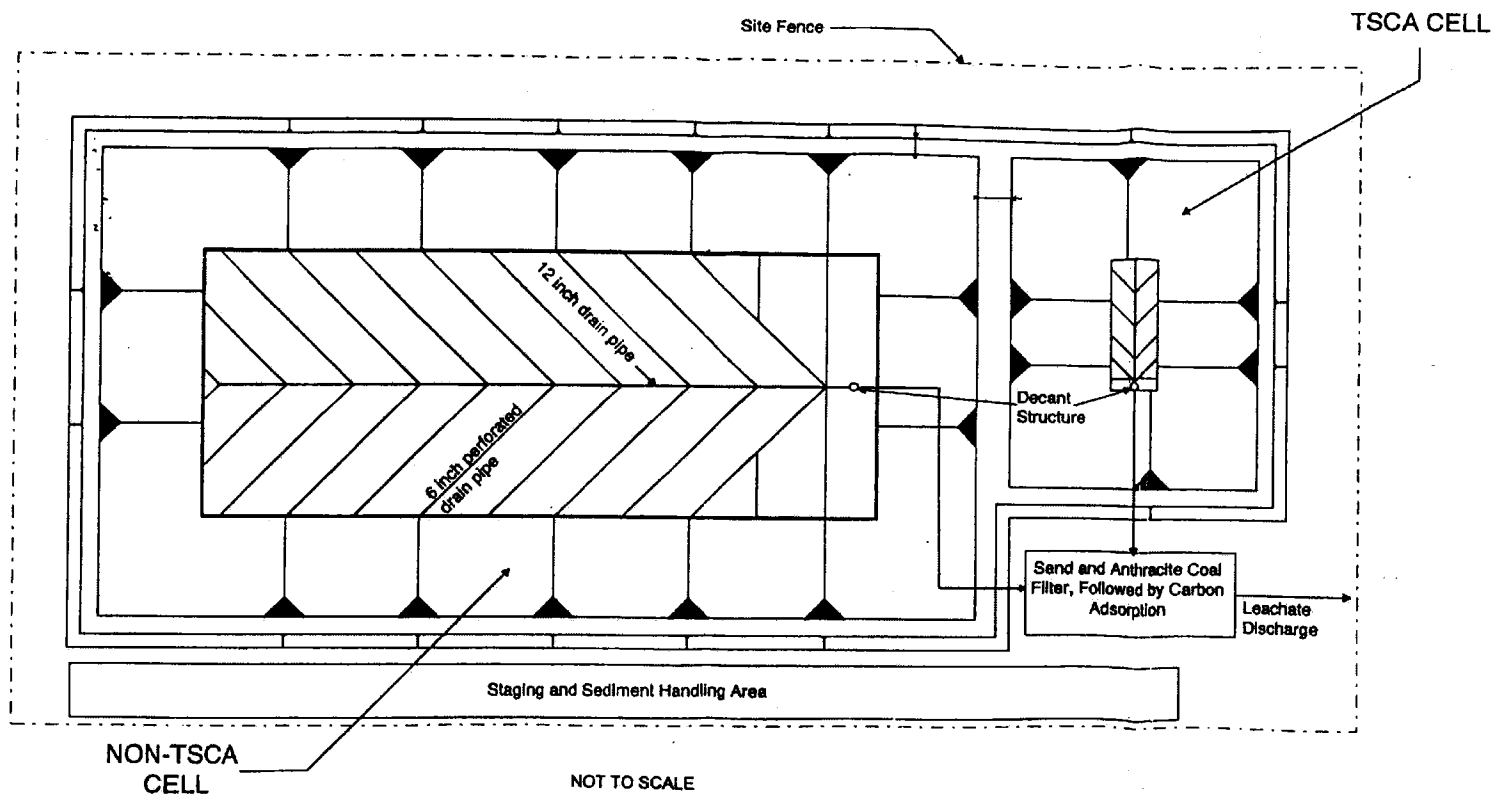

Figure 5-5c: Conceptual Plan View Layout of TSCA and Non-TSCA Landfill Disposal Facility for Ashtabula River Dredged Sediments.

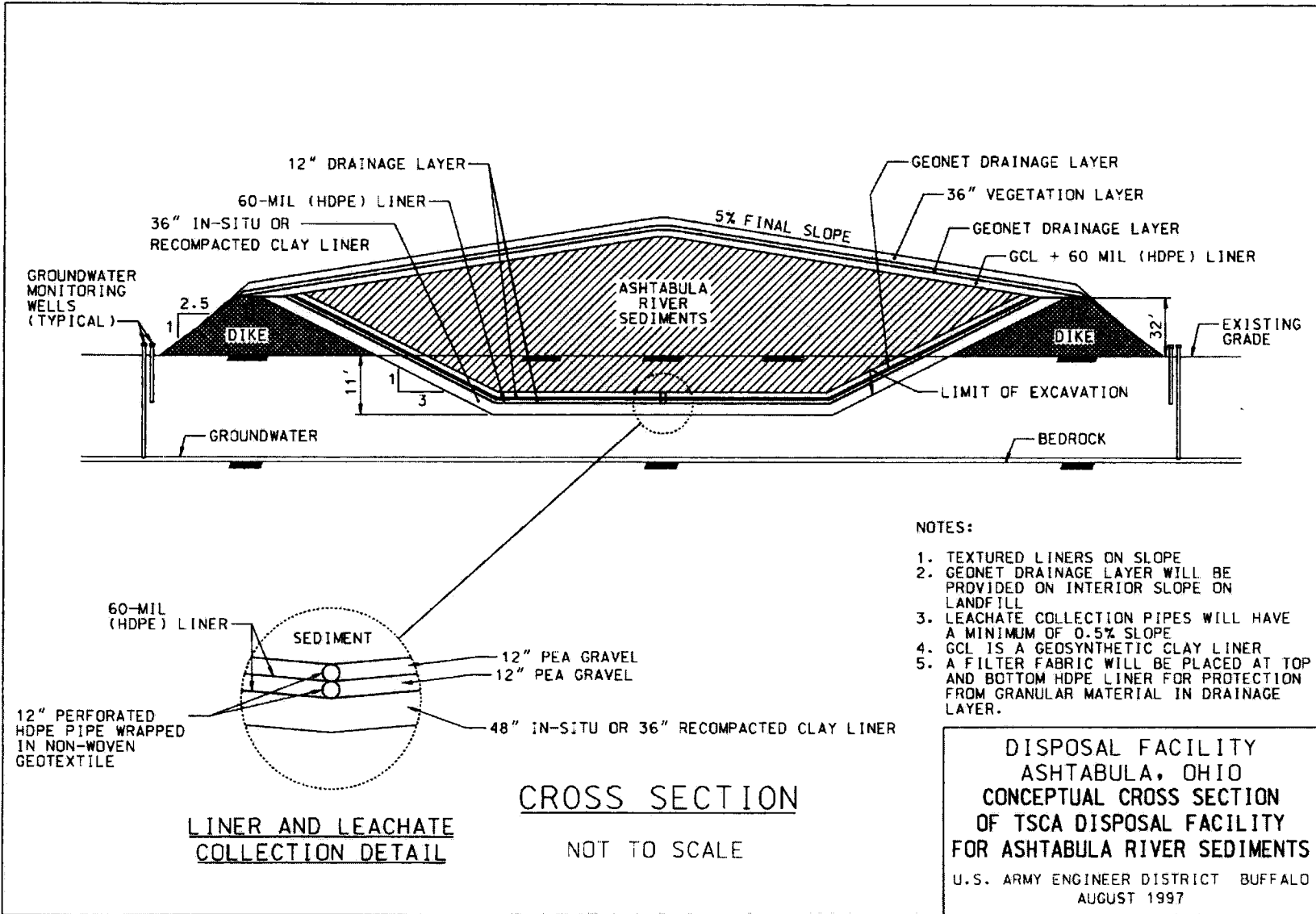

Figure 5-5d: Conceptual Cross-Section of TSCA Landfill Disposal Facility.

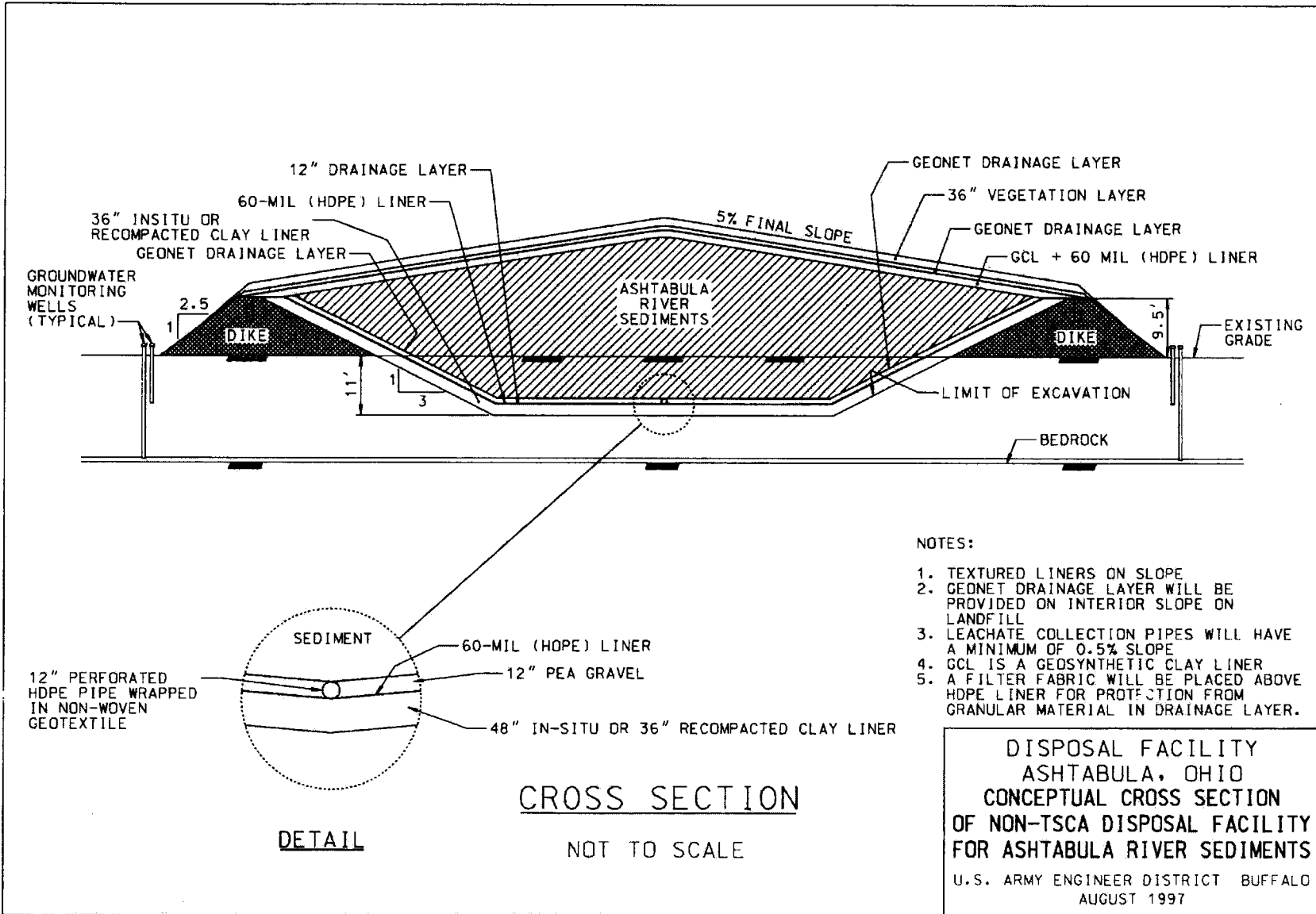

Figure 5-5e: Conceptual Cross-Section of Non-TSCA Landfill Disposal Facility.

to and disposal of dredged dewatered Non-TSCA sediments in an existing (at the time of project implementation) solid waste disposal facility that would accept the material and could accept the material under current or modified permit. A number of such facilities may exist within a 60-mile radius of the harbor.

For the alternative disposal option to become the preferred disposal method for the ARP project, the costs would need to be at least equal to or less than the costs associated with the proposed upland State Road site alternative. Economic benefits would likely remain the same, therefore the benefit to cost ratios would be equal to or greater than those for the proposed upland State Road site alternative under the equal to or less than cost scenario. There are a number of uncertainties associated with this option however, including: approvals, participation, and equal or reduced costs.

5.2 Related Aquatic Ecosystem Restoration Measures

The selected related aquatic ecosystem restoration measures constitute the recommended alternatives for supplemental aquatic ecosystem restoration in ARP Project Area. Restoration would address the loss of physical fish and wildlife habitat resulting from facilitated structural (i.e., bulkheading, and channelization), and non-structural (i.e., industrial activity) related impacts. The recommended alternatives for EAA 2 and EAA 3 are practical optimized plans of moderate cost, providing “problem area” protected aquatic fishery shallows of substantial length, which accomplish the ARP’s goals and objectives. The restored areas would be interfaced with the lake/river regime and would provide fish passage, cover, feeding and spawning habitat.

5.2.1 Environmental Assessment Area 2 (EAA 2)

The ARP recommended the implementation of restoration Plan 4 for EAA 2. Under this plan, shoreline property would be acquired, including the Conrail Slip (Slip 5A), and an aquatic fishery shelf would be cut along the east embankment channel for about 2,500 feet. Some bulkheading would be left in place as a buffer between the recreational channel and the shelf. The cut would be about two feet below low water datum (LWD) and a minimum 8 to 10 feet wide. Improvements would be made to the bottom of the cut to include contouring, soil and aquatic planting areas, gravel areas, and some cover structures. The shoreline area would also be improved with cover/food plantings or artificial cover structures, as necessary (see Figures 4-12 through 4-19 in Section 4.0 for more detail on these alternatives).

5.2.2 Environmental Assessment Area 3 (EAA 3)

The ARP recommended the implementation of restoration Plan 2 for EAA 3. With this plan, a property easement would be acquired and an artificial aquatic fishery shelf would be hung along the existing sheetpile bulkheading in unit sections of about 30 feet for about 2,500 feet. The unit sections would be constructed of standard or custom pre-cast concrete units about 10 feet long, with a cover feature and stone placed along the lower shelf. The shelf could have a grate bottom to allow silt and coal dust to move through the stone and shelf. Please reference Figures 4-12 through 4-19 in Section 4.0 for more detail on the recommended alternatives.

5.2.3 Alternative Long-term Dredging Scenarios for Aquatic Ecosystem Restoration

The aquatic ecosystem restoration alternatives also include an alternative long-term dredging scenario upstream of the 5th Street Bridge to reduce the river channel to recreational navigation depths, as is being done at present. This would provide aquatic shallow areas along the lower river shoreline in the distant future at no cost (see Figures 4-23). A similar alternative calls for an eight feet or more decrease in the width of the maintained recreational navigation channel to the west upstream of the 5th Street Bridge between the Conrail Slip (Slip 5A) and the Upper Turning Basin. This would provide additional aquatic shallow area along the east embankment in the distant future at no cost and likely Federal navigation channel maintenance cost savings (see Figure 4-24 for more detail).

5.3 Summation of Recommended Environmental Dredging Plan Cumulative Effects Assessment

Dredging the Ashtabula River sediments may have short-term detrimental effects on the river and to a far lesser extent, Ashtabula Harbor and Lake Erie. However, the long-term beneficial impacts far outweigh the adverse effects. Dredging the sediments from the river will remove those contaminants associated with the sediments from the aquatic ecosystem. This will eliminate the ability of these contaminants to be resuspended and transported down river and into Lake Erie. Future sediment deposits should be essentially clean and would be able to support less pollution tolerant benthic organisms. This would enable the river and lake to achieve a higher diversity of aquatic species.

It is expected that within several years of project implementation sediment and benthos quality will be improved markedly; and, that within another few years the area fishery will be improved markedly. It is expected that the project will accomplish project goals and objectives and remediate the six beneficial use impairments identified with the exception of limitations along the commercial channel area. This will remediate one of the 42 Great Lakes Areas of concern. The Lake Erie/Ashtabula River Area of Concern has been identified as a priority area for remediation in Sections 205 and 515 of WRDA 96 and in the U.S. Army Corps of Engineers PGL No. 49 section 5. c. Even though the ARP may disband once dredging is completed, several monitoring programs will be conducted within five to ten years after project completion by USACE, possibly in conjunction with OEPA and ODH, to evaluate the extent of the improvements.

The recovery of the Ashtabula lacustrine fish community is expected to influence fish communities in surrounding areas both upstream and in the lake. Species such as northern pike and muskellunge moderate fish communities through predation and drive community structure towards greater ecological integrity. Greater ecological integrity results in even higher numbers of top carnivores, endangered species and sensitive species. Historically, the muskie and northern pike were very abundant and commercially important. The destruction of lacustrine habitats throughout Lake Erie has resulted in drastic reductions of the two species' populations and the positive influences they had on the Lake's ecosystem. The restoration of the Ashtabula lacustrine will allow it to resume its historic contribution to top carnivore populations (including northern pike and muskellunge).

Species listed as sensitive can all be expected to increase in numbers after sediment removal and a consequent influx of clean sediment from upstream areas. Species presently not found in the Ashtabula but found in the Grand and Conneaut will return to the Ashtabula. The sensitive species that are absent from the Ashtabula represent all trophic levels of the fish community. Ecosystems cannot function with such large components missing.

The ecosystem of the open waters of Lake Erie is presently experiencing dramatic recovery of its fish community. This recovery is expected to continue with further recovery of additional species. The removal of contaminated sediments will prepare the Ashtabula for the entrance of species such as lake sturgeon, mooneye, muskellunge, pugnose minnow, blackchin shiner, blacknose shiner, pugnose shiner, longnose sucker, lake chubsucker, creek chubsucker, tadpole matom, banded killifish, burbot and sand darter into the system. Some of these species (burbot, lake sturgeon, muskellunge and sand darter) are already showing signs of recovery in the lake. Areas such as the Ashtabula lacustrine are an important component of these species life history. Full recovery of the above listed species will depend on the environmental quality of Lake Erie's lacustrine habitats.

The speed and degree of ecological recovery in the Ashtabula River lacustrine will depend on the rate of sedimentation. Near shore depths of two to ten feet are ideal for healthy fish communities and the aquatic plants they depend upon. The influx of clean sediments from upstream areas will eventually occur, and active intervention in the form of replacing dredged sediments with clean sediments will greatly enhance the process.

The implementation of the recommended related aquatic ecosystem restoration measures (i.e., fishery shelves) would expedite recovery and constitutes ecological restoration, as possible, for loss of protected aquatic fishery shallows due to facilitated structural (i.e. bulkheading, channelization), and activities impacts (see Figures 4-20 and 4-21). The aquatic ecosystem restoration measures are practical optimized plans of moderate cost providing problem area protected aquatic fishery shallows of substantial length which accomplish, as possible, goals and objectives, in this regard. The restoration areas would be interfaced with the lake/river regime and would soon provide passage, cover, feeding, and spawning habitat.

It is clear that no improvement will occur if contaminated sediments are not removed. Present Ohio EPA fish community data show declining trend of IBI values at River Mile 1.3 of the Ashtabula River. It is possible that this trend could continue, resulting in still lower quality fish communities in the future. There is further concern that without the project, shipping could shift from the Ashtabula area to Conneaut Harbor. This will result in a greater degree of environmental disturbance in the Conneaut and will negatively impact fish communities. Impacting both the Ashtabula and Conneaut fisheries, lower quality fish communities will result in the Central Basin. The last three large Central Basin south shore tributaries and associated lacustrines are the Grand, Ashtabula and Conneaut (from west to east). Numerous Central Basin fish stocks require these areas for reproductive purposes. Restoration of the Ashtabula will not only enhance Central Basin fish stocks but will also prevent their further decline.

The recommended use of the State Road site over Site 7 would, among other things, significantly reduce the scope and magnitude of direct and indirect environmental impacts to wetlands, associated habitats and transient and resident wildlife.

Implementation of the Recommended Environmental Dredging Plan would restore the integrity of the harbor from the environmental, economic, and social perspectives. It also provides a plan for future harbor operations and maintenance needs. It would substantially benefit community and regional sustenance and growth needs.

5.4 Post Project Harbor Operation and Maintenance Dredging and Disposal

Harbor channel sediments will continue to be sampled and analyzed in accordance with applicable sampling and analysis guidelines. It is expected that post project dredged sediments will be suitable for unrestricted open-lake disposal at the Lake Erie open lake disposal site. If, however, in the event that some dredged sediments may not be suitable for unrestricted open lake disposal, it is expected that these latter dredged sediments would be dredged and dewatered utilizing marine based dewatering facilities and then transferred/transported to a low bidder upland disposal site for disposal or to beneficial use sites. Other alternatives may be reassessed in the future. It is expected that all sediments removed in the future may be dredged and transported by conventional methods.

5.5 Ashtabula Harbor Long-term Management Plan

The U.S. Environmental Protection Agency and the Ohio Environmental Protection Agency and the U.S. Natural Resources Conservation Service are engaged in various best management programs (BMPs) relative to pollution and sedimentation control. The BMPs will serve to minimize contaminated sediments and the amount of sediments needed to be dredged from navigation channels in the future.

In recent years, with thoughts to limit open lake disposal of dredged sediment and the proliferation of construction of dredged sediment confined disposal facilities (CDFs) on the Great Lakes, significant consideration is being given to beneficial use of dredged sediment. Beneficial use considerations include use for:

- a. landfill cover;
- b. construction fill material;
- c. manufactured soils viability and market (i.e., dredged sediment, sludge, kiln mix);
- d. environmental restorations (i.e. cover, wetlands, islands, peninsulas, etc.);
- e. landscaped lands (i.e. parks, ski/sled hills, wildlife areas); and
- f. Interception/redistribution (i.e., catch settling basins, redistribution to regional/county/town distribution centers, redistribution to farmlands, etc.).

Several of these beneficial uses show promise and could be considered for Ashtabula Harbor sediment in the future, assuming economic feasibility and environmental acceptability.

Considering PCB contamination levels, currently, the acceptable level (per USEPA and OEPA) for PCBs in dredged sediment and/or manufactured soils for land applications is < 1 ppm, which may be reached by mixing (Based on Toledo Harbor Long-term Management Plan pilot study information). Higher concentrations may be acceptable in other applications (i.e., landfill cover). Other parameters, statutes, and regulations would also need to be considered and met.

Although some sediments exposed after dredging may contain approximately 1 to 10 ppm PCB concentrations, future cover sediments and material dredged from Ashtabula Harbor should have very low contaminant levels and should be suitable for either open-lake disposal or for beneficial use, should it prove to be economically feasible. Therefore, in addition to the expected long-term harbor maintenance dredging and open-lake disposal, other long-term considerations may include, for example:

1. Sediment maintenance dredging and dewatering via water based (i.e. barge) facilities with direct barge transport to, or harbor area transfer/transport to identified beneficial use sites.
2. Sediment maintenance dredging and dewatering via developed harbor area facilities and transfer/transport to identified beneficial use sites. Perhaps public or private retention of sediment dewatering facilities developed for this immediate project may be considered to accommodate future long-term beneficial use programs.
3. Long-term monitoring to assess post-dredging conditions.

5.6 Summary of ARP Project Costs; Benefits; Cost Share; and Basis for Selection of the Recommended Environmental Dredging Plan

5.6.1 Overview of ARP Project Economic Analysis

The development and assessment of ARP project alternatives was an iterative process that took place over a five-year period from 1994 through 2000. During this period, a large number of preliminary project component alternatives were developed by the Ashtabula River Partnership to address ARP goals upstream and downstream of the 5th Street Bridge in the Ashtabula River Project Area, which are defined as follows (see Figure 1-1):

1. Downstream (or north) of the 5th Street Bridge: The portion of the Ashtabula River Project Area extending northward to Station 120+00.
2. Upstream (or south) of the 5th Street Bridge: The Ashtabula River Project Area extending from the 5th Street Bridge southward past the Upper Turning Basin to the upper limit of the authorized Federal channel.

These River demarcations are important with regard to the separate economic and ecosystem-based analysis undertaken in each area during plan formulation, alternatives analysis, and selection of the recommended plan. Operation and Maintenance (O&M) and 312(a) authorities were found to be applicable to that reach of the Project Area downstream of the 5th Street Bridge and a “traditional” economic cost/benefit analysis and NED plan determination was completed for this portion of Project Area.

Upstream of the 5th Street Bridge an ecosystem-based (“312(b) Analysis”) assessment was employed that based alternatives assessment and selection on ecosystem-based parameters, cost effectiveness, and the subjective maximization of net environmental benefits through an incremental cost analysis.

In 1997 the Shallow Dredge, Deep Dredge, and Bank-to-Bank-to-Bedrock dredging alternatives were identified as warranting detailed assessment. Downstream of the 5th Street Bridge a traditional economic analysis compared and assessed these three dredging alternatives and associated project components (i.e., transfer/dewatering and disposal) to determine which alternative met ARP planning objectives and maximized the net NED benefits over NED costs.

5.6.2 Overview of ARP Project Ecosystem Based Analysis

Initially, in response to the USACE Headquarters guidance, the entire ARP Project Area (up and downstream of the 5th Street Bridge) was reviewed under the Section 312(b) authority for environmental dredging per “*The Criteria for Decision Making for Ecological Restoration/Preservation*” identified in EC 1105-2- 210. This EC was also specified in PGL No 49 pertaining to Section 312 Analyses. The ARP 312(b) Project Sub-Committee prepared a “312(b) Analysis” report setting forth the results of the ecosystem based analysis of the ARP project alternatives. The 312(b) Analysis report is included in the Final EIS as Appendix EA-J.

An ecosystem-based assessment was undertaken that based alternatives assessment and selection on ecosystem-based parameters, cost effectiveness, and the subjective maximization of net environmental benefits through an incremental cost analysis. This ecosystem-based assessment was in addition to standard engineering, economic, and environmental measures used to assess and evaluate project alternatives.

The evaluation used a habitat assessment procedure (HAP) developed by the State of Ohio Environmental Protection Agency (OEPA). Specifically, the Ohio Habitat Assessment Procedure Biological Indices: Qualitative Habitat Evaluation Index (QHEI), Fishery Index of Biotic Integrity (IBI), and Macroinvertebrate Invertebrate Community Index (ICI). The HAP analyses utilized comparative reference sites and biological field survey data and developed indices to identify problems and needs and to compare existing environments and remedial alternatives in terms of habitat units or indices. Adjacent Conneaut River and Harbor served as the primary comparative river regime. Other supplemental references include Presque Isle, the Grand River, and the Black River.

The “Section 312(b) and Section 206 Ecological Restoration/Preservation Analyses” 312(b) examined the Ashtabula River by Ecological Assessment Area (EAA) reaches and the three dredging scenarios were assessed with respect to criteria including the following:

- costs;
- practicality;
- ecological improvement (rank);
- volume removed;
- shoreline bulkheads affected;
- contaminated mass removed;
- surface contaminants;
- beneficial uses addressed;
- scour release potentials;
- benthic habitat chemically restored;
- aquatic shallows;
- Ohio Habitat Assessment Procedures Biological Indices:
 - Qualitative Habitat Evaluation Index (QHEI)
 - Fishery Index of Biotic Integrity (IBI) (incl. T&E Species)
 - Macroinvertebrate Invertebrate Community Index (ICI)
 - Anomaly Reductions
 - Improvements
 - Accomplishment of Sediment Contaminant Reduction; and
- Objective and accomplishment of total ecological restoration objective.

The ecological benefits derived from each of the three dredging alternatives were measured through incremental changes in IBI scores compared dredging costs. Figures 4-20 through 4-22 set forth the QHEI, IBI, and ICI cost/benefit comparison.

5.6.3 Recommended Environmental Dredging Plan Costs

For this report, the costs and benefits associated with the Recommended Environmental Dredging Plan have been evaluated and adjusted to reflect October 2000 price levels, a 6.375% annual Federal Discount Rate and 1998 vessel movements, commodities and tonnage's.

The cost estimate for the Recommended Environmental Dredging Plan was prepared using the Micro Computer-Aided Cost Estimating System (MCACES) software, which was developed by Building Systems Design Inc., of Atlanta, GA. The MCACES software system includes a project database and supporting databases including the unit price book, crews, labor rates, and equipment ownership schedule costs. All the databases work in conjunction with each other to produce a detail cost estimate.

The cost estimate is based upon all the construction features associated with the current FY00 level of design for the Recommended Environmental Dredging Plan, which includes changes to the disposal site and water treatment technologies at the dewatering facility. The cost estimate

for the Recommended Environmental Dredging Plan is in accordance with the policy, guidance and procedures described in the Department of the Army's Engineering Regulation (ER) 1110-2-1302.

The cost estimate provided by Cost Estimating was \$47,615,000. This included costs for construction of the project as well as monitoring and maintenance costs that would be incurred over the 50 year life of the project. The monitoring and maintenance costs included Disposal Site Post Construction Monitoring (\$1,301,300) and Annual Maintenance Expenditures at the disposal site (\$1,307,900). These type of costs are normally presented as average annual costs. Consequently, these expenditures were subtracted from the \$47,615,000 to arrive at a construction cost of \$45,005,800. These Post Construction Disposal Site Monitoring Costs (\$1,301,300) and Post Construction Disposal Site Maintenance Costs (\$1,307,900) were converted to average annual dollars and are reflected in Disposal Site Average Annual Costs.

Total First Costs for the Recommended Environmental Dredging Plan are \$45,005,800. Table 5-1 provides the derivation of average annual costs associated with the Recommended Environmental Dredging Plan (October 2000 Prices) and a summary of First Costs, Investment Costs and Average Annual Costs. First Costs are basically Construction Costs, Study Costs, Engineering and Design Costs, Construction Management

Costs and Real Estate Costs associated with building the Recommended Environmental Dredging Plan.

The aquatic ecosystem restoration measures related to the ARP project and presented in the CMP would be pursued and implemented as a separate project under the Section 206 authority. Accordingly, costs for the aquatic ecosystem restoration measures will be addressed in later planning reports specific to that project.

Construction Costs associated with contaminated sediment remediation came to \$37,202,100. This \$37,202,100 included: dredging costs (\$11,460,200), construction of the transfer/dewatering facility and operation thereof (\$4,895,600), TSCA related landfill construction costs (\$2,834,700), Non-TSCA related landfill construction costs (\$10,319,800), sampling and analysis costs for the construction period (\$816,600) and sampling and analysis at the disposal facility after construction (\$173,100). Construction Contingencies were \$6,702,100.

Engineering and Design costs during construction included study costs and were \$4,876,200. Construction Management costs were \$2,555,100 Real estate costs were \$372,400 O&M and Section 312. Total Project First Costs came to \$45,005,800.

Interest During Construction assumed a 4-year construction period, starting in May of 2002 and ending in September 2005. It was assumed minimal construction took place in January February or March. Construction cost time streams were developed for 16 cost categories on a monthly expenditure basis. Interest During Construction was computed using a 6.375% annual interest rate and monthly compounding. Interest During Construction came to \$5,531,600.

Interest During Construction (\$5,531,600) was added to Project First Costs (\$45,005,800) to arrive at project Investment costs. Project Investment costs came to \$50,537,400. Post construction expenditures that would be made after the project was constructed consist of Disposal Site expenditures.

Disposal Site expenditures included post construction monitoring (sampling and laboratory analysis) of the completed disposal facility and operations and maintenance expenditures associated with the TSCA and Non-TSCA portion of the landfill. Each of these costs would be incurred every year over a 50-year period. Since these costs would be incurred every year, these are average annual costs. These average annual costs reflect a 6.375 percent annual interest rate and a 50-year evaluation period. The 50-year period is for purposes of the economic analysis in this report. Post construction monitoring and maintenance will continue as long as the project is authorized. These yearly expenditures will now be discussed.

After the project is completed, post construction monitoring will take place at the disposal facility on a yearly basis. Test wells at the final disposal site would be inspected and monitored annually for the next 50-years or as long as the project is authorized. Annual Post Construction Monitoring Costs were placed at \$ 26,000. Post Construction monitoring

Table 5-1: Derivation of Average Annual Costs associated with the Recommended Environmental Dredging Plan (October 2000 Prices).

<u>Total Project Construction Costs And First Costs</u>	
Construction Costs	
Dredging Costs	\$11,460,200
Dewatering Costs	\$ 4,895,600
Landfill Costs-TSCA	\$ 2,834,700
Landfill Costs- Non TSCA	\$10,319,800
Sampling And Analysis	
During Dredging & At The Transfer Facility	\$ 816,600
At The Disposal facility- After Construction	\$ 173,100
Construction Contingencies	\$ 6,702,100

<u>Total Construction Costs</u>	\$37,202,100
Study Costs And Engineering And Design During Construction	\$ 4,876,200
Construction Management	\$ 2,555,100
Real Estate- Section 312, O&M	\$ 372,400

<u>First Costs</u> ¹	\$45,005,800
<u>Investment Costs</u>	
Project First Costs To Be Average Annualized	\$45,005,800
Interest During Construction ²	\$ 5,531,600

Investment Costs To Be Average Annualized	\$50,537,400
<u>Average Annual Costs</u>	
Interest And Amortization (.06678897)	\$ 3,375,400
Disposal Site	
Post Construction Monitoring ³	\$ 26,000
Annual Maintenance ⁴	\$ 26,200

Average Annual Costs ⁵	\$ 3,427,600
Present Worth Factor for 6.375%	14.97253
Present Worth Of Average Annual Costs	\$51,319,853
Rounded PW of Average Annual Costs	\$51,319,900

-
- (1) Project First Costs provided by Cost Estimating came to \$47,615,000. Included in these costs were expenditures over the 50-year life of the project for: Disposal Site Post Construction Monitoring (\$1,301,300) and Annual Maintenance Expenditures at the Disposal Site (\$1,307,900). These type of costs are normally presented as average annual costs. Consequently, these expenditures were subtracted from the \$47,615,000 to arrive at a construction cost of \$45,005,800. These Post Construction Disposal Site Monitoring Costs (\$1,301,300) and Post Construction Disposal Site Maintenance Costs (\$1,307,900) were converted to average annual dollars and are reflected in Disposal Site Average Annual Costs.
- (2) Construction Costs used to develop Interest During Construction (\$44,633,400) were computed by subtracting from Total First Costs (\$45,005,800), the projects Real Estate costs (\$372,400). IDC was based on 16 different construction cost components, a four year construction period and monthly compounding using a 6.375 percent annual interest rate.
- (5) Disposal Site Post Construction Monitoring costs for a 50 year evaluation period were \$1,301,300. These costs were converted to an average annual dollar value. This average annual value came to \$26,000. This average annual value reflects a 6.375 percent annual interest rate, a 50 year project life and October 2000 price levels.
- (6) Disposal Site Maintenance costs for the 50 year evaluation period were \$1,307,900. These costs were converted to an average annual dollar value. This average annual value came to \$26,200. This average annual value reflects a 6.375 percent annual interest rate, a 50 year project life and October 2000 price levels.
- (5) Average Annual Costs reflect a 6.375 annual interest rate, a 50-year project life and October 2000 price levels.

includes groundwater sampling, groundwater laboratory analysis, groundwater statistical analysis and reporting, NPDES sampling, NPDES monthly analysis, NPDES semi-annual analysis, NPDES annual organic analysis, NPDES reporting and miscellaneous monitoring.

Another annual cost at the disposal site was associated with annual maintenance of the landfill after construction. After the project is completed, the final disposal site would incur some annual maintenance costs for the next 50-years or as long as the project is authorized. Annual Maintenance Costs were placed at \$26,200. These annual costs included such items as: repair of the capping system; re-vegetation; sedimentation basin clean-out; mowing; fence repair; monitoring well repairs; quarterly inspections and reports; implementation of a leachate management system; leachate transportation and disposal from the TSCA and Non-TSCA cells of the disposal site; maintenance of facility roads; and other miscellaneous items.

Total average annual project costs for the Recommended Environmental Dredging Plan came to \$3,427,600. These average annual costs had two components: average annual costs associated with sediment remediation and Disposal Site costs. The conversion of sediment remediation related project costs and post construction Disposal Site costs to average annual costs, used a 6.375% annual interest rate and a 50-year project evaluation period. All costs reflect October 2000 price levels.

5.6.4 Recommended Environmental Dredging Plan Costs by Authority

Although the ARP Recommended Plan is an overall plan to clean up the river, project costs can be separated into costs by authority. There are basically four authorities that would be used to implement the “Recommended Environmental Dredging Plan”. Section 1 of the Rivers and Harbors Act of 1937 would be used to remove all polluted sediments located inside the Federal channel downstream of the 5th Street Bridge. Section 101 of WRDA 1986 would be used to dispose of all polluted sediments located inside the Federal channel downstream of the 5th Street Bridge. Section 312(a) would be used for the removal and disposal of all polluted sediments located outside of the Federal channel downstream of the 5th Street Bridge. Section 312(b) would be used to remove and dispose of all polluted sediments located upstream of the 5th Street Bridge, inside and outside the Federal channel.

Section 206 is a fifth authority that could be used to implement the related aquatic ecosystem restoration measures in the ARP Project Area, as recommended. These measures would be

implemented as a separate, but related project. Accordingly, costs associated with these measures will be addressed in the planning documents for this project. However, aquatic ecosystem restoration measure costs are not part of the “Recommended Environmental Dredging Plan” costs. Consequently, whenever “Recommended Environmental Dredging Plan” costs are discussed, they do not include ecosystem restoration measure costs.

Total Recommended Environmental Dredging Plan First Costs come to \$45,005,800. Project First Costs associated with removing and disposing of sediments located within the Federal channel downstream of the 5th Street Bridge (O&M Authority) were \$4,021,200. Project First Costs associated with removing and disposal of sediments located outside the Federal

channel downstream of the 5th Street Bridge (Section 312(a) authority) were \$3,414,400. Project First Costs associated with removing and disposal of sediments located upstream of the 5th Street Bridge (Section 312(b) authority) were \$37,570,200. Project First Costs for the Recommended Environmental Dredging Plan are presented in Table 5-2.

Average annual costs were calculated for the Recommended Environmental Dredging Plan. Average annual costs for the Recommended Environmental Dredging Plan total \$3,427,600. Project average annual costs associated with Section 312(b) (upstream of the 5th Street Bridge) total \$2,861,300. Project average annual costs associated with the Rivers and Harbors act of 1937 and Section 101 of WRDA 1986 (removal and disposal of polluted sediments located inside the federal channel downstream of the 5th Street Bridge) total \$306,200. Project average annual costs associated with Section 312(a) (the removal and disposal of polluted sediments located outside the federal channel downstream of the 5th Street Bridge) total \$260,100.

5.6.5 Benefit To Cost Ratios

An analysis of a range of ecological restoration measures was conducted and is presented and discussed in more detail in the EIS, Appendix EA-J, and “Section 312(b) *and* Section 206 Ecological Restoration/Preservation Analysis.” This analysis assumed that cleanup of the river upstream and downstream of the 5th Street Bridge would be accomplished under Section 312(b). Benefits generated by plan would depend upon how fully functioning the ecosystem becomes after the plan being evaluated has been implemented.

The analyses referenced various environmental indices to describe the restoration of the ecosystem infrastructure. Benefits associated with Section 312(b) were characterized by a series of environmental indicators. The biological measures that have been developed to assess the health of the Ashtabula River before and after restoration takes place, include such indicators as: water (sediment) quality, fish species diversity, fish abundance, percent of fish with external anomalies, the Index of Biological Integrity (IBI), the return of endangered species, the Invertebrate Community Index (ICI) and the environmental risk of a major scouring of PCB’s into Lake Erie. The change in these environmental indicators between the “Without Project” and “With Project” condition are the benefits associated with the environmental restoration (see Figures 4-20 and 4-21).

The Section 312(b) assessment found the Recommended Environmental Dredging Plan to be justified under the authority. The project was reviewed per “Criteria for Decision Making for Ecological Restoration/Preservation” and was found to be: total and incrementally cost effective, acceptable to the Ashtabula River Partnership, complete, efficient, effective, developed by and to be implemented in a ARP Context, and reasonable in Cost. Both ecological and economic (total and incremental) benefits exceed associated project costs.

Although the Section 312(b) authority does not call for the presentation of benefits in a monetary format, the ARP did develop a range of benefit categories and their associated monetary values. Table 5-3 presents summaries of calculated economic Average Annual Benefits, and provides

Present Worth Values of goods and services that would result from the implementation of various environmental restoration scenarios evaluated in Plan Formulation.

To provide the most comprehensive picture of the economic value of benefits associated with the various Ashtabula River cleanup plans, a monetary value was placed upon a wide range of goods and services that would be provided by each of the plans evaluated. The benefits generated by each plan assumed that cleanup of the river upstream and downstream of the 5th Street Bridge was accomplished under Section 312(b). Benefits generated by plan would depend upon how fully functioning the ecosystem becomes after the plan being evaluated has been implemented.

The calculation of benefits was not limited to NED benefit categories, but included Regional Economic Development benefit categories. The benefits associated with the various benefit categories were developed in present worth values for comparison to the investment costs of the various cleanup plans. Table 5-3 presents a summary of the present worth of all benefits and costs associated with the Recommended Environmental Dredging Plan. The benefit to cost ratio for the Recommended Environmental Dredging Plan came to 2.66. A more detailed description of these benefits is presented in Section 9.

Table 5-4 shows that if the Recommended Environmental Dredging Plan were implemented solely under Section 312(b), the cleanup would be economically viable. Given that the cleanup was fully justified using Section 312(b) authority, various components of the cleanup plan were examined with respect to the applicability of other authorities: Section 1 of the Rivers and Harbors Act of 1937, Section 101 of WRDA 1986, and Section 312(a).

Tables 5-5 to 5-7 present benefit to cost ratios associated with remediation work located downstream of the 5th Street Bridge. The NED benefit to cost ratio for all remediation work located downstream of the 5th Street Bridge (Table 5-5) came to 2.31 to 1. The benefit to cost ratio for all remediation work located downstream of the 5th Street Bridge within the Federal channel (Table 5-6) came to 4.27 to 1. Table 5-7 presents the benefit to cost ratio associated with remediation work located downstream of the 5th Street Bridge outside of the Federal Channel (Section 312 (a)). The benefit to cost ratio for remediation work performed under Section 312(a) came to 3.17 to 1. A more detailed description of the benefits associated with these authorities is presented in Section 9.0. Table 5-8 presents the proposed project conceptual cost shares for the Recommended Environmental Dredging Plan.

Table 5-2: Recommended Environmental Dredging Plan - Average Annual Project Costs By Area By Authority.

		Sediment Removal and Disposal Downstream of the 5 th Street Bridge			Sediment Removal & Disposal Upstream of the 5th Street Bridge	Total Project Costs
Authority		Section 1 of R&HA 1937 & Section 101 WRDA 1986	Section 312(a)	Total Downstream	Section 312(b)	All Authorities
Cost Item	Location	Within The Federal Channel	Adjacent to the Federal Channel	Total Downstream of 5th St Bridge	Within & Adjacent to Fed Channel	All Locations
<u>Investment Costs</u>						
Project First Costs		\$4,021,200	\$3,414,400	\$7,435,600	\$37,570,200	\$45,005,800
Interest During Construction ¹		\$ 494,200	\$ 419,700	\$ 913,900	\$ 4,617,700	\$ 5,531,600
		-----	-----	-----	-----	-----
<u>Investment Costs To Be Average Annualized</u>		\$4,515,400	\$3,834,100	\$8,349,500	\$42,187,900	\$50,537,400
<u>Average Annual Costs</u>						
Interest And Amortization (.066789)		\$ 301,600	\$ 256,100	\$ 557,700	\$ 2,817,700	\$ 3,375,400
Disposal Site						
Post Construction Monitoring ²		\$ 2,300	\$ 2,000	\$ 4,300	\$ 21,700	\$ 26,000
Annual Maintenance ³		\$ 2,300	\$ 2,000	\$ 4,300	\$ 21,900	\$ 26,200
		-----	-----	-----	-----	-----
<u>Average Annual Costs</u> ⁴		\$ 306,200	\$ 260,100	\$ 566,300	\$ 2,861,300	\$ 3,427,600

- (1) Interest During Construction Costs is based on total first costs (\$45,005,800) less Real Estate costs (\$372,400). IDC was based on a four-year construction period, a 6.375% annual interest rate and monthly compounding. IDC was allocated among the various authorities based on each authorities percentage of Project First costs.
- (2) Disposal Site Post Construction Monitoring – Based on an annual expenditure of \$26,000 over a 50-year period. This was rationed among R&HA of 1937, Section 312 (a) and Section 312 (b) based on each authorities percent of total Project First Costs.
- (3) Disposal Site Annual Maintenance – Based on an annual expenditure of \$26,200 over a 50 year period. Rationing same as Disposal Site Post Construction Monitoring.
- (4) Average Annual Costs reflect a 6.375 percent annual interest rate, a 50-year project life and October 2000 price levels.

Table 5-3: Recommended Environmental Dredging Plan: Average Annual Benefits and Present Worth of Outputs by Plan.

Average Annual Benefits (All Benefits reflect a 6.375% annual interest rate, a 50-year project life and October 2000 Price levels.)

	Shallow Dredge	Deep Dredge	Deep Plus Eco System Restoration	Bank To Bank
<u>NED Benefits</u>				
Commercial Navigation Benefits	\$0	\$1,308,500	\$1,308,500	\$1,308,500
Boating (Consumer Surplus)	0	\$78,100	\$83,200	\$67,000
Fishing (Consumer Surplus)	\$98,000	\$184,000	\$196,000	\$157,900
Passive Use Values (Consumer Surplus)	\$475,900	\$885,200	\$952,100	\$739,900
Change In Property Values	\$238,800	\$477,500	\$477,500	\$477,500
Risk Reduction To Lake Erie Fishery	\$785,900	\$859,300	\$859,300	\$1,026,900
	-----	-----	-----	-----
Subtotal	\$1,598,600	\$3,792,600	\$3,876,600	\$3,777,700
<u>Regional Economic Development Benefits</u>				
Local Economic Impacts(Retain Commercial Navigation)	\$0	\$4,321,500	\$4,321,500	\$4,321,500
Boating (Total Impact Of Expenditures On Output)	\$131,400	\$246,700	\$262,800	\$211,900
Fishing (Total Impact Of Expenditures On Output)	\$409,500	\$769,200	\$819,200	\$660,500
	-----	-----	-----	-----
Subtotal	\$540,900	\$5,337,400	\$5,403,500	\$5,193,900
Total	\$2,139,500	\$9,130,000	\$9,280,100	\$8,971,600

Present Worth Value of Benefits (All Benefits reflect a 6.375% annual interest rate, a 50 year project life and October 2000 Price levels.)

	Shallow Dredge	Deep Dredge	Deep Plus Eco System Restoration	Bank To Bank
<u>NED Benefits</u>				
Commercial Navigation Benefits	\$0	\$19,591,600	\$19,591,600	\$19,591,600
Boating (Consumer Surplus)	\$0	\$1,169,200	\$1,245,400	\$1,003,400
Fishing (Consumer Surplus)	\$1,467,200	\$2,755,200	\$2,934,800	\$2,364,600
Passive Use Values (Consumer Surplus)	\$7,125,700	\$13,254,300	\$14,254,800	\$11,077,700
Change In Property Values	\$3,575,000	\$7,150,000	\$7,150,000	\$7,150,000
Risk Reduction To Lake Erie Fishery	\$11,767,100	\$12,865,300	\$12,865,300	\$15,375,600
	-----	-----	-----	-----
Subtotal	\$23,935,000	\$56,785,600	\$58,041,900	\$56,562,900
<u>Regional Economic Development Benefits</u>				
Local Economic Impacts(Retain Commercial Navigation)	\$0	\$64,704,100	\$64,704,100	\$64,704,100
Boating (Total Impact Of Expenditures On Output)	\$1,966,800	\$3,694,300	\$3,934,300	\$3,172,100
Fishing (Total Impact Of Expenditures On Output)	\$6,131,600	\$11,517,000	\$12,265,200	\$9,888,900
	-----	-----	-----	-----
Subtotal	\$8,098,400	\$79,915,400	\$80,903,600	\$77,765,100
Total	\$32,033,400	\$136,701,000	\$138,945,500	\$134,328,000
Downstream Of 5th Street Bridge	\$0	\$84,295,700	\$84,295,700	\$84,295,700
Upstream Of 5th Street Bridge	\$32,033,400	\$52,405,300	\$54,649,800	\$50,032,300

Table 5-4: Recommended Environmental Dredging Plan: Overall Project Viability.

	October 2000 Prices
A. Present Worth of All Project Benefits	
1. <u>NED Benefits</u>	
Commercial Navigation Benefits	\$ 19,591,600
Boating (Consumer Surplus)	\$ 1,169,200
Fishing (Consumer Surplus)	\$ 2,755,200
Passive Use Values (Consumer Surplus)	\$ 13,254,300
Change In Property Values	\$ 7,150,000
Risk Reduction To Lake Erie Fishery	\$ 12,865,300

Subtotal	\$ 56,785,600
2. <u>Regional Economic Development Benefits</u>	
Local Economic Impacts(Retain Commercial Navigation)	\$ 64,704,100
Boating (Total Impact Of Expenditures On Output)	\$ 3,934,300
Fishing (Total Impact Of Expenditures On Output)	\$ 11,517,000

Subtotal	\$ 79,915,400
3. <u>Total Benefits</u>	
Downstream of the 5th Street Bridge	\$ 84,295,700
Upstream of the 5th Street Bridge	\$ 52,405,300

Total	\$136,701,000
B. <u>Present Worth of all Project Costs</u>	
1. Project Costs	
Average Annual Costs For the Recommended Env. Dredging Plan	\$3,427,600
Present Worth Factor for 6.375% and 50 year project life	14.97253267

Present Worth of All Project Costs	51,319,900
C. <u>Benefit To Cost Comparison-Recommended Environmental Dredging Plan</u>	
Present Worth Of All Project Benefits	\$136,701,000
Present Worth Of All Project Costs	\$51,319,900
Ratio of Present Worth Benefits to Present Worth Costs	2.66

Table 5-5: Benefit to Cost ratio for all Work Located Downstream of the 5th Street Bridge.

Average Annual Benefits ¹	\$ 1,308,500
Average Annual Costs ¹	\$ 566,300
Net Benefits	\$ 742,200
Benefit To Cost Ratio	2.31

(1) All average annual benefits and costs reflect a 6.375% annual interest rate, October 2000 prices and a 50-year project life.

Table 5-6: Benefit to Cost Ratio for all Work Located Downstream of the 5th Street Bridge and Within the Federal Channel.

Average Annual Benefits ¹	\$ 1,308,500
Average Annual Costs ¹	\$ 306,200
Net Benefits	\$ 1,002,300
Benefit To Cost Ratio	4.27

(1) All average annual benefits and costs reflect a 6.375% annual interest rate, October 2000 prices and a 50-year project life.

Table 5-7: Benefit to Cost Ratio for Section 312(a) Work Located Downstream of the 5th Street Bridge.

Average Annual Benefits ¹	\$825,400
Average Annual Costs ¹	\$260,100
Net Benefits	\$565,300
Benefit To Cost Ratio	3.17

(1) All average annual benefits and costs reflect a 6.375% annual interest rate, October 2000 prices and a 50-year project life.

Table 5-8: Recommended Environmental Dredging Plan: Proposed Project Conceptual Cost Shares.

COST ITEM	FEDERAL COST SHARE	NON- FEDERAL COST SHARE	TOTAL COST
<u>Dredging Downstream of the 5th Street Bridge</u>			
Within The Federal Channel (Section 1 of R&HA of 1937)	\$ 2,299,000 (100%)	- (0%)	\$ 2,299,000
Adjacent To The Federal Channel (Section 312 a)	\$ 1,952,000 (100%)	- (0%)	\$ 1,952,000
<u>Dredging Upstream of the 5th Street Bridge</u>			
Within And Adjacent To The Federal Channel (Section 312 (b))	\$13,961,000 (65%)	\$ 7,517,000 (35%)	\$21,478,000
<u>Disposal Downstream of the 5th Street Bridge</u>			
Within The Federal Channel (Section 101 Of WRDA 1986)	\$ 1,351,500 (80%)	\$ 337,400 (20%)	\$ 1,688,900
Adjacent To The Federal Channel (Section 312 a)	\$ 1,147,300 (80%)	\$ 286,800 (20%)	\$ 1,434,100
<u>Disposal Upstream of the 5th Street Bridge</u>			
Within And Adjacent To The Federal Channel (Section 312 (b))	\$10,257,200 (80%)	\$ 5,523,600 (20%)	\$15,783,800
<u>LERRDS</u>			
Acquisition Costs	\$ 0 (0%)	\$ 261,000 (100%)	\$ 261,000
Administrative Costs	\$ 43,000 (38%)	\$ 69,000 (62%)	\$ 112,000
<u>First Cost Totals</u>			
	\$31,011,000 (68.9%)	\$13,994,800 (31.1%)	\$45,005,800
<u>Monitoring And Maintenance</u>			
Cubic Yards From Below 5 th St Bridge & Inside the Federal Channel	\$ 186,500 (80%)	\$ 46,600 (20%)	\$ 233,100
Cubic Yards From Below 5 th St Bridge & Outside the Federal Channel	\$ 158,300 (80%)	\$ 39,600 (20%)	\$ 197,900
Cubic Yards From Above the 5 th St Bridge			
Non TSCA	\$ 1,050,200 (65%)	\$ 565,500 (35%)	\$ 1,615,700
TSCA	\$ 365,600 (65%)	\$ 196,900 (35%)	\$ 562,500
	\$ 1,760,600	\$ 848,600	\$,2,609,200
<u>Cost Estimating Control Totals</u>			
	\$32,771,600 (68.8%)	\$14,843,400 (31.2%)	\$47,615,000

5.6.6. Basis for Selection of the Recommended Environmental Dredging Plan

5.6.6.1 Upstream of the 5th Street Bridge

The Section 312(b) and Section 206 Ecological Restoration/Preservation Analyses found the entire ARP project area to be justified under the 312(b) authority. Both total and incremental ecological and economic benefits were found to exceed associated project costs. Fishery and macroinvertebrate community status were recognized during the Section 312(b) and Section 206 Ecological Restoration/Preservation Analyses to be “key indicators” of improvements (benefits) derived from each dredging alternative. Within targeted River segments EAA 2 and EAA 3 ecological benefits were measured through incremental changes in fishery and macroinvertebrate IBI Scores compared to dredging costs (reference Figures 4-20 through 4-22).

Summary of Fishery IBI Score and Dredging Alternatives Cost Comparison

Dredge Alternative	Cost ¹	IBI Score	Cost/IBI Unit
EAA 2 (Upstream of the 5th Street Bridge)			
Deep	\$46,895,000	+12	\$3,907,917
Bank-to-Bank-to-Bedrock	\$63,295,000	+12	\$5,274,583
Shallow	\$42,195,000	+10	\$4,219,500
EAA 3 (Downstream of the 5th Street Bridge)			
Deep	\$9,605,000	+3	\$3,201,667
Bank-to-Bank-to-Bedrock	\$9,605,000	+3	\$3,201,667
Shallow	\$9,605,000	+2	\$4,802,500

(1): Costs are based on dredging quantities removed and reflect 1997 price levels used during plan formulation and alternatives assessment.

(2): Tables based on information in Figure 4-22 of the CMP.

Summary of Macroinvertebrate IBI Score and Dredging Alternatives Cost Comparison

Dredge Alternative	Cost ¹	IBI Score	Cost/IBI Unit
EAA 2 (Upstream of the 5th Street Bridge)			
Deep	\$46,895,000	+20	\$2,344,750
Bank-to-Bank-to Bedrock	\$63,295,000	+20	\$3,164,750
Shallow	\$42,195,000	+18	\$2,344,167
EAA 3 (Downstream of the 5th Street Bridge)			
Deep	\$9,605,000	+3	\$3,201,667
Bank-to-Bank-to Bedrock	\$9,605,000	+3	\$3,201,667
Shallow	\$9,605,000	+2	\$4,802,500

(1): Costs are based on dredging quantities removed and reflect 1997 price levels used during plan formulation and alternatives assessment.

(2): Tables based on information in Figure 4-21 of the CMP.

The selection of the Recommended Environmental Dredging Plan upstream of the 5th Street Bridge was based upon the Cost/IBI Unit value for River segment EAA 2. Overall the Section 312(b) and Section 206 Ecological Restoration/Preservation Analyses affirmed the Deep Dredge alternative as the optimized plan and the ARP Recommended Environmental Dredging Plan.

The Bank-to-Bank-to-Bedrock alternative would be very costly; would present more shoreline structural stability concerns; and was determined to be considerably more dredging than needed to meet River clean-up goals. The Cost/IBI Unit value for Shallow Dredge was very similar to the Deep Dredge alternative, but the Shallow Dredge alternative left some elevated contaminants and an associated elevated contaminant ecological and human risk that was considered comparatively unacceptable.

The Section 312(b) and Section 206 Ecological Restoration/Preservation Analyses and also found that:

- a) Substantial ecological and moderate economic benefits could be realized upstream of the 5th Street Bridge through the upper Federal channel area.
- b) Substantial economic and moderate ecological benefits could be realized in the reach downstream of the 5th Street Bridge to the mouth of the river (the large vessel commercial channel reach).

Accordingly, the findings of the “traditional” economic analysis were the basis for project justification and selection of the Recommended Environmental Dredging Plan downstream of the 5th Street Bridge under the Operations and Maintenance (O&M) and Section 312(a) authorities. The findings of the 312(b) Analysis were the basis for project justification and selection of the Recommended Environmental Dredging Plan upstream of the 5th Street Bridge under the Section 312(b) authority.

5.6.6.2 Downstream of the 5th Street Bridge

The economic analysis of the 1997 “original” project alternatives identified the Deep Dredge alternative as the NED and optimized plan with \$122,384,300 in net benefits. Table 5-9 is a comparative summary of the costs and benefits associated with the three 1997 “original” ARP project dredging alternatives¹ reflected in both October 1997 and 2000 price levels and the “updated” project dredging alternatives (reflecting the 2000 disposal site change) in October 2000 Price levels. The October 1997 and 2000 project alternatives price level comparison

¹ Each dredging alternative includes associated project components for transfer, dewatering, and disposal of dredged material.

supports the original selection of the Deep Dredge alternative as the NED and optimized plan. Specifically, the 1997 “original” project alternative costs updated to October 2000 price levels result in the Deep Dredge alternative having the greatest net benefits of \$76,219,000. The “updated” project alternatives at October 2000 price levels support the Deep Dredge alternative selection with \$91,695,200 in net benefits.

Table 5-9: Total ARP Project Average Annual Benefits: October 1997 and 2000 Price Level Comparison of 1997 “Original” Project Alternatives and 2000 “Updated” Project Alternatives.

	Original Project Alternatives ¹ (October 1997 Price Levels) (3.6%)			Original Project Alternatives ¹ (October 2000 Price Levels) (6.375%)			“Updated” ² Project Alternatives ¹ (October 2000 Price Levels) (6.375%)		
	Shallow Dredge	Deep Dredge	Bank-to-Bank Dredge	Shallow Dredge	Deep Dredge	Bank-to-Bank Dredge	Shallow Dredge	Deep Dredge	Bank-to-Bank Dredge
Present Worth of Average Annual Benefits	\$36,086,000 ³	\$178,884,300 ³	\$176,235,500 ³	\$32,033,400 ⁵	\$136,701,000 ⁵	\$134,328,000 ⁵	\$32,033,400 ⁵	\$136,701,000 ⁵	\$134,328,000 ⁵
Present Worth of Average Annual Costs	\$51,800,000 ⁴	\$56,500,000 ⁴	\$72,900,000 ⁴	\$55,494,000 ⁶	\$60,482,000 ⁶	\$78,086,000 ⁶	\$39,285,400 ⁷	\$45,005,800 ⁷	\$66,674,300 ⁷
Present Worth of Net Benefits	-\$15,714,000	\$122,384,300	\$103,335,500	-\$23,460,600	\$76,219,000	\$56,242,000	-\$7,252,000	\$91,695,200	\$67,653,700

- (1): Alternatives include the dredging alternatives and associated plan component alternatives (i.e., transfer/dewatering site and disposal site).
- (2): “Updated” project alternatives refers to the 2000 change in the project disposal site from Site 7 to the RMI (State Road) site.
- (3): Benefits reflect October 1997 prices and a 3.6% annual percentage rate.
- (4): Costs Reflect October 1997 prices a 3.6% annual percentage rate.
- (5): Benefits reflect October 2000 prices and a annual percentage rate of 6.375%
- (6): Original project alternatives (i.e., Disposal Site = Site 7) updated to October 2000 prices by Buffalo District.
- (7): ARP project alternatives with new disposal site (State Road site) reflecting October 2000 prices by Buffalo District.

6.0 LANDFILL DESIGN SUMMARY

Design requirements were developed for the construction, operation, maintenance, and closure of a landfill used for disposal of sediments dredged primarily from the Ashtabula River. The objectives in siting and designing a landfill are to provide long-term environmental protection, ensure regulatory compliance, and achieve cost-effective utilization of resources, manpower, equipment, and space. The preliminary design requirements provided will form the basis for the cost estimate to determine if landfill construction is an appropriate and cost effective alternative for the disposal of dredged contaminated sediments. The purpose of this section is to identify and summarize conceptual landfill design criteria from the various possibilities. It should be noted that the final landfill design will include a contingency to ensure that if the actual quantity of dredged material is greater than the estimated quantity, the material can be disposed of onsite.

The selection of the most appropriate design criteria was based upon discussions with Federal and State Regulators and on the specific conditions likely to be found at the potential landfill sites. Design information, provided by companies with similar landfills for industrial waste landfill in Ashtabula County was also used, along with information from the USEPA on the design of TSCA landfills in Michigan. Appendix M, “Geotechnical Engineering”, includes a summary of the geotechnical information available for the potential disposal sites along with a geotechnical analysis of the conceptual design. Appendix P, “Landfill Design Criteria”, summarizes design requirements for the construction, maintenance and closure of a landfill used to dispose of sediments dredged from the Ashtabula River. This is a feasibility level design, which was used to form the basis for a cost estimate to determine if landfill construction is an appropriate and cost effective alternative for the disposal of Ashtabula River sediments.

As discussed in Appendix P the primary difference between the TSCA cell and the Non-TSCA cell is in the construction of the bottom liner and leachate collection system; leachate is liquid that leaches out of sediment to the bottom of the cell. The TSCA cell includes a double liner with double leachate collection and leak detection monitoring. Although this level of protection is not specifically mandated by TSCA regulation, USEPA has indicated that this level of construction will likely be required because groundwater is not deeper than 50 feet from the bottom of the landfill.

Table 6-1 shows the components of the bottom liner and leachate collection system for the TSCA and Non-TSCA cells, going from top to bottom in the landfill.

Table 6-2 shows the parameters that are common to both disposal cells. Figure 5-5b shows the conceptual layout of the disposal facilities at the State Road site and Figures 5-5c through 5-5e show conceptual plan view and cross-sections of the proposed TSCA and Non-TSCA facilities. Both of the cross-sections represent the recommended Deep Dredging alternative. Appendix O includes typical cross-sections based on the Bank-to-Bank-to-Bedrock and the Shallow Dredging alternatives.

Table 6-1. Landfill Base and Leachate Collection Components for TSCA and non-TSCA Cells.

TSCA Cell	Non –TSCA Cell
<p>Primary Drainage Layer 12" pea gravel with PVC piping Geonet on side slopes Filter fabric 60 mil HDPE FML Secondary Drainage Layer 12" pea gravel with PVC piping Geonet on side slopes Filter fabric 60 mil HDPE FML 48" in-situ or 36"recompacted clay liner</p>	<p>Drainage Layer 12" pea gravel with PVC piping Geonet on side slopes Filter fabric 60 mil HDPE FML 48" in-situ or 36" recompacted clay liner</p>

Table 6-2. Conceptual Landfill Design Parameters Common to Both Disposal Cells.

Landfill Parameter	Proposed Design Requirement
Soil Base	material with $k=10^{-7}$ cm/sec
Soil Base Slope	2%
Soil Side Slope	1 vertical to 3 horizontal in interior 1 vertical to 2.5 horizontal on exterior
Synthetic Membrane Liner	60 mil high density polyethylene textured to increase friction coefficients
Drainage Layer Above Liner	material with $k=10^{-2}$ cm/sec
Site Survey	three third order benchmarks
Explosive Gas Monitoring	May be required dependent on OEPA evaluation of additional information on disposed material
Cap System	36 inches vegetation geonet drainage layer geosynthetic clay liner 60 mil HDPE liner
Leachate Collection	6" perforated PVC pipes spaced about 100 foot feeding main 12" PVC pipe.
Leachate Treatment	granular media filter followed by carbon adsorption.
Leachate Discharge	through outfall, Ashtabula POTW, or other permitted process.
Post Closure	quarterly groundwater sampling and site maintenance
Site Fence	6 foot high woven mesh fence around entire facility

6.1 Landfill Design Considerations

One option under consideration both to decrease cost and protect the environment is to dispose of the Non-TSCA sediment in a residual waste landfill. A residual waste landfill is a sanitary landfill, which exclusively disposes of one or any combination of nontoxic residual wastes, such as flyash, bottom ash and foundry sand. Although dredged sediment is not specifically mentioned in the Ohio Administrative Code (OAC) as being a residual waste, it appears generally to fit in with the other types of wastes categorized as such and to meet the intent of the regulation. Residual waste landfills include four classifications: Class I, Class II, Class III and Class IV. Class I is the most protective landfill and has requirements substantially equivalent to the construction of a solid waste sanitary landfill. The design and construction requirements become less strict as the class number of the landfill increases, with a Class IV landfill being used for the least contaminated wastes.

The determination of which class of residual waste landfill is appropriate for a given residual waste is made by comparing Toxicity Characteristic Leachate Procedure (TCLP) analysis of the waste against standards outlined in Appendix I of OAC, Chapter 3745-30-04. TCLP testing of the Ashtabula River sediments was conducted during the 1995 sampling of the Ashtabula River. The OEPA and USEPA approved sampling plan included taking samples from the areas of the river with the highest potential for failing the TCLP test based on earlier studies. The analysis showed that none of the samples taken from the river would be regulated under Resource Conservation and Recovery Act (RCRA). Since the samples were taken from the most highly contaminated areas of the river and were below RCRA levels, both USEPA and OEPA agreed that none of the dredged sediment would be considered a RCRA hazardous waste.

In addition, on June 12, 2000 the ODH/BRP, in response to an ARP letter of request, clarified its regulatory position on the disposal of Ashtabula River sediments with regard to radionuclides. The ODH/BRP has classified the river sediments: as radioactive material in accordance with the definition set forth in Ohio Revised Code 3748.01(O); as source material in accordance 10 CFR 40.4 as delineated in OAC 3701-39-021; and as low-level radioactive waste as defined in RC 3748.01(L). It is the understanding of the ODH/BRP that the sediments are not regulated pursuant to 40 CFR 240 and therefore are not classified as mixed wastes. The ODH/BRP continues to assert that the sediments can be placed in a properly designed cell as described in the CMP/EIS "Recommended Environmental Dredging Plan".

Table 6-3 and Figure 6-1 show a comparison of the 1995 TCLP sampling results versus the residual waste landfill classification requirements. The samples where standards were exceeded are shown in bold in the table below. As can be seen, only one sample from the river exceeds the Class III standard (Arsenic at 186-B) and only two samples exceed the Class IV standards (Arsenic at 186-B and Cadmium at 189-D). It is important to note that sediments in the area where samples exceed the Class III and IV standards are also contaminated with PCBs at levels exceeding TSCA. Consequently, these sediments will be disposed of in a TSCA landfill which will exceed the requirements of a Class I or sanitary landfill. More detail on this comparison can be found in Appendix P, "Landfill Design Criteria"

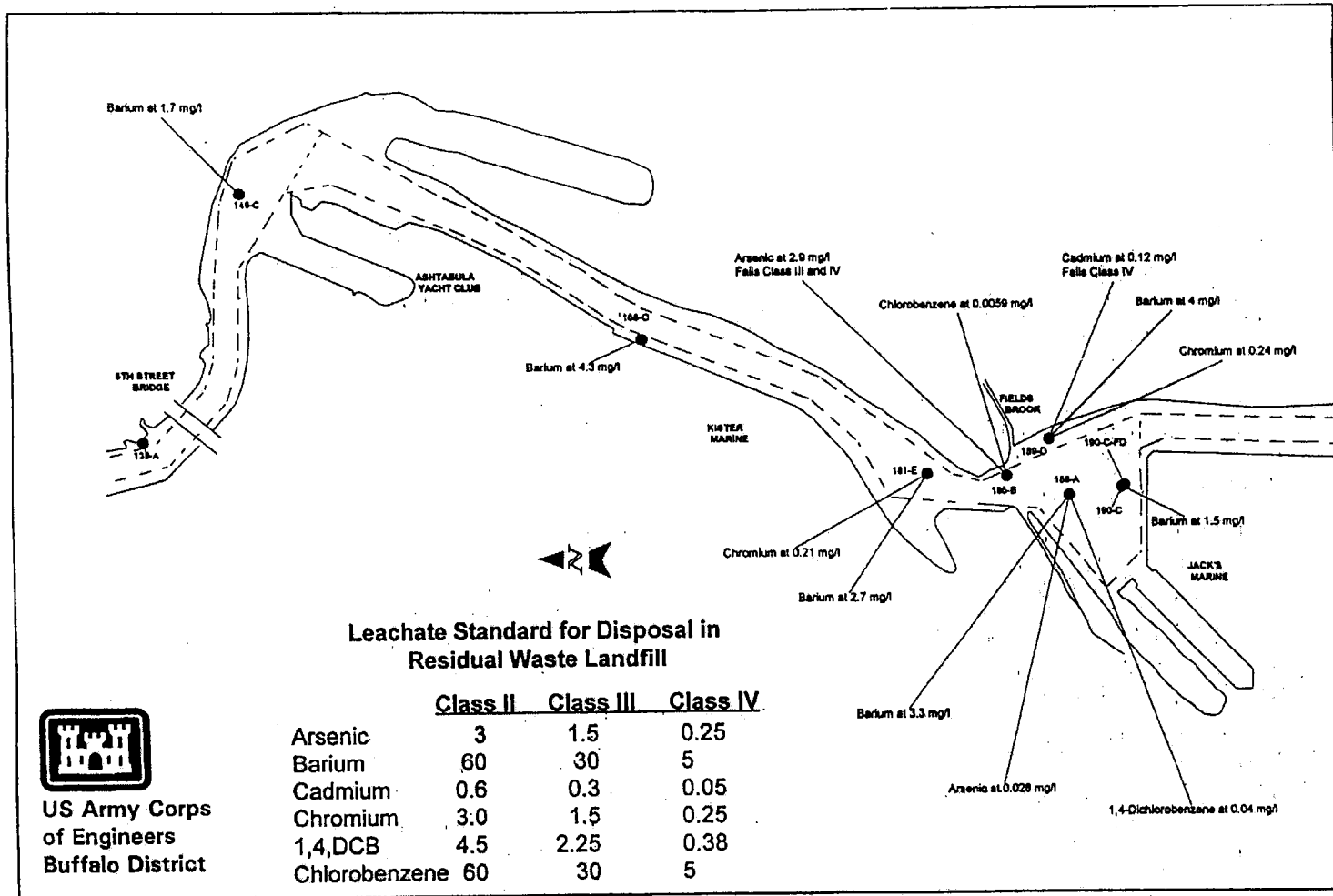

Figure 6-1: Ashtabula River Sediment TCLP Concentrations Compared to Regulatory Levels for Residual Waste.

Table 6-3. TCLP Results From Ashtabula River Sediments Compared to Residual Waste Landfill Standards

Sample Station	Contaminant	Measured TCLP Value (mg/l)	Class II Standards (mg/l)	Class III Standards (mg/l)	Class IV Standards (mg/l)
186-B	Arsenic	2.9	3.0	1.5	0.25
149-C	Barium	1.7	60	30	5
168-C	Barium	4.3	60	30	5
181-E	Barium	2.7	60	30	5
188-A	Barium	3.3	60	30	5
189-D	Barium	4	60	30	5
190-C	Barium	1.5	60	30	5
189-D	Cadmium	0.12	0.6	0.3	0.05
181-E	Chromium	0.21	3	1.5	0.25
189-D	Chromium	0.24	3	1.5	0.25
188-A	1,4 – Dichlorobenzene	0.04	4.50	2.25	0.38
189-D	Chlorobenzene	0.006	60	30	5

Disposal of the Non-TSCA sediments in a Class III or Class IV residual waste landfill would reduce requirements and costs for the cap and bottom liner system, along with monitoring and post-closure care requirements. Additionally, the required isolation distance between the bottom of the landfill and an aquifer is reduced to 10 feet for a Class II residual waste landfill and to 5 feet for a Class III residual waste landfill (OAC Chapter 3745-30-06 (15)).

The State of Ohio has indicated that ongoing policy discussions and investigations could result in approval to dispose of Non-TSCA sediment in a residual waste landfill (probably Class III). This could be done by approving and permitting the landfill under the residual waste landfill statutes. It is also possible that the landfill could be permitted and approved under Ohio Revised Code 6111.45. This authority allows the OEPA to grant approval for disposal of "industrial wastes" in a manner acceptable to the OEPA Director. Although there are no specific construction standards associated with landfills permitted under this authority, discussions with the OEPA have indicated that requirements would be substantially the same as for a Class III residual waste landfill. This is one of several issues expected to be explored during the detailed design phase of this project.

7.0 CONSTRUCTION SEQUENCING AND PROJECT IMPLEMENTATION

Construction of project facilities and operations for implementation of environmental dredging is addressed in the following paragraphs. The project will likely occur over a five-year time frame to include in the first two years contractor mobilization, construction of project facilities (i.e., transfer/dewatering facilities and landfill disposal facilities) and three years for dredging and disposal operations. Aquatic ecosystem restoration, as it is related to this project, will be undertaken as a separate project under the Section 206 (or similar) authority, assuming the availability of Section 206 funds and a Non-Federal sponsor, concurrent with the design and implementation of environmental dredging.

7.1 Dredging

Dredging operations will begin following completion of the transfer/dewatering facility and upland landfill, most likely in the second year of the project and continuing for three dredging seasons. Dredging may require mobilization of multiple barges to allow continuous dredging with little or no delays (barges will be moored at the transfer facility and will sit idle until standing water can be pumped out). A derrick barge carrying a crane fitted with an environmental clamshell bucket will perform the majority of the dredging. Environmental controls to contain suspended sediments caused by disturbance of the sediments, will be installed around the dredging operation. Tugboats will handle movement of barges between the dredging operation and the transfer facility. Removal of small pockets or a final thin bottom layer may be performed with a hydraulic dredge. Water quality sampling will be conducted during dredging operations to monitor environmental compliance. Refer to Appendix I, “Dredging Alternatives and Selection”, for more information on this subject.

At the transfer/dewatering facility, the barges would be moored until the sediments settle and the standing water decanted. The water from the barge will be pumped through the treatment plant or into a storage cell for treatment at a later time. Once decanted, the sediments will be transferred to a storage cell and allowed further drying time. When the sediments meet the dewatered criteria, they will be loaded into highway carriers.

7.2 Transfer/Dewatering Facility

The performance period scheduled for the removal and disposal of the contaminated Ashtabula River sediments includes a requirement to construct a sediment transfer/dewatering facility and an upland landfill confined disposal facility, which will serve as the final storage facility for the TSCA and Non-TSCA contaminated sediments. This section describes the events that will be required to complete the project.

The Recommended Environmental Dredging Plan includes dredging the contaminated sediments and transporting the sediments to a transfer/dewatering facility along the east shore of the Ashtabula River on Norfolk Southern property (see Figures 5-2 and 5-3). A berthing area for mooring of the filled barges will be located adjacent to the transfer/dewatering facility.

Construction of the transfer/dewatering facility will be the first phase of the project and will be completed during the first year of the project, concurrent with the upland landfill construction.

Prior to construction of the transfer/dewatering facility, the existing Interim Dredging CDF sediments at the site will be excavated and placed at an appropriate storage location. The 1993 Interim Dredging facility consists of approximately 40,000 cu. yds. of dike material and 30,000 cu. yds. of interim dredged material for a total of 70,000 cu. yds. Ultimately, the estimated 30,000 cu. yds. of contaminated dredged material would be disposed of in the ARP Non-TSCA landfill. The relatively clean dike material will likely initially be utilized to construct part of the dewatering facility then later either graded over the transfer/dewatering site or disposed of elsewhere as fill material possibly at the ARP Non-TSCA disposal site.

The facility will include construction of storage cells that will hold decanted water from the barges before treatment through the on-site multi-media filtration and carbon polishing water treatment units constructed adjacent to the holding cell. Also included in the facility will be a storage cell which can contain sediments in the event that barges need to be unloaded quickly and returned to the dredging operation. The transfer/dewatering facility will include an equipment decontamination station, site roads, loading areas for highway carriers of the sediments, and safety and security features. Appendix O, "Conceptual Dewatering Facility Design" addresses details on the dewatering facility.

7.3 Construction of Upland Landfill Disposal Facility

Construction of an upland landfill at the State Road site in the City of Ashtabula would begin shortly after award of the contract. Construction of the landfill is essential in the first year. Construction that will allow acceptance of sediments will include the following activities generally in this order:

- a. clear site of trees, brush, and other vegetation;
- b. excavate the TSCA and Non-TSCA cells, using the excavated soil for berm construction;
- c. complete the berms for the two cells with soil furnished from a borrow area;
- d. construct the clay liner and the leachate collection systems;
- e. construct the water treatment plant and sampling wells; and
- f. Construct site roads, safety, and security features.

The State Road site has been disturbed by past development and recent demolitions, is of little value to fish and wildlife and contains only one minor wetland at the eastern boundary in the northeast corner of the site, which will be avoided by the project. Overall, the recommended use of the State Road site over previously recommended Site 7 would, among other things, significantly reduced the scope and magnitude of direct and indirect environmental impacts to wetlands, associated habitats and transient and resident wildlife. Details of the upland landfill conceptual design are included in Section 5 and covered in more complete detail in Appendix P, "Landfill Design Criteria"

7.4 Sediment Landfill Disposal

Disposal of dredged dewatered sediments at the upland landfill will depend on the type of contamination. The TSCA-regulated sediments (equal to or above 40 ppm PCBs) will be deposited into one cell, and Non-TSCA sediments into a larger adjacent cell. Upon completion of a dredging season and filling of the cells, a temporary cover will be placed over the cells until sufficient settlement and compaction provides a stable surface for construction of the landfill caps.

Material used to construct the dike walls of the transfer/dewatering facility will also be placed in the upland landfill, upon demolition of the transfer/dewatering facility. Demolition will require restoration of the land to its original condition just prior to the interim dredging project.

The first stage of the landfill cap construction will be the placement of a manufactured Geosynthetic Clay Liner (GCL) over the sediments. This will be followed with a manufactured Geonet drainage layer. Completing the cap will be a vegetation layer of a 32-inch-thick soil cover topped with 4 inches of seeded topsoil. The seeded topsoil will also be placed on the side slopes of the landfill berms down to original grade.

7.5 Landfill Closure

The completion of the cap will essentially end the construction phase of this project. Monitoring and sampling of groundwater will occur at prescribed frequencies during the next 30 years. Occasional pumping and removal of leachate may also be required. Grounds maintenance will include mowing of the landfill and surrounding grass, and inspection and periodic maintenance of the site security fence.

8.0 FINANCIAL VIABILITY OF THE NON-FEDERAL COST SHARE SPONSOR

The ARP has been successful in developing Federal, state, and private resources to fund ARP activities leading up to the construction phase of the project. This multi-party cooperative effort has laid a foundation upon which to structure and obtain the Non-Federal cost share. Because the project is designed to satisfy multiple goals such as regulatory compliance, navigation and environmental restoration, development of the Non-Federal cost share contribution is unique and complex.

The Ashtabula City Port Authority is the legal Non-Federal sponsor for project and funding which will be assembled from multiple sources into a unified financial package that will be finalized pending the resolution of complex legal and financial issues. The Ashtabula City Port Authority provided a letter of intent (LOI), dated November 2, 2000, to serve as the Non-Federal Sponsor. The Ashtabula City Port Authority's LOI stated that the ACPA has the capabilities, under Ohio State statute, to fulfill the responsibilities of the Non-Federal sponsor. The ARP emphasizes the strategy employed is expected to yield full financial participation of state and local governments and private industry, at the time that actual funding is required to execute the Project Cooperation Agreement.

8.1 Letters Of Intent

To demonstrate the future financial viability of the Non-Federal sponsor, the ARP has organized an exchange of Letter Of Intent (LOI) among the parties of interest. Concern for potential liability under various environmental regulations provides incentives to the parties towards successful implementation of the project.

The ARP has requested federal and state regulators to provide Letters Of Intent confirming that the ARP dredging plan will satisfy regulatory concerns and, ultimately serve as a component in resolving and limiting liability for the Ashtabula River Cooperating Group (ARCG), (Appendix U: Cost Sharing and Non-Federal Responsibilities- partnership letter asking for Letter Of Intent). This action is contingent upon private interests funding a significant portion of the Non-Federal cost share on a voluntary basis. Resolving federal Superfund (CERCLA) and NRDA liability has a value to the regulated parties that is intended to provide the motivation for a financially significant voluntary contribution.

The Letters Of Intent obtained from the “regulators” including the Ohio Environmental Protection Agency, the United States Environmental Protection Agency and the United States Fish and Wildlife service are included in Appendix U.

The Letter Of Intent from the ARCG indicating a willingness to fund a significant portion of the project and signed by the fifteen Potentially Responsible Parties is also found in Appendix U.

Additional financial participation from the State of Ohio is provided in a letter of assurance confirming a contribution of \$7,000,000 million in state funding to the Non-Federal sponsor. (see Technical Appendix U). The State of Ohio has also provided financial expertise from the State Ohio Water Development Authority to assist in developing bonding scenarios that will serve to heighten private interest and lead to successful financing of the project.

9.0 BENEFIT EVALUATION

9.1 Benefit Definitions

Any project that the Corps of Engineers participates in must demonstrate that the National Economic Development (NED) benefits from the project are greater than the costs. For every dollar spent in making the project operational, there must be at least a corresponding dollars worth of benefit. All benefits and costs are expressed in a common value format (average annual dollars), evaluation period (usually 50 years) and common interest rate (the current federal discount rate for the type of project being evaluated). For a project to be economically justified, the benefit to cost ratio must be at least 1.0.

NED benefits are any increases in the net value of the national output of goods and services or increases in economic efficiency. NED benefits are always the average annual difference in the costs of goods and services between two future scenarios called the “Without Project” condition and the “With Project” condition. These two conditions span a specific period of time, or

evaluation period, usually 50 years; the appropriate current federal discount rate is used to convert present values to average annual values.

9.2 The “Without Project” Condition and The “With Project” Condition

The ecological conditions in the Ashtabula River AOC under the “Without Project” condition (a.k.a. “No Action” alternative) are best described in the report entitled “Biological Community Status of the Lower Ashtabula River and Harbor Within the Area of Concern” (OEPA, 1992) and the report entitled “Biological and Water Quality Study of the Grand and Ashtabula River Basins” (OEPA, 1997).

Essentially, the “Without Project” condition means that the ARP would take no action to implement a sediment removal project on the Ashtabula River based on the final findings of this study. The “Without Project” values are the set of conditions expected to occur in the year 2050 if a one-time cleanup of the PCB contaminated sediment is not carried out. Without a project, “Without Project” conditions would be assumed and would serve as the basis of comparison to the “With Project” conditions, which are the conditions expected to prevail as a result of the implementation of the Recommended Environmental Dredging Plan. Sub-Section 4.2.1 of this report (Plan Formulation Section) sets forth a detailed description of the expected “Without Project” conditions.

For Economic Evaluation purposes, the “Without Project” condition describes the pattern of project outputs (i.e., activities, damages, operating costs) that would exist over the evaluation period if no remediation took place. “With Project” conditions describes the pattern of outputs that would exist over the evaluation period if a ARP project were built. The difference in outputs between the “Without Project” condition and the “With Project” condition are average annual benefits attributable to implementation of the project.

For environmental purposes, the “Without Project” conditions describes the persistence of existing ecological conditions in the Ashtabula River AOC in the absence of the ARP project. The comparison of the “Without Project” conditions to the change in the status of the ecological conditions expected to result from the implementation of the Recommended Environmental Dredging Plan (“With Project” conditions) constitutes the environmental (Section 312(b)) benefits attributable to the implementation of the ARP project.

The change in the status of the Ashtabula River ecological conditions is based on an evaluation of "Environmental Indicators" and the Recommended Environmental Dredging Plan. The Environmental Indicators are described in more detail in the following sub-sections. The expectations pertaining to the attainment of environmental improvements (benefits) with the implementation of the ARP project, is based upon a comparative analysis of the Ashtabula River and a model (standard) environment, which was selected to be Conneaut Creek in Ohio.

9.3 Benefits Associated with the One-Time Cleanup of Contaminated Sediments

To determine the benefits associated with the cleanup of contaminated sediments in the Ashtabula River ARP Project Area, the ARP conducted a “Section 312(b) and Section 206 Ecological Restoration/Preservation Analyses”. The “Section 312(b) and Section 206 Ecological Restoration/Preservation Analyses” first evaluated an array of scenarios that would accomplish the cleanup of contaminated sediments and restoration of disrupted aquatic habitat. All scenarios were evaluated assuming the removal of contaminated sediment took place solely under the Section 312(b) authority. Benefits associated with Section 312(b) can best be characterized by a series of “Environmental Indicators”, which are the biological measures developed to assess the health of the Ashtabula River before and after restoration. These indicators were developed to assess the status of the of the Ashtabula River ecological conditions under the “Without Project” and “With Project” conditions.

1. Water (sediment) quality
2. Fish species diversity
3. Fish abundance
4. Percent of fish with external anomalies
5. The Index of Biological Integrity (IBI)
6. The return of endangered species
7. The Invertebrate Community Index (ICI)
8. The environmental risk of a major blowout of PCB’s into Lake Erie

The change in the status of these Environmental Indicators between the “Without Project” and “With Project” conditions represent the benefits associated with the removal of contaminated sediments through the implementation of the ARP project. The following sub-section describes the various Environmental Indicators in more detail.

9.3.1 Environmental Indicators

Water quality is a measure of the weighted concentration of PCBs (measured as kg of PCBs present) in the sediment of the Ashtabula River. This relates to potential scour turbidity and resuspension of contaminated sediments and solubilities.

Fish species diversity and abundance are measures of the quality of the fish community. The presence or absence of species that are sensitive to contaminants and species that are plant loving are good indicators of the effects of contaminated sediments in the river bottom. The higher the number of individuals and the number of species present, the higher the quality of the fish community. Fish samples collected in the Ashtabula River lacustrary indicates there is a portion of the overall fish population with external anomalies. Environmental stressors, especially chemical contaminants, are a common cause of external anomalies.

The Index of Biological Integrity (IBI) is a multi-metric index that measures the status of the aquatic communities health and well being (habitat and fisheries). The IBI index is based on species richness, trophic composition, diversity, presence of pollution-tolerant individuals or

species, abundance of bio-mass, and the presence of diseased or abnormal organisms (OEPA). The IBI is quantitative as an ordinal, if not linear measure, which responds in an intuitively correct manner to known environmental gradients. As an aggregation of community information, the IBI provides a way to organize data and reduce it to a scale, which is interpretable against communities of known condition. There is no complex transformation of data accomplished, just an improved stratification and organization of complex ecological information. Simply stated, multi-metric indices can satisfy the demand for a straightforward numerical evaluation that expresses a relative value of aquatic community health and well being which allows program managers to, in effect, “visualize” relative levels of biological integrity.

With regard to the return of endangered species, by removing the PCB’s from the Ashtabula River there is a good chance of a return of two endangered species to the river, muskellunge and blacknose shiner. Both of these are plant loving species that are found in Lake Erie that should be present in the Ashtabula River.

The Invertebrate Community Index (ICI) is a multi-metric index that measures the status of the macro-invertebrate community. Similar to the IBI, the ICI index is based on species richness, trophic composition, diversity, presence of pollution-tolerant individuals or species, abundance of bio-mass, and the presence of diseased or abnormal organisms (OEPA).

Lastly, environmental risk is an assessment consisting of a qualitative and/or quantitative evaluation of the actual or potential impacts of contaminants on humans, animals and plants. The human health risk assessment evaluates the potential for unacceptable risk to humans through exposure to contaminants from an Area Of Concern. The ecological risk assessment evaluates the potential impacts of contaminants from an Area Of Concern on animals and plants. A qualitative rather than quantitative risk assessment approach was deemed most appropriate for this project. For more detail on the risk assessment, see Technical Appendix F, “Environmental Risk Assessment and Management Considerations for Dredging the Ashtabula River and Harbor.”

9.3.2 Section 312(b) Ecosystem Restoration Benefits

The results of the comparison of dredging alternatives and the ecological restoration benefits shown to result from contaminated sediment removal are shown on Table 9-1. The three dredging alternatives evaluated in Plan Formulation were addressed in addition to a fourth dredging alternative scenario. The four dredging alternatives included: “Shallow Dredge, “Deep Dredge, “Deep Dredge plus related aquatic ecosystem restoration” and “Bank To Bank Dredging.” The addition of related aquatic ecosystem restoration measures to the Deep Dredge alternative is intended to shorten the time frame in which full benefits are realized for this alternative. The addition of clean silt and the implementation of the selected related aquatic ecosystem measures will reduce the amount of time before the plant and fish communities are re-established. The related aquatic ecosystem restoration measures are necessary, particularly for EAA 2 and EAA 3, because there are essentially no clean, protected, shallow areas of any substantial length in these reaches. Such areas are needed to provide food, cover, spawning habitat, and passage of fish through the area necessary for a quality environment. The

assessment, evaluation and selection of the related aquatic ecosystem restoration measures is included in Sub-section 4.4 “Related Alternatives for Aquatic Ecosystem Restoration” of this report.

The estimates of improvements in Table 9-1 were derived in several ways. They represent both quantitative engineering analyses and qualitative experience with similar projects. The water quality estimate of PCB’s present is based on an engineering analysis of core samples. For the fish species diversity, fish abundance, and fish with external anomalies, the findings for Conneaut Creek (River Mile 1.5) were taken as the standard against which improvements in the Ashtabula River (River Mile 1.3) would be gauged. Figures 4-20 through 4-22 in Section 4 show the expected improvement in the QHEI, IBI and ICI scores for the Ashtabula River based on the implementation of the Recommended Environmental Dredging Plan and the additional improvement expected with the implementation of the related aquatic ecosystem restoration measures.

The Without Project and Shallow Dredging alternatives were assumed to achieve one third of the possible improvement due to some burial of contaminated sediments. Deep Dredging and Bank-to-Bank Dredging were expected to achieve two-thirds of the possible improvement. Deep Dredging with the implementation of related aquatic ecosystem restoration was assumed to achieve the Conneaut Creek levels or better. Ashtabula and Conneaut Creek IBI and ICI levels were established by Ohio EPA staff. Risk was estimated by the Corps of Engineers and encompasses both probability of a major scouring event and severity of PCB loadings to Lake Erie. The Corps estimated project costs.

A comparison of the biological indicators between the Shallow Dredging alternative and the “Without Project” alternative shows that there is very little ecological improvement. With the exception of removing a significant quantity of contaminated sediment, and thereby reducing the risk of a major scouring of contaminants into Lake Erie, there is very little evidence of any restoration of ecological functions as seen in such indicators as fish diversity and density, and the IBI and ICI indices (please refer to Figures 4-21 and 4-22). . Based upon alternative costs developed during Plan Formulation , the environmental gains for an expenditure of nearly \$52 million in preliminary total project cost appears to be minimal for the Shallow Dredge alternative.

A similar examination of the biological indicators for the Deep Dredge alternative compared to the “Without Project” scenario shows substantial improvement in all indicators. The significance of the reduction in PCB contaminated sediment is demonstrated in both increases in fish diversity and abundance. The percent of fish with external anomalies decreases and modest improvements in both the IBI and ICI indices indicate that ecosystem functions are being restored. The risk of a major scouring of PCBs into Lake Erie is significantly reduced. Based upon alternative costs developed during Plan Formulation, r an incremental expenditure of \$4.7 million over the Shallow Dredging alternative would result in a significant improvement in ecological function . For example, fish species and diversity increase by 33 percent and 68 percent respectively under shallow dredging. The same indicators increase by 66 percent and 137 percent respectively for the Deep Dredge alternative.

Table 9-1: Comparison of Project Alternatives and Associated Ecosystem Restoration Benefits.

Indicator	Data Source	Present Condition	Target	Without Project	Shallow Dredge	Deep Dredge	Deep + Ecological Restoration	Bank to Bank
Year Endpoint Achieved	---	1995	---	2000	2006	2008	2006	2013
Share of Target	---	---	---	0	1/3	2/3	1	2/3
<i>Ecosystem Restoration Benefits</i>								
Water Quality: Kg of PCB's Present	EA	11,018	0	11,018	2,797	1,952	1,952	274
Fish Species Diversity (#spp present)	C	15	30	20	20	25	30	25
Fish Abundance (#/bank km.)	C	228	695	384	384	540	695	540
Fish with External Anomalies (%)	C	6 Highly	3 Moderately	5 Strongly	5 Strongly	4 Strongly	3 Moderately	4 Strongly
Index of Biological Integrity (IBI)	OEPA	27 Poor	46 Good	31 Poor+	35 Fair	43 Good	46 Good	43 Good
Invertebrate Community Index (ICI)	OEPA	15 Poor	43 Good	19 Poor	27 Fair-	39 Fair	41 Fair+	39 Fair
Risk (probability of major blowout)	COE	High	Low	High	Medium	Low	Low	Low
Timing (years to maturation)	---	---	Fewest	---	3	5	3	10
PCB Mass Removed (%)	COE	---	100	0	75	82	82	98

The sources of the data are as follows: EA-Engineering Analysis, as found in the CMP, C-Conneaut Creek, OEPA-Ohio Environmental Protection Agency, COE-Corps of Engineers.

The Bank-to-Bank dredging alternative would be expected to produce the same level of ecosystem restoration as the Deep Dredge alternative. The significant reduction in PCBs from Bank-to-Bank dredging is the major difference that separates the two alternatives. However, for an incremental expenditure of approximately \$16 million over the cost of the Deep Dredge alternative, developed during Plan Formulation, very little additional ecosystem restoration improvement is expected from the Bank-to-Bank dredging alternative.

9.3.3 Related (Section 206) Aquatic Ecosystem Restoration Measures

After dredging occurs, it will take a number of years before clean silt is washed downstream and produces a high quality and productive aquatic environment. The amount of time required before ecosystem functions begin to produce substantial benefits after dredging can be reduced significantly with the implementation aquatic ecosystem restoration. This ecological recovery period can be shortened with the addition of restorative measures subsequent to the completion of Deep Dredging to remove contaminated sediments. The CMP includes recommended measures for the restoration of physical aquatic habitats along the Ashtabula River. Specifically, Section 4.4 of this report discusses the assessment, evaluation and selection of the recommended related aquatic ecosystem restoration measures. The targeted Ashtabula River segments consist of EAA 2 and EAA 3.

It is the intention of the ARP to undertake the planning, design and implementation of the restorative measures as an independent, but related, project supplementary to the ARP contaminated sediment remediation project. It is the intention of the ARP to complete the planning and design of the related restorative measures concurrent with the implementation of environmental dredging so that aquatic ecosystem restoration measures can be implemented in the target areas when dredging is complete to optimize realization of overall environmental benefits.

9.3.4 The Recommended Environmental Dredging Plan and Corresponding Section 312(b) Benefits

The Recommended Environmental Dredging Plan for the ARP project is the implementation of the Deep Dredge alternative to remove contaminated sediments from the Ashtabula River Project Area. Upon the completion of the dredging project, the selected related aquatic ecosystem restoration measures would be implemented as an independent project under either the Section 206 authority or a similar authority.

The Recommended Environmental Dredging Plan will achieve the project objectives at the least cost and in the shortest time possible. Section 312(b) benefits associated with the Recommended Environmental Dredging Plan were measured basically by a series of environmental indicators. Again, a target, or model environment (Conneaut River) was used to evaluate the current condition of the Ashtabula River and the levels it could potentially attain after remediation has taken place. The comparison of the biological indices for the Recommended Environmental Dredging Plan, with subsequent aquatic ecosystem restoration measures, produces the greatest improvement over the “Without Project” set of biological values (see Figures 4-20 through

4-22). The “Without Project” values are the set of conditions expected to occur in the year 2050 if a one-time cleanup of the PCB contaminated sediment is not carried out.

All the indices presented in Table 9-1 showed considerable improvement with the implementation of the Recommended Environmental Dredging Plan with subsequent completion of aquatic ecosystem restoration measures. The indices with the most pronounced improvement included water quality, the invertebrate community index, fish abundance and percentage of PCB mass removed.

The Recommended Environmental Dredging Plan calls for the removal of 696,000 cubic yards of polluted sediments. Kilograms of PCB’s present in the riverine system falls from 11,018 kilograms under “Without Project” conditions to 1,952 kilograms under the Recommended Environmental Dredging Plan.

The Invertebrate Community Index shows over a 100 percent improvement from implementation of the Recommended Environmental Dredging Plan. The invertebrate community index reflects the status of Ashtabula River’s macro invertebrate community. The index essentially reflects the well being of the food chain. The Invertebrate Community Index changes from 19 under “Without Project” conditions to 41 under the Recommended Environmental Dredging Plan.

Fish abundance shows over an 80 percent improvement from implementation of the Recommended Environmental Dredging Plan. The Fish abundance is the number of fish found in the river per each kilometer (.6 miles) of shoreline. Fish abundance changes from 384 fish per kilometer of shoreline under “Without Project” conditions to 695 fish per kilometer of shoreline under the Recommended Environmental Dredging Plan.

Finally, the percentage of PCB mass removed is very high under for the “Recommended Environmental Dredging Plan”: 82 percent. Removal of this much of the PCB mass results in the probability of a major blowout of contaminated sediments into the Lakes ecosystem to change from a rating of “High” under “Without Project” Conditions to “Low” with implementation of the “Recommended Environmental Dredging Plan.”

Under the Recommended Environmental Dredging Plan dramatic improvements in the river will be realized by removing PCB-laden sediment. With the subsequent implementation of the selected related aquatic ecosystem restoration measures, ecosystem improvements can be achieved in 3 years following dredging as compared to 5 years for the Deep Dredge scenario alone. This will lead to achieving the greatest ecosystem restoration benefits in the shortest amount of time.

The Section 312(b) assessment found the Recommended Environmental Dredging Plan to be justified under the 312(b) authority. The project was reviewed per Criteria for Decision Making for Ecological Restoration/Preservation and was found to be: Total and Incrementally Cost Effective, Acceptable to the Ashtabula River Partnership, Complete, Efficient, Effective, Developed and to be Implemented in a ARP Context, and Reasonable in Cost. Both ecological and economic total and incremental benefits exceed associated project costs.

9.3.5 Further Information on the Section 312(b) Evaluation

A full discussion of the “Section 312(b) and Section 206 Ecological Restoration/Preservation Analyses” can be found in the Environmental Impact Statement and its Appendix EA-J, “Section 312(b) and Section 206: Ecological Restoration/Preservation Analyses.” This appendix documents the planning process with respect to Section 312(b) and covers such topics as: Corps Federal Interest, Assessment Output Measures and Ohio (HAP), Ecology, Problems Goals and Objectives, Without ARP Project Conditions, Dredging Ecological Restoration/Preservation Scenarios, Other Assessment Output Measures, Supplemental Dredging Ecological Restoration/Preservation Measures For Protected Aquatic Fishery Shallows, Economic Values, Project Recommendations, Summary Cost And Assessment Tables, Monitoring and Criteria For Decision Making For Ecological Restoration/Preservation Review.

9.4 Project Authorities Used to Implement the Ashtabula Harbor: Comprehensive Master Plan Recommended Environmental Dredging Plan and the Associated River Areas

The “Section 312(b) and Section 206 Ecological Restoration/Preservation Analyses” found the Recommended Environmental Dredging Plan to be justified under the Section 312(b) authority. The “Section 312(b) and Section 206 Ecological Restoration/Preservation Analyses” assumed that cleanup of contaminated sediments upstream and downstream of the 5th Street Bridge would be performed under this authority. However, as discussed in Section 2 of this report, the ARP proposed that, the CMP overall Ashtabula Harbor Recommended Environmental Dredging Plan be implemented using a range of authorities: the Environmental Dredging to be accomplished under Section 312, WRDA 1990, as amended; and the Aquatic Ecosystem Restoration to be accomplished under Section 206, WRDA 1996, or some similar authority.

Upstream of the 5th Street Bridge, the removal and final disposition of polluted sediments (TSCA and Non-TSCA) would be performed under Section 312(b). In the commercial navigation portion of the project, downstream of the 5th Street Bridge, the following three different authorities would be used to accomplish the removal and final disposition of polluted sediments (Non-TSCA only).

1. Section 1 of the Rivers and Harbors Act of 1937: Dredging of sediment within the Federal channels downstream of the 5th Street Bridge.
2. Section 101, of WRDA 1986: The disposal operation costs and disposal facility costs for dredged sediment from within the Federal channels downstream of the 5th Street Bridge.
3. Section 312(a) of WRDA 1990, as amended by Section 205 of WRDA 1996: To accomplish the dredging and disposal of contaminated sediments located outside of and adjacent to the federal channel, downstream of the 5th Street Bridge.

Follow-up related aquatic ecosystem restoration actions (upstream and downstream of the 5th Street Bridge) would be accomplished subsequent to the completion of the environmental dredging project as a separate project under the authority of Section 206 of WRDA 1996 or some similar type authority.

Each of these authorities uses different benefit categories to show government interest. The benefits and costs associated with each of these authorities will be discussed.

9.5 Recommended Environmental Dredging Plan Benefits Associated with a One-time Cleanup of Contaminated Sediments Upstream of the 5th Street Bridge

The ARP recommends the use of Section 312(b) of WRDA 1990, as amended by section 205 of WRDA 1996 and Section 224 WRDA 1999, Environmental Restoration and Water Quality, to remove and dispose of all contaminated sediments (TSCA and Non-TSCA) located upstream of the 5th Street Bridge. Again, a range of environmental indicators, as presented in Table 9-1 can best describe benefits associated with Section 312(b). A description of the environmental enhancements used to justify the costs associated with Section 312(b) is included in the “Section 312(b) and Section 206 Ecological Restoration/Preservation Analyses” report included in the EIS as Appendix EA-J. Recommended Environmental Dredging Plan Project First Costs associated with cleanup of contaminated sediments located upstream of the 5th Street Bridge are provided in Table 5-2. These costs came to \$37,570,200 and would be supported by Section 312(b) environmental outputs.

9.6 Recommended Environmental Dredging Plan Benefits Associated with a One-Time Cleanup of Contaminated Sediments Downstream of the 5th Street Bridge

The ARP proposed the use of three authorities to accomplish any sediment remediation located downstream of the 5th Street Bridge, in the commercial navigation portion of the project. Two of the authorities dealt with the remediation of polluted sediments located within the Federal channel. Dredging of sediment within the Federal channels downstream of the 5th Street Bridge would be accomplished under Section 1 of the Rivers and Harbors Act of 1937. This authority governs the Corps Operations and Maintenance authorities/programs in this section of the river, to insure continued use of the channels for commercial navigation purposes. The use of Section 101, of WRDA 1986 will address the disposal operations and disposal facility for these sediments. Benefits associated with the use of these two authorities would be the avoidance of cost increases for commercial navigation transportation .

The use of Section 312(a) of WRDA 1990, as amended by Section 205 of WRDA 1996 and Section 224 WRDA 1999, would be used to accomplish dredging and disposal of contaminated sediments located outside/adjacent to the Federal channel, downstream of the 5th Street Bridge. Section 312(a) may be considered if costs of restoration are economically justified based on savings in future operation and maintenance costs.

The Project Area downstream of the 5th Street Bridge must be cleaned up as part of this project if the ARP's goal of open lake disposal of all future dredging is to be achieved. Federal participation in cleanup of the lower river requires an economic justification.

Table 5-2 in Section 5 presents Recommended Environmental Dredging Plan Project First Costs broken down by Authority/study area. Recommended Environmental Dredging Plan Project First Costs for all cleanup located downstream of the 5th Street Bridge totals \$7,435,600 Average Annual Costs for this downstream area totals \$566,300.

The first step would be to demonstrate that there are enough benefits to justify the First Cost investment of \$7,435,600 (average annual costs of \$566,300) to cleanup the polluted sediments located downstream of the 5th Street Bridge. The main benefit category associated with cleanup of the Ashtabula River downstream of the 5th Street Bridge is commercial navigation transportation cost savings. Benefits become the difference in average annual commercial navigation transportation costs between the "Without Project" condition and the "With Project" condition.

9.6.1 Commercial Navigation Benefits

To calculate commercial navigation transportation costs under "Without Project" and "With Project" conditions, these two conditions must be defined. Benefits become the difference in average annual commercial navigation transportation costs between the "Without Project" condition and the "With Project" condition.

9.6.1.1 Description of the "Without Project" And "With Project" Conditions

For Economic Evaluation purposes, the "Without Project" condition describes the pattern of activities that would exist over the 50-year evaluation period in the Ashtabula Harbor approach and Ashtabula River channels in the absence of a one-time cleanup effort of contaminated bottom sediments. Under "Without Project" conditions, contaminated bottom sediments would continue to migrate downstream. Since there is no disposal facility available for these sediments, they cannot be dredged. Maintenance Dredging of the entire commercial navigation channels downstream of the 5th Street Bridge will cease within 6-years and would not be dredged during the 50-year project evaluation period (2006-2055). In addition no dredging would be performed upstream of the 5th Street Bridge. Dredging costs associated with commercial navigation for federal channels located downstream of the 5th Street Bridge become zero. Without any maintenance dredging, the commercial navigation channels downstream of the 5th Street Bridge would shoal up over a 50-year period to 17 foot channel depths.

Bulk commodity users currently being serviced via Ashtabula Harbor would wish to continue to use the harbor over the 50-year evaluation period if economically feasible to do so. As Ashtabula Harbor's navigation channels become shallower, bulk commodity users that currently source their bulk commodities through Ashtabula Harbor would see their delivered bulk commodity costs rise. Shippers would have increasingly less water column as the harbor silts up. This reduced water column would reduce the number of tons of commodities that could be carried on

any one trip. Shippers would have to make more trips per season to deliver the same annual tonnage. More trips per season would increase the delivered price of the bulk commodity. This situation is already occurring at the R.W. Sidley cement and stone facility downstream of the 5th Street Bridge. Ships need to light load to get close enough to conveyer their stone to the dock, resulting in higher costs.

Bulk commodity users would likely continue to use the Port of Ashtabula, in the short term. However, this increase in the water portion of the transport bill would eventually drive up the delivered cost of a commodity via Ashtabula Harbor. Once the delivered price associated with using Ashtabula Harbor, and its decreasing channel depths, exceeded the total transportation costs associated with use of an alternative port; bulk commodity users would shift to alternative harbors. From this time on, total transportation costs would equal the transportation costs associated with using the alternative port.

Similarly, the "With Project" condition reflects the pattern of activities that would occur at Ashtabula Harbor over the 50-year evaluation period, relative to a one-time cleanup of contaminated bottom sediments. In addition, once this one-time cleanup has taken place, all future dredged sediment taken from downstream of the 5th Street Bridge could be disposed of in the open lake. The Corps of Engineers would continue to maintain the commercial navigation channels located downstream of the 5th Street Bridge at currently maintained depths. Consequently, all commercial vessel users would have channel depths of 27 to 28 feet LWD in the Outer Harbor and channel depths of 27 feet and 18 feet LWD in the lower portion of the Ashtabula River. All current bulk commodity harbor users would continue to use Ashtabula harbor over the 50 year evaluation period.

9.6.1.2 Other Economic Data

The economic impact on the port's major bulk commodity users was evaluated by calculating total transportation costs under "Without Project" and "With Project" conditions for iron ore, coal and limestone. Total transportation costs included a water component and a rail/truck component. A waterborne commerce computer model developed by the Army Corps of Engineers, Buffalo District, was used to develop water transportation costs. Rail and truck costs were developed from data provided by the Tennessee Valley Authority. The TVA maintains a computer data base that can be used to generate rail costs and truck costs.

The Ashtabula 1994 commercial navigation season was assumed to be representative of traffic levels that would take place during each year of the 50-year evaluation period under "With" and "Without Project" conditions. The Harbor's 1994 iron ore, coal and limestone sourcing patterns, origin destination pairs, tons moved, rail lines used, vessels used to move the bulk commodities, and the location of bulk commodity suppliers and end users were assumed to remain the same under "With Project" and "Without Project" conditions. There were seven origin/destination routes involved in sourcing iron ore, twenty-five origin/destination routes associated with coal movements, and four origin/destination routes associated with limestone movements.

9.6.1.3 "Without Project" Conditions Average Annual Total Commercial Navigation Transportation Costs

Ashtabula Harbor is a major transshipment point for bulk commodities. The major bulk commodities are iron ore, coal and limestone. Iron ore is received at Ashtabula Harbor from Lake Superior ports. The iron ore is loaded onto railroad cars at Ashtabula and transported to inland steel mills in Ohio, Pennsylvania and West Virginia. Coal is railed from Ohio, Pennsylvania and West Virginia to Ashtabula Harbor, loaded onto Great Lakes vessels and shipped to electrical generating stations and other consumers in the United States and Canada. Limestone is shipped to Ashtabula from a number of ports on Michigan's north shore. The majority of this limestone is trucked to local area users. Some of this limestone is used in Ashtabula to make cement for local area use.

Under "Without Project" conditions it is assumed that contaminated bottom sediments have migrated to areas downstream of the 5th Street Bridge by the year 2006 (Project Year 1.) Movement of contaminated sediment to this area would require that all sediment dredged from this area be placed in a confined dike disposal area. Since no dike disposal area currently exists in Ashtabula, all commercial navigation channel dredging would eventually cease. The termination of dredging would result in the continual shoaling of the Federal navigation channels. This would decrease the channel's water column and the usable vessel draft of commercial vessels using Ashtabula Harbor. The decrease in commercial vessel draft would result in a reduction in the number of tons of bulk commodities being carried per trip to and from the harbor. More trips would have to be made to deliver the same amount of bulk materials to the various end users.

As Ashtabula Harbor's navigation channels become shallower, bulk commodity users that currently source their bulk commodities through Ashtabula Harbor would, see their delivered costs rise. These users would likely continue to use the Port of Ashtabula, in the short term. However, their primary interest is the final delivered price of the bulk commodities. This delivered price may include a water component, a rail component, a truck component, or some combination thereof, associated with using Ashtabula Harbor as the transshipment port. As long as the delivered price via Ashtabula is less than a delivered price associated with using another port or transport mode (e.g., all train), the end user would continue to source commodities through Ashtabula. Eventually, reduced channel water depths would cause an increase in the water portion of the bulk commodities total transport bill associated with using Ashtabula Harbor. This increase in the water portion of the transport bill would eventually drive up the delivered cost of a commodity via Ashtabula Harbor until it equaled the delivered price of the same commodity via an alternative harbor or mode of transportation. Once the delivered price associated with using Ashtabula Harbor with its decreased channel depths exceeded the total transportation costs associated with use of an alternative port, bulk commodity users would shift to alternative harbors. From this time on, total transportation costs would equal the transportation costs associated with using the alternative port.

Total transportation costs (water plus rail/truck) were calculated for each year of the 50-year evaluation period, under "Without Project" conditions, for each of the origin destination pairs identified for iron ore, coal and limestone. Total transportation costs associated with using

Ashtabula Harbor for moving iron ore, coal and limestone were allowed to increase over time until they equaled total transportation costs associated with using an alternative port. The alternative port for iron ore was Cleveland Harbor, Ohio. The alternative port for coal and limestone was Conneaut Harbor, Ohio. Once the switch was made to an alternative port, total transportation costs for the years remaining in the evaluation period were transportation costs associated with using the alternative port. These alternative port total transportation costs did not increase over the remaining evaluation period years. The transportation-cost time streams were converted to average annual dollars using a 6.375% annual interest rate and a 50-year project life. All transportation costs reflect October 2000 price levels. Table 9-2 provides a summary of these average annual costs, by commodity, by origin destination route and by transportation mode. Total average annual transportation costs, under “Without Project” conditions, totaled \$144,800,400.

9.6.1.4 "With Project" Conditions Average Annual Total Commercial Navigation Transportation Costs

“With Project” condition total transportation costs (water plus rail/truck) were also calculated for iron ore, coal and limestone and their respective origin/destination routes. The “With Project” condition assumed that currently maintained harbor depths (27 to 28 feet LWD in the Outer Harbor and channel depths of 27 feet and 18 feet LWD on the lower portion of the Ashtabula River) would be available during each year of the 50-year evaluation period. Under these conditions, all bulk commodities would continue to use Ashtabula Harbor throughout the 50-year evaluation period. Total yearly transportation costs for any given origin/destination route would be the same for any year during the 50-year evaluation period. These transportation-cost time streams were converted to average annual dollars using a 6.375% annual interest rate and a 50-year project life. All transportation costs reflect October 2000 price levels. Table 9-3 provides a summary of these average annual costs, by commodity, by origin destination route, and transportation mode. Total average annual commercial navigation transportation costs, under “With Project” conditions, totaled \$143,491,900.

Table 9-2: Total Average Annual “Without Project” Conditions Commercial Navigation Transportation Costs (October 2000)

<u>ORIGIN DESTINATION PAIR</u>	<u>WOP AVERAGE ANNUAL WATER RAIL COSTS</u>	<u>WOP AVERAGE ANNUAL TRNSPRTATN COSTS</u>	<u>TOTAL WOP AVERAGE ANNUAL TRNSPRTATN COSTS</u>
IRON ORE-Alternate Port = Cleveland, Ohio			
DULUTH, MINNESOTA	\$ 1,733,800	\$ 821,100	\$ 2,554,900
ESCANABA, MICHIGAN	\$ 1,101,800	\$ 855,200	\$ 1,957,000
PRESQUE ISLE, MICHIGAN	\$13,581,400	\$ 8,504,000	\$ 22,085,400
ST. LAWRENCE RIVER	\$ 4,057,900	\$ 1,675,800	\$ 5,733,700
SILVER BAY, MINNESOTA	\$ 1,281,500	\$ 986,900	\$ 2,268,400
SUPERIOR WISCONSIN	\$ 8,949,700	\$ 6,063,100	\$ 15,012,800
TWO HARBORS MINNESOTA	\$ 297,800	\$ 117,700	\$ 415,500
	-----	-----	-----
	\$31,003,900	\$19,023,800	\$ 50,027,700
COAL-Alternate Port = Conneaut			
ADVANCE, MICHIGAN	\$ 875,300	\$ 953,400	\$ 1,828,700
BATH, ONTARIO	\$ 257,900	\$ 656,400	\$ 914,300
CHARLEVOIX, MICHIGAN	\$ 1,309,500	\$ 2,154,600	\$ 3,464,100
CLARKSON, ONTARIO	\$ 470,800	\$ 1,410,600	\$ 1,881,400
COURTWRIGHT, ONTARIO	\$ 1,271,600	\$ 5,129,000	\$ 6,400,600
DETROIT, MICHIGAN	\$ 126,000	\$ 428,600	\$ 554,600
DUNKIRK, NEW YORK	\$ 53,200	\$ 248,800	\$ 302,000
GLADSTONE, MICHIGAN	\$ 194,000	\$ 214,500	\$ 408,500
GRAND HAVEN, MICHIGAN	\$ 164,400	\$ 138,200	\$ 302,600
GREENBAY, WISCONSIN	\$ 3,647,800	\$ 3,354,800	\$ 7,002,600
MANISTEE HARBOR, MICHIGAN	\$ 832,100	\$ 939,500	\$ 1,771,600
MARINETTE, WISCONSIN	\$ 161,600	\$ 172,300	\$ 333,900
MARYSVILLE, MICHIGAN	\$ 59,100	\$ 169,200	\$ 228,300
MILWAUKEE, WISCONSIN	\$ 5,840,100	\$ 5,900,100	\$ 11,740,200
NANTICOKE, ONTARIO	\$ 1,629,100	\$11,245,400	\$ 12,874,500
NIAGARA RIVER, NEW YORK	\$ 312,400	\$ 1,213,200	\$ 1,525,600
ONTONAGON HARBOR, MICHIGAN	\$ 456,000	\$ 386,500	\$ 842,500
PICTON, ONTARIO	\$ 716,200	\$ 1,846,400	\$ 2,562,600
PORT STANLEY, ONTARIO	\$ 108,700	\$ 794,700	\$ 903,400
PORT WASHINGTON, WISCONSIN	\$ 3,533,100	\$ 3,999,700	\$ 7,532,800
PRESQUE ISLE, MICHIGAN	\$ 2,914,800	\$ 5,950,800	\$ 8,865,600
ST. CLAIR, MICHIGAN	\$ 992,900	\$ 3,657,600	\$ 4,650,500
ST. LAWRENCE RIVER & ABOVE	\$ 2,728,800	\$ 4,080,600	\$ 6,809,400
SUPERIOR WISCONSIN	\$ 507,200	\$ 405,900	\$ 913,100
THUNDERBAY, ONTARIO	\$ 1,603,900	\$ 2,360,000	\$ 3,963,900
	-----	-----	-----
	\$30,766,500	\$57,810,800	\$ 88,577,300
LIMESTONE-Alternate Port = Conneaut			
CALCITE, MICHIGAN	\$ 1,103,500	\$ 580,700	\$ 1,684,200
MARBLEHEAD, OHIO	\$ 320,500	\$ 314,600	\$ 635,100
PORT INLAND, MICHIGAN	\$ 2,046,700	\$ 1,024,000	\$ 3,070,700
STONEPORT, MICHIGAN	\$ 603,900	\$ 201,500	\$ 805,400
	-----	-----	-----
	\$ 4,074,600	\$ 2,120,800	\$ 6,195,400
Total WOP Avg. Annual Transportation Costs	\$65,845,000	\$78,955,400	\$144,800,400

Table 9-3: Total Average Annual “With Project” Condition Commercial Navigation Transportation Costs (October 2000)

<u>ORIGIN DESTINATION PAIR</u>	<u>WP AVERAGE ANNUAL WATER COSTS</u>	<u>WP AVERAGE ANNUAL RAIL COSTS</u>	<u>WP TOTAL AVERAGE ANNUAL TRNSPRTATN COSTS</u>
IRON ORE			
DULUTH, MINNESOTA	\$ 1,733,800	\$ 821,100	\$ 2,554,900
ESCANABA, MICHIGAN	\$ 1,101,800	\$ 855,200	\$ 1,957,000
PRESQUE ISLE, MICHIGAN	\$13,581,400	\$ 8,504,000	\$ 22,085,400
ST. LAWRENCE RIVER	\$ 3,914,500	\$ 1,604,100	\$ 5,518,600
SILVER BAY, MINNESOTA	\$ 1,323,300	\$ 939,000	\$ 2,262,300
SUPERIOR WISCONSIN	\$ 9,256,300	\$ 5,729,900	\$ 14,986,200
TWO HARBORS MINNESOTA	\$ 297,800	\$ 117,700	\$ 415,500
	-----	-----	-----
	\$31,208,900	\$18,571,000	\$ 49,779,900
COAL			
ADVANCE, MICHIGAN	\$ 870,500	\$ 948,100	\$ 1,818,600
BATH, ONTARIO	\$ 259,300	\$ 646,300	\$ 905,600
CHARLEVOIX, MICHIGAN	\$ 1,298,900	\$ 2,141,600	\$ 3,440,500
CLARKSON, ONTARIO	\$ 472,400	\$ 1,395,200	\$ 1,867,600
COURTWRIGHT, ONTARIO	\$ 1,224,500	\$ 5,083,800	\$ 6,308,300
DETROIT, MICHIGAN	\$ 124,000	\$ 427,200	\$ 551,200
DUNKIRK, NEW YORK	\$ 53,500	\$ 248,300	\$ 301,800
GLADSTONE, MICHIGAN	\$ 192,900	\$ 213,200	\$ 406,100
GRAND HAVEN, MICHIGAN	\$ 164,000	\$ 137,800	\$ 301,800
GREENBAY, WISCONSIN	\$ 3,632,000	\$ 3,334,500	\$ 6,966,500
MANISTEE HARBOR, MICHIGAN	\$ 828,200	\$ 934,200	\$ 1,762,400
MARINETTE, WISCONSIN	\$ 160,900	\$ 171,300	\$ 332,200
MARYSVILLE, MICHIGAN	\$ 57,800	\$ 167,800	\$ 225,600
MILWAUKEE, WISCONSIN	\$ 5,794,600	\$ 5,864,400	\$ 11,659,000
NANTICOKE, ONTARIO	\$ 1,611,200	\$11,159,900	\$ 12,771,100
NIAGARA RIVER, NEW YORK	\$ 314,800	\$ 1,206,400	\$ 1,521,200
ONTONAGON HARBOR, MICHIGAN	\$ 450,400	\$ 384,700	\$ 835,100
PICTON, ONTARIO	\$ 719,900	\$ 1,818,000	\$ 2,537,900
PORT STANLEY, ONTARIO	\$ 105,000	\$ 792,900	\$ 897,900
PORT WASHINGTON, WISCONSIN	\$ 3,513,900	\$ 3,973,600	\$ 7,487,500
PRESQUE ISLE, MICHIGAN	\$ 2,862,900	\$ 5,876,200	\$ 8,739,100
ST. CLAIR, MICHIGAN	\$ 974,700	\$ 3,640,200	\$ 4,614,900
ST. LAWRENCE RIVER & ABOVE	\$ 2,752,100	\$ 3,993,300	\$ 6,745,400
SUPERIOR WISCONSIN	\$ 505,300	\$ 403,100	\$ 908,400
THUNDERBAY, ONTARIO	\$ 1,584,400	\$ 2,323,800	\$ 3,908,200
	-----	-----	-----
	\$30,528,100	\$57,285,800	\$ 87,813,900
LIMESTONE			
CALCITE, MICHIGAN	\$ 1,071,800	\$ 511,700	\$ 1,583,500
MARBLEHEAD, OHIO	\$ 306,300	\$ 297,800	\$ 604,100
PORT INLAND, MICHIGAN	\$ 1,995,600	\$ 909,500	\$ 2,905,100
STONEPORT, MICHIGAN	\$ 603,900	\$ 201,500	\$ 805,400
	-----	-----	-----
	\$ 3,977,600	\$ 1,920,500	\$ 5,898,100
Total WP Transportation Costs	\$65,714,600	\$77,777,300	\$143,491,900

9.6.1.5 Average Annual Commercial Navigation Transportation Benefits

The difference between average annual commercial navigation transportation costs under the "Without Project" and the "With Project" condition is average annual transportation costs that would not be incurred if a one-time cleanup of contaminated channel bottom sediment was performed. These average annual transportation costs avoided reflect the economic benefit of a one-time cleanup of contaminated channel bottom sediments to commercial transportation users. These benefits came to \$1,308,500 . These average annual benefits reflect a 6.375 percent annual interest rate, a 50-year project life and October 2000 price levels. Table 9-4 provides a summary of average annual commercial navigation transportation benefits by commodity and by origin/destination pair.

Average annual benefits associated with restoration of the Ashtabula River downstream of the 5th Street Bridge are \$1,308,500 while the average annual costs for this area are \$566,300. Net benefits associated with the restoration of the Ashtabula River downstream of the 5th Street Bridge are \$742,200. The benefit to cost ratio for restoration of the Ashtabula River, downstream of the 5th Street Bridge, is 2.31. These figures are summarized in Table 9-5.

Average Annual Commercial Navigation Benefits (\$1,308,500) are greater than the average annual costs associated with cleanup of the Ashtabula River downstream of the 5th Street Bridge (\$566,300). A more complete discussion of the derivation of commercial navigation benefits is provided in Technical Appendix S, Supplement 1.

Table 9-4: Total Average Annual Commercial Navigation Benefits.

<u>ORIGIN DESTINATION PAIR</u>	<u>Average Annual WOP Transportation Costs</u>	<u>Average Annual WP Transportation Costs</u>	<u>Total Average Annual Transportation Benefits</u>
IRON ORE			
DULUTH, MINNESOTA	\$ 2,554,900	\$ 2,554,900	\$ 0
ESCANABA, MICHIGAN	\$ 1,957,000	\$ 1,957,000	\$ 0
PRESQUE ISLE, MICHIGAN	\$ 22,085,400	\$ 22,085,400	\$ 0
ST. LAWRENCE RIVER	\$ 5,733,700	\$ 5,518,600	\$ 215,100
SILVER BAY, MINNESOTA	\$ 2,268,400	\$ 2,262,300	\$ 6,100
SUPERIOR WISCONSIN	\$ 15,012,800	\$ 14,986,200	\$ 26,600
TWO HARBORS MINNESOTA	\$ 415,500	\$ 415,500	\$ 0
	-----	-----	-----
	\$ 50,027,700	\$ 49,779,900	\$ 247,800
COAL			
ADVANCE, MICHIGAN	\$ 1,828,700	\$ 1,818,600	\$ 10,100
BATH, ONTARIO	\$ 914,300	\$ 905,600	\$ 8,700
CHARLEVOIX, MICHIGAN	\$ 3,464,100	\$ 3,440,500	\$ 23,600
CLARKSON, ONTARIO	\$ 1,881,400	\$ 1,867,600	\$ 13,800
COURTWRIGHT, ONTARIO	\$ 6,400,600	\$ 6,308,300	\$ 92,300
DETROIT, MICHIGAN	\$ 554,600	\$ 551,200	\$ 3,400
DUNKIRK, NEW YORK	\$ 302,000	\$ 301,800	\$ 200
GLADSTONE, MICHIGAN	\$ 408,500	\$ 406,100	\$ 2,400
GRAND HAVEN, MICHIGAN	\$ 302,600	\$ 301,800	\$ 800
GREENBAY, WISCONSIN	\$ 7,002,600	\$ 6,966,500	\$ 36,100
MANISTEE HARBOR, MICHIGAN	\$ 1,771,600	\$ 1,762,400	\$ 9,200
MARINETTE, WISCONSIN	\$ 333,900	\$ 332,200	\$ 1,700
MARYSVILLE, MICHIGAN	\$ 228,300	\$ 225,600	\$ 2,700
MILWAUKEE, WISCONSIN	\$ 11,740,200	\$ 11,659,000	\$ 81,200
NANTICOKE, ONTARIO	\$ 12,874,500	\$ 12,771,100	\$ 103,400
NIAGARA RIVER, NEW YORK	\$ 1,525,600	\$ 1,521,200	\$ 4,400
ONTONAGON HARBOR, MICHIGAN	\$ 842,500	\$ 835,100	\$ 7,400
PICTON, ONTARIO	\$ 2,562,600	\$ 2,537,900	\$ 24,700
PORT STANLEY, ONTARIO	\$ 903,400	\$ 897,900	\$ 5,500
PORT WASHINGTON, WISCONSIN	\$ 7,532,800	\$ 7,487,500	\$ 45,300
PRESQUE ISLE, MICHIGAN	\$ 8,865,600	\$ 8,739,100	\$ 126,500
ST. CLAIR, MICHIGAN	\$ 4,650,500	\$ 4,614,900	\$ 35,600
ST. LAWRENCE RIVER & ABOVE	\$ 6,809,400	\$ 6,745,400	\$ 64,000
SUPERIOR WISCONSIN	\$ 913,100	\$ 908,400	\$ 4,700
THUNDERBAY, ONTARIO	\$ 3,963,900	\$ 3,908,200	\$ 55,700
	-----	-----	-----
	\$ 88,577,300	\$ 87,813,900	\$ 763,400
LIMESTONE			
CALCITE, MICHIGAN	\$ 1,684,200	\$ 1,583,500	\$ 100,700
MARBLEHEAD, OHIO	\$ 635,100	\$ 604,100	\$ 31,000
PORT INLAND, MICHIGAN	\$ 3,070,700	\$ 2,905,100	\$ 165,600
STONEPORT, MICHIGAN	\$ 805,400	\$ 805,400	\$ 0
	-----	-----	-----
	\$ 6,195,400	\$ 5,898,100	\$ 297,300
Total Transportation Benefits	\$144,800,400	\$143,491,900	\$1,308,500

Table 9-5: Benefits and Costs Associated with the Restoration of the Ashtabula River Downstream of the 5th Street Bridge.

Average Annual Benefits ¹	\$ 1,308,500
Average Annual Costs ¹	\$ 566,300
Net Benefits	\$ 742,200
Benefit To Cost Ratio	2.31

(1) All average annual benefits and costs reflect a 6.375% annual interest rate, October 2000 prices and a 50-year Project life.

9.6.2 Section 312(a) Benefits

Since the Federal interest in the cleanup of the Ashtabula River downstream of the 5th Street Bridge has been demonstrated, the justification of the usage of Section 312(a) can now be addressed. Section 312(a) benefits are based upon the savings in future operation and maintenance costs. Therefore, operation and maintenance costs need to be calculated over the evaluation period under two assumptions (scenarios):

1. “Normal Maintenance-Contaminated Sediments Present” (NMCSPP) – Section 312(a) contaminated sediments remain in the River; and
2. “Normal Maintenance-Contaminated Sediments Removed” (NMCSR) - Contaminated sediments removed through implementation of Section 312(a) authority.

9.6.2.1 Description of Two Alternative “Future Maintenance” Conditions Scenarios

Section 312(a) is the authority used to remove contaminated sediments located downstream of the 5th Street Bridge and adjacent to the Federal channel (52,800 cubic yards). Benefits associated with Section 312(a) are Operation and Maintenance Costs Avoided. Two above listed alternative “Future Maintenance” scenarios were developed to determine the potential increase in Operation and Maintenance costs that would be avoided through the implementation of the dredging project. The two “Future Maintenance” scenarios assume the Ashtabula Harbor will continue to be maintained over the 50-year evaluation period. The two Future Maintenance scenarios are as follows:

The label “Normal Maintenance-Contaminated Sediments Present” (NMCSPP) assumes that Section 312(a) contaminated sediments (52,800 cubic yards) have not been removed from the Project Area downstream of the 5th Street Bridge. However, to isolate the impacts on Operation and Maintenance costs from leaving just Section 312(a) contaminated sediments in the River downstream of the 5th Street Bridge, it is assumed all other contaminated bottom sediments located downstream of the 5th Street Bridge (62,200 cyd) and upstream of the 5th Street Bridge (581,000 cyd) have been removed.

Table 9-6: “Normal Maintenance-Contaminated Sediments Present” (NMCSP) Future Scenario: Sediment Volumes and Method of Sediment Disposal by Year.

<u>Location</u>	<u>River</u>	<u>River</u>	<u>Outer Harbor</u>	<u>All Locations</u>
<u>CDF Method Of Disposal</u>	<u>Open Non TSCA</u>	<u>Open Lake Disposed</u>	<u>Total Lake Disposed</u>	<u>Cubic Yards</u>
Project Year				
1	20,000	30,000	50,000	100,000
120+ to Bridge	62,200			62,200
3	20,000	30,000	50,000	100,000
5	20,000	30,000	50,000	100,000
7	20,000	30,000	50,000	100,000
9	20,000	30,000	50,000	100,000
11	20,000	30,000	50,000	100,000
13	20,000	30,000	50,000	100,000
15	20,000	30,000	50,000	100,000
17	20,000	30,000	50,000	100,000
19	20,000	30,000	50,000	100,000
21		50,000	50,000	100,000
23		50,000	50,000	100,000
25		50,000	50,000	100,000
27		50,000	50,000	100,000
29		50,000	50,000	100,000
31		50,000	50,000	100,000
33		50,000	50,000	100,000
35		50,000	50,000	100,000
37		50,000	50,000	100,000
39		50,000	50,000	100,000
41		50,000	50,000	100,000
43		50,000	50,000	100,000
45		50,000	50,000	100,000
47		50,000	50,000	100,000
49		50,000	50,000	100,000
	-----	-----	-----	-----
	262,200	1,050,000	1,250,000	2,562,200

This allows Operation and Maintenance Costs generated to reflect the cost associated with leaving the 312(a) contaminated sediments (52,800 cubic yards) in the river.

Under the NMCSPP scenario, the contaminated sediments downstream of the 5th Street Bridge and adjacent to the federal Channel (52,800 cubic yards) would remain in the river over the 50-year project evaluation period (see Figure 9-6). These contaminated sediments would continue to migrate downstream into the Federal navigation channel. This contaminated sediment will mix with cleaner sediment material that needs to be removed for commercial navigation purposes. This mixing will cause the dredged sediments to be classified as polluted, and be required to be placed in a confined disposal facility.

No confined disposal facility is currently available at Ashtabula Harbor. Consequently, this contaminated dredged sediment will have to be disposed of into a current area landfill with capacity, a new landfill or a new confined disposal facility. The additional costs incurred from dredging contaminated sediments and having to place them into a confined disposal area, will increase Operation and Maintenance costs. These increased costs will continue to be incurred as long as sediments need to be removed for commercial navigation purposes are classified as needing confinement.

To calculate NMCSPP Operation and Maintenance costs, information needs to be provided on a range of variables that will affect these dredging costs. Such variables include: the number of cubic yards that need to be removed per dredging cycle, by location, throughout the harbor (river versus outer harbor), the dredging interval (yearly, every other year) the quality of the sediment of these cubic yards (number of cubic yards capable of being open lake disposed, number of cubic yards that need to be confined), cost per cubic yard for removal, transportation, and discharge of non-contaminated bottom sediments at an open lake disposal site, cost per cubic yard for removal, transportation, and discharge of contaminated bottom sediments to a contained disposal facility, cost for construction of the disposal facility, and cost for maintenance of the disposal facility.

Under “Normal Maintenance-Contaminated Sediments Removed” (NMCSR), Section 312(a) contaminated sediments (58,200 cubic yards) have been removed from the Project Area downstream of the 5th Street Bridge. In addition, it is assumed all other contaminated bottom sediments downstream of the 5th Street Bridge and upstream of the 5th Street Bridge were removed. This allows all sediments dredged from the river to be open lake disposed. Consequently, Operation and Maintenance costs under NMCSR are the maintenance costs associated with open lake disposal. Again such information as the number of cubic yards needed to be removed per dredging cycle, the length of the dredging cycle, and a cost per cubic yard for open lake disposal needs to be developed.

Section 312(a) benefits are the difference between the NMCSPP and the NMCSR average annual Operation and Maintenance costs. NMCSPP Operation and Maintenance costs assume that 312(a) contaminated sediments have been left in the river downstream of the 5th Street Bridge. Consequently NMCSPP Operation and Maintenance Costs increase since the contaminated 312(a) sediments migrate downstream and mix with clean bottom sediments. These mixed bottom

sediments have to be placed in a confined disposal facility, as opposed to being open lake disposed. Scenario 2 assumes the ARP's cleanup plan for the entire Ashtabula River (upstream and downstream of the 5th Street Bridge) has been completed. Consequently, all sediments removed for commercial navigation, over the 50-year life of the project, can be open lake disposed.

9.6.2.2 "Normal Maintenance-Contaminated Sediments Present" Operation And Maintenance Costs

"Normal Maintenance-Contaminated Sediments Present" assumes that all contaminated sediment upstream of the 5th Street Bridge was removed as through the ARP Plan. It also assumes that in project year 1, all contaminated sediments located in the Federal channel downstream of the 5th Street Bridge will be removed (62,200 cubic yards.) This removes all the sources of contaminated sediments entering the Federal Channel except from the area adjacent to the Federal channel downstream of the 5th Street Bridge. This source of pollution is the Section 312(a) cubic yards: 52,800.

The number of cubic yards needed to be removed from the commercial navigation channel was investigated under the 1990 "Letter Report And Draft Environmental Impact Statement Ashtabula Harbor Ohio, Ashtabula Confined Disposal Facility Project." The Letter Report was not approved for public release due to the lack of policy guidance required for project cost sharing. Quantities dredged on an every other year basis for the whole harbor ranged from 172,000 cubic yards to 233,500 cubic yards. Data on historical dredging volumes from the Chief of Engineers Annual Reports for a 22 year period (1973 to 1994) indicate approximately 272,000 cubic yards are removed every other year for total harbor maintenance. In recent years, fewer cubic yards have been removed from the Harbor due to the contaminated nature of sediments located downstream of the 5th Street Bridge. The estimated number of cubic yards that have been recently removed, on an every other year basis, is 130,000 cubic yards, of which 50,000 are located in the river.

Given the uncertainties of cubic yards removed in the future , it is assumed that 100,000 cubic yards will be removed on an every other year basis. It is assumed 50,000 cubic yards will come from the river, and 50,000 cubic yards from the outer harbor.

Since the 312(a) sediment is not removed, it will continue contaminating the Federal project dredging. Thus a portion of the dredged sediment will have to be disposed of in a CDF. Total cubic yards of 312(a) sediment is 52,800 cubic yards. The level of PCB toxicity of these cubic yards is not exactly known but ranges from undetectable levels to 20 ppm. Assume the average level of contamination is 10. Given that open lake disposal calls for 1 ppm or less, it is estimated that this area of contaminated sediment could cause 528,000 cubic yards of dredged sediment to be classified as unsuitable for open lake disposal and would need to be placed in a confined disposal facility. The following assumptions on mixing were made. Out of the 50,000 cubic yards that would be removed from the river on an every other year basis, 20,000 cubic yards would need to be contained. The remaining 30,000 cubic yards in the river would be open lake disposed, as well as the 50,000 cubic yards removed from the outer harbor. This mixing would continue over a 20 year time frame. After 20 years, all river and outer harbor sediments could be

open lake disposed. Total cubic yards that needed to be contained came to 262,200. A time stream of cubic yards removed by year and their method of disposal, for NMCSF, is presented in Table 9-7.

Table 9-7: Average Annual Operation and Maintenance Costs Under “Normal Maintenance-Contaminated Sediments Present” (NMCSF) Future Scenario

Dike Construction Costs	\$10,260,900
Present Worth Of Dike Maintenance Costs	\$ 438,700
Present Worth Of Annual Sand Bypass Costs	\$ 490,600
Present Worth Of Polluted Sediment Disposal Dredging Costs	\$ 1,806,500
Present Worth Of Open Lake Sediment Disposal Dredging Costs	\$ 3,659,600

Total Present Worth Costs	\$16,656,300
Partial Payment Factor (6.375% and 50 year project life)	.06678897

Average Annual NMCSF Operation And Maintenance Costs	\$ 1,112,500

A number of different disposal facilities could be used to hold the contaminated sediment. Current landfills could be used, a new CDF could be built at Ashtabula, or a new upland disposal site could be built. This analysis assumes that the disposal facility will be a new CDF at Ashtabula. Information on potential dike locations and costs were obtained from the December 1992 "Letter Report Confined Disposal Facility Ashtabula Harbor Ashtabula Ohio." The location of the dike would be approximately 3 miles east of the harbor, which is located and contacted to the lake shoreline (Site 1 Plant). This was the site recommended in the 1992 Letter Report prepared by Buffalo District. Construction first costs for this facility were updated from October 1991 prices to October 2000 prices using the ENR Construction Cost index. Construction first costs included Contractors Earnings and Contingencies, Engineering and Design, Construction Management and LERRDs. Also included in the evaluation were costs associated with building a breakwall and mooring facilities for the scows that carry the contaminated sediment to the CDF, as well as pumpout equipment needed to remove the sediment from the scows and place it in the CDF. These costs in October 2000 prices came to \$23, 541,200. This plan was sized to hold approximately 1,300,000 cubic yards.

However, Normal Maintenance-Contaminated Sediments Present” calls for 262,200 cubic yards to be confined. Construction costs were adjusted to reflect the lower number of cubic yards needing containment. Construction costs associated with holding 262,200 cubic yards came to \$10,260,900. To these costs were added the present worth of annual dike maintenance costs (\$438,700), the present worth of annual sand bypass costs (\$490,600), the present worth of dredging costs associated with removing, transporting and placement into the dike of contaminated sediment (\$1,806,500 based on a dredging/transport/disposal cost of \$10.43 per cubic yard), and the present worth of dredging costs associated with removing, transporting and open lake disposal of clean sediment (\$3,659,600 based on a dredging/transport/disposal cost of \$5.57 per cubic yard). All discounting took place over a 50-year evaluation period, used a 6.375

percent annual interest rate and reflected October 2000 price levels. The present worth costs for NMCSF came to \$16,656,300. These Present Worth costs were converted to average annual dollars using a 50-year project life and a 6.375 percent annual interest rate (See Table 9-8). Average annual NMCSF Operation and Maintenance Costs came to \$1,112,500.

9.6.2.3 “Normal Maintenance- Contaminated Sediments Removed” Operation and Maintenance Costs

NMCSR assumes the current ARP project is implemented. This will result in a cleanup of polluted and toxic harbor sediments currently located upstream and downstream of the 5th Street Bridge. The cleanup of contaminated sediments will insure that any future sediment moving downstream and into the commercial navigation channel is clean and acceptable for open lake disposal. This cleanup will allow all future dredging for commercial navigation purposes to be open lake disposed. The federal channels located downstream of the 5th Street Bridge will be maintained at their current channel depths.

Assumptions on the number of cubic yards dredged per cycle (100,000) and the frequency of dredging (once every two years) was assumed to be the same as discussed previously. The difference between NMCSF and NMCSR is that NMCSR allows all sediment dredged over the 50- year evaluation to be open lake disposed. Given a dredging cost per cubic yard of \$5.57 for removing, transporting and open lake disposal of clean sediment, 100,000 cubic yards being removed once every two years, the present worth of open lake disposal costs came to \$4,298,700. All discounting took place over a 50-year evaluation period, used a 6.375 percent annual interest rate and reflected October 2000 price levels. The derivation of NMCSR Present Worth costs is presented in Table 9-9. These Present Worth costs were converted to average annual dollars using a 50-year project life and a 6.375 percent annual interest rate. Average annual “Normal Maintenance-Contaminated Sediments Removed” Operation And Maintenance Costs came to \$287,100.

9.6.2.4 Section 312(a) Benefits Summary

Benefits associated with Section 312(a) are the difference between NMCSF and NMCSR average annual Operation and Maintenance costs. NMCSF Operation and Maintenance costs assume Section 312(a) contaminated sediments have been left in the river downstream of the 5th Street Bridge.

NMCSR assumes the ARP’s cleanup plan for the entire Ashtabula River (upstream and downstream of the 5th Street Bridge) has been completed. It assumes all contaminated sediments located outside the federal channel downstream of the 5th Street Bridge, have been removed under the authority of Section 312(a). Consequently all sediments that need to be removed for commercial navigation, over the 50-year life of the project, can be open lake disposed.

NMCSF average annual Operation and Maintenance Costs were \$1,112,500. NMCSR average annual Operation and Maintenance Costs were \$287,100 . The difference between the NMCSF and the NMCSR average annual Operation and Maintenance costs is \$825,400, which represents the benefits attributable to Section 312(a) (see Table 9-9).

Table 9-8: Average Annual Operation and Maintenance Costs Under “Normal Maintenance- Contaminated Sediments Removed” (NMCSR) Future Scenario

Year	Cu. Yd. Open Lake Disposed	Cost/Cu. Yd. For Open Lake Disposal	Open Lake Dredge Costs	Present Worth Factor	Present Worth Value
1	100,000	\$5.57	\$557,000	0.940070505	\$523,619
3	100,000	\$5.57	\$557,000	0.830770909	\$462,739
5	100,000	\$5.57	\$557,000	0.734179298	\$408,938
7	100,000	\$5.57	\$557,000	0.648818147	\$361,392
9	100,000	\$5.57	\$557,000	0.573381719	\$319,374
11	100,000	\$5.57	\$557,000	0.506716091	\$282,241
13	100,000	\$5.57	\$557,000	0.447801506	\$249,425
15	100,000	\$5.57	\$557,000	0.395736769	\$220,425
17	100,000	\$5.57	\$557,000	0.349725466	\$194,797
19	100,000	\$5.57	\$557,000	0.30906378	\$172,149
21	100,000	\$5.57	\$557,000	0.273129723	\$152,133
23	100,000	\$5.57	\$557,000	0.241373628	\$134,445
25	100,000	\$5.57	\$557,000	0.213309733	\$118,814
27	100,000	\$5.57	\$557,000	0.188508756	\$104,999
29	00,000	\$5.57	\$557,000	0.166591324	\$92,791
31	100,000	\$5.57	\$557,000	0.147222177	\$82,003
33	100,000	\$5.57	\$557,000	0.13010503	\$72,469
35	100,000	\$5.57	\$557,000	0.114978051	\$64,043
37	100,000	\$5.57	\$557,000	0.101609847	\$56,597
39	100,000	\$5.57	\$557,000	0.089795929	\$50,016
41	100,000	\$5.57	\$557,000	0.079355586	\$44,201
43	100,000	\$5.57	\$557,000	0.070129115	\$39,062
45	100,000	\$5.57	\$557,000	0.061975382	\$34,520
47	100,000	\$5.57	\$557,000	0.054769662	\$30,507
49	100,000	\$5.57	\$557,000	0.048401734	\$26,960

					\$4,298,659
					Rounded
					\$4,298,700

					Partial Payment Factor
					0.066788968

					\$287,106
					Rounded
					\$287,100

Table 9-9: Section 312(a) Benefits

MCSA Average Annual Operation And Maintenance Costs	\$1,112,500
MCSR Average Annual Operation And Maintenance Costs	\$ 287,100

Section 312 (a) Average Annual Benefits	\$ 825,400

Average annual costs associated with Section 312(a) were \$260,100 (See Section 4, Table 4-5). Net benefits associated with Section 312(a) are \$825,400. The benefit to cost ratio for Section 312(a) is 3.17 to 1 . These figures are summarized in Table 9-10.

Table 9-10: Benefits and Costs Associated With Section 312(a)

Average Annual Benefits ¹	\$825,400
Average Annual Costs ¹	\$260,100
Net Benefits	\$565,300
Benefit To Cost Ratio	3.17

A more complete discussion of the derivation of Section 312(a) benefits (operation and maintenance costs avoided) is provided in Appendix S.

9.7 Benefits Associated with Related Aquatic Ecosystem Restoration Measures

The ARP recommends the use of Section 206, or some similar authorization, to accomplish any aquatic ecosystem restoration associated with the ARP project . The CMP has set forth selected alternatives for ecosystem restoration on the lower Ashtabula River upstream of the 5th Street Bridge (Plan 4 for Area 2) and downstream of the 5th Street Bridge (Plan 2 for Area 3). The aquatic ecosystem restoration costs would also be supported by environmental outputs. For further discussion of the expected environmental outputs, refer to EIS, Appendix EA-J, “Section 312(b) and Section 206 Ecological Restoration/Preservation Analyses.”

9.8 Summary of Benefits Associated with the Ashtabula River Cleanup Plans

9.8.1 Introduction

Traditional NED economic measures of benefits were computed for the cleanup taking place downstream of the 5th Street Bridge. The analysis in Section 9.6.1. showed the benefit to cost ratio for cleanup of the river located downstream of the 5th Street Bridge was 2.31 to 1 for the ARP Recommended Environmental Dredging Plan.

Benefits associated with cleanup of the river located upstream of the 5th Street Bridge (Section 312(b)) were in terms of improvement in various environmental indicators. Section 907 of WRDA 86 states the costs of all project measures associated with environmental quality, have by definition an equal number of benefits associated with them. However, the placement of a monetary value on ecosystem restoration improvements is problematic. Traditional economic

measures of benefits do not adequately portray all of the values associated with a functioning ecosystem. Most economic analyses focus on the goods and services that the public receives and not the infrastructure that produces the goods and services. The many interrelationships between species that are required for a fully functioning ecosystem are not independently recognized and valued by the public. For example, the value of catching game fish has been the focus of many studies. However, the value of the prey species sought by the game fish has not been included in the benefit evaluation. It is fairly easy to estimate the economic value of game fish. It is very difficult to estimate the economic value of the ecological infrastructure that supports game fish.

To provide the most comprehensive picture of the benefits associated with the various Ashtabula River cleanup plans, a monetary value was placed upon the value of a wide range of goods and services that would be provided by each of the plans evaluated. The benefits generated by each plan assumed cleanup of the river upstream and downstream of the 5th Street Bridge was accomplished under Section 312(b). Benefits generated by plan would depend upon how fully functioning the ecosystem becomes after the plan being considered has been implemented.

The calculation of benefits was not limited to NED benefit categories, but included Regional Economic Development benefit categories. The benefits associated with the various benefit categories were developed in present worth values for comparison to the investment costs of the various cleanup plans. This would provide perspective to one of the major questions posed by Federal and Non-Federal sponsors: given the cost of the various plans of improvement, is there an interest in pursuing any of the alternatives proposed. Secondly, is there an interest in pursuing the Recommended Environmental Dredging Plan and how does it compare to the other plans evaluated. A listing of the benefit categories considered, and their corresponding monetary values by plan, is presented below.

9.8.2 Benefit Category Evaluation Summary

Cleanup of the Ashtabula River will have major impacts on the users of the Ashtabula River. The main users of the Ashtabula River include: commercial navigation vessels moving bulk commodities, small craft boaters, fishermen, etc. In addition to users who directly use the water resource, the cleanup or absence of a river cleanup will indirectly impact other groups. Other groups affected would include passive recreational users of the harbor, local area property owners, the viability of the Lake Erie walleye fishery, the local economy involved in servicing the commercial navigation industry, local expenditures by boaters and fishermen, as well as local public revenue generated from sales and property taxes of people directly and indirectly linked to the rivers usage.

The benefits associated with these users were evaluated using nine benefit categories. The nine benefit categories are: navigation (commercial transportation cost increases avoided), boating (consumer surplus), fishing (consumer surplus), passive use values (consumer surplus), change in property values, risk reduction to the Lake Erie walleye fishery, local economic impacts, boating expenditure impacts and fishing expenditure impacts. The value of these listed benefits for each of the alternative plans evaluated during the Plan Formulation period, is presented in Table 5-3 in Section 5.0 of the CMP.

The present worth value of goods and services presented in Table 5-3 reflects a 3.6 percent annual interest rate and a 50-year project evaluation period. Table 9-11 indicates the value of goods and services generated by each plan are greater than the plans investment costs for all plans except the Shallow Dredge plan. The present worth of goods and services associated with the Recommended Environmental Dredging Plan are over \$181,000,000. This is more than triple the present worth value (\$50,252,500) of the Recommended Environmental Dredging Plans average annual costs.

In addition to the benefit categories evaluated, there is a number of other benefit categories that have yet to be evaluated. A sample of remaining benefit categories include: the increase in value to general recreationists of using the harbors current and anticipated future components, the increase in net income to charter boat operators, the value of environmental restoration and the existence value of Ashtabula County residents associated with a one time cleanup of the harbor. The inclusion of the value of these goods and services would make the ratio of present worth benefits to present worth costs even greater. A summary of the process used to develop present worth values for each of the nine benefit categories follows.

9.8.3 The Present Worth Value of Benefits By Benefit Category

Table 5-3 presents the Present Worth Value of all benefit categories using a 3.6% annual interest rate and a 50-year project life. Values show the difference between the “Without” project condition and the “With Project” condition alternative in annualized, discounted present worth values of 1996 dollars.

Changes in the Ashtabula River ecosystem will take place over time after the environmental dredging and the subsequent related aquatic ecosystem restoration measures have been implemented. Consequently, the value of some benefit categories will grow over time. It is projected that the ecosystem could achieve its new level of productivity in 3 years after a 3-year construction phase in the Shallow Dredge and Deep Dredge plus subsequent related aquatic ecosystem restoration measures. The Deep Dredge option alone is assumed to require 5 years to recover. The Bank-to-Bank alternative is assumed to take 10 years to recover. These estimated varying time streams of benefits accounts for the difference in the level of benefits associated with any one plan of improvement for a number of benefit categories evaluated. A summary of the derivation of benefits by benefit category follows. A more complete description of the benefit evaluation process can be found in Appendix S, “Economic Evaluation” and Appendix EA-J of the EIS, “Section 312(b) and Section 206 Ecological Restoration/Preservation Analyses.”

9.8.3.1 Commercial Navigation (Reduction in Transport Costs)

The average annual savings to shippers, the difference in average annual transportation costs between the “Without” and “With Project” condition, came to \$1,308,500 (Section 9.7.1.). These benefits reflect a 6.375 percent annual interest rate, a 50-year project life and October 2000 price levels. This converts to a present worth value of \$19,591,600 ($\$1,308,500 \times 14.97253$).

Because Shallow Dredging leaves a considerable amount of the PCB load in place, the Shallow Dredging alternative does not generate navigation benefits (i.e., future commercial navigation dredging will not be able to be open lake disposed). However, the Deep Dredging, Deep Dredging and subsequent aquatic ecosystem restoration, and the Bank-to-Bank-to-Bedrock alternatives remove a substantial portion of the potential contamination. This will allow all future dredging quantities to be disposed of in the open lake. Consequently, all three generate present worth navigation savings of \$19,591,600.

9.8.3.2 Boating (Consumer Surplus)

The greatest contact many people have with the river is through recreation. Fishing, boating, and nearby beaches draw thousands of visitors to Ashtabula each year. The results of the related aquatic ecosystem restoration project will be experienced and appreciated through these activities.

People pursuing any recreational activity derive pleasure from the activity greater than what they pay to experience it. If they did not, they would be indifferent between pursuing the activity and doing anything else. They would find something more rewarding to do. Economists put a dollar value on this extra pleasure by asking people how much money the activity would need to cost before they would stop doing it. That amount is called the “consumer surplus,” or “willingness to pay.” An improvement in the quality of the river ecosystem can be expected to improve the boating experience and so increase boaters’ willingness to pay. Ecosystem improvements will also attract additional boaters to Ashtabula Harbor.

There are 1,058 boat slips and 11 launch ramps in the Ashtabula River upstream of the 5th Street Bridge. There are eleven marinas/yacht clubs providing a variety of services to boaters from all over northeastern Ohio. It is estimated that these marinas/yacht clubs generate 159,018 boating days, 70 percent (111,313) are related to fishing while 30 percent (47,705) are strictly boating related.

A recent survey by the Ohio Sea Grant College Program showed an association between boating on Lake Erie and awareness of Ashtabula River pollution problems. In addition, contamination of sediments in the river between Fields Brook and the 5th Street Bridge prevent open lake disposal of dredge spoil from that reach, preventing channel maintenance. As a consequence the recreational channel is becoming shallower and will become impassable for many boats within the planning horizon of this project. Boaters will benefit from the cleaner and deeper river this project provides.

The U.S. Forest Service unit day value for motorized boating at a “less than standard site” was placed at an October 2000 price level value of \$9.61. The Feasibility Report estimates a 10 percent improvement in quality of the river experience with the project versus without it through a subjective point scoring system. The improved experience was assumed to generate a linear increase in boating consumer surplus. This increase is made up of some improved experience of present boaters and some new boaters drawn to the activity by the improved quality of the river. With a 10 percent improvement, the 47,705 boating days would generate benefits of \$45,797

annually (47,705 x \$0.96) and the new boaters would generate an additional \$45,840 annually (4,770 x \$9.61) in consumer surplus.

Total annual maximum boating consumer surplus came to \$91,640. This maximum annual consumer surplus was used to develop a 50-year time stream of boater consumer surplus benefits for each of the plans evaluated. Ecosystem restoration was assumed to take 3, 5, and 10 years respectively, for Deep Dredge alternative (the Recommended Environmental Dredging Plan) with subsequent related aquatic ecosystem restoration measures, Deep Dredge, and Bank to Bank to Bedrock. (There are no boating consumer surplus benefits associated with the Shallow Dredge option). Annual boating consumer surplus values started at zero and rose to \$91,637 based upon the number of years needed to achieve full ecological restoration. The present worth value of boating consumer surplus for the Deep Dredge, the Deep Dredge alternative (the Recommended Environmental Dredging Plan) plus subsequent related aquatic ecosystem restoration measures, and Bank-to-Bank alternative came to \$1,169,200, \$1,245,500, and \$1,003,400 respectively. The derivation of boating consumer surplus benefits is presented in Appendix EA-J of the EIS, "Section 312(b) Ecological Restoration/Preservation Analyses."

9.8.3.3 Fishing (Consumer Surplus)

A similar process was followed to derive consumer surplus values associated with boaters who are fishermen. There are 111,313 fishing days originating from Ashtabula Harbor. Most of these occur in Lake Erie. The condition of the river fishery is secondary except that it contributes to the fishing in the lake. High quality habitat in the lacustrary would improve fishing in the lake by providing spawning areas and food sources.

Estimates of Ohio Lake Erie anglers' willingness to pay were placed at \$9.70 per day in October 2000 dollars. The evaluation assumes that the project will improve fishing in such a way that consumer surplus increases 10 percent. The increase can be viewed as both a quality and quantity change. The combination of increased fish populations and varieties, increased interest in fishing, and increased peace of mind when consumption advisories are lifted will improve the quality of the experience for current anglers and attract more anglers to the area. Jakus et al. (1997) found removal of a fishing advisory alone increased anglers' consumer surplus 6 to 8 percent.

The increase in valuation implies a fishing consumer surplus benefit of \$107,974 annually ($\$0.97 \times 111,313$) for current anglers and an additional \$107,971 annually for new anglers ($\$9.70 \times 11,131$) attracted by the higher quality fishing. Total annual maximum consumer surplus values came to \$215,944. This maximum annual surplus value was used to develop a 50-year time stream of fishing consumer surplus benefits for each of the plans evaluated. The analysis used the same assumptions as the boater consumer surplus with respect to number of years needed to achieve full restoration, project length and interest rate.

The present worth value of fishing consumer surplus for the Deep Dredge, the Deep Dredge alternative (the Recommended Environmental Dredging Plan) plus subsequent related aquatic ecosystem restoration measures, and Bank To Bank alternative came to \$2,755,200, \$2,934,800

and \$2,364,600. As the shallow dredge option accomplishes less restoration of the resource, the fishing consumer surplus for the Shallow Dredge was placed at about one-half that of the Deep Dredge alternative (the Recommended Environmental Dredging Plan) plus subsequent related aquatic ecosystem restoration measures. The present worth value of fishing consumer surplus for the Shallow Dredge alternative came to \$1,467,200. A presentation of fishing consumer surplus benefits is presented in Appendix EA-J of the EIS, “Section 312(b) and Section 206 Ecological Restoration/Preservation Analyses.”

9.8.3.4 Passive Use Values (Consumer Surplus)

People often value aspects of the environment even though they will never use or visit those environments. Many people, for example, like the fact that Alaska is largely untouched by human beings even though they themselves will never go there.

The Ohio Sea Grant survey, mentioned earlier asked a series of questions to find Ashtabula county residents’ value for a clean Ashtabula Harbor. The results indicated the lower bound mean annual amount was \$35.27 in October 2000 prices. The valuation question could be interpreted to include both use and non-use values. Some of the measured willingness to pay may have represented anticipated improvements in boating and fishing experiences. For this reason, those households operating boats (26.8 %) those households where the residents were non-boaters (73.2 %). It was assumed the lower bound mean applies to all non-boating households. To obtain the value for households operating boats, the consumer surplus value for boaters of \$9.61 was subtracted from the lower bound mean obtained in the survey (\$35.27). This resulted in a boater consumer surplus value of \$25.66 for boating households.

Given 36,800 households in Ashtabula county, the annual willingness to pay for harbor cleanup for 30 years is \$1,203,200 ($\$1,203,162 = \$35.27 \times 26,938$ plus $\$25.66 \times 9,862$). Again, these maximum annual expenditures were used to develop a 50-year time stream of passive use consumer surplus benefits for each of the plans evaluated. Annual passive use consumer surplus values started at zero and rose to \$1,203,200 based upon the number of years needed to achieve full ecological restoration (3 years, 5 years, and 10 years). All benefits were assumed to accrue yearly for only 30-years, the length of time the contribution would be in effect based upon the survey. Consequently, from project year 31 to 50, passive use consumer surplus benefits were set to zero.

The present worth value of passive use consumer surplus for the Deep Dredge, the Deep Dredge alternative (the Recommended Environmental Dredging Plan) plus subsequent related aquatic ecosystem restoration measures, and Bank To Bank alternative came to \$13,254,300, \$14,254,800 and \$11,077,700. Again, benefits associated with the Shallow Dredge plan was placed at about one-half that of the Deep Dredge Plus Ecological restoration. The present worth value of passive use consumer surplus for the Shallow Dredge plan was \$7,125,700. A presentation of passive use benefits is presented in Appendix EA-J of the EIS, “Section 312(b) and Section 206 Ecological Restoration/Preservation Analyses.”

Actual passive use values may be much larger than those presented. As the concept extends to people who will not use the resource, people distant from the site may hold a passive use value for it. Anyone aware of the river or lake ecosystem may have a value for it. Certainly, vacationers in the region would probably be willing to pay for the river cleanup too. This is considered a conservative estimate of passive use value. Similar studies in other areas have found values in the same range for similar environmental improvements. In a recent report (U.S. EPA, 1995), a survey of studies where both use and non-use values were estimated showed that the ratio of non-use values to use values ranged from .5 to 2.5, depending on whether aesthetic value is considered part of passive use value. Applying this method to the Ashtabula/Conneaut region of Lake Erie, results in a passive use value of \$13 to \$65 per year.

9.8.3.5 Change in Property Values

The value of properties located in an area that contains contaminants, or adjacent to an area that contains contaminants, have been known to fall in value once the pollution effect is widely known. The Ashtabula situation is similar to New Bedford, Massachusetts. In New Bedford, historical industrial areas, which were subject to Superfund cleanups, had left PCB contaminated sediment in the harbor. A study published in 1991 found that “once the pollution effect is widely known the panel models detect a significant reduction in housing values associated with the timing and location of the waste site area [i.e., the harbor]. Affected properties were estimated to have fallen between \$7,000 and \$10,000 (1989 dollars) in value as a result of their proximity to the hazardous wastes in nearby waters.” (Mendelsohn, et al. 1991, page 268-9). The average house price in the New Bedford study area was \$71,630, in 1989 dollars, so the contamination’s effect on housing values was substantial (ranging from 10 to 14 percent). Mendelsohn estimated the total lost value of 4,600 homes at \$35.9 million.

Some geographic area around the Ashtabula River is probably stigmatized by the presence of contaminants in the water. A rough idea of the scale of the possible effect on housing prices can be estimated by applying the 10 percent change in value Mendelsohn found to the value of housing in Ashtabula Harbor. The median sales value of single homes in Ashtabula county in 2000 prices was placed at \$71,500. A 10 percent increase in value would increase the median house value \$7,150. An estimated one thousand housing units are in the affected area, the resulting change in housing value is \$7,150,000.

The other benefits discussed in this section represent annual flows of benefits while the change in housing value is a one-time change in the value of an asset. The Deep Dredging Plan, the Deep Dredge alternative (the Recommended Environmental Dredging Plan) plus subsequent related aquatic ecosystem restoration measures, and Bank To Bank plans would all generate a \$7,150,000 increase in housing value. Again, since the Shallow Dredge plan accomplishes less restoration of the resource, its value was placed at about one-half that of the Deep Dredge alternative (the Recommended Environmental Dredging Plan) plus subsequent related aquatic ecosystem restoration. The present worth value of restored property values for the Shallow Dredge plan was \$3,575,000. A presentation of change in housing value benefits is presented in Appendix EA-J of the EIS, “Section 312(b) and Section 206 Ecological Restoration/Preservation Analyses.”

9.8.3.6 Risk Reduction to Lake Erie Walleye Fishery.

In 1996, 37 percent of all Great Lakes anglers fished in Lake Erie making it the most popular of the Great Lakes for fishing (U. S. Department of the Interior, Fish and Wildlife Service 1997). In all, there were 746,000 anglers who fished in Lake Erie for an estimated 6.7 million days. The most popular species sought in Lake Erie was walleye. The State of Ohio portion of Lake Erie had an estimated 311 thousand anglers fishing for walleye for 1.4 million days. This included both state residents and non-residents going to Ohio to fish. The consumer surplus of the Lake Erie walleye fishery is placed at \$64.4 million annually (6.7 mil. days x \$9.61).

The potential impacts of PCB release from the Ashtabula River to Lake Erie are substantial. It is estimated that a release of 1 to 10 percent of the current PCB load from the Ashtabula River would be enough to increase the level of PCBs in walleye fillets to the point of having States advise sport anglers not to consume walleye from Lake Erie and lead to a closing of the commercial walleye fishery in Lake Erie. The removal of PCB laden sediment from the Ashtabula River will lower the probability of a storm or some other event transferring the PCB mass to Lake Erie.

Lake Erie walleye fishery benefits by plan were calculated by determining the present worth of the walleye fisheries annual consumer surplus (\$64.4 million) over a 50-year project evaluation period. This value was then multiplied by the probability of a 100-year flood event. This resulted in a present worth value of approximately \$15,400,000 . This was then multiplied times the percentage of total PCB's removed under each of the various plans. The present worth of Lake Erie walleye fishery benefits for the Shallow Dredge, Deep Dredge, the Deep Dredge alternative(the Recommended Environmental Dredging Plan) plus subsequent related aquatic ecosystem restoration measures, and Bank-to- Bank plans came to \$11,767,100, \$12,865,300 \$12,865,300 and \$15,375,600 respectively. The development of Lake Erie walleye fishery benefits are presented in Appendix EA-J of the EIS, "Section 312(b) Ecological Restoration/Preservation Analyses."

9.8.3.7 Local Economic Impacts

Allowing the Ashtabula River to shoal to its natural channel depth will have impacts on the local economy, as well as the county. Currently, approximately 150 local area jobs are directly connected to bulk commodities moving through Ashtabula Harbor. Direct Harbor employment is concentrated at Pinney Dock, Sidley Dock and Conrail's coal transshipment facility on the west bank of the Ashtabula River. These local area jobs generate income, which is spent in the area. This expenditure of income locally makes possible the existence of other local jobs in such diverse areas as restaurants, food stores, and local government. The movement of the bulk commodity trade to some other port would mean the loss of these jobs to the local economy. The income generated by these lost jobs would no longer be part of the local area's economy. Job loss could result in part of the local labor force moving to another area to find employment. This could result in a reduction in local government services due to a reduction in local tax revenues (sales tax, property tax, school taxes, etc).

An estimate of the economic impacts on the Ashtabula County economy of losing all jobs associated with commercial navigation, and the fiscal impacts on local governments was developed using a regional general equilibrium model (REGEM). REGEM is a state of the art regional model that projects changes in industry output, intermediate purchases, employment, migration, exports, imports, household consumption, and spending and revenue of governments. The REGEM model was configured with ten industries: agriculture; construction; non-durable goods manufacturing; durable goods manufacturing; water transportation; retail; finance, insurance and real estate; personal services; business services; and miscellaneous services.

Economic and fiscal impacts were developed under Without and With Project conditions. Economic impacts were measured in terms of changes in (1) total county employment, and (2) county gross product (i.e. Net income accruing to households, firms, and local governments.). Fiscal impacts were measured in terms of changes in (1) revenues, and 2, expenditures of local governments in Ashtabula County.

The regional model calculated gross regional product accruing to households, firms, and local governments under the Without and With Project scenario that was used for calculating commercial navigation benefits. Additional gross regional product generated due to the implementation of the project was calculated. The present value of additional gross regional product, over the 50-year evaluation period, was \$64,704,100, using a 6.375% annual interest rate.

This is the value of regional economic impacts associated with retaining all commercial navigation traffic in the harbor. All plans evaluated would generate these level of regional benefits except the Shallow Dredge plan. The Shallow Dredge plan has no Regional Commercial Navigation Benefits. Implementation of the Shallow Dredge plan is not expected to allow open lake disposal of all future dredged sediment. Consequently, maintenance of the Federal channels downstream of the 5th Street Bridge would cease, and the harbors commercial navigation traffic and consequently, commercial navigation jobs would not be retained. The derivation of Regional Economic benefits is presented in Appendix S (Sub-Appendix S2) and Appendix EA-J of the EIS, “Section 312(b) and Section 206 Ecological Restoration/Preservation Analyses.”

9.8.3.8 Boating (Impact of Expenditures on Output)

When the river becomes cleaner, more people will want to go boating on it and those who already boat on it may use it more often. In addition, the project will permit continued maintenance of the recreational channel and so permit larger boats to go farther upriver. Such increased activity leads to increased spending and so stimulates the local economy.

The Feasibility Report estimates a 10 percent increase in quality of the boating experience using a subjective point scale. Assuming a 10 percent increase in quality implies a 10 percent increase in demand for boating trips, there will be 4,770 more boating days per year after the project. This is based upon the existence of 47,700 existing boating days being generated by harbor users. (Reference Section 9.8.3.2 Boating (Consumer Surplus). These 4,770 new boating days corresponds to the additional trips by “new boaters”, assuming there is sufficient capacity for the added demand in Ashtabula Harbor.

The National Survey of Fishing, Hunting, and Wildlife-Associated Recreation is conducted every five years (U. S. Department of the Interior, Fish and Wildlife Service 1997). It collects information about anglers' expenditures, along with a great deal of other information. The survey is conducted to provide valid statistics at the state level. No specific expenditure information is available about people taking fishing trips to Lake Erie. The mean daily expenditures for all anglers using Lake Erie, in October 2000 prices, came to \$64.15. Boaters are assumed to have similar expenditure patterns as anglers except for guide fees, equipment rental, bait, and ice, which relate specifically to fishing. The costs associated with these types of expenditures were subtracted from the mean daily angler expenditures. This resulted in mean daily boater expenditures of \$48.00. This implies an additional \$229,000 in annual spending by boaters attributable to the ecological improvements from the project. These increases in local spending have a ripple effect in the local economy.

The ripple effect was measured using Input-Output Analysis (IO). When someone spends a dollar at a local store, the merchant spends it on something else, perhaps to pay an employee. The employee then spends his wages somewhere else and so generates additional income in the community. The IO analysis contained a model of the local economy which simulated how the boater's dollar circulates through the economy. For this study, the local economic area was defined as Ashtabula, Geauga, and Lake counties. The \$229,000 that boaters are expected to spend annually if the project is completed would add a total of \$329,400 to regional output annually when all of the indirect and induced economic activity is included. The increased spending would generate 5.2 new jobs and \$90,900 in added employment income.

Again, this maximum annual value of \$329,400 was used to develop a 50-year time stream of boating expenditure benefits for each of the plans evaluated. The time stream of these benefits differed from one plan to another based on the number of years needed to achieve full ecological restoration (3 years, 5 years 10 years). These time streams of additional expenditures were converted to present worth values using a 50 year project evaluation period and a 6.375 % annual interest rate. All benefits reflect October 2000 price levels.

The present worth value of boater expenditures for the Deep Dredge, the Deep Dredge alternative (the Recommended Environmental Dredging Plan) plus subsequent related aquatic ecosystem restoration measures, and Bank- to-Bank alternative came to \$3,694,300, \$3,934,300 and \$3,172,100. Again, benefits associated with the Shallow Dredge plan were placed at about one-half that of the Deep Dredge alternative (the Recommended Environmental Dredging Plan) plus subsequent related aquatic ecosystem restoration measures. The present worth value of boater expenditures for the Shallow Dredge plan was \$1,966,800. The derivation of boater expenditure impacts is presented in Appendix EA-J of the EIS, "Section 312(b) and Section 206 Ecological Restoration/Preservation Analyses."

9.8.3.9 Fishing (Impact of Expenditures on Output)

The previous discussion about boating expenditures applies even more strongly to recreational fishing. As the habitat of the river improves, anglers can expect to see a greater number and variety of fish in the harbor and nearby waters. Some of these will be more desirable quarry such as pike, walleye, and salmonids. If the 10 percent improvement in the Feasibility Report

subjective index is reflected linearly in increased fishing activity, there will be 11,131 more fishing days per year when the project is completed. This is based upon the existence of 111,313 existing fishing days being generated by harbor users. (Reference Section 9.8.3.2, Boating (Consumer Surplus)).

Again, Section 9.8.3.8. indicated total average expenditures associated with a day of fishing on Lake Erie are \$64.15 (October 2000 dollars). Multiplying this by the increase in fishing days from the ecosystem restoration (11,131) suggests a \$714,000 increase in local expenditures related to fishing. This implies an additional \$714,000 in annual spending by fishermen attributable to the ecological improvements from the project.

These increases in local spending also have a ripple effect in the local economy. The ripple effect of fishermen spending was calculated using a regional Input Output model. The IO analysis contained a model of the local economy which simulated how the fisherman's dollar circulates through the economy. For this study, the local economic area was defined as Ashtabula, Geauga, and Lake counties. The \$714,000 that fishermen are expected to spend annually if the project is completed would add a total of \$1,026,900 to regional output annually when all of the indirect and induced economic activity is included. The increased spending would generate 16.2 new jobs and \$283,500 in additional employee compensation to the local economy.

Again, this maximum annual value of \$1,026,900 was used to develop a 50-year time stream of fishing expenditure benefits for each of the plans evaluated. The time stream of these benefits differed from one plan to another with respect to when the maximum expenditures would be reached based on the number of years needed to achieve full ecological restoration (3 years, 5 years 10 years). These time streams of additional expenditures were converted to present worth values using a 50-year project evaluation period and a 6.375 % annual interest rate. All benefits reflect October 2000 price levels.

The present worth value of fishermen expenditures for the Deep Dredge, the Deep Dredge alternative (the Recommended Environmental Dredging Plan) plus subsequent related aquatic ecosystem restoration measures, and Bank-to-Bank alternative came to \$11,517,000, \$12,265,200 and 9,888,900. Again, benefits associated with the Shallow Dredge plan were placed at about one-half that of the Deep Dredge alternative (the Recommended Environmental Dredging Plan) plus subsequent related aquatic ecosystem restoration measures. The present worth value of fishermen boater expenditures for the Shallow Dredge plan was \$6,131,600. The derivation of fishermen boat expenditure impacts is presented in Appendix EA-J of the EIS "Section 312(b) and Section 206 Ecological Restoration/Preservation Analyses."

10.0 LOCAL COOPERATION AND REAL ESTATE REQUIREMENTS

10.1 Local Sponsor and Items of Local Cooperation

The Ashtabula City Port Authority has provided a LOI, dated November 2, 2000, accepting the role of Non-Federal sponsor for the project (See Technical Appendix U, "Cost Sharing and Non-Federal Responsibilities"). The Non-Federal sponsor must be a public entity that has the

financial and technical capabilities to coordinate local project activities. The Ashtabula **City** Port Authority will act as the single point of contact for the USACE and undertake the Non-Federal responsibility:

Prior to initiation of construction, a Non-Federal public agency, legally empowered and financially capable under state law, would be required to enter into a Project Cooperation Agreement with the Secretary of the Army to provide the following items of local cooperation:

- a. Provide 35 percent of the separable project costs allocated to environmental dredging and disposal under Section 312(b) of WRDA 1990, as amended by Section 205 of WRDA 1996 and Section 224 WRDA 1999, for the purpose of environmental enhancement and water quality, as further specified below:
 - (1) enter into an agreement, which provides, prior to execution of a project cooperation agreement (PCA) for the project, 25 percent of design costs;
 - (2) provide, during construction, any additional funds needed to cover the Non-Federal share of design costs;
 - (3) provide all lands, easements, and rights-of-way, including suitable borrow and dredged or excavated material disposal areas, and perform or assure the performance of all relocations determined by the Government to be necessary for the construction, operation, and maintenance of the project;
 - (4) provide or pay to the Government the cost of providing all retaining dikes, waste weirs, bulkheads, and embankments, excavation of subsaqueous pits, capping/liner requirements, including all monitoring features and stilling basins, that may be required at any dredged or excavated material disposal areas required for the construction, operation, and maintenance of the project; and
 - (5) Provide, during construction, any additional costs as necessary to make its total contribution equal to 35 percent of the separable project costs allocated to environmental enhancement and water quality.
- b. Provide the Non-Federal share of total project costs allocated to navigation, as further provided below:
 - (1) enter into an agreement which provides, through the execution of the project cooperation agreement, in accordance with the provisions of Section 221 of the Rivers, Harbors, and Flood Control Act of 1970, as amended;
 - (2) provide, during the first year of construction, any additional funds needed to cover the Non-Federal share of design costs;

- (3) provide, during the period of construction, a cash contribution equal to 10 percent of the total cost of construction of the general navigation features (which include the construction of land-based and aquatic dredged material disposal facilities that are necessary for the disposal of dredged material required for project construction, operation, or maintenance and for which a contract for the federal facility's construction or improvement was not awarded on or before October 12, 1996); and
- (4) Pay with interest, over a period not to exceed 30 years following completion of the period of construction of the project, up to an additional 10 percent of the total cost of construction of general navigation features. The value of lands, easements, rights-of-way, and relocations provided by the Non-Federal sponsor for the general navigation features, described below, may be credited toward this required payment. If the amount of credit exceeds 10 percent of the total cost of construction of the general navigation features, the Non-Federal sponsor shall not be required to make any contribution under this paragraph, nor shall it be entitled to any refund for the value of lands, easements, rights-of-way, and relocations in excess of 10 percent of the total cost of construction of the general navigation features;
- c. Provide all lands, easements, and rights-of-way, and perform or ensure the performance of all relocations determined by the Federal Government to be necessary for the construction, operation, maintenance, repair, replacement, and rehabilitation of the general navigation features (including all lands, easements, and rights-of-way, and relocations necessary for dredged material disposal facilities).
- d. Accomplish all removals determined necessary by the Federal Government other than those removals specifically assigned to the Federal Government;
- e. Give the Federal Government a right to enter, at reasonable times and in a reasonable manner, upon property that the Non-Federal sponsor owns or controls for access to the general navigation features for the purpose of inspection, and, if necessary, for the purpose of operating, maintaining, repairing, replacing, and rehabilitating the general navigation features;
- f. Hold and save the United States free from all damages arising from the construction, operation, maintenance, repair, replacement, and rehabilitation of the project, any betterments, and the local service facilities, except for damages due to the fault or negligence of the United States or its contractors;

- g. Keep, and maintain books, records, documents, and other evidence pertaining to costs and expenses incurred pursuant to the project, for a minimum of 3 years after completion of the accounting for which such books, records, documents, and other evidence is required, to the extent and in such detail as will properly reflect total cost of construction of the general navigation features, and in accordance with the standards for financial management systems set forth in the Uniform Administrative Requirements for Grants and Cooperative Agreements to State and local governments at 32 CFR, Section 33.20;
- h. Perform, or cause to be performed, any investigations for hazardous substances as are determined necessary to identify the existence and extent of any hazardous substances regulated under the Comprehensive Environmental Response, Compensation, and Liability Act (CERCLA), 42 U.S.C. 9601-9675, that may exist in, on, or under lands, easements, or rights-of-way that the Federal Government determines to be necessary for the construction, operation, maintenance, repair, replacement, or rehabilitation of the general navigation features. However, for lands that the Government determines to be subject to the navigation servitude, only the Government shall perform such investigation unless the Federal Government provides the Non-Federal sponsor with prior specific written direction, in which case the Non-Federal sponsor shall perform such investigations in accordance with such written direction;
- i. Assume complete financial responsibility, as between the Federal Government and the Non-Federal sponsor, for all necessary cleanup and response costs of any CERCLA regulated materials located in, on, or under lands, easements, or rights-of-way that the Federal Government determines to be necessary for the construction, operation, maintenance, repair, replacement, and rehabilitation of the general navigation features;
- j. To the maximum extent practicable, perform its obligations in a manner that will not cause liability to arise under CERCLA;
- k. Comply with the applicable provisions of the Uniform Relocation Assistance and Real Property Acquisition Policies Act of 1970, Public Law 91-646, as amended by Title IV of the Surface Transportation and Uniform Relocation Assistance Act of 1987, and the Uniform Regulations contained in 49 CFR Part 24, in acquiring lands, easements, and rights-of-way, required for construction, operation, maintenance, repair, replacement, and rehabilitation of the general navigation features, and inform all affected persons of applicable benefits, policies, and procedures in connection with said act;
- l. Comply with all applicable Federal and State laws and regulations, including, but not limited to, Section 601 of the Civil Rights Act of 1964, Public Law 88-352 (42 U.S.C. 2000d), and Department of Defense Directive 5500.11 issued pursuant thereto, as well as Army Regulation 600-7, entitled "Nondiscrimination on the

Basis of Handicap in Programs and Activities Assisted or Conducted by the Department of the Army”;

- m. Provide a cash contribution equal to the Non-Federal cost share of the project’s total historic preservation mitigation and data recovery costs attributable to commercial navigation that are in excess of 1 percent of the total amount authorized to be appropriated for commercial navigation; and
- n. Do not use Federal funds to meet the Non-Federal sponsor’s share of total project costs unless the Federal granting agency verifies in writing that the expenditure of such funds is authorized.

The Non-Federal sponsor will be the permit holder (permittee) for landfill and other necessary permits for project construction. The agent responsible for project implementation will be considered the operator (for purposes of the landfill) and is responsible for overall project (landfill) performance.

The Non-Federal sponsor will be the permit holder (permittee) for landfill and other necessary permits required for project construction. The Federal agent (i.e., USACE) proceeding with and responsible for project implementation will be considered the operator (for purposes of the landfill) and is responsible for overall project (landfill) performance. The agent will advertise/award a contract for actual project construction. The agent usually looks to the contractor responsible for the failed design element to remedy the problem. The Non-Federal sponsor and Federal agent will execute a Memorandum of Agreement (MOA) to delineate the types of permits and information required for those permits up front.

The Ashtabula City Port Authority has been identified a potential Non-Federal sponsor for the aquatic ecosystem restoration under Section 206 of WRDA '96. A Section 206 project will be developed as a separate, but related, project under this authority and will examine, in depth, all aspects including all costs, outputs and justification. Study findings will be presented in a Section 206 report, which will establish cost sharing, Non-Federal responsibilities and all necessary LERRD’s. The project would be implemented after completion of the environmental dredging work.

10.2 Local Sponsorship Agreement

To undertake a navigational project, a written Project Cooperation Agreement, must be executed between the Secretary of the Army and the Ashtabula City Port Authority prior to commencement of construction. The Ashtabula City Port Authority must furnish the assurances required for projects of this nature, including the Non-Federal financial contribution and is also responsible for acquiring all lands, easements, rights-of-way, relocations and dike disposal areas (LERRDs), and for accomplishing Non-Federal construction. The Agreement will establish the working and financial relationship between the parties and will include provisions that hold and save the United States free from damages which may occur as a result of the construction, operation and maintenance of the project.

Implementation of Section 312 WRDA 1990, as amended, will require agreement by the Non-Federal sponsor to provide its share of all costs related to the disposal of contaminated sediment. Under this policy, disposal costs are considered those costs not directly related to removal (dredging), remediation (treatment), and transport of the material to reasonable proximate disposal site(s). In addition, under Section 101 of WRDA 1986, as amended, the costs of dredging, transportation and placement of material into a disposal facility resulting from operation and maintenance of a Federal navigation channel is a 100 percent Federal operation and maintenance cost. Section 312(a) costs for disposal facilities will be cost shared in accordance with Section 101, WRDA 86 while Section 312(b) costs will be cost shared in accordance with Section 312, WRDA 1990, as amended by Section 205, WRDA 96 and Section 224, WRDA 99.

10.3 Real Estate Acquisitions

The Ashtabula River Partnership Plan will require the acquisition of land for the construction of a sediment dewatering/transfer facility and to construct and maintain disposal facilities for dredged river sediments. The Non-Federal Sponsor will not be required to acquire land where the sediment is dredged from the Ashtabula River because Navigation Servitude applies.

An estimated volume of 696,000 cubic yards of contaminated sediments will be removed from the Ashtabula River for the ARP Project and placed in the ARP's upland landfill disposal facility. In addition, sediment from the 1993 Interim Dredging CDF (which has been stored in a confined disposal facility located on the site of the dewatering/transfer facility) will be placed in the ARP's disposal facility. The 1993 Interim Dredging facility consists of approximately 40,000 cu. yds. of dike material and 30,000 cu. yds. of interim dredged material for a total of 70,000 cu. yds. The estimated 30,000 cu. yds. of contaminated dredged material would be disposed of in the ARP Non-TSCA landfill. The relatively clean dike material will likely initially be utilized to construct part of the dewatering facility then later either graded over the transfer/dewatering site or disposed of elsewhere as fill material possibly at the ARP Non-TSCA disposal site.

The dredged sediment will be placed in and transferred by barges to the Ashtabula Norfolk and Southern Yard where the contaminated sediments will be transferred to the dewatering facility. After dewatering trucks will transfer the sediments to permanent confined disposal facilities.

The Real Estate Plan for the Norfolk and Southern locations calls for a five year Temporary Work Area Easement for 10.01-acre area for the dewatering/transfer facility. Of the 10.01 acres, 8.3 acres will be used primarily for the dewatering/transfer facility the area is vacant and the remaining 1.7-acre area is used for access by the Fish City Marina to their docks and Norfolk and Southern to the back of their property. The use of the area does not involve crossing tracks.

The Real Estate Plan for the State Road Industrial Development, LLC site calls for the acquisition of 19.86 acres. A 1.1-acre area is required for a five-year temporary work site. A 0.6-acre area is required for a permanent access road from State Road to a confined disposal facility. A 18.16-acre area in Fee Simple is required for a Non-TSCA dredged material disposal facility.

The Real Estate Plan for the Di Maximus Inc. site calls for the acquisition of 13.89 acres. A 2.6-acre area is required for a TSCA dredged material disposal facility. A 10.39-acre area is required for a five-year temporary work. A 0.90-acre area is required for a permanent access road from State Road to the confined disposal facility.

HTRW and Environmental issues are addressed in Appendix N-1. However if there are concerns or issues they will be resolved before acquisitions will take place.

Corps appraisals were done to determine the value of the required lands, easements, rights-of-way, relocations, and disposal areas (LERRD). The total value of the for the required 43.76 acres including Federal and Non-Federal associated acquisition cost is estimated at \$350,000.00.

A more detailed explanation of the real estate requirements is presented in the Real Estate Plan, Appendix T.

11.0 PROJECT DISCUSSION AND RATIONALE FOR FEDERAL COST-SHARE SUPPORT

11.1 Project Review

The Ashtabula River Partership's actions over the past six years have demonstrated the viability of a cooperative approach that will result in the accomplishment of multiple Federal, state, and local environmental and navigation missions while reducing overall time and costs for all participants. Most significantly, the ARP has coordinated all state and Federal regulators, and has met project milestones on schedule, including river characterization and site selection for a disposal facility. ARP motivation is intense due to a potential for closure of the Port of Ashtabula and the dire economic consequences of such an action on the community and local region.

The driving principal of the Ashtabula River Partnership is the development of a citizen-driven cooperative and voluntary approach to accomplish timely remediation of contaminated sediments in the Ashtabula River and Harbor. Two potential Federal actions have impacted the direction of the ARP's actions:

1. the potential extension of the Fields Brook Superfund Site to include a Superfund designation for the Federal Navigation Channel and Outer Harbor downstream of Fields Brook, creating additional financial liability and uncertainty; and
2. The discontinuance of Operations and Maintenance (O&M) dredging by the U. S. Army Corps of Engineers (USACE) due to the presence of contaminated sediments unsuitable for open-lake disposal and the lack of a Confined Disposal Facility for sediment containment.

The ARP recognized the linkage and impacts of upstream sources of contamination (historically contaminated sediments) and the prohibition of open-lake disposal of navigation channel dredge

sediments. In 1994, the ARP, working with USACE, had identified the Federal navigation interest, which could impact future O&M costs due to contaminated sediments upstream of the Federal navigation channel. The discussions pursuant to the Federal navigation channel have resulted in the budgeting of Federal funding for the development of a feasibility-level remedial action plan study under ARP guidance. Open-lake disposal of future dredged sediments from the Federal navigation channel is a primary goal of the ARP and is a critical project element that justifies Federal participation of the USACE from the perspective of future cost savings.

Tasks leading to submittal of the CMP were funded by a unique mix of Federal and state authorities with other financial commitments, totaling over \$2 million. Funds were made available for the development of the CMP/EIS (\$1,800,000), establishment of an ARP Office and employment of a Project Coordinator (\$250,000) and local resources/personnel being committed to the development of the study.

Development of the ARP's Comprehensive Management Plan (CMP) has identified and coordinated all tasks required prior to detailed design and construction of the landfill(s). Critical tasks have included additional river testing, site selection for the sediment disposal facility, preparation of the Environmental Impact Statement, ecological and human health risk assessments, ecological restoration justification, community outreach and determination of a cost-sharing formula among Federal and Non-Federal parties for facility construction and sediment removal. The USACE participated in this effort by dedicating O&M funding and the first-time use of the WRDA '90 Section 401 authority, cost-shared by the State of Ohio and the Support for Others program funding from USEPA.

To continue with the project and proceed with Phase II, i.e., Preconstruction, Engineering and Design (PED), Ashtabula City Port Authority has been identified as a Non-Federal sponsor. The Ashtabula City Port Authority is a local government entity with all of the authority, capability and responsibility to provide the required items of local cooperation, cost-sharing funds and to accept the Non-Federal project liabilities.

11.2 Justification of Cost Share Formula

The basis for development of the cost-sharing formula is Federal law and associated Congressional guidance as reflected in WRDA 1986, 1990, and 1996. The Ashtabula River Project Area has been divided into two segments (upstream and downstream of the 5th Street Bridge) that are further characterized by applicable Federal authorities and sediment volume, yielding cost percentages assigned to the Federal and Non-Federal project sponsor. Downstream (or north) of the 5th Street Bridge is a portion of the River which has been regularly maintained as a Federal navigation channel. Upstream (or south) of the 5th Street Bridge is that portion of the River from the 5th Street Bridge extending past the Upper Turning Basin to the upper limit of the authorized Federal channel. The aquatic ecosystem restoration features and recommendations set forth in this report (i.e., fishery shelves and habitat restoration) will be addressed separately under Section 206 of WRDA 1996 as an independent project.

11.2.1 Ashtabula River - Downstream of the 5th Street Bridge

- a. Sediment within the Federal navigation channel will be removed to project depth (-18' LWD) at 100 percent Federal cost under general navigation O&M authorities as previously presented in Section 2. Disposal will be cost-shared pursuant to Section 101(a) WRDA`86, as amended by Section 201 WRDA`96: the Non-Federal sponsor will, during construction, pay 10 percent of the cost of the disposal facility for this segment of the work. The Non-Federal sponsor will also provide the lands, easements, rights-of-way and relocations (LERRs) necessary for the landfill(s). The Non-Federal sponsor will also be required to pay an additional 10 percent of the cost of the landfill(s) over a period not to exceed 30 years but with the value of LERRs credited against this additional 10 percent.
- b. Contaminated sediment outside the boundary of the navigation channel is considered to impact regular operation and maintenance of the Federal navigation channel and will be removed at 100 percent Federal cost, per Section 312(a) WRDA`90, as amended by Section 205 WRDA`96. Disposal will be in accordance with Section 312(d) WRDA`90, Environmental Dredging Authority, as amended by Section 205 WRDA`96.

11.2.2 Ashtabula River - Upstream of the 5th Street Bridge

- a. All contaminated sediment upstream of the 5th Street Bridge will be removed under Section 312(b) WRDA`90, as amended by Section 205 WRDA`96 and Section 224, WRDA 99, at 65 percent Federal and 35 percent Non-Federal of the costs of removal and remediation. The non-federal Sponsor will be required to provide LERRDs and retaining dikes, bulkheads, embankments, excavation of subaqueous pits, capping/linear requirements, and maintenance and management of the disposal area.
- b. All of the above environmental actions have been evaluated and are economically Justified as a result of the ecological restoration justification, previously presented in this report, for the purpose of environmental enhancement and water quality improvement in accordance with Section 312(b) WRDA `90 as amended.
- c. Additionally, the ARP notes that Section 205(3) of WRDA`96 directs the Secretary of the Army to give priority in carrying out Section 205 to five localities, including the Ashtabula River, Ohio.

11.2.3 Aquatic Ecosystem Restoration

Based upon the legal sufficiency review of overall project features, scope and purpose, it was determined that the aquatic ecosystem restoration features presented in the “Section 312(b) *and* Section 206 Ecological Restoration/Preservation Analyses” and this report are properly

addressed under the Section 206, WRDA 96, authority. The Section 312 and O&M, General, authorities address the removal and disposal of channel/river sediments but not the implementation of aquatic ecosystem restoration features. It is intended that the further planning and design of the aquatic ecosystem restoration measures be undertaken as an independent, but related, project concurrent with the implementation of the environmental dredging project.

11.3 Cost Sharing Breakdown by Components

Cost-sharing is dependent on guidance received from the USACE, Director of Civil Works in the form of Policy Guidance Letter No. 49 dated 28 January 1998, based upon the WRDA 1996. Cost sharing may be impacted by the classification and volume of sediments regulated by the Toxic Substances Control Act (TSCA), volumes associated with Environmental Dredging (contaminated sediments outside of the Federal channel) and volumes of sediments associated with commercial navigation. An assessment and breakdown of project features and the associated Federal and Non-Federal share of project costs based on sediment classification is presented in Table 11-1.

Cost sharing is based on quantities associated with the different authorities represented in the Recommended Environmental Dredging Plan:

- Downstream of the 5th Street Bridge - O&M lower river dredging (downstream of the 5th Street Bridge) costs are 100 percent Federal \$2,299,000. Disposal costs are 80 percent Federal \$1,538,000 and 20 percent Non-Federal (with credit for LERRs) \$384,000. Dredging costs outside of and adjacent to the channel under Section 312(a) is 100 percent Federal \$1,952,000. Disposal costs for Section 312(a) are 20 percent Non-Federal \$326,000, and 80 percent Federal \$1,306,000.
- Upstream of the 5th Street Bridge - Environmental dredging is cost-shared 65 percent Federal \$13,961,000 and 35 percent Non-Federal \$7,517,000. Disposal costs under Section 312(b) for both TSCA and Non-TSCA sediments is 35 percent Non-Federal \$1,623,000 and \$4,633,000 respectively. In addition, and upon completion of the environmental dredging, the Non-Federal Sponsor will be responsible for 91 percent OMRR&R and the Federal Government 9 percent of the disposal facility.
- Aquatic Ecosystem Restoration - Under Section 206, project features are cost-shared 65 percent, and 35 percent. The study findings for this project will examine, in depth, all aspects including all costs, outputs and justification, which will establish cost sharing, Non-Federal responsibilities and all necessary LERRD's.

Table 11-1: Breakdown of Federal and Non-Federal Cost Sharing of Project Features.

PROJECT FEATURES	FEDERAL	NON-FEDERAL
DREDGING¹		
■ O&M Dredging downstream of the 5 the Street Bridge; total of 62,200 CY Non-TSCA	\$2,299,000.00	\$0.00
■ 312(a) Dredging downstream of the 5 the Street Bridge; total of 52,800 CY Non-TSCA	\$1,952,000.00	\$0.00
■ 312(b) Dredging upstream of the 5 the Street Bridge; total of 581,000 CY of TSCA and Non-TSCA sediments	\$13,961,000.00	\$7,517,000.00
SUBTOTAL	\$18,212,000.00	\$7,517,000.00
DISPOSAL		
■ O&M disposal of 62,200 CY of Non-TSCA sediments (section 101, WRDA 86)	\$1,538,000.00	\$384,000.00
■ Section 312(a) disposal of 52,800 CY of Non-TSCA sediments	\$1,306,000.00	\$326,000.00
■ Section 312(b) disposal of TSCA (150,000 CY) sediments	\$3,014,000.00	\$1,623,000.00
■ Section 312(b) disposal of Non-TSCA (431,000 CY) sediments	\$8,659,000.00	\$4,663,000.00
SUBTOTAL	\$14,517,000.00	\$6,996,000.00
LERRDs		
■ Acquisition Cost	\$0.00	\$261,000.00
■ Administrative Costs	\$43,000.00	\$69,000.00
SUBTOTAL	\$43,000.00	\$330,000.00
TOTAL PROJECT COST SHARE²	\$32,772,000.00	\$14,843,000.00

(1) For purposes of this feasibility CMP/EIS, the costs associated with the dredging, transport, and dewatering of TSCA and non-TSCA sediments are the same.

(2) The total project costs are estimated to be \$47,615,000. However, annual monitoring costs (\$1,301,300) and disposal facility maintenance costs (\$1,307,900) are included in that total. The total construction costs are \$45,005,800.

12.0 CONCLUSIONS AND RECOMMENDATIONS

The CMP recognizes the impairments of beneficial uses in the Ashtabula Area of Concern (AOC), and addresses the goals of the Ashtabula River Partnership: (1) environmental remediation of the lower river; (2) maintenance of an uncontaminated outer harbor-shipping channel by dredging and open-lake disposal. The CMP sets forth a proposed Recommended Environmental Dredging Plan that would address contaminated sediment removal and disposal as well as recommendations for associated, but independent, aquatic ecosystem restoration measures. It is expected that the project will accomplish project incremental goals/objectives and work towards remediation of the six beneficial use impairments identified in the Ashtabula River AOC, thus attaining the goals of the ARP.

Remediation of the contaminated sediments in the Ashtabula River is proposed under the Environmental Dredging Act (Section 312 of the Water Resources Development Act of 1990, as amended by Section 205 of WRDA 96 and Section 224, WRDA 99), following an approach that expedites the remediation and is less costly than other alternatives considered. Upstream of the 5th Street Bridge all cleanup would be performed under Section 312(b), Environmental Restoration and Water Quality. A Section 312(b) Ecological Restoration/Preservation Analysis was conducted as part of the planning process. Downstream of the 5th Street Bridge all cleanup would be achieved under multiple authorities: Section 312(a), O&M General, and Section 101 of WRDA 1986, as amended by Section 201 of WRDA 96. Section 312(a) is the basis for cleanup downstream of the 5th Street Bridge adjacent to the Federal channel. O&M General (dredging and disposal) Section 101 of WRDA 1986 is the basis for accomplishing all river cleanup downstream of the 5th Street Bridge, within the Federal channel. The project was determined to be justified under these authorities.

The Project Area and associated problems were assessed from an ecological perspective. Common problem matters were identified for different areas in the river, and goals and objectives were developed. In addition to considering the No Action scenario, the Ashtabula River Partnership considered a wide array of alternatives pertaining to sediment dredging, aquatic ecosystem restoration, transfer/dewatering, treatment technologies, transportation, and disposal of TSCA and Non-TSCA dredged sediment. Alternatives were assessed for environmental and social acceptability, for engineering and economic feasibility, and for optimizing project objectives. Three alternative dredging scenarios were assessed and evaluated during Plan Formulation: Shallow Dredge, Deep Dredge, and Bank-to-Bank-to-Bedrock Dredging. The assessment identified the Deep Dredge scenario as the optimized and Recommended Environmental Dredging Plan for contaminated sediment removal. The Deep Dredge scenario removes the amount of contaminated sediment consistent with the ARP's goals, moderates costs and adverse impacts, and meets ecological restoration goals for the river. The assessment also identified measures for aquatic ecosystem restoration to be pursued as a separate project, but related component, of the Recommended Environmental Dredging Plan. These measures would be undertaken under the Section 206, or similar, authority.

The Recommended Environmental Dredging Plan involves:

1. dredging (environmentally) of approximately 696,000 cubic yards of contaminated sediments, including up to 150,000 cubic yards that would be handled and disposed of in accordance with Toxic Substances Control Act (TSCA) regulations based upon available dredging technology, marine equipment and levels of PCB contamination;
2. developing and utilizing a transfer/dewatering facility at Norfolk Southern property located between Slip 5A (a.k.a. the Conrail Slip) and the Ashtabula River;
3. transport of the dewatered dredged sediment to a developed upland landfill at the State Road disposal site; and
4. Disposing of the sediment, as appropriate, in the developed upland landfill facilities at the State Road disposal site.

Dredging would be performed by a marine operation utilizing a derrick boat to excavate contaminated sediments with an environmental or enclosed clamshell bucket, or other low turbidity dredge technology. The sediments would be loaded into dredge scows and transported to a transfer/dewatering site. The use of this special clamshell bucket in combination with silt curtains placed around the excavation would minimize the dispersion of resuspended sediments. Environmental protection measures were incorporated into the Recommended Environmental Dredging Plan and will be further addressed in the detailed project design, construction, operation, and maintenance plans to meet Federal, State, and local regulations.

The Recommended Environmental Dredging Plan includes a shoreline transfer/dewatering facility located between Slip 5A (a.k.a. the Conrail Slip) and the Ashtabula River on Norfolk Southern property. The area estimated for the transfer/dewatering facility is between 5 - 10 acres in size and includes the 1993 Interim Dredging and Disposal CDF. All the dredged sediment would be transported by scow to the transfer/dewatering facility staging area where the sediments would be off-loaded, dewatered to meet the legal requirements for containment of no free liquid prior to being final landfilled, and loaded into trucks for transport to the final disposal facility. The transfer/dewatering facility would employ the use of passive technologies for sediment dewatering, and collection and treatment of decant and elutriate water to meet state water quality discharge standards. The Recommended Environmental Dredging Plan includes the use of multi-media filtration and carbon column treatment methods to treat decant and elutriate water.

When project remedial actions are completed, the transfer/dewatering site would be razed and sediment from the 1993 Interim Dredging CDF will be placed in the ARP's disposal facility. The 1993 Interim Dredging facility consists of approximately 40,000 cu. yds. of dike material and 30,000 cu. yds. of interim dredged material for a total of 70,000 cu. yds. The estimated 30,000 cu. yds. of contaminated dredged material would be disposed of in the ARP Non-TSCA

landfill. The relatively clean dike material will likely initially be utilized to construct part of the dewatering facility then later either graded over the transfer/dewatering site or disposed of elsewhere as fill material possibly at the ARP Non-TSCA disposal site.

The Recommended Environmental Dredging Plan includes the use of the State Road site as the upland landfill disposal site for the project. The State Road site has been disturbed by past development and recent demolitions, is of little value to fish and wildlife, and contains a small wetland within the northeast corner of the site that would be avoided. The Fields Brook Superfund remediation project material is being disposed of at the State Road site. There is sufficient site capacity for the Ashtabula River Partnership dredged elevated PCB and RAD material to be disposed of in a new landfill facility adjacent to the Fields Brook disposal facility. There is also sufficient capacity for the Non-TSCA ARP dredged contaminated material to be disposed of in a new landfill facility adjacent to the Fields Brook disposal facility. Assessment/evaluation determined that this is the overall preferred disposal alternative and accordingly is the Recommended Environmental Dredging Plan for the project disposal component. The upland landfill disposal facilities at the State Road site would also include leachate collection, treatment, and monitoring facilities, closure, and post closure monitoring measures.

An alternative plan for contaminated sediment disposal would be the use of existing disposal facilities to store TSCA and/or Non-TSCA classified sediments. The ARP would like to reserve the option whereby the ARP and/or project contractor could dispose of the Non-TSCA dredged sediments in appropriate existing environmentally acceptable disposal facilities, if demonstrated to be substantially more cost-effective. Specifically, dewatered Non-TSCA dredged sediments would be transported to, and disposal of, in an existing solid waste disposal facility that could accept the material under a current or modified permit.

The Ashtabula River Partnership Section 312(b) Sub-Committee evaluated an array of alternatives for dredging and aquatic ecosystem (habitat) restoration to identify optimized plans. The evaluation included use of the Ohio Habitat Assessment Procedure (OHAP) and associated indices. Indicators include such items as; water quality, Qualitative Habitat Evaluation Index (QHEI), Invertebrate Community Index (ICI); the Fishery Index of Biological Integrity (IBI), percent of fish with external anomalies, and the return of endangered species. The procedure and evaluation utilized biological survey data from creeks and rivers similar to the Ashtabula River but without contaminants, bulkheading, or significant vessel traffic. Data primarily from Conneaut Creek and Grand River were used. This comparison provides information on what Ashtabula River ecological conditions would be with various measures for removal of contaminants and habitat restoration. Restoration opportunities were particularly evident in the area between the 5th Street Bridge and the upper turning basin.

The evaluation identified the potential for considerable improvements in physical, benthic, and fishery habitat with extensive contaminant removal and even more with habitat restoration, as possible. Restoration of more than 20 acres of aquatic and fishery habitat, resulting in increases of tens of quality fish species and hundreds of fish per kilometer could be expected. This was further related to human economic values.

The recommendations set forth in the CMP for aquatic ecosystem restoration will not be addressed in the design document for the environmental dredging project. The ARP's environmental dredging project addresses contaminated sediment removal only. It is the intent of the ARP to undertake the recommended aquatic ecosystem restoration measures as an independent, but related, project under the Section 206 (or similar) authority. Presuming funds are available, it is the further intent of the ARP to complete the planning and design of the aquatic ecosystem restoration measures concurrent with the design and implementation of environmental dredging so that when dredging is complete, the aquatic habitat restoration measures would be implemented in the target areas.

Construction of project facilities and operations for implementation of environmental dredging is addressed in the following paragraphs. The project will likely occur over a five-year time frame to include in the first two years contractor mobilization, construction of project facilities (i.e., transfer/dewatering facilities and landfill disposal facilities) and three years for dredging and disposal operations. Aquatic ecosystem restoration, as it is related to this project, will be undertaken as a separate project under the Section 206 (or similar) authority, assuming the availability of Section 206 funds and a Non-Federal sponsor, concurrent with the design and implementation of environmental dredging. Construction of this project would follow completion of the remediation of Fields Brook.

Dredging the Ashtabula River sediments may have short-term negative environmental effects on the river and, to a lesser extent, Ashtabula Harbor and Lake Erie. However, the long-term beneficial impacts far outweigh the adverse effects, most notably environmental remediation and the continuation of commercial shipping and recreational boating. Dredging sediments from the river would eliminate the ability of these contaminants to be resuspended and transported downstream and into Lake Erie. Dredged sediments from operations and maintenance dredging, and/or shoreline excavated sediment discharged into the initially dredged area would provide an immediate clean cover and expedite ecological recovery. Future sediment deposits would be essentially clean and able to support a better variety of benthic organisms, enabling the river to achieve a higher diversity of aquatic species.

The ARP project features addressing environmental dredging will be cost shared between Federal and Non-Federal sources in accordance with the available/pertinent authorities, policies, and guidance's. The Federal and Non-Federal project cost sharing presented herein are those costs apportioned to the different authorities and associated project river segments. The costs are not fixed and will vary with dredging volumes for TSCA and Non-TSCA classified sediments and the distribution within and adjacent to the different river segments/Federal navigation channel.

The total estimated Project Cost, with contingencies, is \$47,615,000¹. The project is estimated to be cost-shared \$32,772,000 Federal and \$14,843,000 Non-Federal, based on project outputs (commercial navigation and environmental restoration), and in accordance with the authorities

¹ Included in these costs were expenditures over the 50-year life of the project for: Disposal Site Post Construction Monitoring (\$1,301,300) and Annual Maintenance Expenditures at the Disposal Site (\$1,307,900).

addressed in the CMP. The Ashtabula City Port Authority has been identified as the project's local sponsor and will provide all the necessary items of local cooperation, including real estate requirements and the collection and distribution from local and private sources of the Non-Federal share of overall project costs. The State of Ohio has pledged \$7,000,000 toward the project. The present worth of the proposed project costs is \$51,319,900. An evaluation of the benefits of completing the ARP Project results in a favorable benefit-cost ratio of 2.66.

The ARP effort has involved a comprehensive planning process, resulting in this CMP that provides a long-term dredging and disposal management plan for future Ashtabula Harbor operations and maintenance needs. Implementation of the project is expected to result in full environmental, economic and social use and development of the lower Ashtabula River and Harbor.

ASHTABULA RIVER PARTNERSHIP

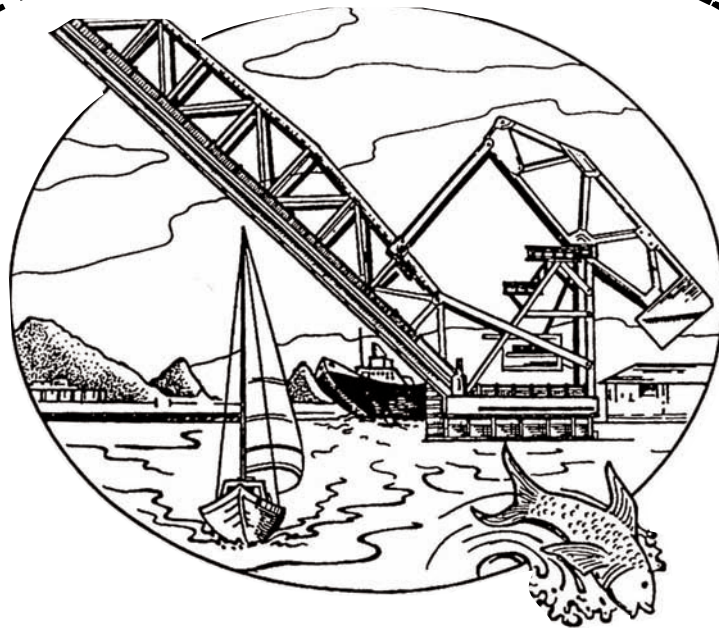

Part of the Solution
Ashtabula River & Harbor • Ashtabula, Ohio
Final

Environmental Impact Statement & Appendices

Comprehensive Management Plan

June 2001

Remedial Actions for Environmental Enhancement and General Navigation, Dredging & Disposal of Contaminated Sediments



OhioEPA



US Army Corps
of Engineers®
Buffalo District



FINAL ENVIRONMENTAL IMPACT STATEMENT

ASHTABULA RIVER AND HARBOR DREDGING AND DISPOSAL ASHTABULA COUNTY, OHIO

The responsible lead agency is the U.S Army Corps of Engineers, Buffalo District. The U.S. Environmental Protection Agency, Region V, is a cooperating agency. The Ohio Environmental Protection Agency is a cooperating agency. The tentatively identified local cooperator is the Ashtabula Harbor Port Authority. Cooperating parties are all the partners of the Ashtabula River Partnership.

ABSTRACT: Ashtabula Harbor is located at the mouth of the Ashtabula River on the south shore of Lake Erie, Ashtabula County, Ohio. The Ashtabula River Partnership (ARP) has investigated problems and needs pertaining to contaminated sediments and disturbed habitat in the Lower Ashtabula River. These conditions have resulted in restricted operations and maintenance dredging and disposal of dredged material and have limited full environmental, economic, and social use and development of the harbor. In addition to considering the No (ARP) Action (Without Project Conditions) alternative, the Ashtabula River Partnership considered a wide array of Plans and Component Alternatives pertaining to Dredging, Habitat Restoration, Transfer/Dewatering/Transfer, Transportation, and Disposal. Plans and Component Alternatives were assessed/evaluated for engineering and economic feasibility, environmental and social acceptability, and/or for best meeting the project planning objectives. The recommended plan involves: 1) deep dredging (environmentally/low turbidity) of approximately 696,000 cubic yards (in situ) of contaminated sediments (150,000 cubic yards of which is significantly PCB contaminated and would (for planning estimates) be handled and disposed of in accordance with Toxic Substance Control Act (TSCA) guidelines), 2) developing and utilizing a transfer/dewatering/transfer facility in the harbor area, 3) trucking the dewatered dredged material to a developed upland disposal site, and, 4) disposing of the material, as appropriate, in the developed TSCA and Non-TSCA disposal facilities. The facilities would also include leachate collection, treatment, and monitoring facilities, and closure, and post closure monitoring measures. The project also recommends restoration (by separate authority) of several acres of aquatic/fishery shallows areas and associated shoreline. Approximately 150,000 cubic yards of operations and maintenance dredged material and/or shoreline excavated material would be discharged in the initially dredged area in order to provide an immediate clean cover and to expedite ecological recovery. Environmental protection measures have been incorporated into the project planning and will be further incorporated into project design, construction, operation, and maintenance plans to meet Federal, State, and local regulations.

THE OFFICIAL CLOSING DATE FOR THE RECEIPT OF COMMENTS IS 30 DAYS FROM THE DATE ON WHICH THE NOTICE OF AVAILABILITY OF THIS FINAL EIS APPEARS IN THE FEDERAL REGISTER.

If you would like further information on this Environmental Impact Statement, contact:

Mr. John Mahan, Coordinator
Ashtabula River Partnership
1123 Bridge Street
Ashtabula, Ohio 44004
Telephone: (440) 964-0277

NOTE: Information, displays, maps, etc. discussed in the Ashtabula Harbor Comprehensive Management Plan Feasibility Report and Appendices may be incorporated by reference in this Environmental Impact Statement.

FINAL ENVIRONMENTAL IMPACT STATEMENT

ASHTABULA RIVER AND HARBOR DREDGING AND DISPOSAL ASHTABULA COUNTY, OHIO

SUMMARY

MAJOR CONCLUSIONS AND FINDINGS

The Lake Erie/Ashtabula River Area of Concern has been identified as a priority area for remediation in Section 205 of the Water Resources Development Act (WRDA) of 1996 and in the U.S. Army Corps of Engineers PGL No. 49 section 5.c. The Ashtabula River Partnership assessed the Ashtabula River Partnership Lower Ashtabula River Remediation Project with regard to Section 312 (b) of WRDA 1990, Environmental Dredging, as Amended by Section 205 and 206 of WRDA 1996, as promulgated by Corps of Engineers Policy Guidance Letter No. 49 and EC 1105-2-210. Also, Section 224 WRDA 1999.

Justification for dredging under the 312(b) and 206 authorities must include a habitat assessment procedure (HAP) analyses. In this case a HAP developed by the State of Ohio Environmental Protection Agency was utilized. Essentially, the HAP analyses utilizes comparative biological field survey data and developed indices to identify problems and to compare existing environments and remedial alternatives. The Ohio Habitat Assessment Procedure (HAP) and assessment/evaluation is presented and discussed in more detail in EIS APPENDIX EA- J SECTION 312(b) AND 206 ECOLOGICAL RESTORATION/ PRESERVATION ANALYSES. (Part of this report. Follows these text). Portions of this appendix are summarized and integrated into portions of this Environmental Impact Statement.

The 312(b) and 206 assessment/evaluation found the project to be justified under the authority. Both ecological and economic total and incremental benefits exceed associated project costs. However, the 312(b) and 206 assessment/evaluation also found that, for both the Dredging (Ecological Restoration/Preservation) for Substrate Contaminant Removal and Supplemental Dredging for Protected Aquatic/Fishery Shallows: 1) substantial ecological and more moderate economic benefits could be realized in the upstream reach from the Fifth Street Bridge upstream through the Upper Harbor area, 2) substantial economic and more moderate ecological benefits could be realized in the reach from the mouth of the River upstream to the Fifth Street Bridge (the large vessel commercial channel reach). Therefore, the latter channel area was examined from an O&M and 312(a) perspective also. The O&M and 312(a) authorities were found to be applicable to that channel area. Substantial ecological and economic benefits (primarily from prevention of outflow of contaminants) could also be realized for the Outer Harbor and immediate Lake Erie area of the Great Lakes.

The recommended project was reviewed per Criteria for Decision Making for Ecological Restoration/Preservation and is found to be: Total and Incrementally Cost Effective, Acceptable to

the Ashtabula River Partnership, Complete, Efficient, Effective, developed and to be implemented in a Partnership Context, and Reasonable in Cost.

Ashtabula Harbor is located at the mouth of the Ashtabula River on the south shore of Lake Erie, Ashtabula County, Ohio. The Ashtabula River Partnership (ARP) has investigated problems and needs pertaining to contaminated sediments and disturbed habitat in the Lower Ashtabula River. These conditions have resulted in restricted operations and maintenance dredging and disposal of dredged material and have limited full environmental, economic, and social use and development of the harbor. In addition to considering the No (ARP) Action (Without Project Conditions) alternative, the Ashtabula River Partnership considered a wide array of Plans and Component Alternatives pertaining to Dredging, Habitat Restoration, Transfer/Dewatering/Transfer, Transportation, and Disposal. Plans and Component Alternatives were assessed/evaluated for engineering and economic feasibility, environmental and social acceptability, and/or for best meeting the project planning objectives. The recommended plan involves: 1) deep dredging (environmentally/low turbidity) of approximately 696,000 cubic yards (in situ) of contaminated sediments (150,000 cubic yards of which is significantly PCB contaminated and would (for planning estimates) be handled and disposed of in accordance with Toxic Substance Control Act (TSCA) guidelines), 2) developing and utilizing a transfer/dewatering/transfer facility in the harbor area, 3) trucking the dewatered dredged material to a developed upland disposal site, and, 4) disposing of the material, as appropriate, in the developed TSCA and Non-TSCA disposal facilities. The facilities would also include leachate collection, treatment, and monitoring facilities, and closure, and post closure monitoring measures. The project also recommends restoration (by separate authority) of several acres of aquatic/fishery shallows areas and associated shoreline. Approximately 150,000 cubic yards of operations and maintenance dredged material and/or shoreline excavated material would be discharged in the initially dredged area in order to provide an immediate clean cover and to expedite ecological recovery. Environmental protection measures have been incorporated into the project planning and will be further incorporated into the project design, construction, operation, and maintenance plans to meet Federal, State, and local regulations.

IRREVERSIBLE COMMITMENT OF RESOURCES

Implementation of the proposed plans would involve the irreversible commitment of Federal, State, and Local funds, energy resources, and construction materials. Confined Disposal Facility construction at the upland site would convert approximately 32 acres of a former industrial site (brownfield) to a disposal area.

Natural Resources (Trustees) Damages. Nothing in this environmental impact statement shall be construed either explicitly or implicitly to irreversibly or irretrievably commit natural resources either directly or indirectly associated with the proposed dredging of the Ashtabula Harbor Channel beyond those areas outside of the area of dredging.

AREAS OF CONTROVERSY

To date, the Ashtabula River Partnership formation and operation have been very cooperative and non-controversial.

Deep dredging (environmentally/low turbidity), transfer/dewatering/transfer, transport, and appropriate disposal of approximately 696,000 cubic yards (in situ) of sediment, (150,000 cubic yards of which is significantly PCB contaminated and would (for planning estimates) be handled and disposed of in accordance with Toxic Substance Control Act (TSCA) guidelines), is a difficult and complex task and understandably leads to some controversy. Some differences of opinions understandably arose over aspects of various Plans and Component Alternatives considered and during assessment/evaluation and trade-off discussions, particularly pertaining to estimated costs and some environmental impact issues. These have been essentially resolved, however, through continued assessment/evaluation and discussion.

Project authorities and associated cost sharing and liability issues have been pursued.

Trucking of the material from the harbor area to the disposal site may present some controversy and will need to be examined further to try to minimize any adverse impacts.

Extensive efforts were and are being made to keep the Press and Public aware of the Ashtabula River Remedial Action Plan and Ashtabula River Partnership activities and planning process and to provide for Public input. There has been little controversy (ie. some concerns relative to those items previously mentioned) from that arena.

UNRESOLVED ISSUES

Hopefully, major project planning issues have been resolved for this phase of planning. Some items which need to be finalized include:

- * Some Alternative Disposal Option items need to be pursued/resolved.
- * Cost sharing and liability items need to be finalized and associated Federal, State, and Local Cooperation Agreements need to be finalized.
- * Trucking of the dewatered dredged material from the harbor area to the disposal site will need to be examined further to try to minimize any adverse impacts.
- * The Final Feasibility and Environmental Impact Statement and Appendices need to be coordinated with agencies, interests, and the public for formal review and comment and comments addressed. A Record of Decision needs to be signed and coordinated.
- * Project Plans and Specifications and Operation and Maintenance Plans need to be finalized. Associated permits need to be obtained.
- * Lands, easements, and rights of way need to be acquired. The project needs to be contracted, constructed, and carried out. Operation and Maintenance Plans need to be implemented.

RELATIONSHIP TO ENVIRONMENTAL PROTECTION STATUTES AND OTHER ENVIRONMENTAL REQUIREMENTS

Summary Tables S1 which follows, briefly summarizes anticipated environmental impacts by assessment/evaluation parameters for final plans considered in detail. These are discussed in more detail in the Comparative Impacts of Alternatives tables at the end of SECTION 2 – CONSIDERED ALTERNATIVES AND THE RECOMMENDED PLAN and in SECTION 4 – ENVI-RONMENTAL EFFECTS of this Environmental Impact Statement.

Summary Table S2, which follows, briefly indicates the relationship of final plans considered in detail to Federal Environmental Protection Statutes, Executive Orders, Memoranda. Reference SECTION 6 - PUBLIC INVOLVEMENT of this Environmental Impact Statement.

TABLE S1 - Comparative Impacts of Final Considered Alternatives

Item	Final Considered Alternative Plans		
	No Action (Without Project Conditions)	Proposed Upland State Road Site Plan	Alternative Disposal Plan
Federal Cost		\$ 31,011,000	
Non-Federal Cost		\$ 13,994,800	
Total First Cost	NA	\$ 45,005,800	NC
Benefits (PW)		\$136,701,000	
Costs (PW)		\$ 51,319,900	
B/C		2.66	

(1) All benefits and Costs reflect a 50 year project life, a 6.375% annual interest rate and October 2000 prices.
 (2) Reference the Feasibility Report and Technical Appendices: Cost Estimating, Cost Sharing, and Economic Analyses for Details.
 (NA)=Not Applicable, (NC)=Not Calculated, (PW)=Present Worth.

Environmental Assessment - Comparative Impacts of Final Considered Alternatives
 ST: = Short Term (i.e., Construction), LT: = Long Term

Evaluation Parameters	Considered Alternatives					
	No Action (Without Project)	Channel Dredging	Transfer/Dewater Harbor Shoreline	Transfer/Dewater Harbor Barge	Upland CDF Development	Existing Landfill (Permitted)
Physical/Natural						
Air Quality	ST: Not Significant LT: Not Significant Migration of contaminated sediments downstream. Dredged/harbor activity limited.	ST: Minor Adverse LT: Not Significant Construction equipment fumes. Some initial dredged material volatilization.	ST: Minor Adverse LT: Not Significant Construction equipment fumes. Some dredged material volatilization.	ST: Minor Adverse LT: Not Significant Construction equipment fumes. Some dredged material volatilization.	ST: Minor Adverse LT: Not Significant Construction equipment fumes. Some initial dredged material volatilization.	ST: Minor Adverse LT: Not Significant Transport equipment fumes. Some initial dredged material volatilization.
Water Quality	ST: Minor Adverse LT: Moderate Adverse Migration of contaminated sediments downstream. Dredging and disposal increasingly limited.	ST: Moderate Adverse LT: Moderate Beneficial Dredging turbidity within the mixing zone. Removal of contaminated sediment from the river.	ST: Minor Adverse LT: Not Significant Construction runoff. Treated discharges.	ST: Minor Adverse LT: Not Significant Construction runoff. Treated discharges.	ST: Minor Adverse LT: Minor Adverse Construction runoff. Treated discharges.	ST: Minor Adverse LT: Minor Adverse Transport runoff. Treated discharges.
Sediment Quality	ST: Moderate Adverse LT: Major Adverse Migration of contaminated sediments downstream. Dredging and disposal increasingly limited.	ST: Moderate Beneficial LT: Major Beneficial Dredging turbidity within the mixing zone. Removal of contaminated sediment from the river.	ST: Minor Adverse LT: Not Significant Construction runoff. Transfer processing. Treated discharges.	ST: Minor Adverse LT: Not Significant Construction runoff. Transfer discharges.	ST: Minor Adverse LT: Minor Adverse Construction runoff. Confined disposal of contaminated material.	ST: Minor Adverse LT: Minor Adverse Placement in CDF. Confined disposal of contaminated material.
Benthos	ST: Moderate Adverse LT: Major Adverse Migration of contaminated sediments downstream. Dredging and disposal restricted.	ST: Minor Adverse LT: Moderate Beneficial Dredging excavation of benthos. Recolonization in cleaner sediments.	ST: Not Significant LT: Not Significant	ST: Not Significant LT: Not Significant	ST: Not Significant LT: Not Significant	ST: Not Significant LT: Not Significant
Fisheries	ST: Minor Adverse LT: Moderate Adverse Migration of contaminated sediments downstream. Dredging and disposal restricted. Wider contamination.	ST: Minor Adverse LT: Moderate Beneficial Dredging turbidity within the mixing zone. Removal of contaminated sediment from the river.	ST: Not Significant LT: Not Significant Transfer operation.	ST: Not Significant LT: Not Significant Transfer operation.	ST: Not Significant LT: Not Significant	ST: Not Significant LT: Not Significant
Vegetation	ST: Minor Adverse LT: Minor Adverse Migration of contaminated sediments downstream. Dredging and disposal limited.	ST: Minor Adverse LT: Moderate Beneficial Dredging excavation of vegetation. Recolonization in cleaner sediments.	ST: Minor Adverse LT: Not Significant Clear and grub about 5 acres of low value vegetation. Grass/legume slope cover. Restoration.	ST: Not Significant LT: Not Significant Use existing docking facilities.	ST: Minor Adverse LT: Not Significant Clear and grub about 32 acres of low value vegetation. Grass/legume slope cover. Restoration.	ST: Not Significant LT: Not Significant Existing development.
Wildlife	ST: Minor Adverse LT: Moderate Adverse Migration of contaminated sediments downstream. Dredging and disposal limited.	ST: Minor Adverse LT: Moderate Beneficial Dredging disruptions. Removal of contaminated sediments from the river.	ST: Not Significant LT: Not Significant Clear and grub about 5 acres of low value habitat. Grass/legume slope cover. Restore.	ST: Not Significant LT: Not Significant Use existing docking facilities.	ST: Not Significant LT: Not Significant Clear and grub about 32 acres of low value habitat. Grass/legume slope cover. Restore.	ST: Not Significant LT: Minor Beneficial Existing development. Eventual fill cover.
Threatened and Endangered Species	ST: Not Significant LT: Not Significant Transient species.	ST: Not Significant LT: Not Significant Transient species.	ST: Not Significant LT: Not Significant Transient species only, no residents.	ST: Not Significant LT: Not Significant Transient species only.	ST: Not Significant LT: Not Significant Transient species only, no residents.	ST: Not Significant LT: Not Significant Existing development.
Wetlands	ST: Minor Adverse LT: Moderate Adverse Migration of contaminated sediments downstream. Contamination.	ST: Not Significant LT: Not Significant Small riparian areas may be impacted.	ST: Minor Adverse LT: Not Significant Small riparian area construction impact.	ST: Not Significant LT: Not Significant Use existing docking facilities.	ST: Minor Adverse LT: Not Significant Small riparian area construction impact.	ST: Not Significant LT: Not Significant Existing development.
General Soils Geology and Ground Water	ST: Minor Adverse LT: Minor Adverse Migration of contaminated sediments downstream. Dredging	ST: Minor Adverse LT: Moderate Beneficial Dredging turbidity and excavation of sediments. Removal of contaminated	ST: Minor Adverse LT: Not Significant Construction disruption. Facility operations. Resoration.	ST: Not Significant LT: Not Significant Use existing docking facilities.	ST: Moderate Adverse LT: Minor Adverse Construction disruption. CDF construction. Containment of	ST: Not Significant LT: Not Significant Existing development containment of

Evaluation Parameters	Considered Alternatives					
	No Action (Without Project) and disposal limited.	Channel Dredging sediment from the river.	Transfer/Dewater Harbor Shoreline	Transfer/Dewater Harbor Barge	Upland CDF Development contaminated sediment	Existing Landfill (Permitted) contaminated sediments.
Human (Man-Made)						
Community and Regional Growth	ST: Moderate Adverse LT: Major Adverse Migration of contaminated sediments downstream. Dredging and disposal restricted. Harbor activity restricted. Associated adverse impacts to the community.	ST: Minor Adverse LT: Major Beneficial Construction, dredging, and disposal operations disruptions. Removal of contaminated sediments from the harbor CDF containment. Harbor O&M.	ST: Minor Adverse LT: Moderate Beneficial Construction, facilities operations, transport disruption. Harbor dredged. Cleaner river sediments. Area restoration.	ST: Minor Adverse LT: Moderate Beneficial Facilities operations transport disruption. Harbor dredged. Cleaner river sediments. Existing docking facilities.	ST: Minor Adverse LT: Moderate Beneficial Construction, dredging, and disposal operations disruptions. Local CDF containment of contaminated sediments. Some O&M disposal capacity. Use lower value land.	ST: Minor Adverse LT: Moderate Beneficial Construction, transfer, transport disruptions. Regional upland CDF disposal of TSCA contaminated sediments. Existing facility.
Displacement of People	ST: Minor Adverse LT: Moderate Adverse Harbor activity restricted. Possible loss of businesses.	ST: Not Significant LT: Not Significant No displacement of residences or developments.	ST: Not Significant LT: Not Significant No displacement of residences or developments.	ST: Not Significant LT: Not Significant No displacement of residences or developments.	ST: Not Significant LT: Not Significant No displacement of residences or developments.	ST: Not Significant LT: Not Significant Existing facility.
Displacement of Farms	ST: Not Significant LT: Not Significant	ST: Not Significant LT: Not Significant	ST: Not Significant LT: Not Significant No farmland.	ST: Not Significant LT: Not Significant	ST: Not Significant LT: Not Significant No farmland.	ST: Not Significant LT: Not Significant Existing facility.
Business/Industry Employment/Income	ST: Moderate Adverse LT: Major Adverse Migration of contaminated sediments downstream. Dredging and disposal restricted. Harbor activity restricted. Possible loss of businesses.	ST: Minor Adverse LT: Major Beneficial Construction, dredging, and disposal operations and costs. Removal of contaminated sediments from the harbor CDF containment. Harbor O&M.	ST: Minor Beneficial LT: Minor Beneficial Construction, facilities operation work, disruption. Costs. Harbor dredged. Area restoration.	ST: Minor Beneficial LT: Minor Beneficial Use existing facilities. Facilities operation work, disruption. Costs. Harbor dredged.	ST: Minor Beneficial LT: Moderate Beneficial Construction, dredging, and disposal operations. Costs. Removal of contaminated sediments from the harbor. CDF containment. Harbor O&M.	ST: Minor Beneficial LT: Moderate Beneficial Construction, transfer, transport, disposal operations. Cost. Regional up-land CDF Containment of TSCA contaminated sediment. Existing facility.
Public Facilities and Services	ST: Moderate Adverse LT: Major Adverse Migration of contaminated sediments downstream. Dredging and disposal restricted. Harbor activity restricted. Possible loss of businesses.	ST: Minor Adverse LT: Moderate Beneficial Construction, dredging, and disposal operations needs. Removal of contaminated sediments from the harbor. CDF containment. Harbor O&M.	ST: Minor Adverse LT: Not Significant Construction and facilities operation needs. Transport impacts. Harbor dredged. Area restoration.	ST: Minor Adverse LT: Not Significant Use existing facilities. Facilities operation work, disruption. Costs. Harbor dredged.	ST: Minor Adverse LT: Moderate Beneficial Construction, dredging, and disposal operations needs. Local CDF containment facility. Some O&M disposal capacity. Serves harbor O&M.	ST: Minor Adverse LT: Moderate Beneficial Construction, transfer, transport, disposal operation needs. Regional up-land TSCA facility. Existing facility.
Recreation	ST: Moderate Adverse LT: Major Adverse Migration of contaminated sediments downstream. Dredging and disposal restricted. Contamination wider. Possible lose marina activity/businesses.	ST: Minor Adverse LT: Major Beneficial Construction, dredging, and disposal operations disruptions. Removal of contaminants from the harbor. CDF containment. Harbor O&M.	ST: Minor Adverse LT: Minor Beneficial Construction and facilities operation disruptions. Harbor dredged. Cleaner river sediments. Area restoration.	ST: Minor Adverse LT: Minor Beneficial Construction and facilities operation disruptions. Harbor dredged. Cleaner river sediments. Existing facility.	ST: Minor Adverse LT: Minor Adverse Construction and disposal operations disruptions. Local DCF containment of contaminated sediments. Grass/legume cover. Use lower value land.	ST: Not Significant LT: Not Significant Existing facility.
Property Value and Tax Revenue	ST: Moderate Adverse LT: Major Adverse Migration of contaminated sediments downstream. Dredging and disposal restricted. Harbor activity restricted. Possible loss of business/tax.	ST: Minor Adverse LT: Minor Beneficial Construction, dredging, and disposal operations and costs. Removal of contaminated sediments from the harbor CDF containment. Harbor O&M.	ST: Minor Adverse LT: Minor Beneficial Construction and facilities operation and costs. Use interim disposal area. Area restoration.	ST: Not Significant LT: Not Significant Use existing docking facilities. Facilities operation and costs.	ST: Minor Adverse LT: Minor Adverse Construction and disposal operations and costs. Local CDF containment of contaminated sediments. Grass/legume cover. Use lower value land.	ST: Minor Adverse LT: Not Significant Construction, transfer, transport, and disposal operations and costs. Regional TSCA upland CDF. Existing facility.
Noise and Aesthetics	ST: Minor Adverse LT: Moderate Adverse Migration of contaminated sediments downstream. Dredging and disposal restricted. Harbor activity restricted. Possible loss of business and delapidations.	ST: Moderate Adverse LT: Minor Beneficial Construction, dredging, and disposal operations disruptions. Removal of contaminated sediments from the harbor. CDF containment. Harbor O&M.	ST: Moderate Adverse LT: Not Significant Construction and facilities operation disruptions. Transport disruptions. Area restoration.	ST: Moderate Adverse LT: Not Significant Use existing docking facilities. Facilities operation disruptions. Transport disruptions.	ST: Moderate Adverse LT: Minor Adverse Construction and disposal operations disruptions. Local CDF containment of contaminated sediments. Grass/legume cover. Use lower value land.	ST: Minor Adverse LT: Not Significant Construction, transfer, transport, and disposal operations disruptions. Regional TSCA upland facility. Existing facility.
Community Cohesion	ST: Moderate Adverse LT: Major Adverse Migration of contaminated sediments downstream. Dredging and disposal restricted. Harbor activities restricted. Associated adverse impacts to the community.	ST: Minor Adverse LT: Moderate Beneficial Construction, dredging, and disposal operations disruptions. Removal of contaminated sediments from the harbor. CDF containment. Harbor O&M.	ST: Minor Adverse LT: Moderate Beneficial Construction, facilities operations, transport disruption. Harbor dredged. Cleaner river sediments. Area restoration.	ST: Minor Adverse LT: Moderate Beneficial Facilities operation transport disruption. Harbor dredged. Cleaner river sediments. Existing docking facilities.	ST: Minor Adverse LT: Minor Adverse Construction and disposal operations disruptions. Local CDF containment of contaminated sediments. Use lower value land.	ST: Minor Adverse LT: Minor Adverse Construction, transfer, transport, and disposal operations disruptions. Regional TSCA upland facility. Existing facility.
Cultural Resources	ST: Not Significant LT: Not Significant None identified in the dredging areas.	ST: Not Significant LT: Not Significant None identified in the dredging areas.	ST: Not Significant LT: Not Significant None identified in the interim disposal site area.	ST: Not Significant LT: Not Significant Use existing docking facility.	ST: Not Significant LT: Not Significant None identified in the site area.	ST: Not Significant LT: Not Significant Existing facility.

Summary Table S2 - Relationship of Plans to Environmental Protection Statutes and Other Environmental Requirements.

<u>Federal Statutes</u>	<u>Plan Compliance</u>	
	<u>Upland State Road Site</u>	<u>Alternative Disposal</u>
*Historical and Archaeological Data Preservation Act, 16 USC 649, et seq.	N/A	N/A
*National Historic Preservation Act, 16 USC 470 et seq.	Full	Full
*Clean Air Act, 42 USC 7401 et seq.	Full	Full
*Clean Water Act (Water Pollution Control Act) 33 USC 1251 et seq.	Full	Full
*National Environmental Policy Act, 42 USC 4321 et seq.	Full	Full
*Fish and Wildlife Coordination Act, 16 USC 661 et seq.	Full	Full
*Endangered Species Act, 16 USC 1531 et seq.	Full	Full
*Estuary Protection Act, 16 USC 1221 et seq.	N/A	N/A
*Marine Protection Research and Sanctuaries Act, 16 USC 1401, et seq.	N/A	N/A
*Rivers and Harbors Act, 33 USC 401 et seq.	Full	Full
*Water Resources Development Act(s)	Full	Full
*Water Resources Planning Act, 42 USC 1962 et seq.	Full	Full
*Federal Water Project Recreation Act, 16 USC 4601-12 et seq.	Full	Full
*Land and Water Conservation Fund Act, 16 USC 4601-4	Full	Full
*Wild and Scenic Rivers Act, 16 USC 1271 et seq.	Full	Full
*Coastal Zone Management Act, 16 USC 1451 et seq.	Full	Full
*Watershed Protection and Flood Prevention Act, 16 USC 1001 et seq.	Full	Full
*Farmland Protection Policy Act, 7 USC 4201 et seq.	Full	Full
<u>Hazardous, Toxic, Radioactive Waste (HTRW) (Legislation/Regulations)</u>		
*Resource Conservation and Recovery Act (RCRA), 1976, 42 USC 6901 et seq.	Full	Full
*Hazardous and Solid Waste Amendments (HSWA), 1984.	Full	Full
*Comprehensive Environmental Response, Compensation, and Liabilities Act (CERCLA or SUPERFUND), 1980, 42 USC 9601 et seq.	Full	Full
*Superfund Amendments and Reauthorization Act (SARA) 1986.	Full	Full
*Toxic Substance Control Act (TSCA), 1976, 15 USC 2601.	Full	Full
*Pollution Prevention Act, 1990, 42 USC 13101 et seq.	Full	Full

Executive Orders, Memoranda, etc.

*Protection and Enhancement of Environmental Quality (EO 11514).	Full	Full
*Protection and Enhancement of the Cultural Environment (EO 11591).	Full	Full
*Flood Plain Management (EO 11988).	Full	Full
*Protection of Wetlands (EO 11990).	Full	Full
*Environmental Effects Abroad of Major Federal Actions (EO 12114).	Full	Full
*Analysis of Impacts on Prime and Unique Farmlands (CEQ Memorandum, 30 August 76).	Full	Full
*Federal Compliance with Pollution Control Standards (EO 12088).	Full	Full
*Superfund Implementation (EO 12580).	Full	Full
*Federal Compliance with Right to Know laws and Pollution Prevention Requirements (EO 128856).	Full	Full
*Environmental Justice	Full	Full

Ohio State Environmental Protection

*Ohio State Administrative Code		
-Title 3745 - Environmental Protection Agency	Full	Full
-Clean Water Act 401 Certification	Full	Full
-State Pollution Discharge Elimination System	Full	Full
-Permit to Install	Full	Full
-Solid Waste Disposal Regulations	Full	Full
*Ohio Revised Code		
-Hazardous Waste and Solid Waste Laws	Full	Full
-Water Pollution Control Laws	Full	Full
* Ohio Department of Health (RAD)	Full	Full
*State Coastal Management Program Consistency Determination	Full	Full

Local Land Use Plans

*Ashtabula County Solid Waste Disposal Facility (Siting Criteria)	Full	Full
*Town of Ashtabula Local Land Use Plans	Full	Full

Compliance categories used in this table were assigned based on the following definitions:

- Full Compliance - All requirements of the statute, EO, or other policy and related regulations have been met for this stage of the study.
- Partial Compliance - Some requirements of the statute, EO, or other policy and related regulations, which are normally met by this stage of the study, remain to be met.
- Non compliance - None of the requirements of the statute, or EO, or other policy and related regulations have been met.
- N/A - The statute, EO, or other policy and related regulations are not applicable for this study.

SUMMATION (CUMMULATIVE EFFECTS) ASSESSMENT

Dredging the Ashtabula River sediments will have short-term detrimental effects on the river and to a far lesser extent, Ashtabula Harbor and Lake Erie. However, the long-term beneficial impacts should far outweigh the adverse effects. Dredging the sediments from the river will remove those contaminants associated with the sediments from the aquatic ecosystem. This will eliminate the ability of these contaminants to be resuspended and transported down river and into Lake Erie. Future sediment deposits should be essentially clean and would be able to support less pollution tolerant benthic organisms. This would enable the river and lake to achieve a higher diversity of aquatic species.

It is expected that within several years of project implementation sediment and benthos quality will be improved markedly; and, that within another few years the area fishery will be improved markedly. It is expected that the project will accomplish project incremental goals/objectives and work towards remediation of the six beneficial use impairments identified with the exception of limitations along the commercial channel area. This will work towards remediation of one of the 42 Great Lakes Areas of concern. The Lake Erie/Ashtabula River Area of Concern has been identified as a priority area for remediation in Sections 205 and 515 of WR-DA 96 and in the U.S. Army Corps of Engineers PGL No. 49 section 5. c. Several monitoring programs will be conducted within five to ten years of project completion to assess/evaluate this.

The recovery of the Ashtabula lacustrine fish community is expected to influence fish communities in surrounding areas both upstream and in the lake. Species such as northern pike (*Esox lucius*) and muskellunge (*Esox masquinongy*) moderate fish communities through predation and drive community structure towards greater ecological integrity. Greater ecological integrity results in even higher numbers of top carnivores, endangered species and sensitive species. Historically, the muskie and northern pike were very abundant and commercially important. The destruction of lacustrine habitats throughout Lake Erie has resulted in drastic reductions of the two species' populations and the positive influences they had on the Lake's ecosystem. The restoration of the Ashtabula lacustrine will allow it to resume its historic contribution to top carnivore populations (including northern pike and muskellunge).

Species listed as sensitive can all be expected to increase in numbers after sediment removal and a consequent influx of clean sediment from upstream areas. Species presently not found in the Ashtabula but found in the Grand and Conneaut will return to the Ashtabula. The sensitive species that are absent from the Ashtabula represent all trophic levels of the fish community. Ecosystems cannot function with such large components missing.

The ecosystem of the open waters of Lake Erie is presently experiencing dramatic recovery of its fish community. This recovery is expected to continue with further recovery of additional species. The removal of contaminated sediments will prepare the Ashtabula for the possible entrance of species such as: lake sturgeon (*Acipenser fulvescens*), mooneye (*Hiodon tergisus*), muskellunge (*Esox masquinongy*), pugnose shiner (*Notropis anogenus*), longnose sucker (*Cutostomus cutostomus*), lake chubsucker (*Erimyzon sucetta*), creek chubsucker (*Erimyzon oblongus*), tad-pole madtom (*Noturus gyrinus*), burbot (*Lota lota*); and possibly: pugnose minnow (*Opsopoeodus emiliae*), blackchin shiner (*Notropis heterodon*), blacknose shiner (*Notropis heterolepis*), banded killifish (*Fundulus diaphanus*), and sand darter (*Ammocrypta pellucida*) into the system. Some of these species (burbot, lake sturgeon, muskellunge and sand darter)

are already showing signs of recovery in the lake. Areas such as the Ashtabula lacustrine are an important component of these species life history. Full recovery of the above listed species will depend on the environmental quality of Lake Erie's lacustrine habitats.

The speed and degree of ecological recovery in the Ashtabula River lacustrine will depend on the rate of sedimentation. Near shore depths of two to ten feet are ideal for healthy fish communities and the aquatic plants they depend upon. The influx of clean sediments from upstream areas will eventually occur, and active intervention in the form of replacing dredged sediments with clean sediments will greatly enhance the process.

Aquatic/fishery shelves would expedite recovery and constitutes ecological restoration, as possible, for loss of protected aquatic/fishery shallows due to facilitated structural (i.e. bulk-heading, channelization), and activities impacts. These are practical optimized plans of moderate cost providing problem area protected aquatic/fishery shallows of substantial length which accomplish, as possible, goals/objectives, in this regard. The areas would be interfaced with the lake/river regime and would soon provide passage, cover, feeding, and spawning habitat.

It is clear that little improvement will occur if contaminated sediments are not removed. Present Ohio EPA fish community data show declining trend of IBI values at RM 1.3 of the Ashtabula River. It is possible that this trend could continue, resulting in still lower quality fish communities in the future. There is further concern that without the project, shipping could shift from the Ashtabula area to Conneaut Harbor. This will result in a greater degree of environmental disturbance to Conneaut and will negatively impact fish communities. With impacts to both the Ashtabula and Conneaut fisheries lower quality fish communities will result in the Central Basin. The last three large Central Basin south shore tributaries and associated lacustrines are the Grand, Ashtabula and Conneaut (from west to east). Numerous Central Basin fish stocks require these areas for reproductive purposes. Restoration of the Ashtabula will not only enhance Central Basin fish stocks but will also prevent their further decline.

Implementation of the project would work toward restoration of the integrity of the harbor from the environmental, economic, and social perspectives. It also provides a plan for future harbor operations and maintenance needs. It would substantially benefit community and regional sustenance and growth needs.

CONTINUED HARBOR OPERATION AND MAINTENANCE DREDGING AND DISPOSAL

Harbor channel sediments will continue to be sampled and analyzed in accordance with applicable sampling and analysis guidelines. It is expected that post project dredged sediments will be suitable for unrestricted open-lake disposal at the open lake disposal site. If, however, some dredged sediments may not be suitable for unrestricted open lake disposal, it is expected that these latter dredged sediments would be dredged and dewatered utilizing marine based dewatering facilities and then transferred/transported to a low bidder upland disposal site for disposal or to beneficial use sites. Other alternatives may be reassessed in the future. It is expected that all of the sediments in the future may be dredged and transported by conventional methods.

ASHTABULA HARBOR LONG-TERM MANAGEMENT PLAN

The U.S. Environmental Protection Agency and the Ohio Environmental Protection Agency and the U.S. Natural Resources Conservation Service are engaged in various best management programs relative to pollution and sedimentation control. These will serve to minimize contaminated sediments and the amount of sediments needed to be dredged from navigation channels in the future.

In recent years, with thoughts to limit open lake disposal of dredged material and the proliferation of construction of dredged material confined disposal facilities (CDFs), considerable consideration is being given to beneficial use of dredged material. Beneficial use considerations include, use for:

- * Landfill Cover
- * Construction Fill Material
- * Manufactured Soils Viability and Market (ie. dredged material, sludge, kiln mix)
- * Environmental Restorations (ie. cover, wetlands, islands, peninsulas, etc.)
- * Landscaped Lands (ie. parks, ski/sled hills, wildlife areas)
- * Interception/Redistribution (ie. catch settling basins, redistribution to Regional/County/Town distribution centers, redistribution to farmlands, etc.)

Several of these beneficial uses show some promise and could be considered for Ashtabula Harbor some time in the future.

Considering PCB contamination levels, currently, the acceptable guideline level (per USEPA and OEPA) for PCBs in dredged material and/or manufactured soils for land applications is < 1 ppm, which may be reached by mixing (Based on Toledo Harbor Long-Term Management Plan pilot study information). Subject to review and approval. Higher concentrations may be acceptable in other applications (ie. landfill cover). Other parameters and regulations would also need to be considered and met.

Although some after project dredging exposed sediments may have about 1 to 10 ppm PCB concentrations, cover sediments and material dredged in the future from Ashtabula Harbor should have very low contaminant levels and should be suitable for either open-lake disposal or for beneficial use, should it prove to be economically feasible. Therefore, in addition to the expected long-term harbor maintenance dredging and open-lake disposal, other long-term considerations may include, for example:

- * Sediment maintenance dredging and dewatering via waterbased (ie. barge) facilities with direct barge transport to, or harbor area transfer/transport to identified beneficial use sites.
- * Sediment maintenance dredging and dewatering via developed harbor area facilities and transfer/transport to identified beneficial use sites.

Ashtabula Harbor currently has no sediment dewatering or suitable/economical dredged material confined disposal facilities.

FINAL ENVIRONMENTAL IMPACT STATEMENT

**ASHTABULA RIVER AND HARBOR DREDGING AND DISPOSAL
ASHTABULA COUNTY, OHIO**

ABSTRACT

SUMMARY

TABLE OF CONTENTS

<u>DESCRIPTION</u>	<u>PAGE</u>
SECTION 1 - NEED FOR AND OBJECTIVES OF THE ACTION	1
INTRODUCTION	1
STUDY AUTHORITIES	1
PROBLEMS, NEEDS, GOALS/OBJECTIVES (PURPOSE)	2
SECTION 2 - ALTERNATIVE CONSIDERATIONS AND THE RECOMMENDED PLAN	9
INTRODUCTION	9
WITHOUT PROJECT CONDITIONS (NO ARP ACTION)	9
ALTERNATIVE CONSIDERATIONS AND RECOMMENDED PLAN	10
RECOMMENDED PLAN	23
IRREVERSIBLE COMMITMENT OF RESOURCES	28
REAL ESTATE	42
MONITORING	42
ALTERNATIVE DISPOSAL PLAN	43
COMPARATIVE IMPACTS OF FINAL CONSIDERED ALTERNATIVES	44
CONTINUED HARBOR OPERATION AND MAINTENANCE DREDGING AND DISPOSAL	51

<u>DESCRIPTION</u>	<u>PAGE</u>
ASHTABULA HARBOR LONG-TERM MANAGEMENT PLAN	51
SECTION 3 - ENVIRONMENTAL SETTING AND AFFECTED ENVIRONMENT	53
INTRODUCTION	53
GENERAL ENVIRONMENTAL CONDITIONS	53
SIGNIFICANT RESOURCES	57
PHYSICAL/NATURAL ENVIRONMENT (RESOURCES) - ECOLOGICAL SETTING	57
HUMAN ENVIRONMENT (MAN-MADE RESOURCES) - HARBOR AND VICINITY	105
CULTURAL RESOURCES	118
POTENTIAL TRANSFER/DISPOSAL SITE – GENERAL INFORMATION	122
SECTION 4 - ENVIRONMENTAL EFFECTS	127
INTRODUCTION	127
PROJECT ECONOMIC COSTS/BENEFITS (TABLES)	128
PHYSICAL/NATURAL ENVIRONMENT (RESOURCES)	131
HUMAN ENVIRONMENT (MAN-MADE RESOURCES)	155
CULTURAL RESOURCES	163
BORROW AREA IMPACT ASSESSMENT STATEMENT	163
IRREVERSIBLE COMMITMENT OF RESOURCES	164
SUMMATION (CUMMULATIVE EFFECTS) ASSESSMENT	164
SECTION 5 - LIST OF PREPARERS	167

<u>DESCRIPTION</u>	<u>PAGE</u>
SECTION 6 - PUBLIC INVOLVEMENT	169
INTRODUCTION	169
PUBLIC INVOLVEMENT PROGRAM	169
REQUIRED PLANNING AND NATIONAL ENVIRONMENTAL POLICY ACT (NEPA) COORDINATION AND COMPLIANCE	170
STATEMENT RECIPIENTS	183
PUBLIC VIEWS AND RESPONSES	185

ENVIRONMENTAL APPENDICES

EA-A	INDEX AND REFERENCES
EA-B	CLEAN WATER ACT PUBLIC NOTICE AND SECTION 404(b)(1) EVALUA- TION REPORT (Pertains to State 401 Certification, and N/SPDES and PTI Permits, also.)
EA-C	ENVIRONMENTAL RISK MANAGEMENT CONSIDERATIONS FOR THE ASHTABULA RIVER AND HARBOR (Chemistry and Radionuclides)
EA-D	U.S. FISH AND WILDLIFE COORDINATION ACT REPORT
EA-E	PRELIMINARY WETLAND DETERMINATIONS
EA-F	BOTULISIM CONTROL PLAN
EA-G	COASTAL MANAGEMENT CONSISTENCY DETERMINATION
EA-H	CULTURAL RESOURCES ASSESSMENT
EA-I	ENVIRONMENTAL JUSTICE
EA-J	SECTION 312(b) AND 206 ECOLOGICAL RESTORATION/PRESERVATION ANALYSES
EA-K	REQUIRED ENVIRONMENTAL CORRESPONDENCE
EA-L	COMMENTS/RESPONSES ON THE DRAFT FEASIBILITY AND EIS REPORTS

SECTION 1 - NEED FOR AND OBJECTIVES OF THE ACTION

INTRODUCTION

1.01 This section briefly summarizes Study Authorities, Problems, Needs, and Goals/Objectives (Purpose).

STUDY AUTHORITIES

1.02 This study is being conducted under the authority of the U.S. Rivers and Harbors Act from 1919 to 1965, as amended, as it pertains to Ashtabula Harbor; authorities associated with the Ashtabula River Partnership (ARP); and Section 401 of the 1990 Water Resources Development Act (WRDA) pertaining to technical assistance to OEPA to develop an Ashtabula River Remedial Action Plan (RAP).

1.03 The Ashtabula River Partnership assessed the Ashtabula River Partnership Lower Ashtabula River Remediation Project with regard to Section 312 (b) of the Water Resources Development Act of 1990, Environmental Dredging, as Amended by Section 205 and 206 of the Water Resources Development Act of 1996, as promulgated by Corps of Engineers Policy Guidance Letter No. 49 and EC 1105-2-210. Also, Section 224 WRDA 1999.

1.04 Justification for dredging under the 312(b) and 206 authorities must include a habitat assessment procedure (HAP) analyses. In this case a HAP developed by the State of Ohio Environmental Protection Agency was utilized. Essentially, the HAP analyses utilizes comparative biological field survey data and developed indices to identify problems and to compare existing environments and remedial alternatives. The Ohio Habitat Assessment Procedure (HAP) and assessment/evaluation is presented and discussed in more detail in EIS APPENDIX EA- J SECTION 312(b) AND 206 ECOLOGICAL RESTORATION/ PRESERVATION ANALYSIS. (Part of this report. Follows these text). Portions of this appendix are summarized and integrated into portions of this Environmental Impact Statement.

1.05 The 312(b) and 206 assessment/evaluation found the project to be justified under the authority. Both ecological and economic total and incremental benefits exceed associated project costs. However, the 312(b) and 206 assessment/evaluation also found that, for both the Dredging (Ecological Restoration/Preservation) for Substrate Contaminant Removal and Supplemental Dredging (Ecological Restoration/Preservation) for Protected Aquatic/Fishery Shallows measures: 1) substantial ecological and more moderate economic benefits could be realized in the upstream reach from the Fifth Street Bridge upstream through the Upper Harbor area, and 2) substantial economic and more moderate ecological benefits could be realized in the reach from the mouth of the River up to the Fifth Street Bridge (the large vessel commercial channel reach). Therefore, the latter channel area was examined from an O&M 312(a) perspective also. The O&M and 312(a) authorities were found to be applicable to that channel area. Substantial ecological and economic benefits (primarily from prevention of outflow of contaminants) could also be realized for the Outer Harbor and immediate Lake Erie area of the Great Lakes.

1.06 The project was reviewed per Criteria for Decision Making for Ecological Restoration/ Preservation and is found to be: Total and Incrementally Cost Effective, Acceptable to the Ashtabula River Partnership, Complete, Efficient, Effective, developed and to be implemented in a Partnership Context, and Reasonable in Cost.

PROBLEMS, NEEDS, AND GOALS/OBJECTIVES (PURPOSE)

1.07 Ashtabula Harbor is located at the mouth of the Ashtabula River on the south shore of Lake Erie, Ashtabula County, Ohio. It is a significant Great Lakes and St. Lawrence Seaway harbor. It is situated among the significant water and ecological resources of the Great Lakes, Lake Erie, and the Ashtabula River Watershed. Reference Figures 1.1 and 1.2. The Harbor (including the lower Ashtabula River) includes both commercial and recreational developments. Commodities, such as limestone, iron and other ores, coal and other bulk commodities, pig iron, iron products, raw rubber, and general cargo, transit the harbor. Several marina developments docking hundreds of recreational vessels are situated along the lower river and harbor.

1.08 Over the years, run-off from urban and primarily industrial developments have resulted in the contamination of water and sediments in adjacent streams (i.e. Fields Brook) and the lower Ashtabula River.

1.09 The lower Ashtabula River has been identified as a Great Lakes Area of Concern by the International Joint Commission. The Area of Concern has been designated as the lower two miles of the Ashtabula River, including Fields Brook, and the nearshore areas of Lake Erie.

1.10 Fields Brook has been placed on the USEPA National Priorities List of uncontrolled hazardous waste sites (Superfund), and is being remediated under that authority. Remediation must be completed before this project action is implemented.

1.11 About 1,150,000 cubic yards of minor to heavily contaminated sediments are situated in the harbor area of the lower Ashtabula River. Elevated inorganic parameters include: arsenic, cadmium, chromium, lead, and mercury. Elevated organic parameters include: polychlorinated biphenyls (PCBs), industrial solvents and polynuclear aromatic hydrocarbons (PAHs). Some PCBs (~29,000 CY) are in excess of 50 mg/kg. Managed material with PCBs equal to or in excess of 50 mg/kg are regulated under the Toxic Substance Control Act (TSCA) and must be appropriately handled and disposed of. Low level radionuclides (RAD) such as uranium, radium, and thorium (above background) are also present in some of the sediments and must be appropriately handled and disposed of. Sediments with elevated levels of contaminants above reference may not be disposed of at open lake disposal sites and must be appropriately disposed of by alternate disposal methods.

1.12 Harbor structural developments and accumulated contaminants have caused significant problems pertaining to benthic and fishery habitat and the ecology and harbor operations and maintenance dredging. Most of the contaminated sediments have collected within the Federal authorized channels. Storm events cause scour and the resuspension of sediments and possibly associated contaminants which may periodically compromise water quality standards. Contaminated sediments continue to migrate down stream into the Lower River, Outer Harbor, and Lake Erie. Navigation channel maintenance has been limited in the lower Ashtabula River,

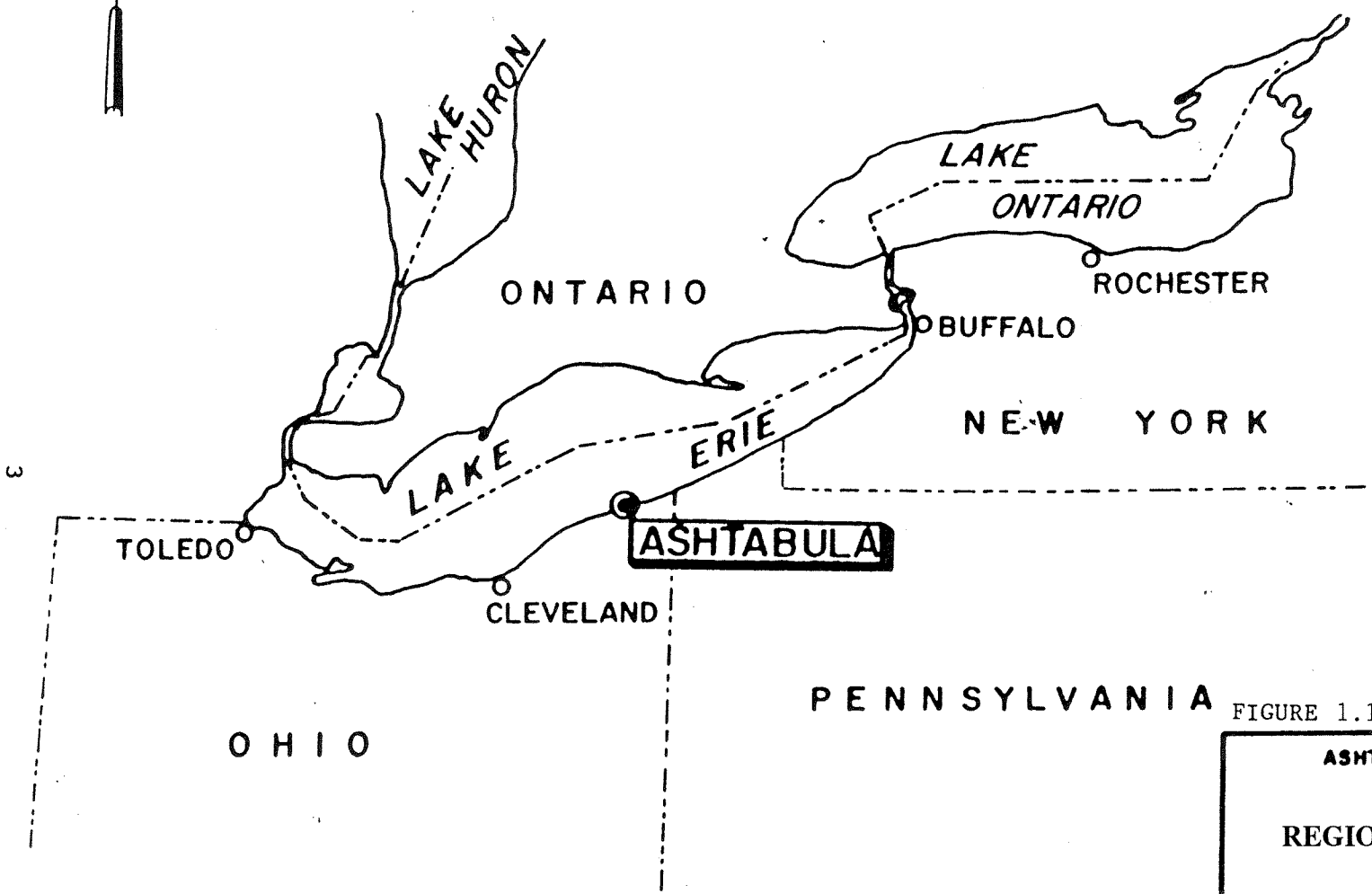
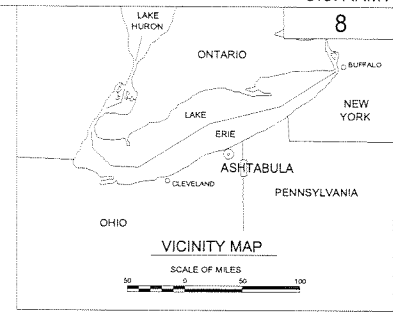

FIGURE 1.1

ASHTABULA HARBOR, OHIO
REGIONAL LOCATION MAP



- : ARP Project Area
- : Federal Navigation Project
- : Ashtabula River Shoreline



Dredging would occur within the river channel in Areas F and G up to and through the upper turning basin.

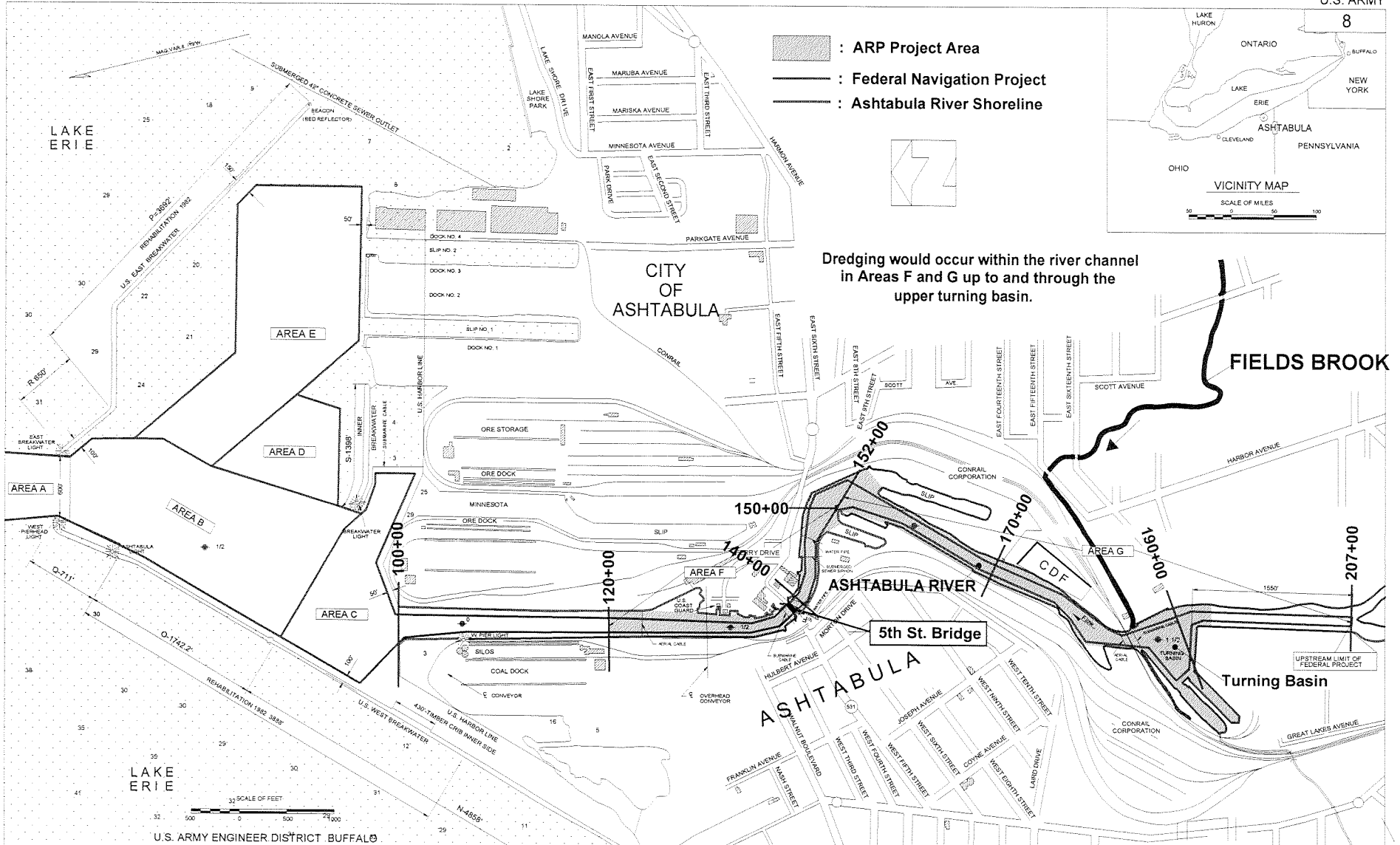

U.S. ARMY ENGINEER DISTRICT BUFFALO
MAY 2000

Project depths and soundings are referred to Low Water Datum, elevation 569.2 feet above Mean Water Level at Rimouski, Quebec (IGLD 1985) (International Great Lakes Datum 1985)

Aerial Cables have 120' clearance at Low Water Datum

1 1/2 Indicates miles above West Pier Light near outer end of Conrail Corp Ore Dock

4 Indicates sounding

41 Indicates State Route



AREA	PROJECT DEPTHS	
	IN SOFT MATERIAL	IN HARD MATERIAL
A	29'	30'
B	26'	28'
C	27'	28'
D	22'	23'
E	28'	28'
F	18'	18'
G	15'	15'

Figure 1.2
ARP PROJECT
SEDIMENT DREDGING
AREAS MAP

since there are concerns about dredging and appropriate disposal of contaminated sediments. Appropriate disposal facilities for contaminated sediments are required, but, presently unavailable, or, not economical. Structural developments (i.e. channelization, bulkheading, etc.) have substantially reduced aquatic/fishery shallow areas. Dredging and vessel activities have caused resuspension of sediments suffocating bottom organisms and disrupting fish habitat.

1.13 The Ohio Environmental Protection Agency is coordinating a Remedial Action Plan (RAP) for the area. This involves formation and activities of a RAP Committee working toward public awareness, identification of specific problems and needs, and overall formulation, assessment, evaluation, and implementation of remedial measures, as possible.

1.14 It was resolved that in lieu of remediation of the Lower Ashtabula River condition via the Superfund legislation, it would benefit all those involved to work together in a partnership. This would likely expedite greater remediation and would likely be less expensive.

1.15 Subsequently, in conjunction with the RAP Committee, the Ashtabula River Partnership was formed in 1994. The Ashtabula River Partnership is a coalition of public and private interests working toward remediation of the lower Ashtabula River. Remediation of the contamination and to some degree the structural problems along the lower Ashtabula River would serve to alleviate harbor impaired use and operations and maintenance restrictions, water quality and aquatic habitat issues, and health and safety concerns.

1.16 In 1985, when the International Joint Commission designated the Ashtabula River as one of 42 AOCs, they recognized six of 14 impairments of beneficial uses, i.e. changes in chemical, physical, or biological integrity of the ecosystem, as listed under the Great Lakes Water Quality Act (GLWQA). A comprehensive report titled the Ashtabula River Stage 1 Investigation Report, published in December 1991, describes in detail six beneficial use impairments associated with the Ashtabula River AOC, which are:

- 1. Restriction on Fish and Wildlife Consumption.**
- 2. Degradation of Fish and Wildlife Populations.**
- 3. Fish Tumors and Other Deformities.**
- 4. Degradation of Benthos.**
- 5. Restrictions on Dredging Activities.**
- 6. Loss of Fish and Wildlife Habitat.**

1.17 The project area and associated problems were assessed from an ecological perspective for this study. The primary ecological area of consideration includes that in the Ashtabula River watershed upstream of the harbor area to downstream through the harbor area and out into Lake Erie. Reference Figure 1.3. In summary, three primary problem areas have been identified in the Ashtabula Harbor Area of Concern (Excluding Fields Brook). They are: to some degree the Outer Harbor Area (Ecological Assessment Area 4), the lower river from the mouth upstream to the Fifth Street Bridge (Ecological Assessment Area 3), and the lower river from the Fifth Street Bridge upstream through the Upper Turning Basin (Ecological Assessment Area 2). The watershed area upstream of the developed harbor area (Ecological Assessment Area 1) is in comparatively better condition. Primary problems that exist in the Outer Harbor are those associated with commercial harbor development channels, dredging and use of the commercial navigation channels, and contaminants in the sediments (primarily PAHs,

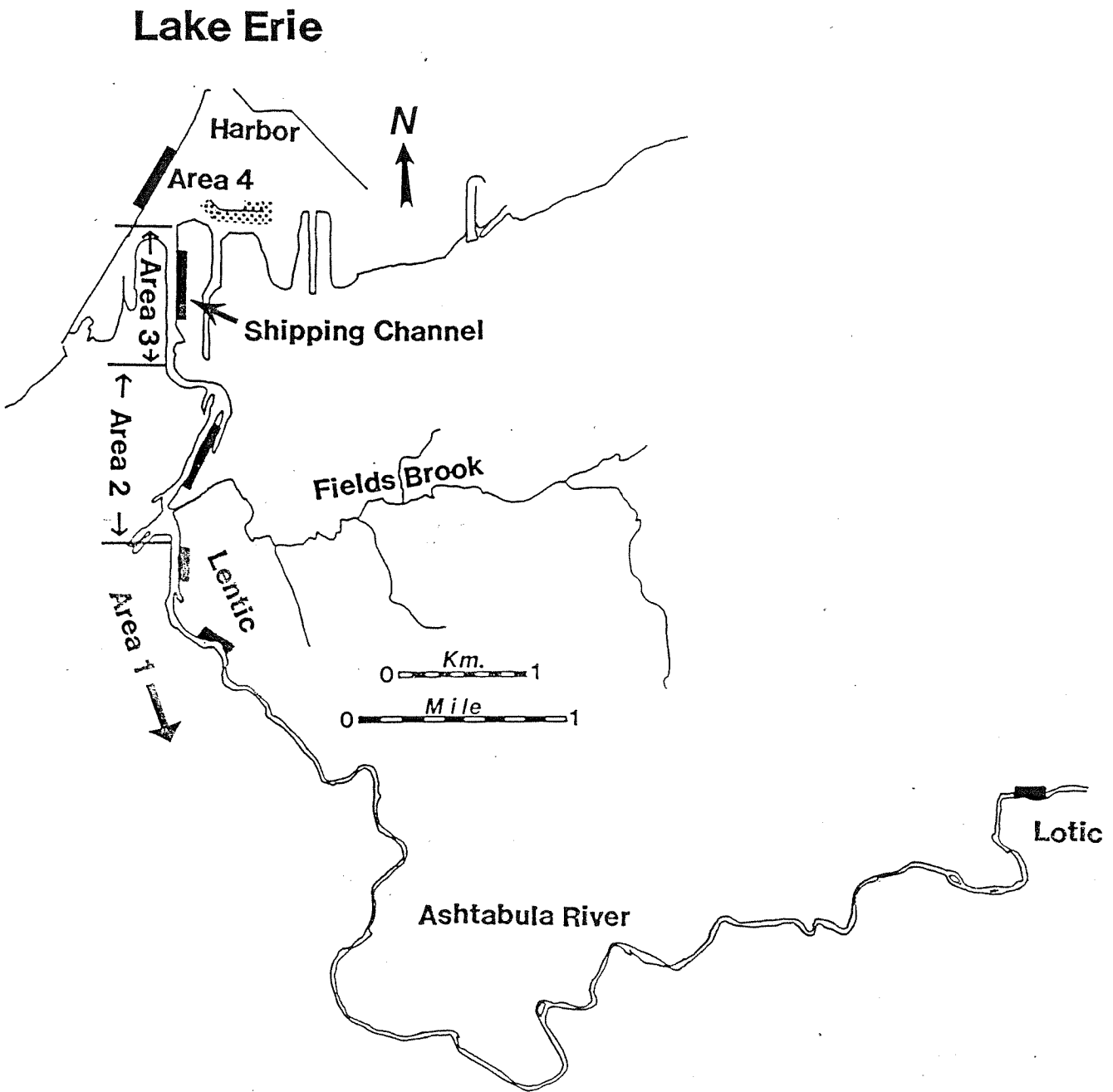

Fig 1.3 Ashtabula River study area and fish community sampling site locations (shaded areas). Benthic macroinvertebrate sampling sites are contained within the fish community sampling sites.

likely associated with the coal dock developments in the immediate area and other contaminated sediments including PCBs, RADs, and metals migrating out from the river). Primary problems that exist in the Lower River from the mouth up-stream to the 5th Street Bridge are those associated with commercial harbor development bulk-heading, dredging and use of the commercial navigation channel, and contaminants in the sediments (primarily PAHs, likely associated with the coal dock developments in the immediate area and other contaminated sediments migrating in from upstream). Primary problems that exist in the Lower River from the 5th Street Bridge up-stream to the end of the Federal navigation channel are those associated with recreational harbor development bulk-heading, dredging and use of the recreational navigation channel, and primarily contaminants in the sediments (primarily PCBs, some equal to or in excess of 50 mg/kg and other contaminants). Benthic and fishery habitat has been significantly degraded in these areas in this regard, as compared to quality warm water habitat criteria.

1.18 Considering the above, three common problem matters can be identified, those being: contaminated sediments, loss of protected riparian aquatic/fishery shallows, and dredging and commercial and recreational vessel traffic.

1.19 Under the 1978 GLWQA the overall goals of a RAP are to restore all beneficial uses to an Area of Concern, prohibit the discharge of toxic substances in toxic amounts, and virtually eliminate the discharge of persistent toxic substances. All of the beneficial use impairments in the Ashtabula River AOC may be related to contaminated sediment, with particular reference to the PCB, RAD, metals, and PAH contaminated sediment. Removal and remediation of the PCB, RAD, metal, and PAH contaminants is critical to comprehensive restoration of the ecological integrity of the lake/harbor/watershed. Some of the beneficial use impairments are related to loss of protected aquatic/fishery riparian shallow areas and lower river activities. Cleanup of the Ashtabula River via the Ashtabula River Partnership recommendations should substantially reduce all of the use impairments assigned to the lower river.

1.20 Considering the three common problem matters discussed previously, those being: contaminated sediments, loss of protected riparian aquatic/fishery shallows, and dredging and commercial and recreational vessel traffic; more specific objectives were developed to address contaminants and loss of protected riparian aquatic/fishery shallows that could also be applied to remediate/restore beneficial uses, as follows. It is understood that commercial and recreational facilities and activities will remain.

A. Project authorities, reference studies, and subsequent investigations indicate that an optimized dredging contaminant removal plan be developed for the problem areas. It should initially leave no worse than existing conditions PCB, RAD, and PAH sediment surface concentrations; remove all TSCA and scour risk PCB, RAD, and PAH mass; and, considering siltation or placement cover of relatively clean material, leave long-term (after several years) surface/substrate sediment (several feet) with targeted concentrations for PCBs, RAD, and PAHs of equal to or less than 0.35 ppm, 2 pCi/g, and 10 to 20 ppm respectively.

Focus has been on the main contaminants of concern in the Ashtabula River Area of Concern (AOC) due to their level and extent of contamination. Specifically, the focus is on PCBs, RADs, and to a lesser extent PAHs. There are other contaminants of concern in the AOC, as

discussed previously. However, it is determined that by focusing on PCBs, RADs, and PAHs, the other contaminants of concern will be addressed due to co-location of contaminants.

B. Replacement of protected aquatic/fishery shallow areas, as possible, for lengths as long as possible along the river problem areas. These developments would include measures such as a shoreline aquatic/fishery shelf cut or provision and miscellaneous improvements such as soil cover, aquatic and terrestrial plantings, placement of stone/gravel, and placement of cover structures. This would provide missing habitat for fisheries and benthos for passage, cover, feeding, and possibly spawning. The goal/objective would be to reach a quality warm water habitat condition along the problem reaches, as possible.

These would be applied to remediate/restore beneficial uses, as follows:

- 1. Remediate Restriction on Fish and Wildlife Consumption: Apply A.**
- 2. Remediate Degradation of Fish and Wildlife Populations: Apply A and B.**
- 3. Remediate Fish Tumors and Other Deformities: Apply A.**
- 4. Remediate Degradation of Benthos: Apply A and B.**
- 5. Remediate Restrictions on Dredging Activities: Apply A.**
- 6. Remediate Loss of Fish and Wildlife Habitat: Apply A and B.**

SECTION 2 - ALTERNATIVE CONSIDERATIONS AND THE RECOMMENDED PLAN

INTRODUCTION

2.00 This section briefly identifies and describes considered alternatives, assessment and evaluation of the most feasible alternatives, and selection of the recommended plan. This is discussed in more detail in the Feasibility Report and associated appendices.

2.01 A number of standard engineering, economic, and environmental measures are used to assess/evaluate alternative scenarios. In addition, justification for dredging under the 312(b) and 206 authorities must include a habitat assessment procedure (HAP) analyses. In this case a HAP developed by the State of Ohio Environmental Protection Agency was utilized. Essentially, the HAP analyses utilizes comparative biological field survey data and developed indices to identify problems and to compare existing environments and remedial alternatives in terms of habitat units or indices. Reference the introduction to SECTION 4 – ENVIRONMENTAL EFFECTS, also. In this case, adjacent Conneaut River and Harbor served as the primary comparative quality stream regime. Although it has a similar level of commercial and recreational development, it does not have appreciable levels of contaminations. Other supplemental references include Presque Isle, the Grand River, and the Black River. The Ohio Habitat Assessment Procedure (HAP) and assessment/evaluation is presented and discussed in more detail in EIS APPENDIX EA- J SECTION 312(b) AND 206 ECOLOGICAL RESTORATION/ PRESERVATION ANALYSES. (Part of this report. Follows these text). Portions of this appendix are summarized and integrated into portions of this Environmental Impact Statement.

WITHOUT PROJECT CONDITIONS (NO ARP ACTION)

2.02 The Without Project Conditions or the No ARP Action scenario indicates that the Ashtabula River Partnership could take no action based on final findings of this study. With no action, without project conditions would be assumed. The no action without project conditions serves as a basis of comparison by which other alternatives may be compared.

2.03 The Ashtabula River Partnership (ARP) project is a comprehensive project aimed at Lower Ashtabula River and near lakeshore area remediation. If the Ashtabula River Partnership project were not implemented, similar to existing conditions problems would likely persist well into the future. A Superfund contaminant remediation level action would likely occur in the more distant future; but, would probably not be remediation to the extent of the ARP project. Migration of residual contaminated sediments into the harbor navigation channels would likely continue, and the potential for a major storm event washout would persist. In order to maintain harbor navigation channels and dispose of contaminated dredgings, the Corps of Engineers and local sponsors would likely still need to consider development and use of an in-lake confined disposal facility (CDF)(opposed to by U.S. Fish and Wildlife and other natural resource agencies); or, development and use of a dewatering and upland confined disposal facility or use of an existing upland confined disposal facility. Other ecological restoration programs may enable some limited ecological restoration measures. Total time and moneys expended would likely be substantially higher. Fewer immediate and long-term environmental/ecological benefits would be realized.

ALTERNATIVE CONSIDERATIONS AND RECOMMENDED PLAN (PLAN DEVELOPMENT)

2.04 In addition to considering the No (ARP) Action (Without Project Conditions) alternative, the Ashtabula River Partnership considered a wide array of Plans and Component Alternatives pertaining to Dredging, Habitat Restoration, Transfer/Dewatering/Transfer, Treatment Technologies, Transportation, and Disposal of TSCA and Non-TSCA dredged material. Plans and Component Alternatives were assessed/evaluated for engineering and economic feasibility, environmental and social acceptability, and/or for best meeting the project planning objectives. Reference the Comprehensive Management Plan (CMP) Main Feasibility Report, also.

2.05 **NOTE:** Development of plan component alternatives and assessment and evaluation of those alternatives is an iterative process over time. Although developed quantities are comparable for the time, they may change as the alternatives are refined over time. Therefore, quantities such as considered dredged quantities, acreage, costs, etc. discussed may vary and reflect comparative quantities used for assessment/evaluation at the time as compared to those reflected for the final developed recommended plan. Present considered quantities are those reflected for and in the RECOMMENDED PLAN.

2.06 Dredging (Environmentally/low turbidity) pertains primarily to dredging with equipment that will minimize turbidity and the resuspension of contaminated sediments. Criteria for selecting the dredging equipment to accomplish this removal action were identified. More than twenty dredge types including mechanical, hydraulic, and special purpose dredges were listed, characterized, and evaluated using the selection criteria. Several options appear acceptable, including: the closed bucket clamshell, cutterhead, and horizontal auger dredge, respectively. Measures such as operations controls, an oil boom, and silt curtains would also be incorporated, as appropriate. Reference the CMP and Technical Appendix I, also.

2.07 The Ashtabula River Partnership assessed/evaluated several dredging scenarios in order to determine the amount of material that needed to be dredged, which would minimize project costs, while meeting River clean-up goals. This pertains to the project reach upstream of the Fifth Street Bridge where PCB, *RAD*, and metal contamination were identified as the primary contaminants of concern. Reference the CMP and Technical Appendices C, E, and F; and, EIS Appendix J, also.

2.08 Basically, three alternative scenarios were assessed/evaluated, those being: 1) a Shallow Dredge leaving a small amount of elevated PCB contaminated sediments, some lower level contaminated sediments, and virgin sediments that would be extensively covered by new clean sediments; 2) a Deep Dredge involving more extensive dredging removing all of the elevated PCB contaminated sediments; but, leaving some lower level contaminated sediments and virgin sediments that would be extensively covered by new clean sediments; and 3) a Bank to Bank to Bedrock Dredge involving extensive dredging removing all of the elevated PCB contaminated sediments and all of the contaminated sediments that would, in time, be replaced by new clean sediments. The latter would be very costly, would present more shoreline structural stability concerns, and was determined to be considerably more than that needed to meet River clean-up goals in light of the study gathered information. During the assessment/evaluation of these scenarios, the River project area was broken down into reaches and assessed/evaluated for dredging using study information gathered and criteria particular to each reach. River reach dredging assessment/evaluation criteria included items such as: contamination levels and location of contaminated sediments, shoreline structural stability, dredge idiosyncrasies, channel

limits, future sedimentation and scour, etc. Cross sections identifying contamination levels and location of contaminated sediments were available for every one hundred feet of the River project area. Reference Figure 2.1 and Table 2.1.

2.09 The Ashtabula River Partnership (ARP) considered Without Project Conditions scenarios and further assessed/evaluated the three incremental dredging (ecological restoration/preservation) scenarios for substrate contaminant removal. Considering developed ecological clean-up restoration/preservation goals/objectives, initial primary assessment/evaluation parameters included items such as: Costs, Economic Benefits, Practicality, Ecological Improvement (Rank), Quantities Dredged, Elevated PCB and RAD Material Removed, Shoreline Bulkhead Affected, PCB/RAD/PAH Mass Removed, Initial Remaining PCB/RAD/PAH Surface Concentrations, Beneficial Uses Addressed (Open Lake Disposal, Recreation/Commercial Shipping, Fish Advisory Lifted, Long-Term Risk Reduction, Habitat Quality), and Scour Release Potential (incl. to Lake). Other assessment/evaluation parameters included items such as: PCB Bio-Accumulation in Fish Tissue and Advisories, Water Quality (Turbidity), Benthic Habitat Chemically Restored, Benthic Habitat and Scour Protection Area Chemically Restored, Aquatic/Fishery Shallows Initially Impacted, Ohio Habitat Assessment Procedures (HAP) Biological Indices (Qualitative Habitat Evaluation Index QHEI, Fishery Index of Biotic Integrity IBI (incl. T&E Species), Macroinvertebrate Invertebrate Community Index ICI, Anomaly Reductions) Improvements, Accomplishment of Sediment Contaminant Reduction Objective and Accomplishment of Total Ecological Restoration Objective.

2.10 The assessment/evaluation identified the **Deep Dredge** scenario as the optimized plan and recommended plan. It removes the amount of contaminated material that needs to be removed, moderating costs, while meeting River ecological clean-up restoration/preservation goals/objectives. The recommended plan involves deep dredging (environmentally/low turbidity) of approximately 581,000 cubic yards (in situ) of contaminated sediments, 150,000 cubic yards of which is significantly PCB contaminated and would (for planning estimates) be expected to be handled and disposed of in accordance with TSCA regulations.

2.11 In the project reach from the Fifth Street Bridge downstream to station 120+00 located about half way down to the Lake, PAH and accumulated contamination was considered to be the primary contaminants of concern. Considering this, it was determined that dredging and disposal of approximately 115,000 cubic yards of sediment from this reach would address this problem. This brings the total material to be dredged for this project to 696,000 cubic yards.

2.12 Clean material dredged from the channel area upstream of the Upper Turning Basin and possibly from the Outer Harbor area should be deposited as cover into the Deep Dredge Area for at least one operations and maintenance dredging cycle to expedite clean benthic cover material recovery at no additional O&M cost and likely savings.

2.13 One alternative scenario considered initially was a River Capping Alternative. Basically, with this alternative, sheetpile sediment containment barriers would be placed in several locations across the river and an upper buffer area of contaminated sediments would be dredged and disposed of, and replaced with an impermeable barrier and several feet of clean material. The contaminated substrate material would, therefore, be contained/capped in place and protected from even extreme storm flows. This alternative, however, was not favorable from the perspective of the RAP or ARP organizations goal of a "total" river clean-up. Also, consid-

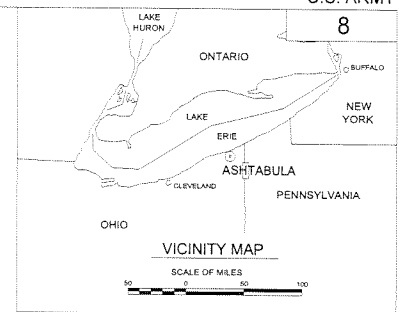

- : ARP Project Area
- : Federal Navigation Project
- : Ashtabula River Shoreline

Dredging would occur within the river channel in Areas F and G up to and through the upper turning basin.

12

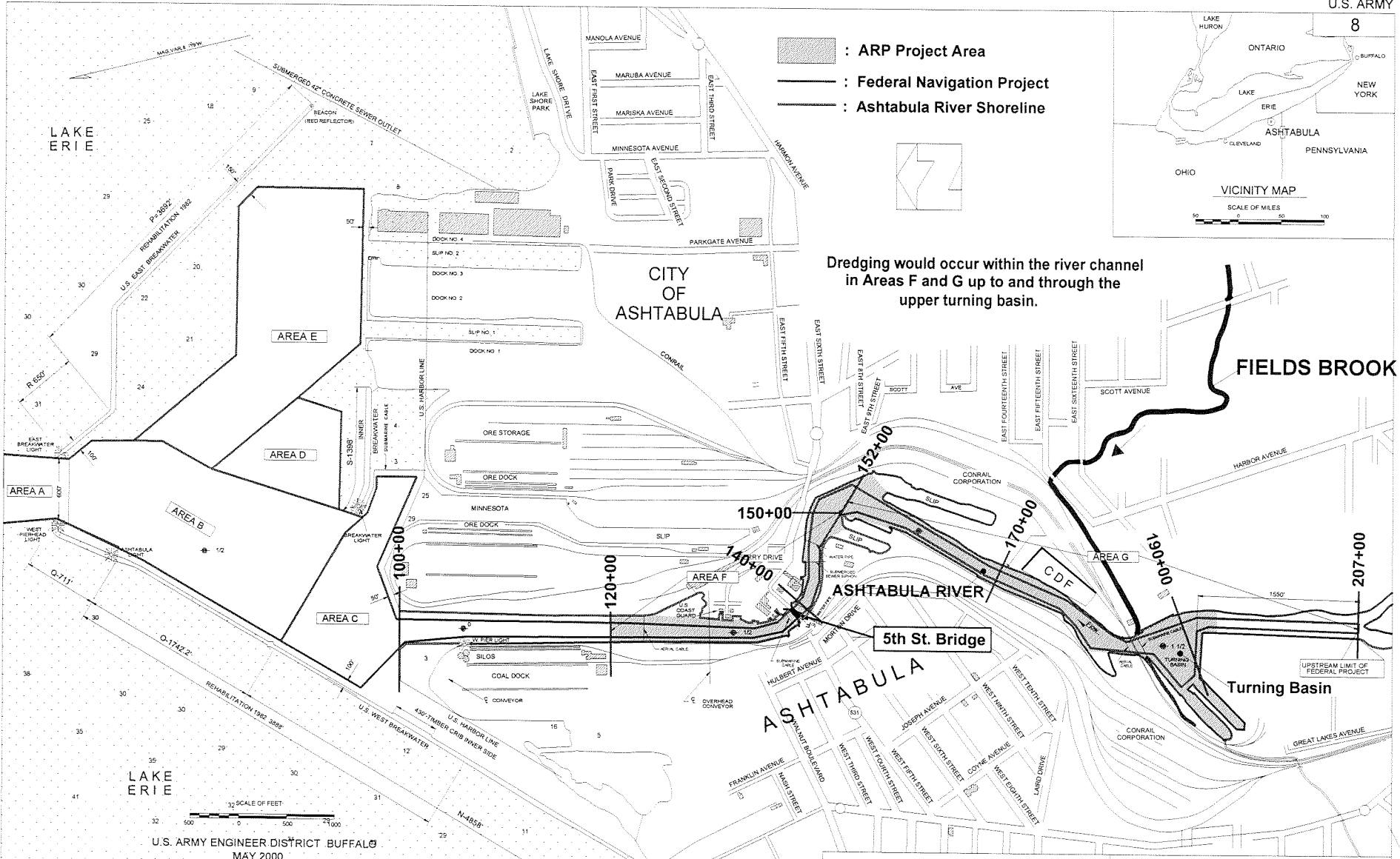

U.S. ARMY ENGINEER DISTRICT BUFFALO
MAY 2000

Project depths and soundings are referred to Low Water Datum, elevation 569.2 feet above Mean Water Level at Rimouski, Quebec (IGLD 1985) (International Great Lakes Datum 1985)

Aerial Cables have 120' clearance at Low Water Datum

◆ 1 1/2 Indicates miles above West Pier Light near outer end of Conrail Corp Ore Dock

4 Indicates sounding

41 Indicates State Route



AREA	PROJECT DEPTHS	
	IN SOFT MATERIAL	IN HARD MATERIAL
A	29	30
B	28	29
C	22	28
D	26	23
E	26	26
F	18	18
G	16	16

Figure 2.1
ARP PROJECT
SEDIMENT DREDGING
AREAS MAP

Table 2.1 - Dredging Ecological Restoration/Preservation Scenarios for Contaminant Removal and Assessment/Evaluation Items

Item	Dredging for Contaminant Removal		
	Bank to Bank To Bedrock	Deep Dredge	Shallow Dredge
Construction			
First Cost \$			
Dredge :	30,448,750	20,153,500	17,742,000
Disposal:	35,051,250	29,746,500	27,758,000
Total :	65,500,000	49,900,000	45,500,000
Study			
E&D			
S&A			
RE			
Project Cost: (Present Worth)	72,900,000	56,500,000 (62,038,800)	51,800,000
Project Economic Benefits (Present Worth)			
NED :	65,347,100	65,616,200	23,813,100
Regional :	110,888,400	113,268,100	12,272,900
Total :	176,235,500	(178,884,300)	36,086,000
(1997)(Sept 1996 Price Levels)			
Practicality*	Poor	Good	Good
Ecological Improvement Rank	2	1	3
Dredged (CY)	1,150,000	696,000	592,000
TSCA (CY)			
Material Removed	All 150,000	All 150,000	Most 149,500

Item	Dredging for Contaminant Removal		
	Bank to Bank To Bedrock	Deep Dredge	Shallow Dredge
Shoreline Bulkhead Affected	21,000 (Ft)	7,500 (Ft)	5,700 (Ft)
PCB Mass Removed	98%	82%	75%
PCB ppm Surface Concentrate Initial(6.29)	8.58	7.47	6.27
<u>Beneficial Uses Addressed</u>			
-Open Lake Disposal	Excellent	Good	No Dif.
-Recreation/ Commercial Shipping	Excellent	Excellent	Good
-Fish Advisory Lifted	Excellent	Good	No Dif.
-Long-term Risk Reduction	Excellent	Good	No Dif.
-Habitat Quality	Good	Excellent	Good
<u>Scale: (Poor, Low, No Difference, Good, Excellent)(Reference the Risk Assessment)</u>			
Scour Release Potential (& to Lake)	Low	Low	Medium
<u>Scale: (Low, Medium, High)(Reference the Risk Assessment)</u>			

Item	<u>Dredging for Contaminant Removal</u>		
	<u>Bank to Bank To Bedrock</u>	<u>Deep Dredge</u>	<u>Shallow Dredge</u>
Water Quality Turbidity	Low	Low	Medium
Benthic Habitat Chemically Restored (3' Deep)	~ 20 Acres ~ 100,000 (CY)	~ 20 Acres ~ 100,000 (CY)	< 20 Acres < 100,000 (CY)
Benthic Habitat & Scour Protection Restored (6' Deep)	~ 20 Acres ~ 200,000 (CY)	~ 20 Acres ~ 200,000 (CY)	< 20 Acres < 200,000 (CY)
Aquatic/Fishery Shallows (Acres) Initially Impacted	~ 10.5	~ .33	~ .33
Physical Habitat Improvement (HAP QHEI up to)	NA	NA	NA
14 Fishery Improvement (HAP IBI up to)	Good +12	Good +12	Fair +10
Macroinvertebrate Improvement (HAP ICI up to)	Good +20	Good +20	Fair +18
Anomally Reduction (HAP)	Good	Good	Fair

Item	<u>Dredging for Contaminant Removal</u>		
	<u>Bank to Bank To Bedrock</u>	<u>Deep Dredge</u>	<u>Shallow Dredge</u>
Accomplishment of Sediment Contaminant Reduction Objective	Good	Good	Poor
Accomplishment of Total Ecological Restoration Objective	Good	Good	Poor

Notes:

- * Cost, volume, and bulkheading concerns.
- General Scales: (Good, Fair, Poor) (Low, Medium, High)
- Scale: (Poor, Low, No Difference, Good, Excellent) (Reference the Risk Assessment)
- EAA - Ecological Assessment Area
- EAA 3 - Mouth of River to Fifth Street Bridge
- EAA 2 - Fifth Street Bridge through Upper Turning Basin
- (HAP QHEI) - Habitat Assessment Procedures Qualitative Habitat Evaluation Index
- (HAP IBI) - Habitat Assessment Procedure Index of Biotic Integrity
- (HAP ICI) - Habitat Assessment Procedure Invertebrate Community Index
- NA - Not Applicable

ering dredging authorities, comparable costs of other alternatives, and engineering and environmental trade-offs and risks, this alternative was eliminated from further consideration. The project is being accomplished via Federal dredging authorities. Federal funding would be limited to applicable authorities. It would require dredging, transfer/dewatering/transfer, disposal, and capping. The alternative would leave very high levels of exposed surface contaminated sediments prior to capping with interim exposure, scour and migration of high level contaminated sediments. Cover placement mixing with contaminated material, stability, and security would be in question. This alternative would also impair any future restoration of commercial channels and associated economic expansion.

2.14 Further, Supplemental Dredging (Ecological Restoration/Preservation) Measures for Protected Aquatic/Fishery Shallows were developed to address the lack of protected aquatic/fishery shallows in the lower River. Two major problem areas were identified in this regard. From the mouth of the River to the Fifth Street Bridge (Ecological Assessment Area 3) and from the Fifth Street Bridge through the upper navigation channels (Ecological Assessment Area 2). Reference Figure 1.3. Measures that could be applied to Ecological Assessment Area 3 are very limited since the area continues to be utilized for commercial shipping and docking and transfer of primarily coal, ore, and limestone. One measure that has been considered at other harbors for similar situations is the construction of a man-made aquatic habitat shelf along the channel reach primarily to facilitate movement of fisheries through the reach. More opportunity and better measures can be applied to Ecological Assessment Area 2. Measures considered for these reaches, in this regard, included acquisition of river shoreline property, and construction of aquatic/fishery shallows, as possible. This would include a mix of aquatic and shoreline plantings, stone/gravel bottom areas, and cover structures. The areas would be interfaced with the lake/river regime and would provide passage, cover, feeding, and spawning habitats. Reference the CMP and EIS Appendix J, also.

2.15 Three incremental plans were developed and assessed/evaluated for Ecological Assessment Area 3 and four incremental plans were developed and assessed/evaluated for Ecological Assessment Area 2. Reference Figures 1.3 and 2.2 through 2.7, and Table 2.2. Considering developed ecological restoration/preservation goals/objectives, primary assessment/evaluation parameters included items such as: Costs, Economic Benefits, Practicality, Ecological Improvement (Rank), Shoreline Improvement (Acres), Shallows Improvement (Acres), Fishery Passage Length, Ohio Habitat Assessment Procedures (HAP) Biological Indices (Qualitative Habitat Evaluation Index QHEI, Fishery Index of Biotic Integrity IBI (incl. T&E Species), Macroinvertebrate Invertebrate Community Index ICI) Improvements, and Accomplishment of Supplemental Ecological Restoration Objective.

2.16 The assessment/evaluation identified an **Aquatic/Fishery Shelf Plan** for the Ecological Assessment Area 3 problem area and an **Acquire Conrail Slip and Aquatic/Fishery Shelf Cut Plan** for the Ecological Assessment Area 2 problem area. This constitutes ecological restoration, as possible, for loss of protected aquatic/fishery shallows due to facilitated structural (i.e. bulkheading, channelization), and activities impacts. These are practical optimized plans of moderate cost providing problem area protected aquatic/fishery shallows of substantial length which accomplish, as possible, goals/objectives, in this regard. The areas would be interfaced with the lake/river regime and would provide passage, cover, feeding, and spawning habitat. It should be noted that these or similar measures would be pursued by separate authority/study (i.e. 206) subsequent and contingent to this projects dredging for removal of contaminants.

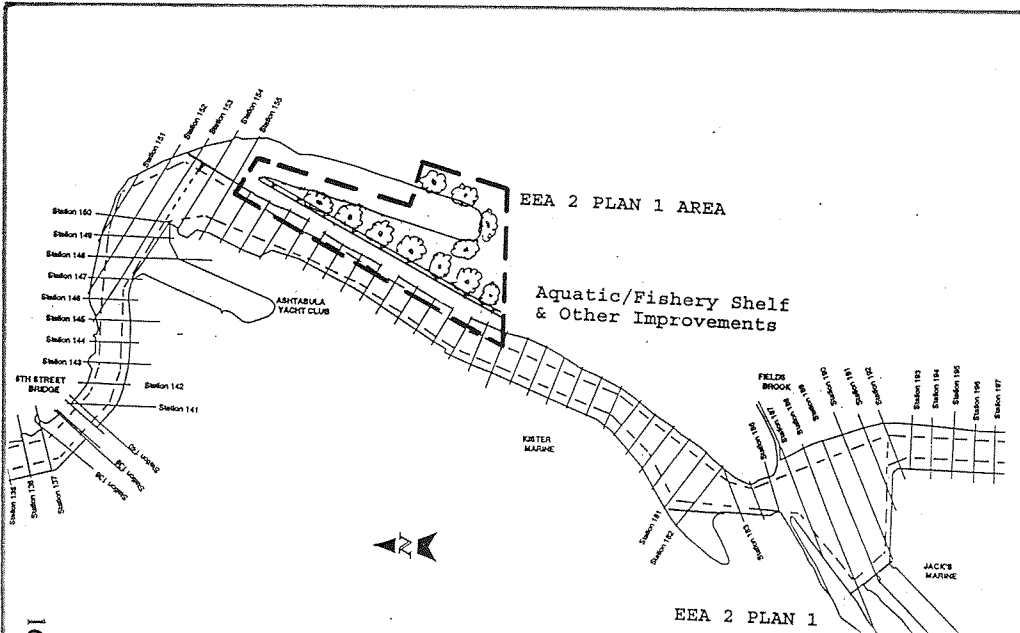

FIGURE 2.2

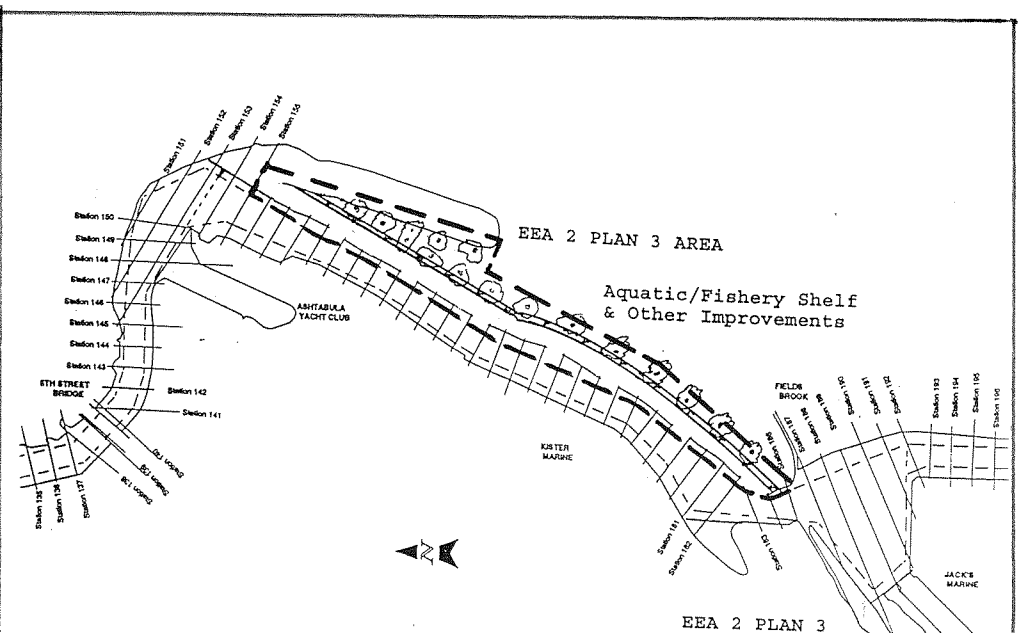

FIGURE 2.4

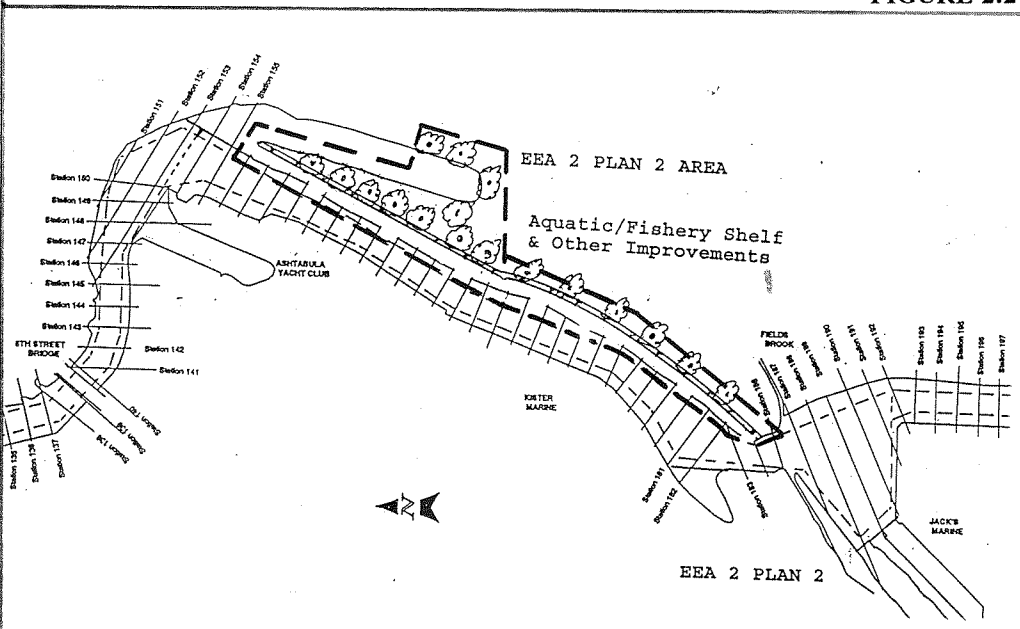

FIGURE 2.3

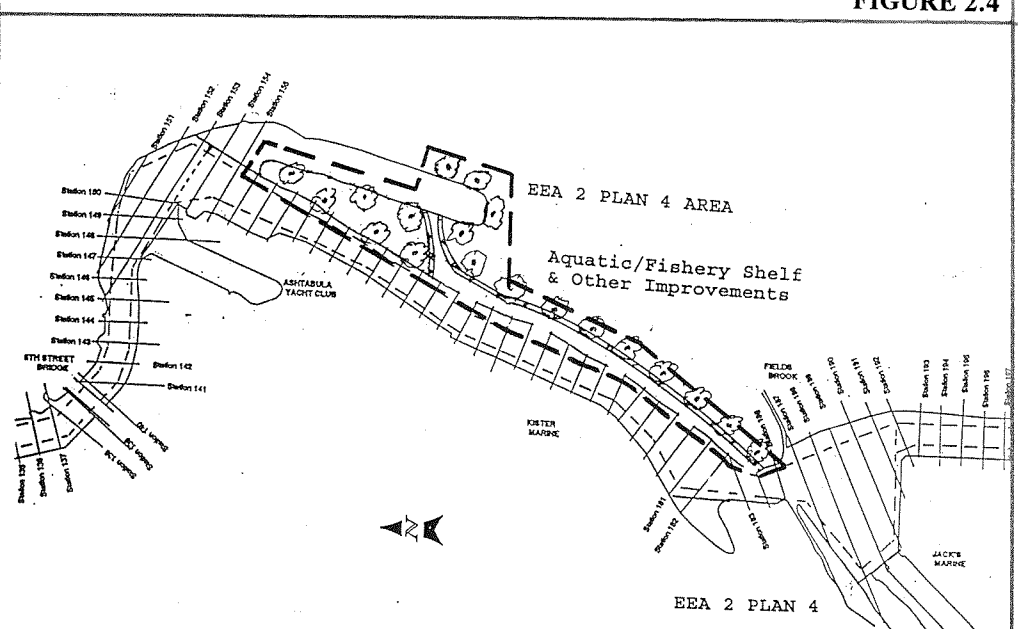
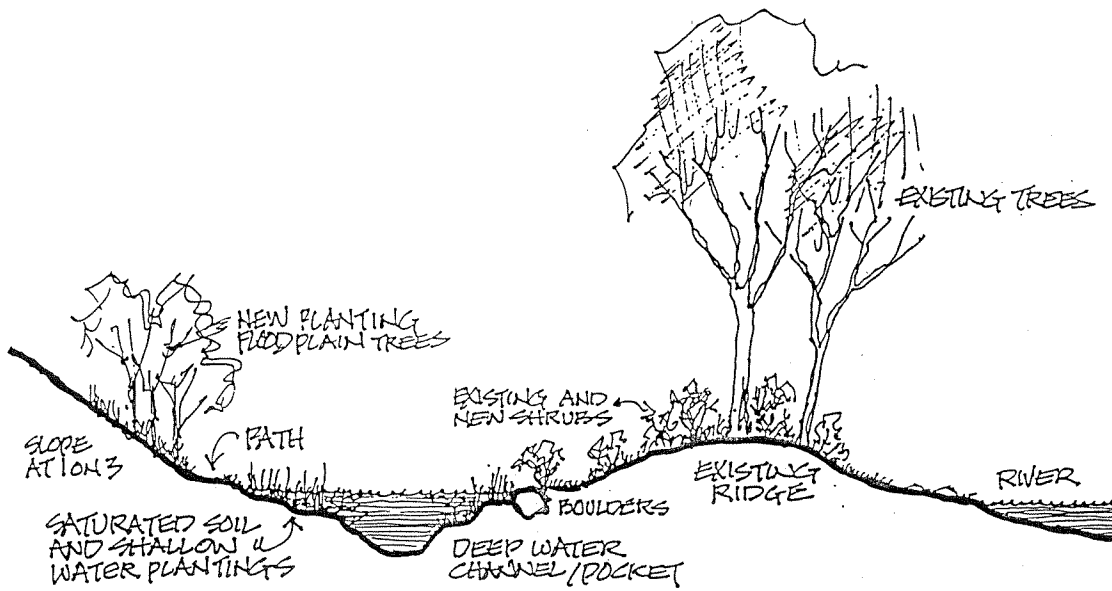
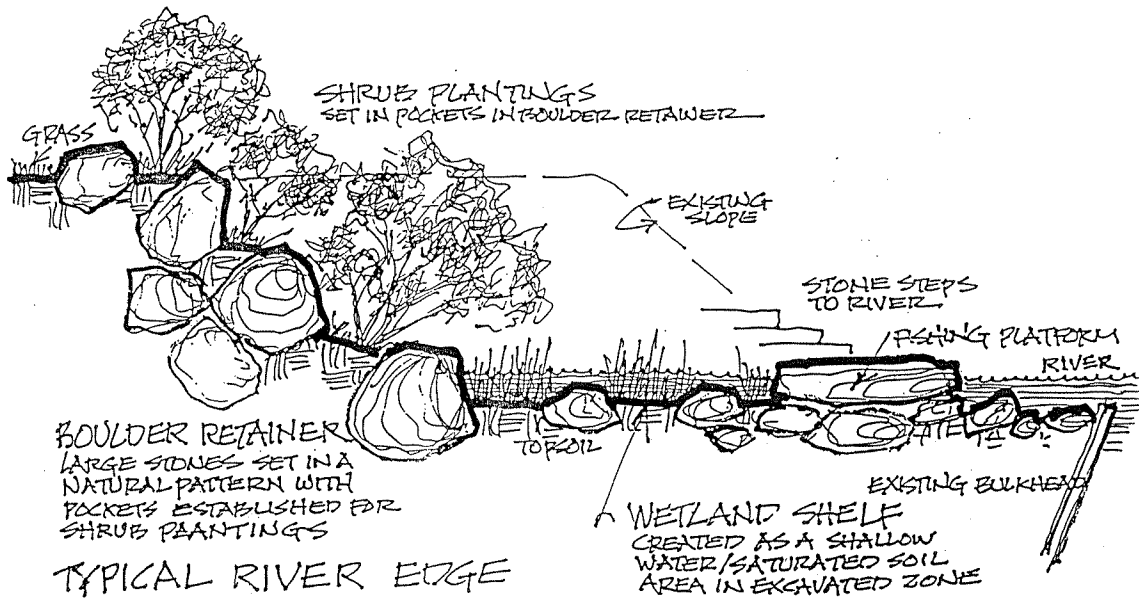

FIGURE 2.5



Source: Buffalo River Remedial Action Plan
 (Sterns and Wheler) (Integrated Site, Inc.)

FIGURE 2.6
 AQUATIC/FISHERY
 DIVERSION/BYPASS
 CUT



Source: Buffalo River Remedial Action Plan
 (Sterns and Wheler) (Integrated Site, Inc.)

FIGURE 2.7
 FISHERY SHELF
 (EMBANKMENT CUTBACK)

TABLE 2.2 - Supplemental Dredging Ecological Restoration/Preservation Measures for Aquatic Fishery Shallows (EAA) Assessment/Evaluation

Summary Assessment Items Item	(Ecological Assessment Area 3 Plans)			(Ecological Assessment Area 2 Plans)			
	Plan 1	Plan 2	Plan 3	Plan 1	Plan 2	Plan 3	Plan 4
	Aquatic/Fishery Shelf Cut	Aquatic/Fishery Shelf Hung	Aquatic/Fishery By-Pass Cut	Conrail Slip & Aquatic/Fishery Shelf Cut	Conrail Slip & Aquatic/Fishery Shelf Extended	Aquatic/Fishery Shelf Cut	Conrail Slip & Aquatic/Fishery Shelf Cut
Construction First Cost (+12.5%)	\$ 400,662	\$ 313,111	\$ 787,313	\$ 1,250,004	\$ 1,537,136	\$ 400,662	\$ 447,237
Project Cost: (Present Worth)	\$ 450,745	\$ 352,250	\$ 885,727	\$ 1,406,255	\$ 1,729,279	\$ 450,745	\$ 503,142
Project Economic Benefits (Present Worth)							
NED :		302,508					\$ 817,892
Regional :		280,962					\$ 759,638
Total : (1997) (Sept 1996 Price Levels)	(+/-)	\$ 583,470	(+/-)	(+/-)	(+/-)	(+/-)	\$1,577,530
Practicality*	Poor	Fair	Poor	Good	Good	Good	Good
Ecological Improvement Rank	1	3	2	2	1	4	3
Shoreline Improvement (Acres)	0.7	0.5	1.5	3.5	4.0	0.7	0.7+Acq.
Shallows Improvement (Acres)	0.7	0.1	1.5	2.5	3.0	0.7	0.7+Acq.
Fishery Passage Length	Good	Good	Good	Poor	Good	Good	Good
Physical Habitat Improvement (HAP QHEI up to)	Fair +5	Fair +4	Fair +5	Good +8	Good +9	Good +7	Good +8
Fishery Improvement (HAP IBI up to)	Fair +4	Fair +3	Fair +4	Good +11	Good +12	Good +10	Good +11
Macroinvertebrate Improvement (HAP ICI up to)	Fair +4	Poor +2	Fair +4	Good +13	Good +14	Good +12	Good +13
Supplemental Accomplishment of Ecological Restoration Objective	Fair	Fair	Fair	Good	Good	Good	Good

Notes:

* Commercial shipping activities pertaining to coal transshipment and storage. Coal dust problem.

* Recreational boating channel area. Available shoreline area.

General Scale: (Good, Fair, Poor)(Aqu. = Acquisition)

(HAP QHEI) - Habitat Assessment Procedure Qualitative Habitat Evaluation Index

(HAP IBI) - Habitat Assessment Procedure Index of Biotic Integrity

(HAP ICI) - Habitat Assessment Procedure Invertebrate Community Index

2.17 Other long-term dredging measures recommended in this regard include:

* Maintain long-term channel maintenance dredging upstream of the Fifth Street Bridge to recreational navigation (*versus commercial navigation*) depths as is being done at present. This will provide aquatic shallow areas along the River shoreline in the distant future at no cost. *Reference Figure 2.8.*

* Decrease the width of the maintained recreational navigation channel to the west upstream of the Fifth Street Bridge between the Conrail slip and the Upper Turning Basin about eight feet or more, as possible. This would provide additional aquatic shallow area along the east embankment in the distant future at no cost and likely savings. *Reference Figure 2.9.*

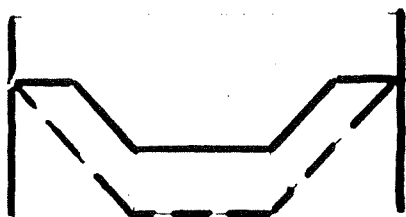

Cross-Section
FIGURE 2.8
REDUCE DEPTH

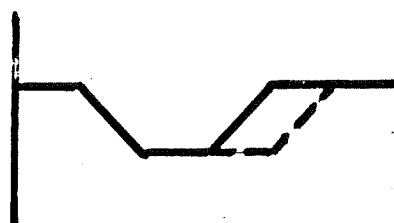

Cross-Section
FIGURE 2.9
REDUCE WIDTH

2.18 It is expected that sediments dredged in the future for channel maintenance will be clean enough for open-lake disposal. Approximately 150,000 cubic yards of sediment are dredged from Ashtabula Harbor federal navigation channels every two years with the total river sediment loading/deposition calculated at 260,000 cubic yards every two years.

2.19 It is expected that within several years of project implementation sediment and benthos quality will be improved markedly; and, that within another few years the area fishery will be improved markedly. It is expected that the project will reasonably accomplish project *incremental* goals/objectives and *work towards remediation* of the six beneficial use impairments identified with the exception of limitations along the commercial channel area. Several monitoring programs will be conducted within five to ten years of project completion to assess/evaluate this. *Reference the CMP and EIS Appendix J, also.*

2.20 An Ashtabula River Recontamination Assessment was conducted for the study. It considered the Fields Brook remediation scenario and low, average, and high flow events from Fields Brook and the Ashtabula River. Based upon the results of the recontamination assessment, the low level of PCB that is deposited into the Ashtabula River from Fields Brook is less than 2 (ppb) parts per billion under all of the scenarios that were modeled. This presents a negligible recontamination scenario. *Reference the CMP and Technical Appendix H, also.*

2.21 Numerous dewatering technologies were reviewed including passive dewatering technologies (i.e. primary settling, solar evaporation, surface drainage, subsurface drainage, wick drains), mechanical dewatering technologies (i.e. belt filter press, centrifugation, gravity thickeners, chamber filtration, vacuum filtration), and active evaporation technologies. These were assessed and evaluated in light of the scope of the project (sediment volumes and quality) and

economic, engineering, and environmental efficiencies. It is recommended that the Ashtabula River sediments be dewatered using essentially passive dewatering technologies, regardless of whether the sediments are dredged mechanically or hydraulically. The treatment train includes settling, flocculation, clarification, multi-media filtration and activated carbon polishing. Reference the CMP and Technical Appendix J, also.

2.22 A number of alternative PCB contaminated sediment treatment and disposal measures were assessed/evaluated. The conclusion is that treatment and disposal of the residual material is considerably more expensive than dewatering and appropriate disposal of the dewatered dredged material. Reference the CMP and Technical Appendices L, also.

2.23 Initially, four vicinity and some 11 specific sites were assessed and evaluated as potential sites for development of dredged material transfer/dewatering/transfer facilities. General assessment/evaluation parameters included associated: costs; availability; capacity; ease of access/transport, and engineering, environmental, community, and cultural resources considerations. Dredging and disposal site considerations were also included. A harbor area barge and/or shoreline transfer/dewatering/transfer facility has been identified. Reference Figure 2.10 and Table 2.3.

2.24 Initially, some 36 sites were assessed/evaluated as potential sites for development of disposal facilities. Reference Figure 2.10 and Table 2.3. Potential disposal sites were initially identified primarily via previous studies, committee member knowledge of potential available areas, and by identifying non-wetland areas as depicted by the U.S. Fish and Wildlife Service National Wetlands Inventory Map, thus minimizing potential mitigation needs in this regard. Assessment/evaluation parameters were developed per various Federal, State, and Local siting criteria and considerations. Further, sites and alternative scenarios were assessed/evaluated per various planning objectives and associated engineering, economic, and environmental (physical/natural, human/community/ social, cultural resources) parameters. The 36 sites were narrowed down to five and then to two upland sites (Sites 5 and 7), and one potential in-lake diked confined disposal facility site (Site P). The latter could be utilized only for disposal of Non-TSCA dredged material. Use of existing disposal facilities (as appropriate) was also considered.

2.25 More detailed geotechnical and environmental studies were conducted on Sites 5 and 7. The results of these studies indicated that either Site 5 or Site 7 would be geotechnically suited for development of upland disposal facilities; but, that there would be problems with existing fill material at Site 5 and that a full scale development would have greater environmental impacts, particularly to wetlands, at Site 5 than at Site Site 7. Subsequently, it was determined that, if a newly developed upland disposal facility was to be part of the proposed project, it would be constructed at Site 7.

2.26 Considering about a 46 acre development situated at Site 7, about 11 acres of mostly wooded wetland would be unavoidably impacted. Wetland impacts would be appropriately mitigated for under the guidance established by the Clean Water Act, Section 401 and 404. A

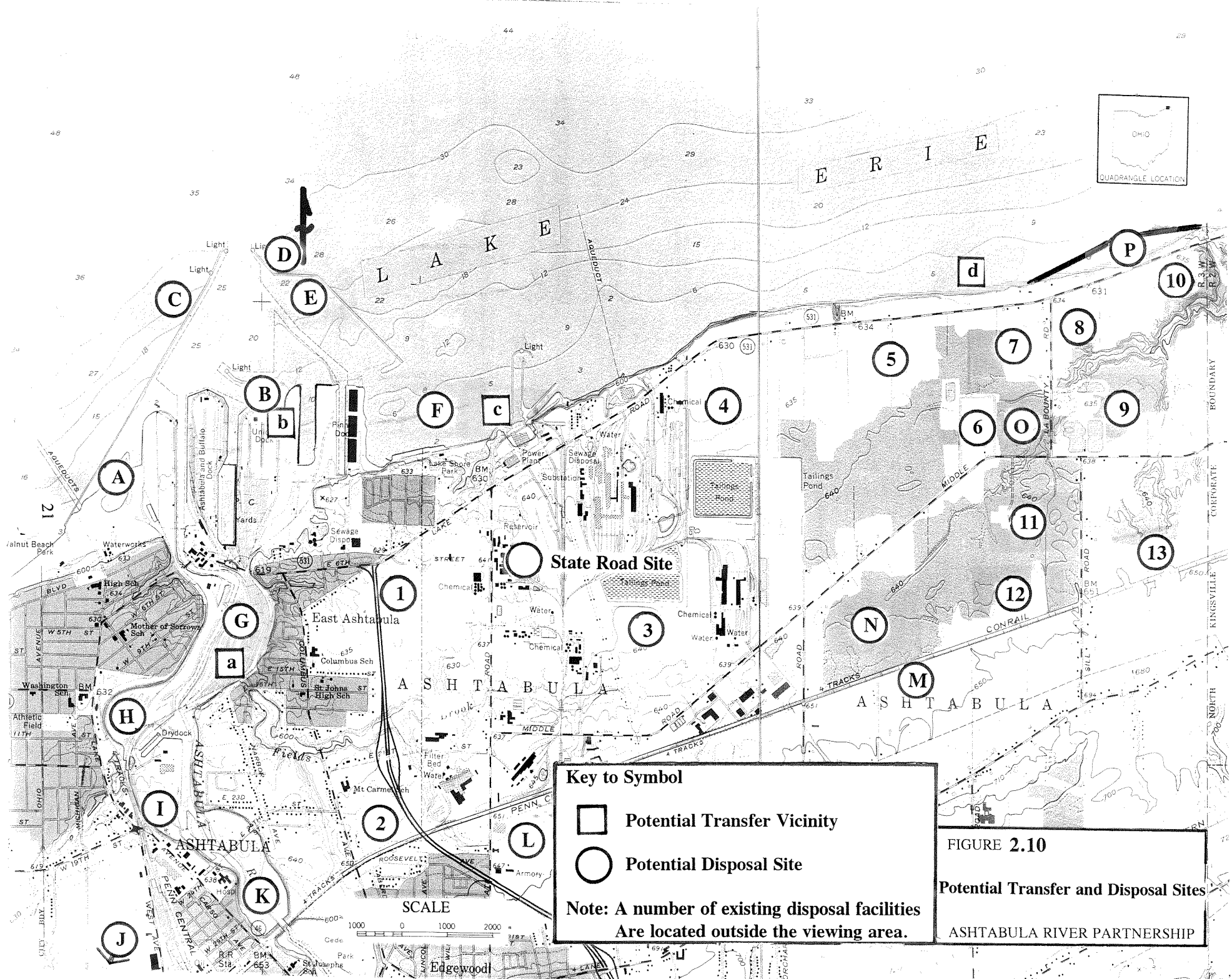

Key to Symbol

□ Potential Transfer Vicinity

○ Potential Disposal Site

**Note: A number of existing disposal facilities
Are located outside the viewing area.**

FIGURE 2.10
Potential Transfer and Disposal Sites
ASHTABULA RIVER PARTNERSHIP

ASSESSMENT/EVALUATION MATRIX
 ASSESS/EVAL PARAMETERS, CONSIDERED SITES, AREAS OF CONCERN

ASSESSMENT/EVALUATION PARAMETERS	CONSIDERED SITES									
ECONOMICS										
Federal Cost										
Non Federal Cost										
Total Cost										
Benefits										
Net Benefits										
Average Annual Benefits										
Average Annual Costs										
B/C										
GENERAL & PRELIMINARY ENGINEERING										
Boundary (Ashtabula C/T,N of RR)										
Distance (Pew Miles From Harbor)										
Site Capacity (TSCA -15A, Total -30A)										
Availability (TBD)										
Transportation Facilities (Pipe,Truck,Rail)										
Location and Community Acceptability (Land Use, Safety, etc Perceptions)										
Soils/Geology & Design Material Friendly (TBD) Likely										
Location Restrictions (3745-27)										
Generally Solid Waste Material Shall Not Be Placed (some exceptions):										
1. within partially excavated sand/gravel pit										
2. within limestone/sandstone quarry										
3. within National/State park or recreation area										
4. within public water supply (5 year area soils migration limit)										
5. above sole source aquifer										
6. within 1000 feet of Federal/State Significant Natural/Historic Resource Area										
7. above underground mine										
8. above unconsolidated aquifer or within 1000 feet of associated water supply well (>100g/min/24hr)										
9. within 1000 feet of a water supply well/spring										
10. within 300 feet of the facility property line										
11. within 1000 feet of a domicile										
12. within 200 feet of a stream, lake, or wetland										
13. within 15 feet of the uppermost aquifer and the bottom of the clay liner										
14. within 10,000 feet of a jetport within 5,000 feet of a propport										
15. within a regulatory floodplain (100 year flood)										
16. within 200 feet of a (holocene) fault										
17. within a significant seismic impact zone										
18. within an unstable area										
19. within 2000 feet of any residence, school, hospital, jail, or prison (pertains to TSCA material)										
20. within any naturally occurring wetlands (TSCA)										
21. within any flood hazardous area, if the applicant cannot show that the facility will be designed, constructed, operated, and maintained to prevent washout by a 100 year flood or that procedures will be in effect to remove the waste before flood waters can reach it (TSCA)										
Safety (TBD)										

Key

- Major concern which essentially contributed to the elimination of the site from further consideration.
- Potential Parameter of Concern
- ⊙ Parameter could be of some concern, but not enough current information to be sure.
- Parameter probably not of significant concern based on current information.

ASSESSMENT/EVALUATION MATRIX (Continued)
 ASSESS/EVAL PARAMETERS, CONSIDERED SITES, AREAS OF CONCERN

EVALUATION/ASSESSMENT PARAMETERS	CONSIDERED SITES									
ENVIRONMENTAL										
Natural Resources										
Air Quality										
Water Quality										
Sediment Quality										
Benthos										
Aquatic Vegetation										
Fisheries										
Wetlands										
Riparian										
Terrestrial Vegetation										
Wildlife										
Threatened Endangered										
Human (ManMade) Resources										
Community and Regional Growth										
Displacement of People										
Displacement of Farms										
Business/Industry Employment/Income										
Public Facilities and Services										
Recreational Resources										
Property Value and Tax Revenue										
Noise and Aesthetics										
Community Cohesion										
Cultural Resources										
Archeological										
Historical										

TABLE 2.3 - Site Assessment/Evaluation Matrix (Sample).

preliminary assessment/evaluation and plan was presented in the draft reports. More specific plans would be formulated for the final reports and detailed with project plans and specifications.

2.27 Remaining Plans and Component Alternatives were subsequently assessed/evaluated in greater detail (1997). Impact trade-off discussions ensued. Development of pumpout/pipeline facilities and use of existing disposal facilities were essentially eliminated due to substantially higher costs. Of considerable discussion was the option of developing an in-lake diked confined disposal facility at Site P for the disposal of Non-TSCA material. Although this option presented some potential project cost savings and reduced transportation impacts, it also presented considerable environmental concerns including those pertaining to: water quality, fish and wildlife, long-term O&M and contaminated sediment containment, coastal processes, the Coastal Zone Management Program, and public perception. It was decided that an upland confined disposal facility would be better suited for disposal of the contaminated dredged material involved in this project, and the Site P development option was eliminated from further consideration. Based on this assessment/evaluation of Plan Component Alternatives a recommended plan was formulated.

2.28 Subsequent to the Draft Reports, a number of additional evolved alternative disposal facilities and alternatives were assessed/evaluated. Use of existing disposal facilities can not be utilized because RAD material can not be co-mingled with other disposed material and must have its own disposal facility. In this regard, the former RMI Sodium Plant site (State Road Site) has become available. The site has been disturbed by past plant development and recent demolitions and is of little value to fish and wildlife and contains only minor wetlands at the eastern boundary and north-east corner. The Fields Brook remediation project material is being disposed of in part of this property. There is room for the Ashtabula River Partnership dredged elevated PCB and RAD material to be disposed of in a developed facility adjacent to the Fields Brook remediation project disposal facility. There is also just enough room for the Ashtabula River Partnership dredged contaminated material to be disposed of in a developed facility adjacent to the other disposal facilities. Assessment/evaluation indicates that this is the overall preferred possible disposal alternative and is now the project disposal component plan.

RECOMMENDED PLAN

2.29 The recommended plan involves: 1) deep dredging (environmentally/low turbidity) of approximately 696,000 cubic yards (in situ) of contaminated sediments, 150,000 cubic yards of which is significantly PCB contaminated and would (for planning estimates) be handled and disposed of in accordance with Toxic Substance Control Act guidelines; 2) developing and utilizing a transfer/dewatering/transfer facility in the harbor area; 3) trucking the dewatered dredged material to a developed upland disposal site; and 4) disposing of the material, as appropriate, in TSCA and Non-TSCA disposal facilities. The facilities would also include leachate collection, treatment, and monitoring facilities, and closure, and post closure monitoring measures. The project also recommends restoration (by separate authority) of several acres of aquatic/fishery shallows areas and associated shoreline. Approximately 150,000 cubic yards of operations and maintenance dredged material and/or shoreline excavated material would

be discharged in the initially dredged area in order to provide an immediate clean cover and to expedite ecological recovery. Environmental protection measures have been incorporated into the project planning and will be further incorporated into the project design, construction, operation, and maintenance plans to meet Federal, State, and local regulations. Reference Figures 2.11 through 2.23.

2.30 The reach of the lower river to be dredged for this project is essentially that from the upper turning basin downstream to just past the U.S. Coast Guard Station. TSCA material is located primarily in the reach from the upper turning basin to just past Kister Marine. Reference Figures 2.11.

2.31 Table 2.4 presents a summary of potentially dredged, processed, and disposed of volumes of sediment/water for the various dredging scenarios considered. Volumes utilized in various sections of this report may vary pertaining to estimated volumes utilized for assessment/evaluation at the time. The summary and recommended plan volumes pertain to those associated with the Deep Dredge Plan (in situ) and mechanical dredging.

2.32 Dredging (particularly of TSCA material) would need to be accomplished in a manner that would minimize turbidity and resuspension of sediments and associated contaminants. Generally, contaminants are adsorbed (tightly bound) to fine sediment particulates. Applicable water quality controls, dredging operation controls, and/or environmental controls will be placed on the dredging operation to limit adverse impacts of this sediment removal action. Water quality controls would include placing limits on the amount of turbidity or concentrations of PCBs or other contaminants allowed in the water column outside the immediate dredging area. Dredge operation controls would include limiting the bucket cycle time, prohibiting nighttime dredging operations, and allowing scows to be only partially filled. Environmental controls that would be used around the dredging operation include oil booms and adsorbents to capture oil film released by the dredging action. Silt curtains would also be used, especially during dredging of the TSCA material, to limit the spread of resuspended sediments and associated contaminants. In addition, water tight scows would be required for transporting sediments. Cover of TSCA sediments would also be required. While it is virtually impossible to completely eliminate the adverse environmental impacts of this dredging action, controls such as these can greatly reduce impacts.

2.33 A shoreline area proposed for the dewatering facility is located between slip 5a and the Ashtabula River, and contains the upland disposal area (approximately a 2-acre area) used for the 1993 Interim Dredging project. The area estimated for the dewatering facility will total approximately 5.48 acres (roughly 300 feet X 800 feet). The dewatering facility would consist of a sediment transfer basin and a series of settling basins, and filtering and treatment plants. Sediment would be allowed (hours to days) to settle out from the dredged slurry, initially in the barges and transfer basin. At times, this would be facilitated with the use of flocculants. Most pollutants are essentially adsorbed (tightly bound) to the sediments and would settle out from the slurry with the sediments. Water would be decanted from the barges and transfer basin into a series of settling basins for further settling and then filtered to remove more particulates and associated pollutants. Depending on the source, if particulate/contaminant removal cannot

TABLE 2.4

**Rounded Values for Volume of Sediment Dredged and Capacity of Landfill
for Use in Ashtabula Reports**

Dredging Volumes (cy)

	TSCA	Non-TSCA			TOTAL	Overdredging (If used)
		GMS	to St 120+00	Total non-TSCA		
BBB	150,000	860,000	115,000	975,000	1,125,000	25,000
Deep	150,000	410,000	115,000	525,000	675,000	21,000
Shallow	150,000	310,000	115,000	425,000	575,000	17,000

When bulking, dewatering and settling are considered, along with disposal of 70,000 cubic yards from the interim disposal facility, the required capacity of the landfill is as follows

Capacity of Disposal Facility (cy)

	TSCA	non-TSCA
BBB	100,000	700,000
Deep	100,000	400,000
Shallow	100,000	350,000

meet parameter water quality standards (generally, 50 to 100 ppm particulate meets most parameter water quality standards), further water quality filtration/treatment (i.e. sand and anthracite coal filter, possibly followed by carbon adsorption) would be applied, as necessary. Water discharged into Fields Brook and the Ashtabula River or Lake would need to meet water quality discharge requirements. Reference Figures 2.13 through 2.15. Sediments would need to be worked in the transfer basin sufficiently to attain dryness for transport and disposal. Reference the CMP and Technical Appendix M, also.

2.34 Transportation of material would be conducted in accordance to regulations pertaining to the transport of TSCA and contaminated dredged Non-TSCA material, as appropriate.

2.35 Development of the disposal facilities at the State Road Site would require about 32 acres. The area to be developed is a brownfield site. The site supports primarily upland open field, patchy herbaceous regrowth and common reed, which is consistent with urban industrial sites. The area impacted would be developed with disposal cells and elutriate treatment facilities, as described. Gradual and long-term vegetation replacement would likely be with grasses or legumes on facility slopes. Reference Figures 2.13 and 2.16 through 2.19.

2.36 Transfer/Dewatering/Transfer facilities (marine and/or shoreline based) would be designed to accommodate the dewatering processes described previously and to facilitate handling of TSCA material, since they would be utilized to transfer/dewater/transfer both the TSCA and Non-TSCA dredged material. Specific reference for PCB regulations applicable to the technical requirements for a TSCA chemical waste landfill are found at 40 CFR Section 761.75. Developed upland TSCA disposal facilities would be designed with reference to these regulations. Reference the CMP and Technical Appendices M, and P, also.

2.37 With regard to Non-TSCA substantially contaminated dredged material, although it is not regulated as a solid waste, associated water discharges would need to meet Clean Water Act and associated water quality discharge standards. Reasonably, the best way to accomplish that is to provide contaminated dredged material containment and water control and treatment facilities (i.e. reliable solid waste disposal containment and water control and treatment facilities).

2.38 The conceptual Non-TSCA disposal facility plan has been designed with reference to Ohio's Revised Code Chapter 6111 Water Pollution Control Laws 6111.45 Approval of Plans for Disposal of Waste, Department of Surface Waters 0400-028 Policy - Industrial Other Waste, and Ohio's Solid Waste Best Available Technologies (BAT) Rules (RCRA Subtitle D) effective July 1, 1994.

2.39 Transfer/Dewatering/Transfer and Disposal Facilities would incorporate filtration/treatment systems in order to meet discharge water quality requirements. Reference the CMP and Technical Appendices M, and P, and EIS Appendix B, also.

2.40 Further, Supplemental Dredging (Ecological Restoration/Preservation Measures) for Protected Aquatic/Fishery Shallows were developed to address the lack of protected aquatic/fishery shallows in the lower River. Two major problem areas were identified in this regard. From the mouth of the River to the Fifth Street Bridge (Ecological Assessment Area 3) and from the Fifth Street Bridge through the upper navigation channels (Ecological Assessment Area 2). Three incremental plans were developed and assessed/evaluated for Ecological Assessment Area 3 and four incremental plans were developed and assessed/evaluated for Ecological Assessment Area 2. Considering developed ecological restoration/preservation goals/objectives, and an array of assessment/evaluation output measures the assessment/evaluation identified an **Aquatic/Fishery Shelf Plan** for the Ecological Assessment Area 3 problem area and an **Acquire Conrail Slip and Aquatic/Fishery Shelf Cut Plan** for the Ecological Assessment Area 2 problem area. Reference Figures 2.20 through 2.23. Reference EIS Appendix J, also. It should be noted that these or similar measures would be pursued by separate authority/study (i.e. 206) subsequent and contingent to this projects dredging for removal of contaminants.

2.41 Other long-term dredging measures recommended in this regard include:

* Maintain long-term channel maintenance dredging upstream of the Fifth Street Bridge to recreational navigation depths (versus commercial navigation) as is being done at present. This will provide aquatic shallow areas along the lower River shoreline in the distant future at no cost.

* Decrease the width of the maintained recreational navigation channel to the west upstream of the Fifth Street Bridge between the Conrail slip and the Upper Turning Basin about eight feet or more, as possible. This would provide additional aquatic shallow area along the east embankment in the distant future at no cost and likely savings.

2.42 It was also resolved during the planning process that about 30,000 cubic yards of Non-TSCA dredged material from the 1993 Interim Dredging and Disposal project would be disposed of at the Ashtabula River Partnership Non-TSCA disposal facility. The non-contaminated levee material (~ 40,000 cubic yards) could be graded and revegetated at the interim disposal site in area restoration.

2.43 On May 18, 1999, the ODH/BRP issued an opinion letter to the Partnership regarding the ARP remedial action design. The ODH/BRP opinion letter stated: "...that based on the review of the ARP draft CMP/EIS and given the presently known radionuclide concentrations within the sediments of the Ashtabula river, the recommended plan for disposal of the sediments is consistent with State requirements". Considering additional analyses, the ODH/BRP continues to believe that the sediments can be placed in a properly designed cell as described in the CMP/EIS "recommended plan". Reference the CMP and Technical Appendices D and G, also.

2.44 (Radiological Risk Assessment) Risk assessments were made by the U.S. Environmental Protection Agency (USEPA) Region 5 involving inadvertent and unknowing use of Ashtabula River sediments (Reference EIS Appendix C and CMP Technical Appendix F). The first was based upon a resident applying these sediments, left below the cutline for chemical removal, to their property and growing foodstuffs there. There were potentials for external exposure, plant ingestion, soil ingestion and dust inhalation (including radon + decay products) risks. The se-

cond was based upon a worker being exposed as they dredged the chemically contaminated sediments or as they unknowingly dredged sediments above the cutline. There were potentials for external exposure and soil ingestion risks

2.45 The results for the Resident-Farmer showed that the total risk from all pathways to a resident (born on the property and living there for 30 years) was about 1×10^{-4} . The risk was about equally apportioned between external exposure, plant ingestion, and inhalation of radon + decay products. The greatest impact was on the older age groups; older child (6 - 12 years), teenager (13 - 19 years) and adult (20 - 30 years) who had longer exposure periods. The other age groups [baby (0 - 1 year), older baby (1 - 2 years), young child (3 - 5 years)] were lesser impacted. 1×10^{-4} is at the upper bound of the acceptable risk range for lifetime cancer risk found in USEPA's guiding document, the National Oil and Hazardous Substances Pollution Contingency Plan (NCP). The sediment concentrations that led to this risk were found in the Uranium, Thorium and Actinium Decay Series. In no case were any concentrations more than twice background levels for the river and in most cases these were 50% or less over background. The levels measured here are one picocurie per gram (pCi/g) or less background and less than 0.5 pCi/g additional in the sediments. Thus, even though the 30 year risk is at the upper end of the NCP risk range, the small deviation from background radiation sediment levels does not warrant further dredging of the river.

2.46 For the Worker-Dredger the total risk for 2 year plus 4 month excavation project is about 5×10^{-5} . This risk is within the 10^{-6} to 10^{-4} risk range in the NCP. The maximum levels found in these sediments reach about 45 pCi/g uranium-238 + decay products (over background) and about 57 pCi/g uranium-234 (over background) and. These concentrations diverge substantially from background and warrant a health and safety plan and worker protection. However, during the chemical cleanup workers will be under such a plan and will be wearing protective clothing. Thus, if the health and safety plan specifically deals with radiation and the worker is monitored for radiation (e.g., dosimeter, radiation frisking, etc.) this should be adequate.

2.47 In the case of an unknowing worker-dredger, the high radioactive concentrations should be a matter of concern even if the risks are still within the NCP risk range. In radiation public health, the philosophy of ALARA (radiation exposures should be As Low As Reasonably Achievable) is always applied. Removal of these contaminated sediments is a prudent action that would prevent inadvertent exposure of a worker-dredger and keep their potential doses ALARA.

2.48 It is expected that construction of project facilities would take about two years, while the subsequent dredging, transfer/dewatering/transfer, and disposal operations would take about three years. Dredging, transfer/dewatering/transfer, and disposal of the dredged TSCA material would take place the first year. Dredging would likely occur from upstream to downstream, if possible, in order to try to recapture any resuspended sediments and associated contaminants. Some marine docks would need to be progressively temporarily removed or their placement delayed in order to accommodate dredging.

IRREVERSIBLE COMMITMENT OF RESOURCES

2.49 Implementation of the proposed plans would involve the irreversible commitment of Federal, State, and Local funds, energy resources, and construction materials. Confined Disposal Facility construction at the upland site would convert approximately 32 acres of a former industrial site (brownfield) to a disposal area.

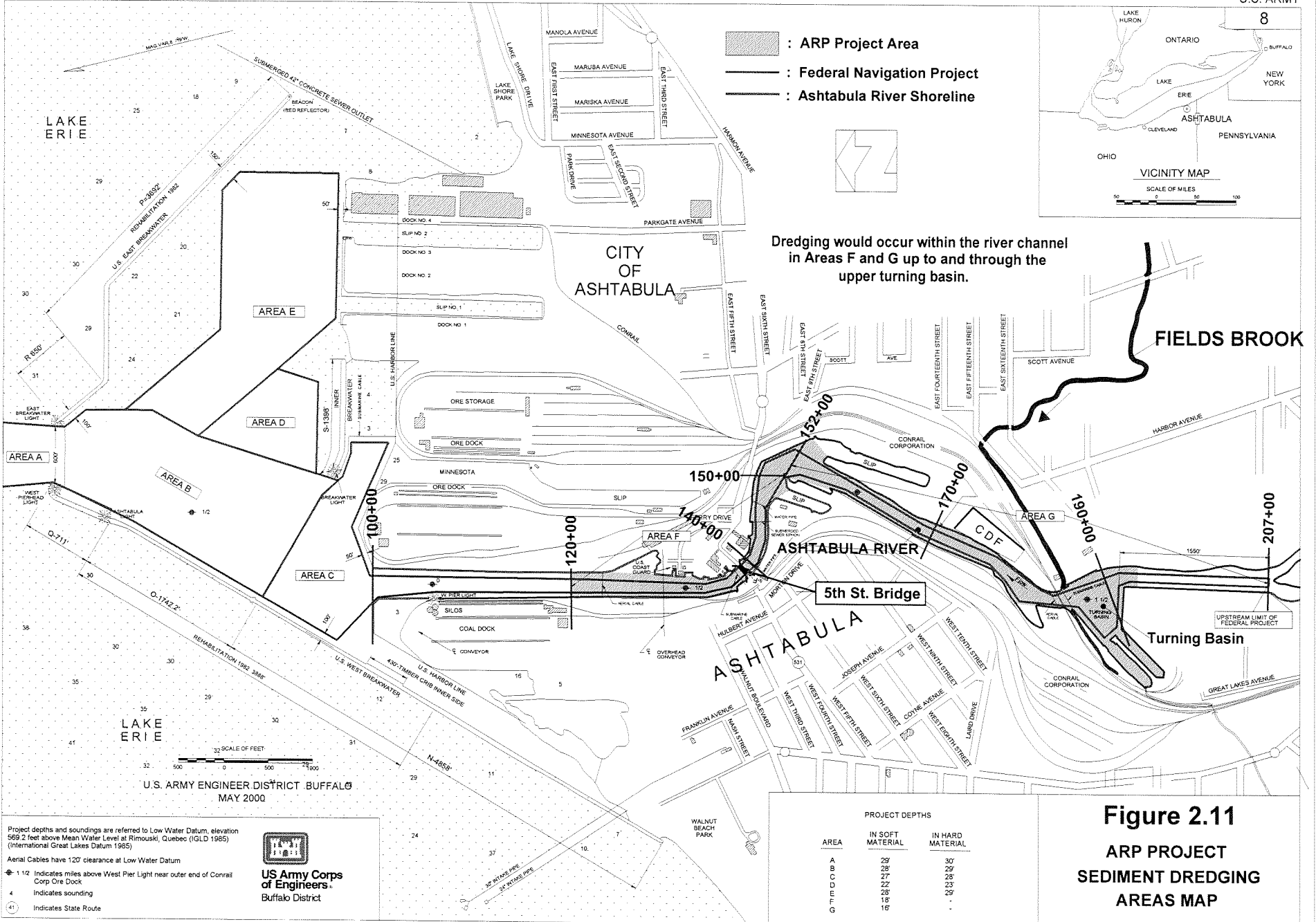

29

Project depths and soundings are referred to Low Water Datum, elevation 569.2 feet above Mean Water Level at Rimouski, Quebec (IGLD 1985) (International Great Lakes Datum 1985)

Aerial Cables have 120' clearance at Low Water Datum

1/2 Indicates miles above West Pier Light near outer end of Conrail Corp Ore Dock

4 Indicates sounding

41 Indicates State Route



U.S. ARMY ENGINEER DISTRICT, BUFFALO
MAY 2000

Figure 2.11
ARP PROJECT
SEDIMENT DREDGING
AREAS MAP

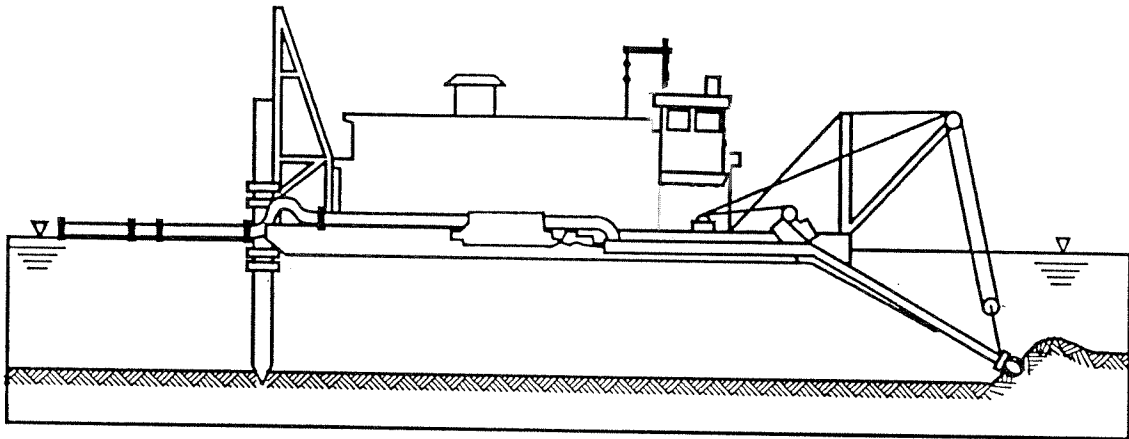

Cutterhead pipeline dredge

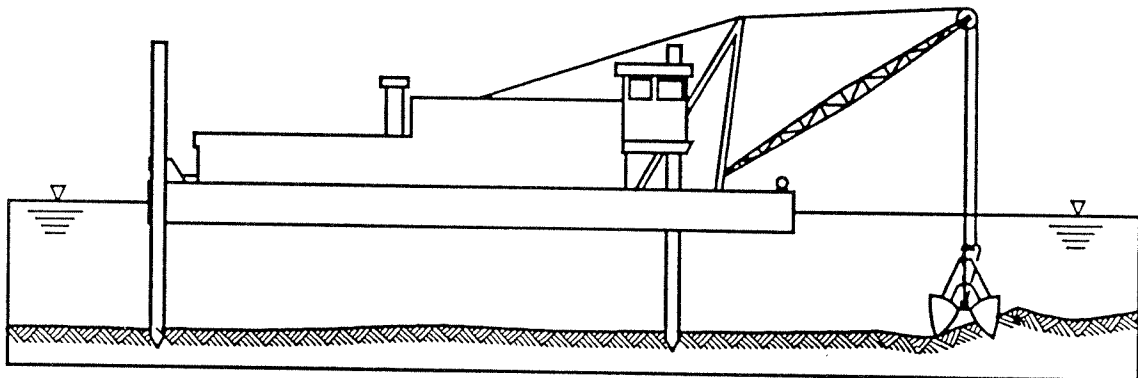

Clamshell dredge

FIGURE 2.12

Ashtabula River Partnership

Dredge (Environmentally)

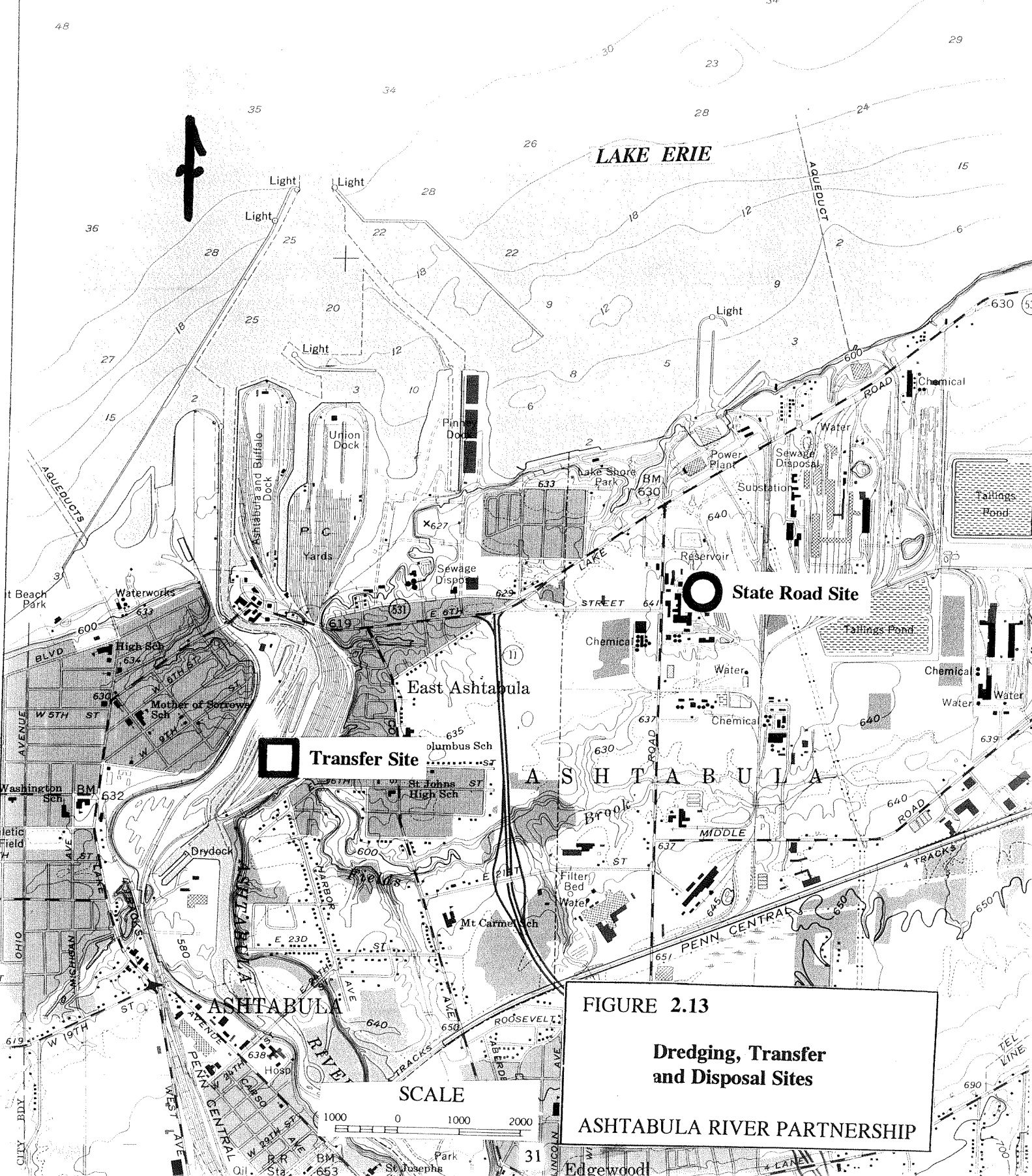
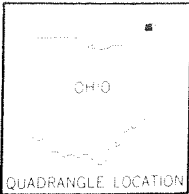
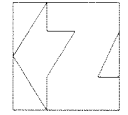
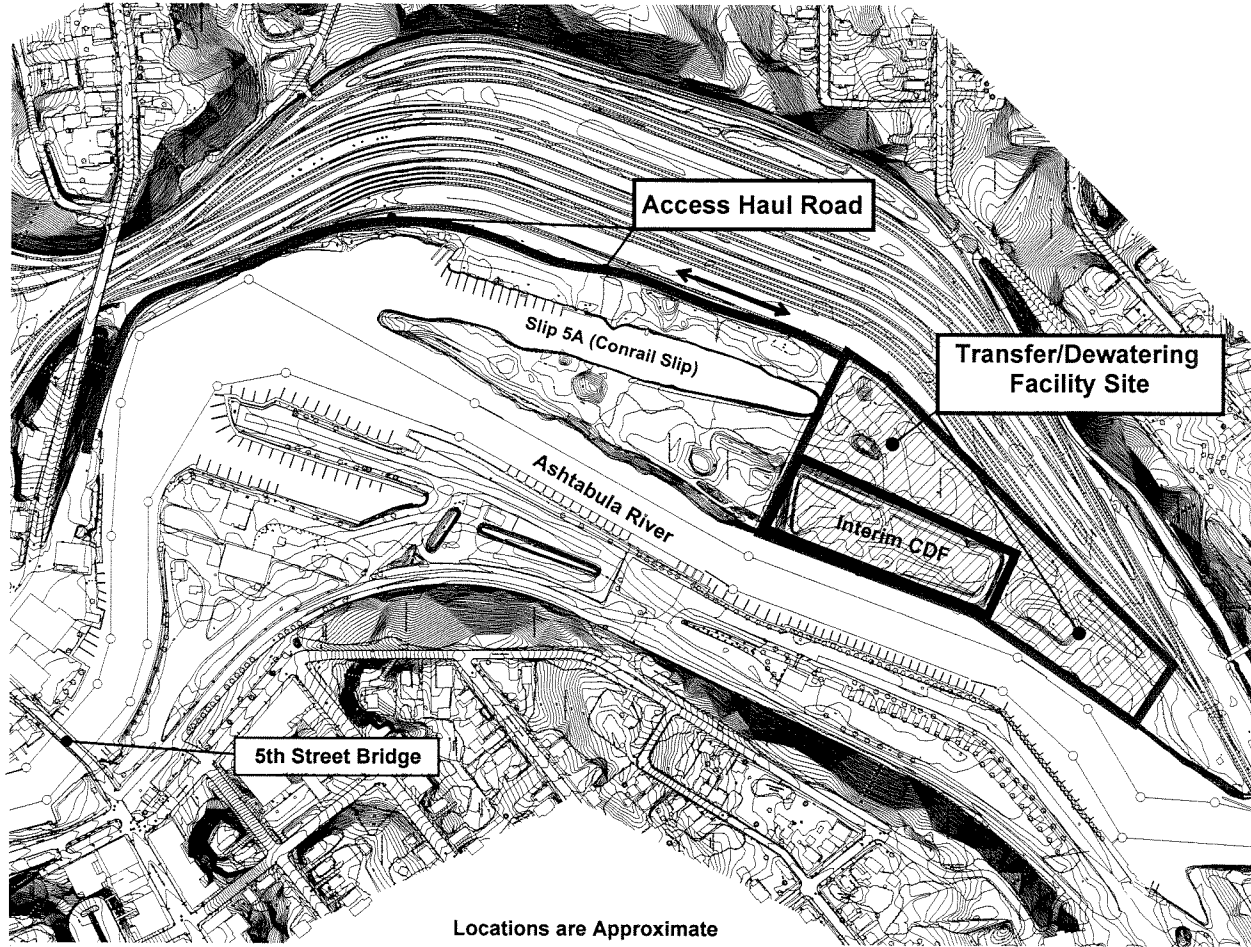

FIGURE 2.13

Dredging, Transfer and Disposal Sites

ASHTABULA RIVER PARTNERSHIP



Locations are Approximate



-  : Transfer/Dewatering Facility Site
-  : Access Haul Road
-  : Federal Navigation Project

Figure 2.14
SHORELINE TRANSFER/DEWATERING
FACILITY SITE
 Map Not To Scale



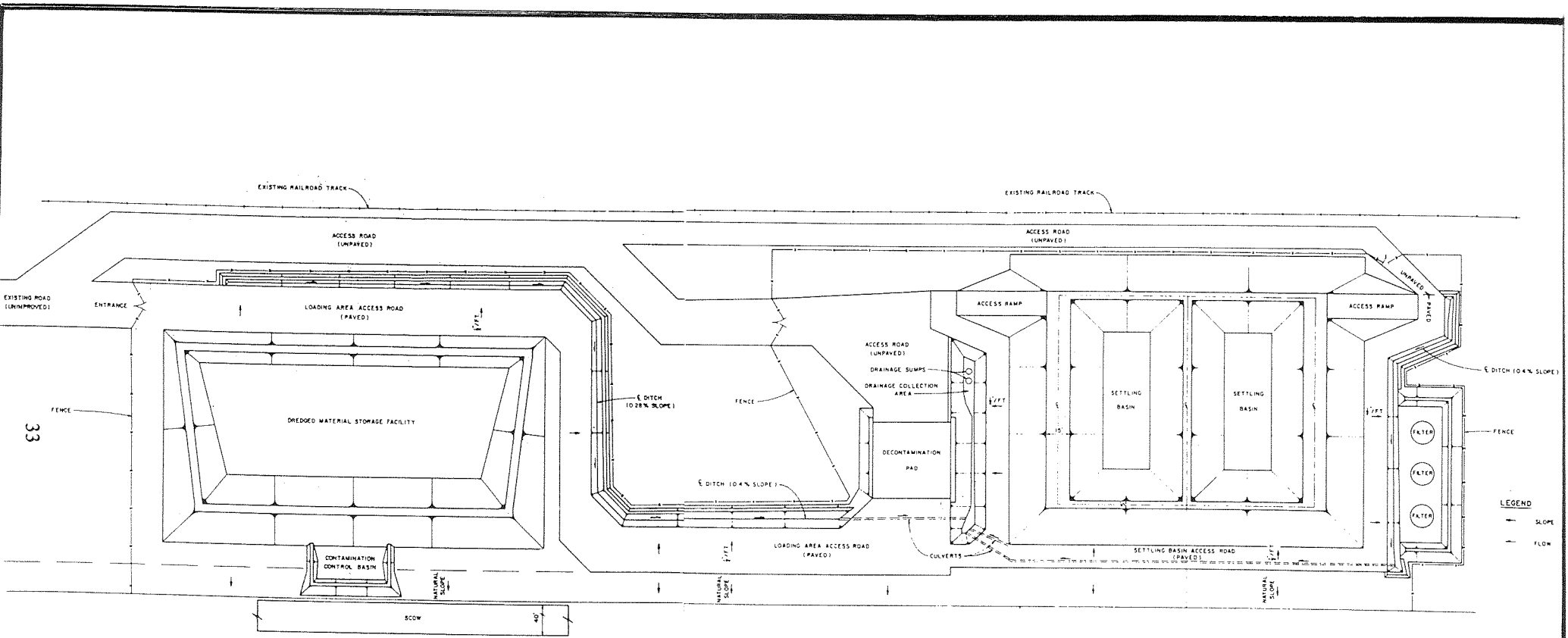

FIGURE 2.15A : Conceptual (Typical) Transfer/Dewatering Site Facilities Operational Systems Layout.

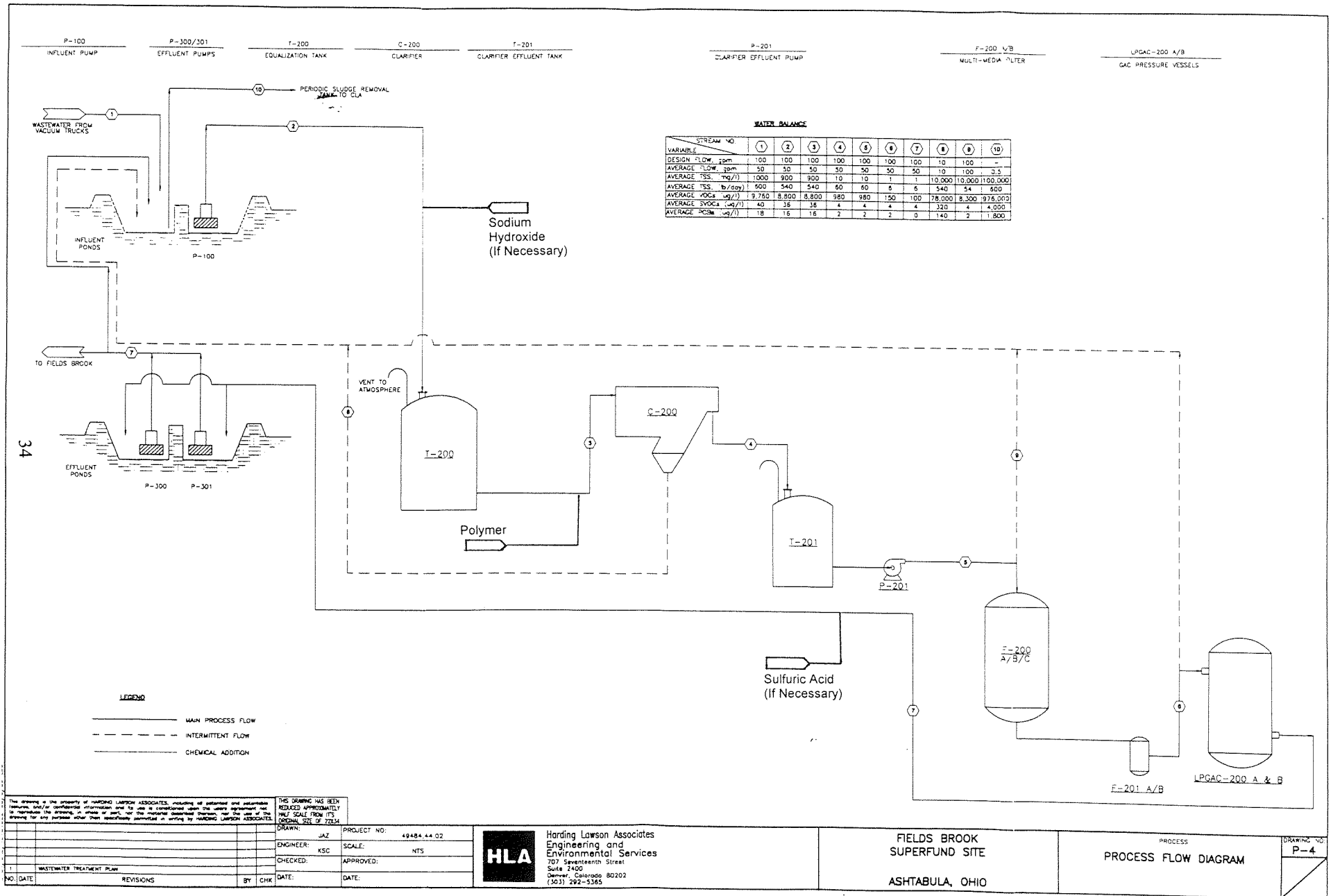

FIGURE 2.15B: Typical Transfer/Dewatering Facility Water Treatment Train Diagram.

- : Investigation Boundary
- [Hatched Box] : Buildings, Bare Urban Land, Demolition Rubble and Patchy Upland Herbaceous Vegetation
- [Solid Black Box] : Lagoon
- [Dotted Box] : Upland Open Field
- [Dark Grey Box] : Wetland
- [Light Dotted Box] : Monotypic Common Reed Growth
- [Small Dotted Box] : Lawn

Avoid impact to any adjacent wetland areas.

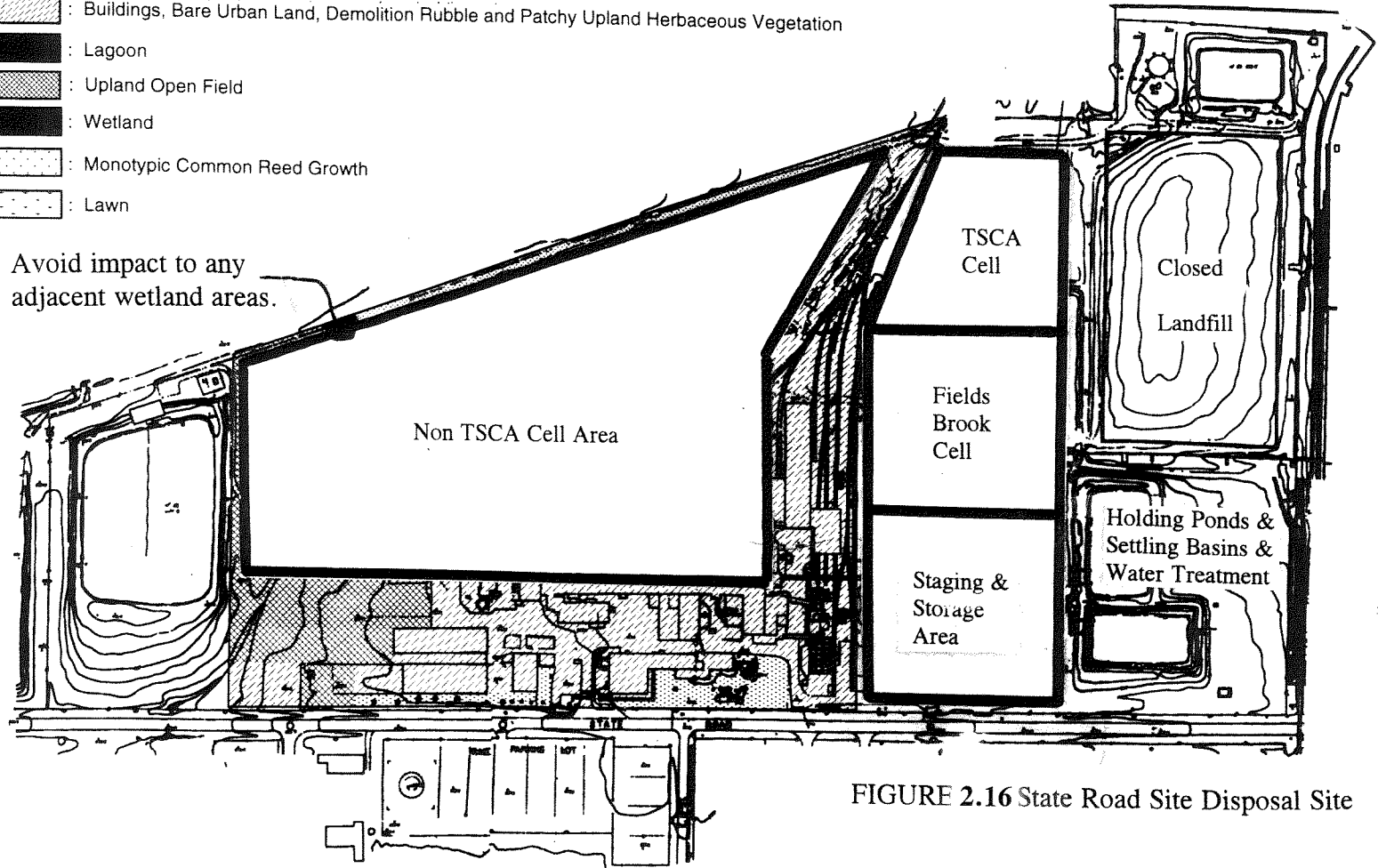
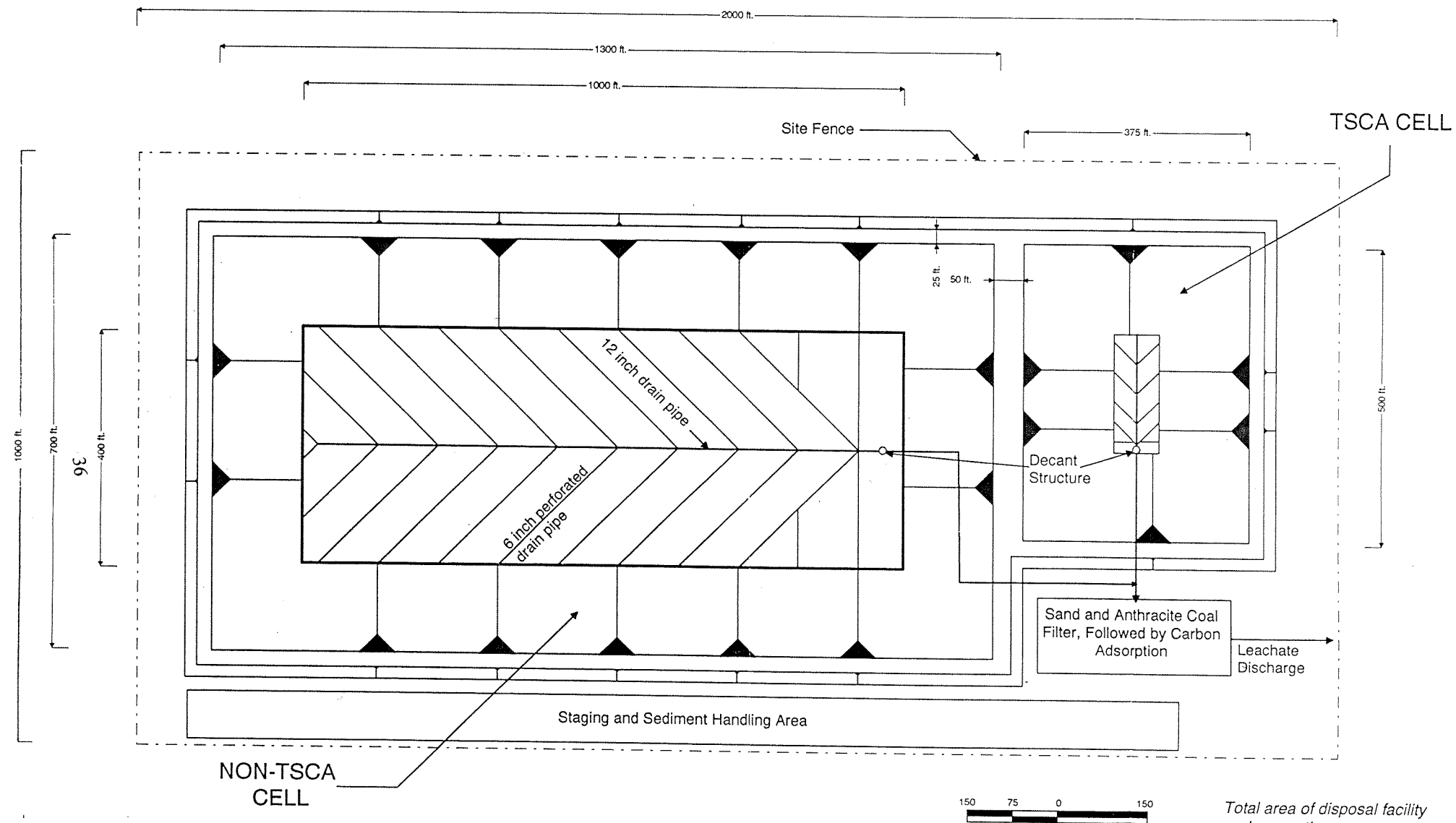
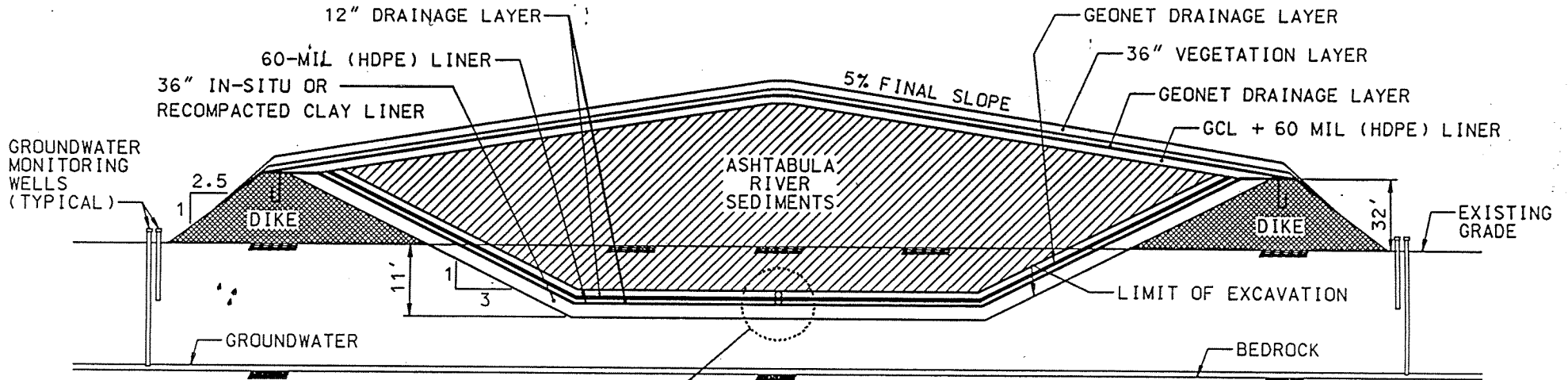

FIGURE 2.16 State Road Site Disposal Site



Total area of disposal facility and supporting structures and facilities is about 46 acres.

FIGURE 2.17 Conceptual Layout of Disposal Facility for Ashtabula River Sediments



NOTES: FIGURE 2.18

1. TEXTURED LINERS ON SLOPE
2. GEONET DRAINAGE LAYER WILL BE PROVIDED ON INTERIOR SLOPE ON LANDFILL
3. LEACHATE COLLECTION PIPES WILL HAVE A MINIMUM OF 0.5% SLOPE
4. GCL IS A GEOSYNTHETIC CLAY LINER
5. A FILTER FABRIC WILL BE PLACED AT TOP AND BOTTOM HDPE LINER FOR PROTECTION FROM GRANULAR MATERIAL IN DRAINAGE LAYER.

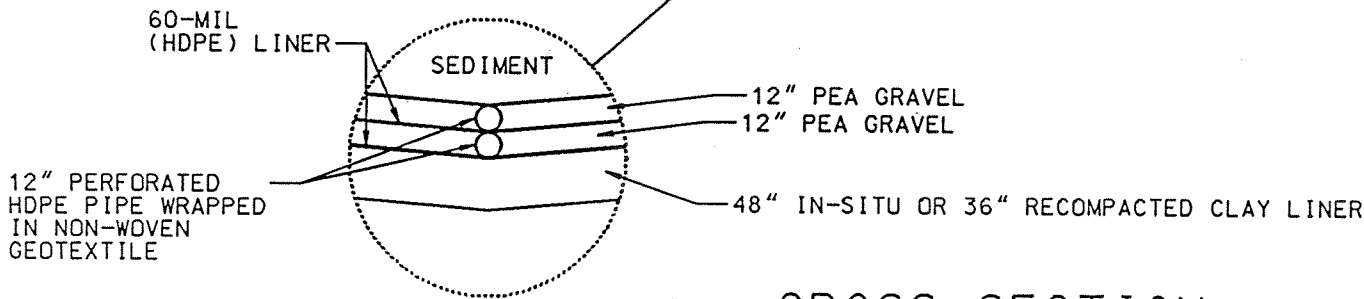

LINER AND LEACHATE COLLECTION DETAIL

CROSS SECTION

NOT TO SCALE

DISPOSAL FACILITY
 ASHTABULA, OHIO
 CONCEPTUAL CROSS SECTION
 OF TSCA DISPOSAL FACILITY
 FOR ASHTABULA RIVER SEDIMENTS

U.S. ARMY ENGINEER DISTRICT BUFFALO
 AUGUST 1997

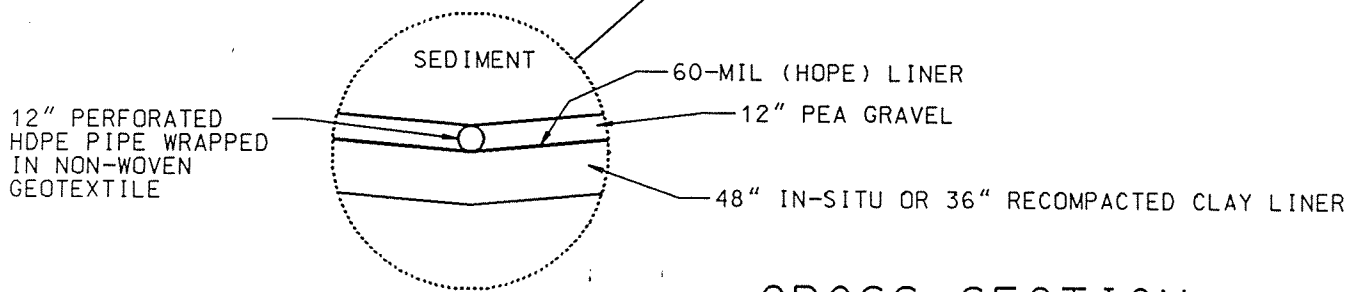
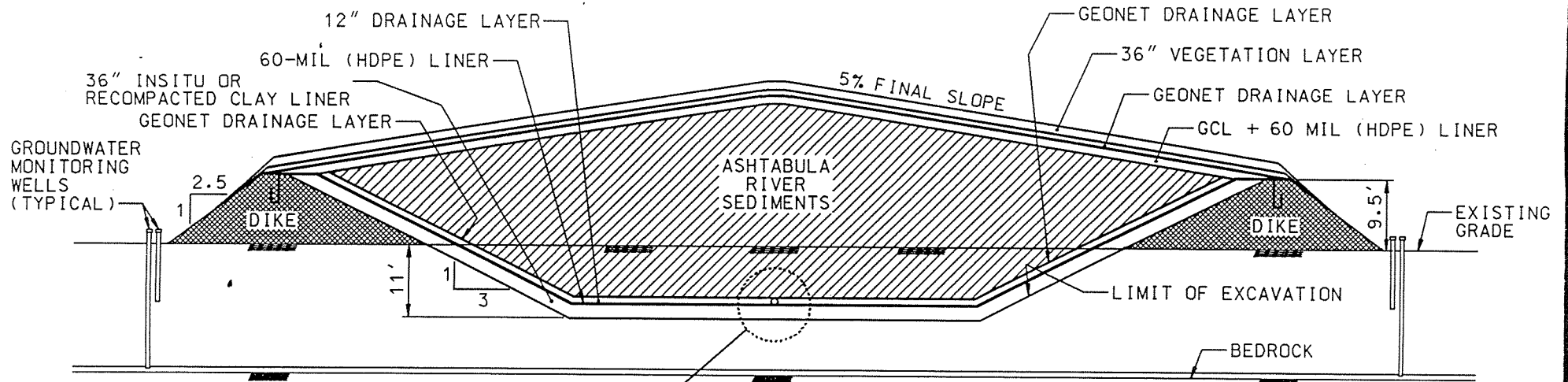

DETAIL

CROSS SECTION

NOT TO SCALE

NOTES: FIGURE 2.19

1. TEXTURED LINERS ON SLOPE
2. GEONET DRAINAGE LAYER WILL BE PROVIDED ON INTERIOR SLOPE ON LANDFILL
3. LEACHATE COLLECTION PIPES WILL HAVE A MINIMUM OF 0.5% SLOPE
4. GCL IS A GEOSYNTHETIC CLAY LINER
5. A FILTER FABRIC WILL BE PLACED ABOVE HDPE LINER FOR PROTECTION FROM GRANULAR MATERIAL IN DRAINAGE LAYER.

DISPOSAL FACILITY
 ASHTABULA, OHIO
 CONCEPTUAL CROSS SECTION
 OF NON-TSCA DISPOSAL FACILITY
 FOR ASHTABULA RIVER SEDIMENTS

U.S. ARMY ENGINEER DISTRICT BUFFALO
 AUGUST 1997

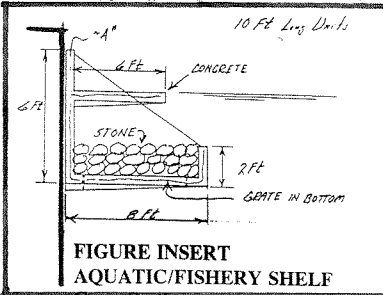
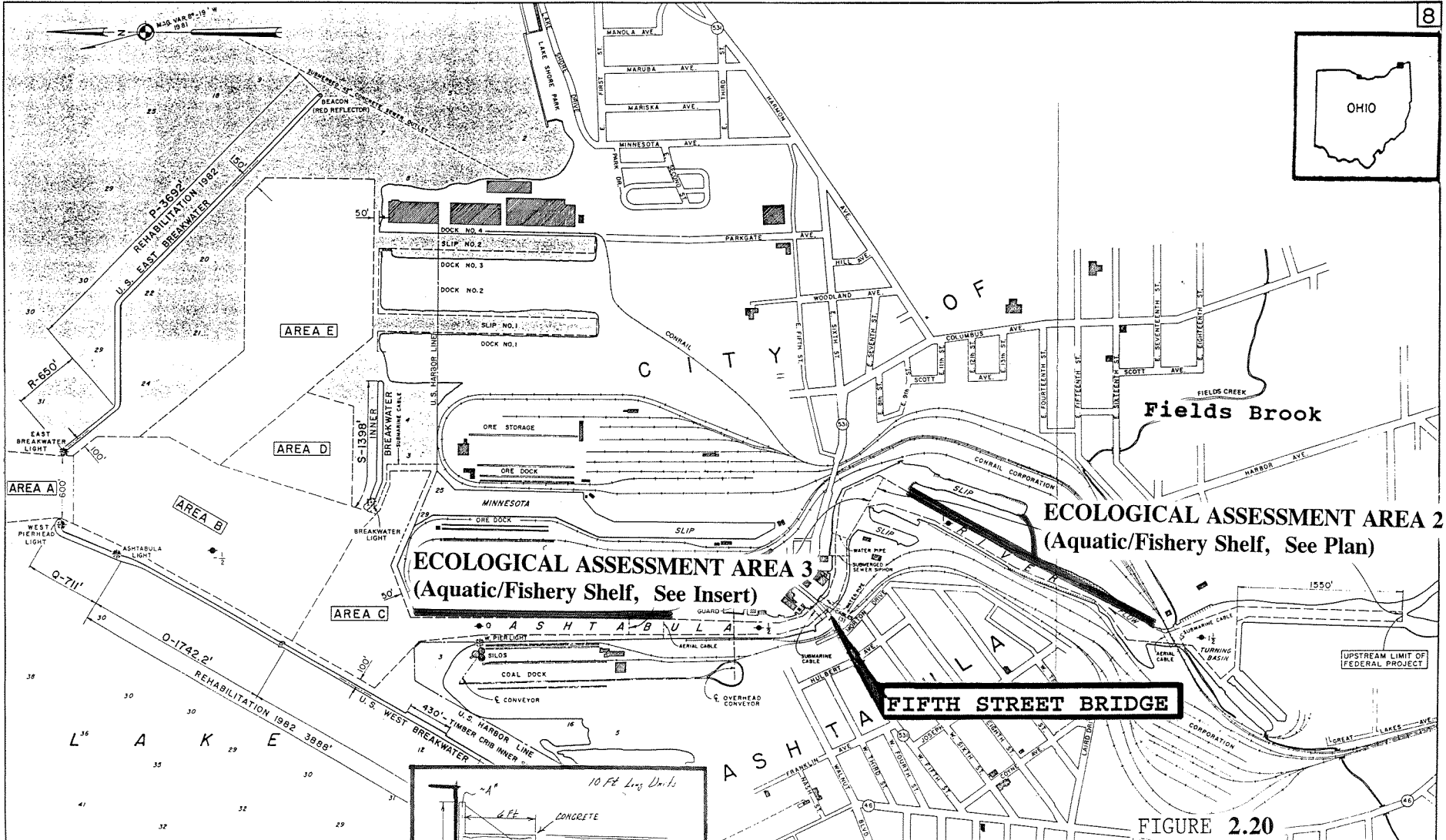

**FIGURE INSERT
AQUATIC/FISHERY SHELF**

AREA	PROJECT DEPTHS	
	IN SOFT MATERIAL	IN HARD MATERIAL
A	29'	30'
B	28'	29'
C	27'	28'
D	22'	23'
E	28'	29'
F	18'	-
G	16'	-

ASHTABULA HARBOR
OHIO
SUPPLEMENTAL ECOLOGICAL RESTORATION PLAN
U.S. ARMY ENGINEER DISTRICT BUFFALO
30 SEPTEMBER 1989

Project depths and soundings are referred to low water datum, elevation 568.6 feet above Mean Water Level at Father Point, Quebec (IGLD 1955) (International Great Lakes Datum 1955)

Aerial Cables have 120' clearance at Low Water Datum.

● indicates miles above West Pier Light near outer end of Conrail Corp. Ore Dock

* indicates sounding

⊕ indicates Shore Route

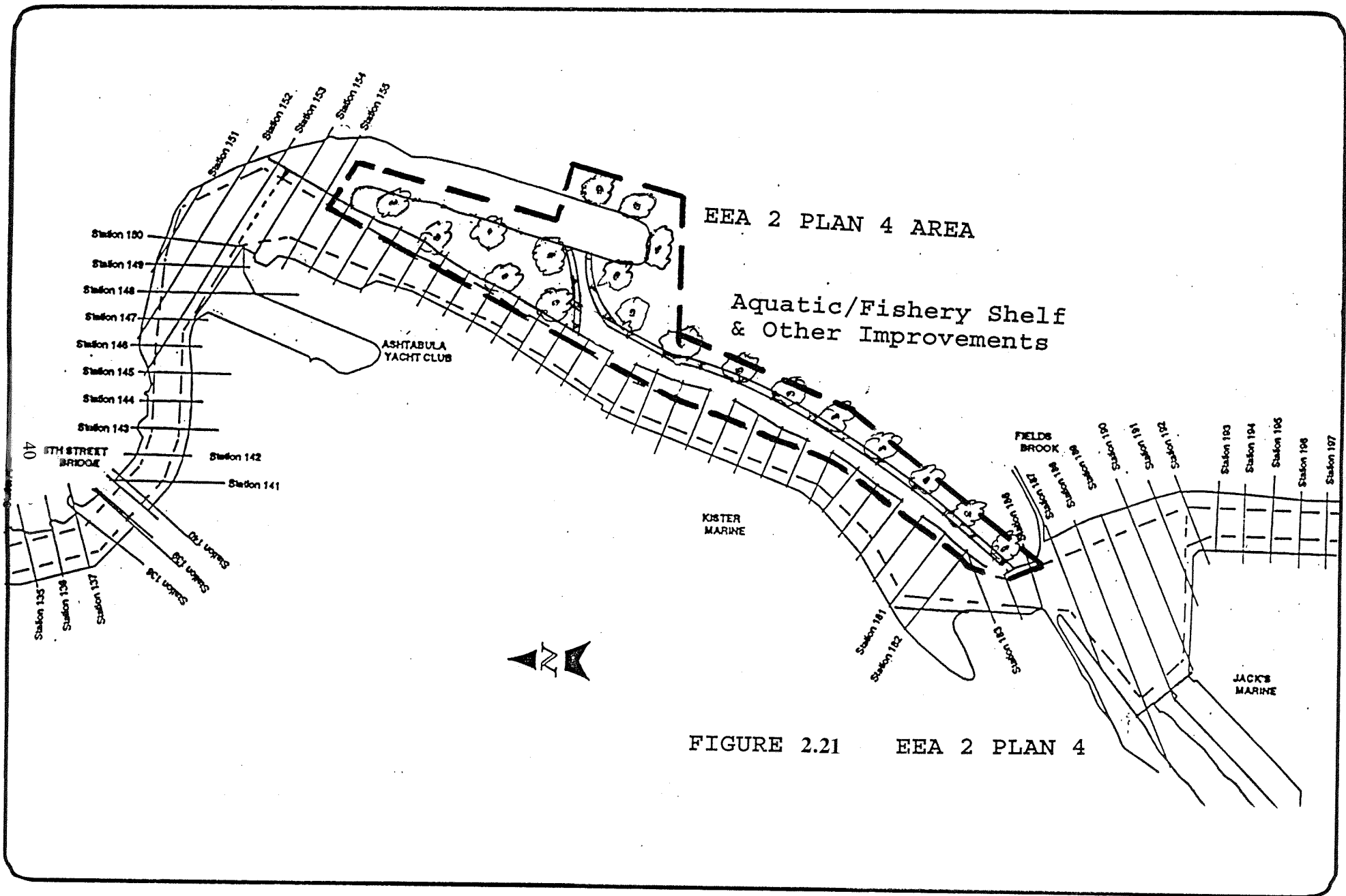

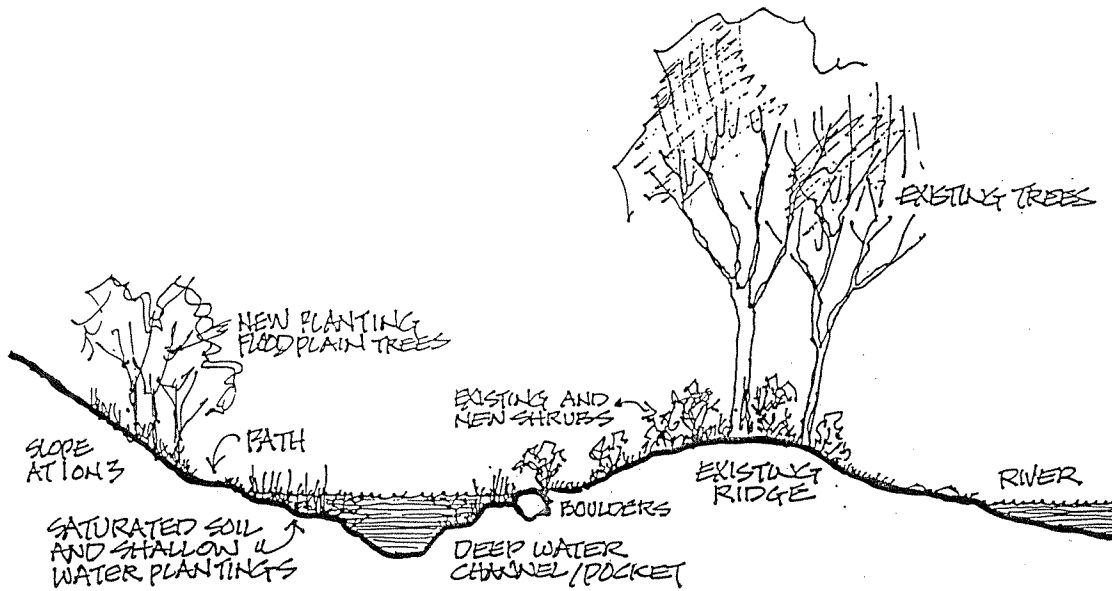

Source: Buffalo River Remedial Action Plan
 (Sterns and Wheler) (Integrated Site, Inc.)

FIGURE 2.22
AQUATIC/FISHERY
DIVERSION/BYPASS
CUT

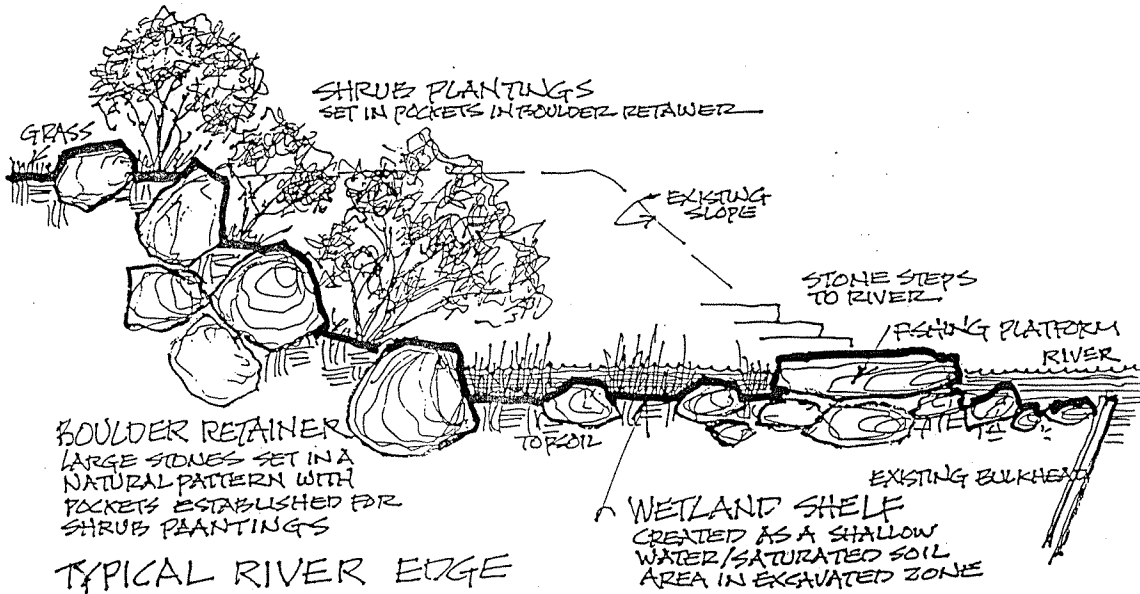

Source: Buffalo River Remedial Action Plan
 (Sterns and Wheler) (Integrated Site, Inc.)

FIGURE 2.23
FISHERY SHELF
(EMBANKMENT CUTBACK)

2.50 Natural Resources (Trustees) Damages. Nothing in this environmental impact statement shall be construed either explicitly or implicitly to irreversibly or irretrievably commit natural re-sources either directly or indirectly associated with the proposed dredging of the Ashtabula Harbor Channel beyond those areas outside of the area of dredging.

REAL ESTATE

2.51 The project real estate is presented in considerable detail in the Feasibility Report and Appendix R - Real Estate Requirements. Reference the CMP and Technical Appendix R, also.

Environmental Dredging Project Requirements:	Acreage:
Landfill Construction	22.26
Associated Lands	11.49
Sediment Transer/Dewater/Transfer Facility Construction	8.31
Associated Lands and Easements	1.70
	(43.76) *1
Potential Supplemental Ecosystem Restoration Requirements	
Section 206 (Total LERRD required)	24.21 *2

*1 Cummulative acreage for the environmental dredging project; permanent easement totals 22.26 acres and temporary land and easements totals 21.50 acres. *2 Comprised of 17.72 acres for the permanent easement and 6.49 acres for temporary (access) easements.

MONITORING

2.52 Sampling and analysis would be incorporated for project short and long-term dredging, transfer, and CDF disposal facilities activities, as appropriate, and as agreed to with USEPA OEPA, and ODH. Generally, existing, project construction and operations, and future post project conditions would be profiled/monitored. A project health and safety plan will be prepared for project implementation with project plans and specifications.

2.53 With implementation of the Deep Dredging plan, water quality will be monitored up-stream and downstream of the dredging activities as agreed upon with the U.S. Environmental Protection Agency, the Ohio Environmental Protection Agency, and the Ohio Department of Health. This usually includes periodic sampling and expeditious analyses and then possibly correlated suspended particulate methodologies so that dredging activities and resulting resuspension of sediments and associated contaminants can be controlled within acceptable parameters.

2.54 The U.S. Environmental Protection Agency has also recommended several biological monitoring methodologies. For example, bio-monitoring using caged bivalves, such as zebra mussels, could be used to assess whether resuspended sediments are being transported from the dredging site and being taken up by the bivalves. Cages could be situated at a reference station upstream of the areas being dredged and at several locations downstream of the dredging area. This could serve to verify whether resuspended sediments are being carried outside of the project area and whether or not their associated contaminants are bioavailable. These are included in project cost estimates.

2.55 The Corps of Engineers periodically (about every five years) samples and analyzes federal channel sediments for the Harbor Operations and Maintenance program. This can also be utilized to provide basic monitoring information with regard to sediment contaminant levels and benthos quality. The Corps of Engineers will conduct such a survey for the Ashtabula Harbor area and report the findings within five to ten years of completion of the project.

Post construction monitoring and maintenance of the Section 206 aquatic/fishery shelves habitat restoration features is required via cooperators for the first three to five years after project construction and will be included in the total project cost and cost shared as required. It is anticipated that the non-Federal sponsor may desire to continue yearly monitoring and maintenance (about every five years) for the next 50 years or as long as the project is authorized.

2.56 The Ohio Environmental Protection Agency Habitat Assessment Procedure (HAP) can be utilized in the future to monitor or measure anticipated project outputs. The Ohio Environmental Protection Agency has been conducting these surveys periodically and will conduct such a survey and report the findings within five to ten years of completion of the project. Subsequent habitat, fishery, and macroinvertebrate survey results and indications of ecological improvements or outputs are/will be reflected by these studies.

2.57 The Ohio Environmental Protection Agency conducts fish sampling and tissue analyses periodically and will conduct such a survey for the Ashtabula Harbor area and report the findings within five to ten years of completion of the project.

2.58 The U.S. Fish and Wildlife Service will be asked to provide any updated available information pertaining to significant Federal species for the Ashtabula Harbor area within five to ten years of completion of the project.

2.59 Post construction monitoring and maintenance will take place at the disposal facility on a yearly basis for the next 50 years or as long as the project is authorized. Monitoring includes test well(s) groundwater sampling, laboratory analysis, statistical analysis and reporting; and, National Pollution Discharge Elimination System (NPDES) sampling, monthly analysis, semi-annual analysis, annual organic analysis, reporting and miscellaneous monitoring. Maintenance includes maintenance of capping system, revegetation, sediment basin cleanout, mowing, fence repair, monitoring well repairs, quarterly inspections and reports, operation of a leachate management system, leachate transportation and disposal from the TSCA and non-TSCA cells of the disposal site, maintenance of facility roads, and other miscellaneous items.

2.60 Minor to moderate adjustments can be made through this or similar authorities or associated operations and maintenance procedures/programs, if the anticipated ecological restoration outputs do not meet reasonable expectations. A memorandum of agreement and funding may be programmed to facilitate monitoring review and assessment/evaluation of the project and possible modifications within five to ten years of completion of the project.

ECONOMIC COSTS/BENEFITS

2.61 The project economic assessment/evaluation is presented in considerable detail in the Feasibility Report Appendix Q - Economic Evaluation. (Three ring binder Technical Appendices)

2.62 The following Tables provide summary cost, benefit/cost (B/C), and conceptual Federal/Non-Federal first cost sharing information for the proposed project. Table 2.5 provides information pertaining to the proposed project itemized and first costs, and derivation of average annual costs. Tables 2.6 through 2.9 provide information pertaining to various benefits/costs ratios. Table 2.10 provides information pertaining to the proposed project first cost

Federal and Non-Federal cost shares.

2.63 An economic analysis of ecological restoration measures was conducted and is presented and discussed in more detail in EIS APPENDIX EA - J SECTION 312(b) ECOLOGICAL RESTORATION/PRESERVATION ANALYSIS and Appendix Economic Analysis. (Part of this report. Follows these text). The analyses referenced various environmental indices to describe the restoration of the ecosystem infrastructure. Those changes affect the level of human use and enjoyment of the ecosystem. Activities such as navigation and recreation, and the general enjoyment derived from living in an area where the ecosystem is not impaired are key elements in maintaining and enhancing the quality of life. Table 4.0 in EIS Section 4 presents summaries of calculated economic Average Annual Benefits and Present Worth Values of goods and services that would be available under alternative environmental restoration scenarios. Calculated benefits exceed project costs.

2.64 Further, Section 907 of the Water Resources Development Act 1996 states that economic costs of all project measures associated with environmental quality, have by definition an equal number of economic benefits associated with them. The removal of polluted sediments located outside of the federal channel may be associated with environmental quality. Consequently, the cost associated with the removal of all polluted sediments located outside the federal channel have a corresponding equal number of benefits and therefore, a benefit to cost ratio of at least 1.

ALTERNATIVE DISPOSAL PLAN

2.65 Although planning assessment/evaluation indicates that construction of disposal facilities at the State Road Site and disposal of the dredged material in the facilities is the current recommended plan, the Ashtabula River Partnership would like to reserve the option whereby the Ashtabula River Partnership and/or project contractor could dispose of the material in appropriate existing or developed (at the time of project implementation) disposal facilities (those that would and could accept the material under current or modified permit), if demonstrated to be substantially more cost effective while remaining environmentally acceptable.

COMPARATIVE IMPACTS OF FINAL CONSIDERED ALTERNATIVES

2.66 Table 2.11 briefly describes in a comparative fashion, by parameters, anticipated environmental impacts of the most feasible dredging and dredged material disposal plans for Ashtabula Harbor, Ohio. For a more detailed description of anticipated alternative impacts of the final considered plans, the reader is referred to SECTION 4 - ENVIRONMENTAL EFFECTS of this Environmental Impact Statement.

Table 2.5-Derivation Of Average Annual Costs-Recommended Plan-October 2000 Prices

Total Project Construction Costs And First Costs	
Construction Costs	
Dredging Costs	\$11,460,200
Dewatering Costs	\$ 4,985,600
Landfill Costs-TSCA	\$ 2,834,700
Landfill Costs- Non TSCA	\$10,319,800
Sampling And Analysis	
During Dredging & At The Transfer Facility	\$ 816,600
At The Disposal facility- After Construction	\$ 173,100
Construction Contingencies	\$ 6,702,100

Total Construction Costs	\$37,202,100
Study Costs And Engineering And Design During Construction	\$ 4,876,200
Construction Management	\$ 2,555,100
Real Estate- Section 312, O&M	\$ 372,400

First Costs 1	\$45,005,800
Investment Costs	
Project First Costs To Be Average Annualized	\$45,005,800
Interest During Construction 2	\$ 5,531,600

Investment Costs To Be Average Annualized	\$50,537,400
Average Annual Costs	
Interest And Amortization (.06678897)	\$ 3,375,400
Disposal Site	
Post Construction Monitoring 3	\$ 26,000
Annual Maintenance 4	\$ 26,200

Average Annual Costs 5	\$ 3,427,600
Present Worth Factor for 6.375%	14.97253
Present Worth Of Average Annual Costs	\$51,319,853
Rounded PW of Average Annual Costs	\$51,319,900

- (1) Project First Costs provided by Cost Estimating came to \$47,615,000. Included in these costs were expenditures over the 50 year life of the project for: Disposal Site Post Construction Monitoring (\$1,301,300) and Annual Maintenance Expenditures At The Disposal Site (\$1,307,900). These type of costs are normally presented as average annual costs. Consequently, these expenditures were subtracted from the \$47,615,000 to arrive at a construction cost of \$45,005,800. These Post Construction Disposal Site Monitoring Costs (\$1,301,300) and Post Construction Disposal Site Maintenance Costs (\$1,307,900) were converted to average annual dollars and are reflected in Disposal Site Average Annual Costs.
- (2) Construction Costs used to develop Interest During Construction (\$44,633,400) were computed by subtracting from Total First Costs (\$45,005,800), the projects Real Estate costs (\$372,400). IDC was based on 16 different construction cost components, a four year construction period and monthly compounding using a 6.375 percent annual interest rate.
- (3) Disposal Site Post Construction Monitoring costs for a 50 year evaluation period were \$1,301,300. These costs were converted to an average annual dollar value. This average annual value came to \$26,000. This average annual value reflects a 6.375 percent annual interest rate, a 50 year project life and October 2000 price levels.
- (4) Disposal Site Maintenance costs for the 50 year evaluation period were \$1,307,900. These costs were converted to an average annual dollar value. This average annual value came to \$26,200. This average annual value reflects a 6.375 percent annual interest rate, a 50 year project life and October 2000 price levels.
- (5) Average Annual Costs reflect a 6.375 annual interest rate, a 50 year project life and October 2000 price levels.

Table 2.6 - Overall Project Viability-Recommended Plan

	October 2000 Prices
A. Present Worth Of All Project Benefits	
1. NED Benefits	
Commercial Navigation Benefits	\$ 19,591,600
Boating (Consumer Surplus)	\$ 1,109,200
Fishing (Consumer Surplus)	\$ 2,755,200
Passive Use Values (Consumer Surplus)	\$ 13,254,300
Change In Property Values	\$ 7,150,000
Risk Reduction To Lake Erie Fishery	\$ 12,865,300

Subtotal	\$ 56,785,600
2. Regional Economic Development Benefits	
Local Economic Impacts(Retain Commercial Navigation)	\$ 64,704,100
Boating (Total Impact Of Expenditures On Output)	\$ 3,694,300
Fishing (Total Impact Of Expenditures On Output)	\$ 11,517,000

Subtotal	\$ 79,915,400
3. Total Benefits	
Downstream Of The 5th Street Bridge	\$ 84,295,700
Upstream Of The 5th Street Bridge	\$ 52,405,300

Total	\$136,701,000
B. Present Worth Of All Project Costs	
1. Project Costs	
Average Annual Costs For The Recommended Plan	\$3,427,600
Present Worth Factor for 6.375% and 50 year project life	14.97253267

Present Worth Of All Project Costs	\$51,319,900
C. Benefit To Cost Comparison-Recommended Plan	
Present Worth Of All Project Benefits	\$136,701,000
Present Worth Of All Project Costs	\$51,319,900
Ratio of Present Worth Benefits to Present Worth Costs	2.66

Table 2.7 - Benefit To Cost ratio For All Work Located Downstream Of The 5th Street Bridge.

Average Annual Benefits¹	\$ 1,308,500
Average Annual Costs¹	\$ 566,300
Net Benefits	\$ 742,200
Benefit To Cost Ratio	2.31

1. All average annual benefits and costs reflect a 6.375% annual interest rate, October 2000 prices and a 50 year project life.

Table 2.8 - Benefit To Cost Ratio For All Work Located Downstream Of The 5th Street Bridge And Within The Federal Channel.

Average Annual Benefits¹	\$ 1,308,500
Average Annual Costs¹	\$ 306,200
Net Benefits	\$10,002,300
Benefit To Cost Ratio	4.27

1. All average annual benefits and costs reflect a 6.375% annual interest rate, October 2000 prices and a 50 year project life.

Table 2.9 - Benefit To Cost Ratio For Section 312 (a) Work Located Down Stream Of The 5th Street Bridge.

Average Annual Benefits¹	\$ 825,400
Average Annual Costs¹	\$ 260,100
Net Benefits	\$ 565,300
Benefit To Cost Ratio	3.17

1. All average annual benefits and costs reflect a 6.375% annual interest rate, October 2000 prices and a 50 year project life.

Table 2.10 Recommended Plan: Proposed Project Conceptual Cost Shares

Cost Item	Federal Cost Share	Non Federal Cost Share	Total Cost
<u>Dredging Downstream Of The 5th Street Bridge</u>			
Within The Federal Channel (Section 1 of R&HA of 1937)	\$ 2,299,000 (100%)	(0%)	\$ 2,299,000
Adjacent To The Federal Channel (Section 312 a)	\$ 1,952,000 (100%)	(0%)	\$ 1,952,000
<u>Dredging Upstream Of The 5th Street Bridge</u>			
Within And Adjacent To The Federal Channel (Section 312 (b))	\$13,961,000 (65%)	\$ 7,517,000 (35%)	\$21,478,000
<u>Disposal Downstream Of The 5th Street Bridge</u>			
Within The Federal Channel (Section 101 Of WRDA 1986)	\$ 1,351,500 (80%)	\$ 337,400 (20%)	\$ 1,688,900
Adjacent To The Federal Channel (Section 312 a)	\$ 1,147,300 (80%)	\$ 286,800 (20%)	\$ 1,434,100
<u>Disposal Upstream Of The 5th Street Bridge</u>			
Within And Adjacent To The Federal Channel (Section 312 (b))	\$10,257,200 (80%)	\$ 5,523,600 (20%)	\$15,783,800
<u>LERRDS</u>			
Administrative Costs	\$ 0 (0%)	\$ 261,000 (100%)	\$ 261,000
Acquisition Costs	\$ 43,000 (38%)	\$ 69,000 (62%)	\$ 112,000
	-----	-----	-----
First Cost Totals	\$31,011,000 (68.9%)	\$13,994,800 (31.1%)	\$45,005,800
<u>Monitoring And Maintenance</u>			
Cubic Yards From Below 5 th St Bridge & Inside the Federal Channel	\$ 186,500 (80%)	\$ 46,600 (20%)	\$ 233,100
Cubic Yards From Below 5 th St Bridge & Outside the Federal Channel	\$ 158,300 (80%)	\$ 39,600 (20%)	\$ 197,900
Cubic Yards From Above the 5 th St Bridge			
Non TSCA	\$ 1,050,200 (65%)	\$ 565,500 (35%)	\$ 1,615,700
TSCA	\$ 365,600 (65%)	\$ 196,900 (35%)	\$ 562,500
	-----	-----	-----
	\$ 1,760,600	\$ 848,600	\$2,609,200
Cost Estimating Control Totals	\$32,771,600 (68.8%)	\$14,843,400 (31.2%)	\$47,615,000

TABLE 2.11 - Comparative Impacts of Final Considered Alternatives

Item	Final Considered Alternative Plans		
	No Action (Without Project Conditions)	Proposed Upland State Road Site Plan	Alternative Disposal Plan
Federal Cost		\$ 31,011,000	
Non-Federal Cost		\$ 13,994,800	
Total First Cost	NA	\$ 45,005,800	NC
Benefits (PW)		\$136,701,000	
Costs (PW)		\$ 51,319,900	
B/C		2.66	

(1) All benefits and Costs reflect a 50 year project life, a 6.375% annual interest rate and October 2000 prices.
 (2) Reference the Feasibility Report and Technical Appendices: Cost Estimating, Cost Sharing, and Economic Analyses for Details.
 (NA)=Not Applicable, (NC)=Not Calculated, (PW)=Present Worth.

Environmental Assessment - Comparative Impacts of Final Considered Alternatives
 ST: = Short Term (i.e., Construction), LT: = Long Term

Evaluation Parameters	Considered Alternatives					
	No Action (Without Project)	Channel Dredging	Transfer/Dewater Harbor Shoreline	Transfer/Dewater Harbor Barge	Upland CDF Development	Existing Landfill (Permitted)
Physical/Natural						
Air Quality	ST: Not Significant LT: Not Significant Migration of contaminated sediments downstream. Dredging/harbor activity limited.	ST: Minor Adverse LT: Not Significant Construction equipment fumes. Some initial dredged material volatilization.	ST: Minor Adverse LT: Not Significant Construction equipment fumes. Some dredged material volatilization.	ST: Minor Adverse LT: Not Significant Construction equipment fumes. Some dredged material volatilization.	ST: Minor Adverse LT: Not Significant Construction equipment fumes. Some initial dredged material volatilization.	ST: Minor Adverse LT: Not Significant Transport equipment fumes. Some initial dredged material volatilization.
Water Quality	ST: Minor Adverse LT: Moderate Adverse Migration of contaminated sediments downstream. Dredging and disposal increasingly limited.	ST: Moderate Adverse LT: Moderate Beneficial Dredging turbidity within the mixing zone. Removal of contaminated sediment from the river.	ST: Minor Adverse LT: Not Significant Construction runoff. Treated discharges.	ST: Minor Adverse LT: Not Significant Construction runoff. Treated discharges.	ST: Minor Adverse LT: Minor Adverse Construction runoff. Treated discharges.	ST: Minor Adverse LT: Minor Adverse Transport runoff. Treated discharges.
Sediment Quality	ST: Moderate Adverse LT: Major Adverse Migration of contaminated sediments downstream. Dredging and disposal increasingly limited.	ST: Moderate Beneficial LT: Major Beneficial Dredging turbidity within the mixing zone. Removal of contaminated sediment from the river.	ST: Minor Adverse LT: Not Significant Construction runoff. Transfer processing. Treated discharges.	ST: Minor Adverse LT: Not Significant Construction runoff. Transfer discharges.	ST: Minor Adverse LT: Minor Adverse Construction runoff. Confined disposal of contaminated material.	ST: Minor Adverse LT: Minor Adverse Placement in CDF. Confined disposal of contaminated material.
Benthos	ST: Moderate Adverse LT: Major Adverse Migration of contaminated sediments downstream. Dredging and disposal restricted.	ST: Minor Adverse LT: Moderate Beneficial Dredging excavation of benthos. Recolonization in cleaner sediments.	ST: Not Significant LT: Not Significant	ST: Not Significant LT: Not Significant	ST: Not Significant LT: Not Significant	ST: Not Significant LT: Not Significant
Fisheries	ST: Minor Adverse LT: Moderate Adverse Migration of contaminated sediments downstream. Dredging and disposal restricted. Wider contamination.	ST: Minor Adverse LT: Moderate Beneficial Dredging turbidity within the mixing zone. Removal of contaminated sediment from the river.	ST: Not Significant LT: Not Significant Transfer operation.	ST: Not Significant LT: Not Significant Transfer operation.	ST: Not Significant LT: Not Significant	ST: Not Significant LT: Not Significant
Vegetation	ST: Minor Adverse LT: Minor Adverse Migration of contaminated sediments downstream. Dredging and disposal limited.	ST: Minor Adverse LT: Moderate Beneficial Dredging excavation of vegetation. Recolonization in cleaner sediments.	ST: Minor Adverse LT: Not Significant Clear and grub about 5 acres of low value vegetation. Grass/legume slope cover. Restoration.	ST: Not Significant LT: Not Significant Use existing docking facilities.	ST: Minor Adverse LT: Not Significant Clear and grub about 32 acres of low value vegetation. Grass/legume slope cover. Restore. Restoration.	ST: Not Significant LT: Not Significant Existing development.
Wildlife	ST: Minor Adverse LT: Moderate Adverse Migration of contaminated sediments downstream. Dredging and disposal limited.	ST: Minor Adverse LT: Moderate Beneficial Dredging disruptions. Removal of contaminated sediments from the river.	ST: Not Significant LT: Not Significant Clear and grub about 5 acres of low value habitat. Grass/legume slope cover. Restore.	ST: Not Significant LT: Not Significant Use existing docking facilities.	ST: Not Significant LT: Not Significant Clear and grub about 32 acres of low value habitat. Grass/legume slope cover. Restore.	ST: Not Significant LT: Minor Beneficial Existing development. Eventual fill cover.
Threatened and Endangered Species	ST: Not Significant LT: Not Significant Transient species.	ST: Not Significant LT: Not Significant Transient species.	ST: Not Significant LT: Not Significant Transient species only, no residents.	ST: Not Significant LT: Not Significant Transient species only.	ST: Not Significant LT: Not Significant Transient species only, no residents.	ST: Not Significant LT: Not Significant Existing development.
Wetlands	ST: Minor Adverse LT: Moderate Adverse Migration of contaminated sediments downstream. Contamination.	ST: Not Significant LT: Not Significant Small riparian areas may be impacted.	ST: Minor Adverse LT: Not Significant Small riparian area construction impact.	ST: Not Significant LT: Not Significant Use existing docking facilities.	ST: Minor Adverse LT: Not Significant Small riparian area construction impact.	ST: Not Significant LT: Not Significant Existing development.
General Soils Geology and Ground Water	ST: Minor Adverse LT: Minor Adverse Migration of contaminated sediments downstream. Dredging	ST: Minor Adverse LT: Moderate Beneficial Dredging turbidity and excavation of sediments. Removal of contaminated	ST: Minor Adverse LT: Not Significant Construction disruption. Facility operations. Resoration.	ST: Not Significant LT: Not Significant Use existing docking facilities.	ST: Moderate Adverse LT: Minor Adverse Construction disruption. CDF construction. Containment of	ST: Not Significant LT: Not Significant Existing development containment of

Evaluation Parameters	Considered Alternatives					
	No Action (Without Project) and disposal limited.	Channel Dredging sediment from the river	Transfer/Dewater Harbor Shoreline	Transfer/Dewater Harbor Barge	Upland CDF Development contaminated sediment.	Existing Landfill (Permitted) contaminated sediments.
Human (Man-Made)						
Community and Regional Growth	ST: Moderate Adverse LT: Major Adverse Migration of contaminated sediments downstream. Dredging and disposal restricted. Harbor activity restricted. Associated adverse impacts to the community.	ST: Minor Adverse LT: Major Beneficial Construction, dredging, and disposal operations disruptions. Removal of contaminated sediments from the harbor. CDF containment. Harbor O&M.	ST: Minor Adverse LT: Moderate Beneficial Construction, facilities operations, transport disruption. Harbor dredged. Cleaner river sediments. Area restoration.	ST: Minor Adverse LT: Moderate Beneficial Facilities operations transport disruption. Harbor dredged. Cleaner river sediments. Existing docking facilities.	ST: Minor Adverse LT: Moderate Beneficial Construction, dredging, and disposal operations disruptions. Local CDF containment of contaminated sediments. Some O&M disposal capacity. Use lower value land.	ST: Minor Adverse LT: Moderate Beneficial Construction, transfer, transport disruptions. Regional upland CDF disposal of TSCA contaminated sediments. Existing facility.
Displacement of People	ST: Minor Adverse LT: Moderate Adverse Harbor activity restricted. Possible loss of businesses.	ST: Not Significant LT: Not Significant No displacement of residences or developments.	ST: Not Significant LT: Not Significant No displacement of residences or developments.	ST: Not Significant LT: Not Significant No displacement of residences or developments.	ST: Not Significant LT: Not Significant No displacement of residences or developments.	ST: Not Significant LT: Not Significant Existing facility.
Displacement of Farms	ST: Not Significant LT: Not Significant	ST: Not Significant LT: Not Significant	ST: Not Significant LT: Not Significant No farmland.	ST: Not Significant LT: Not Significant	ST: Not Significant LT: Not Significant No farmland.	ST: Not Significant LT: Not Significant Existing facility.
Business/Industry Employment/Income	ST: Moderate Adverse LT: Major Adverse Migration of contaminated sediments downstream. Dredging and disposal restricted. Harbor activity restricted. Possible loss of businesses.	ST: Minor Adverse LT: Major Beneficial Construction, dredging, and disposal operations and costs. Removal of contaminated sediments from the harbor. CDF containment. Harbor O&M.	ST: Minor Beneficial LT: Minor Beneficial Construction, facilities operation work, disruption. Costs. Harbor dredged. Area restoration.	ST: Minor Beneficial LT: Minor Beneficial Use existing facilities. Facilities operation work, disruption. Costs. Harbor dredged.	ST: Minor Beneficial LT: Moderate Beneficial Construction, dredging, and disposal operations needs. Removal of contaminated sediments from the harbor. CDF containment. Harbor O&M.	ST: Minor Beneficial LT: Moderate Beneficial Construction, transfer, transport, disposal operations. Cost. Regional up-land CDF Containment of TSCA contaminated sediment. Existing facility.
Public Facilities and Services	ST: Moderate Adverse LT: Major Adverse Migration of contaminated sediments downstream. Dredging and disposal restricted. Harbor activity restricted. Possible loss of businesses.	ST: Minor Adverse LT: Moderate Beneficial Construction, dredging, and disposal operations needs. Removal of contaminated sediments from the harbor. CDF containment. Harbor O&M.	ST: Minor Adverse LT: Not Significant Construction and facilities operation needs. Transport impacts. Harbor dredged. Area restoration.	ST: Minor Adverse LT: Not Significant Use existing facilities. Facilities operation work, disruption. Costs. Harbor dredged.	ST: Minor Adverse LT: Moderate Beneficial Construction, dredging, and disposal operations needs. Local CDF containment facility. Some O&M disposal capacity. Serves harbor O&M.	ST: Minor Adverse LT: Moderate Beneficial Construction, transfer, transport, disposal operation needs. Regional up-land TSCA facility. Existing facility.
Recreation	ST: Moderate Adverse LT: Major Adverse Migration of contaminated sediments downstream. Dredging and disposal restricted. Contamination wider. Possible lose marina activity/businesses.	ST: Minor Adverse LT: Major Beneficial Construction, dredging, and disposal operations disruptions. Removal of contaminants from the harbor. CDF containment. Harbor O&M.	ST: Minor Adverse LT: Minor Beneficial Construction and facilities operation disruptions. Harbor dredged. Cleaner river sediments. Area restoration.	ST: Minor Adverse LT: Minor Beneficial Construction and facilities operation disruptions. Harbor dredged. Cleaner river sediments. Existing facility.	ST: Minor Adverse LT: Minor Adverse Construction and disposal operations disruptions. Local DCF containment of contaminated sediments. Grass/legume cover. Use lower value land.	ST: Not Significant LT: Not Significant Existing facility.
Property Value and Tax Revenue	ST: Moderate Adverse LT: Major Adverse Migration of contaminated sediments downstream. Dredging and disposal restricted. Harbor activity restricted. Possible loss of business/tax.	ST: Minor Adverse LT: Minor Beneficial Construction, dredging, and disposal operations and costs. Removal of contaminated sediments from the harbor. CDF containment. Harbor O&M.	ST: Minor Adverse LT: Minor Beneficial Construction and facilities operation and costs. Use interim disposal area. Area restoration.	ST: Not Significant LT: Not Significant Use existing docking facilities. Facilities operation and costs.	ST: Minor Adverse LT: Minor Adverse Construction and disposal operations and costs. Local CDF containment of contaminated sediments. Grass/legume cover. Use lower value land.	ST: Minor Adverse LT: Not Significant Construction, transfer, transport, and disposal operations and costs. Regional TSCA upland CDF. Existing facility.
Noise and Aesthetics	ST: Minor Adverse LT: Moderate Adverse Migration of contaminated sediments downstream. Dredging and disposal restricted. Harbor activity restricted. Possible loss of business and deceptions.	ST: Moderate Adverse LT: Minor Beneficial Construction, dredging, and disposal operations disruptions. Removal of contaminated sediments from the harbor. CDF containment. Harbor O&M.	ST: Moderate Adverse LT: Not Significant Construction and facilities operation disruptions. Transport disruptions. Area restoration.	ST: Moderate Adverse LT: Not Significant Use existing docking facilities. Facilities operation disruptions. Transport disruptions.	ST: Moderate Adverse LT: Minor Adverse Construction and disposal operations disruptions. Local CDF containment of contaminated sediments. Grass/legume cover. Use lower value land.	ST: Minor Adverse LT: Not Significant Construction, transfer, transport, and disposal operations disruptions. Regional TSCA upland facility. Existing facility.
Community Cohesion	ST: Moderate Adverse LT: Major Adverse Migration of contaminated sediments downstream. Dredging and disposal restricted. Harbor activities restricted. Associated adverse impacts to the community.	ST: Minor Adverse LT: Moderate Beneficial Construction, dredging, and disposal operations disruptions. Removal of contaminated sediments from the harbor. CDF containment. Harbor O&M.	ST: Minor Adverse LT: Moderate Beneficial Construction, facilities operations, transport disruption. Harbor dredged. Cleaner river sediments. Area restoration.	ST: Minor Adverse LT: Moderate Beneficial Facilities operation transport disruption. Harbor dredged. Cleaner river sediments. Existing docking facilities.	ST: Minor Adverse LT: Minor Adverse Construction and disposal operations disruptions. Local CDF containment of contaminated sediments. Use lower value land.	ST: Minor Adverse LT: Minor Adverse Construction, transfer, transport, and disposal operations disruptions. Regional TSCA upland facility. Existing facility.
Cultural Resources	ST: Not Significant LT: Not Significant None identified in the dredging areas.	ST: Not Significant LT: Not Significant None identified in the dredging areas.	ST: Not Significant LT: Not Significant None identified in the interim disposal site area.	ST: Not Significant LT: Not Significant Use existing docking facility.	ST: Not Significant LT: Not Significant None identified in the site area.	ST: Not Significant LT: Not Significant Existing facility.

CONTINUED HARBOR OPERATION AND MAINTENANCE DREDGING AND DISPOSAL

2.67 Harbor channel sediments will continue to be sampled and analyzed in accordance with applicable sampling and analyses guidelines. It is expected that post project dredged sediments will be suitable for unrestricted open-lake disposal at the open lake disposal site. If, however, some dredged sediments may not be suitable for unrestricted open lake disposal, it is expected that these latter dredged sediments would be dredged and dewatered utilizing marine based dewatering facilities and then transferred/transported to a low bidder upland disposal site for disposal or to beneficial use sites. Other alternatives may be reassessed in the future. It is expected that all of the sediments in the future may be dredged and transported by conventional methods.

ASHTABULA HARBOR LONG-TERM MANAGEMENT PLAN

2.68 The U.S. Environmental Protection Agency and the Ohio Environmental Protection Agency and the U.S. Natural Resources Conservation Service are engaged in various best management programs relative to pollution and sedimentation control. These will serve to minimize contaminated sediments and the amount of sediments needed to be dredged from navigation channels in the future.

2.69 In recent years, with thoughts to limit open lake disposal of dredged material and the proliferation of construction of dredged material confined disposal facilities (CDFs), considerable consideration is being given to beneficial use of dredged material. Beneficial use considerations include, use for:

- * Landfill Cover
- * Construction Fill Material
- * Manufactured Soils Viability and Market
(ie. dredged material, sludge, kiln mix)
- * Environmental Restorations
(ie. cover, wetlands, islands, peninsulas, etc.)
- * Landscaped Lands (ie. parks, ski/sled hills, wildlife areas)
- * Interception/Redistribution (ie. catch settling basins, redistribution to Regional/County/Town distribution centers, redistribution to farmlands, etc.)

Several of these beneficial uses show some promise and could be considered for Ashtabula Harbor some time in the future.

2.70 Considering PCB contamination levels, currently, the acceptable *guideline* level (per USEPA and OEPA) for PCBs in dredged material and/or manufactured soils for land applications is < 1 ppm, which may be reached by mixing (Based on Toledo Harbor Long-Term Management Plan pilot study information). Subject to review and approval. Higher concentrations may be acceptable in other applications (ie. landfill cover). Other parameters and regulations would also need to be considered and met.

2.71 Although some after project dredging exposed sediments may have about 1 to 10 ppm PCB concentrations, cover sediments and material dredged in the future from Ashtabula Harbor should have very low contaminant levels and should be suitable for either open-lake disposal or for beneficial use, should it prove to be economically feasible. Therefore, in addition to the expected long-term harbor maintenance dredging and open-lake disposal, other long-term considerations may include, for example:

- * Sediment maintenance dredging and dewatering via waterbased (ie. barge) facilities with direct barge transport to, or harbor area transfer/transport to identified beneficial use sites.

- * Sediment maintenance dredging and dewatering via developed harbor area facilities and transfer/transport to identified beneficial use sites.

2.72 Ashtabula Harbor currently has no sediment dewatering or suitable/economical dredged material confined disposal facilities.

SECTION 3 - ENVIRONMENTAL SETTING AND AFFECTED ENVIRONMENT

INTRODUCTION

3.01 The purpose of this section is to present an overview of the environmental setting in the general vicinity of the potential project, in order to provide a basis by which to assess and evaluate the various alternative plans.

3.02 A number of standard engineering, economic, and environmental measures are used to assess/evaluate alternative scenarios. In addition, justification for dredging under the 312(b) and 206 authorities must include a habitat assessment procedure (HAP) analyses. In this case a HAP developed by the State of Ohio Environmental Protection Agency was utilized. Essentially, the HAP analyses utilizes comparative biological field survey data and developed indices to identify problems and to compare existing environments and remedial alternatives in terms of habitat units or indices. Reference the introduction to SECTION 4 – ENVIRONMENTAL EFFECTS, also. In this case, adjacent Conneaut River and Harbor served as the primary comparative quality stream regime. Although it has a similar level of commercial and recreational development, it does not have appreciable levels of contaminations. Other supplemental references include Presque Isle, the Grand River, and the Black River. The Ohio Habitat Assessment Procedure (HAP) and assessment/evaluation is presented and discussed in more detail in EIS APPENDIX EA- J SECTION 312(b) AND 206 ECOLOGICAL RESTORATION /PRESERVATION ANALYSIS. (Part of this report. Follows these text). Portions of this appendix are summarized and integrated into portions of this Environmental Impact Statement.

GENERAL ENVIRONMENTAL CONDITIONS

3.03 Ashtabula Harbor is located at the mouth of the Ashtabula River on the south shore of Lake Erie, Ashtabula County, Ohio. It is a significant Great Lakes and St. Lawrence Seaway harbor. Reference Figures 1.1, 3.1, and 3.2. The populations for the city of Ashtabula and the county of Ashtabula were about 21,633 and 99,821, respectively, in 1990. The vicinity of Ashtabula Harbor contains industrial, commercial, residential, and recreational developments.

3.04 The existing Federal navigation project consists of a breakwater protected outer harbor in Lake Erie and an interior harbor in the Ashtabula River. The outer harbor includes a system of channels with turning basins and encompasses about 185 acres. The interior harbor consists of a channel and a turning basin and extends upstream to approximately river mile 1.8. Reference Figure 3.1. The river channel from the mouth upstream to the Fifth Street Bridge (0.7 miles) is commercial. Commodities, such as limestone, iron and other ores, coal and other bulk commodities, pig iron, iron products, raw rubber, and general cargo, transit the harbor. The river channel from the Fifth Street Bridge through the upper channel area is no longer maintained for commercial navigation; but, is utilized primarily for recreational navigation. Several marina developments docking hundreds of recreational vessels are situated along the lower river and harbor.

3.05 Harbor structural developments and accumulated contaminants have caused significant problems pertaining to benthic and fishery habitat and the ecology and harbor operations and

maintenance dredging. Most of the contaminated sediments have collected within the Federal authorized channels. Storm events cause scour and the resuspension of sediments and associated contaminants which *may* periodically compromise water quality standards. Contaminated sediments continue to migrate down stream from the lower river into the outer harbor and Lake Erie. Structural developments (i.e. channelization, bulkheading, etc.) have essentially eliminated aquatic/fishery shallow areas. Dredging and vessel activities have caused resuspension of sediments suffocating bottom organisms and disrupting fish habitat.

3.06 Generally, as one moves from the outer harbor area to the upstream river area, sediment sampling and testing indicates that sediments to be dredged from the Federal channels for harbor maintenance range from suitable for unrestricted open-lake disposal to contaminated and not suitable for unrestricted open-lake disposal. Contaminants were generated in the past from both point and non-point sources. Avoidance in dredging contaminated and not suitable for unrestricted open-lake disposal sediments for channel maintenance is becoming increasingly difficult. Dredging of these contaminated sediments will require disposal in a confined disposal facility (CDF) and/or by alternative disposal measure. Ashtabula Harbor currently has no operations and maintenance dredging CDF facility and/or alternative disposal measure.

3.07 Fisheries habitat inside and outside the existing stone breakwaters of Ashtabula Harbor is predominantly deep open water. Water depths within the protected harbor vary from about 2 to 3 feet in some places along shore, but range up to about 25 feet in deeper areas offshore. Just outside the breakwaters, water depths range from about 6 feet near shore to 30 feet or more toward the outward ends of these structures. In general, the fishery in the vicinity of the harbor contains a variety of warmwater species that include alewives (*Alosa pseudoharengus*), gizzard shad (*Dorosoma cepedianum*), rainbow smelt (*Osmerus mordax*), carp, shiners (*Notropis*), logperch (*Percina caprodes*), white bass (*Morone chrysops*), smallmouth bass (*Micropterus dolomieu*), northern pike (*Esox lucius*) (in vegetated areas inside the harbor), yellow perch (*Perca flavescens*), and walleye (*Stizostedion vitreum*).

3.08 Wildlife utilizing the open water zone, breakwaters, and immediate coastal shoreline consist mostly of aquatic birds such as seagulls, terns, waterfowl, and shorebirds. The shoreline banks - although subjected to extensive developmental disturbance - provide some degree of feeding, nesting, and cover habitat for songbirds, raptors, and upland mammals such as deer, cottontail rabbit, raccoon, mice, Norway rat, opossum, and probably some species of reptiles and amphibians (i.e., snakes, frogs, salamanders).

3.09 Previous coordination for similar projects in this regard identified a likely area for potential disposal site development, as that generally east of the harbor and north of the railroad tracks in the Ashtabula Township, Ashtabula County, Ohio. This area contains similar developments and is zoned for heavy industry. The western portion of this area is almost fully developed with harbor and city development and then to the east with industrial developments. The eastern portion of this area is a mix of abandoned farmland (now emergent scrub/shrub and mature wooded areas), disposal facilities and associated mitigation (preserved natural wildlife areas), and a few scattered residential properties primarily along the shoreline and Lake Road. Numerous wetland areas are scattered throughout the area. The Whitman's Creek watershed is located in the eastern most section of this area. A variety of associated wildlife species inhabit the natural areas. Reference Figures 3.1 and 3.2.

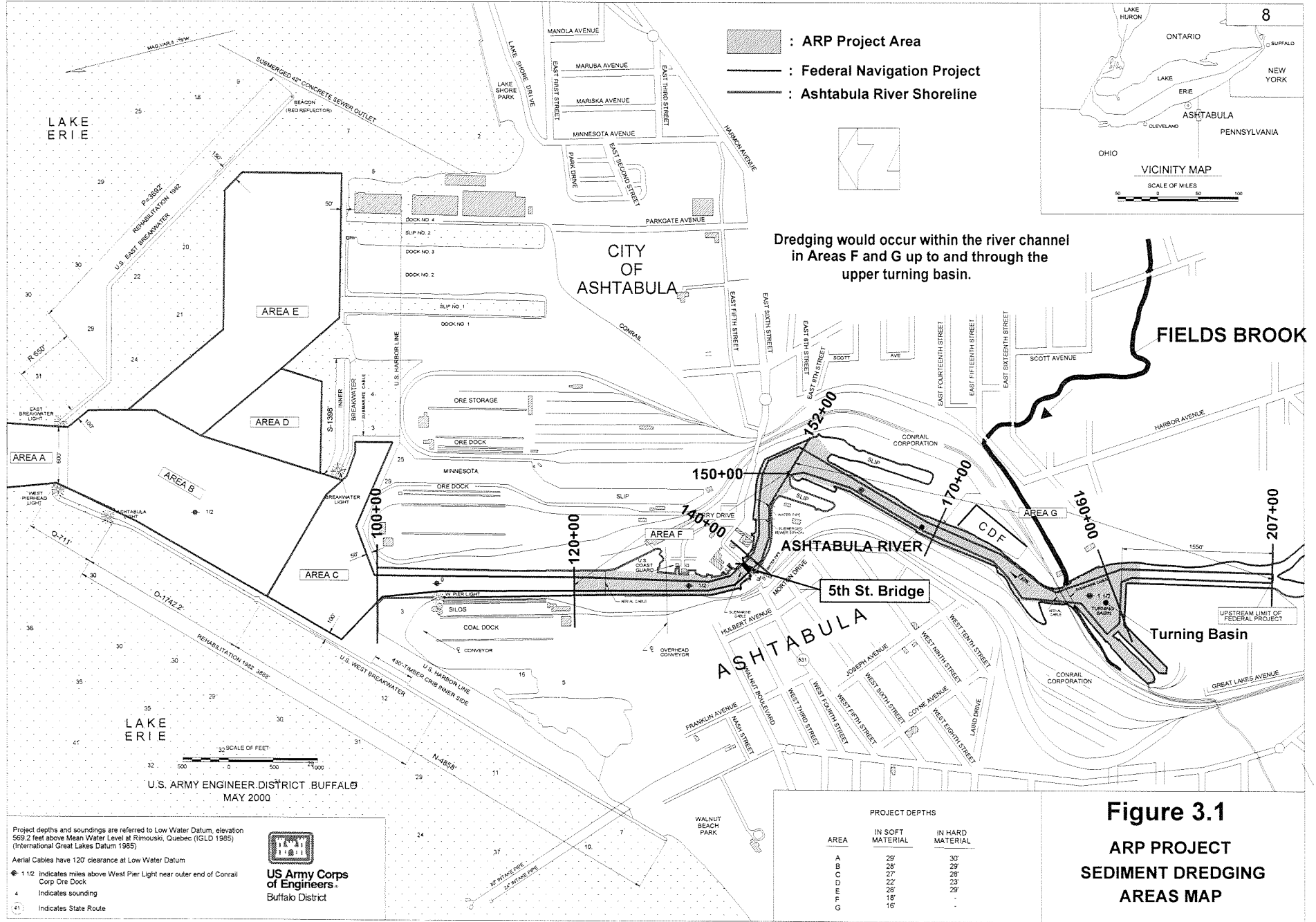

Figure 3.1
ARP PROJECT
SEDIMENT DREDGING
AREAS MAP

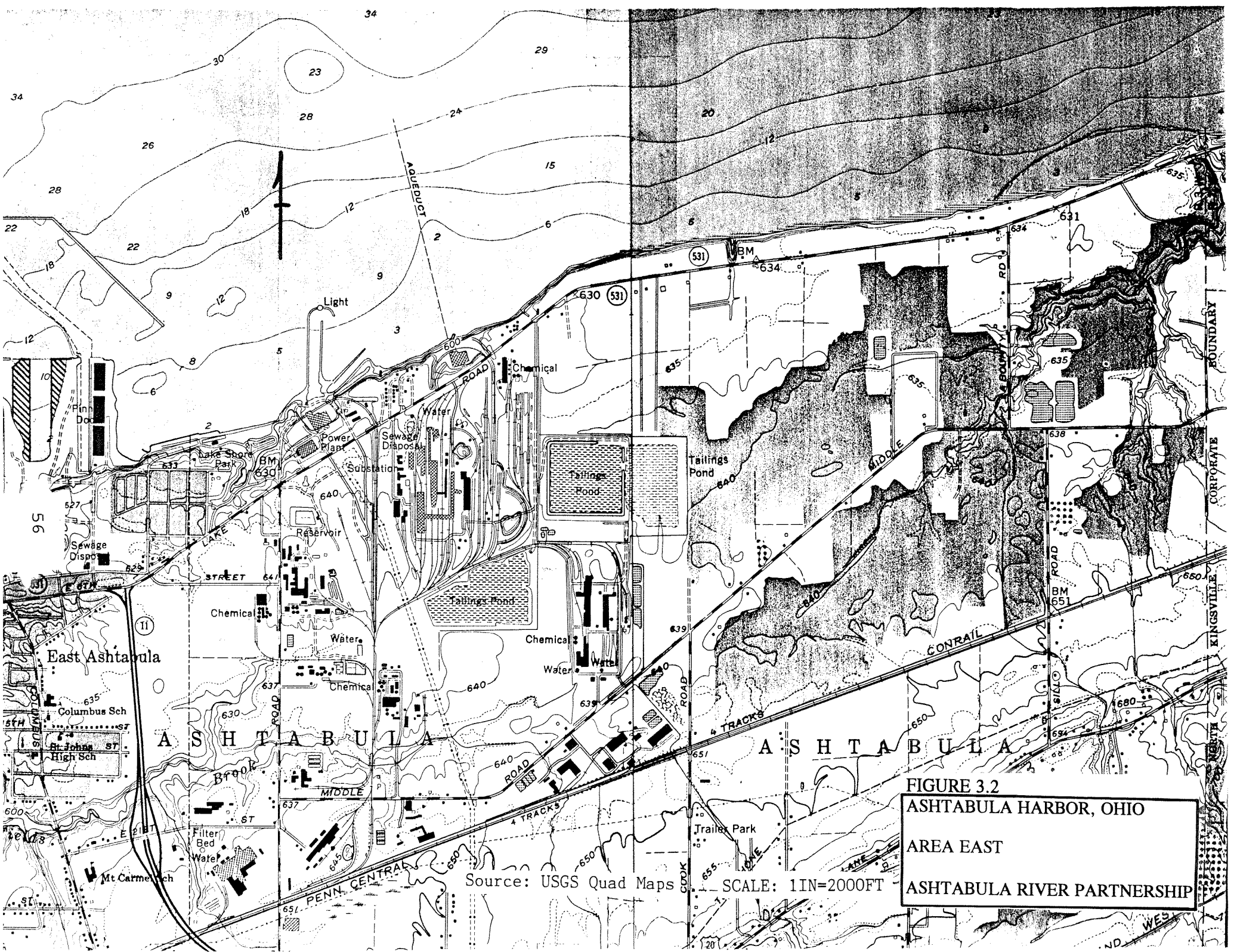

FIGURE 3.2
 ASHTABULA HARBOR, OHIO
 AREA EAST
 ASHTABULA RIVER PARTNERSHIP

Source: USGS Quad Maps SCALE: 1IN=2000FT

SIGNIFICANT RESOURCES

3.10 The following are identified as significant resource parameters which are examined, but in this case, are found not to be significant to the project area or would not be significantly affected by final project alternatives implementation. They are: Air Quality, and Cultural Resources.

3.11 The following are identified as significant resource parameters which are examined and are important to the project area and/or could be affected (adversely or beneficially) with some significance by project alternatives implementation. They are: Geology, Water Quality, Sediment Quality, Benthos, Fisheries, Vegetation, Wildlife, Threatened and Endangered Species, Wetlands, Community and Regional Growth, Business/Industry/Employment/Income, Public Facilities and Services, Recreation, Property Value and Tax Revenue, Noise and Aesthetics, and Community Cohesion.

PHYSICAL/NATURAL ENVIRONMENT (RESOURCES) - ECOLOGICAL SETTING

3.12 **The Great Lakes and Lake Erie.** Ashtabula River flows into the central basin of Lake Erie. Lake Erie is one of the five Great Lakes. The Great Lakes -- SUPERIOR, MICHIGAN, HURON, ERIE, and ONTARIO -- are located in east central North America at the border between Canada and the United States. With an area of 95,145 square miles, they are collectively the world's largest body of fresh water. The lakes' drainage basin of some 295,000 square miles extends 690 miles north to south and 860 miles west to east. The lakes drain generally from west to east through the Saint Lawrence River/Seaway into the Atlantic Ocean.

3.13 Lake Erie, fourth in size of the five North American GREAT LAKES, is situated between Ontario, Canada, to the North, and the United States -- abutting New York, Pennsylvania, Ohio, and Michigan. The lake is 241 miles long and 57 miles across at its widest point. Its surface area is 9,930 square miles. The shallowest of the five Great Lakes, it has a mean depth of 58 feet. Numerous rivers/creeks flow into Lake Erie including from the United States: the Detroit, the Huron, the Raisin, the Maumee, the Sandusky, the Black, the Cuyahoga, the Grand, the Ashtabula, Chataqua, Canadaway, Cattaraugus, Eighteen Mile, and the Buffalo River. The lake discharges into the Niagara River, which flows over Niagara Falls and into Lake Ontario. (Grolier). Reference Figure 1.1.

3.14 Lake Erie is the shallowest and warmest of the Great Lakes, holds the least amount of water and has the fastest flow through time for its waters. It is also the most biologically productive and has the greatest diversity of fish species. More than 130 species from at least 24 different families range throughout its wide variety of habitats. Many species reach their greatest abundance here, providing one of the world's largest fresh water fisheries and more fish protein than all other Great Lakes combined. Lake Erie supplies fish and fish protein to people all over the world including the 13 million people living along its shore. Most sought after sport and commercial fish in the Lake Erie Central Basin include, (Sport): Walleye (*Stizostedion vitreum*), Yellow Perch (*Perca flavescens*), Smallmouth Bass (*Micropterus dolomieu*), Rainbow Trout (*Oncorhynchus nykiss*); and (Commercial): Walleye, Yellow Perch, Rainbow Smelt (*Osmerus mordax*), and White Bass (*Morone chrysops*).

3.15 Ashtabula Harbor is located on both the Atlantic and Mississippi flyways with over three million ducks and geese using this corridor on a north-south and east-west routes (Bell-rose, 1976). Many species use the harbor and adjacent areas as a resting and/or feeding areas during migration while a few species nest in the area. Gulls and terns nest on the outer breakwalls. In addition to water fowl, many species of shorebirds, hawks, woodpeckers, and song-birds inhabit the area. This may be attributed to the abundant water, shoreline, wetland, and wooded upland in the area. Ashtabula County is reported to have more birds than any other county in Ohio.

3.16 Over the last 200 years, the Lake Erie ecosystem has experienced many rapid changes due to a wide range of human activities. Primary problems include: pollution, shoreline structural and functional changes, and introduction of foreign species.

3.17 **The Ashtabula River and Harbor.** The Ashtabula River is a major United States tributary to the Lake Erie Central Basin.

3.18 **General Physical Characteristics.** The Ashtabula River basin, (not including Conneaut Creek and Lake Erie tributaries), drains an area of 137.14 square miles or 87,770 square acres. Reference Figure 3.3. The Ashtabula River mainstem originates in eastern Ashtabula County. In general, the Ashtabula River flows in a northwesterly direction, to the City of Ashtabula, where it discharges to Lake Erie. The mainstem is 39.7 river miles in length (including West Branch). The Ashtabula River mainstem falls an average gradient of 11.6 feet per mile, (from an elevation of 1033 to 573 feet above mean sea level). Principal tributaries to the Ashtabula River include Ashtabula Creek, Hubbard Run, West Branch, and East Branch. No significant surface water impoundments are located within the Ashtabula River watershed.

3.19 **Geography and Geology.** The Ashtabula River watershed is situated within the gently rolling dissected glacial plateau of the Erie/Ontario Lake Plain ecoregion. During the Pleistocene era varying thickness of glacial drift were deposited over Devonian shales. The majority of this watershed exists in ground moraines and end moraines. Sediments deposited by former beach ridges, arranged parallel to the existing Lake Erie shoreline, are composed of sand, gravel, and cobble. The preglacial valleys within the underlying bedrock shale were buried by glacial clays, sands, and gravels down to depths of 200 feet from ground surface. The watershed is primarily woodland and agricultural in the upper basin, and primarily developed and industrial in the lower basin.

3.20 The general natural surfacial soil type in the project area is Conneaut-Swanton-Clavetack association which is deep, nearly level sloping, poorly drained and moderately well drained silty and sandy soils on the lake plain. Natural overburden deposits consist primarily of glacial till; several to 15 feet of orange brown mottled clay/silt (weathered glacial till) and 35 to 50 feet of grey silt/clay (unweathered glacial till). Bedrock in the study area consists of Devonian age shales generally from 50 to 60 feet deep. The bedrock is generally flat lying and has a gradual slope from east to west. Depth to groundwater varies throughout the area; but, generally from near surface to about 15 feet. The trend is south to north. Well yields are poor.

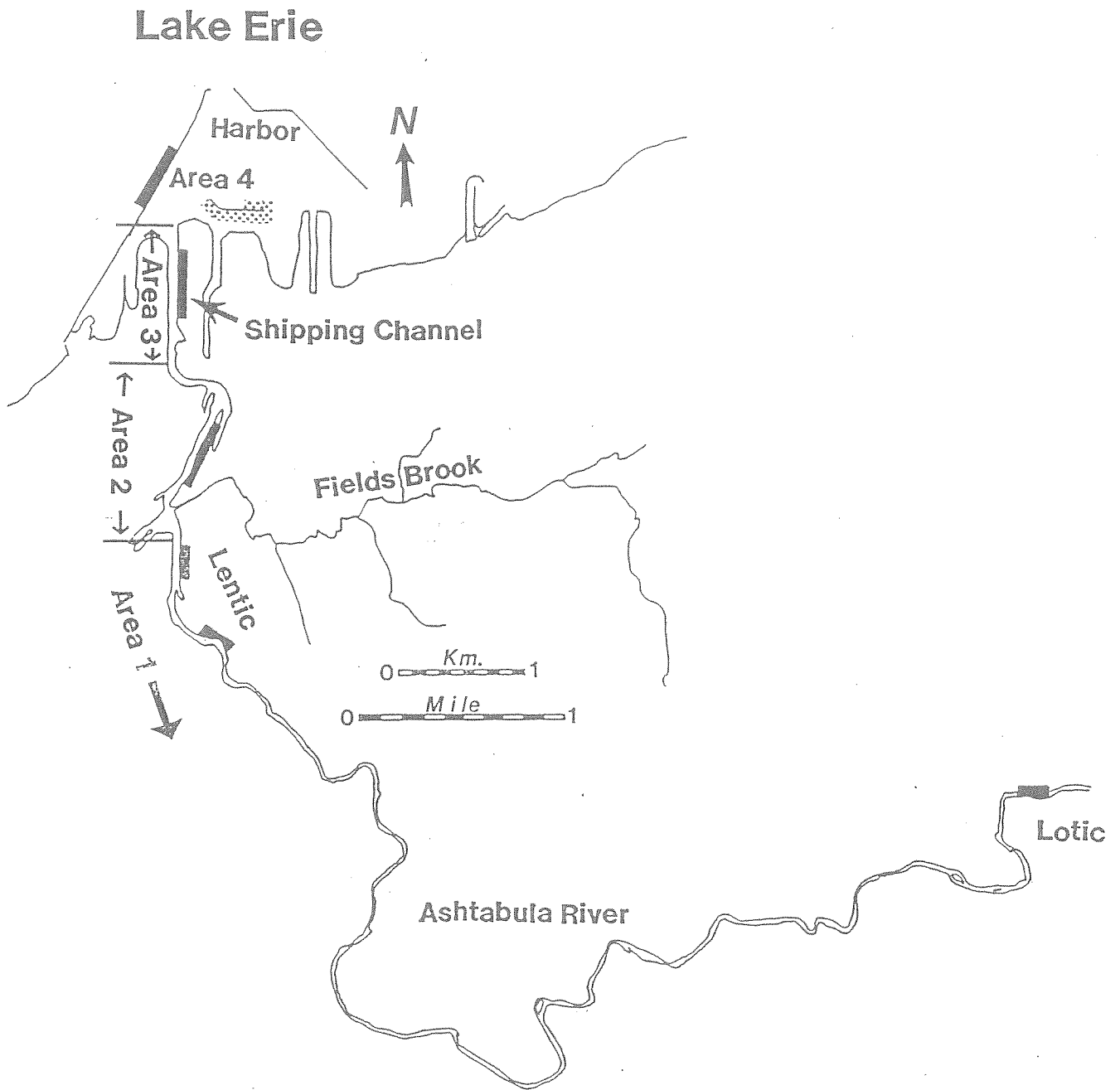

FIGURE 3.3 Ashtabula River study area and fish community sampling site locations (shaded areas). Benthic macroinvertebrate sampling sites are contained within the fish community sampling sites.

3.21 Ashtabula Harbor. Ashtabula Harbor is located at the mouth of the Ashtabula River on the south shore of Lake Erie Ashtabula County, Ohio. Reference Figure 3.1. It is a significant Great Lakes and St. Lawrence Seaway harbor. The existing Federal navigation project consists of a breakwater protected Outer Harbor in Lake Erie and an interior harbor in the Ashtabula River. The Outer Harbor includes a system of channels with turning basins and encompasses about 185 acres. The interior harbor consists of a channel and a turning basin and extends upstream to approximately river mile 1.8. The river channel from the mouth upstream to the Fifth Street Bridge (0.7 miles) is commercial. Commodities, such as limestone, iron and other ores, coal and other bulk commodities, pig iron, iron products, raw rubber, and general cargo, transit the harbor. The river channel from the Fifth Street Bridge through the upper channel area is no longer maintained for commercial navigation; but, is utilized primarily for recreational navigation. Several marina developments docking hundreds of recreational vessels are situated along the lower river and harbor. Some ecological problems associated with harbor developments were summarized previously and will be discussed in future paragraphs.

3.22 Air Quality. The potential project area lies within the Ohio Air Quality Control Region (AQCR) referred to as Northwest Pennsylvania Youngstown #178 (which includes the Counties of Ashtabula, Trumbull, and Mahoning). Boundaries for each region were set by consideration of air pollution levels, population density, geography, and common meteorological conditions. In the publication entitled, "Ohio Air Quality Report 1989" prepared by the Air Quality and Analysis Unit Division of Air Pollution Control, Ohio Environmental Protection Agency, the following criteria pollutant parameters were monitored in the aforementioned AQCR #178. Total Suspended Particulates (TSP), sulfur dioxide (SO₂), particulate matter smaller than or equal to 10 micrometers (PM-10), and Ozone (O₃). No monitoring stations for nitrogen dioxide (NO₂), carbon monoxide (CO), and lead (Pb) were indicated for AQCR #178. TSP was intermittently monitored at one station; PM-10 was intermittently monitored at three stations; and SO₂ as well as O₃ were each monitored continuously at three stations.

3.23 Relative to the aforementioned criteria pollutant parameters, the 1989 report indicates the following for Ashtabula County (within which the proposed project would be located):

- No violation of the Primary National Ambient Air Quality Standard for TSP.
- No monitoring stations for PM-10 were indicated for Ashtabula County in the report. Trumbull County immediately south of Ashtabula county recorded the highest annual mean concentration of PM-10 as being 32 ug/m³ - which is below the U.S. EPA and Ohio EPA primary ambient air quality standard of 50 ug/m³.
- The highest annual arithmetic mean concentration for SO₂ in Ashtabula County was 21 ug/m³, which is well below the U.S. EPA and Ohio EPA Primary Ambient Air Quality Standard of 80 ug/m³.
- No data was provided on NO₂ for the county in the report. The U.S. EPA and Ohio EPA Primary Ambient Air Quality Standard for this parameter is 100 ug/m³.

- No data was provided on CO for Ashtabula County in the report. The U.S. EPA and Ohio EPA Primary Ambient Air Quality Standard this parameter is 10 ug/m³.

- The highest 1-hour concentration for Ashtabula County for O₃ was indicated as being 233 ug/m³. The U.S. EPA and Ohio EPA Primary Ambient Air Quality Standard for this parameter is 244 ug/m³.

- Data was not provided on Pb for the county in the report. The U.S. EPA and Ohio EPA Primary Ambient Air Quality Standard for Pb is 1.5 ug/m³.

3.24 Water Quality. Ohio Water Quality Standards (WQS; OAC 3745-1-25), consist of designated aquatic life and non-aquatic life uses, and chemical, biological, and physical criteria designed to represent measurable properties of the environment that are consistent with the goals specified by each use designation. The mainstem of the Ashtabula and conjoining tributaries have been designated warmwater habitat (WWH), which defines the "typical" warmwater assemblages of aquatic organisms for Ohio rivers and streams. Reference Figure 3.3. The current non-aquatic life use designations for the Ashtabula River system are: agricultural and industrial water supply and primary contact recreation (PCR). The criteria for PCR is simply having a water depth of at least one meter over an area of at least 100 square feet or where canoeing is a feasible activity. With regard to Lake Erie, the lake is designated as being exceptional warmwater habitat, State resource water, a source of public- agricultural-industrial water supply and use for recreational bathing, and will meet criteria set forth in Rules 3745-1-01 to 3745-1-07 in the above mentioned chapter of the Administrative Code.

3.25 In the upper watershed, the most recent sampling and analysis was conducted in 1996 for river mile (RM) 2.5 to 27.2. Concentrations of phosphorus and oxidized nitrogen (nitrate-nitrite), measured in water quality grab samples collected from the Ashtabula River were at or near detection levels in most samples (Figure 3.4) reflecting the lack of point sources and relatively low intensity land use within the watershed. Ammonia nitrogen levels, while generally low were elevated in several samples, especially from those collected at Benetka Road (RM 19.1) and East 24th Street (RM 2.5). The highest ammonia-nitrogen levels were recorded during rain event sampling (see plot of fecal coliform - Figure 3.4), and likely represent runoff from livestock waste in the upper and middle reaches, and unsewered inputs in the lower reach (i.e., RM 2.5). Similarly, fecal coliform bacterial levels were also elevated in rain event samples. Correspondingly, chemical oxygen demand was higher in the headwater reaches compared with downstream. Other parameters indicative of organic enrichment (i.e., TKN and TDS) were not elevated, suggesting the enrichment was not acute. Mean dissolved oxygen (DO) concentrations measured in grab samples from the Ashtabula River were above the twenty-four hour average minimum Warmwater Habitat (WWH) Water Quality Standard of 5.0 mg/l (Figure 3.4). However, DO concentrations at or below the minimum Water Quality Standard of 4.0 mg/l were detected at RM 19.1 of the mainstem and in both branches. The low concentrations were caused primarily by the very low and intermittent flows observed in late summer, but may have been exacerbated by organic loadings.

3.26 Concentrations of water column metals in the Ashtabula River were low and well within the WWH water quality criteria. Arsenic, lead, copper and zinc were detected at concentra-

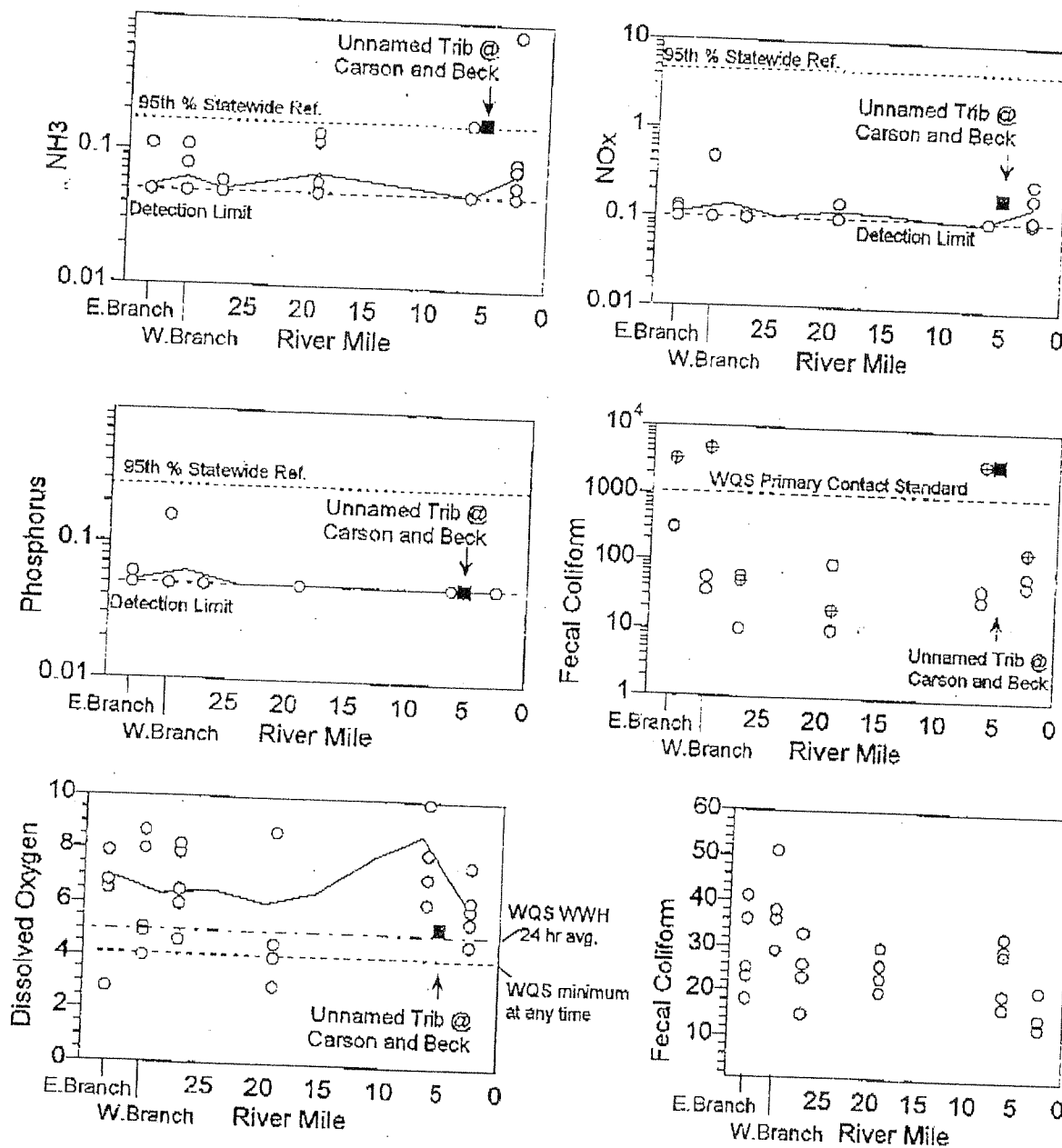

FIGURE 3.4

Select water quality parameters measured in grab samples collected from the Ashtabula River, 1995. Solid lines conjoin means. 95th percentile values are for wadeable statewide reference sites. Marked data points in the fecal coliform plot show rain event samples. Dection limits and Water Quality Standards (WQS) are shown where appropriate.

tions very close to their analytical detection limits (maximum observed concentrations: As=6 ug/l at West Branch Ashtabula @ Beckwith Road, Pb=8 ug/l at West Branch Ashtabula @ Beckwith Road, Cu=15 ug/l at RM 6.3, Zn=73 ug/l at Beckwith Road).

3.27 Sediment metal concentrations in the Ashtabula River were elevated compared to background concentrations described by Kelly and Hite (1984) for Illinois streams and exceeded the lowest effect level described by Persaud et al. (1994) for arsenic, chromium, copper, lead and mercury. The levels do not indicate contamination from point sources, but are more likely due to the parent bedrock and glacial deposits. Concentrations of all metals, excluding cadmium, were higher at RM 2.5 than RM 27.1, reflecting the increased contamination from urban runoff.

3.28 Table 3.1 provides a summary of some past water quality standards violations measured in the Ashtabula River Area of Concern. Presently, pollutants in the water column are less prevalent and violations of water quality standards are infrequent and localized due to current discharge controls and some cover of contaminated sediments with cleaner sediments. The primary problem pertaining to contaminants and water quality is that associated with the resuspension of sediments and associated contaminants. Substantial storm flows may cause scour and resuspension of sediments and associated contaminants (including metals, pesticides, nutrients, PCBs, RADs, PAHs, and a number of chlorinated organic compounds) which *may* compromise associated water quality standards. Table 3.2 presents some Ohio EPA Water Quality Standards for Lake Erie for some contaminants of concern.

3.29 Pertaining to radionuclides, it is the recommendation of the Ohio Department of Health, Bureau of Radiation Protection (ODH/BRP) and the United States Environmental Protection Agency, Region 5, (USEPA) that all water discharges, associated with the processes of this project, to public waterways, meet the USEPA Safe Drinking Water Act (SDWA) Maximum Contaminant Levels for gross alpha @ 15 picocuries per liter (pCi/L), the combined radium (Ra-226 + Ra-228) Maximum Contaminant Level @ 5 pCi/L, a maximum contaminant level for beta particle and photon radioactivity @ 4 millirem per year, the average annual concentration of gross beta particle activity @ 50 pCi/L and the proposed Maximum Contaminant Level for uranium (30 pCi/L or 20 ug/L).

3.30 Dissolved oxygen (DO) levels have been a problem in the lower river during the low flow period of June through September. Corps of Engineers' sediment analysis over the years indicate sediments are moderately contaminated with oxygen demanding materials. Dissolved oxygen concentrations in the lower river, however, are strongly influenced by harbor morphology, low flow, meteorological conditions, and lake levels, so, low DOs are not related solely to chemically degraded water quality. However, low DOs are an aquatic problem whether related to pollution or alteration of the natural river morphology.

3.31 As previously indicated, water quality standards for Lake Erie will meet criteria set forth in Rules 3745-1-01 to 3745-1-07 of the Ohio EPA Administrative Code. However, where applicable, the criteria set forth in this rule (3745-1-31) entitled "Lake Erie Standards" - which applies outside the mixing zone - supersedes the above rules. In this rule, "the following criteria are expressed as total concentration unless specified otherwise" (Ohio EPA, 1990) -

TABLE 3.1

A summary of ambient Water Quality Standards violations measured in the Ashtabula River AOC. (All concentrations are ug/l).

Site Parameter	Concentrations						Ohio WQS		U.S. EPA Criteria		GLWQA Objectives
	Max.	Min.	Mean	Standard Deviation	Number of Samples	Detection Limits	Aquatic Life	Human Health ¹	Aquatic Life	Human Health	
Ashtabula River											
* Cadmium	5.9	1.0	2.1	1.4	11	1.	1.8(5) ²	---	1.5(6)	---	0.2(11)
* Iron	800.	160.	516.	193.	11	20.	1000.	---	1000.	---	300.(10)
* Aldrin & Dieldrin	0.21	0.0	0.02	0.060	11	0.1	0.1(1)	0.00079(1)	3.0	0.00079(1)	0.001(1)
* Mercury	0.3	0.2	0.21	0.029	11	0.2	0.2(2)	0.012(2)	0.012(2)	0.146(2)	0.2(2)
* Lead	29.	5.	9.8	7.1	11	5.	11(3)	---	4.9(6)	---	25.(1)
* Zinc	130.	10.	31.	33.7	11	10.	140.	---	141.	---	30.(3)
** Dissolved Oxygen (mg/l)	15.2	2.5	9.0	3.7	48	---	4.0(8)	---	4.0(8)	---	6.0(13)
x Copper	129.	0.0	13.5	30.6	23	2.4	16(2)	---	16(2)	---	5.(9)
x Cadmium	3.5	0.0	0.15	0.7	23	3.2	1.8(1)	---	1.5(1)	---	0.2(1)
x Iron	4850.	353.	900.	860.	23	13.7	1000.(2)	---	1000.(2)	---	300.(23)
x Lead	7.8	0.0	1.29	2.26	23	1.5	11.	---	4.9(4)	---	25.
x Zinc	62.3	6.8	16.0	14.6	23	1.4	140.	---	141.	---	30(2)
x Endosulfan	0.13	0.0	0.01	0.03	23	.05	.003(2)	2.0	.056(2)	159	---
Fields Brook											
* Cadmium	13.	1.	2.2	3.0	18	1.	6.4(1)	---	5.2(2)	---	3
* Mercury	0.7	0.2	0.3	0.16	18	0.2	0.2(7)	0.012(7)	0.012(7)	0.146(7)	---
* 1,1,2,2-tetrachloroethane	1900 ⁴	5.	42.4	24.5	9	5.	360.(1)	107.(1)	2400.	107.(1)	---
* Tetrachloroethene	230 ⁴	5	22.5	14.9	9	5.	73.(1)	3500.	840.	8.85(7)	---
* Trichloroethene	1300 ⁴	7.5	44.3	25.9	9	5.	75.(1)	807.(1)	21900.	807.(1)	---
* Iron	3310.	275.	1117.	856.4	18	20.	1000.(5)	---	1000(5)	---	---
+ Total Dissolved Solids—See Figure 8											
Lake Erie (Water intake)											
+ 1985											
Cadmium	0.7	0.2	0.4	0.29	3	0.2	1.8	10.	1.5	10.	0.2(1)
Chromium	70.	30.	43.	23.1	3	30.	270.	50.(1)	270.	170000.	50.(1)
Copper	30.	10.	14.	8.9	5	10.	16.(1)	1000.	16.(1)	---	5(1)
Iron ⁵	22600.	280.	4874.	9911.	5	20.	1000.	---	1000.	300.	300.
Lead	22.	2.	6.	8.9	5	2.	11.(1)	50.	4.9(1)	50.	25.
Zinc	115.	10.	65.	70.7	5	10.	140.	5000.	141.	---	30.(1)
x 1990											
Copper	35.5	4.8	17.5	.75	12	2.4	16.(7)	1000.	16.(7)	---	5(11)
Iron	4810.	892.	2502.	1610.4	12	13.7	1000.(8)	---	1000.(8)	300.(12)	300.(12)
Zinc	41.0	6.0	19.7	9.81	12	1.4	140.	5000.	141.	---	30.(2)
Total Diss. Solids (mg/l)	227.	169.	194.2	17.1	12	10.	1500.	---	---	---	200(4)
Mercury	0.5	0.0	0.05	0.15	12	0.4	0.2(1)	0.012(1)	0.012(1)	0.146(1)	0.2(1)
Bis(2-ethylhexyl)phthalate	13.0	0.0	1.08	3.59	12	10	8.4(1)	59.	---	50000.	0.6(1)
++Lake Erie (nearshore)⁵											
Cadmium	57.	0	4.9	---	78	2.	1.8	10.	1.5	10.	0.2
Copper	217.	0	31.2	---	78	10.	16.	1000.	16.	---	5.
Mercury	1.0	0	0.18	---	77	0.2	0.2	0.012	0.012	0.146	0.2
Iron	4710.	8.	602.	---	78	20.	1000.	---	1000.	---	300.
Zinc	325.	4.	49.	---	78	5.	140.	5000.	141.	---	30.
Nickel	139.	0	17.	---	78	20.	232.	610.	210.	13.4	25.
Lead	313.	0	10.	---	78	50.	11.	50.	4.9	50.	25.

¹ Human health standards for the Ashtabula River and Fields Brook are based on surface water concentrations that could bioaccumulate in fish tissue making fish consumption potentially deleterious to human health. Human health standards for Lake Erie include consumption of water as well since Lake Erie is designated as public water supply.

² The number in parenthesis indicates the actual number of violations recorded during the sampling period. Due to the nature of the data, individual violations are not listed for Lake Erie nearshore data.

³ GLWQA objectives are not applicable to Fields Brook as it is not considered a boundary water (not at lake level).

⁴ These values indicate localized extreme maximums on the DS tributary. They were not used to calculate means or standard deviations.

⁵ Exact number of violations could not be determined.

Sources:

* CH₂M Hill 1985

** U.S.G.S. Water Resources Data 1968-1979

+ Ohio EPA STORET data

++ 1978-1979 U.S. EPA STORET data

x Woodward Clyde Consultants 1991

TABLE 3.2 Ohio Environmental Protection Agency Lake Erie Basin Water Quality Standards (1999)

Chemical	Aquatic Life (ug/l)				Human Health (ug/l)		
	Tier	IMZM	OMZM	OMZA	Tier	Drink	Nondrink
Arsenic - TR	I	680	340	150	I	50	580
Barium	II	4,000	2,000	220	I	2,000	160,000
Cadmium - TR	I	9.0 (2)	4.5 (2)	2.5 (2)	I	14	730
Chromium - TR	I	3,600 (2)	1,800 (2)	86 (2)	I	140	14,000
Copper - TR	I	28 (2)	14 (2)	9.3 (2)	I	790	64,000
Lead - TR	I	240 (2)	120 (2)	6.4 (2)	I	14	190
Mercury (b) - TR	I	3.4	1.7	0.91	I	0.0031	0.0031
Nickel - TR	I	940 (2)	470 (2)	52 (2)	I	470	43,000
Zinc - TR	I	240 (2)	120 (2)	120 (2)	I	5,000	35,000
COD	NS	NS	NS	NS	NS	NS	NS
TKN	NS	NS	NS	NS	NS	NS	NS
Ammonia	I		12.1 mg/l (3)	1.1 mg/l (3)			
Oil/Grease	I		10,000				
1,2,4-Trichlorobenzene	NS	NS	NS	NS	NS	NS	NS
1,4-Dichlorobenzene	II	110	57	9.4	I	24c	240c
Hexachlorobenzene(4)					I	0.00045c	0.00045c
Hexachlorobutadiene					II	0.22c	0.24c
1,2-Dichlorobenzene	II	190	96	23	I	2,000	11,000
1,3-Dichlorobenzene	II	160	79	22	II	5,200	9,300
Chlorobenzene	II	850	420	47	I	470	3,200
Bis 2-Ethylhexyl Phthalane	NS	NS	NS	NS	NS	NS	NS
PAHs (5)		See Criteria Individual Chemicals.				See Crit. Ind. Chem.	
Acenaphthene	II	95	48	9.4	II	570	890
Fluoranthene	II	4.5	2.3	0.48	II	9.4	9.5
Napthalene	II	320	160	21	I	540	1,200
PCBs					I	0.000026 c (4)	0.000026 c (4)

TABLE - Continued.

Legend:

All criteria and values are expressed as total unless specified otherwise.

IMZM = Inside Mixing Zone Maximum.

OMZM = Outside Mixing Zone Maximum.

OMZA = Outside Mixing Zone Average.

Drink = Human Health Criterion applicable to Public Water Supply streams (2-route exposure).

Nondrink = Human Health Criterion - non Public Water Supply (1- route exposure).

TR = total recoverable.

Blank Space = Criterion not calculated; contact OEPA Standards & Technical Support section.

NS = No Standard

Footnotes:

a = No chlorine is to be discharged.

b = See Table 33-5 for applicable wildlife criterion.

c = This criterion is based on a carcinogenic endpoint.

Footnotes:

(1) = Average Value given as 1/2 maximum.

(2) = Value depends on water hardness. Lowest value taken on table in standards.

(3) = Temperature and pH dependent. Value derived from a temperature of <30 degrees centigrade and a pH of <7.6.

(4) = As listed, unrealistic.

(5) = Sum of EPA list of 16 minus acenaphthene, acenaphthylene, and fluoranthene.

(6) = Human health 30 day average.

TABLE REFERENCES

State of Ohio Water Quality Standards, 1999; Chapter 3745-1 of the Administrative Code; Ohio Environmental Protection Agency, Division of Water Quality Planning and Assessment; 1999.

(1) Hydrogen Sulfide (undissociated) - 2.0 ug/l

(2) Temperature

(a) There shall be no water temperature changes as a result of human activity that cause mortality, long-term avoidance or exclusion from habitat, or adversely affect the reproductive success of representative aquatic species.

(b) At no time shall water temperature exceed the average or daily maximum temperatures indicated in Tables 31-1a and 31-1b to this rule."

(c) The temperature of the hypolimnetic waters of Lake Erie shall not exceed at any time the daily maximum temperatures indicated in Table 31-1c to this rule."

3.32 Additional information relative to water quality standards applicability in Ohio waters (including Lake Erie) is provided in Rule 3745-1-01 of the Ohio EPA Administrative Code.

3.33 Harbor Sediment Quality and Dredging. Historically, sediments dredged from federal navigation channels at harbors along Lake Erie were disposed of at open lake disposal areas located several miles out from the harbors. Continued degradation of lake waters and sediments, however, helped to stimulate significant environmental legislation in the late 1960's and 1970's (particularly the Water Pollution Control Act, 1972). Water and sediment testing and analyses programs were initiated in order to identify problem areas and to assess various ongoing (i.e. dredging and open-lake disposal) and potential remedial actions. In Ashtabula, subsequent sediment sampling and analyses identified surface and substrate contaminated sediment areas of concern in the vicinity of the upper federal navigation channels of the lower Ashtabula River.

3.34 Over the years, run-off from urban and primarily industrial developments have resulted in the contamination of water and sediments in adjacent streams (i.e. Fields Brook) and the lower Ashtabula River. Most of the contaminated sediments have settled into the Lower River channel reaches from the Upper Turning Basin (where Fields Brook enters) downstream to the Fifth Street Bridge and from the Fifth Street Bridge downstream to river reach Station 120, about half way between the Fifth Street Bridge and the mouth of the River. Reference Figure 3.5. Elevated inorganic parameters include: arsenic, cadmium, chromium, lead, and mercury. Elevated organic parameters include: polychlorinated biphenyls (PCBs), industrial solvents and polynuclear aromatic hydrocarbons (PAHs). Low level radionuclides (RAD) such as uranium, radium, and thorium (above background) are also present in some of the sediments and must be appropriately handled and disposed of.

3.35 Ashtabula Harbor includes the Outer Harbor channel area, which is basically the lake area along the shoreline protected by the harbor breakwaters, and the Ashtabula River channel areas, Reference Figures 3.5. As part of the U.S. Army Corps of Engineers, Buffalo District Dredging Program, sediments are periodically (every few years) sampled from federal navigation channel areas and analyzed for levels of pollutants. Sediments are analyzed in accordance with the Great Lakes Testing Manual. Results of these analyses are coordinated with the U.S.

Environmental Protection Agency, the Ohio Environmental Protection Agency, and other interests for concurrence of appropriate dredging and disposal procedures. Generally, recent past analyses have determined that material that would be dredged from the Federal channel from the Outer Harbor and up river to Station 120+00 would be suitable for open lake disposal. Material that would be dredged from any substantial depth from the Federal channel from Station 120+00 upstream through the upper turning basin would not be suitable for open lake disposal. Material that would be dredged from the Federal channel from upstream of the upper turning basin to the upper Federal channel limit would be suitable for open lake disposal.



3.36 About 150,000 cubic yards of sediment (considered suitable for open lake disposal) are dredged from Ashtabula Harbor federal navigation channels every two years and disposed of at the harbor open lake disposal site. Total river sediment loading/deposition is calculated at about 260,000 cubic yards every two years.

3.37 Deep dredge commercial navigation channels (-18 and -16 feet LWD) have not been maintained in the problem area from Station 120 to the turning basin just upstream of the Fifth Street Bridge since 1979 and from the turning basin just upstream of the Fifth Street Bridge to the upstream Federal channel limits since 1962 due to contaminated sediments which require confined disposal. No economical disposal facility has been available. Upper channel commercial navigation developments (excluding some charter fishing) are gone. Channels have silted in with contaminated sediments in many areas to less than six feet. Contaminant concentrations are deep in the channels and some-what less, but, still a problem in the surface sediments. Reference Figure 3.6.

3.38 The most recent U.S. Army Corps of Engineers, Buffalo District Operations and Maintenance Dredging Program sediment sampling and bulk physical and chemical analyses for Ashtabula Harbor occurred in 2000. Sediment samples were taken from the Outer Harbor (western portion) and lower Ashtabula River federal navigation channels and Lake Erie reference areas (several miles northwest of the harbor). Harbor sediment sampling sites are shown on Figure 3.7. The testing phase involved primarily surface grab or probe sampling and bulk physical and chemical (inorganic and organic) analyses. Composite samples were prepared for the management areas. Results indicated that sediments are comprised primarily of silts and fine sands. Contaminant concentrations for the 2000 sediment samples are presented on Reference Table 3.3. Bold values represent those greater than reference values. Generally, management areas with somewhat elevated surface sediment contaminants included: AH-3, and AR-3 through AR-5.

3.39 Sediment testing for organism toxicity and growth was also conducted utilizing the 2000 sediment samples. Results are presented on Reference Table 3.4. Large bold values indicate no statistically significant difference between site and reference sediments. Generally, management areas with somewhat elevated mortality and reduced growth included: AH-1, AH-3, and AR-3 through AR-5.

3.40 In 1989/1990, the Ashtabula River Group contracted to have core sediments samples take along the Ashtabula River from the mouth upstream to the federal navigation channels project

-  : ARP Project Area
-  : Federal Navigation Project
-  : Ashtabula River Shoreline

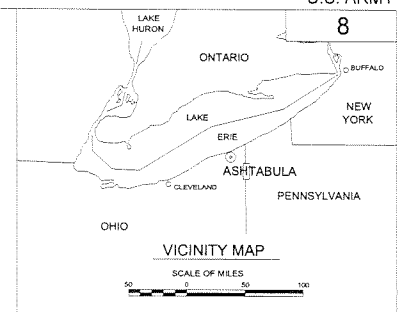

Dredging would occur within the river channel in Areas F and G up to and through the upper turning basin.

89

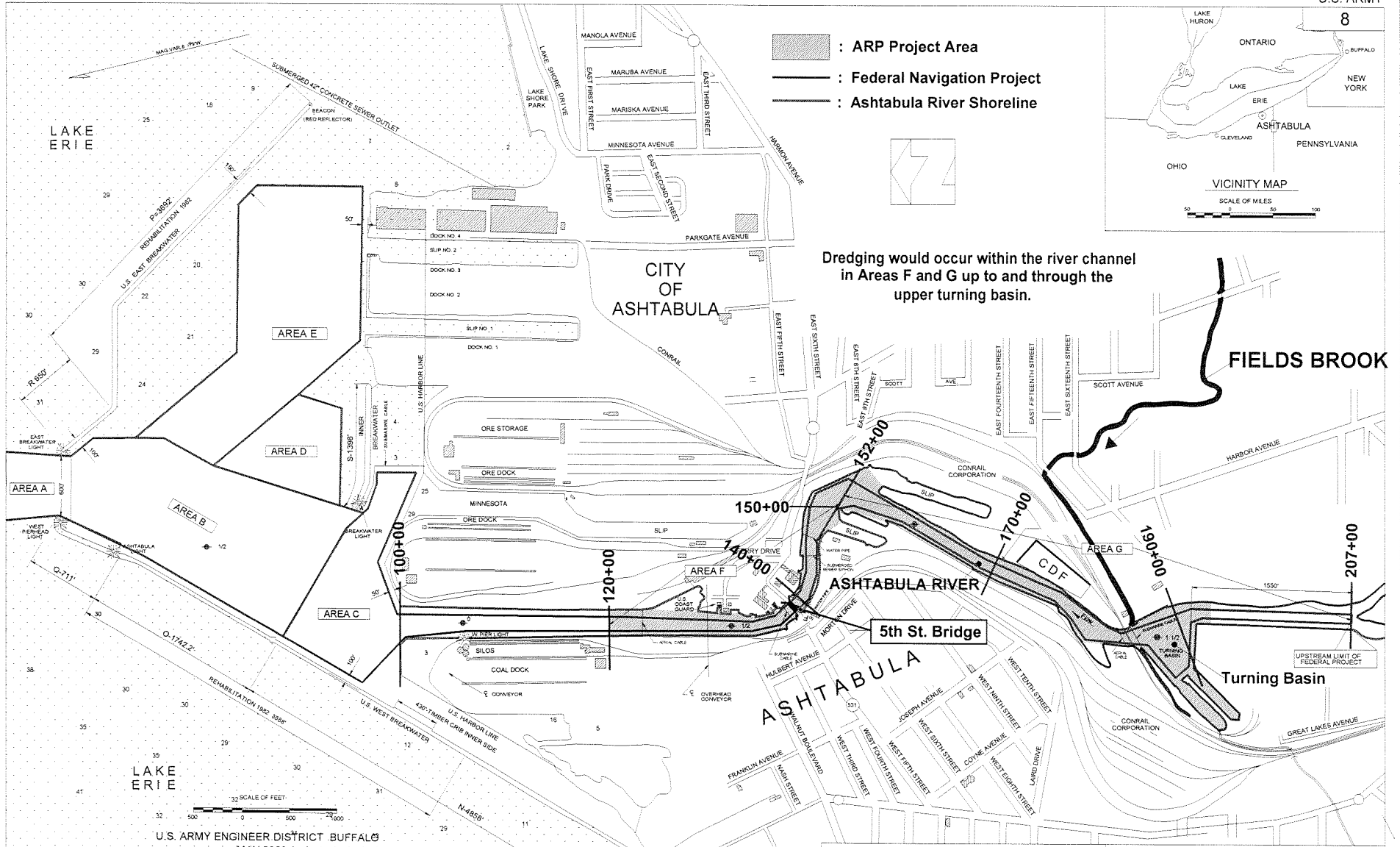

U.S. ARMY ENGINEER DISTRICT BUFFALO
MAY 2000

Project depths and soundings are referred to Low Water Datum, elevation 569.2 feet above Mean Water Level at Rimouski, Quebec (IGLD 1985) (International Great Lakes Datum 1985)

Aerial Cables have 120' clearance at Low Water Datum

1/2 Indicates miles above West Pier Light near outer end of Conrail Corp Ore Dock

4 Indicates sounding

41 Indicates State Route



PROJECT DEPTHS

AREA	IN SOFT MATERIAL	IN HARD MATERIAL
A	29'	30'
B	28'	29'
C	27'	28'
D	22'	23'
E	28'	29'
F	18'	.
G	16'	.

Figure 3.5
ARP PROJECT
SEDIMENT DREDGING
AREAS MAP

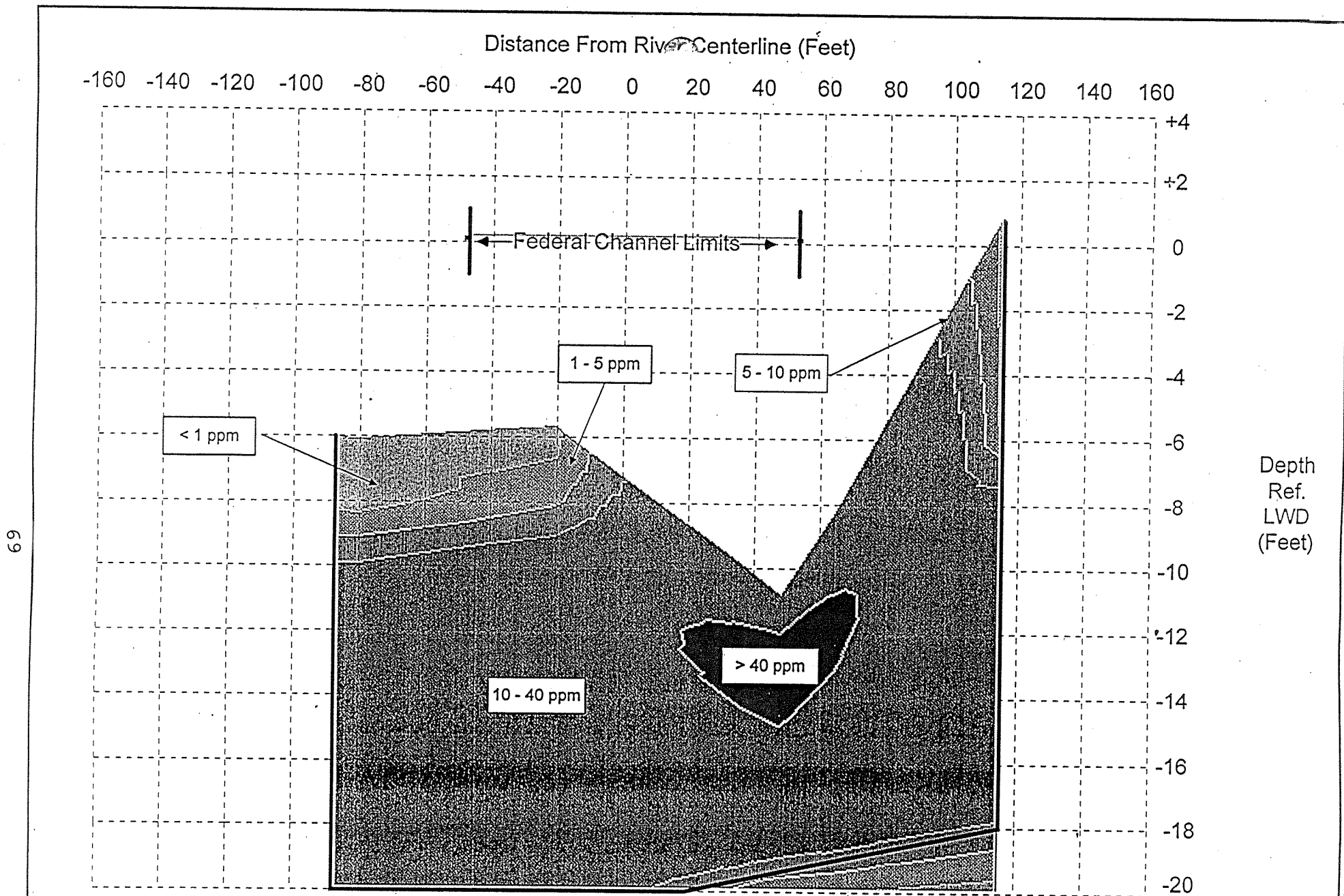

— Dredge Lines
PCBs ppm

Figure 3.6
Ashtabula River Cross Section 170+00

Depth measurement is shown exaggerated by a factor of 10.

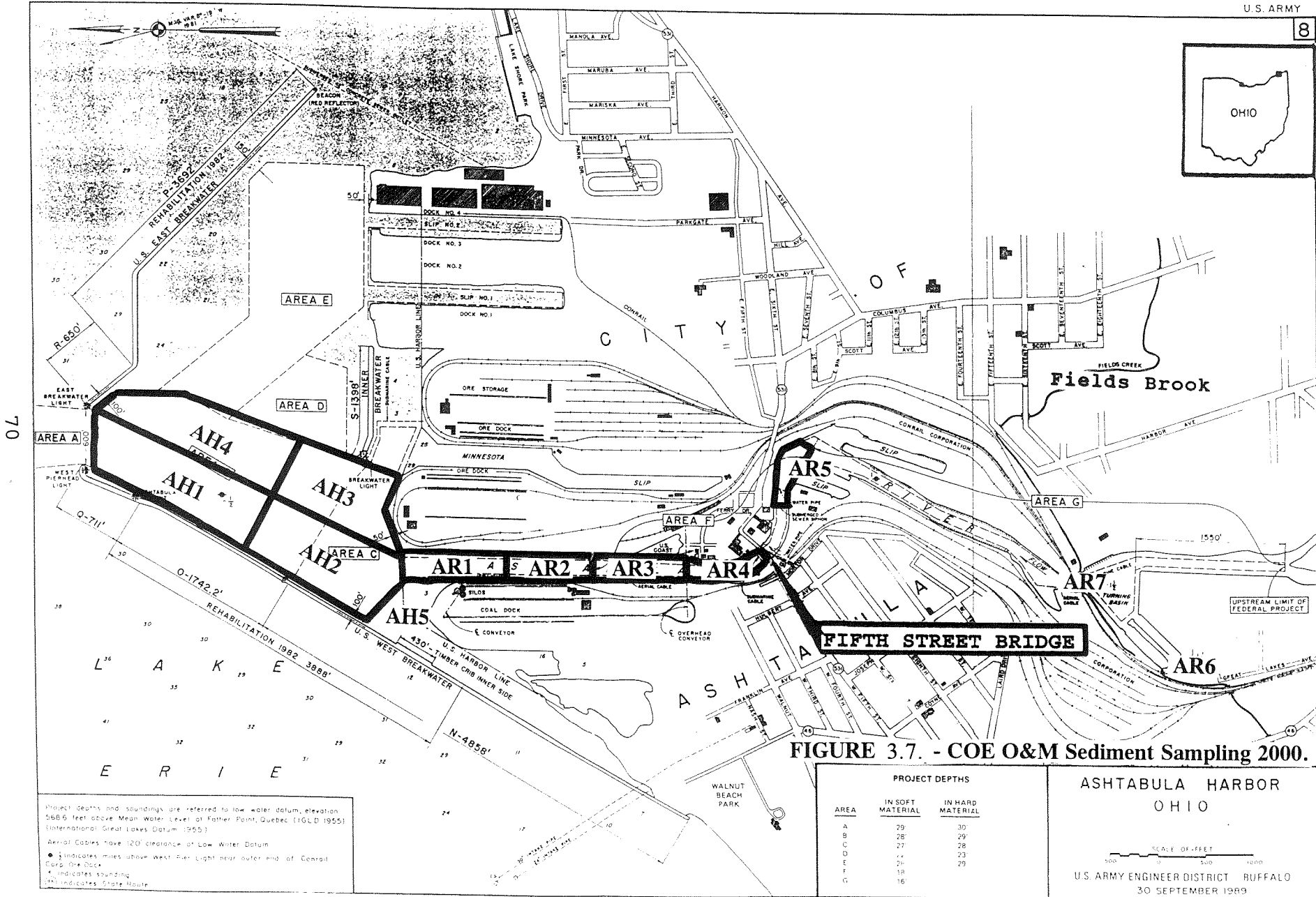

FIGURE 3.7. - COE O&M Sediment Sampling 2000.

Project depths and soundings are referred to low water datum, elevation 566.6 feet above Mean Water Level at Father Point, Quebec (IGLD 1955) (International Great Lakes Datum, 1955).
 Aerial Cables have 120' clearance at Low Water Datum.
 ● indicates miles above West Pier Light near outer end of Conrail Cigar Pier Dock.
 * indicates sounding.
 [Symbol] indicates State Route.

AREA	PROJECT DEPTHS	
	IN SOFT MATERIAL	IN HARD MATERIAL
A	29	30
B	28	29
C	27	28
D	27	28
E	27	28
F	18	19
G	16	

ASHTABULA HARBOR
 OHIO

SCALE OF FEET
 0 500 1000

U.S. ARMY ENGINEER DISTRICT BUFFALO
 30 SEPTEMBER 1989

Table 3.3.

Ashtabula River 2000 Sediment Testing Results (units are in ppm [dry weight])

Parameter	HARBOR AREA				Sampling Sites RIVER AREA						Ref
	AH-1	AH-2	AH-3	AH-4	AR-1	AR-2	AR-3	AR-4	AR5-U	AR5-L	
As	12.1*	13.3	14.4	14.2	10.8	13	11.3	12.6	14.6	13	
Ba	48.9	72.6	70.6	60.2	45.7	86.7	78	191	110	142	11.8
Cd	0.33	0.47	0.42	0.32	1.40	0.29	0.61	1.4	0.5	0.81	57.9
Cr	18.1	25.8	24.1	21.2	15.3	25.2	30.3	199	194	65.4	1.2
Cu	25.3	29.7	30.5	30.1	19.5	28.2	27.6	35.8	31.2	31.2	27.1
Pb	18.3	23.8	22.8	21.3	16.0	25.6	26.2	44.9	31.7	36.4	37.1
Hg	0.05	0.1	0.06	0.06	<0.06	0.09	0.12	0.52	0.2	0.27	31.6
Ni	26	30.8	31.6	30.8	22.2	31.6	30.7	36.5	35.1	30.4	0.11
Zn	108	120	122	113	104	121	117	184	136	122	32.7
											151

Ashtabula River 2000 Sediment Testing Results (units are in ppm [dry weight])

Parameter	HARBOR AREA				Sampling Sites RIVER AREA						REF
	AH-1	AH-2	AH-3	AH-4	AR-1	AR-2	AR-3	AR-4	AR-5U	AR-5L	
Naphthalene	ND*	0.038*	0.062	ND	ND	0.041	0.038	0.068	ND	ND	ND
Acenaphthylene	ND	ND	0.120	ND	ND	ND	0.550	ND	ND	ND	ND
Acenaphthene	ND	0.280	0.049	ND	ND	ND	0.031	0.120	ND	ND	ND
Fluorene	ND	0.410	0.078	ND	ND	ND	0.039	0.150	ND	0.290	0.320
Phenanthrene	0.150	0.280	0.430	0.190	0.064	0.210	0.280	0.150	ND	ND	0.420
Anthracene	0.037	0.700	0.180	0.048	ND	0.520	ND	0.870	0.220	0.200	0.290
Fluoranthene	0.190	0.380	1.300	0.240	0.078	0.290	0.370	1.300	0.340	0.540	0.900
Pyrene	0.210	0.410	1.600	0.260	0.097	0.380	0.420	1.000	0.330	0.310	0.490
Benzo(a)Anthracene	0.098	0.230	0.930	0.120	0.051	0.150	0.180	0.430	0.150	0.120	0.570
Chrysene	0.100	0.200	0.760	0.140	0.057	0.190	0.210	0.450	0.190	0.140	0.260
Benzo(b)Fluoranthene	0.120	0.290	1.100	0.170	ND	0.230	0.260	0.530	0.250	0.170	0.270
Benzo(k)Fluoranthene	ND	ND	0.390	ND	ND	ND	ND	0.220	ND	ND	0.350
Benzo(a)Pyrene	0.085	0.019	0.800	0.110	0.049	0.150	0.160	0.380	0.170	0.120	ND
Indeno(1,2,3-cd)Pyrene	ND	0.110	0.310	ND	ND	ND	0.098	0.220	ND	ND	0.250
Dibenzo(a,h)Anthracene	ND	ND	0.120	ND	ND	ND	ND	ND	ND	ND	0.140
Benzo(ghi)Perylene	ND	ND	0.300	ND	ND	ND	0.110	0.280	ND	ND	ND
Total PAH	0.99	3.35	8.53	1.28	0.40	1.69	2.20	6.78	1.55	1.91	0.150
TEQ	0.107	0.082	1.16	0.054	0.132	0.188	0.214	0.501	0.210	0.149	3.74
											0.325

Ashtabula River 2000 Sediment Testing Results (units are in ppb [dry weight])

PCB	HARBOR AREA				Sampling Sites RIVER AREA						REF
	AH-1	AH-2	AH-3	AH-4	AR-1	AR-2	AR-3	AR-4	AR-5U	AR-5L	
Aroclor 1016	ND*	ND	ND	ND	ND	ND	ND	ND	ND	ND	REF
Aroclor 1221	ND	ND	ND	ND	ND	ND	ND	ND	ND	ND	ND
Aroclor 1232	ND	ND	ND	ND	ND	ND	ND	ND	ND	ND	ND
Aroclor 1242	ND	ND	ND	ND	ND	ND	ND	ND	ND	ND	ND
Aroclor 1248	150*	370	250	130	290	420	750	7800	1100	1500	ND
Aroclor 1254	ND	ND	ND	ND	ND	ND	ND	ND	ND	ND	ND
Aroclor 1260	ND	ND	ND	ND	ND	ND	ND	ND	ND	ND	120
Total PCB	150	370	250	130	290	420	750	7800	1100	1500	120

* No Detect

* Bold values greater than reference

Table 3.4.

Ashtabula Harbor 2000 Sediment Testing for Organism Toxicity & Growth

(Bolded values are compatible with reference)

Harbor	<i>Hyalella azteca</i> Toxicity Survival	<i>Chironomus tentans</i> Toxicity Survival	<i>Chironomus tentans</i> Growth
AH-1	62^{+/-}19 ^{1,2,3}	94 ^{+/-} 5	1.19 ^{+/-} 0.07
AH-2	80^{+/-}10	94 ^{+/-} 5	1.36 ^{+/-} 0.14
AH-3	68^{+/-}13 ³	86^{+/-}13	1.26 ^{+/-} 0.19
AH-4	96^{+/-}9	100 ^{+/-} 0	1.46 ^{+/-} 0.23
River			
AR-1	92^{+/-}13	92 ^{+/-} 13	1.23 ^{+/-} 0.14
AR-2	92^{+/-}13	98 ^{+/-} 4	1.10 ^{+/-} 0.18
AR-3	74^{+/-}38	92 ^{+/-} 8	1.16 ^{+/-} 0.14
AR-4	64^{+/-}21 ³	78 ^{+/-} 15	0.84 ^{+/-} 0.07
AR-5U	78^{+/-}26	92 ^{+/-} 8	1.42 ^{+/-} 0.59
AR-5L	74^{+/-}11	82^{+/-}13	0.95 ^{+/-} 0.9
Control	98 ^{+/-} 4	82 ^{+/-} 13	0.82 ^{+/-} 0.20
Reference	92 ^{+/-} 13	74 ^{+/-} 32	0.87 ^{+/-} 0.29

¹ The first number is the average followed by the variation.

² Large bolded values indicate no statistically significant difference between site and reference sediments

³ Although there was a low average, the sample was not statistically different because of the spread of replicate survival.

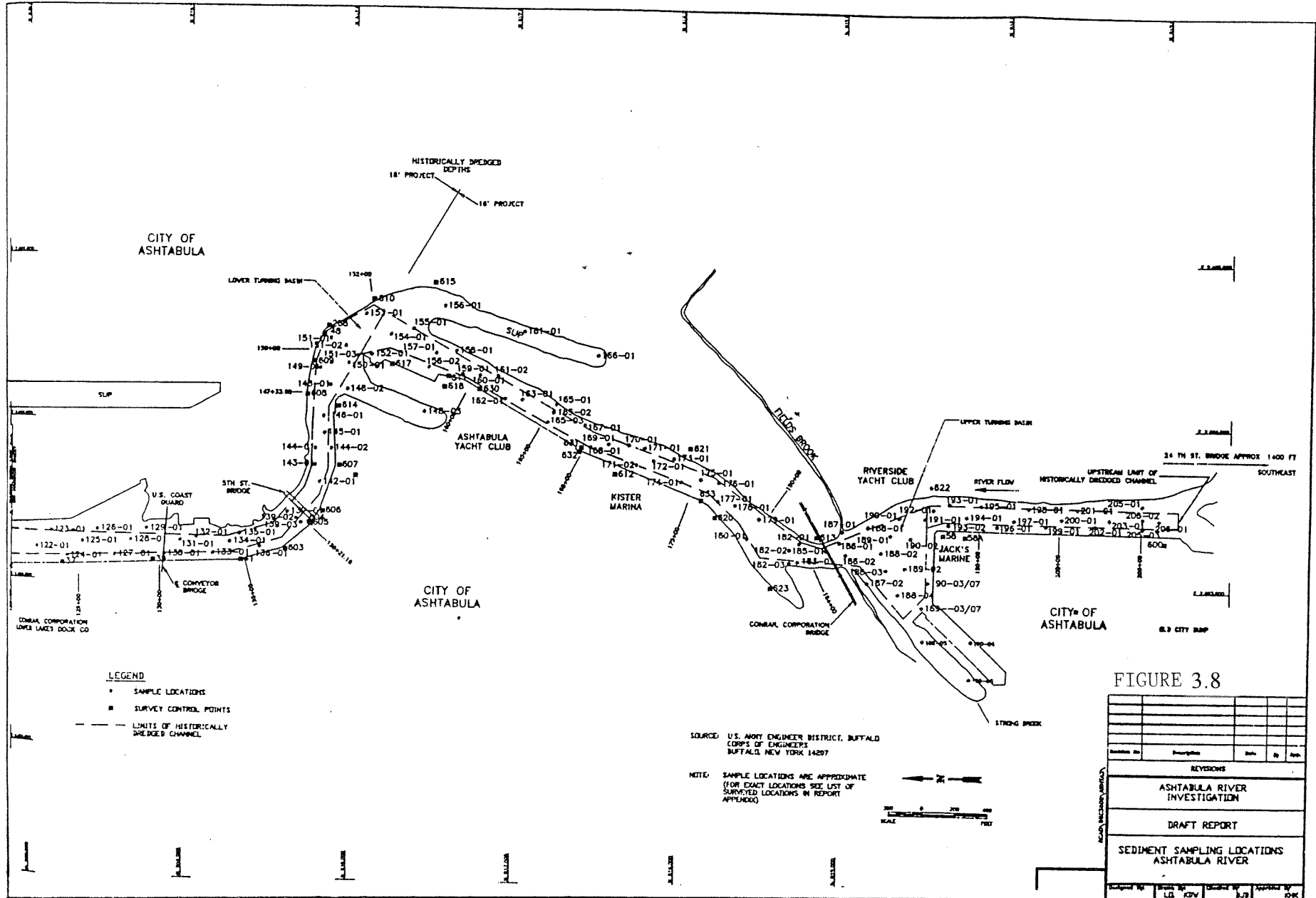

FIGURE 3.8

Revision No.	Description	Date	By	App'd.
REVISIONS				
ASHTABULA RIVER INVESTIGATION				
DRAFT REPORT				
SEDIMENT SAMPLING LOCATIONS ASHTABULA RIVER				
Prepared By	Drawn By	Checked By	Approved By	
Date				
FEBRUARY 1991	DEC 1990			
Woodward-Clyde Consultants				2.2.3

ASHTABULA RIVER RAP

TABLE 3.5

Table Summary of Woodward Clyde Consultants' data for sediment pollutant concentrations in the Ashtabula River navigation channel.

Parameter	Number of Samples	Number Detected	Mean	Minimum	Maximum
<u>Metals and PCBs (mg/kg)</u>					
Arsenic	130	130	12.9	4.5	31.1
Barium	130	130	399.5	27.6	2,152.0
Cadmium	130	88	2.7	0.0	25.0
Chromium	130	130	399.8	12.4	5,739.9
Copper	130	130	44.1	14.4	414.0
Iron	58	58	30,201.4	18,442.6	48,387.1
Lead	130	130	59.9	8.5	248.1
Manganese	58	58	491.4	124.4	2,900.4
Mercury	130	93	1.0	0.0	11.3
Nickel	130	130	41.1	13.6	142.0
Zinc	130	130	208.6	62.5	1,161.2
PCBs	402	322	11.9	0.0	660.1
<u>Other Organics (ug/kg)</u>					
1,2,4-trichlorobenzene	130	2	39.8	0.0	3,418.8
1,2-dichlorobenzene	130	1	5.2	0.0	675.9
1,3-dichlorobenzene	130	35	1,937.8	0.0	28,627.5
1,4-dichlorobenzene	130	15	364.5	0.0	15,047.0
2-chloronaphthalene	130	6	364.5	0.0	16,181.8
Hexachlorobenzene	130	49	734.7	0.0	26,524.4
Hexachlorobutadiene	130	34	4,562.8	0.0	560,000.0
Hexachlorethane	130	1	0.6	0.0	80.8
4,4'-DDD	62	1	11.9	0.0	738.9
2-methylnaphthalene	62	1	7.3	0.0	453.4
Anthracene	62	5	80.5	0.0	1,455.6
Benzo(a)anthracene	62	12	259.3	0.0	2,772.9
Benzo(a)pyrene	62	7	134.0	0.0	2,037.9
Benzo(b)fluoranthene	62	18	392.6	0.0	3,639.0
Benzo(g,h,i)perylene	62	2	42.6	0.0	1,601.2
Benzo(k)fluoranthene	62	5	96.1	0.0	2,079.7
Butyl benzyl phthalate	62	1	14.5	0.0	895.9

ASHTABULA RIVER RAP

Table : Summary of Woodward Clyde Consultants' data for sediment pollutant concentrations in the Ashtabula River navigation channel. (Cont.)

Parameter	Number of Samples	Number Detected	Mean	Minimum	Maximum
Chrysene	62	12	266.1	0.0	2,805.3
Di-n-butyl phthalate	62	6	292.2	0.0	7,785.9
Fluoranthene	62	37	923.6	0.0	5,822.4
Fluorene	62	2	30.0	0.0	1,251.8
Indeno(1,2,3-cd)pyrene	62	3	57.4	0.0	1,746.7
Naphthalene	62	2	23.8	0.0	1,018.9
Octachlorostyrene	58	10	367.9	0.0	6,000.0
Phenanthrene	62	36	1,185.8	0.0	15,185.2
Pyrene	62	25	812.5	0.0	11,093.8
Bis(2-ethylhexyl)phthalate	62	36	4,346.5	0.0	49,327.4
2-butanone	126	1	0.2	0.0	20.4
Acetone	130	91	69.1	0.0	1,254.1
Chlorobenzene	130	69	366.6	0.0	10,416.7
Chloromethane	130	5	6.8	0.0	396.3
Ethyl benzene	130	5	92.8	0.0	11,842.1
Methylene chloride	126	55	49.5	0.0	2,181.8
Toluene	130	86	38.9	0.0	731.1
Xylenes	130	22	465.3	0.0	59,210.5

ASHTABULA RIVER RAP

TABLE 3.6

Table Summary of Woodward Clyde Consultants' data for sediment pollutant concentrations in slips outside the Ashtabula River navigation channel.

Parameter	Number of Samples	Number Detected	Mean	Minimum	Maximum
Metals and PCBs (mg/kg)					
Arsenic	24	24	12.3	6.8	21.2
Barium	24	24	342.2	35.7	1,123.1
Cadmium	24	20	3.6	0.0	15.1
Chromium	24	24	115.6	12.6	587.8
Copper	24	24	53.8	20.5	152.3
Iron	9	9	30,288.2	15,344.5	40,566.0
Lead	24	24	108.3	9.4	284.9
Manganese	9	9	333.2	104.1	468.3
Mercury	24	17	0.5	0.0	3.2
Nickel	24	24	39.0	23.1	71.4
Zinc	24	24	497.6	65.9	2,463.1
PCBs	34	15	12.8	0.0	369.4
Other Organics (ug/kg)					
1,2,4-trichlorobenzene	24	1	245.1	0.0	5,882.4
1,2-dichlorobenzene	24	2	426.5	0.0	8,755.1
1,3-dichlorobenzene	24	2	655.6	0.0	7,936.5
1,4-dichlorobenzene	24	4	1,849.3	0.0	24,024.0
2-chloronaphthalene	24	1	547.4	0.0	13,136.3
Hexachlorobenzene	24	3	1,975.2	0.0	45,143.6
Hexachlorobutadiene	24	6	1,673.7	0.0	34,199.7
4,4'-DDD	13	2	369.6	0.0	4,429.3
4,4'-DDE	13	1	31.5	0.0	408.9
4,4'-DDT	13	1	11.7	0.0	151.6
Dieldrin	13	1	160.6	0.0	2,087.7
4-methylphenol	9	1	4,612.2	0.0	41,509.4
Acenaphthene	13	1	769.2	0.0	10,000.0
Anthracene	13	1	1,275.8	0.0	16,585.4

ASHTABULA RIVER RAP

Table : Summary of Woodward Clyde Consultants' data for sediment pollutant concentrations in slips outside the Ashtabula River navigation channel. (Continued)

Parameter	Number of Samples	Number Detected	Mean	Minimum	Maximum
Benzo(a)anthracene	13	1	1,876.2	0.0	24,390.2
Benzo(a)pyrene	13	1	1,519.7	0.0	19,756.1
Benzo(b)fluoranthene	13	3	1,922.7	0.0	22,926.8
Fluorene	13	1	1,332.1	0.0	17,317.1
Benzo(g,h,i)perylene	13	1	975.6	0.0	12,682.9
Benzo(k)fluoranthene	13	1	919.3	0.0	11,951.2
Chrysene	13	2	2,496.3	0.0	31,707.3
Di-n-butylphthalate	13	2	480.9	0.0	3,699.1
Fluoranthene	13	5	5,776.6	0.0	65,853.7
Indeno(1,2,3-cd)pyrene	13	1	1,069.4	0.0	13,902.4
Phenanthrene	13	5	7,414.3	0.0	87,804.9
Pyrene	13	5	6,131.1	0.0	73,170.7
Bis(2-ethylhexyl)phthalate	13	3	1,048.5	0.0	9,439.1
2-butanone	20	1	1.7	0.0	34.0
Acetone	24	15	316.2	0.0	5,636.7
Chlorobenzene	24	5	56.8	0.0	1,085.6
Ethyl benzene	24	2	10.6	0.0	238.5
Methylene chloride	20	7	9.3	0.0	66.4
Tetrachloroethene	24	1	0.6	0.0	13.6
Toluene	24	12	15.2	0.0	162.2
Trichloroethene	24	2	0.7	0.0	9.5
Xylenes	24	6	75.2	0.0	1,419.6

TABLE 3.7

Pollutants identified in the Ashtabula River Area of Concern. This table was compiled from the results of a number of studies conducted in the area since 1975. This table documents only positive identification of pollutants.

PARAMETER	PRIORITY POLLUTANT	CARCINOGEN	PERSISTANT TOXIC*	WATER				SEDIMENT				FISH
				OUTER HARBOR	ASHTABULA RIVER	FIELDS BROOK	LAKE ERIE	OUTER HARBOR	ASHTABULA RIVER	FIELDS BROOK	LAKE ERIE	
<u>Inorganics</u>												
Aluminum	N	N	N	X	X	X	-	X	X	X	X	-
Arsenic	Y	Y	Y	-	-	-	X	X	X	X	X	X
Barium	N	N	N	X	X	X	X	X	X	X	X	X
Beryllium	Y	Y	-	-	-	-	-	X	X	X	X	-
Cadmium	Y	N	Y	X	X	X	X	X	X	X	X	X
Chromium	Y	N	Y	X	X	X	X	X	X	X	X	-
Copper	Y	N	Y	X	X	X	X	X	X	X	X	-
Cyanide	Y	N	N	-	X	-	-	X	X	X	X	X
Iron	N	N	Y	X	X	X	X	X	X	X	X	-
Lead	Y	N	Y	X	X	X	X	X	X	X	X	-
Manganese	N	N	N	X	X	X	-	X	X	X	X	X
Mercury	Y	N	Y	X	X	X	X	X	X	X	X	X
Nickel	Y	N	Y	X	-	-	X	X	X	X	X	-
Nitrogen (Ammonia)	N	N	N	X	X	X	X	X	-	-	X	-
Nitrate + Nitrite	N	N	N	X	X	X	X	X	-	-	X	-
Phosphorus	N	N	N	X	X	X	X	X	-	-	X	-
Oil and Grease	N	N	N	-	-	-	-	X	X	-	X	-
Silver	Y	N	-	-	-	-	-	X	X	-	X	-
Zinc	Y	N	Y	X	X	X	X	X	X	X	X	X
Total Dissolved Solids	N	N	Y	X	X	X	X	-	-	-	-	-
Phenols	Y	N	-	-	-	-	-	X	X	-	X	-
<u>Organics</u>												
Aldrin + Dieldrin	Y	Y	Y	X	X	-	X	-	X	-	-	-
PCBs	Y	Y	Y	-	-	-	X	X	X	X	X	X
<u>PAHs</u>												
Acenaphthene	Y	Y	-	-	-	-	-	X	-	-	-	-
Anthracene	Y	Y	-	-	-	-	-	X	X	-	-	-
Benzo(a)anthracene	Y	Y	-	-	-	-	-	X	X	-	X	-
Benzo(a)pyrene	Y	Y	-	-	-	-	-	X	X	X	X	-
Benzo(b)fluoranthene	Y	Y	-	-	-	-	-	X	X	-	X	-
Chrysene	Y	Y	-	-	-	-	-	X	X	-	X	-
Fluoranthene	Y	Y	-	-	-	-	-	X	X	X	X	X
Fluorene	Y	Y	-	-	-	-	-	X	X	-	X	-
Naphthalene	Y	Y	-	-	-	-	X	X	X	-	-	-
Phenanthrene	Y	Y	-	-	-	-	-	X	X	X	X	-
Pyrene	Y	Y	-	-	-	-	-	X	X	-	-	-
2-chloronaphthalene	-	-	-	-	-	-	-	-	X	-	-	-
Benzo(k)fluoranthene	Y	Y	-	-	-	-	-	-	X	-	-	-
<u>Other Organics</u>												
Acetone	N	N	-	-	-	-	-	-	X	X	-	-
Benzene	Y	Y	-	-	-	-	-	-	-	X	-	-
Bis(2-ethylhexyl) phthalate	Y	N	Y	-	-	-	-	X	X	X	X	-
2-butanone	N	N	-	-	-	-	-	-	X	X	-	-
Butylbenzyl phthalate	Y	N	Y	-	-	-	-	-	X	X	-	-
Chlorobenzene	Y	N	-	-	-	-	X	-	X	-	-	-
Chloroform	Y	Y	-	-	-	X	-	-	-	-	-	-
1,1-dichloroethane	Y	Y	-	-	-	-	-	-	-	X	-	-
Diethyl phthalate	Y	N	Y	-	-	X	-	-	-	-	X	-
Dimethyl phthalate	Y	N	Y	-	-	-	-	-	-	-	X	-
Di-n-butyl phthalate	Y	N	Y	-	-	-	-	-	-	X	X	-
Ethylbenzene	Y	N	-	-	-	-	-	-	X	X	-	-
Fluorotrichloromethane	N	N	-	-	-	-	-	-	-	X	-	-
Hexachlorobenzene	Y	Y	-	-	-	X	X	-	X	X	-	X
Hexachlorobutadiene	Y	Y	-	-	-	X	-	-	X	X	-	X
Hexachloroethane	Y	Y	-	-	-	-	-	-	X	X	-	X
Methylene chloride	Y	Y	-	-	X	X	-	-	X	X	-	-
1,2-Dichlorobenzene	Y	N	-	-	X	X	X	-	X	X	X	-
1,3-Dichlorobenzene	Y	N	-	-	-	X	X	-	X	-	-	-
1,4-Dichlorobenzene	Y	N	-	-	-	X	X	-	X	-	-	-
n-nitrosodiphenylamine	Y	Y	-	-	-	X	-	-	-	-	-	-
Carbon tetrachloride	Y	Y	-	-	-	X	X	-	-	-	-	-
Octachlorostyrene	N	N	-	-	-	-	-	-	X	-	-	X
Xylene	N	N	-	-	-	-	-	-	-	X	-	-
Pentachlorobenzene	N	N	-	-	-	-	X	-	-	X	-	-
1,1,1,2-tetrachloroethane	N	N	-	-	-	-	-	-	X	-	-	X
1,1,2,2-tetrachloroethane	Y	Y	-	X	X	X	-	-	-	X	-	-
Tetrachloroethane	Y	Y	-	X	X	X	-	-	X	X	-	X
1,2-transdichloroethane	N	N	-	-	-	X	-	-	-	X	-	-
1,1,2-trichloroethane	Y	Y	-	-	-	X	-	-	-	X	-	-
1,1,1-trichloroethane	Y	N	-	-	-	-	-	-	-	X	-	-
Trichloroethane	Y	N	-	X	X	X	-	-	-	X	-	X
Toluene	Y	N	-	-	-	-	-	-	X	X	-	X
Vinyl chloride	Y	Y	-	-	-	-	-	-	X	X	-	-
1,2,4-trichlorobenzene	N	N	-	-	-	-	-	-	-	X	-	-
1,2-dichloroethane	Y	Y	-	-	-	X	-	-	X	-	-	-
1,3,5-trichlorobenzene	N	Y	-	-	-	-	X	-	-	-	-	-
1,2,3,4-tetrachlorobenzene	N	Y	-	-	-	-	X	-	-	-	-	-

* As Identified in the Great Lakes Water Quality Agreement
 X - Yes
 Y - Pollutant detected in medium
 "n" - Pollutant not present or not tested

limit. The initial sampling sites are depicted on Figure 3.8. Subsequently, physical (particulate size) and bulk chemical (inorganic and organic) analyses of the samples was performed (Woodward/Clyde). Sediment contaminant levels are summarized in Tables 3.5 through 3.7. The purpose of the bulk chemical analyses of core sediment samples was to evaluate the distribution of various contaminants with respect to area and depth. These sampling and analyses were supplemented in 1995/1996 and 1998 to reaffirm and to fill in associated information gaps for use for this Ashtabula River Partnership study/project.

3.41 Summary Analysis - Particle size analysis of the Ashtabula River sediment samples indicated that the sediments are comprised primarily of silts and fine sands. Inorganic and organic analyses of the sediment samples indicate that most Ashtabula River core sediments are generally considered contaminated and not suitable for unrestricted open-lake disposal. The sediments were assigned this pollution classification because of a number of elevated inorganic parameters including Arsenic, Barium, Cadmium, Chromium, Cyanide, Lead, Mercury, and Zinc. Most of the other inorganic parameters tested in the sediment samples showed non-contamination to moderate levels of contamination. Organic analysis of the sediment samples showed appreciable levels of Di, Tri, and Hexachlorobenzenes in most of the sediment samples and some showed very low levels of Polynuclear Aromatic Hydrocarbons (PAH's). Dry weight concentrations of Polychlorinated Biphenyls (PCB's) in sediment samples collected downstream of the Fifth Street bridge above -18 feet LWD (Low Water Datum) or authorized project depth were measured at generally low levels. Sediment PCB concentrations in this reach were all < 5 ppm (parts per million) and most were < 1 ppm, with the exception of one area just downstream of the Fifth Street bridge, which showed 16 ppm at -18 feet LWD. Upstream concentrations were also generally low in sediment samples collected above -6 feet LWD. While most Ashtabula River surface sediment showed relatively low levels of PCB's, some samples in the vicinity of the mouth of Fields Brook (mostly in the River Turning Basin) show higher levels of PCB's at or below -6 or -8 feet LWD. Some of these deeper sediment samples have PCB levels equal to or in excess of 50 ppm. Per the Toxic Substance Control Act, 1976, dredged material with PCB concentrations equal to or greater than 50 parts per million must be handled/addressed in accordance with guidelines set forth by the Act.

3.42 In 1993, a special cooperative interim dredging and dredged material disposal project took place in the upper federal and local navigation channel of the lower Ashtabula River, in order to facilitate area commercial and recreational boating needs. Approximately 23, 500 cubic yards of sediments were dredged and disposed of into a small reconditioned shoreline upland dewatering and confined disposal facility. The material dredged was not suitable for unrestricted open lake disposal; but, was not regulated under the Toxic Substance Control Act. Contaminants of concern included low levels of PCBs and heavy metals. Reference Figure 3.9.

3.43 About 1,150,000 cubic yards of minor to heavily contaminated sediments are situated in the harbor area of the lower Ashtabula River. Elevated inorganic parameters include: arsenic, cadmium, chromium, lead, and mercury. Elevated organic parameters include: polychlorinated biphenyls (PCBs), industrial solvents and polynuclear aromatic hydrocarbons (PAHs). Some PCBs (~ 29,000 CY) are in excess of 50 mg/kg. Dredged material with PCBs equal to or in excess of 50 mg/kg are regulated under the Toxic Substance Control Act (TSCA) and must be appropriately handled and disposed of. Low level radionuclides (RAD) such as uran-

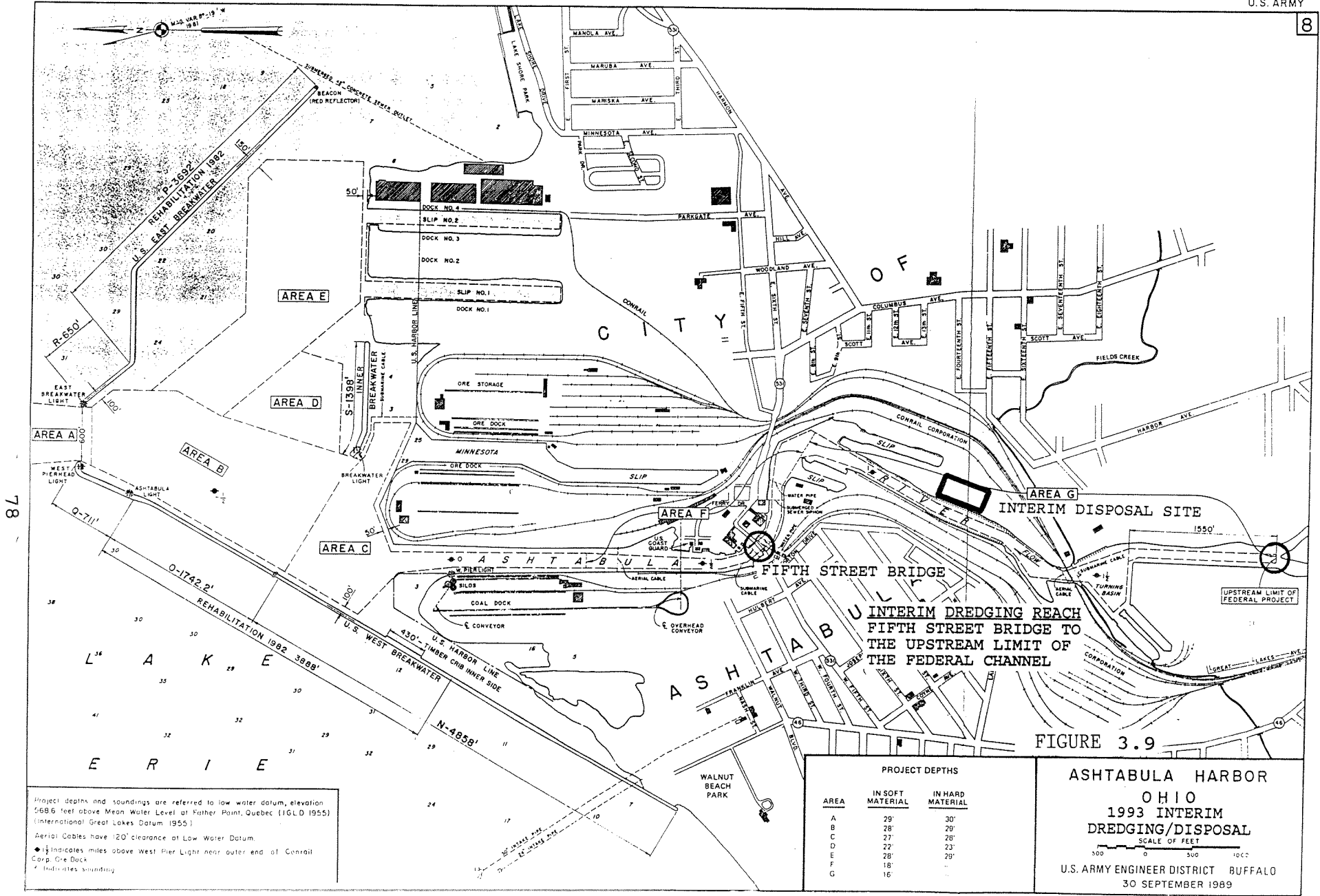

78

+

ium, radium, and thorium (above background) are also present in some of the sediments and must be appropriately handled and disposed of. Sediments with elevated levels of contaminants above reference may not be disposed of at open lake disposal sites and must be appropriately disposed of by alternate disposal methods.

3.44 The primary contaminants of concern within the reach from the Upper Turning Basin downstream to the Fifth Street Bridge are PCBs (primarily) and radionuclides and metals. The primary contaminants of concern within the reach from the Fifth Street Bridge to Station 120 are PAHs (primarily) and migrated PCBs, radionuclides, and metals.

3.45 Focus has been on the primary contaminants of concern in the Ashtabula River Area of Concern (AOC) due to their level and extent of contamination. Specifically, the focus is on PCBs, RADs, and to a somewhat lesser extent PAHs. There are other contaminants of concern in the AOC (notably metals), as discussed previously. However, it is calculated that by focusing on PCBs, RADs, and PAHs, the other contaminants of concern will be addressed due to co-location of contaminants. The contaminants that have been detected in Ashtabula River sediment, surface water, and fish are summarized in Table 3.7 (Ohio EPA, Stage 1 Report, 1991).

3.46 The statistical analysis of 1990 and 1995 Ashtabula River sediment sampling data reported a maximum PCB concentration of 660 mg/kg and 160 mg/kg, respectively and an average concentration of detected samples of 18.2 mg/kg and 15.7 mg/kg, respectively. The sampling locations closest to Fields Brook contain the highest concentrations as expected and decrease with distance down the river.

3.47 The volume of PCB contaminated sediments that are equal to or greater than 50 mg/kg (ppm), is estimated at 28,740 cubic yards. The USEPA, OEPA, and the COE, Buffalo District decided for planning purposes (given the uncertainties in the volume estimate/modeling) to use 40 mg/kg (ppm) as a cutoff for sediments that would be handled and disposed as TSCA waste. An estimate of 150,000 cubic yards is used based on the 49,375 cubic yards of sediment with PCB concentrations exceeding 40 mg/kg, plus an engineering analysis of possible dredging techniques which has determined the most feasible dredging plan.

3.48 Utilizing the data from the 1989/1990 (Woodward/Clyde) and the 1995/1996 Ashtabula River Partnership core sediment sampling and analyses reports, the U.S. Army Corps of Engineers Waterway Experiment Station (WES) was able to generate three dimensional depictions of various concentrations of PCB contaminated Ashtabula River sediments. Reference the CMP Feasibility Report Technical Appendix C. Figures 3.10 through 3.11B depict PCB Sample Locations, Plan View of 50 ppm PCB Plume, and Elevation View of 50 ppm PCB Plume, respectively. Tables 3.8 and 3.9 depict Surface Area Weighted Sediment Concentrations (PCBs) and Volume of Contaminated Sediment (PCBs) above each of the given threshold value. As noted previously, dredged material with PCB concentrations equal to or greater than 50 parts per million (ppm) must be handled/addressed in accordance with guidelines set forth by the Toxic Substance Control Act, 1976.

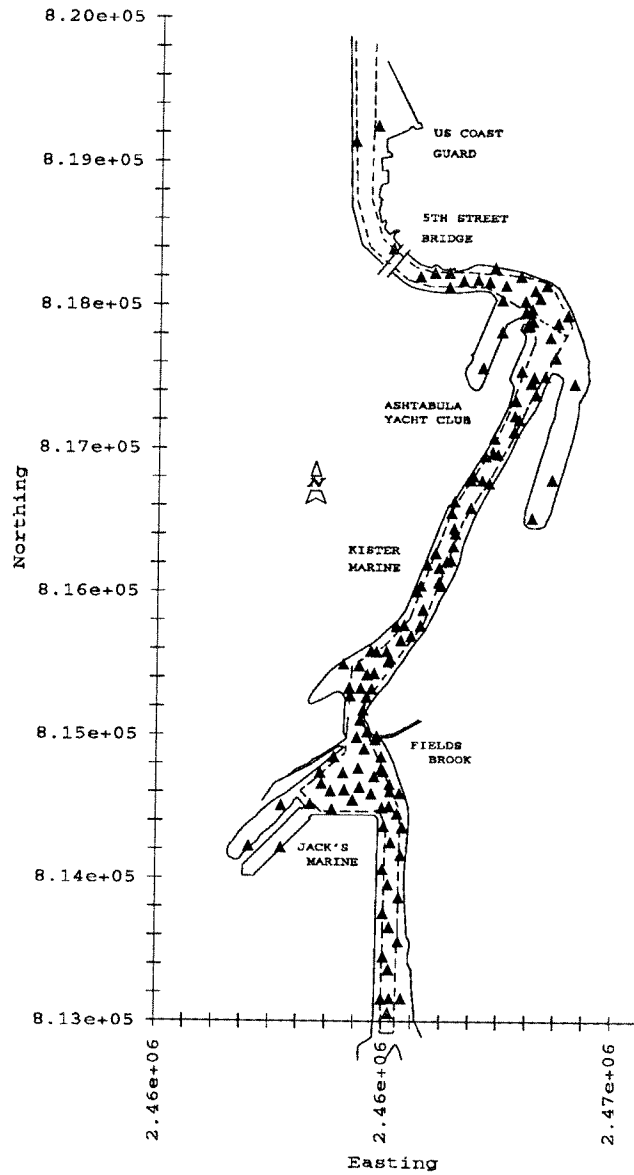

FIGURE 3.10. : Ashtabula River PCB Sample Locations.

TABLE 3.8 Surface Area Weighted Sediment Concentrations

Initial Conditions				
Concentration Range (ppm)	Average Concentration (ppm)	Surface Area in Range (sf)	Percent of Total Surface Area	Surface Area Weighted Concentration (ppm)
>50	75	5,019	0%	0.18
40-50	45	12,983	1%	0.28
30-40	35	60,075	3%	1.00
20-30	25	125,701	6%	1.50
10-20	15	204,444	10%	1.46
5-10	7.5	286,404	14%	1.02
1-5	3	434,456	21%	0.62
0-1	0.5	969,437	46%	0.23
Total		2,098,519	100%	6.29

TABLE 3.9 Comparison of Sediment Volume and PCB Mass

Initial Conditions					
Threshold Value	Cubic Feet Between Threshold Values	Cubic Yards Between Threshold Values	Cumulative Volume (CY)	Mass Between Threshold Values (kg)	Cumulative Mass (kg)
50 ppm	775,980	28,740	28,740	1735	1735
40 ppm	557,150	20,635	49,375	801	2,537
30 ppm	1,346,300	49,863	99,238	1505	4,042
20 ppm	2,788,900	103,293	202,531	2228	6,270
10 ppm	4,838,500	179,204	381,734	2320	8,589
5 ppm	4,922,400	182,311	564,046	1180	9,769
1 ppm	4,987,100	184,707	748,753	1196	10,964
0.5 ppm	1,144,200	42,378	791,131	27	10,992
0.1 ppm	1,259,800	46,659	837,790	12	11,004
0	8,223,300	304,567	1,142,357	14	11,018

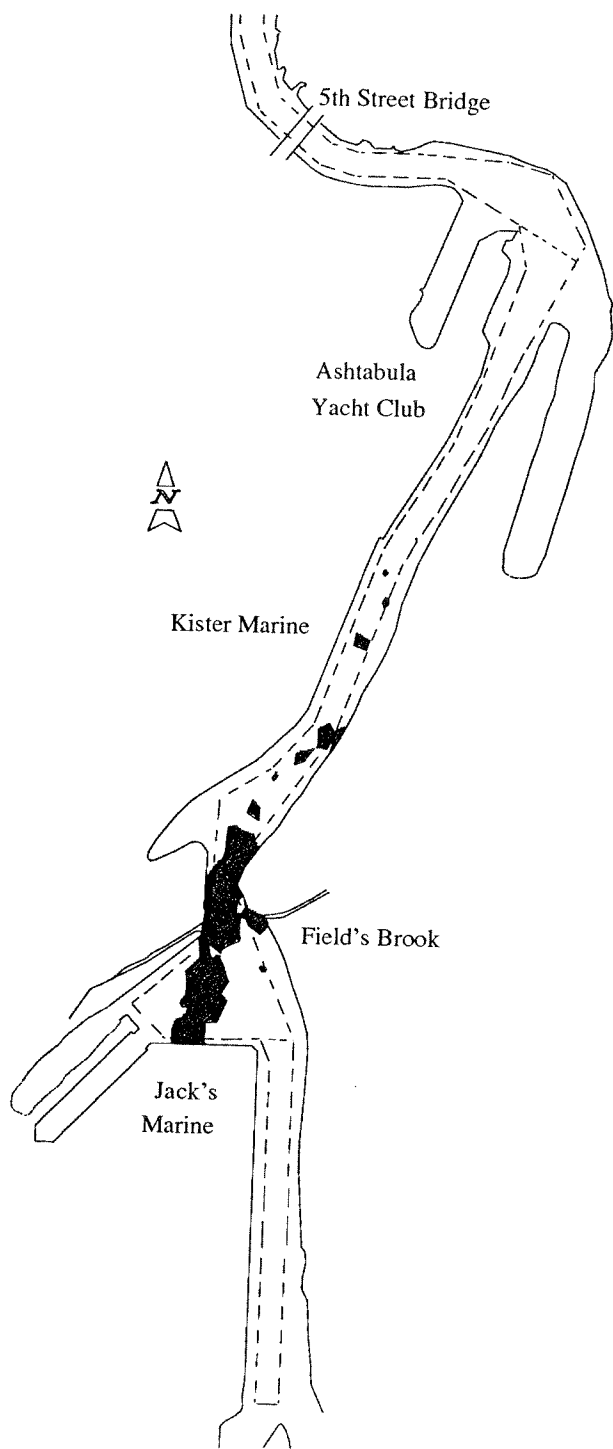

FIGURE 3.11 : Plan View of 50 ppm PCB Plume Generated From IDW Interpolation
With Quadratic Nodal Functions.

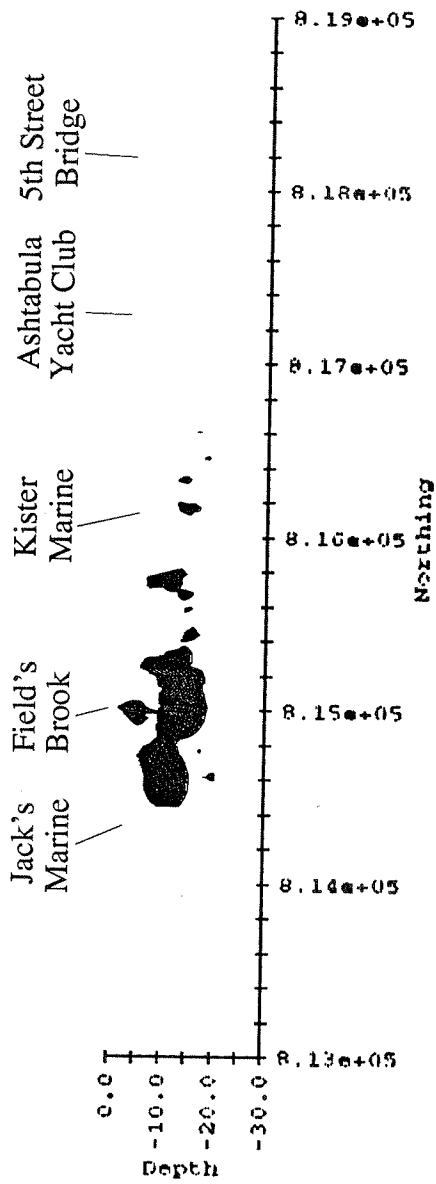

FIGURE 3.11B : Side View of 50 ppm PCB Plume Generated From IDW Interpolation With Quadratic Nodal Functions.

3.49 (Radionuclides) The U. S. Environmental Protection Agency, (USEPA) Great Lakes National Program Office (GLNPO) and the Partnership had concerns regarding radionuclide contamination within the river sediments. This prompted the Partnership to initiate a review analytical data for radionuclides that the USEPA collected at 12 sediment-sampling locations in late 1990. Reference Figure 3.12. The 12 sites were identified as “hot spot” areas with numerous chemical contaminants, based on a comprehensive Ashtabula River sediment study completed in early 1990. That sampling was done to determine whether river sediments contained high levels of radioactive material. The highest concentrations of radionuclides were found at depths in sediment of 4 to 15 feet, in the area of the upper turning basin. The concentrations of total uranium (U-234 + U-235 + U-238) detected in the sampling ranged from 2.4 to 22.3 picocuries per gram (pCi/g), with an average value of 10.1 pCi/g. The concentrations of total radium (Ra-226 + Ra-228) detected in the sampling ranged from 2.6 to 20.6 pCi/g, with an average value of 10.8 pCi/g. In October 1990, USEPA issued a press release about the sample results, stating “these values, are well below the 30 pCi/g guideline limit set by the Nuclear Regulatory Commission, for unrestricted use of cleaned-up land. Based on the results of this sampling, EPA sees no need to employ special precautions for radionuclides during the dredging and disposal of these river sediments”.

3.50 In August 1992, the Ohio General assembly enacted Senate Bill 130, which required that Low-Level Radioactive Waste not be disposed of without a license issued by the Nuclear Regulatory Commission and/or the Director of the Ohio Department of Health. The Ohio Department of Health, Bureau of Radiation Protection (ODH/BRP), as the State of Ohio Radiation Control Agency, and as a member of the Ashtabula River Partnership, is reviewing the conceptual, and subsequent detailed versions, of the design plans for dredging, transfer/dewatering and disposal of river sediments to provide assurance that the river cleanup project is consistent with State requirements and will be protective of public health

3.51 In early 1998, after a review of the analytical data from Ashtabula river sediments collected, beginning in 1996, by Michael E. Ketterer, then a chemistry professor at John Carroll University, and a re-review of their own 1990 analytical data, the USEPA decided to add radioactivity as an analysis parameter for the planned sediment sampling later that year. In May 1998, the USEPA collected eight sediment samples from six depositional areas in the lower river. Reference Figure 3.12. This scoping survey was done for several reasons. Historically, sediment sampling analysis had been focused primarily on uranium. Several radionuclides are naturally occurring substances found in coal and titanium ore, which is processed in the area. Additional analysis was necessary to determine the extent of the presence of other radionuclides within river sediments. Additionally, the USEPA was reviewing risk based cleanup goals for Fields Brook (an Ashtabula River tributary and USEPA Superfund site) and required additional verification sampling/analysis. The highest concentrations of radionuclides were found at depths in sediment of 4 to 15 feet, in the area of the confluence of Fields Brook. The concentrations of total uranium detected in the sampling ranged from 1.6 to 64.7 pCi/g, with an average value of 11.9 pCi/g. The concentrations of total radium detected in the sampling ranged from 1.0 to 17.3 pCi/g, with an average value of 4.1 pCi/g. The maximum total uranium concentration is about twice that being applied to a commercial cleanup on Fields Brook. The maximum total radium concentration is about 30% more than the commercial cleanup criterion and about 3 times the residential cleanup criterion for Fields Brook. From this data,

it became evident to the Partnership that radionuclides were part of the contaminants of concern for the Ashtabula River clean up.

3.52 On May 18, 1999, the ODH/BRP issued an opinion letter to the Partnership regarding the ARP remedial action design. The ODH/BRP opinion letter stated: "...that based on the review of the ARP draft CMP/EIS and given the presently known radionuclide concentrations within the sediments of the Ashtabula river, the recommended plan for disposal of the sediments is consistent with State requirements". Ohio Revised Code Title 37 – Chapter 48 and the rules promulgated there under delineate the regulatory authority under which the ODH/BRP performed its review. During its consideration of this matter, ODH/BRP staff reviewed the criteria in 10 CFR 61 as delineated in Ohio Administrative Code (OAC) 3701-39-021. The ODH/BRP takes the position that the dredging and disposal of low-level radioactive sediments from the Ashtabula River does not require a 10 CFR 61 as delineated in OAC 3701-39-021 disposal action. The ODH/BRP has and will continue to implement the State of Ohio's regulations consistent with a 10CFR 20.2002 as delineated in OAC 3701-39-021 on-site remediation and disposal action.

3.53 During the week of August 23-29, 1999, a radiological characterization of the sediments in the Ashtabula River was conducted by members of the Radiation staff of the USEPA's Superfund Division (USEPA-SD) and personnel from the ODH/BRP. The USEPA's Research Vessel "Mudpuppy" was used to collect 106 sediment samples. Reference Figure 3.12. Radiological analysis of the samples was performed by USEPA's National Air and Radiation Environmental Lab (NAREL). The highest concentrations of radionuclides were found at depths in sediment of 4 to 15 feet, in the area of the upper turning basin. The concentrations of total uranium detected in the sampling ranged from 0.98 to 109.99 pCi/g, with an average value of 6.95 pCi/g. The concentrations of total radium detected in the sampling ranged from 1.8 to 16.1 pCi/g, with an average value of 4.2 pCi/g. This information was used towards the determination of specific project objectives. Those objectives included, determining if the Non-TSCA area sediments differ statistically from upstream background sediments, and obtaining an adequate amount of data in order to perform radiological risk assessments.

3.54 Statistical evaluation of the Non-TSCA area sediment sample data was performed by USEPA Region 5 statisticians under direction of USEPA-SD and ODH/BRP Radiation staff. The statistical procedures used to compare background to sediment sample site concentrations were the parametric two-sample T test and the non-parametric Mann-Whitney U and the Wilcoxon Rank Sum tests. Both parametric and non-parametric procedures were used because environmental data rarely adheres to a normal data distribution. The results showed that there is a statistical difference between the unaffected background sediments, i.e., upstream of the confluence of Fields Brook, and the downstream, Non-TSCA area sediments. The details of the USEPA statistical analysis can be found in Technical Appendix C-Rad.

3.55 On June 12, 2000 the ODH/BRP, in response to a ARP letter of request, clarified it's regulatory position on the disposal of Ashtabula river sediments. The ODH/BRP has classified the river sediments: as radioactive material in accordance with the definition set forth in Ohio Revised Code 3748.01(O); as source material in accordance 10 CFR 40.4 as delineated in OAC 3701-39-021; and as low-level radioactive waste as defined in RC 3748.01(L). It is the

understanding of the ODH/BRP that the sediments are not regulated pursuant to 40 CFR 240 and therefore are not classified as mixed wastes. The ODH/BRP continues to believe that the sediments can be placed in a properly designed cell as described in the CMP/EIS "recommended plan".

3.56 (Radiological Risk Assessment) Risk assessments were made by the U.S. Environmental Protection Agency (USEPA) Region 5 involving inadvertent and unknowing use of Ashtabula River sediments (Reference EIS Appendix C and CMP Technical Appendix F). The first was based upon a resident applying these sediments, left below the cutline for chemical removal, to their property and growing foodstuffs there. There were potentials for external exposure, plant ingestion, soil ingestion and dust inhalation (including radon + decay products) risks. The second was based upon a worker being exposed as they dredged the chemically contaminated sediments or as they unknowingly dredged sediments above the cutline. There were potentials for external exposure and soil ingestion risks

3.57 The results for the Resident-Farmer showed that the total risk from all pathways to a resident (born on the property and living there for 30 years) was about 1×10^{-4} . The risk was about equally apportioned between external exposure, plant ingestion, and inhalation of radon + decay products. The greatest impact was on the older age groups; older child (6 - 12 years), teenager (13 - 19 years) and adult (20 - 30 years) who had longer exposure periods. The other age groups [baby (0 - 1 year), older baby (1 - 2 years), young child (3 - 5 years)] were lesser impacted. 1×10^{-4} is at the upper bound of the acceptable risk range for lifetime cancer risk found in USEPA's guiding document, the National Oil and Hazardous Substances Pollution Contingency Plan (NCP). The sediment concentrations that led to this risk were found in the Uranium, Thorium and Actinium Decay Series. In no case were any concentrations more than twice background levels for the river and in most cases these were 50% or less over background. The levels measured here are one picocurie per gram (pCi/g) or less background and less than 0.5 pCi/g additional in the sediments. Thus, even though the 30 year risk is at the upper end of the NCP risk range, the small deviation from background radiation sediment levels does not warrant further dredging of the river.

3.58 For the Worker-Dredger the total risk for 2 year plus 4 month excavation project is about 5×10^{-5} . This risk is within the 10^{-6} to 10^{-4} risk range in the NCP. The maximum levels found in these sediments reach about 45 pCi/g uranium-238 + decay products (over background) and about 57 pCi/g uranium-234 (over background) and. These concentrations diverge substantially from background and warrant a health and safety plan and worker protection. However, during the chemical cleanup workers will be under such a plan and will be wearing protective clothing. Thus, if the health and safety plan specifically deals with radiation and the worker is monitored for radiation (e.g., dosimeter, radiation frisking, etc.) this should be adequate.

3.59 In the case of an unknowing worker-dredger, the high radioactive concentrations should be a matter of concern even if the risks are still within the NCP risk range. In radiation public health, the philosophy of ALARA (radiation exposures should be As Low As Reasonably Achievable) is always applied. Removal of these contaminated sediments is a prudent action that would prevent inadvertent exposure of a worker-dredger and keep their potential doses ALARA.



FIGURE 3.12
COMPOSITE MAP OF
ALL RADIOLOGICAL
SAMPLING LOCATIONS

3.60 For PAHs, based on 1990, 1992, and supplemental 1998 sediment chemistry data for the lower river, the highest concentrations (100 - 400 ppm) were found in the vicinity of the Ashtabula Yacht Club inlet and the Fifth Street Bridge and high concentrations (50 - 100) were found in sections of the Lower River and Outer Harbor below the Fifth Street Bridge. Reference Figure 3.13. PAHs are prime suspects for poor mortality rates for bioassays conducted on harbor sediment samples from the area downstream from the Fifth Street Bridge.

3.61 Contaminated Sediments Migration - Contaminants have and continue to migrate downstream into the Lower River, Outer Harbor, and Lake Erie. Figures 3.14 and 3.15, and Table 3.10 serve to summarize sediment sampling and analyses results for PCBs for several areas in the Lower River and Outer Harbor and interim dredgings indicating continued migration of contaminants downstream and into the Lower River and Outer Harbor and Lake Erie.

3.62 A scour analysis was conducted for the project study and for the U. S. Army Corps of Engineers, Buffalo District by the Waterways Experiment Station in Vicksburg, Mississippi (WES 1997). Generally, the study determined that with a 100 year event flow through the navigation area of the Lower Ashtabula River, considering 1995 survey bathmetric conditions, up to three feet of material could be scoured from some locations and about 63,000 cubic yards of material displaced. Supplemental analysis indicated that this would move PCB contaminated sediments into the Lower River and to a lesser degree out into the Outer Harbor and Lake. Supplemental analysis also indicates that PCB contaminated sediments will continue to move into the Lower River and out into the Outer Harbor and Lake on an average annual basis.

3.63 It should be noted here that river scour is dynamic and somewhat unpredictable. Many factors circumstances (i.e. a fallen tree debris, sunken boat, etc.) can alter scour patterns and depth. To leave substantial masses of contaminants in the river sediments leaves considerable risk for future scour/resuspension/movements of contaminants. Also, while mixing of lower level contaminated sediments with cleaner sediments may delute resulting contaminant levels to those acceptable for open lake disposal, mixing of higher level contaminated sediments with cleaner sediments can result in greater volumes of contaminated sediments not suitable for open lake disposal.

3.64 Physical Habitat for Aquatic Life. Reference paragraph 3.02 pertaining to Ohio's Habitat Assessment Procedure (HAP). In the upper Ashtabula River basin, a comprehensive assessment of habitat quality was completed in 1995 for River Mile (R.M.) 3.5 to 27.2. Reference Figures 3.1, 3.3, and 3.16. The quality of the macro habitats at five locations sampled for fish in the lotic Ashtabula River, and at sites sampled in the East and West Branches, were assessed using the Qualitative Habitat Evaluation Index (QHEI - Rankin 1989). The mean QHEI score for the basin was 73.2 ± 5.93 s.d., indicating generally good to excellent habitat quality and the capability of supporting a diverse aquatic fauna. The absence of anthropogenic modifications to the river is demonstrated by the low ratio (<0.5) of modified habitat attributes to warmwater habitat attributes. The positive warmwater habitat attributes encountered in the lotic Ashtabula River is largely ascribed to a lack of channelization, wide mature riparian areas, and small acreage farms using conservative practices in the basin. Riffle and channel substrates were unembedded and generally silt free. Glacial till and fractured bedrock provided a variety of substrate sizes and habitat complexity, especially in the upper watershed. Al-

Ashtabula River: 1990 and 1992 PAH Samples

FIGURE 3.13

PAH, ppm

- < 1
- 1 - 5
- 5 - 50
- 50 - 100
- 100 - 400
- ⊕ Grab

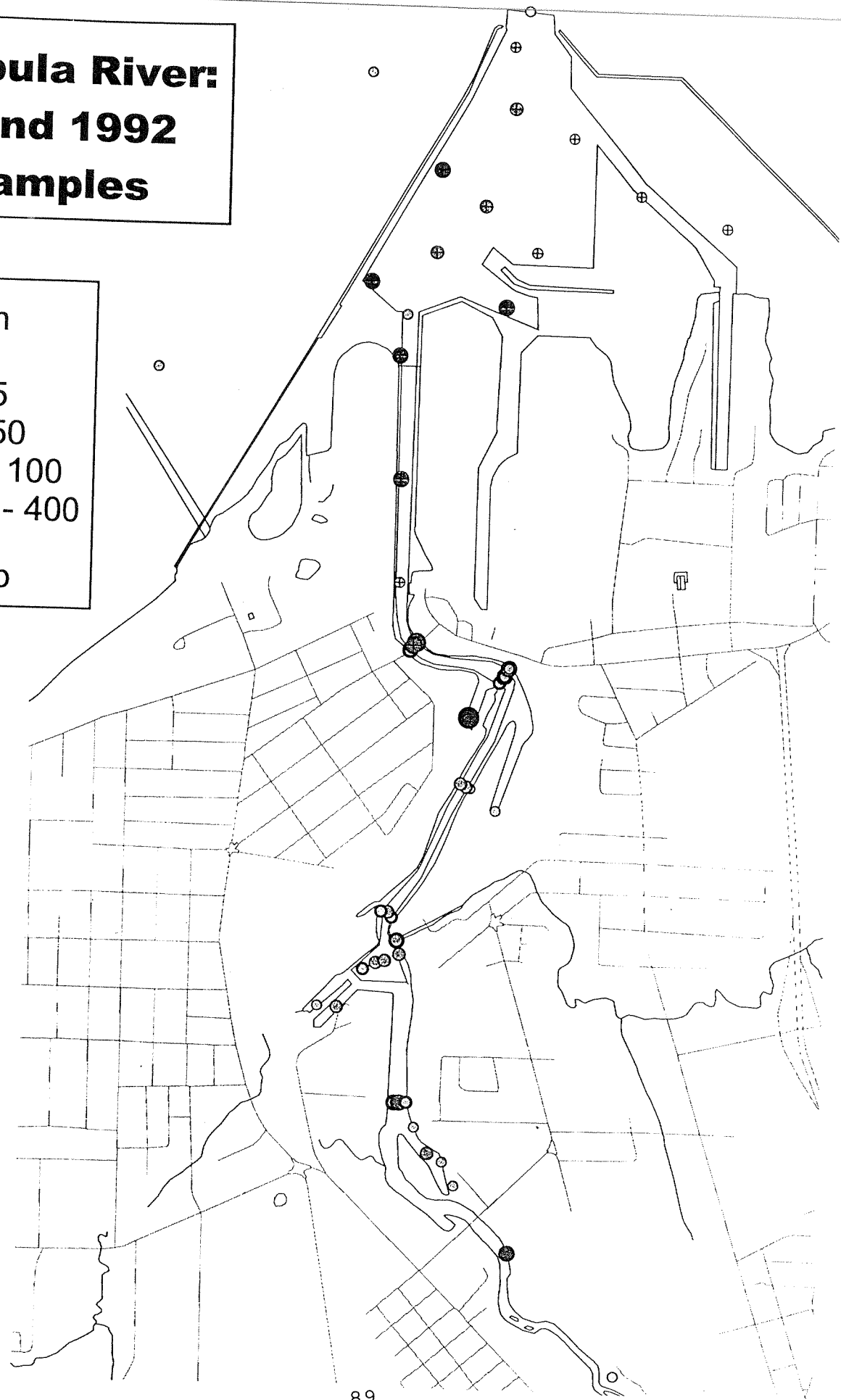

0 0.1 0.2 Miles

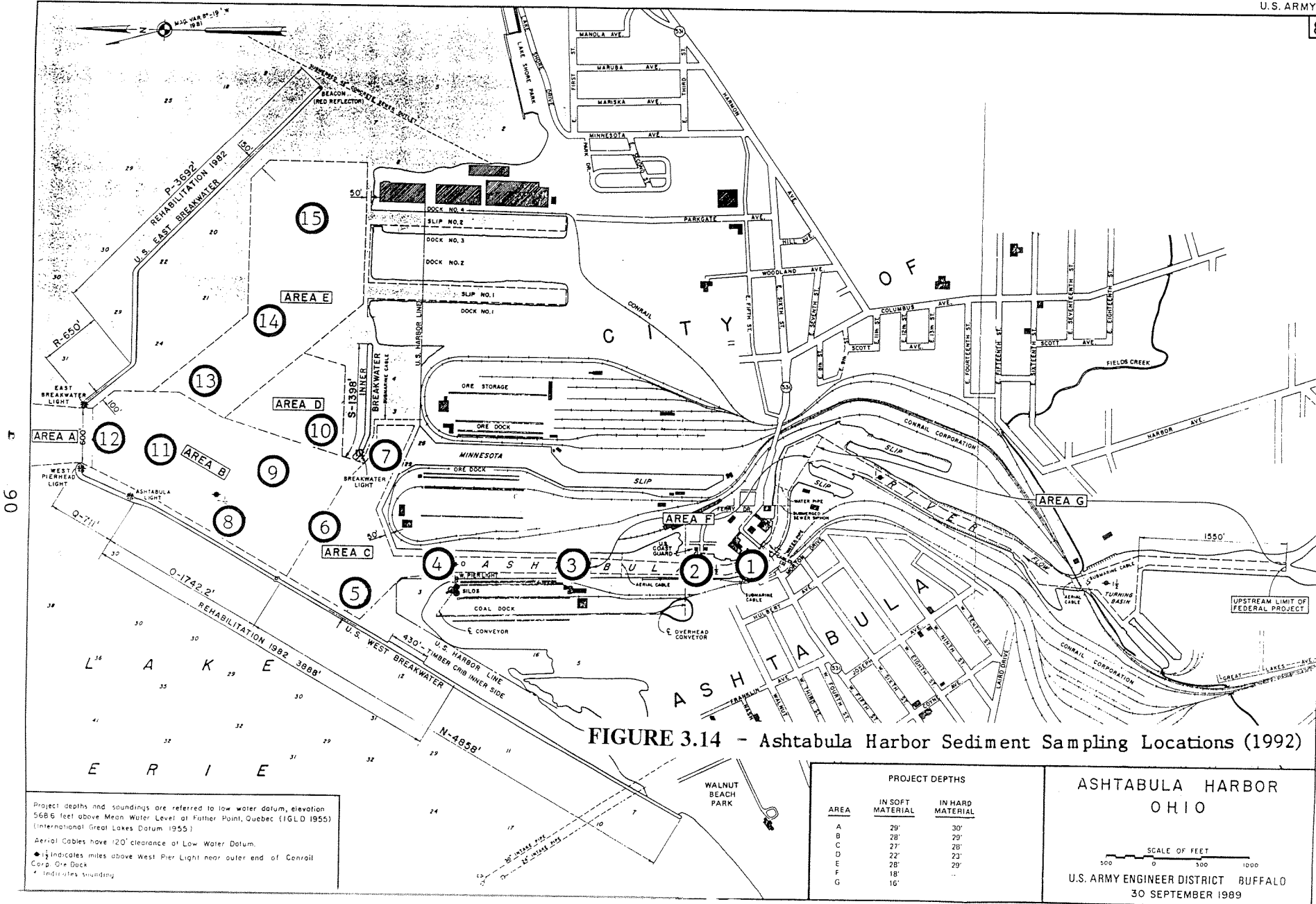

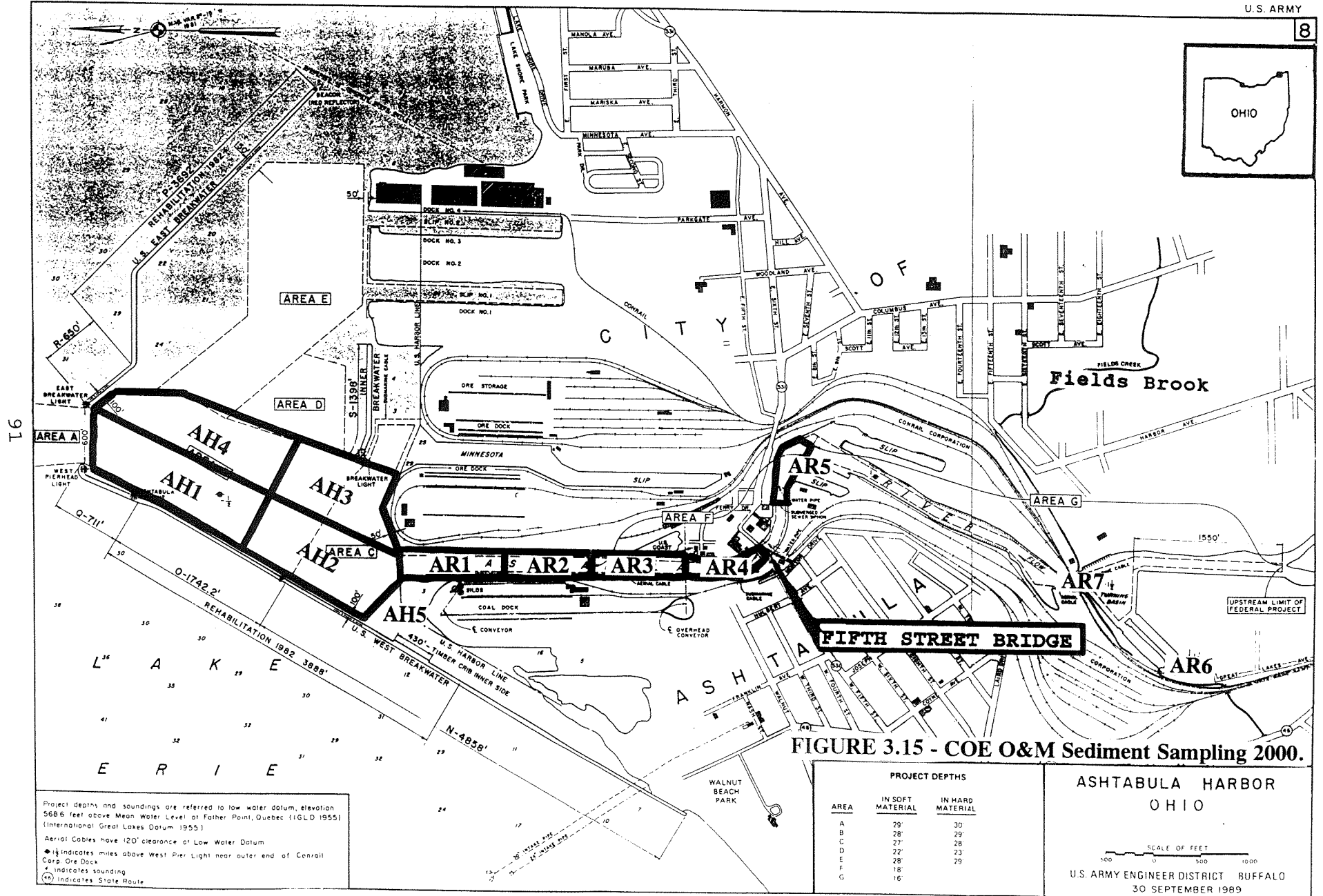

Project depths and soundings are referred to low water datum, elevation 5686 feet above Mean Water Level at Father Point, Quebec (IGLD 1955) (International Great Lakes Datum 1955)

Aerial Cables have 120' clearance at Low Water Datum

• indicates miles above West Pier Light near outer end of Conrail Corp Ore Dock

• indicates sounding

(*) indicates State Route

AREA	PROJECT DEPTHS	
	IN SOFT MATERIAL	IN HARD MATERIAL
A	29'	30'
B	28'	29'
C	27'	28'
D	22'	23'
E	28'	29'
F	18'	
G	16'	

ASHTABULA HARBOR
OHIO

SCALE OF FEET
0 500 1000

U.S. ARMY ENGINEER DISTRICT BUFFALO
30 SEPTEMBER 1989

FIGURE 3.15 - COE O&M Sediment Sampling 2000.

TABLE 3.10 - Indication of Movement of Contaminated Sediments Based on O&M Sediment Sampling and Analysis for PCBs From Stations in the Lower River and Immediate Outer Harbor.

Year Sample	Previous Year Dredged	Sample Site PCB Concentration (mg/kg unless noted otherwise)						Note	Open Lake Disposal Parameter
1980 08/80	1979 12/79	(2) 6.7	(4) 0.9	(5) 1.3	(7) 1.8		Figure 3.14 (PCB 1248)Dry	< 10 ppm	
1984 05/84	1983 07/83 09/83	(2) 0.8	(3) 1.1	(4) 0.7	(5) 0.2		"	"	
1985 (Significant Storm Event Year)									
1988 05/88	1987 06/87 06/87	(2) 5.3	(3) 3.2	(4) 1.8	(5) 2.0		"	"	
1992	1990	(1) 0.8	(2) 0.6	(3) 0.7	(4) 0.2	(5) 0.2	(6) 0.3	"	< 1 ppm
1992		R-17 <0.1	R-18 <0.3	R-19 <0.2				Ref. Site	
1993	1990		R-1 Low	R-2 Low	R-3 High	R-4 High	Figure 3.15 (PCB 1248)Dry	Bioassay Mortality	
2000		Ref. Site (Total PCB) 0.12							
2000	1995	AH-2 0.37	AH-3 0.25	AR-1 0.29	AR-2 0.42	AR-3 0.75	AR-4 7.80	"	"
2000	1995	AH-2 Elev	AH-3	AR-1	AR-2	AR-3 Elev	AR-4 Elev	"	"

Sampling Analysis Consultants

- 1980 - Recra Research Inc.
- 1984 - Aqua Tech
- 1988 - T.P. Associates
- 1992 - ARDL
- 1993 - ES&E
- 2000 - E&E

though the physical habitat is very good, extremely low or intermittent flows occur every summer in the Ashtabula River (USGS reference) limiting the amount of habitat available to aquatic fauna. The low flows in summer are due to the limited ground water capacity of the shale bedrock aquifers. High volumes of stream discharge (> 5000 cfs, max ~ 11,100 cfs in 1959), emanating from snowmelt, scours and denudes the lower reach of the Ashtabula River. Consequently, QHEI scores decreased with proximity to Ashtabula mainly because of the increased prevalence of unbroken shale bedrock and less cover.

3.65 In the Ashtabula lacustrary, the slope, texture and shape of ship channel banks affects QHEI scores and the overall suitability of aquatic habitat for biological communities. Reference Figures 3.16 through 3.18. The lower quality of the habitat is reflected in the results of the Index of Biotic Integrity (IBI) and the Invertebrate Community Index (ICI). In the upstream areas of the Ashtabula lacustrary (RM 1.3), the quality of physical habitat (i.e. slope, texture, and shape) is much better. The factors that govern habitat quality in lacustraries are the slope of the shoreline, hardening of the shoreline, and the availability of cover. Gradual shoreline slopes (45° or less) are better than steep vertical slopes. The contaminated Ashtabula site has much lower biological scores. It has been concluded (in the biological section) that contaminated sediments are the major cause of lower fish community scores at this Ashtabula site. The upper reaches of the lacustrary attain higher QHEI values that reflect the undisturbed habitat conditions found there.

3.67 Much cover is provided by the growth of aquatic plants in waters shallower than twelve feet. Downed trees and boulders in the water also provide cover for fish and invertebrates. Presently the site downstream of Fields Brook at RM 1.3 of the Ashtabula has abundant aquatic plant growth, logs and woody debris and boulders. Habitat quality at this site is high and provides abundant cover for diverse communities of organisms.

3.68 **Macroinvertebrate.** The macroinvertebrate community is in good condition in the vicinity of 24th Street (River Mile (RM) 2.5 to RM 2.3) based on sampling conducted at three sites in 1995 and 1996. Reference Figures 3.1, 3.3 and 3.17. The good ranking was made using Ohio EPA's Invertebrate Community Index (ICI), a measure of stream ecological health that is based on macroinvertebrate species richness, composition, abundance, condition, and food web composition. River areas associated with the 24th Street bridge, which lies at the upstream limit of the lacustrary, benefit from a bedrock substrate and the periodic flushing of sediment during high flows. Here, oligochaetes (pollution-tolerant marine worms) dominate the macroinvertebrate community in terms of their sheer numbers, yet the area also supports a variety of pollution-sensitive mayflies, caddisflies, and midges. In fact, a significant number of different types of macroinvertebrates were collected at these three sites ranging from 61 to 72 taxa, when combining results from both quantitative and qualitative sampling.

3.69 The macroinvertebrate community is impacted by altered habitat and is in poor condition in the Ashtabula River between RM 1.9 (upstream of Fields Brook) and the mouth of the river. Six samples have been collected from this area since 1989. This portion of the lacustrary is lined with sheet piling and/or boat docks. A ship channel extends from the river mouth to RM 0.7. Fields Brook empties into the Ashtabula River at RM 1.6. Sediment contamination has been well documented downstream from Fields Brook. Pollution tolerant midges

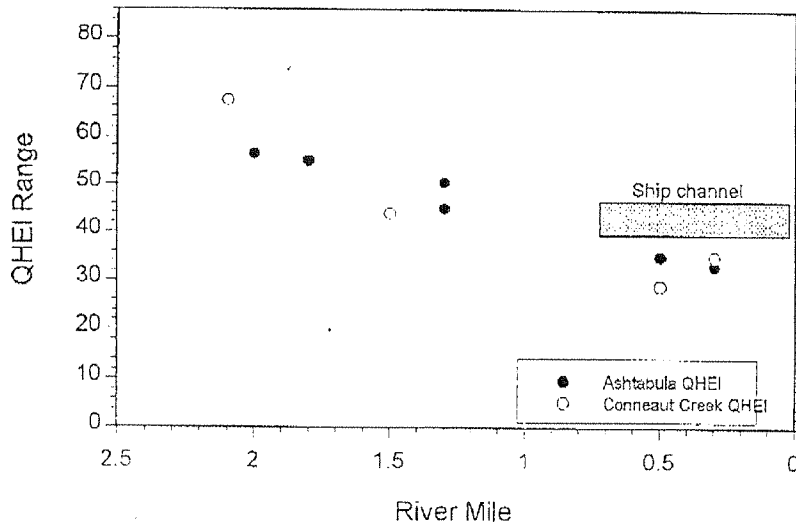

FIGURE 3.16 A comparison of relative habitat quality of the Ashtabula and Conneaut lacustuary areas.

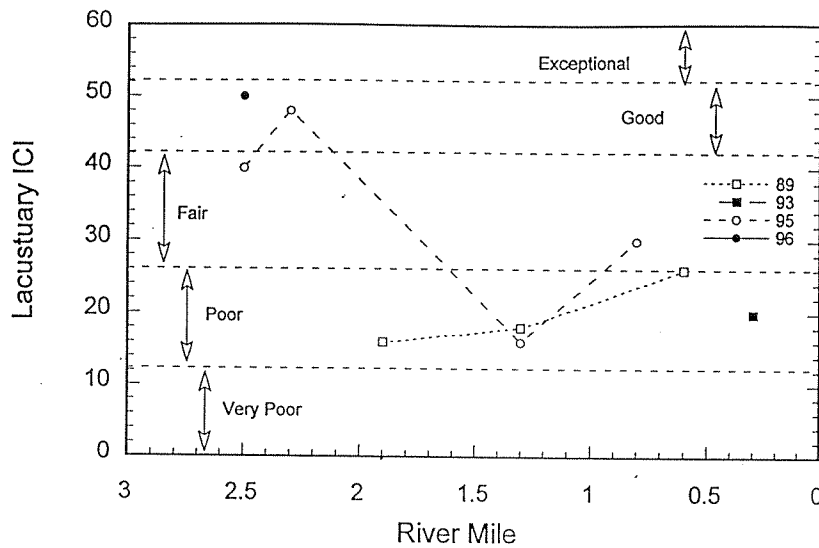

FIGURE 3.17 Macroinvertebrate community status in the Ashtabula River lacustuary as measured by the Invertebrate Community Index (ICI).

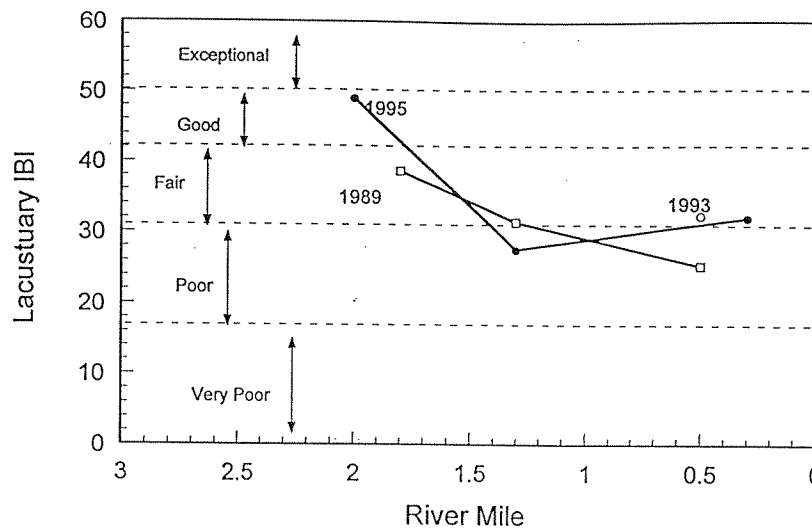

FIGURE 3.18 Fish community status of the Ashtabula River lacustuary as measured by the Index of Biotic Integrity (IBI).

predominate at RM 1.9 and downstream from Fields Brook where the stream bottom consists of soft, often oily, silt. Closer to the river mouth, where the ship channel is maintained, zebra mussels predominate followed by oligochaetes. The number of different types of macroinvertebrates collected from each of the six sites ranged from 28 to 35.

3.70 The macroinvertebrate community within Ashtabula Harbor benefits from wave protection afforded by breakwalls and resultant growths of rooted aquatic vegetation. A total of 44 different types of macroinvertebrates were identified from three harbor sampling sites in 1995. The single most diverse sampling location was a protected inner breakwall with macrophytes immediately adjacent. The lake nearshore community is predominated by zebra mussels and scuds (*Gammarus fasciatus*). Good numbers of mayflies and caddisflies are present along with a relatively diverse midge fauna.

3.71 **Fisheries.** The Ashtabula River AOC is classified as Warmwater Habitat (WWH) in the Ohio Water Quality Standards. Upstream from the AOC, the river is fully attaining the WWH status. Reference Figure 3.1, 3.3 and 3.20. The positive warmwater habitat attributes encountered in the lotic Ashtabula River is largely ascribed to a lack of channelization, wide mature riparian areas, and small acreage farms using conservative practices in the basin. Riffle and channel substrates were unembedded and generally silt free. Glacial till and fractured bedrock provided a variety of substrate sizes and habitat complexity, especially in the upper watershed. Although the physical habitat is very good, extremely low or intermittent flows occur every summer in the Ashtabula River (USGS reference) limiting the amount of habitat available to aquatic fauna. Typical fish species include: rosyface shiner (*Notropis rubellus*), black redhorse (*Moxostoma duquesnei*), rainbow darter (*Etheostoma caeruleum*), central stoneroller minnow (*Camptostoma anomalum pollum*), rockbass (*Ambloplites rupestris*), mimic shiner (*Notropis volucellus*), and bluntnose minnow (*Pimephales notatus*). There is a high relative abundance of mimic shiner and bigeye chub (*Hybopsis amblops*), species requiring clear, silt free habitats to thrive. Note: The bigeye chub, a rare species in Ohio and an indicator of exceptional water quality, flourishes throughout the upper watershed beginning at the upstream limit of the AOC at River Mile (RM) 2.0.

3.72 In the upper turning basin, including the area near the mouth of Fields Brook, the biological community does not meet WWH standards and is impacted by discharge from Fields Brook as well as habitat destruction and extensive recreational boat traffic. The lower 0.7 miles of the river have been lined with vertical sheet piling, railroad ties and concrete docks for commercial activities. This area is frequently deep dredged. In addition, there is a PAH problem in the area. These conditions have severely altered the natural habitat, resulting in an adversely impacted biological community within the AOC. This effect appears to be localized as fish population and diversity recover in the outer harbor where habitat conditions improve and the impacts from Fields Brook discharges have dissipated.

3.73 The Ashtabula outer harbor supports a diverse fish community of river and lake species, particularly in a vegetated area protected by the inner breakwall. Protected areas of the harbor usually contain relatively large numbers of yellow perch (*Perca flavescens*), white bass (*Morone chrysops*), pumpkinseed (*Lepomis gibbosus*), white crappie (*Pomoxis annularis*), goldfish (*Carassius auratus*) and emerald shiner (*Notropis atherinoides*), while more open water areas

contain lower densities of gizzard shad (*Dorosoma cepedianum*), yellow perch (*Perca flavescens*), carp (*Cyprinus carpio*), goldfish (*Carassius auratus*), brown bullhead (*Ameiurus natalis*) and emerald shiner (*Notropis atherinoides*). The banded killifish (*Fundulus diaphanus*), listed by ODNR as an Ohio endangered species, has been recorded here. Here, the fish community achieves partial to full attainment of WWH biological standards considering diversity and abundance. Much of the nearshore provides nursery and spawning grounds for the local fish community. The breakwall and gravel bars near the CEI power plant provide spawning grounds for rainbow smelt (*Osmerus mordax*), carp (*Cyprinus carpio*), spottail shiner (*Notropis hudsonius*), shiner species, logperch (*Percia caprodes*), walleye (*Stizostedion vitreum*) and freshwater drum (*Aplodinotus grunniens*). The outer harbor breakwalls and the breakwalls lakeward of Lakeshore Park provide spawning sites for alewife (*Alosa pseudoharengus*), gizzard shad (*Dorosoma cepedianum*), smallmouth bass (*Micropterus dolomieu*), rainbow smelt (*Osmerus mordax*), brown bullhead (*Ameiurus nebulosus*) and Johnny darter (*Etheostoma nigrum*). The deeper nearshore waters provide spawning grounds for burbot (*Lota lota*), mottled sculpin (*Cottus bairdi*) and yellow perch (*Perca flavescens*) (Goodyear, et al 1982). Various lake and stream species of fish migrate to and from the lower Ashtabula River when water conditions are favorable. Spawning migration runs for walleye (*Stizostedion vitreum*) and smallmouth bass (*Micropterus dolomieu*) occur in the spring (U.S. Fish and Wildlife Service 1984a). Species composition is typical of the warmwater fish community in Lake Erie river mouths. Cold water species such as the Steelhead trout (*Oncorhynchus mykiss*) also move up the Ashtabula River on a limited bases and are sought by river anglers. If not for the contaminant problem, the Ashtabula River could be a prime site for salmonid stocking consideration.

Three fish species, of special concern in Ohio, have been recorded historically in the Ashtabula River lacustrary. The species are Great Lakes muskellunge (*Esox masquinongy*), black nose shiner (*Notropis neterolepis*) and lake sturgeon (*Acipenser fulvescens*). The first two species are vegetation loving species and should be present in the Ashtabula now.

3.74 Anomalies - The Ohio EPA observed highly elevated levels of external anomalies (tumors, lesions, eroded fins, deformities) on fish taken from downstream of the confluence with Fields Brook in the Ashtabula lacustrary. Sites outside contaminated sediment areas displayed moderately elevated anomaly levels. Some of these anomalies likely originated primarily as a consequence of heavy wave action that resulted in abrasions to those fish species that live near or in the breakwaters. Many of these fish consequently developed lesions.

3.75 Fish Advisories - A series of fish tissue contamination level studies have been conducted for the Ashtabula Harbor and near lake shore area. Studies were conducted in 1981 (Veith, et al), 1983 (Armstrong), 1990 (Woodward Clyde Consultants 1991), and 1994 (Ohio EPA). Fish species sampled included (whole and fillet): Carp, Bullhead, Small/Large Mouth Bass, Bluegill, Brown Bullhead.

3.76 The 1981 and 1983 information was the basis for the issuance of a fish consumption advisory for the lower two miles of the river and harbor by the Ohio Department of Health and Ohio EPA in 1983. The advisory recommended that no fish caught in the river from the 24th Street Bridge to the harbor mouth be eaten. The advisory sites PCB concentrations ranging from 2.4 to 58.3 mg/kg in the edible portion (skin-on fillet). The current Food and Drug

Administration level for safe consumption is 2 mg/kg for the edible portion. The FDA action level at the time the advisory was issued was 5 mg/kg. (RAP, 1991)

3.77 There are no criteria for the other organic chemicals listed in the advisory, but the presence of so many different chemicals is a concern. Listing the other pollutants was precautionary to keep the advisory in effect in the event that the PCB problem was corrected but other chemicals were still elevated (J. Estenik, Ohio EPA, personal communication 1990). (RAP, 1991)

3.78 In addition to the advisory in the Ashtabula River, a general advisory is in effect for Lake Erie. Based on elevated PCB concentrations in skin-on fillets, it is recommended that no carp or channel catfish from the lake be consumed. (RAP, 1991)

3.79 More recent fish data are now available for the Ashtabula River. Ohio EPA collected several species of fish in 1994 (large mouth bass, small mouth bass, carp, rock bass, catfish, red-house, walleye, and drum). On average, PCB concentrations in fish increased approximately 0.5 parts per million over the concentrations in 1990 indicating that fish in the river continue to be contaminated with PCBs. The levels of PCBs have not declined to completely safe levels and those consuming a larger number of fattier fish such as carp and catfish have the greatest risk. (Risk Assessment, 1997)

3.80 The States of Ohio, Pennsylvania, and New York issue sport Fish Consumption Advisories based on a sliding scale. When PCB concentrations in edible portions equal or exceed 0.05 ug/g they advise the general public not to consume more than one meal per week, and that women of child bearing years and young children avoid consumption. At concentrations of 2 ug/g they advise that no one consume the fish. The U.S. Food and Drug Administration prohibits interstate sale of fish exceeding 2 ug/g. State Agricultural Departments prohibit intra-state sale at 2 ug/g.

3.81 In 1997, the fish consumption advisory was revised based on decreased levels of PCBs more recently measured in fish. The current fish advisory is less stringent. It places specific limits on the amounts of smallmouth bass, largemouth bass, walleye, channel catfish, and common carp that can be safely consumed. Because common carp and channel catfish contain the highest levels of PCBs, the amount of these species that can be consumed is much less than for other species. The amount of fish that can be safely consumed were determined by the Ohio Department of Health using the Great Lakes Sport Fish Advisory Task Force September 1993 protocol titled " Protocol for a uniform Great Lakes Sport Fish Consumption Advisory".

3.82 **Vegetation.** Landuse in the watershed is predominantly rural and agricultural, with the City of Ashtabula the only significant urbanized area. Reference Figures 3.1, 3.3 and 3.16. Several park areas are located just upstream of the harbor area. Undisturbed shorelines exist upstream from RM 2.0 where, the benefits of conservation farming practices paired with intact riparian vegetation and low density development are manifest, especially in the middle reaches. Dominant tree species include: Red and Silver Maple, Pin Oak, and Green Ash. Associated species include: Tulip Tree, Yellow Birch, Scourgum, and occasionally Black Cherry. Scrubshrub species include: Northern Arrowwood, Red Osier, and Silk and Gray Dogwood.

3.83 The best natural forest on the lower river is on the east valley wall south of the mouth of Fields Brook above and south of Riverside Marina. The best natural forest is within a ravine on the east valley wall of the river about .2 mile south of the mouth of Fields Brook. Most of the canopy, understory shrubs and herbaceous plants within the ravine are native.

3.84 The forest on the slope around Riverside marina and south of Fields Brook is a closed canopy forest dominated by pin oak (Quercus palustris), bitternut hickory (Carya cordiformis) and a few black cherry (Prunus serotina). Many of the understory species are non-indigenous: privet (Ligustrum vulgare), Japanese honeysuckle, garlic mustard (Allaria petiolata). A small clone of myrtle (Vinca minor) is present in the open woods upslope from the marina. A few native plants are frequent in the understory including yellow trout lily (Erythronium americana), bluestem goldenrod (Solidago caesia), autumn bentgrass (Agrostis perennans), jewelweed (Impatiens capensis) and kidney-leaved buttercup (Ranunculus abortivus).

3.85 The canopy of the natural forest within the ravine 0.2 miles south of the mouth of Fields Brook is dominated by sugar maple (Acer saccharum) and red oak (Quercus rubra). Hop hornbeam (Ostrya virginiana) and black cherry are occasional in the canopy. A single pignut hickory (Carya glabra) is growing on the dry valley rim just north of the ravine mouth. Several native shrubs are frequent within the mouth of the ravine. The most common understory shrub on the slopes of the ravine is witch hazel (Hamamelis virginiana). American hornbeam (Carpinus caroliniana) is frequent in the ravine. Choke cherry (Prunus virginiana) is common in open woods near the mouth of the ravine and maple leaved viburnum (Viburnum acerifolium) is locally common at the mouth of the ravine. Glaucous honeysuckle (Lonicera dioica var. glaucocens) is local in the ravine. Native herbaceous plants in the ravine include sedge (Carex communis), aster (Aster divaricatus), bluestem goldenrod, spring beauty (Claytonia virginica).

3.86 A single medium-sized American elm (Ulmus americana) grows on the west side of the river across from the mouth of Fields Brook. A single clump of nannyberry (Viburnum lentago) is located on the east river edge about .2 miles south of Fields Brook mouth. Two native willows, sandbar willow and heartleaf willow, may be observed in an open seepage along marina road on the east valley wall of the river south of Fields Brook.

3.87 Many of the plants growing on the open banks, roadsides and railroad yards in the Ash-tabula Harbor north and south of the Lake Road bridge are non-indigenous species. The only assemblage of high quality natural forest is on the east valley wall of the river just south of the mouth of Fields Brook. Undeveloped sections of the valley walls and river flats on both sides of the river, from Lake Road south to the mouth of Fields Brook are second growth woody thickets dominated by a mixture of native and non-native trees: silver maple, tree of heaven (Ailanthus altissima), box elder (Acer negundo), crack willow (Salix fragilis), black locust (Robinia pseudo), cottonwood. Black cherry (Prunus serotina), quaking aspen (Populus tremuloides) and white ash (Fraxinus americana) are locally common along the west side of the river, west of Fields Brook. Common shrubs in the second growth thickets include staghorn sumac (Rhus typhina), multiflora rose (Rosa multiflora), Morrow's honeysuckle (Lonicera morrowi), red osier dogwood (Cornus sericea), buckthorn (Rhamnus frangula), hawthorn (Crataegus sp.) and black-berry (Rubus allegheniensis). Common vines in the thickets are

Japanese honeysuckle (Lonicera japonica) and bittersweet nightshade (Solanum dulcamara).
3.76 Common herbaceous species on open banks and flats north and south of Lake Road include common mullein (Verbascum thapsis), mugwort (Artemisia vulgaris), winter cress (Barbarea vulgaris), red clover (Trifolium pratense), white clover (Trifolium repens), white sweet clover (Melilotus alba), paniced aster (Aster simplex), tall goldenrod (Solidago canadensis), bugloss (Echium vulgare), switchgrass (Panicum virgatum), yarrow (Achillea millefolium), teasel (Dipsacus sylvestris), evening primrose (Oenothera biennis), early goldenrod (Solidago juncea), coltsfoot (Tussilago farfara), quack grass (Agropyron repens), Kentucky bluegrass (Poa pratensis), Canada bluegrass (Poa compressa), burdock (Arctium minus) and Japanese knotweed (Polygonum cuspidatum). Japanese honeysuckle is frequent throughout the valley on open meadows and slopes.

3.88 Phragmites (Phragmites australis) is frequent to locally abundant on open, poorly drained flats and along the river edge. Canary grass (Phalaris arundinacea) is locally common along the river edge about .2 miles south of the mouth of Fields Brook.

3.89 The best remnants of natural vegetation are within the open waters between the western breakwall and harbor mouth, along the sandy shores to the west of the harbor mouth and along the east valley wall of the river south of the mouth of Fields Brook.

3.90 Construction of breakwalls west of the river mouth coupled with harbor dredging in the nineteenth century shifted the position of the emergent marsh, aquatic bed, palustrine sand plain and dune community from the mouth of the river to west of the mouth. The dune species including switchgrass, Canada wildrye, beach pea (Lathyrus japonicus), sea rocket (Cakile edentula), sandbar willow and cottonwood became established on the sandy beaches and low dunes that built to the west of the breakwalls. Emergent marshes and palustrine sand plain communities established along the shores east of the breakwalls and the aquatic bed community established within the quiet waters east of the breakwalls.

3.91 Today, the aquatic bed community in the open water between the breakwall and the Ash-tabula Harbor is dominated by European water milfoil (Myriophyllum spicatum), eelgrass (Vallisneria spiralis), small pondweed (Potamogeton pusillus), Eurasian naiad (Najas minor), elodea (Elodea canadensis) and Richardson's pondweed (Potamogeton richardsonii).

3.92 The emergent marshes along the shoreline east of the breakwall are today dominated by phragmites (Phragmites australis), narrow-leaved cattail (Typha angustifolia) and purple loose-strife (Lythrum salicaria). Small remnants of the former native marsh still survive within the Phragmites, including arrowhead (Sagittaria latifolia) pickerel weed (Pontederia cordata), soft-stem bulrush (Schoenoplectus tabernaemontanae) and American three-square (Schoenoplectus pungens)

3.93 Prior to piling of coal in the early 1980s, the best Palustrine Sand Plain Communities lined open inland sandy ponds and the bay shoreline east of the breakwall. The shallow ponds were lined with several rare plants including fringed gentian (Gentiana crinita), golden-fruited sedge (Carex aurea), alpine rush (Juncus alpinoarticulatus) and silverweed (Potentilla anserina). Another rare plant bushy cinquefoil (Potentilla paradoxa) was rare along the sand shore

flats of the bay. Palustrine Sand Plain community plants still survive along the shore east at the break-wall including alpine rush, articulated rush, umbrella sedge, common rush (Juncus acuminatus), sedge (Carex scoparia), common spikerush (Eleocharis obtusa), matted spikerush (Eleocharis acicu-laris) and red-stemmed spikerush (Eleocharis erythropoda).

3.94 The sand dunes, dominated by beach grass (Ammophila brevilgulata) east of the Ashtabula River mouth are the finest beach grass dunes in Ohio. The dunes extend from Walnut Beach to one quarter mile east of the park. Beach grass established at Walnut Beach sometime after the early 1930s. A study in the early 1930s described the following species as common on the dunes: switchgrass, Canada wildrye, poison ivy (Toxicodendron radicans), beach pea, sandbar willow, riverside grape and cottonwood. In addition to the beach pea and beach grass, other rare plants growing on the dunes today include: Schweinitz's umbrella sedge (Cyperus schwein-itzi), purple sand grass (Triplasis purpurea), sea rocket (Cakile edentula) and seaside spurge (Euphorbia purpurea). Wafer ash (Ptelea trifoliata) is a noteworthy shrub on the dunes. This shrub, a member of the citrus family, is rare east of Cleveland except on sandy areas along Lake Erie. A book published in 1912 documents a population of giant swallowtail butterflies at Walnut Beach in association with the wafer ash. Heartleaf willow (Salix erio-cephala) is another common shrub on the dunes.

3.95 **Rare Plant Species** - Per ODNR's current Natural Heritage database, a number of rare plant species thrive throughout the watershed, including: pale sedge, necklace sedge, beaded sedge, schwenitz's umbrella sedge, woodland horsetail, marsh bedstraw, turk's cap lily, cat-berry, green woodland orchid, autumn willow, northern blue-eyed grass, painted trillium, and hobble-bush

3.96 Previous coordination for similar projects in this regard identified a likely area for potential disposal site development as that generally east of the harbor and north of the railroad tracks in the Ashtabula Township, Ashtabula County, Ohio. This area contains similar developments and is zoned for heavy industry. The western portion of this area is almost fully developed with the harbor and city developments and then to the east with industrial developments. The eastern portion of this area is a mix of abandoned farmland (now emergent scrub/shrub and mature wooded areas), disposal facilities and associated mitigation (preserved natural wildlife areas), and a few scattered residential properties primarily along the shoreline and lake Road. Numerous wetland areas are scattered throughout the area. The Whitman's Creek watershed is located in the eastern most section of this area. A variety of associated wildlife species inhabit the natural areas. Reference Figure 3.2.

3.97 **Wildlife. Birds-** Breeding birds of the upper Ashtabula River are typical for northeast Ohio. The upper watershed includes many different habitats, such as floodplain forests, dry up-land forests, and hemlock ravines, which tend to attract a wide variety of breeding birds. In the floodplain forests, typical northern Ohio woodland breeders are observed such as Downy Wood-pecker, Blackcapped Chickadee, Cerulean Warbler, Scarlet Tanager, and Baltimore Oriole. The drier upland forests tend to attract species such as Wood Thrush and Ovenbird. The deeper south-facing hemlock ravines host species such as Winter Wren, Magnolia Warbler, Canada Warbler, and Dark-eyed Junco, all endangered in Ohio. Other species readily observed near the river's confluence with the West Branch are Sora, Virginia Rail, Barn Owl,

and Blackthroated Green Warbler. A turkey vulture roost lies further upstream on the West Branch. Near the river headwaters is a large great blue heron rookery. By conducting more field work, additional state listed species would more than likely be added to the list, as this is high quality habitat.

3.98 Lake Erie's south shore is an extremely important flyway for migrating small birds, raptors, and waterbirds. Migrating small birds will avoid crossing Lake Erie and end up concentrating along the lakeshore. They then follow the shoreline till they find a safe location for crossing. As a result, a shoreline location such as Ashtabula Harbor is a very important stop-over site for these birds. Hawks also will avoid crossing the open waters of Lake Erie, following the shoreline instead. Large numbers of migrating hawks often cross over the harbor during southwest winds in the spring. Bald Eagles and Peregrine Falcons are not uncommon visitors and may even remain a few days hunting the harbor. Birds also use waterways such as the Ashtabula River as migration corridors. The importance of migration corridor habitat such as the Lake Erie shoreline and the Ashtabula River, has just recently been recognized. These areas may be as important as breeding habitat in the survival of these birds.

3.99 Large numbers of waterbirds move along the Lake Erie shoreline and readily use Ashtabula Harbor for resting, feeding, and for shelter in storms. Typical species include: Great Blue Heron, Great Egret, Mallard, Canada Goose, Common Loon, and Black-backed Gull. It is not uncommon in the fall or spring to see several thousand Red-breasted Mergansers feeding within the outer breakwalls. Rare species of ducks seen include: Barrow's Goldeneye, King Eider, and Harlequin Duck. Thousands of gulls are often seen feeding in the harbor and resting on the ore piles. Thirteen species of gulls have been found in the Ashtabula Harbor area including such rarities as California Gull, Iceland Gull, Franklin's Gull, and Black-legged Kittiwake. Directly west of Ashtabula Harbor lies Walnut Beach which is noted for its shore-bird numbers and variety. Good numbers of shorebirds are possible, depending on the amount of sandbar showing. The first North American record away from Alaska for Red-necked Stint, a type of shorebird, was from Walnut Beach. This is a very rare stray from Asia.

3.100 Two hundred sixty-eight species of birds have been recorded from the Ashtabula River and Ashtabula Harbor. This is an impressive number of species. When you consider the relative lack of birders using the area, the importance of this area becomes clear. This area is relied upon heavily by large numbers of nesting, migrating, feeding, and resting birds.

3.101 **Other Wildlife** - The Ashtabula area supports many species of wildlife such as: deer, squirrel, cottontail rabbit, opossum, skunk, raccoon, mice, and a variety of reptiles, amphibians, birds, and other small mammals. Also, a small beaver community inhabits the AOC. The small amount of natural shoreline remaining in the harbor area supports some reptiles, amphibians, birds, and mammals. Most are limited to the adjacent wetland and park areas. Critical mammalian habitat is limited to a few scattered areas left to natural growth, and the Ashtabula River wetland. This Palustrine wetland serves as a bird sanctuary and is located inside the west harbor breakwall. The wetland covers about 7 acres, has little relief and is strongly influenced by lake levels.

3.102 The Ohio Department of Natural Resources Division of Natural Areas & Preserves cur-

rently lists ermine as an animal of special interest found in the Ashtabula River watershed. Mink, too, may be readily observed feeding in areas immediately adjacent to Ashtabula Harbor. Until the 1960s, there was a substantial mink population throughout the watershed. Lake Erie mink farmers reported their mink stocks dying out as a direct result of being fed Great Lakes fish unknowingly contaminated with PCBs. Mink feed almost exclusively upon fish; contaminants associated with fish interferes with mink reproduction. To date, the historic mink population has not fully recovered.

3.103 The following pertains to the area considered for upland confined disposal facility development that is generally east of the harbor and north of the railroad tracks in the Ashtabula Township, Ashtabula County, Ohio. The western portion of this area is almost fully developed with the harbor and city developments and then to the east with industrial developments. The eastern portion of this area is a mix of abandoned farmland (now emergent scrub/shrub and mature wooded areas), disposal facilities and associated mitigation (preserved natural wildlife areas), and a few scattered residential properties primarily along the shoreline and lake Road. Numerous wetland areas are scattered throughout the area. The Whitman's creek watershed is located in the eastern most section of this area. A variety of associated wildlife species inhabit the natural areas. Reference Figure 3.2.

3.104 **Threatened and Endangered Species.** Project coordination was and is being conducted with the U.S. Fish and Wildlife Service (USFWS) and the Ohio State Department of Natural Resources in this regard. The U.S. Fish and Wildlife Service in their Coordination Act Report indicated that the proposed project lies within the range of the Indiana bat, bald eagle, and piping plover, Federally listed endangered or threatened species; but, that they do not anticipate that the proposed project will impact any of these species or habitat. The Ohio Department of Natural Resources did not identify any State protected species or associated habitats that would be *adversely* impacted by project implementation.

3.105 **Wetlands.** Although much of the breakwater protected harbor area is in deep water ranging in depth from about 10 to 25 feet, shallower lacustrine zones around 2-3 feet deep exist in the zone between the Union Dock and the short detached stone breakwater, as well as in the embayment area east of this Dock and west of Pinney Dock. These shallow areas contain some degree of submergent aquatic vegetation. During the summer of 1984, a 10 acre aquatic site located within Ashtabula Harbor west of Pinney Dock and south of the inner breakwater was investigated by the U.S. Fish and Wildlife Service. In mid-May, little aquatic vegetation was found at the aforementioned site. However, in July, several areas of the site contained thick stands of submergent vegetation such as coontail, eelgrass, pondweed, waterweed, and milfoil (USFWS, 1984). The U.S. Fish and Wildlife Service's draft "National Wetlands Inventory Map" for Ashtabula identifies the harbor area protected by the stone breakwaters as being a littoral, limnetic permanent open water zone. The immediate shallow water margins along the existing stone breakwaters are classified as being lacustrine, littoral rocky shore zones artificially created. Reference Figure 3.19.

3.106 Approximately 1-1/2 miles southwest of the existing west breakwater entrance channel light there is a palustrine emergent wetland referred to as the "Ashtabula River Wetland" located inside the Harbor's west breakwater. This wetland is strongly influenced by lake levels.

3.107 Numerous wetland areas are located in the area primarily considered for potential development of a new upland disposal site as depicted by Figure 3.19 extracted from the U.S. Fish and Wildlife Services National Wetland Inventory Map.

3.108 Approximately 70 acres at the Site 5 vicinity were investigated for wetland delineations. Of the 70 acres investigated, approximately 6 plus acres are fill (flyash material) upland, 19 acres are scrub/shrub and/or wooded upland, one acre is open water, and 44 acres are scrub/shrub and/or wooded wetland. Approximately 96 acres at Site 7 were investigated for wetland delineations. Of the 96 acres investigated, approximately 76 acres are scrub/shrub and/or (mostly) wooded upland and 20 acres are scrub/shrub and/or (mostly) wooded wetland.

3.109 The U. S. Army Corps of Engineers, Buffalo District conducted an on-site investigation within an approximately 35 acre portion of the State Road Disposal Site. The investigation was conducted to determine the presence and extent of jurisdictional wetland within the site pursuant to Section 404 of the Clean Water Act and to characterize the prevailing site ecology and other physical and biological site features. Personnel applied methods specified by the Corps of Engineers Wetlands Delineation Manual (January 1987). A preliminary review of available information for the area pertaining to vegetation, soils, and hydrology was implemented prior to conducting the field investigation. Sources of information included: U.S. Geological Survey maps, the U.S.D.A. Soil Survey, National Wetland Inventory maps, and aerial photographs. Based on findings of the field investigation, the Buffalo District determined that the site is best classified as industrial urban land. The site supports primarily upland open field, patchy herbaceous regrowth and common reed, which is consistent with urban industrial sites. One man-made depressional wetland located on soil fill was identified within the northern third of the site along the eastern site boundary. The wetland is approximately 0.02 acre in size and is not functionally significant; but, meets the criteria for delineation based on vegetation and hydrology. During the site investigation the Buffalo District personnel observed no threatened or endangered species or critical habitat.

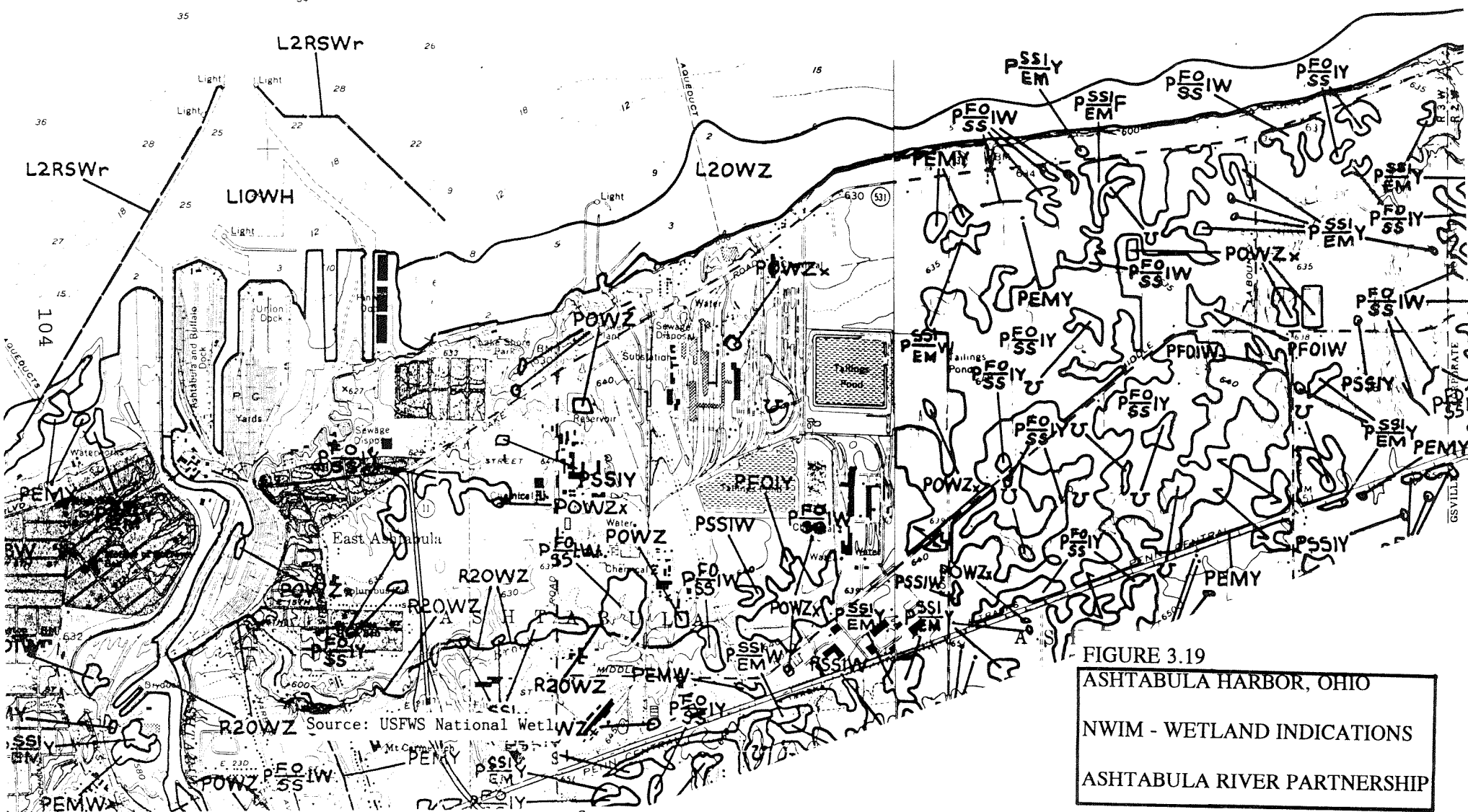

Source: USFWS National Wetland Inventory Maps SCALE: 1IN=2000FT

HUMAN ENVIRONMENT (MAN-MADE RESOURCES) - HARBOR AND VICINITY

3.110 Community and Regional Growth. Ashtabula Harbor is located at the mouth of the Ashtabula River on the south shore of Lake Erie Ashtabula County, Ohio. Ashtabula is an important Great Lakes port city. Because of its location and transportation facilities, it has become an important local, State, Regional, National, and International port of industry and commerce. This is expected to continue into the future. Reference Figures 1.1, 3.20 and 3.21.

3.111 Population - The population for the city of Ashtabula and the county of Ashtabula were about 21,633 and 100,924, respectively in 1990. The population in Ashtabula County is approximately 52 percent female and 48 percent male. The population in Ashtabula County is approximately 96 percent white and 4 percent black and other. Approximately 16 percent of this population is 0-24 years old, 49 percent is 25-64 years old, and 15 percent is 65 years old or older. The area population is expected to experience a moderate growth over the next few decades. (1990 OBERS).

3.112 Ashtabula Harbor and Associated Water and Land Use and Developments - Ashtabula Harbor breakwater facilities, navigation channels, and associated upland areas are depicted on Figures 3.20 and 3.21. The existing Federal navigation project consists of a breakwater protected Outer Harbor in Lake Erie and an interior harbor in the Ashtabula River. The Outer Harbor includes a system of channels with turning basins and encompasses about 185 acres. The interior harbor consists of a channel and a turning basin and extends upstream to approximately river mile 1.8. The river channel from the mouth upstream to the Fifth Street Bridge (0.7 miles) is commercial. Commodities, such as limestone, iron and other ores, coal and other bulk commodities, pig iron, iron products, raw rubber, and general cargo, transit the harbor. The river channel from the Fifth Street Bridge through the upper channel area is no longer maintained for commercial navigation; but, is utilized primarily for recreational navigation. Several marina developments docking hundreds of recreational vessels are situated along the lower river and harbor. Some ecological problems associated with harbor developments were summarized previously.

3.113 The Ashtabula Harbor vicinity is composed of a variety of land uses which include: industrial, commercial, residential, park, public use, and marina. Reference Figures 3.22 and 3.23.

3.114 Industrial land uses are mainly located at the mouth of the Ashtabula River. Commercial uses are along Bridge Street in the Historic District adjacent to the Ashtabula River and along Lake Avenue. Residential land uses comprise the areas east and west of the Ashtabula River, above the bluffs. Two major parks are located along the lakeshore. Walnut Beach Park is located on the west side of the City of Ashtabula, adjacent to the Historic District. Lakeshore Park, in Ashtabula Township, is located at the eastern side of the City of Ashtabula. A third park, Point Park is owned by the City and is located at the east end of Walnut Boulevard. The park is located at the top of the bluffs which provides a tremendous overlook of the City of Ashtabula and Harbor area. Directly south of the harbor area, along the river, is Township Park.

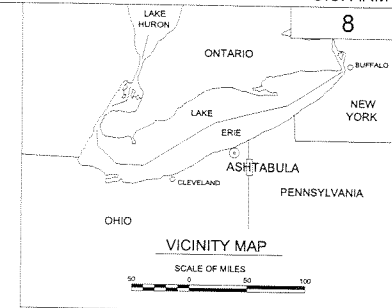

- : ARP Project Area
- : Federal Navigation Project
- : Ashtabula River Shoreline

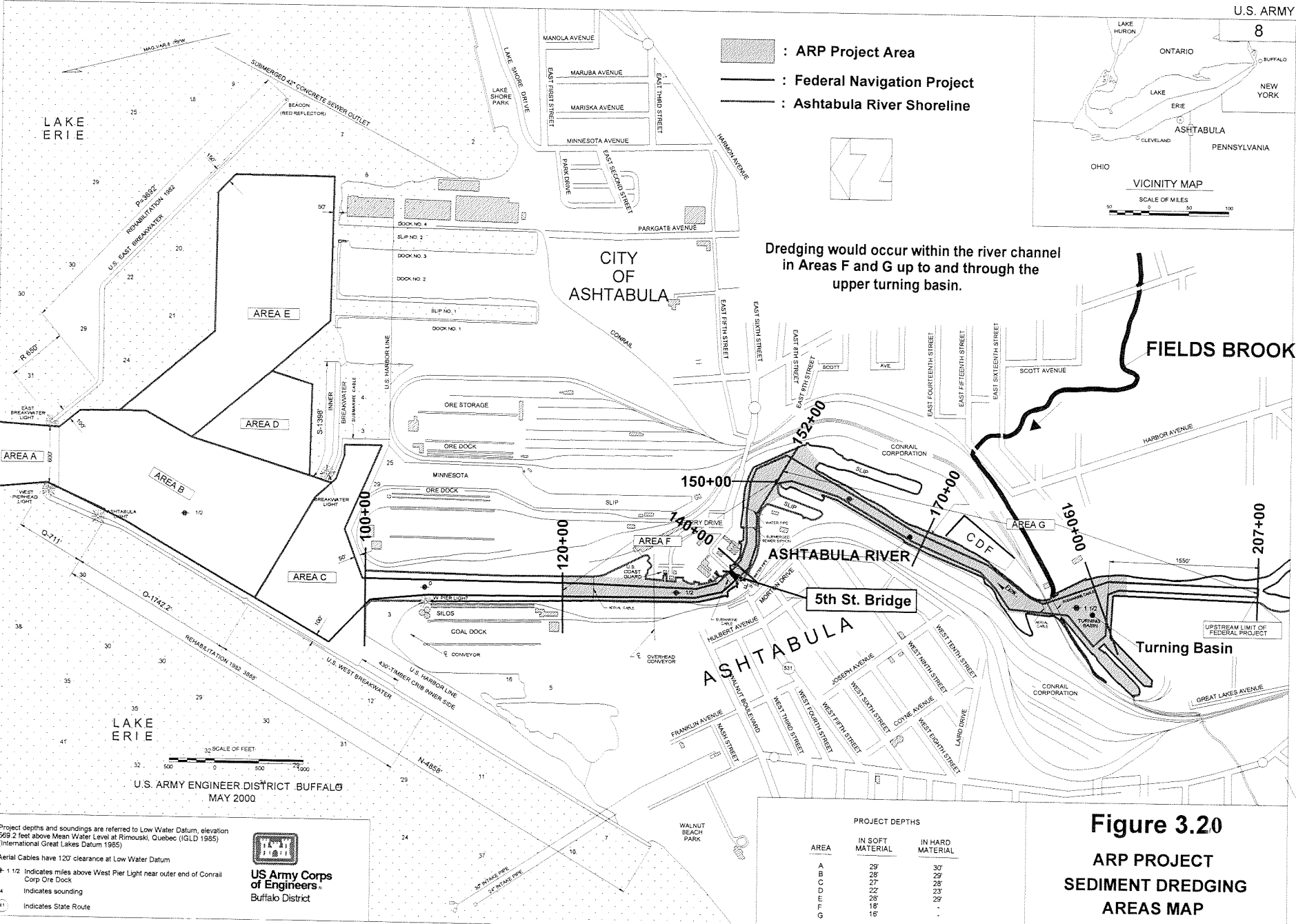

Dredging would occur within the river channel in Areas F and G up to and through the upper turning basin.

AREA	PROJECT DEPTHS	
	IN SOFT MATERIAL	IN HARD MATERIAL
A	25'	30'
B	28'	29'
C	27'	28'
D	22'	23'
E	26'	25'
F	18'	·
G	16'	·

Figure 3.20
ARP PROJECT
SEDIMENT DREDGING
AREAS MAP

106

Project depths and soundings are referred to Low Water Datum, elevation 569.2 feet above Mean Water Level at Rimouski, Quebec (IGLD 1985) (International Great Lakes Datum 1985)

Aerial Cables have 120' clearance at Low Water Datum

1/12 Indicates miles above West Pier Light near outer end of Conrail Corp Ore Dock

4 Indicates sounding

41 Indicates State Route



U.S. ARMY ENGINEER DISTRICT BUFFALO
 MAY 2000

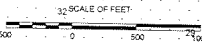

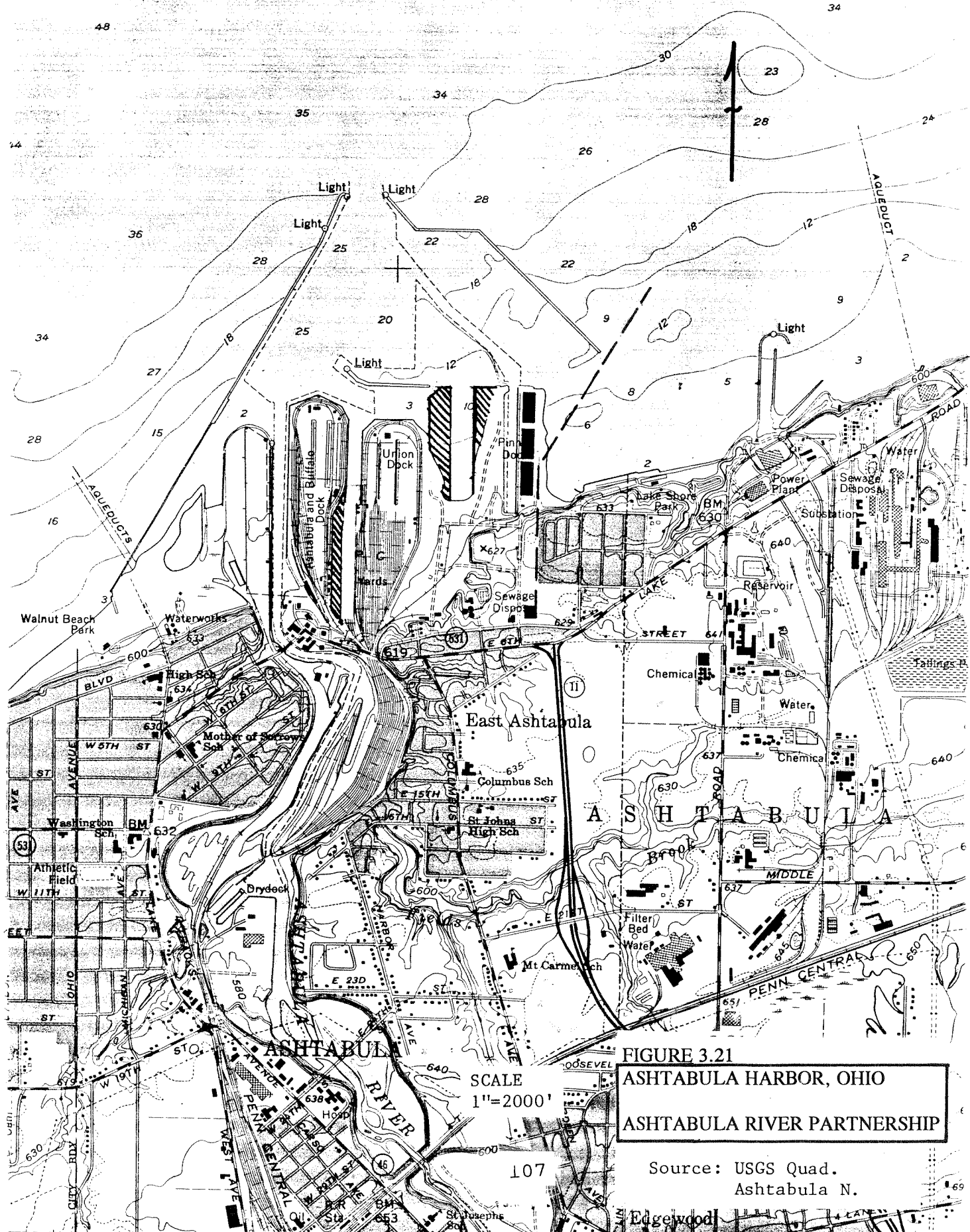









FIGURE 3.21
ASHTABULA HARBOR, OHIO
ASHTABULA RIVER PARTNERSHIP

SCALE
 1"=2000'

Source: USGS Quad.
 Ashtabula N.

107

Edgewood

- LEGEND**
-  RESIDENTIAL
 -  COMMERCIAL
 -  INDUSTRIAL
 -  PARK
 -  PUBLIC USE
 -  MARINA
 -  VACANT
 - * BED AND BREAKFAST

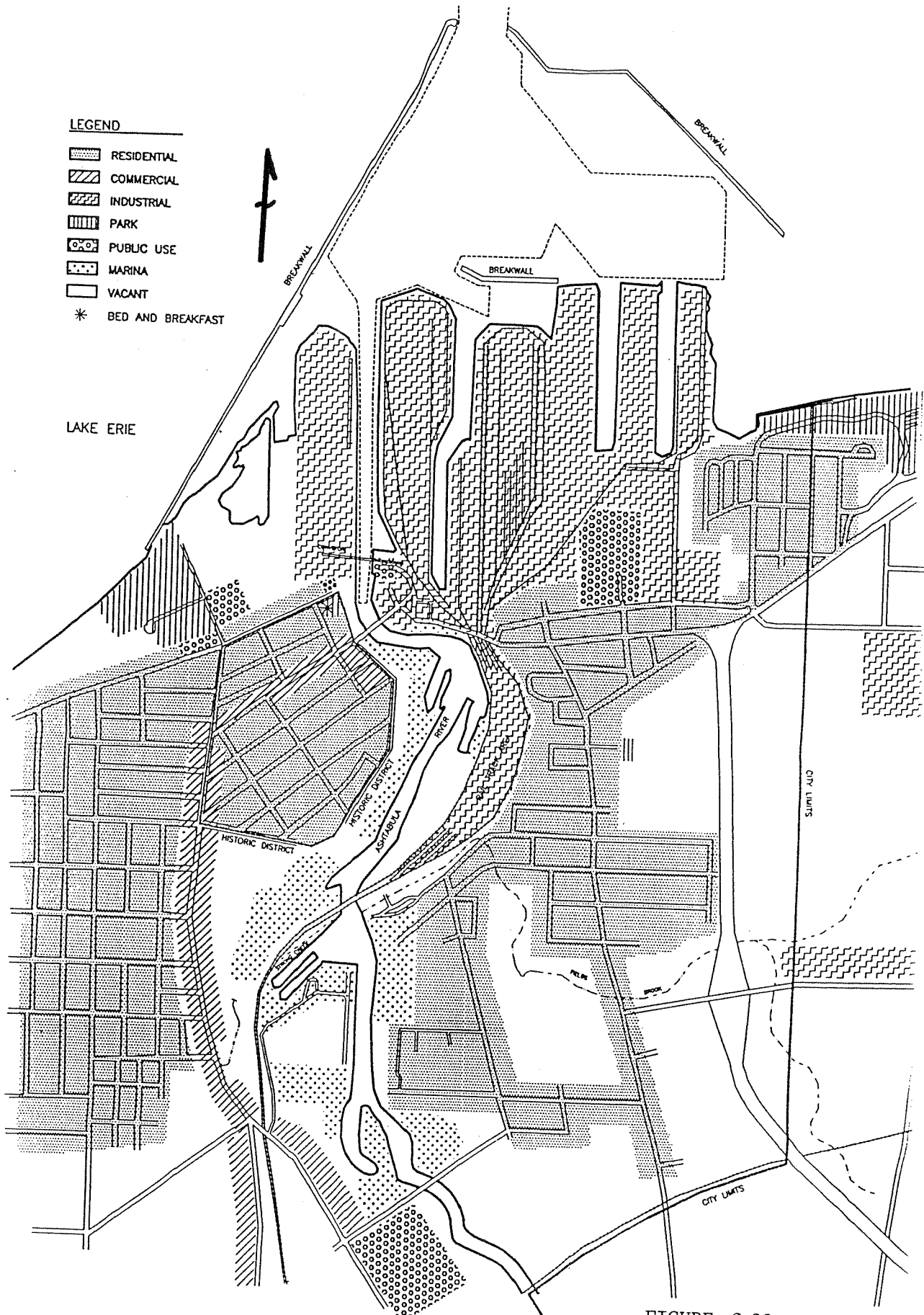

FIGURE 3.22

**ASHTABULA
PORT AUTHORITY**

**EXISTING
LAND USE STUDY**



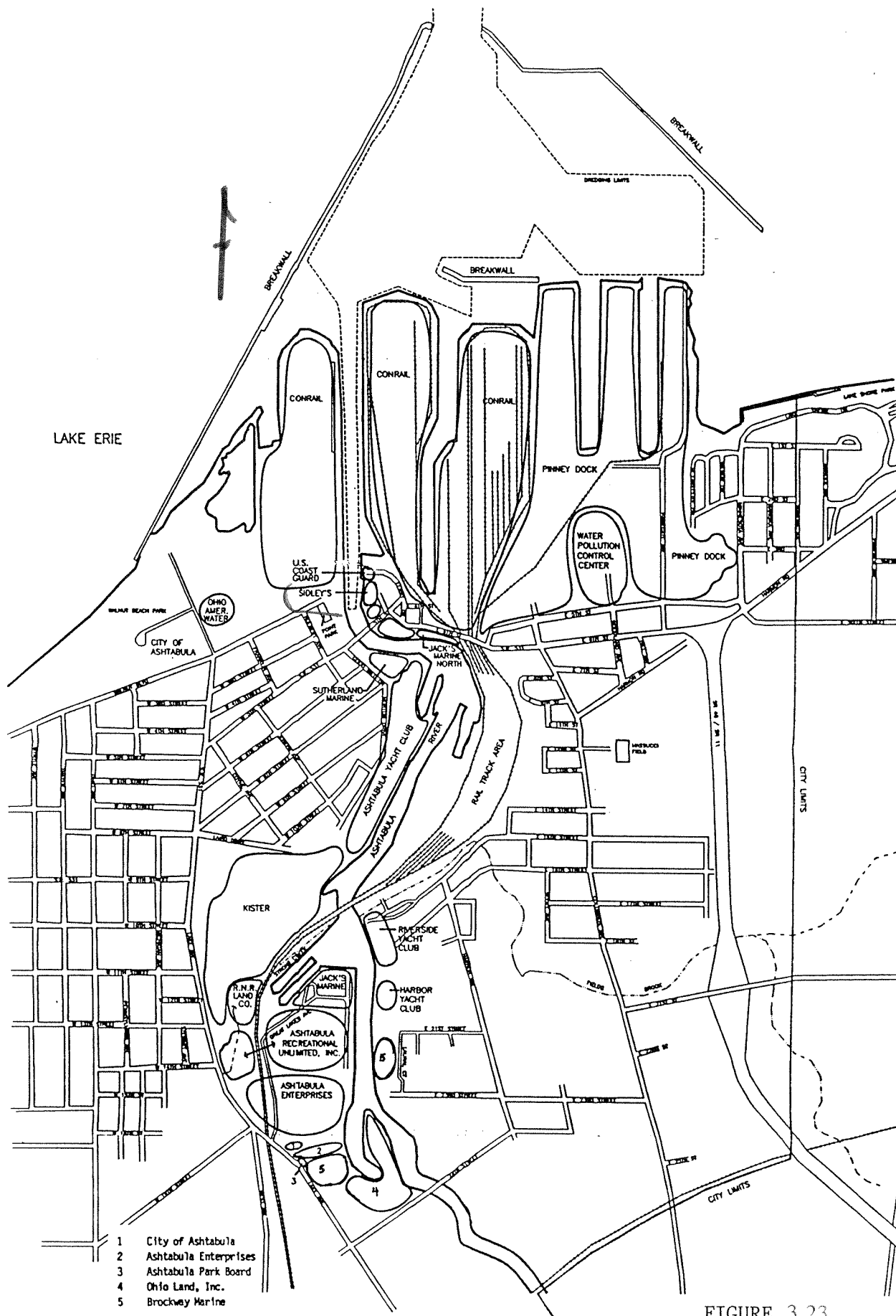

FIGURE 3.23

ASHTABULA PORT AUTHORITY

FACILITIES



3.115 Public land uses include the wastewater treatment facilities located on East 5th Street, and the Ohio American Water facilities located north of Walnut Boulevard, adjacent to Walnut Beach Park. Other public facilities include the U.S. Coast Guard located on the *west* bank of the Ashtabula River, north of Bridge Street and two museums and a library near Walnut Beach Park and Point Park of the west bank. Two bed and breakfasts are located adjacent to the museums and Point Park.

3.116 Land adjacent to the Ashtabula River, from the mouth of the Ashtabula River upstream to 24th Street, mainly consists of two land uses: industrial and marina. The marinas are located between the 24th Street Bridge and Bridge Street. The industrial uses are north of the Bridge Street.

3.117 Heavy industrial development is located along the eastern side of the Ashtabula River in the drainage area of Fields Brook. Upland area comprise the City of Ashtabula with mixed industrial, commercial, residential, public, and recreational developments. Farther upstream of the city, beyond the upstream limit of the Federal navigation channel, forested brushland and rural farmland occupy the majority of acreage.

3.118 The area identified for potential upland disposal site development, is that generally east of the harbor and north of the railroad tracks in the Ashtabula Township, Ashtabula County, Ohio. Reference Figures 3.24 and 3.25. This area contains similar developments and is zoned for heavy industry. The western portion of this area is almost fully developed with the harbor and city development and then to the east with industrial developments. The eastern portion of this area is a mix of abandoned farmland (now emergent scrub/shrub and mature wooded areas), disposal facilities and associated mitigation (preserved natural wildlife areas), and a few scattered residential properties primarily along the shoreline and Lake Road. Numerous wetland areas are scattered throughout the area. The Whitman's Creek watershed is located in the eastern most section of this area. A variety of associated wildlife species inhabit the natural areas.

3.119 Several property owners own the majority of the land adjacent to the Ashtabula River. These owners fall within three types of land uses: industrial, commercial/recreational and public. Reference Figures 3.20 and 3.23. The major industrial property owners include Sidley, Pinney Docks, and Conrail. The commercial/recreational property owners include Jack's Marine, Ashtabula Yacht Club, Kister's Marina, R.N.R. Land Co., Ashtabula Recreational Unlimited, Brockway Marine, and Ashtabula Enterprises. Public properties include water and wastewater treatment facilities, and public parks along the lakeshore.

3.120 Several property owners own the majority of the land in the area primarily considered for potential development of a new upland disposal sites, as depicted on Figure 3.25. The majority property owners include: Centerior Energy Inc. (CEI), Elkem Metals, Reactive Metals Inc. (RMI), ABC Chemicals, Union Carbide Corp, and Reserve Environmental Services (RES).

3.121 The Ashtabula Harbor study area is zoned into several different districts. Reference Figures 3.22 and 3.23. The majority of the area is zoned M-2, Heavy Industrial. This district

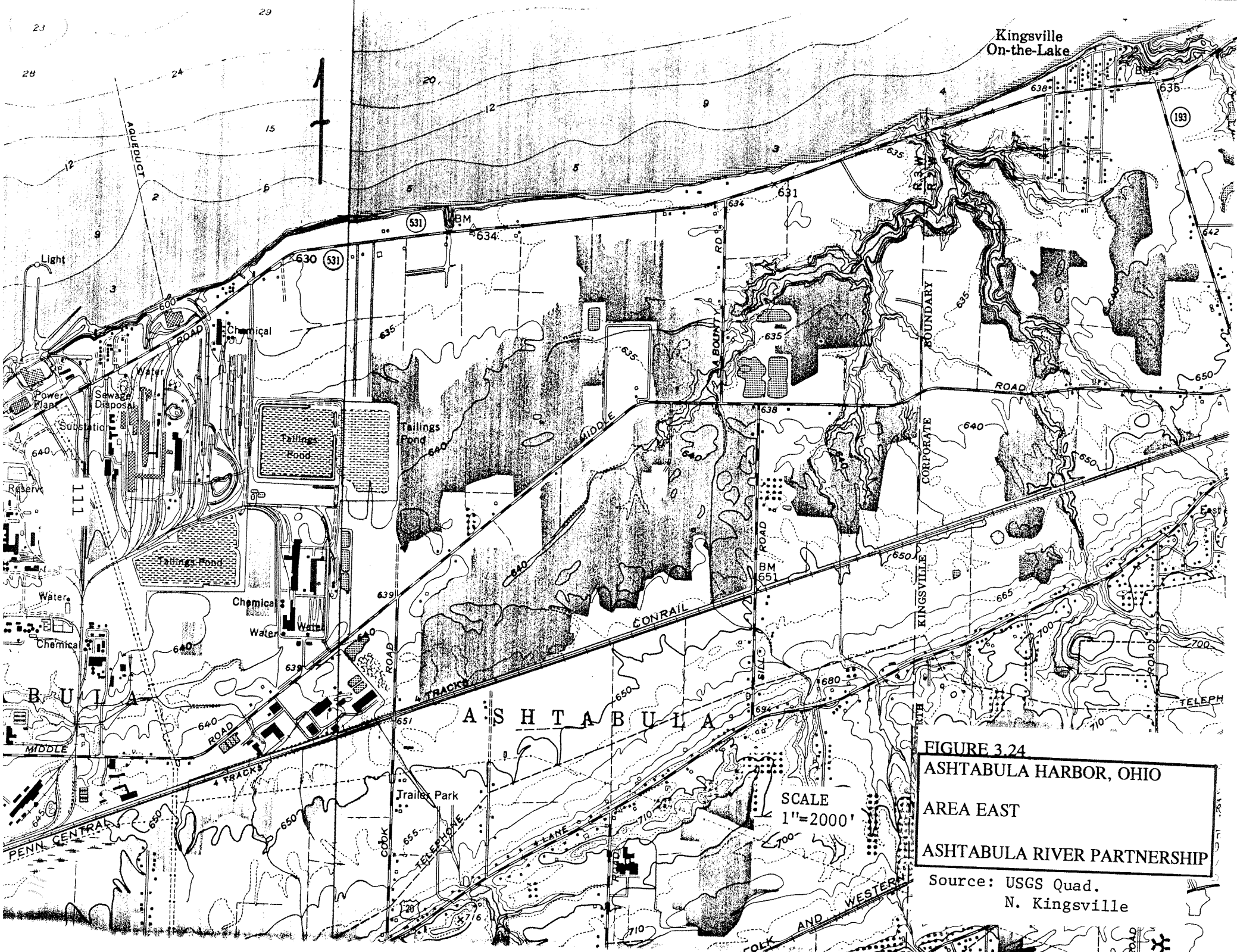

FIGURE 3.24
ASHTABULA HARBOR, OHIO
AREA EAST
ASHTABULA RIVER PARTNERSHIP
 Source: USGS Quad.
 N. Kingsville

SCALE
1"=2000'

ASHTABULA TOWNSHIP

ASHTABULA COUNTY
OHIO

SCALE: 1"=1,000'

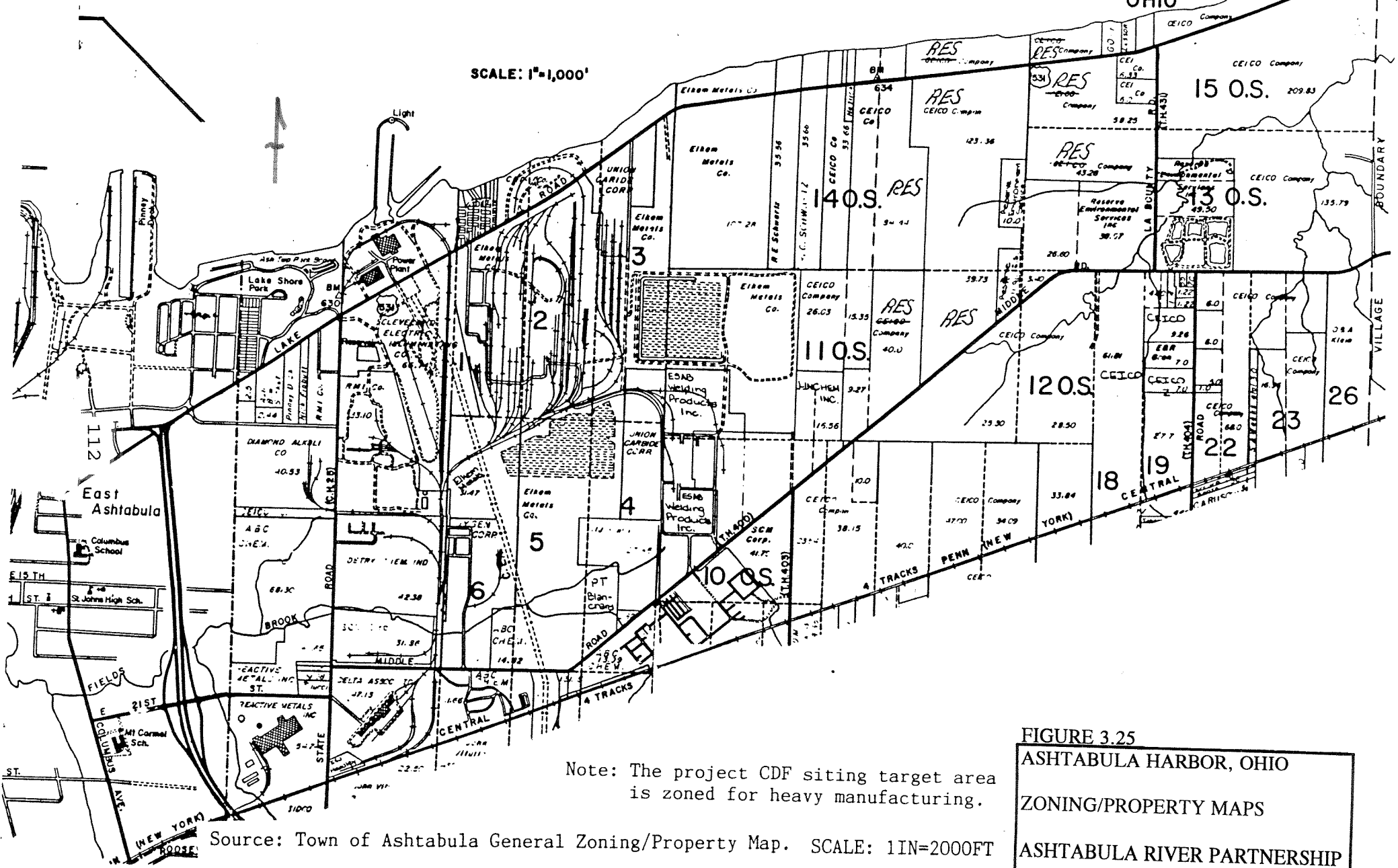

Note: The project CDF siting target area is zoned for heavy manufacturing.

Source: Town of Ashtabula General Zoning/Property Map. SCALE: 1IN=2000FT

FIGURE 3.25
ASHTABULA HARBOR, OHIO
ZONING/PROPERTY MAPS
ASHTABULA RIVER PARTNERSHIP

allows all land uses except residential uses. The M-2 Zoning District includes both sides of the Ashtabula River, extending from the 24th Street Bridge north to the lakefront. Zoning districts adjacent to the M-2 District include General Commercial (C-2), Central Business (C-3), Light Industrial (M-1), and the Residential District (R-3, R-4 and R-5). In addition, the Harbor Historical District (H-1) consists of the area around Bridge Street, extending from Walnut Boulevard to Morton Drive, Laird Drive and Lake Avenue. The Historical District requires development according to a Harbor Master Plan with enforcement by the Architectural Review Board. To the east of the Ashtabula River, property adjacent to Pinney Dock up to SR 11 is zoned C-2, C-3, and R-3 .

3.122 The area primarily considered for potential development of a new upland confined disposal site (See Figure 3.25) is zoned by the Ashtabula Township as M-2 for Heavy Industrial.

3.123 **Business and Industry and Employment and Income.** Commodities handled through the Port of Ashtabula include coal (exported), iron ore, sand, gravel, stone and limestone (imported).

3.124 Conrail's coal dock is the only exporter of coal in the Ashtabula Port. Coal is brought to the dock via rail from West Virginia and Pennsylvania coal fields for shipping. Principal customers are electric generating utilities in Canada. The largest customer is Ontario Hydro in Toronto. Recent new business includes the European market. Lake vessels are loaded at the Port of Ashtabula and off-loaded into large ocean vessels on the St. Lawrence River for movement to Europe.

3.125 Ohio coal has a high sulfur content, which has been linked to acid rain. Clean air regulations have established maximum allowable sulfur dioxide emissions for coal burning facilities. For power plants to comply with the regulations, they must either install expensive pollution controlling scrubbers or switch to low sulfur coal from out of state sources. While this has had an effect on the coal market, utilities, such as Ontario Hydro have installed the scrubbers and continue to use Ohio coal shipped through Ashtabula Harbor.

3.126 Conrail's current facility has a ground storage capacity of 1.2 million net tons, which allows stockpiling of coal year round. One problem associated with stockpiling coal is coal dust, which blows onto recreational boats and areas of the Ashtabula Harbor. Conrail routinely sprays stockpiled coal with water. In addition, they wash the U.S. Coast Guard building once per month.

3.127 Competition for coal movement comes from the port of Toledo, Sandusky and Conneaut in Ohio and from the Chicago, Illinois and Erie, Pennsylvania ports.

3.128 Iron ore is shipped into Pinney Dock for transport out via rail to steel plants in Youngstown and the Weirton, West Virginia area. In addition to iron ore, Pinney Dock also imports stone, bulk cement, potash and other bulk and general cargoes. Sidley's Dock imports stone. Both docks transport building materials by truck and Pinney Dock also transports materials by rail to sites in northeastern Ohio. Sidley's Dock presently has problems with shipping due to the shallowness of the Ashtabula River. Their incoming loads must be reduced by one-third, so the barges do not run aground.

3.129 Maintenance of harbor facilities is important in facilitating these activities. Hundreds of people are employed in these activities.

3.130 As indicated previously, in the area primarily considered for potential development of a new upland disposal site, as depicted on Figure 3.25, major business/industrial developments include those for: Cleveland Electric Illuminating (CEI), Elkem Metals, Reactive Metals, Inc. (RMI), ABC Chemicals, Union Carbide Crop., and Reserve Environmental Services (RES). These business/industry developments provide employment for thousands of area residents.

3.131 In 1987, there were some 1,701 non-farm related business establishments located in the Ashtabula County vicinity. In 1991, of the 41,452 civilian labor force in Ashtabula County, 37,195 were employed and 4,257 were unemployed for an unemployment rate of about 10 percent. Major employment sectors (based on 1990 40,782 employed) included manufacturing at 29 percent, wholesale/retail at 20 percent, and health services at 10 percent, followed by agriculture at 4 percent, finance, insurance, and real estate at 3 percent and public administration at 2 percent. Area employment is expected to experience a moderate increase (1990 OBERS). Expected employment growth sectors include: transportation and public utilities, wholesale/retail, services, and finance, insurance, and real estate.

3.132 In 1990, personal income (per capita) in Ashtabula County was about \$13,499. Gradual moderate growth in income is expected.

3.133 **Public Facilities and Services.** Within the Ashtabula area, the project vicinity is adequately serviced by major facility and service developments including: water, sewer, gas, electric, telephone, police, fire, emergency (rescue) medical, transportation, and sanitation developments. All of the various utility agencies and companies that serve the City of Ashtabula have facilities in or provide service to the harbor area.

3.134 **Water and Sewer** - No municipal or public drinking waters come from the Ashtabula River or its tributaries. Groundwater yield in the Ashtabula watershed basin is very low. The yields can range from less than 3 gallons per minute, up to 10 gallons per minute, this may not provide enough water during peak domestic usage. The major urban industrialized areas near the mouth of the Ashtabula River obtain their water from Lake Erie.

3.135 The City of Ashtabula's water supply is provided by a private utility company, Ohio American Water Company. Water lines are in place throughout the project area. There do not appear to be significant limitations on supply or distribution. The system should be capable of supporting any future development assuming the development does not include an unusually high volume water user. City water intakes are located west of the U.S. West Breakwater, while the upland water plant is located south of Walnut Beach and west of the Ashtabula River and Harbor.

3.136 The City of Ashtabula owns and operates the sanitary sewer system. All developed portions of the harbor area are served by sanitary sewers with the exception of a portion of the made land of the dock areas located at the mouth of the Ashtabula River. Several of the marinas have constructed force mains attending to sanitary sewers in streets located above the river

valley. The sewage treatment plant is located south of the Outer Harbor and east of the Ashtabula River and Harbor. The outflow is situated east of the U.S. East Breakwater. Reference Figure 3.29.

3.137 The Centerior Energy power plant intake/discharge canals are located along the shoreline just east of Lake Shore Park and north of the plant. A major industrial water intake is located about 7,500 feet east of the U.S. East Breakwater entrance light. The Reserve Environmental Services facility discharge pipeline extends out into Lake Erie from their facilities located about 2.5 miles east of the city.

3.138 **Transportation** - As indicated previously, Ashtabula is a significant commercial harbor on Lake Erie. The harbor is served by major rail lines and roadways. Reference Figures 3.20 and 3.24.

3.139 Rail service in the Ashtabula Harbor area is provided by Conrail. Conrail's New York Central Chicago-Buffalo main line, the "water level route," runs east and west through the area approximately 2 miles south of the Harbor. A line extends northerly along the west side of the Ashtabula River to a point north of the central business district, whence the rail crosses the Ashtabula River to the east bank.

3.140 Just north of this river crossing is a yard consisting of approximately 8 tracks. To the north of the yard, three tracks pass under the 6th Street Bridge. One of these tracks serves the rotary car dumper located on the east bank of the Ashtabula River, which feeds coal to the cross-river conveyor. Coal storage is located on the west bank of the Ashtabula River mouth on a 1.2 million net ton ground storage site owned and operated by Conrail. A stacker-reclaimer distributes coal on the site. Loading of coal barges occurs at the Conrail docks. Approximately 5.5 to 6.0 million tons of coal is transported per year, primarily to Ontario Hydro, in Canada.

3.141 Incoming iron ore is unloaded from self unloading vessels at the Pinney dock facilities and loaded into ore cars. The loaded ore cars move southward ultimately to steel mills in the Youngstown, Ohio/Weirton, West Virginia area. Approximately 3.5 to 4.0 million long tons of ore are transported per year.

3.142 Interstate 90 (I-90) runs east/west and is located approximately 5 miles south of the Ashtabula Harbor. The Interstate provides Ashtabula with regional access to major markets east and west of the City, such as Chicago, Illinois, and Buffalo, New York. SR 11, a four-lane restricted access highway, services Ashtabula with an exit at I-90 and runs north/south terminating at SR 531. SR 11 extends south providing additional access to major markets in Ohio, Pennsylvania, and West Virginia.

3.143 SR 531, an east/west two-lane highway, primarily serves local traffic to and from the project area. SR 531 connects the Harbor with Geneva-on-the-Lake to the west and Conneaut to the east. The northern terminus of SR 11 is located within the project area at its intersection with SR 531. Traffic on SR 531 is periodically interrupted at the Ashtabula River by the lift bridge. Other secondary routes servicing the project area include SR 20 (east/west) and SR 45

3.144 **Recreation.** The Ashtabula Harbor vicinity includes recreational park, trail, fishing, boating and tourist areas. Figures 3.20 through 3.23 depict the Ashtabula Harbor area including many water oriented recreational facilities.

3.145 Walnut Beach and Lakeshore Park are the two largest public recreational beaches in the Ashtabula Harbor area. Walnut Beach Park is located at the western end of the Outer Harbor and contains bath houses, restrooms, a beach area, tennis courts, concession stands, and the Ashtabula River wetland. Land access is possible to the west harbor breakwater, where extensive recreational fishing occurs. Lakeshore Park is located at the eastern end of the Outer Harbor and contains a pavilion overlooking the lake, a beach, picnic shelters, parking areas, a 40-unit trailer park, a small animal petting zoo, two duck ponds, tennis courts, an athletic field, a playground, and concession stands. Point Park, has undergone improvements, to include an observation deck which provides a tremendous views of the City, Harbor area, and lakefront. New walkways create a connection between the historic commercial area, Point Park, and the marine museum. The City's bed and breakfasts are located adjacent to Point Park.

3.146 Fishing is popular in the vicinity along the Harbor shoreline, Outer Harbor breakwaters, and from boats over shoal areas. A variety of fish species inhabit the Harbor area.

3.147 Recreational boating is the most visible form of recreation in the Ashtabula Harbor area. The majority of recreational navigation facilities in Ashtabula are located along the Ashtabula River upstream of the Fifth Street bridge. Reference Figures 3.20 through 3.23. Boaters presently using the Ashtabula Harbor Area marina/yacht club services come from all over northeast Ohio, including Ashtabula, Trumbull, Mahoning, Geauga, and Lake Counties, and from northern Pennsylvania as well. The Ashtabula Harbor boasts eleven marinas and yacht clubs located along the Ashtabula Riverfront. These marinas and yacht clubs provide a variety of services to their clientele. A survey was undertaken in October 1992 to determine the existing facilities, needs, and concerns of the marina community. Ten marinas responded with a variety of comments. The following table displays some of the information revealed in the survey of local marinas.

TABLE 3.11 Number of marinas with the following facilities:

1. Yacht Club	5
2. Dry Slips	2
3. Floating Docks	7
4. Fixed Docks	7
5. Boat Launch Services	5
6. Inside Boat Storage	5
7. Outside Boat Storage	9
8. Sanitary Pumpouts	4
9. Transient Dock Space	8
10. Picnic Facilities	8

Estimated Number of Wet Slips	1,058
Estimated Number of Boat Launch Ramps	11
Number of Reported Transient Dock Spaces	7

Other Harbor related activities include fish charters. Six marina/yacht clubs currently have fishing charter services operating out of their facilities.

3.148 The most frequent comment noted is the shallowness of the Ashtabula River. Other comments include the need to clean up the Ashtabula River, the lack of transient dockage and pumpout facilities, the lack of promotion/advertisement of the Harbor area, and the need for more support from the City and County to make the Harbor area a viable recreational area. Many marinas indicated that more space is needed, especially for winter storage of boats. Other marinas are interested in expanding their dock areas and increasing other services and are likely to do so in the near future. Facilities or services that marina/yacht club owners feel are needed in the Harbor include waterfront restaurants, a facility for disposing of fish waste, an indoor boat storage area, a maintenance shop and boat launch service.

3.149 Recreational statistics indicate that even with past decrease in area population, demand for sufficient water-oriented recreational activities and facilities continues to grow. This may be attributed to several factors including: community developmental changes, improved water quality, and increased leisure time and income. Recent regional, county, and city studies also identify demands to improve and develop water-related recreational facilities including: beaches, parks, and marinas. The State, county, town and city continue to develop plans and facilities in addressing these needs.

3.150 The City and County of Ashtabula have many points of interest that draw tourists to the area. The County is known for its many antique shop and wineries. The City of Ashtabula offers many antique shops as well. The historic commercial area, located adjacent to the Harbor area, lends itself especially well to the tourist trade. This area is the Historic District of the City of Ashtabula. In the 1970's federal funding allowed building facades to be restored to reflect the 1880 - 1925 period. Many specialty shops and restaurants are located in this area, as well as two bed and breakfasts and the Great Lakes Marine Museum. Many festivals and events that are attractive to tourists are held throughout the County during the year. Specific events held in the Ashtabula Harbor Area include the Blessing of the Fleet, Harbor Days, Santa Arrives by Boat, and a fishing festival.

3.151 **Property Values and Tax Revenue.** The average value of farmland (land and buildings) in Ashtabula County is roughly estimated at \$1,800 per acre. The value of lakefront property would be expected to be considerably higher. Local tax revenues generally include revenue sharing (Federal, State, Local), and local property, service district, and sales taxes.

3.152 **Noise and Aesthetics.** Noise and aesthetics in the Ashtabula Harbor locale area is that associated with various harbor area developments including: navigation facilities, industrial and commercial developments, transportation and recreational facilities. The primary source

of noise generation includes industrial activities, and noise generated by vehicular movement within the area including ships, trains, trucks, autos, and boats. The aesthetic conditions of Ashtabula Harbor are greatly influenced by extensive commercial shipping activity and the presence of industrial, railroad, and storage facilities. Most views of the outer harbor include rail yards, docks, and ship loading/unloading facilities. Industrial and commercial facilities, a few marinas, and the U.S. Coast Guard Station are present along the lower Ashtabula River. The upper river area is dominated by marina developments. Views of the Outer Harbor can be enjoyed from Walnut Beach Park, Point Park, and Lake-shore Park, which are located along the Lake Erie shore at the western and eastern ends of the Outer Harbor, respectively. Areas of higher aesthetic values include shoreline areas with a view to or from the lake, parks, marinas, and restaurant areas.

3.153 Community Cohesion. Community cohesion, as in most cases, is a result of a number of social and economic factors. Most Ashtabula vicinity residents are long-time residents of varied ethnic backgrounds. Generally, community pride (cohesion) is strong. Relative to the harbor area, in the last decade, a general shift from primarily industrial and commercial activity to more mixed activity and developments - particularly recreation - has affected previous community cohesion factors and interests (community structure and development, employment and income, environment, etc.). Community efforts have sought to sustain remaining business and industrial development, where possible, while looking for-ward to new alternative developmental potentials-particularly recreation. The most likely development appears to be one of well-planned mixed usage. Reference Figures 3.22, 3.23, and 3.26.

3.154 Relative to continued Harbor operation and maintenance, most interests agree that the Harbor should be maintained to facilitate industry/commerce and recreation and associated community economic and social well-being, and that dredged material should be appropriately disposed.

CULTURAL RESOURCES

3.155 Cultural Resources. In response to project scoping letters, the Ohio State Historic Preservation Office indicated that, based on a brief check of cultural resource records, aquatic and terrestrial sites in the Ashtabula area may be archaeologically or historically sensitive and that an archaeological survey should be conducted for sites finally considered.

3.156 Large conical mounds in which human skeletons have been found and evidences of burial grounds were discovered many years ago along the banks of the Ashtabula River several miles from Lake Erie. These mounds have long since been destroyed. The vicinity location of these archaeological sites is shown on Figure 3.27.

3.157 The Indian tribe native to Ohio was the Erie, who occupied the south shore of Lake Erie in northeastern Ohio, including portions of the current study area. The Erie Indian tribe resided in the Ashtabula area until 1656, when they were driven out by the invading Iroquois Confederacy. Following the Iroquoian conquest, this area remained a virtual "no man's land" for over 50 years. The first western explorer to settle the area was Moses Cleaveland, hired by the Connecticut Land Company to survey parts of Ohio and clear Indian claims. Cleave-

119

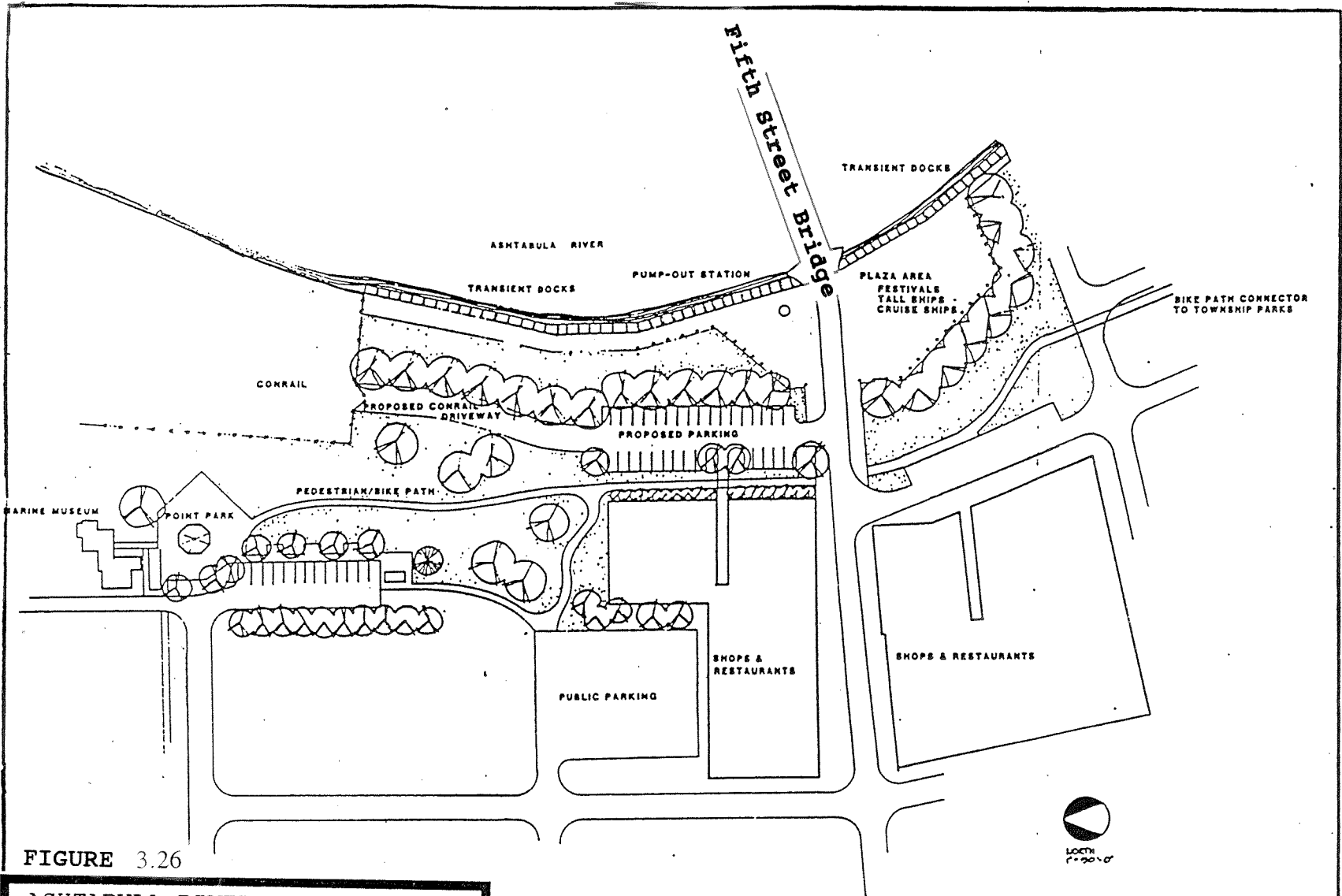

FIGURE 3.26

ASHTABULA RIVER PARTNERSHIP
 COMPREHENSIVE MANAGEMENT PLAN

PROPOSED & COMPLETED PLANS
 FOR HARBOR IMPROVEMENTS

October 1997



ASHTABULA PORT AUTHORITY
 PLAN B
 PROPOSED HARBOR ENTRANCE

CT CONSULTANTS, INC.

1. *Sunken Schooner 'Joy'*
2. *Conical Mounds*
3. *Col. William Hubbard House*
4. *Ashtabula Lighthouse and Light Stations*

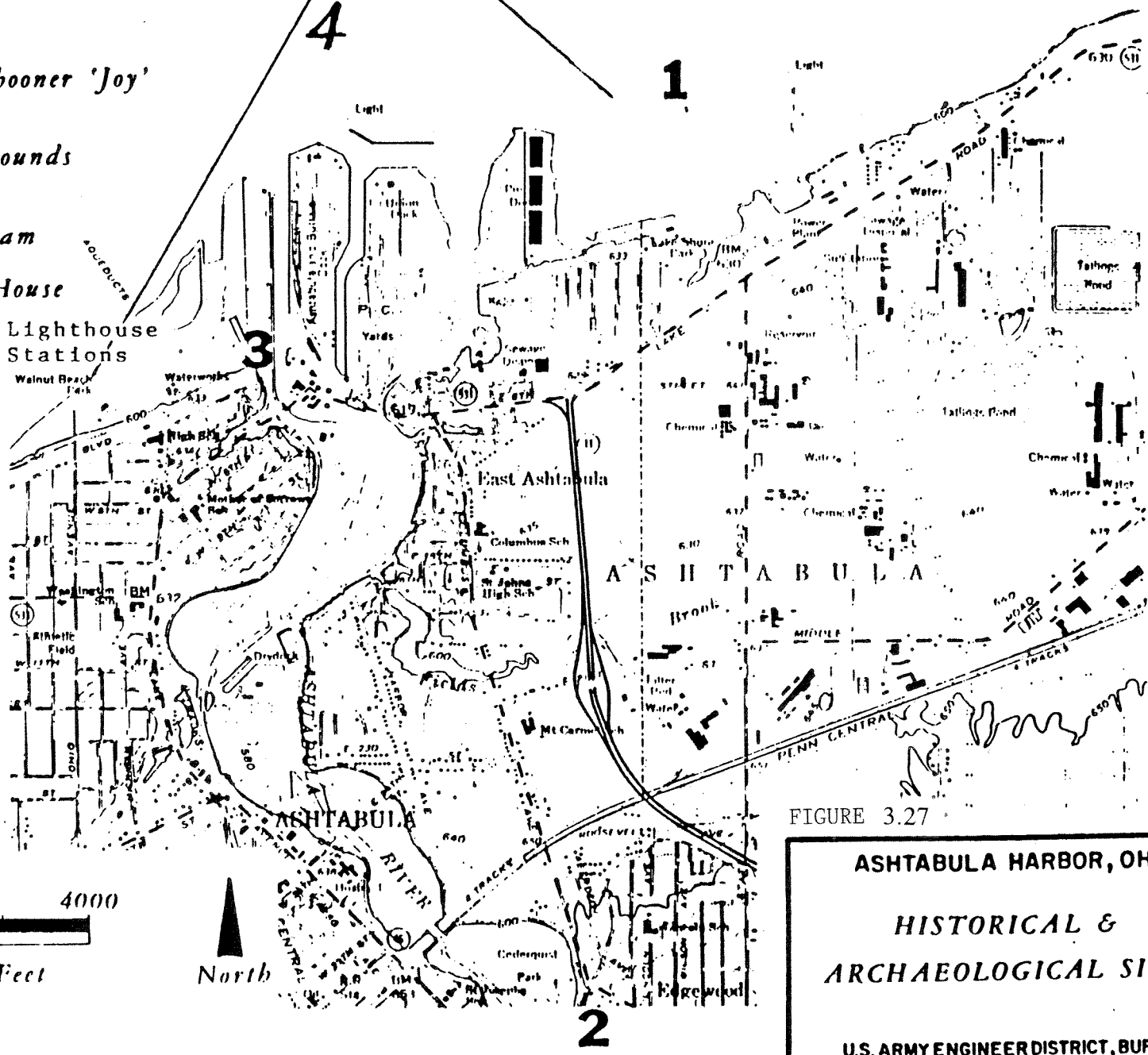

FIGURE 3.27

ASHTABULA HARBOR, OHIO

HISTORICAL & ARCHAEOLOGICAL SITES

U.S. ARMY ENGINEER DISTRICT, BUFFALO

land's explorations took him through much of Ohio, with various members of his party occasionally staying behind to settle areas, such as Conneaut and Ashtabula, in 1796. Ashtabula Township was organized in 1808. Lands west of the river were organized as the Borough of Ashtabula in 1831. Growth continued over the years, spurred by the introduction of the railroads which stimulated the fishing industry, as well as other businesses.

3.158 In 1887, a 150-foot schooner, the JOY, sank off Ashtabula, carrying millstones and ore. Currently, many large sections of this vessel are lying on the bottom in about 15 feet of water, approximately 100 feet southeast of the east end of the east breakwater at Ashtabula Harbor. The vicinity of this sunken vessel is shown on Figure 3.27.

3.159 National Register Property listed on the National Register of Historic Places include the Ashtabula Harbor Light(s) (U.S. Coast Guard Lighthouses and Light Stations on the Great Lakes) located on the harbor breakwaters, and the Colonel William Hubbard House, on the northwest corner of Lake Avenue and Walnut Boulevard in Ashtabula. The Ashtabula Harbor Light, 51 feet above the water, is shown from a white cylindrical tower on a white square house near the outer end of the west breakwater. The Colonel William Hubbard House, now a community house, was formerly the best known of Ashtabula's Underground Railroad Stations. The location of these properties is shown on Figure 3.27.

3.160 A cultural resources survey was conducted in 1992 for potential CDF sties (D, E, and P). Findings were coordinated with the Ohio State Historic Preservation Office (SHPO). No significant cultural resource items were identified at sites (D or P). A potential cultural resource item was identified within site E that could be disturbed by use of the site and could require mitigation procedures prior to use of the site, if the site were selected. Additional investigation would be required to determine significance. Reference Figure 2.10.

3.161 The project area river channels have been previously significantly disturbed by channel dredging. The project area potential shoreline transfer/dewater/transfer sites have been previously significantly disrupted by shoreline developments. The Conrail site has previously been utilized for disposal of dredged material and was utilized for rehabilitation of dikes and disposal of interim dredged material in 1993. No significant cultural resource items would be expected to be located in these areas. Reference Figures 3.9 and 3.28 item a.

3.162 A cultural resources survey (Shaffer) was conducted in the vicinities of Sites 5 and 7 in 1997. Reference Figures 2.10 and 3.28. Although several twentieth century farmstead sites were known to have existed in the vicinities, and noted, no cultural resources items of significance were identified in the vicinities. The survey report was coordinated with the State Historic Preservation Office with a letter dated May 16, 1997. The State Historic Preservation Office provided a letter dated June 30, 1997 stating that: "Therefore it is our finding that the project will have no effect on any properties listed or eligible for the National Register of Historic Places. No further coordination is necessary unless the scope of the project should change." Reference EIS Appendix EA-H CULTURAL RESOURCES ASSESSMENT, also.

3.163 A letter dated September 18, 2000 was coordinated with the State Historic Preservation Office pertaining to potential development of disposal facilities at State Road Site. Enclosures

included: a list of documents prepared for remediation of the site, an extract from one of the documents pertaining to the industrial development and use of the site, a wetland and ecological site walkover investigation prepared by the Buffalo District, a memo pertaining to existing site conditions prepared by the Buffalo District, and a site photo index and photos taken during site demolition. The State Historic Preservation Office provided a letter dated November 7, 2000 reaffirming that the project will have no effect on any properties listed or eligible for the National Register of Historic Places. No further coordination is necessary unless the scope of the project should change. If new or additional properties are discovered, the State Historic Preservation Office should be notified. Reference EIS Appendix EA-H CULTURAL RESOURCES ASSESSMENT, also.

POTENTIAL TRANSFER/DISPOSAL SITE GENERAL INFORMATION

3.164 Previous coordination for similar projects in this regard identified a likely area for potential disposal site development, as that generally east of the harbor and north of the railroad tracks in the town of Ashtabula, Ashtabula County, Ohio. Reference Figure 3.28. This area contains similar developments and is zoned for heavy industry. The western portion of this area is almost fully developed with harbor and city development and then to the east with industrial developments. The eastern portion of this area is a mix of abandoned farmland (now emergent scrub/shrub and mature wooded areas), disposal facilities and associated mitigation (preserved natural wildlife areas), and a few scattered residential properties primarily along the shoreline and Lake Road. Numerous wetland areas are scattered throughout the area. The Whitman's Creek watershed is located in the eastern most section of this area. A variety of associated wildlife species inhabit the natural areas.

3.165 The following briefly discusses existing conditions at the considered project shoreline transfer/dewater/transfer site.

1993 Interim Disposal Site. The site is currently owned by Conrail. In 1993, a special cooperative interim dredging and dredged material disposal project took place in the upper federal and local navigation channel of the lower Ashtabula River, in order to facilitate area commercial and recreational boating needs. Approximately 23,500 cubic yards of sediments were dredged and disposed of into a small reconditioned shoreline upland dewatering and confined disposal facility. The site is currently covered with grass/legume vegetation. Reference Figures 3.9 and 3.28 item a.

3.166 The following briefly discusses existing conditions at the final six considered project disposal facilities development sites. Reference Figure 3.28.

Site 3 Vicinity. Site 3 vicinity is currently owned by Elkem Metals Co. It is abandoned farmland with successional (mostly wooded, primarily oak) vegetation growth on it. There are some scattered wooded wetlands and perimeter wetlands. The area supports a variety of typical regional vegetation and animal species.

Site 5 Vicinity. Site 5 vicinity is currently owned by Reserve Environmental Services (RES). It is abandoned farmland with successional vegetation growth on it. Approximately 70

Source: USGS Quad.
Ashtabula N.

Source: USGS Quad.
N. Kingsville

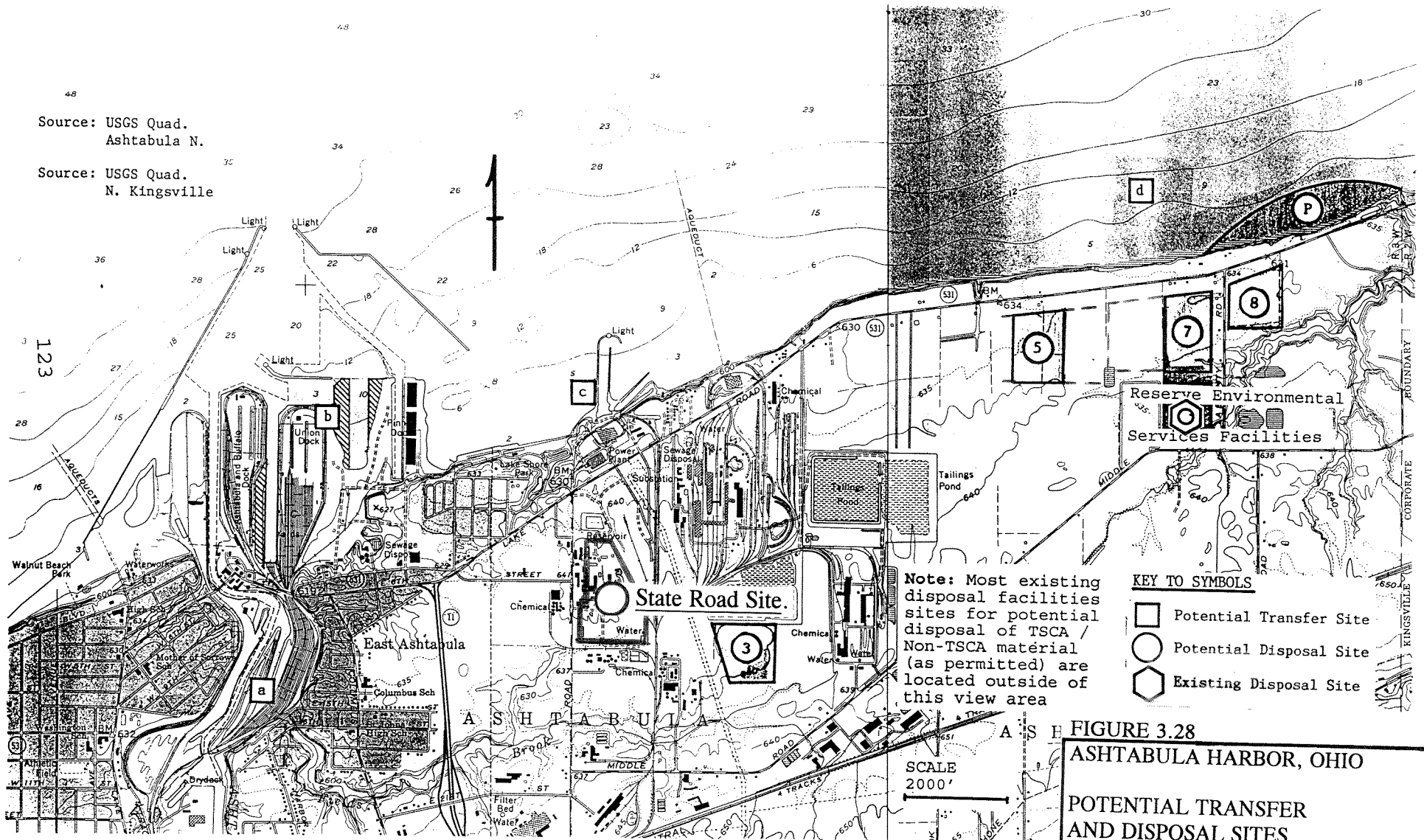

FIGURE 3.28
ASHTABULA HARBOR, OHIO
POTENTIAL TRANSFER AND DISPOSAL SITES
ASHTABULA RIVER PARTNERSHIP

acres of this vicinity was investigated for wetland delineations. Of the 70 acres investigated, approximately 6 plus acres are fill (flyash material) upland, 19 acres are scrub/shrub and/or wooded upland, one acre is open water, and 44 acres are scrub/shrub and/or wooded wetland. The area supports a variety of typical regional vegetation and animal species.

Site 7 Vicinity. Site 7 vicinity is currently owned by Reserve Environmental Services (RES). It is abandoned farmland with successional (mostly wooded) vegetation growth on it. Approximately 96 acres were investigated for wetland delineations. Of the 96 acres investigated, approximately 76 acres are scrub/shrub and/or (mostly) wooded upland and 20 acres are scrub/shrub and/or (mostly) wooded wetland. The area supports a variety of typical regional vegetation and animal species.

Site 8 Vicinity. Site 8 vicinity is currently owned by Centerior Energy Corp. It is abandoned farmland with successional (mostly wooded) vegetation growth on it. There are some scattered wooded wetlands and perimeter wetlands. The area supports a variety of typical regional vegetation and animal species. There could be a development problem due to its limited acreage and closer proximity to shoreline/water resources.

Site P Vicinity. The shoreline area in the vicinity of Site P is currently owned by Centerior Energy Corp. In the vicinity of the potential CDF Site P, the shoreline is characterized by a steep eroded bluff, the front of which contains sporadic very narrow sand/gravel beaches. The bluff is founded on shale and contains glacial till with an intertill layer of clay and silt. Lakeward from shore, bedrock is at or just below the lake bottom. The lake bottom is generally bedrock with some algae and a thin sprinkling of silt.

State Road Site. The State Road Site is currently owned by State Road Development Corp. Subsequent to this coordination of the draft reports, the Partnership has been considering development of disposal facilities (if feasible and all things considered) at an alternate site that has become available. It is a recently demolished industrial site located just a few miles east of Ashtabula Harbor and adjacent to the Fields Brook remediation project disposal site. Use of this site would avoid potential impacts to wetlands and wildlife habitat at Site 7. Briefly, the site has been highly disturbed by industrial development and subsequent demolition activities. The surrounding area is developed industrial and is zoned manufacturing. It appears that the plant area was once a marsh area. The site contains up to seven feet of fill material (clay, sand, brick, coal). The plant was developed between 1948 and 1950. Pure elemental sodium was produced at the plant in electrolytic cells. The plant recently ceased operations. A remediation plan pertaining to contaminants was prepared, approved, and implemented. Except for a few office and warehouse buildings that will remain, most of the plant developments have been demolished. The area south of the railroad spur is being utilized for disposal and treatment facilities from the plant and from the Fields Brook remediation project. It is proposed that part of this area also be utilized for disposal of the more highly contaminated sediments dredged from the river for the Ashtabula River Partnership project. It is proposed that part of the area north of the railroad spur be utilized for disposal of the lesser contaminated sediments dredged from the river for the Ashtabula River Partnership project.

The U. S. Army Corps of Engineers, Buffalo District conducted an on-site investigation within an approximately 35 acre portion of the State Road Disposal Site. The investigation was conducted to determine the presence and extent of jurisdictional wetland within the site pursuant to Section 404 of the Clean Water Act and to characterize the prevailing site ecology and other physical and biological site features. Personnel applied methods specified by the Corps of Engineers Wetlands Delineation Manual (January 1987). A preliminary review of available information for the area pertaining to vegetation, soils, and hydrology was implemented prior to conducting the field investigation. Sources of information included: U.S. Geological Survey maps, the U.S.D.A. Soil Survey, National Wetland Inventory maps, and aerial photographs. Based on findings of the field investigation, the Buffalo District determined that the site is best classified as industrial urban land. The site supports primarily upland open field, patchy herbaceous regrowth and common reed, which is consistent with urban industrial sites. One man-made depressional wetland located on soil fill was identified within the northern third of the site along the eastern site boundary. The wetland is approximately 0.02 acre in size and is not functionally significant; but, meets the criteria for delineation based on vegetation and hydrology. During the site investigation the Buffalo District personnel observed no threatened or endangered species or critical habitat.

3.167 Reference paragraph 3.163, also.

SECTION 4 - ENVIRONMENTAL EFFECTS

INTRODUCTION

4.01 This section briefly compares anticipated environmental effects of the most feasible alternative plan proposals relative to the various environmental assessment evaluation parameters. It describes in more detail the anticipated impacts identified in Summary Table S1 and Table 2.10 - Comparative Impacts of Alternatives in SECTION 2 - ALTERNATIVE CONSIDERATIONS AND THE RECOMMENDED PLAN.

4.02 A number of standard engineering, economic, and environmental measures are used to assess/evaluate alternative scenarios. In addition, justification for dredging under the 312(b) and 206 authorities must include a habitat assessment procedure (HAP) analyses. In this case a HAP developed by the State of Ohio Environmental Protection Agency was utilized. Essentially, the HAP analyses utilizes comparative biological field survey data and developed indices to identify problems and to compare existing environments and remedial alternatives in terms of benefits, or habitat units gained, to costs. In this way optimized remedial measures can be selected.

4.03 The Ohio Environmental Protection Agency has developed a Habitat Assessment Procedure (HAP) based on the premise of ecological analyses. They have inventoried a number of ecosystems examining habitat, macroinvertebrate, fisheries, and community and have been able to develop a number of assessment/evaluation indices accordingly. These include such indices as the QHEI - Qualitative Habitat Evaluation Index, the ICI - Invertebrate Community Index, the IBI - Index of Biotic Integrity, and the MIwb - Modified Index of well being. Comparing data and utilizing these measures can provide an assessment/evaluation of existing conditions, ecological potential, degradation or ADV - area of degradation values, likely causes, and improvement measures. In this case, adjacent Conneaut River and Harbor served as the primary comparative quality stream regime. Although it has a similar level of commercial and recreational development, it does not have appreciable levels of contaminations. Other supplemental references include Presque Isle, the Grand River, and the Black River. The Ohio Habitat Assessment Procedure assessments/evaluations serve to provide primary project ecological output measures.

4.04 The Ohio Habitat Assessment Procedure (HAP) and assessment/evaluation is presented and discussed in more detail in EIS APPENDIX EA- J SECTION 312(b) AND 206 ECOLOGICAL RESTORATION/ PRESERVATION ANALYSIS. (Part of this report. Follows these text). Portions of this appendix are summarized and integrated into portions of this Environmental Impact Statement.

4.05 The U.S. Environmental Protection Agency, the Ohio Environmental Protection Agency, and the Ohio Department of Health have prepared Environmental Risk Management Considerations for the Ashtabula River and Harbor. Reference EIS Appendix EA-C. (Part of this report. Follows these text).

ENVIRONMENTAL EFFECTS - PROJECT ECONOMIC COSTS/BENEFITS

Economic Costs/Benefits:

- 4.06 No Action (Without Project Conditions). The No Action (Without Project Conditions) scenario indicates that the Ashtabula River Partnership could take no action based on the final findings of this study. Similar to existing conditions would persist for some time. The area would likely be referred to and remediated, to the extent possible, under SUPERFUND.
- 4.07 Proposed Upland State Road Site Plan. Project economic costs, benefits, and cost sharing were discussed in SECTION 2 pages 45 through 49.
- 4.08 The project economic assessment/evaluation is presented in considerable detail in the Feasibility Report and Technical Appendix S - Economic Evaluation. (Three ring binder Technical Appendices)
- 4.09 An economic analysis of ecological restoration measures was conducted and is presented and discussed in more detail in EIS APPENDIX EA- J SECTION 312(b) ECOLOGICAL RESTORATION/PRESERVATION ANALYSIS. (Part of this report. Follows these text). The analyses referenced various environmental indices to describe the restoration of the ecosystem infrastructure. Those changes affect the level of human use and enjoyment of the ecosystem. Activities such as navigation and recreation, and the general enjoyment derived from living in an area where the ecosystem is not impaired are key elements in maintaining and enhancing the quality of life. Table 4.0 presents summaries of calculated economic Average Annual Benefits and Present Worth Values of goods and services that would be available under alternative environmental restoration scenarios. Calculated benefits exceed project costs.
- 4.10 Alternative Disposal Options Plan. In order for the Alternative Disposal Options Plan to become the preferred or recommended plan, the costs would need to become at least equal to or less than the Proposed Upland State Road Site Plan. Economic benefits would likely remain the same, therefore the benefit to cost ratios would be equal to or greater than those for the Proposed Upland State Road Site Plan under the equal to or less than cost scenario. There are a number of uncertainties associated with this plan however, including: approvals, participation, and equal or reduced costs.

Table 4.0 Present Worth Of Outputs By Plan

Average Annual Benefits (1)

	Shallow Dredge	Deep Dredge	Deep Plus Eco System Restoration	Bank To Bank
NED Benefits				
Commercial Navigation Benefits	\$0	\$1,308,500	\$1,308,500	\$1,308,500
Boating (Consumer Surplus)	0	\$78,100	\$83,200	\$67,000
Fishing (Consumer Surplus)	\$98,000	\$184,000	\$196,000	\$157,900
Passive Use Values (Consumer Surplus)	\$475,900	\$885,200	\$952,100	\$739,900
Change In Property Values	\$238,800	\$477,500	\$477,500	\$477,500
Risk Reduction To Lake Erie Fishery	\$785,900	\$859,300	\$859,300	\$1,026,900
Subtotal	\$1,598,600	\$3,792,600	\$3,876,600	\$3,777,700
Regional Economic Development Benefits				
Local Economic Impacts(Retain Commercial Navigation)	\$0	\$4,321,500	\$4,321,500	\$4,321,500
Boating (Total Impact Of Expenditures On Output)	\$131,400	\$246,700	\$262,800	\$211,900
Fishing (Total Impact Of Expenditures On Output)	\$409,500	\$769,200	\$819,200	\$660,500
Subtotal	\$540,900	\$5,337,400	\$5,403,500	\$5,193,900
Total	\$2,139,500	\$9,130,000	\$9,280,100	\$8,971,600

(1) All Benefits reflect a 6.375% annual interest rate, a 50 year project life and October 2000 Price levels.

Present Worth Value Of Benefits (1)

	Shallow Dredge	Deep Dredge	Deep Plus Eco System Restoration	Bank To Bank
NED Benefits				
Commercial Navigation Benefits	\$0	\$19,591,600	\$19,591,600	\$19,591,600
Boating (Consumer Surplus)	\$0	\$1,169,200	\$1,245,400	\$1,003,400
Fishing (Consumer Surplus)	\$1,467,200	\$2,755,200	\$2,934,800	\$2,364,600
Passive Use Values (Consumer Surplus)	\$7,125,700	\$13,254,300	\$14,254,800	\$11,077,700
Change In Property Values	\$3,575,000	\$7,150,000	\$7,150,000	\$7,150,000
Risk Reduction To Lake Erie Fishery	\$11,767,100	\$12,865,300	\$12,865,300	\$15,375,600
Subtotal	\$23,935,000	\$56,785,600	\$58,041,900	\$56,562,900
Regional Economic Development Benefits				
Local Economic Impacts(Retain Commercial Navigation)	\$0	\$64,704,100	\$64,704,100	\$64,704,100
Boating (Total Impact Of Expenditures On Output)	\$1,966,800	\$3,694,300	\$3,934,300	\$3,172,100
Fishing (Total Impact Of Expenditures On Output)	\$6,131,600	\$11,517,000	\$12,265,200	\$9,888,900
Subtotal	\$8,098,400	\$79,915,400	\$80,903,600	\$77,765,100
Total	\$32,033,400	\$136,701,000	\$138,945,500	\$134,328,000
Downstream Of 5th Street Bridge	\$0	\$84,295,700	\$84,295,700	\$84,295,700
upstream Of 5th Street Bridge	\$32,033,400	\$52,405,300	\$54,649,800	\$50,032,300

(1) All Benefits reflect a 6.375% annual interest rate, a 50 year project life and October 2000 Price levels.

ENVIRONMENTAL EFFECTS - PHYSICAL/NATURAL ENVIRONMENT RESOURCES

Geography and Geology:

4.11 No Action (Without Project Conditions). The No Action (Without Project Conditions) scenario indicates that the Ashtabula River Partnership could take no action based on the final findings of this study. Similar to existing conditions/problems would persist for some time. Contaminated sediments would likely continue to migrate downstream into the lower river and then into the harbor and Lake Erie. This would result in further area dredging and dredged material disposal problems, in turn, further adversely affecting environmental conditions and economic and beneficial use of the river and harbor. It is likely that the lower Ashtabula River remediation would be pursued via an alternate authority (i.e. Superfund) and a similar project (somewhat less) would be implemented/enforced. Impacts would be similar (somewhat less) to those indicated for a with project conditions (below), but at a later date.

4.12 Proposed Upland State Road Site Plan. Potential impacts on this parameter would pertain primarily from the development of Transfer/Dewatering/Transfer, and Disposal Facilities. Soils in development areas would be excavated to facility design depth and utilized in facility berm construction. Indications are that the material would be well suited for this use. Special liner material, geofabrics and/or clay would be brought into the sites for use as impermeable linings (per design) to keep the contaminated materials confined, to control precipitation infiltration and run-off and to keep ground water out. Leachate collection and treatment facilities and monitoring wells, as appropriate, would be installed to further protect surface and ground water. With appropriate engineered design measures (ie. impermeable barriers) a 50 feet clearance between the bottom of the TSCA containment facility and normal high ground water would likely be waived. This is not uncommon. The site proposed for upland disposal facility development (State Road Site) is setback from areas of higher ground water pollution potential.

4.13 Alternative Disposal Options Plan. Impacts would be expected to be similar to those described for the Proposed Upland State Road Site Plan except that, if the dredged material is transported to an area existing (permitted) disposal facility, associated impacts would occur along those transportation routes and at that disposal facility. Use of existing disposal sites would not significantly adversely affect the parameter due to construction; since they have been constructed previously. Existing disposal sites would need to have appropriate design and construction and operations to accommodate the dredged material disposed.

Air Quality:

4.14 No Action (Without Project Conditions). Similar statement as that for paragraph 4.11; however pertaining to this parameter.

4.15 Proposed Upland State Road Site Plan. Operation of heavy construction equipment would generate associated exhaust fumes in the immediate construction activity areas. This would not be expected to be a significant adverse air quality impact.

4.16 Some earthy/organic odor may occur in the immediate area of the dredged material. This would not be expected to be a problem over a large area or for a long time. If a substantial problem is noted, some odor abatement measures (operations or applications) may be implemented.

4.17 Some minor volatilization of contaminants would occur during the dredging and handling of dredged material. The only potential time and area of any substantial concern in this regard would be during the dredging and immediate handling of PCB TSCA material in the immediate area of the dredged material. Appropriate monitoring and protective wear would be worn by workers at these times and in these areas. Appropriate restriction areas will be established. Volatile losses from the water during dredging would be low because of very low contaminant concentrations in the water column (due to their hydrophobic low solubility nature) and the large volume of water available for dispersion of the dissolved PCBs before they become available for volatilization. The contaminant flux from moist sediment is extremely high immediately after exposure to air. The flux then drops off quickly as the sediment pore water evaporates. However, the flux increases, if the sediment resaturates, as would be the case during a significant rainfall. Canopy cover measures would significantly reduce volatilization of contaminants during handling and transport.

4.18 Alternative Disposal Options Plan. Similar statement as that for paragraph 4.13; however pertaining to this parameter.

Water Quality:

4.19 No Action (Without Project Conditions). Similar statement as that for paragraph 4.11; however pertaining to this parameter.

4.20 The PCB mass in the Ashtabula Area of Concern is estimated by the U.S. Army Corps of Engineers to be approximately 11,018 Kg. A major concern of the Ashtabula River Partnership, US Fish and Wildlife Service, US Environmental Protection Agency, and Ohio Environmental Protection Agency is that storm events or other activities may cause a portion of this PCB mass to move into Lake Erie. USFWS used an equilibrium partitioning water quality model to estimate the effect of PCB release from the Ashtabula Area of Concern on PCB concentrations in Lake Erie and the resulting impacts on the Lake Erie walleye fishery, and fish and wildlife species in the basin. The results indicate that PCBs in bottom sediments of the Ashtabula River and Harbor pose a serious ecological threat to Lake Erie and, potentially the entire Great Lakes ecosystem downstream of Ashtabula, OH. This threat is in two forms. The past and present PCB loading from the Ashtabula (while not quantifiable due to the lack of data) likely significantly contributes to the existing PCB loading to Lake Erie. This loading is unacceptably high as evidenced by exceedences of water quality criteria based on the toxicity of PCBs to fish and wildlife species, as well as humans consuming fish from the lake. In addition the PCB mass contained in sediments of the Ashtabula represent an ecological "time bomb". A storm event which moves as little as 1 to 10 percent of this mass would have catastrophic affects on Lake Erie. Toxicity to fish and wildlife species would more than double from current levels. Sport and commercial fisheries would be forced to close as criteria for the protection of human health were exceeded. Reference EIS APPENDIX EA- J SECTION

312(b) ECOLOGICAL RESTORATION/ PRESERVATION ANALYSIS. (Part of this report. Follows these text)

4.21 Proposed Upland State Road Site Plan. Dredging will cause temporary and localized increases in the levels of suspended solids and turbidity. The turbidity of the water column around dredging operations will be monitored to determine if the dredging operation is causing unacceptable levels of resuspension. If so, modifications could be made to the dredging operation to lower the turbidity levels and any unacceptable levels of contaminants.

4.22 When contaminated sediments are disturbed, such as during dredging operations or flood events, contaminants may be transferred to the water column through resuspension of sediment solids, dispersal of interstitial water, or desorption from the resuspended solids. An investigation of the dredging of PCB contaminated sediment has shown that almost all of the transfer of contaminants to the water column was a result of resuspension of solids. The release of contaminants could therefore be reduced by selecting a dredge type that would minimize the resuspension of sediments during dredging operations in a manner that would minimize sediment resuspension. Three dredging options were presented as alternatives for excavating the Ashtabula River sediments. Each of the dredge methods proposed is capable of removing sediments while generating low levels of turbidity, thus limiting the loss of sediment associated contaminants to the water column. Reference CMP Technical Appendix I.

4.23 In a "Concept Plan" involving the remediation of PCB contaminated Ashtabula River sediments, it was assumed that a closed clamshell bucket dredge would be used to remove the sediment from the river bottom. The loss mechanisms that were discussed for the dredging operation included resuspension of the contaminated sediment and desorption of sediment contaminants into the water column. The amount of PCBs desorbed would be small because of the hydrophobic nature of PCBs.

4.24 The concept plan assumed a PCB concentration of 60 mg/kg (dry weight), which is considered typical of significant portions of the sediment in the Ashtabula River. The scenario assumed the use of a closed bucket, with a cycle time of two minutes. The cycle time refers to the time it takes to lower the bucket through the water column, retrieve a bucket full of sediment, raise the bucket through the water column, deposit the sediments in the scow, and return the empty bucket to start a new cycle. The estimated loss of PCBs during dredging was approximately 14 grams/hour. The loss of PCBs to the environment for the removal of 100,000 cubic yards of Ashtabula River sediment material is shown in Table 4.1. In the scenario, only 0.28 percent of the total PCBs in the sediments are lost.

Table 4.1 - PCB Losses Associated with Remediation Options for the 100,000 Cubic Yard Dredging Scenario from the Ashtabula River.

Remediation Component	Grams Lost	Percent of Total PCBs Treated
Dredging	9,000 grams	0.28 %
Transportation and Offloading	1,400 grams	0.04 %
Temporary Storage	1,000 grams	0.03 %
Total	11.4 kilograms	0.35 %

4.25 The use of silt curtains and oil booms would further reduce the loss of PCBs resulting from the dredging operation. In addition, most of the resuspended sediment and the associated contaminants that are "lost" during the dredging process would settle out of the water column within 500 to 1000 feet of the dredging operation. If dredging proceeds in the downstream direction most of this resettled material should subsequently be dredged.

4.26 Further in reference to the concept plan study and Table 4.1, some spillage during transportation and off-loading can result in the loss of contaminants to the environment. These losses can be limited by filling the scows only partially full, by using only watertight scows, and by careful operation during off-loading. Off-loading would be performed with a closed-bucket clamshell and spill tarp and any spillage should be collected and cleaned up. Contaminant losses occurring during any hydraulic transport of sediments would be minimal. A properly designed, constructed, and maintained pipeline would have very little spillage.

4.27 Also in reference to the concept plan and Table 4.1, an impervious membrane, clay liner, and leachate collection system would be constructed as part of the dewatering/storage and disposal facilities. Therefore, losses from leachate are expected to be virtually non-existent.

4.28 Ohio Environmental Protection Agency (OEPA) water quality standards and harbor sediment testing and analyses were discussed in paragraphs 3.24 through 3.57 of this EIS. Table 4.2 provides a listing of Ohio Environmental Protection Agency (OEPA) water quality standards (1999) for potential parameters of concern and expected water quality contaminant levels during TSCA and contaminated sediment dredging and for dewatering activities. Expected water quality contaminant levels are based on a number of elutriate, settling, and filtration tests done on sediments taken from the Ashtabula or Cleveland harbors. Sediment contaminant levels considered are representative and were between average and maximum contaminant levels as identified in the Woodward/Clyde and supplemental reports. Water quality standards may unavoidably be exceeded for several parameters for several hundred feet downstream from the dredging activity while dredging the more contaminated sediments and an associated

TABLE 4.2 Ohio Environmental Protection Agency Lake Erie Basin Water Quality Standards (1999) and Activities and Expected Project Activities Water Quality

Chemical	Aquatic Life (ug/l)				Human Health (ug/l)			Project Activities (ug/l)					
	Tier	IMZM	OMZM	OMZA	Tier	Drink	Nondrink	Sediment Contam.	Dredging ~700' (7)	Settling (8)	Dewater Treat (9)	Disposal Treat (9)	
Arsenic - TR	I	680	340	150	I	50	580		~4	<4			
Barium	II	4,000	2,000	220	I	2,000	160,000		~360	<50			
Cadmium - TR	I	9.0 (2)	4.5 (2)	2.5 (2)	I	14	730		~5	<5			
Chromium - TR	I	3,600 (2)	1,800 (2)	86 (2)	I	140	14,000		~20	~6			
Copper - TR	I	28 (2)	14 (2)	9.3 (2)	I	790	64,000		<2	<2			
Lead - TR	I	240 (2)	120 (2)	6.4 (2)	I	14	190		<5	<5			
Mercury (b) - TR	I	3.4	1.7	0.91	I	0.0031	0.0031		<0.4	<0.4			
Nickel - TR	I	940 (2)	470 (2)	52 (2)	I	470	43,000		~32	~8			
Zinc - TR	I	240 (2)	120 (2)	120 (2)	I	5,000	35,000		~29	~10			
COD	NS	NS	NS	NS	NS	NS	NS		~80 mg/l	~80			
TKN	NS	NS	NS	NS	NS	NS	NS		~10 mg/l	~10			
Ammonia	I		12.1 mg/l (3)	1.1 mg/l (3)					~10 mg/l	~10			
Oil/Grease	I		10,000						~1 mg/l	~1			
1,2,4-Trichlorobenzene	NS	NS	NS	NS	NS	NS	NS		~22	~10			
1,4-Dichlorobenzene	II	110	57	9.4	I	24c	240c		<1	<1			
Hexachlorobenzene(4)					I	0.00045c	0.00045c		<0.4	<0.1			
Hexachlorobutadiene					II	0.22c	0.24c		<0.2	<0.2			
1,2-Dichlorobenzene	II	190	96	23	I	2,000	11,000		<1	<1			
1,3-Dichlorobenzene	II	160	79	22	II	5,200	9,300		~17	~15			
Chlorobenzene	II	850	420	47	I	470	3,200		<1	<1			
Bis 2-Ethylhexyl Phthalane	NS	NS	NS	NS	NS	NS	NS		<3	<3			
PAHs (5)		See Criteria Individual Chemicals.					See Crit. Ind. Chem.			<1(10,11)	<1 (10)	<1(10,11)	<1(10,11)
Acenaphthene	II	95	48	9.4	II	570	890		<0.1	<0.05			
Fluoranthene	II	4.5	2.3	0.48	II	9.4	9.5		<0.5	<0.2			
Napthalene	II	320	160	21	I	540	1,200		<0.1	<0.05			
PCBs					I	0.000026 c (4)	0.000026 c (4)		<4 (11,12)	<2	<1 (11,12)	<1 (11,12)	

TABLE - Continued.

Legend:

All criteria and values are expressed as total unless specified otherwise.

IMZM = Inside Mixing Zone Maximum.

OMZM = Outside Mixing Zone Maximum.

OMZA = Outside Mixing Zone Average.

Drink = Human Health Criterion applicable to Public Water Supply streams (2-route exposure).

Nondrink = Human Health Criterion – non Public Water Supply (1- route exposure).

TR = total recoverable.

Blank Space = Criterion not calculated; contact OEPA Standards & Technical Support section.

NS = No Standard

Footnotes:

a = No chlorine is to be discharged.

b = See Table 33-5 for applicable wildlife criterion.

c = This criterion is based on a carcinogenic endpoint.

Footnotes:

Considers sediment contaminant levels between average and maximum per Woodward-Clyde.

(1) = Average Value given as 1/2 maximum.

(2) = Value depends on water hardness. Lowest value taken on table in standards.

(3) = Temperature and pH dependent. Value derived from a temperature of <30 degrees centigrate and a pH of <7.6.

(4) = As listed, unrealistic.

(5) = Sum of EPA list of 16 minus acenaphthene, acenaphthylene, and fluoranthene.

(6) = Human health 30 day average.

(7) = Values from settling tests for about two hours.

(8) = Values from settling tests for 16/24 hours settling, except as noted. (7)&(8)(~100 - 50 ppm particulate)

(9) = Treatment includes multimedia filtering and carbon adsorption, as necessary.

(10) = Estimated from higher value PAH sediment values.

(11) = Need about 300 feet mixing zone.

(12) = No realistic mixing zone.

TABLE REFERENCES

State of Ohio Water Quality Standards, 1999; Chapter 3745-1 of the Administrative Code; Ohio Environmental Protection Agency, Division of Water Quality Planning and Assessment; 1999.

The Analysis of Sediments from the Ashtabula Harbor, Ohio; Floyd Browne Associates, Limited (Aqua Tech); 1983. (Settling)

Slurry Clarification and Column Leachate Tests on Polluted Harbor Sediments; U.S. Army Corps of Engineers, Buffalo; (Seeger & Leonard); 1984.

1986. Aqua Tech. The Analyses of Sediment and Water Samples from Ashtabula Dewatering Pilot Plant Project; for USACE, Buffalo. (Includes Stock Feed with PCBs ~6.5 to 16.3 mg/kg)

“Ashtabula River Sediment Summary”, Ashtabula, Ohio; Woodward Clyde Consultants, 1990.

Draft Ashtabula River Investigation, Ashtabula, Ohio; Woodward Clyde Consultants; 1991.

Ashtabula Remedial Action Plan, Stage 1; Ohio Environmental Protection Agency, Division of Water Quality Planning and Assessment; 1991.

Ashtabula Harbor, Ohio; Sediment Analysis; ARDL; 1992. (Elutriate)

U.S. Environmental Protection Agency. 1993. “Concept Plans for the Remediation of Contaminated Sediments in the Great Lakes.” EPA 905-R93-005. Great Lakes National Program Office, Chicago, IL.

U.S. Army Corps of Engineers, Chicago District. 1994. “Indiana Harbor and Canal Maintenance Dredging and Disposal Activities, Comprehensive Management Plan, Appendix H – Dredging Technologies and Impacts.”

Carbon Adsorption Isotherms for Toxic Organics, USEPA, 1980.

Fields Brook Remediation Project Reports.

Contaminant and Standards		Activities				
Contaminant	Standard	Sediment Contam. (pCi/g)	Dredging ~700' (7) (pCi/l)	Settling Treat (8) (pCi/l)	Dewater Treat (9) (pCi/l)	Disposal Treat (9) (pCi/l)
USEPA Safe Drinking Water Act Maximum Contaminant Level for Gross Alpha	15 picocuries/liter (pCi/l)		<	<	<	<
Combined Radium (Ra-226 + Ra-228) Maximum Contaminant Level	5 pCi/l	1.8 -16.1 (Av. 4.2)	< 1.61	< 1.61	< 1.61	< 1.61
Maximum Contaminant Level for Beta Particle and Photon Radioactivity	4 millirem/year		<	<	<	<
Average Annual Concentration Of Gross Beta Particle	50 pCi/l Activity		<	<	<	<
Maximum Contaminant Level for Uranium	30 pCi/l or 20 ug/l	.98-109.9 (Av. 6.9)	< 10.99	< 10.99	< 10.99	< 10.99

Notes:

- * Values based on 1999 sampling data ranges (high values).
- * Reference paragraphs pertaining to radionuclides and risk assessments which follow.

- (7) = Values from settling tests for about two hours (calculated).
- (8) = Values from settling tests for 16/24 hours settling (calculated), except as noted. (7)&(8) (~100 - 50 ppm particulate)
- (9) = Treatment includes multimedia filtering and carbon adsorption, as necessary.

mixing zone (~ 500 to 700 feet) will need to be recognized. Water quality standards should, however, be met for most parameters outside that mixing zone. PAHs and PCBs will likely require extended mixing zones (300 feet and undetermined, respectively).

4.29 Pertaining to radionuclides, it is the recommendation of the Ohio Department of Health, Bureau of Radiation Protection (ODH/BRP) and the United States Environmental Protection Agency, Region 5, (USEPA) that all water discharges, associated with the processes of this project, to public water-ways, meet the USEPA Safe Drinking Water Act (SDWA) Maximum Contaminant Levels for gross alpha @ 15 picocuries per liter (pCi/L), the combined radium (Ra-226 + Ra-228) Maximum Contaminant Level @ 5 pCi/L, a maximum contaminant level for beta particle and photon radioactivity @ 4 millirem per year, the average annual concentration of gross beta particle activity @ 50 pCi/L and the proposed Maximum Contaminant Level for uranium (30 pCi/L or 20 ug/L). Reference Table 4.3.

4.30 Dredging may increase the oxygen demand upon the water column in two ways. Sediments that are uncovered by dredging may exert a higher sediment oxygen demand than the existing surficial sediments. This impact will continue until the new surface sediments are oxidized or are covered by incoming sediments. In addition, sediment resuspension will increase oxygen demand in the vicinity of the dredge which may result in localized dissolved oxygen reduction.

4.31 A small amount of oil and grease in the sediments will be released by resuspension during dredging and form a film or sheen on the water surface. Hydrophobic contaminants such as PCBs will be dissolved in the oil and grease. The migration of the oil film can be minimized by the use of an oil boom and adsorbants to remove the contaminated oil and dissolved contaminants.

4.32 Dewatering and disposal facility effluent discharges will need to meet OEPA water quality requirements for the body of water receiving the discharges or pretreatment standards if discharged into the Ashtabula Waste Water Treatment system. Appropriate permits and/or certifications would be required. Dewatering may be accomplished primarily via settling. Adsorption of pollutants to sediments and the settling of sediments and associated pollutants out from the water column is generally recognized as the primary pollutant removal/containment process within a dewatering facility. Pollutants associated with dredged materials are strongly attached (adsorbed) to the organic and clay fractions. As the particulates settle out, the pollutants adsorbed to the particulates are also removed from the water column and contained in the sediments. In most cases, settling to 50 to 100 parts per million particulates will meet water quality discharge requirements. Reference Table 4.2. This may take one to several days to settle to this level, however. In order to expedite the process, various flocculation, clarification, median filtration/treatment processes will be implemented. Elutriate with elevated PAH and PCB and RAD contamination will require more advanced filtration/treatment processes such as the sand and anthracite coal filter and carbon adsorption process.

4.33 The disposal facility leachate filtration/treatment effluent discharge will need to meet water quality discharge requirements. A sand and anthracite coal filter and carbon adsorption filtration/treatment process has been included. Reference paragraph 4.28, also.

4.34 This is discussed in more detail in EIS Appendix B - Clean Water Act Public Notice and Section 404(b)(1) Evaluation Report. (Part of this report and follows these texts).

4.35 Dredging the Ashtabula River sediments will have short-term detrimental effects on the river and to a far lesser extent, Ashtabula Harbor and Lake Erie. However, the long-term beneficial impacts should far outweigh the adverse effects. Dredging the sediments from the river will remove those contaminants associated with the sediments from the aquatic ecosystem. This will eliminate the ability of these contaminants to be resuspended and transported down river and into Lake Erie.

4.36 As indicated previously, the primary present water quality problem associated with contaminants in the Lower Ashtabula River is that associated with various storm events and flows and resuspension of sediments and associated contaminants. As indicated by the dredging plans assessment/evaluation and the associated risk assessment/evaluation, the initial after dredging problem would be no worse than existing conditions. The long-term scour release potential would be low for the Bank to Bank to Bedrock and the Deep Dredges and medium for the Shallow Dredge due to the locations and amounts of contaminants removed. The problem would be expected to be essentially eliminated for low flow events a few years after dredging as clean material fills in the dredged areas and covers any more contaminated residual sediments. Problems with DO and PH would approach more natural levels the more contaminants are removed from the system.

4.37 Alternative Disposal Options Plan. Similar statement as that for paragraph 4.13; however pertaining to this parameter.

Harbor Sediment Quality and Dredging:

4.38 No Action (Without Project Conditions). Similar statement as that for paragraph 4.11; however pertaining to this parameter.

4.39 Reference paragraph 4.21, also.

4.40 Proposed Upland State Road Site Plan. Reference the previous section on Water Quality. Dredging the Ashtabula River sediments will have short-term minor to moderate detrimental effects on the river and to a lesser extent, Ashtabula Harbor and Lake Erie. However, the long-term beneficial impacts should far outweigh the adverse impacts. Dredging the sediments from the river will remove those contaminants associated with the sediments from the aquatic ecosystem. This will eliminate the ability of these contaminants to be resuspended and transported down river and into the harbor and Lake Erie. As indicated by the dredging plans assessment/evaluation and the associated risk assessment/evaluation the initial after dredging problem would be no worse than existing conditions. The long-term scour release potential would be low for the Bank to Bank to Bedrock and the Deep Dredges and medium for the Shallow Dredge due to the locations and amounts of contaminants removed.

4.41 The dredging will be performed with low turbidity dredges and environmental protection measures and will occur from upstream to downstream so that most of the contaminated

sediments not captured in the initial dredgings will be captured in the subsequent dredgings. Contaminated dredged material will be disposed of in appropriately designed and managed confined disposal facilities to protect the environment from the contaminants. A contingency plan has been developed for some future dredgings in the event that there is some residual contaminants in the near future that could make the near future dredged material not suitable for unrestricted open lake disposal.

4.42 With the initial placement of clean cover sediment and subsequent clean cover sedimentation, a marked improvement in surface sediment quality would be expected almost immediately after project completion.

4.43 An Ashtabula River Recontamination Assessment was conducted for the study. It considered the Fields Brook remediation scenario and low, average, and high flow events from Fields Brook and the Ashtabula River. Based upon the results of the recontamination assessment, the low level of PCB that is deposited into the Ashtabula River from Fields Brook is less than 2 (ppb) parts per billion under all of the scenarios that were modeled. This presents a negligible recontamination scenario.

4.44 Over a multi-year period sediments moving into the lower river will replace the material dredged during this project. It is expected that the filling sediments will be essentially clean material, creating an essentially non-contaminated sediment environment. It is expected that sediments dredged in the future will be sufficiently clean for unrestricted open lake disposal and will be disposed of at the Ashtabula Harbor Lake Erie open lake disposal site accordingly.

4.45 As indicated previously, the dredged material will be dewatered at a Transfer/Dewater/Transfer facility. Sediments and associated contaminants will be contained within the facility. Effluent water discharges will be treated to meet discharge water quality requirements. Dewatered sediments will be trucked to the State Road Site vicinity and disposed of in specially designed and newly constructed disposal facilities (cells). Again, small amounts of effluent/leachate water discharges will be treated to meet discharge water quality requirements. It is expected that the TSCA material will be placed within the TSCA cell within one year, while the Non-TSCA material will be placed within the Non-TSCA cell within another two years. The cells will then be capped, as designed. The facility will be inspected periodically for any maintenance needs and monitoring wells will be installed and sampled periodically to assure facility contaminant containment. Remedial action plans will be prepared and on file, should there ever be a problem. The likelihood of a problem for this material and in this case is almost zero. Reference paragraph 2.14 Insert, also.

4.46 On May 18, 1999, the ODH/BRP issued an opinion letter to the Partnership regarding the ARP remedial action design. The ODH/BRP opinion letter stated: "...that based on the review of the ARP draft CMP/EIS and given the presently known radionuclide concentrations within the sediments of the Ashtabula river, the recommended plan for disposal of the sediments is consistent with State requirements". Ohio Revised Code Title 37 – Chapter 48 and the rules promulgated there under delineate the regulatory authority under which the ODH/BRP performed its review. During its consideration of this matter, ODH/BRP staff reviewed the criteria in 10 CFR 61 as delineated in Ohio Administrative Code (OAC) 3701-39-

021. The ODH/BRP takes the position that the dredging and disposal of low-level radioactive sediments from the Ashtabula River does not require a 10 CFR 61 as delineated in OAC 3701-39-021 disposal action. The ODH/BRP has and will continue to implement the State of Ohio's regulations consistent with a 10CFR 20.2002 as delineated in OAC 3701-39-021 on-site remediation and disposal action. The ODH/BRP continues to believe that the sediments can be placed in a properly designed cell as described in the CMP/EIS "recommended plan".

4.47 (Radiological Risk Assessment) Risk assessments were made by the U.S. Environmental Protection Agency (USEPA) Region 5 involving inadvertent and unknowing use of Ashtabula River sediments (Reference EIS Appendix C and CMP Technical Appendix F). The first was based upon a resident applying these sediments, left below the cutline for chemical removal, to their property and growing foodstuffs there. There were potentials for external exposure, plant ingestion, soil ingestion and dust inhalation (including radon + decay products) risks. The second was based upon a worker being exposed as they dredged the chemically contaminated sediments or as they unknowingly dredged sediments above the cutline. There were potentials for external exposure and soil ingestion risks

4.48 The results for the Resident-Farmer showed that the total risk from all pathways to a resident (born on the property and living there for 30 years) was about 1×10^{-4} . The risk was about equally apportioned between external exposure, plant ingestion, and inhalation of radon + decay products. The greatest impact was on the older age groups; older child (6 - 12 years), teenager (13 - 19 years) and adult (20 - 30 years) who had longer exposure periods. The other age groups [baby (0 - 1 year), older baby (1 - 2 years), young child (3 - 5 years)] were lesser impacted. 1×10^{-4} is at the upper bound of the acceptable risk range for lifetime cancer risk found in USEPA's guiding document, the National Oil and Hazardous Substances Pollution Contingency Plan (NCP). The sediment concentrations that led to this risk were found in the Uranium, Thorium and Actinium Decay Series. In no case were any concentrations more than twice background levels for the river and in most cases these were 50% or less over background. The levels measured here are one picocurie per gram (pCi/g) or less background and less than 0.5 pCi/g additional in the sediments. Thus, even though the 30 year risk is at the upper end of the NCP risk range, the small deviation from background radiation sediment levels does not warrant further dredging of the river.

2.49 For the Worker-Dredger the total risk for 2 year plus 4 month excavation project is about 5×10^{-5} . This risk is within the 10^{-6} to 10^{-4} risk range in the NCP. The maximum levels found in these sediments reach about 45 pCi/g uranium-238 + decay products (over background) and about 57 pCi/g uranium-234 (over background) and. These concentrations diverge substantially from background and warrant a health and safety plan and worker protection. However, during the chemical cleanup workers will be under such a plan and will be wearing protective clothing. Thus, if the health and safety plan specifically deals with radiation and the worker is monitored for radiation (e.g., dosimeter, radiation frisking, etc.) this should be adequate.

2.50 In the case of an unknowing worker-dredger, the high radioactive concentrations should be a matter of concern even if the risks are still within the NCP risk range. In radiation public health, the philosophy of ALARA (radiation exposures should be As Low As Reasonably Achievable) is always applied. Removal of these contaminated sediments is a prudent action

that would prevent inadvertent exposure of a worker-dredger and keep their potential doses ALARA.

4.51 Alternative Disposal Options Plan. Similar statement as that for paragraph 4.13; however pertaining to this parameter.

Physical Habitat for Aquatic Life:

4.52 No Action (Without Project Conditions). Similar statement as that for paragraph 4.11; however pertaining to this parameter.

4.53 Proposed Upland State Road Site Plan. Reference this sub-section of **Water Quality, Sediment Quality and Dredging, Benthos (Macroinvertebrate), and Fisheries**.

4.54 The assessment/evaluation identified an **Aquatic/Fishery Shelf Plan** for the Ecological Assessment Area 3 problem area and an **Acquire Conrail Slip and Aquatic/Fishery Shelf Cut Plan** for the Ecological Assessment Area 2 problem area and other long-term dredging measures. This constitutes ecological restoration, as possible, for loss of protected aquatic/fishery shallows due to facilitated structural (i.e. bulkheading, channelization), and activities impacts. These are practical optimized plans of moderate cost providing problem area protected aquatic/fishery shallows of substantial length which accomplish, as possible, goals/objectives, in this regard. The areas would be interfaced with the lake/river regime and would provide passage, cover, feeding, and spawning habitat. It should be noted that these or similar measures would be pursued by separate authority/study (i.e. 206) subsequent and contingent to this projects dredging for removal of contaminants.

4.55 Figure 4.1 depicts the existing and expected improvement in the Ohio Habitat Assessment Procedure (HAP) Qualitative Habitat Evaluation Index (QHEI) (for physical habitat) for reaches of the lower Ashtabula River with recommended project measures. Reference EIS APPENDIX EA - J SECTION 312(b) AND 206 ECOLOGICAL RESTORATION/ PRESERVATION ANALYSES. (Part of this report. Follows these text)

4.56 Alternative Disposal Options Plan. Similar statement as that for paragraph 4.13; however pertaining to this parameter.

Benthos (Macroinvertebrate):

4.57 No Action (Without Project Conditions). Similar statement as that for paragraph 4.11; however pertaining to this parameter.

4.58 Proposed Upland State Road Site Plan. The dredging excavation of the river bottom sediments would remove most of the benthic organisms from the river area that is dredged. Resettling of resuspended sediments could smother some benthic organisms in the area just downstream of the project area. Recolonization would likely occur within a few months to a few years in the newly exposed sediments and future sediment deposits. Future sediment de-

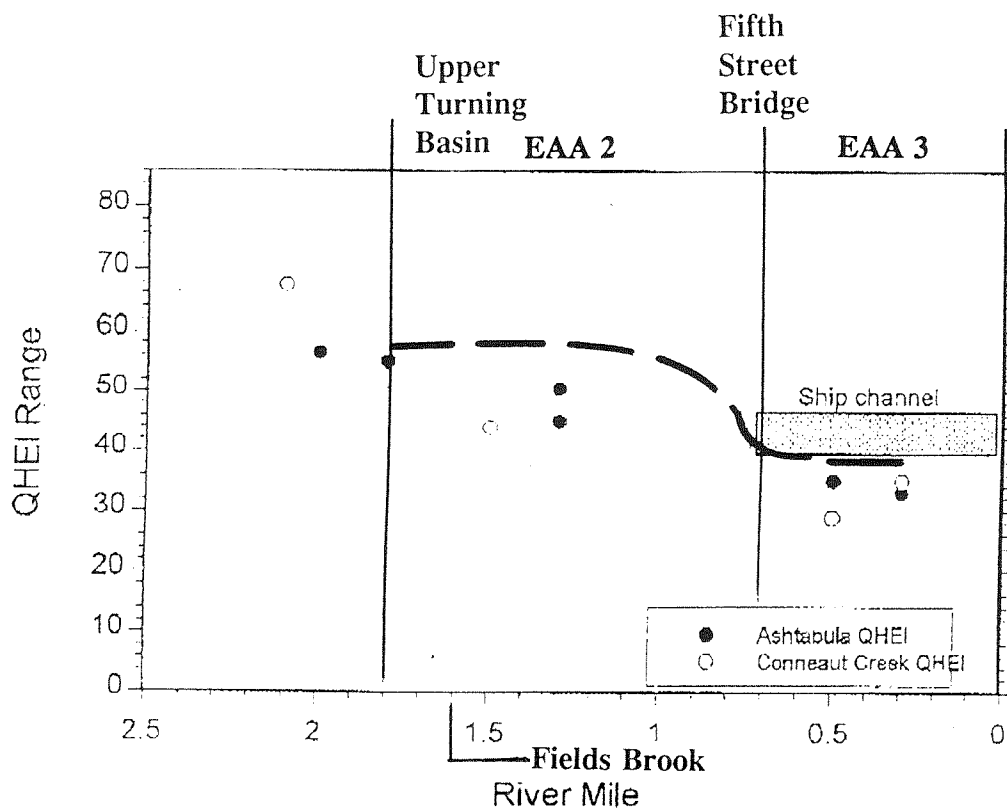

FIGURE 4.1 (Reference Baseline Survey Figure 3.16)

A comparison of relative habitat quality of the Ashtabula and Conneaut lacustrary areas.

HQEI - Qualitative Habitat Evaluation Index (Physical)

IMPROVEMENT MEASURES

Dredging/Aquatic/Fishery Shallows (* Recommended Plan)

Reference Baseline Survey



posits should be essentially clean and would be able to support less pollution tolerant benthic organisms. This would enable the river to achieve a higher diversity of aquatic species.

4.59 The simplest ecological measure associated with the proposed dredging project is that associated with restoration of clean benthic habitat. Simple calculations indicate that of the approximate 40 acre area to be dredged, about 20+ acres has surface and benthic (~ 3 feet depth) and scour area (~ another 3 feet depth) subsurface PCB contamination levels of >5 ppm or elevated PAHs. Correspondingly, this equates to about 100,000 cubic yards of significantly contaminated benthos habitat and considering potential for about 3 feet of scour about another 100,000 cubic yards considering reasonable scour protection for a total of about 200,000 cubic yards. This benthic habitat currently dominated by pollution tolerant (i.e. Oligochaeta) species would soon be complimented with somewhat more diverse and better quality less pollution tolerant (i.e. mayflies, caddisflies, and midges) species. Reference Figure 4.2.

4.60 The assessment/evaluation identified an **Aquatic/Fishery Shelf Plan** for the Ecological Assessment Area 3 problem area and an **Acquire Conrail Slip and Aquatic/Fishery Shelf Cut Plan** for the Ecological Assessment Area 2 problem area and other long-term dredging measures. This constitutes ecological restoration, as possible, for loss of protected aquatic/fishery shallows due to facilitated structural (i.e. bulkheading, channelization), and activities impacts. These are practical optimized plans of moderate cost providing problem area protected aquatic/fishery shallows of substantial length which accomplish, as possible, goals/objectives, in this regard. The areas would be interfaced with the lake/river regime and would provide clean shallow benthic area along the river. It should be noted that these or similar measures would be pursued by separate authority/study (i.e. 206) subsequent and contingent to this projects dredging for removal of contaminants.

4.61 Figure 4.3 depicts the existing and expected improvement in the Ohio Habitat Assessment Procedure (HAP) Invertebrate Community Index (ICI) (macroinvertebrates) for reaches of the lower Ashtabula River with recommended project measures. Reference EIS APPENDIX EA - J SECTION 312(b) ECOLOGICAL RESTORATION/ PRESERVATION ANALYSES. (Part of this report. Follows these text)

4.62 Alternative Disposal Options Plan. Similar statement as that for paragraph 4.13; however pertaining to this parameter.

Fisheries:

4.63 No Action (Without Project Conditions). Similar statement as that for paragraph 4.11; however pertaining to this parameter.

4.64 Proposed Upland State Road Site Plan. The physical operation of the dredge (noise and increased turbidity) may disturb the activities of local fish populations, attracting some species and dispersing others. Some fish may be captured, injured, or killed by physical contact with the dredging equipment. The resuspension of sediment may irritate or clog some fish gill or breathing organisms injuring or killing some fish in the dredging area. The resuspension of sediments and food particles will increase the availability of contaminants to transient and local

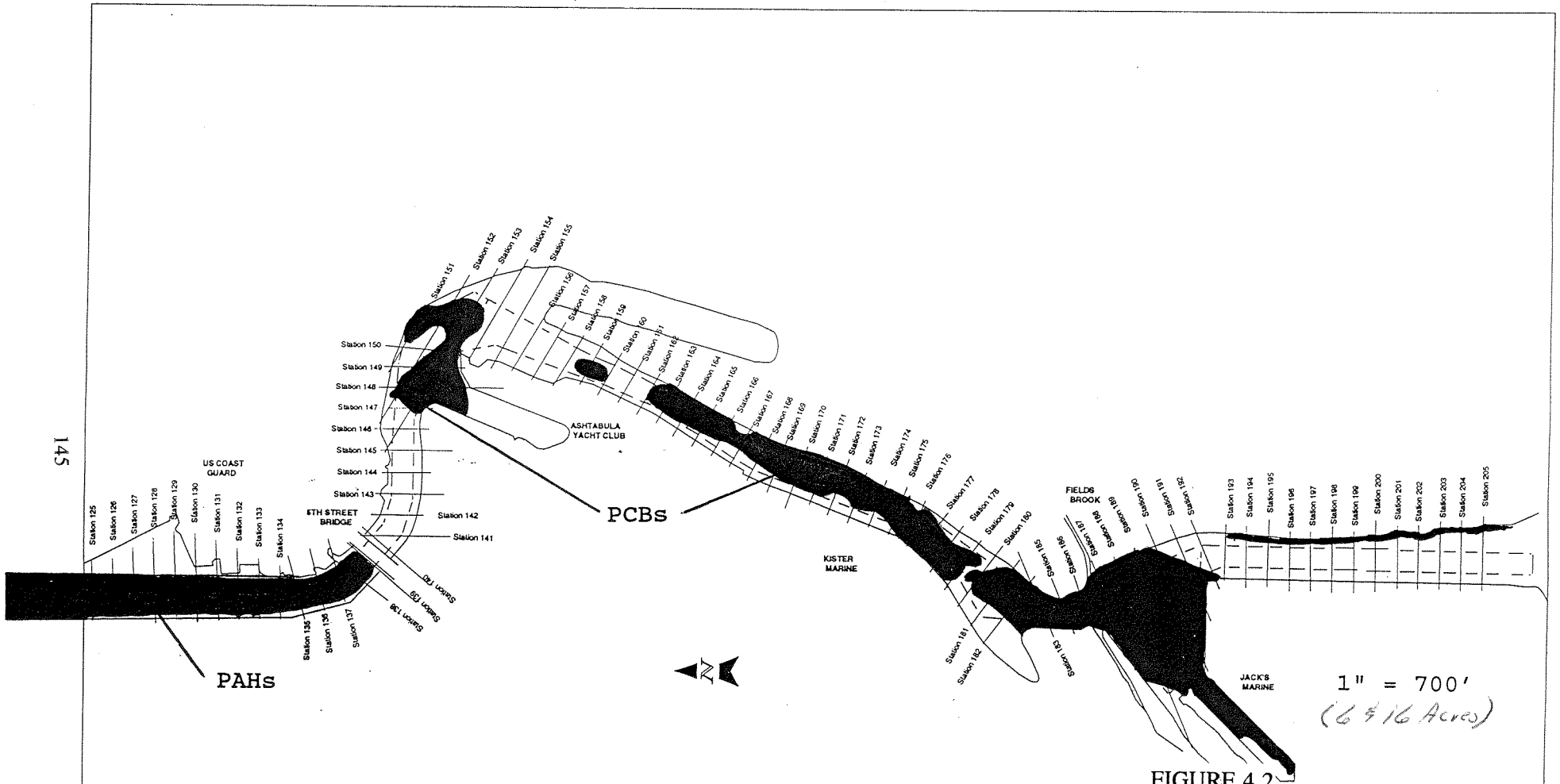

FIGURE 4.2
ASHTABULA HARBOR, OHIO
 SURFACE VIEW (1995)
 PAH AREA & PCB > 5 PPM
 ASHTABULA RIVER PARTNERSHIP

Reference: Dredging Scenarios and Sediment Volume Estimates Appendix.

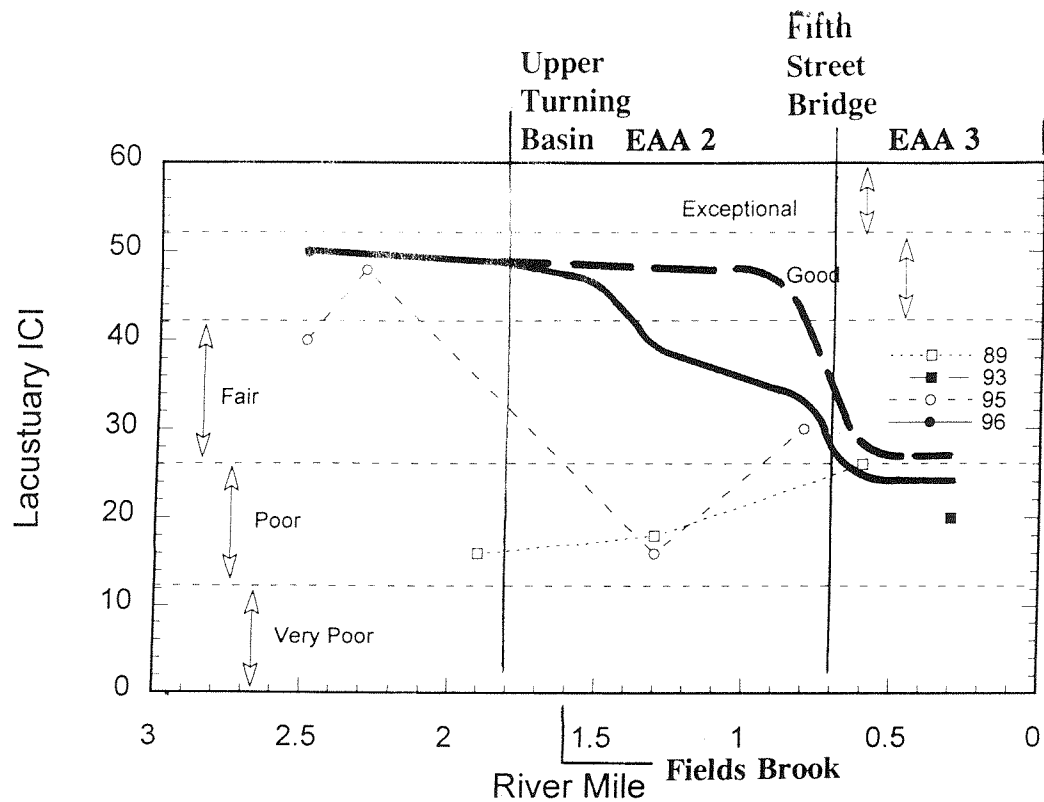

FIGURE 4.3 Macroinvertebrate community status in the Ashtabula River lacustuary as measured by the Invertebrate Community Index (ICI). (Reference Baseline Survey Figure 3.17)

ICI - Invertebrate Community Index

IMPROVEMENT MEASURES

Dredging/Aquatic/Fishery Shallows (* Recommended Plan)



Dredging/Contaminant Removal (* Recommended Plan)



Reference Baseline Survey

fish populations and subsequently may result in a short-term (i.e. hours) increase in the potential for some increased bioaccumulation and toxic effects.

4.65 Localized degradation of water quality around the dredge may be severe enough to cause death to some fish. Increased levels of ammonia and reduction of dissolved oxygen may cause acute toxicity effects on some fish. However, those fish more likely to be attracted to the dredging operation are more pollution tolerant. Less pollution tolerant species are more likely to avoid disturbances caused by the dredge and localized water quality impairments.

4.66 Oil released by sediment disturbance will cause some surface slicks. These slicks would be a thin film and would be contained in the immediate area encircled by the oil boom. Fish should not be affected by these slicks to any significant degree and the removal of oil by the use of adsorbants would minimize effects on the other organisms.

4.67 The dredging excavation of the river bottom sediments would remove the contaminated sediments from the river area that is dredged. Future sediment deposits should be essentially clean and would be able to support less pollution tolerant benthic organisms. This would enable the river to achieve a higher diversity of aquatic species.

4.68 The assessment/evaluation identified an **Aquatic/Fishery Shelf Plan** for the Ecological Assessment Area 3 problem area and an **Acquire Conrail Slip and Aquatic/Fishery Shelf Cut Plan** for the Ecological Assessment Area 2 problem area and other long-term dredging measures. This constitutes ecological restoration, as possible, for loss of protected aquatic/fishery shallows due to facilitated structural (i.e. bulkheading, channelization), and activities impacts. These are practical optimized plans of moderate cost providing problem area protected aquatic/fishery shallows of substantial length which accomplish, as possible, goals/objectives, in this regard. The areas would be interfaced with the lake/river regime and would provide passage, cover, feeding, and spawning habitat. It should be noted that these or similar measures would be pursued by separate authority/study (i.e. 206) subsequent and contingent to this projects dredging for removal of contaminants.

4.69 Figure 4.3 depicts the existing and expected improvement in the Ohio Habitat Assessment Procedure (HAP) Index of Biotic Integrity (IBI) (fishery) for reaches of the lower Ashtabula River with recommended project measures. Table 4.4 presents a comparison of existing lower Ashtabula River fisheries, and those expected with removal of contaminants (Conneaut Creek) and some additional expected with aquatic/fishery shelves (Grand River). Reference EIS APPENDIX EA - J SECTION 312(b) ECOLOGICAL RESTORATION/ PRESERVATION ANALYSIS. (Part of this report. Follows these text)

4.70 In the Black River lacustuary contaminated sediments were removed in 1990 and data from before and after show a declining trend in the occurrence of external anomalies on fish taken from the lacustuary. It is anticipated that the incidence of anomalies will continue to decline in the Black River. A similar trend is expected for the Ashtabula following the removal of contaminated sediment.

4.71 In all aspects considered, the Ashtabula River fish community (in areas of contaminated sediments) has a high potential for recovery post sediment removal. Endangered species, top carnivores (game fish), species diversity, pollution-sensitive species, numbers of individuals and incidence of external anomalies will all show improvement. The removal of contaminated sediments from the Black River lacustrary in 1990 continues to result in improving ecological conditions as measured by the IBI. Initial recovery was much more rapid and dramatic than present rates, though recovery continues.

4.72 The recovery of the Ashtabula lacustrary fish community is expected to influence fish communities in surrounding areas both upstream and in the lake. Species such as northern pike (*Esox lucius*) and muskellunge (*Esox masquinongy*) moderate fish communities through predation and drive community structure towards greater ecological integrity. Greater ecological integrity results in even higher numbers of top carnivores, endangered species and sensitive species. Historically, the muskie and northern pike were very abundant and commercially important. The destruction of lacustrary habitats throughout Lake Erie has resulted in drastic reductions of the two species' populations and the positive influences they had on the Lake's ecosystem. The restoration of the Ashtabula lacustrary will allow it to resume its historic contribution to top carnivore populations (including northern pike and muskellunge).

4.73 Those species listed as sensitive in Table 4.4 can all be expected to increase in numbers after sediment removal and a consequent influx of clean sediment from upstream areas. Species presently not found in the Ashtabula but found in the Grand and Conneaut will return to the Ashtabula. The sensitive species that are absent from the Ashtabula represent all trophic levels of the fish community. Ecosystems cannot function with such large components missing.

4.74 The ecosystem of the open waters of Lake Erie is presently experiencing dramatic recovery of its fish community. This recovery is expected to continue with further recovery of additional species. The removal of contaminated sediments will prepare the Ashtabula for the possible entrance of species such as: lake sturgeon (*Acipenser fulvescens*), mooneye (*Hiodon tergisus*), muskellunge (*Esox masquinongy*), pugnose shiner (*Notropis anogenus*), longnose sucker (*Cutostomus cutostomus*), lake chubsucker (*Erimyzon sucetta*), creek chubsucker (*Erimyzon oblongus*), tad-pole madtom (*Noturus gyrinus*), burbot (*Lota lota*); and possibly: pugnose minnow (*Opsopoeodus emiliae*), blackchin shiner (*Notropis heterodon*), blacknose shiner (*Notropis heterolepis*), banded killifish (*Fundulus diaphanus*), and sand darter (*Ammocrypta pellucida*) into the system. Some of these species (burbot, lake sturgeon, muskellunge and sand darter) are already showing signs of recovery in the lake. Areas such as the Ashtabula lacustrary are an important component of these species life history. Full recovery of the above listed species will depend on the environmental quality of Lake Erie's lacustrine habitats.

4.75 The speed and degree of ecological recovery in the Ashtabula River lacustrary will depend on the rate of sedimentation. Near shore depths of two to ten feet are ideal for healthy fish communities and the aquatic plants they depend upon. The influx of clean sediments from upstream areas will eventually occur, and active intervention in the form of replacing dredged sediments with clean sediments will greatly enhance the process.

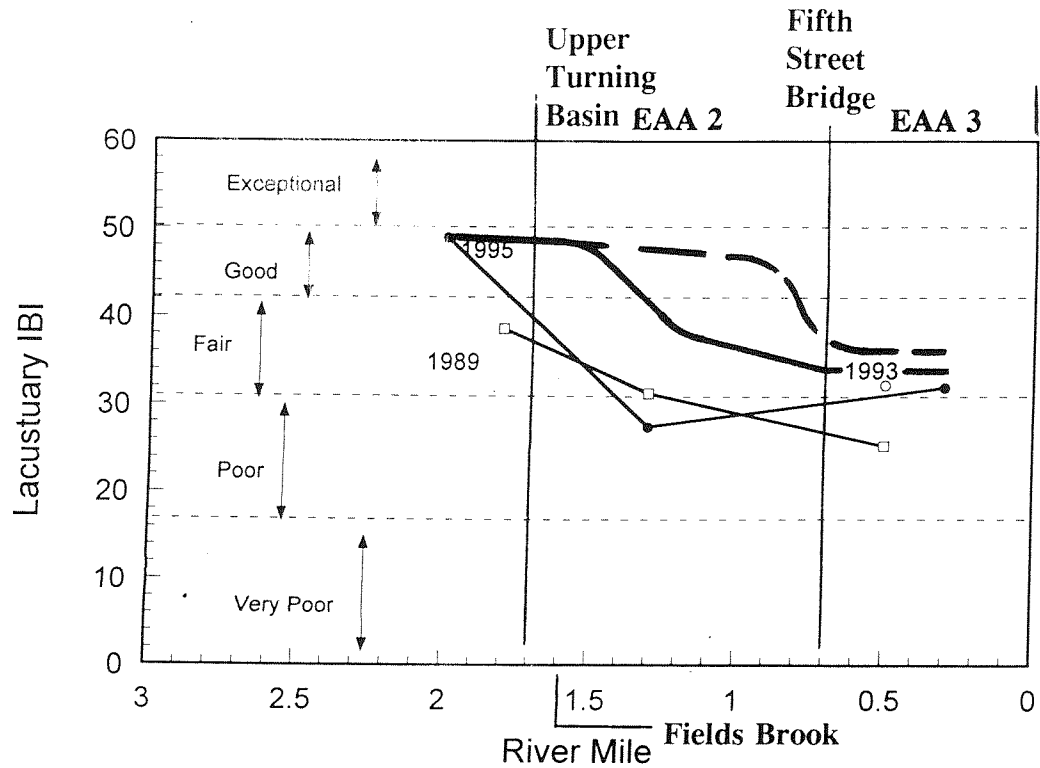

FIGURE 4.4 Fish community status of the Ashtabula River lacustuary as measured by the Index of Biotic Integrity (IBI). (Reference Baseline Survey Figure 3.18)

IBI - Index of Biotic Integrity (Fishery)

IMPROVEMENT MEASURES

Dredging/Aquatic/Fishery Shallows (* Recommended Plan)



Dredging/Contaminant Removal (* Recommended Plan)



Reference Baseline Survey

Table 4.4 - A comparison of the relative number (per kilometer) of fish species collected at electrofishing sites on the Grand River, Conneaut Creek, and Ashtabula River lacustuaries. Species in **bold** have been found by Ohio EPA to respond negatively to degraded environments and are considered sensitive to environmental degradation.

Stream	Conneaut Creek	Ashtabula River	Grand River	
Year	1995	1989	1995	1987
River Mile:	1.50	1.30	1.30	0.6
longnose gar (<i>Lepisosteus osseus</i>)	0.80	--	--	--
bowfin (<i>Amia calva</i>)	1.00	1.60	--	2.00
alewife (<i>Alosa pseudoharengus</i>)	1.00	--	--	--
gizzard shad (<i>Dorosoma cepedianum</i>)	2.00	7.20	5.44	80.00
northern pike (<i>Esox lucius</i>)	--	1.11	--	--
bigmouth buffalo (<i>Ictiobus cyprinellus</i>)	1.00	--	--	--
smallmouth buffalo (<i>Ictiobus bubalus</i>)	1.00	--	--	--
silver redhorse (<i>Moxostoma anisurum</i>)	8.00	--	--	0.67
black redhorse (<i>Moxostoma duquesnei</i>)	7.00	1.20	--	--
golden redhorse (<i>Moxostoma erythrurum</i>)	0.40	--	--	3.33
shorthead redhorse (<i>Moxostoma macrolepidotum</i>)	12.00	--	--	--
white sucker (<i>Catostomus commersoni</i>)	3.00	--	--	--
common carp (<i>Cyprinus carpio</i>)	27.00	4.00	35.56	6.00
goldfish (<i>Carassius auratus</i>)	24.00	0.80	3.00	2.00
carp x goldfish	1.60	3.33	--	--
golden shiner (<i>Notemigonus crysoleucas</i>)	150.00	7.20	11.11	16.67
bigeye chub (<i>Hybopsis amblops</i>)	6.00	--	--	--
emerald shiner (<i>Notropis atherinoides</i>)	0.40	--	--	12.00
striped shiner (<i>Luxilus chrysocephalus</i>)	8.00	0.40	--	12.00
spottail shiner (<i>Notropis hudsonius</i>)	--	--	--	8.67
spotfin shiner (<i>Cyprinella spiloptera</i>)	2.00	--	--	--
bluntnose minnow (<i>Pimephales notatus</i>)	148.00	0.40	2.00	1.33
central stoneroller minnow (<i>Campostoma anomalum pollum</i>)	--	--	--	0.67
channel catfish (<i>Ictalurus punctatus</i>)	10.00	--	4.44	--
yellow bullhead (<i>Ameiurus natalis</i>)	1.00	2.00	1.00	--
brown bullhead (<i>Ameiurus nebulosus</i>)	24.00	1.60	9.78	36.67
eastern banded killifish (<i>Fundulus diaphanus</i>)	2.00	--	--	--
trout-perch (<i>Percopsis omiscomaycus</i>)	--	--	--	0.67
brook silverside (<i>Labidesthes sicculus</i>)	22.00	--	--	--
white bass (<i>Morone chrysops</i>)	2.00	--	--	3.33
white perch (<i>Morone americana</i>)	--	--	--	25.33
white crappie (<i>Pomoxis annularis</i>)	--	--	--	1.33
black crappie (<i>Pomoxis nigromaculatis</i>)	4.00	--	--	1.33
rock bass (<i>Ambloplites rupestris</i>)	69.00	1.60	13.56	11.33
smallmouth bass (<i>Micropterus dolomieu</i>)	2.00	1.20	--	9.33
largemouth bass (<i>Micropterus salmoides</i>)	29.00	7.60	9.33	34.00
green sunfish (<i>Lepomis cyanellus</i>)	0.40	--	--	0.67
bluegill sunfish (<i>Lepomis macrochirus</i>)	41.00	10.00	70.78	48.67
pumpkinseed sunfish (<i>Lepomis gibbosus</i>)	43.00	20.00	80.11	56.00
sunfish hybrids (<i>Lepomis</i> sp.)	--	1.00	--	--
walleye (<i>Stizostedion vitreum</i>)	3.00	--	--	--
yellow perch (<i>Perca flavescens</i>)	62.00	0.40	2.11	60.67
logperch (<i>Percina caprodes</i>)	--	--	--	11.33
freshwater drum (<i>Aplodinotus grunniens</i>)	2.00	0.40	1.11	2.00
Total Relative Number	695.00	93.20	227.92	448.00
Number of Species	30.00	22.0	15.0	27.0
Number of Hybrids	0.0	1.0	2.0	0.0
Kilometers Sampled	1.00	2.50	0.95	1.50
Number of Passes	2.0	5.0	2.0	3.0
Number of species most abundant	15.0	3.0	6.0	15.0

4.76 It is clear that little improvement will occur if contaminated sediments are not removed. Present Ohio EPA fish community data show declining trend of IBI values at Rm 1.3 of the Ashtabula River. It is possible that this trend could continue, resulting in still lower quality fish communities in the future. There is further concern that without the project, shipping could shift from the Ashtabula area to Conneaut Harbor. This will result in a greater degree of environmental disturbance in the Conneaut and will negatively impact fish communities. With impacts to both the Ashtabula and Conneaut fisheries lower quality fish communities will result in the Central Basin. The last three large Central Basin south shore tributaries and associated lacustraries are the Grand, Ashtabula and Conneaut (from west to east). Numerous Central Basin fish stocks require these areas for reproductive purposes. Restoration of the Ashtabula will not only enhance Central Basin fish stocks but will also prevent their further decline.

4.77 If either Bank to Bank to Bedrock or Deep Dredging were implemented, it is expected with high certainty that the fish consumption advisory will be lifted and long-term protection will be achieved because the majority of the PCB mass will be removed. (Risk Assessment, 1997) It is expected that, at a minimum, within several years of completion of dredging enough clean material will have silted into the dredged area to provide a sufficient cover (about two feet) to initiate benthos and fishery recovery with regard to contaminants. Within several more years it should become apparent that the bio-accumulation chain is broken.

4.78 Alternative Disposal Options Plan. Similar statement as that for paragraph 4.13; however pertaining to this parameter.

Vegetation:

4.79 No Action (Without Project Conditions). Similar statement as that for paragraph 4.11; however pertaining to this parameter.

4.80 Proposed Upland State Road Site Plan. The dredging excavation of the river bottom sediments would remove most of the sparse vegetation from the river area that is dredged. Resettling of resuspended sediments could smother some vegetation species in the area just downstream of the project area. Recolonization would likely occur within a few months to a few years in the newly exposed sediments and future sediment deposits. Future sediment deposits should be essentially clean and would be able to support less pollution tolerant vegetation species. This would enable the river to achieve a higher diversity of aquatic species.

4.81 The assessment/evaluation identified an **Aquatic/Fishery Shelf Plan** for the Ecological Assessment Area 3 problem area and an **Acquire Conrail Slip and Aquatic/Fishery Shelf Cut Plan** for the Ecological Assessment Area 2 problem area and other long-term dredging measures. This constitutes ecological restoration, as possible, for loss of protected aquatic/fishery shallows due to facilitated structural (i.e. bulkheading, channelization), and activities impacts. These are practical optimized plans of moderate cost providing problem area protected aquatic/fishery shallows of substantial length which accomplish, as possible, goals/objectives, in this regard. The areas would be interfaced with the lake/river regime and would

provide a clean shallow vegetated aquatic and shoreline area along the river. It should be noted that these or similar measures would be pursued by separate authority/study (i.e. 206) subsequent and contingent to this projects dredging for removal of contaminants.

4.82 If a water based barge Dewatering/Transfer operation is utilized essentially no impacts to vegetation would occur due to facility development and operation. Development of a shoreline Transfer/Dewater/Transfer site would require clearing and grubbing of about a five to ten acre site. If the 1993 Interim Dredged Material Disposal Site is utilized for Transfer/Dewater/Transfer facilities development, the existing levee and dredged material would likely be utilized to build the dewatering basins. The existing essentially grass cover would be dug under and likely replaced temporarily by more grass or legume vegetation along the levee and dredged material within the dewatering basins. After the transfer/dewater/transfer operations are complete, the 1993 dredged material would be excavated, transported, and disposed of in the project Non-TSCA disposal site. The other material could be regraded in the area and revegetated, probably with grasses or legumes.

4.83 Development of the disposal facilities at the State Road Site would require about 32 acres. The area to be developed is a brownsfied site. The site supports primarily upland open field, patchy herbaceous regrowth and common reed, which is consistent with urban industrial sites. The area impacted would be developed with disposal cells and elutriate treatment facilities, as described. Gradual and long-term vegetation replacement would likely be with grasses or legumes on facility slopes

4.84 Alternative Disposal Options Plan. Similar statement as that for paragraph 4.13; however pertaining to this parameter.

Wildlife (Habitat):

4.85 No Action (Without Project Conditions). Similar statement as that for paragraph 4.11; however pertaining to this parameter.

4.86 Proposed Upland State Road Site Plan. Some avian species, particularly seagulls, would likely be attracted to the dredging, dewatering, and disposal activities looking for food. The resuspension of sediments and food particles will increase the availability of contaminants to such bird populations and subsequently may result in a short-term increase in the potential for some increased bioaccumulation and toxic effects. Efforts will be made to minimize exposure of bird to contaminated sediments (i.e. use of low turbidity dredges, oil booms and silt curtains, noise, exposure area, etc.).

4.87 The dredging excavation of the river bottom sediments would remove the contaminated sediments from the river area that is dredged. Future sediment deposits should be essentially clean and would be able to support less pollution tolerant organisms. This would enable the river to achieve a higher diversity of species. It is expected that, at a minimum, within several years of completion of dredging enough clean material will have silted into the dredged area to provide a sufficient cover (about two feet) to initiate benthos and fishery recovery with

regard to contaminants. Within several more years it should become apparent that the bioaccumulation chain is broken.

4.88 The assessment/evaluation identified an **Aquatic/Fishery Shelf Plan** for the Ecological Assessment Area 3 problem area and an **Acquire Conrail Slip and Aquatic/Fishery Shelf Cut Plan** for the Ecological Assessment Area 2 problem area and other long-term dredging measures. This constitutes ecological restoration, as possible, for loss of protected aquatic/fishery shallows due to facilitated structural (i.e. bulkheading, channelization), and activities impacts. These are practical optimized plans of moderate cost providing problem area protected aquatic/fishery shallows of substantial length which accomplish, as possible, goals/objectives, in this regard. The areas would be interfaced with the lake/river regime and would provide a clean shallow vegetated aquatic and shoreline area along the river. It should be noted that these or similar measures would be pursued by separate authority/study (i.e. 206) subsequent and contingent to this projects dredging for removal of contaminants.

4.89 If a water based barge Dewatering/Transfer operation is utilized essentially no impacts to wildlife would occur due to facility development and operation. Development of a shoreline Transfer/Dewater/Transfer site would require clearing and grubbing of about a five to ten acre site. If the 1993 Interim Dredged Material Disposal Site is utilized for Transfer/Dewater/Transfer facilities development, the existing levee and dredged material would likely be utilized to build the dewatering basins. The existing essentially grass cover would be dug under and likely replaced temporarily by more grass or legume vegetation along the levee and dredged material within the dewatering basins. After the transfer/dewater/transfer operations are complete, the 1993 dredged material would be excavated, transported, and disposed of in the project Non-TSCA disposal site. The other material could be regraded in the area and revegetated, probably with grasses or legumes.

4.90 Development of the disposal facilities at the State Road Site would require about thirty two acres. The area to be developed is a brownsfield site. The site supports primarily upland open field, patchy herbaceous regrowth and common reed, which is consistent with urban industrial sites. The area supports little wildlife. The area impacted would be developed with disposal cells and elutriate treatment facilities, as described. Gradual and long-term vegetation replacement would likely be with grasses or legumes on facility slopes. This would support limited; but, some wildlife.

4.91 Alternative Disposal Options Plan. Similar statement as that for paragraph 4.13; however pertaining to this parameter.

Threatened and Endangered (T&E) Species:

4.92 No Action (Without Project Conditions). Similar statement as that for paragraph 4.11; however pertaining to this parameter.

4.93 Proposed Upland State Road Site Plan. Project coordination was and is being conducted with the U.S. Fish and Wildlife Service (USFWS) and the Ohio State Department of Natural Resources in this regard. The U.S. Fish and Wildlife Service in their Coordination Act Report

indicated that the proposed project lies within the range of the Indiana bat, bald eagle, and piping plover, Federally listed endangered or threatened species; but, that they do not anticipate that the proposed project will impact any of these species or habitat. The Ohio Department of Natural Resources did not identify any State protected species or associated habitats that would be *adversely* impacted by project implementation. Removal of contaminants and restoration of habitat would likely protect and/or benefit any threatened and endangered species should they occur in the vicinity.

4.94 Alternative Disposal Options Plan. Similar statement as that for paragraph 4.13; however pertaining to this parameter.

Wetlands:

4.95 No Action (Without Project Conditions). Similar statement as that for paragraph 4.11; however pertaining to this parameter.

4.96 Proposed Upland State Road Site Plan. The dredging excavation of the river bottom sediments would remove most of the sparse wetland/vegetation from the river area that is dredged. Slip area wetlands should not be significantly affected. Future sediment deposits should be essentially clean. Eventually, some riverine wetlands will likely establish along shallow recreational channels being maintained.

4.97 The assessment/evaluation identified an **Aquatic/Fishery Shelf Plan** for the Ecological Assessment Area 3 problem area and an **Acquire Conrail Slip and Aquatic/Fishery Shelf Cut Plan** for the Ecological Assessment Area 2 problem area and other long-term dredging measures. This constitutes ecological restoration, as possible, for loss of protected aquatic/fishery shallows due to facilitated structural (i.e. bulkheading, channelization), and activities impacts. These are practical optimized plans of moderate cost providing problem area protected aquatic/fishery shallows of substantial length which accomplish, as possible, goals/objectives, in this regard. The areas would be interfaced with the lake/river regime and would provide a clean shallow vegetated aquatic, wetland, and shoreline area along the river. It should be noted that these or similar measures would be pursued by separate authority/study (i.e. 206) subsequent and contingent to this projects dredging for removal of contaminants.

4.98 If a water based barge Transfer/Dewatering/Transfer operation is utilized barges would be positioned to avoid significant impacts to wetlands. Development of shoreline Transfer/Dewatering/Transfer facilities at the 1993 Interim Dredged Material Disposal Site would be situated to avoid significant impacts to wetlands.

4.99 Development of the disposal facilities at the State Street Site would be situated to avoid significant impacts to wetlands. One man-made depressional wetland located on soil fill was identified within the northern third of the site along the eastern site boundary. This will be avoided.

4.100 Alternative Disposal Options Plan. Similar statement as that for paragraph 4.13; however pertaining to this parameter.

ENVIRONMENTAL EFFECTS - HUMAN ENVIRONMENT (MAN-MADE RESOURCES)

Community and Regional Growth (Includes Health and Safety):

4.101 No Action (Without Project Conditions): The No Action (Without Project Conditions) scenario indicates that the Ashtabula River Partnership could take no action based on the final findings of this study. Similar to existing conditions/problems would persist for some time. Contaminated sediments would likely continue to migrate downstream into the lower river and then into the harbor and Lake Erie. This would result in further area dredging and dredged material disposal problems, in turn, further adversely affecting environmental conditions and economic and beneficial use of the river and harbor. It is likely that the lower Ashtabula River remediation would be pursued via an alternate authority (i.e. Superfund) and a similar project (somewhat less) would be implemented/enforced. Impacts would be similar (somewhat less) to those indicated for a with project conditions (below), but at a later date.

4.102 Proposed Upland State Road Site Plan. Some disruption associated with construction activities would occur and be noticeable within the community during construction of transfer/dewatering/transfer and disposal facilities construction and during the dredging and disposal activities.

4.103 (Health and Safety) Measures will be incorporated into the project design and implementation to assure that the project is carried out as safely as possible during project implementation and is safe in the future. Reference associated sections of **SECTION 2 - RECOMMENDED PLAN** and **MONITORING**. Reference **EIS APPENDICES EA-B and EA-C**, also.

4.104 If a harbor area barge Dewater/Transfer operation is utilized to dewater the dredged material, only a small existing or developed shoreline transfer site would be needed. If a shoreline Transfer/Dewater/Transfer operation is utilized it is expected that about five to ten acres of upland area would be required for development of a Transfer/Dewater/Transfer site. This would be developed in the harbor shoreline vicinity. For a new upland disposal facility, it is expected that about thirty two acres of land would be required. Land would likely be acquired at reasonable market value by the Ashtabula River Partnership or a local authority (ie. The Port Authority) for the project. Development would likely be bid competitively, and contracted. The potential development site (State Road Site) is a brownsfield site and is currently owned by State Road Development Corp. and is zoned for heavy manufacturing/industry.

4.105 It is expected that within several years of project implementation sediment and benthos quality will be improved markedly; and, that within another few years the area fishery will be improved markedly. It is expected that the project will accomplish project incremental goals/objectives and work toward remediation of the six beneficial use impairments identified with the exception of limitations along the commercial channel area. Several monitoring programs will be conducted within five to ten years of project completion to assess/evaluate this. Implementation of the project would work toward restoration of the integrity of the harbor from the environmental, economic, and social perspectives. It also provides a plan for future harbor

operations and maintenance needs. It would substantially benefit community and regional growth needs.

4.106 Alternative Disposal Options Plan. Impacts to Community and Regional Growth would be expected to be similar to those described for the Proposed Upland State Road Site Plan except that, if the dredged material is transported to an existing (permitted) disposal facility, associated impacts would occur along those transportation routes and at that disposal facility. Use of existing disposal sites would not have a significant adverse effect on the parameter due to construction; since they have been constructed previously.

Displacement of People:

4.107 No Action (Without Project Conditions). Similar statement as that for paragraph 4.101; however, pertaining to this parameter.

4.108 Proposed Upland Site 7 Plan. If a harbor area barge Transfer/Dewater/Transfer operation is utilized to dewater the dredged material, only a small existing or developed shoreline transfer site would be needed. If a shoreline Transfer/Dewater/Transfer operation is utilized it is expected that about five to ten acres of upland area would be required for development of a Transfer/Dewater/Transfer site. This would be developed in the harbor shoreline vicinity. For a new upland disposal facility, it is expected that about thirty two acres of land would be required. Land would likely be acquired at reasonable market value by the Ashtabula River Partnership or a local authority (i.e. The Port Authority) for the project. Development would likely be bid competitively, and contracted. The potential development site (State Road Site) is a brownfield site and is currently owned by State Road Development Corp. and is zoned for heavy manufacturing/ industry.

4.109 Alternative Disposal Options Plan. Similar statement as that for paragraph 4.106; however, pertaining to this parameter.

Displacement of Farms:

4.110 No Action (Without Project Conditions): Similar statement as that for paragraph 4.101; however, pertaining to this parameter.

4.111 Proposed Upland State Road Site Plan. The site considered for the Harbor Area Shoreline Transfer/Dewater/Transfer facility development is a previous interim dredged material disposal site. The site (State Road Site) considered for the potential new upland confined disposal facility development is a former industrial site. No active farms or farmland would be taken. The area is zoned for heavy manufacturing/industry.

4.112 Alternative Disposal Options Plan. Similar statement as that for paragraph 4.106; however, pertaining to this parameter.

Business and Industry and Employment and Income:

4.113 No Action (Without Project Conditions). Similar statement as that for paragraph 4.101; however, pertaining to this parameter.

4.114 Proposed Upland State Road Site Plan. Project implementation would provide business, industry, employment, and income to construction, supply, and service industries during initial project and future operation and maintenance activities.

4.115 Dredging activities would need to be well planned in order to avoid significant adverse impacts to adjacent infrastructures (i.e. sheetpiling, cribbing, embankments, etc.)

4.116 Dredging activities would likely disrupt normal docking and recreational vessel traffic in the vicinity of the dredging activities. Docks would likely need to be temporarily removed in the immediate dredging area in order to get at all the sediments to be dredged. This would need to be well coordinated with the marinas. Vessel traffic and other recreational activities would likely be restricted in an area around the dredging activities.

4.117 Much of the project costs would be incurred by area industries, or Primary Responsible Parties. Project implementation would demonstrate industries resolve to work in partnership with other interests to resolve the contaminated sediment problem.

4.118 Project implementation would provide for initial harbor sediment cleanup and navigation channel maintenance and a future operations and maintenance program. This would serve to restore the environmental, economic, and social integrity to the harbor. Continued operation and maintenance of navigation facilities facilitates both commercial and recreational enterprises.

4.119 If a harbor area barge Dewater/Transfer operation is utilized to dewater the dredged material, only a small existing or developed shoreline transfer site would be needed. If a shoreline Transfer/Dewater/Transfer operation is utilized it is expected that about five to ten acres of upland area would be required for development of a Transfer/Dewater/Transfer site. This would be developed in the harbor shoreline vicinity. For a new upland disposal facility, it is expected that about thirty two acres of land would be required. Land would likely be acquired at reasonable market value by the Ashtabula River Partnership or a local authority (i.e. The Port Authority) for the project. Development would likely be bid competitively, and contracted. The potential development site (State Road Site) is a brownsfield site and is currently owned by State Road Development Corp. and is zoned for heavy manufacturing/industry. It is not expected that any business developed properties would need to be acquired.

4.120 Alternative Disposal Options Plan. Similar statement as that for paragraph 4.106; however, pertaining to this parameter.

Public Facilities and Services:

4.121 No Action (Without Project Conditions): Similar statement as that for paragraph 4.101; however, pertaining to this parameter.

4.122 Proposed Upland State Road Site Plan. A number of public facilities and services would likely be utilized during project implementation including: water and sewer, electrical, telephone, shipping, roads, rail, police, standby medical emergency, health department, etc. It is expected that facilities and services are adequate to facilitate project implementation needs.

4.123 It is not expected that dredging or disposal will have a significant adverse effect on water quality at any potable water intakes.

4.124 Essentially, the project plan and/or developments would become part of public facilities and services. Implementation of the plan would likely require some expansion of facilities and services mentioned previously to facilitate the plan and or developments.

4.125 If water discharged from project facilities are discharged into public sewage facilities, pre-discharge quality standards will need to be met.

4.126 Utilities will need to be located to avoid damage and or disruption to services during implementation of the project.

4.127 Some construction equipment and material (ie. bulldozers, trucks, clay, geofabric, filter equipment, etc.) would likely be trucked into the Harbor Area Shoreline Transfer/Dewatering/Transfer development site and into the Upland State Road Disposal Facility site from commercial sources for facilities construction. This would probably involve several hundred truckloads.

4.128 With the Harbor area Transfer/Dewater/Transfer facility development, dewatered material would likely be trucked to the developed (State Road Site) disposal facility during initial and possibly some subsequent operations and maintenance dredging and disposal operations. During the initial dredging and disposal operations, tens of thousands of truckloads of material would travel the route over a several year disposal operations period. Routes would need to be determined to minimize impacts to traffic sensitive areas. Road maintenance programs would need to be coordinated/implemented.

4.129 Project implementation would provide for initial harbor sediment cleanup and navigation channel maintenance and a future operations and maintenance program. Continued operations and maintenance of navigation facilities facilitates both commercial and recreational navigation and associated enterprises. Existing associated public facilities and services would be maintained and possibly expanded.

4.130 Alternative Disposal Options Plan. Similar statement as that for paragraph 4.106; however, pertaining to this parameter.

Recreation:

4.131 No Action (Without Project Conditions): Similar statement as that for paragraph 4.101; however, pertaining to this parameter.

4.132 Proposed Upland State Road Site Plan. Dredging activities would likely disrupt normal docking and recreational vessel traffic in the vicinity of the dredging activities. Docks would likely need to be temporarily removed in the immediate dredging area in order to get at all the sediments which need to be removed. This would need to be well coordinated with the marinas. Vessel traffic and other recreational activities would likely be restricted in an area around the dredging activities.

4.133 Project implementation would provide for initial harbor sediment cleanup and navigation channel maintenance and a future operation and maintenance program. This would serve to restore the environmental, economic, and social integrity to the harbor. Continued operation and maintenance of navigation facilities facilitates recreational enterprises.

4.134 During dredging, the resuspension of sediments and food particles may increase the availability of contaminants to transient and local fish populations and subsequently may result in the potential for some increased bioaccumulation and toxic effects. Dredging the sediments from the river, however, will remove those contaminants associated with the sediments from the aquatic ecosystem. It is expected that, at a minimum, within several years of completion of dredging enough clean material will have silted into the dredged area to provide a sufficient cover (about two feet) to initiate benthos and fishery recovery with regard to contaminants. Within several more years it should become apparent that the bioaccumulation chain is broken. It is expected with high certainty that the fish consumption advisory for the river will be lifted and long-term protection will be achieved because the majority of the PCB mass will be removed. Recreational fishing in the area would be expected to improve accordingly.

4.135 If a water based barge Dewatering/Transfer operation is utilized essentially no impacts to wildlife would occur due to facility development and operation. Development of a shore-line Transfer/Dewater/Transfer site would require clearing and grubbing of about a five to ten acre site. If the 1993 Interim Dredged Material Disposal Site is utilized for Transfer/Dewater/Transfer facilities development, the existing levee and dredged material would likely be utilized to build the dewatering basins. The existing essentially grass cover would be dug under and likely replaced temporarily by more grass or legume vegetation along the levee and dredged material within the dewatering basins. After the Transfer/Dewater/Transfer operations are complete, the 1993 dredged material would be excavated, transported, and disposed of in the project Non-TSCA disposal site. The other material could be regraded in the area and revegetated, probably with grasses or legumes.

4.136 Development of the disposal facilities at the State Road Site would require about thirty two acres. The area to be developed is a brownfield site. The site supports primarily upland open field, patchy herbaceous regrowth and common reed, which is consistent with urban industrial sites. The area supports little wildlife. The area is not utilized by area hunters. The area impacted would be developed with disposal cells and elutriate treatment facilities, as

decribed. Gradual and long-term vegetation replacement would likely be with grasses or legumes on facility slopes. This would support limited; but, some wildlife.

4.137 Alternative Disposal Options Plan. Similar statement as that for paragraph 4.106; however, pertaining to this parameter.

Property Values and Tax Revenues:

4.138 No Action (Without Project Conditions): Similar statement as that for paragraph 4.101; however, pertaining to this parameter.

4.139 Proposed Upland Site 7 Plan. Some business, employment, and income would be generated in the area due to project implementation and construction. Project costs would be allocated primarily in accordance with project benefits. A number of avenues were utilized in financing the project study with government, grant, and private funds. A number of avenues will be utilized in funding the project implementation.

4.140 Project implementation would provide for initial harbor sediment cleanup and navigation channel maintenance and a future operation and maintenance program. This would serve to restore the environmental, economic, and social integrity to the harbor. Continued operation and maintenance of navigation facilities facilitates both commercial and recreational enterprises. Land use would likely be maintained or redeveloped to slightly higher value developments. Associated property value and tax revenues would likely be similar or slightly increased.

4.141 If a harbor area barge Dewater/Transfer operation is utilized to dewater the dredged material, only a small existing or developed shoreline transfer site would be needed. If a shoreline Transfer/Dewater/Transfer operation is utilized it is expected that about five to ten acres of upland area would be required for development of a Transfer/Dewater/Transfer site. This would be developed in the harbor shoreline vicinity. For a new upland disposal facility, it is expected that about thirty two acres of land would be required. Land would likely be acquired at reasonable market value by the Ashtabula River Partnership or a local authority (i.e. The Port Authority) for the project. Development would likely be bid competitively, and contracted. The potential development site (State Road Site)) is a brownsfield site and is currently owned by State Road Development Corp. and is zoned for heavy manufacturing/ industry. It is not expected that any residences or developed properties would need to be acquired. It is expected that property values and associated tax revenues in the area of the transfer/dewater/ transfer and disposal sites would be similar to existing conditions or increase slightly with project implementation/development, and would decrease somewhat and stabilize when completed since potential new development use would be eliminated.

4.142 Alternative Disposal Options Plan. Similar statement as that for paragraph 4.106; however, pertaining to this parameter.

Noise and Aesthetics:

4.143 No Action (Without Project Conditions): Similar statement as that for paragraph 4.101; however, pertaining to this parameter.

4.144 Proposed Upland State Road Site Plan. Noise would be generated in the project construction areas due to the operation of heavy equipment during construction, dredging, transfer, and disposal operations. This should not be a significant adverse impact since dredging occurs from time to time and in light of the project construction and transport area settings and sufficient distance from noise sensitive areas.

4.145 Some turbidity and resuspension of sediments would be noticeable in the river in the area of the dredging activities and when discharged into the Transfer/Dewater/Transfer facilities. All practical measures will be utilized to minimize these impacts.

4.146 Some earthy/organic odor may occur in the immediate area of the dredged material. This would not be expected to be a problem over a large area or for a long time. If a substantial problem is noted, some odor abatement measures (operations or applications) may be implemented.

4.147 The areas would be disrupted by construction, dredging, and transport activities. All practical measures would be implemented to minimize impacts of these activities.

4.148 Project implementation would provide for initial harbor sediment cleanup and navigation channel maintenance and a future operations and maintenance program. This would work to restore the environmental, economic, and social integrity to the harbor. Continued operation and maintenance of navigation facilities facilitates both commercial and recreational enterprises. These would be expected to continue operations similar to existing conditions or possibly expanded levels. Associated harbor noise and aesthetic conditions would be expected.

4.149 If a water based barge Transfer/Dewatering/Transfer operation is utilized associated impacts to noise and aesthetics would occur due to facility development and operation. Development of a shoreline Transfer/Dewater/Transfer site would require clearing and grubbing of about a five to ten acre site. If the 1993 Interim Dredged Material Disposal Site is utilized for Transfer/Dewater/Transfer facilities development, the existing levee and dredged material would likely be utilized to build the dewatering basins. The existing essentially grass cover would be dug under and likely replaced temporarily by more grass or legume vegetation along the levee and dredged material within the dewatering basins. After the Transfer/ Dewater/Transfer operations are complete, the 1993 dredged material would be excavated, transported, and disposed of in the project Non-TSCA disposal site. The other material could be regraded in the area and revegetated, probably with grasses or legumes.

4.150 Development of the disposal facilities at the State Road Site would require about thirty two acres. The area to be developed is a brownsfield site. The site supports primarily upland open field, patchy herbaceous regrowth and common reed, which is consistent with urban industrial sites. The area supports little wildlife. The area impacted would be developed with

disposal cells and elutriate treatment facilities, as described. Gradual and long-term vegetation replacement would likely be with grasses or legumes on facility slopes. This would support limited; but, some wildlife.

4.151 Alternative Disposal Options Plan. Similar statement as that for paragraph 4.106; however, pertaining to this parameter.

Community Cohesion:

4.152 No Action (Without Project Conditions): Similar statement as that for paragraph 4.101; however, pertaining to this parameter.

4.153 Proposed Upland State Road Site Plan. Formation and implementation of a project via the Ashtabula River Partnership demonstrates community cohesion and resolve in remediation of contaminated sediments in the Ashtabula River system.

4.154 Some disruption associated with construction activities would occur and be noticeable within the community during construction of Transfer/Dewatering/Transfer and disposal facilities construction and during the dredging and disposal activities.

4.155 (Health and Safety) Measures will be incorporated into the project design and implementation to assure that the project is carried out as safely as possible during project implementation and is safe in the future. Reference associated sections of **SECTION 2 - RECOMMENDED PLAN** and **MONITORING**. Reference **EIS APPENDICES EA-B and EA-C**, also.

4.156 If a harbor area barge Dewater/Transfer operation is utilized to dewater the dredged material, only a small existing or developed shoreline transfer site would be needed. If a shoreline Transfer/Dewater/Transfer operation is utilized it is expected that about five to ten acres of upland area would be required for development of a Transfer/Dewater/Transfer site. This would be developed in the harbor shoreline vicinity. The area considered is a interim dredged material disposal site. For a new upland disposal facility, it is expected that about thirty two acres of land would be required. Land would likely be acquired at reasonable market value by the Ashtabula River Partnership or a local authority (i.e. The Port Authority) for the project. Development would likely be bid competitively, and contracted. The potential development site (State Road Site) is a brownsfield site and is currently owned by State Road Development Corp. and is zoned for heavy manufacturing/industry.

4.157 Implementation of the project would work toward restoration of the integrity of the harbor from the environmental, economic, and social perspectives. It also provides a plan for future harbor operations and maintenance needs. It would substantially benefit Community Cohesion.

4.158 Alternative Disposal Options Plan. Similar statement as that for paragraph 4.106; however, pertaining to this parameter.

ENVIRONMENTAL EFFECTS - CULTURAL RESOURCES

Cultural Resources:

4.159 No Action (Without Project Conditions). Similar statement as that for paragraph 4.101; however, pertaining to this parameter.

4.160 Proposed Upland State Road Site Plan. The river dredging area and potential Transfer/Dewatering/Transfer sites have been disrupted by previous fairly recent activities, and no significant cultural resource items would be expected at these sites.

4.161 A letter dated September 18, 2000 was coordinated with the State Historic Preservation Office pertaining to potential development of disposal facilities at State Road Site. Enclosures included: a list of documents prepared for remediation of the site, an extract from one of the documents pertaining to the industrial development and use of the site, a wetland and ecological site walkover investigation prepared by the Buffalo District, a memo pertaining to existing site conditions prepared by the Buffalo District, and a site photo index and photos taken during site demolition. The State Historic Preservation Office provided a letter dated November 7, 2000 reaffirming that the project will have no effect on any properties listed or eligible for the National Register of Historic Places. No further coordination is necessary unless the scope of the project should change. If new or additional properties are discovered, the State Historic Preservation Office should be notified. Reference EIS Appendix EA-H CULTURAL RESOURCES ASSESSMENT, also.

4.162 Alternative Disposal Options Plan. Similar statement as that for paragraph 4.106; however, pertaining to this parameter.

ENVIRONMENTAL EFFECTS - BORROW AREA IMPACT ASSESSMENT STATEMENT

Borrow Areas:

4.163 No Action (Without Project Conditions): Similar statement as that for paragraph 4.101; however, pertaining to this parameter.

4.164 Proposed Upland State Road Site Plan. Some clay construction material would be obtained from a permitted/licensed commercial source. Generally, due to construction contract language requirements and potential savings to the partnership and government, project contractors are allowed to select alternate project borrow areas provided material standards and Federal, State, and local permit/license requirements are met. A list of some potential suitable sources are listed as follows. Most are located in the Ohio regional area. Clay would likely be transported from the borrow site along major routes by truck to the project vicinity. Since these major routes are commonly utilized for transportation of such material, except for some increased traffic, and wear and tear, and associated impacts, no significant adverse impacts in this regard would be anticipated. Environmental assessment of borrow area extraction of ma-

terial is generally addressed or referenced via borrow site operations permits/licenses. Generally, environmental impacts of borrow extraction would pertain to minor adverse impacts to noise and air quality due to operation of heavy equipment, and minor to moderate adverse impacts to aesthetics, wildlife, vegetation, soil/geology, water, previous land use, and possibly cultural resources due to material extraction; with long-term minimization of impacts as directed by permit/license and restoration considerations. Generally, beneficial impacts of borrow operations would pertain to community and regional growth, business/industry/employment/income, tax revenues; and potential eventual aesthetics, water, soil, vegetation, wildlife, and land use restoration impacts.

4.165 Alternative Disposal Options Plan. Similar statement as that for paragraph 4.106; however, pertaining to this parameter.

IRREVERSIBLE COMMITMENT OF RESOURCES

4.166 Implementation of the proposed plans would involve the irreversible commitment of Federal, State, and Local funds, energy resources, and construction materials. Confined Disposal Facility construction at the upland site would convert approximately 32 acres of a former industrial site (brownfield) to a disposal area.

4.167 Natural Resources (Trustees) Damages. Nothing in this environmental impact statement shall be construed either explicitly or implicitly to irreversibly or irretrievably commit natural resources either directly or indirectly associated with the proposed dredging of the Ashtabula Harbor Channel beyond those areas outside of the area of dredging.

SUMMATION (CUMMULATIVE EFFECTS) ASSESSMENT

4.168 Dredging the Ashtabula River sediments will have short-term detrimental effects on the river and to a far lesser extent, Ashtabula Harbor and Lake Erie. However, the long-term beneficial impacts should far outweigh the adverse effects. Dredging the sediments from the river will remove those contaminants associated with the sediments from the aquatic ecosystem. This will eliminate the ability of these contaminants to be resuspended and transported down river and into Lake Erie. Future sediment deposits should be essentially clean and would be able to support less pollution tolerant benthic organisms. This would enable the river and lake to achieve a higher diversity of aquatic species.

4.169 It is expected that within several years of project implementation sediment and benthos quality will be improved markedly; and, that within another few years the area fishery will be improved markedly. It is expected that the project will accomplish project incremental goals/objectives and work toward remediation of the six beneficial use impairments identified with the exception of limitations along the commercial channel area. This will work toward remediation of one of the 42 Great Lakes Areas of concern. The Lake Erie/Ashtabula River Area of Concern has been identified as a priority area for remediation in Sections 205 and 515 of WRDA 96 and in the U.S. Army Corps of Engineers PGL No. 49 section 5. c. Several monitoring programs will be conducted within five to ten years of project completion to assess/evaluate this.

4.170 The recovery of the Ashtabula lacustrine fish community is expected to influence fish communities in surrounding areas both upstream and in the lake. Species such as northern pike (*Esox lucius*) and muskellunge (*Esox masquinongy*) moderate fish communities through predation and drive community structure towards greater ecological integrity. Greater ecological integrity results in even higher numbers of top carnivores, endangered species and sensitive species. Historically, the muskie and northern pike were very abundant and commercially important. The destruction of lacustrine habitats throughout Lake Erie has resulted in drastic reductions of the two species' populations and the positive influences they had on the Lake's ecosystem. The restoration of the Ashtabula lacustrine will allow it to resume its historic contribution to top carnivore populations (including northern pike and muskellunge).

4.171 Species listed as sensitive can all be expected to increase in numbers after sediment removal and a consequent influx of clean sediment from upstream areas. Species presently not found in the Ashtabula but found in the Grand and Conneaut will return to the Ashtabula. The sensitive species that are absent from the Ashtabula represent all trophic levels of the fish community. Ecosystems cannot function with such large components missing.

4.172 The ecosystem of the open waters of Lake Erie is presently experiencing dramatic recovery of its fish community. This recovery is expected to continue with further recovery of additional species. The removal of contaminated sediments will prepare the Ashtabula for the possible entrance of species such as: lake sturgeon (*Acipenser fulvescens*), mooneye (*Hiodon tergisus*), muskellunge (*Esox masquinongy*), pugnose shiner (*Notropis anogenus*), longnose sucker (*Cutostomus cutostomus*), lake chubsucker (*Erimyzon sucetta*), creek chubsucker (*Erimyzon oblongus*), tad-pole madtom (*Noturus gyrinus*), burbot (*Lota lota*); and possibly: pugnose minnow (*Opsopoeodus emiliae*), blackchin shiner (*Notropis heterodon*), blacknose shiner (*Notropis heterolepis*), banded killifish (*Fundulus diaphanus*), and sand darter (*Ammocrypta pellucida*) into the system. Some of these species (burbot, lake sturgeon, muskellunge and sand darter) are already showing signs of recovery in the lake. Areas such as the Ashtabula lacustrine are an important component of these species life history. Full recovery of the above listed species will depend on the environmental quality of Lake Erie's lacustrine habitats.

4.173 The speed and degree of ecological recovery in the Ashtabula River lacustrine will depend on the rate of sedimentation. Near shore depths of two to ten feet are ideal for healthy fish communities and the aquatic plants they depend upon. The influx of clean sediments from upstream areas will eventually occur, and active intervention in the form of replacing dredged sediments with clean sediments will greatly enhance the process.

4.174 The aquatic/fishery shelves would expedite recovery and constitute ecological restoration, as possible, for loss of protected aquatic/fishery shallows due to facilitated structural (i.e. bulkheading, channelization), and activities impacts. These are practical optimized plans of moderate cost providing problem area protected aquatic/fishery shallows of substantial length which accomplish, as possible, goals/objectives, in this regard. The areas would be interfaced with the lake/river regime and would soon provide passage, cover, feeding, and spawning habitat. It should be noted that these or similar measures would be pursued by separate authority/study (i.e. 206) subsequent and contingent to this project's dredging for removal of contaminants.

4.175 It is clear that little improvement will occur if contaminated sediments are not removed. Present Ohio EPA fish community data show declining trend of IBI values at Rm 1.3 of the Ashtabula River. It is possible that this trend could continue, resulting in still lower quality fish communities in the future. There is further concern that without the project, shipping could shift from the Ashtabula area to Conneaut Harbor. This will result in a greater degree of environmental disturbance in the Conneaut and will negatively impact fish communities. With impacts to both the Ashtabula and Conneaut fisheries lower quality fish communities will result in the Central Basin. The last three large Central Basin south shore tributaries and associated lacustraries are the Grand, Ashtabula and Conneaut (from west to east). Numerous Central Basin fish stocks require these areas for reproductive purposes. Restoration of the Ashtabula will not only enhance Central Basin fish stocks but will also prevent their further decline.

4.176 If a harbor area barge Dewater/Transfer operation is utilized to dewater the dredged material, only a small existing or developed shoreline transfer site would be needed. If a shoreline Transfer/Dewater/Transfer operation is utilized it is expected that about five to ten acres of upland area would be required for development of a Transfer/Dewater/Transfer site. This would be developed in the harbor shoreline vicinity. The area considered is a interim dredged material disposal site. For a new upland disposal facility, it is expected that about thirty two acres of land would be required. Land would likely be acquired at reasonable market value by the Ashtabula River Partnership or a local authority (i.e. The Port Authority) for the project. Development would likely be bid competitively, and contracted. The potential development site (State Road Site) is a brownsfield site and is currently owned by State Road Development Corp. and is zoned for heavy manufacturing/industry.

4.177 Implementation of the project would work toward restoration of the integrity of the harbor from the environmental, economic, and social perspectives. It also provides a plan for future harbor operations and maintenance needs. It would substantially benefit community and regional sustenance and growth needs.

SECTION 5 - LIST OF PREPARERS

5.01 The following U.S. Army Corps of Engineers, Buffalo District people are primarily responsible for drafting the project Feasibility Report and this Environmental Impact Statement.

<u>SECTION AND NAME</u>	<u>POSITION</u>	<u>EXPERIENCE</u>	<u>EXPERTISE</u>
PROJECT MANAGEMENT BRANCH			
Mr. Brian Troyer	Project Manager	Project Management Branch, USA-COE Buffalo, (30 Years)	Project Management, Civil Engineering
PLANNING BRANCH			
Mr. Stephen Golyski	Project Manager	Plan Formulation and Technical Management Branch, USA-COE Buffalo, (26 Years)	Plan Formulation and Technical Management, Civil Engineering
Mr. Ron Guido (Final)	Project Management	Business Office USA-COE, Buffalo (30 Years)	Business and Economics
Ms. Traci Clever (Final)	Project Management	Environmental Analysis Section USA-COE, Buffalo (1 Year)	Plan Formulation and Biology
ENVIRONMENTAL ANALYSIS SECTION			
Mr. David Conboy	Team Leader, Environ- mental Analysis Section	Environmental Analysis Section, USA-COE, Buffalo (10 Years)	Environmental and Civil Engineering
Mr. Tod Smith (NEPA Coordinator)	Community Planner	Environmental Analysis Section USA-COE, Buffalo (24 Years)	Community/Environmental Planning
Mr. Bill Janowski	Fisheries & Wildlife Biologist	Environmental Analysis Section USA-COE, Buffalo, (5 Years)	Fisheries & Wildlife Biology
Mr. William Butler	Environmental Specialist	Environmental Analysis Section USA-COE, Buffalo, (24 Years)	Environmental Planning and Cultural Resources
Mr. David Melfi	Environmental Scientist	Environmental Analysis Section USA-COE, Buffalo, (24 Years)	Chemistry/Environmental Science
ENVIRONMENTAL ENGINEERING SECTION			
Mr. Frederick Boglione	Team Leader, Environ- mental Engineering Section	Environmental Engineering Section, USA-COE, Buffalo (20 Years)	Environmental and Civil Engineering
Ms. Judith Leithner	Chemical Engineer	Environmental Engineering Section, USA-COE, Buffalo (10 Years)	Chemical Engineer
Mr. Thomas Kenna	Environmental and Civil Engineer	Environmental Engineering Section, USA-COE, Buffalo (25 Years)	Environmental and Civil Engineering
ECONOMICS			
Mr. Rodger Haberly	Regional Economist	Economics Section, USA-COE, Buffalo, (20 Years)	Economic Analysis

5.02 The following Ashtabula River Partnership people provided significant input and review for preparing the project Feasibility Report and this Environmental Impact Statement.

10/25/00

ASHTABULA RIVER PARTNERSHIP Committee Structure

<u>Name</u>	<u>Organization</u>
John Mahan	Coordinator
<u>Coordinating Committee</u>	
Rick Brewer (Co-Chair)	Earthline Technologies
Fred Leitert (C-Chair)	OxyChem
Carl Anderson	Ashtabula RAP
Stuart Breslow	ARCG
Leonard Eames	Ashtabula RAP/City P.A.
Natalie Farber	Ohio EPA
Ron Guido	USACE
Chris Hess	Off. of Congressman LaTourette
Brett Kaull	Citizen
Frank Lichtkoppler	Ohio Sea Grant
Charles McCracken	Ohio Department of Health
Rick Mason	RMI Titanium Company
Jo Misener	Ashtabula City Council
Amy Mucha	USEPA
Rick Nagle	USEPA
Elizabeth Shaw	First Energy Corporation
Brian Troyer	USACE
<u>Outreach Committee</u>	
Carl Anderson (Chair)	Ashtabula RAP
Rick Brewer	Earthline Technologies
Paula Westcott DeMichele	Citizen
Leonard Eames	Ashtabula RAP/City P.A.
Joseph Heimbuch	demaximis, inc.
Betty Layport	Ashtabula Mall
Frank Lichtkoppler	Ohio Sea Grant
Rick Mason	RMI Titanium Company
Joanne Prickett	Citizen
Xavier Turchetta	Citizen
Frank Vaccariello	Kent State Ashtabula
Nancy Zangerle	Ash. Co. Port Authority

Ashtabula River Partnership Committee Structure

<u>Name</u>	<u>Organization</u>
<u>Project Committee</u>	
Rick Mason (Chair)	RMI Titanium Company
Gibson Barbee	Norfolk Southern Corporation
Yogi Chokshi	Reserve Environmental Services
Traci Clever	USACE
Leonard Eames	Ashtabula RAP/City P.A.
Dave English	R. W. Sidley
Natalie Farber	Ohio EPA
Joseph Heimbuch	ARCG (de maximis, Inc.)
Larry Jensen	USEPA
Brett Kaull	Citizen
Charles McCracken	Ohio Department of Health
Stuart Messur	ARCG (BBL)
Amy Mucha	USEPA
Ken Multerer	U.S F&WS
Robert Neuman	Roy F. Weston, Inc.
Don Povolny	Ohio Dept. of Nat. Resources
Kurt Princic	Ohio EPA
Wayne Reiber	ARCG (Cabot)
Richard Rowley	Ash. Co. Port Authority
Ray Saporito	Ash. Co. Health Department
James Schwendeman	First Energy Corporation
Mary Ann Smith	Ash. Township Trustees
Tod Smith	USACE
Jana Todd	Reserve Environmental Services
Brian Troyer	USACE
Sig Williams	Ohio EPA
Tony Wolfskill	ARCG
<u>Resources Committee</u>	
Brett Kaull (Co-Chair)	Citizen
Brian Troyer (Co-Chair)	USACE
Bill Binning	Ohio Dept. of Development
Rick Brewer	Earthline Technologies
Fred Leitert	OxyChem
Rick Mason	RMI Titanium Company
Rick Nagle	USEPA
John C. Palo	Ash. Co. Port Authority
Sig Williams	Ohio EPA
Mike Zullo	Ashtabula City Auditor

SECTION 6 - PUBLIC INVOLVEMENT

INTRODUCTION

6.01 This section briefly describes the study's public involvement program, required coordination, statement recipients, and public views and responses.

PUBLIC INVOLVEMENT PROGRAM

6.02 The Ashtabula River Partnership concept was initiated in January of 1994. The Partnership was formally founded and a charter signed in July of 1994.

6.03 The Ashtabula River Partnership, comprised of private citizens, government officials, and business and industry leaders, is dedicated to exploring how to effectively remediate the contaminated sediments in the Ashtabula River and Harbor. The goal is to look beyond traditional approaches to determine a comprehensive solution for remediation of the contaminated sediments not suitable for open-lake disposal. Successful remediation of contaminated sediments in the Ashtabula River and Harbor will ultimately enhance economic, environmental, and social development opportunities in the Ashtabula region.

6.04 The Ashtabula River Partnership utilizes a Coordinator and various Committees to develop and accomplish various goals and objectives. Committees include the: Coordinating Committee, Project Committee, Siting Committee, Resources Committee, and Outreach Committee. (The Project and Siting Committees were combined into the Project Committee with completion of the Siting Committee's work.) Committee Chairpersons and committee members are identified in the previous SECTION 5.

6.05 The Outreach Committee is responsible for developing and implementing both internal and external outreach communications strategies and public involvement program.

6.06 As indicated just previously, the Partnership utilizes a Coordinator and various Committees to accomplish various goals and objectives. Generally, Committees meet monthly, while Committee task groups often meet more frequently. Full partnership meetings are held quarterly and are usually open to the press and public.

6.07 A Critical Path Method (CPM) workplan was developed for the project in accordance with Federal Planning and National Environmental Policy Act (NEPA) guidelines. It incorporates various milestones and decision points. In conjunction with these milestones the Outreach Committee coordinated numerous public workshops/meetings and/or news conferences to communicate with the public on project status/progress.

6.08 The Outreach Committee work is extensive and the Public Involvement Program includes a proactive government and media relations program to assure that two way feedback with constituents occurs. Study activities have been and are being extensively coordinated with government agencies, interest groups, and the public. Public Involvement Program activities include: scoping correspondence, surveys, educational outreach sessions, public workshops/meetings,

and formal draft and final report review procedures.

6.09 A speaker's bureau was formed from which the Coordinator, Committee Chairpersons, and members of the Partnership make presentations about the Partnership and project to various local, regional, national, and even international interest groups.

6.10 The following page highlights some Ashtabula River Partnership Remediation Project Awards and Recognitions, Milestones, and Key Activities and Events.

6.11 The Public Involvement Program serves to facilitate the project planning process, in: outlining existing and anticipated future environmental conditions; identifying specific problems, needs, and objectives (goals); developing alternative solution plans; and assessing/evaluating alternative solution plans in order to identify a recommended plan.

6.12 Alternatives have been developed and assessed/evaluated for engineering and economic feasibility, and environmental and social acceptability. The alternative selected reflects the best overall response in meeting the developed project objectives/goals. A Comprehensive Management Plan (Feasibility Study Report) and Environmental Impact Statement has been prepared and will be coordinated in accordance with Federal Planning and National Environmental Policy Act (NEPA) guidelines. (Reference paragraph 6.15, also.) The study has been and is being conducted to comply with the various Federal and State environmental statutes and executive orders and associated review procedures.

REQUIRED PLANNING AND NATIONAL ENVIRONMENTAL POLICY ACT (NEPA) COORDINATION AND COMPLIANCE.

6.13 In January of 1994, an initial scoping meeting was held locally involving key Federal and State agencies and local interests. Subsequent meetings followed. In June 1995, supplemental scoping letters were coordinated with agencies and others known to have an interest in the study.

6.14 A Notice of Intent to prepare a Draft Environmental Impact Statement (DEIS) was prepared for the Ashtabula River Partnership by the Buffalo District and published in the Federal Register on January 24, 1996. An EIS is being prepared for this project because it is a major Federal action that will significantly affect the human environment.

6.15 Notice was made in the Federal Register (*September 10, 1999*) and the Draft EIS was coordinated for a 45-day review period with Federal, State, local, and public interests. Notice will be made and the Final EIS will be coordinated for a 30-day review period. If the proposed project is approved, a Record of Decision will be signed and coordinated. Subsequent preparation of final plans and specifications, and construction would follow.

6.16 As summarized in Summary Table S2, (reference the EIS Summary) compliance with

SIGNIFICANT MILESTONES

1994

January Partnership Concept Proposed.
July Partnership Formed/Charter Signed.
August Initial Organizational Meeting.

1995

March Approval of By-Laws.
June Project Supplemental Scoping Letters.
June Five Potential CDF (Confined Disposal Facility) Sites Announced.
June Initiate Work on the Preliminary Draft Comprehensive Management Plan (CMP) and Environmental Impact Statement (EIS) and Appendices.
July Coordinator Hired.
August Speakers Bureau Formed.
December Three Potential CDF Sites Announced.

1996

January Notice of Intent to Prepare an Environmental Impact Statement.
- Project Studies Work
December Ashtabula River Foundation Formed.

1997

February Preferred CDF Upland Site Selected.
May First Preliminary Draft Comprehensive Management Plan (CMP) and Environmental Impact Statement (EIS) and Appendices to the Partnership.
September Preliminary Draft Comprehensive Management Plan (CMP) and Environmental Impact Statement (EIS) and Appendices to the Partnership.
December U.S. Army Corps of Engineers Review Conference.
December Section 312(b) Authority Project Sub-Committee Formed and Work Initiated.

1998

May Preliminary Draft 312(b) Authority Report to the Partnership.
May Project Authority Conference at U.S. Army Corps of Engineers at Cincinnati, Ohio.
October Revised Preliminary Draft Comprehensive Management Plan (CMP) and Environmental Impact Statement (EIS) and Appendices to the Partnership.

1999

- Revisions to Draft Comprehensive Management Plan (CMP) and Environmental Impact Statement (EIS) and Appendices (incl. Preliminary Wetland Mitigation Plans).
July Revised Draft Comprehensive Management Plan (CMP) and Environmental Impact Statement (EIS) and Appendices to the Partnership.
September Draft Comprehensive Management Plan (CMP) and Environmental Impact Statement (EIS) and Appendices to the Public and Subsequent Public Meeting.

2000

- Advance Preliminary Design and Value Engineering Review.
July Assessment/Evaluation of the State Road (brownfield) Site as a Disposal Site.
- Supplemental Radionuclide Sampling and Analyses.
- Respond to Comments on the Draft Reports and Revise Reports.

2001

January Preliminary Final Comprehensive Management Plan (CMP) and Environmental Impact Statement (EIS) and Appendices to Independent Technical Review and to the Partnership.
- Final Comprehensive Management Plan (CMP) and Environmental Impact Statement (EIS) and Appendices to the Public.
- Response to Comments and Record of Decision (ROD) to the Public.

key Federal and State environmental statutes is as follows:

6.17 Preservation of Historical Archaeological Data Act of 1974, 16 USC et seq.; National Historic Preservation Act of 1966 as amended, 16 USC 470 et seq.; Executive Order 11593, Protection and Enhancement of the Cultural Environment, 13 May 1971. Project coordination was and is being conducted with the U.S. Department of the Interior - National Park Service, and the Ohio State Historic Preservation Office in this regard. The Ashtabula Harbor area is considered to be archaeologically and historically sensitive. The harbor lighthouse and light stations on the harbor breakwaters are listed on the National Register of Historic Places.

6.18 The river dredging area and potential Transfer/Dewater/Transfer sites have been disrupted by previous fairly recent activities, and no significant cultural resource items would be expected at these sites.

6.19 A letter dated September 18, 2000 was coordinated with the State Historic Preservation Office pertaining to potential development of disposal facilities at State Road Site. Enclosures included: a list of documents prepared for remediation of the site, an extract from one of the documents pertaining to the industrial development and use of the site, a wetland and ecological site walkover investigation prepared by the Buffalo District, a memo pertaining to existing site conditions prepared by the Buffalo District, and a site photo index and photos taken during site demolition. The State Historic Preservation Office provided a letter dated November 7, 2000 reaffirming that the project will have no effect on any properties listed or eligible for the National Register of Historic Places. No further coordination is necessary unless the scope of the project should change. If new or additional properties are discovered, the State Historic Preservation Office should be notified. Reference EIS Appendix EA-H CULTURAL RESOURCES ASSESSMENT, also.

6.20 Clean Air Act, as amended, 42 USC 7401 et seq. Project coordination was and is being conducted with the U.S. Environmental Protection Agency, the Ohio State Environmental Protection Agency, and the Ohio State Department of Natural Resources in this regard. Except for minor emissions associated with the operation of construction equipment and some potential temporary earthy odor associated with discharge of dredged material, no significant adverse impacts to air quality would be expected due to project implementation.

6.21 Some minor volatilization of contaminants would occur during the dredging and handling of dredged material. The only potential time and area of any substantial concern in this regard would be during the dredging and immediate handling of PCB TSCA material in the immediate area of the dredged material. Appropriate monitoring and protective wear would be worn by workers at these times and in these areas. Appropriate restriction areas will be established. Volatile losses from the water during dredging would be low because of very low contaminant concentrations in the water column (due to their hydrophobic low solubility nature) and the large volume of water available for dispersion of the dissolved PCBs before they become available for volatilization. The contaminant flux from moist sediment is extremely high immediately after exposure to air. The flux then drops off quickly as the sediment pore water evaporates. However, the flux increases, if the sediment resaturates, as would be the case during a significant rainfall. Canopy cover measures would significantly reduce volatilization

of contaminants during handling and transport.

6.22 This Environmental Impact Statement is being coordinated with the U.S. Environmental Protection Agency, the Ohio State Environmental Protection Agency, and the Ohio State Department of Natural Resources in this regard.

6.23 Clean Water Act of 1977 (Federal Water Pollution Control Act Amendments of 1972) 33 USC 1251 et seq; Ohio State Administrative Code, Title 3745 - Environmental Protection Agency, Chapter 3745 (Water Quality and associated permits items) and Ohio Revised Code, Chapter 6111 Water Pollution Control Laws). Project coordination was and is being conducted with the U.S. Environmental Protection Agency, the U.S. Army Corps of Engineers, the Ohio State Environmental Protection Agency, the Ohio Department of Health, and the Ohio State Department of Natural Resources in this regard.

6.24 A Clean Water Act Public Notice and Section 404(b)(1) Evaluation Report was coordinated with the Draft Environmental Impact Statement as EIS Appendix EA-B. (Part of the report and followed these text). This addressed project related activities such as: dredging activities, placement of fill or dredged material in U.S. waters (including wetlands), wetland mitigation, and filtered/treated water discharges and associated water quality requirements and compliance.

6.25 Subsequent to the Draft Reports, a number of additional evolved alternative disposal facilities and alternatives were assessed/evaluated. Use of existing disposal facilities can not be utilized because RAD material can not be co-mingled with other disposed material and must have its own disposal facility. In this regard, the former RMI Sodium Plant site (State Road Site) has become available. The site has been disturbed by past plant development and recent demolitions and is of little value to fish and wildlife and contains only a minor wetlands at the eastern boundary and northeast corner. This will be avoided. The Fields Brook remediation project material is being disposed of in part of this property. There is room for the Ashtabula River Partnership dredged elevated PCB and RAD material to be disposed of in a developed facility adjacent to the Fields Brook remediation project disposal facility. There is also just enough room for the Ashtabula River Partnership dredged contaminated material to be disposed of in a developed facility adjacent to the other disposal facilities. Assessment/evaluation indicates that this is the overall preferred possible disposal alternative and is now the project disposal component plan.

6.26 The final proposed project is the same as that proposed in the draft reports except that the material would be disposed of at developed disposal facilities at the State Road Site. Since this would avoid impacts to any wetlands and reduce impacts to U. S. Waters and fish and wildlife resources from that discussed in the Draft reports, a new Clean Water Act Public Notice and Section 404(b)(1) Evaluation Report will not be issued. Actions specific to development and disposal of material at the brownfields State Road Site (no discharge to U.S. Waters including wetlands) is not subject to Clean Water Act Section 404/401.

6.27 The Ashtabula River Partnership forwarded an initial Application For Ohio EPA Section 401 Water Quality Certification with the draft reports. This was withdrawn due to project plan disposal revisions and limited preliminary design information. The Ohio EPA however, issued an interim letter of concurrence on feasibility in this regard pertaining to sufficient planning and preliminary design and indicated that a Final Application For Ohio EPA Section 401 Water Quality Certification should be submitted with more detailed final design and support documentation. The Ashtabula River Partnership will be forwarding a Final Application For Ohio EPA Section 401 Water Quality Certification with design and support documentation.

6.28 Pertaining to radionuclides, it is the recommendation of the Ohio Department of Health, Bureau of Radiation Protection (ODH/BRP) and the United States Environmental Protection Agency, Region 5, (USEPA) that all water discharges, associated with the processes of this project, to public water-ways, meet the USEPA Safe Drinking Water Act (SDWA) Maximum Contaminant Levels for gross alpha @ 15 picocuries per liter (pCi/L), the combined radium (Ra-226 + Ra-228) Maximum Contaminant Level @ 5 pCi/L, a maximum contaminant level for beta particle and photon radioactivity @ 4 millirem per year, the average annual concentration of gross beta particle activity @ 50 pCi/L and the proposed Maximum Contaminant Level for uranium (30 pCi/L or 20 ug/L). The ODH/BRP, with the cooperation of, and in conjunction with the Ohio Environmental Protection Agency, Division of Surface Water (OEPA/ DSW), will institute these SDWA requirements concurrently with the OEPA/DSW approval of the ARP State Water Quality Certification.

6.29 The Ashtabula River Partnership is also coordinating with the Ohio Environmental Protection Agency with regard to the National/State Pollution Discharge Elimination System permit and criteria, and the Ohio Environmental Protection Agency Division of Water Pollution Control Permit to Install or Plan Approval Application, as necessary, and any other permit requirements, as necessary.

6.30 National Environmental Policy Act, 42 USC 470a, et seq; Protection and Enhancement of Environmental Quality (EO11514). Alternative plans are developed and evaluated in accordance with environmental considerations as set forth by this Act, as promulgated by the Department of the Army's: Principles and Guidelines, ER 200-2-2 Environmental Quality - Policies and Procedures for Implementing NEPA, and the Rivers and Harbors Act COE Section 122 Guidelines. Requirements of the Act are accomplished via the planning and coordination process.

6.31 Fish and Wildlife Coordination Act, 16 USC 661 et seq. Project coordination was and is being conducted with the U.S. Department of the Interior - Fish and Wildlife Service, as well as with the Ohio State Department of Natural Resources in this regard. These agencies provided information and impact assessment pertaining to fish and wildlife resources and threatened or endangered species and/or habitat in the project vicinity. The Fish and Wildlife Service Coordination Act Report is included as EIS Appendix EA-D. (Part of this report and follows these text).

6.32 Endangered Species Act, as amended, 16 USC 1531 et seq. Project coordination was and is being conducted with the U.S. Fish and Wildlife Service (USFWS) and the Ohio State

Department of Natural Resources in this regard. The U.S. Fish and Wildlife Service in their Coordination Act Report indicated that the proposed project lies within the range of the Indiana bat, bald eagle, and piping plover, Federally listed endangered or threatened species; but, that they do not anticipate that the proposed project will impact any of these species or habitat. The Ohio Department of Natural Resources did not identify any State protected species or associated habitats that would be adversely impacted by project implementation.

6.33 Estuary Protection Act, 16 USC et seq. Not applicable in this case.

6.34 Marine Protection Research and Sanctuaries Act of 1972, as amended, 16 USC 1401 et seq. Not applicable in this case.

6.35 Rivers and Harbors Act, 33 USC 401 et seq; Water Resources Development Act(s); Water Resources Planning Act, 42 USC 1962 et seq. Project coordination was and is being conducted with an array of Federal, State, and local agencies and interests in this regard. These statutes provide major authority for U.S. Army Corps of Engineers activities pertaining to development and operations and maintenance of River and Harbor facilities. The study is being conducted in accordance with requirements of these statutes and related regulations.

6.36 Executive Order 11990, Protection of Wetlands, 24 May 1977. Project coordination was and is being conducted with the U.S Army Corps of Engineers, the U.S. Fish and Wildlife Service, the Ohio Environmental Protection Agency, and the Ohio Department of Natural Resources in this regard. One consideration carried throughout the planning process was to avoid or minimize impacts to wetland areas. Reference maps and information and specific site investigations were considered. Even with this consideration, some wetland areas would unavoidably be impacted with development of initially considered disposal sites and would require some level of compensation or mitigation. The final proposed plan avoids any significant adverse impacts to wetlands.

6.37 Federal Water Project Recreation Act, as amended, 16 USC 460-1(12) et seq. Project coordination was and is being conducted with the U.S. Department of the Interior, the U.S. Fish and Wildlife Service, and the Ohio State Department of Natural Resources. It appears that the proposed project would be consistent with long-term land and associated water use plans including those for recreational developments.

6.38 Land and Water Conservation Fund Act, 16 USC 4601 et seq. Project coordination was and is being conducted with the U.S. Department of the Interior in this regard. The proposed project is expected to be consistent with their comprehensive outdoor recreation plan.

6.39 Wild and Scenic Rivers Act, 16 USC 1271 et seq. Project coordination was and is being conducted with the U.S. Department of the Interior and the Ohio Department of Natural Resources in this regard. In accordance with the National Wild and Scenic Rivers Act, Public Law 90-542, the final lists of rivers identified as meeting the criteria for eligibility dated January 1981 were consulted. The lower Ashtabula River was not listed.

6.40 Coastal Zone Management Act, as amended, 16 USC 1451 et seq. Project coordination was and is being conducted with various agencies including the U.S. Department of Commerce, National Oceanic and Atmospheric Administration, Office of Ocean and Coastal Resource Management, and the Ohio Department of Natural Resources, Coastal Management Program in this regard. A Coastal Zone Management Consistency Determination Report has been prepared and is included with this Environmental Impact Statement as EIS Appendix EA-G. It has been determined that the project is consistent with the Coastal Management Program to the extent possible. Concurrence from the Ohio Department of Natural Resources Coastal Management Program Office is requested and expected.

6.41 Watershed Protection and Flood Prevention Act, 16 USC 1001 et seq., and Executive Order 11988, Flood Plain Management, 24 May 1977. Project coordination was and is being conducted with various agencies including the U.S. Department of Agriculture - Soil Conservation Service, and the Federal Emergency Management Agency in this regard. The city of Ashtabula is involved in the regular program of the National Flood Insurance Program. By this stage, flood insurance and flood plain management maps have been developed. Local ordinances pertaining to new or redevelopment in the flood plain and flood protection to the intermediate regional (100-year event) flood level have been enacted. In this way, flood insurance would help to compensate residents for flood damages to existing developments, while flood plain development ordinances would reduce the potential of flood damages of any future developments or redevelopments. It is not expected that the proposed harbor project would significantly affect the community flood plain areas. It should be noted, however, that continued maintenance dredging may provide some degree of flood reduction along the lower Ashtabula River.

6.42 Farmland Protection Policy Act (PL 97-98) and Executive Memorandum - Analysis of Impacts on Prime and Unique Farmlands. Project coordination was and is being conducted with the U.S. Department of Agriculture - Natural Resources Conservation Service in this regard. No significant adverse impact to any important farmland or farm activity would be expected due to the proposed project implementation. The site considered for the Harbor Area Shoreline Transfer/Dewater/Transfer facility development is a previous interim dredged material disposal site. The (State Road Site) site proposed for the new upland confined disposal facility development is a former industrial (brownfield) site. No active farms or farmland would be taken.

6.43 Executive Order 12114, Environmental Effects Abroad of Major Federal Actions, 4 January 1979. Project coordination was and is being conducted with the International Joint Commission as it pertains to Great Lakes Areas of Concern and Remedial Action Plans. This project pertains to remediation of the Lower Ashtabula River (including appropriate dredging and disposal of contaminated sediments) and continued operation and maintenance of Federal and local navigation facilities at Ashtabula Harbor with disposal of suitable for unrestricted open-lake disposal dredged material at the open-lake disposal site or for beneficial use.

6.44 Executive Order 12898, Environmental Justice. Project coordination was and is being conducted with the U.S. Environmental Protection Agency in this regard. The U.S. Environmental Protection Agency prepared an analysis in this regard included as EIS Appendix EA-I

Environmental Justice. (Part of this report and follows these text). In general, environmental justice refers to fair treatment of all races, cultures and income levels with respect to development, implementation, and enforcement of environmental laws, policies and actions. At the federal level, the obligation of government agencies to take environmental justice into account is outlined in Executive Order 12898. In a memorandum accompanying Executive Order 12898, President Clinton also directed agencies to analyze "the environmental effects, including human health, economic and social effects, of federal actions, including effects on minority communities and low-income communities, when such analysis is required by the National Environmental Policy Act of 1969." The Comprehensive Management Plan for the Ashtabula River Dredging Project and Combined Disposal Facility (Ashtabula River Proposal) conforms to the U.S. government's policy of insuring that federal projects do not disproportionately impact a community's right to a safe and clean environment. The project poses no significant risks to the health of nearby residents or the surrounding environment. Rather, the project is expected to improve long-term environmental conditions in the areal, benefiting up- and down-stream habitats, and recreational activities, that depend on their quality.

6.45 Hazardous, Toxic, and Radioactive Wastes (HTRW). The primary hazardous, toxic, and radioactive waste (HTRW) Federal statutes and Executive Orders (EO) referenced for this project include: Resource Conservation and Recovery Act (RCRA), 1976; Hazardous and Solid Waste Amendments (HSWA), 1984; Comprehensive Environmental Response, Compensation, and Liability Act (CERCLA or SUPERFUND), 1980; Superfund Amendments and Reauthorization Act (SARA), 1986; Toxic Substance Control Act (TSCA), 1986; Pollution Prevention Act, 1990, 42 USC 13101; Executive Orders 12088, 12580, and 12856. Reference Ohio State Department of Health (Radionuclides (RAD)). that follows, also. Project coordination was and is being coordinated with various agencies including the U.S. Environmental Protection Agency, the Ohio Environmental Protection Agency, the Ohio Department of Health, and the Public in this regard. The project is not currently subject to RCRA/HSWA and/or CERCLA/SARA regulation, per say. Ashtabula River PCB contaminated sediments were tested (1995/1996) and were determined to be non-RCRA. However, if the remediation of the Ashtabula River sediment contamination can not be accomplished through this Ashtabula River Partnership study/project, remediation may be pursued via CERCLA/SARA and/or RCRA/HSWA. Dredged material with PCBs equal to or in excess of 50 mg/kg are regulated under TSCA and must be appropriately handled and disposed. The study/project has been pursued accordingly. Other sediments with elevated levels of contaminants may not be disposed at open lake disposal sites and must be appropriately disposed by alternate disposal methods. This has also been pursued accordingly.

6.46 Transfer/Dewatering/Transfer facilities (marine and/or shoreline based) would be designed to accommodate the dewatering processes described previously and to facilitate handling of TSCA material, since they would be utilized to transfer/dewater/transfer both the TSCA and Non-TSCA dredged material. Specific reference for PCB regulations applicable to the technical requirements for a TSCA chemical waste landfill are found at 40 CFR Section 761.75. Developed upland TSCA disposal facilities would be designed with reference to these regulations.

6.47 With regard to Non-TSCA substantially contaminated dredged material, although it is not regulated as a solid waste, associated water discharges would need to meet Clean Water Act and associated water quality discharge standards. Reasonably, the best way to accomplish that is to provide contaminated dredged material containment and water control and treatment facilities (i.e. reliable solid waste disposal containment and water control and treatment facilities).

6.48 The conceptual Non-TSCA disposal facility plan has been designed with reference to Ohio's Revised Code Chapter 6111 Water Pollution Control Laws 6111.45 Approval of Plans for Disposal of Waste, Department of Surface Waters 0400-028 Policy - Industrial Other Waste, and Ohio's Solid Waste Best Available Technologies (BAT) Rules (RCRA Subtitle D) effective July 1, 1994.

6.49 Transfer/Dewatering/Transfer and Disposal Facilities would incorporate filtration/treatment systems in order to meet discharge water quality requirements.

6.50 (Health and Safety) Measures will be incorporated into the project design and implementation to assure that the project is carried out as safely as possible during project implementation and is safe in the future. Reference associated sections of **SECTION 2 - RECOMMENDED PLAN** and **MONITORING**. Reference **EIS APPENDICES EA-B and EA-C**, also.

6.51 Federal, State, and Local laws and regulations will need to be complied with for handling and disposal of the various levels of contaminated dredged material, the most critical pertaining to those regulated per TSCA for dredged sediments with PCBs equal to or in excess of 50 mg/ kg and radionuclides. Some of the more pertinent Federal, State and local regulations (not all inclusive) referenced include those listed on following pages 182 and 183.

6.52 Ohio State Department of Health (Radionuclides (RAD)). The U. S. Environmental Protection Agency, (USEPA) Great Lakes National Program Office (GLNPO) and the Partnership had concerns regarding radionuclide contamination within the river sediments. This prompted the Partnership to initiate a review analytical data for radionuclides that the USEPA collected at 12 sediment-sampling locations in late 1990. The 12 sites were identified as "hot spot" areas with numerous chemical contaminants, based on a comprehensive Ashtabula River sediment study completed in early 1990. That sampling was done to determine whether river sediments contained high levels of radioactive material. The highest concentrations of radionuclides were found at depths in sediment of 4 to 15 feet, in the area of the upper turning basin. The concentrations of total uranium (U-234+U-235+U-238) detected in the sampling ranged from 2.4 to 22.3 picocuries per gram (pCi/g), with an average value of 10.1 pCi/g. The concentrations of total radium (Ra-226+Ra-228) detected in the sampling ranged from 2.6 to 20.6 pCi/g, with an average value of 10.8 pCi/g. In October 1990, USEPA issued a press release about the sample results, stating "these values, are well below the 30 pCi/g guideline limit set by the Nuclear Regulatory Commission, for unrestricted use of cleaned-upland. Based on the results of this sampling, EPA sees no need to employ special precautions for radionuclides during the dredging and disposal of these river sediments".

6.53 In August 1992, the Ohio General assembly enacted Senate Bill 130, which required that

Low-Level Radioactive Waste not be disposed of without a license issued by the Nuclear Regulatory Commission and/or the Director of the Ohio Department of Health. The Ohio Department of Health, Bureau of Radiation Protection (ODH/BRP), as the State of Ohio Radiation Control Agency, and as a member of the Ashtabula River Partnership, is reviewing the conceptual, and subsequent detailed versions, of the design plans for dredging, transfer/dewatering and disposal of river sediments to provide assurance that the river cleanup project is consistent with State requirements and will be protective of public health

6.54 In early 1998, after a review of the analytical data from Ashtabula river sediments collected, beginning in 1996, by Michael E. Ketterer, then a chemistry professor at John Carroll University, and a re-review of their own 1990 analytical data, the USEPA decided to add radioactivity as an analysis parameter for the planned sediment sampling later that year. In May 1998, the USEPA collected eight sediment samples from six depositional areas in the lower river. This scoping survey was done for several reasons. Historically, sediment sampling analysis had been focused primarily on uranium. Several radionuclides are naturally occurring substances found in coal and titanium ore, which is processed in the area. Additional analysis was necessary to determine the extent of the presence of other radionuclides within river sediments. Additionally, the USEPA was reviewing risk based cleanup goals for Fields Brook (an Ashtabula River tributary and USEPA Superfund site) and required additional verification sampling/analysis. The highest concentrations of radionuclides were found at depths in sediment of 4 to 15 feet, in the area of the confluence of Fields Brook. The concentrations of total uranium detected in the sampling ranged from 1.6 to 64.7 pCi/g, with an average value of 11.9 pCi/g. The concentrations of total radium detected in the sampling ranged from 1.0 to 17.3 pCi/g, with an average value of 4.1 pCi/g. The maximum total uranium concentration is about twice that being applied to a commercial cleanup on Fields Brook. The maximum total radium concentration is about 30% more than the commercial cleanup criterion and about 3 times the residential cleanup criterion for Fields Brook. From this data, it became evident to the Partnership that radionuclides were part of the contaminants of concern for the Ashtabula River clean up.

6.55 On May 18, 1999, the ODH/BRP issued an opinion letter to the Partnership regarding the ARP remedial action design. The ODH/BRP opinion letter stated: "...that based on the review of the ARP draft CMP/EIS and given the presently known radionuclide concentrations within the sediments of the Ashtabula river, the recommended plan for disposal of the sediments is consistent with State requirements". Ohio Revised Code Title 37 - Chapter 48 and the rules promulgated there under delineate the regulatory authority under which the ODH/BRP performed its review. During its consideration of this matter, ODH/BRP staff reviewed the criteria in 10 CFR 61 as delineated in Ohio Administrative Code (OAC) 3701-39-021. The ODH/BRP takes the position that the dredging and disposal of low-level radioactive sediments from the Ashtabula River does not require a 10 CFR 61 as delineated in OAC 3701-39-021 disposal action. The ODH/BRP has and will continue to implement the State of Ohio's regulations consistent with a 10CFR 20.2002 as delineated in OAC 3701-39-021 on-site remediation and disposal action.

6.56 During the week of August 23-29, 1999, a radiological characterization of the sediments in the Ashtabula River was conducted by members of the Radiation staff of the USEPA's

Superfund Division (USEPA-SD) and personnel from the ODH/BRP. The USEPA's Research Vessel "Mudpuppy" was used to collect 106 sediment samples. Radiological analysis of the samples was performed by USEPA's National Air and Radiation Environmental Lab (NAREL). The highest concentrations of radionuclides were found at depths in sediment of 4 to 15 feet, in the area of the upper turning basin. The concentrations of total uranium detected in the sampling ranged from 0.98 to 109.99 pCi/g, with an average value of 6.95 pCi/g. The concentrations of total radium detected in the sampling ranged from 1.8 to 16.1 pCi/g, with an average value of 4.2 pCi/g. This information was used towards the determination of specific project objectives. Those objectives included, determining if the Non-TSCA area sediments differ statistically from upstream background sediments, and obtaining an adequate amount of data in order to perform radiological risk assessments.

6.57 Statistical evaluation of the Non-TSCA area sediment sample data was performed by USEPA Region 5 statisticians under direction of USEPA-SD and ODH/BRP Radiation staff. The statistical procedures used to compare background to sediment sample site concentrations were the parametric two-sample T test and the non-parametric Mann-Whitney U and the Wilcoxon Rank Sum tests. Both parametric and non-parametric procedures were used because environmental data rarely adheres to a normal data distribution. The results showed that there is a statistical difference between the unaffected background sediments, i.e., upstream of the confluence of Fields Brook, and the downstream, Non-TSCA area sediments. The details of the USEPA statistical analysis can be found in Technical Appendix C-Rad.

6.58 On June 12, 2000 the ODH/BRP, in response to a ARP letter of request, clarified it's regulatory position on the disposal of Ashtabula river sediments. The ODH/BRP has classified the river sediments: as radioactive material in accordance with the definition set forth in Ohio Revised Code 3748.01(O); as source material in accordance 10 CFR 40.4 as delineated in OAC 3701-39-021; and as low-level radioactive waste as defined in RC 3748.01(L). It is the understanding of the ODH/BRP that the sediments are not regulated pursuant to 40 CFR 240 and therefore are not classified as mixed wastes. The ODH/BRP continues to believe that the sediments can be placed in a properly designed cell as described in the CMP/EIS "recommended plan".

6.59 (Radiological Risk Assessment) Risk assessments were made by the U.S. Environmental Protection Agency (USEPA) Region 5 involving inadvertent and unknowing use of Ashtabula River sediments (Reference EIS Appendix C and CMP Technical Appendix F). The first was based upon a resident applying these sediments, left below the cutline for chemical removal, to their property and growing foodstuffs there. There were potentials for external exposure, plant ingestion, soil ingestion and dust inhalation (including radon + decay products) risks. The second was based upon a worker being exposed as they dredged the chemically contaminated sediments or as they unknowingly dredged sediments above the cutline. There were potentials for external exposure and soil ingestion risks

6.60 The results for the Resident-Farmer showed that the total risk from all pathways to a resident (born on the property and living there for 30 years) was about 1×10^{-4} . The risk was about equally apportioned between external exposure, plant ingestion, and inhalation of radon + decay products. The greatest impact was on the older age groups; older child (6 - 12

years), teenager (13 - 19 years) and adult (20 - 30 years) who had longer exposure periods. The other age groups [baby (0 - 1 year), older baby (1 - 2 years), young child (3 - 5 years)] were lesser impacted. 1×10^{-4} is at the upper bound of the acceptable risk range for lifetime cancer risk found in USEPA's guiding document, the National Oil and Hazardous Substances Pollution Contingency Plan (NCP). The sediment concentrations that led to this risk were found in the Uranium, Thorium and Actinium Decay Series. In no case were any concentrations more than twice background levels for the river and in most cases these were 50% or less over background. The levels measured here are one picocurie per gram (pCi/g) or less background and less than 0.5 pCi/g additional in the sediments. Thus, even though the 30 year risk is at the upper end of the NCP risk range, the small deviation from background radiation sediment levels does not warrant further dredging of the river.

6.61 For the Worker-Dredger the total risk for 2 year plus 4 month excavation project is about 5×10^{-5} . This risk is within the 10^{-6} to 10^{-4} risk range in the NCP. The maximum levels found in these sediments reach about 45 pCi/g uranium-238 + decay products (over background) and about 57 pCi/g uranium-234 (over background) and. These concentrations diverge substantially from background and warrant a health and safety plan and worker protection. However, during the chemical cleanup workers will be under such a plan and will be wearing protective clothing. Thus, if the health and safety plan specifically deals with radiation and the worker is monitored for radiation (e.g., dosimeter, radiation frisking, etc.) this should be adequate.

6.62 In the case of an unknowing worker-dredger, the high radioactive concentrations should be a matter of concern even if the risks are still within the NCP risk range. In radiation public health, the philosophy of ALARA (radiation exposures should be As Low As Reasonably Achievable) is always applied. Removal of these contaminated sediments is a prudent action that would prevent inadvertent exposure of a worker-dredger and keep their potential doses ALARA.

6.63 Natural Resources (Trustees) Damages. Nothing in this environmental impact statement shall be construed either explicitly or implicitly to irreversibly or irretrievably commit natural resources either directly or indirectly associated with the proposed dredging of the Ashtabula Harbor Channel beyond those areas outside of the area of dredging.

6.64 State and Local Land Use Plans. It appears that the proposed project is consistent with considered local and regional land and associated water use plans. Ashtabula County has an Ashtabula County Solid Waste Management District Plan per ORC Chapter 3734, which directs county waste disposition that was referenced during the study. The proposed project is supported by the local sponsors.

FEDERAL REGULATIONS

TITLE 29 - LABOR

- TITLE 33 - NAVIGATION AND NAVIGABLE WATERS
- PART 1910 - OCCUPATIONAL SAFETY AND HEALTH STANDARDS
- PART 154 - FACILITIES TRANSFERRING OIL OR HAZARDOUS MATERIAL IN BULK
- PART 155 - OIL OR HAZARDOUS MATERIAL POLLUTION PREVENTION REGULATIONS FOR VESSELS
- PART 156 - OIL OR HAZARDOUS MATERIAL TRANSFER OPERATIONS
- PART 320 - GENERAL REGULATORY POLICIES
- PART 322 - PERMITS FOR STRUCTURES OR WORK IN OR AFFECTING NAVIGABLE WATERS OF THE UNITED STATES
- PART 323 - PERMITS FOR DISCHARGES OF DREDGED OR FILL MATERIAL INTO WATERS OF THE UNITED STATES
- PART 330 - NATIONWIDE PERMITS
- TITLE 40 - PROTECTION OF THE ENVIRONMENT
- PART 4 - UNIFORM RELOCATION ASSISTANCE AND REAL PROPERTY ACQUISITION FOR FEDERAL AND FEDERALLY ASSISTED PROGRAMS
- PART 25 - PUBLIC PARTICIPATION IN PROGRAMS UNDER THE RESOURCE CONSERVATION AND RECOVERY ACT, THE SAFE DRINKING WATER ACT, AND THE CLEAN WATER ACT.
- PART 26 - PROTECTION OF HUMAN SUBJECTS.
- PART 116 - DESIGNATION OF HAZARDOUS SUBSTANCES.
- PART 117 - DETERMINATION OF REPORTABLE QUANTITIES FOR HAZARDOUS SUBSTANCES
- PART 122 - EPA ADMINISTERED PERMIT PROGRAMS: THE NATIONAL POLLUTANT DISCHARGE ELIMINATION SYSTEM (SEE STATE).
- PART 123 - STATE PROGRAM REQUIREMENTS
- PART 129 - TOXIC POLLUTANT EFFLUENT STANDARDS
- PART 130 - WATER QUALITY PLANNING AND MANAGEMENT
- PART 131 - WATER QUALITY STANDARDS
- PART 132 - WATER QUALITY GUIDANCE FOR THE GREAT LAKES SYSTEM
- PART 136 - GUIDANCE ESTABLISHING TEST PROCEDURES FOR THE ANALYSIS OF POLLUTANTS
- PART 141 - NATIONAL PRIMARY DRINKING WATER
- PART 142 - REGULATIONS/IMPLEMENTATION
- PART 143 - NATIONAL SECONDARY DRINKING WATER REGULATIONS IMPLEMENTATION
- PART 149 - SOLE SOURCE AQUIFERS
- PART 225 - CORPS OF ENGINEERS DREDGED MATERIAL PERMITS
- PART 230 - SECTION 404(b)(1) GUIDELINES FOR SPECIFICATION OF DISPOSAL SITES FOR DREDGED OR FILL MATERIAL
- PART 240 - GUIDELINES FOR THE THERMAL PROCESSING OF SOLID WASTES

- PART 241 - GUIDELINES FOR THE LAND DISPOSAL OF SOLID WASTES
- PART 243 - GUIDELINES FOR THE STORAGE AND COLLECTION OF RESIDENTIAL, COMMERCIAL, AND INSTITUTIONAL SOLID WASTE
- PART 257 - CRITERIA FOR CLASSIFICATION OF SOLID WASTE DISPOSAL FACILITIES AND PRACTICES
- PART 258 - CRITERIA FOR MUNICIPAL SOLID WASTE LANDFILLS
- PART 260 - HAZARDOUS WASTE MANAGEMENT SYSTEM: GENERAL
- PART 261 - IDENTIFICATION AND LISTING OF HAZARDOUS WASTE
- PART 262 - STANDARDS APPLICABLE TO GENERATORS OF HAZARDOUS WASTE
- PART 263 - STANDARDS APPLICABLE TO TRANSPORTERS OF HAZARDOUS WASTE
- PART 264 - STANDARDS FOR OWNERS AND OPERATORS OF HAZARDOUS WASTE TREATMENT, STORAGE, AND DISPOSAL FACILITIES
- PART 266 - STANDARDS FOR THE MANAGEMENT OF SPECIFIC HAZARDOUS WASTES AND SPECIFIC TYPES OF HAZARDOUS WASTE MANAGEMENT FACILITIES
- PART 268 - LAND DISPOSAL RESTRICTIONS
- PART 270 - EPA ADMINISTERED PERMIT PROGRAMS: THE HAZARDOUS WASTE PROGRAMS
- PART 272 - APPROVED STATE HAZARDOUS WASTE MANAGEMENT PROGRAMS
- PART 273 - STANDARDS FOR UNIVERSAL WASTE MANAGEMENT
- PART 300 - NATIONAL OIL AND HAZARDOUS SUBSTANCES POLLUTION CONTINGENCY PLAN
- PART 302 - DESIGNATION, REPORTABLE QUANTITIES, AND NOTIFICATION
- PART 307 - COMPREHENSIVE ENVIRONMENTAL RESPONSE, COMPENSATION, AND LIABILITY ACT (CERCLA) CLAIMS PROCEDURES
- PART 311 - WORKER PROTECTION
- PART 372 - TOXIC CHEMICAL RELEASE REPORTING: COMMUNITY RIGHT-TO-KNOW
- PART 403 - GENERAL PRETREATMENT REGULATIONS FOR EXISTING AND NEW SOURCES OF POLLUTION
- PART 501 - STATE SLUDGE MANAGEMENT
- PART 503 - USE OR DISPOSAL OF SEWAGE SLUDGE
- PART 750 - PROCEDURES FOR RULEMAKING UNDER SECTION 6 OF THE TOXIC SUBSTANCES CONTROL ACT
- PART 761 - POLYCHLORINATED BIPHENYLS (PCBs) MANUFACTURING, PROCESSING, DISTRIBUTION IN COMMERCE, AND USE PROHIBITIONS
- PART 1501 - NEPA AND AGENCY PLANNING
- TITLE 49 - TRANSPORTATION
- PART 107 - HAZARDOUS MATERIALS PROGRAM PROCEDURES
- PART 171 - GENERAL INFORMATION, REGULATIONS, AND DEFINITIONS
- PART 172 - HAZARDOUS MATERIALS TABLES, HAZARDOUS MATERIALS COMMUNICATIONS REQUIREMENTS AND EMERGENCY RESPONSE INFORMATION REQUIREMENTS

PART 173 - SHIPPERS - GENERAL REQUIREMENTS FOR SHIPMENTS AND PACKAGING
 PART 174 - CARRIAGE BY RAIL
 PART 176 - CARRIAGE BY VESSEL
 PART 177 - CARRIAGE BY PUBLIC HIGHWAY
 PART 178 - SPECIFICATIONS FOR PACKAGING
 PART 190 - PIPELINE SAFETY PROGRAM PROCEDURES
 PART 195 - TRANSPORTATION OF HAZARDOUS LIQUIDS BY PIPELINE
 PART 386 - RULES OF PRACTICE FOR MOTOR CARRIER SAFETY AND HAZARDOUS MATERIALS PROCEEDINGS

PCB COMPLIANCE PROGRAM NOTICES

- ° ENVIRONMENTAL PROTECTION AGENCY POLICY ON LIABILITY FOR PCB-CONTAINING EQUIPMENT (No. 6-PCB-1)
- ° ENVIRONMENTAL PROTECTION AGENCY POLICY ON PCB SEPARATION METHODS (No. 6-PCB-2)
- ° ENVIRONMENTAL PROTECTION AGENCY POLICY ON RESIDUAL PCBs IN PROCESSED LIQUIDS AND SOLIDS (No. 6-PCB-3)
- ° ENVIRONMENTAL PROTECTION AGENCY POLICY ON DISPOSAL METHODS FOR PCBs IN SLUDGE (No. 6-PCB-4)

STATE (OHIO STATE ADMINISTRATIVE CODE)

TITLE 3745 - ENVIRONMENTAL PROTECTION AGENCY

- Chapter 3745-1 Water Quality Standards
- Chapter 3745-3 Pretreatment Regulations
- Chapter 3745-9 Water Well Standards
- Chapter 2745-27 Solid Waste Disposal Regulations
- Chapter 3745-30 Residual Waste Landfill Facilities
- Chapter 3745-31 Permit to Install New Sources of Pollution
- Chapter 3745-32 Section 401 Water Quality Certifications
- Chapter 3745-33 Ohio NPDES Permit
- Chapter 3745-36 Ohio Indirect Discharge Permits
- Chapter 3745-37 Solid Waste Disposal Licenses
- Chapter 3745-38 National Pollutant Discharge Elimination System Permits
- Chapter 3745-50 Hazardous Waste Rules - General Provisions
- Chapter 3745-51 Hazardous Wastes Subject to Regulations
- Chapter 3745-52 Generators of Hazardous Waste
- Chapter 3745-53 Transporters of Hazardous Waste
- Chapter 3745-54 Standards for the Management of Hazardous Wastes
- Chapter 3745-55 Management of Hazardous Waste: Closure and Post-Closure
- Chapter 3745-56 Standards for Surface Impoundments, Waste Piles, and Tanks; Closure and Post-Closure
- Chapter 3745-57 Standards for Incinerators: Closure
- Chapter 3745-58 Miscellaneous Methods of Waste Treatment

- Chapter 3745-59 Hazardous Waste-Lake Disposal
- Chapter 3745-66 Closures and Post-Closure Requirements; Containers; Tanks
- Chapter 3745-67 Surface Impoundments, Waste Piles, and Land Treatment Facilities
- Chapter 3745-68 Landfills; Incinerators; Thermal Treatment; Open Burning and Detonation of Waste explosives
- Chapter 3745-69 Miscellaneous Methods of Hazardous Waste Treatment
- Chapter 3745-77 Title V Permits
- Chapter 3745-81 Public Water System Primary Contaminant Control
- Chapter 3745-82 Public Water Supply - Secondary Contaminants Standards

Ohio Revised Code (ORC)

- Chapter 3734 Hazardous Waste & Solid Waste Laws
- Chapter 6111 Water Pollution Control Laws

TITLE 3701 - OHIO DEPARTMENT OF HEALTH

Chapter 3701-39-021

Ohio Revised Code (ORC)

- Chapter 3748*
- Chapter 3734*

ASHTABULA COUNTY

Ashtabula County Solid Waste Management District Plan
 (Disposal Facility Siting and Criteria)

STATEMENT RECIPIENTS

6.65 The following representatives, agencies, and interest groups have been and/or are being coordinated with pertaining to this study.

Congressional

U.S. Senator Michael DeWine
U.S. Senator George Voinovich
U.S. Representative Steven LaTourette

Federal

U.S. Department of Agriculture
 * Natural Resources Conservation Service
U.S. Department of Commerce
U.S. Department of Defense
U.S. Army Corps of Engineers
U.S. Environmental Protection Agency
U.S. Federal Emergency Management Agency
U.S. Department of Health and Human Services
U.S. Department of Housing and Urban Development
U.S. Department of the Interior
 ◦ Fish and Wildlife Service
U.S. Department of Transportation
 ◦ U.S. Coast Guard
U.S. Department of State

State

Ohio State Clearinghouse
Ohio State Department of Health
Ohio State Department of Natural Resources
Ohio State Department of Transportation
Ohio State Environmental Protection Agency
Ohio State Historic Preservation Office
Ohio State Sea Grant

Ashtabula - Planning

Eastgate Development and Transportation Agency
Northeast Ohio Areawide Coordinating Agency
County of Ashtabula
 ◦ Planning & Development
 ◦ Health Department
Town of Ashtabula

City of Ashtabula
Ashtabula RAP
Ashtabula Port Authority
Ashtabula County Growth Partnership

Ashtabula - Riverfront Business/Industry

Ashtabula Yacht Club
Ashtabula Enterprises
Ashtabula Recreational Unlimited
Brockway Marine
Conrail
Jack's Marina
Kister
Ohio Land Inc
Pinney Dock
RND Land Co.
Sidley Dock
Sutherland Marina

Ashtabula - East Upland Industries

Acme Scrap
Centerior Energy Inc. (CEI)
Cleveland Electric Illuminating
Delta Associates
DETRX Chemical
Elkem Metals
ESAB Welding Products
Lin Chem
North Point Environmental
Olin Chemical
Oxy Chem
Reactive Metals Inc. (RMI)
Reserve Environmental Services (RES)
SCM Corp
Union Carbide
Ashtabula River Cooperating Group
State Road Properties

Ashtabula - East Upland Resident Properties

The Blanchards (S-3)
The Goffs (S-7)
The Hendricks (S-5)
The Konters (S-3)

The Lessons (S-7)
The RE Schwartzs (S-5)
The RC Schwartzs (S-5)

Some Landfills

BFI Industrial Waste Services (AC-OH)
Doherty Sanitary Landfill (AC-OH)
Reserve Environmental Services (AC-OH)
Stein Landfill (AC-OH)
ECDC (Utah)
U.S. Pollution Control (TSCA) (Utah)
Wayne Disposal (TSCA) (Mich)

Other Organizations

Great Lakes Commission
Great Lakes United
Lake Carriers Association
International Longshoreman's Association
Kent State University - Ashtabula
National Wildlife Federation
Sierra Club

Others

Some others are not listed here; but, a complete mailing list is on file at the Ashtabula River Partnership office.

PUBLIC VIEWS AND RESPONSES

6.66 Reference the Summary, SECTIONS 1, 2, and 6 of this Environmental Impact Statement (EIS), and EIS Appendices EA-D, EA-H, and EA-J. (Part of this report and follows these text).

6.67 The views of the local sponsors and concerned resource agencies played a major role in the assessment/evaluation and selection of the proposed dredging, transfer/dewatering/transfer, and disposal alternatives. The following lists some key planning agencies and publics, and some issues expressed during this study to date. Reference EIS Appendix EA-K - Required Environmental Correspondence, also.

U.S. Environmental Protection Agency

Supports the Ashtabula River Partnership concept and goals/objectives.
Supports expeditious and cost-effective remediation of the Ashtabula River Sediments.
Supports protection/enhancement to the natural and human environment.
Reviews for associated permits, as applicable.

TSCA material handling, disposal, disposal site design review.

U.S Army Corps of Engineers, Buffalo District

Supports the Ashtabula River Partnership concept and goals/objectives.
Supports expeditious and cost-effective remediation of the Ashtabula River Sediments.
Supports protection/enhancement to the natural and human environment.
Supports a long-term comprehensive Harbor operation and maintenance (O&M), and dredging and disposal plan.
Reviews for associated permits or waivers, as applicable.
TSCA material handling and disposal, planning and design.

U.S Department of the Interior Fish and Wildlife Service

Supports the Ashtabula River Partnership concept and goals/objectives.
Supports expeditious and cost-effective remediation of the Ashtabula River sediments.
Supports protection/enhancement to the natural and human environment.
Supports protection/enhancement, particularly to the natural (fish and wildlife resources) environment and recreation.
Supports protection/mitigation/enhancement to wetland areas.
Generally opposed to construction of in-lake confined disposal facilities (CDFs) in the Lake littoral zone.

Ohio Environmental Protection Agency

Initiated & supports the Ashtabula River Partnership concept and goals/objectives
Supports expeditious and cost-effective remediation of the Ashtabula River sediments
Supports protection/enhancement to the natural and human environment.

- Reviews for associated permits, as applicable.
- Clean Water Act 401 Certifications
- TSCA material handling, disposal, disposal site design review.

Ohio Department of Natural Resources

Supports the Ashtabula River Partnership concept and goals/objectives.
Supports expeditious and cost-effective remediation of the Ashtabula River sediments.
Supports protection/enhancement to the natural and human environment.
Supports protection/enhancement particularly to the natural (fish and wildlife resources) environment and recreation.
Coastal Program office supports protection/enhancement particularly to Coastal Zone resources and environment.
Will review for Coastal Zone Consistency Determination

Ohio Department of Health

Supports the Ashtabula River Partnership concept and goals/objectives.
Supports expeditious and cost-effective remediation of the Ashtabula River sediments.
Supports protection/enhancement to the natural and human environment.

- Reviews for associated permits, as applicable.
- Radionuclide material handling, disposal, disposal site design review.

Ohio Historic Preservation Office

Supports the Ashtabula River Partnership concept and goals/objectives.
Supports expeditious and cost-effective remediation of the Ashtabula River sediments.
Supports protection/enhancement to the natural and human environment.
Supports protection/enhancement, particularly to the human (cultural resources) environment.

County of Ashtabula

Supports the Ashtabula River partnership concept and goals/objectives.
Supports expeditious and cost-effective remediation of the Ashtabula River sediments.
Supports protection/enhancement to the natural and human environment.
Somewhat apprehensive about siting the disposal facility in the county. Acceptable with safe handling/disposal design.

County of Ashtabula Port Authority

Supports the Ashtabula River partnership concept and goals/objectives.
Supports expeditious and cost-effective remediation of the Ashtabula River sediments.
Supports protection/enhancement to the natural and human environment.
Supports a long-term comprehensive Harbor operation and maintenance (O&M), and dredging and disposal plan.
Project local sponsor

Ashtabula Township

Supports the Ashtabula River partnership concept and goals/objectives.
Supports expeditious and cost-effective remediation of the Ashtabula River sediments.
Supports protection/enhancement to the natural and human environment.
Somewhat apprehensive about siting the disposal facility in the town. Acceptable with safe handling/disposal design. Limited area to the east of the city and north of the railroad tracks zoned industrial/manufacturing.

City of Ashtabula

Supports the Ashtabula River partnership concept and goals/objectives.
Supports expeditious and cost-effective remediation of the Ashtabula River sediments.
Supports protection/enhancement to the natural and human environment.
Supports environmental dredging and disposal, and use of the River for commercial and recreational activities.

Ashtabula River Remedial Action Plan (RAP)

Initiated and supports the Ashtabula River partnership concept and goals/objectives.
Supports expeditious and cost-effective remediation of the Ashtabula River sediments.
Supports protection/enhancement to the natural and human environment.
The study/project facilitates the goals and objectives of the RAP

Ashtabula Riverfront Business/Industry

Supports the Ashtabula River partnership concept and goals/objectives.
Supports expeditious and cost-effective remediation of the Ashtabula River sediments.
Supports protection/enhancement to the natural and human environment.

Supports environmental dredging and disposal, and use of the River for commercial and recreational activities.

Ashtabula East Upland Industries

Supports the Ashtabula River partnership concept and goals/objectives.

Supports expeditious and cost effective remediation of the Ashtabula River sediments.

Supports protection/enhancement to the natural and human environment.

Ashtabula East Upland Resident Properties

Supports the Ashtabula River partnership concept and goals/objectives.

Supports expeditious and cost effective remediation of the Ashtabula River sediments.

Supports protection/enhancement to the natural and human environment.

Somewhat apprehensive about siting the disposal facility in the area. Acceptable with safe handling/disposal design. Desire safe and reasonable setbacks from disposal sites and activities and trucking. Desire protection of air and water (ground/surface) and land resources.

Other Organizations

Supports the Ashtabula River partnership concept and goals/objectives.

Supports expeditious and cost effective remediation of the Ashtabula River sediments.

Supports protection/enhancement to the natural and human environment.

6.68 Comments/Responses on the Draft Comprehensive Management Plan, Draft Environmental Impact Statement, and Appendices are included as Environmental Appendix EA – L Comments/Responses on the Draft Comprehensive Management Plan, Draft Environmental Impact Statement, and Appendices.



1123 Bridge Street
Ashtabula, Ohio 44004
(216) 964-0277 Office
(216) 964-5158 Fax

John Mahan, Ph.D
Coordinator

Rick Brewer
Co-Chairman
Coordinating Committee

Fred Leitert
Co-Chairman
Coordinating Committee

Steve Golyski
Chairman
Project Committee

Rick Mason
Chairman
Siting Committee

Brett Kaull
Chairman
Resource Committee

Michelle Rowley
Chairperson
Outreach Committee

Ashtabula River and Harbor

Comprehensive Management Plan

Dredging and Disposal

FINAL

FEASIBILITY REPORT AND

ENVIRONMENTAL IMPACT STATEMENT

ENVIRONMENTAL APPENDIX

ENVIRONMENTAL APPENDICES

- EA-A INDEX AND REFERENCES
- EA-B CLEAN WATER ACT PUBLIC NOTICE AND SECTION 404(b)(1) EVALUATION REPORT (Pertains to State 401 Certification, and N/SPDES and PTI Permits, also.)
- EA-C ENVIRONMENTAL RISK MANAGEMENT CONSIDERATIONS FOR THE ASHTABULA RIVER AND HARBOR
- EA-D U.S. FISH AND WILDLIFE COORDINATION ACT REPORT
- EA-E PRELIMINARY WETLAND DETERMINATIONS
- EA-F BOTULISIM CONTROL PLAN
- EA-G COASTAL MANAGEMENT CONSISTENCY DETERMINATION
- EA-H CULTURAL RESOURCES ASSESSMENT
- EA-I ENVIRONMENTAL JUSTICE
- EA-J SECTION 312(b) AND 206 ECOLOGICAL RESTORATION/PRESERVATION ANALYSES
- EA-K REQUIRED ENVIRONMENTAL CORRESPONDENCE
- EA-L COMMENTS/RESPONSES ON THE DRAFT FEASIBILITY AND EIS REPORTS

City of Ashtabula
Town of Ashtabula
County of Ashtabula
State of Ohio

2001



1123 Bridge Street
Ashtabula, Ohio 44004
(216) 964-0277 Office
(216) 964-5158 Fax

John Mahan, Ph.D
Coordinator

Rick Brewer
Co-Chairman
Coordinating Committee

Fred Leitert
Co-Chairman
Coordinating Committee

Steve Golyski
Chairman
Project Committee

Rick Mason
Chairman
Siting Committee

Brett Kaul
Chairman
Resource Committee

Michelle Rowley
Chairperson
Outreach Committee

Ashtabula River and Harbor

Comprehensive Management Plan

Dredging and Disposal

FINAL
FEASIBILITY REPORT AND
ENVIRONMENTAL IMPACT STATEMENT
ENVIRONMENTAL APPENDIX

EA-A INDEX AND REFERENCES

City of Ashtabula
Town of Ashtabula
County of Ashtabula
State of Ohio

2000

ASHTABULA RIVER PARTNERSHIP - REPORT INDEX AND REFERENCES

<u>REPORT ITEMS</u>	<u>EIS</u>	<u>CMP</u>
ALTERNATIVE CONSIDERATIONS AND RECOMMENDED PLAN	10, 23	39, 101
ALTERNATIVE DISPOSAL PLAN	43	114
ASHTABULA HARBOR LONG-TERM MANAGEMENT PLAN	51	121
AUTHORITIES	1	11
BENEFIT EVALUATION	44, 127	142
BORROW AREA IMPACT ASSESSMENT STATEMENT	163	
COMPARATIVE IMPACTS OF FINAL CONSIDERED ALTERNATIVES	44, 127	88
CONCLUSIONS AND RECOMMENDATIONS		188
CONSTRUCTION SEQUENCE	28	139
CONTINUED HARBOR OPERATION AND MAINTENANCE DREDGING AND DISPOSAL	51	120
COST SHARE	43	183
CULTURAL RESOURCES	118	
ENVIRONMENTAL SETTING AND AFFECTED ENVIRONMENT	53	1, 21
ENVIRONMENTAL EFFECTS	127	39, 142
- PROJECT ECONOMIC COSTS/BENEFITS (TABLES)	128	122
- PHYSICAL/NATURAL ENVIRONMENT (RESOURCES)	131	1, 21
- HUMAN ENVIRONMENT (MAN-MADE RESOURCES)	155	1, 21
- CULTURAL RESOURCES	163	
EXECUTIVE SUMMARY	1	ii
FINANCIAL VIABILITY OF NONFEDERAL COST SHARE		141
GENERAL ENVIRONMENTAL CONDITIONS	53	1, 21
HUMAN ENVIRONMENT (MAN-MADE RESOURCES)	105	1, 21
IRREVERSIBLE COMMITMENT OF RESOURCES	164	

<u>REPORT ITEMS</u>	<u>EIS</u>	<u>CMP</u>
LANDFILL DESIGN	26	133
LIST OF PREPARERS	167	
LOCAL COOPERATION		178
MONITORING	42	
NEED FOR AND OBJECTIVES OF THE ACTION	1	35
PHYSICAL/NATURAL ENVIRONMENT (RESOURCES)	131	1, 21
PLANNING PROCESS	1, 9	18
PLAN FORMULATION	10	39
POTENTIAL TRANSFER/DISPOSAL SITE - GENERAL INFORMATION	122	1, 21, 39
PROBLEMS, NEEDS, GOALS/OBJECTIVES (PURPOSE)	2	35
PROJECT ECONOMIC COSTS/BENEFITS (TABLES)	128	122
PUBLIC INVOLVEMENT	169	18
PUBLIC INVOLVEMENT PROGRAM	169	18
PUBLIC VIEWS AND RESPONSES	185	18
REAL ESTATE	42	178
RECOMMENDED PLAN	23	182
REQUIRED PLANNING AND NATIONAL ENVIRONMENTAL POLICY ACT (NEPA) COORDINATION AND COMPLIANCE	170	11, 18
SIGNIFICANT RESOURCES	57	1, 21
STATEMENT RECIPIENTS	183	18
STUDY AUTHORITIES	1	11
SUMMARY	1	ii
SUMMATION (CUMMULATIVE EFFECTS) ASSESSMENT	164	119
WITHOUT PROJECT CONDITIONS (NO ARP ACTION)	9	40, 143

ENVIRONMENTAL APPENDICES

EA-A	INDEX AND REFERENCES
EA-B	CLEAN WATER ACT PUBLIC NOTICE AND SECTION 404(b)(1) EVALUATION REPORT (Pertains to State 401 Certification, and N/SPDES and PTI Permits, also.)
EA-C	ENVIRONMENTAL RISK MANAGEMENT CONSIDERATIONS FOR THE ASHTABULA RIVER AND HARBOR (Chemistry and Radionuclides)
EA-D	U.S. FISH AND WILDLIFE COORDINATION ACT REPORT
EA-E	PRELIMINARY WETLAND DETERMINATIONS
EA-F	BOTULISIM CONTROL PLAN
EA-G	COASTAL MANAGEMENT CONSISTENCY DETERMINATION
EA-H	CULTURAL RESOURCES ASSESSMENT
EA-I	ENVIRONMENTAL JUSTICE
EA-J	SECTION 312(b) AND 206 ECOLOGICAL RESTORATION/PRESERVATION ANALYSES
EA-K	REQUIRED ENVIRONMENTAL CORRESPONDENCE
EA-L	COMMENTS/RESPONSES ON THE DRAFT FEASIBILITY AND EIS REPORTS

CMP : TECHNICAL APPENDICES

A	Ashtabula River Partnership Structure
B	Federal Project Authorizations and Past Studies
C	Ashtabula River Sediment Sampling and Analysis of Extent of Contamination
D	Ashtabula River Sediment Sampling and Analysis of Extent of Radionuclide Contamination
E	Dredging Scenarios and Sediment Volume Estimates
F	Environmental Risk Assessment and Management Considerations for Dredging the Ashtabula River and Harbor
G	Radiological Risk Assessments for Ashtabula River, Ashtabula, Ohio
H	Ashtabula River Recontamination Assessment
I	Dredging Alternatives and Selection
J	Sediment Dewatering Alternatives and Selection
K	Environmental Monitoring
L	Screening of Treatment Technologies and Cost Comparison of Potentially Feasible Alternatives
M	Geotechnical Engineering
N	HTRW Evaluation of Potential Landfill Sites
O	Conceptual Dewatering Facility Design
P	Landfill Design Criteria
Q	Coastal Engineering Design
R	Project Cost Estimates
S	Economic Evaluation
T	Real Estate Requirements
U	Cost Sharing and Non-Federal Responsibilities
V	Environmental Justice

REFERENCES

FILES and APPENDICES

Ashtabula River Partnership
Working Committee Minutes and Files

Ashtabula River Partnership Remediation Project
Comprehensive Management Plan (Feasibility Study)
Technical Appendices

Ashtabula River Partnership Remediation Project
Environmental Impact Statement Appendices

ENVIRONMENTAL NEPA DOCUMENTATION (USA-COE, Buffalo):

1975. U.S. Army Corps of Engineers, Buffalo District. "Final Environmental Impact Statement; Operation and Maintenance; Ashtabula Harbor; Ashtabula County, Ohio".

1975. U.S. Army Corps of Engineers, Buffalo District. "Statement of Findings, Operation and Maintenance, Ashtabula Harbor, Ashtabula County, Ohio".

1975. USACE, Buffalo. Summary of Environmental Considerations (Reconnaissance), Harbor Operations and Maintenance. (Dredging, Open Lake, CDF#3 to be built, Breakwaters)

1975. U.S. Army Corps of Engineers, Buffalo District. "Draft Environmental Impact Statement; Diked Disposal Facility Site No. 3; Lake Erie, Ashtabula Harbor, Ashtabula, Ohio".

1975. U.S. Army Corps of Engineers, Buffalo District. "Summary of Environmental Considerations, Shoreline Stabilization, Lake Shore Park, Ashtabula, Ohio".

1977. U.S. Army Corps of Engineers, Buffalo District. "Ashtabula Harbor, Ohio; Breakwater Removal; Environmental Assessment and Section 404 Evaluation".

1979. U.S. Army Corps of Engineers, Buffalo District. "Operation and Maintenance of Ashtabula Harbor, Ohio; Section 404 Evaluation Report". et. seq.

1980. U.S. Army Corps of Engineers, Buffalo District. "Ashtabula Harbor, Ohio; East and West Breakwater Rehabilitation; Supplemental Information Report (Environmental Assessment) and Section 404 Evaluation Report".

1982. USACE, Buffalo. Summary of Environmental Considerations, Confined Dredged Spoil Facility (#15), Ashtabula Harbor, Ohio. (Unsigned) (Shallows near Pinney)

1987. U.S. Army Corps of Engineers, Buffalo District. "Ashtabula Harbor, Ohio; Final Environmental Impact Statement; Dredging and Disposal of Polluted River Sediments".

1992. USACE, Buffalo. Pilot Scale Demonstration Project, Remediation Of Contaminated Sediments, Ashtabula River, Ashtabula, Ohio. (Environmental Assessment and Finding of No Significant Impact and Clean Water Act Public Notice and 404(b)(1) Evaluation Report) (ARCS Dredging (15 cubic yards) and Thermal Dissorption Treatment)

1993. U.S. Army Corps of Engineers, Buffalo District. Letter Report, Preliminary Draft Environmental Impact Statement, Harbor Maintenance and New Confined Disposal Facility (Site P) for Dredged Polluted Material at Ashtabula Harbor, Ashtabula County, Ohio, 1993.

1993. U.S. Army Corps of Engineers, Buffalo District. Environmental Assessment, Public Notice, and 404(b)(1) Evaluation Report, Upper Ashtabula River Interim Dredging, Ashtabula Harbor, City of Ashtabula, Ohio, 1993.

1999. U.S. Army Corps of Engineers, Buffalo District. Ashtabula River Partnership. Draft Environmental Impact Statement and Appendices.

SEDIMENT, WATER, AND ASSOCIATED ANALYSES (USA-COE, Buffalo):

1972. Cornell Aeronautical Laboratory, Inc. Assessment of the Environmental Effects Accompanying Upland Disposal of Polluted Harbor Dredgings, Ashtabula Harbor, Ohio; for USACE, Buffalo. (Site South of Middle Road, East of Cook Road, North of Railroad Tracks)(1999 Site N)

1975. USEPA, Region V. Ashtabula Harbor, Ohio; Report of the Degree of Pollution of Bottom Sediments; 1975 Harbor Sediment Sampling Program. (Outer Harbor: Particle, Chemistry, Elutriate)

1978. Water Quality Laboratory. Ninety-six Hour Toxicity Bioassay Tests of Ashtabula Harbor (Ohio); for USACE, Buffalo. (Outer Harbor and River Harbor)

1978. Environmental Research Group, Inc. Field Sampling Analysis of Core Sediment Samples Ashtabula River, Ohio; for USEPA, Region V. (Upper River Harbor: Chemistry)

1979. Aqua Tech. A 96-hour Sediment Bioassay of the Ashtabula River; Toxicity of Sediments from Different Strada; for USACE, Buffalo. (Outer Harbor and River Harbor)

1980. Recra Research, Inc. Analytical Comments, USACE, Buffalo, Sampling and Analyses of Sediments from Ashtabula Ohio; for USACE, Buffalo. (Outer Harbor and Lower River Harbor: Chemistry (oil & grease))

1983. Aqua Tech. Analysis of Sediment from Ashtabula River, Ashtabula, Ohio; for USACE, Buffalo. (Upper River Harbor (Slip 5a through Upper Turning Basin) Core Samples: Sediment Mechanical Analyses, Bulk Sediment Testing, EP Toxicity Tests, Column Leach Tests, Settling Tests)

1983. Aqua Tech. 1983. Analysis of Sediment from Ashtabula River, Ashtabula, Ohio; for USACE, Buffalo. (14 Samples Assume Outer Harbor and Lower River Harbor: Particle, Chemistry)

1984. Aqua Tech. Analysis of Sediment from Ashtabula River, Ashtabula, Ohio; for USACE, Buffalo. (Outer Harbor and Lower River Harbor: Particle, Chemical, Elutriate, Bioassay)

1984. Seger, E.S. and R.P. Leonard, 1984. Slurry Clarification and Column Leachate Tests on Polluted Harbor Sediments. U.S. Army Corps of Engineers, 1776 Niagara Street, Buffalo, New York.

1986. Aqua Tech. The Analyses of Sediment and Water Samples from Ashtabula Dewatering Pilot Plant Project; for USACE, Buffalo. (Includes Stock Feed with PCBs ~6.5 to 16.3 mg/kg)

1988. T.P. Associates International, Inc. The Analyses of Sediments from Ashtabula Harbor; for USACE, Buffalo. (Outer Harbor and Lower River Harbor: Particle, Chemical, Elutriate, Bioassay)

1989. Aqua Tech. Sediment Analyses, Ashtabula Harbor, Ashtabula, Ohio. for USACE, Buffalo. (Disposal Site: Particle, Chemical)

1989. U.S. Environmental Protection Agency, 1989; Coordination Letter to Mr. K. Hallock, US Army Corps of Engineers, Buffalo District Office from the United States Environmental Protection Agency, Region 5, 230 South Dearborn Street, Chicago Illinois 60604. 2 pp.

1990. Aqua Tech. Sediment Analyses, Ashtabula Harbor, Ashtabula, Ohio. for USACE, Buffalo. (Disposal Area: Particle, Chemical)

1992. ARDL, Inc. ARDL Report No. 6024, Corps of Engineers, Buffalo District, Ashtabula River Sediment Testing Site; for USACE, Buffalo. (River: Chemical, Toxicity Characteristic Leach Procedure (TCLP))

1992. ARDL, Inc. ARDL Report No. 6025, Corps of Engineers, Buffalo District, Ashtabula River Sediment Testing Site; for USACE, Buffalo. (Interim Disposal Area: Particle, Chemical)

1992. ARDL, Inc. ARDL Report No. 6029, Corps of Engineers, Buffalo District, Ashtabula River Sediment Testing Site; for USACE, Buffalo. (Outer Harbor, Lower River Harbor, Other: Particle, Chemical)

1992. ARDL, Inc. ARDL Report No. 6030, Corps of Engineers, Buffalo District, Ashtabula River Sediment Testing Site; for USACE, Buffalo. (Outer Harbor, Lower River Harbor, Other: Particle, Chemical)

1992. ARDL, Inc. ARDL Report No. 6053, Corps of Engineers, Buffalo District, Ashtabula River Shoal Site; for USACE, Buffalo. (River Harbor: Chemical)

1993. ARDL, Inc. ARDL Report No. 6032, Corps of Engineers, Buffalo District, Ashtabula River Shoal Site; for USACE, Buffalo. (Harbor: Chemical (TOCs for PCBs))

1993. Environmental Science and Engineering, Inc. Evaluation of Sediments from the Ashtabula Harbor Area, Ashtabula, Ohio; for USACE, Buffalo. (Outer Harbor, Lower River Harbor: Toxicity, Bioaccumulation)

1995. Laboratory Resources, Inc. (Three Reports PCBs)(See 1995 Engineering and Environment, Inc.)

1995. Darby. Report on Particle Size Test Results for the Ashtabula River Samples; for USACE, Buffalo.

1995. Engineering and Environment, Inc. 1995 Sampling and PCB Bioaccumulation Study for the Ashtabula River, Ashtabula, Ohio; for USACE, Buffalo. (Includes Laboratory Resources, Inc. reports) (5th Street Bridge through upper turning basin. Several core samples.)

1995/96 Ashtabula River Partnership, Ashtabula River, Supplemental Core Sediment Sampling and Analysis, Ashtabula, Ohio, 1995/1996.

1998. Anacon, Inc. Sediment Sampling for Chemical and Grain Size Analysis at Ashtabula Harbor, Ohio; for USACE, Buffalo. (Phosphorous, Mercury, Mercury - Water, Metals, Metals - Water)

2000. Engineering and Environment, Inc. Sediment Sampling for Biological, Chemical, and Physical Analysis at Ashtabula Harbor & River, Ohio; for USACE, Buffalo. (West Outer Harbor, Lower River Harbor, Supplemental Other: Physical, Chemical, Elutriate, Biological, (some core)) (Has elutriate for PCB 7.8 mg/kg sediment below 1 ug/l)

U.S. Army Corps of Engineers, Buffalo District; Review of Permits.

2000. USEPA and Ohio Department of Health. Ashtabula River Sediment Sampling and Analysis of Extent of Radionuclide Contamination. (Outer Harbor, River Harbor (core)).

SEDIMENT, WATER, AND ASSOCIATED ANALYSES (OTHER):

Carbon Adsorption Isotherms for Toxic Organics, USEPA, 1980.

U.S. Environmental Protection Agency - Region V, 1974; "Ashtabula Harbor, Ohio; Harbor Sediment Sampling Program.

U.S. Environmental Protection Agency - Region V, 1975; "Ashtabula Harbor, Ohio; Report on the Degree of Pollution of Bottom Sediments; 1975 Harbor Sediment Sampling Program.

Terlecky, P.M.; Michalovic, J.C.; and Peck, S.L.; 1975. "Water Pollution Investigation, Ashtabula Area. Report prepared under contract for USEPA, Region 5, Chicago, Illinois. Report EPA 905/9-74-008. 145 pp.

U.S. Environmental Protection Agency - Region V, 1977; "Ashtabula, Ohio; Report of the Degree of Pollution of Bottom Sediments (Sampled June 22, 1977).

Kaiser, K. and I. Valdmanis. 1979. Volatile chloro and chlorofluorocarbons in Lake Erie 1977 and 1978. Great Lakes Resources 5(2): 160-169.

Applied Biology, Inc., 1979e; Section 316(b) Intake Monitoring Program, Ashtabula A and B Plant, final report.

Applied Biology, Inc., 1979d; Section 316(b) Intake Monitoring Program, Ashtabula C Plant, final report.

Rathke, D.E., 1984. Lake Erie Intensive Study 1978-1979. Prepared for U.S. Environmental Protection Agency, Great Lakes National Program Office. EPA - 905/4-84-001.

CH2M Hill, 1985. Final Remedial Investigation Report, Fields Brook Site, Ashtabula, Ohio. WA 19.5L46.0, W65246. CO. March 28, 1985. Prepared for U.S. Environmental Protection Agency, Hazardous Site Control Division, under EPA Contract No. 68- 01- 6692.

Woodward-Clyde Consultants, 16 April 1990; "Ashtabula River Sediment Summary; Ashtabula, Ohio.

Woodward-Clyde Consultants, 1991. Draft Ashtabula River Investigation. Ashtabula, Ohio. Prepared for the Ashtabula River Group.

OEPA, 1991. Ashtabula Remedial Action Plan, Stage 1 Report. Ohio Environmental Protection Agency, Division of Water Quality Planning and Assessment. December 1991.

U.S. Environmental Protection Agency. 1993. "Concept Plans for the Remediation of Contaminated Sediments in the Great Lakes." EPA 905-R93-005. Great Lakes National Program Office, Chicago, IL.

Myers, T.E., M.R. Palermo, T.J. Olin, D.E. Averett, D.D. Reible, J.L. Martin and S.C. McCutcheon. 1994. Final Draft Report, Estimating Contaminant Losses from Components of Remediation Alternatives for Contaminated Sediments, (Prepared for USEPA Great Lakes National Program Office), U.S. Army Corps of Engineers, Waterways Experiment Station, Vicksburg, Miss.

U.S. Environmental Protection Agency. 1994. "ARCS Remediation Guidance Document." EPA 905-B94-003. Great Lakes National Program Office, Chicago, IL.

U.S. Environmental Protection Agency, 1996; ARCS Program, Calculation and Evaluation of Sediment effect Concentrations for the Amphipod and the Midge; USEPA.

OEPA, 1999; State of Ohio Water Quality Standards, Chapter 3745-1 of the Administrative Code; Ohio

Environmental Protection Agency, Division of Water Quality Planning and Assessment, Post Office Box 1049, Columbus, Ohio 43216-0149.

2000. USEPA and Ohio Department of Health. Ashtabula River Sediment Sampling and Analysis of Extent of Radionuclide Contamination. (Outer Harbor, River Harbor (core)).

1999/2000 Disposal Facility Design (Maxim)

2000 Dewatering Facility (Phase 1 - Review, Phase 2 - Technologies) (Black and Veatch)

2000 Blasland, Bouck & Lee, Ashtabula River Partnership, Sediment Dewatering Investigation.

OTHER PROJECTS REFERENCES:

* Alcoa Aluminum, Massena, New York

* Fields Brook, Ashtabula, Ohio

* Indiana Harbor, East Chicago, Lake County, Indiana

U.S. Army Corps of Engineers, Chicago District. 1994. "Indiana Harbor and Canal Maintenance Dredging and Disposal Activities, Comprehensive Management Plan, Feasibility Plan and Environmental Impact Statement and Appendices.

U.S. Army Corps of Engineers, Chicago District. 1994. "Indiana Harbor and Canal Maintenance Dredging and Disposal Activities, Comprehensive Management Plan, Appendix H - Dredging Technologies and Impacts."

BIOLOGICAL

Aquatic Ecology Associates, 1976; "An Aquatic Ecological Study of the Inshore Area of Lake Erie in the Vicinity of the Ashtabula Steam Electric Generating Stations, Ashtabula, Ohio"; Submitted to the Cleveland Electric Illuminating, CO.

Hubbard, W.; 1977. "Studies of Fish Larvae Distribution and Abundance Near Ashtabula, Ohio. Paper presented at the Annual Ohio Academy of Science Meeting. Columbus, Ohio.

Sweeney, R.A.; 1978. "Aquatic Disposal Field Investigations - Ashtabula River Disposal Site, Ohio; Appendix A: Planktonic Communities, Benthic Assemblages, and Fishery; U.S. Army Corps of Engineers, Dredged Materials Research Tech. Report. D-77-42".

U.S. Army Corps of Engineers, 1979; "Final Environmental Impact Statement: Permit Application by United States Steel Corp. Proposed Lakefront Steel Mill, Conneaut, Ohio, Volume 1 and 2"; U.S. Army Corps of Engineers, Buffalo, New York.

Odin, C.R.; 1979. Letter to Colonel Robert V. Vermillion, U.S. Army Engineer, Detroit District; Nov. 2, 1979.

Goodyear, C.D.; Edsall, T.A.; Moss, G.D.; Polanski, P.E.; 1982. Atlas of the Spawning and Nursery Areas of Great Lakes Fishes - Volume IX - Lake Erie; Office of Biological Services, U.S. Fish and Wildlife Service, U.S. Department of the Interior, Washington, D.C. 20240. 194 pp.

Wickliff, E.L.; 1982a. Distribution of Fry in the West End of Lake Erie, Exclusive of the North Shore from May 16 - August 28, 1982; Ohio Division of Fish and Game, Columbus, Ohio.

USFWS, 1983; Draft Fish and Wildlife Coordination Act Report"; U.S. Fish and Wildlife Service, Columbus

Field Office, 3090 East Broad Street, Columbus, Ohio 43216-5000.

USFWS, 1984; Final Fish and Wildlife Coordination Act Report; U.S. Fish and Wildlife Service, Columbus Field Office, 3090 East Broad Street, Columbus, Ohio 43216-5000.

U.S. Army Corps of Engineers; 1990; "Assessment of Avian Botulism Control Pilot Project at the Dike 14 Confined Dredged Material Disposal Facility, Cleveland, Ohio.

USFWS, 1991; Biological Report on the Proposed Confined Disposal Facilities at Ashtabula County, Ohio;" U.S. Fish and Wildlife Service, 6950-H Americana Parkway, Reynoldsburg, Ohio. 6 pp. plus map and tables.

U.S. Fish and Wildlife Service, Reynoldsburg, Ohio, 1992; U.S. Fish and Wildlife Service Coordination Act Report; for the U.S. Army Corps of Engineers, Buffalo District.

US Fish and Wildlife Service (USFWS), 1997; Ashtabula River Partnership Remediation Project; Draft Fish and Wildlife Coordination Act Report; U.S. Fish and Wildlife Service, Reynoldsburg, Ohio.

Ashtabula River Partnership; Section 312(b) Ecological Restoration/Preservation Analyses; Ashtabula River Partnership, 1998.

U.S. Army Corps of Engineers, 1999; Preliminary Wetland Investigations (Potential Disposal Sites 5 and 7) Ashtabula, Ohio; U.S. Army Corps of Engineers, Buffalo, New York.

U.S. Army Corps of Engineers, 2000; Wetland and Ecological Site Walkover Investigation, RMI Sodium Plant Site, Ashtabula, Ohio; U.S. Army Corps of Engineers, Buffalo, New York.

US Fish and Wildlife Service (USFWS), 2000; Ashtabula River Partnership Remediation Project; Final Fish and Wildlife Coordination Act Report; U.S. Fish and Wildlife Service, Reynoldsburg, Ohio.

STATE ROAD SITE REMEDIAL ACTION REPORTS

1990. Eckenfelder Inc. RCRA Facility Investigation Report, RMI Sodium Plant, Ashtabula, Ohio; prepared for RMI Titanium Company, Niles, Ohio.

1991. Eckenfelder Inc. Supplemental Investigation Report for the RCRA Facility Investigation, RMI Sodium Plant, Ashtabula, Ohio; prepared for RMI Titanium Company, Niles Ohio.

1995. Eckenfelder Inc. Final Corrective Measures Study, RMI Sodium Plant, Ashtabula, Ohio; prepared for RMI Titanium Company, Niles Ohio.

1997. Woodward-Clyde. Final SCRI Report; Source Control Operable Unit, Fields Brook Site, Ashtabula, Ohio; prepared for Fields Brook Action Group, Ashtabula, Ohio.

1998. Woodward-Clyde. Geotechnical and Environmental Siting Study Report, Proposed Consolidation/Landfill Area at the RMI Sodium Plant, Ashtabula, Ohio; prepared for Fields Brook Action Group, Ashtabula, Ohio.

1999. Brown and Caldwell. Supplement to the Revised Final Corrective Measures Study, RMI Sodium Plant, Ashtabula, Ohio; prepared for RMI Titanium Company, Niles Ohio.

CULTURAL RESOURCES

U.S. Army Corps of Engineers, Buffalo District, 1975; Cultural Resources Reconnaissance Study (Coordination and Correspondence).

Notice: Tuesday, February 7, 1984; Federal Register; National Register of Historic Places Annual Supplemental Listing of Historic Properties.

Department of the Interior, National Park Service; The National Register of Historic Places.

Brose, David; 1985. "Cultural Resources Reconnaissance Study of Site 17 at the Ashtabula Disposal Area, Ashtabula County, Ohio" for the U.S. Army Corps of Engineers, Buffalo District.

Clifford, Laura; Phase I/II Cultural Resources Report for Proposed Confined Disposal Facility in Lake Erie, Ashtabula, Ohio; for the U.S. Army Corps of Engineers, Buffalo District; 1992; Kemron Environmental Services.

Shaffer, Scott; Phase I Reconnaissance Level Cultural Resources Investigation for the Proposed Ashtabula Harbor Confined Dredged Disposal Facility Sites, Ashtabula Township, Ashtabula County, Ohio, 1997; for the U.S. Army Corps of Engineers, Buffalo District; Shaffer Archeological and Historical Consulting.

U.S. Army Corps of Engineers, Buffalo District, 2000; Cultural Resources (State Road Site) (Coordination and Correspondence).

DEMOGRAPHY AND LAND USE

Aerial Photos (series); US Army Corps of Engineers.

Ashtabula County; Highway Map.

Ashtabula Harbor Boating Facilities Survey 1992.

Ashtabula Township General Zoning/Property Map.

C T Consultants, Inc., Ashtabula Port Action Plan, Ashtabula Port Authority, 1994.

Ohio Department of Natural Resources (ODNR); Ground Water Pollution Potential of Ashtabula County, Ohio; Ohio Department of Natural Resources, Division of Water, 1991.

Ohio Department of Natural Resources (ODNR); Ground Water Re-sources of Ashtabula County, Ohio; Department of Natural Re-sources, Division of Water, 1978.

Remedial Action Plan Newsletter(s); Great Lakes - Areas of Concern; Ashtabula River.

U.S. Army Corps of Engineers, Buffalo District; Ashtabula Harbor, Ohio; Harbor Project Map and Cross Sections.

U.S. Department of Agriculture, Soil Conservation Service (USDA-SCS); General Soil Map; Ashtabula County, Ohio.

USDA; Prime Farmland Map Units for Ohio; U.S. Department of Agriculture, Soil Conservation Service, 1981.

USDA-SCS; Prime Farmlands of Ashtabula County; U.S. Department of Agriculture, Soil Conservation Service.

USDA-SCS; Soil Survey of Ashtabula County, 1973; U.S. Department of Agriculture, Soil Conservation Service.

U.S. Department of Commerce, Bureau of the Census; 1990 Census Data. (Internet).

U.S. Department of Commerce, Bureau of the Census; City and County Data Book 1988.

U.S. Department of Commerce, Bureau of the Census; 1980-1985 Census of Population and Housing.

U.S. Department of Commerce, Bureau of Economic Analysis; 1985 OBERS BEA Regional Projections.

U.S. Department of Commerce, National Oceanic and Atmospheric Administration; United States Coast Pilot, Great Lakes.

U.S. Department of Housing and Urban Development, Federal Insurance Administration; Effective Date: February 1, 1980; Flood Insurance Rate Map; City of Ashtabula, Ohio; National Flood Insurance Program.

U.S. Department of the Interior, Geological Survey; 1979; North Kingsville, Ohio; Quadrangle Map.

U.S. Department of the Interior, Geological Survey; 1978; Ashtabula North, Ohio; Quadrangle Map.

U.S. Department of the Interior, Fish and Wildlife Service; National Wetlands Inventory Map; Ashtabula, Ohio; U.S. Fish and Wildlife Service.



1123 Bridge Street
Ashtabula, Ohio 44004
(216) 964-0277 Office
(216) 964-5158 Fax

John Mahan, Ph.D
Coordinator

Rick Brewer
Co-Chairman
Coordinating Committee

Fred Leitert
Co-Chairman
Coordinating Committee

Steve Golyski
Chairman
Project Committee

Rick Mason
Chairman
Siting Committee

Brett Kaul
Chairman
Resource Committee

Michelle Rowley
Chairperson
Outreach Committee

Ashtabula River and Harbor

Comprehensive Management Plan

Dredging and Disposal

FINAL

FEASIBILITY REPORT AND

ENVIRONMENTAL IMPACT STATEMENT

ENVIRONMENTAL APPENDIX

EA-B CLEAN WATER ACT PUBLIC NOTICE AND SECTION
404(b)(1) EVALUATION REPORT (Pertains to State 401
Certification, and N/SPDES and PTI Permits, also.)

City of Ashtabula
Town of Ashtabula
County of Ashtabula
State of Ohio

2001

ASHTABULA RIVER PARTNERSHIP

NOTICE: A Clean Water Act Public Notice and Section 404(b)(1) Evaluation Report was coordinated with the Ashtabula River Partnership Draft Environmental Impact Statement and Appendices in August of 1999. No significant comments were received specific to the Clean Water Act Public Notice and Section 404(b)(1) Evaluation Report.

Subsequent to the Draft Reports, a number of additional evolved alternative disposal facilities and alternatives were assessed/evaluated. Use of existing disposal facilities can not be utilized because RAD material can not be co-mingled with other disposed material and must have its own disposal facility. In this regard, the former RMI Sodium Plant site (State Road Site) has become available. The site has been disturbed by past plant development and recent demolitions and is of little value to fish and wildlife and contains only minor wetlands at the eastern boundary and north-east corner. The Fields Brook remediation project material is being disposed of in part of this property. There is room for the Ashtabula River Partnership dredged elevated PCB and RAD material to be disposed of in a developed facility adjacent to the Fields Brook remediation project disposal facility. There is also just enough room for the Ashtabula River Partnership dredged contaminated material to be disposed of in a developed facility adjacent to the other disposal facilities. Assessment/evaluation indicates that this is the overall preferred possible disposal alternative and is now the project disposal component plan.

The final proposed project is the same as that proposed in the draft reports except that the material would be disposed of at developed disposal facilities at the State Road Site. Since this would avoid impacts to any wetlands and reduce impacts to U. S. Waters and fish and wildlife resources from that discussed in the Draft reports, a new Clean Water Act Public Notice and Section 404(b)(1) Evaluation Report will not be issued. Actions specific to development and disposal of material at the brownfields-State Road Site (no discharge to U.S. Waters including wetlands) is not subject to Clean Water Act Section 404/401.

An application for a Clean Water Act Section 401 State Certification was initially submitted with the draft reports. This was withdrawn in September of 2000 considering project disposal modifications and requests for more design level information prior to issuance of the certification/permit. Application will be re-submitted when further design and treated water discharges bench test information is available. Associated applications for National/State Pollution Discharge Elimination System and State Permit to Install permits are also coordinated at that time. The Ohio State Environmental Protection Agency has issued an interim letter of concurrence in this regard.



State of Ohio Environmental Protection Agency

NF

STREET ADDRESS:

Lazarus Government Center
122 S. Front Street
Columbus, Ohio 43215

TELE: (614) 644-3020 FAX: (614) 644-2329

MAILING ADDRESS:

P.O. Box 1049
Columbus, OH 43216-1049

November 7, 2000

David J. Conboy
Environmental Analysis Section
Department of the Army
U.S. Buffalo, District, Corps of Engineers
1776 Niagara Street
Buffalo, New York 14207-3199

Dear Mr. Conboy:

Ohio EPA received your letter requesting a withdrawal of the Buffalo District Corps of Engineers Section 401 application on behalf of the Ashtabula Partnership for remediation of the lower Ashtabula River. Your application was officially withdrawn on September 19, 2000. We understand the Corps will re-submit a Section 401 certification application once additional information can be provided to Ohio EPA in the Design Phase of project development.

Ohio EPA strongly supports the efforts of the Corps and the Ashtabula Partnership to develop a remediation project for the Ashtabula River. We are pleased to issue this Letter of Concurrence for the work that has been done by the Corps in the Preliminary Design Phase of the project development. We look forward to working with the Corps through the Design Phase of the project to bring this project to fruition.

Once additional information about scope, design and potential water quality impacts are submitted with another Section 401 certification application, we will take an action on the certification.

If you have any questions, please contact Linda Merchant in the Division of Surface Water at (614) 644-2135.

Sincerely,

Christopher Jones
Director

CJ:lm

out\concur_lm.wpd

Bob Taft, Governor
Maureen O'Connor, Lieutenant Governor
Christopher Jones, Director

ASHTABULA RIVER
PARTNERSHIP

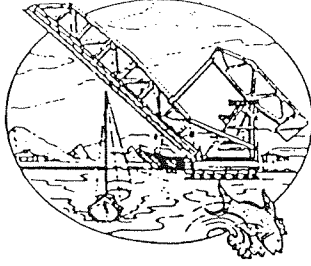

1123 Bridge Street
Ashtabula, Ohio 44004
(216) 964-0277 Office
(216) 964-5158 Fax

John Mahan, Ph.D
Coordinator

Rick Brewer
Co-Chairman
Coordinating Committee

Fred Leitert
Co-Chairman
Coordinating Committee

Steve Golyski
Chairman
Project Committee

Rick Mason
Chairman
Siting Committee

Brett Kaull
Chairman
Resource Committee

Michelle Rowley
Chairperson
Outreach Committee

Ashtabula River and Harbor

Comprehensive Management Plan

Dredging and Disposal

FINAL

FEASIBILITY REPORT AND

ENVIRONMENTAL IMPACT STATEMENT

ENVIRONMENTAL APPENDIX

EA-C ENVIRONMENTAL RISK MANAGEMENT CONSIDERATIONS
FOR THE ASHTABULA RIVER AND HARBOR

- CONTAMINANT REMOVAL (PCBs, etc.)
- RADIONUCLIDES (RAD)

City of Ashtabula
Town of Ashtabula
County of Ashtabula
State of Ohio

2001

**SUB-APPENDIX
CONTAMINANT REMOVAL (PCBs, etc.)**

**ENVIRONMENTAL RISK ASSESSMENT AND MANAGEMENT
CONSIDERATIONS FOR DREDGING THE ASHTABULA RIVER AND
HARBOR**

**U.S. ENVIRONMENTAL PROTECTION AGENCY
1996**

ASHTABULA RIVER PARTNERSHIP

Environmental Risk Assessment and Management Considerations for Dredging the Ashtabula River and Harbor

Purpose

The purpose of this appendix is to discuss environmental issues involved in remediating the contaminated sediment in the Ashtabula River and Harbor. Generally, a risk assessment consists of a qualitative and/or quantitative evaluation of the actual or potential impacts of contaminants on humans, animals, and plants. A qualitative risk assessment approach is deemed most appropriate for this project because of the project specific issues which include the following: 1) the three dredging alternatives being evaluated in the EIS result in similar post-remedial surface area weighted concentrations for PCBs (i.e. all within a few ppm PCBs) and therefore would not result in much different quantitative risk estimates; 2) because the most highly contaminated sediments are at deeper depths, dredging must continue below navigable depths (i.e. 6-8 feet), otherwise the most highly contaminated sediments would be left at the surface and available for uptake by biota; and 3) an important goal of the partnership is to ensure that sediment dredged in the future can be open-water disposed, which cannot be predicted using standard risk assessment techniques. Therefore, the scope of this appendix is to provide a qualitative analysis of the human health and ecological risk considerations, in support of the EIS' goal of developing and evaluating alternatives for the project.

Background

Contamination in the sediment has transferred to fish, affected habitat quality, and has restricted lower Ashtabula River commercial and recreational use. Due to natural sedimentation and shoaling, the Ashtabula River and Harbor need to be dredged on a regular basis to maintain adequate navigation depths. However, because of the levels of contaminants in the sediment, these sediments are not suitable for unrestricted open-lake disposal and, instead require confined disposal. Currently, there is no confined disposal facility (CDF) available to contain dredged Ashtabula River sediment. As a result, navigable channel maintenance cannot be conducted. In addition, the total mass of PCBs in the River is such that future events could reasonably result in continued downstream migration of PCBs and other contaminants of concern into Lake Erie resulting in sediment and fish contamination well into the future. Removal of the bulk of this mass will dramatically reduce potential ecological and human health risk from the site, not only in the present, but also significantly reduce the potential for release in the future.

The Ashtabula River Partnership has been described earlier in this document, however, the goals of the Partnership's sediment remediation project bear repeating:

- Full recreational and commercial use of the River, including recreational boating and fishing,
- Future dredged sediments will be suitable for open-lake disposal once remediation has been completed,
- Long-term risk reduction to human health and the environment, including complete removal of the fish advisory,
- Preventing recontamination of the River and loadings to Lake Erie by addressing those sediments that could be released and redistributed via scouring and storm events,
- Remove as much PCB mass, and other contaminants of concern, as feasible (e.g. technical, economic), and,
- Restoration of fish and benthic communities, wildlife populations (e.g. fish-eating birds and mammals), and ecological habitat.

All of the above goals help in evaluating and selecting remedial alternatives. However, when actually selecting an appropriate alternative, the issues of project feasibility and cost are also important.

Contaminants of Concern

The sediment has been well characterized in the Ashtabula River and Harbor, and has been discussed extensively in this document. This appendix will focus on the main contaminants of concern in the Ashtabula River Area of Concern (AOC) due to their level and extent of contamination. Specifically, the focus will be on PCBs and to a somewhat lesser degree, PAHs. There are other contaminants in the AOC, specifically metals (e.g., chromium, cadmium, mercury, arsenic) and organics (e.g., hexachlorobenzene, octochlorostyrene) which while not discussed explicitly are also of concern. It is assumed in this analysis that by focusing on PCBs and PAHs, the other contaminants of concern will be addressed due to the co-localization of contaminants. The contaminants that have been detected in Ashtabula River sediment, surface water and fish are summarized in Table 9 (Ohio EPA, Stage I Report, 1991).

Risk

Generally, a risk assessment consists of a qualitative and/or quantitative evaluation of the actual or potential impacts of contaminants on humans, animals, and plants. The human health risk assessment evaluates the potential for unacceptable risk to humans through exposure to contaminants from an area of concern or site. The ecological risk assessment evaluates the

potential impacts of contaminants from an AOC or another site on animals and plants. As discussed above, a qualitative rather than a quantitative risk assessment approach is deemed most appropriate for this project for a number of reasons. As discussed in Appendix ____, the sediment post-remedial surface area weighted PCB concentrations for the three dredging alternatives being evaluated in the EIS are all within a few ppm of each other and therefore, would result in similar risk estimates.

PCBs are a mixture of many different compounds or aroclors which can vary in terms of their toxicity, degree of chlorination, and log K_{ow} (degree to which compound is hydrophobic). In general, the more highly chlorinated the aroclor, the more stable and lipid soluble, less degradable, and more strongly adsorbed by sediment it becomes. PCBs can biomagnify in aquatic and terrestrial food chains which means they increase in concentration at each step of the food chain. They remain in aquatic food chains for a long time due to their persistence. Some of the higher chlorinated aroclors are found in the Ashtabula River sediment and fish tissue, specifically aroclors 1248 and 1260.

PCBs build up in the environment and cause a number of harmful effects, including both cancer and noncancer adverse effects. Non-carcinogenic health effects such as reproductive impairment, neurotoxicity, developmental toxicity, endocrine disruption, and immunosuppression have also been associated with exposure to PCBs. Some PAHs have been found to cause cancer in both humans and animals. PAHs have also been found to cause noncancer adverse health effects including difficulties in reproduction, decreased body weight, immunosuppression, and harmful effects to the skin.

Human Health

There are several potential ways that contaminated sediment in the Ashtabula River and Harbor could potentially impact human health. The contaminants in the sediment can be taken up by fish and cause adverse health effects to those who consume the contaminated fish. This is specifically an issue for PCBs because the higher chlorinated aroclors, many of which are found in Ashtabula, are persistent and bioaccumulative compounds. In addition, people swimming and recreating in the River could come into contact with the surface water and sediments.

The Assessment and Remediation of Contaminated Sediments (ARCS) program of the Great Lakes National Program Office (GLNPO) developed a risk assessment of the Ashtabula River and Harbor (Crane, 1992). This document dated December, 1992, presented a screening level risk assessment of human health only for the AOC. This risk assessment found that out of all exposure pathways investigated, consumption of contaminated fish was the most significant exposure (over ingestion of contaminated surface water, and dermal exposure to sediment). Further, it found that the PCB-contaminated fish in the River were posing a level of carcinogenic risk to various types of anglers in the range of 10^{-3} (i.e. the probability of one excess cancer in 1000 people) to 10^{-9} (i.e. the probability of one excess cancer in one billion people). This risk range is due to different assumptions on how much and what type of fish people may consume from the Ashtabula River.

The risk assessment used the average levels of contamination found in large mouth bass, small mouth bass, bluegill, and carp caught in the Ashtabula River. The concentrations of PCBs in bass, blue gill, and whole carp used in the risk assessment were: non-detect, non-detect, and 0.81 respectively (1990, Woodward-Clyde). The cancer risk estimated for fish with non-detect levels of PCBs were from other contaminants, such as 1,1,2,2-tetrachloroethane. The 10^{-3} risk correlates with the assumption that people eat 130 grams a day of whole carp from the Ashtabula River 350 days a year whereas the 10^{-9} risk is for people who eat 19 grams a day of bass filets, on average, 350 days a year. In addition to carcinogenic risks, fish contaminated with PCBs have been implicated in non-carcinogenic health effects such as neurotoxicity, developmental toxicity, endocrine disruption, and immunosuppression.

More recent fish data are now available. Ohio EPA collected several species of fish in 1994 (large mouth bass, small mouth bass, carp, rock bass, catfish, redhorse, walleye and drum). On average, PCB concentrations in fish increased by approximately 0.5 parts per million over the concentrations reported in 1990. Although this is not considered to be a statistically significant increase, it does indicate that fish in the Ashtabula River continue to be contaminated with PCBs. The levels of PCBs have not declined to completely safe levels and those consuming a larger number of fattier fish such as carp have the greatest risk.

This is consistent with the Ohio Department of Health's (ODH) fish advisory. In 1983, ODH issued a fish consumption advisory on all species in the Ashtabula River based on significantly elevated levels of PCBs in fish tissue samples. In 1997, the fish consumption advisory was revised based on decreased levels of PCBs more recently measured in fish. The current fish consumption advisory is less stringent. It places specific limits on the amounts of smallmouth bass, largemouth bass, walleye, channel catfish, and common carp that can be safely consumed. Because common carp and channel catfish contain the highest levels of PCBs, the amount of these species that can be safely consumed is much less than for other species. The amounts of fish that can be safely consumed were determined by ODH using the Great Lakes Sport Fish Advisory Task Force September 1993 protocol titled "Protocol for a Uniform Great Lakes Sport Fish Consumption Advisory." This protocol is used consistently by ODH to issue fish advisories in Ohio.

The less stringent 1997 fish consumption advisory is due, in part, to the more highly contaminated sediments being buried by cleaner sediments, which are therefore less available for uptake by biota. The lower river has not been dredged since 1962, due to the contaminated sediments which require confined disposal. So, sedimentation in the watershed over the long-term has yielded some benefit to the fish community. It has also resulted in the need for substantial dredging to maintain navigable depths for both commercial and recreational purposes.

If either bank-to-bank-to-bedrock or deep dredging is implemented and the majority of PCB mass is removed, long-term protection is expected to be achieved. Ongoing sedimentation in the Ashtabula River, while historically low on an annual basis, will gradually cover any low level residual contaminants left behind. Since 1983, significant reductions in the concentration of

PCBs in fish have occurred due in part to cleaner sediments burying contaminated sediments, and also due to discharger compliance. After cleanup, it is expected the fish consumption advisory will be lifted and long-term protection will be achieved, because the majority of the PCB mass will be removed. In order to maintain navigable depths for recreational purposes, future dredging in the lower river will likely be conducted to no more than -8 feet depth. Therefore, an adequate buffer will exist between any residual contamination and clean sediment that will eventually cover it, ensuring long-term protection of human health.

Ecological

PCBs are a particular concern to aquatic food chains because of the process known as biomagnification where contaminant concentrations increase at each step of the food chain. For instance, microscopic floating aquatic plants known as phytoplankton containing very low levels of PCBs are eaten by zooplankton, primarily microscopic floating aquatic animals. Zooplankton are eaten by small fish, which are then eaten by larger fish. Fish-eating birds, such as herons and kingfishers, and fish-eating mammals, such as mink, then eat the fish, resulting in significantly elevated PCB levels compared to those measured in animals lower in the food chain. Highly elevated levels of PCBs have been measured in bird eggs as well. Because of the concentrations of PCBs detected in fish and the ability of PCBs to biomagnify up into the food web, fish-eating birds and mammals have the highest potential to experience any associated toxicological effects.

Direct exposure pathways to PCBs in aquatic systems include the ingestion of surface water and sediment as well as dietary exposure through the food chain. Exposure of aquatic organisms to PCBs has been documented to result in a number of sublethal effects including reduced growth, reduced reproduction, and biochemical perturbations. The most significant route of PCB exposure in birds is through dietary exposures which have been documented to adversely affect growth, reproduction, behavior, metabolism, and hepatic metabolism (e.g. affects liver function). The interspecies sensitivities to PCBs varies widely even between species that are taxonomically closely related. For instance, mink have been found to be extremely sensitive to PCBs which cause adverse effects on reproduction even at very low levels. In aquatic plants, PCBs have been found to cause reduced growth through a reduction in photosynthetic activity as a result of diminished chlorophyll content.

Sediment screening values, also commonly referred to as sediment quality criteria or ecologically-based benchmarks, can be defined as contaminant concentrations above which there is sufficient concern regarding adverse ecological effects to warrant further site investigation (USEPA, 1996). In USEPA (1996) *Ecotox Thresholds*, the ecotox threshold for total PCBs is 0.023 mg/kg which is based on the Long et al. (1995) effects range- low (ERL) value. The ERL is defined by Long et al. (1995) as the lower 10th percentile of the data analyzed from a variety of marine and freshwater environments and indicates the low end of the range of concentrations in which adverse effects have been observed or predicted in various studies. Similarly, the ERL reported in USEPA (1996) from Long et al. (1995) is 4.0 mg/kg for PAHs. These screening values are considered to be conservative and are not clean up goals. They are values below

which further study is generally not warranted.

The statistical analysis of 1990 and 1995 Ashtabula River sediment sampling data reported a maximum PCB concentration of 660 mg/kg and 160 mg/kg, respectively and an average concentration of detected samples of 18.2 mg/kg and 15.7 mg/kg, respectively. The sampling locations closest to Fields Brook contain the highest concentrations as expected and decrease with distance down the river (refer to Table 7 of Draft 1997 Feasibility and Planning Report). Therefore, exposure to the areas nearest to Fields Brook have the highest potential for adverse effects to ecological receptors. Because of the concentrations of PCBs detected in fish and the ability of PCBs to biomagnify up into the terrestrial food web, fish-eating birds and mammals have the highest potential to experience any associated toxicological effects.

If either bank-to-bank-to-bedrock or deep dredging is implemented and the majority of PCB mass is removed, long-term protection is expected to be achieved. Ongoing sedimentation in the Ashtabula River, while historically low on an annual basis, will gradually cover any low level residual contaminants left behind. Since 1983, significant reductions in the concentration of PCBs in fish have occurred due in part to cleaner sediments burying contaminated sediments, and also due to discharger compliance. After cleanup, it is expected the fish consumption advisory will be lifted and long-term protection will be achieved because the majority of the PCB mass will be removed. In order to maintain navigable depths for recreational purposes, future dredging in the lower river will likely be conducted to no more than -8 feet depth. Therefore, an adequate buffer will exist between the residual contamination left behind and the amount of clean sediment that will eventually cover it to help ensure long-term protection of the environment.

Assessing Future Open-Lake Disposal Suitability

In 1993, USACE-Buffalo analyzed sediment in the lower river and harbor for suitability for open-water disposal, in accordance with the revised Clean Water Act Section 404 Great Lakes Dredge Material Testing and Evaluation Guidance (1997). This guidance utilizes the results of bioassays to determine environmental quality of sediments, instead of relying solely upon sediment chemistry. Twelve management units, or sediment areas, were defined for this testing (6 in the lower River and 6 in the Harbor--see Figure 3.7, CMP). The results of the bioassays from these test areas were then compared to results obtained from sediments at a lake reference site to determine any significant difference. This comparison was the primary criterion used to determine the suitability of the harbor sediments for open-lake disposal. Based on the contamination information known about the sediments, the following bioassays were done:

- Toxicity tests using *Chironomus tentans* (midge larvae) and *Hyallela azteca* (amphipod); assessing toxicity of PAHs and metals, and,
- Quantitation of the bioaccumulation of total PCBs using *Lumbriculus variegatus* (aquatic earthworm).

Based on the results of these assays, all of the Harbor management units and the two most downstream River management units were considered suitable for open water-disposal (management units H1-6, and R1 and R2). However, three upstream River management units (R3, R5a and R5b) did not pass one or more of the assays. The main contaminants considered to be responsible for the toxicity observed in these tests are PCBs for the bioaccumulation, and PAHs plus other contaminants for the toxicity tests. Note: Due to the presence of multiple contaminants, the toxicity cannot be attributed solely to a particular contaminant or group of contaminants for the toxicity tests.

The highest level to pass this bioaccumulation test (a “pass” indicates that the bioaccumulation of PCBs was not significantly elevated when compared to the reference exposures) was 0.95 ppm PCBs dry weight in the sediment. The lowest levels found to cause significant bioaccumulation using *Lumbriculus variegatus* was 2.6 ppm PCBs dry weight in the sediment. River management units R3, R5a and R5b had significantly higher PCB tissue concentrations compared to the reference sites. It is important to note that a limitation of this test is that it does not address biomagnification for animals higher in the food chain. Therefore, the results from this test cannot be used to determine whether these concentrations are protective of fish-eating birds and mammals. However, in the preliminary Draft 1997 report titled “Development of Polychlorinated Biphenyl (PCB) Sediment Cleanup Guidelines for Ashtabula Harbor (Upper River), Ohio” (Pickard 1997), it was determined that total PCB concentrations of 0.32 and 0.40 ppm are concentrations near which Ashtabula River sediments would not cause bioaccumulation to levels greater than those present in Lake Erie environs and would therefore be suitable for open-water disposal.

For PAHs, the most relevant sediment chemistry data for the lower river is from 1992. (Bioassays were done in 1993.) Because these analyses were done at different times, the location of the samples taken do not exactly match the management units chosen in 1993, but there is significant overlap (see Figure 3.4, CMP). The highest level found to pass the *Chironomus tentans* toxicity test (a “pass” indicates that the results from the test sites are not significantly different when compared to the reference site results) was 11.6 ppm total PAHs. The lowest level found to cause significant adverse effects in this organism is 27.7 ppm total PAHs. Therefore, a range of 10-20 ppm total PAHs may be an appropriate target. In addition, it needs to be noted that there is a high level of uncertainty regarding the impacts from PAHs versus other contaminants because of the multiple contaminants present. However, due to the co-localization of contaminants in the sediment, addressing the removal of PAHs and PCBs in sediment should help address the other contaminants present.

PCB Mass

The Ashtabula River AOC currently contains approximately 11,000 kg of PCBs, of which 1700 kg is TSCA-regulated material (≥ 50 ppm PCBs). To ensure removal of all TSCA material, the ARP has agreed to use 40 ppm as the cutoff for TSCA-regulated material. Therefore, this mass will be greater than 1700 kg. The PCB mass contributes to risk in two main ways. First, the

exposed sediment has transferred into ongoing fish contamination. Secondly, the mass of PCBs can be released and redistributed during storm events, scouring, etc. allowing for recontamination of the river and a continued loading of available PCBs and other contaminants in the future to the river and potentially the Great Lakes Basin.

It is important to realize that the Ashtabula River is a dynamic system. Sediment from cleaner upstream areas continues to cover the contaminants. However, it is clear that river sediments are mobile, and that contaminated sediment currently buried may become exposed and bioavailable during a future storm or scouring event, and thereby contribute to risk in the future. And, unfortunately, as sedimentation slowly continues without dredging being conducted, the minimum depth needed for recreational and commercial activities will not exist. The contaminated sediment cannot be open-water disposed. Therefore, the overall best long-term approach is removal of the PCB mass, which will ensure long-term protection and open-water disposal in the future.

Choosing and Evaluating Dredging Alternatives

As discussed in the draft EIS (See Dredging Scenarios Appendix), there are currently three dredging alternatives under consideration: bank-to-bank-to-bedrock, shallow and deep. The bank-to-bank-to-bedrock alternative seeks to remove all of the sediment in the river, to the maximum extent possible. The deep alternative removes all of the sediment starting from the upper turning basin down to station 158 (near the lower turning basin), and then, downstream of that point, removes all sediments greater than 10 ppm (from roughly the lower turning basin to the Harbor). This alternative does not dredge sediment in river sideslips nor the upstream areas of the AOC (roughly station 207 to station 193). The shallow dredging option is similar to the deep in that it also removes all sediment from the upper turning basin and continues downstream, removing all sediments greater than 10 ppm PCBs, except for river sideslips and upstream of station 193. The shallow option differs from deep dredging in that it does not dredge the most downstream TSCA-regulated (>50 ppm PCBs) area, near station 158. The deep dredging option removes this TSCA-regulated mass, which is estimated to be 489 cubic yards.

To meet the goals of the partnership remediation, sediments need to be dredged to maintain navigable depths and to ensure that future dredged sediments will be eligible for open-water disposal. However, dredging will reveal significantly higher levels of contamination at a depth for recreational navigation (-8 feet), and therefore dredging will need to continue beyond this depth. Although a quantitative risk assessment is often used to develop cleanup goals that help drive the selection and evaluation of remedial alternatives, a full quantitative risk assessment is not sufficient in this case to select remedial alternatives, given the following project issues:

- most of the highly contaminated sediment lies at considerable depth, therefore once dredging begins it is critical to continue dredging in many areas down to bedrock to remove highly contaminated material;
- given where the mass of contaminants are and the goal of open-water disposal for future

dredged sediments, the range of possible alternatives is limited, and requires that any alternative be fairly comprehensive (i.e. high amount of removal is necessary), and

-the current alternatives under consideration are reasonable and appropriate, and a quantitative cleanup goal analysis would in all likelihood generate similar alternatives.

Therefore, to best evaluate the proposed dredging alternatives, a weight of evidence approach that considers several factors, not just risk, is employed. A matrix with the three dredging alternatives was developed, and considers the following factors: 1) PCB mass removed; 2) surficial PCB sediment concentration after dredging; 3) beneficial uses addressed; and 4) scour/release potential (see Table 1). Note: In addition to these factors, both cost and feasibility need to be considered when weighing the dredging alternatives.

The post-remedial surface area weighted sediment concentrations of the Ashtabula River were estimated by USACE-Buffalo, using the Groundwater Modeling System (GMS) computer simulation program. The amount of PCB mass removed was also calculated by USACE-Buffalo and utilized the same model of the River to estimate PCB mass before and after the different remedial dredging alternatives (Table 1). All sediment sampling data including location, volume, and contaminant level were entered into the GMS to create a three dimensional "mesh" of the River. The model uses this 3-D mesh to calculate the contours of sediment at the surface in terms of width, depth, and PCB concentration, as well as the volume of sediment and mass of PCBs that will be removed. To compare the dredging alternatives, post-remedial conditions were modeled using the GMS, whereupon the model graphically shows the river bottom where sediment is dredged under each scenario. Dredging efficiencies are taken into account to calculate the PCB concentrations and volumes of sediment left at the river bottom after dredging.

It may seem surprising that this analysis shows that the *less* that is dredged, the *lower* the resulting surface concentration (Table 1). This is due to the PCB contaminant distribution associated with the sediment. In general, the bank-to-bank-to-bedrock and deep dredging scenarios require more river bottom to be dredged, thus exposing more contaminated material which results in higher overall post-dredging concentrations. In addition, dredging is not a 100% efficient technology, and accordingly may leave behind a small residue. As a result, dredging high volumes of the most contaminated areas of the river bottom will leave behind the most contaminated residue. Although post-dredging PCB surface concentrations are somewhat elevated, it is expected that they will gradually decrease in their overall concentration, as natural mixing with cleaner sediment occurs during post-cleanup years.

The matrix in Table 1 clearly shows that taking no action will not reduce long-term risk and future potential release into the lake, nor address beneficial use impairments. In addition, the shallow dredging option leaves behind TSCA-regulated sediments, which is generally unacceptable to the TSCA program and increases the uncertainty of whether dredged river sediments will be eligible for open-water disposal in the future. In all three dredging scenarios, relative current risk reduction is not significantly different. The reason for this is that post-

remedial surface area weighted PCB sediment concentration for each dredging scenario varies by only a few parts per million, which will not generate measurable differences in risk.

If either bank-to-bank-to-bedrock or deep dredging is implemented and the majority of PCB mass is removed, long-term protection is expected to be achieved. The GMS model indicates that after dredging, surface area weighted PCB sediment concentrations will approximate current surficial concentrations. Ongoing sedimentation in the Ashtabula River, while historically low on an annual basis, will gradually cover any low level residual contaminants left behind. Since 1983, significant reductions in the concentration of PCBs in fish have occurred due in part to cleaner sediments burying contaminated sediments, and also due to discharger compliance. After cleanup, it is expected the fish consumption advisory will be lifted and long-term protection will be achieved because the majority of the PCB mass will be removed. In order to maintain navigable depths for recreational purposes, future dredging in the lower river will likely be conducted to no more than -8 feet depth. Therefore, an adequate buffer will exist between the residual contamination left behind and the amount of clean sediment that will gradually cover it to help ensure long-term protection of human health and the environment.

The bank-to-bank to-bedrock alternative is the most protective and conservative in terms of PCB mass reduction, addressing most use impairments, and reducing scour potential. It attempts to remove practically all of the PCBs in this system. However, the bank-to-bank to-bedrock alternative also has extremely high implementation costs and concerns regarding river bank stability. The deep dredging alternative provides a similar degree of protectiveness and accomplishes much of what the bank to bank to bedrock does at a significantly lower cost. Deep dredging removes all TSCA material and a significant PCB mass (82%), substantially reducing any future scouring and potential release of elevated levels of contaminants. In addition, this large PCB mass removal gives greater assurance of open-water disposal for future dredging. In addition, deep dredging will likely facilitate river bank stability, help sustain habitat diversity, and perhaps, generate the least impact to ecological communities along the channel edges, compared to bank-to-bank to-bedrock dredging. Given the high costs and logistical issues inherent with bank-to-bank to-bedrock, and the positive anticipated results of the deep dredging alternative, the deep dredging alternative is the recommended starting point.

The dredging alternatives discussed are primarily based on PCB contamination. As noted previously, there are other contaminants of concern in this system, notably PAHs. Most of the PAH contamination is in the downstream portion of the River, starting at station 138. Currently, the draft EIS calls for dredging 120,000 yds³ of the lower river and Harbor sediments, in areas where PAH contamination is of greatest concern. Utilizing the approach discussed in the Assessing Open-Lake Disposal Suitability section above, it is recommended to dredge those areas with the greatest likelihood of being unsuitable for open-water disposal (i.e., >10 ppm total PAHs) as the highest priority areas for the 120,000 yds³. In addition, post-remedial design should include habitat restoration to further address impaired beneficial uses. It is anticipated that a habitat restoration plan will be developed at a later date with appropriate parties.

References

Crane, J.L. 1992. Baseline Human Health Risk Assessment: Ashtabula River, Ohio, Area of Concern. Environmental Research Laboratory, Office of Research and Development, U.S. Environmental Protection Agency. EPA-905-R92-007.

Long, E.R., D. D. MacDonald, S. S. Smith, and F. D. Calder. 1995. Incidence of adverse biological effects within ranges of chemical concentrations in marine and estuarine sediments. Environmental Management Vol. 19, No. 1, pp. 81-97.

Ohio EPA. 1991. Ashtabula River Area of Concern Stage 1 Report.

Pickard, S. W. 1997. DRAFT Development of Polychlorinated Biphenyl (PCB) Sediment Cleanup Guidelines for Ashtabula Harbor (Upper River), Ohio. U.S. Army Corps of Engineers.

U.S. EPA. 1996. Ecotox Thresholds. Eco Update. Office of Emergency and Remedial Response. Publication 9345.0-12FSI, EPA 540/F-95/038.

Table 1. Alternatives Matrix

<i>Dredging Scenarios</i>	PCB Mass Removed¹	PCB Sediment Concentration Left Behind in ppm^{1,2} (Surface Area Weighted)	Beneficial Uses Addressed (Including Open-Lake Disposal and Risk)	Scour/Release Potential (Future risk and loading to the Lake)
No Action	none	6.3	none	High
Bank to Bank to Bedrock	98%	4 8.6	open-lake disposal ++ recreational and commercial shipping ++ fish advisory lifted ++ long-term risk reduction ++ habitat quality +	Low
Deep	82%	3.6 7.5	open-lake disposal + recreational and commercial shipping ++ fish advisory lifted + long-term risk reduction + habitat quality ++	Low
Shallow	75% (one TSCA regulated mass remains)	3 6.3	open-lake disposal +/- recreational and commercial shipping + fish advisory lifted +/- long-term risk reduction +/- habitat quality +	Medium

¹Surface concentrations and percent mass removal estimates are from Dave Conboy, USACE-Buffalo

²The two concentrations shown refer to whether dredging will be one pass (second number) or two passes to increase efficiency (first number)

Where: - - - +/- + ++
 poor low no difference good excellent

Table 9: Pollutants identified in the Ashtabula River Area of Concern. This table was compiled from the results of a number of studies conducted in the area since 1975. This table documents only positive identification of pollutants.

PARAMETER	PRIORITY POLLUTANT	CARCINOGEN	PERSISTANT TOXIC*	WATER				SEDIMENT				FISH
				OUTER HARBOR	ASHTABULA RIVER	FIELDS BROOK	LAKE ERIE	OUTER HARBOR	ASHTABULA RIVER	FIELDS BROOK	LAKE ERIE	
<u>Inorganics</u>												
Aluminum	N	N	N	X	X	X	-	X	X	X	-	-
Arsenic	Y	Y	Y	-	-	-	X	X	X	X	X	X
Barium	N	N	N	X	X	X	X	X	X	X	X	-
Beryllium	Y	Y	-	-	-	-	-	-	X	X	-	X
Cadmium	Y	N	Y	X	X	X	X	X	X	X	X	-
Chromium	Y	N	Y	X	X	X	X	X	X	X	X	-
Copper	Y	N	Y	X	X	X	X	X	X	X	X	X
Cyanide	Y	N	N	-	X	-	-	X	X	X	-	-
Iron	N	N	Y	X	X	X	X	X	X	X	X	-
Lead	Y	N	Y	X	X	X	X	X	X	X	X	X
Manganese	N	N	N	X	X	X	-	X	X	X	X	-
Mercury	Y	N	Y	X	X	X	X	X	X	X	X	X
Nickel	Y	N	Y	X	-	-	X	X	X	X	X	-
Nitrogen (Ammonia)	N	N	N	X	X	X	X	X	-	-	X	-
Nitrate + Nitrite	N	N	N	X	X	X	X	X	-	-	X	-
Phosphorus	N	N	N	X	X	X	X	X	-	-	X	-
Oil and Grease	N	N	N	-	-	-	-	X	X	-	X	-
Silver	Y	N	-	-	-	-	-	-	X	X	-	X
Zinc	Y	N	Y	X	X	X	X	X	X	X	X	X
Total Dissolved Solids	N	N	Y	X	X	X	X	-	-	-	-	-
Phenols	Y	N	-	-	-	-	-	X	X	-	X	-
<u>Organics</u>												
Aldrin + Dieldrin	Y	Y	Y	X	X	-	X	-	X	-	-	-
PCBs	Y	Y	Y	-	-	-	X	X	X	X	X	X

Table 9: Pollutants identified in the Ashtabula River Area of Concern. (Continued)

PARAMETER	PRIORITY POLLUTANT	CARCINOGEN	PERSISTANT TOXIC*	WATER				SEDIMENT				FISH
				OUTER HARBOR	ASHTABULA RIVER	FIELDS BROOK	LAKE ERIE	OUTER HARBOR	ASHTABULA RIVER	FIELDS BROOK	LAKE ERIE	
<u>PAHs</u>												
Acenaphthene	Y	Y	-	-	-	-	-	X	-	-	-	-
Anthracene	Y	Y	-	-	-	-	-	X	X	-	-	-
Benzo(a)anthracene	Y	Y	-	-	-	-	-	X	X	-	X	-
Benzo(a)pyrene	Y	Y	-	-	-	-	-	X	X	X	X	-
Benzo(b)fluoroanthene	Y	Y	-	-	-	-	-	X	X	-	X	-
Chrysene	Y	Y	-	-	-	-	-	X	X	-	X	-
Fluoranthene	Y	Y	-	-	-	-	-	X	X	X	X	X
Fluorene	Y	Y	-	-	-	-	-	X	X	-	-	-
Naphthalene	Y	Y	-	-	-	X	-	X	X	-	-	-
Phenanthrene	Y	Y	-	-	-	-	-	X	X	X	X	-
Pyrene	Y	Y	-	-	-	-	-	X	X	-	-	-
2-chloronaphthalene	-	-	-	-	-	-	-	-	X	-	-	-
Benzo(k)fluoranthene	Y	Y	-	-	-	-	-	-	X	-	-	-
<u>Other Organics</u>												
Acetone	N	N	-	-	-	-	-	-	X	X	-	-
Benzene	Y	Y	-	-	-	-	-	-	-	X	-	-
Bis(2-ethylhexyl) phthalate	Y	N	Y	-	-	-	-	X	X	X	X	-
2-butanone	N	N	-	-	-	-	-	-	X	X	-	-
Butylbenzyl phthalate	Y	N	Y	-	-	-	-	-	X	X	-	-
Chlorobenzene	Y	N	-	-	-	-	X	-	X	-	-	-
Chloroform	Y	Y	-	-	-	X	-	-	-	X	-	-
1,1-dichloroethene	Y	Y	-	-	-	-	-	-	-	X	-	-
Diethyl phthalate	Y	N	Y	-	-	X	-	-	-	X	-	-
Dimethyl phthalate	Y	N	Y	-	-	-	-	-	-	X	-	-
Di-n-butyl phthalate	Y	N	Y	-	-	-	-	-	X	X	-	-
Ethylbenzene	Y	N	-	-	-	-	-	-	X	X	-	-

Table 9: Pollutants identified in the Ashtabula River Area of Concern. (Continued)

PARAMETER	PRIORITY POLLUTANT	CARCINOGEN	PERSISTANT TOXIC*	WATER				SEDIMENT				FISH	
				OUTER HARBOR	ASHTABULA RIVER	FIELDS BROOK	LAKE ERIE	OUTER HARBOR	ASHTABULA RIVER	FIELDS BROOK	LAKE ERIE		
<u>Other Organics (Continued)</u>													
Fluorotrichloromethane	N	N	-	-	-	-	-	-	-	-	X	-	-
Hexachlorobenzene	Y	Y	-	-	-	X	X	-	X	X	X	-	X
Hexachlorobutadiene	Y	Y	-	-	-	X	-	-	X	X	X	-	X
Hexachloroethane	Y	Y	-	-	-	-	-	-	X	X	X	-	-
Methylene chloride	Y	Y	-	-	X	X	-	X	X	X	X	X	-
1,2-Dichlorobenzene	Y	N	-	-	-	X	X	-	-	-	-	-	-
1,3-Dichlorobenzene	Y	N	-	-	-	X	X	-	X	-	-	-	-
1,4-Dichlorobenzene	Y	N	-	-	-	X	X	-	X	-	-	-	-
n-nitrosodiphenylamine	Y	Y	-	-	-	X	-	-	-	-	-	-	-
Carbon tetrachloride	Y	Y	-	-	-	X	X	-	-	-	-	-	-
Octachlorostyrene	N	N	-	-	-	-	-	-	X	-	-	-	X
Xylene	N	N	-	-	-	-	-	-	X	X	X	-	-
Pentachlorobenzene	N	N	-	-	-	-	X	-	-	-	-	-	X
1,1,1,2-tetrachloroethane	N	N	-	-	-	-	-	-	X	-	-	-	-
1,1,2,2-tetrachloroethane	Y	Y	-	X	X	X	-	-	-	X	X	-	-
Tetrachloroethene	Y	Y	-	X	X	X	-	-	X	X	X	-	X
1,2-transdichloroethene	N	N	-	-	-	X	-	-	-	-	X	-	-
1,1,2-trichloroethane	Y	Y	-	-	-	X	-	-	-	-	X	-	-
1,1,1-trichloroethane	Y	N	-	-	-	-	-	-	-	-	X	-	-
Trichloroethene	Y	N	-	X	X	X	-	-	X	X	X	-	X
Toluene	Y	N	-	-	-	-	-	-	X	X	X	-	-
Vinyl chloride	Y	Y	-	-	-	-	-	-	-	-	X	-	-
1,2,4-trichlorobenzene	N	N	-	-	-	-	X	-	X	-	-	-	-
1,2-dichloroethane	Y	Y	-	-	-	X	-	-	-	-	-	-	-
1,3,5-trichlorobenzene	N	Y	-	-	-	-	X	-	-	-	-	-	-
1,2,3,4-tetrachlorobenzene	N	Y	-	-	-	-	X	-	-	-	-	-	-

* As identified in the Great Lakes Water Quality Agreement

Y - Yes

X - Pollutant detected in medium

N - No

"-" - Pollutant not present or not tested

**SUB-APPENDIX
RADIONUCLIDES (RAD)**

**RISK ASSESSMENTS FOR
ASHTABULA RIVER, ASHTABULA, OHIO**

Resident- Farmer

and

Worker, Dredger

**Larry Jensen
Amy Mucha
U.S. Environmental Protection Agency
November 2000**

Overview

In May 1998 and August 1999 measurements were made by the U.S. Environmental Protection Agency (USEPA) and the Ohio Department of Health, Bureau of Radiation Protection (ODH/BRP), of radionuclide concentrations in sediments of the Ashtabula River, northeast of Cleveland Ohio. Radiological constituents were believed to have entered the river from Fields Brook on which a titanium ore processing plant is operating and a uranium extrusion plant once operated. Titanium ores at the processing plant contain Naturally Occurring Radioactive Materials (uranium, thorium and actinium decay series radionuclides). Uranium at the extrusion plant was purified radioactive metal containing uranium-238, uranium-234 and uranium-235. These sediment measurements were intended to enhance the database on the contamination already known to include hazardous chemicals, including polychlorinated biphenyls (PCBs). See Map 1, 1998 sampling sites, and Map 2, 1999 sampling sites in Attachment A.

Plans are already being drawn up to remove chemically contaminated sediments above a depth known as the cutline. At the least, radiological constituents could be removed along with the chemical constituents. It is also possible that the remedy action will have to be enhanced to remove additional radiological constituents at greater depths.

In order to assess this situation, radiological risk assessments under two scenarios are performed in this document. This follows in the section labeled Radiological Risk Assessment. A risk assessment for uranium as a chemical contaminant of concern was also performed and is found further below in the section labeled Chemical Risk Assessment.

The first radiological scenario is of a resident-farmer. The assumption is that after overlying contaminated sediments were dredged from the Ashtabula River the underlying sediments, containing some degree of residual radioactivity, are later dredged up and inadvertently spread on residential land where foodstuffs are grown. This scenario is designated the **Resident-Farmer Scenario**. It is intended to answer the question of whether more sediments, below the cutline, will have to be removed.

The resulting radiological exposure is taken to be from birth to 30 years of age with six subdivisions for exposure periods of

- a baby (1 year),
- an older baby (1 year),
- a young child (3 years),
- an older child (7 years),

- a teenager (7 years) and
- an adult (11 years).

Exposure pathways for the baby and the older baby, indoors and outdoors, were

- external exposure,
- radon decay product inhalation.

Exposure pathways for the young child, the older child, the teenager and the adult, indoors and outdoors, were

- external exposure
- plant ingestion
- soil ingestion and
- dust inhalation (including radon decay product inhalation).

Risks were computed as excess risk (over background radiation risks).

The second radiological scenario, where workers were assumed to be exposed while dredging sediments from the Ashtabula River, focuses on the peak values found in the sediments above the cutline. This is the risk with no remedial action and no protective action for the workers. This scenario was designated the **Worker-Dredger Scenario**. It is intended to answer the question of whether protective measures will have to be instituted for workers involved in dredging operations. All risks are excess risks due to over background radiological concentrations.

Exposure pathways were

- external exposure and
- soil ingestion.

The period of exposure was for the two-year plus 4 month period estimated for dredging the river.

Chemical risks from uranium were also computed since soluble uranium is a chemical hazard as well. Only the residential scenario was used. Pathways were dermal exposure and incidental ingestion of soil. Estimates were made for a full lifetime of exposure, with 0-18 year olds estimated separately from 18-70 year olds. This was

done to specifically ensure that childhood and adolescent exposures were estimated accurately, because they can differ from exposure patterns in adults. Concentrations were based upon the 95% Upper Confidence Limit and the maximum level. Risks were expressed as a Hazard Index where the estimated exposure is compared to a safe threshold or level of no effects.

RADIOLOGICAL RISK ASSESSMENTS

Resident-Farmer Scenario

Scenario overview: Under this scenario, it is assumed that chemical and radiological contaminants have been dredged from the upper layer of Ashtabula River sediments, the cutline depth set by chemical criteria. The issue addressed by this assessment is, "What risk do the radiological constituents found below the cutline pose?" Alternatively, "Under the plans proposed for the chemical cleanup, will the risk from underlying radiological constituents require further dredging or will the proposed dredging be sufficient?"

Under this scenario, the dredged materials are spread over the residential property where home farming is done. The resident is exposed outdoors and indoors to these radionuclides and their decay products for a period of 30 years, from birth until 30 years of age. Thirty years is a span USEPA associates with an average residence time at one property. This span was subdivided into 6 age ranges in order to assess risk for both younger and older individuals.

Under this scenario, the dredged materials are spread over the residential property where home farming is done. The resident is exposed outdoors and indoors to these radionuclides and their decay products. No exposure occurs when the person leaves the residential property. The exposure occurs in 6 age groups **Baby** (0 - 1 year), **Older Baby** (1 - 2 years), **Young Child** (3 - 5 years), **Older Child** (6 - 12 years), **Teenager** (13 - 19 years) and **Adult** (20 - 30 years). Daily activities were defined for each age group and time allotted to each so that the time fractions indoors, outdoors and away from home could be computed.

Measurement Sites: Background sites for this assessment were selected upstream of the Turning Basin, based upon 1999 sampling sites. The designations correspond to sites shown in Map 2. Data for this assessment came from 1999 data, although both 1998 and 1999 data were consulted. Both 1998 and 1999 data comprise the total database for this assessment (see Attachment C).

Contaminants of Concern: The contaminants of concern are the complete Uranium (U-238) Decay Series, the complete Thorium (Th-232) Decay Series, and the complete Actinium (U-235) Decay Series. See Attachment B.

Within each series, radionuclides were grouped individually and also by parent with immediate decay products of less than one year half-life (+ D). These groups are

URANIUM DECAY SERIES

•	Uranium-238 + D	[U-238 + D]
•	Uranium-234	[U-234]
•	Thorium-230	[Th-230]
•	Radium-226	[Ra-226]
•	Radon-222 + D	[Rn-220 + D]
•	Lead-210 + D	[Pb-210 + D]

THORIUM DECAY SERIES

•	Thorium-232	[Th-232]
•	Radium-228	[Ra-228]
•	Actinium-228	[Ac-228]
•	Thorium-228	[Th-228]
•	Radium-224	[Ra-224]
•	Radon-220 + D	[Rn-220 + D]

ACTINIUM DECAY SERIES

•	Uranium-235 + D	[U-235 + D]
•	Protactinium-231	[Pa-231]
•	Actinium-227 + D	[Ac-227 + D]

These groupings correspond to slope factor groups (risk coefficients) in the U.S. Environmental Protection Agency's (USEPA) 1995 Health Effects Assessment Summary Tables (HEAST).

Contaminant Concentrations: Gross sediment concentrations by isotope were measured below the depth intended for dredging of chemicals. These are listed in Attachment C for both 1998 and 1999 data sets. Background levels were measured upstream of the Turning Basin. These are listed in Attachment C as well. For this scenario, the average background levels were subtracted from peak sediment concentrations, giving net concentrations for the risk calculations.

Exposure periods/pathways: A 30-year residence was assumed, based upon USEPA default exposure factors. This was further broken down into 6 age groups because of the differences in exposure pathways and exposure factors over time. These age groups, with the exposure pathways, were

- **Baby (0 - 1 years)**—External exposure, radon/thoron decay product inhalation
- **Older Baby (1 - 2 years)**—External exposure, radon/thoron decay product inhalation
- **Young Child (3 - 5 years)**—External exposure, plant ingestion, soil ingestion, dust inhalation (including radon/thoron decay product inhalation)
- **Older Child (6 - 12 years)**—External exposure, plant ingestion, soil ingestion, dust inhalation (including radon/thoron decay product inhalation)
- **Teenager (13 - 19 years)**—External exposure, plant ingestion, soil ingestion, dust inhalation (including radon/thoron decay product inhalation)
- **Adult (20 - 30 years)**—External exposure, plant ingestion, soil ingestion, dust inhalation (including radon/thoron decay product inhalation)

Risk equations: Risk calculations were made for each age group, for each pathway and for each radionuclide group. Risk equations for external exposure, plant ingestion, soil ingestion and dust inhalation are based on USEPA's Review Draft of the Technical Support Document for the Development of Radionuclide Cleanup Levels for Soil. Radon-220 + decay product and radon-222 + decay product equations were developed specifically for this assessment (see Attachment D). The risk equations and all the parameters by symbol, name and numerical value are listed in Attachment D.

Slope factors: Slope factors for external exposure, ingestion and inhalation are from the FY-1995 HEAST Supplement.

Other parameters: Exposure factors were taken from USEPA's Exposure Factors Handbook (1989). Additional factors were taken from USEPA'S Draft Technical Support Document for the Development of Radionuclide Cleanup Standards for Soil (soil-to-plant transfer factors);

Indoor/outdoor exposure times: Exposures are affected by whether the exposed individual is inside the home, outside the home or away from home. (e.g., radon decay product exposure is greatest inside the home; gamma ray exposure rates are diminished within a home, when there is an outdoor source, because of shielding by the walls; no exposure occurs when the individual is off the property).

-
- Radon refers to radon-222, a radioactive gas produced in the Uranium Decay Series, and thoron refers to radon-220, a radioactive gas produced in the Thorium Decay Series.

Annual time percentages for inside and outside the home and for away from home were computed by estimating time usage over each hour of the day, over weekdays and weekends, and over seasons specifically for this project. There are no USEPA default values for these times. See Attachment E.

Worker, Dredger Scenario

Scenario overview: Under this scenario, workers dredging the Ashtabula River are not aware that it is radiologically contaminated and, thus, they have taken no personal protection. The levels to which they are exposed are the maximum levels seen in 1998 and 1999 data (see Attachment C). The pathways of exposure are external exposure and soil ingestion. The period of exposure is the total time needed to dredge the river, two years and four months.

Contaminants of Concern: The contaminants of concern are the complete Uranium (U-238) Decay Series, the complete Thorium (Th-232) Decay Series, and the complete Actinium (U-235) Decay Series. See Attachment B.

Within each series, radionuclides were grouped individually and also by parent with immediate decay products of less than one year half-life (+ D). These groups are

URANIUM DECAY SERIES

•	Uranium-238 + D	[U-238 + D]
•	Uranium-234	[U-234]
•	Thorium-230	[Th-230]
•	Radium-226	[Ra-226]
•	Radon-222 + D	[Rn-220 + D]
•	Lead-210 + D	[Pb-210 + D]

THORIUM DECAY SERIES

•	Thorium-232	[Th-232]
•	Radium-228	[Ra-228]
•	Actinium-228	[Ac-228]
•	Thorium-228	[Th-228]
•	Radium-224	[Ra-224]
•	Radon-220 + D	[Rn-220 + D]

ACTINIUM DECAY SERIES

•	Uranium-235 + D	[U-235 + D]
•	Protactinium-231	[Pa-231]

• Actinium-227 + D

[Ac-227 + D]

These groupings correspond to slope factor groups (risk coefficients) in the USEPA HEAST FY-1995 supplementary tables.

Contaminant Concentrations: Gross sediment concentrations by isotope were measured in the Ashtabula River sediments in 1998 and 1999 (see Attachment C). The maximum measured was used in this scenario. Background levels were measured upstream of the Turning Basin in 1998 and 1999. The 1999 concentrations were used for this risk assessment because they were taken at several sites and were taken in a formal way specifically to investigate the extent and degree of contamination seen in previous investigations. Net concentrations for the computation of excess risk were taken as gross concentrations minus background concentrations. See Attachment C.

Exposure periods: A two year plus four month exposure period was assumed based upon a U.S. Army Corps of Engineers estimate of the time needed to dredge the river.

Risk equations: Risk equations are based on USEPA's Review Draft of the Technical Support Document for the Development of Radionuclide Cleanup Levels for Soil. These were external exposure and soil ingestion (see Attachment D). The risk equations and all the parameters by symbol, name and numerical value are listed in Attachment D.

Risk Evaluation

Risks can be evaluated against the acceptable exposure levels for lifetime cancer risk to an individual of 10^{-6} to 10^{-4} found in Title 40, Part 300.430 (e)(2)(I)(A)(2) of the Code of Federal Regulations, also known as the National Oil and Hazardous Substances Pollution Contingency Plan. 10^{-6} is the point of departure for establishing acceptable risk. Risks beyond this require justification.

Radiological Results for the Resident-Farmer Scenario

Risks for this scenario are summarized in Attachment F, Tables 1 - 6.

For maximum concentrations, the leading contributors are evident in Table 2.

- For external exposure, an adult (ages 20 - 30 years) is most at risk from Thorium Decay Series radionuclides [9.35E-6].
- For plant ingestion, an adult is most at risk from Uranium Decay Series radionuclides [9.69E-6].

- For soil ingestion, an older child (ages 6 - 12 years) is most at risk from Uranium Decay Series radionuclides [5.79E-8].
- For dust inhalation with radon decay product inhalation included, the adult is most at risk from Uranium Decay Series radionuclides [1.08E-5].
- For total, all pathway, risk the adult is most at risk due to dust inhalation with radon + decay products from Uranium Decay Series radionuclides [1.08E-5].

The cause for these maximums are shown in Table 3.

- External exposure risk is due, about equally, radon-222 + decay products and radon-220 + decay products in all age groups.
- Plant ingestion risk is due to radium-226 and radium-228 with radium-226 slightly higher.
- Soil ingestion risk is due to lead-210 + decay products.
- Dust inhalation risk is due to radon-222 + decay products.
- The highest overall risk for all age groups and all pathways is dust inhalation radon-222 + decay products. The adult risk is the dominant risk.

When 95% Upper Confidence Level (95UCL) concentrations are used changes occur

- Plant ingestion uranium and thorium decay series risks are about equal for an adult,
- Total, all pathway, risk where uranium and thorium risks are about equal with Thorium Decay Series risks slightly higher, and
- Numerical risk drops.

The cause for these maximums are shown in Tables 2 and 4. The only difference in conclusions, as compared to that for maximum concentrations, is

- Plant ingestion risk is more strongly caused by radium-226.

Overall, risk is dominated by radon-222 + decay product inhalation. Significant secondary risks are caused by external exposure to radon-222 + decay products and radon-220 + decay products, plant ingestion of radium-226 and radium-228, and dust inhalation of radon-220 + decay products.

Comparisons to Criteria

The risk from this scenario is about 1×10^{-4} (1.38×10^{-4} using maximum concentrations, 8.66×10^{-5} using 95%UCL concentrations). The "excess upper bound lifetime cancer risk to an individual," under the National Oil and Hazardous Substances Pollution Contingency Plan (known as the NCP) is 10^{-6} to 10^{-4} where 10^{-4} is not specifically or rigidly quantified. Thus, under this comparison the 10^{-6} point of departure is exceeded. Acceptance of criteria with risks at 10^{-4} must, thus, be justified.

Commonly used cleanup criteria in Region 5 are 5 pCi/g combined radium (Ra-226 + Ra-228) from U.S. Environmental Protection Agency standards for uranium and thorium mill tailings (found in Title 40, Part 192 of the Code of Federal Regulations, 40 CFR 192) and 30 pCi/g combined for enriched uranium (U-238 + U-234 + U-235) set out in the Nuclear Regulatory Commission's Branch Technical Position (found in Vol. 46, No. 205, p 52061-52063, of the Federal Register, October 23, 1981). 5 pCi/g combined radium was the criterion set for residential area cleanups on Fields Brook, the stream that feeds into Ashtabula River. 30 pCi/g combined uranium was the criterion set for Fields Brook as well.

Radiological Conclusions for the Resident-Farmer Scenario

The total risk from all radionuclides and all pathways is about 1×10^{-4} . This is at the upper end of the NCP risk range. Risk is about equally apportioned between external exposure, plant ingestion and inhalation of radon + decay products and has the greatest impact on older age groups (older child, teenager, adult) where the exposure period is longer.

The measured excess sediment concentrations are considerably under 5 pCi/g combined radium and 30 pCi/g combined for enriched uranium.

Radiological Results for the Worker- Dredger Scenario

Risks for this scenario are summarized in Attachment F, Tables 7 - 11.

For maximum concentrations, the leading contributors are evident in Table 8.

- For external exposure, thorium contributes the highest risk [4.60E-5].
- For soil ingestion, uranium contributes the highest risk [4.12E-7].
- For total risk from both pathways, thorium contributes the most risk [4.61E-5].

The causes for maximums are shown in Table 10.

- External exposure risk is primarily due to radon decay products with radon-222 + decay products about equal to radon-220 + decay products [2.81 - 2.97E-5].
- Soil ingestion risk is due to lead-210 + decay products [1.85E-7]
- Total risk is due primarily to radon + decay products with radon-222 + decay products about equal to radon-220 + decay products [2.81 - 2.98E-5].
- The maximum risk is due to radon-220 + decay products [2.97E-5].

When 95%UCL concentrations are used (Table 7)

- External exposure risk, total exposure risk and maximum risk are due primarily to uranium (radon-222 + decay products).
- Soil ingestion risk is still due to uranium (lead-210 + decay products).
- The maximum risk is due to external exposure from radon-222 + decay products.
- All numerical risks drop.

Radiological Conclusions for the Worker-Dredger Scenario

The conclusion is that the predominance of risk is due to external exposure caused by radon + decay products in the Uranium Decay Series and the Thorium Decay Series. The risk is about equal for both decay series, about 3×10^{-5} .

CHEMICAL RISK ASSESSMENT

Chemical Risks from Uranium - Ashtabula River, Ohio

(accompanying data and spreadsheets: Attachment G)

In addition to assessing the risk from uranium as a radionuclide, uranium can also be assessed for its effects as a chemical - from exposures such as ingestion or dermal contact. To assess the toxicity of a chemical, EPA utilizes IRIS (Integrated Risk Information System) as its toxicity database (www.epa.gov/iris). IRIS contains toxicity information on uranium only (for chemical risks). Therefore, only uranium chemical risks were assessed in this section. Uranium as soluble salts has toxicity information to assess non-cancer risks only - specifically body weight loss and moderate nephrotoxicity. Therefore this assessment provides estimates of non-cancer risks of uranium as a chemical. For all other risks from uranium and the other radionuclides

found in the Ashtabula River sediment, please see Radiological Risk Assessments above.

Uranium data were used from the August, 1999 sampling of the Ashtabula River. The data used to drive this analysis were those sample results below the cutline, or what would potentially be left behind after dredging (see Attachment G). Therefore the risks are for exposures to the residual, or remaining, sediment. In order to be conservative and be sure to estimate the worst-case scenario risks, the sediment was assumed to be applied to residential land, where people could be exposed in their everyday lives. Therefore, they could become exposed both via dermal contact as well as through incidental ingestion. Both the dermal and incidental ingestion routes were estimated. Estimates were made for a full lifetime of exposure, with the 0-18 year olds estimated separately from 18-70 year olds. This was done to specifically ensure that childhood and adolescent exposures were estimated accurately, because they can differ from exposure patterns in adults. For the mass concentration term (what levels people would be exposed to), two estimates were used. It is EPA Superfund policy to use the 95% upper confidence limit (UCL) on the mean (a more conservative measure of the mean) and this term was therefore estimated and used. To ensure again that a conservative and protective estimate was done, the maximum concentration of uranium was also used. Therefore, in the risk estimates provided below, a range is given to indicate the 95%UCL and maximum terms used.

As a result, conversion of the different type of data was needed to assess chemical-based risks. The data needed to be converted to a mass/mass basis (e.g. ug/g) instead of on a picocurie/gram basis. Conversion was made using this formula.

$$G = A * T_{1/2} * C_1 * C_2 * C_3 / [C_4 * C_5]$$

where: G = mass concentration, parts per million (ppm)/micrograms per gram (ug/g)
A = activity concentration in picocuries per gram (pCi/g)
T_{1/2} = half-life in seconds (s) of specific radionuclide
C₁ = constant, 10⁶ micrograms per gram (ug/g)
C₂ = constant, 3.7 x 10⁻² disintegrations per second per picocurie [(d/s)/pCi]
C₃ = constant, atomic mass of specific radionuclide per mole (g/mole)
C₄ = constant, natural logarithm of 2 (unitless)
C₅ = constant, 6.023 x 10²³ atoms per mole (atoms/mole)

For details on parameters used in the risk estimates, see Attachment G.

Because we are assessing non-cancer risks, we are assuming there is a safe level of exposure, or a threshold of effect. Risk is described as a ratio or hazard index comparing the estimated exposure to a safe threshold or level that no effects are expected:

Estimate of site-specific exposure
Safe level of exposure or RfD (Reference Dose)

Therefore, to interpret non-cancer risk estimates, a ratio of 1 or lower is considered acceptable because the estimate of exposure is less than or equal to a safe level.

In no case did the non-cancer risk estimate reach 1 or greater, meaning all were acceptable risks because all estimates were well below a level where effects would be seen (below 1). Note that the range is due to using both maximum contaminant level and an estimate of the mean (95% upper confidence limit). Results were as follows:

PATHWAY AND TOTAL, LIFETIME, URANIUM CHEMICAL RISK (HAZARD INDEX)

Pathway	Range (95%UCL to Maximum)
Dermal	9.4E-5 – 1.4E-4
Incidental ingestion	3.1E-3 – 4.6E-3
Total	3.2E-3 – 4.7E-3

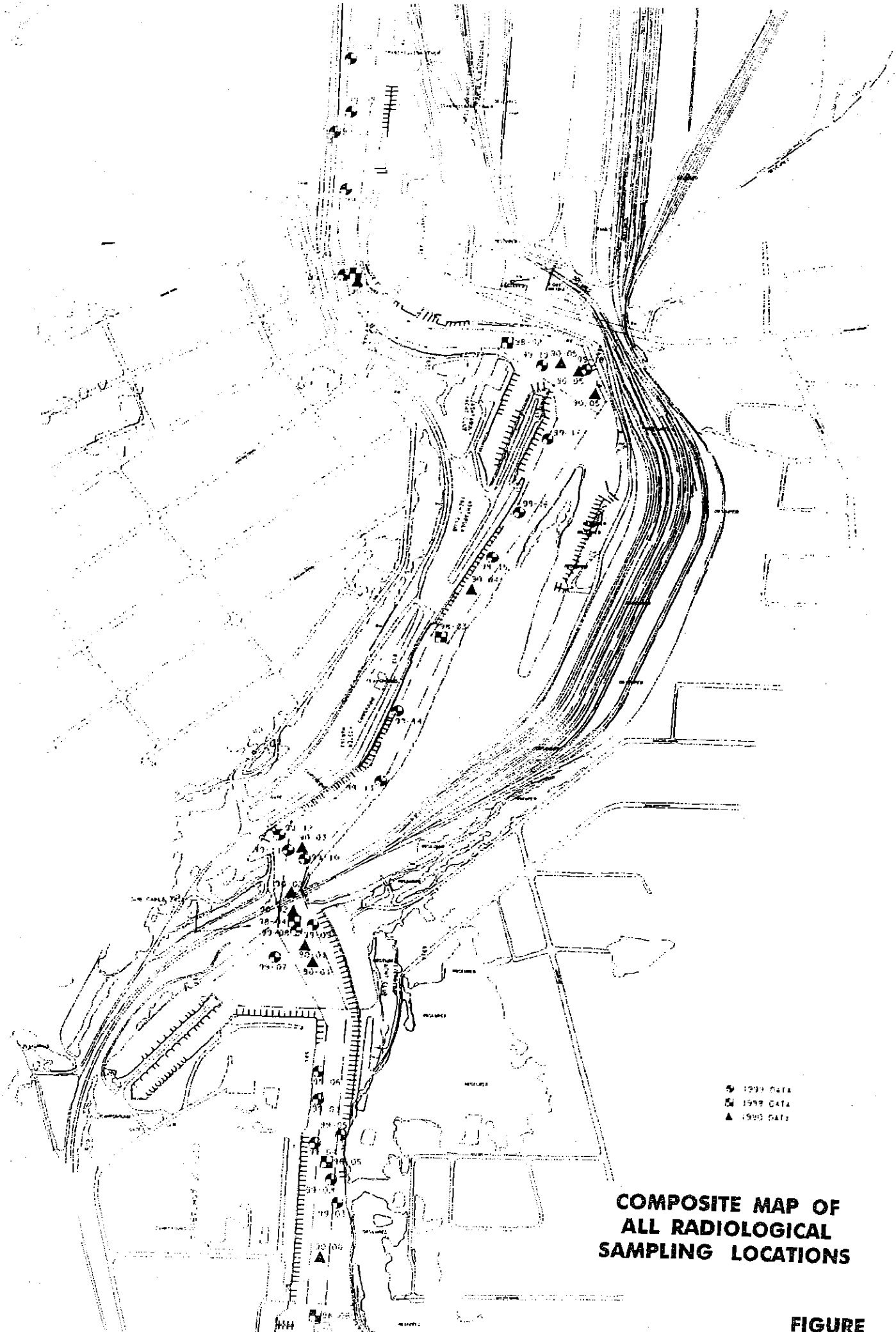

**COMPOSITE MAP OF
ALL RADIOLOGICAL
SAMPLING LOCATIONS**

FIGURE

**ATTACHMENTS A - G ARE NOT INCLUDED HERE; BUT, ARE INCLUDED
IN TECHNICAL APPENDIX G - RADIOLOGICAL RISK ASSESSMENT FOR
ASHTABULA RIVER, ASHTABULA, OHIO.**

ALSO REFERENCE IN THE TECHNICAL APPENDICES:

**TECHNICAL APPENDIX D - ASHTABULA RIVER SEDIMENT SAMPLING
AND ANALYSIS OF EXTENT OF RADIONUCLIDE CONTAMINATION.**

**TECHNICAL APPENDIX G - RADIOLOGICAL RISK ASSESSMENT FOR
ASHTABULA RIVER, ASHTABULA, OHIO.**

ASHTABULA RIVER
PARTNERSHIP

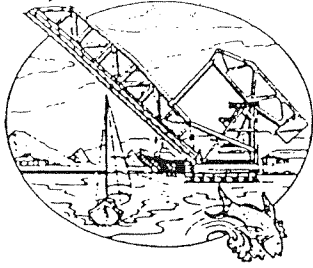

1123 Bridge Street
Ashtabula, Ohio 44004
(216) 964-0277 Office
(216) 964-5158 Fax

John Mahan, Ph.D
Coordinator

Rick Brewer
Co-Chairman
Coordinating Committee

Fred Leitert
Co-Chairman
Coordinating Committee

Steve Golyski
Chairman
Project Committee

Rick Mason
Chairman
Siting Committee

Brett Kaull
Chairman
Resource Committee

Michelle Rowley
Chairperson
Outreach Committee

Ashtabula River and Harbor

Comprehensive Management Plan

Dredging and Disposal

FINAL

FEASIBILITY REPORT AND

ENVIRONMENTAL IMPACT STATEMENT

ENVIRONMENTAL APPENDIX

EA-D U.S. FISH AND WILDLIFE COORDINATION ACT REPORT

City of Ashtabula
Town of Ashtabula
County of Ashtabula
State of Ohio

2001



United States Department of the Interior

FISH AND WILDLIFE SERVICE

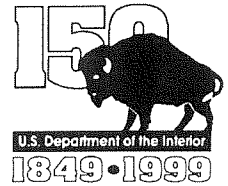

Ecological Services
6950 Americana Parkway, Suite H
Reynoldsburg, Ohio 43068-4127
(614) 469-6923/FAX (614) 469-6919
November 16, 2000

Lt. Colonel Glen R. DeWillie
District Engineer
Buffalo District, Corps of Engineers
1776 Niagara Street
Buffalo, New York 14207

Attn: Environmental Resources Unit, Tod Smith

Dear Colonel DeWillie:

This is our Final Fish and Wildlife Coordination Act Report on the proposed removal and confinement of contaminated sediments from the Ashtabula River. Some of the contaminated sediments will be removed and confined under the provisions of the Toxic Substance Control Act (TSCA). The project is located in the City of Ashtabula, Ashtabula County, Ohio.

These comments have been prepared under the authority of the Fish and Wildlife Coordination Act, the Endangered Species Act of 1973, as amended, and are considered consistent with the intent of the National Environmental Policy Act of 1969, and the U.S. Fish and Wildlife Service's Mitigation Policy. The positions in this letter are not representative of any future position that the Department of the Interior may assert as National Resources Trustee in the Ashtabula River.

The Ohio Division of Wildlife has reviewed this report and their Letter of concurrence dated November 14, 2000 is attached.

DESCRIPTION OF AREA

The Ashtabula River basin (approximately 137 square Miles) is located in northeast Ohio and flows into Lake Erie at the City of Ashtabula. The main stem of the river is 23 miles long and originates at the confluence of the East and West Branches. The average annual flow of the river at Ashtabula is approximately 150 cubic feet per second. The major tributaries include Fields Brook, East Branch, Hubbard Run and Ashtabula Creek. Land use in the watershed is primarily rural and agricultural, with the city of Ashtabula the only significant urbanized area. There is some industrial development in Ashtabula west of the river, but most of the industrial development is located east of the river around the Fields Brook tributary.

The Federal navigation project at Ashtabula includes an outer harbor area (about 185 acres) protected by two converging breakwaters. The Federal channel in the river begins at the mouth and extends 1,550 feet upstream of the upper turning basin (see Figure 1).

BACKGROUND

Discharges to the Ashtabula River have polluted the sediments, primarily from the turning basin downstream. The primary source of these pollutants appears to be past industrial discharges to Fields Brook (a Superfund site) which joins the river on the east side in the vicinity of the turning basin. Other potential sources of pollution include point and non-point sources.

Numerous contaminants have been identified in sediment samples from the Ashtabula River taken by Woodward Clyde in 1990 and by contractors under the supervision of the Buffalo District Corps of Engineers. Data were obtained for eight metals, polychlorinated biphenyls (PCB's), hexachlorobutadiene (HCBD), hexachlorobenzene (HCB), and chlorobenzene (CB). An example of the highest concentrations include, 31 parts per million (ppm) for arsenic, 2,152 ppm for barium, 5,740 ppm for chromium, 560 ppm for HCBD and 660 ppm for PCB's.

The Buffalo District Corps of Engineers has been attempting to dredge contaminated sediments from the Ashtabula River for nearly 30 years. However, the Corps and others have not been able to find a locally acceptable disposal site for the material. Numerous attempts have been made over the years to find an acceptable site and until this time, all attempts have been unsuccessful.

DESCRIPTION OF PROPOSED PROJECT

The proposed project is being promoted and sponsored by the Ashtabula River Partnership (ARP) of which the Buffalo District Corps of Engineers plays a vital role coordinating most of the planning and technical aspects. The ARP is a public and private partnership working to remediate polluted sediments in the lower Ashtabula River and Harbor. The Corps of Engineers and the U.S. Fish and Wildlife Service are members of the Ashtabula River Partnership.

Conceptually, the proposed project would involve deep dredging of the contaminated sediments. The project will also involve a method of dewatering/transporting the sediments to the appropriate disposal facility.

Approximately 696,000 cubic yards of contaminated sediments would be dredged from the lower Ashtabula River from just downstream of the Fifth Street bridge to the upper turning basin. The volume of sediments that are TSCA-classified (PCB concentrations greater than 50 ppm), is estimated at 28,740 cubic yards. The U.S. Environmental Protection Agency, the Ohio Environmental Protection Agency and the Buffalo District Corps of Engineers have agreed that given the uncertainties of the volume estimates/modeling and dredging, to use 40 ppm as a cut-off for sediments to be disposed as TSCA material. This increased the volume of potential TSCA material to about 150,000 cubic yards.

The Ashtabula River Partnership passed a resolution to include the disposal of the 1993 Interim Dredging sediments/containment dikes, (approximately 30,000 cubic yards) in the Partnership's disposal facility. Thus, the ~~total non-TSCA classified~~ sediments total is 726,000 Cubic yards.

The cleanup goal is that in future years, after this initial dredging and the cleanup of the Fields Brook, dredged sediments from the navigation channels and harbor will be of a quality acceptable for disposal in established open lake disposal sites.

DREDGING-DEWATERING-DISPOSAL

Dredging

The most environmentally sound dredging method should be used to remove the contaminated sediments from the river. One method being discussed is the use of various types of "closed" buckets and hydraulic suction dredges. Regardless of what type of dredging method is employed, minimization of turbidity should have a high priority. Also, silt screens should be deployed around the dredge and perhaps at a downstream location. If necessary, an absorbent float could be attached to the top of the silt screen to collect any "oil" which may come to the surface during dredging operations.

Dewatering

A number of options have been discussed regarding the methods which could be used to handle the material from the time it is dredged to the point of disposal. The most likely scenario appears to be a harbor or river dewatering facility with several settling basins with a final filtering/treatment process. The water discharged to Lake Erie or the Ashtabula River would be required to meet all water quality requirements of the Ohio Environmental Protection Agency. It appears that the Conrail site on the east side of the river near the upper turning basin is a possible location for the dewatering facility.

Disposal

Originally, 36 sites were being investigated as disposal sites for the contaminated material dredged from the Ashtabula River. The project siting committee spent considerable time evaluating alternative sites until two upland disposal areas referred to as Sites 5 and 7, and one inwater site referred to as site P, remained (see Figure 2).

Within the past year, the Project Committee and the Corps of Engineers have completed an on-site investigation within an approximately 35 acre portion of the RMI Sodium Plant site (RMI site) located within the City of Ashtabula. The RMI site (see Figure 2) is located east of State Road, and south of Lake Road.

The RMI site consists of a former industrial facility in varying stages of demolition although there are some open field areas, rubble and debris, roadways, abandoned railroad tracks, and lagoons. The site is underlain by Made-land (soil and non-soil fill). Drainage on the site is controlled and varies across the site. Along the eastern boundary, a wetland approximately 0.02 acres in size has developed. Development of the site as a disposal area will not impact this wetland. Vegetation within the upland open field and other areas consists of herbaceous grass and forb species.

The Project Committee and the ARP has selected the RMI site as the disposal site for the TSCA as well as the non-TSCA disposal facilities. Details of the design of the facilities will be forthcoming.

FISH AND WILDLIFE RESOURCES

The fish and wildlife resources of the Ashtabula River are many and varied. The lower river and harbor contain numerous benthic organisms, dominated by pollution tolerant species. The lower river and harbor also contain numerous game fish species such as bass, walleye and northern pike along with a variety of forage species including minnows and shiners. While the fish are available, the Ohio

Department of Health has issued a "Do Not Eat" fish advisory for all fish species in the Ashtabula River from the 24th Street Bridge to Lake Erie. The small amount of natural shoreline remaining supports some reptiles, amphibians, birds and mammals.

A more complete treatment of fish and wildlife resources has been provided in our August 30, 1996 Biological Report on Ashtabula River and Harbor, Remediation Project, Ashtabula County, Ohio. We have not undertaken any new, site specific, fish or wildlife surveys for this project. Wildlife information used in this letter and the biological report is based on information in our files, field reviews and works done by others.

DISCUSSION

Dredging the toxic and contaminated sediments from the Ashtabula River will resolve a long standing problem in the Ashtabula area. While the actual dredging operation may cause some temporary increases in turbidity and water quality degradation in the river and harbor areas, the long term benefits will greatly outweigh the temporary adverse impacts.

Many questions still remain to be answered regarding the actual dredging techniques, type of equipment, and safety precautions to be implemented. We are confident that these questions will be resolved in a fashion that will protect the aquatic resources in the river and harbor to the fullest extent possible. We will make specific recommendations to protect aquatic resources when the type and extent of dredging is known. However, as mentioned previously, silt screens will most likely be recommended.

Handling of the sediments after dredging is also under discussion. Dewatering, transfer sites and methods of transporting the dredged material are active topics of discussion.

Section 312 of the Water Resource Development Act (WRDA) of 1990 entitled "Environmental Dredging " authorizes the Corps of Engineers to remove contaminated sediments from the navigable waters of the United States. Section 312 (a) provides for removal of contaminated sediments outside the boundaries of and adjacent to a Federal navigation project. Section 206 of WRDA 1996 is a new general authority that can be used to carry out aquatic ecosystem restoration with cost being shared 65% Federal and 35% non-federal.

Section 312 (b) provides dredging authority for sediment removal and ecosystem restoration. An ecosystem restoration based evaluation was conducted and is included as appendix EA-J to the Environmental Impact Statement. The Ashtabula River partnership 312(b) subcommittee evaluated an array of alternatives for dredging and habitat restoration. Replacement of protected aquatic shallow areas and a shoreline shelf cut were two measures recommended. This would entail the purchase and development of the Conrail slip(slip 51/2) and other improvement along the east side of the river upstream of the Ashtabula Yacht Club. We recommend that this restoration be instituted as part of a comprehensive plan to restore the aquatic and riparian habitat in the project area.

ENDANGERED AND THREATENED SPECIES

The proposed project lies within the range of the Indiana bat, bald eagle, and piping plover, Federally listed endangered or threatened species. At this time, we do not anticipate that the proposed project will impact any of these species or their habitats. However, we will need to make a final determination when the final plans are provided.

We will continue to be involved with the Partnership, and particularly, the Buffalo District Corps of Engineers. Our goal is to support a project that will make the Ashtabula River a better place for people and fish and wildlife resources.

Sincerely,



Kent E. Kroonemeyer
Supervisor

REFERENCE

- Ohio EPA. 1991. Ashtabula River Remedial Action Plan, Stage one Report, Background Investigation, Division of Water Quality Planning and Assessment, Columbus, Ohio.
- U.S. Corps of Engineers. 1992. Pilot-scale Demonstration Project for Remediation of Contaminated Sediments, Ashtabula River, Ohio. Buffalo District, Buffalo, New York.
- U.S. Corps of Engineers. 1996. Draft Summary Report of the 1995 Sampling of the Ashtabula River. Buffalo District, Buffalo, New York.
- U.S. Corps of Engineers. 1997. Ashtabula River Partnership Upland Site Investigation for Sediment Disposal Facility, Buffalo District, Buffalo, New York.
- U.S. Corps of Engineers, 2000. Wetland and Ecological Site Walkover Investigation, RMI Sodium Plant Site, Buffalo District, Buffalo, New York.

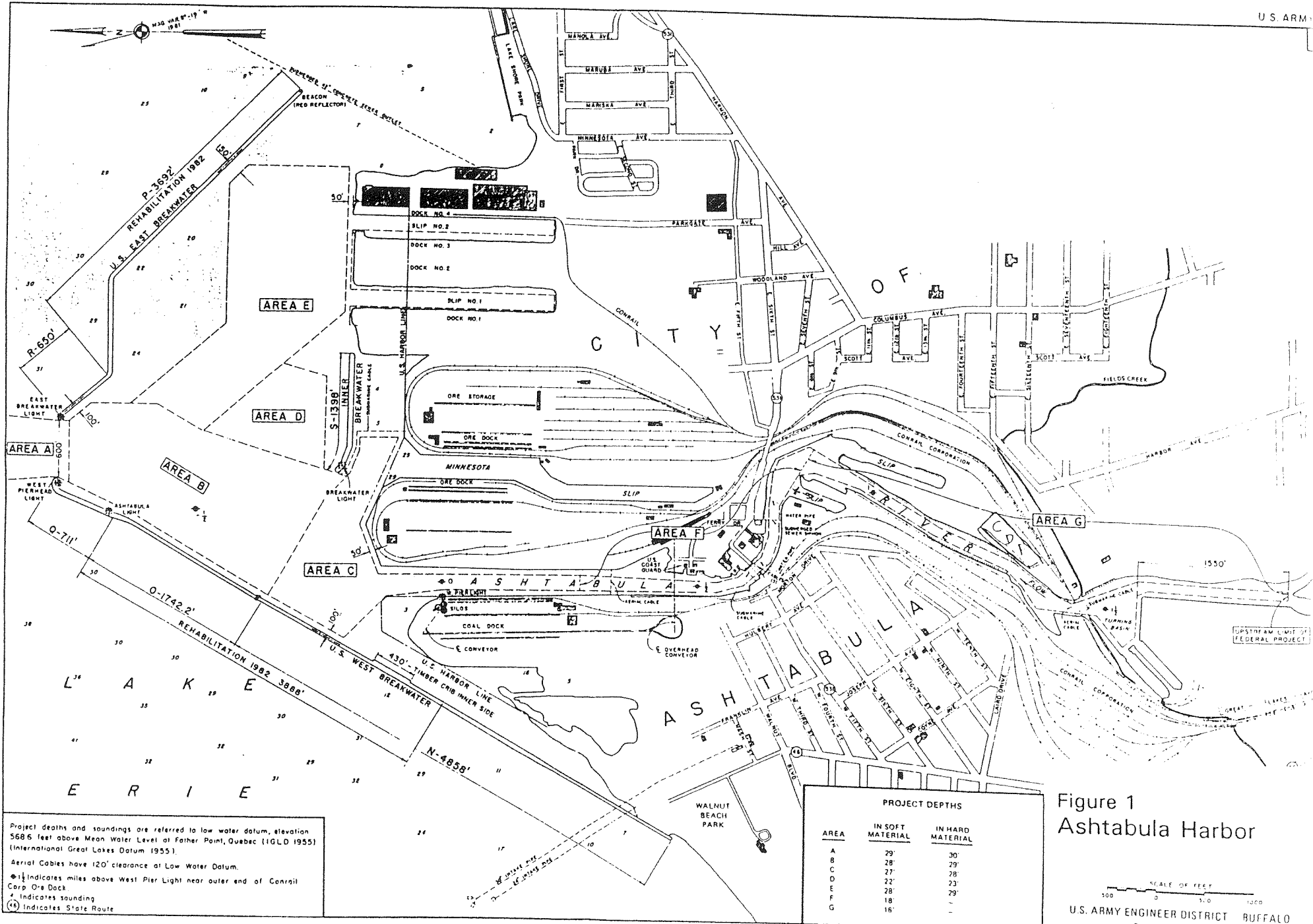

Project depths and soundings are referred to low water datum, elevation 568.6 feet above Mean Water Level at Father Point, Quebec (IGLD 1955) (International Great Lakes Datum 1955).
 Aerial Cables have 120' clearance at Low Water Datum.
 ① indicates miles above West Pier Light near outer end of Conrail Corp O-R Dock
 * indicates sounding
 (R) indicates State Route

PROJECT DEPTHS		
AREA	IN SOFT MATERIAL	IN HARD MATERIAL
A	29'	30'
B	28'	29'
C	27'	28'
D	22'	23'
E	28'	29'
F	18'	-
G	16'	-

Figure 1
Ashtabula Harbor

SCALE OF FEET
 100 500 1000
 U.S. ARMY ENGINEER DISTRICT BUFFALO
 30 SEPTEMBER 1989

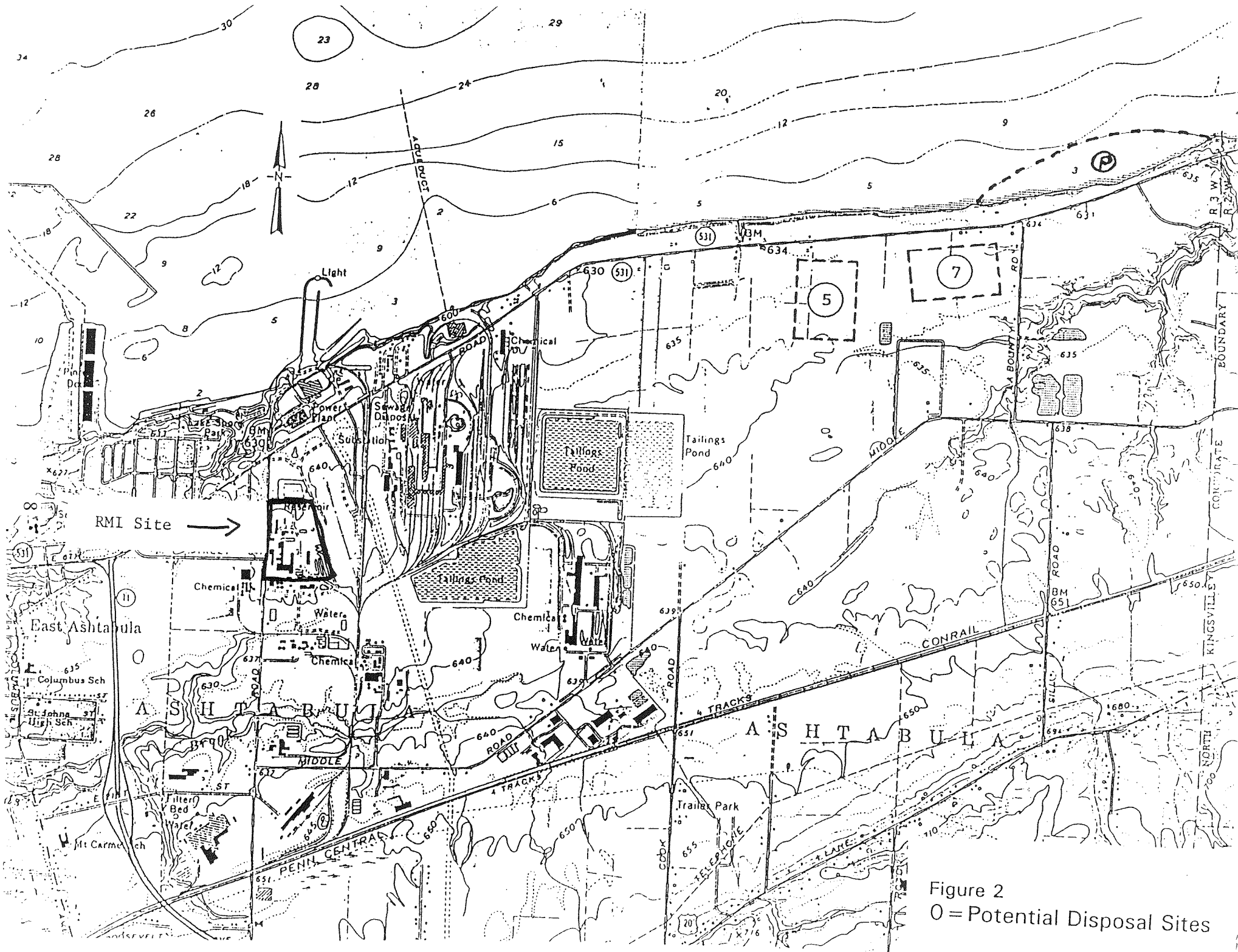

Figure 2
 O = Potential Disposal Sites



Ohio Department of Natural Resources

BOB FLETCHER, GOVERNOR

SAMUEL W. SPECK, DIRECTOR

Division of Wildlife

Michael J. Budzik, Chief
1840 Belcher Drive
Columbus, OH 43224-1300
Phone: (614) 265-6300

November 14, 2000

Mr. Kent E. Kroonemeyer
U.S. Fish and Wildlife Service
6950 Americana Parkway, Suite H
Reynoldsburg, OH 43068-4127

RE: Ashtabula River, Final Fish and Wildlife Coordination Report

Dear Mr. Kroonemeyer:

Division of Wildlife has reviewed your Final Fish and Wildlife Coordination Act Report for the above referenced project. We agree with your findings and concerns for a long awaited remediation of polluted sediments from the lower Ashtabula River and Harbor.

We appreciate this opportunity to review this report. If you have any questions, please contact Bob Fletcher at 265-6308.

Sincerely,

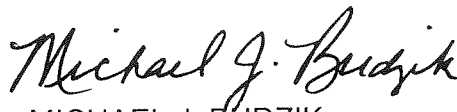
MICHAEL J. BUDZIK
Chief

cc: file

ASHTABULA RIVER
PARTNERSHIP

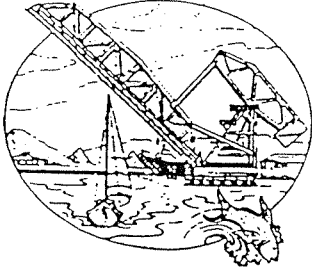

1123 Bridge Street
Ashtabula, Ohio 44004
(216) 964-0277 Office
(216) 964-5158 Fax

John Mahan, Ph.D
Coordinator

Rick Brewer
Co-Chairman
Coordinating Committee

Fred Leitert
Co-Chairman
Coordinating Committee

Steve Golyski
Chairman
Project Committee

Rick Mason
Chairman
Siting Committee

Brett Kaull
Chairman
Resource Committee

Michelle Rowley
Chairperson
Outreach Committee

Ashtabula River and Harbor

Comprehensive Management Plan

Dredging and Disposal

FINAL

FEASIBILITY REPORT AND

ENVIRONMENTAL IMPACT STATEMENT

ENVIRONMENTAL APPENDIX

EA-E PRELIMINARY WETLAND DETERMINATIONS

City of Ashtabula
Town of Ashtabula
County of Ashtabula
State of Ohio

2001

(WITHDRAWN)

ASHTABULA RIVER
PARTNERSHIP

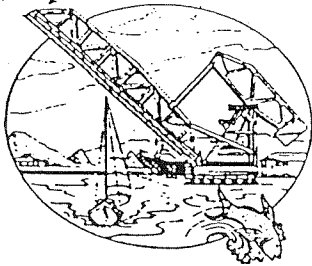

1123 Bridge Street
Ashtabula, Ohio 44004
(216) 964-0277 Office
(216) 964-5158 Fax

John Mahan, Ph.D
Coordinator

Rick Brewer
Co-Chairman
Coordinating Committee

Fred Leitert
Co-Chairman
Coordinating Committee

Steve Golyski
Chairman
Project Committee

Rick Mason
Chairman
Siting Committee

Brett Kaull
Chairman
Resource Committee

Michelle Rowley
Chairperson
Outreach Committee

Ashtabula River and Harbor

Comprehensive Management Plan

Dredging and Disposal

FINAL

FEASIBILITY REPORT AND

ENVIRONMENTAL IMPACT STATEMENT

ENVIRONMENTAL APPENDIX

EA-F BOTULISIM CONTROL PLAN

City of Ashtabula
Town of Ashtabula
County of Ashtabula
State of Ohio

2001

BOTULISM CONTROL MANAGEMENT PLAN
ASHTABULA HARBOR DEWATERING AND DISPOSAL SITE
ASHTABULA COUNTY, OHIO

1. GENERAL

1.2 Avian Botulism - also referred to as Western duck sickness - has its source in toxin-producing bacterium *Clostridium botulinum*. These bacteria are widely distributed as spores in organic soils. It is believed that the spores themselves can do little harm. However, in a favorable environment - namely, under anaerobic (absence of oxygen) conditions, with the right temperature (ranging from about 60°F to 97°F), a source of animal protein (i.e., invertebrate/vertebrate carcasses) and pH in the range of about 5.7 to 8.0 - the spores can germinate into active vegetative cells and produce a dangerous virulent toxin. The toxin affects the nervous system, causing progressive muscle paralysis. Although there are a number of types (strains) of botulism toxin, "Type C" is the one frequently associated with die-offs of waterfowl and shorebirds. "Favorable environmental conditions occur in the tissues of decaying animal and insect carcasses. The decomposition process uses up all available oxygen in the carcass, creating anaerobic conditions. Bacterial spores ingested during the life of the animal germinate after death. As the bacteria multiply and die, toxin is released. Outbreaks of avian botulism occur when the toxin is taken in by the birds. The die-off may begin as birds feed directly on invertebrate carcasses that contain the toxin, or as a result of feeding on live maggots of flesh flies and blowflies. Flies lay their eggs on dead vertebrates, and the resulting maggots store botulinal toxin in their bodies as they consume the carcass" (Reference: Friend, M., Locke, Louis N., and Kennelly, James J. - USDI undated publication entitled Avian Botulism). If the aforementioned conditions become present in a CDF environment, the potential for a botulism outbreak in the facility is established.

1.2 In developing the following Botulism Control Management Plan for the Ashtabula CDF - Site, as shown on the attached location map, consideration was given to the data collection phase, early action phase, long-range operation phase, and coordination.

2. DATA COLLECTION PHASE

2.1 Site Inspections:

15 June - 15 September -- Inspect the CDF site once every week during this time period. Start such inspections when dredged material is initially placed in the CDF. Continue monitoring inspections annually during the time period indicated, until the entire CDF site is completely filled with dredged material to design capacity.

2.2 Monitoring:

A. A supervisor of the Buffalo District's Cleveland Area Office will designate a representative from that office as the point of contact (POC) for implementation of the Botulism Control Management Plan. The POC will monitor the CDF site in order to insure that inspections are accomplished according to the time schedule provided in paragraph 2.1 above. The name and telephone number of the designated POC will be provided to the Chiefs of: Construction Operations, Plan Formulation and Technical Management, and Environmental Analysis Section (Environmental) located at the Buffalo District Office.

B. The following action will be required once dredged material in the CDF accumulates to a point where the material becomes exposed to form "mudflat-like" conditions: Annually, during the period 15 June through 15 September - When the CDF site is being inspected on a weekly basis - the POC will record information for items #1 through #9 as shown on the attached sheet entitled "Botulism Control Field Inspection Form." Record data on items #8 and #9 where access to shallow, pooled water is possible in the general vicinity of exposed dredged material. Utilize the pH Kit and water temperature recording thermometer to obtain data on these parameters. Note: The pH Kit and thermometer will be provided to the Cleveland Area Office after the CDF dike construction is completed or before discharge of dredged material into the facility is initiated.

Select water sampling locations in shallow pooled areas that are representative of the CDF.

C. Once the action in item B (above) has been initiated, from then on, during annual dredged material discharge into the CDF, a representative photograph of the CDF site prior to, as well as during and following completion of dredged material discharge operations will be taken by the POC and mailed to the Buffalo District (Environmental Analysis Section).

3. EARLY ACTION PHASE

3.1 An early sign of botulism sickness in birds is their inability to fly. Waterfowl, for example, often propel themselves across mudflats or water with their wings when their leg muscles become paralyzed and when they are unable to fly. In the event that the Corps POC observes either dead birds or what appears to be sick birds, the POC will immediately notify the following individuals:

- (1) Ms. Sook C. Reid
Supervisor, Cleveland Area Office
U.S. Army Corps of Engineers
Foot of East Ninth Street
Cleveland, Ohio 44114-1003
Phone: (216) 522-4957

(2) Mr. Kent Kroonemeyer
Supervisor, Reynoldsburg Field Office
U.S. Department of the Interior
Fish and Wildlife Service
6950-H Americana Parkway
Reynoldsburg, Ohio 43069
Phone: (614) 469-6923

(3) Mr. David Conboy
Chief, Environmental Analysis Section
U.S. Army Corps of Engineers
1776 Niagara Street
Buffalo, New York 14207
Phone: (716) 879-4436

3.2 Specimens of birds suspected of possibly being poisoned by botulism will be collected at the CDF site by the USFWS representative and Corps POC. Guidance will be provided by the USFWS representative as to whether or not the bird specimens should be sent to the U.S. Fish and Wildlife Service's "National Wildlife Health Center" for more detailed diagnostic determination, in order to confirm presence or absence of botulism. The Center's address is 6006 Schroeder Road, Madison, Wisconsin 53711. Instructions on how to properly ship specimens to the Center will either be provided by the USFWS representative or by telephoning the Center at (608) 264-5411.

3.3 If botulism is determined to be the source of the problem, the Buffalo District will expeditiously initiate a contract to: (a) implement the use of noise-making devices (i.e., carbide cannons) to scare aquatic birds out of the facility as much as possible; (b) promptly remove and properly dispose of dead bird carcasses (by incineration) found in the CDF - in order to remove important sources of bacterial toxin production and carcasses upon which maggots develop. **IT IS VERY IMPORTANT TO THOROUGHLY REMOVE AND PROPERLY DISPOSE OF DEAD VERTEBRATES FOUND ON SITE**, in order to help reduce potential for perpetuation of the botulism problem in the CDF. Thousands of toxic maggots can be produced from a single dead duck carcass. As such, maggots are ingested by healthy waterfowl or shorebirds, these birds in turn become intoxicated to continue the botulism cycle.

3.4 Additionally, a determination will be made by Contract Administration personnel (Contracting Officer) as to whether or not immediate operational changes should be initiated in response to the botulism outbreak. This could include one or more of the following operational changes:

- * Cease disposal operations, provide drainage, as possible, let material dry.

- * Placement of material to avoid moisture ponding of water and provide drainage.

- * Limit disposal activities to cooler weather periods.
- * Plant vegetation to make area less desirable to birds.

4. LONG-RANGE OPERATIONAL PHASE

4.1 On the basis that water-related management practices are the key to the successful control of botulism outbreaks within the CDF, the long-range operational phase includes the following:

a. Timing of Dredged Material Discharge.

If feasible, discharge dredged material into the CDF as late in the year as practically possible. Cool weather (i.e., <67°F) precludes bacterial growth and inhibits production of the toxin. Sediments could be kept drier during warmer summer months by restricting the placement of dredged material in the facility to later, cooler periods. Placement of dredged material during cooler weather periods also has the added advantage of holding back the protein substrate (i.e., the organic matter in the dredged material which *C. botulinum* requires for growth) until after it is too late in the year for the bacteria to grow.

b. Planned Distribution of Dredged Material within the CDF.

Place dredged material directly into well drained areas during discharge operations. This action will allow mud flat areas to dry out.

c. Drying of Sediments within the CDF.

Evaporative drying removes water from the upper few inches of dredged material by capillary resupply of the soil, resulting in crust formation. This aids precipitation runoff via desiccation cracks. Evaporative drying would be accelerated by good surface layer drainage, rapid removal of precipitation, and the prevention of ponding by surface water. Surface drainage would be accomplished by the construction of drainage trenches in the CDF as follows:

(1) Excavate a perimeter trench (using either a dragline or backhoe) approximately 10 to 15 feet interior of the dike walls. The perimeter trench should be about 6 to 8 feet wide and 2 to 3 feet deep. This operation should normally begin at the weir, where a sump pit would be dug to extend into the disposal area - using the maximum reach of the dragline or back-hoe. Excavated material should be side-cast to form a low berm inside the CDF along the interior side of the perimeter trench;

(2) Interior drainage via trenches should be initiated when: (a) the perimeter trenching decreases the fluid consistency of the dredged material below the thin drying skin in order to

allow trench construction; and (b) when the support capacity of the soil allows conventional low ground pressure construction equipment (utilizing mats, if required) safe entrance onto the disposal area to construct drainage trenches. NOTE: Surface trenching and "drying-out" of sediment within the CDF not only decreases the chance of botulism outbreaks, but also aids in preventing mosquito problems and firms soils within the facility. Additionally, drying of sediments also contributes toward increasing capacity of the CDF.

5. COORDINATION

5.1 The POC, Cleveland Area Office, will maintain coordination with (Environmental) via brief monitoring reports sent to the Buffalo District Office and by telephone, as needed.

5.2 (Environmental) will maintain coordination with the USFWS (Reynoldsburg Office, OH) and ODNR (Division of Wildlife, Fountain Square, Columbus, OH - Telephone # 614-265-6300) regarding status of conditions at the CDF, if a problem is suspected.

5.3 (Environmental)(located at the Buffalo District Office) will maintain coordination with research biologists at the U.S. Army Engineer Waterways Experiment Station (WES) located at Vicksburg, Mississippi, in order to obtain further recommendations and to arrange site visits if needed, that would provide the basis for immediate advice, as well as possibly longer range study of CDF management with regard to minimizing potential for botulism outbreaks. The specific contact at WES is Dr. John Simmers, Research Biologist - Telephone # 601-634-2803.

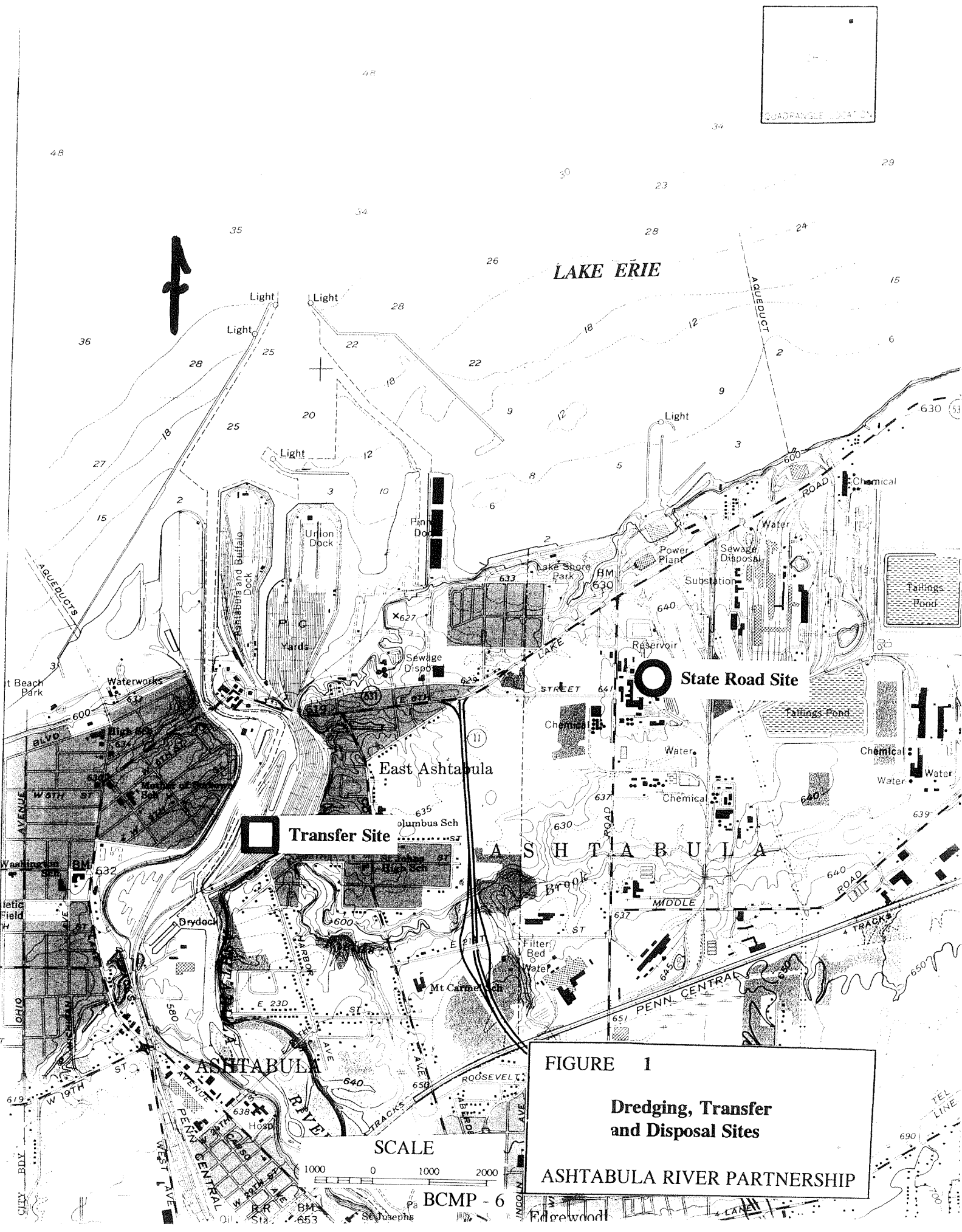

FIGURE 1
Dredging, Transfer and Disposal Sites
ASHTABULA RIVER PARTNERSHIP

SCALE
 1000 0 1000 2000

BCMP - 6

BOTULISM CONTROL INSPECTION FORM
ASHTABULA HARBOR DEWATERING AND DISPOSAL SITE
ASHTABULA COUNTY, OHIO

Item 1. SHEET NO. _____

Item 2. INSPECTION DATE: DAY _____ MONTH _____ YEAR _____

Item 3. TIME OF INSPECTION _____ (a.m. or p.m.)

Item 4. NAME OF RECORDER (INSPECTOR): _____

Item 5. GENERAL WEATHER CONDITIONS:

Item 6. AIR TEMPERATURE _____ *F OR _____ *C

Item 7. AQUATIC BIRDS (ducks/geese/shorebirds) UTILIZING THE
CDF ON THE DAY OF SITE INSPECTION:

* a) Estimated No. of Waterfowl _____
(Waterfowl have webs between their three front
toes. Examples: Geese, Swans, Ducks)

* b) Estimated No. of Shorebirds _____
(Shorebirds typically have long-legs and pointed
wings; most shorebirds feed along the shoreline.
Examples: Sandpipers, killdear, willet, snipe,
phalarope, plovers, and turnstones)

NOTE: * If no waterfowl and/or shorebirds were
observed at the time of inspection,
indicate "NONE."

Item 8. WATER TEMPERATURE: _____

Item 9. pH: _____

ASHTABULA RIVER
PARTNERSHIP

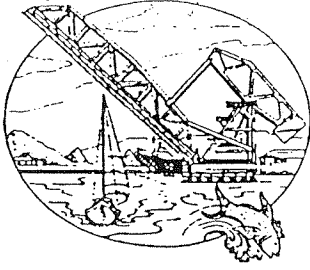

1123 Bridge Street
Ashtabula, Ohio 44004
(216) 964-0277 Office
(216) 964-5158 Fax

John Mahan, Ph.D
Coordinator

Rick Brewer
Co-Chairman
Coordinating Committee

Fred Leitert
Co-Chairman
Coordinating Committee

Steve Golyski
Chairman
Project Committee

Rick Mason
Chairman
Siting Committee

Brett Kaull
Chairman
Resource Committee

Michelle Rowley
Chairperson
Outreach Committee

Ashtabula River and Harbor

Comprehensive Management Plan

Dredging and Disposal

FINAL

FEASIBILITY REPORT AND

ENVIRONMENTAL IMPACT STATEMENT

ENVIRONMENTAL APPENDIX

EA-G COASTAL MANAGEMENT CONSISTENCY DETERMINATION

City of Ashtabula
Town of Ashtabula
County of Ashtabula
State of Ohio

2001

CONSISTENCY CERTIFICATION STATEMENT

I, LTC Mark D. Feierstein do certify that the proposed activity identified in this permit application complies with Ohio's approved coastal management program and will be conducted in a manner consistent with such program (15C.F.R. 930.57).

Address: U.S. Army Corps of Engineers, Buffalo District, 1776 Niagara Street

City: Buffalo State: New York Zip Code: 14207-3199

Telephone #: Area Code (716) 879-4175 (POC Mr. Tod Smith)

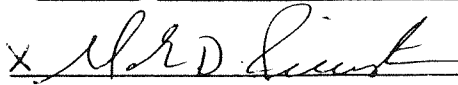
Applicant's Signature: X  Date: 13 Aug 99
District Commander

Project Name/Description: Ashtabula River Partnership Remedial Project

Coastal Management Program Consistency Determination Report

Introduction and Determination

The Ashtabula River Partnership has reviewed the proposed project with respect to applicable policies of the State of Ohio Coastal Management Program, as follows, and has determined that the proposed action complies with the policies of the Program and will be conducted in a manner that is consistent, to the extent possible, with those policies.

The proposed plan descriptions and associated expected impacts are described in more detail in appropriate sections of these reports, particularly the Recommended Plan, the Environmental Effects sections, and Clean Water Act Section 404(b)(1) Evaluation Report Appendix of this EIS.

Reference the attached list of State of Ohio Coastal Management Policies which follows this evaluation for the complete list of and more detailed policy statements. Determined applicable policies include: 6,8,10,11,12,13,14,16,17,18,19,20,21,23,24,26,27, 28,29,30,31,33, and 41.

The Project and Recommended Plan (Reference Figures 1 through 14).

Ashtabula Harbor is located at the mouth of the Ashtabula River on the south shore of Lake Erie, Ashtabula County, Ohio. The Ashtabula River Partnership (ARP) has investigated problems and needs pertaining to contaminated sediments and disturbed habitat in the Lower Ashtabula River. These conditions have resulted in restricted operations and maintenance dredging and disposal of dredged material and have limited full environmental, economic, and social use and development of the harbor. In addition to considering the No (ARP) Action (Without Project Conditions) alternative, the Ashtabula River Partnership considered a wide array of Plans and Component Alternatives pertaining to Dredging, Habitat Restoration, Transfer/Dewatering/Transfer, Transportation, and Disposal. Plans and Component Alternatives were assessed/evaluated for engineering and economic feasibility, environmental and social acceptability, and/or for best meeting the project planning objectives. The recommended plan involves: 1) deep dredging (environmentally/low turbidity) of approximately 696,000 cubic yards (in situ) of contaminated sediments (150,000 cubic yards of which is significantly PCB contaminated and would (for planning estimates) be handled and disposed of in accordance with Toxic Substance Control Act (TSCA) guidelines), 2) developing and utilizing a transfer/dewatering/transfer facility in the harbor area, 3) trucking the dewatered dredged material to a developed upland disposal site, and, 4) disposing of the material, as appropriate, in the developed TSCA and Non-TSCA disposal facilities. The facilities would also include leachate collection, treatment, and monitoring facilities, and closure, and post closure monitoring measures. The project also recommends restoration (by separate authority) of several acres of aquatic/fishery shallows areas and associated shoreline. Approximately 150,000 cubic yards of operations and

maintenance dredged material and/or shoreline excavated material would be discharged in the initially dredged area in order to provide an immediate clean cover and to expedite ecological recovery. Environmental protection measures have been incorporated into the project planning and will be further incorporated into the project design, construction, operation, and maintenance plans to meet Federal, State, and local regulations.

Actions That Will Be Taken to Minimize Impacts

Construction contractors would be required to comply with the Corps of Engineers Civil Works Construction Specification entitled, "Environmental Protection" (CW-01430, dated July 1978) pertaining to practical measures to be applied during construction/operations to protect significant water and associated land environmental resources (ie. noise, turbidity, dust, erosion controls, etc.)

National/State Pollution Discharge Elimination System environmental protection measures will be required of the contractors during and with construction of the Transfer/Dewatering/Transfer and Disposal Facilities.

Dredging activities would be monitored and controlled to minimize turbidity. Dredging activities would be accomplished with low turbidity dredging equipment in order to minimize resuspension and dispersion of contaminated sediments. An oil boom and silt curtain would be utilized during dredging activities, as necessary, particularly during dredging of the TSCA material.

Approximately 150,000 cubic yards of operations and maintenance dredged material and/or shoreline excavated material would be discharged in the initially dredged area in order to provide an immediate clean cover and to expedite ecological recovery.

Aquatic/fishery shelves would provide additional aquatic/fishery habitat (~ 1 + acres). It should be noted that these or similar measures would be pursued by separate authority/study (i.e. 206) subsequent and contingent to this projects dredging for removal of contaminants.

Some earthy/organic odor may occur in the immediate area of the dredging activity and dredged material. This would not be expected to be a problem over a large area or for a long time. If a substantial problem is noted, some odor abatement measures (operations or applications) may be implemented.

With respect to volatilization of contaminants the following measures will be taken to minimize impacts. Appropriate protective wear would be worn by workers. Appropriate restriction areas will be established. Canopy cover measures would significantly reduce volatilization of contaminants during handling and transport.

Some spillage during transportation and off-loading can result in the loss of contaminants to the environment. These losses can be limited by filling the scows only partially full, by using only watertight scows, and by careful operation during off-loading. Off-loading should be performed with a closed-bucket clamshell and spill tarp and any spillage would be collected and clean-

ed up. Contaminant losses occurring during any hydraulic transport of sediments should be minimal. A properly designed, constructed, and maintained pipeline should have very little spillage.

The U. S. Fish and Wildlife Service National Wetlands Inventory Maps were referenced during the initial siting and assessment/evaluation of potential dredged material disposal sites in an attempt to avoid wetland areas and/or to avoid and/or minimize impacts to wetlands with any potential upland site developments. Subsequently more detailed site specific wetland investigations were conducted to provide more information on potential impacts to wetlands and to facilitate site specific considerations on facilities siting to avoid and/or minimize impacts to wetlands.

The Transfer/Dewater/Transfer and Disposal Facilities would be located to avoid and/or minimize impacts to wetland areas. During construction of the Upland Disposal Facilities measures (i.e. berms, slurry walls, culverts, etc.) will be taken to preserve any adjacent area wetland hydrology/hydraulic features and water quality. Associated impacts should be minor.

The proposed project disposal facility is set back from the coastal resources designated area.

The Transfer/Dewatering/Transfer and Disposal Facilities are designed for excellent stability and containment of dredged material and associated contaminants. Special liner material, geofabrics and clay would be brought into the sites for use as impermeable linings (per design) to keep the contaminated materials confined, to control precipitation run-off, and to keep ground water out. Leachate collection, treatment, and monitoring facilities and monitoring wells, as appropriate, would be installed to further protect surface and ground water.

Dewatering and disposal facility effluent discharges will need to meet water quality requirements outside of the containment basins or cells. Most parameters can be met through standard settling and filtration processes; but, some (i.e. PAHs, PCBs, RADs), at times, may require more advance filtration/treatment processes such as the sand and anthracite coal filter and carbon ad-sorption process proposed.

A Clean Water Act Section 401(a) Public Notice and 404(b)(1) Evaluation Report has been prepared (EIS Appendix EA - B) and coordinated with these reports. The evaluation provides considerable detail pertaining to expected impacts to water quality and the aquatic environment. A 401 Certification will be requested for the project with more detailed information. An interim letter of concurrence of feasibility has been received from the Ohio Environmental Protection Agency in this regard.

A project Health and Safety Plan would be prepared and implemented to protect workers and the public from exposure to contaminants.



4

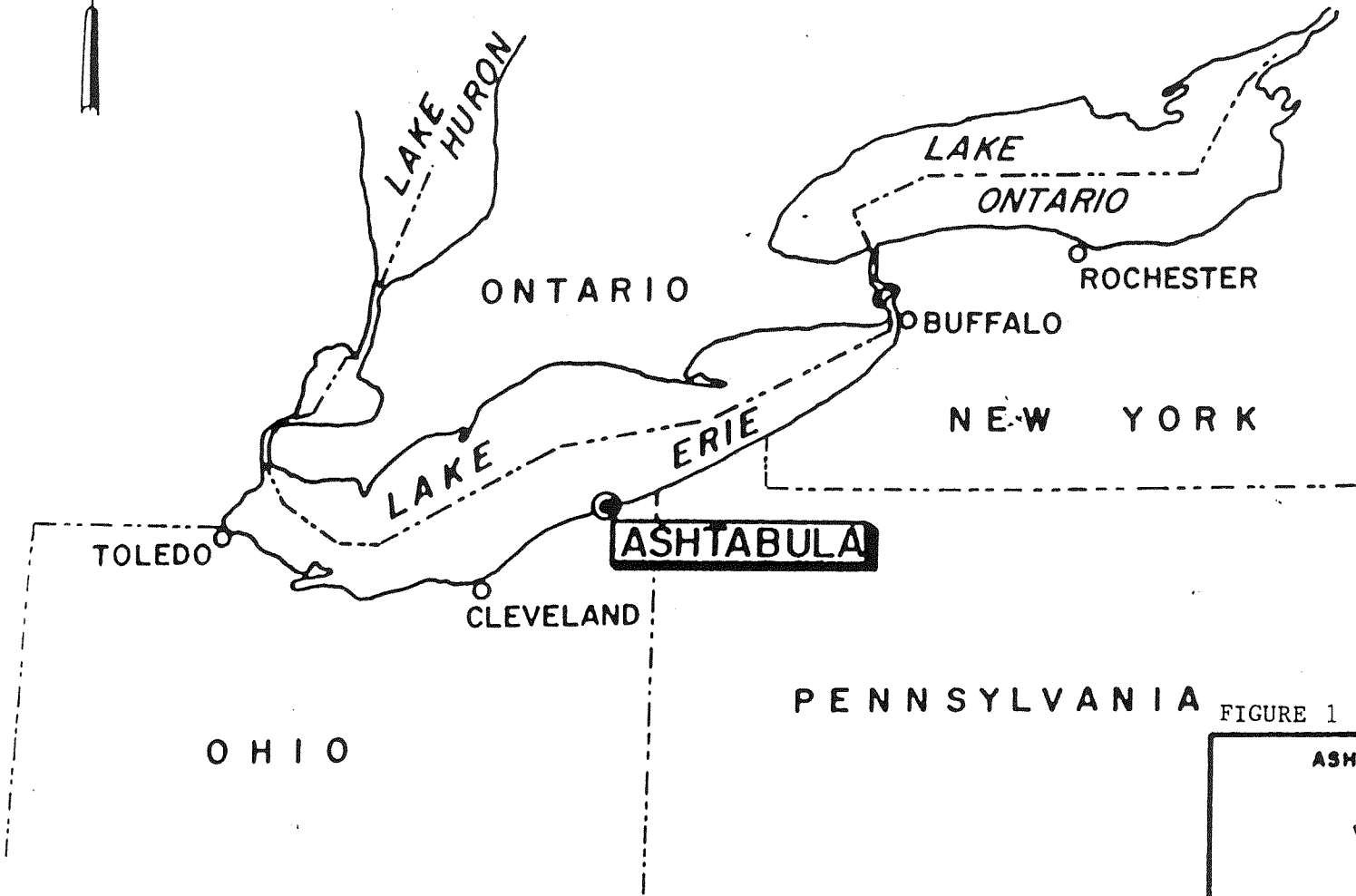

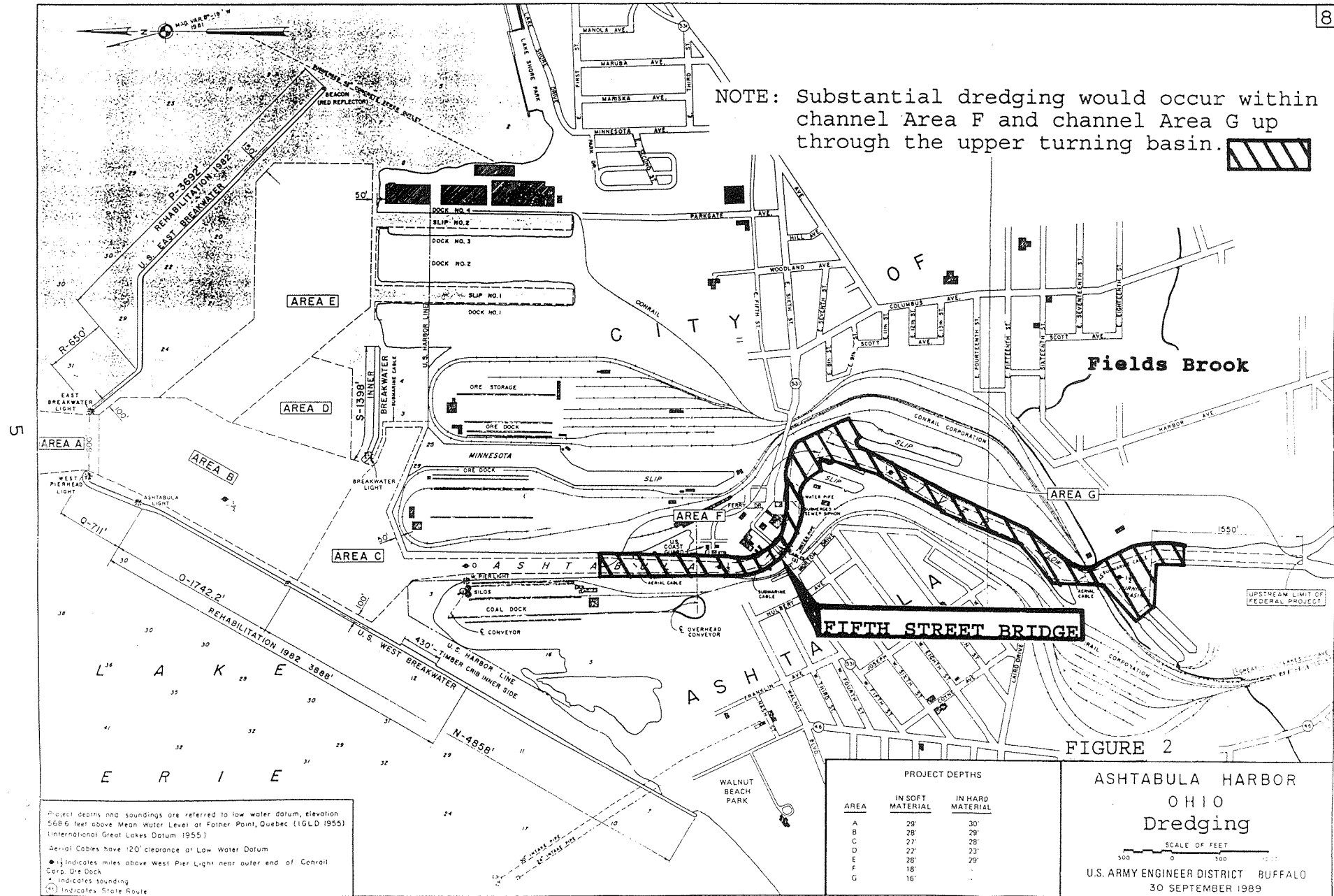

FIGURE 1

ASHTABULA HARBOR, OHIO
VICINITY MAP

NOTE: Substantial dredging would occur within channel Area F and channel Area G up through the upper turning basin. 



Project depths and soundings are referred to low water datum, elevation 568.6 feet above Mean Water Level at Father Point, Quebec (IGLD 1955) (International Great Lakes Datum 1955)

Aerial Cables have 120' clearance at Low Water Datum

• indicates miles above West Pier Light near outer end of Conrail Corp. Ore Dock

▲ indicates sounding

⊙ indicates State Route

AREA	PROJECT DEPTHS	
	IN SOFT MATERIAL	IN HARD MATERIAL
A	29'	30'
B	28'	29'
C	27'	28'
D	22'	23'
E	28'	29'
F	18'	-
G	18'	-

ASHTABULA HARBOR
OHIO
Dredging

SCALE OF FEET
300 0 300

U.S. ARMY ENGINEER DISTRICT BUFFALO
30 SEPTEMBER 1989

FIGURE 2

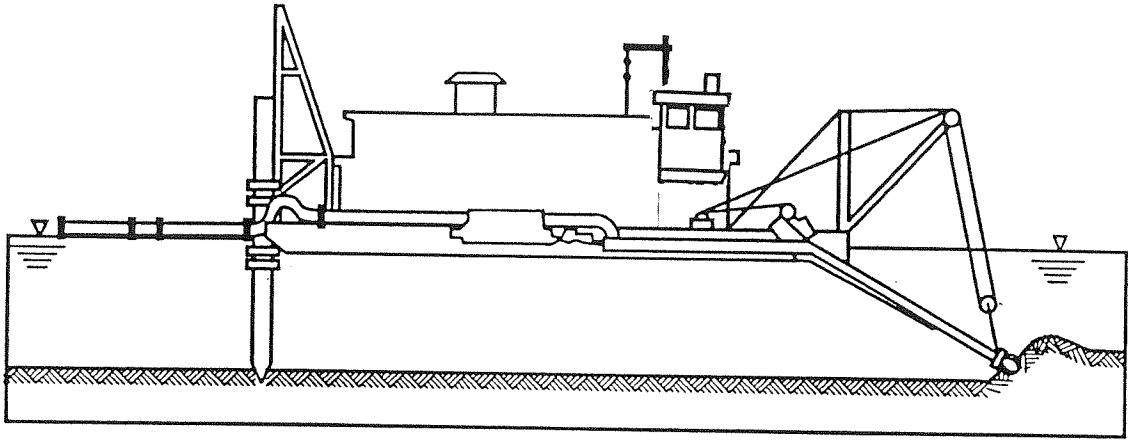

Cutterhead pipeline dredge

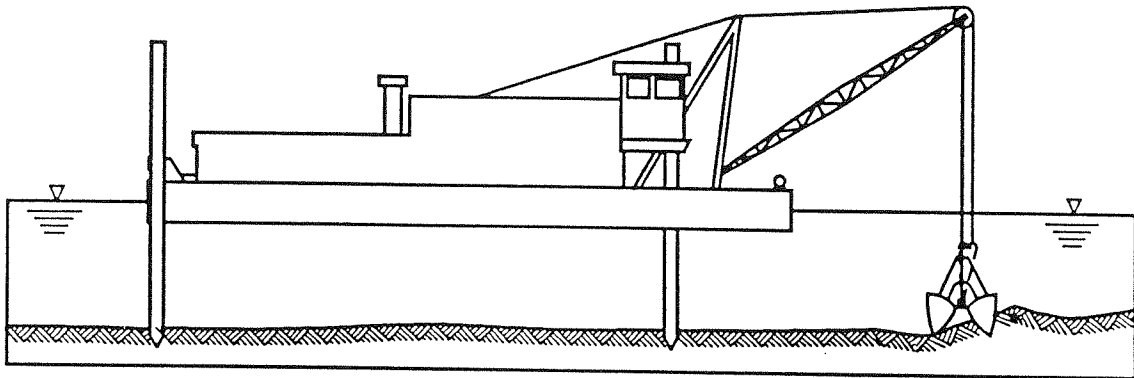

Clamshell dredge

FIGURE 3

Ashtabula River Partnership

Dredge (Environmentally)

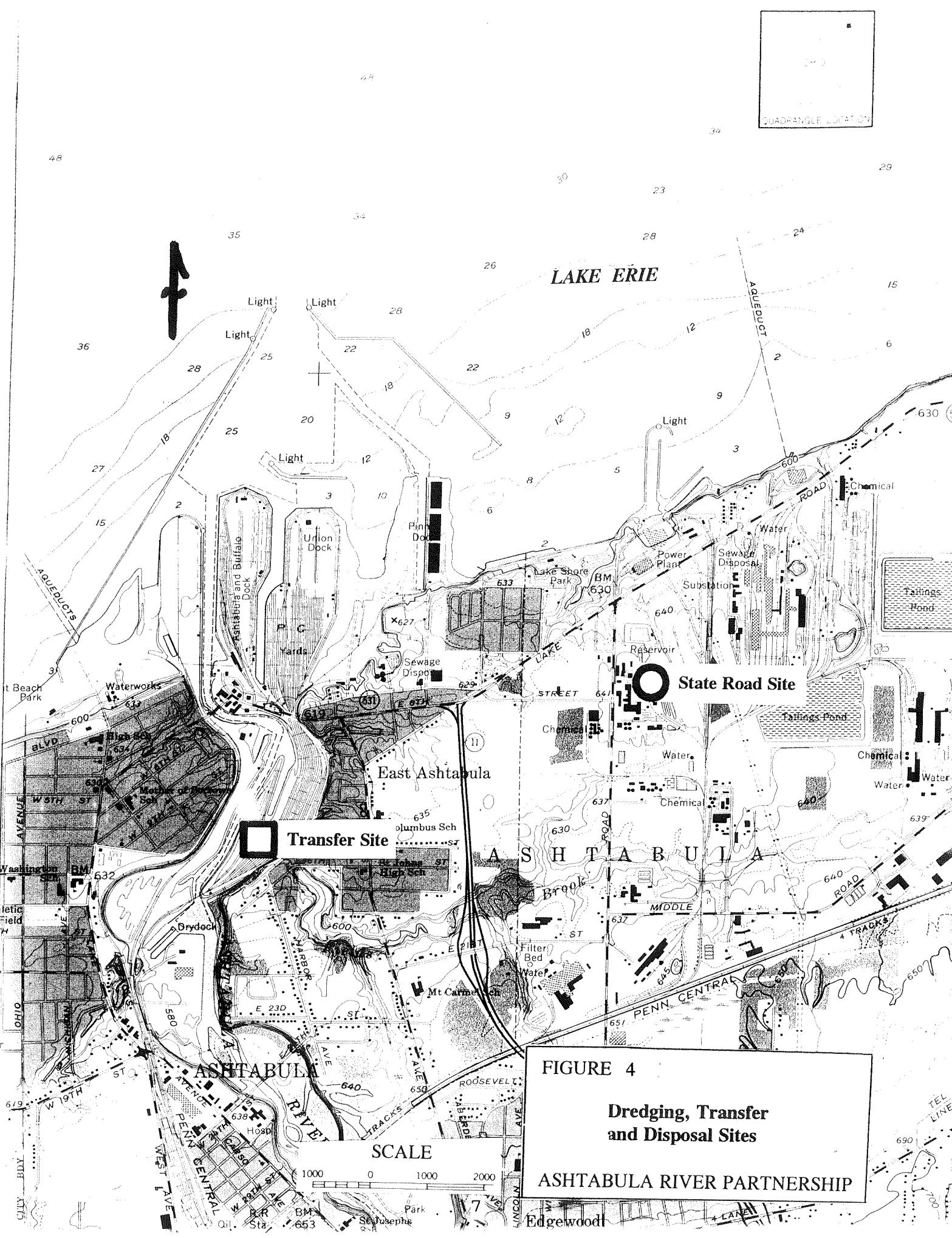

Transfer Site

State Road Site

FIGURE 4
Dredging, Transfer and Disposal Sites
ASHTABULA RIVER PARTNERSHIP

SCALE

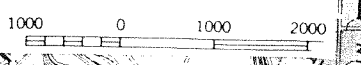

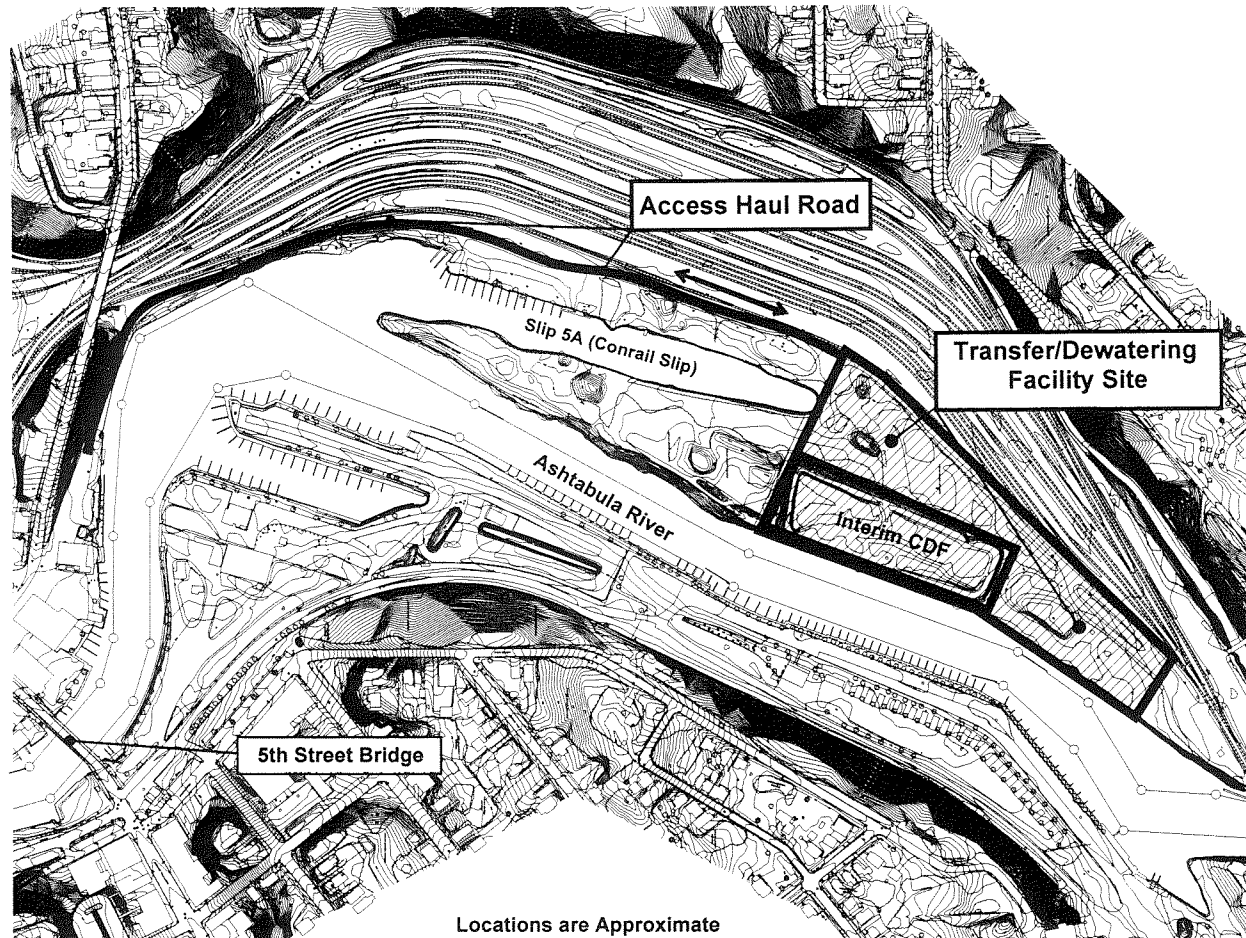

US Army Corps
of Engineers
Buffalo District



-  : Transfer/Dewatering Facility Site
-  : Access Haul Road
-  : Federal Navigation Project

Figure 5
SHORELINE TRANSFER/DEWATERING
FACILITY SITE

Map Not To Scale

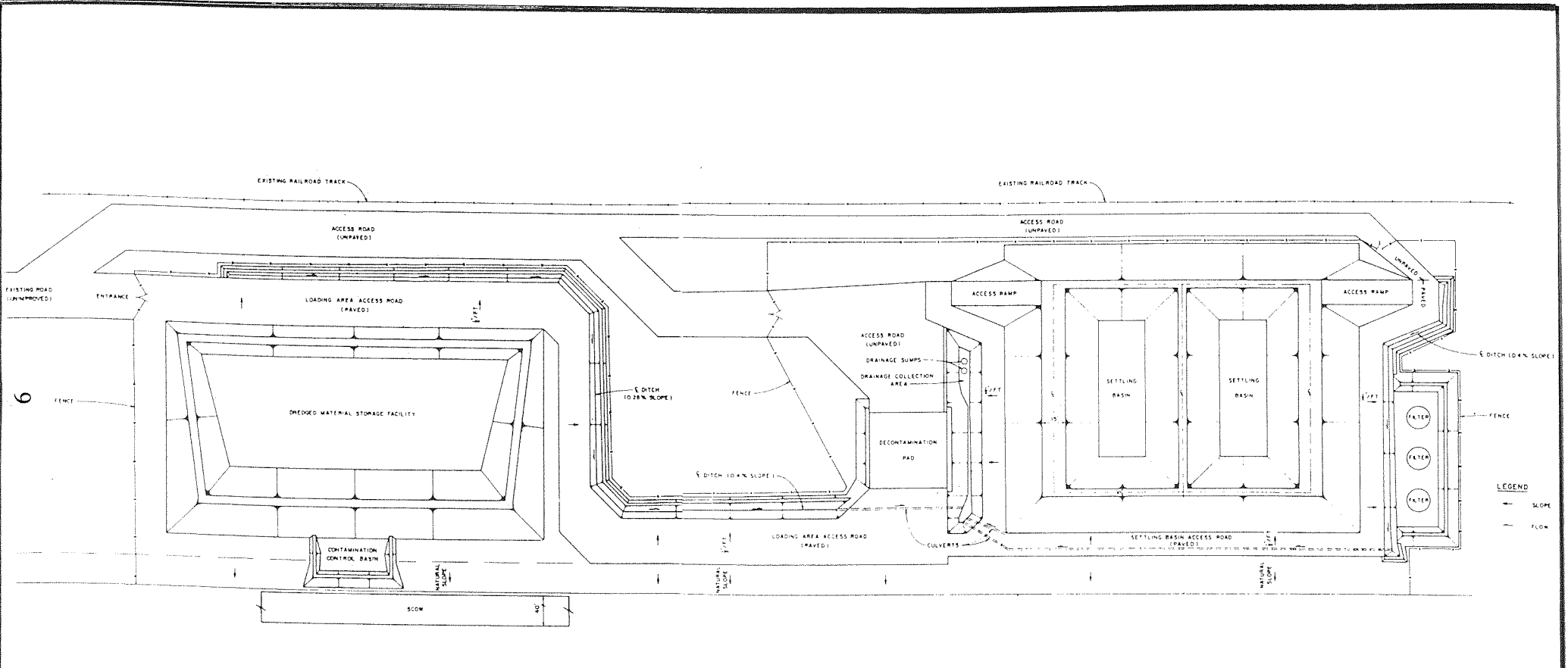

FIGURE 6 : Conceptual (Typical) Transfer/Dewatering Site Facilities Operational Systems Layout.

— : Investigation Boundary

[Hatched Box] : Buildings, Bare Urban Land, Demolition Rubble and Patchy Upland Herbaceous Vegetation

[Solid Black Box] : Lagoon

[Dotted Box] : Upland Open Field

[Solid Black Box] : Wetland

[Dotted Box] : Monotypic Common Reed Growth

[Dotted Box] : Lawn

Avoid impact to any adjacent wetland areas.

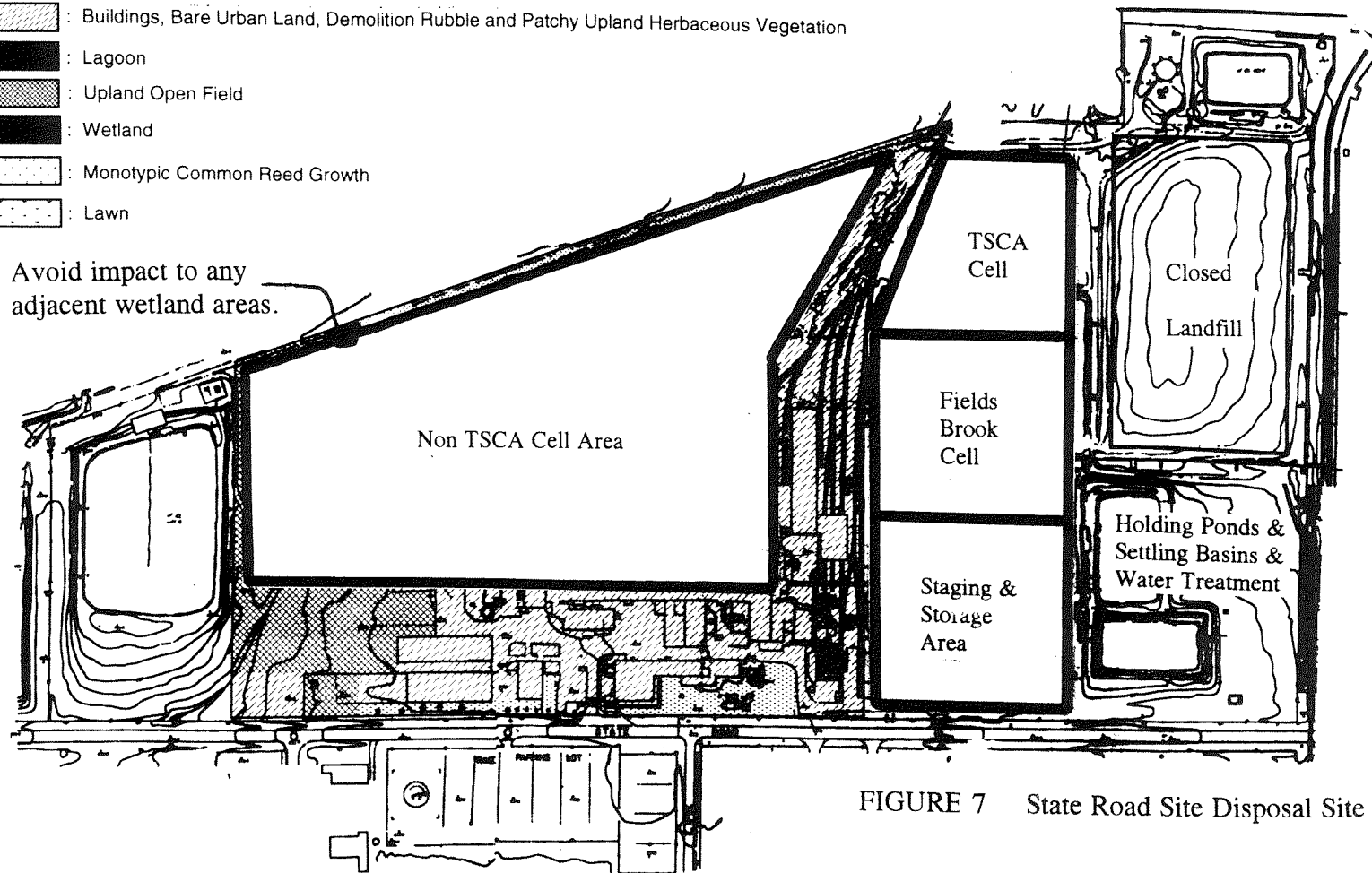
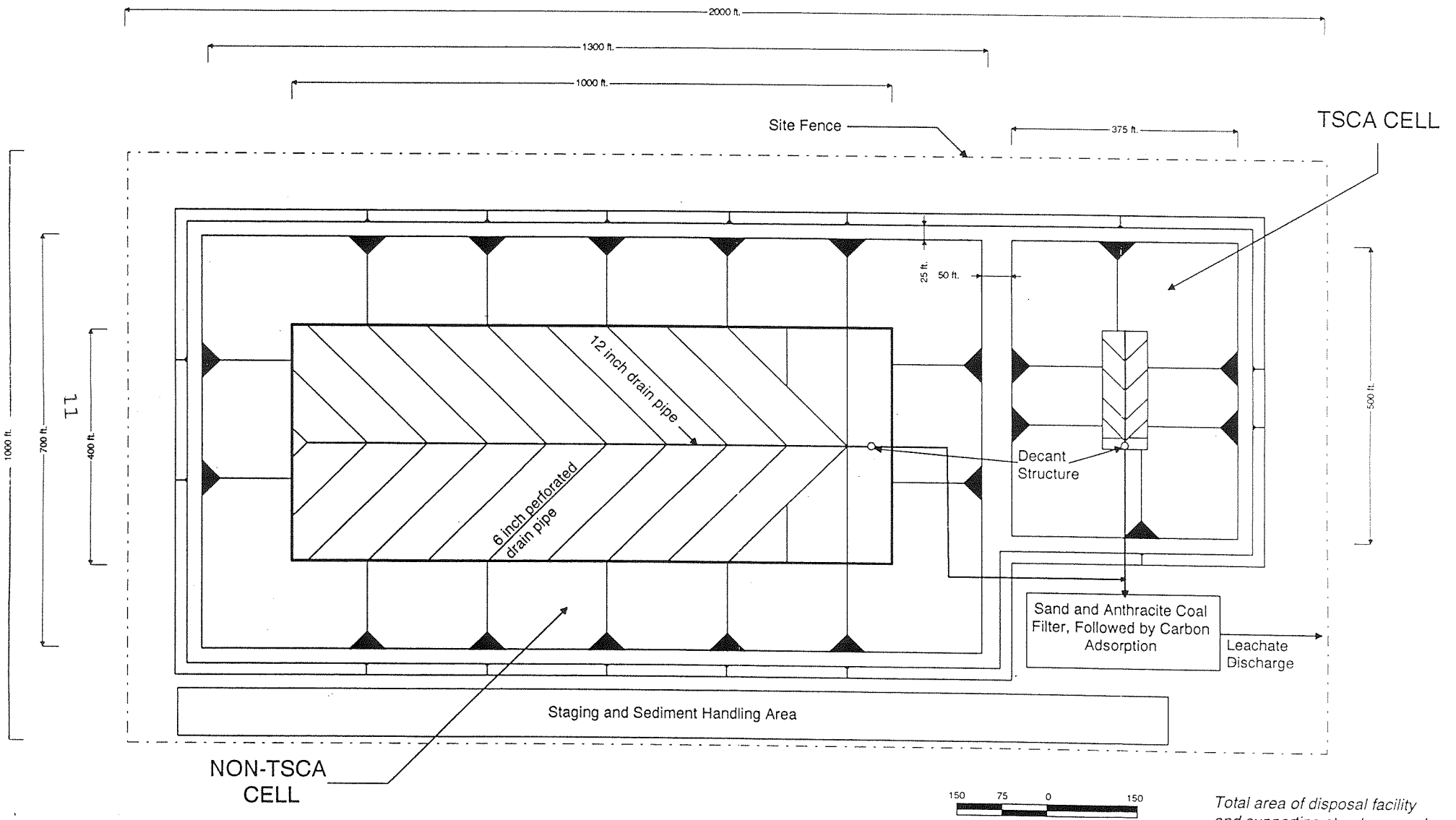
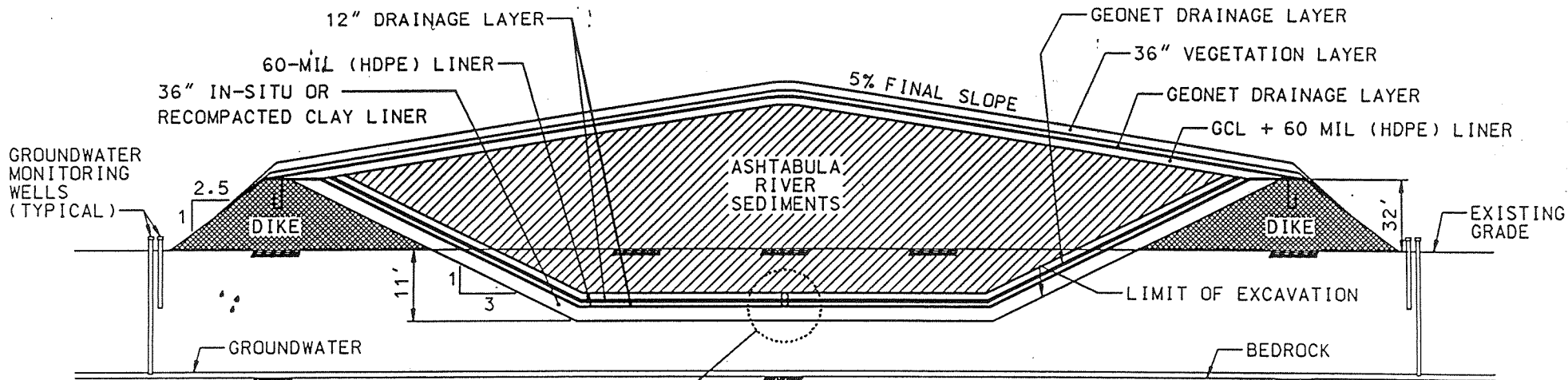

FIGURE 7 State Road Site Disposal Site



Total area of disposal facility and supporting structures and facilities is about 46 acres.

FIGURE 8 Conceptual Layout of Disposal Facility for Ashtabula River Sediments



12

NOTES: FIGURE 9

1. TEXTURED LINERS ON SLOPE
2. GEONET DRAINAGE LAYER WILL BE PROVIDED ON INTERIOR SLOPE ON LANDFILL
3. LEACHATE COLLECTION PIPES WILL HAVE A MINIMUM OF 0.5% SLOPE
4. GCL IS A GEOSYNTHETIC CLAY LINER
5. A FILTER FABRIC WILL BE PLACED AT TOP AND BOTTOM HDPE LINER FOR PROTECTION FROM GRANULAR MATERIAL IN DRAINAGE LAYER.

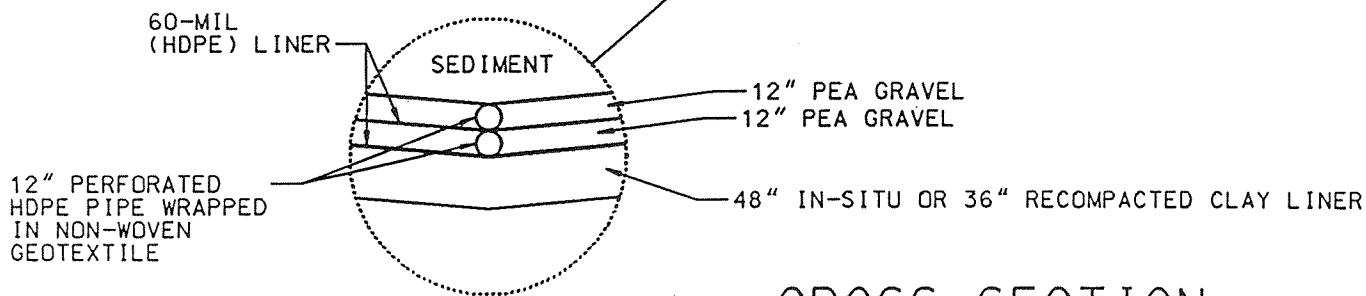

LINER AND LEACHATE COLLECTION DETAIL

CROSS SECTION

NOT TO SCALE

DISPOSAL FACILITY
 ASHTABULA, OHIO
 CONCEPTUAL CROSS SECTION
 OF TSCA DISPOSAL FACILITY
 FOR ASHTABULA RIVER SEDIMENTS

U.S. ARMY ENGINEER DISTRICT BUFFALO
 AUGUST 1997

13

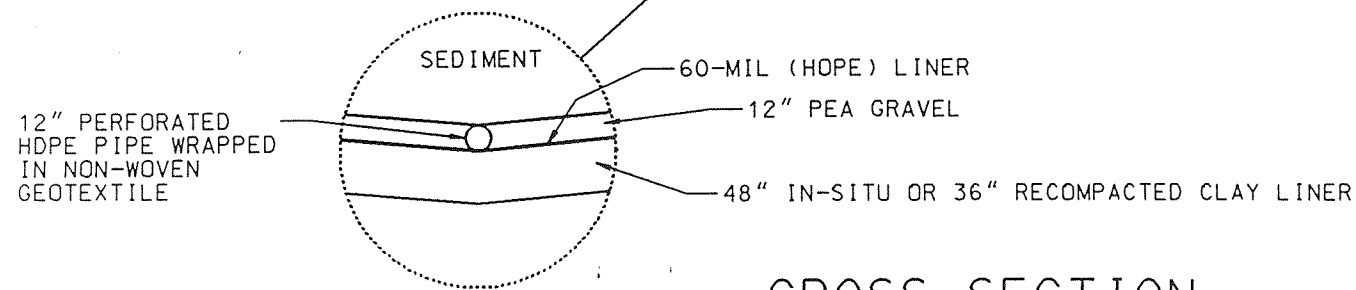
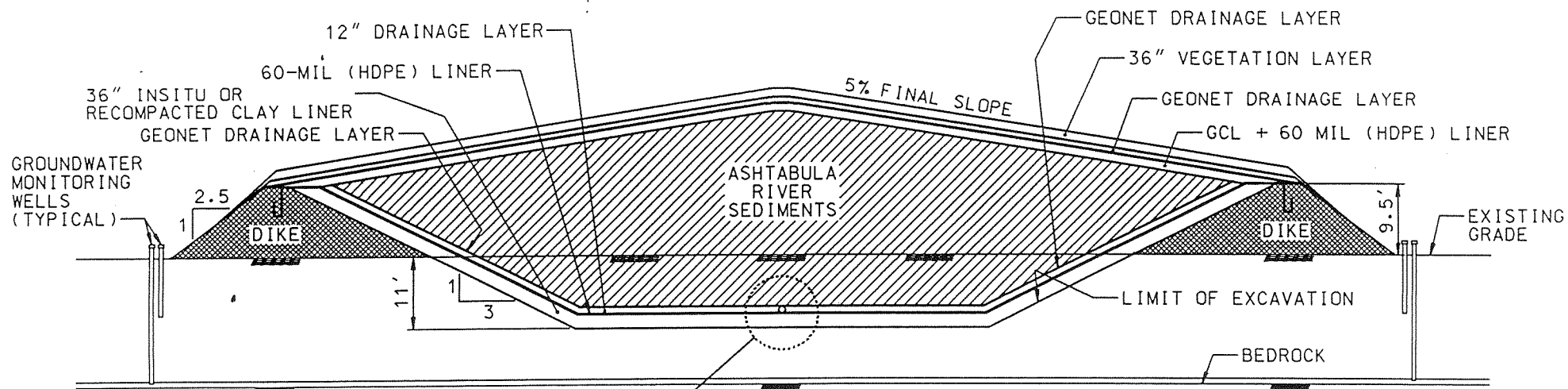

DETAIL

CROSS SECTION

NOT TO SCALE

NOTES: FIGURE 10

1. TEXTURED LINERS ON SLOPE
2. GEONET DRAINAGE LAYER WILL BE PROVIDED ON INTERIOR SLOPE ON LANDFILL
3. LEACHATE COLLECTION PIPES WILL HAVE A MINIMUM OF 0.5% SLOPE
4. GCL IS A GEOSYNTHETIC CLAY LINER
5. A FILTER FABRIC WILL BE PLACED ABOVE HDPE LINER FOR PROTECTION FROM GRANULAR MATERIAL IN DRAINAGE LAYER.

DISPOSAL FACILITY
 ASHTABULA, OHIO
 CONCEPTUAL CROSS SECTION
 OF NON-TSCA DISPOSAL FACILITY
 FOR ASHTABULA RIVER SEDIMENTS

U.S. ARMY ENGINEER DISTRICT BUFFALO
 AUGUST 1997

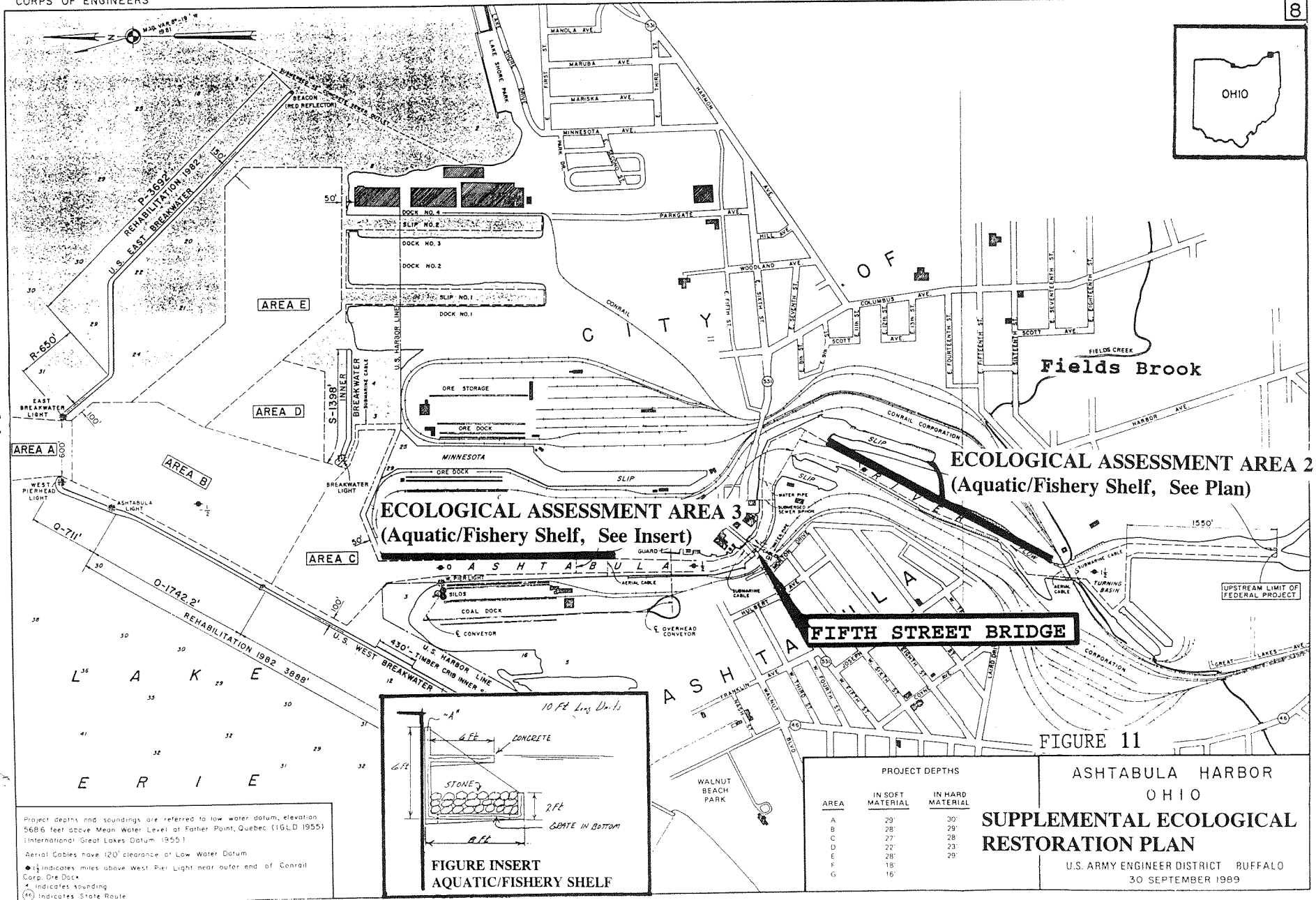

Project depths and soundings are referred to low water datum, elevation 568.6 feet above Mean Water Level at Father Point, Quebec (19GLD 1955) (International Great Lakes Datum 1955).
 Aerial Cables have 120' clearance at Low Water Datum.
 ● indicates miles above West Pier Light near outer end of Conrail Corp. Ore Dock.
 * indicates sounding.
 (R) indicates State Route.

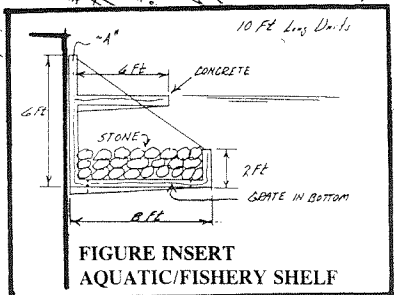

AREA	PROJECT DEPTHS	
	IN SOFT MATERIAL	IN HARD MATERIAL
A	29'	30'
B	28'	29'
C	27'	28'
D	22'	23'
E	28'	29'
F	18'	
G	16'	

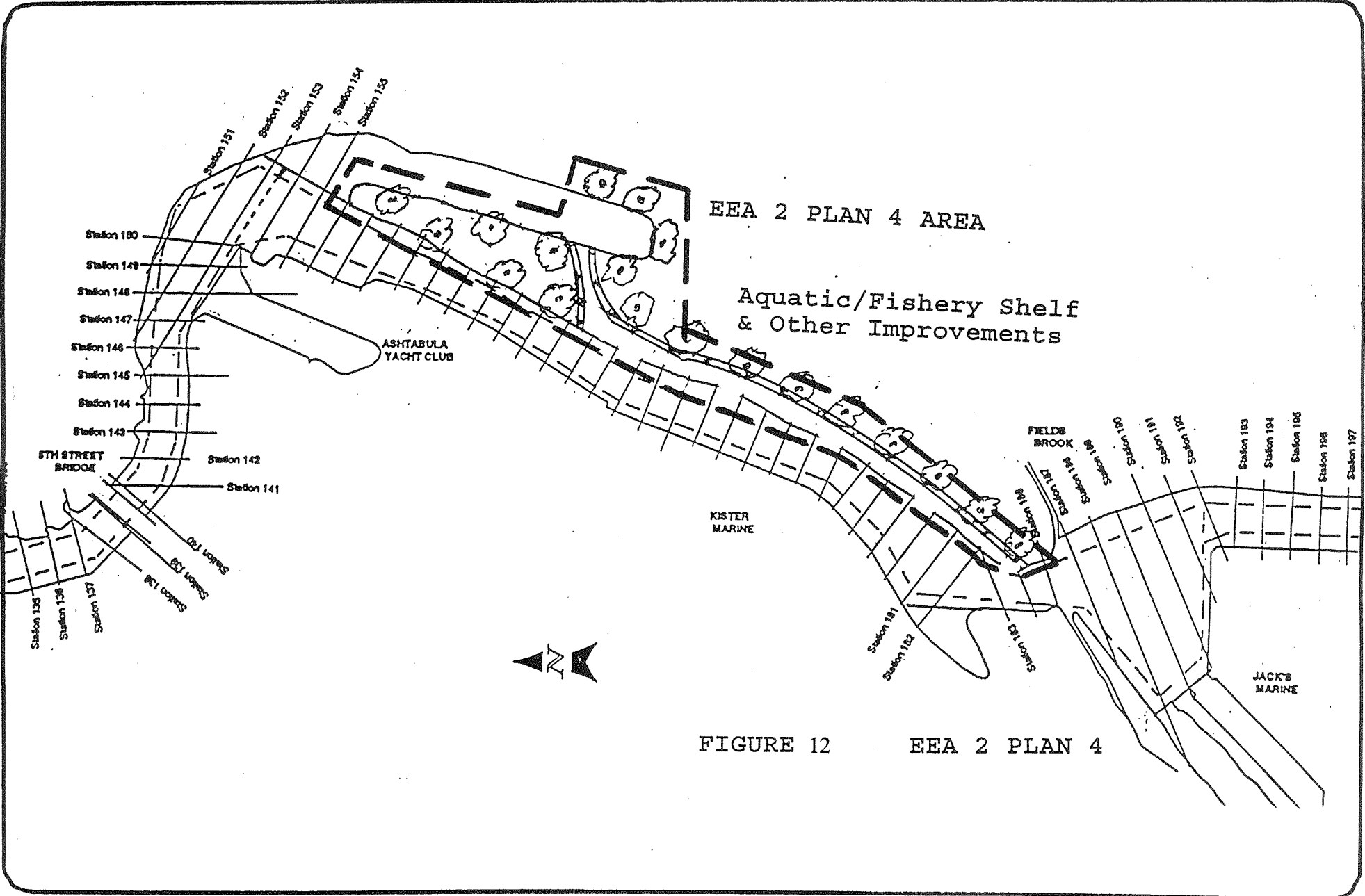

EEA 2 PLAN 4 AREA

Aquatic/Fishery Shelf & Other Improvements

FIGURE 12

EEA 2 PLAN 4

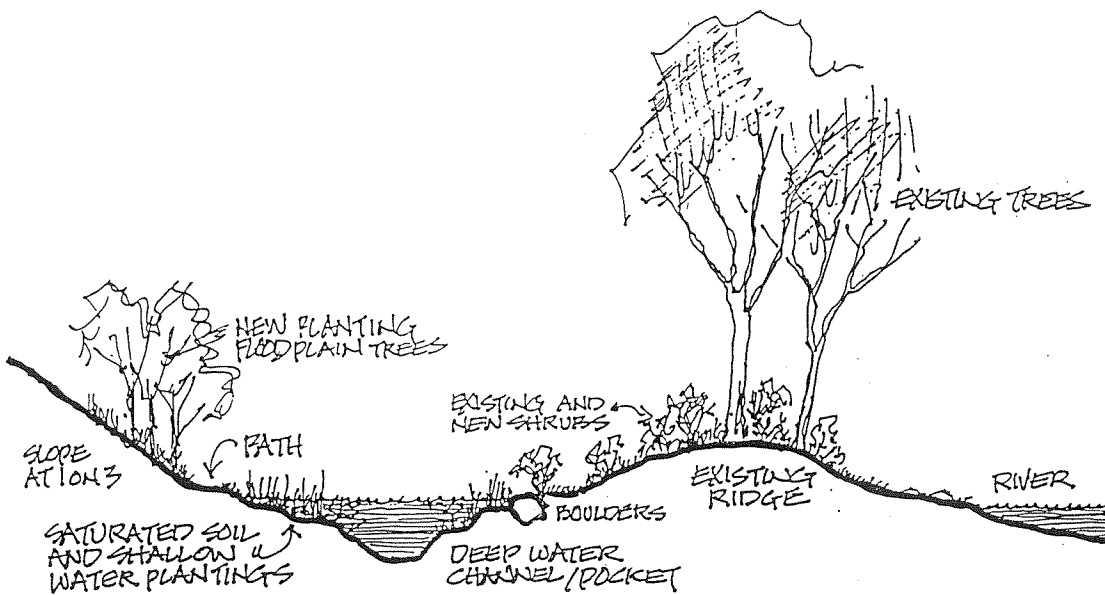

Source: Buffalo River Remedial Action Plan

(Sterns and Wheler) (Integrated Site, Inc.)

FIGURE 13
AQUATIC/FISHERY
DIVERSION/BYPASS
CUT

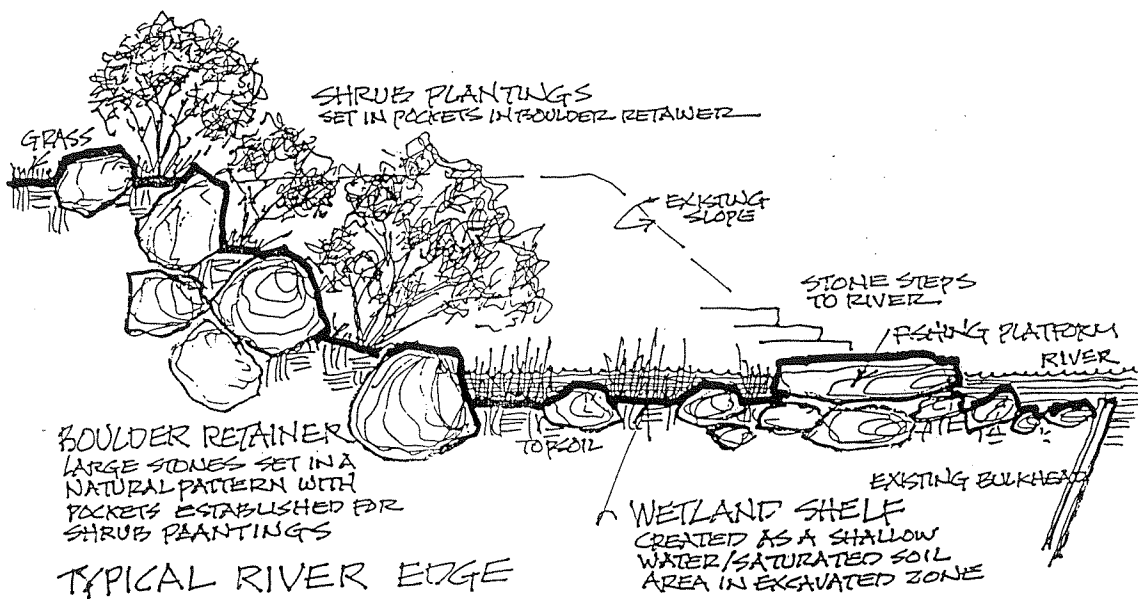

Source: Buffalo River Remedial Action Plan

(Sterns and Wheler) (Integrated Site, Inc.)

FIGURE 14
FISHERY SHELF
(EMBANKMENT CUTBACK)

Evaluation (Applicable Policies)

Policy 6 - Water Quality.

Compliance Statement. The proposed project is the primary remedial action for the Ashtabula River Area of Concern Remedial Action Plan and is being coordinated with International, Federal, State, and local interests.

The Ashtabula River Partnership is a cooperating organization of public and private interests working toward remediation of the lower Ashtabula River. The Ashtabula River Partnership (ARP) has investigated problems and needs pertaining to contaminated sediments and disrupted habitats in the Lower Ashtabula River which have restricted operations and maintenance dredging and disposal of dredged material and full environmental, economic, and social use and development of the harbor.

The recommended plan involves: 1) deep dredging (environmentally/low turbidity) of approximately 696,000 cubic yards (in situ) of contaminated sediments, 150,000 cubic yards of which is significantly PCB contaminated and would (for planning estimates) be handled and disposed of in accordance with Toxic Substance Control Act guidelines; 2) developing and utilizing a transfer/dewatering/transfer facility in the harbor area; 3) trucking the dewatered dredged material to a developed upland disposal site; and 4) disposing of the material, as appropriate, in TSCA and Non-TSCA disposal facilities. The facilities would also include leachate collection, treatment, and monitoring facilities, and closure, and post closure monitoring measures. The project also recommends restoration (by separate authority) of several acres of aquatic/fishery shallows areas and associated shoreline. Approximately 150,000 cubic yards of operations and maintenance dredged material and/or shoreline excavated material would be discharged in the initially dredged area in order to provide an immediate clean cover and to expedite ecological recovery. Environmental protection measures have been incorporated into the project planning and will be further incorporated into the project design, construction, operation, and maintenance plans to meet Federal, State, and local regulations.

Dredging the Ashtabula River sediments will have short-term detrimental effects on the river and to a lesser extent, Ashtabula Harbor and Lake Erie due to the minor temporary resuspension of some sediments during dredging activities. However, the long-term beneficial impacts should far outweigh the adverse effects. Dredging the sediments from the river will remove those contaminants associated with the sediments from the aquatic ecosystem. This will eliminate the ability of these contaminants to be resuspended and transported down river and into Lake Erie. Approximately 150,000 cubic yards of operations and maintenance dredged material and/or shoreline excavated material would be discharged in the initially dredged area in order to provide an immediate clean cover and to expedite ecological recovery. Future sediment deposits should be essentially clean and would be able to support less pollution tolerant benthic organisms. This would enable the river to achieve a higher diversity of aquatic species. Implementation of the project would work toward restoration *of* the integrity of the harbor from the environmental, economic, and social perspectives.

Project coordination was and is being conducted with the U.S. Environmental Protection Agen-

cy, the U.S. Army Corps of Engineers, the Ohio State Environmental Protection Agency, the Ohio Department of Health, and the Ohio State Department of Natural Resources in this regard.

A Clean Water Act Public Notice and Section 404(b)(1) Evaluation Report was coordinated with the Draft Environmental Impact Statement as EIS Appendix EA-B. (Part of the report and followed these text). This addressed project related activities such as: dredging activities, placement of fill or dredged material in U.S. waters (including wetlands), wetland mitigation, and filtered/treated water discharges and associated water quality requirements and compliance.

Subsequent to the Draft Reports, a number of additional evolved alternative disposal facilities and alternatives were assessed/evaluated. Use of existing disposal facilities can not be utilized because RAD material can not be co-mingled with other disposed material and must have its own disposal facility. In this regard, the former RMI Sodium Plant site (State Road Site) has become available. The site has been disturbed by past plant development and recent demolitions and is of little value to fish and wildlife and contains only a minor wetlands at the eastern boundary and northeast corner. This will be avoided. The Fields Brook remediation project material is being disposed of in part of this property. There is room for the Ashtabula River Partnership dredged elevated PCB and RAD material to be disposed of in a developed facility adjacent to the Fields Brook remediation project disposal facility. There is also just enough room for the Ashtabula River Partnership dredged contaminated material to be disposed of in a developed facility adjacent to the other disposal facilities. Assessment/evaluation indicates that this is the overall preferred possible disposal alternative and is now the project disposal component plan.

The final proposed project is the same as that proposed in the draft reports except that the material would be disposed of at developed disposal facilities at the State Road Site. Since this would avoid impacts to any wetlands and reduce impacts to U. S. Waters and fish and wildlife resources from that discussed in the Draft reports, a new Clean Water Act Public Notice and Section 404(b)(1) Evaluation Report will not be issued. Actions specific to development and disposal of material at the brownfields State Road Site (no discharge to U.S. Waters including wetlands) is not subject to Clean Water Act Section 404/401.

The Ashtabula River Partnership forwarded an initial Application For Ohio EPA Section 401 Water Quality Certification with the draft reports. This was withdrawn due to project plan disposal revisions and limited preliminary design information. The Ohio EPA however, issued an interim letter of concurrence on feasibility in this regard pertaining to sufficient planning and preliminary design and indicated that a Final Application For Ohio EPA Section 401 Water Quality Certification should be submitted with more detailed final design and support documentation. The Ashtabula River Partnership will be forwarding a Final Application For Ohio EPA Section 401 Water Quality Certification with design and support documentation.

The Ashtabula River Partnership is also coordinating with the Ohio Environmental Protection

Agency with regard to the National/State Pollution Discharge Elimination System permit and criteria, and the Ohio Environmental Protection Agency Division of Water Pollution Control Permit to Install or Plan Approval Application, as necessary, and any other permit requirements, as necessary.

The project facilities design, construction, and operation plans are being coordinated with Federal, State, and local interests for necessary permits.

Policy 8 - Non Point Source Pollution.

Compliance Statement. A National/State Pollution Discharge Elimination System general permit has been obtained. The project will be designed and constructed to meet conditions of the permit.

Policy 10 - Area of Concern Remedial Action Plans.

Compliance Statement. The proposed project is the primary remedial action for the Ashtabula River Area of Concern Remedial Action Plan and is being coordinated with International, Federal, State, and local interests.

Policy 11 - Ground Water.

Compliance Statement. As indicated in the project Environmental Impact Statement, the project disposal facility is set back from the coastal resources designated area of higher potential for ground water contamination. The disposal facility is designed to securely contain dredged contaminated sediments and to protect ground water resources and quality. The project includes ground water quality monitoring wells and remedial contingency plans. The facility will have the necessary Federal, State, and local permits.

Policy 12 - Wetlands.

Compliance Statement. The dredging excavation of the river bottom sediments would remove most of the sparse wetland/vegetation from the river area that is dredged. Slip area wetlands should not be significantly affected. Future sediment deposits should be essentially clean. Eventually, some riverine wetlands will likely establish along shallow recreational channels being maintained.

The assessment/evaluation identified an **Aquatic/Fishery Shelf Plan** for the Ecological Assessment Area 3 problem area and an **Acquire Conrail Slip and Aquatic/Fishery Shelf Cut Plan** for the Ecological Assessment Area 2 problem area and other long-term dredging measures. This constitutes ecological restoration, as possible, for loss of protected aquatic/fishery shallows due to facilitated structural (i.e. bulkheading, channelization), and activities impacts. These are practical optimized plans of moderate cost providing problem area protected aquatic/fishery shallows of substantial length which accomplish, as possible, goals/objectives, in this regard. The areas would be interfaced with the lake/river regime and would provide a clean shallow vegetated aquatic, wetland, and shoreline area along the river. It should be noted

that these or similar measures would be pursued by separate authority/study (i.e. 206) subsequent and contingent to this projects dredging for removal of contaminants.

Aquatic/fishery shelves would provide additional aquatic/fishery habitat (~ 1 + acres).

If a water based barge Transfer/Dewatering/Transfer operation is utilized barges would be positioned to avoid significant impacts to wetlands. Development of shoreline Transfer/Dewatering/Transfer facilities at the 1993 Interim Dredged Material Disposal Site would be situated to avoid significant impacts to wetlands.

A primary consideration in identifying, assessing/evaluating, and selecting potential project upland disposal sites was to avoid and/or minimize impacts to wetlands. Development of the disposal facilities at the State Street Site would be situated to avoid significant impacts to wetlands. One man-made depressional wetland located on soil fill was identified within the northern third of the site along the eastern site boundary. This will be avoided.

Policy 17 - Dredging and Dredged Material Disposal.

Compliance Statement. The proposed project is the primary remedial action for the Ashtabula River Area of Concern Remedial Action Plan and is being coordinated with International, Federal, State, and local interests.

The Ashtabula River Partnership is a cooperating organization of public and private interests working toward remediation of the lower Ashtabula River. The Ashtabula River Partnership (ARP) has investigated problems and needs pertaining to contaminated sediments and disrupted habitats in the Lower Ashtabula River which have restricted operations and maintenance dredging and disposal of dredged material and full environmental, economic, and social use and development of the harbor.

The recommended plan involves: 1) deep dredging (environmentally/low turbidity) of approximately 696,000 cubic yards (in situ) of contaminated sediments, 150,000 cubic yards of which is significantly PCB contaminated and would (for planning estimates) be handled and disposed of in accordance with Toxic Substance Control Act guidelines; 2) developing and utilizing a transfer/dewatering/transfer facility in the harbor area; 3) trucking the dewatered dredged material to a developed upland disposal site; and 4) disposing of the material, as appropriate, in TSCA and Non-TSCA disposal facilities. The facilities would also include leachate collection, treatment, and monitoring facilities, and closure, and post closure monitoring measures. The project also recommends restoration (by separate authority) of several acres of aquatic/fishery shallows areas and associated shoreline. Approximately 150,000 cubic yards of operations and maintenance dredged material and/or shoreline excavated material would be discharged in the initially dredged area in order to provide an immediate clean cover and to expedite ecological recovery. Environmental protection measures have been incorporated into the project planning and will be further incorporated into the project design, construction, operation, and maintenance plans to meet Federal, State, and local regulations.

Dredging the Ashtabula River sediments will have short-term detrimental effects on the river;

and, to a lesser extent, Ashtabula Harbor and Lake Erie due to the minor temporary resuspension of some sediments during dredging activities. However, the long-term beneficial impacts should far outweigh the adverse effects. Dredging the sediments from the river will remove those contaminants associated with the sediments from the aquatic ecosystem. This will eliminate the ability of these contaminants to be resuspended and transported down river and into Lake Erie. Approximately 150,000 cubic yards of operations and maintenance dredged material and/or shoreline excavated material would be discharged in the initially dredged area in order to provide an immediate clean cover and to expedite ecological recovery. Future sediment deposits should be essentially clean and would be able to support less pollution tolerant benthic organisms. This would enable the river to achieve a higher diversity of aquatic species. Implementation of the project would work toward restoration *of* the integrity of the harbor from the environmental, economic, and social perspectives.

The project will provide for long term operations and maintenance dredging and disposal, primarily dredging and approved open-lake disposal or beneficial use of dredged material.

See Policy 6 – Water Quality also.

Policy 18 - Local Lakeshore Development.

Compliance Statement. The proposed project is the primary remedial action for the Ashtabula River Area of Concern Remedial Action Plan and is being coordinated with International, Federal, State, and local interests.

Dredging the sediments from the river will remove those contaminants associated with the sediments from the aquatic ecosystem. This will eliminate the ability of these contaminants to be resuspended and transported down river and into Lake Erie. Approximately 150,000 cubic yards of operations and maintenance dredged material and/or shoreline excavated material would be discharged in the initially dredged area in order to provide an immediate clean cover and to expedite ecological recovery. Future sediment deposits should be essentially clean and would be able to support less pollution tolerant benthic organisms. The project would also restore several acres of aquatic/fishery shallows areas and associated shoreline. This would enable the river to achieve a higher diversity of aquatic species. Implementation of the project would work toward restoration *of* the integrity of the harbor from the environmental, economic, and social perspectives. The project will provide for continued long-term dredging of clean sediments and disposal at the Lake Erie open-lake disposal site. This will facilitate local lakeshore development plans.

The proposed plan descriptions and associated expected impacts are described in more detail in appropriate sections of these reports, particularly the Recommended Plan, the Environmental Effects sections, and Clean Water Act Section 404(b)(1) Evaluation Report Appendix of this EIS.

Policy 19 - Lake Erie Ports.

Compliance Statement. Same statement as for Policy 18.

Policy 20 - Transportation Facilities.

Compliance Statement. Same statement as for Policy 18.

Policy 21 - Lake Shore Recreation and Access.

Compliance Statement. Same statement as for Policy 18.

Policy 23 - Recreational Boating.

Compliance Statement. Same statement as for Policy 18.

Policy 24 - Fishing and Hunting.

Compliance Statement. Same statement as for Policy 18. Also, reference Policy 12 - Wetlands. It is expected that the project will facilitate the lifting of fishery advisories in due time.

Policy 26 - Preservation of Cultural Resources.

Compliance Statement. Project coordination was conducted with the Ohio Historic Preservation Office. A cultural resources survey was conducted for non-disturbed or previously non-surveyed project areas. No significant cultural resources were found and none would be expected to be disturbed by project implementation. The Ohio Historic Preservation Office concurred with this finding in a letter dated June 30, 1997 and November 7, 2000. Reference EIS Appendix EA-H.

Policy 27 - Fisheries Management.

Compliance Statement. Same statement as for Policy 18.

See Policy 6 – Water Quality also. The Clean Water Act Section 401(a) Public Notice and 404(b)(1) Evaluation Report provides considerable detail pertaining to expected impacts to water quality and the aquatic environment.

It is expected that the project will facilitate the lifting of fishery advisories in due time. The project facilities design, construction, and operation plans are being coordinated with Federal, State, and local interests for necessary permits.

Policy 28 - Fisheries Research and Interstate Cooperation.

Compliance Statement. Same statement as for Policy 18.

Policy 29 - Wildlife Management.

Compliance Statement. Same statement as for Policy 18. Also, reference Policy 12 - Wetlands. Also, the project disposal facility is set back from the designated Coastal Program

coastal area.

Policy 30 - Air Quality.

Compliance Statement. Operation of heavy construction equipment would generate associated exhaust fumes in the immediate construction activity areas. This would not be expected to be a significant adverse air quality impact.

Some earthy/organic odor may occur in the immediate area of the dredged material. This would not be expected to be a problem over a large area or for a long time. If a substantial problem is noted, some odor abatement measures (operations or applications) may be implemented.

Some minor volatilization of contaminants would occur during the dredging and handling of dredged material. The only potential time and area of any substantial concern in this regard would be during the dredging and immediate handling of PCB TSCA material in the immediate area of the dredged material. Appropriate protective wear would be worn by workers at these times and in these areas. Appropriate restriction areas will be established. Volatile losses from the water during dredging would be low because of very low contaminant concentrations in the water column (due to their hydrophobic low solubility nature) and the large volume of water available for dispersion of the dissolved PCBs before they become available for volatilization. The contaminant flux from moist sediment is extremely high immediately after exposure to air. The flux then drops off quickly as the sediment pore water evaporates. However, the flux increases, if the sediment resaturates, as would be the case during a significant rainfall. Canopy cover measures would significantly reduce volatilization of contaminants during handling and transport.

Policy 31 - Hazardous, Solid, and Infectious Waste Management.

Compliance Statement. The proposed project is the primary remedial action for the Ashtabula River Area of Concern Remedial Action Plan and is being coordinated with International, Federal, State, and local interests.

The Ashtabula River Partnership is a cooperating organization of public and private interests working toward remediation of the lower Ashtabula River. The Ashtabula River Partnership (ARP) has investigated problems and needs pertaining to contaminated sediments in the Lower Ashtabula River which have restricted operations and maintenance dredging and disposal of dredged material and full environmental, economic, and social use and development of the harbor.

The recommended plan involves: 1) deep dredging (environmentally/low turbidity) of approximately 696,000 cubic yards (in situ) of contaminated sediments, 150,000 cubic yards of which is significantly PCB contaminated and would (for planning estimates) be handled and disposed of in accordance with Toxic Substance Control Act guidelines; 2) developing and utilizing a transfer/dewatering/transfer facility in the harbor area; 3) trucking the dewatered dredged material to a developed upland disposal site; and 4) disposing of the material, as appropri-

ate, in TSCA and Non-TSCA disposal facilities. The facilities would also include leachate collection, treatment, and monitoring facilities, and closure, and post closure monitoring measures. The project also recommends restoration (by separate authority) of several acres of aquatic/fishery shallows areas and associated shoreline. Approximately 150,000 cubic yards of operations and maintenance dredged material and/or shoreline excavated material would be discharged in the initially dredged area in order to provide an immediate clean cover and to expedite ecological recovery. Environmental protection measures have been incorporated into the project planning and will be further incorporated into the project design, construction, operation, and maintenance plans to meet Federal, State, and local regulations.

Dredging the Ashtabula River sediments will have short-term detrimental effects on the river; and, to a lesser extent, Ashtabula Harbor and Lake Erie due to the minor temporary resuspension of some sediments during dredging activities. However, the long-term beneficial impacts should far outweigh the adverse effects. Dredging the sediments from the river will remove those contaminants associated with the sediments from the aquatic ecosystem. This will eliminate the ability of these contaminants to be resuspended and transported down river and into Lake Erie. Approximately 150,000 cubic yards of operations and maintenance dredged material and/or shoreline excavated material would be discharged in the initially dredged area in order to provide an immediate clean cover and to expedite ecological recovery. Future sediment deposits should be essentially clean and would be able to support less pollution tolerant benthic organisms. This would enable the river to achieve a higher diversity of aquatic species. Implementation of the project would work toward restoration of the integrity of the harbor from the environmental, economic, and social perspectives. The project will provide for continued long-term dredging of clean sediments and disposal at the Lake Erie open lake disposal site or beneficial use.

See Policy 6 – Water Quality also. The Clean Water Act Section 401(a) Public Notice and 404(b)(1) Evaluation Report provides considerable detail pertaining to expected impacts to water quality and the aquatic environment.

As indicated in the project Environmental Impact Statement, the project disposal facility is set back from the coastal resources designated area of higher potential for ground water contamination. The disposal facility is designed to securely contain dredged contaminated sediments and to protect ground water resources and quality. The project includes ground water quality monitoring wells and remedial contingency plans.

The project facilities design, construction, and operation plans are being coordinated with Federal, State, and local interests for necessary permits.

The proposed plan descriptions and associated expected impacts are described in more detail in appropriate sections of these reports, particularly the Recommended Plan, the Environmental Effects sections, and Clean Water Act Section 404(b)(1) Evaluation Report Appendix of this EIS.

Policy 33 - Visual and Aesthetic Quality.

Compliance Statement. Same statement as for Policy 18. Also, reference Policy 12 – Wetlands. Also, the project disposal facility is set back from the designated Coastal Program coastal area.

Policy 41 - Water Management.

Compliance Statement. The proposed project is the primary remedial action for the Ashtabula River Area of Concern Remedial Action Plan and is being coordinated with International, Federal, State, and local interests.

The Ashtabula River Partnership is a cooperating organization of public and private interests working toward remediation of the lower Ashtabula River. The Ashtabula River Partnership (ARP) has investigated problems and needs pertaining to contaminated sediments and disrupted habitats in the Lower Ashtabula River which have restricted operations and maintenance dredging and disposal of dredged material and full environmental, economic, and social use and development of the harbor.

The recommended plan involves: 1) deep dredging (environmentally/low turbidity) of approximately 696,000 cubic yards (in situ) of contaminated sediments, 150,000 cubic yards of which is significantly PCB contaminated and would (for planning estimates) be handled and disposed of in accordance with Toxic Substance Control Act guidelines; 2) developing and utilizing a transfer/dewatering/transfer facility in the harbor area; 3) trucking the dewatered dredged material to a developed upland disposal site; and 4) disposing of the material, as appropriate, in TSCA and Non-TSCA disposal facilities. The facilities would also include leachate collection, treatment, and monitoring facilities, and closure, and post closure monitoring measures. The project also recommends restoration (by separate authority) of several acres of aquatic/fishery shallows areas and associated shoreline. Approximately 150,000 cubic yards of operations and maintenance dredged material and/or shoreline excavated material would be discharged in the initially dredged area in order to provide an immediate clean cover and to expedite ecological recovery. Environmental protection measures have been incorporated into the project planning and will be further incorporated into the project design, construction, operation, and maintenance plans to meet Federal, State, and local regulations.

Dredging the Ashtabula River sediments will have short-term detrimental effects on the river; and, to a lesser extent, Ashtabula Harbor and Lake Erie due to the minor temporary resuspension of some sediments during dredging activities. However, the long-term beneficial impacts should far outweigh the adverse effects. Dredging the sediments from the river will remove those contaminants associated with the sediments from the aquatic ecosystem. This will eliminate the ability of these contaminants to be resuspended and transported down river and into Lake Erie. Approximately 150,000 cubic yards of operations and maintenance dredged material and/or shoreline excavated material would be discharged in the initially dredged area in order to provide an immediate clean cover and to expedite ecological recovery. Future sediment deposits should be essentially clean and would be able to support less pollution tolerant benthic organisms. This would enable the river to achieve a higher diversity of aquatic species. Imple-

mentation of the project would work toward restoration of the integrity of the harbor from the environmental, economic, and social perspectives.

See Policy 6 – Water Quality also. The Clean Water Act Section 401(a) Public Notice and 404(b)(1) Evaluation Report provides considerable detail pertaining to expected impacts to water quality and the aquatic environment.

The project facilities design, construction, and operation plans are being coordinated with Federal, State, and local interests for necessary permits.

STATE OF OHIO
COASTAL MANAGEMENT PROGRAM POLICIES

(1)

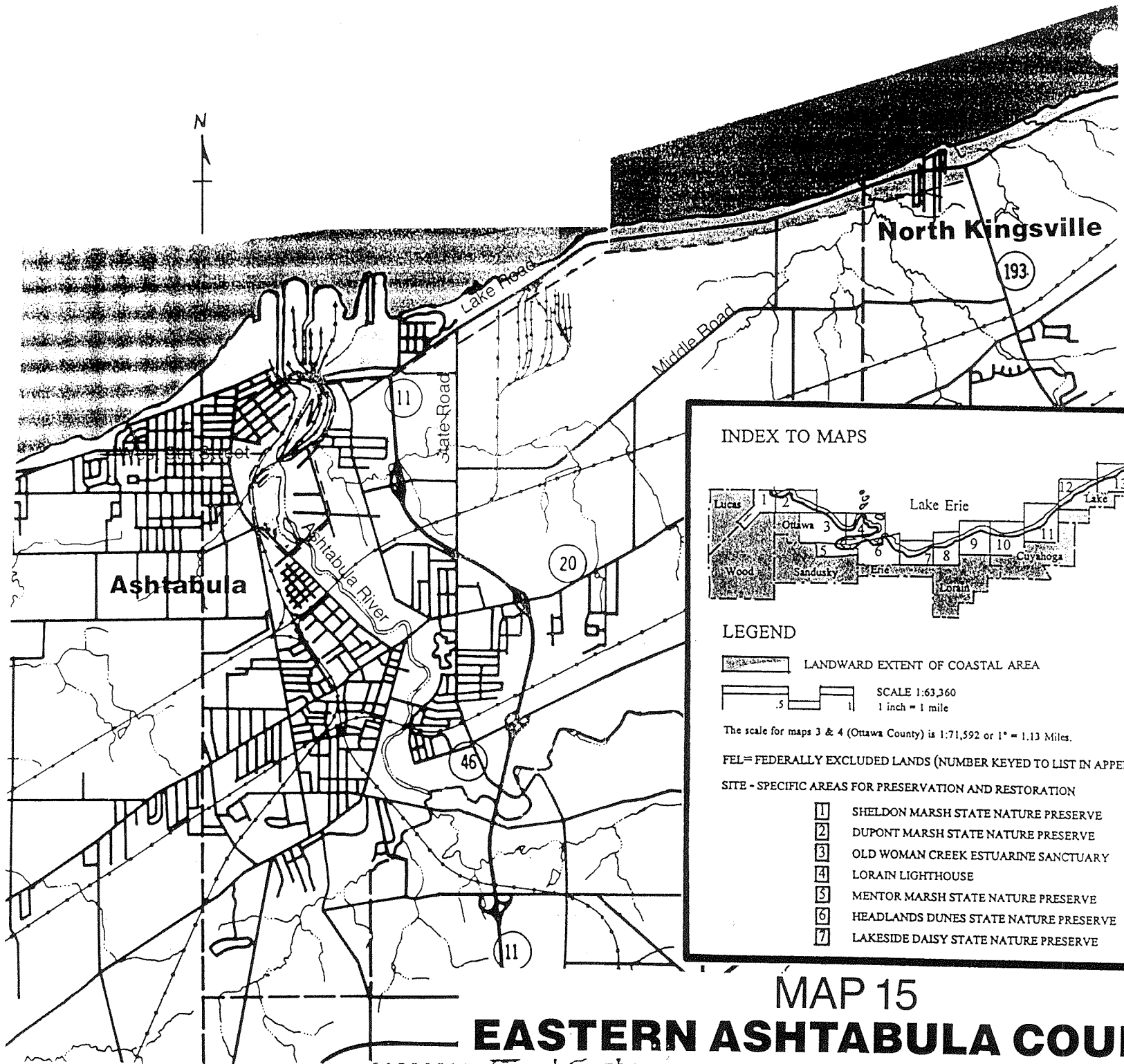

INDEX TO MAPS

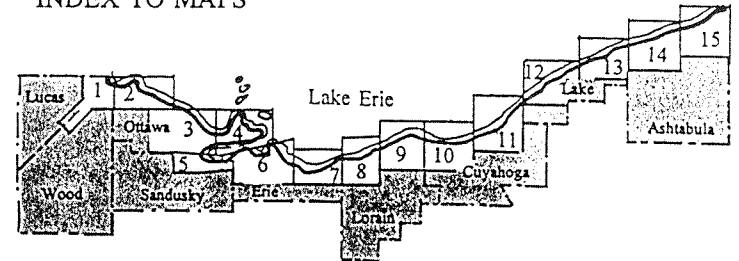

LEGEND

LANDWARD EXTENT OF COASTAL AREA

SCALE 1:63,360
1 inch = 1 mile

The scale for maps 3 & 4 (Ottawa County) is 1:71,592 or 1" = 1.13 Miles.

FEL = FEDERALLY EXCLUDED LANDS (NUMBER KEYED TO LIST IN APPENDIX P)

SITE - SPECIFIC AREAS FOR PRESERVATION AND RESTORATION

- 1** SHELDON MARSH STATE NATURE PRESERVE
- 2** DUPONT MARSH STATE NATURE PRESERVE
- 3** OLD WOMAN CREEK ESTUARINE SANCTUARY
- 4** LORAIN LIGHTHOUSE
- 5** MENTOR MARSH STATE NATURE PRESERVE
- 6** HEADLANDS DUNES STATE NATURE PRESERVE
- 7** LAKESIDE DAISY STATE NATURE PRESERVE

MAP 15

EASTERN ASHTABULA COUNTY

OHIO CZM POLICIES DRAFT 9/96

POLICY 1 - LAKE ERIE COASTAL EROSION AREA MANAGEMENT

IT IS THE POLICY OF THE STATE OF OHIO TO MINIMIZE THREATS TO HUMAN SAFETY AND PROPERTY DUE TO LAKE ERIE-RELATED EROSION WHILE PROTECTING THE FUNCTIONS OF NATURAL SHORE FEATURES BY:

- A. DELINEATING THE BOUNDARIES OF LAKE ERIE COASTAL EROSION AREAS (O.R.C. § 1506.06 AND O.A.C. 1501:6-10 THROUGH 1501:6-13);
- B. ADMINISTERING AND ENFORCING A PERMIT PROGRAM FOR CONSTRUCTION ACTIVITIES IN LAKE ERIE COASTAL EROSION AREAS (O.R.C. § 1506.07, O.A.C. 1501:6-21 THROUGH 1501:6-28);
- C. REQUIRING OWNERS OF PROPERTY IN LAKE ERIE COASTAL EROSION AREAS TO NOTIFY BUYERS OF THE LAND'S STATUS PRIOR TO ANY TRANSACTION (O.R.C. § 1506.06(F)); AND
- D. ENCOURAGE STRATEGIC RETREAT WHERE NATURAL FUNCTIONS OF BLUFFS, DUNES AND COASTAL BARRIERS CAN BE MAINTAINED EFFECTIVELY AND SELECTIVE FORTIFICATION TO PROTECT EXISTING DEVELOPMENT VULNERABLE TO LONG-TERM RAPID EROSION.

POLICY 2 - SHORE EROSION CONTROL

IT IS THE POLICY OF THE STATE OF OHIO TO PROMOTE SOUND DECISIONS REGARDING CONTROL OF SHORE EROSION BY:

- A. ISSUING PERMITS FOR CONSTRUCTION OF SHORELINE EROSION CONTROL STRUCTURES (O.R.C. § 1507.04);
- B. PROVIDING TECHNICAL ASSISTANCE TO THE PUBLIC ON SHORELINE EROSION CONTROL STRUCTURES (O.R.C. § 1507.10); AND
- C. DEVELOPING A PLAN FOR THE CONTROL OF SHORE EROSION AND MAKING THE PLAN AVAILABLE TO THE PUBLIC (O.R.C. § 1507.10).

POLICY 3 - FLOODPLAIN MANAGEMENT

IT IS THE POLICY OF THE STATE OF OHIO TO MINIMIZE FUTURE FLOOD DAMAGES AND PREVENT POTENTIAL LOSS TO EXISTING DEVELOPMENT IN COASTAL FLOODPLAINS BY:

- A. REQUIRING ALL COUNTIES AND MUNICIPALITIES WITH COASTAL FLOOD HAZARD AREAS TO PARTICIPATE IN THE NATIONAL FLOOD INSURANCE PROGRAM OR TO ADOPT ORDINANCES MEETING OR EXCEEDING PROGRAM STANDARDS (O.R.C. § 1506.04 AND O.A.C. 1501:22-1-01 THROUGH 1501:22-1-08);
- B. REQUIRING THAT ANY STATE FUNDED OR FINANCED DEVELOPMENT LOCATED WITHIN THE 100-YEAR FLOODPLAIN COMPLY WITH THE FLOODPLAIN MANAGEMENT CRITERIA OF THE NATIONAL FLOOD INSURANCE PROGRAM. ANY STATE AGENCY HAVING REGULATORY JURISDICTION THAT PREEMPTS THE AUTHORITY OF POLITICAL SUBDIVISIONS TO REGULATE DEVELOPMENT IN FLOODPLAINS SHALL ENSURE THAT BEFORE GRANTING A LICENSE, PERMIT, OR OTHER AUTHORIZATION, THE DEVELOPMENT COMPLIES WITH THE NATIONAL FLOOD INSURANCE PROGRAM CRITERIA (O.R.C. § 1521.14);
- C. REQUIRING THAT NO STATE FINANCIAL ASSISTANCE IN CONNECTION WITH A FLOOD DISASTER SHALL BE DISBURSED TO OR WITHIN ANY COUNTY OR MUNICIPALITY THAT DOES NOT COMPLY WITH THE FLOODPLAIN MANAGEMENT CRITERIA OF THE NATIONAL FLOOD INSURANCE PROGRAM (O.R.C. § 1521.14); AND
- D. REQUIRING THAT ALL STATE AGENCY AND POLITICAL SUBDIVISIONS, PRIOR TO EXPENDITURE OF FUNDS FOR CONSTRUCTION OF BUILDINGS, STRUCTURES, ROADS, BRIDGES, OR OTHER FACILITIES IN LOCATIONS THAT MAY BE SUBJECT TO FLOODING OR FLOOD DAMAGE, NOTIFY AND CONSULT WITH THE DIVISION OF WATER AND SHALL FURNISH SUCH INFORMATION AS THE DIVISION MAY REASONABLY REQUIRE IN ORDER TO AVOID THE UNECONOMIC, HAZARDOUS OR UNNECESSARY USE OF FLOODPLAINS IN CONNECTION WITH SUCH FACILITIES (O.R.C. § 1521.14).

POLICY 4 - FLOOD PROTECTION AND MITIGATION

IT IS THE POLICY OF THE STATE OF OHIO TO PROMOTE EFFECTIVE FLOOD PROTECTION BY:

- A. REGULATING THE DESIGN AND CONSTRUCTION OF DAMS, DIKES AND LEVEES, AND INSPECTING THEIR USE AND OPERATION (O.R.C. § 1521.06 et seq.);
- B. CONDUCTING DETAILED STUDIES AND INVESTIGATIONS OF ALL FACTORS RELATING TO FLOODS AND FLOOD PROTECTION;
- C. ESTABLISHING CONSERVANCY DISTRICTS WHERE LOCALLY DESIRED; AND
- D. PROMOTING THE PROTECTION AND RESTORATION OF WETLANDS FOR

POLICY 5 - SHORE EROSION AND FLOOD HAZARD MITIGATION ASSISTANCE

IT IS THE POLICY OF THE STATE OF OHIO TO ASSIST LAKE ERIE COASTAL COMMUNITIES EXPERIENCING FLOODING AND SHORE EROSION PROBLEMS TO MINIMIZE FUTURE DAMAGES BY:

- A. ADMINISTERING FUNDS FOR PROTECTION OF LAKE ERIE SHORES AND WATERS (O.R.C. § 1507.05); AND
- B. PROVIDING TECHNICAL INFORMATION AND ASSISTANCE FOR ADDRESSING EROSION AND FLOOD HAZARD CONCERNS (O.R.C. § 1507.10).

POLICY 6 - WATER QUALITY

IT IS THE POLICY OF THE STATE OF OHIO TO MAINTAIN AND IMPROVE THE QUALITY OF THE STATE'S COASTAL WATERS FOR THE PURPOSE OF PROTECTING THE PUBLIC HEALTH AND WELFARE AND TO ENABLE THE USE OF SUCH WATERS FOR PUBLIC WATER SUPPLY, INDUSTRIAL AND AGRICULTURAL NEEDS, AND PROPAGATION OF FISH, AQUATIC LIFE AND WILDLIFE BY:

- I. ASSURING ATTAINMENT OF STATE WATER QUALITY STANDARDS AND OTHER WATER QUALITY RELATED REQUIREMENTS (O.A.C. 3745-1) THROUGH:
 - A. CONTROLLING DISCHARGES INTO WATERS OF THE STATE BY REQUIRING PERMITS TO CONSTRUCT FACILITIES AND BY ESTABLISHING AND ENFORCING EFFLUENT LIMITATIONS UNDER THE NATIONAL POLLUTANT DISCHARGE ELIMINATION SYSTEM (NPDES, SECTION 402 CWA, O.R.C. § 6111.03);
 - B. ADMINISTERING A PERMIT SYSTEM TO CONTROL INJECTION WELL DRILLING IN COMPLIANCE WITH THE "SAFE DRINKING WATER ACT" AND THE CWA (O.R.C. § 6111.043 AND 6111.044);
 - C. REGULATING DISCHARGE OF DREDGE OR FILL MATERIAL INTO SURFACE WATERS INCLUDING WETLANDS IN ACCORDANCE WITH SECTION 401 OF THE CLEAN WATER ACT (O.R.C. § 6111.03);
 - D. ESTABLISHING UNIFORM REGULATIONS REGARDING SOLID WASTE DISPOSAL SITES AND FACILITIES (O.R.C. 3734.02 AND 3734.05);
 - E. PROHIBITING THE SALE OR DISTRIBUTION FOR SALE OF PHOSPHORUS-CONTAINING HOUSEHOLD LAUNDRY DETERGENTS IN THE LAKE ERIE BASIN (O.R.C. § 6111.10);

- F. PREPARING A STATE WATER QUALITY MANAGEMENT PLAN TO ASSESS TECHNICAL NEEDS FOR POLLUTION CONTROL AND INSTITUTIONAL MECHANISMS TO ENFORCE CONTROLS (O.R.C. § 6111.41 AND 6111.42); AND

- G. ADMINISTERING A STATE REVOLVING LOAN FUND PROGRAM TO PROVIDE FINANCIAL ASSISTANCE FOR PUBLICLY OWNED WASTEWATER TREATMENT FACILITIES (O.R.C. § 6111.03 AND 6121.03).

- II. COORDINATING, THROUGH THE LAKE ERIE COMMISSION, STATE AND LOCAL POLICIES AND PROGRAMS PERTAINING TO LAKE ERIE WATER QUALITY; REVIEWING, AND MAKING RECOMMENDATIONS CONCERNING, THE DEVELOPMENT AND IMPLEMENTATION OF POLICIES, PROGRAMS AND ISSUES FOR LONG-TERM, COMPREHENSIVE PROTECTION OF LAKE ERIE WATER RESOURCES AND WATER QUALITY THAT ARE CONSISTENT WITH THE GREAT LAKES WATER QUALITY AGREEMENT AND GREAT LAKES TOXIC SUBSTANCES CONTROL AGREEMENT (O.R.C. § 1506.21).

- III. USING THE LAKE ERIE PROTECTION FUND (LEPF) TO ESTABLISH A FIRM SCIENTIFIC BASE FOR IMPLEMENTING A BASINWIDE SYSTEM OF WATER QUALITY MANAGEMENT FOR LAKE ERIE AND ITS TRIBUTARIES; SUPPORTING RESEARCH TO IMPROVE THE SCIENTIFIC KNOWLEDGE ON WHICH LAKE ERIE AQUATIC RESOURCE PROTECTION POLICIES ARE BASED (O.R.C. § 1506.23).

POLICY 7 - ENVIRONMENTAL CONTAMINANTS: PREVENTION AND EMERGENCY RESPONSE

IT IS THE POLICY OF THE STATE OF OHIO TO PREVENT AND/OR MINIMIZE TO THE GREATEST EXTENT POSSIBLE, DAMAGES TO THE PUBLIC HEALTH, SAFETY AND WELFARE, AND TO THE ENVIRONMENT FROM CONTAMINANTS BY:

- A. REQUIRING OWNERS OF FACILITIES SUBJECT TO O.R.C. CHAPTER 3750, EMERGENCY PLANNING, TO COMPLY WITH THE STATE'S RIGHT TO KNOW AND SPILL PREVENTION LAWS; AND
- B. PROVIDING FOR EMERGENCY RESPONSE TO ALL SPILLS WITH A COORDINATED AND PLANNED EFFORT MAXIMIZING RESOURCES AND MINIMIZING ENVIRONMENTAL DAMAGE (O.R.C. CHAPTERS 6111 AND 3750).

POLICY 8 - NONPOINT SOURCE POLLUTION

IT IS THE POLICY OF THE STATE OF OHIO TO CONTROL NONPOINT SOURCE WATER POLLUTION IN ORDER TO REDUCE SEDIMENT, NUTRIENTS AND OTHER POLLUTANTS AND OTHERWISE IMPROVE THE WATER QUALITY OF LAKE ERIE AND ITS TRIBUTARIES, THUS REDUCING DAMAGE TO AQUATIC HABITATS AND LOWERING COSTS OF WATER TREATMENT AND CHANNEL DREDGING, BY USING A BROAD ARRAY OF STATE AND LOCAL AUTHORITIES TO REGULATE AND MANAGE THE CONTRIBUTING SOURCES AND ACTIVITIES.

POLICY 9 - POTABLE WATER SUPPLY

IT IS THE POLICY OF THE STATE OF OHIO TO ENSURE THAT A SAFE SUPPLY OF WATER IS AVAILABLE FOR PRIVATE, COMMUNITY, INDUSTRIAL, AGRICULTURAL AND COMMERCIAL USES ALONG LAKE ERIE BY:

- (4)
- A. ADMINISTERING THE STATE SAFE DRINKING WATER ACT (O.R.C. CHAPTER 6109);
 - B. SUPERVISING THE DESIGN, CONSTRUCTION, AND OPERATION OF PUBLIC WATER SUPPLY TREATMENT AND DISTRIBUTION SYSTEMS (O.R.C. § 6109.07); AND
 - C. REGULATING PRIVATE WATER SYSTEMS (O.R.C. § 3701.344, O.A.C. 3701-28).

POLICY 10 - AREA OF CONCERN REMEDIAL ACTION PLANS

IT IS THE POLICY OF THE STATE OF OHIO TO COORDINATE THE DEVELOPMENT AND IMPLEMENTATION OF REMEDIAL ACTION PLANS FOR OHIO'S FOUR LAKE ERIE BASIN AREAS OF CONCERN AS IDENTIFIED IN THE INTERNATIONAL JOINT COMMISSION'S (IJC) REPORTS ON GREAT LAKES WATER QUALITY.

POLICY 11 - GROUND WATER

IT IS THE POLICY OF THE STATE OF OHIO TO PROMOTE THE PROTECTION AND MANAGEMENT OF OHIO'S GROUND WATER RESOURCES BY:

- A. REGULATING ACTIVITIES AND ENFORCING RULES REGARDING THE CONSTRUCTION AND OPERATION OF WATER SUPPLY AND WASTE-WATER DISPOSAL SYSTEMS (O.R.C. § 3701.04, O.R.C. § 6111.03, O.R.C. § 6109.07, AND O.A.C. 3745-9);
- B. REGULATING UNDERGROUND HAZARDOUS AND PETROLEUM MATERIALS STORAGE FACILITIES AND ABOVE-GROUND HAZARDOUS WASTE STORAGE (O.R.C. § 3737.87, 3737.88, 3737.881, 3737.882 AND O.A.C. 1301:7-2 AND 3745-54);

- C. REGULATING OIL, GAS, COAL AND MINERAL OPERATIONS (O.R.C. CHAPTER 1509, 1513 AND 1514, O.R.C. § 1509.22);
- D. REGULATING SUBSURFACE INJECTION OF BRINE AND OTHER WASTES ASSOCIATED WITH OIL AND GAS OPERATIONS (O.R.C. § 1509.22);
- E. PREPARING GROUND WATER POLLUTION POTENTIAL MAPS; AND
- F. COORDINATING STATE ACTIVITIES REGARDING GROUND WATER ISSUES.

POLICY 12 - WETLANDS

IT IS THE POLICY OF THE STATE OF OHIO TO PROTECT, PRESERVE AND MANAGE WETLANDS WITH THE OVERALL GOAL TO RETAIN THE STATE'S REMAINING WETLANDS, AND, WHERE FEASIBLE, RESTORE AND CREATE WETLANDS TO INCREASE THE STATE'S WETLANDS RESOURCE BASE BY:

- A. REGULATING ACTIVITIES IN WETLANDS THROUGH THE ENFORCEMENT OF OHIO WATER QUALITY STANDARDS FOR ANY ACTIVITY THAT MAY RESULT IN ANY DISCHARGE INTO WETLANDS AND OTHER WATERS OF THE STATE (O.R.C. § 6111.03(O), O.R.C. § 6111.03(P), O.A.C. 3745-1 AND 3745-32);
- B. PROVIDING LEADERSHIP AND TAKING ACTION TO MINIMIZE ADVERSE EFFECTS TO WETLANDS IN CARRYING OUT STATE AGENCY RESPONSIBILITIES, AND, TO THE EXTENT PERMITTED BY LAW, AVOIDING UNDERTAKING CONSTRUCTION OR PROVIDING FINANCIAL ASSISTANCE FOR CONSTRUCTION THAT WILL SUBSTANTIALLY DEGRADE OR DESTROY THE NATURAL AND BENEFICIAL FUNCTIONS OF WETLANDS (GOVERNOR'S EXECUTIVE ORDER 90-68);
- C. ACQUIRING WETLANDS OR INTEREST IN WETLANDS AND THE BUFFER LANDS THAT MAY BE NEEDED FOR THEIR PROTECTION; RESTORING AND MANAGING PREVIOUSLY CONVERTED OR DEGRADED WETLANDS; AND PROVIDING ASSISTANCE TO PRIVATE OWNERS FOR WETLANDS RESTORATION AND MANAGEMENT;
- D. COOPERATING WITH THE OLD WOMAN CREEK NATIONAL ESTUARINE RESEARCH RESERVE, THE OHIO SEA GRANT COLLEGE PROGRAM AND OTHER INSTITUTIONS IN EDUCATION AND RESEARCH. THE STATE WILL ENCOURAGE WETLANDS RESEARCH AND PRIORITIZE FUNDING ASSISTANCE FOR RESEARCH THAT ENHANCES COASTAL MANAGEMENT; AND
- E. PROVIDING INFORMATION ON WETLANDS RESOURCES AND TECHNICAL ASSISTANCE TO ORGANIZATIONS AND INDIVIDUALS REQUESTING HELP IN WETLANDS CONSERVATION PROJECTS.

POLICY 13 - NATURAL AREAS AND FEATURES

IT IS THE POLICY OF THE STATE OF OHIO TO PRESERVE SIGNIFICANT NATURAL AREAS AND OTHER OUTSTANDING FEATURES OF OHIO'S NATURAL HERITAGE BY:

- A. ACQUIRING, DEDICATING AND MANAGING STATE NATURE PRESERVES (O.R.C. § 1517.05, 1517.06);
- B. MANAGING THE STATE'S NATIONAL ESTUARINE RESEARCH RESERVE PROGRAM;
- C. CREATING AND MAINTAINING WILD, SCENIC AND RECREATIONAL RIVERS (O.R.C. § 1517.14 THROUGH § 1517.18);
- D. MAINTAINING AN UP-TO-DATE INVENTORY OF NATURAL AREAS AND OTHER NATURAL FEATURES AND ENCOURAGING THEIR PRESERVATION THROUGH PRIVATE ORGANIZATION PROTECTION EFFORTS AND LOCAL GOVERNMENT REGULATION; AND
- E. RECOGNIZING AS NATURAL LANDMARKS PRIVATELY OWNED NATURAL AREAS NOT SCHEDULED FOR ACQUISITION.

POLICY 14 - RARE AND ENDANGERED SPECIES

IT IS THE POLICY OF THE STATE OF OHIO TO PRESERVE AND PROTECT RARE, THREATENED AND ENDANGERED PLANT AND ANIMAL SPECIES TO PREVENT THEIR POSSIBLE EXTINCTION BY:

- A. RESTRICTING THE TAKING OR POSSESSION OF NATIVE ANIMAL SPECIES, OR THEIR EGGS OR OFFSPRING, THAT ARE THREATENED WITH STATEWIDE EXTINCTION (O.R.C. § 1531.25 AND O.R.C. § 1531.99);
- B. REGULATING THE TAKING, POSSESSION, REMOVAL, TRANSPORTATION OR SALE OF NATIVE PLANT SPECIES LISTED AS ENDANGERED OR THREATENED WITH EXTIRPATION (O.R.C. 1518.03); AND
- C. PROTECTING THE WATERS THAT PROVIDE A HABITAT FOR RARE AND ENDANGERED SPECIES (O.R.C. 6111.03(O), O.R.C. § 6111.03(R), O.A.C. 3745-1-05(C)).

POLICY 15 - EXOTIC SPECIES

IT IS THE POLICY OF THE STATE OF OHIO TO PREVENT INTRODUCTION OF AND CONTROL EXOTIC SPECIES TO PRESERVE THE BALANCE AND DIVERSITY OF NATURAL ECOSYSTEMS OF OHIO'S LAKE ERIE REGION BY:

- A. REGULATING THE SALE AND PROPAGATION OF PURPLE LOOSESTRIFE (O.R.C. § 927.682);
- B. REGULATING THE IMPORTATION, SALE AND POSSESSION FOR PURPOSES OF INTRODUCTION INTO WATERWAYS OF EXOTIC SPECIES OF FISH OR HYBRIDS THEREOF (O.A.C. 1501:31-19-01);
- C. ESTABLISHING AND IMPLEMENTING CONTROL MEASURES FOR NON-NATIVE FLORA AS PART OF MANAGEMENT PLANS FOR ODNR-MANAGED PRESERVES AND WILDLIFE AREAS;
- D. INFORMING THE PUBLIC REGARDING PROPER PROCEDURES TO PREVENT FURTHER SPREAD OF ZEBRA MUSSELS;
- E. CONDUCTING AND SUPPORTING SCIENTIFIC RESEARCH TO ASSIST IN UNDERSTANDING THE EFFECTS OF ZEBRA MUSSELS AND CARP UPON THE LAKE'S ECOLOGY AND TO ASSESS A VARIETY OF MEANS TO CONTROL THE SPECIES; AND
- F. PARTICIPATING ON THE GREAT LAKES PANEL ON AQUATIC NUISANCE SPECIES AND CONDUCTING OTHER ACTIVITIES TO SUPPORT AND MAINTAIN CONSISTENCY WITH THE PURPOSES OF THE NONINDIGENOUS AQUATIC NUISANCE SPECIES PREVENTION AND CONTROL ACT OF 1990.

POLICY 16 - PUBLIC TRUST LANDS

IT IS THE POLICY OF THE STATE OF OHIO TO PROTECT THE PUBLIC TRUST HELD WATERS AND LANDS UNDERLYING THE WATERS OF LAKE ERIE, PROTECT PUBLIC USES OF LAKE ERIE AND MINIMIZE THE OCCUPATION OF PUBLIC TRUST LANDS FOR PRIVATE BENEFIT BY:

- A. REGULATING OFFSHORE DEVELOPMENT AND IMPROVEMENT PROJECTS BY REQUIRING A LEASE FOR THE USE OF SUBMERGED LANDS (O.R.C. § 1506.10 AND 1506.11 AND O.A.C. 1501-6-01 THROUGH 1501-6-06);
- B. REGULATING RECOVERY OF SUBMERGED ABANDONED PROPERTY THROUGH PERMITS (O.R.C. § 1506.32); AND
- C. ESTABLISHING AND ENFORCING LAKE ERIE SUBMERGED LANDS PRESERVES (O.R.C. § 1506.31).

POLICY 17 - DREDGING AND DREDGED MATERIAL DISPOSAL

IT IS THE POLICY OF THE STATE OF OHIO TO PROVIDE FOR THE DREDGING OF HARBORS, RIVER CHANNELS AND OTHER WATERWAYS AND TO PROTECT THE WATER QUALITY, PUBLIC RIGHT TO NAVIGATION, RECREATION AND NATURAL RESOURCES ASSOCIATED WITH THESE WATERS IN THE DISPOSAL OF THE DREDGED MATERIAL BY:

- (6)
- A. REGULATING, THROUGH THE OHIO ENVIRONMENTAL PROTECTION AGENCY WATER QUALITY CERTIFICATION, THE DISCHARGE OR DISPOSAL OF DREDGED MATERIAL (O.R.C. § 6111.03(P) AND O.A.C. 3745-1);
 - B. REQUIRING A LEASE FOR STATE-ADMINISTERED SUBMERGED LANDS THROUGH THE DEPARTMENT OF NATURAL RESOURCES BEFORE INITIATING THE CONFINED DISPOSAL OF DREDGED MATERIAL IN THE WATERS OR ON LANDS UNDERLYING THE WATERS OF LAKE ERIE (O.R.C. § 1506.11);
 - C. REGULATING COMMERCIAL DREDGING OF MINERAL RESOURCES (O.R.C. § 1505.07 AND O.R.C. § 1505.99); AND
 - D. COORDINATING INTERDISCIPLINARY REVIEWS OF DREDGING PROJECTS AT OHIO'S LAKE ERIE PORTS AND PROVIDING TECHNICAL AND FUNDING ASSISTANCE TO HELP SELECT AND IMPLEMENT ENVIRONMENTALLY SOUND DREDGING AND DREDGED SEDIMENT MANAGEMENT PRACTICES.

POLICY 18 - LOCAL LAKESHORE DEVELOPMENT

IT IS THE POLICY OF THE STATE OF OHIO TO ENCOURAGE LOCAL GOVERNMENTS TO PLAN FOR AND CONTROL SHORE DEVELOPMENT TO PROVIDE FOR THE WISE USE OF THE SHORE AND COASTAL RESOURCES BY:

- A. PROVIDING PLANNING AND MANAGEMENT ASSISTANCE FOR THE DEVELOPMENT AND IMPLEMENTATION OF COMPREHENSIVE SHORE MASTER PLANS;
- B. COLLECTING, ANALYZING AND PUBLISHING RESOURCE DATA THROUGH THE OHIO DEPARTMENT OF NATURAL RESOURCES, OHIO CAPABILITY ANALYSIS PROGRAM, FOR USE BY LOCAL GOVERNMENTS IN THEIR PLANNING AND DECISION-MAKING PROCESSES; AND
- C. ASSISTING LOCAL GOVERNMENTS TO PREPARE ORDINANCES AND RESOLUTIONS NECESSARY TO EFFECTIVELY ADMINISTER THESE PLANS.

POLICY 19 - LAKE ERIE PORTS

IT IS THE POLICY OF THE STATE OF OHIO TO PROMOTE AND PROVIDE FOR MARITIME COMMERCE AND RELATED ECONOMIC DEVELOPMENT ALONG THE LAKE ERIE SHORE BY:

- A. PROVIDING ASSISTANCE TO, AND ASSISTING IN THE PROCUREMENT OF FEDERAL FUNDS FOR PORT DEVELOPMENT ACTIVITIES FOR, LOCAL GOVERNMENTS AND PORT AUTHORITIES THAT HAVE THE POWERS TO PLAN, IMPROVE, ACQUIRE, ENLARGE, OPERATE, MAINTAIN AND FINANCE PORT ACTIVITIES AND PROJECTS; AND
- B. ENCOURAGING THE DEVELOPMENT OF COMPREHENSIVE PORT FACILITY AND EXPANSION MASTER PLANS AND IMPROVEMENT PROJECTS THROUGH FINANCIAL ASSISTANCE FROM THE OHIO DEPARTMENT OF TRANSPORTATION.

POLICY 20 - TRANSPORTATION FACILITIES

IT IS THE POLICY OF THE STATE OF OHIO TO INCORPORATE COASTAL CONCERNS AND RESOURCE PROTECTION INTO COASTAL TRANSPORTATION PLANNING THROUGH COORDINATION WITH THE OHIO DEPARTMENT OF TRANSPORTATION, REGIONAL TRANSPORTATION AGENCIES AND LOCAL MUNICIPALITIES.

POLICY 21 - LAKESHORE RECREATION AND ACCESS

IT IS THE POLICY OF THE STATE OF OHIO TO PROVIDE LAKESHORE RECREATIONAL OPPORTUNITIES AND PUBLIC ACCESS AND ENCOURAGE TOURISM ALONG LAKE ERIE BY:

- A. PROVIDING FOR PUBLIC ACCESS TO COASTAL AREAS WITHIN THE STATE NATURE PRESERVE SYSTEM THROUGH ARTICLES OF DEDICATION WHEREVER POSSIBLE AND CONSISTENT WITH PRESERVATION AND PROTECTION OF THE LAND (O.R.C. § 1517.05);
- B. PROTECTING PUBLIC ACCESS RIGHTS TO LAKE ERIE WATERS AND SHORELINE AREAS WHERE COMPATIBLE WITH EXISTING AND PLANNED USES OF WATERFRONT AREAS THROUGH THE LAKE ERIE SUBMERGED LANDS LEASING PROGRAM (O.R.C. § 1506.11 AND O.A.C. 1506-6-01 THROUGH 1501-6-06);
- C. DEVELOPING AND MAINTAINING SHOREFRONT STATE PARKS (O.R.C. CHAPTER 1541);

POLICY 23 – RECREATIONAL BOATING

IT IS THE POLICY OF THE STATE OF OHIO TO SATISFY AND SERVE THE PUBLIC INTEREST FOR RECREATIONAL BOATING OPPORTUNITIES AND WATERCRAFT SAFETY IN THE COASTAL AREA BY:

- (7)
- D. PROVIDING FOR COMPREHENSIVE ASSESSMENT OF RECREATIONAL NEEDS AND PLANNING FOR FACILITIES TO MEET THOSE NEEDS THROUGH THE STATEWIDE COMPREHENSIVE OUTDOOR RECREATION PLAN (SCORP) AND LAKE ERIE ACCESS PROGRAM (LEAP);
 - E. ASSISTING LOCAL GOVERNMENTS TO DEVELOP LAKESHORE AND URBAN WATERFRONT RECREATIONAL AREAS BY PROVIDING FINANCIAL AND TECHNICAL ASSISTANCE;
 - F. PROVIDING FOR RECREATIONAL OPPORTUNITIES SUCH AS HIKING, BIRD WATCHING AND INTERPRETIVE SERVICES AT STATE PARKS, WILDLIFE AREAS AND NATURE PRESERVES AND ENCOURAGING LOCAL GOVERNMENTS AND OTHER AGENCIES TO PROVIDE GREATER ACCESS TO THE SHORE OF LAKE ERIE; AND
 - G. ENCOURAGING THE INCORPORATION OF PUBLIC ACCESS AND APPLICABLE RECREATIONAL OPPORTUNITIES INTO THE PLANNING OF PRIVATE DEVELOPMENTS AND PUBLIC INSTITUTIONS LOCATING ALONG THE SHORE OR RIVERS IN THE COASTAL AREA.

POLICY 22 – LAKE ERIE BEACHES AND PUBLIC BATHING

IT IS THE POLICY OF THE STATE OF OHIO TO PROVIDE PUBLIC BEACH ACCESS AND SAFE PUBLIC BATHING AREAS ALONG LAKE ERIE BY:

- A. DEVELOPING AND MAINTAINING BEACHES AND BATHING AREAS ON STATE-OWNED LAND;
- B. PARTICIPATING JOINTLY WITH THE U.S. ARMY CORPS OF ENGINEERS, SHORELINE PROPERTY OWNERS AND LOCAL LAKESHORE GOVERNMENTS IN BEACH AND LITTORAL NOURISHMENT PROJECTS;
- C. PROVIDING FOR CONTINUING STUDY OF BATHING BEACH WATER QUALITY ALONG THE LAKE ERIE SHORE AND ADVISING APPROPRIATE AUTHORITIES OF WATER TEST RESULTS WITHIN THEIR RESPECTIVE JURISDICTIONS; AND
- D. ENCOURAGING LOCAL AUTHORITIES TO ESTABLISH BEACH SAMPLING AND SANITATION PROGRAMS.

POLICY 24– FISHING AND HUNTING

IT IS THE POLICY OF THE STATE OF OHIO TO PROVIDE EXPANDED SPORT FISHING AND SAFE HUNTING OPPORTUNITIES IN THE COASTAL AREA BY:

- A. REQUIRING LICENSURE FOR HUNTING, TRAPPING AND FISHING (O.R.C. § 1533.10, 1533.111 AND 1533.32);
- B. REQUIRING COMPLETION OF THE OHIO DEPARTMENT OF NATURAL RESOURCES HUNTER SAFETY AND TRAPPER EDUCATION COURSES FOR FIRST-TIME LICENSE BUYERS BEFORE ISSUING A HUNTING LICENSE OR TRAPPING PERMIT (O.R.C. § 1533.10 AND 1533.111);
- C. ACQUIRING AND DEVELOPING AND ASSISTING LOCAL GOVERNMENTS IN DEVELOPING FISHING ACCESS AREAS;
- D. ESTABLISHING AND MAINTAINING WILDLIFE AREAS AND WETLANDS, AND EXPANDING THE USE OF OTHER STATE-OWNED LANDS FOR THE REGULATED TAKING OF WILDLIFE; AND
- E. ENCOURAGING PRIVATE LANDOWNERS TO ALLOW FISHING AND HUNTING ON THEIR LAND UNDER THE OHIO WILDLIFE COOPERATIVE FISHING AND HUNTING PROGRAM.

POLICY 25 - SURPLUS PUBLIC PROPERTY

IT IS THE POLICY OF THE STATE OF OHIO TO, WHEREVER APPROPRIATE, RETAIN SURPLUS STATE LAKESHORE PROPERTY IN PUBLIC OWNERSHIP AND TO OBTAIN FEDERAL LAKESHORE PROPERTY TO USE OR REDEVELOP SUCH AREAS FOR OTHER PUBLIC SHORELINE ACCESS AND PUBLIC PURPOSES.

POLICY 26 - PRESERVATION OF CULTURAL RESOURCES

IT IS THE POLICY OF THE STATE OF OHIO TO PROVIDE FOR THE PRESERVATION OF CULTURAL RESOURCES TO ENSURE THAT THE KNOWLEDGE OF OHIO'S HISTORY AND PRE-HISTORY IS MADE AVAILABLE TO THE PUBLIC AND IS NOT WILLFULLY OR UNNECESSARILY DESTROYED OR LOST, BY:

- A. PROTECTION OF CULTURAL RESOURCES ON OR ELIGIBLE FOR STATE AND NATIONAL REGISTERS OF HISTORIC PLACES (O.R.C. § 149.51 THROUGH 149.55);
- B. REGULATING RECOVERY OF SUBMERGED ABANDONED PROPERTY THROUGH PERMITS (O.R.C. § 1506.32); AND
- C. ESTABLISHING AND ENFORCING LAKE ERIE SUBMERGED LANDS PRESERVES (O.R.C. § 1506.31).

POLICY 27 - FISHERIES MANAGEMENT

IT IS THE POLICY OF THE STATE OF OHIO TO ASSURE THE CONTINUAL ENJOYMENT OF THE BENEFITS RECEIVED FROM THE FISHERIES OF LAKE ERIE AND TO MAINTAIN AND IMPROVE THESE FISHERIES BY:

- A. REGULATING THE TAKING OF FISH (O.R.C. § 1531.08 AND O.A.C. 1501:31);
- B. PROSECUTING PERSONS RESPONSIBLE FOR STREAM LITTER AND FOR WATER POLLUTION RESULTING IN FISH KILLS (O.R.C. § 1531.29 AND 1531.02);
- C. PROTECTING FISH HABITAT THROUGH OHIO EPA'S SECTION 401 WATER QUALITY CERTIFICATION AUTHORITY (O.R.C. § 6111.03(O) AND 6111.03(P) AND O.A.C. 3745-1 AND 3745-32);
- D. CONSIDERING THE PROTECTION OF FISH HABITAT THROUGH THE REVIEW OF STATE AND FEDERAL PERMIT APPLICATIONS;
- E. ESTABLISHING STATE WILDLIFE AREAS FOR FISH AND WILDLIFE HABITAT (O.R.C. § 1531.06);
- F. SURVEYING FISH POPULATIONS AND TRENDS AND CONDUCTING OTHER FISHERY RESEARCH STUDIES;

G. PROVIDING ACCESS TO THE FISHERY; AND

H. PROVIDING TECHNICAL AND GENERAL INFORMATION ABOUT THE LAKE ERIE FISHERIES.

POLICY 28 - FISHERIES RESEARCH AND INTERSTATE COOPERATION

IT IS THE POLICY OF THE STATE OF OHIO TO COOPERATE IN GREAT LAKES BASINWIDE FISHERIES MANAGEMENT EFFORTS AND TO CONTINUALLY RESEARCH BETTER FISHERIES USE AND MANAGEMENT.

POLICY 29 - WILDLIFE MANAGEMENT

IT IS THE POLICY OF THE STATE OF OHIO TO PROVIDE FOR THE MANAGEMENT OF WILDLIFE IN THE COASTAL AREA TO ASSURE THE CONTINUED ENJOYMENT OF BENEFITS RECEIVED FROM WILDLIFE BY:

- A. PROTECTING ALL WILDLIFE INCLUDING NONGAME AND ENDANGERED SPECIES (O.R.C. § 1531.02, 1531.08 AND 1531.25);
- B. REGULATING THE TAKING OF WILDLIFE (O.R.C. CHAPTER 1533 AND O.A.C. 1501:31);
- C. ESTABLISHING STATE WILDLIFE AREAS AND PROVIDING RECREATION OPPORTUNITIES;
- D. PROVIDING FOOD, COVER AND HABITAT FOR WILDLIFE, AND
- E. PROVIDING NONGAME WILDLIFE RESEARCH AND EDUCATION FUNDING.

POLICY 30 - AIR QUALITY

IT IS THE POLICY OF THE STATE OF OHIO TO ATTAIN AND MAINTAIN AIR QUALITY LEVELS THAT PROTECT PUBLIC HEALTH AND PREVENT INJURY TO PLANT AND ANIMAL LIFE AND PROPERTY BY SURVEYING AND MONITORING AIR QUALITY; ENFORCING NATIONAL AMBIENT AIR QUALITY STANDARDS THROUGH PERMITS AND VARIANCES; AND RESTRICTING OPEN BURNING. (O.R.C. CHAPTERS 3745, 3706 AND 5709).

POLICY 31 – HAZARDOUS, SOLID AND INFECTIOUS WASTE MANAGEMENT

IT IS THE POLICY OF THE STATE OF OHIO TO ENSURE THAT THE GENERATION OF SOLID, INFECTIOUS AND HAZARDOUS WASTES IS REDUCED AS MUCH AS POSSIBLE BY:

- (6)
- A. ADMINISTERING A PERMIT PROGRAM FOR THE SITING OF NEW FACILITIES AND THE MODIFICATION, REVISION AND OPERATION OF EXISTING FACILITIES (O.R.C. CHAPTER 3734);
 - B. COMPLIANCE MONITORING AND ENFORCEMENT OF REQUIREMENTS OF O.R.C. CHAPTER 3734, DEVELOPED PURSUANT TO AND IN ACCORDANCE WITH PROVISIONS OF THE FEDERAL RESOURCE CONSERVATION AND RECOVERY ACT (RCRA) AND THE FEDERAL COMPREHENSIVE ENVIRONMENTAL RESPONSE, COMPENSATION AND LIABILITY ACT (CERCLA) (O.A.C. 3745-50 THROUGH 58 AND 3745-65 THROUGH 69);
 - C. ESTABLISHING LONG-RANGE SOLID AND HAZARDOUS WASTE MANAGEMENT PLANS (O.R.C. § 3734); AND
 - D. ENCOURAGING THE ADOPTION OF POLLUTION PREVENTION PRACTICES THAT EMPHASIZE A PREFERENCE FOR SOURCE REDUCTION AND ENVIRONMENTALLY SOUND RECYCLING OVER TREATMENT AND DISPOSAL.

POLICY 32 – MARINA FACILITIES

IT IS THE POLICY OF THE STATE OF OHIO TO REGULATE MARINA CONSTRUCTION THROUGH THE OHIO DEPARTMENT OF HEALTH AND LOCAL HEALTH DEPARTMENTS IN ORDER TO ASSURE THAT MARINAS WILL PROVIDE ADEQUATE SANITARY FACILITIES FOR THE WATERCRAFT USING THE MARINA, AND THAT SUCH MARINAS WILL BE CONSTRUCTED, LOCATED, MAINTAINED, AND OPERATED IN A SANITARY MANNER SO AS NOT TO CREATE A NUISANCE OR CAUSE A HEALTH HAZARD (O.R.C. § 3733.21 THROUGH 3733.30 AND O.A.C. 3701-35).

POLICY 33 – VISUAL AND AESTHETIC QUALITY

IT IS THE POLICY OF THE STATE OF OHIO TO PROTECT THE VISUAL AND AESTHETIC AMENITIES OF LAKE ERIE AND ITS SHORELINE TO ENHANCE THE RECREATIONAL, ECONOMIC, CULTURAL AND ENVIRONMENTAL VALUES INHERENTLY ASSOCIATED WITH THE COASTAL AREA BY:

- A. PROHIBITING THE DUMPING OF LITTER AND REFUSE INTO OR ALONG THE WATERS OF LAKE ERIE AND ITS TRIBUTARIES, AND MAINTAINING LAW ENFORCEMENT ACTIVITIES TO APPREHEND VIOLATORS (O.R.C. § 1531.29 AND 3767.32);
- B. ENFORCING STATE WATER QUALITY STANDARDS (O.R.C. CHAPTER 6111, O.A.C. 3745-1-04); AND
- C. PRESERVING AESTHETIC RESOURCE AREAS OF STATEWIDE SIGNIFI-

POLICY 34 – ENERGY FACILITY SITING

IT IS THE POLICY OF THE STATE OF OHIO TO PROVIDE FOR ENVIRONMENTALLY SOUND SITING OF MAJOR ELECTRIC ENERGY GENERATING AND TRANSMISSION FACILITIES IN THE COASTAL AREA, AND TO REGULATE THE SITING OF THESE FACILITIES TO PROTECT THE HEALTH, SAFETY, AND WELFARE OF OHIO'S CITIZENS AND THE NATURAL RESOURCES OF THE STATE BY:

- A. REQUIRING CERTIFICATION OF ANY MAJOR UTILITY FACILITY THROUGH THE OHIO POWER SITING BOARD IN A PROCESS WHICH ENSURES PUBLIC PARTICIPATION (O.R.C. CHAPTER 4906 AND O.A.C. 4906) AND
- B. REQUIRING 10-YEAR DEMAND, RESOURCE AND SITE INVENTORY FORECASTS FOR ALL ENERGY GENERATION AND TRANSMISSION ACTIVITY IN THE STATE (O.R.C. § 4935.04).

POLICY 35 – ENERGY RESOURCE STORAGE AND TRANSHIPMENT

IT IS THE POLICY OF THE STATE OF OHIO TO REGULATE THE STORAGE OF ENERGY RELATED RESOURCES (COAL, OIL AND GAS) IN THE COASTAL AREA THROUGH PLANNING ASSISTANCE AND PERMIT REVIEW TO ASSURE THE SAFE AND EFFICIENT USE OF THESE RESOURCES; AND TO ENSURE THAT AIR, WATER AND OTHER ENVIRONMENTAL STANDARDS ARE MET (O.R.C. § 4906.06 AND O.A.C. 4906-13-02).

POLICY 36 – OIL AND NATURAL GAS DRILLING

IT IS THE POLICY OF THE STATE OF OHIO TO PROTECT PUBLIC SAFETY AND WELFARE AND THE ENVIRONMENT AND TO ASSURE WISE MANAGEMENT BY:

- A: REGULATING OIL AND GAS DRILLING ONSHORE BY REQUIRING A PERMIT TO DRILL FROM ODNR (O.R.C. § 1509.05); AND
- B. DISCOURAGING OFFSHORE OIL AND NATURAL GAS DRILLING IN OHIO WATERS OF LAKE ERIE.

POLICY 37 – OFFSHORE MINERAL EXTRACTION

IT IS THE POLICY OF THE STATE OF OHIO TO PROVIDE FOR AND REGULATE THE EXTRACTION OF MINERALS AND OTHER SUBSTANCES FROM AND FROM UNDER THE BED OF LAKE ERIE, THROUGH THE ISSUANCE OF OHIO DEPARTMENT OF NATURAL RESOURCES MINERAL LEASES AND PERMITS, TO PROTECT THE PUBLIC SAFETY AND WELFARE, AND TO MINIMIZE ADVERSE ENVIRONMENTAL IMPACTS (O.R.C. § 1505.07).

POLICY 38 - SURFACE MINING

IT IS THE POLICY OF THE STATE OF OHIO TO REGULATE SURFACE MINING ACTIVITIES TO MINIMIZE ADVERSE ENVIRONMENTAL IMPACTS, PREVENT DAMAGE TO ADJOINING PROPERTY, AND ENSURE RECLAMATION OF ALL AFFECTED AREAS THROUGH THE ISSUANCE OF OHIO DEPARTMENT OF NATURAL RESOURCES PERMITS (O.R.C. § 1514.02 AND O.R.C. § 1514.021.

POLICY 39 - WATER DIVERSION

IT IS THE POLICY OF THE STATE OF OHIO TO MANAGE DIVERSION OF LAKE ERIE AND TRIBUTARY WATERS BY:

- A. REGULATING WATER DIVERSIONS OF LAKE ERIE BASIN WATERS THROUGH THE OHIO DEPARTMENT OF NATURAL RESOURCES PERMIT PROCESS (O.R.C. § 1501.30 THROUGH 1501.32);
- B. OBTAINING THE PERMISSION OF THE GREAT LAKES STATES' GOVERNORS PRIOR TO APPROVING PERMITS FOR DIVERSIONS OF LAKE ERIE WATERS (O.R.C. § 1501.32); AND
- C. REVIEWING ALL NEW DIVERSIONS OUT OF THE GREAT LAKES BASIN AND ANY PROPOSED FEDERAL STUDIES THAT WOULD INVOLVE DIVERSIONS OUT OF THE GREAT LAKES BASIN.

POLICY 40 - LAKE ERIE WATER LEVELS

IT IS THE POLICY OF THE STATE OF OHIO TO PROMOTE THE DEVELOPMENT AND IMPLEMENTATION OF A LAKE LEVELS MANAGEMENT PLAN AGREEABLE TO THE UNITED STATES AND CANADA CONCERNING THE WATER LEVELS OF LAKE ERIE AND THE GREAT LAKES.

POLICY 41 - WATER MANAGEMENT

IT IS THE POLICY OF THE STATE OF OHIO TO COLLECT AND ANALYZE WATER RESOURCES INFORMATION TO PROMOTE WATER RESOURCES PLANNING AND MANAGEMENT BY:

- A. REQUIRING LARGE WATER WITHDRAWAL FACILITIES TO REGISTER THEIR CAPACITY AND SUBMIT ANNUAL WITHDRAWAL REPORTS (O.R.C. § 1521.16);
- B. PREPARING WATER SUPPLY PLANS;
- C. PREPARING A LONG-TERM WATER RESOURCES PLAN FOR THE LAKE ERIE DRAINAGE BASIN;

- D. REQUIRING THE FILING OF WELL LOGS AND WELL-SEALING REPORTS (O.R.C. § 1521.05);
- E. PREPARING TECHNICAL STUDIES AND MAPPING, DESIGNATING GROUND WATER STRESS AREAS, AND ASSISTING IN CONFLICT RESOLUTION (O.R.C. § 1521.03(E) AND 1521.16(B)); AND
- F. PARTICIPATING WITH THE OTHER GREAT LAKES STATES AND PROVINCES IN COOPERATIVE PROGRAMS AND MANAGEMENT OF GREAT LAKES BASIN WATER RESOURCES.



1123 Bridge Street
Ashtabula, Ohio 44004
(216) 964-0277 Office
(216) 964-5158 Fax

John Mahan, Ph.D
Coordinator

Rick Brewer
Co-Chairman
Coordinating Committee

Fred Leitert
Co-Chairman
Coordinating Committee

Steve Golyski
Chairman
Project Committee

Rick Mason
Chairman
Siting Committee

Brett Kaull
Chairman
Resource Committee

Michelle Rowley
Chairperson
Outreach Committee

Ashtabula River and Harbor

Comprehensive Management Plan

Dredging and Disposal

FINAL

FEASIBILITY REPORT AND

ENVIRONMENTAL IMPACT STATEMENT

ENVIRONMENTAL APPENDIX

EA-H CULTURAL RESOURCES ASSESSMENT

City of Ashtabula
Town of Ashtabula
County of Ashtabula
State of Ohio

2001

ASHTABULA RIVER AND HARBOR DREDGING AND DISPOSAL ASHTABULA COUNTY, OHIO

CULTURAL RESOURCES ASSESSMENT

THE PROJECT

Ashtabula Harbor is located at the mouth of the Ashtabula River on the south shore of Lake Erie, Ashtabula County, Ohio. It is a significant Great Lakes and St. Lawrence Seaway harbor. The Harbor, including the lower Ashtabula River, includes both commercial and recreational developments. Commodities, such as limestone, iron and other ores, coal and other bulk commodities, pig iron, iron products, raw rubber, and general cargo, transit the harbor. Several marina developments docking hundreds of recreational vessels are situated along the lower river and harbor. The population for the city of Ashtabula and the county of Ashtabula were about 21,633 and 99,821, respectively, in 1990. Reference Figures 1 and 2.

The Ashtabula River Partnership (ARP) has investigated problems and needs pertaining to contaminated sediments and disturbed habitat in the Lower Ashtabula River. These conditions have resulted in restricted operations and maintenance dredging and disposal of dredged material and have limited full environmental, economic, and social use and development of the harbor. In addition to considering the No (ARP) Action (Without Project Conditions) alternative, the Ashtabula River Partnership considered a wide array of Plans and Component Alternatives pertaining to Dredging, Habitat Restoration, Transfer/Dewatering/Transfer, Transportation, and Disposal. Plans and Component Alternatives were assessed/evaluated for engineering and economic feasibility, environmental and social acceptability, and/or for best meeting the project planning objectives. The recommended plan involves: 1) deep dredging (environmentally/low turbidity) of approximately 696,000 cubic yards (in situ) of contaminated sediments (150,000 cubic yards of which is significantly PCB contaminated and would (for planning estimates) be handled and disposed of in accordance with Toxic Substance Control Act (TSCA) guidelines); 2) developing and utilizing a transfer/dewatering/transfer facility in the harbor area (1993 Interim Disposal Site); 3) trucking the dewatered dredged material to a developed upland disposal site (State Road Site); and, 4) disposing of the material, as appropriate, in developed TSCA and Non-TSCA disposal facilities. The facilities would also include leachate collection, treatment, and monitoring facilities, and closure, and post closure monitoring measures. The project also recommends restoration (by separate authority) of several acres of aquatic/fishery shallows areas and associated shoreline. Approximately, 150,000 cubic yards of operations and maintenance dredged material and/or shoreline excavated material would be discharged in the initially dredged area in order to provide an immediate clean cover and to expedite ecological recovery. Environmental protection measures have been incorporated into the project planning and will be further incorporated into project design, construction, operation, and maintenance plans to meet Federal, State, and local regulations.

REQUIRED COORDINATION AND COMPLIANCE

Preservation of Historical Archaeological Data Act of 1974, 16 USC et seq.; National Historic Preservation Act of 1966 as amended, 16 USC 470 et seq.; Executive Order 11593, Protection and Enhancement of the Cultural Environment, 13 May 1971. Project coordination was and is being conducted with the U.S. Department of the Interior - National Park Service, and the Ohio State Historic Preservation Office in this regard.

In response to project scoping letters, the Ohio State Historic Preservation Office indicated that, based on a brief check of cultural resource records, aquatic and terrestrial sites in the Ashtabula area may be archaeologically or historically sensitive and that an archaeological survey should be conducted for sites finally considered.

Reference the following, also.

GENERAL BACKGROUND INFORMATION

Large conical mounds in which human skeletons have been found and evidences of burial grounds were discovered many years ago along the banks of the Ashtabula River several miles from Lake Erie. These mounds have long since been destroyed. The vicinity location of these archaeological sites is shown on Figure 3.

The Indian tribe native to Ohio was the Erie, who occupied the south shore of Lake Erie in northeastern Ohio, including portions of the current study area. The Erie Indian tribe resided in the Ashtabula area until 1656, when they were driven out by the invading Iroquois Confederacy. Following the Iroquoian conquest, this area remained a virtual "no man's land" for over 50 years. The first western explorer to settle the area was Moses Cleaveland, hired by the Connecticut Land Company to survey parts of Ohio and clear Indian claims. Cleaveland's explorations took him through much of Ohio, with various members of his party occasionally staying behind to settle areas, such as Conneaut and Ashtabula, in 1796. Ashtabula Township was organized in 1808. Lands west of the river were organized as the Borough of Ashtabula in 1831. Growth continued over the years, spurred by the introduction of the railroads which stimulated the fishing industry, as well as other businesses.

In 1887, a 150-foot schooner, the JOY, sank off Ashtabula, carrying millstones and ore. Currently, many large sections of this vessel are lying on the bottom in about 15 feet of water, approximately 100 feet southeast of the east end of the east breakwater at Ashtabula Harbor. The vicinity of this sunken vessel is shown on Figure 3.

National Register Property listed on the National Register of Historic Places include the Ashtabula Harbor Light(s) (U.S. Coast Guard Lighthouses and Light Stations on the Great Lakes) located on the harbor breakwaters, and the Colonel William Hubbard House, on the northwest corner of Lake Avenue and Walnut Boulevard in Ashtabula. The Ashtabula Harbor Light, 51

feet above the water, is shown from a white cylindrical tower on a white square house near the outer end of the west breakwater. The Colonel William Hubbard House, now a community house, was formerly the best known of Ashtabula's Underground Railroad Stations. The location of these properties is shown on Figure 3.

SITE INVESTIGATIONS SUMMARY

Navigation Channels

The project area river channels have been previously significantly disturbed by channel dredging. No significant cultural resource items would be expected to be located in these areas. Reference Figures 1 and 2.

Lake Sites

A cultural resources survey was conducted in 1992 for potential CDF sites (D, E, and P). Findings were coordinated with the Ohio State Historic Preservation Office (SHPO). No significant cultural resource items were identified at sites (D or P). A potential cultural resource item was identified within site E that could be disturbed by use of the site and could require mitigation procedures prior to use of the site, if the site were selected. Additional investigation would be required to determine significance. Reference Figure 2.

Transfer Site

1993 Interim Disposal Site. The site is currently owned by Conrail. In 1993, a special cooperative interim dredging and dredged material disposal project took place in the upper federal and local navigation channel of the lower Ashtabula River, in order to facilitate area commercial and recreational boating needs. Approximately 23,500 cubic yards of sediments were dredged and disposed of into a small reconditioned shoreline upland dewatering and confined disposal facility. The site is currently covered with grass/legume vegetation. Reference Figure 3.6 and Figure 3.9, See a.

The Conrail site has previously been utilized for disposal of dredged material and was utilized for rehabilitation of dikes and disposal of interim dredged material in 1993. No significant cultural resource items would be expected to be located in these areas. Reference Figures 1 and 2.

Upland Disposal Sites

Previous coordination for similar projects in this regard identified a likely area for potential disposal site development, as that generally east of the harbor and north of the railroad tracks in the town of Ashtabula, Ashtabula County, Ohio. Reference Figure 2. This area contains similar developments and is zoned for heavy industry. The western portion of this area is almost fully developed with harbor and city development and then to the east with industrial developments. The eastern portion of this area is a mix of abandoned farmland (now emer-

gent scrub/shrub and mature wooded areas), disposal facilities and associated mitigation (preserved natural wildlife areas), and a few scattered residential properties primarily along the shoreline and Lake Road. Numerous wetland areas are scattered throughout the area. The Whitman's Creek watershed is located in the eastern most section of this area. A variety of associated wildlife species inhabit the natural areas.

Sites 5 and 7

Site 5 Vicinity. Site 5 vicinity is currently owned by Reserve Environmental Services (RES). It is abandoned farmland with successional vegetation growth on it. Approximately 70 acres of this vicinity was investigated for wetland delineations. Of the 70 acres investigated, approximately 6 plus acres are fill (flyash material) upland, 19 acres are scrub/shrub and/or wooded upland, one acre is open water, and 44 acres are scrub/shrub and/or wooded wetland. The area supports a variety of typical regional vegetation and animal species.

Site 7 Vicinity. Site 7 vicinity is currently owned by Reserve Environmental Services (RES). It is abandoned farmland with successional (mostly wooded) vegetation growth on it. Approximately 96 acres were investigated for wetland delineations. Of the 96 acres investigated, approximately 76 acres are scrub/shrub and/or (mostly) wooded upland and 20 acres are scrub/shrub and/or (mostly) wooded wetland. The area supports a variety of typical regional vegetation and animal species.

A cultural resources survey (Shaffer) was conducted in the vicinities of Sites 5 and 7 in 1997 Reference Figures 2. Although several twentieth century farmstead sites were known to have existed in the vicinities, and noted, no cultural resources items of significance were identified in the vicinities. The survey report was coordinated with the State Historic Preservation Office with a letter dated May 16, 1997. The State Historic Preservation Office provided a letter dated June 30, 1997 stating that: "Therefore it is our finding that the project will have no effect on any properties listed or eligible for the National Register of Historic Places. No further coordination is necessary unless the scope of the project should change."

State Road Site

State Road Site. The State Road Site is currently owned by State Road Development Corp. It is a recently demolished industrial site located just a few miles east of Ashtabula Harbor and adjacent to the Fields Brook remediation project disposal site. Use of this site would avoid potential impacts to wetlands and wildlife habitat at Site 7. Briefly, the site has been highly disturbed by industrial development and subsequent demolition activities. The surrounding area is developed industrial and is zoned manufacturing. It appears that the plant area was once a marsh area. The site contains up to seven feet of fill material (clay, sand, brick, coal). The plant was developed between 1948 and 1950. Pure elemental sodium was produced at the plant in electrolytic cells. The plant recently ceased operations. A remediation plan pertaining to contaminants was prepared, approved, and implemented. Except for a few office and warehouse buildings that will remain, most of the plant developments have been demolished. The

area south of the railroad spur is being utilized for disposal and treatment facilities from the plant and from the Fields Brook remediation project. It is proposed that part of this area also be utilized for disposal of the more highly contaminated sediments dredged from the river for the Ashtabula River Partnership project. It is proposed that part of the area north of the railroad spur be utilized for disposal of the lesser contaminated sediments dredged from the river for the Ashtabula River Partnership project.

The U. S. Army Corps of Engineers, Buffalo District conducted an on-site investigation within an approximately 35 acre portion of the State Road Disposal Site. The investigation was conducted to determine the presence and extent of jurisdictional wetland within the site pursuant to Section 404 of the Clean Water Act and to characterize the prevailing site ecology and other physical and biological site features. Personnel applied methods specified by the Corps of Engineers Wetlands Delineation Manual (January 1987). A preliminary review of available information for the area pertaining to vegetation, soils, and hydrology was implemented prior to conducting the field investigation. Sources of information included: U.S. Geological Survey maps, the U.S.D.A. Soil Survey, National Wetland Inventory maps, and aerial photographs. Based on findings of the field investigation, the Buffalo District determined that the site is best classified as industrial urban land. The site supports primarily upland open field, patchy herbaceous regrowth and common reed, which is consistent with urban industrial sites. One man-made depressional wetland located on soil fill was identified within the northern third of the site along the eastern site boundary. The wetland is approximately 0.02 acre in size and is not functionally significant; but, meets the criteria for delineation based on vegetation and hydrology. During the site investigation the Buffalo District personnel observed no threatened or endangered species or critical habitat.

A letter dated September 18, 2000 was coordinated with the State Historic Preservation Office pertaining to potential development of disposal facilities at State Road Site. Enclosures included: a list of documents prepared for remediation of the site, an extract from one of the documents pertaining to the industrial development and use of the site, a wetland and ecological site walkover investigation prepared by the Buffalo District, a memo pertaining to existing site conditions prepared by the Buffalo District, and a site photo index and photos taken during site demolition. The State Historic Preservation Office provided a letter dated November 7, 2000 reaffirming that the project will have no effect on any properties listed or eligible for the National Register of Historic Places. No further coordination is necessary unless the scope of the project should change. If new or additional properties are discovered, the State Historic Preservation Office should be notified.

ENVIRONMENTAL EFFECTS - CULTURAL RESOURCES

Cultural Resources:

No Action (Without Project Conditions): The No Action (Without Project Conditions) scenario indicates that the Ashtabula River Partnership could take no action based on the final

findings of this study. Similar to existing conditions/problems would persist for some time. Contaminated sediments would likely continue to migrate downstream into the lower river and then into the harbor and Lake Erie. This would result in further area dredging and dredged material disposal problems, in turn, further adversely affecting environmental conditions and economic and beneficial use of the river and harbor (including that relative to Cultural Resources). It is likely that the lower Ashtabula River remediation would be pursued via an alternate authority (i.e. Superfund) and a similar project (somewhat less) would be implemented/enforced. Impacts would be similar (somewhat less) to those indicated for a with project conditions (below), but at a later date.

Proposed Upland State Road Site Plan. The river dredging area and potential Transfer/ Dewatering/Transfer sites have been disrupted by previous fairly recent activities, and no significant cultural resource items would be expected at these sites.

A letter dated September 18, 2000 was coordinated with the State Historic Preservation Office pertaining to potential development of disposal facilities at State Road Site. Enclosures included: a list of documents prepared for remediation of the site, an extract from one of the documents pertaining to the industrial development and use of the site, a wetland and ecological site walkover investigation prepared by the Buffalo District, a memo pertaining to existing site conditions prepared by the Buffalo District, and a site photo index and photos taken during site demolition. The State Historic Preservation Office provided a letter dated November 7, 2000 reaffirming that the project will have no effect on any properties listed or eligible for the National Register of Historic Places. No further coordination is necessary unless the scope of the project should change. If new or additional properties are discovered, the State Historic Preservation Office should be notified.

Alternative Disposal Options Plan. Impacts to Cultural Resources would be expected to be similar to those described for the Proposed Upland State Road Site Plan except that, if the dredged material is transported to an existing (permitted) disposal facility, associated impacts would occur along those transportation routes and at that disposal facility. Use of existing disposal sites would not have a significant adverse effect on cultural resources due to construction, since they have been constructed previously.

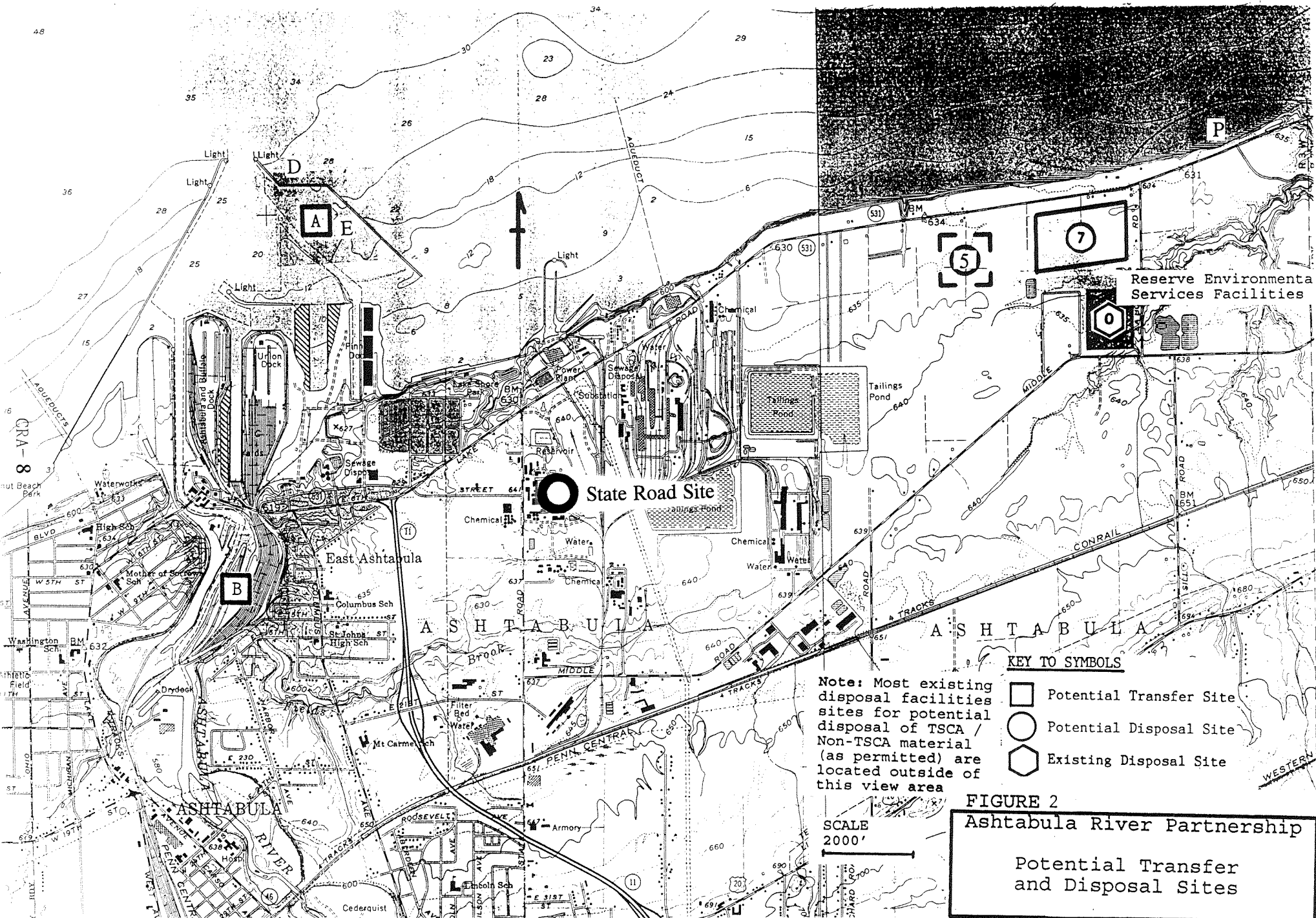

KEY TO SYMBOLS

- Potential Transfer Site
- Potential Disposal Site
- ⬡ Existing Disposal Site

Note: Most existing disposal facilities sites for potential disposal of TSCA / Non-TSCA material (as permitted) are located outside of this view area

FIGURE 2
Ashtabula River Partnership
Potential Transfer and Disposal Sites

SCALE
 2000'

CRA-9

1. *Sunken Schooner 'Joy'*
2. *Conical Mounds*
3. *Col. William Hubbard House*
4. *Ashtabula Lighthouse and Light Stations*

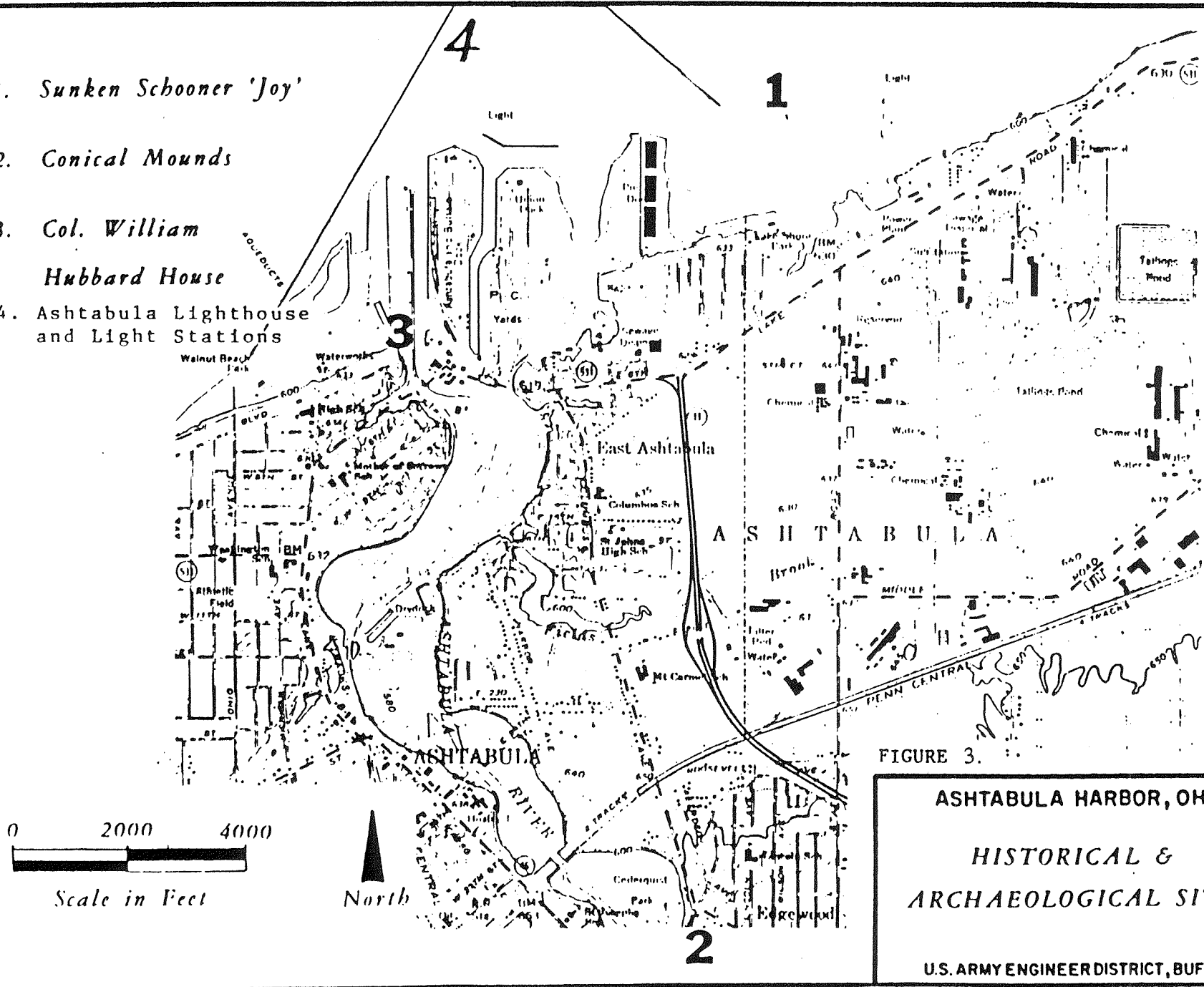

FIGURE 3.

ASHTABULA HARBOR, OHIO
 HISTORICAL &
 ARCHAEOLOGICAL SITES

U.S. ARMY ENGINEER DISTRICT, BUFFALO

Ohio Historic Preservation Office

Ohio Historical Center
1982 Velma Avenue
Columbus, Ohio 43211-2497
614/297-2470
Fax: 297-2546

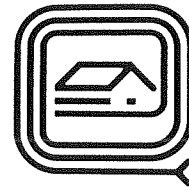

OHIO
HISTORICAL
SOCIETY
SINCE 1885

July 5, 1995

Mr. Todd Smith
Environmental Analysis Section
U.S. Army Corps of Engineers, Buffalo
1776 Niagara Street
Buffalo, New York 14207-3199

Dear Mr. Smith:

RE: Remediation of Contaminated Sediments in Ashtabula River and Harbor,
Ashtabula River Partnership, Ashtabula, Ashtabula County

This is in response to your letter received June 6, 1995 requesting information on the potential effect of cultural resources for the Ashtabula River Partnership Project Area. Our comments are submitted in accordance with the provision of Section 106 of the National Historic Preservation Act of 1966, as amended (36 CFR 800).

We have checked the Ohio Archaeological Inventory files. There are known archaeological sites in the vicinity of the project area. Before we can make any recommendations as to potential effect, we will need the specific site location for the proposed dredging and disposal activities. We wish to recognize the early coordination efforts of your agency and we hope that the goals of all interested parties are met in the most efficient manner possible.

If you have any questions please contact Todd Tucky at the above number. His hours are from 8:00 a.m.-12:00 p.m. Thank you for your cooperation.

Sincerely,

Martha J. Raymond, Department Head
Technical and Review Services

MJR/TMT:tt

May 16, 1997

Environmental Analysis Section

SUBJECT: Cultural Resources Phase I Reconnaissance Report on
Proposed Confined Disposal Facility Sites,
Ashtabula Harbor, Ashtabula County, Ohio

Mr. W. Ray Luce
State Historic Preservation Officer
Ohio Historic Preservation Office
567 East Hudson Street
Columbus, Ohio 43211-1030

Dear Mr. Luce:

Enclosed for your review is a copy of a draft report entitled, Phase I Reconnaissance Level Cultural Resources Investigation for Proposed Ashtabula Harbor Confined Dredge Disposal Facility Sites, Ashtabula Township, Ashtabula County Ohio. Please review this document and forward any comments or recommendations you may have to me at the above address by June 20, 1997.

If you have any questions in this regard, please contact me at 716-879-4171.

Sincerely,

Enclosure

Timothy T. Daly Cultural
Resources Coordinator

Phase I Reconnaissance
Level Cultural Resources
Investigation for Proposed
Ashtabula Harbor Confined
Dredge Disposal Facility
Sites, Ashtabula Township,
Ashtabula County, Ohio

Corps of Engineers Contract # DACW49-97-M-0076

SAHC # 22

Prepared for:
Department of the Army
US Army Engineer District, Buffalo
1776 Niagara Street
Buffalo, NY 14207-3199

Prepared by:
Scott C. Shaffer,
Principal Investigator

Shaffer Archeological and Historical Consulting
P.O. Box 1144
Salem, Ohio 44460

May 1997

MANAGEMENT SUMMARY

The following report was undertaken in order to assess the presence or absence of cultural resources in areas that will be impacted by proposed construction of a confined dredge disposal facility in Ashtabula Township, Ashtabula County, Ohio. In relation to the proposed construction activities, the United States Army Corps of Engineers Buffalo District has requested that a Phase I reconnaissance level cultural resources survey be carried out in order to identify potentially significant historic properties. The entire proposed impact areas, totaling 473,452 square meters (or 47 hectares) were investigated. As required by the Ohio Historic Preservation Office, the methodology employed during the present investigation included a pre-field records review, pedestrian survey, and subsurface shovel testing (n=1193). No previously reported archeological sites were identified within or adjacent to the current project survey areas during the site records review. A review of historic county and township maps suggested the presence of several historic period cultural resources adjacent to or within the survey areas. Soils within the survey area were found to be similar to those described by the Soil Conservation Service, with the exception that they were moderately impacted beneath an area of coal ash/cinder fill material. One archeological site (33AB173) was encountered within the project survey areas.

Site 33AB173 represents the remains of a twentieth century farmstead site. Machine-made bottles and twentieth century-dating cans were observed on the surface at this site, none were collected for curation. A small concrete foundation and the probable location of the residential structure were also noted. No artifacts were recovered from the twelve shovel tests excavated at this site and no subsurface cultural features were identified. The low density of cultural artifacts located within the current project survey area indicates a low potential to yield significant data. The site appears to represent a redundant, late-dating farmstead type which poses marginal research value. Additionally, the site's simple association with twentieth century agricultural development is not enough to qualify it as significant. Evaluated within the historic context of twentieth century regional agricultural development, this site appears to be non significant. No further work is recommended.

Despite the rigorous testing strategy undertaken throughout the survey areas, no artifacts or cultural features were encountered during the investigations outside of site 33AB173. In view of the non-significance of archeological sites 33AB173 and the negative findings throughout the remainder of the survey area, it is recommended that the U. S. Army Corps of Engineers be given clearance to proceed with the proposed confined dredge disposal facility construction activities.

Ohio Historic Preservation Office

567 East Hudson Street
Columbus, Ohio 43211-1030
614/297-2470
Fax: 297-2496

June 30, 1997

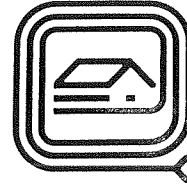

OHIO
HISTORICAL
SOCIETY
SINCE 1885

Timothy T. Daly
Cultural Resources Coordinator
Department of the Army
Buffalo District, Corps of Engineers
1776 Niagara Street
Buffalo, NY 14207-3199

Dear Mr. Daly:

RE: Ashtabula Harbor Confined Dredge Disposal Facility, Ashtabula Township, Ashtabula County

This is in response to receipt of the report "Phase I Reconnaissance Level Cultural Resources Investigation for Proposed Ashtabula Harbor Confined Dredge Disposal Facility Sites, Ashtabula Township, Ashtabula County, Ohio" by Shaffer Archaeological and Historical Consulting. My staff has reviewed this information. Based on their recommendations I have the following comments submitted in accordance with Section 106 of the National Historic Preservation Act of 1966, as amended (36 CFR 800).

The survey consisted of a literature review, pedestrian survey and shovel testing of the project area. The reconnaissance survey detected one previously unrecorded archaeological resource (33AB173). This site is an early to mid-twentieth century farmstead with a low-density cultural assemblage. The site is interpreted as a commercial farm which supplied the nearby communities with food supplies. Based on the results of the survey, we concur with author's recommendation that 33AB173 is not eligible for inclusion to the National Register of Historic Places. Therefore, it is our finding that the project will have no effect on any properties listed or eligible for the National Register of Historic Places. No further coordination is necessary unless the scope of the project should change.

If you have any questions concerning this project, please contact Todd Tucky at (614) 297-2470, between the hours of 8 am. to 5 pm. E-mail queries can be sent to tmtucky@freenet.columbus.oh.us Thank you for your cooperation.

Sincerely,

Martha J. Raymond, Department Head
Technical and Review Services

MJR/TMT:tt



DEPARTMENT OF THE ARMY
BUFFALO DISTRICT, CORPS OF ENGINEERS
1776 NIAGARA STREET
BUFFALO, NEW YORK 14207-3199

REPLY TO
ATTENTION OF:

Environmental Analysis Section

SEP 18 2000

SUBJECT: Cultural Resources and the Ashtabula River Partnership Project Potential
Alternative Dredged Material Confined Disposal Facility Site, Ashtabula
Township, Ashtabula County, Ohio.

Mr. Ray Luce
State Historic Preservation Officer
Ohio Historic Preservation Office
567 East Hudson Street
Columbus, Ohio 43211-1030
Attn: Mr. Todd Tucky

Dear Mr. Luce:

This is supplemental to previous correspondence on the Ashtabula River Partnership project. A Draft Comprehensive Management Plan and Environmental Impact Statement and Appendices were coordinated in September of 1999. These reports discussed development of disposal facilities at Site 7.

Subsequent to this coordination the Partnership has been considering development of disposal facilities (if feasible and all things considered) at an alternate site that has become available. It is a recently demolished industrial site located just a few miles east of Ashtabula Harbor and adjacent to the Fields Brook remediation project disposal site. Reference Figure 1 and 2. Use of this site would avoid potential impacts to wetlands and wildlife habitat at Site 7.

The Ashtabula River Partnership is requesting concurrence that development of the alternate site for disposal of contaminated sediments dredged from the river for the Ashtabula River Partnership project would have no effect on any properties listed or eligible for the National Register of Historic Places.

Briefly, the site has been highly disturbed by industrial development and subsequent demolition activities. The surrounding area is developed industrial and is zoned manufacturing. It appears that the plant area was once a marsh area. The site contains up to seven feet of fill material (clay, sand, brick, coal). The plant was developed between 1948 and 1950. Pure elemental sodium was produced at the plant in electrolytic cells. The plant recently ceased operations. A remediation plan pertaining to contaminants was prepared, approved, and implemented. Except for a few office and warehouse buildings that will remain, most of the plant developments have been demolished. The area south of the railroad spur is being utilized for disposal and treatment facilities from the plant and from the Fields Brook remediation project. It is proposed that part of this area also be utilized for disposal of the more highly contaminated sediments dredged from the river for the Ashtabula River Partnership project. It is proposed that part of the area north of the railroad spur be utilized for disposal of the lesser contaminated sediments dredged from the river for the Ashtabula River Partnership project.

For your information, we have enclosed:

1. A list of documents prepared for remediation of the site.
2. An extract from one of the documents pertaining to the industrial development and use of the site.
3. A Wetland and Ecological Site Walkover Investigation prepared by the Buffalo District.
4. A memo pertaining to existing site conditions prepared by the Buffalo District.
5. A site photo index and photos taken during site demolition.

Please respond within 30 days of the date of this letter, since we are trying to finalize the Comprehensive Management Plan and Environmental Impact Statement and Appendices at this time. My point of contact pertaining to this matter is Mr. Tod Smith, who can be contacted by calling commercial number 716-879-4175 (FAX 716-879-4355, Email: tod.d.smith@usace.army.mil), or by writing to him at the above address. Thank you for your attention to this matter.

Sincerely,

David J. Conboy, P.E.
Team Leader
Environmental Analysis Section

Enclosures

Ohio Historic Preservation Office

567 East Hudson Street
Columbus, Ohio 43211-1030
614/ 298-2000 Fax: 614/ 298-2037

Visit us at www.ohiohistory.org/resource/histpres/

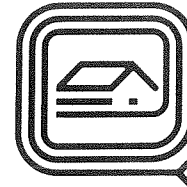

OHIO
HISTORICAL
SOCIETY
SINCE 1885

November 7, 2000

Tod Smith
U.S. Army Corps of Engineers, Buffalo District
Attn: Environmental Analysis Section
1776 Niagara Street
Buffalo, NY 14207-3199

Re: RMI Remediation
Ashtabula, Ashtabula County, Ohio

Dear Mr. Smith,

This is in response to correspondence from your office dated September 18, 2000 (received September 20) regarding the above referenced project. The comments of the Ohio Historic Preservation Office (OHPO) are submitted in accordance with provisions of the National Historic Preservation Act of 1966, as amended (16 U.S.C. 470 [36 CFR 800]).

The project involves remediation of a superfund site including demolition of structures dating back to the 1950s, removal and/or treatment of contaminated soils, and, recently added, use of the area as a disposal site. This office has previously completed the Section 106 review for this facility. In correspondence dated July 13, 1992, and April 30, 1998, we concurred with findings that the buildings were not eligible for inclusion in the National Register of Historic Places and that the entire area had been severely disturbed so that there was no reasonable opportunity for archaeology. A check of our records shows that there are currently no known properties, including listed historic districts, in the area immediately surrounding the 35 acre project. This letter affirms our previous statements that there will be no historic properties affected by the proposed remediation of this facility, including the proposed use of this area as a disposal site. No further coordination with this office is necessary for this project unless there is a change in the scope of work. In addition, if new or additional properties are discovered, this office should be notified [36 CFR 800.13].

Any questions concerning this matter should be addressed to David Snyder at (614) 298-2000, between the hours of 8 am. to 5 pm. Thank you for your cooperation.

Sincerely,

David Snyder, Archaeology Reviews Manager
Resource Protection and Review

DMS/ds

Enclosure (copies of OHPO letters)

on Office
Street
Ohio 43211-1030
297-2470 Fax: 614/ 297-2496
Visit us at www.ohiohistory.org/resource/histpres/

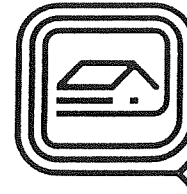

OHIO
HISTORICAL
SOCIETY
SINCE 1885

April 30, 1998

Gabrille M. Fay
NES, Inc.
44 Shelter Rock Road
Danbury, CT 06810

Re: RMI Extrusion Plant, Ashtabula, Ohio

Dear Ms. Fay,

This is in response to correspondence from your office dated April 3, 1998 (received April 6) regarding the above referenced project. The comments of the Ohio Historic Preservation Office (OHPO) are submitted in accordance with provisions of the National Historic Preservation Act of 1966, as amended (16 U.S.C. 470 [36 CFR 800]).

A check of the Ohio Archaeological Inventory, the Ohio Historic Inventory, and the National Register of Historic Places shows that no historic properties have been located to date within the project boundaries or in the immediate vicinity. Previous correspondence provided information concerning the buildings and it is our opinion that they are not architecturally significant. Based on available information, it appears that the project area has been disturbed and therefore it is unlikely that the project area contains significant archaeological remains. It is my opinion that the project will have no effect on any properties that are listed or eligible for listing in the National Register of Historic Places. No further coordination with this office is necessary unless there is a change in the scope of work. In addition, if new or additional properties are discovered, this office should be notified [36 CFR 800.11(d)(1)].

Any questions concerning this matter should be addressed to David Snyder at (614) 297-2470, between the hours of 8 am. to 5 pm. Thank you for your cooperation.

Sincerely,

David Snyder, Archaeology Reviews Manager
Resource Protection and Review

DMS/ds

RMI
Titavusix

Ohio Historical Center
1982 Velma Avenue
Columbus, Ohio 43211-2497
614/297-2470
Fax: 297-2411



OHIO
HISTORICAL
SOCIETY
SINCE 1885

July 13, 1992

Louise E. Watson
RMI Titanium Company
Extrusion Plant
P.O. Box 579
Astabula, Ohio 44004-0579

Dear Ms. Watson:

Re: Environmental Assessment, Extrusion Plant, Ashtabula, Ohio

This is in response to your letters dated June 5 and 29, 1992 regarding the preparation of the environmental assessment of the existing extrusion plant. A check of the Ohio Archaeological Inventory, the Ohio Historic Inventory, and the National Register of Historic Places show no historic properties have been located to date within the project boundaries or in the immediate vicinity. The photographs you provided indicate that the existing buildings, constructed in the 1950's, are not architecturally significant. Based on the information that the site has been industrial since the late 1950's, I assume all areas have some disturbance and the potential for the site to contain archaeological remains is low. It is my opinion that the project will have no effect on any properties that are listed or eligible for the National Register of Historic Places. These comments are submitted in accordance to the provisions of the Section 106 of the National Historic Preservation Act of 1966, as amended. No further coordination with this office is necessary unless the scope of the undertaking changes.

Please contact Julie Quinlan at the above number if you have any questions. Her hours are from 5-11 a.m. Thank you for your cooperation.

Sincerely,

Martha J. Raymond, Department Head
Technical and Review Services

MJR/JAQ:jq



1123 Bridge Street
Ashtabula, Ohio 44004
(216) 964-0277 Office
(216) 964-5158 Fax

John Mahan, Ph.D
Coordinator

Rick Brewer
Co-Chairman
Coordinating Committee

Fred Leitert
Co-Chairman
Coordinating Committee

Steve Golyski
Chairman
Project Committee

Rick Mason
Chairman
Siting Committee

Brett Kaul
Chairman
Resource Committee

Michelle Rowley
Chairperson
Outreach Committee

Ashtabula River and Harbor

Comprehensive Management Plan

Dredging and Disposal

FINAL

FEASIBILITY REPORT AND

ENVIRONMENTAL IMPACT STATEMENT

ENVIRONMENTAL APPENDIX

EA-I ENVIRONMENTAL JUSTICE

City of Ashtabula
Town of Ashtabula
County of Ashtabula
State of Ohio

2001

ENVIRONMENTAL JUSTICE ASSESSMENT

Summary of Analysis:

The Comprehensive Management Plan for the Ashtabula River Dredging Project and Confined Disposal Facility (Ashtabula River Proposal) conforms to the U.S. government's policy of insuring that federal projects do not disproportionately impact a community's right to a safe and clean environment. The project poses no significant risks to the health of nearby residents or the surrounding environment. Rather, the project is expected to improve long-term environmental conditions in the areal, benefiting up- and downstream habitats, and recreational activities, that depend on their quality.

Section I: Executive Directive and Agency Guidance

This Appendix of this Environmental Impact Statement (EIS) addresses environmental justice concerns raised by the Ashtabula River Proposal. In general, environmental justice refers to fair treatment of all races, cultures, and income levels with respect to development, implementation and enforcement of environmental laws, policies, and actions.

At the federal level, the obligation of government agencies to take environmental justice into account is outlined in Executive Order 12898. The Order signed by President Clinton on February 11, 1994, calls for federal agencies to incorporate environmental justice considerations in decision-making activities. Significantly, Section 1-101 of the Order states:

"... each Federal Agency shall make achieving environmental justice part of its mission by identifying and addressing, as appropriate, disproportionately high and adverse human health or environmental effects of its programs, policies, and environmental activities on minority populations and low-income populations in the United States and its territories and possessions, the District of Columbia, the Commonwealth of Puerto Rico, and the Commonwealth of the Mariana Islands."

In a memorandum accompanying Executive Order 12898, President Clinton also directed agencies to analyze "the environmental effects, including human health, economic and social effects, of federal actions, including effects on minority communities and low-income communities, when such analysis is required by the National Environmental Policy Act of 1969." To carry out this objective, on July 19, 1995, EPA issued "Draft Guidance for Consideration of Environmental Justice in Clean Air Act Section 309 Reviews." This document lists factors and conditions that may be considered in preparing environmental justice evaluations in environmental impact statements.

This appendix addresses environmental justice issues in terms of area demographics, ecological, environmental and health impacts, and the proposed site's logistical impacts on nearby residents as specified in Executive Order 12898. To provide context, a number of subjects addressed at length elsewhere in this EIS are briefly summarized.

Section II: Project Description

A. Background.

The Ashtabula River and Harbor project (Project), located in Ashtabula County, Ohio, has filled, over time, with an accumulation of sediment, some of which is contaminated with hazardous and other industrial materials. This accumulation restricts commercial navigation, inhibits economic growth, impairs up- and downstream aquatic habitats, and potentially threatens public water supplies.

The project consists of two main components: (1) Dredging of the River (*including transfer/dewatering/transfer*), and (2) Disposal of the sediment at the proposed CDF site.

The proposed dredging plan calls for the removal of approximately 700,000 cubic yards of sediment from the River. The extent of the dredging stretches from the upper turning basin near the mouth of Field's Brook to the lower turning basin. The sediments will be removed over the course of five years using a closed clam-shell dredge that will lift the sediments into a barge. The barge will float to a specially constructed transfer dock constructed at the ConRail facility. At the transfer facility the sediments will be dried out and then placed into trucks and shipped to a confined disposal facility (CDF). *Reference Figures 1 and 2.*

The proposed CDF Site is a 32 acre parcel that is generally east of the Harbor near *State Road* and just south of *Lake Road*. The parcel is within an area owned by *State Road Development Corp.* The property is a *former industrial (demolished/remediated brownfield) site.*

Section III: Description of Area Near Site

The Ashtabula Harbor is located at the mouth of the Ashtabula River on the south shore of Lake Erie in eastern Ohio. The Harbor and lower Ashtabula River contain both commercial and recreational development, but little residential development along the waterfront. There are over 6000 residents within a one-mile radius of the dredging project, but most of those are west of the harbor extending into the historic harbor district. Other residential development has occurred in East Ashtabula, south, and east of the ConRail Bridge Yard. The preferred disposal site is located in an industrial setting east of the Harbor. The area is dominated by industrial facilities and (*further east*) abandon farmland. This disposal site is a considerable distance from *any residences.*

Section IV: Demographic Factors

Demographic data from 1990 indicates that Ashtabula County had a total population of 99,821. The City of Ashtabula had a 1990 Census-based population of 21,633. Based on a projected 1994 population of 101,939, the 4,065 members of the minority population comprise just under 4% of the total population. The County population is also 52% female and 48% male. (1990 Census data). Thus, a more extensive environmental justice analysis within this draft EIS is not merited based on the County race or sex demographics.

[NOTE: See Table 9 Appendix T, p.30, “Demographic Profile of Ashtabula County”]

In 1991, the civilian work force in Ashtabula County was 41,452 with an unemployment rate of approximately 10%. The unemployment rate has declined, dropping to below 8% by 1995. Major employment sectors include: Manufacturing (29%), Wholesale/Retail (20%), Health Service (10%), Agriculture (4%), Finance (3%), Insurance (3%), Real Estate (3%), and Public Administration (2%). In 1990, the personal income (per capita) in Ashtabula County was \$13,499. Median family income was \$28,610 in 1989 ranking Ashtabula County 65th out of 88 counties. The Poverty Rate, which is the percentage of the population living at or below the federally defined poverty level, was 17.1% in 1995 (Council for Economic Opportunities Report). This Poverty Rate is down from a high of 18.7% in 1993. Thus, based on the Poverty Rate, it is appropriate to consider the impacts on low income residents in more detail at this point.

There are over approximately 6,460 residents within a one-mile radius of the dredging project based on the 1990 STF3A Census data summarized in block groups. Approximately 41% of those people live in households with income levels less than twice the amount set for poverty level income. Approximately half of those people have incomes at or below the poverty income level. The two largest residential areas potentially affected by the dredging are the historic Harbor District and East Ashtabula. See (*Figure 3*) Map 1, “Census Blocks Within One Miles of Fields Brook” attached.

Section V: Impacts on Community

A. Logistics and Social Impacts.

Dredging activities associated with the proposed CDF will have an impact on the immediate area. As with any construction project, vehicle and equipment traffic will be ongoing, especially during the construction stage of the project. During dredging operations, traffic within the River will also increase with barges delivering material to the site.

Traffic delays and rerouting due to the influx of vehicles and drawbridge use on Highway 41 are also a probability. However, virtually all of the motorists affected will be workers at the site or one of the immediately adjacent facilities, or possibly truck operators making deliveries to these locations. Nearby residents can be expected to continue to use other routes to come and go. At present, there is modest pedestrian traffic through the project area. Additional traffic planning will be incorporated into the detailed design to avoid traffic congestion problems. The roads proposed for use are not residential in nature and should pose no greater burden on the residents than on the general population using these commercial thoroughfares. No significant impact on low-income community activities appears imminent.

Social impacts on the community will not be significant. The proposed CDF site will not require displacement of businesses or private residences. Nor will access to critical local institutions such as churches, community centers, or government offices be impacted. The CDF site has historically been used for industrial purposes only, and the proposed dredging project is not expected to have any sort of negative impact on nearby facilities.

B. Local Ecosystem.

A short-term ecological impact on the River is expected. Dredging will result in increased turbidity and decreases in dissolved oxygen levels. However, long-term improvements in water quality and benthic communities will almost certainly result from the removal of the contaminated sediment. The improved aquatic environment should, in turn, improve the size, diversity and health of fish communities in the Ashtabula River.

The present CDF site is of nominal ecological value. Its history of past agricultural or heavy industrial use has resulted in unexceptional plant habitat and limited use by animal life. Herbaceous plants, small trees, and some shrubs are present, though regarded as ecologically insignificant. There is minimal evidence of bird or small mammal *use or* nesting activity at the site.

Somewhat more common--and unlikely to be significantly affected by the CDF--are waterfowl migrating along the shore of Lake Erie and the Northeastern Ohio's inland ponds and river network. However, the lack of suitable habitat has, to this point, not attracted much waterfowl interest.

Dredged sediments deposited at the CDF pose extremely little risk to either surface water or drinking water used by area residents. Disposal plans for waters used in pretreatment and treatment are outlined at length elsewhere in this EIS.

At present, the River offers plentiful recreational use. There is some swimming and considerable recreational boating. Subsistence fishing is discouraged, with warning signs posted in the Harbor area. Once the dredging is complete, improved water *and sediment* quality and a deeper channel will enhance the potential use of the area for recreational activities.

C. Public Health Factors.

The project will not significantly increase environmental health risks faced by local residents. Some volatile organic compounds (VOCs), polychlorinated biphenyls (PCBs), and polycyclic aromatic hydrocarbons (PAHs) will be released to the air during sediment dredging and disposal. However, these represent a small increase in current releases in the area and will not significantly increase background levels. As mentioned previously, a low level of volatilized PCBs and PAHs will also be released into the air during disposal operations. Analysis done for this and other dredging projects indicates that the contaminants of concern, PCBs and volatile organics, will not present a significant risk within 1000 feet of the CDF or point of dredging in the River before being dispersed into the atmosphere. Odors from organic decomposition should not reach more than several hundred feet onto the shore even under the worst case circumstances.

With simple standard and proper protection measures/precautions, handling of material with low level radionuclides will not present a substantial risk to workers or the public. Material will be safely and properly disposed of. A health and safety plan is developed for and included in project design and plans and specifications.

The disposal site is situated in the middle of a heavy industry zone. The risk evaluation indicates that the proposed CDF site is not likely to add to the current pollutant load in a significant way. When the project is complete, it is expected that ecological conditions at the disposal site should be similar *or better* to those disrupted. The public is also not likely to be at risk of dermal contact. A seven foot cyclone fence currently encloses the CDF site to deter trespassers. Once the CDF begins operation, security guards will be posted. As sediment is placed in the CDF, a berm will be constructed around its perimeter, further preventing migration of contaminants. Some of the adjacent industrial properties are similarly fenced and monitored with apparently no problems reported by local residents.

D. Additional Exposures.

Based on past Agency experience, three additional exposure issues have been considered: noise, odors, and visual obstructions.

Concerns about noise stem from the expected influx of construction and material handling equipment at the CDF property. A scientific analysis of noise impacts on nearby communities has not been conducted. However, due to the distance from residential areas and the use of conventional construction equipment, the CDF is not likely to result in significant noise impacts.

Landfill sitings in other communities have raised questions about odors. In the case of the proposed CDF, this is not likely to be a nuisance problem. The likely pathways of odors from the CDF are projected to disperse within one mile of the site. Because the principle odor-causing agent contained in the channel sediment is PAHs, the actual odors, if any, will be similar to the scent of motor oil exposed on a beach.

On an exceptionally hot and windy day, it is conceivable that odors from the site could drift into surrounding communities. However, on those occasions, the perceptible differences in odor conditions are expected to be insignificant in all but the most exceptional circumstances. Significantly, a recent Army Corps dredging project in Michigan City, Indiana raised similar questions. To date, the project has not had a noticeable impact on area residents.

When complete, the CDF will reach a height of about 30 feet. Without a doubt, the CDF will be more visible than the current flat, overgrown site. However, in contrast with the adjacent highway, industrial, the site will not be inordinately tall. At a height of no more than three stories, the CDF will not have much visual impact on residential areas at least one-half to one mile away.

E. Economic Impacts.

Currently, the lack of dredging in the river has resulted in transportation difficulties for some of the commercial and recreational concerns. Economic development in the Harbor area has been slowed to some degree because of concerns over the loss of beneficial uses caused by the contaminated sediments.

In contrast, the proposed CDF (and dredging activity) aims to enhance economic development

opportunities by increasing marine transportation and recreation capability in the area.

F. Public Outreach.

Public participation in the project design and siting process has been exceptional. Meetings discussing design of the project and siting of a the disposal facility have been held at least once a month and are open to the public. The disposal site candidates were announced to the public in 1996 through a press conference and those candidate sites received widespread press coverage. Public outreach will continue through the NEPA process, which includes: release of the plan to the community, several public meetings, and the response to comments received on the Environmental Impact Statement.

Section VI: Conclusions

Taking all of the above factors into consideration, the Comprehensive Management Plan for the proposed Ashtabula River dredging project and proposed CDF does not conflict with the federal government's policy on environmental justice.

Overall, and relying on extremely conservative calculations of environmental risk factors, the CDF appears unlikely to pose significant increased hazards. In fact, the CDF should improve environmental conditions in the area. Dredging will remove contaminants from the Canal and reduce the risk of contaminants in public drinking water intakes. Stormwater runoff will be monitored and controlled. Opportunities for new economic activity will be enhanced. Residential areas are situated far enough away to be out of recognized pollutant pathways and will not be adversely affected.

Therefore, it is U.S. EPA's view that the inhabitants of Ashtabula--encompassing a wide spectrum of income levels and socio-economic backgrounds will realize cumulative environmental and economic benefits from the dredging of contaminated sediment from the River and the siting of the proposed CDF.

NOTE: Substantial dredging would occur within channel Area F and channel Area G up through the upper turning basin. 

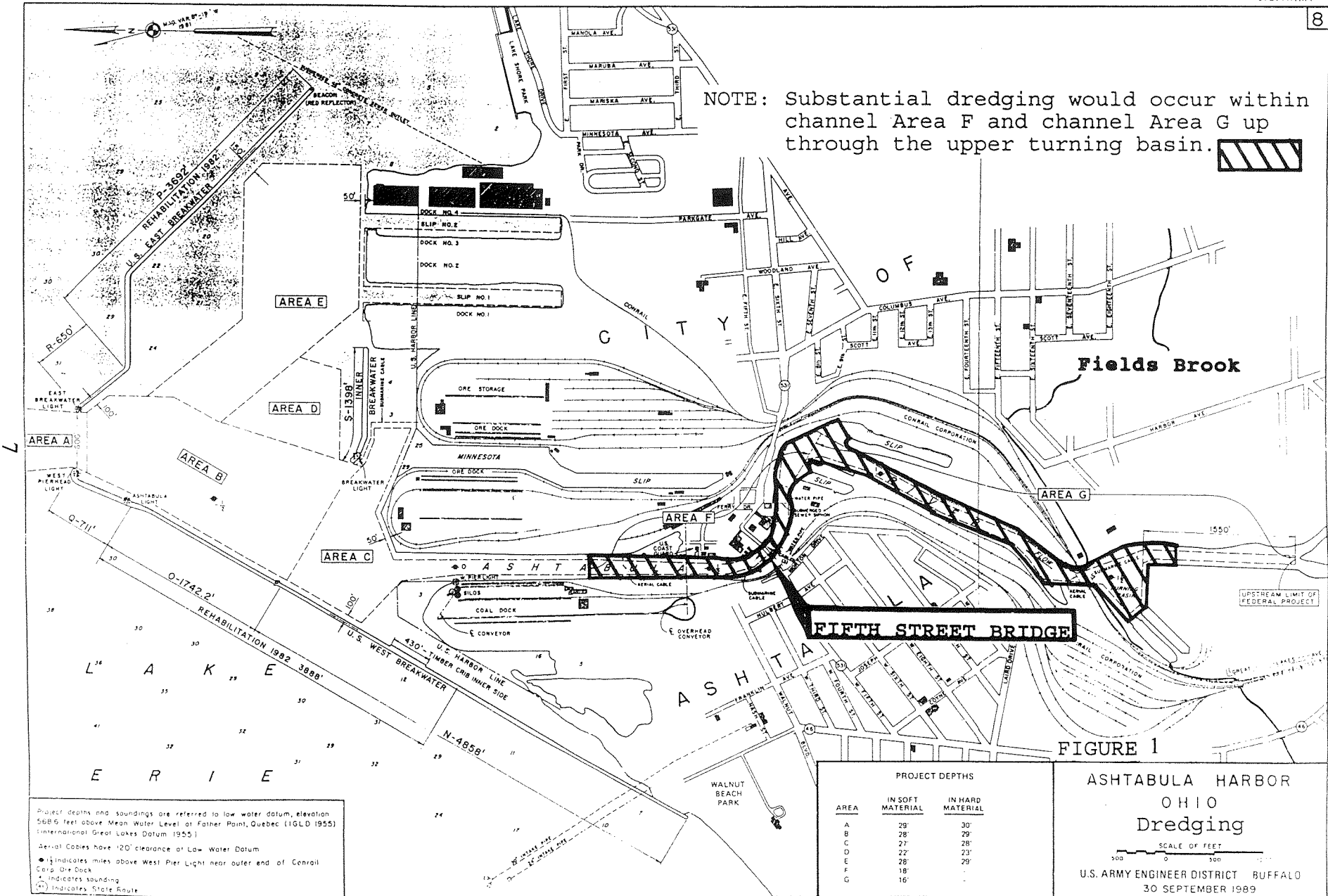

Project depths and soundings are referred to low water datum, elevation 568.6 feet above Mean Water Level at Father Point, Quebec (IGLD 1955) International Great Lakes Datum 1955.
 Aerial Cables have 120' clearance at Low Water Datum.
 ● indicates miles above West Pier Light near outer end of Conrail Corp. Ore Dock
 * indicates sounding
 (R) indicates State Route

AREA	PROJECT DEPTHS	
	IN SOFT MATERIAL	IN HARD MATERIAL
A	29'	30'
B	28'	29'
C	27'	28'
D	22'	23'
E	26'	29'
F	18'	-
G	16'	-

ASHTABULA HARBOR
 OHIO
 Dredging
 SCALE OF FEET
 0 100 200
 U.S. ARMY ENGINEER DISTRICT BUFFALO
 30 SEPTEMBER 1989

FIGURE 1

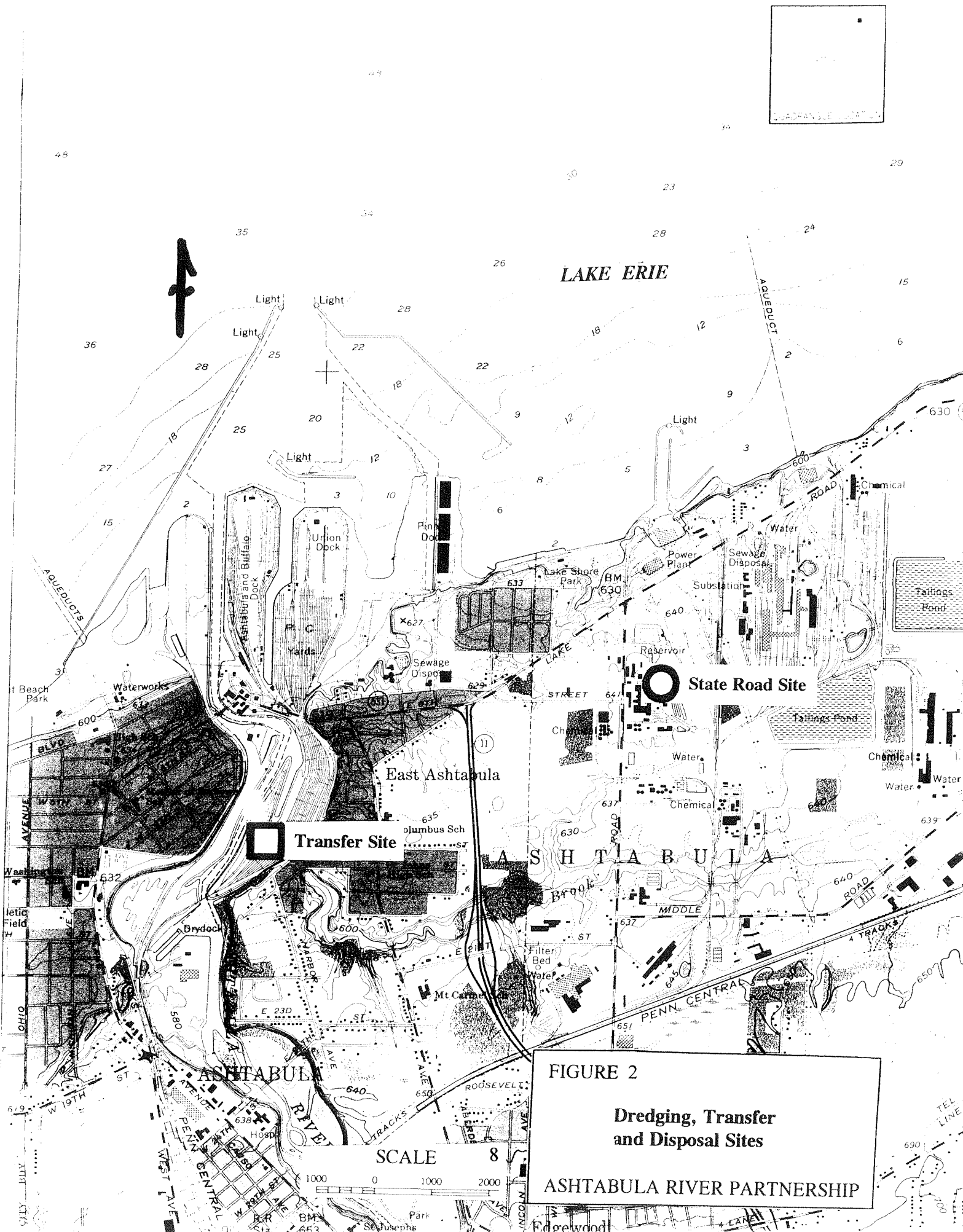
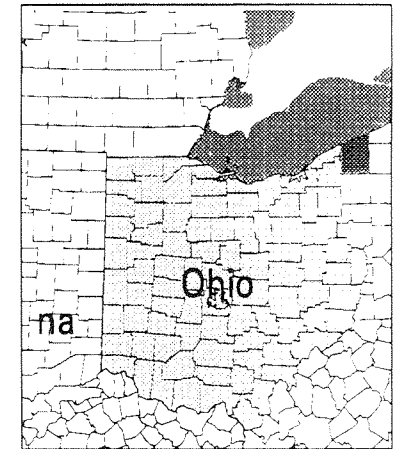
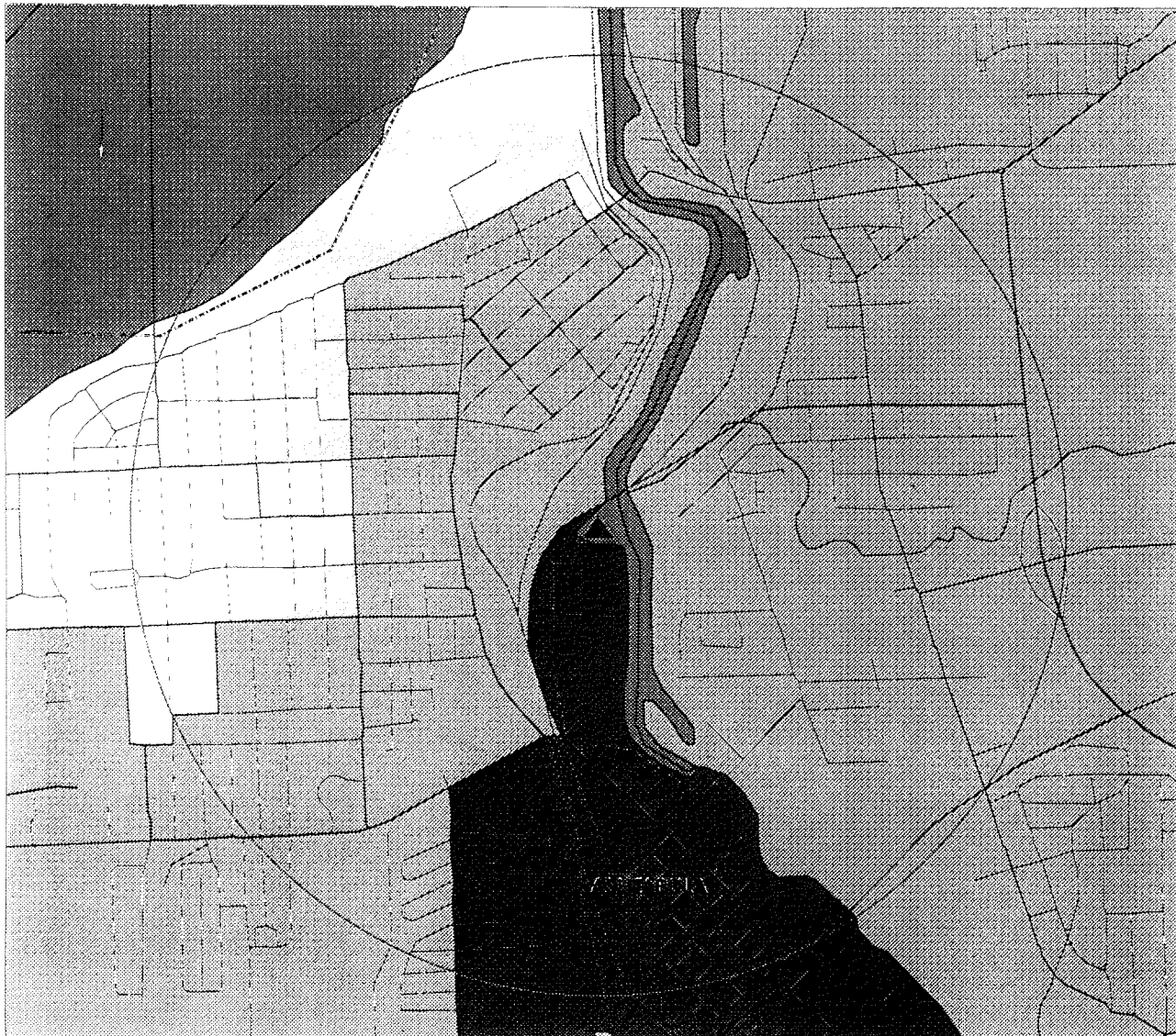

FIGURE 2
Dredging, Transfer and Disposal Sites
ASHTABULA RIVER PARTNERSHIP

Fields Brook

Census Blocks within One Miles of Fields Brook



- Facility
- Interstate Highway
- Primary Road
- County Road
- Neighborhood Road
- Railroad
- Perennial Stream
- Drain or Intermittent Stream
- County Border
- Block Group Boundary

- Region 5 EJ Guidelines
- Low Income and Minority Less than or equal to State Percentage
 - Low Income or Minority Greater than State Percentage but less than twice State Percentage
 - Low Income or Minority Equal to or greater than twice State Percentage
 - Uninhabited or No Data
 - Water

Population are considered in the low income group when the household income is less than double the poverty level. Minorities are considered everyone but white non-hispanic.

The data are summarized at the block group level, from 1990 STF3A data.

FIGURE 3 (MAP 1)

TOTAL POPULATION 6,460	PERCENT MINORITIES 7.8	PERCENT POVERTY 21.0	PERCENT NATIVE POPULATION 0.2
PERCENT LOW INCOME 41.2	PERCENT CHILDREN 8.2	PERCENT NO ENGLISH 1.8	PERCENT HOUSING PRE 1980 98.9

State Low Income Population Percentage: 28

State Minority Population Percentage: 13



1123 Bridge Street
Ashtabula, Ohio 44004
(216) 964-0277 Office
(216) 964-5158 Fax

John Mahan, Ph.D
Coordinator

Rick Brewer
Co-Chairman
Coordinating Committee

Fred Leitert
Co-Chairman
Coordinating Committee

Steve Golyski
Chairman
Project Committee

Rick Mason
Chairman
Siting Committee

Brett Kaull
Chairman
Resource Committee

Michelle Rowley
Chairperson
Outreach Committee

Ashtabula River and Harbor

Comprehensive Management Plan

Dredging and Disposal

FINAL
FEASIBILITY REPORT AND
ENVIRONMENTAL IMPACT STATEMENT
ENVIRONMENTAL APPENDIX

EA - J SECTION 312(b) AND 206 ECOLOGICAL RESTORATION/
PRESERVATION ANALYSES
(ARP SUB-COMMITTEE 1998)

City of Ashtabula
Town of Ashtabula
County of Ashtabula
State of Ohio

2001

SECTION 312(b) AND 206 ECOLOGICAL RESTORATION/PRESERVATION ANALYSES (ARP SUB-COMMITTEE 1998)

SUMMARY

The Ashtabula River Partnership assessed the Ashtabula River Partnership Lower Ashtabula River Remediation Project with regard to Section 312 (b) of the Water Resources Development Act of 1990, Environmental Dredging, as Amended by Section 205 *and* 206 of the Water Resources Development Act of 1996, as promulgated by Corps of Engineers Policy Guidance Letter No. 49 and EC 1105-2-210.

Ashtabula Harbor is located at the mouth of the Ashtabula River on the south shore of Lake Erie, Ashtabula County, Ohio. It is a significant harbor on the Great Lakes and Saint Lawrence Seaway shipping system. It is situated among the significant water and ecological resources of the Great Lakes, Lake Erie, and the Ashtabula River Watershed. The project Area of Concern (AOC), as established by the Ashtabula River Remedial Action Plan Advisory Council, is the lower two miles of the Ashtabula River, Ashtabula Harbor and the adjacent Lake Erie nearshore, considering the Fields Brook Superfund investigation and cleanup as a complementary project.

Harbor structural developments and accumulated contaminants have caused significant problems pertaining to benthic and fishery habitat and the ecology and harbor operations and maintenance dredging. The Corps of Engineers has played a significant role in development and maintenance of various harbor features and in facilitating development and maintenance of others. Most of the contaminated sediments have collected within the Federal authorized channels. Storm events cause scour and the resuspension of sediments and associated contaminants which periodically compromise water quality standards. Contaminated sediments continue to migrate down stream from the lower river into the outer harbor and Lake Erie. Structural developments (i.e. channelization, bulkheading, etc.) have essentially eliminated aquatic/fishery shallow areas. Dredging and vessel activities have caused resuspension of sediments suffocating bottom organisms and disrupting fish habitat.

In 1985, the International Joint Commission designated the Ashtabula River as one of 42 AOCs, recognizing six of 14 impairments of beneficial uses, i.e. changes in chemical, physical, or biological integrity of the ecosystem, as listed under the GLWQA. A comprehensive report titled the Ashtabula River Stage 1 Investigation Report, published in December 1991, describes in detail six beneficial use impairments associated with the Ashtabula River AOC, which are:

- 1. Restriction on Fish and Wildlife Consumption.**
- 2. Degradation of Fish and Wildlife Populations.**
- 3. Fish Tumors and Other Deformities.**
- 4. Degradation of Benthos.**
- 5. Restrictions on Dredging Activities.**
- 6. Loss of Fish and Wildlife Habitat.**

For purposes of this report analyses, the project area and associated problems were assessed from an ecological perspective. The primary ecological area of consideration includes that in the Ashtabula River watershed upstream of the harbor area to downstream through the harbor area and

out into Lake Erie. In summary, three primary problem areas have been identified in the Ashtabula Harbor Area of Concern (Excluding Fields Brook): to some degree the Outer Harbor Area (Ecological Assessment Area 4), the lower river from the mouth upstream to the Fifth Street Bridge (Ecological Assessment Area 3), and the lower river from the Fifth Street Bridge upstream through the Upper Turning Basin (Ecological Assessment Area 2). The watershed area upstream of the developed harbor area (outside the AOC lines) (Ecological Assessment Area 1) is in relatively good condition. Primary problems that exist in the Outer Harbor are those associated with commercial harbor development channels, dredging and use of the commercial navigation channels, and contaminants in the sediments (primarily PAHs likely associated with the coal dock developments in the immediate area and other contaminated sediments including PCBs migrating out from the river). Primary problems that exist in the Lower River from the mouth upstream to the 5th Street Bridge are those associated with commercial harbor development bulkheading, dredging and use of the commercial navigation channel, and contaminants in the sediments (primarily PAHs likely associated with the coal dock developments in the immediate area and other contaminated sediments migrating in from upstream). Primary problems that exist in the Lower River from the 5th Street Bridge upstream to the end of the Federal navigation channel are those associated with recreational harbor development bulkheading, dredging and use of the recreational navigation channel, and primarily contaminants in the sediments (primarily PCBs, some equal to or in excess of 50 mg/kg or TSCA material). Benthic and fishery habitat has been significantly degraded in these areas in this regard as compared to quality warm water habitat criteria.

Considering the above, three common problem matters can be identified, those being: contaminated sediments, loss of protected riparian aquatic/fishery shallows, and dredging and commercial and recreational vessel traffic.

Under the 1978 GLWQA the overall goals of a RAP are to restore all beneficial uses to an Area of Concern, prohibit the discharge of toxic substances in toxic amounts, and virtually eliminate the discharge of persistent toxic substances. All of the beneficial use impairments in the Ashtabula River AOC are directly related to contaminated sediment, more specifically to the PCB and PAH mass associated with the contaminated sediment. Removal and remediation of the PCB and PAH mass is critical to comprehensive restoration of the ecological integrity of the lake/watershed. Some of the beneficial use impairments are related to loss of protected aquatic/fishery riparian shallow areas and lower river activities. Cleanup of the Ashtabula River via the Ashtabula River Partnership should eliminate all of the use impairments assigned to the lower river. The Lake Erie/Ashtabula River Area of Concern has been identified as a priority area for remediation in Sections 205 and 515 of WRDA 96 and in the U.S. Army Corps of Engineers PGL No. 49 section 5. c.

Considering the three common problem matters discussed previously, those being: contaminated sediments, loss of protected riparian aquatic/fishery shallows, and dredging and commercial and recreational vessel traffic; more specific objectives were developed to address contaminants and loss of protected riparian aquatic/fishery shallows that could also be applied to remediate/restore beneficial uses. It is understood that commercial and recreational facilities and activities will remain.

More specific objectives were developed to address contaminants and loss of protected riparian aquatic/fishery shallows that could also be applied to remediate/restore beneficial uses, as follows:

A. Reference studies and subsequent investigations indicate that an optimized dredging contaminant removal plan be developed for the problem areas that will leave no worse than existing conditions PCB and PAH sediment surface concentration initially, removal of all TSCA and scour (from a 100 year storm event) risk PCB and PAH mass, and, considering siltation or placement cover of relatively clean material, long-term (after several years) surface/substrate sediment (several feet) with targeted concentrations for PCBs and PAHs of equal to or less than 0.35 ppm and 10 to 20 ppm, respectively.

Focus has been on the main contaminants of concern in the Ashtabula River Area of Concern (AOC) due to their level and extent of contamination. Specifically, the focus is on PCBs and to a lesser extent PAHs. There are other contaminants of concern in the AOC, as discussed previously. However, it is assumed that by focusing on PCBs and PAHs, the other contaminants of concern will be addressed due to co-location of contaminants.

B. Replacement of protected aquatic/fishery shallow areas, as possible, for lengths as long as possible along the river problem areas. These developments would include measures such as a shoreline aquatic/fishery shelf cut or provision and miscellaneous improvements such as soil cover, aquatic and terrestrial plantings, placement of stone/gravel, and placement of cover structures. This would provide missing habitat for fisheries and benthos for passage, cover, feeding, and possibly spawning. The goal/objective would be to reach a quality warm water habitat condition (per HAP) along the problem reaches, as possible.

The Ashtabula River Partnership (ARP) considered Without Project Conditions scenarios and developed and assessed/evaluated three incremental dredging ecological restoration/preservation scenarios for substrate contaminant removal. Considering developed ecological clean-up restoration/preservation goals/objectives, initial primary assessment/evaluation output measures included items such as: Costs, Economic Benefits, Practicality, Ecological Improvement (Rank), Quantities Dredged, TSCA (PCB) Material Removed, Shoreline Bulkhead Affected, PAH/PCB Mass Removed, Initial PAH/PCB Surface Concentrations, Beneficial Uses Addressed (Open Lake Disposal, Recreation/Commercial Shipping, Fish Advisory Lifted, Long-Term Risk Reduction, Habitat Quality), and Scour Release Potential (incl. to Lake). Other assessment/evaluation output measures included items such as: PCB Bio-Accumulation in Fish Tissue and Advisories, Water Quality (Turbidity), Benthic Habitat Chemically Restored, Benthic Habitat and Scour Protection Area Chemically Restored, Aquatic/Fishery Shallows

Initially Impacted, Ohio Habitat Assessment Procedures (HAP) Biological Indices [Qualitative Habitat Evaluation Index QHEI, Fishery Index of Biotic Integrity IBI (incl. T&E Species), Macroinvertebrate Invertebrate Community Index ICI, Anomaly Reductions] Improvements, Accomplishment of Sediment Contaminant Reduction Objective and Accomplishment of Total Ecological Restoration Objective and Environmental Risk Assessment.

The assessment/evaluation identified the Deep Dredge scenario as the optimized plan and recommended plan. It removes the amount of contaminated material that needs to be removed,

moderating costs, while meeting River ecological clean-up restoration/preservation goals/objectives. The recommended plan involves deep dredging (environmentally) of approximately 581,000 cubic yards (in situ) of contaminated sediments, 150,000 cubic yards of which is significantly PCB contaminated and would be handled and disposed of in accordance with TSCA regulations.

In the project reach from the Fifth Street Bridge downstream to station 120+00 located about halfway down to the Lake, PAH contamination was considered to be the primary contaminant of concern. Considering this, it was determined that dredging and disposal of approximately 115,000 cubic yards of sediment from this reach would address this problem.

Clean material dredged from the channel area upstream of the Upper Turning Basin and possibly from the Outer Harbor area should be deposited as cover into the Deep Dredge Area for at least one operations and maintenance dredging cycle to expedite clean benthic cover material recovery at no additional O&M cost and likely savings.

Several surface cut and cover alternatives were contemplated. However, these would create several severe project related problems. Such alternatives would not remove all of the TSCA level material and would not meet TSCA clean-up objectives. Such alternatives would leave very high levels of exposed surface PCB contaminated sediments (even to TSCA level) with immediate substantial adverse impacts relative to benthos and the aquatic food chain and potential scour and migration of high level PCB contaminated sediments.

Further, Supplemental Dredging Ecological Restoration/Preservation Measures for Protected Aquatic/Fishery Shallows were developed to address the lack of protected aquatic/fishery shallows in the lower River. Two major problem areas were identified in this regard. From the mouth of the River to the Fifth Street Bridge (Ecological Assessment Area 3) and from the Fifth Street Bridge through the upper navigation channels (Ecological Assessment Area 2). Measures that could be applied to Ecological Assessment Area 3 are very limited since the area continues to be utilized for commercial shipping and docking and transfer of primarily coal, ore, and limestone. One measure that has been considered at other harbors for similar situations is the construction of a man-made aquatic habitat shelf along the channel reach primarily to facilitate movement of fisheries through the reach. More opportunity and better measures can be applied to Ecological Assessment Area 2. Measures considered for these reaches, in this regard, included acquisition of river shoreline property, and construction of aquatic/fishery shallows, as possible. This would include a mix of aquatic and shoreline

plantings, stone/gravel bottom areas, and cover structures. The areas would be interfaced with the lake/river regime and would provide passage, cover, feeding, and spawning habitats.

Three incremental plans were developed and assessed/evaluated for Ecological Assessment Area 3 and four incremental plans were developed and assessed/evaluated for Ecological Assessment Area 2. Considering developed ecological restoration/preservation goals/objectives, primary assessment/evaluation output measures included items such as: Costs, Economic Benefits, Practicality, Ecological Improvement (Rank), Shoreline Improvement (Acres), Shallows Improvement (Acres), Fishery Passage Length, Ohio Habitat Assessment Procedures (HAP) Biological Indices (Qualitative Habitat Evaluation Index QHEI, Fishery Index of Biotic Integrity IBI (incl. T&E

Species), Macroinvertebrate Invertebrate Community Index ICI) Improvements, and Accomplishment of Supplemental Ecological Restoration Objective.

The assessment/evaluation identified **2. Aquatic/Fishery Shelf Plan** for the Ecological Assessment Area 3 problem area and **4. Acquire Conrail Slip and Aquatic/Fishery Shelf Cut Plan** for the Ecological Assessment Area 2 problem area. This constitutes ecological restoration, as possible, for loss of protected aquatic/fishery shallows due to facilitated structural (i.e. bulkheading, channelization), and activities impacts. These are practical optimized plans of moderate cost providing problem area protected aquatic/fishery shallows of substantial length which accomplish, as possible, goals/objectives, in this regard. The areas would be interfaced with the lake/river regime and would provide passage, cover, feeding, and spawning habitat.

Other long-term dredging measures recommended in this regard include:

- * Maintain long-term channel maintenance dredging upstream of the Fifth Street Bridge to recreational navigation depths as is being done at present. This will provide aquatic shallow areas along the lower River shoreline in the distant future at no cost.

- * Decrease the width of the maintained recreational navigation channel to the west upstream of the Fifth Street Bridge between the Conrail slip and the Upper Turning Basin about eight feet or more, as possible. This will provide additional aquatic shallow area along the east embankment in the distant future at no cost and likely savings.

It is expected that within several years of project implementation sediment and benthos quality will be improved markedly; and, that within another few years the area fishery will be improved markedly. It is expected that the project will accomplish project goals/objectives and remediate the six beneficial use impairments identified with the exception of limitations along the commercial channel area. Several monitoring programs will be conducted within five to ten years of project completion to assess/evaluate this.

The 312(b) *and* 206 assessment/evaluation found the project, which is estimated at a total cost of \$56,500,000, to be justified under the *authorities*. Both ecological and economic total and Incremental benefits exceed associated project costs. However, the 312(b) *and* 206 assessment/

evaluation also found that, for both the Dredging Ecological Restoration/Preservation for Substrate Contaminant Removal and Supplemental Dredging Ecological Restoration/Preservation for Protected Aquatic/Fishery Shallows measures, substantial ecological and more moderate economic benefits could be realized in the upstream reach from the Fifth Street Bridge up-stream through to the upstream limit of the project, and substantial economic and more moderate ecological benefits could be realized in the reach from the mouth of the River up to the Fifth Street Bridge (the large vessel commercial channel reach). The latter channel area was examined from a 312(a) perspective. Substantial ecological and economic benefits (primarily from prevention of outflow of contaminants) could also be realized for the Outer Harbor, Lake Erie, and the immediate Great Lakes area.

The project was reviewed per Criteria for Decision Making for Ecological Restoration/Preservation and is found to be: Total and Incrementally Cost Effective, Acceptable to the Ashtabula

River Partnership, Complete, Efficient, Effective, developed and to be implemented in a Partnership Context, and Reasonable in Cost.

Note: Portions of this appendix have been integrated into the Ashtabula River Partnership Comprehensive Management Plan Feasibility Report and Environmental Impact Statement and Appendices. This 312(b) and 206 report does not discuss in significant detail many aspects of the overall project including, for example: selected dredging technologies (Technical Appendix G), dredged material dewatering (Technical Appendix H) and disposal (Technical Appendix N), economic benefits (Technical Appendix Q), and all aspects of impacts to the human and community environment (DRAFT Environmental Impact Statement).

SECTION 312(b) AND 206 ECOLOGICAL RESTORATION/PRESERVATION ANALYSES

TABLE OF CONTENTS

<u>SECTION</u>	<u>PAGE</u>		<u>PAGE</u>
SUMMARY			
TABLE OF CONTENTS			
INTRODUCTION	1		
CORPS FEDERAL INTEREST	1		
ASSESSMENT/EVALUATION OUTPUT MEASURES AND OHIO (HAP)	5		
ECOLOGY	6		
ECOLOGICAL PAST	6		
WITHOUT HARBOR PROJECT CONDITIONS	6		
ECOLOGICAL SETTING	6		
PROBLEMS, GOALS/OBJECTIVES	37		
PROBLEMS	37		
GOALS/OBJECTIVES	40		
WITHOUT ARP PROJECT CONDITIONS	41		
DREDGING ECOLOGICAL RESTORATION/PRESERVATION SCENARIOS FOR SUBSTRATE CONTAMINANT REMOVAL AND ASSESSMENT/EVALUATIONS	43		
DREDGING SCENARIOS	43		
		ENVIRONMENTAL RISK ASSESSMENT AND MANAGEMENT CONSIDERATIONS/RECOMMENDATIONS	50
		RECONTAMINATION ASSESSMENTS	53
		SUPPLEMENTAL DREDGING MEASURES FOR SUBSTRATE COTAMINANT REMOVAL AND ECOLOGICAL RECOVERY	54
		OTHER ASSESSMENT/EVALUATION OUTPUT MEASURES	57
		PCB BIO-ACCUMULATION IN FISH TISSUE AND ADVISORIES	57
		WATER QUALITY	62
		RESTORED BENTHIC HABITAT	62
		OHIO HABITAT ASSESSMENT PROCEDURE	64
		Introduction	
		Ashtabula and Conneaut Physical Habitat for Aquatic Life	
		Fish Community Assessments	
		Macroinvertebrate Community Status	
		External Anomalies	
		Anticipated Ecological Improvements	
		POTENTIAL IMPACT OF PCB RELEASE FROM THE ASHTABULA RIVER TO LAKE ERIE	83
		OPEN LAKE DISPOSAL	88
		ASSESSMENT/EVALUATION REVIEW TABLE AND RECOMMENDATIONS	91

SUPPLEMENTAL DREDGING ECOLOGICAL RESTORATION/PRESER- VATION MEASURES FOR PROTECTED AQUATIC/FISHERY SHALLOWS	94
PROBLEMS, NEEDS, OBJECTIVES REVIEW STATEMENT	94
EXISTING CONDITIONS REVIEW	94
SUPPLEMENTAL ECOLOGICAL MEASURES	94
SUPPLEMENTAL DREDGING ECOLOGICAL RESTORATION/PRESER- VATION MEASURES FOR PROTECTED AQUATIC/FISHERY SHALLOWS AND ASSESSMENT/EVALUATIONS	102
ECOLOGICAL ASSESSMENT PROBLEM AREA 3 PLANS/ASSESSMENTS	102
ECOLOGICAL ASSESSMENT PROBLEM AREA 2 PLANS/ASSESSMENTS	104
SUPPLEMENTAL DREDGING MEASURES	108
RIVER PUMP FLOW AUGMENTATION	109
ASSESSMENT/EVALUATION REVIEW TABLES AND RECOMMENDA- TIONS	117
ECONOMIC VALUES	123
ECONOMIC FRAMEWORK	123
ECONOMIC VALUE	124
National Economic Benefits	
- Navigation	
- Boating	
- Fishing	
- Passive Use Values	
- Change in Property Values	
- Risk Reduction to Lake Erie Walleye Fishery	
Regional Economic Development Benefits	
- Local Economic Impacts	
- Boating	
- Fishing	

PROJECT RECOMMENDATIONS	135
DREDGING ECOLOGICAL RESTORATION/PRESERVATION MEASURES FOR SUBSTRATE CONTAMINANT REMOVAL	135
SUPPLEMENTAL DREDGING ECOLOGICAL RESTORATION/ PRESERVATION MEASURES FOR PROTECTED AQUATIC/ FISHERY SHALLOWS	135
SUMMARY COST AND ASSESSMENT/EVALUATION TABLES	136
MONITORING	137
CRITERIA FOR DECISION MAKING FOR ECOLOGICAL RESTORATION/PRESERVATION REVIEW	138
GENERAL	138
COST EFFECTIVENESS AND INCREMENTAL COST	138
ACCEPTABILITY	140
COMPLETENESS	141
EFFICIENCY	142
EFFECTIVENESS	142
PARTNERSHIP CONTEXT	143
REASONABLENESS OF COST	144
SOME KEY REFERENCES	145
THANKS TO THE COMMITTEE	146
312(b) AND 206 APPENDIX - Ashtabula River Comprehensive Management Plan Economic Analysis	

SECTION 312(b) AND 206 ECOLOGICAL RESTORATION/PRESERVATION ANALYSES

INTRODUCTION

This section discusses Section 312 (b) of the Water Resources Development Act of 1990, Environmental Dredging, as Amended by Section 205 *and* 206 of the Water Resources Development Act of 1996, as promulgated by U. S. Army Corps of Engineers CECW-AA/CECW-OD Policy Guidance Letter No. 49, dated 28 January 1998, and Engineer Circular (EC) 1105-2-210 in regard to the Ashtabula River Partnership Lower Ashtabula River Project.

The primary ecological area of consideration includes that in the Ashtabula River watershed upstream of the harbor area to downstream through the harbor area and out into Lake Erie. The primary degraded harbor channel reaches of concern in this regard are those of the Outer Harbor, to some degree, (Ecological Assessment Area 4), from the mouth of the river upstream to the 5th Street Bridge (Ecological Assessment Area 3), and primarily upstream of the 5th Street Bridge through the harbor upper turning basin (Ecological Assessment Area 2). Reference Figure 1 and 2.

CORPS FEDERAL INTEREST

Per Policy Guidance Letter No. 49 and EC 1105 - 2 - 210, the Corps of Engineers may appropriately consider ecological restoration measures, if the measures pertain to traditional water and associated land resources, and measures are associated with restoration of ecological structure and function (i.e. hydrology and substrate) essentially disrupted by and/or disruption has been facilitated by Corps harbor development and/or activities.

Harbor structural developments and accumulated contaminants have caused significant problems pertaining to benthic and fishery habitat and the ecology and harbor operations and maintenance dredging. The Corps of Engineers has played a significant role in development and maintenance of various harbor features and in facilitating development and maintenance of others. Most of the contaminated sediments have collected within the Federal authorized channels. Reference Figures 2 and 3. Although the channels have acted as settling basins catching sediments and preventing much of the contaminated sediments from migrating out into the Lake, it has generated associated problems in the river. Storm events cause scour and the resuspension of sediments and associated contaminants which periodically compromise water quality standards. Contaminated sediments continue to migrate down stream into the Lower River, Outer Harbor, and Lake Erie. Structural developments (i.e. channelization, bulkheading, etc.) have essentially eliminated aquatic/fishery shallow areas. Dredging and vessel activities have caused resuspension of sediments suffocating bottom organisms and disrupting fish habitat. Specific areas and associated problems are summarized in paragraphs which follow.

Although the Policy Guidance Letter and EC indicate that the Corps should not consider alternatives for purely contaminated sediments clean-up where others may be liable (i.e. hazardous or toxic); there is room for consideration where a connection can be made, as stated previously, and where the project is being pursued through a partnership and mutual partnership benefits can be derived, as is the case for this project.

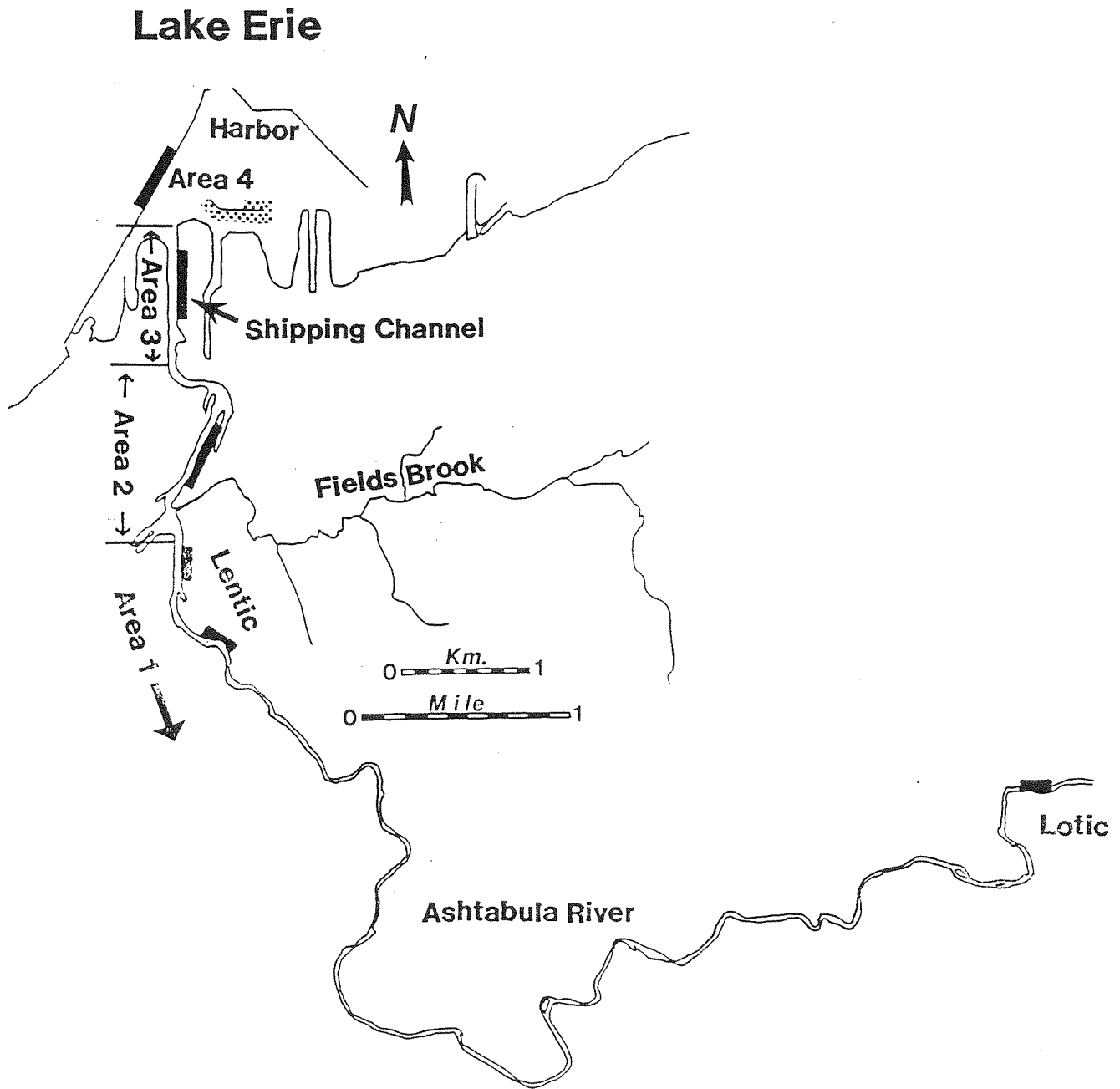
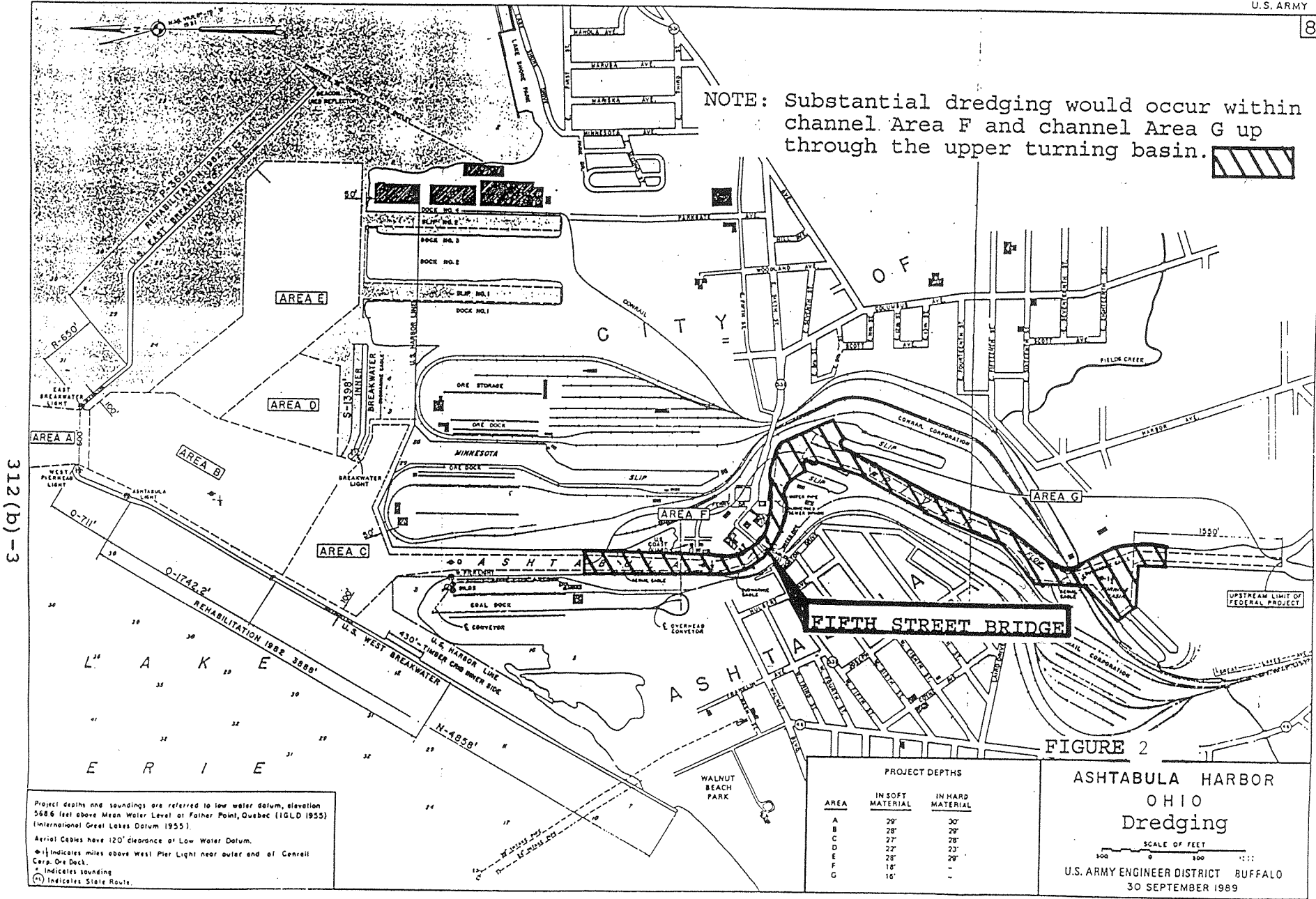

Figure 1 Ashtabula River study area and fish community sampling site locations (shaded areas). Benthic macroinvertebrate sampling sites are contained within the fish community sampling sites.

NOTE: Substantial dredging would occur within channel Area F and channel Area G up through the upper turning basin.



312 (b) - 3

Project depths and soundings are referred to low water datum, elevation 568.6 feet above Mean Water Level at Fairport Point, Quebec (IGLD 1955) (International Great Lakes Datum 1955).
 Aerial Cables have 120' clearance at Low Water Datum.
 ⊕ indicates miles above West Pier Light near outer end of Conrail Corp. Ore Dock.
 * indicates sounding.
 ⊙ indicates State Route.

AREA	PROJECT DEPTHS	
	IN SOFT MATERIAL	IN HARD MATERIAL
A	29'	30'
B	28'	29'
C	27'	28'
D	27'	23'
E	28'	29'
F	18'	-
G	16'	-

FIGURE 2
 ASHTABULA HARBOR
 OHIO
 Dredging
 SCALE OF FEET
 100 0 100 100
 U.S. ARMY ENGINEER DISTRICT BUFFALO
 30 SEPTEMBER 1989

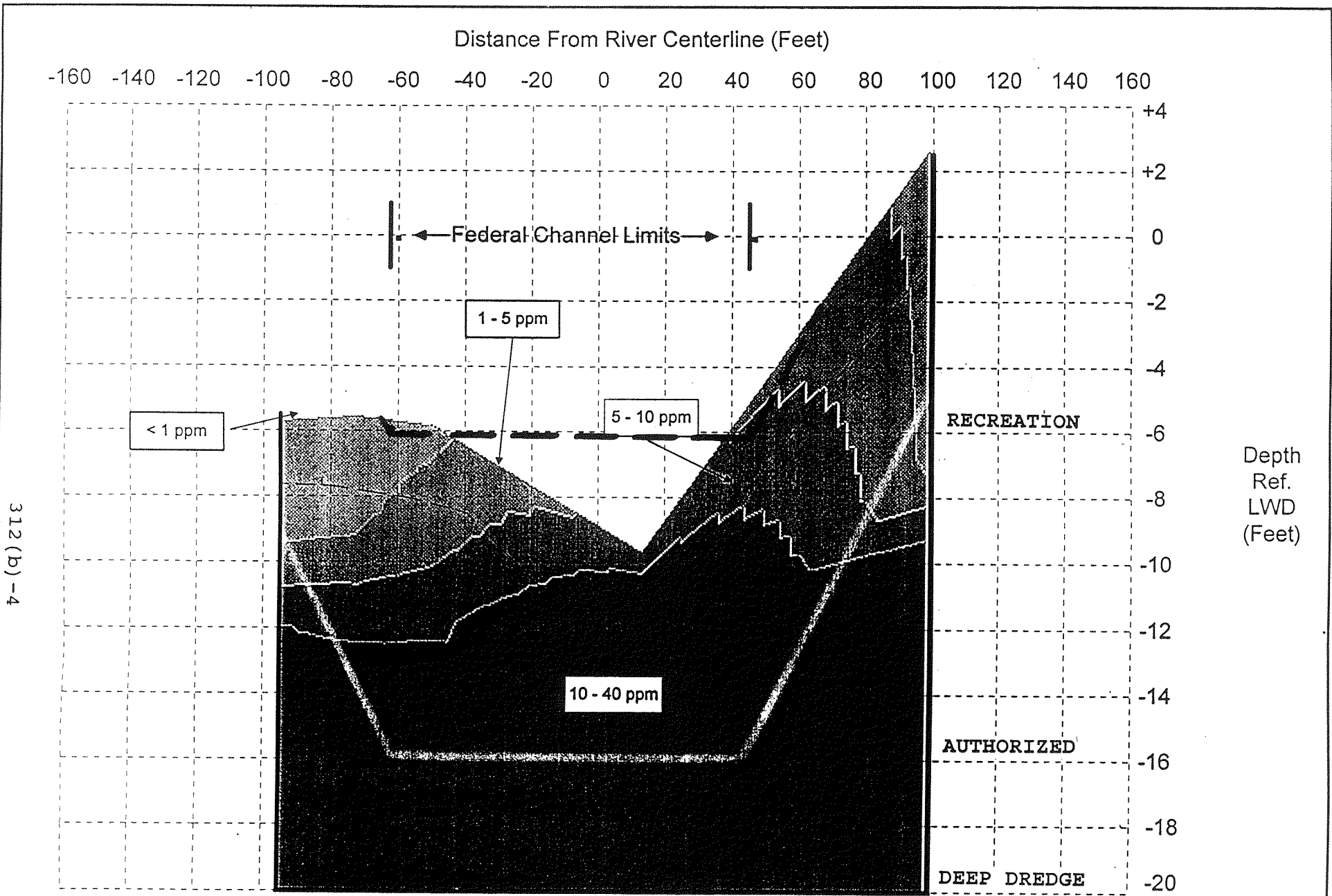

FIGURE 3 TYPICAL CROSS SECTION PCBs ppm
Ashtabula River Cross Section 168+00

--- Scour Impact
 — Dredge Lines

Depth measurement is shown exaggerated by a factor of 10.

The project will also contribute to International agreement objectives, primarily those associated with the Great Lakes Water Quality Agreement of 1978, as amended.

The lower Ashtabula River and lake nearshore has been identified as a Great Lakes Area of Concern (AOC) by the International Joint Commission primarily due to impaired use and impacts to the ecology due to contaminated sediments and shoreline structural and functional changes. Primary contaminants of concern include PCBs, PAH, metals, and others. The Lake Erie/Ashtabula River Area of Concern has been identified as a priority area for remediation in Section 205 of WRDA 96 and in the U.S. Army Corps of Engineers PGL No. 49 section 5. c. Problems are being addressed through a partnership effort.

ASSESSMENT/EVALUATION OUTPUT MEASURES AND OHIO (HAP)

A number of standard engineering, economic, and environmental measures are used to assess/evaluate alternative scenarios. In addition, an ecological Habitat Assessment Procedure (HAP) developed by the State of Ohio is utilized to provide an assessment/evaluation of existing conditions and alternative scenarios.

The Ashtabula Area of Concern lies within the Erie/Ontario Lake Plain ecoregion. The ecology of a region has a significant impact on the type of biological community that region will support. Knowledge of the ecology of an area allows one to anticipate what type of ecological community the area will support. An assessment of the biological community can be compared with the standards for that particular ecoregion to evaluate whether or not the area is impacted by pollution, developments, and/or activities. (RAP, 1991)

The ecological assessment area includes that in the Ashtabula River watershed upstream of the harbor area to downstream through the harbor area and out into the Lake.

The Ohio Environmental Protection Agency has developed a Habitat Assessment Procedure (HAP) based on the premise of ecological analyses. They have inventoried a number of ecosystems examining habitat, fisheries, macroinvertebrate, and community and have been able to develop a number of assessment/evaluation indices accordingly. These include such indices as the QHEI - Qualitative Habitat Evaluation Index, the IBI - Index of Biotic Integrity, MIwb - Modified Index of well being, and the ICI - Invertebrate Community Index. Comparing data and utilizing these measures can provide an assessment for ecological potential, conditions, degradation or ADV - area of degradation values, likely causes, and improvement measures.

The Ohio Habitat Assessment Procedure (HAP) is presented and discussed in detail in the following documentation:

Biological Criteria for the Protection of Aquatic Life:

- * Volume I: The Role of Biological Data in Water Quality Assessment, July 1987, OEPA.
- * Volume II: Users Manual for Biological Field Assessment of Ohio Surface Waters, October 1988, OEPA.
- * Volume III: Standardized Biological Field Sampling and Laboratory Methods for Assessing Fish and Macroinvertebrate Communities, September 1989, OEPA.

* The Qualitative Habitat Evaluation Index: Rationale, Methods, and Application; November 1989; OEPA.

The Ohio Habitat Assessment Procedure assessments/evaluations will serve to provide primary project ecological output measures.

ECOLOGY

ECOLOGICAL PAST

Past history suggests that the Ashtabula River was once a highly productive fishery. Indeed, the name Ashtabula originated from an Iroquis Indian word meaning "river of many fish". Early settlers survived hard winters and the rigors of the War of 1812 by eating river fish. (Ashtabula River RAP, OEPA, 12/1991)

WITHOUT HARBOR PROJECT CONDITIONS

If the Harbor had never been constructed, natural Lake/River interface conditions would likely exist with natural hydrologic/shoaling and riparian shoreline conditions (shallows and cover), likely including more and improved lineal riparian wetland areas but, fewer man-made slip wetlands. Quality Warm Water Habitat (WWH) conditions would likely exist. Although up-land industrial developments (partial sources of contaminants) are not harbor dependent, the harbor and associated community developments and infrastructure likely had some influence in their development. There would likely have been less of these industrial developments without the harbor and community developments and infrastructure and less contamination to the river.

ECOLOGICAL SETTING

The Great Lakes and Lake Erie. Ashtabula River flows into the central basin of Lake Erie. Lake Erie is one of the five Great Lakes. The Great Lakes -- SUPERIOR, MICHIGAN, HURON, ERIE, and ONTARIO -- are located in east central North America at the border between Canada and the United States. With an area of 95,145 square miles, they are collectively the world's largest body of fresh water. The lakes' drainage basin of some 295,000 square miles extends 690 miles north to south and 860 miles west to east. The lakes drain generally from west to east through the Saint Lawrence River/Seaway into the Atlantic Ocean. (Grolier).

Lake Erie, fourth in size of the five North American GREAT LAKES, is situated between Ontario, Canada, to the North, and the United States -- abutting New York, Pennsylvania, Ohio, and Michigan. The lake is 241 miles long and 57 miles across at its widest point. Its surface area is 9,930 square miles. The shallowest of the five Great Lakes, it has a mean depth of 58 feet. Numerous rivers/creeks flow into Lake Erie including from the United States: the Detroit, the Huron, the Raisin, the Maumee, the Sandusky, the Black, the Cuyahoga, the Grand, the Ashtabula, Chatauqua, Canadaway, Cattaraugus, Eighteen Mile, and the Buffalo River. The lake discharges into the Niagara River, which flows over Niagara Falls and into Lake Ontario. (Grolier).

Lake Erie is the shallowest and warmest of the Great Lakes, holds the least amount of water and has the fastest flow through time for its waters. It is also the most biologically productive and has the greatest diversity of fish species. More than 130 species from at least 24 different families range throughout its wide variety of habitats. Many species reach their greatest abundance here, providing one of the world's largest fresh water fisheries and more fish protein than all other Great Lakes combined. Lake Erie supplies fish and fish protein to people all over the world including the 13 million people living along its shore. Most sought after sport and commercial

fish in the Lake Erie Central Basin include, (Sport): Walleye (*Stizostedion vitreum*), Yellow Perch (*Perca flavescens*), Smallmouth Bass (*Micropterus dolomieu*), Rainbow Trout (*Oncorhynchus nykiss*); and (Commercial): Walleye, Yellow Perch, Rainbow Smelt (*Osmerus mordax*), and White Bass (*Morone chrysops*). (LAMP)

Ashtabula Harbor is located on both the Atlantic and Mississippi flyways with over three million ducks and geese using this corridor on a north-south and east-west routes (Bellrose, 1976). Many species use the harbor and adjacent areas as a resting and/or feeding areas during migration while a few species nest in the area. Gulls and terns nest on the outer break-walls. In addition to water fowl, many species of shorebirds, hawks, woodpeckers, and song-birds inhabit the area. This may be attributed to the abundant water, shoreline, wetland, and wooded upland in the area. Ashtabula County is reported to have more birds than any other county in Ohio.

Over the last 200 years, the Lake Erie ecosystem has experienced many rapid changes due to a wide range of human activities. Primary problems include: pollution, shoreline structural and functional changes, and introduction of foreign species.

The Ashtabula River and Harbor. The Ashtabula River is a major United States tributary to the Lake Erie Central Basin.

General Physical Characteristics: The Ashtabula River basin, (not including Conneaut Creek and Lake Erie tributaries), drains an area of 137.14 square miles or 87,770 square acres. The Ashtabula River mainstem originates in eastern Ashtabula County. In general, the Ashtabula River flows in a northwesterly direction, to the City of Ashtabula, where it discharges to Lake Erie. The mainstem is 39.7 river miles in length (including West Branch). The Ashtabula River mainstem falls an average gradient of 11.6 feet per mile, (from an elevation of 1033 to 573 feet above mean sea level). Principal tributaries to the Ashtabula River include Ashtabula Creek, Hubbard Run, West Branch, and East Branch. No significant surface water impoundments are located within the Ashtabula River watershed.

Geology and Geography: The Ashtabula River watershed is situated within the gently rolling dissected glacial plateau of the Erie/Ontario Lake Plain ecoregion. During the Pleistocene era varying thickness of glacial drift were deposited over Devonian shales. The majority of this watershed exists in ground moraines and end moraines. Sediments deposited by former beach ridges, arranged parallel to the existing Lake Erie shoreline, are composed of sand, gravel, and cobble. The preglacial valleys within the underlying bedrock shale were buried by glacial clays, sands, and gravels down to depths of 200 feet from ground surface. The watershed is primarily woodland and agricultural in the upper basin, and primarily developed and industrial in the lower basin.

Ashtabula Harbor. Ashtabula Harbor is located at the mouth of the Ashtabula River on the south shore of Lake Erie Ashtabula County, Ohio. It is a significant Great Lakes and St. Lawrence Seaway harbor. The existing Federal navigation project consists of a breakwater protected Outer Harbor in Lake Erie and an interior harbor in the Ashtabula River. The Outer Harbor includes a system of channels with turning basins and encompasses about 185 acres. The interior harbor consists of a channel and a turning basin and extends upstream to approximately river

mile 1.8. The river channel from the mouth upstream to the Fifth Street Bridge (0.7 miles) is commercial. Commodities, such as limestone, iron and other ores, coal and other bulk commodities, pig iron, iron products, raw rubber, and general cargo, transit the harbor. The river channel from the Fifth Street Bridge through the upper channel area is no longer maintained for commercial navigation; but, is utilized primarily for recreational navigation. Several marina developments docking hundreds of recreational vessels are situated along the lower river and harbor. Some ecological problems associated with harbor developments were summarized previously and will be discussed in future paragraphs.

Sediment Quality and Problems. The Ashtabula River Partnership (ARP) has investigated problems and needs pertaining to contaminated sediments in the Lower Ashtabula River. Available information on sediment quality in the Ashtabula River Area of Concern was presented in the Ashtabula River Remedial Action Plan (OEPA 1991) and summarized in associated sections of the Ashtabula River Partnership Environmental Impact Statement. These contaminants have resulted in restricted: operations and maintenance dredging and disposal of dredged material, and full environmental, economic, and social use and development of the harbor.

Over the years, run-off from urban and primarily industrial developments (most of the latter are located along Fields Brook) have resulted in the contamination of water and sediments in adjacent streams (i.e. Fields Brook) and the lower Ashtabula River. Inorganics (such as cadmium, mercury, and arsenic) and organic compounds (such as PCBs, some in excess of 50 mg/kg., and industrial solvents) are the major types of contaminants found in sediments. Sediments with PCBs equal to or in excess of 50 mg/kg are regulated under the Toxic Sub-stance Control Act (TSCA) and must be appropriately handled and disposed of. Other sediments with elevated levels of contaminants may not be disposed of at open lake disposal sites and must be appropriately disposed of by alternate disposal methods.

The lower Ashtabula River has been identified as a Great Lakes Area of Concern by the International Joint Commission. The Area of Concern has been designated as the lower two miles of the Ashtabula River, including Fields Brook, and the nearshore areas of Lake Erie.

Fields Brook has been placed on the USEPA National Priorities List of uncontrolled hazardous waste sites (Superfund), and is being remediated under that authority. Remediation must be completed before this project action is implemented.

Most of the contaminated sediments have settled into the Lower River channel reaches from the Upper Turning Basin (where Fields Brook enters) downstream to the Fifth Street Bridge and from the Fifth Street Bridge downstream to river reach Station 120, about half way between the Fifth Street Bridge and the mouth of the River. Reference Figure 4. Contaminated sediments have been settling into the Lower River channels since the beginning of industrial developments in the vicinity (~1820). Deep dredge commercial navigation channels (-18 and -16 feet LWD) have not been maintained in the problem area from Station 120 to the turning basin just upstream of the Fifth Street Bridge since 1979 and from the turning basin just up-stream of the Fifth Street Bridge to the upstream Federal channel limits since 1962 due to contaminated sediments which require confined disposal. No economical disposal facility has been available. Upper channel commercial navigation developments (excluding some charter fishing) are gone. Channels have

NOTE: Substantial dredging would occur within channel Area F and channel Area G up through the upper turning basin. 

312 (b) -10

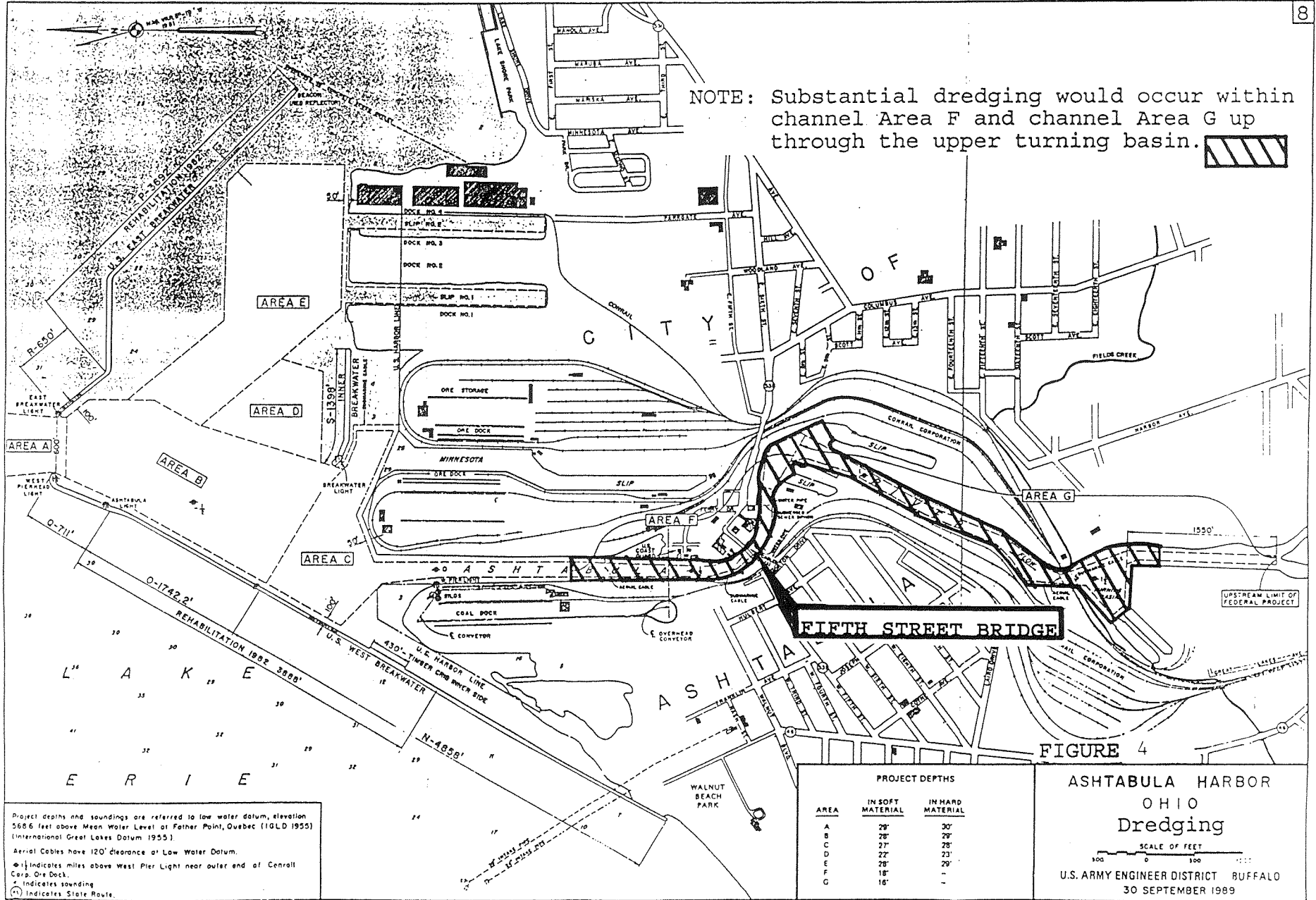

PROJECT DEPTHS

AREA	IN SOFT MATERIAL	IN HARD MATERIAL
A	29'	30'
B	28'	29'
C	27'	28'
D	22'	23'
E	28'	29'
F	18'	-
G	18'	-

ASHTABULA HARBOR
OHIO
Dredging

SCALE OF FEET
300 0 300

U.S. ARMY ENGINEER DISTRICT BUFFALO
30 SEPTEMBER 1989

Project depths and soundings are referred to low water datum, elevation 5686 feet above Mean Water Level at Father Point, Quebec (IGLD 1955) (International Great Lakes Datum 1955).
Aerial Cables have 120' clearance at Low Water Datum.
● indicates miles above West Pier Light near outer end of Conrail Corp. Ore Dock.
○ indicates sounding
⊙ indicates State Route.

312 (b) -11

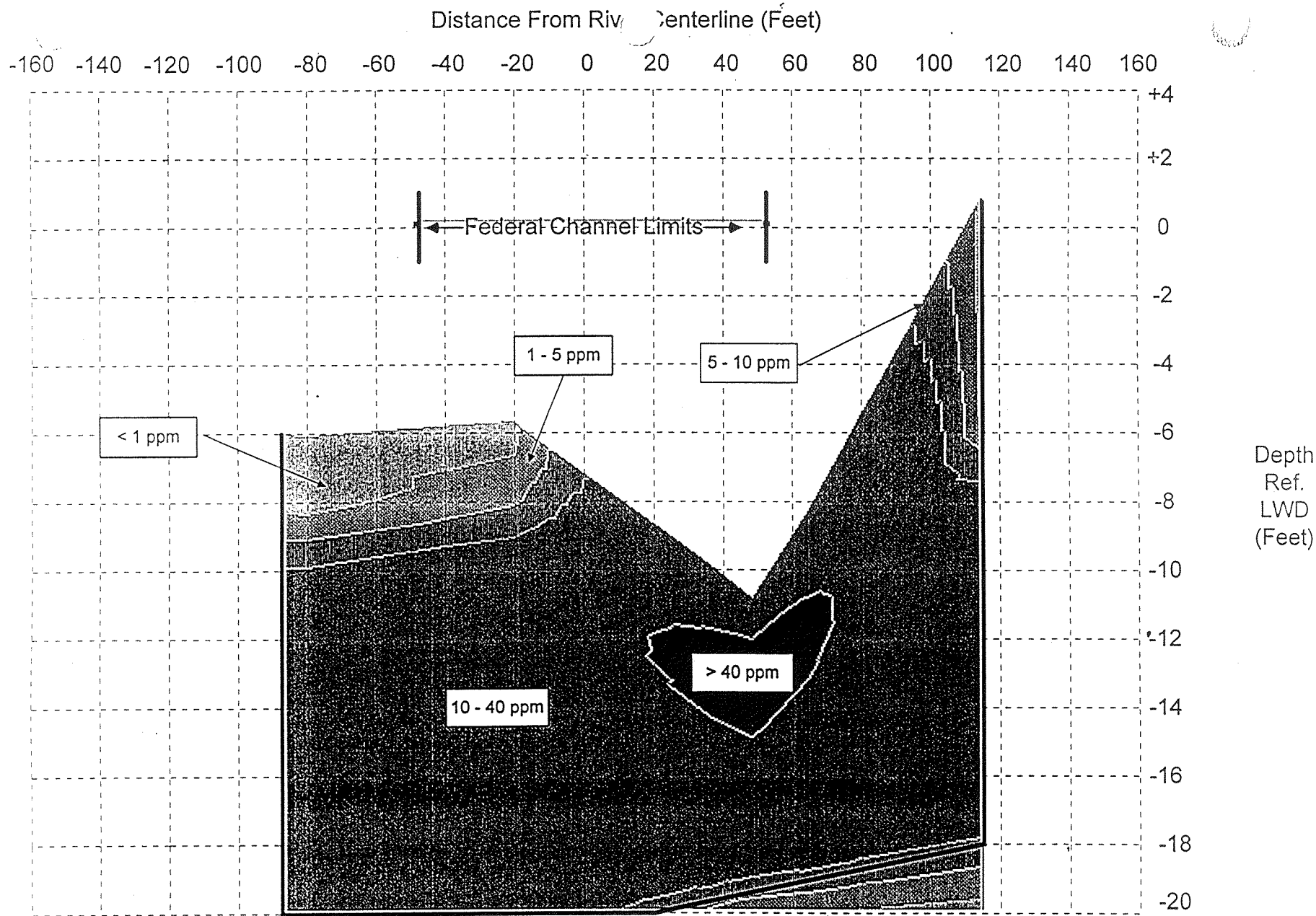

— Dredge Lines
PCBs ppm

Figure 5
Ashtabula River Cross Section 170+00

Depth measurement is shown exaggerated by a factor of 10.

Table 1. Pollutants identified in the Ashtabula River Area of Concern. This table was compiled from the results of a number of studies conducted in the area since 1975. This table documents only positive identification of pollutants.

ASHTABULA RIVER RAP

PARAMETER	PRIORITY POLLUTANT	CARCINOGEN	PERSISTANT TOXIC*	WATER				SEDIMENT				FISH
				OUTER HARBOR	ASHTABULA RIVER	FIELDS BROOK	LAKE ERIE	OUTER HARBOR	ASHTABULA RIVER	FIELDS BROOK	LAKE ERIE	
<u>Inorganics</u>												
Aluminum	N	N	N	X	X	X	-	X	X	X	-	-
Arsenic	Y	Y	Y	-	-	-	X	X	X	X	X	X
Barium	N	N	N	X	X	X	X	X	X	X	X	-
Beryllium	Y	Y	-	-	-	-	-	X	X	X	-	X
Cadmium	Y	N	Y	X	X	X	X	X	X	X	X	-
Chromium	Y	N	Y	X	X	X	X	X	X	X	X	-
Copper	Y	N	Y	X	X	X	X	X	X	X	X	X
Cyanide	Y	N	N	-	X	-	-	X	X	X	-	-
Iron	N	N	Y	X	X	X	X	X	X	X	X	-
Lead	Y	N	Y	X	X	X	X	X	X	X	X	X
Manganese	N	N	N	X	X	X	-	X	X	X	X	-
Mercury	Y	N	Y	X	X	X	X	X	X	X	X	X
Nickel	Y	N	Y	X	-	-	X	X	X	X	X	-
Nitrogen (Ammonia)	N	N	N	X	X	X	X	-	-	-	X	-
Nitrate + Nitrite	N	N	N	X	X	X	X	-	-	-	X	-
Phosphorus	N	N	N	X	X	X	X	-	-	-	X	-
Oil and Grease	N	N	N	-	-	-	-	X	X	X	-	-
Silver	Y	N	-	-	-	-	-	X	X	X	-	X
Zinc	Y	N	Y	X	X	X	X	X	X	X	X	X
Total Dissolved Solids	N	N	Y	X	X	X	X	-	-	-	-	-
Phenols	Y	N	-	-	-	-	-	X	X	X	-	-
<u>Organics</u>												
Aldrin + Dieldrin	Y	Y	Y	X	X	-	X	-	X	-	-	-
PCBs	Y	Y	Y	-	-	-	X	X	X	X	X	X
<u>PAHs</u>												
Acenaphthene	Y	Y	-	-	-	-	-	X	-	-	-	-
Anthracene	Y	Y	-	-	-	-	-	X	X	-	-	-
Benzo(a)anthracene	Y	Y	-	-	-	-	-	X	X	-	X	-
Benzo(a)pyrene	Y	Y	-	-	-	-	-	X	X	X	X	-
Benzo(b)fluoranthene	Y	Y	-	-	-	-	-	X	X	-	X	-
Chrysene	Y	Y	-	-	-	-	-	X	X	-	X	-
Fluoranthene	Y	Y	-	-	-	-	-	X	X	X	X	X
Fluorene	Y	Y	-	-	-	-	-	X	X	-	-	-
Naphthalene	Y	Y	-	-	-	X	-	X	X	-	-	-
Phenanthrene	Y	Y	-	-	-	-	-	X	X	X	X	-
Pyrene	Y	Y	-	-	-	-	-	X	X	-	-	-
2-chloronaphthalene	-	-	-	-	-	-	-	-	X	-	-	-
Benzo(k)fluoranthene	Y	Y	-	-	-	-	-	-	X	-	-	-
<u>Other Organics</u>												
Acetone	N	N	-	-	-	-	-	-	X	X	-	-
Benzene	Y	Y	-	-	-	-	-	-	-	X	-	-
Bis(2-ethylhexyl) phthalate	Y	N	Y	-	-	-	-	X	X	X	X	-
2-butanone	N	N	-	-	-	-	-	-	X	X	-	-
Butylbenzyl phthalate	Y	N	Y	-	-	-	-	-	X	X	-	-
Chlorobenzene	Y	N	-	-	-	-	X	-	X	-	-	-
Chloroform	Y	Y	-	-	-	X	-	-	-	X	-	-
1,1-dichloroethane	Y	Y	-	-	-	-	-	-	-	X	-	-
Diethyl phthalate	Y	N	Y	-	-	X	-	-	-	X	-	-
Dimethyl phthalate	Y	N	Y	-	-	-	-	-	-	X	-	-
Di-n-butyl phthalate	Y	N	Y	-	-	-	-	-	X	X	-	-
Ethylbenzene	Y	N	-	-	-	-	-	-	X	X	-	-
Fluorotrichloromethane	N	N	-	-	-	-	-	-	-	X	-	-
Hexachlorobenzene	Y	Y	-	-	-	X	X	-	X	X	-	X
Hexachlorobutadiene	Y	Y	-	-	-	X	-	-	X	X	-	X
Hexachloroethane	Y	Y	-	-	-	-	-	-	X	X	-	-
Methylene chloride	Y	Y	-	-	X	X	-	X	X	X	X	-
1,2-Dichlorobenzene	Y	N	-	-	-	X	X	-	-	-	-	-
1,3-Dichlorobenzene	Y	N	-	-	-	X	X	-	X	-	-	-
1,4-Dichlorobenzene	Y	N	-	-	-	X	X	-	X	-	-	-
n-nitrosodiphenylamine	Y	Y	-	-	-	X	-	-	-	-	-	-
Carbon tetrachloride	Y	Y	-	-	-	X	X	-	-	-	-	-
Octachlorostyrene	N	N	-	-	-	-	-	-	X	-	-	X
Xylene	N	N	-	-	-	-	-	-	X	X	-	-
Pentachlorobenzene	N	N	-	-	-	-	X	-	-	-	-	X
1,1,1,2-tetrachloroethane	N	N	-	-	-	-	-	-	X	-	-	-
1,1,2,2-tetrachloroethane	Y	Y	-	X	X	X	-	-	-	X	-	-
Tetrachloroethane	Y	Y	-	X	X	X	-	-	X	X	-	X
1,2-transdichloroethane	N	N	-	-	-	X	-	-	-	X	-	-
1,1,2-trichloroethane	Y	Y	-	-	-	X	-	-	-	X	-	-
1,1,1-trichloroethane	Y	N	-	-	-	-	-	-	-	X	-	-
Trichloroethane	Y	N	-	X	X	X	-	-	X	X	-	X
Toluene	Y	N	-	-	-	-	-	-	X	X	-	-
Vinyl chloride	Y	Y	-	-	-	-	-	-	-	X	-	-
1,2,4-trichlorobenzene	N	N	-	-	-	-	X	-	X	-	-	-
1,2-dichloroethane	Y	Y	-	-	-	X	-	-	-	-	-	-
1,3,5-trichlorobenzene	N	Y	-	-	-	-	X	-	-	-	-	-
1,2,3,4-tetrachlorobenzene	N	Y	-	-	-	-	Y	-	-	-	-	-

* As Identified in the Great Lakes Water Quality Agreement
 Y - Yes
 X - Pollutant detected in medium
 n-n - Pollutant not present or not tested

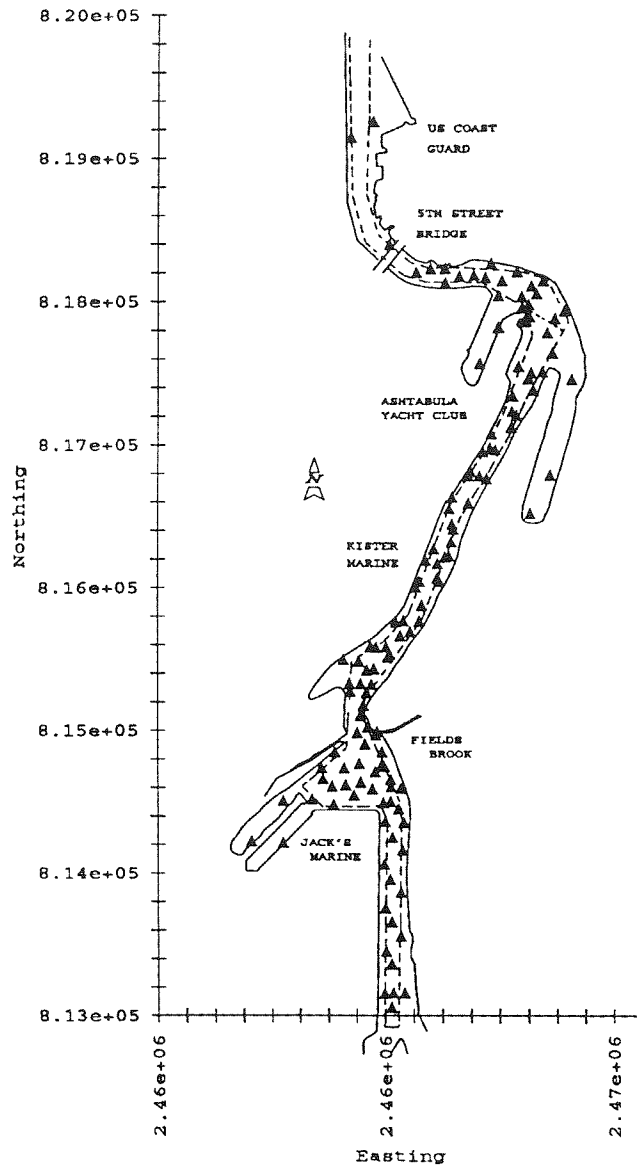

FIGURE 6 : Ashtabula River PCB Sample Locations.

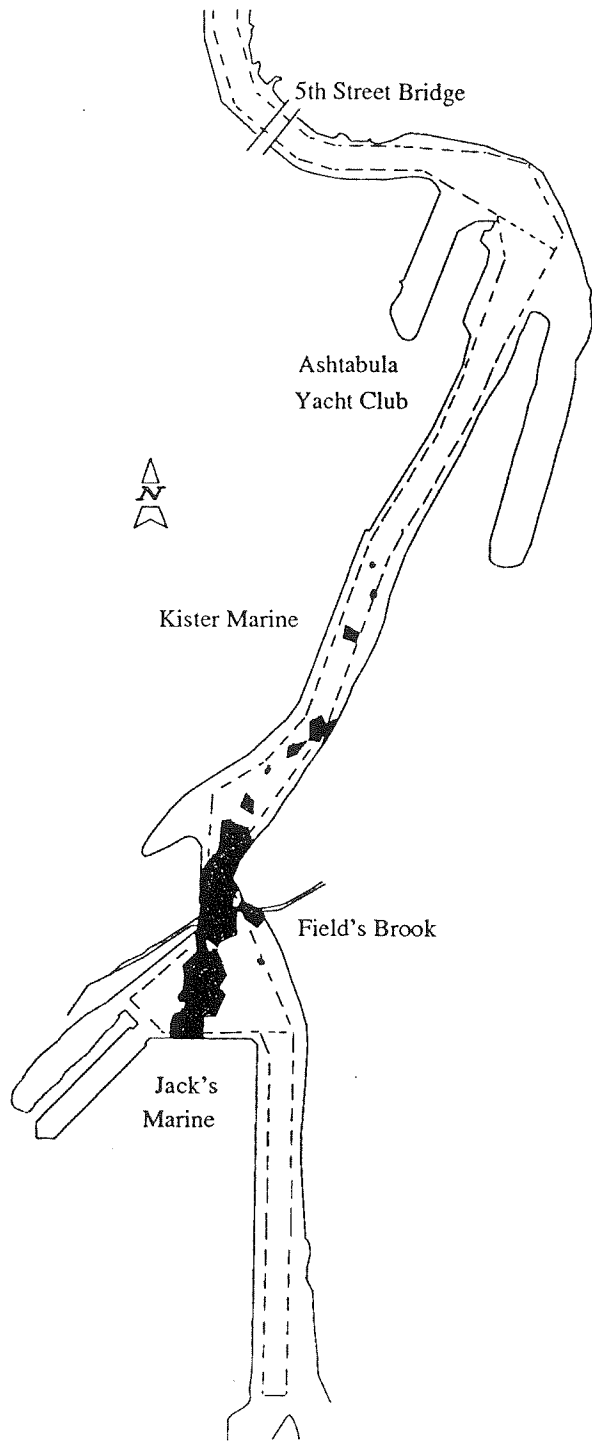

FIGURE 7 : Plan View of 50 ppm PCB Plume Generated From IDW Interpolation
With Quadratic Nodal Functions.

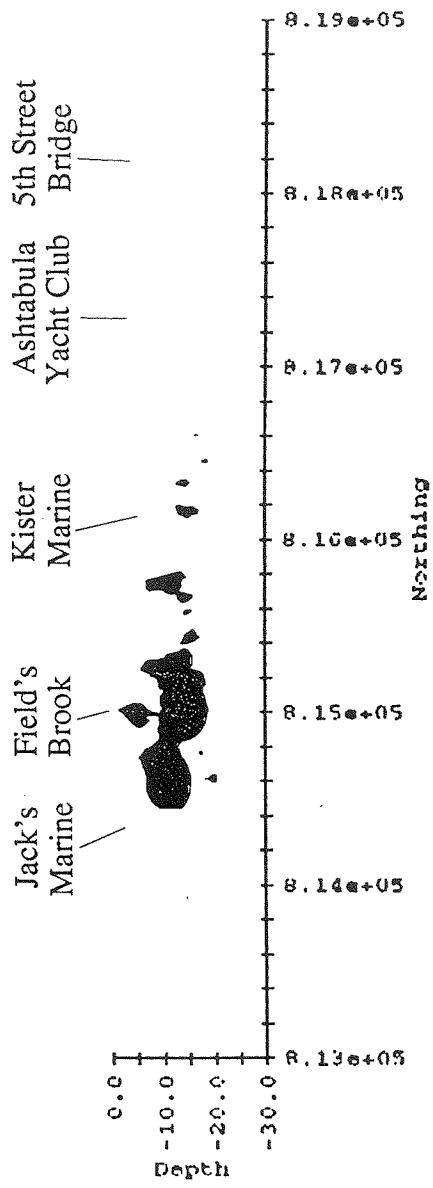

FIGURE 8 : Side View of 50 ppm PCB Plume Generated From IDW Interpolation With Quadratic Nodal Functions.

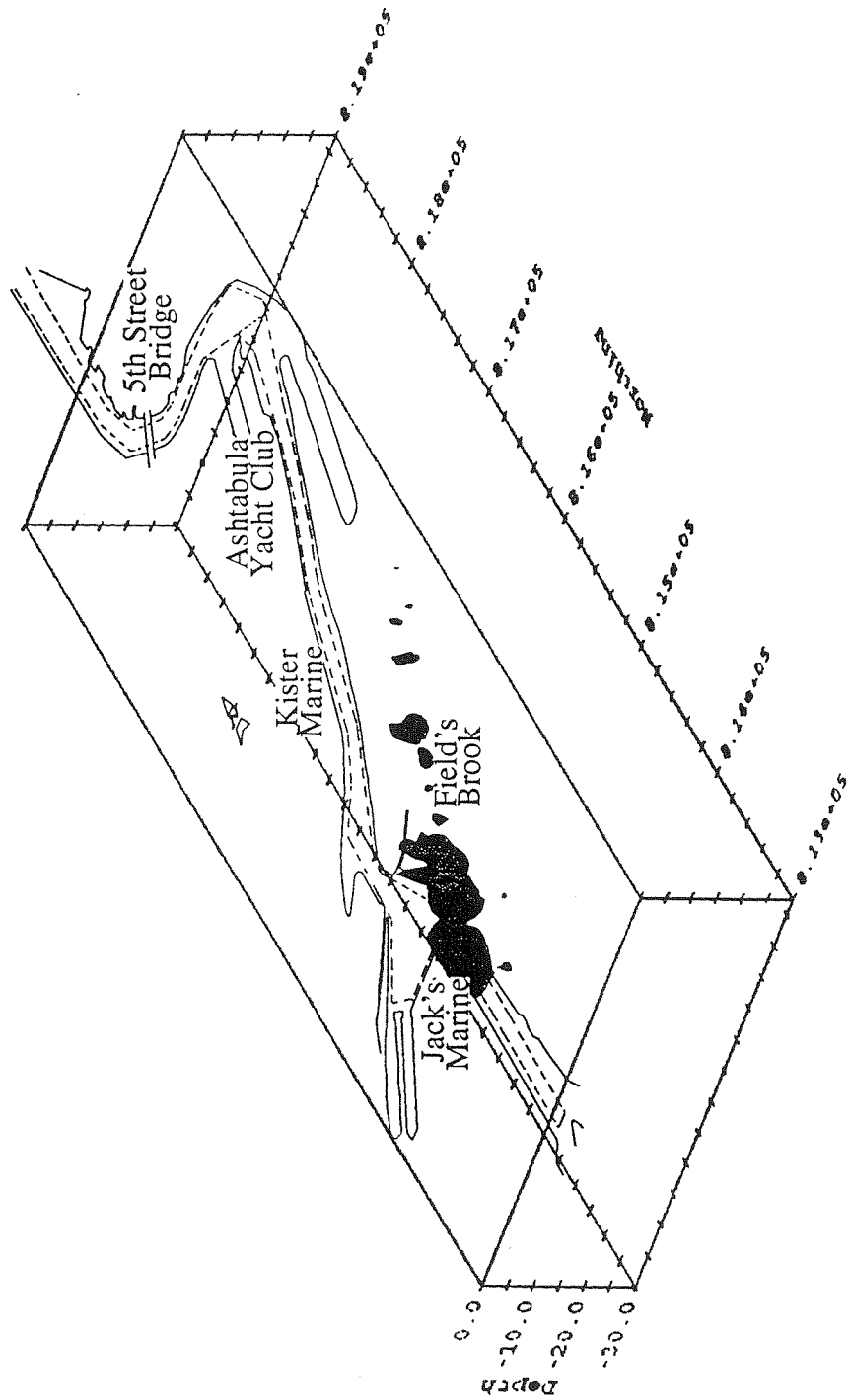

FIGURE 9 Oblique View of 50 ppm PCB Plume Generated From IDW Interpolation With Quadratic Nodal Functions.

Table 2 Surface Area Weighted Sediment Concentrations

Initial Conditions				
Concentration Range (ppm)	Average Concentration (ppm)	Surface Area in Range (sf)	Percent of Total Surface Area	Surface Area Weighted Concentration (ppm)
>50	75	5,019	0%	0.18
40-50	45	12,983	1%	0.28
30-40	35	60,075	3%	1.00
20-30	25	125,701	6%	1.50
10-20	15	204,444	10%	1.46
5-10	7.5	286,404	14%	1.02
1-5	3	434,456	21%	0.62
0-1	0.5	969,437	46%	0.23
Total		2,098,519	100%	6.29

Table 3 Comparison of Sediment Volume and PCB Mass

Initial Conditions					
Threshold Value	Cubic Feet Between Threshold Values	Cubic Yards Between Threshold Values	Cumulative Volume (CY)	Mass Between Threshold Values (kg)	Cumulative Mass (kg)
50 ppm	775,980	28,740	28,740	1735	1735
40 ppm	557,150	20,635	49,375	801	2,537
30 ppm	1,346,300	49,863	99,238	1505	4,042
20 ppm	2,788,900	103,293	202,531	2228	6,270
10 ppm	4,838,500	179,204	381,734	2320	8,589
5 ppm	4,922,400	182,311	564,046	1180	9,769
1 ppm	4,987,100	184,707	748,753	1196	10,964
0.5 ppm	1,144,200	42,378	791,131	27	10,992
0.1 ppm	1,259,800	46,659	837,790	12	11,004
0	8,223,300	304,567	1,142,357	14	11,018

silted in with contaminated sediments in many areas to less than six feet. Contaminant concentrations are deep in the channels and some-what less, but, still high in the surface areas. Reference Figure 5.

1990 and 1995 core sediment sampling and analyses indicates that there is approximately 1,150,000 cubic yards of material in the river that would not be suitable for open-lake disposal, 150,000 cubic yards (bulked, includes a number of dredging considerations) of which is significantly PCB contaminated and would be handled as TSCA material, and would need to be appropriately dredged, dewatered, and disposed of.

The primary contaminant of concern within the reach from the Upper Turning Basin downstream to the Fifth Street Bridge is PCBs. The primary contaminant of concern within the reach from the Fifth Street Bridge to Station 120 is PAHs.

Focus has been on the main contaminants of concern in the Ashtabula River Area of Concern (AOC) due to their level and extent of contamination. Specifically, the focus is on PCBs and to a lesser extent PAHs. There are other contaminants of concern in the AOC, as discussed previously. However, it is assumed that by focusing on PCBs and PAHs, the other contaminants of concern will be addressed due to co-location of contaminants. The contaminants that have been detected in Ashtabula River sediment, surface water, and fish are summarized in Table 1 (Ohio EPA, Stage 1 Report, 1991).

The statistical analysis of 1990 and 1995 Ashtabula River sediment sampling data reported a maximum PCB concentration of 660 mg/kg and 160 mg/kg, respectively and an average concentration of detected samples of 18.2 mg/kg and 15.7 mg/kg, respectively. The sampling locations closest to Fields Brook contain the highest concentrations as expected and decrease with distance down the river.

Utilizing the data from the 1989/1990 (Woodward/Clyde) and the 1995/1996 Ashtabula River Partnership core sediment sampling and analyses reports, the U.S. Army Corps of Engineers Waterway Experiment Station (WES) was able to generate three dimensional depictions of various concentrations of PCB contaminated Ashtabula River sediments. Reference the Feasibility Report Appendix C. Figures 6 through 9 depict PCB Sample Locations, Plan View of 50 ppm PCB Plume, Side View of 50 ppm PCB Plume, and Oblique View of 50 ppm Plume respectively. Tables 2 and 3 depict Surface Area Weighted Sediment Concentrations (PCBs) and Volume of Contaminated Sediment (PCBs) above each of the given threshold value. As noted previously, those sediments with PCB concentrations equal to or greater than 50 parts per million (ppm) must be handled/addressed in accordance with guidelines set forth by the Toxic Substance Control Act, 1976.

For PAHs, to most relevant sediment chemistry data for the lower river is from 1990 and 1992. The highest concentrations (100 - 400 ppm) were found in the vicinity of the Ashtabula Yacht Club inlet and the Fifth Street Bridge and high concentrations (50 - 100) were found in sections of the Lower River and Outer Harbor below the Fifth Street Bridge. Reference Figure 10. PAHs are prime suspects for poor mortality rates for bioassays conducted on harbor sediment samples from the area downstream from the Fifth Street Bridge.

Ashtabula River: 1990 and 1992 PAH Samples

FIGURE 10

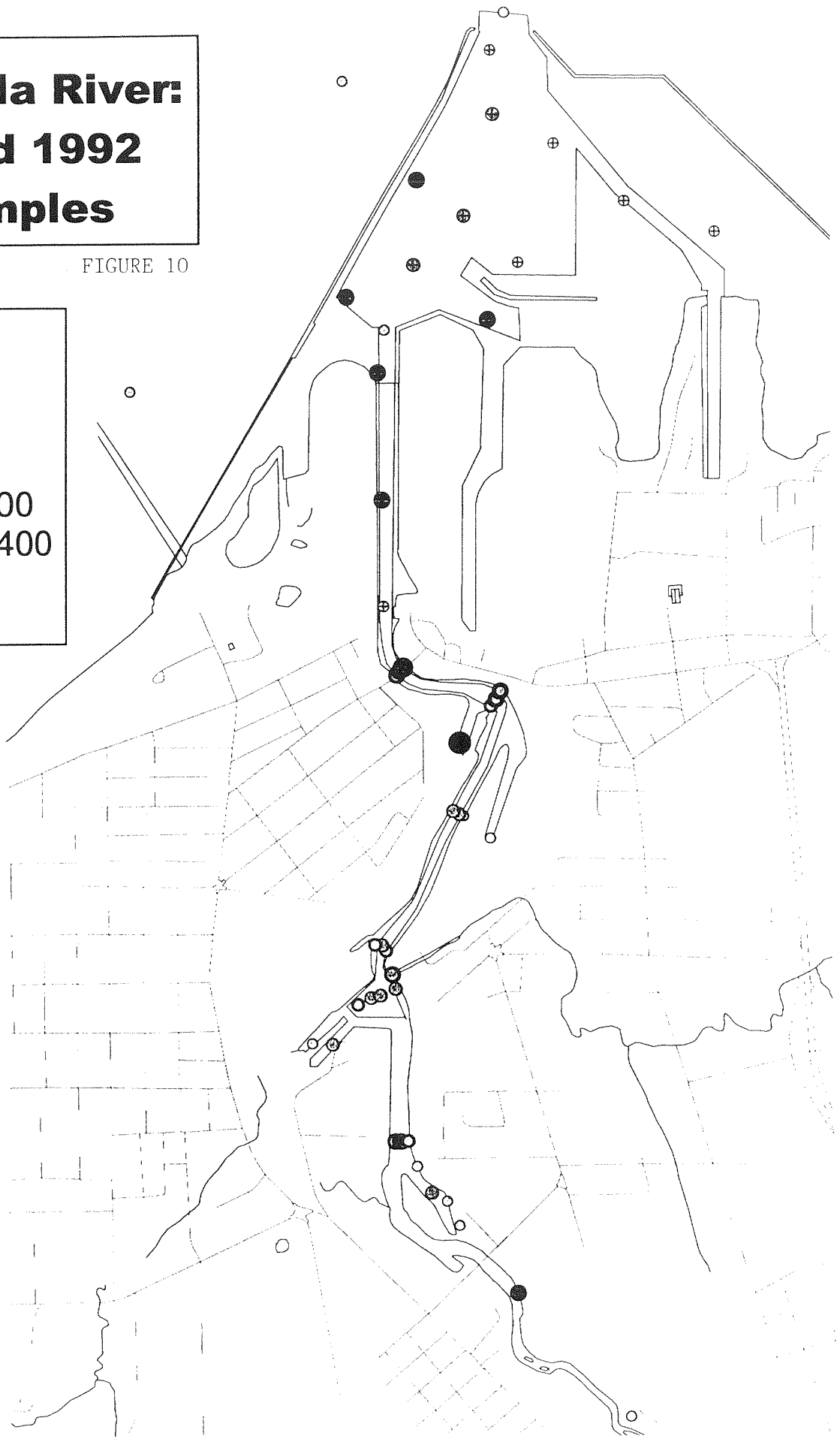
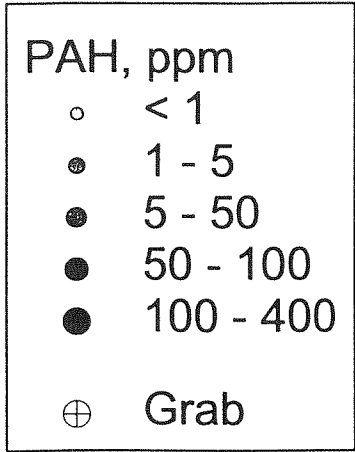

Table 4 Indication of Movement of Contaminated Sediments Based on O&M Sediment Sampling and Analysis for PCBs From Stations in the Lower River and Immediate Outer Harbor.

Year	Previous Sample Year	Sample Site	PCB Concentration				Note	Open Lake Disposal Parameter
_____	<u>Dredged</u>	<u>(mg/kg unless noted otherwise)</u>						
1980	1979	(2)	(4)	(5)	(7)		(1248)	< 10 ppm
08/80	12/79	6.7	0.9	1.3	1.8		Dry	
1984	1983	(2)	(3)	(4)	(5)		"	"
05/84	07/83	0.8	1.1	0.7	0.2			
	09/83							
1985 (Significant Storm Event Year)								
1988	1987	(2)	(3)	(4)	(5)		"	"
05/88	06/87	5.3	3.2	1.8	2.0			
	06/87							
1992	1990	(1)	(2)	(3)	(4)	(5)	(6)	" < 1 ppm
		0.8	0.6	0.7	0.2	0.2	0.3	
1992		R-17	R-18	R-19				Ref. Site
		<0.1	<0.3	<0.2				
1993	1990	R-1	R-2	R-3	R-4	R-5		Bioassay Mortality
		Low	Low	High	High	High		

Note: Sample site locations approximate to 1992 sample site locations.

Sampling Analysis Consultants

- 1980 - Recra Research Inc.
- 1984 - Aqua Tech
- 1988 - T.P. Associates
- 1992 - ARDL
- 1993 - ES&E

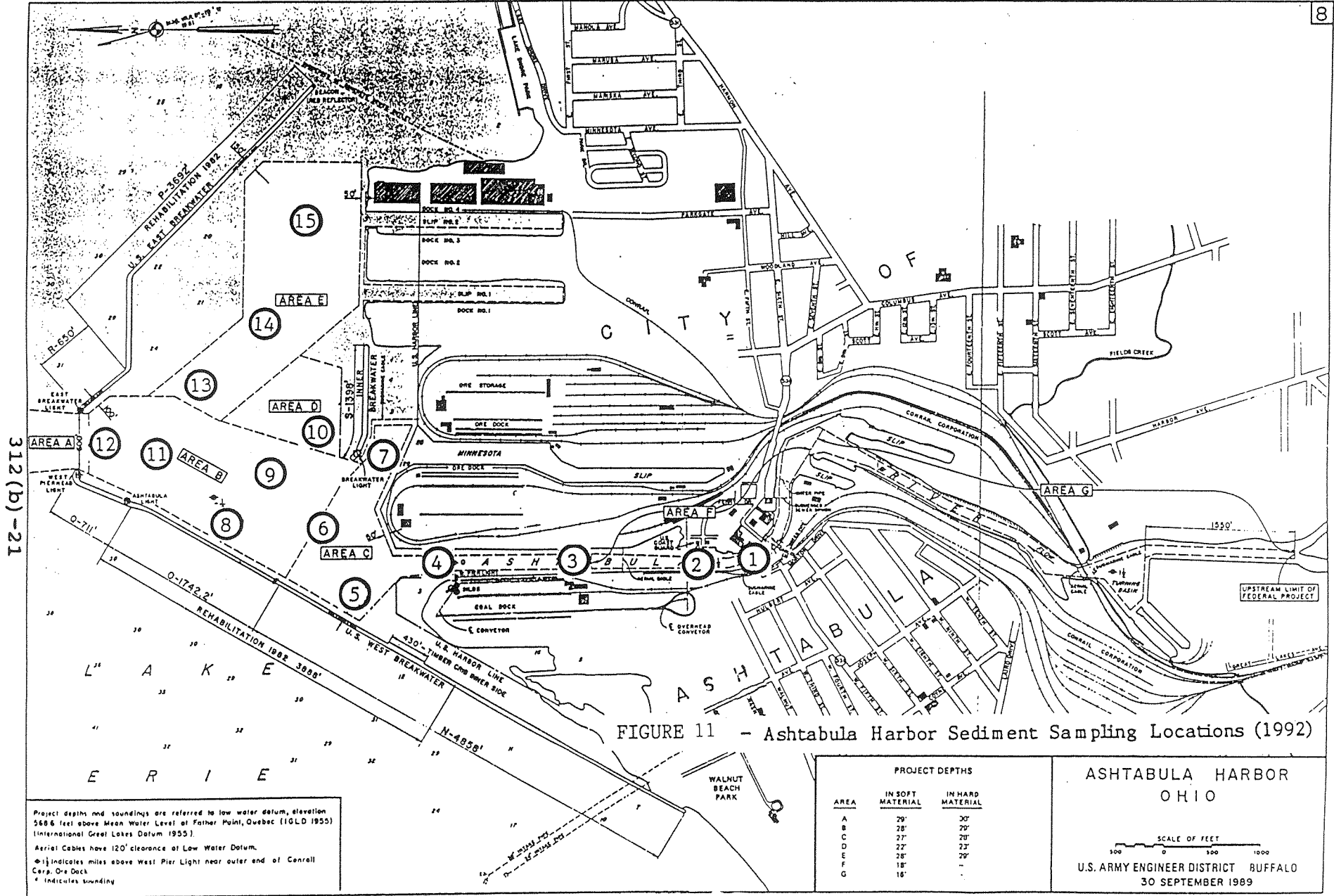

312 (b) -21

FIGURE 11 - Ashtabula Harbor Sediment Sampling Locations (1992)

Project depths and soundings are referred to low water datum, elevation 568.6 feet above Mean Water Level of Father Point, Quebec (IGLD 1955) (International Great Lakes Datum 1955).
 Aerial Cables have 120' clearance at Low Water Datum.
 * indicates miles above West Pier Light near outer end of Conrail Corp. Ore Dock
 * indicates boundary

AREA	PROJECT DEPTHS	
	IN SOFT MATERIAL	IN HARD MATERIAL
A	20'	30'
B	28'	20'
C	27'	20'
D	22'	23'
E	28'	20'
F	18'	-
G	18'	-

ASHTABULA HARBOR
OHIO

SCALE OF FEET
0 100 1000

U.S. ARMY ENGINEER DISTRICT BUFFALO
30 SEPTEMBER 1989

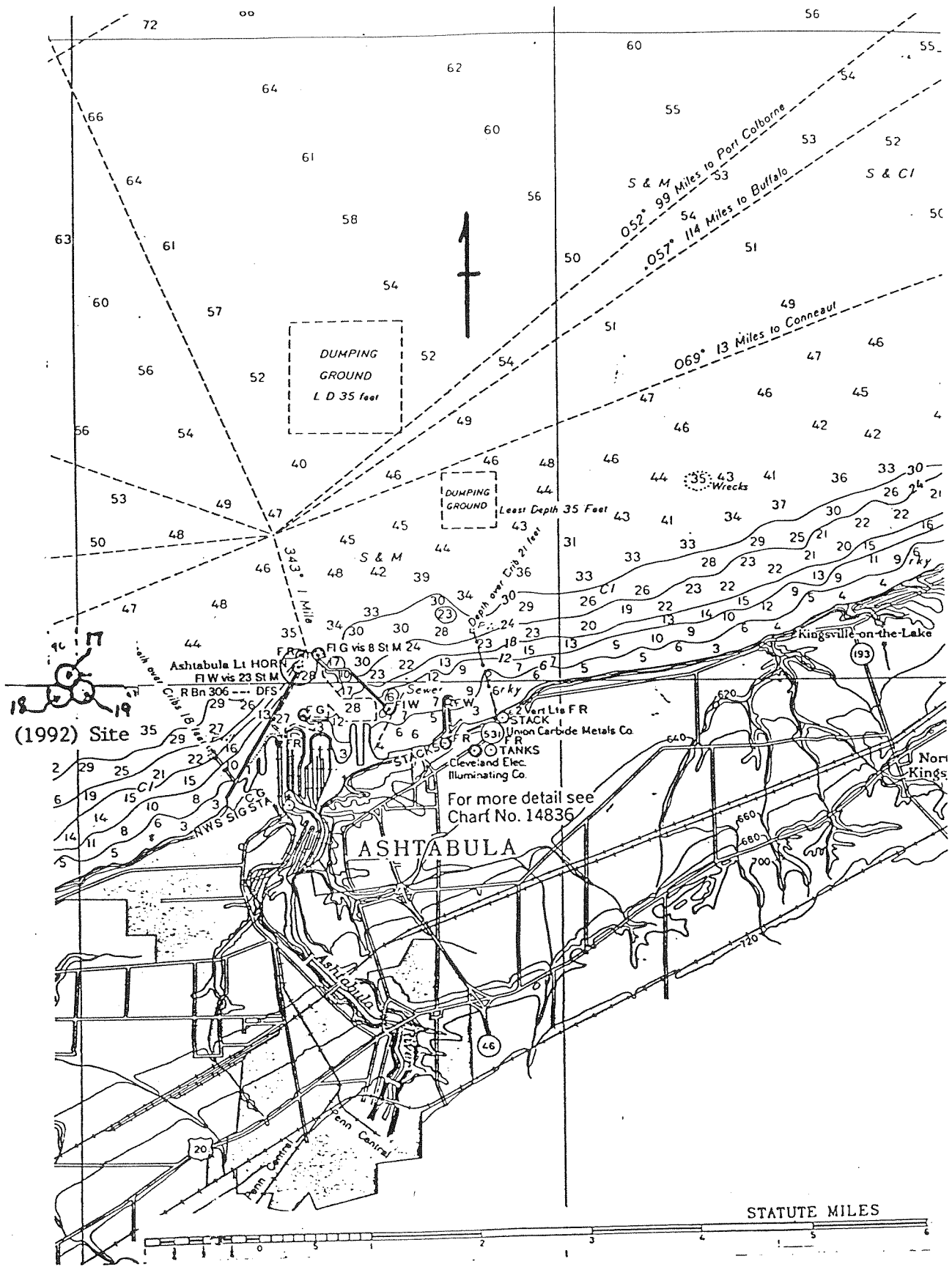

FIGURE 12 Ashtabula Harbor Open Lake Disposal Sites and Reference Sediment Sampling Locations.

ASHTABULA HARBOR, OHIO
PARTNERING CDF SITING
OPEN LAKE DISPOSAL SITE

FIGURE Sediment sampling sites for Ashtabula Lower River and Outer Harbor sediments.

CORPS OF ENGINEERS

U.S. ARMY

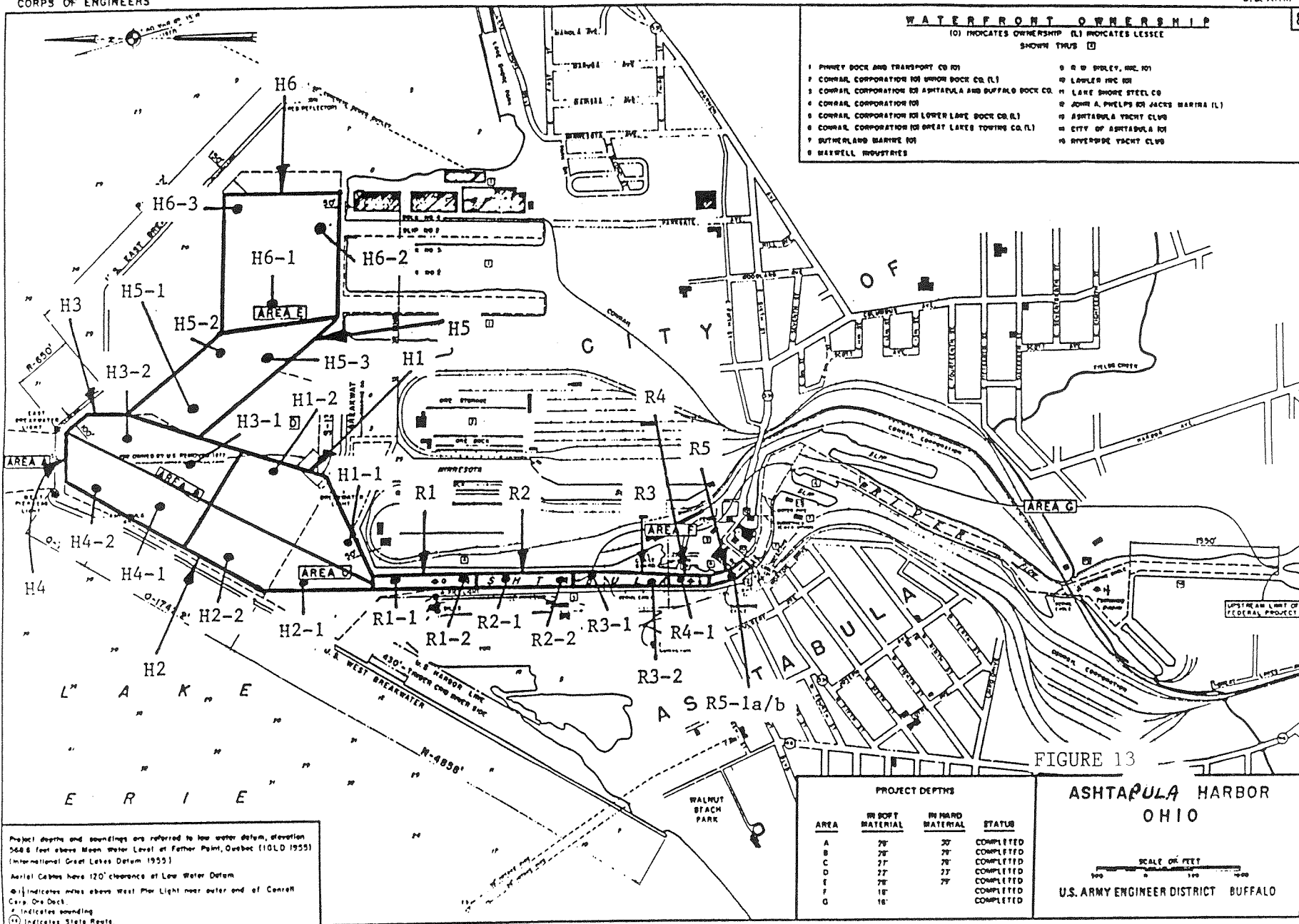

Contaminated Sediments Migration. Contaminants have and continue to migrate down stream into the Lower River, Outer Harbor, and Lake Erie. Table 4 and Figures 11 through 13 serve to summarize sediment sampling and analyses results for PCBs for several areas in the Lower River and Outer Harbor and interim dredgings indicating continued migration of contaminants downstream and into the Lower River and Outer Harbor and Lake Erie.

A scour analysis was conducted for the project study and for the U. S. Army Corps of Engineers, Buffalo District by the Waterways Experiment Station in Vicksburg, Mississippi (WES 1997). Generally, the study determined that with a 100 year event flow through the navigation area of the Lower Ashtabula River, considering 1995 survey bathymetric conditions, up to three feet of material could be scoured from some locations and about 63,000 cubic yards of material displaced.

Supplemental analysis indicated that this would move PCB contaminated sediments into the Lower River and to a lesser degree out into the Outer Harbor and Lake. Supplemental analysis also indicates that PCB contaminated sediments will continue to move into the Lower River and out into the Outer Harbor and Lake on an average annual basis.

It should be noted here that river scour is dynamic and somewhat unpredictable. Many factors circumstances (i.e. a fallen tree debris) can alter scour patterns and depth. To leave substantial masses of contaminants in the river sediments leaves considerable risk for future scour/resuspension/movements of contaminants.

Also, while mixing of lower level contaminated sediments with cleaner sediments may delute resulting contaminant levels to those acceptable for open lake disposal, mixing of higher level contaminated sediments with cleaner sediments can result in greater volumes of contaminated sediments not suitable for open lake disposal.

Surface Water. In the upper watershed, the most recent sampling and analysis was conducted in 1996 for river mile (RM) 2.5 to 27.2. Concentrations of phosphorus and oxidized nitrogen (nitrate-nitrite), measured in water quality grab samples collected from the Ashtabula River were at or near detection levels in most samples (Figure 14) reflecting the lack of point sources and relatively low intensity land use within the watershed. Ammonia nitrogen levels, while generally low were elevated in several samples, especially from those collected at Benetka Road (RM 19.1) and East 24th Street (RM 2.5). The highest ammonia-nitrogen levels were recorded during rain event sampling (see plot of fecal coliform - Figure 14), and likely represent runoff from livestock waste in the upper and middle reaches, and unsewered inputs in the lower reach (i.e., RM 2.5). Similarly, fecal coliform bacterial levels were also elevated in rain event samples (Figure 14). Correspondingly, chemical oxygen demand was higher in the head-water reaches compared with downstream. Other parameters indicative of organic enrichment (i.e., TKN and TDS) were not elevated, suggesting the enrichment was not acute. Mean dissolved oxygen (DO) concentrations measured in grab samples from the Ashtabula River were above the twenty-four hour average minimum Warmwater Habitat (WWH) Water Quality Standard of 5.0 mg/l (Figure 14). However, DO concentrations at or below the minimum Water Quality Standard of 4.0 mg/l were detected at RM 19.1 of the mainstem and in both branches. The low concentrations were caused primarily by the very low and intermittent flows observed in late summer, but may have been exacerbated

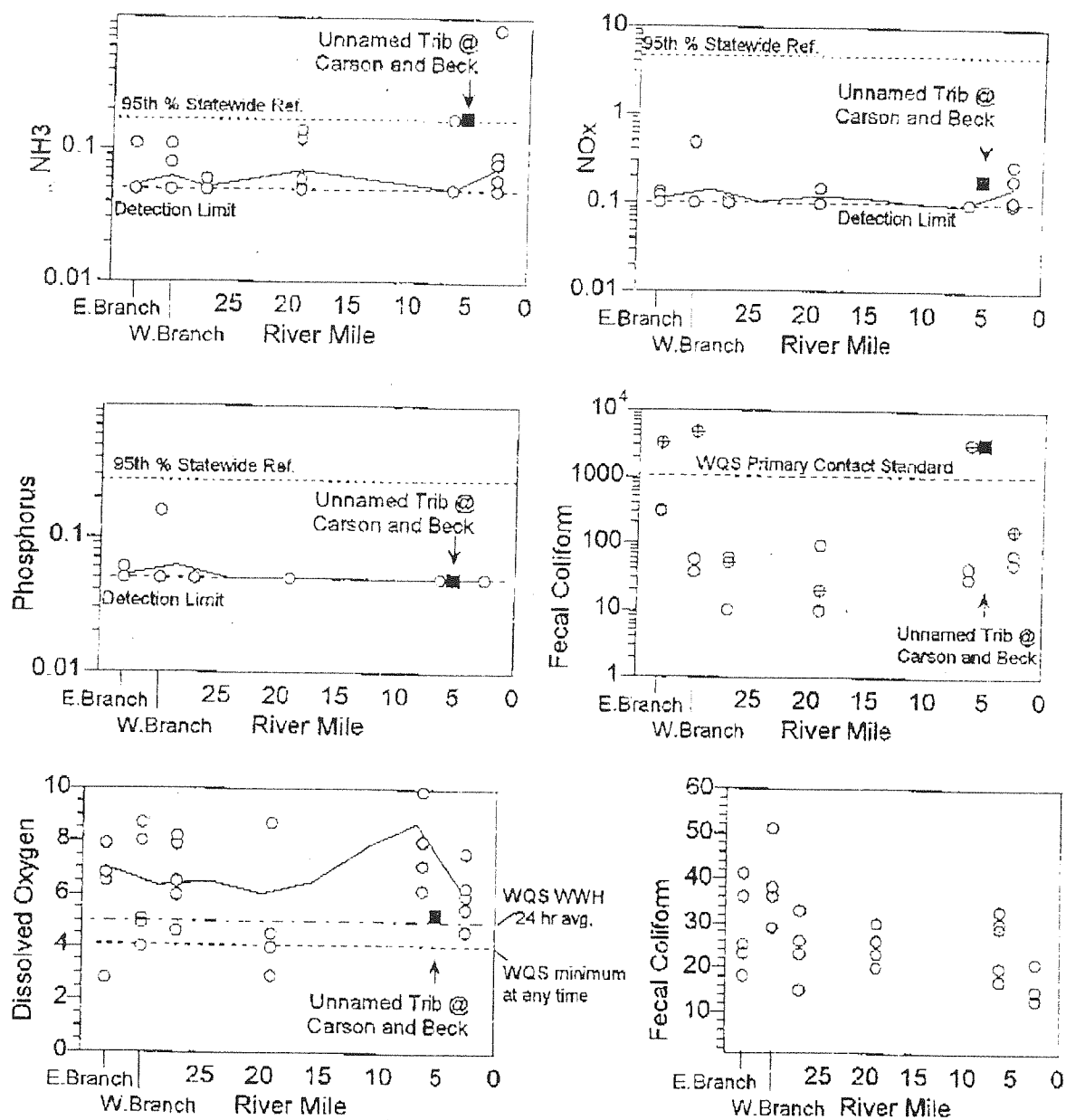

Figure 14 Select water quality parameters measured in grab samples collected from the Ashtabula River, 1995. Solid lines conjoin means. 95th percentile values are for wadeable statewide reference sites. Marked data points in the fecal coliform plot show rain event samples. Detection limits and Water Quality Standards (WQS) are shown where appropriate.

Table 5 A summary of ambient Water Quality Standards violations measured in the Ashtabula River AOC.
(All concentrations are ug/l).

Site Parameter	Concentrations				Number of Samples	Detection Limits	Ohio WQS		U.S. EPA Criteria		GLWQA Objectives
	Max.	Min.	Mean	Standard Deviation			Aquatic Life	Human Health ¹	Aquatic Life	Human Health	
<u>Ashtabula River</u>											
* Cadmium	5.9	1.0	2.1	1.4	11	1.	1.8(5) ²	---	1.5(6)	---	0.2(11)
* Iron	800.	160.	516.	193.	11	20.	1000.	---	1000.	---	300.(10)
* Aldrin & Dieldrin	0.21	0.0	0.02	0.060	11	0.1	0.1(1)	0.00079(1)	3.0	0.00079(1)	0.001(1)
* Mercury	0.3	0.2	0.21	0.029	11	0.2	0.2(2)	0.012(2)	0.012(2)	0.146(2)	0.2(2)
* Lead	29.	5.	9.8	7.1	11	5.	11(3)	---	4.9(6)	---	25.(1)
* Zinc	130.	10.	31.	33.7	11	10.	140.	---	141.	---	30.(3)
** Dissolved Oxygen (mg/l)	15.2	2.5	9.0	3.7	48	---	4.0(8)	---	4.0(8)	---	6.0(13)
x Copper	129.	0.0	13.5	30.6	23	2.4	16(2)	---	16(2)	---	5.(9)
x Cadmium	3.5	0.0	0.15	0.7	23	3.2	1.8(1)	---	1.5(1)	---	0.2(1)
x Iron	4850.	353.	900.	860.	23	13.7	1000.(2)	---	1000.(2)	---	300.(23)
x Lead	7.8	0.0	1.29	2.26	23	1.5	11.	---	4.9(4)	---	25.
x Zinc	62.3	6.8	16.0	14.6	23	1.4	140.	---	141.	---	30(2)
x Endosulfan	0.13	0.0	0.01	0.03	23	.05	.003(2)	2.0	.056(2)	159	---
<u>Fields Brook</u>											
* Cadmium	13.	1.	2.2	3.0	18	1.	6.4(1)	---	5.2(2)	---	3
* Mercury	0.7	0.2	0.3	0.16	18	0.2	0.2(7)	0.012(7)	0.012(7)	0.146(7)	---
* 1,1,2,2-tetrachloroethane	1900 ⁴	5.	42.4	24.5	9	5.	360.(1)	107.(1)	2400.	107.(1)	---
* Tetrachloroethene	230 ⁴	5	22.5	14.9	9	5.	73.(1)	3500.	840.	8.85(7)	---
* Trichloroethene	1300 ⁴	7.5	44.3	25.9	9	5.	75.(1)	807.(1)	21900.	807.(1)	---
* Iron	3310.	275.	1117.	856.4	18	20.	1000.(5)	---	1000(5)	---	---
+ Total Dissolved Solids—See Figure B											
<u>Lake Erie (Water intake)</u>											
+ 1985											
Cadmium	0.7	0.2	0.4	0.29	3	0.2	1.8	10.	1.5	10.	0.2(1)
Chromium	70.	30.	43.	23.1	3	30.	270.	50.(1)	270.	170000.	50.(1)
Copper	30.	10.	14.	8.9	5	10.	16.(1)	1000.	16.(1)	---	5(1)
Iron ⁵	22600.	280.	4874.	9911.	5	20.	1000.	---	1000.	300.	300.
Lead	22.	2.	6.	8.9	5	2.	11.(1)	50.	4.9(1)	50.	25.
Zinc	115.	10.	65.	70.7	5	10.	140.	5000.	141.	---	30.(1)
x 1990											
Copper	35.5	4.8	17.5	.75	12	2.4	16.(7)	1000.	16.(7)	---	5(11)
Iron	4810.	892.	2502.	1610.4	12	13.7	1000.(8)	---	1000.(8)	300.(12)	300.(12)
Zinc	41.0	6.0	19.7	9.81	12	1.4	140.	5000.	141.	---	30.(2)
Total Diss. Solids (mg/l)	227.	169.	194.2	17.1	12	10.	1500.	---	---	---	200(4)
Mercury	0.5	0.0	0.05	0.15	12	0.4	0.2(1)	0.012(1)	0.012(1)	0.146(1)	0.2(1)
Bis(2-ethylhexyl)phthalate	13.0	0.0	1.08	3.59	12	10	8.4(1)	59.	---	50000.	0.6(1)
++Lake Erie (nearshore) ⁵											
Cadmium	57.	0	4.9	---	78	2.	1.8	10.	1.5	10.	0.2
Copper	217.	0	31.2	---	78	10.	16.	1000.	16.	---	5.
Mercury	1.0	0	0.18	---	77	0.2	0.2	0.012	0.012	0.146	0.2
Iron	4710.	8.	602.	---	78	20.	1000.	---	1000.	---	300.
Zinc	325.	4.	49.	---	78	5.	140.	5000.	141.	---	30.
Nickel	139.	0	17.	---	78	20.	232.	610.	210.	13.4	25.
Lead	313.	0	10.	---	78	50.	11.	50.	4.9	50.	25.

- ¹ Human health standards for the Ashtabula River and Fields Brook are based on surface water concentrations that could bioaccumulate in fish tissue making fish consumption potentially deleterious to human health. Human health standards for Lake Erie include consumption of water as well since Lake Erie is designated as public water supply.
- ² The number in parenthesis indicates the actual number of violations recorded during the sampling period. Due to the nature of the data, individual violations are not listed for Lake Erie nearshore data.
- ³ GLWQA objectives are not applicable to Fields Brook as it is not considered a boundary water (not at lake level).
- ⁴ These values indicate localized extreme maximums on the DS tributary. They were not used to calculate means or standard deviations.
- ⁵ Exact number of violations could not be determined.

Sources:

- * CH₂M Hill 1985
- ** U.S.G.S. Water Resources Data 1968-1979
- + Ohio EPA STORET data
- ++ 1978-1979 U.S. EPA STORET data
- x Woodward Clyde Consultants 1991

TABLE 6 Ohio Environmental Protection Agency Lake Erie Basin Water Quality Standards (1999)

Chemical	Aquatic Life (ug/l)			Human Health (ug/l)			
	Tier	IMZM	OMZM	OMZA	Tier	Drink	Nondrink
Arsenic - TR	I	680	340	150	I	50	580
Barium	II	4,000	2,000	220	I	2,000	160,000
Cadmium - TR	I	9.0 (2)	4.5 (2)	2.5 (2)	I	14	730
Chromium - TR	I	3,600 (2)	1,800 (2)	86 (2)	I	140	14,000
Copper - TR	I	28 (2)	14 (2)	9.3 (2)	I	790	64,000
Lead - TR	I	240 (2)	120 (2)	6.4 (2)	I	14	190
Mercury (b) - TR	I	3.4	1.7	0.91	I	0.0031	0.0031
Nickel - TR	I	940 (2)	470 (2)	52 (2)	I	470	43,000
Zinc - TR	I	240 (2)	120 (2)	120 (2)	I	5,000	35,000
COD	NS	NS	NS	NS	NS	NS	NS
TKN	NS	NS	NS	NS	NS	NS	NS
Ammonia	I		12.1 mg/l (3)	1.1 mg/l (3)			
Oil/Grease	I		10,000				
1,2,4-Trichlorobenzene	NS	NS	NS	NS	NS	NS	NS
1,4-Dichlorobenzene	II	110	57	9.4	I	24c	240c
Hexachlorobenzene(4)					I	0.00045c	0.00045c
Hexachlorobutadiene					II	0.22c	0.24c
1,2-Dichlorobenzene	II	190	96	23	I	2,000	11,000
1,3-Dichlorobenzene	II	160	79	22	II	5,200	9,300
Chlorobenzene	II	850	420	47	I	470	3,200
Bis 2-Ethylhexyl Phthalane	NS	NS	NS	NS	NS	NS	NS
PAHs (5)		See Criteria Individual Chemicals.				See Crit. Ind. Chem.	
Acenaphthene	II	95	48	9.4	II	570	890
Fluoranthene	II	4.5	2.3	0.48	II	9.4	9.5
Napthalene	II	320	160	21	I	540	1,200
PCBs					I	0.000026 c (4)	0.000026 c (4)

27

TABLE - Continued.

Legend:

All criteria and values are expressed as total unless specified otherwise.
 IMZM = Inside Mixing Zone Maximum.
 OMZM = Outside Mixing Zone Maximum.
 OMZA = Outside Mixing Zone Average.
 Drink = Human Health Criterion applicable to Public Water Supply streams (2-route exposure).
 Nondrink = Human Health Criterion - non Public Water Supply (1- route exposure).
 TR = total recoverable.
 Blank Space = Criterion not calculated; contact OEPA Standards & Technical Support section.
 NS = No Standard

Footnotes:

a = No chlorine is to be discharged.
 b = See Table 33-5 for applicable wildlife criterion.
 c = This criterion is based on a carcinogenic endpoint.

Footnotes:

(1) = Average Value given as 1/2 maximum.
 (2) = Value depends on water hardness. Lowest value taken on table in standards.
 (3) = Temperature and pH dependent. Value derived from a temperature of <30 degrees centigrate and a pH of <7.6.
 (4) = As listed, unrealistic.
 (5) = Sum of EPA list of 16 minus acenaphthene, acenaphthylene, and fluoranthene.
 (6) = Human health 30 day average.

TABLE REFERENCES

State of Ohio Water Quality Standards, 1999;
 Chapter 3745-1 of the Administrative Code; Ohio Environmental Protection Agency, Division of Water Quality Planning and Assessment; 1999.

by organic loadings.

Concentrations of water column metals in the Ashtabula River were low and well within the WWH water quality criteria. Arsenic, lead, copper and zinc were detected at concentrations very close to their analytical detection limits (maximum observed concentrations: As=6 ug/l at West Branch Ashtabula @ Beckwith Road, Pb=8 ug/l at West Branch Ashtabula @ Beckwith Road, Cu=15 ug/l at RM 6.3, Zn=73 ug/l at Beckwith Road).

Sediment metal concentrations in the Ashtabula River were elevated compared to background concentrations described by Kelly and Hite (1984) for Illinois streams and exceeded the lowest effect level described by Persaud et al. (1994) for arsenic, chromium, copper, lead and mercury. The levels do not indicate contamination from point sources, but are more likely due to the parent bedrock and glacial deposits. Concentrations of all metals, excluding cadmium, were higher at RM 2.5 than RM 27.1, reflecting the increased contamination from urban runoff.

Available information on water quality in the Ashtabula River Area of Concern was presented in the Ashtabula River Remedial Action Plan (OEPA 1991) and summarized in associated sections of the Ashtabula River Partnership Environmental Impact Statement. Table 5 provides a summary of some past water quality standards violations measured in the Ashtabula River Area of Concern. Presently, pollutants in the water column are less prevalent and violations of water quality standards are infrequent and localized due to current discharge controls and some cover of contaminated sediments with cleaner sediments. The primary problem pertaining to contaminants and water quality is that associated with the resuspension of sediments and associated contaminants. Substantial storm flows will cause scour and resuspension of sediments and associated contaminants (including metals, pesticides, nutrients, PCBs, PAHs, and a number of chlorinated organic compounds) compromising associated water quality standards. Table 6 presents some Ohio EPA Water Quality Standards for Lake Erie for some contaminants of concern.

Dissolved oxygen (DO) levels have been a problem in the lower river during the low flow period of June through September. Corps of Engineers' sediment analysis over the years indicates sediments are moderately contaminated with oxygen demanding materials. Dissolved oxygen concentrations in the lower river, however, are strongly influenced by harbor morphology, low flow, meteorological conditions, and lake levels, so, low DOs are not related solely to chemically degraded water quality. However, low DOs are an aquatic problem whether related to pollution or alteration of the natural river morphology.

Environmental Use Designations: Ohio Water Quality Standards (WQS; OAC 3745-1-25), consist of designated aquatic life and non-aquatic life uses, and chemical, biological, and physical criteria designed to represent measurable properties of the environment that are consistent with the goals specified by each use designation. The mainstem of the Ashtabula and conjoining tributaries have been designated warmwater habitat (WWH), which defines the "typical" warm water assemblages of aquatic organisms for Ohio rivers and streams. The current non-aquatic life use designations for the Ashtabula River system are: agricultural and industrial water supply and primary contact recreation (PCR). The criteria for PCR is simply having a water depth of at least one meter over an area of at least 100 square feet or where canoeing is a feasible activity. No municipal or public drinking waters come from the Ashtabula River or its tributaries.

Groundwater yield in the Ashtabula watershed basin is very low. The yields can range from less than 3 gallons per minute, up to 10 gallons per minute, this may not provide enough water during peak domestic usage. The major urban industrialized areas near the mouth of the Ashtabula River obtain their water from Lake Erie.

Biological Community and Habitat: (Note: Much of this is extracted from the Ohio HAP)

Fish Community: The Ashtabula River AOC is classified as Warmwater Habitat (WWH) in the Ohio Water Quality Standards. Upstream from the AOC, the river is fully attaining the WWH status. The positive warmwater habitat attributes encountered in the lotic Ashtabula River is largely ascribed to a lack of channelization, wide mature riparian areas, and small acreage farms using conservative practices in the basin. Riffle and channel substrates were unembedded and generally silt free. Glacial till and fractured bedrock provided a variety of substrate sizes and habitat complexity, especially in the upper watershed. Although the physical habitat is very good, extremely low or intermittent flows occur every summer in the Ashtabula River (USGS reference) limiting the amount of habitat available to aquatic fauna. Typical fish species include: rosyface shiner (*Notropis rubellus*), black red-horse (*Moxostoma duquesnei*), rainbow darter (*Etheostoma caeruleum*), central stoneroller minnow (*Campostoma anomalum pollum*), rockbass (*Ambloplites rupestris*), mimic shiner (*Notropis volucellus*), and bluntnose minnow (*Pimephales notatus*). There is a high relative abundance of mimic shiner and bigeye chub (*Hybopsis amblops*), species requiring clear, silt free habitats to thrive. Note: The bigeye chub, a rare species in Ohio and an indicator of exceptional water quality, flourishes throughout the upper watershed beginning at the upstream limit of the AOC at River Mile (RM) 2.0.

In the upper turning basin, including the area near the mouth of Fields Brook, the biological community does not meet WWH standards and is impacted by discharge from Fields Brook as well as habitat destruction and extensive recreational boat traffic. The lower 0.7 miles of the river have been lined with vertical sheet piling, railroad ties and concrete docks for commercial activities. This area is frequently deep dredged. In addition, there is a PAH problem in the area. These conditions have severely altered the natural habitat, resulting in an adversely impacted biological community within the AOC. This effect appears to be localized as fish population and diversity recover in the outer harbor where habitat conditions improve and the impacts from Fields Brook discharges have dissipated.

The Ashtabula outer harbor supports a diverse fish community of river and lake species, particularly in a vegetated area protected by the inner breakwall. Protected areas of the harbor usually contain relatively large numbers of yellow perch (*Perca flavescens*), white bass (*Morone chrysops*), pumpkinseed (*Lepomis gibbosus*), white crappie (*Pomoxis annularis*), goldfish (*Carassius auratus*) and emerald shiner (*Notropis atherinoides*), while more open water areas contain lower densities of gizzard shad (*Dorosoma cepedianum*), yellow perch (*Perca flavescens*), carp (*Cyprinus carpio*), goldfish (*Carassius auratus*), brown bullhead (*Ameiurus natalis*) and emerald shiner (*Notropis atherinoides*). The banded killifish (*Fundulus diaphanus*), listed by ODNR as an Ohio endangered species, has been recorded here. Here, the fish community achieves partial to full attainment of WWH biological standards considering diversity and abundance. Much of the nearshore provides nursery and spawning grounds for the local fish community. The breakwall and gravel bars near the CEI power plant provide spawning grounds for rainbow smelt

(*Osmerus mordax*), carp (*Cyprinus carpio*), spottail shiner (*Notropis hudsonius*), shiner species, logperch (*Percia caprodes*), walleye (*Stizostedion vitreum*) and freshwater drum (*Aplodinotus grunniens*). The outer harbor breakwalls and the breakwalls lakeward of Lakeshore Park provide spawning sites for alewife (*Alosa pseudoharengus*), gizzard shad (*Dorosoma cepedianum*), smallmouth bass (*Micropterus dolomieu*), rainbow smelt (*Osmerus mordax*), brown bullhead (*Ameiurus nebulosus*) and Johnny darter (*Etheostoma nigrum*). The deeper nearshore waters provide spawning grounds for burbot (*Lota lota*), mottled sculpin (*Cottus bairdi*) and yellow perch (*Perca flavescens*) (Goodyear, et al 1982). Various lake and stream species of fish migrate to and from the lower Ashtabula River when water conditions are favorable. Spawning migration runs for walleye (*Stizostedion vitreum*) and smallmouth bass (*Micropterus dolomieu*) occur in the spring (U.S. Fish and Wildlife Service 1984a). Species composition is typical of the warmwater fish community in Lake Erie river mouths. Cold water species such as the Steelhead trout (*Oncorhynchus mykiss*) also move up the Ashtabula River on a limited basis and are sought by river anglers. If not for the contaminant problem, the Ashtabula River could be a prime site for salmonid stocking consideration.

Endangered Fish Species: Three fish species, of special concern in Ohio, have been recorded historically in the Ashtabula River lacustrary. The species are Great Lakes muskellunge (*Esox masquinongy*), black nose shiner (*Notropis neterolepis*) and lake sturgeon (*Acipenser fulvescens*). The first two species are vegetation loving species and should be present in the Ashtabula now.

Macroinvertebrates: The macroinvertebrate community is in good condition in the vicinity of 24th Street (River Mile (RM) 2.5 to RM 2.3) based on sampling conducted at three sites in 1995 and 1996. The good ranking was made using Ohio EPA's Invertebrate Community Index (ICI), a measure of stream ecological health that is based on macroinvertebrate species richness, composition, abundance, condition, and food web composition. River areas associated with the 24th Street bridge, which lies at the upstream limit of the lacustrary, benefit from a bedrock substrate and the periodic flushing of sediment during high flows. Here, oligochaetes (pollution-tolerant marine worms) dominate the macroinvertebrate community in terms of their sheer numbers, yet the area also supports a variety of pollution-sensitive mayflies, caddisflies, and midges. In fact, a significant number of different types of macroinvertebrates were collected at these three sites ranging from 61 to 72 taxa, when combining results from both quantitative and qualitative sampling.

The macroinvertebrate community is impacted by altered habitat and is in poor condition in the Ashtabula River between RM 1.9 (upstream of Fields Brook) and the mouth of the river. Six samples have been collected from this area since 1989. This portion of the lacustrary is lined with sheet piling and/or boat docks. A ship channel extends from the river mouth to RM 0.7. Fields Brook empties into the Ashtabula River at RM 1.6. Sediment contamination has been well documented downstream from Fields Brook. Pollution-tolerant midges predominate at RM 1.9 and downstream from Fields Brook where the stream bottom consists of soft, often oily, silt. Closer to the river mouth, where the ship channel is maintained, zebra mussels predominate followed by oligochaetes. The number of different types of macroinvertebrates collected from each of the six sites ranged from 28 to 35.

The macroinvertebrate community within Ashtabula Harbor benefits from wave protection afforded by breakwalls and resultant growths of rooted aquatic vegetation. A total of 44 different types of macroinvertebrates were identified from three harbor sampling sites in 1995. The single most diverse sampling location was a protected inner breakwall with macrophytes immediately adjacent. The lake nearshore community is predominated by zebra mussels and scuds (*Gammarus fasciatus*). Good numbers of mayflies and caddisflies are present along with a relatively diverse midge fauna.

Terrestrial Flora and Fauna:

Riparian Corridor - Landuse in the watershed is predominantly rural and agricultural, with the City of Ashtabula the only significant urbanized area. Several park areas are located just upstream of the harbor area. Undisturbed shorelines exist up-stream from RM 2.0 where, the benefits of conservation farming practices paired with intact riparian vegetation and low density development are manifest, especially in the middle reaches. Dominant tree species include: Red and Silver Maple, Pin Oak, and Green Ash. Associated species include: Tulip Tree, Yellow Birch, Scourgum, and occasionally Black Cherry. Scrub-shrub species include: Northern Arrowwood, Red Osier, and Silk and Gray Dogwood.

Historical Perspective on Lower Ashtabula River Vegetation - Prior to settlement and development of the Ashtabula Harbor, a riverine marsh was located at the mouth of the Ashtabula River. Low sandy beaches on the west side of the river mouth sometimes built across the mouth forcing the waters upstream from the sand beach to be higher than the level of Lake Erie. The presettlement riverine marsh was lined with emergent marsh dominated by greater bur reed (*Sparganium eurycarpum*), bulrush (*Schoenoplectus tabernaemontanae*), American three-square (*Schoenoplectus pungens*), sedges (*Carex* sp.) arrowheads (*Sagittaria latifolia* and *Sagittaria rigida*) and pickerel weed (*Pontederia cordata*). Buttonbush (*Cephalanthus occidentalis*) and red osier (*Cornus sericea*) were probably occasional shrubs within the marsh. Pond lily (*Nuphar advens*) and white water lily (*Nymphaea odorata*) grew in the deeper waters. The deepest waters of the riverine marsh supported the aquatic bed natural community. Species that probably dominated the aquatic bed community include pondweeds (*Potamogeton nodosus*, *Potamogeton pusillus*, *Potamogeton pectinalius* and *Potamogeton illinoensis*), bladderwort (*Utricularia vulgaris*) and eelgrass (*Vallisneria americana*).

A rare community called the Palustrine Sand Plain Community occasionally flourished on the moist sandy shores of the marsh when conditions caused water levels in the marsh to fall. Common members of this community usually include American three square, sedges (*Carex scoparia* and *Carex stricta*), articulated rush (*Juncus articulatus*), umbrella sedges (*Cyperus bipartitus* and *Cyperus flavescens*) and spikerushes (*Eleocharis obtusa* and *Eleocharis erythropoda*).

Upslope from the sandy beaches on the west side of the river, there were probably low sand dunes dominated by switchgrass (*Panicum virigatum*), Canada wild-rye (*Elymus canadensis*) riverside grape (*Vitis riparia*), sandbar willow (*Salix exigua*) and cottonwood (*Populus deltoides*). Floodplain forests dominated by cottonwood, sycamore (*Platanus occidentalis*), silver maple (*Acer sacharrinum*), black walnut (*Juglans nigra*) and elm (*Ulmus americana*) covered the low floodplain terraces on both sides of the river.

Mixed mesophytic forests dominated by sugar maple (*Acer saccharum*), tuliptree (*Liriodendron tulipifera*), beech (*Fagus grandifolia*), red oak (*Quercus rubra*), basswood (*Tilia americana*), bitternut hickory (*Carya cordiformis*) and cucumber magnolia (*Magnolia acuminata*) probably covered the valley slopes from the mouth of the river upstream to Fields Brook and beyond. Dry forests dominated by white oak (*Quercus alba*), black oak (*Quercus velutina*), shagbark hickory (*Carya ovata*), pignut hickory (*Carya glabra*) and red oak (*Quercus rubra*) probably grew on the lake bluffs on both sides of the river mouth.

Modern Vegetation of the Lower Ashtabula River - The best remnants of natural vegetation are within the open waters between the western breakwall and harbor mouth, along the sandy shores to the west of the harbor mouth and along the east valley wall of the river south of the mouth of Fields Brook.

Construction of breakwalls west of the river mouth coupled with harbor dredging in the nineteenth century shifted the position of the emergent marsh, aquatic bed, palustrine sand plain and dune community from the mouth of the river to west of the mouth. The dune species including switchgrass, Canada wild-rye, beach pea (*Lathyrus japonicus*), sea rocket (*Cakile edentula*), sandbar willow and cottonwood became established on the sandy beaches and low dunes that built to the west of the breakwalls. Emergent marshes and palustrine sand plain communities established along the shores east of the breakwalls and the aquatic bed community established within the quiet waters east of the breakwalls.

Today, the aquatic bed community in the open water between the breakwall and the Ashtabula Harbor is dominated by European water milfoil (*Myriophyllum spicatum*), eelgrass (*Vallisneria americana*), small pondweed (*Potamogeton pusillus*), Eurasian naiad (*Najas minor*), elodea (*Elodea canadensis*) and Richardson's pondweed (*Potamogeton richardsonii*).

The emergent marshes along the shoreline east of the breakwall are today dominated by phragmites (*Phragmites australis*), narrow-leaved cattail (*Typha angustifolia*) and purple loosestrife (*Lythrum salicaria*). Small remnants of the former native marsh still survive within the Phragmites, including arrowhead (*Sagittaria latifolia*) pickerel weed (*Pontederia cordata*), soft-stem bulrush (*Schoenoplectus tabernaemontanae*) and American three-square (*Schoenoplectus pungens*)

Prior to piling of coal in the early 1980s, the best Palustrine Sand Plain Communities lined open inland sandy ponds and the bay shoreline east of the breakwall. The shallow ponds were lined with several rare plants including fringed gentian (*Gentiana crinita*), golden-fruited sedge (*Carex aurea*), alpine rush (*Juncus alpinoarticulatus*) and silverweed (*Potentilla anserina*). Another rare plant bushy cinquefoil (*Potentilla paradoxa*) was rare along the sand shore flats of the bay. Palustrine Sand Plain community plants still survive along the shore east at the breakwall including alpine rush, articulated rush, umbrella sedge, common rush (*Juncus acuminatus*), sedge (*Carex scoparia*), common spikerush (*Eleocharis obtusa*), matted spikerush (*Eleocharis acicularis*) and red-stemmed spikerush (*Eleocharis erythropoda*).

The sand dunes, dominated by beach grass (*Ammophila brevilgolata*) east of the Ashtabula River mouth are the finest beach grass dunes in Ohio. The dunes extend from Walnut Beach to one quarter mile east of the park. Beach grass established at Walnut Beach sometime after the early

1930s. A study in the early 1930s described the following species as common on the dunes: switchgrass, Canada wild-rye, poison ivy (Toxicodendron radicans), beach pea, sandbar willow, riverside grape and cottonwood. In addition to the beach pea and beach grass, other rare plants growing on the dunes today include: Schweinitz's umbrella sedge (Cyperus schweinitzii), purple sand grass (Triplasis purpurea), sea rocket (Cakile edentula) and seaside spurge (Euphorbia purpurea). Wafer ash (Ptelea trifoliata) is a noteworthy shrub on the dunes. This shrub, a member of the citrus family, is rare east of Cleveland except on sandy areas along Lake Erie. A book published in 1912 documents a population of giant swallowtail butterflies at Walnut Beach in association with the wafer ash. Heartleaf willow (Salix eriocephala) is another common shrub on the dunes.

Many of the plants growing on the open banks, roadsides and railroad yards in the Ashtabula Harbor north and south of the Lake Road bridge are non-indigenous species. The only assemblage of high quality natural forest is on the east valley wall of the river just south of the mouth of Fields Brook. Undeveloped sections of the valley walls and river flats on both sides of the river, from Lake Road south to the mouth of Fields Brook are second growth woody thickets dominated by a mixture of native and non-native trees: silver maple, tree of heaven (Ailanthus altissima), box elder (Acer negundo), crack willow (Salix fragilis), black locust (Robinia pseudo), cottonwood. Black cherry (Prunus serotina), quaking aspen (Populus tremuloides) and white ash (Fraxinus americana) are locally common along the west side of the river, west of Fields Brook. Common shrubs in the second growth thickets include staghorn sumac (Rhus typhina), multiflora rose (Rosa multiflora), Morrow's honeysuckle (Lonicera morrowi), red osier dogwood (Cornus sericea), buckthorn (Rhamnus frangula), hawthorn (Crataegus sp.) and blackberry (Rubus allegheniensis). Common vines in the thickets are Japanese honeysuckle (Lonicera japonica) and bittersweet nightshade (Solanum dulcamara).

Common herbaceous species on open banks and flats north and south of Lake Road include common mullein (Verbascum thapsis), mugwort (Artemisia vulgare), winter cress (Barbarea vulgaris), red clover (Trifolium pratense), white clover (Trifolium repens), white sweet clover (Melilotus alba), paniced aster (Aster simplex), tall goldenrod (Solidago canadensis), bugloss (Echium vulgare), switchgrass (Panicum virgatum), yarrow (Achillea millifolium), teasel (Dipsacus sylvestris), evening primrose (Oenothera biennis), early goldenrod (Solidago juncea), coltsfoot (Tussilago farfara), quack grass (Agropyron repens), Kentucky bluegrass (Poa pratensis), Canada bluegrass (Poa compressa), burdock (Arctium minus) and Japanese knotweed (Polygonum cuspidatum). Japanese honeysuckle is frequent throughout the valley on open meadows and slopes.

Phragmites (Phragmites australis) is frequent to locally abundant on open, poorly drained flats and along the river edge. Canary grass (Phalaris arundinacea) is locally common along the river edge about .2 miles south of the mouth of Fields Brook.

The best natural forest on the lower river is on the east valley wall south of the mouth of Fields Brook above and south of Riverside Marina. The best natural forest is within a ravine on the east valley wall of the river about .2 mile south of the mouth of Fields Brook. Most of the canopy, understory shrubs and herbaceous plants within the ravine are native.

The forest on the slope around Riverside marina and south of Fields Brook is a closed canopy

forest dominated by pin oak (Quercus palustris), bitternut hickory (Carya cordiformis) and a few black cherry (Prunus serotina). Many of the understory species are non-indigenous: privet (Ligustrum vulgare), Japanese honeysuckle, garlic mustard (Allaria petiolata). A small clone of myrtle (Vinca minor) is present in the open woods upslope from the marina. A few native plants are frequent in the understory including yellow trout lily (Erythronium americana), bluestem goldenrod (Solidago caesia), autumn bentgrass (Agrostis perennans), jewelweed (Impatiens capensis) and kidney-leaved buttercup (Ranunculus abortivus).

The canopy of the natural forest within the ravine 0.2 miles south of the mouth of Fields Brook is dominated by sugar maple (Acer saccharum) and red oak (Quercus rubra). Hop hornbeam (Ostrya virginiana) and black cherry are occasional in the canopy. A single pignut hickory (Carya glabra) is growing on the dry valley rim just north of the ravine mouth. Several native shrubs are frequent within the mouth of the ravine. The most common understory shrub on the slopes of the ravine is witch hazel (Hamamelis virginiana). American hornbeam (Carpinus caroliniana) is frequent in the ravine. Choke cherry (Prunus virginiana) is common in open woods near the mouth of the ravine and maple leaved viburnum (Viburnum acerifolium) is local-ly common at the mouth of the ravine. Glaucous honey-suckle (Lonicera dioica var. glaucescens) is local in the ravine. Native herbaceous plants in the ravine include sedge (Carex communis), aster (Aster divaricatus), bluestem goldenrod, spring beauty (Claytonia virginica).

A single medium-sized American elm (Ulmus americana) grows on the west side of the river across from the mouth of Fields Brook. A single clump of nannyberry (Viburnum lentago) is located on the east river edge about .2 miles south of Fields Brook mouth. Two native willows, sandbar willow and heartleaf willow, may be observed in an open seepage along marina road on the east valley wall of the river south of Fields Brook.

Rare Plant Species - Per ODNR's current Natural Heritage database, a number of rare plant species thrive throughout the watershed, including: pale sedge, necklace sedge, beaded sedge, schwenitz's umbrella sedge, woodland horsetail, marsh bedstraw, turk's cap lily, catberry, green woodland orchid, autumn willow, northern blue-eyed grass, painted trillium, and hobblebush.

Birds: Breeding birds of the upper Ashtabula River are typical for northeast Ohio. The upper watershed includes many different habitats, such as floodplain forests, dry upland forests, and hemlock ravines, which tend to attract a wide variety of breeding birds. In the floodplain forests, typical northern Ohio woodland breeders are observed such as Downy Woodpecker, Black-capped Chickadee, Cerulean Warbler, Scarlet Tanager, and Baltimore Oriole. The drier upland forests tend to attract species such as Wood Thrush and Ovenbird. The deeper south-facing hemlock ravines host species such as Winter Wren, Magnolia Warbler, Canada Warbler, and Dark-eyed Junco, all endangered in Ohio. Other species readily observed near the river's confluence with the West Branch are Sora, Virginia Rail, Barn Owl, and Black-throated Green Warbler. A turkey vulture roost lies further upstream on the West Branch. Near the river headwaters is a large great blue heron rookery. By conducting more field work, additional state-listed species would more than likely be added to the list, as this is high quality habitat.

Lake Erie's south shore is an extremely important flyway for migrating small birds, raptors, and waterbirds. Migrating small birds will avoid crossing Lake Erie and end up concentrating along

the lakeshore. They then follow the shoreline till they find a safe location for crossing. As a result, a shoreline location such as Ashtabula Harbor is a very important stopover site for these birds. Hawks also will avoid crossing the open waters of Lake Erie, following the shoreline instead. Large numbers of migrating hawks often cross over the harbor during southwest winds in the spring. Bald Eagles and Peregrine Falcons are not uncommon visitors and may even remain a few days hunting the harbor. Birds also use waterways such as the Ashtabula River as migration corridors. The importance of migration corridor habitat such as the Lake Erie shoreline and the Ashtabula River, has just recently been recognized. These areas may be as important as breeding habitat in the survival of these birds.

Large numbers of waterbirds move along the Lake Erie shoreline and readily use Ashtabula Harbor for resting, feeding, and for shelter in storms. Typical species include: Great Blue Heron, Great Egret, Mallard, Canada Goose, Common Loon, and Black-backed Gull. It is not uncommon in the fall or spring to see several thousand Red-breasted Mergansers feeding within the outer breakwalls. Rare species of ducks seen include: Barrow's Goldeneye, King Eider, and Harlequin Duck. Thousands of gulls are often seen feeding in the harbor and resting on the ore piles. Thirteen species of gulls have been found in the Ashtabula Harbor area including such rarities as California Gull, Iceland Gull, Franklin's Gull, and Black-legged Kittiwake. Directly west of Ashtabula Harbor lies Walnut Beach which is noted for its shorebird numbers and variety. Good numbers of shorebirds are possible, depending on the amount of sandbar showing. The first North American record away from Alaska for Red-necked Stint, a type of shorebird, was from Walnut Beach. This is a very rare stray from Asia.

Two hundred sixty-eight species of birds have been recorded from the Ashtabula River and Ashtabula Harbor. This is an impressive number of species. When you consider the relative lack of birders using the area, the importance of this area becomes clear. This area is relied upon heavily by large numbers of nesting, migrating, feeding, and resting birds.

Other Wildlife - The Ashtabula area supports many species of wildlife such as: deer, squirrel, cottontail rabbit, opossum, skunk, raccoon, mice, and a variety of reptiles, amphibians, birds, and other small mammals. Also, a small beaver community inhabits the AOC. The small amount of natural shoreline remaining in the harbor area supports some reptiles, amphibians, birds, and mammals. Most are limited to the adjacent wetland and park areas. Critical mammalian habitat is limited to a few scattered areas left to natural growth, and the Ashtabula River wetland. This Palustrine wetland serves as a bird sanctuary and is located inside the west harbor breakwall. The wetland covers about 7 acres, has little relief and is strongly influenced by lake levels.

The Ohio Department of Natural Resources Division of Natural Areas & Preserves currently lists ermine as an animal of special interest found in the Ashtabula River watershed. Mink, too, may be readily observed feeding in areas immediately adjacent to Ashtabula Harbor. Until the 1960s, there was a substantial mink population throughout the watershed. Lake Erie mink farmers reported their mink stocks dying out as a direct result of being fed Great Lakes fish unknowingly contaminated with PCBs. Mink feed almost exclusively upon fish; contaminants associated with fish interferes with mink reproduction. To date, the historic mink population has not fully recovered.

Physical Habitat for Aquatic Life: In the upper Ashtabula River basin, a comprehensive assessment of habitat quality was completed in 1995 for R.M. 3.5 to 27.2. The quality of the macrohabitats at five locations sampled for fish in the lotic Ashtabula River, and at sites sampled in the East and West Branches (Table 8), were assessed using the Qualitative Habitat Evaluation Index (QHEI - Rankin 1989). The mean QHEI score for the basin was 73.2 ± 5.93 s.d., indicating generally good to excellent habitat quality and the capability of supporting a diverse aquatic fauna. The absence of anthropogenic modifications to the river is demonstrated by the low ratio (<0.5) of modified habitat attributes to warmwater habitat attributes. The positive warmwater habitat attributes encountered in the lotic Ashtabula River is largely ascribed to a lack of channelization, wide mature riparian areas, and small acreage farms using conservative practices in the basin. Riffle and channel substrates were unembedded and generally silt free. Glacial till and fractured bedrock provided a variety of substrate sizes and habitat complexity, especially in the upper watershed. Although the physical habitat is very good, extremely low or intermittent flows occur every summer in the Ashtabula River (USGS reference) limiting the amount of habitat available to aquatic fauna. The low flows in summer are due to the limited ground water capacity of the shale bedrock aquifers. High volumes of stream discharge (>5000 cfs, max $\sim 11,100$ cfs in 1959), emanating from snowmelt, scours and denudes the lower reach of the Ashtabula River. Consequently, QHEI scores decreased with proximity to Ashtabula mainly because of the increased prevalence of unbroken shale bedrock and less cover.

In the Ashtabula lacustrary, the slope, texture and shape of ship channel banks affects QHEI scores and the overall suitability of aquatic habitat for biological communities (Figure 1). The lower quality of the habitat is reflected in the results of the Index of Biotic Integrity (IBI) and the Invertebrate Community Index (ICI). In the upstream areas of the Ashtabula lacustrary (RM 1.3), the quality of physical habitat (i.e. slope, texture, and shape) is much better. The factors that govern habitat quality in lacustraries are the slope of the shoreline, hardening of the shoreline, and the availability of cover. Gradual shoreline slopes (45° or less) are better than steep vertical slopes. The contaminated Ashtabula site has much lower biological scores. It has been concluded (in the biological section) that contaminated sediments are the major cause of lower fish community scores at this Ashtabula site. The upper reaches of the lacustrary attain higher QHEI values that reflect the undisturbed habitat conditions found there.

Much cover is provided by the growth of aquatic plants in waters shallower than twelve feet. Downed trees and boulders in the water also provide cover for fish and invertebrates. Presently the site downstream of Fields Brook at RM 1.3 of the Ashtabula has abundant aquatic plant growth, logs and woody debris and boulders. Habitat quality at this site is high and provides abundant cover for diverse communities of organisms.

PROBLEMS, GOALS/OBJECTIVES

PROBLEMS

Fourteen beneficial use impairments are described in Annex 2 of the 1978 Great Lakes Water Quality Agreement (GLWQA) which was amended by Protocol in 1987. Annex 2 requires development and implementation of a Remedial Action Plan (RAP) for Areas of Concern (AOC). In 1985, the International Joint Commission designated the Ashtabula River as one of 42 AOCs, recognizing six of 14 impairments of beneficial uses, i.e. changes in chemical, physical, or biological integrity of the ecosystem, as listed under the GLWQA. A comprehensive report titled the Ashtabula River Stage 1 Investigation Report, published in December 1991, describes in detail six beneficial use impairments associated with the Ashtabula River AOC, which are:

1. Restrictions on Fish and Wildlife Consumption. An advisory was issued in 1983 by the Ohio Department of Health and Ohio EPA recommending that no fish caught in the lower two miles of the Ashtabula River be eaten. The advisory was based on the results of fish tissue sampling from 1978 to 1981. Forty-five organic chemicals had been detected in fish tissue. Those of greatest concern included PCBs, hexachlorobenzene, hexachlorobutadiene, pentachlorobenzene, tetrachloroethane and octachlorostyrene. Many of the identified chemicals were classified as carcinogens, so their mere presence was of concern.

In 1997, the Ohio Department of Health revised the fish advisory to restricted consumption of some species, based upon more recent fish tissue samples. Contaminant levels decreased significantly by 1990. This decrease is primarily associated with improved source discharge control. PCB levels in fish tissue; however, appear to have increased slightly in 1994. Residual PCB contaminants in sediments is a problem. The levels of PCBs have not declined to completely safe levels and those consuming a larger number of fattier fish such as carp and catfish have the greatest risk. (Risk Assessment, 1997)

In addition to the advisory in the Ashtabula River, a general advisory is in effect for Lake Erie. Based on elevated PCB concentrations in skin-on fillets, it is recommended that no carp or channel catfish from the lake be consumed. (RAP, 1991)

2. Degradation of Fish and Wildlife Populations. The Ashtabula River AOC is classified as Warmwater Habitat (WWH) in the Ohio Water Quality Standards. Upstream from the AOC, the river is fully attaining the WWH status. In the upper turning basin, including the area near the mouth of Fields Brook, the biological community does not meet WWH standards and is impacted by discharge from Fields Brook (PCBs, etc.) as well as habitat destruction and extensive recreational boat traffic. The lower 0.7 mile of the river has been lined with vertical sheet piling, railroad ties, and concrete docks for commercial activities. This area is frequently deep dredged. There is a PAH problem in the area. These conditions have severely altered the natural habitat, resulting in the poorest biological community in the AOC. The 1991 RAP report also indicated that, if not for the contaminant problem, the

Ashtabula River would be a prime site for salmonid stocking considerations. Reference the following, also.

3. Fish Tumors or Other Deformities. Local fishermen and surveys have reported the presence of tumors and lesions on fish. A community of brown bullhead (*Ameiurus nebulosus*) in the area inside the west breakwall were discovered to have a high incidence of lip and skin tumors and precancerous conditions. This situation appears to be related to sources of pollution at the river mouth. Black material lining the bottom sand ripples was noted in large amounts. This material appears to be coal dust. There is a coal handling facility on the west bank and upwind of the river which is a source of coal dust. Tumors in brown bullhead are associated with PAHs as found in coal tars.

PCBs build up in the environment and cause a number of harmful effects, including cancer and non-cancer adverse effects. Non-carcinogenic health effects such as reproductive impairment, neurotoxicity, developmental toxicity, endocrine disruption, and immunosuppression have also been associated with exposure to PCBs. Some PAHs have also been found to cause noncancer adverse health effects including difficulty in reproduction, decreased body weight, immunosuppression, and harmful effects to the skin.

PCBs are a particular concern to aquatic food chains because of the process known as biomagnification where contaminant concentrations increase at each step in the food chain. For instance, microscopic floating aquatic plants known as phytoplankton containing very low levels of PCBs are eaten by zooplankton, primarily microscopic floating animals. Zooplankton are eaten by small fish, which are then eaten by larger fish. Fish eating birds and mammals then eat the fish, resulting in significantly elevated PCB levels compared to those measured in animals lower in the food chain. Highly elevated levels of PCBs have been measured in bird eggs as well. Because of the concentrations of PCBs detected in fish and the ability of PCBs to biomagnify up the food web, fish eating birds and mammals have the highest potential to experience any associated toxicological effects.

The interspecies sensitivities to PCBs and PAHs varies widely even between species that are taxonomically closely related. For instance, mink have been found to be extremely sensitive to PCBs which cause adverse effects to reproduction even at very low levels. In aquatic plants, PCBs have been found to cause reduced growth through a reduction in photosynthetic activity as a result of diminished chlorophyll content.

There currently is no information available on deformities or tissue concentrations of contaminants in any birds or mammals at Ashtabula.

4. Degradation of Benthos. The macroinvertebrate community exhibits similar WWH attainment status as the fish community. Biological indices are high in flowing sections of the river, but decreased downstream from Fields Brook. Again, the major impacts appear to be habitat related and affected by the heavy commercial and recreational use of the river. Chemical impact was recorded near and downstream of the confluence of Fields Brook and in the commercial channel area and outer harbor. The macroinvertebrate community in the nearshore is indicative of moderate organic enrichment and similar to the community found throughout the southern central basin nearshore. The harbor is more polluted and there is a noticeable gradient of decreasing pollution in an offshore direction.

5. Restrictions on Dredging Activities. Navigation channel maintenance has been limited in the lower Ashtabula River. Deep dredge commercial navigation channels (-18 and -16 feet LWD) have not been maintained in the problem area from Station 120 to the turning basin just upstream of the Fifth Street Bridge since 1979, and from the turning basin just upstream of the Fifth Street Bridge to the upstream Federal channel limits since 1962, due to contaminated sediments which require confined disposal. Appropriate disposal facilities for contaminated sediments are required, but, presently unavailable, or, not economical. Contaminated sediments in the lower Ashtabula River continue to migrate toward the outer harbor and lake.

6. Loss of Fish and Wildlife Habitat. This is a significant problem in the Ashtabula River AOC. The results of the 1989 Ohio EPA survey and subsequent surveys indicate non-attainment of WWH status at the river mouth is largely due to lack of habitat (Ohio EPA 1990c). Sediments are contaminated and continue to migrate toward the outer harbor and lake. Few protected aquatic/fishery shallow areas exist. Much of the river shoreline has been developed for marinas. The lower section of the river has been completely bulkheaded for commercial docking facilities and activities and is the site of the poorest biological community. Heavy recreational boat traffic and commercial vessel traffic continually resuspend bottom sediment, covering macroinvertebrate on the river bottom.

In summary, three primary problem areas have been identified in the Ashtabula Harbor Area of Concern (Excluding Fields Brook): to some degree the Outer Harbor Area (Ecological Assessment Area 4), the lower river from the mouth upstream to the Fifth Street Bridge (Ecological Assessment Area 3), and the lower river from the Fifth Street Bridge upstream through the Upper Turning Basin (Ecological Assessment Area 2). The watershed area up-stream of the developed harbor area (Ecological Assessment Area 1) is in relatively good condition. Primary problems that exist in the Outer Harbor are those associated with commercial harbor development channels, dredging and use of the commercial navigation channels, and contaminants in the sediments (primarily PAHs likely associated with the coal dock developments in the immediate area and other contaminated sediments including PCBs migrating out from the river). Primary problems that exist in the Lower River from the mouth upstream to the 5th Street Bridge are those associated with commercial harbor development bulkheading, dredging and use of the commercial navigation channel, and contaminants in the sediments (primarily PAHs likely associated with the coal dock developments in the immediate area and other contaminated sediments migrating in from upstream). Primary problems that exist in the Lower River from the 5th Street Bridge upstream to the end of the Federal navigation channel are those associated with recreational harbor development bulkheading, dredging and use of the recreational navigation channel, and primarily contaminants in the sediments (primarily PCBs, some equal to or in excess of 50 mg/kg or TSCA material). Benthic and fishery habitat has been significantly degraded in these areas in this regard as compared to quality warm water habitat criteria.

Considering the above, three common problem matters can be identified, those being: contaminated sediments, loss of protected riparian aquatic/fishery shallows, and dredging and commercial and recreational vessel traffic.

GOALS/OBJECTIVES

Goals/Objectives: Under the 1978 GLWQA (aka the RAP member's Bible), the overall goals of a RAP are to restore all beneficial uses to an Area of Concern, prohibit the discharge of toxic substances in toxic amounts, and virtually eliminate the discharge of persistent toxic substances. All of the beneficial use impairments in the Ashtabula River AOC are directly related to contaminated sediment, more specifically to the PCB and PAH mass associated with the contaminated sediment. Removal and remediation of the PCB and PAH mass is critical to comprehensive restoration of the ecological integrity of the lake/watershed. Some of the beneficial use impairments are related to loss of protected aquatic/fishery riparian shallow areas and lower river activities. Cleanup of the Ashtabula River via the Ashtabula River Partnership should eliminate all of the use impairments assigned to the lower river.

Considering the three common problem matters discussed previously, those being: contaminated sediments, loss of protected riparian aquatic/fishery shallows, and dredging and commercial and recreational vessel traffic; more specific objectives were developed to address contaminants and loss of protected riparian aquatic/fishery shallows that could also be applied to remediate/restore beneficial uses. It is understood that commercial and recreational facilities and activities will remain.

(NOTE: It is understood that discharge sources of pollutants have been remediated. Fields Brook is being remediated by separate authority and will be remediated prior to implementation of the Ashtabula River Partnership project. Best management practices will be in effect by the coal and Fields Brook industries.)

More specific objectives were developed to address contaminants and loss of protected riparian aquatic/fishery shallows that could also be applied to remediate/restore beneficial uses, as follows:

A. Reference studies and subsequent investigations indicate that an optimized dredging contaminant removal plan be developed for the problem areas that will leave no worse than existing conditions PCB and PAH sediment surface concentration initially, removal of almost all of the PCB and PAH mass, and, considering siltation or placement cover of relatively clean material, long-term (after several years) surface/substrate sediment (several feet) with targeted concentrations for PCBs and PAHs of equal to or less than 0.35 ppm and 10 to 20 ppm respectively. Reference Table 7.

B. Replacement of protected aquatic/fishery shallow areas, as possible, for lengths as long as possible along the river problem areas. These developments would include measures such as a shoreline aquatic/fishery shelf cut or provision and miscellaneous improvements such as soil cover, aquatic and terrestrial plantings, placement of stone/gravel, and placement of cover structures. This would provide missing habitat for fisheries and benthos for passage, cover, feeding, and possibly spawning. The goal/objective would be to reach a quality warm water habitat condition (per HAP) along the problem reaches, as possible. These would be applied to remediate/restore beneficial uses, as follows:

- 1. Remediate Restriction on Fish and Wildlife Consumption: Apply A.**
- 2. Remediate Degradation of Fish and Wildlife Populations: Apply A and B.**
- 3. Remediate Fish Tumors and Other Deformities: Apply A.**
- 4. Remediate Degradation of Benthos: Apply A and B.**
- 5. Remediate Restrictions on Dredging Activities: Apply A.**
- 6. Remediate Loss of Fish and Wildlife Habitat: Apply A and B.**

WITHOUT ARP PROJECT CONDITIONS

The Ashtabula River Partnership (ARP) project is a comprehensive project aimed at the lower 2 miles of the Ashtabula River and near lakeshore area remediation. If the Ashtabula River Partnership project were not implemented, subsequent attempts at remediation efforts would likely not fully or comprehensively address the problems. Similar to existing conditions problems would likely persist well into the future. A Superfund contaminant remediation level action would likely occur in the more distant future; but, would probably not be remediation to the extent of the ARP project. Migration of residual contaminated sediments from the Superfund cleanup into the harbor navigation channels would likely continue, and the potential for a major storm event washout would persist. In order to maintain harbor navigation channels and dispose of contaminated dredgings, the Corps of Engineers and local sponsors would likely still need to consider development and use of an in-lake confined disposal facility (CDF; which has received opposition from the U.S. Fish and Wildlife and other natural resource agencies); or, development and use of a dewatering and upland con-fined disposal facility or use of an existing upland con-fined disposal facility. Other ecological restoration programs may enable some limited ecological restoration measures. Total time and moneys expended would be substantially higher. Fewer immediate and long-term environmental/ ecological benefits would be realized.

Ashtabula River Partnership

TABLE 7

SEDIMENT QUALITY CLEAN-UP RATINGS BASED ON AVAILABLE INFORMATION

<u>PCBs ppm</u>	<u>Rating</u>	<u>Comment</u>	<u>Reference</u>
0 - .023	Exceptional	No noticable effects to Ashtabula (Potential) benthos and fishery.	1,4
.023 - .3	Excellent	Negligible effects to Ashtabula (potential) benthos and fishery. Comparative to that for Lake Reference Sites.	1,2,3,4
.3 - 1	Very Good	Very minor effects to Ashtabula (Potential) benthos and fishery.	1,2,3
1 - 3	Good	Minor effects to Ashtabula (potential) benthos and fishery.	1,2
3 - 10	Fair	Noticable effects to Ashtabula (potential) Benthos and Fishery.	1,2

PAHs ppm

0 - 4	Excellent	Negligible effects to Ashtabula (potential) benthos and fishery. Comparative to that for Lake Reference Sites.	1,2,4
4 - 10	Very Good	Very minor effects to Ashtabula (Potential) benthos and fishery.	1
10 - 20	Good	Minor effects to Ashtabula (potential) benthos and fishery.	1

REFERENCES

- 1) Ashtabula River Partnership, Environmental Risk Assessment and Management Considerations for Dredging the Ashtabula River and Harbor, Ohio, 1997, Ashtabula River Partnership.
- 2) Pickard, S. W., (DRAFT) Development of Polychlorinated Biphenyl (PCB) Sediment Cleanup Guidelines for Ashtabula Harbor (Upper River), Ohio. U.S. Army Corps of Engineers.
- 3) U.S. EPA, Assessment and Remediation of Contaminated Sediments (ARCS) Program, Calculation and Evaluation of Sediment Effect Concentrations for the Amphipod (*Hyalella Azteca*) and the Midge (*Chironomus Riparius*), 1996, U.S. EPA.
- 4) U.S. EPA, Ecotox Thresholds, Eco Update, Office of Emergency and Remedial Response, Publication 9345.0-12FSI, EPA 540/F-95/038.

DREDGING ECOLOGICAL RESTORATION/PRESERVATION SCENARIOS FOR CONTAMINANT REMOVAL AND ASSESSMENT/EVALUATIONS

DREDGING SCENARIOS

Three primary dredging plans (Bank to Bank To Bedrock, Deep Dredge, and Shallow Dredge) were formulated to address removal of contaminated sediments and assessed and evaluated; as summarized in the project's Comprehensive Management Plan and Environmental Impact Statements (CMP/EIS)/feasibility reports and which is described in detail in the CMP /EIS Volume 2, Technical Appendices, Appendix D - Dredging Scenarios and Sediment Volume Estimates. These were also assessed and evaluated from a human and ecological risk perspective as described in the Feasibility Report Appendix E and EIS Appendix EA - C Environmental Risk Assessment and Management Considerations for the Ashtabula River and Harbor.

The Ashtabula River Partnership assessed/evaluated several dredging scenarios in order to determine the amount of material that needed to be dredged, which would moderate project costs, while meeting River clean-up goals. This pertains to the project reach upstream of the Fifth Street Bridge where PCB contamination was identified as the primary contaminant of concern. The following methodology was used:

Develop the Dredging Scenarios

- Develop cross sections of the River every 100 feet
- Interpolate PCB Sampling data to cross section
- Plot isoconcentration lines
- Evaluate cross sections and develop dredging alternatives
- Develop a post-dredging surface in GMS based on dredging cut lines

Assessment/Evaluation of Dredging Scenarios

- Determine post dredging surface weighted PCB concentrations for each scenario
- Determine sediment volume removed for each scenario
- Determine PCB mass removed for each scenario
- Determine linear feet of bank affected for each scenario
- Assessment/evaluation considering cost and environmental items

Basically, three alternative scenarios were assessed/evaluated, those being: 1) a Shallow Dredge leaving a small amount of TSCA PCB contaminated sediments, some lower level contaminated sediments, and virgin sediments that would be extensively covered by new clean sediments (removal of 75% of total estimated PCB mass), 2) a Deep Dredge involving more extensive dredging removing all of the TSCA PCB contaminated sediments but leaving some lower level contaminated sediments and virgin sediments that would be extensively covered by new clean sediments (removal of 82% of total estimated PCB mass), and 3) a Bank to Bank to Bedrock Dredging involving extensive dredging removing all of the TSCA PCB contaminated sediments and all of the contaminated sediments that would in time be replaced by new clean sediments. The latter would be very costly, would presented more shoreline structural stability concerns, and was determined to be considerably more than that needed to meet River clean-up goals in light of the study gathered information. Regeneration of existing benthos/habitat removed under the third

dredging scenario would take the longest ver-sus the first or second scenario. During the assessment/evaluation of these scenarios, the River project area was broken down into reaches and assessed/evaluated for dredging using study in-formation gathered and criteria particular to each reach. Cross sections identifying contamination levels and location of contaminated sediments were developed for every one hundred feet of the River project area. River reach dredging assessment/evaluation criteria included items such as: contamination levels and location of contaminated sediments, dredge idiosyn-crasies, channel limits, surface area weighted PCB concentrations, sediment volume removed, PCB mass removed, linear feet of bank affected, and asso-ciated costs.

In the project reach from the Fifth Street Bridge downstream to station 120+00 located about half way down to the Lake, PAH contamination was considered to be the primary contaminant of concern. Considering this, it was determined that dredging and disposal of approximately 115,000 cubic yards of sediment from this reach would address this problem.

Figure 15 depicts the river reach where contaminated sediment would be dredged. Table 8 presents Dredging for Contaminant Removal Measures (Costs). Table 9 presents comparison initial and Post-Dredging Surface Area Weighted Sediment Concentrations for Ashtabula River Dredging Scenarios. Table 10 presents Comparison of Sediment Volume and PCB Mass Removal for Ashtabula Dredging Scenarios. Table 11 presents Linear Feet of Sheet Piling Affected in Different Dredging Scenarios.

NOTE: Substantial dredging would occur within channel Area F and channel Area G up through the upper turning basin. 

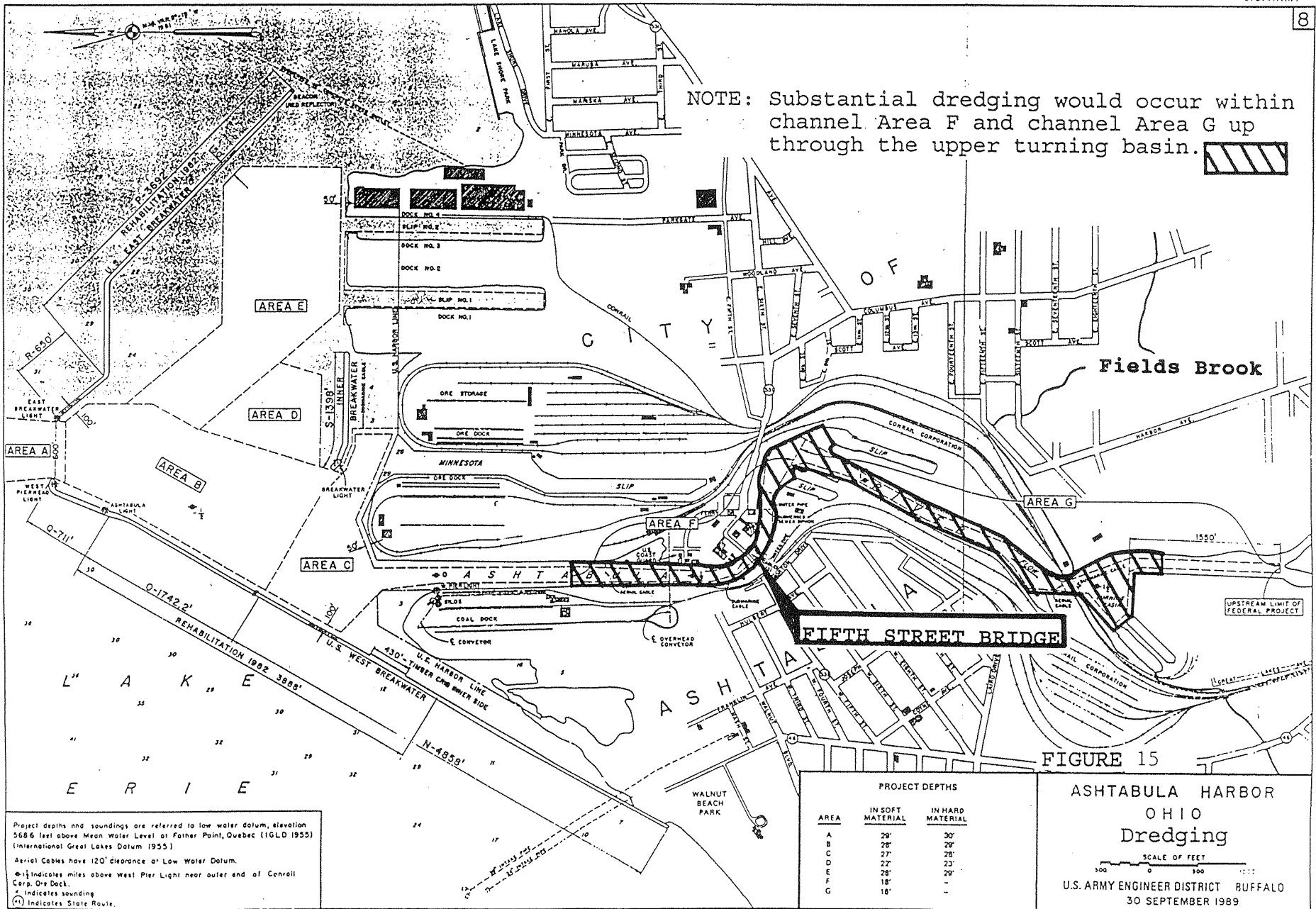

312 (b) -45

AREA	PROJECT DEPTHS	
	IN SOFT MATERIAL	IN HARD MATERIAL
A	29'	30'
B	28'	29'
C	27'	28'
D	22'	23'
E	28'	29'
F	18'	-
G	16'	-

**ASHTABULA HARBOR
OHIO
Dredging**

SCALE OF FEET
0 100 200

U.S. ARMY ENGINEER DISTRICT BUFFALO
30 SEPTEMBER 1989

Project depths and soundings are referred to low water datum, elevation 568.6 feet above Mean Water Level at Father Point, Quebec (IGLD 1955) (International Great Lakes Datum 1955).
Aerial Cables have 120' clearance at Low Water Datum.
⊙ indicates miles above West Pier Light near outer end of Conrail Corp. Dry Dock.
• indicates sounding
Ⓜ indicates State Route.

FIGURE 15

Table 8 - Dredging for Contaminant Removal Measures (Costs)

Item	<u>Dredging for Contaminant Removal</u>		
	<u>Bank to Bank To Bedrock</u>	<u>Deep Dredge</u>	<u>Shallow Dredge</u>
Construction			
First Cost \$			
Dredge :	30,448,750	20,153,500	17,742,000
Disposal:	35,051,250	29,746,500	27,758,000
Total :	65,500,000	49,900,000	45,500,000
Study			
E&D			
S&A			
RE			
Project Cost:	72,900,000	56,500,000	51,800,000

Note: The material proposed to be dredged downstream of the Fifth Street Bridge (115,000 CY) constitutes about 17% of the total material to be dredged (696,000 CY) for the Deep Dredge Plan.

Table 9 Post-Dredging Surface Area Weighted Sediment Concentrations for Ashtabula River Dredging Scenarios

Initial Conditions

Concentration Range (ppm)	Average Concentration (ppm)	Surface Area in Range (sf)	Percent of Total Surface Area	Surface Area Weighted Concentration (ppm)
>50	75	5,019	0%	0.18
40-50	45	12,983	1%	0.28
30-40	35	60,075	3%	1.00
20-30	25	125,701	6%	1.50
10-20	15	204,444	10%	1.46
5-10	7.5	286,404	14%	1.02
1-5	3	434,456	21%	0.62
0-1	0.5	969,437	46%	0.23
Total		2,098,519	100%	6.29

Calculations on left hand side assume that sediments > 10 ppm at bedrock interface are redredged with a specialty dredge.

Calculations on right hand side assume that sediments > 10 ppm at bedrock interface are left in place.

Bank to Bank to Bedrock Dredging

Concentration Range (ppm)	Average Concentration (ppm)	Surface Area in Range (sf)	Percent of Total Surface Area	Surface Area Weighted Concentration (ppm)
5-10	7.5	601,654	29%	2.15
5	5	633,045	30%	1.51
1 - 5	3	214,392	10%	0.31
0.5 - 1.0	0.75	40,937	2%	0.01
0 - 0.5	0.25	608,491	29%	0.07
Total		2,098,519	100%	4.05

Concentration Range (ppm)	Average Concentration (ppm)	Surface Area in Range (sf)	Percent of Total Surface Area	Surface Area Weighted Concentration (ppm)
5-10	7.5	601,654	29%	2.15
> 10	20	633,045	30%	6.03
1 - 5	3	214,392	10%	0.31
0.5 - 1.0	0.75	40,937	2%	0.01
0 - 0.5	0.25	608,491	29%	0.07
Total		2,098,519	100%	8.58

Deep Dredging

Concentration Range (ppm)	Average Concentration (ppm)	Surface Area in Range (sf)	Percent of Total Surface Area	Surface Area Weighted Concentration (ppm)
5-10	7.5	526,580	25%	1.88
5	5	542,260	26%	1.29
1 - 5	3	218,476	10%	0.31
0.5 - 1.0	0.75	49,106	2%	0.02
0 - 0.5	0.25	762,097	36%	0.09
Total		2,098,519	100%	3.59

Concentration Range (ppm)	Average Concentration (ppm)	Surface Area in Range (sf)	Percent of Total Surface Area	Surface Area Weighted Concentration (ppm)
5-10	7.5	526,580	25%	1.88
> 10	20	542,260	26%	5.17
1 - 5	3	218,476	10%	0.31
0.5 - 1.0	0.75	49,106	2%	0.02
0 - 0.5	0.25	762,097	36%	0.09
Total		2,098,519	100%	7.47

Shallow Dredging

Concentration Range (ppm)	Average Concentration (ppm)	Surface Area in Range (sf)	Percent of Total Surface Area	Surface Area Weighted Concentration (ppm)
5-10	7.5	436,364	21%	1.56
5	5	432,642	21%	1.03
1 - 5	3	321,960	15%	0.46
0.5 - 1.0	0.75	71,944	3%	0.03
0 - 0.5	0.25	835,609	40%	0.10
Total		2,098,519	100%	3.18

Concentration Range (ppm)	Average Concentration (ppm)	Surface Area in Range (sf)	Percent of Total Surface Area	Surface Area Weighted Concentration (ppm)
5-10	7.5	436,364	21%	1.56
> 10	20	432,642	21%	4.12
1 - 5	3	321,960	15%	0.46
0.5 - 1.0	0.75	71,944	3%	0.03
0 - 0.5	0.25	835,609	40%	0.10
Total		2,098,519	100%	6.27

Table 10 Comparison of Sediment Volume and PCB Mass Removal for Ashtabula River Dredging Scenarios

Initial Conditions					
Threshold Value	Cubic Feet Between Threshold Values	Cubic Yards Between Threshold Values	Cumulative Volume (CY)	Mass Between Threshold Values (kg)	Cumulative Mass (kg)
50 ppm	775,980	28,740	28,740	1735	1735
40 ppm	557,150	20,635	49,375	801	2,537
30 ppm	1,346,300	49,863	99,238	1505	4,042
20 ppm	2,788,900	103,293	202,531	2228	6,270
10 ppm	4,838,500	179,204	381,734	2320	8,589
5 ppm	4,922,400	182,311	564,046	1180	9,769
1 ppm	4,987,100	184,707	748,753	1196	10,964
0.5 ppm	1,144,200	42,378	791,131	27	10,992
0.1 ppm	1,259,800	46,659	837,790	12	11,004
0	8,223,300	304,567	1,142,357	14	11,018

Bank to Bank to Bedrock					
Threshold Value	Cubic Feet Between Threshold Values	Cubic Yards Between Threshold Values	Cumulative Volume Removed (CY)	Mass Between Threshold Values (kg)	Cumulative Mass Removed (kg)
50 ppm	775,848	28,735	28,735.11	1735	1735
40 ppm	555,638	20,579	49,314	799	2,534
30 ppm	1,337,337	49,531	98,845	1495	4,029
20 ppm	2,723,117	100,856	199,701	2175	6,205
10 ppm	4,595,420	170,201	369,902	2203	8,408
5 ppm	4,687,910	173,626	543,529	1124	9,531
1 ppm	4,858,800	179,956	723,484	1165	10,696
0.5 ppm	1,130,614	41,875	765,359	27	10,723
0.1 ppm	1,243,234	46,046	811,404	12	10,735
0	5,247,400	194,348	1,005,753	9	10,744
PCB Mass Removal =					98%

Deep Dredging					
Threshold Value	Cubic Feet Between Threshold Values	Cubic Yards Between Threshold Values	Cumulative Volume (CY)	Mass Between Threshold Values (kg)	Cumulative Mass (kg)
50 ppm	775,836	28,735	28,734.67	1735	1735
40 ppm	554,569	20,540	49,274	797	2,532
30 ppm	1,334,065	49,410	98,684	1492	4,024
20 ppm	2,723,697	100,878	199,562	2176	6,200
10 ppm	4,025,860	149,106	348,668	1930	8,130
5 ppm	2,229,700	82,581	431,249	534	8,664
1 ppm	1,627,100	60,263	491,512	390	9,054
0.5 ppm	370,390	13,718	505,230	9	9,063
0.1 ppm	130,500	4,833	510,064	1	9,064
0	1,119,300	41,456	551,519	2	9,066
PCB Mass Removal =					82%

Shallow Dredging					
Threshold Value	Cubic Feet Between Threshold Values	Cubic Yards Between Threshold Values	Cumulative Volume (CY)	Mass Between Threshold Values (kg)	Cumulative Mass (kg)
50 ppm	771,751	28,583	28,583	1726	1726
40 ppm	524,962	19,443	48,026	755	2,481
30 ppm	1,297,562	48,058	96,084	1451	3,932
20 ppm	2,698,220	99,934	196,018	2155	6,087
10 ppm	3,290,500	121,870	317,889	1577	7,664
5 ppm	1,201,300	44,493	362,381	288	7,952
1 ppm	1,081,400	40,052	402,433	259	8,212
0.5 ppm	318,350	11,791	414,224	8	8,219
0.1 ppm	15,100	559	414,783	0	8,219
0	1,173,800	43,474	458,257	2	8,221
PCB Mass Removal =					75%

Table 11 Linear Feet Of Sheet Piling Affected in Different Dredging Scenarios

Shallow Dredging Option					Deep Dredging Option					Bank to Bank to Bedrock
Left Bank	Feet Impacted	Right Bank	Feet Impacted	Total Feet Impacted	Left Bank	Feet Impacted	Right Bank	Feet Impacted	Total Feet Impacted	Total Feet Impacted
192	100	189	100	200	194	100	189	100	200	
191	100	188	100	200	193	100	188	100	200	
190	100	187	100	200	192	100	187	100	200	
189	100	186	100	200	191	100	186	100	200	
187	100	185	100	200	190	100	185	100	200	
186	100	184	100	200	189	100	184	100	200	
185	100	183	100	200	187	100	183	100	200	
184	100	182	100	200	186	100	182	100	200	
183	100	181	100	200	185	100	181	100	200	
179	100	180	100	200	184	100	180	100	200	
178	100	179	100	200	183	100	179	100	200	
177	100	178	100	200	179	100	178	100	200	
176	100	177	100	200	178	100	177	100	200	
175	100	176	100	200	177	100	176	100	200	
174	100	175	100	200	176	100	175	100	200	
173	100	174	100	200	175	100	174	100	200	
172	100	173	100	200	174	100	173	100	200	
171	100	172	100	200	173	100	172	100	200	
170	100	171	100	200	172	100	171	100	200	
169	100	170	100	200	171	100	170	100	200	
168	100	169	100	200	170	100	169	100	200	
167	100	168	100	200	169	100	168	100	200	
166	100	167	100	200	168	100	167	100	200	
165	100	166	100	200	167	100	166	100	200	
164	100	165	100	200	166	100	165	100	200	
163	100	164	100	200	165	100	164	100	200	
162	100	163	100	200	164	100	163	100	200	
161	100	162	100	200	163	100	162	100	200	
		161	100	100	162	100	161	100	200	
					161	100	159	100	200	
					159	100	158	100	200	
					158	100	157	100	200	
					157	100	156	100	200	
					156	100	152	100	200	
					155	100			100	
					154	100			100	
					153	100			100	
					152	100			100	
					150	100			100	
					149	100			100	
					148	100			100	
	2800		2900	5,700		4100		3400	7,500	21,000

Table shows cross section where dredging causes removal of at least 4 feet of the bank
 100 feet is used as the impact at each cross section because this is the approximate distance between cross sections
 Impact of sheet piling for the bank to bank to bedrock scenario was determined using Mapinfo

ENVIRONMENTAL RISK ASSESSMENT AND MANAGEMENT CONSIDERATIONS/RECOMMENDATIONS

Purpose

The purpose of this analysis is to discuss environmental issues involved in remediating the contaminated sediment in the Ashtabula River and Harbor. Generally, a risk assessment consists of a qualitative and/or quantitative evaluation of the actual or potential impacts of contaminants on humans, animals, and plants. A qualitative risk assessment approach is deemed most appropriate for this project because of the project specific issues which include the following: 1) the three dredging alternatives being evaluated in the report result in similar post-remedial surface area weighted concentrations for PCBs (i.e. all within a few ppm PCBs) and therefore would not result in much different quantitative risk estimates; 2) because the most highly contaminated sediments are at deeper depths, dredging must continue below navigable depths (i.e. 6-8 feet), otherwise the most highly contaminated sediments would be left at the surface and available for uptake by biota; and 3) an important goal of the partnership is to ensure that sediment dredged in the future can be open-water disposed, which cannot be predicted using standard risk assessment techniques. Therefore, the scope of this analysis is to provide a qualitative analysis of the human health and ecological risk considerations, in support of the goal of developing and evaluating alternatives for the project.

Background

Contamination in the sediment has transferred to fish, affected habitat quality, and has restricted lower Ashtabula River commercial and recreational use. Due to natural sedimentation and shoaling, the Ashtabula River and Harbor need to be dredged on a regular basis to maintain adequate navigation depths. However, because of the levels of contaminants in the sediment, these sediments are not suitable for unrestricted open-lake disposal and, instead require confined disposal. Currently, there is no confined disposal facility (CDF) available to contain dredged Ashtabula River sediment. As a result, navigable channel maintenance cannot be conducted. In addition, the total mass of PCBs in the River is such that future events could reasonably result in continued downstream migration of PCBs and other contaminants of concern into Lake Erie resulting in sediment and fish contamination well into the future. Removal of the bulk of this mass will dramatically reduce potential ecological and human health risk from the site, not only in the present, but also significantly reduce the potential for re-release in the future.

Choosing and Evaluating Dredging Alternatives

As discussed in the DREDGING SCENARIOS paragraph, the dredging alternatives under consideration were: bank-to-bank-to-bedrock, shallow and deep. The bank-to-bank-to-bed-rock alternative seeks to remove all of the sediment in the river, to the maximum extent possible. The deep alternative removes all of the sediment starting from the upper turning basin down to Station 158 (near the lower turning basin), and then, downstream of that point, removes all sediments greater than 10 ppm (from roughly the lower turning basin to the Harbor). This alternative does not dredge sediment in river sideslips nor the upstream areas of the AOC (roughly Station 207 to Station 193). The shallow dredging option is similar to the deep in that it also removes all

sediment from the upper turning basin and continues downstream, removing all sediments greater than 10 ppm PCBs, except for river sideslips and upstream of Station 193. The shallow option differs from deep dredging in that it does not dredge the most down-stream TSCA-regulated (>50 ppm PCBs) area, near station 158. The deep dredging option removes this TSCA-regulated mass, which is estimated to be 489 cubic yards.

To best evaluate the proposed dredging alternatives, a weight of evidence approach that considers several factors, not just risk, was employed. A matrix with the three dredging alternatives, Table 12: Alternatives Matrix, was developed which considered the following factors: 1) PCB mass removed; 2) surficial PCB sediment concentration after dredging; 3) beneficial uses addressed; and 4) scour/release potential.

If either bank-to-bank-to-bedrock or deep dredging is implemented and the majority of PCB mass is removed, long-term protection is expected to be achieved. The GMS model indicates that after dredging, surface area weighted PCB sediment concentrations will approximate current surficial concentrations. Ongoing sedimentation in the Ashtabula River, while historically low on an annual basis, will gradually cover any low level residual contaminants left behind. Since 1983, significant reductions in the concentration of PCBs in fish have occurred due in part to cleaner sediments burying contaminated sediments, and also due to discharger compliance. After cleanup, it is expected the fish consumption advisory will be lifted and long-term protection will be achieved because the majority of the PCB mass will be removed. In order to maintain navigable depths for recreational purposes, future dredging in the lower river will likely be conducted to no more than -8 feet depth. Therefore, an adequate buffer will exist between the residual contamination left behind and the amount of clean sediment that will gradually cover it to help ensure long-term protection of human health and the environment.

The bank-to-bank to-bedrock alternative is the most protective and conservative in terms of PCB mass reduction, addressing most use impairments, and reducing scour potential. It attempts to remove practically all of the PCBs in this system. However, the bank-to-bank to-bedrock alternative also has extremely high implementation costs and concerns regarding river bank stability. The deep dredging alternative provides a similar degree of protectiveness and accomplishes much of what the bank to bank to bedrock does at a significantly lower cost. Deep dredging removes all TSCA material and a significant PCB mass (82%), substantially reducing any future scouring and potential release of elevated levels of contaminants. In addition, this large PCB mass removal gives greater assurance of open-water disposal for future dredging. In addition, deep dredging will likely facilitate river bank stability, help sustain habitat diversity, and perhaps, generate the least impact to ecological communities along the channel edges, compared to bank-to-bank to-bedrock dredging. Given the high costs and logistical issues inherent with bank-to-bank to-bedrock, and the positive anticipated results of the deep dredging alternative, the deep dredging alternative is the recommended starting point.

Table 12 Alternatives Matrix

<i>Dredging Scenarios</i>	PCB Mass Removed ¹	PCB Sediment Concentration Left Behind in ppm ^{1,2} (Surface Area Weighted)	Beneficial Uses Addressed (Including Open-Lake Disposal and Risk)	Scour/Release Potential (Future risk and loading to the Lake)
No Action	none	6.3	none	High
Bank to Bank to Bedrock	98%	4 8.6	open-lake disposal ++ recreational and commercial shipping ++ fish advisory lifted ++ long-term risk reduction ++ habitat quality +	Low
Deep	82%	3.6 7.5	open-lake disposal + recreational and commercial shipping ++ fish advisory lifted + long-term risk reduction + habitat quality ++	Low
Shallow	75% (one TSCA regulated mass remains)	3 6.3	open-lake disposal +/- recreational and commercial shipping + fish advisory lifted +/- long-term risk reduction +/- habitat quality +	Medium

¹Surface concentrations and percent mass removal estimates are from Dave Conboy, USACE-Buffalo

²The two concentrations shown refer to whether dredging will be one pass (second number) or two passes to increase efficiency (first number)

Where:

--	-	+/-	+	++
poor	low	no difference	good	excellent

RECONTAMINATION ASSESSMENTS

An Ashtabula River Recontamination Assessment was conducted for the study. It considered the Fields Brook remediation scenario and low, average, and high flow events from Fields Brook and the Ashtabula River. Based upon the results of the recontamination assessment, the low level of PCB that is deposited into the Ashtabula River from Fields Brook is less than 2 (ppb) parts per billion under all of the scenarios that were modeled. This presents a negligible recontamination scenario. The recontamination assessment/evaluation is presented in considerable detail in the Feasibility Report Appendix F - Recontamination Assessment. (Technical Appendices).

Further in this regard, some clean material does accumulate in the upper most reaches of the recreational navigation channel and should be considered for use as clean cover or fill in deep dredged areas of the river. Surface sediment sampling and analysis was done in 1993 and 1994 (USACOE - ORDL) to verify that interim dredging done in 1993 did not expose surface sediments with PCB concentrations greater than 10 ppm and that settling cover sediment does not have PCB concentrations greater than 10 ppm. Sediment sampling analysis indicates that sediments settling into the upper channel area above the upper turning basin have PCB concentrations of <0.1 ppm. However, the amount of this material available is limited presently to about 8,000 cubic yards.

Review of 1995 soundings upstream of the 5th Street Bridge as compared to the 1993 Interim Channel Dredging dimensions, indicate that approximately 4,500 cubic yards of relatively clean material has silted in annually in the upper channel reach upstream of the upper turning basin. About 16,000 cubic yards has silted in annually in the channel reach upstream of the 5th Street Bridge through the upper turning basin.

The WRDA 1990 Section 312 Initial Appraisal Report, Ashtabula Harbor, Ohio, Appendix E - Sedimentation Study indicates that approximately 12,500 cubic yards silt in annually in the Lower River channel reach downstream of the 5th Street Bridge. Approximately 22,000 cubic yards silt into the immediate Outer Harbor Area (C) and 83,750 cubic yards into rest of the Outer Harbor.

All this totals approximately 138,600 cubic yards annually, reasonably consistent with the estimate of harbor/river sedimentation load of approximately 260,000 cubic yards every two years as previously stated in the Feasibility Report and EIS. Considering this and the likely-hood that the river deep dredge areas will act like setting basins, even the most conservative estimates would indicate a substantial clean cover and substantial improvement in benthic habitat relative to contaminant levels would occur within about three years. Reference Figure 15 and Table 13. This will significantly clean-up the area bioavailability and food chain and bioaccumulation and magnification of PCBs, with a high certainty of removal of the area fish advisory within about six to 10 years. This will also prevent with high certainty the migration of problem contaminated sediments down stream and into the Outer Harbor and Lake Erie.

This recovery may be expedited by periodically dredging the relatively clean material that settles in the most upstream channel area (~ 4,400 cubic yards per year) and discharging it into the pro-

ject area deep dredge areas until the harbor regains maintained channel dimension equilibrium. Reference Figure 15 and Table 13 scenarios.

The Corps of Engineers periodically (every few years) samples and analyses federal channel sediments for the Harbor Operations and Maintenance program. This can also provide basic monitoring information in this regard.

SUPPLEMENTAL DREDGING MEASURES FOR CONTAMINANT REMOVAL AND ECOLOGICAL RECOVERY

Several dredging measures were noted for the channel areas upstream of the Fifth Street Bridge that would facilitate and/or expedite ecological recovery in this reach.

1. One is to dredge relatively clean material from channels above and/or below the ARP project dredging area during routine operation and maintenance dredging and disposal and place it over the dredged area as clean cover. This would initiate almost immediate recovery to benthic and fishery habitat rather than gradual (several years) recovery as relatively clean material silts into the ARP project dredged area. Reference Figure 15 and Table 13. This would probably work best as a one time effort, since after about a year of recovery, this would likely result in as many disturbance problems as cover benefits.

2. If the channels are only maintained to recreational depths, eventually shallow aquatic/shelf areas will develop. However, at normal siltation rates, full potential/recovery would not be expected for decades. Reference Figures 15, Table 13, and Figure 16. Initial construction of such shelves does not appear practical.

3. If the recreational channels were maintained to a somewhat lesser width, about 5 to 10 feet, eventually associated wider shallow aquatic/shelf areas will form (+/.34 Acres). However, at normal siltation rates, full potential/recovery would not be expected for decades. Reference Figures 15, Table 13, and Figure 17. Initial construction of such shelves does not appear practical.

Additional costs associated with these measures is minimal (i.e. administrative) with likely savings in the future, and should be implemented.

Table 13 - Dredging Plan and Re-sedimentation Ecological Recovery

DREDGING PLAN	ECOLOGICAL RECOVERY		COST
	Partial Min. Benthic Cover ~ 20 Acres @ 2 Feet (64,533 CY)	Full Benthic Cover And Shallows	
Bank to Bank			
@ 1,150,000 CY			
- Siltation @ 16,000 CY/YR	4.0 YR	71.9 YR	0
- Siltation/Dredge From Upstream @ 20,500 CY/YR	3.1 YR	56.1 YR	
- Siltation/Dredge Upstream/Outer (4,500/75,000) @ 95,500 CY/YR	1.0 YR	12.0 YR	
Deep Dredge			
@ 696,000 CY			
- Siltation @ 16,000 CY/YR	4.0 YR	43.5 YR	0
- Siltation/Dredge From Upstream @ 20,500 CY/YR	3.1 YR	33.9 YR	
- Siltation/Dredge Upstream/Outer (4,500/75,000) @ 95,500 CY/YR	1.0 YR	7.3 YR	

Note: More than one time outer harbor dredging disposal may be more disturbance than value.

The Corps dredges about 150,000 CY of material from the outer harbor area about every two years and disposes of it at the open-lake disposal site.

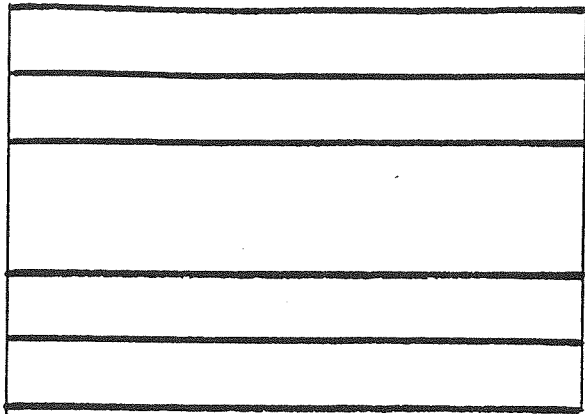

Plan View

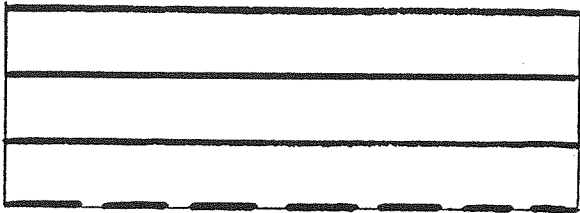

Elevation

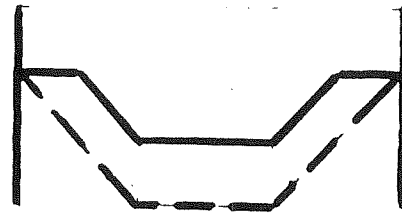

Cross-Section

FIGURE 16
REDUCE DEPTH

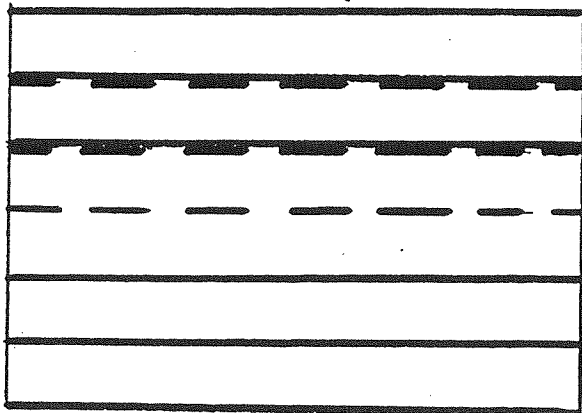

Plan View

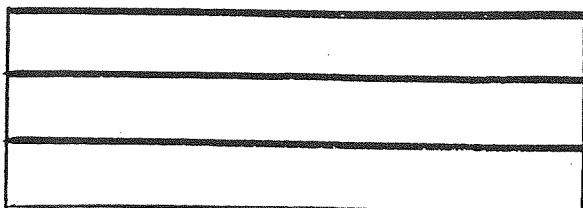

Elevation

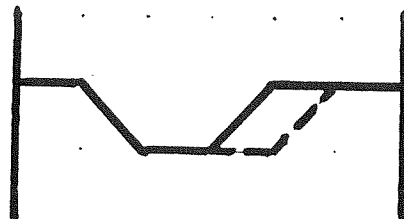

Cross-Section

FIGURE 17
REDUCE WIDTH

OTHER ASSESSMENT/EVALUATION OUTPUT MEASURES

PCB BIO-ACCUMULATION IN FISH TISSUE AND ADVISORIES

Ashtabula Harbor:

A series of fish tissue contamination level studies have been conducted for the Ashtabula Harbor and near lake shore area. Studies were conducted in 1981 (Veith, et al), 1983 (Armstrong), 1990 (Woodward Clyde Consultants 1991), and 1994 (Ohio EPA). Fish species sampled included (whole and fillet): Carp, Bullhead, Small/Large Mouth Bass, Bluegill, Brown Bullhead. Results are presented in Tables 14, 15, and 16.

The 1981 and 1983 information was the basis for the issuance of a fish consumption advisory for the lower two miles of the river and harbor by the Ohio Department of Health and Ohio EPA in 1983. The advisory recommended that no fish caught in the river from the 24th Street Bridge to the harbor mouth be eaten. The advisory sites PCB concentrations ranging from 2.4 to 58.3 mg/kg in the edible portion (skin-on fillet). The current Food and Drug Administration level for safe consumption is 2 mg/kg for the edible portion. The FDA action level at the time the advisory was issued was 5 mg/kg. (RAP, 1991)

There are no criteria for the other organic chemicals listed in the advisory, but the presence of so many different chemicals is a concern. Listing the other pollutants was precautionary to keep the advisory in effect in the event that the PCB problem was corrected but other chemicals were still elevated (J. Estenik, Ohio EPA, personal communication 1990). (RAP, 1991)

In addition to the advisory in the Ashtabula River, a general advisory is in effect for Lake Erie. Based on elevated PCB concentrations in skin-on fillets, it is recommended that no carp or channel catfish from the lake be consumed. (RAP, 1991)

More recent fish data are now available for the Ashtabula River. Ohio EPA collected several species of fish in 1994 (large mouth bass, small mouth bass, carp, rock bass, catfish, redhouse, walleye, and drum). On average, PCB concentrations in fish increased approximately 0.5 parts per million over the concentrations in 1990 indicating that fish in the river continue to be contaminated with PCBs. The levels of PCBs have not declined to completely safe levels and those consuming a larger number of fattier fish such as carp and catfish have the greatest risk. (Risk Assessment, 1997)

The States of Ohio, Pennsylvania, and New York issue sport Fish Consumption Advisories based on a sliding scale. When PCB concentrations in edible portions equal or exceed 0.05 ug/g they advise the general public not to consume more than one meal per week, and that women of child bearing years and young children avoid consumption. At concentrations of 2 ug/g they advise that no one consume the fish. The U.S. Food and Drug Administration prohibits interstate sale of fish exceeding 2 ug/g. State Agricultural Departments prohibit intrastate sale at 2 ug/g.

In 1997, the fish consumption advisory was revised based on decreased levels of PCBs more recently measured in fish. The current fish advisory is less stringent. It places specific limits on

the amounts of smallmouth bass, largemouth bass, walleye, channel catfish, and common carp that can be safely consumed. Because common carp and channel catfish contain the highest levels of PCBs, the amount of these species that can be consumed is much less than for other species. The amount of fish that can be safely consumed were determined by the Ohio Department of Health using the Great Lakes Sport Fish Advisory Task Force September 1993 protocol titled " Protocol for a uniform Great Lakes Sport Fish Consumption Advisory". (Risk Assessment, 1997)

If either Bank to Bank to Bedrock or Deep Dredging were implemented, it is expected with high certainty that the fish consumption advisory will be lifted and long-term protection will be achieved because the majority of the PCB mass will be removed. (Risk Assessment, 1997) It is expected that, at a minimum, within several years of completion of dredging enough clean material will have silted into the dredged area to provide a sufficient cover (about two feet) to initiate benthos and fishery recovery with regard to contaminants. Within several more years it should become apparent that the bio-accumulation chain is broken.

It should be noted here that it is critical that a sufficient amount of contaminants be removed from the Lower Ashtabula River environment and in combination with Supplemental Dredging Ecological Restoration/Preservation Measures for Protected Aquatic/Fishery Shallows so that the Supplemental Measures don't encourage more fish into a potential recontaminated contaminated environment.

The Ohio Environmental Protection Agency conducts these surveys periodically and will conduct such a survey and report the findings within five to ten years of completion of the project.

TABLE 14 Mean concentrations of selected organic compounds in fish samples collected within a .5 mile area of the Fields Brook-Ashtabula River confluence in 1980 and 1981. The fish consumption advisory was largely based on this information. (Armstrong 1983).

Samples	Length (mm)	Weight (g)	Lipid Content (mg/g)	Total PCB (ug/g)	Hexachloro- benzene (ug/g)	Pentachloro- benzene (ug/g)	1,1,1,2 Tetrachloroethane (ug/g)	1,1,2,2 Tetrachloroethane (ug/g)
Carp, whole (25 samples)								
Range	172 - 454	184 - 2910	51 - 304	4.0 - 152.6	.28 - 7.49	.06 - .63	1.08 - 5.70	.01 - .62
Mean	318	1053	211	50.0	3.40	0.22	2.60	.22
Std. Dev.	77	701	234	46.1	2.40	0.16	1.80	.15
Carp, Fillet (21 samples)								
Range	75 - 506	246 - 4320	21 - 267	2.4 - 58.3	.37 - 5.80	.03 - .36	.02 - 3.66	.02 - .51
Mean	359	2317	203	19.0	2.0	0.14	1.50	0.16
Std. Dev.	107	2841	250	18.0	1.5	0.08	1.00	0.11
Bullhead, Whole (11 samples)								
Range	146 - 282	73 - 574	25 - 79	.94 - 8.53	.04 - 1.13	.01 - .06	.01 - .39	.004 - .04
Mean	197	222	77	4.44	0.57	0.03	0.07	.02
Std. Dev.	47	175	62	2.86	0.37	0.02	0.13	.01
Bullhead, Fillet (26 samples)								
Range	ND	39 - 574	4 - 138	.60 - 28.0	.003 - 4.66	0* - 0.19	0* - .84	.002 - 1.05
Mean	ND	195	38	5.6	0.96	0.04	0.06	0.07
Std. Dev.	ND	152	28	6.4	1.11	0.04	0.17	0.20

0* Indicates less than detection limit.

TABLE 15 Mean concentrations of chemicals in fish tissue samples collected in the lower two miles of the Ashtabula River in 1990. All samples were composites. Hexachlorobenzene, 1,1,1,2-tetrachloroethane and pentachlorobenzene were not detected. (Woodward Clyde Consultants 1991).

Sample	Length (mm)	Weight (g)	Lipid Content (%)	Total PCB (ug/g)	1,1,2,2 Tetrachloroethane (ug/g)	Tetrachloroethane (ug/g)	Trichloroethane (ug/g)
Carp, whole (4 samples)							
Range	490-557	1638-2478	.2-4.7	.07-.81	.006-.028	.025-.270	.007-.040
Mean	531	2150	1.6	0.28	.017	.094	.018
Std. Dev.	30.2	375	1.9	0.31	.016	.102	.019
Small/Largemouth Bass, whole (4 samples)							
Range	218-361	128-752	1.4-1.8	.09-.20	.01-.04	.02-.45	.01-.07
Mean	301	474	1.5	.14	.02	.18	.04
Std. Dev.	61.9	273	0.2	.05	.02	.23	.04
Small/Largemouth Bass, fillet (2 samples)							
Range	292-308	405-455	.06-.14	ND	--	.04-.15	--
Mean	300	430	.10	ND	.01	.10	.01
Std. Dev.	11.3	35	.06	ND	--	.08	--
Bluegill, fillet (2 samples)							
Range	130-147	53-74	.06	ND	ND	ND	ND
Mean	139	64	.06	ND	ND	ND	ND
Std. Dev.	12.0	14.8	--	ND	ND	ND	ND
Brown Bullhead (1 sample)							
	NA	NA	.67	0.7	NA	NA	NA

ND - Not detected
NA - Not available

Table 16- Mean concentrations of chemicals in fish tissue samples (fish fillet) collected in the lower two miles of the Ashtabula River and at the mouth of Fields Brook in 1994.

Sample	Length (mm)	Weight (g)	Lipid Content %	Total PCB (ug/g)	Hexachlo robenzene (ug/g)
Brown Bullhead Ashtabula Mouth (1 Sample 287)					
Range	311.0	386	0.89	0.16	0.02
Mean	311.0	386	0.89	0.16	0.02
Largemouth Bass Ashtabula Mouth (3 Samples 288)					
Range	205-216	137-167			
Mean	210	150	0.63	0.42	0.02
Common Carp (5th - RRB) (2 Samples 289)					
Range	484-496	1450-1500			
Mean	490	1475	3.30	0.53	0.08
Largemouth Bass (5th - RRB) (2 Samples 290)					
Range	341-380	600-920			
Mean	361	760	0.73	0.48	0.05
Common Carp Fields Brook Mouth (2 Samples 291)					
Range	556-585	2850-2950			
Mean	571	2900	8.70	3.62	ND
Largemouth Bass Fields Brook Mouth (1 Sample 292)					
Range					
Mean	299	408	0.49	1.19	0.06

Note: Ohio Department of Health guidelines for hexachlorobenzene within which range they see no human health problem is 0-800 ug/l.

Scippo Creek (Example):

In 1962, PPG Industries, Inc. (PPG) built a Coatings and Resins Plant south of Circleville, Ohio. A gravity drain storm sewer was constructed in 1965 to convey storm water runoff and non-contact cooling water. A hot oil heat exchange system containing Aroclor 1248, a polychlorinated biphenol compound or PCB, was used at the plant and was discharged through the storm water sewer line into Scippo Creek. PPG drained the hot oil heat exchange system in 1972 and replaced it with a non-PCB oil. However, PPG found PCB residues in the storm water sewer line that discharged to Scippo Creek in 1987.

As a result of this discovery, PPG implemented a remediation program from 1987 to 1990 that included the removal and replacement of major portions of the plant storm water system, the removal of 675 tons of PCB-contaminated sediments from Scippo Creek, and the installation of a new storm water discharge line to Scippo Creek. In addition, a number of Interim Action activities were conducted under the direction of Ohio EPA from 1992 through 1993 in the former discharge pipeline to Scippo Creek and included: removing and disposing of all liquids, sediments, and debris remaining in the pipeline at an off-site disposal facility; removing the outfall structure including the concrete and rip-rap spillway; sealing both ends of the pipeline and welding shut all manholes; and cleaning the interior of the pipeline. An additional 25 tons of soil were excavated from the former discharge system spillway in September 1995 to eliminate concerns regarding concentrations of Aroclor 1248.

In a March 1989 report prepared by Metcalf & Eddy, Inc. for PPG titled *Biological Sampling Fish Tissue*, fish were collected in the summer of 1988 and February 1989 from both Scippo Creek and the Scioto River for fish tissue analysis. Scippo Creek is a tributary to the Scioto River. Sediment concentrations of Aroclor 1248 ranged from nondetect to 90 mg/kg, with the highest detected levels from the location immediately downstream from the outfall. From the 1988/1989 fish tissue analyses, Aroclor 1248 fish tissue concentrations in Scippo Creek ranged from nondetect to 1300 mg/kg. A number of the fish tissue analyses indicated significantly elevated concentrations of Aroclor 1248 (e.g. 290 mg/kg, 360 mg/kg, 410 mg/kg, 430 mg/kg, 620 mg/kg, 920 mg/kg, 1200 mg/kg and 1300 mg/kg). These significantly elevated fish tissue concentrations were obtained from fish collected in Scippo Creek approximately 500-750 feet upstream of the outfall and fish collected approximately 600 feet and three-fourths of a mile downstream from the outfall, with the most highly elevated concentrations reported for fish collected 500-750 feet downstream from the outfall. These fish tissue concentrations are among the highest ever reported in Ohio for PCBs. The fish obtained from the Scioto River all had nondetect fish tissue concentrations for Aroclor 1248. The PPG outfall is approximately 4.0 miles upstream from the confluence with the Scioto River.

In September 1994, fish tissue analyses were again conducted in Scippo Creek. This sampling was conducted after the majority of the remediation had occurred with the most significant removal actions occurring between 1987 and 1990. Sixteen whole body fish samples and twelve fish fillet samples were analyzed for PCBs. Aroclor 1248 concentrations were from nondetect to 1.2 mg/kg. The concentrations of Aroclor 1248 reported were orders of magnitude below

those reported in the 1988/1989 fish tissue analyses, and were in some cases three orders of magnitude lower. This is a significant reduction that can be primarily attributed to the remediation efforts conducted by PPG. In addition, the biological integrity of the fish and benthic macroinvertebrate communities in Scippo Creek have improved in comparison with earlier studies conducted by Ohio EPA and USEPA.

WATER QUALITY

As indicated previously, the primary present water quality problem associated with contaminants in the Lower Ashtabula River is that associated with various storm events and flows and resuspension of sediments and associated contaminants. As indicated by the dredging plans assessment/evaluation and the associated risk assessment/evaluation the initial after dredging problem would be no worse than existing conditions while the long-term scour release potential would be low for the Bank to Bank to Bedrock and the Deep Dredges and medium for the Shallow Dredge due to the locations and amounts of contaminants removed. The problem would be expected to be essentially eliminated for low flow events a few years after dredging as clean material fills in the dredged areas and covers any more contaminated residual sediments.

Problems with DO and PH would approach more natural levels the more contaminants are removed from the system.

RESTORED BENTHIC HABITAT

The simplest ecological measure associated with the proposed dredging project is that associated with restoration of clean benthic habitat. Simple calculations indicate that of the approximate 40 acre area to be dredged, about 20+ acres has surface and benthic (~ 3 feet depth) and scour area (~ another 3 feet depth) subsurface PCB contamination levels of >5 ppm or elevated PAHs. Correspondingly, this equates to about 100,000 cubic yards of significantly contaminated benthos habitat and considering potential for about 3 feet of scour about another 100,000 cubic yards considering reasonable scour protection for a total of about 200,000 cubic yards. This benthic habitat currently dominated by pollution tolerant (i.e. Oligochaeta) species would soon be complimented with somewhat more diverse and better quality less pollution tolerant (i.e. mayflies, caddisflies, and midges) species. Reference Figure 18.

The Corps of Engineers periodically (every few years) samples and analyses federal channel sediments for the Harbor Operations and Maintenance program. This can also provide basic monitoring information in this regard.

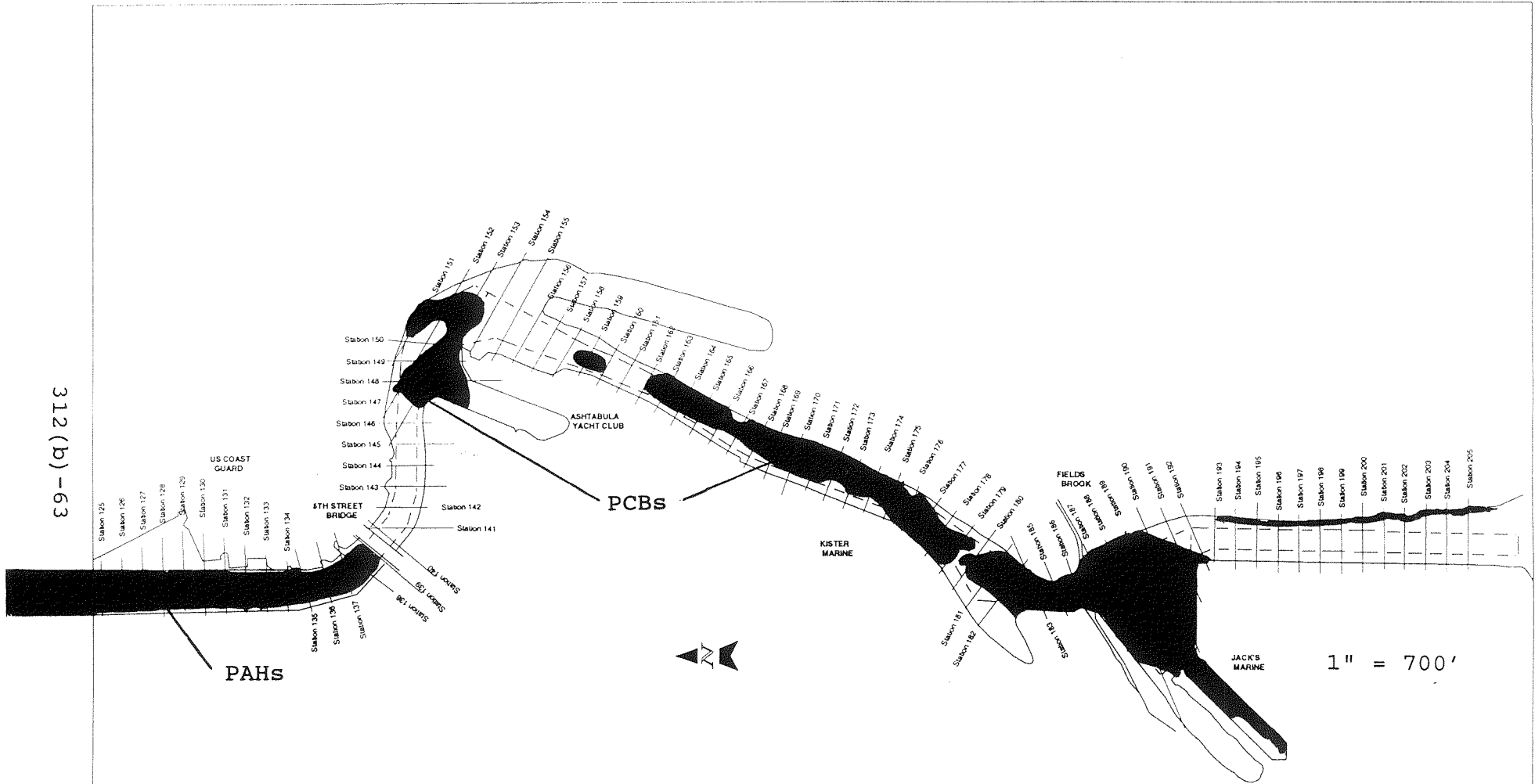

FIGURE 18

Ashtabula River Partnership

1995 Surface Exposure > 5 ppm PCBs

Reference: Dredging Scenarios and Sediment
Volume Estimates Appendix.

OHIO HABITAT ASSESSMENT PROCEDURE (HAP)

Introduction: The ecology of a region has a significant impact on the type of biological community that region will support. Knowledge of the ecology of an area allows one to anticipate what type of ecological community the area will support. An assessment of the biological community can be compared with the standards for that particular ecoregion to evaluate whether or not the area is impacted by pollution, developments, and/or activities. (RAP, 1991)

The Ohio Environmental Protection Agency has developed a Habitat Assessment Procedure (HAP) based on the premise of ecological analyses. They have inventoried a number of ecosystems examining habitat, fisheries, macroinvertebrate, and community and have been able to develop a number of assessment/evaluation indices accordingly. These include such indices as the QHEI - Qualitative Habitat Evaluation Index, the IBI - Index of Biotic Integrity, Miwb - Modified Index of well being, and the ICI - Invertebrate Community Index. Comparing data and utilizing these measures can provide an assessment for ecological potential, conditions, degradation or ADV - area of degradation values, likely causes, and improvement measures.

In 1990, the Ohio Environmental Protection Agency conducted a habitat assessment procedure for the International Joint Commission identified Ashtabula River Area of Concern. (Reference Biological Community Status of the Lower Ashtabula River and Harbor Within the Area of Concern (AOC), Ashtabula Harbor, Ohio, January 14, 1992, OEPA.) Attention in the report was focused on the present day effects of pollution on the biological communities of the Ashtabula River. The report also references information/reports on past conditions, as available. The Area of Concern has been designated as the lower two miles of the Ashtabula River, including Fields Brook, and the near shore areas of Lake Erie.

The Ashtabula River study area of the 1992 report consists of the Ashtabula River from River Mile (RM) 10.0 downstream to the mouth and includes the harbor area enclosed by the breakwaters. Reference Figure 19. The study area was further broken down into four distinct sub-areas or reaches. Area 1 (RM 10 downstream to RM 1.8) is a minimally disturbed stream area upstream of the harbor area. The lower 0.4 miles is developed with some recreational channelization, shoreline bulkheading, and some marina development. Area 2 (RM 1.8 downstream to RM 0.7) is an area modified by recreational channelization, shoreline bulkheading, marina developments, and predominantly an accumulation of area contaminated (PCBs and other) sediments into the former and deeper commercial navigation channel and Turning Basin. In the Ashtabula River, marina development exists on about 50% of the river's shoreline from RM 0.7 to RM 2.2 with some undisturbed shoreline still present along the east bank. In Area 3 (RM 0.7 to RM 0.0 and downstream of the 5th Street Bridge), the lower 0.7 miles of the river channel has been modified for use by commercial freighters. The channels have been dredged to a depth of approximately 25 feet with shoreline steel, concrete, or railroad tie vertical bulk-head. Habitat quality for the supporting fish communities is very poor in the ship canals. Also coal handling facilities are developed along the shipping channel areas. Area 4 is the Outer Harbor area where Lake Erie is enclosed by the harbor breakwaters and areas are periodically dredged to provide deep draft access for commercial freighters.

Three primary problem areas have been identified in the Ashtabula Harbor Area of Concern

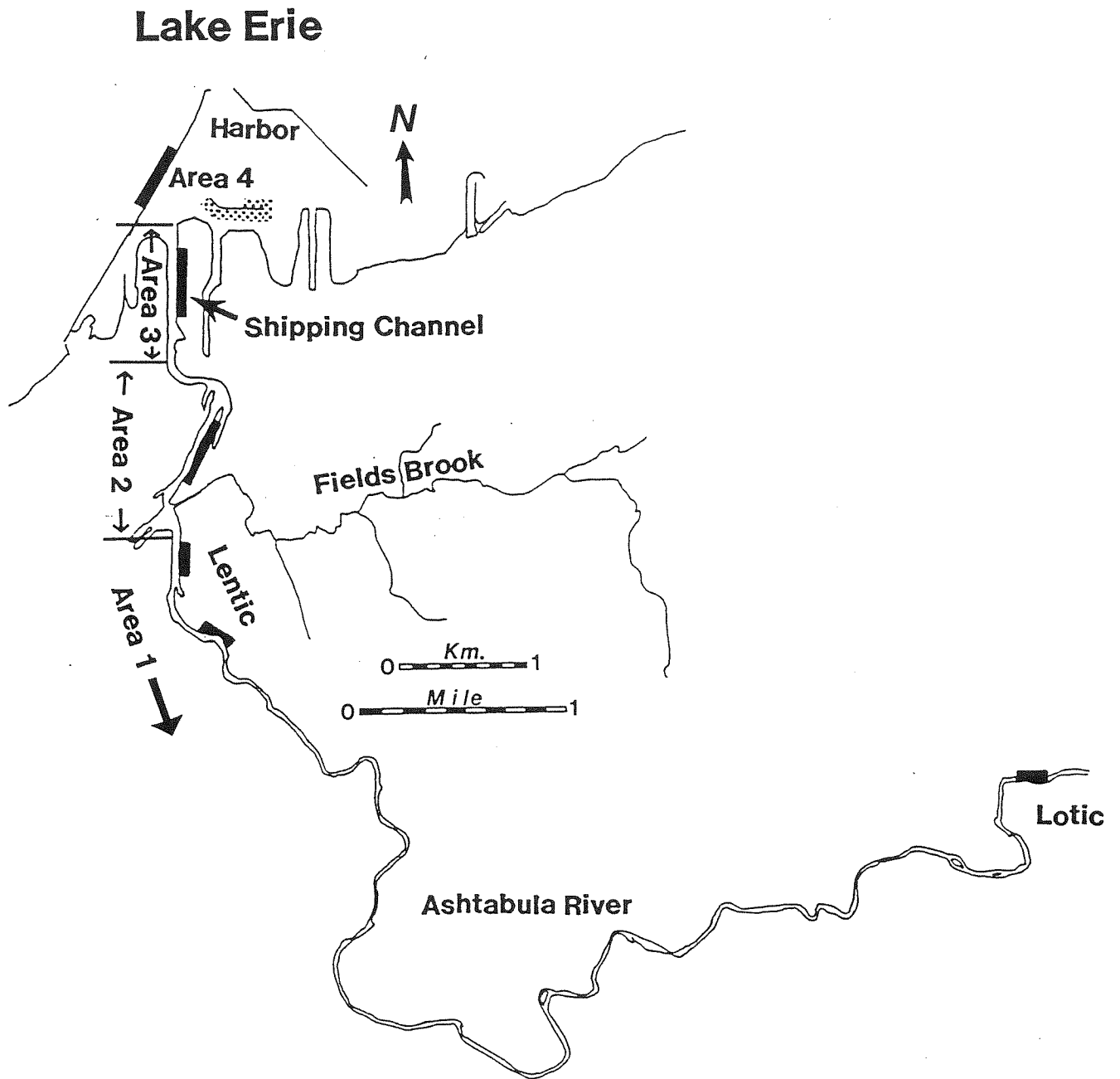

Figure 19 Ashtabula River study area and fish community sampling site locations (shaded areas). Benthic macroinvertebrate sampling sites are contained within the fish community sampling sites.

(Excluding Fields Brook): to some degree the Outer Harbor Area (Ecological Assessment Area 4), the lower river from the mouth upstream to the Fifth Street Bridge (Ecological Assessment Area 3), and the lower river from the Fifth Street Bridge upstream through the Upper Turning Basin (Ecological Assessment Area 2). The watershed area upstream of the developed harbor area (Ecological Assessment Area 1) is in relatively good condition. Primary problems that exist in the Outer Harbor are those associated with commercial harbor development channels, dredging and use of the commercial navigation channels, and contaminants in the sediments (primarily PAHs likely associated with the coal dock developments in the immediate area and other contaminated sediments including PCBs migrating out from the river). Primary problems that exist in the Lower River from the mouth upstream to the 5th Street Bridge are those associated with commercial harbor development bulkheading, dredging and use of the commercial navigation channel, and contaminants in the sediments (primarily PAHs likely associated with the coal dock developments in the immediate area and other contaminated sediments migrating in from upstream). Primary problems that exist in the Lower River from the 5th Street Bridge upstream to the end of the Federal navigation channel are those associated with recreational harbor development bulkheading, dredging and use of the recreational navigation channel, and primarily contaminants in the sediments (primarily PCBs, some equal to or in excess of 50 mg/kg or TSCA material). Benthic and fishery habitat has been significantly degraded in these areas in this regard as compared to quality warm water habitat criteria.

Subsequently, in 1995, the Ohio Environmental Protection Agency conducted habitat assessment procedures for the Grand and Ashtabula River Basins. (Reference Biological and Water Quality Study of The Grand and Ashtabula River Basins, January 1997, OEPA.) This provides further comparative data for analyses and assessments/evaluation.

Utilizing the data from these reports as a basis of comparison and through the use of Ohio's developed habitat assessment procedure (Reference Biological Criteria for the Protection of Aquatic Life, Volumes I through III, 1987 - 1989, OEPA) various ecological indices have and can be developed to show in a comparative manner various project area alternative scenario differences or outputs including anticipated values for:

- * Ecological Past
- * Without Existing Project
- * Existing Project
- * Anticipated Future Without ARP Project
- * Anticipated Future With ARP Dredging Ecological Restoration/Preservation Scenarios for Contaminant Removal
- * Anticipated Future With ARP Dredging Ecological Restoration/Preservation

Scenarios for Contaminant Removal and Supplemental Dredging Ecological/Restoration Measures for Protected Aquatic/Fishery Shallows

A number of key comparisons will be presented for this study in this regard. One is the comparison of Conneaut Creek conditions to Ashtabula River conditions. Conneaut Creek flows into Lake Erie 12 miles east of Ashtabula, Ohio. Although it has a similar level of commercial and recreational development, the creek does not contain appreciable levels of PCB contamination.

Data from the Conneaut Creek lacustrine serves as a model for a restored Ashtabula River Ecosystem, in this regard. Other discussions will reference Presque Isle, the Grand River, and the Black River.

Ashtabula and Conneaut Physical Habitat for Aquatic Life:

In the upper Ashtabula River basin, a comprehensive assessment of habitat quality was completed in 1995 for R.M. 3.5 to 27.2. The quality of the macro habitats at five locations sampled for fish in the lotic Ashtabula River, and at sites sampled in the East and West Branches were assessed using the Qualitative Habitat Evaluation Index (QHEI - Rankin 1989). The mean QHEI score for the basin was 73.2 ± 5.93 s.d., indicating generally good to excellent habitat quality and the capability of supporting a diverse aquatic fauna. The absence of anthropogenic modifications to the river is demonstrated by the low ratio (<0.5) of modified habitat attributes to warmwater habitat attributes. The positive warmwater habitat attributes encountered in the lotic Ashtabula River is largely ascribed to a lack of channelization, wide mature riparian areas, and small acreage farms using conservative practices in the basin. Riffle and channel substrates were unembedded and generally silt free. Glacial till and fractured bedrock provided a variety of substrate sizes and habitat complexity, especially in the upper watershed. Although the physical habitat is very good, extremely low or intermittent flows occur every summer in the Ashtabula River (USGS reference) limiting the amount of habitat available to aquatic fauna. The low flows in summer are due to the limited ground water capacity of the shale bedrock aquifers. High volumes of stream discharge (>5000 cfs, max ~ 11,100 cfs in 1959), emanating from snow melt, scours and denudes the lower reach of the Ashtabula River. Consequently, QHEI scores decreased with proximity to Ashtabula mainly because of the increased prevalence of unbroken shale bedrock and less cover. Similar scores were identified for Conneaut. Reference Figure 20.

In the Ashtabula and Conneaut lacustrines, the slope, texture and shape of ship channel banks affects QHEI scores and the overall suitability of aquatic habitat for biological communities (Figure 20). The lower quality of the habitat is reflected in the results of the Index of Biotic Integrity (IBI) and the Invertebrate Community Index (ICI). In the upstream areas of the Ashtabula and Conneaut lacustrines (RM 1.3 & 1.5, respectively), the quality of physical habitat (i.e. slope, texture, and shape) is much better. The factors that govern habitat quality in lacustrines are the slope of the shoreline, hardening of the shoreline and the availability of cover. Gradual shoreline slopes (45° or less) are better than steep vertical slopes. Both upstream areas (Rms 1.3 & 1.5) have very similar QHEI scores though biological conditions are considerably different. The contaminated Ashtabula site has much lower biological scores than the clean Conneaut site. It has been concluded (in the biological section) that contaminated sediments are the single cause of lower fish community scores at the Ashtabula site. The upper reaches of both lacustrines attain higher and similar QHEI values that reflect the undisturbed habitat conditions found there.

Much cover is provided by the growth of aquatic plants in waters shallower than twelve feet. Downed trees and boulders in the water also provide cover for fish and invertebrates. Presently the site downstream of Fields Brook at RM 1.3 of the Ashtabula has abundant aquatic plant growth, logs and woody debris and boulders. Habitat quality at this site is high and provides abundant cover for communities of organisms that could be as diverse as Conneaut Creek.

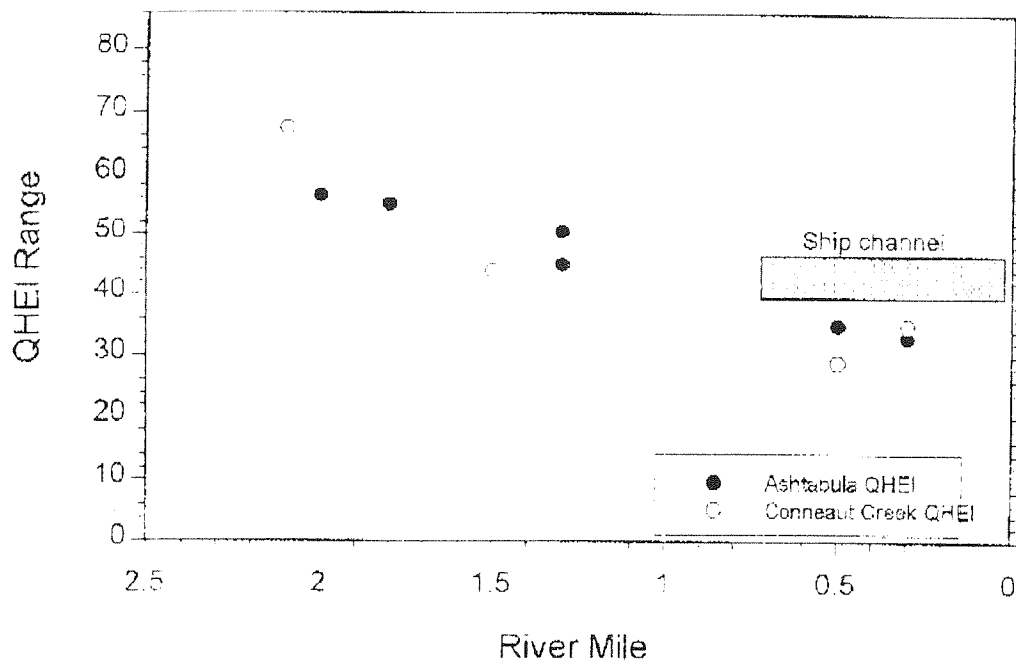

Figure 20 A comparison of relative habitat quality of the Ashtabula and Conneaut lacustrine areas.

Fish Community Assessment:

Ashtabula River

Seven sites have been sampled for fish by Ohio EPA since 1989 in the 2.5 mile (4 km) length of the Ashtabula River lacustrary. Downstream RM 2.3 much of the waterway was lined with sheet piling or boat docks. A ship channel extends from the river mouth to RM 0.7. Fields Brook joins the Ashtabula River at RM 1.6. Sediment contamination has been documented downstream of Fields Brook at RM 1.3. River mile 1.3 was an area with a more natural habitat on its shoreline. In 1989, fish community sampling was conducted to evaluate the degree of impact associated with chemical degradation originating from Fields Brook and habitat alteration of the lacustrary in general. It was concluded that both shoreline development and chemical pollutants were impacting fish communities in the lower Ashtabula River. In general, IBIs were good to fair in upper reaches, fair to poor near Fields Brook, and fair to poor in the ship channel area (Figure 21). A follow up sampling in 1995 revealed that community conditions had improved in the upstream area, declined in the vicinity of Fields Brook and remained about the same in the ship channel area. The follow up 1995 survey, combined with data from other lacustraries and new analysis techniques, indicated that the poor fish community performance near Fields Brook was due primarily to in-place contaminated sediments. The habitat quality of the sampling site is high in that there was abundant growth of submerged aquatic plants, a habitat component critical to fish community structure. Improved water column chemistry in the area should have resulted in improvements in fish communities; but, fish community condition declined. At present, the only identifiable environmental insult at RM 1.3 is contaminated sediments.

Conneaut Creek

The Conneaut Creek lacustrary extends 2.2 miles (3.5 km) upstream from its mouth. A total of 5 sites have been sampled for fish (Ohio EPA) since 1989. Very little environmental deterioration was seen in the lotic (upstream) portions of the system and extensive areas of the basin are wooded. The lower 0.5 mile of the stream's habitat was a ship channel with deep sheet piling lined banks while upstream from RM 0.5, habitat was shallower and at least partially vegetated along the banks; most of this reach was relatively narrow with moderate accumulations of silt and sediment. An area of thick silt and sediment with a large expanse of emergent and submergent vegetation was present at RM 1.0. This area was similar to RM 1.3 of the Ashtabula.

Upstream of the ship channel, in the area of vegetation, IBI scores were in the marginally good range while ship channel sites (RMs 0.3 and 0.6) had IBI scores in the poor range (Figure 22). The dichotomy of near good and poor community conditions found in this lacustrary illustrate the strong effect that habitat alterations can have on biological conditions even in areas where no impacts from water column chemistry exist. The fish community conditions upstream of the ship channel provides a good comparison to conditions that could be expected in the Ashtabula after sediment removal and a consequent influx of clean sediments from upstream areas.

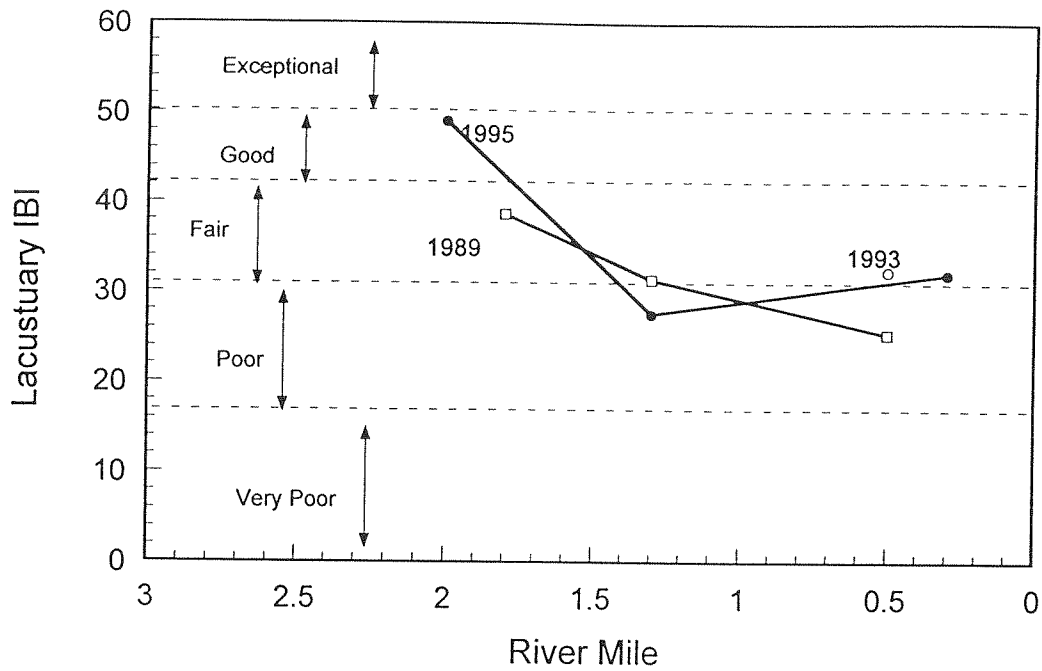

Figure 21 Fish community status of the Ashtabula River lacustrary as measured by the Index of Biotic Integrity (IBI).

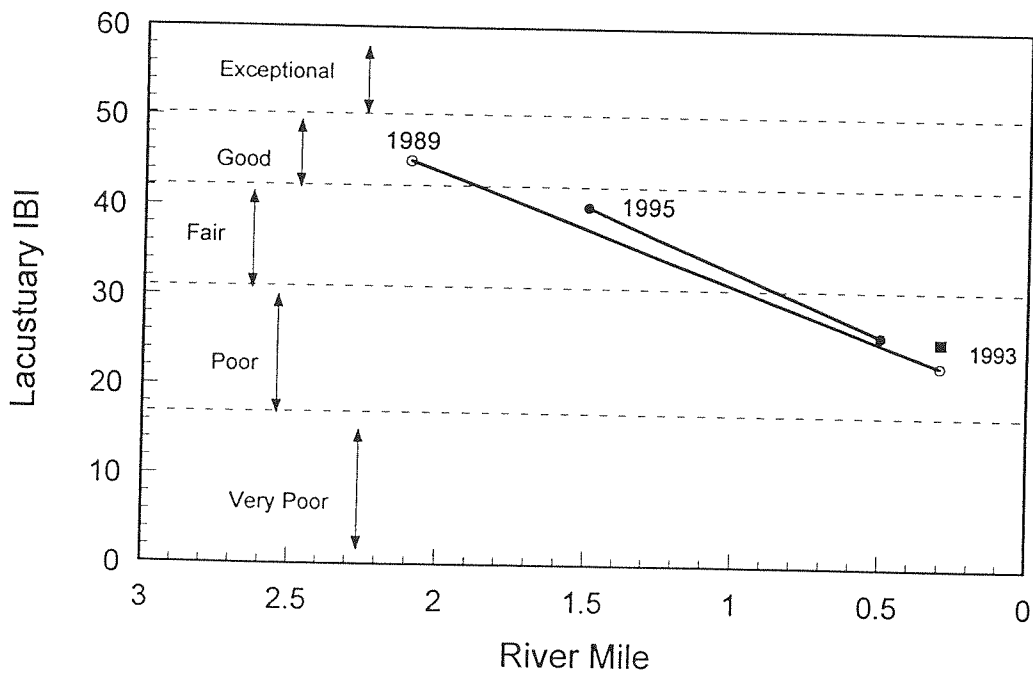

Figure 22 Fish community status of the Conneaut Creek lacustrary as measured by the Index of Biotic Integrity (IBI).

Community Level Comparison

The two Conneaut Creek sites in the vicinity of Rms 2.1 (1989) and 1.5 (1995) displayed habitat traits similar to the Ashtabula site impacted by contaminated sediments (Rm 1.3, located just downstream of Fields Brook). The two Conneaut Creek sites harbored 36 and 30 species of fish respectively while Rm 1.3 had only 22 (1989) and 15 (1995) species. The relative abundances of fish displayed a similar trend. River miles 2.1 and 1.5 had 431.2 and 695.0 individual fish per kilometer while Rm 1.3 had 93.2 and 254.1 per kilometer. Figure 23 gives a graphic presentation of species numbers and relative numbers for these sites and illustrates the higher quality of the Conneaut Creek sites, sites that do not have contaminated sediments associated with them. A site from the mouth of the Grand River (RM 0.6) is included as an example of fish community potential in areas of high boat traffic (like in the Ashtabula) and the effects of a habitat shelf. As a consequence of a historic accident RM 0.6 has an area of submerged land in the form of a shelf that was constructed at a time when Lake Erie water levels were much lower. Consequent flooding of the area has resulted in an artificial habitat with shallow water and abundant submerged aquatic vegetation (SAV). This area provides a good example of the conditions that could occur in the Ashtabula post dredging with some habitat enhancement.

Fish community samples collected in ship channel habitats in the Ashtabula River did not differ strikingly from other ship channel areas throughout the Lake Erie basin. Two years samples had 11 and 8 species in the Ashtabula. Two years samples in the Conneaut ship channel had 7 and 11 species. Relative numbers were also similar for the two areas. The reason for this similarity is that habitat constraints in ship channel areas are so strong, they overshadow the effects of other environmental disturbances.

Fish community samples were also collected from the various harbor/lake interface areas. Comparisons were made between Ashtabula Harbor, the most disturbed area (man-made impacts and contaminants); Conneaut Creek Harbor, (moderately disturbed); and Presque Isle; the least disturbed area (most closely approximating a natural bay shoreline in Lake Erie). Ashtabula and Conneaut Harbor were dominated by rock and concrete breakwaters or large sections of steel sheet pile bulkheads. For the most part, there were very few areas which contained submerged aquatic macrophyte beds, a preferred fish habitat. Where macrophytes were found, plant species diversity was low with *Myriophyllum exalbescens* (an exotic pollution tolerant species) dominating. Presque Isle on the otherhand, would be best described as a wetlands/vegetated shallows area having large areas with a high diversity of submerged and emergent aquatic macrophytes present. Shorelines at Presque Isle had lower angles of slope and aquatic macrophyte beds grew farther into the bay.

When examining the data collected at these three locations, several fish community trends are evident. Centrarchid species such as largemouth bass (*Micropterus salmoides*), bluegill sunfish (*Lepomis macrochirus*), pumpkinseed sunfish (*Lepomis gibbosus*), and pecidae species such as yellow perch (*Perca flavescens*) occur in significantly higher numbers at the Presque Isle site compared to the numbers of fish found in Ashtabula and Conneaut Harbors. All three of these species thrive in aquatic macrophyte beds which dominate the Presque Isle site, but for the most part are lacking at the two harbor areas. The data also showed pollution intolerant species such as the banded killifish (*Fundulus diaphanus*) had higher numbers in the Presque Isle sites. Ex-

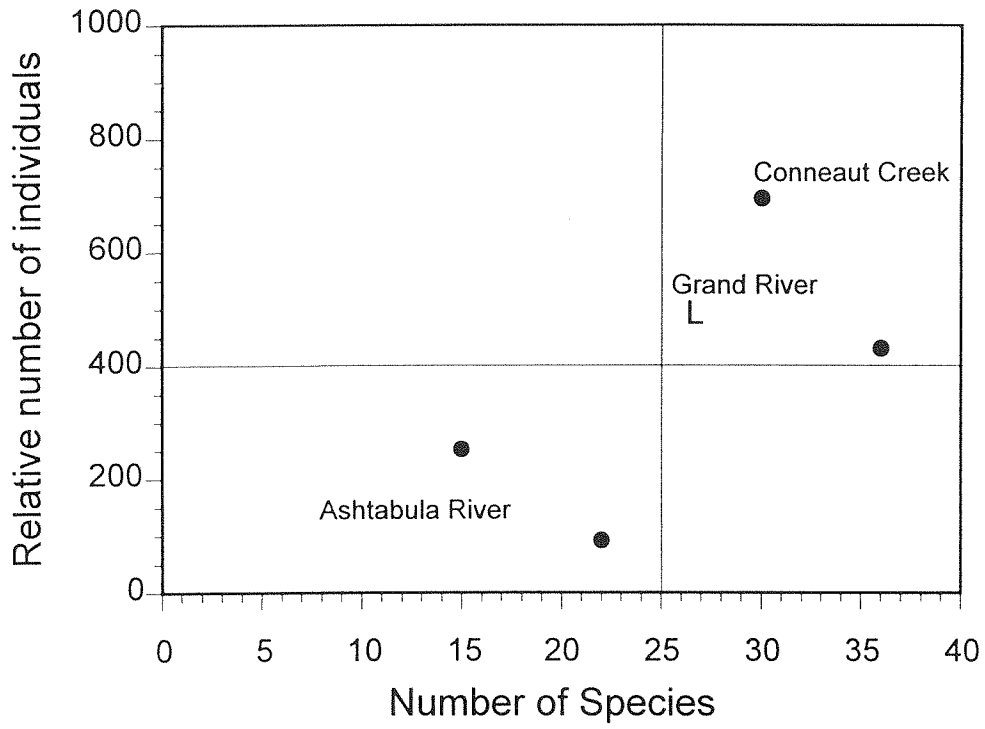

Figure 23 Comparison of the overall abundance and number of species in the Ashtabula, Black and Conneaut lacustraries. The farther to the right and higher a point falls the better the fish community is.

cept for 1 fish captured in the 1989 at Conneaut Harbor, the banded killifish was not found in the two Harbors. In addition, the more disturbed areas (Ashtabula and Conneaut Harbors) had higher numbers of pollutant tolerant species such as carp (*Cyprinus carpio*) and goldfish (*Carassius auratus*). Some of the tolerant species numbers can be attributed to the rivers themselves which shelter higher numbers of tolerant species (Table 17), which may have a "spilling over" effect into the actual harbor areas. It is expected that if the Ashtabula River/Harbor area were to be "cleaned up" through the use of environmental dredging, one would see not only a positive change in species diversity, but also a positive change in species composition that would more closely resemble the one found in the Presque Isle area.

It should also be noted that the Ashtabula Harbor area has the potential to serve as a nursery for fish produced occurring in the lacustrine portion of the system. If spawning areas were rehabilitated, habitat would be available for juvenile fish in the harbor.

Fish Species Comparison

A species by species comparison (Table 17) of the polluted Ashtabula River site with the clean Conneaut Creek site and a Grand River site exposed to boat traffic further illustrates the poor quality of the Ashtabula site. Seventeen of the twenty four species found to be more abundant in Conneaut Creek than in the Ashtabula were species that have some degree of sensitivity to environmental degradation. Nine of the species are of interest to sport fishing. In the Ashtabula, half as many species and two hybrids were found to be more abundant than in Conneaut Creek. Hybrids have been found to increase in areas of environmental disturbance. Only one species, the northern pike (*Esox lucius*), is a sport species. In the vegetated portions of Ashtabula Harbor, outside of areas heavily influenced by contaminated sediments, northern pike were more than twice as abundant as at the site downstream of Fields Brook. It is believed the northern pike observed at RM 1.3 were derived from the harbor population and are not permanent components of the RM 1.3 community. Largemouth bass, a species common in vegetated habitats is more than three times as abundant in the clean Conneaut Creek site. Two other vegetation loving species, yellow perch (*Perca flavescens*) and golden shiner (*Notemigonus crysoleucas*), are significantly more abundant at the Conneaut Creek site. In light of the fact that the Ashtabula site has abundant aquatic plant populations, it is reasonable to expect a fish community reflective of those conditions. The low abundance of vegetation loving species is not a consequence of habitat conditions but of the presence of contaminated sediments. The lower species diversity is also a consequence of contaminated sediments. There is little other physical difference between the sites sampled in the two lacustrines. The Ashtabula does differ from the Conneaut in that considerable boat traffic exists in the Ashtabula lacustrine. A site on the Grand River near the mouth (Rm 0.6) that is also subjected to high boat traffic is used as a comparison site to illustrate the fish community that can be expected in boat traffic areas without contaminated sediments. Twenty-one species were more abundant in the Grand River lacustrine. Again, yellow perch (*Perca flavescens*) and largemouth bass (*Micropterus salmoides*) were more abundant. Overall community composition indicates the Grand River (with boat traffic) and Conneaut Creek (without boat traffic) are much more similar than either is to the Ashtabula site. It can only be concluded that boat traffic is not the driving factor in structuring the Ashtabula fish community.

Table 17 - A comparison of the relative number (per kilometer) of fish species collected at electrofishing sites on the Grand River, Conneaut Creek, and Ashtabula River lacustuaries. Species in **bold** have been found by Ohio EPA to respond negatively to degraded environments and are considered sensitive to environmental degradation.

Stream	Conneaut Creek	Ashtabula River	Grand River	
Year	1995	1989	1995	1987
River Mile:	1.50	1.30	1.30	0.6
longnose gar (<i>Lepisosteus osseus</i>)	0.80	-.	-.	-.
bowfin (<i>Amia calva</i>)	1.00	1.60	-.	2.00
alewife (<i>Alosa pseudoharengus</i>)	1.00	-.	-.	-.
gizzard shad (<i>Dorosoma cepedianum</i>)	2.00	7.20	5.44	80.00
northern pike (<i>Esox lucius</i>)	-.	1.11	-.	-.
bigmouth buffalo (<i>Ictiobus cyprinellus</i>)	1.00	-.	-.	-.
smallmouth buffalo (<i>Ictiobus bubalus</i>)	1.00	-.	-.	-.
silver redhorse (<i>Moxostoma anisurum</i>)	8.00	-.	-.	0.67
black redhorse (<i>Moxostoma duquesnei</i>)	7.00	1.20	-.	-.
golden redhorse (<i>Moxostoma erythrurum</i>)	0.40	-.	-.	3.33
shorthead redhorse (<i>Moxostoma macrolepidotum</i>)	12.00	-.	-.	-.
white sucker (<i>Catostomus commersoni</i>)	3.00	-.	-.	-.
common carp (<i>Cyprinus carpio</i>)	27.00	4.00	35.56	6.00
goldfish (<i>Carassius auratus</i>)	24.00	0.80	3.00	2.00
carp x goldfish	1.60	3.33	-.	-.
golden shiner (<i>Notemigonus crysoleucas</i>)	150.00	7.20	11.11	16.67
bigeye chub (<i>Hybopsis amblops</i>)	6.00	-.	-.	-.
emerald shiner (<i>Notropis atherinoides</i>)	0.40	-.	-.	12.00
striped shiner (<i>Luxilus chrysocephalus</i>)	8.00	0.40	-.	12.00
spottail shiner (<i>Notropis hudsonius</i>)	-.	-.	-.	8.67
spotfin shiner (<i>Cyprinella spiloptera</i>)	2.00	-.	-.	-.
bluntnose minnow (<i>Pimephales notatus</i>)	148.00	0.40	2.00	1.33
central stoneroller minnow (<i>Campostoma anomalum pollum</i>)	-.	-.	-.	0.67
channel catfish (<i>Ictalurus punctatus</i>)	10.00	-.	4.44	-.
yellow bullhead (<i>Ameiurus natalis</i>)	1.00	2.00	1.00	-.
brown bullhead (<i>Ameiurus nebulosus</i>)	24.00	1.60	9.78	36.67
eastern banded killifish (<i>Fundulus diaphanus</i>)	2.00	-.	-.	-.
trout-perch (<i>Percopsis omiscomaycus</i>)	-.	-.	-.	0.67
brook silverside (<i>Labidesthes sicculus</i>)	22.00	-.	-.	-.
white bass (<i>Morone chrysops</i>)	2.00	-.	-.	3.33
white perch (<i>Morone americana</i>)	-.	-.	-.	25.33
white crappie (<i>Pomoxis annularis</i>)	-.	-.	-.	1.33
black crappie (<i>Pomoxis nigromaculatis</i>)	4.00	-.	-.	1.33
rock bass (<i>Ambloplites rupestris</i>)	69.00	1.60	13.56	11.33
smallmouth bass (<i>Micropterus dolomieu</i>)	2.00	1.20	-.	9.33
largemouth bass (<i>Micropterus salmoides</i>)	29.00	7.60	9.33	34.00
green sunfish (<i>Lepomis cyanellus</i>)	0.40	-.	-.	0.67
bluegill sunfish (<i>Lepomis macrochirus</i>)	41.00	10.00	70.78	48.67
pumpkinseed sunfish (<i>Lepomis gibbosus</i>)	43.00	20.00	80.11	56.00
sunfish hybrids (<i>Lepomis</i> sp.)	-.	1.00	-.	-.
walleye (<i>Stizostedion vitreum</i>)	3.00	-.	-.	-.
yellow perch (<i>Perca flavescens</i>)	62.00	0.40	2.11	60.67
logperch (<i>Percina caprodes</i>)	-.	-.	-.	11.33
freshwater drum (<i>Aplodinotus grunniens</i>)	2.00	0.40	1.11	2.00
Total Relative Number	695.00	93.20	227.92	448.00
Number of Species	30.00	22.0	15.0	27.0
Number of Hybrids	0.0	1.0	2.0	0.0
Kilometers Sampled	1.00	2.50	0.95	1.50
Number of Passes	2.0	5.0	2.0	3.0
Number of species most abundant	15.0	3.0	6.0	15.0

Endangered Fish Species

Three fish species, of special concern in Ohio, have been recorded historically in the Ashtabula River lacustrary. With restoration of the ecosystem these species could be expected to return to the area as there are populations of all three still extant in the Lake Erie basin. The species are: Great Lakes muskellunge (*Esox masquinongy*), blacknose shiner (*Notropis neterolepis*) and lake sturgeon (*Acipenser fulvescens*). The first two species are vegetation loving species and should be present in the Ashtabula now.

Macroinvertebrate Community Status:

Ashtabula River

Studies conducted in Ashtabula Harbor (1978-1979) reveal a benthic community indicative of organically polluted sites. The oligochaete, Limnodrilus hoffmeisteri, is the most abundant species (Krieger 1984). A 1983 study conducted for the Corps of Engineers (Swanson Environmental 1983) also revealed oligochaetes to be the most abundant species. Oligochaetes are always a dominant taxa in lentic (lake like) water bodies. The Ohio EPA found the harbor population dominated by tubificids, oligochaete species that are tolerant of gross organic enrichment. Compared to Goodnight and Whitley (1961), the macroinvertebrate community indicated polluted conditions. Howmiller and Scott (1977) proposed a Trophic Condition Index (TCI) to compare harbor sites with open water sites. On a scale of 0 to 2, with 0 indicating a pollution sensitive community and 2 indicating a pollution tolerant community, the Ashtabula Harbor had a TCI of 1.9 (Ohio EPA 1990c). However, this value is similar to all other monitored Lake Erie harbors in Ohio. In Strong Brook, only six species of macroinvertebrates were identified in Ohio EPA's use designation survey of 1990.

The 1989 Ohio EPA biological survey data indicated a highly diverse macroinvertebrate community in the free-flowing section of the Ashtabula River (upstream from the AOC). Diversity decreased with distance downstream and in lentic sections of the river. The diversity at RM 1.9, upstream from Fields Brook, was much lower than expected. Moderate to heavy siltation was observed on the artificial substrate samplers suggesting that heavy recreational boat traffic was impacting the colonization of the samplers by resuspending silt. This same problem was observed at RM 1.3 downstream from Fields Brook. The study concluded boating activities and shoreline modifications overshadowed impacts resulting from Fields Brook contaminants (Ohio EPA 1990c). Reference Figure 24.

As with fish communities, commercial ship channel modifications alter macroinvertebrate community composition and diversity. Over 80 percent of the organisms collected in the ship channel area were zebra mussels or oligochaetes, resulting in poor community scores.

A total of nine sites in the Ashtabula River lacustrary have been sampled by Ohio EPA since 1989. The sites were distributed along the 2.5 mile length of the lacustrary. Downstream from RM 2.3 much of the waterway is lined with sheet piling and/or boat docks. A ship channel extends from the river mouth to RM 0.7. Fields Brook confluent with the Ashtabula River at

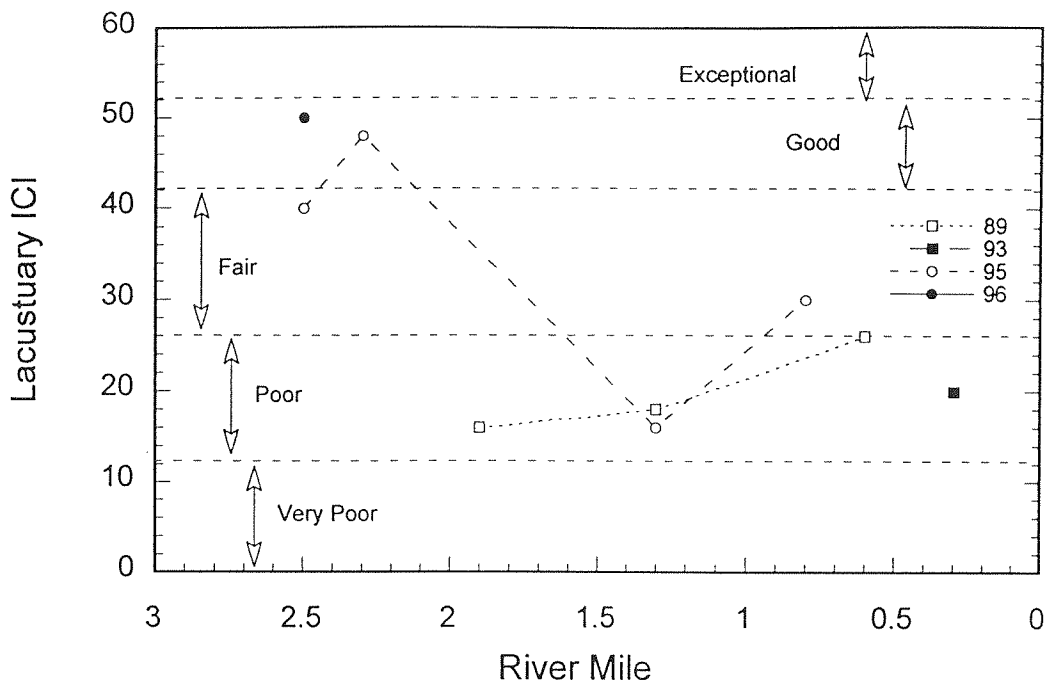

Figure 24 Macroinvertebrate community status in the Ashtabula River lacustrine as measured by the Invertebrate Community Index (ICI).

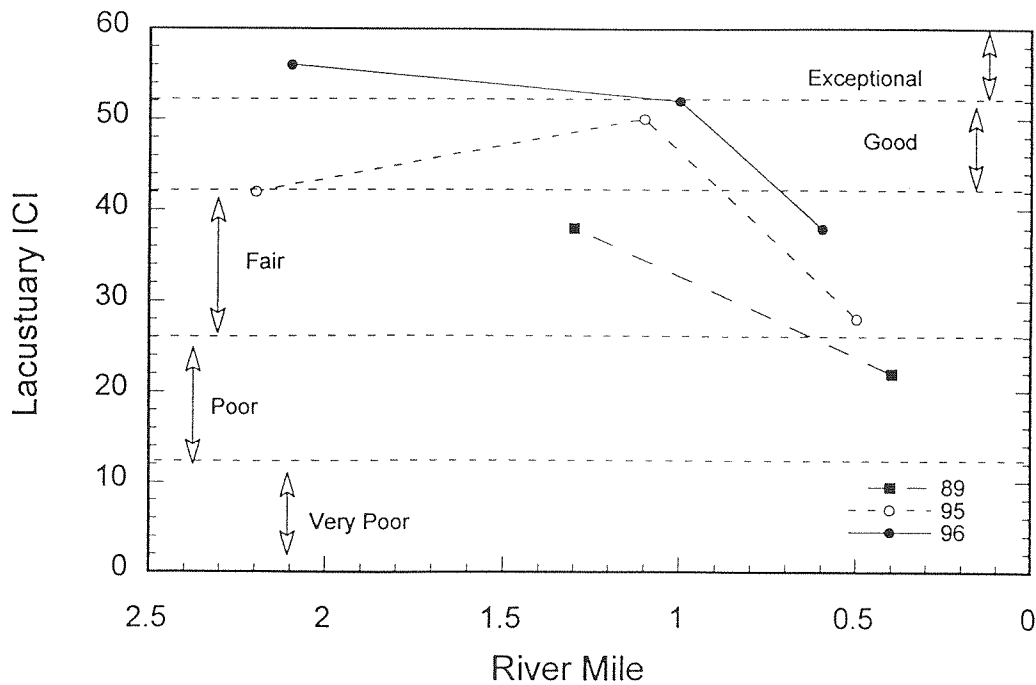

Figure 25 Macroinvertebrate community status in the Conneaut Creek lacustrine as measured by the Invertebrate Community Index (ICI).

RM 1.6. Sediment contamination has been documented downstream from Fields Brook. In 1989, macroinvertebrate sampling was conducted at RMs 1.8, 1.3 and 0.6 in order to evaluate the degree of impact associated with chemical degradation originating from Fields Brook and habitat alteration of the lacustrine (Ohio EPA, 1992. Biological Community Status of the Lower Ashtabula River and Harbor Within the Area of Concern (AoC)). In that study the lotic ICI was used to aid in the evaluation. The conclusion was that shore-line development and contaminated sediments were the principle factors impacting on the benthos in the lower Ashtabula River. The condition of the macroinvertebrate community at RM 1.3 was rated as fair in 1989. Re-examination of the results of the 1989 study using the lacustrine ICI generally is in agreement with previous conclusions; the exception being that a narrative evaluation of poor both upstream from Fields Brook (RM 1.9) and downstream (RM 1.3) seems more appropriate.

Three samples collected near the upstream limit of the lacustrine (RMs 2.5 and 2.3) in 1995 and 1996 demonstrated that the sites were in fair to good condition. Two of the three samples had ICI scores in the good range (ICI>42). The biological condition in the ship channel was slightly better than those areas around Fields Brook and rated as fair to poor based on samples collected in 1989 and 1995.

Conneaut Creek

The Conneaut Creek lacustrine extends for 2.2 miles upstream from the mouth. A total of eight sites have been sampled by Ohio EPA since 1989. The lower half mile is a ship channel with deep sheet piling lined banks. Upstream from RM 0.5, the channel was shallower and at least partially vegetated along the banks; most of this reach was relatively narrow with moderate accumulations of silt and sediment. An area of thick silt and sediment was present at RM 1.0. This site supported the largest expanse of emergent and submergent vegetation in the lacustrine. Reference Figure 25.

Upstream from the ship channel, four of six samples produced ICI scores in the good to exceptional range. Two other sites (RMs 1.3 and 0.6) had ICI scores in the fair range. The macroinvertebrate community in the non-ship channel sections of Conneaut Creek displayed good numbers of relatively sensitive organisms and lower overall abundances than more impacted lacustrine sites throughout the state. The Conneaut Creek lacustrine has maintained a greater degree of biological integrity than any other lacustrine within Ohio. Conneaut Creek above the ship channel is inaccessible to Lake Erie recreational boat traffic. In the absence of boat traffic and contaminated sediments, macroinvertebrate communities score near exceptional.

As in the Ashtabula, the macroinvertebrate community of the Conneaut ship channel was limited by habitat constraints and subsequently ICI values were below the interim criteria, in the fair to poor range.

External Anomalies:

In both 1989 and 1995 the Ohio EPA observed highly elevated levels of external anomalies (Fig. 26) on fish taken from Rm. 1.3 in the Ashtabula lacustrine. The comparable site on Conneaut Creek (Rm 1.5) displayed moderately elevated levels (Fig. 27). In the Ashtabula lacustrine, sites

outside contaminated sediment areas displayed moderately elevated anomaly levels. The highly elevated anomaly levels observed at Rm 0.5 in Conneaut Creek are due in part to the very few individuals captured there. A few individuals with anomalies can cause percentages to rise sharply.

A comparison of the Ashtabula and Conneaut harbors shows that both areas exhibited highly elevated external anomalies (Fig. 28). These anomalies originated primarily as a consequence of heavy wave action that resulted in abrasions to those fish species that live near or in the breakwaters. Many of these fish consequently developed lesions. The degree to which contaminated sediments influence anomaly occurrence is unclear for fish communities sampled in the harbor.

In the Black River lacustrine contaminated sediments were removed in 1990 and data from before and after (Fig.29) show a declining trend in the occurrence of external anomalies on fish taken from the lacustrine. It is anticipated that the incidence of anomalies will continue to decline in the Black River. A similar trend is expected for the Ashtabula following the removal of contaminated sediment.

Anticipated Ecological Improvements:

In all aspects considered, the Ashtabula River fish community (in areas of contaminated sediments) has a high potential for recovery post sediment removal. Endangered species, top carnivores (game fish), species diversity, pollution-sensitive species, numbers of individuals and incidence of external anomalies will all show improvement. The removal of contaminated sediments from the Black River lacustrine in 1990 continues to result in improving ecological conditions as measured by the IBI (fig. 30). Initial recovery was much more rapid and dramatic than present rates, though recovery continues.

The recovery of the Ashtabula lacustrine fish community is expected to influence fish communities in surrounding areas both upstream and in the lake. Species such as northern pike (*Esox lucius*) and muskellunge (*Esox masquinongy*) moderate fish communities through predation and drive community structure towards greater ecological integrity. Greater ecological integrity results in even higher numbers of top carnivores, endangered species and sensitive species. Historically, the muskie and northern pike were very abundant and commercially important. The destruction of lacustrine habitats throughout Lake Erie has resulted in drastic reductions of the two species' populations and the positive influences they had on the Lake's ecosystem. The restoration of the Ashtabula lacustrine will allow it to resume its historic contribution to top carnivore populations (including northern pike and muskellunge).

Those species listed as sensitive in Table 17 can all be expected to increase in numbers after sediment removal and a consequent influx of clean sediment from upstream areas. Species presently not found in the Ashtabula but found in the Grand and Conneaut will return to the Ashtabula. The sensitive species that are absent from the Ashtabula represent all trophic levels of the fish community. Ecosystems cannot function with such large components missing.

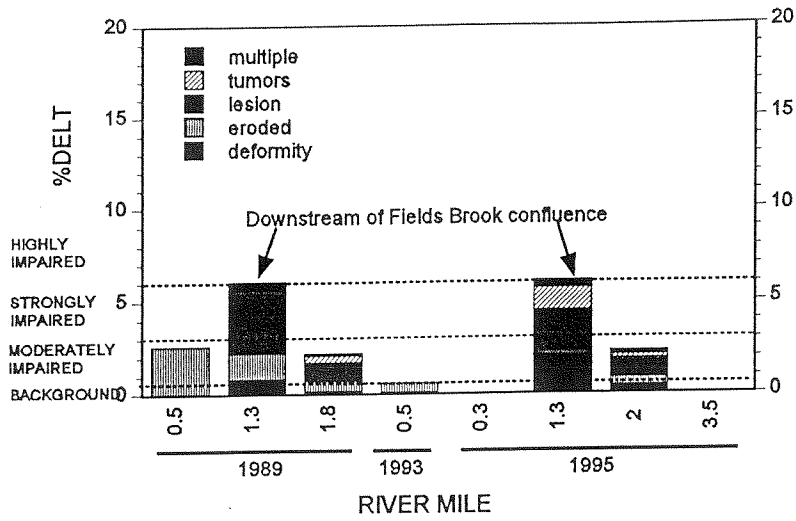

Figure 26 Percent external anomalies observed on fish collected in the Ashtabula River lacustruary (D=deformities, E=eroded fins, L=lesions, T=tumors).

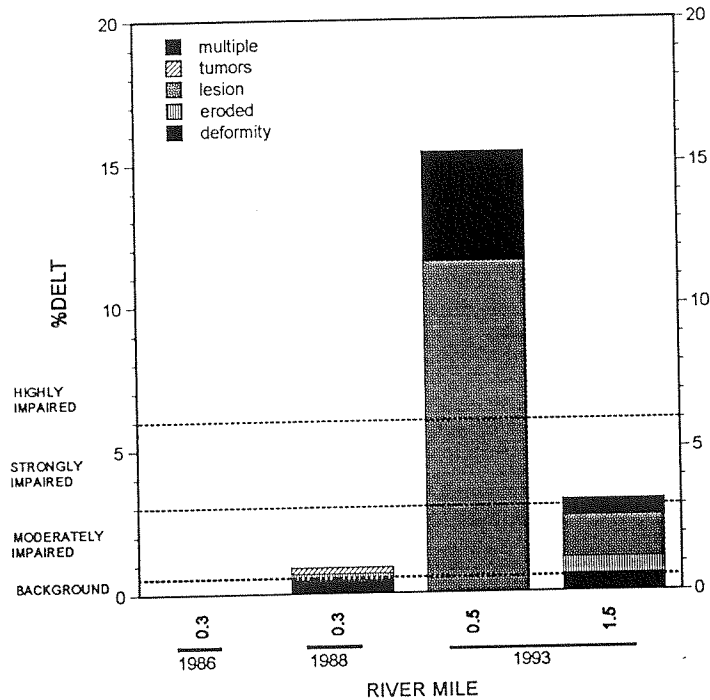

Figure 27 Percent external anomalies (DELT) observed on fish collected in the Conneaut Creek lacustruary (D=deformities, E=eroded fins, L=lesions, T=tumors)

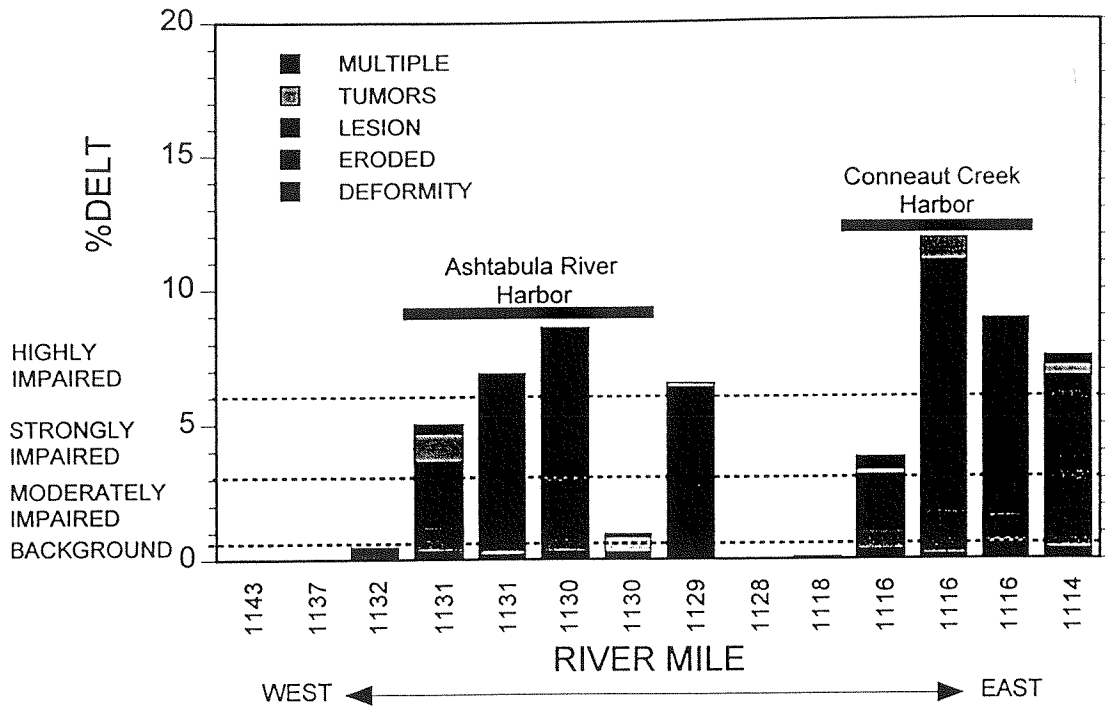

Figure 28 Percent external anomalies (DELT) observed on fish collected from the Lake Erie shoreline in Ashtabula County (D=deformities, E=eroded fins, L=lesions, T=tumors).

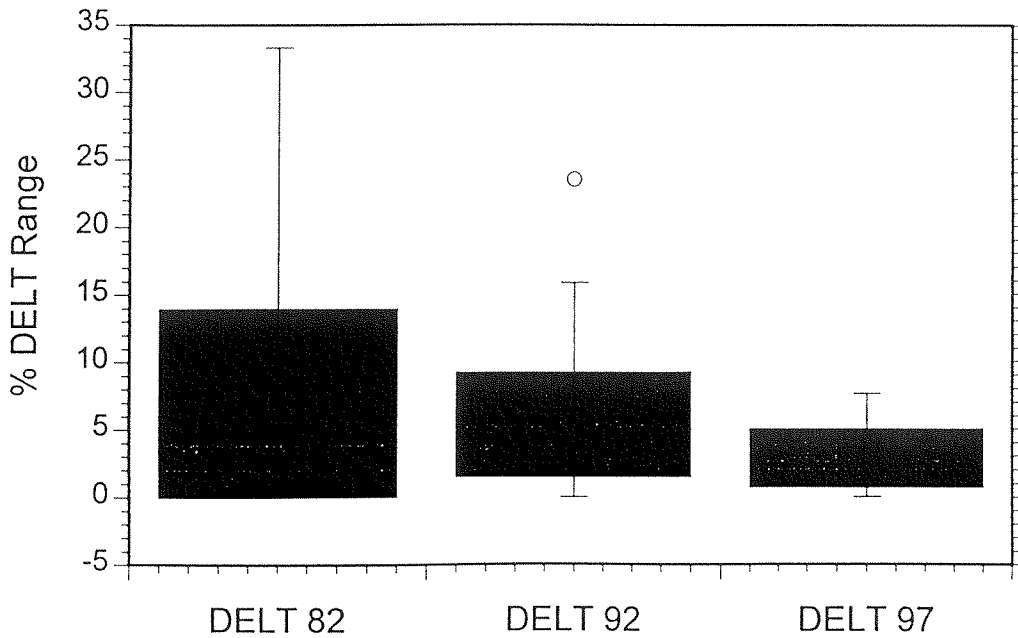

Figure 29 Declining trends in DELT anomalies observed on fish collected from the Black River lacustruary. Boxes represent the range with outliers, 75 percentile, mean and 25th percentile.

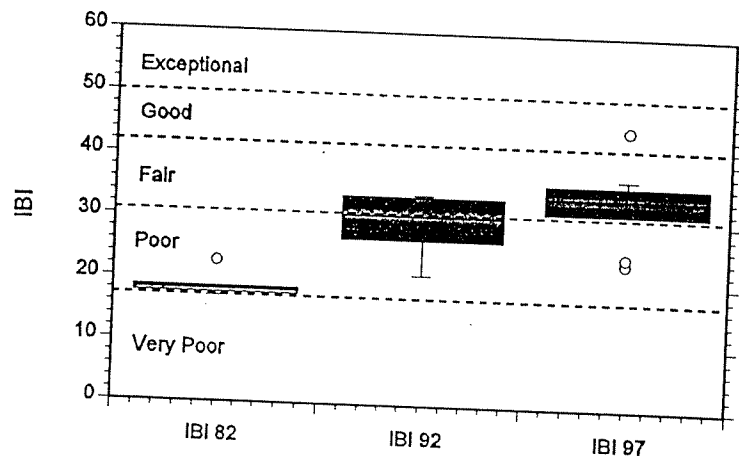

Figure 30 Improving IBI trends for the Black River lacustrary. Before and after sediment dredging in 1990. Boxes represent the range with outliers, 75th percentile, mean and 25th percentile.

The ecosystem of the open waters of Lake Erie is presently experiencing dramatic recovery of its fish community. This recovery is expected to continue with further recovery of additional species. The removal of contaminated sediments will prepare the Ashtabula for the possible entrance of species such as: lake sturgeon (*Acipenser fulvescens*), mooneye (*Hiodon tergisus*), muskellunge (*Esox masquinongy*), pugnose shiner (*Notropis anogenus*), longnose sucker (*Cutostomus cutostomus*), lake chubsucker (*Erimyzon sucetta*), creek chubsucker (*Erimyzon oblongus*), tad-pole madtom (*Noturus gyrinus*), burbot (*Lota lota*); and possibly: pugnose minnow (*Opsopoeodus emiliae*), blackchin shiner (*Notropis heterodon*), blacknose shiner (*Notropis heterolepis*), banded killifish (*Fundulus diaphanus*), and sand darter (*Ammocrypta pellucida*) into the system. Some of these species (burbot, lake sturgeon, muskellunge and sand darter) are already showing signs of recovery in the lake. Areas such as the Ashtabula lacustrine are an important component of these species life history. Full recovery of the above listed species will depend on the environmental quality of Lake Erie's lacustrine habitats.

The speed and degree of ecological recovery in the Ashtabula River lacustrine will depend on the rate of sedimentation. Near shore depths of two to ten feet are ideal for healthy fish communities and the aquatic plants they depend upon. The influx of clean sediments from up-stream areas will eventually occur, and active intervention in the form of replacing dredged sediments with clean sediments will greatly enhance the process.

It is clear that little improvement will occur if contaminated sediments are not removed. Present Ohio EPA fish community data show declining trend of IBI values at Rm 1.3 of the Ashtabula River. It is possible that this trend could continue, resulting in still lower quality fish communities in the future. There is further concern that without the project, shipping could shift from the Ashtabula area to Conneaut Harbor. This will result in a greater degree of environmental disturbance in the Conneaut and will negatively impact fish communities. With impacts to both the Ashtabula and Conneaut fisheries lower quality fish communities will result in the Central Basin. The last three large Central Basin south shore tributaries and associated lacustrines are the Grand, Ashtabula and Conneaut (from west to east). Numerous Central Basin fish stocks require these areas for reproductive purposes. Restoration of the Ashtabula will not only enhance Central Basin fish stocks but will also prevent their further decline.

Monitoring:

The Ohio Environmental Protection Agency conducts these surveys periodically and will conduct such a survey and report the findings within five to ten years of completion of the project. Subsequent habitat, fishery, macroinvertebrate, and anomalies survey results and indications of ecological improvements or outputs are/will be reflected by these studies.

POTENTIAL IMPACT OF PCB RELEASE FROM THE ASHTABULA RIVER TO LAKE ERIE

Introduction: The PCB mass in the Ashtabula Area of Concern is estimated by the U.S. Army Corps of Engineers to be approximately 11,018 Kg. A major concern of the Ashtabula River Partnership, US Fish and Wildlife Service, US Environmental Protection Agency and Ohio Environmental Protection Agency is that storm events or other activities may cause a portion of this PCB mass to move into Lake Erie. We have used an equilibrium partitioning water quality model to estimate the effect a of PCB release from the Ashtabula Area of Concern on PCB concentrations in Lake Erie and the resulting impacts on the Lake Erie walleye (*Stizostedion vitreum*) fishery, and fish and wildlife species in the basin.

Methods: An equilibrium partitioning water quality model was obtained from Dr. Donald Mackay at the University of Toronto. The model contains modules for Lake Superior and Lake Ontario. The code of the Lake Ontario module was modified to reflect Lake Erie. Table 31 shows the changes made to the model to better reflect Lake Erie. Surface area, volume, and hydraulic retention time were obtained from USEPA/GOC (1995). Water column solids concentrations are from unpublished US EPA data collected in the spring of 1993.

Table 31. Water Quality Parameters for Lakes Erie and Ontario.

	Lake Ontario	Lake Erie
Surface Area (m²)	1.9x10 ¹⁰	2.57x10 ¹⁰
Volume (m³)	1.67x10 ¹²	4.84x10 ¹¹
Sediment Active Layer (m)	0.005	0.005
Hydraulic Retention Time (yrs)	6.5	2.6
Solids Deposition Rate (g/m²/day)	1.4	3.0
Solids Resuspension Rate (g/m²/day)	0.58	1.5
Solids Burial Rate (g/m²/day)	0.589	0.25
Water Column Solids Concentration (mg/l)	0.5	4.0
Fractional Volume of Particles in Surface Sediments	0.15	0.15
Density of Sediment Particles (Kg/m³)	1500	1500

Required inputs to the model are; loadings from various source categories, the atmospheric PCB concentration, and the rate of change in PCB concentrations in the water column and sediments.

Eisenreich and Strachan (1992) reported atmospheric PCB concentrations of 0.1, 0.2 and 0.4 ng/m³ in winter, spring/fall, and summer for a mean concentration of 0.225 ng/m³. We have rounded this to 0.2 ng/m³ for modeling purposes. The atmospheric concentration was confirmed through discussions with Drs. Ronald Hites (Indiana University) and Deborah Swackhamer (University of Minnesota). DeVault et al. (1995) reported a total tributary loading of 741 Kg/yr. The tributary loading was described by De Vault et al. (1995) as only a rough approximation. However, it is the only estimate currently available and was, therefore, used.

There are no known data with which to determine the rate of change in the water column and sediment PCB concentrations in Lake Erie. However, De Vault et al. (1996) observed that, in Lakes Michigan and Superior, rates of change in fish tissue residues were similar to those observed in the water column, if sufficient time periods were allowed to mediate the effects of biological factors such as changes in food web structure. De Vault et al (1988) reported a loss rate for PCBs in coho salmon fillets of -0.26 over the period 1980 through 1984. A PCB loss rate of $-0.18/\text{yr.}$ observed for Lake Erie walleye (De Vault et. al. 1996) over the period 1977 through 1982. We have chosen to use the loss rate observed for walleye because, unlike coho salmon, walleye are distributed throughout the lake. A loss rate of $-0.18/\text{yr}$ was assumed to represent both the water column and the sediments.

Results:

Water Column: When the Model was run using the Parameters in Table 31, a tributary loading of 741 Kg/yr., an atmospheric concentration of 0.2 ng/m^3 and loss rates of $-0.18/\text{yr.}$ for both water and sediments, the predicted PCB concentration was 0.79 ng/l. This agrees very well with the mean concentration of 0.81 ng/l observed in the spring of 1993 by US EPA (USEPA, Great Lakes National Program Office unpublished data). Because of the good agreement between calculated and observed concentrations, these values (Table 32) were used in all subsequent model runs.

Table 32. Input Parameters.

Tributary Loading	741 Kg/yr.
Atmosphere Concentration	0.2 ng/m^3
Rate of Concentration Change in Sediments	$-0.18/\text{yr.}$
Rate of change in Water Column Concentrations	$-0.18/\text{yr.}$

The Model was then run with additional loadings from the Ashtabula River added as “loadings from areas of Concern”. The results of these runs are in Table 33.

Table 33. Potential Ashtabula PCB Loadings and the Resulting Open Lake Concentrations

Ashtabula Loading	Predicted Concentration in Lake Erie (ng/l)
0 Kg (No additional loading from Ashtabula)	0.79
11 Kg (0.1% of the Ashtabula PCB mass)	0.80
110 Kg (1% of the Ashtabula PCB mass)	0.89
1101 Kg (10% of the Ashtabula PCB mass)	1.78
2754 Kg (25% of the Ashtabula PCB mass)	3.26
5509 Kg (50% of the Ashtabula PCB mass)	5.73
11018 Kg (100% of the Ashtabula PCB mass)	10.67

Fish Tissue: As indicated in Table 33, if PCBs were to be discharged from the Ashtabula River during storm events, there would be a large impact on Lake Erie. The impact of such increases in water column concentrations on the walleye fishery may be approximated by applying the appropriate bioaccumulation factor. De Vault (1996) reported a mean PCB concentration of 2.2 ug/g in whole walleye (487 mm total length) collected from Lake Erie in the fall of 1992. Using these data and the water column data collected by U.S. EPA in the spring of 1993 we calculate a water to walleye bioaccumulation factor of 2.7×10^6 . Using this bioaccumulation factor, we calculated the whole fish concentrations in Table 34. Assuming a fillet to whole fish ratio of 0.75, we calculate the fillet concentrations in Table 34.

Table 34. Predicted PCB concentrations in whole walleye and walleye filets.

Percent Ashtabula PCB Mass	Water Column Concentration (ng/l)	Concentration in Whole Walleye (ug/g)	Concentration in Walleye Filets (ug/g)
0%	0.79	2.13	1.60
0.1%	0.80	2.16	1.62
1.0%	0.89	2.40	1.80
10%	1.78	4.81	3.60
25%	3.26	8.80	6.60
50%	5.73	15.47	11.6
100%	10.67	28.81	21.6

Environmental Impacts: The States of Ohio, Pennsylvania, and New York issue Sport Fish Consumption Advisories based on a sliding scale. When PCB concentrations in edible portions equal or exceed 0.05 ug/g they advise that the general public not to consume more than one meal per week, and that women of child bearing age and young children avoid consumption. At concentrations of approximately 2 ug/g they advise that no one consume the fish. The U.S. Food and Drug Administration prohibits interstate sale of fish exceeding 2 ug/g. State Agriculture Departments prohibit intrastate sale at 2 ug/g. Table 44 indicates that release of between 1% and 10% of the PCB mass in the Ashtabula River could be sufficient to cause the States to advise sport anglers not to consume walleye and would result in closure of the commercial fishery. There would probably also be, as yet unquantified impacts on Lake Ontario as PCBs moved downstream through the Niagara River.

One approach to evaluating the toxicity of complex mixtures, such as PCBs, is to express concentrations as dioxin equivalents (TEQs). This expresses the toxic effects of planar PCBs, chlorinated furans and chlorinated dioxins in terms of the most toxic of the group, 2,3,7,8-tetra-chlor-dibenzo-p-dioxin (2,3,7,8-TCDD). We have applied this approach to the evaluation of the increased toxicity to fish and avian species which would result from an increased PCB loading from the Ashtabula River. We have calculated TEQs for Lake Erie walleye and birds for the entire suite of chlorinated dioxins, chlorinated furans and planar PCBs based on existing data. We have assumed that increased loading from the Ashtabula River would only contain PCBs (no dioxins) and that increased risks to fish and birds would be the result of only increases in

planar PCBs. As a result, we have probably underestimated the toxicity.

To calculate the TEQs we used existing literature reports on the chlorinated dioxin, chlorinated furan concentrations in Lake Erie walleye along with the PCB estimates generated above for various Ashtabula loading scenarios. These concentration were then multiplied by the appropriate World Health Organization Toxic Equivalency Factor (TEF) for each congener. The resulting TEFs concentrations were then summed to yield the TEQ. Polychlorinated dibenzofuran and polychlorinated dibenzopdioxin data from Lake Erie walleye in 1984 were obtained from De Vault et al. (1989). Planar PCB concentrations were determined by multiplying the above total PCB concentrations by the percentage (percent of total PCB) of each planar compound observed in chinook salmon by Williams et al. (1992). Williams et al. (1992) demonstrated that the percentage contribution of the individual planar PCB congeners to total PCB was fairly constant over several species of fish from a wide variety of water bodies. Concentrations of dioxins and furans were held constant for all calculations. Concentrations of planar PCBs were proportionally adjusted for changes in total PCB in fish tissue under different loading scenarios.

Table 35. Dioxin Toxic Equivalents Calculated under Different Ashtabula River Loading Scenarios.

Percent Ashtabula PCB Mass	Water Column PCB Concentration (1)	PCB Concentration in Whole Walleye (2)	TEQ to Fish (3)	TEQ to Birds (3)
0%	0.79	2.13	1036	9131
0.1%	0.80	2.16	1050	9259
1.0%	0.89	2.40	1166	10286
10%	1.78	4.81	2330	20596
25%	3.26	8.80	4257	37665
50%	5.73	15.47	7479	66200
100%	10.67	28.81	13922	123268

(1) ng/l

(2) ng/g

(3) pg/g

As indicated above, release of between 1 and 10% of the PCBs in the Ashtabula River sediments would more than double the toxicity to fish and avian species in Lake Erie.

TEQs between 217 and 1029 pg/g have been observed to cause adverse impacts on reproduction in species such as Caspian terns. Impacts include direct toxicity to the developing embryo and indirect effects such as aberrant nesting behavior by adults. Similar affects have been observed in herring gulls at TEQs around 557 pg/g (Giesy et al. (1994).

Due to the dioxin like toxicity associated with planar PCBs, U.S. EPA has recommended a PCB

water quality Criteria of 0.074 ng/l for the protection of wildlife and 0.0039 ng/l for the protection of human health in the Great Lakes system (US EPA 1995). Ludwig et al. (1993) have used TEQs to calculate that a Water Quality Criterion protective of a range of avian species (bald eagles, herring gulls, Caspian terns, double crested cormorants) would be between 0.001 and 0.031 ng/l. PCB concentrations in Lake Erie currently exceed these concentrations, however concentrations are declining in response to regulatory actions.

These declines are occurring as a result of declines in both atmospheric PCB loadings and in tributary loadings. Our modeling indicates that the wildlife criteria will be approached as atmospheric concentrations approach 0.1 ng/m³ and tributary loadings approach 0. Hites and co workers at Indiana University, using data from the U.S. Environmental Protection Agency and Environment Canada, have demonstrated the atmospheric concentrations across the Great Lakes are declining with a half-life of approximately 3 years (Dr. Ron Hites, Indiana University personal communications). However, meeting the wildlife and human health criteria will also require major reductions in the existing loads from rivers such as the Ashtabula. While we do not have data with which to calculate the PCB loading from the Ashtabula River, the extremely high concentrations observed in both fish and sediments indicate that the load is substantial.

Summary: The PCBs in bottom sediments of the Ashtabula River and Harbor pose a serious ecological threat to Lake Erie and, potentially the entire Great Lakes ecosystem downstream of Ashtabula, OH. This threat is in two forms. The past and present PCB loading from the Ashtabula (while not quantifiable due to the lack of data) likely significantly contributes to the existing PCB loading to Lake Erie. This loading is unacceptably high as evidenced by exceedences of water quality criteria based on the toxicity of PCBs to fish and wildlife species, as well as humans consuming fish from the lake. In addition the PCB mass contained in sediments of the Ashtabula represent an ecological "time bomb". A storm event which moves as little as 1 to 10 percent of this mass would have catastrophic affects on Lake Erie. Toxicity to fish and wildlife species would more than double from current levels. Sport and commercial fisheries would be forced to close as criteria for the protection of human health were exceeded.

OPEN LAKE DISPOSAL

Introduction: Contamination in the sediment has transferred to fish, affected habitat quality, and has restricted lower Ashtabula River commercial and recreational use. Because of the levels of contaminants in the sediment, they are not suitable for unrestricted open-lake disposal and instead require disposal in a confined disposal facility (CDF). Navigation channel maintenance has been limited. Deep dredge commercial navigation channels (-18 and -16 feet LWD) have not been maintained in the problem area from Station 120 to the turning basin just upstream of the Fifth Street Bridge since 1979, and from the turning basin just upstream of the Fifth Street Bridge to the upstream Federal channel limits since 1962 due to contaminated sediments. Appropriate disposal facilities for contaminated sediments are required, but, presently unavailable, or, not economical. Contaminated sediments in the lower Ashtabula River continue to migrate toward the Outer Harbor and Lake. An important and significant goal of the partnership is to ensure that once remediation has been completed, sediments dredged in the future are suitable for open-lake disposal.

To meet the goals of the partnership remediation, sediments need to be dredged to maintain navigable depths and to ensure that future dredged sediments will be eligible for open-water disposal. However, dredging will reveal significantly higher levels of contamination at a depth for recreational navigation (-8 feet), and therefore dredging will need to continue beyond this depth.

Assessing Future Open-Lake Disposal Suitability:

In 1993, USACE-Buffalo analyzed sediment in the lower river and harbor for suitability for open-water disposal, in accordance with the revised Clean Water Act Section 404 Great Lakes Dredge Material Testing and Evaluation Guidance (1997). This guidance utilizes the results of bioassays to determine environmental quality of sediments, instead of relying solely upon sediment chemistry. Twelve management units, or sediment areas, were defined for this testing (6 in the lower River and 6 in the Harbor--see Figure 13). The results of the bioassays from these test areas were then compared to results obtained from sediments at a lake reference site to determine any significant difference. This comparison was the primary criterion used to determine the suitability of the harbor sediments for open-lake disposal. Based on the contamination information known about the sediments, the following bioassays were done:

- Toxicity tests using *Chironomus tentans* (midge larvae) and *Hyallolella azteca* (amphipod); assessing toxicity of PAHs and metals, and,
- Quantitation of the bioaccumulation of total PCBs using *Lumbriculus variegatus* (aquatic earthworm).

Based on the results of these assays, all of the Harbor management units and the two most downstream River management units were considered suitable for open lake-disposal (management units H1-6, and R1 and R2). However, three upstream River management units (R3, R5a and R5b - downstream from the 5th Street bridge) did not pass one or more of the bioassays. The main contaminants considered to be responsible for the toxicity observed in these tests are PCBs for the bioaccumulation, and PAHs plus other contaminants for the toxicity tests. It is important to note that due to the presence of multiple contaminants, the toxicity cannot be attributed solely to a particular contaminant or group of contaminants.

The highest level to pass this bioaccumulation test (a "pass" indicates that the bioaccumulation of PCBs was not significantly elevated when compared to the reference exposures) was 0.95 ppm PCBs dry weight in the sediment. The lowest levels found to cause significant bioaccumulation using *Lumbriculus variegatus* was 2.6 ppm PCBs dry weight in the sediment. River management units R3, R5a and R5b had significantly higher PCB tissue concentrations compared to the reference sites. It is important to note that a limitation of this test is that it does not address biomagnification for animals higher in the food chain. Therefore, the results from this test cannot be used to determine whether these concentrations are protective of fish-eating birds and mammals. However, in the preliminary Draft 1997 report titled "Development of Polychlorinated Biphenyl (PCB) Sediment Cleanup Guidelines for Ashtabula Harbor (Upper River), Ohio" (Pickard 1997), it was determined that total PCB concentrations of 0.32 and 0.40 ppm are concentrations near which Ashtabula River sediments would not cause bioaccumulation to levels greater than those present in Lake Erie environs and would therefore be suitable for open-water disposal.

For PAHs, the most relevant sediment chemistry data for the lower river is from 1992. (Bioassays were done in 1993.) Because these analyses were done at different times, the location of the samples taken do not exactly match the management units chosen in 1993, but there is significant overlap (see Figure 10). The highest level found to pass the *Chironomus tentans* toxicity test (a “pass” indicates that the results from the test sites are not significantly different when compared to the reference site results) was 11.6 ppm total PAHs. The lowest level found to cause significant adverse effects in this organism is 27.7 ppm total PAHs.

Therefore, a range of 10-20 ppm total PAHs may be an appropriate target. In addition, it needs to be noted that there is a high level of uncertainty regarding the impacts from PAHs versus other contaminants because of the multiple contaminants present. However, due to the co-localization of contaminants in the sediment, addressing the removal of PAHs and PCBs in sediment should help address the other contaminants present.

Bioassays were not conducted on sediments upstream of the 5th Street bridge. However, based on the overall higher concentrations of contaminants further upstream closer to Fields Brook, it is anticipated that these sediments will not pass the bioassay tests. Additional chemical sampling and bioassay analyses are being planned for late Spring 1998 to better define the nature and extent of contamination and more accurately identify sediments which require confined disposal.

PCB Mass:

The Ashtabula River AOC currently contains approximately 11,000 kg of PCBs, of which 1700 kg is TSCA-regulated material (≤ 50 ppm PCBs). To ensure removal of all TSCA material, the ARP has agreed to use 40 ppm as the cutoff for TSCA-regulated material. Therefore, this mass will be greater than 1700 kg. The PCB mass contributes to risk in two main ways. First, the exposed sediment has transferred into ongoing fish contamination. Secondly, the mass of PCBs can be released and redistributed during storm events, scouring, etc. allowing for recontamination of the river and a continued loading of available PCBs and other contaminants in the future to the river and potentially the Great Lakes Basin.

It is important to realize that the Ashtabula River is a dynamic system. Sediment from cleaner upstream areas continues to cover the contaminants. However, it is clear that river sediments are mobile, and that contaminated sediment currently buried may become exposed and bioavailable during a future storm or scouring event, and thereby contribute to risk in the future. And, unfortunately, as sedimentation slowly continues without dredging being conducted, the minimum depth needed for recreational and commercial activities will not exist. The contaminated sediment cannot be open-lake disposed. Therefore, the overall best long-term approach is removal of the PCB mass, which will ensure long-term protection and open-lake disposal in the future.

ASSESSMENT/EVALUATION REVIEW TABLE AND RECOMMENDATIONS

The following table presents in a comparative/incremental summary manner considered **DREDGING ECOLOGICAL RESTORATION/PRESERVATION SCENARIOS FOR CONTAMINANT REMOVAL** and assessment/evaluation output items discussed in the previous sections. It provides support for selection of the Deep Dredge Plan, in this regard, as the optimized plan removing the minimum amount of material that would need to be dredged, which would make the dredging cost effective, while meeting River clean-up goals/objectives. The recommended plan involves deep dredging (environmentally) and disposal of approximately 696,000 cubic yards (in situ) of contaminated sediments, 150,000 cubic yards of which is significantly PCB contaminated and would be handled and disposed of in accordance with TSCA regulations. The initial dredge would remove limited existing shallow areas (~.33 Acres <2 Ft) and aquatic vegetation from the main channel area; but, not the inlets; and, not nearly to the extent of the originally considered Bank to Bank to Bedrock dredge.

Note: The material proposed to be dredged downstream of the Fifth Street Bridge (115,000 CY) constitutes about 17% of the total material to be dredged (696,000 CY) for the Deep Dredge Plan.

Several other SUPPLEMENTAL DREDGING MEASURES FOR CONTAMINANT REMOVAL AND ECOLOGICAL RECOVERY were considered for problem areas upstream of the Fifth Street Bridge that would facilitate and/or expedite ecological recovery. Additional costs associated with these measures is minimal (i.e. administrative) with likely savings in the future, and should be implemented initially and in the long-term.

1. Dredge relatively clean material from channels above and/or below the ARP project dredging area during routine operation and maintenance dredging and disposal and place it over the dredged area as clean cover. This would initiate almost immediate recovery to benthic and fishery habitat rather than gradual (several years) recovery as relatively clean material silts into the ARP project dredged area. This would probably work best as a one time effort, since after about a year of recovery, this would likely result in as many disturbance problems as cover benefits.
2. If the channels are only maintained to recreational depths, eventually shallow aquatic/shelf areas will develop.
3. If the recreational channels were maintained to a somewhat lesser width, about 5 to 10 feet, eventually associated wider shallow aquatic/shelf areas will form (+/- .34 Acres).

Table 36a - Dredging Ecological Restoration/Preservation Scenarios for Contaminant Removal and Assessment/Evaluation Items

Item	Dredging for Contaminant Removal			Shallow Dredge
	Bank to Bank To Bedrock	Deep Dredge		
		EAA 3	EAA 2	
Construction First Cost \$				
Dredge :	30,448,750	3,325,328	16,828,172	17,742,000
Disposal:	35,051,250	4,908,173	24,838,327	27,758,000
Total :	65,500,000	8,233,500	41,666,500	45,500,000
Study E&D S&A RE				
Project Cost: (Present Worth)	72,900,000	9,322,500	47,177,500	51,800,000
		10,236,402	51,802,398	
		(62,038,800)		
Project Economic Benefits (Present Worth)				
NED :		27,328,300	38,287,900	
Regional :		89,755,800	23,512,300	
Total :	(+/-)	117,084,100	61,800,200	(+/-)
		(178,884,300)		
Practicality*	Poor	Good	Good	Good
Ecological Improvement Rank	2		1	3
Dredged (CY)	1,150,000	115,000	581,000	592,000
TSCA (CY) Material	All	NA	All	Most
Removed	150,000		150,000	149,500

312(b)-92

Item	Dredging for Contaminant Removal			
	Bank to Bank To Bedrock	Deep Dredge		Shallow Dredge
		EAA 3	EAA 2	
Shoreline Bulkhead Affected	21,000 (Ft)	1,238 (Ft)	6,262 (Ft)	5,700 (Ft)
PCB Mass Removed	98%	NA(PAH)	82%	75%
PCB ppm Surface Concentrate Initial(6.29)	8.58	NA(PAH)	7.47	6.27
<u>Beneficial Uses Addressed</u>				
-Open Lake Disposal	Excellent	Good	Good	No Dif.
-Recreation/ Commercial Shipping	Excellent	Excellent	Excellent	Good
-Fish Advisory Lifted	Excellent	Good	Good	No Dif.
-Long-term Risk Reduction	Excellent	Good	Good	No Dif.
-Habitat Quality	Good	Excellent	Excellent	Good
<u>Scale: (Poor, Low, No Difference, Good, Excellent)(Reference the Risk Assessment)</u>				
Scour Release	Low	Low	Low	Medium
Potential (& to Lake)				
<u>Scale: (Low, Medium, High)(Reference the Risk Assessment)</u>				

Item	Dredging for Contaminant Removal			
	Bank to Bank To Bedrock	Deep Dredge		Shallow Dredge
		EAA 3	EAA 2	
Water Quality Turbidity	Low	Low	Low	Medium
Benthic Habitat Chemically Restored (3' Deep)	~20 Acres ~100,000 (CY)	(PAHs)	~20 Acres ~100,000 (CY)	<20 Acres <100,000 (CY)
Benthic Habitat & Scour Protection Restored (6' Deep)	~20 Acres ~200,000 (CY)	(PAHs)	~20 Acres ~200,000 (CY)	<20 Acres <200,000 (CY)
Aquatic/Fishery Shallows (Acres) Initially Impacted	~10.5	0	~.33	~.33
Physical Habitat Improvement (HAP QHEI up to)	NA	NA	NA	NA
Fishery Improvement (HAP IBI up to)	Good +12	Fair +3	Good +12	Fair +10
Macroinvertebrate Improvement (HAP ICI up to)	Good +20	Fair +3	Good +20	Fair +18
Anomally Reduction (HAP)	Good	Fair	Good	Fair

Item	Dredging for Contaminant Removal			
	Bank to Bank To Bedrock	Deep Dredge		Shallow Dredge
		EAA 3	EAA 2	
Accomplishment of Sediment Contaminant Reduction Objective	Good	Good	Good	Poor
Accomplishment of Total Ecological Restoration Objective	Good	Fair	Good	Poor

Notes:

* Cost, volume, and bulkheading concerns.

General Scales: (Good, Fair, Poor) (Low, Medium, High)

Scale: (Poor, Low, No Difference, Good, Excellent) (Reference the Risk Assessment)

EAA - Ecological Assessment Area

EAA 3 - Mouth of River to Fifth Street Bridge

EAA 2 - Fifth Street Bridge through Upper Turning Basin

(HAP QHEI) - Habitat Assessment Procedures Qualitative Habitat Evaluation Index

(HAP IBI) - Habitat Assessment Procedure Index of Biotic Integrity

(HAP ICI) - Habitat Assessment Procedure Invertebrate Community Index

NA - Not Applicable

SUPPLEMENTAL DREDGING ECOLOGICAL RESTORATION/PRESERVATION MEASURES FOR PROTECTED AQUATIC/FISHERY SHALLOWS

PROBLEMS, NEEDS, OBJECTIVES REVIEW STATEMENT

As discussed previously, in addition to the problems associated with contaminated sediments, there are problems associated with structural developments and associated activities in the Area of Concern, particularly Ecological Assessment Areas 3 and 2, as identified in the Ohio Environmental Protection Agency habitat assessment reports. Reference Figures 19, 31, and 37. There are essentially no clean, protected, aquatic/fishery shallow areas of any substantial length in these reaches. Such areas are needed to provide a quality aquatic/fisheries environment and to provide for items such as: cover, feeding, and possibly spawning habitat, and passage of fish through the area. Measures were developed and assessed/evaluated with an objective of providing at least a minimum of clean, protected, aquatic/fishery shallow areas of some length missing from these reaches.

EXISTING CONDITIONS REVIEW

Review of some existing conditions information pertaining to Properties, Bulkhead Areas, Recreational Boating Docking Areas, primarily Main Channel Areas <Two Feet, and Shoreline Large Tree Cover (Reference Figures 31 through 37) provides some idea on possible Supplemental Ecological Measures that may be utilized in the problem Ecological Assessment Areas (EAA) 3 and 2

SUPPLEMENTAL ECOLOGICAL MEASURES

Other supplemental water resource measures considered pertaining to ecological restoration and/or preservation relative to structure and function in the harbor problem areas include:

Supplemental Ecological Measures	EAA Reach Applicability			
	1	2	3	4
<u>Acquisition and Improvement of Shoreline</u>				
-Aquatic/Fishery Shelf Cut/Hang		X	X	
-Soils Placement/Grading		X	X	
-Plantings (Aquatic and/or Terrestrial)		X	X	
-Artificial Shoreline Cover Structures		X	X	
-Riprap/Gravel Areas		X	X	
<u>Supplemental Dredging Measures</u>				
-Maintain Only Recreational Channel Depth Upstream of the Fifth Street Bridge.	X	X		
-Reduce Recreational Channel Width Upstream of the Fifth Street Bridge.	X	X		
<u>River Pump-Flow Augmentation</u>		X	X	

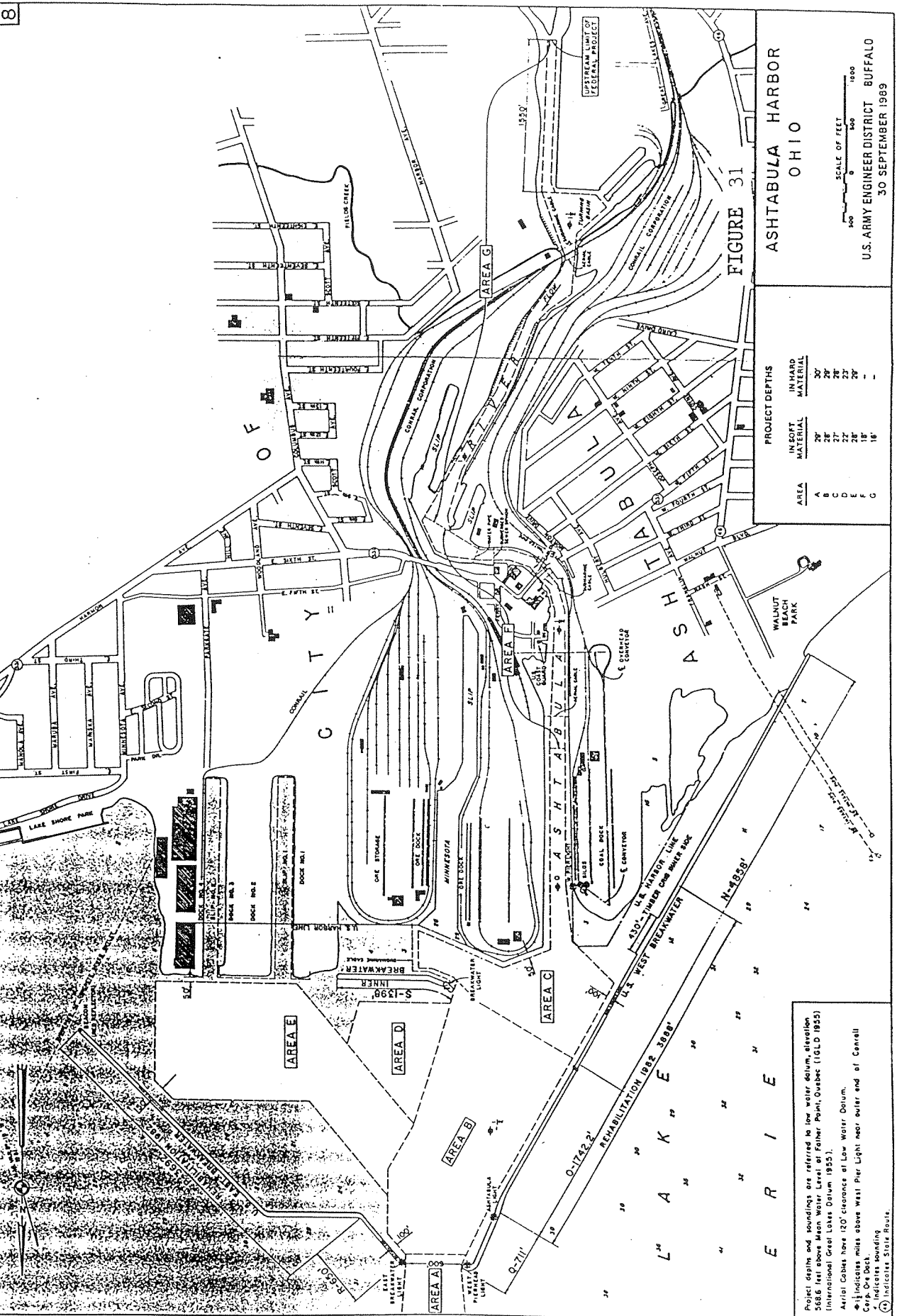

FIGURE 31

ASHTABULA HARBOR
OHIO
U.S. ARMY ENGINEER DISTRICT BUFFALO
30 SEPTEMBER 1969

AREA	PROJECT DEPTHS	
	IN-SOFT MATERIAL	HARDB MATERIAL
A	20'	20'
B	28'	20'
C	27'	23'
D	28'	20'
E	28'	18'
F	18'	-
G	-	-

Project depths and soundings are referred to low water datum, elevation 568.6 feet above Mean Water Level of Father Point, Quebec (IGLD 1955) (International Great Lakes Datum 1955).
 Aerial Cobas have 120' clearance at Low Water Datum.
 * indicates miles above West Pier Light near outer end of Canal
 * indicates sounding
 * indicates State Route.

312 (b) -96

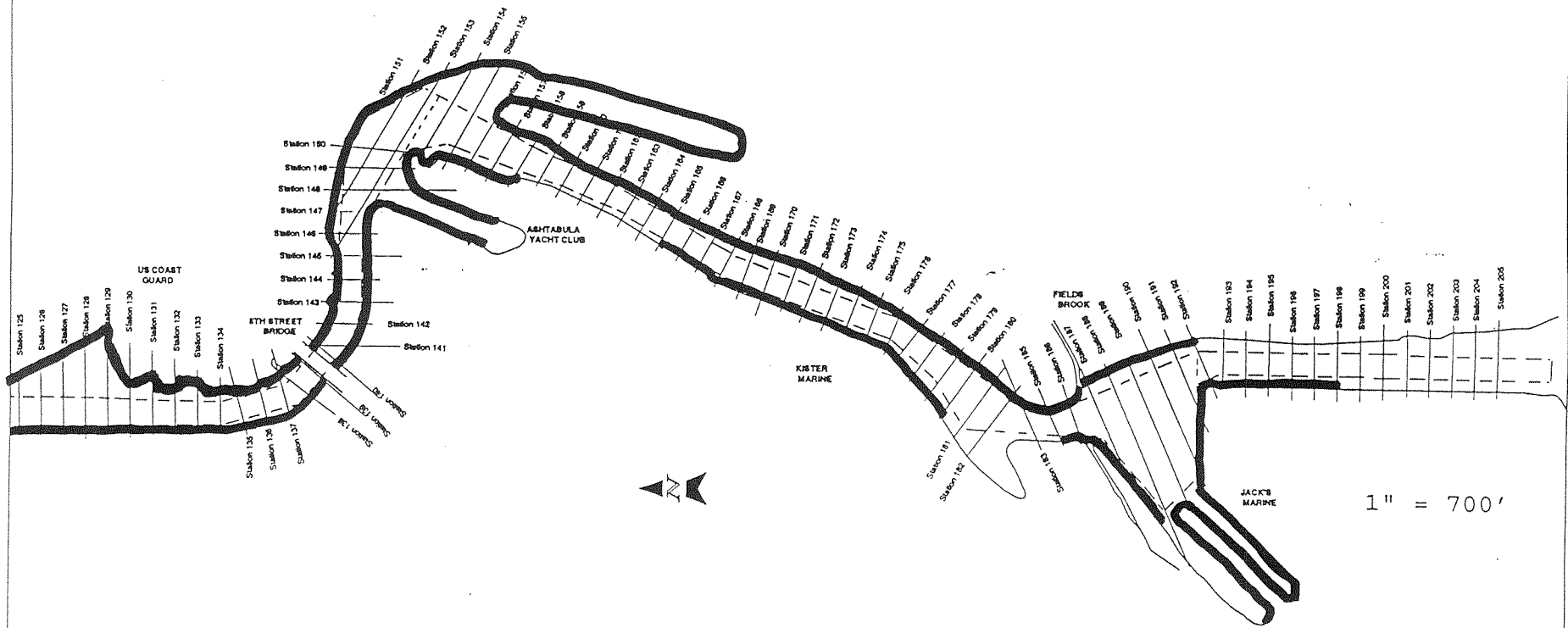

FIGURE 32

Ashtabula River Partnership
Bulkhead Areas

Reference 1997 Survey.

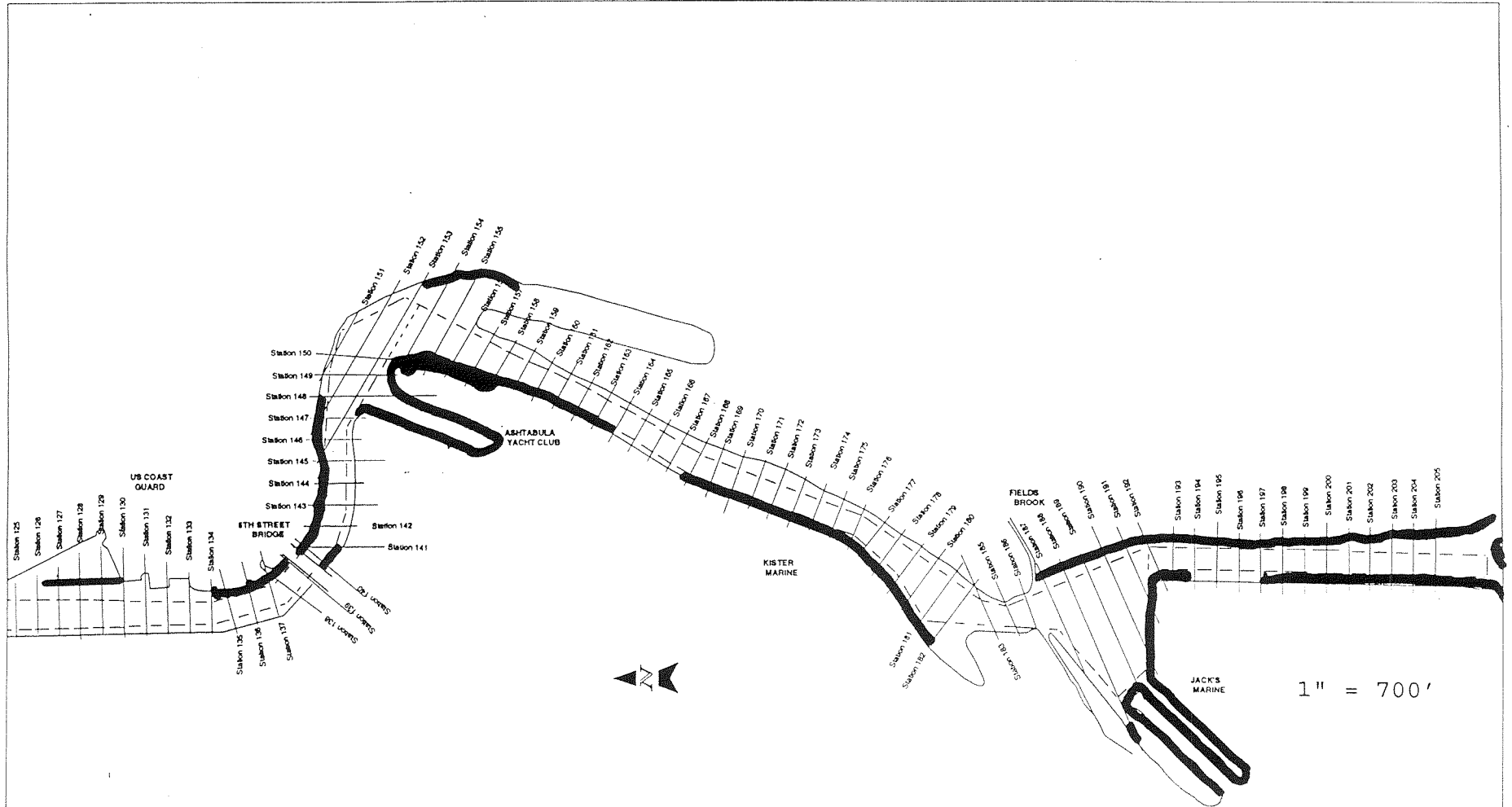

FIGURE 33

Ashtabula River Partnership
Recreational Boating Docking

Reference 1996 Air Photos

312(b)-98

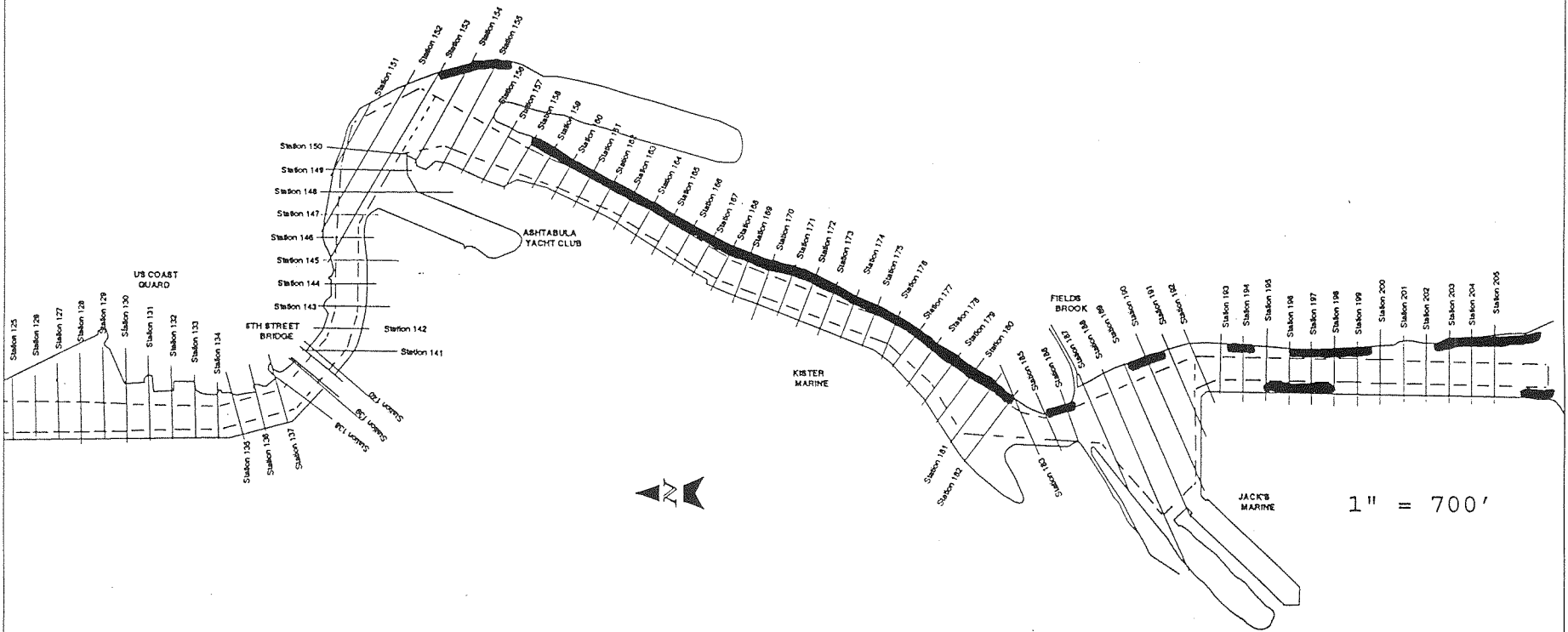

FIGURE 34

Ashtabula River Partnership
Main Channel Area < -2 Ft.

Reference 1995 Channel Survey

312 (b) -100

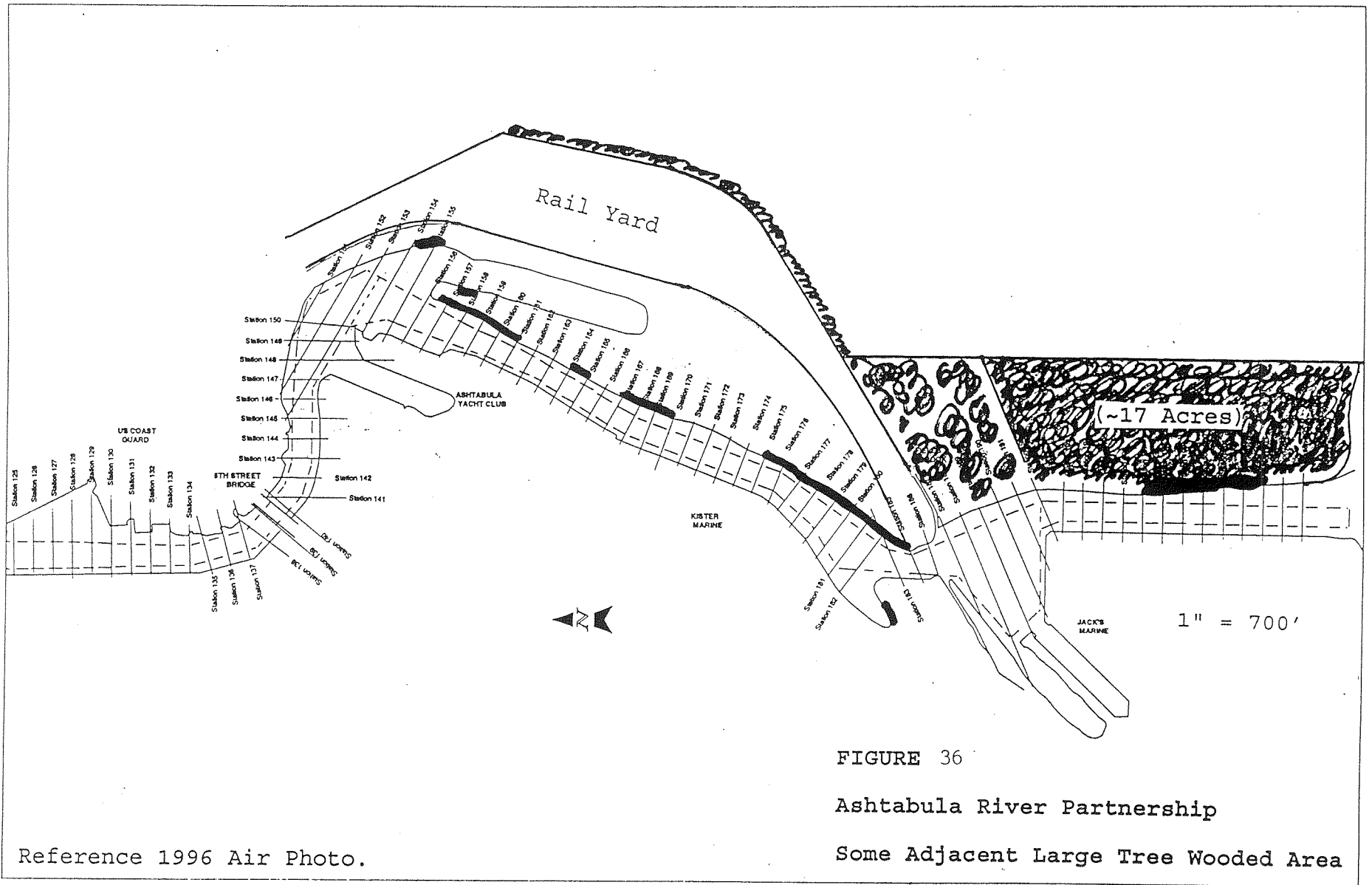
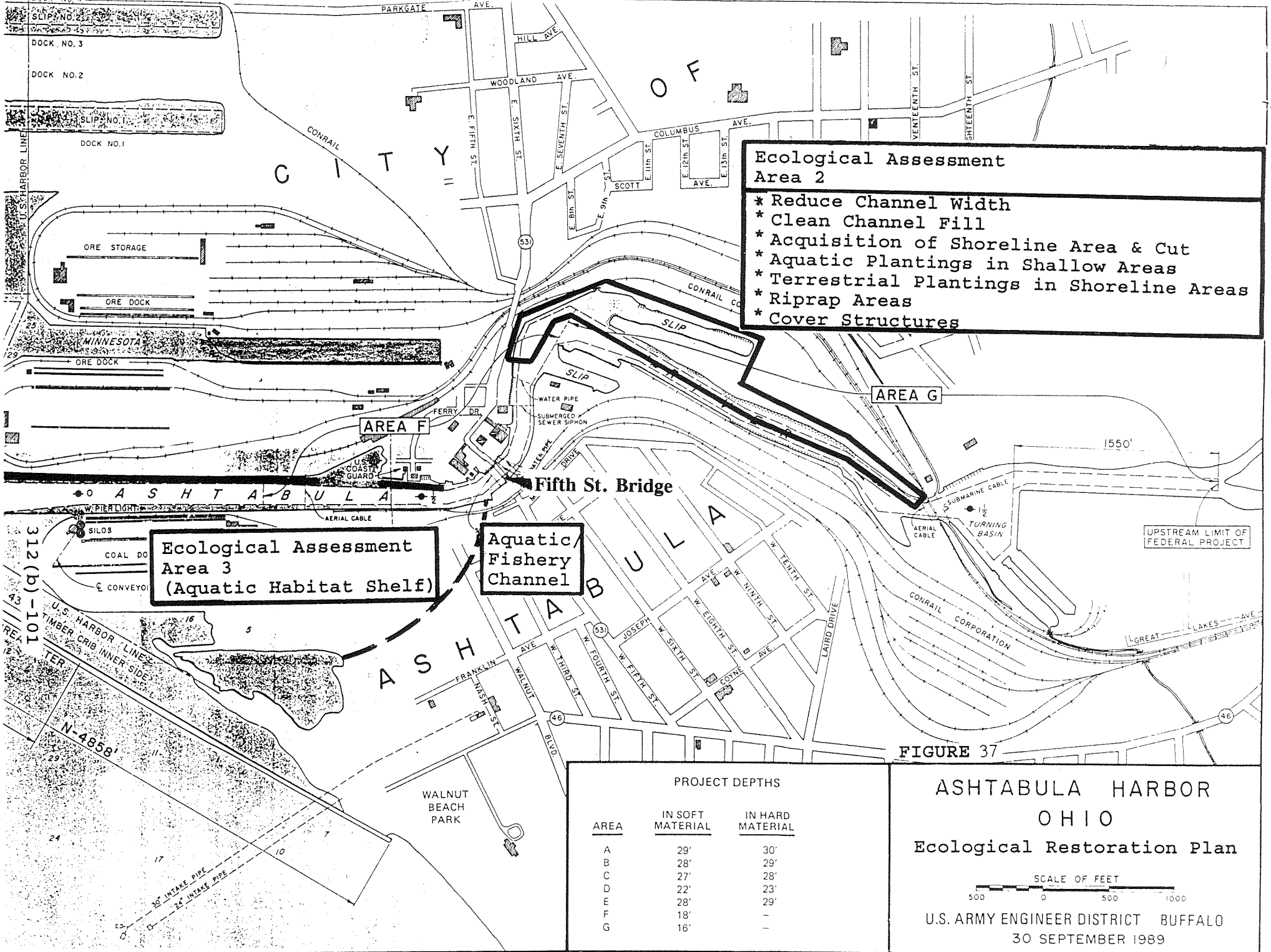

FIGURE 36

Ashtabula River Partnership

Some Adjacent Large Tree Wooded Area



- Ecological Assessment Area 2**
- * Reduce Channel Width
 - * Clean Channel Fill
 - * Acquisition of Shoreline Area & Cut
 - * Aquatic Plantings in Shallow Areas
 - * Terrestrial Plantings in Shoreline Areas
 - * Riprap Areas
 - * Cover Structures

Ecological Assessment Area 3 (Aquatic Habitat Shelf)

Aquatic Fishery Channel

FIGURE 37

AREA	PROJECT DEPTHS	
	IN SOFT MATERIAL	IN HARD MATERIAL
A	29'	30'
B	28'	29'
C	27'	28'
D	22'	23'
E	28'	29'
F	18'	-
G	16'	-

ASHTABULA HARBOR OHIO
Ecological Restoration Plan

SCALE OF FEET
 500 0 500 1000

U.S. ARMY ENGINEER DISTRICT BUFFALO
 30 SEPTEMBER 1989

SUPPLEMENTAL DREDGING ECOLOGICAL RESTORATION/PRESERVATION MEASURES FOR PROTECTED AQUATIC/FISHERY SHALLOWS AND ASSESSMENT/EVALUATIONS

ECOLOGICAL ASSESSMENT PROBLEM AREA 3 PLANS AND ASSESSMENT

Supplemental Ecological Measures that could be applied to Ecological Assessment Area 3 are very limited since the area continues to be utilized for commercial shipping and docking and transfer of primarily coal and limestone. One measure that has been considered at other harbors for similar situations is the construction of a man-made aquatic habitat shelf along the channel reach or a bypass channel primarily to facilitate movement of fisheries through the reach.

The Ecological Restoration Sub-Committee formulated several alternative plans believed to at least somewhat remediate ecological problems in Ecological Assessment Area 3. These were then assessed/evaluated relative to costs and comparative restoration results, as follows:

1. Aquatic/Fishery Shelf Cut. With this plan shoreline property would be acquired and an aquatic/fishery shelf would be cut along the east embankment channel area for about 2,500 feet. Some bulkheading would be left in place as a buffer between the commercial channel and the shelf. The cut would be about two feet below low water datum (LWD) and at a minimum about 8 -10 feet wide. Improvements would be made to the bottom of the cut to include: contouring, soil and aquatic planting areas, gravel areas, and some cover structures. The shoreline area would also be improved with cover/food plantings or artificial cover structures, as possible. Reference Figures 37 and 38. The estimated cost for this measure would be about \$ 400,662. Reference the estimate work sheets which follow.

This is the second most costly plan considered for the area. It is not particularly practical for the area considering the commercial activity in the area (coal storage/transport) and potential exposure to coal dust. It could provide substantial ecological benefits to the area, if not for the potential coal dust problem and is comparative to Plan 3.

This would provide an aquatic/fishery shelf area feature presently missing due to the current channel reach development and activity. It would provide ecological benefits to the benthic and fishery as best measured via the Ohio EPA Habitat Assessment Procedure assessment/evaluation discussion. Reference the previous associated section and summary Figures 43 and 44, and Table 37. The area would be interfaced with the lake/river regime and would provide passage, cover, feeding, and possibly spawning habitat.

2. Aquatic/Fishery Shelf Hung. With this plan a property easement would be acquired and an artificial aquatic/fishery shelf would be hung along the existing sheetpile bulkheading in unit sections for about 30 feet every thirty feet for about 2,500 feet. The unit sections would be constructed of standard or custom concrete units about 10 feet long, as depicted in the plan cross-section, with a cover feature and stone placed along the lower shelf. The shelf could have a grate bottom to allow silt/coal dust to move through the stone and shelf. Reference Figures 37 and 39.

The estimated cost for this measure would be about \$ 313,111.
Reference the estimate work sheets which follow.

This is the least costly plan considered for the area. It is the most practical plan for the area considering the commercial activity in the area (coal storage/transport) and potential exposure to coal dust. It provides somewhat lesser ecological benefits to the area.

This would provide an aquatic/fishery shelf area feature presently missing due to the current channel reach development and activity. It would provide ecological benefits primarily to the fishery as best measured via the Ohio EPA Habitat Assessment Procedure assessment/evaluation discussion. Reference the previous associated section and summary Figures 43 and 44 and Table 37. The area would be interfaced with the lake/river regime and would provide primarily cover and fishery passage, and possibly feeding and spawning habitat.

3. Aquatic/Fishery Diversion/By-Pass Cut. With this plan property would be acquired and a diversion channel would be cut between the river and the western outer harbor Walnut Beach wetland area for a distance of about 2,500 feet. It would be about 12 feet deep with a channel bottom of about 10 feet wide. Improvements would be made to the bottom of the cut to include: contouring, soil and aquatic planting areas, gravel areas, and some cover structures. The shoreline area would also be improved with cover/food plantings or artificial cover structures, as possible. Culverts would need to be constructed under access roads and railroad tracks. Reference Figures 37 and 40.

The estimated cost for this measure would be about \$ 787,313.
Reference the estimate work sheets which follow.

This is the most costly plan considered for the area. It is not particularly practical for the area considering the commercial activity in the area (coal storage/transport) and potential exposure to coal dust. It could provide substantial ecological benefits to the area, if not for the potential coal dust problem and is comparative to Plan 1.

This would provide an aquatic/fishery access channel past the ecological problem area caused by current channel reach development and activity. It would provide ecological benefits to the benthic and fishery as best measured via the Ohio EPA Habitat Assessment Procedure assessment/evaluation discussion. Reference the previous associated section and summary Figures 43 and 44, and Table 37. The area would be interfaced with the lake/river regime and would provide passage, cover, feeding, and possibly spawning habitat.

A similar plan could be considered between the Pinney Minnesota Slip and the River.

ECOLOGICAL ASSESSMENT PROBLEM AREA 2 PLANS AND ASSESSMENT

A number of Supplemental Ecological Measures could be applied to Ecological Assessment Area 2. A combination of measures would likely provide a good variety of habitats and benefits.

The Ecological Restoration Sub-Committee formulated several alternative plans believed to substantially remediate ecological problems in Ecological Assessment Area 2. These were then assessed/evaluated relative to costs and comparative restoration results, as follows:

1. Conrail Slip and Aquatic/Fishery Shelf Cut. With this plan shoreline property would be acquired along the east embankment channel area and an aquatic/fishery shelf would be cut between the river and the Conrail Slip. Some bulkheading would be left in place as a buffer between the recreational channel and the shelf. The cut would be about two feet below low water datum (LWD). Improvements would be made to the bottom of the cut and possibly to the existing slip to include: contouring, soil and aquatic planting areas, gravel areas, and some cover structures. The shoreline area would also be improved with cover/food plantings. Reference Figures 37, 38, and 40.

The estimated cost for this measure would be about \$ 1,213,779.
Reference the estimate work sheets which follow.

This is the second most costly plan considered for the area. It is practical for the area. It takes advantage of the opportunity to utilize the existing slip adjacent to the river. It would provide substantial ecological benefits to the area. It may not however, provide sufficient passage for the length of the problem area.

This would provide an aquatic/fishery shelf area feature lost due to project dredging and/or presently missing due to past channel reach development and activity. It would provide ecological benefits to the benthic and fishery as best measured via the Ohio EPA Habitat Assessment Procedure assessment/evaluation discussion. Reference the previous associated section and summary Figures 43, 44 and Table 37. The area would be interfaced with the lake/river regime and would provide passage, cover, feeding, and spawning habitat.

2. Conrail Slip and Aquatic/Fishery Shelf Cut Extended. This plan would include the Conrail Slip and Aquatic/Fishery Shelf Cut plan and would provide an extended aquatic/ fishery shelf cut. With this plan additional shoreline property would be acquired and an aquatic/fishery shelf extension would be cut along the east embankment channel area for about another 1,500 feet. Some bulkheading would be left in place as a buffer between the recreational channel and the shelf. The cut would be about two feet below low water datum (LWD) and at a minimum about 8-10 feet wide. Improvements would be made to the bottom of the cut to include: contouring, soil and aquatic planting areas, gravel areas, and some cover structures. The shoreline area would also be improved with cover/food plantings, as necessary. Reference Figures 37, 38, and 40.

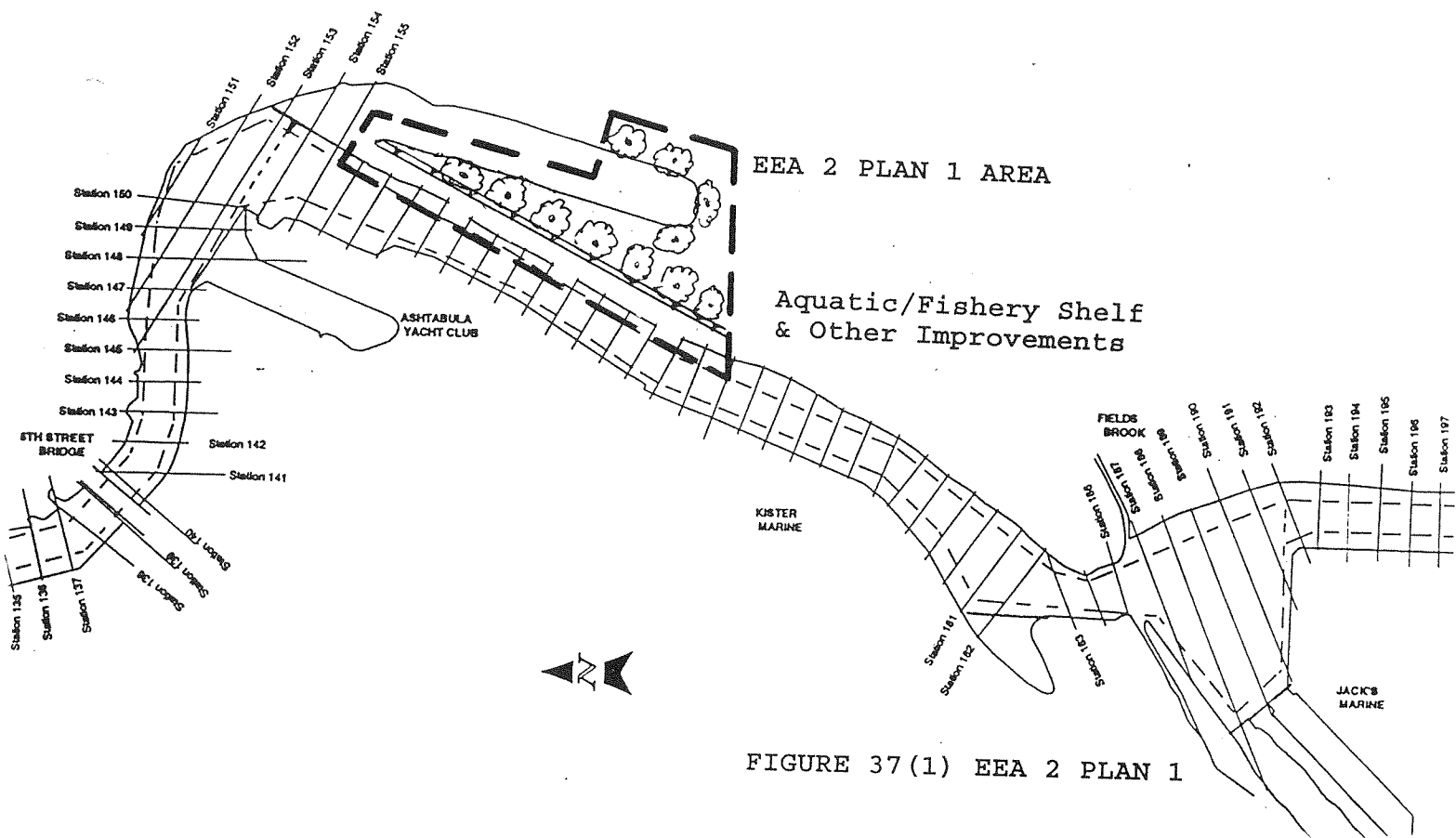

FIGURE 37(1) EEA 2 PLAN 1

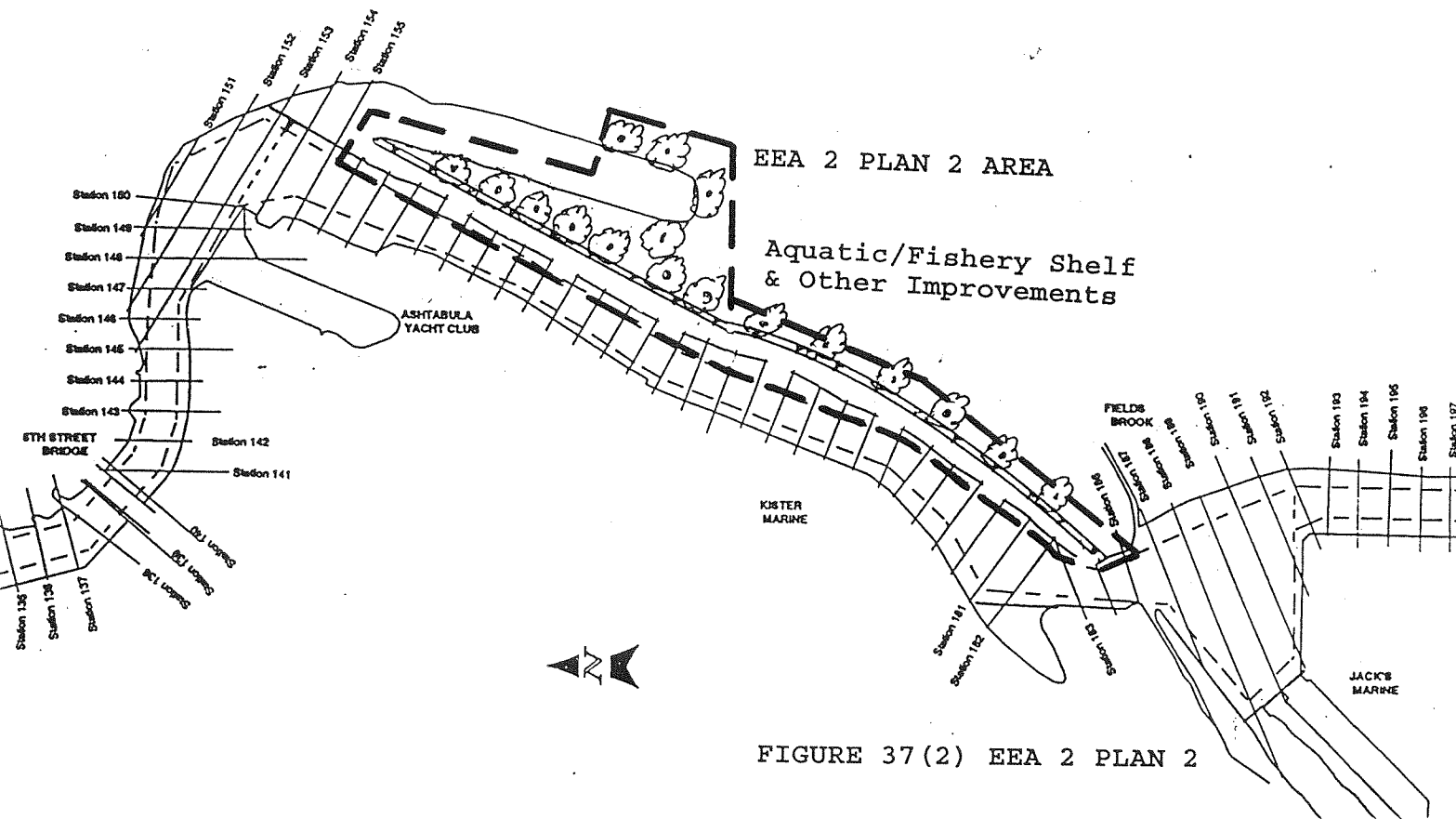

FIGURE 37(2) EEA 2 PLAN 2

The estimated cost for this measure would be about \$ 1,500,911.
Reference the estimate work sheets which follow.

This is the most costly plan considered for the area. It is practical for the area. It takes advantage of the opportunity to utilize the existing slip adjacent to the river. It would provide substantial and the greatest ecological benefits to the area, and full passage through the problem area.

This would provide an aquatic/fishery shelf area feature lost due to project dredging and/or presently missing due to past channel reach development and activity. It would provide ecological benefits to the benthic and fishery as best measured via the Ohio EPA Habitat Assessment Procedure assessment/evaluation discussion. Reference the previous associated section and summary Figures 43 and 44, and Table 37. The area would be interfaced with the lake/ river regime and would provide passage, cover, feeding, and spawning habitat.

3. Aquatic/Fishery Shelf Cut. With this plan shoreline property would be acquired and an aquatic/fishery shelf would be cut along the east embankment channel area for about 2,500 feet. Some bulkheading would be left in place as a buffer between the recreational channel and the shelf. The cut would be about two feet below low water datum (LWD) and at a minimum about 8-10 feet wide. Improvements would be made to the bottom of the cut to include: contouring, soil and aquatic planting areas, gravel areas, and some cover structures. The shoreline area would also be improved with cover/food plantings or artificial cover structures, as necessary. Reference Figures 37 and 38.

The estimated cost for this measure would be about \$ 400,662.
Reference the estimate work sheets which follow.

This is the least costly plan considered for the area. It is practical for the area. It does not take full advantage of the opportunity to utilize the existing slip adjacent to the river. It would provide substantial ecological benefits to the area, and full passage through the problem area.

This would provide an aquatic/fishery shelf area feature presently missing due to the current channel reach development and activity. It would provide ecological benefits to the benthic and fishery as best measured via the Ohio EPA Habitat Assessment Procedure assessment/evaluation discussion. Reference the previous associated section and summary Figures 43 and 44, and Table 37. The area would be interfaced with the lake/river regime and would provide passage, cover, feeding, and possibly spawning habitat.

4. Acquire Conrail Slip and Aquatic/Fishery Shelf Cut. With this plan shoreline property would be acquired including the Conrail slip and an aquatic/fishery shelf would be cut along the east embankment channel area for about 2,500 feet. Some bulkheading would be left in place as a buffer between the recreational channel and the shelf. The cut would be about two feet below low water datum (LWD) and at a minimum about 8-10 feet wide. Improvements

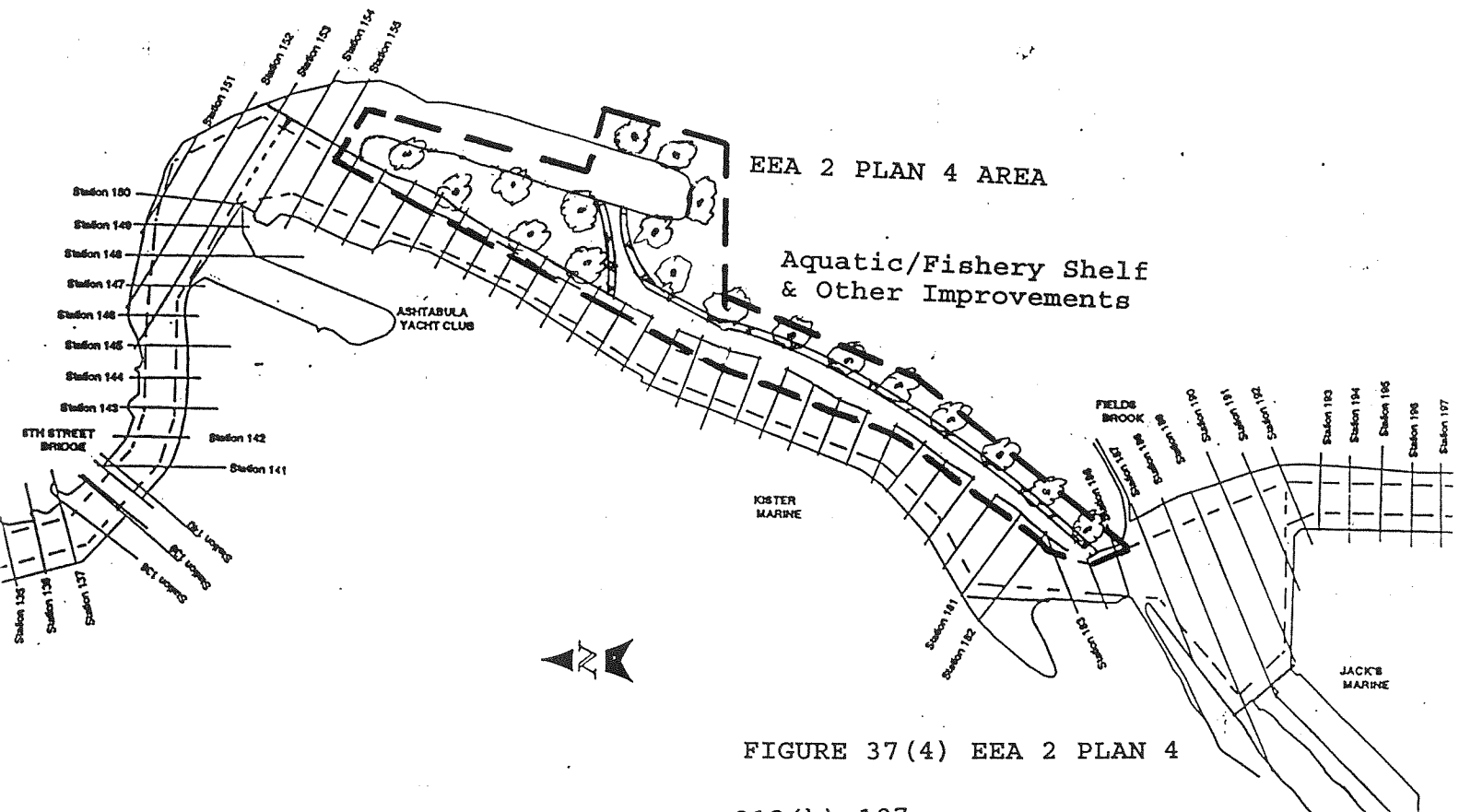
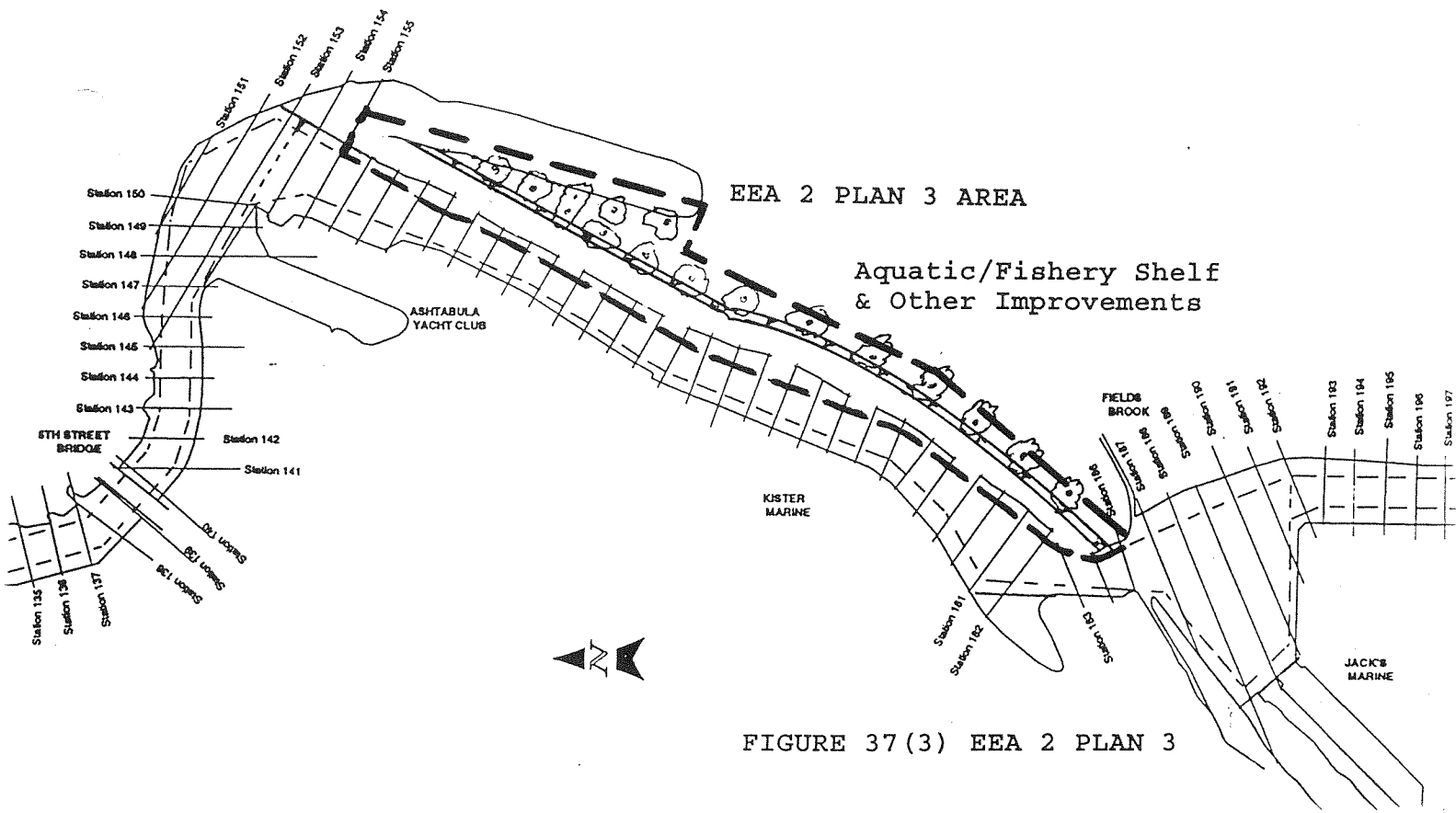

would be made to the bottom of the cut to include: contouring, soil and aquatic planting areas, gravel areas, and some cover structures. The shoreline area would also be improved with cover/food plantings or artificial cover structures, as necessary. Reference Figures 37, 38, and 39.

The estimated cost for this measure would be about \$ 447,237.
Reference the estimate work sheets which follow.

This is the second least costly plan considered for the area. It is practical for the area. It takes advantage of the opportunity to utilize the existing slip adjacent to the river; but, with only minor improvements. It would provide substantial ecological benefits to the area, and full passage through the problem area.

This would provide an aquatic/fishery shelf area feature presently missing due to the current channel reach development and activity. It would provide ecological benefits to the benthic and fishery as best measured via the Ohio EPA Habitat Assessment Procedure assessment/evaluation discussion. Reference the previous associated section and summary Figures 43 and 44, and Table 37. The area would be interfaced with the lake/river regime and would provide passage, cover, feeding, and possibly spawning habitat.

Long-Term Preservation

These areas would be turned over to and maintained by the local sponsor or possibly a nature conservancy group to be preserved as harbor ecological restoration areas.

Upstream of the Upper Turning Basin

The authorized commercial channel has not been dredged in this reach for a very long time. The area along the recreational channel has shoaled in creating shallow areas and improved habitat areas. The U.S. Fish and Wildlife Service also proposed further improvements (i.e. placement of boulders) in these shallow areas along the uppermost recreational channel reach. Review of existing conditions however, indicates that the area is extensively utilized for recreational boat docking. Such ecological improvements would create a hazard to navigation. Therefore, ecological measures in this area were not pursued further.

SUPPLEMENTAL DREDGING MEASURES (AQUATIC/FISHERY SHELF)

As mentioned previously, several dredging measures were noted for the channel areas up-stream of the Fifth Street Bridge that would facilitate ecological recovery in this regard in this reach including:

* If the channels are only maintained to recreational depths, eventually shallow aquatic/shelf areas will develop. However, at normal siltation rates, full potential/recovery would not be expected for decades. Reference Figures 37 and 41. Initial construction of such shelves does not appear practical.

* If the recreational channels were maintained to a somewhat lesser width, about 5 to 10 feet, eventually associated wider shallow aquatic/shelf areas will form (+~.34 Acres). However, at normal siltation rates, full potential/recovery would not be expected for decades. Reference Figures 37 and 42. Initial construction of such shelves does not appear practical.

Additional costs associated with these measures is minimal (i.e. administrative) with likely savings in the future, and should be implemented for the long-term.

RIVER PUMP-FLOW AUGMENTATION

Another measure that could facilitate ecological improvement in the lower Ashtabula River from the upper turning basin through the mouth would be river pump flow augmentation.

One noted water quality problem pertains to the low flow and stagnation in the summer months. In Ashtabula, as at many harbor areas, water supplies are drawn from the Lake and treated water is discharged into the tributaries/river. At times, this discharge constitutes the major flow discharge through and from the river. This flow of clean water can help the water quality situation in the area. This process may be considered for further utilization in this regard during particularly low flow periods in the summer.

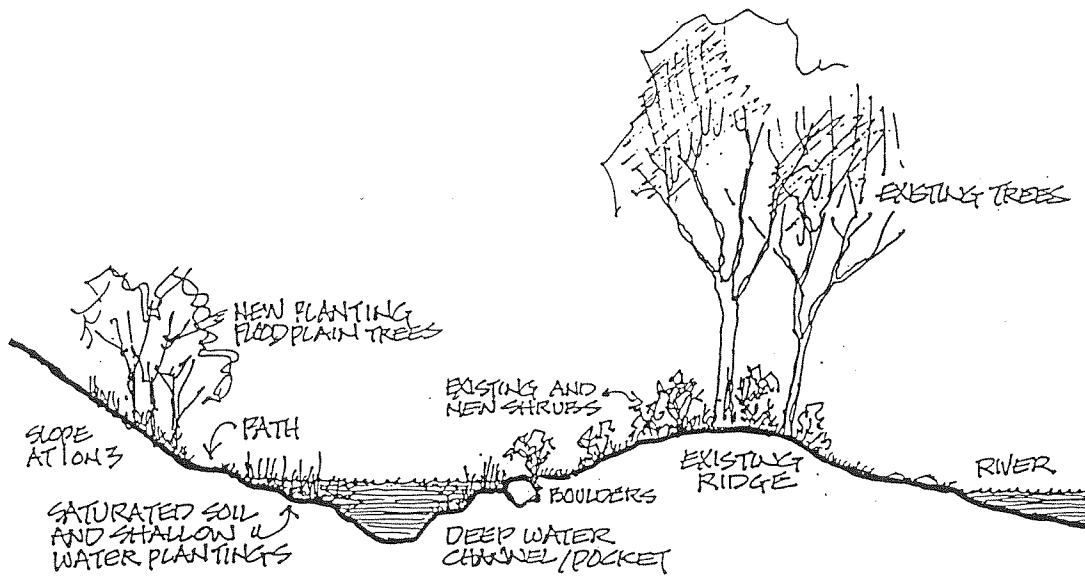

Source: Buffalo River Remedial Action Plan
 (Sterns and Wheler) (Integrated Site, Inc.)

FIGURE 38
 AQUATIC/FISHERY
 DIVERSION/BYPASS
 CUT

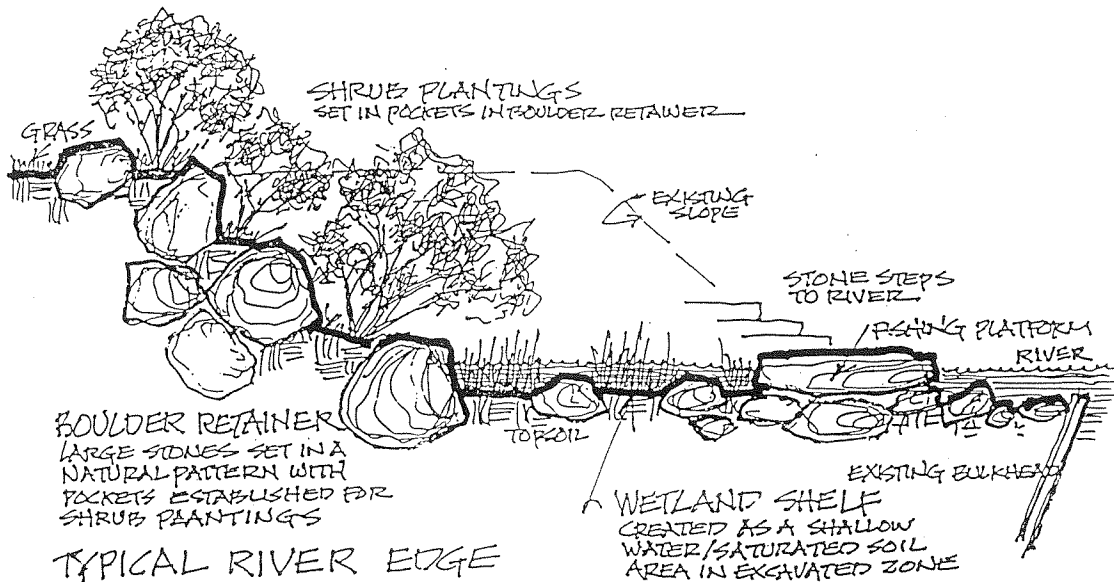

Source: Buffalo River Remedial Action Plan
 (Sterns and Wheler) (Integrated Site, Inc.)

FIGURE 40
 FISHERY SHELF
 (EMBANKMENT CUTBACK)

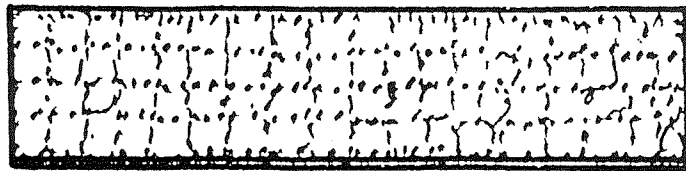

Plan View

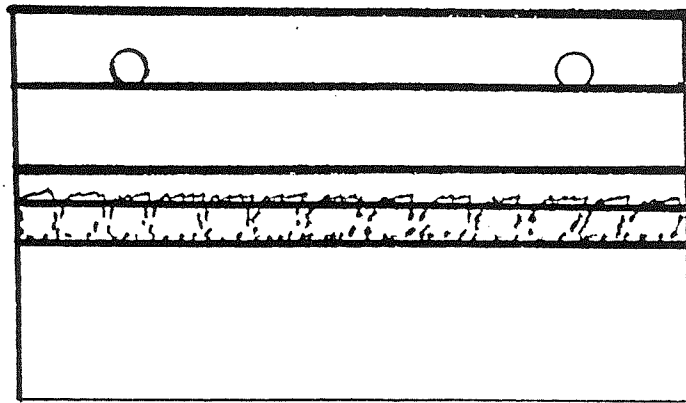

Elevation

FIGURE 39
FISHERY SHELF

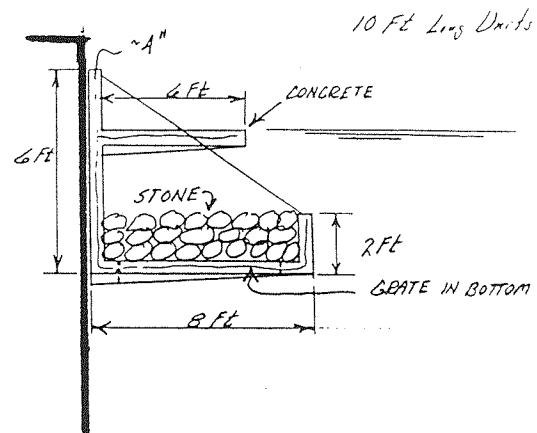

Cross-Section

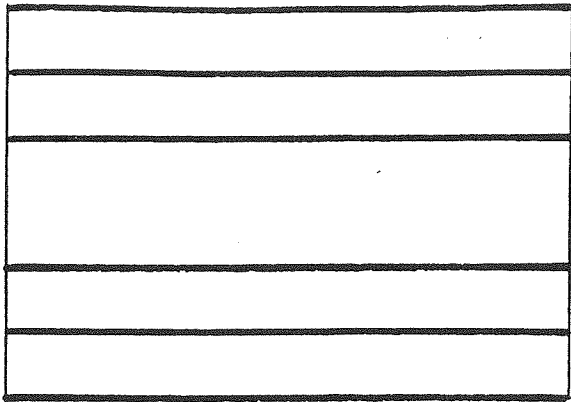

Plan View



Elevation

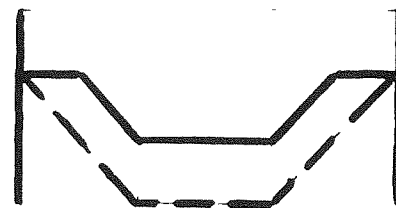

Cross-Section

FIGURE, 41
REDUCE DEPTH

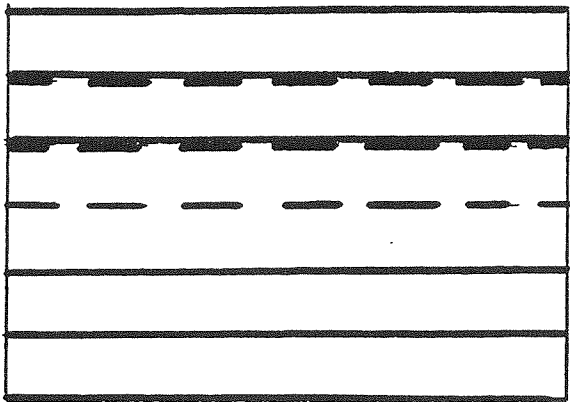

Plan View

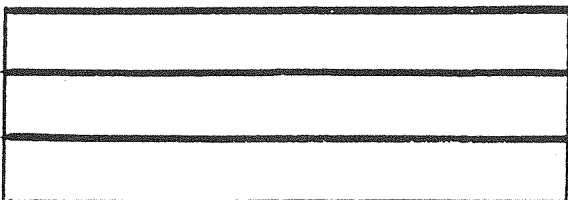

Elevation

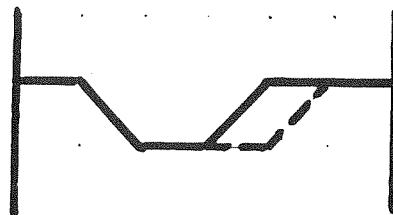

Cross-Section

FIGURE 42
REDUCE WIDTH

NOT OFFICIAL
CORR ESTIMATES

GENERAL FIRST COST ESTIMATES

Ecological Assessment Area 3

Plan 1. Aquatic/Fishery Shelf Cut

	\$
1. Acquire Lineal Property/Easment (2,500' x 25' = 62,500 SF = 1.4 Acres @ \$4,500/Acre)	6,457
2. Mobilize/Demobilize Equipment (LS = \$2,000)	2,000
3. Lineal Excavation/Disposal (2,500' x 10' = 25,000 SF x 10' = 9,259 CY @ \$20/CY)	185,185
4. Miscellaneous Improvements	
- Soil Cover (12,500 SF @ 6" @ \$.25/SF)	3,125
- Plantings	
- Terrestrial (2,500' @ \$2.00/Ft)	5,000
- Aquatic (12,500 SF @ \$.15/SF)	1,875
- Stone/Gravel (12,500 SF @ 1.5 Ft = 694 CY @ \$40/CY)	27,760
- Cover Structures (1,250' @ \$40/Ft)	50,000
5. Remove/Cut Bulkheading (1,675' @ \$40/Ft)	67,000
6. Sub Total	<u>348,402</u>
7. Construction Contingencies (@ 15%)	52,260
8. Total Construction Cost	<u>400,662</u>

312(b)-113

GENERAL FIRST COST ESTIMATES

Ecological Assessment Area 3

Plan 2. Aquatic/Fishery Shelf Hung

	\$
1. Acquire Lineal Property/Easment (2,500' x 15' = 37,500 = .9 Acres @ \$4,500/Acre)	4,050
2. Mobilize/Demobilize Equipment (LS = \$2,000)	2,000
3. Hang Artificial Aquatic/Fishery Shelves (40 Hrs x \$100/Hr = \$4,000)	4,000
4. Miscellaneous Improvements (Shelves/Shoreline)	
- Soil Cover (NA)	
- Plantings	
- Terrestrial (2,500' @ 2.00/Ft)	5,000
- Aquatic (NA)	
- Stone/Gravel (1,675' x 8' x 2' = 26,800 CF = 993 CY @ \$40/CY)	39,720
- Cover Structures (1,675' @ \$100/Ft)	167,500
5. Re-enforce Bulkheading (LS = 50,000)	50,000
6. Sub-Total	<u>272,270</u>
7. Construction Contingencies (@ 15%)	40,841
8. Total Construction Cost	<u>313,111</u>

GENERAL FIRST COST ESTIMATES

Ecological Assessment Area 3

<u>Plan 3. Diversion/Bypass Aquatic/Fishery Cut</u>		<u> \$ </u>
1. Acquire Lineal Property/Easment (2,200' x 70' = 154,000 SF = 3.5 Acres @ \$4,500/Acre)	15,750	
2. Mobilize/Demobilize Equipment (LS = \$2,000)	2,000	
3. Lineal Excavation/Disposal (2,200' x 30' x 10' = 660,000 CF = 24,444 CY @ \$20/CY)	488,880	
4. Miscellaneous Improvements		
- Soil Cover (1,100' x 10' = 11,000 SF @ \$.25/SF)	2,700	
- Plantings		
- Terrestrial (2,200' @ \$2.00/Ft)	4,400	
- Aquatic (11,000 SF @ \$.15/SF)	1,650	
- Stone/Gravel (11,000 SF @ 1.5 Ft = 611 CF @ \$40/CF)	24,440	
- Cover Structures (1,100' @ \$40/Ft)	44,000	
5. Remove/Cut Bulkheading (20' @ \$40/Ft)	800	
6. Road/Track Culverts (LS = 100,000)	100,000	
7. Sub-Total	<u>684,620</u>	
8. Construction Contingencies (@ 15%)	102,693	
9. Total Construction Cost	<u>787,313</u>	

312(b)-114

312 (b) - 115

GENERAL FIRST COST ESTIMATES

Ecological Assessment Area 2

<u>Plan 1. Conrail Slip and Aquatic/Fishery Shelf Cut</u>	<u>\$</u>
1. Acquire Area Property/Easment (10 Acres @ \$4,500/Acre)	45,500
2. Mobilize/Demobilize Equipment (LS = 2,000)	2,000
3. Peninsula (~5 Acres) Excavation/Disposal (Part -1/2) (105,000 SF x 10 Ft = 38,889 CY @ \$20/CY)	777,780
4. Miscellaneous Improvements	
- Soil Cover (52,500 SF @ 6" @ \$.25/SF)	13,125
- Plantings	
- Terrestrial (1,500' @ \$2.00/Ft)	3,000
- Aquatic (52,500 SF @ \$.15/SF)	7,875
- Stone/Gravel (52,500 SF @ 1.5 Ft = 2,917 CY @ \$40/CY)	116,680
- Cover Structures (750' @ \$40/Ft)	30,000
5. Remove/Cut Bulkheading (1,500' @ \$40/Ft)	60,000
6. Sub Total	<u>1,055,460</u>
7. Construction Contingencies (@ 15%)	158,319
8. Total Construction Cost	<u>1,213,779</u>

GENERAL FIRST COST ESTIMATES

Ecological Assessment Area 2

<u>Plan 2. Conrail Slip and Aquatic/Fishery Shelf Cut - Extended</u>	<u>\$</u>
<u>Conrail Slip and Aquatic/Fishery Shelf Cut - Extended</u>	<u>1,213,779</u>
1. Acquire Linear Property/Easment (1,800' x 25' = 45,000 SF = 1.0 Acres @ \$4,500/Acre)	4,500
2. Mobilize/Demobilize Equipment (LS = \$2,000)	2,000
3. Lineal Excavation/Disposal (1,800' x 10' = 18,000 SF x 10' = 6,667 CY @ \$20/CY)	133,340
4. Miscellaneous Improvements	
- Soil Cover (9,000 SF @ 6" @ \$.25/SF)	2,250
- Plantings	
- Terrestrial (1,000' @ \$2.00/Ft)	2,000
- Aquatic (9,000 SF @ \$.15/SF)	1,350
- Stone/Gravel (9,000 SF @ 1.5 Ft = 500 CY @ \$40/CY)	20,000
- Cover Structures (900' @ \$40/Ft)	36,000
5. Remove/Cut Bulkheading (1,206' @ \$40/Ft)	48,240
6. Sub Total (Extended)	<u>249,680</u>
7. Construction Contingencies (@ 15%)	37,452
8. Sub Total (Extended)	<u>287,132</u>
9. Total Construction Cost	<u>1,500,911</u>

GENERAL FIRST COST ESTIMATES

Ecological Assessment Area 2

Plan 3. Aquatic/Fishery Shelf Cut

	\$
1. Acquire Lineal Property/Easment (2,500' x 25' = 62,500 SF = 1.4 Acres @ \$4,500/Acre)	6,457
2. Mobilize/Demobilize Equipment (LS = \$2,000)	2,000
3. Lineal Excavation/Disposal (2,500' x 10' = 25,000 SF x 10' = 9,259 CY @ \$20/CY)	185,185
4. Miscellaneous Improvements	
- Soil Cover (12,500 SF @ 6" @ \$.25/SF)	3,125
- Plantings	
- Terrestrial (2,500' @ \$2.00/Ft)	5,000
- Aquatic (12,500 SF @ \$.15/SF)	1,875
- Stone/Gravel (12,500 SF @ 1.5 Ft = 694 CY @ \$40/CY)	27,760
- Cover Structures (1,250' @ \$40/Ft)	50,000
5. Remove/Cut Bulkheading (1,675' @ \$40/Ft)	67,000
6. Sub Total	<u>348,402</u>
7. Construction Contingencies (@ 15%)	52,260
8. Total Construction Cost	<u>400,662</u>

GENERAL FIRST COST ESTIMATES

Ecological Assessment Area 2

Plan 4. Acquire Conrail Slip & Aquatic/Fishery Shelf Cut

	\$
1. Acquire Conrail Slip Property/Easement (9 Acres @ \$4,500/Acre)	40,500
Acquire Lineal Property/Easment (2,500' x 25' = 62,500 SF = 1.4 Acres @ \$4,500/Acre)	6,457
2. Mobilize/Demobilize Equipment (LS = \$2,000)	2,000
3. Lineal Excavation/Disposal (2,500' x 10' = 25,000 SF x 10' = 9,259 CY @ \$20/CY)	185,185
4. Miscellaneous Improvements	
- Soil Cover (12,500 SF @ 6" @ \$.25/SF)	3,125
- Plantings	
- Terrestrial (2,500' @ \$2.00/Ft)	5,000
- Aquatic (12,500 SF @ \$.15/SF)	1,875
- Stone/Gravel (12,500 SF @ 1.5 Ft = 694 CY @ \$40/CY)	27,760
- Cover Structures (1,250' @ \$40/Ft)	50,000
5. Remove/Cut Bulkheading (1,675' @ \$40/Ft)	67,000
6. Sub Total	<u>388,902</u>
7. Construction Contingencies (@ 15%)	58,335
8. Total Construction Cost	<u>447,237</u>

312(b)-116

ASSESSMENT/EVALUATION REVIEW TABLES AND RECOMMENDATIONS

As discussed in the previous appendix section, Ohio Habitat Assessment Procedures (HAP) Assessment/Evaluation, the dredging removal of contaminated sediments would be expected to provide significant ecological improvements to the lake, harbor, and watershed areas. Supplemental Dredging Ecological Restoration/Preservation Measures for Protected Aquatic/Fishery Shallows would provide even further significant ecological improvements as discussed. Figures 43, 44, and 45 carried from the previous section and modified, generally depict expected improvements to (HAP) QHEI, IBI and ICI indices with removal of contaminants and further improvements with considered Supplemental Dredging Ecological Restoration/ Preservation Measures for Protected Aquatic/Fishery Shallows. An incremental ranking is also provided which can be compared to associated costs and other considerations. Table 37 carried from the previous section and discussed previously provides fishery information on the Grand River depicting substantial improvements related to aquatic/fishery shelf measures. Improvements are limited in Ecological Assessment Area 3 assuming continued commercial activities. Improvement opportunities are more substantial in Ecological Assessment Area 2.

The following Tables 38 and 39 present in a comparative/incremental summary manner considered **SUPPLEMENTAL DREDGING ECOLOGICAL RESTORATION/PRESERVATION MEASURES FOR PROTECTED AQUATIC/FISHERY SHALLOWS** and assessment/evaluation output items discussed in the previous sections. It provides support for selection of **Plan 2. Aquatic/Fishery Shelf Hung** for Ecological Assessment Area 3 and **Plan 4. Acquire Conrail Slip and Aquatic/Fishery Shelf Cut** for Ecological Assessment Area 2. These are practical optimized plans of moderate cost providing problem area protected aquatic/fishery shallows of substantial length which accomplish, as possible, goals/objectives, in this regard. The areas would be interfaced with the lake/river regime and would provide passage, cover, feeding, and possibly spawning habitat.

As mentioned previously, several other dredging measures were considered, in this regard, for problem areas upstream of the Fifth Street Bridge that would facilitate ecological restoration with regard to aquatic/fishery shallows. Additional costs associated with these measures is minimal (i.e. administrative) with likely savings in the future, and should be implemented for the long-term.

* If the channels are only maintained to recreational depths, eventually shallow aquatic/shelf areas will develop.

* If the recreational channels were maintained to a somewhat lesser width, about 5 to 10 feet, eventually associated wider shallow aquatic/shelf areas will form (+~.34 Acres).

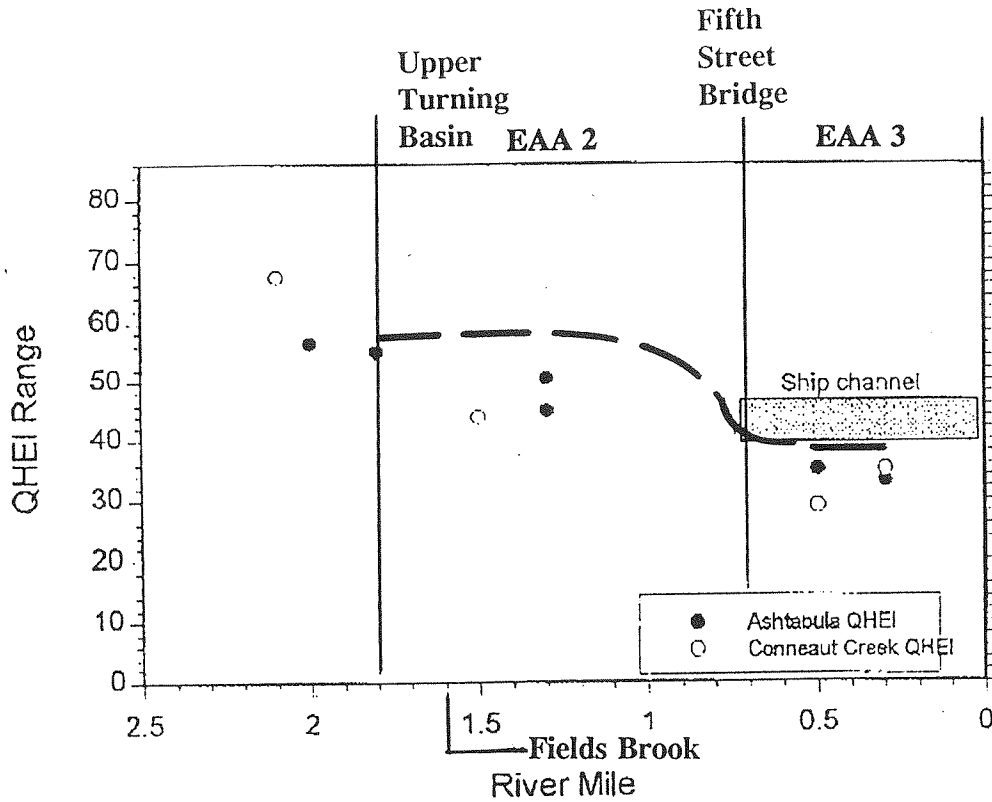

Figure 43 A comparison of relative habitat quality of the Ashtabula and Conneaut lacustrary areas.

HQEI - Qualitative Habitat Evaluation Index (Physical)

IMPROVEMENT MEASURES

Dredging/Aquatic/Fishery Shallows (* Recommended Plan)
(Plans Ecological Improvements Rank)

	Cost	IBI Score	Cost/Unit
<u>Ecological Assessment Area (EAA) 3</u>			
Plan 1 - Aquatic/Fishery Shelf Cut	\$ 450,745	+5	\$ 90,149
Plan 3 - Aquatic/Fishery Diversion/By-Pass Cut	\$ 885,727	+5	\$ 177,145
* Plan 2 - Aquatic/Fishery Shelf Hung	\$ 352,250	+4	\$ 88,063
<u>Ecological Assessment Area (EAA) 2</u>			
Plan 2 - Conrail Slip and Aquatic/Fishery Shelf Cut Extended	\$ 1,729,279	+ 9	\$ 192,142
Plan 1 - Conrail Slip and Aquatic/Fishery Shelf Cut	\$ 1,406,255	+8	\$ 127,841
* Plan 4 - Acquire Conrail Slip and Aquatic/Fishery Shelf Cut	\$ 503,142	+8	\$ 62,893
Plan 3 - Aquatic/Fishery Shelf Cut	\$ 450,745	+7	\$ 64,392

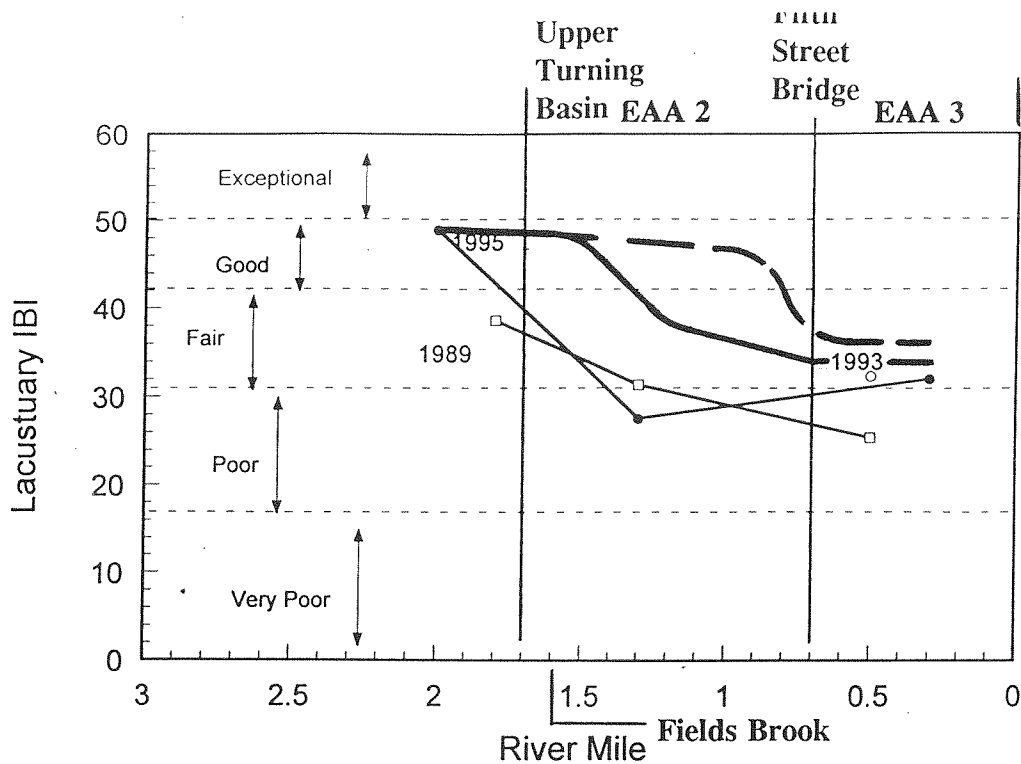

Figure 44 Fish community status of the Ashtabula River lacustrary as measured by the Index of Biotic Integrity (IBI).

IBI - Index of Biotic Integrity (Fishery)

IMPROVEMENT MEASURES

Dredging/Aquatic/Fishery Shallows (* Recommended Plan) (Plans Ecological Improvements Rank)

	Cost	IBI Score	Cost/Unit
<u>Ecological Assessment Area (EAA) 3</u>			
Plan 1 - Aquatic/Fishery Shelf Cut	\$ 450,745	+4	\$ 112,686
Plan 3 - Aquatic/Fishery Diversion/By-Pass Cut	\$ 885,727	+4	\$ 221,432
* Plan 2 - Aquatic/Fishery Shelf Hung	\$ 352,250	+3	\$ 117,417
<u>Ecological Assessment Area (EAA) 2</u>			
Plan 2 - Conrail Slip and Aquatic/Fishery Shelf Cut Extended	\$ 1,729,279	+12	\$ 144,107
Plan 1 - Conrail Slip and Aquatic/Fishery Shelf Cut	\$ 1,406,255	+11	\$ 127,841
* Plan 4 - Acquire Conrail Slip and Aquatic/Fishery Shelf Cut	\$ 503,142	+11	\$ 45,740
Plan 3 - Aquatic/Fishery Shelf Cut	\$ 450,745	+10	\$ 45,075

Dredging/Contaminant Removal (* Recommended Plan) (Plans Ecological Improvements Rank)

	Cost	IBI Score	Cost/Unit
<u>Ecological Assessment Area (EAA3)</u>			
* Deep Dredge	\$ 9,605,000	+3	\$ 3,201,667
Bank to Bank	\$ 9,605,000	+3	\$ 3,201,667
Shallow Dredge	\$ 9,605,000	+2	\$ 4,802,500
<u>Ecological Assessment Area (EAA2)</u>			
* Deep Dredge	\$ 46,895,000	+12	\$ 3,907,917
Bank to Bank	\$ 63,295,000	+12	\$ 5,274,583
Shallow Dredge	\$ 42,195,000	+10	\$ 4,219,500

Table 37 A comparison of the relative number (per kilometer) of fish species collected at electrofishing sites on the Grand River, Conneaut Creek, and Ashtabula River lacustraries. Species in **bold** have been found by Ohio EPA to respond negatively to degraded environments and are considered sensitive to environmental degradation.

Stream	Conneaut Creek	Ashtabula River		Grand River
Year	1995	1989	1995	1987
River Mile:	1.50	1.30	1.30	0.6
longnose gar (<i>Lepisosteus osseus</i>)	0.80	--	--	--
bowfin (<i>Amia calva</i>)	1.00	1.60	--	2.00
alewife (<i>Alosa pseudoharengus</i>)	1.00	--	--	--
gizzard shad (<i>Dorosoma cepedianum</i>)	2.00	7.20	5.44	80.00
northern pike (<i>Esox lucius</i>)	--	1.11	--	--
bigmouth buffalo (<i>Ictiobus cyprinellus</i>)	1.00	--	--	--
smallmouth buffalo (<i>Ictiobus bubalus</i>)	1.00	--	--	--
silver redhorse (<i>Moxostoma anisurum</i>)	8.00	--	--	0.67
black redhorse (<i>Moxostoma duquesnei</i>)	7.00	1.20	--	--
golden redhorse (<i>Moxostoma erythrurum</i>)	0.40	--	--	3.33
shorthead redhorse (<i>Moxostoma macrolepidotum</i>)	12.00	--	--	--
white sucker (<i>Catostomus commersoni</i>)	3.00	--	--	--
common carp (<i>Cyprinus carpio</i>)	27.00	4.00	35.56	6.00
goldfish (<i>Carassius auratus</i>)	24.00	0.80	3.00	2.00
carp x goldfish	1.60	3.33	--	--
golden shiner (<i>Notemigonus crysoleucas</i>)	150.00	7.20	11.11	16.67
bigeye chub (<i>Hybopsis amblops</i>)	6.00	--	--	--
emerald shiner (<i>Notropis atherinoides</i>)	0.40	--	--	12.00
striped shiner (<i>Luxilus chrysocephalus</i>)	8.00	0.40	--	12.00
spottail shiner (<i>Notropis hudsonius</i>)	--	--	--	8.67
spotfin shiner (<i>Cyprinella spiloptera</i>)	2.00	--	--	--
bluntnose minnow (<i>Pimephales notatus</i>)	148.00	0.40	2.00	1.33
central stoneroller minnow (<i>Campostoma anomalum pollum</i>)	--	--	--	0.67
channel catfish (<i>Ictalurus punctatus</i>)	10.00	--	4.44	--
yellow bullhead (<i>Ameiurus natalis</i>)	1.00	2.00	1.00	--
brown bullhead (<i>Ameiurus nebulosus</i>)	24.00	1.60	9.78	36.67
eastern banded killifish (<i>Fundulus diaphanus</i>)	2.00	--	--	--
trout-perch (<i>Percopsis omiscomaycus</i>)	--	--	--	0.67
brook silverside (<i>Labidesthes sicculus</i>)	22.00	--	--	--
white bass (<i>Morone chrysops</i>)	2.00	--	--	3.33
white perch (<i>Morone americana</i>)	--	--	--	25.33
white crappie (<i>Pomoxis annularis</i>)	--	--	--	1.33
black crappie (<i>Pomoxis nigromaculatis</i>)	4.00	--	--	1.33
rock bass (<i>Ambloplites rupestris</i>)	69.00	1.60	13.56	11.33
smallmouth bass (<i>Micropterus dolomieu</i>)	2.00	1.20	--	9.33
largemouth bass (<i>Micropterus salmoides</i>)	29.00	7.60	9.33	34.00
green sunfish (<i>Lepomis cyanellus</i>)	0.40	--	--	0.67
bluegill sunfish (<i>Lepomis macrochirus</i>)	41.00	10.00	70.78	48.67
pumpkinseed sunfish (<i>Lepomis gibbosus</i>)	43.00	20.00	80.11	56.00
sunfish hybrids (<i>Lepomis</i> sp.)	--	1.00	--	--
walleye (<i>Stizostedion vitreum</i>)	3.00	--	--	--
yellow perch (<i>Perca flavescens</i>)	62.00	0.40	2.11	60.67
logperch (<i>Percina caprodes</i>)	--	--	--	11.33
freshwater drum (<i>Aplodinotus grunniens</i>)	2.00	0.40	1.11	2.00
Total Relative Number	695.00	93.20	227.92	448.00
Number of Species	30.00	22.0	15.0	27.0
Number of Hybrids	0.0	1.0	2.0	0.0
Kilometers Sampled	1.00	2.50	0.95	1.50
Number of Passes	2.0	5.0	2.0	3.0
Number of species most abundant	15.0	3.0	6.0	15.0

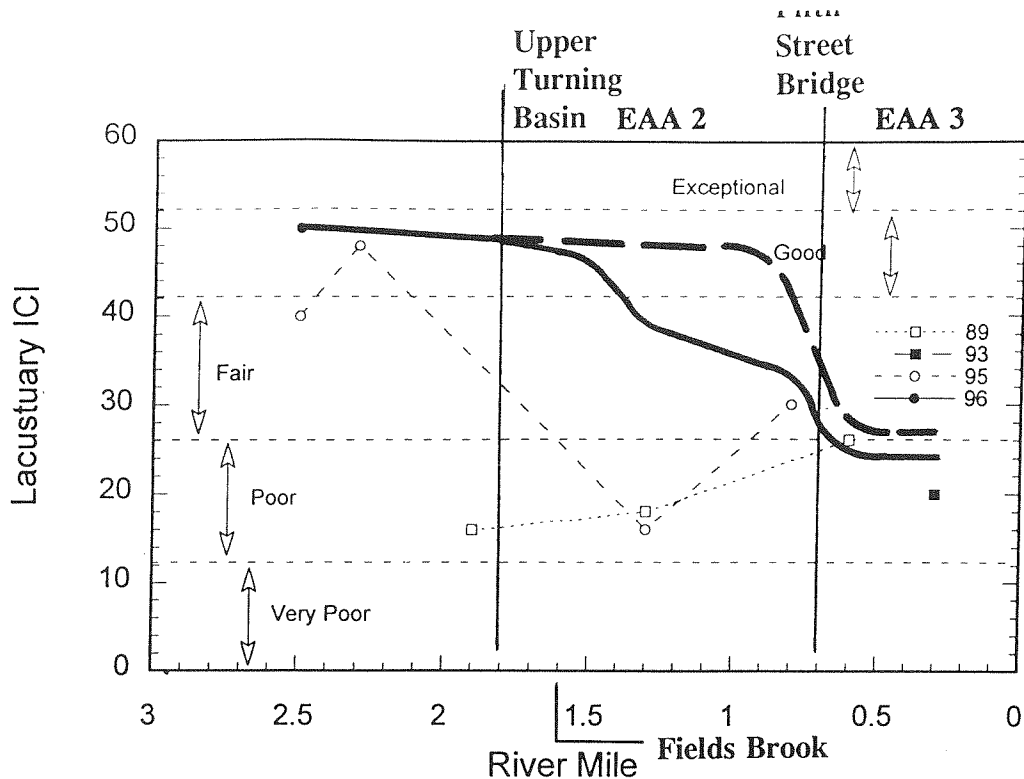

Figure 45 Macroinvertebrate community status in the Ashtabula River lacustruary as measured by the Invertebrate Community Index (ICI).

ICI - Index of Biotic Integrity (Fishery)

IMPROVEMENT MEASURES

Dredging/Aquatic/Fishery Shallows (* Recommended Plan)
(Plans Ecological Improvements Rank)

Ecological Assessment Area (EAA) 3

	Cost	ICI Score	Cost/Unit
Plan 1 - Aquatic/Fishery Shelf Cut	\$ 450,745	+4	\$ 112,686
Plan 3 - Aquatic/Fishery Diversion/By-Pass Cut	\$ 885,727	+4	\$ 221,432
* Plan 2 - Aquatic/Fishery Shelf Hung	\$ 352,250	+2	\$ 176,125

Ecological Assessment Area (EAA) 2

Plan 2 - Conrail Slip and Aquatic/Fishery Shelf Cut Extended	\$ 1,729,279	+14	\$ 123,520
Plan 1 - Conrail Slip and Aquatic/Fishery Shelf Cut	\$ 1,406,255	+13	\$ 108,174
* Plan 4 - Acquire Conrail Slip and Aquatic/Fishery Shelf Cut	\$ 503,142	+13	\$ 38,703
Plan 3 - Aquatic/Fishery Shelf Cut	\$ 450,745	+12	\$ 37,562

Dredging/Contaminant Removal (* Recommended Plan)
(Plans Ecological Improvements Rank)

Ecological Assessment Area (EAA3)

	Cost	IBI Score	Cost/Unit
* Deep Dredge	\$ 9,605,000	+3	\$ 3,201,667
Bank to Bank	\$ 9,605,000	+3	\$ 3,201,667
Shallow Dredge	\$ 9,605,000	+2	\$ 4,802,500

Ecological Assessment Area (EAA2)

* Deep Dredge	\$ 46,895,000	+20	\$ 2,344,750
Bank to Bank	\$ 63,295,000	+20	\$ 3,164,750
Shallow Dredge	\$ 42,195,000	+18	\$ 2,344,167

TABLE - Supplemental Dredging Ecological Restoration/Preservation Measures for Aquatic Fishery Shallows (EAA) Assessment/Evaluation

Table 38 Summary Assessment Items (Ecological Assessment Area 3 Plans)				Table 39 (Ecological Assessment Area 2 Plans)			
Item	Plan 1	Plan 2	Plan 3	Plan 1	Plan 2	Plan 3	Plan 4
	Aquatic/Fishery Shelf Cut	Aquatic/Fishery Shelf Hung	Aquatic/Fishery By-Pass Cut	Conrail Slip & Aquatic/Fishery Shelf Cut	Conrail Slip & Aquatic/Fishery Shelf Extended	Aquatic/Fishery Shelf Cut	Conrail Slip & Aquatic/Fishery Shelf Cut
Construction First Cost (+12.5%)	\$ 400,662	\$ 313,111	\$ 787,313	\$ 1,250,004	\$ 1,537,136	\$ 400,662	\$ 447,237
Project Cost: (Present Worth)	\$ 450,745	\$ 352,250	\$ 885,727	\$ 1,406,255	\$ 1,729,279	\$ 450,745	\$ 503,142
Project Economic Benefits (Present Worth)							
NED :		302,508					\$ 817,892
Regional :		280,962					\$ 759,638
Total :	(+/-)	\$ 583,470	(+/-)	(+/-)	(+/-)	(+/-)	\$1,577,530
Practicality*	Poor	Fair	Poor	Good	Good	Good	Good
Ecological Improvement Rank	1	3	2	2	1	4	3
Shoreline Improvement (Acres)	0.7	0.5	1.5	3.5	4.0	0.7	0.7+Acq.
Shallows Improvement (Acres)	0.7	0.1	1.5	2.5	3.0	0.7	0.7+Acq.
Fishery Passage Length	Good	Good	Good	Poor	Good	Good	Good
Physical Habitat Improvement (HAP QHEI up to)	Fair +5	Fair +4	Fair +5	Good +8	Good +9	Good +7	Good +8
Fishery Improvement (HAP IBI up to)	Fair +4	Fair +3	Fair +4	Good +11	Good+ +12	Good +10	Good +11
Macroinvertebrate Improvement (HAP ICI up to)	Fair +4	Poor +2	Fair +4	Good +13	Good+ +14	Good +12	Good +13
Supplemental Accomplishment of Ecological Restoration Objective	Fair	Fair	Fair	Good	Good	Good	Good

Notes:

* Commercial shipping activities pertaining to coal transshipment and storage. Coal dust problem.

* Recreational boating channel area. Available shoreline area.

General Scale: (Good, Fair, Poor)(Aqu. = Acquisition)

(HAP QHEI) - Habitat Assessment Procedure Qualitative Habitat Evaluation Index

(HAP IBI) - Habitat Assessment Procedure Index of Biotic Integrity

(HAP ICI) - Habitat Assessment Procedure Invertebrate Community Index

ECONOMIC VALUES

ECONOMIC FRAMEWORK

The primary focus of this analysis is to estimate the benefits of alternative options for restoring the ecosystem components that have been damaged in the Ashtabula River. Traditional economic measures of benefits do not adequately portray all the values associated with a functioning ecosystem. Most economic analyses focus on the goods and services that the public receives and not the infrastructure that produces the goods and services. The many interrelationships between species that are required for a fully functioning ecosystem are not independently recognized and valued by the public. For example, the value of catching game fish has been the focus of many studies, but seldom has the value of the prey species sought by game fish been estimated. In an economic context, the demand for game fish generates a derived demand for the ecosystem components that produce the game fish. It is fairly easy to estimate the economic value of game fishing. It is very difficult to estimate the economic value of the ecological infrastructure that supports game fish.

In order to provide the most comprehensive picture of the benefits of restoring the ecosystem functions in the Ashtabula River and nearby waters, this analysis is divided into two parts. The first part describes the infrastructure changes for selected biological characteristics of different levels of ecosystem restoration. The second part contains the economic value of goods and services that the public would expect to receive at alternative levels of restoration. The monetized economic benefits are the values placed by the public on the goods and services provided by a functioning ecosystem. By valuing the goods and services provided by a functioning ecosystem, we can gain insight into the minimum economic value of the ecosystem itself.

The proper framework for analyzing the restoration of ecosystem functions in the Ashtabula River is an economic analysis based on “with” and “without” project conditions. The “with” project conditions reflect the pattern of activities and biological conditions that are expected to occur over a 50 year evaluation period. These conditions would be expected after a one-time cleanup of contaminated river bottom sediments. The projected future conditions would not reach full benefit potential in the first year but would phase in depending on the restoration alternative being considered. There are three alternative dredging scenarios and an ecological supplement attached to the deep dredging alternative to make four alternatives to consider. The four alternatives will produce different levels of restoration, different timing of restoration, and different effects on the risk of a major PCB contamination of Lake Erie.

The “without” project scenario is the economic baseline. The baseline is the pattern of activities that would exist in the Ashtabula River over the evaluation period in the absence of a one-time cleanup effort of contaminated bottom sediments. Subtracting the “with” project set of environmental characteristics from the “without” project characteristics is the measure of improvement brought about and directly attributable to the project, i.e. the project benefits. For the economic values of the goods and services that would be available under alternative environmental restoration scenarios, the annualized value is calculated in order to take into account the different time periods involved and produce a single best estimate of the annual benefits of the alternative being considered.

ECONOMIC VALUE

The previous section used various environmental indices to describe the restoration of the ecosystem infrastructure. Those changes affect the level of human use and enjoyment of the ecosystem. Activities such as navigation and recreation, and the general enjoyment derived from living in an area where the ecosystem is not impaired are key elements in maintaining and enhancing the quality of life. The following section estimates the economic values associated with the cleanup of the whole Ashtabula River (upstream and downstream of the 5th Street Bridge) under Section 312(b) of the Water Resources Development Act of 1990 - environmental restoration.

National Economic Development Benefits

The results of the analysis of national economic development benefits are shown in Tables 40a and 40b. The tables present the estimated value of the goods and services associated with each of the environmental dredging alternatives. Table 40a presents these values in average annual dollars using a 50 year project life. Table 40b presents the benefits in discounted present values using a 50 year project life and a 3.6% annual interest rate, for each of the benefit streams generated by navigation and recreation activity, and the value placed by citizens on removing contaminated sediment from the Ashtabula River.

Commercial Navigation Benefits

Ashtabula Harbor is a major trans-shipment point for bulk commodities. Iron ore arrives from Lake Superior ports and is shipped to inland steel mills in Ohio, Pennsylvania, and West Virginia. Coal is brought by rail from Appalachian mines and shipped to electricity generating stations and other consumers around the Great Lakes. Limestone from northern Michigan is used in the local area. Without the project, contaminated sediments will fill the commercial navigation channel. Lacking a confined disposal area for the contaminated dredge spoil in the Ashtabula area, dredging will stop and the channel will shoal, effectively stopping commercial navigation.

If commercial navigation is impeded by the shallow harbor, shippers will seek alternate routes and carriers. They will incur added costs to deliver their products. The analysis of commercial navigation benefits compares these added costs to shippers in the “without” project scenario to a “with” project scenario in which the contaminated sediments are removed before they reach the navigation channel. With the project, open lake disposal of dredge spoil is permitted and channel dredging continues. There is no interruption in shipping traffic through Ashtabula Harbor. The “with” project analysis assumes that shipping continues at the same level and pattern as occurred in 1994 during the 50 year analysis period. The average annual savings to shippers’, the difference in average annual transportation costs between the without and with project conditions, is \$1,186,200. This average annual benefit was calculated using a 7.625% annual interest rate and a 50 year project life. Because shallow dredging leaves a considerable amount of the PCB load in place, the shallow dredging alternative does not generate any navigation benefits. Both deep dredging alternatives and the bank-to-bank-to-bedrock alternative remove a substantial portion of the potential contamination. Consequently, all three generate average annual nav-

Table 40a and 40b

Average Annual Benefits-Summary based on rounded figures provided by the partnership

	Max Average Annual Benefit	Shallow Dredge	Deep Dredge	Deep + Eco REstoration	Bank To Bank
NED Benefits					
Navigation(Reduction in transport Costs by maintaining Ashtabula) (1)	\$1,186,200	\$0	\$1,186,200	\$1,186,200	\$1,186,200
Boating (consumer Surplus) (2)	\$84,400	\$0	\$67,200	\$70,100	\$60,400
Fishing (Consumer Surplus) (2)	\$199,000	\$82,600	\$158,300	\$165,300	\$142,300
Passive Use Values (Consumer Surplus) (2)	\$1,108,700	\$347,000	\$655,400	\$694,200	\$566,100
Change In Property Values (2)	\$477,200	\$133,000	\$266,100	\$266,100	\$266,100
Risk reduction to Lake Erie Walleye Fishery (2)	\$615,400	\$471,000	\$514,900	\$514,900	\$615,400
Subtotal	\$3,670,900	\$1,033,600	\$2,848,100	\$2,896,800	\$2,836,500
Regional Economic Development benefits					
Local Economic Impacts (From retaining Commercial navigation) (1)	\$3,895,900	\$0	\$3,895,900	\$3,895,900	\$3,895,900
Boating (total impact of expenditures on output) (2)	\$300,800	\$124,900	\$239,200	\$249,800	\$215,000
Fishing (total impact of expenditures on output) (2)	\$937,800	\$389,300	\$745,300	\$778,900	\$670,400
Subtotal	\$5,134,500	\$514,200	\$4,880,400	\$4,924,600	\$4,781,300
Total	\$8,805,400	\$1,547,800	\$7,728,500	\$7,821,400	\$7,617,800

(1) Average Annual Values Use 7 5/8 % annual interest rate

(2) Average Annual Values Use 3.6 % annual interest rate

Present Worth Values Reflects 3.6% Annual Interest Rate

	Max Discounted Present Worth Values	Shallow Dredge	Deep Dredge	Deep + Eco REstoration	Bank To Bank
NED Benefits					
Navigation(Reduction in transport Costs by maintaining Ashtabula)	\$27,328,300	0	\$27,328,300	\$27,328,300	\$27,328,300
Boating (consumer Surplus)	\$1,944,500	\$0	\$1,547,400	\$1,615,300	\$1,390,600
Fishing (Consumer Surplus)	\$4,584,700	\$1,903,400	\$3,647,200	\$3,807,400	\$3,277,800
Passive Use Values (Consumer Surplus)	\$17,037,900	\$7,994,500	\$15,100,500	\$15,992,800	\$13,042,900
Change In Property Values	\$10,990,000	\$3,065,000	\$6,130,000	\$6,130,000	\$6,130,000
Risk reduction to Lake Erie Walleye Fishery	\$14,177,500	\$10,850,200	\$11,862,800	\$11,862,800	\$14,177,500
Subtotal	\$76,062,900	\$23,813,100	\$65,616,200	\$66,736,600	\$65,347,100
Regional Economic Development benefits					
Local Economic Impacts (From retaining Commercial navigation)	\$89,755,800		\$89,755,800	\$89,755,800	\$89,755,800
Boating (total impact of expenditures on output)	\$6,930,000	\$2,981,100	\$5,709,200	\$5,962,200	\$5,131,600
Fishing (total impact of expenditures on output)	\$21,605,500	\$9,291,800	\$17,803,100	\$18,590,700	\$16,001,000
Subtotal	\$118,291,300	\$12,272,900	\$113,268,100	\$114,308,700	\$110,888,400
Total	\$194,354,200	\$36,086,000	\$178,884,300	\$181,045,300	\$176,235,500

Downstream Of 5th Street Bridge

Upstream Of 5th Street Bridge

\$0 \$117,084,100 \$117,084,100 \$117,084,100
\$36,086,000 \$61,800,200 \$63,961,200 \$59,151,400

igation benefits of \$1,186,200. Table 40b presents these navigation benefits in present worth terms (\$27,328,300) assuming an annual percentage rate of 3.6%.

Boating - Consumer Surplus

The greatest contact many people have with the river is through recreation. Fishing, boating, and nearby beaches draw thousands of visitors to Ashtabula each year. The results of the proposed ecosystem restoration projects will be experienced and appreciated through these activities.

There are 1,058 boat slips and 11 launch ramps in the Ashtabula River above the Fifth Street bridge. Eleven marinas/yacht clubs line the bank providing a variety of services to boaters from all over northeastern Ohio (U.S. Army Corps of Engineers 1997). People pursuing any recreational activity derive pleasure from the activity greater than what they pay to experience it. If they did not, they would be indifferent between pursuing the activity and doing anything else. They would find something more rewarding to do. Economists put a dollar value on this extra pleasure by asking people how much money the activity would need to cost before they would stop doing it. That amount is called the “consumer surplus,” or “willingness to pay.” An improvement in the quality of the river ecosystem can be expected to improve the boating experience and so increase boaters’ willingness to pay. Ecosystem improvements will also attract additional boaters to Ashtabula Harbor. Consumer surplus changes from changes in resource quality are national economic development benefits (U.S. Water Resources Council 1983).

This analysis assumes that boaters respond positively to improvements in water quality. A recent survey by the Ohio Sea Grant College Program showed an association between boating on Lake Erie and awareness of Ashtabula River pollution problems (Lichtkoppler 1998). In addition, contamination of sediments in the river between Fields Brook and the Fifth Street bridge prevent open lake disposal of dredge spoil from that reach, preventing channel maintenance. As a consequence the recreational channel is becoming shallower and will become impassable for many boats within the planning horizon of this project. Boaters will benefit from the cleaner and deeper river this project portends.

About 70 percent of boaters approached by the Ohio DNR creel survey were fishing rather than boating for the sake of boating (Bador 1998). Anglers tend to have higher consumer surplus values than people strictly boating and so will be discussed separately. The Feasibility Report assumes that each of the 1,058 slips accounts for 25 boat usages per season and that 4.44 people participate in the average boat usage (U.S. Army Corps of Engineers 1997). Multiplying these estimates together implies 117,438 individual boating days from slips. Assuming 1,000 launches per season from each of the 11 launch ramps and an average of 3.78 persons per launched boat implies 41,580 individual boating days from launch ramps. Of the 159,018 boating days, 70 percent (111,313) are related to fishing while 30 percent (47,705) are strictly boating related. The U.S. Forest Service unit day value for motorized boating at a “less than standard site” was \$6 in 1985 (Walsh 1986, Table 8-10); at a “standard” site the value was \$12. Inflating the \$6 to 1996 price levels using the CPI for entertainment purchases implies a 1996 value of \$8.85.

The Feasibility Report estimates a 10 percent improvement in quality of the river experience “with” the project versus “without” it through a subjective point scoring system. For simplicity,

assume the improved experience generates a linear increase in boating consumer surplus. This increase is made up of some improved experience of present boaters and some new boaters drawn to the activity by the improved quality of the river. More sophisticated estimates of changes in boating participation would involve estimation of boating demand equations and the capacity constraints of the river which are not feasible with the data available. With a 10 percent improvement, the 47,705 boating days would generate maximum benefits of \$42,200 annually ($= 47,705 \times \0.885) and the new boaters would generate an additional \$42,200 annually ($= 4,770 \times \8.85) in consumer surplus. (For some boaters, this amount is far too low. Many boats will not be able to use their current slips or launch ramps if the channel is not maintained. Those boaters' losses will include the costs of traveling to a different marina, perhaps in a different city. These costs of substitution are not included in this estimate.)

Total annual maximum boating consumer surplus values came to \$84,400. This maximum annual surplus value was used to develop a 50 year time stream of boater consumer surplus benefits for each of the plans evaluated. Ecosystem restoration was assumed to take 3, 5, and 10 years, respectively, for Deep Dredge & Eco Restoration, Deep Dredge, and Bank to Bank to Bedrock. Annual boating consumer surplus values started at \$0.00 and rose to \$84,400 based upon the number of years needed for full eco-restoration (3, 5, 10). The conversion of these time streams of values to average annual values is presented in Table 40a. This conversion used a 3.6% annual percentage rate and a 50 year project life. Table 40b presents the present worth of these time streams.

Fishing - Consumer Surplus

As mentioned above, there are 111,313 fishing days originating from Ashtabula Harbor. Most of these occur in Lake Erie. The condition of the river fishery is secondary except that it contributes to the fishing in the lake. High quality habitat in the lacustrary would improve fishing in the lake by providing spawning areas and food sources. The central basin of Lake Erie is undergoing rapid changes in the sport fishery. Improved water quality and clarity, control of invasive species, and other factors are reducing fishing success and appear to be discouraging anglers. After a build up of fishing related development in the 1980's, recent trends suggest a fall off in fishing interest (Greenwire 1998; Bador 1998). The "without" project assumption is a continuation of the 1996 level of fishing activity.

Estimates of Ohio Lake Erie anglers' willingness to pay range from \$0.30 to \$36.26 per day (1996\$) (Dutta 1984; Brown and Hay 1987; Hushak et al. 1988; Glenn 1995). A 1992 survey provides local estimates of angler consumer surplus applicable to the Ashtabula region. Glenn (1995) estimated the values of anglers who used the Lorain county artificial reef and those who fished nearby but did not use the reef. The angling experience of those who did not use the reef is similar to angling in the Ashtabula portion of Lake Erie. Updated to 1996 dollars, the study estimated willingness to pay as \$8.94 per day (Glenn 1995). Ideally, increased catch rates from changes in fish populations in the river would be imputed to derive a change in the consumer surplus from each project alternative. While modeling the actual train of events, such a method would give only the facade of accuracy as the parameters at each step would be rough estimates. Recognizing this uncertainty, assume that the project will improve fishing in such a way that consumer surplus increases 10 percent, as in the Feasibility Report. The increase can be viewed

as both a quality and quantity change. The combination of increased fish populations and varieties, increased interest in fishing, and increased peace of mind when consumption advisories are lifted will improve the quality of the experience for current anglers and attract more anglers to the area. Jakus et al. (1997) found removal of a fishing advisory alone increased anglers' consumer surplus 6 to 8 percent. The increase in valuation implies a fishing consumer surplus benefit of \$99,500 annually ($= \$0.894 \times 111,313$) for current anglers and an additional \$99,500 annually for new anglers ($= \$8.94 \times 11,131$) attracted by the higher quality fishing. As the shallow dredge option accomplishes less restoration of the resource, the consumer surplus is prorated by half.

Total annual maximum fishing consumer surplus values came to \$199,000. This maximum annual surplus value was used to develop a 50 year time stream of fishing consumer surplus benefits for each of the plans evaluated. The analysis used the same assumptions as the boater consumer surplus analysis, with respect to the number of years needed to achieve full eco-restoration and interest rate assumptions. The result of converting these time streams of values to average annual values is presented in Table 40a. Again, this conversion used a 3.6% annual percentage rate and a 50 year project life. Table 40b presents the present worth of these fishing consumer surplus time streams.

Passive Use Value - Consumer Surplus

People often value aspects of the environment even though they will never use or visit those environments. Many people, for example, like the fact that Alaska is largely untouched by human beings even though they themselves will never go there. Survey techniques have been developed which encourage people to reveal these values and attach a dollar amount to them. The Ohio Sea Grant survey, mentioned earlier asked a series of questions to find Ashtabula county residents' value for a clean Ashtabula Harbor. The results indicate the median Ashtabula county household was willing to contribute \$25 per year for 30 years toward the cleanup (Lichtkoppler 1998). The survey is flawed in that \$25 was the lowest positive amount the respondent could select. The valuation question could be interpreted to include both use and non-use values. Some of the measured willingness to pay may have represented anticipated improvements in boating and fishing experiences. For this reason, the survey responses were separated by those households operating boats (26.8 %) and those households where the residents were non-boaters (73.2 %). Many respondents were willing to pay higher amounts than the \$25 minimum indicated on the survey form. The lower bound mean annual amount was \$32.50. If we assume that the lower bound mean applies to all non-boating households and subtract \$8.85 from the lower bound mean for boating households (so as to avoid double counting) then for the 36,800 households in Ashtabula county, the annual willingness to pay for harbor cleanup for 30 years is \$1,108,700 ($= \$32.50 \times 26,938 = \$875,500$ plus $\$23.65 \times 9,862 = \$233,200$).

Again, these maximum annual consumer surplus values were used to develop a 50 year time stream of passive use consumer surplus benefits for each of the plans evaluated. The time stream of these benefits differed from one plan to another based upon the number of years needed to achieve full eco-restoration (3 years, 5 years, 10 years). Also, benefits were assumed to accrue yearly for only 30 years (the length of time the contribution would be in effect based upon the survey). Consequently, from project year 31 to 50, passive use consumer surplus benefits were

set to zero. The conversion of these time streams of value to average annual values is presented in Table 40a. This conversion used a 3.6% annual interest rate and a 50 year evaluation period. Table 40b presents the present worth of these streams, again using a 3.6% annual interest rate, a 50 year evaluation period, and a benefits generation length of 30 years.

Actual passive use value may be much larger than this. As the concept extends to people who will not use the resource, people distant from the site may hold a passive use value for it. Anyone aware of the river or lake ecosystem may have a value for it. Certainly, vacationers in the region would probably be willing to pay for the river cleanup too. This is a conservative estimate of passive use value. Similar studies in other areas have found values in the same range for similar environmental improvements. In a recent report (U.S. EPA,1995), a survey of studies where both use and non-use values were estimated showed that the ratio of non-use values to use values ranged from .5 to 2.5, depending on whether aesthetic value is considered part of passive use value. Applying this method to the Ashtabula/Conneaut region of Lake Erie, results in a passive use value of \$12 to \$60 per year.

Changes in Property Values

The awareness of contaminants in an area can reduce the value of property. In the most extreme circumstances, such as Love Canal, no potential buyers would accept the property at any price. The Ashtabula situation is similar to New Bedford, Massachusetts. In New Bedford, historical industrial areas which were subject to Superfund cleanups had left PCB contaminated sediment in the harbor. A study published in 1991 found "Once the pollution effect is widely known the panel models detect a significant reduction in housing values associated with the timing and location of the waste site area [i.e. the harbor]. Affected properties were estimated to have fallen between \$7,000 and \$10,000 (1989 dollars) in value as a result of their proximity to the hazardous wastes in nearby waters." (Mendelsohn, et al. 1991, page 268-9). The average house price in the New Bedford study area was \$71,630, in 1989 dollars, so the contamination's effect on housing values was substantial (ranging from 10 to 14 percent). Mendelsohn estimated the total lost value of 4,600 homes at \$35.9 million.

Applying the methods used in the New Bedford study to Ashtabula would require new surveys of housing sales transactions to determine the extent of influence of harbor attributes on housing values. Some geographic area around the river is probably stigmatized by the presence of contaminants in the water. A rough idea of the scale of the possible effect on housing prices can be estimated by applying the 10 percent change in value Mendelsohn found to the value of housing in Ashtabula Harbor. The median sales value of single homes in Ashtabula county in 1996 is \$61,300 (Crains Cleveland Business, April 1998). A 10 percent increase in value would increase the median house value \$6,130. An estimated one thousand housing units are in the affected area. The resulting change in housing value is about \$6.1 million.

The other benefits discussed in this section represent annual flows of benefits while the change in housing value is a one time change in the value of an asset. The average annual value of change in property values, assuming a 50 year project life and a 3.6% annual interest rate is \$266,100.

Preservation of Lake Erie Benefits

In 1996, 37 percent of all Great Lakes anglers fished in Lake Erie making it the most popular of the Great Lakes for fishing (U. S. Department of the Interior, Fish and Wildlife Service 1997). In all, there were 746,000 anglers who fished in Lake Erie for an estimated 6.7 million days. The most popular species sought in Lake Erie was walleye. The State of Ohio portion of Lake Erie had an estimated 311 thousand anglers fishing for walleye for 1.4 million days. This included both State residents and non-residents going to Ohio to fish. The consumer surplus of the Lake Erie walleye fishery is \$59.4 million annually (=6.7 mil. days x 8.85). Of this total, approximately \$12 million (=1.4 mil. days x \$8.85= \$12,390,000) in annual consumer surplus is attributable to anglers fishing from Ohio waters.

The potential impacts of PCB release from the Ashtabula River to Lake Erie are substantial. It is estimated that a release of 1 to 10 percent of the current PCB load from the Ashtabula River would be enough to increase the level of PCB's in walleye fillets to the point of having States advise sport anglers not to consume walleye from Lake Erie and lead to a closing of the commercial walleye fishery in Lake Erie. The removal of PCB laden sediment from the Ashtabula River will lower the probability of a storm or some other event transferring the PCB mass to Lake Erie. Lake Erie Walleye Fishery benefits by plan were calculated by determining the present worth of the Lake's walleye fishery. This value was then multiplied by the probability of a 100 year flood event. This resulted in a present worth value of approximately \$14,200,000. This was then multiplied times the percentage of total PCBs that would be removed by implementation of any one plan. The benefit of this risk reduction is demonstrated by the walleye fishery, which will be protected from this source of PCB contamination.

Regional Economic Development Benefits

Local Economic Impacts

Allowing the Ashtabula river to shoal to its natural channel depth will have impacts on the local economy, as well as the county. Currently, approximately 150 local area jobs are directly connected to bulk commodities moving through Ashtabula Harbor. Direct Harbor employment is concentrated at Piney Dock, Sidley Dock and conrails coal transshipment facility on the west bank of the Ashtabula River. These local area jobs generate income which is spent in the area. This expenditure of income locally makes possible the existence of other local jobs in such diverse areas as restaurants, food stores, and local government. The movement of the bulk commodity trade to some other port would mean the loss of these jobs to the local economy. The income generated by these lost jobs would no longer be part of the local areas economy. Job loss could result in part of the local labor force moving to another area to find employment. This could result in a reduction in local government ser-vices due to a reduction in local tax revenues (sales tax, property tax, school taxes, etc).

An estimate of the economic impacts on the Ashtabula County economy, and the fiscal impacts on local governments was developed using a regional general equilibrium model (REGEM). REGEM is a state of the art regional model that projects changes in industry output, intermediate purchases, employment, migration, exports, imports, household consumption, and spending and revenue of governments. The REGEM model was configured with ten industries: agriculture; construction; nondurable goods manufacturing; durable goods manufacturing; water transportation; retail; finance, insurance and real estate; personal services; business services; and miscellaneous services.

Economic and fiscal impacts were developed under Without and With Project conditions. Economic impacts were measured in terms of changes in (1) total county employment, and (2) county gross product (ie. Net income accruing to households, firms, and local governments.). Fiscal impacts were measured in terms of changes in (1) revenues, and 2, expenditures of local governments in Ashtabula County.

The regional model calculated gross regional product accruing to households, firms, and local governments under the Without and With Project scenario. Additional gross regional product generated due to the implementation of the project was calculated. The present value of additional gross regional product, over the 50 year evaluation period was \$49.8 million. This converts to an average annual value of \$3,895,900. This evaluation used a 7.625% annual interest rate and a 50 year evaluation period (Table 40a). Table 40b provides the same regional benefits; but, using a 3.6% annual interest rate and a 50 year project evaluation period.

Because shallow dredging leaves a considerable amount of PCB's in place, the shallow dredging alternative does not generate Local Economic Impacts. However, both deep dredging alternatives and the bank-to-bank-to-bedrock alternative remove a substantial portion of the potential contamination and so all three generate similar Local Economic Impacts.

Boating - Expenditures

When the river becomes cleaner more people will want to go boating on it and those who already boat on it may use it more often. In addition, the project will permit continued maintenance of the recreational channel and so permit larger boats to go farther upriver. Such increased activity leads to increased spending and so stimulates the local economy. Such effects are not considered national economic development effects. The recreational spending would have occurred elsewhere in the country if it had not occurred in the local region (U.S. Water Resources Council 1983). The environmental improvement is a competitive advantage that attracts outsiders away from other places they might have gone boating and so stimulates the local economy.

The Feasibility Report estimates a 10 percent increase in quality of the boating experience using a subjective point scale. The relationship between quality and boating days may not be linear but any other assumption involves a detailed assessment of the demand for boating opportunities in Ashtabula which is beyond the scope of this report. Increased demand may derive from more trips by the existing boats, more people per boating trip, or more boats. Assuming a 10 percent increase in quality implies a 10 percent increase in demand for boating trips, and there is sufficient capacity for the added demand in Ashtabula Harbor, the calculations above imply there will be 4,770 more boating days per year after the project. This corresponds to the additional trips by “new boaters” described earlier.

The National Survey of Fishing, Hunting, and Wildlife-Associated Recreation is conducted every five years (U. S. Department of the Interior, Fish and Wildlife Service 1997). It collects information about anglers’ expenditures, along with a great deal of other information. The survey is conducted to provide valid statistics at the state level. So specific expenditure information is available about people taking fishing trips to Lake Erie. (Narrowing the sample size further to trips to Lake Erie from Ohio reduces the number of observations in the survey to an unacceptable level.) Table 41 shows the mean daily expenditures for all anglers in Lake Erie. Boaters are assumed to have a similar pattern as anglers except for guide fees, equipment rental, bait, and ice which relate specifically to fishing. The sum of boating items per day is \$43.84 in 1996 dollars; this implies an additional \$209,100 in annual spending by boaters attributable to the ecological improvements from the project. Increases in spending have a ripple effect in the local economy.

The ripple effect is measured using Input-Output Analysis (IO). When someone spends a dollar at a local store, the merchant spends it on something else, perhaps to pay an employee. The employee then spends his wages somewhere else and so generates additional income in the community. IO software contains a model of the local economy which simulates how the boater’s dollar circulates through the economy. For this study, the local economic area is defined as Ashtabula, Geauga, and Lake counties. The \$209,100 that boaters are expected to spend annually if the project is completed would add a total of \$300,800 to regional output annually when all of the indirect and induced economic activity is included. The increased spending would generate 4.7 new jobs and \$83,000 in added employment income.

Again, this maximum annual value of \$300,800 was used to develop a 50 year time stream of boating expenditure benefits for each of the plans evaluated. The time stream of these benefits

differed from one plan to another based upon the number of years needed to achieve full eco-

Table 41. Expenditures per day by Lake Erie Anglers, 1996

<i>Spending Category</i>	<i>Dollars per day</i>
Food	15.51
Lodging	6.31
Transportation	10.83
Access fees	1.14
Boat Costs	
Fuel	4.18
Launching fee	0.31
Other boat costs	<u>5.56</u>
<i>Sub-total, Boating spending per day</i>	<i>43.84</i>
<i>Fishing costs</i>	
Guide fees	8.75
Fishing Equipment rental	1.67
Bait	3.25
Ice	<u>1.07</u>
<i>Total</i>	<i>58.58</i>

Source: 1996 National Survey of Fishing, Hunting, and Wildlife-related Recreation data files.

restoration (3 years, 5 years, 10 years). Table 40a presents the results of converting these time streams of value to average annual values. Table 40b presents the present worth of these boating expenditure values. Both analyses used a 3.6% annual interest rate and a 50 year evaluation period.

Fishing - Expenditures

The discussion above about boating applies even more strongly to recreational fishing. As the habitat of the river improves, anglers can expect to see a greater number and variety of fish in the harbor and nearby waters. Some of these will be more desirable quarry such as pike, walleye, and salmonids. If the 10 percent improvement in the Feasibility Report subjective index is reflected linearly in increased fishing activity, there will be 11,131 more fishing days per year when the project is completed.

Table 41 shows the total average expenditures for a day of fishing on Lake Erie are \$58.58 (1996 dollars). Multiplying this by the increase in fishing days from the ecosystem restoration suggests a \$652,100 increase in local expenditures related to fishing. The ripple effect of spending also applies to these expenditures. The ripple effect of anglers spending \$652,100 increases total local output to \$937,800. This will contribute 14.8 new jobs and \$258,900 in additional employee compensation to the local economy. Perhaps not as impressive as a new factory, these gains are derived from cleaning up the environment, rather than despoiling it, and are in addition to improvements in property values, navigation, and ecosystem health.

Again, this maximum annual fishing expenditures value of \$937,800 was used to develop a 50 year time stream of fishing expenditure benefits for each of the plans evaluated. The time stream of these benefits differed from one plan to another with respect to when the maximum expenditures would be reached based upon the number of years needed to achieve full eco-restoration (3 years, 5 years, 10 years). Table 40a presents the results of converting this time stream of fishing expenditures to average annual values. Table 40b presents the present worth of these fishing expenditure values. Both analyses used a 3.6% annual interest rate and a 50 year evaluation period.

PROJECT RECOMMENDATIONS

Based on review of considered alternatives and associated assessment/evaluation the Ashtabula River Partnership recommends the following and requests support to the degree possible.

DREDGING ECOLOGICAL RESTORATION/PRESERVATION MEASURES FOR SUBSTRATE CONTAMINANT REMOVAL AND RECOVERY

- 1) **Implement the Deep Dredge Plan as the optimized plan** that reasonably achieves the project objectives, in this regard, at the least cost under 312(b) Authority. This constitutes associated ecological restoration through environmental dredging for contaminated substrate removal/restoration within and just outside of the authorized Federal navigation channel.
- 2) Clean material dredged from the channel area upstream of the Upper Turning Basin and possibly from the Outer Harbor area should be deposited as cover into the Deep Dredge Area for at least one operations and maintenance dredging cycle to expedite clean benthic cover material recovery at no additional cost and likely savings.

SUPPLEMENTAL DREDGING ECOLOGICAL RESTORATION/PRESERVATION MEASURES FOR PROTECTED AQUATIC/FISHERY SHALLOWS

- 1) **Implement 2. Aquatic/Fishery Shelf Plan** in the Ecological Assessment Area 3 problem area (mouth of River to Fifth Street Bridge). This constitutes ecological restoration, as possible, for loss of protected aquatic/fishery shallows due to facilitated structural (i.e. bulkheading, channelization), and activities impacts under 206 authority. These are practical optimized plans of moderate cost providing problem area protected aquatic/fishery shallows of substantial length which accomplish, as possible, goals/objectives, in this regard. The areas would be interfaced with the lake/river regime and would provide passage, cover, and possibly feeding and spawning habitat. The area would still fall short of quality warm water habitat assuming that commercial shipping activity would continue in the area.
- 2) **Implement 4. Acquire Conrail Slip and Aquatic/Fishery Shelf Cut Plan** in the Ecological Assessment Area 2 problem area (Fifth Street Bridge through the Upper Turning Basin). This constitutes ecological restoration, as possible, for loss of protected aquatic/fishery shallows due to facilitated structural (i.e. bulkheading, channelization), and activities impacts under 206 authority. These are practical optimized plans of moderate cost providing problem area protected aquatic/fishery shallows of substantial length which accomplish, as possible, goals/objectives, in this regard. It takes advantage of the opportunity to utilize the existing slip area adjacent to the river and provides improvements along the reach long enough to enable passage of fisheries. The areas would be interfaced with the lake/river regime and would provide passage, cover, feeding, and possibly spawning habitat. The area should reach quality warm water habitat status. Recreational boating activity would continue in the area.

3) Maintain long-term channel maintenance dredging upstream of the Fifth Street Bridge to recreational navigation depths as is being done at present. This will provide aquatic shallow areas along the lower River shoreline in the distant future at no cost.

4) Decrease the width of the maintained recreational navigation channel to the west upstream of the Fifth Street Bridge between the Conrail slip and the Upper Turning Basin about eight feet or more, as possible. This will provide additional aquatic shallow area along the east embankment in the distant future at no cost and likely savings.

SUMMARY COST AND ASSESSMENT/EVALUATION TABLES

Associated project costs and assessment/evaluation items were discussed previously and were presented in summary in Tables 36, 38, and 39. Recommended project costs:

Table 40 - Project Feature Costs and Total Costs.

<u>Item</u>	Deep Dredge Plan <u>(EAA 3 & 2)</u>	Plan 2 Aquatic/Fishery Shelf Hung <u>(EAA 3)</u>	Plan 4 Conrail Slip & Aquatic/Fishery Shelf Cut <u>(EAA 2)</u>	TOTAL <u>_____</u>
Construction				
First Cost \$				
Dredge :	20,153,500			
Disposal:	29,746,500			
Total :	49,900,000	313,111	447,237	50,660,348
Study				
E&D				
S&A				
RE				
Project Cost:	56,500,000	352,250	503,142	57,355,392

Note: The material proposed to be dredged downstream of the Fifth Street Bridge (115,000 CY) constitutes about 17% of the total material to be dredged (696,000 CY) for the Deep Dredge Plan.

Reference Assessment/Evaluation Tables 36, 38, and 39.

MONITORING

With implementation of the Deep Dredging plan, water quality will be monitored upstream and downstream of the dredging activities as agreed upon with the U.S. Environmental Protection Agency and the Ohio Environmental Protection Agency. This usually includes periodic sampling and expeditious analyses and then possibly correlated suspended particulate methodologies so that dredging activities and resulting resuspension of sediments and associated contaminants can be controlled within acceptable parameters.

The U.S. Environmental Protection Agency has also recommended several biological monitoring methodologies. For example, bio monitoring using caged bivalves, such as zebra mussels, could be used to assess whether resuspended sediments are being transported from the dredging site and being taken up by the bivalves. Cages could be situated at a reference station upstream of the areas being dredged and at several locations downstream of the dredging area. This could serve to verify whether resuspended sediments are being carried outside of the project area and whether or not their associated contaminants are bioavailable. These are included in project cost estimates.

The Corps of Engineers periodically (about every five years) samples and analyzes federal channel sediments for the Harbor Operations and Maintenance program. This can also be utilized to provide basic monitoring information with regard to sediment contaminant levels and benthos quality. The Corps of Engineers will conduct such a survey for the Ashtabula Harbor area and report the findings within five to ten years of completion of the project.

The Ohio Environmental Protection Agency Habitat Assessment Procedure (HAP) can be utilized in the future to monitor or measure anticipated project outputs. The Ohio Environmental Protection Agency has been conducting these surveys periodically and will conduct such a survey and report the findings within five to ten years of completion of the project. Subsequent habitat, fishery, and macroinvertebrate survey results and indications of ecological improvements or outputs are/will be reflected by these studies.

The Ohio Environmental Protection Agency conducts fish sampling and tissue analyses periodically and will conduct such a survey for the Ashtabula Harbor area and report the findings within five to ten years of completion of the project.

The U.S. Fish and Wildlife Service will review available data or conduct a survey pertaining to the significant species for the Ashtabula Harbor area and report the findings within five to ten years of completion of the project.

Minor to moderate adjustments can be made through this or similar authorities or associated operations and maintenance procedures/programs, if the anticipated ecological restoration outputs do not meet reasonable expectations. A memorandum of agreement and funding may be programmed to facilitate monitoring review and assessment/evaluation of the project and possible modifications within five to ten years of completion of the project.

CRITERIA FOR DECISION MAKING FOR ECOLOGICAL RESTORATION/ PRESERVATION REVIEW

GENERAL

The lower Ashtabula River and lake nearshore has been identified as a Great Lakes Area of Concern (AOC) by the International Joint Commission primarily due to impaired use and impacts to the ecology due to contaminated sediments and shoreline structural and functional changes. Primary contaminants of concern include PCBs, PAH, metals, and others. Some of the beneficial use impairments are related to loss of protected aquatic/fishery riparian shallow areas and lower river activities. The Lake Erie/Ashtabula River Area of Concern has been identified as a priority area for remediation in Section 205 of WRDA 96 and in the U.S. Army Corps of Engineers PGL No. 49 section 5. c. The project will also contribute to International agreement objectives, primarily those associated with the Great Lakes Water Quality Agreement of 1978, as amended. Problems are being addressed through a partnership effort.

COST EFFECTIVENESS AND INCREMENTAL COST

As discussed in the previous sections, the Ashtabula River Partnership (ARP) considered Without Project Conditions scenarios and developed and assessed/evaluated three incremental dredging ecological restoration/preservation scenarios for substrate contaminant removal. Considering developed ecological clean-up restoration/preservation goals/objectives, initial primary assessment/evaluation output measures included items such as: Costs, Economic Benefits, Practicality, Ecological Improvement (Rank), Quantities Dredged, TSCA (PCB) Material Removed, Shoreline Bulkhead Affected, PAH/PCB Mass Removed, Initial PAH/ PCB Surface Concentrations, Beneficial Uses Addressed (Open Lake Disposal, Recreation/ Commercial Shipping, Fish Advisory Lifted, Long-Term Risk Reduction, Habitat Quality), and Scour Release Potential (incl. to Lake). Other assessment/evaluation output measures included items such as: PCB Bio-Accumulation in Fish Tissue and Advisories, Water Quality (Turbidity), Benthic Habitat Chemically Restored, Benthic Habitat and Scour Protection Area Chemically Restored, Aquatic/Fishery Shallows Initially Impacted, Ohio Habitat Assessment Procedures (HAP) Biological Indices (Qualitative Habitat Evaluation Index QHEI, Fishery Index of Biotic Integrity IBI (incl. T&E Species), Macroinvertebrate Invertebrate Community Index ICI, Anomaly Reductions) Improvements, Accomplishment of Sediment Contaminant Reduction Objective and Accomplishment of Total Ecological Restoration Objective. A brief Comparative Summary Table was presented as Table 36.

The assessment/evaluation identified the Deep Dredge scenario as the optimized plan and recommended plan. It removes the amount of contaminated material that needs to be removed, moderating costs, while meeting River ecological clean-up restoration/preservation goals/ objectives. The recommended plan involves deep dredging (environmentally) of approximately 581,000 cubic yards (in situ) of contaminated sediments, 150,000 cubic yards of which is significantly PCB contaminated and would be handled and disposed of in accordance with TSCA regulations.

In the project reach from the Fifth Street Bridge downstream to station 120+00 located about half way down to the Lake, PAH contamination was considered to be the primary contaminant of

concern. Considering this, it was determined that dredging and disposal of approximately 115,000 cubic yards of sediment from this reach would address this problem.

These two volumes account for the project 696,000 cubic yards.

Clean material dredged from the channel area upstream of the Upper Turning Basin and possibly from the Outer Harbor area should be deposited as cover into the Deep Dredge Area for at least one operations and maintenance dredging cycle to expedite clean benthic cover material recovery at no additional O&M cost and likely savings.

Several surface cut and cover alternatives were contemplated. However, these would create several severe project related problems. Such alternatives would not remove all of the TSCA level material and would not meet TSCA clean-up objectives. Such alternatives would leave very high levels of exposed surface PCB contaminated sediments (even to TSCA level) with immediate substantial adverse impacts relative to benthos and the aquatic food chain and potential scour and migration of high level PCB contaminated sediments.

Further, Supplemental Dredging Ecological Restoration/Preservation Measures for Protected Aquatic/Fishery Shallows were developed to address the lack of protected aquatic/fishery shallows in the lower River. Two major problem areas were identified in this regard. From the mouth of the River to the Fifth Street Bridge (Ecological Assessment Area 3) and from the Fifth Street Bridge through the upper navigation channels (Ecological Assessment Area 2). Measures that could be applied to Ecological Assessment Area 3 are very limited since the area continues to be utilized for commercial shipping and docking and transfer of primarily coal, ore, and limestone. One measure that has been considered at other harbors for similar situations is the construction of a man-made aquatic habitat shelf along the channel reach primarily to facilitate movement of fisheries through the reach. More opportunity and better measures can be applied to Ecological Assessment Area 2. Measures considered for these reaches, in this regard, included acquisition of river shoreline property, and construction of aquatic/fishery shallows, as possible. This would include a mix of aquatic and shoreline plantings, stone/gravel bottom areas, and cover structures. The areas would be interfaced with the lake/river regime and would provide passage, cover, feeding, and spawning habitats.

Three incremental plans were developed and assessed/evaluated for Ecological Assessment Area 3 and four incremental plans were developed and assessed/evaluated for Ecological Assessment Area 2. Considering developed ecological restoration/preservation goals/objectives, primary assessment/evaluation output measures included items such as: Costs, Economic Benefits, Practicality, Ecological Improvement (Rank), Shoreline Improvement (Acres), Shallows Improvement (Acres), Fishery Passage Length, Ohio Habitat Assessment Procedures (HAP) Biological Indices (Qualitative Habitat Evaluation Index QHEI, Fishery Index of Biotic Integrity IBI (incl. T&E Species), Macroinvertebrate Invertebrate Community Index ICI) Improvements, and Accomplishment of Supplemental Ecological Restoration Objective. Brief Comparative Summary Tables were presented as Tables 38 and 39.

The assessment/evaluation identified **2. Aquatic/Fishery Shelf Plan** for the Ecological Assessment Area 3 problem area and **4. Acquire Conrail Slip and Aquatic/Fishery Shelf Cut Plan**

for the Ecological Assessment Area 2 problem area. This constitutes ecological restoration, as possible, for loss of protected aquatic/fishery shallows due to facilitated structural (i.e. bulkheading, channelization), and activities impacts. These are practical optimized plans of moderate cost providing problem area protected aquatic/fishery shallows of substantial length which accomplish, as possible, goals/objectives, in this regard. The areas would be interfaced with the lake/river regime and would provide passage, cover, feeding, and possibly spawning habitat.

Other long-term dredging measures recommended in this regard include:

* Maintain long-term channel maintenance dredging upstream of the Fifth Street Bridge to recreational navigation depths as is being done at present. This will provide aquatic shallow areas along the lower River shoreline in the distant future at no cost.

* Decrease the width of the maintained recreational navigation channel to the west upstream of the Fifth Street Bridge between the Conrail slip and the Upper Turning Basin about eight feet or more, as possible. This will provide additional aquatic shallow area along the east embankment in the distant future at no cost and likely savings.

The 312(b) *and* 206 assessment/evaluation found the project to be justified under the authorities. Both ecological and economic total and incremental benefits exceed associated project costs. However, the 312(b) *and* 206 assessment/evaluation also found that, for both the Dredging Ecological Restoration/Preservation for Substrate Contaminant Removal and Supplemental Dredging Ecological Restoration/Preservation for Protected Aquatic/Fishery Shallows measures, substantial ecological and more moderate economic benefits could be realized in the upstream reach from the Fifth Street Bridge upstream through the Upper Harbor area, and substantial economic and more moderate ecological benefits could be realized in the reach from the mouth of the River up to the Fifth Street Bridge (the large vessel commercial channel reach). The latter channel area is to be examined from a 312(a) perspective also. Substantial ecological and economic benefits (primarily from prevention of outflow of contaminants) could also be realized for the Outer Harbor, Lake Erie, and the immediate Great Lakes area.

These recommended measures are considered to be overall and incrementally cost effective in meeting the project goals/objectives.

ACCEPTABILITY

The Ashtabula River Partnership (ARP) is a coalition of over 50 public and private interests working toward mutual remediation of problems along the Lower Ashtabula River. The ARP includes key Federal, State, and Local interests. The ARP operates primarily via a committee process. Project problems, needs, objectives, and considered alternatives have been identified and assessed/evaluated by the ARP. Preliminary Draft Reports have been prepared, coordinated, and reviewed by the ARP members and (pending the U. S. Army Corps of Engineers HQ) the Preliminary Draft Reports and recommended plans have been acceptable, thus far. Public workshops/meetings have presented enthusiastic and favorable support for the project, thus far. Reference associated sections of the Environmental Impact Statement. The Draft Reports are due to be coordinated with agencies and the public for formal Draft review. The Preliminary

Draft Reports and the recommended plans have been acceptable to the non-Federal cost-sharing partner, thus far. A policy conference will be rescheduled to discuss primarily authorities, policies, and project cost sharing.

The Ashtabula River Partnership (Excluding the Corps of Engineers) prefers that the commercial channel area and associated areas outside of the commercial channel be dredged via Corps O&M and 312(a) Authority and that the remainder be dredged via 312(b) authority. If the project is all done under 312(b) Authority the local cost share would be several million dollars more considering current cost estimates. This jeopardizes project local cost sharing acceptability.

COMPLETENESS

The potential and recommended plans provide and account for necessary investments or other actions needed to ensure the realization of the planned restoration outputs, through the Draft report. Monitoring measures have been included, as previously described. Minor to moderate adjustments can be made through this or similar authorities or associated operations and maintenance procedures/programs, if the anticipated ecological restoration outputs do not meet reasonable expectations.

The project was designed to address the identified ecological contaminant problems and, to the degree possible, the lack of protected aquatic/fishery shallows due to developments along the Lower River. It is understood that the commercial and recreational boating activities will continue. Remediation in the lower River commercial channel (Ecological Assessment Area 3) is limited due to commercial developments and activities. Given the nature of commercial activities in that reach, somewhat limited results can be expected with regard to attaining a quality warm water habitat.

In addition to addressing the identified ecological contaminant problem and, to the degree possible, the lack of protected aquatic/fishery shallows due to developments along the Lower River; the project will alleviate commercial shipping and recreational navigation channel maintenance problems, higher potential human health issues, and provide a better balance of natural and human environment and associated benefits.

EFFICIENCY

As discussed in the previous sections, the Ashtabula River Partnership (ARP) considered Without Project Conditions scenarios and developed and assessed/evaluated three incremental dredging ecological restoration/preservation scenarios for substrate contaminant removal. Considering developed ecological clean-up restoration/preservation goals/objectives, the assessment/evaluation identified the Deep Dredge scenario as the optimized plan and recommended plan. It removes the amount of contaminated material that needs to be removed, moderating costs, while meeting River ecological clean-up restoration/preservation goals/objectives. This optimization generates some risk, although finally determined acceptable, in terms of acceptability, completeness, and effectiveness.

Further, Supplemental Dredging Ecological Restoration/Preservation Measures for Protected

Aquatic/Fishery Shallows were developed to address the lack of protected aquatic/fishery shallows in the lower River. Three incremental plans were developed and assessed/evaluated for Ecological Assessment Area 3 and four incremental plans were developed and assessed/evaluated for Ecological Assessment Area 2. The assessment/evaluation identified **2. Aquatic/ Fishery Shelf Plan** for the Ecological Assessment Area 3 problem area and **4. Acquire Conrail Slip and Aquatic/Fishery Shelf Cut Plan** for the Ecological Assessment Area 2 problem area. This constitutes ecological restoration, as possible, for loss of protected aquatic/fishery shallows due to facilitated structural (i.e. bulkheading, channelization), and activities impacts. These are practical optimized plans of moderate cost providing problem area protected aquatic/fishery shallows of substantial length which accomplish, as possible, goals/objectives, in this regard. The areas would be interfaced with the lake/river regime and would provide pass-age, cover, feeding, and possibly spawning habitat.

These are considered to be the most efficient means determined to meet project goals/objectives considering alternatives/incremental assessment/evaluation analyses.

The Lower Ashtabula River Remedial Actions Project is being accomplished via the Ashtabula River Partnership. Remediation of the contamination and habitat problems along the lower Ashtabula River will serve to alleviate harbor impaired use and operations and maintenance restrictions, water quality and aquatic habitat issues, and health and safety concerns.

It can be reasonably demonstrated that through this Partnership problems can be resolved and mutual benefits attained more quickly and less expensively than through a number of unilateral authorities, projects, sometimes similar efforts.

EFFECTIVENESS

Although partnerships and remediation of Great Lakes Areas of Concern and associated measures of effectiveness on this project scale are relatively new and limited, there are examples of similar project measures implemented and effects measured that demonstrate project measures effectiveness. These are discussed in considerable detail in the assessment/evaluation sections of these reports. For example, marked improvements have been measured in PCBs in fish tissue with removal of PCBs from Scippo Creek. Also, the Ohio Habitat Assessment Procedure section discusses biological indices comparisons of the similar but relatively non-contaminated Conneaut Creek regime to the contaminated Ashtabula River. Also discussed are measured improvements along the Black River and the Grand River with removal of contaminants and development of an aquatic/fishery shallow/shelf, respectively.

There are some risks in this regard associated with incremental assessment/evaluations to optimize the project plans relative to costs while attaining project goals/objectives.

The project was designed to address the identified contaminant problem and, to the degree possible, the lack of protected aquatic/fishery shallows due to developments along the Lower River. It is understood that the commercial and recreational boating developments and activities, which present some ecological problems, will continue. It is expected that based on incremental assessment/evaluation and risk analyses that the proposed project measures will be effective in address-

ing identified problems, needs, goals/objectives. Remediation in the lower River commercial channel (Ecological Assessment Area 3) is limited due to commercial developments and activities. Given the nature of commercial activities in that reach, somewhat limited results can be expected with regard to attaining a quality warm water habitat. Fish will continue to have to run a gauntlet through the commercial navigation channel area and parts of the recreational navigation channel area. This presents some risk to the expected effectiveness of the proposed measures upstream.

PARTNERSHIP CONTEXT

The Lower Ashtabula River Remedial Actions Project is being accomplished via the Ashtabula River Partnership formed in 1994. The Ashtabula River Partnership is a coalition of public and private interests working toward remediation of the lower Ashtabula River. Remediation of the contamination problems along the lower Ashtabula River will serve to alleviate harbor impaired use and operations and maintenance restrictions, water quality and aquatic habitat issues, and health and safety concerns. It can be reasonably demonstrated that through this Partnership problems can be resolved and mutual benefits attained more quickly and less expensively than through a number of unilateral sometimes similar efforts. Federal, State, Local, and private interests have been involved in the project planning and preparation of the preliminary draft reports. The project will also contribute to International agreement objectives, primarily those associated with the Great Lakes Water Quality Agreement of 1978, as amended. The Lower Ashtabula River and the near lakeshore has been identified as a Great Lakes Area of Concern and identified as one of several priority restoration Areas of Concern, accordingly.

The Ashtabula River partnership is a rather unique association of Federal, State, and Local community and business interests who have formulated and support “a plan” to remediate the Great Lakes Area of Concern. The project presents a unique opportunity to remediate the Area of Concern cooperatively and rather simply through appropriate dredging and disposal procedures, long-term maintenance dredging modifications, and possibly some shoreline structural modifications. This restoration is likely more readily achieved than at most of the other areas of concern that are more industrially developed in the river/harbor area. The project has generated significant local, State, Federal, and International interest.

REASONABLENESS OF COST

As discussed previously, considering developed project goals/objectives a number of plans were developed and assessed/evaluated relative to costs, benefits, and associated risks. The recommended plans are considered to be practical optimized plans, moderating costs, while meeting River ecological clean-up restoration/preservation goals/objectives. The Preliminary Draft Report costs are considered to be somewhat conservative and could very well decrease as reports and plans are finalized. Also, as stated previously, it can be reasonably demonstrated that through this Partnership problems can be resolved and mutual benefits attained more quickly and less expensively than through a number of unilateral and sometimes similar efforts and the costs are reasonable. Conceivably, this partnership project cost could be compared to the cost of a primary responsible party Superfund project, a Corps of Engineers and local confined disposal facility (CDF) for contaminated dredged material project, and associated ecological restoration

projects. Benefits of partnership, cooperation, mutual accomplishment can also be captured with this project.

SOME KEY REFERENCES

Ashtabula River Partnership; (Preliminary Draft) Ashtabula River Partnership, Comprehensive Management Plan, Feasibility Report, Ashtabula River and Harbor, Ashtabula, Ohio, 1997; Ashtabula River Partnership.

Ashtabula River Partnership; (Preliminary Draft) Ashtabula River Partnership, Comprehensive Management Plan, Environmental Impact Statement and Appendices, Ashtabula River and Harbor, Ashtabula, Ohio, 1997; Ashtabula River Partnership.

EA-B CLEAN WATER ACT PUBLIC NOTICE AND SECTION 404(b)(1) EVALUATION REPORT (Pertains to State 401 Certification, and N/SPDES and PTI Permits, also.)

EA-C ENVIRONMENTAL RISK MANAGEMENT CONSIDERATIONS FOR THE ASHTABULA RIVER AND HARBOR

EA-D U.S. FISH AND WILDLIFE COORDINATION ACT REPORT

EA-G COASTAL MANAGEMENT CONSISTENCY DETERMINATION

Ashtabula River Partnership; (Preliminary Draft) Ashtabula River Partnership, Comprehensive Management Plan, Feasibility Report Technical Appendices, Ashtabula River and Harbor, Ashtabula, Ohio, 1997; Ashtabula River Partnership.

B - Federal Project Authorizations and Past Studies.

C - Ashtabula River Sediment Sampling and Analysis of Extent of Contamination.

* D - Dredging Scenarios and Sediment Volume Estimates.

* E - Environmental Risk Assessment.

F - Recontamination Assessment.

Q - Economic Evaluation

S - Cost Sharing and Non Federal Responsibility.

Ashtabula River Partnership; Ashtabula River Partnership, Environmental Risk Assessment and Management Considerations for Dredging the Ashtabula River and Harbor, 1997; Ashtabula River Partnership.

Charbonneau, John; (Draft) Ashtabula River Comprehensive Management Plan, Economic Analysis, 1998; U.S. Fish and Wildlife Service, Division of Economics.

DeVault, David; (Draft) Potential Impacts of PCB Release from the Ashtabula River to Lake Erie, 1998; US Fish and Wildlife Service, Ecological Services.

Interagency; The Keystone National Policy Dialogue on Ecosystem Management, Final Report, 1996; Interagency.

OEPA; Ashtabula River Remedial Action Plan (RAP) Stage 1 Investigation Report, December 1991, OEPA.

OEPA; Biological Criteria for the Protection of Aquatic Life:

* Volume I: The Role of Biological Data in Water Quality Assessment, July 1987, OEPA.

* Volume II: Users Manual for Biological Field Assessment of Ohio Surface Waters, October 1988, OEPA.

* Volume III: Standardized Biological Field Sampling and Laboratory Methods for Assessing Fish and Macroinvertebrate Communities, September 1989, OEPA.

* The Qualitative Habitat Evaluation Index: Rationale, Methods, and Application; November 1989; OEPA.

OEPA; Biological Community Status of the Lower Ashtabula River and Harbor within the Area of Concern, Ashtabula County, Ohio; January 1992; OEPA.

OEPA; Biological and Water Quality Study of the Grand and Ashtabula River Basins including Arcola Creek, Cowles Creek, and Conneaut Creek, January 7, 1997; OEPA.

OEPA; 1994 Fish Tissue Data, Ashtabula AOC; OEPA.

Pickard, S. W. ; (Draft) Development of Polychlorinated Biphenyl (PCB) Sediment Cleanup Guidelines for Ashtabula Harbor (Upper River Channel), Ohio, 1997; U.S. Army Corps of Engineers, Buffalo District.

Thoma, Roger F.; (Draft) Ashtabula River Partnership Project Ohio Habitat Assessment Procedure Assessments, 1998; OEPA.

U.S. Army Corps of Engineers, Buffalo District; Ashtabula Harbor; WRDA 1990 Section 312 Initial Appraisal Report, Ashtabula Harbor, Ohio; U.S. Army Corps of Engineers, Buffalo District. (Includes Appendix E - Sedimentation Study).

US Department of Health and Human Services; Public Health Implications of Persistent Toxic Substances in the Great Lakes and St. Lawrence Basins; US Department of Health and Human Services.

US Environmental Protection Agency; Assessment and Remediation of Contaminated Sediments (ARCS) Program, Calculation and Evaluation of Sediment Effect Concentrations for the Amphipod and the Midge, 1996; USEPA.

US Environmental Protection Agency; Ecotox Thresholds, Eco Update, Office of Emergency and Remedial Response, Publication 9345.0-12FSI, EPA 540/F-95/038.

US Fish and Wildlife Service, An Ecosystem Approach to Fish and Wildlife Conservation, 1995; USFWS.

Woodward-Clyde Report, 1990, and Summary Report: Ashtabula River Sampling, 1995.

THANKS TO THE COMMITTEE !

Ashtabula River Partnership Ecological Restoration 312(b) and 206 Sub-Committee

<u>Name</u>	<u>Organization</u>
John Mahan (Project Coordinator)	Ashtabula River Partnership
Tod Smith (Chair)	US Army Corps of Engineers, Buffalo District
Rick Brewer	RMI
John Charbonneau	US Fish and Wildlife Service
Dave DeVault	US Fish and Wildlife Service
Natalie Farber	Ohio Environmental Protection Agency
Bob Fletcher	Ohio Department of Natural Resources
Steve Golyski	US Army Corps of Engineers, Buffalo District
Leroy Hushak	Ohio Sea Grant
Bill Janowsky	US Army Corps of Engineers, Buffalo District
Kent Kroonemeyer	US Fish and Wildlife Service
Bill Kurey	US Fish and Wildlife Service
Drew Laughland	US Fish and Wildlife Service
Frank Lichtkoppler	Ohio Sea Grant
Rick Mason	RMI
Ken Multerer	US Fish and Wildlife Service
Rick Nagle	US Environmental Protection Agency
Amy Pelka	US Environmental Protection Agency
Vanessa Stiegerwald	Ohio Environmental Protection Agency
Roger Thoma	Ohio Environmental Protection Agency

SECTION 312(b) and 206 APPENDIX SUB-APPENDIX

Ashtabula River Comprehensive Management Plan Economic Analysis

Economic Value of Ecosystem Restoration

Economic Framework

The primary focus of this analysis is to estimate the benefits of alternative options for restoring the ecosystem components that have been damaged in the Ashtabula River. Traditional economic measures of benefits do not adequately portray all the values associated with a functioning ecosystem. Most economic analyses focus on the goods and services that the public receives and not the infrastructure that produces the goods and services. The many interrelationships between species that are required for a fully functioning ecosystem are not independently recognized and valued by the public. For example, the value of catching game fish has been the focus of many studies, but seldom has the value of the prey species sought by game fish been estimated. In an economic context, the demand for game fish generates a derived demand for the ecosystem components that produce the game fish. It is fairly easy to estimate the economic value of game fishing. It is very difficult to estimate the economic value of the ecological infrastructure that supports game fish.

In order to provide the most comprehensive picture of the benefits of restoring the ecosystem functions in the Ashtabula River and nearby waters, this analysis is divided into two parts. The first part describes the infrastructure changes for selected biological characteristics of different levels of ecosystem restoration. The second part contains the economic value of goods and services that the public would expect to receive at alternative levels of restoration. The monetized economic benefits are the values placed by the public on the goods and services provided by a functioning ecosystem. By valuing the goods and services provided by a functioning ecosystem, we can gain insight into the minimum economic value of the ecosystem itself.

The proper framework for analyzing the restoration of ecosystem functions in the Ashtabula River is an economic analysis based on “with” and “without” project conditions. The “with” project conditions reflect the pattern of activities and biological conditions that are expected to occur over a 50 year evaluation period. These conditions would be expected after a one-time cleanup of contaminated river bottom sediments. The projected future conditions would not reach full benefit potential in the first year but would phase in depending on the restoration alternative being considered. There are three alternative dredging scenarios and an ecological supplement attached to the deep dredging alternative to make four alternatives to consider. The four alternatives will produce different levels of restoration, different timing of restoration, and different effects on the risk of a major PCB contamination of Lake Erie.

The “without” project scenario is the economic baseline. The baseline is the pattern of activities that would exist in the Ashtabula River over the evaluation period in the absence of a one-time cleanup effort of contaminated bottom sediments. Subtracting the “with” project set of environmental characteristics from the “without” project characteristics is the measure of improvement

brought about and directly attributable to the project, i.e. the project benefits. For the economic values of the goods and services that would be available under alternative environmental restoration scenarios, the annualized value is calculated in order to take into account the different time periods involved and produce a single best estimate of the annual benefits of the alternative being considered.

Background

The lower Ashtabula River has been identified as a Great Lakes Area of Concern by the International Joint Commission. The Area of Concern has been designated as the lower two miles of the Ashtabula River, including Fields Brook, and the nearshore areas of Lake Erie. Fields Brook has been placed on the United States Environmental Protection Agency National Priorities List of uncontrolled hazardous wastes sites (Superfund), and is being remediated under that authority. This analysis will focus on the benefits of restoring the ecosystem functions in the lower two miles of the Ashtabula River.

The present ecological conditions at the Ashtabula River Area of Concern are best described in the report entitled "Biological Community Status of the Lower Ashtabula River and Harbor Within the Area of Concern" (OEPA 1992) and the report entitled "Biological and Water Quality Study of the Grand and Ashtabula River Basins" (OEPA 1997). Primary problems that exist in the Lower River from the 5th Street Bridge upstream to the end of the Federal navigation channel are contaminants in the sediments (primarily PCBs, some equal to or in excess of 50 mg/kg) and recreational harbor development (bulkheading, dredging, and use of the recreational navigation channel). Benthic and fishery habitat has been significantly degraded in these areas as compared to quality warm water habitat criteria. Primary problems that exist in the Lower River from the mouth upstream to the 5th Street Bridge are those associated with commercial harbor development bulkheading, dredging and use of the commercial navigation channel, and contaminants in the sediments (primarily PAHs likely associated with the coal dock developments in the immediate area and other contaminated sediments migrating in from upstream).

The Ashtabula River Partnership (ARP) has investigated problems and needs pertaining to contaminated sediments in the Lower Ashtabula River. Available information on sediment quality in the Ashtabula River Area of Concern was presented in the Ashtabula River Remedial Action Plan (OEPA 1991). These contaminants have restricted operations and maintenance, raised the cost of disposal of dredged material, and limited use and development of the harbor.

The ARP has focused on PCBs, and to a lesser extent PAHs in the Ashtabula River Area of Concern (AOC) due to their higher levels and wide area of contamination. There are other contaminants of concern in the AOC. However, it is assumed that by focusing on PCBs and PAHs, the other contaminants of concern will be addressed due to co-location of contaminants.

When PCBs build up in the environment they cause a number of harmful effects, including cancer and non-cancer adverse effects. Non-carcinogenic health effects such as reproductive impairment, neurotoxicity, developmental toxicity, endocrine disruption, and immunosuppres-

sion have also been associated with exposure to PCBs. Some PAHs have also been found to cause noncancer adverse health effects including difficulty in reproduction, decreased body weight, immunosuppression, and harmful effects to the skin.

PCBs are a particular concern to aquatic food chains because of the process known as biomagnification where contaminant concentrations increase at each step in the food chain. For instance, microscopic floating aquatic plants known as phytoplankton containing very low levels of PCBs are eaten by zooplankton, primarily microscopic floating animals. Zooplankton are eaten by small fish, which are then eaten by larger fish. Fish eating birds, such as heron and kingfishers, and fish eating mammals, such as mink, then eat the fish, resulting in significantly elevated PCB levels compared to those measured in animals lower in the food chain. Highly elevated levels of PCBs have been measured in bird eggs as well. Because of the concentrations of PCBs detected in fish and the ability of PCBs to biomagnify up the food web, fish eating birds and mammals have the highest potential to experience any associated toxicological effects.

The interspecies sensitivities to PCBs and PAHs varies widely even between species that are taxonomically closely related. For instance mink have been found to be extremely sensitive to PCBs which cause adverse effects to reproduction even at very low levels. In aquatic plants, PCBs have been found to cause reduced growth through a reduction in photosynthetic activity as a result of diminished chlorophyll content.

Three primary dredging plans (bank to bank to bedrock, deep dredge, and shallow dredge) were formulated to address the removal of contaminated sediments. These plans were assessed and evaluated from a human and ecological risk perspective as described in the Feasibility Report Appendix E, EIS Appendix EA-C, and in the 1997 Survey Report. The Ashtabula River Partnership assessed/evaluated the dredging scenarios to determine how the plans met the River clean-up goals while minimizing the amount of material needed to be dredged, which would moderate project costs.

Ecosystem Restoration Benefits - Environmental Indicators.

The benefits of restoring an ecosystem's functions can best be characterized by a series of environmental indicators. It is the combination of indicators that provide the best overall picture of ecosystem health and demonstrate that vital processes are restored and functioning to produce not only the goods and services the public receives but the necessary infrastructure of the ecosystem itself. The biological measures that have been developed to assess the health of the Ashtabula River include such indicators as water quality, fish species diversity, fish abundance, percent of fish with external anomalies, the index of biological integrity (IBI), invertebrate community index (ICI), and environmental risk of a major blowout of PCBs into Lake Erie. In addition, by removing the PCB's from the Ashtabula River there is a good chance of a return of two endangered species to the river, muskellunge and blacknose shiner. Both of these are plant loving species that are found in Lake Erie that should be present in the Ashtabula River. Each of these indicators is described below.

Water quality is a measure of the weighted concentration of PCBs (measured as kg of PCBs present) in the sediment of the Ashtabula River. This relates to potential scour turbidity and resuspension of contaminated sediments and solubilities.

Fish species diversity and abundance are measures of the quality of the fish community. The presence or absence of species that are sensitive to contaminants and species that are plant loving species are good indicators of the effects of contaminated sediments in the river bottom. The higher the number of individuals and the number of species present, the higher the quality of the fish community.

Fish with external anomalies is a measure of the percent of external anomalies observed on fish collected in the Ashtabula River lacustrary.

Index of biological integrity (IBI) (Steedman 1988) is based on simple, definable ecological relationships. The IBI is quantitative as an ordinal, if not linear measure, which responds in an intuitively correct manner to known environmental gradients. As an aggregation of community information, the IBI provides a way to organize data and reduce it to a scale which is interpretable against communities of known condition. There is no complex transformation of data accomplished, just an improved stratification and organization of complex ecological information. Simply stated, multimetric indices can satisfy the demand for a straightforward numerical evaluation that expresses a relative value of aquatic community health and well being which allows program managers to, in effect, “visualize” relative levels of biological integrity (Yoder and Rankin 1995).

Invertebrate community index (ICI) is a multi-metric index that measures the status of the macroinvertebrate community. Similar to the IBI, the ICI index is based on species richness, trophic composition, diversity, presence of pollution-tolerant individuals or species, abundance of bio-mass, and the presence of diseased or abnormal organisms (OEPA).

Environmental risk is an assessment consisting of a qualitative and/or quantitative evaluation of the actual or potential impacts of contaminants on humans, animals, and plants. The human health risk assessment evaluates the potential for unacceptable risk to humans through exposure to contaminants from an Area of Concern. The ecological risk assessment evaluates the potential impacts of contaminants from an Area of Concern on animals and plants. A qualitative rather than quantitative risk assessment approach was deemed most appropriate for this project (Ashtabula River Partnership, Draft EIS app. C).

Baseline Conditions

In order to identify the ecosystem improvements that would take place at Ashtabula Harbor from various remediation plans, Ashtabula Harbor’s current ecosystem needed to be compared to some target or model environment. The target environment chosen was Conneaut Creek, Ohio.

Conneaut Creek flows into Lake Erie 12 miles east of Ashtabula, Ohio. This creek’s levels of

commercial and recreational development are similar to Ashtabula's. However, Conneaut Creek does not contain appreciable levels of PCB contamination. Data from the Conneaut Creek lacustrary serves as a model for a restored Ashtabula River ecosystem and forms the basis of the target levels used for evaluating the effectiveness of the various dredging scenarios.

For a fish community assessment of Conneaut Creek, a total of five sites were sampled for fish by Ohio EPA since 1989. Very little environmental deterioration was seen in the upstream portions of the system and extensive areas of the basin are wooded. The lower 0.5 mile of the stream was a ship channel with deep sheet piling lined banks while upstream from river mile 0.5, the channel was shallower and at least partially vegetated along the bank. Most of this reach was relatively narrow with moderate accumulations of silt and sediment. An area of thick silt and sediment with a large expanse of emergent and submergent vegetation was present at river mile 1.0. Upstream of the ship channel, in the area of vegetation, IBI scores were in the marginally good range while ship channel sites had IBI scores in the poor range. The dichotomy of near good and poor community conditions found in this lacustrary illustrate the strong effect that habitat alterations can have on biological conditions even in areas where no impacts from water column chemistry exist.

Comparison of Alternatives

The results of the comparison of alternatives and their resulting ecosystem restoration benefits are shown on Table 1. In all, three dredging alternatives were evaluated for restoration potential of the Ashtabula River. The addition of ecological restoration to the deep dredge alternative is an attempt to shorten the time frame in which full benefits are realized for this alternative. The addition of clean silt, aquatic shelves, and banking for shallow areas will reduce the amount of time before the plant and fish communities are re-established. Supplemental ecological measures are necessary, particularly for Ecological Assessment Areas 2 and 3, because there are essentially no clean, protected, shallow areas of any substantial length in these reaches. Such areas are needed to provide food, cover, spawning habitat, and passage of fish through the area necessary for a quality environment. Table 2 summarizes the supplemental ecological restoration plans.

The estimates of improvements in Table 1 were derived in several ways. They represent both quantitative engineering analyses and qualitative experience with similar projects. The water quality estimate of PCBs present is an engineering analysis of core samples. For the fish species diversity, fish abundance, and fish with external anomalies, the findings for Conneaut Creek (River Mile 1.5) were taken as the standard against which improvements in the Ashtabula River (River Mile 1.3) would be gauged. Without Project and Shallow Dredging were assumed to achieve one third of the possible improvement due to burial of contaminated sediments. Deep Dredging and Bank-to-Bank were assumed to achieve two thirds of the possible improvement. Deep Dredging with Ecological Restoration was assumed to achieve the Conneaut Creek levels. Starting levels and changes to the IBI and ICI were estimated by OEPA staff. Risk was estimated by the Corps of Engineers and encompasses both probability of a blowout event and severity of PCB loadings to Lake Erie. Project costs were estimated by the Corps.

A comparison of the biological indicators between the shallow dredging alternative and the “without project” alternative shows that there is very little ecological improvement. With the exception of removing a significant quantity of contaminated sediment and thereby reducing the risk of a blowout of contaminants into Lake Erie, there is very little evidence of any restoration of ecological functions as seen in such indicators as fish diversity and density, and the IBI and ICI indices. The environmental gains for an expenditure of nearly \$52 million in total project cost appears to be minimal for this dredging alternative.

A similar examination of the biological indicators for the deep dredge alternative compared to the “without project” scenario shows substantial improvement in all indicators. The significance of the reduction in PCB contaminated sediment is demonstrated in both increases in fish diversity and abundance. The percent of fish with external anomalies decreases and modest improvements in both the IBI and ICI indices indicate that ecosystem functions are being restored. The risk of a major blowout of PCBs into Lake Erie is significantly reduced. For an incremental expenditure of \$4.7 million over the shallow dredging alternative, a significant improvement in ecological functions is anticipated. For example, fish species and diversity increased by 33% and 68%, respectively, under shallow dredging. The same indicators increased by 66% and 137%, respectively, for the deep dredge alternative.

The bank to bank dredging alternative is expected to produce the same level of ecosystem restoration as the deep dredge alternative. The significant reduction in PCBs from bank to bank dredging is the major difference that separates the two alternatives. For an incremental expenditure of approximately \$16 million over the cost of the deep dredge alternative, very little additional ecosystem restoration improvement is expected from the bank to bank dredging alternative. The amount of time required before ecosystem functions begin to produce substantial benefits can be reduced significantly with the addition of remedial ecological restoration. After deep dredging occurs, it will take a number of years before clean silt is washed downstream and produces a high quality and productive aquatic environment. This time period to full recovery can be shortened with the addition of clean fill and other ecological measures after deep dredging the river. The ecological restoration alternatives considered are shown in Table 2.

Ecological restoration activities increase the amount of shallow habitat which is needed by aquatic plants and some species of fish. By changing the contours of the river, the deep dredge with ecological restoration alternative adds more, diverse habitat to the ecosystem resulting in a more diverse biota. The comparison of the biological indices for the deep dredge alternative with ecological restoration produces the greatest improvement over the “without project” set of biological values. The “without project” values are the set of conditions expected to occur in the year 2050 if a one-time cleanup of the PCB contaminated sediment is not carried out. The indices with the most pronounced improvement for the deep dredge with ecological restoration are the fish diversity and abundance indices. Dramatic improvements in the river environment brought about by removing PCB laden sediment can be achieved in 3 years following dredging and the addition of clean fill as compared to 5 years for the deep dredge scenario. For an incremental expenditure of approximately \$855 thousand over the cost of the deep dredge alternative, the indicators of ecosystem health of the Ashtabula River can be significantly enhanced in a shorter amount of time

than would occur with natural recovery. This will lead to achieving the greatest ecosystem restoration benefits in the shortest amount of time.

The overall goals of RAP are to restore all beneficial uses of the Area of Concern, prohibit the discharge of toxic substances in toxic amounts, and virtually eliminate the discharge of persistent toxic substances. The restoration of beneficial uses of the Ashtabula River can be summarized into the following six objectives: remediate the restriction on the consumption of fish caught in the Ashtabula River; remediate the degradation of fish populations, remediate fish tumors and other deformities, remediate the degradation of benthos, remediate restrictions on dredging activities, and remediate the loss of fish habitat. Under the deep dredge alternative with ecological restoration all six of these objectives are addressed.

Implementation of the deep dredge alternative along with supplemental ecological restoration measures, as described in Plan 4 for Area 2 and Plan 2 for Area 3, will achieve the project objectives at least cost and in the shortest time possible. This option constitutes ecological restoration through environmental dredging within and just outside the authorized Federal navigation channel. Clean material dredged from the channel upstream of the Upper Turning Basin and possibly from the Outer Harbor area should be deposited as cover into the deep dredged area for at least one operations and maintenance dredging cycle to expedite clean benthic cover material recovery. The width of the maintained recreational navigation channel to the west upstream of the 5th Street Bridge between the Conrail slip and the Upper Turning Basin will be decreased by about eight feet or more, as possible, to provide additional aquatic shallow area along the east embankment in the future. The supplemental ecological restoration measures serve to ensure fishery passage and, in addition, Plan 4 for Area 2 restores quality warm water habitat.

Table 1. Comparison of Alternatives' Ecosystem Restoration Benefits.

Indicator	Data Source	Present Condition	Target	Without Project	Shallow Dredge	Deep Dredge	Deep + Eco Restoration	Bank to Bank
Year Endpoint Achieved	---	1995	---	2000	2006	2008	2006	2013
% Share of Potential Improvement	---	---	---	0	33%	66%	100%	66%
<i>Ecosystem Restoration Benefits</i>								
Water Quality (kg of PCBs Present)	EA	11,018	0	11,018	2,797	1,952	1,952	274
Fish Species Diversity (#spp present)	C	15	30	20	20	25	30	25
Fish Abundance (#/bank km.)	C	228	695	384	384	540	695	540
Fish with External Anomalies (%)	C	6 Highly	3 Moderately	5 Strongly	5 Strongly	4 Strongly	3 Moderately	4 Strongly
Index of Biological Integrity (IBI)	OEPA	27 Poor	46 Good	31 Poor+	35 Fair	43 Good	46 Good	43 Good
Invertebrate Community Index (ICI)	OEPA	15 Poor	43 Good	19 Poor	27 Fair-	39 Fair	41 Fair+	39 Fair
Risk (probability of major blowout)	COE	High	Low	High	Medium	Low	Low	Low
Timing (years to maturation)	---	---	Fewest	---	3	5	3	10
PCB Mass Removed (%)	COE	---	100	0	75	82	82	98
<i>Project Costs</i>								
Dredging Only (1997\$ thousands)	--	--		--	\$17,742	\$20,153.5	\$20,153.5	\$30,448.75
Total Project (1997\$ thousands)	--	--		--	\$51,800	\$56,500	\$57,355	\$72,900

Notes:

The code for the sources of the data are as follows: EA - Engineering Analysis, C - Conneaut Creek, OEPA - Ohio Environmental Protection Agency, COE - Corps of Engineers.

Year Endpoint Achieved: Assume the dredging portion of the project is completed in 2003. Each alternative requires a different period to achieve its expected endpoint.

Share of Standard: For each of the next three indicators below water quality, the findings for Conneaut Creek (River Mile 1.5) were taken as the standard which would be attained in the Ashtabula River (River Mile 1.3) with complete restoration. Without Project and Shallow Dredging were assumed to achieve one third of the possible improvement due to burial of contaminated sediments. Deep Dredging and Bank-to-Bank were assumed to achieve two thirds of the possible improvement. Deep Dredging with Ecological Restoration was assumed to achieve the Conneaut Creek levels.

Fish Species Diversity and Fish Abundance: Table 1, A comparison of the relative number (per kilometer) of fish species collected at electrofishing sites on the Conneaut Creek and Ashtabula River lacustraries in Roger Thoma's 2/4/98 handout, *Fish Community Assessment*.

Fish with External Anomalies: Figures 6 and 7, Percent of external anomalies observed on fish collected in the Ashtabula River lacustrary in Roger Thoma's 2/4/98 handout, *Fish Community Assessment*. Adjective describes degree of impairment, e.g. the current condition is highly impaired.

Index of Biological Integrity: Figures 1 and 2, Fish community status for the Ashtabula River lacustrary as measured by the Index of Biotic Integrity, in Roger Thoma's 2/4/98 handout, *Fish Community Assessment*. Improvements from the starting level were taken from the Assessment/Evaluation Summary Table, page 86 of Tod Smith's 4/20/98 fax, *Section 312(b) Ecological Restoration/Preservation (Draft)*. A plus sign (+) indicates the index value is within the confidence limits of the next higher characterization, e.g. "Fair+" is within the confidence limits of the "Good" range.

Invertebrate Community Index: Figures 4 and 5, Macroinvertebrate community status in the Ashtabula River lacustrary as measured by the Invertebrate Community Index, in Roger Thoma's 2/4/98 handout, *Fish Community Assessment*. Improvements from the starting level were taken from the Assessment/Evaluation Summary Table, page 86 of Tod Smith's 4/20/98 fax, *Section 312(b) Ecological Restoration/Preservation (Draft)*. A plus sign (+) indicates the index value is within the confidence limits of the next higher characterization, e.g. "Fair+" is within the confidence limits of the "Good" range.

Risk: Table 9, Alternatives matrix, page 11 of Tod Smith's 2/4/98 handout, *Section 312(b) Ecological Restoration/Preservation (Draft)*.

Timing: Professional estimate from experience at Maumee River and similar restoration sites.

Project Costs: Table 8, Dredging Project Costs, page 9 of Tod Smith's 2/4/98 handout, *Section 312(b) Ecological Restoration/Preservation (Draft)*.

Table 2. Supplemental Ecological Restoration Plans

	----- Area 3 -----			----- Area 2 -----			
	Plan 1 Aquatic/Fishery Shelf Cut	Plan 2 Aquatic/Fishery Shelf Hung	Plan 3 Aquatic/Fishery By-Pass Cut	Plan 1 Conrail Slip & Aquatic/Fishery Shelf Cut	Plan 2 Conrail Slip & Aquatic/Fishery Shelf Extended	Plan 3 Aquatic/Fishery Shelf Cut	Plan 4 Acquire Conrail Slip & Aquatic/Fishery Shelf Cut
Construction Cost	\$400,662	\$313,111	\$787,313	\$1,250,004	\$1,537,136	\$400,662	\$447,237
Project Cost	\$450,745	\$352,250	\$885,727	\$1,406,255	\$1,729,279	\$450,745	\$503,142
Shoreline Improvement (Acres)	.7	.5	1.5	3.5	4	.7	.7+Acq.
Shallows Improvement (Acres)	.7	.1	1.5	2.5	3	.7	.7+Acq.
Fishery Improvement (IBI)	+4	+3	+4	+11	+12	+10	+11
Macro-invertebrate Improvement (ICI)	+4	+2	+4	+13	+14	+11	+12

The previous section used various environmental indices to describe the restoration of the ecosystem infrastructure. Those changes affect the level of human use and enjoyment of the ecosystem. Activities such as navigation and recreation, and the general enjoyment derived from living in an area where the ecosystem is not impaired are key elements in maintaining and enhancing the quality of life. The following section estimates the economic values associated with the cleanup of the whole Ashtabula River (upstream and downstream of the 5th Street Bridge) under Section 312(b) of the Water Resources Development Act of 1990 - environmental restoration.

National Economic Development Benefits

The results of the analysis of national economic development benefits are shown in Tables 3a and 3b. The tables present the estimated value of the goods and services associated with each of the environmental dredging alternatives. Table 3a presents these values in average annual dollars using a 50 year project life. Table 3b presents the benefits in discounted present values using a 50 year project life and a 3.6% annual interest rate, for each of the benefit streams generated by navigation and recreation activity, and the value placed by citizens on removing contaminated sediment from the Ashtabula River.

Commercial Navigation Benefits

Ashtabula Harbor is a major trans-shipment point for bulk commodities. Iron ore arrives from Lake Superior ports and is shipped to inland steel mills in Ohio, Pennsylvania, and West Virginia. Coal is brought by rail from Appalachian mines and shipped to electricity generating stations and other consumers around the Great Lakes. Limestone from northern Michigan is used in the local area. Without the project, contaminated sediments will fill the commercial navigation channel. Lacking a confined disposal area for the contaminated dredge spoil in the Ashtabula area, dredging will stop and the channel will shoal, effectively stopping commercial navigation.

If commercial navigation is impeded by the shallow harbor, shippers will seek alternate routes and carriers. They will incur added costs to deliver their products. The analysis of commercial navigation benefits compares these added costs to shippers in the "without" project scenario to a "with" project scenario in which the contaminated sediments are removed before they reach the navigation channel. With the project, open lake disposal of dredge spoil is permitted and channel dredging continues. There is no interruption in shipping traffic through Ashtabula Harbor. The "with" project analysis assumes that shipping continues at the same level and pattern as occurred in 1994 during the 50 year analysis period. The average annual savings to shippers', the difference in average annual transportation costs between the without and with project conditions, is \$1,186,200. This average annual benefit was calculated using a 7.625% annual interest rate and a 50 year project life. Because shallow dredging leaves a considerable amount of the PCB load in place, the shallow dredging alternative does not generate any navigation benefits. Both deep dredging alternatives and the bank-to-bank-to-bedrock alternative remove a substantial portion of the potential contamination. Consequently, all three generate average annual navigation benefits of \$1,186,200. Table 3b presents these navigation benefits in present worth terms (\$27,328,300) assuming an annual percentage rate of 3.6%.

Table 3a. Average Annual Benefits of the Ashtabula River Ecosystem Restoration By Plan.
Average Annual Benefits are in Thousands of 1996 Dollars.

	Average Annual Benefits				
	Maximum Yearly Benefits	Shallow Dredge ²	Deep Dredge	Deep + Eco Restoration	Bank to Bank
<i>National Economic Development Benefits</i>					
Navigation (reduction in transport costs by maintaining port of Ashtabula)	1,186.2 ¹	---	1,186.2 ¹	1,186.2 ¹	1,186.2 ¹
Boating (consumer surplus)	84.4	---	67.2	70.1	60.4
Fishing (consumer surplus)	199.0	82.6	158.3	165.3	142.3
Passive Use Values (consumer surplus)	1,108.7	347.0	655.4	694.2	566.1
Change in Property Values	477.2	133.0	266.1	266.1	266.1
Risk Reduction to Lake Erie Walleye Fishery	615.4	471.0	514.9	514.9	615.4
<i>Regional Economic Development Benefits</i>					
Local Economic Impacts (From Retaining Commercial Navigation)	3,895.9 ¹		3,895.9 ¹	3,895.9 ¹	3,895.9 ¹
Boating (total impact of expenditures on output)	300.8	124.9	239.2	249.8	215.0
Fishing (total impact of expenditures on output)	937.8	389.3	745.3	778.9	670.4

Values show the difference between the “without” project condition and the alternative in annualized values of 1996 dollars in thousands. An annual discount rate of 7.625% was used to calculate Navigation benefits and Local Economic Impacts benefits. All other benefits were calculated using a real discount rate of 3.6 percent per year. The ecosystem is expected to achieve its new level of productivity in 3 years after a 3 year construction phase in the Shallow Dredge and Deep Dredge Plus Ecosystem Restoration. The Deep Dredge option is assumed to require 5 years to recover. The Bank to Bank alternative is assume to take 10 years to recover.

¹ Annualized value discounted at 7.6 percent per year, given a 50 year project life. All other benefits are discounted using a 3.6% annual interest rate.

² Shallow Dredge does not permit ongoing maintenance of the recreational channel nor does it remove the bulk of the contaminated sediments; so, benefits are prorated to one half of benefits associated with Deep Dredging and Eco Restoration.

Table 3b. Benefits of Ashtabula River Ecosystem Restoration If Total River Is Cleaned Up Under Section 312(b) of the Water Resources Development Act of 1990. Discounted Present Worth Values in 1996 Dollars.

	Maximum Discounted Present Worth Values	Shallow Dredge ¹	Deep Dredge	Deep + Eco Restoration	Bank to Bank
	(Recovery Yrs)	---	5	3	10
<i>National Economic Development Benefits</i>					
Navigation (reduction in transport costs by maintaining port of Ashtabula)	\$27,328,300	---	\$ 27,328,300	\$ 27,328,300	\$ 27,328,300
Boating (consumer surplus)	\$ 1,944,500 ¹	---	\$ 1,547,400	\$ 1,615,300	\$ 1,390,600
Fishing (consumer surplus)	\$ 4,584,700	\$ 1,903,400	\$ 3,647,200	\$ 3,807,400	\$ 3,277,800
Passive Use Values (consumer surplus)	\$ 17,037,900	\$ 7,994,500	\$ 15,100,500	\$ 15,992,800	\$ 13,042,900
Change in Property Values	\$ 10,990,000	\$ 3,065,000	\$ 6,130,000	\$ 6,130,000	\$ 6,130,000
Risk Reduction to Lake Erie Walleye Fishery	\$ 14,177,500	\$ 10,850,200	\$ 11,862,800	\$ 11,862,800	\$ 14,177,500
<i>Regional Economic Development Benefits</i>					
Local Economic Impacts (From Retaining Commercial Navigation)	\$ 89,755,800	\$ 0	\$ 89,755,800	\$ 89,755,800	\$ 89,755,800
Boating (total impact of expenditures on output)	\$ 6,930,000	\$ 2,981,100	\$ 5,709,200	\$ 5,962,200	\$ 5,131,600
Fishing (total impact of expenditures on output)	\$ 21,605,500	\$ 9,211,800	\$ 17,803,100	\$ 18,590,700	\$ 16,001,000

Values show the difference between the "without" project condition and the alternative in discounted present values of 1996 dollars in thousands. A real discount rate of 3.6 percent was used. The ecosystem is expected to achieve its new level of productivity in 3 years after a 3 year construction phase in the Shallow Dredge and Deep Dredge Plus Ecosystem Restoration. The Deep Dredge option is assumed to require 5 years to recover. The Bank to Bank alternative is assumed to take 10 years to recover.

¹ Shallow Dredge does not permit ongoing maintenance of the recreational channel nor does it remove the bulk of the contaminated sediments. Consequently, there are no Commercial Navigation Transportation Cost Savings or Local Economic Impacts benefits associated with retaining the commercial navigation. The Shallow Dredge benefits associated with all other benefit categories (including risk reduction to Lake Erie Walleye fishery) are pro-rated to one half of the benefit level associated with Deep Dredge and Eco Restoration.

Boating - Consumer Surplus

The greatest contact many people have with the river is through recreation. Fishing, boating, and nearby beaches draw thousands of visitors to Ashtabula each year. The results of the proposed ecosystem restoration projects will be experienced and appreciated through these activities.

There are 1,058 boat slips and 11 launch ramps in the Ashtabula River above the Fifth Street bridge. Eleven marinas/yacht clubs line the bank providing a variety of services to boaters from all over northeastern Ohio (U.S. Army Corps of Engineers 1997). People pursuing any recreational activity derive pleasure from the activity greater than what they pay to experience it. If they did not, they would be indifferent between pursuing the activity and doing anything else. They would find something more rewarding to do. Economists put a dollar value on this extra pleasure by asking people how much money the activity would need to cost before they would stop doing it. That amount is called the "consumer surplus," or "willingness to pay." An improvement in the quality of the river ecosystem can be expected to improve the boating experience and so increase boaters' willingness to pay. Ecosystem improvements will also attract additional boaters to Ashtabula Harbor. Consumer surplus changes from changes in resource quality are national economic development benefits (U.S. Water Resources Council 1983).

This analysis assumes that boaters respond positively to improvements in water quality. A recent survey by the Ohio Sea Grant College Program showed an association between boating on Lake Erie and awareness of Ashtabula River pollution problems (Lichtkopler 1998). In addition, contamination of sediments in the river between Fields Brook and the Fifth Street bridge prevent open lake disposal of dredge spoil from that reach, preventing channel maintenance. As a consequence the recreational channel is becoming shallower and will become impassable for many boats within the planning horizon of this project. Boaters will benefit from the cleaner and deeper river this project portends.

About 70 percent of boaters approached by the Ohio DNR creel survey were fishing rather than boating for the sake of boating (Bador 1998). Anglers tend to have higher consumer surplus values than people strictly boating and so will be discussed separately. The Feasibility Report assumes that each of the 1,058 slips accounts for 25 boat usages per season and that 4.44 people participate in the average boat usage (U.S. Army Corps of Engineers 1997). Multiplying these estimates together implies 117,438 individual boating days from slips. Assuming 1,000 launches per season from each of the 11 launch ramps and an average of 3.78 persons per launched boat implies 41,580 individual boating days from launch ramps. Of the 159,018 boating days, 70 percent (111,313) are related to fishing while 30 percent (47,705) are strictly boating related. The U.S. Forest Service unit day value for motorized boating at a "less than standard site" was \$6 in 1985 (Walsh 1986, Table 8-10); at a "standard" site the value was \$12. Inflating the \$6 to 1996 price levels using the CPI for entertainment purchases implies a 1996 value of \$8.85.

The Feasibility Report estimates a 10 percent improvement in quality of the river experience "with" the project versus "without" it through a subjective point scoring system. For simplicity, assume the improved experience generates a linear increase in boating consumer surplus. This increase is made up of some improved experience of present boaters and some new boaters drawn to the activity by the improved quality of the river. More sophisticated estimates of changes in boating participation would involve estimation of boating demand equations and the

capacity constraints of the river which are not feasible with the data available. With a 10 percent improvement, the 47,705 boating days would generate maximum benefits of \$42,200 annually ($= 47,705 \times \0.885) and the new boaters would generate an additional \$42,200 annually ($= 4,770 \times \8.85) in consumer surplus. (For some boaters, this amount is far too low. Many boats will not be able to use their current slips or launch ramps if the channel is not maintained. Those boaters' losses will include the costs of traveling to a different marina, perhaps in a different city. These costs of substitution are not included in this estimate.)

Total annual maximum boating consumer surplus values came to \$84,400. This maximum annual surplus value was used to develop a 50 year time stream of boater consumer surplus benefits for each of the plans evaluated. Ecosystem restoration was assumed to take 3, 5, and 10 years, respectively, for Deep Dredge & Eco Restoration, Deep Dredge, and Bank to Bank to Bedrock. Annual boating consumer surplus values started at \$0.00 and rose to \$84,400 based upon the number of years needed for full eco-restoration (3, 5, 10). The conversion of these time streams of values to average annual values is presented in Table 3a. This conversion used a 3.6% annual percentage rate and a 50 year project life. Table 3b presents the present worth of these time streams.

Fishing - Consumer Surplus

As mentioned above, there are 111,313 fishing days originating from Ashtabula Harbor. Most of these occur in Lake Erie. The condition of the river fishery is secondary except that it contributes to the fishing in the lake. High quality habitat in the lacustrary would improve fishing in the lake by providing spawning areas and food sources. The central basin of Lake Erie is undergoing rapid changes in the sport fishery. Improved water quality and clarity, control of invasive species, and other factors are reducing fishing success and appear to be discouraging anglers. After a build up of fishing related development in the 1980's, recent trends suggest a fall off in fishing interest (Greenwire 1998; Bador 1998). The "without" project assumption is a continuation of the 1996 level of fishing activity.

Estimates of Ohio Lake Erie anglers' willingness to pay range from \$0.30 to \$36.26 per day (1996\$) (Dutta 1984; Brown and Hay 1987; Hushak et al. 1988; Glenn 1995). A 1992 survey provides local estimates of angler consumer surplus applicable to the Ashtabula region. Glenn (1995) estimated the values of anglers who used the Lorain county artificial reef and those who fished nearby but did not use the reef. The angling experience of those who did not use the reef is similar to angling in the Ashtabula portion of Lake Erie. Updated to 1996 dollars, the study estimated willingness to pay as \$8.94 per day (Glenn 1995). Ideally, increased catch rates from changes in fish populations in the river would be imputed to derive a change in the consumer surplus from each project alternative. While modeling the actual train of events, such a method would give only the facade of accuracy as the parameters at each step would be rough estimates. Recognizing this uncertainty, assume that the project will improve fishing in such a way that consumer surplus increases 10 percent, as in the Feasibility Report. The increase can be viewed as both a quality and quantity change. The combination of increased fish populations and varieties, increased interest in fishing, and increased peace of mind when consumption advisories are lifted will improve the quality of the experience for current anglers and attract more anglers to the area. Jakus et al. (1997) found removal of a fishing advisory alone increased anglers' consumer surplus 6 to 8 percent. The increase in valuation implies a fishing consumer surplus bene-

fit of \$99,500 annually ($= \$0.894 \times 111,313$) for current anglers and an additional \$99,500 annually for new anglers ($= \$8.94 \times 11,131$) attracted by the higher quality fishing. As the shallow dredge option accomplishes less restoration of the resource, the consumer surplus is prorated by half.

Total annual maximum fishing consumer surplus values came to \$199,000. This maximum annual surplus value was used to develop a 50 year time stream of fishing consumer surplus benefits for each of the plans evaluated. The analysis used the same assumptions as the boater consumer surplus analysis, with respect to the number of years needed to achieve full eco-restoration and interest rate assumptions. The result of converting these time streams of values to average annual values is presented in Table 3a. Again, this conversion used a 3.6% annual percentage rate and a 50 year project life. Table 3b presents the present worth of these fishing consumer surplus time streams.

Passive Use Value - Consumer Surplus

People often value aspects of the environment even though they will never use or visit those environments. Many people, for example, like the fact that Alaska is largely untouched by human beings even though they themselves will never go there. Survey techniques have been developed which encourage people to reveal these values and attach a dollar amount to them. The Ohio Sea Grant survey, mentioned earlier asked a series of questions to find Ashtabula county residents' value for a clean Ashtabula Harbor. The results indicate the median Ashtabula county household was willing to contribute \$25 per year for 30 years toward the cleanup (Lichtkoppler 1998). The survey is flawed in that \$25 was the lowest positive amount the respondent could select. The valuation question could be interpreted to include both use and non-use values. Some of the measured willingness to pay may have represented anticipated improvements in boating and fishing experiences. For this reason, the survey responses were separated by those households operating boats (26.8 %) and those households where the residents were non-boaters (73.2 %). Many respondents were willing to pay higher amounts than the \$25 minimum indicated on the survey form. The lower bound mean annual amount was \$32.50. If we assume that the lower bound mean applies to all non-boating households and subtract \$8.85 from the lower bound mean for boating households (so as to avoid double counting) then for the 36,800 households in Ashtabula county, the annual willingness to pay for harbor cleanup for 30 years is \$1,108,700 ($= \$32.50 \times 26,938 = \$875,500$ plus $\$23.65 \times 9,862 = \$233,200$).

Again, these maximum annual consumer surplus values were used to develop a 50 year time stream of passive use consumer surplus benefits for each of the plans evaluated. The time stream of these benefits differed from one plan to another based upon the number of years needed to achieve full eco-restoration (3 years, 5 years, 10 years). Also, benefits were assumed to accrue yearly for only 30 years (the length of time the contribution would be in effect based upon the survey). Consequently, from project year 31 to 50, passive use consumer surplus benefits were set to zero. The conversion of these time streams of value to average annual values is presented in Table 3a. This conversion used a 3.6% annual interest rate and a 50 year evaluation period. Table 3b presents the present worth of these streams, again using a 3.6% annual interest rate, a 50 year evaluation period, and a benefits generation length of 30 years.

Actual passive use value may be much larger than this. As the concept extends to people who

will not use the resource, people distant from the site may hold a passive use value for it. Anyone aware of the river or lake ecosystem may have a value for it. Certainly, vacationers in the region would probably be willing to pay for the river cleanup too. This is a conservative estimate of passive use value. Similar studies in other areas have found values in the same range for similar environmental improvements. In a recent report (U.S. EPA, 1995), a survey of studies where both use and non-use values were estimated showed that the ratio of non-use values to use values ranged from .5 to 2.5, depending on whether aesthetic value is considered part of passive use value. Applying this method to the Ashtabula/Conneaut region of Lake Erie, results in a passive use value of \$12 to \$60 per year.

Changes in Property Values

The awareness of contaminants in an area can reduce the value of property. In the most extreme circumstances, such as Love Canal, no potential buyers would accept the property at any price. The Ashtabula situation is similar to New Bedford, Massachusetts. In New Bedford, historical industrial areas which were subject to Superfund cleanups had left PCB contaminated sediment in the harbor. A study published in 1991 found "Once the pollution effect is widely known the panel models detect a significant reduction in housing values associated with the timing and location of the waste site area [i.e. the harbor]. Affected properties were estimated to have fallen between \$7,000 and \$10,000 (1989 dollars) in value as a result of their proximity to the hazardous wastes in nearby waters." (Mendelsohn, et al. 1991, page 268-9). The average house price in the New Bedford study area was \$71,630, in 1989 dollars, so the contamination's effect on housing values was substantial (ranging from 10 to 14 percent). Mendelsohn estimated the total lost value of 4,600 homes at \$35.9 million.

Applying the methods used in the New Bedford study to Ashtabula would require new surveys of housing sales transactions to determine the extent of influence of harbor attributes on housing values. Some geographic area around the river is probably stigmatized by the presence of contaminants in the water. A rough idea of the scale of the possible effect on housing prices can be estimated by applying the 10 percent change in value Mendelsohn found to the value of housing in Ashtabula Harbor. The median sales value of single homes in Ashtabula county in 1996 is \$61,300 (Crains Cleveland Business, April 1998). A 10 percent increase in value would increase the median house value \$6,130. An estimated one thousand housing units are in the affected area. The resulting change in housing value is about \$6.1 million.

The other benefits discussed in this section represent annual flows of benefits while the change in housing value is a one time change in the value of an asset. The average annual value of change in property values, assuming a 50 year project life and a 3.6% annual interest rate is \$266,100.

Preservation of Lake Erie Benefits

In 1996, 37 percent of all Great Lakes anglers fished in Lake Erie making it the most popular of the Great Lakes for fishing (U. S. Department of the Interior, Fish and Wildlife Service 1997). In all, there were 746,000 anglers who fished in Lake Erie for an estimated 6.7 million days. The most popular species sought in Lake Erie was walleye. The State of Ohio portion of Lake Erie had an estimated 311 thousand anglers fishing for walleye for 1.4 million days. This in-

cluded both State residents and non-residents going to Ohio to fish. The consumer surplus of the Lake Erie walleye fishery is \$59.4 million annually ($=6.7 \text{ mil. days} \times 8.85$). Of this total, approximately \$12 million ($=1.4 \text{ mil. days} \times \$8.85 = \$12,390,000$) in annual consumer surplus is attributable to anglers fishing from Ohio waters.

The potential impacts of PCB release from the Ashtabula River to Lake Erie are substantial. It is estimated that a release of 1 to 10 percent of the current PCB load from the Ashtabula River would be enough to increase the level of PCB's in walleye fillets to the point of having States advise sport anglers not to consume walleye from Lake Erie and lead to a closing of the commercial walleye fishery in Lake Erie. The removal of PCB laden sediment from the Ashtabula River will lower the probability of a storm or some other event transferring the PCB mass to Lake Erie. Lake Erie Walleye Fishery benefits by plan were calculated by determining the present worth of the Lake's walleye fishery. This value was then multiplied by the probability of a 100 year flood event. This resulted in a present worth value of approximately \$14,200,000. This was then multiplied times the percentage of total PCBs that would be removed by implementation of any one plan. The benefit of this risk reduction is demonstrated by the walleye fishery, which will be protected from this source of PCB contamination.

Regional Economic Development Benefits

Local Economic Impacts

Allowing the Ashtabula river to shoal to its natural channel depth will have impacts on the local economy, as well as the county. Currently, approximately 150 local area jobs are directly connected to bulk commodities moving through Ashtabula Harbor. Direct Harbor employment is concentrated at Piney Dock, Sidley Dock and conrails coal transshipment facility on the west bank of the Ashtabula River. These local area jobs generate income which is spent in the area. This expenditure of income locally makes possible the existence of other local jobs in such diverse areas as restaurants, food stores, and local government. The movement of the bulk commodity trade to some other port would mean the loss of these jobs to the local economy. The income generated by these lost jobs would no longer be part of the local areas economy. Job loss could result in part of the local labor force moving to another area to find employment. This could result in a reduction in local government services due to a reduction in local tax revenues (sales tax, property tax, school taxes, etc).

An estimate of the economic impacts on the Ashtabula County economy, and the fiscal impacts on local governments was developed using a regional general equilibrium model (REGEM). REGEM is a state of the art regional model that projects changes in industry output, intermediate purchases, employment, migration, exports, imports, household consumption, and spending and revenue of governments. The REGEM model was configured with ten industries: agriculture; construction; nondurable goods manufacturing; durable goods manufacturing; water transportation; retail; finance, insurance and real estate; personal services; business services; and miscellaneous services.

Economic and fiscal impacts were developed under Without and With Project conditions. Economic impacts were measured in terms of changes in (1) total county employment, and

(2) county gross product (ie. Net income accruing to households, firms, and local governments.). Fiscal impacts were measured in terms of changes in (1) revenues, and 2, expenditures of local governments in Ashtabula County.

The regional model calculated gross regional product accruing to households, firms, and local governments under the Without and With Project scenario. Additional gross regional product generated due to the implementation of the project was calculated. The present value of additional gross regional product, over the 50 year evaluation period was \$49.8 million. This converts to an average annual value of \$3,895,900. This evaluation used a 7.625% annual interest rate and a 50 year evaluation period (Table 3a). Table 3b provides the same regional benefits; but, using a 3.6% annual interest rate and a 50 year project evaluation period.

Because shallow dredging leaves a considerable amount of PCB's in place, the shallow dredging alternative does not generate Local Economic Impacts. However, both deep dredging alternatives and the bank-to-bank-to-bedrock alternative remove a substantial portion of the potential contamination and so all three generate similar Local Economic Impacts.

Boating - Expenditures

When the river becomes cleaner more people will want to go boating on it and those who already boat on it may use it more often. In addition, the project will permit continued maintenance of the recreational channel and so permit larger boats to go farther upriver. Such increased activity leads to increased spending and so stimulates the local economy. Such effects are not considered national economic development effects. The recreational spending would have occurred elsewhere in the country if it had not occurred in the local region (U.S. Water Resources Council 1983). The environmental improvement is a competitive advantage that attracts outsiders away from other places they might have gone boating and so stimulates the local economy.

The Feasibility Report estimates a 10 percent increase in quality of the boating experience using a subjective point scale. The relationship between quality and boating days may not be linear but any other assumption involves a detailed assessment of the demand for boating opportunities in Ashtabula which is beyond the scope of this report. Increased demand may derive from more trips by the existing boats, more people per boating trip, or more boats. Assuming a 10 percent increase in quality implies a 10 percent increase in demand for boating trips, and there is sufficient capacity for the added demand in Ashtabula Harbor, the calculations above imply there will be 4,770 more boating days per year after the project. This corresponds to the additional trips by "new boaters" described earlier.

The National Survey of Fishing, Hunting, and Wildlife-Associated Recreation is conducted every five years (U. S. Department of the Interior, Fish and Wildlife Service 1997). It collects information about anglers' expenditures, along with a great deal of other information. The survey is conducted to provide valid statistics at the state level. So specific expenditure information is available about people taking fishing trips to Lake Erie. (Narrowing the sample size further to trips to Lake Erie from Ohio reduces the number of observations in the survey to an unacceptable level.) Table 4 shows the mean daily expenditures for all anglers in Lake Erie. Boaters are assumed to have a similar pattern as anglers except for guide fees, equipment rental, bait, and ice

which relate specifically to fishing. The sum of boating items per day is \$43.84 in 1996 dollars; this implies an additional \$209,100 in annual spending by boaters attributable to the ecological improvements from the project. Increases in spending have a ripple effect in the local economy.

The ripple effect is measured using Input-Output Analysis (IO). When someone spends a dollar at a local store, the merchant spends it on something else, perhaps to pay an employee. The employee then spends his wages somewhere else and so generates additional income in the community. IO software contains a model of the local economy which simulates how the boater's dollar circulates through the economy. For this study, the local economic area is defined as Ashtabula, Geauga, and Lake counties. The \$209,100 that boaters are expected to spend annually if the project is completed would add a total of \$300,800 to regional output annually when all of the indirect and induced economic activity is included. The increased spending would generate 4.7 new jobs and \$83,000 in added employment income.

Again, this maximum annual value of \$300,800 was used to develop a 50 year time stream of boating expenditure benefits for each of the plans evaluated. The time stream of these benefits differed from one plan to another based upon the number of years needed to achieve full eco-restoration (3 years, 5 years, 10 years). Table 3a presents the results of converting these time streams of value to average annual values. Table 3b presents the present worth of these boating expenditure values. Both analyses used a 3.6% annual interest rate and a 50 year evaluation period.

Fishing - Expenditures

The discussion above about boating applies even more strongly to recreational fishing. As the habitat of the river improves, anglers can expect to see a greater number and variety of fish in the harbor and nearby waters. Some of these will be more desirable quarry such as pike, walleye, and salmonids. If the 10 percent improvement in the Feasibility Report subjective index is reflected linearly in increased fishing activity, there will be 11,131 more fishing days per year when the project is completed.

Table 4 shows the total average expenditures for a day of fishing on Lake Erie are \$58.58 (1996 dollars). Multiplying this by the increase in fishing days from the ecosystem restoration suggests a \$652,100 increase in local expenditures related to fishing. The ripple effect of spending also applies to these expenditures. The ripple effect of anglers spending \$652,100 increases total local output to \$937,800. This will contribute 14.8 new jobs and \$258,900 in additional employee compensation to the local economy. Perhaps not as impressive as a new factory, these gains are derived from cleaning up the environment, rather than despoiling it, and are in addition to improvements in property values, navigation, and ecosystem health.

Again, this maximum annual fishing expenditures value of \$937,800 was used to develop a 50 year time stream of fishing expenditure benefits for each of the plans evaluated. The time stream of these benefits differed from one plan to another with respect to when the maximum expenditures would be reached based upon the number of years needed to achieve full eco-restoration (3 years, 5 years, 10 years). Table 3a presents the results of converting this time stream of fishing expenditures to average annual values. Table 3b presents the present worth of these fishing expenditure values. Both analyses used a 3.6% annual interest rate and a 50 year eval-

uation period.

Table 4. Expenditures per day by Lake Erie Anglers, 1996

<i>Spending Category</i>	<i>Dollars per day</i>
Food	15.51
Lodging	6.31
Transportation	10.83
Access fees	1.14
Boat Costs	
Fuel	4.18
Launching fee	0.31
Other boat costs	<u>5.56</u>
<i>Sub-total, Boating spending per day</i>	<i>43.84</i>
<i>Fishing costs</i>	
Guide fees	8.75
Fishing Equipment rental	1.67
Bait	3.25
Ice	<u>1.07</u>
<i>Total</i>	<i>58.58</i>

Source: 1996 National Survey of Fishing, Hunting, and Wildlife-related Recreation data files.

References

- Bador, Tim. 1998. Personal Communication. Ohio Creel Survey, Fairport Field Office of Ohio Department of Natural Resources.
- Brown, Gardner, jr. and Michael J. Hay. 1987. *New Economic Recreation Values for Deer and Waterfowl Hunting and Trout Fishing, 1980*. Washington:U.S. Fish and Wildlife Service working paper.
- Crains Cleveland Business, April 1998.
- Dutta, N. 1984. *The Value of Recreational Boating and Fishing in the Central Basin of Ohio's Portion of Lake Erie*. Ohio Sea Grant Technical Bulletin OH SU-TB-18.
- "Ecological Benefits Assessment Model: Documentation Manual, U.S. Environmental Protection Agency, Office of Pollution Prevention and Toxics, Prepared by Industrial Economics, March 1995.
- Glenn, Sophia J. 1995. *Travel Cost Model of the Economic Value of the Lorain County, Ohio, Artificial Reef*. The Ohio State University, M.S. Thesis.
- Greenwire, The Environmental News Daily. March 6, 1998. *Canada: Anglers say cleaner Lake Erie hurts fish*. Item 20.
- Hushak, L.J., J. M. Winslow, and N. Dutta. 1988. "Economic Value of Great Lakes Sportfishing: The Case of Private Boat Fishing in Ohio's Lake Erie." *Transactions of the American Fisheries Society* 117:363-373.
- Jakus, Paul M., Mark Downing, Mark S. Bevelhimer, and J. Mark Fly. 1997. "Do Sportfish Consumption Advisories Affect Reservoir Anglers' Site Choice?." *Agricultural and Resource Economics Review* 26(2 October):196-204.
- Kraybill, David S. 1996. *An Economic and Fiscal Impact Study of the Ashtabula Harbor Dredging Project, Final Report*. September 30, 1996. Sub-Appendix Q1 to *Ashtabula River Partnership Comprehensive Management Plan, Feasibility Report (EIS)*. U.S. Army Corps of Engineers, Buffalo District.
- Lichtkoppler, Frank. 1998. *Ohio Sea Grant, Ashtabula RAP Council, 1997 Citizens Survey, Key Findings*. Ohio State University (Press Release, February 10, 1998).
- Mendelsohn, Robert, Daniel Hellerstein, Michael Huguenin, Robert Unsworth, and Richard Brazee. 1992. "Measuring Hazardous Waste Damages with Panel Models." *Journal of Environmental Economics and Management* 22:259-271.
- Ohio Environmental Protection Agency. 1997. *Biological and Water Quality Study of the Grand and Ashtabula River Basins*.

- Steedman, R. J. 1988. Modification and assessment of an index of biotic integrity to quantify stream quality in southern Ontario. *Canadian Journal of Fish and Aquatic Science*, 45:492-501.
- U.S. Army Corps of Engineers, Buffalo District. 1997. *Ashtabula River Partnership Comprehensive Management Plan, Feasibility Report*.
- U.S. Department of the Interior, Fish and Wildlife Service. 1997. *1996 National Survey of Fishing, Hunting, and Wildlife-Associated Recreation*.
- U.S. Water Resources Council. 1983. *Economic and Environmental Principles and Guidelines for Water and Related Land Resources Implementation Studies*. March 10, 1983.
- Walsh, Richard G. 1986. *Recreation Economic Decisions: Comparing benefits and costs*. State College, Pa.: Venture Publishing.
- Yoder, C.O. and E.T. Rankin. 1995. *The Role of Biological Criteria in Water Quality Monitoring, Assessment, and Regulation*. Ohio EPA, Division of Surface Water publication MAS/95-1-3. Page 16.



1123 Bridge Street
Ashtabula, Ohio 44004
(216) 964-0277 Office
(216) 964-5158 Fax

John Mahan, Ph.D
Coordinator

Rick Brewer
Co-Chairman
Coordinating Committee

Fred Leitert
Co-Chairman
Coordinating Committee

Steve Golyski
Chairman
Project Committee

Rick Mason
Chairman
Siting Committee

Brett Kaull
Chairman
Resource Committee

Michelle Rowley
Chairperson
Outreach Committee

Ashtabula River and Harbor

Comprehensive Management Plan

Dredging and Disposal

FINAL

FEASIBILITY REPORT AND

ENVIRONMENTAL IMPACT STATEMENT

ENVIRONMENTAL APPENDIX

EA-K REQUIRED ENVIRONMENTAL CORRESPONDENCE

City of Ashtabula
Town of Ashtabula
County of Ashtabula
State of Ohio

2001

ASHTABULA RIVER PARTNERSHIP

June 1, 1995

To: Stakeholders and other interested parties

Subject: Ashtabula River Partnership (ARP) status of project siting for river sediment -
supplemental information / scoping report

One of the four major strategies identified by the ARP to get the Ashtabula River dredged includes the development of a detailed plan for sediment remediation. Part of that plan is to determine the best location to store the sediments removed from the river as a result of the dredging operation.

As part of the ARP's desire to keep you informed, I have attached the latest report discussing the status of the ARP Siting Committee's efforts to date in evaluating potential locations for river sediment storage.

Should you have any questions concerning this information, please contact Todd Smith whose address and phone number are at the end of the attached report. Should you want to contact me, I can be reached by telephone at 216-993-1981.

The ARP intends to keep you informed on issues such as this and encourages your support on such an important project to Ashtabula and the surrounding area.

Very truly yours



N. F. Brewer

Co- Chair, ARP Coordinating Comm.

cc: F. Leitert
Attachments



ASHTABULA RIVER PARTNERSHIP

JUNE 1, 1995

SUBJECT: Ashtabula River Partnership (ARP) Project Siting -
Supplemental Information/Scoping Report

To All Interested Parties:

Implementation of the National Environmental Policy Act (NEPA) of 1969, as amended, requires that Federal planners initiate "an early and open process for determining the scope of the issues to be addressed and for identifying the significant issues related to a proposed action." As part of this process, we wish to invite your participation in a cooperative approach for remediation of the Ashtabula River.

The Ashtabula River Partnership (ARP) is an organization of public and private interests working toward clean-up of polluted sediments from the lower Ashtabula River. An ARP Fact Sheet follows as Attachment I. The lower Ashtabula River area is depicted on Figure 1 of Attachment II. The River clean-up will serve to alleviate harbor beneficial use and operations and maintenance restrictions, water quality and aquatic habitat issues, and health and safety concerns. This is in conjunction with various other on-going clean-up activities in the Ashtabula Harbor area.

The ARP approach recognizes the need for environmental dredging, dewatering/transport, and disposal of various contaminated sediments from the Ashtabula Harbor, the lower river, and possibly the Fields Brook Superfund site. Between 300,000 and 750,000 cubic yards (plus) of material is being considered for dredging and disposal. Conceptually, the material would be disposed of at one appropriately designed confined disposal facility (CDF). The ARP approach of a multi-purpose and multi-party disposal site is based upon a similar model project at Indiana Harbor, Indiana. Generally, contaminants of concern include metals such as chromium and lead, and chlorinated organic

compounds including PCBs in excess of 50 mg/kg. Some future harbor operations and maintenance dredged material disposal capacity would also be included.

Transportation of material could be via barge, pipe, truck, and/or rail, as appropriate. Generally, it is expected that: if the material is piped to a site, it would need to be dewatered at the site; if it is trucked/railed to the site, it would probably need to be primarily dewatered at a developed shoreline transfer site.

The project Siting Committee is currently working to identify, assess, and evaluate various potential CDF sites. Previous coordination for similar projects in this regard identified a likely area for such development as that generally east of the harbor and north of the railroad tracks in the ~~City~~ ^{Town} of Ashtabula, Ashtabula County, Ohio (Reference Figure 2 of Attachment II). This area contains similar developments and is zoned for heavy manufacturing. Existing regional permitted disposal landfills are also being considered for disposal of dredged material, as appropriate.

Previously considered and additional sites are being evaluated. Figure 3 and the Assessment/Evaluation Matrix of Attachment II identify some recently considered potential disposal sites and some required and/or developed siting assessment/evaluation parameters. Per preliminary assessment/evaluation, it appears that Sites 3, 5W/5, 7, and 8/10, should be considered in some further detail. Sites 0 (RES) and BFI (existing permitted disposal landfills) and Site P (a potential diked CDF site) will be considered, as appropriate.

The Partnership is pursuing a project that is acceptable from the environmental, social, economic, and engineering perspectives. All planning, design, and activities are to be in compliance with applicable Federal, State, and local laws and regulations. It is expected that it will take several years for the project to progress through careful planning and design phases to construction and implementation.

In order to identify any significant resources within the project vicinity and to fully assess potential impacts resulting from this project, we welcome any information on any significant resources that we should know about, and any project assessment

input, comments, concerns, and/or recommendations you may have relative to the project and your interest or jurisdiction. Please provide written comments within 30 days (July 2, 1995) of the date of this notice.

Correspondence pertaining to this matter should be directed to:

Mr. Tod Smith
Environmental Analysis Section
U.S. Army Corps of Engineers, Buffalo
1776 Niagara Street
Buffalo, New York 14207-3199

telephone (716) 879-4175.

Attachments

Ashtabula River Partnership Fact Sheet

Our Purpose:

The Ashtabula River Partnership, comprised of private citizens, government officials and business and industry leaders, is dedicated to exploring how to effectively remediate the contaminated sediments in the Ashtabula River and Harbor.

Our Goal:

Our goal is to look beyond traditional approaches to determine a comprehensive solution for remediation of the contaminated sediments not suitable for open lake disposal. Successful remediation of the Ashtabula River and Harbor will ultimately enhance economic development opportunities in Ashtabula County.

Our Strategy:

Our consensus-based partnership will:

- Define contaminated sediments to be addressed.
- Develop a detailed plan for sediment remediation.
- Identify resource needs for implementation.
- Generate timeline of milestones and activities.

Our Commitment:

To date, over 32 members/entities have joined our Partnership. Members have committed to volunteer their time, resources, knowledge and technical skills to forward the goals of the project.

Contact Information:

Coordinating Committee Co-Chair	Rick Brewer (216)993-1981
Coordinating Committee Co-Chair	Fred Leitert (216)992-3201

ATTACHMENT III

8

WATERFRONT OWNERSHIP

(O) INDICATES OWNERSHIP (L) INDICATES LESSEE SHOWN THUS (O)

- | | |
|-------------------------------------|-------------------------------|
| 1 PINNEY DOCK AND TRANSPORT CO. (O) | 9 ASHTABULA YACHT CLUB (O) |
| 2 CONRAIL CORPORATION (O) | 10 RISTER'S MARINA (O) |
| 3 R W SIDLEY, INC. (O) | 11 JOHN & PATRICIA PHELPS (O) |
| 4 LAKE SHORE STEEL CO. (O) | 12 RALPH S. DETTELBACK (O) |
| 5 JOHN A. PHELPS (O) | |
| 6 RIVERSIDE YACHT CLUB (O) | |
| 7 PENN CENTRAL R.R. (O) | |
| 8 SUTHERLAND MARINELAND INC. (O) | |

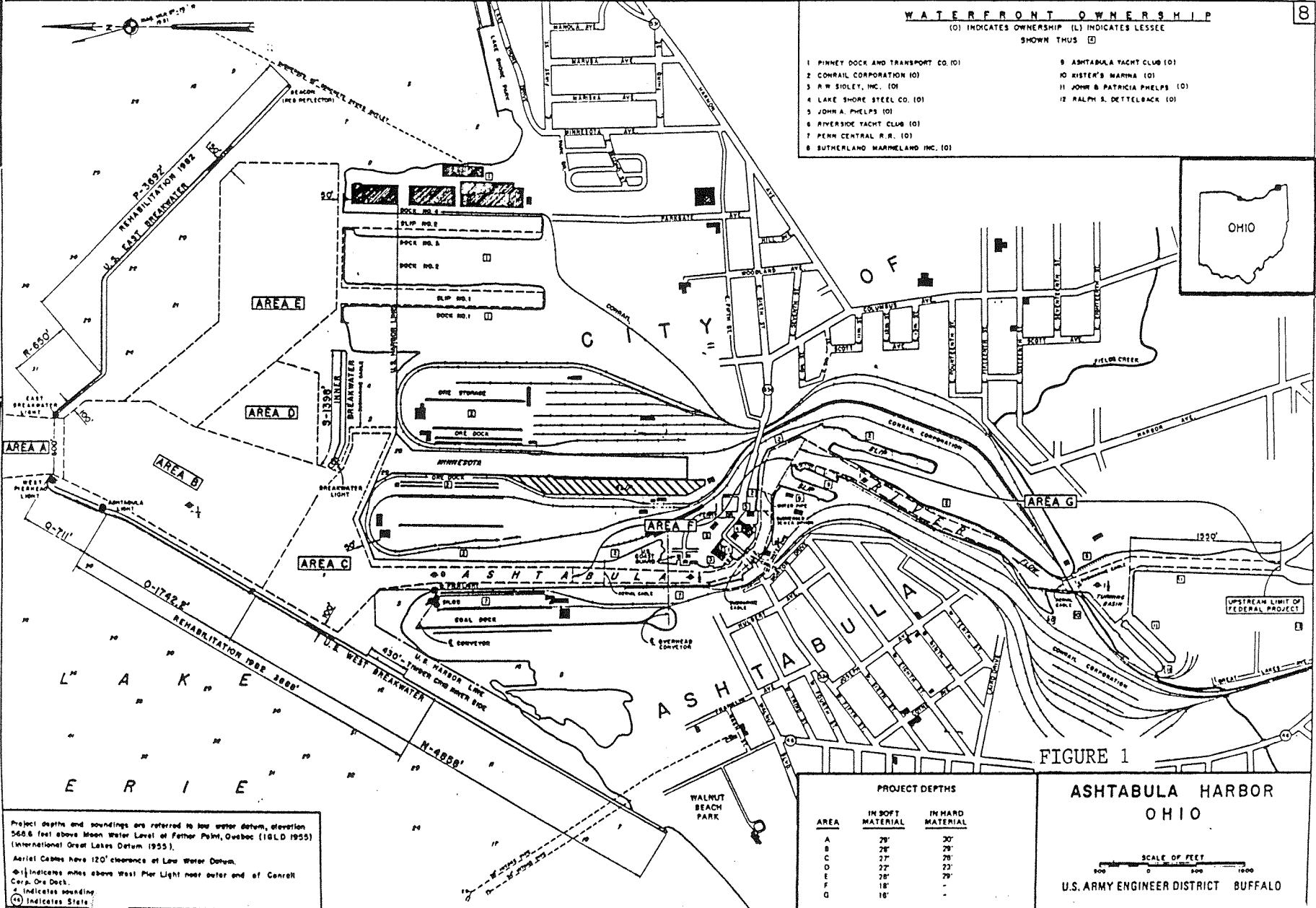

FIGURE 1

ASHTABULA HARBOR OHIO

AREA	PROJECT DEPTHS	
	IN SOFT MATERIAL	IN HARD MATERIAL
A	29'	30'
B	28'	28'
C	27'	26'
D	22'	23'
E	28'	29'
F	18'	-
G	18'	-

SCALE OF FEET
0 500 1000
U.S. ARMY ENGINEER DISTRICT BUFFALO

Project depths and soundings are referred to low water datum, elevation 568.6 feet above Mean Water Level of Father Point, Quebec (IGLD 1955) (International Great Lakes Datum 1955).
Aerial Cables have 120' clearance at Low Water Datum.
⊕ indicates piles above West Pier Light near outer end of Conrail Corp. Ore Dock.
⊙ indicates sounding
Ⓞ indicates State

ASHTABULA TOWNSHIP

ASHTABULA COUNTY
OHIO

SCALE: 1"=1,000'

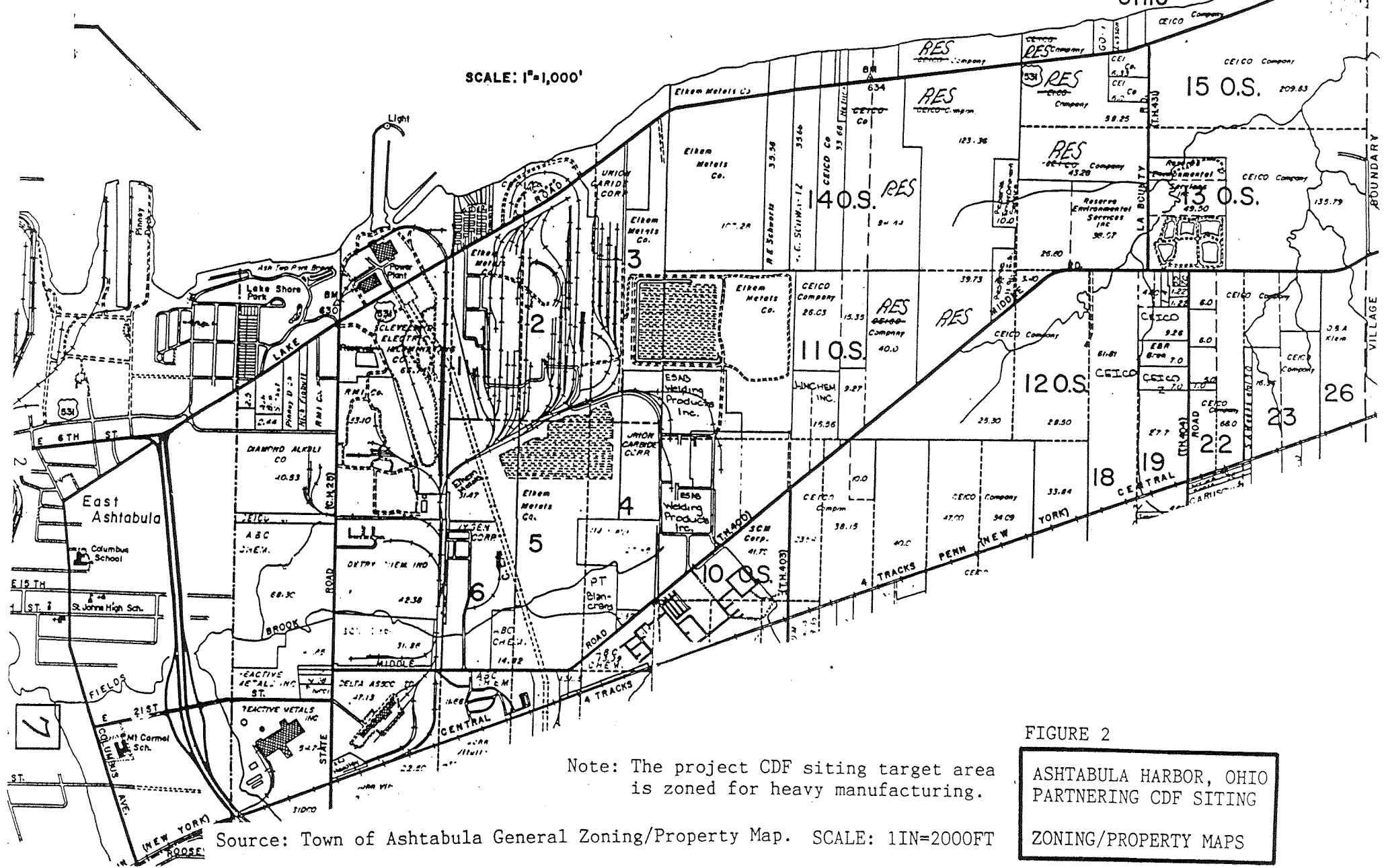

Note: The project CDF siting target area is zoned for heavy manufacturing.

Source: Town of Ashtabula General Zoning/Property Map. SCALE: 1IN=2000FT

FIGURE 2
ASHTABULA HARBOR, OHIO
PARTNERING CDF SITING
ZONING/PROPERTY MAPS

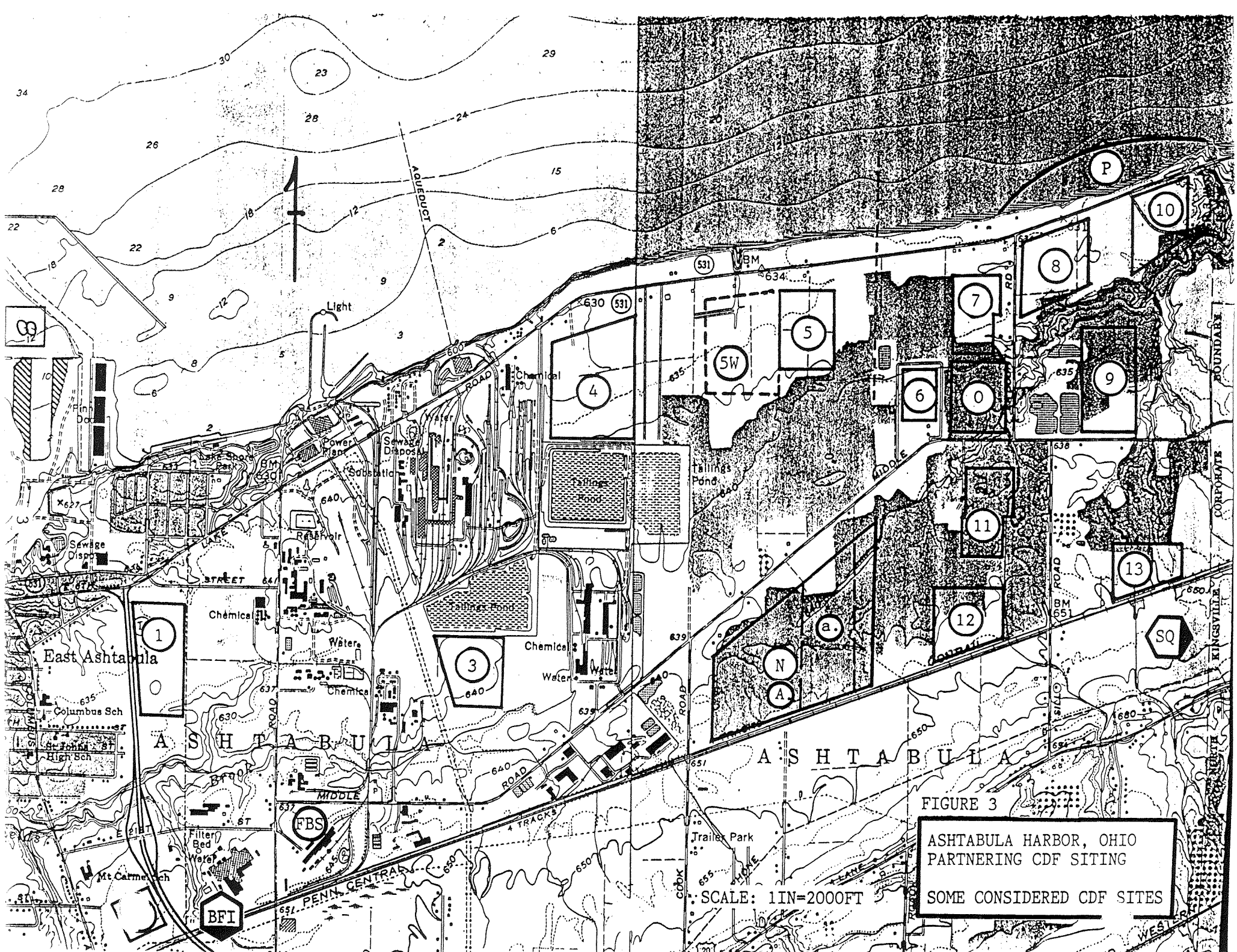

<u>EVALUATION PARAMETERS</u>	CONSIDERED SITES				
<u>ENVIRONMENTAL</u>					
<u>Natural Resources</u>					
Air Quality					
* Water Quality					
Sediment Quality					
Benthos					
Aquatic Vegetation					
Fisheries					
* Wetlands					
* Riparian					
Terrestrial Vegetation					
Wildlife					
* Threatened Endangered					
<u>Human (ManMade) Resources</u>					
* Community and Regional Growth					
* Displacement of People					
Displacement of Farms					
* Business/Industry Employment/Income					
* Public Facilities and Services					
Recreational Resources					
* Property Value and Tax Revenue					
Noise and Aesthetics					
* Community Cohesion					
<u>Cultural Resources</u>					
* Archeological					
* Historical					



MR KENT KROONEMEYER
U S FISH & WILDLIFE SERVICE
DIVISION OF ECOLOGICAL SERVICE
6950-H AMERICANA PARKWAY
REYNOLDSBURG OH 43068-4115



MR W RAY LUCE
STATE HISTORIC PRESERVATION
OFFICE
1982 VELMA AVENUE
COLUMBUS OH 43211-2497

HONORABLE GEORGE VOINOVICH
GOVERNOR OF OHIO
STATEHOUSE
COLUMBUS OH 43215-4204

MR RAY SAPORITO
ASH COUNTY HEALTH DEPT
27 WEST JEFFERSON STREET
JEFFERSON OH 44047-1092



MR DONALD ANDERSON, DIRECTOR
OHIO DEPT OF NATURAL
RESOURCES
FOUNTAIN SQUARE
COLUMBUS OH 43224

MR JACK ARMSTRONG
ASHTABULA PORT AUTHORITY
P O BOX 889
ASHTABULA OH 44005-0889

MR ROBERT LUCAS
CORPS OF ENGINEERS LIAISON
OHIO DEPT OF NATURAL
RESOURCES
FOUNTAIN SQUARE BLDG D-2
COLUMBUS OH 43224

R. W. SIDLEY INC
P O BOX 150
PAINESVILLE OH 44077

CONSOLIDATED RAIL CORP
P O BOX 2886
ASHTABULA OH 44004

MR MICHAEL COLVIN
ENVIRONMENTAL REVIEW COORD
OHIO DEPT OF NATURAL
RESOURCES
FOUNTAIN SQUARE BLDG A-3
COLUMBUS OH 43224

SUTHERLAND MARINE CO
P O BOX 2896
ASHTABULA OH 44004



VAL ADAMKUS
USEPA - REGION 5
77 WEST JACKSON BLVD
CHICAGO IL 60604-3590

ALICE CHAMBERLIN
INTL JOINT COMMISSION
1250 23rd STREET
WASHINGTON DC 20008

TOM GREENWOOD
ITEN INDUSTRIES
P O BOX 9
ASHTABULA OH 44005-0009

CARL ANDERSON
2916 FAIRVIEW DRIVE
ASHTABULA OH 44004

DONALD CIPOLLO
TRANS-END TECHNOLOGY
1302 WEST 38TH STREET
ASHTABULA OH 44004

HARBOR YACHT CLUB
P O BOX 3042
ASHTABULA OH 44005-3042

X ASHTABULA CO TRUSTEES ASSOC
C/O DANIEL WHITMIRE
P O BOX 134
AUSTINBURG OH 44010

THOMAS P. PENDERGAST
CONRAIL
2001 MARKET STREET 3C
PHILADELPHIA PA 19101-1403

BERNIE HAYTCHER
ASHLAND CHEMICAL COMPANY
P O BOX 1159
ASHTABULA OH 44005-1159

ASHTABULA YACHT CLUB
P O BOX 225
ASHTABULA OH 44004

FLOYD CULVER
ASH CHAMBER OF COMMERCE
P O BOX 96
ASHTABULA OH 44005-0096

STEVEN C JOHNSON
OLIN CORPORATION
120 LONG RIDGE ROAD
STAMFORD CT 06904

KEN BEACON
ASHTABULA CITY COUNCIL
4400 MAIN STREET
ASTABULA OH 44004

JOE DELPRIORE
PINNEY DOCK & TRANSPORT
P O BOX 41
ASHTABULA OH 44005-0041

DAVE KANANEN
DETREX CORPORATION
P O BOX 1398
ASHTABULA OH 44005-1398

X JEANNE BENTO
ASH COUNTY COMMISSIONER
706 LYNDON AVENUE
ASHTABULA OH 44004

LEONARD EAMES
2000 GREAT LAKES AVENUE
ASHTABULA OH 44004

BRETT KAULL
OFFICE OF CONGRESSMAN
STEVE LaTOURETTE
1508 LONGWORTH HOUSE BLDG.
WASHINGTON DC 20515-3519

BILL BINNING
OHIO DEPT OF DEV
1200 STAMBAUGH CT
YOUNGSTOWN OH 44502

NATALIE FARBER
OHIO EPA/DSW
P O BOX 1049
COLUMBUS OH 43216-1049

BRUCE KIRSCHNER
INTERNATIONAL JOINT
COMMISSION
P.O. BOX 32869
DETROIT, MI 48232-2869

STATE SENATOR ROBERT BOGGS
STATE HOUSE
COLUMBUS OH 43266-0604

STEVE GEGAN
CONRAIL COAL DOCK
P O BOX 2886 HARBOR STATION
ASHTABULA OH 44004

RONALD KISTER
ASHTABULA PORT AUTHORITY
P O BOX 768
ASHTABULA OH 44005-0768

REPRESENTATIVE ROSS BOGGS
STATEHOUSE
COLUMBUS OH 43215

DOY GILLESPIE
ASH CO MEDICAL CENTER
2420 LAKE AVENUE
ASHTABULA, OH 44004

FRED LEITERT
OXYCHEM
P O BOX 438
ASHTABULA OH 44005-0438

JIM BROWN
SUTHERLAND MARINE
970 BRIDGE STREET
ASHTABULA OH 44004

STEVE GOLYSKI
US ARMY CORPS OF ENGINEERS
1776 NIAGARA STREET
BUFFALO NY 14207-3199

FRANK LICHTKOPPLER
OHIO SEA GRANT
99 EAST ERIE STREET
PAINESVILLE OH 44077

DAVE ENGLISH
R W SIDLEY
P O BOX 150
NESVILLE OH 44077

DON SCHREGARDUS, DIRECTOR
OHIO EPA
P O BOX 1049
COLUMBUS OH 43266 -1049

JOSEPH MAYERNICK
GROWTH PARTNERSHIP ASH CO
36 WEST WALNUT STREET
JEFFERSON OH 44047

ELIZABETH SHAW
CENTERIOR ENERGY CORP
P O BOX 94661
CLEVELAND OH 44101-4661

RICK NAGLE
OFFICE OF REGIONAL COUNCIL
USEPA CM-3T
77 WEST JACKSON BLVD
CHICAGO IL 60604-3590

✶ MARY ANN SMITH
ASH TOWNSHIP TRUSTEE
3408 SCHENLEY AVENUE
ASHTABULA OH 44004

COL WALTER NEITZKE
US ARMY CORPS OF ENGINEERS
1776 NIAGARA STREET
BUFFALO NY 14207-3199

TOD SMITH
US ARMY CORPS OF ENGINEERS
1776 NIAGARA STREET
BUFFALO NY 14207-3199

NORTHCOAST MARINA
347 WEST 24TH STREET
ASHTABULA OH 44004

FRANK TEDESCHI
SCM CHEMICALS - PLANT I
P O BOX 310
ASHTABULA OH 44005-0310

AMY PELKA, WS-16 J
USEPA/WD
77 WEST JACKSON BLVD
CHICAGO IL 60604-3590

✶ MR HUGH THOMAS
CITY MANAGER
MUNICIPAL BUILDING
4400 MAIN STREET
ASHTABULA OH 44004

JOHN PHELPS JR
JACK'S MARINE
2000 GREATLAKES AVENUE
ASHTABULA OH 44004

DOUG TOWNER
SCM CHEMICALS - PLANT II
P O BOX 160
ASHTABULA OH 44005-0160

ROBERT RIDDELL
MOLDED FIBER GLASS
1315 W. 40TH
P.O. BOX 675
ASHTABULA, OH 44005-0675

JOSEPH C VENDEL
CEI
2133 LAKE ROAD EAST
ASHTABULA OH 44004

RIVER MARINE
465 EAST 5TH STREET
ASHTABULA OH 44004

JOHN WHEELER
OXY CHEM
5005 LBJ FREEWAY
DALLAS TX 75244

ROWLEY
WREO/WFUN RADIO
P O BOX 738
ASHTABULA OH 44005-0738

ADAM ZANGERLE
WARREN & YOUNG
P O BOX 278
ASHTABULA OH 44004

Ohio Historic Preservation Office

Ohio Historical Center
1982 Velma Avenue
Columbus, Ohio 43211-2497
614/297-2470
Fax: 297-2546

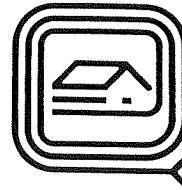

OHIO
HISTORICAL
SOCIETY
SINCE 1885

July 5, 1995

Mr. Todd Smith
Environmental Analysis Section
U.S. Army Corps of Engineers, Buffalo
1776 Niagara Street
Buffalo, New York 14207-3199

Dear Mr. Smith:

RE: Remediation of Contaminated Sediments in Ashtabula River and Harbor,
Ashtabula River Partnership, Ashtabula, Ashtabula County

This is in response to your letter received June 6, 1995 requesting information on the potential effect of cultural resources for the Ashtabula River Partnership Project Area. Our comments are submitted in accordance with the provision of Section 106 of the National Historic Preservation Act of 1966, as amended (36 CFR 800).

We have checked the Ohio Archaeological Inventory files. There are known archaeological sites in the vicinity of the project area. Before we can make any recommendations as to potential effect, we will need the specific site location for the proposed dredging and disposal activities. We wish to recognize the early coordination efforts of your agency and we hope that the goals of all interested parties are met in the most efficient manner possible.

If you have any questions please contact Todd Tucky at the above number. His hours are from 8:00 a.m.-12:00 p.m. Thank you for your cooperation.

Sincerely,

Martha J. Raymond, Department Head
Technical and Review Services

MJR/TMT:tt

13 JUL 95 13 40

JUL 13 1995

Environmental Analysis Section

SUBJECT: Ashtabula River Partnership (ARP) Remediation Project - Scope of Work for a U.S. Fish and Wildlife Service Coordination Act Report.

Mr. Kent Kroonemeyer
Field Office Supervisor
U.S. Fish and Wildlife Service
6950-H Americana Parkway
Reynoldsburg, Ohio 43068-4115

Dear Mr. Kroonemeyer:

This is subsequent to the recent ARP scoping letter dated June 1, 1995. Enclosed is a Scope of Work (SOW) for U.S. Fish and Wildlife Service studies and reporting pertaining to the subject project and the U.S. Fish and Wildlife Service Coordination Act.

Please provide me with your written cost estimate of funding needed in order to accomplish the SOW by your office staff, so that I can initiate timely preparation of DD Form 2544 to obligate funding for this work. Please respond within 30 days of the date of this letter.

My point of contact pertaining to this matter is Mr. Tod Smith of my Environmental Analysis Section, who can be contacted by calling commercial number (716) 879-4175, or by writing to him at the above address.

Sincerely,

DO NOT PROCEED IN THIS AREA

Richard P. Leonard, Chief
Environmental Analysis Section

Enclosure

CF: CENCB-PE-PT
CENCB-PE-EA ✓
CONCUR: CENCB-PE-PT
(S. Golyski *SG 7/12*)

T. Smith *[Signature]*
W. Janowski *[Signature]*
R. Leonard *[Signature]*

4 15



Christine L. Kesselmann
 Assistant Administrator
 Ohio Coastal Management Program
 Division of Real Estate and
 Land Management

Fountain Square, C-4
 Columbus, OH 43224-1366
 E-mail: chris.kesselmann@dnr.ohio.gov
 RECORDS UNIT

Phone: (614) 266-6391
 FAX: (614) 267-2981

800 648 666

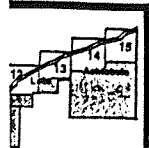

LANDWARD EXTENT OF COASTAL AREA

SCALE 693,280
 1 inch = 1 mile

The scale for Maps 2 & 4 (Cleveland County) is 171,520 or 1 inch = 1/3 mile.

SITE-SPECIFIC AREAS FOR PRESERVATION AND RESTORATION

- ☐ SHELTON MARSH STATE NATURE PRESERVE
- ☐ DUPONT MARSH STATE NATURE PRESERVE
- ☐ OLD WOMAN CREEK ESTUARINE SANCTUARY
- ☐ LORAIN LIGHTHOUSE
- ☐ MENTOR MARSH STATE NATURE PRESERVE
- ☐ HEADLANDS DUNES STATE NATURE PRESERVE

16

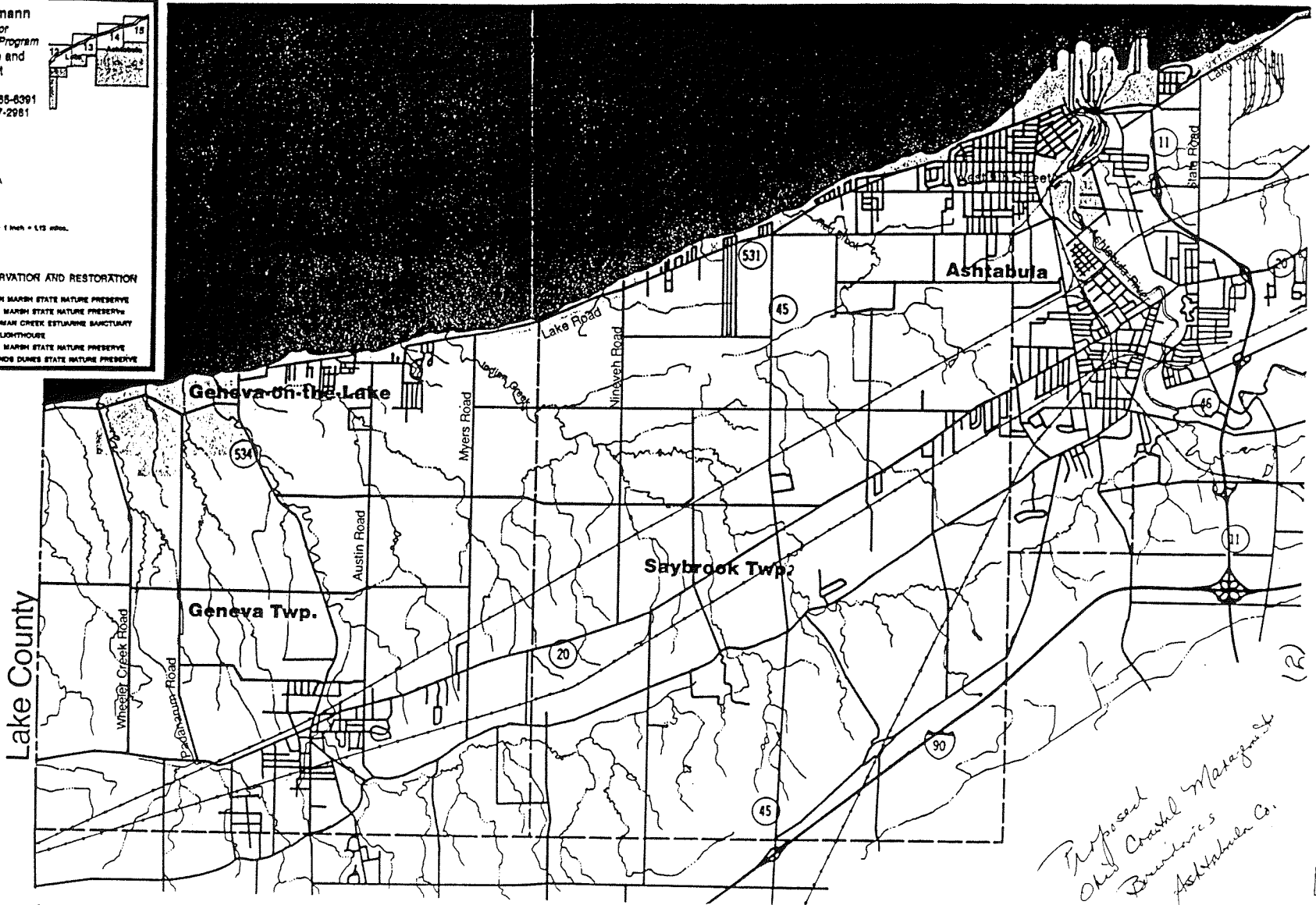

*Proposed
 Ohio Coastal Management
 Boundaries
 Ashtabula Co.*

MAP 14
 WESTERN ASHTABULA COUNTY



State of Ohio Environmental Protection Agency

STREET ADDRESS:

J WaterMark Drive
Columbus, OH 43215-1099

TELE: (614) 644-3020 FAX: (614) 644-2329

MAILING ADDRESS:

P.O. Box 1049
Columbus, OH 43216-1049

August 1, 1995

Mr. Tod Smith
USACE Buffalo District
Environmental Analysis Section
1776 Niagara Street
Buffalo, NY 14207-3199

Dear Mr. Smith:

Ohio EPA has reviewed the Scoping Report and enclosures for the Ashtabula River Partnership (ARP) initiative that you recently provided. The opportunity for review and input is greatly appreciated. Judging from the Scoping Report, the progress made thus far is encouraging.

As an ARP partner, Ohio EPA has been actively involved in this project since its inception, so we have no additional comments to add at this time. My representative for this project is Natalie Farber, the Ashtabula RAP Coordinator, as you are already aware. Ms. Farber will continue to provide input, make recommendations, transmit concerns, and otherwise provide technical assistance to the partnership, as necessary, throughout this worthwhile project. Ohio EPA is committed to working together with you and the other members of the partnership through the planning and design phases in order to implement the remedial action plan for the Ashtabula River.

Sincerely,

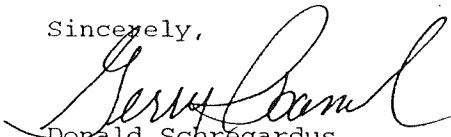
Donald Schregardus
Director
1eu\scope.121

- cc: Jennifer Tiell, Dir Office
- Ava Hottman, DSW
- Carl Anderson, RAP Co-Chair
- Rick Brewer, ARP Co-Chair
- Natalie Farber, DSW
- Tom Behlen, DSW
- Julie Letterhos, DSW
- Leonard Eames, RAP Co-Chair
- Fred Leitert, ARP Co-Chair
- Regan Williams, DERR/NEDO

17

3 JAN 95 11 15

CENCB-PE-EA (200-1a)

HALLROOM
CENCB-PE-EA

MEMORANDUM FOR Commander, U.S. Army Publications and Printing
Command, ATTN: Mr. Ken Denton, Army Federal
Register Liaison Officer (ASQZ-PD-SS),
Alexandria, Virginia 22331-0302

SUBJECT: Notice of Intent, Ashtabula Harbor, Ashtabula River
Partnership, Dredging and Confined Disposal Facility, Ashtabula
County, Ohio

1. Enclosed for processing for publication in the Federal Register are three copies of the Notice of Intent to Prepare a Draft Environmental Impact Statement (DEIS) for the subject study.
2. My point of contact pertaining to this matter is Mr. Tod Smith of my Environmental Analysis Section, who can be contacted by calling 716-879-4175, or by writing to his attention at the above address.

NOT FOR PROCESSING BY MAIL ROOM

Enclosure (trip)

WALTER C. NEITZKE
COL, EN
Commanding

CF:
CENCB-PA
CENCB-PE-EA ✓
CENCB-PE-PT

ARP
John Mahan
Rick Mason

Concur:
CENCB-PE-PT
(Golyski SG 12/18)
(DeJohn MCW 12/18)
CENCB-PE-P
(Berkeley PGS)

T. Smith /ls JAS 12/18/95
Leonard RJE 12/18
Yaksich [Signature]
Coniglio [Signature] 12/18
Brooks [Signature]
COL Neitzke [Signature]

DEPARTMENT OF DEFENSE

CORPS OF ENGINEERS, DEPARTMENT OF THE ARMY 3710-GP

Intent to Prepare a Draft Environmental Impact Statement (DEIS) for the Ashtabula River Partnership (ARP) feasibility study and Comprehensive Management Plan (CMP) and development of a Dredging and Confined Disposal Facilities (CDFs) Project for Ashtabula Harbor, Ashtabula County, Ohio.

AGENCY: U.S. Army Corps of Engineers, DOD for the Ashtabula River Partnership.

ACTION: Notice of Intent

SUMMARY: The proposed project involves appropriate sediment dredging, dewatering, treatment, transport, and use of existing and/or developed confined disposal facilities (CDFs) for disposal of polluted material dredged from the Lower Ashtabula River. Material will be dredged for initial River clean-up and for continued maintenance of harbor navigation channels. Project CDFs will be designed and used initially for confining some initially dredged Toxic Substance Control Act (TSCA) sediments.

FOR FURTHER INFORMATION CONTACT: Tod Smith, 716-879-4175, U.S. Army Corps of Engineers, Buffalo District, Environmental Analysis Section, 1776 Niagara Street, Buffalo, New York 14207-3199.

SUPPLEMENTAL INFORMATION:

Authority - This study is being conducted under the authorities of the U.S. Rivers and Harbors Acts from 1919 to 1965, as amended, as they pertain to Ashtabula Harbor; authorities associated with the Ashtabula River Partnership (ARP); and Section 401 of the 1990 Water Resources Development Act pertaining to technical assistance to OEPA to develop ARP plans.

Proposed Action - The proposed action involves dredging (environmentally) approximately 750,000 cubic yards of contaminated material (approximately 300,000 cubic yards of which may be PCB TSCA) from the lower Ashtabula River and appropriate dewatering, treatment, transport and disposal in appropriately designed existing and/or developed confined disposal facilities (CDFs). Generally, contaminants of concern include metals such as chromium and lead and chlorinated organic compounds including PCBs in excess of 50 mg/kg. Some future disposal capacity for harbor operations and maintenance dredged material (not suitable for unrestricted open-lake disposal) will also be included.

Alternatives - The Ashtabula River Partnership and the U.S. Army Corps of Engineers, Buffalo District are investigating several associated alternative scenarios and have investigated some 36 sites for potential CDF development. The Project Siting Committee recently recommended that four upland sites, one in-lake CDF, and three existing landfill areas be assessed in further detail. The "No Action" alternative must also be a

consideration.

Scoping Process - Study activities are being coordinated with government agencies, interest groups, and the general public. The intent is to gain assistance in: identifying and scoping problems, needs, and concerns; developing feasible alternative solutions; assessing/evaluating alternative solutions; and identifying the preferred and the selected plans. The public involvement process for the study incorporates a public involvement (outreach) program, written correspondence, telephone communications, public meetings/workshops, and draft and final report review procedures.

An initial local scoping meeting for this project was conducted in January of 1994. Subsequent meetings followed. In June 1995, supplemental scoping letters were coordinated with agencies and others known to have an interest in the study. Coordination continues. Additional scoping input from potentially affected Federal, State, and local agencies and interests is invited by this notice.

Significant Issues - The Ashtabula River Partnership, comprised of private citizens, government officials, and business and industry leaders, is dedicated to exploring how to effectively remediate the contaminated sediments in the Ashtabula River and Harbor. The goal is to look beyond traditional approaches to determine a comprehensive solution for remediation of the contaminated sediments not suitable for open-lake disposal. Successful remediation of contaminated sediments in

the Ashtabula River and Harbor will ultimately enhance economic, environmental, and social development opportunities in the Ashtabula region. Alternatives will be developed and evaluated for engineering and economic feasibility, and environmental and social acceptability. The alternative selected will reflect the best overall response to meeting the developed project objectives. The U.S. Army Corps of Engineers, Buffalo District has taken the leadership role as the Partnership's project manager to prepare its Comprehensive Management Plan and Environmental Impact Statement to address sediment remediation. The study shall be conducted to comply with the various Federal and State Environmental Statutes and Executive Orders and associated review procedures. When the Draft Environmental Impact Statement is completed, it will be filed with the U.S. Environmental Protection Agency and coordinated and reviewed under the National Environmental Policy Act procedures.

Scoping Meeting: Since Federal, State, and local interests have been involved with initiation of the study, and adequate coordination is already being conducted, no new formal initial scoping meeting is scheduled.

Availability - It is expected that the Draft Environmental Impact Statement will be made available to the public about October 1997.

Date: _____

Walter C. Neitzke
Colonel, U.S. Army
Commanding

Army Science Board; Notice of Partially Closed Meeting

In accordance with Section 10(a)(2) of the Federal Advisory Committee Act (Pub. L. 92-463), announcement is made of the following Committee Meeting:

Name of Committee: Army Science Board (ASB)

Date of Meeting: 24 & 25 January 1996

Time of Meeting: 0900-1100, 24 January 1996 (Closed)

1200-1600, 24 January 1996 (Open)

0930-1600, 25 January 1996 (Open)

Place: Pentagon—Washington, DC

Agenda: The Army Science Board's Ad Hoc Study on "Army Digitization Information Systems Vulnerabilities and Security" will meet for briefings and discussions relative to the study subject. The open portions of these meetings are open to the public. Any person may attend, appear before or file statements with the committee. The closed portion of these meetings will be closed to the public in accordance with Section 552b(c) of title 5, U.S.C., specifically subparagraph (4) thereof, and Title 5, U.S.C., Appendix 2, subsection 10(d).

FOR FURTHER INFORMATION CONTACT:
Michelle Diaz (703) 695-0781.

Michelle P. Diaz,

Acting Administrative Officer, Army Science Board.

[FR Doc. 96-977 Filed 1-23-96; 8:45 am]

BILLING CODE 3710-08-M

Army Science Board; Notice of Closed Meeting

In accordance with Section 10(a)(2) of the Federal Advisory Committee Act (Pub. L. 92-463), announcement is made of the following Committee Meeting:

Name of Committee: Army Science Board (ASB)

Date of Meeting: 22 & 23 January 1996

Time of Meeting: 0900-1730, 22 January 1996
0900-1500, 23 January 1996

Place: Pentagon—Washington, DC

Agenda: The Army Science Board (ASB) TRADOC Issue Group on "Operational Architecture" will meet for briefings and discussions on the study subject. These meetings will be closed to the public in accordance with Section 552b(c) of title 5, U.S.C., specifically subparagraph (4) thereof, and Title 5, U.S.C., Appendix 2, subsection 10(d). The proprietary matters to be discussed are so inextricably intertwined so as to preclude opening any portion of these meetings.

FOR FURTHER INFORMATION CONTACT:
Michelle Diaz (703) 695-0781.

Michelle P. Diaz,

Acting Administrative Officer, Army Science Board.

[FR Doc. 96-978 Filed 1-23-96; 8:45 am]

BILLING CODE 3710-08-M

Army Science Board; Notice of Closed Meeting

In accordance with Section 10(a)(2) of the Federal Advisory Committee Act (Pub. L. 92-463), announcement is made of the following Committee Meeting:

Name of Committee: Army Science Board (ASB)

Dates of Meetings: 0900-1600, 17 January 1996

0800-1500, 18 January 1996

0900-1500, 18 January 1996

0900-1500, 19 January 1996

Places: US Army Aviation, Troop Support Command, Federal Center, St. Louis, MO (17 Jan 96)

US Army Tank Automotive Command, Warren, MI (18 Jan 96)

US Army Missile Command, Huntsville, AL (18 Jan 96)

US Army Communications & Electronics Command, Fort Monmouth, NJ (19 Jan 96)

Agenda: The Army Science Board (ASB) Independent Assessment Panel on "Reengineering the Acquisition and Modernization Processes of the Institutional Army, T&E Subgroup" will meet for briefings and discussions on the study subject. These meetings will be closed to the public in accordance with Section 552b(c) of title 5, U.S.C., specifically subparagraph (4) thereof, and Title 5, U.S.C., Appendix 2, subsection 10(d). The proprietary matters to be discussed are so inextricably intertwined so as to preclude opening any portion of these meetings.

FOR FURTHER INFORMATION CONTACT:
Michelle P. Diaz (703) 695-0781.

Michelle P. Diaz,

Acting Administrative Officer, Army Science Board.

[FR Doc. 96-979 Filed 1-23-96; 8:45 am]

BILLING CODE 3710-08-M

Army Science Board; Notice of Closed Meeting

In accordance with Section 10(a)(2) of the Federal Advisory Committee Act (Pub. L. 92-463), announcement is made of the following Committee Meeting:

Name of Committee: Army Science Board (ASB)

Date of Meeting: 25-26 January 1996

Time of Meeting: 1000-1600, 25 January 1996
0800-1400, 26 January 1996

Place: Pentagon—Washington, DC

Agenda: The Army Science Board's (ASB) Independent Assessment on "Reengineering the Acquisition and Modernization Processes of the Institutional Army" will meet for briefings and discussions on the study subject. These meetings will be closed to the public in accordance with Section 552b(c) of Title 5, U.S.C., specifically paragraph (1) thereof, and Title 5, U.S.C., Appendix 2, subsection 10(d). The classified and unclassified matters to be discussed are so inextricably intertwined so as to preclude opening any portion of these meetings.

FOR FURTHER INFORMATION CONTACT:
Michelle Diaz (703) 695-0781.

Michelle P. Diaz,

Acting Administrative Officer, Army Science Board.

[FR Doc. 96-980 Filed 1-23-96; 8:45 am]

BILLING CODE 3710-08-M

Department of the Army, Corps of Engineers

Intent To Prepare a Draft Environmental Impact Statement (DEIS) for the Ashtabula River Partnership (ARP) Feasibility Study and Comprehensive Management Plan (CMP) and Development of a Dredging and Confined Disposal Facility (CDFs) Project for Ashtabula Harbor, Ashtabula County, OH

AGENCY: U.S. Army Corps of Engineers, DOD for the Ashtabula River Partnership.

ACTION: Notice of intent.

SUMMARY: The proposed project involves appropriate sediment dredging, dewatering, treatment, transport, and use of existing and/or developed confined disposal facilities (CDFs) for disposal of polluted material dredged from the Lower Ashtabula River. Material will be dredged for initial River clean-up and for continued maintenance of harbor navigation channels. Project CDFs will be designed and used initially for confining some initially dredged Toxic Substance Control Act (TSCA) sediments.

FOR FURTHER INFORMATION CONTACT:
Tod Smith, 716-879-4175, U.S. Army Corps of Engineers, Buffalo District, Environmental Analysis Section, 1776 Niagara Street, Buffalo, New York 14207-3199.

SUPPLEMENTARY INFORMATION:**Authority**

This study is being conducted under the authorities of the U.S. Rivers and Harbors Acts from 1919 to 1965, as amended, as they pertain to Ashtabula Harbor; authorities associated with the Ashtabula River Partnership (ARP); and Section 401 of the 1990 Water Resources

Development Act pertaining to technical assistance to OEPA to develop ARP plans.

Proposed Action

The proposed action involves dredging (environmentally) approximately 750,000 cubic yards of contaminated material (approximately 300,000 cubic yards of which may be PCB TSCA) from the lower Ashtabula River and appropriate dewatering, treatment, transport and disposal in appropriately designed existing and/or developed confined disposal facilities (CDFs). Generally, contaminants of concern include metals such as chromium and lead and chlorinated organic compounds including PCBs in excess of 50 mg/kg. Some future disposal capacity for harbor operations and maintenance dredged material (not suitable for unrestricted open-lake disposal) will also be included.

Alternatives

The Ashtabula River Partnership and the U.S. Army Corps of Engineers, Buffalo District are investigating several associated alternative scenarios and have investigated some 36 sites for potential CDF development. The Project Siting Committee recently recommended that four upland sites, one in-lake CDF, and three existing landfill areas be assessed in further detail. The "No Action" alternative must also be a consideration.

Scoping Process

Study activities are being coordinated with government agencies, interest groups, and the general public. The intent is to gain assistance in: identifying and scoping problems, needs, and concerns; developing feasible alternative solutions; assessing/evaluating alternative solutions; and identifying the preferred and the selected plans. The public involvement process for the study incorporates a public involvement (outreach) program, written correspondence, telephone communications, public meetings/workshops, and draft and final report review procedures.

An initial local scoping meeting for this project was conducted in January of 1994. Subsequent meetings followed. In June 1995, supplemental scoping letters were coordinated with agencies and others known to have an interest in the study. Coordination continues. Additional scoping input from potentially affected Federal, State, and local agencies and interests is invited by this notice.

Significant Issues

The Ashtabula River Partnership, comprised of private citizens, government officials, and business and industry leaders, is dedicated to exploring how to effectively remediate the contaminated sediments in the Ashtabula River and Harbor. The goal is to look beyond traditional approaches to determine a comprehensive solution for remediation of the contaminated sediments not suitable for open-lake disposal. Successful remediation of contaminated sediments in the Ashtabula River and Harbor will ultimately enhance economic, environmental, and social development opportunities in the Ashtabula region. Alternatives will be developed and evaluated for engineering and economic feasibility, and environmental and social acceptability. The alternative selected will reflect the best overall response to meeting the developed project objectives. The U.S. Army Corps of Engineers, Buffalo District has taken the leadership role as a Partnership's project manager to prepare its Comprehensive Management Plan and Environmental Impact Statement to address sediment remediation. The study shall be conducted to comply with the various Federal and State Environmental Statutes and Executive Orders and associated review procedures. When the Draft Environmental Impact Statement is completed, it will be filed with the U.S. Environmental Protection Agency and coordinated and reviewed under the National Environmental Policy Act procedures.

Scoping Meeting: Since Federal, State, and local interests have been involved with initiation of the study, and adequate coordination is already being conducted, no new formal initial scoping meeting is scheduled.

Availability

It is expected that the Draft Environmental Impact Statement will be made available to the public about October 1997.

Dated: January 2, 1996.

Walter C. Neitzke,

Colonel, U.S. Army, Commanding.

[FR Doc. 96-914 Filed 1-23-96; 8:45 am]

BILLING CODE 3710-6P-M

Department of the Navy

Record of Decision for the Disposal and Reuse of Naval Hospital, Long Beach, California, Parcel A

The Department of the Navy (Navy), pursuant to section 102(2) of the National Environmental Policy Act of 1969 (NEPA), 42 U.S.C. 4321 *et seq.*, and the Regulations of the Council on Environmental Quality that implement NEPA procedures, 40 CFR parts 1500-1508, hereby announces its decision to dispose of Parcel A of the property comprising the Naval Hospital at Long Beach, California.

Navy intends to dispose of the property in a manner that is consistent with the proposed reuse and redevelopment plan submitted by The City of Long Beach, the Local Redevelopment Authority (LRA), described as the Retail Sales Alternative in the Final Environmental Impact Statement (FEIS).

Background

The 1991 Defense Base Closure and Realignment Commission recommended closure of the Naval Hospital at Long Beach and Naval Station Long Beach. These recommendations were then approved by President Bush and the One Hundred Second Congress. Operations at the Naval Hospital ceased on March 31, 1994, and the property has been in caretaker status since that date. Operations at Naval Station Long Beach ceased on September 30, 1994.

The Naval Hospital property is located within The City of Long Beach, California, and consists of two parcels. Parcel A is a 30.5 acre site which contains the hospital buildings, associated barracks, and warehouses. Parcel B is an adjacent 34.7 acre site that contains a parking lot, helicopter landing pad, and Navy housing. Ownership of Parcel B reverted from Navy to The City of Long Beach on October 17, 1995, by operation of law under the terms of the original land acquisition agreement.

A Notice of Intent was published in the Federal Register on January 28, 1994, stating that Navy would prepare an Environmental Impact Statement that analyzed the impacts of disposal and reuse of Parcel A of the Naval Hospital property. A 90-day public scoping period was established, and two scoping meetings were held in the cities of Long Beach and Lakewood on April 5 and 6, 1995. An additional scoping meeting where Navy's presentation was translated into Spanish was held in the adjacent City of Hawaiian Gardens on July 19, 1994.



18 August 1999

Environmental Analysis Section

31 AUG 1999

SUBJECT: Draft Comprehensive Management Plan and Environmental Impact Statement and Appendices for the Ashtabula Partnership Remediation Project, Ashtabula County, Ohio

TO ALL INTERESTED PARTIES:

We are pleased to announce the coordination of the subject reports. Copies are enclosed for your information.

The Ashtabula River Partnership is a coalition of public and private interests working toward remediation of the lower Ashtabula River, an International Joint Commission Great Lakes Area of Concern. Remediation of the contamination and habitat problems along the lower Ashtabula River will serve to alleviate harbor-impaired use and operations and maintenance restriction, water quality and aquatic habitat issues, and health and safety concerns.

The Ashtabula River Partnership has identified project problems and needs and specific areas of sediment contamination, developed project component alternatives, assessed and evaluated alternatives, and identified recommended plans. The plans involve environmental dredging (low turbidity) to remove contaminated sediments from the river, sediment transfer/dewatering/transfer facilities, and transport of sediments to an appropriate disposal at developed and/or existing upland confined disposal facilities. The project would also restore several acres of aquatic/fishery shallows areas and associated shoreline. Environmental protection measures have been incorporated into the project design, construction, operation, and maintenance plans to meet Federal, State and local regulations.

The Draft Environmental Impact Statement (DEIS) has been prepared in accordance with the Council on Environmental Quality's "Regulations for Implementing the Procedural Provisions of the National Environmental Policy Act (NEPA)" 40 CFR 1500-1508, as promulgated in Corps of Engineers Regulation ER-200-2-2 "Environmental Quality: Policies and Procedures for Implementing NEPA."

1123 Bridge Street
Ashtabula, Ohio 44004
(440) 964-0277 Office
(440) 964-5158 Fax

John Mahan, Ph.D
Coordinator

Carl Anderson
Co-Chairman
Outreach Committee

Rick Brewer
Co-Chairman
Coordinating Committee

Fred Leitert
Co-Chairman
Coordinating Committee

Steve Golyski
Co-Chairman
Project Committee

Rick Mason
Co-Chairman
Project Committee

Brett Kaull
Chairman
Resource Committee

Michelle Rowley
Co-Chairperson
Outreach Committee

25

"Part Of The Solution"

A Clean Water Act, Public Notice and Section 404(b)(1) Evaluation Report, and Coastal Consistency Determination are included in the DEIS Environmental Appendices. Wetland mitigation plans will be further detailed for the final report. It is expected that sediments dredged in the future for channel maintenance will be clean enough for open-lake disposal.

These reports have been filed with the U.S. Environmental Protection Agency and are being coordinated for planning and NEPA 45-day agency and public draft review. If you have any comments on these reports, correspondence should be directed to John Mahan, Partnership Coordinator, within 45 days of the date of Notice of Availability (NOA) in the *Federal Register*. The date of the NOA should be several days later than the date of this letter. Public review comments on these reports will be addressed and incorporated into the subsequent final reports.

Please feel free to contact John Mahan at the telephone number included on this letter or via his e-mail address: erse@Suite224.net

Sincerely,



N.F. Brewer
Co-Chair, Coordinating Committee



Fred C. Leitert
Co-Chair, Coordinating Committee

Enclosures

Note: Substantial additional correspondence is located in the project files.

Reference Environmental Impact Statement Environmental Appendix:

EA-L - COMMENTS/RESPONSES ON THE DRAFT FEASIBILITY AND EIS REPORTS which follows this appendix, also.



1123 Bridge Street
Ashtabula, Ohio 44004
(216) 964-0277 Office
(216) 964-5158 Fax

John Mahan, Ph.D
Coordinator

Rick Brewer
Co-Chairman
Coordinating Committee

Fred Leitert
Co-Chairman
Coordinating Committee

Steve Golyski
Chairman
Project Committee

Rick Mason
Chairman
Siting Committee

Brett Kaull
Chairman
Resource Committee

Michelle Rowley
Chairperson
Outreach Committee

Ashtabula River and Harbor

Comprehensive Management Plan

Dredging and Disposal

FINAL

FEASIBILITY REPORT AND

ENVIRONMENTAL IMPACT STATEMENT

ENVIRONMENTAL APPENDIX

**EA-L COMMENTS/RESPONSES ON THE DRAFT FEASIBILITY AND EIS
REPORTS**

City of Ashtabula
Town of Ashtabula
County of Ashtabula
State of Ohio

2001

Comments/Responses on the Ashtabula River Partnership Draft Comprehensive Management Plan and Environmental Impact Statement and Appendices.

Agency or Interest	Date
Ohio Department of Natural Resources Division of Real Estate and Land Management	22 September 1999
Grant Brockway	14 October 1999
Ohio Department of Health	21 October 1999
Jack's Marine, Inc. (And Previous Letters)	2 November 1999
Ohio Department of Natural Resources	5 November 1999
Luedtke Engineering Company	6 November 1999
United States Department of the Interior	8 November 1999
Ohio Environmental Protection Agency	8 November 1999
First Energy	9 November 1999
United States Environmental Protection Agency – Region 5	9 November 1999
United States Environmental Protection Agency – Region 5 Superfund Division	16 November 1999
Ashtabula River Cooperation Group (Blasland, Bouck & Lee, INC.)	9 November 1999



Bob Taft • Governor

Samuel W. Speck • Director

 Division of Real Estate and Land Management

September 22, 1999

Lt. Colonel Mark D. Feierstein
 District Engineer
 U.S. Army Corps of Engineers
 Buffalo District
 1776 Niagara Street
 Buffalo, New York 14207-3199

ATTN: Tod Smith

Re: Ashtabula River Partnership Project

Dear Lt. Colonel Feierstein:

The Ohio Department of Natural Resources received a draft of the above referenced project which included a consistency determination on September 1, 1999. Unless we request an extension, we have 45 days to concur or object to consistency. The 45 day consistency review period will expire on October 15, 1999.

An initial review of the draft, and communications with the Ohio EPA indicate that at a minimum, a 401 water quality permit will be needed to attain consistency. A permit to install (PTI), and possibly some additional permits, depending on the final location of some of the segments of the project, may also be required. The 401 water quality permit alone could not be issued in the 45 day time period. If other permits are needed, it would further delay the process. The Ohio EPA has told us that final issuance of necessary permits could take months.

Our Ohio Coastal Management Program allows us to negotiate consistency review time extensions with you at your discretion. To avoid having to object to consistency based on the 45 day review period and to avoid having to request future time extensions if some of the necessary permits have not yet been issued, we are requesting an extension to the consistency review period until all necessary permits have been issued. This will not delay our consistency concurrence in any way. It will merely avoid us having to request additional time extensions, or to object to consistency should some permits still be needed,

If you have any questions, please contact Don Povolny of my staff at (614) 265-6649.

Sincerely,

for Wayne R. Warren, Chief
 REALM

WRW/dlp

cc: Tod Smith, Buffalo District, COE

Mission: To ensure a balance between wise use and protection of our natural resources for the benefit of all.

Ohio Department of Natural Resources
Division of Real Estate and Land Management

22 September 1999

RESPONSES (Thank you for your review and comments. Numbered responses pertain to numbered comments.)

1. The Ashtabula River Partnership concurs with your proposal for extension of concurrence as described in the letter.

Grant G. Brockway
115 East 24th Street
Ashtabula, Ohio 44004
440-998-6272

October 14, 1999

Ashtabula River Partnership
1123 Bridge Street
Ashtabula, Ohio 44004

I would like to address three issues:

1. The flooding of the Ashtabula River from the Railroad Bridge upstream.
2. Dredging of the Ashtabula River from the Railroad Bridge upstream to the 24th street bridge.
3. The ecological restoration of the Ashtabula river.

Flooding

1 There was extreme flooding above the railroad bridge during spring thaw in 1999. A great amount of damage was done to the marinas in the area. The depth of the river was the main reason for this flooding. I am very concerned that the Comprehensive Management Plan does not address this issue.

Dredging

2 The Comprehensive Management Plan does not show dredging of the upper Ashtabula River. The navigation channel extends approximately 2000 feet up river from the railroad bridge. In 1986 the Army Corp. of Engineers issued a permit to change the course of the Ashtabula River north of 24th Street bridge there by extending navigation to that bridge. We realize the Comprehensive Management Plan only covers the polluted areas of the river. However, it is because of the down river pollution that the upper river has not been dredged since 1964. More than half of the recreation boats are docked in this area. These boaters have all paid their dock tax to the Ashtabula Port Authority for several years. We feel it mandatory to include the upper river dredging in this plan.

Ecological Restoration

3 The aquatic and fishing restoration in the Comprehensive Management Plan shows one area only in the lower Ashtabula river. It is my belief that fish restoration would be better on the gravel bars in the upper river. There are twelve miles of the Ashtabula River owned by the public. This area along with Cedarquist Park and the Brick Pond should be considered for fish propagation.

In closing, I believe all three issues could be resolved with the following suggestion:

4 The river be dredged to the 24th Street and the dredgings in that area, which are mostly washed gravel, could be used for covering of fish shelves in the lower river area. This would be less costly than bringing in material from elsewhere to build fish shelves in the lower river as well as benefiting more than half the boaters in the Ashtabula River. More than ten million dollars in commercial marina investment has been spent in the upper river area. The boaters and commercial establishments have been very patient since 1964. The extended dredging would be a small percentage of the total project.

Sincerely,



Grant G. Brockway

RESPONSES (Thank you for your review and comments. Numbered responses pertain to numbered comments.)

1. The project is not oriented toward flood control. This would need to be addressed by another authority, as warranted. However, incidentally, if the project were not implemented and channels could not be readily maintained at recreational or commercial depths, as warranted, there could be some minor associated problems with channel capacity and flooding. On the other hand, if the project were implemented and channels could be readily maintained at recreational or commercial depths, as warranted, there could be some minor benefits associated with channel capacity and flood control.

2. Your comment addresses a portion of the river dredged under existing Federal/USACE Operations and Maintenance authorities and a portion permitted under the Corps' Regulatory program. As you have pointed out, the authorized Federal channel terminates 2,000 feet upstream of the railroad bridge; areas dredged upstream were performed by a permit holder and this permit does not extend the Federally authorized channel.

As you indicated, the area is outside of the project authority problem (heavily contaminated sediments) area. The area is addressed, as possible, via authorized Federal operations and maintenance dredging or dredging via permit. This will be better facilitated subsequent to removal of heavily contaminated sediments.

One of the goals of the Ashtabula River Partnership is to provide a project where post project dredged material may be dredged and acceptable for discharge at the harbor open-lake discharge site. Current analyses, forgoing any unforeseen circumstances, indicate that that should be the case within a few years after the project. Available sediment sampling and analyses for sediments located upstream of the partnership project indicate that those sediments should be suitable for open-lake discharge. This sediment data is available for local interest use and/or reference. However, Federal and local dredging and discharge operations will still have to be appropriately reviewed and/or permitted.

The proposed Partnership plan includes consideration for post project Operation and Maintenance dredging of available harbor sediments determined to be suitable for open-lake discharge and discharge of material primarily into the partnership project dredged holes in order to improve surface sediment quality, followed by long-term natural re-sedimentation. Clean gravel material may be used as a layer on the aquatic/fisheries shallows.

3. The ecological analyses indicate that primary area in need of ecological restoration including contaminant removal and aquatic/fishery shallows restoration needs is in the lower Ashtabula River harbor area, as possible, and, as indicated. It was understood that existing commercial and recreational facilities would not be disturbed. Gravel bars in the upper river indicate existing quality habitat there. It is anticipated that the proposed measures would enable fisheries to move through the existing problem reaches to better utilize the upper river areas. Upstream areas are somewhat out of the project authority and development area. Your suggestions for enhancement of these upstream areas may be considered in the future under other programs as the proposed project is shown to be successful.

4. Reference items 2 and 3.



OHIO DEPARTMENT OF HEALTH

246 North High Street
Post Office Box 118
Columbus, Ohio 43266-0118
Telephone: (614) 466-3543



Bob Taft
Governor

J. Nick Baird, M.D.
Director of Health

October 21, 1999

John Mahan, Ph.D., Coordinator
Ashtabula River Partnership
1123 Bridge Street
Ashtabula, Ohio 44004

SUBJECT: Comments from the review of the ARP draft CMP/EIS.

Dear John:

1 The Ohio Department of Health, Bureau of Radiation Protection (ODH) as the State of Ohio's Radiation Control Agency, became involved with the Ashtabula River Partnership (ARP) to ensure that the approach to the clean up, with respect to the radionuclides within the sediments of the Ashtabula River, is consistent with State requirements. After a review of the draft Comprehensive Management Plan / Environmental Impact Statement (CMP/EIS), ODH issued an opinion letter on May 18, 1999 stating that, "...the recommended plan for disposal of the sediments is consistent with state requirements". The "recommended plan" as approved includes an ARP commitment to conduct all phases of the project in accordance with all appropriate State, Federal and Local regulations. This includes Ohio Administrative Code (OAC) 3701-39-021, Standards for Handling Radioactive Material.

2 It is the opinion of ODH that the draft CMP/EIS, dated August 1999, as written does not contain sufficient detail with regards to the radioactive materials component of this clean up project. The sole mention of the radionuclide issue is found in Section 5.1, on page 139, of Volume 1 of 2, Feasibility Report. ODH is of the opinion that the currently known concentrations of radioactive contamination present within the sediments of the Ashtabula River are sufficient enough to warrant their incorporation into the final CMP/EIS as a contaminant of concern.

3 ODH's review of the draft CMP/EIS has identified the following examples of radiological Health and Safety concerns that still need to be addressed, in some manner, prior to the issuance of the final CMP/EIS:

- Radiological controls during dredging operations.
- Radiological controls during dewatering operations, including discharge monitoring.
- Radiological controls during transfer and transportation of sediments.
- Disposal facility radiological controls.
- Disposal facility leachate monitoring.

7

4

ODH recommends that, at a minimum the ARP include the following acknowledgements in the final version of the CMP/EIS:

- Radionuclides are a contaminant of concern with this project,
- Ohio Administrative Code 3701-39-021, Standards for Handling Radioactive Material, is the State of Ohio Regulatory Guidance document for the radionuclide component of the project.
- The ODH/BRP will be providing regulatory over site on this project to ensure that the appropriate radiological controls are established and implemented during the appropriate phases of the clean up, and to ensure that the health and safety of workers and the general public are not compromised during the clean up.

If you have any questions regarding this letter, please contact Mr. Charles McCracken of my staff at 614-466-5136.

Sincerely,

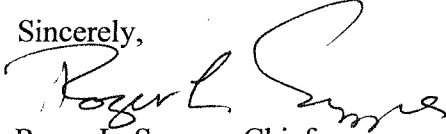

Roger L. Suppes, Chief
Bureau of Radiation

RLS/CDM/cdm

Cc: R. Vandegrift, Supervisor, BRP/Decommissioning
L. Jensen, CHP, USEPA Region 5
N. Farber, OEPA RAP Coordinator
C. McCracken, HP, BRP/Decommissioning
file

This letter supplements the letter from the Ohio Department of Health dated May18, 1999.

RESPONSES (Thank you for your review and comments. Numbered responses pertain to numbered comments.)

1. Concur

2. The Ashtabula River Partnership concurs that as written, the Draft CMP/EIS does not contain sufficient detail with regards to the radioactive materials component of this clean-up project. This issue resurfaced fairly late in the draft phase of the project and some information was not able to be included in the draft reports.

Actually, the draft reports initially discussed or referenced this issue in sections pertaining to sediment sampling and analyses and subsequently briefly in the CMP page 139, and in the Environmental Impact Statement (EIS) Summary page 10, page EIS-93, and in the EIS Harbor Sediment Quality and Dredging Section beginning on page EIS-134 and page EIS-150. Page EIS-93 also states that a project health and safety plan will be prepared for project implementation with project plans and specifications.

Subsequently, additional sediment sampling and analyses has been conducted in this regard. Findings have been incorporated into the Final reports.

3. and 4. Concur. Subsequently, additional sediment sampling and analyses has been conducted in this regard. Findings and items have been incorporated into the Final reports.

JACK'S MARINE, INC.

2000 GREAT LAKES AVENUE

ASHTABULA, OHIO 44004

(216) 997-5060 FAX (216) 992-0515
440 440

November 2, 1999

For your information, please find enclosed two letters we have sent on the CMP/EIS of the Ashtabula River Partnership.

We would like you to be informed, and would appreciate any attention you can provide during talks or negotiations.

Sincerely,

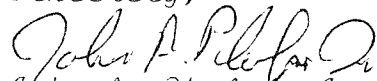
John A. Phelps, Jr.
Vice President



Ron Phelps
Vice President

cc: Rep. Steve LaTourette
Sen. Robert Gardner
Ashtabula City Council
Ashtabula City Manager
Ashtabula City Port Authority
U.S. Army Corps of Engineers

10

JACK'S MARINE, INC.

2000 GREAT LAKES AVENUE
ASHTABULA, OHIO 44004
(216) 997-8060 FAX (216) 992-0818

September 28, 1999

Ashtabula River Partnership
1104 Bridge St.
Ashtabula, Ohio 44004

Attention: John Mahan, Co-ordinator

It has come to our attention in reading the CMP/EIS that there are no provisions for cleaning up the wet slip located at Jack's Marine, and to take care of the problem associated with Strong Brook which empties into the wet slip of the old shipyard.

We would expect that problems associated with Strong Brook would be addressed during any cleanup of the river or upper turning basin.

We feel that the wet slip should be cleaned entirely and also given a clean bill of health so that future dredging can be disposed of without regulation.

Jack's Marine is a contributing partner for the Ashtabula River Partnership and wants to see a clean and better river environment.

We look forward to having a response from the Ashtabula River Partnership.

Sincerely,

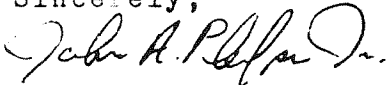
John A. Phelps, Jr.
V. President

Ron Phelps
V. President



COMPLETE MARINE SALES & SERVICE
DOCKAGE & STORAGE

JACK'S MARINE, INC.

2000 GREAT LAKES AVENUE
ASHTABULA, OHIO 44004
(216) 997-5060 FAX (216) 992-0515

November 2, 1999

Ashtabula River Partnership
1104 Bridge St.
Ashtabula, Ohio 44004

To: ARP Coordinator John Mahan

It has come to our attention that there may be a discrepancy in the depth and width of the Federal navigation channel upstream to the "upper turning basin" and the wet and dry dock facility at Jack's Marine.

We facilitate, and have for years (since 1980), winter layover and refitting of commercial and industrial vessels and equipment. Our history has been to accommodate deep draft tug and barge combinations that require 9' or more of water. It is our understanding that 16' is the required federal depth. We wish to solicit future commercial accounts, not reduce our capabilities.

It is of vital importance that Jack's Marine provide this service at this station on the south shore of Lake Erie and great State of Ohio, County of Ashtabula, not be deprived of revenues due to an incomplete or inadequate dredging scheme.

Jack's Marine has always provided commercial services and would be distressed if our former shipyard facility scope was limited due to contaminated sediments threatening scouring action our inadequate depth while positioned on a federal channel.

Jack's Marine also accommodates commercial fishing vessel use, both for seasonal and off-season services. These vessels need a place to port.

Please advise the question of depth and permit process post ARP dredge to accommodate the necessary depth of more than 9'.

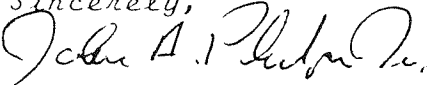
Sincerely,

John A. Phelps, Jr.
V. President

Ron Phelps
V. President



COMPLETE MARINE SALES & SERVICE
DOCKAGE & STORAGE

Jack's Marine, Inc.
(And Previous Letters)

2 November 1999

RESPONSES (Thank you for your review and comments.)

One of the goals of the Ashtabula River Partnership is to provide a project where post project dredged material may be dredged and acceptable for discharge at the harbor open-lake discharge site. Current analyses, forgoing any unforeseen circumstances, indicate that that should be the case within a few years after the project. However, Federal and local dredging and discharge operations will still have to be appropriately reviewed and/or permitted.

The authorized depth in the Federal channel in the upstream portion of the Ashtabula River is 16 feet below low water datum (LWD). The current plan for environmental dredging is to full depth to a point well upstream of the upper turning basin. Strong brook being an immediate tributary of the Ashtabula River qualifies the "wet slip" for consideration under the environmental dredging plan. Contaminated sediments disposed in the slip at the confluence of the brook would be removed as part of the overall river remediation project. Any remaining material requiring dredging to provide servicable depths would be suitable for open-lake disposal.

Smith, Tod D LRB

From: Povolny, Don [Don.Povolny@dnr.state.oh.us]
Sent: Monday, October 04, 1999 11:08 AM
To: 'Mahan, John'
Cc: Lee, Tara; Hopewell, Jim; Stefan, Bridget; Colvin, Mike; 'Smith, Tod'; Becky Jenkins; Bob Fletcher; Capuzzi, Kelly; Davis, Duane; Guy, Don; John Marshall; Kevin Elder; Lammers, Kenneth; Malone, Steve; Merchant, Linda; Multerer, Kenneth; Pat Fagan; Pat Jones; Price, Robert; Scovanner, Josie; Smith, Mike; Tim Shearer
Subject: Ashtabula River Partnership Project



ashtabulanorth.bmp



ashtabulasouth.bmp



Northkingsville.bmp

(Ashtabula County)

The Ohio Department of Natural Resources (ODNR) has completed a review of the above referenced project. These comments were generated by an inter-disciplinary review in consultation with the Division of Wildlife and other divisions within the Department. These comments have been prepared under the authority of the Fish and Wildlife Coordination Act (16 U.S.C. 661 et seq.), the National Environmental Policy Act and other applicable laws and regulations.

Natural Heritage maps and files for the proposed project were reviewed for records involving endangered, threatened or special interest species in the immediate project vicinity. The numbers on the list below correspond to the areas marked in red on the accompanying maps. A circle represents an exact location, a triangle a general location within a square mile, and a square a general location within greater than a square mile. Scientific name, common name and status are given for each species. None of the following species have a federal designation; all designations given are state statuses.

We have no data in the wetland mitigation project area on the Dorset Quad in the Dorset Wildlife Area.

Ashtabula North Quad

1. *Carex bebbii* - Bebb's Sedge, potentially threatened
2. *Lota lota* - Burbot, special interest
3. Ring-billed Gull Colony (breeding animal concentration, no status)
4. *Cakile edentula* - Inland Sea-rocket, potentially threatened
5. *Juncus balticus* - Baltic Rush, potentially threatened
Potamogeton richardsonii - Richardson's Pondweed, potentially threatened
6. *Sagittaria rigida* - Deer's-tongue Arrowhead, threatened
7. *Triplasis purpurea* - Purple Sand-grass, potentially threatened
8. *Juncus alpinus* - Alpine Rush, potentially threatened
9. *Sporobolus cryptandrus* - Sand Dropseed, potentially threatened
Cyperus schweinitzii - Schweinitz's Umbrella-sedge, potentially threatened
10. *Ammophila breviligulata* - American Beach Grass, threatened
Cakile edentula - Inland Sea-rocket, potentially threatened
Lathyrus japonicus - Inland Beach-pea, threatened
11. *Lathyrus japonicus* - Inland Beach-pea, threatened
Ammophila breviligulata - American Beach Grass, threatened
Cakile edentula - Inland Sea-rocket, potentially threatened
Triplasis purpurea - Purple Sand-grass, potentially threatened
Sporobolus cryptandrus - Sand Dropseed, potentially threatened
Cyperus schweinitzii - Schweinitz's Umbrella-sedge, potentially threatened
12. *Euphorbia polygonifolia* - Seaside Spurge, potentially threatened
13. *Myriophyllum heterophyllum* - Two-leaved Water-milfoil, endangered
13. Beach-Dune Plant Community
Ammophila breviligulata - American Beach Grass, threatened
Cakile edentula - Inland Sea-rocket, potentially threatened
Euphorbia polygonifolia - Seaside Spurge, potentially threatened
Lathyrus japonicus - Inland Beach-pea, threatened
Triplasis purpurea - Purple Sandgrass, potentially threatened

Do Not Include TSE Locations

Sagittaria perus schweinitzii - Schweinitz's Umbrella-sedge, potentially threatened

14. *Notropis amblops* - Bigeye Chub (inventoried by Division of Natural Areas and Preserves but has not been assigned an official state status)

<<ashtabulanorth.bmp>>

Ashtabula South Quad

1. American Beech Ohio Champion Big Tree (no status)
2. *Shepherdia canadensis* - Canadian Buffalo-berry, potentially threatened
3. *Melampyrum lineare* - Cow-wheat, threatened
4. *Viburnum alnifolium* - Hobblebush, potentially threatened

<<ashtabulasouth.bmp>>

North Kingsville Quad

1. *Ligumia nasuta* - Eastern Pondmussel, endangered
Ligumia recta - Black Sandshell, threatened
2. *Gentianopsis procera* - Small Fringed Gentian, potentially threatened
3. *Acer pensylvanicum* - Striped Maple, endangered
4. *Betula populifolia* - Gray Birch, potentially threatened
5. *Betula populifolia* - Gray Birch, potentially threatened

<<Northkingsville.bmp>>

A fourth map icon will be forwarded in another supplemental message .

2
A 401 water quality permit will be needed to attain consistency. A permit to install (PTI), and possibly some additional permits, depending on the final location of some of the segments of the project, may also be required.

3
You must certify that this project complies with Ohio's Coastal Management Program. We will inform you when consistency has been attained.

We appreciate the opportunity to provide these comments. If you have any questions, please contact me.

From: Povolny, Don <Don.Povolny@dnr.state.oh.us>
To: 'Mahan, John' <erse@suite224.net>; 'Golyski, Steve' <stephen.j.golyski@usace.army.mil>
Cc: 'Smith, Tod' <Tod.D.Smith@lrb01.usace.army.mil>; Becky Jenkins <Becky.Jenkins@dnr.state.oh.us>; Bob Fletcher <Bob.Fletcher@dnr.state.oh.us>; Capuzzi, Kelly <kelly.capuzzi@epa.state.oh.us>; Davis, Duane <duane.davis@epa.state.oh.us>; Guy, Don <don.guy@dnr.state.oh.us>; John Marshall <John.Marshall@dnr.state.oh.us>; Kevin Elder <Kevin.Elder@dnr.state.oh.us>; Lammers, Kenneth <Kenneth_Lammers@fws.gov>; Malone, Steve <steve.malone@epa.state.oh.us>; Merchant, Linda <linda.merchant@epa.state.oh.us>; Multerer, Kenneth <kenneth_multerer@fws.gov>; Pat Fagan <Pat.Fagan@dnr.state.oh.us>; Pat Jones <Pat.Jones@dnr.state.oh.us>; Price, Robert <robert.price@epa.state.oh.us>; Scovanner, Josie <Josie.Scovanner@epa.state.oh.us>; Smith, Mike <mike.smith@epa.state.oh.us>; Tim Shearer <Tim.Shearer@dnr.state.oh.us>
Date: Friday, November 05, 1999 11:51 AM
Subject: FW: Ashtabula River Partnership Project

Additional Comments:

CMP, Section 3.4.6.2 Disposal Facility - Mitigation Plan

4 On Page 77, under Total Construction Costs, item 3) a. - It states that a park ranger/biologist will conduct field site visits/inspections. This is incorrect. ODNR has a policy not to assume wetland mitigation monitoring requirements when such projects are done on our wildlife areas. Any and all monitoring will remain the responsibility of the local sponsor.

The same statement regarding site visits/inspections is also made on page 79.

5 On Page 77, under Total construction Cost, item 3) b. - It states that the project monitoring /maintenance is being projected over the 50 year economic life of the project. It should be pointed out that this requirement is far beyond what is normally required for wetland mitigation under the CWA, Section 401/404 permitting process. Normal requirements are for monitoring to be conducted on an annual basis and for only a five-year period following completion of the wetland mitigation project.

The same statement regarding projecting costs for the 50-year economic life of the project is also made on page 79.

RESPONSES (Thank you for your review and comments. Numbered responses pertain to numbered comments.)

1. Thank you for the ODNR Natural Heritage information on State endangered, threatened, or special interest species potentially in the project proximity. Considering the immediate project area and proposed project, it does not appear that species identified would occur in or be impacted by the proposed project.
2. The Ashtabula River Partnership forwarded an initial Application For Ohio EPA Section 401 Water Quality Certification with the draft reports. This was withdrawn due to project plan disposal revisions and limited preliminary design information. The Ohio EPA however, issued an interim letter of concurrence on feasibility in this regard pertaining to sufficient planning and preliminary design and indicated that a Final Application For Ohio EPA Section 401 Water Quality Certification should be submitted with more detailed final design and support documentation. The Ashtabula River Partnership will be forwarding a Final Application For Ohio EPA Section 401 Water Quality Certification with design and support documentation. More advanced contaminant analyses and facilities design is underway and is being coordinated. National/State Pollution Discharge Elimination System (N/SPDES) general and specific permits for construction and facilities will be coordinated for and items incorporated into the project design and plans and specifications. A Permit to Install will be coordinated for when more specific facility design information is available.
3. A Coastal Program Consistency Determination has been coordinated requesting State Concurrence pending other associated permit approvals.
4. Subsequent to the Draft Reports, a number of additional evolved alternative disposal facilities and alternatives were assessed/evaluated. Use of existing disposal facilities can not be utilized because RAD material can not be co-mingled with other disposed material and must have its own disposal facility. In this regard, the former RMI Sodium Plant site (State Road Site) has become available. The site has been disturbed by past plant development and recent demolitions and is of little value to fish and wildlife and contains only minor wetlands at the eastern boundary and north-east corner. The Fields Brook remediation project material is being disposed of in part of this property. There is room for the Ashtabula River Partnership dredged elevated PCB and RAD material to be disposed of in a developed facility adjacent to the Fields Brook remediation project disposal facility. There is also just enough room for the Ashtabula River Partnership dredged contaminated material to be disposed of in a developed facility adjacent to the other disposal facilities. Assessment/evaluation indicates that this is the overall preferred possible disposal alternative and is now the project disposal component plan.

Development of the disposal facilities at the State Street Site would be situated to avoid significant impacts to wetlands. One man-made depressional wetland located on soil fill was identified within the northern third of the site along the eastern site boundary. This will be avoided.

5. Reference Item 4.

LUEDTKE

SHORE PROTECTIONS
BRIDGES - BREAKWATERS
DOCKS - LIGHTHOUSES
DREDGING - CAUSEWAYS
SUBAQUEOUS BORINGS
SURVEYS - CABLES
INTAKES - MAINS

ENGINEERING COMPANY

MARINE CONTRACTING

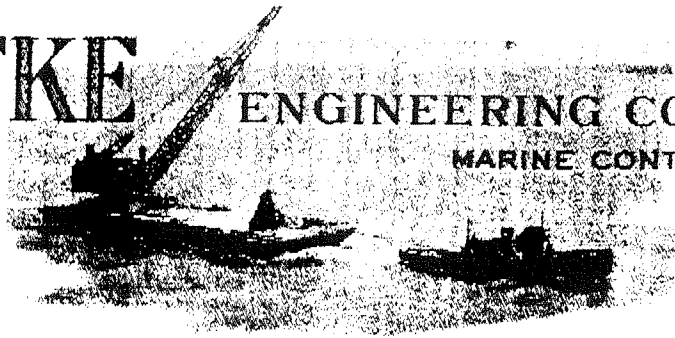

P.O. BOX 111 • 10 FOURTH STREET
FRANKFORT, MICHIGAN 49635-0111

November 6, 1999

TELEPHONE (616) 352-9631
FAX (616) 352-7178
New Area Code 231

Mr. John Mahan
Ashtabula River Partnership
1104 Bridge Street
Ashtabula, Ohio 44004

Dear Mr. Mahan:

It has come to our attention that there may be a discrepancy in the depth and width of the Federal Navigation Channel upstream to the upper turning basin and the wet and dry dock facility at Jack's Marine.

We have been mooring and repairing our commercial vessels at Jack's marine since 1980. We require 9' or more of water in order to accommodate our tugs, dredges and barges. It is of great importance to our operations that Jack's Marine provide adequate water depths for our vessels.

Jack's Marine has always provided us excellent service over the years due to the strategic location of Ashtabula on Lake Erie and it would be a unfortunate if there ship repair facility was limited due to contaminated sediments restricting access and forcing us to move our operations elsewhere.

Sincerely,

Kurt R. Luedtke
President

cc: U.S. Representative Steve Latorrette
Senator Robert Gardner
Ashtabula City Council
Ashtabula Port Authority - Lefty Corbissaro
Department of Army, Buffalo District - LTC Mark D. Feierstein

Luedtke Engineering Company

6 November 1999

RESPONSES (Thank you for your review and comments.)

1. Reference response to Jack's Marine letter (2 November 1999).

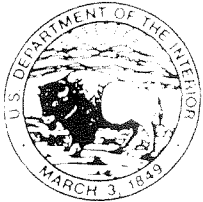

IN REPLY REFER TO

United States Department of the Interior

OFFICE OF THE SECRETARY
Office of Environmental Policy and Compliance
Custom House, Room 244
200 Chestnut Street
Philadelphia, Pennsylvania 19106-2904

November 8, 1999

ER-99/805

Lt. Colonel Michael J. Conrad, Jr.
District Engineer
Buffalo District, Corps of Engineers
1776 Niagara Street
Buffalo, New York 14207

Dear Colonel Conrad:

1 The U.S. Department of the Interior (Department) has reviewed the Draft Comprehensive Management Plan (CMP) and Environmental Impact Statement (EIS) for the Ashtabula River Partnership remediation project in the City of Ashtabula, Ashtabula County, Ohio. The U.S. Army Corps of Engineers (Corps), Buffalo District, served as Project Manager in the preparation of the draft CMP and EIS. We offer the following comments and recommendations for your consideration.

GENERAL COMMENTS

2 The current draft CMP and EIS is the result of many years of effort on the part of the Corps, the U.S. Environmental Protection Agency (USEPA), the Ohio Environmental Protection Agency, the Ohio Department of Natural Resources, the U.S. Fish and Wildlife Service (USFWS), the Ashtabula River Partnership (ARP), and many other interested organizations and individuals.

2 The USFWS has provided a number of reviews and reports, including an August 29, 1996, Planning Aid Letter and Biological Report and a September 12, 1997, Draft Fish and Wildlife Coordination Act (FWCA) Report. The USFWS is presently scheduled to provide its final (updated) FWCA Report by July 2000. The USFWS has also served on the Project Committee of the ARP and served on the Ecological Restoration 312(b) Sub-Committee and the Wetlands Sub-Committee.

3 The Department anticipates that the proposed dredging will have significant overall environmental benefits on the Ashtabula River and Harbor and on Lake Erie. In addition, we offer no objection to the selection of Disposal Site 7 for an upland confined disposal facility, provided that unavoidable adverse impacts to wetlands are properly and fully mitigated.

4 While we support the scope of the Selected Plan ("Deep Dredging" Alternative) and the selection of Site 7 as the disposal area, we are concerned that over two tons of polychlorinated biphenyls (PCBs) will be left in the Ashtabula River. The Department, through the USFWS, will continue to work with the ARP to ensure that the proposed project is successfully completed and the natural resources of the Ashtabula River and Lake Erie are protected.

5 As pointed out by the USFWS at several meetings, the Secretary of the Interior (Secretary) is a designated Federal trustee for certain natural resources, such as migratory birds; interjurisdictional and anadromous fishes; federally listed threatened and endangered species, as well as food chain and physical habitat required by these species; and Departmental lands. Under the Comprehensive Environmental Response Compensation and Liability Act (CERCLA), the Oil Pollution Act (OPA) and the National Contingency Plan (NCP), the Secretary is mandated to assess any oil and hazardous substance-induced injuries to our trust natural resources, including any lost services, and to seek compensation from responsible parties to restore trust resources and replace lost services. Although the proposed dredging and disposal may help to minimize the future potential for injuries, natural resource damage assessment work may result in the identification of additional actions necessary to protect and restore trust resources and replace lost services.

The Department requests the Corps' cooperation while we pursue these responsibilities. Specifically, we request your patience and careful consideration of recommendations that we may make to the Corps or potentially responsible parties as an outgrowth of our efforts to protect and restore our trust resources within the Ashtabula River and Harbor area. We request this cooperation, given the unique circumstances of this project and in view of your cooperative efforts with the USEPA over the last few years to meld navigation needs with environmental cleanup.

Most of the issues addressed in the draft CMP are also discussed in the draft EIS. Thus, the specific comments provided below regarding the draft CMP would also apply to similar sections of the draft EIS.

SPECIFIC COMMENTS on the DRAFT CMP

6 **Coal Dock and Polyaromatic Hydrocarbons (PAHs):** Information on page 50, Section 3.4.2.1, and page 52, Section 3.4.2.2, of the draft CMP indicates that PAHs are located primarily in the lower reaches of the Ashtabula River and in the Outer Harbor area. Page 25, Section 3.2.3, states that the PAHs "are likely associated with the coal dock development in the immediate area." From this statement, we conclude that the coal piles are, or could be, a significant source of PAHs (which have been demonstrated as carcinogens in fish) to the Ashtabula River and Harbor.

On page 26, second paragraph, it is stated that "cleanup of the Ashtabula River via the Ashtabula River Partnership should eliminate all of the use impairments assigned to the lower river." Those impairments associated with PAHs in sediment will remain after cleanup if the coal piles are not

6 addressed as a source of contamination. Also, the third paragraph on page 26 states in part: "It is also understood that discharge sources of pollutants have been remediated." This statement would seem to be in error if the coal piles remain unaddressed after cleanup of the rest of the river. We believe that the issue of the coal piles as a primary source of PAH contamination should be addressed in more detail in the CMP and EIS. The final documents should address the potential for, and possible rate of, re-contamination of the river and harbor area subsequent to the removal of the PAH-laden sediments if the coal piles are still present. Assuming that the coal piles are the primary source of the PAHs in the river and harbor, the documents should address possible enforcement actions to control this source of PAHs. The question of who has the legal authority to carry out such enforcement actions should also be addressed.

7 **Dredging Scenarios:** On page 52, Section 3.4.2.2, the CMP briefly discusses the three primary dredging scenarios formulated to address removal of contaminated sediments: "Shallow Dredging," "Deep Dredging," and "Bank to Bank to Bedrock." Table 3-6, page 49, compares sediment volume and PCBs mass removal for these dredging scenarios. The selected plan, "Deep Dredging," will remove 82 percent (9,066 kg) of the total mass (11,018 kg) of PCBs from the river. Thus, approximately 4,200 pounds of PCBs will remain in the River. The "Bank to Bank to Bedrock Dredging" would remove 98 percent of the total PCB mass, leaving about 600 pounds of PCBs in the river. However, the "Bank to Bank to Bedrock" dredging was not selected because it would be very costly, would present more shoreline structural stability concerns, and was determined to be more extensive than required to meet project goals and objectives. We find the selection of the "Deep Dredging" Alternative acceptable. However, the fact remains that with implementation of the Selected Plan over two tons of PCBs will remain in the Ashtabula River, representing a potential threat to fish and wildlife resources and the public.

8 **Aquatic Habitat Shelf:** Pages 58-61, Sections 3.4.3 and 3.4.3.1 and Figure 3-15; page 107 and Figure 3-36; and page 143, Section 6.7, of the draft CMP provide information on and recommend that a man-made, 2,500-foot-long by 8-foot-wide aquatic habitat shelf be hung on the existing sheet steel bulkheading along the east side of the Ashtabula River channel from the mouth of the river upstream to the 5th Street Bridge. This would be a valuable structure for providing shelter to young-of-year fish moving from upstream spawning and nursery areas to the harbor and Lake Erie. However, this structure could pose a maintenance problem due to ice damage and damage from ships in the channel. We recommend that a study of this design's durability in the face of winter ice and commercial ship traffic be undertaken before further consideration is given to the possible use of the shelf system. If a decision is made to construct the habitat shelf, adequate resources need to be established to provide for the long-term maintenance of the structure.

9 **Disposal Site P:** Page 73, Section 3.4.6, of the draft CMP states, in part, that Site P (the Lake Erie, in-water, disposal site) was deleted from further consideration due to inherent problems with the level of contaminants in the sediments. This section further states that Site P could only be used for non-TSCA (Toxic Substances Control Act) dredged sediments. Non-TSCA material can contain up to 50 parts per million (ppm) of PCBs. Site P is also one of the alternatives still listed on the "Remaining Alternative Components (Options) - Assessment/Evaluation/Selection" matrix

9 on pages 87 and 88. It has been the long-standing position of the USFWS that in-water confined disposal facilities are not appropriate for this type of material, especially when the sediments could contain up to 50 ppm of PCBs. Therefore, we recommend that Site P be removed from further consideration for disposal of the non-TSCA dredged sediments.

10 **Mitigation Needs Associated With Disposal Site 7:** Page 73, Section 3.4.6.2, of the draft CMP discusses mitigation needs if Site 7 becomes the location for a new disposal facility to contain the TSCA as well as non-TSCA material. Approximately 11 acres of wooded wetlands would be impacted by construction at Site 7. Compensatory mitigation to offset these impacts is proposed to be accomplished at the Dorset Wildlife Area and would consist of 11 acres of wooded wetland restoration and 44 acres of preservation/enhancement. Since the proposed mitigation area (Dorset Wildlife Area) is already owned by the Ohio Division of Wildlife, we do not believe any credit for preservation would be appropriate.

SPECIFIC COMMENTS on the DRAFT EIS

11 **Suitability of Outer Harbor Sediments As Cover Material:** The fourth full paragraph on page 6 of the Summary states: "Clean material dredged from the channel area upstream of the Upper Turning Basin and possibly from the Outer Harbor area should be deposited as cover into the Deep Dredge Area for at least one operations and maintenance dredging cycle to expedite clean benthic cover material recovery at no additional O&M cost and likely savings." We do not believe that the downstream material in the Outer Harbor should necessarily be considered "clean material" because it could be contaminated with PCBs, PAHs, metals, and other contaminants. Such material would have to be demonstrated to be clean through chemical analysis prior to its use.

12 **Post-Project Surveys by USFWS:** Page EIS-94, Section 2.149, states: "The U.S. Fish and Wildlife Service will review available data or conduct a survey pertaining to the significant species for the Ashtabula Harbor area and report the findings within five to ten years of completion of the project." We are unaware of any commitment made by the USFWS to conduct surveys in the harbor area. If post-project surveys are needed, they should be included as part of the post-construction monitoring plan.

13 **Federal Threatened and Endangered Species:** Page EIS-219, Section 4.84, states, in part: "Although the project lies within the range of the bald eagle and Indian bat, both Federally listed and [sic] endangered species, no adverse impact on these species is anticipated." The EIS should be corrected to indicate that the bald eagle is now federally listed as threatened, rather than endangered. The USFWS's September 12, 1997, draft Fish and Wildlife Coordination Act Report concluded that the USFWS did not anticipate impacts on any federally listed species. Since then, the USFWS has conducted a more thorough investigation of Disposal Site 7 and has determined that some potential summer habitat for the Indian bat does exist on Site 7.

Summer habitat requirements for the Indiana bat are not well defined, but the following are thought to be of importance:

1. Dead trees and snags along riparian corridors, especially those with exfoliating bark or cavities in the trunk or branches, which may be used as maternity roost areas.
2. Live trees (such as shagbark hickory) which have exfoliating bark.
3. Stream corridors, riparian areas, and nearby woodlots which provide forage sites.

13

The USFWS recommends that wherever possible, if trees with cavities or exfoliating bark (which could be potential roost trees) are encountered in the project area, they and surrounding trees be saved. If they must be cut, cutting should be conducted outside of the summer use period of April 15 to September 15.

If potential roost trees are present and if the above time restriction is unacceptable, mist netting or other suitable survey methods will need to be used to determine if Indiana bats are present. The survey should be designed and conducted in coordination with Mr. Buddy Fazio, the endangered species coordinator for the USFWS's Reynoldsburg, Ohio, Field Office. The survey should be conducted in June or July because the peak local population of Indiana bats would be expected at this time of year.

14

The Department, through the USFWS, has a continuing interest in working with the Corps and the other partners in the Ashtabula River Partnership to support implementation of the CMP. For continued coordination and consultation regarding fish and wildlife matters and threatened and endangered species, please continue to contact the Field Supervisor, U.S. Fish and Wildlife Service, 6950 Americana Parkway, Suite H, Reynoldsburg, Ohio 43068-4127, Telephone: 614-469-6923.

We appreciate the opportunity to review the documents and provide these comments.

Sincerely,

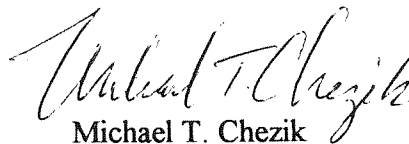

Michael T. Chezik
Regional Environmental Officer

cc: Mr. John Mahan, Ph.D
Coordinator
Ashtabula River Partnership
1123 Bridge Street
Ashtabula, Ohio 44004

RESPONSES (Thank you for your review and comments. Numbered responses pertain to numbered comments.)

1. Thank you for your review and comments.

GENERAL COMMENTS

2. Thank you for your valuable work and input on the project.
3. Subsequent to the Draft Reports, a number of additional evolved alternative disposal facilities and alternatives were assessed/evaluated. Use of existing disposal facilities can not be utilized because RAD material can not be co-mingled with other disposed material and must have its own disposal facility. In this regard, the former RMI Sodium Plant site (State Road Site) has become available. The site has been disturbed by past plant development and recent demolitions and is of little value to fish and wildlife and contains only minor wetlands at the eastern boundary and north-east corner. The Fields Brook remediation project material is being disposed of in part of this property. There is room for the Ashtabula River Partnership dredged elevated PCB and RAD material to be disposed of in a developed facility adjacent to the Fields Brook remediation project disposal facility. There is also just enough room for the Ashtabula River Partnership dredged contaminated material to be disposed of in a developed facility adjacent to the other disposal facilities. Assessment/evaluation indicates that this is the overall preferred possible disposal alternative and is now the project disposal component plan.

Development of the disposal facilities at the State Street Site would be situated to avoid significant impacts to wetlands. One man-made depressional wetland located on soil fill was identified within the northern third of the site along the eastern site boundary. This will be avoided.

4. Concur. Based on overall assessment/evaluation (plus/minus) of considered dredging plans, the deep dredge plan is a reasonable compromise plan. The plan includes dredging removal, dewatering, and appropriate disposal of all (in situ) TSCA related PCB sediments and most PCB and other contaminated sediment mass. Placement of dredged material suitable for open-lake disposal and subsequent natural re-sedimentation over residual contaminated sediments deep and below the harbor channels is expected to provide dilution, a cover, and buffer to the long-term surface sediments and benthos zone. Still, there is some minor risk through unusual deep scour scenarios (i.e. debris jam, sunken vessel, etc.) that residual contaminated sediments could be introduced to the surface sediments and benthos zone. However, with removal of significant mass deep and below the harbor channels residual contaminated sediments introduced to the surface sediments and benthos zone would likely be well diluted and have minor impact.
5. Natural Resources (Trustees) Damages. Nothing in this environmental impact statement shall be construed either explicitly or implicitly to irreversibly or irretrievably commit natural resources either directly or indirectly associated with the proposed dredging of the Ashtabula Harbor Channel beyond those areas outside of the area of dredging.

SPECIFIC COMMENTS on the DRAFT CMP

6. Concur. Yes, this is an important issue. As stated on EIS page EIS-9, paragraph 1.18, post project conditions include that best management practices be in effect by the coal and Fields Brook industries. This includes best management of run-off and air born coal dust. Best management practices should be reviewed with the coal industries and enforced by Federal and State environmental protection agencies. Discussion has been expanded and incorporated into the reports in this regard.

7. See response 4.

8. The Ashtabula River Partnership has reviewed the Aquatic Habitat Shelf measure in terms of ice damage, ship activities, and maintenance. Theoretically, bumper dolphins could be placed adjacent to the hung fishery shelves to serve to protect the shelves from ship and flow ice damage. This and the ice damage issue would have to be assessed further. There are also real estate issues with the recommended aquatic shelf measures. It should be noted that these or similar measures would be pursued by separate authority/study (i.e. 206) subsequent and contingent to this projects dredging for removal of contaminants. Discussion has been expanded and incorporated into the reports in this regard.

9. The Assessment/Evaluation work sheets and report narrative text should have been better integrated. They were out of sequence. The figures/matrices/tables on pages 82 through 89 were utilized as reference sheets in assessment/evaluation of remaining alternative components options in order to identify a recommended basic dredging, de-watering, and disposal plan. There was a summary discussion of this assessment/evaluation discussion on page 80. Development and utilization of Site P for discharge of dredged non-TSCA material was eliminated from further consideration. Revisions have been made to the final reports.

10. Reference Item 3.

SPECIFIC COMMENTS on the DRAFT EIS

11. Concur. Perhaps the more appropriate term should be “dredged material determined to be suitable for open-lake discharge”. The U.S. Army Corps of Engineers, Buffalo District by way of it’s Operations and Maintenance program periodically performs sediment sampling and analyses (per current developed guidelines) of sediments that would be dredged to maintain Federal navigation channels. (In some cases sediment sampling may be waived if sufficient evidence of non-contaminated sediments can be demonstrated) Sediments determined to be suitable for open-lake discharge may be discharged at the harbor open-lake discharge site.

The proposed Partnership plan includes consideration for post project Operation and Maintenance dredging of available harbor sediments determined to be suitable for open-lake discharge and discharge of material primarily into the partnership project dredged holes in order to improve surface sediment quality, followed by long-term natural re-sedimentation. Reference Environmental Impact Statement page EIS – 87, paragraph 2.116.

12. Concur. Sorry. It was understood that the U.S. Fish and Wildlife Service in conjunction with the Ohio Department of Natural Resources would routinely keep tabs on significant species

(sometime through surveys) and could report information within five to ten years of completion of the project. The statement has been revised to indicate "consulted" pertaining to significant harbor species or removed. A more detailed monitoring plan will be/has been developed.

13. Concur. The statement referenced the Draft Coordination Act Report. The statement has been revised. Reference Item 3.

14. Concur. We will continue to coordinate. Again, thank you for your review and comments and project input.



State of Ohio Environmental Protection Agency

STREET ADDRESS:

Lazarus Government Center
122 South Front St.
Columbus, OH 43215

TELE: (614) 644-3020 FAX: (614) 644-2329

MAILING ADDRESS:

Lazarus Government Center
P. O. Box 1049
Columbus, OH 43216-1049

November 8, 1999

John Mahan, Ph.D., Coordinator
Ashtabula River Partnership
1123 Bridge Street
Ashtabula, Ohio 44004

Dear Dr. Mahan:

As requested, Ohio EPA reviewed the draft Ashtabula River Comprehensive Management Plan/ Environmental Impact Statement (CMP/EIS) and Technical Appendices that the Buffalo District prepared at the request of the Ashtabula River Partnership (Partnership) for remediation of contaminated Ashtabula River sediments. In general, we found the draft remedial action plan (RAP) to be quite comprehensive in its assessment of many alternatives about the dredging and restoration of the lower Ashtabula River. The Ashtabula community is to be commended for its dedication and persistence toward resolving historic river and harbor pollution.

1 2 3

The Partnership goal of environmental and economic recovery of the watershed will be fully realized when the 1983 fish consumption advisory is lifted, future dredged sediments are eligible for open-water disposal, and overall water quality improves. Ohio EPA shares the Partnership goal, and expects that remedial design and implementation will be appropriate, scientifically sound, achieved in a timely manner, and result in the most improvement to the Area of Concern.

In our review of the draft CMP/EIS, we have identified the following issues that must be addressed in the final CMP/EIS to achieve our mutual goals:

General Comments

4

- ▶ It is critical that the river remediation project be coordinated closely with the timing of the Fields Brook remediation to prevent recontamination of the lower river from Fields Brook; this coordination will enable a smooth transition of legal, financial, and technical aspects to readily achieve desired endpoints, e.g. resolution of claims, cost-sharing agreements, and final design plans.

Dredging

5

- ▶ The Ashtabula River dredging operation will be regulated under a Section 401 Certification which shall ensure at all times full compliance with Ohio Water Quality Standards (WQS). No NPDES permit is anticipated in this portion of the operation. Any type of wastewater treatment or conveyance system used in association with the dredging operation will require the approval of an Ohio EPA permit to install (PTI).

Bob Taft, Governor
Maureen O'Connor, Lieutenant Governor
Christopher Jones, Director

28

- 6
- ▶ A detailed environmental monitoring plan for the dredge site should be developed for Ohio EPA approval. For example, specifications need to be developed to describe the means by which impacts to water quality will be minimized at the dredge site. The overall effectiveness of silt screens is in question, given the flow of this river.
- 7
- ▶ Wave action over the last two summers has deposited extensive sand inside the west harbor breakwall. Prior to remedial dredging commencing in 2002, current lake levels are expected to drop even further. These natural phenomena impact Ashtabula marinas and Port of Ashtabula operations and may lead to a need for more sediment dredging and confined disposal than currently calculated in the draft CMP/EIS. It will be critical for the Partnership to continue in its role of broad public involvement over the interim to incorporate changes in dredging volumes and corresponding project scope into the final CMP/EIS.

Dewatering

- 8
- ▶ Similar to the dredging comments above, this project component will also be regulated under a Section 401 Certification which shall ensure at all times full compliance with Ohio Water Quality Standards (WQS). No NPDES permit is anticipated in this portion of the operation. Any type of wastewater treatment or conveyance system used in association with the dewatering operation will require the approval of an Ohio EPA PTI.
- 9
- ▶ The basis of design for the dewatering facility and its operation must ensure that Ohio WQS are adequately protected. As such, the final engineering design plan must take into account additional pollutants in conjunction with suspended solids, e.g., PCBs, PAHs and metals. In so doing, additional means of treatment may be required to meet the applicable standards.

Disposal

- 10
- ▶ Ohio EPA comments regarding the conceptual landfill design were previously forwarded to the Partnership. It is expected that the ongoing work of the Partnership Landfill Design subcommittee, which includes technical assistance from Ohio EPA, will result in a final engineering design plan for the proposed disposal facility at Site 7.
- 11
- ▶ Construction of the proposed disposal facility at Site 7 will be regulated under the requirements contained in Ohio Revised Code (ORC) 6111. The PTI should address all requirements regarding its construction and operation. In addition, the permit will address the conveyance and treatment of storm water leaving the disposal facility.
 - ▶ All point source discharges associated with the proposed disposal facility will require an Ohio EPA NPDES individual permit. This permit will regulate the discharge of treated storm water to waters of the State, such that the discharge will not cause or contribute to any violation of Ohio WQS.

- 12
- ▶ The wetland delineation conducted at Site 7 indicates the presence of an estimated 11 acres of mostly wooded wetlands, some of which may be unavoidably impacted. A Section 401/404 water quality certification will be required to address these impacts.

Post-Remediation Considerations

- 13
- ▶ It appears advantageous to all parties involved if ecological restoration activities planned by the Partnership are closely coordinated with potential restoration activities contemplated by Trustees under Natural Resource Damage Assessment (NRDA) authority, one of which is Ohio EPA, especially as a final agreement is negotiated between the NRDA Trustees and interested parties comprising the Ashtabula River Cooperating Group.
- 14
- ▶ There is mention throughout the draft CMP/EIS of post-remediation monitoring over a 5 to 10 year period to assess restoration of lost beneficial uses. However, with the exception of landfill monitoring and some monitoring under Section 206, no monitoring costs are included for derivation of average annual costs. Post-dredging monitoring should be an integral part of the final CMP/EIS with respect to assessing recovery of all lost beneficial uses.

15

In closing, my understanding of why the partnership approach works so well in Ashtabula is that the decision-making for remedial actions is based upon consensus among all stakeholders, where consensus means everybody gives input and nearly unanimous agreement is reached. I look forward to building consensus with the partners to address these issues in the final CMP/EIS, so that we may move quickly to implement the final remedy for the Ashtabula River. Thank you for the opportunity to work together on this worthwhile project.

Sincerely,

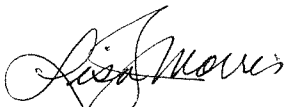

Lisa J. Morris, Chief
Division of Surface Water

nfarber/cmpeisRvw11-99.wpd

cc: Jenny Tiell, Assistant Director
Bill Skowronski, NEDO
Bob Wysenski, NEDO
Erm Gomes, DSW, NEDO
Sheila Abraham, DERR, NEDO
Greg Smith, Legal
Cindy Hafner, Chief, DERR
Julie Letterhos, DSW

John Childs, Deputy Director
Rod Beals, DERR, NEDO
Regan Williams, DERR, NEDO
Kurt Princic, DSIWM, NEDO
Barb Brdicka, Chief, DSIWM
Jeff Hurdley, Legal
George Elmaraghy, DSW
Natalie Farber, DSW

RESPONSES (Thank you for your review and comments. Numbered responses pertain to numbered comments.)

GENERAL

1. The Comprehensive Management Plan (Planning Feasibility Report) and Associated Environmental Impact Statement and Appendices (to meet U.S. Army Corps of Engineers requirements to authorize and fund a project) is generally supposed to be a planning and preliminary design level document. It should reasonably identify the Ashtabula River Partnership; problems, needs, and objectives; alternative measures (very important to include implementation authorities to be able to implement), impact assessment/alternative evaluation [engineering/ economic/environmental (includes natural/social/cultural resources) and trade-offs] and recommended plan; and public and environmental coordination/in-put and compliance. Usually, enough preliminary design work is done on most feasible measures or alternatives to facilitate assessment and evaluation to identify a recommended plan (in this case perhaps a bit more). This is to avoid wasting a lot of resources on detailed design of too many alternatives/plans. These items are contained in support Technical Appendices. Subsequently, more detailed design is done in the next project phase on a project plan. This is then followed by preparation of construction plans and specifications.

2. The Comprehensive Management Plan Feasibility Report and Environmental Impact Statement and Appendices are aimed at a wide spectrum audience. The Comprehensive Management Plan concentrates on summarizing for agencies and the public plan formulation and selection including summation of environmental assessments/evaluations. The Environmental Impact Statement concentrates on summarizing for agencies and the public environmental assessment/evaluation including summation of plan formulation and selection. The technical appendices provide technical support documentation. This describes the interface as presented at several public meetings.

3. Subsequent to the Draft Reports, a number of additional evolved alternative disposal facilities and alternatives were assessed/evaluated. Use of existing disposal facilities can not be utilized because RAD material can not be co-mingled with other disposed material and must have its own disposal facility. In this regard, the former RMI Sodium Plant site (State Road Site) has become available. The site has been disturbed by past plant development and recent demolitions and is of little value to fish and wildlife and contains only minor wetlands at the eastern boundary and north-east corner. The Fields Brook remediation project material is being disposed of in part of this property. There is room for the Ashtabula River Partnership dredged elevated PCB and RAD material to be disposed of in a developed facility adjacent to the Fields Brook remediation project disposal facility. There is also just enough room for the Ashtabula River Partnership dredged contaminated material to be disposed of in a developed facility adjacent to the other disposal facilities. Assessment/evaluation indicates that this is the overall preferred possible disposal alternative and is now the project disposal component plan.

General Comments

4. Concur. The project will occur following remedial measures of Fields Brook.

Dredging

5. Concur. The Ashtabula River Partnership forwarded an initial Application For Ohio EPA Section 401 Water Quality Certification with the draft reports. This was withdrawn due to project plan disposal revisions and limited preliminary design information. The Ohio EPA however, issued an interim letter of concurrence on feasibility in this regard pertaining to sufficient planning and preliminary design and indicated that a Final Application For Ohio EPA Section 401 Water Quality Certification should be submitted with more detailed final design and support documentation. The Ashtabula River Partnership will be forwarding a Final Application For Ohio EPA Section 401 Water Quality Certification with design and support documentation. More advanced contaminant analyses and facilities design is underway and is being coordinated. A Permit to Install will be coordinated for when more specific facility design information is available.

6. Concur. A detailed environmental monitoring plan for the dredge site will be developed for Ohio EPA approval.

7. Concur. The dredging that you discuss may be separate from this project and addressed under Federal and permitted Operations and Maintenance dredging. Federal channels to be dredged are evaluated in terms of directed priorities, economic, engineering, and environmental considerations. The U.S. Army Corps of Engineers, Buffalo District is currently assessing/evaluating Operations and Maintenance dredging at Ashtabula Harbor. The U.S. Army Corps of Engineers, Buffalo District by way of it's Operations and Maintenance program periodically performs sediment sampling and analyses (per current developed guidelines) of sediments that would be dredged to maintain Federal navigation channels. (In some cases sediment sampling may be waived if sufficient evidence of non contaminated sediments can be demonstrated) Sediments determined to be suitable for open-lake discharge may be discharged at the harbor open-lake discharge site. Material considered to be not suitable for open-lake discharge would have to be disposed of in a confined disposal facility. Currently, in Ashtabula, there is no economic Federal/local provided confined disposal site for the Federal government to dredge and dispose of material determined to be not suitable for open-lake discharge. Contaminated sediments have been and continue to be a problem in this regard.

Similarly, local interests may by permit periodically performs sediment sampling and analyses (per current developed guidelines) of sediments that would be dredged to maintain local navigation channels. (In some cases sediment sampling may be waived if sufficient evidence of non-contaminated sediments can be demonstrated). Sediments determined to be suitable for open-lake discharge may be discharged at the harbor open-lake discharge site. Material considered to be not suitable for open-lake discharge would have to be disposed of in a confined disposal facility. Currently, in Ashtabula, there is no economic Federal/local provided confined disposal site for the local interests to dredge and dispose of material determined to be unsuitable for open-lake discharge. Contaminated sediments have been and continue to be a problem in this regard. This does not preclude the local interests from developing a permitted dredging and de-watering scheme (i.e. barges or other) and disposal of sediments considered to be not suitable for open-lake discharge at a developed or existing disposal facility, if considered to be worthwhile to them.

One of the goals of the Ashtabula River Partnership is to provide a project where post project dredged material may be dredged and acceptable for discharge at the harbor open-lake discharge

site. Current analyses, forgoing any unforeseen circumstances, indicate that that should be the case within a few years after the project. Available sediment sampling and analyses for sediments located outside the channels to be dredged for the partnership project indicate that those sediments should be suitable for open-lake discharge. This sediment data is available for local interest use and/or reference. However, Federal and local dredging and discharge operations will still have to be appropriately reviewed and/or permitted.

The proposed Partnership plan includes consideration for post project Operation and Maintenance dredging of available harbor sediments determined to be suitable for open-lake discharge and discharge of material primarily into the partnership project dredged holes in order to improve surface sediment quality, followed by long-term natural re-sedimentation.

Dewatering

8. Concur. The Ashtabula River Partnership forwarded an initial Application For Ohio EPA Section 401 Water Quality Certification with the draft reports. This was withdrawn due to project plan disposal revisions and limited preliminary design information. The Ohio EPA however, issued an interim letter of concurrence on feasibility in this regard pertaining to sufficient planning and preliminary design and indicated that a Final Application For Ohio EPA Section 401 Water Quality Certification should be submitted with more detailed final design and support documentation. The Ashtabula River Partnership will be forwarding a Final Application For Ohio EPA Section 401 Water Quality Certification with design and support documentation. More advanced contaminant analyses and facilities design is underway and is being coordinated. National/State Pollution Discharge Elimination System (N/SPDES) general and specific permits for construction and facilities will be coordinated for and items incorporated into the project design and plans and specifications. A Permit to Install will be coordinated for when more specific facility design information is available.

9. Concur. More advanced contaminant analyses and facilities design is underway and is being coordinated.

Disposal

10. Concur. More advanced contaminant analyses and facilities design is underway and is being coordinated. Reference Item 3.

11. Concur. The Ashtabula River Partnership forwarded an initial Application For Ohio EPA Section 401 Water Quality Certification with the draft reports. This was withdrawn due to project plan disposal revisions and limited preliminary design information. The Ohio EPA however, issued an interim letter of concurrence on feasibility in this regard pertaining to sufficient planning and preliminary design and indicated that a Final Application For Ohio EPA Section 401 Water Quality Certification should be submitted with more detailed final design and support documentation. The Ashtabula River Partnership will be forwarding a Final Application For Ohio EPA Section 401 Water Quality Certification with design and support documentation. More advanced contaminant analyses and facilities design is underway and is being coordinated. National/State Pollution Discharge Elimination System (N/SPDES) general and specific permits for construction and facilities will be coordinated for and items incorporated into the project design

and plans and specifications. A Permit to Install will be coordinated for or by the local sponsor when more specific facility design information is available.

12. Reference Item 3. Development of the disposal facilities at the State Street Site would be situated to avoid significant impacts to wetlands. One man-made depression wetland located on soil fill was identified with-in the northern third of the site along the eastern site boundary. This will be avoided.

Post-Remediation Considerations

13. Concur. The Ashtabula River Partnership project would be implemented within the scope of several U.S. Army Corps of Engineers dredging and (possibly) environmental restoration authorities. The project would provide measures of ecological restoration in terms of removal of most contaminants by dredging and limited physical restoration. It should be noted that these latter or similar measures would be pursued by separate authority/study (i.e. 206) subsequent and contingent to this projects dredging for removal of contaminants. These analyses are somewhat different and separate than that associated with NRDA authority; but, would be complimentary to some degree. Physical restoration measures particularly will likely need to be further coordinated and integrated.

Natural Resources (Trustees) Damages. Nothing in this environmental impact statement shall be construed either explicitly or implicitly to irreversibly or irretrievably commit natural resources either directly or indirectly associated with the proposed dredging of the Ashtabula Harbor Channel beyond those areas outside of the area of dredging.

14. Concur. As indicated in the Draft CMP/EIS much of the monitoring may be accomplished as a matter of course. More advanced contaminant analyses and facilities design is underway and is being coordinated. More detailed monitoring plans and associated costs will be/have been incorporated into the Final reports and even more detailed monitoring plans and associated costs will be prepared in detailed design and preparation of project plans and specifications.

IN CLOSING

15. Concur. We look forward to continuing to work with you on the Ashtabula River Partnership. Again, thank you for your review and comments and project input.



76 South Main St.
Akron, Ohio 44308

330-384-5151

November 9, 1999

Mr. John Mahan, Coordinator
Ashtabula River Partnership
1123 Bridge street
Ashtabula, OH 44004

Re: Comments on the Ashtabula River Partnership Draft Comprehensive Management Plan and Environmental Impact Statement

Dear Mr. Mahan:

We have carefully reviewed the above referenced document. The following comments are submitted on the draft plan on behalf of the First Energy Corporation:

1. The document reflects the long term effort that has gone into the selection of the remedy and the preparation of the Comprehensive Management Plan/Environmental Impact Statement.
2. We urge the Partnership to make all reasonable efforts to control costs during the implementation of this remedy. An immediate opportunity for cost control exists during the upcoming value engineering effort. All ideas presented during these proceedings should be examined. Any proposals that results in cost reductions while still meeting the Ashtabula River Partnership goals should be adopted.
3. Any reasonable opportunities to expedite the remediation process should also be considered. Moving the project schedule forward or avoiding unnecessary delays will allow the benefits of the project to be available to the public at an earlier date. A shorted schedule for the implementation of this remediation will also tend to reduce the uncertainties that are inherent in longer running projects.

We appreciate the opportunity to comment on the Comprehensive Management Plan/Environmental Impact Statement. Thank you for your time and consideration.

Sincerely yours,

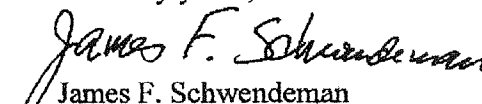
James F. Schwendeman

cc: E. J. Shaw
D. J. Weber

First Energy Corporation
First Energy Corporation

RESPONSES (Thank you for your review and comments. Numbered responses pertain to numbered comments.)

1. Concur.
2. Concur. All ideas presented during the Value Engineering proceedings have been examined. As depicted in the Ashtabula River Partnership goals, the project will need to be a balance of feasibility from economic and engineering perspectives and acceptability from environmental and social perspectives. Implementation authorities and associated costs and cost sharing will also be an important consideration in this regard.
3. Concur. Although, a number of issues still need to be addressed and an array of processes must be accomplished per authorities and permits. Also, the Fields Brook remediation project must be accomplished prior to the Ashtabula River Partnership project to address potential re-contamination.

Again, thank you for your review and comments and project input.



UNITED STATES ENVIRONMENTAL PROTECTION AGENCY
REGION 5
77 WEST JACKSON BOULEVARD
CHICAGO, IL 60604-3590

NOV 09 1999

REPLY TO THE ATTENTION OF:

B-19J

Lieutenant Colonel Mark D. Feirstein
District Engineer
Department of the Army
Army Corps of Engineers, Buffalo District
1776 Niagara Street
Buffalo, New York 13207-3199

Dear Lieutenant Colonel Feirstein:

1 In accordance with our responsibilities under the National Environmental Policy Act (NEPA) and Section 309 of the Clean Air Act, the United States Environmental Protection Agency Region 5, (USEPA) has reviewed the Comprehensive Management Plan and Draft Environmental Impact Statement (DEIS) for the Ashtabula River and Harbor located in Ashtabula County, Ohio. The proposed plan would address the dredging and disposal of contaminated sediments and the restoration of adjacent aquatic ecosystems. The recommended plan consists of the dredging and disposal of approximately 700,000 cubic yards of contaminated sediments. Approximately 150,000 cubic yards of the contaminated sediments are regulated under the Toxic Substance Control Act (TSCA) due to the significant PCB concentrations. The remaining sediment will be placed in a non-TSCA disposal facility. The sediment will be transferred by truck to the appropriate disposal facility. The proposal will also require the development and utilization of a transfer/dewatering/transfer facility in the harbor area. The upland disposal facilities will have leachate collection, treatment and monitoring facilities.

2 Based on our review of the information provided in the DEIS, we have rated this project EC-2. The "EC" indicates that we have environmental concerns with the proposed project. The "2" indicates that additional information needs to be provided to support the impact analysis documented in the DEIS. This rating will be published in the Federal Register. These comments center on wetland mitigation and TSCA regulations.

Wetland Mitigation

3 The DEIS did not provide sufficient details regarding the proposed wetland mitigation plan. The final EIS must provide a detailed description of the plan used to obtain the review, comment, and concurrence by the appropriate agencies. The plan should list the species that will be planted, number of trees per acre, whether saplings or seedlings will be used, invasive species control methods, and mortality action level. The DEIS only listed Pin Oak and Sugar Maple as species to be used to provide mitigation. Therefore it is not clear whether other high quality species such as Swamp White Oak, Shag Bark Hickory, and Butternut Hickory are being considered. The plan

should describe at what mortality rate actions will be taken to offset the loss of wetland species. The plan also needs to indicate what will be considered as successful mitigation at the end of the 10 year monitoring period.

TSCA Regulations

4 Our agency would like to draw your attention to several incorrect statements made in the DEIS regarding TSCA regulations. These misstatements are in regards to land applications, landfill liability, and alternative disposal options. The final EIS will need to correct these misstatements.

The first sentence in the last paragraph on page 20 is incorrect. The approval to land apply PCB contaminated material under 1 ppm is still required.

5 On page EIS-73, section 2.94, the statement is made that perpetuity requirement for post closure care of TSCA chemical waste landfills is estimated to extend for fifty years. This is an incorrect statement. The landfill owner/operator will be continually responsible for caring for the landfill. This misstatement is made in several sections of the document. On page 92 of the EIS in Section 1.137, the specific reference for the PCB regulations applicable to the technical requirements for a TSCA chemical waste landfill are found at 40 CFR Section 761.75. This section also contains the incorrect statement regarding the fifty year estimate for perpetual post-closure care.

6 The chart shown on page EIS-83 in the "Remaining Alternative Components Option(s) - Assessment/Evaluation/Selection" section, the Sediment Disposal Options-TSCA line refers to three options including an Option C for a TSCA Alternative Disposal Option. The PCB disposal regulations were amended on June 29, 1998. The TSCA alternative disposal option as defined under 40 CFR section 761.60(a)(5) was eliminated from the revised regulations. The approval for Ohio Environmental Protection Agency to dispose of PCB contaminated material in their best available technology solid waste landfills will have to be accomplished through an USEPA issued risk based disposal approval as defined under 40 CFR section 761.61(c). This reference to the TSCA alternative disposal option is also made in several sections of this document. Page 113 of the EIS under the TSCA Alternative Disposal Options section, also refers to the alternative disposal option which no longer exists in the revised PCB disposal regulations and has been replaced by a risk-based disposal option.

7 We appreciate the opportunity to review and comment on this project and look forward to reviewing the final EIS. We are willing to meet to discuss our concerns with you. If you have any question or comments, please contact Al Fenedick at (312) 886-6872 or by E-mail at fenedick.al@epa.gov.

Sincerely,

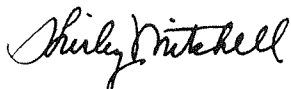

Shirley Mitchell, Deputy Director
Office of Strategic Environmental Analysis

RESPONSES (Thank you for your review and comments. Numbered responses pertain to numbered comments.)

1. Thank you for your review and comments.
2. Additional information will be provided to support the plan formulation and impact analysis documented in the CMP/EIS.

Wetland Mitigation

3. Subsequent to the Draft Reports, a number of additional evolved alternative disposal facilities and alternatives were assessed/evaluated. Use of existing disposal facilities can not be utilized because RAD material can not be co-mingled with other disposed material and must have its own disposal facility. In this regard, the former RMI Sodium Plant site (State Road Site) has become available. The site has been disturbed by past plant development and recent demolitions and is of little value to fish and wildlife and contains only minor wetlands at the eastern boundary and north-east corner. The Fields Brook remediation project material is being disposed of in part of this property. There is room for the Ashtabula River Partnership dredged elevated PCB and RAD material to be disposed of in a developed facility adjacent to the Fields Brook remediation project disposal facility. There is also just enough room for the Ashtabula River Partnership dredged contaminated material to be disposed of in a developed facility adjacent to the other disposal facilities. Assessment/evaluation indicates that this is the overall preferred possible disposal alternative and is now the project disposal component plan.

Development of the disposal facilities at the State Street Site would be situated to avoid significant impacts to wetlands. One man-made depression wetland located on soil fill was identified within the northern third of the site along the eastern site boundary. This will be avoided.

TSCA Regulations

4. Concur. The statements have been revised.
5. Concur. The reference to 50 years pertained to the dredging project authority/economic estimate life and mandatory site monitoring. The reference has been deleted and the statements have been revised.
6. Concur. As discussed on page EIS-75, the chart shown on page EIS-83 was utilized in assessment/evaluation discussions in early 1997. This section of the report documents what was utilized at that time and accordingly should not be revised. Reference to this in the present will be eliminated or revised, as appropriate, in the Final reports. Also, we were not able to catch all the revisions in Federal and State regulations and associated revisions to these reports from the time that this document was primarily written to the time of release.
7. Again, thank you for your review and comments and project input.

UNITED STATES ENVIRONMENTAL PROTECTION AGENCY
REGION 5
SUPERFUND DIVISION
77 WEST JACKSON BOULEVARD
CHICAGO, ILLINOIS 60604-3590

November 16, 1999

Dr. John Mahan
Coordinator
Ashtabula River Partnership
1123 Bridge Street
Ashtabula, Ohio 44004

Dear Dr. Mahan:

I would like to submit the following comments on the Comprehensive Management Plan (CMP) and Environmental Impact Statement (EIS) for the Ashtabula River and Harbor.

1 My review showed that there was no mention of radiological contaminants in the Executive Summary for the Comprehensive Management Plan, nor in the Abstract for the Draft Environmental Impact Statement. The Summary of Major Conclusions and Findings for the Draft Environmental Impact Statement included a single reference to radiation, a quote from a May 18, 1999 letter of the Ohio Department of Health, Bureau of Radiation Protection (ODH), that stated, radiologically, ODH found the draft CMP/EIS to be "consistent with State requirements." This was the only mention of radiation in this summary. This affirmation, it should be noted, was written before ODH and the U.S. Environmental Protection Agency (EPA) conducted an extensive sediment sampling project on the Ashtabula River in August 1999. When laboratory results are returned and interpreted it is reasonable that ODH will review their affirmation. Finally, Section 5.1 of the CMP did contain a single page devoted to "Radionuclide Issues."

2 I think it is important, in the CMP/EIS, to make note of several facts. Specifically, after re-review of USEPA's 1990 radiological data and after collection of 8 limited characterization samples that were analyzed for radionuclides in 1998 (2 of these were background samples), it was evident that radionuclides should be contaminants for further investigation in the Ashtabula River. The 1998 data showed uranium sediment levels up to about 70 times background and radium sediment levels up to about 20 times background. The maximum uranium concentration was about twice that being applied to a commercial cleanup on Fields Brook. The maximum radium concentration was about 30% more than the commercial cleanup criterion and about 3 times the residential cleanup criterion for Fields Brook. From this data, it became evident to USEPA and ODH that radionuclides were part of the contaminants of concern for Ashtabula River.

As a result, the two agencies conducted an extensive sampling effort in August 1999, collecting close to 150 sediment samples for radiological analyses. Isotopic uranium, isotopic thorium and isotopic radium levels are being measured and results for critical areas will be compared to PCB and PAH concentrations in paired samples. Scenarios will be run to determine risk to unprotected dredge workers and resident farmers, the groups considered most at risk. These could lead to additional cleanup criteria for sediments and have the potential to modify the cleanup plan.

3 In summary, along with an expanded history of radiological investigations, there should be, in the CMP/EIS, an inclusion of radiological data, an inclusion of results of estimated risk, an inclusion of any radiological cleanup criteria that may be developed (whether through Applicable or Relevant and Appropriate Requirements or through direct derivation) and a discussion of any impacts on the chemically driven cleanup plan for Ashtabula River, due to radionuclides. These are essential facts and issues for this CMP/EIS. For thoroughness, these should be included even if radionuclides do not impact the cleanup action.

Overall, it seems appropriate to expand the CMP/EIS to address radiological issues more fully.

Sincerely,

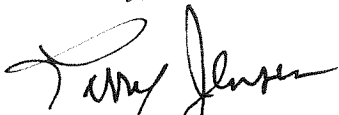

Larry Jensen, CHP
Regional Radiation Expert

16 November 1999

This letter supplements letters from the Ohio Department of Health dated May 18, 1999 and October 21, 1999.

RESPONSES (Thank you for your review and comments. Numbered responses pertain to numbered comments.)

1. The Ashtabula River Partnership concurs that as written, the Draft CMP/EIS does not contain sufficient detail with regards to the radioactive materials component of this clean-up project. This issue resurfaced fairly late in the draft phase of the project and some information was not able to be included in the draft reports.

Actually, the draft reports initially discussed or referenced this issue in sections pertaining to sediment sampling and analyses and subsequently briefly in the CMP page 139, and in the Environmental Impact Statement (EIS) Summary page 10, page EIS-93, and in the EIS Harbor Sediment Quality and Dredging Section beginning on page EIS-134 and page EIS-150. Page EIS-93 also states that a project health and safety plan will be prepared for project implementation with project plans and specifications.

As you have indicated, additional sediment sampling and analyses has been conducted in this regard. Findings and items have been incorporated into the Final reports.

Section 5.1 of the CMP summarized the situation as understood at the time and indicated that additional sediment sampling and analyses were being conducted in this regard. Findings and items have been incorporated into the Final reports.

2. Most of the analysis information that you discuss was not available when these reports were written and before release. As you have indicated, additional sediment sampling and analyses has been conducted in this regard. Findings and items have been incorporated into the Final reports.

3. Concur. As you have indicated, additional sediment sampling and analyses has been conducted in this regard. Findings and items have been incorporated into the Final reports.



Transmitted Via Federal Express Priority

November 9, 1999

John Mahan, Ph.D.
Coordinator
Ashtabula River Partnership
1123 Bridge Street
Ashtabula, OH 44004

Dear Dr. Mahan:

On behalf of the Ashtabula River Cooperation Group (ARCG), enclosed are comments on the Draft Ashtabula River Comprehensive Management Plan, dated August 1999. The enclosed represents a hard copy of the comments that were transmitted to you via e-mail, earlier today. The comments are provided in sections as follows:

- I. General Comments;
- II. Primary Specific Comments;
- III. Secondary Specific Comments;
- IV. References; and

Attachment A.

Please note that to ease the burden of segregating these comments, they have been flagged to identify the likely Ashtabula River Partnership (ARP) Standing Committee that would likely review and respond to each comment. Comments to be addressed by the Project, Landfill, Dewatering/Transfer and Wetland Committees are noted with the letters P, L, D and W, respectively.

Thank you for the opportunity to provide these comments. Please call with any questions.

BLASLAND, BOUCK & LEE, INC.

Stuart Messur/dmn
Stuart D. Messur
Vice President

KJ/lec

FAUSERSLECS8291383.WPD

Enclosure

cc: Joseph A. Heimbuch, *de maximis, inc.* (w/o encl.)

The ARP thanks the Ashtabula River Cooperation Group for its interest and comments on the Ashtabula River Dredging Project Draft Comprehensive Management Plan, Environmental Impact Statement and related appendices. We have attempted to respond to all your comments.

BBL comments are followed by Ashtabula River Partnership responses.

ARP GENERAL CLARIFICATION: The Ashtabula River Partnership Comprehensive Management Plan (CMP) is the Feasibility Report for the Ashtabula River Partnership Project. Accordingly, the following ARP Responses use "CMP" in reference to the Feasibility Report.

ARP CMP RESPONSE REFERENCES: The ARP has formulated responses to the BBL General Comments and Primary Specific Comments pertaining to the CMP (Feasibility Report) and the EIS. In addition, The ARP prepared an "EIS Reference Introductory Response" to address the "Secondary Specific Comments pertaining to the EIS and EIS Appendices. The following responses to the BBL Secondary Specific Comments pertaining to the CMP make reference to these prior ARP responses and are referred to based on the following categories followed by the response number.

1. "General Comment Response"
2. "Primary Specific Comment Response"
3. "EIS Reference Introductory Response"

**ASHTABULA RIVER COOPERATION GROUP
COMMENTS ON THE DRAFT
ASHTABULA RIVER COMPREHENSIVE MANAGEMENT PLAN**

The Ashtabula River Partnership (ARP) has developed a Comprehensive Management Plan (i.e., the "Draft Plan") (dated August 1999) for "cleanup of contaminated sediment and ecological restoration of the lower Ashtabula River and Harbor." The three-volume Draft Plan incorporates the draft Environmental Impact Statement (the "EIS") and the draft Feasibility Report (the "FR"). The Draft Plan is a tangible reflection of the ARP's progress towards a remedial solution for the Ashtabula River and Harbor. As an active ARP member, the Ashtabula River Cooperation Group (the "ARCG"), has developed the following comments to support the continued progress of the ARP. The ARCG is a cooperative group of companies, many of whom maintain an active presence in Ashtabula, who have agreed to cooperatively participate in the ARP.

As suggested by the ARP, the ARCG's comments address all three volumes. The ARCG's comments are divided into three categories:

- I. General Comments - A general overview of the ARCG's major concerns with the Draft Plan;
- II. Primary Specific Comments - More detailed discussions and comments on ARCG's major concerns; and
- III. Secondary Specific Comments - Supporting comments that address specific areas of the Draft Plan.

Comments beginning with "EIS" are comments that apply to the Draft EIS. Comments beginning with "FR" are those that apply to the feasibility report. Comments beginning with a single letter (e.g., "H," "M," or "S") apply to the FR appendix with the corresponding letter.

It is the understanding of the ARCG that the ARP standing committees (i.e., Project Committee, Landfill Committee, etc.) will discuss and respond to those public comments that are pertinent to the individual committees. In order to ease the burden of segregating these comments, the ARCG has marked up a hand copy of this comment package which identifies each specific comment according to which ARP standing committee would likely review and respond.

Introduction

The ARP goals (FR, Page 8) include:

- Environmental remediation of the lower River; and
- Maintenance of an uncontaminated outer harbor shipping channel by dredging and open-lake disposal.

ARP RESPONSE #1 - *It should also be understood that an additional goal is maintain recreational navigation in the lower river.*

The ARCG understands these ARP goals. However, the ARCG has serious questions concerning whether all of the goals are achievable, even with successful implementation of the Draft Plan. Furthermore, excessive sediment removal as proposed in the Draft Plan does not bring with it proportional benefits in achieving these goals. The ARCG believes the Draft Plan can be further developed and modified during predesign (e.g., during value engineering review) and design to optimize the opportunities to meet these goals. Further, the ARCG believes the beneficial uses for the River can be restored sooner and with less impacts to the community and environment. In summary, the ARCG strongly believes that further modifications and refinements to the Draft Plan will:

- **Improve the ability of the Final Plan to achieve the stated goals;**
- **Minimize the recovery time of the entire River system;**
- **Minimize impacts to existing bulkheads and docks;**
- **Minimize disruption to the community and eco-system;**
- **Maximize cost effectiveness; and**
- **Minimize the implementation time of the Final Plan.**

I. GENERAL COMMENTS

1. **The Draft Plan needs to recognize the uncertainties associated with fully realizing the stated project goals. A number of factors contribute to the impairment of beneficial uses in the lower Ashtabula River. It is highly unlikely that the impairments will be “eliminated” and the stated ARP goals fully realized by implementing the Draft Plan. The Draft Plan should have more accurately described the merits and the uncertainties associated with goal achievement.**

The Draft Plan acknowledges that environmental impairment of the Ashtabula River has resulted from a number of factors other than contaminated sediments. These factors include runoff from urban and industrial developments, structural developments, periodic dredging and heavy vessel activities. Addressing contaminated sediments will not address beneficial use impairments attributable to these factors. As stated in the Draft Plan, PAHs and other constituents in runoff from urban and industrial activities may be responsible for fish tumors and the degradation of the benthic community. Structural development, (i.e., channelization, bulkheading, etc.) has resulted in substantial loss of fish and wildlife habitat. Heavy commercial and recreational use of the River and periodic dredging are responsible for degradation of fish, wildlife and macroinvertebrate community and habitat. The Draft Plan has not properly documented and differentiated the potential effects of other sediment contaminants and the effects of other habitat-related stressors.

The Draft Plan does not demonstrate that future open water disposal of dredged sediment can be achieved. PAHs, metals, and other constituents in runoff from future industrial/commercial

activities, heavy recreational/commercial use along the River, and naturally occurring inorganics in sediments will continue to impact sediment quality. In addition, the migration of surface residual sediments, prior to a full natural covering, will affect harbor sediment quality. No data or assessment are provided in the Draft Plan to indicate whether future deposited sediment will be suitable to allow open-lake disposal following implementation.

ARP RESPONSE # 2: Urban run-off of water with lead contamination has been addressed separately through the regulation of leaded gasoline. 2. Potential impact from PAHs is being determined through sampling in the suspect areas. 3. ARP recognizes that there will be habitat impacts as a result of the navigational uses of the river and feel the long term benefits far off set them. 4. Sediments from upstream areas are similar to neighboring Conneaut and Grand River and thus once the natural cap is in place, should enable open lake disposal as it is done in those harbors.

- 2. The project elements in the Draft Plan have not been fully developed. The Draft Plan significantly overestimates the effectiveness, implementability and performance of environmental dredging. The optimum limits of removal (i.e., volume of sediment) is that which best achieves the stated project goals. Dredging beyond this increases the potential for adverse impacts and reduces benefits. The value of adjusting some of the dredge cut lines and the active placement of clean sediment over the dredged areas to maximize the potential to achieve the stated goals should be carefully considered. The document should be refined, by adjusting the cut lines (increase lateral extent, reduce depth) and placing a clean sediment cover following dredging to improve the ability of the Plan to achieve the ARP goals and achieve the beneficial uses sooner.**

Based on a review of dredging data collected by the USACE during pilot studies and others during full-scale remediation, the surface PCB concentrations following dredging will be considerably higher than predicted (Attachment A). An objective of the dredging plan is to “leave surface sediment PCB and PAH concentrations no worse than existing conditions.” However, there are inherent operational problems associated with dredging that limit the target level that can be achieved. Sediments become resuspended and subsequently mix and settle on the dredged surface, leaving behind constituent concentrations higher than predicted.

ARP RESPONSE #3: It is recognized that there will be a short term increase in surficial PCB concentrations after a dredging of this type, however the long term benefits are anticipated to off set this by orders of magnitude. This is also the reason the ARP believes significant mass removal is important.

Placement of clean cover on the dredged surface residuals has been prematurely screened out as a viable project element in the Draft Plan. However, the Draft Plan proposes the natural deposition of clean sediment to provide a cover within several years which will “ensure long-term protection of human health and the environment.” During these initial years, while natural deposition is slowly occurring, the dredged surface will be available for exposure and transport to the Outer

Harbor. In addition, some contaminated sediments are proposed to be left behind in shallow water, which are prone to erosion/transport due to sloughing, disturbance from recreational use and high flow events. The Draft Plan acknowledges that a clean cover material is needed, following dredging, in order for the ARP goals to be achievable, and states that the goals could be achieved more quickly through “addition of clean fill.” Placement of clean cover following dredging should be further developed and included in the document.

ARP RESPONSE # 4: 1. Any capping scenario would need to provide sufficient depth to meet navigational needs. 2. USACE classification of the Federal Navigation Channel needs the ability to dredge to authorized depths. 3. There is no federal funding authority for capping to support the project.

Dredging of 700,000 cu yd of sediment is not required to improve and maintain commercial and recreational navigation in the Ashtabula River and to mitigate the cited beneficial use impairments. The dredging cut lines were established based on a desire to remove a large percentage of the PCB mass and achieve a particular exposed surficial, sediment PCB concentration. However, at this site, neither of these factors should drive selection of the cut lines, since:

- Mass removal does not equate to risk reduction; and
- An acceptable surficial sediment concentration in the Draft Plan is only achieved following deposition of clean material.

ARP RESPONSE # 5: Mass removal does reduce the risk of contamination of the outer harbor versus removing less contaminated sediment. The ARP is in agreement with expeditious recovering of the dredged areas, however see responses above.

If the dredged residuals were isolated immediately after dredging through placement of a clean sediment cover designed to mitigate the potential for scour/transport and bioavailability, less sediment could be removed, and the same benefits achieved sooner and the inherent risk and negative impacts associated with dredging minimized.

ARP RESPONSE # 6: In the long term the risk following natural cover will be lower under the current proposal due to greater mass removal of PCBs.

3. **The estimated cost to implement the Draft Plan is significantly underestimated. Certain cost items, support information and assumptions for the cost estimates were not provided in the Draft Plan. The cost to implement the Draft Plan could increase by a factor of 2 or more. Further plan development should consider actual costs at other environmental dredging projects, omissions, the results of recent sampling events and treatability studies, and the economic impacts of regulatory decisions. Cost estimates should be updated. Detailed cost spreadsheets, which support each component of the cost estimate should be included.**

The Draft Plan estimates the unit cost for project implementation to be \$61 per cubic yard. Dredging costs from other environmental dredging projects have generally ranged from \$100-300 per cubic yard. For example, USEPA anticipates spending \$266 to address PCB-containing sediment at the New Bedford Harbor Superfund Site (USEPA, 1998) and the State of New York has recently awarded a contract at \$210 per cubic yard for removal of 120,000 cu yd of PCB-containing sediments in Lake Champlain (NYSDEC, 1999). Another comparable project is the Bayou Bonfouca site, where the cost for dredging alone (i.e., excluding dredged material management and disposal) of 169,000 cu yd of sediment was \$125 per cubic yard.

Omitted from the Draft Plan are a number of significant cost items, including:

- The cost for stabilizing an estimated 7,500 linear feet of bulkhead that, according to the Draft Plan, will be impacted during dredging; and
- The handling/disposal of an estimated 100,000 cu yd of additional soil/sediment from: ongoing deposition in the River (1995-2003); the 1993 interim dredging material; and material that would be removed to install fish shelves.

In addition, it should be noted that the USACE has recently identified and is evaluating what may amount to an additional 200,000 cu yd of PAH contaminated sediments that may require dredging and upland disposal.

In the Draft Plan, it is assumed that through gravity dewatering alone, the pre-dredged, in-situ volume (700,000 cu yd) would be reduced by 30% (500,000 cu yd), prior to transport/disposal. Based on a recent dewatering study performed on Ashtabula River sediments, it appears that the post-dewatering sediment volume will be approximately equivalent to the pre-dredging volume (700,000 cu yd). Furthermore, based on shear strength results of the same material, it appears that the addition of a stabilization agent (and a resultant increase in the disposal volume) or use of specialized equipment may be required in order to place the material in the landfill. These findings will increase the volume and cost significantly.

A number of technical issues are still pending regulatory decisions, which could have significant financial implications on Plan implementation. Recently obtained sediment radionuclide (RAD) sampling results are currently being assessed by Ohio Department of Health (ODH). ODH's determination will have a dramatic impact on dredge cut lines and the landfill design. As noted previously, bioassay and toxicity testing are being conducted by USEPA on recently obtained lower River and Harbor samples to determine whether additional sediments containing PAHs or other constituents are at levels requiring removal, and potential upland disposal. A regulatory decision has not yet been made regarding the viability of using the Fields Brook Superfund Site landfill for disposal of Ashtabula River (i.e., "offsite") sediments which contain PCB concentrations in excess of 50 ppm.

II. PRIMARY SPECIFIC COMMENTS

COMMENT 1. THE DRAFT PLAN MUST RECOGNIZE THE UNCERTAINTIES ASSOCIATED WITH FULLY REALIZING THE PROJECT GOALS

The Draft Plan makes two erroneous conclusions which affect the ability to fully realize project goals. The first is that the Draft Plan does not properly evaluate the existing and future impacts to the ecological system of the Ashtabula River. The Draft Plan immediately assumes that contaminated sediments cause the majority of problems in the river, and discounts potential effects from other factors. The second is that the Draft Plan does not properly assess the potential for improvement in the system when developing and comparing remedial alternatives. The Draft Plan uses unsubstantiated and arbitrary improvement rankings for the river, which are based on an over-simplified comparison of the Ashtabula River and Conneaut Creek. Both of these may increase the uncertainty that the Draft Plan will actually achieve the project goals. These issues are discussed further below.

A. The Draft Plan Does Not Accurately Assess Potential Impacts

The Draft Plan states that the six beneficial use impairments in the Ashtabula River AOC are directly related to contaminated sediments (e.g., page EIS-4). The specific beneficial use impairments supposedly impacted by contaminated sediments are: 1) loss of fish and wildlife habitat; 2) degradation of fish and wildlife populations; 3) degradation of benthos; 4) fish tumors and other deformities; 5) restrictions on fish and wildlife consumption; and 6) restriction on dredging activities. As described below, data presented in the Draft Plan directly contradict the assumption that contaminated sediment is directly related to all of these beneficial use impairments. Information indicates that the impairments are either not as severe as presented in the Draft Plan, or are likely caused by factors other than contaminated sediment.

1. Loss of Fish and Wildlife Habitat

The Draft Plan incorrectly assumes that contaminated sediment are the primary reason for loss of fish and wildlife habitat within the Ashtabula River. In truth, the lower Ashtabula River and Harbor are located in a highly developed residential, commercial, and industrial area, and receive many impacts from the surrounding land use. The land use of the area and existing man-made structures along the river have significantly reduced the availability of quality habitat. Riparian wetlands which are critical for support of fish and wildlife populations have also been eliminated. The Draft EIS (Page 2) states that "structural developments (i.e. channelization, bulkheading, etc.) have essentially eliminated aquatic/fishery shallow areas." Increased human use of the system through recreation and

commercial boat traffic have also served to increase the disturbance of the system in terms of fish and wildlife habitat.

2. Degradation of Fish and Wildlife Populations

The Draft Plan improperly assumes that contaminated sediment are the primary cause for impacts to fish and wildlife populations. As stated above, fish and wildlife habitat of the lower river have been destroyed due to historical development and associated human use.

Naturally, this severe lack of high-quality habitat also accounts for the majority of impacts to fish and wildlife populations. For example, according to the Draft Plan, areas downstream of Fields Brook have low biological scores, demonstrating the effect of habitat modification.

Further downstream, conditions in the commercial shipping lane are said to be “highly stressful” for fish as a result of boat traffic. Given these conditions, habitat limitations (and not contaminated sediment) are the most significant impact to fish populations. In terms of wildlife usage, the Draft Plan does not describe any studies which verify the impacts on local wildlife populations (i.e., birds, mammals, herptiles). Regardless, it is likely that poor habitat quality, and not sediment contamination, is the limiting factor impairing wildlife usage.

The Draft Plan also claims that if not for the contaminant problem, the Ashtabula River could be a prime site for salmonid stocking (e.g., page EIS-6). This statement is not supported in the report. Currently, contaminant concentrations in resident fish from the Ashtabula River are relatively low. Migratory salmonids, which would spend a limited portion of their lifetime in the river, would be expected to have even lower concentrations.

In fact, data from other Great Lakes sites (e.g., the Sheboygan River) indicate that sediment PCB concentrations from rivers where salmonids were stocked do not contribute to PCB levels in adult migratory fish. As such, it is more likely that habitat limitations (e.g., bulkheading, low flow) limit the river's potential for salmonid stocking.

3. Degradation of Benthos

The Draft Plan incorrectly assumes that contaminated sediment are responsible the degradation of benthic macroinvertebrates in the lower river and harbor. Biological studies conducted by Ohio EPA (1992) on the Ashtabula River and harbor concluded that contaminated sediment were not responsible for current impairments of benthic macroinvertebrates. The Draft EIS (Page 2) states that “dredging and vessel activities have caused resuspension of sediments suffocating bottom organisms and disrupting fish habitat.”

The fact that the macroinvertebrate community is considered poor both upstream of Fields Brook (rivermile 1.9) and downstream of Fields Brook (rivermile 1.3) indicates that sediment contaminants are not responsible for potential impacts. In many areas of the river (e.g., Ashtabula River harbor), the macroinvertebrate communities were no different than non-contaminated sites. In areas where impacts were observed, Ohio EPA reported that

boating activities and shoreline modifications overshadowed any effects that could be related to the contaminants.

4. Tumors and Other Anomalies in Fish

The Draft Plan states that tumors and other anomalies have been observed in fish from the Ashtabula River, and that these occurrences are related to contaminated sediments (e.g., page EIS-28). Although it is acknowledged that several of the contaminants detected in sediment (e.g., PAHs) are known to cause anomalies, the Draft Plan has not established that sediment-related constituents are the cause. Natural factors, including viruses, infections, bacteria, and protozoan parasites may cause anomalies. The Draft EIS even points out that wave action in the harbor area may cause fish anomalies. A variety of stressors, including elevated water temperature and low dissolved oxygen (as reported for the Ashtabula River) make fish more susceptible to anomalies. The fact that fish anomalies are naturally occurring is acknowledged in the Draft Plan, which presents data that the percentage of fish anomalies from a supposedly clean site (Conneaut Creek) is actually higher than the percentage of anomalies in fish from the Ashtabula River.

5. Restrictions on Fish and Wildlife Consumption

As stated in the Draft Plan, fish consumption advisories have been in place in the Ashtabula River since 1983. In 1997 the fish consumption advisories were lessened in response to more recent fish data, which indicated that fish PCB concentrations had since declined significantly. Currently, fish PCB concentrations for the Ashtabula River are relatively low (i.e., less than 2 ppm), and are expected to continually decrease through natural attenuation of the system. In fact, the current fish consumption advisory for the Ashtabula River is generally no more stringent than the fish consumption advisory for Lake Erie. According to the Ohio Department of Health (1999), the chemical that drives the existing fish consumption advisory is mercury, and not PCBs.

According to the baseline human health risk assessment (Crane, 1992), potential human health risks are below levels of concern using reasonable exposure assumptions (e.g., average consumption of typical sport fish fillets). The only elevated potential human health risks are based on overly-conservative scenarios, such as subsistence fishermen or individuals eating whole carp. Many of the potential risks under these scenarios are from copper and mercury, not PCBs.

Given this information, it is clear that sediment-related PCBs are not responsible for the primary impact on restrictions on fish and wildlife consumption. However, the potential effects of mercury and other contaminants are not evaluated in the Draft Plan. Therefore, it is unclear whether the proposed alternative will totally remove the beneficial use impairment of restrictions on fish consumption.

6. Restrictions on Dredging Activities

The inability to dispose of dredged sediments at an open-lake disposal site has been cited as a significant problem related to maintenance dredging. The focus on PCBs in the Draft Plan has overshadowed the impacts of other constituents. However, the Draft EIS (Page 142, para. 3.42) states that “most” sediments from the Ashtabula River AOC are classified as unsuitable for open lake disposal due to elevated inorganics concentrations including arsenic, barium, cadmium, chromium, cyanide, lead, mercury, and zinc. Since there appear to be ongoing sources of inorganics to the river sediments (as discussed below), it is unclear how removal of the sediment in the Ashtabula River AOC and upstream sediments based on PCB and PAH concentrations will ensure that future sediments can be open lake disposed.

The Draft EIS (Page 131, para. 3.26) states that the surface sediments have elevated levels of several inorganics due to both native watershed parent materials with high inorganics and urban runoff. This implies that there are sources of elevated inorganics unrelated to the sources of PCBs, indicating that the inorganics sources may continue in the future despite elimination of PCB containing sediments and sources. It also appears that PAHs have significant impacts on the potential for open-lake disposal below the Fifth Street bridge.

Current methods for assessing the acceptability of material for open-water disposal have not been thoroughly applied. Testing should be performed in reference to the USACE “green book” which describes testing procedures for determining whether dredged sediment can be open-water disposed. Results from some recent sampling activities by the USEPA may aid in assessing the viability of open-water disposal, but currently this evaluation has not been completed.

ARP RESPONSE # 8: 1. Comparison with Conneaut Creek illustrates the types of improvements we can anticipate. Furthermore, bulkheading is typical in any harbor in the U. S. and is a requirement for commercial and recreational use of the harbor. 2. Per conversations with R. Thoma of the OEPA, the difference between classifying the Ashtabula River as a warm water habitat versus a cold water habitat is that it is not stocked with fish and the reason is it is contaminated with PCBs and other contaminants. When the contaminants are removed via dredging, the river will be stocked when deemed appropriate and become a cold water habitat. 3. The lower Ashtabula River is an estuary and sources of contamination affect both river mile 1.9 and 1.3. 4. It is believed that as long as high levels of contaminants remain in the River, there will always be a high degree of uncertainty concerning the cause of tumors and other anomalies. 5. ODH continues to post “no consumption of fish” signs at the Ashtabula River. 6. A basic premise of the CMP is that other contaminants are collocated with the PCBs.

B. The Draft Plan Does Not Accurately Assess Potential Improvement

The Draft Plan evaluates the potential biological improvement for the Ashtabula River based, in part, on Ohio EPA habitat assessment procedures (HAP). The HAP is an evaluation system based

on multimetric indices, which Ohio EPA has adopted into the Ohio Water Quality Standards (WQS) regulations. The biological indices are based on measurable characteristics of aquatic communities, such as species richness, key taxonomic groupings, feeding guilds, environmental tolerance, and signs of stress. The specific indices used in the HAP include index of biological integrity (IBI) for fish, the invertebrate community index (ICI) for benthos, and the qualitative habitat evaluation index (QHEI) for habitat characteristics. In theory, this approach, used in conjunction with expert biological judgement, provides a practical method of evaluating ecological communities.

The general approach of using the HAP could prove useful in evaluating existing and future conditions in the Ashtabula River. However, the specific HAP evaluation used in the Draft Plan is incorrect. In the Draft Plan, existing conditions of the Ashtabula River were compared to HAP indice measures from Conneaut Creek. Specifically, the target values based on Conneaut Creek data included an IBI score of 46 and an ICI score of 43. Using current measurements as a baseline, conditions (as measured by the indices) were assumed to improve to one-third of the Conneaut Creek values under shallow dredging, two-thirds under deep dredging or bank-to-bank dredging, and full attainment under deep dredging coupled with ecological restoration. Ecological improvement ranks are then generated for both the ecological restoration/preservation methods (e.g., page EIS-15, Table S-2) and the various dredging scenarios (e.g., FR page 148, Table 8-1). The problem with the approach used in the Draft Plan is that Conneaut Creek is classified as coldwater habitat (proposed to be exceptional warmwater habitat), while the Ashtabula River is classified as a warmwater habitat. Conneaut Creek also has less boat traffic (EIS page 312(b)-28), and other potential differences. Therefore, the direct comparison of future Ashtabula River biological indice scores to Conneaut Creek is inappropriate. It should be noted that the target values given in Table 8-1 of the FR for biological indicators are rarely met in Ashtabula River upstream areas, the Conneaut Creek Ship Channel, and other nearby creeks and rivers (Ohio EPA 1997). The assumption of one-third, two-third, and full attainment of Conneaut Creek scores under the various options is not fully described, and appears arbitrary.

A more appropriate method would evaluate potential improvements using the biological scores developed by Ohio EPA for attainment of warmwater habitat. Such an approach is supported by the Draft Plan. As stated in the Draft EIS (page EIS-11), the goal/objective of the river project should be "to reach a quality warmwater habitat condition." As described on page 312(b)-5 of the Draft EIS, an assessment of the biological community can be compared to standards for that particular ecoregion to evaluate whether or not the area is impacted. As such, numerical biological criteria for warmwater habitat should be used. According to Ohio EPA (1992), this use represents the principal restoration target for the majority of water resource management efforts in Ohio. It should be noted that full attainment of warmwater habitat criteria may not be possible without reducing the amount of bulkheads and developed shoreline.

***ARP RESPONSE # 9:** It is recognized that no two bodies of water are exactly the same in terms of habitat life, however, the Ashtabula River and Conneaut Creek are within 13 miles of each other and share adjacent and similar water sheds. The difference in classification by the OEPA of warm versus cold water habitat is arbitrary and based on the fact that the Ashtabula River is not stocked with salmonids because it is contaminated. The Grand River is similar to the Ashtabula River in that extensive recreational and commercial boat traffic exist as well as bulkheading. The Grand River is routinely stocked with fish, as it is not contaminated.*

COMMENT 2. THE PROJECT ELEMENTS IN THE DRAFT PLAN HAVE NOT BEEN FULLY DEVELOPED

The Draft Plan proposes to achieve the project goals by dredging an estimated 700,000 in-situ cu yd of sediment with upland disposal, constructing aquatic eco-restoration structures, and allowing time for new, cleaner sediments to cover the contaminated sediments left behind. During development and evaluation of the Draft Plan, a number of factors were overlooked which will restrict achievement of the ARP goals. Refinements can be made to the Plan which will improve the performance, and reduce some of the environmental, engineering and economic uncertainties and adverse impacts. A more detailed description of concerns identified and refinements proposed is presented below.

A. Concerns Regarding the Criteria Used to Define Dredging Extent

The need to remove 700,000 cu yd of sediment was determined based on an assessment of: 1) PCB massed removed; 2) surficial sediment PCB concentration after dredging; 3) beneficial uses addressed; and 4) scour and release potential. By using these as dredging criteria, extensive removal, to depths up to 20 ft. LWD, have been inappropriately proposed. A number of concerns have been identified with use of such criteria to define dredging extent:

1. Dredging depths up to 20 feet are not required to improve and maintain future commercial and recreational navigation in the Ashtabula River (ARP Goal #1). Based on the 1995 bathymetric data from the River, less than 50,000 cu yd of the 581,000 cu yd of sediment proposed for removal above the 5th Street Bridge is required to achieve the -6 ft. LWD specified for future recreational use. Modeling performed in the Draft Plan to determine what sediments might scour/transport to the Lower Harbor during a high flow storm event determined that scouring would not occur beyond 3 feet deep (an estimated total volume of 63,100 cu yd).

***ARP RESPONSE # 10:** It is the ARPs position that as much of the contaminated sediment as feasible should be removed for reasons stated above and all sediment should be removed with PCBs at levels > 50ppm. The dredging scenario of 20 foot depths is primarily driven by the > 50 ppm PCBs removal.*

2. Dredging depths up to 20 feet are not required to mitigate the cited beneficial use impairments (ARP Goal #2). After the dredging is complete, the Draft Plan states that several years of natural deposition of clean material over the remaining residual contaminated sediment will be required to mitigate the beneficial use impairments. Since goal achievement is dependent upon the subsequent placement of a clean cover following dredging, there is no technical justification to support dredging to a particular surface sediment PCB/PAH concentration.

ARP RESPONSE # 11: The ARP makes a distinction between the veneer of PCB surface contamination that results from re-suspension during dredging and exposing a surface with deep PCB contamination. Stated in response #3., it is anticipated that there will be a short-term increase in surface contamination, however it is offset by the long term benefits.

3. Based on a review of dredging data collected by the USACE during pilot studies and by others during full-scale remediation, the surface concentrations of chemical constituents following dredging will be considerably higher than predicted (Attachment A). When dredging is employed as a means of removing sediments, there are inherent operational difficulties associated with dredging which will limit the cleanup level that can practically be achieved. Dredging limitations are caused in part by resuspended sediments subsequently mixing and resettling within the dredged area. The degree of sediment disturbance, and hence resuspension and mixing, varies with the dredging equipment used, the operational handling of this equipment, and the physical nature of the sediments. Data collected during the dredging activities at several PCB sites have indicated that low PCB cleanup levels [e.g., in the range of 10 parts per million (ppm) or lower] generally are not achievable and even higher PCB cleanup levels may likewise be unattainable. The United States Army Corps of Engineers (USACE) has stated that “no existing dredge type is capable of dredging a thin surficial layer of contaminated material without leaving behind a portion of that layer and/or mixing a portion of the surficial layer with underlying clean sediment” (Palermo, 1991). Therefore, even though the dredge may be capable of removing substantial volumes of sediment, the sediments which the dredge misses (or those that eventually settle as a result of resuspension) will remain as a potential future PCB source. These findings further support the conclusion that there is no technical justification to establish cut lines based on a particular “assumed” (i.e., using existing data) surface sediment PCB/PAH concentration.

ARP RESPONSE # 12: See response # 11.

4. There are inherent risks and negative impacts associated with dredging that are greatly exacerbated by “massive” removal. While dredging in 20+ feet of water, it will be very difficult controlling releases of suspended contaminants from the work area that could impact downstream, as well as newly dredged areas. Recreational use will be impeded during the anticipated 3 year dredging timeframe, as will nearby businesses that utilize the

water front. (The Draft Plan has noted that an estimated 7,500 linear feet of bulkheading will require stabilizing to prevent bank failure resulting from the deep vertical dredge cuts.) With a reported 200-300 vehicle trips per day expected to haul sediment to the landfill (Appendix K), disruption to the local community in the form of traffic problems and potential spills should also be anticipated.

ARP RESPONSE # 13: *These potential issues are off set by the benefits of mass removal. See response # 5.*

5. Active placement of clean cover on the dredged surface residuals has been prematurely and inappropriately screened out as a viable project element in the Draft Plan. The Draft Plan acknowledges that a clean cover material is needed, following dredging, in order for the ARP goals to be achievable, and states that the goals could be achieved more quickly through "addition of clean fill." It is, therefore, unclear how reduction of sediment surface concentrations through natural deposition of clean sediment is acceptable; while placement of clean sediment to achieve the same goal is not. A scour-resistant cover consisting of coarse geologic materials such as sand and/or gravel at an acceptable depth would facilitate navigation and could easily be removed in the future, if deemed necessary. Additionally, this cap would be covered on an ongoing basis by newly depositing sediment.

ARP RESPONSE # 14: *See response # 4*

Covering of surficial sediment is a viable alternative (or alternative component) that is widely accepted by the regulatory (USEPA and USACE) and academic communities. According to the USEPA, "in-situ capping is a potentially economical and effective approach for remediation of contaminated sediment. A number of sites have been remediated by in-situ capping operations worldwide" (Palermo, 1998). A representative example has been recently noted in USEPA's proposed plan for the Sheboygan River and Harbor Site. In the Sheboygan Harbor, PCB concentrations in sediment decrease towards the surface, similar to the distribution observed in the Ashtabula River. The proposed plan for the Sheboygan River and Harbor includes dredging of approximately 100,000 cy of sediment from the Inner Harbor to provide for navigation, and placement of a 2-foot cap of clean sediment to isolate the underlying PCBs from the environment.

ARP RESPONSE # 15: *See response # 4.*

6. Achievement of the project goals does not require that a certain percentage of PCB mass first be removed. Much of the deeper PCB-containing sediment currently proposed for removal is isolated/contained at-depth and unavailable for exposure to humans or aquatic organisms, and far below any dredging depths required to support future planned river uses.

For potential ecological effects to occur, organisms must first be exposed to PCBs, either from the water, shallow sediments, or the food chain. It is therefore more appropriate to focus on PCB "bioavailability" than PCB mass removal when evaluating the effectiveness of project elements. Bioavailability refers to the potential for chemical exposure to the biological community, where it may pose a risk. As such, PCBs that are not, and cannot become bioavailable, pose little risk to wildlife.

For sediment-related constituents, the potential for maximum bioavailability is at the surface water-sediment interface. Therefore, PCBs that are most readily bioavailable are those that are in the surface sediments. This is implicitly recognized in the Draft Plan's reliance on natural or active placement of clean sediment over the dredged surface in order to reduce surficial concentrations in the long term. Although a majority of the PCB mass may be removed by the Draft Plan's "deep dredge" alternative, the assessment of dredging effectiveness must also consider the reasons/benefits to dredging deep, and the PCB concentration that remains in the surficial (i.e., bioavailable) sediments after dredging. PCBs that are buried below the layer of sediments where organisms can be exposed through burrowing and/or scour and resuspension should not be of concern when evaluating risk reduction. Removal to depths where PCBs do not contribute significantly to PCB export or fish exposure will do little, if anything, to reduce potential risk or restore beneficial use. On the other hand, during several years following dredging under the Draft Plan, residual contaminants present on the dredged surface will be available for exposure and transport to the Outer Harbor.

ARP RESPONSE # 16: It is agreed that there is no guarantee that open lake disposal will be attained. However, it is the ARPs position that mass removal greatly increases the long-term likelihood of open-lake disposal.

Post-dredge sloughing of sideslopes represents a potential source of exposure to biota and a source of recontamination that might affect the future potential for open-lake disposal of dredged sediment. In the Draft Plan, post-dredge angles of repose are not specifically referenced. However, slopes of approximately 1V:5H are depicted in cross-sections provided by USACE. According to the Draft FR (Page 15), "it is reasonable to anticipate that PCB-contaminated sediments exist in the cross sectional area between the short [1V:2H to 1V:3H] and long term [1V:6H to 1V:8H] cases, and it is fully anticipated that this sediment will slough off into the Federal channel at sometime in the near future and will impact on future disposal operations and options." Since the angle of repose proposed by the Draft Plan (as best as can be determined) is steeper than the long-term angles that can be maintained, according to the Draft Plan, this sloughing of sediment containing PCBs can be expected to occur following implementation of the Deep Dredge alternative. This represents a potential source of exposure to biota and a source of recontamination that might affect the future potential for open-lake disposal of dredged sediment. The

Final Plan should highlight this as a potential drawback with the deep dredge scenario. It should be noted that an alternative involving dredging from bank to bank to a shallower, more uniform depth (not considered in the Draft Plan) would minimize post-dredge sloughing.

ARP RESPONSE # 17: The final design will better define what the side slope issues will be relative to the comment and minimize them to the greatest extent possible and still take out the greatest mass of PCBs.

B. Refinements Which Will Improve the Plan

With achievement of the ARP goals in mind, refinements can be made to the Draft Plan which will improve performance and reduce some of the environmental, engineering and economic uncertainties and adverse impacts. As noted previously, the Draft Plan proposes to achieve the ARP goals through the natural deposition of clean sediments (i.e., capping), which will take several years to occur after dredging is complete. And yet, despite the general acceptance of capping as a viable remedy component, the active placement of a cap over the dredged sediment surface was eliminated during the technology screening stage. In the absence of any valid technical or economic justification for screening (i.e., the "Initial Appraisal Report," dated November 1994, although cited as the basis for screening, was never finalized and is not available for public review), the Plan should be refined to include active placement of clean cover material, following dredging. As highlighted previously, the advantages of placing a cap are many.

1. It alleviates concerns regarding exposure and transport of the surface residual sediment contaminants which will otherwise exist for several years following dredging under the current (draft) Plan.
2. It eliminates the dependence on mother nature (which is an unknown) to assist in goal achievement.
3. Cap placement, following dredging, alleviates concerns regarding the assumption that "by focusing on PCBs and PAHs, the other contaminants of concern will be addressed due to co-location of contaminants" (EIS-page 4).
4. As noted in the Draft Plan, the cap material could potentially be obtained through more extensive dredging of clean upstream sediments and/or from future maintenance dredging of the Outer Harbor. Both these options would provide economic, as well as future use benefits.
5. Most importantly, with a properly designed and installed cover of sand and/or gravel placed over the dredged material, less sediment could be removed, the remedy performance improved and implementation time reduced. By reducing the depth of some of the dredge

cut lines and increasing the depth and extent of others, the following benefits could be recognized:

- The dredging depth specified for recreational use above the 5th Street Bridge is -6 ft. LWD. Even if several more feet were removed and a sand and/or gravel cover was subsequently placed, future recreational navigation could be maintained with less than 581,000 cu yd removed. Cover placement would reduce exposure potential by physically and chemically isolating the contaminated sediment from the biological community. The sediment cover could also be designed to sufficiently resist future scour and ensure that PCBs and other constituents in sediment do not become bioavailable in the future. Additionally, the cover material could be selected such that the deposited material provides a suitable substrate for macroinvertebrates. Money spent on more extensive lateral sediment removal and subsequent placement of a clean cover, rather than on sediment removal to excessive depths, would serve to increase the likelihood of future dredged material being open water disposed, and restore beneficial uses much sooner than the Draft Plan.
- As stated in the Draft Plan, following implementation of the Draft Plan, the potential exists for scour and release of residual PCB-sediments, until sufficient deposition of cleaner sediments covers the dredged surface. Improvement to the Draft Plan (i.e., reduced scour and release potential) could be achieved at a cost savings, by removing less sediment and isolating the dredged surface through placement of a clean cover (e.g., sediment, sand and/or gravel). The particle size of the material to be used as cover and the thickness of the layer could be selected so that the material, when placed, can withstand erosive forces and provide a protective barrier against migration of residual contaminants.
- The concerns and costs associated with bulkhead stability could be mitigated, if dredging to excessive depths up against the bulkheads were not required.
- The potential community and environmental impacts to the River/Harbor due to “massive” dredging and disposal (e.g., the acreage of wetland impacted) would be reduced.
- The amount of time needed to implement the Plan could be significantly reduced.
- The project costs could potentially be significantly reduced.

ARP RESPONSE # 18: See response # 4.

In summary, the Draft Plan could be refined to more effectively and quickly achieve progress towards the ARP goals, through removal of a smaller, but more appropriate (i.e., based on bioavailability considerations, rather than percent constituent mass) sediment volume and active covering of the exposed, dredged sediment surface with clean sand and/or gravel. Recreational dredging would be accommodated, chemicals in underlying sediment would be isolated from overlying receptors and prevent downstream scour/transport, costs would be significantly reduced, landfill volume requirements would be less and hence any wetland (e.g., at Site 7 location proposed for landfill) destruction and impacts of a large-scale dredging project on the community and the environment also would be reduced. Additionally, it would reduce concerns related to the stability of an estimated 7,500 linear feet of bulkhead currently in question, through establishment of shallower cut lines adjacent to the bulkheads.

COMMENT 3. THE ESTIMATED COST TO IMPLEMENT THE DRAFT PLAN IS SIGNIFICANTLY UNDERESTIMATED

The estimated cost to implement the Draft Plan is significantly underestimated, based on comparison to other environmental dredging projects, and recognition of omissions and incorrect assumptions in the cost estimate.

A. First Cut Review

No detailed cost spreadsheets were presented to support the Draft Plan cost estimate. For example, no details of the size of the dredge, the bucket size, cycle time, down time the number of scows, work boats, crew size, the affect of debris and/or environmental monitoring on efficiency are included. Without this information, it is difficult to validate the \$16/cy dredging estimate, which appears low. This potential underestimate was also identified in a review of the cost estimate conducted on behalf of the ARP by Metcalf & Eddy (M&E, 1998). This review indicated that relevant details were lacking and that the underestimate of dredging costs could increase the total project costs by over \$3,500,000.

Although the cost to remove contaminated sediment is very site specific, when comparing the Draft Plan unit cost of \$61 per cubic yard (\$42,380,000/696,000 cu yd) with available costs (both estimates and completed) for other large environmental dredging projects, the cost estimate appears to be significantly underestimated:

- A Proposed Plan (PP) was recently issued by USEPA for the Sheboygan River and Harbor Superfund site. The PP presents are estimated cost of \$26.9 million to remove 100,000 cu yd of sediment containing PCB from the Harbor, using mechanical excavation, with off-site disposal (i.e., \$269 per cubic yard).

- At the Manistique River and Harbor site, the project-to-date cost to hydraulically dredge and off-site disposal of 93,000 cu yd of sediment containing PCBs is reportedly \$300 per cubic yard.
- At the Bayou Bonfouca site, 169,000 cu yd of contaminated sediment was mechanically dredged, under the oversight of the USACE. The cost for dredging “alone” (i.e., excluding dredged material management and disposal) was \$125 per cubic yard (compared to \$16 per cubic yard in the Draft Plan).
- At the United Heckathonn site in Richmond Harbor, California, the cost to mechanically dredge 65,000 cu yd of contaminated sediment (specified cutlines) was estimated at \$112-115 per cubic yard.
- The State of New York has recently awarded a contract to hydraulically remove/dispose 130,000 cu yd of PCB-containing sediment in Lake Champlain, for \$178 per cubic yard.
- The cost for mechanic removal and aquatic disposal (without water management) of low-level PAH containing sediment from the Boston Harbor Navigation project is reportedly \$100 per cubic yard.

B. Cost Estimate Omissions and Updates

Based on a review of the Draft Plan text, a number of significant cost-related items have been noted that are either not currently included, or have been incorrectly considered in the cost estimate.

1. Bulkhead Support

The report notes (FR-page 54) that are estimated 7,500 linear feet of sheetpiling will be affected by implementation of the Draft Plan. However, no money is included in the cost estimate to address this. With no available information regarding current bulkhead integrity on bank stability, the cost to install 7,500 feet of sheeting to a sufficient depth to support dredging up to 20 feet could approach \$4 million.

2. Water Treatment

In the EIS (page 48, par. 2.51) it states that discharging treated water with 50 to 100 ppm particulate “meets most parameter water quality standards”, and thus assumes that water filtration/treatment (i.e., sand and anthracite coal filter, possibly followed by carbon absorption) should suffice. At a number of sites where contaminated sediments have been dredged (e.g. Ruck Pond - Wisconsin, Unnamed Tributary - Ohio, Town Branch Creek - Kentucky, Sheboygan River - Wisconsin) water treatment to meet surface water or POTW discharge limits has required use of a multi-phased treatment system, typically including an

oil/water separator, a flocculent tank and clarifier, bag filters and carbon polishing. Unless data is available to support filtration only and monitoring for TSS only, the Final Plan text and cost estimate should be revised to reflect what can more likely be expected. This could add millions of dollars to the project cost.

3. Dredging and Disposal Volumes

Based on review of the Draft Plan, it appears that the current cost estimate reflects the removal, handling, transport, and disposal of 696,000 cu yd of sediment, broken down as follows:

	<u>Dredged Volume (cy)</u>	<u>Disposal Volume (cy)</u>
TSCA	150,000	100,000
Non-TSCA	<u>546,000</u>	<u>400,000</u>
Total	696,000	500,000

Based on omissions and recent information, the volume of material requiring removal, handling, transport and disposal has been significantly underestimated, with a more realistic, ultimate disposal volume possibly approaching 1,000,000 cy and associated cost increases of tens of millions of dollars. A description of the major omissions/updates is presented below.

a. Ongoing Deposition

It is understood that the removal volume presented in the Draft Plan is based on calculations done on a modeled sediment surface generated from 1995 data. The Draft Plan reports that the Ashtabula River has a sedimentation rate of 6 inches per year (Page 66). This would lead to an additional deposition of 40,000 to 50,000 cy per year. The Draft Plan does not appear to include a likely volume increase (or cost) associated with ongoing sedimentation in its volume estimate (1995-2003).

b. 1993 Interim Dredged Materials

The Recommended Plan (Section 3.5 of the Draft Plan) makes no reference to the 1993 Interim Dredging materials, but instead references the 696,000 cy of materials as comprised of 581,000 cy to be dredged from upstream of the 5th Street Bridge, and 115,000 cy to be dredged from downstream of the bridge (shown on Figure 3-26 of the FR). However, as stated on page 186 of the FR, up to 70,000 cy (Maxim 1999) of the Interim Dredging materials will be handled and disposed in the landfill as part of the program. No costs are included to address this.

c. Impacted Work Area Materials

Handling and disposing of sediments inherently involves working with wet, sloppy materials. As such, there is always some spillage during handling and transportation

that results in contamination of surficial soils in work areas and on-site roadways. These materials are generally removed and disposed as part of normal operations, particularly where spills occur in areas that are susceptible to uncontained stormwater runoff. Also, decommissioning of dewatering facilities, PPE, and other contaminated items will need to be disposed in the landfill. At present, there does not appear to be an additional contingency volume (or cost) to accommodate these materials.

d. Aquatic Shelf Construction

As part of the ecological restoration efforts, the Draft Plan (Page107) proposes that an aquatic fishery shelf would be cut along the east embankment channel of the Ashtabula River by the Conrail slip. In addition, a 10 ft wide channel is to be excavated between the river and the Conrail slip at the same elevation as the aquatic fish shelf. Based on descriptions provided in the Draft Plan, it appears that approximately 30,000 cu yd of soil will need to be excavated to accommodate the aquatic fish shelf. At present, it does not appear that excavation and transport/disposal (or cost) of this material has been included.

e. Lack of consolidation or strength from gravity dewatering

(i) Consolidation

It has been assumed in the Draft Plan that following gravity dewatering, the sediment volume to be disposed would be 30 % less than the estimated in-place volume. However, the proposed dewatering/transfer facility presented in Appendix K is designed to dewater the sediments only to the original in-situ solids content.

Appendix H to the FR (Page 20) eliminates the potential use of any mechanically aided drainage due to cost and delays, except for potentially using surface trenching or vacuum assisted underdrainage. However, the pilot studies on site specific sediments that demonstrate that a belt filter press and gravity dewatering have been unable to achieve better than a 65 percent solids indicate that the prospects of achieving the assumed solids content of 70 percent using gravity dewatering are remote. This is supported by recent gravity dewatering studies conducted using Ashtabula River sediments (BBL, 1999). Based on the available information, it appears that the Draft Plan should assume that the dewatered sediment volume will be approximately equal to the pre-dredging in-situ volume. This will require increasing the estimated disposal volumes currently being contemplated in the Draft Plan by about 30 percent (200,000 cu yd), and adjusting the costs accordingly.

(ii) Strength

It is assumed in Appendix H of the Draft FR (Page 19) that passing the paint filter test is the only criteria for landfilling the dewatered sediments. However, Appendix N assumes that the sediments will be placed at a solids content of 70 percent with an unconfined compressive strength greater than 10 psi. The 10 psi strength is described as being necessary for the landfill stability and to allow moving the sediment within the landfill with standard equipment. This assumption is carried into the Draft Design Report (Maxim 1999). Based on the pilot test results, it appears that the as-delivered shear strength to the landfill will generally be 0.5 psi or less. To address this, the Draft Plan cost estimate should be revised to either reflect the use of specialized equipment to place dredged sediment in the landfill, alternative placement techniques or the addition of a stabilizing agent (with an increase in volume) prior to placement.

ARP RESPONSE # 19: See response # 7. The ARP recognizes the desire for the ARCG to understand the total project cost and will work with the ARCG to provide refinements to the existing cost estimate as soon as practical.

III. SECONDARY SPECIFIC COMMENTS/RESPONSES DRAFT ENVIRONMENTAL IMPACT STATEMENT

Ashtabula River Cooperation Group
(Blasland, Bouck & Lee, INC.)

9 November 1999

The ARP thanks the Ashtabula River Cooperation Group for its interest and comments on the Ashtabula River Dredging Project Draft Comprehensive Management Plan, Environmental Impact Statement and related appendices. We have attempted to respond to all your comments.

EIS GENERAL INTRODUCTION REFERENCE RESPONSES

GENERAL

1. Unfortunately the ARCG reviewers did not have the benefit of being involved with the project and the planning from the near beginning. Many comment items were hashed over extensively through the committee and planning process. It was a goal in the partnership process to attempt to avoid extensive comment/response during draft public reviews through stakeholder hands-on involvement and outreach.

2. *Many comments are repeated for summary, main text, and technical appendices levels of the report. Technical questions should more appropriately be directed and addressed at the more technical levels of the reports. Many comments are on statements removed from immediate, section, and report context. Discussions in the reports that address many of the questions and comments appear to be overlooked and questions and comments were not edited out.*

DOCUMENTATION

3. The Comprehensive Management Plan (Planning Feasibility Report) and Associated Environmental Impact Statement and Appendices (to meet U.S. Army Corps of Engineers requirements to authorize and fund a project) is generally supposed to be a planning and preliminary design level document. It should reasonably identify the Ashtabula River Partnership; problems, needs, and objectives; alternative measures (very important to include implementation authorities to be able to implement), impact assessment/alternative evaluation [engineering/economic/environmental (includes natural/social/cultural resources) and trade-offs] and recommended plan; and public and environmental coordination/in-put and compliance. Usually, enough preliminary design work is done on most feasible measures or alternatives to facilitate assessment and evaluation to identify a recommended plan (in this case perhaps a bit more). This is to avoid wasting a lot of resources on detailed design of too many alternatives/plans. These items are contained in support Technical Appendices. Subsequently, more detailed design is done in the next project phase on a project plan. This is then followed by preparation of construction plans and specifications.

4. The Comprehensive Management Plan Feasibility Report and Environmental Impact Statement and Appendices are aimed at a wide spectrum audience. The Comprehensive Manage-

ment Plan concentrates on summarizing for agencies and the public plan formulation and selection including summation of environmental assessments/evaluations. The Environmental Impact Statement concentrates on summarizing for agencies and the public environmental assessment/evaluation including summation of plan formulation and selection. The technical appendices provide technical support documentation. *Summary and main text sections and paragraphs are usually summary items. Introductory paragraphs reference the technical appendix where the subject is discussed in further detail.* This describes the interface as presented at several public meetings. More technical information should be found in the technical appendices and technical review should accordingly be directed primarily at the technical appendices, not summaries or even considerably to the main text.

5. The reports were reviewed and revised many (about eight) times over the last few years and finally approved for release by the Corps of Engineers and the Ashtabula River Partnership.

6. There are a number of inconsistencies in the report. Most of these pertain to reporting comparative information that was utilized in progressive assessment/evaluations at the time (i.e. appendices) that can't/shouldn't be changed. Committee decisions were made with best available information at the time. That's the information that was utilized at the time. There are also a number of paragraphs that explain those inconsistencies. For example, EIS paragraph 2.35 on volumes, EIS paragraph 2.102 on comparative assessment/evaluation at the time and refined recommended plan information. There are also some inconsistencies that were just not caught in revising the main reports and appendices many times.

7. The partnership had hoped to give the reports a final once-over to cleanup figures and tables, reduce repetition (i.e. CMP and EIS plan formulation discussions), reduce or address inconsistencies, better incorporate late emergent items (CMP plan formulation discussions, 312(b), radionuclides, wetland mitigation), etc.; but, considering that it's a draft and facing another layer of review and in order to meet a pressing schedule, the approved draft reports were released. These items have been better addressed in the final report.

8. A Value Engineering Committee process has been conducted to review and refine a number of issues in question. These included review consideration of: a dredge and cover alternative, dewatering processes, disposal options, and project associated costs. Findings and associated revisions have been incorporated into the final reports.

9. There are approximately 640 pages (320 sheets) and 1,760 pages (880 sheets) of support documentation in the Environmental Impact Statement Appendices and the Main Report Technical Appendices, respectively. There are also Committee Meeting Minutes and file drawers full of general and specific working information files.

THE ARP AND GOALS, OBJECTIVES, ALTERNATIVES, ASSESSMENT/EVALUATION AND SELECTION

10. The Ashtabula River Partnership is a cooperative group that tries to consider the interests of all involved.

11. Partnership goals/objectives, alternatives, assessments/evaluations are not necessarily

limited to regulatory technical items. The Ashtabula River Partnership developed and utilized what it felt to be appropriate assessment/evaluation criteria considering the project authorities and interests.

12. A number of Partnership interests believe that removal of contaminant masses discharged into the river is a reasonable and important goal/objective for this project. Many want simply to get the contaminants out of the river and do not want the river used as a final dump site.

13. It has always been an ARP objective from the start that, considering the dredging authorities, is to remove all the TSCA material and as much contaminated sediments from the river regime as possible on all accounts. As long as there are substantial contaminants in the river regime, there is a higher long-term contaminant and bio-availability risk for the river regime than if they are removed. The deep dredge plan is a compromise plan in this regard as compared to the bank to bank and shallow dredge plans.

312(b) ANALYSES

14. The 312(b) Project Sub-Committee consisted of an interdisciplinary group of people. The Committee assessed the Ashtabula River Partnership Lower Ashtabula River Remediation Project with regard to Section 312 (b) of the Water Resources Development Act of 1990, Environmental Dredging, as Amended by Section 205 and 206 of the Water Resources Development Act of 1996, as promulgated by Corps of Engineers Policy Guidance Letter No. 49 and EC 1105-2-210. This required and included reasonable analysis utilizing a Habitat Assessment Procedure (HAP). A HAP has been developed by the State of Ohio Environmental Protection Agency that was acceptable and utilized. The persons that prepared the HAP analysis were intricate in developing the HAP and in preparing the HAP analysis for this project 312(b) assessment/evaluation. It was considered to be a reasonable and acceptable analysis for the 312(b) assessment/evaluation by the Committee, the Ashtabula River Partnership, and the Corps of Engineers to justify 312(b) dredging.

15. There has been extensive sediment sampling and analyses done for the project.

16. Contaminants may be associated with all problems identified, and removal associated with all remedial actions. Reference the 312(b) Appendix.

17. If only the existing physical habitat were better or improved, contaminants would likely be noted as even more of a problem because there could be more benthos and fisheries subjected to the contaminants.

18. There is substantial evidence presented (and even more now) that the contaminants in the river and surface sediments continues to be a major existing and potential problem and that contaminants are moving. Reference EIS section beginning paragraph 3.31 Harbor Sediment Quality and Dredging. 1) Table 3.9 on EIS page EIS-157 depicts surface sediment sampling data for PCBs chemistry and bioassay as available for proximate sampling stations. Reference EIS Figure 3.7, EIS page EIS 139. It demonstrates the periodic elevated presence and dredging removal and reappearance of PCBs and/or contaminants at the stations. 2) 1990 and 1995 core and supplemental sediment samplings (Reference EIS paragraph 3.41) three dimensional

charting indicate sub-surface pockets and surficial (within 0 to 2 feet) plumes of substantially PCB contaminated sediments. Reference EIS Figure 3.12, EIS page EIS-145; EIS Figure 3.6, EIS page EIS-137; EIS Figure 3.16, EIS page EIS-155; and EIS Figure 4.2, EIS page EIS-209. 3) Surface sediments within the Federal navigation channel from station 120 through the upper turning basin have in the substantial past failed chemistry and bioassay testing determining them to be not suitable for open lake disposal and have recently failed bioassay tests (1998) in that regard. There is some evidence of further contaminant migration and problems into the outer harbor (1998).

19. While cleaner sediments migrate in and cover and dilute surface sediments, surface sediment contamination levels increase when these cleaner sediments are removed in maintenance dredging (i.e. after the 1993 interim recreational channel maintenance dredging) and scour, and problems fluctuate and persist.

20. Also consider as stated in EIS paragraph: 3.52 It should be noted here that river scour is dynamic and somewhat unpredictable. Many factors circumstances (i.e. a fallen tree debris, sunken boat, etc.) can alter scour patterns and depth. To leave substantial masses of contaminants in the river sediments leaves considerable risk for future scour/re-suspension/movements of contaminants. Also, while mixing of lower level contaminated sediments with cleaner sediments may delute resulting contaminant levels to those acceptable for open lake disposal, mixing of higher level contaminated sediments with cleaner sediments can result in greater volumes of contaminated sediments not suitable for open lake disposal.

21. Fish advisories are discussed in the EIS beginning on page EIS-162 and the 312(b) Appendix beginning on page 312(b) - 57. The discussions (and associated data) indicate that there was a significant reduction of PCBs in fish from 1981 to 1991; but, slightly increased for 1994 and continues to be a problem. A river advisory still exists.

22. Environmental justice warrants that fishermen that catch and consume bottom feeder species warrant environmental protection also.

23. Conneaut Harbor and Creek should be acceptable as a comparative quality stream regime to Ashtabula Harbor and River. They are in relatively close proximity and parallel and with removal of contaminants from the Ashtabula River and some adjacent shallows restoration would be similar. The State has classified Conneaut as salmonid because of its existing suitability and stocking program. Ashtabula is not currently classified as salmonid because of its existing unsuitability and non-stocking program. It could be classified as salmonid with improved suitability and subsequent stocking program.

24. The 312(b) assessment/evaluation and Habitat Assessment Procedure (HAP) does discuss relative measure of impacts and recovery to the Ashtabula River ecology due to contaminants, lack of adjacent shallows and cover, and dredging and vessel traffic, as discussed and depicted in more detail in the 312(b) appendix.

DREDGING AND CAPPING

25. The current recommended Ashtabula River Partnership Plan is to be accomplished via

several U.S. Army Corps of Engineers dredging authorities. Thus, dredging to remove contaminants was a primary consideration that could be implemented with Corps authority and funding. A dredging and capping plan presents considerable problems in this regard with placement of the cap in the Federal channel. The Federal channel would likely need to be deauthorized by Congress and the capping paid for by other than the Corps.

General Comments Pertaining to Refined Outline Scenario (Cut and Cover).

- *Conflict with "Dredging Authorities"*
- *Conflict with maintaining potential for "Authorized Federal Channels" and depths. Cap below channels ?*
- *Conflict with developed ARP remediation goals, as understood, pertaining to removal of contaminants (mass) from the river.*
- *Most interests want the contaminants removed from the river and do not want the river utilized as a disposal site.*
- *Would need re-assessment/evaluation per 312(b) dredging authority, etc.*
- *The plan introduces another processes at the river (dredge and permanent cover) vs one (dredge). Usually two processes are more costly.*
- *Cover placement/mix, stability, and long-term reliability ?*
- *Costs? How sure are we of these costs ?*

26. The partnership dredging plan includes: upstream to downstream dredging, as possible, in order to substantially recapture resuspended sediments and associated contaminants, use of low turbidity dredges, consideration of special purpose dredging for final surface and constricted area dredging, silt curtains, and consideration of operations and maintenance harbor dredging and discharge of material suitable for open-lake discharge into primarily the partnership project dredged holes in order to improve surface sediment quality, followed by long-term natural re-sedimentation. Reference Comprehensive Management Plan page 90 and Environmental Impact Statement page EIS – 85.

27. As stated on EIS page EIS-9, paragraph 1.18, post project conditions include that best management practices be in effect by the coal and Fields Brook industries.

28. A capping scenario would need to accommodate a cap and at least two to three feet of sediment suitable for benthos (scour could remove this), as well as Federal authorized channel considerations.

29. Many interests just do not believe in the long-term reliability of an in river capping system.

30. There are a number of project examples and articles that counter your (Attachment A) after dredging elevated surface sediment contaminant levels and project success including those pertaining to: Scippo Creek, Ohio; Fox River, Wisconsin; and Manistique, Michigan.

**ASHTABULA RIVER COOPERATION GROUP
COMMENTS ON THE DRAFT
ASHTABULA RIVER COMPREHENSIVE MANAGEMENT PLAN**

III. SECONDARY SPECIFIC COMMENTS

A. DRAFT ENVIRONMENTAL IMPACT STATEMENT

EIS-1. Page 2, para. 1. The first full sentence of Page 2 of the EIS does not accurately reflect the contaminants associated with river sediment.

PAHs and metals should be referenced as classes of organic and inorganic chemicals found in river sediment.

***ARP RESPONSE:** Agreed. Will rephrase.*

EIS-2. Page 2, para. 5. The statement that "storm events cause scour and the resuspension of sediments and associated contaminants which periodically compromise water quality standards_ is not supported.

This comment also applies to a similar statement on Page EIS-2, para. 1.11; FR-20, para. 3.

There are no data presented in the Draft Plan to support this statement. The text should be modified to state "...associated contaminants which may periodically comprise water quality standards," or deleted.

***ARP RESPONSE:** Agreed. Will rephrase. However, the Corps of Engineers and others, have not been able to dredge and open-lake discharge material from the upper reaches of the harbor river channels based on sediment samplings and analysis which indicates that re-suspension of the sediments and associated contaminants would violate some water quality standards.*

EIS-3. Page 2, para. 5. The statement that _contaminated sediments continue to migrate downstream into the Lower River, Outer Harbor, and Lake Erie,_ is not supported in the Draft Plan.

This comment also applies to a similar statement on Page EIS-2 para. 1.11.

The Report does not contain or reference sampling data to support the statement that contaminated sediments are migrating to Lake Erie. Text should be modified to state "...are likely migrating downstream in the Lower River and towards the Outer Harbor," as stated on Page EIS-7.

ARP RESPONSE:** Do not agree. Periodic sampling of the harbor demonstrates continual increases in PCB concentrations at the river mouth, which demonstrate the migration of contaminated sediments to Lake Erie. Reference **SECONDARY SPECIFIC COMMENTS/RESPONSES DRAFT EIS GENERAL INTRODUCTION REFERENCE RESPONSES 18, also.

EIS-4. Page 3, para. 2. The Draft EIS states that "(t)he watershed area upstream of the developed harbor area (Ecological Assessment Area 1) is in relatively good condition."

This comment also applies to a similar statement on Page FR-25, para. 4.

The report should note that potential impacts to the Ashtabula River in this area have been documented. For example, Ohio EPA (1997) describes only partial attainment of warm water habitat (WWH) criteria in some parts of the river. Effects from intermittent flow and anthropogenic sources, including sewage disposal and livestock access, contribute to the partial attainment.

ARP RESPONSE: *Do not agree. The ARP believes that “relatively good condition” is an adequate description. This is only a summary paragraph. This is discussed further in the main text that follows and in the EIS Appendix EA-J Section 312(b) and 206 Ecological Restoration/Preservation Analyses.*

EIS-5. Page 3, para. 2. The statement that _primary problems_ in sediment from the 5th Street Bridge upstream to the end of the navigation channel include the presence of PCBs in sediment with _some equal to or in excess of 50 mg/kg or TSCA material_ is misleading.

This comment also applies to similar statements on Page EIS-2 (para. 1.10) and EIS-9 (para. 1.15).

The 50 mg/kg threshold established by TSCA is a disposal criterion for removed material. The statement should be clarified to state that in-situ concentrations of PCBs exceeding 50 mg/kg are not subject to TSCA until they are removed.

ARP RESPONSE: *The ARP agrees that “or TSCA material” may be incorrect within the text and will modify the sentence (See comment EIS-11, also). Will modify explanation on page 2, 4th paragraph also.*

EIS-6. EIS Page 4, para. 1. The statement that _cleanup of the Ashtabula River via the Ashtabula River Partnership should eliminate all of the use impairments assigned to the lower river_ is misleading.

This comment also applies to similar statements on Pages: EIS-9, para. 1.17; FR 192, Section 11.0

Ecological restoration efforts proposed in the Draft Plan would be most responsible for elimination of three of the six beneficial use impairments, if achieved. The ecological restoration components of the draft recommended plan could be implemented independently of the Draft Plan or other remedial alternatives selected for the site.

ARP RESPONSE: *Do not agree. Restrictions on dredging activities due to concern over contaminated sediment effectively prevent implementation of ecological restoration measures in several ways, including: 1) concern that existing pollutants will contaminate any new structures, 2) high cost-to-benefit ratio of adding restoration features to a contaminated ecosystem, and 3) what the ARP hopes is the temporary nature of the current configuration and the relatively small underwater area currently available.*

Contaminants may be associated with all problems identified (including degradation of benthos and loss of fish and wildlife habitat), and removal associated with all remedial actions. Benthos living in contamination and the associated fish and wildlife food chain does contribute to degradation of benthos and loss of fish and wildlife habitat. This is discussed further in the summary text, the main text that follows and in the EIS Appendix EA-J Section 312(b) and 206 Ecological Restoration/Preservation Analyses. Also, the ecological restoration measures of the draft recommended plan include removal of contaminants and development of

aquatic shelves, as possible, which would be accomplished under separate authorities. Some limitations are discussed also. Reference Secondary Specific Comments EIS General Introduction Reference Response 24, also.

EIS-7. EIS Page 4, para. 1. The statement that “(a)ll of the beneficial use impairments in the Ashtabula River AOC are directly related to contaminated sediment, more specifically to the PCB and PAH mass associated with the contaminated sediment,” is misleading, and should be appropriately modified or deleted.

This comment also applies to similar statements on: EA-J Page 312(b) - 2 para. 3; EA-J Page 312(b) - 81 para. 3; EIS-9 para. 1.17.

ARP RESPONSE: See response to EIS-6.

- a. Statements of this type, which reference contaminated sediments as the primary cause for impairments in the Ashtabula River, exist throughout the report. Biological studies have clearly documented that several beneficial use impairments (e.g., degradation of benthos, loss of fish and wildlife habitat) are directly related to marina development and associated boat traffic and habitat modification for international shipping (Ohio EPA, 1992).
- b. The potential for chemical-related impairments are not directly related to chemical mass, but are related to chemical concentrations in surficial sediment. For potential ecological effects to occur, organisms must first be exposed to PCBs, either from the water, shallow sediments, or the food chain. It is therefore more appropriate to focus on PCB “bioavailability” than PCB mass removal when evaluating the effectiveness of project elements. Bioavailability refers to the availability of chemicals to be exposed to the biological community, where the chemicals may pose a risk. As such, PCBs that are not, and cannot become bioavailable pose little risk to wildlife.

For sediment-related constituents, the potential for maximum bioavailability is at the surface water-sediment interface. Therefore, PCBs that are most readily bioavailable are those that are in the surface sediments. A more appropriate measure of risk reduction is the PCB’s surface weighted average concentration (SWAC). The SWAC represents an average PCB concentration in the biologically active zone of sediment in the River (USEPA, 1998). Although a majority of the PCB mass may be removed by the Plan’s “deep dredge” alternative, the assessment of dredging effectiveness must also consider the benefits for deep dredging, and the PCBs that remain (i.e., bioavailable) in the surficial sediments after dredging. PCBs that are buried below the bioavailable layer of sediments where organisms can be exposed through burrowing and/or scour and resuspension, should not be of concern when evaluating risk reduction. Removal of sediment to depths where buried PCBs do not contribute to PCB export or fish exposure will incur costs but will do little to reduce potential risk.

When surface weighted concentrations are generated for the post removal surface of the deep dredge alternative, it is expected, based on dredging data collected at other sites (Attachment A) that the surface weighted average concentration (SWAC) will be increased as a result of exposing buried sediments containing higher PCB concentrations that resuspend and settle out on the dredged sediment surface. In this case, the misconception of mass removal equaling risk reduction would lead to increased exposure and consequently increased risk to the environment.

As outlined above, the primary step in reducing potential exposure (and hence risk) to fish and wildlife is reducing the extent of exposure pathways by which a contaminant may come in contact with an organism. In many cases this can be more effectively done through the use of scour-resistant cover. Sediment covering may involve the careful placement of several inches to several feet of clean granular material such as sand or soil over the contaminated sediment. Covering reduces PCB exposure by physically and chemically isolating the PCB contaminated sediment from the biological community. A cover would effectively reduce the SWAC from current levels, and eliminate PCB exposure pathways.

The sediment cover can be designed with armoring (as necessary) to sufficiently resist future scour, and prevent PCBs from becoming bioavailable or mobile in the future. Additionally, the cover material can be selected such that the deposited material provides a suitable substrate for macroinvertebrates.

ARP RESPONSE: *ARP agrees that risk is driven by bioavailable chemicals, However, ARP believes that, in the long term, removal of significant PCB mass decreases the likelihood of PCBs becoming bioavailable in the future. See response to EIS-3 and EIS-6, also. Reference SECONDARY SPECIFIC COMMENTS/RESPONSES DRAFT EIS GENERAL INTRODUCTION REFERENCE RESPONSES 18, 25, 28, 29, also.*

EIS-8. **Page 4, para. 4.** **The assumption that _by focussing on PCBs and PAHs, the other contaminants of concern will be addressed due to co-location of contaminants_ should be supported in the Draft Plan with more details.**

This comment also applies to similar statements on EA-J Page312(b) - 9 last para.; EA-C Page2; EIS-11 para. 1.19; FR Page43, para.4; FR Page 188, Section 10.1.

Achievement of the ARP goals (i.e., environmental remediation and open water disposal of future dredged sediments) are dependent upon the reduction of potential impacts from other contaminants. Therefore, the data evaluation conducted to support this conclusion should be included and thoroughly described in the Final Plan.

ARP RESPONSE: *The ARP believes the discussion on pages 129-158 adequately supports the collocation of contaminants. This is supported in discussions pertaining to sediment sampling and dredging in the main text and technical appendices.*

The Draft EIS (Page 142, para. 3.42) states that "most" sediments from the Ashtabula River are classified as unsuitable for open lake disposal due to elevated metals concentrations. The levels of PCBs and PAHs in many of these samples, particularly below Fifth Street Bridge, are apparently acceptable for open lake disposal. Since there appear to be ongoing sources of metals to the river sediments (as discussed below), it is unclear how removal of these sediments and upstream sediments based on PCB and PAH concentrations will ensure that future sediments can be open lake disposed.

The Draft EIS (Page 131, para. 3.26) states that the surface sediments have elevated levels of several metals due to both native parent materials with high metals and urban runoff. This implies that there are sources of elevated metals unrelated to the sources of PCBs, indicating that the metal sources may continue in the future despite elimination of PCB-containing sediments and sources. The Final Plan should compare expected metals concentrations from natural sediments

and current urban runoff impacting the Ashtabula River to conditions at proposed lake disposal site locations using the “greenbook” to evaluate if future open lake disposal is feasible.

ARP RESPONSE: See **GENERAL COMMENTS** response # 2.

The section in which the referenced paragraphs are located discusses an array of sediment sampling and analysis that was done for both operations and maintenance dredging and special studies. It discusses analyses pertaining to both inorganic and organic contaminants. Results and discussion may vary with time and circumstance (i.e. pre and post dredgings). Both inorganic and organic contaminants are a problem. This is discussed in the referenced paragraphs also. Paragraph 3.40 discussed an initial 1993 “greenbook” analyses. Basically, Federal channel areas upstream of station 120 (located about half way between the mouth and the Fifth Street Bridge) failed suitability for open-lake disposal. A similar sampling and analysis and similar results occurred in 1998/1999. Section paragraphs and dredging risk assessment sections discuss the significance of PCBs and PAHs and suspect toxicity and available sampling information makes co-location of contaminants a reasonable assumption. Some additional information has been incorporated into the reports in this regard.

EIS-9. Page 6, para. 2. Several of the _initial primary assessment/evaluation output measures_ are inappropriate for use as measures of the effectiveness of the alternatives considered.

This comment also applies to similar statements on Pages: EIS-34 para. 2.32.

The measures of _TSCA (PCB) material removed_ and _PCB/PAH Mass removed_ are inappropriate as used in the Draft Plan for “initial primary assessment/evaluation output measures.” Much of the sediment containing PCBs are isolated at depths which: 1) render the PCBs unavailable to humans or aquatic organisms, and 2) are below dredging depths that would be required for future uses of the river. Mass removal, in and of itself, does not represent an appropriate measure of the benefits to be achieved through a given remedy.

As acknowledged in the Draft Plan (see FR Page 40, para. 1), dredging and removal of these sediments would inevitably cause resuspension and spreading of PAH/PCBs, making them available to biota. Since resuspension and subsequent settling of the PAH/PCBs in dredged areas will likely increase initial PAH/PCB surface concentrations (one of the proposed project elements), a better measure would evaluate the quality of sediments in the bioavailable zone after placement of the cover proposed in the Draft Plan (see Page EIS-16, para. 2.06). This would be a measure directly targeted at the goal of environmental restoration of the river, and would recognize that elevated initial surface concentrations after dredging would simply be an implementation issue that is addressed by the proposed cover.

ARP RESPONSE: Do not agree. See **GENERAL COMMENTS** response # 3. Item statements in your first discussion paragraph are not necessarily true. See EIS response # 7. Reference **SECONDARY SPECIFIC COMMENTS/RESPONSES DRAFT EIS GENERAL INTRODUCTION REFERENCE RESPONSES** 18 and 25, also. ARP agrees that risk is driven by bioavailable chemicals; however, ARP believes that, in the long term, removal of significant PCB mass via dredging authorities decreases the likelihood of PCBs becoming bioavailable in the future.

EIS-10. Page 6, para. 3. Two of the three measures used to assess/evaluate dredging scenarios, as stated by the Draft Plan, are inappropriate.

This comment also applies to similar statements on: Pages EIS-34 para. 2.33; EIS-25 para. 2.20.

- a. Meeting river clean-up goals is an appropriate measure for evaluating remedial alternatives. However, determin[ing] the amount of material that needs to be dredged and moderating project costs are not. The amount of material to be dredged is a function of a defined river clean-up goal; it is an independent result of a remedy, not a goal. Moderating costs is also an inappropriate measure for evaluating remedial alternatives. More appropriate measures would be to minimize costs, or to combine costs with benefits to measure total cost-effectiveness of the project. Acceptance of moderate cost can result in the selection of a remedy that is moderate in cost but low in effectiveness.

ARP RESPONSE: *Do not agree. Assessment/evaluation needs to consider engineering, economic, and environmental (Physical/Natural, Community/Social, Cultural Resources) aspects of the project (including authority implementation). An array of considered parameters may be developed. This facilitates identifying considered implementable alternatives that accomplish acceptable environmental goals and at what cost. A reasonable dredging alternative developmental question was: Can we dredge less (considering authority implementation) at a lesser cost that accomplishes acceptable environmental or river clean-up goals/objectives.*

- b. As stated in the comment that applies to EIS Page 4, ecological clean-up restoration/preservation goals/objectives are attained by the restoration component of the draft recommended plan, not the environmental remediation (i.e. dredging) component.

ARP RESPONSE: *See response to EIS-6. The ecological restoration pertains to both removal of contaminants and development of aquatic shelves, as possible. This is discussed further in the main text that follows and in the EIS Appendix EA-J Section 312(b) and 206 Ecological Restoration/Preservation Analyses.*

EIS-11. Page 6, para. 6. The statement that alternatives other than the draft recommended plan are not acceptable because such alternatives would not remove all of the TSCA level material and would not meet TSCA clean-up objectives is misleading.

This comment also applies to a similar statement on Page EIS-16, para. 2.06.

TSCA level material (material exceeding 50 mg/kg PCBs) are materials whose disposal is regulated under TSCA. The criteria do not apply to materials currently in the environment and are not intended for use as cleanup objectives. Thus, it is inappropriate to evaluate remedial alternatives with respect to TSCA criteria. The quality of sediments in the bioavailable zone, following remedy implementation is more appropriate for use in evaluating the effectiveness of remedial alternative(s).

ARP RESPONSE: *Do not agree. See response to EIS-7. Keeping in mind “dredging authorities” removal of TSCA level material at a minimum was an “understood” from the beginning. Reference intro comment 13.*

EIS-12. Page 6, para. 6. The statement that, in addition to leaving very high levels of exposed surface PCB-contaminated sediments (even to TSCA level) impacts to benthos and the aquatic food chain and potential scour and migration of high level PCB contaminated sediments could occur as the result of remedial alternatives other than the draft recommended plan is incorrect.

This comment also applies to a similar statement on Page: EIS-37 para.2.37.

A very limited array of alternatives (all including dredging) was evaluated in the Draft Plan. There are other alternatives, or alternative components that could be coupled with less dredging to better facilitate project goals. Placement of a cover of clean sediment, appropriately sized in terms of sediment size and thickness, above the dredged surface could minimize impacts to benthos and prevent scour of residual, surficial PCBs. This would mitigate the short-term impacts anticipated as part of the Draft Plan.

ARP RESPONSE: *See GENERAL COMMENTS response # 4.* The project is being accomplished under dredging authorities. Reference **SECONDARY SPECIFIC COMMENTS/RESPONSES DRAFT EIS GENERAL INTRODUCTION REFERENCE RESPONSES 25, 28, 29.** The subsequent Value Engineering Committee also rejected consideration of a cut/cover alternative. Some additional information has been incorporated into the reports in this regard.

EIS-13. Page 7, paras. 4 and 5. The Draft EIS states that long-term channel maintenance dredging will provide aquatic shallow areas along the river shoreline.

The report should specify how the long-term maintenance dredging of sediment will increase shallow water areas.

ARP RESPONSE: *The statement references recreational channel. Dredging to recreation channel depths and associated widths versus commercial channel depths and widths allow shallow areas to develop or silt in over time along the recreational channels. This is only a summary paragraph. This is discussed and illustrated further in the main text that follows and in the EIS Appendix EA-J Section 312(b) and 206 Ecological Restoration/Preservation Analyses.*

EIS-14. Page 8, para. 1. The statement that it is expected that sediments dredged in the future for channel maintenance will be clean enough for open-lake disposal should be clarified in the Final Plan.

This comment also applies to similar statements on Pages: EIS-39 para. 2.42; EIS-11 para. 1.21.

The Draft EIS (Page 131, para. 3.26) states that the surface sediments have elevated levels of several metals due to both native parent materials with high metals and urban runoff. The Draft EIS (Page 142, para. 3.42) states that “most” sediments from the Ashtabula River are classified as unsuitable for open lake disposal due to elevated metals concentrations. Current methods for assessing the acceptability of material for open-water disposal have not been thoroughly applied. Results from some recent sampling activities by the USEPA may aid in assessing the viability of open-water disposal, but currently this evaluation has not been completed.

The Final Plan should compare expected metals concentrations from natural sediments and current urban runoff impacting the Ashtabula River to conditions at proposed lake disposal site locations using the “greenbook” to evaluate if future open lake disposal is feasible.

ARP RESPONSE: *See GENERAL COMMENTS response # 2. See response to EIS 8.*

EIS-15. Page 8, para. 2. It is stated that several monitoring programs will be conducted within five to ten years of project completion, in order to evaluate improvement in sediment and benthos; however the scope is not defined and costs are not explicitly included in costs estimates provided elsewhere in the Draft Plan.

This comment also applies to Page EIS-39, para. 2.43.

The scope of such monitoring programs (and the threshold values to be evaluated) should be described in the Draft Plan, and the estimated costs should be included in cost estimates for the project.

ARP RESPONSE: *This is only a summary paragraph. This is discussed and illustrated further in the main text that follows (EIS-93) and in the EIS Appendix EA-J Section 312(b) and 206 Ecological Restoration/Preservation Analyses. Some of the monitoring is specifically project related and is included with project cost. Some of the monitoring is agency program related and will likely be done regardless and therefore is not included with project costs. Some additional information has been incorporated into the reports in this regard.*

EIS-16. Page 8, para. 4. The use of passive dewatering as recommended by the Draft Plan is not likely to meet necessary landfill requirements

This comment also applies to a similar statement on Page EIS-47, para. 2.49.

As discussed in Comment K-6 (related to the FR Technical Appendix K), it is unlikely that passive dewatering will achieve sufficient solids content and strength to facilitate landfilling, as proposed.

ARP RESPONSE: *Agreed in part. The material would be transfer managed and dried further before transport to the disposal site. This is being further addressed and will be even further addressed in the design stage. Some additional information has been incorporated into the reports in this regard.*

EIS-17. Page 15, Table S2. Table S-2 presents unsubstantiated ecological improvement ranks (1, 2, 3, or 4) and arbitrary measures of habitat quality improvement (measured by the QHEI score), fishery improvement (measured by the IBI score), and macroinvertebrate improvement (measured by the ICI score) for each of the ecological restoration/preservation methods.

This comment also applies to identical tables on Pages: EIS-117, Tables S-2; EIS-45, Table 2.13; EA-J Page312(b) - 122; EA-J Page312(b) - 92.

Details need to be provided which present the basis for the ecological improvement ranking. The rankings appear arbitrary, and are not tied to concrete restoration goals.

ARP RESPONSE: *ARP feels the table S-2 sufficiently supports the conclusions. Reference **SECONDARY SPECIFIC COMMENTS/RESPONSES DRAFT EIS GENERAL INTRODUCTION REFERENCE RESPONSES** 3, 4, 14, 24. This is a summary table. This is discussed and illustrated further in the main text that follows and in the EIS Appendix EA-J Section 312(b) and 206 Ecological Restoration/Preservation Analyses.*

EIS-18. Page 17, paras. 3 and 4. The Draft EIS describes how sensitive species can all be expected to increase in numbers after sediment removal, but does not distinguish between benefits achieved through sediment removal and benefits achieved through habitat restoration.

This comment also applies to a similar statement on Pages 36 (para. 1) and 146 (para. 2) of the FR.

The text should reflect that the majority of impairments to the Ashtabula River and harbor are related to habitat deficiencies. Potential improvements to the fishery (e.g., increases in muskellunge and northern pike) will be related to habitat improvement, not sediment removal.

ARP RESPONSE: *Do not agree. Reference SECONDARY SPECIFIC COMMENTS/RESPONSES DRAFT EIS GENERAL INTRODUCTION REFERENCE RESPONSES 14, 16, 24. See response to EIS 6 and EIS 7. This is a summary paragraph. This is discussed and illustrated further in the main text that follows and in the EIS Appendix EA-J Section 312(b) and 206 Ecological Restoration/Preservation Analyses.*

EIS-19. Page 17. The letters (HAP) at the end of most of the paragraphs is unclear.

This comment also applies to similar references on Pages EIS-158 to EIS-162.

The acronym stands for Ohio Habitat Assessment Procedures, which are an evaluation technique and not studies specific to the Ashtabula River. If (HAP) is intended as a reference, it should be properly stated.

ARP RESPONSE: *Agree. This was a draft internal note. Will delete or revise.*

EIS-20. Page 18, para. 4. The statement that, "(i)t is clear that no improvement will occur if contaminated sediments are not removed," is incorrect.

This comment also applies to similar statements on Pages EA-J Page 312(b) - 81 (para. 6), EIS-215 para. 4.67.

The Draft Plan acknowledges that improvement is ongoing in the Ashtabula River, as clean sediment is deposited, and the bioavailability of PCBs and other constituents decreases. Page 24 of the FR states that "contaminant levels decreased significantly by 1990," relative to levels observed from 1978 to 1981. Given that habitat deficiencies within the river have clearly impacted fish and macroinvertebrate communities, habitat restoration (with or without sediment mass removal) should significantly improve the existing conditions.

ARP RESPONSE: *Agree in part. Will revise the statement. See response to EIS-6. Your discussion paragraph is misleading and depicts only a small part of the situation. Although the report discusses some improvements in some areas, it also discusses that serious problems persist and even more potential serious problems exist. Reference response EIS 2 and EIS 6. Reference SECONDARY SPECIFIC COMMENTS/RESPONSES DRAFT EIS GENERAL INTRODUCTION REFERENCE RESPONSES 12, 13, 14, 15, 16, 17, 18, 19, 20, 21, 24, 25.*

EIS-21. Page EIS-1 para. 1.04. A. The statement that _ecological and economic benefits (primarily from prevention of outflow of contaminants) could also be realized for the Outer Harbor, Lake Erie, and the immediate Great Lakes area_ is not supported.

No data are presented that link contaminants in the Ashtabula River sediment to ecological impairment of Lake Erie and the Great Lakes. This statement should be deleted.

ARP RESPONSE: *Do not agree. See response EIS 3. See **SECONDARY SPECIFIC COMMENTS/RESPONSES DRAFT EIS GENERAL INTRODUCTION REFERENCE RESPONSES** 18. This is discussed and illustrated further in the main text that follows and in the EIS Appendix EA-J Section 312(b) and 206 Ecological Restoration/Preservation Analyses.*

EIS-22. EIS-1 para. 1.05. The statement that the project was found to be: totally and incrementally cost effective, acceptable to the Ashtabula River Partnership, complete, efficient, effective, developed and to be implemented in a partnership context, and reasonable in cost is not supported by the Draft Plan.

- a. Measures used to quantify prospective benefits and effectiveness associated with the Draft Plan are either inappropriate or incorrectly measured. Ecosystem restoration benefits associated with various alternatives are either assumed or are expressed as a function of PCB mass (removed or left in-place) in Chapter 8. Ecosystem benefits are expressed in terms of: 1) water quality, 2) fish species diversity, 3) fish abundance, 4) fish with external anomalies, 5) index of Biological Integrity (IBI), 6) invertebrate community index (ICI), 7) risk, and 8) PCB mass removed (Table 8-1). Of these criteria, quantification of improvement is arbitrarily assigned (“assumed”) for the diversity, abundance, anomalies, IBI, and ICI criteria. No scientific basis for improvement is presented in the Plan, appendices or in the EIS. Water quality is assumed to be a direct function of the mass of PCBs remaining in-place following each scenario. There is no basis for this relationship. The measure of risk (expressed as the likelihood of a major scour event under each alternative) is also inappropriate. Furthermore, estimates of scour presented in the draft recommended plan are questionable (see comment relating to Page 14, para. 3 of the FR).
- b. Cost-effectiveness of the draft recommended plan was not quantitatively evaluated in comparison with other alternatives. Without a more sound cost/benefit analysis and a detailed comparison with other possible remedial alternatives, conclusions concerning the relative completeness, cost-efficiency or effectiveness of the draft recommended plan are not tenable.
- c. As discussed in the comments relating to Appendix P of the FR, the costs for the draft recommended plan are significantly underestimated. Although “reasonable in cost” is not defined in the Draft Plan, it is likely that if the cost estimate for the draft recommended remedy is updated to include omissions and address incorrect assumptions, the cost would no longer be considered “reasonable.”
- d. The selection of the deep dredge remedy is based on inappropriate objectives such as mass removal, removal of sediment with greater than 50 ppm PCBs (regardless of location), a limited alternative screening process, anticipated but unsupported benefits and at a cost that is underestimated.

Following the removal of nearly 600,000 cu yd of sediment under the “shallow dredge” alternative, it is unclear why the Draft Plan concludes that there would be “no difference” in long-term risk reduction, the potential to lift the fish advisory, and to open lake dispose in the future. It is also unclear why there is a significant difference in risk/scour potential for the shallow dredge alternative, compared to the Deep Dredge option. The Final Plan should either present the technical support for what the ARCG believes is inappropriately low scoring for the shallow dredge alternative, or make it consistent with the Deep Dredge Scenario.

ARP RESPONSE: Do not agree. See responses to EIS 9, and EIS 10. Reference **SECONDARY SPECIFIC COMMENTS/RESPONSES DRAFT EIS GENERAL INTRODUCTION REFERENCE RESPONSES** 3, 4, 5, 9, 12, 13, 14, 16, 18, 19, 20, 24, 25. This is discussed and illustrated further in the main text that follows and in the EIS Appendix EA-J Section 312(b) and 206 Ecological Restoration/Preservation Analyses.

EIS-23. Page EIS-5, para. 4. In the section describing Restrictions on Fish and Wildlife Consumption, the Draft EIS does not provide an accurate and comprehensive summary of the potential human health effects from fish and wildlife consumption.

This comment also applies to similar statements on Pages: EA-J Page 312(b)-5; 312(b)-57,58.

- a. The Draft EIS should note that the fish PCB concentrations from the Ashtabula River are relatively low (i.e., all less than 2 ppm). According to the baseline human health risk assessment (Crane, 1992), potential health risks using reasonable exposure scenarios (i.e., average consumption of sport fish fillets) are below levels of concern. The only elevated potential health risks are based on the “conservative” assumption of subsistence fishermen, or the unlikely assumption that an individual eats whole carp as a significant portion of his or her diet. Many of the potential risks under these scenarios are not due to PCBs, but are primarily due to copper and methylmercury (Crane, 1992).
- b. The Draft EIS should also state that the fish consumption advisory for the Ashtabula River is generally the same as the fish consumption advisory for Lake Erie. The consumption advisories for both areas limits meal frequency for channel catfish and carp to 1 meal every 2 weeks. For the Ashtabula River, restrictions on largemouth bass and walleye are one meal per month, and smallmouth bass are one meal a week. For Lake Erie, restrictions on walleye are one meal a week, and smallmouth bass are one meal a month (Ohio Department of Health, 1999).
- c. The Draft EIS should also state that the chemical that drives the fish consumption advisory for largemouth bass and walleye for the Ashtabula River is mercury (Ohio Department of Health, 1999).
- c. According to the Draft EIS (Page EIS-6), “(t)here currently is no information available on deformities or tissue concentrations of contaminants in any birds or mammals at Ashtabula.” Therefore, restrictions on wildlife consumption (e.g., duck or geese) for the Ashtabula River do not exist. The text in this section should reflect the lack of this information.

ARP RESPONSE: Do Not Concur. Discusses fish consumption advisories. This is discussed in further detail in the EIS, page EIS-162, beginning with paragraph 3.63 and in EIS Appendix EA-C Environmental Risk Management Considerations for the Ashtabula River and Harbor, beginning on pages 3 and 5, EIS Appendix EA-J Section 312 (b) and 206 Ecological Restoration/Preservation Analyses, page 312(b)-57.

EIS-24. Page EIS-6, para. 1. The statement that “(I)f not for the contaminant problem, the Ashtabula River could be a prime site for salmonid stocking,” is not supported.

This comment also applies to EA-J Page 312(b) - 37; EA-J Page 312(b) - 29; EIS-162 para. 1.

- a. There is no information to support this statement, and the statement should be removed from the report. PCB concentrations in resident fish (fish that spend the majority of their lifetime in the Ashtabula River) are relatively low. Migratory salmonids spend a limited portion of their lifetime in the River, and would be expected to have even lower PCB concentrations. Data from other Great Lakes sites (e.g., the Sheboygan River) indicate that sediment PCB concentrations do not contribute to adult migratory fish PCB levels (WDNR, 1995).
- b. Based on a review of the FR, it is the habitat limitations (e.g., heavy siltation, low flow, boat traffic) that limit the site's potential for salmonid stocking.

ARP RESPONSE: Do not agree. See PRIMARY SPECIFIC COMMENTS response # 9. Reference SECONDARY SPECIFIC COMMENTS/RESPONSES DRAFT EIS GENERAL INTRODUCTION REFERENCE RESPONSES 16, 18, 23, and 24.

EIS-25. Page EIS-6, para. 1. The statement that the 0.7 mile of the river has the lowest biological score of the AOC, should reflect the effects of habitat modification.

The text should be revised to point out that according to Ohio EPA (1992), in the absence of Fields Brook associated effects, this area would have scored the same, demonstrating the overriding effect of habitat modification to achieve improvements, rather than PCB mass removal.

ARP RESPONSE: Do not concur – Habitat modification is considered since the Ashtabula is compared to Conneaut Creek which has very similar habitat modification. The paragraph already reflects the effects of habitat modifications.

EIS-26. Page EIS-6, para. 2. The Draft EIS states that fish tumors or other deformities have been reported, and that the situation appears to be related to sources of pollution at the river mouth.

This comment also applies to similar statements on Pages: EA-J Page 312(b)-38, 78 to 80; EIS-162, para. 3.

- a. References should be provided for the observations.
- b. The text should be revised to state that although anomalies have been reported, their occurrence does not imply that sediment-related constituents are the cause. Fish anomalies can be caused by a number of natural factors, including viruses, infections, bacteria, and protozoan parasites. The incidence of fish anomalies may occur as a result of a variety of stressors, including low or marginal dissolved oxygen or elevated temperatures (both of which are known to occur in the Ashtabula River). In fact, subsequent sections of the Draft EIS (e.g., Page 312(b)-78 of the Ecological Restoration/Preservation Analysis) state that "(t)he degree to which contaminated sediments influence anomaly occurrence is unclear for fish communities sampled in the harbor."
- c. The percentage of fish anomalies observed in Conneaut Creek (a supposedly clean site that the Draft EIS uses to define reference conditions) are much higher (approximately 15%) than the percentage of fish anomalies observed in the Ashtabula River (approximately 6%).

ARP RESPONSE: Do not agree. This is discussed further in the main text that follows and in the EIS Appendix EA-J Section 312(b) and 206 Ecological Restoration/Preservation Analyses.

EIS-27. Page EIS-7, para. 1. Under the heading Degradation of Benthos, the Draft EIS states that chemical impact was recorded near and downstream of the confluence of Fields Brook.

This comment also applies to a similar statement on Page 51 of the FR (para. 3).

This statement implies that impacts to benthic macroinvertebrates are associated with chemical impact from Fields Brook. Biological studies [e.g., Ohio EPA (1992)] indicate that contamination does not impact the benthic community of the river. The Draft EIS fails to acknowledge studies by the Ohio EPA (1992), which concluded that "in areas adjacent to Fields Brook boating activities and shoreline modifications overshadow any effects that could be attributed to contaminants." Ohio EPA (1992) also stated that downstream of Fields Brook, there appeared to be little or no difference in quality of the macroinvertebrate communities in comparison to non-impacted sites. Similarly, for the harbor, the Ohio EPA (1992) concluded that "there was no evidence that residual contaminated sediments from Fields Brook pollutants were having a significant negative influence on the quality of the Ashtabula harbor communities." The Draft EIS should clearly recognize that chemicals in sediment have no noticeable impacts on the benthic community.

ARP RESPONSE: *Do not agree. This is discussed further in the main text that follows and in the EIS Appendix EA-J Section 312(b) and 206 Ecological Restoration/Preservation Analyses. Species surveys discussed indicate contamination conditions. There were supplemental surveys (i.e. 1995/97) and assessments to the 1992 that are discussed in the reports also. See responses to EIS 2, and EIS 6. Reference **SECONDARY SPECIFIC COMMENTS/RESPONSES DRAFT EIS GENERAL INTRODUCTION REFERENCE RESPONSES 15, 16, 18, 19, 20, 21, 24.***

EIS-28. Page EIS-7, para. 3. A full citation should be provided for the reference "Ohio EPA, 1990c."

ARP RESPONSE: **Concur.** Will revise or delete.

EIS-29. Page EIS-7, para. 1.15. The statement that contaminants in sediments are a primary problem (from an ecological perspective) in each of the three areas (the Outer harbor, lower River from the mouth upstream to the 5th Street bridge, and from the 5th Street bridge upstream to the end of the navigation channel) is unsupported.

Sediment contaminants are not a primary problem from an ecological perspective. Biological studies by Ohio EPA (1992) have indicated that in two of these areas (the outer harbor and the lower River), there was no evidence that residual contaminated sediments were having a significant negative impact on the quality of the biological communities. As stated previously, according to the Draft EIS (Page 312(b)-75), for macroinvertebrates, trophic conditions in the Ashtabula Harbor are "similar to all other monitored Lake Erie harbors in Ohio."

ARP RESPONSE: *Do not agree. See response to EIS 27.*

EIS-30. Page EIS-10 (Table 1.1). Sediment quality cleanup ratings are inappropriately presented as site-specific values.

This comment also applies to tables on Pages: EA-J Page 312(b)-42 Table 7.

- a. The ratings and comments presented in the table appear subjective. Additional information on the derivation of the conclusions should be provided.

- b. With the possible exception of reference #2 for the table (which is apparently unavailable), none of the references used to develop the ranges contain site-specific sediment effects data as presented in the table. In the absence of site-specific data, the table should be revised to reflect that general ratings are presented within, and may not be directly applicable to the Ashtabula River.

ARP RESPONSE: *Do not concur. Sufficient back up is provided in the text. There appears to be substantial correlation of available Ashtabula Harbor sediment sampling and analyses and reference material.*

EIS-31. Page EIS-11, para. 1.20. The benefits of applying more specific objectives (i.e. sediment removal, habitat restoration) as described in the Draft Plan are inappropriately applied to the restoration of beneficial uses of the river.

This comment also applies to similar statements on Pages EIS-31 and FR-28.

The removal of sediment is purported to address beneficial use impairments associated with loss of fish and wildlife habitat, degradation of benthos, and degradation of fish and wildlife populations. As documented in the Draft Plan (Pages EIS-5 to EIS-7), however, the primary causes of these beneficial use impairments are physical deterioration of the river ecosystem resulting from dredging, channelization, and vessel traffic.

ARP RESPONSE: *See PRIMARY SPECIFIC COMMENTS response # 9.*

The Draft Plan includes only two options (A - Leave surface sediment PCB and PAH concentrations no worse than existing conditions; and B - remove all TSCA and scour-risk PCB and PAH mass) to address beneficial use impairment. More appropriately, the option of habitat restoration should be included under several beneficial uses (i.e., b - Remediate degradation of fish and wildlife populations; d - remediate degradation of benthos; f - remediate loss of fish and wildlife habitat).

ARP RESPONSE: *Do not agree. See response to EIS 27.*

EIS-32. Page EIS-13, para. 1.31. Use of Conneaut Creek as a reference site for the project is inappropriate.

This comment also applies to similar statements on Pages: EA-J Page 312(b) 68-69; FR 147, para. 3.

- a. The comparison of Ashtabula River habitat to Conneaut Creek habitat is inappropriate, and should not be included in the report. Conneaut Creek is classified as a coldwater system (Ohio EPA, 1997), while the Ashtabula River is classified as a warmwater system (Draft EIS, Page 312(b)-28; Ohio EPA, 1997). A coldwater system is typically higher quality habitat than a warmwater system and therefore represents an unrealistic reference for a warmwater River. Additionally, the Ashtabula River differs from the Conneaut River in that considerable boat traffic exists in the Ashtabula lacustrary (Draft EIS, Page 312(b)-75).
- b. As previously stated in the Draft EIS (Page EIS-11), the goal/objective of the river project should be "to reach a quality warm water habitat condition." As described on Page 312(b)-5

of the Draft EIS, "(k)nowledge of the ecology of an area allows one to anticipate what type of ecological community the area will support. An assessment of the biological community can be compared with the standards for that particular ecoregion to evaluate whether or not the area is impacted by pollution, developments, and/or activities." Using this approach, it would be more appropriate to evaluate potential restoration of the ecological community for the Ashtabula River based on Ohio EPA attainment status criteria for warmwater habitat within the Erie-Ontario Lake Plain ecoregion.

ARP RESPONSE: *Do not agree. See PRIMARY SPECIFIC COMMENTS response # 9.*

Reference ***SECONDARY SPECIFIC COMMENTS/RESPONSES DRAFT EIS GENERAL INTRODUCTION REFERENCE RESPONSES*** 14 and 23.

EIS-33. Page EIS-15, para. 2.03. The text contained in this paragraph is purely speculative and arbitrary, and serves to lessen the scientific validity of the Draft Plan.

Paragraph 2.03 should be deleted.

ARP RESPONSE: *Do not agree. The Without Project Conditions (No ARP Action) section is required in the document outline (ER 200-2-2). Futures are often somewhat speculative; but, indications are that this is what would happen. Your view and rationale would be a more appropriate comment.*

EIS-34. Page EIS-16, para. 2.06. The statement that _such [cover] alternatives would leave very high levels of exposed surface PCB contaminated sediments (even to TSCA level) with immediate substantial adverse impacts relative to benthos and the aquatic food chain and potential scour and migration of high level PCB contaminated sediments_ is incorrect.

- a. As confirmed by the USEPA (1998), a cover consisting of coarse geologic materials would exhibit surficial PCB concentrations much lower than the residual surface after implementation of any of the alternatives (which consist solely of dredging) considered by the Draft Plan. In this manner, adverse effects from exposing buried PCBs in the Deep Dredge alternative, would be mitigated.
- b. A discussion of the technical limitations of removing sediment containing PCBs is included as Attachment A to these comments. This attachment indicates that residual PCB concentration subsequent to sediment removal projects are generally greater, and thus pose more ecological risk, than projects where cover is included as a component of the remedial alternative.
- c. A cover may be appropriately designed to withstand scour and erosion of covered sediments. Selection of an appropriate layer thickness and material size would ensure that structural integrity could be maintained.

ARP RESPONSE: *Do not agree. See GENERAL COMMENTS response # 4. The referenced statement pertained primarily to the immediate exposure period between the dredging and capping. The paragraph also briefly discusses other problems that may be associated with a cut and cover plan for this project. This will be expanded even further. Reference SECONDARY SPECIFIC COMMENTS/RESPONSES DRAFT EIS GENERAL INTRODUCTION REFERENCE RESPONSES 12, 25, 28, 29.*

EIS-35 Page EIS -16, para. 2.06. The statement that "[the cover] alternative is not favorable from the perspective of the Ashtabula River Remediation Action Plan and Ashtabula River

Partnership goal of a ‘total’ river clean-up” is not adequately supported. [“Total river clean-up” is not defined.]

This comment also applies to a similar statement on Page FR-37.

The specific goals that are described in these sections 1 and 3 of the FR give specific guidance for defining environmental remediation. These include :

- Leaving surface sediment PCB and PAH concentrations no worse than existing conditions;
- Remove all TSCA and scour-risk PCB and PAH mass; and
- Set long-term surface sediment concentrations for PCBs and PAHs of equal to or less than 0.35 ppm and 10-20 ppm respectively. These targets consider siltation or placement of clean sediment.

It is unclear how reduction of sediment surface concentrations by natural siltation or placement of clean sediment is different from covering using clean sediment to reduce surface concentrations and protect underlying sediments from scour.

The Bank-to-Bank dredging scenario is the only scenario considered by the ARP that would be close to a "total" river clean-up, yet it was rejected in favor of the Deep Dredge option due to cost.

ARP RESPONSE: *Do not agree. See response to EIS 10, and EIS 34.*

EIS-36 Page EIS-16, para. 2.06. The statement that “considering comparable costs for other considered alternatives, alternative long-term reliability and environmental trade-offs and risks, this [cover] alternative was eliminated from further consideration” is unsupported.

- a. Insufficient cost information is presented for the cover alternative in the Draft Plan; thus cost-effectiveness with respect to other alternatives cannot be independently verified.
- b. Covering is an accepted technology that has been utilized for long-term remediation.
- c. The term “environmental trade-offs and risks” is vague. The term is not further defined or supported, and cannot be independently evaluated.
- d. In general, a cover can be designed and maintained to be reliable and is very protective over the long term.

ARP RESPONSE: *Do not agree. See GENERAL COMMENTS response # 4. See response to EIS 34, and EIS 35.*

EIS-37 Page EIS-17, para. 2.11. The document should be revised to state that turbidity barriers will be used during the project, not that they will _possibly_ be used.

This comment also applies to similar statements on Pages: EIS-86, Section 2.111; FR 40 para. 1; FR 141, Section 6.3.

According to Appendix G to the Draft FR (Page 33), the effects of losses of PCBs to the water column during dredging would be catastrophic if allowed to reach Lake Erie. Thus, the use of silt curtains, and more effective contaminant measures if necessary, should be prescribed for the

project given the potential impacts identified by the Draft Plan. The project scope and estimated costs presented in the Draft Plan should be revised to explicitly reflect that turbidity barriers and other environmental controls will be used during the implementation of the draft recommended plan for all dredging activities.

ARP RESPONSE: *Agree to some extent. Will delete “possible”. There are some limited low contaminated areas that may be able to be dredged without use of turbidity barriers and/or oil booms. This would expedite dredging in those areas. This will be detailed further in the project design and plans and specifications. Reference SECONDARY SPECIFIC COMMENTS/RESPONSES DRAFT EIS GENERAL INTRODUCTION REFERENCE RESPONSES 3 and 4.*

EIS-38 Page EIS-18, para. 2.12. The project schedule and production rate provided in Table 2.1 are inconsistent with those presented elsewhere in the Draft Plan.

- a. Table 2.1 provides for a 6-month construction season which is not consistent with either the 9-month construction season presented on Page 110 of the Draft Plan or the 5-month construction season discussed in Appendix K of the Draft FR (Page 15).
- d. A 10-hr work day is not consistent with the 24-hr day specified in Appendix K (p.15) of the Draft FR.

ARP RESPONSE: *Agree. Reference SECONDARY SPECIFIC COMMENTS/RESPONSES DRAFT EIS GENERAL INTRODUCTION REFERENCE RESPONSES 3, 4, 6. These are items summarized from sub-assessment studies. The recommended plan description should be referenced for the recommended schedule and production rate. This will be detailed further in the final report and project design and plans and specifications.*

EIS-39 Page EIS-22, para. 2.15. References to the use of water quality controls, dredging operation controls, and environmental controls must be more definitive and specific.

The Draft Plan must be more definitive concerning whether water quality controls, dredging operation controls, and environmental controls will be implemented as part of the draft recommended plan. Furthermore, instead of examples of the types of water quality controls, dredging operation controls and environmental controls that might be utilized as part of the project, the types assumed in the Draft Plan should be specified. It is not possible to evaluate cost estimates and schedules that are presented, without sufficient backup in the Draft Plan. Use of water quality controls, dredging operation controls, and environmental controls will be necessary to prevent unacceptable impacts, noted in the Draft Plan, that result from dredging operations.

ARP RESPONSE: *Agree to some extent. Reference SECONDARY SPECIFIC COMMENTS/RESPONSES DRAFT EIS GENERAL INTRODUCTION REFERENCE RESPONSES 3, 4, 6. These are items summarized from sub-assessment studies. The recommended plan description should be referenced for use of water quality controls, dredging operation controls, and environmental controls. This will be detailed further in the final report and project design and plans and specifications.*

EIS-40 Page EIS-24, para. 2.16. The statement that some minor volatilization “would occur” should be substantiated or reworded to state, “is expected based on. . .”

This comment also applies to a similar: statement on Page EIS-244, para. 6-21.

ARP RESPONSE: *Do not agree. Reference SECONDARY SPECIFIC COMMENTS/RESPONSES DRAFT EIS GENERAL INTRODUCTION REFERENCE RESPONSES 3, and 4. These are items summarized from sub-assessment studies. Reference paragraphs 2.08 and 2.09. The first sentence of the DREDGING TECHNOLOGIES section references the technical appendix where the subject is discussed in further detail.*

EIS-41 Page EIS-24, para. 2.16. **The statement that _the only potential time and area of any substantial concern [related to volatilization] would be during the dredging and immediate handling of PCB TSCA material in the immediate area of the dredged material_ is not supported and is inappropriate.**

This comment also applies to a similar statement on: EIS-244 para. 6.21.

No data are presented to support a relationship between the handling of TSCA material and the risk of exposure. Furthermore, use of TSCA criteria for determining the potential for exposure is unsubstantiated and inappropriate. The TSCA 50 mg/kg criterion is used to determine disposal requirements. The value is not based on human health effects and is therefore inappropriate for use in determining where human health impacts may occur as a result of handling sediment containing PCBs.

ARP RESPONSE: *Do not agree. Reference SECONDARY SPECIFIC COMMENTS/RESPONSES DRAFT EIS GENERAL INTRODUCTION REFERENCE RESPONSES 3, 4. These are items summarized from sub-assessment studies. Reference paragraphs 2.08 and 2.09. The first sentence of the DREDGING TECHNOLOGIES section references the technical appendix where the subject is discussed in further detail. Worker risks will be addressed further in final design.*

EIS-42 Page EIS-25, para. 2.21. **The basis used to assess/evaluate alternatives are either vague, qualitative, or unsupported.**

Based on a review of dredging data collected by the USACE during pilot studies and others during full-scale remediation, the surface PCB concentrations following dredging will be considerably higher than predicted (Attachment A). An objective of the dredging plan is to “leave surface sediment PCB and PAH concentrations no worse than existing conditions.” However, there are inherent operational problems associated with dredging that limit the target level that can be achieved. Sediments become resuspended and subsequently mix and settle on the dredged surface, leaving behind constituent concentrations higher than predicted.

Placement of clean cover on the dredged surface residuals has been prematurely screened out as a viable project element in the Draft Plan. However, the Draft Plan proposes the natural deposition of clean sediment to provide a cover within several years which will “ensure long-term protection of human health and the environment.” During these initial years, the dredged surface will be available for exposure and transport to the Outer Harbor. In addition, some contaminated sediments are proposed to be left behind in shallow water, which are prone to erosion/transport due to sloughing, disturbance from recreational use and high flow events. The Draft Plan acknowledges that a clean cover material is needed, following dredging, in order for the ARP goals to be achievable, and states that the goals could be achieved more quickly through “addition of clean fill.” Placement of clean cover following dredging should be further developed and included in the final Plan.

Dredging of 700,000 cu yd of sediment is not required to improve and maintain commercial and recreational navigation in the Ashtabula River and to mitigate the cited beneficial use impairments. The dredging cut lines were established based on a desire to remove a large percentage of the PCB mass and achieve a particular exposed surficial, sediment PCB concentration. However, at this site, neither of these factors should drive selection of the cut lines, since:

- Mass removal does not equate to risk reduction; and
- An acceptable surficial sediment concentration in the Draft Plan is only achieved following slow natural deposition of clean material.

If the dredged residuals were isolated immediately after dredging through placement of a clean sediment cover, designed to mitigate the potential for scour/transport and bioavailability, less sediment could be removed and the same benefits achieved sooner.

ARP RESPONSE: *Do not agree. See responses EIS 3, EIS 4, and EIS 7. The Ashtabula River Partnership developed and utilized what it felt to be appropriate assessment/evaluation criteria considering the project authorities. Reference SECONDARY SPECIFIC COMMENTS/RESPONSES DRAFT EIS GENERAL INTRODUCTION REFERENCE RESPONSES 26, 25, 12, 13, 28, 29.*

EIS-43 Page EIS-25, para. 2.22. **The basis for stating that the removal of 115,000 cu yd of sediment from the river downstream of the 5th Street Bridge is necessary in order to address PAH contamination must be supported.**

Data are not presented in the Draft Plan to support that removal of 115,000 cu yd of sediment downstream of the 5th St. Bridge would remediate PAH contamination such that sediment from future maintenance dredging would qualify for open-lake disposal. Testing or modeling, or both may be performed in order to better support the statement that future dredged sediment will qualify for open- water disposal. Such testing should be performed in reference to the USACE green book which describes procedures for determining whether dredged sediment can be open-water disposed.

ARP RESPONSE: *Agree to some extent. The 115, 000 cu yd of sediment downstream of the 5th Street Bridge was based on sediment sampling and analyses available through the draft reports. Subsequent sediment sampling and analyses have been completed since the draft reports and findings have been included with the final reports and will be addressed further in final design. Reference SECONDARY SPECIFIC COMMENTS/RESPONSES DRAFT EIS GENERAL INTRODUCTION REFERENCE RESPONSES 27.*

EIS-44 Page EIS-26, para. 2.23. **Total construction costs presented in Table 2.6 for the draft recommended remedy are not consistent with those presented elsewhere in the Draft Plan.**

This comment also applies to tables on Pages: EIS-34 para. 2.34.

ARP RESPONSE: *Agree. Reference SECONDARY SPECIFIC COMMENTS/RESPONSES DRAFT EIS GENERAL INTRODUCTION REFERENCE RESPONSES 6. There are items summarized from sub-assessment studies Noted: (Preliminary Comparative Costs). The recommended plan description should be referenced for the recommended plan construction costs. This will be detailed further in the final report and project design and plans and specifications.*

EIS-45 Page EIS-30, Table 2.9. The methodology used to calculate the linear feet of sheet piling for each alternative should be described in the Final Plan, and the related response actions should be reflected in the cost estimates.

ARP RESPONSE: *Agree to some extent. Reference SECONDARY SPECIFIC COMMENTS/RESPONSES DRAFT EIS GENERAL INTRODUCTION REFERENCE RESPONSES 3, and 4. These are items summarized from sub-assessment studies. Reference paragraphs 2.08 and 2.17, 2.19, 2.24. These paragraphs reference the technical appendix where the subject is discussed in further detail. This will be detailed further in the final report and project design and plans and specifications. Repair will be property owners responsibility.*

EIS-46 Page EIS-31, para. 2.25. When conducting a qualitative risk assessment to assess and compare the remedial effectiveness of the three dredging scenarios, the following points should be recognized in the Report.

This comment also applies to similar statements on Pages: EA-J Page 312(b)-50 para. 1; EA-C Page 1 para. 1.

- a. The text should be revised to state that surficial sediment concentrations, and not sediment PCB mass, is related to potential human health or ecological risks (see comment relating to EIS Page 4, para. 1). For example, the Draft EIS (e.g., Page EIS-32) recognizes significant reductions in fish PCB concentrations since 1983. During this same time period, it has not been the reduction of PCB mass in the system which has lowered fish PCB concentrations, but it has been the lower surficial sediment PCB concentrations.
- b. The Draft Plan states that since "...the most highly contaminated sediments are at deeper depths, dredging must continue below navigable depths, otherwise the most highly contaminated sediments would be left at the surface and available for uptake by biota_. This is contrary to how the effectiveness of the Draft Plan is assessed. The Draft Plan assesses effectiveness following deposition (or placement) of clean material on the dredged surface. As such, dredging to depths below that required for navigation is only necessary to provide a buffer zone for placement of a clean cover and accommodate future deposition, not to get to clean material as the Draft Plan states.
- c. If open-water disposal _cannot be predicted using standard risk assessment techniques_ as stated by the Draft Plan, then achievement of the goal of open-water disposal amounts to a speculative effort. Sampling should be employed to quantitatively determine the likelihood that future dredged sediment will qualify for open-lake disposal prior to implementation of a costly remedial program.

ARP RESPONSE: *Do not agree. See responses EIS 5, EIS 6, EIS 11, and EIS 11.*

EIS-47 Page EIS-31, para. 2.26. The statement that _the total mass of PCBs in the River is such that future [storm] events could reasonably result in continued downstream migration of PCBs. . . _ is not supported.

This comment also applies to a similar statement on Page FR-8 (para. 6).

- a. Downstream migration of in-situ sediment containing PCBs is related to potentially mobile surficial sediment containing PCBs, cohesiveness of the sediment, and to river hydrodynamics, not to total mass of PCBs in the river.
- b. As stated in the comment relating to Page 14, para. 4 of the FR, scour modeling performed in support of the Draft Plan is questionable; thus, conclusions regarding the transport of PCBs as a result of storm events cannot be reasonably supported. As stated elsewhere in the Draft Plan, the depth at which PCBs have been detected in river sediment suggests that continued burial of these residuals is occurring, not transport.

ARP RESPONSE: *Do not agree. See GENERAL COMMENTS response # 5. See response EIS 7. Reference SECONDARY SPECIFIC COMMENTS/RESPONSES DRAFT EIS GENERAL INTRODUCTION REFERENCE RESPONSES 18, 19, 20, 21. Paragraph 3.50 and several that follow discussed contaminated sediment migration. Summary and main text sections and paragraphs are usually summary items. Introductory paragraphs reference the technical appendix where the subject is discussed in further detail.*

EIS-48 Page EIS-31, para. 2.26. The statement that _removal of the bulk of this [PCB] mass will dramatically reduce potential ecological and human health risk from the site, not only in the present, but also significantly reduce the potential for release in the future_ is both incorrect and unsupported.

- a. As discussed on Page 120 of the Draft FR, removal of the bulk of the PCB mass through an extensive dredging program will result in the resuspension of PCB residues and will thus result in a short-term increase in ecological and human health risk (over the extended period of dredging) through the increased bioavailability of PCBs which were formerly buried.
- b. As stated in the comment relating to Page 14, para. 4 of the FR, scour modeling performed in support of the Draft Plan is questionable; thus, conclusions regarding the release of PCBs as a result of storm events cannot be technically supported.

ARP RESPONSE: *Do not agree. See responses to EIS 5, EIS 6, EIS 7, EIS 11, and EIS 47. Reference SECONDARY SPECIFIC COMMENTS/RESPONSES DRAFT EIS GENERAL INTRODUCTION REFERENCE RESPONSES 11, 18, 19, 20, 21. This is only a summary paragraph. This is discussed further in the main text that follows and in the EIS Appendices EA-C Environmental Risk Management Considerations for the Ashtabula River and Harbor, and EA-J Section 312(b) and 206 Ecological Restoration/Preservation Analyses.*

EIS-49 Page EIS-32, para. 2.27. The description of the _deep alternative_ appears inconsistent.

- a. The description states that the alternative removes all of the sediment starting from the upper turning basin down to Station 158. According to Appendix D of the Draft FR (Page 3) the alternative prescribes the removal of sediment exceeding 10 ppm in this area.
- b. The description incorrectly states that the alternative prescribes the removal of sediment containing 10 ppm or greater from the lower turning basin (Station 158) to the Harbor. According to Appendix D of the Draft FR (Page 3), the alternative actually specifies removal of sediment exceeding 10 pm downstream to the 5th St. Bridge, then dredging to the commercial navigation depth of -18 ft LWD from the 5th St. Bridge north to the Harbor.

ARP RESPONSE: *The 10 ppm was used to determine where the cut lines would be as the dredging criteria and nothing more. Appears that perception is taken out of context (mass vs cut). From EA-C Environmental Risk Management Considerations for the Ashtabula River and Harbor vs Technical Appendix D Dredging Scenarios and Sediment Volume Estimates.*

EIS-50 Page EIS-32, para. 2.27. The description of the shallow dredging option appears inconsistent.

The description incorrectly states that the alternative specifies removal of all river sediment exceeding 10 ppm. According to Appendix D of the Draft FR (Page 3) the alternative prescribes the removal of sediment exceeding 10 ppm which would be exposed following dredging to the recreational navigation depth of -6 ft LWD.

ARP RESPONSE: *See previous ARP RESPONSE. Appears that perception is taken out of context (mass vs cut). From EA-C Environmental Risk Management Considerations for the Ashtabula River and Harbor vs Technical Appendix D Dredging Scenarios and Sediment Volume Estimates.*

EIS-51 Page EIS-33, para. 2.30. Measures used to evaluate and compare remedial alternatives presented in Table 2.10 are both inappropriate and in some cases improperly represented.

This comment also applies to: EIS-35, 36 Table 2.11; EIS-34 para. 2.32.

The Draft Plan recommended plan proposes to achieve the project goals by dredging an estimated 700,000 in-situ cu yd of sediment with upland disposal, constructing aquatic eco-restoration structures, and allowing time for new, cleaner sediments to cover the lower level contaminated sediments left behind (i.e., the recommended plan). According to the report, the need to remove 700,000 cu yd was determined based on an assessment of: 1) PCB mass removed; 2) surficial sediment PCB concentration after dredging; 3) beneficial uses addressed; and 4) scour and release potential. The ARCG agrees that some sediment removal is necessary, supports the construction of eco-restoration structures, and use of cleaner deposited materials to help achieve the project goals. However, the ARCG believes that refinements can be made to the recommended plan which will improve its performance and reduce some of the environmental, engineering and economic concerns as discussed below.

(a) *Mass removal should not drive selection of the implementation plan*

Achievement of the project goals does not require that a certain percentage of PCB mass first be removed. Much of the deeper PCB-containing sediment currently proposed for removal is isolated/contained at depth and unavailable for exposure to humans or aquatic organisms, and below any dredging depths required to support future planned river uses.

If properly covered through placement of a cover of clean sediment and continuing natural deposition of additional cleaner sediments, less sediment would be necessary and the same benefits/endpoints achieved. By reducing the depth of the dredge cutlines, the following benefits would be recognized:

- improved ability of the final plan to achieve stated goals;
- minimization of the recovery time of the entire river system;
- the concerns and costs associated with bulkhead stability could be mitigated;
- plan implementation time would be reduced;

- the potential community and environmental impacts to the River/Harbor due to dredging and disposal (e.g., the acreage of wetland impacted) would be reduced; and
- the project costs also would be reduced.

(b) *Surficial post-dredging PCB concentrations should not drive cutline depth selection*

The depth of sediment slated for removal was selected to “leave surface sediment PCB and PAH concentrations no worse than existing conditions, initially” (FR Page 26). Since no immediate covering with clean sediments following dredging was proposed, this led to dredging of depths up to -20 ft LWD.

The ultimate solution provided in the Draft FR to address residual surficial PCBs following dredging is that “PCBs that remain in the River will be sufficiently covered with in-place sediments to prevent future downstream migration.” The Draft Plan states that the covering may occur as a result of natural deposition of clean material over time, or by actively covering the exposed sediment surface with sediments removed from cleaner upstream areas. The dredging cutline depths should therefore not be driven by anticipated post-removal surficial PCB concentrations, but in this case the necessary future-use depths and the technical viability of installing a stable cover of cleaner sediment (to accelerate restoration) and an assessment of the depositional nature of the cutline surface.

(c) *Mitigating impairments does not require removal of 700,000 cu yd of sediment*

Dredging of 700,000 cu yd is not required to improve and maintain future commercial and recreational navigation in the Ashtabula River, or mitigate the cited beneficial use impairments. Based on the 1995 bathymetric data from the River, less than 50,000 cu yd of the 581,000 cu yd proposed volume (upstream of the 5th Street Bridge) of sediment require dredging to achieve the -6 ft LWD specified for recreational dredging. Even if several more feet were removed and a sand and/or gravel cover was subsequently placed, future recreational navigation could be maintained with less than 581,000 cu yd removed. Money spent on placement of a clean cover rather than on sediment removal to excessive depths would serve to increase the likelihood of future dredged material being open water disposed, and restore beneficial uses much sooner than the draft recommended plan.

(d) *The Draft Plan can be refined to more definitely address scour/release potential*

As stated in the Draft FR, following implementation of the Draft Plan the potential exists for scour and release of residual PCB-sediments, until sufficient deposition of cleaner sediments covers the dredged surface. Improvement to the Draft Plan (i.e., reduced scour and release potential) could be achieved at a cost savings, by removing less sediment and isolating the dredged surface through placement of a clean cover (e.g., sediment, sand and/or gravel). The particle size of the material to be used as cover and the thickness of the layer could be selected so that the material, when placed, can withstand erosive forces and provide a protective barrier against migration of residual contaminants.

In summary, the Draft Plan could be refined to more effectively and quickly achieve progress towards the ARP goals, through removal of a smaller sediment volume and active covering of the exposed, dredged sediment surface with clean sediment or equivalent geologic material. Recreational dredging would be accommodated, chemicals in underlying sediment would be isolated from overlying receptors and prevent downstream scour/transport, costs would be significantly reduced, landfill volume requirements would be less and hence any wetland (e.g., at Site 7 location proposed for landfill) destruction and impacts of a large-scale dredging project

on the community and the environmental also would be reduced. Additionally, it would reduce concerns related to the stability of an estimated 7,500 linear feet of bulkhead currently in question, through establishment of shallower cutlines adjacent to the bulkheads.

ARP RESPONSE: *Do not agree. See responses to EIS 4, EIS 5, EIS 6, EIS 11, and EIS 48.*

EIS-52 Page EIS-34, para. 2.30. **Statements such as _facilitate river bank stability,_ _help sustain habitat diversity,_ _logistical issues,_ and _positive anticipated results_ are not defined, supported, or consistently applied where used to support the draft recommended plan.**

- a. The Draft Plan cites “facilitation of river bank stability” in support of the draft recommended plan over the bank-to-bank-to-bedrock alternative. However, the Draft Plan fails to address the benefits with respect to river bank stability of alternatives (including the shallow dredge alternative presented in the Draft Plan) which remove less sediment.
- b. Ecological restoration measures proposed as a component of the draft recommended plan would be responsible for habitat improvements. Thus, any remedial scenario including that considered by the FR, when combined with the proposed ecological restoration measures, would achieve equivalent “habitat diversity.”
- c. “Logistical issues” associated with the draft recommended plan would be significant and are documented in comments presented herein relating to: 1) bulkhead and river bank stabilization; and 2) dredging, dewatering, transfer, transport and disposal of a large (possibly underestimated) volume of sediment. The Draft Plan should present a more comprehensive evaluation of logistical issues as they relate to the beneficial aspects of alternatives requiring the removal of less sediment.

ARP RESPONSE: *Do not agree. Previous statements in the text support this summary paragraph. The paragraph simply highlights some of the assessment/evaluation items associated with the deep dredge plan. a. River bank stability items are comparatively discussed and illustrated (including the shallow dredge alternative) in previous and subsequent discussions and tables. b. See response to EIS 6. Actually, as discussed in a number of main text sections and appendices, there are more potential ecological (assessed/evaluated) problems associated with the shallow (i.e. contaminants) and the bank to bank (i.e. removal of existing and recovery of shallows) plans. c. Logistical issues also are comparatively discussed and illustrated in previous and subsequent discussions and tables. Also reference **SECONDARY SPECIFIC COMMENTS/RESPONSES DRAFT EIS GENERAL INTRODUCTION REFERENCE RESPONSES 25, 28, 29.***

EIS-53 Page EIS-34, para. 2.30. **The meaning of the phrase “the deep dredging alternative is the recommended starting point” is not clear.**

- a. The Final Plan should either state why ecological restoration structures were not paired with the “bank-to-bank” or “shallow” dredge scenarios (as they were with deep dredging), or modify the evaluation/table to include it.
- b. Under the “Accomplishment of sediment containment reduction objective,” the rankings conflict with the SWAC values presented in Table 2.10. Justification or correction is warranted.

ARP RESPONSE: Do not agree. See **PRIMARY SPECIFIC COMMENTS** response # 11. As discussed previously, ecological restoration and the project were assessed/evaluated in terms of individual and combined components. The statement pertains to the dredging authorities contaminant removal and dredging components, respectively. Also, the plan will be progressively detailed in design and plans and specifications. Assume a and b pertain to Table 2.11. a. Just a breakdown of the recommended Dredging, sufficient narratives elsewhere. b. Exclusive.

EIS-54 Page EIS-38. Dredging and disposal volumes presented in Table 2.12 are incorrect due to omissions and incorrect assumptions. The volume estimates should be updated.

Soils, sediments and construction debris generated for disposal during implementation of the sediment removal process must all be considered when developing cost estimates for the Ashtabula River Plan. Costs must be developed to include material removal, handling, transport and disposal. Based on a review of the Draft Plan text, it appears that the current cost estimate reflects the removal, handling, transport, and disposal of 696,000 cu yd of sediment, broken down as follows:

	<u>Dredged Volume (cy)</u>	<u>Disposal Volume (cy)</u>
TSCA	150,000	100,000
Non-TSCA	546,000	400,000

Based on apparent omissions and recently available information, the volume of material requiring removal, handling, transport and disposal has been significantly underestimated. A more realistic ultimate disposal volume possibly approaches 1,000,000 cy. A description of the major omissions/updates is presented below.

Five major areas that could lead to increases in volume to be dredged and/or disposed are:

1. Deposition since the measured baseline date of 1995;
 2. Disposal of the 1993 interim dredging materials;
 3. Disposal of ancillary materials, such as contaminated on-site roadway materials;
 4. Soil excavated to create an aquatic shelf during restoration; and
 5. Lack of consolidation from gravity dewatering.
1. Ongoing Deposition
It is understood that the removal volume presented in the Draft Plan is based on calculations done on a modeled sediment surface generated from 1995 data. The Draft Plan reports that the Ashtabula River has a sedimentation rate of 6 inches per year (Page 66). This would likely lead to an additional deposition of approximately 30,000 cu yd per year within the navigation channel. The Draft Plan does not appear to include a likely volume increase associated with ongoing sedimentation in its volume estimate.
 2. 1993 Interim Dredged Materials
The Recommended Plan (Section 3.5 of the FR) makes no reference to the 1993 Interim Dredging materials, but instead references the 696,000 cu yd of materials. This volume comprised of 581,000 cu yd to be dredged from upstream of the 5th Street Bridge, and 115,000 cu yd to be dredged from downstream of the bridge (shown on Figure 3-26 of the FR). However, as stated on Page 186 of the FR up to 70,000 cu yd (Maxim 1999) of the Interim Dredging materials will be handled and disposed in the landfill as part of the program.

3. Construction Debris

Handling and disposing of sediments inherently involves working with wet, sloppy materials. As such, there is always some spillage during handling and transportation that results in contamination of surficial soils in work areas and on-site roadways. These materials are generally removed and disposed as part of normal operations, particularly where spills occur in areas that are susceptible to uncontained stormwater runoff. Also, decommissioning of dewatering facilities, personal protective equipment (PPE), and other contaminated items will need to be disposed in the landfill. At present, there does not appear to be an additional contingency volume included to accommodate these materials.

4. Aquatic Shelf Construction

As part of the ecological restoration efforts, the Draft Plan (p.107) proposes that an aquatic fishery shelf would be cut along the east embankment channel of the Ashtabula River by the Conrail slip. In addition, a 10 ft wide channel is to be excavated between the river and the Conrail slip at the same elevation as the aquatic fish shelf. Based on descriptions provided in the Draft Plan, it appears that approximately 30,000 cu yd of soil will need to be excavated to accommodate the aquatic fish shelf. At present, it does not appear that excavation and transport/disposal of this material has been included.

5. Lack of consolidation or strength from gravity dewatering

(a) Consolidation

It has been assumed in the Draft Plan that following gravity dewatering, the sediment volume to be disposed would be 30 % less than the estimated in-place volume. Appendix H to the Plan (Page 20) eliminates the potential use of any mechanically aided drainage due to cost and delays, except for potentially using surface trenching or vacuum assisted underdrainage. However, the pilot studies on site specific sediments that demonstrate that a belt filter press and gravity dewatering have been unable to achieve better than a 65 percent solids indicate that the prospects of achieving the assumed solids content of 70 percent using gravity dewatering are remote. This is supported by recent gravity dewatering studies conducted using Ashtabula River sediments (BBL 1999). Based on the available information, it appears that the Draft Plan should assume that the gravity dewatered sediment volume will be approximately equal to the estimated pre-dredging in-situ volume. This will require increasing the estimated disposal volumes currently being contemplated in the Draft Plan by about 30 percent.

(b) Strength

It is assumed in Appendix H of the Draft FR (Page 19) that passing the paint filter test is the only criterion for landfilling the dewatered sediments. However, Appendix N assumes that the sediments will be placed at a solids content of 70 percent with an unconfined compressive strength greater than 10 psi. The 10 psi strength is described as being necessary for the landfill stability and to allow moving the sediment within the landfill with standard equipment. This assumption is carried into the Draft Design Report (Maxim 1999). Based on the pilot test results, it appears that the as-delivered shear strength to the landfill will generally be 0.5 psi or less.

ARP RESPONSE: Agree to some extent. The discussion indicates that the table pertains to the dredged material. It also notes the 70,000 cu yds from the interim dredging and disposal project. A number of

contingencies factors are included in subsequent cost estimates. Item 1 may add some volume, although there may be some further interim or alternate dredging and disposal, as possible. Item 2 was noted and considered, although only about 30,000 cu yds would be considered contaminated. Item 3 may add some volume. Item 4 will be implemented under separate authority and was estimated under a separate estimate and added into total project cost. Disposal would not necessarily go to the ARP disposal site. Items 5 and 6 were estimated based on available information for the draft reports. This will be detailed further in the final report and project design and plans and specifications.

EIS-55 Page EIS-48, para. 2.51. It is stated that discharging treated water with 50 to 100 ppm particulate “meets most parameter water quality standards,” and thus assumes that water filtration/treatment should suffice.

This comment also applies to similar statements in FR Appendix K, Pages 4 and 12.

At a number of sites where PCBs containing sediment has been dredged (e.g. Ruck Pond-Wisconsin, Unnamed Tributary-Ohio, Town Branch Creek-Kentucky; Sheboygan River-Wisconsin) water treatment to meet surface water or POTW discharge limits has required use of a multi-phased treatment system, typically including an oil/water separator, a flocculent tank and clarifier, bag filters and carbon polishing. Unless data are available to support filtration and monitoring for TSS only, the Final Plan text and cost estimate should be revised to reflect a more likely scenario.

ARP RESPONSE: *Agree to some extent. The draft report essentially considered OEPA 1996 water quality standards. Previous standards for PCBs and PAH may have been met utilizing particulate settling and filtration techniques. The 1996 standards required further preliminary filtration and carbon treatment calculations presented in the report. Subsequently, the standards have been revised again which will require even further treatment and best available technology considerations. The radionuclide issue will also require further consideration in this regard. This will be detailed further in the final report and project design and plans and specifications.*

EIS-56 Page EIS-75, Section 2.101 and 2.102. The text describes a series of meetings where alternative components were evaluated and modifications made.

The basis for these modifications and actual process used in their evaluation are not presented. This basis should be presented to justify the eventual outcomes and decisions of these meetings.

ARP RESPONSE: *Do not agree. Reference **SECONDARY SPECIFIC COMMENTS/RESPONSES DRAFT EIS GENERAL INTRODUCTION REFERENCE RESPONSES** 3, 4, 6. These items are summarily presented here. The EIS is a result of the meetings and is representative of meeting conclusions. Further information may be found in the meeting minutes and project files.*

EIS-57 Page EIS-77. Volumes presented are inconsistent with those presented elsewhere.

The environmental dredging description includes sediment volumes for disposal totaling 726,000 cu yd (150,000 cu yd TSCA, 546,000 yds non-TSCA, and 30,000 cu yd of the 1993 interim dredged material). These volumes are inconsistent with the FR total removal and disposal volumes of 696,000 cu yd and 500,000 cy, respectively.

ARP RESPONSE: *Agree. This is discussed in paragraph 2.102. Reference intro comment 6. Final developed draft recommended plan quantities are discussed in the recommended plan description. Final design will address*

EIS-58 Page EIS p-77, A. Harbor Area Barge Operations. Alternative components are not fully developed.

An option is mentioned where water tight barges would be used as settling basins for dredged material. Dewatering studies (BBL, 1999) show that without underdrainage, minimal dewatering of the sediment would occur. The Draft Plan should be revised to reflect this. The text further states that water removal from the sediment would be filtered to meet river or lake discharge requirements. Since filtering alone typically does not meet stringent river or lake discharge requirements, a basis for this approach needs to be provided.

ARP RESPONSE: *Agree. Reference SECONDARY SPECIFIC COMMENTS/RESPONSES DRAFT EIS GENERAL INTRODUCTION REFERENCE RESPONSE 6. Reference paragraphs 2.101 and 2.102. See response EIS 55. This option was meant to reflect similar filter treatment. Final design will address further.*

EIS-59 Page EIS-77, B. Harbor Area Shore Operation alternative components are not fully developed.

The Conrail Interim Diked disposal area would be used to construct settling basins for dredged material. It is unclear where the previously dredged material that is currently at the Site, would be staged. Additionally, comments noted above regarding filtering to meet river and lake discharge requirements also applies here.

ARP RESPONSE: *Agree to some extent. Reference SECONDARY SPECIFIC COMMENTS/RESPONSES DRAFT EIS GENERAL INTRODUCTION REFERENCE RESPONSE 6. Reference paragraphs 2.101 and 2.102. It was expected that material at the site would be utilized for settling basin construction. About 30, 000 cu yds would be disposed of as contaminated material. About 40,000 cu yds could be graded or used as fill material. See response EIS 55.*

EIS-60 Page EIS-77, Incomplete information is provided for Treatment Technologies.

A number of PCB contaminated sediment treatment and disposal measures were assessed/evaluated. It is unclear where this evaluation is reported, what exactly was evaluated and what was the basis for the screening.

ARP RESPONSE: This was discussed back on page EIS-48.

EIS-61 Page EIS-78, Comparative Costs. The cost table is inconsistent with previous text.

The text on Page EIS-77 indicates that volume of material were revised (basis not provided), however, the unrevised volumes are used in the comparative cost evaluation. Also, the backup details and assumptions for these costs are not apparent and should be included in its entirety or by reference.

ARP RESPONSE: *Reference SECONDARY SPECIFIC COMMENTS/RESPONSES DRAFT EIS GENERAL INTRODUCTION REFERENCE RESPONSE 3, 4, 6. Reference paragraphs 2.101 and*

2.102. *These items are summarily presented here. Further information may be found in the meeting minutes and project files. Final design will address further.*

EIS-62 Page EIS-79 through EIS-82. The evaluation is reported as very brief phrases without an explanation of what the phrases mean or what they are based upon.

Several evaluation parameters are used in an assessment of comparative impacts of considered alternatives. This assessment should be clarified to support the evaluation or omitted from the document.

ARP RESPONSE: *Reference SECONDARY SPECIFIC COMMENTS/RESPONSES DRAFT EIS GENERAL INTRODUCTION REFERENCE RESPONSE 3, 4, 6. Reference paragraphs 2.101 and 2.102. These items are summarily presented here. Further information may be found in the meeting minutes and project files.*

EIS-63 Page EIS-84. Insufficient details are provided in support of the evaluation process.

In one paragraph, an “assessment/evaluation/selection discussion” is presented. It appears that an evaluation process was undertaken to develop a recommended plan and an alternative disposal option plan. However, the one paragraph does not provide the details or the basis of the assessment/evaluation/selection process. In this paragraph mention is made of a confined disposal facility being screened out based on considerable environmental concerns. Several areas to which the concerns pertain are noted, but the actual effect upon these areas and the trade-offs are not presented. Presentation of this information would serve to support the decisions made in the document.

ARP RESPONSE: *Adequately supported as written. Reference SECONDARY SPECIFIC COMMENTS/RESPONSES DRAFT EIS GENERAL INTRODUCTION REFERENCE RESPONSES 3, 4, 6. Reference paragraphs 2.101 and 2.102. These items are summarily presented here. Further information may be found in the meeting minutes and project files.*

EIS-64 Page EIS-85, para. 2.105. Where the Plan notes that dredging is to occur from upstream to downstream in order to recapture resuspended sediment, it should note that diurnal and storm-related Lake Erie elevation changes might influence the direction of flow, spreading resuspended material upstream.

This comment also applies to a similar statement on Page: FR-iv, para. 3.

The Plan states that dredging will occur from upstream to downstream in order to try to recapture any resuspended materials that may have resettled. During the low flow periods typically used to perform dredging, lake seiches may affect the direction of flow, which could transport materials suspended during dredging upstream to previously dredged areas. These effects should be considered when proposing environmental controls (i.e. silt curtains) for the project.

ARP RESPONSE: *We'll consider this. This will be detailed further in the final report and project design and plans and specifications.*

EIS-65 Page EIS-86, para. 2.107. Estimated costs are low.

This comment also applies to costs presented on Pages: EIS-110; FR-vi; FR-84;FR-109; FR-113; FR-116; FR-191; Q-7; Q4-9.

See comments on Appendix P.

ARP RESPONSE: *The referenced page and paragraph do not correspond to the comment. This will be detailed further in the final report and project design and plans and specifications.*

EIS-66 Page EIS-86, para. 2.112. It is not clear whether costs for the shoreline stability survey are included in project costs.

The final Plan should include assumptions included in costs (including costs for a shoreline stability survey during dredging).

ARP RESPONSE: *This has been coordinated with shoreline property owners. I would be a shoreline property owner responsibility and expense. This will be detailed further in the final report and project design and plans and specifications.*

EIS-67 Page EIS-86, para. 2.111 Significant release of contaminant could still occur during the dredging process.

The dredging operational controls described do not address the potential for contaminant release from the pore water, especially considering any enhanced solubility due to other hydrocarbons present. This dissolved component would escape from the system. In addition, due to the increased exposure to the water column during prolonged dredging, a high rate of desorption is possible. Also the FR states that "silt curtains would also be used, particularly during dredging of TSCA sediment." This statement appears to imply that for at least some non-TSCA sediment no such barrier is being considered, potentially leading to a significant release of suspended sediment.

ARP RESPONSE: *Agree to some extent. Water quality impacts are discussed in further detail in the Environmental Effects Section pertaining to Water Quality beginning on page EIS-198 and EIS-199. There are some limited low contaminated areas that may be able to be dredged without use of turbidity barriers and/or oil booms. This would expedite dredging in those areas. This will be detailed further in the final report and project design and plans and specifications.*

EIS-68 Page EIS-87. para. 2.115 The potential for recontamination of sediments below 5th Street Bridge is not addressed

The report states that downstream of the 5th Street Bridge, PAH contamination is the major concern. With the continuation of commercial navigation, a proposed plan addressing the potential for future PAH contamination, following dredging, should be included.

ARP RESPONSE: *Agree to some extent. Reference **SECONDARY SPECIFIC COMMENTS/RESPONSES DRAFT EIS GENERAL INTRODUCTION REFERENCE RESPONSE 27.** As stated on EIS page EIS-9, paragraph 1.18, post project conditions include that best management practices be in effect by the coal and Fields Brook industries. These practices need to be enforced, as possible.*

EIS-69 Page EIS-87, 88, Sections 2.117 and 2.118. There is a lack of protected aquatic fishery shallows.

Consideration should be given to minimizing the depth of sediment removal to maintain the shallowest water depth feasible, to facilitate better fish habitat.

ARP RESPONSE: Agree. See GENERAL COMMENTS response # 4 Also, considering the project authorities and all the other considerations.

EIS-70 . Page EIS-89. A table is presented with costs and “some trade-off concerns” with no supporting discussion, explanation or further information.

This table should be explained or omitted.

ARP RESPONSE: Do not agree. The referenced page and paragraph do not correspond to the comment. Assume one means page 83. Reference SECONDARY SPECIFIC COMMENTS/RESPONSES DRAFT EIS GENERAL INTRODUCTION REFERENCE RESPONSES 3, 4, 6. Reference paragraphs 2.101 and 2.102. These items are summarily presented here. Further information may be found in the meeting minutes and project files.

EIS-71 Page EIS-89, para. 2.122. Addition of flocculent could significantly increase volume for disposal.

The Plan states that flocculent might be used to facilitate settling of sediments. If used, the flocculent could have an effect on the computed disposal volume (and associated costs). Relevant assumptions should be noted in the final plan and considered in the cost estimates.

ARP RESPONSE: Agree to some extent. This will be detailed further in the final report and project design and plans and specifications.

EIS-72 EIS-89, paragraph 2.126. The option of the Harbor Area Shore Operation is represented as a dewatering alternative distinct from the Harbor Area Barge Operation. This is incorrect.

The drawings depicting the proposed layout are from Appendix K of the FR. The facility described in Appendix K is not intended to be used as an on-shore dewatering facility. A design or technical basis for an on-shore dewatering facility is not presented in the Draft Plan.

The Appendix K design is based on the premise that the dewatering will occur in the scows, similar to the Harbor Area Barge Operation described in EIS paragraph 2.125. The settling basins described in paragraph 2.126 as being designed for settling dredged material are in fact designed for treatment of supernatant water pumped out of the scows, contact stormwater, and water from the dredged material storage facility. The dredged material storage facility is designed for temporary containment of dewatered dredged materials if insufficient trucking transport is available. The staging facility design assumes that most of the dredged material will be transported directly from the scows to the upland disposal facility without any on-shore dewatering. Therefore, the option of the Harbor Area Shore Operation is not actually developed anywhere in the documents.

ARP RESPONSE: *Agree to some extent. Options were to include a total barge operation and a barge and shoreline operation. Descriptions will be clarified. Final design will address further.*

EIS-73 Page EIS-89, Section 2.124. The evaluation process used to develop recommendations is not sufficiently presented.

The screening process should to be included or referenced.

ARP RESPONSE: *Do not agree. Reference SECONDARY SPECIFIC COMMENTS/RESPONSES DRAFT EIS GENERAL INTRODUCTION REFERENCE RESPONSES 3, 4, and 6. Reference paragraphs 2.101 and 2.102. These items are summarily presented here. Further information may be found in the meeting minutes and project files.*

EIS-74 Page EIS-91, Section 2.132. Operations to be adjusted as necessary, to process the TSCA and Non-TSCA Material are not specified.

ARP RESPONSE: *Reference SECONDARY SPECIFIC COMMENTS/RESPONSES DRAFT EIS GENERAL INTRODUCTION REFERENCE RESPONSES 3, and 4. Will be addressed in final design.*

EIS-75 Page EIS-110, Table 2.20. Costs presented in Table 2.20 are not consistent with those presented on Page EIS-78.

ARP RESPONSE: *Agree. Reference SECONDARY SPECIFIC COMMENTS/RESPONSES DRAFT EIS GENERAL INTRODUCTION REFERENCE RESPONSE 6. Page EIS-78 items are summarized from sub-assessment studies. Noted: (Preliminary Comparative Costs). The recommended plan description should be referenced for the developed recommended plan construction costs. Reference Table 2.20. This will be detailed further in the final report and project design and plans and specifications.*

EIS-76 Page EIS-113, para. 2.156 Alternative Disposal Options Plan. Any off-site disposal at a commercial facility would greatly increase costs.

This section of the Plan notes that the use of an off-site existing disposal facility is retained as an option. A cost analysis of disposal costs at these type of facilities would readily indicate that the existing \$11M budget for disposal would be quickly exhausted. The copy of this approach should be put in perspective in the final plan.

ARP RESPONSE: *That's what our initial assessment/evaluation determined. However, a preliminary value engineering (VE) study indicated that disposal of the Non-TSCA level material at one or more existing commercial disposal facilities would be less.*

EIS-77 Page EIS-160, 1st Paragraph. The statement that "contaminated sediments are the major cause of lower fish community scores at this Ashtabula site," is unsupported.

This comment also applies to a similar statement on Page 312(b)-36 of EA-J.

- a. Although contaminated sediment downstream of Fields Brook may have some effect on the fish community in this area, there are likely other reasons for the lower fish community score. For example, problems identified in this area (Draft EIS, Page 312(b)-39) include recreational harbor development bulkheading, dredging, and use of the recreational

navigation channel. Boating activities and shoreline modifications in this area have been reported to affect the macroinvertebrate community (Ohio EPA, 1997). Therefore, it is likely that these conditions have also impacted the fish community.

- b. Additionally, even if the habitat in this area is relatively good, fish communities rely on surrounding areas for recruitment. If one small area of good habitat exists in an area of relatively poor habitat, the community within that area does not reach its maximum potential.
- e. Fish communities are also affected by the availability of food, and many species of fish eat macroinvertebrates. The Ohio EPA (1997) reports that boating activities and shoreline modifications have impacted macroinvertebrate communities in this area. Because these non-sediment related impacts have reduced the macroinvertebrate community, then a like reduction in the fish community would also be expected due to the decreased availability of food.

ARP RESPONSE: *Do not agree. See PRIMARY SPECIFIC COMMENTS response # 8. This is discussed further in the EIS Appendix EA-J Section 312(b) and 206 Ecological Restoration/Preservation Analyses. Species surveys discussed indicate contamination conditions. There were supplemental surveys (i.e. 1995/97) and assessments to the 1992 that are discussed in the reports also. See responses to EIS 2, and EIS 6. Reference SECONDARY SPECIFIC COMMENTS/RESPONSES DRAFT EIS GENERAL INTRODUCTION REFERENCE RESPONSES 15, 16, 18, 19, 20, 21, 24.*

EIS-78 Page EIS-160, 4th Paragraph. The Draft EIS improperly states that the macroinvertebrate community is impacted between rivermile 1.9 (upstream of Fields Brook) and the mouth of the river. The Draft EIS also states that sediment contamination has been well documented downstream of Fields Brook, implying a cause for the impairment.

The Report should not allude that sediment contamination is the reason for an impacted macroinvertebrate community. As previously discussed, studies by the Ohio EPA (1992), concluded that downstream of Fields Brook, there appeared to be little or no difference in quality of the macroinvertebrate communities in comparison to non-impacted sites. The fact that macroinvertebrate community is considered poor both upstream of Fields Brook (rivermile 1.9) and downstream (rivermile 1.3) (Draft EIS, Page 312(b)-77) indicates that sediment contaminants are not responsible for potential impacts. Similarly, for the harbor, the Ohio EPA (1992) concluded that "there was no evidence that residual contaminated sediments from Fields Brook pollutants were having a significant negative influence on the quality of the Ashtabula harbor communities."

ARP RESPONSE: *Do not agree. This is discussed further in the EIS Appendix EA-J Section 312(b) and 206 Ecological Restoration/Preservation Analyses. Species surveys discussed indicate contamination conditions. There were supplemental surveys (i.e. 1995/97) and assessments to the 1992 that are discussed in the reports also. See responses to EIS 2, and EIS 6. Reference SECONDARY SPECIFIC COMMENTS/RESPONSES DRAFT EIS GENERAL INTRODUCTION REFERENCE RESPONSES 15, 16, 18, 19, 20, 21, 24.*

EIS-79 Page EIS-207, Figure 4.1. Figure 4.1 shows alleged improvement in the physical habitat of the Ashtabula River (as measured by the QHEI) following the proposed project measures, without rationale.

This comment also applies to the figures on Page: EA-J Page 312 Page 312(b)-118.

The report needs to describe the rationale for the expected improvement in the QHEI scores. For example, it is not specified which habitat parameter (e.g., epifaunal substrate/available cover, pool variability, channel alteration, sediment deposition, bank stability) in the QHEI will be affected. Additionally, the report needs to differentiate which improvements will be from habitat restoration, and which improvements (if any) will be from mass sediment removal.

ARP RESPONSE: Do not agree. See **PRIMARY SPECIFIC COMMENTS response # 8.** As indicated by the table and key, the table pertains to *Qualitative Habitat Evaluation Index (Physical)* and improvements pertain primarily to *Dredging/Aquatic/Fishery Shallows of the Recommended Plan.* Similar subsequent tables also include more relevant improvements pertaining to *Dredging/Contaminant Removal of the Recommended Plan.* This is discussed further in the *EIS Appendix EA-J Section 312(b) and 206 Ecological Restoration/Preservation Analyses.* See response to EIS 6. Reference **SECONDARY SPECIFIC COMMENTS/RESPONSES DRAFT EIS GENERAL INTRODUCTION REFERENCE RESPONSES 2, 3, 4, 24.**

EIS-80 Page EIS-210, Figure 4.3. **Figure 4.3 shows alleged improvement in the macroinvertebrate community of the Ashtabula River (as measured by the ICI) following the proposed project measures.**

This comment also applies to the figure on Page: EA-J Page 312(b)-121.

The report needs to describe the rationale for the expected improvement in the ICI scores. The report should differentiate which improvements will be from habitat restoration, and which improvements (if any) will be from mass sediment removal. This is an important distinction, because according to the studies conducted by the Ohio EPA (1992), downstream of Fields Brook, there appeared to be little or no difference in quality of the macroinvertebrate communities in comparison to non-impacted sites.

ARP RESPONSE: Do not agree. See **PRIMARY SPECIFIC COMMENTS response # 8.** As indicated by the table and key, the table pertains to *Invertebrate Community Index* and improvements pertain to both to *Dredging/Contaminant Removal of the Recommended Plan* and to *Dredging/Aquatic/Fishery Shallows of the Recommended Plan.* This is discussed further in the *EIS Appendix EA-J Section 312(b) and 206 Ecological Restoration/Preservation Analyses.* Species surveys discussed indicate contamination conditions. There were supplemental surveys (i.e. 1995/97) and assessments to the 1992 that are discussed in the reports also. See responses to EIS 2, and EIS 6. Reference **SECONDARY SPECIFIC COMMENTS/RESPONSES DRAFT EIS GENERAL INTRODUCTION REFERENCE RESPONSES 2,3, 4, 15, 16, 18, 19, 20, 21, 24.**

EIS-81 Page EIS-213, Figure 4.4. **Similar to the previous figures, Figure 4.3 shows alleged improvement in the fish community of the Ashtabula River (as measured by the IBI) following the proposed project measures.**

This comment also applies to the figure on Page: EA-J Page 312(b)-119.

The report needs to describe the rationale for the expected improvement in the IBI scores. The report should differentiate which improvements will be from habitat restoration, and which improvements (if any) will be from mass sediment removal. Most of the impacts associated with the Ashtabula River are habitat related; thus most of the improvement in biological conditions is expected to be from habitat improvement, not sediment mass removal.

ARP RESPONSE: Do not agree. See **PRIMARY SPECIFIC COMMENTS response # 8**. As indicated by the table and key, the table pertains to Index of Biotic Integrity (fishery) and improvements pertain to both to Dredging/Contaminant Removal of the Recommended Plan and to Dredging/Aquatic/Fishery Shallows of the Recommended Plan. This is discussed further in the EIS Appendix EA-J Section 312(b) and 206 Ecological Restoration/Preservation Analyses. Fishery surveys discussed indicate contamination conditions. There were supplemental surveys (i.e. 1995/97) and assessments to the 1992 that are discussed in the reports also. See responses to EIS 2, and EIS 6. Reference **SECONDARY SPECIFIC COMMENTS/RESPONSES DRAFT EIS GENERAL INTRODUCTION REFERENCE RESPONSES 2, 3, 4, 15, 16, 18, 19, 20, 21, 24**.

EIS-82 Page EIS-215, para. 4.66. According to the Draft EIS, the speed and ecological recovery of the Ashtabula River will depend on the rate of sedimentation.

This comment also applies to a similar statement on Page FR-120 (para. 4).

As stated on Page 151 of the Draft FR, the text should note that recovery can be accelerated through "addition of clean fill."

ARP RESPONSE: Agree. There are other factors/measures also. **No change necessary.**

EIS-83 Page EIS-245 para. 6.24. The statement that "it is not expected that any significant adverse water quality impacts would be caused by project construction or future operation and maintenance procedures" is unreasonable.

According to the Draft Plan (Page 40), dredging will be performed using a closed bucket mechanical dredge. As stated in Table 2-2 of the Draft Plan (Page EIS-19), use of mechanical dredges inevitably results in increased turbidity in the water column as well as resuspension of sediment which may cause the dissolution of contaminants associated with sediment, if present. Table S1 (EIS Page 13) states that "moderate adverse" impacts on water quality will occur as a result of channel dredging.

ARP RESPONSE: Do not agree. Reference **SECONDARY SPECIFIC COMMENTS/RESPONSES DRAFT EIS GENERAL INTRODUCTION REFERENCE RESPONSE 26**. The **ENVIRONMENTAL EFFECTS Water Quality** Section (page EIS – 199) discussed (five pages) water quality. It also includes discussion of a mixing zone. Granted revised State water quality standards make this more pressing. There is more detailed discussion in Technical Appendix G – Dredging Alternatives and Selection. EIS paragraph 4.30 references EIS Appendix EA-B Clean Water Act Public Notice and 404(b)(1) Evaluation Report which discusses water quality in more detail. Some supplemental revisions will be made for the final report. This will be detailed further in the final report and project design and plans and specifications.

Appendix EA-B: Clean Water Act Public Notice and Section 404(b)(1) Evaluation Report

EIS-84 Page 404-30. The description of potential effects on the aquatic food web should include an evaluation of the potential for increased exposure to, and uptake of, PCBs and other chemicals following dredging.

As acknowledged in the report, dredging will likely lead to immediate re-suspension of sediment particles, and will leave behind elevated surficial sediment concentrations of materials which were previously covered by cleaner deposits. These effects will likely increase exposure to fish and benthic macroinvertebrates, causing possible increases in fish PCB concentrations.

ARP RESPONSE: Do not agree. See ***PRIMARY SPECIFIC COMMENTS response # 11.*** Reference ***SECONDARY SPECIFIC COMMENTS/RESPONSES DRAFT EIS GENERAL INTRODUCTION REFERENCE RESPONSE 26.*** This is sufficiently discussed in this and other related sections of the reports. Reference sections on dredging, risk assessment, water quality, sediment quality, fisheries and advisories, etc. This is discussed further in the Technical Appendix G – Dredging Alternatives and Selection, EIS Appendix EA - C Environmental Risk Management Considerations and EIS Appendix EA-J Section 312(b) and 206 Ecological Restoration/Preservation Analyses. Some supplemental revisions will be considered for the final report.

Appendix EA-C: Environmental Risk Management Considerations for the Ashtabula River and Harbor

EIS-85. Page 3, para. 1. According to the Appendix EA-C, “the sediment post-removal surface area weighted PCB concentrations for the three dredging alternatives being evaluated in the EIS are all within a few ppm of each other and therefore, would result in similar risk estimates.” This statement is based on inappropriate assumptions regarding dredging effectiveness and the “final” surface. The text should be revised to reflect the following.

- a. When surface weighted average concentrations (SWAC) are generated for the post removal surface of each alternative, dredging data collected at other sites (Attachment A) indicates that the SWAC will increase as a result of exposing buried sediments containing higher PCB concentrations that resuspend and settle out on the dredged sediment surface.
- b. “Acceptable risk” from the proposed remedy is not achieved until cleaner material is deposited on the dredged surface, which is estimated to take 5 years (pg 151, draft FS Report). In the short-term, risk evaluations should not consider the silted-over post-dredge surface, since remedy implementation (natural covering) is not yet complete.

ARP RESPONSE: Do not agree. See ***PRIMARY SPECIFIC COMMENTS response # 11.*** Reference ***SECONDARY SPECIFIC COMMENTS/RESPONSES DRAFT EIS GENERAL INTRODUCTION REFERENCE RESPONSE 26.*** This is sufficiently discussed in this and other related sections of the reports. Reference sections in the main report and appendices pertaining to dredging, risk assessment, water quality, sediment quality, fisheries and advisories, etc. This is discussed further in the Technical Appendix G – Dredging Alternatives and Selection, EIS Appendix EA - B Clean Water Act Public Notice and 404(b)(1) Evaluation Report and EIS Appendix EA - J Section 312(b) and 206 Ecological Restoration/Preservation Analyses. Some supplemental revisions will be considered for the final report. Also, there are a number of project examples and articles that counter your (Attachment A) after dredging elevated surface sediment contaminant levels and project success include those pertaining to: Scippo Creek, Ohio; Fox River, Wisconsin; and Manistique, Michigan.

EIS-86. Page 4, para. 4. Appendix EA-C states that “(t)he less stringent 1997 fish consumption advisory is due, in part, to the more highly contaminated sediments being buried by cleaner sediments, which are therefore less available for uptake by biota.”

As stated, the reduction in fish PCB concentrations is likely the result of natural attenuation of the river. However, it is important to note that this trend will likely be interrupted by the disruption caused by intrusive dredging.

ARP RESPONSE: Do not agree. Reference ***SECONDARY SPECIFIC COMMENTS/RESPONSES DRAFT EIS GENERAL INTRODUCTION REFERENCE RESPONSE 18, 20, 21, 26.*** This is sufficiently discussed in this and other related sections of the reports. Reference sections in the main report and appendices pertaining to dredging, risk assessment, water quality, sediment quality, fisheries and advisories, etc. This is discussed further in the Technical Appendix G – Dredging Alternatives and Selection, EIS Appendix EA - B Clean Water Act Public Notice and 404(b)(1) Evaluation Report, EIS Appendix EA - C Environmental Risk Management Considerations, and EIS Appendix EA - J Section 312(b) and 206 Ecological Restoration/Preservation Analyses.

Appendix EA-G: Coastal Management Consistency Determination

EIS-87. Page CMP-27, para. 4. Appendix EA-G states that sediment removal and discharge of shoreline excavated material should be essentially clean and would be able to support less pollution tolerant benthic organisms, and enable the river to achieve a higher diversity of aquatic species.

The assumption that excavated material will support a higher diversity of aquatic species needs further explanation. The text incorrectly assumes that sediment quality is currently the limiting factor causing impairment within the river. This assumption fails to consider the prevalence of other habitat related factors (e.g., marina development, boat traffic, loss of shallow aquatic areas, problems with dissolved oxygen and low flow) which are likely to limit use of the River by aquatic species.

ARP RESPONSE: Do not agree. See ***PRIMARY SPECIFIC COMMENTS response # 8.*** Your summary statement mixes statements and is incorrect. The section subject and accordingly the content does not relate to other habitat related factors; although, these are considered in many other appropriate sections of the reports.

Appendix EA-I: Environmental Justice

EIS-88. Page 4, para. 3. The Appendix states “long-term improvements in water quality and benthic communities will almost certainly result from the removal of the contaminated sediment. The improved aquatic environment should, in turn, improve the size, diversity and health of fish communities in the Ashtabula River.”

This statement assumes that contaminated sediment is the limiting factor for fish and benthic communities. An improved aquatic community will more likely be the result of habitat restoration, not sediment mass removal. The text should be revised accordingly.

ARP RESPONSE: Do not agree. See ***GENERAL COMMENTS responses 3 and 5.*** See response EIS 6. Reference ***SECONDARY SPECIFIC COMMENTS/RESPONSES DRAFT EIS GENERAL INTRODUCTION REFERENCE RESPONSES 2, 16, and 24.*** The appendix and section subject and accordingly the content does not particularly relate to other habitat related factors; although, these are considered in many other appropriate sections of the reports.

Appendix EA-J: Section 312(b) and 206 Ecological Restoration/Preservation Analyses

EIS-89. Page 312(b)-58, para. 2. The Draft EIS states that “(I)f either Bank to Bank to Bedrock or Deep Dredging were implemented, it is expected with high certainty that the fish consumption advisory would be lifted and long-term protection will be achieved because the

majority of the PCB mass will be removed, (Risk Assessment, 1997). It is expected that, at a minimum, within several years of completion of dredging enough clean material will have silted into the dredged area to provide a sufficient cover (about two feet) to initiate benthos and fishery recovery with regards to contaminants.”

- a. The evaluation of fish tissue data which supports this statement should be provided. The current fish consumption advisory is no more restrictive than that for Lake Erie. Additionally, the major risk driver for a portion of the consumption advisory is methyl mercury, yet the Draft EIS has not provided any information to suggest future reductions in fish mercury concentrations.
- b. As noted on Page 151 of the Draft FR, the text should be expanded to state that recovery could be accelerated with a higher degree of effectiveness, through “addition of clean fill.”

ARP RESPONSE: Do not agree. These items are discussed in adjacent just previous and later paragraphs or sections of the appendix. Reference SECONDARY SPECIFIC COMMENTS/RESPONSES DRAFT EIS GENERAL INTRODUCTION REFERENCE RESPONSE 2.

EIS-90. Page 312(b)-62. Restored Benthic Habitat. The Draft EIS states that following dredging the current benthic community “would soon be complemented with somewhat more diverse and better quality, less pollution tolerant (i.e., mayflies, caddisflies, and midges) species.”

This statement is not entirely true, and should be revised accordingly. If sediment contaminants are not the reason for current impacts to the benthic community (as stated in the Ohio EPA (1997) report) then sediment mass removal will serve little to improve the benthic community. According to the Draft EIS (Page 312(b)-75), for macroinvertebrates, trophic conditions in the Ashtabula Harbor are “similar to all other monitored Lake Erie harbors in Ohio.”

ARP RESPONSE: Do not agree. See response EIS 2 and EIS 6. Reference SECONDARY SPECIFIC COMMENTS/RESPONSES DRAFT EIS GENERAL INTRODUCTION REFERENCE RESPONSE 14, 15, 16, 17, 18, 19, 20, 21, 24. Also, the third paragraph on page 312(b)-77 and surrounding paragraphs discuss that shoreline development and contaminated sediments were the principle factors impacting on benthos in the lower Ashtabula River. This is discussed further in adjacent sections of EIS Appendix EA - J Section 312(b) and 206 Ecological Restoration/Preservation Analyses.

EIS-91. Page 312(b)-71, and Page 312(b)-72, Figure 23. Community Level Comparison. The Draft EIS compares Conneaut Creek sites with Ashtabula River sites, and concludes that the differences in fish abundance and composition is due to contaminated sediment.

- a. The Draft EIS has not provided sufficient information to identify contaminated sediment as
 - b. a major impact to fish in the Ashtabula River, and this statement should be removed.
 - c. Additionally, Conneaut Creek is inappropriate as a reference site. The Ashtabula River is classified as warmwater habitat, while the Conneaut River is classified as coldwater habitat. Additionally, the Ashtabula differs from the Conneaut in that considerable boat traffic exists in the Ashtabula lacustrary (Draft EIS, Page 312(b)-75).
- b. According to the legend for Figure 23, fishery data from the Black River are included in the comparison. However, these data do not appear on the figure.

ARP RESPONSE: Do not agree. See ***PRIMARY SPECIFIC COMMENTS response # 8.*** See response EIS 2 and EIS 6. Reference ***SECONDARY SPECIFIC COMMENTS/RESPONSES DRAFT EIS GENERAL INTRODUCTION REFERENCE RESPONSES 14, 15, 16, 17, 18, 19, 20, 21, 23, 24.*** This is discussed further in adjacent sections of EIS Appendix EA - J Section 312(b) and 206 Ecological Restoration/Preservation Analyses. Revise Black to Grand.

EIS-92. Page 312(b)-75, para. 1. The Draft EIS states that, based on a comparison to the Grand River, “boat traffic is not the driving factor in structuring the Ashtabula fish community.”

There are many factors which affect the structuring of a fish community. These factors may include surface water quality, availability of sufficient food, habitat suitability, and presence of human disturbance. As such, boat traffic may not be the driving factor, but may only be a contributing factor. The text should be revised to reflect this.

ARP RESPONSE: Do not agree. See response EIS 2 and EIS 6. Reference ***SECONDARY SPECIFIC COMMENTS/RESPONSES DRAFT EIS GENERAL INTRODUCTION REFERENCE RESPONSES 14, 15, 16, 17, 18, 19, 20, 21, 23, 24.*** This is discussed further in adjacent sections of EIS Appendix EA - J Section 312(b) and 206 Ecological Restoration/Preservation Analyses.

Appendix EA-K: Required Environmental Correspondence

EIS-93. Page 5, para. 2. It is stated that the ARP’s goal “is to look beyond traditional approaches to determine a comprehensive solution for remediation of the contaminated sediments not suitable for open lake disposal,” however, only dredging scenarios are evaluated in any detail in the Draft Plan.

More thorough evaluation of the cover and other alternatives as part the Draft Plan would support that the ARP is looking beyond traditional approaches to sediment remediation.

ARP RESPONSE: Do not agree. Reference ***SECONDARY SPECIFIC COMMENTS/RESPONSES DRAFT EIS GENERAL INTRODUCTION REFERENCE RESPONSES 3, 25, 28, 29.*** A traditional remediation measure is to contain contaminants in place. However this was rejected on several accounts three of which are that, in this case, it conflicts with dredging and authorized channel authorities, most interests want the contaminants removed from the river and do not want the river utilized as the final disposal site, most interests have a problem with the long-term reliability of a cover alternative, etc. However, some supplemental discussion will be considered for the final report.

**ASHTABULA RIVER COOPERATION GROUP
COMMENTS ON THE DRAFT
ASHTABULA RIVER COMPREHENSIVE MANAGEMENT PLAN**

III. SECONDARY SPECIFIC COMMENTS (Continued)

ARP GENERAL CLARIFICATION: *The Ashtabula River Partnership Comprehensive Management Plan (CMP) is the Feasibility Report for the Ashtabula River Partnership Project. Accordingly, the following ARP Responses use “CMP” in reference to the Feasibility Report.*

ARP CMP RESPONSE REFERENCES: *The ARP has formulated responses to the BBL General Comments and Primary Specific Comments pertaining to the CMP (Feasibility Report) and the EIS. In addition, The ARP prepared an “EIS Reference Introductory Response” to address the “Secondary Specific Comments pertaining to the EIS and EIS Appendices. The following responses to the BBL Secondary Specific Comments pertaining to the CMP make reference to these prior ARP responses and are referred to based on the following categories followed by the response number.*

1. “General Comment Response”
2. “Primary Specific Comment Response”
3. “EIS Reference Introductory Response”

B. DRAFT FEASIBILITY STUDY

FR-1. Page ii, para. 3. The statement that (t)he consequences of accumulated contaminants are many, including restrictions on fish consumption, reduced commercial shipping and recreational boating, habitat loss, and impacts on biota is misleading, and should be revised to better reflect the evaluations presented in the report.

This comment also applies to a similar statement on page: Page 6 of the FR.

- a. Specifically, the report has not positively identified a causal relationship between sediment-associated contaminants and either habitat loss or impacts to biota.
- b. Reportedly, habitat loss in the Ashtabula River is primarily due to loss of shallow aquatic areas, marina development, and boat traffic.
- c. Although PCBs and other constituents have accumulated to some degree in Ashtabula River fish, detected concentrations are relatively low, and bioaccumulation in and of itself does not necessarily imply impact. Also, Page EIS-6 states that there is no information available on deformities or tissue concentrations of contaminants in any birds or mammals at Ashtabula.

ARP RESPONSE: *Do not agree. Contaminants may be associated with all problems identified (including degradation of benthos and loss of fish and wildlife habitat), and removal associated with all remedial actions. Benthos living in contamination and the compounded affects on the*

fish and wildlife food chain does not contribute to degradation of benthos and loss of fish and wildlife habitat? The environmental and ecological degradation of the Ashtabula River Area of Concern is not a result of a singular degrading factor or condition. Sediment contamination, water quality and the loss/degradation of physical habitat including vegetated emergent and submergent shallows have comprehensively resulted in the current river condition. Accordingly, the ARP Comprehensive Management Plan recognizes these circumstances and sets forth the plans for future action to address the compounding problems of sediment contamination and physical habitat loss. In addition to environmental dredging, the aquatic ecosystem restoration measures outlined in the CMP Recommended Plan include the development of aquatic shelves, as possible, which would be accomplished under separate authorities. This issue is discussed further in the EIS Appendix EA-J Section 312(b) and 206 Ecological Restoration/Preservation Analyses. Reference into response EIS-24.

FR-2. Page iv, para. 4. The statements that the initially dredged area would provide an immediate clean cover and future sediment deposits would be essentially clean and able to support a better variety of benthic organisms is misleading, and should be omitted from the report.

This comment also applies to a similar statement on FR Page 120, para. 4.

These statements incorrectly assume that the limiting factor suppressing the benthic macroinvertebrate community is sediment contamination. However, studies by Ohio EPA (1992) indicate that the effects of shoreline modifications and boating activities overshadow any effects that could be related to sediment contamination.

ARP RESPONSE: Do not agree. This is discussed further in the EIS Appendix EA-J Section 312(b) and 206 Ecological Restoration/Preservation Analyses. Species surveys discussed indicate contamination conditions. There were supplemental surveys (i.e. 1995/97) and assessments to the 1992 that are discussed in the reports also. See "General Comment Responses" #2 and #6. Reference into response "EIS Reference Introductory Responses" 15, 16, 18, 19, 20, 21 and 24.

FR-3. Page iv, para. 4. The first sentence should be revised to read dredging the Ashtabula River sediments will have short-term negative environmental effects on the river and, to a lesser extent may have an effect on the Ashtabula Harbor and Lake Erie if proper environmental controls are not utilized.

Dredging, particularly mechanical dredging, inevitably results in some deterioration to surrounding water quality, and, if contaminants are present, likely sediment quality, as well.

ARP RESPONSE: Do not agree. It is a distinct possibility that the dredging of sediments may have a temporary negative environmental effect on the river and the harbor areas. This possibility has been clearly recognized by the ARP and expressed in the referenced paragraph of the CMP. The revision of "might" to "will" as suggested in this comment implies certainty in this regard, which is inappropriate at the planning stage. The purpose of a planning study is to identify the potential environmental (and other) effects of a proposed project action. The purpose of the subsequent design phase of the project is to take these possible effects into consideration and include measures in the project design (i.e., environmental controls) that will eliminate and/or

minimize the recognized effects.

FR-4. Page iv, para. 4. The statement that the long-term beneficial impacts [of the project] far outweigh the adverse effects is subjective and inadequately supported in the Draft Plan. As discussed in comments relating to Page EIS-16 (para. 2.06) of the Plan, refinements can be made to the Draft Plan which would minimize adverse impacts and improve the ability of the remedy to achieve the ARP goals.

ARP RESPONSE: Do not agree. See previous response, “General Comment Responses” #3 and #7 and “EIS Reference Introductory Responses” 18 and 25.

FR-5. Page iv, para. 4. The statement that future sediment deposits would be essentially clean and able to support a better variety of benthic organisms, enabling the river to achieve a higher diversity of aquatic species is not supported in the Draft Plan.

The Draft Plan does not provide sufficient information to evaluate the quality of sediment that may be deposited in the River in the future. Also, the Draft Plan has not evaluated the possibility that PAHs and other constituents in runoff from industrial/commercial activities, coupled with future heavy recreational/commercial use of the river may affect future sediment quality.

ARP RESPONSE: See “General Comment Response #2”.

FR-6. Page viii, Table of Contents. Various errors are present in the table of contents.

- a. Section 1.4 □ Ashtabula River Partnership Goals is omitted.
- b. The title for Chapter 6 is not consistent with that of the text.
- c. Section 8.4 should read Recommended Plan Benefits associated with a one-time Cleanup of Contaminated Sediments Located Upstream of the 5th Street Bridge.
- d. Several Sections are referenced to incorrect page numbers (e.g. Sections 3.5.2.3 and 3.5.3)

ARP RESPONSE: Agree. Will correct.

FR-7. Page xi, List of Tables.

The list of tables is absent.

ARP RESPONSE: Agree. Will correct.

FR-8. Page xii, List of Figures.

The list of figures is absent.

ARP RESPONSE: Agree. Will correct.

FR-9. Page 6, para. 1. It is incorrectly stated that PCBs and the other identified contaminants are further discussed in Technical Appendix E of the Draft Plan.

Technical Appendix E (Environmental Risk Assessment and Management Considerations for Dredging the Ashtabula River and Harbor) is focussed almost exclusively on PCBs. PAHs are addressed with respect to potential for open-water disposal. Risk associated with other contaminants present in Ashtabula River sediment is not addressed.

ARP RESPONSE: As discussed on page 2 of Appendix E, under “contaminants of concern” PCBs and to a lesser extent PAHs are the main contaminants of concern.

FR-10. Page 7, para. 3. Stage 2 of the Remedial Action Plan (RAP) is not defined.

In order to facilitate interpreting the meaning and possible implications of the RAP becoming stymied at Stage 2, the stages of a RAP should likely be defined in the Draft Plan.

ARP RESPONSE: Do not agree. Current text contains significant detail.

FR-11. Page 8, para. 3. The steps of the process should be revised to reflect that value engineering and an independent technical review will occur, prior to finalizing the Plan.

ARP RESPONSE: Current paragraph is only discussing major steps and is all-inclusive.

FR-12. Page 11, Sec. 2.1. The Initial Appraisal Report is cited but is not publicly available (i.e., included in the Administrative Record).

This document must either not be referenced in the Draft Plan or must be made available as part of the Administrative Record for the project. Potentially viable remedial alternatives (e.g., covering, which is a component of the draft recommended Plan) cannot be screened out without providing the documentation to support the screening.

ARP RESPONSE: Report returned unapproved and not available for public release.

FR-13. Page 13, para. 2. The statement that (s)ubstantial ecological and economic benefits (primarily from outflow of contaminants) could also be realized for the Outer Harbor, Lake Erie and the immediate Great Lakes area is misleading, and should be revised.

This statement is misleading, because many of the foreseen benefits will result from Habitat improvement, and not from the mass removal of contaminated sediments.

ARP RESPONSE: Do not agree. See “EIS Reference Introductory Response”18. This also is discussed and illustrated further in the main text that follows and in the EIS Appendix EA-J Section 312(b) and 206 Ecological Restoration/Preservation Analyses.

FR-14. Page 14, para. 2. The Draft Plan states that cleanup of sediment outside the Federal navigation channel may be considered if costs are economically justified. However, the benefits evaluation used to support the project is flawed.

See comments on Pages 144-187 of the FR.

ARP RESPONSE: *Assuming the above refers to sediment located outside the Federal channel and downstream of the 5th Street Bridge, this is essentially the 312(a) analysis. Benefits as defined by the Corps for such an authorization, is essentially maintenance costs avoided. The evaluation performed, documented the maintenance costs avoided associated with removing the 312(a) polluted sediments. The benefits claimed in the report for 312(a) work followed Corps guidance on calculating benefits associated with 312(a).*

FR-15. Page 14, para. 3. The draft recommended plan is justified based on the potential that future migration of contaminated sediment resulting from vessel agitation would affect future maintenance dredging. However, the potential for migration of contaminants associated with unsustainable angles of repose following implementation of the draft recommended remedy is not addressed.

Post-dredge sloughing of sideslopes represents a potential source of exposure to biota and a source of recontamination that might affect the future potential for open-lake disposal of dredged sediment. Post-dredge angles of repose are not specifically referenced. However, slopes of approximately 1V:5H are depicted in cross-sections provided by USACE. According to the Draft FR (Page 15), it is reasonable to anticipate that PCB-contaminated sediments exist in the cross sectional area between the short [1V:2H to 1V:3H] and long term [1V:6H to 1V:8H] cases, and it is fully anticipated that this sediment will slough off into the Federal channel at sometime in the near future and will impact on future disposal operations and options. Since the angle of repose proposed by the Draft Plan (as best as can be determined) is steeper than the long-term angles that can be maintained, according to the Draft Plan, this sloughing of contaminated sediment can be expected to occur following implementation of the Deep Dredge alternative. This represents a potential source of exposure to biota and a source of recontamination that might affect the future potential for open-lake disposal of dredged sediment. The Final Plan should highlight this as a potential drawback with the deep dredge scenario. It should be noted that an alternative involving dredging from bank to bank to a shallower, more uniform depth (not considered in the Draft Plan) would minimize post-dredge sloughing.

ARP RESPONSE: *See "Primary Specific Comment Response" #17. The design phase will take into account slope stability and related issues. The final design will account for the side slope issues relative to the comment and minimize them to the greatest extent possible.*

FR-16. Page 14, para. 4. The estimates of scour presented in the Draft Plan are based on questionable modeling and are thus likely to be erroneous.

This comment also applies to a statement regarding scour and migration that appears on Page FR-37 (para. 2).

Little technical documentation supporting the modeling performed by WES is presented in the Draft Plan. It appears, however, that the model made much use of data presented in the Ashtabula River Investigation (ARI) prepared by Woodward-Clyde (1993). There are a series of errors presented in the ARI report that result in apparent erroneous results from the model. The ARI incorrectly presents a 1% duration (1,616 cfs) storm event as a 1% recurrence interval (□ 12,000 cfs) event. In addition, the scour calculation results in an overestimate of the potential sediment resuspension. The results predict erosion of 24 years worth of deposition several times annually, which is intuitively incorrect. Several factors contribute to this error, including misapplication of the equation to determine shear stress, a Mannings value too high for site conditions, use of a resuspension equation without calibration to site-specific conditions, and not factoring in the effects of siltation and variable bulk densities with depth, into the calculations. These errors indicate that the magnitude of scour of the existing sediment bed during a 100-yr storm event is significantly overestimated in the FR.

ARP RESPONSE: *The model presented in the Draft Plan performed by WES was not based on data presented in the Ashtabula River Investigation. WES used the 100 -year return period flood. They used a Mannings n of 0.25 which is representative of the relatively smooth fine grained bed observed in the river. The shear stress was determined by collecting cores in the field and laboratory testing them. The model assumed a 3- layer system with different values for erosion rate constant, critical shear stress and density. The magnitude of scour appears to be reasonable.*

FR-17. Page 15, para. 2. The statement that PCBs are the contaminant of concern and are the driving contamination of concern for determining sediment suitability for open-lake disposal [downstream of the 5th Street Bridge], is inconsistent with other statements in the Draft Plan (e.g. Page 25. para. 4) which refer to PAHs as the principal contaminant of concern downstream of the 5th Street Bridge. The text should be corrected.

ARP RESPONSE: *The referenced paragraph discusses downstream transport of PCBs and is correct in context.*

FR-18. Page 16-17. No documentation is presented in the Draft Plan to support the statement that remedial technologies and components (including an in-river shear cap) were evaluated with respect to engineering and economic feasibility, and environmental and social acceptability to select ..the best overall response in meeting, the developed project planning goals and objectives. Documentation should be provided, or the text appropriately modified.

ARP RESPONSE: *See “General Comment Response” #4 and “EIS Reference Introductory Responses” 25, 2 and, 29.*

FR-19. Page 23, para. 3. The use of a threshold of 40 mg/kg (instead of 50 mg/kg) for TSCA [to] be used for the modeled data, is inappropriate for the intended purpose.

The purpose of this delineation is for appropriate disposal of sediment with PCB concentrations at, or above, 50 ppm. The FR estimates that this volume of material totals approximately 30,000 cu yd. However, it is recognized that a significant volume (at least

twice the TSCA volume) of non-TSCA sediment will be removed as a buffer as determined by the location of the TSCA sediment and the precision of available dredging equipment. Therefore, use of 50 ppm for delineation purposes is appropriate since a larger volume of buffer material will necessarily be included.

TSCA (40 CFR Part 761) states that disposing of PCB remediation waste shall be done on the basis of the concentration at which the PCBs are found. As described in the FR, GMS was used to depict the areas at which TSCA-regulated PCBs are found in the river based on the collection of a significant number of samples in 1990 and 1995.

ARP RESPONSE: Given the limitations and uncertainty associated with any modeling effort, the Ashtabula River Partnership decided that it was prudent to use the 40 mg/kg threshold to estimate areas impacted by TSCA contaminated sediment. It was also recognized that it was not possible to surgically remove the areas that contained sediments above the threshold. Consequently, cut lines approximating what could reasonably be achieved with typical dredging equipment were established in an effort to provide a more accurate estimate of the true volume of TSCA material likely to be encountered.

While less conservative assumptions could have been used in estimating the volume, the assumptions that were used were determined to be appropriate given the nature of the material, the level of information available and the feasibility study level of the report.

Ultimately, some testing could be done during the actual dredging operation to ensure that only sediment actually in excess of 50 mg/kg was disposed in the TSCA cell.

FR-20. Page 26, para. 3. The statement that discharge sources of pollutants have been remediated, is incorrect.

As stated elsewhere in the FR, no known efforts have been made to address non-point sources of pollutants, particularly PAHs downstream of the 5th Street Bridge.

ARP RESPONSE: See “General Comment Response #2”.

FR-21. Page 33-34, Figures 3-4 and 3-5. The figures comparing fish communities from the Ashtabula River and Conneaut Creek are inappropriate, and should be removed from the report.

The comparison of Ashtabula River habitat to Conneaut Creek habitat is inappropriate, and should not be included in the report. Conneaut Creek is classified as a coldwater system (Ohio EPA, 1997) which is a higher quality habitat, while the Ashtabula River is classified as a warmwater system (draft EIS, page 312(b)-28; Ohio EPA, 1997). Additionally, the Ashtabula differs from the Conneaut in that considerable boat traffic exists in the Ashtabula lacustrary (see draft EIS, page 312(b)-75).

ARP RESPONSE: Do not agree. Reference “Primary Specific Comment Responses” #8 and #9 and “EIS Reference Introductory Responses” 14 and 23.

FR-22. Page 35, para. 5. The statement that (t)he Ashtabula River fish community in areas of contaminated sediments has a high potential for recovery after sediment removal is misleading, and should be revised.

- a. This statement assumes that sediment contaminants are the limiting factor for the fish community in Area 2. This assumption is not fully supported, as other factors such as extensive recreational development and boat traffic are likely to limit the fishery in this area.
- b. As previously discussed, even if the habitat in this area is of acceptable quality, for one small area of good habitat in an area of relatively poor habitat, the fish community within that area may not reach its maximum potential.

ARP RESPONSE: See “Primary Specific Comment Response” #8.

FR-23. Page 37, para. 2. No reference is provided to support that the United States Fish and Wildlife Service (USF&WS) and other natural resource agencies oppose construction of a CDF.

ARP RESPONSE: Not a significant omission.

FR-24. Page 37, para. 2. Remedial technologies other than dredging are prematurely eliminated from consideration in the Draft Plan.

- a. The Draft Plan quickly dismisses other potentially viable remedial approaches in a referenced document (FR - page 11) entitled the Initial Appraisal Report, dated November, 1994. This remedial technology screening lacks the appropriate level of detail and as a result, has prematurely eliminated technologies that may be still applicable to the Draft Plan. In one case, the screening eliminates a remedial technology that is a key component of the recommended remedy (covering of surficial sediment). In contrast to statements made within the Draft Plan regarding the elimination of covering of surficial sediment as a remedial technology, the Draft Plan widely uses this approach within the recommended remedy (e.g. page 151). Recognizing this, and the opportunity to increase the ability of the recommended remedy to achieve the project goals, the recommended remedy can be refined during the scheduled VE and ITR tasks. The refinement would include a balancing of dredging and covering without delaying the project. To conduct such a process is consistent with the Department of the Army's own procedures for reviewing the recommended remedy for an environmental restoration project. These procedures mandate that the remedial response for a site will reduce the risk to an appropriate level and will be an effective and efficient use of the Army's environmental restoration funds (USACE, 1999).
- b. Within the Initial Appraisal Report, several remedial technologies were supposedly eliminated (document not publicly available) from further consideration that ultimately reduced the range of remedial alternatives considered in the Draft Plan to three dredging scenarios (followed by covering with cleaner sediment to a lesser degree). Other alternatives such as less dredging, less dredging followed by

covering, use of a shoreline CDF for sediment disposal, or a more widespread use of natural recovery were not evaluated in the Draft Plan with the three (primarily dredging) alternatives. Given the widespread acceptance within the Draft Plan for the covering surficial sediment as a remedial technology, the elimination of covering *per se*, within the document seems somewhat contradictory. However, within the context of refining the recommended remedy, this apparent inconsistency can be readily clarified.

- c. According to Section 3.3.2 of the FR, an alternative involving covering of Ashtabula River sediment was not favorable, given the ARP's goal of a total river clean-up and due to the impairments to navigation and future economic expansion. As stated earlier, a combination of dredging and covering of surficial sediment can achieve a goal of a river clean-up. A myopic focus on dredging as the primary remedial measure will result in an alternative that is less effective, causes unnecessary environmental impacts, and requires additional time and resources to complete. The Draft Plan does not present the technical basis to refute how a cover, if placed below the dredging depth deemed acceptable for recreational navigation, would impair navigation and future economic expansion. A cover consisting of coarse geologic materials such as sand and/or gravel at an acceptable depth would facilitate navigation and could easily be removed in the future, if deemed necessary. Additionally, this cover would be amended on an ongoing basis by newly depositing sediment.
- d. Covering of surficial sediment is a viable alternative (or alternative component) that is widely accepted by the regulatory (USEPA and USACE) and academic communities. According to the USEPA, in-situ capping is a potentially economical and effective approach for remediation of contaminated sediment. A number of sites have been remediated by in-situ capping operations worldwide (Palermo, 1998). Together with a dredging approach that recognizes the water-borne uses of the Ashtabula River upstream of the 5th Street Bridge, a covering of surface sediment following dredging could be readily implemented within the context and time-frame of the current recommended remedy. This refined remedy is more likely to meet the current project goals, minimize environmental impacts associated with dredging and require less resources and time to complete.

A representative example is USEPA's proposed plan for the Sheboygan River and Harbor Site. In the Sheboygan Harbor, PCB concentrations in sediment decrease towards the surface, similar to the distribution observed in the Ashtabula River. The proposed plan for the Sheboygan River and Harbor includes dredging of approximately 100,000 cy of sediment from the Inner Harbor to provide for navigation and placement of a 2-foot cover of clean sediment to isolate the underlying PCBs from the environment. Examples of sites where sediment covers have been applied successfully include, but are not limited to:

- Duwamish Waterway - Seattle, Washington;
- Several sites in Puget Sound, Seattle, Washington;
- Sheboygan River and Harbor, Sheboygan, Wisconsin;

- Central Long Island Sound Disposal Site (CLIS) - Long Island, New York
 - Mud Dump Site - New York Bight, New York.
- e. The covering of surface sediment as a remedial technology is summarily dismissed within the Draft Plan (Page EIS-16). Yet in both concept and application, the technology is widely embraced within the Draft Plan as an acceptable method for covering PCB-containing sediments. Given this, and the fact that dredging to accommodate current or foreseeable water-borne uses of the River upstream of the 5th Street Bridge does not require dredging to 16 to 18 feet LWD, it is prudent to examine a further refinement of the recommended remedy. This refinement would include less dredging, revised cut lines for shoreline protection and habitat enhancement, and possibly a more active covering of the surficial sediment following the dredging. Again, it is important to note that such a refinement is in agreement with the general technical approach for the recommended remedy and can be accomplished within the overall schedule of this project.

ARP RESPONSE: See “General Comment Response” #4. “EIS Reference Introductory Response” 8. *An in river capping alternative was not favorable from the perspective of the Ashtabula River RAP and ARP goal of a "total" river cleanup. The recommended Ashtabula River Partnership Plan is to be accomplished via several U.S. Army Corps of Engineers dredging authorities. Thus, dredging to remove contaminants was a primary consideration that could be implemented with Corps authority and funding. A dredging and capping plan presents considerable problems in this regard with placement of the cap in the Federal channel. The Federal channel would likely need to be deauthorized by Congress and the capping paid for by other than the Corps. Accordingly, this alternative was deleted from further consideration due to the impairments to navigation and future economic expansion.*

The ARP’s Recommended Plan consists of the Deep Dredge alternative. The CMP contains references the cover of the newly dredged surfaces with relatively clean sediments in the context specified as a complementary recovery measure follow-up to dredging not as a remedial measure. In addition to natural sediment migration and cover, the CMP specifies that dredging of clean sediment from the river channel upstream of the Upper Turning Basin (and possibly from the Outer Harbor), may be possible to complete as part of the Corps’ normal O & M program. This sediment could be deposited as cover into the Deep Dredge area for at least one cycle of the operations and maintenance dredging program. This could expedite the formation of a clean sediment cover for benthic recovery at no additional O&M cost and possibly savings.

FR-25. Page 40, 3.4.2.1, para. 2. Sediments are described as being not suitable for unrestricted open-lake disposal due to the presence of elevated inorganics including Arsenic, Barium, Cadmium, Chromium, Cyanide, Lead, Mercury, and Zinc. It is not demonstrated that natural and anthropogenic sources of these elements have

been eliminated such that future open-lake disposal can occur even if the current sediments are dredged and disposed in a landfill.

ARP RESPONSE: See “General Comment Response #2.

FR-26. Page 52, last para. According to the Draft Plan, potential risks were evaluated in the appendices Technical Appendix E - Environmental Risk Assessment and Management Considerations for Dredging the Ashtabula River and Harbor and EIS Appendix EA-C Environmental Risk Management Considerations for the Ashtabula River and Harbor.

Given that fish consumption is the primary exposure pathway at the site, these appendices should include an evaluation, which determines the potential decreases in fish concentrations under the proposed remedy options.

ARP RESPONSE: Appendix E discusses projected trends in fish tissue contamination. See “EIS Reference Introductory Responses” 18, 20, 21, 26.

FR-27. Page 55, 3.4.2.3, para. 3. It is stated that Bank-to-Bank or Deep Dredging will achieve long-term protectiveness by removing the majority of the PCB mass. Shallow dredging was described on Page 52 as removing 75 percent of the PCB mass. Apparently 82 percent is considered a majority, but 75 percent is not. There is no basis presented for this conclusion.

ARP RESPONSE: See “General Comment Response #5”.

FR-28. Page 56, Table 3.8. Table 3.8 indicates that the Shallow Dredge option will make no difference for open lake disposal, lifting the fish advisory, and long-term risk reduction while the Deep Dredge option will provide a good chance of all of these. The rationale for this assessment is unclear and should be clarified.

ARP RESPONSE: Do not agree. See Response to EIS-10 and “EIS Reference Introductory Responses” 3, 4, 5, 9, 12, 13, 14, 16, 18, 19, 20, 24, 25. This is discussed and illustrated further in the EIS Appendix EA-J Section 312(b) and 206 Ecological Restoration/Preservation Analyses.

FR-29. Page 57, 3.4.2.4, para.1. It is stated that Table 3.8 should be referred to for more detail on assessment parameters including PCB Bioaccumulation in Fish Tissue and Advisories, Water Quality (Turbidity), Benthic Habitat Chemically Restored, Benthic Habitat and Scour Protection Chemically Restored, Aquatic Shallows Initially Impacted, Ohio Habitat Assessment Procedures Biological Indices Improvements, Accomplishment of Sediment Contaminant Reduction Objective, and Accomplishment of Total Ecological Restoration Objective. These parameters are not addressed in Table 3.8.

ARP RESPONSE: The referenced paragraph of the CMP lists the above listed parameters in the context of the initial primary assessment output measures evaluated by the ARP to assess scenarios for substrate contaminant removal. Table 3-8 “Alternative Dredging Scenarios for Contaminant Removal and Ecological Restoration and Preservation” summarizes this evaluation.

- FR-30. Page 59, para. 1. The statement that following construction of the aquatic habitat shelf, the ecosystem of the Ashtabula River will experience a marked recovery with the return of extinct and sensitive species, is not supported.**

Although construction of the ecorestoration structures alone may improve species diversity/use in the River, there is no basis to state that extinct and sensitive species will return. As noted throughout the Draft Plan, there are a number of habitat stressors (e.g., heavy commercial and recreational use, periodic dredging, point/non point discharges) that will continue to influence the ecosystem following remedy implementation.

ARP RESPONSE: See "Primary Specific Comment Response" #8.

- FR-31. Page 61, Fig. 3-15. The Draft Plan should note whether the fishery shelves have been successfully installed at other projects, and whether they had an effect on fish populations.**

ARP RESPONSE: Do not agree.

- FR-32. Page 66, 3.4.5.1. The duration of the project and the size of the expected upland disposal facility is used as justification for using passive technologies. This appears to indicate that the upland disposal facility is to be used as an integral component of the passive dewatering process. This is contrary to the assumptions made in Appendices M and N and the draft Design Report (Maxim, 1999).**

The landfill design assumes that the sediments will arrive at the landfill fully dewatered and with an unconfined compressive strength of at least 10 psi. It appears as if the costs to fully dewater the sediments are not addressed, as each component assumes that another will complete the job.

ARP RESPONSE: Comment noted. The Ashtabula River sediments will be actively managed in the project dewatering facility to aid the dewatering process. This active management, which may include an underdrainage system, will assist in achieving the sediment volume reduction. The Ashtabula River sediments will be dewatered at the project dewatering facility prior to transfer to the landfill, so the time required to achieve the desired solids content will not affect the landfill operation. Specifications and requirements in this regard will be developed during the project design phase.

- FR-33. Page 69, 3.4.6.1 para.2. The potential use of an in-lake CDF was eliminated due to inherent environmental problems with the level of contamination.**

ARP RESPONSE: Agree. However, level of sediment contamination was one of several reasons why the in-lake CDF was eliminated from further consideration as a disposal option.

- FR-34. Page 80, 3.4.7. The in-lake CDF was screened out for non-TSCA sediments in this section due to considerable environmental concerns. The opposite conclusion is actually supported by the detailed assessment presented on pages 81 through 89 of the FR. Based on the cost and environmental assessment issues developed, the in-lake CDF is more cost-efficient, with environmental impacts equivalent to use of**

local existing landfills. The upland CDF is demonstrated to have the most environmental impact of the three non-TSCA disposal options. Clarification or correction is needed.

This comment also applies to a similar statement on Page 69 (Section 3.4.6.1, para. 2).

- a. As stated previously, sediments with similar levels of contamination have been placed in CDFs at other sites.
- b. The Environmental Assessment Matrix provided on pages 88 and 89 of the FR contains 20 comprehensive environmental issues that are rated as major adverse to moderately beneficial for both short-term and long-term impacts of each option. A summary of the non-TSCA disposal options is provided in the table below. Part of the summary includes a simple weighting system of -3 for major adverse to +2 for moderately beneficial.

Based on a qualitative review and this simple numerical assessment, it is clear that the preferred options based on environmental impact are the in-lake CDF and disposal at an existing landfill. The cost summary on Page 84 (that is part of the assessment) demonstrates that the in-lake CDF costs substantially less than disposal in an existing landfill and the Environmental Assessment Matrix shows that the environmental impacts of these two options are similar, suggesting the preferred alternative should be an in-lake CDF for disposal of the non-TSCA sediments.

Option	Long or Short Term Impact	Major Adverse (-3)	Moderate Adverse (-2)	Minor Adverse (-1)	Not Significant (0)	Minor Beneficial (+1)	Moderate Beneficial (+2)	Total Score
Upland CDF (Site 7)	ST	1	4	9	5	1	0	-19
	LT	0	2	8	7	0	3	-6
In-Lake CDF (Site P)	ST	0	2	9	7	2	0	-11
	LT	0	0	6	7	4	3	+4
Existing Landfill	ST	0	0	8	11	1	0	-7
	LT	0	0	3	13	1	3	+4

ARP RESPONSE: Since the draft CMP, the ARP identified an alternative upland landfill Disposal site on State Road (former RMI Sodium Plant site). The use of this site is the preferred alternative for disposal of dredged TSCA and Non-TSCA sediments with regard to environmental impacts. The State Road site supercedes all previously considered sites. Accordingly, this comment is no longer relevant.

FR-35. Page 140, Section 6.1. The document indicates that a storage cell, which can contain sediments in the event that the scows need to unload quickly... Under what circumstance would this rapid unloading occur?

For example, is this an upset conditioning or just a shortage of scows? In responding to these questions, a conceptual level materials handling plan should be included for both the solids and liquid that will be generated during the dewatering and water treatment steps.

ARP RESPONSE: Section 5.1.1.2 of the CMP “Transfer/Dewatering Component: Shoreline Norfolk Southern Site” sets forth the planning level details of the Recommended Plan for the transfer/dewatering component of the ARP Project. Obviously, any suitable design will include contingency measures to accommodate events such as the need to unload barges/scows quickly. The detailed layout and specifications of the barge/scow operation and the transfer/dewatering facility site will be completed during the design phase of the project.

FR-36. Page 140, Section 6.1. The proposed transfer/dewatering facility site is likely to have limited open space available for storage of the excavated Interim Dredging materials.

The appropriate storage location should be evaluated and presented in the Final Plan.

ARP RESPONSE: The 1993 Interim Dredging sediments have been identified as a variable that will be taken into account during the design phase of the ARP Project. It is understood that space is a consideration and accordingly design will accommodate this need.

FR-37. Page 140, Section 6.1. The proposed transfer/dewatering facility will include a storage cell which can contain sediments in the event that scows need to be unloaded quickly and returned to the dredging operation.

This statement confirms the intent to perform the dewatering in the scows barring unusual events. It also clearly states that the on-shore facilities are to be used as contingency storage facilities and are not intended to be used for dewatering the sediments to a higher degree than will occur in the scows.

ARP RESPONSE: See response to comment FR-35.

FR-38. Page 141, Section 6.2. Site 7 is described as 46-acres in this section but was only 31 acres during the HTRW evaluation (FS Appendix L, Page 3). What size is it?

ARP RESPONSE: Site 7 is no longer considered an alternative for the ARP Project.

FR-39. Page 141, Section 6.3. The Draft Plan is unclear as to the size, number of pieces of construction equipment, operating rates, operating efficiencies, etc.

Consistent with a feasibility study-level document, this needs to be clarified such that impacts to recreational boat use, estimated construction costs, and the duration of construction activities can be appropriately quantified.

ARP RESPONSE: *This information will be specified in the design phase documents.*

FR-40. Page 141, Section 6.3. It is unclear how long it will take to dewater the sediments at the sediment transfer/dewatering facility.

The text states that the sediments will be transferred to a storage cell and allowed further drying time. When the sediments meet the dewatered criteria, they will be loaded... Section 6.1 on the previous page states that the on-land facility will only be used occasionally. The transfer/ dewatering facility described in Appendix K is not designed for ongoing dewatering of sediments.

ARP RESPONSE: *During the project design phase, bench scale tests will be performed to determine extent of dewatering and to obtain design parameters for both dewatering and treatment of decant water. Specifications in this regard will be contained in the design phase documents.*

FR-41. Page 141, Section 6.3. What happens to sediments that meet the dewatering criteria at the sediment transfer/dewatering facility, yet fail the criteria at the landfill following transportation?

Have appropriate dewatering facilities been incorporated into the landfill design or will the sediment have to be transported back to the transfer/dewatering facility? What percentage of the sediments have been assumed will require additional dewatering following transportation to the landfill?

ARP RESPONSE: *The Ashtabula River sediments will be dewatered at the project dewatering facility prior to transfer to the landfill. The Ashtabula River sediments will be actively managed in the project dewatering facility to aid the dewatering process. This active management, which may include an underdrainage system, will assist in achieving the sediment volume reduction. We expect the dewatering facility to achieve a solids content of 65 to 70% (see response to comment K-6). The need for supplementary dewatering measures at the landfill site will be evaluated and addressed during the detailed project design.*

FR-42. FR Page 141, Section 6.4. The disposal of materials with PCB concentrations less than 50 ppm is not regulated under TSCA.

Therefore, the Draft Plan should be revised to reflect that all sediment with PCB concentrations less than 50 ppm that are removed, should not be treated as if TSCA disposal regulations apply. Moreover, the Draft Plan should be revised to reflect that TSCA does provide a process where all of the sediment from the Ashtabula River could be placed in a single cell that does not meet all of the requirements of TSCA, provided it is revised to reflect protection of human health and the environment. This approach was embraced by the USEPA for the New Bedford Harbor site where 450,000 cy of PCB-containing sediments with average PCB concentrations well in excess of 50 ppm are being placed in four shoreline CDFs. These CDF do not meet all the requirements of TSCA, yet have been determined to be protective by USEPA, the state and the natural resource trustees.

ARP RESPONSE: Comment noted. However, the differentiation of the TSCA and Non-TSCA sediment characteristics and regulation has been sufficiently established in the CMP and discussed during Plan Formulation. Further, as a result of alternatives consideration and the Plan Formulation process, the ARP has set forth a recommended plan for a disposal site and a conceptual landfill layout to accommodate the storage of TSCA and Non-TSCA dredged sediments.

FR-43. Page 142, Section 6.4. Since sediment in the landfill will behave more like dredged material placed within a CDF than a landfill (given the excess moisture that will likely be present), has the Draft Plan considered that 3 to 5 years of drying may be required before a cap can be placed?

ARP RESPONSE: Comment noted. The Ashtabula River sediments will be dewatered at the project dewatering facility prior to transfer to the landfill, so the time required to achieve the desired solids content will not affect the landfill operation. The Ashtabula River sediments will be actively managed in the project dewatering facility to aid the dewatering process. This active management, which may include an underdrainage system, will assist in achieving the sediment volume reduction. We expect the dewatering facility to achieve a solids content of 65 to 70% (see response to comment K-6). Specifications and requirements in this regard, will be developed further during the project detailed design phase.

FR-44. Page 148, Table 8-1 in the Draft Plan defines nine specific project benefits that are used in the cost benefit analysis. Target values have been established for each of these benefits. The biological target values are inappropriate as discussed below. The issues related to PCB mass, risk, and timing are discussed elsewhere.

- a. As previously stated, it would be more appropriate to evaluate potential restoration of the ecological community for the Ashtabula River based on Ohio EPA attainment status criteria for warmwater habitat within the Erie-Ontario Lake Plain ecoregion.
- b. The assumption that Without Dredging and Shallow Dredging assume one-third the potential improvement, Deep Dredging and Bank-to-Bank Dredging assume two-thirds the potential improvement, and Deep Dredging with Ecological Improvement assume Conneaut Creek levels or better appears arbitrary, and should be more fully explained in the report.
- c. Available data indicate that the Draft Plan target values are rarely attained anywhere along the River, including reaches that are up to 27 miles away from Lake Erie and are located in rural communities despite these reaches being classified as achieving full attainment for a Warmwater Habitat (Ohio EPA, 1997). Based on the proven inability of similar Lake Erie habitats elsewhere and the undeveloped areas of the Ashtabula River to meet the targets presented in the Draft Plan, it is surprising that nearly all of the biological target goals are listed as being attainable under the deep dredging with habitat restoration scenario in Table 8-1. In particular, some of the expected results are presented with great precision, such as 695 fish per bank km, without presentation of the detailed analysis used for a basis.

- d. The revised target criteria indicate that the without project condition listed in Table 8-1 does not reach full attainment, indicating that the remedial project is still necessary. However, all four of the dredging alternatives listed in the table achieve attainment of the revised target criteria indicating that they all can reach the biological conditions that Ohio EPA uses to demonstrate full attainment in this type of environment. The ecological restoration components proposed in the Draft Plan should still be included in the proposed remediation even though the Shallow Dredge option is shown to achieve full attainment without them. These ecological restoration components would allow the estuary to achieve its maximum potential, which would be beneficial to the community and Great Lakes environment.

ARP RESPONSE: See “Primary Specific Comment Response” #9 and “EIS Reference Introductory Responses” 14, 23 and 24.

FR-45. Page 149, last para. to 150, para. 1. The statement that (t)he environmental gains for an expenditure of nearly \$52 million in preliminary total project cost appears to be minimal for the Shallow Dredge alternative is based on what appears to be a highly subjective and possibly faulty evaluation of the alternative, and should be clarified or deleted.

- a. The evaluation of the environmental gains (e.g., fish diversity and density, and the IBI and ICI indices) is based on an over-simplified comparison of the Ashtabula River to Conneaut Creek. As previously described, this evaluation is inappropriate.
- b. As an alternative, if Ohio EPA warmwater attainment status criteria for warmwater habitat within the Erie-Ontario Lake Plain ecoregion were used as a target level, according to Table 8-1 of the report, combining the Shallow Dredge alternative with the Supplemental Ecological Restoration Plans (Table 8-2) would result in the Ashtabula River exceeding attainment status.

ARP RESPONSE: Do not agree. See “Primary Specific Comment Responses” #9 and #10. Reference EIS Appendix EA-J Section 312 (b) and 206 Ecological Restoration/Preservation Analyses. Also Reference “EIS Reference Introductory Responses” 3, 4, 5, 9, 12, 13, 14, 16, 18, 19, 20, 24, 25. This is discussed and illustrated further in the EIS Appendix EA-J Section 312(b) and 206 Ecological Restoration/Preservation Analyses.

FR-46. Page 150, para. 2. Statements that the significance of the reduction in PCB contaminated sediment is demonstrated in both increases in fish diversity and abundance, and (t)he percent of fish with external anomalies decreases and modest improvements in both the IBI and ICI indices indicate that ecosystem functions are being restored are again based on a highly subjective and faulty evaluation of the alternative, and should be deleted.

- a. Again, the evaluation of the environmental gains (e.g., fish diversity and density, and the IBI and ICI indices) is based on an over-simplified comparison of the Ashtabula River to Conneaut Creek. As previously described, this evaluation is inappropriate.

- b. The alleged improvements fail to consider other factors, such as human disturbance (e.g., boat traffic), water quality issues (low flow, increased nutrient loads) that have been reported, which may continue to affect the ecology of the Ashtabula River.

ARP RESPONSE: Do not agree. Reference EIS Appendix EA-J Section 312 (b) and 206 Ecological Restoration/Preservation Analyses. Also, see "Primary Specific Comment Responses" #9 and #10 and "EIS Reference Introductory Responses" 3, 4, 5, 9, 12, 13, 14, 16, 18, 19, 20, 23,24, 25.

- FR-47. Page 150, para. 2. The statement that fish species and diversity increase by 33 percent and 68 percent respectively under shallow dredging... and 66 percent and 137 percent respectively for the Deep Dredging alternative are again based on a highly subjective and perhaps faulty evaluation of the alternative.**

As previously stated, these projections are based on comparison to Conneaut Creek data, and do not consider more realistic attainment goals.

ARP RESPONSE: Do not agree. See "Primary Specific Comment Responses" #8 and #9 the ARP response to comment FR-46 and "EIS Reference Introductory Response" 23.

- FR-48. Page 151, paras. 4 and 5. The assumption that the invertebrate community index shows a 100 percent improvement from implementation of the Recommended Plan, and fish abundance shows over an 80 percent improvement are based on the erroneous comparison of current Ashtabula River conditions to Conneaut Creek.**

As previously described, this evaluation is inappropriate.

ARP RESPONSE: Do not agree. See response to comment FR-47.

- FR-49. Page 151, para. 7. The statement that dramatic improvements in the river environment will be brought about by removing PCB-laden sediment is unsupported and should be deleted.**

As previously described, the evaluation used to support this statement is inappropriate.

ARP RESPONSE: Do not agree. See "Primary Specific Responses" #11,#6 and #5, response to EIS-7 and 47. Reference into responses 11, 18, 19, 20, 21. This is a summary paragraph see EA-J Section 312(b) and 206 Ecological Restoration/Preservation Analyses.

- FR-50 Page 175, para. 4. No citation is provided for a feasibility report cited as the source for a 10% improvement in quality of the river as a result of remediation.**

ARP RESPONSE: The referenced "Feasibility Report" is the 1996 Ashtabula Partnership Report. The ARP determined there would be a 10% improvement in the quality of the river experience. This applied to the "Deep Dredge alternative" with Ecosystem restoration scenario. This was a partnership decision, which was used to quantify recreational impacts from environmental improvements that would take place due to plan implementation.

FR-51 Page 175, para. 5. Benefits associated with recreational navigation are not appropriately attributed to the Shallow Dredge Alternative

The shallow dredge alternative involves dredging to a minimum of -6 ft LWD to provide for adequate draft for recreational navigation. The report states that boaters will benefit from the cleaner and deeper river this project provides. Since boaters will benefit by a deeper river, it would seem that the shallow dredge alternative would inevitably provide a consumer surplus to recreational boaters.

ARP RESPONSE: Agree, there would be some benefits associated with the Shallow Dredge Alternative. However, the benefits would be less than those associated with either the Deep Dredge or the Bank-to-Bank-to-Bedrock alternatives and would not change the ranking of these alternatives.

FR-52 Page 178, para. 8.7.3.6. The risk reduction to the Lake Erie walleye fishery uses similar assumptions regarding increased value associated with benefits as those discussed above for recreational boaters and fisherman on the Ashtabula River. The same issues apply to this evaluation. Other issues are as follows:

- a. The FR states that a release of 1% to 10% of the current PCB load from the Ashtabula River would be enough to increase the level of PCBs in walleye fillets to the point where a consumption advisory would be implemented and the Lake Erie walleye fishery closed. This analysis is not cited (USFWS model? see pg. EIS-199). However, if this estimate is correct, the potential release of PCBs associated with a dredging operation should be addressed with respect to this potential impact and compared with the risk posed by the release from a flood event.
- b. The FR states that the fish advisory for the river would be lifted as a result of remedial action. However, the EIS (pg. 162) states that listing of other pollutants [in the advisory] was precautionary to keep the advisory in effect in the event that the PCB problem was corrected but other chemicals were still elevated.

ARP RESPONSE: The modeling referenced in the first part of the comment was supplemental support modeling done by USFWS, MN (Dave DeVault) for the 312(b) analyses and included in the report. This was also followed by a discussion from OEPA about the Scippo Creek clean-up and the reduction in PCB in fish for that area. As indicated in several sections of the CMP, measures will be implemented to minimize resuspension and movement of resuspended sediments from the dredging area. Expected impacts are discussed and measures will likely be further advanced during preparation of project detailed design and plans and specifications in order to satisfy OEPA water quality requirements.

As stated several times in the CMP, primary contaminants of concern and other contaminants (by co-location) are expected to be sufficiently removed from the system.

FR-53 Page 187, Section 10.0. This section of the Draft Plan should be revised to reflect the federal and non-federal funding provided in the August 1999 Amendments to WRDA.

ARP RESPONSE: Agree. CMP has been updated accordingly.

FR-54 Page 194, Section 11, para. 2. The text states that an array of alternatives for dredging and habitat restoration were evaluated. However, the process for conducting this evaluation was questionable.

Mass removal is inappropriate for use as the primary metric for determining effectiveness and protectiveness. The analysis avoids the realistic current and future uses of the Ashtabula River in terms of the water depth required, and projects a highly questionable outcome in terms of open-water disposal of future dredge spoils and ecological restoration of the River.

ARP RESPONSE: See "Primary Specific Comment Response" #16 and "EIS Referenced Introductory Responses" 18, 19 and 20.

FR-55 Page 195, Section 11, para. 2. The project volumes and costs should be revised to reflect the current base of information (August 1999).

The project costs split between federal and non-federal need to be revised to reflect the recent WRDA Amendment including increased removal volumes and an underestimate of costs.

ARP RESPONSE: Agree. The Final CMP will reflect updated costs by authority based on current legislation.

**ASHTABULA RIVER COOPERATION GROUP
COMMENTS ON THE DRAFT
ASHTABULA RIVER COMPREHENSIVE MANAGEMENT PLAN**

III. SECONDARY SPECIFIC COMMENTS (Continued)

ARP GENERAL CLARIFICATION: *The Ashtabula River Partnership Comprehensive Management Plan (CMP) is the Feasibility Report for the Ashtabula River Partnership Project. Accordingly, the following ARP Responses use "CMP" in reference to the Feasibility Report.*

ARP CMP RESPONSE REFERENCES: *The ARP has formulated responses to the BBL General Comments and Primary Specific Comments pertaining to the CMP (Feasibility Report) and the EIS. In addition, The ARP prepared an "EIS Reference Introductory Response" to address the "Secondary Specific Comments pertaining to the EIS and EIS Appendices. The following responses to the BBL Secondary Specific Comments pertaining to the CMP make reference to these prior ARP responses and are referred to based on the following categories followed by the response number.*

4. "General Comment Response"
5. "Primary Specific Comment Response"
6. "EIS Reference Introductory Response"

APPENDIX C

ASHTABULA RIVER SEDIMENT SAMPLING AND ANALYSIS OF EXTENT OF CONTAMINATION

- C-1. **Page 1. para. 3. The statement "the bathymetry of the Ashtabula River was used as the upper surface of the grid" is unclear.**

Does this imply that the sediment/water interface is the upper surface of the model, and if so, how was any change in the surface between 1990 and 1995 accommodated?

ARP RESPONSE: *The bathymetry of the Ashtabula River was used as the upper surface of the three dimensional grid that was used to represent the sediment in the river. The bathymetry was from a 1995 civil survey that was completed by Buffalo District. The bathymetric survey, and the sampling information from 1990 and 1995 were all referenced to low water datum (LWD) for Lake Erie. Consequently, although the sediment surface changed between 1990 and 1995, the relative position of the sample locations with respect to low water datum did not. For instance the depth of a sample taken at - 10 ft LWD which was covered by 6 feet of sediment in 1990 would still be -10 ft LWD even if 2 additional feet of sediment were deposited and it was now covered by 8 feet of sediment. . The ability to maintain this consistency was one of the keys to being able to do a fully three-dimensional analysis of the modeled PCB contamination in the river. Consequently, since all points were referenced to LWD, no adjustment or accommodation of the data was necessary to correct for differences in the sediment surface between 1990 and 1995.*

APPENDIX D

DREDGING SCENARIOS AND SEDIMENT “VOL. UME ESTIMA TES

- D-1. Page 3, para. 2. The removal of 696,000 cu yd of sediment (i.e., Deep Dredging Scenario) is driven by a desire to achieve a PCB concentration of 10 ppm. According to Appendix D, 10 ppm was selected as “a starting point for developing dredging scenarios,” because it would allow the development of dredging alternatives that were “sufficiently different from the bank-to-bank to bedrock to allow comparison and analysis.”**

The arbitrary decision to develop cutlines using 10 ppm (i.e., the deep dredge and shallow dredge alternatives) should not then be the basis and justification to remove 696,000 cu yd of sediment. Although acceptable as a “starting point”, the cutlines should ultimately be developed based on achievement of the ARP goals.

ARP RESPONSE: Do not agree. There were three dredging alternatives presented to the Ashtabula River Partnership. The bank-to-bank-to-bedrock dredging, shallow dredging and deep dredging. The deep dredging alternative involved removing all sediments that were modeled to exceed 10 ppm PCBs. After evaluation of the alternatives, the partnership determined that the deep dredging alternative best met the goals of the partnership when considering cost, removal of PCBs from the river system, post dredging PCB surface area weighted concentration, restoration of beneficial uses of the river and other factors.

- D-2. Page 3, paras. 3 and 4. The Appendix indicates that achievement of one of the ARP goals (future recreational use) requires dredging to a minimum depth of -6 feet LWD, yet a number of cutlines extend to 20 feet (bedrock) because of the 10 ppm “starting point” (See Comment 1).**

ARP RESPONSE: One of the ARP goals was restoration of future recreational uses by maintaining a federal channel at -6 LWD. However, there were other factors that the partnership considered, such as removal of PCBs from the river system, post dredging PCB surface area weighted concentration, restoration of other beneficial uses of the river and project cost. Ultimately, it was decided that the deep dredging alternative best met the goals of the partnership.

- D-3. Pages 4,5, and 6. There is mention that hydraulic dredging may be applied to dredge material below 19.5 feet LWD and help reduce the surface weighted average PCB concentration (SWAC).**

- a. The FS and ELS do not propose (or cost) use of hydraulic dredging. This inconsistency needs to be corrected.
- b. Dredging studies conducted at other sites has indicated that resuspended sediments with higher PCB concentrations subsequently mix and resettle within the dredged area, making it difficult to achieve low PCB cleanup levels (e.g., in the range of 10 ppm or lower) (see Attachment A). Since dependable post-removal SWAC’s cannot be estimated, and the deposition of cleaner material is ultimately responsible for goal achievement, the cutlines should not be established based on SWAC’s (see comment regarding pg. EIS-34, para. 2.30).

ARP RESPONSE: For a and b, the difficulty in completely dredging at the top of an uneven bedrock surface, as well as the resuspension inevitably associated with a mechanical dredging operation prompted the consideration of a specialty type hydraulic dredge as a final clean-up measure. As the commenter noted, it is often difficult to get to a low PCB cleanup level due to resuspension during traditional mechanical dredging operations. A specialty hydraulic dredge will resuspend less sediment and will ensure a more complete removal of sediment and associated PCB contamination. As indicated in the report, this is just an option that should be considered and the issue will be resolved as part of the final project design.

D-4. Tables 1 and 2. Consideration of other alternatives could reduce the volume removed.

Based upon the numbers given in Tables 1 and 2. for the shallow dredging alternative. "shallow" extends down to -19.5 LWD for 21% of the area. The volumetric difference between the amount computed to reach -19.5 ft and that which is needed to achieve the desired 6-ft channel depth for recreational vehicles in just this "21%" area is 220,000 cy³. If dredging were used in association with capping, dredging in this limited area could be significantly reduced and would be more likely to achieve the ARP goals.

ARP RESPONSE: There were three dredging alternatives presented to the Ashtabula River Partnership. The bank-to-bank-to-bedrock dredging, shallow dredging and deep dredging. These three alternatives presented a range of options in terms of cost, volume of sediment removed and other factors. After evaluation of the alternatives, the partnership determined that the deep dredging alternative best met the goals of the partnership when considering cost, removal of PCBs from the river system, post dredging PCB surface area weighted concentration, restoration of beneficial uses of the river and other factors. (See also "General Comment Response" #4).

APPENDIX E ENVIRONMENTAL RISK ASSESSMENT

E-1 Appendix E is virtually identical to Appendix EA-C of the EIS. See comments regarding EIS Appendix EA-C.

ARP RESPONSE: See "Primary Specific Comment Response" #11.

APPENDIX G DREDGING ALTERNATIVES AND SELECTION

ARP GENERAL RESPONSE: Appendix G, Dredging Alternatives and Selection, and Appendix H, Sediment Dewatering Alternatives and Selection, were prepared as screening level documents, intended to present the various dredging and dewatering technologies, evaluate and screen these technologies, and select feasible alternatives for dredging and dewatering operations. These appendices were not intended to be, and are not, design phase documents.

Specific project design details will be determined later in the project. It would be inappropriate to dictate project specifics, such as dredge type and dewatering details, at this time. Remedial action contractors should be left with some flexibility so that they are able to use their experience and knowledge to best achieve the project goals.

- G-1. Page 25. para. 2. The appendix should be revised to reflect that silt curtains or other environmental controls will be used during the project, not that they “may” be used.

Environmental controls including, but not limited to, silt curtains will be necessary to reduce potential impacts on surrounding water quality and recontamination of surrounding sediment.

ARP RESPONSE: Agree. However, the CMP (not Appendix G) will be revised to include discussion of environmental control alternatives that will be used, if necessary to reduce the environmental impacts of dredging on surrounding water quality and recontamination of surrounding sediment. The specific array of environmental control measures for the ARP Project will be determined during detailed design phase.

- G-2. Page 37. para. 2. The use of water quality controls, dredge operation controls and/or environmental controls is suggested. The potential impacts on production, schedule and cost should be accounted for in the Final Plan.

ARP RESPONSE: Comment noted. Anticipated dredging rates are discussed in Appendix G based upon the assumption that 696,000 cubic yards of sediment would be dredged over a three year period. The potential impacts of environmental controls on these project components will be considered during the detailed design phase of the ARP Project.

- G-3. Page 37, para. 3. The text suggests that “overdredging” (i.e., additional sediment volume) will be necessary to achieve the effectiveness that the specialty dredge (screened out in this Appendix) would otherwise achieve.

How does this affect the current sediment removal volume of 696,000 cu yd? The final plan should indicate whether this additional volume is included in the 696,000 cubic yard estimate.

ARP RESPONSE: Comment noted. The point being made in this portion of Appendix G is that normally there is less vertical control associated with mechanical dredging operations than there is with specialty dredges. It may be necessary to overdredge to insure that the desired cleanup level is achieved. Using specialized equipment to better control the dredging depth may reduce the amount of overdredging necessary to achieve the desired cleanup level. This equipment may include specialized dredge buckets, cameras, Global Positioning System (GPS) equipment, pressure transducers, sonar, etc. The 696,000 cu yd estimate includes the estimated overdredged volume of sediment.

APPENDIX H

SEDIMENT DEWATERING ALTERNATIVES AND SELECTION

- H-I. Page 1, para. 3. It is stated that “although several of the dewatering methods are very effective in removing water, the solids often are not sufficiently dry to meet requirements for final disposal, and require further treatment to fixate or solidify the material.”

The ARCG agrees and notes that existing data indicates that this statement applies to sediments from the Ashtabula River. See comment regarding FR Appendix K.

ARP RESPONSE: Comment noted. The dredged Ashtabula River sediments will be dewatered at the project dewatering facility prior to transfer to the landfill. The dewatering facility will be located at the sediment transfer facility. It is not anticipated that any additive will be added to the Ashtabula River sediment to fixate or solidify the material. Specifications and requirements in this regard will be developed during the project design phase.

H-2. Page 2, 2.0. About 50 percent solids is noted to be typical for fine grained sediments such as the Ashtabula River sediments. It is expected that mechanically dredged sediment will have a similar solids content to the in-situ condition.

Review of site-specific information (Woodward-Clyde, 1993) indicates that a reasonable in-situ solids content would be about 55 percent.

ARP RESPONSE: Comment noted. There is little statistical difference between "about 50 percent" and "about 55 percent". Modification of Appendix H is not necessary based on this comment.

H-3. Page 4, 2.0. It is stated that mechanically dredged sediment may not have volume reduction equal to the volume of water drained because air may replace the water. It is noted that some dewatering technologies may increase the volume.

Despite these observations, a 30 percent reduction in volume after dewatering is consistently assumed throughout the Draft Plan.

ARP RESPONSE: Comment noted. The dredged Ashtabula River sediment will be dewatered at the project dewatering facility prior to transfer to the landfill. The dewatering facility will be located at the sediment transfer facility for the project. It is not anticipated that any additive will be added to the Ashtabula River sediment to fixate or solidify the material. Therefore, there should not be an increase in the volume of material. A 30 percent reduction is approximately consistent with previous calculations concerning Ashtabula River sediment.

H-4. Pages 4-7, 2.1. This section focuses on passive dewatering techniques used during operation of a CDF. These techniques are designed to be effective over an extended period of time.

They are not applicable to this project because the landfill design (FR Appendix N) assumes that the sediments are already fully dewatered prior to landfilling and that the landfill will not be operated as a CDF.

ARP RESPONSE: Comment noted. The dredged Ashtabula River sediments will be dewatered at the project dewatering facility prior to transfer to the landfill. The dewatering facility will be located at the sediment transfer facility.

H-5. Page 5, 2.1.3. para. I. It is noted that mechanical dredging releases limited free water for ponding. It is also noted that ponding occurs due to heavy rain.

The implications on material placement and landfill closure used to be considered.

ARP RESPONSE: Comment noted. Ponding of free water or water due to heavy rain during transfer/dewatering operations will be addressed during the detailed design phase for the ARP project. The dredged Ashtabula River sediments will be dewatered at the project transfer/dewatering facility prior to transfer to the landfill. The transfer/dewatering facility will be located at the sediment transfer facility. Specifications and requirements in this regard will be developed during the project design phase.

H-6. Page 6, 2.1.3. para. 4. Drying time using surface drainage techniques is noted to take months to years.

This is consistent with similar experience at Ashtabula (BBL, 1999). This is inconsistent with the assumption throughout the Draft Plan that a 30 percent reduction will occur with 24-hours of passive dewatering.

ARP RESPONSE: Comment noted. The Ashtabula River sediments will be actively managed in the project dewatering facility to aid the dewatering process. This active management, which may include an underdrainage system, will assist in achieving the sediment volume reduction. As noted above, the Ashtabula River sediments will be dewatered at the project dewatering facility prior to transfer to the landfill, so the time required to achieve the desired solids content will not affect the landfill operation. Specifications and requirements in this regard will be developed during the project design phase.

H-7. Pages 7-10, 2.2. This section described mechanical dewatering techniques. It is stated that they can achieve 70 percent solids content, but most techniques increase the solids content to levels comparable to the in-situ condition, typically about 50 percent solids.

A belt filter press test on Ashtabula River sediments is reported to achieve 50 to 60 percent solids content with a throughput of 25 tons per hour. These site specific mechanical dewatering test results are substantially less than the 70 percent solids content assumed to be achievable throughout the Draft Plan.

ARP RESPONSE: Comment noted. The inability of mechanical dewatering equipment to achieve the desired solids content is one reason mechanical dewatering was not proposed for the Ashtabula River sediments.

H-8. Pages 18-19. It is assumed that the Paint Filter Test needs to be passed in order to be landfilled and that this test would be passed at a solids content of 60 to 70 percent for the Ashtabula River sediments.

Appendix N and the draft Design Report require an undrained compressive test of 10 psi and a solids content of 70 percent in order to have sufficient strength and capacity for the proposed landfill. Appendix H in the final Plan should be updated to include these requirements.

ARP RESPONSE: Comment noted. Appendix H is discussing dewatering operations and the anticipated solids content, 60 to 70 percent, required to pass the Paint Filter Liquids Test and

allow for landfill disposal. Appendix H is not intended to present project geotechnical requirements. These requirements are presented in the Geotechnical Engineering appendix and the Landfill Design appendix.

H-9. Pages 18-19. It is concluded that the use of several different passive dewatering techniques over several months would match the solids content achievable with mechanical dewatering equipment. Free water is expected to pond on the surface of the sediments.

This will require that the landfill be operated as a CDF. It is currently designed to be operated as a conventional landfill with normal earthmoving equipment. The assumptions regarding the landfilled sediment conditions and operational requirements need to be evaluated and made consistent in the Final Plan. At present, it appears that the actual procedure and cost of dewatering to 70 percent solids content has not been addressed in the Draft Plan.

ARP RESPONSE: Comment noted. Specifications and requirements in this regard will be developed during the project design phase. The project landfill will not need to be operated as a CDF. Ponding of water due to heavy rain during dewatering operations will not be an issue for the landfill operation. The dredged Ashtabula River sediments will be dewatered at the project dewatering facility prior to transfer to the landfill. The dewatering facility will be located at the sediment transfer facility. Specifications and requirements in this regard will be developed during the project design phase.

H-10. Page 20, para. 2. The use of a belt filter press is eliminated from consideration due to time and expense. Costs of \$16 to \$55 per cubic yard for a 40 percent solids feed stock are cited based on experience from several sites.

Effectiveness of the various methods does not appear to have been considered. Alternate techniques to achieve the specified results are not proposed nor have costs been estimated and included.

ARP RESPONSE: Comment noted. This appendix was intended to be a feasibility level planning document prepared based upon available information. In addition to the belt filter press, other mechanical dewatering technologies, as well as passive dewatering technologies, were considered. The belt filter press, and other mechanical dewatering technologies, were not considered feasible for technical reasons, such as production capacity, ability to handle dredged sediment, ability to achieve the required solids content, etc.

H-11. Page 21, para. 2. The conclusion that the use of surface trenching, evaporation, underdrainage, and possibly vacuum assisted underdrainage will be used at the upland disposal facility to accomplish the dewatering through passive means is inconsistent with the facility design presented in Appendix N and the draft Design Report.

ARP RESPONSE: Agree. The dredged Ashtabula River sediments will be dewatered at the project transfer/dewatering facility prior to transfer to the landfill. The dewatering facility will be located at the sediment transfer facility. An underdrainage system will be considered and included at the dewatering facility if bench scale tests indicate this is necessary and practical. Specifications and requirements in this regard will be developed during the project design phase.

- H-12. Page 22, para. 2. The summarized recommendation is that the upland disposal facility be used for dewatering using several passive dewatering techniques despite the large area and long dewatering time that is required is not consistent with the Draft Plan.**

The Draft Plan assumes that all dewatering will be done by gravity alone in scows on the river and that sediments achieving a solids content of 70 percent and an unconfined compressive strength of 10 psi will be delivered to the upland disposal facility.

ARP RESPONSE: Comment noted. The Corps of Engineers recognizes that a solids content of 70 percent and an undrained compressive strength of 10 psi are probably not achievable using settling in the dredge scow. This is why a temporary storage area for dewatering has been included in the project. The dredged Ashtabula River sediments will be dewatered at the project transfer/dewatering facility prior to transfer to the landfill. The dewatering facility will be located at the sediment transfer facility. River sediments will not be dewatered at the landfill or in scows on the river. Specifications and requirements in this regard will be developed during the project design phase.

- H-13. Page 22, para. 3. It is recommended that the sediments be dewatered passively, “regardless of whether the sediments are dredged mechanically or hydraulically.”**

It is unclear why hydraulic dredging is considered, after screening it out in Appendix G (page 38). The dewatering techniques proposed in the Draft Plan could not accommodate the large volumes of water that would be generated with hydraulically dredged sediment. The reference to hydraulic dredging should be reconciled.

ARP RESPONSE: Agree. However, this statement is not proposing hydraulic dredging of the Ashtabula River sediments. The statement is simply saying that passive dewatering techniques could also be applied to hydraulically dredged sediments under certain conditions.

- H-14. Page 22, para. 3. The statement that “... the expected upland disposal facility size should be sufficient to achieve dewatering using passive technologies” is contrary to the Draft Plan, which assumes that dewatering is to occur prior to placement.**

This text should be clarified in the Final Plan.

ARP RESPONSE: Agree. The dredged Ashtabula River sediments will be dewatered at the project shoreline transfer/dewatering facility prior to transfer to the landfill.

APPENDIX I ENVIRONMENTAL MONITORING

- I-1. Page 3, Section 3.0. The statement that water generated from “... sediment dewatering operations, leachate collection, surface water runoff, etc will be treated to meet effluent discharge limits. At a minimum PCB, oil, and grease, and TSS discharge limits will be established and monitored for the project” is inconsistent with the Draft Plan, which assumes discharge of 50-100 mg/L of TSS.**

This text indicates that monitoring of these parameters during pre-, during- and post-

project conditions will result in a large complex monitoring program that has yet to be accounted for within the cost estimate. This inconsistency should be corrected, and the cost estimate adjusted accordingly.

ARP RESPONSE: *Comment noted. The level of environmental monitoring discussed in various portions of this document will be further addressed for the project during the design phase.*

I-2. Page 3, Section 3.0. The document discusses action levels for dredging-related release to surface water, the water treatment system and ambient air monitoring.

ARP RESPONSE: *Comment noted. Details of the required environmental monitoring, including action levels, will be determined during discussions with the regulating agencies, PRPs, and PRP contractors, during the design phase of this project.*

I-3. Page 11, Section 4.0. A component of the post-dredge monitoring program is to determine “whether or not the target cleanup goal has been met.” Appendix I suggests that the target cleanup goal will be defined by a comparison of pre- and post-bathymetric surveys (i.e., when pre-defined dredging depths are achieved).

This should be clarified in the Final Plan.

ARP RESPONSE: *Comment noted. As stated above, details of the required environmental monitoring will be determined during discussions with the regulating agencies, PRPs, and PRP contractors, during the design phase of this project. This environmental monitoring would include, but may not be limited to, pre-dredge and post-dredge bathymetric surveys, though these types of surveys have been required for some environmental dredging projects in the past.*

APPENDIX J

SCREENING OF TREATMENT TECHNOLOGIES AND COST COMPARISON OF POTENTIALLY FEASIBLE ALTERNATIVES

J-1. Page 7, Section 5.1. Based on treatment technology assessments conducted at other sites, the cost of treating the wet sediment dredged from the Ashtabula River will be significantly higher than the estimates presented in this section of the document.

At the New Bedford Harbor site for both technologies (USEPA, 1997), USEPA’s estimate for thermal desorption of \$5 13/ton is a factor of 2 to 3 higher than estimated by USEPA for the Ashtabula River.

ARP RESPONSE: *It is suspected that thermal desorption cost could be higher than the amount in appendix J, but this is not considered in the CMP.*

J-2. Page 7, Section 5.2. While the appendix reaches the appropriate conclusion that permanent containment in an appropriate facility is more cost effective than treatment, the conclusion that TSCA regulated sediments would “likely not receive regulatory approval” is not supported by regulatory precedent.

For example, the majority of the 450,000 of PCB-containing sediment that will be dredged at the New Bedford Harbor Site and placed in four shoreline CDFs contain PCBs at concentrations exceeding 50 ppm.

ARP RESPONSE: *The recommended plan for disposal is an upland landfill. Accordingly, this comment, although informative, has no bearing on the ARP project.*

APPENDIX K DEWATERING FACILITY

K-1. Cover Sheet. A 1984 design document is used for this feasibility study.

This appendix should have been revised to account for cost inflation, a revised schedule, the use of a dedicated landfill, technical differences in the dredging program, revised water quality criteria, and new data available for the site.

ARP RESPONSE: *It is beyond the scope and resources of the CMP to update and revise historical documents, such as price levels, costs and benefits that contributed to the Plan Formulation process. However, limited updates have been made to Appendix K to reflect current, year 2000, conceptual design, location, treatment requirements (i.e., activated carbon treatment), and treatment standards (e.g. 1ug/l PCB in discharge water).*

Plan Formulation for this project is complete, and was an iterative process that took place over a five-year period from 1991 through 1996. Plan Formulation had its own cost and benefit evaluation matrix that was comprised of a number of different price levels and interest rate bases, which were consistent within themselves. Accordingly, the costs and benefits presented in the text, tables and figures in Plan Formulation in this report reflect the information used at that point in the analysis.

K-2. Page 1, para. 4(c). The dewatering strength requirements for disposal of wet sediment materials in a facility with mixed waste may be different than in a dedicated landfill.

Disposal of the dewatered materials in a landfill with other waste streams may allow for a lower strength material with a higher water content to be placed in the landfill. This is because the other wastes may have higher permeabilities and lower water contents and can absorb water from the sediments. This could hasten the final dewatering stage in the landfill.

ARP RESPONSE: *Since the facility to be designed / constructed must be dedicated to toxic and highly contaminated sediments, a mixed waste facility is not practical.*

K-3. Page 2, para. 2.a.(2). The location shown on Plate 2 and the subsequent site description under 2.b. describes the Minnesota Slip location, which the ARCG understands to be unavailable.

As outlined in this section, the proposed location of the dewatering facility is on the east side of the Minnesota Slip. However, according to the Draft FR (Page90), a dewatering facility is to be constructed at the site of the Interim CDF, which is located adjacent to the Conrail Slip on the east bank of the river. On page 105. the Draft FR suggests that the dewatering facility will be constructed “somewhere”

along the river. Later in the document, the FR contradicts itself and suggests that the dewatering facility is to be located near the harbor region (Page 140). Conrail Slip is located near the Ashtabula River. However, the siting of the dewatering facility adjacent to the Conrail Slip was also corroborated in Appendix P (Page3).

The siting of the dewatering facility is important as the design presented in Appendix K and reprinted in the Draft FR (Pages 95-96) is based on site conditions and subsurface properties expected at the Minnesota Slip. Expected site conditions at the location of Minnesota Slip are described on page 2, Section 2 (b) of Appendix K. Therefore, the dewatering facility will have to be redesigned to reflect actual site conditions at the Interim CDF near Conrail's Slip. This will also require a geotechnical investigation to characterize subsurface conditions.

ARP RESPONSE: *Agree. Since current plans are to now locate the dewatering facility at the Norfolk Southern (formerly) Conrail site, all specific references and design considerations specific to the Minnesota slip site have been removed from the CMP and Appendix K. General conceptual design elements have been retained. Detailed design factors specific to the Norfolk Southern site will be addressed in the design phase documentation.*

K-4. Page 3, para. 2.c. The stated function of the facility is to be a staging area for transfer of dredged material from scows to haul trucks, not a dewatering facility.

The staging area is to allow direct transfer of dredged material from scows to haul trucks or to a temporary storage facility. The so called dewatering facility as described in Appendix K and reprinted on pages 95 and 96 of the FR is actually intended as a temporary holding facility to allow continuous transfer and hauling of dredged materials. As such the design of the temporary storage facility does not include under drainage and is not compatible for possible use of dewatering techniques such as gravity dewatering (other than by settling) or vacuum under drainage.

ARP RESPONSE: *We recognize that the temporary holding facility may need underdrainage to maximize dewatering before hauling sediment to the landfill. The specifications of underdrainage will be evaluated during the design phase and incorporated into the final design if necessary.*

K-5. Page 4, para. 2.d. The objectives of the “dewatering” facility are to remove excess water from the scows introduced during dredging, pumping the supernatant from the scows to settling basins, and treating the effluent to a standard of 50 mg/l of suspended solids. No dewatering other than in the scows is proposed.

Sediments removed from the scows are proposed to be placed directly into haul trucks or placed in a temporary storage facility until haul trucks are available. All of the dewatering is proposed to occur in the scows over a period of 24 hours or less. Based on the high expectations of the dewatering, it is unclear if this is all that is proposed.

ARP RESPONSE: *We recognize that sufficient dewatering in a scow may not occur and have included the temporary storage facility as a probable option. During the project design phase, bench scale tests will be performed to determine extent of dewatering in either facility and to obtain design parameters for both dewatering and treatment of decant water. It should be noted that current plans (Year 2000) call for a reduction of the dredging rate from 4000 cu yds per day to 1600 cu yds. per day. This will allow for further settling time in a temporary dewatering facility Dredging would only be done for 10 hrs. per day six days per week over a 8 month (April – December) period per year for three years.*

K-6. Page 4, para. 2.d.(1). The first objective of the dewatering facility is to remove the excess water so that the dredged material will have a water content similar to the in-situ sediment. This contradicts the assumption of significantly decreased water contents and volumes included in the Draft FR, Appendices H and N, and the Draft Design Report.

The proposed “dewatering” facility is not designed to reduce the water content significantly below the in-situ water contents.

It has been assumed in the Draft Plan that following gravity dewatering, the sediment volume to be disposed would be 30 % less than the estimated in-place volume. Appendix H to the Draft FR (Page20) eliminates the potential use of any mechanically aided drainage due to cost and delays, except for potentially using surface trenching or vacuum assisted underdrainage. However, the pilot studies on site specific sediments that demonstrate that a belt filter press and gravity dewatering have been unable to achieve better than a 65 percent solids indicate that the prospects of achieving the assumed solids content of 70 percent using gravity dewatering are remote. Based on the available information, ...cost estimates for the project should be prepared using the assumption that the dewatered sediment volume will be approximately equal to the predredging in-situ volume. This will require the estimated disposal volumes currently being contemplated in the Draft Plan to be about 30 percent.

Two site-specific dewatering studies have been performed on Ashtabula River sediments. The first was performed in 1986, and as reported in Appendix H of the Draft FR, the belt filter press pilot study was only able to achieve a solids content of 50 to 60 percent. The second was performed in 1999 (BBL, 1999) and demonstrated that gravity dewatering with underdrainage was only able to achieve a solids content of 60 to 65 percent. It should be noted that neither the scow nor the dewatering facility described in Appendix K appear to have provisions for underdrains.

The geotechnical characteristics of the samples in the 1999 study, similar to the median characteristics reported in the RI of the Ashtabula River sediments which have a median in-situ water content of 65 percent, indicated that gravity dewatering is most likely to approach or reach the in-situ solids content but is unlikely to be significantly higher. Some of the sediments have relatively high organic and clay contents with associated very high water contents. As a result, the average solids content of the in-situ sediments is about 55 percent, compared to the median of 65 percent. Since it appears that gravity dewatering is only able to approach the original in-situ solids contents, the average dewatered solids content should be expected to be about 55 percent, which is within the range of the results reported from the 1986 belt filter press pilot study.

Sediment that was dredged in May 1999 and stored at the Ashtabula Yacht Club was also tested in August 1999 (BBL, 1999). These sediments had been exposed to four months of drying under drought conditions but only achieved internal solids contents of 65 percent or less. These results indicate that surface trenching and drying as recommended in Appendix H of the Draft FR (Page2 1) would be ineffective at significantly improving the geotechnical characteristics of the landfilled materials in the short time frame (days or weeks) that sediments would be exposed to the atmosphere in the dewatering facility or the landfill.

Reliance on atmospheric drying implies that the operations will be heavily weather dependent. However, there do not appear to be significant allowances made for down time due to weather. The schedule could increase by one to two years if there is significant inclement weather during the six-month construction season. It should be noted that June through September historically have the highest average precipitation

during the year in Ashtabula. The four months of May *through* August are the only *months* with net evaporation during the year as reported in Appendix M, Table M-4. The net evaporation of water during these months is only 4.5 inches. Considering that a season's worth of dredging will probably result in a 10 to 15 feet increase in thickness of sediments in the landfill, 4.5 inches of net evaporation will be unlikely to change the solids content by a measurable amount. In two of the proposed landfilling months there would actually be a net increase in water content due to net precipitation which could cause construction delays in those months.

Appendix H of the Draft FR (Page 7) suggests that gravity dewatering can be enhanced using vacuum underdrainage. This would be more practical if the sediments are placed in a relatively thin layer, such as in the dewatering facility. However, the dewatering facility design provided in Appendix K does not appear to have provisions for underdrainage by gravity, and therefore would be difficult to retrofit for vacuum underdrainage as well. Additionally, sediment dewatered by vacuum is expected to have a higher resultant water content than what could be achieved with a belt filter press.

ARP RESPONSE: *As discussed previously, we recognize that under drainage will probably be required to achieve solids content above in-situ (i.e., ~55 %) We estimate to achieve 65 to 70 % solids or at least a solids content to pass the paint filter test. Final design will be predicated on solids content that can be achieved in bench scale testing. BBL cites a 1999 study in which sediments were high in both organic content and clay, which greatly impede dewatering . The Buffalo District has sampled Ashtabula River sediments numerous times over the last 15 years and mechanical analyses showed the sediments to consist primarily of silts and fine sands with minor amounts of clay and organic matter. Perhaps the BBL study was conducted on Fields brook sediments. We expect more efficient dewatering of Ashtabula River sediments.*

K-7. Page 5, 2.d.(3). It is stated that transferring the materials at the transfer facility could allow for release of dredged materials back into the river, which would not be protective.

Discharges from the transferring process could recontaminate already dredged sediment surfaces if it occurs on the River.

ARP RESPONSE: *The transfer facility and operations will be designed so as to collect and treat all runoff. Runoff is expected to be de minimus and will not recontaminate sediments in the river.*

K-8. Page 5, 3.b.(2). The truck trips in Appendix K appear to be based on 4,000 cy per day.

The truck traffic numbers should be recalculated to reflect the lower dredging rate proposed elsewhere in the Draft Plan (e.g., draft EIS, Page 18 says 1,611 cy per day).

ARP RESPONSE: *Agree. The truck traffic in Appendix K was based on 4000 cyds. per day The Appendix has been revised state that if dredging is reduced to ~1600 cyds. per day truck traffic would be reduced from ~70 to 100 per day depending on settling time and truck size.*

K-9. Page 9, 5.c.(2). The storage facility is designed to have a slope of 6 feet in 140 feet (4%) based on the expected maximum slope expected of the dredged materials clammed into the temporary storage facility.

This should be used as an indicator in Appendix N of the maximum slope that can be expected of the sediments during and immediately after landfilling.

ARP RESPONSE: *The specifications in this regard will be evaluated and specified during the project design phase.*

K-10. Page 9, 5.c.(4-5). The only drainage provided in the temporary holding facility is a drainage pipe around the perimeter.

This does not allow for efficient gravity dewatering. It also does not allow for significant use of vacuum enhanced underdrainage.

ARP RESPONSE: *The project component designs presented in the Technical Appendices and the CMP are “typical” conceptual designs illustrative of layouts and design concepts that will be evaluated and specified in the detailed design phase of the project. Accordingly, under drainage and enhanced vacuum drainage will be considered in detailed design as well as longer retention time in a temporary dewatering facility.*

K-11. Page 15, 9.c. It is unclear whether the use of an allowance of 1 foot over the proposed depth to account for equipment inaccuracy has been carried over into the Draft Plan as part of the 696,000 cy.

It appears to be included on page EIS-38, but is not described in the Draft FR. Clarification is necessary in the Final Plan.

ARP RESPONSE: *Agree. Will change*

K-12. Page 15-17. The duration, costs, and benefits should be updated from the 1984 proposal to be consistent with the details provided elsewhere in the Draft Plan.

ARP RESPONSE: *It is beyond the scope and resources of the CMP to update and revise historical documents, such as price levels, costs and benefits that contributed to the Plan Formulation process. However, limited updates have been made to Appendix K to reflect current, year 2000, conceptual design, location, treatment requirements (i.e., activated carbon treatment), and treatment standards (e.g. 1ug/l PCB in discharge water).*

Plan Formulation for this project is complete, and was an iterative process that took place over a five-year period from 1991 through 1996. Plan Formulation had its own cost and benefit evaluation matrix that was comprised of a number of different price levels and interest rate bases, which were consistent within themselves. Accordingly, the costs and benefits presented in the text, tables and figures of Plan Formulation in this report reflect the information used at that point in the analysis.

APPENDIX L

HTRW EVALUATION OF POTENTIAL LANDFILL

L-1. Page 1, para. 3. The volume of dredged sediment is assumed to be 1,200,000 cy. This is inconsistent with the volume of 696,000 cy generally presented in the Draft Plan.

ARP RESPONSE: *The 696,000 cy presented in the Draft Plan is for the Deep Dredging alternative. The 1,200,000 cy volume presented in the above referenced paragraph of Appendix L is for the Bank to Bank dredging alternative. After evaluation of the alternatives, the partnership determined that the deep dredging scenario best met the goals of the*

partnership.

L-2. Page 1, para. 3. A land size of 50 acres is envisioned, yet both sites evaluated in detail were listed as smaller than 35 acres.

The increase in disposal volume described previously may render the considered sites unsuitable due to lack of space.

ARP RESPONSE: *The estimated land size of 50 acres was for alternative disposal sites No.5 and No.7, which have been eliminated for consideration as possible locations for the proposed landfill. These sites required 50 acres in order to construct water retention ponds and access roads in order to minimize impacts to designated wetland areas. The new State Road site will not require these water retention ponds. This site has about 33 acres to construct the landfill containment cells, which should provide sufficient area to construct these cells.*

APPENDIX M GEOTECHNICAL ENGINEERING

M-1. Page M4, Figure M5. The seismic risk map is out of date as they date back to the early 1970's.

In 1990, USGS provides a revised peak acceleration with a 90 percent probability of not being exceeded in 250 years on Map MF-2 20

Map MF-2 120 was explicitly used to define the location of seismic impact zones in the 1993 USEPA Subtitle D revisions. Subsequently, USGS has reevaluated the peak accelerations in a new series of maps (Open File Report 97-13 1). One of the maps provides a peak acceleration with a 2 percent probability of being exceeded in 50 years which is approximately equivalent to the 1990 mapping.

The 1997 map indicates that the site would not fall within a seismic impact zone (although the 1990 map would). This mapping should be discussed with the regulatory agencies to see if seismicity needs to be considered at all.

Even if seismicity is considered, the US Army Corps of Engineers Waterways Experimental Station developed a modified pseudo- static approach in 1984 that allows half of the peak acceleration to be used in a pseudo-static analysis and only requires that a factor of safety of 1 .0 met before additional evaluations are required. This method is presented in the USEPA RCRA Subtitle D (258) Seismic Design Guidance for Municipal Solid Waste Landfill Facilities (EPA/600/R-95/051) published in 1995. We suggest that this approach be used in future analyses.

ARP RESPONSE: *Agree. The appropriate regulatory requirements will be used in future analysis during the design phase.*

M-2. Page Mb. The conceptual layout of the disposal facility has been superseded by the draft design prepared by Maxim (1999).

The revised layout should be used as the basis for analysis presented in Appendix M.

ARP RESPONSE: *The conceptual layout proposed by Maxim is for Site No.7. Site No. 7 has been eliminated from further consideration due to impacts to the wetlands. A new conceptual layout will be developed by Buffalo District COE for the new State Road Site.*

M-3. Page M10. The total area of the disposal facility and associated structures and facilities is given as 46 acres.

Both Site 5 and Site 7 are listed as less than 35 acres in Appendix L. It appears that there is insufficient space for the facilities envisioned in the Draft Plan.

ARP RESPONSE: The estimated land size of 50 acres was for Alternative disposal sites No.5 and No.7, which have been eliminated as possible locations for the proposed landfill. These sites required 50 acres in order to construct water retention ponds and access roads in order to minimize impacts to designated wetland areas. The new State Road site (former RMI Sodium Plant site) will not require these water retention ponds. This site has about 33 acres to construct the landfill containment cells, which should provide sufficient area to construct these cells.

M-4. Page M14, M3.1 (b) (2). Material properties assumed for the dredged material may not be representative.

The undrained strengths assumed were based on dredged material at Cleveland Dike 14 and Toledo disposal sites. Vane shear tests from the recent dewatering study (BBL, 1999) indicate that shear strengths of less than 100 psf should generally be expected for the as-delivered condition. The amount of strength gain that will be achieved over time is uncertain. Based on the Woodward-Clyde 1993 data, it appears that much of the sediments are likely to be organic silts. Therefore the parameters may not match those assumed for soft clays.

ARP RESPONSE: Agree. During the detailed design phase for this project the ARP will review the Woodward-Clyde data and select appropriate material types and design parameters for the dredge fill.

M-5. Page M18, M3.2(b), para. 2-3. It is assumed that the sediments will be dewatered from a solids content of 50 percent to 70 percent in an off-site dewatering facility.

Appendix H assumes that most dewatering will occur in the CDF (Landfill). If the staging facility is designed to remove only the excess water entrained during dredging, as described in Appendix K, the delivered solids content should be assumed to be the original in-situ solids content. The average solids content in the sediments tested by Woodward-Clyde is 55 percent. This would be a reasonable assumption for the solids content of the dewatered sediment (see Comment K-6).

ARP RESPONSE: In response to comment K-6, we expect the dewatering facility to achieve a solids content of 65 to 70%. In reviewing our data on the sediments in the river Atterberg Limits show that this material consists primarily of low plasticity silts (ML,OL) and sand. Maxim also looked at this data and found that the average in-situ solids content is 61%.

M-6. Page M18, M3.2(b), para. 4. It is assumed that no settling and self-weight consolidation will occur in the facility assuming materials are trucked in.

The staging facility described in Appendix K is designed to remove only the excess water entrained during dredging so settling and self-weight consolidation should be expected during filling with the associated fluid flows that will need to be handled.

ARP RESPONSE: See response to comment K-6. It is expected that the sediments in the dewatering facility will achieve a solids contents of 65 to 70%. In this case settling and self weight consolidation would occur in the dewatering facility. If this solids content cannot be achieved as you allude to in comment K-6, then your premise would be correct that settling and self weight consolidation should be expected during filling.

M-7. Page M20. The void ratio vs. permeability graph indicates that permeabilities of 1×10^5 to 1×10^6 ft/mm should be expected for the dredged materials in the landfill. These are relatively low permeabilities, which will cause slow drainage as the sediments consolidate.

The ability of the sediments to drain water downward to the leachate collection layer within the construction time frame should be evaluated carefully. If the sediments cannot drain sufficiently during this time frame then the shear strength of the sediments will be less than assumed in the Draft Plan and Draft Design Report.

ARP RESPONSE: A computer model (PCDDF90) was used to estimate the sediment time rate of consolidation. This data will be used during the design phase to estimate the sediment shear strength during the construction time frame.

M-8. Page M22, Table M4. Only four months in the summer have greater evaporation than precipitation rates.

Evaporation and desiccation will unlikely play a significant role in drying the surface of the dredged materials.

ARP RESPONSE: A computer model (PCDDF90) was used to determine the settlement and time rate of settlement of the dredged fill materials. This computer model considers the effects of evaporation and precipitation. Results of the computer analysis show that evaporation and desiccation does not have a significant contribution to the settlement of the dredged fill.

M-9. Page M24, M3.2(e). The capacity analysis should be performed on the actual proposed landfill geometries given in the Draft Design Report.

The Draft Design Report landfill has thicker sediments that will slow down consolidation rates, which could reduce the available volume.

ARP RESPONSE: Site No.7 has been eliminated from further consideration as a potential landfill location. It is expected that the landfill geometry will change for the new proposed location (State Road site). The capacity analysis will be performed using the new landfill geometries during the design phase of the project.

M-10. Page M24, Table M5 and Page M25, Table M6. These tables provide dredging and disposal volumes that do not match the Deep Dredging scenario described in the Draft Plan.

These tables also present a volume of 508,919 cy (at the time of disposal) that will need to be placed in the landfill. This volume includes 103,649 cy of TSCA material. This is inconsistent with the 696,000 cy of sediments that will require disposal considering that the staging facility is not designed to achieve volume reduction. It also assumes a significant reduction in volume due to dewatering which is incorrect (see comments related to FR Appendix K).

Table M6 in FR Appendix M (PageM25) presents a non-TSCA volume of 586,519 cy and a TSCA volume of 150,000 cy for a total in-situ dredge volume of 736,519 cy for the Deep Dredge scenario. This is different from the total in-situ volume of 696,000 cy referenced in much of the Draft Plan and the 476,000 cy presented in the Draft Design Report as the basis of design.

ARP RESPONSE: *The in-place volumes presented in Table M5 (586,519 cy non-TSCA) for the deep dredging alternative were supplied by others which was apparently changed to 546,000 cy (696,000 cy total) after this appendix was prepared. Maxim computed the post dewatering volumes using the 696,000 cy total volume (546,000 cy non-TSCA and 150,000 cy TSCA). Assuming a solids content of 70% after dewatering Maxim estimated the volumes to be as follows: 469,000 cy non-TSCA and 129,000 cy TSCA. For the new landfill location and design the current volumes will be used in the capacity analysis.*

The Technical Appendices of the CMP are planning document utilized and referenced during the Plan Formulation process for the ARP Project. It is beyond the scope and resources of the CMP to update and revise historical documents that contributed to the Plan Formulation process. Plan Formulation for this project is complete, and was an iterative process that took place over a five-year period from 1994 through 1999. Plan Formulation had its own dredge volume estimates comprised of a number of different dredge scenarios, which were consistent within themselves. Accordingly, the volume estimates presented in the text, tables and figures in the Technical Appendices reflect the information used at that point in the analysis.

The Recommended Plan section of the CMP contains updated year 2000 volume totals and that supercede any previous volume estimates in this regard.

M-11. Page M33, M3.6. The hydrostatic uplift calculations should be performed for the revised landfill design in the Draft Design Report.

The critical design condition for hydrostatic uplift is immediately after the liner is constructed and before filling commences. This case is not evaluated.

ARP RESPONSE: *Since Site No.7 has been eliminated the groundwater conditions at Site No.7 are no longer applicable to the design of the landfill. However, the new State Road site is geologically similar to Site No.7. Previous investigations at the RMI site show that there is a shallow and deep groundwater table. A landfill was recently constructed on this site for the Fields Brook Superfund Site. During construction of this landfill the shallow groundwater infiltrated into the excavation, which resulted in construction of a perimeter drain to control the groundwater infiltration. After this drain was constructed there were no problems with respect to uplift on the underlying geomembrane liner. It is expected that similar controls be applied to the proposed non-TSCA and TSCA landfills, but specifications will be set forth during the detailed design phase of the project.*

APPENDIX N LANDFILL DESIGN

ARP GENERAL RESPONSE: *Appendix N, Landfill Design, was prepared as a feasibility level planning document, intended to serve as a guideline for design of the landfill. This appendix is not intended to be a final design document. Specific project design details will be*

determined later in the project.

- N-1. Page 2, para. 1.0. This appendix has been superseded and should be replaced by the Draft Design Report, which represents the ARP's current plans for the landfill design.**

ARP RESPONSE: As stated in paragraph 1.0, this is a feasibility level design. The Draft Design Report represented plans for the previously considered Sites 5 and 7 on the RES property. Since the location of the potential disposal site has been changed, the Draft Design Report is not directly applicable to the new site. Additionally, this appendix is intended to function as a guideline for design of a landfill and not as a detailed design.

- N-2. Page 2, Para. 2.0, 1. The volume of sediments to be dredged is assumed to be 696,000 cy, including 21,000 cy of extra dredging using specialty dredging equipment.**

The Draft Plan (FR. p.40) indicates that the hydraulic dredging is no longer being considered and that the 696,000 cy does not include the extra 21,000 cy. The specialty dredging volume of 21,000 is also not included in the 736,519 cu yd shown in Table M6 for the volume of the Deep Dredge volume.

ARP RESPONSE: As indicated in the response to Comment D-3, the use of a specialty hydraulic dredge is just an option that should be considered and the issue will be resolved as part of the final project design.

- N-3. Page 2, para. 2.0, 3. Additional dredging volumes are shown as including 70,000 cy from the Interim Dredging and 115,000 cy from dredging downstream of 5th Street Bridge to Station 120+00. There is confusion about whether or not the 70,000 cy volume is included in the 696,000 cy referenced through the Draft Plan.**

Table 3-4 (FR p.47) and Page 52 of the Draft FR reference 115,000 cy to be dredged downstream of 5th Street. However, Table 3-6 (FR p.49) shows dredging of 551,519 cy from areas upstream of 5th Street. The Draft Design Report (p.1-3) reports this upstream volume as 361,000 cy with a downstream volume of 115,000 cy. Based on the various references, this amount should actually be 581,000 cy (as referenced on p.0 of the FR) based on the total dredging amount of 696,000 cy and the 115,000 cy to be dredged below 5th Street.

The Draft Design Report (Page 1-3) specifically assumes that both the 70,000 cy interim dredging volume and the 115,000 cy downstream dredging quantities are included in the 546,000 cy of non-TSCA materials and therefore are also included in the 696,000 cy total volume. Page 186 of the Draft FR also states this. It appears as if this assumption is also carried through the Draft Plan. The Draft Plan (FR, Page 83) assumes the 70,000 cy can be reduced to 30,000 cy by assuming the levee materials are not impacted. If the Interim Dredging site is included in the 696,000 cy, then the revised volume of 30,000 cy in the Draft Plan should be used to revise the total dredging volume downward to 656,000 cy. If the Interim Dredging and downstream sites are not included, then the dredging volume may rise up to 881,000 cy.

ARP RESPONSE: The dredging volume of 696,000 cubic yards is referenced in the CMP and was estimated using the following quantities:

± 581,000 (upstream of the 5th Street Bridge)
± 115,000 cy (downstream of the 5th Street Bridge)

Since the additional quantities referenced in bullet 3 of Section 2.0 are actually included in the total volume of 696,000 cy (it was assumed that the 70,000 cubic yards can be reduced to 30,000 cy if the levee materials are not impacted), this bullet will be eliminated. Additionally, the final landfill design will include a contingency to ensure that if the actual quantity of dredged material is greater than the estimated quantity, the material can be disposed of onsite in the landfill. (Also see response N-6).

N-4. Page 3, para. 2.0, 4. Appendix N assumes that the landfill areas that are available and have been investigated are about 50 acres.

Appendix L reports that the investigated site are less than 35 acres in size which means there may be inadequate room for the proposed disposal facility.

ARP RESPONSE: Since the location of the proposed disposal site has been changed, the landfill areas that are available have been modified. The available properties at the revised site location should be adequate to accommodate the proposed disposal facility.

N-5. Page 3, para.2.0, 4. Appendix N assumes that the sediments will have a solids content of at least 70 percent with an unconfined compression strength of at least 10 psi. These values are 'defined as being required to ensure stability of the landfill and allow moving the sediment within the landfill using standard equipment. This assumption is carried into the Draft Design Report (Maxim 1999).

This strength requirement has very serious implications regarding the effectiveness of the proposed dewatering program. A pilot dewatering study (BBL, 1999) included vane shear testing to aid in evaluating the likely strength of the dewatered sediments. The measured shear strengths ranged from 0.01 to 1.3 psi after 72 hours of dewatering. The shear strength was limited to less than 0.1 psi for the drum that did not have underdrainage. The average shear strength of the sediments dewatered using the underdrain was 0.5 psi. The sediments in the pilot dewatering test are believed to represent the median sediments; however the average sediment characteristics are believed to have higher than median water and organic contents and lower solids contents. Therefore, it is likely that the average dewatered sediments will have lower strengths than achieved in the pilot dewatering study.

Based on the pilot test, it appears that the as delivered shear strength to the landfill will generally 0.5 psi or less. This would require we use or construction equipment with less than a 0.5 psi bearing pressure to move the sediments in the landfill. This eliminates all conventional earthmoving equipment. Only specialty marsh construction equipment with wide tracks could possibly be used on these materials. No wheeled vehicles could be used, requiring an additional handling step as sediments are transferred into equipment that could place the sediments into the landfill from dump trucks used to transport the materials through town. Also, the average person exerts a bearing pressure greater than 0.5 psi when walking. Therefore, direct access to the sediment surface will probably not be possible. Alternatively, mats will need to be placed on the sediments to allow construction equipment to access the landfill surface. These mats will need to be moved regularly to access all areas of the landfill and allow placement of the subsequent lifts. This is difficult and expensive to implement during a 2,000 cy per day earthmoving operation in a confined work area.

Much of the sediment dewatering due to consolidation in the landfill will result in water moving upwards to the surface as the sediment thickness increases and the bottom layers consolidate and decrease their permeability. This will make it difficult to improve the surficial strength by ditching and drying in the very short periods (typically less than a month) needed to prepare the surface for placement of the next lift. The relative ineffectiveness of surface drying has been demonstrated at the Ashtabula Yacht Club sediment storage area where four months of drying in record setting drought conditions failed to significantly increase the solids content.

The shear strength of the sediments will also determine the maximum allowable slope and the maximum height of the landfill. Unless the shear strength of the dewatered sediments in the upper part of the landfill can be increased substantially beyond 0.5 psi, the maximum height of the landfill will be severely limited which will reduce or eliminate the potential increase in landfill volume available by raising the maximum height and slopes. An unconfined compressive strength of 10 psi (assumed condition in the Draft Plan after dewatering) would limit the maximum height of the landfill above the surrounding berm to about 35 feet with a factor of safety of 1.5. This height would not allow for significant additional volume to be available. It appears that there is a significant likelihood that the addition of a stabilization agent will be required to achieve sufficient shear strengths to allow for stable slopes during and after landfilling which will further increase disposal volumes. This information needs to be considered prior to finalizing the Plan.

ARP RESPONSE: As previously indicated, this is a feasibility level document intended for planning purposes. Specific design detail issues will be resolved as part of the final project design.

N-6. Page 3, para. 2.0, 6. It is assumed that the sediment will be delivered in a fully dewatered condition and that only 500,000 cy of total landfill space will be required. This assumption is not consistent with the staging facility that is to be designed to dewater the sediments to the pre-dredging in-situ solids content. This implies the disposal volume will be equal to the in-situ volume of sediment.

Section 6.2 of the Draft Design Report presents a set of calculations and arrives at the conclusion ~ the volume requiring disposal will be 469,000 cy of non-TSCA sediments and 129,000 cy of TSCA sediments.

Appendix B of the Draft FR and the Draft EIS indicates that the actual dredged volume in the 1993 Interim Dredging program was 23,500 to 23,800 cy. The current condition of 30,000 cy of dredged material assumed in the Draft Plan to require disposal indicates that bulking of the sediments is likely after dredging.

The landfill(s) is being designed for a specific volume in both the Draft Plan and the Draft Design Report, although the computed volumes are significantly different in these two documents. For a given plan geometry landfill, it is possible to have a wide range of available volumes based on the cap geometry. Given the large uncertainty relative to the volume of sediment that will need to be landfilled, for planning purposes we recommend that the landfill design be presented as a flexible envelope with cost, design, and visual Impact issues provided for the critical conditions.

For example, the community impact will be greatest if the volume is substantially

greater than anticipated. Therefore, the scenario showing the maximum potential slopes and height of the landfill should be presented to the public for their review and comment in the EES. Likewise, the greatest stability issues related to the sediment strength and cover system will occur if the landfill volume needs to be maximized with 4H: IV slopes. The design requirements for this condition should be provided in the Plan.

ARP RESPONSE: *As previously stated, this is a feasibility level document intended for planning purposes. Specific design and sizing issues will be resolved as part of the final project design. Additionally, the final landfill design will include a contingency to ensure that if the actual quantity of dredged material is greater than the estimated quantity, the material can be disposed of onsite in the landfill.*

N-7. Page 3, para. 3.0. A basic assumption driving the disposal facility design is the separation of the TSCA and non-TSCA sediments. This may not be the most cost efficient approach for the project as a whole.

The proposed dredging program requires separate dredging and disposal of 150,000 cy of sediments in order to address an estimated 28,700 cy of sediments with PCB levels in excess of 50 ppm. An additional 546,000 cy of sediments will be dredged separately

and handled as “non-TSCA” materials. It appears that the primary purpose for this is to reduce perceived landfilling costs by using two separate landfills, the smaller of which will • a double liner system.

While there is insufficient breakdown in the dredging cost estimates to evaluate the differential costs between the TSCA and non-TSCA dredging, the additional complexity of attempting to carve out a specific area to a specific depth and then come back and dredge surrounding area will add additional costs, disruption, and risk to the program. Landfilling costs could increase significantly if the “TSCA” material volumes increase substantially beyond 150,000 cy, requiring additional TSCA landfill space to be constructed in a hurry to accommodate the increase volume.

We note that landfill per cubic yard disposal capital costs are driven primarily by the ratio of volume to plan area of the landfill due to the expense of liners and caps. The per cubic yard disposal cost generally drops significantly as individual landfills get larger with an increasing volume to plan area ratio. Therefore, a single large landfill could be more economical than two landfills with the same total volume.

The ARP should review the benefits of performing all of the dredging in a single pass instead of the proposed separate dredging programs. The reduction in complexity of the dredging and landfilling components of the program may significantly reduce the average unit cost and reduce the risk of variable volume splits between the “TSCA” and “non-TSCA” materials.

ARP RESPONSE: *The possibility of combining TSCA and non-TSCA classified sediments into a single cell landfill was considered by the ARP during the Value Engineering process. It should be noted that the separation of the dredged sediments is primarily driven by different regulatory requirements associated with the disposal of PCB contaminated sediments and that the disposal and post closure requirements for TSCA sediments is more stringent than for non-TSCA sediments. If the TSCA landfill requirements were required for the single celled landfill it would increase overall landfilling costs by \$2,500,000. If a single composite, combined cell is used approximately \$2,300,000 in relative savings can be gained in landfilling*

costs.

Furthermore, it was the opinion of the Value Engineering Team that a cost savings could be realized in dredging if the anticipated dredging controls required for TSCA materials was eliminated. The VE recommendation is that the ARP should explore the combined cell, single composite liner option during the PED phase of the project. This will mean gaining USEPA, OEPA and ODH approval of the single composite liner for TSCA material. A USEPA waiver would have to be applied for based on the health-based risk but has the potential for delaying project implementation.

N-8. Page 17, para. 5.4. Section 5.4 and Table 2 define water quality concentrations based on State of Ohio Water Quality Standards and Ashtabula POTW requirements. This type of performance based disposal requirements should be expected for the staging facility design as well as the landfill leachate.

ARP RESPONSE: Appendix N addresses landfill design and not staging facility design.

APPENDIX P PROJECT COST ESTIMATES

P-1. Page 1, Section 1. The document states that “future detailed design will affect the project costs, possibly increasing costs for various components above that which the applied contingency attempts to cover.”

Recognizing this, has an evaluation of sensitivity and uncertainty been conducted for the estimated costs to identify those components of the recommended remedy that may most likely increase the estimated costs?

ARP RESPONSE: A new Current Working Estimate (CWE) for the recommended plan is based upon the conceptual design described in the CMP and is developed in accordance with ER 1110-2-1302. The CWE is to be updated throughout the project schedule as the design is further detailed. The new CWE contains contingency allocations specifically related to the project uncertainties, which can be changed through additional investigations or studies. Final design costs will reflect on this.

Page 1, Section 1 has been changed to state the policies, guidance and procedures for contingencies stated in ER 1110-2-1302.

The new CWE has been prepared with an appropriate amount of contingency for the design detail available to support this stage of the project development.

P-2. Page 1, Section 2. The document indicates that the “document was broken into several components to allow the PRP Partnership the greatest flexibility in selecting the most attractive means of accomplishing the project objective, removing contaminated sediments from the Ashtabula River.”

This should be reworded to state that sediment removal was “one of” the project objectives.

ARP RESPONSE: The new cost estimate in the final CMP addresses the recommended plan, which is the removal of 696,000 cy of TSCA & Non-TSCA dredge material.

P-3. Page 1, Section 3. No details for the estimated dredging costs are included.

For example, no details of the size of the dredge, the bucket size, cycle time, the number of scows, work boats, crew size, the affect of debris and/or environmental monitoring on efficiency are included. Without this information, it is difficult to validate the \$16/cy dredging estimate, which appears low. This potential underestimate was also identified in a review of the cost estimate conducted on behalf of the ARP by Metcalf & Eddy (M&E, 1998). This review also indicated that relevant details were lacking and that the underestimate of dredging costs could increase the total project costs by over \$3,500,000).

The \$16/cy dredging cost is low compared to other environmental dredging projects. For example, a sediment removal project conducted under the oversight of the USACE at Bayou Bonfouca using mechanical equipment experienced \$ 125/cy for dredging costs alone. Dredging details assumed when developing the \$1 6/cy need to be included in the Final Plan.

ARP RESPONSE: The new CWE is based upon the current level of design, unit prices for the dredging were taken from the FY00 dredging of Fairport Harbor which was competitively bid and is far lower then \$16/cy stated. Keeping in mind the easy excavation, the short scow transport, low water velocity and general vicinity of the material the unit price is considered reasonable. The CWE is based on dredging and processing 150 cy of dredge material per hour working 10 hrs/day (1,500cy/day). Using a 6 cy environmental bucket and the appropriate marine equipment this production rate could be easily achieved as the CWE. Detailed cost estimates will be updated as we approach final design

Additionally, detail on the \$125/cy experienced at Bayou Bonfouca would need to be investigated. The mob/demob, testing, transport, dewatering, trucking, landfilling, etc. are all estimated separately in the new CWE.

P-4. Page 2, Section 4.1. No details for the estimated construction cost of \$2,180,000 and operational costs of \$2.55/cy are provided for the dewatering/transfer facility and as a result, many questions are unanswered including:

1. Does the construction cost include preparation and remediation costs for the Conrail site?

ARP RESPONSE: The new CWE includes installation, operation, disassembly, removal and disposal of all necessary components of the transfer/dewatering facility. The site will be left in as good a condition as before the project. Specifications in this regard will be set forth during detailed project design.

2. Is the previous design that was updated for this site directly applicable?

ARP RESPONSE: The CMP recommended alternative has details for the construction of a Transfer / Dewater / Transfer Shoreline facility which has been estimated in the new CWE. Additional water treatment equipment and operational costs have also been estimated.

3. What is the conceptual basis of design for materials handling in terms of solids and liquid per day?

ARP RESPONSE: The CWE is based on dredging and processing 150 cy of dredge material per hour working 10 hrs/day (1,500cy/day). Using a 6 cy environmental bucket and the appropriate marine equipment this production rate could be easily achieved. Additionally, included are water settling basins, water treatment equipment and labor has been added which would handle 200 gallon/min, this is assumed to be sufficient.

4. What are the assumed influent and effluent concentrations for the water developed during the dewatering processes?

ARP RESPONSE: Technical Appendix K, Dewatering Facility Design, Area 7 - Staging Area Settling Basins was designed with two basins each designed to contain 25,650 cf of water. A 4,000 CY/day dredging scenario is said to produce 25,500 cf of supernatant, additionally the maximum storm runoff is considered in the design.

If only 1,500 cy is dredged per day it estimated that approx. 9,600 cf of supernatant will be produce per day far less than what the original design capacity of the facility can handle.

5. Is the cost of water treatment to 50 to 100 mg/L contemplated in the Draft Plan included in the operations cost of \$2.55/cy. If so, what was the estimated volume of water to be treated per cy of material dredged.

ARP RESPONSE: The new CWE is estimated to process the volumes of supernatant mentioned above in response to P-4.4.

6. What would be the impact on the estimated cost if the criteria for treated water included low level PCB concentrations and/or whole water effluent toxicity testing were required?

ARP RESPONSE: The new CWE contains costs for environmental monitoring of the treatment facility effluent, the effluent must meet State of Ohio water quality discharge standards. Estimated was one pesticide/PCB (8080) sample per day of discharge any additional sampling of the effluent obviously would increase the project costs.

7. Dewatering/transfer facility details assumed which support the construction and operation costs need to be included in the Final Plan. If not apparent in the details, a response to the six questions noted above is also requested.

ARP RESPONSE: Refer to above comment responses. Detailed cost estimates will be updated as we approach final design.

P-5. Page 2, Section 5. The preferred disposal method is described as an “upland CDF”. However, the design presented in Appendix N and the draft Design Report is for a “landfill.” A CDF incorporates dewatering as one of its primary functions while the landfill, as designed, does not.

The operating costs shown in Tables 1 through 3 for the upland CDF operating costs are less than those shown for the lakefront CDF. Since the landfill design presented in Appendix N and the draft Design Report assumes that the sediments will be dewatered to a 70 percent solids content and an unconfined compressive shear strength of 10 psi, it appears that these cost tables assume that the dewatering costs will be born in the dewatering facility cost. Therefore, it appears as if the upland facility’s costs are estimated based on it being constructed and operated as a landfill.

not a CDF as reported in Section 5. Please clarify.

ARP RESPONSE: It was assumed that CDF and landfill were being used interchangeably, we weren't aware of any official distinction.

P-6. Page 2, Section 5. Section 5 states that costs were prepared for an offshore CDF. However, no costs are shown for the construction of a lakefront CDF in Tables through 3, only for operation.

The differences between construction of lakefront CDF and an upland landfill are significant and warrant preparation and inclusion of a separate cost estimate.

ARP RESPONSE: Agree. Tables 1 through 3 do not use any of the cost data supplied for the lake front CDF. Although discussed as an alternative during Plan Formulation, due to sediment contaminant concentrations, a lake front CDF is not considered further.

P-7. Page 2, Section 5. The volumes presented in Table I for disposal indicate that only 100,000 cy of TSCA material and 400,000 cy of non-TSCA material is included in the cost estimate for both the upland CDF and the lakefront CDF. The 500,000 cy total is substantially less than the proposed 696,000 cy to be dredged (plus other materials to be included).

This volume reduction applies to both transport and disposal. It therefore appears that these cost estimates assume that sediments will be delivered to both CDF's in a fully dewatered state that results in a volume reduction of 30 percent. Based on the results of a recent dewatering study conducted using Ashtabula River sediment, a volume reduction following gravity dewatering should not be anticipated (BBL, 1999). Also, the purpose of a CDF includes dewatering and so it appears that the costs of the both the upland and lakefront CDFs do not include any dewatering costs. Also, since it is likely that volumes will be significantly higher than included in the cost estimates, the disposal Cost and CDF operation will be about 30 percent higher. Recognizing these issues, the text/costs should be appropriately modified in the Final Plan.

ARP RESPONSE: Again, tables 1 through 3 do not use any of the cost data supplied for the lake front CDF. Although discussed as an alternative during Plan Formulation, due to sediment contaminant concentrations, a lake front CDF is not an option for the ARP Project but is discussed in the CMP.

According to Appendix M - Geotechnical Laboratory tests have been performed on the sediments which shows a reduction in the volume of material and that is what the landfills are designed around. During final design this will be addressed in the detailed cost estimate.

P-8. Page 3, Section 6.1 Dewatering and Sediment Transfer. This section states that sediments "will be transported to a transfer facility where the sediments will be dewatered to acceptable levels and then transferred...to the disposal facility" and a "storage cell will contain the sediments until they are acceptable for disposal." The proposed staging and transfer facility is designed for immediate transfer from the scows to trucks and there are no provisions for the storage cell to effectively dewater sediments.

The staging facility presented in Appendix K is designed for the trucks to be immediately loaded from the scows and then transport these sediments to the disposal facility without additional dewatering.

The staging facility design presented in Appendix K only provides for 4,000 cy of on-site storage that is to be used if the trucks are slow or unavailable for direct transfer from the scows to the disposal facility. The storage facility has only nominal drainage consisting of pipes around the base of the perimeter berm to facilitate dewatering. It is not designed to remove anything but free water that easily flows from the sediments in the short-time (one to two days).

The only consistent dewatering proposed is settling in the scows for less than a day. As stated in Appendix K, this dewatering is expected to remove excess water contained during dredging. Based on-site specific tests, it is unlikely to remove more than that (BBL, 1999). It should be anticipated that the sediments placed in the trucks will be wet and will have approximately the original dredged density and solids content.

It appears that the landfill design in Appendix N assumes that dewatering to 70 percent solids content will occur at a dewatering facility and Appendix K assumes that dewatering to 70 percent solids content will occur at the landfill. Since these assumptions are mutually exclusive, it appears that the cost to dewater or otherwise stabilize the sediments sufficiently to allow landfilling has been ignored and is not included in the cost estimates. This could be a major cost that could be in excess of \$ 10 million that must be evaluated before completing the project decision making. Recognizing these issues, the text/costs should be appropriately modified in the Final Plan.

ARP RESPONSE: In Plan Formulation, dewatering facilities were presented at both the transfer area and the landfill. Since it was determined that the dredge material needs to pass a paint filter test at the transfer facility, with a solid concentration of ~70% before it will be transported to the landfill, dewatering will occur there. At the landfill further dewatering & compaction of the sediments will occur during placement. Off loading dredged material directly from scows to trucks for transport was only one of the options considered.

The new CWE considers dewatering at both the transfer & landfill.

P-9. Page 3, Section 6.2. The document refers to the upland disposal facility as a “CDF.” Why is it not designed to be operated as a CDF?

This should be clarified in the Final Plan.

ARP RESPONSE: Agree (see response to P-5). References to the upland landfill disposal site and facility will be changed from CDF to “landfill”.

P-10. Page 5, Section 9. As noted in comments above and in Comment EIS-76, the volume of sediment discussed in this section may be underestimated by 40% or more and the estimated costs need to be increased to reflect this additional material.

ARP RESPONSE: Could not find reference to 40% as stated, but again the new CWE is based on the 696,000 cu yd of dredge from the Ashtabula River and place in the landfill facility as described in the CMP. The estimate may change during the design phase as further information is developed.

P-11. Page 5, Section 10. What is the basis for the mob/demob cost of \$580,000?

For example, how many dredges, scows and work boats are included? Was it anticipated that this equipment would be dormant during the months when dredging was not occurring (4-6 months per year)? Is there backup information for the remaining components of the remedy (other than dredging) that demonstrate where mob/demob costs have been included? The details responding to these questions should be included in the Final Plan.

ARP RESPONSE: *The new CWE attempts to address much of your question. What you are asking would depend on the dredging contractor selected which is unknown at this time and will be treated in the final design phase of the project.*

The following would be a possible construction scenario:

- ❖ *A derrickboat with a 6 cy environmental bucket, using up to three 1,500 CY scows assisted by a small tug. (There are a variety of contractors capable of supplying similar equipment).*
- ❖ *The scows would be unloaded at the transfer facility by a crane with a clamshell bucket supported by a bulldozer and/or front end loader.*
- ❖ *Trucks would be loaded by either a backhoe and/or front end loader at the loading facility and transport material to the landfill.*
- ❖ *At the landfill the material would be further dewatered as it is placed in the landfill be a front end loader, bulldozer and compacted by a roller.*

All of the above was considered for a 3 year period and would require much more \$ than the amount on Page 5, Section 10.

P-12. Page 5, Section 10. The estimate for environmental monitoring includes approximately \$321,600 to support dredging and dewatering/water treatment operations.

Assuming this covers labor, materials/supplies and outside services such as analytical chemistry, the specific monitoring activities these funds are designed to cover over the estimated construction period? It should be noted that the estimated \$321,600 represents less than 1% of the First Construction Cost. This is low compared to other environmental dredging projects like the New Bedford Harbor Project where monitoring costs are expected to exceed 2% of the total construction costs

ARPRESPONSE: *The new CWE is based on Appendix I - Environmental Monitoring and will easily exceed the amount suggested above.*

P-13. Page 7, Section 10. The cost sharing allocation should be revised to reflect the recent Amendments to WRDA (August 1999).

ARP RESPONSE: *Agree. Updates will be made accordingly.*

APPENDIX T ENVIRONMENTAL JUSTICE

T-1 Pages 1-7. The appendix is focused on the landfill only, traffic or other impacts as a result of the dewatering facility are not addressed, and should be.

ARP RESPONSE: *Do not agree. The appendix discusses dredging through disposal and*

associated impact areas. Per dredging authorities, transfer/dewatering/transfer may be considered part of the dredging operations. This will be clarified. Further, Section I, 4th paragraph, incorporates other more detailed EIS discussions by reference.

ATTACHMENT A.

ARP RESPONSE: *There are a number of project examples and articles that counter your (Attachment A) after dredging elevated surface sediment contaminant levels and project success including those pertaining to: Scippo Creek, Ohio; Fox River, Wisconsin; and Manistique, Michigan.*

References

ATTACHMENT A

Technical Limitations Associated with the Removal of Sediments Containing PCBs

A. General

When dredging is employed as a means of removing sediments, there are inherent operational difficulties associated with dredging which will limit the cleanup level that can practically be achieved. Dredging limitations are caused in part by resuspended sediments subsequently mixing and resettling within the dredged area, ultimately resulting in an overlying layer of sediments containing polychlorinated biphenyls (PCBs). The degree of sediment disturbance, and hence resuspension and mixing, varies with the dredging equipment used, the operational handling of this equipment, and the physical nature of the sediments.

Data collected during the dredging activities at some PCB sites have indicated that low PCB cleanup levels [e.g., in the range of 10 parts per million (ppm) or lower] generally are not achievable and even higher PCB cleanup levels may likewise be unattainable. The United States Army Corps of Engineers (USACE) has stated that "no existing dredge type is capable of dredging a thin surficial layer of contaminated material without leaving behind a portion of that layer and/or mixing a portion of the surficial layer with underlying clean sediment" (Palermo, 1991). Therefore, even though the dredge may be capable of removing substantial volumes of sediment, the sediments which the dredge misses (or those that eventually settle as a result of resuspension) will remain as a potential future PCB source.

The effectiveness of dredging sediments containing PCBs has been evaluated at several sites in the United States. These sites include Grasse River (New York), New Bedford Harbor (Massachusetts), Sheboygan River and Harbor (Wisconsin), St. Lawrence River (New York), Willamette River (Oregon), Duwamish Waterway (Washington), Ruck Pond (Wisconsin), the Shiawassee River (Michigan), and other sites across the country. In each case, results from these activities exhibited final residual PCB concentrations (i.e., the concentrations remaining after dredging was completed) that were highly variable.

B. Site Profiles

Although dredging has been used extensively for river and harbor maintenance activities throughout the United States, dredging of PCB-containing sediments where removal efficiency was documented through post-removal PCB sampling has been limited. Several sites where such information is available are discussed below.

Grasse River, New York

Approximately 3,000 cubic yards (cy) of sediment, boulders, and debris were removed in 1995 from two areas (i.e., river area and adjacent outfall structure) of the Grasse River located in Massena, New York. The goal of this removal action was to remove all sediment to the extent practicable within a relatively small isolated area of the river.

As part of the sediment removal operations, it was necessary to remove boulders and debris from a portion of the river removal area. Nearly 400 cy of boulders were removed from a "boulder zone" within the river area using a mechanical excavator (with a specialized perforated bucket) mounted on a barge. Approximately 2,400 cy of sediments from the river removal area were removed using a horizontal auger hydraulic dredge. After removal operations were complete, sediment probing and sediment sampling activities were performed to document existing conditions. While the average sediment depth at this site prior to remediation was approximately 22 inches, the

References

sediment depths remaining (after removal to the extent practicable) still averaged 4 inches and ranged up to 14 inches. Pre-removal PCB concentrations in the river removal area sediment ranged from approximately non-detect (ND) to 11,000 ppm and averaged 1,109 ppm. Post-removal PCB concentrations in the remaining sediment ranged from 1.1 to 260 ppm and averaged 75 ppm. Approximately 30 percent of the sample locations in the river removal area exhibited increased PCB concentrations in the upper 1.0 foot of post-removal sediment.

Approximately 200 cy of sediment from the facility's active outfall area were removed to the extent practicable, using manually-positioned suction hoses manifolded to the hydraulic dredge. Pre-removal PCB concentrations in the sediment ranged from 120 to 680 ppm and averaged approximately 300 ppm, while post-removal PCB concentrations averaged 108 ppm.

New Bedford Harbor, Massachusetts

Perhaps the most extensive evaluation of this subject was performed by the USACE in a full-scale pilot dredging study at New Bedford Harbor, Massachusetts (USACE, 1990). Three hydraulic dredges were evaluated: hydraulic cutterhead; horizontal auger (mudcat); and, matchbox. The study utilized two small dredging areas which were characterized as shallow (less than 5 feet of water) with sediment characteristics consisting of between 15 to 80 percent silts and clays. A discussion of each dredging area, and its resulting data for dredging efficiency is presented below.

Dredging Area 1

Dredging Area 1 had an area of approximately 62,500 square feet (250 feet by 250 feet). Six sediment sample cores were collected prior to dredging. The average pre-dredging PCB concentrations by depth were as follows:

Depth (inches)	Average PCB Concentration (ppm)	Range of PCB Concentration (ppm)
0-6	230	150 to 260
6-12	12	8.9 to 17
12-18	7.6	4.1 to 10
18-24	3.8	2.1 to 7.3
24-30	0.8	0.2 to 1.9
30-36	0.3	0.1 to 0.7

A cutterhead dredge and a horizontal auger dredge were tested at Dredging Area 1. One pass of the cutterhead dredge removed 1.5 feet of sediment. The average PCB concentration in the remaining surficial (top 3 inches) sediment was 80 ppm. The PCB concentrations ranged from 8.2 to 189 ppm in a total of 32 samples composited into eight analyses. Four passes of the horizontal auger dredge also removed 1.5 feet of sediment. The average PCB concentration in the remaining surficial (top 3 inches) sediment was 66.4 ppm. The PCB concentrations ranged from 9.3 to 270 ppm in a total of 32 samples composited into eight analyses.

Dredging Area 2

References

Dredging Area 2 had an area of approximately 32,400 square feet (180 feet by 180 feet). Six sediment sample cores were collected prior to dredging. The average pre-dredging PCB concentrations by depth were as follows:

Depth (inches)	Average PCB Concentration (ppm)	Range of PCB Concentration (ppm)
0-6	380	300 to 580
6-12	34	11 to 92
12-18	4.6	1.9 to 9.7
18-24	1.0	0.2 to 2.3
24-30	0.18	0.1 to 0.4
30-36	0.01	ND to 0.04

A cutterhead dredge and a matchbox dredge were tested at Dredging Area 2. Two passes of the cutterhead dredge removed 1.1 feet of sediment. The average PCB concentration in the remaining surficial (top 3 inches) sediment was 8.6 ppm. The PCB concentrations ranged from 0.5 to 15 ppm in a total of 16 samples composited into four analyses. Two passes of the matchbox dredge removed 1.5 feet of sediment. The average PCB concentration in the remaining surficial (top 3 inches) sediment was 5.4 ppm. The PCB concentrations ranged from 3.0 to 9.6 ppm in a total of 16 samples composited into four analyses.

The actual dredging efficiency results presented above were compared to theoretically computed or predicted average residual PCB concentrations. This comparison follows:

Area	Type of Dredge	# of Passes	Depth Removed (ft)	Average Residual PCB Concentration (ppm)		
				Predicted(1)	Actual	% of Predicted(2)
Dredge Area 1	Cutterhead	1	1.5	5.2	80.5	1548
	Horizontal Auger	4	1.5	5.2	66.4	1277
Dredge Area 2	Cutterhead	2	1.1	4.89	8.6	176
	Matchbox	2	1.5	1.33	5.4	406

(1) Predicted residual PCB concentration is the estimated concentration which is expected to remain after removal of 1.1 or 1.5 feet of sediment, assuming removal of all sediment with no mixing of underlying material and no settling of suspended solids. This value is based on interpolation of baseline PCB data for the 1.1 and 1.5 foot depths.

(2) The percentage of the predicted residual concentration remaining is based on the actual residual concentration divided by the predicted value.

These data demonstrate that in all trials the actual residual PCB concentrations far exceeded the predicted concentrations. In area 1, the observed post-dredging residual PCB concentration was an order of magnitude greater than predicted. Since the residual PCB concentrations were determined on composite samples, it is possible that analysis of individual samples would have provided even higher actual post-dredging PCB concentrations. Based on the range of residual PCB concentrations observed during the study, it is unlikely that removal can consistently achieve low residual PCB concentrations.

References

Remediation for this site was specified for two operable units. The United States Environmental Protection Agency (USEPA) issued a Record of Decision (ROD) for the first operable unit (hot-spot areas with greater than 4,000 ppm PCBs) in April 1990. The dredging portion of this phase was initiated in April 1994 and was completed in September 1995. A total of 10,000 cy of sediment was removed from the harbor during the 16.5 month project duration. Status reports for the project show that the dredging activities were much more inefficient than originally anticipated. This was due, in part, to ambient air PCB concentrations above predetermined action levels, which subsequently required modifications to dredging operations. In addition, PCB concentrations in sediment remaining after dredging have ranged up to 3,600 ppm. USEPA's proposed cleanup plan for remediation of the second operable unit, which covers the remainder of the site (approximately 170 acres), was issued in November 1996. The proposed plan calls for dredging approximately 450,000 cy of sediments which contain PCBs greater than 10 and 50 ppm PCBs (depending upon location with the harbor) with containment in confined disposal facilities located immediately within the harbor. The project is projected to take eight years using two dredges.

Sheboygan River and Harbor, Wisconsin

Dredging activities were performed during 1989 and 1990 at the Sheboygan River and Harbor Superfund Site (Sheboygan County, Wisconsin) as part of the overall Remedial Investigation/Feasibility Study (RI/FS) for the site. Approximately 1,600 cy of sediment were removed over a seven-month period from nine sediment areas using a modified closed clamshell mechanical dredge. These sediments were placed in a confined treatment facility (CTF) during removal efforts associated with an Alternative Specific Remedial Investigation (ASRI) [Blasland, Bouck & Lee, Inc. (BBL), 1995b]. The CTF is located adjacent to the Sheboygan River. Dredging was performed within the confines of a silt containment system comprised of an internal geotextile silt screen and external geomembrane silt curtain. In general, two dredge passes were performed in each area followed by sampling and analysis. The first dredge pass was performed in an effort to remove as much sediment as possible (i.e., to hard subgrade material). Following the first pass, the resuspended sediment within the silt containment system was allowed to settle, and a second dredge pass subsequently followed. Additional dredge passes were utilized if post-dredging sampling results exhibited elevated PCB levels.

In addition to the sediment removal activities performed as part of the ASRI, approximately 2,700 cy were removed under a Removal Action required by USEPA (BBL, 1995b). Sediments were removed over a six-month period (not including site preparation, access, and restoration) and were placed in a "sediment management facility" located near the CTF adjacent to the Sheboygan River. The dredging methods used were identical to those utilized for the ASRI activities.

Data associated with both dredging events further support the fact that final residual PCB concentrations are highly variable and very low PCB levels are not consistently achievable. Additionally, PCB levels in the water column and caged fish rose as a result of the dredging activities.

A total of 23 different sediment areas were dredged. Initial PCB concentrations in these areas ranged from 44 ppm to 1,130 ppm. Residual PCB levels in nine of these areas were reduced to concentrations below 5 ppm. In the remainder, however, residual PCB levels ranged as high as 800 ppm after multiple passes. There was no statistically significant correlation between pre-dredge and post-dredge mean PCB concentrations in these areas. This means that post-dredging residual PCB concentrations cannot be simply predicted from pre-dredging PCB concentrations. Histograms of pre-dredge and post-dredge surficial sediment PCB levels are presented in Figure D-1. Residual PCB concentrations in five of these areas were contained by placement of engineered sediment caps on top of the area that was dredged.

References

St. Lawrence River, New York

Approximately 13,800 in-situ cy of material including sediment, boulders, cobbles and debris were removed in 1995 from the St. Lawrence River in northern New York. According to the ROD for this site, the cleanup goal for river sediments containing PCBs was 1 ppm.

At the onset of remedial activities, certain locations within the removal area contained sediments with greater than 500 ppm PCBs. Prior to removal, a sheet-pile silt containment system was installed around the entire targeted removal area. The removal area was subsequently divided into six subareas to facilitate dredging activities.

Sediment removal in shallow water and shoreline areas was performed by excavating "in-the-dry" using portable dams and conventional earth-moving equipment. Barge-mounted excavation equipment (i.e., backhoe) was used to remove rocks, debris and other dredge impediments from the river bottom. Removal of sediment was performed using hydraulic dredging. Typically, two to six dredge passes, from shore to the sheet-pile wall, were performed before advancing to an adjacent area.

Despite these efforts and the comparatively small area and volume of sediment targeted by the remedy, initial hydraulic dredging attempts did not meet the 1 ppm PCB cleanup goal in some areas. Subsequently, remaining residual sediments were removed to the extent practicable by modifying the hydraulic dredging head to a vacuum head arrangement. Furthermore, mechanical excavation equipment was used in some instances to supplement the hydraulic removal efforts.

Although extensive efforts were made to remove all sediment, the final PCB levels did not achieve the 1 ppm cleanup goal in all cases. Except for Subarea 3, the average PCB concentration in the remaining subareas was approximately 3 ppm with all detections less than 10 ppm. River sediments in Subarea 3 exhibited the highest initial levels of PCBs, and also was the most extensively dredged area. The final samples, however, averaged 27 ppm PCBs with no sample exceeding 100 ppm. This subarea was subsequently capped using a multi-layer cap consisting of sand and two different stone media. The cap was not part of the original remediation plan and was designed during remediation in an effort to address the residual PCBs.

Willamette River, Oregon

A dredging remediation project was undertaken in the Willamette River in Portland, Oregon under the auspices of the Oregon Department of Environmental Quality (ODEQ). Low-volume dredging involved a diver and a vacuum pump/suction hose operation to remove a small sediment volume. The cleanup goal was to remove approximately 100 cy of sediment to the greatest extent practicable up to a depth of 2 feet. According to the final report on sediment remediation, "dredging to a 2-foot depth was not achievable in the majority of the areas because of the presence of debris and large rocks." In fact, only approximately 14 cy actually were removed while working around large debris. PCB concentrations were detected as high as 190 ppm (average 29 ppm) prior to dredging, with an average PCB concentration of 8 ppm (and a high of 21 ppm) after dredging. A sediment cap was placed over the entire area from which sediments were removed.

Duwamish Waterway, Washington

A dredging effort was implemented at the Duwamish Waterway in Seattle, Washington to clean up sediments from a 255-gallon spill of PCB Aroclor 1242. Extensive dredging was performed with a PNEUMA pump dredge in an effort to achieve maximum removal of PCBs near the spill source. However, after several dredge passes, 50 ppm PCBs remained in the sediments (USEPA, 1977).

References

Ruck Pond, Wisconsin

The remediation goal for this project was to remove sediment to the extent practicable using conventional earth-moving equipment (Praeger et al., 1996). This site utilized mechanical excavation equipment to remove approximately 7,500 cy of in-situ sediments from the stream bed impoundment located in USEPA Region 5. The scope of remediation at this site included hydraulic isolation of a portion of the impoundment targeted for sediment removal and excavation "in-the-dry." Two primary difficulties were encountered at the site (BBL, 1995a):

- Dewatering - Control of groundwater infiltration from the underlying bedrock to the sediment was a continual problem.
- Excavation - Saturated stream bed conditions made it difficult to maneuver excavation equipment and effectively remove sediments.

Following removal of the soft sediment to the extent practicable, the post-removal PCB concentrations remaining in the sediment ranged from approximately 10 to 300 ppm (average concentration of 94 ppm). It should be noted that pre-removal PCB concentrations ranged from less than the detection limit to 2,500 ppm.

Shiawasse River, Michigan

Data regarding the effectiveness of hydraulic dredging are available from a specialized small-scale removal operation in the South Branch of the Shiawasse River as reported by Environmental Research Group (ERG, 1982). The sediment area consisted of an organic lens (3- to 4-inch depth) with average PCB concentrations up to 520 ppm surrounded by upper sands (averaging 24 ppm) and lower sands (averaging 0.5 ppm). After removal of approximately 2 cy of sediments (the river bed elevation was reduced by approximately 4 to 6 inches in the test area) with a vacuum system, the remaining sediment was sampled. Results from a 2-foot core sample showed that 7.2 ppm remained at the sediment interface with an average remaining PCB composite (over 2-foot length) concentration of 4.2 ppm.

Rice and White (1987) found that PCBs in resettled sediment particles were still available for uptake several months after dredging had ceased in the South Branch of the Shiawasse River. This study involved the monitoring of caged fingernail clams (*Sphaerium striatinum*) and fathead minnows (*Pimephales promelas*) at locations downstream and in the area of dredging. At these locations, there was an increase in bioavailability of PCBs for at least six months following the dredging operation. For example, PCB concentrations in clams in the dredged zone increased from 14 to 18 ppm (dry weight), while PCBs in fish increased from 64 to 88 ppm (dry weight). Post-dredging uptake also was higher seven miles downstream.

C. Summary

A review of these sites shows that efforts at dredging sediments containing PCBs have exhibited varied removal efficiencies, even with repeated passes. Greater efficiencies have been achieved only in some small-scale, specialized removals, and even then remedial goals, if expressed as PCB cleanup levels, have not been met. Efforts to achieve maximum PCB removal at Duwamish Waterway using the PNEUMA pump dredge left 50 ppm PCBs in the sediments (USEPA, 1977). During the pilot study, USACE achieved reductions in PCBs from the 200 to 400 ppm range to the 5 to 80 ppm range in New Bedford Harbor (where USEPA has subsequently proposed a 50 ppm cleanup goal, with limited removal to 10 ppm in sensitive biological areas) with a hydraulic cutterhead dredge (EBASCO, 1989). Up to 3,600 ppm remain in the dredged "hot-spot" areas of New Bedford Harbor. Use of a horizontal auger hydraulic dredge at the Grasse River in New York reduced PCB levels from the nondetect to 11,000 ppm range (average of 1,109 ppm) to a 1.1 to 260 ppm range (average of 75 ppm). Hydraulic dredging at the Shiawasse River reduced PCB levels from the 24 to

References

520 ppm range to the 10 ppm range after a small-scale specialized removal (ERG, 1982). Results from mechanical dredging at the Sheboygan River and Harbor Site exhibited highly variable residual PCB concentrations up to 800 ppm. Small-scale vacuum pump/suction hose operations at the Willamette River site were not capable of removing 2 feet of sediment and resulted in residual PCB concentrations up to 21 ppm. Even the excavation "in-the-dry" remediation techniques used at Ruck Pond were not capable of removing all sediment containing PCBs. After much effort to remove sediment to the extent practicable, residual PCB concentrations still ranged from 10 to 300 ppm.

References

REFERENCES

- BBL. *Construction Documentation Report: Ruck Pond Sediment Removal Action*, August 1995a.
- BBL. *Alternative Specific Remedial Investigation Report: Sheboygan River and Harbor*, October 1995b.
- EBASCO. *Draft Final Hot Spot Feasibility Study, New Bedford Harbor*, July 1989.
- ERG, *Polychlorinated Biphenyl-Contaminated Sediment Removal from the South Branch Shiawasse River*, 1982.
- Palermo, M.R. "Equipment Choices for Dredging Contaminated Sediments." *Remediations*. 1991.
- Praeger, T.H., S.D. Messur, R.P. DiFiore. "Remediation of PCB-containing Sediments Using Surface Water Diversion 'Dry Excavation': A Case Study." *Water Science Technology*, Vol. 33, No. 6, p. 239-245. Elsevier Science Ltd, 1996.
- Rice, C.P., White, D.S., "PCB Availability Assessment of River Dredging Using Caged Clams and Fish." *Environmental Toxicology and Chemistry*, 6, pp. 259-274. 1987.
- USACE. "New Bedford Harbor Superfund Pilot Study - Evaluation of Dredging and Dredged Material Disposal." May 1990.
- USEPA. "Monitoring of Trace Constituents During PCB Recovery Dredging Operations, Duwamish Waterway." August 1977.

Response # 168 : The Ashtabula River initial cleanup criteria is not level of PCBs, but rather "cut lines" and therefore we see no relationship to the cleanup sites discussed above and the Ashtabula River.