



U.S. CONSUMER PRODUCT SAFETY COMMISSION  
WASHINGTON, D.C. 20207

December 8, 1997

Mr. Sam Cristy  
Editor - Product Safety Letter  
Washington Business Information  
1117 North 19th Street  
Arlington, VA 22209-1798

A large, stylized handwritten signature in black ink, appearing to be "AS".

Re: FOIA Request S710111C: Shindaiva, Inc., Model 300S Chain Saw, Model ED-45 Back Pack Blower Recall / CPSC File RP960077

Dear Mr. Cristy:

Thank you for your Freedom of Information Act (FOIA) request seeking information from the Commission. The records from the Commission files responsive to your request have been processed and copies are enclosed. The enclosed records include file information generated by the Commission itself or its contractors for regulatory or enforcement purposes. These records are in file RP960077 and are identified as memoranda, correspondence, notes and documents. The Commission has established management systems under which supervisors are responsible for reviewing the work of their employees or contractors. The file information materials are final and have been prepared and accepted by the Commission's staff under such review systems. The Commission believes that it has taken reasonable steps to assure the accuracy of the information.

Processing this request, performing the file searches and preparing the information, cost the Commission \$60.00. In this instance, we have decided to waive all of the charges. Thank you for your interest in consumer product safety.

Sincerely,

Handwritten initials "BS" in black ink.

Todd A. Stevenson  
Deputy Secretary and  
Freedom of Information Officer  
Office of the Secretary

Enclosures

82

SHINDA IWA • RP 960077

MEMORANDUM OF  
TELEPHONE  
CALL

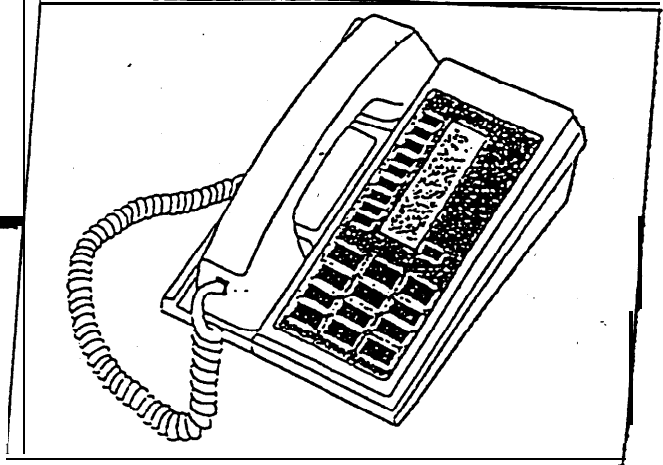

DATE: 4-9-90  
TIME: \_\_\_\_\_

NAME AND TITLE: Luc Myers  
FIRM: Shindawa  
TELEPHONE: (503) 692-3070  
SUBJECT: \_\_\_\_\_

- requested cust/dealer list - she will send in  
A couple days.

MFR/PRVLR NOTIFIED 12/2/90  
 No Comments made  
 Comments attached  
 Excisions/Revisions  
 Firm has not requested  
further notice



*Handwritten initials and date: 3/27/96*

U.S. CONSUMER PRODUCT SAFETY COMMISSION  
WASHINGTON, D.C. 20207

OFFICE OF COMPLIANCE

Division of  
Corrective Actions  
Tel: 301-504-0608  
Fax: 301-504-0359

Certified Mail

28 MAR 1996

Michael F. Breitbach  
Director, Operations and Administration  
Shindaiwa, Inc.  
11975 S.W. Herman Road  
P.O. Box 1090  
Tualatin, OR 97062

Re: CPSC RP960077  
Shindaiwa, Inc.  
Model 300S Chain Saw, Model EB-45 Back Pack Blower

Dear Mr. Breitbach:

Thank you for your report of January 25, 1996, under section 15(b) of the Consumer Product Safety Act, as amended (CPSA), 15 U.S.C. § 2064(b), and for promptly initiating a corrective action plan to address the reported problem. In your report you identified a fuel leak problem with both the Shindaiwa model 300S chain saw, and the model EB-45 back pack blower.

To address the-problem, the firm has agreed to take the following action:

1. Fax communication to all Shindaiwa distributors and letters to all Shindaiwa dealers.
2. Letters to all registered owners of both the 300S chain saw and EB-45 back pack blower.
3. Nationwide press release issued in cooperation with CPSC to announce the recall.
4. Store posters distributed to Shindaiwa dealers.
5. Replacement of all fuel tanks in Shindaiwa's inventory and replacement of fuel tanks returned by consumers with a redesigned tank which prevents fuel leaks.

CORRESPONDENCE	
SYMBOL	CCA
SUBNAME	<i>J. H. ...</i>
DATE	3-26-96

*Handwritten notes: NY, C of P, 3/27/96*

*Handwritten number: 2*

The staff of the Office of Compliance of the U.S. Consumer Product Safety Commission has reviewed the actions submitted by Shindaiwa. Acting under delegation from the **Commission**, the **staff** has accepted the plan as adequate.

Please continue the corrective actions implemented and initiate any others contained in the plan accepted by the staff. The Division of Corrective Actions will be monitoring the firm's corrective action plan. Please submit monthly progress reports of the recall, using the enclosed form, to **Tina Adeyeye**, U.S. Consumer Product Safety Commission, Division of Corrective Actions, 4330 East West Highway, Room 613, Washington, D.C. 20207-0001 by the first of each month or fax to (301)504-0359. If you have any questions, please contact **Tina** on (301)504-0608 extension 1223. Please reference the CPSC file number in your response,

The Division of Corrective Actions will evaluate the effectiveness of the plan. The staff could seek broader corrective action if the corrective action plan does not prove effective.

If the firm receives or learns of any information concerning other incidents or injuries, or information affecting the scope, prevalence or seriousness of the defect or hazard, it must report that information to this Division immediately. Additionally, if the firm receives information which might indicate that its corrective actions are not satisfactory in eliminating the defect or hazard or that the effectiveness of the corrective action program is less than has been anticipated, it must report that **information** to this Division immediately.

When the **firm** determines the corrective action plan has been implemented to the best of its ability and as many products as possible have been removed from the marketplace, it may submit a **final** progress report, referencing the file number, and request that the file be closed. At that time the staff will review the plan's progress and decide whether the file should be closed.

Section 6(b)(1) **requires** the Commission to give notice thirty days in advance of the intended disclosure of information that identifies the manufacturer or private labeler of a product. The staff is enclosing a summary of the corrective action plan. The Commission publishes a list of product recalls and other corrective actions initiated by firms in an Annual Report to Congress. This information is also occasionally used in lists for specific product categories. This letter gives the firm its opportunity under section 6(b)(1) of the Consumer Product Safety Act (CPSA), 15 U.S.C. § 2055(b)(1), and 16 C.F.R. Part 1101, to comment on the accuracy of the information.

The staff has made every effort to assure that the enclosed information is accurate. If, however, the firm believes that the information is not accurate, please send comments to John Shumlansky. The firm's comments must be received within twenty-three calendar days of your receipt of this certified letter if they are to be considered. Please include with any



comments specific information to support any claim that the information is not accurate. If the Commission decides to disclose the information, unchanged, over any accuracy objections, it will give the **firm** ten (10) working days notice, as required by section 6(b)(2) of the CPSA, 15 U.S.C. § 2055(b)(2)..

Thank you for your continued cooperation in this matter. If you have any questions, please contact John **Shumlansky** on (301) 504-0608 extension 1366.

Sincerely yours,

Marc J. Schoem  
Director  
Division of Corrective Actions

Enclosures:

Progress Report Form  
Corrective Action Summary

cc: Consumer Product Safety Commission  
Western Regional Center  
600 Harrison Street  
Room 245  
San Francisco, CA 24107-1370

4

Voluntary Corrective Action Plans Under Section 15  
of the Consumer Product Safety Act and  
Section 15 of the Federal Hazardous Substances Act

The following is a list of voluntary corrective action plans recently accepted by the Commission (or the staff acting under authority delegated by the Commission). A firm's taking corrective action does not constitute admission by the firm that a substantial product hazard exists.

Space does not permit the staff to give a complete list of the specific model numbers of the products involved in each of these corrective actions. Consumers who believe that they have a product affected by one of these actions should follow the instructions given in this list or contact either the manufacturer or the Commission to determine if their product is one of those affected.

5

) )

Voluntary Corrective Action Plans Under  
Section **15** of the Consumer Product Safety Act **and**  
Section 15 of the Federal **Hazardous** Substances Act

<b>DATE</b>	<b>FIRM AND PRODUCT</b>	<b>ALLEGED HAZARD</b>	<b>REMEDY</b>
<b>00/00</b>	Shindaiwa, Inc. <b>Tualatin, OR</b>  Model <b>EB-45</b> Gas Powered Back Pack Blower, and Model 3005 Chain Saw	Chemical burn or fire hazard from a fuel leak	Return to a Shindaiwa authorized service center for <b>replacment</b> of the fuel tank

# News from CPSC

## U.S. Consumer Product Safety Commission

Office of Information and Public Affairs

Washington, D.C. 20207

For Immediate Release  
March 27, 1996  
Release # 96-087

Contact: Kate Premo  
(301) 504-0580 Ext. 1187

### CPSC, SHINDAIWA ANNOUNCE RECALL OF BACKPACK BLOWERS AND CHAIN SAWS

WASHINGTON, DC. - In cooperation with the U.S. Consumer Product Safety Commission (CPSC), Shindaiwa Inc. of Tualatin, Ore., is announcing the recall of approximately 18,500 Shindaiwa model EB-45 backpack blowers, and 4,970 Shindaiwa model 300S chain saws. The tools' fuel tanks could leak, presenting a possible chemical burn or fire hazard. Shindaiwa is not aware of any injuries involving these products.

The red blower is mounted on a black metal backpack frame with shoulder straps, black blower tubes, and a white fuel tank with "Shindaiwa . . . model number EB-45" printed in the center. The red chain saw has a gray guide bar and "model number 300S" printed on the pull-start housing.

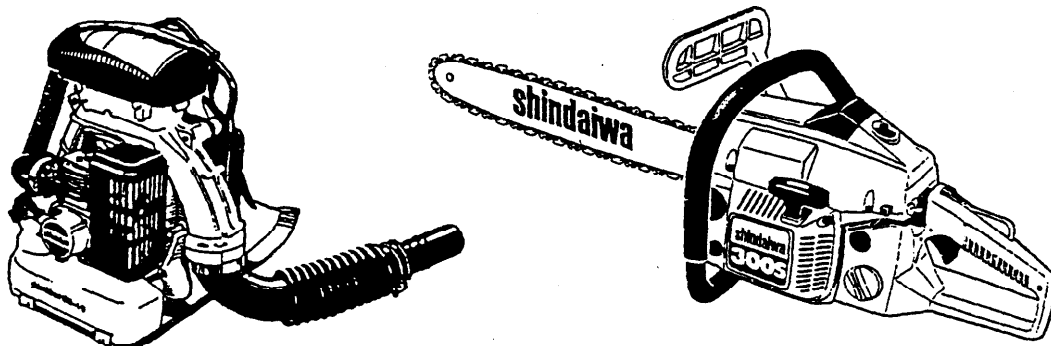

Authorized Shindaiwa dealers nationwide sold these tools from April 1992 to June 1995. The backpack blowers sold for approximately \$430 each and the' chain saw for approximately \$300 each.

---MORE---

7



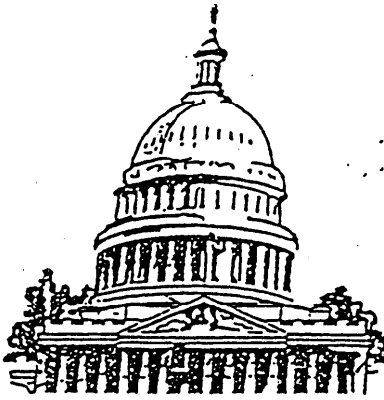

U.S. CONSUMER PRODUCT SAFETY COMMISSION  
WASHINGTON, DC 20207

OFFICE OF COMPLIANCE

DIVISION OF  
CORRECTIVE ACTIONS

\_\_\_\_ CONFIRMATION COPY TO FOLLOW BY U.S. MAIL  
 FAX TRANSMISSION ONLY

Tel: 301-504-0608  
FAX: 301-504-0359

DATE: 3 128 196 PAGES TRANSMITTED 2 + cover

TO: MIKE Breitbach

TITLE: \_\_\_\_\_

OFFICE: SHINDAIWA

FAX #: (503) 692-6696

Resend -  
DID not go through  
3-29

FROM: John Skonlansky

REMARKS: Ryobi / Sears Press Release

NOTE: If all pages are not received, or if you have problems with this transmittal, please contact the person listed above.

THIS MESSAGE IS INTENDED ONLY FOR THE USE OF THE INDIVIDUAL OR ENTITY TO WHICH IT IS ADDRESSED AND MAY CONTAIN INFORMATION THAT IS PRIVILEGED, CONFIDENTIAL, AND EXEMPT FROM DISCLOSURE UNDER APPLICABLE LAW. IF THE READER OF THIS MESSAGE IS NOT THE INTENDED RECIPIENT: YOU ARE HEREBY NOTIFIED THAT ANY DISSEMINATION, DISTRIBUTION, OR COPYING OF THIS COMMUNICATION IS STRICTLY PROHIBITED. IF YOU HAVE RECEIVED THIS COMMUNICATION IN ERROR, PLEASE NOTIFY US IMMEDIATELY BY TELEPHONE. AND RETURN THE ORIGINAL MESSAGE TO US AT THE ABOVE ADDRESS VIA THE U.S. POSTAL SERVICE. THANK YOU.

8

## U.S. Consumer Product Safety Commission

Office of Information and Public Affairs

Washington, D.C. 20207

For Immediate Release  
March 27, 1996  
**Release # 96-088**

Contact: Kate Premo  
(301) 504-0580 Ext. 1187

### CPSC, RYOBI AND SEARS ANNOUNCE TABLE SAW SWITCH RECALL FOR REPAIR

WASHINGTON, D.C. - In cooperation with the U.S. Consumer Product Safety Commission (CPSC), Ryobi America Corporation of Anderson, S.C., is announcing a recall to repair approximately 150,000 10-inch table saws. On some saws, the power switch lock-off mechanism may not work, and as a result, children and others who should not have access to the saw could be injured by the moving blade.

Ryobi has not received reports of any injuries associated with this problem.

All table saws which may have this problem have large rectangular ON/OFF buttons. In order to turn the saw on, a switch lock-off key (referred to in the owner's manual as a key plate) must be in place around the ON button. In some cases, if the OFF button is not completely depressed, consumers may be able to restart the table saw without the key. As a result, consumers could be accidentally cut or injured.

The saws, 'weighing 75 pounds each, have a 10-inch blade and a sliding miter table. The table saws were sold under the brand names and model numbers "Ryobi BT3000" and "Sears Craftsman Model 3 15.22 185."

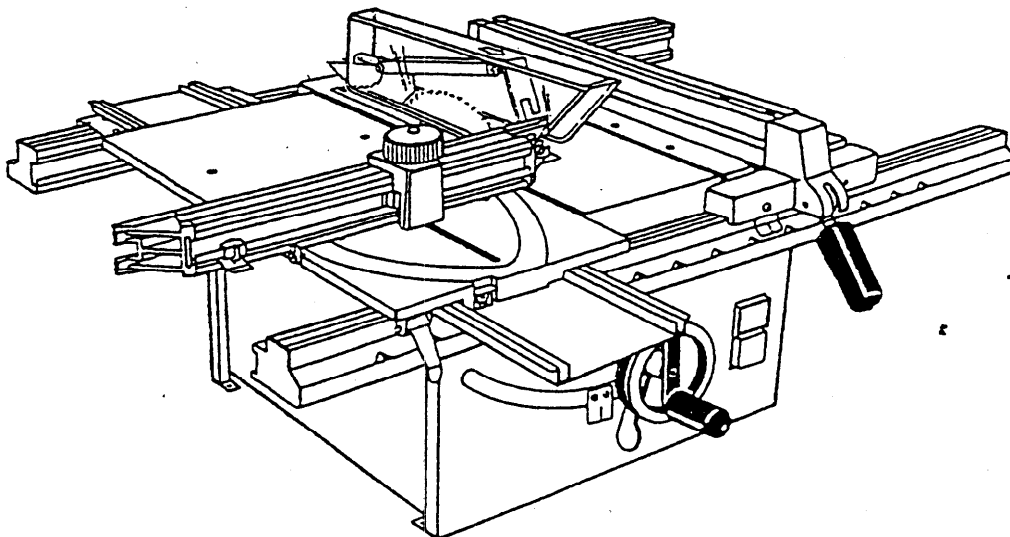

-more-

9

Various home centers and hardware stores sold the Ryobi saws nationwide starting in May 1991. Sears stores sold the Craftsman saws nationwide starting in July 1994. Both table saws sold for approximately \$400 to \$600 each.

The table saws have a serial number located on a data plate on the right side of the saw. Consumers who own Ryobi BT3000 10-Inch Table Saws with serial numbers ending in four digits lower than 9608 or Sears Craftsman Model 3 15.22185 10-Inch Table Saws should call (800) 867-9624 immediately with the serial number of their saw. Replacement switches will be installed without charge. Consumers are also encouraged to confirm full release of the ON button when removing **their** "lock-off key" and to always remove the plug from its power source when the table saw is not in use.

The U.S. Consumer Product Safety Commission protects the public from the unreasonable risk of injury or death from 15,000 types of consumer products under the agency's jurisdiction. To report a dangerous product or a product-related injury and for information on CPSC's **fax-on-demand** service, call CPSC's hotline at (800) 638-2772 or CPSC's teletypewriter at (800) 63843270. To order a press release through fax-on-demand, call (301) 504-005 1 from the handset of your fax machine and enter the release number. Consumers can obtain this release and recall information via Internet gopher services at [cpsc.gov](http://cpsc.gov) or report product hazards to [info@cpsc.gov](mailto:info@cpsc.gov).

####





U.S. CONSUMER PRODUCT SAFETY COMMISSION  
WASHINGTON, DC 20207

OFFICE OF COMPLIANCE

DIVISION OF  
CORRECTIVE ACTIONS  
Tel: 30-f-504-0608  
FAX: 301-504-0359

CONFIRMATION COPY TO FOLLOW BY U.S. MAIL  
 FAX TRANSMISSION ONLY

DATE: 3/25/96 PAGES TRANSMITTED 2 + cover

TO: Sue Meyer

TITLE: \_\_\_\_\_

OFFICE: Shiraz

FAX #: (503) 692-6696

FROM: John Shumansky

REMARKS: Press Release w/ Picture.

NOTE: If all pages are not received, or if you have problems with this transmittal, please contact the person listed above.

THIS MESSAGE IS INTENDED ONLY FOR THE USE OF THE INDIVIDUAL OR ENTITY TO WHICH IT IS ADDRESSED AND MAY CONTAIN INFORMATION THAT IS PRIVILEGED, CONFIDENTIAL, AND EXEMPT FROM DISCLOSURE UNDER APPLICABLE LAW. IF THE READER OF THIS MESSAGE IS NOT THE INTENDED RECIPIENT, YOU ARE HEREBY NOTIFIED THAT ANY DISSEMINATION, DISTRIBUTION, OR COPYING OF THIS COMMUNICATION IS STRICTLY PROHIBITED. IF YOU HAVE RECEIVED THIS COMMUNICATION IN ERROR, PLEASE NOTIFY US IMMEDIATELY BY TELEPHONE, AND RETURN THE ORIGINAL MESSAGE TO US AT THE ABOVE ADDRESS VIA THE U.S. POSTAL SERVICE. THANK YOU.

11

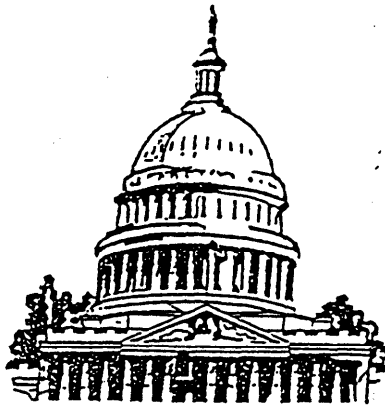

U.S. CONSUMER PRODUCT SAFETY COMMISSION  
WASHINGTON, DC 20207

OFFICE OF COMPLIANCE

DIVISION OF  
CORRECTIVE ACTIONS

CONFIRMATION COPY TO FOLLOW BY U.S. MAIL  
 FAX TRANSMISSION ONLY .

Tel: 3014040608  
F A X : 301-504-0359 .

DATE: 9/6/14 PAGES TRANSMITTED 1 + cover

TO: SUE Meyer

TITLE: \_\_\_\_\_

OFFICE: Shindana

FAX #: (503) 692-6696

FROM: John Shumlaszky

REMARKS: Press Release w/ your recent  
corrections.

NOTE: If all pages are not received, or if you have problems with this transmittal, please contact the person listed above.

THIS MESSAGE IS INTENDED ONLY FOR THE USE OF THE INDIVIDUAL OR ENTITY TO WHICH IT IS ADDRESSED AND MAY CONTAIN INFORMATION THAT IS PRIVILEGED, CONFIDENTIAL, AND EXEMPT FROM DISCLOSURE UNDER APPLICABLE LAW. IF THE READER OF THIS MESSAGE IS NOT THE INTENDED RECIPIENT, YOU ARE HEREBY NOTIFIED THAT ANY DISSEMINATION, DISTRIBUTION, OR COPYING OF THIS COMMUNICATION IS STRICTLY PROHIBITED. IF YOU HAVE RECEIVED THIS COMMUNICATION IN ERROR, PLEASE NOTIFY US IMMEDIATELY BY TELEPHONE, AND RETURN THE ORIGINAL MESSAGE TO US AT THE ABOVE ADDRESS VIA THE U.S. POSTAL SERVICE. THANK YOU.

12

## U.S. CONSUMER PRODUCT SAFETY COMMISSION

OFFICE OF INFORMATION AND PUBLIC AFFAIRS

WASHINGTON, D.C. 20207

FOR IMMEDIATE RELEASE  
1996  
Release # 96

CONTACT:  
(301) 504-0580 Est.

**DRAFT**

### CPSC, SHINDAIWA ANNOUNCE RECALL OF BACKPACK BLOWERS AND CHAIN SAWS

WASHINGTON, D.C. - In cooperation with the U.S. Consumer Product Safety Commission (CPSC), Shindaiwa Inc. of Tualatin., Ore., is announcing the recall of approximately 18,500 Shindaiwa model EB-45 backpack blowers, and 4,970 Shindaiwa model 300S chain saws. The tool's fuel tanks could leak, presenting a possible chemical burn or fire hazard. Shindaiwa is not aware of any injuries involving these products.

The red blower is mounted on a black metal backpack frame with shoulder straps, black blower tubes, and a white fuel tank with "Shindaiwa . . . model number EB-45" printed in the center. The red chain saw has a gray guide bar and "model number 300S" printed on the pull-start housing.

#### LINE DRAWING

Authorized Shindaiwa dealers nationwide sold these tools from April 1992 to June 1995. The backpack blowers sold for approximately \$430 each and the chain saw for approximately \$300 each.

Consumers who own the recalled backpack blowers or chain saws should stop using them immediately and return them to any authorized Shindaiwa servicing dealer. The backpack blower and chain saw will be fitted with a redesigned fuel tank at no charge. For more information, consumers should call Shindaiwa toll-free at (800) 5X-7733.

Shindaiwa is conducting this recall to prevent the possibility of injury.

The U.S. Consumer Product Safety Commission protects the public from the unreasonable risk of injury or death from 15,000 types of consumer products under the agency's jurisdiction. To report a dangerous product or a product-related injury and for information on CPSC's fax-on-demand service, call CPSC's hotline at (800) 638-2772 or CPSC's teletypewriter at (SOO) 638-8270. To order a press release through fax-on-demand, call (301) 504-0051 from the handset of your fax machine and enter the release number. Consumers can obtain this release and recall information via Internet gopher services at [cpsc.gov](http://cpsc.gov) or report product hazards to [info@cpsc.gov](mailto:info@cpsc.gov).

####

13

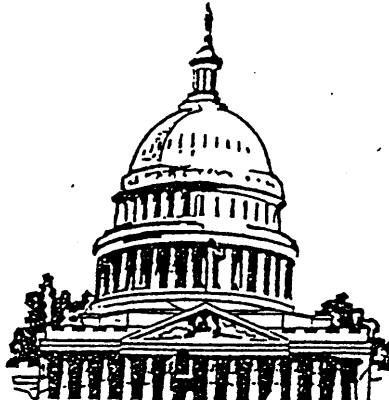

U.S. CONSUMER PRODUCT SAFETY COMMISSION  
WASHINGTON, DC 20207

OFFICE OF COMPLIANCE

DIVISION OF  
CORRECTIVE ACTIONS  
Tel: 301-504-0608  
FAX: 301-504-0359

CONFIRMATION COPY TO FOLLOW BY U.S. MAIL  
FAX TRANSMISSION ONLY

DATE: 9/13/06 PAGES TRANSMITTED 1 + cover

TO: SUE MEYER

TITLE: \_\_\_\_\_

OFFICE: Shin DAIWA

FAX #: (503) 692-6696

FROM: \_\_\_\_\_

REMARKS: CUSTOMER LETTERS LOOK GOOD. PLEASE HAVE THEM SENT OUT AS SOON AS POSSIBLE. WE ADDED THE INFO. YOU PROVIDED TO THE ATTACHED PRESS RELEASE. LET ME KNOW IF THURSDAY, MARCH 21<sup>ST</sup> IS A GOOD DAY TO ISSUE THE RELEASE. THANKS.

NOTE: If all pages are not received, or if you have problems with this transmittal, please contact the person listed above.

THIS MESSAGE IS INTENDED ONLY FOR THE USE OF THE INDIVIDUAL OR ENTITY TO WHICH IT IS ADDRESSED AND MAY CONTAIN INFORMATION THAT IS PRIVILEGED, CONFIDENTIAL, AND EXEMPT FROM DISCLOSURE UNDER APPLICABLE LAW. IF THE READER OF THIS MESSAGE IS NOT THE INTENDED RECIPIENT, YOU ARE HEREBY NOTIFIED THAT ANY DISSEMINATION, DISTRIBUTION, OR COPYING OF THIS COMMUNICATION IS STRICTLY PROHIBITED. IF YOU HAVE RECEIVED THIS COMMUNICATION IN ERROR, PLEASE NOTIFY US IMMEDIATELY BY TELEPHONE, AND RETURN THE ORIGINAL MESSAGE TO US AT THE ABOVE ADDRESS VIA THE U.S. POSTAL SERVICE. THANK YOU.

14

Sill



U.S. CONSUMER PRODUCT SAFETY COMMISSION  
WASHINGTON, DC 20207

OFFICE OF COMPLIANCE

DIVISION of  
CORRECTIVE ACTIONS  
Tel: 301-504-0608  
FAX: 301-504-0359

CONFIRMATION COPY TO FOLLOW BY U.S. MAIL  
FAX TRANSMISSION ONLY

DATE: 3/13/96 PAGES TRANSMITTED: 6 + e r

TO: SUE MEYER

TITLE: \_\_\_\_\_

OFFICE: SHINDRIVER

FAX #: (503) 692-6696

3/13/96

FROM: Sue M: John - March 21<sup>st</sup> is o.k. to issue the Release. Please make the few corrections attached + we'll send to distributors with their 3/14 mailing... i.e.

REMARKS: CUSTOMER LETTERS look good. Please have them sent out as soon as possible. We added the info. you provided to the attached

Press Release. Let me know if Thursday, March 21<sup>st</sup> is a good day to issue the Release. THANKS.

NOTE: If all pages are not received, or if you have problems with this transmittal, please contact the person listed above.

THIS MESSAGE IS INTENDED ONLY FOR THE USE OF THE INDIVIDUAL OR ENTITY TO WHICH IT IS ADDRESSED AND MAY CONTAIN INFORMATION THAT IS PRIVILEGED, CONFIDENTIAL, AND EXEMPT FROM DISCLOSURE UNDER APPLICABLE LAW. IF THE READER OF THIS MESSAGE IS NOT THE INTENDED RECIPIENT, YOU ARE HEREBY NOTIFIED THAT ANY DISSEMINATION, DISTRIBUTION, OR COPYING OF THIS COMMUNICATION IS STRICTLY PROHIBITED. IF YOU HAVE RECEIVED THIS COMMUNICATION IN ERROR, PLEASE NOTIFY US IMMEDIATELY BY TELEPHONE, AND RETURN THE ORIGINAL MESSAGE TO US AT THE ABOVE ADDRESS VIA THE U.S. POSTAL SERVICE. THANK YOU.

please fax  
me a  
corrected c

Thanks,  
[Signature]



**U.S. CONSUMER PRODUCT SAFETY COMMISSION**

OFFICE OF INFORMATION AND PUBLIC AFFAIRS

WASHINGTON, D.C.

20207

FOR IMMEDIATE **RELEASE**

1996

Release # 94

**CONTACT:**

(301) 504-0580 Ext.

**CPSC, SHINDAIWA ANNOUNCE RECALL OF BACKPACK BLOWERS AND CHAIN SAWS**

WASHINGTON, D.C. - In cooperation with the U.S. Consumer Product Safety Commission (CPSC), Shindaiwa Inc. of Tualatin, Ore., is announcing the recall of approximately 18,500 Shindaiwa model <sup>EB-45</sup> ~~EB-45~~ backpack blowers, and 4,970 Shindaiwa model 300S chain saws. The tool's fuel tanks could leak, presenting a possible chemical burn or fire hazard. Shindaiwa is not aware of any injuries involving these products.

The red blower is mounted on a black metal backpack frame with shoulder straps, black blower tubes, and a white fuel tank with Shindaiwa model number "EB-45" printed in the center. The red chain saw has a gray guide bar and model number "300S" printed on the pull-start housing.

LINE DRAWING

**DRAFT**

guide bar (2 words)

Authorized Shindaiwa dealers nationwide sold these tools from April 1992 to June 1995. The backpack blowers sold for approximately \$430 each and the chain saw for approximately \$300 each.

Consumers who own the recalled backpack blowers or chain saws should stop using them immediately and return them to any authorized Shindaiwa <sup>S.E.</sup> servicing dealer. The backpack blower and chain saw will be fitted with a redesigned fuel tank at no charge. For more information, consumers should call Shindaiwa toll-free at (800) 521-7733.

Shindaiwa is conducting this recall to prevent the possibility of injury.

The U.S. Consumer Product Safety Commission protects the public from the unreasonable risk of injury or death from 15,000 types of consumer products under the agency's jurisdiction. To report a dangerous product or a product-related injury and for information on CPSC's fax-on-demand service, call CPSC's hotline at (800) 638-2772 or CPSC's teletypewriter at (800) 638-8270. To order a press release through fax-on-demand, call (301) 504-0051 from the handset of your fax machine and enter the release number. Consumers can obtain this release and recall information via Internet gopher services at [cpsc.gov](http://cpsc.gov) or report product hazards to [info@cpsc.gov](mailto:info@cpsc.gov).

16

# NEWS from CPSC

## U.S. CONSUMER PRODUCT SAFETY COMMISSION

OFFICE OF INFORMATION AND PUBLIC AFFAIRS

WASHINGTON, D.C.

20207

**FOR IMMEDIATE RELEASE**

**1996**

**Release # 96**

**CONTACT:**

**(301) 504-0580 Ext.**

### **CPSC, SHINDAIWA ANNOUNCE RECALL OF BACKPACK BLOWERS AND CHAIN SAWS**

WASHINGTON, D.C. - In cooperation with the U.S. Consumer Product Safety Commission (CPSC), Shindaiwa Inc. of Tualatin, Ore., is announcing the recall of approximately 18,500 Shindaiwa model EB45 backpack blowers, and 4,970 Shindaiwa model 300S chain saws. The tool's fuel tanks could leak, presenting a possible chemical burn or fire hazard. Shindaiwa is not aware of any injuries involving these products.

The red blower is mounted on a black metal backpack frame with shoulder straps, black blower tubes, and a white fuel tank with "Shindaiwa" and model number "EB45" printed in the center. The red chain saw has a gray guidebar and model number "300S" printed on the pull-start housing.

LINEDRAWING

Authorized Shindaiwa dealers nationwide sold these tools from April 1992 to June 1995. The back pack blowers sold for approximately \$430 each and the chain saw for approximately \$300 each

Consumers who own the recalled back pack blowers or chain saws should stop using them immediately and return them to any authorized Shindaiwa Servicing dealer. The backpack blower and chain saw will be fitted with a redesigned fuel tank at no charge. For more information, consumers should call Shindaiwa toll-free at (800) 521-7733.

Shindaiwa is conducting this recall to prevent the possibility of injury.

The U.S. Consumer Product Safety Commission protects the public from the unreasonable risk of injury or death from 15,000 types of consumer products under the agency's jurisdiction. To report a dangerous product or a product-related injury and for information on CPSC's fax-on-demand service, call CPSC's hotline at (800) 638-2772 or CPSC's teletypewriter at (800) 638-8270. To order a press release through fax-on-demand, call (301) 504-0051 from the handset of your fax machine and enter the release number. Consumers can obtain this release and recall information via Internet gopher services at [cpsc.gov](http://cpsc.gov) or report product hazards to [info@cpsc.gov](mailto:info@cpsc.gov).

13



U.S. CONSUMER PRODUCT SAFETY COMMISSION  
WASHINGTON, DC 20207

OFFICE OF COMPLIANCE

DIVISION OF  
CORRECTIVE ACTIONS  
FAX: 301-504-0359

Tel: 301-604-0608

DATE: 1966 PAGES TRANSMITTED 1 + cover

TO: Michael Breitbach

TITLE: Director, Operations and Admin.

OFFICE: Shimodaira

FAX #: (503) 692-6696

- Confirmation copy to follow  U.S. Mail
- Fax Transmission Only

FROM: John Humlansky

REMARKS: Please Review and provide any comments to our Revisions of the Press Release. Thank you.

NOTE: If all pages are not received, or if you have problems with this transmittal, please contact the person listed above.

THIS MESSAGE IS INTENDED ONLY FOR THE USE OF THE INDIVIDUAL OR ENTITY TO WHICH IT IS ADDRESSED AND MAY CONTAIN INFORMATION THAT IS PRIVILEGED, CONFIDENTIAL, AND EXEMPT FROM DISCLOSURE UNDER APPLICABLE LAW. IF THE READER OF THIS MESSAGE IS NOT THE INTENDED RECIPIENT, YOU ARE HEREBY NOTIFIED THAT ANY DISSEMINATION, DISTRIBUTION, OR COPYING OF THIS COMMUNICATION IS STRICTLY PROHIBITED. IF YOU HAVE RECEIVED THIS COMMUNICATION IN ERROR, PLEASE NOTIFY US IMMEDIATELY BY TELEPHONE, AND RETURN THE ORIGINAL MESSAGE TO US AT THE ABOVE ADDRESS VIA THE U.S. POSTAL SERVICE. THANK YOU.

146

# NEWS from CPSC

## U.S. CONSUMER PRODUCT SAFETY COMMISSION

OFFICE OF INFORMATION AND PUBLIC AFFAIRS

WASHINGTON, D.C.

20207

**FOR IMMEDIATE RELEASE**  
**1996**  
**Release # 96**

**CONTACT:**  
**(301) 504-0580 Ext.**

### **CPSC, SHINDAIWA ANNOUNCE RECALL OF BACKPACK BLOWERS AND CHAIN SAWS**

WASHINGTON, D.C. - In cooperation with the U.S. Consumer Product Safety Commission (CPSC), Shindaiwa Inc. of Tualatin, Ore., is announcing the recall of approximately MJMBER Shindaiwa model EB45 backpack blowers, and NUMBER Shindaiwa model 300S chain saws. The tool's fuel tanks could leak, presenting a possible chemical burn or fire hazard. Shindaiwa is not aware of any injuries involving these products.

The red blower is mounted on a black metal backpack frame with shoulder straps, black blower tubes, and a white fuel tank with "Shindaiwa model number EB45" printed in the center. The red chain saw has a gray handlebar and "model number 300S" printed on the pull-start housing.

LINE DRAWING

Authorized Shindaiwa dealers nationwide sold these tools from MONTH, YEAR to MONTH, YEAR. The back pack blowers sold for approximately HOW MUCH each and the chain saw for approximately HOW MUCH each.

Consumers who own the recalled back pack blowers or chain saws should stop using them immediately and return them to any authorized Shindaiwa Servicing dealer. The backpack blower and chain saw will be fitted with a redesigned fuel tank at no charge. For more information, consumers should call Shindaiwa toll-free at (800) 521-7733.

Shindaiwa is conducting this recall to prevent the possibility of injury.

The U.S. Consumer Product Safety Commission protects the public from the unreasonable risk of injury or death from 15,000 types of consumer products under the agency's jurisdiction. To report a dangerous product or a product-related injury and for information on CPSC's fax-on-demand service, call CPSC's hotline at (800) 638-2772 or CPSC's teletypewriter at (800) 638-8270. To order a press release through fax-on-demand, call (301) 504-005 1 from the handset of your fax machine and enter the release number. Consumers can obtain this release and recall information via Internet gopher services at [cpsc.gov](http://cpsc.gov) or report product hazards to [info@cpsc.gov](mailto:info@cpsc.gov).

19

id on the reverse side?

**SENDER:**

- Complete items 1 and/or 2 for additional services.
- Complete items 3 and 4a & b.
- Print your name and address on the reverse of this form so that we can return this card to you.
- Attach this form to the front of the mailpiece, or on the back if space does not permit.
- Write "Return Receipt Requested" on the mailpiece below the article number.
- The Return Receipt will show to whom the article was delivered and the date delivered.

I also wish to receive the following services (for an extra fee):

- 1.  Addressee's Address
- 2.  Restricted Delivery

Consult postmaster for fee.

3. Article Addressed to:

Michael F. Breitbach  
 Director, operations and Administration  
 Shindaiwa, Inc.  
 11975 SW Herman Road  
 PO Box 1090  
 Tualatin, OR 97062

4a. Article Number

068 859 320

Service Type

- Registered  Insured
- Certified   COD
- Express Mail  Return Receipt for Merchandise

Date of Delivery

2/21/96

Is your RETURN

5. Signature (Addressee)

*Michael F. Breitbach*

6. Signature (Agent)

8. Addressee's Address (Only if requested and fee is paid)

20

Thank you for using Return Receipt Service.

PS Form 3811, December 1991

U.S. GPO: 1993-352-714

DOMESTIC RETURN RECEIPT

1/75

SHINDAIWA INC.

SUE MEYER  
EXECUTIVE SECRETARY  
11975 S.W. HERMAN ROAD  
TUALATIN, OR 97062

TELEPHONE (503) 692-3070  
FAX (503) 692-6696  
DIRECT LINE (503) 691-4641

VIA FAX

Date: March 12, 1996

To: John Shumlansky, CPSC

From: Sue Meyer

Subject: Revised Documents for EB-45 and 300S Recall

96 MAR 13 AM 8:29  
CPSC COMMUNICATIONS DIVISION  
FEDERAL GOVERNMENT

John, as we discussed on the phone this morning, following are copies of documents to complete these two recalls:

- Fax communication to Distributors
- Letter to Dealers
- Parts Revisions Nos. PR-114 (2 page), PR- 142 for the EB-45 blower and PR-126R for the 300S chain saw
- Letter to EB-45 Registered Owner
- Letter to 300S Registered Owner
- Copy of 12" x 18" poster to be displayed in Dealer's shop
- Inventory Disposition Certification form to be completed by distributors and dealers
- Copy of Press Release (as discussed, to be released on the date provided by Shindaiwa Inc. early next week)
- Two line drawings for use in the Press Release

Sorry for the delay in getting these revised forms to you. We have spent a great deal of time getting input from the proper people in order to make the documents as accurate as well as clear and understandable as possible. I will send the full packet UPS Next Day Air today.

As we discussed, you will be letting me know by return if these documents are acceptable to the CPSC so we can proceed with printing.

Sincerely,



Sue Meyer

c: Mike Breitbach

21

Shindaiwa Inc.

11975 S.W. Herman Road  
P.O. Box 1090  
Tualatin, Oregon 97062

Phone 503 692-3070  
FAX 503 692-6696

**DISTRIBUTOR COMMUNICATION VIA FAX**

March 12, 1996

To: **All Distributors**

From: **Pete Fernald  
Technical Services Manager**

Re: **EB-45 Product Recall  
300S Product Recall--Extension of August 1993 Recall**

**shindaiwa**

In cooperation with the Consumer Product Safety Commission, we are recalling two Shindaiwa units due to possible fuel tank problems. First, the EB-45 blower has a potential leak on the rear side of the fuel tank. Additionally, the model 300S chain saw has a potential leak in its fuel tank. The 300S recall is a continuation of an earlier recall in August 1993.

Enclosed are copies of important documents regarding these two recalls. Please carefully read these documents and ensure that the appropriate people in your organization (sales, inside sales, and technical people, etc.) also have copies and are **fully** informed.

- I. Letter to dealers regarding the product recall
2. Copies of Parts Revisions Nos. PR-114 and PR-142 for the model EB-45 and PR-126R for model 300S
3. Letters to both EB-45 and 300S registered owners announcing the recall
4. Copy of a 12" x 18" poster to be placed in a visible location in the dealer's shop
5. Inventory Disposition Certification form. Distributors will process warranty claims as described in the letter to dealers, including completion of the Inventory Disposition Certification form.

Thanks in advance for your assistance. If you have any questions, please contact your Technical Services Representative at 1-800-521-7733.

Pete Fernald

Attachments



22

Shindaiwa Inc.

11975 S.W. Herman Road  
P.O. Box 1090  
Tualatin, Oregon 97062

Phone 503 692-3070  
FAX 503 692-6696

**WARNING!**

**IMPORTANT SAFETY NOTICE**

March 12, 1996

**shindaiwa**

Dear Shindaiwa Dealer:

In cooperation with the **U.S. Consumer Product Safety Commission**, Shindaiwa is requesting that you take the following actions to minimize potential hazard from fuel tank leakage on the **EB-45 backpack blower and the 300S chain saw**. We are sending notification to registered owners to return affected units to their nearest dealer for inspection and possible fuel tank replacement at no charge to the owner.

**EB45**

1. Remove tank and perform a visual inspection of EB-45 units within **Serial No. 2039911 to 4058110**. Focus on **front** and rear bracket areas for signs of leakage.
2. Verify that improved **front** brackets have been installed per PR-114.
3. If no leakage is detected, the old tank can be reused provided you inspect the rear mounting bracket for rough edges and file smooth. However, if the vinyl cushion (P/N 7002985 130) has been damaged or is otherwise unusable, replace the complete tank and cushion with the full improved tank assembly per PR-142.
4. If there are obvious signs of wear or leakage on the tank, replace with new tank assembly per PR- 142.
5. Destroy all previous versions of the fuel tank in spare parts and wholetoods inventories. Complete. the Inventory Disposition Certification form attached. Process these as warranty along with recall units. Multiple units can be processed on the same claim. as long as all serial numbers are listed and the claim lists exactly the same part numbers for each unit listed.

**300S**

1. Inspect all 300S chain saws per PR-126R with the newly extended **Serial No. range 2056736 to 3066305** (previous range was 2055086 to 2056735).



23



We have attached the following important information to assist in this recall:

1. Parts Revisions **PR-114** and **PR-142** for the model **EB-45** and **PR-126R** for model **300S**. Both contain fuel tank improvements and important changes in the **affected** serial numbers.
2. Copies of letters to both EB-45 and 300S registered owners
3. **A warning sign. This must be displayed in a publicly visible location** in your place of business. It is to be posted immediately and maintained in place through September 30, 1996.
4. Inventory Disposition Certification form

During the period of this recall, you may be visited by a representative of the Consumer Product Safety Commission. They will be doing spot checks of Shindaiwa dealers to measure the effectiveness of this effort.

Thank you in advance for your cooperation. You are a valued customer and we appreciate your business. If you need further information or assistance, please contact your Shindaiwa distributor.

Sincerely,

Pete Femald  
Technical Services Manager

Attachments



Handwritten signature or initials in the bottom right corner.

# shindaiwa® SERVICE BULLETIN

**CORRECTED COPY!**

SERVICE AND ENGINEERING BULLETIN

BULLETIN No.: PR-114

(page 1 of 2 pages)

SUBJECT: PARTS REVISION

DATE: 01/10/93

MODELS AFFECTED: EB-45

DESCRIPTION: Fuel Tank Mounting

REASON FOR CHANGE: Possible tank failures resulting from metal bracket comers contacting tanks.

INTERCHANGEABILITY: NONE (Do Not Use Old Parts)

REVISION DATE: 07/13/92

SERIAL NUMBERS: 0028891-2039910 (Units 203991 1 & after will feature these parts).

Details of change: New tank holder is offset approx. 3/16" to accomodate larger (captive) rubber cushion. Slotted-head fastening is replaced by an allen-head screw.

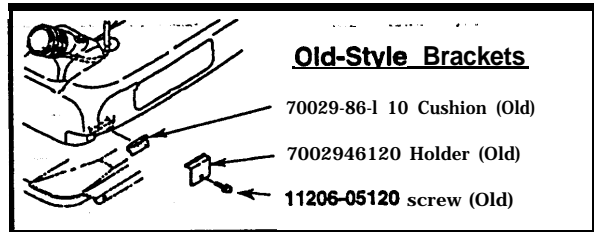

7002945130  
Tank Cushion

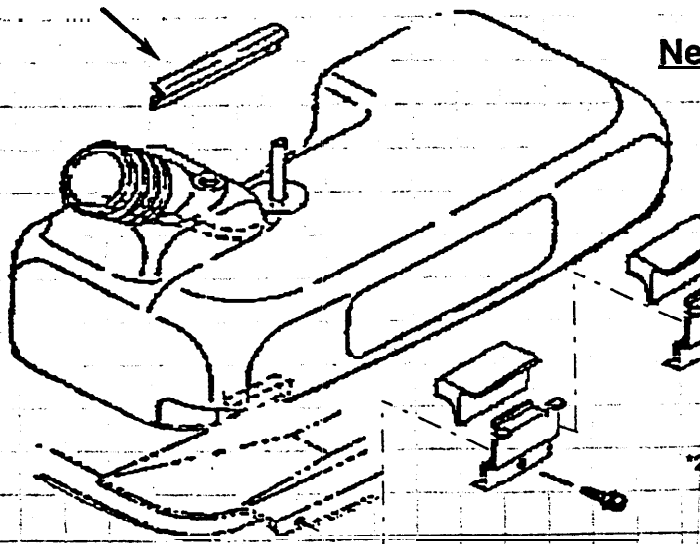

**New-Style Brackets & Cushions**

1)

on (new)

er (new)

w (new)

909-157

*John  
"Clearer" copy  
than faxed  
@*

**CORRECTED  
COPY!**

**Note:** Tank failures from old-style brackets may result from "cocking" brackets against the tank shell during assembly, and the new-style brackets should be installed on inventoried units during dealer set-up. Any suspect tank(s) should be inspected/pressure-tested for cracks during bracket replacement, with special attention given to potential leakage at the tank mounting areas. When both tank and brackets are to be replaced on the same unit, they may be ordered as an assembly under (temporary) p/n 99909-1 53. Note that stabilizing a tank on an older or high-time unit may also require the (non-warranty) replacement of p/n 70029-85130 Tank Cushion.

**Claims:** Bracket replacement claims should be submitted on a Shindaiwa warranty form.

- \*Multiple claims may be listed on one form.**
- Serial numbers must be provided for each EB-45 listed.**
  - Claims submitted without serial number documentation will be returned.**
- A labor rate of .1-hour will be paid for each set of brackets replaced.**

leaking tanks may be replaced under a normal warranty claim, and defective tanks are to be destroyed. Dealers are requested to exchange all old-stye brackets through their distributors. Shindaiwa will replace distributor-level inventory of old-style brackets and cushions on an exchange basis.

	<b>New P/N</b>	<b>Old P/N</b>
Tank Holder	70029-86111	70029-861 10
Cushion	70029-86121	70029-86120
Screw	01020-05 100	11206-05 120
Washer	(obsolete)	72444-1 6150

\***Complete** bracket set only (2-each of above), order p/n 99909-157  
\*Tank w/bracket set (no hoses or cap included) order p/n99909-153



Handwritten signature or initials at the bottom right of the page.

# SHINDAIWA TECHNICAL INFORMATION

Parts Revision  
No: PR-142  
3/1/96

## Parts Revision No: PR-142

The EB-45 fuel tank has been improved. All replacement fuel tanks in your parts inventory should be replaced with the new part.

The fuel tank material has been changed. The radius at all comers has been increased to reduce stress at the mounting

points. Additionally, the recess for the product label has been eliminated. Also, the rear cushion has been improved.

## Affected Part Numbers:

Description	Old P/N	New P/N	List Price (2/96)
Tank and mounting kit. Includes: tank, cap, fuel pickup tube, filter holders, front/rear cushions and screws	99909-153	99909-301	\$35.00
Tank assembly (now includes cap, fuel tube, filter and rear cushion)	70029-65002	70029-65003	\$30.00
Bare tank only (now includes rear cushion)	70029-85102	70029-85103	\$15.00
Rear cushion	70029-W 30	70029-85131	\$ 1.52
Front cushion'	70029-86121	No change	\$ 2.86
Holder'	70029-66111	No change	\$ .62

<sup>1</sup> Two-each required: ref. Shindaiwa PR-114: 01/10/93

## EB-45 Fuel Tank Identification

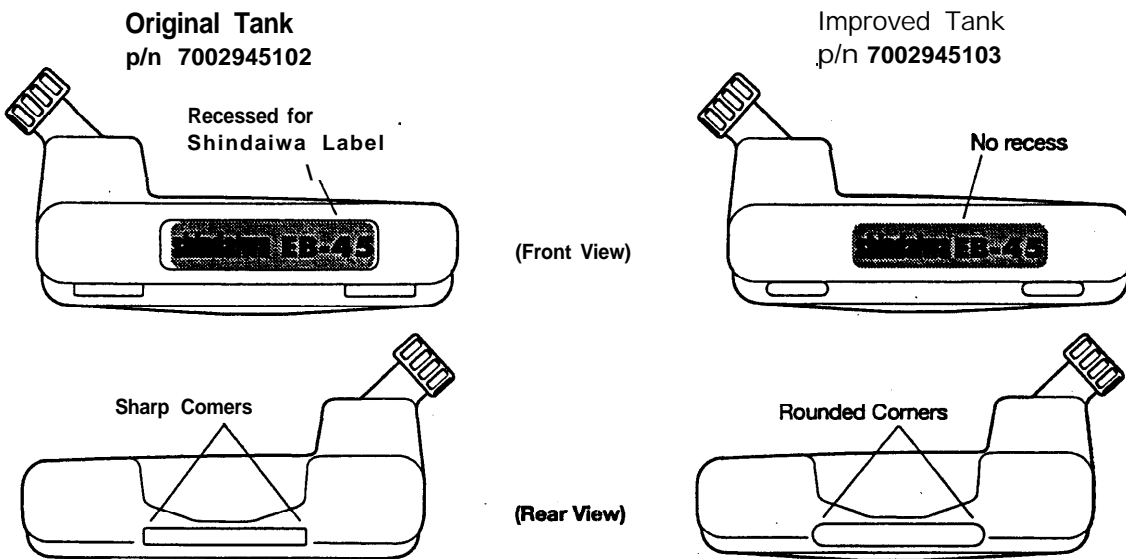

## Cushion Installation

Rear cushion p/n 70029-86131 wraps around sides of frame bracket

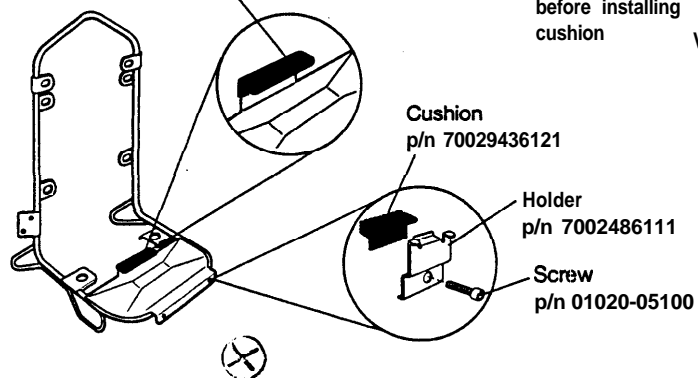

Inspect for rough edges and file before installing cushion

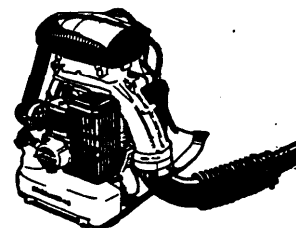
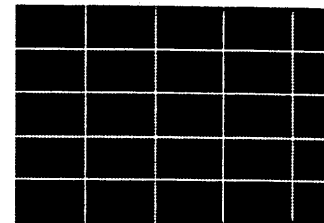
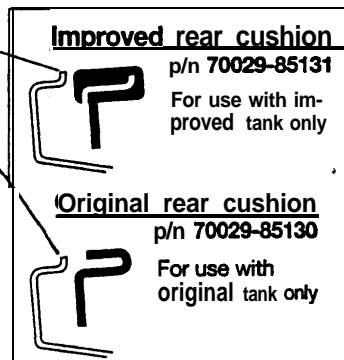

**Subject:**  
EB-45 Fuel tank

**Models affected:**  
EB-45 Blower

**Description:**  
Improved fuel tank and rear mounting cushion

**Reason for change:**  
Improved tank durability

**Interchangeability:**  
NONE When upgrading from earlier tank versions, fuel tank and rear cushion must be replaced as an assembly only!

# shindaiwa

Shindaiwa, Inc.  
P.O. Box 1090  
Tualatin, Oregon 97062  
Telephone 503 692-307  
FAX 503 692-6696

# SHINDAIWA TECHNICAL INFORMATION

Parts Revision  
No: PR-126R  
3/1/96

## Parts Revision No: PR-126R

### Description:

This is an extension of a previous notice regarding fuel tank leakage. The serial number range has been extended from our previous Parts Revision No. PR-126. Fuel tanks must be tested within the new range, as well as any units not tested from the previous range<sup>1</sup> (see serial numbers affected).

### Details of change:

Tooling has been revised to provide increased durability at seam of handle to prevent potential leakage.

### Claims:

Tank replacement claims should be submitted to Shindaiwa on a standard warranty claim form. Shindaiwa will pay a labor charge of .4 hour for each tank replaced.

### Fuel Tank Inspection Procedure:

1. Remove the fuel tank assembly as follow:
  - a) For your convenience you may want to remove the front handle (4 fasteners).
  - b) Remove cylinder cover (3 fasteners).
  - c) Disconnect the fuel line at the carburetor.
  - d) Remove the anti-vibe cushion (5 fasteners) and remove the rear handle assembly.
2. To pressure test the fuel tank:
  - a) Remove the vent tube and block off the vent opening with a suitable tool. (smooth tapered center punch or drift punch).
  - b) Attach a pressure gauge to the fuel line.
  - c) Pressurize the tank to 7-8 psi and submerge in water, to check for a leak at the seam indicated in the drawing below.
  - d) If a leak is found, replace the rear handle assembly. Do not attempt to repair. Destroy old tanks.

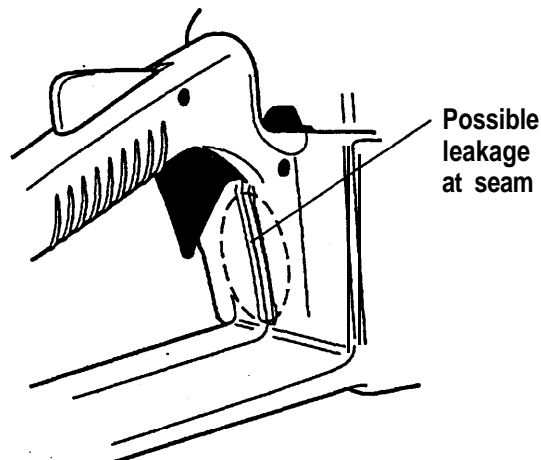

Replace leaking tanks with new p/n 99909-300S

3. If you have any 300S units in new, factory sealed boxes within the serial number range listed, at your option you may either replace the tanks on these units or return them to your Shindaiwa distributor for exchange.

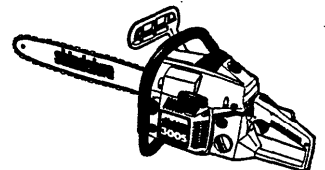
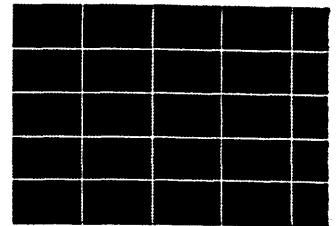

### Subject:

Extension of affected serial numbers

### Models affected:

300S Chain Saw

### Description:

Rear handle p/n 72303-33200 is replaced by p/n 99909-300S

### Serial numbers affected:

2056736 to 3066305  
(previous range was 2055066 to 2056735)

# shindaiwa

Shindaiwa, Inc.  
P.O. Box 1090  
Tualatin, Oregon 97062  
Telephone 503 692-3070  
FAX 503 692-6696



Shindaiwa Inc.

11975 S.W. Herman Road  
P.O. Box 1090  
Tualatin, Oregon 97062

Phone 503 692-3070  
FAX 503 692-6696

**WARNING!**

**IMPORTANT SAFETY NOTICE**

March 12, 1996

**shindaiwa**

Dear Shindaiwa Customer:

Our records show you have purchased a Shindaiwa model EB-45 backpack blower. If the engine serial number of your blower is within the sequence listed below (or if you have any question as to which serial number you have); we request that you immediately contact an authorized Shindaiwa dealer for an inspection and **possible** replacement of your blower's **fuel** tank at no charge to you. **Some of these tanks may fail, causing a gasoline leak and posing a possible chemical burn or fire hazard.**

**Affected Serial Numbers: 2039911 to 4058110**

Your dealer will determine if your unit requires a replacement **tank**. If so, this **will** only take a few minutes of your time and will be **free** of charge.

Thank you in advance for your cooperation; you are a valued customer and we appreciate your business. If you need assistance locating your nearest dealer, call us toll-free at 1-800-521-7733 weekdays from 7 am. to 5 p.m. PST.

Sincerely,

Pete Femald  
Technical Services Manager

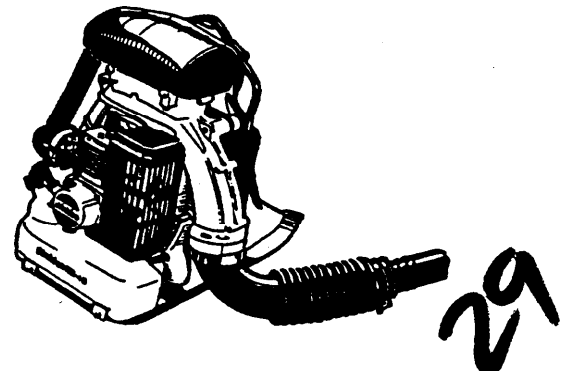

29

Shindaiwa Inc.

11975 S.W. Herman Road  
P.O. Box 1090  
Tualatin, Oregon 97062

Phone 503 692-3070  
FAX 503 692-6696

**WARNING!**

**IMPORTANT SAFETY NOTICE**

March 12, 1996

**shindaiwa**

Dear Shindaiwa Customer:

Our records show you have purchased a Shindaiwa model 300S chain saw. If the engine serial number of your saw is within the sequence listed below (or if you have any question as to which serial number you have), we request that you immediately contact an authorized Shindaiwa dealer for an inspection and possible replacement of your saw's fuel tank at no charge to you. **Some of these tanks may fail, causing a gasoline leak and posing a possible chemical burn or fire hazard.**

**Affected Serial Numbers: 2056736 to 3066305**

Your dealer will determine if your unit requires a replacement tank. If so, this will only take a few minutes of your time and will be free of charge.

Thank you in advance for your cooperation; you are a valued customer and we appreciate your business. If you need assistance locating your nearest dealer, call us toll-free at 1-800-521-7733 weekdays from 7 a.m. to 5 p.m. PST.

Sincerely,

Pete Femald  
Technical Services Manager

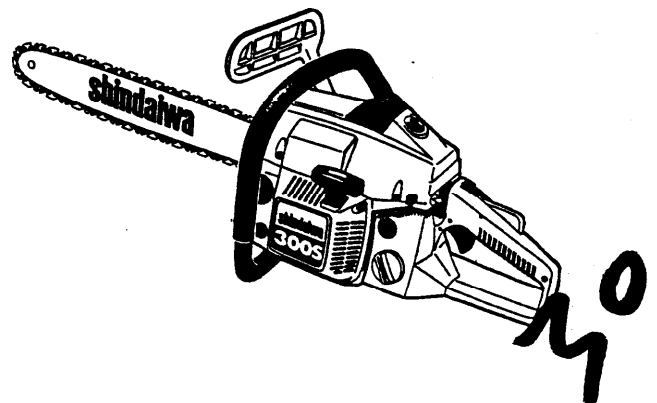

# WARNING! IMPORTANT SAFETY NOTICE!

*Extension of earlier NOTICE of August 1993*

**Certain Shindaiwa model EB-45 backpack blowers and model 300S chain saws have defective fuel tanks which may develop a leak, posing a chemical burn or fire hazard.**

**If you own a model EB-45 or a model 300S within the range of serial numbers listed below and have not had its tank inspected or replaced, please return the unit to your dealer immediately for a free inspection and possible replacement of the unit's fuel tank at no charge.**

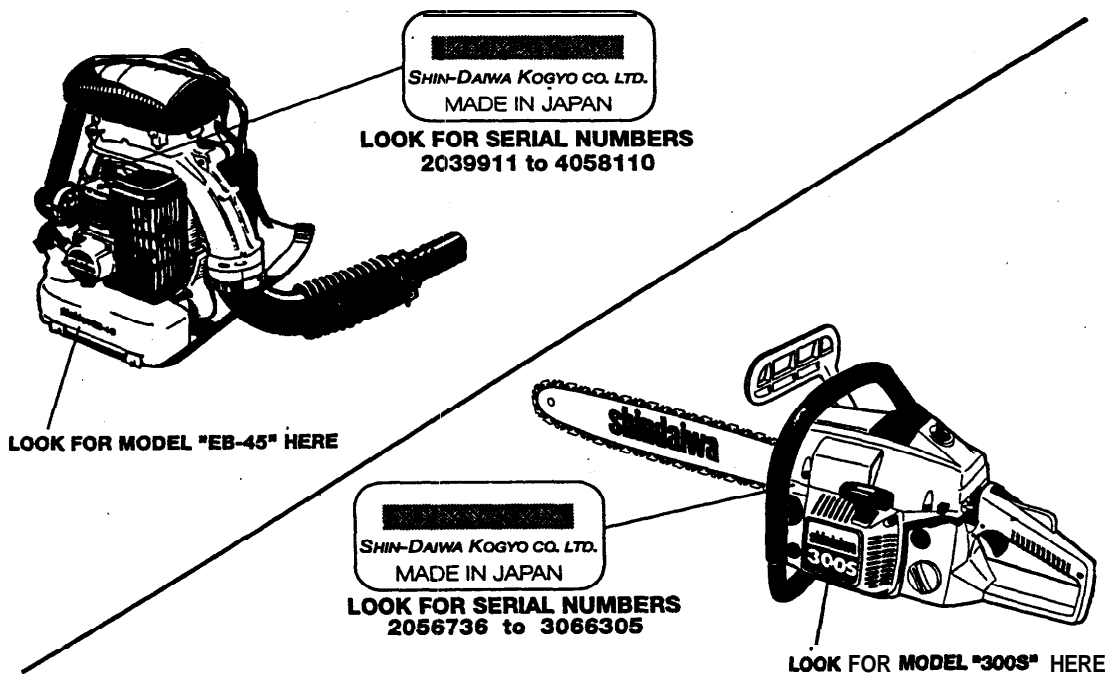

**NOTE=** The original serial number range of 2055086 to 2056735 has been extended to include 2056736 through 3066305.

**Attention dealer: This notice must be displayed until September 30, 1996**  
March 7996, Shindaiwa Inc., Tualatin, OR



31



**DISTRIBUTOR/DEALER  
INVENTORY DISPOSITION CERTIFICATION**

In conjunction with the March 1996 recall of the Shindaiwa model EB-45 blower and model 300S chain saw, I \_\_\_\_\_ certify that inventory has been destroyed or rendered unusable as follows:

EB-45 Fuel Tanks Spare Parts Inventory	_____	Quantity
EB-45 Fuel Tanks <b>from</b> Whole Goods Inventory	_____	Quantity
300S Fuel Tanks Spare Parts Inventory	_____	Quantity
300S Fuel Tanks <b>from</b> Whole Goods Inventory	_____	Quantity

Company Name \_\_\_\_\_  
Authorized Signature \_\_\_\_\_ Date \_\_\_\_\_

**DISTRIBUTOR/DEALER  
INVENTORY DISPOSITION CERTIFICATION**

In conjunction with the March 1996 recall of the Shindaiwa model EB-45 blower and model 300S chain saw, I \_\_\_\_\_ certify that inventory has been destroyed or rendered unusable as follows:

EB-45 Fuel Tanks Spare Parts Inventory	_____	Quantity
EB-45 Fuel Tanks from Whole Goods Inventory	_____	Quantity
300S Fuel Tanks Spare Parts Inventory	_____	Quantity
300S Fuel Tanks from Whole Goods Inventory	_____	Quantity

Company Name \_\_\_\_\_  
Authorized Signature \_\_\_\_\_ Date \_\_\_\_\_



32 ✓

# NEWS from CPSC

## US, CONSUMER PRODUCT SAFETY COMMISSION

OFFICE OF INFORMATION AND PUBLIC AFFAIRS

WASHINGTON, D.C.

20297

FOR IMMEDIATE RELEASE  
1996  
Release # 96

CONTACT:  
(301) 504-0580 Ext.

### CPSC, SHINDAIWA ANNOUNCE RECALL OF BACKPACK BLOWERS AND CHAIN SAWS

WASHINGTON, D.C. - In cooperation with the U.S. Consumer Product Safety Commission (CPSC), Shindaiwa Inc. of Tualatin, Ore., is announcing the recall of approximately

<sup>4,970</sup> ~~NUMBER~~ Shindaiwa model EB45 backpack blowers, and ~~NUMBER~~ Shindaiwa model 300S chain saws. The tool's fuel tanks could leak, presenting a possible chemical burn or fire hazard. Shindaiwa is not aware of any injuries involving these products.

The red blower is mounted on a black metal backpack frame with shoulder straps, black blower tubes, and a white fuel tank with "Shindaiwa" and "model number EB45" printed in the center. The red chain saw has a gray handle with "model number 300S" printed on the pull-start housing.

**DRAFT**

LINE DRAWING

guide bar

Authorized Shindaiwa dealers nationwide sold these tools from ~~MONTH, YEAR~~ <sup>April 1992</sup> to ~~MONTH, YEAR~~ <sup>#430</sup>. The back pack blowers sold for approximately ~~HOW MUCH~~ <sup>\$300</sup> each and the chain saw for approximately ~~HOW MUCH~~ each.

Consumers who own the recalled back pack blowers or chain saws should stop using them immediately and return them to any authorized Shindaiwa Servicing dealer. The backpack blower and chain saw will be fitted with a redesigned fuel tank at no charge. For more information, consumers should call Shindaiwa toll-free at (800) 521-7733.

Shindaiwa is conducting this recall to prevent the possibility of injury.

The U.S. Consumer Product Safety Commission protects the public from the unreasonable risk of injury or death from 15,000 types of consumer products under the agency's jurisdiction. To report a dangerous product or a product-related injury and for information on CPSC's fax-on-demand service, call CPSC's hotline at (800) 638-2772 or CPSC's teletypewriter at (800) 638-8270. To order a press release through fax-on-demand, call (301) 504-0051 from the handset of your fax machine and enter the release number. Consumers can obtain this release and recall information via Internet gopher services at cpsc.gov or report product hazards to info@cpsc.gov.



33

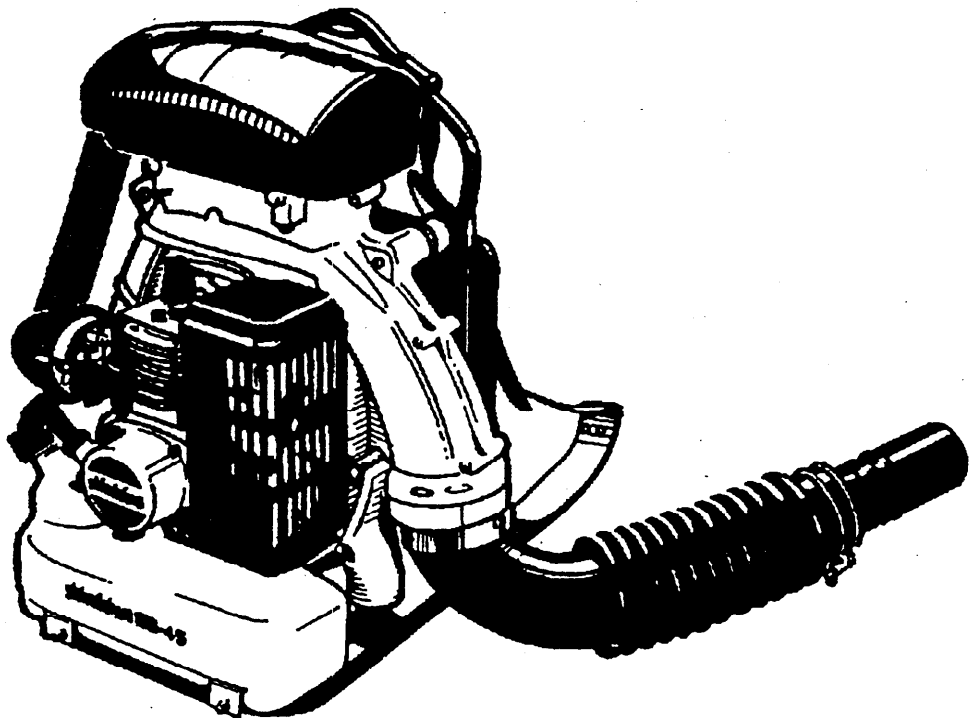

34

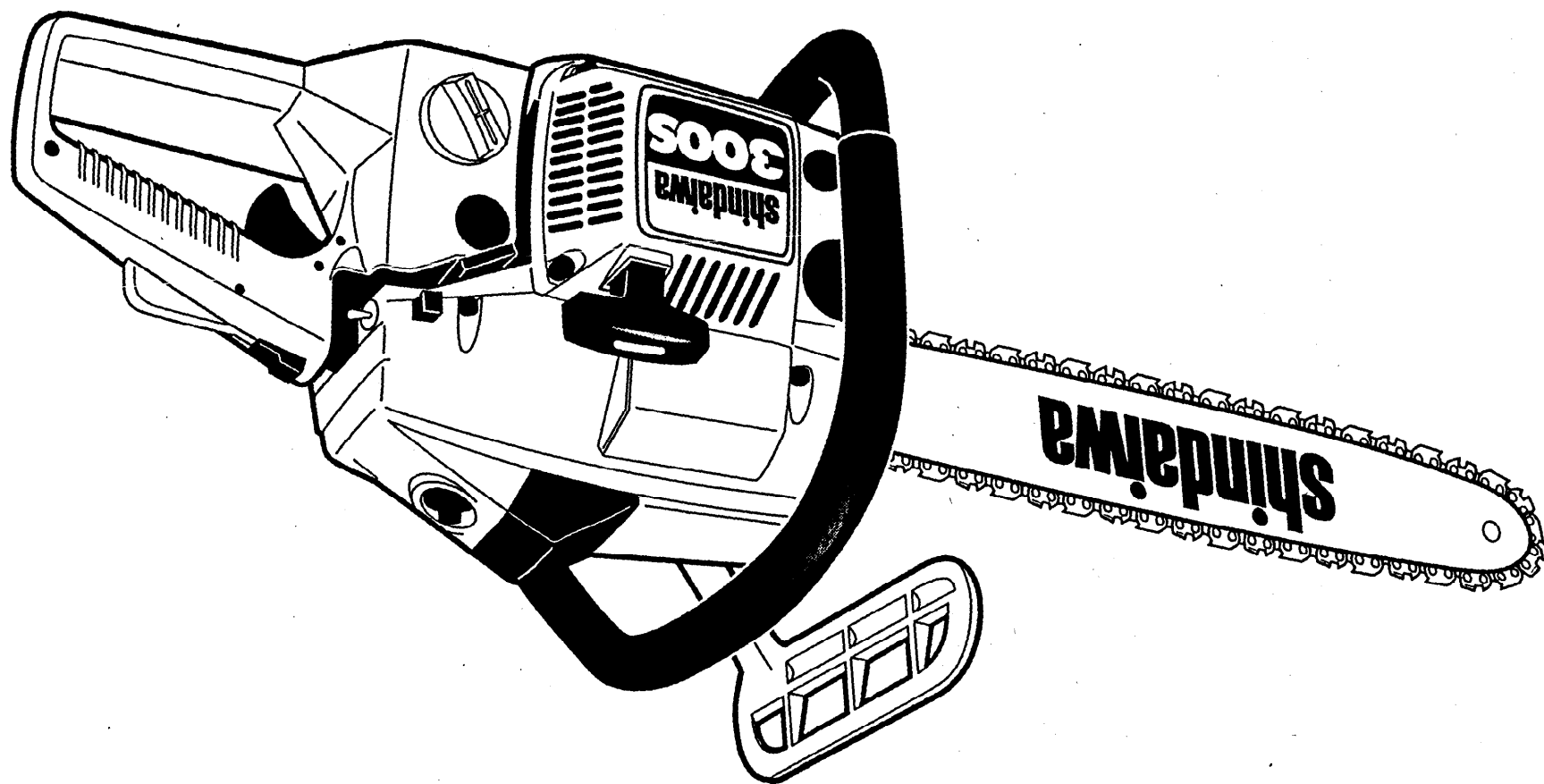

41

1/15

SHINDAIWA INC.

SUE MEYER  
EXECUTIVE SECRETARY  
11975 S.W. HERMAN ROAD  
TUALATIN, OR 97062

TELEPHONE (503) 692-3070  
FAX (503) 692-6696  
DIRECT LINE (503) 6914641

V I A F A X

Date: March 12, 1996

To: John Shumlansky, CPSC

From: Sue Meyer

Subject Revised Documents for EB-45 and 300S Recall

John, as we discussed on the phone this morning, following are copies of documents to complete these two recalls:

**Fax communication to Distributors**  
**Letter to Dealers**

Parts Revisions Nos. PR-114 (2 page), PR-142 for the EB-45 blower and PR-126R for the 300s chain saw

**Letter to EB-45 Registered Owner**

Letter to 300s Registered Owner

Copy of 12" x 18" poster to be displayed in Dealer's shop

**Inventory Disposition Certification form to be completed by distributors and dealers**

**Copy of Press Release (as discussed, to be released on the date provided by Shindaiwa Inc. early next week)**

**Two line drawings for use in the Press Release**

Sorry for the delay in getting these revised forms to you. We have spent a great deal of time getting input from the proper people in order to make the documents as accurate as well as clear and understandable as possible. I will send the full packet UPS Next Day Air today.

As we discussed, you will be letting me know by return if these documents are acceptable to the CPSC so we can proceed with printing.

Sincerely,

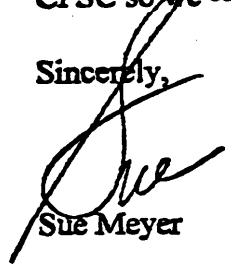

Sue Meyer

36

c: Mike Breitbach

Shindaiwa Inc.

11975 S.W. Herman Road  
P.O. Box 1090  
Tualatin, Oregon 97062

Phone 5036923070  
FAX 503 692-6696

**DISTRIBUTOR COMMUNICATION**

**VIA FAX**

**March 12, 1996**

To: All Distributors

From: **Pete Fernald**  
Technical Services Manager

Re: **EB-45 Product Recall**  
**300S Product Recall—Extension of August 1993 Recall**

**shindaiwa**

In cooperation with **the** Consumer Product Safety Commission, **we** are **recalling** **two Shindaiwa** units due to possible **fuel** tank problems. First, the EB-45 **blower** has a potential **leak on** the rear side of the **fuel** tank. Additionally, the model **300S** chain saw has a potential leak in its fuel tank. The **300S recall** is a continuation of **an earlier recall in August** 1993.

Enclosed are copies of important documents regarding **these** two recalls. Please carefully read these documents and ensure **that** the appropriate people in your organization (sales, inside sales, and technical people, etc.) also have copies and **are fully informed**.

1. Letter to **dealers** regarding the product recall
2. Copies of Parts Revisions Nos. PR-I 14 and **PR-142** for the model **EB-45** and **PR-126R** for model **300S**
3. **Letters** to both **EB-45** and **300S** registered owners announcing the recall
4. Copy of a **12" x 18"** poster to be placed in a visible location in the dealer's **shop**
5. Inventory Disposition Certification form. Distributors **will process** **warranty** claims as described in **the** letter to **dealers**, including completion of **the Inventory** Disposition Certification form.

Thanks in advance **for** your assistance. If you **have** any questions, please contact your **Technical Services** Representative at L-800-521-7733.

Pete Fernald

Attachments

37

Shindaiwa Inc.

11975 S.W. Herman Road  
P.O. Box 1090  
Tualatin, Oregon 97062

Phone 503 692-3070  
FAX 503 692-6696

**WARNING!**

**IMPORTANT SAFETY NOTICE**

March 12, 1996

**shindaiwa**

Dear Shindaiwa Dealer:

In cooperation with the U.S. Consumer Product Safety Commission, Shindaiwa is requesting that you **take** the **following** actions to minimize **potential hazard from fuel tank leakage on the EB-45 backpack blower and the 300S chain saw**. We **are** sending notification to registered **owners** to **return affected** units to their nearest dealer for inspection and **possible fuel** tank replacement at no charge to the owner.

**EB45**

1. Remove tank and **perform** a **visual** inspection of EB-45 units **within** Serial No. 2039911 to 4058110. **Focus on front** and rear bracket areas for signs of leakage.
2. **Verify** that improved **front** brackets have been **installed** per PR-114.
3. If no leakage is detected, the old tank can be reused provided you inspect the rear mounting bracket for rough edges and fife smooth. However, if the vinyl cushion (P/N 7002945130) has been damaged or is **otherwise** unusable, **replace the complete tank and cushion with the full improved tank assembly per PR-142**.
4. **If** there are obvious signs of wear or leakage on the **tank**, replace with new **tank** assembly per PR-1142.
5. Destroy **all** previous versions of the **fuel** tank in spare parts and **wholetoods** inventories. Complete the Inventory Disposition Certification form attached. Process these as **warranty** along with recall units. **Multiple** units can be processed on the Same claim as **long as all serial numbers are listed and the claim lists** exactly the same part numbers for each **unit listed**.

**300S**

1. **Inspect all 300S** chain saws **per PR-126R with** the newly extended **Serial No.** range 2056736 to 3066305 (previous range was 2055086 to 2056735).

46  
21

We **have** attached the following important **information** to assist in this recall:

1. Parts **Revisions PR-1 14 and PR-142** for the **model EB-45 and PR-126R** for model **300S**. **Both** contain fuel tank improvements and important changes in the **affected serial numbers**.
2. Copies of letters **to both EB-45 and 300S registered** owners
3. **A warning sign. This must be displayed in a publicly visible location** in your place of business. It is to be posted immediately and **maintained in place** through September **30, 1996**.
4. Inventory Disposition Certification form

During the **period** of this recall, you may be visited by a representative of the Consumer Product Safety Commission. They will be doing spot checks of **Shindaiwa** dealers to measure the **effectiveness** of this effort.

Thank you in advance: for your cooperation. -**You** are a valued customer and we appreciate your business. If you need **further** information or assistance, please contact your **Shindaiwa distributor**.

Sincerely,

Pete Femald  
Technical Services **Manager**

Attachments

39



SUBJECT: PARTS REVISION

DATE: 10/28/92

MODELS AFFECTED: EB-45

DESCRIPTION: Fuel Tank Mounting

REASON FOR CHANGE: Tank failures resulting from metal bracket corners contacting tanks.

INTERCHANGEABILITY: NONE (Do Not Use Old Parts)

REVISION DATE: 07/13/92

SERIAL NUMBERS: 0028891-2039910 (Units after 2039911 will feature these parts)

Details of change: New tank holder is offset approx. 3/16" to accommodate larger (captive) rubber cushion. Slotted-head fastening is replaced by an allen-head screw.

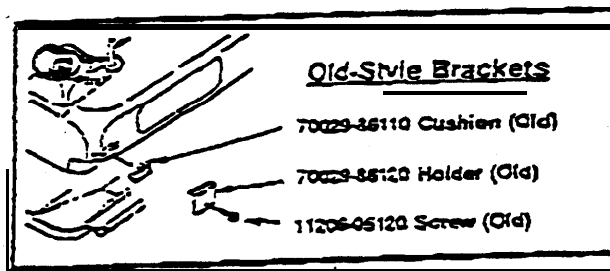

70029-85130  
Tank Cushion

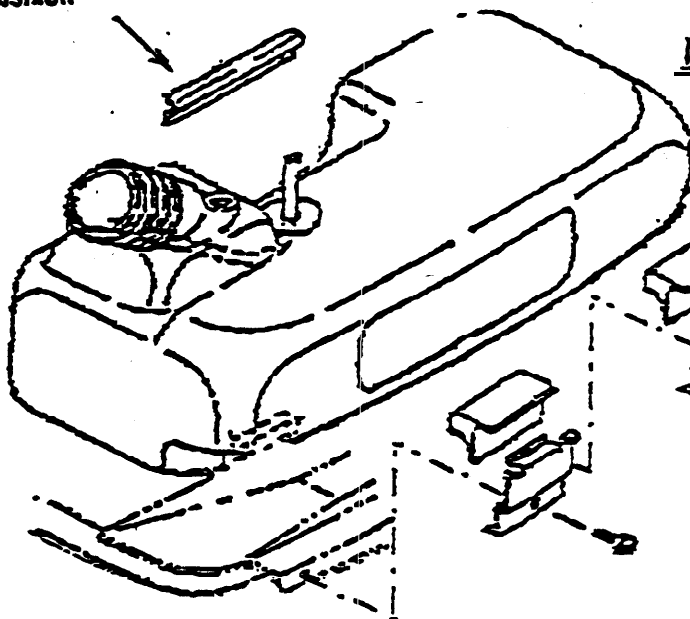

New-Style Brackets & Cushions  
(standard after s/n 2039911)

70029-86111 Cushion (new)

70029-86121 Holder (new)

01020-05100 Screw (new)

RECEIVED  
COPY!

Note: Tank failures from **old-style** brackets may result from "cocking" brackets against the tank shell during **assembly**, and the new-style brackets should be installed on inventoried units during **dealer** set-up. Any suspect tank(s) should be inspected/pressure-tested for cracks during bracket replacement, **with** special attention given to potential leakage **at** the tank mounting areas. When both tank and brackets are to be replaced on the same unit, they **may** be ordered as an assembly under **(temporary) p/n 99909-153**. Note that stabilizing a tank on an older or high-time unit may also require the **(non-warranty) replacement** of p/n 70029-85130 Tank Cushion.

**Claims:** Bracket **replacement** claims should be submitted on a **Shindaiwa warranty form**.

- **Multiple claims may be listed on one form.**
- **Serial numbers must be provided for each EB-45 listed.**
- **Claims submitted without serial number documentation will be returned.**
- **A labor rate of .1-hour will be paid for each set of brackets replaced.**

Leaking tanks may be replaced under a normal warranty **claim**, and defective tanks are **to** be destroyed. Dealers are requested to exchange **all old-style** brackets **through their** distributors. Shindaiwa **will** replace distributor-level inventory of **old-style** brackets and cushions on an **exchange basis**.

	New P/N	Old P/N
Tank Holder	70029-86111	<b>70029-86110</b>
Cushion	70029-86121	<b>70029-86120</b>
screw	<b>01020-05100</b>	11206-05120
Washer	(obsolete)	72444-j <b>6150</b>

Complete **bracket set only** (2-each of above), order p/n 99909-157  
 \*Tank **w/bracket** set (no hoses or cap included) order **p/n99909-153**

41

# SHINDAIWA TECHNICAL INFORMATION

Parts Revision  
No: m-142  
3/1/96

## Parts Revision No: PR-142

The EB-45 fuel tank has been improved. All replacement fuel tanks in your parts inventory should be replaced with the new part.

The fuel tank material has been changed. The radius at all corners has been increased to reduce stress at the mounting points.

Additionally, the recess for the product label has been eliminated. Also, the rear cushion has been improved.

### Affected Part Numbers=

Description	Old P/N	New P/N	List Price (2/96)
Tan&and mounting kit. Includes: tank, cap, fuel pickup tube, filter holders, front/rear cushions and screws	99909-153	99909-301	\$35.00
Tank assembly (now includes cap, fuel tube, filter and rear cushion)	70029-85002	70029-85003	\$30.00
Bare tank only (now includes rear cushion)	70029-85102	70029-85103	\$15.00
Rear cushion	70029-85130	70029-85131	\$ 1.52
Front cushion <sup>1</sup>	70029-86121	No change	\$ 2.86
Holder <sup>1</sup>	70029-86111	No change	\$ .82

<sup>1</sup> Two-each required: ref. Shindaiwa PR-114: 01/10/93

### EB-45 Fuel Tank Identification

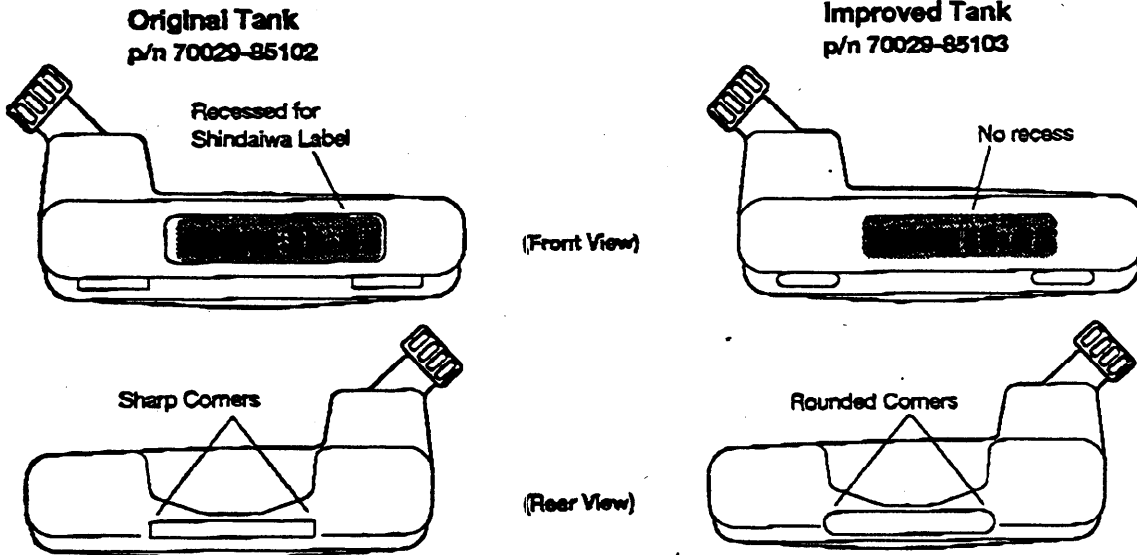

### Cushion Installation

Rear cushion p/n 70029-85131 wraps around sides of frame bracket

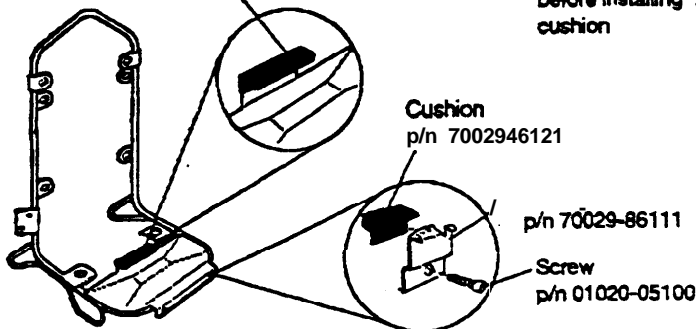

Inspect for rough edges and file before installing cushion

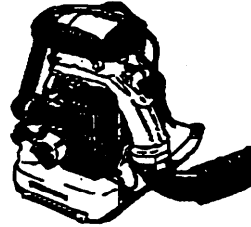
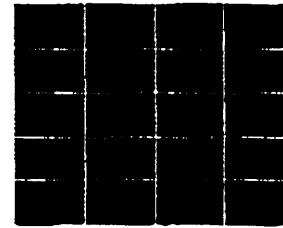

**Subject:**  
EB-45 Fuel tank

**Models affected:**  
EB-45 Blower

**Description:**  
Improved fuel tank and rear mounting cushion

**Reason for change:**  
Improved tank durability

**Interchangeability:**  
**NONE:** When upgrading from earlier tank versions, fuel tank and rear cushion must be replaced as an assembly only!

# shindaiwa

Shindaiwa, Inc.  
P.O. Box 1090  
Tualatin, Oregon 97062  
Telephone 503 692-3070  
FAX 503 692-6696

42

# SHINDAIWA TECHNICAL INFORMATION

Parts Revision  
No: PR-126R  
3/1/96

## Parts Revision No: PR-126R

### Description:

This is an extension of a previous notice regarding fuel tank leakage. The serial number range has been extended from our previous Parts Revision No. PR-126. Fuel tanks must be tested within the new range, as well as any units not tested from the previous range<sup>1</sup> (see serial numbers affected).

### Details of change:

Tooling has been revised to provide increased durability at seam of handle to prevent potential leakage.

### Claims:

Tank replacement claims should be submitted to Shindaiwa on a standard warranty claim form. Shindaiwa will pay a labor charge of .4 hour for each tank replaced.

### Fuel Tank Inspection Procedure:

#### 1. Remove the fuel tank assembly as follow:

- a) For your convenience you may want to remove the front handle (4 fasteners).
- b) Remove cylinder cover (3 fasteners).
- c) Disconnect the fuel line at the carburetor.
- d) Remove the anti-vibe cushion (5 fasteners) and remove the rear handle assembly.

#### 2. To pressure test the fuel tank:

- a) Remove the vent tuba and block off the vent opening with a suitable tool. (smooth tapered center punch or drift punch).
- b) Attach a pressure gauge to the fuel line.
- c) Pressurize the tank to 7-8 psi and submerge in water to check for a leak at the seam indicated in the drawing below.
- d) If a leak is found, replace the rear handle assembly. Do not attempt to repair. Destroy old tanks.

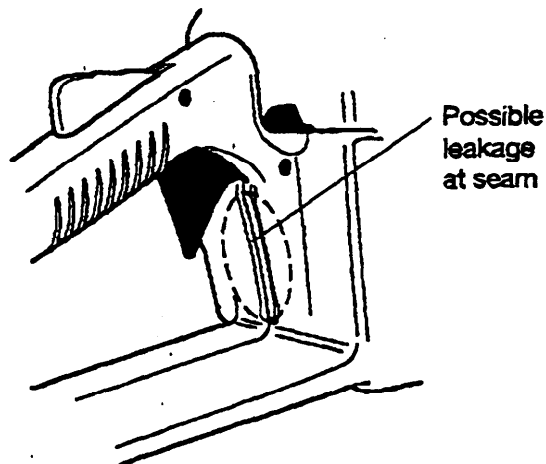

3. If you have any 300S units in new, factory sealed boxes within the serial number range listed, at your option you may either replace the tanks on these units or return them to your Shindaiwa distributor for exchange.

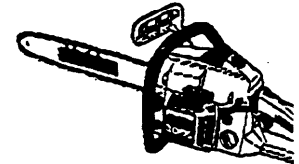
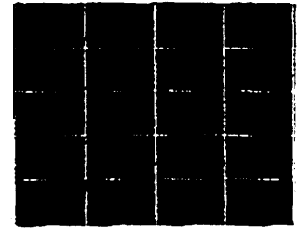

### Subject:

Extension of affected serial numbers

**Models affected:**  
300S Chain Saw

### Description:

Rear handle p/n 72303-33200 is replaced by p/n 99909-300s

### Serial numbers affected:

2056736 to 3066305  
(previous range was 2055086 to 2056735)

# shindaiwa

Shindaiwa, Inc.  
P.O. Box 1090  
Tualatin, Oregon 97062  
Telephone 503 692-307  
FAX 503 692-6696

43

Shindaiwa Inc.

11975 S.W. Herman Road  
P.O. Box 1090  
Tualatin, Oregon 97062

Phone 503 692-3070  
FAX 503 692-6696

**WARNING!**

**IMPORTANT SAFETY NOTICE**

March 12, 1996

**shindaiwa**

Dear Shindaiwa Customer:

Our records **show you** have purchased a Shindaiwa model EB-45 backpack **blower**. If the engine **serial** number of your blower is within the **sequence** listed **below** (or if you have any question as to which serial number you have), we request that you **immediately** contact an authorized **Shindaiwa** dealer for an inspection and possible **replacement** of your blower's **fuel** tank at no charge to you. Some of **these tanks** may fail, **causing a gasoline leak and posing a possible chemical burn or fire hazard-**

**Affected Serial Numbers: 2039911 to 4058110**

Your dealer will **determine** if your unit requires a replacement tank. If so, this **will** only take **a** few minutes of your time and will be **free** of charge.

**Thank** you in **advance** for your cooperation; you **are** a valued customer and we appreciate your business. If you need assistance locating your nearest **dealer**, call us **toll-free** at 1-800-521-7733 **weekdays from 7 a.m. to 5 p.m. PST.**

sincerely,

**Pete Fernald**  
Technical **Services** Manager

44

**DISTRIBUTOR/DEALER  
INVENTORY DISPOSITION CERTIFICATION**

In conjunction with the March 1996 recall of the Shindaiwa model EB-45 blower and model 300S chain saw, I \_\_\_\_\_ certify that inventory has been destroyed or rendered unusable as follows:

EB-45 Fuel Tanks Spare Parts Inventory	_____	Quantity
EB-45 Fuel Tanks from Whole Goods Inventory	_____	Quantity
300S Fuel Tanks Spare Parts Inventory	_____	Quantity
300S Fuel Tanks from Whole Goods Inventory	_____	Quantity

Company Name \_\_\_\_\_  
Authorized Signature \_\_\_\_\_ Date \_\_\_\_\_

**DISTRIBUTOR/DEALER  
INVENTORY DISPOSITION CERTIFICATION**

In conjunction with the March 1996 recall of the Shindaiwa model EB-45 blower and model 300S chain saw, I \_\_\_\_\_ certify that inventory has been destroyed or rendered unusable as follows:

EB-45 Fuel Tanks Spare Parts Inventory	_____	Quantity
EB-45 Fuel Tanks from Whole Goods Inventory	_____	Quantity
300S Fuel Tanks Spare Parts Inventory	_____	Quantity
300S Fuel Tanks from Whole Goods Inventory	_____	Quantity

Company Name \_\_\_\_\_  
Authorized Signature \_\_\_\_\_ Date \_\_\_\_\_

45

# NEWS from CPSC

## U.S. CONSUMER PRODUCT SAFETY COMMISSION

OFFICE OF INFORMATION AND PUBLIC AFFAIRS

WASHINGTON, D.C.

**FOR IMMEDIATE RELEASE**

1996

Release # 96

**CONTACT:**

(301) 504-0580 Ext.

### CPSC, SHINDAIWA ANNOUNCE RECALL OF BACKPACK BLOWERS AND CHAIN SAWS

WASHINGTON, D.C. - In cooperation with the U.S. Consumer Product Safety Commission (CPSC), Shindaiwa Inc. of Tualatin, Ore., is announcing the recall of approximately

18,500

~~NUMBER~~ Shindaiwa model EB45 backpack blowers, and ~~NUMBER~~ <sup>4,970</sup> Shindaiwa model 300S chain saws. The tool's fuel tanks could leak, presenting a possible chemical burn or fire hazard. Shindaiwa is not aware of any injuries involving these products.

The red blower is mounted on a black metal backpack frame with shoulder straps, black blower tubes, and a white fuel tank with "Shindaiwa" and "model number EB45" printed in the center. The red chain saw has a gray handle with "model number 300S" printed on the pull-start housing.

LINE DRAWING

**DRAFT**

guide bar

Authorized Shindaiwa dealers nationwide sold these tools from ~~MONTH, YEAR~~ <sup>April 1992</sup> to ~~MONTH, YEAR~~ <sup>#430</sup>. The back pack blowers sold for approximately ~~HOW MUCH~~ <sup>\$300</sup> each and the chain saw for approximately ~~HOW MUCH~~ each.

Consumers who own the recalled back pack blowers or chain saws should stop using them immediately and return them to any authorized Shindaiwa Servicing dealer. The backpack blower and chain saw will be fitted with a redesigned fuel tank at no charge. For more information, consumers should call Shindaiwa toll-free at (800) 521-7733.

Shindaiwa is conducting this recall to prevent the possibility of injury.

The U.S. Consumer Product Safety Commission protects the public from the unreasonable risk of injury or death from 15,000 types of consumer products under the agency's jurisdiction. To report a dangerous product or a product-related injury and for information on CPSC's fax-on-demand service, call CPSC's hotline at (800) 638-2772 or CPSC's teletypewriter at (800) 638-8270. To order a press release through fax-on-demand, call (301) 504-0051 from the handset of your fax machine and enter the release number. Consumers can obtain this release and recall information via Internet gopher services at [cpsc.gov](http://cpsc.gov) or report product hazards to [info@cpsc.gov](mailto:info@cpsc.gov).

46

۲۷

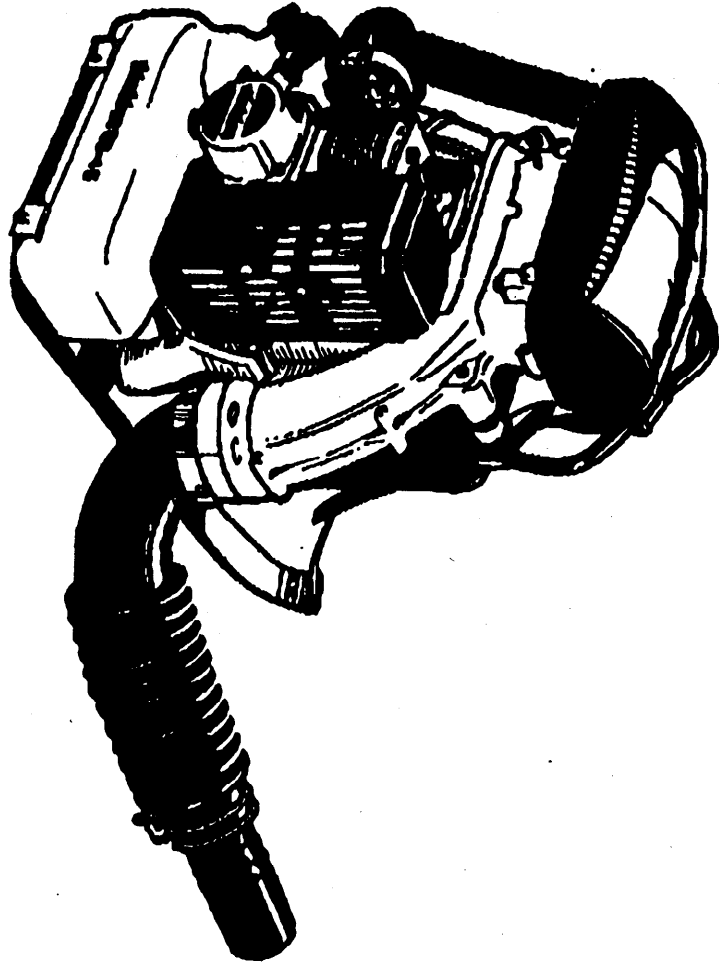



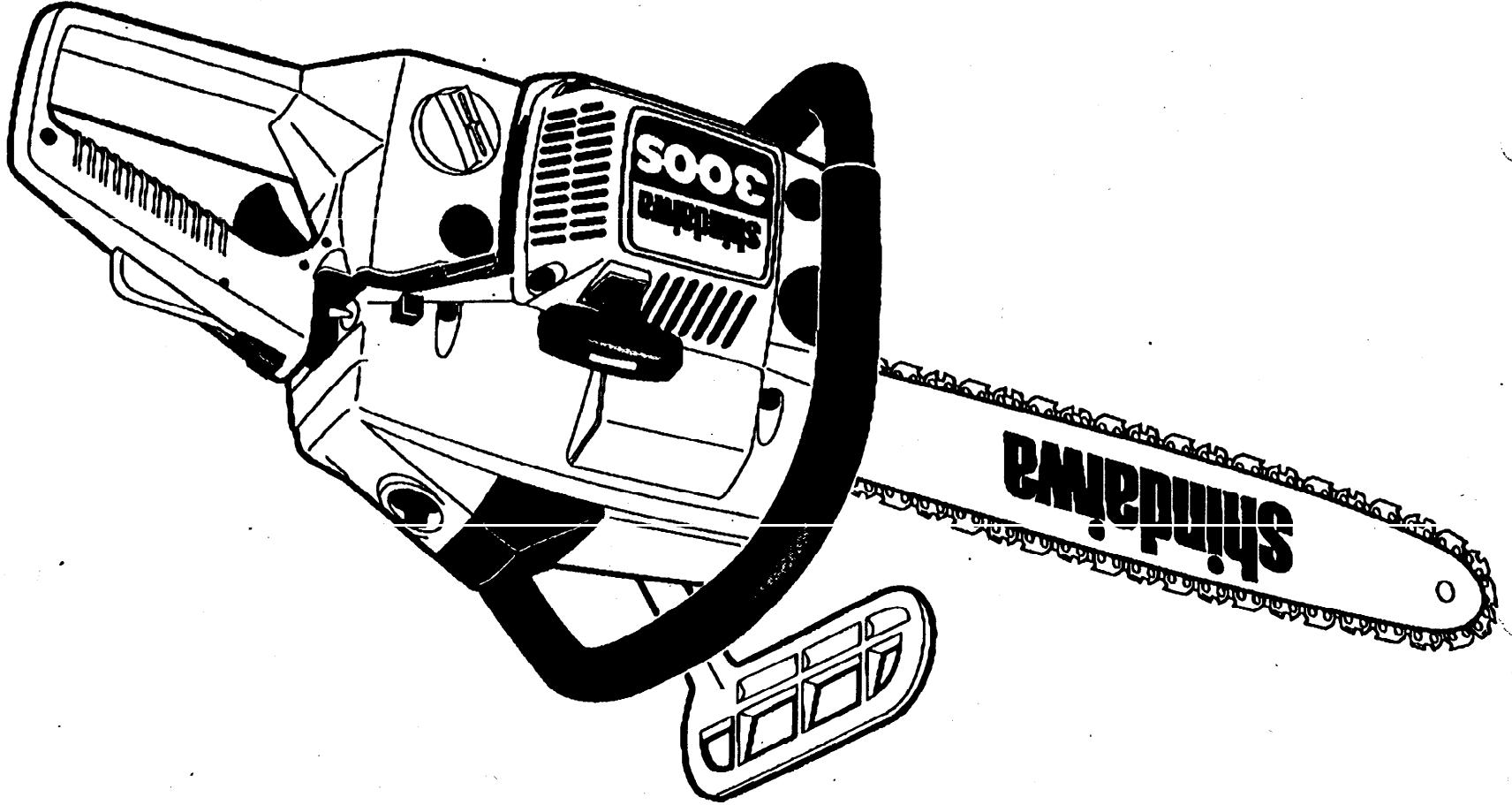

18

TOTAL P.15

1/13

2 6 FEB REC'D

SHINDAIWA INC.

SUE MEYER  
EXECUTIVE SECRETARY  
11975 S.W. HERMAN ROAD  
TUALATIN, OR 97062

TELEPHONE (503) 692-3070  
FAX (503) 692-6696  
DIRECT LINE (503) 6914641

VIA FAX

Date: February 21, 1996

To: John Shumlansky  
Division of Corrective Actions, CPSC

From: Sue Meyer

Subject: Documents for Recall of EB45 and 300S

Following are copies of documents we propose to use in our recall of Model EB45 backpack blower and Model 300S chain saw.

Thank you for your patience in waiting till these documents were fine-tuned. I will be sending the originals to you via UPS Next Day Air tomorrow.

Please let us know if you need any further information.

Sincerely,

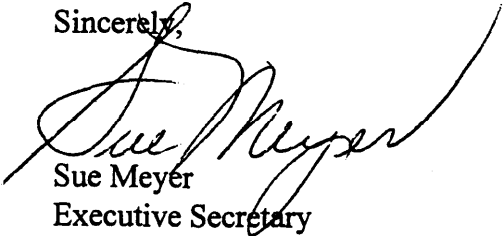

Sue Meyer  
Executive Secretary

Attachments

(X)

49

Shindaiwa Inc.

11975 S.W. Herman Road  
P.O. Box 1090  
Tualatin, Oregon 97062

Phone 503 6923070  
FAX 503 6924696

**DISTRIBUTOR COMMUNICATION VIA FAX**

February 21, 1996

To: **All Distributors** From: **Pete Fernald**  
**Technical Services** Manager

Re: **EB45 Improved Fuel Tank**  
**300S Tank Replacement--Extension of Serial Numbers**

**shindaiwa**

Following are copies of several documents we are mailing to each of your **offices** today regarding an improved fuel tank for our EB45 fuel tank replacement program, as well as an extension of the **300S** inspection/replacement program, Please take the time to read all documents.

In addition to the letters of explanation, you will receive pertinent updated service bulletins and warranty procedures as well as installation instructions for the **300S** tank.

Also included are copies of the letters we are sending to all dealers and end-users who registered EB45 units in the specified serial number range and **300S** units in the extended serial number range, so that you are fully aware of what they have been told.

When the mailed packet arrives at your office, please be sure that **all** your sales managers, salesmen, service managers, and inside sales personnet receive copies. They need to be fully informed so they can help make this program a success,

Thanks in advance for your assistance in getting these problems resolved. Please do not hesitate to contact your Technical Services Representative at 1-800-521-7733 if you have further questions.

PF

Attachments



50

Shindaiwa Inc.

11975 S.W. Herman Road  
Portland, Oregon 97062

Phone 503 692-3070  
FAX 503 692-6696.

## DISTRIBUTOR COMMUNICATION

February 21, 1996

FIELD(1)  
FIELD(2)

Re: **EB45 Fuel Tanks - Further Improvements**

**shindaiwa**

Dear FIELD(3):

When PR-114 was issued in 1992, improved front brackets were added to further protect the fuel tank **from** leakage in the bracket area. This has cut our **failure** rate of those tanks to **only** a fraction of the prior rate. Since that time, we have seen that if a further failure does occur on a later unit, it is due to one of two reasons: the **frame** was damaged **from** being dropped and/or the metal bracket at the rear of the tank has caused a crack: at one side or the other of the rear tank mounting recess.

To take care of this problem, we requested (and SDK completed) a further improvement to the tank and mounting system. (See attached Service **Bulletin**). Though the rear leakage **problem** applies primarily to units in the serial number range of **2039911 ~ 4058110**, this tank can and should be used as the replacement for **any** EB45 with a leaking fuel tank.

Though the EB45 has been out of production since August 1994, we want to be sure users have a replacement fuel tank that is durable enough for normal field conditions. For that reason, we are again notifying distributors, dealers **and** purchasers that a further improved tank and new rear bracket are available and should be used as the replacement fuel tank assembly for an EB45; **regardless of serial number**.

To facilitate fuel tank replacement, we are offering a **complete fuel** tank assembly; tank, fuel tube system, front brackets, and the new rear bracket. This tank will take dealers only seconds to install. Please note that we are including the **front** brackets in this assembly, in case there are some units in the field that do not have the improved front brackets already installed.

Tanks will be invoiced at their normal replacement part cost. Dealers submit claims under the normal warranty procedure and can put multiple serial numbers



41

**FIELD(1)**

Page 2

February 21, 1996

on the same claim as long as unit serial numbers are listed and the claim **lists exactly** the same part **number** for each unit listed.

We will be advising all registered dealers of the availability of this improved assembly for our **replacement** program. A copy of this letter is included for your information.

If you have **further** questions or concerns, please call your Technical Services Representative at 1-800-52 1-7733.

Sincerely,

Pete Femald  
Technical Services Manager

**FIELD(4)**

Attachments



52

Shindaiwa Inc.

11975 S.W. Herman Road  
P.O. Box 1090  
Tualatin, Oregon 97062

Phone 503 692-3070  
FAX 503 692-6696

**WARNING!**

**IMPORTANT SAFETY NOTICE**

February 21, 1996

Dear Shindaiwa Dealer:

**shindaiwa**

In cooperation with the **U.S. Consumer Product Safety Commission**, Shindaiwa is requesting that you take the following actions to minimize potential injuries from **fuel tank** leakage on the **EB-45 backpack blower and the 300S chain saw**. We are sending notification to registered owners to return **affected** units for inspection and possible fuel tank replacement at no charge to the owner. Please use the following important information to assist in this recall:

1. Attached are **PR-126R** for the model **300S** and **PR-142** (2 pages) for the **EB-45**. Both contain fuel tank improvements and important changes in the affected serial numbers.
2. Serial numbers for the **affected EB-45: 2039911 - 4058110**  
Serial numbers for the **affected 300S: 2056736 - 3066305**
3. Fuel Tank ID and Inspection Procedures for both the **EB-45** and **300S** are attached.
4. Copies of letters to both **EB-45** owners as well as **300S** owners are attached.
5. **The enclosed sign must be displayed in a publicly visible location in your place of business.** It is to be posted immediately and maintained in place through August 31, 1996. Also, during the period of this recall, you may be visited by a representative of the Consumer Product **Safety** Commission, They will be doing **spot** checks of Shindaiwa dealers to measure the effectiveness of this effort.

Thank you in advance for your cooperation. You are a valued customer and we appreciate your business. If you need further information or assistance, please **contact** your Shindaiwa distributor.

Sincerely,

Pete Femald  
Technical Services Manager



Attachments

53

# shindaiwa® SERVICE BULLETIN

SERVICE AND ENGINEERING BULLETIN

BULLETIN No.: PR-126 R

SUBJECT: PARTS REVISION — *EXTENSION of AFFECTED SERIAL NUMBERS*

DATE: ~~07/27/93~~ 2/19/96

MODELS AFFECTED: 300-S

99909-300s \*

DESCRIPTION: Rear Handle p/n 72303-33200 is replaced by p/n ~~22107-33100~~

REASON FOR CHANGE: Possible Fuel Leakage at seam (see illustration below)

REVISION DATE: 3/1/93

SERIAL NUMBERS AFFECTED: ~~2055086 to 2056705~~ *2056736 to 3066305 (PREVIOUS RANGE WAS 2055086 to 2056735)*

DETAILS of CHANGE: Tooling has been revised to provide increased durability at seam.

CLAIMS: Tank replacement claims should be submitted to Shindaiwa on a standard warranty claim form. Shindaiwa will pay a labor charge of .4 hour for each tank replaced.

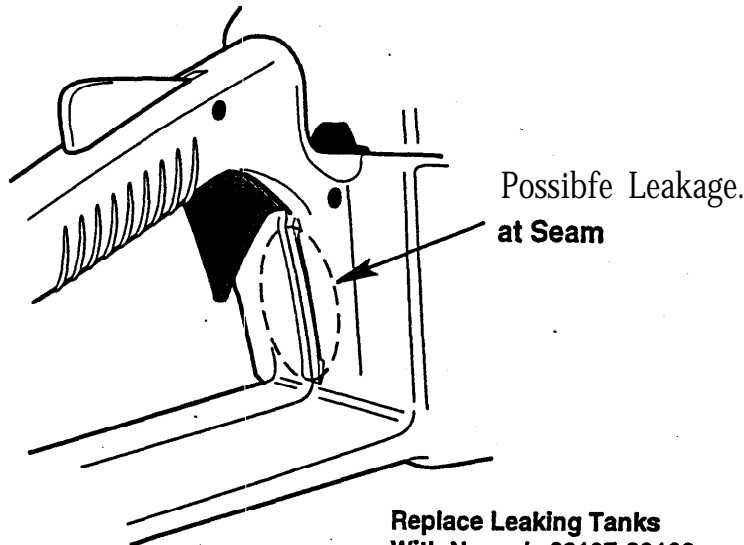

Replace Leaking Tanks  
With New p/n ~~22107-33100~~  
99909-300S \*

*\*(includes decals Referred to below.  
22137-33100 is tank without decals.)*

		<b>IMPORTANT!</b>		<p>Always wear eye protection when operating this machine.</p>
p/n 72229-75180		User-safety decals p/n 7222943130 "Eye Protection..." and p/n 72229-75180 (kickback/blade thrust warning) <u>must</u> be installed on all replacement handles!		p/n 72229-53130

54

# shindaiwa® SERVICE BULLETIN

142

SERVICE AND ENGINEERING BULLETIN

BULLETIN No: ~~PR-143~~ /42

SUBJECT: EB-45 Fuel Tank Improvement

DATE: 2/19/96

MODELS AFFECTED: EB-45 Blower

DESCRIPTION: Improved fuel tank and rear mounting cushion

REASON FOR CHANGE: Improved tank durability

INTERCHANGEABILITY: NONE. When upgrading from earlier tank versions, fuel tank and rear cushion must be replaced as an assembly only!

DETAILS: Fuel tank material has been changed to allow easier molding. The new tank is molded with increased radius at all corners, with special 'attention to reducing stresses at the three molded-in tank cushion mounting points. Likewise, the molded-in recess for the product label has been eliminated. The vinyl-strip rear cushion p/n 70029-85130 has been replaced with a larger molded rubber cushion p/n 70029-85131.

Affected Part Numbers

<u>Description</u>	<u>Old P/N</u>	<u>List Price</u>	<u>Price (2/96)</u>
Tank & mounting kit. Includes tank, cap, fuel pickup tube, filter, holders, front/rear cushions and screws	999094 53	99909-301	\$35.00
Tank assembly (now includes cap, fuel tube, filter and rear cushion)	70029-85002	70029-85003	\$30.00
Bare tank only (now includes rear cushion)	70029-85102	70029-85 103	\$15.00
Rear cushion	70029-85 130	70029-85131	\$ 1.52
Front Cushion <sup>1</sup>	70029-86121	No change	\$ 2.86
Holder <sup>1</sup>	70029-86111	No change	\$ .62

<sup>1</sup>Two-each required: ref. Shindaiwa PR-114:01 /10/93

55



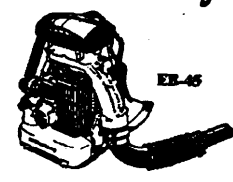

# EB-45 Fuel Tank Identification

## **ORIGINAL TANK**

p/n 70029435102

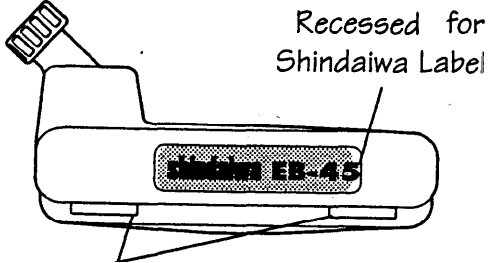

Recessed for Shindaiwa Label

SHINDAIWA EB-45

Sharp corners at cushion recess

(Front View)

## **IMPROVED TANK**

p/n 70029-85103

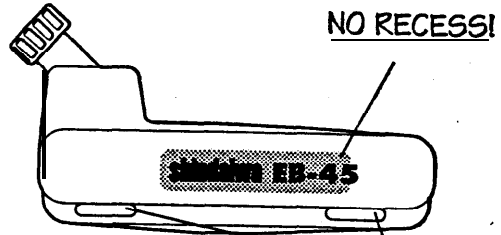

NO RECESS!

SHINDAIWA EB-45

Rounded corners

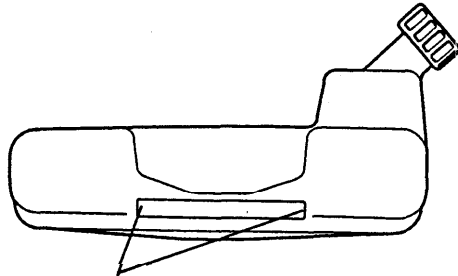

Sharp Corners

(Rear View)

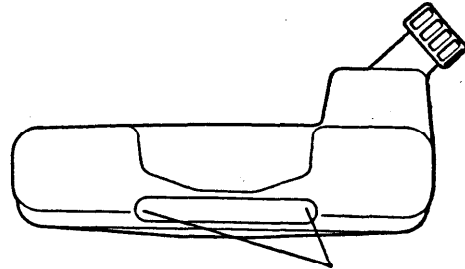

Rounded Corners

## Cushion Installation

File rough frame edges before installing cushion

Rear cushion p/n 70029-85131 wraps around sides of frame bracket

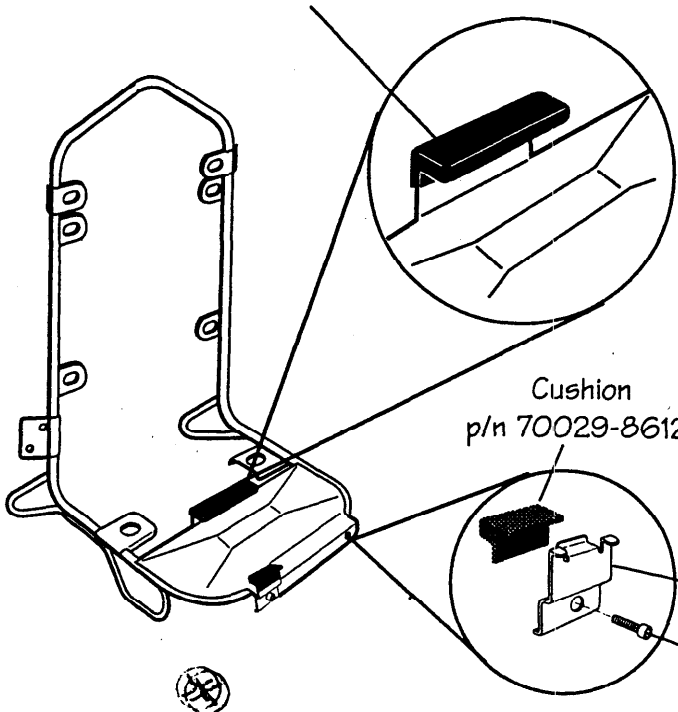

Cushion p/n 70029-86121

Bracket p/n 70029-8611

Screw p/n 01020-05100

<b>IMPROVED REAR CUSHION</b>	
	p/n 70029-85131
<b>ORIGINAL REAR CUSHION</b>	
	p/n 70029-85130
<b><u>DO NOT USE!</u></b>	

56

# 300S

## FUEL TANK INSPECTION PROCEDURE

1. The following serial number range is affected:

Serial numbers ~~2055086 through 2056735~~ <sup>2056736 to 3066305</sup>

Please check units for numbers within this range.

2. Remove the fuel tank assembly as follows:
  - a. For your convenience you may want to remove the front handle (4 fasteners).
  - b. Remove cylinder cover (3 fasteners).
  - c. Disconnect the fuel line at the carburetor.
  - d. Remove the anti-vibe cushion (5 fasteners) and remove the rear handle assembly.
3. To pressure test the fuel tank:
  - a. Remove the vent tube and block off the vent opening with a suitable tool.: (Smooth tapered center punch or drift punch).
  - b. Attach a pressure gauge to the fuel line.
  - c. Pressurize the tank to 7-8 psi and submerge in water to **check** for a leak at the seam indicated in SB-126.
  - d. If a leak is found, replace the rear handle assembly. Do not attempt to repair. Destroy old tanks.
4. If you have any 300S units in new, sealed factory boxes within the serial number range listed, at your option you may either replace the tanks on these units or return them to Shindaiwa.



57

Shindaiwa Inc.

11975 SW. Herman Road  
P.O. Box 1090  
Tualatin, Oregon 97062

Phone 503 6923070  
FAX 503 692-6696

**WARNING!**

**IMPORTANT SAFETY NOTICE**

February 21, 1996

**shindaiwa**

Dear Shindaiwa Customer:

Our records show you have purchased a Shindaiwa model EB45 backpack **blower**. If the engine serial number of your blower is within the sequence listed below (or if you have any question as to which serial number you have), we request that you immediately contact an authorized Shindaiwa dealer for a no-charge inspection and possible replacement of your blower's fuel tank at no charge to you. **Some of these tanks may fail, causing a gasoline leak and posing a chemical burn or fire hazard.**

**Affected Serial Numbers: 2039911 ~ 4058110**

Your dealer will determine if your unit requires a replacement **tank**. **If so, this will** only take a few minutes of your time and will be free of charge.

Thank you in advance for your cooperation; you are a valued customer and we appreciate your business. **If you need assistance locating your nearest dealer, call us toll-free at 1-800-521 -7733 weekdays from 7 a.m. to 5 p.m. PST.**

Sincerely,

Pete Femald  
Technical Services Manager



58

Shindaiwa Inc.

11975 S.W. Herman Road  
P.O. Box 1090  
Tualatin, Oregon 97062

Phone 503 6923070  
FAX 503 692-6696

**WARNING!**

**IMPORTANT SAFETY NOTICE**

February 21, 1996

**shindaiwa**

Dear Shindaiwa Customer:

Our records show you have purchased a Shindaiwa model 300S chain saw. If the engine serial number of your saw is within the sequence listed below (or if you have any question as to which serial number you have), we request that you immediately contact an authorized Shindaiwa dealer for a no-charge inspection and possible replacement of your saw's fuel tank at no charge to you. **Some of these tanks may fail, causing a gasoline leak and posing a chemical burn or fire hazard.**

**Affected Serial Numbers: 2056736 ~ 3066305**

Your dealer will determine: if your unit requires a replacement tank. If so, this **will** only take a few minutes of your time and will be **free** of charge.

Thank you in advance for your cooperation; you are a valued customer and we appreciate your business. If you need assistance locating your nearest dealer, **call** us **toll-free** at 1-800-521-7733 weekdays **from** 7 a.m. to 5 p.m. PST.

Sincerely,

Pete Femald  
Technical Services Managerr

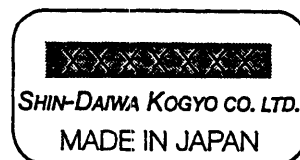

(Look for serial number here)

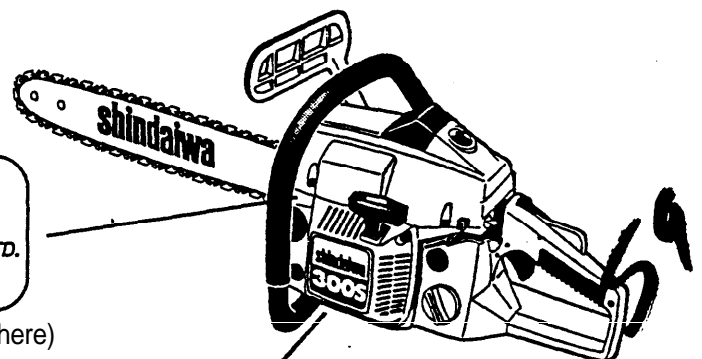

Concerns Model 300S Only



12" x 18"

# WARNING! IMPORTANT SAFETY NOTICE!

**Extension of earlier NOTICE of August 1993**

*and model EB45 backpack blowers*

Certain Shindaiwa model 300S chain saws have defective fuel tanks which may develop a leak, posing a *chemical burn or* fire hazard.

*or a model EB 45*

If you own a model 300S<sup>Y</sup> within the range of serial numbers listed below and have not had its tank inspected or replaced, please return the unit to your dealer immediately for a free inspection and possible replacement of the unit's fuel tank at no charge.

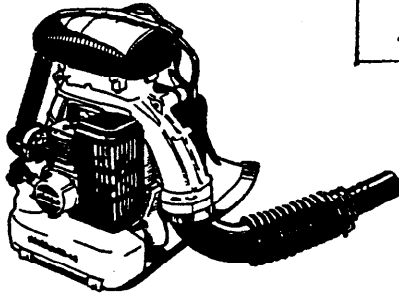

Serial Numbers  
2039911 to 4058110

Shindaiwa  
EB45

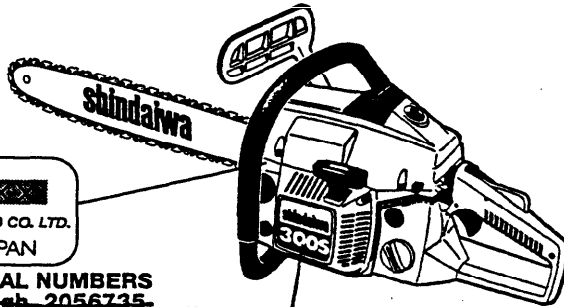

SHIN-DAIWA Kogyo CO. LTD.  
MADE IN JAPAN

LOOK FOR SERIAL NUMBERS  
~~2055086 through 2056735~~  
~~2056736 to 3066305~~

NOTE: The original serial number range has been extended to include ~~2055086~~ through 2056736  
3066305.

LOOK FOR MODEL "300S" HERE

Attention dealer: This notice must be displayed until ~~August~~ **March 31, 1996**

~~October 1995~~, Shindaiwa Inc., Tualatin, OR  
February 1996

\* of ~~2055086~~ to 2056735

60

**PROPOSED PRESS RELEASE**  
**SHINDAIWA INC.**  
**February 21, 1996**

**CPSC AND SHINDAIWA RECALL BACKPACK BLOWERS AND CHAIN SAWS**

WASHINGTON, D.C. - In cooperation with the U.S. Consumer Product **Safety** Commission (CPSC), Shindaiwa Inc. of Tualatin, OR is announcing the recall of the Shindaiwa model EB45 backpack blower and model 300S chain saw. These products' fuel tanks could leak, presenting a possible chemical burn or fire hazard.

The blower is red on a black metal backpack frame with shoulder straps, a white **fuel** tank, and black blower tubes. The name and model number EB45 is printed in the center of the blower's fuel tank. The chain saw is red with a gray bar and model number 300S on the recoil housing,

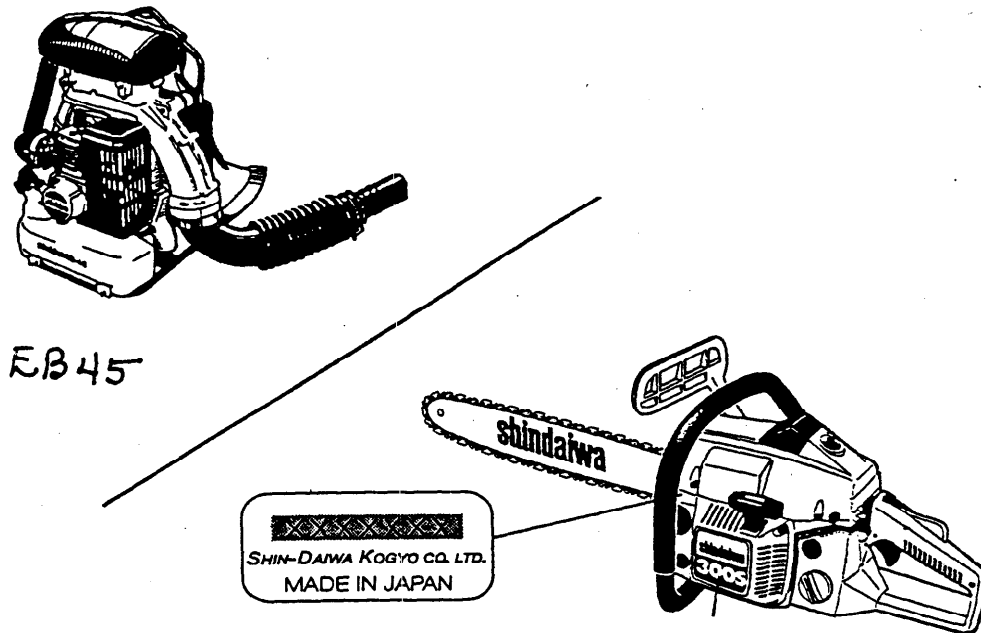

The products were sold nationwide from XXXX to XXXX at authorized Shindaiwa **dealers**.

Consumers who own the **affected** model numbers should stop using them immediately and return them to any Authorized Shindaiwa Servicing dealer. The product will be fitted with a redesigned fuel tank at no charge. For more information, consumers should call Shindaiwa **toll-free** at (800) 521-7733.

Shindaiwa believes there is a small chance of serious injury. However they are conducting this recall to prevent the possibility of injury.

The U.S. Consumer Product Safety Commission protects the public from the unreasonable risk of injury or death from **15,000** types of consumer products under the agency's jurisdiction. To report a dangerous product or a product-related injury and for information on **CPSC's** fax-on-demand service, call **CPSC's** hotline at (800) 638-2772 or **CPSC's** teletypewriter at (800) 638-8270. To order a press release through fax-on-demand, call (301) 504-005 1 from the handset of your fax machine and enter the release number. Consumers can obtain this release and recall information via Internet gopher services at **cpsc.gov** or report product hazards to info@cpsc.gov.



####

61

Shindaiwa Inc.

11975 S.W. Herman Road  
P.O. Box 1090  
Tualatin, Oregon 97062

Phone 503 692-3070  
FAX 503 692-6696

January 25, 1996

Mr. John Shumlansky  
U.S. Consumer Product Safety Commission  
Division of Corrective Actions  
4330 East West Hwy., Room 613  
Washington, D . C . 20207-000 1

RECEIVED

EEB-2 P.M.

Re: CPSC Shindaiwa Inc.  
Model EB-45 Gas-powered Back Pack Lawn Blower

**shindaiwa**

Dear Mr. Shumlansky:

We are enclosing our initial voluntary report concerning the Shindaiwa gas powered back pack blower model EB-45.

This report is related to a fuel tank defect. We **previously** reported a **fuel** tank defect with this model in early 1993. Your **file** reference is **CA930045**, Shindaiwa Inc., Model E13-45, Gas-powered Lawn Blower.

There have been no claims of injury regarding this specific **fuel** tank defect, However, there were two injury claims related to this product which were reported in our 1993 report referred to in the previous paragraph. These claims arose from a different **defect** in the same fuel tank.

We will forward additional information as soon as possible.

Sincerely



Michael F. Breitbach  
Director, Operations and Administration

62

INITIAL PRODUCT REPORT TO CPSC

RE: SHINDAIWA INC.  
Model EB-45 Gas Blower **Fuel** Tank

This is a voluntary initial report to the CPSC in accordance with 16 C.F.R., Sec. I 115.13 (d). There have been no injury claims related to this specific fuel tank defect. However, there were two claims of injury related to this product which were reported in our 1993 report to the CPSC; reference CA930045, Shindaiwa Inc., Gas-powered Lawn Blower. These claims arose from a different defect in the same fuel tank.

Shindaiwa is reporting this problem out of an abundance of caution and 'without any admission of liability. Further, the nature of this report is confidential and proprietary.

1. The product is a Shindaiwa Model EB-45 Back Pack Gas-powered Lawn Blower.
2. The manufacturer is Shin-Daiwa Kogyo Co., Ltd., 35, Ooaza Shin-Ujigami, Chiyoda-cho Yanagata-gun, Hiroshima 73 1-1 5 JAPAN. .
3. Fuel tank leaks at the rear mount. The extent of the failure is not yet known.
4. Injury could be caused by contact with gasoline resulting in a chemical burn or a potential burn from a fire.
5. The person informing the commission. is Michael F. Breitbach, employed by Shindaiwa Inc. at 11975 S.W. Herman Road, Tualatin. Oregon, 97062.
6. The Company became aware of this defect based on an increase in warranty claims **which** started to increase in the second quarter of 1995.

63



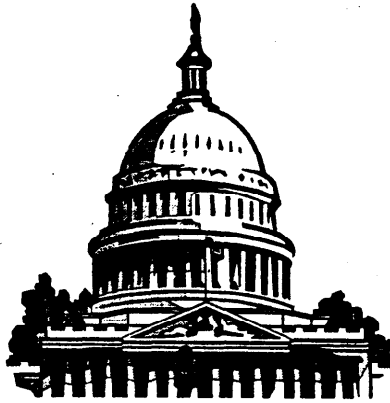

U.S. CONSUMER PRODUCT SAFETY COMMISSION  
WASHINGTON, DC 20207

OFFICE OF COMPLIANCE

Tel: 301-504-0608

DIVISION OF  
CORRECTIVE ACTIONS

F A X : 301-504-0359

DATE: 2/20/96 . PAGES TRANSMITTED 2 + cover

TO: Michael Breitbart

TITLE: Director, Operations and Admin.

OFFICE: Shindai wa

FAX #: (503) 692-6696

Confirmation copy to follow by U.S. Mail

Cl  Transmission Only

FROM: John Shumlansey

REMARKS: ATTACHED IS A COPY of the Tanaka  
Back Back Blows Press Release.

NOTE: If all pages are not received, or if you have problems with this transmittal, please contact the person listed above.

THIS MESSAGE IS INTENDED ONLY FOR THE USE OF THE INDIVIDUAL OR ENTITY TO WHICH IT IS ADDRESSED AND MAY CONTAIN INFORMATION THAT IS PRIVILEGED, CONFIDENTIAL, AND EXEMPT FROM DISCLOSURE UNDER APPLICABLE LAW. IF THE READER OF THIS MESSAGE IS NOT THE INTENDED RECIPIENT, YOU ARE HEREBY NOTIFIED THAT ANY DISSEMINATION, DISTRIBUTION, OR COPYING OF THIS COMMUNICATION IS STRICTLY PROHIBITED. IF YOU HAVE RECEIVED THIS COMMUNICATION IN ERROR, PLEASE NOTIFY US IMMEDIATELY BY TELEPHONE, AND RETURN THE ORIGINAL MESSAGE TO US AT THE ABOVE ADDRESS VIA THE U.S. POSTAL SERVICE. THANK YOU.

64

# NEWS from CPSC

## U.S. CONSUMER PRODUCT SAFETY COMMISSION

OFFICE OF INFORMATION AND PUBLIC AFFAIRS

WASHINGTON, D.C. 20207

FOR IMMEDIATE RELEASE  
December 20, 1995  
Release # 96-050

CONTACT: Kate Premo  
(301) 504-0580 Ext. 1187

### CPSC AND TANAKA RECALL BACKPACK BLOWERS

WASHINGTON, D.C. - In cooperation with the U.S. Consumer Product Safety Commission (CPSC), Tanaka America of Kent, Wash., is announcing the recall of approximately 11,000 Tanaka and Ariens leaf blowers. The blower's fuel tank could leak, presenting a possible fire hazard.

The blowers are mounted on a black metal backpack frame with padded shoulder straps, an orange fuel tank, and black blower tubes. The names and model numbers of the manufacturer are printed in the center of the blower's fuel tank or on the recoil starter. Tanaka models TBL-455 and TBL-500 and the Ariens model BB-430 blowers are involved in this recall.

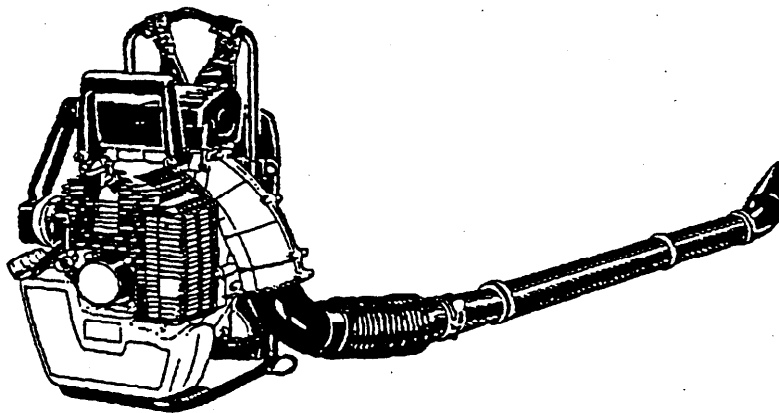

The leaf blowers were sold nationwide from January 1986 to December 1992 for between \$400 and \$460 each.

Consumers who own Tanaka and Ariens blowers with these model numbers should stop using them immediately and return them to any Authorized Tanaka Servicing dealer. The backpack blowers will be fitted with a redesigned fuel tank at no charge. For more information, consumers should call Tanaka toll-free at (800) 3 13-5580.

---MORE---

65

(blower)

-2-

Tanaka has not received any reports of consumers who were injured in incidents involving the fuel leaks. Tanaka is conducting this recall to prevent the possibility of injury.

The U.S. Consumer Product Safety Commission protects the public from the unreasonable risk of injury or death from 15,000 types of consumer products under the agency's jurisdiction. To report a dangerous product or a product-related injury and for information on CPSC's fax-on-demand service, call CPSC's hotline at (800) 638-2772 or CPSC's teletypewriter at (800) 638-8270. To order a press release through fax-on-demand, call (301) 504-0051 from the handset of your fax machine and enter the release number. Consumers can obtain this release and recall information via Internet gopher services at [cpsc.gov](http://cpsc.gov) or report product hazards to [info@cpsc.gov](mailto:info@cpsc.gov).

####

66

MEMORANDUM OF  
TELEPHONE -  
CALL

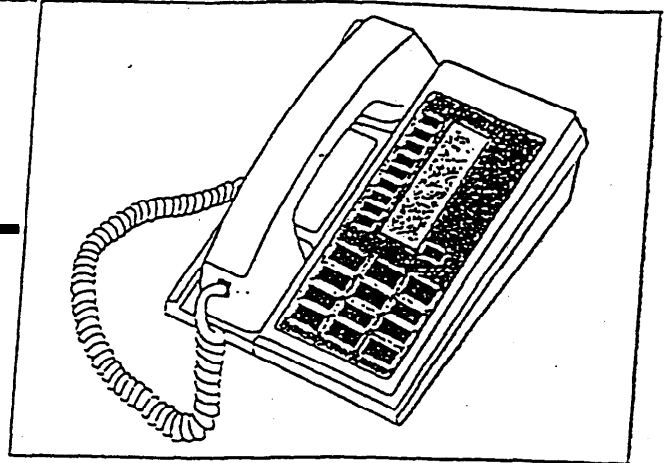

DATE: 2-27-96  
TIME: \_\_\_\_\_

NAME AND TITLE: Mr. Sue  
FIRM: Shindaiwa  
TELEPHONE: (503) 692-3070 OR  
SUBJECT: (800) 521-7933

left a message for

- #'s Distributed For Chain Saw/Blower
- Dates (mo/yr) Sold
- Retail Prices

MIKE BREITBACH x 625

~~3-26-96~~ - left a message for Mike Breitbach  
that the PR would go out tomorrow

67



**FOR OFFICIAL USE ONLY**

U.S. CONSUMER PRODUCT SAFETY COMMISSION  
WASHINGTON, D.C. 20207

OFFICE OF COMPLIANCE

Division of  
Corrective Actions  
Tel: 3014040608  
Fax: 301-504-0359

FEB 16 1996

Certified Mail  
By Fax: (503) 692-6696

Michael F. Breitbart  
Director, Operations and Administration  
Shindaiwa, Inc.  
11975 S.W. Herman Road  
P.O. Box 1090  
Tualatin, OR 97062

Re: CPSC RP960077  
Shindaiwa, Inc.  
Model 300S Chain Saw, Model EB-45 Back Pack Blower

Dear Mr. Breitbart:

Thank you for your report of January 25, 1996 under section 15(b) of the Consumer Product Safety Act, as amended (CPSA), 15 U.S.C. § 2064(b). In your report, you identified potential problems with two Shindaiwa products, the Model EB-45 back pack blower, and the Model 300S chain saw. Both products involve cracking and potential leaking of fuel from the fuel tank. Injury could be caused by contact with gasoline resulting in a chemical burn or a potential burn from a fire.

You also noted that the firm wishes to participate in the Commission's Pilot Program announced in the Federal Register August 17, 1995. Enclosed for your information is some information regarding the Pilot Program. The essential part is that all of the information needed by the staff to evaluate and approve a firm's corrective action plan (CAP), including the information requested for a full report at 16 C.F.R. 1115(13) and all draft notice material, must be submitted in time for review and approval so that the CAP can be announced in 20 working days from the date of the initial report.

648

In addition, John Shumlansky of my staff discussed with you the possible need for Shindaiwa an CPSC to issue a joint press release to announce the recalls. Attached is a copy of a recent press release issued by CPSC announcing the recall of a back pack blower. Please use this release as a reference to develop a draft press release for both the chain saw and back pack blower.

In order to facilitate the staffs review, please provide needed information by **telephone or telefax** as soon as you receive it. If you seek assistance or if you have any questions, you may contact John Shumlansky, Division of Corrective Actions, U.S. Consumer Product Safety Commission, 4330 East West Highway, Room 613, Washington, D.C. 20207-0001, telephone: (301) 504-0608, extension 1366.

Sincerely,

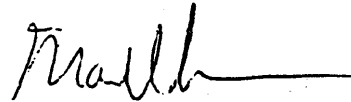

Marc J. Schoem  
Director  
Division of Corrective Actions

Enclosures

CPSC Pilot Program Information  
Press release

69

\*\*\*\*\*  
\*\*\* ACTIVITY REPORT \*\*\*  
\*\*\*\*\*

-TRANSMISSION OK

TX/RX NO. ✓ 8627

CONNECTION TEL 915036926696 .

CONNECTION ID

START **TIME** 02/16 12:49

USAGE TIME 01'43

PAGES 3

RESULT OK

70

✓ 8627



U.S. CONSUMER PRODUCT SAFETY COMMISSION  
WASHINGTON, DC 20207

OFFICE OF COMPLIANCE

Tel: 301-504-0608

DIVISION OF  
CORRECTIVE ACTIONS  
FAX: 301-504-0359

DATE: 2/16/96 PAGES TRANSMITTED 2 cover

TO: Michael F. Breitbart

TITLE: Director, Operations & Admin

OFFICE: Shindaiwa Inc

FAX #: 503-692-6696

- Confirmation copy to follow by U.S. Mail
- Fax Transmission Only

FROM: John Shumlansky

Compliance Officer

REMARKS: ENCLOSURES MAILED

NOTE: If all pages are not received, or if you have problems with this transmittal, please contact the person listed above.

THIS MESSAGE IS INTENDED ONLY FOR THE USE OF THE INDIVIDUAL OR ENTITY TO WHICH IT IS ADDRESSED AND MAY CONTAIN INFORMATION THAT IS PRIVILEGED, CONFIDENTIAL, AND EXEMPT FROM DISCLOSURE UNDER APPLICABLE LAW. IF THE READER OF THIS MESSAGE IS NOT THE INTENDED RECIPIENT, YOU ARE HEREBY NOTIFIED THAT ANY DISSEMINATION, DISTRIBUTION, OR COPYING OF THIS COMMUNICATION IS STRICTLY PROHIBITED. IF YOU HAVE RECEIVED THIS COMMUNICATION IN ERROR, PLEASE NOTIFY US IMMEDIATELY BY TELEPHONE, AND RETURN THE ORIGINAL MESSAGE TO US AT THE ABOVE ADDRESS VIA THE U.S. POSTAL SERVICE. THANK YOU.

71



MEMORANDUM OF  
TELEPHONE  
CALL

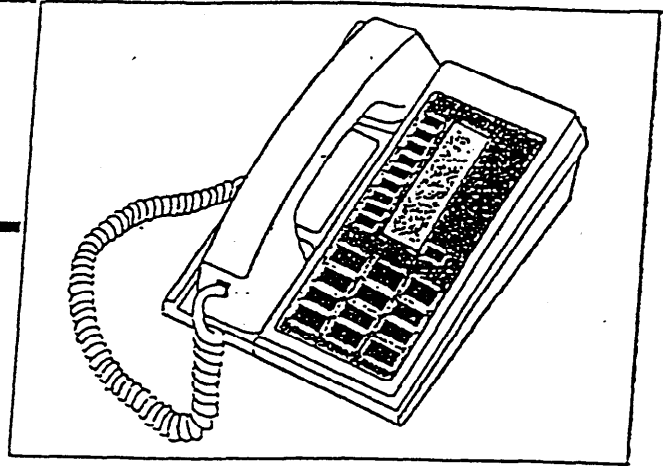

DATE: 2-15-96  
TIME: \_\_\_\_\_

NAME AND TITLE: Mike Bretbach  
FIRM: Shindarwo  
TELEPHONE: (503) 692-3070  
SUBJECT: \_\_\_\_\_

- they want to do a recall  
notify registered owners, dealers & distributors

300s chain saw - was recalled

300s - 1993 - Serial # sequence extended

EB-45 - orig recall for fuel tank in '91  
reported to CPSC in '93 - Accepted CAP + close

now same fuel tank, diff problem

72

MEMORANDUM OF  
TELEPHONE  
CALL

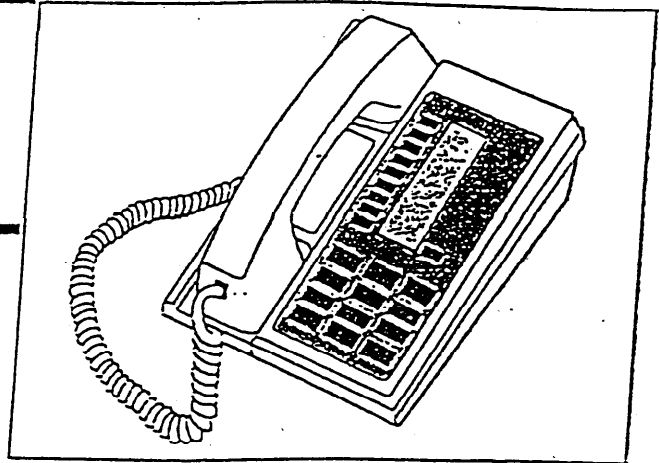

DATE: 1-31-96  
TIME: \_\_\_\_\_

NAME AND TITLE: Mike Breitbach  
FIRM: Shin Daiwa  
TELEPHONE: (503) 692-3070  
SUBJECT: \_\_\_\_\_

The previous Recall had 4688 out of 5099  
returned

-411 not notified

2-13-96

left a message for Mike Breitbach to call

2-15-96

left a message for Mike Breitbach to call

73

MEMORANDUM OF  
TELEPHONE  
CALL

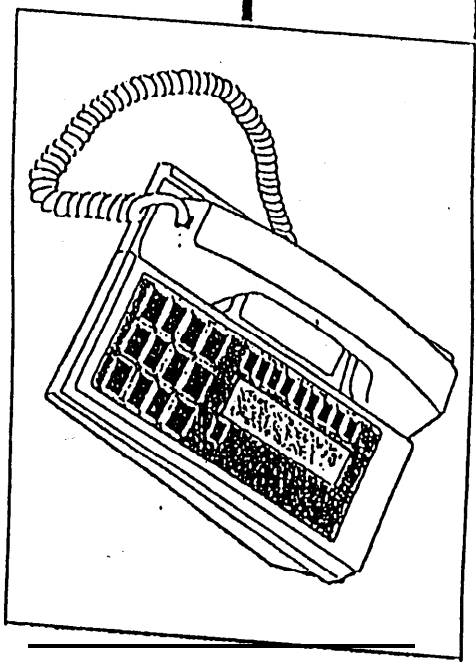

DATE: 1-30-96  
TIME: \_\_\_\_\_

NAME AND TITLE: Michael F. BREIBACH  
FIRM: Shin Dairyo  
TELEPHONE: (503) 692-3070  
SUBJECT: \_\_\_\_\_

- They learned about the problem a few months ago
- No injuries w/ the new problem
- They found out about this problem through warranty claims
- He will provide tomorrow the # of warranty claims and the return rate for the previous Recall
- I told him we may want to consider a press Release

NY

MEMORANDUM OF  
TELEPHONE  
CALL

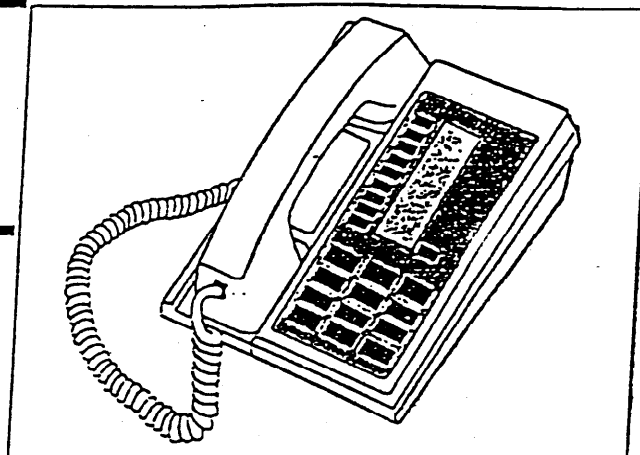

DATE: 1-17-96  
TIME: \_\_\_\_\_

NAME AND TITLE: Joe Meyer  
FIRM: Shindaiwa  
TELEPHONE: 800 521-7733  
SUBJECT: CHAIN Saw RP930127

THE CAP included:

- letters to Dealers
- Store posters
- Registered owners contacted

- No claims received

1-29-96 - left a message for Mike Bicitback to call

75

Shindaiwa Inc.

11975 S.W. Herman Road  
P.O. Box 1090  
Tualatin, Oregon 97062

Phone 503 6923070  
FAX 503 692-6696

January 25, 1996

Mr. John Shumlansky  
U. S. Consumer Product Safety Commission  
Division of Corrective Actions  
4330 East West Hwy., Room 613  
Washington, D. C. 20207-0001

Re: CPSC Shindaiwa Inc.  
Model 300 Chain Saw

**shindaiwa**

Dear Mr. Shumlansky:

In response to your inquiry regarding the 1993 recall and number of units involved and it's replacement rate, please refer to the attached copy of my letter of October 23, 1995.

I hope this will provide you with the information you need. If you have further questions please feel free to call me. My telephone number is (503) 691-4625.

Sincerely,

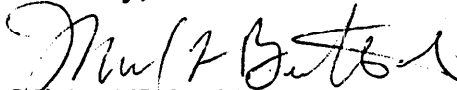

Michael F. Breitbach  
Director, Operations and Administration

**RECEIVED**

**EEB - 2 P.M.**

76

Shindaiwa Inc.

11975 S.W. Herman Road  
P.O. Box 1090  
Tualatin, Oregon 97062

Phone 503 692-3070  
FAX 603 692-6696

1/44

HP960077

January 25, 1996

Mr. John Shumlansky  
U.S. Consumer Product Safety Commission  
Division of Corrective Actions  
4330 East West Hwy., Room 613  
Washington, D.C. 202074001

Re: CPSC Shindaiwa Inc.  
Model EB-45 Gas-powered Back Pack Lawn Blower

shindaiwa

Dear Mr. Shumlansky:

We are enclosing our initial voluntary report concerning the Shindaiwa gas powered back pack blower model EB-45.

This report is dated to a fuel tank defect. We previously reported a fuel tank defect with this model in early 1993. Your file reference is CA930045, Shindaiwa Inc., Model EB-45, Gas-powered Lawn Blower-

There have been no claims of injury regard\* this specific fuel tank defect. However, there were two injury claims related to this product which were reported in our 1993 report referred to in the previous paragraph. These claims arose from a different defect in the same fuel tank.

We will forward additional information as soon as possible,

Sincerely

Michael F. Breitbach  
Director, Operations and Administration

17

**INITIAL PRODUCT REPORT TO CPSC**

**RE: SHINDAIWA INC.  
Model EB-45 Gas Blower Fuel Tank**

This is a **voluntary initial** report to the CPSC in **accordance** with I6 C.F.R., Sec. I 115.13 (a). There have been no injury claims related to **this** specific **fuel** tank defect. However, **there** were two **claims** of injury **related** to **this** product which were reported **in** our 1993 report to the CPSC; reference **CA930045, Shindaiwa Inc., Gas-powered Lawn Blower**. These claims arose **from** a **different** defect in the **same fuel tank**.

Shindaiwa **is** reporting **this** problem out of an abundance of caution and without **any admission of** liability. Further, **the** nature of **this** report is confidential and **proprietary**.

1. The product is a **Shindaiwa Model EB-45 Back Pack Gas-powered Lawn Blower**.
2. The **manufacturer** is **Shin-Daiwa Kogyo Co., Ltd., 35, Ooaza Shin-Ujigami, Chiyoda-cho Yanagata-gun, Hiroshima 73 1-13 JAPAN**.
3. Fuel tank leaks at the rear mount. The **extent** of the **failure** is not yet **known**.
4. Injury could be caused by contact **with** gasoline **resulting** in a chemical **burn** or a **potential** burn **from** a fire.
5. The person informing the commission is **Michael F. Breitbach, employed by Shindaiwa Inc.** at 11975 S.W. Herman Road, **Tualatin**, Oregon, 97062.
6. The Company became aware of this defect based on an increase in **warranty claims which** started to increase in the **second** quarter of 1995.

78

January 25, 1996

**Mr. John Shumlansky**  
U.S. Consumer Product **Safety** Commission  
Division of Corrective Actions  
4330 East West **Hwy.**, **Room** 613  
Washington, **D.C.** 202074001

Re: CPSC **Shindaiwa Inc.**  
**Model 300** Chain Saw

**shindaiwa**

**Dear Mr. Shumlansky:**

In response to your **inquiry** regarding the 1993 **recall** and number of **units** involved and it's **replacement** rate, **please** refer to the attached copy of my **letter** of October 23, 1995.

I hope this **will** provide you with the information you need. If you have **further** questions **please** feel **free** to call me. My telephone number is (503) **691-4625**.

Sincerely,



**Michael F. Breitbach**  
Director, **Operations** and Administration

79



Shindaiwa Inc.

11975 SW. Herman Road  
P.O. Box 1090  
Tualatin, Oregon 97062

Phone 503 692-3070  
FAX 503 692-6696

October 23, 1995

Mr. Dave Johnson  
U.S. Consumer Product Safety Commission  
Division of Corrective Actions  
4330 East West Hwy., Room 613  
Washington, D.C. 20207-0001

Re: CPSC RP930127  
Shindaiwa Inc.  
Model 300S Chain Saw

**shindaiwa**

Dear Mr. Johnson:

Sue Meyer informed me of your inquiry regarding the results of the 1993 recall for the 300S chain saw.

Of the population of approximately 950 units then identified as defective, and for which we gave notice users, we incurred 345 warranty claims (36%) within the original serial number sequence.

I will be on the east coast for the remainder of the week. So, if you have questions please contact Sue Meyer. Her telephone number is (503) 691 4641. She will be able to get in contact with me if needed.

Very truly yours

Mike Breitbach  
Director, Operations and Administration

80

J S

Client 148

This Clipping Processed by  
MDDC PRESS CLIPS, INC.  
Baltimore, Maryland

Phila. Inquire/r  
Philadelphia, PA  
Cir: 515,523-D  
994,530-s

**MAR 28 1996**

**Saws and blowers found  
to have potential problems**

ASSOCIATED PRESS

WASHINGTON — Ryobi America Corp. is recalling 150,000 table saws because switches that are supposed to lock in the "off" position may not work, the government said yesterday.

The 75-pound saws have 10-inch blades and a sliding miter table. The Consumer Product Safety Commission said they were sold nationwide by home centers and hardware and Sears stores with the following names and model numbers: Ryobi BT3000 and Sears Craftsman Model 315.22185. Owners should contact Ryobi, based in Anderson, S.C., at 1-800-867-9624.

Also, Shindaiwa Inc. of Tualatin, Ore., is recalling its model EB-45 backpack blowers and model 300S chain saws because the fuel tanks could leak and possibly cause chemical burns or fire, the CPSC said. The tools were sold nationwide from April 1992 to June 1995. For more information, call 1-800-521-7723.

81

7

☆ U.S. GOVERNMENT PRINTING OFFICE: 1982-322-772

1. STORAGE LOCATION		2. NAME OF PRODUCT		3. SAMPLE NO.			
A.	C.	CHAIN SAW - BACK PACK BLOWER		96-793-0130			
B.	D.	4. NAME AND ADDRESS OF FIRM					
5. DATE SAMPLE RECEIVED		6. BY WHOM RECEIVED		7. DATE RECORDS RECEIVED			
3-19-96		John SHUMLAWSKY					
8. METHOD OF SHIPMENT	A. PERSONALLY FROM		C. SHIPPED FROM				
	Sue Meyer		SHINDAIWA				
B. VIA		D. SHIPPING RECORDS (Type and Identity)					
UPS							
9. DESCRIPTION OF SHIPMENT	A. SHIPPING CONTAINERS	NUMBER	TYPE	CONDITION			
	B. SAMPLE PACKAGES	NUMBER	SIZE, TYPE, ETC.	CONDITION			
	C. SEAL INSCRIPTION	COPY IN FULL		CONDITION			
10. SAMPLE DELIVERY			11. SAMPLE RETURNED				
DATE	AMOUNT	FROM	TO	DATE	AMOUNT	TO	FROM
12A. SAMPLE DISPOSITION						B. BY WHOM	C. DATE

CPSC FORM NO. 159 (REV. 4/77)

SAMPLE ACCOUNTABILITY RECORD  
(Custodian Copy)

29