

# *XXI NOTES*

## ASSEMBLY INSTRUCTIONS



U.S. Department of Justice

**UNICOR**

Federal Prison Industries, Inc.

**XXI Notes**

# *XXI NOTES*

## ASSEMBLY INSTRUCTIONS

### TABLE OF CONTENTS

Basic Desk .....	3
Hanging Pedestal .....	4
Overhead Storage Unit .....	5
Overhead Shelf .....	7
Square, Rectangular, Corner, and Keyboard Transitionals .....	8
Triangular Transitionals .....	9
Privacy Screens .....	10
Peninsula Table .....	11
Conference End .....	12
Keyboard Drawer .....	13
Center Drawer .....	14
Work Bar .....	15
Task Light .....	16
Letter Tray .....	17
Binder Bin .....	18
Slanted Storage Tray .....	19
Turntable .....	20
Hardware Reference List .....	21

# Basic Desk

**Note:** The printer stand is not illustrated but is assembled in the same manner as the desk.

1. To avoid scratching the work surface, place the top face down onto a soft protective surface.
2. Attach (2) leg sets to work surface bottom by aligning legs to pre-drilled holes and inserting [24" surface uses (2) #12 x 3" screws, 30" surface uses (3) #12 x 3" screws] per leg set. (Figure 1)
3. Align modesty panel between leg sets and insert (2) #12 x 3/4" screws per left and right side. Insert #10 x 1" screws through the modesty panel and the bottom of the work surface -- **DO NOT TIGHTEN**. Tighten all screws attaching the leg sets to the modesty panel. (Figure 1)
4. Determine placement of the wireway, either inside or outside the modesty panel. Insert wireway between modesty panel and work surface as shown in Figure 2. Ensure the wireway slots are aligned with existing modesty panel screws. Tighten modesty panel screws.

**Note:** If a pedestal cabinet is included with this desk, proceed to Hanging Pedestal Instructions.

5. Stand desk right side up.
6. Both door wireways are shipped installed. The access doors are facing the inside and open inward. (Figure 3) These wireways are reversible and may be removed and reinserted.
7. Level work surface by turning (4) leg levelers either in or out.

**Note:** If a pedestal cabinet is included with this desk, proceed to Hanging Pedestal Instructions.

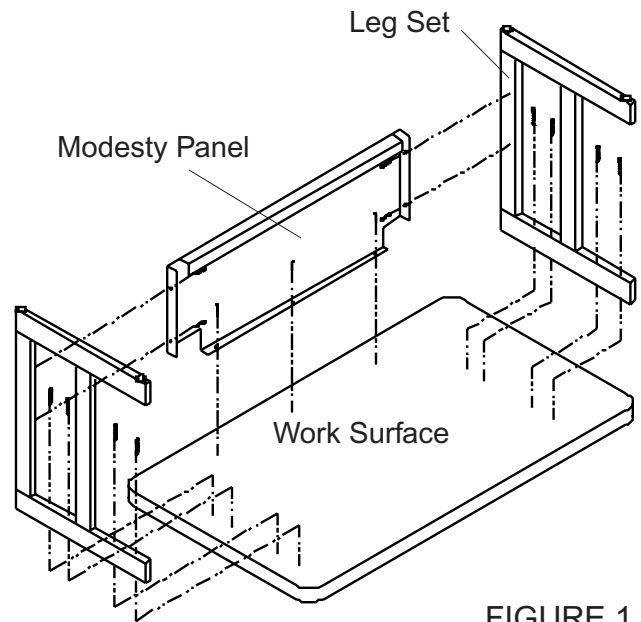

FIGURE 1

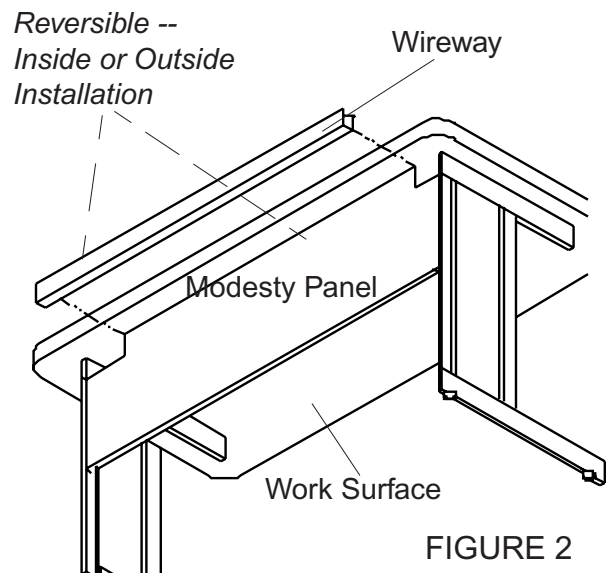

FIGURE 2

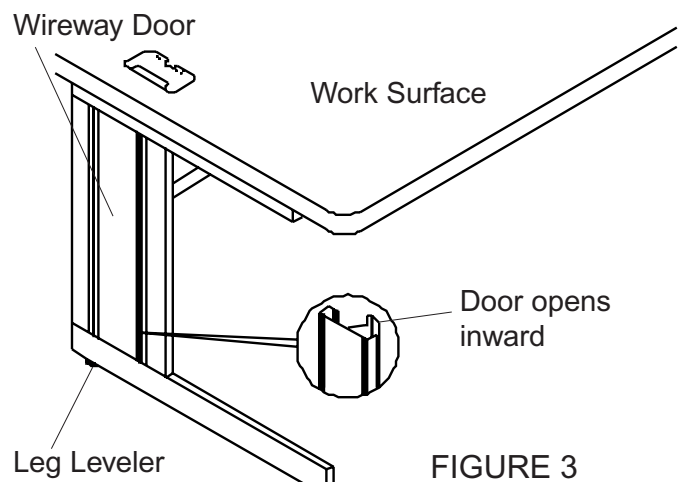

FIGURE 3

# Hanging Pedestal

## Quick-Mount Pedestal Attachment to Work Surface (Option 1)

1. Place work surface face down on floor.
2. Determine on which side (left or right) the pedestal will be used.
3. Install four (4) hanger bolts into work surface.

**Caution:** Do not over tighten. (Figure 1)

4. Position back of pedestal to engage with back hanger bolts and slide backward enough to allow front key slots to engage. Continue the push backward until engagement is reached.

5. Install thumb screw through pedestal top and into predrilled hole in the work surface. Thumb screw must be installed to lock pedestal to the work surface. (Figure 2)

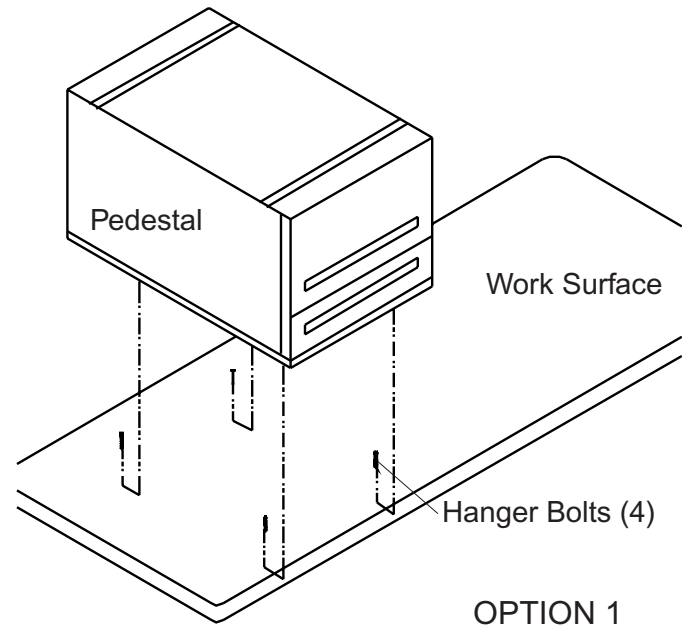

OPTION 1

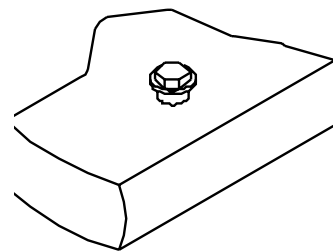

FIGURE 1

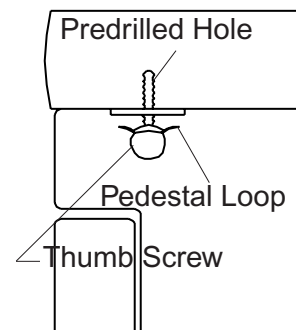

FIGURE 2

## Quick-Mount Pedestal Attachment to Work Surface (Option 2)

**Note:** Option 2 is suggested when attaching a pedestal to a fixed work surface that cannot be turned face down.

1. Follow instruction in Option 1 excluding step one (1).

### Drawer Removal

Pull drawer all the way out. Locate the tabs at the front of both drawer slides. Pull both tabs up to unlock the drawer bin. Push drawer bin back to disengage back tabs, then lift bin up and out.

**Caution:** Due to the weight of the pedestal this assembly option requires more than one person, thus avoiding personal injury.

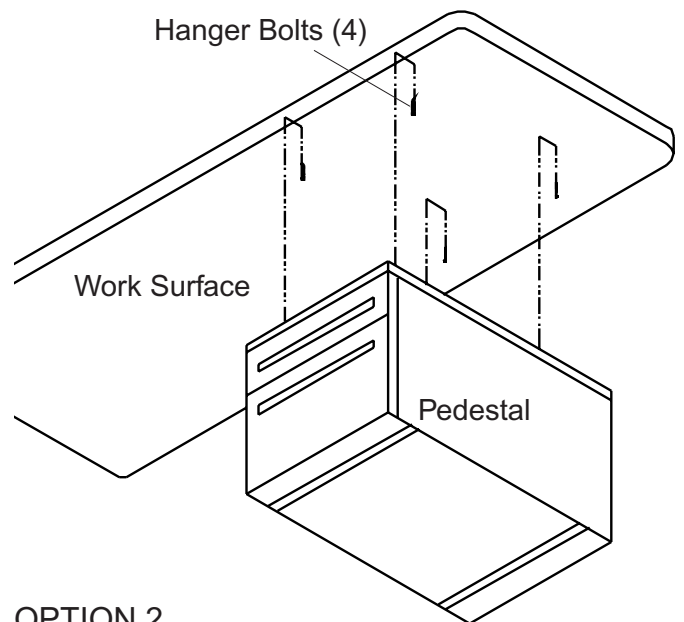

OPTION 2

# Overhead Storage Unit

1. To avoid scratching the uprights and back, place them on a soft, protected surface for assembly.
2. Insert (4) connecting bolts into holes on both uprights and (4) cam locks into holes on back. Arrows on cam locks must be facing toward the upright being fastened (open position). (Figure 1)
3. Align connecting bolts with arrows on cam locks (in open position) and insert. (Figure 1)
4. With a Phillips screwdriver, rotate cam lock clockwise to secure sides.
5. Add (4) #10 x 5/8" screws one-half way into predrilled holes of uprights. (Figure 2)
6. The shelf sides have slots that fit onto screws in the upright. Slide shelf into position and tighten screws. (Figure 2)
7. Insert (4) #10 x 5/8" screws through the holes in shelf and into predrilled holes in back and tighten.

**Note:** Steps 8 - 10 are only required on 60" and 72" overhead storage units. For 48" units, go to step 11.

8. Insert (2) nuts into holes on center of back and (2) nuts into holes on partition. Arrows on cam lock must be facing toward partition (open position). (Figure 3)
9. Align connecting bolt with arrows on cam lock (in open position) and insert. With a Phillips screwdriver rotate clockwise to secure partition.
10. Align screw holes in the bottom of partition and the shelf. Insert (2) #10 x 5/8" screws and tighten. (Figure 3)
11. Assemble top in the same manner as the shelf.
12. **Stand the shelf assembly up onto the work surface.** Align (2) overhead mounting brackets with predrilled holes in uprights and work surface legs, insert (4) #10 x 5/8" screws and tighten. (Figure 4)

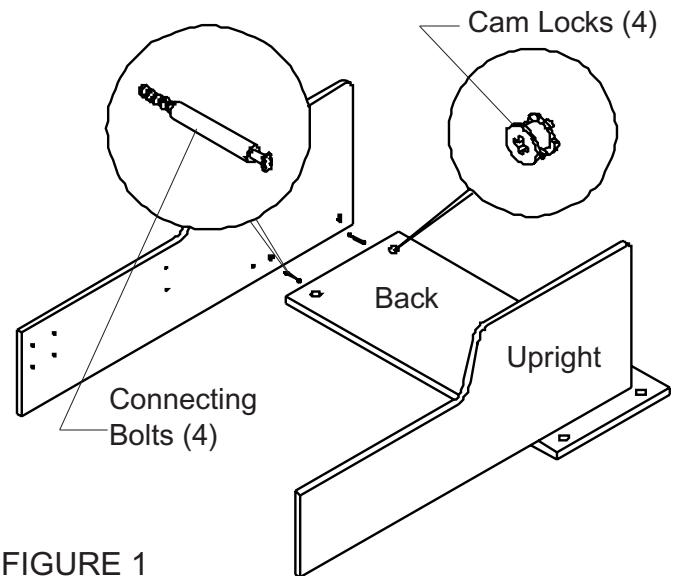

FIGURE 1

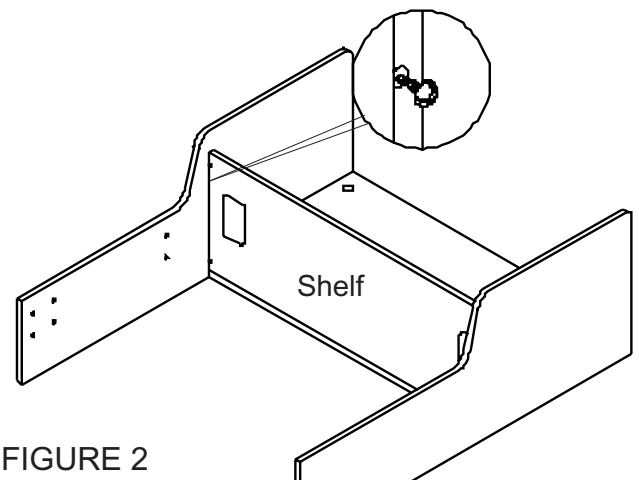

FIGURE 2

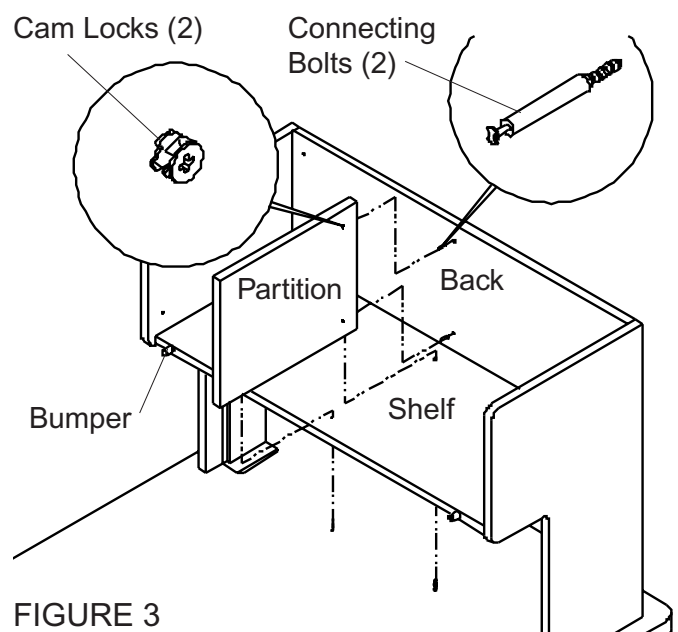

FIGURE 3

# Overhead Storage Unit

(CONTINUED)

13. Lay door back side up and attach (2) slide hinges per door back with (4) #8 x 5/8" flat head screws per hinge. (Figure 7) Rollers should be toward the top of the door.
14. Attach keyed lock from back side of door with (2) #10 x 5/8" screws. Add trim collar from front side of door. (Figure 7)
15. Peel adhesive back off door bumpers and attach to front of shelf as shown. (Figure 3)
16. Turn over door and position it onto the top of the overhead storage unit. Align slider hinge to predrilled holes in top shelf and insert (3) #10 x 5/8" screws per hinge. **DO NOT** tightens screws in this step. (Figure 8)
17. Center door to opening and tighten screws on slider hinges. (Figure 8)
18. Attach (2) wireway mounting clips per upright with (2) #10 x 5/8" screws per clip. (Figure 5)
19. Break off v-mold knock-out on work surface hole cover to accommodate wireway. Attach work surface grommet into the (2) opening on the top of the work surface. Snap hole cover into grommet. (Figure 6)
20. Snap wireway onto wireway clips after attaching work surface grommet. (Figure 5)

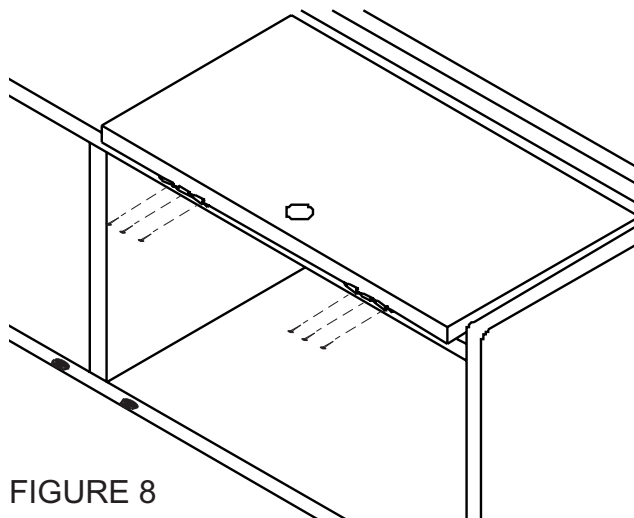

FIGURE 8

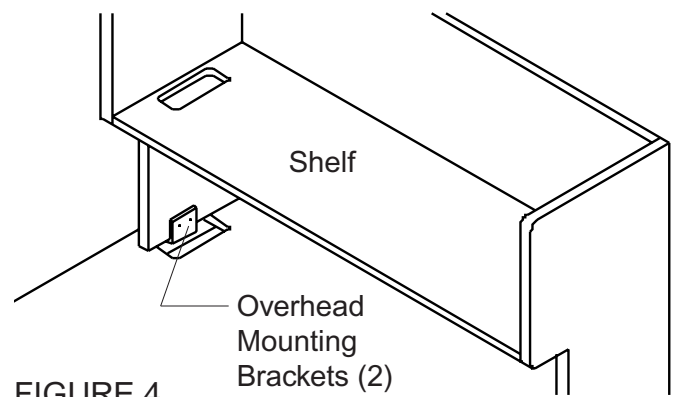

FIGURE 4

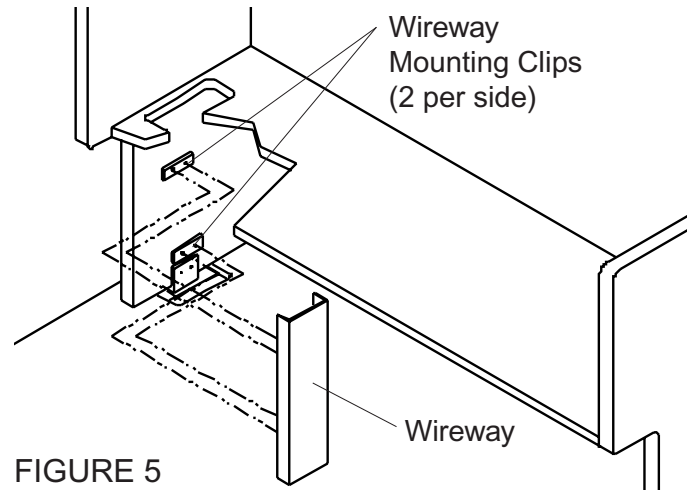

FIGURE 5

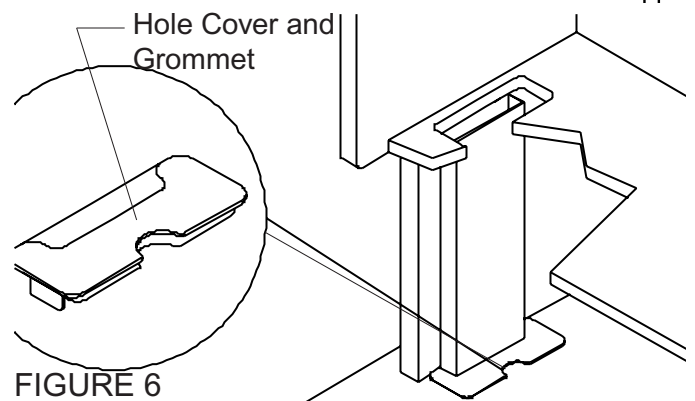

FIGURE 6

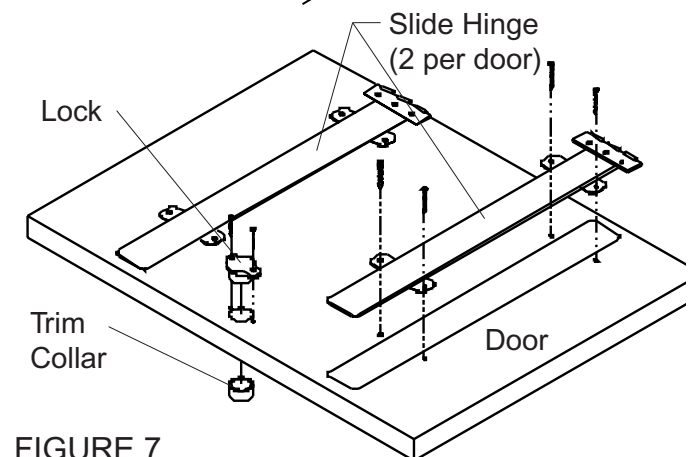

FIGURE 7

# Overhead Shelf

1. To avoid scratching the uprights and back, place them on a soft, protected surface for assembly.
2. Insert (4) connecting bolts into holes on both uprights and (4) cam locks into holes on back. Arrows on cam locks must be facing toward the upright being fastened (open position). (Figure 1)
3. Align connecting bolts with arrows on cam locks (in open position) and insert. (Figure 1)
4. With a Phillips screwdriver, rotate cam lock clockwise to secure sides.
5. Add (4) #10 x 5/8" screws one-half way into predrilled holes of uprights. (Figure 2)
6. The shelf sides have slots that fit onto screws in the upright. Slide shelf into position and tighten screws. (Figure 2)
7. Insert (4) #10 x 5/8" screws through the holes in shelf and into predrilled holes in back and tighten.
8. **Stand the shelf assembly up onto the work surface.** Align (2) overhead mounting brackets with predrilled holes in uprights and work surface legs, insert (4) #10 x 5/8" screws and tighten. (Figure 3)
9. Attach (2) wireway mounting clips per upright with (2) #10 x 5/8" screws per clip. (Figure 4)
10. Break off v-mold knock-out on work surface hole cover to accommodate wireway. Attach work surface grommet into the (2) opening on the top of the work surface. Snap hole cover into grommet. (Figure 5)
11. Snap wireway onto wireway clips after attaching work surface grommet. (Figure 4)

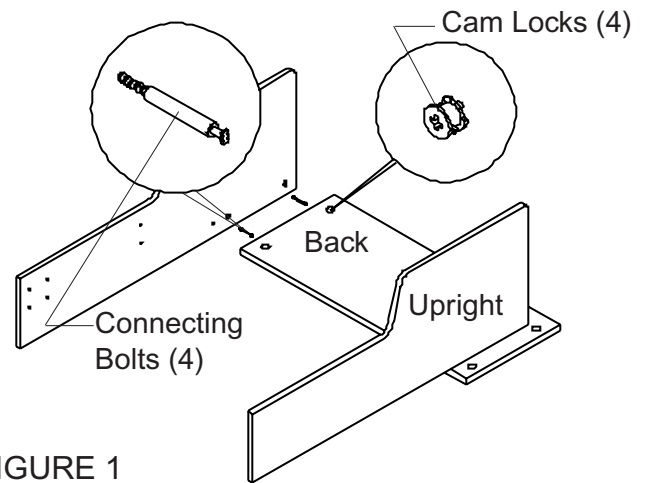

FIGURE 1

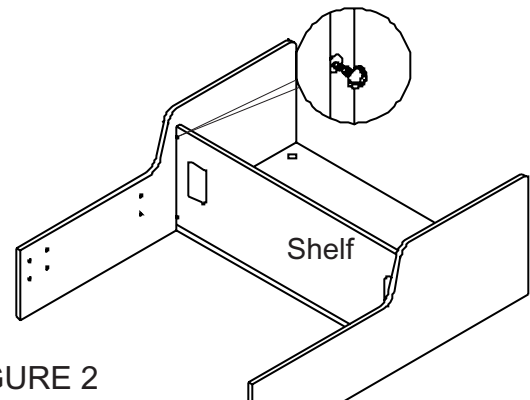

FIGURE 2

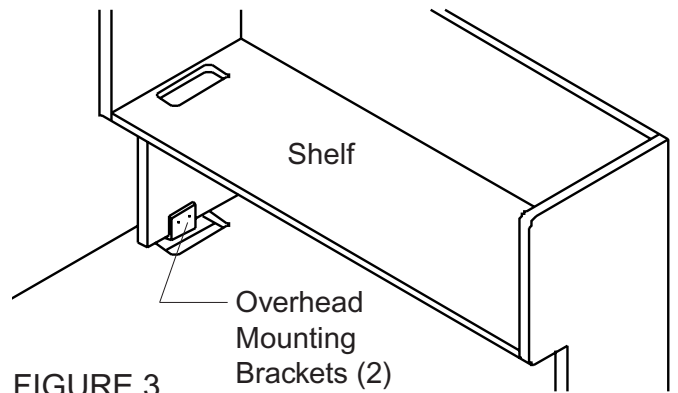

FIGURE 3

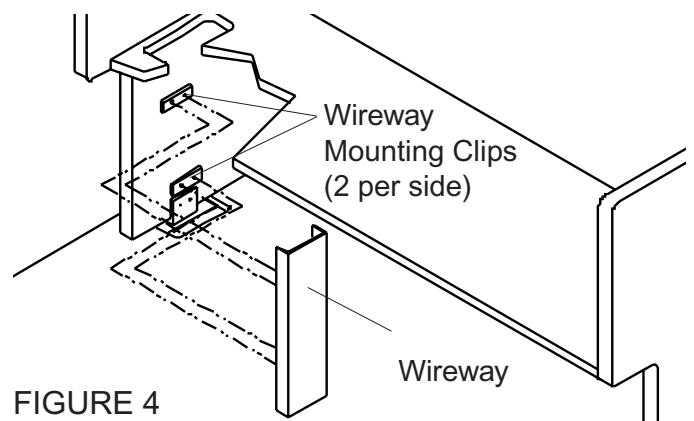

FIGURE 4

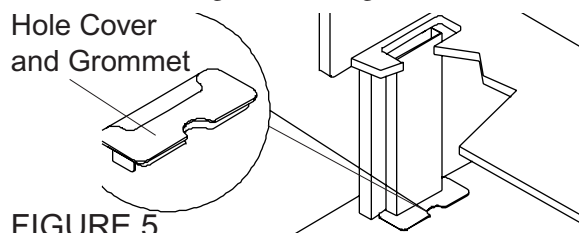

FIGURE 5

# Square, Rectangular, Keyboard Pad, and Corner Transitionals

**Note:** The square, rectangular, and corner transitionals are not illustrated but are assembled in the same manner as the keyboard pad transitional.

1. Attach splice plate to primary work surface using (3) #10 x 1" screws. (Figure 1)
2. Attach the second splice plate to the return work surface also using (3) #10 x 1" screws. (Figure 1)
3. Set the transitional work surface face down on a soft surface to protect it from scratching. Attach corner leg to transitional work surface with (4) #10 x 1" screws. The corner leg has two sides with holes that are used in the next step. Make sure that these holes are facing both the primary and return basic work surfaces. (Figure 2)
4. Determine placement of transition wireway, either inside or outside the transitive modesty panel. Insert wireway slots over screws and tighten screws. Repeat for remaining wireway. (Figure 2)
5. Flip transitional assembly right side up and align holes in splice plates with predrilled holes in transitional surface. Insert (6) #10 x 1" screws, (3) per side, and tighten. (Figure 3)
6. Slide one modesty panel behind wireway and wrap around legs from primary or return work surface. Attach to corner leg and transitional leg using (4) #12 x 3/4" screws (2) per leg. Repeat for second modesty panel.

**Note:** In a step-down installation use a transition mounting bracket instead of a splice plate. Transition mounting brackets are installed in the same manner as a slice plate.

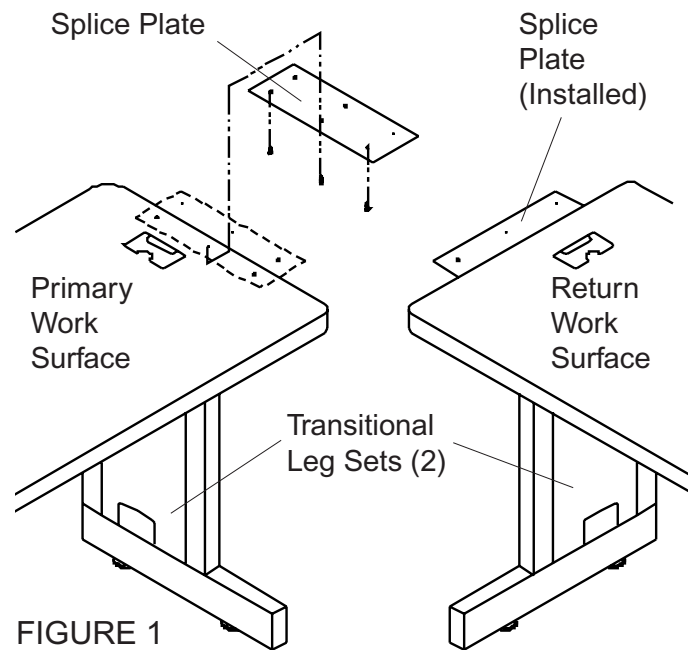

FIGURE 1

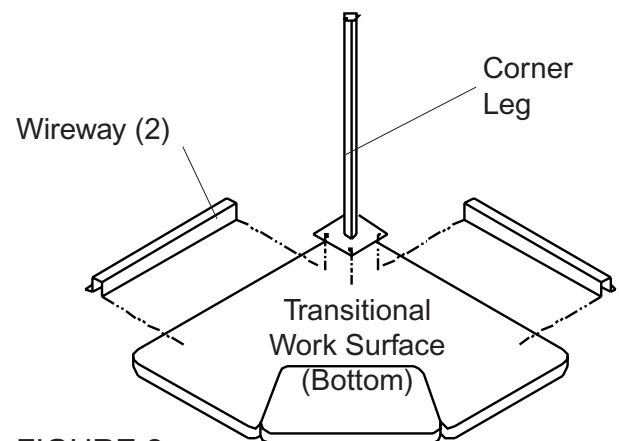

FIGURE 2

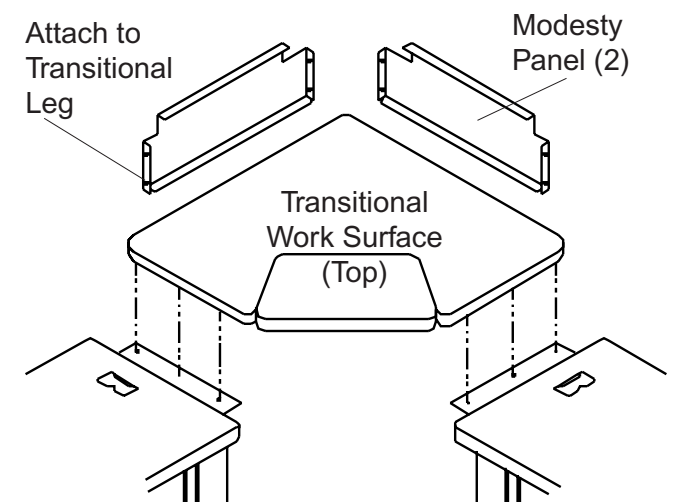

FIGURE 3



# Triangular Transitional

1. Attach splice plate to primary work surface using (3) #10 x 1" screws. (Figure 1)
2. Attach the second splice plate to the return work surface also using (3) #10 x 1" screws. (Figure 1)
3. Determine placement of transition wireway; either inside or outside the transition modesty panel. Attach to transition using (3) #10 x 1" screws. (Figure 2)
4. Attach triangular transitional work surface to splice plates with (6) #10 x 1" screws, (3) per side, and tighten. (Figure 3)
5. Slide modesty panel behind wireway and wrap around adjoining transitional legs from both primary and return work surfaces. Attach to legs using (4) #12 x 3/4" screws (2) per side. Tighten screws. (Figure 3)

**Note:** In a step down installation use a transition mounting bracket instead of a splice plate. Transition mounting brackets are installed in the same manner as a splice plate.

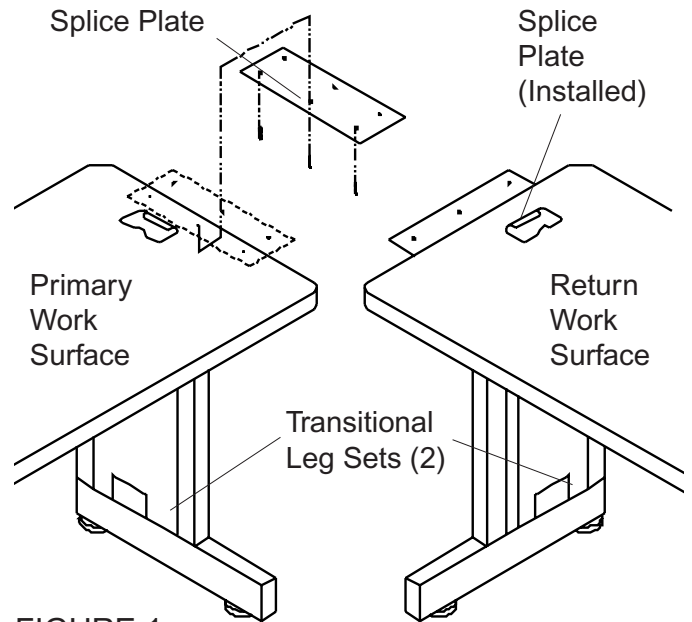

FIGURE 1

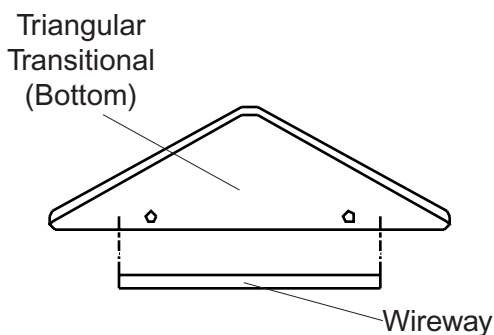

FIGURE 2

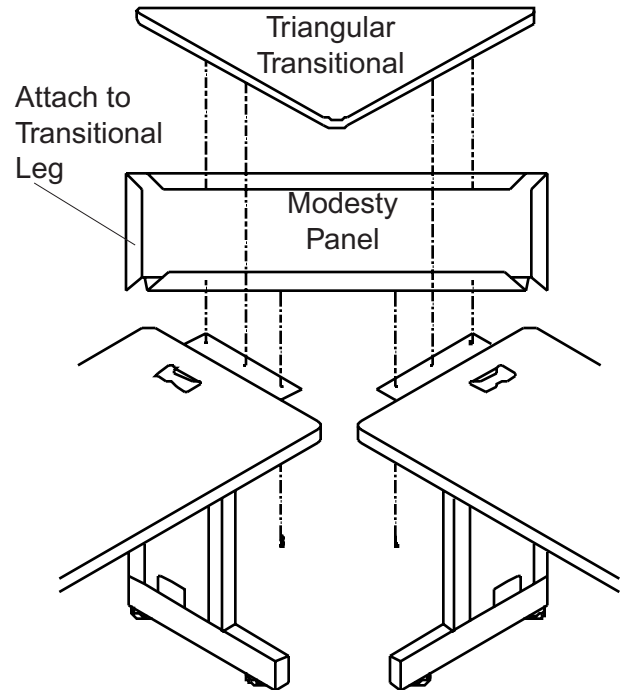

FIGURE 3

# Privacy Screens

## 36", 48", 60" and 72" Units

**Note:** Start at one end of a run and work your way around to the other end.

1. Position privacy screen with bracket on the top back edge of the work surface. Line up the left and right edges of the privacy screen with the left and right edges of the work surface. (Figure 1)
2. Attach to pre-drilled holes in work surface with #10 x 1" screws. (Figure 1)
3. Add splice plate between adjoining privacy screens to ensure stability. Splice plates slip into the left or right edges of the privacy screen as needed. (Figure 2)

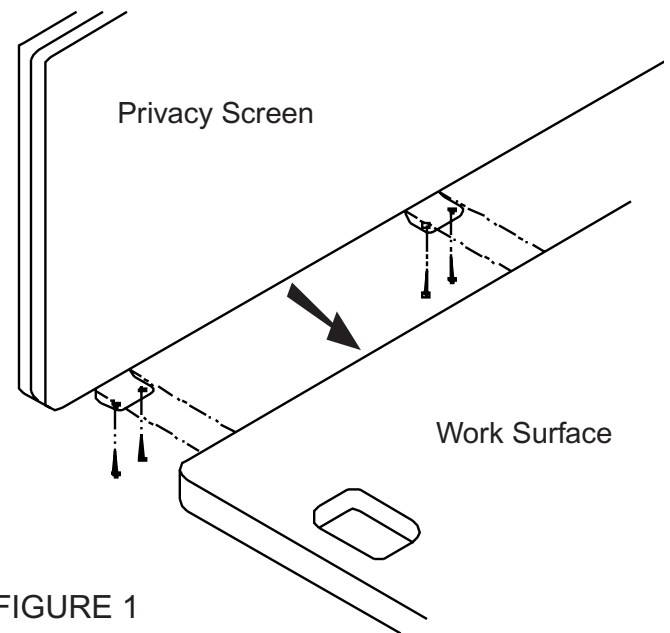

FIGURE 1

## Transitions

Privacy screen and splice plate assembly procedures are the same as in a straight run. (Figure 3)

- A) Keyboard Transitional Surface (90° splice plate)
- B) Rectangular transitional Surface (90° splice plate)
- C) Square Transitional Surface (90° splice plate)
- D) Triangular Transitional Surface (45° splice plate)

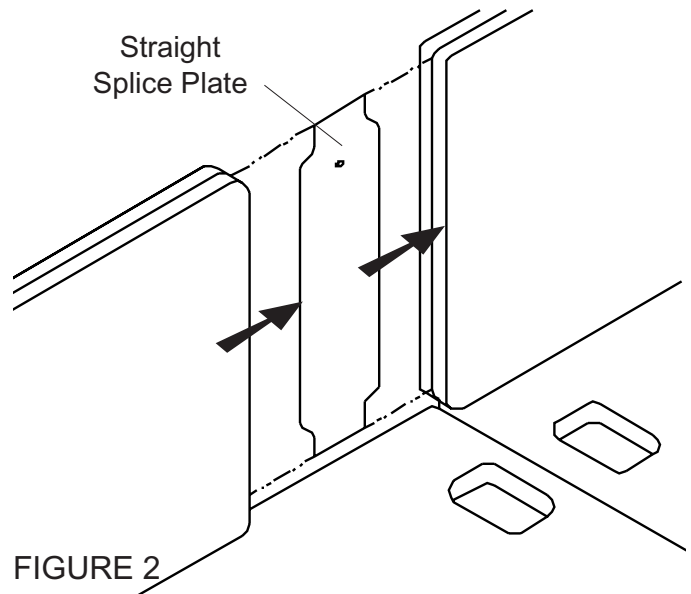

FIGURE 2

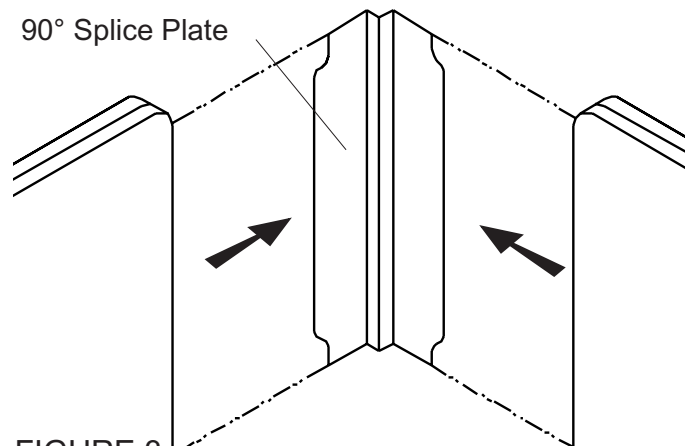

FIGURE 3

# Peninsula Table

1. Set the peninsula end surface face down on a soft surface to protect it from scratching. Attach adjustable leg to transitional work surface with (4) #10 x 1" screws. (Figure 1)
2. Align the holes in the splice plate with the predrilled holes in the peninsula end. Attach splice plate to peninsula end using (3) #10 x 1" screws. (Figure 1)
3. Place peninsula end right side up and align the holes in the splice plate with the predrilled holes in the work surface. (Figure 2)
4. Insert (3) #10 x 1" screws and tighten to secure the peninsula end to work surface. (Figure 2)
5. Level work surface by turning leveler either in or out.

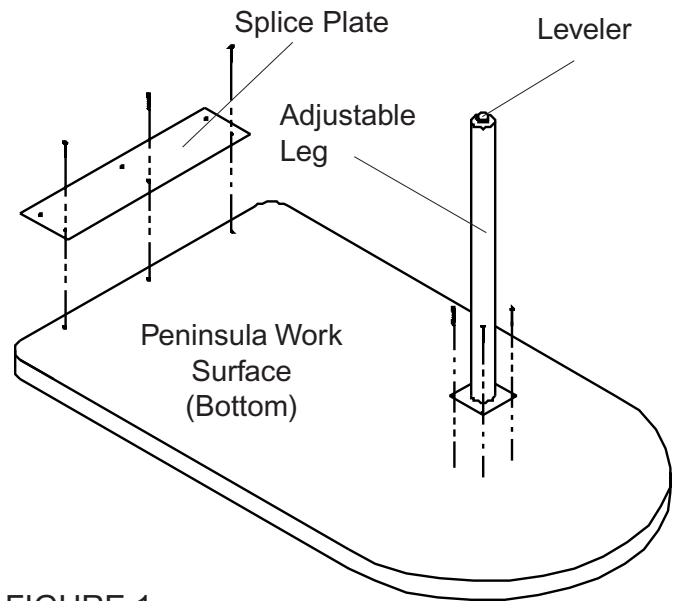

FIGURE 1

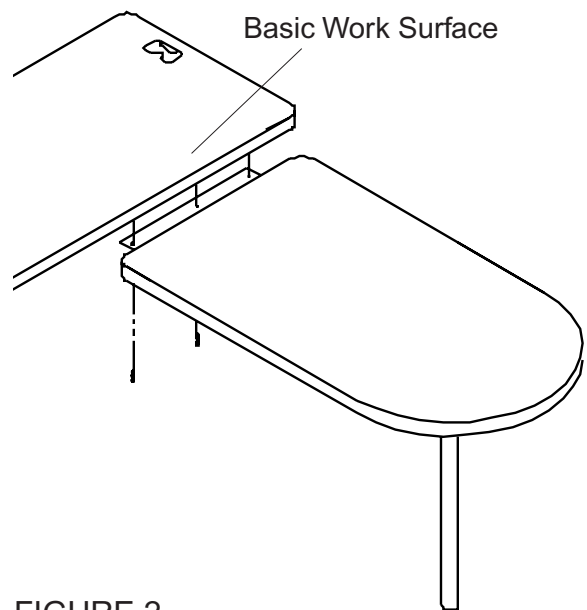

FIGURE 2

# Conference End

1. Attach splice plate to either left or right sides of a basic work surface using (3) #10 x 1" screws. (Figure 1)
2. Set the conference end surface face down on a soft surface to protect it from scratching. Attach adjustable leg to conference end work surface with (4) #10 x 1" screws. (Figure 2)
3. Place conference end right side up and align the holes in the splice plate with the pre-drilled holes in the conference end. (Figure 3)
4. Insert (3) #10 x 1" screws and tighten to secure the conference end to basic work surface. (Figure 3)
5. Level work surface by turning leveler either in or out.

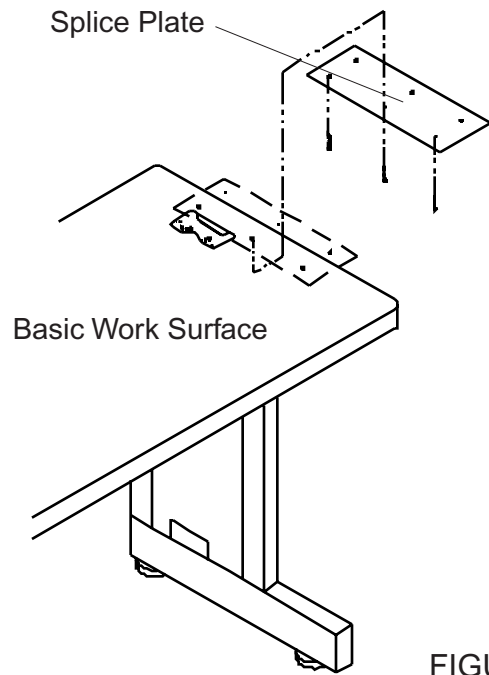

FIGURE 1

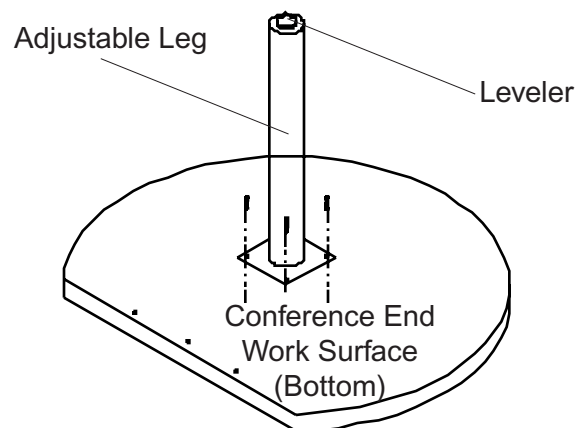

FIGURE 2

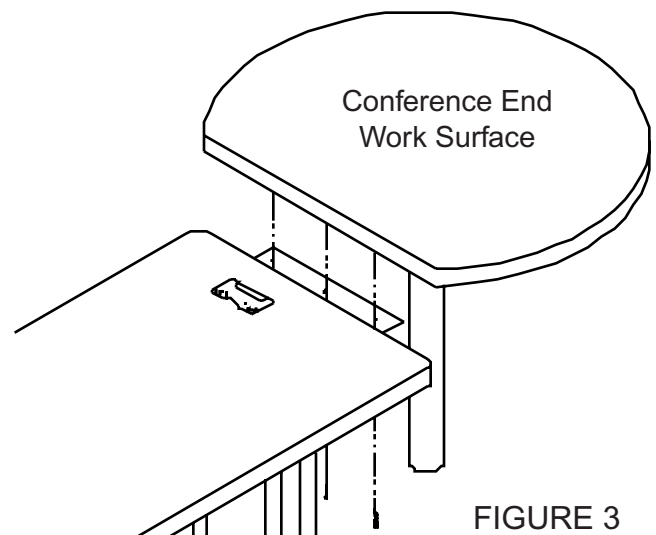

FIGURE 3

# Keyboard Drawer

**Note:** Make sure the work surface is properly assembled before attempting to add an accessory to it.

1. Place work surface face down on a soft protective surface. Position keyboard template in the desired position on the under side of the work surface. Make sure the front edge of the template is flush with the front edge of the work surface. (Figure 1)
2. Tape template securely onto work surface to prevent movement. At the points indicated on the template, make an indentation into the work surface bottom with an awl and a hammer. (Six indentations total.) (Figure 1)
3. Remove template and drill 1/8" diameter holes 1/2" deep at each indentation.

**Note:** When installing the keyboard drawer, additional clearance may be needed for thicker keyboards. Plastic mounting plates are provided for use as spacers in the event it is necessary to accommodate a thicker keyboard pad.

4. Insert (6) 3/4" wood screws into the keyboard drawer mounting holes. Use a Phillips screwdriver to mount the keyboard drawer. (Figure 2)
5. Return work surface to an upright position.

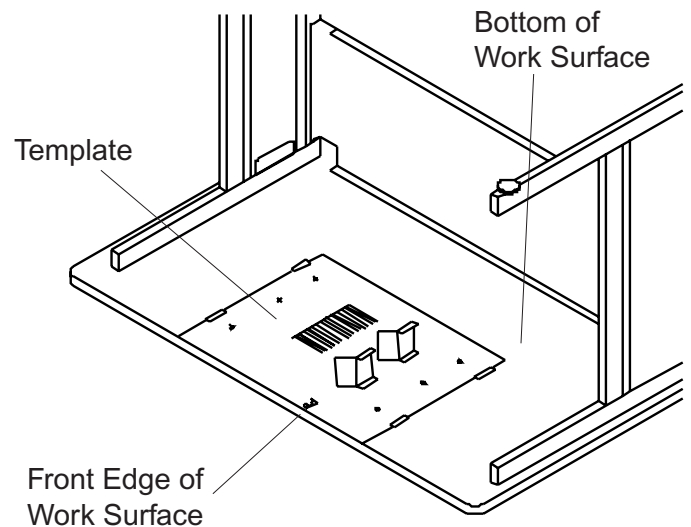

FIGURE 1

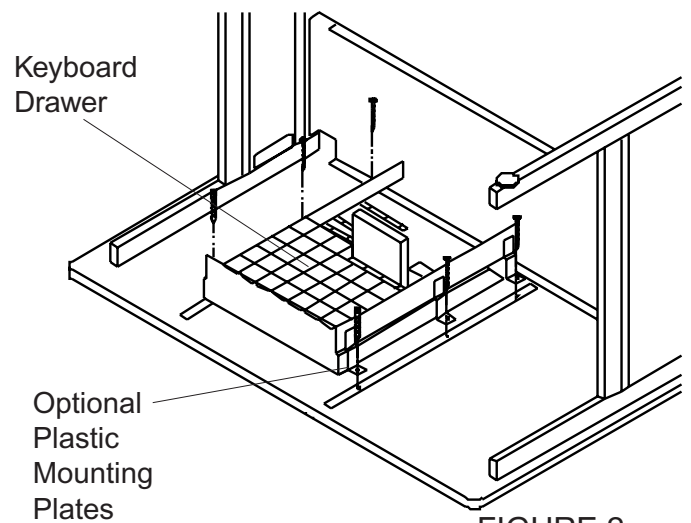
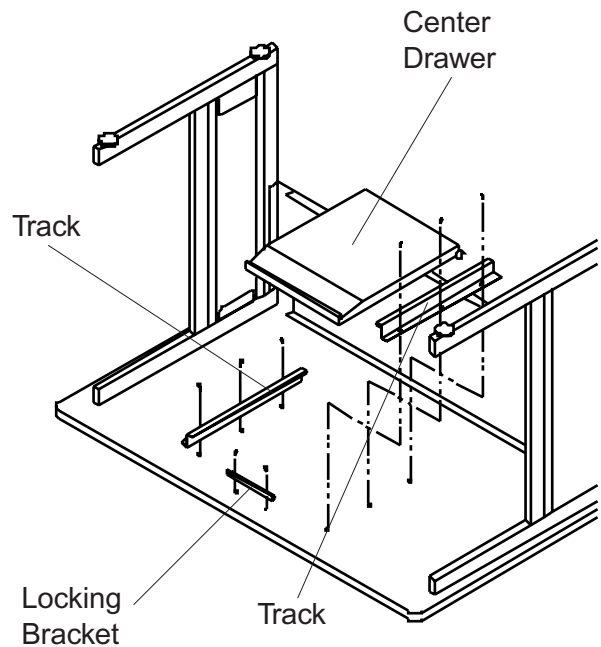

FIGURE 2

# Center Drawer

**Note:** Make sure the work surface is properly assembled before attempting to add an accessory to it.

1. Place work surface face down on a soft protective surface.
2. Position locking bracket, bent edge facing front edge of work surface, and align holes in locking bracket with predrilled holes in work surface. Attach locking bracket with (2) #10 x 5/8" screws and tighten securely.
3. Position the first drawer track on work surface with roller facing front and center of work surface. Align drawer track holes with the predrilled holes on work surface and attach with (3) #10 x 5/8" screws. **DO NOT** tighten screws completely at this step.
4. Position center drawer into the previously installed drawer track. Be sure that locking bracket is positioned inside the drawer.
5. Position the second drawer track on the work surface as in step 3. Make sure the center drawer is correctly positioned into second drawer track.
6. Adjust center drawer evenly between the two drawer tracks. Completely tighten all screws.



# Work Bar

1. There are predrilled holes on either shelf sides to attach the work bar. (Figure 1)
2. Screw in (2) #10 x 5/8" screws per shelf side. Do not tighten completely. (Figure 1)
3. Insert brackets into both ends of work bar. (Figure 2)
4. Position work bar so that its end brackets slide into the screw heads in shelf sides. Push back and down to lock work bar into place. (Figure 1)
5. Add trim cap into each end to cover any gaps that may occur. (Figure 3)

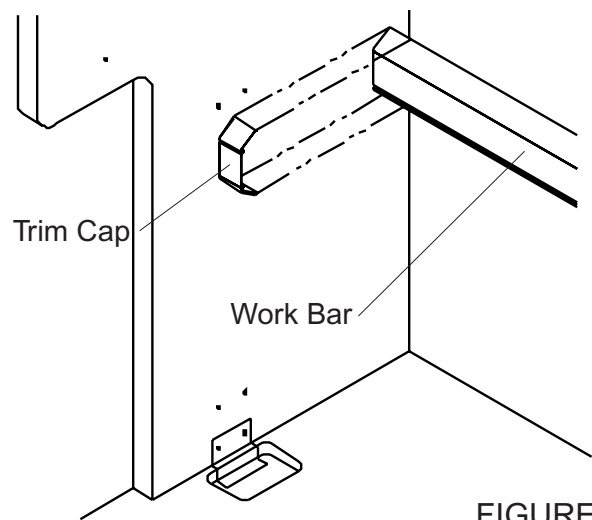
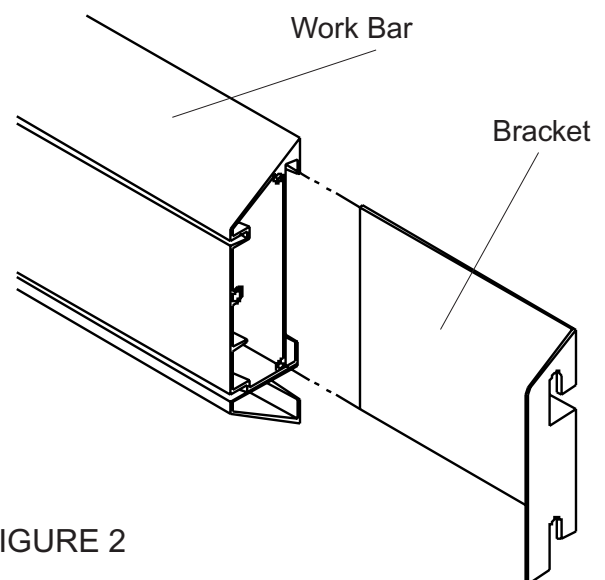
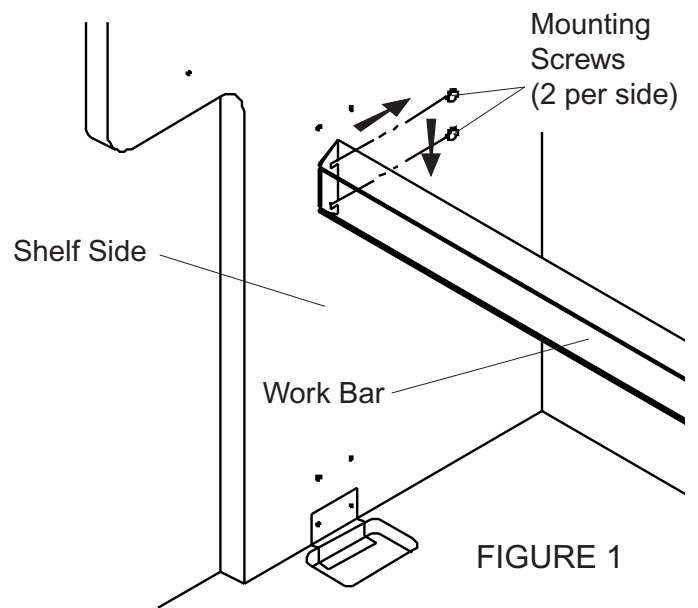

# Task Light

1. Carefully remove task light and brackets from carton.
2. Assemble task light and brackets by sliding brackets into both short ends of the task light. (Figure 1)
3. Locate front of task light brackets inside front lip of overhead shelf bottom. (Figure 2)
4. Flex rear of task light brackets outward until brackets will pass over rear lip of shelf bottom and slide in place. (Figure 3)
5. Route power cord out of sight to a 115V. grounded outlet.

**Note:** Route electrical cord with other cords through the vertical wireway provided on shelf side.

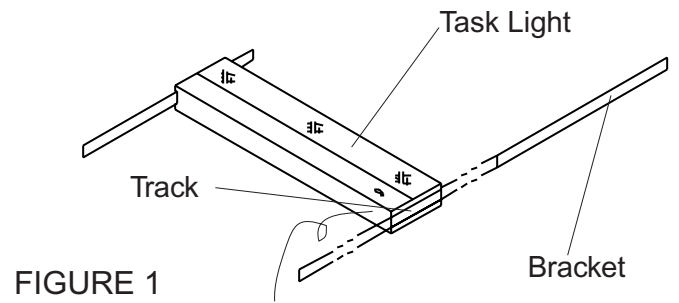

FIGURE 1

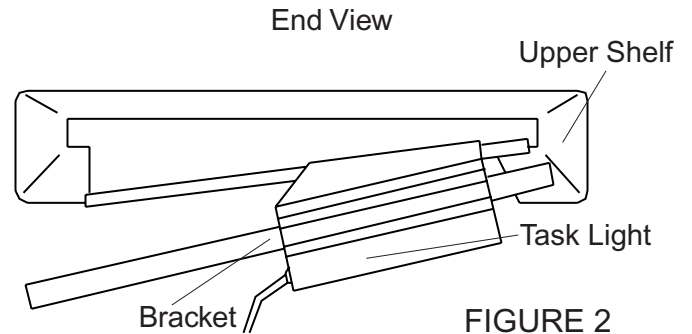

FIGURE 2

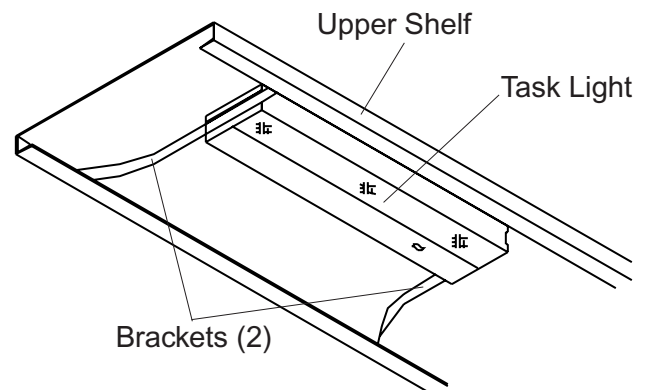

FIGURE 3



# Letter Tray

1. Slide the mounting clip hem up into the top back slot of the letter tray. (Figure 1)
2. Hold the front edge of the letter tray up and fit the mounting clip into the upper slot of the work bar. (Figure 2)
3. Lower the front edge of the letter tray until it rests fully onto the work bar. (Figure 3)

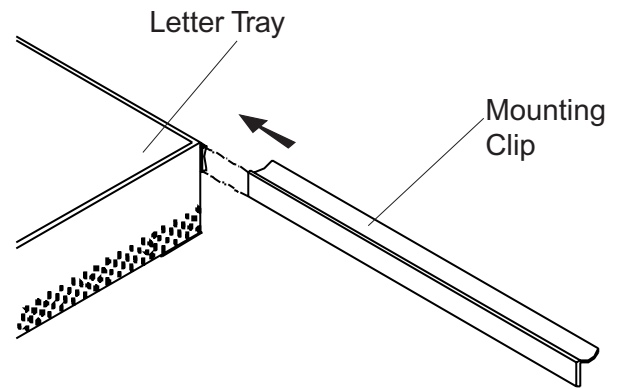

FIGURE 1

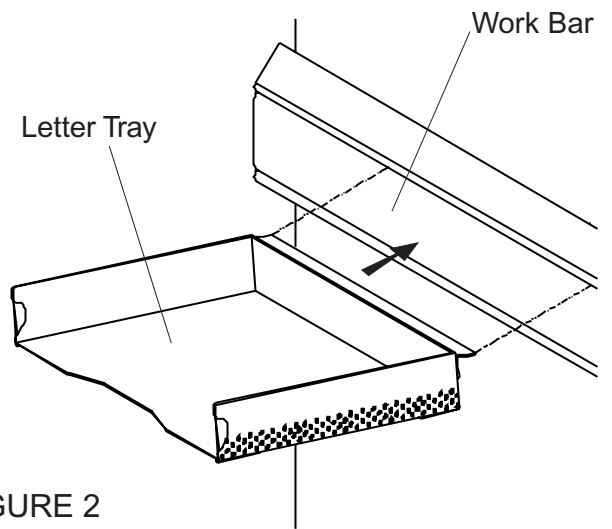

FIGURE 2

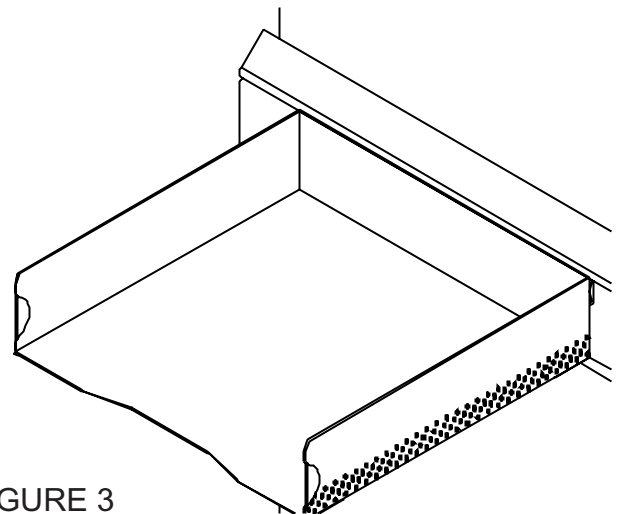
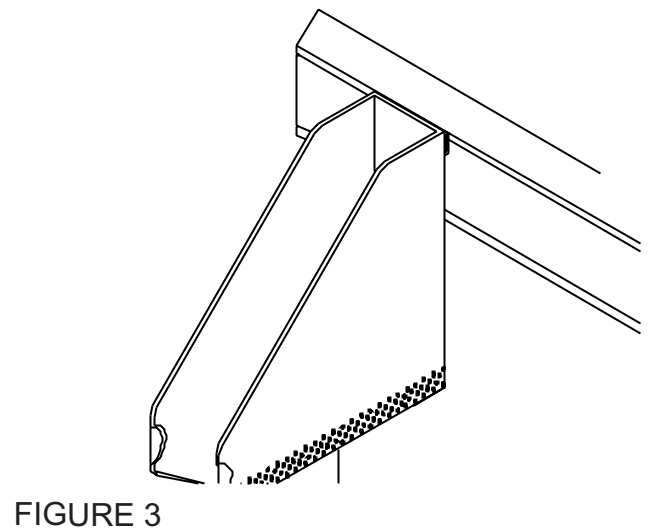
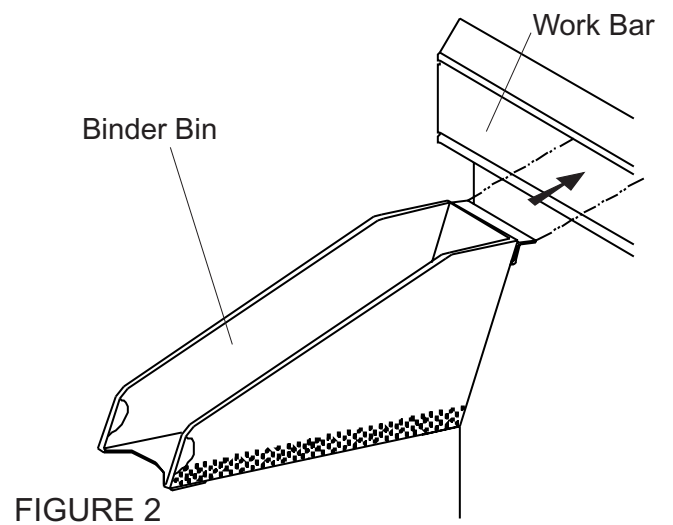
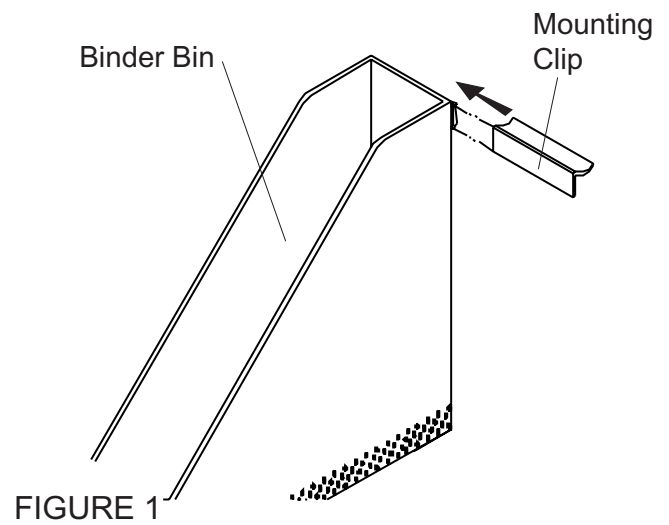

FIGURE 3

# Binder Bin

1. Slide the mounting clip hem up into the top back slot of the binder bin. (Figure 1)
2. Hold the front edge of the binder bin up and fit the mounting clip into the upper slot of the work bar. (Figure 2)
3. Lower the front edge of the binder bin until it rests fully onto the work bar. (Figure 3)



# Slanted Storage Tray

1. Slide the mounting clip hem up into the top back slot of the slanted storage tray. (Figure 1)
2. Hold the front edge of the slanted storage tray up and fit the mounting clip into the upper slot of the work bar. (Figure 2)
3. Lower the front edge of the slanted storage tray until it rests fully onto the work bar. (Figure 3)

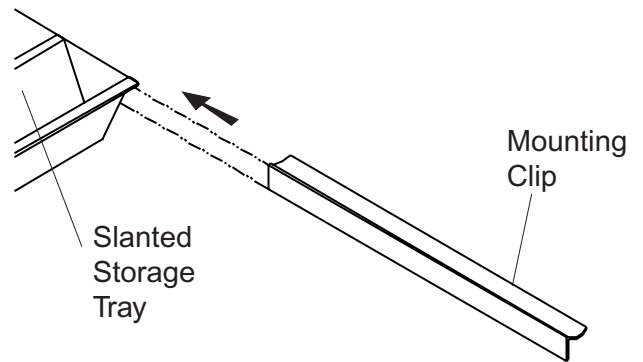

FIGURE 1

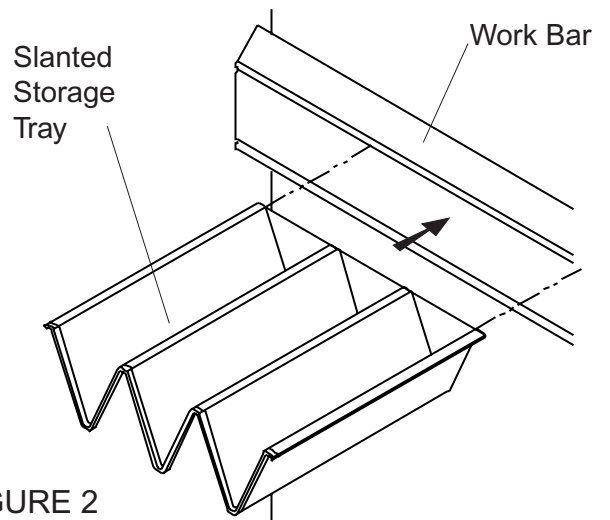

FIGURE 2

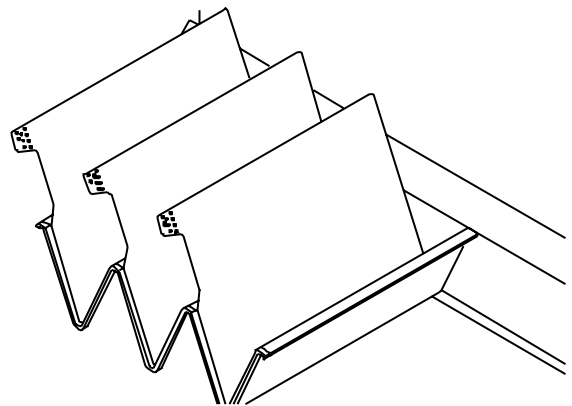
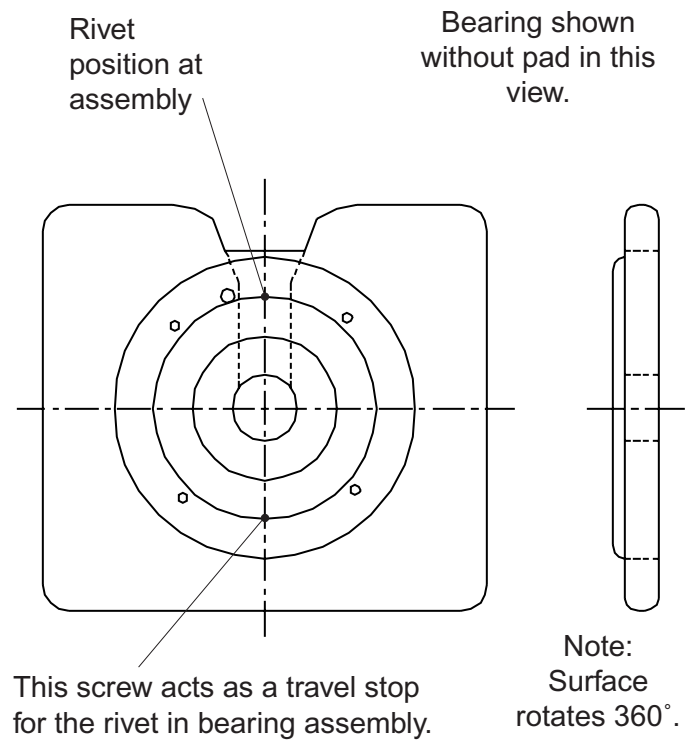

FIGURE 3

# Turntable

1. Place turntable assembly on top of work surface in desired location.
2. Place equipment on top of turntable.



# HARDWARE REFERENCE LIST

#10 x 5/8" TAPPING SCREW (steel, black) .....

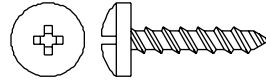

#10/24 x 1/4" TAPPING SCREW (black) .....



#8 x 5/8" TAPPING SCREW (black) .....

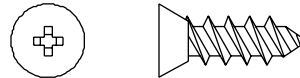

#12 x 3" PAN HEAD SCREW (steel silver) .....

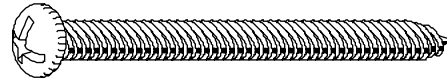

#8 x 3/8" PAN HEAD (steel) .....



#10 x 1" PAN HEAD (steel) .....

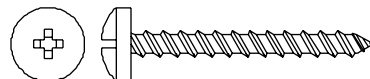

#12 x 3/4" HEX WASHER HEAD (steel silver)...

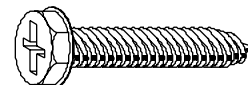

LEVELER (steel, plastic) .....

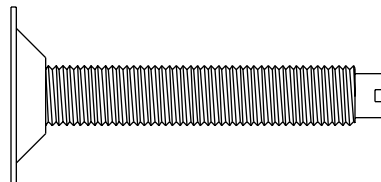

# HARDWARE REFERENCE LIST

(continued)

WIREWAY CLIPS (plastic, black) .....

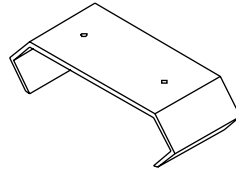

MOUNTING BRACKETS (steel, black) .....

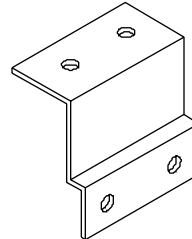

COVER CAPS (plastic) .....



5/32" HEX WRENCH (steel) .....

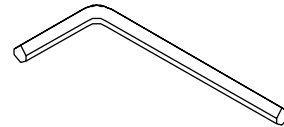

HOUSING CAM (steel, bronze) .....



CONNECTING BOLT (steel, silver) .....

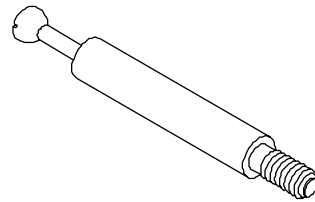

INSERT NUT (steel, bronze) .....

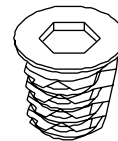

BUMPERS (plastic, gray) .....

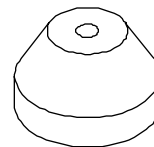

**XXI Notes**