

**CLASSIC XXI SYSTEM**



Installation Instructions  
BOOK 1

**UNICOR**

**TABLE OF CONTENTS**

Preinstallation of Panels.....1-1-1  
 Recommended Tools  
 Before You Begin

Suggested Installation Sequence .....1-1-2  
 Panel Terminology  
 Installation

Cable Management .....1-1-3  
 Cables Through Top & Side of Panel

Panel-to-Panel Attachment .....1-1-4

90° Panel Junction .....1-1-5

Three-Way Panel Junction.....1-1-6

End-of-Run, Top Cap & Raceway Covers .....1-1-7  
 End-of-Run Assembly  
 Top Cap Installation  
 Raceway Cover Attachment

Two-Way Panel Junction & Four-Way  
 Panel Junction.....1-1-8  
 Two-Way Panel Junction  
 Four-Way Panel Junction

Two Height Panel Junction.....1-1-9  
 Two Height Panel-to-Panel Connections  
 90° Assembly Instructions  
 180° Assembly Instructions

Curved Panel .....1-1-10  
 Curved Panel  
 Top Cap Installation  
 Raceway Cover Installation

Wall Mounts .....1-1-11

Panel Center Mount .....1-1-12  
 Installation

Panel Doors.....1-1-13  
 Tools Needed  
 Installation

Panel Door Thresholds .....1-1-14  
 Installation

ERP Panels .....1-1-15  
 ERP (Extended Raceway Panel) Panels  
 180° Panel Connection  
 90° Panel Connections (2, 3, or 4 Panel Intersections)

Stackable Panel Sections &  
 Stackable Panel Trim .....1-1-16  
 Tools Required  
 Parts Included with Stackable Panel Section  
 Attachment Bracket Assembly  
 Stackable Return Panels  
 Installation of Stackable Panel Trim

**PREINSTALLATION OF PANELS**

**Recommended Tools**

- Safety Glasses
- Steel Tape Rule
- Level
- Utility Knife
- Hacksaw
- Electric Screwdriver
- Phillips Head Screwbits (#2 & #4)
- Straight Slotted Screwdriver
- Torx Driver (T-25)
- Rubber Mallet
- Ball Peen Hammer
- Allen Wrench (3/16")
- Chalk Line
- Glide Wrench (7/16" open end)
- Flat Pry Bar

5. Review the panel terminology drawings before starting.
6. Mount carpet grippers with a ball peen hammer (to prevent damage to gripper) and turn all glides out 3/8". This should be done after panels are taken from stack for setting in place. (A carpet gripper must be installed on a carpeted floor since it provides a non-sliding "connection" between panel and floor.)

**Before You Begin**

To simplify the installation of the panels, the following recommendations should be considered:

1. Stage the order by panel size, height, power, and color. Sort the cartons by top caps, raceway cover, and hinges. Then sort by size and color.
2. Make sure the area is clear and ready for panel installation.
3. Verify all room dimensions vs. the installation print. Measure power infeed locations to insure proper relation to panels. If using top feed power, put top feed harnesses through the specified panel ends.
4. Use masking tape or a white chalk line to create a plot on the floor where the panel will be installed. Chalk line may be snapped to right, left, or center of panel. (Alternative is to fasten a string to both end panels, pull tight, then line up all panels in between.)

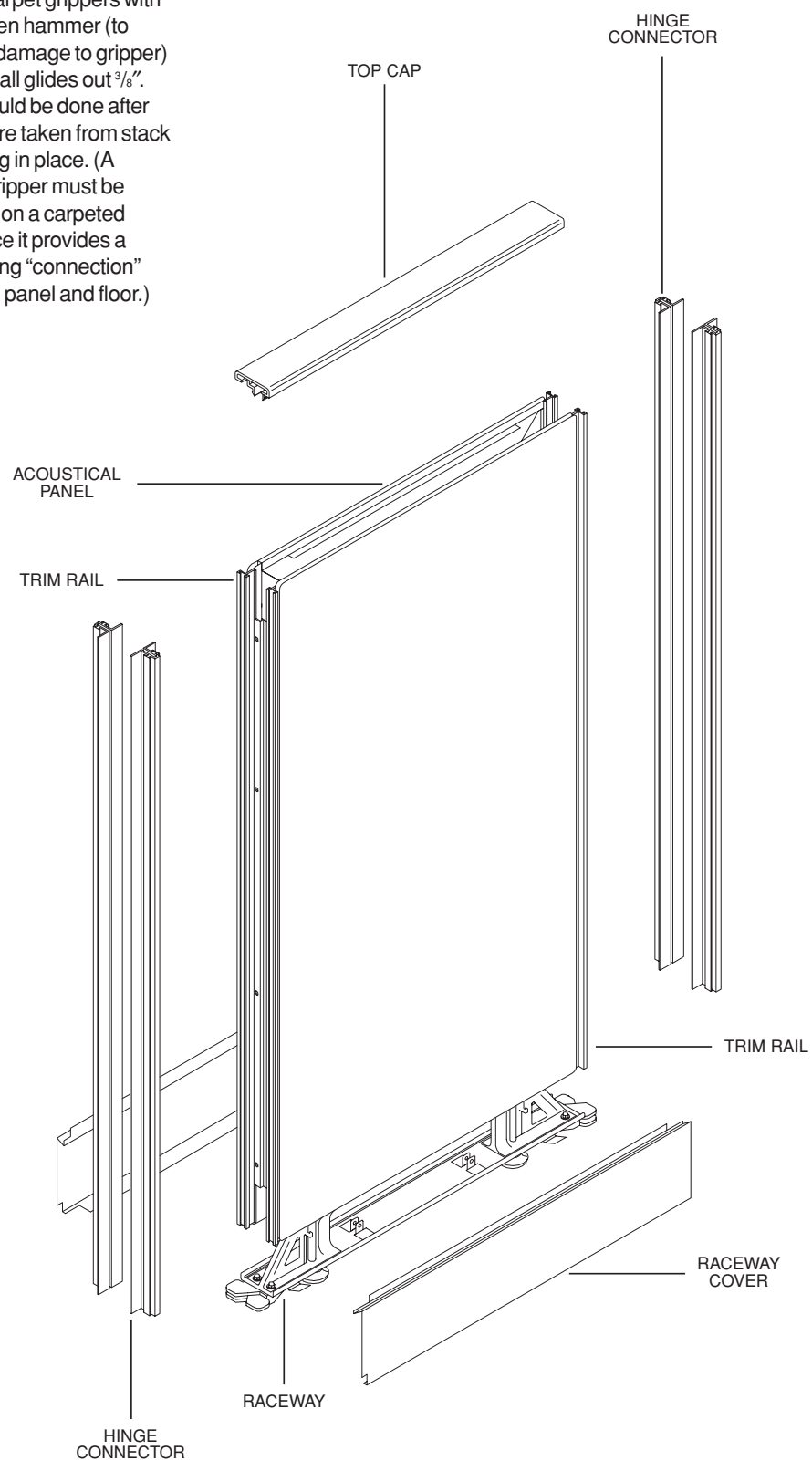

**SUGGESTED INSTALLATION SEQUENCE**

**Panel Terminology**

Each panel assembly includes (2) hinge connectors, (1) top cap, and (2) raceway covers.

**Rigid Connector blocks are needed if panels are electrified.**

**Installation**

Review the panel layout drawing to determine if there are any wall mount conditions. If there are, this is a good place to start. If not, you will want to start where panels come together at a 90° corner. If there are any "T" mount conditions, you will want to make them before attaching to adjacent panel with hinges (See 90° and "T" mount attachment).

1. Start panels in corners and three-way situations.

**Note: Install raceway covers on the back side of panels that will be against walls (and inaccessible later). See page 1-1-7.**

2. While installing, be sure to set the center of the panel directly over the center of the chalk line to assure straight panel runs (or directly over the left or right hand mark if you are using this option).

3. Leveling should be done as each panel is assembled. Level each panel before adjoining the next. (Having the glides already turned out 3/8" will help with the leveling at this point in case the floor is uneven.)

4. Once panels are completed, the next step should be to install the rigid electrical connections and receptacles.

5. Installation of top feeds and power poles can now be accomplished. As stated on page 1-1-1, step 3, when installing top feeds, run the flexible conduit through the panel before the panel is installed.
6. Install flipper door units or shelves where specified. Task lights can now be installed.
7. Install any Classic XXI System accessories (see Book 2).
8. Install base feeds (as required).
9. Install exterior raceway covers.

**CABLE MANAGEMENT**

Before finished ends, top caps or raceway covers are installed, you should consider where wires will be routed. Panels have wire management capabilities through top and base raceways as well as both side frames. Cables also may be laid in through the side frame at the end of a panel run before the end post assembly is installed.

**Cables Through Top and Side of Panel**

1. The top raceway of the panel can accommodate up to ten 25-pair telephone cables. These cables may be routed across the top raceway along a run of panels or they may be routed down the side frame to reach the base raceway or a worksurface height communications access door.
2. Cables with small connectors may be threaded down through the side frames without removing the trim rail. To route large connectors through the side frame, remove the trim rail.

**Caution: If removing the trim rail, support both adjacent panels so they remain standing when the trim rail is released.**

3. To remove the trim rail, lay the panel on edge and using a torx driver or phillips driver (depending on the screw type), take out the screws connecting the trim rail to the frame. Tap up on the trim rail if necessary and it will slide off panel frame. To replace, repeat above steps in reverse order.

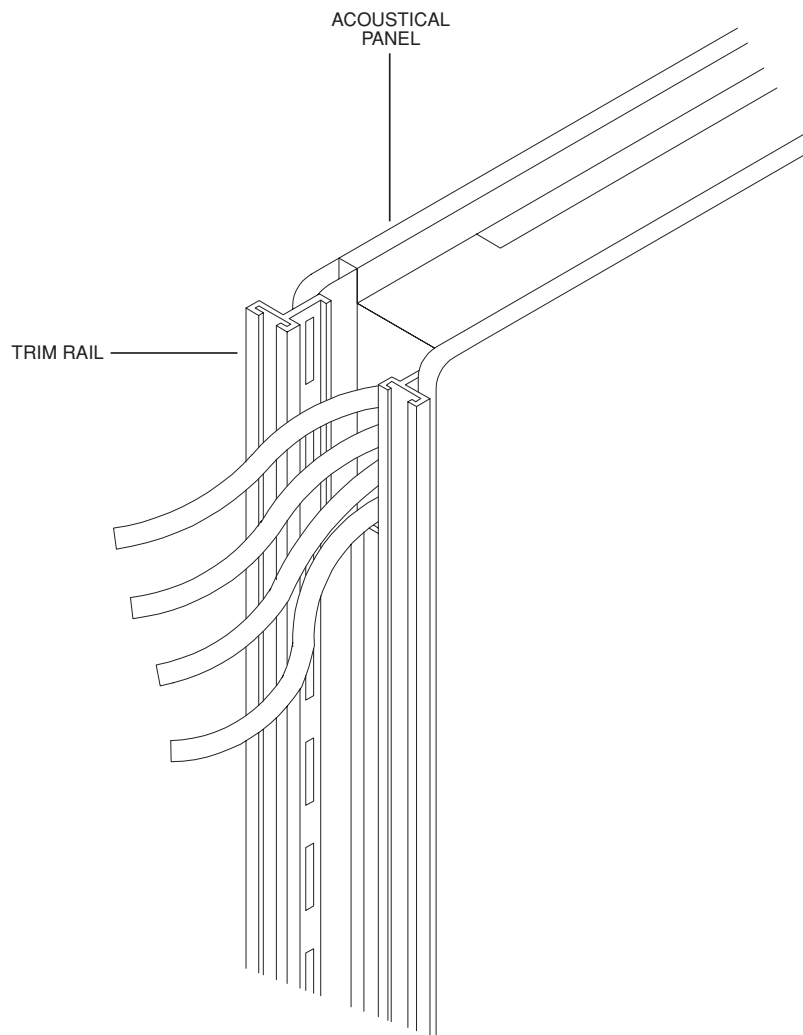

**PANEL-TO-PANEL ATTACHMENT**

1. To attach one panel to the next, bring the panels into position, making sure the interlocks are aligned (Figure 1). Slide the hinge connectors down the grooves provided, making sure the light shields are inside the panel (Figure 2).
2. Repeat the above steps until all panels are installed.

**Level the panels as they are being installed by adjusting the glides at the bottom of the panel. All carpet grippers should be in place before this is done.**

**Caution: Refer to panel specification guidelines for limits on panel runs.**

**Note: When installing panels in a 90° junction, you may find it easier to line the panels up in a line (180°), slide in the hinge that forms the inside corner, then pivot the panel to the 90° position.**

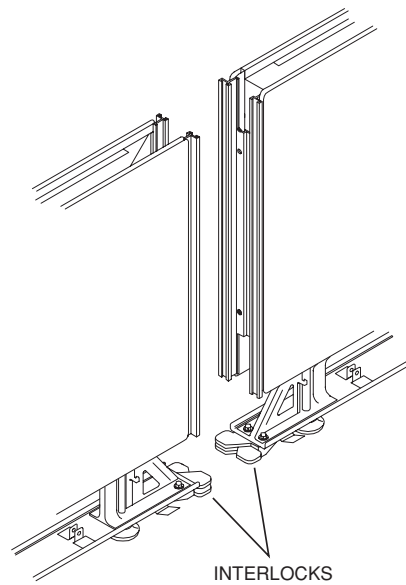

FIG. 1

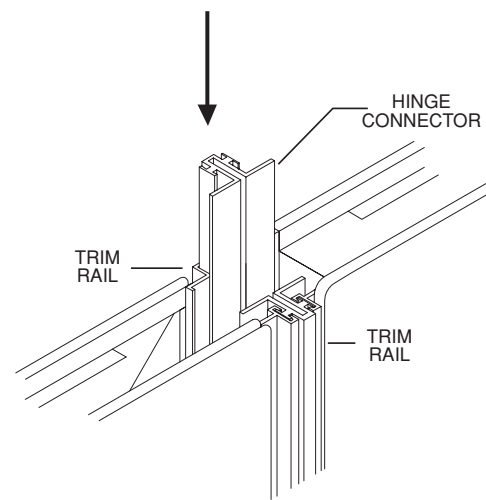

FIG. 2

**90° PANEL JUNCTION**

1. When installing panels in a 90° junction, you may find it easier to line the panels up in a line (180°), slide in the hinge that forms the inside corner, then pivot the panel to the 90° position.
2. Position corner post and slide hinge connectors down grooves provided into the trim rail and corner post (Figure 1).
3. Once corner post is in place, the panel junction may be finished by locating the top cap corner piece on top of the corner post with sleeves inserted in adjoining top caps (Figure 2).

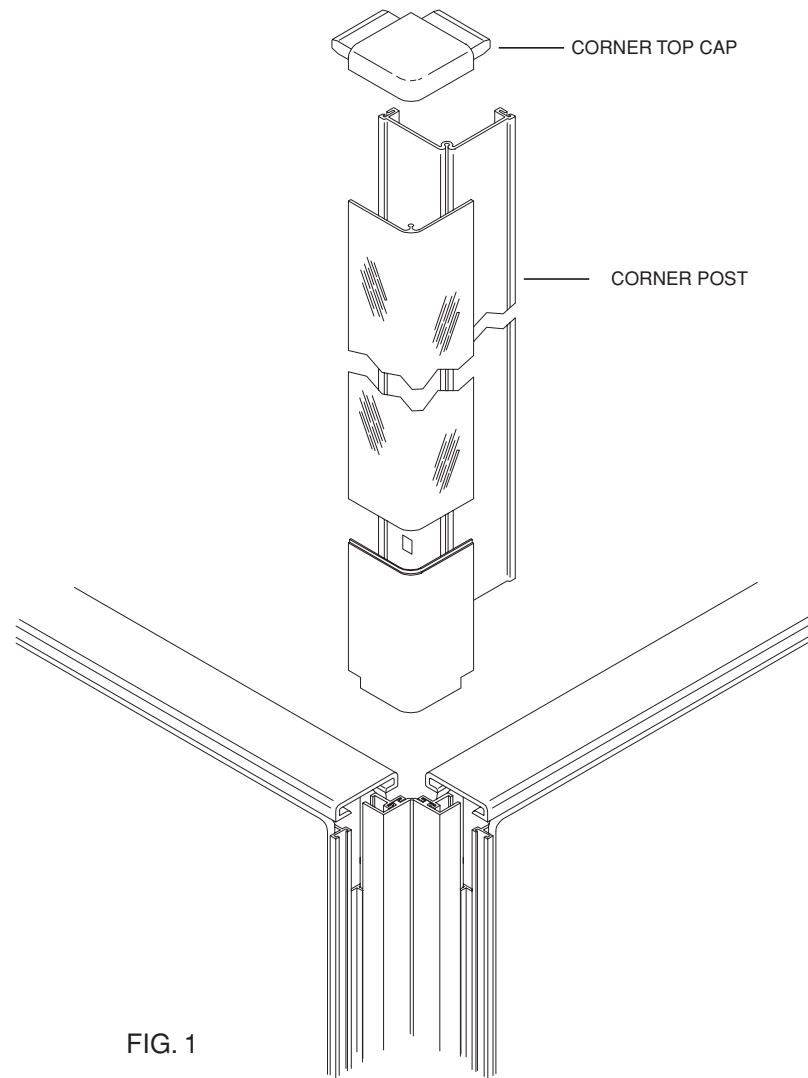

FIG. 1

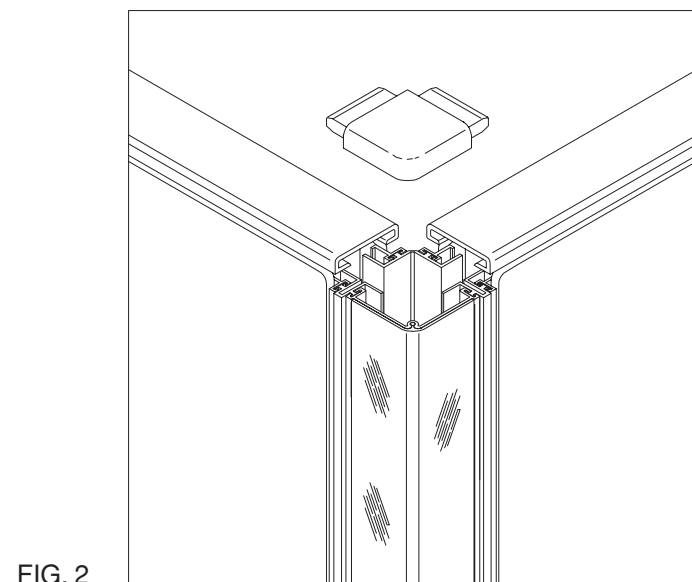

FIG. 2

**THREE-WAY PANEL JUNCTION**

1. Position T-post and slide hinge connector down into grooves provided in the trim rail and T-post (Figure 1).
2. Once T-post is in place, position the T-post cap on top of the junction of the three panels, with all 3 top caps not snapped in place.
3. Push the sleeves of the T-post cap into the 3 top caps, and snap them in place.

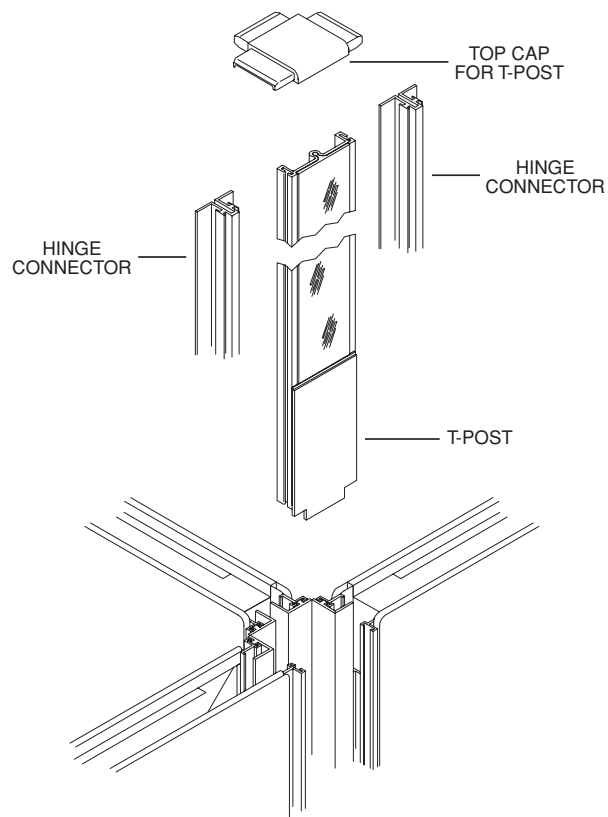

FIG. 1

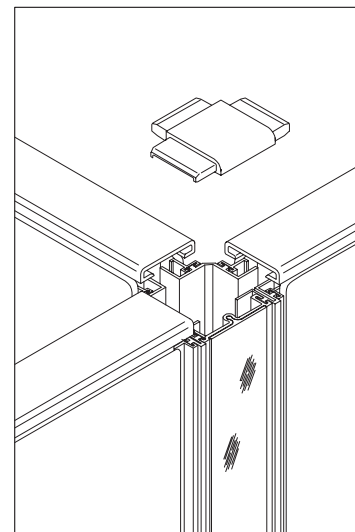

FIG. 2



**End-of-Run Assembly**

1. An end-of-run trim is needed to finish a panel at the end of a panel run.
2. To attach the end-of-run trim, rest one end of the trim piece on the interlock at the base of the panel. Snap it into place on the trim rail of the panel (Figure 1).

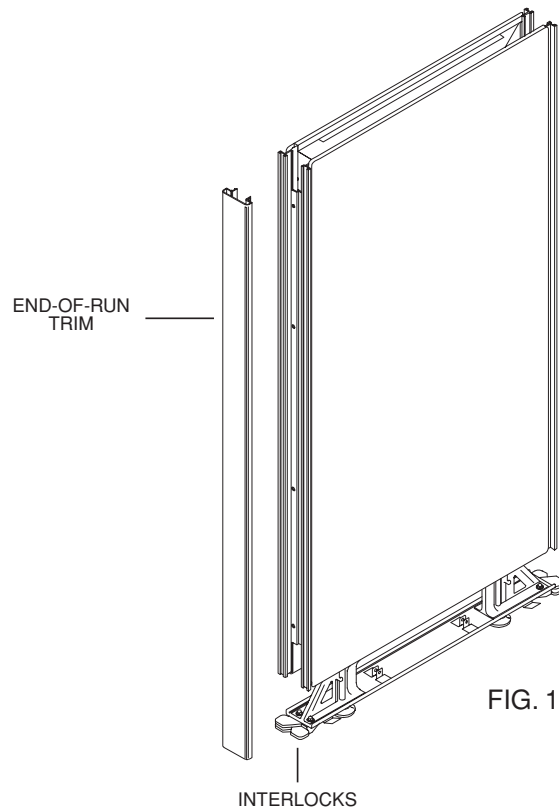

FIG. 1

**Top Cap Installation**

1. Once all panels are installed, you may install the top caps and end-of-run trim. Insert the end cap sleeve into the adjoining top cap. Insert the other end of the end cap sleeve into the end-of-run trim. Push straight down on one end of the top cap and work your way to the other end (Figure 2).
2. A top cap sleeve should be inserted into two adjacent top caps when they are in a 180° configuration.

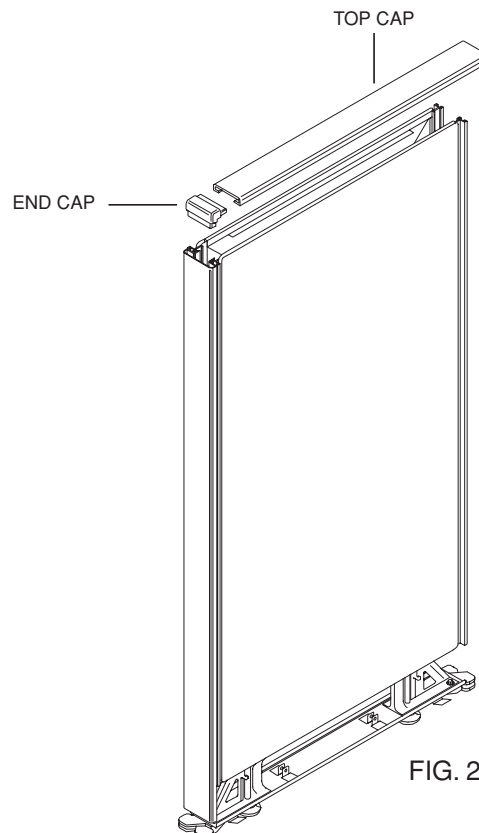

FIG. 2

**Raceway Cover Attachment**

1. With panels installed, panel-to-panel connectors in place, receptacles located, and all other wiring completed (see section two of this book), the last step is to install the raceway covers. Hook the appropriate length raceway cover into place on the tabs of the support housings. Swing the raceway cover down until the spring clips on the pan snap onto the notch provided (Figure 3).

**Spring clips must be located WITHIN the raceway cover as shown.**

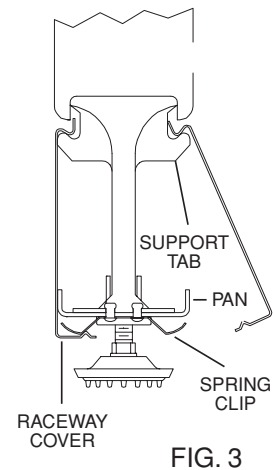
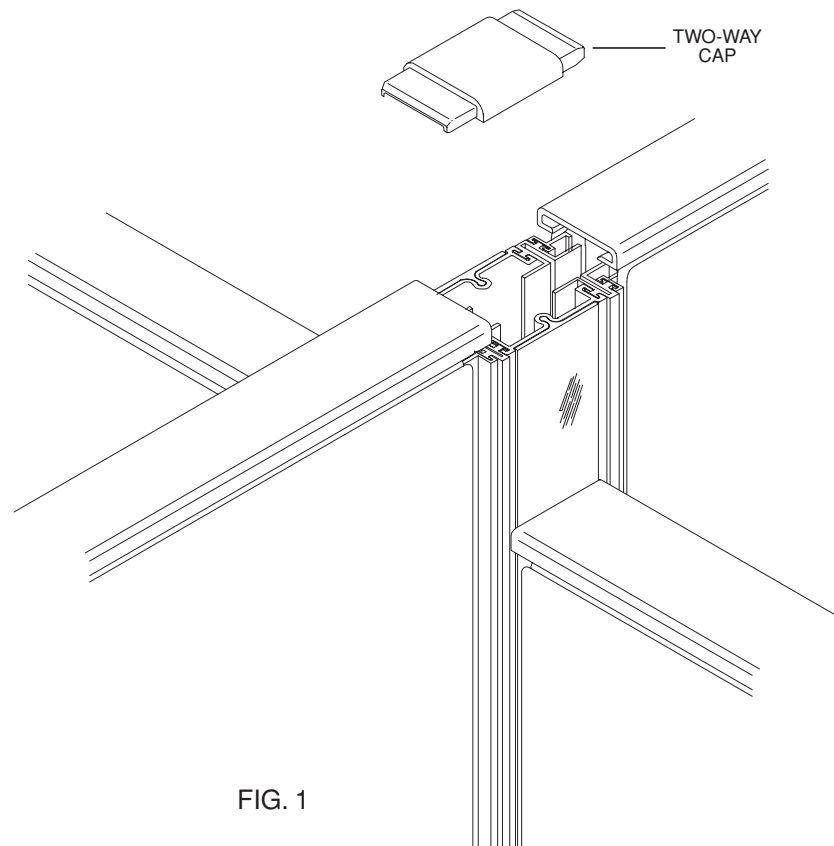

FIG. 3

**TWO-WAY PANEL JUNCTION & FOUR-WAY PANEL JUNCTION****Two-Way Panel Junction**

1. Position the two-way cap on top of the junction of two panels intersecting the junction of two lower panels, but with the two upper top caps not snapped in place.
2. Push the sleeves of the two-way cap into each of the two adjoining top caps, then snap the two top caps into place (Figure 1).

**Four-Way Panel Junction**

1. Position the four-way cap on top of the junction of the four panels, with all four top caps not snapped in place.
2. Push the sleeves of the four-way cap into each of the two adjoining top caps, then snap the four top caps into place (Figure 2).

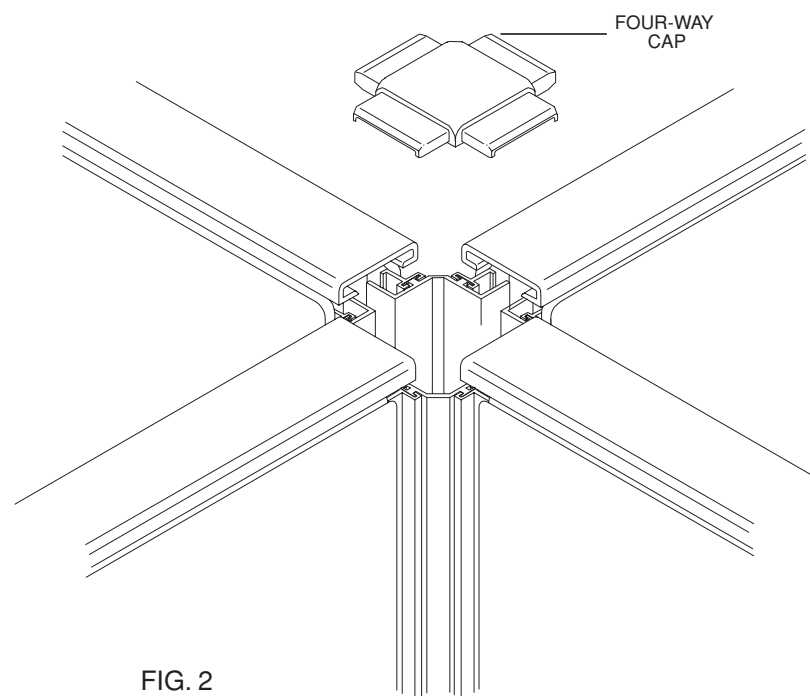

TWO HEIGHT PANEL JUNCTION

Two Height Panel-to-Panel Connections

90° Assembly Instructions

1. Place the lower corner post in place (with hinge connectors), as described for a standard 90° corner.
2. Set corner post top cap in place.

**Note: The top cap sleeve must be cut off one side of the corner post top cap in order for it to fit properly, and not interfere with the upper panel trim rail.**

3. Slide the lower panel top cap onto the corner post top cap sleeve, then snap the top cap onto the lower panel.
4. Snap end-of-run trim into place. The end-of-run will sit on corner post top cap.
5. Put the upper panel top cap and end-of-run top in place (Figure 1).

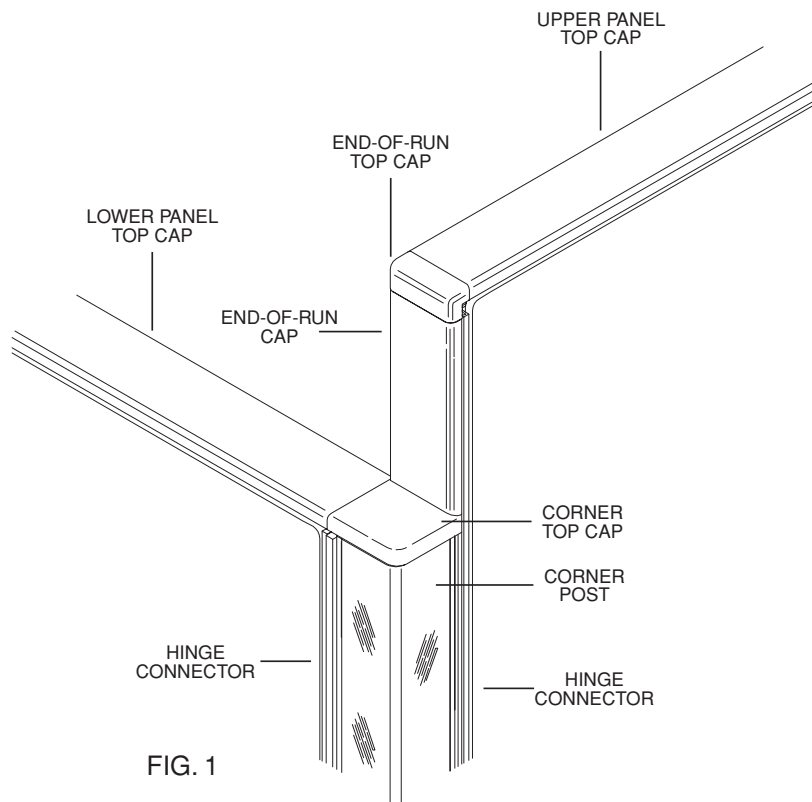

180° Assembly Instructions

1. Put lower panel top cap in place as usual.
2. Snap end-of-run trim into place. End-of-run will sit on lower top cap.

**When a countertop is placed on the lower panel, the end-of-run must be shortened to accommodate the countertop.**

3. Put the upper panel top cap and end-of-run top cap in place (Figure 2).

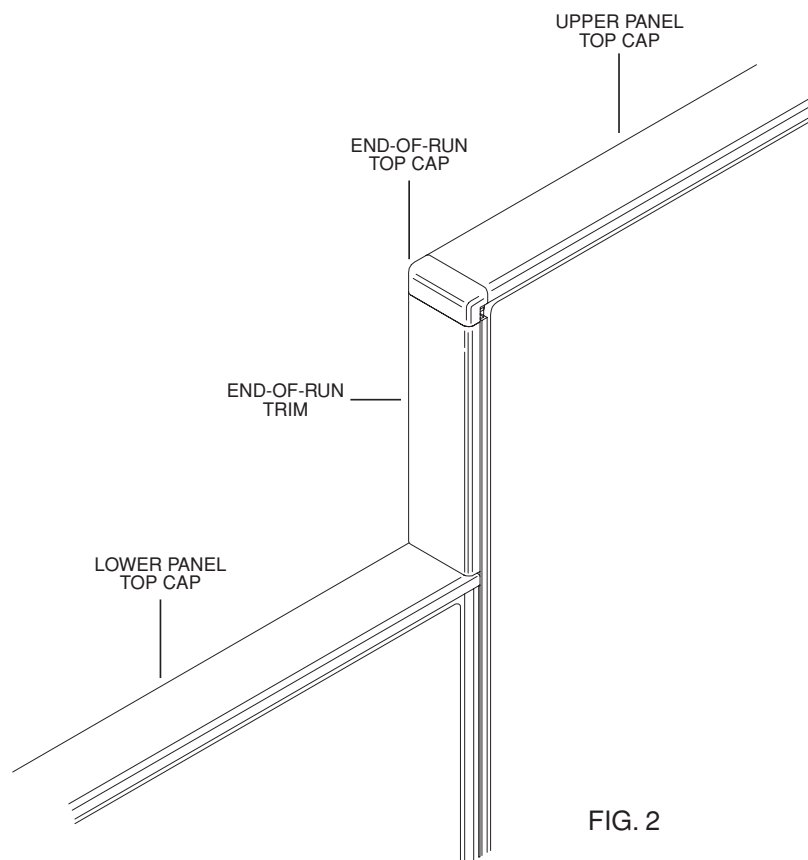

**CURVED PANEL**

**Curved Panel**

A curved panel will come completely assembled except for the following items (Figure 1):

1. Raceway (inner/outer)
2. Top cap
3. Hinges

**Top Cap Installation**

1. To install the curved panel top cap, carefully slide a top cap sleeve into each end of the curved top cap, and into the adjoining top cap. Push straight down on the curved top cap to connect the dual-lock tabs (Figure 2).

**Raceway Cover Installation**

1. With panels installed and all wiring completed, the last step is to install the raceway covers. There are spring clips on the backside of the raceway covers. Push the raceway cover down until the spring clips snap onto the fingers provided (Figure 3).

**Note: The inside raceway cover is shorter in length than the outside raceway cover.**

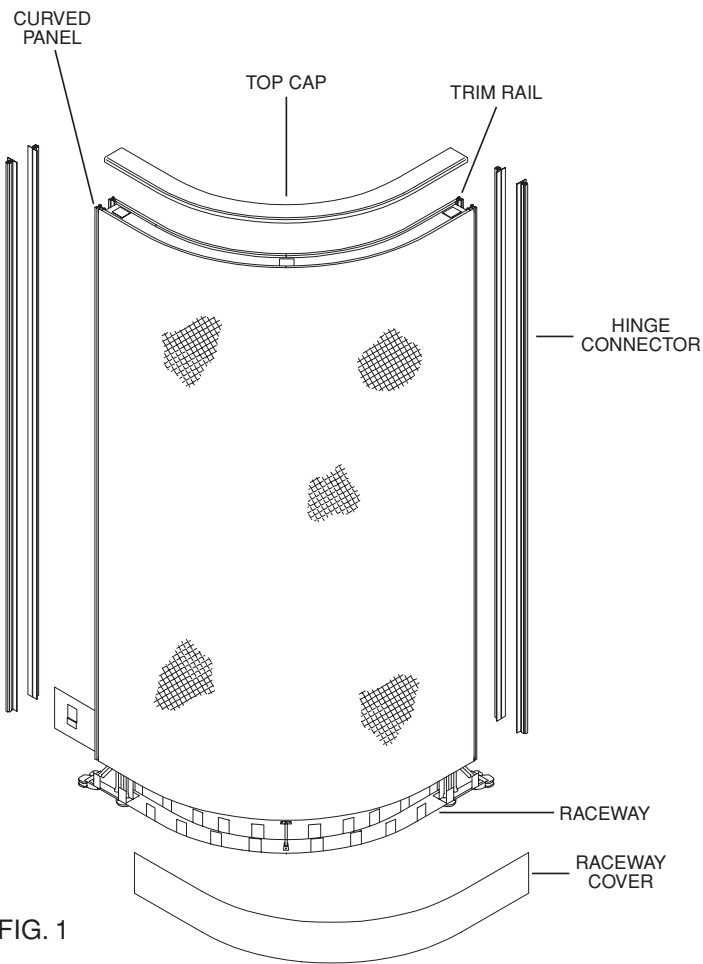

FIG. 1

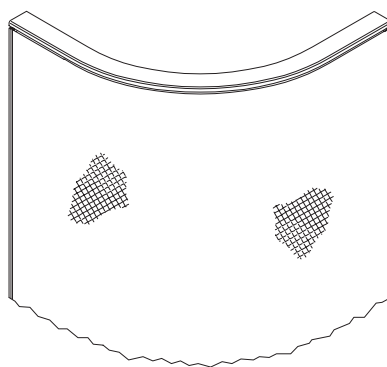

FIG. 2

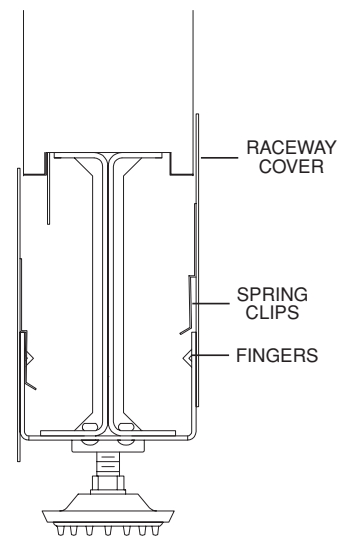

FIG. 3

**WALL MOUNTS**

**Note: Instructions are for an adjustable wall mount kit. In the standard wall mount kit you will not receive the "U" channel or the spacers, but the installation technique is the same.**

**Caution: Determine the type of wall construction. The wall mount extrusion must be mounted only to a structurally sound wall using the type of connector best suited for the wall. Mounting into studs is recommended.**

1. Determine the desired location of the wall mount for the panel to be mounted to the wall.
2. Remove the panel interlock (take out interlock bolts) from the bottom of the panel which is to be butted against the wall (Figure 1). This requires the use of a  $\frac{3}{8}$ " wrench.

Reinstall interlock bolts (which were holding the interlock in place) with two (1/4-20) nuts provided in the wall mount kit. (This secures the black support housing in place.)

3. To determine the proper mounting height, you must first level the panel to be attached to the wall mount. When level, move this panel against the wall and mark the wall at the top of the trim rail.
4. Using the steel "U" channel, hold it at the mark on the wall. Hold a level to this "U" channel and measure the difference at each mounting hole.
5. Stick the proper amount of  $\frac{1}{8}$ " cork spacers to the "U-channel" at each hole (Figure 2) to fill any

difference between the level and the "U" channel.

6. Attach the wall mount to the wall checking the level both vertically and horizontally.
7. The panel is now ready for attachment to the wall mount extrusion. This utilizes the same hinge connector attachment which joins all other panels (Figure 2). (You may trim off the light block portion of the hinge on the wall mount side to facilitate installation, if necessary.)

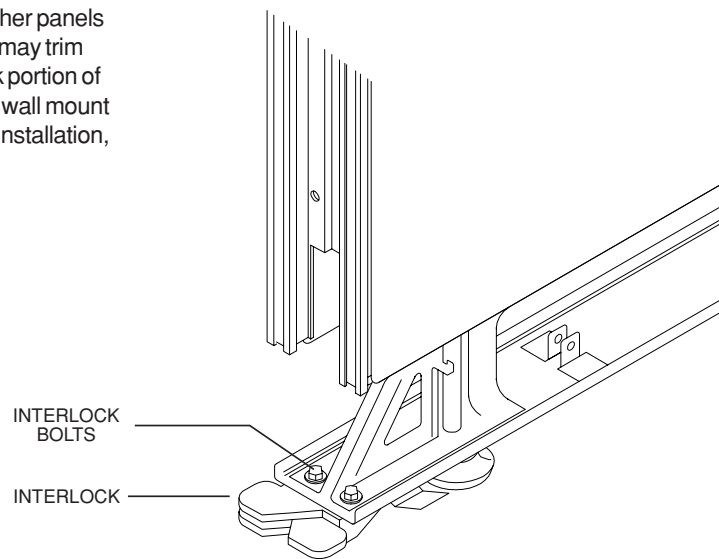

FIG. 1

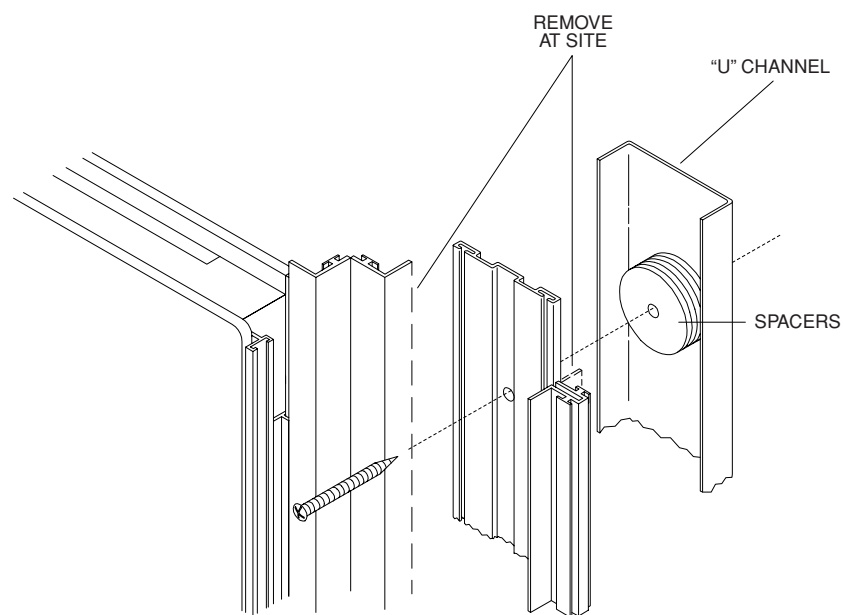

FIG. 2

PANEL CENTER MOUNT

Installation

1. Remove top caps from both panels (Figure 1).
2. Remove raceway covers from panel to be attached. Remove (1) interlock from the end you wish to attach to the other panel. Replace interlock with (2) 1/4" hex nuts provided in hardware kit.
3. Remove the raceway cover on the side of the panel where the panel is to be attached. Insert one of the aluminum clips into the welting groove at approximately the center of where the panel is to be attached (Figure 1). Replace the cover and the clip will stay in the groove (Figure 2).
4. Take the panel to be attached (the end with the interlock removed) and slide the threaded rod down the vertical frame member. Lift the panel to be attached and guide the clip up the frame with the threaded rod through the (2) holes in the clip (Figure 3).

Install flat washer, lock-washer and nut to the end of the threaded rod (Figure 3).

5. Adjust the panel being attached to the exact placement and install top clip, washer, lockwasher and nut (Figure 1).

6. Plumb panel, tighten nuts with deep 1/2" socket until snug, replace raceway covers and top caps.

**Note: If panel or panels being attached with panel center mount are to be powered, then they must have their own power feed.**

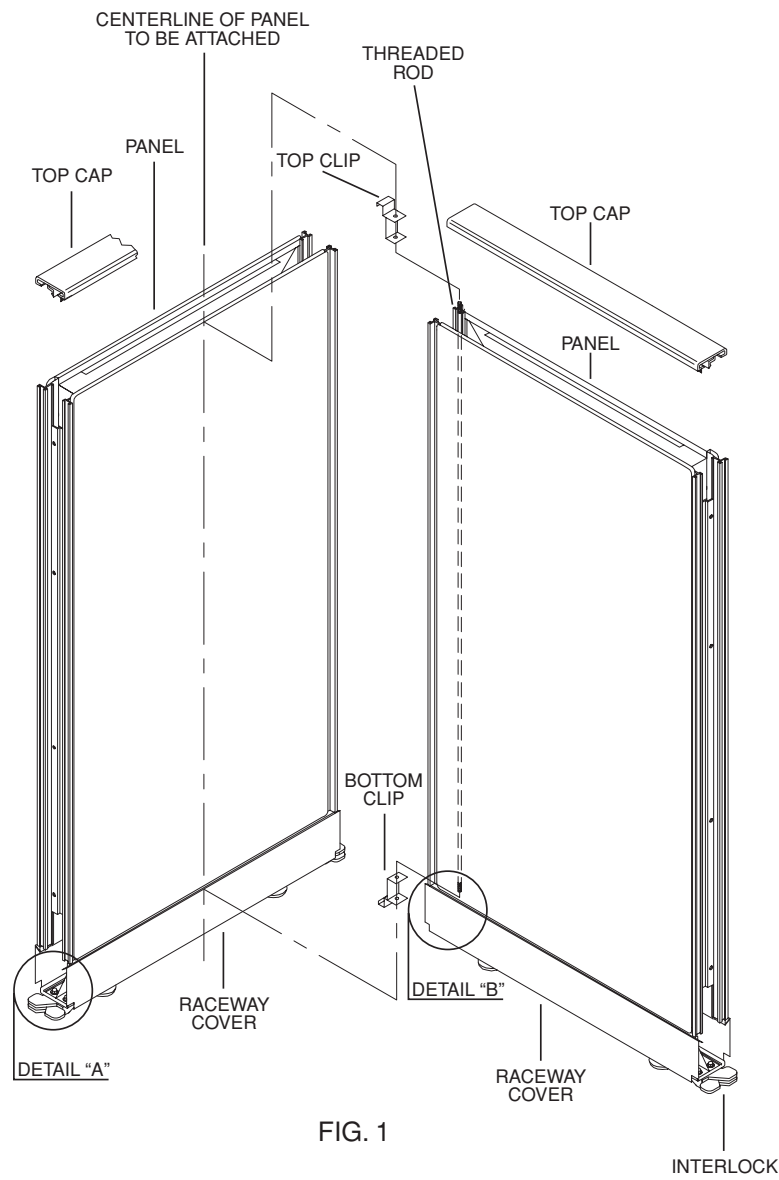

FIG. 1

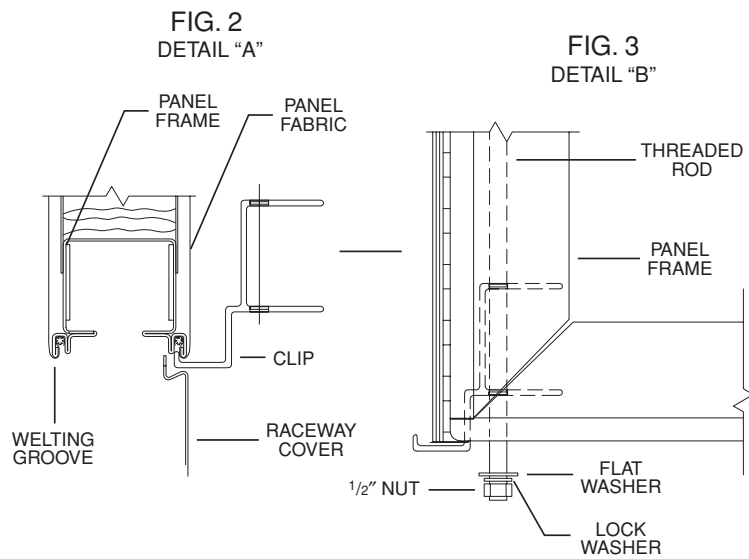

FIG. 2  
DETAIL "A"

FIG. 3  
DETAIL "B"

**PANEL DOORS**

**Tools Needed**

- A. Torx (T-25) Tipped driver
- B.  $\frac{3}{8}$ " Open End Wrench
- C.  $\frac{7}{16}$ " Open End Wrench
- D.  $\frac{1}{2}$ " Open End Wrench  
(If you are using a threshold)

**Installation**

1. Lay the door frame/door assembly flat on a clean surface, or on the cardboard carton it came in. Remove the (2) torx head screws from each side trimrail, and slide the trimrails about 12" toward the top of the door (Fig. 1).
2. Attach an "L" shaped support bracket with the adjusting glide, at the bottom of each frame member. The "L" bracket mounts on the inner flange of the frame member using (4)  $\frac{3}{8}$ " torx screws on each bracket (Fig. 2).
3. Slide the two trimrails back in position and attach them to the frame with (12)  $\frac{3}{8}$ " torx screws in each trimrail.
4. Remove the interlock bolts from the panels adjacent to the door location using the  $\frac{3}{8}$ " open end wrench. Set the interlocks aside and save the bolts for attaching the "L" brackets on the door frame to the adjacent panels.

**Note: If installing a door threshold, refer to instructions on page 1-1-14. If not, continue with step 5.**

5. Stand the panel door assembly in place between the adjacent panels (with interlocks removed) and adjust the door glides so the trimrails on the door and the panels match, and the "L" bracket on each side touch the bottom of the raceway pans on the adjacent panels. Secure the "L" brackets to the adjacent panel raceway pans, using the bolts you saved in step 4 and the nuts included in the hardware kit.
6. Slide the vinyl hinges into connect the door trimrails to the adjacent panel trimrails.

**Note: If the door is being installed at a 90° corner or T-configuration, you will need to attach the 1 $\frac{3}{4}$ " x 2 $\frac{3}{4}$ " flat plate with the 4 holes between the "L" bracket and the adjacent panel at a 90° angle.**

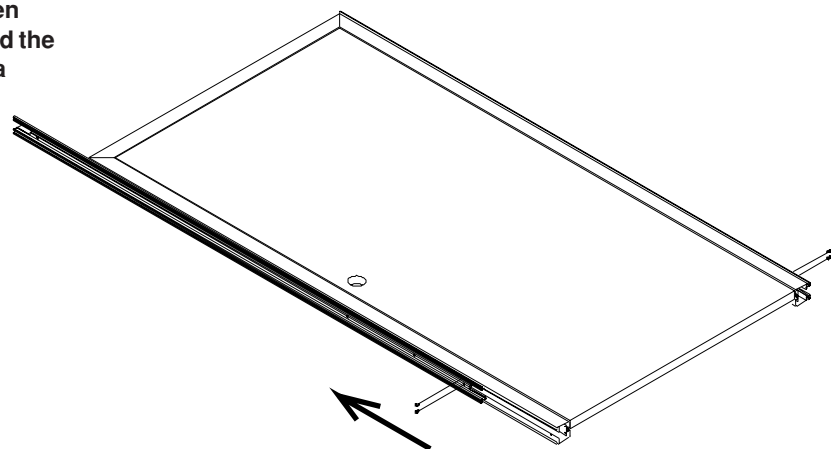

FIG. 1

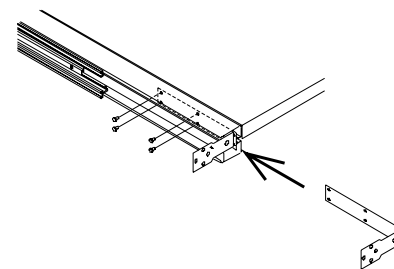

FIG. 2

**PANEL DOOR THRESHOLDS**

**Installation**

**Note: Before starting the threshold installation, steps 1-4 on page 1-1-13 should be complete.**

1. Remove a glide from an "L" bracket installed on the door frame.
2. Slide the glide through the hole in the threshold end clip. Turn the  $\frac{5}{16}$ " nut down onto the glide stem until it is within  $\frac{1}{8}$ " of the clip (Fig. 1).
3. Repeat steps 1 and 2 on the other end of the threshold.
4. Screw the glides back into the "L" brackets on the door frame. Adjust the glide so the distance from the bottom of the glide to the top of the "L" bracket matches the distance from the bottom of the glide to the bottom of the raceway pan on the adjacent panel (Fig. 2, dim A).

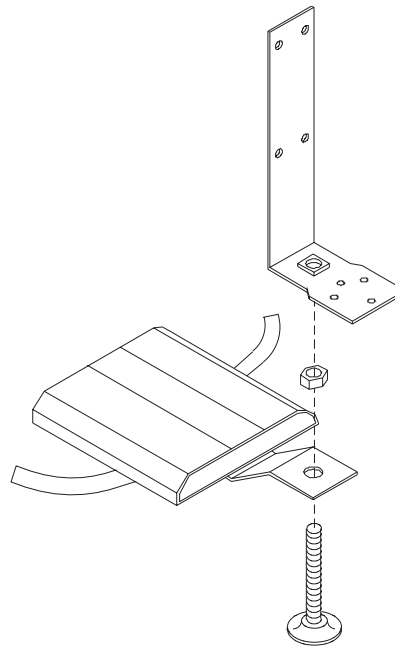

FIG. 1

5. While maintaining dim. A, tighten the nut down so it secures the threshold clip between the nut and the glide nut.
6. Peel back all four ends of the two double stick tape strips on the bottom of the threshold about 2". The tape covers will be peeled off as a final step to help adhere the threshold to the floor (Fig. 1).

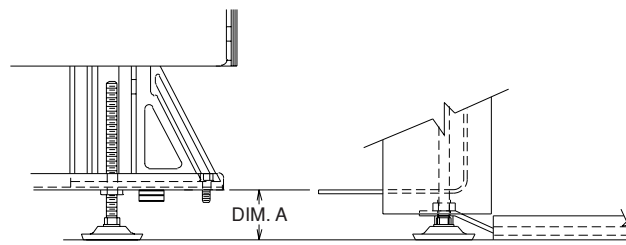

FIG. 2

7. Refer back to steps 5 and 6 on page 1-1-13, to attach door in place. Once all final adjustments are made to the door, carefully pull the tape covers off the bottom of the threshold. You may need to lift up on the adjacent panels to pull the tape off.



**ERP PANELS**

**ERP (Extended Raceway Panel) Panels**

**Note: The installation of ERP panels, trim and electrical is identical to that of standard panels. The only additional installation step is the use of the septum bridges. See the steps below for the installation of the septum bridges.**

**180° Panel Connection**

**Note: Each ERP panel will include (1) 180° septum bridge.**

1. Install ERP panels the same as the standard panels, but leave the raceway cover off one side of each panel.
2. Bend the 4 tabs down 90° on the steel 180° septum bridge (Fig. 1).
3. Set the 180° septum bridge into the ends of the two steel septums in the ERP raceway of the adjacent panels. The 4 tabs bent down in step 2 will fit into the slots in the steel septums.
4. When the 180° septum bridge is lying flush with the surface of both steel septums, bend the tabs in under the steel septum to secure them in place.
5. Install the ERP raceway covers as usual.

**90° Panel Connections (2, 3, or 4 panel intersections)**

**Note: Each ERP 90° trim includes (1) 90° steel septum bridge. Each ERP T-post trim includes (2) 90° steel septum bridges.**

1. Install the ERP panels the same as the standard panels, but leave the raceway cover off one side of each panel.
2. Bend the 4 tabs down 90° on each end of the steel 90° steel septum bridges (Fig. 1).
3. Set one 90° septum bridge into the ends of the two steel septums in the ERP raceways of two of the panels. If you are working with a 3 or 4 panel corner, place a second 90° septum bridge in position on the remaining panels so it overlaps the first bridge.

4. When the 90° septum bridge(s) is lying flush with the surface of the steel septums, bend the tabs in under the steel septum to secure them in place.
5. Install the ERP raceway covers as usual.

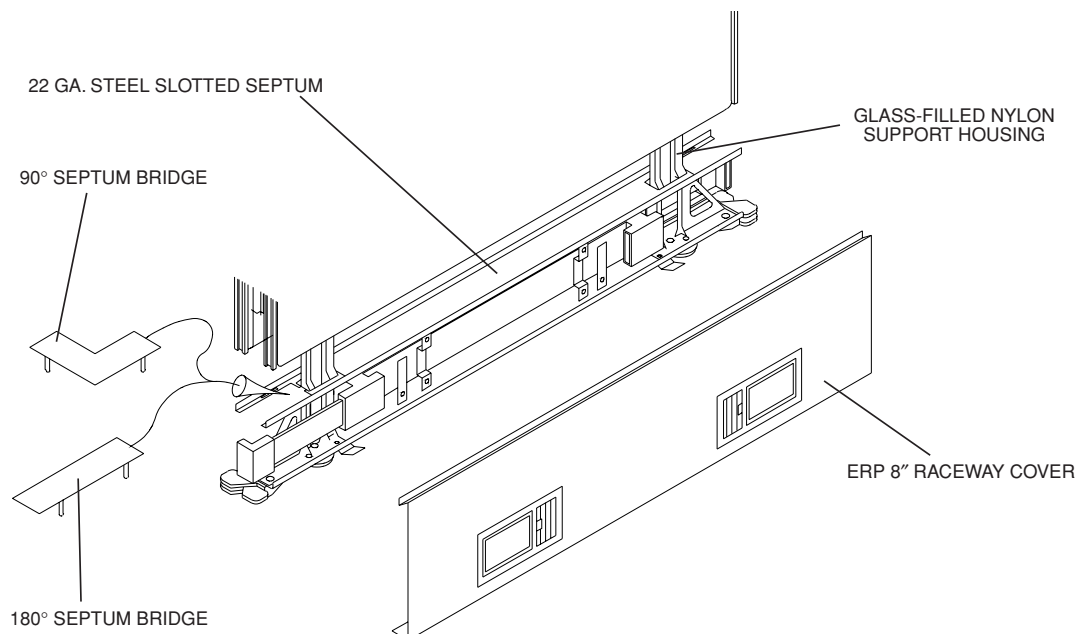

FIG. 1

## CLASSIC XXI SYSTEM

## SECTION 1 - PANELS

### STACKABLE PANEL SECTIONS & STACKABLE PANEL TRIM

#### Tools Required:

Phillips Screwdriver

#### Parts Included with Stackable Panel Section

- (1) Stackable Section
- (2) Stackable Attachment Brackets
- (5) 1/2" Phillips Screws
- (1) H-Shaped Spacer
- (2) Stackable Section Hinges

#### Attachment Bracket Assembly

1. Set the stackable panel section on its edge as illustrated to allow access to the lower end of the trimrail that does not have screws in it (Fig. 1).
2. The attachment brackets will attach to the stackable panel section with two screws provided. Position the attachment bracket as shown and slide the bracket into the slotted trimrail at the "no screw" end (Fig. 1).
3. Align the two mounting holes of the attachment bracket with the holes in the trimrail. Secure the attachment bracket to the trimrail with two 1/2" self tapping screws (Fig. 2).
4. Carefully turn the stackable panel section over and attach the second attachment bracket to the other trimrail as described in the instructions above.

**Note: It is recommended that two people complete the installation of each stackable panel section.**

5. To install the stackable panel section, first remove the plastic top cap from the existing panel. Then place the H-spacer on top of the existing panel as shown (Fig. 3).

6. Hold the stackable panel section over the existing panel so the 1/2" wide leg of each attachment bracket lines up directly over the 1/2" wide groove on the trimrails of the existing panel (Fig. 3).
7. Carefully lower the stackable section down onto the existing panel until it is fully seated on the H-spacer (Fig. 3). There will be about a 1/8" gap the entire width of the panel, and the hook on each bracket will catch the trimrail of the existing panel, when the stackable section is fully seated.

8. Slide the stackable hinges (not shown) into the trimrail of the stackable section and trimrail of the adjacent panels or other stackable sections if applicable.
9. Install any other stackable trim that may have been ordered separately.
10. Snap the top cap, from the existing panel, onto the stackable section (Fig. 3).

#### Stackable Return Panels

11. When a stackable panel section is used as a return for a loaded stackable section, or a loaded standard panel, an additional 1/2" self tapping screw should be driven through the leg of the attachment bracket and into the full panel trimrail. Drill a 1/8" pilot hole into the trimrail of the full panel first, using the bracket leg as a guide (Fig. 4).

#### STACKABLE PANEL TRIM

##### Installation of Stackable Panel Trim

**Note: All of the stackable panel trim installs the same as standard panel trim. You do, however, have to specify the trim lengths that correspond to the stackable section height.**

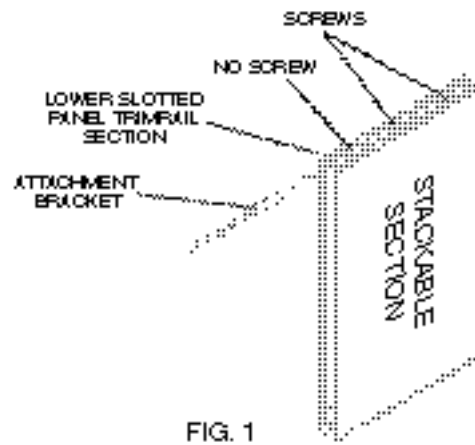

FIG. 1

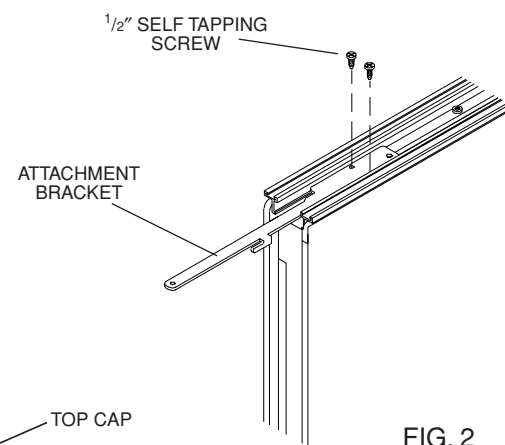

FIG. 2

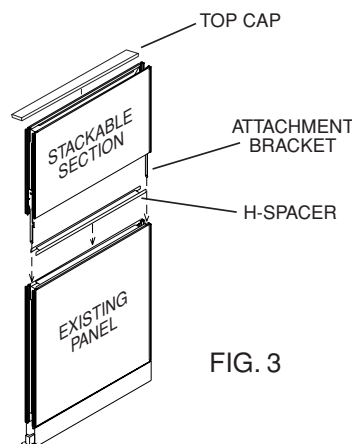

FIG. 3

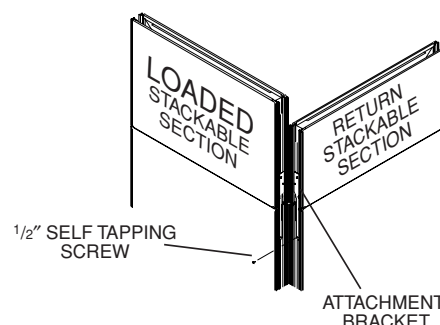

FIG. 4

**TABLE OF CONTENTS**

General Electrical Information .....1-2-1  
    General Electrical Information  
    Ceiling Distribution  
    Floor Distribution  
Identification of Parts .....1-2-2  
Suggested Electrical Installation Sequence .....1-2-3  
    Before You Begin: Caution  
    Installation Instructions  
Panel-to-Panel Electrical  
Connections 8-Wire .....1-2-4  
Panel-to-Panel Electrical  
Connections 10-Wire .....1-2-5  
Circuit Separator Blocks 8-Wire Only .....1-2-6  
Receptacle Installation .....1-2-7  
Base Power Infeed Harness Installation .....1-2-8  
    Base Power Infeed Installation  
Top Power Infeed Harness/Power Pole  
Installation .....1-2-9  
    Top Power Infeed Installation  
8-Wire Connection Diagrams .....1-2-10  
    8-Wire Installation  
    Power Infeed to Building Connections  
10-Wire Connection Diagrams .....1-2-11  
    10-Wire Installation  
    Power Infeed to Building Connections

**General Electrical Information**

Office furniture systems unite the day-to-day equipment with the services of the building.

1. Electrical power enters the panel system by one of two means: ceiling distribution (top fed) or floor distribution (base fed).

**Ceiling Distribution**

Ceiling distribution is one method of accessing the building's electrical and telecommunications. This method is accomplished by routing wires and cables through the ceiling, down the top feed power infeed and into the panel.

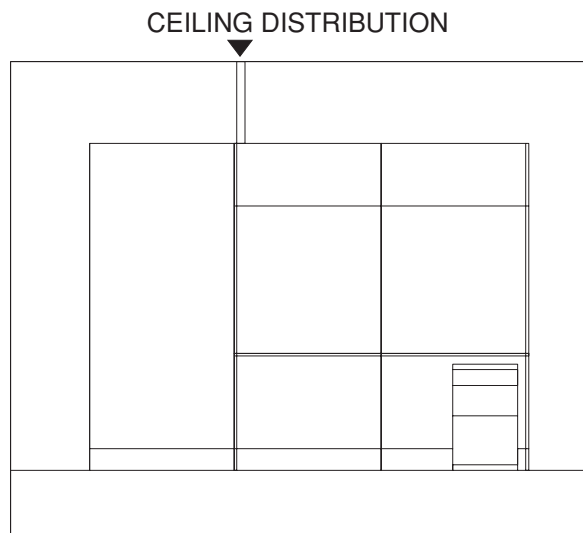

**Floor Distribution**

Floor distribution is another method of tapping into the building's electrical and telecommunications system. This method can be accomplished several different ways. You will encounter a variety of situations that will require different solutions, depending if the building feed is in the floor or in the wall.

2. There are two types of electrical systems available on Classic XXI System panels, 8-wire and 10-wire. Depending on the electrical system you choose, your building will need to supply the correct configuration of wires. See pages 1-2-10 and 1-2-11 for the connection diagrams for 8- and 10-wire systems.

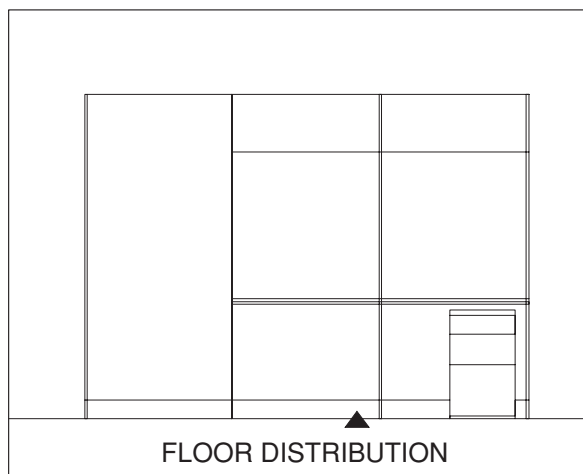

**IDENTIFICATION OF PARTS**

1. Familiarize yourself with the common electrical parts before you begin your electrical installation.

2. To help you identify the three different types of electrical product, the UL labels are color coded as follows:  
 8-wire – white  
 10-wire 442 – yellow  
 10-wire 622 – purple

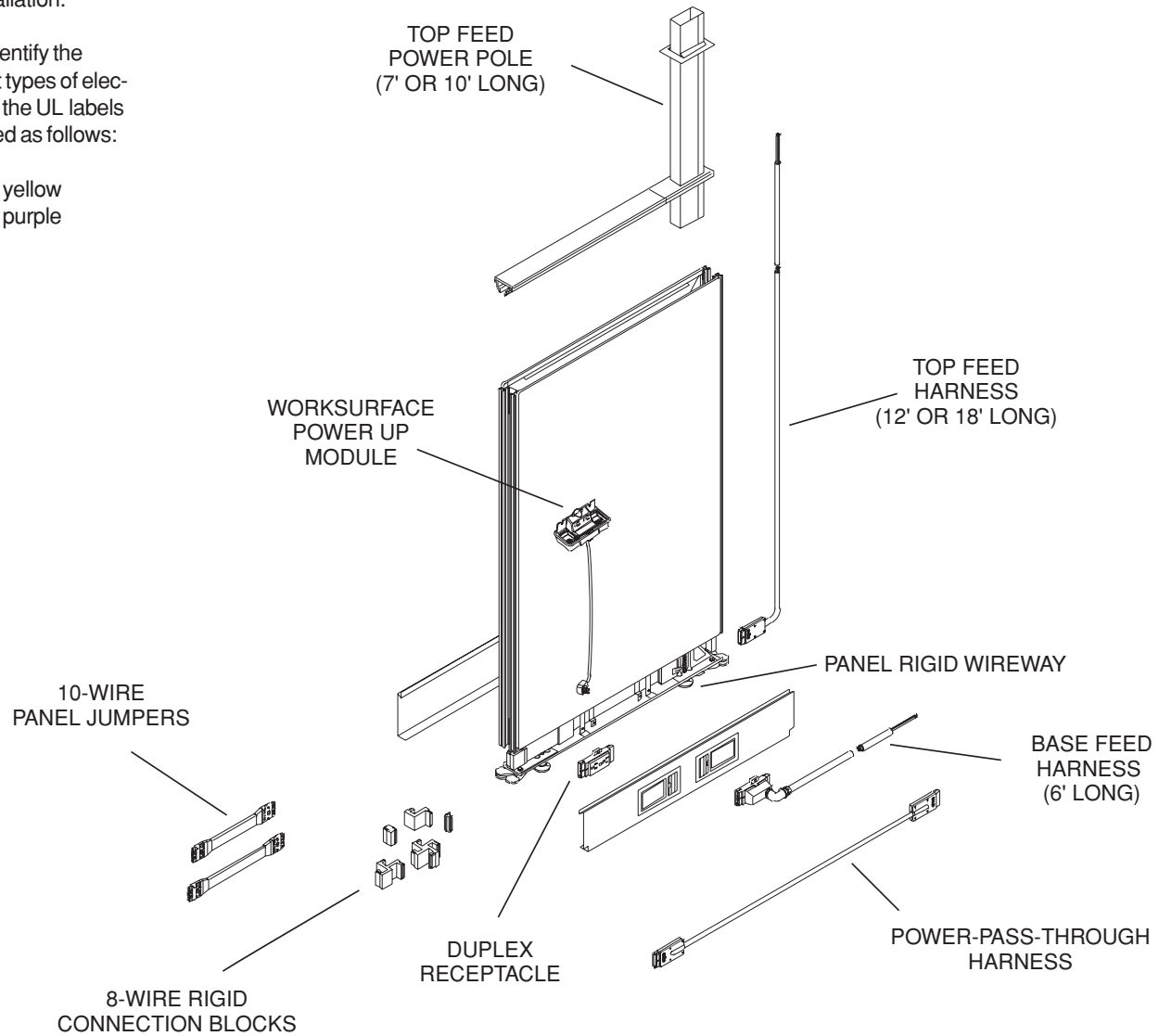

**SUGGESTED ELECTRICAL INSTALLATION SEQUENCE****Before You Begin:  
Caution**

**1. Before installing electrical components, consult inspector or authorities for local codes. Connection to building power supply may be made ONLY after all panel wiring has been completed. Connections must be made only by a licensed electrician following local codes in effect at the building site.**



**2. Each circuit must be individually protected with a 120-volt, 20-amp circuit breaker device which will provide disconnect and overload protection.**

**Installation Instructions**

1. Familiarize yourself with the electrical parts and the locations of the top feeds or base feeds.
2. Install the top feed harness in the appropriate panel as the panels are being installed.
3. If base feed harnesses are to be located between a panel and a building wall, install the base feed harness as the panels are being installed. Leave access for the electrician to make the final hardwire connection of the base feed harness to the building.
4. Install all the Panel-to-Panel jumpers (for 10-wire), rigid connector blocks (for 8-wire) or the Power-Pass-Through harness as shown on the spaceplanning drawing. Be sure all connections are tight.

5. Install all receptacles in the locations shown on the spaceplanning drawing.
6. Check the electrical continuity at the furthest point from the power infeed location.
7. Install the panel raceway covers on the appropriate panels.

1. Power is carried between straight adjacent panels by rigid connector blocks (see Figures A - H for which blocks to use with different panel configurations).
2. Attach the rigid connector block to the festoon connectors that are on the end of each panel rigid wireway by pushing them together until locked.
3. If connecting a curved panel or passing power through a non-powered panel, plug the correct length power-pass-through into the adjacent panel wireways (Figures I - N).
4. Check the continuity from panel-to-panel with a voltmeter.

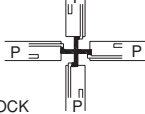
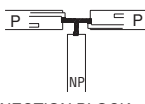
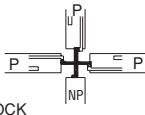
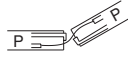
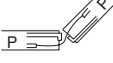
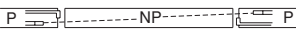
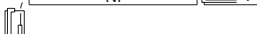
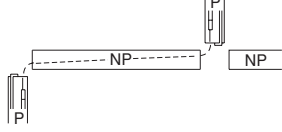
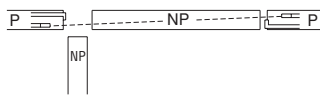
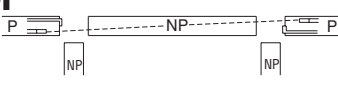
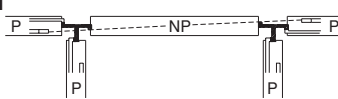
<p><b>A</b></p>  <p>YOU USE: (1) 180° CONNECTION BLOCK</p>	<p><b>B</b></p>  <p>YOU USE: (1) 90° CONNECTION BLOCK</p>
<p><b>C</b></p>  <p>YOU USE: (1) 3T CONNECTION BLOCK</p>	<p><b>D</b></p>  <p>YOU USE: (1) 4X CONNECTION BLOCK</p>
<p><b>E</b></p>  <p>YOU USE: (1) 3T CONNECTION BLOCK</p>	<p><b>F</b></p>  <p>YOU USE: (1) 4X CONNECTION BLOCK</p>
<p><b>G</b></p>  <p>YOU USE: (1) 14" SPAN CONNECTOR</p>	<p><b>H</b></p>  <p>YOU USE: (1) 14" SPAN CONNECTOR</p>
<p><b>I</b></p>  <p>YOU USE: (1) POWER-PASS-THROUGH THE SAME SIZE AS THE NON-POWERED PANEL</p>	<p><b>J</b></p>  <p>YOU USE: (1) POWER-PASS-THROUGH THE SAME SIZE AS THE NON-POWERED PANEL</p>
<p><b>K</b></p>  <p>YOU USE: (1) POWER-PASS-THROUGH <b>ONE SIZE LARGER</b> THAN THE NON-POWERED PANEL, (WITH EXCEPTION OF 60" NP PANELS)</p>	<p><b>L</b></p>  <p>YOU USE: (1) POWER-PASS-THROUGH <b>ONE SIZE LARGER</b> THAN THE NON-POWERED PANEL, (WITH EXCEPTION OF 60" NP PANELS)</p>
<p><b>M</b></p>  <p>YOU USE: (1) POWER-PASS-THROUGH <b>ONE SIZE LARGER</b> THAN THE NON-POWERED PANEL, (WITH EXCEPTION OF 60" NP PANELS)</p>	<p><b>N</b></p>  <p>YOU USE: (2) 3T CONNECTION BLOCKS, (1) POWER-PASS-THROUGH <b>ONE SIZE LARGER</b> THAN THE NON-POWERED PANEL, (WITH EXCEPTION OF 60" NP PANELS)</p>

**PANEL-TO-PANEL ELECTRICAL CONNECTIONS 10-WIRE**

1. Power is carried between straight adjacent panels by panel jumpers. (See Figures A - H, for which jumper to use with different panel configurations.)
2. Attach the panel jumpers to the plug-in ports that are on the end of each panel wireway by pushing them together until they are locked.
3. If connecting a curved panel, or passing power through a non-powered panel, plug the correct length power-pass-through into the adjacent panel wireways (See Figures I - L).
4. Check the continuity from panel to panel with a voltmeter.

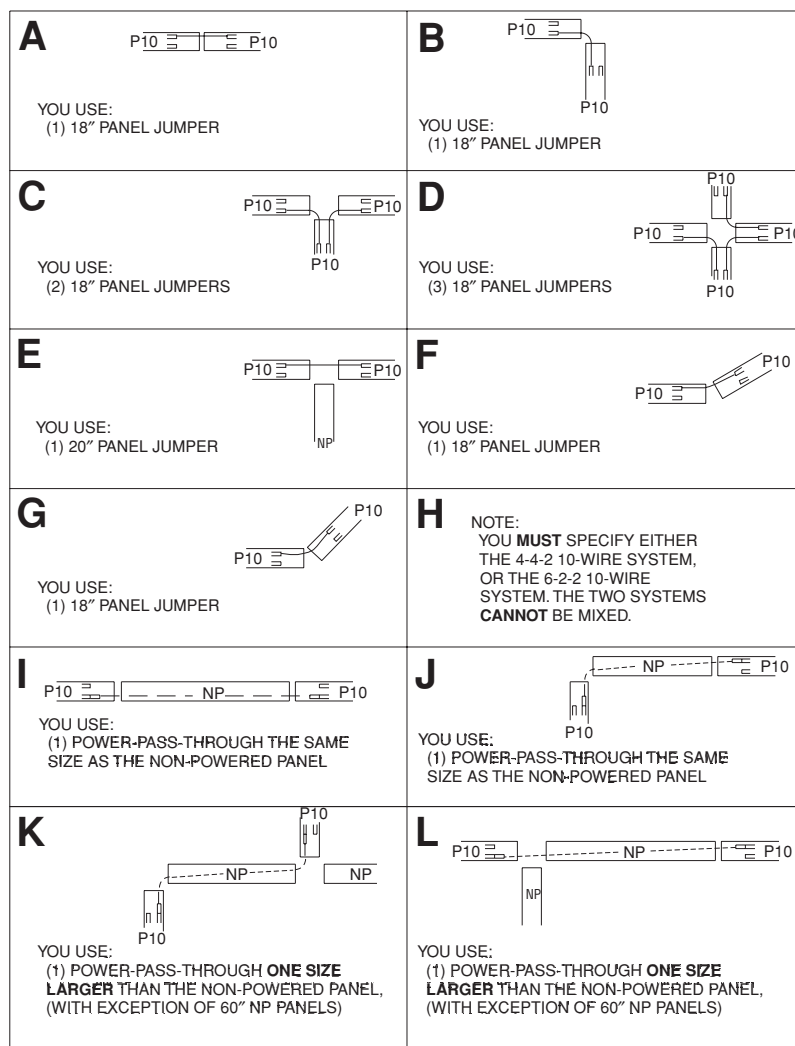



1. Circuit Separator Blocks are used on 8-wire systems when two power supplies meet at adjacent panels. The circuit separator block prevents any type of rigid connector block from being placed between the panels (See Figures A-F).

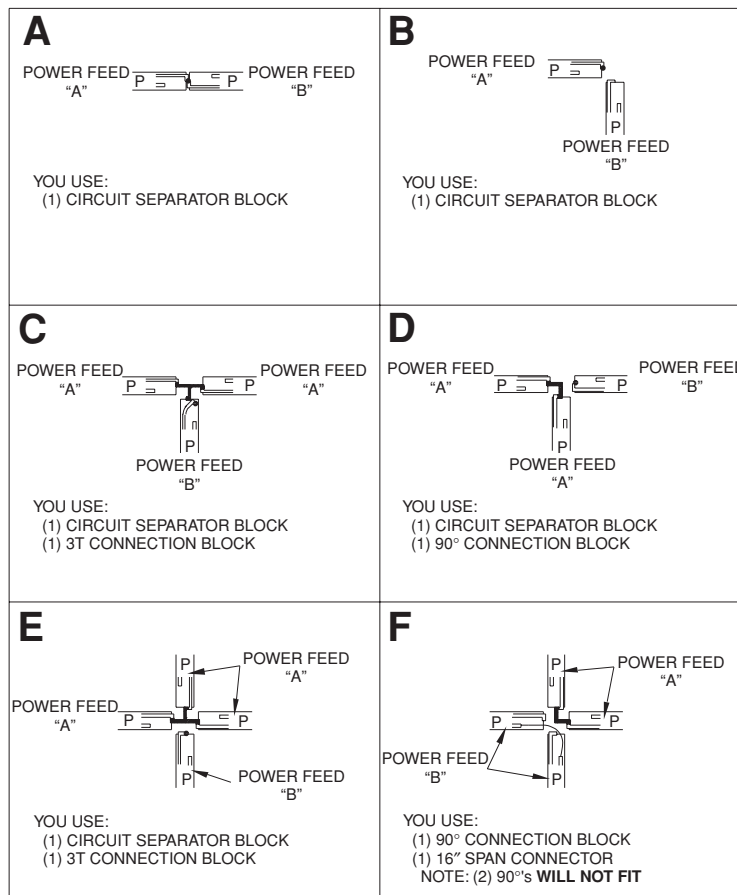

1. Duplex receptacles should be connected after wireways are installed but BEFORE power is connected to the building supply.
2. Follow the installation drawings to install the duplex receptacles for the circuit desired in the correct locations.
3. To install the individual receptacle, slide the receptacle female inserts into place in the corresponding male part of the rigid wireway. Align the slots (top and bottom) of the receptacle with corresponding holes in the rigid wireway. Attach together with (2) provided #8-32 UNC x 7/16" PH tapping screws (Figure 1).
4. To remove a receptacle, simply remove the screws and slide the receptacle to the side.

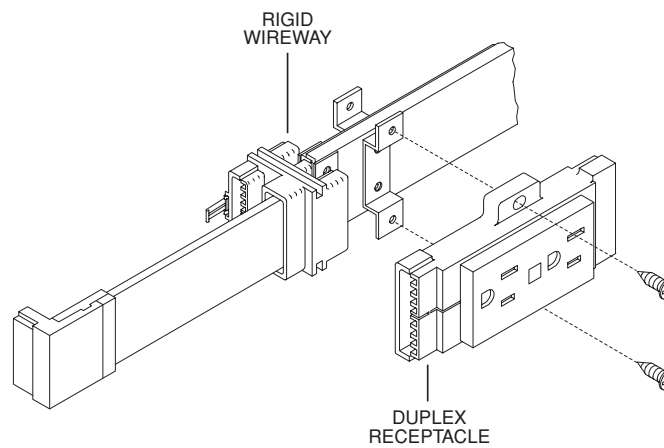

FIG. 1

**Caution: This step should be done with great care. Do not insert a screwdriver into electrical outlet. Do not remove the receptacle while it is under load.**

**Note: Receptacles must be installed BEFORE raceway covers. Covers must be removed to add, move, or change receptacles.**

**Note: Cut or push the 1 3/4" x 2 7/8" plastic filler out of the plastic receptacle frame on the steel raceway cover anywhere you install a receptacle.**

**BASE FEED HARNESS INSTALLATION**

**Base Power Infeed Installation**

**Caution: The wires in the end of the base feed power infeed must be hard-wired later by an electrician. It is not safe to perform the following steps if these wires are already connected.**

1. Install the panel base power infeed before the raceway cover is attached (Figure 1). If the raceway cover is already installed, pull the cover out and up from the bottom.
2. Determine from the layout which panel wireway will receive the power feed. Align the power feed the same way you would a duplex receptacle if you were installing it in a rigid wireway.
3. Slide the power feed female inserts into place in the corresponding male part of the rigid wireway. Align slots (top and bottom) at the power feed with corresponding holes in the rigid wireway. Attach with provided (2) #8-32 UNC x 7/16" PH tapping screws.
4. Feed the conduit end of the power feed through the receptacle access opening on the raceway cover. Install the raceway cover on the panel base. Hook the raceway cover onto the tabs on the two black support housings. Swing the raceway cover down until it snaps into place.
5. The base power infeed shown is an 8-wire right-hand. Left-hand and straight power feeds are also available. The left or right refers to the direction the conduit goes as you look at the panel. The infeed will fit in any usual receptacle port.
6. The base power infeeds for 10-wire are also specified as left or right, but it does not refer to the conduit direction. The left or right refers to the receptacle port it installs into as you look at the panel. The conduit on 10-wire base power infeeds can pivot to go to either the right or left.

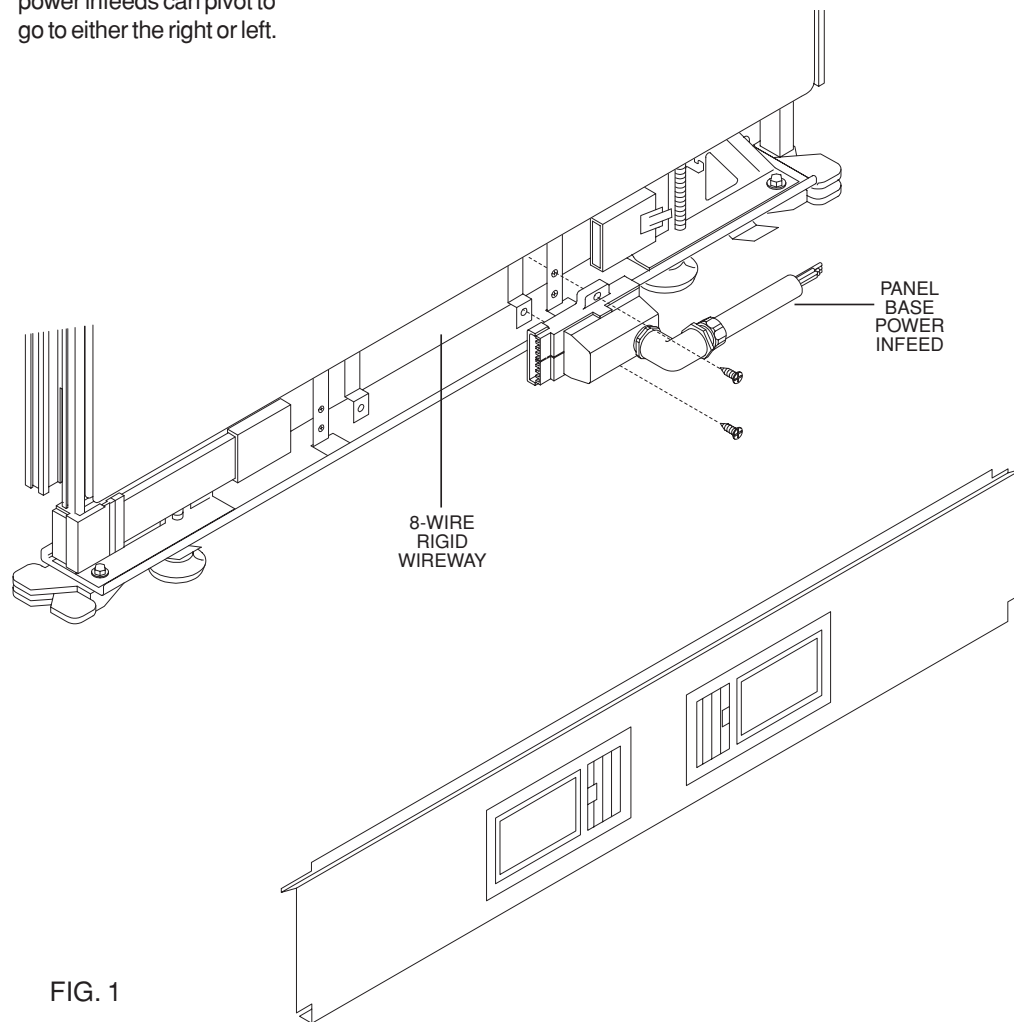

FIG. 1

**Top Power Infeed Installation**

**Caution: The wires in the loose end of the top power infeed must be hard-wired later by an electrician. It is not safe to perform any of the following steps if these wires are already connected.**

1. Cut the top cap, from the panel you are installing the top feed on, 6" shorter. Be sure you make a clean straight 90° cut.
2. Snap the infeed trim cap in place.

**Note: Before measuring the pole, be certain the panel is level and in its final location.**

3. Drop a plumb line from the ceiling to a corner of the rectangular hole in the top infeed trim cap. At the ceiling, mark a 2<sup>5/8</sup>" by 1<sup>1/2</sup>" hole starting at the same corner. The 2<sup>5/8</sup>" dimension corresponds to the direction of the panel run. Cut out the hole in the ceiling tile.
4. Place the top infeed pole next to the panel so that the top of the pole touches the ceiling.

Mark a point 4" longer than the distance from the top of the trim cap to the ceiling. Use a hacksaw to cut the pole at this point (Figure 1). Be sure all burrs or sharp edges are removed after cutting.

5. Feed the top infeed harness conduit up the panel side wireway from the bottom of the panel (Figure 2). Guide the conduit through the top infeed trim cap when it reaches the top of the panel. In the raceway of the panel,

plug the female terminal on the top power infeed into the male terminal of the rigid wireway.

6. Slide a ceiling trim plate around the top of the top infeed pole. Feed the top infeed harness conduit through the small channel of the top infeed pole. When the conduit has reached the top of the pole, guide the pole into the hole in the ceiling. Continue to feed the conduit into the bottom of the pole until the top infeed pole can be set into the hole in the top infeed trim cap (Figure 3).
7. Slide the trim plate up the top infeed pole until it is tight against the ceiling.

**For Electrician's Reference:**

To reach the infeed conduit for hard-wiring above the ceiling, remove adjacent ceiling tile. Communication cables may be fed down the larger channel of the top infeed pole at a later time.

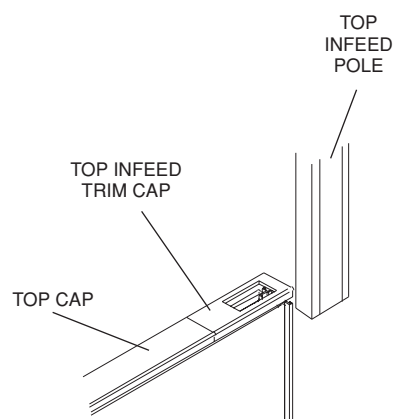

FIG. 1

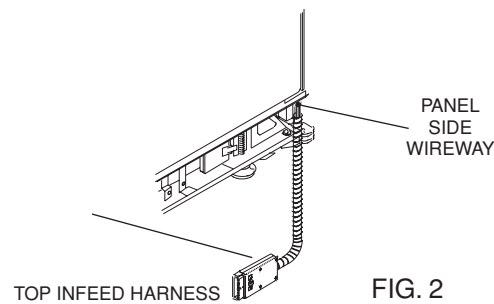

FIG. 2

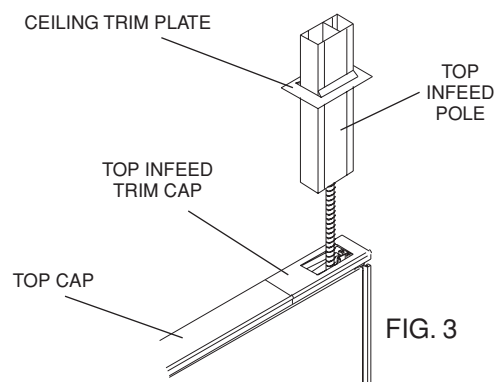

FIG. 3

**8-WIRE CONNECTION DIAGRAMS**

**8-Wire Installation**

**Power Infeed to Building Connections**

Have a certified electrician hard-wire the panel power infeed to the building power source according to the National Electrical Code and any other applicable local codes. See the chart for proper wiring connection to available power.

Receptacles Energized	Wires to be Used	Gauge of Wire
Receptacle 1	Black White #1 Green	12 10 12
Receptacle 2	Red White #1 Green	12 10 12
Receptacle 3	Blue White #1 Green	12 10 12
Receptacle 4I	Pink White #2 Green/Yellow	12 10 12

**Note:**

White #1 has black lettering  
White #2 has red lettering

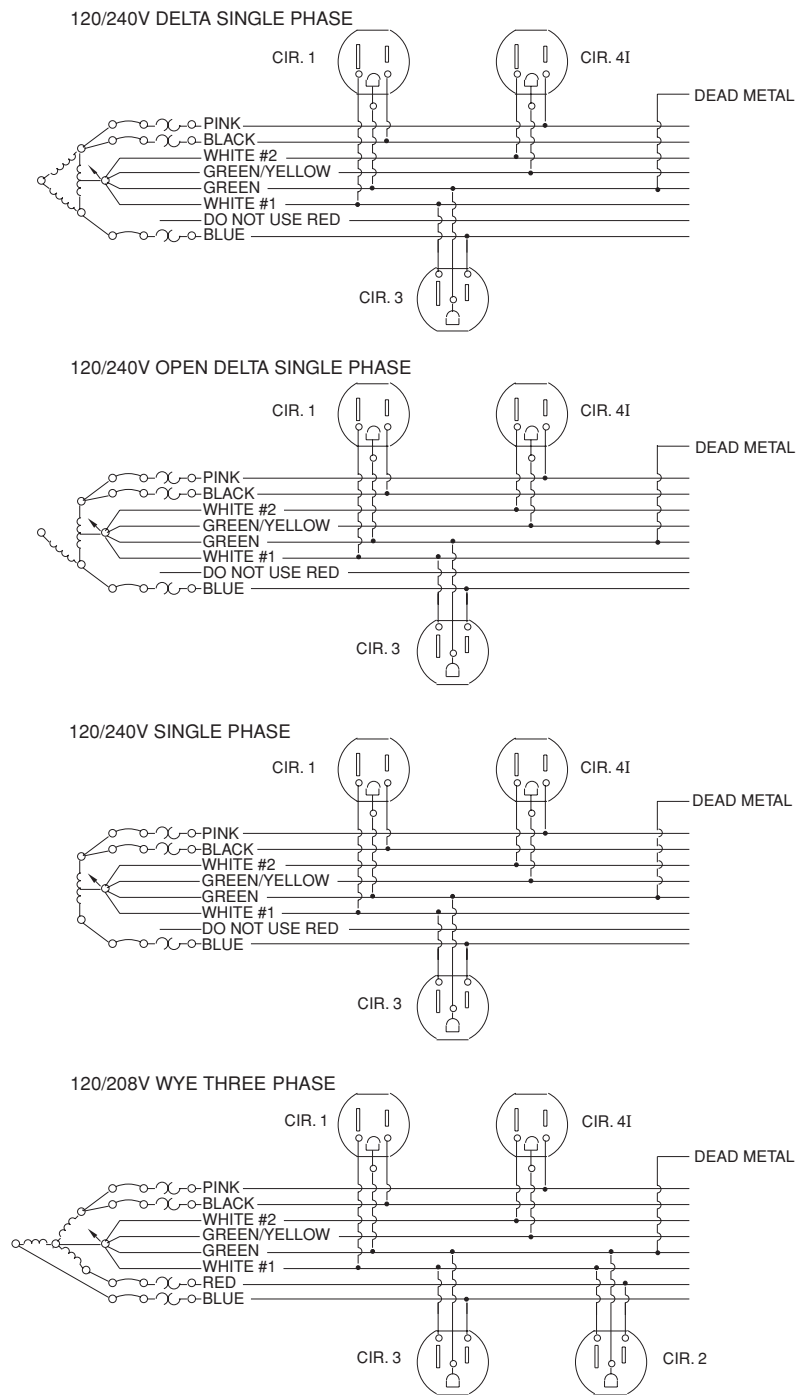

**CONNECTION DIAGRAM**  
Risk of fire or electrical shock. Do not electrically connect panel to more than one supply source. Always determine that the panel is electrically connected to one and only one source of supply.

**10-Wire Installation**

**Power Infeed to Building Connections**

Have a certified electrician hard-wire the panel power infeed to the building power source according to the National Electrical Code and any other applicable local codes. See the chart for proper wiring connection to available power.

**10-WIRE ELECTRICAL 4-4-2 CONNECTION DIAGRAMS**

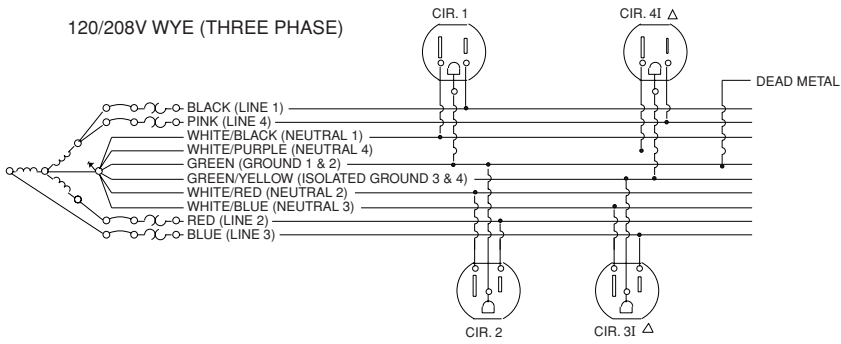
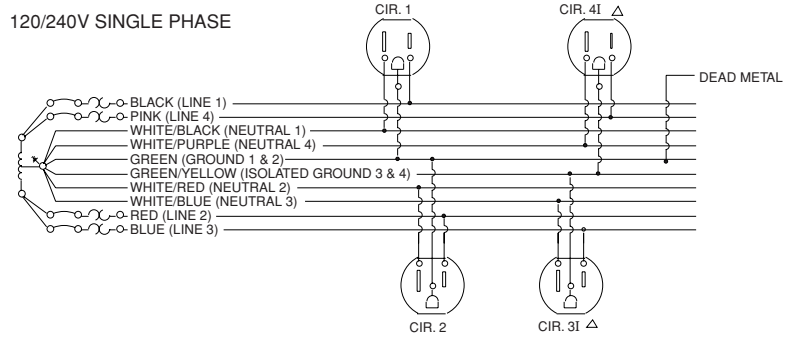

**422 10-WIRE**

Receptacles Energized	Wires to be Used	Gauge of Wire
Circuit 1	Black White/Black Letters Green	12 10 12
Circuit 2	Red White/Red Letters Green	12 10 12
Circuit 3I	Blue White/Blue Letters Green/Yellow Stripe	12 10 12
Circuit 4I	Pink White/Purple Letters Green/Yellow Stripe	12 10 12

**622 10-WIRE**

Receptacles Energized	Wires to be Used	Gauge of Wire
Circuit 1	Black White/Black Letters Green	12 10 12
Circuit 2	Red White/Black Letters Green	12 10 12
Circuit 3	Blue White/Black Letters Green	12 10 12
Circuit 4I	Black/Blue Stripe White/Red Letters Green/Yellow Stripe	12 10 12
Circuit 5I	Red/Blue Stripe White/Red Letters Green/Yellow Stripe	12 10 12
Circuit 6I	Blue/Pink Stripe White/Red Letters Green/Yellow Stripe	12 10 12

**10-WIRE ELECTRICAL 6-2-2 CONNECTION DIAGRAMS**

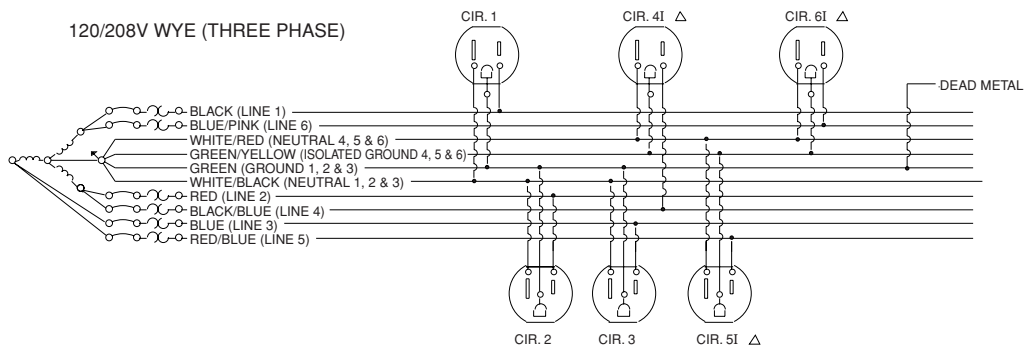
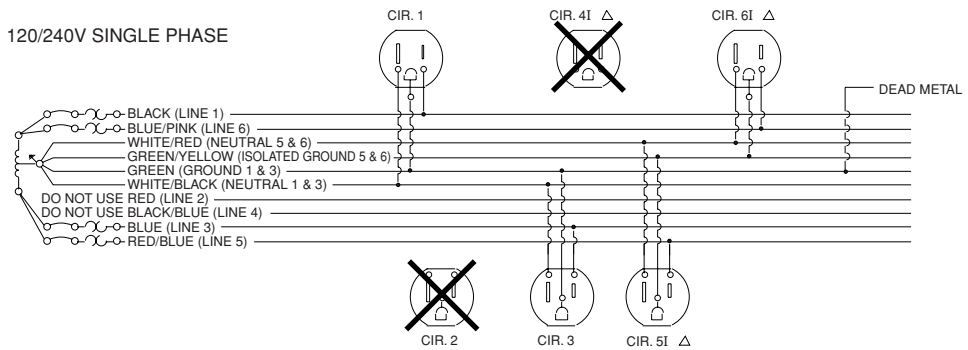

CLASSIC XXI SYSTEM



U.S. Department of Justice

**UNICOR**

Federal Prison Industries, Inc.

CATPIEP400A

[www.unicor.gov](http://www.unicor.gov)

(800) 827-3168

