

Installation of Sprinkler Systems

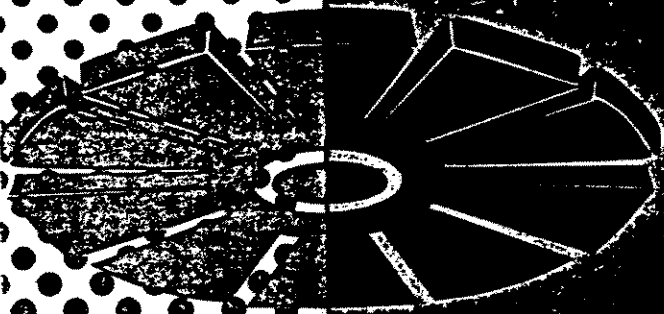

NFPA

13

1996 Edition



National Fire Protection
Association

An International Codes and Standards Organization

NOTICE

All questions or other communications relating to this document should be sent only to NFPA headquarters, addressed to the attention of the Committee responsible for the document.

For information on the procedures for requesting Technical Committees to issue Formal Interpretations, proposing Tentative Interim Amendments, proposing amendments for Committee consideration, and appeals on matters relating to the content of the document, write to the Secretary, Standards Council, National Fire Protection Association, 1 Batterymarch Park, P.O. Box 9101, Quincy, MA 02269-9101.

A statement, written or oral, that is not processed in accordance with Section 5 of the Regulations Governing Committee Projects shall not be considered the official position of NFPA or any of its Committees and shall not be considered to be, nor be relied upon as, a Formal Interpretation.

Users of this document should consult applicable federal, state and local laws and regulations. NFPA does not, by the publication of this document, intend to urge action that is not in compliance with applicable laws, and this document may not be construed as doing so.

Policy Adopted by NFPA Board of Directors on December 3, 1982

The Board of Directors reaffirms that the National Fire Protection Association recognizes that the toxicity of the products of combustion is an important factor in the loss of life from fire. NFPA has dealt with that subject in its technical committee documents for many years.

There is a concern that the growing use of synthetic materials may produce more or additional toxic products of combustion in a fire environment. The Board has, therefore, asked all NFPA technical committees to review the documents for which they are responsible to be sure that the documents respond to this current concern. To assist the committees in meeting this request, the Board has appointed an advisory committee to provide specific guidance to the technical committees on questions relating to assessing the hazards of the products of combustion.

Licensing Provision—This document is copyrighted by the National Fire Protection Association (NFPA).

1. Adoption by Reference—Public authorities and others are urged to reference this document in laws, ordinances, regulations, administrative orders, or similar instruments. Any deletions, additions, and changes desired by the adopting authority must be noted separately. Those using this method are requested to notify the NFPA (Attention: Secretary, Standards Council) in writing of such use. The term "adoption by reference" means the citing of title and publishing information only.

2. Adoption by Transcription—A. Public authorities with lawmaking or rule-making powers only, upon written notice to the NFPA (Attention: Secretary, Standards Council), will be granted a royalty-free license to print and republish this document in whole or in part, with changes and additions, if any, noted separately, in laws, ordinances, regulations, administrative orders, or similar instruments having the force of law, provided that: (1) due notice of NFPA's copyright is contained in each law and in each copy thereof; and (2) that such printing and republication is limited to numbers sufficient to satisfy the jurisdiction's lawmaking or rule-making process. B. Once this NFPA Code or Standard has been adopted into law, all printings of this document by public authorities with lawmaking or rule-making powers or any other persons desiring to reproduce this document or its contents as adopted by the jurisdiction in whole or in part, in any form, upon written request to NFPA (Attention: Secretary, Standards Council), will be granted a nonexclusive license to print, republish, and vend this document in whole or in part, with changes and additions, if any, noted separately, provided that due notice of NFPA's copyright is contained in each copy. Such license shall be granted only upon agreement to pay NFPA a royalty. This royalty is required to provide funds for the research and development necessary to continue the work of NFPA and its volunteers in continually updating and revising NFPA standards. Under certain circumstances, public authorities with lawmaking or rule-making powers may apply for and may receive a special royalty where the public interest will be served thereby.

3. Scope of License Grant—The terms and conditions set forth above do not extend to the index to this document.

(For further explanation, see the Policy Concerning the Adoption, Printing, and Publication of NFPA Documents, which is available upon request from the NFPA.)

Statement on NFPA Procedures

This material has been developed under the published procedures of the National Fire Protection Association, which are designed to assure the appointment of technically competent Committees having balanced representation. While these procedures assure the highest degree of care, neither the National Fire Protection Association, its members, nor those participating in its activities accept any liability resulting from compliance or noncompliance with the provisions given herein, for any restrictions imposed on materials or processes, or for the completeness of the text.

NFPA has no power or authority to police or enforce compliance with the contents of this document, and any certification of products stating compliance with requirements of this document is made at the peril of the certifier.

SC-AM-96

Copyright © 1996 NFPA, All Rights Reserved

NFPA 13
Standard for the
Installation of Sprinkler Systems
1996 Edition

This edition of NFPA 13, *Standard for the Installation of Sprinkler Systems*, was prepared by the Technical Committee on Automatic Sprinklers and acted on by the National Fire Protection Association, Inc., at its Annual Meeting held May 20-23, 1996, in Boston, MA. It was issued by the Standards Council on July 18, 1996, with an effective date of August 9, 1996, and supersedes all previous editions.

Changes other than editorial are indicated by a vertical rule in the margin of the pages on which they appear. These lines are included as an aid to the user in identifying changes from the previous edition.

This document has been submitted to ANSI for approval.

Origin and Development of NFPA 13

NFPA 13 represents the first standard published under the auspices of the NFPA Committee on Automatic Sprinklers. Originally titled *Rules and Regulations of the National Board of Fire Underwriters for Sprinkler Equipments, Automatic and Open Systems*, the standard has been continuously updated to keep in step with change.

Full information about the NFPA actions on various changes will be found in the NFPA Proceedings. The dates of successive editions are as follows: 1896, 1899, 1902, 1905, 1907, 1908, 1912, 1913, 1915, 1916, 1917, 1919, 1920, 1921, 1922, 1923, 1924, 1925, 1926, 1927, 1928, 1929. In 1930 a separate standard was published on "Class B" systems. This was integrated into the 1931 edition. Further revisions were adopted in 1934, 1935, and 1936. A two-step revision was presented in the form of a progress report in 1939 and finally adopted in 1940. Further amendments were made in 1947, 1950, 1953, 1956, 1958, 1960, 1961, 1963, 1964, 1965, 1966, 1968, 1969, 1971, 1972, 1973, 1974, 1975, 1976, 1978, 1980, 1982, 1984, 1986, and 1989.

The 1991 edition incorporated an entire rewrite of the standard to make the overall format user friendly. Substantive changes were made to numerous terms, definitions, and descriptions, with additional refinements made in 1994.

This centennial edition contains a major reformatting of those portions of the chapter on installation of sprinklers. A number of subsections have been added to allow the installation requirements for each type of style of sprinkler to be readily located. These include positioning rules, spacing rules, and area of coverage rules to be found in one location for each type of sprinkler. Other changes have been made to mainstream the extended coverage sprinkler and to recognize the benefits of fast-response sprinkler technology.

Technical Committee on Automatic Sprinklers

Chester W. Schirmer, Chair
Schirmer Engr Corp., NC

Stephen R. Hoover, Secretary
Kemper Nat'l Insurance Cos., IL
(Nonvoting)

Charles B. Barnett, Badger Fire Protection Inc., OH
Rep. Nat'l Fire Sprinkler Assn.
Kerry M. Bell, Underwriters Laboratories Inc., IL
Edward K. Budnick, Hughes Assoc., Inc., MD
Albert M. Comly, Jr., Vitetta Group, PA
Rep. American Inst. of Architects
Thomas G. Daly, Hilton Hotels Corp., CA
Rep. American Hotel & Motel Assn.
Robert E. Duke, Fire Control Inc., IL
Russell P. Fleming, Nat'l Fire Sprinkler Assn., NY
Rep. Nat'l Fire Sprinkler Assn.
Christopher M. Goddard, Zeneca Inc., DE
Rep. NFPA Industrial Fire Protection Section
Richard E. Hughey, ISO Commercial Risk Services, Inc., NJ
Rolf H. Jensen, Rolf Jensen & Assoc., Inc., IL
Andrew Kim, Nat'l Research Council of Canada, ON, Canada
Kenneth W. Linder, Industrial Risk Insurers, CT
Rep. Industrial Risk Insurers
B.J. Lukes, Grinnell Fire Protection System Co. Ltd, Canada
Rep. Canadian Automatic Sprinkler Assn.
Daniel Madrzykowski, U.S. Nat'l Inst. of Standards & Technology, MD
Wayne M. Martin, Los Angeles City Fire Dept., CA

M. L. "Larry" Maruskin, U.S. Fire Administration, MD
(Vote limited to NFPA 13D, NFPA 13R)
Francis J. Mildoucich, Eastman Kodak, Co., NY
Gerald R. Myers, Liberty Mutual Insurance Co., PA
Rep. The Alliance of American Insurers
Joseph G. Novak, South Pasadena Fire Dept., FL
Rep. Fire Marshals Assn. of North America
John G. O'Neill, Gage-Babcock & Assoc., Inc., VA
Thomas L. Siegfried, Altamonte Springs Fire Dept., FL
Rep. Int'l Assn. of Fire Chiefs
Neil P. Stong, Joseph Stong Inc., PA
Rep. American Fire Sprinkler Assn., Inc.
Willie R. Templin, American Automatic Sprinkler, Inc., TX
Rep. American Fire Sprinkler Assn., Inc.
William L. Testa, Grinnell Fire Protection Systems Co. Inc., RI
Rep. Nat'l Fire Sprinkler Assn.
John J. Walsh, United Assn. of Journeymen & Apprentices of
the Plumbing & Pipe Fitting Industry of the U.S. & Canada,
MD
William E. Wilcox, Factory Mutual Research Corp., MA
Reginald John Wright, Underwriters Laboratories of Canada,
ON, Canada

Alternates

James R. Bell, Marriott Corp., DC
(Alt. to T. G. Daly)
Antonio C. M. Braga, Factory Mutual Research Corp., MA
(Alt. to W. E. Wilcox)
James A. Bychowski, Schirmer Engr Corp., IL
(Alt. to C. W. Schirmer)
Don R. Dean, Dow Chemical Co., TX
(Alt. to C. M. Goddard)
David D. Evans, Center for Fire Research, MD
(Alt. to D. Madrzykowski)
John Galt, Canadian Automatic Sprinkler Assn., ON, Canada
(Alt. to B. J. Lukes)
Ralph Gerdes, Ralph Gerdes Consultants, IN
(Alt. to A. M. Comly, Jr.)
James Golinveaux, Central Sprinkler Corp., PA
(Alt. to C. B. Barnett)
Kenneth E. Isman, Nat'l Fire Sprinkler Assn., NY
(Alt. to R. P. Fleming)
George E. Laverick, Underwriters Laboratories Inc., IL
(Alt. to K. M. Bell)
Edward R. Lising, Underwriters Laboratories of Canada,
ON, Canada
(Alt. to R. J. Wright)
Maurice Marvi, ISO Commercial Risk Services, Inc., NJ
(Alt. to R. E. Hughey)

Peter J. McWilliams, Eastman Kodak Co., NY
(Alt. to F. J. Mildoucich)
Robert J. Pearce, Jr., Industrial Risk Insurers, CA
(Alt. to K. W. Linder)
J. Kenneth Richardson, Nat'l Research Council of Canada,
ON, Canada
(Alt. to A. Kim)
Paul E. Rousseau, HFP Sprinkler Inc., MA
(Alt. to W. R. Templin)
Gerald R. Schuitz, Gage-Babcock & Assoc., Inc., IL
(Alt. to J. G. O'Neill)
Harry Shaw, Harry Shaw & Assoc., Inc., MD
(Alt. to T. L. Siegfried)
Jack Thacker, Allan Automatic Sprinkler Corp. of Southern
California, CA
(Alt. to W. L. Testa)
Lynn K. Underwood, Wausau HPR Engr, WI
(Alt. to G. R. Myers)
James B. Visger, Road Sprinkler Fitters Union, MD
(Alt. to J. J. Walsh)
William A. Webb, Rolf Jensen & Assoc., Inc., IL
(Alt. to R. H. Jensen)

Nonvoting

William E. Koffel, Jr., Koffel Assoc., Inc., MD
Rep. Safety to Life Committee
Morgan J. Hurley, U.S. Coast Guard, Washington, D.C.

Barry M. Lee, Wormald Australia Party Ltd
John Nigel Stephens, Loss Prevention Council, England

Robert E. Solomon/Milosh T. Puchovsky, NFPA Staff Liaisons

This list represents the membership at the time the Committee was balloted on the text of this edition. Since that time, changes in the membership may have occurred.

NOTE: Membership on a Committee shall not in and of itself constitute an endorsement of the Association or any document developed by the Committee on which the member serves.

Committee Scope: This Committee shall have primary responsibility for documents on the design and installation of automatic and of open sprinkler systems, including the character and adequacy of water supplies, and the selection of sprinklers, piping, valves, and all materials and accessories; this committee does not cover the installation of fire pumps, nor the construction and installation of gravity and pressure tanks and towers, nor the installation, maintenance, and use of central station, proprietary, auxiliary, and local signaling systems for watchmen, fire alarm, and supervisory service, nor the care of valves controlling water supplies, nor the design of fire department hose connections, nor the installation of private fire service mains and their appurtenances.

Contents

Chapter 1 General Information	13- 5	4-12 In-Rack Sprinklers	13- 48
1-1 Scope	13- 5	4-13 Special Situations	13- 48
1-2 Purpose	13- 5	4-14 Piping Installation	13- 52
1-3 Retroactivity Clause	13- 5	4-15 System Attachments	13- 61
1-4 Definitions	13- 5	Chapter 5 Design Approaches	13- 63
1-5 Abbreviations	13- 9	5-1 General	13- 63
1-6 Level of Protection	13- 9	5-2 Occupancy Hazard Fire Control Approach	13- 63
Chapter 2 System Components and Hardware	13- 10	5-3 Special Design Approaches	13- 66
2-1 General	13- 10	5-4 In-Rack Sprinklers	13- 67
2-2 Sprinklers	13- 10	Chapter 6 Plans and Calculations	13- 67
2-3 Pipe and Tube	13- 11	6-1 Working Plans	13- 67
2-4 Fittings	13- 12	6-2 Hydraulic Calculation Forms	13- 68
2-5 Joining of Pipe and Fittings	13- 13	6-3 Water Supply Information	13- 68
2-6 Hangers	13- 14	6-4 Hydraulic Calculation Procedures	13- 68
2-7 Valves	13- 17	6-5 Pipe Schedules	13- 71
2-8 Fire Department Connections	13- 17	6-6 In-Rack Sprinklers	13- 73
2-9 Waterflow Alarms	13- 17	Chapter 7 Water Supplies	13- 73
Chapter 3 System Requirements	13- 18	7-1 General	13- 73
3-1 Wet Pipe Systems	13- 18	7-2 Types	13- 73
3-2 Dry Pipe Systems	13- 18	Chapter 8 System Acceptance	13- 74
3-3 Preaction Systems and Deluge Systems	13- 19	8-1 Approval of Sprinkler Systems	13- 74
3-4 Combined Dry Pipe and Preaction Systems	13- 20	8-2 Acceptance Requirements	13- 74
3-5 Antifreeze Systems	13- 22	8-3 Circulating Closed Loop Systems	13- 77
3-6 Automatic Sprinkler Systems with Nonfire Protection Connections	13- 22	8-4 Instructions	13- 77
3-7 Outside Sprinklers for Protection against Exposure Fires	13- 25	8-5 Hydraulic Design Information Sign	13- 79
3-8 Refrigerated Spaces	13- 26	8-6 Circulating Closed Loop Systems	13- 79
3-9 Commercial-Type Cooking Equipment and Ventilation	13- 26	Chapter 9 Marine Systems	13- 79
Chapter 4 Installation Requirements	13- 27	9-1 General	13- 79
4-1 Basic Requirements	13- 27	9-2 System Components, Hardware, and Use	13- 80
4-2 System Protection Area Limitations	13- 27	9-3 System Requirements	13- 81
4-3 Use of Sprinklers	13- 28	9-4 Installation Requirements	13- 81
4-4 Application of Sprinkler Types	13- 29	9-5 Design Approaches	13- 82
4-5 Position, Location, Spacing, and Use of Sprinklers	13- 30	9-6 Water Supplies	13- 82
4-6 Standard Pendent and Upright Spray Sprinklers	13- 31	9-7 Plans and Calculations	13- 83
4-7 Sidewall Standard Spray Sprinklers	13- 34	9-8 System Acceptance	13- 83
4-8 Extended Coverage Upright and Pendent Spray Sprinklers	13- 38	9-9 System Maintenance	13- 83
4-9 Extended Coverage Sidewall Spray Sprinklers	13- 41	Chapter 10 System Maintenance	13- 84
4-10 Large-Drop Sprinklers	13- 42	10-1 General	13- 84
4-11 Early Suppression Fast-Response Sprinklers	13- 46	Chapter 11 Referenced Publications	13- 84
		Appendix A Explanatory Material	13- 86
		Appendix B Miscellaneous Topics	13-138
		Appendix C Referenced Publications	13-139
		Index	13-140

NFPA 13
Standard for the
Installation of Sprinkler Systems
1996 Edition

NOTICE: An asterisk (*) following the number or letter designating a paragraph indicates explanatory material on that paragraph in Appendix A.
 Information on referenced publications can be found in Chapter 11 and Appendix C.

Chapter 1 General Information

1-1 Scope. This standard provides the minimum requirements for the design and installation of automatic fire sprinkler systems and exposure protection sprinkler systems, including the character and adequacy of water supplies and the selection of sprinklers, piping, valves, and all materials and accessories, but not including the installation of private fire service mains and water supplies.

NOTE: Consult other NFPA standards for additional requirements relating to water supplies.

Storage in excess of 12 ft (3.7 m) in height or storage in excess of 5 ft (1.5 m) in height of high hazard materials such as Level II and III aerosols, idle pallets, rubber tires, rolled paper stored on end, plastics, and flammable liquids are outside the scope of this standard. (For guidance and limitations regarding areas, quantities, or methods of storage for high hazard materials, see NFPA 30, 30B, 40, 58, 231, 231C, 231D, 231F, and 409.)

Exception No. 1: Wooden pallets stored up to 6 ft (1.8 m) in height or plastic pallets up to 4 ft (1.2 m) in height with not over four stacks of wooden pallets or two stacks of plastic pallets separated from other stacks by at least an 8-ft (2.4-m) aisle. (For heights or quantities exceeding these limits, see NFPA 231, Standard for General Storage.)

Exception No. 2: Storage of rubber tires that is incidental to the main use of the building and not more than 2,000 ft² (185.8 m²). On-tread storage, regardless of piling method, shall not exceed 25 ft (7.62 m) in the direction of the wheel hole. Laced tires in racks shall not exceed 5 ft (1.52 m) in height. Storage arrangements that are acceptable as miscellaneous storage are:*

- (a) On floor, on side storage less than 12 ft (3.66 m) in height, or
- (b) On floor, on tread storage less than 5 ft (1.52 m) in height, or
- (c) Double row or multi-row portable or fixed rack storage less than 5 ft (1.52 m) in height, or
- (d) Single row portable or fixed rack storage less than 12 ft (3.66 m) in height.

Exception No. 3: Miscellaneous storage is within the scope of this standard.

1-2 Purpose. The purpose of this standard is to provide a reasonable degree of protection for life and property from fire through standardization of design, installation, and testing requirements for sprinkler systems based upon sound engineering principles, test data, and field experience. This standard endeavors to continue the excellent record that has been established by sprinkler systems while meeting the needs of

changing technology. Nothing in this standard is intended to restrict new technologies or alternate arrangements, provided the level of safety prescribed by this standard is not lowered. Materials or devices not specifically designated by this standard shall be utilized in complete accord with all conditions, requirements, and limitations of their listings.

NOTE 1: A sprinkler system is a specialized fire protection system and requires knowledgeable and experienced design and installation.

NOTE 2: Since its inception, this document has been developed on the basis of standardized materials, devices, and design practices. However, certain paragraphs, such as 2-3.5, 4-4.9, and this one, allow the use of materials and devices not specifically designated by this standard, provided such use is within parameters established by a listing organization. In using such materials or devices, it is important that all conditions, requirements, and limitations of the listing be fully understood and accepted and that the installation be in complete accord with such listing requirements.

1-3 Retroactivity Clause. The provisions of this document are considered necessary to provide a reasonable level of protection from loss of life and property from fire. They reflect situations and the state of the art at the time the standard was issued.

Unless otherwise noted, it is not intended that the provisions of this document be applied to facilities, equipment, structures, or installations that were existing or approved for construction or installation prior to the effective date of this document.

Exception: In those cases where it is determined by the authority having jurisdiction that the existing situation involves a distinct hazard to life or property, this standard shall apply.

1-4 Definitions.

1-4.1 NFPA Definitions.

Approved.* Acceptable to the authority having jurisdiction.

Authority Having Jurisdiction.* The organization, office, or individual responsible for approving equipment, an installation, or a procedure.

Listed.* Equipment, materials, or services included in a list published by an organization acceptable to the authority having jurisdiction and concerned with evaluation of products or services that maintains periodic inspection or production of listed equipment or materials or periodic evaluation of services and whose listing states either that the equipment, material, or service meets identified standards or has been tested and found suitable for a specified purpose.

Shall. Indicates a mandatory requirement.

Should. Indicates a recommendation or that which is advised but not required.

Standard. A document, the main text of which contains only mandatory provisions using the word "shall" to indicate requirements, which is in a form generally suitable for mandatory reference by another standard or code or for adoption into law. Nonmandatory provisions shall be located in an Appendix, footnote, or fine-print note and are not to be considered a part of the requirements of a standard.

1-4.2 General Definitions.

Compartment. As used in 4-4.5.3 and 6-4.4.4, a space completely enclosed by walls and a ceiling. The compartment enclosure is permitted to have openings to an adjoining space if the openings have a minimum lintel depth of 8 in. (203 mm) from the ceiling.

Drop-Out Ceiling. A suspended ceiling system with listed translucent or opaque panels that are heat sensitive and fall from their setting when exposed to heat. This ceiling system is installed below the sprinklers.

Dwelling Unit. One or more rooms arranged for the use of one or more individuals living together, as in a single housekeeping unit normally having cooking, living, sanitary, and sleeping facilities.

For purposes of this standard, dwelling unit includes hotel rooms, dormitory rooms, apartments, condominiums, sleeping rooms in nursing homes, and similar living units.

Fire Control. Limiting the size of a fire by distribution of water so as to decrease the heat release rate and pre-wet adjacent combustibles, while controlling ceiling gas temperatures to avoid structural damage.

Fire Suppression. Sharply reducing the heat release rate of a fire and preventing its regrowth by means of direct and sufficient application of water through the fire plume to the burning fuel surface.

High Challenge Fire Hazard. A fire hazard typical of that produced by fires in combustible high-piled storage.

High-Piled Storage. Solid-piled, palletized, rack storage, bin box, and shelf storage in excess of 12 ft (3.7 m) in height. (See 5-2.3.1.1.)

Hydraulically Designed System. A calculated sprinkler system in which pipe sizes are selected on a pressure loss basis to provide a prescribed water density, in gallons per minute per square foot [(L/min)/m²], or a prescribed minimum discharge pressure or flow per sprinkler, distributed with a reasonable degree of uniformity over a specified area.

Limited-Combustible Material. As applied to a building construction material, a material not complying with the definition of noncombustible material that, in the form in which it is used, has a potential heat value not exceeding 3500 Btu per lb (8141 kJ/kg) and complies with one of the following paragraphs, (a) or (b). Materials subject to increase in combustibility or flame spread rating beyond the limits herein established through the effects of age, moisture, or other atmospheric condition shall be considered combustible.

(a) Materials having a structural base of noncombustible material, with a surfacing not exceeding a thickness of 1/8 in. (3.2 mm) that has a flame spread rating not greater than 50.

(b) Materials, in the form and thickness used, other than as described in (a), having neither a flame spread rating greater than 25 nor evidence of continued progressive combustion and of such composition that surfaces that would be exposed by cutting through the material on any plane would have neither a flame spread rating greater than 25 nor evidence of continued progressive combustion.

Miscellaneous Storage.* Storage that does not exceed 12 ft (3.66 m) in height and is incidental to another occupancy use group as defined in 1-4.7 (see 5-2.3.1.1). Such storage shall not constitute more than 10 percent of the building

area or 4,000 sq ft (372 m²) of the sprinklered area, whichever is greater. Such storage shall not exceed 1,000 sq ft (93 m²) in one pile or area, and each such pile or area shall be separated from other storage areas by at least 25 ft (7.62 m). Protection criteria for miscellaneous storage are within the scope of this standard.

Noncombustible Material. A material that, in the form in which it is used and under the conditions anticipated, will not ignite, burn, support combustion, or release flammable vapors when subjected to fire or heat. Materials that are reported as passing ASTM E136, *Standard Test Method for Behavior of Materials in a Vertical Tube Furnace at 750°C*, shall be considered noncombustible materials.

Pipe Schedule System. A sprinkler system in which the pipe sizing is selected from a schedule that is determined by the occupancy classification. A given number of sprinklers are allowed to be supplied from specific sizes of pipe.

Shop Welded. As used in this standard, shop in the term shop welded means either:

- At a sprinkler contractor's or fabricator's premise.
- In an area specifically designed or authorized for such work such as a detached outside location, maintenance shop, or other area (either temporary or permanent) of noncombustible or fire-resistive construction free of combustible and flammable contents and suitably segregated from adjacent areas.

Small Rooms. Rooms of Light Hazard Occupancy classification having unobstructed construction and floor areas not exceeding 800 sq ft (74.3 m²). (See 1-4.7.1.) Rooms shall be enclosed by walls and a ceiling. Openings to the adjoining space are permitted if the minimum lintel depth is 8 in. (203 mm) from the ceiling.

Sprinkler System.* For fire protection purposes, an integrated system of underground and overhead piping designed in accordance with fire protection engineering standards. The installation includes one or more automatic water supplies. The portion of the sprinkler system aboveground is a network of specially sized or hydraulically designed piping installed in a building, structure, or area, generally overhead, and to which sprinklers are attached in a systematic pattern. The valve controlling each system riser is located in the system riser or its supply piping. Each sprinkler system riser includes a device for actuating an alarm when the system is in operation. The system is usually activated by heat from a fire and discharges water over the fire area.

NOTE: The design and installation of water supply facilities such as gravity tanks, fire pumps, reservoirs or pressure tanks, and underground piping are covered by the following NFPA standards: NFPA 20, *Standard for the Installation of Centrifugal Fire Pumps*; NFPA 22, *Standard for Water Tanks for Private Fire Protection*; and NFPA 24, *Standard for the Installation of Private Fire Service Mains and Their Appurtenances*.

Thermal Barrier. A material that will limit the average temperature rise of the unexposed surface to not more than 250°F (121°C) after 15 minutes of fire exposure complying with the standard time-temperature curve of NFPA 251, *Standard Methods of Fire Tests of Building Construction and Materials*.

1-4.3 Sprinkler System Type Definitions.

Antifreeze System. A wet pipe sprinkler system employing automatic sprinklers attached to a piping system containing an antifreeze solution and connected to a water sup-

ply. The antifreeze solution is discharged, followed by water, immediately upon operation of sprinklers opened by heat from a fire.

Circulating Closed-Loop System. A wet pipe sprinkler system having non-fire-protection connections to automatic sprinkler systems in a closed-loop piping arrangement for the purpose of utilizing sprinkler piping to conduct water for heating or cooling. Water is not removed or used from the system, but only circulated through the piping system.

Combined Dry Pipe-Preaction System. A sprinkler system employing automatic sprinklers attached to a piping system containing air under pressure with a supplemental detection system installed in the same areas as the sprinklers. Operation of the detection system actuates tripping devices that open dry pipe valves simultaneously and without loss of air pressure in the system. Operation of the detection system also opens listed air exhaust valves at the end of the feed main, which usually precedes the opening of sprinklers. The detection system also serves as an automatic fire alarm system.

Deluge System. A sprinkler system employing open sprinklers attached to a piping system connected to a water supply through a valve that is opened by the operation of a detection system installed in the same areas as the sprinklers. When this valve opens, water flows into the piping system and discharges from all sprinklers attached thereto.

Dry Pipe System. A sprinkler system employing automatic sprinklers attached to a piping system containing air or nitrogen under pressure, the release of which (as from the opening of a sprinkler) permits the water pressure to open a valve known as a dry pipe valve. The water then flows into the piping system and out the opened sprinklers.

Gridded System.* A sprinkler system in which parallel cross mains are connected by multiple branch lines. An operating sprinkler will receive water from both ends of its branch line while other branch lines help transfer water between cross mains.

Looped System.* A sprinkler system in which multiple cross mains are tied together so as to provide more than one path for water to flow to an operating sprinkler and branch lines are not tied together.

Preaction System. A sprinkler system employing automatic sprinklers attached to a piping system containing air that may or may not be under pressure, with a supplemental detection system installed in the same areas as the sprinklers. Actuating means of the valve are described in 3-3.2.1. Actuation of the detection system opens a valve that permits water to flow into the sprinkler piping system and to be discharged from any sprinklers that are open.

Wet Pipe System. A sprinkler system employing automatic sprinklers attached to a piping system containing water and connected to a water supply so that water discharges immediately from sprinklers opened by heat from a fire.

1-4.4* System Component Definitions.

Branch Lines. The pipes in which the sprinklers are placed, either directly or through risers.

Cross Mains. The pipes supplying the branch lines, either directly or through risers.

Feed Mains. The pipes supplying cross mains either directly or through risers.

Flexible Listed Pipe Coupling. A listed coupling or fitting that allows axial displacement, rotation, and at least 1 degree of angular movement of the pipe without inducing harm on the pipe.

Exception: For pipe diameters of 8 in. (203.2 mm) and larger, the angular movement shall be permitted to be less than 1 degree but not less than 0.5 degrees.

Risers. The vertical supply pipes in a sprinkler system.

Sprig-up. A line that rises vertically and supplies a single sprinkler.

Supervisory Devices. Devices arranged to supervise the operative condition of automatic sprinkler systems.

System Riser. The aboveground horizontal or vertical pipe between the water supply and the mains (cross or feed), which contains a control valve (either directly or within its supply pipe) and a waterflow alarm device.

1-4.5 Sprinkler Definitions.

1-4.5.1* The characteristics of a sprinkler that define its ability to control or extinguish a fire are:

(a) **Thermal Sensitivity.** A measure of the rapidity with which the thermal element operates as installed in a specific sprinkler or sprinkler assembly. One measure of thermal sensitivity is the Response Time Index (RTI) as measured under standardized test conditions.

1. Sprinklers defined as fast response have a thermal element with an RTI of 50 (meters-seconds) $\frac{1}{2}$ or less, or

2. Sprinklers defined as standard response have a thermal element with an RTI of 80 (meters-seconds) $\frac{1}{2}$ or more.

(b) **Temperature Rating.**

(c) **Orifice Size.** See Chapter 2.

(d) **Installation Orientation** (see 1-4.5.3).

(e) **Water Distribution Characteristics** (i.e., application rate, wall wetting).

(f) **Special Service Conditions** (see 1-4.5.4).

1-4.5.2 Sprinklers defined according to design and performance characteristics:

Early Suppression Fast-Response (ESFR) Sprinkler.* A type of fast-response sprinkler that meets the criteria of 1-4.5.1(a) and is listed for its capability to provide fire suppression of specific high challenge fire hazards.

Extended Coverage Sprinkler. A type of spray sprinkler that complies with the extended protection areas defined in Chapter 4.

Large-Drop Sprinkler. A type of sprinkler that is capable of producing characteristic large water droplets and that is listed for its capability to provide fire control of specific high challenge fire hazards.

Nozzles. Devices for use in applications requiring special water discharge patterns, directional spray, or other unusual discharge characteristics.

Old-Style/Conventional Sprinkler. Sprinklers that direct from 40 to 60 percent of the total water initially in a downward direction and that are designed to be installed with the deflector either upright or pendent.

Open Sprinklers. Sprinkler that do not have actuators or heat-responsive elements.

Quick-Response (QR) Sprinkler. A type of spray sprinkler that meets the criteria of 1-4.5.1(a)1 and is listed as a quick-response sprinkler for its intended use.

Quick-Response Early Suppression (QRES) Sprinkler.* A type of quick-response sprinkler that meets the criteria of 1-4.5.1(a)1 and is listed for its capability to provide fire suppression of specific fire hazards.

Quick-Response Extended Coverage Sprinkler. A type of quick-response sprinkler that meets the criteria of 1-4.5.1(a)1 and complies with the extended protection areas defined in Chapter 4.

Residential Sprinkler. A type of fast-response sprinkler that meets the criteria of 1-4.5.1(a)1 that has been specifically investigated for its ability to enhance survivability in the room of fire origin and is listed for use in the protection of dwelling units.

Special Sprinkler. Sprinklers that have been tested and listed as prescribed in 4-4.9.

Spray Sprinkler. A type of sprinkler listed for its capability to provide fire control for a wide range of fire hazards.

1-4.5.3 Sprinklers defined according to orientation:

Concealed Sprinkler. Recessed sprinklers with cover plates.

Flush Sprinkler. Sprinklers in which all or part of the body, including the shank thread, is mounted above the lower plane of the ceiling.

Pendent Sprinkler. Sprinklers designed to be installed in such a way that the water stream is directed downward against the deflector.

Recessed Sprinkler. Sprinklers in which all or part of the body, other than the shank thread, is mounted within a recessed housing.

Sidewall Sprinkler. Sprinklers having special deflectors that are designed to discharge most of the water away from the nearby wall in a pattern resembling one quarter of a sphere, with a small portion of the discharge directed at the wall behind the sprinkler.

Upright Sprinkler. Sprinklers designed to be installed in such a way that the water spray is directed upwards against the deflector.

1-4.5.4 Sprinklers defined according to special application or environment:

Corrosion-Resistant Sprinkler. Sprinklers fabricated with corrosion-resistant material or with special coatings or platings to be used in an atmosphere that would normally corrode sprinklers.

Dry Sprinkler.* Sprinklers secured in an extension nipple that has a seal at the inlet end to prevent water from entering the nipple until the sprinkler operates. Dry sprinklers are intended to extend into an unheated area from a wet pipe system or (for dry-pendent sprinklers) to be used on a dry pipe system in the pendent position.

Intermediate Level Sprinkler/Rack Storage Sprinkler. Sprinklers equipped with integral shields to protect their operating elements from the discharge of sprinklers installed at higher elevations.

Ornamental/Decorative Sprinkler. Sprinklers that have been painted or plated by the manufacturer.

1-4.6 Construction Definitions.

Obstructed Construction.* Construction where beams, trusses, or other members impede heat flow or water distribution in a manner that materially affects the ability of sprinklers to control or suppress a fire.

Unobstructed Construction.* Construction where beams, trusses, or other members do not impede heat flow or water distribution in a manner that materially affects the ability of sprinklers to control or suppress a fire. Unobstructed construction has horizontal structural members that are not solid, where the openings are at least 70 percent of the cross section area, and the depth of the member does not exceed the least dimension of the openings, or all construction types where the spacing of structural members exceeds 7½ ft (2.3 m) on center.

For descriptions of construction types, see A-1-4.6(a) and (b).

1-4.7* Classification of Occupancies. Occupancy classifications for this standard relate to sprinkler installations and their water supplies only. They are not intended to be a general classification of occupancy hazards.

1-4.7.1* Light Hazard Occupancies. Occupancies or portions of other occupancies where the quantity and/or combustibility of contents is low, and fires with relatively low rates of heat release are expected.

1-4.7.2 Ordinary Hazard Occupancies.

1-4.7.2.1* Ordinary Hazard (Group 1). Occupancies or portions of other occupancies where combustibility is low, quantity of combustibles is moderate, stockpiles of combustibles do not exceed 8 ft (2.4 m), and fires with moderate rates of heat release are expected.

1-4.7.2.2* Ordinary Hazard (Group 2). Occupancies or portions of other occupancies where quantity and combustibility of contents is moderate to high, stockpiles do not exceed 12 ft (3.7 m), and fires with moderate to high rates of heat release are expected.

1-4.7.3 Extra Hazard Occupancies.

1-4.7.3.1* Occupancies or portions of other occupancies where quantity and combustibility of contents is very high and flammable and combustible liquids, dust, lint, or other materials are present, introducing the probability of rapidly developing fires with high rates of heat release.

1-4.7.3.2 Extra hazard occupancies involve a wide range of variables that may produce severe fires. The following shall be used to evaluate the severity of Extra Hazard Occupancies:

Extra Hazard (Group 1) includes occupancies described in 1-4.7.3.1 with little or no flammable or combustible liquids.

Extra Hazard (Group 2) includes occupancies described in 1-4.7.3.1 with moderate to substantial amounts of flammable or combustible liquids or where shielding of combustibles is extensive.

1-4.7.4 Special Occupancy Hazards.

1-4.7.4.1* Other NFPA standards contain sprinkler system design criteria for fire control or suppression of specific hazards. These are listed in Chapter 11 and include but are not limited to NFPA 30, *Flammable and Combustible Liquids Code*; NFPA 30B, *Code for the Manufacture and Storage of Aerosol Products*; NFPA 40, *Standard for the Storage and Handling of*

Cellulose Nitrate Motion Picture Film; NFPA 58, *Standard for the Storage and Handling of Liquefied Petroleum Gases*; NFPA 231, *Standard for General Storage*; NFPA 231C, *Standard for Rack Storage of Materials*; NFPA 231D, *Standard for Storage of Rubber Tires*; NFPA 231E, *Recommended Practice for the Storage of Baled Cotton*; NFPA 231F, *Standard for the Storage of Roll Paper*; NFPA 232, *Standard for the Protection of Records*; and NFPA 409, *Standard on Aircraft Hangars*.

1-4.7.4.2 Miscellaneous storage as defined herein shall be classified as to occupancy group in accordance with Table 1-4.7.4.2.

1-4.7.4.2.1 The commodity classifications and storage characteristics in Table 1-4.7.4.2 shall be as defined in NFPA 231, *Standard for General Storage*, and NFPA 231C, *Standard for Rack Storage of Materials*.

1-5 Abbreviations. The standard abbreviations in Table 1-5 shall be used on the hydraulic calculation form.

1-6 Level of Protection.

1-6.1 A building, where protected by an automatic sprinkler system installation, shall be provided with sprinklers in all areas.

Exception: Where specific sections of this standard permit the omission of sprinklers.

1-6.2 Limited Area Systems. When partial sprinkler systems are installed, the requirements of this standard shall be used insofar as they are applicable. The authority having jurisdiction shall be consulted in each case.

Table 1-4.7.4.2 Occupancy Group Classification for Miscellaneous Storage 12 ft (3.7 m) or Less in Height*†

Group A Plastics			Cartoned		Exposed	
Height of Storage	Ceiling Clearance to Top of Storage	Rack-R or Palletized-P	Solid	Expanded	Solid	Expanded
To 5 ft	No limit	R-P	OH-2	OH-2	OH-2	OH-2
Over 5 ft to 10 ft	To 5 ft	R-P	EH-1	EH-1	EH-2	EH-2
Over 5 ft to 10 ft	Over 5 ft to 10 ft	R-P	EH-2	EH-2	EH-2	
Over 5 ft to 8 ft	Over 5 ft	P				EH-2
Over 10 ft to 12 ft	To 15 ft	P	EH-2	EH-2		
Over 10 ft to 12 ft	Over 5 ft	R	OH-2 +1 level in rack	OH-2 +1 level in rack	OH-2 +1 level in rack	OH-2 +1 level in rack
Over 10 ft to 12 ft	To 5 ft	R-P	EH-2**	EH-2**	EH-2**	EH-2

Miscellaneous Tire Storage		
Piling Methods	Height of Storage	Occupancy Group
On floor, on side	5 ft to 12 ft	EH-1
On floor, on tread or side	To 5 ft	OH-2
Single, double, or multi-row racks	To 5 ft	OH-2
Single row rack, portable	5 ft to 12 ft	EH-1
Single row rack, fixed	5 ft to 12 ft	EH-1 or OH-2 plus 1 level of in-rack sprinklers

Rolled Paper Stored on End		
	Height of Storage	Occupancy Group
Heavy and medium weight	To 8 ft	OH-2
	Over 8 ft to 12 ft	EH-1
Tissue	To 10 ft	EH-1

Idle Pallet Storage		
	Height of Storage	Occupancy Group
	To 6 ft wooden	OH-2
	To 4 ft plastic	OH-2

For SI Units: 1 ft = 0.3048 m.

*For storage heights or clearance to ceiling in excess of the above configurations, see NFPA 231, 231C, 231D, or 231F as appropriate.

**For rack storage, OH-2 +1 Level in rack shall also be permitted.

†The design of the sprinkler system shall be based on the conditions that will routinely or periodically exist in the building creating the greatest water demand, including pile height and clearance.

Table I-5 Hydraulic Symbols

Symbol or Abbreviation	Item
P	Pressure in psi
gpm	U.S. gallons per minute
q	Flow increment in gpm to be added at a specific location
Q	Summation of flow in gpm at a specific location
P _t	Total pressure in psi at a point in a pipe
P _f	Pressure loss due to friction between points indicated in location column
P _e	Pressure due to elevation difference between indicated points. This can be a plus value or a minus value. Where minus, the (-) shall be used; where plus, no sign need be indicated.
P _v	Velocity pressure in psi at a point in a pipe
P _n	Normal pressure in psi at a point in a pipe
E	90° Ell
EE	45° Ell
Lt.E	Long-turn elbow
Cr	Cross
T	Tee—flow turned 90°
GV	Gate valve
BV	Butterfly (wafer) check valve
Del V	Deluge valve
ALV	Alarm valve
DPV	Dry pipe valve
CV	Swing check valve
WCV	Butterfly (wafer) check valve
St	Strainer
psi	Pounds per square inch
v	Velocity of water in pipe in feet per second

Chapter 2 System Components and Hardware

2-1 General. This chapter provides requirements for correct use of sprinkler system components.

2-1.1* All materials and devices essential to successful system operation shall be listed.

Exception No. 1: Equipment as permitted in Table 2-3.1, Table 2-4.1, and the Exceptions to 2-6.1 and 2-6.1.1 shall not be required to be listed.

Exception No. 2: Components that do not affect system performance such as drain piping, drain valves, and signs need not be listed. The use of reconditioned valves and devices other than sprinklers as replacement equipment in existing systems shall be permitted.

2-1.2 System components shall be rated for the maximum working pressure to which they are exposed but not less than 175 psi (12.1 bars).

2-2 Sprinklers.

2-2.1 Only new sprinklers shall be installed.

2-2.2 Sprinkler Discharge Characteristics.

2-2.2.1 The K factor, relative discharge, and identification for sprinklers having different orifice sizes shall be in accordance with Table 2-2.2.

Exception No. 1: Listed sprinklers having pipe threads different from those shown in Table 2-2.2 shall be permitted.

Exception No. 2: Sprinklers with a larger orifice diameter and which increase the flow by a 50-percent increment when compared with a 1/2-in. (12.7-mm) orifice sprinkler shall be permitted where listed in accordance with 4-4.9.

2-2.2.2 Large drop and ESFR sprinklers shall be minimum 3/8 in. nominal orifice size. The ESFR sprinkler orifice shall be selected as appropriate for the hazard. (See Chapter 5.)

2-2.3 Limitations.

2-2.3.1 Sprinklers shall not be listed for protection of a portion of an occupancy classification.

Exception No. 1: Residential sprinklers.

Exception No. 2: Special sprinklers shall be permitted to be listed for protection of a specific construction feature in a portion of an occupancy classification. (See 4-4.9.)

2-2.3.2 For Light Hazard Occupancies not requiring as much water as is discharged by a nominal 1/2-in. (12.7-mm) orifice sprinkler operating at 7 psi (0.5 bar), sprinklers having a smaller orifice shall be permitted subject to the following restrictions:

(a) The system shall be hydraulically calculated. (See Chapter 6.)

(b) Small-orifice sprinklers shall be installed in wet systems only.

Exception: Small-orifice outside sprinklers for protection from exposure fires installed in conformance with Section 3-7 shall be permitted.

(c) A listed strainer shall be provided on the supply side of sprinklers having nominal orifice sizes smaller than 3/8 in. (9.5 mm).

2-2.3.3 Sprinklers having orifice sizes exceeding 1/2 in. (12.7 mm) and having 1/2 in. (12.7 mm) NPT shall not be installed in new sprinkler systems.

2-2.4* Temperature Characteristics.

2-2.4.1 The standard temperature ratings of automatic sprinklers are shown in Table 2-2.4.1. Automatic sprinklers shall have their frame arms colored in accordance with the color code designated in Table 2-2.4.1.

Exception No. 1: A dot on the top of the deflector, or the color of the coating material, or colored frame arms shall be permitted for color identification of corrosion-resistant sprinklers.

Exception No. 2: Color identification shall not be required for ornamental sprinklers such as factory-plated or factory-painted sprinklers or for recessed, flush, or concealed sprinklers.

Exception No. 3: The frame arms of bulb-type sprinklers shall not be required to be color coded.

2-2.4.2 The liquid in bulb-type sprinklers shall be color coded in accordance with Table 2-2.4.1.

2-2.5 Special Coatings.

2-2.5.1* Listed corrosion-resistant sprinklers shall be installed in locations where chemicals, moisture, or other corrosive vapors sufficient to cause corrosion of such devices exist.

Table 2-2.2 Sprinkler Discharge Characteristics Identification

Nominal Orifice Size (in.)	(mm)	K Factor ¹	Percent of Nominal 1/2 in. Discharge	Thread Type	Pintle	Nominal Orifice Size Marked On Frame
1/4	6.4	1.3-1.5	25	1/2 in. NPT	Yes	Yes
5/16	8.0	1.8-2.0	33.3	1/2 in. NPT	Yes	Yes
3/8	9.5	2.6-2.9	50	1/2 in. NPT	Yes	Yes
7/16	11.0	4.0-4.4	75	1/2 in. NPT	Yes	Yes
1/2	12.7	5.3-5.8	100	1/2 in. NPT	No	No
5/8	15.9	7.4-8.2	140	3/4 in. NPT or 1/2 in. NPT	Yes	Yes
3/4	19.0	11.0-11.5	200	1/2 in. NPT or 3/4 in. NPT	Yes	Yes
		13.5-14.5	250	3/4 in. NPT	Yes	Yes

¹K factor is the constant in the formula $Q = K\sqrt{P}$ where Q = Flow in gpm, P = Pressure in psi

For SI Units: $Q_m = K_m\sqrt{P_m}$ where Q_m = Flow in L/min, P_m = Pressure in bars, $K_m = 14 K$

Table 2-2.4.1 Temperature Ratings, Classifications, and Color Codings

F	Max. Ceiling Temp. °C	Temperature Rating		Temperature Classification	Color Code	Glass Bulb Colors
		F	°C			
100	38	135 to 170	57 to 77	Ordinary	Uncolored or black	Orange or red
150	66	175 to 225	79 to 107	Intermediate	White	Yellow or green
225	107	250 to 300	121 to 149	High	Blue	Blue
300	149	325 to 375	163 to 191	Extra high	Red	Purple
375	191	400 to 475	204 to 246	Very extra high	Green	Black
475	246	500 to 575	260 to 302	Ultra high	Orange	Black
625	329	650	343	Ultra high	Orange	Black

2-2.5.2* Corrosion-resistant coatings shall be applied only by the manufacturer of the sprinkler.

Exception: Any damage to the protective coating occurring at the time of installation shall be repaired at once using only the coating of the manufacturer of the sprinkler in the approved manner so that no part of the sprinkler will be exposed after installation has been completed.

2-2.5.3* Unless applied by the manufacturer, sprinklers shall not be painted, and any sprinklers that have been painted shall be replaced with new listed sprinklers of the same characteristics, including orifice size, thermal response, and water distribution.

Exception: Factory-applied paint or coating to sprinkler frames in accordance with 2-2.4.1 shall be permitted.

2-2.5.4 Ornamental finishes shall not be applied to sprinklers by anyone other than the sprinkler manufacturer, and only sprinklers listed with such finishes shall be used.

2-2.6 Escutcheon Plates.

2-2.6.1 Nonmetallic escutcheon plates shall be listed.

2-2.6.2* Escutcheon plates used with a recessed or flush-type sprinkler shall be part of a listed sprinkler assembly.

2-2.7* Guards and Shields. Sprinklers subject to mechanical injury shall be protected with listed guards.

2-2.8 Stock of Spare Sprinklers.

2-2.8.1 A supply of spare sprinklers (never fewer than 6) shall be maintained on the premises so that any sprinklers that have operated or been damaged in any way can be promptly replaced. These sprinklers shall correspond to the types and temperature ratings of the sprinklers in the property. The sprinklers shall be kept in a cabinet located where the temperature to which they are subjected will at no time exceed 100°F (38°C).

2-2.8.2 A special sprinkler wrench shall also be provided and kept in the cabinet to be used in the removal and installation of sprinklers.

2-2.8.3 The stock of spare sprinklers shall include all types and ratings installed and shall be as follows:

(a) For systems having less than 300 sprinklers, not fewer than 6 sprinklers.

(b) For systems with 300 to 1000 sprinklers, not fewer than 12 sprinklers.

(c) For systems with over 1000 sprinklers, not fewer than 24 sprinklers.

2-3 Pipe and Tube.

2-3.1 Pipe or tube used in sprinkler systems shall meet or exceed one of the standards in Table 2-3.1 or be in accordance with 2-3.5. In addition, steel pipe must be in accordance with 2-3.2 and 2-3.3, copper tube must be in accordance with 2-3.4, and nonmetallic pipe must be in accordance with 2-3.5 and with the portions of the ASTM standards specified in Table 2-3.5 that apply to fire protection service.

Table 2-3.1 Pipe or Tube Materials and Dimensions

Materials and Dimensions	Standard
Ferrous Piping (Welded and Seamless)	
Spec. for Black and Hot-Dipped Zinc Coated (Galvanized) Welded and Seamless Steel Pipe for Fire Protection Use.....	ASTM A 795
Spec. for Welded and Seamless Steel Pipe.....	ANSI/ ASTM A 53
Wrought Steel Pipe.....	ANSI B36.10M
Spec. for Elec.-Resistance Welded Steel Pipe.....	ASTM A 135
Copper Tube (Drawn, Seamless)	
Spec. for Seamless Copper Tube.....	ASTM B 75
Spec. for Seamless Copper Water Tube.....	ASTM B 88
Spec. for General Requirements for Wrought Seamless Copper and Copper-Alloy Tube.....	ASTM B 251
Fluxes for Soldering Applications of Copper and Copper Alloy Tube.....	ASTM B 813
Brazing Filler Metal (Classification BCuP-3 or BCuP-4).....	AWS A5.8
Solder Metal, 95-5 (Tin-Antimony-Grade 95TA).....	ASTM B 32 ASTM B 446
Alloy Materials.....	ASTM B 467

2-3.2* When steel pipe listed in Table 2-3.1 is used and joined by welding as referenced in 2-5.2 or by roll-grooved pipe and fittings as referenced in 2-5.3, the minimum nominal wall thickness for pressures up to 300 psi (20.7 bars) shall be in accordance with Schedule 10 for sizes up to 5 in. (127 mm); 0.134 in. (3.40 mm) for 6 in. (152 mm); and 0.188 in. (4.78 mm) for 8- and 10-in. (203- and 254-mm) pipe.

Exception: Pressure limitations and wall thickness for steel pipe listed in accordance with 2-3.5 shall be in accordance with the listing requirements.

2-3.3 When steel pipe listed in Table 2-3.1 is joined by threaded fittings referenced in 2-5.1 or by fittings used with pipe having cut grooves, the minimum wall thickness shall be in accordance with Schedule 30 [in sizes 8 in. (203 mm) and larger] or Schedule 40 [in sizes less than 8 in. (203 mm)] pipe for pressures up to 300 psi (20.7 bars).

Exception: Pressure limitations and wall thickness for steel pipe specially listed in accordance with 2-3.5 shall be in accordance with the listing requirements.

2-3.4* Copper tube as specified in the standards listed in Table 2-3.1 shall have a wall thickness of Type K, L, or M where used in sprinkler systems.

2-3.5* Other types of pipe or tube investigated for suitability in automatic sprinkler installations and listed for this service, including but not limited to polybutylene, chlorinated polyvinyl chloride (CPVC), and steel, differing from that provided in Table 2-3.1 shall be permitted where installed in accordance with their listing limitations, including installation instructions. Pipe or tube shall not be listed for portions of an occupancy classification. Bending of pipe conforming to 2-3.5 shall be permitted as allowed by the listing.

2-3.6 Pipe Bending. Bending of Sch-10 steel pipe, or any steel pipe of wall thickness equal to or greater than Sch-10 and Types K and L copper tube shall be permitted when

Table 2-3.5 Specially Listed Pipe or Tube Materials and Dimensions

Materials and Dimensions	Standard
Nonmetallic Piping	
Specification for Special Listed Chlorinated Polyvinyl Chloride (CPVC) Pipe.....	ASTM F 442
Specification for Special Listed Polybutylene (PB) Pipe.....	ASTM D 3309

bends are made with no kinks, ripples, distortions, reductions in diameter, or any noticeable deviations from round. For Sch-40 and copper tubing, the minimum radius of a bend shall be 6 pipe diameters for pipe sizes 2 in. (51 mm) and smaller, and 5 pipe diameters for pipe sizes 2½ in. (64 mm) and larger. For all other steel pipe, the minimum radius of a bend shall be 12 pipe diameters for all sizes.

2-3.7 Pipe Identification. All pipe, including specially listed pipe allowed by 2-3.5, shall be marked continuously along its length by the manufacturer in such a way as to properly identify the type of pipe. This identification shall include the manufacturer's name, model designation, or schedule.

2-4 Fittings.

2-4.1 Fittings used in sprinkler systems shall meet or exceed the standards in Table 2-4.1 or be in accordance with 2-4.2. In addition to the standards in Table 2-4.1, CPVC fittings shall also be in accordance with 2-4.2 and with the portions of the ASTM standards specified in Table 2-4.2 that apply to fire protection service.

2-4.2* Other types of fittings investigated for suitability in automatic sprinkler installations and listed for this service, including but not limited to polybutylene, chlorinated polyvinyl chloride (CPVC), and steel differing from that provided in Table 2-4.1, shall be permitted when installed in accordance with their listing limitations, including installation instructions.

2-4.3 Fittings shall be extra-heavy pattern where pressures exceed 175 psi (12.1 bars).

Exception No. 1: Standard weight pattern cast-iron fittings 2 in. (51 mm) in size and smaller shall be permitted where pressures do not exceed 300 psi (20.7 bars).

Exception No. 2: Standard weight pattern malleable iron fittings 6 in. (152 mm) in size and smaller shall be permitted where pressures do not exceed 300 psi (20.7 bars).

Exception No. 3: Fittings shall be permitted for system pressures up to the limits specified in their listings.

2-4.4* Couplings and Unions. Screwed unions shall not be used on pipe larger than 2 in. (51 mm). Couplings and unions of other than screwed-type shall be of types listed specifically for use in sprinkler systems.

2-4.5 Reducers and Bushings. A one-piece reducing fitting shall be used wherever a change is made in the size of the pipe.

Exception No. 1: Hexagonal or face bushings shall be permitted in reducing the size of openings of fittings when standard fittings of the required size are not available.

Exception No. 2: Hexagonal bushings as permitted in 4-13.18.1 are acceptable.

Table 2-4.1 Fittings Materials and Dimensions

Materials and Dimensions	Standard
Cast Iron	
Cast Iron Threaded Fittings, Class 125 and 250	ANSI B16.4
Cast Iron Pipe Flanges and Flanged Fittings	ANSI B16.1
Malleable Iron	
Malleable Iron Threaded Fittings, Class 150 and 300	ANSI B16.3
Steel	
Factory-made Wrought Steel Buttweld Fittings	ANSI B16.9
Buttwelding Ends for Pipe, Valves, Flanges, and Fittings	ANSI B16.25
Spec. for Piping Fittings of Wrought Carbon Steel and Alloy Steel for Moderate and Elevated Temperatures	ASTM A 234 ANSI B16.5
Steel Pipe Flanges and Flanged Fittings	
Forged Steel Fittings, Socket Welded and Threaded	ANSI B16.11
Copper	
Wrought Copper and Bronze Solder- Joint Pressure Fittings	ANSI B16.22
Cast Bronze Solder-Joint Pressure Fittings	ANSI B16.18

Table 2-4.2 Specially Listed Fittings Materials and Dimensions

Materials and Dimensions	Standard
Chlorinated Polyvinyl Chloride (CPVC) Specification for Schedule 80 CPVC Threaded Fittings	ASTM F 437
Specification for Schedule 40 CPVC Socket-type Fittings	ASTM F 438
Specification for Schedule 80 CPVC Socket-type Fittings	ASTM F 439

2-5 Joining of Pipe and Fittings.

2-5.1 Threaded Pipe and Fittings.

2-5.1.1 All threaded pipe and fittings shall have threads cut to ANSI/ASME B1.20.1, *Pipe Threads, General Purpose*.

2-5.1.2* Steel pipe with wall thicknesses less than Schedule 30 [in sizes 8 in. (203 mm) and larger] or Schedule 40 [in sizes less than 8 in. (203 mm)] shall not be joined by threaded fittings.

Exception: A threaded assembly investigated for suitability in automatic sprinkler installations and listed for this service shall be permitted.

2-5.1.3 Joint compound or tape shall be applied only to male threads.

2-5.2* Welded Pipe and Fittings.

2-5.2.1 Welding methods that comply with all of the requirements of AWS D10.9, *Specification for Qualification of Welding Procedures and Welders for Piping and Tubing*, Level AR-3, are acceptable means of joining fire protection piping.

2-5.2.2* Sprinkler piping shall be shop welded.

Exception No. 1: Welding of tabs for longitudinal earthquake bracing to in-place piping shall be permitted where the welding process is performed in accordance with NFPA 51B, Standard for Fire Prevention in Use of Cutting and Welding Processes.

Exception No. 2: Where the design specifications call for all or part of the piping to be welded in place, welding of sprinkler piping in place shall be permitted where the welding process is performed in accordance with NFPA 51B, and the mechanical fittings required by 4-13.15 and 4-13.22 are provided.

2-5.2.3 Fittings used to join pipe shall be listed fabricated fittings or manufactured in accordance with Table 2-4.1. Such fittings joined in conformance with a qualified welding procedure as set forth in this section are an acceptable product under this standard, provided that materials and wall thickness are compatible with other sections of this standard.

Exception: Fittings are not required where pipe ends are butt welded.

2-5.2.4 No welding shall be performed if there is impingement of rain, snow, sleet, or high wind on the weld area of the pipe product.

2-5.2.5 When welding is performed:

(a)* Holes in piping for outlets shall be cut to the full inside diameter of fittings prior to welding in place of the fittings.

(b) Discs shall be retrieved.

(c) Openings cut into piping shall be smooth bore, and all internal slag and welding residue shall be removed.

(d) Fittings shall not penetrate the internal diameter of the piping.

(e) Steel plates shall not be welded to the ends of piping or fittings.

(f) Fittings shall not be modified.

(g) Nuts, clips, eye rods, angle brackets, or other fasteners shall not be welded to pipe or fittings.

Exception: Only tabs welded to pipe for longitudinal earthquake braces shall be permitted. (See 4-14.4.3.5.5.)

2-5.2.6 When the pipe size in a run of piping is reduced, a reducing fitting designed for that purpose shall be used.

2-5.2.7 Torch cutting and welding shall not be permitted as a means of modifying or repairing sprinkler systems.

2-5.2.8 Qualifications.

2-5.2.8.1 A welding procedure shall be prepared and qualified by the contractor or fabricator before any welding is done. Qualification of the welding procedure to be used and the performance of all welders and welding operators is required and shall meet or exceed the requirements of American Welding Society Standard AWS D10.9, Level AR-3.

2-5.2.8.2 Contractors or fabricators shall be responsible for all welding they produce. Each contractor or fabricator shall have available to the authority having jurisdiction an established written quality assurance procedure ensuring compliance with the requirements of 2-5.2.5.

2-5.2.9 Records.

2-5.2.9.1 Welders or welding machine operators shall, upon completion of each weld, stamp an imprint of their identification into the side of the pipe adjacent to the weld.

2-5.2.9.2 Contractors or fabricators shall maintain certified records, which shall be available to the authority having jurisdiction, of the procedures used and the welders or welding machine operators employed by them along with their welding identification imprints. Records shall show the date and the results of procedure and performance qualifications.

2-5.3 Groove Joining Methods.

2-5.3.1 Pipe joined with grooved fittings shall be joined by a listed combination of fittings, gaskets, and grooves. Grooves cut or rolled on pipe shall be dimensionally compatible with the fittings.

2-5.3.2 Grooved fittings including gaskets used on dry pipe systems shall be listed for dry pipe service.

2-5.4* Brazed and Soldered Joints. Joints for the connection of copper tube shall be brazed.

Exception No. 1: Solder joints shall be permitted for exposed wet pipe systems in Light Hazard Occupancies where the temperature classification of the installed sprinklers is ordinary or intermediate.

Exception No. 2: Solder joints shall be permitted for wet pipe systems in Light Hazard and Ordinary Hazard (Group 1) Occupancies where the piping is concealed, irrespective of sprinkler temperature ratings.

2-5.4.1* Soldering fluxes shall be in accordance with Table 2-3.1. Brazing fluxes, if used, shall not be of a highly corrosive type.

2-5.5 Other Types. Other joining methods investigated for suitability in automatic sprinkler installations and listed for this service shall be permitted where installed in accordance with their listing limitations, including installation instructions.

2-5.6 End Treatment. After cutting, pipe ends shall have burrs and fins removed.

2-5.6.1 Pipe used with listed fittings and its end treatment shall be in accordance with the fitting manufacturer's installation instructions and the fitting's listing.

2-6 Hangers.

2-6.1* General. Types of hangers shall be in accordance with the requirements of Section 2-6.

Exception: Hangers certified by a registered professional engineer to include all of the following shall be acceptable:

(a) Hangers are designed to support five times the weight of the water-filled pipe plus 250 lb (114 kg) at each point of piping support.

(b) These points of support are adequate to support the sprinkler system.

(c) The spacing between hangers shall not exceed the value given for the type of pipe as indicated in Table 4-14.2.2.1.

(d) Hanger components shall be ferrous.

Detailed calculations shall be submitted, when required by the reviewing authority, showing stresses developed in hangers, piping, and fittings, and safety factors allowed.

2-6.1.1 The components of hanger assemblies that directly attach to the pipe or to the building structure shall be listed.

Exception: Mild steel hangers formed from rods need not be listed.

2-6.1.2 Hangers and their components shall be ferrous.

Exception: Nonferrous components that have been proven by fire tests to be adequate for the hazard application, that are listed for this purpose, and that are in compliance with the other requirements of this section shall be acceptable.

2-6.1.3 Sprinkler piping shall be substantially supported from the building structure, which must support the added load of the water-filled pipe plus a minimum of 250 lb (114 kg) applied at the point of hanging.

Exception: Branch line hangers under metal deck shall be permitted only for the support of pipe 1 in. (25.4 mm) or smaller in size, by drilling or punching vertical members and using through bolts. The distance from the bottom of the bolt hole to the bottom of the vertical member shall be not less than 3/8 in. (9.5 mm).

2-6.1.4 Where sprinkler piping is installed below ductwork, piping shall be supported from the building structure or from the ductwork supports, provided such supports are capable of handling both the load of the ductwork and the load specified in 2-6.1.3.

2-6.1.5* For trapeze hangers, the minimum size of steel angle or pipe span between purlins or joists shall be such that the available section modulus of the trapeze member from Table 2-6.1.5(b) equals or exceeds the section modulus required in Table 2-6.1.5(a).

Any other sizes or shapes giving equal or greater section modulus shall be acceptable. All angles shall be used with the longer leg vertical. The trapeze member shall be secured to prevent slippage. Where a pipe is suspended from a pipe trapeze of a diameter less than the diameter of the pipe being supported, ring, strap, or clevis hangers of the size corresponding to the suspended pipe shall be used on both ends.

2-6.1.6 The size of hanger rods and fasteners required to support the steel angle iron or pipe indicated in Table 2-6.1.5(a) shall comply with 2-6.4.

2-6.1.7* Sprinkler piping or hangers shall not be used to support nonsystem components.

2-6.2 Hangers in Concrete.

2-6.2.1 The use of listed inserts set in concrete to support hangers shall be permitted.

2-6.2.2 Listed expansion shields for supporting pipes under concrete construction shall be permitted to be used in a horizontal position in the sides of beams. In concrete having gravel or crushed stone aggregate, expansion shields shall be permitted to be used in the vertical position to support pipes 4 in. (102 mm) or less in diameter.

2-6.2.3 For the support of pipes 5 in. (127 mm) and larger, expansion shields, if used in the vertical position, shall alternate with hangers connected directly to the structural members, such as trusses and girders, or to the sides of concrete beams. In the absence of convenient structural members, pipes 5 in. (127 mm) and larger shall be permitted to be supported entirely by expansion shields in the vertical position, but spaced not over 10 ft (3 m) apart.

2-6.2.4 Expansion shields shall not be used in ceilings of gypsum or similar soft material. In cinder concrete, expansion shields shall not be used except on branch lines where they shall alternate with through-bolts or hangers attached to beams.

Table 2-6.1.5(a) Section Modulus Required for Trapeze Members (in.³)

Span of Trapeze	1 in.	1 1/4 in.	1 1/2 in.	2 in.	2 1/2 in.	3 in.	3 1/2 in.	4 in.	5 in.	6 in.	8 in.	10 in.
1 ft 6 in.	.08 .08	.09 .09	.09 .09	.09 .10	.10 .11	.11 .12	.12 .13	.13 .15	.15 .18	.18 .22	.24 .30	.32 .41
2 ft 0 in.	.11 .11	.12 .12	.12 .12	.13 .13	.15 .15	.16 .16	.18 .18	.20 .20	.21 .25	.24 .30	.29 .40	.43 .54
2 ft 6 in.	.14 .14	.14 .15	.15 .15	.16 .16	.17 .18	.18 .21	.20 .22	.21 .25	.25 .30	.29 .36	.36 .50	.48 .68
3 ft 0 in.	.17 .17	.17 .18	.18 .18	.19 .20	.20 .22	.22 .25	.24 .27	.26 .30	.31 .36	.36 .43	.48 .60	.65 .82
4 ft 0 in.	.22 .22	.23 .24	.24 .24	.25 .26	.27 .29	.29 .33	.32 .36	.34 .40	.41 .48	.48 .58	.59 .80	1.09 1.08
5 ft 0 in.	.28 .28	.29 .29	.30 .30	.31 .33	.34 .37	.37 .41	.40 .45	.43 .49	.51 .60	.59 .72	.80 1.00	1.37 1.30
6 ft 0 in.	.33 .34	.35 .35	.36 .36	.38 .39	.41 .44	.44 .49	.48 .54	.51 .59	.61 .72	.71 .87	.97 1.20	1.30 1.64
7 ft 0 in.	.39 .39	.40 .41	.41 .43	.44 .46	.47 .51	.52 .58	.55 .63	.60 .69	.71 .84	.83 1.01	1.13 1.41	1.52 1.92
8 ft 0 in.	.44 .45	.46 .47	.47 .49	.50 .52	.54 .59	.59 .66	.63 .72	.68 .79	.81 .96	.95 1.16	1.29 1.61	1.73 2.19
9 ft 0 in.	.50 .50	.52 .53	.53 .55	.56 .59	.61 .66	.66 .74	.71 .81	.77 .89	.92 1.08	1.07 1.30	1.45 1.81	1.95 2.46
10 ft 0 in.	.56 .56	.58 .59	.59 .61	.63 .65	.68 .74	.74 .82	.79 .90	.85 .99	1.02 1.20	1.19 1.44	1.61 2.01	2.17 2.74

For SI Units: 1 in. = 25.4 mm; 1 ft = 0.3048 m.

Top values are for Schedule 10 pipe; bottom values are for Schedule 40 pipe.

NOTE: The table is based on a maximum allowable bending stress of 15 KSI and a midspan concentrated load from 15 ft (4.6 m) of water-filled pipe, plus 250 lb (114 kg).

2-6.2.5 Where expansion shields are used in the vertical position, the holes shall be drilled to provide uniform contact with the shield over its entire circumference. Depth of the hole shall not be less than specified for the type of shield used.

2-6.2.6 Holes for expansion shields in the side of concrete beams shall be above the center line of the beam or above the bottom reinforcement steel rods.

2-6.3 Powder-Driven Studs and Welding Studs.

2-6.3.1* Powder-driven studs, welding studs, and the tools used for installing these devices shall be listed. Pipe size, installation position, and construction material into which they are installed shall be in accordance with individual listings.

2-6.3.2 Powder-driven fasteners shall not be used to attach hangers to the building structure where the systems are required to be protected against earthquakes using a horizontal force factor exceeding 0.50 Wp.

Exception: Powder-driven fasteners shall be permitted where they are specifically listed for horizontal force factors in excess of 0.50 Wp.

2-6.3.3* Representative samples of concrete into which studs are to be driven shall be tested to determine that the studs will hold a minimum load of 750 lb (341 kg) for 2-in. (51-mm) or smaller pipe, 1000 lb (454 kg) for 2 1/2-, 3-, or 3 1/2-in. (64-, 76-, or 89-mm) pipe, and 1200 lb (545 kg) for 4- or 5-in. (102- or 127-mm) pipe.

2-6.3.4 Increaser couplings shall be attached directly to the powder-driven studs or welding studs.

2-6.3.5 Welding studs or other hanger parts shall not be attached by welding to steel less than U.S. Standard, 12 gauge.

2-6.4 Rods and "U" Hooks.

2-6.4.1 Hanger rod size shall be the same as that approved for use with the hanger assembly, and the size of rods shall not be less than that given in Table 2-6.4.1.

Exception: Rods of smaller diameter shall be permitted where the hanger assembly has been tested and listed by a testing laboratory and installed within the limits of pipe sizes expressed in individual listings. For rolled threads, the rod size shall not be less than the root diameter of the thread.

2-6.4.2 U-Hooks. The size of the rod material of U-hooks shall not be less than that given in Table 2-6.4.2. Drive screws shall be used only in a horizontal position as in the side of a beam in conjunction with U-hangers only.

2-6.4.3 The size of the rod material for eye rods shall not be less than specified in Table 2-6.4.3. Where eye rods are fastened to wood structural members, the eye rod shall be backed with a large flat washer bearing directly against the structural member, in addition to the lock washer.

2-6.4.3.1 Eye rods shall be secured with lock washers to prevent lateral motion.

Table 2-6.1.5(b) Available Section Moduli of Common Trapeze Hangers

Pipe	Modulus	Angles			Modulus
Schedule 10					
1 in.	.12	1 1/2 x 1 1/2	x	3/16	.10
1 1/4 in.	.19	2 x 2	x	1/4	.13
1 1/2 in.	.26	2 x 1 1/2	x	3/16	.18
2 in.	.42	2 x 2	x	1/4	.25
2 1/2 in.	.69	2 x 2	x	3/16	.28
3 in.	1.04	2 1/2 x 1 1/2	x	3/16	.29
3 1/2 in.	1.38	2 1/2 x 2	x	3/16	.30
4 in.	1.76	2 x 2	x	3/16	.30
5 in.	3.03	2 1/2 x 2 1/2	x	3/8	.35
6 in.	4.35	2 x 2	x	1/4	.39
		2 1/2 x 2 1/2	x	3/16	.41
		3 x 2	x	3/16	.43
		3 x 2 1/2	x	3/16	.44
		3 x 3	x	3/16	.48
		2 1/2 x 2 1/2	x	1/4	.54
		3 x 2	x	3/8	.55
		2 1/2 x 2	x	3/8	.57
		2 1/2 x 2 1/2	x	1/4	.58
		3 x 3	x	3/16	.71
		3 x 3	x	1/2	.72
		2 1/2 x 2 1/2	x	1/4	.75
		3 1/2 x 2 1/2	x	3/8	.81
		3 x 2 1/2	x	3/8	.83
		3 x 3	x	3/16	.93
		3 1/2 x 2 1/2	x	7/16	.95
		3 x 3	x	1/4	1.05
		4 x 4	x	1/2	1.07
		3 x 3	x	3/16	1.23
		4 x 3	x	3/16	1.29
		4 x 4	x	3/8	1.46
		4 x 3	x	3/8	1.52
		4 x 4	x	3/16	1.94
		5 x 3 1/2	x	1/2	1.97
		4 x 4	x	3/8	2.40
		4 x 4	x	1/4	2.81
		4 x 4	x	3/8	3.32
		6 x 4	x	1/2	4.33
		6 x 4	x	3/4	6.25
		6 x 6	x	1	8.57

For SI Units: 1 in. = 25.4 mm; 1 ft = 0.3048 m.

Table 2-6.4.1 Hanger Rod Sizes

Pipe Size	Diam. of Rod		Pipe Size	Diam. of Rod	
	in.	mm		in.	mm
Up to and including 4 in.	3/8	9.5	5, 6, and 8 in.	1/2	12.7
			10 and 12 in.	3/8	15.9

For SI Units: 1 in. = 25.4 mm.

Table 2-6.4.2 U-Hook Rod Sizes

Pipe Size	Hook Material Diameter	
	in.	mm
Up to 2 in.	3/16	7.9
2 1/2 to 6 in.	3/8	9.5
8 in.	1/2	12.7

For SI Units: 1 in. = 25.4 mm.

Table 2-6.4.3 Eye Rod Sizes

Pipe Size	Diameter of Rod		Diameter of Rod	
	With Bent Eye	With Welded Eye	With Bent Eye	With Welded Eye
	in.	mm	in.	mm
Up to 4 in.	3/8	9.5	3/8	9.5
5 to 6 in.	1/2	12.7	1/2	12.7
8 in.	3/4	19.1	1/2	12.7

For SI Units: 1 in. = 25.4 mm.

2-6.4.4 Threaded sections of rods shall not be formed or bent.

2-6.4.5 Screws. For ceiling flanges and U-hooks, screw dimensions shall not be less than those given in Table 2-6.4.5.

Exception: When the thickness of planking and thickness of flange do not permit the use of screws 2 in. (51 mm) long, screws 1 3/4 in. (44 mm) long shall be permitted with hangers spaced not over 10 ft (3 m) apart. When the thickness of beams or joists does not permit the use of screws 2 1/2 in. (64 mm) long, screws 2 in. (51 mm) long shall be permitted with hangers spaced not over 10 ft (3 m) apart.

Table 2-6.4.5 Screw Dimensions for Ceiling Flanges and U-Hooks

Pipe Size	2 Screw Flanges
Up to 2 in.	Wood screw No. 18 x 1 1/2 in. or Lag screw 3/16 in. x 1 1/2 in.
Pipe Size	3 Screw Flanges
Up to 2 in.	Wood screw No. 18 x 1 1/2 in.
2 1/2 in., 3 in., 3 1/2 in.	Lag screw 3/8 in. x 2 in.
4 in., 5 in., 6 in.	Lag screw 1/2 in. x 2 in.
8 in.	Lag screw 3/4 in. x 2 in.
Pipe Size	4 Screw Flanges
Up to 2 in.	Wood screw No. 18 x 1 1/2 in.
2 1/2 in., 3 in., 3 1/2 in.	Lag screw 3/8 in. x 1 1/2 in.
4 in., 5 in., 6 in.	Lag screw 1/2 in. x 2 in.
8 in.	Lag screw 3/4 in. x 2 in.
Pipe Size	U-Hooks Flanges
Up to 2 in.	Drive screw No. 16 x 2 in.
2 1/2 in., 3 in., 3 1/2 in.	Lag screw 3/8 in. x 2 1/2 in.
4 in., 5 in., 6 in.	Lag screw 1/2 in. x 3 in.
8 in.	Lag screw 3/4 in. x 3 in.

For SI Units: 1 in. = 25.4 mm.

2-6.4.6 The size bolt or lag (coach) screw used with an eye rod or flange on the side of the beam shall not be less than specified in Table 2-6.4.6.

Exception: Where the thickness of beams or joists does not permit the use of screws 2 1/2 in. (64 mm) long, screws 2 in. (51 mm) long shall be permitted with hangers spaced not over 10 ft (3 m) apart.

2-6.4.7 Wood screws shall be installed with a screwdriver. Nails are not acceptable for fastening hangers.

2-6.4.8 Screws in the side of a timber or joist shall be not less than 2 1/2 in. (64 mm) from the lower edge where supporting branch lines and not less than 3 in. (76 mm) where supporting main lines.

Exception: This requirement shall not apply to 2-in. (51-mm) or thicker nailing strips resting on top of steel beams.

Table 2-6.4.6 Minimum Bolt or Lag Screw Sizes

Size of Pipe	Size of Bolt or Lag Screw		Length of Lag Screw Used with Wood Beams	
	in.	mm	in.	mm
Up to and including 2 in.	5/8	9.5	2 1/2	64
2 1/2 to 6 in. (inclusive)	1/2	12.7	3	76
8 in.	3/4	15.9	3	76

For SI Units: 1 in. = 25.4 mm.

2-6.4.9 The minimum plank thickness and the minimum width of the lower face of beams or joists in which lag screw rods are used shall be as given in Table 2-6.4.9.

Table 2-6.4.9 Minimum Plank Thicknesses and Beam or Joist Widths

Pipe Size	Nominal Plank Thickness		Nominal Width of Beam or Joist Face	
	in.	mm	in.	mm
Up to 2 in.	3	76	2	51
2 1/2 to 3 1/2 in.	4	102	2	51
4 in. and 5 in.	4	102	3	76
6 in.	4	102	4	102

For SI Units: 1 in. = 25.4 mm.

2-6.4.10 Lag screw rods shall not be used for support of pipes larger than 6 in. (152 mm). All holes for lag screw rods shall be predrilled 1/8 in. (3.2 mm) less in diameter than the maximum root diameter of the lag screw thread.

2-7 Valves.

2-7.1 Types of Valves to Be Used.

2-7.1.1 All valves controlling connections to water supplies and to supply pipes to sprinklers shall be listed indicating valves. Such valves shall not close in less than 5 sec when operated at maximum possible speed from the fully open position.

Exception No. 1: A listed underground gate valve equipped with a listed indicator post shall be permitted.

Exception No. 2: A listed water control valve assembly with a reliable position indication connected to a remote supervisory station shall be permitted.

Exception No. 3: A nonindicating valve, such as an underground gate valve with approved roadway box complete with T-wrench, accepted by the authority having jurisdiction, shall be permitted.

2-7.1.2 When water pressures exceed 175 psi (12.1 bars), valves shall be used in accordance with their pressure ratings.

2-7.1.3 Wafer-type valves with components that extend beyond the valve body shall be installed in a manner that does not interfere with the operation of any system components.

2-7.2 Drain Valves and Test Valves. Drain valves and test valves shall be approved.

2-7.3* Identification of Valves. All control, drain, and test connection valves shall be provided with permanently marked weather-proof metal or rigid plastic identification signs. The sign shall be secured with corrosion-resistant wire, chain, or other approved means.

2-8 Fire Department Connections.

2-8.1 The fire department connection(s) shall be internal threaded swivel fitting(s) having threads compatible with those of the local fire department.

Exception: The use of threadless couplings shall be permitted where required by the authority having jurisdiction and where listed for such use.

2-8.2 Connections shall be equipped with listed plugs or caps.

2-9 Waterflow Alarms.

2-9.1 Waterflow alarm apparatus shall be listed for the service and so constructed and installed that any flow of water from a sprinkler system equal to or greater than that from a single automatic sprinkler of the smallest orifice size installed on the system will result in an audible alarm on the premises within 5 min after such flow begins and until such flow stops.

2-9.2 Waterflow Detecting Devices.

2-9.2.1 Wet Pipe Systems. The alarm apparatus for a wet pipe system shall consist of a listed alarm check valve or other listed waterflow detecting alarm device with the necessary attachments required to give an alarm.

2-9.2.2 Dry Pipe Systems. The alarm apparatus for a dry pipe system shall consist of listed alarm attachments to the dry pipe valve. When a dry pipe valve is located on the system side of an alarm valve, connection of the actuating device of the alarms for the dry pipe valve to the alarms on the wet pipe system is permitted.

2-9.2.3 Preaction and Deluge Systems. The alarm apparatus for deluge and preaction systems shall consist of alarms actuated independently by the detection system and the flow of water.

2-9.2.4* Paddle-type waterflow alarm indicators shall be installed in wet systems only.

2-9.3 Attachments — General.

2-9.3.1* An alarm unit shall include a listed mechanical alarm, horn, or siren or a listed electric gong, bell, speaker, horn, or siren.

2-9.3.2* Outdoor water motor operated or electrically operated bells shall be weatherroofed and guarded.

2-9.4 All piping to water motor operated devices shall be galvanized or brass or other corrosion-resistant material acceptable under this standard and of a size not less than 3/4 in. (19 mm).

2-9.5* Attachments — Electrically Operated.

2-9.5.1 Electrically operated alarm attachments forming part of an auxiliary, central station, local protective, proprietary, or remote station signaling system shall be installed in accordance with NFPA 72, National Fire Alarm Code.

Exception: Sprinkler waterflow alarm systems that are not part of a required protective signaling system need not be supervised and shall be installed in accordance with NFPA 70, National Electrical Code®, Article 760.

2-9.5.2 Outdoor electric alarm devices shall be listed for outdoor use.

2-9.6 Drains from alarm devices shall be so arranged that there will be no overflowing at the alarm apparatus, at domestic connections, or elsewhere with the sprinkler drains wide open and under system pressure. (See 4-14.3.6.1.)

Chapter 3 System Requirements

3-1 Wet Pipe Systems.

3-1.1 Pressure Gauges. A listed pressure gauge conforming to 4-15.3.2 shall be installed in each system riser. Pressure gauges shall be installed above and below each alarm check valve where such devices are present.

3-1.2 Relief Valves. A gridded wet pipe system shall be provided with a relief valve not less than 1/4 in. (6.4 mm) in size set to operate at pressures not greater than 175 psi (12.1 bars).

Exception No. 1: When the maximum system pressure exceeds 165 psi (11.4 bars), the relief valve shall operate at 10 psi (0.7 bars) in excess of the maximum system pressure.

Exception No. 2: Where auxiliary air reservoirs are installed to absorb pressure increases, a relief valve shall not be required.

3-1.3 Auxiliary Systems. A wet pipe system shall be permitted to supply an auxiliary dry pipe, preaction, or deluge system, provided the water supply is adequate.

3-2* Dry Pipe Systems.

3-2.1 Pressure Gauges. Listed pressure gauges conforming with 4-15.3.2 shall be connected:

- (a) On the water side and air side of the dry pipe valve,
- (b) At the air pump supplying the air receiver where one is provided,
- (c) At the air receiver where one is provided,
- (d) In each independent pipe from air supply to dry pipe system, and
- (e) At exhausters and accelerators.

3-2.2 Upright Sprinklers. Only upright sprinklers shall be installed on dry pipe systems.

Exception No. 1: Listed dry sprinklers shall be permitted.*

Exception No. 2: Pendent sprinkles installed on return bends shall be permitted where both the sprinklers and the return bends are located in a heated area.

Exception No. 3: Horizontal sidewall sprinklers, installed so that water is not trapped, shall be permitted.

3-2.3* Size of Systems.

3-2.3.1* Volume Limitations. Not more than 750 gal (2839 L) system capacity shall be controlled by one dry pipe valve.

Exception: Piping volume shall be permitted to exceed 750 gal (2839 L) for nongridded systems if the system design is such that water is delivered to the system test connection in not more than 60 sec, starting at the normal air pressure on the system and at the time of fully opened inspection test connection.

3-2.3.2 Gridded dry pipe systems shall not be installed. (See 4-14.3.5.3.3.)

3-2.4 Quick-Opening Devices.

3-2.4.1 Dry pipe valves shall be provided with a listed quick-opening device where system capacity exceeds 500 gal (1893 L).

Exception: A quick-opening device shall not be required if the requirements of 3-2.3.1 Exception can be met without such a device.

3-2.4.2 The quick-opening device shall be located as close as practical to the dry pipe valve. To protect the restriction orifice and other operating parts of the quick-opening device against submergence, the connection to the riser shall be above the point at which water (priming water and back drainage) is expected when the dry pipe valve and quick-opening device are set, except where design features of the particular quick-opening device make these requirements unnecessary.

3-2.4.3 A soft disc globe or angle valve shall be installed in the connection between the dry pipe sprinkler riser and the quick-opening device.

3-2.4.4 A check valve shall be installed between the quick-opening device and the intermediate chamber of the dry pipe valve. If the quick-opening device requires pressure feedback from the intermediate chamber, a valve type that will clearly indicate whether it is opened or closed shall be permitted in place of that check valve. This valve shall be constructed so that it may be locked or sealed in the open position.

3-2.4.5 A listed antiflooding device shall be installed in the connection between the dry pipe sprinkler riser and the quick-opening device.

Exception: Where the quick-opening device has built-in antiflooding design features.

3-2.5* Location and Protection of Dry Pipe Valve.

3-2.5.1 The dry pipe valve and supply pipe shall be protected against freezing and mechanical injury.

3-2.5.2 Valve rooms shall be lighted and heated. The source of heat shall be of a permanently installed type. Heat tape shall not be used in lieu of heated valve enclosures to protect the dry pipe valve and supply pipe against freezing.

3-2.5.3 The supply for the sprinkler in the dry pipe valve enclosure shall be from the dry side of the system.

3-2.5.4 Protection against accumulation of water above the clapper shall be provided for a low differential dry pipe valve. An automatic high water level signaling device or an automatic drain device is acceptable.

3-2.6 Air Pressure and Supply.

3-2.6.1 Maintenance of Air Pressure. Air or nitrogen pressure shall be maintained on dry pipe systems throughout the year.

3-2.6.2* Air Supply. The compressed air supply shall be from a source available at all times and having a capacity capable of restoring normal air pressure in the system within 30 min.

Exception: In refrigerated spaces maintained below 5°F (-15°C), normal system air pressure shall be restored within 60 min.

3-2.6.3 Air Filling Connection. The connection pipe from the air compressor shall not be less than 1/2 in. (13 mm) in diameter and shall enter the system above the priming water level of the dry pipe valve. A check valve shall be installed in this air line, and a shutoff valve of the renewable disc type shall be installed on the supply side of this check valve and shall remain closed unless filling the system.

3-2.6.4 Relief Valve. A listed relief valve shall be provided between the compressor and controlling valve, set to relieve at a pressure 5 psi (0.3 bars) in excess of maximum air pressure carried in the system.

3-2.6.5 Shop Air Supply. Where the air supply is taken from a shop system having a normal pressure greater than that required for dry pipe systems and an automatic air maintenance device is not used, the relief valve shall be installed between two control valves in the air line, and a small air cock, which is normally left open, shall be installed in the fitting below the relief valve. (See Figure 3-2.6.5.)

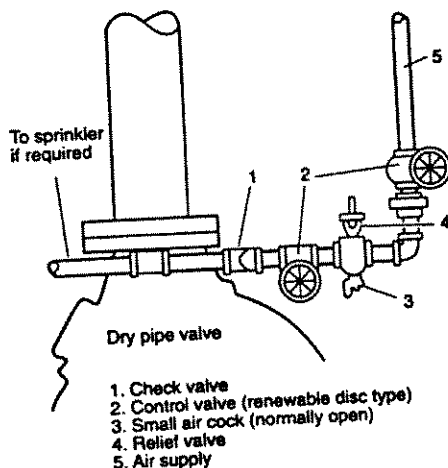

Figure 3-2.6.5 Air supply from shop system.

3-2.6.6 Automatic Air Compressor. Where a dry pipe system is supplied by an automatic air compressor or plant air system, any device or apparatus used for automatic maintenance of air pressure shall be of a type specifically listed for such service and capable of maintaining the required air pressure on the dry pipe system. Automatic air supply to more than one dry pipe system shall be connected to enable individual maintenance of air pressure in each system. A check valve or other positive backflow prevention device shall be installed in the air supply to each system to prevent air- or waterflow from one system to another.

3-2.6.7 System Air Pressure. The system air pressure shall be maintained in accordance with the instruction sheet furnished with the dry pipe valve, or 20 psi (1.4 bars) in excess of the calculated trip pressure of the dry pipe valve, based on the highest normal water pressure of the system supply. The permitted rate of air leakage shall be as specified in 8-2.3.

3-2.6.8 Nitrogen. Where used, nitrogen shall be introduced through a pressure regulator set to maintain system pressure in accordance with 3-2.6.7.

3-3 Preaction Systems and Deluge Systems.

3-3.1* General.

3-3.1.1 All components of pneumatic, hydraulic, or electrical systems shall be compatible.

3-3.1.2 The automatic water control valve shall be provided with hydraulic, pneumatic, or mechanical manual means for operation that is independent of detection devices and of the sprinklers.

3-3.1.3 Pressure Gauges. Listed pressure gauges conforming with 4-15.3.2 shall be installed as follows:

(a) Above and below preaction valve and below deluge valve.

(b) On air supply to preaction and deluge valves.

3-3.1.4 A supply of spare fusible elements for heat-responsive devices, not less than two of each temperature rating, shall be maintained on the premises for replacement purposes.

3-3.1.5 Hydraulic release systems shall be designed and installed in accordance with manufacturer's requirements and listing for height limitations above deluge valves or deluge valve actuators to prevent water column.

3-3.1.6 Location and Spacing of Detection Devices. Spacing of detection devices, including automatic sprinklers used as detectors, shall be in accordance with their listing and manufacturer's specifications.

3-3.1.7 Devices for Test Purposes and Testing Apparatus.

3-3.1.7.1 Where detection devices installed in circuits are located where not readily-accessible, an additional detection device shall be provided on each circuit for test purposes at an accessible location and shall be connected to the circuit at a point that will assure a proper test of the circuit.

3-3.1.7.2 Testing apparatus capable of producing the heat or impulse necessary to operate any normal detection device shall be furnished to the owner of the property with each installation. Where explosive vapors or materials are present, hot water, steam, or other methods of testing not involving an ignition source shall be used.

3-3.1.8 Location and Protection of System Water Control Valves.

3-3.1.8.1 System water control valves and supply pipes shall be protected against freezing and mechanical injury.

3-3.1.8.2 Valve rooms shall be lighted and heated. The source of heat shall be of a permanently installed type. Heat tape shall not be used in lieu of heated valve enclosure rooms to protect preaction and deluge valves and supply pipe against freezing.

3-3.2 Preaction Systems.

3-3.2.1 Preaction systems shall be one of the types described in (a) through (c) below.

(a) *Single Interlock System.* Systems that admit water to sprinkler piping upon operation of detection devices.

(b) *Non-Interlock System.* Systems that admit water to sprinkler piping upon operation of detection devices or automatic sprinklers.

(c) **Double Interlock System.** Systems that admit water to sprinkler piping upon operation of both detection devices and automatic sprinklers.

3-3.2.2 Size of Systems. Not more than 1000 automatic sprinklers shall be controlled by any one preaction valve.

Exception: For preaction system types described in 3-3.2.1(c), system volume shall not exceed 750 gal (2839 L) controlled by one preaction valve unless the system is designed to deliver water to the system test connection in not more than 60 sec, starting at the normal air pressure on the system with the detection system operated and at the time of fully opened inspection test connection. Air pressure and supply shall comply with 3-2.6.

3-3.2.3 Supervision. Sprinkler piping and fire detection devices shall be automatically supervised where there are more than 20 sprinklers on the system. All preaction system types described in 3-3.2.1(b) and (c) shall maintain a minimum supervising air pressure of 7 psi (0.5 bars.)

3-3.2.4 Upright Sprinklers. Only upright sprinklers shall be installed on preaction systems.

Exception No. 1:* Listed dry sprinklers shall be permitted.

Exception No. 2: Pendent sprinklers installed on return bends shall be permitted where both the sprinklers and the return bends are located in a heated area.

Exception No. 3: Horizontal sidewall sprinklers, installed so that water is not trapped, shall be permitted.

3-3.2.5 System Configuration. Preaction systems of the type described in 3-3.2.1(c) shall not be gridded.

3-3.3* Deluge Systems.

3-3.3.1 The detection devices or systems shall be automatically supervised.

3-3.3.2 Deluge systems shall be hydraulically calculated.

3-4 Combined Dry Pipe and Preaction Systems.

3-4.1* General.

3-4.1.1* Combined automatic dry pipe and preaction systems shall be so constructed that failure of the detection system shall not prevent the system from functioning as a conventional automatic dry pipe system.

3-4.1.2 Combined automatic dry pipe and preaction systems shall be so constructed that failure of the dry pipe system of automatic sprinklers shall not prevent the detection system from properly functioning as an automatic fire alarm system.

3-4.1.3 Provisions shall be made for the manual operation of the detection system at locations requiring not more than 200 ft (61 m) of travel.

3-4.1.4 Upright Sprinklers. Only upright sprinklers shall be installed on combined dry pipe and preaction systems.

Exception No. 1:* Listed dry sprinklers shall be permitted.

Exception No. 2: Pendent sprinklers installed on return bends shall be permitted where both sprinklers and return bends are located in a heated area.

Exception No. 3: Horizontal sidewall sprinklers, installed so that water is not trapped, shall be permitted.

3-4.2 Dry Pipe Valves in Combined Systems.

3-4.2.1 Where the system consists of more than 600 sprinklers or has more than 275 sprinklers in any fire area, the entire system shall be controlled through two 6-in. (152-mm) dry pipe valves connected in parallel and shall feed into a common feed main. These valves shall be checked against each other. (See Figure 3-4.2.)

3-4.2.2 Each dry pipe valve shall be provided with a listed tripping device actuated by the detection system. Dry pipe valves shall be cross-connected through a 1-in. (25.4-mm) pipe connection to permit simultaneous tripping of both dry pipe valves. This 1-in. (25.4-mm) pipe connection shall be equipped with an indicating valve so that either dry pipe valve can be shut off and worked on while the other remains in service.

3-4.2.3 The check valves between the dry pipe valves and the common feed main shall be equipped with 1/2-in. (13-mm) bypasses so that a loss of air from leakage in the trimmings of a dry pipe valve will not cause the valve to trip until the pressure in the feed main is reduced to the tripping point. An indicating valve shall be installed in each of these bypasses so that either dry pipe valve can be completely isolated from the main riser or feed main and from the other dry pipe valve.

3-4.2.4 Each combined dry pipe and preaction system shall be provided with listed quick-opening devices at the dry pipe valves.

3-4.3* Air Exhaust Valves. One or more listed air exhaust valves of 2-in. (51-mm) or larger size controlled by operation of a fire detection system shall be installed at the end of the common feed main. These air exhaust valves shall have soft-seated globe or angle valves in their intakes; also, approved strainers shall be installed between these globe valves and the air exhaust valves.

3-4.4 Subdivision of System Using Check Valves.

3-4.4.1 Where more than 275 sprinklers are required in a single fire area, the system shall be divided into sections of 275 sprinklers or less by means of check valves. If the system is installed in more than one fire area or story, not more than 600 sprinklers shall be supplied through any one check valve. Each section shall have a 1 1/4-in. (33-mm) drain on the system side of each check valve supplemented by a dry pipe system auxiliary drain.

3-4.4.2 Section drain lines and dry pipe system auxiliary drains shall be located in heated areas or inside of heated cabinets to enclose drain valves and auxiliary drains for each section.

3-4.4.3 Air exhaust valves at the end of a feed main and associated check valves shall be protected against freezing.

3-4.5 Time Limitation. The sprinkler system shall be so constructed and the number of sprinklers controlled shall be so limited that water shall reach the farthest sprinkler within a period of time not exceeding 1 min for each 400 ft (122 m) of common feed main from the time the heat-responsive system operates. Maximum time permitted shall not exceed 3 min.

3-4.6 System Test Connection. The end section shall have a system test connection as required for dry pipe systems.

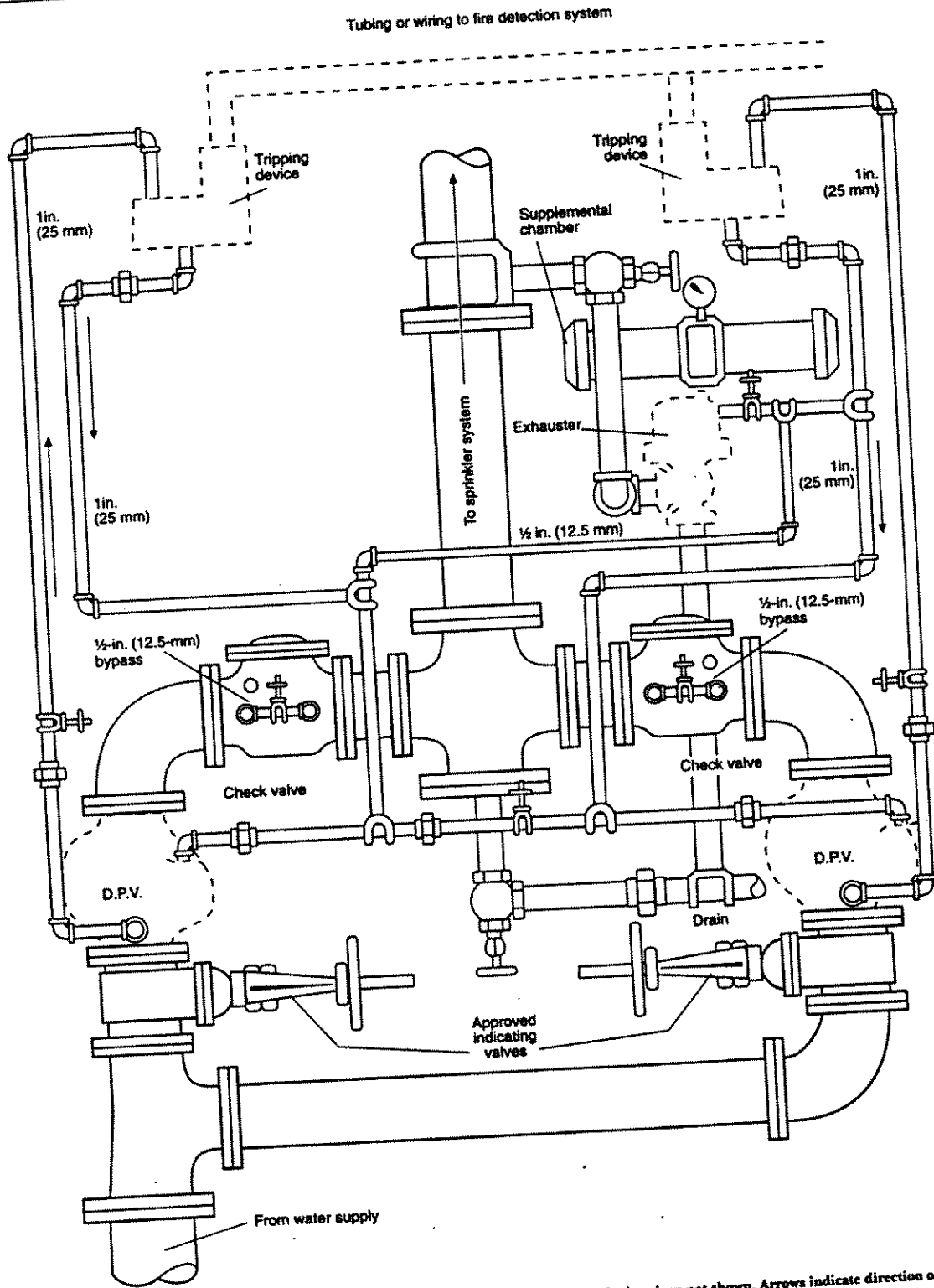

Figure 3-4.2 Header for dry pipe valves installed in parallel for combined systems; standard trimmings not shown. Arrows indicate direction of fluid flow.

3-5 Antifreeze Systems.

3-5.1* Where Used. The use of antifreeze solutions shall be in conformity with state and local health regulations.

3-5.2* Antifreeze Solutions.

3-5.2.1 Where sprinkler systems are supplied by potable water connections, the use of antifreeze solutions other than water solutions of pure glycerine (C.P. or U.S.P. 96.5 percent grade) or propylene glycol shall not be permitted. Suitable glycerine-water and propylene glycol-water mixtures are shown in Table 3-5.2.1.

Table 3-5.2.1 Antifreeze Solutions to Be Used if Potable Water Is Connected to Sprinklers

Material	Solution (by Volume)	Specific Gravity at 60°F (15.6°C)	Freezing Point °F	Freezing Point °C
Glycerine C.P. or U.S.P. Grade*	50% Water	1.133	-15	-26.1
	40% Water	1.151	-22	-30.0
	30% Water	1.165	-40	-40.0
Hydrometer Scale 1.000 to 1.200				
Propylene Glycol	70% Water	1.027	+9	-12.8
	60% Water	1.034	-6	-21.1
	50% Water	1.041	-26	-32.2
	40% Water	1.045	-60	-51.1
Hydrometer Scale 1.000 to 1.200 (Subdivisions 0.002)				

*C.P.—Chemically Pure. U.S.P.—United States Pharmacopoeia 96.5%.

3-5.2.2 If potable water is not connected to sprinklers, the commercially available materials indicated in Table 3-5.2.2 shall be permitted for use in antifreeze solutions.

3-5.2.3* An antifreeze solution shall be prepared with a freezing point below the expected minimum temperature for the locality. The specific gravity of the prepared solution shall be checked by a hydrometer with suitable scale or refractometer having a scale calibrated for the antifreeze solution involved. [See Figures 3-5.2.3(a) and (b).]

3-5.3 Arrangement of Supply Piping and Valves. A control valve and two small solution test valves shall be provided as illustrated in Figures 3-5.3(a) and 3-5.3(b).

3-5.3.1* Where sprinklers are above the water/antifreeze interface, a check valve with a 1/32-in. (0.8-mm) hole in the clapper shall be provided. In most cases, this necessitates the use of a 5-ft (1.5-m) drop pipe or U-loop as illustrated in Figure 3-5.3(a).

Exception: Where the connection between the antifreeze system and the wet pipe system incorporates a backflow prevention device, piping and valves shall be arranged as illustrated in Figure 3-5.3(b). An expansion chamber of appropriate size and pre-charged air pressure shall be provided to compensate for thermal expansion of the antifreeze solution as illustrated in Figure 3-5.3(b).

3-5.3.2 Where a backflow prevention device is provided between the antifreeze system and the wet pipe system, piping and valves shall be arranged as illustrated in Figure 3-5.3(b). An expansion chamber of appropriate size shall be provided to compensate for thermal expansion of the antifreeze solution as illustrated in Figure 3-5.3(b).

Table 3-5.2.2 Antifreeze Solution to Be Used if Nonpotable Water Is Connected to Sprinklers

Material	Solution (by Volume)	Specific Gravity at 60°F (15.6°C)	Freezing Point °F	Freezing Point °C
Glycerine	If glycerine is used, see Table 3-5.2.1.			
Diethylene Glycol	50% Water	1.078	-13	-25.0
	45% Water	1.081	-27	-32.8
	40% Water	1.086	-42	-41.1
Hydrometer Scale 1.000 to 1.120 (Subdivisions 0.002)				
Ethylene Glycol	61% Water	1.056	-10	-23.3
	56% Water	1.063	-20	-28.9
	51% Water	1.069	-30	-34.4
	47% Water	1.073	-40	-40.0
Hydrometer Scale 1.000 to 1.120 (Subdivisions 0.002)				
Propylene Glycol	If propylene glycol is used, see Table 3-5.2.1.			
Calcium Chloride 80% "Flake"	lb CaCl ₂ per gal of Water	2.83	0	-17.8
		3.38	-10	-23.3
Fire Protection Grade†	3.89	-20	-28.9	
Add corrosion inhibitor of sodium bichromate	4.37	-30	-34.4	
1/4 oz per gal water	4.73	-40	-40.0	
	4.93	-50	-45.6	

† Free from magnesium chloride and other impurities.

3-6 Automatic Sprinkler Systems with Nonfire Protection Connections.

3-6.1 Circulating Closed-Loop Systems.

3-6.1.1 System Components.

3-6.1.1.1 A circulating closed-loop system is primarily a sprinkler system and shall comply with all provisions of this standard such as those for control valves, area limitations of a system, alarms, fire department connections, sprinkler spacing, etc.

Exception: Items as specifically detailed within 3-6.1.

3-6.1.1.2 Piping, fittings, valves, and pipe hangers shall meet the requirements specified in Chapter 2.

3-6.1.1.3 A dielectric fitting shall be installed in the junction where dissimilar piping materials are joined, e.g., copper to steel.

Exception: Dielectric fittings are not required in the junction where sprinklers are connected to piping.

3-6.1.1.4 It is not required that other auxiliary devices be listed for sprinkler service; however, these devices, such as pumps, circulating pumps, heat exchangers, radiators, and luminaries, shall be pressure rated at 175 or 300 psi (12.1 or 20.7 bars) (rupture pressure of 5 times rated water working pressure) to match the required rating of sprinkler system components.

3-6.1.1.5 Auxiliary devices shall incorporate materials of construction and be so constructed that they will maintain their physical integrity under fire conditions to avoid impairment to the fire protection system.

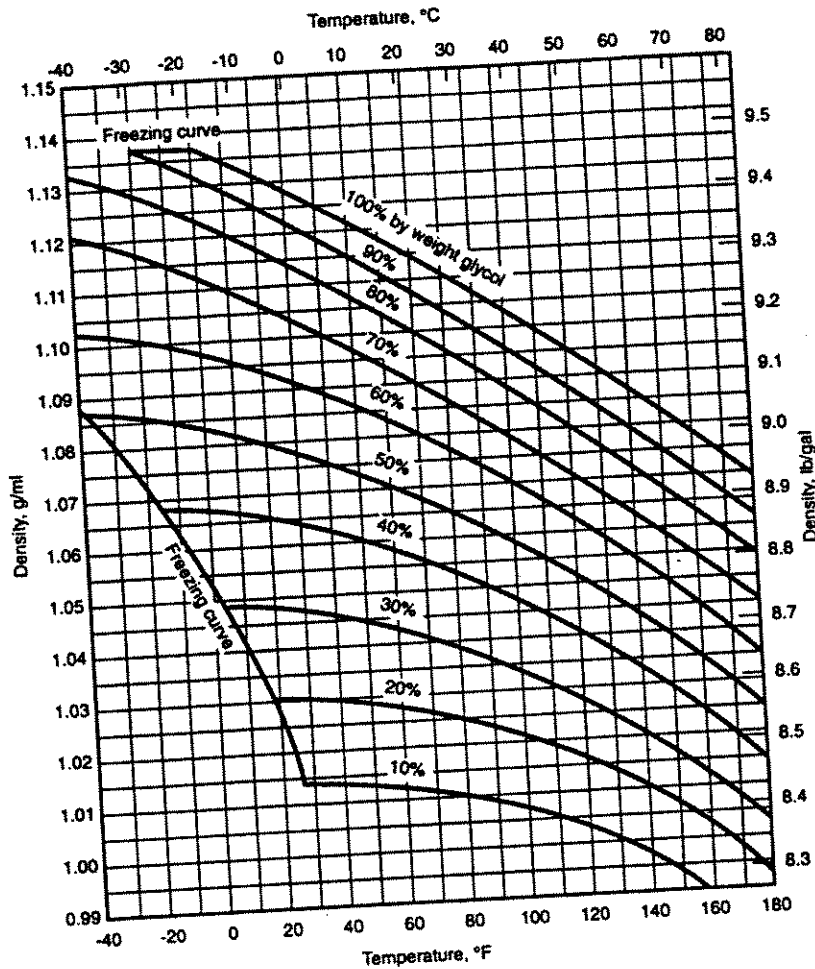

Figure 3-5.2.3(a) Densities of aqueous ethylene glycol solutions (percent by weight).

3-6.1.1.6 Auxiliary devices. where hung from the building structure, shall be supported independently from the sprinkler portion of the system, following recognized engineering practices.

3-6.1.2* Hydraulic Characteristics. Piping systems for attached heating and cooling equipment shall have auxiliary pumps or an arrangement made to return water to the piping system in order to assure the following:

(a) Water for sprinklers shall not be required to pass through heating or cooling equipment. At least one direct path shall exist for waterflow from the sprinkler water supply to every sprinkler. Pipe sizing in the direct path shall be in accordance with design requirements of this standard.

(b) No portions of the sprinkler piping shall have less than the sprinkler system design pressure regardless of the mode of operation of the attached heating or cooling equipment.

(c) There shall be no loss or outflow of water from the system due to or resulting from the operation of heating or cooling equipment.

(d) Shutoff valves and a means of drainage shall be provided on piping to heating or cooling equipment at all points

of connection to sprinkler piping and shall be installed in such a manner as to make possible repair or removal of any auxiliary component without impairing the serviceability and response to the sprinkler system. All auxiliary components, including the strainer, shall be installed on the auxiliary equipment side of the shutoff valves.

3-6.1.3 Water Temperature.

3-6.1.3.1 Maximum. In no case shall maximum water temperature flowing through the sprinkler portion of the system exceed 120°F (49°C). Protective control devices listed for this purpose shall be installed to shut down heating or cooling systems when temperature of water flowing through the sprinkler portion of the system exceeds 120°F (49°C). When water temperature exceeds 100°F (37.8°C), intermediate or higher temperature rated sprinklers shall be used.

3-6.1.3.2 Minimum. Precautions shall be taken to ensure that temperatures below 40°F (4°C) are not permitted.

3-6.1.4 Obstruction to Discharge. Automatic sprinklers shall not be obstructed by auxiliary devices, piping, insulation, etc., from detecting fire or from proper distribution of water.

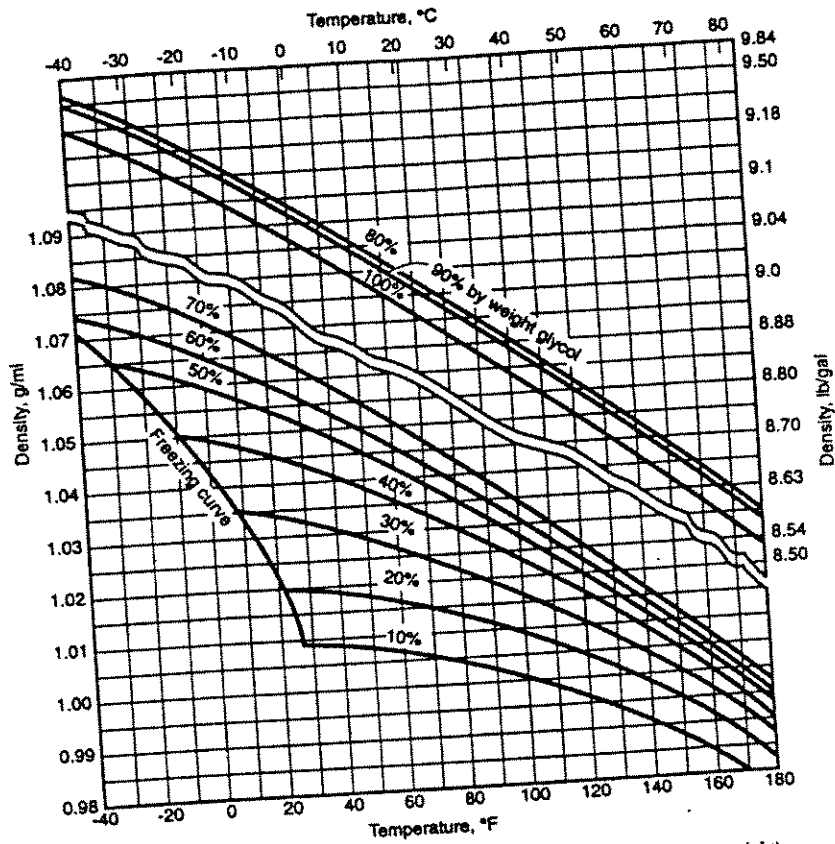
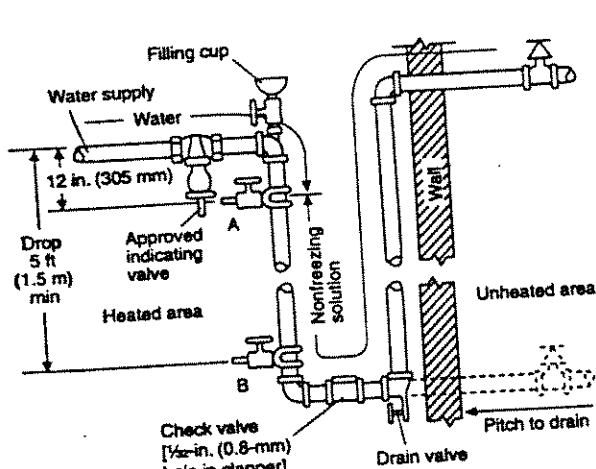

Figure 3-5.2.3(b) Densities of aqueous propylene glycol solutions (percent by weight).



Note 1: Check valve shall be permitted to be omitted where sprinklers are below the level of valve A.
 Note 2: The 1/2-in. (0.8-mm) hole in the check valve clapper is needed to allow for expansion of the solution during a temperature rise, thus preventing damage to sprinklers.

Figure 3-5.3(a) Arrangement of supply piping and valves.

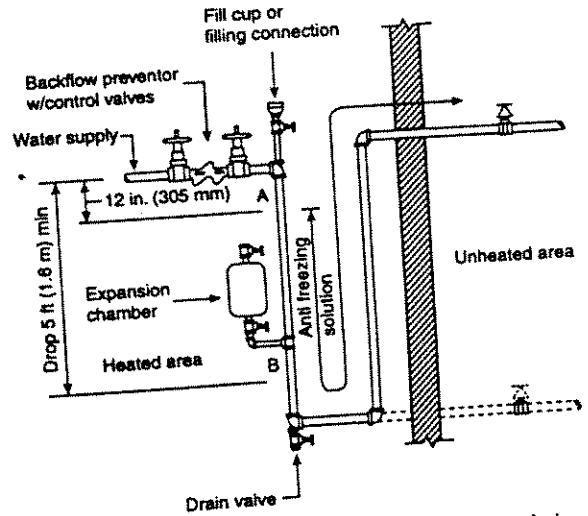

Figure 3-5.3(b) Arrangement of supply piping with backflow device.

3-6.1.5 Signs. Caution signs shall be attached to all valves controlling sprinklers. The caution sign shall be worded as follows:

"This valve controls fire protection equipment. Do not close until after fire has been extinguished. Use auxiliary valves when necessary to shut off supply to auxiliary equipment.

CAUTION: Automatic alarm will be sounded if this valve is closed."

3-6.1.6 Water Additives. Materials added to water shall not adversely affect the fire fighting properties of the water and shall be in conformity with any state or local health regulations. Due care and caution shall be given to the use of additives that may remove or suspend scale from older piping systems. Where additives are necessary for proper system operation, due care shall be taken to ensure that additives are replenished after alarm testing or whenever water is removed from the system.

3-6.1.7 Waterflow Detection. The supply of water from sprinkler piping through auxiliary devices, circulatory piping, and pumps shall not under any condition or operation, transient or static, cause false sprinkler waterflow signals.

3-6.1.7.1 A sprinkler waterflow signal shall not be impaired when water is discharged through an opened sprinkler or through the system test connection while auxiliary equipment is in any mode of operation (on, off, transient, stable).

3-7 Outside Sprinklers for Protection against Exposure Fires.

3-7.1 Applications. Exposure protection systems shall be permitted on buildings regardless of whether the building's interior is protected by a sprinkler system.

3-7.2 Water Supply and Control.

3-7.2.1* Sprinklers installed for protection against exposure fires shall be supplied from a standard water supply as outlined in Chapter 7.

Exception: Where approved, other supplies, such as manual valves or pumps or fire department connections, shall be acceptable.

3-7.2.2 Where fire department connections are used for water supply, they shall be so located that they will not be affected by the exposing fire.

3-7.3 Control.

3-7.3.1 Each system of outside sprinklers shall have an independent control valve.

3-7.3.2 Manually controlled open sprinklers shall be used only where constant supervision is present.

3-7.3.3 Sprinklers shall be of the open or automatic type. Automatic sprinklers in areas subject to freezing shall be on dry pipe systems conforming to Section 3-2 or antifreeze systems conforming to Section 3-5.

3-7.3.4 Automatic systems of open sprinklers shall be controlled by the operation of fire detection devices designed for the specific application.

3-7.4 System Components.

3-7.4.1 Drain Valves. Each system of outside sprinklers shall have a separate drain valve installed on the system side of each control valve.

Exception: Open sprinkler-top fed systems arranged to facilitate drainage.

3-7.4.2 Check Valves. Where sprinklers are installed on two adjacent sides of a building, protecting against two separate and distinct exposures, with separate control valves for each side, the end lines shall be connected with check valves located so that one sprinkler around the corner will operate. (See Figure 3-7.4.2.) The intermediate pipe between the two check valves shall be arranged to drain. As an alternate solution, an additional sprinkler shall be installed on each system located around the corner from the system involved.

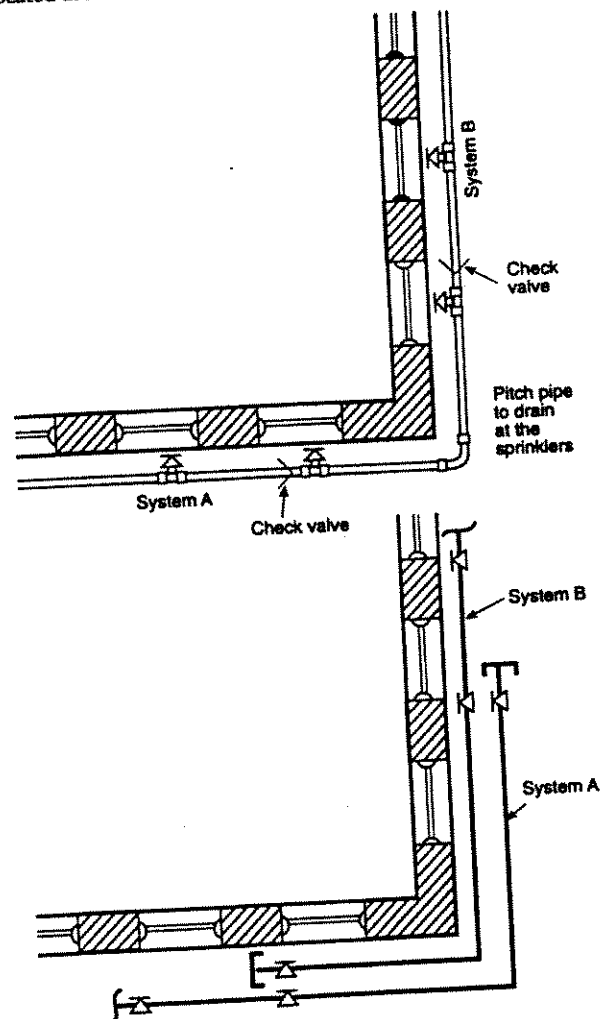

Figure 3-7.4.2 Arrangement of check valves. Top: typical. Bottom: alternate.

3-7.4.3 System Arrangement. Where one exposure affects two sides of the protected structure, the system shall not be subdivided between the two sides, but rather shall be arranged to operate as a single system.

3-7.5 Pipe and Fittings. Pipe and fittings installed on the exterior of the building shall be corrosion resistant.

3-7.6 Strainers. A listed strainer shall be provided in the riser or feed main that supplies sprinklers having nominal orifice sizes smaller than $\frac{3}{8}$ in. (9.5 mm).

3-7.7 Gauge Connections. A listed pressure gauge conforming with 4-15.3.2 shall be installed immediately below the control valve of each system.

3-7.8 Sprinklers. Only sprinklers of such type as are listed for window, cornice, sidewall, or ridge pole service shall be installed for such use except where adequate coverage by use of other types of listed sprinklers and/or nozzles has been demonstrated. Small-orifice or large-orifice sprinklers shall be permitted.

3-8* Refrigerated Spaces.

3-8.1 Spaces Maintained at Temperatures Above 32°F (0°C). Where temperatures are maintained above 32°F (0°C) in refrigerated spaces, the requirements in this section shall not apply.

3-8.2* Spaces Maintained at Temperatures Below 32°F (0°C).

3-8.2.1 Where sprinkler pipe passes through a wall or floor into the refrigerated space, a section of pipe arranged for removal shall be provided immediately inside the space. The removable length of pipe shall be a minimum of 30 in. (762 mm).

3-8.2.2 A low air pressure alarm to a constantly attended location shall be installed.

Exception: Systems equipped with local low pressure alarms and an automatic air maintenance device.

3-8.2.3 Piping in refrigerated spaces shall be installed with pitch as outlined in 4-14.3.3

3-8.2.4* Air supply for systems shall be taken from the room of lowest temperature to reduce moisture content of the air.

Exception: Where compressed nitrogen gas from cylinders is used in lieu of compressed air.

3-8.2.5* An indicating-type control valve for operational testing of the system shall be provided on each sprinkler riser outside of the refrigerated space.

3-8.2.6 A check valve with a $\frac{3}{32}$ -in. (24-mm) diameter hole in the clapper shall be installed in the system riser below the test valve required in 3-8.2.5. The check valve is to prevent evaporation of prime water into the system piping.

Exception: When system dry pipe or preaction valves, if designed to completely drain all water above the seat, and which are listed for installation without priming water remaining and where priming water is not used in the system riser.

3-8.2.7* The air supply piping entering the freezer area shall be equipped with two easily removable supply lines at least 6 ft (1.9 m) long and at least 1 in. (25.4 mm) in diameter as shown in Figure 3-8.2.7. Each supply line shall be equipped with control valves located in the warm area. Only one air supply line shall be open to supply the system air at any one time.

Exception: Where compressed nitrogen gas from cylinders is used in lieu of compressed air.

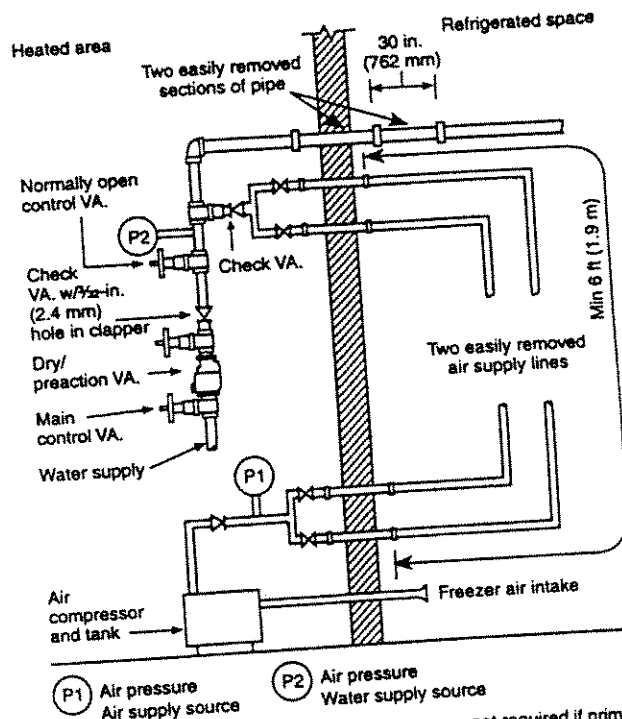

1. Check valve with $\frac{3}{32}$ -in. (2.4-mm) hole in clapper not required if prime water not used.
2. Supply air to be connection to top or side of system pipe.
3. Each removable air line shall be a minimum of 1 in. (25 mm) diameter and minimum of 6 ft (1.9 m) long.

Figure 3-8.2.7 Refrigerator area sprinkler systems to minimize the chances of developing ice-plugs.

3-9 Commercial-Type Cooking Equipment and Ventilation.

3-9.1 In cooking areas protected by automatic sprinklers, additional sprinklers or automatic spray nozzles shall be provided to protect commercial-type cooking equipment and ventilation systems that are designed to carry away grease-laden vapors unless otherwise protected. (See NFPA 96, *Standard on Ventilation Control and Fire Protection of Commercial Cooking Operations*.)

3-9.2* Standard sprinklers or automatic spray nozzles shall be so located as to provide for the protection of exhaust ducts, hood exhaust duct collars, and hood exhaust plenum chambers.

Exception: Sprinklers or automatic spray nozzles in ducts, duct collars, and plenum chambers shall not be required where all cooking equipment is served by listed grease extractors.

3-9.3 Exhaust ducts shall have one sprinkler or automatic spray nozzle located at the top of each vertical riser and at the midpoint of each offset. The first sprinkler or automatic spray nozzle in a horizontal duct shall be installed at the duct entrance. Horizontal exhaust ducts shall have such devices located on 10-ft (3-m) centers beginning no more than 5 ft (1.5 m) from the duct entrance. Sprinkler(s) or automatic spray nozzle(s) in exhaust ducts subject to freezing shall be properly protected against freezing by approved means. (See 4-14.4.1.)

Exception No. 1: Sprinklers or automatic spray nozzles shall not be required in a vertical riser located outside of a building provided the riser does not expose combustible material or provided the interior of a building and the horizontal distance between the hood outlet and the vertical riser is at least 25 ft (7.6 m).

Exception No. 2: Sprinklers or automatic spray nozzles shall not be required where the entire exhaust duct is connected to a listed exhaust hood incorporating a specific duct collar and sprinkler (or automatic spray nozzle) assembly investigated for protection of unlimited length of duct in accordance with the Standard for Fire Testing of Fire Extinguishing Systems for Protection of Restaurant Cooking Areas, UL 300.

3-9.4 Each hood exhaust duct collar shall have one sprinkler or automatic spray nozzle located 1 in. minimum to 12 in. maximum (25.4 mm min. to 305 mm max.) above the point of duct collar connection in the hood plenum. Hoods that have listed fire dampers located in the duct collar shall be protected with a sprinkler or automatic spray nozzle located on the discharge side of the damper and be so positioned as not to interfere with damper operation.

3-9.5 Hood exhaust plenum chambers shall have one sprinkler or automatic spray nozzle centered in each chamber not exceeding 10 ft (3 m) in length. Plenum chambers greater than 10 ft (3 m) in length shall have two sprinklers or automatic spray nozzles evenly spaced with the maximum distance between the two sprinklers not to exceed 10 ft (3 m).

3-9.6 Sprinklers or automatic spray nozzles being used in duct, duct collar, and plenum areas shall be of the extra high temperature classification [325 to 375°F (163 to 191°C)] and shall have orifice sizes not less than 1/4 in. (6.4 mm) and not more than 1/2 in. (13 mm).

Exception: When use of a temperature measuring device indicates temperatures above 300°F (149°C), a sprinkler or automatic spray nozzle of higher classification shall be used.

3-9.7 Access must be provided to all sprinklers or automatic spray nozzles for examination and replacement.

3-9.8 Cooking Equipment.

3-9.8.1 Cooking equipment (such as deep fat fryers, ranges, griddles, and broilers) that is considered to be a source of ignition shall be protected in accordance with the provisions of 3-9.1.

3-9.8.2 A sprinkler or automatic spray nozzle used for protection of deep fat fryers shall be listed for that application. The position, arrangement, location, and water supply for each sprinkler or automatic spray nozzle shall be in accordance with its listing.

3-9.8.3 The operation of any cooking equipment sprinkler or automatic spray nozzle shall automatically shut off all sources of fuel and heat to all equipment requiring protection. Any gas appliance not requiring protection but located under ventilating equipment shall also be shut off. All shut-down devices shall be of the type that requires manual resetting prior to fuel or power being restored.

3-9.9 A listed indicating valve shall be installed in the water supply line to the sprinklers and spray nozzles protecting the cooking and ventilating system.

3-9.10 A listed line strainer shall be installed in the main water supply preceding sprinklers or automatic spray nozzles having nominal orifice sizes smaller than 3/8 in. (9.5 mm).

3-9.11 A system test connection shall be provided to verify proper operation of equipment specified in 3-9.8.3.

3-9.12 Sprinklers and automatic spray nozzles used for protecting commercial-type cooking equipment and ventilating systems shall be replaced annually.

Exception: Where automatic bulb-type sprinklers or spray nozzles are used and annual examination shows no build-up of grease or other material on the sprinklers or spray nozzles.

Chapter 4 Installation Requirements

4-1* Basic Requirements.

4-1.1* The requirements for spacing, location, and position of sprinklers are based on the following principles:

- (a) Sprinklers installed throughout the premises.
- (b) Sprinklers located so as not to exceed maximum protection area per sprinkler.
- (c) Sprinklers positioned and located so as to provide satisfactory performance with respect to activation time and distribution.

Exception No. 1: For locations permitting omission of sprinklers, see 4-13.1, 4-13.2, and 4-13.8.

Exception No. 2: When sprinklers are specifically tested and test results demonstrate that deviations from clearance requirements to structural members do not impair the ability of the sprinkler to control or suppress a fire, their positioning and locating in accordance with the test results shall be permitted.

Exception No. 3: Clearance between sprinklers and ceilings exceeding the maximum specified in 4-6.4.1, 4-7.4.1, 4-8.4.1, 4-9.4.1, 4-10.4.1, and 4-11.4.1 shall be permitted provided that tests or calculations demonstrate comparable sensitivity and performance of the sprinklers to those installed in conformance with these sections.

4-1.2* System valves and gauges shall be accessible for operation, inspection, tests, and maintenance.

4-2 System Protection Area Limitations. The maximum floor area on any one floor to be protected by sprinklers supplied by any one sprinkler system riser or combined system riser shall be as follows:

Light Hazard	52,000 sq ft (4831 m ²)
Ordinary Hazard	52,000 sq ft (4831 m ²)
Extra Hazard	
Pipe Schedule	25,000 sq ft (2323 m ²)
Hydraulically Calculated	40,000 sq ft (3716 m ²)
Storage — High-piled storage	
(as defined in 1-4.2) and storage covered by other NFPA standards	40,000 sq ft (3716 m ²)

Exception No. 1: The floor area occupied by mezzanines shall not be included in the above area.

Exception No. 2: Where single systems protect extra hazard, high-piled storage, or storage covered by other NFPA standards, and ordinary or light hazard areas, the extra hazard or storage area coverage shall not exceed the floor area specified for that hazard and the total area coverage shall not exceed 52,000 sq ft (4831 m²).

4-3 Use of Sprinklers.

4-3.1 General.

4-3.1.1* Sprinklers shall be installed in accordance with their listing.

Exception: Where construction features or other special situations require unusual water distribution, listed sprinklers shall be permitted to be installed in positions other than anticipated by their listing to achieve specific results.

4-3.1.2* Upright sprinklers shall be installed with the frame arms parallel to the branch line.

4-3.1.3 Temperature Ratings.

4-3.1.3.1 Ordinary-temperature-rated sprinklers shall be used throughout buildings.

Exception No. 1: Where maximum ceiling temperatures exceed 100°F (38°C), sprinklers with temperature ratings in accordance with the maximum ceiling temperatures of Table 2-2.4.1 shall be used.

Exception No. 2: Intermediate- and high-temperature sprinklers shall be permitted to be used throughout Ordinary and Extra Hazard Occupancies.

Exception No. 3: Sprinklers of intermediate and high temperature classifications shall be installed in specific locations as required by 4-3.1.3.2.

4-3.1.3.2 The following practices shall be observed to provide sprinklers of other than ordinary temperature classification unless other temperatures are determined or unless

high-temperature sprinklers are used throughout [see Tables 4-3.1.3.2(a) and (b) and Figure 4-3.1.3.2].

(a) Sprinklers in the high temperature zone shall be of the high temperature classification, and sprinklers in the intermediate temperature zone of the intermediate temperature classification.

(b) Sprinklers located within 12 in. (305 mm) to one side or 30 in. (762 mm) above an uncovered steam main, heating coil, or radiator shall be of the intermediate temperature classification.

(c) Sprinklers within 7 ft (2.1 m) of a low-pressure blowoff valve that discharges free in a large room shall be of the high temperature classification.

(d) Sprinklers under glass or plastic skylights exposed to the direct rays of the sun shall be of the intermediate temperature classification.

(e) Sprinklers in an unventilated, concealed space, under an uninsulated roof, or in an unventilated attic shall be of the intermediate temperature classification.

(f) Sprinklers in unventilated show windows having high-powered electric lights near the ceiling shall be of the intermediate temperature classification.

(g) Sprinklers protecting commercial-type cooking equipment and ventilation systems shall be of the high or extra high temperature classification as determined by use of a temperature measuring device. (See 3-9.6.)

4-3.1.3.3 In case of occupancy change involving temperature change, the sprinklers shall be changed accordingly.

Table 4-3.1.3.2(a) Temperature Ratings of Sprinklers Based on Distance from Heat Sources

Type of Heat Condition	Ordinary Degree Rating	Intermediate Degree Rating	High Degree Rating
1. Heating ducts			
(a) Above	More than 2 ft 6 in.	2 ft 6 in. or less	—
(b) Side and below	More than 1 ft 0 in.	1 ft 0 in. or less	—
(c) Diffuser	Any distance except as shown under Intermediate Degree Rating column	Downward Discharge: Cylinder with 1 ft 0 in. radius from edge, extending 1 ft 0 in. below and 2 ft 6 in. above Horizontal Discharge: Semi-cylinder with 2 ft 6 in. radius in direction of flow, extending 1 ft 0 in. below and 2 ft 6 in. above	—
2. Unit heater	—	Discharge Side: 7 ft 0 in. to 20 ft 0 in. radius pie-shaped cylinder [see Figure 4-3.1.3.2] extending 7 ft 0 in. above and 2 ft 0 in. below heater; also 7 ft 0 in. radius cylinder more than 7 ft 0 in. above unit heater	7 ft 0 in. radius cylinder extending 7 ft 0 in. above and 2 ft 0 in. below unit heater
(a) Horizontal discharge	—	7 ft 0 in. radius cylinder extending upward from an elevation 7 ft 0 in. above unit heater	7 ft 0 in. radius cylinder extending from the top of the unit heater to an elevation 7 ft 0 in. above unit heater
(b) Vertical downward discharge [Note: For sprinklers below unit heater, see Figure 4-3.1.3.2.]	—	—	—
3. Steam mains (uncovered)			
(a) Above	More than 2 ft 6 in.	2 ft 6 in. or less	—
(b) Side and below	More than 1 ft 0 in.	1 ft 0 in. or less	7 ft 0 in. or less
(c) Blowoff valve	More than 7 ft 0 in.	—	—

For SI Units: 1 in. = 25.4 mm; 1 ft = 0.3048 m.

Table 4-3.1.3.2(b) Ratings of Sprinklers in Specified Locations

Location	Ordinary Degree Rating	Intermediate Degree Rating	High Degree Rating
Skylights	—	Glass or plastic	—
Attics	Ventilated	Unventilated	—
Peaked roof: Metal or thin boards, concealed or not concealed, insulated or uninsulated	Ventilated	Unventilated	—
Flat roof: Metal, not concealed; insulated or uninsulated	Ventilated or unventilated	Note: For uninsulated roof, climate and occupancy may necessitate intermediate sprinklers. Check on job.	—
Flat roof: Metal, concealed, insulated or uninsulated	Ventilated	Unventilated	—
Show windows	Ventilated	Unventilated	—

Note: A check of job condition by means of thermometers may be necessary.

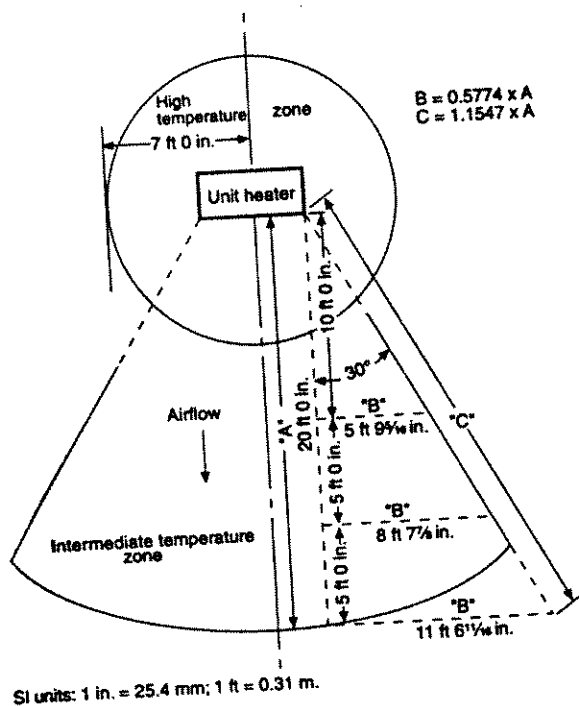

Figure 4-3.1.3.2 High temperature and intermediate temperature zones at unit heaters.

4-4* Application of Sprinkler Types. Sprinklers shall be selected for use as indicated in this section. Sprinklers shall be positioned and spaced as described in Section 4-5.

4-4.1 Upright and Pendent Spray Sprinklers. Upright and pendent spray sprinklers shall be permitted in all occupancy hazard classifications and building construction types.

Exception: Quick-response sprinklers are not permitted for use in extra hazard occupancies under the area-density design method. (See 5-2.3.2.3, Exception No. 1.)

4-4.2 Sidewall Spray Sprinklers. Sidewall sprinklers shall be installed only in light hazard occupancies with smooth, flat ceilings.

Exception: Sidewall sprinklers shall be permitted to be used in Ordinary Hazard Occupancies with smooth, flat ceilings where specifically listed for such use.

4-4.3 Extended Coverage Sprinklers. Extended coverage sprinklers shall be limited to a type of unobstructed construction consisting of flat, smooth ceilings with a slope not exceeding 2 in. per ft. (158 mm/m)

Exception No. 1: Where sprinklers are specifically listed for unobstructed or noncombustible obstructed construction, they shall be permitted for such use.

Exception No. 2: Extended coverage upright and pendent spray sprinklers shall be permitted within trusses or bar joists having web members not greater than 1-in. (25.4-mm) maximum dimension.

Exception No. 3: Where specifically listed for use under smooth, flat ceilings that have slopes not exceeding 4 in. per ft (316 mm/m).

4-4.4 Open Sprinklers. Open sprinklers shall be permitted to be used in deluge systems to protect special hazards or exposures, or in other special locations. Open sprinklers shall be installed in accordance with all applicable requirements of this standard for their automatic counterpart.

4-4.5 Residential Sprinklers.

4-4.5.1* Residential sprinklers shall be permitted in dwelling units and their adjoining corridors provided they are installed in conformance with their listing and the positioning requirements of NFPA 13D, *Standard for the Installation of Sprinkler Systems in One- and Two-Family Dwellings and Manufactured Homes*, or NFPA 13R, *Standard for the Installation of Sprinkler Systems in Residential Occupancies up to and Including Four Stories in Height*.

4-4.5.2' Residential sprinklers shall be used only in wet systems.

Exception: Residential sprinklers shall be permitted for use in dry systems if specifically listed for such service.

4-4.5.3 Where residential sprinklers are installed in a compartment as defined in 1-4.2, all sprinklers within the compartment shall be of the fast-response type that meets the criteria of 1-4.5.1(a)1.

4-4.6 Early Suppression Fast-Response (ESFR) Sprinklers.

4-4.6.1 ESFR sprinklers shall be used only in wet pipe systems.

Exception: ESFR sprinklers shall be permitted for use in dry systems if specifically listed for such service.

4-4.6.2 ESFR sprinklers shall be installed only in buildings where roof or ceiling slope above the sprinklers does not exceed 2 in. per ft (158 mm/m).

4-4.6.3 ESFR sprinklers shall be permitted for use only in buildings with the following types of construction:

(a) Smooth ceiling, joists consisting of steel truss-shaped members, or wood truss-shaped members that consist of wood top or bottom chord members not exceeding 4 in. (102 mm) in depth with steel tube or bar web.

(b) Wood beams of 4 in. by 4 in. (102 mm by 102 mm) or greater nominal dimension, concrete or steel beams spaced 3 1/2 to 7 1/2 ft (0.9 to 2.3 m) on centers and either supported on or framed into girders.

(c) Paragraphs (a) and (b) apply to construction with non-combustible or combustible roof or decks.

(d) Construction with ceiling panels formed by members capable of trapping heat to aid the operation of sprinklers with members spaced greater than 7 1/2 ft (2.3 m) and limited to a maximum of 300 sq ft (27.9 m²) in area.

4-4.6.4 Temperature Rating. Sprinkler temperature ratings shall be ordinary.

Exception: Sprinklers of intermediate and high temperature ratings shall be installed in locations as required by Section 4-3.

4-4.7 Large-Drop Sprinklers.

4-4.7.1 Large-drop sprinklers shall be permitted to be used in wet, dry, or preaction systems.

4-4.7.2* Where steel pipe is used in preaction and dry pipe systems, piping materials shall be limited to internally galvanized steel.

Exception: Nongalvanized fittings shall be permitted.

4-4.7.3 Sprinkler temperature ratings shall be the same as those indicated in Tables 4-3.1.3.2(a) and (b) or those used in large-scale fire testing to determine the protection requirements for the hazard involved.

Exception: Sprinklers of intermediate and high temperature ratings shall be installed in specific locations as required by 4-3.1.3.

4-4.8 QRES. (Reserved)

4-4.9 Special Sprinklers.

4-4.9.1* Special sprinklers that are intended for the protection of specific hazards or construction features shall be permitted where such devices have been evaluated and listed for performance under the following conditions:

- Fire tests related to the intended hazard.
- Distribution of the spray pattern with respect to wetting of floors and walls.
- Distribution of the spray pattern with respect to obstructions.
- Evaluation of the thermal sensitivity of the sprinkler.
- Performance under horizontal or sloped ceilings.
- Area of design.

4-4.9.2 Special sprinklers shall maintain the following characteristics:

(a) Orifice size shall be in accordance with Section 2-2.3.

(b) Temperature ratings shall be in accordance with Table 2-2.4.1.

(c) The protection area of coverage shall not exceed 400 ft² (36 m²) for light hazard and ordinary hazard occupancies.

(d) The protection area of coverage shall not exceed 196 ft² (17 m²) for extra hazard and high pile storage occupancies.

4-5 Position, Location, Spacing, and Use of Sprinklers.

4-5.1 General. Sprinklers shall be located, spaced, and positioned in accordance with the requirements of this section. Sprinklers shall be positioned to provide protection of the area consistent with the overall objectives of this standard by controlling the positioning and allowable area of coverage for each sprinkler. The requirements of 4-5.2 through 4-5.6 shall apply to all sprinkler types unless modified by more restrictive rules in Sections 4-6 through 4-1.1.

4-5.2 Protection Areas per Sprinkler.

4-5.2.1 Determination of the Protection Area of Coverage. The protection area of coverage per sprinkler (A_s) shall be determined as follows:

(a) *Along Branch Lines.* Determine distance between sprinklers (or to wall or obstruction in the case of the end sprinkler on the branch line) upstream and downstream. Choose the larger of either twice the distance to the wall or the distance to the next sprinkler. This dimension will be defined as S.

(b) *Between Branch Lines.* Determine perpendicular distance to the sprinkler on the adjacent branch line (or to a wall or obstruction in the case of the last branch line) on each side of the branch line on which the subject sprinkler is positioned. Choose the larger of either twice the distance to the wall or obstruction or the distance to the next sprinkler. This dimension will be defined as L.

4-5.2.1.1 The protection area of coverage of the sprinkler shall be established by multiplying the S dimension by the L dimension. ($A_s = S \times L$)

4-5.2.2 Maximum Protection Area of Coverage. The maximum allowable protection area of coverage for a sprinkler (A_s) shall be in accordance with the value indicated in the section for each type or style of sprinkler. The maximum area of coverage of any sprinkler shall not exceed 400 ft² (36 m²).

4-5.3 Sprinkler Spacing.

4-5.3.1 Maximum Distance Between Sprinklers. The maximum distance permitted between sprinklers shall be based on the centerline distance between sprinklers on the branch line or on adjacent branch lines. The maximum distance shall be measured along the slope of the ceiling. The maximum distance permitted between sprinklers shall comply with the value indicated in the section for each type or style of sprinkler.

4-5.3.2 Maximum Distance From Walls. The distance from sprinklers to walls shall not exceed one-half of the allowable maximum distance between sprinklers. The distance from the wall to the sprinkler shall be measured perpendicular to the wall.

4-5.3.3 Minimum Distance from Walls. The minimum distance permitted between a sprinkler and the wall shall comply with the value indicated in the section for each type or style of sprinkler. The distance from the wall to the sprinkler shall be measured perpendicular to the wall.

4-5.3.4 Minimum Distance Between Sprinklers. A minimum distance shall be maintained between sprinklers to prevent operating sprinklers from wetting adjacent sprinklers and to prevent skipping of sprinklers. The minimum distance permitted between sprinklers shall comply with the value indicated in the section for each type or style of sprinkler.

4-5.4 Deflector Position.

4-5.4.1 Distance Below Ceilings. The distances between the sprinkler deflector and the ceiling above shall be selected based on the type of sprinkler and the type of construction.

4-5.4.2 Deflector Orientation. Deflectors of sprinklers shall be aligned parallel to ceilings, roofs, or the incline of stairs.

4-5.5 Obstructions to Sprinkler Discharge.

4-5.5.1 Performance Objective.

4-5.5.1.1 Sprinklers shall be located so as to minimize obstructions to discharge as defined in 4-5.5.2 and 4-5.5.3 or additional sprinklers shall be provided to ensure adequate coverage of the hazard. (See Figure 4-5.5.1.1.)

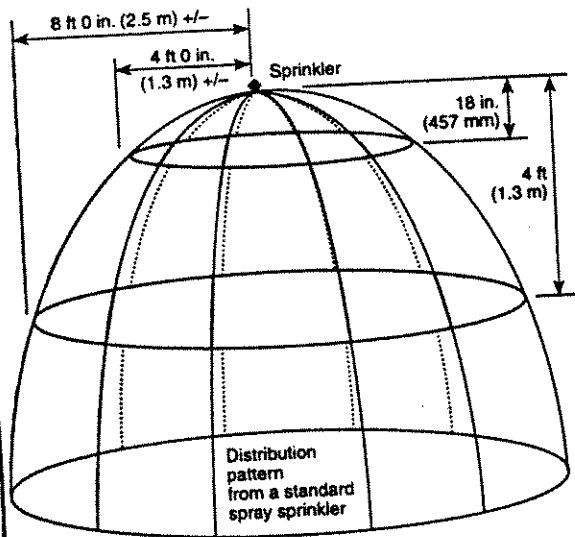

Figure 4-5.5.1.1 Typical distribution pattern from a standard spray sprinkler.

4-5.5.2* Obstructions to Sprinkler Discharge Pattern Development.

4-5.5.2.1 Continuous or noncontinuous obstructions less than 18 in. (457 mm) below the sprinkler deflector that prevent the pattern from fully developing shall comply with this section.

4-5.5.2.2 Sprinklers shall be positioned such that they are located at a distance three times greater than the maximum dimension of an obstruction up to a maximum of 24 in. (609 mm) (e.g., truss webs and chords, pipe, columns, and fixtures).

Exception No. 1: Continuous solid obstructions, such as beams, top chord members, and ducts, that are tight to the ceiling shall comply with 4-6.5.1, 4-7.5.1, 4-8.5.1, 4-9.5.1, 4-10.5.1 and 4-11.5.1.

Exception No. 2: Piping to which an upright sprinkler is directly attached less than 3 in. (75 mm) in diameter.

Exception No. 3: Piping to which pendent and sidewall sprinklers are directly attached.

4-5.5.3* Obstructions that Prevent Sprinkler Discharge from Reaching the Hazard. Continuous or noncontinuous obstructions that interrupt the water discharge in a horizontal plane more than 18 in. (457 mm) below the sprinkler deflector in a manner to limit the distribution from reaching the protected hazard shall comply with this section.

4-5.5.3.1 Sprinklers shall be installed under fixed obstructions over 4 ft (1.2 m) wide such as ducts, decks, cutting tables, and overhead doors.

Exception: Obstructions that are not fixed in place such as conference tables.

4-5.5.3.2 Sprinklers installed under open gratings shall be of the intermediate level/rack storage type or otherwise shielded from the discharge of overhead sprinklers.

4-5.6 Clearance to Storage. The clearance between the deflector and the top of storage shall be 18 in. (457 mm) or greater.

Exception No. 1: Where other standards specify greater minimums, they shall be followed.

Exception No. 2: A minimum clearance of 36 in. (.91 m) shall be permitted for special sprinklers.

Exception No. 3: A minimum clearance of less than 18 in. (457 mm) between the top of storage and ceiling sprinkler deflectors shall be permitted where proven by successful large-scale fire tests for the particular hazard.

4-6 Standard Pendent and Upright Spray Sprinklers.

4-6.1 General. All requirements of Section 4-5 shall apply to standard pendent and upright spray sprinklers except as modified below.

4-6.2 Protection Areas per Sprinkler (Standard Pendent and Upright Spray Sprinklers).

4-6.2.1 Determination of the Protection Area of Coverage. The protection area of coverage per sprinkler (A_s) shall be determined in accordance with 4-5.2.1.

Exception: In a small room as defined in 1-4.2, the protection area of coverage for each sprinkler in the small room shall be the area of the room divided by the number of sprinklers in the room.

4-6.2.2 Maximum Protection Area of Coverage. The maximum allowable protection area of coverage for a sprinkler (A_s) shall be in accordance with the value indicated in Table 4-6.2. In any case, the maximum area of coverage of a sprinkler shall not exceed 225 ft² (21 m²).

Exception No. 1: The following maximum protection areas of coverage shall apply for pipe schedule systems:

Light Hazard— 200 ft² (18.6 m²)

Extra Hazard— 90 ft² (8.4 m²)

Exception No. 2: The maximum protection area of coverage for light hazard systems installed in configurations utilizing combustible construction members spaced less than 3 ft (.91 m) on center shall not exceed 130 ft² (12 m²).

Table 4-6.2 Protection Areas and Maximum Spacing (SSU/SSP)

Construction Type	Light Hazard		Ordinary Hazard		Extra Hazard		High-Piled Storage	
	Protection Area ft ²	Spacing (max.) ft	Protection Area ft ²	Spacing (max.) ft	Protection Area ft ²	Spacing (max.) ft	Protection Area ft ²	Spacing (max.) ft
Noncombustible unobstructed and unobstructed and combustible unobstructed	225	15	130	15	100	12	100	12
Combustible obstructed	168	15	130	15	100	12	100	12

For SI units: 1 ft² = 0.0929 m²; 1 ft = 0.3048 m.

Exception No. 3: Where densities for extra hazard and high piled storage occupancies are less than 0.25 gpm/ft² (10.2 Lpm/m²), the maximum protection area of coverage shall be permitted to be increased to 130 ft² (.91 m²).

4-6.3 Sprinkler Spacing (Standard Pendent and Upright Spray Sprinklers).

4-6.3.1 Maximum Distance Between Sprinklers. The maximum distance permitted between sprinklers shall comply with Table 4-6.2.

Exception No. 1: For extra hazard occupancies and high piled storage in bays 25 ft (7.6 m) wide, a spacing of 12 ft 6 in (3.8 m) shall be permitted.

Exception No. 2: For densities less than 0.25 gpm/ft² (10.2 Lpm/m²), a spacing of 15 ft (4.6 m) shall be permitted.

4-6.3.2* Maximum Distance from Walls. The distance from sprinklers to walls shall not exceed one-half of the allowable distance between sprinklers as indicated in Table 4-6.2. The distance from the wall to the sprinkler shall be measured perpendicular to the wall. Where walls are angled or irregular, the maximum horizontal distance between a sprinkler and any point of floor area protected by that sprinkler shall not exceed 0.75 times the allowable distance permitted between sprinklers, provided the maximum perpendicular distance is not exceeded.

4-6.3.2.1 Under curved surfaces, the horizontal distance shall be measured at the floor level from the wall, or the intersection of the curved surface and the floor to the nearest sprinkler shall not be greater than one-half the allowable distance between sprinklers.

Exception:* Within small rooms as defined in 1-4.2, sprinklers shall be permitted to be located not more than 9 ft (2.7 m) from any single wall. Sprinkler spacing limitations of 4-6.3 and area limitations of Table 4-6.2 shall not be exceeded.

4-6.3.3 Minimum Distance from Walls. Sprinklers shall be located a minimum of 4 in. (102 mm) from a wall.

4-6.3.4 Minimum Distance Between Sprinklers. Sprinklers shall be spaced not less than 6 ft (1.8 m) on center.

Exception No. 1: Sprinklers shall be permitted to be placed less than 6 ft (1.8 m) on center where the following conditions are satisfied:

(a) Baffles shall be installed and located midway between sprinklers and arranged to protect the actuating elements.

(b) Baffles shall be of noncombustible or limited-combustible material that will stay in place before and during sprinkler operation.

(c) Baffles shall be not less than 8 in. (203 mm) wide and 6 in. (152 mm) high. The tops of baffles shall extend between 2 in. to 3 in. (51 to 76 mm) above the deflectors of upright sprinklers. The bottoms of baffles shall extend downward to a level at least even with the deflectors of pendent sprinklers.

Exception No. 2: In-rack sprinklers.

Exception No. 3: Old-style sprinklers protecting fur storage vaults.

4-6.4 Deflector Position (Standard Pendent and Upright Spray Sprinklers).

4-6.4.1 Distance Below Ceilings.

4-6.4.1.1 Under unobstructed construction, the distance between the sprinkler deflector and the ceiling shall be a minimum of 1 in. (25.4 mm) and a maximum of 12 in. (305 mm).

Exception: Ceiling-type sprinklers (concealed, recessed, and flush types) shall be permitted to have the operating element above the ceiling and the deflector located nearer to the ceiling where installed in accordance with their listing.

4-6.4.1.2 Under obstructed construction, the sprinkler deflector shall be located 1 to 6 in. (25.4 to 152 mm) below the structural members and a maximum distance of 22 in. (559 mm) below the ceiling/roof deck.

Exception No. 1: Sprinklers shall be permitted to be installed with the deflector at or above the bottom of the structural member to a maximum of 22 in. (559 mm) below the ceiling/roof deck where the sprinkler is installed in conformance with 4-6.5.1.2.

Exception No. 2: Where sprinklers are installed in each bay of obstructed construction, deflectors shall be a minimum of 1 in. (25.4 mm) and a maximum of 12 in. (305 mm) below the ceiling.

Exception No. 3: Sprinklers shall only be permitted below composite wood joists where joist channels are fire-stopped to the full depth of the joists with material equivalent to the web construction so that individual channel areas do not exceed 300 ft² (27.9 m²).

Exception No. 4:* Deflectors of sprinklers under concrete tee construction with stems spaced less than 7 1/2 ft (2.3 m) but more than 3 ft (0.9 m) on centers shall, regardless of the depth of the tee, be permitted to be located at or above a horizontal plane 1 in. (25.4 mm) below the bottom of the stems of the tees and shall comply with Table 4-6.5.1.2.

4-6.4.1.3* Sprinklers under or near the peak of a roof or ceiling shall have deflectors located not more than 3 ft (0.9 m) vertically down from the peak. [See Figures 4-6.4.1.3(a) and 4-6.4.1.3(b).]

Exception No. 1: Under saw-toothed roofs, sprinklers at the highest elevation shall not exceed a distance of 3 ft (0.9 m) measured down the slope from the peak.

Exception No. 2: Under a steeply pitched surface, the distance from the peak to the deflectors shall be permitted to be increased to maintain a horizontal clearance of not less than 2 ft (0.6 m) from other structural members. [See Figure 4-6.4.1.3(c).]

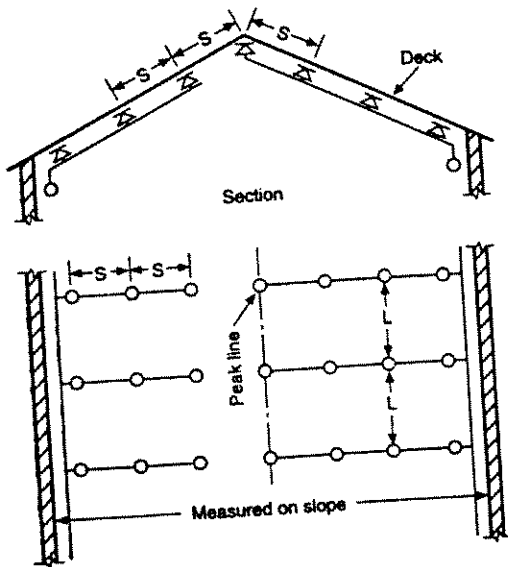

Figure 4-6.4.1.3(a) Sprinklers at pitched roofs; branch lines run up the slope.

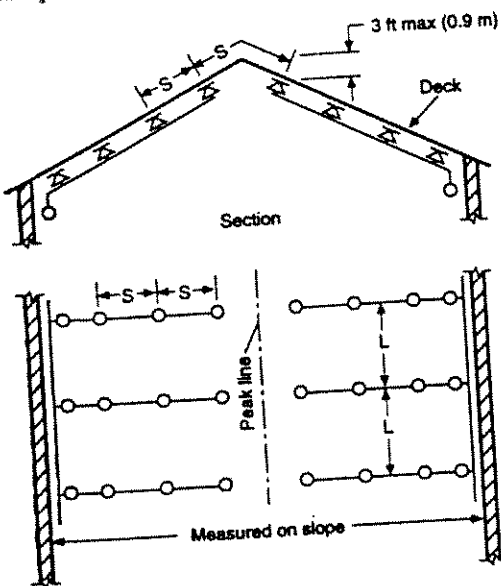

Figure 4-6.4.1.3(b) Sprinklers at pitched roofs; branch lines run up the slope.

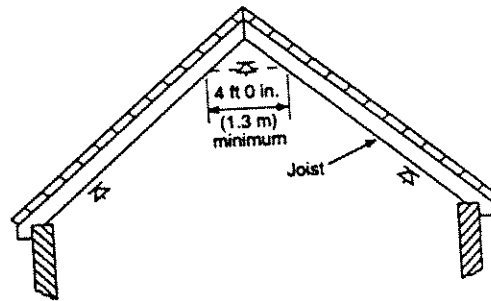

Figure 4-6.4.1.3(c) Horizontal clearance for sprinklers at peak of pitched roof.

4-6.4.1.4 Double Joist Obstructions. Where there are two sets of joists under a roof or ceiling, and there is no flooring over the lower set, sprinklers shall be installed above and below the lower set of joists where there is a clearance of 6 in. (152 mm) or more between the top of the lower joist and the bottom of the upper joist. (See Figure 4-6.4.1.4.)

Exception: Sprinklers are permitted to be omitted from below the lower set of joists where at least 18 in. (457 mm) is maintained between the sprinkler deflector and the top of the lower joist.

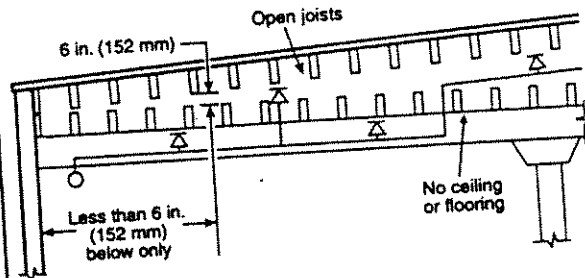

Figure 4-6.4.1.4 Arrangement of sprinklers under two sets of open joists — no sheathing on lower joists.

4-6.4.2* Deflector Orientation. Deflectors of sprinklers shall be aligned parallel to ceilings, roofs, or the incline of stairs.

Exception: Where sprinklers are installed in the peak below a sloped ceiling or roof surface, the sprinkler shall be installed with the deflector horizontal.

4-6.5 Obstructions to Sprinkler Discharge (Standard Pendant and Upright Spray Sprinklers).

4-6.5.1 Performance Objective.

4-6.5.1.1 Sprinklers shall be located so as to minimize obstructions to discharge as defined in 4-6.5.2 and 4-6.5.3 or additional sprinklers shall be provided to ensure adequate coverage of the hazard.

4-6.5.1.2 Sprinklers shall be arranged to comply with 4-5.5.2, Table 4-6.5.1.2, and Figure 4-6.5.1.2(a).

Exception No. 1: Sprinklers shall be permitted to be spaced on opposite sides of obstructions not exceeding 4 ft (1.3 m) in width provided the distance from the centerline of the obstruction to the sprinklers does not exceed one-half the allowable distance permitted between sprinklers.

Exception No. 2: Obstructions located against the wall and that are not over 30 in. (762 mm) in width shall be permitted to be protected in accordance with Figure 4-6.5.1.2(b).

Table 4-6.5.1.2 Positioning of Sprinklers to Avoid Obstructions to Discharge (SSU/SSP)

Distance from Sprinklers to Side of Obstruction (a)	Maximum Allowable Distance of Deflector above Bottom of Obstruction (in.) (b)
Less than 1 ft	0
One ft to less than 1 ft 6 in.	2½
1 ft 6 in. to less than 2 ft	3½
2 ft to less than 2 ft 6 in.	5½
2 ft 6 in. to less than 3 ft	7½
3 ft to less than 3 ft 6 in.	9½
3 ft 6 in. to less than 4 ft	12
4 ft to less than 4 ft 6 in.	14
4 ft 6 in. to less than 5 ft	16½
5 ft and greater	18

For SI Units: 1 in. = 25.4 mm; 1 ft = 0.3048 m.

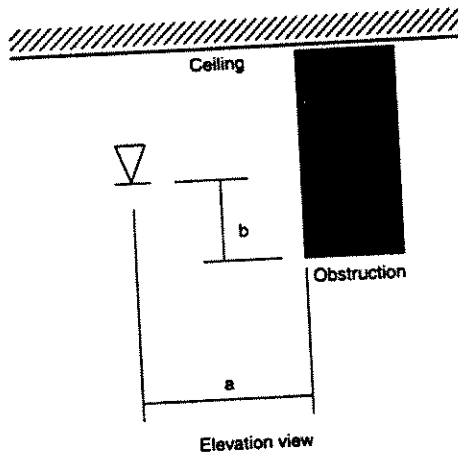

Figure 4-6.5.1.2(a) Positioning of sprinklers to avoid obstructions to discharge (SSU/SSP).

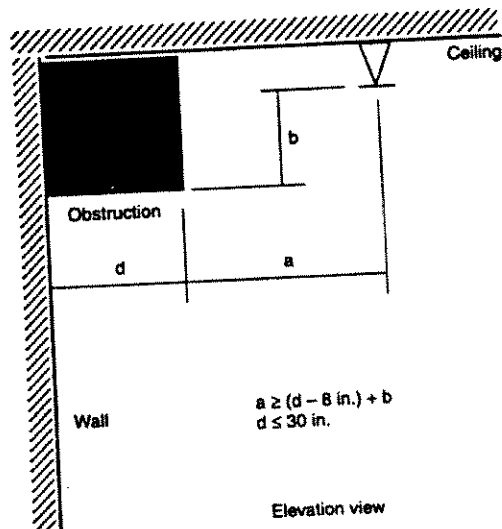

Figure 4-6.5.1.2(b) Obstructions against walls (SSU/SSP).

4-6.5.2 Obstructions to Sprinkler Discharge Pattern Development.

4-6.5.2.1 Continuous or noncontinuous obstructions less than 18 in. (457 mm) below the sprinkler deflector that prevent the pattern from fully developing shall comply with this section.

4-6.5.2.2 Sprinklers shall be positioned such that they are located at a distance three times greater than the maximum dimension of an obstruction up to a maximum of 24 in. (609 mm) (e.g., structural members, pipe, columns, and fixtures). (See Figure 4-6.5.2.2.)

Exception No. 1: Sprinklers shall be permitted to be spaced on opposite sides of the obstruction provided the distance from the centerline of the obstruction to the sprinklers does not exceed one-half the allowable distance between sprinklers.

Exception No. 2: Where the obstruction consists of open trusses 20 in. (.51 m) or greater apart [24 in. (.61 m) on center], sprinklers shall be permitted to be located one-half the distance between the obstruction created by the truss provided that all truss members are not greater than 4 in. (102 mm) (nominal) in width.

Exception No. 3: Where the sprinklers are installed in the centerline of bar joists or a truss.

Exception No. 4: Piping to which an upright sprinkler is directly attached less than 3 in. (75 mm) in diameter.

Exception No. 5: Piping to which pendent sprinklers are directly attached.

4-6.5.3* Obstructions that Prevent Sprinkler Discharge from Reaching the Hazard. Continuous or noncontinuous obstructions that interrupt the water discharge in a horizontal plane more than 18 in. (457 mm) below the sprinkler deflector in a manner to limit the distribution from reaching the protected hazard shall comply with this section.

4-6.5.3.1 Sprinklers shall be installed under fixed obstructions over 4 ft (1.2 m) wide such as ducts, decks, cutting tables, and overhead doors.

Exception: Obstructions that are not fixed in place, such as conference tables.

4-6.5.3.2 Sprinklers installed under open gratings shall be of the intermediate level/rack storage type or otherwise shielded from the discharge of overhead sprinklers.

4-6.5.4* Suspended or Floor-Mounted Vertical Obstructions. The distance from sprinklers to privacy curtains, free standing partitions, room dividers, and similar obstructions in light hazard occupancies shall be in accordance with Table 4-6.5.4 and Figure 4-6.5.4.

4-6.6* Clearance to Storage (Standard Pendent and Upright Spray Sprinklers). The clearance between the deflector and the top of storage shall be 18 in. (457 mm) or greater.

Exception: Where other standards specify greater minimums, they shall be followed.

4-7 Sidewall Standard Spray Sprinklers.

4-7.1 General. All requirements of Section 4-5 shall apply to sidewall standard spray sprinklers except as modified below.

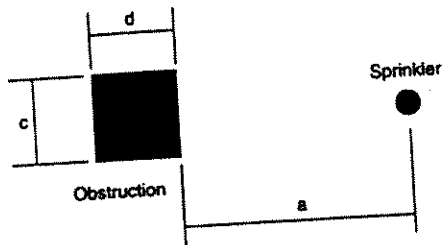

Plan view of column

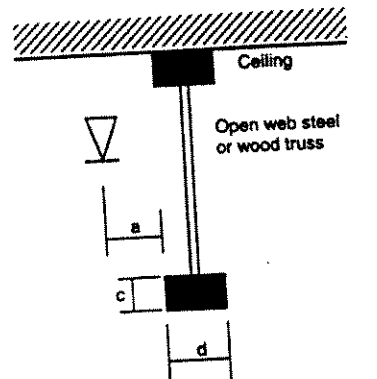

Elevation view of truss

$$a \geq 3c \text{ or } 3d$$

(Use dimension c or d, whichever is greater)

Figure 4-6.5.2.2 Minimum distance from obstruction (SSU/SSP).

Table 4-6.5.4 Suspended or Floor Mounted Obstructions (SSU/SSP)

Horizontal Distance (a)	Minimum Vertical Distance below Deflector (b)
6 in. or less	3 in.
More than 6 in. to 9 in.	4 in.
More than 9 in. to 12 in.	6 in.
More than 12 in. to 15 in.	8 in.
More than 15 in. to 18 in.	9½ in.
More than 18 in. to 24 in.	12 ½ in.
More than 24 in. to 30 in.	15 ½ in.
More than 30 in.	18 in.

For SI Units: 1 in. = 25.4 mm.

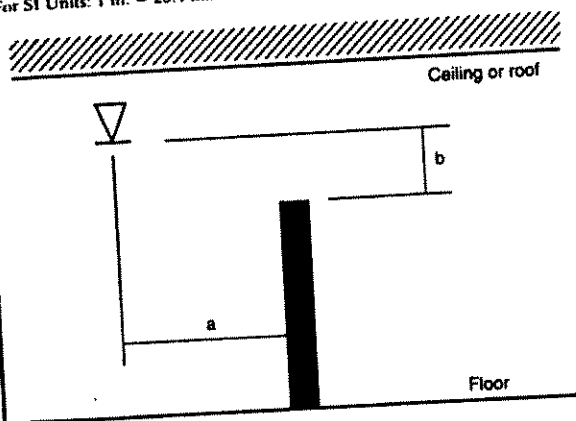

Figure 4-6.5.4 Suspended or floor-mounted obstructions (SSU/SSP).

4-7.2 Protection Areas per Sprinkler (Standard Sidewall Spray Sprinklers).

4-7.2.1 Determination of the Protection Area of Coverage. The protection area of coverage per sprinkler (A_s) shall be determined as follows:

(a) *Along the Wall.* Determine the distance between sprinklers along the wall (or to the end wall or obstruction in the case of the end sprinkler on the branch line) upstream and downstream. Choose the larger of either twice the distance to the end wall or the distance to the next sprinkler. This dimension will be defined as S.

(b) *Across the Room.* Determine the distance from the sprinkler to the wall opposite the sprinklers or to the midpoint of the room where sprinklers are installed on two opposite walls (see 4-7.3.1). This dimension will be defined as L.

4-7.2.1.1 The protection area of the sprinkler shall be established by multiplying the S dimension by the L dimension. ($A_s = S \times L$)

4-7.2.2 Maximum Protection Area of Coverage. The maximum allowable protection area of coverage for a sprinkler (A_s) shall be in accordance with the value indicated in Table 4-7.2. In any case, the maximum area of coverage of a sprinkler shall not exceed 196 ft² (59.7 m²).

4-7.3 Sprinkler Spacing (Standard Sidewall Spray Sprinklers).

4-7.3.1 Maximum Distance Between Sprinklers. The maximum distance permitted between sprinklers shall be based on the centerline distance between sprinklers on the branch line. The maximum distance shall be measured along the slope of the ceiling.

4-7.3.1.1 Sidewall spray sprinklers shall be installed along the length of a single wall of rooms or bays in accordance with the maximum spacing provisions of Table 4-7.2.

Exception No 1: Sidewall sprinklers shall not be installed back-to-back without being separated by a continuous lintel or soffit.

Exception No 2: Where the width of the room or bay exceeds the maximum allowed, up to 24 ft (9.1 m) for Light Hazard Occupancy, or 20 ft (6.1 m) for Ordinary Hazard Occupancy, sidewall sprinklers shall be provided on two opposite walls or sides of bays with spacing as required by Table 4-7.2.

Exception No 3: Sidewall sprinklers shall be permitted to be installed on opposing or adjacent walls provided no sprinkler is located within the maximum protection area of another sprinkler.

Table 4-7.2 Protection Areas and Maximum Spacing (Standard Sidewall Spray Sprinkler)

	Light Hazard		Ordinary Hazard	
	Combustible Finish	Noncombustible or Limited-Combustible Finish	Combustible Finish	Noncombustible or Limited-Combustible Finish
Maximum distance along the wall (S)	14 ft	14 ft	10 ft	10 ft
Maximum room width (L)	12 ft	14 ft	10 ft	10 ft
Maximum protection area	120 ft ²	196 ft ²	80 ft ²	100 ft ²

For SI units: 1 ft = 0.3048 m; 1 sq ft = 0.0929 m².

4-7.3.2 Maximum Distance from Walls. The distance from sprinklers to the end walls shall not exceed one-half of the allowable distance permitted between sprinklers as indicated in Table 4-7.2.

4-7.3.3 Minimum Distance from Walls. Sprinklers shall be located a minimum of 4 in. (102 mm) from a wall. The distance from the wall to the sprinkler shall be measured perpendicular to the wall.

Exception: Horizontal and vertical sidewall sprinklers are permitted to be located with their deflectors less than 4 in. (102 mm) from the wall on which they are mounted.

4-7.3.4 Minimum Distance Between Sprinklers. Sprinklers shall be spaced not less than 6 ft (1.8 m) on center.

4-7.4 Deflector Position from Ceilings and Walls (Standard Sidewall Spray Sprinklers).

4-7.4.1 Distance Below Ceilings and from Walls.

4-7.4.1.1 Sidewall sprinkler deflectors (vertical type) shall be located not more than 6 in. (152 mm) nor less than 4 in. (102 mm) from ceilings.

Exception: Horizontal sidewall sprinklers are permitted to be located in a zone 6 to 12 in. (152 to 305 mm) or 12 to 18 in. (305 mm to 457 mm) below noncombustible ceilings where listed for such use.

4-7.4.1.2 Sidewall sprinkler deflectors shall be located not more than 6 in. (152 mm) nor less than 4 in. (102 mm) from walls.

4-7.4.1.3 Sidewall sprinklers shall only be installed along walls, lintels, or soffits where the distance from the ceiling to the bottom of the lintel or soffit is at least 2 in. (51 mm) greater than the distances from the ceiling to sidewall sprinkler deflectors.

4-7.4.1.3.1 Where soffits are used for the installation of sidewall sprinklers, they shall not exceed 8 in. (203 mm) in width or projection from the wall.

Exception: Soffits shall be permitted to exceed 8 in. (203 mm) where additional sprinklers are installed below the soffit.

4-7.4.2 Deflector Orientation. Deflectors of sprinklers shall be aligned parallel to ceilings or roofs.

4-7.4.2.1 Sidewall sprinklers, where installed under a sloped ceiling, shall be located at the high point of the slope and positioned to discharge downward along the slope.

4-7.5 Obstructions to Sprinkler Discharge (Standard Sidewall Spray Sprinklers).

4-7.5.1 Performance Objective.

4-7.5.1.1 Sprinklers shall be located so as to minimize obstructions to discharge as defined in 4-5.5.2 and 4-5.5.3 or

additional sprinklers shall be provided to ensure adequate coverage of the hazard.

4-7.5.1.2 Sidewall sprinklers shall be installed no closer than 4 ft (2.3 m) from light fixtures or similar obstructions. The distance between light fixtures or similar obstructions located more than 4 ft (2.3 m) from the sprinkler shall be in conformity with Table 4-7.5.1.2 and Figure 4-7.5.1.2.

Table 4-7.5.1.2 Positioning of Sprinklers to Avoid Obstructions (Standard Sidewall Spray Sprinklers)

Distance from Sidewall Sprinkler to Side of Obstruction (a)	Maximum Allowable Distance of Deflector above Bottom of Obstruction (in.) (b)
Less than 4 ft	0
4 ft to less than 5 ft	1
5 ft to less than 5 ft 6 in.	2
5 ft 6 in. to less than 6 ft 6 in.	3
6 ft to less than 6 ft 6 in.	4
6 ft to less than 7 ft	6
7 ft to less than 7 ft 6 in.	7
7 ft 6 in. to less than 8 ft	9
8 ft to less than 8 ft 6 in.	11
8 ft 6 in. or greater	14

For SI Units: 1 in. = 25.4 mm; 1 ft = 0.3048 m.

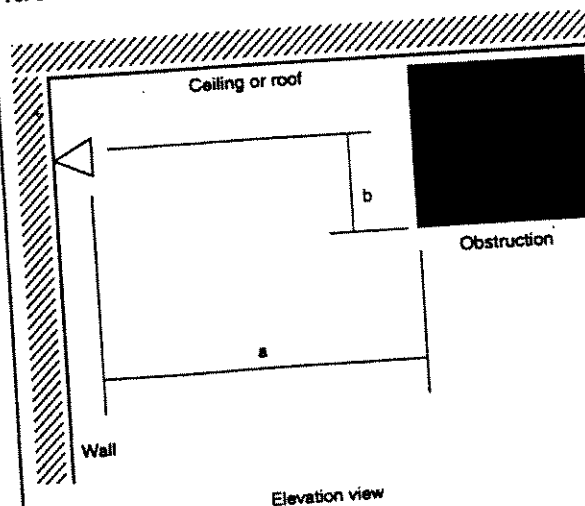

Figure 4-7.5.1.2 Positioning of sprinklers to avoid obstructions (standard sidewall spray sprinklers).

4-7.5.1.3 Obstructions projecting from the same wall as the sidewall sprinkler is mounted shall be in accordance with Table 4-7.5.1.3 and Figure 4-7.5.1.3.

4-7.5.2 Obstructions to Sprinkler Discharge Pattern Development.

4-7.5.2.1 Continuous or noncontinuous obstructions less than 18 in. (457 mm) below the sprinkler deflector that prevent the pattern from fully developing shall comply with this section.

4-7.5.2.2 Sprinklers shall be positioned such that they are located at a distance from an obstruction up to a maximum of 24 in. (609 mm) (e.g., truss webs and chords, pipe, columns, and fixtures). Sidewall sprinklers shall be positioned in accordance with Figure 4-7.5.2.2 where obstructions are present.

Exception: Piping to which sidewall sprinklers are directly attached.

4-7.5.3* Obstructions that Prevent Sprinkler Discharge from Reaching the Hazard. Continuous or noncontinuous obstructions that interrupt the water discharge in a horizontal plane more than 18 in. (457 mm) below the sprinkler deflector in a manner to limit the distribution from reaching the protected hazard shall comply with this section.

4-7.5.3.1 Sprinklers shall be installed under fixed obstructions over 4 ft (1.2 m) wide such as ducts, decks, cutting tables, and overhead doors.

Exception: Obstructions that are not fixed in place such as conference tables.

Table 4-7.5.1.3 Positioning of Sprinklers to Avoid Obstructions Along the Wall (Standard Sidewall Spray Sprinklers)

Distance from Sidewall Sprinkler to Side of Obstruction (a)	Maximum Allowable Distance of Deflector above Bottom of Obstruction (in.) (b)
Less than 6 in.	1
6 in. to less than 1 ft	2
1 ft to less than 1 ft 6 in.	3
1 ft 6 in. to less than 2 ft	4½
2 ft to less than 2 ft 6 in.	5¾
2 ft 6 in. to less than 3 ft	7
3 ft to less than 3 ft 6 in.	8
3 ft 6 in. to less than 4 ft	9¼
4 ft to less than 4 ft 6 in.	10
4 ft 6 in. to less than 5 ft	11½
5 ft to less than 5 ft 6 in.	12¾
5 ft 6 in. to less than 6 ft	14
6 ft to less than 6 ft 6 in.	15
6 ft 6 in. to less than 7 ft	16¼
7 ft to less than 7 ft 6 in.	17½

For SI Units: 1 in. = 25.4 mm; 1 ft = 0.3048 m.

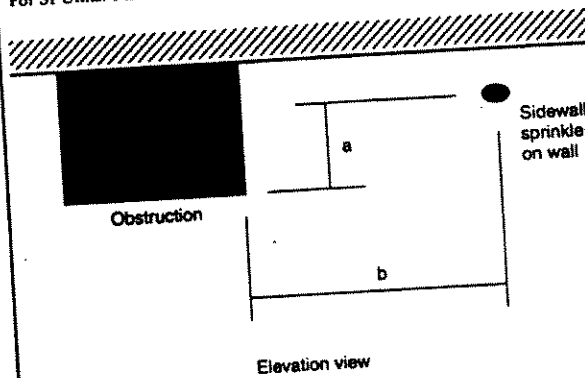
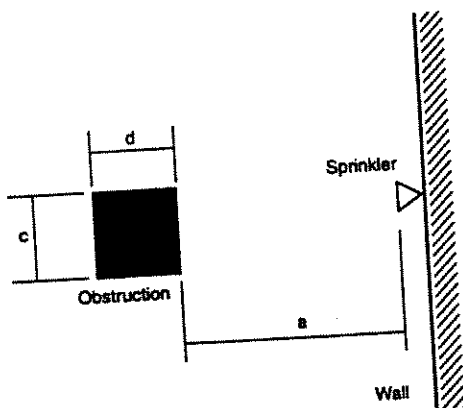
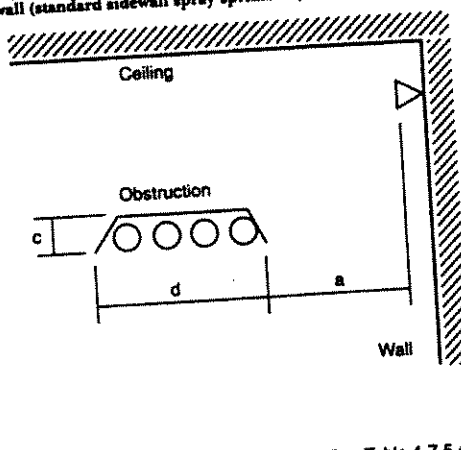

Figure 4-7.5.1.3 Positioning of sprinklers to avoid obstructions along the wall (standard sidewall spray sprinklers).



Plan view of column



Elevation view of pipe conduit or light fixture (See Table 4-7.5.4)

$a \geq 3c$ or $3d$
 $a \leq 24$ in.

(Use dimension c or d, whichever is greater)

Figure 4-7.5.2.2 Minimum distance from obstruction (standard sidewall spray sprinkler).

4-7.5.4 Suspended or Floor-Mounted Vertical Obstructions. The distance from sprinklers to privacy curtains, free-standing partitions, room dividers, and similar obstructions in light hazard occupancies shall be in accordance with Table 4-7.5.4 and Figure 4-7.5.4.

Table 4-7.5.4 Suspended or Floor Mounted Obstructions (Standard Sidewall Spray Sprinklers)

Horizontal Distance (a)	Maximum Vertical Distance below Deflector (b)
6 in. or less	3 in.
More than 6 in. to 9 in.	4 in.
More than 9 in. to 12 in.	6 in.
More than 12 in. to 15 in.	8 in.
More than 15 in. to 18 in.	9½ in.
More than 18 in. to 24 in.	12½ in.
More than 24 in. to 30 in.	15½ in.
More than 30 in.	18 in.

For SI Units: 1 in. = 25.4 mm.

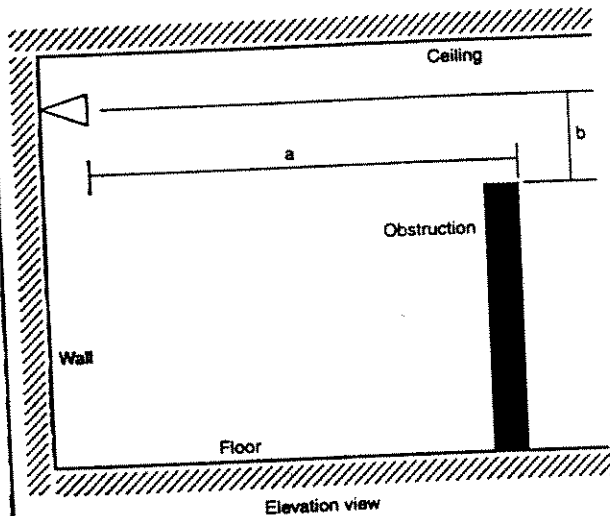

Figure 4-7.5.4 Suspended or floor-mounted obstructions (standard sidewall spray sprinklers).

4-7.6 Clearance to Storage (Standard Sidewall Spray Sprinklers). The clearance between the deflector and the top of storage shall be 18 in. (457 mm) or greater.

4-8 Extended Coverage Upright and Pendent Spray Sprinklers.

4-8.1 General. All requirements of Section 4-5 shall apply to extended coverage upright and pendent sprinklers except as modified below.

4-8.2 Protection Areas per Sprinkler (Extended Coverage Upright and Pendent Spray Sprinklers).

4-8.2.1* Determination of the Protection Area of Coverage. The protection area of coverage (A_p) for extended coverage sprinklers shall be not less than that prescribed by the listing. Listing dimensions shall be even-numbered square protection areas as shown in Table 4-8.2.

4-8.2.2 Maximum Protection Area of Coverage. The maximum allowable area of coverage for a sprinkler (A_p) shall be in accordance with the value indicated in Table 4-8.2. In any case, the maximum area of coverage of a sprinkler shall not exceed 400 sq ft.

4-8.3 Sprinkler Spacing (Extended Coverage Upright and Pendent Spray Sprinklers).

4-8.3.1 Maximum Distance Between Sprinklers. The maximum distance permitted between sprinklers shall be based on the centerline distance between sprinklers on the branch line or on adjacent branch lines. The maximum distance shall be measured along the slope of the ceiling. The maximum distance permitted between sprinklers shall comply with Table 4-8.2.

4-8.3.2 Maximum Distance From Walls. The distance from sprinklers to walls shall not exceed one-half of the allowable distance permitted between sprinklers as indicated in Table 4-8.2. The distance from the wall to the sprinkler shall be measured perpendicular to the wall. Where walls are angled or irregular, the maximum horizontal distance between a sprinkler and any point of floor area protected by that sprinkler shall not exceed 0.75 times the allowable distance permitted between sprinklers.

4-8.3.3 Minimum Distance from Walls. Sprinklers shall be located a minimum of 4 in. (102 mm) from a wall.

Exception: Where sprinklers have been listed for distances less than this, they shall be permitted.

4-8.3.4 Minimum Distance Between Sprinklers. Sprinklers shall be spaced not less than 8 ft (2.4 m) on center.

Exception: Sprinklers shall be permitted to be placed less than 8 ft (2.4 m) on center where the following conditions are satisfied:

(a) Baffles shall be installed and located midway between sprinklers and arranged to protect the actuating elements.

(b) Baffles shall be of noncombustible or limited-combustible material that will stay in place before and during sprinkler operation.

(c) Baffles shall be not less than 8 in. (203 mm) wide and 6 in. (152 mm) high. The tops of baffles shall extend between 2 to 3 in. (51 to 76 mm) above the deflectors of upright sprinklers. The bottoms of baffles shall extend downward to a level at least even with the deflectors of pendent sprinklers. (See A-4-13.3.4.)

4-8.4 Deflector Position (Extended Coverage Upright and Pendent Spray Sprinklers).

4-8.4.1 Distance Below Ceilings.

4-8.4.1.1 Under unobstructed construction, the distance between the sprinkler deflector and the ceiling shall be a minimum of 1 in. (25.4 mm) and a maximum of 12 in. (305 mm).

Exception No. 1. Ceiling-type sprinklers (concealed, recessed, and flush types) shall be permitted to have the operating element above the ceiling and the deflector located nearer to the ceiling where installed in accordance with their listing.

Exception No. 2: Where sprinklers are listed for use under other ceiling construction features or for different distances, they shall be permitted to be installed in accordance with their listing.

4-8.4.1.2 Under obstructed construction, the sprinkler deflector shall be located 1 to 6 in. (25.4 to 152 mm) below the structural members and a maximum distance of 22 in. (559 mm) below the ceiling/roof deck.

Table 4-8.2 Protection Areas and Maximum Spacing (Extended Coverage Upright and Pendent Spray Sprinklers)

Construction Type	Light Hazard		Ordinary Hazard		Extra Hazard		High Pile Storage	
	Protection Area (ft ²)	Spacing (ft)	Protection Area (ft ²)	Spacing (ft)	Protection Area (ft ²)	Spacing (ft)	Protection Area (ft ²)	Spacing (ft)
Unobstructed	400	20	400	20				
	324	18	324	18	196	14	196	14
	256	16	256	16	144	12	144	12
	256	16	144	12				
Obstructed noncombustible (when specifically listed for such use)	400	20	400	20				
	324	18	324	18	196	14	196	14
	256	16	256	16	144	12	144	12
	256	16	144	12				
Obstructed combustible	N/A	N/A	N/A	N/A	N/A	N/A	N/A	N/A

For SI Units: 1 ft = 0.3048 m; 1 ft² = 0.0929 m².

Exception No. 1: Sprinklers shall be permitted to be installed with the deflector at or above the bottom of the structural member to a maximum of 22 in. (559 mm) below the ceiling/roof deck where the sprinkler is installed in conformance with 4-6.5.1.2.

Exception No. 2: Where sprinklers are installed in each bay of obstructed construction, deflectors shall be a minimum of 1 in. (25.4 mm) and a maximum of 12 in. (305 mm) below the ceiling.

Exception No. 3: Where sprinklers are listed for use under other ceiling construction features or for different distances, they shall be permitted to be installed in accordance with their listing.

4-8.4.1.3* Sprinklers under or near the peak of a roof or ceiling shall have deflectors located not more than 3 ft (0.9 m) vertically down from the peak. [See Figures 4-6.4.1.3(a) and 4-6.4.1.3(b).]

4-8.4.2 Deflector Orientation. Deflectors of sprinklers shall be aligned parallel to ceilings or roofs.

4-8.5 Obstructions to Sprinkler Discharge (Extended Coverage Upright and Pendent Spray Sprinklers).

4-8.5.1 Performance Objective.

4-8.5.1.1 Sprinklers shall be located so as to minimize obstructions to discharge as defined in 4-8.5.2 and 4-8.5.3 or additional sprinklers shall be provided to ensure adequate coverage of the hazard.

4-8.5.1.2 Sprinklers shall be arranged to comply with Paragraph 4-5.5.2, Table 4-8.5.1.2, and Figure 4-8.5.1.2(a).

Exception No. 1: Sprinklers shall be permitted to be spaced on opposite sides of obstructions not exceeding 4 ft (1.3 m) in width provided the distance from the centerline of the obstruction to the sprinklers does not exceed one-half the allowable distance permitted between sprinklers.

Exception No. 2: Obstructions located against the wall and that are not over 30 in. (762 mm) in width shall be permitted to be protected in accordance with Figure 4-8.5.1.2(b).

Table 4-8.5.1.2(a) Position of Sprinklers to Avoid Obstructions to Discharge (Extended Coverage Upright and Pendent Spray Sprinklers)

Distance from Sprinklers to Side of Obstruction (a)	Maximum Allowable Distance of Deflector above Bottom of Obstruction (in.) (b)
Less than 1 ft	0
1 ft to less than 1 ft 6 in.	0
1 ft 6 in. to less than 2 ft	1
2 ft to less than 2 ft 6 in.	1
2 ft 6 in. to less than 3 ft	1
3 ft to less than 3 ft 6 in.	3
3 ft 6 in. to less than 4 ft	3
4 ft to less than 4 ft 6 in.	5
4 ft 6 in. to less than 5 ft	7
5 ft to less than 5 ft 6 in.	7
5 ft 6 in. to less than 6 ft	7
6 ft to less than 6 ft 6 in.	9
6 ft 6 in. to less than 7 ft	11
7 ft and greater	14

For SI Units: 1 in. = 25.4 mm; 1 ft = 0.3048 m.

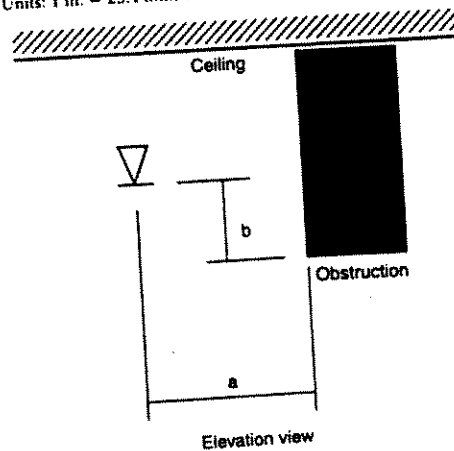

Figure 4-8.5.1.2(a) Position of sprinklers to avoid obstructions to discharge (extended coverage upright and pendent spray sprinklers).

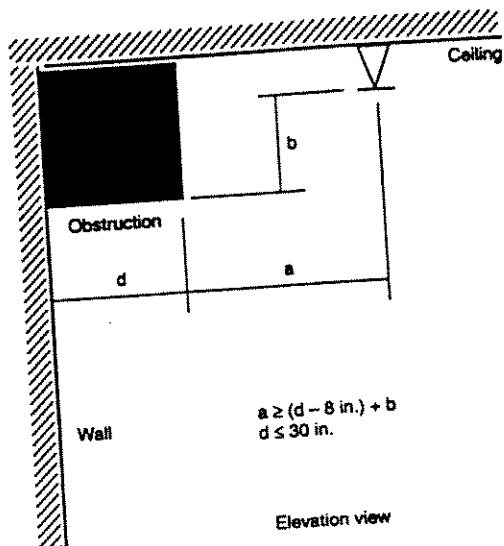

Figure 4-8.5.1.2(b) Obstructions against walls (SSU/SSP).

4-8.5.2 Obstructions to Sprinkler Discharge Pattern Development.

4-8.5.2.1 Continuous or noncontinuous obstructions less than 18 in. (457 mm) below the sprinkler deflector that prevent the pattern from fully developing shall comply with this section.

4-8.5.2.2 Sprinklers shall be positioned such that they are located at a distance four times greater than the maximum dimension of an obstruction up to a maximum of 36 in. (.91 m) (e.g., truss webs and chords, pipe, columns, and fixtures). (See Figure 4-8.5.2.2.)

Exception No. 1: Sprinklers shall be permitted to be spaced on opposite sides of the obstruction provided the distance from the centerline of the obstruction to the sprinklers does not exceed one-half the allowable distance between sprinklers.

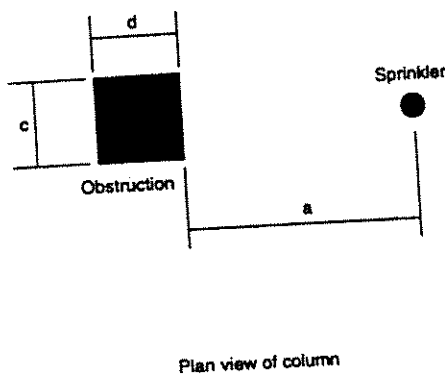

Plan view of column

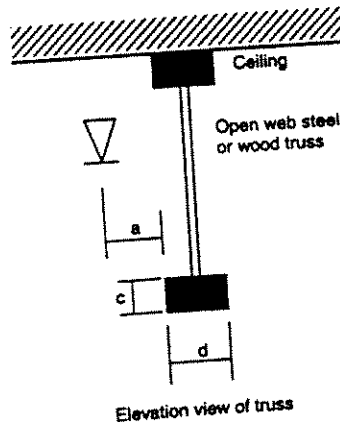

Elevation view of truss

$a \geq 4c \text{ or } 4d$

(Use dimension c or d, whichever is greater)

Figure 4-8.5.2.2 Minimum distance from obstruction (extended coverage upright and pendent spray sprinklers).

Exception No. 2: Where the obstruction consists of open trusses 20 in. (.51 m) or greater apart [24 in. (.61 m) on center], sprinklers shall be permitted to be located one-half the distance between the obstruction created by the truss provided that truss chords do not exceed 4 in. (101 mm) in width and web members do not exceed 1 in. (25.4 mm) in width.

Exception No. 3: Where the sprinklers are installed in the centerline of bar joists or a truss.

Exception No. 4: Piping to which an upright sprinkler is directly attached less than 3 in. (75 mm) in diameter.

Exception No. 5: Piping to which pendent and sidewall sprinklers are directly attached.

4-8.5.3* Obstructions that Prevent Sprinkler Discharge from Reaching the Hazard. Continuous or noncontinuous obstructions that interrupt the water discharge in a horizontal plane more than 18 in. (457 mm) below the sprinkler deflector in a manner to limit the distribution from reaching the protected hazard shall comply with this section.

4-8.5.3.1 Sprinklers shall be installed under fixed obstructions over 4 ft (1.2 m) wide such as ducts, decks, cutting tables, and overhead doors.

Exception: Obstructions that are not fixed in place such as conference tables.

4-8.5.3.2 Sprinklers installed under open gratings shall be of the intermediate level/rack storage type or otherwise shielded from the discharge of overhead sprinklers.

4-8.5.4 Suspended or Floor-Mounted Vertical Obstructions. The distance from sprinklers to privacy curtains, free standing partitions, room dividers, and similar obstructions in light hazard occupancies shall be in accordance with Table 4-8.5.4 and Figure 4-8.5.4.

4-8.6 Clearance to Storage (Extended Coverage Upright and Pendent Spray Sprinklers). The clearance between the deflector and the top of storage shall be 18 in. (457 mm) or greater.

Exception: Where other standards specify greater minimums, they shall be followed.

Table 4-8.5.4 Suspended or Floor Mounted Obstructions (Extended Coverage Upright and Pendent Spray Sprinklers)

Horizontal Distance (a)	Maximum Vertical Distance below Deflector (b)
6 in. or less	3 in.
More than 6 in. to 9 in.	4 in.
More than 9 in. to 12 in.	6 in.
More than 12 in. to 15 in.	8 in.
More than 15 in. to 18 in.	9½ in.
More than 18 in. to 24 in.	12½ in.
More than 24 in. to 30 in.	15½ in.
More than 30 in.	18 in.

For SI Units: 1 in. = 25.4 mm.

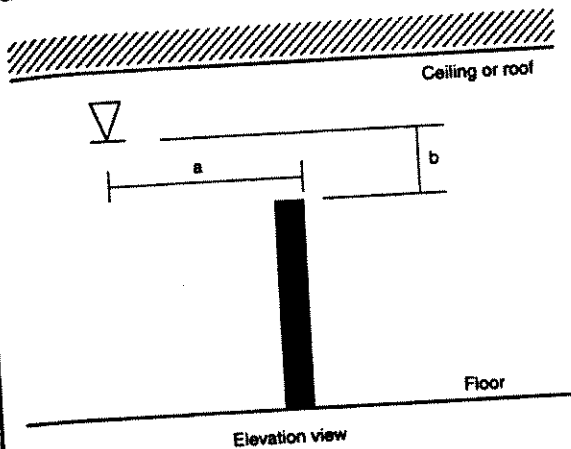

Figure 4-8.5.4 Suspended or floor-mounted obstructions (extended coverage upright and pendent spray sprinklers).

4-9 Extended Coverage Sidewall Spray Sprinklers.

4-9.1 General. All requirements of Section 4-5 shall apply to extended coverage sidewall spray sprinklers except as modified below.

4-9.2 Protection Areas per Sprinkler (Extended Coverage Sidewall Spray Sprinklers).

4-9.2.1* Determination of the Protection Area of Coverage. The protection area of coverage per sprinkler (A_s) for extended coverage sidewall sprinklers shall be not less than that prescribed by the listing. Listing dimensions shall be in 2-ft (.61-m) increments up to 28 ft (8.5 m).

4-9.2.2 Maximum Protection Area of Coverage. The maximum allowable protection area of coverage for a sprinkler (A_s) shall be in accordance with the value indicated in Table 4-9.2. In any case, the maximum area of coverage of a sprinkler shall not exceed 400 sq ft (37.1 m²).

4-9.3 Sprinkler Spacing (Extended Coverage Sidewall Spray Sprinklers).

4-9.3.1 Maximum Distance Between Sprinklers. The maximum distance permitted between sprinklers shall be based on the centerline distance between sprinklers on the branch line along the wall.

Table 4-9.2 Protection Area and Maximum Spacing for Extended Coverage Sidewall Sprinklers

Construction Type	Light Hazard		Ordinary Hazard	
	Protection Area (ft ²)	Spacing (ft)	Protection Area (ft ²)	Spacing (ft)
Unobstructed, smooth, flat	400	28	400	24

4-9.3.1.1 Sidewall spray sprinklers shall be installed along the length of a single wall of a room.

Exception No 1: Sidewall sprinklers shall not be installed back-to-back without being separated by a continuous lintel soffit or baffle.

Exception No 2: Sidewall sprinklers shall be permitted to be installed on opposing or adjacent walls provided no sprinkler is located within the maximum protection area of another sprinkler.

4-9.3.2 Maximum Distance from Walls. The distance from sprinklers to the end walls shall not exceed one-half of the allowable distance permitted between sprinklers as indicated in Table 4-9.2.

4-9.3.3 Minimum Distance from Walls. Sprinklers shall be located a minimum of 4 in. (102 mm) from a wall. The distance from the wall to the sprinkler shall be measured perpendicular to the wall.

Exception: Horizontal sidewall sprinklers are permitted to be located with their deflectors less than 4 in. (102 mm) from the wall on which they are mounted.

4-9.3.4 Minimum Distance Between Sprinklers. No sprinklers shall be located within the maximum protection area of any other sprinkler.

4-9.4 Deflector Position from Ceilings and Walls (Extended Coverage Sidewall Spray Sprinklers).

4-9.4.1 Distance Below Ceilings and from Walls.

4-9.4.1.1 Sidewall sprinkler deflectors shall be located not more than 6 in. (152 mm) nor less than 4 in. (102 mm) from ceilings.

Exception: Horizontal sidewall sprinklers are permitted to be located in a zone 6 to 12 in. (152 to 305 mm) or 12 to 18 in. (305 to 457 mm) below noncombustible ceilings where listed for such use.

4-9.4.1.2 Sidewall sprinkler deflectors shall be located not more than 6 in. (229 mm) nor less than 4 in. (102 mm) from walls.

4-9.4.1.3 Sidewall sprinklers shall only be installed along walls, lintels, or soffits where the distance from the ceiling to the bottom of the lintel or soffit is at least 2 in. (51 mm) greater than the distances from the ceiling to sidewall sprinkler deflectors.

4-9.4.1.3.1 Where soffits are used for the installation of sidewall sprinklers, they shall not exceed 8 in. (203 mm) in width or projection from the wall.

Exception: Soffits shall be permitted to exceed 8 in. (203 mm) where additional sprinklers are installed below the soffit.

4-9.4.2 Deflector Orientation. Deflectors of sprinklers shall be aligned parallel to ceilings or roofs.

4-9.4.2.1 Sidewall sprinklers, where installed under a sloped ceiling, shall be located at the high point of the slope and positioned to discharge downward along the slope.

4-9.5 Obstructions to Sprinkler Discharge (Extended Coverage Sidewall Spray Sprinklers).

4-9.5.1 Performance Objective.

4-9.5.1.1 Sprinklers shall be located so as to minimize obstructions to discharge as defined in 4-5.5.2 and 4-5.5.3 or additional sprinklers shall be provided to ensure adequate coverage of the hazard.

4-9.5.1.2 Sidewall sprinklers shall be installed no closer than 8 ft (2.3 m) from light fixtures or similar obstructions. The distance between light fixtures or similar obstructions located more than 8 ft (4.6 m) from the sprinkler shall be in conformity with Figure 4-9.5.1.2 and Table 4-9.5.1.2.

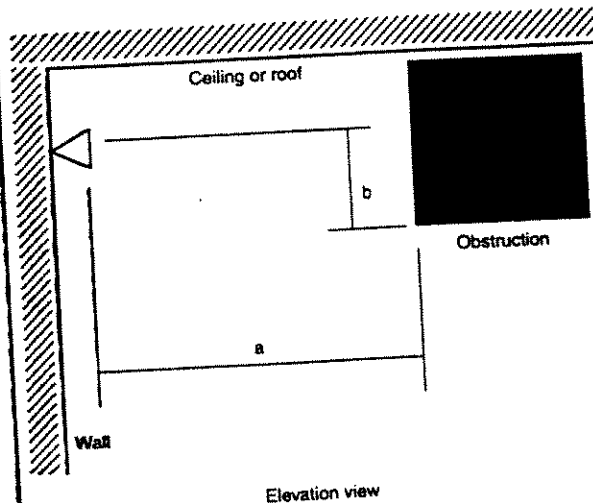

Figure 4-9.5.1.2 Positioning of sprinklers to avoid obstructions (extended coverage sidewall sprinklers).

Table 4-9.5.1.2 Positioning of Sprinklers to Avoid Obstructions (Extended Coverage Sidewall Sprinklers)

Distance from Sidewall Sprinkler to Side of Obstruction (a)	Maximum Allowable Distance of Deflector above Bottom of Obstruction (in.) (b)
8 ft to less than 10 ft	1
10 ft to less than 11 ft	2
11 ft to less than 12 ft	3
12 ft to less than 13 ft	4
13 ft to less than 14 ft	6
14 ft to less than 15 ft	7
15 ft to less than 16 ft	9
16 ft to less than 17 ft	11
17 ft or greater	14

For SI Units: 1 in. = 25.4 mm; 1 ft = 0.3048 m.

4-9.5.2 Obstructions to Sprinkler Discharge Pattern Development.

4-9.5.2.1 Continuous or noncontinuous obstructions less than 18 in. (457 mm) below the sprinkler deflector that prevent the pattern from fully developing shall comply with this section.

4-9.5.2.2 Sprinklers shall be positioned such that they are located at a distance four times greater than the maximum dimension of the obstruction to a maximum of 36 in. (.91 m) from the sprinkler (e.g., truss webs and chords, pipe, columns, and fixtures). Sidewall sprinklers shall be positioned in accordance with Figure 4-9.5.2.2 when obstructions are present.

4-9.5.3* Obstructions that Prevent Sprinkler Discharge from Reaching the Hazard. Continuous or noncontinuous obstructions that interrupt the water discharge in a horizontal plane more than 18 in. (457 mm) below the sprinkler deflector in a manner to limit the distribution from reaching the protected hazard shall comply with this section.

4-9.5.3.1 Sprinklers shall be installed under fixed obstructions over 4 ft (1.2 m) wide such as ducts, decks, cutting tables, and overhead doors.

Exception: Obstructions that are not fixed in place such as conference tables.

4-9.5.4 Suspended or Floor-Mounted Vertical Obstructions. The distance from sprinklers to privacy curtains, free-standing partitions, room dividers, and similar obstructions in light hazard occupancies shall be in accordance with Table 4-9.5.4 and Figure 4-9.5.4.

4-10 Large-Drop Sprinklers.

4-10.1 General. All requirements of Section 4-5 shall apply to large-drop sprinklers except as modified below.

4-10.2* Protection Areas per Sprinkler (Large-Drop Sprinklers).

4-10.2.1 Determination of the Protection Area of Coverage. The protection area of coverage per sprinkler (A_p) shall be determined in accordance with 4-5.2.1.

4-10.2.2 Maximum Protection Area of Coverage. The maximum allowable protection area of coverage for a sprinkler (A_p) shall be in accordance with the value indicated in Table 4-10.2. In any case, the maximum area of coverage of any sprinkler shall not exceed 130 ft² (12.9 m²).

4-10.2.3 Minimum Protection Area of Coverage. The minimum allowable protection area of coverage for a sprinkler (A_p) shall be not less than 80 ft² (7.4 m²).

4-10.3 Sprinkler Spacing (Large-Drop Sprinklers).

4-10.3.1* Maximum Distance Between Sprinklers. The distance between sprinklers shall be limited to not more than 12 ft (3.7 m) between sprinklers as shown in Table 4-10.2.

Exception: Under obstructed combustible construction, the maximum distance shall be limited to 10 ft (3.0 m).

4-10.3.2 Maximum Distance from Walls. The distance from sprinklers to walls shall not exceed one-half of the allowable distance permitted between sprinklers as indicated in Table 4-10.2.

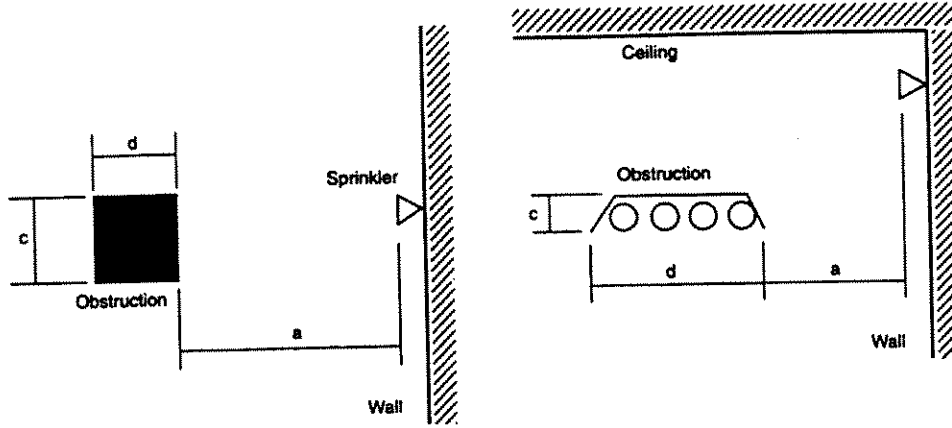

Plan view of column
Elevation view of pipe conduit or light fixture (See Table 4-9.5.4)
 $a \geq 4c$ or $4d$
 $a \leq 36$ in.
(Use dimension c or d, whichever is greater)

Figure 4-9.5.2 Minimum distance from obstruction (extended coverage sidewall).

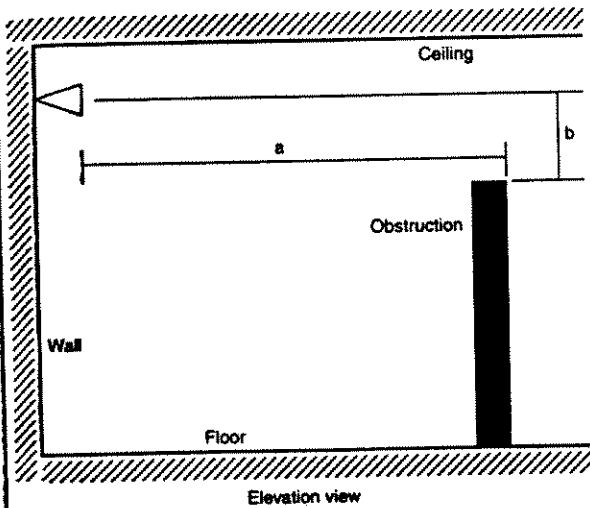

Figure 4-9.5.4 Suspended or floor-mounted obstructions (extended coverage sidewall sprinklers).

Table 4-9.5.4 Suspended or Floor Mounted Obstructions (Extended Coverage Sidewall Sprinklers)

Horizontal Distance (a)	Minimum Allowable Distance below Deflector (b)
6 in. or less	3 in.
More than 6 in. to 9 in.	4 in.
More than 9 in. to 12 in.	6 in.
More than 12 in. to 15 in.	8 in.
More than 15 in. to 18 in.	9½ in.
More than 18 in. to 24 in.	12½ in.
More than 24 in. to 30 in.	15½ in.
More than 30 in.	18 in.

For SI Units: 1 in. = 25.4 mm.

Table 4-10.2 Protection Areas and Maximum Spacing for Large-Drop Sprinklers

Construction Type	Protection Area (ft²)	Maximum Spacing (ft)
Noncombustible unobstructed	150	12
Noncombustible obstructed	150	12
Combustible unobstructed	150	12
Combustible obstructed	100	10

For SI Units: 1 ft = 0.3048 m; 1 ft² = 0.0929 m².

4-10.3.3 Minimum Distance from Walls. Sprinklers shall be located a minimum of 4 in. (102 mm) from a wall.

4-10.3.4 Minimum Distance Between Sprinklers. Sprinklers shall be spaced not less than 8 ft (2.4 m) on center.

4-10.4 Deflector Position (Large-Drop Sprinklers).

4-10.4.1* Distance Below Ceilings.

4-10.4.1.1 Under unobstructed construction, the distance between the sprinkler deflector and the ceiling shall be a minimum of 6 in. (152 mm) and a maximum of 8 in. (203 mm).

4-10.4.1.2 Under obstructed construction, the distance between the sprinkler deflector and the ceiling shall be a minimum of 6 in. (152 mm) and a maximum of 12 in. (305 mm).

Exception: Under wood joist or composite wood joist construction, the sprinklers shall be located 1 to 6 in. (25.4 to 152 mm) below the structural members to a maximum distance of 22 in. (559 mm) below the ceiling/roof or deck.

4-10.4.2 Deflector Orientation. Deflectors of sprinklers shall be aligned parallel to ceilings or roofs.

4-10.5* Obstructions to Sprinkler Discharge (Large-Drop Sprinklers).

4-10.5.1 Performance Objective.

4-10.5.1.1 Sprinklers shall be located so as to minimize obstructions to discharge as defined in 4-5.5.2 and 4-5.5.3 or additional sprinklers shall be provided to ensure adequate coverage of the hazard.

4-10.5.1.2 Sprinklers shall be arranged to comply with Paragraph 4-5.5.2, Table 4-10.5.1.2, and Figure 4-10.5.1.2.

4-10.5.2 Obstructions to Sprinkler Discharge Pattern Development.

4-10.5.2.1 Continuous or noncontinuous obstructions less than 36 in. (914 mm) below the sprinkler deflector that prevent the pattern from fully developing shall comply with this section.

4-10.5.2.2 Sprinklers shall be positioned such that they are located at a distance three times greater than the maximum dimension of the obstruction to a maximum of 24 in. (610 mm) from the sprinkler (e.g., webs and chord members, pipe, columns, and fixtures). Sprinklers shall be positioned in accordance with Figure 4-10.5.2.2 when obstructions are present.

4-10.5.2.3 Where branch lines are larger than 2 in. (51 mm), the sprinkler shall be supplied by a riser nipple to elevate the sprinkler 13 in. (330 mm) for 2½-in. (64-mm) pipe and 15 in. (380 mm) for 3-in. (76-mm) pipe. These dimensions shall be measured from the centerline of the pipe to the deflector.

Exception No. 1: This provision shall not apply where the sprinklers are offset horizontally a minimum of 12 in. (305 mm) from the pipe.

Exception No. 2: Piping to which the sprinkler is directly attached less than 2 in. (51 mm) in diameter.

4-10.5.3* Obstructions that Prevent Sprinkler Discharge from Reaching the Hazard. Continuous or noncontinuous obstructions that interrupt the water discharge in a horizontal plane more than 36 in. (914 mm) below the sprinkler deflector in a manner to limit the distribution from reaching the protected hazard shall comply with this section.

Table 4-10.5.1.2 Positioning of Sprinklers to Avoid Obstructions to Discharge (Large Drop Sprinkler)

Distance from Sprinkler to Side of Obstruction (a)	Maximum Allowable Distance of Deflector above Bottom of Obstruction (in.) (b)
Less than 1 ft	0
1 ft to less than 1 ft 6 in.	1½
1 ft 6 in. to less than 2 ft	3
2 ft to less than 2 ft 6 in.	5½
2 ft 6 in. to less than 3 ft	8
3 ft to less than 3 ft 6 in.	10
3 ft 6 in. to less than 4 ft	12
4 ft to less than 4 ft 6 in.	15
4 ft 6 in. to less than 5 ft	18
5 ft to less than 5 ft 6 in.	22
5 ft 6 in. to less than 6 ft	26
6 ft	31

For SI Units: 1 in. = 25.4 mm; 1 ft = 0.3048 m.

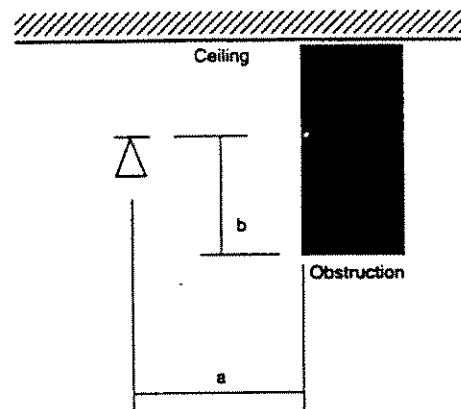
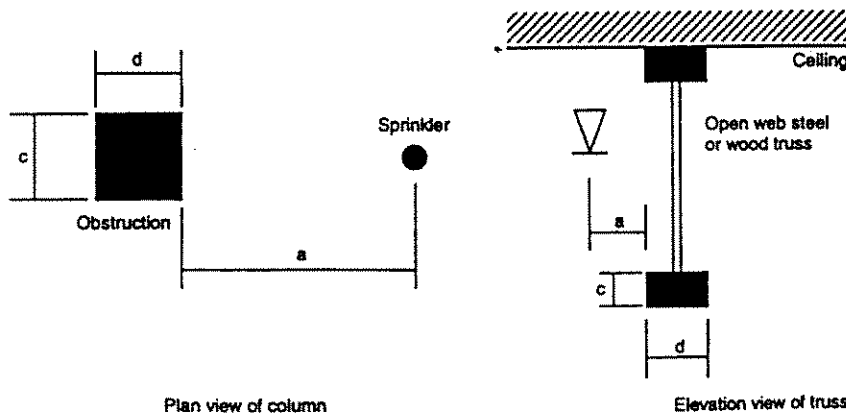

Figure 4-10.5.1.2 Positioning of sprinklers to avoid obstructions to discharge (large-drop sprinkler).



$a \geq 3c$ or $3d$
(Use dimension c or d, whichever is greater)

Figure 4-10.5.2.2 Minimum distance from obstruction (large-drop sprinkler).

4-10.5.3.1 Sprinklers shall be positioned with respect to fluorescent lighting fixtures, ducts, and obstructions more than 24 in. (610 mm) wide and located entirely below the sprinklers so that the minimum horizontal distance from the near side of the obstruction to the center of the sprinkler is not less than the value specified in Table 4-10.5.3.1. (See Figure 4-10.5.3.1.)

Table 4-10.5.3.1 Obstruction Entirely Below the Sprinkler (Large Drop Sprinkler)

Distance of Deflector above Bottom of Obstruction (b)	Minimum Distance to Side of Obstruction (ft) (a)
Less than 6 in.	1½
6 in. to less than 12 in.	3
12 in. to less than 18 in.	4
18 in. to less than 24 in.	5
24 in. to less than 30 in.	5½
30 in. less than 36 in.	6

For SI Units: 1 in. = 25.4 mm; 1 ft = 0.3048 m.

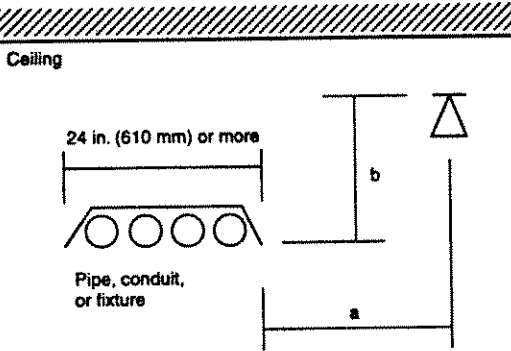

Figure 4-10.5.3.1 Obstruction entirely below the sprinkler (large-drop sprinkler).

4-10.5.3.2 Sprinklers installed under open gratings shall be of the intermediate level/rack storage type or otherwise shielded from the discharge of overhead sprinklers.

4-10.5.3.3 Where the bottom of the obstruction is located 24 in. (610 mm) or more below the sprinkler deflectors:

(a) Sprinklers shall be positioned so that the obstruction is centered between adjacent sprinklers. (See Figure 4-10.5.3.3.)

(b) The obstruction shall be limited to a maximum width of 24 in. (610 mm). (See Figure 4-10.5.3.3.)

Exception: Where the obstruction is greater than 24 in. (610 mm) wide, one or more lines of sprinklers shall be installed below the obstruction.

(c) The obstruction shall not extend more than 12 in. (305 mm) to either side of the midpoint between sprinklers. (See Figure 4-10.5.3.3.)

Exception: Where the extensions of the obstruction exceed 12 in. (305 mm), one or more lines of sprinklers shall be installed below the obstruction.

(d) At least 18 in. (457 mm) clearance shall be maintained between the top of storage and the bottom of the obstruction. (See Figure 4-10.5.3.3.)

4-10.5.3.4 In the special case of an obstruction running parallel to and directly below a branch line:

(a) The sprinkler shall be located at least 36 in. (914 mm) above the top of the obstruction. (See Figure 4-10.5.3.4.)

(b) The obstruction shall be limited to a maximum width of 12 in. (305 mm). (See Figure 4-10.5.3.4.)

(c) The obstruction shall be limited to a maximum extension of 6 in. (152 mm) to either side of the centerline of the branch line. (See Figure 4-10.5.3.4.)

4-10.6 Clearance to Storage (Large-Drop Sprinklers). The clearance between the deflector and the top of storage shall be 36 in. (914 mm) or greater.

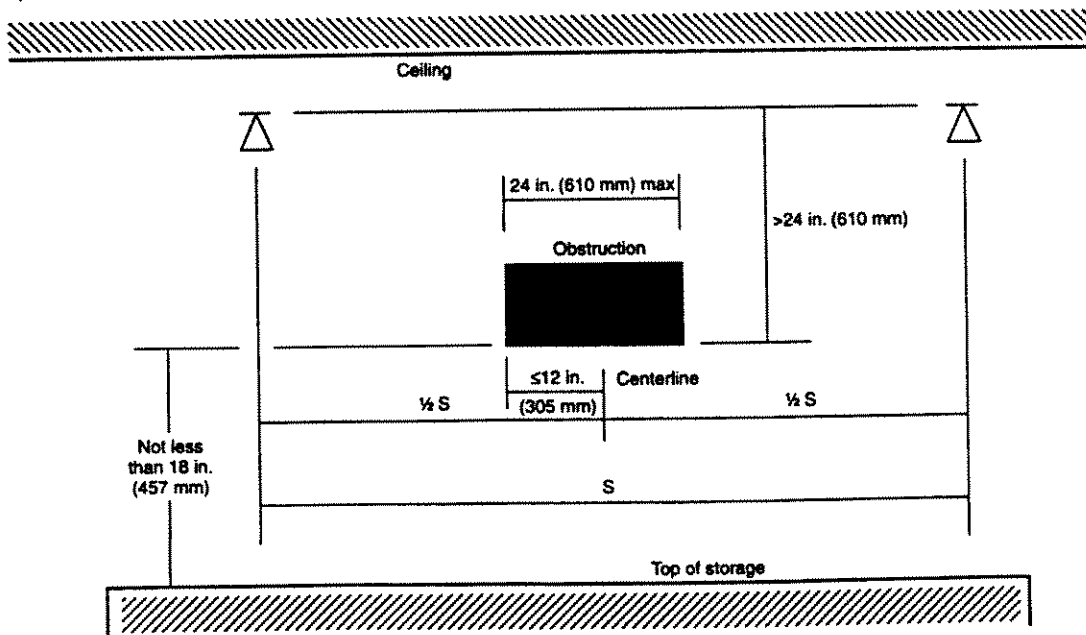

Figure 4-10.5.3.3 Obstruction more than 24 in. (610 mm) below the sprinkler (large-drop sprinkler).

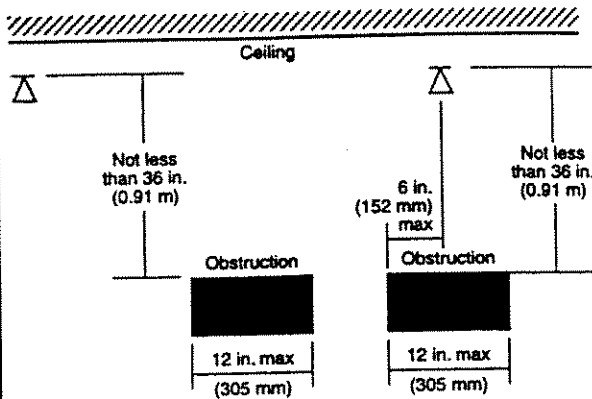

Figure 4-10.5.3.4 Obstruction more than 36 in. (914 mm) below the sprinkler (large-drop sprinkler).

4-11 Early Suppression Fast-Response Sprinklers.

4-11.1 General. All requirements of Section 4-5 shall apply except as modified below.

4-11.2 Protection Areas per Sprinkler (Early Suppression Fast-Response Sprinklers).

4-11.2.1 Determination of the Protection Area of Coverage. The protection area of coverage per sprinkler (A_s) shall be determined in accordance with 4-5.2.1.

4-11.2.2 Maximum Protection Area of Coverage. The maximum allowable protection area of coverage for a sprinkler (A_s) shall be in accordance with the value indicated in Table 4-11.2. In any case, the maximum area of coverage of any sprinkler shall not exceed 100 ft² (9.3 m²).

4-11.2.3 Minimum Protection Area of Coverage. The minimum allowable protection area of coverage for a sprinkler (A_s) shall be not less than 80 ft² (7.4 m²).

4-11.3 Sprinkler Spacing (Early Suppression Fast-Response Sprinklers).

4-11.3.1 Maximum Distance Between Sprinklers. The distance between sprinklers shall be limited to not more than 12 ft (3.7 m) between sprinklers as shown in Table 4-11.2.

Exception: ESFR sprinklers used in buildings with storage heights greater than 25 ft (7.6 m) and ceiling heights greater than 30 ft (9.1 m) shall not be spaced more than 10 ft (3.0 m) between sprinklers.

4-11.3.2 Maximum Distance from Walls. The distance from sprinklers to walls shall not exceed one-half of the allowable distance permitted between sprinklers as indicated in Table 4-11.2.

4-11.3.3 Minimum Distance from Walls. Sprinklers shall be located a minimum of 4 in. (102 mm) from a wall.

4-11.3.4 Minimum Distance Between Sprinklers. Sprinklers shall be spaced not less than 8 ft (2.4 m) on center.

4-11.4 Deflector Position (Early Suppression Fast-Response Sprinklers).

4-11.4.1 Distance Below Ceilings.

4-11.4.1.1 Pendant sprinklers shall be positioned so that deflectors are a maximum 14 in. (356 mm) and a minimum 6 in. (152 mm) below the ceiling. Upright sprinklers shall be positioned so that the deflector is 3 to 5 in. (76.2 to 127 mm) below the ceiling. With obstructed construction, the branch lines shall be permitted to be installed across the beams, but sprinklers shall be located in the bays and not under the beams.

4-11.4.2 Deflector Orientation. Deflectors of sprinklers shall be aligned parallel to ceilings or roofs. Pendant sprinklers shall be positioned so that deflectors are a maximum 14 in. (356 mm) and a minimum 6 in. (152 mm) below the ceiling.

4-11.5 Obstructions to Sprinkler Discharge (Early Suppression Fast-Response Sprinklers).

4-11.5.1 Performance Objective.

4-11.5.1.1 Sprinklers shall be located so as to minimize obstructions to discharge as defined in 4-5.5.2 and 4-5.5.3 or additional sprinklers shall be provided to ensure adequate coverage of the hazard.

4-11.5.1.2 Sprinklers shall be arranged to comply with Paragraph 4-5.5.2, Table 4-11.5.1.2, and Figure 4-11.5.1.2.

4-11.5.2 Obstructions to Sprinkler Discharge Pattern Development. Sprinklers shall be positioned such that they are located at a distance three times greater than the maximum dimension of an obstruction up to a maximum of 24 in. (609 mm) (e.g., structural members, pipe, columns, and fixtures). Sprinklers shall be positioned in accordance with Figure 4-11.5.2 where obstructions are present.

Table 4-11.2 Protection Areas and Maximum Spacing of ESFR Sprinklers

Construction Type	ESFR Sprinkler up to 30 ft in Height		ESFR Sprinkler up to 40 ft in Height	
	Protection Area (ft ²)	Spacing (ft)	Protection Area (ft ²)	Spacing (ft)
Noncombustible unobstructed	100	12	100	10
Noncombustible obstructed	100	12	100	10
Combustible unobstructed	100	12	100	10
Combustible obstructed	N/A	N/A	N/A	N/A

For SI units: 1 ft = 0.3048 m; 1 ft² = 0.0929 m².

Table 4-11.5.1.2 Positioning of Sprinklers to Avoid Obstructions to Discharge (ESFR Sprinkler)

Distance from Sprinkler to Side of Obstruction (a)	Maximum Allowable Distance of Deflector above Bottom of Obstruction (in.) (b)
Less than 1 ft	0
1 ft to less than 1 ft 6 in.	1½
1 ft 6 in. to less than 2 ft	3
2 ft to less than 2 ft 6 in.	5½
2 ft 6 in. to less than 3 ft	8
3 ft to less than 3 ft 6 in.	10
3 ft 6 in. to less than 4 ft	12
4 ft to less than 4 ft 6 in.	15
4 ft 6 in. to less than 5 ft	18
5 ft to less than 5 ft 6 in.	22
5 ft 6 in. to less than 6 ft	26
6 ft	31

For SI Units: 1 in. = 25.4 mm; 1 ft = 0.3048 m.

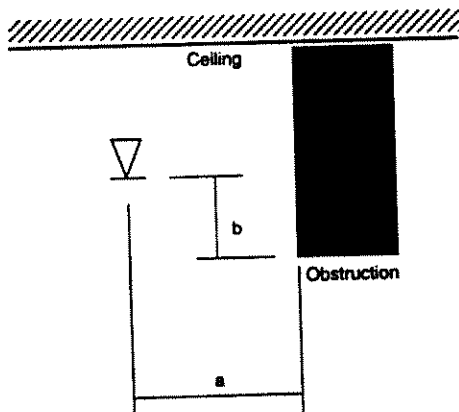
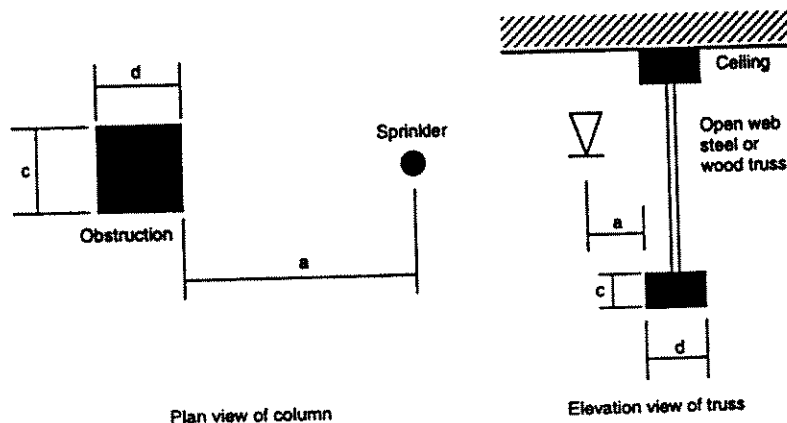

Figure 4-11.5.1.2 Positioning of sprinklers to avoid obstructions to discharge (ESFR sprinkler).



$a \geq 3c$ or $3d$
(Use dimension c or d, whichever is greater)

Figure 4-11.5.2 Minimum distance from obstruction (ESFR sprinkler).

4-11.5.3* Obstructions that Prevent Sprinkler Discharge from Reaching the Hazard.

4-11.5.3.1 Continuous or noncontinuous obstructions that interrupt the water discharge in a horizontal plane more than 36 in. (914 mm) below the sprinkler deflector in a manner to limit the distribution from reaching the protected hazard shall comply with this section.

4-11.5.3.2 Where sprinklers are located entirely above obstructions such as the bottom chords of trusses or joists, ducts, piping, fluorescent lighting fixtures, conveyors, or similar obstructions, the sprinklers shall be positioned so that the maximum distance from the bottom of the obstruction to the deflector does not exceed the values specified in Table 4-11.5.1.2. Upright sprinklers shall also be positioned so that the deflector is a minimum of 7 in. (178 mm) above the top of the sprinkler pipe.

Exception No. 1: ESFR sprinklers shall be positioned so that the deflectors are at least 1 ft (305 mm) horizontally from the nearest edge of any bottom chords at open trusses or open bar joists.

Exception No. 2: Sprinklers shall not be required to meet Table 4-11.5.1.2 where additional sprinklers are located beneath the obstruction and are added to the water demand. If the obstruction is not solid (such as a group of closely spaced pipes or conduit) a barrier shall be placed under the obstruction and above the sprinklers. Sprinklers installed under the barrier or obstruction shall be positioned in accordance with 4-11.4 as if the obstruction or barrier were a ceiling. Paragraph 4-11.6 shall apply to sprinklers located below obstructions.

Exception No. 3: Sprinklers shall not be required to meet Table 4-11.5.1.2 where the sprinkler deflector is at least 1 ft (305 mm) horizontally from the nearest edge of any obstructions up to 2 ft (610 mm) wide and located below a single sprinkler, but not below two or more adjacent sprinklers, including diagonally.

Exception No. 4: Sprinklers shall not be required to meet Table 4-11.5.1.2 where the sprinkler deflectors are at least 1 ft (305 mm) horizontally from the nearest edge of any obstructions up to 1 ft (305 mm) wide that are located below two or more adjacent sprinklers, including diagonally.

Exception No. 5: Sprinklers shall not be required to meet Table 4-11.5.1.2 where the sprinkler deflectors are least 2 ft (610 mm) horizontally from the nearest edge of any obstructions up to 2 ft (610 mm) wide that are located below two or more adjacent sprinklers, including diagonally.

4-11.5.3.3 Sprinklers installed under open gratings shall be of the intermediate level/rack storage type or otherwise shielded from the discharge of overhead sprinklers.

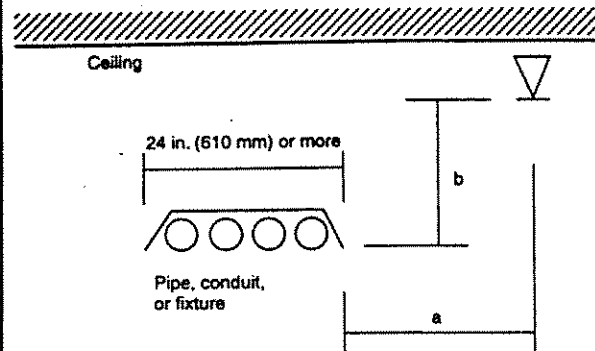

Figure 4-11.5.3.3 Obstruction entirely below the sprinkler (ESFR sprinkler).

4-11.6 Clearance to Storage (Early Suppression Fast-Response Sprinklers). The clearance between the deflector and the top of storage shall be 36 in. (914 mm) or greater.

4-12 In-Rack Sprinklers.

4-12.1 System Size. The area protected by a single system of sprinklers in racks shall not exceed 40,000 ft² (3716 m²) of floor area occupied by the racks, including aisles, regardless of the number of levels of in-rack sprinklers.

4-12.2 Control Valves. Where sprinklers are installed in racks, separate indicating control valves and drains shall be provided for ceiling sprinklers and sprinklers in racks.

Exception No. 1: In-rack installations of 20 or fewer sprinklers.

Exception No. 2: The separate indicating valve shall be permitted to be arranged as sectional control valves where the racks occupy only a portion of the area protected by ceiling sprinklers.

4-12.3 Type of Sprinklers. In-rack sprinklers shall be ordinary temperature 1/2- or 17/32-in. (12.7- or 13.5-mm) sprinklers.

4-12.4 Location of In-Rack Sprinklers.

4-12.4.1 A minimum 6-in. (152-mm) vertical clear space shall be maintained between the sprinkler deflector and the top tier of storage.

4-12.4.2 The maximum spacing between sprinklers shall be 10 ft (3.05 m).

4-12.4.3 Sprinklers shall be located in transverse flue spaces.

4-12.4.4 In-rack sprinklers shall be located at the first tier level at or above one-half of the storage height.

4-12.4.5 Where sprinklers are installed in racks, different distances of deflectors above the bottom of horizontal rack supports shall be permitted when water distribution tests complete with storage commodity above the sprinklers demonstrate essentially equivalent distribution to that obtained with distances as specified in Table 4-6.5.1.2.

4-13 Special Situations.

4-13.1 Concealed Spaces.

4-13.1.1* All concealed spaces enclosed wholly or partly by exposed combustible construction shall be protected by sprinklers.

Exception No. 1: Concealed spaces formed by studs or joists with less than 6 in. (152 mm) between the inside or near edges of the studs or joists. (See Figure 4-6.4.1.4.)

Exception No. 2: Concealed spaces formed by bar joists with less than 6 in. (152 mm) between the roof or floor deck and ceiling.

Exception No. 3: Concealed spaces formed by ceilings attached directly to or within 6 in. (152 mm) of wood joist construction.

Exception No. 4: Concealed spaces formed by ceilings attached directly to the underside of composite wood joist construction, provided the joist channels are firestopped into volumes each not exceeding 160 ft³ (4.53 m³) using materials equivalent to the web construction.

Exception No. 5: Concealed spaces entirely filled with noncombustible insulation.

Exception No. 6: Concealed spaces within wood joist construction and composite wood joist construction having noncombustible insulation filling the space from the ceiling up to the bottom edge of the joist of the roof or floor deck, provided that in composite wood joist construction the joist channels are firestopped into volumes each not exceeding 160 ft³ (4.53 m³). The joists shall be firestopped to the full depth of the joist with material equivalent to the web construction.

Exception No. 7: Concealed spaces over isolated small rooms not exceeding 55 ft² (4.6 m²) in area.

Exception No. 8: Where rigid materials are used and the exposed surfaces have a flame spread rating of 25 or less and the materials have been demonstrated not to propagate fire in the form in which they are installed in the space.

Exception No. 9: Concealed spaces in which the exposed materials are constructed entirely of fire-retardant treated wood as defined by NFPA 703, Standard for Fire Retardant Impregnated Wood and Fire Retardant Coatings for Building Materials.

Exception No. 10: Noncombustible concealed spaces having exposed combustible insulation where the heat content of the facing and substrate of the insulation material does not exceed 1000 Btu per ft² (11 356 kJ/m²).

4-13.1.2 Sprinklers in concealed spaces having no access for storage or other use shall be installed in accordance with the requirements for Light Hazard Occupancy.

4-13.1.3 Where heat-producing devices such as furnaces or process equipment are located in the joist channels above a ceiling attached directly to the underside of composite wood joist construction that would not otherwise require sprinkler protection of the spaces, the joist channel containing the heat-producing devices shall be sprinklered by installing sprinklers in each joist channel, on each side, adjacent to the heat-producing device.

4-13.2 Vertical Shafts.

4-13.2.1 One sprinkler shall be installed at the top of shafts.

Exception No. 1: Noncombustible or limited-combustible, nonaccessible vertical duct shafts.

Exception No. 2: Noncombustible or limited-combustible, nonaccessible vertical electrical or mechanical shafts.

4-13.2.2* Where vertical shafts have combustible surfaces, one sprinkler shall be installed at each alternate floor level. Where a shaft having combustible surfaces is trapped, an additional sprinkler shall be installed at the top of each trapped section.

4-13.2.3 Where accessible vertical shafts have noncombustible surfaces, one sprinkler shall be installed near the bottom.

4-13.2.4 Where vertical openings are not protected by fire-rated enclosures, sprinklers shall be placed so as to fully protect the openings.

4-13.3 Stairways.

4-13.3.1 Sprinklers shall be installed beneath all stairways of combustible construction.

4-13.3.2 In noncombustible stair shafts with noncombustible stairs, sprinklers shall be installed at the top of the shaft and under the first landing above the bottom of the shaft.

Exception: Sprinklers shall be installed beneath landings or stairways where the area beneath is used for storage.

4-13.3.3* Sprinklers shall be installed in the stair shaft at each floor landing where two or more doors open from that landing into separate fire divisions.

4-13.3.4* Where moving stairways, staircases, or similar floor openings are unenclosed, the floor openings involved shall be protected by closely spaced sprinklers in combination with draft stops.

The draft stops shall be located immediately adjacent to the opening, shall be at least 18 in. (457 mm) deep, and shall be of noncombustible or limited-combustible material that will stay in place before and during sprinkler operation. Sprinklers shall be spaced not more than 6 ft (1.8 m) apart and placed 6 to 12 in. (152 to 305 mm) from the draft stop on the side away from the opening. Where sprinklers are closer than 6 ft (1.8 m), cross baffles shall be provided in accordance with 4-6.3.4.

Exception: Closely spaced sprinklers and draft stops are not required around large openings such as those found in shopping malls, atrium buildings, and similar structures where all adjoining levels and spaces are protected by automatic sprinklers in accordance with this standard and where the openings have all horizontal dimensions between opposite edges of 20 ft (6 m) or greater and an area of 1000 ft² (93 m²) or greater.

4-13.4* Building Service Chutes. Building service chutes (linen, rubbish, etc.) shall be protected internally by automatic sprinklers. A sprinkler shall be provided above the top service opening of the chute, above the lowest service opening, and above service openings at alternate levels in buildings over two stories in height. The room or area into which the chute discharges shall also be protected by automatic sprinklers.

4-13.5 Elevator Hoistways and Machine Rooms.

4-13.5.1* Sidewall spray sprinklers shall be installed at the bottom of each elevator hoistway, not more than 2 ft (0.61 m) above the floor of the pit.

Exception: For enclosed, noncombustible elevator shafts that do not contain combustible hydraulic fluids, the sprinklers at the bottom of the shaft are not required.

4-13.5.2* Automatic sprinklers in elevator machine rooms or at the tops of hoistways shall be of ordinary or intermediate temperature rating.

4-13.5.3* Upright or pendent spray sprinklers shall be installed at the top of elevator hoistways.

Exception: Sprinklers are not required at the tops of noncombustible hoistways of passenger elevators whose car enclosure materials meet the requirements of ASME A17.1, Safety Code for Elevators and Escalators.

4-13.6 Spaces under Ground Floors, Exterior Docks, and Platforms. Sprinklers shall be installed in spaces under all combustible ground floors, exterior docks, and platforms.

Exception: Sprinklers shall be permitted to be omitted where all of the following conditions prevail:

(a) *The space is not accessible for storage purposes and is protected against accumulation of wind-borne debris;*

(b) *The space contains no equipment such as conveyors or fuel-fired heating units;*

(c) *The floor over the space is of tight construction;*

(d) *No combustible or flammable liquids or materials that under fire conditions would convert into combustible or flammable liquids are processed, handled, or stored on the floor above the space.*

4-13.7* Exterior Roofs or Canopies.

4-13.7.1 Sprinklers shall be installed under roofs or canopies over areas where combustibles are stored or handled.

Exception: Sprinklers are permitted to be omitted where construction is noncombustible or limited combustible and areas under the roofs or canopies are not used for storage or handling of combustibles.

4-13.7.2 Sprinklers shall be installed under exterior combustible roofs or canopies exceeding 4 ft (1.2 m) in width.

4-13.8 Dwelling Units.

4-13.8.1 Sprinklers are not required in bathrooms that are located within dwelling units, that do not exceed 55 ft² (5.1 m²) in area, and that have walls and ceilings of noncombustible or limited-combustible materials with a 15-min thermal barrier rating including the walls and ceilings behind fixtures.

Exception: Sprinklers are required in bathrooms of nursing homes and in bathrooms opening directly onto public corridors or exitways.

4-13.8.2* Sprinklers are not required in clothes closets, linen closets, and pantries within dwelling units in hotels and motels where the area of the space does not exceed 24 ft² (2.2 m²), the least dimension does not exceed 3 ft (0.9 m), and the walls and ceilings are surfaced with noncombustible or limited-combustible materials.

4-13.9 Library Stack Rooms. Sprinklers shall be installed in every aisle and at every tier of stacks with distance between sprinklers along aisles not to exceed 12 ft (3.6 m). [See Figure 4-13.9(a).]

Exception No. 1: Where vertical shelf dividers are incomplete and allow water distribution to adjacent aisles, sprinklers are permitted to be omitted in alternate aisles on each tier. Where ventilation openings are also provided in tier floors, sprinklers shall be staggered vertically. [See Figure 4-13.9(b).]

Exception No. 2: Sprinklers are permitted to be installed without regard to aisles where there is 18 in. (457 mm) or more clearance between sprinkler deflectors and tops of racks.

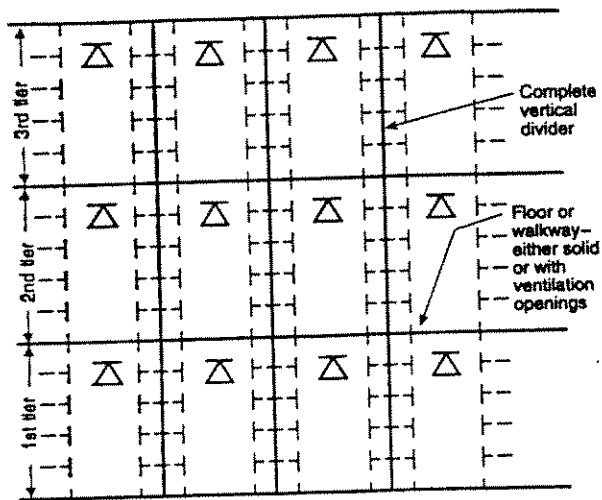

Figure 4-13.9(a) Sprinklers in multitier library bookstacks with complete vertical dividers.

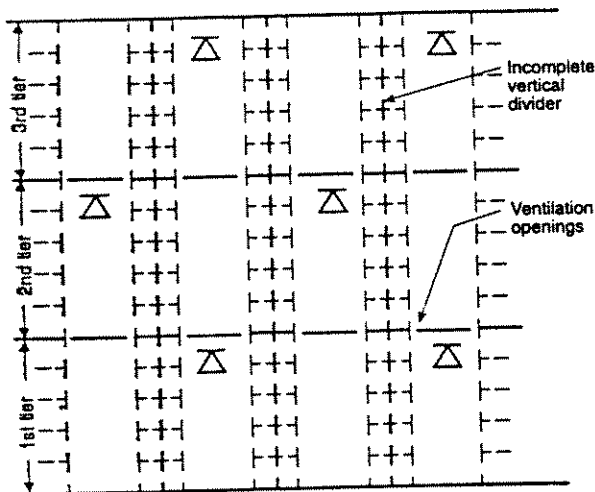

Figure 4-13.9(b) Sprinklers in multitier library bookstacks with incomplete vertical dividers.

4-13.10 Electrical Equipment. Sprinkler protection shall be required in electrical equipment rooms. Hoods or shields installed to protect important electrical equipment from sprinkler discharge shall be noncombustible.

Exception: Sprinklers shall not be required where all of the following conditions are met:

- (a) The room is dedicated to electrical equipment only.
- (b) Only dry-type electrical equipment is used.
- (c) Equipment is installed in a 2-hr fire-rated enclosure including protection for penetrations.
- (d) No combustible storage is permitted to be stored in the room.

4-13.11* Open-Grid Ceilings. Open-grid ceilings shall not be installed beneath sprinklers.

Exception No. 1: Open-grid ceilings in which the openings are $\frac{1}{4}$ in. (6.4 mm) or larger in the least dimension, where the thickness or depth of the material does not exceed the least dimension of the

opening, and where such openings constitute 70 percent of the area of the ceiling material. The spacing of the sprinklers over the open-grid ceiling shall then comply with the following:

(a) In Light Hazard Occupancies where sprinkler spacing (either spray or old-style sprinklers) is less than 10 ft by 10 ft (3 m by 3 m), a minimum clearance of at least 18 in. (457 mm) shall be provided between the sprinkler deflectors and the upper surface of the open-grid ceiling. Where spacing is greater than 10 ft by 10 ft (3 m by 3 m) but less than 10 ft by 12 ft (3 m by 3.7 m), a clearance of at least 24 in. (610 mm) shall be provided from spray sprinklers and at least 36 in. (914 mm) from old-style sprinklers. Where spacing is greater than 10 ft by 12 ft (3 m by 3.7 m), a clearance of at least 48 in. (1219 mm) shall be provided.

(b) In Ordinary Hazard Occupancies, open-grid ceilings shall be permitted to be installed beneath spray sprinklers only. Where sprinkler spacing is less than 10 ft by 10 ft (3 m by 3 m), a minimum clearance of at least 24 in. (610 mm) shall be provided between the sprinkler deflectors and the upper surface of the open-grid ceiling. Where spacing is greater than 10 ft by 10 ft (3 m by 3 m), a clearance of at least 36 in. (914 mm) shall be provided.

Exception No. 2: Other types of open-grid ceilings shall not be installed beneath sprinklers unless they are listed for such service and are installed in accordance with instructions contained in each package of ceiling material.

4-13.12 Drop-Out Ceilings.

4-13.12.1 Drop-out ceilings shall be permitted to be installed beneath sprinklers where ceilings are listed for that service and are installed in accordance with their listings.

Exception: Special sprinklers shall not be installed above drop-out ceilings unless specifically listed for this purpose.

4-13.12.2 Drop-out ceilings shall not be considered ceilings within the context of this standard.

4-13.12.3* Piping installed above drop-out ceilings shall not be considered concealed piping (see 2-5.4, *Exception No. 2*).

4-13.12.4* Sprinklers shall not be installed beneath drop-out ceilings.

4-13.13 Old-Style Sprinklers. Old-style sprinklers shall not be used in a new installation.

Exception No. 1: Old-style sprinklers shall be installed in fur storage vaults. See A-4-13.13 *Exception No. 1*.

Exception No. 2: Use of old-style sprinklers shall be permitted where construction features or other special situations require unique water distribution.

4-13.14 Stages.

4-13.14.1 Sprinklers shall be installed under the roof at the ceiling, in spaces under the stage either containing combustible materials or constructed of combustible materials, and in all adjacent spaces and dressing rooms, storerooms, and workshops.

4-13.14.2 Where proscenium opening protection is required, a deluge system shall be provided with open sprinklers located not more than 3 ft (0.9 m) away from the stage side of the proscenium arch and spaced up to a maximum of 6 ft (1.8 m) on center. (See Chapter 5 for design criteria.)

4-13.15 Provision for Flushing Systems. All sprinkler systems shall be arranged for flushing. Readily removable fittings shall be provided at the end of all cross mains. All cross

mains shall terminate in 1 1/4-in. (33-mm) or larger pipe. All branch lines on gridded systems shall be arranged to facilitate flushing.

4-13.16 Stair Towers. Stairs, towers, or other construction with incomplete floors, if piped on independent risers, shall be treated as one area with reference to pipe sizes.

4-13.17 Return Bends. Return bends shall be used where pendent sprinklers are supplied from a raw water source, mill pond, or from open-top reservoirs. Return bends shall be connected to the top of branch lines in order to avoid accumulation of sediment in the drop nipples. (See Figure 4-13.17.)

Exception No. 1: Return bends are not required for deluge systems.

Exception No. 2: Return bends are not required where dry-pendent sprinklers are used.

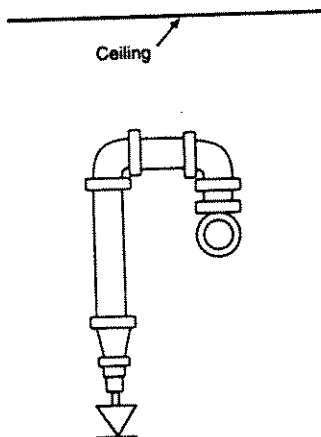

Figure 4-13.17 Return bend arrangement.

4-13.18 Piping to Sprinklers below Ceilings.

4-13.18.1 In new installations expected to supply sprinklers below a ceiling, minimum 1-in. (25-mm) outlets shall be provided.

Exception: Hexagonal bushings shall be permitted to accommodate temporary sprinklers and shall be removed with the temporary sprinklers when the permanent ceiling sprinklers are installed.

4-13.18.2 When pipe schedule systems are revamped, a nipple not exceeding 4 in. (102 mm) in length shall be permitted to be installed in the branch line fitting. All other piping shall be 1 in. (25.4 mm) where it supplies a single sprinkler in an area. [See Figure 4-13.18.2(a).]

Exception No. 1: When it is necessary to pipe 2 new ceiling sprinklers from an existing outlet in an overhead system, the use of a nipple not exceeding 4 in. (102 mm) in length and of the same pipe thread size as the existing outlet shall be permitted, provided that a hydraulic calculation verifies that the design flow rate will be achieved. [See Figure 4-13.18.2(b).]

Exception No. 2: The use of pipe nipples less than 1 in. (25.4 mm) in diameter is not permitted in areas subject to earthquakes.

4-13.18.3 When hydraulically designed systems are revamped, any existing bushing shall be removed and a nipple not exceeding 4 in. (102 mm) in length shall be permitted to be installed in the branch line fitting. Calculations shall be provided to verify that the system design flow rate will be achieved.

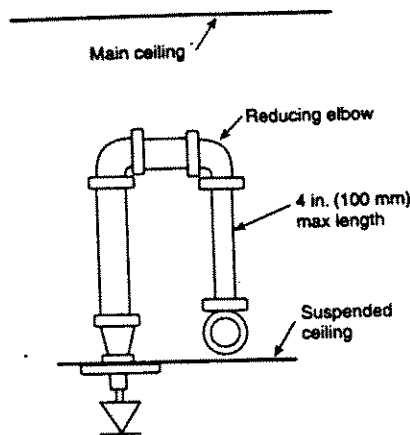

Figure 4-13.18.2(a) Nipple and reducing elbow supplying sprinkler below ceiling.

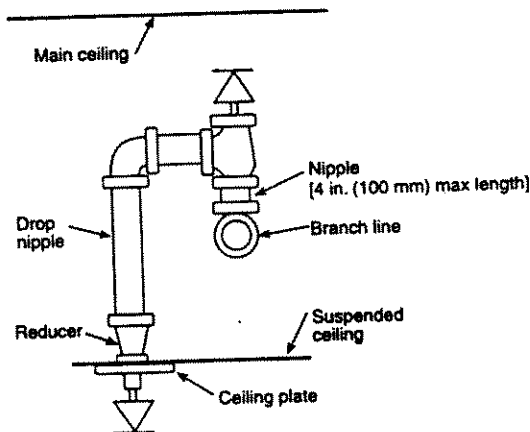

Figure 4-13.18.2(b) Sprinklers in concealed space and below ceiling.

Exception No. 1: When it is necessary to pipe 2 new ceiling sprinklers from an existing outlet in an overhead system, any bushings shall be removed and the use of a nipple not exceeding 4 in. (102 mm) in length and of the same pipe thread size as the existing outlet shall be permitted, provided that a hydraulic calculation verifies that the design flow rate will be achieved.

Exception No. 2: The use of pipe nipples less than 1 in. (25.4 mm) in diameter is not permitted in areas subject to earthquakes.

4-13.19 Dry Pipe Underground. Where necessary to place pipe that will be under air pressure underground, the pipe shall be protected against corrosion (see 4-14.4.2).

Exception: Unprotected cast or ductile iron pipe shall be permitted where joined with a gasketed joint listed for air service underground.

4-13.20* One-and-One-Half-Inch Hose Connections. One- and-one-half-inch [1 1/2-in. (38-mm)] hose used for fire purposes only shall be permitted to be connected to wet sprinkler systems only, subject to the following restrictions:

(a) Hose station's supply pipes shall not be connected to any pipe smaller than 2 1/2 in. (64 mm).

Exception: For hydraulically designed loops and grids, the minimum size pipe between the hose station's supply pipe and the source shall be permitted to be 2 in. (51 mm).

(b) For piping serving a single hose station, pipe shall be minimum 1 in. (25.4 mm) for horizontal runs up to 20 ft (6.1 m), minimum 1¼ in. (33 mm) for the entire run for runs between 20 and 80 ft (6.1 and 24.4 m), and minimum 1½ in. (38 mm) for the entire run for runs greater than 80 ft (24.4 m). For piping serving multiple hose stations, runs shall be a minimum of 1½ in. (38 mm) throughout.

(c) Piping shall be at least 1 in. (25 mm) for vertical runs.

(d) When the pressure at any hose station outlet exceeds 100 psi (6.9 bars), an approved device shall be installed at the outlet to reduce the pressure at the outlet to 100 psi (6.9 bars).

4-13.21* Hose Connections for Fire Department Use. In buildings of Light or Ordinary Hazard Occupancy, 2½-in. (64-mm) hose valves for fire department use are permitted to be attached to wet pipe sprinkler system risers. [See 5-2.3.1.3(d).] The following restrictions shall apply:

(a) Sprinklers shall be under separate floor control valves.

(b) The minimum size of the riser shall be 4 in. (102 mm) unless hydraulic calculations indicate that a smaller size riser will satisfy sprinkler and hose stream demands.

(c) Each combined sprinkler and standpipe riser shall be equipped with a riser control valve to permit isolating a riser without interrupting the supply to other risers from the same source of supply.

(d) For fire department connections serving standpipe and sprinkler systems, refer to Section 2-8.

4-13.22* System Subdivision. Where individual floor/zone control valves are not provided, a flanged joint or mechanical coupling shall be used at the riser at each floor for connections to piping serving floor areas in excess of 5,000 ft² (465 m²).

4-14 Piping Installation.

4-14.1 Valves.

4-14.1.1* Valves Controlling Sprinkler Systems. (See 2-7.1.)

4-14.1.1.1* Each system shall be provided with a listed indicating valve in an accessible location, so located as to control all automatic sources of water supply.

4-14.1.1.2 At least one listed indicating valve shall be installed in each source of water supply.

Exception: There shall be no shutoff valve in the fire department connection.

4-14.1.1.3 Valves on connections to water supplies, sectional control valves, and other valves in supply pipes to sprinklers shall be supervised open by one of the following methods:

(a) Central station, proprietary, or remote station signaling service.

(b) Local signaling service that will cause the sounding of an audible signal at a constantly attended point.

(c) Valves locked in the open position.

(d) Valves located within fenced enclosures under the control of the owner, sealed in the open position, and inspected weekly as part of an approved procedure.

Floor control valves in high-rise buildings and valves controlling flow to sprinklers in circulating closed loop systems shall comply with (a) or (b) above.

Exception: Supervision of underground gate valves with roadway boxes shall not be required.

4-14.1.1.4 Where control valves are installed overhead, they shall be positioned so that the indicating feature is visible from the floor below.

4-14.1.1.5 Where there is more than one source of water supply, a check valve shall be installed in each connection.

4-14.1.1.6 Check valves shall be installed in a vertical or horizontal position in accordance with their listing.

4-14.1.1.7* Where a single wet pipe sprinkler system is equipped with a fire department connection, the alarm valve is considered a check valve and an additional check valve shall not be required.

4-14.1.1.8* In a city connection serving as one source of supply, listed indicating valves or indicator post valves shall be installed on both sides of the check valve required in 4-14.1.1.5.

Exception No. 1: There shall be no control valves in the fire department connection piping. (See 4-14.1.1.2).

Exception No. 2: Where the city connection serves as the only automatic source of supply to a wet pipe sprinkler system, a control valve is not required on the system side of the check valve or the alarm check valve.

4-14.1.2 Pressure-Reducing Valves.

4-14.1.2.1 In portions of systems where all components are not listed for pressure greater than 175 psi (12.1 bars) and the potential exists for normal (nonfire condition) water pressure in excess of 175 psi (12.1 bars), a listed pressure-reducing valve shall be installed and set for an outlet pressure not exceeding 165 psi (2.4 bars) at the maximum inlet pressure.

4-14.1.2.2 Pressure gauges shall be installed on the inlet and outlet sides of each pressure-reducing valve.

4-14.1.2.3* A relief valve of not less than ½ in. (13 mm) in size shall be provided on the discharge side of the pressure-reducing valve set to operate at a pressure not exceeding 175 psi (12.1 bars).

4-14.1.2.4 A listed indicating valve shall be provided on the inlet side of each pressure-reducing valve.

Exception: A listed indicating valve is not required where the pressure-reducing valve meets the listing requirements for use as an indicating valve.

4-14.2 Pipe Support.

4-14.2.1 General.

4-14.2.1.1 Sprinkler piping shall be supported independently of the ceiling sheathing.

Exception: Toggle hangers shall be permitted only for the support of pipe 1½ in. (38 mm) or smaller in size under ceilings of hollow tile or metal lath and plaster.

4-14.2.1.2 Where sprinkler piping is installed in storage racks as defined in NFPA 231C, *Standard for Rack Storage of Materials*, piping shall be supported from the storage rack structure or building in accordance with all applicable provisions of 4-14.2 and 4-14.4.3.

4-14.2.2 Maximum Distance between Hangers.

4-14.2.2.1* The maximum distance between hangers shall not exceed that in Table 4-14.2.2.1.

Exception No. 1: The maximum distance between hangers for steel pipe and copper tube shall be modified as specified in 4-14.2.1 and 4-14.2.2.

Exception No. 2: The maximum distance between hangers for CPVC pipe and polybutylene pipe shall be modified as specified in the individual product listings.

Exception No. 3: Holes through concrete beams shall be acceptable for the support of steel pipe as a substitute for hangers.

4-14.2.3 Location of Hangers on Branch Lines. This subsection applies to the support of steel pipe or copper tube as specified in 2-3.1 and subject to the provisions of 4-14.2.2.

4-14.2.3.1 There shall be not less than one hanger for each section of pipe.

Exception No. 1:* Where sprinklers are spaced less than 6 ft (1.8 m) apart, hangers spaced up to a maximum of 12 ft (3.7 m) shall be permitted.

Exception No. 2: Starter lengths less than 6 ft (1.8 m) shall not require a hanger, unless on the end line of a sidefeed system or where an intermediate cross main hanger has been omitted.

4-14.2.3.2 The distance between a hanger and the centerline of an upright sprinkler shall not be less than 3 in. (76 mm).

4-14.2.3.3* The unsupported length between the end sprinkler and the last hanger on the line shall not be greater than 36 in. (914 mm) for 1-in. (2.5-cm) pipe or 48 in. (1219 mm) for 1 1/4-in. (3.2-cm) pipe, and 60 in. (152 cm) for 1 1/2-in. (3.8-cm) or larger pipe. Where any of these limits is exceeded, the pipe shall be extended beyond the end sprinkler and shall be supported by an additional hanger.

Exception No. 1:* When the maximum pressure at the sprinkler exceeds 100 psi (6.9 bars), and a branch line above a ceiling supplies sprinklers in a pendent position below the ceiling, the hanger assembly supporting the pipe supplying an end sprinkler in a pendent position shall be of a type that prevents upward movement of the pipe.

Exception No. 2:* When the maximum pressure at the sprinkler exceeds 100 psi (6.9 bars), the unsupported length between the end sprinkler in a pendent position or drop nipple and the last hanger on the branch line shall not be greater than 12 in. (305 mm) for steel pipe or 6 in. (152 mm) for copper pipe. When this limit is exceeded, the pipe shall be extended beyond the end sprinkler and supported by an additional hanger. The hanger closest to the sprinkler shall be of a type that prevents upward movement of the piping.

4-14.2.3.4* The length of an unsupported armover to a sprinkler shall not exceed 24 in. (610 mm) for steel pipe or 12 in. (305 mm) for copper tube.

Exception:* Where the maximum pressure at the sprinkler exceeds 100 psi (6.9 bars) and a branch line above a ceiling supplies sprinklers in a pendent position below the ceiling, the length of an unsupported armover to a sprinkler and drop nipple shall not exceed 12 in. (305 mm) for steel pipe and 6 in. (152 mm) for copper tube.

Where the limits of the unsupported armover lengths of 4-14.2.3.4 or this Exception are exceeded, the hanger closest to the sprinkler shall be of a type that prevents upward movement of the piping.

4-14.2.3.5 Wall-mounted sidewall sprinklers shall be restrained to prevent movement.

4-14.2.4 Location of Hangers on Cross Mains. This subsection applies to the support of steel pipe only as specified in 4-14.2.3, subject to the provisions of 4-14.2.2.

4-14.2.4.1 On cross mains there shall be at least one hanger between each two branch lines.

Exception No. 1: In bays having two branch lines, the intermediate hanger shall be permitted to be omitted provided that a hanger attached to a purlin is installed on each branch line located as near to the cross main as the location of the purlin permits. Remaining branch line hangers shall be installed in accordance with 4-14.2.3.

Exception No. 2: In bays having three branch lines, either side or center feed, one (only) intermediate hanger shall be permitted to be omitted provided that a hanger attached to a purlin is installed on each branch line located as near to the cross main as the location of the purlin permits. Remaining branch line hangers shall be installed in accordance with 4-14.2.3.

Exception No. 3: In bays having four or more branch lines, either side or center feed, two intermediate hangers shall be permitted to be omitted provided the maximum distance between hangers does not exceed the distances specified in 4-14.2.2.1 and a hanger attached to a purlin on each branch line is located as near to the cross main as the purlin permits.

4-14.2.4.2 Intermediate hangers shall not be omitted for copper tube.

4-14.2.4.3 At the end of the cross main, intermediate trapeze hangers shall be installed unless the cross main is extended to the next framing member with a hanger installed at this point, in which event an intermediate hanger shall be permitted to be omitted in accordance with 4-14.2.4.1, Exceptions No. 1, No. 2, and No. 3.

Table 4-14.2.2.1 Maximum Distance between Hangers (ft - in.)

Nominal Pipe Size (in.)	3/4	1	1 1/4	1 1/2	2	2 1/2	3	3 1/2	4	5	6	8
Steel pipe except threaded light-wall	N/A	12-0	12-0	15-0	15-0	15-0	15-0	15-0	15-0	15-0	15-0	15-0
Threaded lightwall steel pipe	N/A	12-0	12-0	12-0	12-0	12-0	12-0	N/A	N/A	N/A	N/A	N/A
Copper tube	8-0	8-0	10-0	10-0	12-0	12-0	12-0	15-0	15-0	15-0	15-0	15-0
CPVC	5-6	6-0	6-6	7-0	8-0	9-0	10-0	N/A	N/A	N/A	N/A	N/A
Polybutylene (IPS)	N/A	3-9	4-7	5-0	5-11	N/A	N/A	N/A	N/A	N/A	N/A	N/A
Polybutylene (CTS)	2-11	3-4	3-11	4-5	5-5	N/A	N/A	N/A	N/A	N/A	N/A	N/A

For SI Units: 1 in. = 25.4 mm; 1 ft = 0.3048 m.

NOTE: (IPS) Iron Pipe Size
(CTS) Copper Tube Size

4-14.2.5 Support of Risers.

4-14.2.5.1 Risers shall be supported by pipe clamps or by hangers located on the horizontal connections close to the riser.

4-14.2.5.2 Clamps supporting pipe by means of setscrews shall not be used.

4-14.2.5.3 In multistory buildings, riser supports shall be provided at the lowest level, at each alternate level above, above and below offsets, and at the top of the riser. Supports above the lowest level shall also restrain the pipe to prevent movement by an upward thrust where flexible fittings are used. Where risers are supported from the ground, the ground support constitutes the first level of riser support. Where risers are offset or do not rise from the ground, the first ceiling level above the offset constitutes the first level of riser support.

4-14.2.5.4 Risers in vertical shafts, or in buildings with ceilings over 25 ft (7.6 m) high, shall have at least one support for each riser pipe section.

4-14.3 Drainage.

4-14.3.1* All sprinkler pipe and fittings shall be so installed that the system can be drained.

4-14.3.2 On wet pipe systems, sprinkler pipes shall be permitted to be installed level. Trapped piping shall be drained in accordance with 4-14.3.5.

4-14.3.3 In dry pipe systems and portions of preaction systems subject to freezing, branch lines shall be pitched at least $\frac{1}{2}$ in. per 10 ft (4 mm/m) and mains shall be pitched at least $\frac{1}{4}$ in. per 10 ft (2 mm/m).

Exception: Mains shall be pitched at least $\frac{1}{2}$ in. per 10 ft (4 mm/m) in refrigerated areas.

4-14.3.4 System, Main Drain, or Sectional Drain Connections.
[See Figures 4-14.3.4 and A-4-15.4.2(b).]

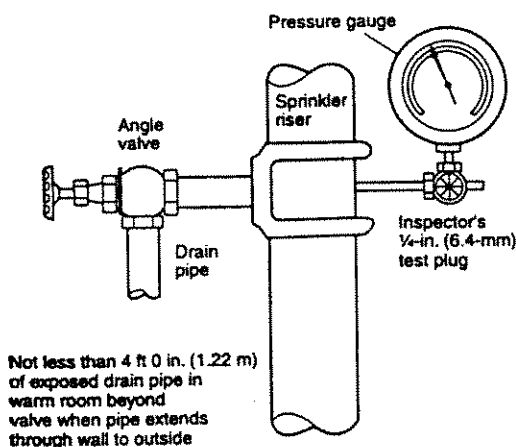

Figure 4-14.3.4 Drain connection for system riser.

4-14.3.4.1 Provisions shall be made to properly drain all parts of the system.

4-14.3.4.2 Drain connections for systems' supply risers and mains shall be sized as shown in Table 4-14.3.4.2.

Table 4-14.3.4.2 Drain Size

Riser or Main Size	Size of Drain Connection
Up to 2 in.	$\frac{3}{4}$ in. or larger
2½ in., 3 in., 3½ in.	1¼ in. or larger
4 in. and larger	2 in. only

For SI Units: 1 in. = 25.4 mm.

4-14.3.4.3 Where interior sectional or floor control valve(s) are provided, they shall be provided with a drain connection sized as shown in Table 4-14.3.4.2 to drain that portion of the system controlled by the sectional valve. Drains shall discharge outside or to a drain connection. [See Figure A-4-15.4.2(b).]

Exception: For those drains serving pressure reducing valves, the drain, drain connection, and all other downstream drain piping shall be sized to permit a flow of at least the greatest system demand supplied by the pressure-reducing valve.

4-14.3.4.4 The test connections required by 4-15.4.1 shall be permitted to be used as main drain connections.

Exception: Where drain connections for floor control valves are tied into a common drain riser, the drain riser shall be one pipe size larger than the largest size drain connection tying into it.

4-14.3.5 Auxiliary Drains.

4-14.3.5.1 Auxiliary drains shall be provided where a change in piping direction prevents drainage of system piping through the main drain valve.

4-14.3.5.2 Auxiliary Drains for Wet Pipe Systems and Preaction Systems in Areas Not Subject to Freezing.

4-14.3.5.2.1 Where the capacity of trapped sections of pipes in wet systems is less than 5 gal (18.9 L), the auxiliary drain shall consist of a nipple and cap or plug not less than $\frac{1}{2}$ in. (12 mm) in size.

Exception No. 1: Auxiliary drains are not required for system piping that can be drained by removing a single pendent sprinkler.

Exception No. 2: Where flexible couplings or other easily separated connections are used, the nipple and cap or plug shall be permitted to be omitted.

4-14.3.5.2.2 Where the capacity of isolated trapped sections of pipe is more than 5 gal (18.9 L) and less than 50 gal (189 L), the auxiliary drain shall consist of a valve $\frac{3}{4}$ in. (19 mm) or larger and a plug or a nipple and cap.

4-14.3.5.2.3* Where the capacity of isolated trapped sections of pipe is 50 gal (18.9 L) or more, the auxiliary drain shall consist of a valve not smaller than 1 in. (25.4 mm), piped to an accessible location.

4-14.3.5.2.4 Tie-in drains are not required on wet pipe and preaction systems.

4-14.3.5.3 Auxiliary Drains for Dry Pipe Systems and Preaction Systems in Areas Subject to Freezing.

4-14.3.5.3.1 Where the capacity of trapped sections of pipe is less than 5 gal (18.9 L), the auxiliary drain shall consist of a valve not smaller than $\frac{1}{2}$ in. (12 mm) and a plug or a nipple and cap.

Exception: Auxiliary drains are not required for pipe drops supplying dry-pendent sprinklers installed in accordance with 3-2.2.

4-14.3.5.3.2 Where the capacity of isolated trapped sections of system piping is more than 5 gal (18.9 L), the auxiliary drain shall consist of two 1-in. (25.4-mm) valves and one 2-in. by 12-in. (50-mm by 300-mm) condensate nipple or equivalent, accessibly located. (See Figure 4-14.3.5.3.2.)

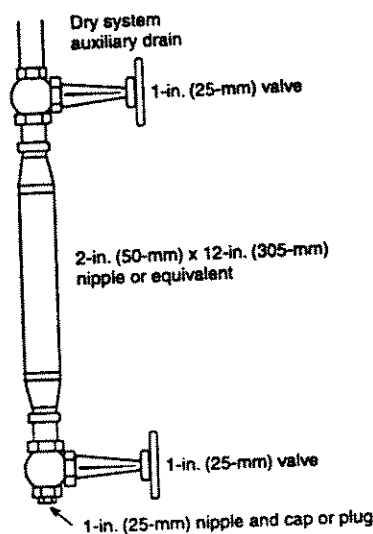

Figure 4-14.3.5.3.2 Dry system auxiliary drain.

4-14.3.5.3.3 Tie-in drains shall be provided for multiple adjacent trapped branch pipes and shall be only 1 in. (25.4 mm). Tie-in drain lines shall be pitched a minimum of 1/2 in. per 10 ft (4 mm/m).

4-14.3.6 Discharge of Drain Valves.

4-14.3.6.1* Direct interconnections shall not be made between sprinkler drains and sewers. The drain discharge shall conform to any health or water department regulations.

4-14.3.6.2 Where drain pipes are buried underground, approved corrosion-resistant pipe shall be used.

4-14.3.6.3 Drain pipes shall not terminate in blind spaces under the building.

4-14.3.6.4 Where exposed to the atmosphere, drain pipes shall be fitted with a turned down elbow.

4-14.3.6.5 Drain pipes shall be arranged to avoid exposing any part of the sprinkler system to freezing conditions.

4-14.4 Protection of Piping.

4-14.4.1 Protection of Piping against Freezing.

4-14.4.1.1 Where portions of systems are subject to freezing and temperatures cannot reliably be maintained at or above 40°F (4°C), sprinklers shall be installed as a dry pipe or preaction system.

Exception: Small unheated areas are permitted to be protected by antifreeze systems or by other systems specifically listed for this purpose. (See 3-5.2.)

4-14.4.1.2 Where water-filled supply pipes, risers, system risers, or feed mains pass through open areas, cold rooms, passageways, or other areas exposed to freezing, the pipe shall be protected against freezing by insulating coverings, frostproof casings, or other reliable means capable of maintaining a minimum temperature of 40°F (4°C).

4-14.4.2 Protection of Piping against Corrosion.

4-14.4.2.1* Where corrosive conditions are known to exist due to moisture or fumes from corrosive chemicals or both, special types of fittings, pipes, and hangers that resist corrosion shall be used or a protective coating shall be applied to all unprotected exposed surfaces of the sprinkler system. (See 2-2.5.)

4-14.4.2.2 Where water supplies are known to have unusual corrosive properties and threaded or cut-groove steel pipe is to be used, wall thickness shall be in accordance with Schedule 30 [in sizes 8 in. (200 mm) or larger] or Schedule 40 [in sizes less than 8 in. (200 mm)].

4-14.4.2.3 Steel pipe, where exposed to weather, shall be externally galvanized or otherwise protected against corrosion.

4-14.4.2.4 Where steel pipe is used underground, the pipe shall be protected against corrosion.

4-14.4.3 Protection of Piping against Damage Where Subject to Earthquakes.

4-14.4.3.1* General. Sprinkler systems shall be protected to prevent pipe breakage where subject to earthquakes in accordance with the requirements of 4-14.4.3.

Exception: Alternative methods of providing earthquake protection of sprinkler systems based on a dynamic seismic analysis certified by a registered professional engineer such that system performance will be at least equal to that of the building structure under expected seismic forces.

4-14.4.3.2* Couplings. Listed flexible pipe couplings joining grooved end pipe shall be provided as flexure joints to allow individual sections of piping 2 1/2 in. (64 mm) or larger to move differentially with the individual sections of the building to which it is attached. Couplings shall be arranged to coincide with structural separations within a building. Systems having more flexible couplings than required here shall be provided with additional sway bracing as required in 4-14.4.3.5.10, Exception No. 4. The sway bracing shall be installed:

(a) Within 24 in. (610 mm) of the top and bottom of all risers.

Exception No. 1: In risers less than 3 ft (0.9 m) in length, flexible couplings are permitted to be omitted.

Exception No. 2: In risers 3 to 7 ft (0.9 to 2.1 m) in length, one flexible coupling is adequate.

(b) Within 12 in. (305 mm) above and below the floor in multistory buildings such that the flexible coupling below the floor is below the main supplying that floor.

(c) On one side of concrete or masonry walls within 3 ft (0.9 m) of the wall surface.

Exception: Flexible pipe couplings are not required where clearance around the pipe is provided in accordance with 4-14.4.3.4.

(d)* At or near building expansion joints.

(e) Within 24 in. (610 mm) of the top and bottom of drops to hose lines, rack sprinklers, and mezzanines, regardless of pipe size.

(f) Within 24 in. (610 mm) of the top of drops exceeding 15 ft (4.6 m) in length to portions of systems supplying more than one sprinkler, regardless of pipe size.

(g) Above and below any intermediate points of support for a riser or other vertical pipe.

4-14.4.3.3* Seismic Separation Assembly. Seismic separation assemblies with flexible fittings shall be installed where sprinkler piping, regardless of size, crosses building seismic separation joints above ground level.

4-14.4.3.4* Clearance. Clearance shall be provided around all piping extending through walls, floors, platforms, foundations, walls or floors, the holes shall be sized such that the diameter of the holes is 2 in. (50 mm) larger than the pipe for 1 in. (25 mm) nominal to 3½ in. (89 mm) nominal and 4 in. (100 mm) larger than the pipe for pipe 4 in. (100 mm) nominal and larger. Clearance from structural members not penetrated or used, collectively or independently, to support the piping shall be at least 2 in. (51 mm).

4-14.4.3.4.1 When sprinkler systems are to be protected against damage from earthquakes, the requirements of 4-14.3.4 shall apply. Where pipe passes through holes in platforms, foundations, walls or floors, the holes shall be sized such that the diameter of the holes is 2 in. (50 mm) larger than the pipe for 1 in. (25 mm) nominal to 3½ in. (89 mm) nominal and 4 in. (100 mm) larger than the pipe for pipe 4 in. (100 mm) nominal and larger. Clearance from structural members not penetrated or used, collectively or independently, to support the piping shall be at least 2 in. (51 mm).

Exception No. 1: Where clearance is provided by a pipe sleeve, a nominal diameter 2 in. (51 mm) larger than the nominal diameter of the pipe is acceptable for pipe sizes 1 in. (25.4 mm) through 3½ in. (89 mm), and the clearance provided by a pipe sleeve of nominal diameter 4 in. (102 mm) larger than the nominal diameter of the pipe is acceptable for pipe sizes 4 in. (102 mm) and larger.

Exception No. 2: No clearance is necessary for piping passing through gypsum board or equally frangible construction that is not required to have a fire resistance rating.

Exception No. 3: No clearance is necessary if flexible couplings are located within 1 ft (0.31 m) of each side of a wall, floor, platform, or foundation.

4-14.4.3.4.2 Where required, the clearance shall be filled with a flexible material such as mastic.

4-14.4.3.5 Sway Bracing.

4-14.4.3.5.1 The system piping shall be braced to resist both lateral and longitudinal horizontal seismic loads and to prevent vertical motion resulting from seismic loads. The structural components to which bracing is attached shall be determined to be capable of carrying the added applied seismic loads.

4-14.4.3.5.2 Sway braces shall be designed to withstand forces in tension and compression.

Exception: Tension only bracing systems shall be permitted for use where listed for this service and where installed in accordance with their listing limitations, including installation instructions.*

4-14.4.3.5.3* The assigned loads for both lateral and longitudinal sway bracing shall be determined using Table 4-14.4.3.5.3, based on a horizontal force of $F_p = 0.5 W_p$, where F_p is the horizontal force factor and W_p is the weight of the water-filled piping.

Exception No. 1: In lieu of using Table 4-14.4.3.5.3, horizontal loads for braces shall be permitted to be determined by analysis. For lateral braces, the load shall include all branch lines and mains (unless the branch lines are provided with longitudinal bracing) within the zone of influence of the brace. For longitudinal braces, the load shall include all mains within the zone of influence of the brace.

Exception No. 2: Where the use of other horizontal force factors is required or permitted by the authority having jurisdiction, the loads of Table 4-14.4.3.5.3, or those determined in accordance with Exception No. 1 shall be adjusted by the following multipliers:

Horizontal Force Factor F_p	Multiplying Factor
0.2 W_p	0.4
0.4 W_p	0.8
0.6 W_p	1.2
0.8 W_p	1.6
1.0 W_p	2.0
1.2 W_p	2.4

Exception No. 3: Lateral braces shall only be permitted to be spaced up to 50 ft (16 m) as permitted only under Exception No. 4 to 4-14.4.3.5.10.

Exception No. 4: If branch lines are provided with lateral bracing or hung with U-hooks bent out at least 30 degrees from vertical, half the assigned load is permitted to be used for longitudinal braces.

4-14.4.3.5.4 Where the horizontal force factors used exceed 0.5 W_p and the brace angle is less than 45° from vertical or where the horizontal force factor exceeds 1.0 W_p and the brace angle is less than 60° from vertical, the braces shall be arranged to resist the net vertical reaction produced by the horizontal load.

Table 4-14.4.3.5.3 Assigned Load Table (Based on Half the Weight of the Water-Filled Pipe)

Spacing of Lateral Braces (ft)	Spacing of Longitudinal Braces (ft)	Assigned Load for Pipe Size to Be Braced (lb)						
		2	2½	3	4	5	6	8
10	20	380	395	410	435	470	655	915
20	40	760	785	815	870	940	1305	1830
25	50	950	980	1020	1090	1175	1630	2290
30	60	1140	1180	1225	1305	1410	1960	2745
40	80	1515	1570	1630	1740	1880	2610	3660
50		1895	1965	2035	2175	2350	3260	4575

For SI Units: 1 ft = 0.3048 m; 1 lb = 0.45 Kg.

4-14.4.3.5.5* Sway bracing shall be tight and concentric. For individual braces, the slenderness ratio (l/r) shall not exceed 300 where l is the length of the brace and r is the least radius of gyration. Where threaded pipe is used as part of a sway brace assembly, it shall not be less than Schedule 30. All parts and fittings of a brace shall lie in a straight line to avoid eccentric loadings on fittings and fasteners. For longitudinal braces only, the brace shall be permitted to be connected to a tab welded to the pipe in conformance with 2-5.2. For individual braces, the slenderness ratio, l/r , shall not exceed 300 where l is the length of the brace and r is the least radius of gyration. For tension only braces, such as pre-stretched color-coded aircraft cable, two tension only brace components opposing each other must be installed at each lateral or longitudinal brace location. For all braces, whether or not listed, the maximum allowable horizontal load shall be based on the weakest component of the brace with safety factors. The loads determined in 4-14.4.3.5.3 shall not exceed the lesser of the maximum allowable loads provided in Table 4-14.4.3.5.5 or the manufacturer's certified maximum allowable horizontal loads for 30-44, 45-59, and 60-90 degree brace angles. These certified allowable horizontal loads must include a minimum safety factor of 1.5 against the ultimate break strength of the brace components and then be further reduced according to the brace angles.

Exception: Other pipe schedules and materials not specifically included in Table 4-14.4.3.5.5 are acceptable for use if certified by a registered professional engineer to support the loads determined in accordance with the above criteria. Calculations shall be submitted where required by the authority having jurisdiction.

4-14.4.3.5.6* For individual fasteners, the loads determined in 4-14.4.3.5.3 shall not exceed the allowable loads provided in Table 4-14.4.3.5.6.

The type of fasteners used to secure the bracing assembly to the structure shall be limited to those shown in Table 4-14.4.3.5.6. For connections to wood, through bolts with washers on each end shall be used. Holes for through bolts shall be $\frac{1}{16}$ in. (1.6 mm) greater than the diameter of the bolt.

Exception: Where it is not practical to install through bolts due to the thickness of the member or inaccessibility, lag screws shall be permitted. Holes shall be pre-drilled $\frac{1}{8}$ in. (3.2 mm) smaller than the maximum root diameter of the lag screw.

4-14.4.3.5.7 Sway brace assemblies shall be listed for a maximum allowable load. The loads shall be reduced as shown in Table 4-14.4.3.5.7 for loads that are less than 90° from vertical.

Exception: Where sway bracing utilizing pipe, angles, flats or rods as shown in Table 4-14.4.3.5.5 is used, the components do not require listing. Bracing fittings and connections used with those specific materials shall be listed.

4-14.4.3.5.8 Longitudinal sway bracing spaced at a maximum of 80 ft (24 m) on center shall be provided for feed and cross mains. Longitudinal braces shall be permitted to serve as lateral braces where they are installed within 24 in. (609 mm) of the piping which is braced laterally.

4-14.4.3.5.9* Tops of risers shall be secured against drifting in any direction, utilizing a four-way sway brace.

4-14.4.3.5.10 Lateral sway bracing spaced at a maximum interval of 40 ft (12.2 m) on center shall be provided for all feed mains, all cross mains, and branchlines with a diameter

of $2\frac{1}{2}$ in. (76 mm) and larger. The last length of pipe at the end of a feed or cross main shall be provided with a lateral brace. Lateral braces shall be allowed to act as longitudinal braces if they are within 24 in. (610 mm) of the centerline of the piping braced longitudinally for lines that are $2\frac{1}{2}$ in. (76 mm) and greater in diameter. The distance between the last brace and the end of the pipe shall not exceed 20 ft (6.1 m). This shall not preclude the use of a lateral brace serving as a longitudinal brace as described in this paragraph.

Exception No. 1: Where the spacing of lateral braces is permitted to be up to 50 ft (7.6 m), the distance between the last brace and the end of the pipe is permitted to be extended to 25 ft (15.2 m).

Exception No. 2: Lateral sway bracing shall not be required on pipes individually supported by rods less than 6 in. (152 mm) long.

Exception No. 3: 'U'-type hooks of the wraparound type or those 'U'-type hooks arranged to keep the pipe tight to the underside of the structural element shall be permitted to be used to satisfy the requirements for lateral sway bracing provided the legs are bent out at least 30 degrees from the vertical and the maximum length of each leg and the rod size satisfies the conditions of Table 4-14.4.3.5.5.

Exception No. 4: Where flexible couplings are installed on mains other than as required in 4-14.4.3.2, a lateral brace shall be provided within 24 in. (610 mm) of every other coupling, but not more than 40 ft (12 m) on center.

Exception No. 5: Where building primary structural members exceed 40 ft (12 m) on center, lateral braces shall be permitted to be spaced up to 50 ft (15.2 m) on center.

4-14.4.3.5.11 Bracing shall be attached directly to feed and cross mains. Each run of pipe between a change in direction shall be provided with both lateral and longitudinal bracing.

Exception: Pipe runs less than 12 ft (3.6 m) in length shall be permitted to be supported by the braces on adjacent runs of pipe.

4-14.4.3.5.12 A length of pipe shall not be braced to sections of the building that will move differentially.

4-14.4.3.5.13* Sway bracing is not required for branch lines.

Exception No. 1: The end sprinkler on a line shall be restrained against excessive vertical and lateral movement by use of a wrap around U-hook (see Figure A-2-6.1) or by other approved means.

Exception No. 2: Where upward or lateral movement of sprinklers would result in an impact against the building structure, equipment, or finish materials, branch lines shall be provided at intervals not exceeding 30 ft (9 m) with a wraparound U-hook, lateral sway brace, or #12, 440-lb (200-kg) splayed seismic brace wire installed at least 45 degrees from the vertical plane and anchored on both sides of the pipe. This bracing shall be located within 2 ft (610 mm) of a hanger. The hanger closest to a splayed wire restraint shall be of a type that resists upward movement of a branch line.*

4-14.4.3.5.14 Where ceilings are seismically braced to prevent horizontal and vertical movement, branch lines and armovers in excess of 2 ft (610 mm) horizontally, if provided, shall be restrained against upward movement and sprinklers shall be provided with a one-piece escutcheon.

Exception: Recessed, flush, and concealed sprinklers shall not be required to be provided with the escutcheon.

4-14.4.3.5.15* Sprig-ups 4 ft (1.2 m) or longer shall be restrained against lateral movement.

Table 4-14.4.3.5.5

Shape and Size	Least Radius of Gyration	Maximum Length for $l/r = 200$	Maximum Horizontal Load (lb)		
			30°-44° Angle from Vertical	45°-59° Angle from Vertical	60°-90° Angle from Vertical
Pipe (Schedule 40)	$= \frac{\sqrt{r_0^2 + r_1^2}}{2}$				
1 in.	.42	7 ft 0 in.	1767	2500	3061
1 1/4 in.	.54	9 ft 0 in.	2393	3385	4145
1 1/2 in.	.623	10 ft 4 in.	2858	4043	4955
2 in.	.787	13 ft 1 in.	3828	5414	6630
Angles					
1 1/2 x 1 1/2 x 1/4 in.	.292	4 ft 10 in.	2461	3481	4263
2 x 2 x 1/4 in.	.391	6 ft 6 in.	3356	4746	5813
2 1/2 x 2 x 1/4 in.	.424	7 ft 0 in.	3792	5363	6569
2 1/2 x 2 1/2 x 1/4 in.	.491	8 ft 2 in.	4257	6021	7374
3 x 2 1/2 x 1/4 in.	.528	8 ft 10 in.	4687	6628	8118
3 x 3 x 1/4 in.	.592	9 ft 10 in.	5152	7286	8923
Rods	$= \frac{r}{2}$				
3/8 in.	.094	1 ft 6 in.	395	559	685
1/2 in.	.125	2 ft 6 in.	702	993	1217
5/8 in.	.156	2 ft 7 in.	1087	1537	1883
3/4 in.	.188	3 ft 1 in.	1580	2235	2737
7/8 in.	.219	3 ft 7 in.	2151	3043	3726
Flats	$= 0.29 h$ (where h is smaller of two side dimensions)				
1 1/2 x 1/4 in.	.0725	1 ft 2 in.	1118	1581	1936
2 x 1/4 in.	.0725	1 ft 2 in.	1789	2530	3098
2 x 3/8 in.	.109	1 ft 9 in.	2683	3795	4648
Pipe (Schedule 40)	$= \frac{\sqrt{r_0^2 + r_1^2}}{2}$				
1 in.	.42	3 ft 6 in.	7068	9996	12242
1 1/4 in.	.54	4 ft 6 in.	9567	13530	16570
1 1/2 in.	.623	5 ft 2 in.	11441	16181	19817
2 in.	.787	6 ft 6 in.	15377	21746	26634
Pipe (Schedule 10)	$= \frac{\sqrt{r_0^2 + r_1^2}}{2}$				
1 in.	.43	3 ft 7 in.	5910	8359	10237
1 1/4 in.	.55	4 ft 7 in.	7600	10749	13164
1 1/2 in.	.634	5 ft 3 in.	8777	12412	15202
2 in.	.802	6 ft 8 in.	11105	15705	19235
Rods	$= \frac{r}{2}$				
3/8 in.	.094	0 ft 9 in.	1580	2234	2737
1/2 in.	.125	1 ft 0 in.	2809	3972	4865
5/8 in.	.156	1 ft 3 in.	4390	6209	7605
3/4 in.	.188	1 ft 6 in.	6322	8941	10951
7/8 in.	.219	1 ft 9 in.	8675	12169	14904
Pipe (Schedule 40)	$= \frac{\sqrt{r_0^2 + r_1^2}}{2}$	$l/r = 300$			
1 in.	.42	10 ft 6 in.	786	1111	1360
1 1/2 in.	.54	13 ft 6 in.	1063	1503	1841
1 1/2 in.	.623	15 ft 7 in.	1272	1798	2202
2 in.	.787	19 ft 8 in.	1666	2355	2885
Rods	$= \frac{r}{2}$				
3/8 in.	.094	2 ft 4 in.	176	248	304
1/2 in.	.125	3 ft 1 in.	312	441	540
5/8 in.	.156	3 ft 11 in.	488	690	845
3/4 in.	.188	4 ft 8 in.	702	993	1217
7/8 in.	.219	5 ft 6 in.	956	1352	1656

For SI Units: 1 in. = 25.4 mm; 1 ft = 0.3048 m; 1 lb = 0.45 Kg.

**Table 4-14.4.3.5.6 Maximum Loads for Various Types of Structure
Maximum Loads for Various Types of Fasteners to Structure**

NOTE: Loads (given in pounds) are keyed to vertical angles of braces and orientation of connecting surface. These values are based on concentric loadings of the fastener. Use figures to determine proper reference within table. For angles between those shown, use most restrictive case. Braces should not be attached to light structure members.

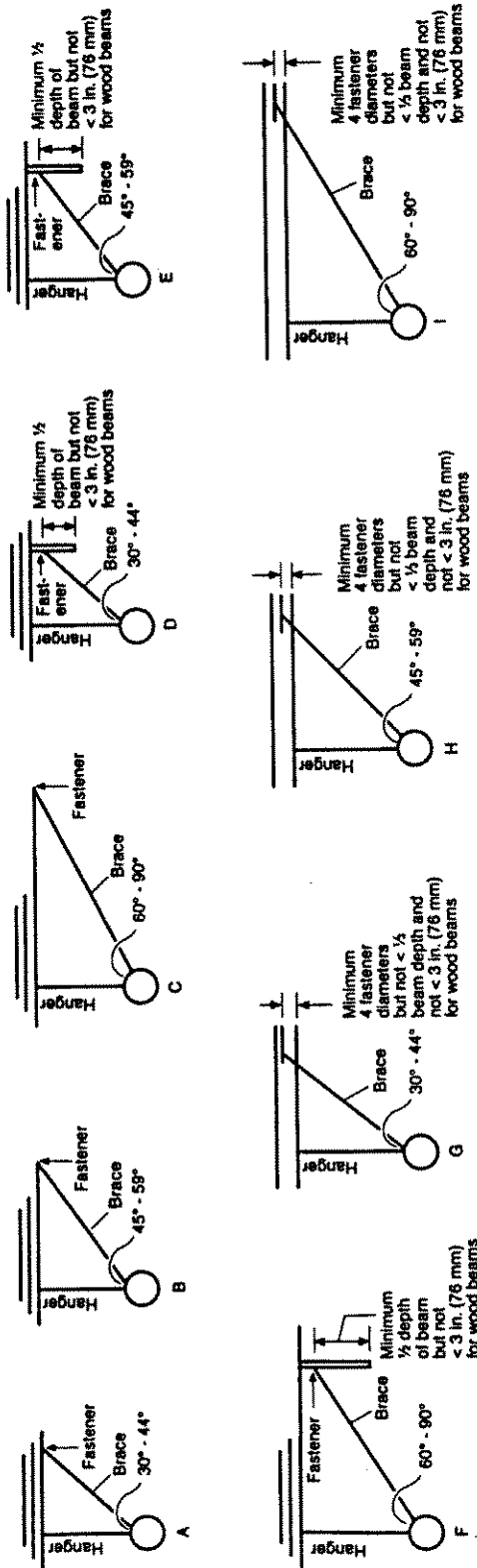

Note: For wooden beams not less than 3 in. (76 mm).

Lag Screws and Lag Bolts in Wood (Load Perpendicular to Grain—Holes Predrilled Using Good Practice)

	Shank Diameter of Lag (in.)																		
	5/8			3/4			7/8			1									
Length	A	B	C	D	E	F	G	H	I	A	B	C	D	E	F	G	H	I	
Under	3	304	325	292	168	325	526	230	324	408	366	—	—	—	—	—	—	—	
Head	4	302	354	517	183	354	678	250	352	435	473	509	456	264	509	618	360	507	626
(in.)	5	476	375	396	194	375	824	265	373	461	592	545	488	282	545	1088	385	542	670
	6	504	382	342	196	382	976	270	380	470	689	559	501	298	559	1192	395	556	687
											805	573	513	296	573	1586	405	570	704
											1044	806	723	416	806	1807	570	803	991
											1297	1365	1223	685	1365	2244	965	1359	1678

For SI Units: 1 in. = 25.4 mm; 1 ft = 0.3048 m; 1 lb = 0.45 kg.

Table 4-14.4.3.5.6 (cont.)

Through Bolts in Wood (Load Perpendicular to Grain)

Length of Bolt in Timber (in.)	Diameter of Bolt (in.)														
	3/8			1/2			5/8			7/8					
	A	B	C	A	B	C	A	B	C	A	B	C	A	B	C
1 1/2	340	197	589	340	197	589	340	197	589	340	197	589	340	197	589
2	420	243	727	420	243	727	420	243	727	420	243	727	420	243	727
2 1/2	480	266	796	480	266	796	480	266	796	480	266	796	480	266	796
3	480	277	831	480	277	831	480	277	831	480	277	831	480	277	831
3 1/2	460	268	797	460	268	797	460	268	797	460	268	797	460	268	797
4	460	268	797	460	268	797	460	268	797	460	268	797	460	268	797

For SI Units: 1 in. = 25.4 mm; 1 lb = 0.45 Kg.

Expansion Shields in Concrete

Min. Depth of Hole (in.)	Diameter of Bolt (in.)														
	1/2			5/8			3/4			7/8					
	A	B	C	A	B	C	A	B	C	A	B	C	A	B	C
1 1/2	1638	2306	2848	1638	2306	2848	1638	2306	2848	1638	2306	2848	1638	2306	2848
2	1638	2306	2848	1638	2306	2848	1638	2306	2848	1638	2306	2848	1638	2306	2848
2 1/2	1638	2306	2848	1638	2306	2848	1638	2306	2848	1638	2306	2848	1638	2306	2848
3	1638	2306	2848	1638	2306	2848	1638	2306	2848	1638	2306	2848	1638	2306	2848
3 1/2	1638	2306	2848	1638	2306	2848	1638	2306	2848	1638	2306	2848	1638	2306	2848
4	1638	2306	2848	1638	2306	2848	1638	2306	2848	1638	2306	2848	1638	2306	2848

For SI Units: 1 in. = 25.4 mm; 1 lb = 0.45 Kg.

Connections to Steel (Values Assume Bolt Perpendicular to Mounting Surface)

Min. Depth of Hole (in.)	Diameter of Unfinished Steel Bolt (in.)														
	1/4			3/8			1/2			5/8					
	A	B	C	A	B	C	A	B	C	A	B	C	A	B	C
1 1/2	2500	3300	3950	2500	3300	3950	2500	3300	3950	2500	3300	3950	2500	3300	3950
2	2500	3300	3950	2500	3300	3950	2500	3300	3950	2500	3300	3950	2500	3300	3950
2 1/2	2500	3300	3950	2500	3300	3950	2500	3300	3950	2500	3300	3950	2500	3300	3950
3	2500	3300	3950	2500	3300	3950	2500	3300	3950	2500	3300	3950	2500	3300	3950
3 1/2	2500	3300	3950	2500	3300	3950	2500	3300	3950	2500	3300	3950	2500	3300	3950
4	2500	3300	3950	2500	3300	3950	2500	3300	3950	2500	3300	3950	2500	3300	3950

For SI Units: 1 in. = 25.4 mm; 1 ft = 0.3048 m; 1 lb = 0.45 Kg.

Table 4-14.4.3.5.7 Allowable Horizontal Load on Brace Assemblies Based on the Weakest Component of the Brace Assembly

Brace Angle	Allowable Horizontal Load
30 degrees from vertical	Ultimate strength divided by safety factor divided by 2.000
45 degrees from vertical	Ultimate strength divided by safety factor divided by 1.414
60 degrees from vertical	Ultimate strength divided by safety factor divided by 1.155

4-14.4.3.5.16 The retaining strap shall be listed for use with a C-type clamp, or shall be a steel strap of not less than 16 gauge thickness and not less than 1 in. (25.4 mm) wide for pipe diameters 8 in. (203 mm) or less and 14 gauge thickness and not less than 1 1/4 in. (31.7 mm) wide for pipe diameters greater than 8 in. (203 mm). The retaining strap shall wrap around the beam flange not less than 1 in. (25.4 mm). A lock nut on a C-type clamp shall not be used as a method of restraint. A lip on a "C" or "Z" purlin shall not be used as a method of restraint.

Where purlins or beams do not provide an adequate lip to be secured by a retaining strap, the strap shall be through-bolted or secured by a self-tapping screw.

4-14.4.3.5.17 C-type clamps (including beam and large flange clamps), with or without retaining straps, shall not be used to attach braces to the building structure.

4-14.4.3.5.18 Powder-driven fasteners shall not be used to attach braces to the building structure.

Exception: Powder-driven fasteners shall be permitted where they are specifically listed for service in resisting lateral loads in areas subject to earthquakes.

4-15 System Attachments.

4-15.1 Sprinkler Alarms.

4-15.1.1* Waterflow Alarms.

4-15.1.1.1 Local waterflow alarms shall be provided on all sprinkler systems having more than 20 sprinklers.

4-15.1.1.2 On each alarm check valve used under conditions of variable water pressure, a retarding device shall be installed. Valves shall be provided in the connections to retarding devices to permit repair or removal without shutting off sprinklers; these valves shall be so arranged that they may be locked or sealed in the open position.

4-15.1.1.3 Alarm, dry pipe, preaction, and deluge valves shall be fitted with an alarm bypass test connection for an electric alarm switch, water motor gong, or both. This pipe connection shall be made on the water supply side of the system and provided with a control valve and drain for the alarm piping. A check valve shall be installed in the pipe connection from the intermediate chamber of a dry pipe valve.

Exception: The alarm test connection at the riser shall be permitted to be made on the system side of an alarm valve.

4-15.1.1.4 An indicating control valve shall be installed in the connection to pressure-type contactors or water-motor-operated alarm devices. Such valves shall be locked or sealed in the open position. The control valve for the retarding chamber on alarm check valves shall be accepted as complying with this paragraph.

4-15.1.1.5* Attachments — Mechanically Operated. For all types of sprinkler systems employing water-motor-operated alarms, a listed 3/4-in. (19-mm) strainer shall be installed at the alarm outlet of the waterflow detecting device.

Exception: Where a retarding chamber is used in connection with an alarm valve, the strainer shall be located at the outlet of the retarding chamber unless the retarding chamber is provided with an approved integral strainer in its outlet.

4-15.1.1.6* Alarm Attachments — High-Rise Buildings. When a fire must be fought internally due to the height of a building, the following additional alarm apparatus shall be provided:

(a) Where each sprinkler system on each floor is equipped with a separate waterflow device, it shall be connected to an alarm system in such a manner that operation of one sprinkler will actuate the alarm system and the location of the operated flow device shall be indicated on an annunciator and/or register. The annunciator or register shall be located at grade level at the normal point of fire department access, at a constantly attended building security control center, or at both locations.

Exception: Where the location within the protected buildings where supervisory or alarm signals are received is not under constant supervision by qualified personnel in the employ of the owner, a connection shall be provided to transmit a signal to a remote central station.

(b) A distinct trouble signal shall be provided to indicate a condition that will impair the satisfactory operation of the sprinkler system.

4-15.2* Fire Department Connections.

4-15.2.1* A fire department connection shall be provided as described in this section. (See Figure 4-15.2.1.)

Exception No. 1: Buildings located in remote areas that are inaccessible for fire department support.

Exception No. 2: Large-capacity deluge systems exceeding the pumping capacity of the fire department.

Exception No. 3: Single-story buildings not exceeding 2000 ft² (186 m²) in area.

4-15.2.2 Size. Pipe size shall be 4 in. (102 mm) for fire engine connections and 6 in. (152 mm) for fire boat connections.

Exception No. 1: For hydraulically calculated systems, fire department connection pipe as small as the system riser shall be permitted where serving one system riser.

Exception No. 2: A single-outlet fire department connection shall be acceptable where piped to a 3-in. (76-mm) or smaller riser.

4-15.2.3* Arrangement. (See Figure 4-15.2.1.)

4-15.2.3.1 The fire department connection shall be on the system side of the water supply check valve.

4-15.2.3.2 For single systems, the fire department connection shall be installed as follows:

(a) *Wet System.* On the system side of system control, check, and alarm valves. (See Figure A-4-14.1.1.)

(b) *Dry System.* Between the system control valve and the dry pipe valve.

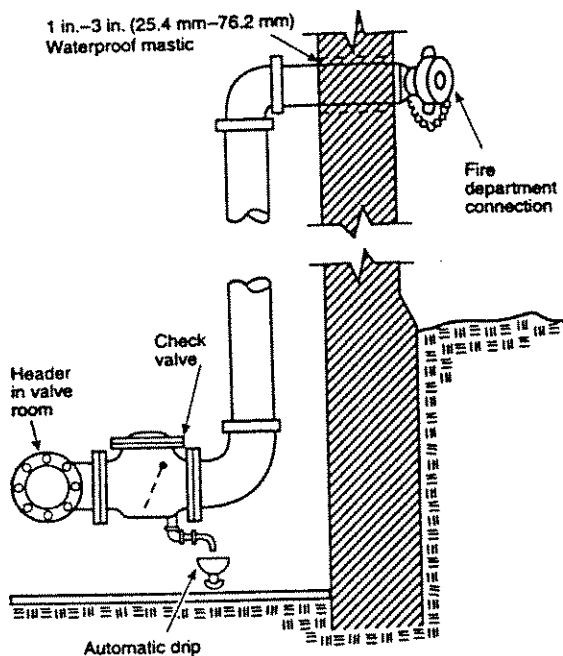

Figure 4-15.2.1 Fire department connection.

(c) *Preaction System.* Between the preaction valve and the check valve on the system side of the preaction valve.

(d) *Deluge System.* On the system side of the deluge valve.

Exception: Connection of the fire department connection to underground piping is acceptable.

4-15.2.3.3 For multiple systems, the fire department connection shall be connected between the supply control valves and the system control valves.

Exception: Connection of the fire department connection to underground piping is acceptable.

4-15.2.3.4 Where a fire department connection services only a portion of a building, a sign shall be attached indicating the portions of the building served.

4-15.2.3.5 Fire department connections shall be located and arranged so that hose can be readily and conveniently attached.

Each fire department connection to sprinkler systems shall be designated by a sign having raised or engraved letters at least 1 in. (25.4 mm) in height on plate or fitting reading service design, e.g., "AUTOSPKR.," "OPEN SPKR. AND STANDPIPE." A sign shall also indicate the pressure required at the inlets to deliver the greatest system demand.

Exception: The sign is not required where the system demand pressure is less than 150 psi (10.3 bars).

4-15.2.3.6 Fire department connections shall not be connected on the suction side of fire pumps.

4-15.2.4 Valves.

4-15.2.4.1 A listed check valve shall be installed in each fire department connection.

4-15.2.4.2 There shall be no shutoff valve in the fire department connection piping.

4-15.2.5 Drainage. The piping between the check valve and the outside hose coupling shall be equipped with an approved automatic drip.

Exception: An automatic drip is not required in areas not subject to freezing.

4-15.3 Gauges.

4-15.3.1 A pressure gauge with a connection not smaller than $\frac{1}{4}$ in. (6.4 mm) shall be installed at the system main drain, at each main drain associated with a floor control valve, and on the inlet and outlet side of each pressure reducing valve. Each gauge connection shall be equipped with a shutoff valve and provisions for draining.

4-15.3.2 The required pressure gauges shall be listed and shall have a maximum limit not less than twice the normal working pressure at the point where installed. They shall be installed to permit removal and shall be located where they will not be subject to freezing.

4-15.4 System Connections.

4-15.4.1 Main Drain Test Connections. Main drain test connections shall be provided at locations that will permit flow tests of water supplies and connections. They shall be so installed that the valve can be opened wide for a sufficient time to assure a proper test without causing water damage. Main drain connections shall be sized in accordance with 4-14.3.4 and 4-14.3.6.

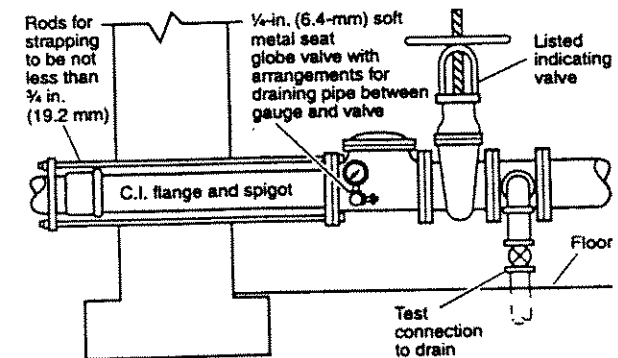

Figure 4-15.4.1 Water supply connection with test connection.

4-15.4.2* Wet Pipe Systems. An alarm test connection not less than 1 in. (25.4 mm) in diameter, terminating in a smooth bore corrosion-resistant orifice, giving a flow equivalent to one sprinkler of a type having the smallest orifice installed on the particular system, shall be provided to test each waterflow alarm device for each system. The test connection valve shall be readily accessible. The discharge shall be to the outside, to a drain connection capable of accepting full flow under system pressure, or to another location where water damage will not result.

4-15.4.3* Dry Pipe Systems. A trip test connection not less than 1 in. (25.4 mm) in diameter, terminating in a smooth bore corrosion-resistant orifice, to provide a flow equivalent to one sprinkler of a type installed on the particular system, shall be installed on the end of the most distant sprinkler pipe in the upper story and shall be equipped with a readily accessible 1-in. (25.4-mm) shutoff valve and plug, at least one of which shall be brass. In lieu of a plug, a nipple and cap shall be acceptable.

4-15.4.4 Preaction Systems. A test connection shall be provided on a preaction system using supervisory air. The connection used to control the level of priming water shall be considered adequate to test the operation of the alarms monitoring the supervisory air pressure.

4-15.4.5 Deluge Systems. A test connection is not required on a deluge system.

4-15.4.6 Backflow Devices.

4-15.4.6.1 Backflow Prevention Valves. Means shall be provided downstream of all backflow prevention valves for floor tests at system demand.

4-15.4.6.2* When backflow prevention devices are to be retroactively installed on existing systems, a thorough hydraulic analysis, including revised hydraulic calculations, new fire flow data, and all necessary system modifications to accommodate the additional friction loss, shall be completed as a part of the installation.

Chapter 5 Design Approaches

5-1 General. Water demand requirements shall be determined from the occupancy hazard fire control approach of Section 5-2.

Exception: Special design approaches shall be permitted for specific hazards in Section 5-3.

5-2 Occupancy Hazard Fire Control Approach.

5-2.1 Occupancy Classifications.

5-2.1.1 Occupancy classifications for this standard relate to sprinkler installations and their water supplies only. They shall not be used as a general classification of occupancy hazards.

5-2.1.2 Occupancies or portions of occupancies shall be classified according to the quantity and combustibility of contents, the expected rates of heat release, the total potential for energy release, the heights of stockpiles, and the presence of flammable and combustible liquids, using the definitions contained in 1-4.7. Classifications are as follows:

Light Hazard

Ordinary Hazard (Groups 1 and 2)

Extra Hazard (Groups 1 and 2)

Special Occupancy Hazard.

5-2.1.3* Sprinklers in light hazard occupancies shall be of the quick-response type as defined in 1-4.5.2.

Exception No. 1: Residential sprinklers are permitted in accordance with 4-4.5.

Exception No. 2: For modifications or additions to existing systems equipped with standard response sprinklers, standard response sprinklers shall be permitted to be used.

Exception No. 3: When individual standard response sprinklers are replaced in existing systems, standard response sprinklers shall be permitted to be used.

5-2.1.3.1 When existing light hazard systems are converted to use quick-response or residential sprinklers, all sprinklers in a compartmented space shall be changed.

5-2.2 Water Demand Requirements—Pipe Schedule Method.

5-2.2.1 Table 5-2.2 shall be used in determining the minimum water supply requirements for Light and Ordinary Hazard Occupancies protected by systems with pipe sized according to the pipe schedules of 6-5. Pressure and flow requirements for Extra Hazard Occupancies shall be based on the hydraulic calculation methods of 5-2.3. The pipe schedule method shall be permitted only for new installations of 5000 ft² (465 m) or less or for additions or modifications to existing pipe schedule systems sized according to the pipe schedules of Section 6-5. Table 5-2.2 shall be used in determining the minimum water supply requirements.

Exception No. 1: The pipe schedule method shall be permitted for use in systems exceeding 5000 ft² (465m²) where the flows required in Table 5-2.2 are available at a minimum residual pressure of 50 psi (3.4 bar) at the highest elevation of sprinkler.

Exception No. 2: The pipe schedule method shall be permitted for additions or modifications to existing extra hazard pipe schedule systems if the pressures and flows are determined to be acceptable to the authority having jurisdiction.

Table 5-2.2 Water Supply Requirements for Pipe Schedule Sprinkler Systems

Occupancy Classification	Minimum Residual Pressure Required	Acceptable Flow at Base of Riser	Duration in Minutes
Light Hazard	15 psi	500-750 gpm	30-60
Ordinary Hazard	20 psi	850-1500 gpm	60-90

For SI Units: 1 gpm = 3.785L/min; 1 psi = 0.0689 bar.

5-2.2.2 The lower duration value of Table 5-2.2 shall be acceptable only where remote station or central station waterflow alarm service is provided.

5-2.2.3* The residual pressure requirement of Table 5-2.2 shall be met at the elevation of the highest sprinkler. (*See the Exceptions to 5-2.2.1.*)

5-2.2.4 The lower flow figure of Table 5-2.2 shall be permitted only where the building is of noncombustible construction or the potential areas of fire are limited by building size or compartmentation such that no open areas exceed 3000 sq ft (279 m²) for Light Hazard or 4000 sq ft (372 m²) for Ordinary Hazard.

5-2.3 Water Demand Requirements—Hydraulic Calculation Methods.

5-2.3.1 General.

5-2.3.1.1* The minimum water supply requirements for a hydraulically designed occupancy hazard fire control sprinkler system shall be determined by adding the hose stream demand from Table 5-2.3 to the water supply for sprinklers determined in 5-2.3.1.2. This supply shall be available for the minimum duration specified in Table 5-2.3.

Exception No. 1: Where other NFPA standards have developed sprinkler system area/density or other design criteria and water supply requirements appropriate for fire control or suppression of Special Occupancy Hazards, they shall take precedence.

Exception No. 2: An allowance for inside and outside hose shall not be required where tanks supply sprinklers only.

Exception No. 3: Where pumps taking suction from a private fire service main supply sprinklers only, the pump need not be sized to accommodate inside and outside hose. Such hose allowance shall be considered in evaluating the available water supplies.

Table 5-2.3 Hose Stream Demand and Water Supply Duration Requirements

Hazard Classification	Inside Hose (gpm)	Total Combined Inside and Outside Hose (gpm)	Duration in Minutes
Light	0, 50, or 100	100	30
Ordinary	0, 50, or 100	250	60-90
Extra Hazard	0, 50, or 100	500	90-120

For SI Units: 1 gpm = 3.785 L/min.

5-2.3.1.2 The water supply for sprinklers only shall be determined either from the area/density curves of Figure 5-2.3 in accordance with the method of 5-2.3.2 or be based upon the room design method in accordance with 5-2.3.3, at the discretion of the designer. For special areas under consideration, as described in 5-2.3.4, separate hydraulic calculations shall be required in addition to those required by 5-2.3.2 or 5-2.3.3.

5-2.3.1.3 Regardless of which of the two methods is used, the following restrictions apply:

(a) For areas of sprinkler operation less than 1500 sq ft (139 m²) used for Light and Ordinary Hazard Occupancies, the density for 1500 sq ft (139 m²) shall be used. For areas of sprinkler operation less than 2500 sq ft (232 m²) for Extra Hazard Occupancies, the density for 2500 sq ft (232 m²) shall be used.

(b)* For buildings having unsprinklered combustible concealed spaces (as described in 4-13.1.1), the minimum area of sprinkler operation shall be 3000 sq ft (279 m²).

Exception No. 1: Combustible concealed spaces filled entirely with noncombustible insulation.

Exception No. 2: Light or Ordinary Hazard Occupancies where noncombustible or limited combustible ceilings are directly attached to the bottom of solid wood joists so as to create enclosed joist spaces 160 cu ft (4.8 m³) or less in volume.*

Exception No. 3: Concealed spaces where the exposed surfaces have a flame spread rating of 25 or less and the materials have been demonstrated to not propagate fire in the form in which they are installed in the space.*

(c) Water demand of sprinklers installed in racks or water curtains shall be added to the ceiling sprinkler water demand at the point of connection. Demands shall be balanced to the higher pressure. (See Chapter 6.)

Water demand of sprinklers installed in concealed spaces or under obstructions such as ducts and cutting tables need not be added to ceiling demand.

(d) Where inside hose stations are planned or are required by other standards, a total water allowance of 50 gpm (189 L/min) for a single hose station installation or 100 gpm (378 L/min) for a multiple hose station installation shall be added to the sprinkler requirements. The water allowance shall be added in 50-gpm (189-L/min) increments beginning at the most remote hose station, with each increment added at the pressure required by the sprinkler system design at that point.

(e) When hose valves for fire department use are attached to wet pipe sprinkler system risers in accordance with 4-13.21, the water supply shall not be required to be

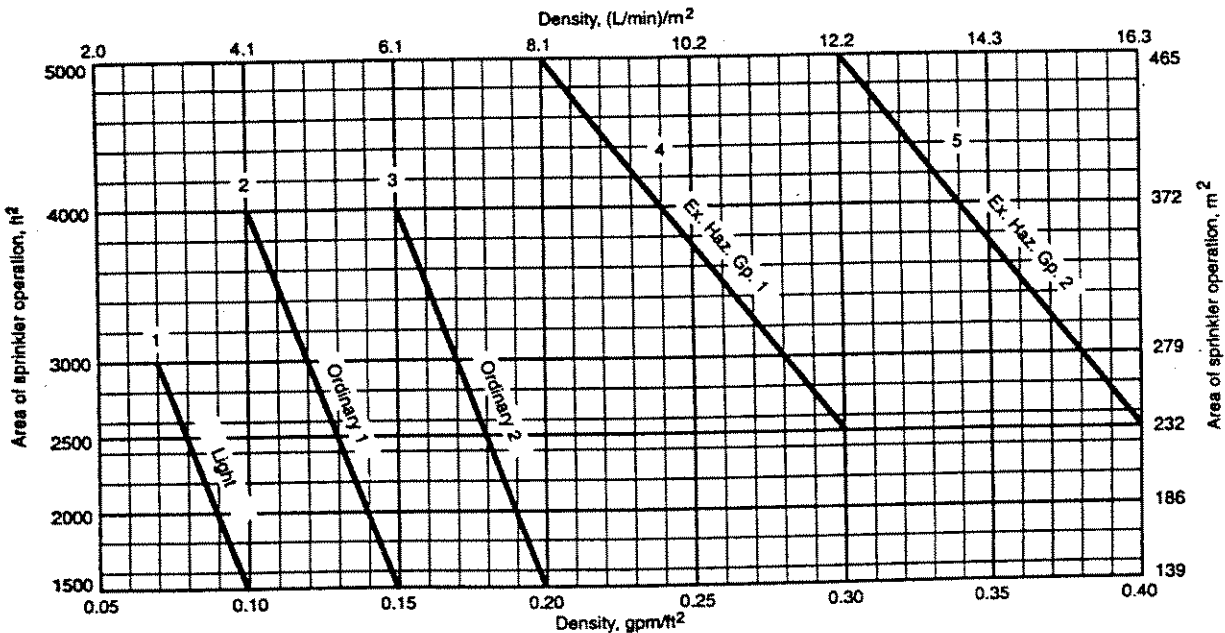

Figure 5-2.3 Area/density curves.

added to standpipe demand as determined from NFPA 14, *Standard for the Installation of Standpipe and Hose Systems*.

Exception No. 1: Where the combined sprinkler system demand and hose stream allowance of Table 5-2.3 exceeds the requirements of NFPA 14, *Standard for the Installation of Standpipe and Hose Systems*, this higher demand shall be used.

Exception No. 2: For partially sprinklered buildings, the sprinkler demand, not including hose stream allowance, as indicated in Table 5-2.3 shall be added to the requirements given in NFPA 14, *Standard for the Installation of Standpipe and Hose Systems*.

(f) Water allowance for outside hose shall be added to the sprinkler and inside hose requirement at the connection to the city water main, or a yard hydrant, whichever is closer to the system riser.

(g) The lower duration values in Table 5-2.3 shall be permitted where remote station or central station waterflow alarm service is provided.

(h) Where pumps, gravity tanks, or pressure tanks supply sprinklers only, requirements for inside and outside hose need not be considered in determining the size of such pumps or tanks.

5-2.3.1.4 Total system water supply requirements shall be determined in accordance with the hydraulic calculation procedures of Section 6-4.

5-2.3.2 Area/Density Method.

5-2.3.2.1 The water supply requirement for sprinklers only shall be calculated from the area/density curves in Figure 5-2.3. The calculations shall satisfy any single point on the appropriate area/density curve as follows:

- (a) Light Hazard Area/Density Curve 1
- (b) Ordinary Hazard (Group 1) Area/Density Curve 2
- (c) Ordinary Hazard (Group 2) Area/Density Curve 3
- (d) Extra Hazard (Group 1) Area/Density Curve 4
- (e) Extra Hazard (Group 2) Area/Density Curve 5.

It is not necessary to meet all points on the selected curve.

5-2.3.2.2 For protection of storage up to 12 ft (3.6 m) in height, the following shall be applicable:

Commodity Classes I through IV

Commodity Classification	Palletized and Bin Box	Rack
I	OH-1	OH-1
II up to 8 ft (2.4 m)	OH-1	OH-1
II over 8 ft (2.4 m)		
III up to 12 ft (3.6 m)	OH-2	OH-2
III	OH-2	OH-2
IV up to 10 ft (3 m)	OH-2	OH-2
IV over 10 ft (3 m) to 12 ft (3.6 m)	OH-2	EH-1

5-2.3.2.3 The densities and areas provided in Figure 5-2.3 are for use only with spray sprinklers. For use with other types of sprinklers, see Section 5-3.

Exception No. 1: Quick-response sprinklers shall not be permitted for use with Curves 4 and 5 (Extra Hazard).

Exception No. 2: Sidewall spray sprinklers shall be permitted for use with Area/Density Curve 1 (Light Hazard) and, if specifically listed, with Area/Density Curves 2 or 3 (Ordinary Hazard).

Exception No. 3: For extended coverage sprinklers, the minimum design area shall be that corresponding to the maximum density for

the hazard in Figure 5-2.3 or the area protected by 5 sprinklers, whichever is greater. Extended coverage sprinklers shall be listed with and designed for the minimum flow corresponding to the density for the smallest area of operation for the hazard as specified in Figure 5-2.3.

5-2.3.2.4 Where listed quick-response sprinklers are used throughout, the system area of operation is permitted to be reduced without revising the density as indicated in Figure 5-2.3.2.4 when all of the following conditions are satisfied:

- Wet pipe system
- Light hazard or ordinary hazard occupancy
- 20-foot (9.0-m) maximum ceiling height.

The number of sprinklers in the design area shall never be less than five.

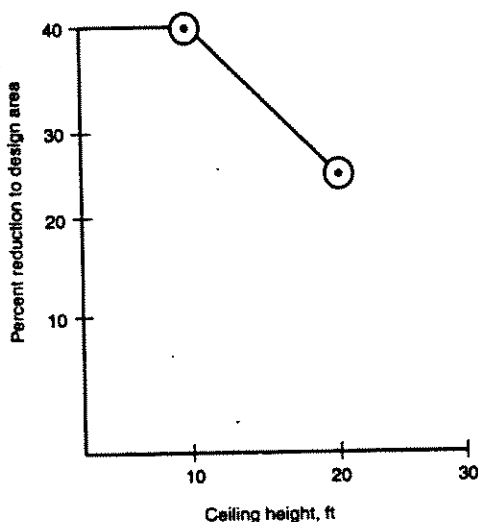

Note: $y = \frac{-3x}{2} + 55$

For ceiling height ≥ 10 ft and ≤ 20 ft, $y = \frac{-3x}{2} + 55$;

For ceiling height < 10 ft, $y = 40$;

For ceiling height > 20 , $y = 0$.

For SI units: 1 ft = 0.31 m.

Figure 5-2.3.2.4

5-2.3.2.5 The system area of operation shall be increased by 30 percent without revising the density when the following types of sprinklers are used on sloped ceilings with a pitch exceeding 2 in. in 12 in. (50 mm in .3 m):

- Standard Spray Upright
- Standard Spray Pendant
- Sidewall Spray
- Large Drop.

5-2.3.2.6 For dry pipe systems and double interlock preaction systems, the area of sprinkler operation shall be increased by 30 percent without revising the density.

5-2.3.2.7 Where high temperature sprinklers are used for Extra Hazard Occupancies, the area of sprinkler operation shall be permitted to be reduced by 25 percent without revising the density, but not to less than 2000 sq ft (186 m²).

5-2.3.3 Room Design Method.

5-2.3.3.1* The water supply requirements for sprinklers only shall be based upon the room that creates the greatest demand. The density selected shall be that from Figure 5-2.3 corresponding to the room size. To utilize this method, all rooms shall be enclosed with walls having a fire-resistance rating equal to the water supply duration indicated in Table 5-2.3.

5-2.3.3.2 If the room is smaller than the smallest area shown in the applicable curve in Figure 5-2.3, the provisions of 5-2.3.1.3(a) shall apply.

5-2.3.3.3 Minimum protection of openings shall be as follows:

- (a) Light Hazard — automatic or self-closing doors.

Exception: Where openings are not protected, calculations shall include the sprinklers in the room plus two sprinklers in the communicating space nearest each such unprotected opening unless the communicating space has only one sprinkler, in which case calculations shall be extended to the operation of that sprinkler. The selection of the room and communicating space sprinklers to be calculated shall be that which produces the greatest hydraulic demand.

(b) Ordinary and Extra Hazard — automatic or self-closing doors with appropriate fire-resistance ratings for the enclosure.

5-2.3.4 Special Design Methods.

5-2.3.4.1 Where the design area consists of a building service chute supplied by a separate riser, the maximum number of sprinklers that needs to be calculated is 3.

5-2.3.4.2 Where the room design method is used, and the area under consideration is a corridor protected by one row of sprinklers, the maximum number of sprinklers that needs to be calculated is 5. (See 5-2.3.1.)

Exception: Where the area under consideration is a corridor protected by a single row of sprinklers and the openings are not protected, the design area shall include all sprinklers in the corridor to a maximum of 7.

5-3 Special Design Approaches.

5-3.1 General. All special design approaches utilize the hydraulic calculation procedures of Section 6-4, except as specified.

5-3.2 Residential Sprinklers.

5-3.2.1* Sprinkler discharge rates shall be provided in accordance with minimum flow rates indicated in individual residential sprinkler listings, both for the single sprinkler discharge and the multiple sprinkler discharge of the design sprinklers.

5-3.2.2* The design area shall be that area that includes the 4 hydraulically most demanding sprinklers. Calculations shall be provided to verify the single (1) operating sprinkler criteria and the multiple (4) operating sprinkler criteria.

5-3.2.3 Where areas such as attics, basements, or other types of occupancies are outside of dwelling units but within the same structure, these areas shall be protected in accordance with the provisions of this standard, including appropriate design criteria of 5-2.3.

5-3.2.4 Hose stream demand and water supply duration requirements shall be in accordance with those for Light Hazard Occupancies in Table 5-2.3.

5-3.3 Quick-Response Early Suppression (QRES) Sprinklers. (Reserved) (See 1-4.5.2 and A-1-4.5.2.)

5-3.4* Large-Drop Sprinklers.

5-3.4.1 Large-drop sprinklers shall be permitted to protect ordinary hazard, miscellaneous storage, and other storage as specified by other NFPA standards.

5-3.4.2 Number of Design Sprinklers.

5-3.4.2.1 Protection shall be provided as specified in Table A-5-3.4 or appropriate NFPA standards in terms of minimum operating pressure and the number of sprinklers to be included in the design area.

5-3.4.2.2 The minimum number of design sprinklers for ordinary hazard and miscellaneous storage in accordance with this standard shall be 15 for wet pipe and preaction systems and 25 for double interlock preaction systems and dry pipe systems. For other storage configurations, the number of design sprinklers shall be in accordance with the appropriate NFPA storage standard.

5-3.4.3 Large-drop sprinkler systems shall be designed such that the minimum operating pressure is not less than 25 psi (170 kPa).

5-3.4.4 For design purposes, 95 psi (650 kPa) shall be the maximum discharge pressure at the hydraulically most remote sprinkler.

5-3.4.5 The design area shall be a rectangular area having a dimension parallel to the branch lines at least 1.2 times the square root of the area protected by the number of sprinklers to be included in the design area. Any fractional sprinkler shall be included in the design area.

5-3.4.6 The nominal diameter of branch line pipes (including riser nipples) shall be not less than 1 1/4 in. (33 mm) nor greater than 2 in. (51 mm).

Exception No. 1: Starter pieces shall be permitted to be 2 1/2 in. (64 mm).

Exception No. 2: Where branch lines are larger than 2 in. (51 mm), the sprinkler shall be supplied by a riser nipple to elevate the sprinkler 13 in. (330 mm) for 2 1/2-in. (64-mm) pipe and 15 in. (380 mm) for 3-in. (76-mm) pipe. These dimensions are measured from the centerline of the pipe to the deflector. In lieu of this, sprinklers may be offset horizontally a minimum of 12 in. (305 mm).

5-3.4.7 Hose stream demand and water supply duration requirements shall be in accordance with those for extra hazard occupancies in Table 5-2.3.

5-3.5* Early Suppression Fast-Response (ESFR) Sprinklers.

5-3.5.1 ESFR sprinklers shall be permitted to protect ordinary hazard, miscellaneous storage, and other storage as specified by other NFPA standards.

5-3.5.1.1* ESFR sprinklers shall be designed such that the minimum operating pressure is not less than 50 psi (3.445 bars).

5-3.5.2 ESFR sprinklers are suitable for use with the hazards listed in Table A-5-3.5 and shall be permitted to be used

in other specific hazard classifications and configurations only when proven by large-scale or other suitable fire testing. ESFR sprinklers listed for use in buildings up to 30 ft (9.1 m) high shall be used only in buildings up to 30 ft (9.1 m) high. ESFR sprinklers listed for use in buildings up to 40 ft (12.2 m) high shall be used where building height exceeds 30 ft (9.1 m) to a maximum of 40 ft (12.2 m).

5-3.5.3 ESFR sprinkler systems shall be designed such that the minimum operating pressure is not less than that indicated in Table A-5-3.5 for type of storage, commodity, storage height, and building height involved.

5-3.5.4 The design area shall consist of the most hydraulically demanding area of 12 sprinklers, consisting of 4 sprinklers on each of 3 branch lines. Design shall include a minimum of 960 sq ft (89 m²).

5-3.5.5 Water supply duration shall be at least 60 min.

5-3.6 Exposure Protection.

5-3.6.1* Piping shall be hydraulically calculated in accordance with Section 6-4 to furnish a minimum of 7 psi (48 kPa) at any sprinkler with all sprinklers facing the exposure operating.

5-3.6.2 Where the water supply feeds other fire protection systems, it shall be capable of furnishing total demand for such systems as well as the exposure system demand.

5-3.7 Water Curtains. Sprinklers in a water curtain as described in 4-13.3.4 shall be hydraulically designed to provide a discharge of 3 gpm per lineal foot [37 (L/min)/m] of water curtain, with no sprinklers discharging less than 15 gpm (56.8 L/min). The number of sprinklers calculated in this water curtain shall be the number in the length corresponding to the length parallel to the branch lines in the area determined by 6-4.4.1(a). If a single fire can be expected to operate sprinklers within the water curtain and within the design area of a hydraulically calculated system, the water supply to the water curtain shall be added to the water demand of the hydraulic calculations and shall be balanced to the calculated area demand. Hydraulic design calculations shall include a design area selected to include ceiling sprinklers adjacent to the water curtain. (See 4-13.14.1).

5-4 In-Rack Sprinklers. In-rack sprinklers mandated by this standard shall meet the requirements of this section.

5-4.1 In-rack sprinklers shall operate at a minimum of 15 psi (1 bar).

5-4.2 Water Demand.

5-4.2.1 Where one level of in-rack sprinklers is installed, water demand shall be based on simultaneous operation of the hydraulically most demanding 4 adjacent sprinklers.

Chapter 6 Plans and Calculations

6-1* Working Plans.

6-1.1* Working plans shall be submitted for approval to the authority having jurisdiction before any equipment is installed or remodeled. Deviation from approved plans will require permission of the authority having jurisdiction.

6-1.1.1 Working plans shall be drawn to an indicated scale, on sheets of uniform size, with a plan of each floor, and shall

show those items from the following list that pertain to the design of the system.

- (a) Name of owner and occupant.
- (b) Location, including street address.
- (c) Point of compass.
- (d) Full height cross section, or schematic diagram, if required for clarity; including ceiling construction and method of protection for nonmetallic piping.
- (e) Location of partitions.
- (f) Location of fire walls.
- (g) Occupancy class of each area or room.
- (h) Location and size of concealed spaces, closets, attics, and bathrooms.
- (i) Any small enclosures in which no sprinklers are to be installed.
- (j) Size of city main in street and whether dead-end or circulating; and, if dead-end, direction and distance to nearest circulating main. City main test results and system elevation relative to test hydrant (see A-7-2.1.)
- (k) Other sources of water supply, with pressure or elevation.
- (l) Make, type, and nominal orifice size of sprinklers.
- (m) Temperature rating and location of high-temperature sprinklers.
- (n) Total area protected by each system on each floor.
- (o) Number of sprinklers on each riser per floor.
- (p) Total number of sprinklers on each dry pipe system, preaction system, combined dry pipe-preaction system, or deluge system.
- (q) Approximate capacity in gal of each dry pipe system.
- (r) Pipe type and schedule of wall thickness.
- (s) Nominal pipe size and cutting lengths of pipe (or center-to-center dimensions).

NOTE: Where typical branch lines prevail, it will be necessary to size only one typical line.

- (t) Location and size of riser nipples.
- (u) Type of fittings and joints and location of all welds and bends. The contractor shall specify on drawing any sections to be shop welded and the type of fittings or formations to be used.
- (v) Type and locations of hangers, sleeves, braces, and methods of securing sprinklers when applicable.
- (w) All control valves, check valves, drain pipes, and test connections.
- (x) Make, type, model, and size of alarm or dry pipe valve.
- (y) Make, type, model, and size of preaction or deluge valve.
- (z) Kind and location of alarm bells.
 - (aa) Size and location of hose outlets, hand hose, and related equipment.
 - (bb) Underground pipe size, length, location, weight, material, point of connection to city main; the type of valves, meters, and valve pits; and the depth that the top of the pipe is laid below grade.
 - (cc) Piping provisions for flushing.
 - (dd) Where the equipment is to be installed as an addition to an existing system, enough of the existing system indicated on the plans to make all conditions clear.