

Desulfurization Effects on a Light-Duty Diesel Vehicle NO_x Adsorber Exhaust Emission Control System

Marek Tatur, Dean Tomazic, Heather Tyrer
FEV Engine Technology, Inc.

Matthew Thornton
National Renewable Energy Laboratory

Joseph Kubsh
Manufacturers of Emission Controls Association

Copyright © 2006 SAE International

ABSTRACT

The U.S. Tier 2 emission regulations require sophisticated exhaust aftertreatment technologies for diesel engines. One of the projects under the U.S. Department of Energy's (DOE's) Advanced Petroleum-Based Fuels – Diesel Emission Controls (APBF-DEC) activity focused on the development of a light-duty passenger car with an integrated NO_x (oxides of nitrogen) adsorber catalyst (NAC) and diesel particle filter (DPF) technology. Vehicle emissions tests on this platform showed the great potential of the system, achieving the Tier 2 Bin 5 emission standards with new, but degreened emission control systems. The platform development and control strategies for this project were presented in 2004-01-0581 [1].

The main disadvantage of the NO_x adsorber technology is its susceptibility to sulfur poisoning. The fuel- and lubrication oil-borne sulfur is converted into sulfur dioxide (SO₂) in the combustion process and is adsorbed by the active sites of the NAC. As a result, they are unavailable for NO_x storage. This leads to a drop in system performance. In order to recover the active sites, the bound sulfates need to be released. The necessary conditions for sulfate release are relatively high temperatures in combination with rich exhaust gas conditions. This process is often referred to as desulfurization.

After the completion of the development phase, the emission control system was aged with 15-ppm sulfur diesel fuel to a full useful life (120,000 miles) condition. During the course of this aging, intermittent desulfurizations were carried out. The desulfurizations were preceded and followed by evaluation procedures to allow a detailed analysis of the desulfurization effects.

Desulfurizations were performed every 150 hours up to 300 hours, every 100 hours up to 1,600 hours, and every 50 hours to the end of aging at 2,200 hours. This paper analyzes the effects on gaseous emissions, before and after desulfurization, over transient driving cycles such as the light-duty Federal Test Procedure (FTP-75).

The results indicate a high degree of recovery, maintaining a low level of tailpipe emissions over the useful lifetime (120,000 miles) of the emission control system.

INTRODUCTION

Despite the upcoming, stringent Tier 2 emission standards, significant efforts are focused on the reintroduction of the diesel engine into the U.S. market. In order for these efforts to succeed, diesel powered vehicles will have to comply with emission standards while maintaining their superior fuel economy. Furthermore, they need to be competitive with their gasoline counterparts in regard to power, engine noise, and transient response behavior. The availability of technologies—such as high-pressure, common-rail fuel injection systems; low-sulfur diesel fuel; NACs; and DPFs—enable the development of powertrain systems that have the potential to comply with these requirements.

Supporting the development of these technologies, DOE is engaged in several test projects under the APBF-DEC activity. These projects primarily address the sulfur tolerance and NAC/DPF system durability implications of varying fuel sulfur levels. A result of the project focusing on the passenger car platform is a fundamental understanding of the integrated emission control system (ECS) strategies and calibration.

PROGRAM OBJECTIVES

The main objective of the APBF-DEC activity was to investigate the sulfur tolerance and durability of different aftertreatment systems such as the NAC/DPF combination.

An integral part of the program was to demonstrate the capability of a state-of-the-art engine and ECS combination to achieve the Tier 2 Bin 5 emission levels [0.07 g/mi NO_x and 0.01 g/mi particulate matter (PM)]. In order to meet these requirements over the lifetime of the ECS, the system needed to be desulfurized to allow for a regain in NO_x conversion efficiency.

The ECS was aged up to 2,200 hours to allow an assessment of the fuel effects on the durability of the systems. The detailed fuel specifications for this project are presented in Appendix A.

HARDWARE DEFINITION

ENGINE PARAMETERS AND CONFIGURATION

The engine used in this project was designed to accommodate the increased demands of emission reduction development. The crankcase, crankshaft, and connecting rods are mass-production parts from Volkswagen AG, Wolfsburg. The cylinder head and the pistons are proprietary components developed by FEV Engine Technology specifically for emission reduction applications. Table 1 shows relevant details of this engine configuration [2].

Table 1: Diesel Future II Engine Specifications

Arrangement	In-Line 4-Cylinder
Displacement	1.9 L
Rated Power	100 kW @ 4000 rpm
Max. Torque	330 Nm @ 2000 rpm
Bore/Stroke	79.5 mm / 95.5 mm
Turbocharger	Garrett GT 17 V
Injection System	Bosch Common Rail, 2 nd Gen.
Valves	2 x Intake / 2 x Exhaust
Compression Ratio	18.2 : 1

Figure 1 shows the Diesel Future II engine prior to installation in the project test cell. With the exception of the components mentioned above, all other engine components are commercially available, including the electronically actuated exhaust gas recirculation (EGR) valve and variable nozzle geometry turbocharger visible in Figure 1.

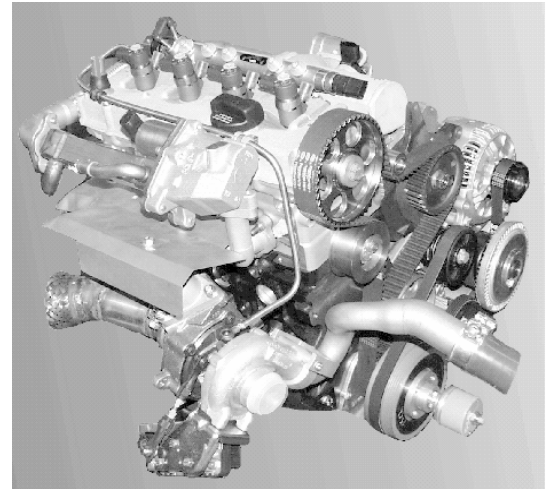

Figure 1: Diesel Future II Engine

The combustion system was configured according to the required emission targets (Euro 4 NO_x level < 0.4 g/mi) while maintaining excellent fuel economy and represents advanced combustion technology.

EMISSION CONTROL SYSTEM SPECIFICATION

The catalysts were designed and developed together with a MECA (Manufacturers of Emissions Controls Association) program participant.

Early discussions with the catalyst supplier resolved initial design questions, such as dimensions and amounts of required catalysts. The next issue was to determine the positioning of the NAC and DPF. Analysis of similar powertrain configurations on other vehicles showed relatively low temperatures downstream of the turbine. Therefore, the decision was made to place the NAC upstream of the DPF. A dual-wall exhaust manifold and air-gap insulated exhaust piping were used to minimize thermal losses between components. These parts were also provided by a MECA project partner.

Pre-Catalyst

Each ECS included a pre-catalyst that served several functions. One of its primary functions was the oxidation of unburned fuel introduced during post-injection events to increase temperature under the following three operating modes:

1. Warm-up
2. DPF regeneration
3. Desulfurization.

The pre-catalyst must also partially oxidize unburned fuel during the transition to rich mode for NO_x regeneration. This is part of the process of preparing the necessary NO_x reduction agents [most preferably hydrogen (H₂) or carbon monoxide (CO)].

Another important function of the pre-catalyst was to act as a sulfur trap during lean operation offering the

underbody NAC a degree of protection from sulfur poisoning.

Two ECSs, denoted as ECS-A2 and ECS-B2, were initially evaluated in this project. The difference between these systems was their pre-catalysts. ECS-A2 comprised a pre-catalyst that was 50% DOC and 50% NAC, while ECS-B2 utilized a 100% NAC pre-catalyst. Specifications for both ECSs are summarized in Table 2.

Table 2: Emission Control System Catalyst Specifications

	ECS A2			ECS B2 and ECS B3		
	Pre-cat	UB-NAC	DPF	Pre-cat	UB-NAC	DPF
Volume [L]	1.34	2.5	4.1	1.34	2.5	4.1
Cross Section [-]	Round			Round		
Diameter [in]	4.16	5.66	5.66	4.16	5.66	5.66
Length [in]	6.00	6.00	10.00	6.00	6.00	10.00
Substrate Material [-]	Cord	Cord	SiC	Cord	Cord	SiC
Wall Thickness [mil]	4.5	4.5	14	4.5	4.5	14
Cell Density [cps]	400	400	200	400	400	200
Pre-Cat Config.	50% DOC – 50% NAC			100% NAC		

Underbody Catalyst

Each ECS included an identical 2.5-liter underbody NAC on a Cordierite substrate. The NACs were coated with a formulation that maximized effectiveness at the lowest possible temperatures to address the typical low exhaust gas temperature level during FTP-75 operation.

DPF

The selection criteria for the DPF material included thermal mass, backpressure characteristics, cost, and durability. Due to durability concerns under potential uncontrolled regeneration conditions, a thermally stable silicon carbide substrate was selected. A catalytic coating contributed to control of hydrocarbon (HC) and CO breakthrough during regeneration events.

During testing, ECS-B2 showed the most promise in reducing NO_x emissions. Therefore, these same

specifications were utilized to create the aging system, ECS-B3.

EMISSION CONTROL SYSTEM SETUP

A schematic overview of the instrumented ECS is depicted in Figure 2.

In the test cell, temperature and pressure measurements were taken at each of the exhaust locations. Emission measurements were taken at system inlet and system outlet (positions I and IV in Figure 2). A differential pressure transducer was installed across the DPF to provide feedback on its loading level.

NO_x sensors were utilized both before and after the NAC to provide real-time efficiency information.

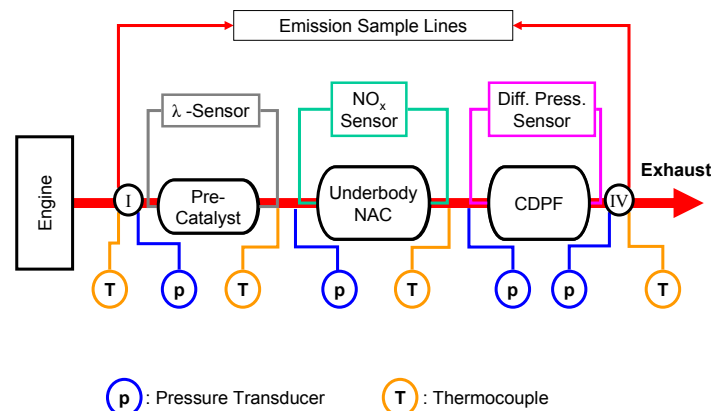

Figure 2: Emission Control System Setup

TEST ENVIRONMENT

Emissions measured in the test cell are sampled with several different devices. For regulated gaseous emissions, such as NO_x, CO, THC, and CO₂, a Horiba emissions bench was used. NO_x sensors and wide range lambda sensors were also utilized (Figure 2). NO_x sensors monitored real-time emissions, but the measurements were used for the NO_x regeneration strategy only, not for collecting emission data.

An Airsense 2000 mass spectrometer was used for unregulated gaseous emissions. During desulfurization, H₂S and SO₂ were the only sulfur species measured. Oxygen was also measured to allow for a time-alignment of the data with the emissions bench.

DESULFURIZATION DEVELOPMENT

Desulfurization represents one of the more challenging aspects of NAC strategy development. A significant amount of effort was invested to optimize the desulfurization process. Desulfurization was run at each designated hour mark. The frequency was every 150 hours up to 300 hours, every 100 hours up to 1,600 hours, then every 50 hours to the end of 2,200 hours. First, transient pre-desulfurization tests were run, and

then the desulfurization was performed under steady-state conditions (2,500 rpm; 8 bar BMEP), followed by transient evaluation cycles (these included a preparation UDDS cycle).

Previous investigations have shown that temperature and lambda management can be challenging during desulfurization conditions [3]. The return to lean operation at the end of the desulfurization proved problematic, especially since significant temperature spikes can lead to excessive thermal aging. Therefore, a 4-stage strategy was developed to address this issue:

1. Start intake throttling.
2. Initiate post injection to maintain target lambda of 0.97 to 0.98 for a duration of 6 minutes.
3. Terminate post-injection.
4. De-throttle following 5-10 second delay.

Stages 3 and 4 were critical as they provided the system with time to purge unburned HC before excess oxygen became available. This process is illustrated in Figure 3.

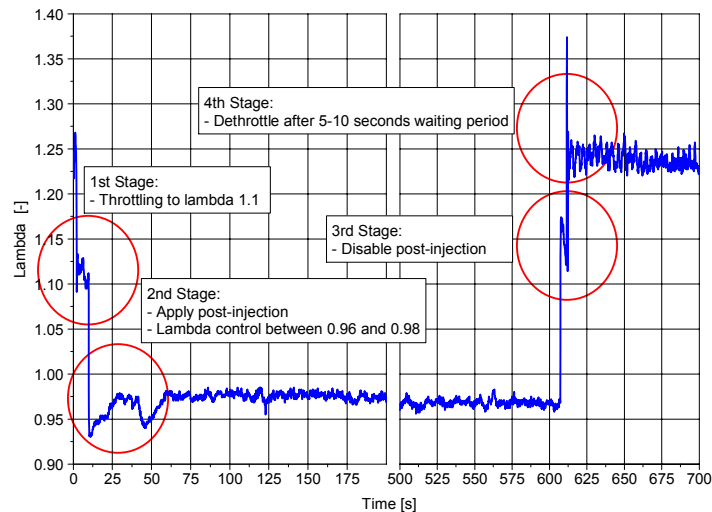

Figure 3: 4-Stage Desulfurization Strategy

AGING AND EVALUATION CYCLE DEFINITION

Aging of the ECS was accomplished by alternating aging and evaluation cycles. The typical test matrix consisted of 100 hours of aging cycles, followed by a transient pre-desulfurization cycle, desulfurization, and finally a transient post-desulfurization evaluation.

AGING CYCLE

The aging cycle used was based on the LA92 driving cycle (shown in Figure 4). This is a high-speed/high-acceleration driving cycle developed by the California Air Resources Board.

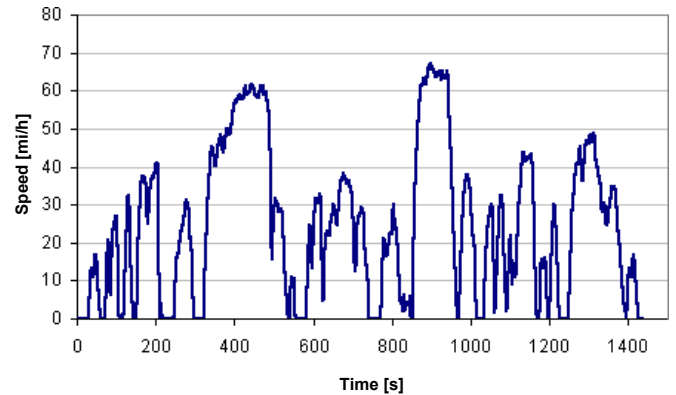

Figure 4: LA92 Driving Cycle

The test was adapted into 14 steady-state points to determine and optimize engine-out emissions. Each of the points was run 43 seconds to accumulate the desired cycle time of 10 minutes. The cycle was then repeated until the subsequent hour mark for the evaluation tests was reached.

During the aging cycles, it became apparent that the ECS was exposed to higher temperatures with the adapted steady-state cycle than with the original transient LA92. Therefore, the points with temperatures above 450°C were moved toward a higher engine speed and lower load. This led to a lower pre-catalyst inlet temperature while maintaining the same fuel flow. Figure 5 shows the 14 steady-state points during the 10-minute aging cycle.

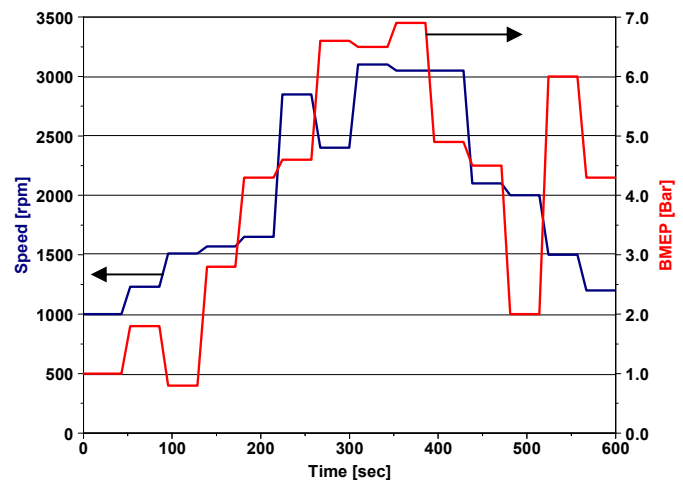

Figure 5: Speed and BMEP of Steady-State Aging Cycle

EVALUATION CYCLES

When the desired ECS age was reached with the aging cycles, transient evaluation tests were run to determine the efficiency of the system. Several procedures were created for different purposes. Each procedure consisted of at least one of each of the following tests: cold and hot UDDS (bags 1 and 2 of the FTP-75), US06,

and HFET. Procedures differed by the amount of times these tests were repeated.

The UDDS cycle is run twice. The first 'cold UDDS' is performed after the overnight soaking period while the second 'hot UDDS' is performed following a 10-minute hot soak. The duration of the UDDS is 1,369 seconds, with a distance covered of approximately 7.45 miles.

The US06 cycle was developed to address shortcomings in the FTP-75 in regard to representing aggressive acceleration and deceleration, as well as high-speed driving. The cycle covers a distance of 8.01 miles over a duration of 596 seconds. In comparison to the FTP-75 cycle, the engine speed and load profile of this test are significantly higher.

The HFET was initially developed to quantify the deterioration in fuel economy of light-duty vehicles. It is a light load and low speed test without any additional low-idle phases. The overall duration of the test cycle is 765 seconds, covering 10.26 miles in distance.

TEST RESULTS

DEVELOPMENTAL RESULTS

Investigations were conducted with desulfurization temperatures ranging from 580°C to 725°C. Figure 6 documents the steps that were taken to determine the minimum desulfurization temperature for further investigations. During preliminary tests with developmental catalysts, the largest increase in catalyst capacity was found at a desulfurization temperature of 700°C. Experience from numerous desulfurizations has demonstrated the capability to achieve 95% and greater recovery of NO_x storage capacity.

While the majority of development was conducted with zero ppm sulfur fuel, the ECS was intentionally sulfur poisoned using standard premium diesel fuel with a sulfur content of 350 ppm in order to conserve valuable test cell time. The engine was operated under moderate load conditions with representative NAC regenerations for 5 hours. This resulted in a massive decrease in catalyst activity in terms of NO_x storage and conversion efficiency. The pre-catalyst was rendered virtually ineffective, while the underbody catalyst NO_x storage capacity was reduced by 64%.

The gradual increase in desulfurization temperature showed improving efficiencies up to the desulfurization temperature of 720°C. In order to limit the effects of thermal aging throughout the useful life of the catalyst system, the more conservative desulfurization temperature level of below 700°C was chosen for the durability testing.

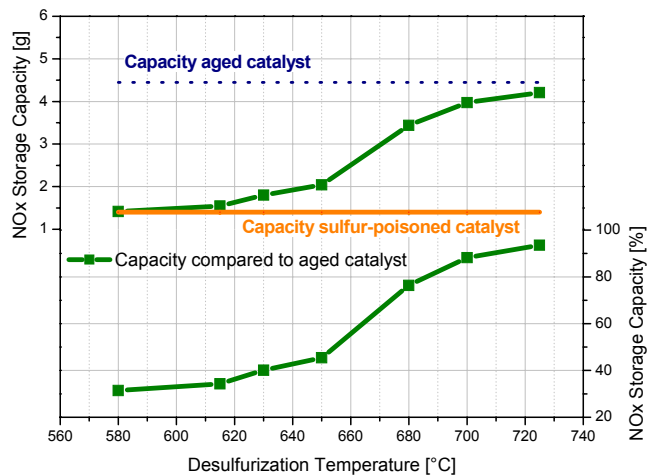

Figure 6: Determination of Minimum Desulfurization Temperature

Figure 7 shows temperature profiles during a typical desulfurization. An exotherm of approximately 50°C was generated over the pre-catalyst during the extended rich operation. The inlet temperature of the underbody catalyst was comparable to the inlet temperature of the pre-catalyst.

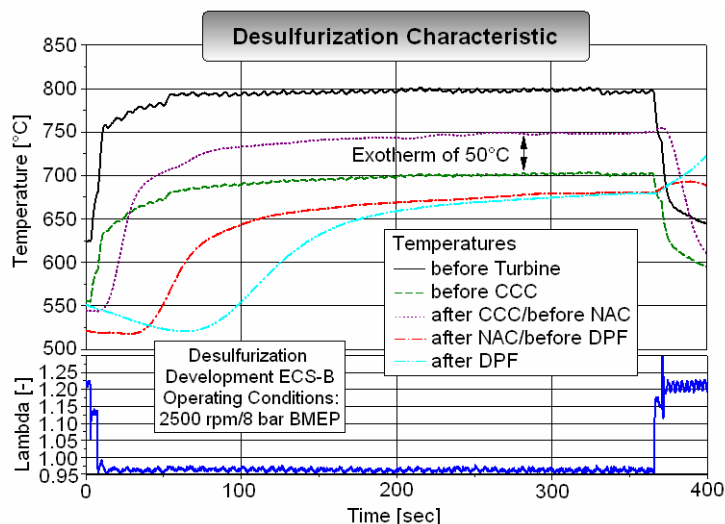

Figure 7: Temperature Profiles during Desulfurization

No temperature spike is visible at the transition to lean operation at the end of the desulfurization event due to the 4-stage transition strategy that was employed.

The final developmental desulfurization strategy utilized a 700°C catalyst inlet temperature, a rich lambda of 0.98, and a duration of 6 minutes. However, later tests showed that this was not long enough to fully purge the system of sulfur. Therefore, sulfur was monitored at real time downstream from the ECS, and desulfurization was discontinued when the sulfur release was no longer significant (below 15 ppm), which was approximately 8 to 13 minutes.

AGING RESULTS

Fresh-Catalyst Effects

Initial developmental desulfurizations were performed on a slightly aged ECS. The operating conditions that gave the desired temperatures were developed based on that ECS's characteristics. During the first desulfurizations on the test systems, it was found that these conditions were too severe for a fresh catalyst. The same developmental inlet temperature resulted in a much higher exotherm (over 100°C) on the aging ECS-B2. It was believed that these high temperatures may have severely thermally aged the catalysts. Therefore, aging with ECS-B3 first used much lower pre-catalyst exotherms.

Figure 8 shows the higher exotherm across the pre-catalyst as compared to the development system (Figure 7).

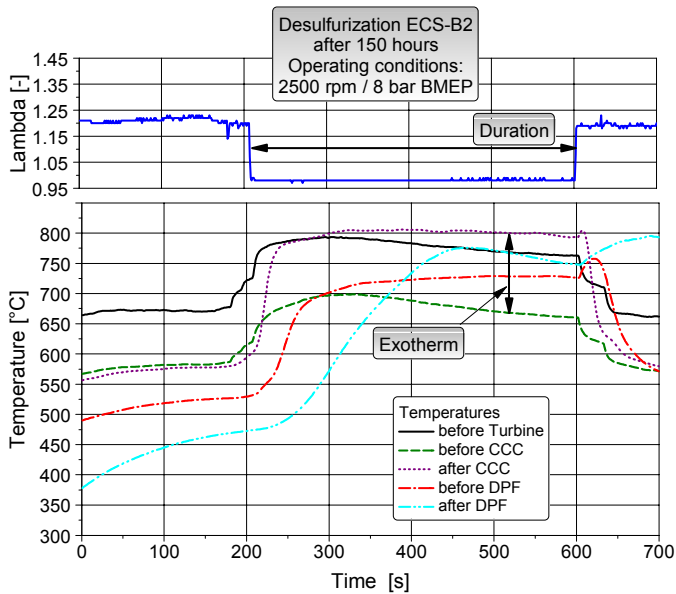

Figure 8: First Desulfurization on a Fresh Catalyst

Desulfurization during Aging

Table 3 shows the desulfurization characteristics for ECS-A2 and ECS-B2. These systems utilized the initial conditions set by the developmental catalysts. Therefore, these systems were subject to the higher exotherms due to the fresh-catalyst effects. Each system was desulfurized only twice before the aging was discontinued.

Desulfurizations at 150 hours on each system had an exotherm of about 150°C (Figure 8). Since these conditions were much too extreme, the calibration was changed at 300 hours to allow for lower pre-catalyst outlet temperatures (i.e., lower exotherm across the pre-catalyst).

However, it was believed that the systems were already severely thermally aged. Tests have shown that NACs suffer a loss in conversion efficiency when exposed to high-temperature, lean-rich conditions. This loss becomes greater as temperature increases [4]. Emissions before desulfurization at 300 hours showed a steep increase in NO_x. Figure 9 illustrates the NO_x emissions for ECS-B2 during hot UDDS tests.

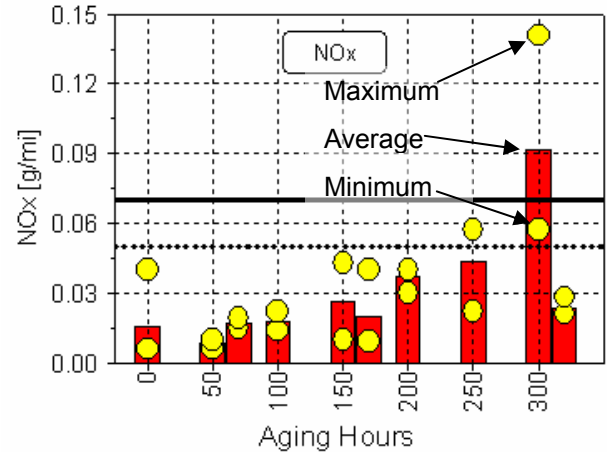

Figure 9: NO_x Emissions for ECS-B2 for Hot LA4

Table 3 shows the desulfurization characteristics for ECS-A2 and ECS-B2. While all desulfurizations result in a gain in NO_x conversion efficiency, both systems are over the composite FTP-75 emission limits before desulfurization at 300 hours.

Table 3: Desulfurization Characteristics for ECS-A2 and ECS-B2

Desulf	Duration	Average System Inlet Temp	Average Temp after CCC	Sulfur Released	Composite FTP75 NO _x	
					Before Desulf	After Desulf
[Hours]	[min]	[°C]	[°C]	[grams]	[g/mi]	[g/mi]
150	6.85	661	748	*	0.067	0.020
300	6.70	614	653	1.70	0.103	0.061

Desulf	Duration	Average System Inlet Temp	Average Temp after CCC	Sulfur Released	Composite FTP75 NO _x	
					Before Desulf	After Desulf
[Hours]	[min]	[°C]	[°C]	[grams]	[g/mi]	[g/mi]
150	6.70	678	789	*	0.035	0.017
300	6.29	661	708	1.17	0.109	0.027

* No data available

Secondary air injection upstream the DPF was used during the 150-hour desulfurizations for ECS-A2 and ECS-B2 to allow for a DPF regeneration. The air injection eliminated the possibility to detect H₂S and SO₂ in the exhaust as those species react the oxygen and form other species that were not captured with the measurement equipment. This procedure was used initially to prove the concept, however was discontinued

to allow real-time sulfur release analysis during the desulfurization event.

Due to variation in engine behavior and fresh-catalyst effects, calibration for ECS-B3 was redeveloped. Table 4 shows the desulfurization characteristics for ECS-B3 up to 2,200 hours.

Table 4: Desulfurization Characteristics for ECS-B3

ECS-B3						
Desulf	Duration	Avg. Sys. Inlet Temp.	Avg. Temp. after CCC	Sulfur Released	Comp. FTP75 NO _x	
					Before Desulf	After Desulf
[hr]	[min]	[C]	[C]	[grams]	[g/mi]	[g/mi]
150	8.13	625	681	4.00	0.037	0.042
300	16.97	612	658	1.77	0.052	0.032
400	13.5	630	677	0.47	0.106	0.038
500	8.58	655	690	1.34	0.086	0.069
600	10.3	685	695	**	0.183	0.041
700	8.62	664	688	**	0.063	0.055
800	8.05	698	728	2.49	0.146	0.071
900	8.55	683	716	2.44	0.151	0.100
1000	15.58	628	650	0.65	0.096	0.043
1100	13.33	691	723	2.25	0.149	0.038
1200	14.32	703	738	3.98	0.211	0.051
1300	13.4	645	713	3.19	0.195	0.234
1400	10.82	712	740	2.14	0.192	0.056
1500	9.32	704	728	1.57	0.297	0.103
1600	7.13	728	742	1.98	0.142	0.054
1650	4.77	708	728	0.44	0.073	0.070
1700	6.7	718	741	0.95	0.056	0.043
1750	4.3	699	722	0.79	0.068	0.063
1800	9.27	667	701	1.11	0.089	0.035
1850	5.35	683	700	0.78	0.117	0.056
1900	5.12	670	695	0.84	0.167	0.103
1950	7.35	702	727	1.42	0.137	0.076
2000	5.35	698	724	0.67	0.085	0.067
2050	5.82	682	706	0.64	0.084	0.078
2100	6.68	721	739	0.94	0.112	0.082
2150	5.42	720	737	0.91	0.069	0.052
2200	7.08	723	732	1.77	0.064	0.042

At 1600 hours, the decision was made to increase the desulfurization frequency from every 100 hours to every 50 hours to improve NO_x emissions over the life of the system. Those cells highlighted show before and after desulfurization results for the hot UDDS only, not the combined composite FTP-75.

While the desulfurization at 150 hours released a large amount of sulfur, the composite FTP-75 emissions actually increased (over the average). This is most likely because the emissions at this age were initially very low. The sulfur released at 300, 400, and 500 hours was much lower. However, the system showed an improvement in NO_x conversion efficiency.

At 600 hours, it was decided to increase the system inlet temperature to release more sulfur. Since the system had been aged to approximately one-quarter of its life, fresh-catalyst effects were not anticipated to be an issue. Engine speed and load were increased to raise the system inlet temperature. Desulfurizations at 600 and 800 hours showed a significant regain in NO_x conversion efficiency.

Desulfurizations at 800 and 900 hours resulted in higher sulfur release. At 1,000 hours, it was noticed that a lower system inlet temperature resulted in a decreased amount of released sulfur. With that in mind, efforts were made to keep the inlet temperature high, but with an open-loop control, the temperature varied from test to test.

At 1,300 hours, the post-desulfurization test was conducted with NO_x regenerations disabled. This resulted in higher NO_x emissions, therefore giving a negative percent improvement. Sulfur release and duration were relatively constant throughout the remainder of the system's lifetime.

Figure 10 shows the duration, system inlet temperature, sulfur released, and percent improvement of NO_x for all desulfurizations for ECS-B3.

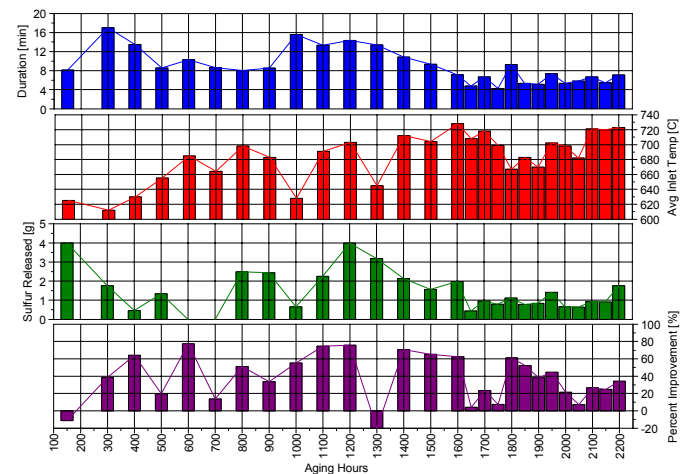

Figure 10: ECS-B3 Desulfurization Overview

Over 100 hours of aging, the ECS is exposed to approximately 6 g of sulfur. With an average improvement of over 40% in NO_x conversion efficiency, it is likely that the majority of the trapped sulfur is released during desulfurization. Therefore, the catalyst traps approximately 30% of the sulfur in the exhaust. It is also possible that sulfur was released in forms other than H₂S and SO₂, which would increase the degree of retention stated above. The desulfurization results show that a greater gain in NO_x conversion efficiency is found at lower releases of the measured sulfur. Presumably, more efficient desulfurization conditions release other forms of sulfur than H₂S and SO₂, which is subject to further investigations.

Emissions during desulfurization were measured downstream from the ECS (tailpipe). Figure 11 shows lambda, oxygen, CO, THC, and NO_x for a typical desulfurization.

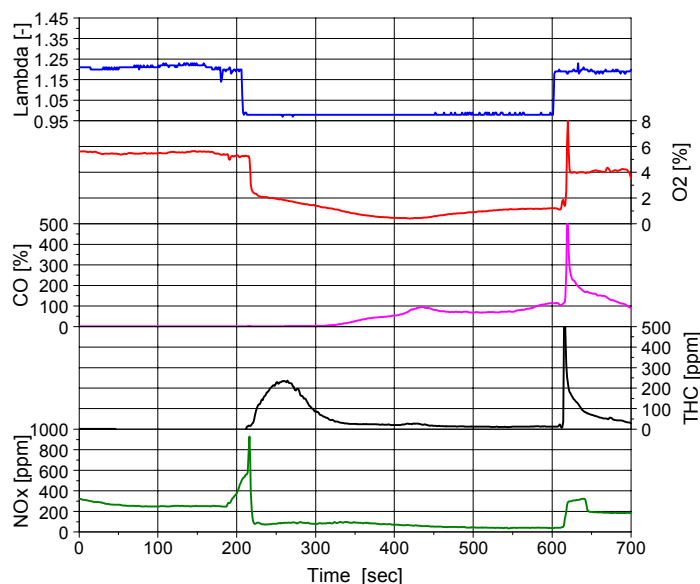

Figure 11: Tailpipe Emissions during Desulfurization

When the engine is operating in a rich or stoichiometric condition, the NAC acts as a three-way catalyst. NO_x is reduced by splitting the molecules into nitrogen and oxygen. This oxygen is then used to oxidize CO and HC. However, since there is not enough oxygen to fully oxidize all the species, some CO and HC slip through, leaving no oxygen downstream from the ECS.

DPF REGENERATION DURING DESULFURIZATION

The remaining element of the strategy development and calibration effort consisted of evaluating the required frequency and efficiency of DPF regeneration events. The quantity of DPF regenerations required over the lifetime of the ECS can have a significant impact on fuel consumption. Therefore, a significant effort was invested in optimizing the efficiency of the DPF regeneration.

During the first desulfurization, air was injected upstream the DPF to aid in DPF regeneration. At high temperatures, the limited addition of oxygen allows the soot to burn at a controlled rate. Figure 12 shows the drop in differential pressure and the associated temperature during desulfurization. This allows the majority of the soot to oxidize before returning to lean conditions, therefore preventing a temperature spike and possible thermal damage.

This method was used on both the ECS-A2 and ECS-B2 at the 150-hour desulfurizations. While air was injected upstream the DPF, sulfur emissions were being measured downstream the DPF (ECS outlet). However, no sulfur was measured during either desulfurization, so it is believed that the air injection interfered with the production of H_2S and SO_2 . Most likely, the addition of oxygen allowed for the formation of other sulfur compounds, such as sulfuric acid, that were not being measured.

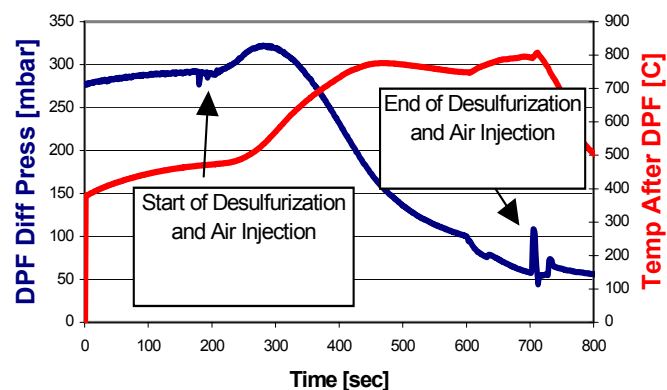

Figure 12: Differential Pressure Drop during Desulfurization

Initially, it was believed that the DPF would need regeneration throughout the aging process. However, early tests showed that the DPF would self-regenerate over the developed aging cycle. As the DPF was self-regenerating during aging, and reading sulfur release during desulfurization was more important, air injection during desulfurization was discontinued after the 150-hour event.

CONCLUSION

Development studies have proven that the NAC in combination with DPF technology has considerable potential in meeting future Tier 2 emissions regulations. However, NACs must also combine desulfurization strategies to regain the lost NO_x storage sites due to sulfur poisoning.

Desulfurization strategies utilized on these ECSs showed that a significant amount of NO_x conversion efficiency could be recovered. Both test cell and vehicle results show that after desulfurization at 120,000 miles (full useful life), the test ECS was able to meet the Tier 2 Bin 5 standard for NO_x and PM emissions.

For the most thorough desulfurization, a more sophisticated desulfurization strategy needs to be developed that not only considers the degree of sulfur poisoning, but also uses the temperatures during the desulfurization as feedback signal and adjusts the parameters accordingly. It was found that fresh catalysts react significantly different to the same engine parameter settings than moderately aged catalysts.

Furthermore, the sulfur release effects could be subject to other studies. A more detailed chemical analysis of the exhaust would show if there is any existence of sulfur other than H_2S and SO_2 . Also, an evaluation of the regain in NO_x conversion efficiency versus the type of sulfur released would give more insight into the most desirable desulfurization conditions.

ACKNOWLEDGMENTS

The authors would like to thank the members of the APBF-DEC Steering Committee, APBF-DEC NO_x Adsorber Workgroup, National Renewable Energy Laboratory, Oak Ridge National Laboratory, MECA, and DOE for their support and guidance. This project and all of the APBF-DEC activities are being conducted with the cooperation of engine and vehicle manufacturers, emission control device manufacturers, energy and additive companies, California State agencies, and the U.S. Environmental Protection Agency. Representatives from all of these organizations and their member companies are represented on the steering committee and the workgroups. This project would not be possible without their help and technical support.

REFERENCES

1. Tomazic D., Tatur M., Thornton M. "Development of a Diesel Passenger Car Meeting Tier 2 Emissions Levels," SAE Paper 2004-01-0581, March 2004, Detroit, Michigan.
2. Tomazic D., Tatur M., Thornton M. "APBF-DEC NO_x Adsorber/DPF Project: Light-Duty Passenger Car Platform," DEER Paper, August 2003, Newport, Rhode Island.
3. Geckler S., Tomazic D., et al. "Development of a Desulfurization Strategy for a NO_x Adsorber Catalyst System," SAE Paper 2001-01-0510, March 2001, Detroit, Michigan.
4. Fang H., Wang J., Yu R., Wan C., Howden K. "Sulfur Management of NO_x Adsorber Technology for Diesel Light-Duty Vehicle and Truck Applications." SAE Paper 2003-01-3245, October 2003, Pittsburgh, Pennsylvania.

CONTACT

Marek Tatur, FEV Engine Technology, Senior Engineer Diesel Combustion Systems. E-Mail: tatur@fev-et.com

DEFINITIONS, ACRONYMS, ABBREVIATIONS

APBF-DEC: Advanced Petroleum-Based Fuels – Diesel Emissions Control

BTDC: Before Top Dead Center

CA: Crank Angle

CO: Carbon Monoxide

CO₂: Carbon Dioxide

DOE U.S. Department of Energy

DPF: Diesel Particle Filter

ECM: Electronic Control Module

ECS: Emission Control System

ECU: Engine Control Unit

EGR: Exhaust Gas Recirculation

EPA: Environmental Protection Agency

ETK: Emulator Task Kopf

FSN: Filter Smoke Number

FTP: Federal Test Procedure

FTP-75: Light-Duty Federal Test Procedure

HC: Hydrocarbon

HFET: Highway Fuel Economy Test

HSDI: High-Speed Direct Injection

LA-4: Bag 1 and Bag 2 of the FTP-75 Cycle

MECA: Manufacturers of Emissions Controls Association

NAC: NO_x Adsorber Catalyst

NMHC: Non-Methane Hydrocarbon

NO: Nitric Oxide

NO₂: Nitrogen Dioxide

NO_x: Oxides of Nitrogen

O₂ Oxygen

OEM: Original Equipment Manufacturer

PM: Particulate Matter

RPM: Revolutions per Minute (engine speed)

SC03: Air Conditioning Test

SCR: Selective Catalytic Reduction

THC: Total Hydrocarbon

UDDS: Urban Dynamometer Driving Schedule

US06: An aggressive chassis dynamometer emissions test procedure, part of the Supplemental FTP

APPENDIX A: FUEL PROPERTIES

The base fuel used in this study is an ultra-low sulfur (0.6-ppm) fuel with properties that are representative of diesel fuels used in the United States, except for its sulfur content. Table A-1 summarizes the properties of the fuel. To achieve higher sulfur levels, without otherwise impacting other fuel properties, a mixture of the sulfur containing compounds (listed in Table A-2) typically found in diesel fuel are doped into the base fuel. The dopant mixture contains a variety of classes of S containing molecules that are in the same boiling range as diesel fuel, with an emphasis on thiophenes. Careful addition of this dopant mixture yields fuels containing 8- and 15-ppm sulfur for use in the catalyst aging experiments that follow this development activity.

Table B-1: Test Fuel Properties

Fuel Property	ASTM Method	Base Fuel	BP15
Density (kg/m ³)	D4052	826.2	837.1
Viscosity @40°C (mm ² /s)	D445	2.3	2.5
Distillation			
IBP (°C)	D86	180	164
10% recovery (°C)	D86	203	201
20% recovery (°C)	D86	219	218
30% recovery (°C)	D86	233	233
40% recovery (°C)	D86	244	246
50% recovery (°C)	D86	251	259
60% recovery (°C)	D86	257	272
70% recovery (°C)	D86	265	286
80% recovery (°C)	D86	279	302
90% recovery (°C)	D86	312	322
FBP (°C)	D86	352	346
Cloud point (°C)	D2500	-26	-12
Pour point (°C)	D97	-23	-18
Flash point, PMCC (°C)	D93	69	64
Sulfur (ppm)	D5453	0.6	13.3
Aromatics (vol. %)	D1319	23.9	29
Olefins (vol. %)	D1319	4.6	
Saturates (vol. %)	D1319	71.4	
Aromatics (vol. %)	D5186	26.9	25
Polyaromatics (vol. %)	D5186	8.4	4.2
Non-aromatics (vol. %)	D5186	64.7	70.8
Cetane number	D613	42.5	51.1
Cetane index	D976	51.5	48.8

Table B-2: Properties of Sulfur Doping Compounds

Concentration (mass %)	Compound	Chemical Formula	Boiling Point (°C)
50	Dibenzo[b,d]thiophene	C ₁₂ H ₈ S	333
30	Benzo[b]thiophene	C ₈ H ₆ S	222
10	Di-t-butyl disulfide	C ₈ H ₁₈ S ₂	200
10	Ethyl phenyl sulfide	CH ₁₀ S	206