

Air Cooling Technology for Power Electronics Thermal Control

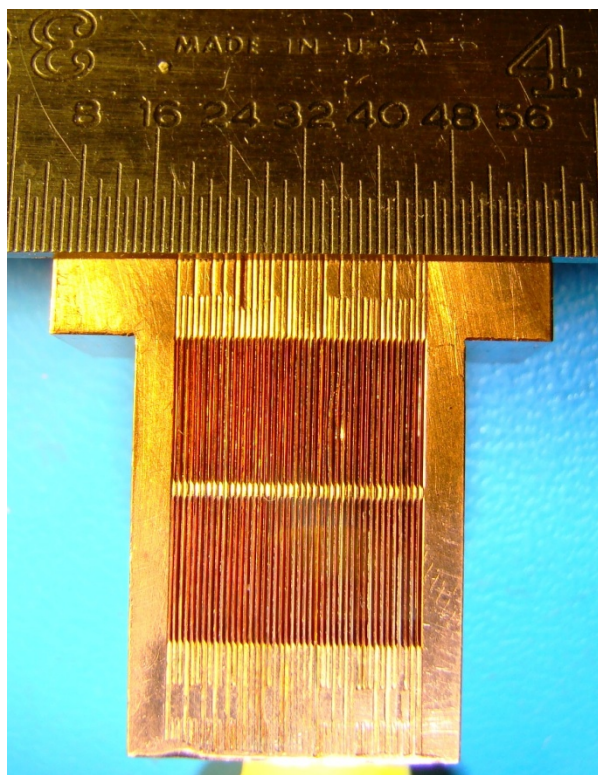

Desikan Bharathan

Email: desikan_bharathan@nrel.gov

Phone: 303-887-4215

Organization: National Renewable Energy Laboratory

Team members:

Charlie King

Ken Kelly

Sreekant Narumanchi

Project Duration: FY06 to FY09

DOE FreedomCAR and Vehicle Technologies Program
Advanced Power Electronics and
Electric Machines Projects
FY08 Kickoff Meeting

National Transportation Research Center
Knoxville, Tennessee

November 14, 2007



*This presentation does not contain any
proprietary or confidential information*

The Problem

- **Eliminate liquid coolant loops.**
- **Enable heat rejection directly to the sink, namely, ambient air. Simplify.**
- **Maintain die temperature below specified operating limits for long-term reliability.**
- **Reduce cost and meet other FreedomCAR goals for year 2020 (\$8/kW for a 55 kW traction system).**

Description of Technology

Advantages

Air is the ultimate sink

Rejecting heat to air can eliminate intermediate fluid loops

Air is benign and need not be carried

Air is a dielectric, and can contact the chip directly

Drawbacks

Air has a low specific heat

Air is a poor heat-transfer fluid

Air density is low

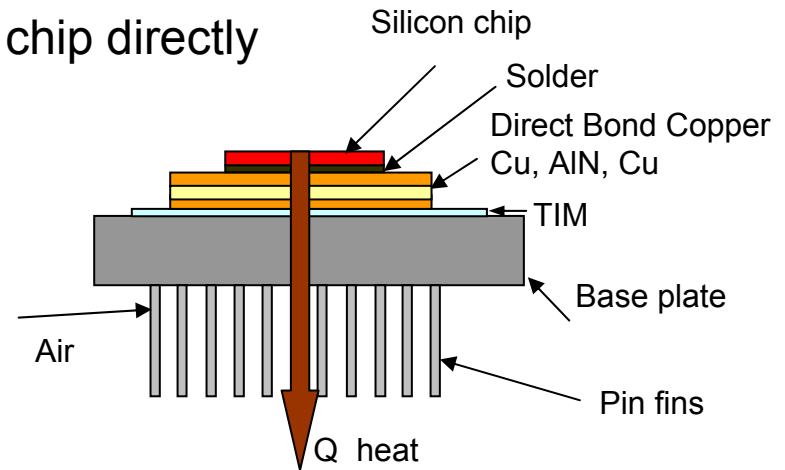

Uniqueness of Project and Impacts

- **Approach looks at simple thermal solutions.**
- **Offers viable heat rejection directly to the sink.**
- **Air cooling offers simplicity and least number of components.**
- **Air cooling offers high degree of reliability.**

Accomplishments to Date

Air-Cooling System for Power Electronics

A Schematic Diagram

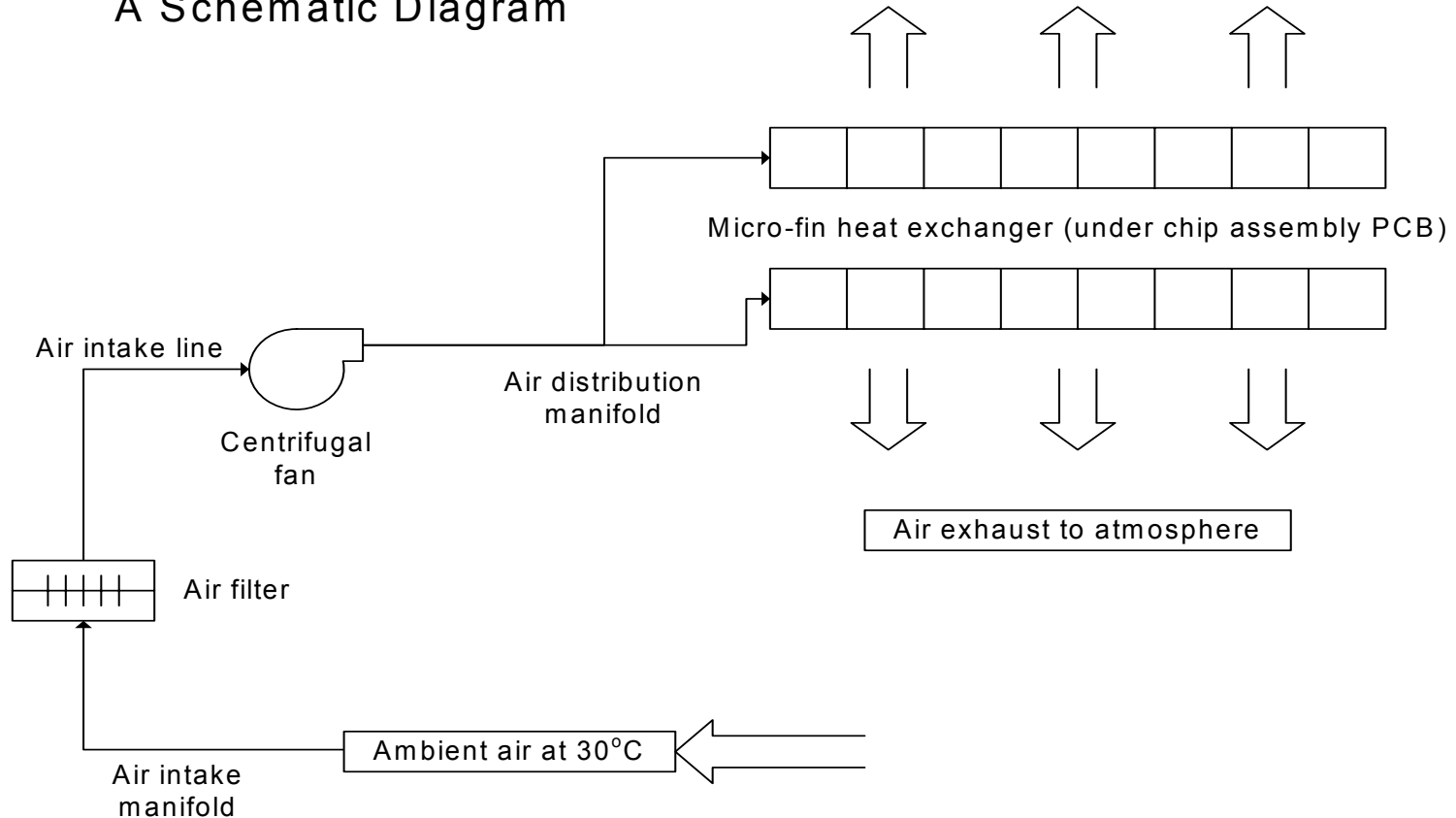

Accomplishments to Date

Micro-fin array geometry

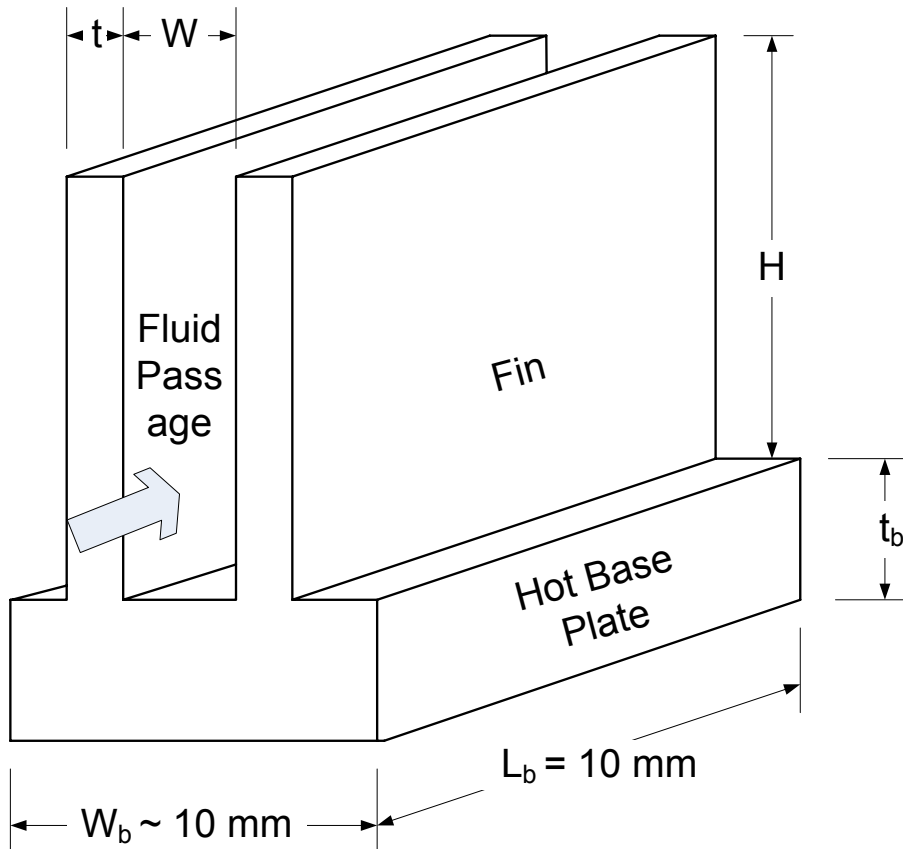

Typical values are:

$W = 130 \mu\text{m}$

$t = 65 \mu\text{m}$

$H = 13 \text{ mm}$ and

$t_b = 1 \text{ mm}$

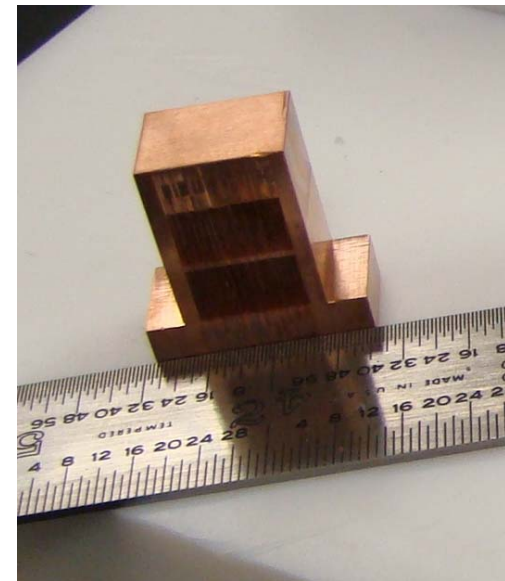

Accomplishments to Date

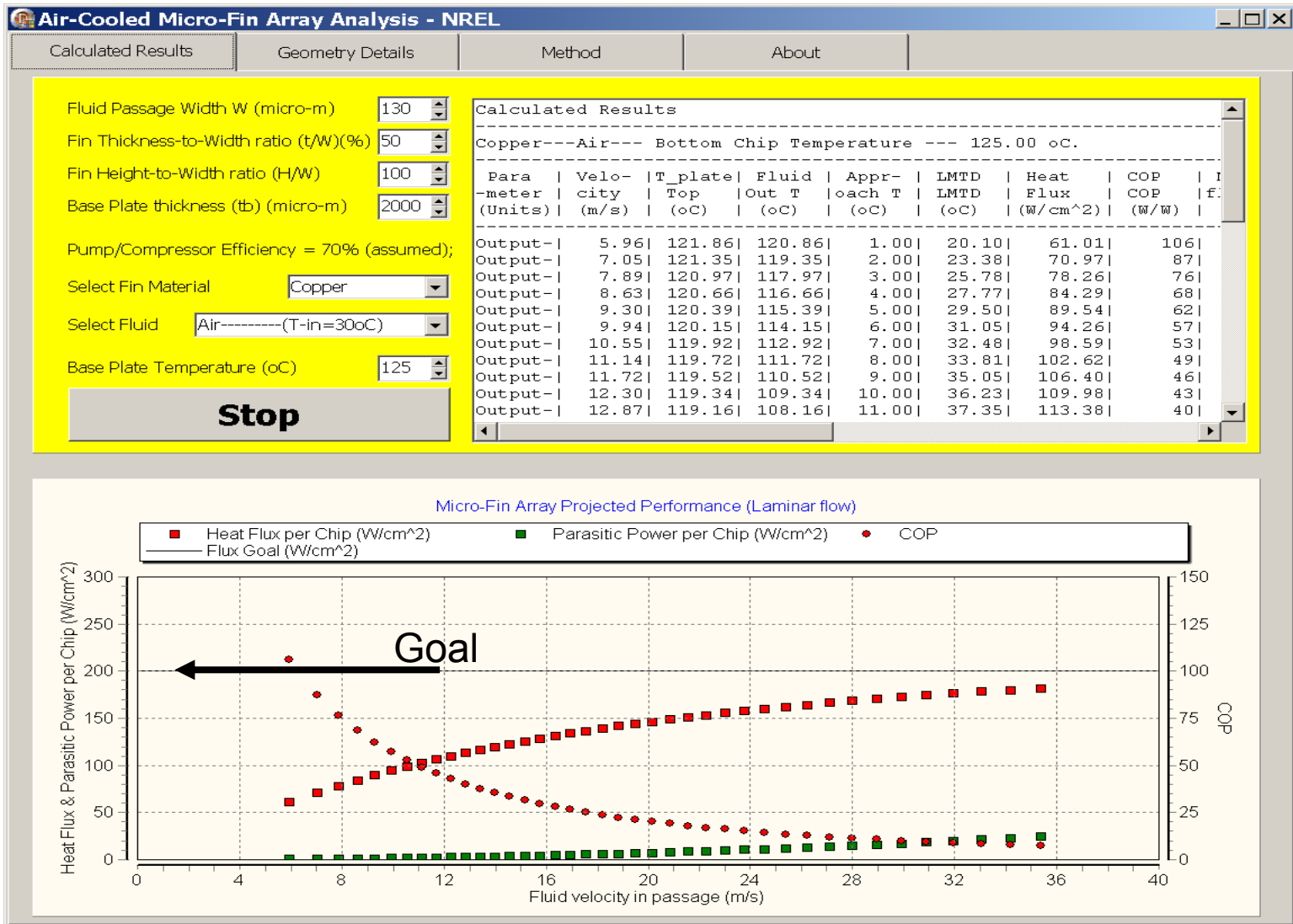

Accomplishments to Date

Models show that:

- Air cooling can remove fluxes up to 150 W/cm^2 for Silicon-based devices.
- Higher chip operating temperatures will increase the flux close to programmatic goal of 200 W/cm^2 .

Comparison with the use of an intermediate liquid cooling loop indicate that:

- Air cooling is simple, less costly, and reliable.

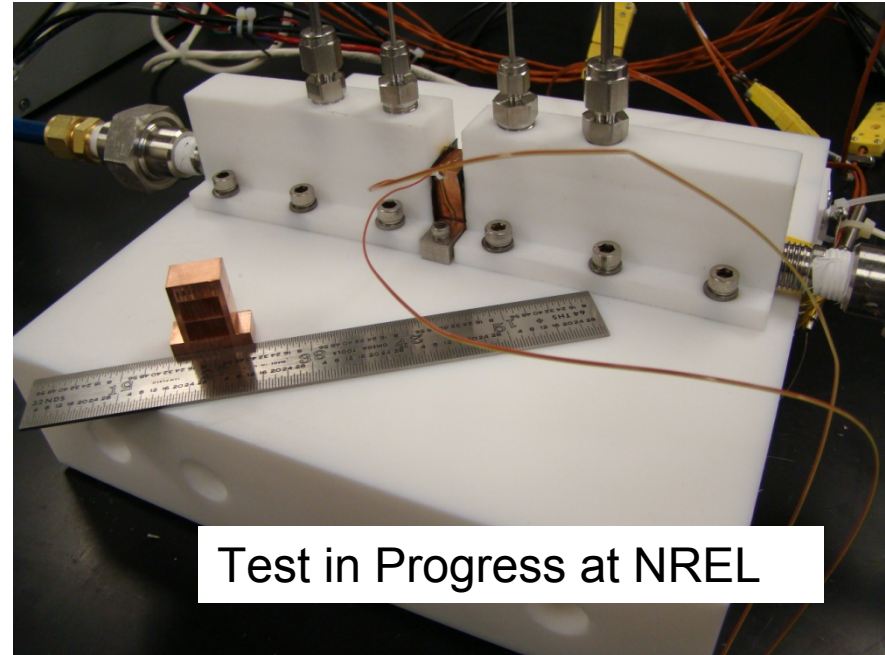

Project Objectives for FY08

- **Implement air cooling**
 - Work with an industrial partner to accommodate technology on a working inverter module to meet FreedomCAR goals.
- **Validate models and design approach.**
- **Contribute to advanced PE development cooling options**
 - Work closely with ORNL in development efforts to meet programmatic goals.

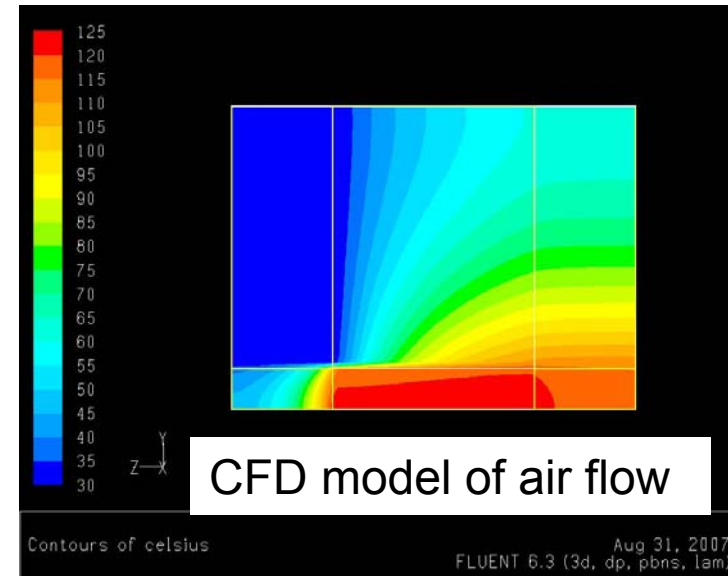

Technical Approach for FY08

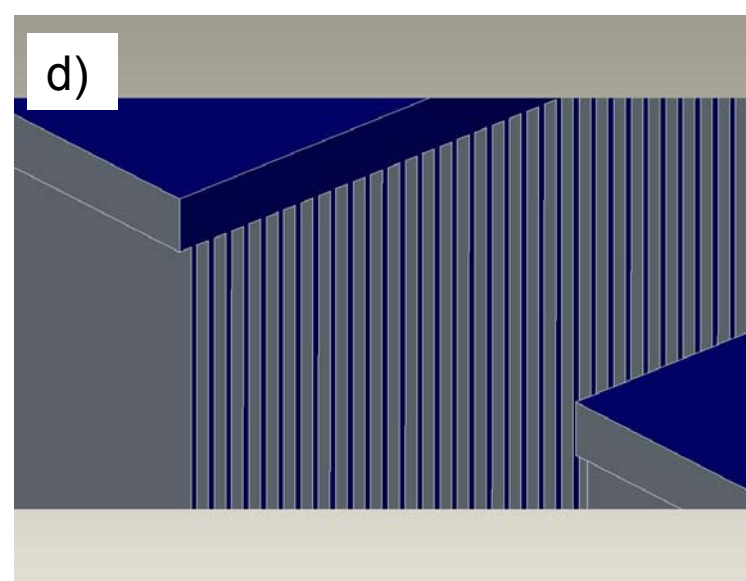
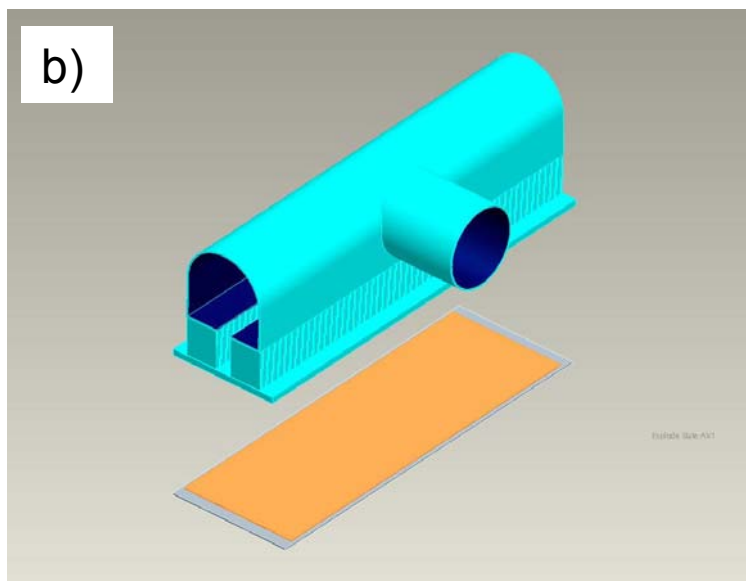
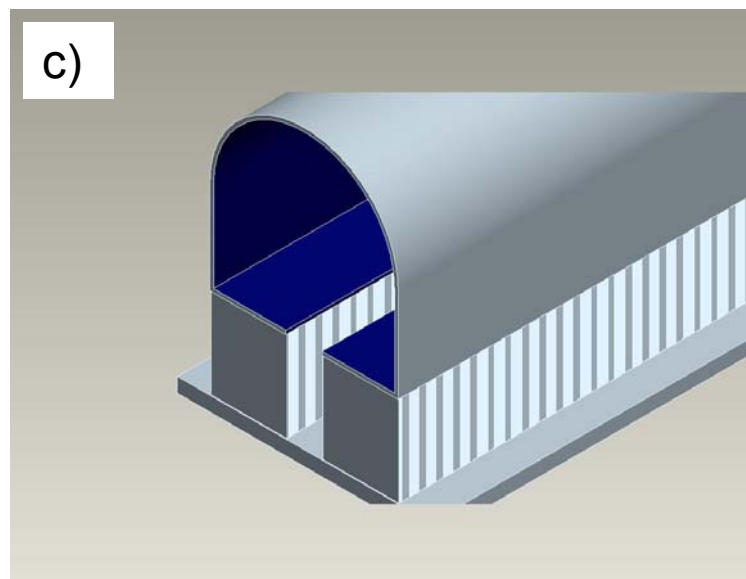
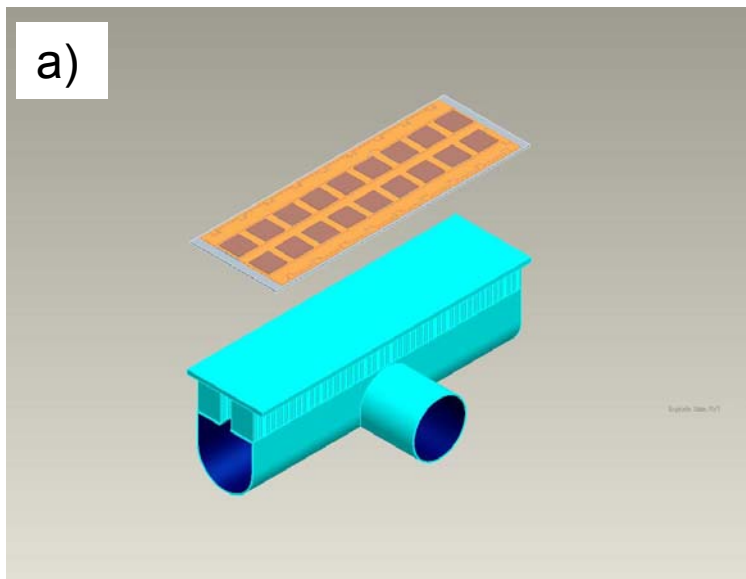

Technical Approach for FY08

1. Design an air cooled micro-channel fin heat exchanger for an inverter module
 - in close collaboration with a chosen industrial manufacturer that meets the performance goals and other manufacturing constraints.
2. Incorporate air cooling device in a production model as a prototype.
3. Test performance of the module under realistic working conditions.
4. Validate design with test data.
5. Develop guidelines for performance estimation, cost, volume, weight and other measures for air cooling for use by the industry.
6. Develop second iteration design and demonstrate air-cooling as a viable option.

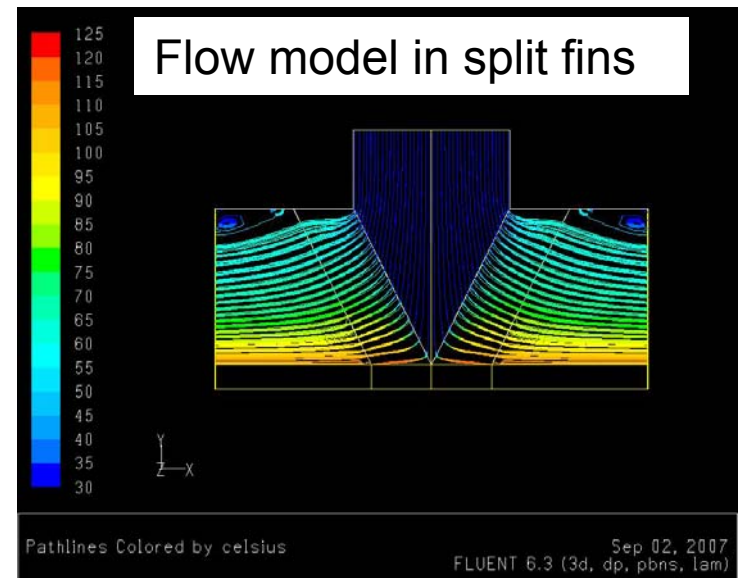

Timeline

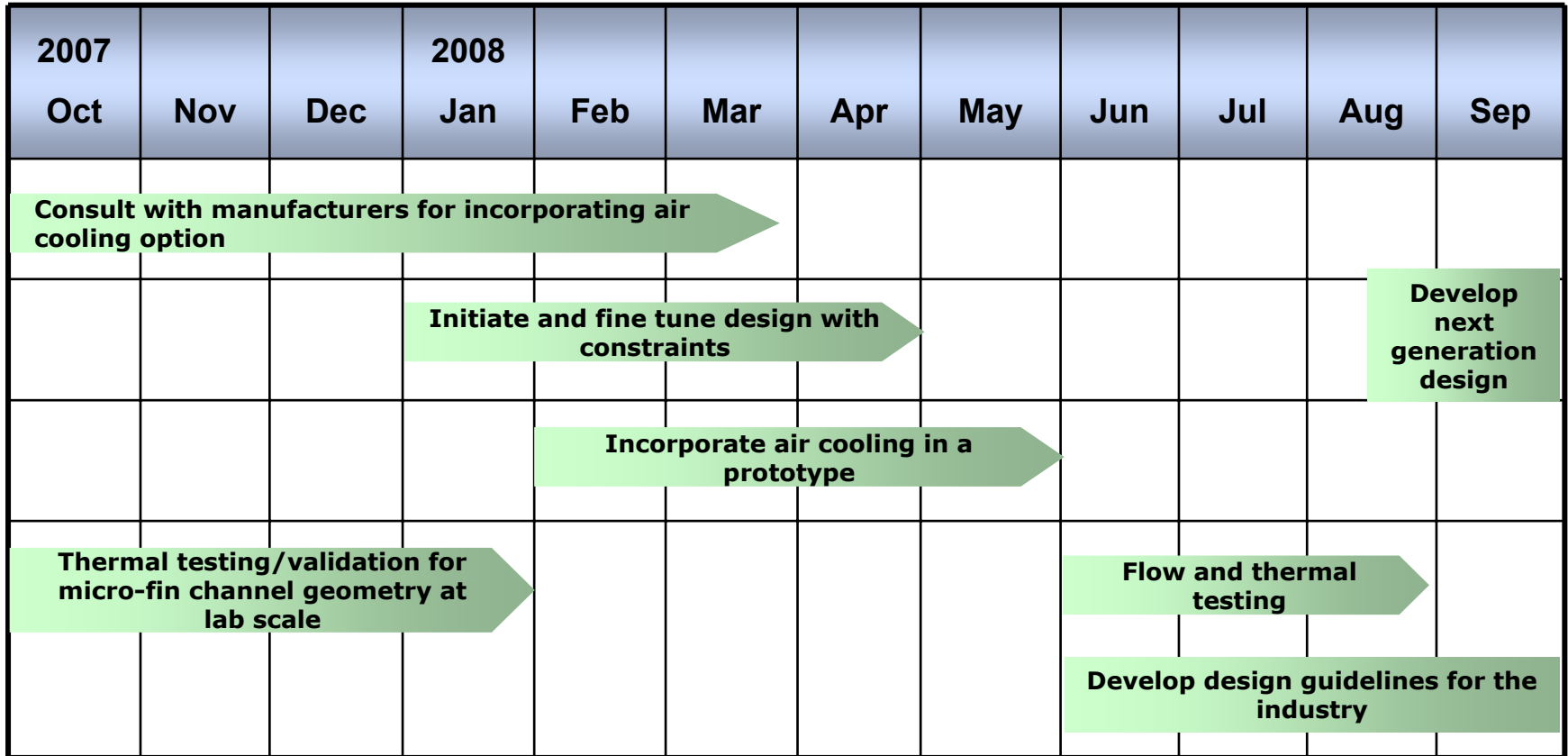

The Challenges/Barriers

To be addressed:

- **Erosion concerns -- due to coolant impingement and long term effects of jet impingement on copper fins.**
- **Potentially low blower efficiency.**
- **Potential noise generation due to air flow on fins.**
- **Difficulties with differential thermal expansions and resulting stresses.**
- **Convince industry this is a viable technology with advantages, while long-term reliability issues are addressed.**

Beyond FY08 -- Integrate the developed thermal control technology with reliability tasks based on a systems level approach

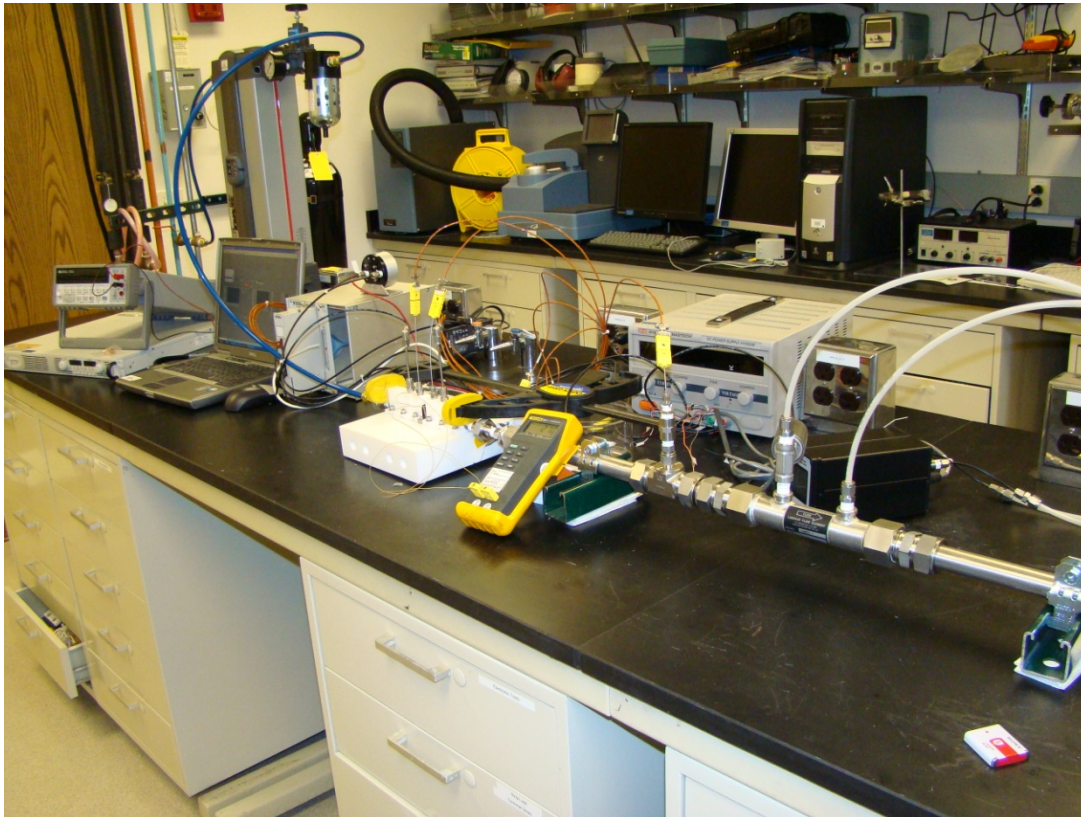

- Analyze pulsed systems to power
- Generate a design tool for air cooling
 - Provide industry with an easy-to-use tool to evaluate all aspects of performance and specifications.

Questions

