

# Validation of Wind Power Plant Dynamic Models

## Preprint

Eduard Muljadi  
*National Renewable Energy Laboratory*

Abraham Ellis  
*Public Service Company of New Mexico*

*To be presented at the 2008 IEEE Power Engineering Society  
General Meeting  
Pittsburgh, Pennsylvania  
July 20–24, 2008*

**Conference Paper**  
**NREL/CP-500-43667**  
**July 2008**

NREL is operated by Midwest Research Institute • Battelle Contract No. DE-AC36-99-GO10337



## NOTICE

The submitted manuscript has been offered by an employee of the Midwest Research Institute (MRI), a contractor of the US Government under Contract No. DE-AC36-99GO10337. Accordingly, the US Government and MRI retain a nonexclusive royalty-free license to publish or reproduce the published form of this contribution, or allow others to do so, for US Government purposes.

This report was prepared as an account of work sponsored by an agency of the United States government. Neither the United States government nor any agency thereof, nor any of their employees, makes any warranty, express or implied, or assumes any legal liability or responsibility for the accuracy, completeness, or usefulness of any information, apparatus, product, or process disclosed, or represents that its use would not infringe privately owned rights. Reference herein to any specific commercial product, process, or service by trade name, trademark, manufacturer, or otherwise does not necessarily constitute or imply its endorsement, recommendation, or favoring by the United States government or any agency thereof. The views and opinions of authors expressed herein do not necessarily state or reflect those of the United States government or any agency thereof.

Available electronically at <http://www.osti.gov/bridge>

Available for a processing fee to U.S. Department of Energy and its contractors, in paper, from:

U.S. Department of Energy  
Office of Scientific and Technical Information  
P.O. Box 62  
Oak Ridge, TN 37831-0062  
phone: 865.576.8401  
fax: 865.576.5728  
email: <mailto:reports@adonis.osti.gov>

Available for sale to the public, in paper, from:

U.S. Department of Commerce  
National Technical Information Service  
5285 Port Royal Road  
Springfield, VA 22161  
phone: 800.553.6847  
fax: 703.605.6900  
email: [orders@ntis.fedworld.gov](mailto:orders@ntis.fedworld.gov)  
online ordering: <http://www.ntis.gov/ordering.htm>



# Validation of Wind Power Plant Dynamic Models

Eduard Muljadi<sup>1</sup>, Senior Member, IEEE

A. Ellis<sup>2</sup> Senior Member, IEEE

**Abstract** – Wind energy will continue to grow at a rapid pace and will provide an increasingly large portion of the total electricity generation. To achieve its full potential, the industry needs adequate wind-turbine generator (WTG) dynamic models to determine the impact of adding wind generation, and establish how the system needs to be upgraded.

For the most part, WTG manufacturers have sponsored the development of WTG dynamic models. Models developed under this paradigm tend to be proprietary and manufacturer-specific. The models are often disclosed under confidential terms for interconnection studies and design of individual projects. However, the use of proprietary models to represent installed wind power plants is incompatible with critical grid planning activities that are conducted by regional reliability organizations as a collaborative effort among many stakeholders. In this context, the use of generic or simplified models is desirable.

To address this industry need, the Western Electricity Coordinating Council (WECC) has embarked on the development of generic positive sequence WTG models for large-scale power system transient stability analysis. As an integral part of this WECC activity, the National Renewable Energy Laboratory (NREL) is engaged in a model validation effort. This paper discusses the process of model validation against field measurements. The procedure is illustrated with a specific example.

**Index Terms** — dynamic model, power system, renewable energy, variable-speed generation, weak grid, wind energy, wind farm, wind power plant, wind turbine, wind integration, systems integration, WECC, wind turbine model, validation.

## I. INTRODUCTION

Modern wind turbine generators (WTGs) utilize power electronics and state-of-the-art real and reactive power controls that allow wind power plants to have much better steady-state and dynamic performance compared to wind power plants of the past. For reliability and cost reasons, it is very important to properly represent steady and dynamic characteristics in large-scale positive-sequence simulations. For the most part, the development of WTG positive-sequence dynamic models has been sponsored by WTG manufacturers. Simulation models developed under this paradigm tend to be proprietary and manufacturer-specific. The models are often disclosed under confidential terms for interconnection studies and design of individual projects. However, the use of

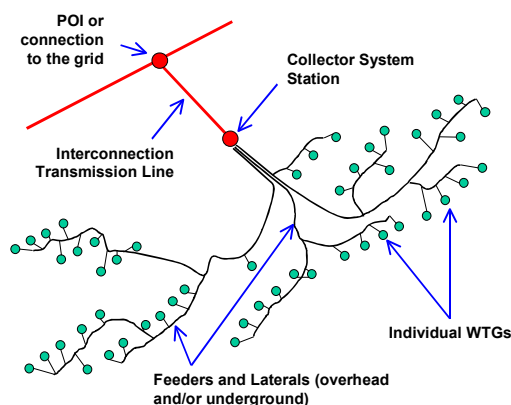

Figure 1a. Simplified single-line diagram of a wind power plant

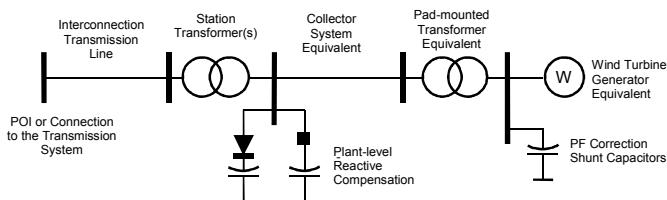

Figure 1b. Single-machine equivalent representation.

proprietary and manufacturer-specific models to represent installed wind power plants is incompatible with critical grid planning activities that are conducted by regional reliability organizations as a collaborative effort among many stakeholders. In this context, the use of generic or simplified models is desirable.

To address this industry need, the Wind Generation Modeling Group (WGMG) of the Western Electricity Coordinating Council (WECC) has embarked on the development of generic positive sequence WTG models for large-scale power system transient stability analysis. This effort is based on the premise that it technically feasible to develop a generic model for each of the four basic WTG configurations that are currently in use: squirrel-cage induction generator, wound-rotor induction generator with adjustable rotor resistance, doubly fed asynchronous generator (DFAG), and a full-power conversion wind turbine generator. Although additional work is required to achieve the stated goals, substantial progress has been made. As an integral part of this WCC WGMG activity, the National Renewable Energy Laboratory (NREL) is engaged in an extensive model validation project aimed at testing the models against field measurements and refining the WECC generic models as needed.

Figure 1a, shows a simplified single-line diagram of a wind power plant. It is possible to capture the essential powerflow and dynamic behavior of the wind power plant using a single-

We acknowledge the financial support provided by the U.S. Department of Energy, California Energy Commission, and Western Electric Coordinating Council.

<sup>1</sup>E. Muljadi is with National Renewable Energy Laboratory, Golden, CO 80401 (email: [eduard\\_muljadi@nrel.gov](mailto:eduard_muljadi@nrel.gov)).

<sup>2</sup>A. Ellis is with Public Service Company of New Mexico, Albuquerque, NM 87158 (e-mail: [aellis@pnm.com](mailto:aellis@pnm.com)).

machine equivalent representation (Figure 1b.). For practical reasons, the single-machine equivalent representation is the preferred way to represent wind power plants in large-scale power system simulations. A method of representing groups of wind turbines by their equivalent is described in [1]. In some cases, where the wind power plant consists of different types of WTGs or has significantly distinct clusters, it may be appropriate to represent the wind power plant with two or more equivalent generators [2]. There are many other references available for readers interested in dynamic models of wind turbines and wind power plants [3-5].

This paper is organized as follows. Section I is devoted to the introduction. Section II describes an actual wind power plant used throughout the paper as an example. The corresponding single-machine equivalent representation is discussed. Section III discusses the general model validation methodology. Simulation and comparison between simulated data and the recorded data is presented in Section IV. And finally, some concluding remarks are offered in Section V.

## II. EXAMPLE WIND POWER PLANT

Although the method described is generic in nature, a specific wind power plant will be used as an illustration. The reference wind power plant has a nameplate rating of 204 MW and consists of 136 1.5-MW DFAG WTGs. It is connected to the transmission system operated by Public Service Company of New Mexico (PNM) at 345 kV. There are a total of eight 34.5 kV-feeders, two of them are overhead and the rest are underground. The collector system station is adjacent to the transmission station. The wind power plant is equipped with a voltage regulator that controls voltage at the transmission station, relying on the reactive capability of the WTGs only. There is no additional reactive compensation within the wind power plant.

The single-machine equivalent representation of the reference wind power plant is shown in Figure 2. All impedances are in a 100-MVA base. The derivation of equivalent impedances is explained in more detail in [1]. The station transformer was modeled explicitly. Node A represents the transmission station or POI. Node B is the generator terminal. Note that C represents the 34.5-kV collector system station.

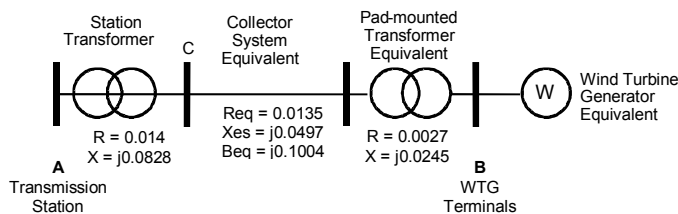

Figure 2. Single-machine equivalent representation for reference wind power plant.

It is important to understand that the impedance between the terminals of each WTG and the transmission station is different; therefore, the terminal behavior during a major

system disturbance would differ. During a major disturbance, it is possible for a portion of the WTGs to experience voltages beyond control or protection limits. It is not possible to capture these differences with the single-machine equivalent representation. The equivalent WTG is meant to represent the aggregate terminal behavior of the “average” WTG in the wind power plant.

In this case, we are interested in checking the performance of the WECC generic DFAG model [6]. This model has been implemented as standard library models in two positive-sequence simulation programs commonly used in the U.S. A high-level block diagram of the model is shown in Figure 3. Since the goal is to illustrate the model validation process, the specific model structure and parameters are not of primary interest in this paper. Default model parameters were used. Additional information about the model can be found in [6] and [7].

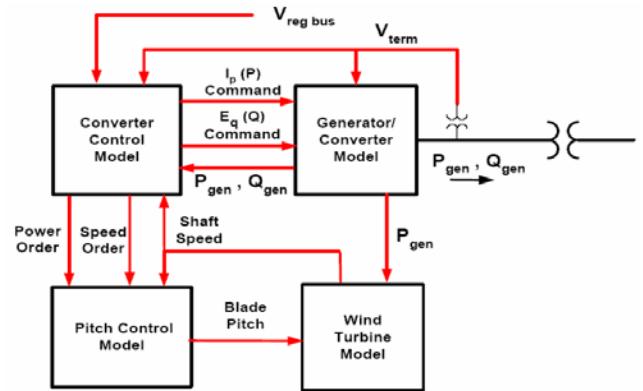

Figure 3. Block diagram of WECC generic DFAG model.

The goal is to compare the output of the model against actual measurements captured at the transmission station, where disturbance recordings can be obtained relatively easily. The disturbance used as an example in this paper consists of a line-to-ground fault in the vicinity of the transmission station, which resulted in a voltage transient large enough to excite a significant dynamic response from the wind power plant, within the design response capability of the generic model (up to about 5 Hz). Data before the fault occurred is required to establish the pre-disturbance powerflow conditions that are used to initialize the model. The disturbance record should extend several seconds after the contingency, consistent with the time frame of interest of positive-sequence transient stability analysis.

## III. METHOD OF ANALYSIS

### A. Transmission system and disturbance representation

It can be difficult to represent the power system network to properly simulate a remote fault. In addition, the nature of the fault in most cases is difficult to characterize. Fortunately, there is a simpler method that uses data captured at the point of interconnection to drive a dynamic simulation. During the

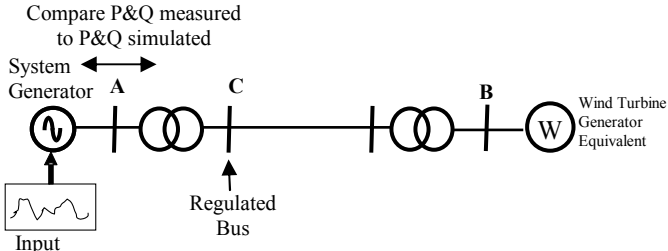

Figure 4. Validation technique used in this paper.

dynamic simulation, the measured positive-sequence voltage and frequency boundary conditions can be imposed at the transmission station POI. This technique has been in use in WECC for some time, and is achieved with the aid of a modified classical generator model (GENCLS) capable of holding terminal voltage and frequency as specified in an input file. This “system generator” is connected at node A in Figure 4, and must be defined as the slack bus in the simulation. A direct comparison between the simulated and measured real and reactive power at the POI can provide some evidence of model performance. It should be kept in mind that some aspects of the model may not be exercised by the disturbance. Therefore, validation requires multiple tests across different system conditions and different wind power plants of the same type of generators.

### B. Raw data preparation

In this section, an example of data preparation is presented. As pointed out earlier, disturbance data was measured at the POI. A window of observation is set up by using a data fault recorder that will capture the entire fault event (a few seconds before, during, and after the fault event). The data recorded are the three-phase voltage and currents at a sampling rate of 3486 Hz.

An example of the per-phase voltage waveform is shown in Figure 5a. The time series of the voltage presented in Figure 5a is shown in a “stationary reference frame.” To integrate this information in a positive-sequence simulation, we need to have the positive-sequence magnitude of the voltage, frequency, as well as the real and reactive power magnitude as a function of time. Most station instrumentation software tools have the capability to make the conversion easily. However, the procedure is not difficult. First, we convert the voltages and currents from a, b, c representation into a d-q axis representation in stationary reference frame. The equation used to perform this transformation is presented in equation [1].

$$\begin{bmatrix} f_{qs} \\ f_{ds} \\ f_{os} \end{bmatrix} = \begin{bmatrix} \frac{2}{3} & -\frac{1}{3} & -\frac{1}{3} \\ 0 & -\frac{1}{\sqrt{3}} & \frac{1}{\sqrt{3}} \\ \frac{1}{3} & \frac{1}{3} & \frac{1}{3} \end{bmatrix} \begin{bmatrix} f_{as} \\ f_{bs} \\ f_{cs} \end{bmatrix} \quad [1]$$

From a stationary reference frame, we convert these variables into its representation in synchronous reference

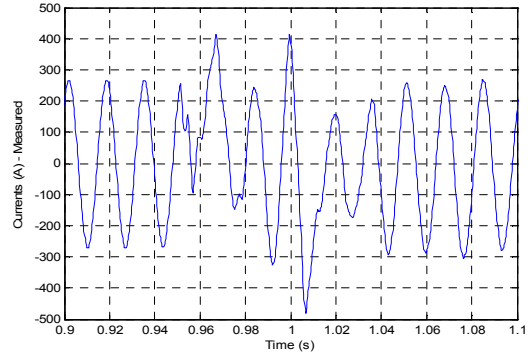

Figure 5a. Phase voltage waveform during the fault

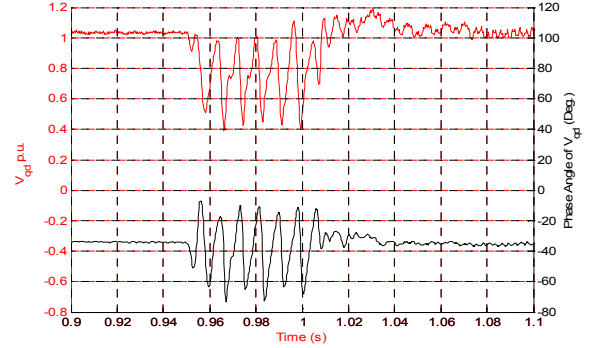

Figure 5b. Phase voltage in phasor form during the fault

frame by using equation [2].

$$\begin{bmatrix} f_{qe} \\ f_{de} \\ f_{oe} \end{bmatrix} = \begin{bmatrix} \cos(\omega_e t + \theta_o) & -\sin(\omega_e t + \theta_o) & 1 \\ \sin(\omega_e t + \theta_o) & \cos(\omega_e t + \theta_o) & 1 \\ 0 & 0 & 1 \end{bmatrix} \begin{bmatrix} f_{qs} \\ f_{ds} \\ f_{os} \end{bmatrix} \quad [2]$$

$$V_{qde} = \sqrt{V_{qe}^2 + V_{de}^2} \angle \theta_{qde}$$

$$\theta_{qde} = \text{atan}^{-1} \left( \frac{V_{de}}{V_{qe}} \right) \quad [3]$$

In this case the variable  $f$  can be substituted with  $v$  for voltage or  $i$  for current. The subscript  $s$  represents the stationary reference frame and the subscript  $e$  represents the synchronous reference frame. Under normal condition, the quantities in the synchronous reference frame will show constant values in the  $d$  and  $q$  axis. Finally, we can convert the voltage or current into its phasor form as shown in equation (3). Thus, we convert the voltages and currents from a three-phase a, b, and c representation into its magnitude and phase angle (in phasor form) to follow the progression of the fault and to show how the voltage phasor changes during the fault. The methods described in this section can be found in more detail in [8].

The frequency change at each step can be derived from the phase angle changes in each time step by using equation 4:

$$\Delta f(t) = \Delta\theta_{qde} / (2\pi \Delta t) \quad [4]$$

Instantaneous real and reactive power can be computed from the measured voltages and currents with the following equations:

$$p = \frac{3}{2} (v_{qe} i_{qe} + v_{de} i_{de}) \quad [5]$$

$$q = \frac{3}{2} (v_{qe} i_{de} - v_{de} i_{qe})$$

The lower case indicates that these quantities are instantaneous values.

The traces shown in Figure 5b are the voltage phasor quantities (magnitude and phase angle) obtained from the measured per-phase voltage and current waveform data recorded by PNM at node A.

The traces presented in Figure 6 show the voltage phasor magnitude and frequency as time varies. Both the voltage magnitude and the frequency are passed through low pass filter to remove the higher frequency component, and the resulting voltage and frequency are used as the input to the GENCLS model. Note, that during the fault, the voltage dips to about 0.73 p.u.

Figure 7 shows the measured real and reactive power. It can be seen that, prior to the disturbance, the wind power plant was operating at an output level of 115 MW, about 56% of rated output (ignoring losses). It can also be seen that the wind power plant output goes down by approximately 9%, after the disturbance. Since wind speed can be assumed to be constant over the time frame of this event (a few seconds), this reduction is an indication that some turbines tripped as a result of the fault. With respect to reactive power, it is noted that there is a significant response during the fault.

#### IV. SIMULATION

##### A. Wind power plant description and representation

To account for the portion of the wind power plant that may have tripped as a result of the disturbance, two generators at node B were used to represent the equivalent generator, as shown in Figure 8. This allows for tripping of part of the wind power plant during the simulation.

In power flow, the output power of the equivalent generators was adjusted to match the total output power measured at the POI (i.e. 115 MW). The equivalent

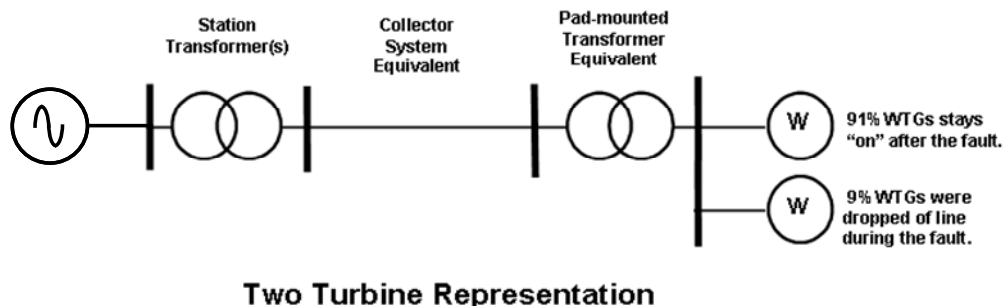

Figure 8. Wind power plant is represented by a two turbine representation.

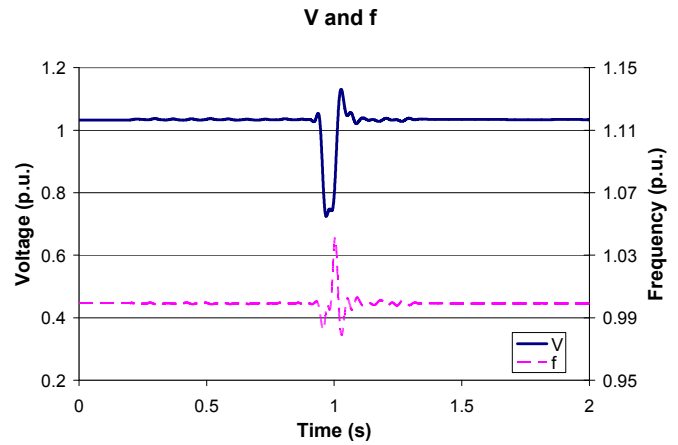

Figure 6 Per unit voltage and frequency during the fault.

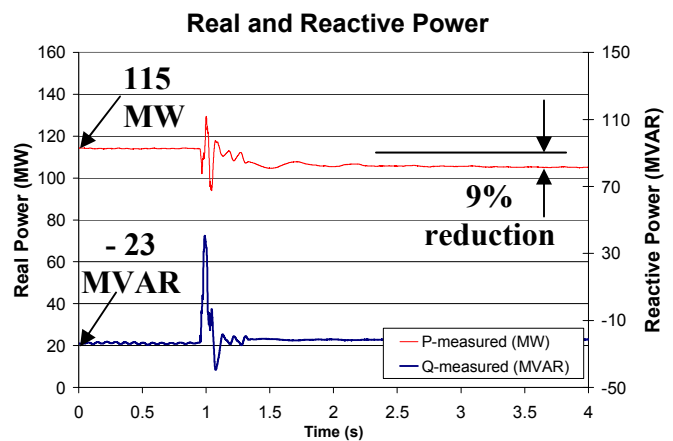

Figure 7. Real and reactive power measured at the POI.

generators are setup to control voltage at node C. Node A is the slack bus, and the scheduled voltage is set to the measured pre-disturbance voltage (i.e., 1.0325 p.u.). The scheduled voltage at node C can be adjusted until the reactive flow matches the measured flow (i.e., -23 MVAR).

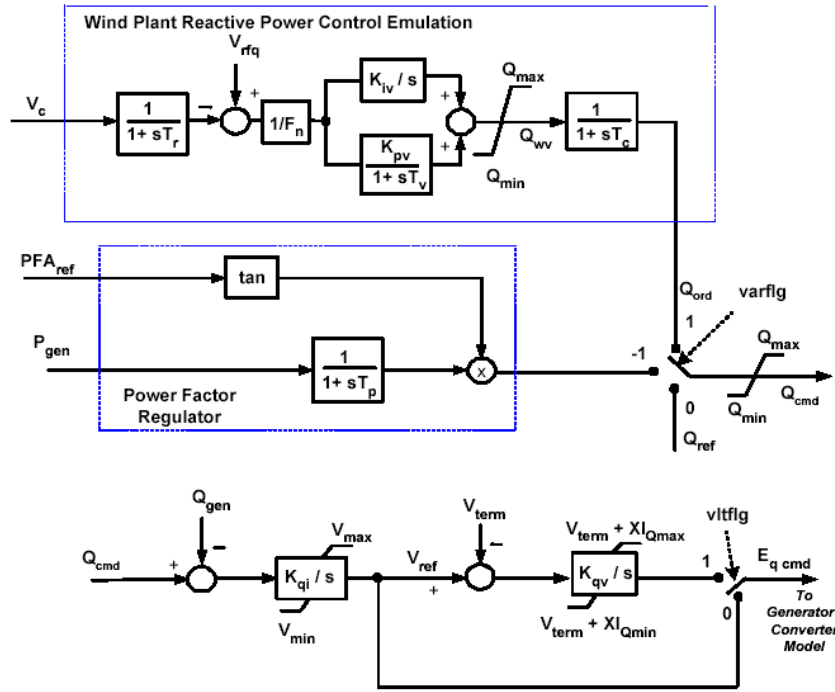

Figure 9. Type 3 WTG Reactive Power Control Model.

### B. Dynamic Simulation

The reactive power control module of the WECC generic DFAG dynamic model (Fig. 9) has the capability that allows for simulation of reactive control modes. As stated before, the wind power plant we are using as an example operates in voltage control mode; therefore, VARFLG is set to 1. Other control modes available are power factor control mode (VARFLG = -1), and reactive power control mode (VARFLG = 0). The vswitch VLTLFG is set to 1, indicating that the reactive power command is constrained by the WTG terminal voltage. Note that a WECC generic model is required for each of the equivalent wind power plant generators represented at Node B. As explained before, a GENCLS model was used for the system generator, with instructions to hold the voltage and frequency in accordance with the disturbance measurements.

A 4 seconds dynamic simulation was conducted with the system setup explained above. The smaller equivalent generator was taken off line during the fault to simulate the observed tripping. The timing at which these turbines trip off line is not recorded, thus, the tripping timing was estimated to be at  $t = 0.99$  seconds.

### C. Comparison of simulated response versus measurements

Figures 10 and 11 compare the simulated real and reactive power response to the measured real and reactive power response at the node A.

Overall, the simulation results follow the measured data closely, especially the reactive power. The simulated response does not reproduce the observed higher-frequency perturbations during the fault; however, these details are of lesser importance in this type of simulation. The generic

dynamic models are not designed to be accurate at that level of detail.

We also simulated the wind power plant in detail, with all 136 turbines and collector system branches. The boundary

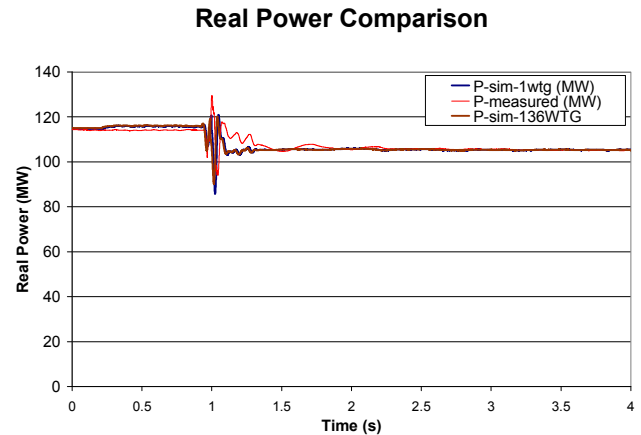

Figure 10. Real power comparison.

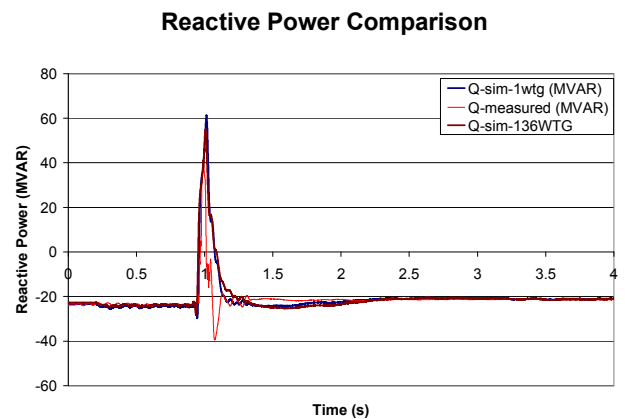

Figure 11. Reactive power comparison.

conditions at the POI were the same as before. The purpose of this exercise was to see the diverse terminal characteristics due to collector system effects resulted in any significant differences with respect to the simplified system representation. The exercise also served to validate the collector system equivalent parameters. The results of that simulation are shown in Figures 10 and 11. Note that there were no significant differences in this particular disturbance."

## V. CONCLUSIONS

This paper presents the methods to validate positive-sequence wind dynamic models. This technique was applied to the WECC generic model as an example.

The validation method described in this paper is applicable for all the four types of wind turbine generators.

The preliminary results of the simulations demonstrated that a generic model of DFIG generators provides an adequate representation of the actual wind turbines under fault conditions. It is also shown that modeling the wind power plant with an equivalent representation preserves the basic response of the wind power plant.

## VI. ACKNOWLEDGEMENT

We acknowledge the support of the U.S. Department of Energy, Public Service Company of New Mexico, and the Western Electric Coordinating Council, and the project funding provided by the California Energy Commission's PIER Program. This work is part of a larger project called WECC Wind Generator Modeling.

## VII. REFERENCES

- [1] E. Muljadi, C.P. Butterfield, A. Ellis, J. Mechenbier, J. Hocheimer, R. Young, N. Miller, R. Delmerico, R. Zavadil, J.C. Smith, "Equivalencing the Collector System of a Large Wind Power Plant", presented at the IEEE Power Engineering Society, Annual Conference, Montreal, Quebec, June 12-16, 2006.
- [2] E. Muljadi, B. Parsons, "Comparing Single and Multiple Turbine Representations in a Wind Farm Simulation," presented at the European Wind Energy Conference (EWEC-2006), Athens, Greece, February 27 – March 2, 2006.
- [3] N. W. Miller, J. J. Sanchez-Gasca, W. W. Price, and R. W. Delmerico, "Dynamic modeling of GE 1.5 and 3.6 MW wind turbine-generators for stability simulations," in Proc. 2003 IEEE Power Engineering Society General Meeting, pp. 1977–1983, June 2003
- [4] J. O. G. Tande, E. Muljadi, O. Carlson, J. Pierik, A. Estanqueiro, P. Sørensen, M. O'Malley, A. Mullane, O. Anaya-Lara, and B. Lemstrom. Dynamic models of wind farms for power system studies—status by IEA Wind R&D Annex 21," European Wind Energy Conference & Exhibition (EWEC), London, U.K., Nov. 22–25, 2004.
- [5] T. Petru and T. Thiringer, "Modeling of wind turbines for power system studies," IEEE Transactions on Power

Systems, Volume 17, Issue 4, Nov. 2002, pp. 1132 – 1139.

- [6] "Generic Type-3 Wind Turbine-Generator Model for Grid Studies", Version 1.1, prepared by WECC Wind Generator Modeling Group, September 14, 2006
- [7] "WECC Wind Power Plant Power Flow Modeling Guide", prepared by WECC Wind Generator Modeling Group, November 2007
- [8] P.C. Krause, Analysis of Electric Machinery, McGraw Hill Co. NY, 1986.

## VIII. BIOGRAPHIES



**Eduard Muljadi** received his Ph. D. (in Electrical Engineering) from the University of Wisconsin, Madison. From 1988 to 1992, he taught at California State University, Fresno, CA. In June 1992, he joined the National Renewable Energy Laboratory in Golden, Colorado.

His current research interests are in the fields of electric machines, power electronics, and power systems in general with emphasis on renewable energy applications. He is member of Eta Kappa Nu, Sigma Xi and a Senior Member of IEEE. He is involved in the activities of the IEEE Industry Application Society (IAS) and Power Engineering Society (PES). He is currently a member of Industrial Drives Committee, Electric Machines Committee, and Industrial Power Converter Committee of the IAS, and a member of the Working Group on Renewable Technologies and the Dynamic Performance of Wind Task Force of the PES. He holds two patents in power conversion for renewable energy.



**Abraham Ellis** received his Ph.D. in Electrical Engineering from New Mexico State University (NMSU) in 2000. He is currently with the Transmission Operations Department at Public Service Company of New Mexico (PNM), where he works on a

wide range of projects related to power system performance analysis, standards development and regulatory matters. Before joining PNM, he worked at NMSU's Southwest Technology Development Institute in the area of renewable energy applications. Currently, Dr. Ellis serves as chair of Western Electricity Coordinating Council's Wind Generator Modeling Group. He is a Senior Member of the IEEE and is a registered Professional Engineer in the State of New Mexico.



# REPORT DOCUMENTATION PAGE

*Form Approved*  
OMB No. 0704-0188

The public reporting burden for this collection of information is estimated to average 1 hour per response, including the time for reviewing instructions, searching existing data sources, gathering and maintaining the data needed, and completing and reviewing the collection of information. Send comments regarding this burden estimate or any other aspect of this collection of information, including suggestions for reducing the burden, to Department of Defense, Executive Services and Communications Directorate (0704-0188). Respondents should be aware that notwithstanding any other provision of law, no person shall be subject to any penalty for failing to comply with a collection of information if it does not display a currently valid OMB control number.

**PLEASE DO NOT RETURN YOUR FORM TO THE ABOVE ORGANIZATION.**

<b>1. REPORT DATE (DD-MM-YYYY)</b> July 2008		<b>2. REPORT TYPE</b> Conference Paper		<b>3. DATES COVERED (From - To)</b>		
<b>4. TITLE AND SUBTITLE</b> Validation of Wind Power Plant Dynamic Models: Preprint			<b>5a. CONTRACT NUMBER</b> DE-AC36-99-GO10337			
			<b>5b. GRANT NUMBER</b>			
			<b>5c. PROGRAM ELEMENT NUMBER</b>			
<b>6. AUTHOR(S)</b> Eduard Muljadi and Abraham Ellis			<b>5d. PROJECT NUMBER</b> NREL/CP-500-43667			
			<b>5e. TASK NUMBER</b> WW1K1000			
			<b>5f. WORK UNIT NUMBER</b>			
<b>7. PERFORMING ORGANIZATION NAME(S) AND ADDRESS(ES)</b> National Renewable Energy Laboratory 1617 Cole Blvd. Golden, CO 80401-3393				<b>8. PERFORMING ORGANIZATION REPORT NUMBER</b> NREL/CP-500-43667		
<b>9. SPONSORING/MONITORING AGENCY NAME(S) AND ADDRESS(ES)</b>				<b>10. SPONSOR/MONITOR'S ACRONYM(S)</b> NREL		
				<b>11. SPONSORING/MONITORING AGENCY REPORT NUMBER</b>		
<b>12. DISTRIBUTION AVAILABILITY STATEMENT</b> National Technical Information Service U.S. Department of Commerce 5285 Port Royal Road Springfield, VA 22161						
<b>13. SUPPLEMENTARY NOTES</b>						
<b>14. ABSTRACT (Maximum 200 Words)</b> This paper discusses the process of wind model validation against field measurements.						
<b>15. SUBJECT TERMS</b> dynamic model; power system; renewable energy; variable-speed generation; weak grid; wind energy; wind farm; wind power plant; wind turbine; wind integration; systems integration; WECC; wind turbine model; validation.						
<b>16. SECURITY CLASSIFICATION OF:</b>			<b>17. LIMITATION OF ABSTRACT</b>  UL	<b>18. NUMBER OF PAGES</b>	<b>19a. NAME OF RESPONSIBLE PERSON</b>	
<b>a. REPORT</b> Unclassified	<b>b. ABSTRACT</b> Unclassified	<b>c. THIS PAGE</b> Unclassified			<b>19b. TELEPHONE NUMBER (Include area code)</b>	

Standard Form 298 (Rev. 8/98)  
Prescribed by ANSI Std. Z39.18