

METHOD 8520

CONTINUOUS MEASUREMENT OF FORMALDEHYDE IN AMBIENT AIR

1.0 SCOPE AND APPLICATION

1.1 This method is applicable to the continuous measurement of formaldehyde (CAS No. 50-00-0) in ambient air. This method is for use primarily for nonoccupational exposure monitoring.

1.2 This method is applicable to concentrations of formaldehyde from 6 to 500 $\mu\text{g}/\text{m}^3$. Detection limits are dependent on sample airflow rate, with a maximum rate set at 1.0 L/min.

1.3 This method is restricted to use by or under the supervision of trained analysts. Each analyst must demonstrate the ability to generate acceptable results with this method.

2.0 SUMMARY OF METHOD

2.1 A modified portable commercial analyzer which consists of a small diaphragm pump, an analytical module, a colorimeter with glass flow cells, a peristaltic pump and tubing, and a 12 volt rechargeable battery for optional DC power operation is used for this method (See Figure 1). An acidified pararosaniline scrubber solution is pumped through the reference cell in the colorimeter and is then diluted 1:1 with a liquid flow stream containing water. The diluted solution then passes into an air scrubber coil where formaldehyde is quantitatively absorbed from the air sample stream. After the liquid and air are separated, the sample solution is mixed 1:1 with a dilute aqueous Na_2SO_3 reagent. A series of time delay coils allow 16 minutes for color development of the chromophore. The colored product is continuously detected as it passes through the sample cell by a UV-Visible spectrophotometer set at 550 nm and is recorded on a strip chart recorder or an automated data acquisition system.

3.0 INTERFERENCES

3.1 Method interferences may be caused by contaminants in reagents, glassware, and sample processing hardware.

3.1.1 Glassware must be scrupulously cleaned. Clean all glassware as soon as possible after use by rinsing with the last solvent used. This should be followed by detergent washing with hot water, and rinses with tap water and organic-free reagent water. It should then be drained dry, and heated in a laboratory oven at 130°C for several hours before use. Solvent rinsing may be substituted for the oven heating. After drying and cooling, glassware should be stored in a clean environment, covered with aluminum foil to prevent any accumulation of dust or other contaminants.

3.1.2 All of these materials and equipment must be routinely demonstrated to be free from interferences under the conditions of the analysis by establishing the analyzer baseline with the introduction of a source of zero air (zero grade compressed air) at the sample inlet.

3.1.3 Instrument Cleaning

3.1.3.1 Reagent Lines - To ensure optimum performance of the analyzer, the three reagent lines should be placed in a reservoir containing 1.0 M nitric acid as a cleaning solution. Operate the analyzer with the zero air supply and pump the cleaning solution through the analyzer for 1 hour. To rinse the lines, pump organic-free reagent water through the system for 2 hours. The cleaning sequence must be performed at frequent intervals (e.g. each second or third day of regular use).

3.1.3.2 Colorimeter Flow Cell - Clean the flow cells by periodically soaking them in commercial bleach or a laboratory detergent solution. After cleaning the cells, rinse them well with organic-free reagent water.

3.2 Although there is some disagreement concerning the mechanism involving the formation of the final product in the reaction between pararosaniline and formaldehyde, it is generally agreed that the chromophore is an alkylsulfonic acid. (Refs. 1,3) Studies have shown that the color-forming reaction of the modified pararosaniline procedure is highly specific to formaldehyde.

3.2.1 Low molecular weight aldehydes exhibit positive interferences, but only when present in large excess over formaldehyde.

3.2.2 Sulfur dioxide, at a concentration of 520 $\mu\text{g}/\text{m}^3$, produces a slight negative interference.

3.3 Sensitivity and color development time are functions of temperature. Good results may be obtained for operating temperatures between 15 and 35°C (with optimum results at 25°C) by performing daily instrument calibrations.

3.4 Baseline drift is negligible, or less than $\pm 2\%$ of full scale after 8 hours of continuous operation, under normal conditions. Periodic baseline checks should be performed to ensure accuracy.

3.5 Low-concentration aqueous formaldehyde standard solutions of 0.02 to 2.0 $\mu\text{g}/\text{mL}$ and dilute sodium sulfite reagent solutions exhibit a limited stability and therefore must be prepared daily.

3.6 The use of high purity reagents and solvents helps to minimize interference problems.

4.0 APPARATUS AND MATERIALS

4.1 Continuous Air Monitor

4.1.1 Automated Wet-chemical Colorimetric Analyzer - CEA Instruments Model TGM 555 air monitor equipped with AMK-4 formaldehyde analytical module or equivalent. The TGM 555 analyzer is equipped with a dual beam colorimeter, set at 550 nm, consisting of glass reference and sample flow cells, a matched pair of photodetectors, a miniature tungsten-halogen lamp, and a signal processing unit. The colorimeter measures the difference in light absorption of the pararosaniline chloride reagent before and after it reacts with formaldehyde.

4.1.2 Spare Parts - A spare parts maintenance kit is available from CEA or the following equipment may be purchased.

4.1.2.1 Silicon rubber peristaltic pump tubes (T-78) - Pump tubes should be replaced after 30 to 45 days of continuous use.

4.1.2.2 Rubber diaphragm in the miniature air pump - The diaphragm should be replaced whenever it becomes worn or defective.

4.1.2.3 Tungsten-halogen colorimeter lamp

4.1.3 Glass Coils (3 mm OD) and Connectors - These are required for modifications of the analytical module to increase residence time for the reactants. The standard version of the AMK-4 analytical module (2 x 25 turn coil) contains a residence mixing time of less than 6 minutes, as measured from the glass double mixing tee to the entrance of the sample cell. By adding additional mixing coils (an additional 120 turns) the residence mixing time was increased to 16 minutes (absorbance reached a maximum when the residence time of the reactants was about 16 minutes or longer). These parts are used extensively in segmented flow colorimetric analyzers such as Technicon Instruments Corporations Autoanalyzer II or an equivalent.

4.1.4 Glass Debubbler - A second glass debubbler was added just ahead of the entrance to the sample cell to overcome the increased frictional drag on the system. The top exit of the debubbler was attached to a T-78 silicon rubber tube on the peristaltic pump so that all of the air between the sample segments is drawn away to waste and approximately 95% of the sample liquid is pushed into the sample cell for measurement. Further, by inverting the glass double mixing tee so that the sample stream enters from the top and the Na_2SO_3 reagent enters from below, smoother operation (i.e., a more regular bubble pattern) resulted. All connections from the exit of the glass double mixing tee to the entrance of the sample cell are 3 mm OD glass tubing.

4.2 Zero Air Supply

4.2.1 A regulated, zero grade compressed air cylinder with connections to the instrument sample inlet through a tee fitting to permit atmospheric dumping of the excess air supply.

4.2.2 Alternatively, formaldehyde-free air may be obtained by scrubbing ambient air through a series of 3 midget impingers, each containing 15 mL of 0.05 M sulfuric acid, followed by a silica-gel packed cartridge for drying the airstream. The impinger solutions should be replaced daily.

NOTE: Avoid the use of organic vapor filters which may be supplied with a commercial instrument. These filters have proven to be unsuitable for use at formaldehyde concentrations less than $500 \mu\text{g}/\text{m}^3$.

4.2.3 Polytetrafluoroethylene (PTFE) Tubing and Valves - FEP tubing with a 0.25 in. OD and a 3-way PTFE valve for switching (manual or solenoid) between the zero air supply and the ambient air sample stream.

4.3 Data Acquisition System - Data acquisition may be accomplished with a manual strip chart recorder or an automated data acquisition system.

4.4 Glassware

4.4.1 Volumetric Flasks, class A - 1 L, 250 mL, and other various sizes.

4.4.2 Pipets, class A - various sizes

4.4.3 Mohr Pipets - 1.0 mL with 0.01 mL graduations

4.4.4 Soap Bubble Flowmeter - 500 mL

4.5 Thermometer - to check the temperature at the time of sampling.

5.0 REAGENTS

5.1 Reagent-grade chemicals shall be used in all tests. Unless otherwise indicated, it is intended that all reagents shall conform to the specifications of the Committee on Analytical Reagents of the American Chemical Society, where such specifications are available. Other grades may be used, provided it is first ascertained that the reagent is of sufficiently high purity to permit its use without lessening the accuracy of the determination.

5.2 Organic-free Reagent Water - All references to water in this method refer to organic-free reagent water, as defined in Chapter One.

5.3 Formaldehyde, CH_2O - ACS certified or assayed 36.5% solution (w/w), store at room temperature and protect from light.

5.4 Hydrochloric acid solution, HCl in water - 2.0 M

5.5 Nitric Acid solution, HNO_3 in water - 1.0 N

5.6 Sodium sulfite, Na_2SO_3 - ACS certified, anhydrous crystal

5.7 2.78 mM Sodium sulfite solution - Dissolve 0.175 anhydrous sodium sulfite crystal in 500 mL of water. This solution should be protected from light during use and must be prepared daily.

5.8 Pararosaniline chloride (Basic Fuchsin), $\text{C}_{20}\text{H}_{20}\text{N}_3\text{Cl}$ - specially purified, 0.2% (w/v) in 1 M HCl (Fisher Scientific, or equivalent).

5.9 1.72 mM Pararosaniline chloride in 0.8 M HCl

5.9.1 Using a 100 mL graduated cylinder, measure and combine 68.5 mL of the stock pararosaniline chloride solution with 66 mL of 2.0 M HCl solution in a 250 mL volumetric flask.

5.9.2 Dilute the mixture with water to a final volume of 250 mL.

5.9.3 This solution should be protected from light during use. The solution may be stored up to 3 months if kept at 4°C and protected from light.

NOTE: The rate of consumption of the 2.78 mM sodium sulfite solution and the 1.72 mM pararosaniline chloride solution is 0.6 L per 24 hours at routine analyzer operation rate of 0.40 mL/min. After mixing the three solutions together with

glass double mixing tee, the final concentration of the reactants should be 0.43 mM Pararosaniline, 0.2. M HCl, and 1.39 mM Na₂SO₃.

5.10 Formaldehyde Stock Standard Solution - Add approximately 2.1 g of 37% formaldehyde solution, weighed to the nearest ± 0.1 mg, to a 1 L volumetric flask and dilute to the mark to make a solution of approximately 777 $\mu\text{g/mL}$. Determine the actual concentration of the solution using Method 8315. The stock standard formaldehyde solution is stable for up to 1 year if it is protected from the light and stored at 4°C.

5.11 Secondary Formaldehyde Standard Solutions - Prepare 2 more solutions by two 25:1 serial dilutions of the stock standard solution with water to approximately 31.1 and 1.24 $\mu\text{g/mL}$. If the concentration of the formaldehyde stock solution is not 777 $\mu\text{g/mL}$, the actual concentration of the secondary standards must be calculated. If the solution are kept in the dark and at 4°C, the 31.1 $\mu\text{g/mL}$ standard may be stored for 3 months and the 1.24 $\mu\text{g/mL}$ standard may be stored for 7 days.

5.12 Formaldehyde Calibration Standard Solutions - Prepare 3 calibration standards with concentrations ranging from approximately 0.03 to 1.24 $\mu\text{g/mL}$. Formaldehyde concentration in the above range are equivalent to air concentrations from 11.2 to 492 $\mu\text{g/m}^3$. Working standards must be prepared daily.

6.0 SAMPLE COLLECTION

6.1 Start-up Procedure

NOTE: The signal response for a 100 ppbv liquid standard remained unchanged for the temperatures in the 20-30°C range. Check the temperature before analysis to assure environment to be analyzed is within the proper temperature range.

6.1.1 Activate the AC power switch and the DC power switch which supplies power to the colorimeter lamp and LED digital display panel. Power to the colorimeter lamp should be left on continuously during periods of regular use to maintain the thermal stability of the unit.

6.1.2 Allow a minimum 2 hour warm-up period before starting the analyzer. During periods of intermittent regular use, keep the AC and DC power switches on continuously, in order to minimize start-up time.

6.1.3 Set the Range switch to the "low" position and the Damp switch to the "high" position.

6.1.4 Install the 7 peristaltic pump tube lines in their proper sequence on the pump rollers. Place the 3 reagent lines in a water reservoir, then switch the sample air inlet valve to the zero air supply position.

6.1.5 Activate the Liquid Flow switch, to start the reagent pump and, at the same time, turn on the Air Flow switch to start the air pump (using the zero air supply). Pump water for 20 to 30 minutes to allow the system flows to stabilize and to verify trouble-free operation.

6.1.6 Deactivate the liquid flow pump and the airflow pump. Place each of the reagent lines in its proper reagent reservoir and restart both pumps. Again, using the zero air supply, allow the reagents to pump through the analyzer for 20 to 30 minutes.

6.1.7 Follow the operational manual procedure for manual adjustment of the optical zero on the colorimeter (if necessary). Use the zero potentiometer to make fine adjustments for setting the baseline response to a zero setting on the display panel. The span potentiometer should be adjusted to the maximum (10.0) setting for most low-concentration formaldehyde measurements.

6.1.8 Activate the strip chart recorder (or data acquisition system) and adjust the baseline response to read 5 to 10 percent of the full scale response. The selection of the full-scale voltage output range depends on the sensitivity required for the particular monitoring application. A 1.0 volt signal response corresponds to approximately $120 \mu\text{g}/\text{m}^3$ formaldehyde in the sample airstream.

6.1.9 Monitor the baseline response of the instrument for 10 to 15 minutes to verify that the signal is stable.

6.2 Routine Operating Procedure

6.2.1 After the instrument baseline has stabilized using the zero air supply, initiate the multipoint calibration procedure (as in Sec. 7.1.3) using the fresh liquid equivalent formaldehyde standard solutions from Sec. 5.11.

6.2.2 After sampling the final liquid standard in the calibration sequence, return the reagent line that is pumping the calibration solutions to the water reservoir and reestablish the instrument baseline.

6.2.3 Record the chart speed and the exact starting time. Begin monitoring the sample atmosphere by switching the sample air inlet valve from the zero air supply to the air sample position. After a lag time of 18 minutes, the instrument will respond quickly (1 to 2 minutes) to the concentration of formaldehyde in the airstream.

6.2.4 Conduct periodic baseline and calibration checks at intervals appropriate to the particular operating characteristics of each analyzer system (see Sec. 7.1.3) and the specific monitoring application.

6.3 Shutdown Procedure

6.3.1 With the sample inlet valve in the zero air supply position and with the monitor in operation, place all 3 of the reagent lines in a reservoir containing water.

6.3.2 Pump water through the instrument for 30 minutes, then, shut off both the liquid flow pump and the airflow pump. Remove the 7 pump tubes from the peristaltic pump rollers if the instrument is to remain shut down for more than 3 hours.

6.3.3 Deactivate the zero air supply (if necessary) and secure the reagent reservoirs for proper storage. Properly dispose of the contents of the waste reservoir in accordance with acceptable environmental procedures.

6.3.4 Keep the colorimeter lamp on unless the instrument is to remain inactive for 7 days or more.

6.4 Analysis of Data

6.4.1 Determine the height of each peak or plateau in the analysis data by measuring from the established baseline.

6.4.2 Determine the time at which any peaks or plateaus occurred during the sampling analysis period.

6.4.3 Using the equation of the calibration curve determined in Sec. 6.2.1, calculate the concentration of the formaldehyde in the air sample. (see Sec. 7.3.2)

7.0 PROCEDURE

7.1 Calibration

7.1.1 Calibration of the Air Pump

7.1.1.1 Using the guidelines in the instrument operating manual, adjust the stroke and electric motor speed to produce a sample airflow rate of approximately 1.0 L/min. (Ref. 5)

7.1.1.2 Using a 500 mL soap bubble flowmeter or other airflow rate calibration device and the airflow control potentiometer, fine tune the airflow rate so that it is calibrated to the nearest 1.0 mL/min.

7.1.1.3 The air pump should be recalibrated every 30 days during regular operation, whenever the pump diaphragm is replaced, or whenever there is a change in operational airflow rate.

7.1.2 Flow Rate of the Formaldehyde Standard Peristaltic Pump Tubing - With analyzer operating normally, connect a 1.0 mL Mohr pipet, with 0.01 mL graduations, in line with the formaldehyde solution delivery tube. Calculate the actual liquid flow rate, to the nearest 0.01 mL/min, by timing small air bubbles introduced into the flow stream as they pass through a fixed volume in the pipet. Recalculate the flow rate after every 7 days of regular operation or after replacement of the pump tubing.

7.1.3 Colorimeter Calibration

7.1.3.1 Prepare 3 calibration standards which bracket the working range of the instrument using the concentration range given in Sec. 5.11. The lowest concentration should be adjusted to just above the method detection limit. Further, the calibration curve working range must bracket the sample analyte concentration.

7.1.3.2 Sample water for at least 10 minutes to establish a baseline and to be sure the system is clean and interference free.

7.1.3.3 Sample each of the 3 standards for 10 to 15 minutes. Between each calibration standard a water sample should be run for 10 minutes. The calibration standards should be analyzed starting with the lowest concentration and ending with highest concentration.

7.1.3.4 Find the established baseline from the analysis data and measure the height of each of the 3 calibration standard peaks. Plot peak height versus concentration ($\mu\text{g}/\text{m}^3$ liquid standard equivalent) and perform a linear regression analysis of the calibration data to verify linearity.

7.1.3.5 A full 3 point calibration should be performed at least once a week during routine operation. Analysis of a single mid-range calibration standard must be performed as a check at the beginning and end of any sampling period. A mid-range calibration standard must also be analyzed once every 4 hours to verify instrument calibration.

NOTE: It is possible to calibrate the TGM 555 analyzer using gaseous formaldehyde standards, however, the procedures required to produce accurate, dynamic, low-concentration standard mixtures in air are non-routine. The techniques developed for use in evaluating this procedure employ a 3-stage dynamic gas dilution system coupled with a constant-rate vapor generation assembly containing a trioxane permeation tube (VICI Medtronics Dynacal permeation device or equivalent) that is maintained at 55°C (See Appendix A). Trioxane vapor is converted stoichiometrically to formaldehyde vapor using a special high-temperature (160°C) catalytic converter assembly. (Ref. 4)

7.2 Determination of Volume to be Sampled - In this method, the volume of ambient air to be sampled is dependent on the fact that the air must be mixed at a certain rate with water. This aqueous solution is then mixed at a certain rate with a reactant to form the chromophore which gives an immediate (after a short time delay) and continuous determination of the target analyte. The sampling rate set for this equipment has been established at about 1.0 L/min. See Sec. 8.4 and Table 2 for information regarding tests to determine the bias of the monitoring system.

7.3 Calculations

7.3.1 Determination of Equivalent Concentration, C_{eq} in units of $\mu\text{g}/\text{m}^3$, of Liquid Formaldehyde Standard Solution.

$$C_{\text{eq}} = \frac{(C_{\text{std}})(\text{LFR})}{(\text{AFR})(\text{AE})}$$

Where:

- C_{std} = Concentration of standard solution in $\mu\text{g}/\text{mL}$
- LFR = Liquid flow rate calculated in Sec. 7.1.2 in mL/min
- AFR = Air flow rate calculated in Sec. 7.1.1 in m^3/min
- AE = Absorption efficiency of the air scrubber coil
(AE = 100% or 1.0 for this procedure)

7.3.2 Determination of Formaldehyde Concentration, X, in Air Samples.

$$X = \frac{(Y - b)}{m}$$

where:

- Y = Height of peak or plateau from analysis data.
- b = The Y intercept of the calibration line from linear regression.
- m = The slope of the calibration line from linear regression.

8.0 QUALITY CONTROL

8.1 Refer to Chapter One and Method 8000 for specific quality control procedures.

8.2 Method Blank - The analysis system is zeroed using a regulated source of zero grade air. This "zero air supply" allows the analyzer to establish a baseline response, help zero the colorimeter, and calibrate the system.

8.3 Calibration Blank - Analyze a blank between each calibration standard.

8.4 Precision and Bias

8.4.1 The precision of replicate liquid equivalent standard analyses should be ± 5 percent, for the determination made within a 24 hour period.

8.4.2 For day to day standard determinations, the precision should be better than ± 10 percent of the calculated known value for the standards. (Ref. 4)

8.4.3 If the analyzer performance does not exceed or meet these requirements, instrument recalibration procedures are required.

9.0 METHOD PERFORMANCE

9.1 Method Sensitivity

9.1.1 Accurate determination of the sensitivity of this procedure is complicated because of the difficulty involved in reproducing dynamic test mixtures at less than $12 \mu\text{g}/\text{m}^3$. (Ref. 4) Very low ambient concentrations, on the order of $6 \mu\text{g}/\text{m}^3$, produce a measurable response (about 10% of the full scale) on the analyzer; however, the precision of such measurements has not been determined.

9.1.2 As the volume of the air sampled is increased, the sensitivity of the method increases proportionally. The standard operating airflow rate for the analyzer is between 0.5 L/min and 1.0 L/min.

9.2 Typical data obtained from a multipoint calibration of the monitor, using a 1.0 volt full-scale output range on the recorder and an airflow rate of 1.0 L/min on the analyzer, is shown in Table 1. (Ref. 4)

9.3 Determination of Bias

9.3.1 Tests performed to measure the bias of this procedure were conducted with a laboratory gas dilution system capable of generating dynamic test mixtures of formaldehyde vapor in air, at flow rates up to 5.0 L/min and concentrations in the range from 12 to 500 $\mu\text{g}/\text{m}^3$. (Ref. 4) The output of the heated permeation tube was determined, at weekly intervals, by accurate weighing on a calibrated analytical balance. See Table 2 for test results.

9.3.2 The results of the tests listed in Table 2 determined that the accuracy of the permeation tube output was on the order of ± 3.5 percent and the accuracy of the several flow calibration devices used to generate the test mixtures is on the order of ± 5 percent. These accuracy results do not indicate that the modified CEA analyzer procedure displays any significant bias.

10.0 REFERENCES

1. Miksch, R.R., Anthon, D.W., Fanning, L.Z., Hallowell, C.D., Revzan, K., and Glanville, J., "Modified Pararosaniline Method for the Determination of Formaldehyde in Air," *Analytical Chemistry*, Vol. 53, 1981, pp. 2118-2123.
2. Lyles, G.R., Dowling, F.B., and Blanchard, V.J., "Quantitative Determination of Formaldehyde in the Parts Per Hundred Million Concentration Level," *Journal of the Air Pollution Control Association*, Vol. 15, 1965, pp. 106-108.
3. West, P.W. and Gaeke, G.C., "Fixation of Sulfur Dioxide as Disulfitomercurate (II) and Subsequent Colorimetric Estimation," *Analytical Chemistry*, Vol. 28, 1956, pp. 1816-1819.
4. Fortune, C.R., Daughtrey, E.H., and McClenny, M.A., "Development of a Portable Continuous Monitor for trace levels of Formaldehyde in Air," in *Proceedings of the Annual Meeting of the Air and Waste Management Association*, June 25-30, 1989, Anaheim, CA, Paper No. 89.81.2.
5. Instrument Operational Manual, CEA Instruments, Inc., 16 Chestnut St., P.O.Box 303, Emerson, N.J. 07630, Model TGM 555-FO.
6. "Standard Test Method for Continuous Measurement of Formaldehyde in Air," Annual Book of ASTM Standards, D5221.

TABLE 1.

MODIFIED CEA MONITOR MULTIPOINT CALIBRATION DATA^{a,b}
(For formaldehyde liquid standard concentrations versus CEA monitor readings)

HCHO Liquid Std. Equivalent ($\mu\text{g}/\text{m}^3$)	CEA Monitor Reading (% of full scale)	Recorder Response (mm)
30.9	26.1	65
61.7	51.7	129
92.5	77.2	193
123.4	101.3	253

^a Analysis performed using a 1.0 volt full-scale output range on the recorder and an air flow rate of 1.0 L/min.

^b Calculated regression coefficients are slope = 0.8144, y-intercept = 1.26, and correlation coefficient (r) = 0.99989.

TABLE 2.

EXAMPLE OF CEA MONITOR DILUTION SYSTEM MEASUREMENTS^a

Dilution System Flow Rates (L/min)				HCHO Conc. ($\mu\text{g}/\text{m}^3$)		
Primary	Secondary	Gas Removal	Total	Calculated	Measured	% Recovery
2.000	0	0	2.200	124.7	124.5	99.8
2.775	0	0	2.975	92.3	87.9	95.2
3.800	0	0	4.000	68.6	65.1	94.9
3.800	1.000	1.000	4.000	51.4	48.2	93.8
3.800	2.000	2.000	4.000	34.3	30.0	87.5
3.800	3.000	3.000	4.000	17.2	10.9	63.4

^a Measurements were performed on 2-7-89 with the standard delivery system operating at an output rate of 274 ± 10 ng/min formaldehyde.

^b Regression analysis of these measurement data taken at 6 air concentrations resulted in: slope = 1.042 and correlation coefficient (r) = 0.99962. The data are presented graphically in Figure 2.

FIGURE 1.

FLOW DIAGRAM OF FORMALDEHYDE ANALYZER

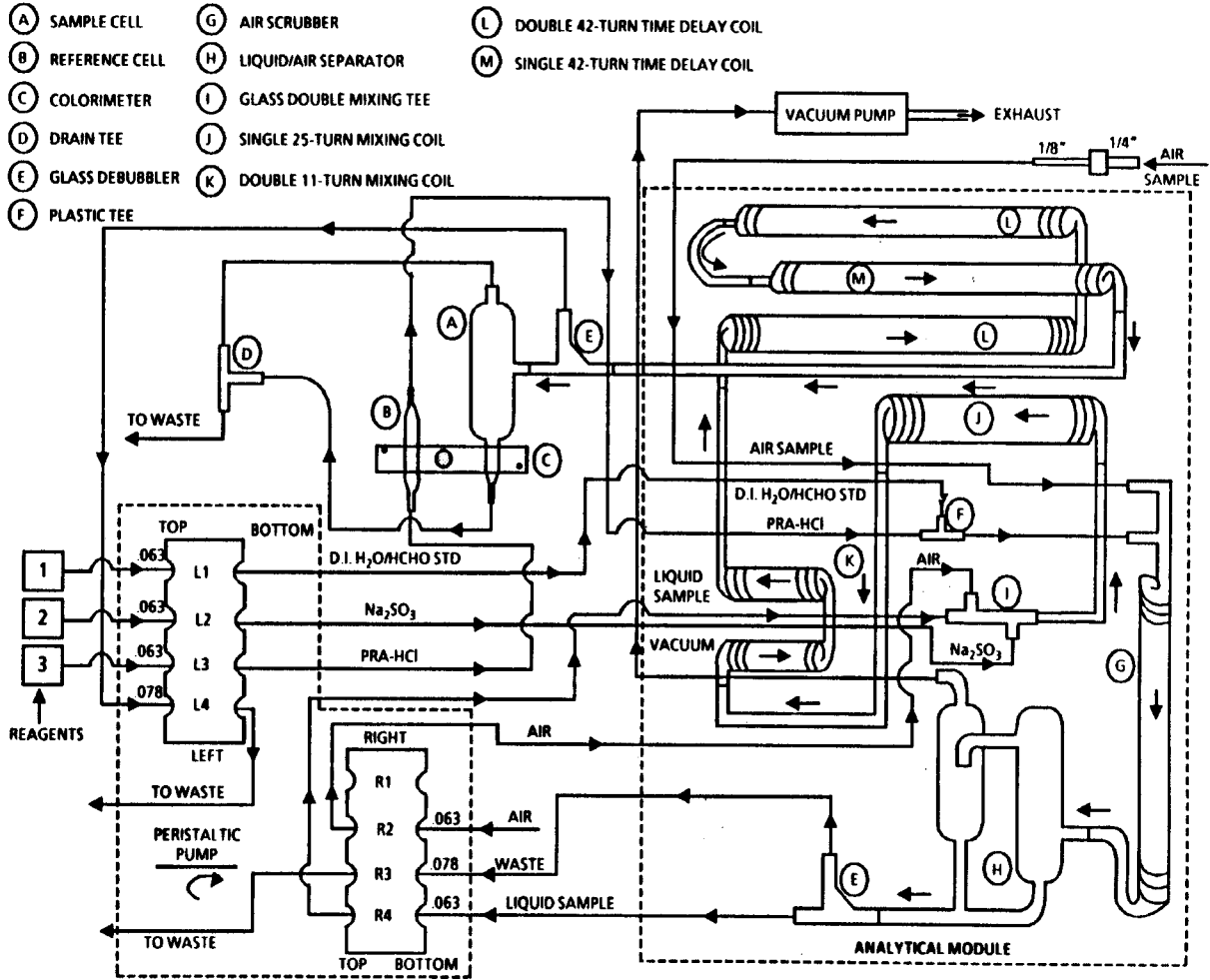
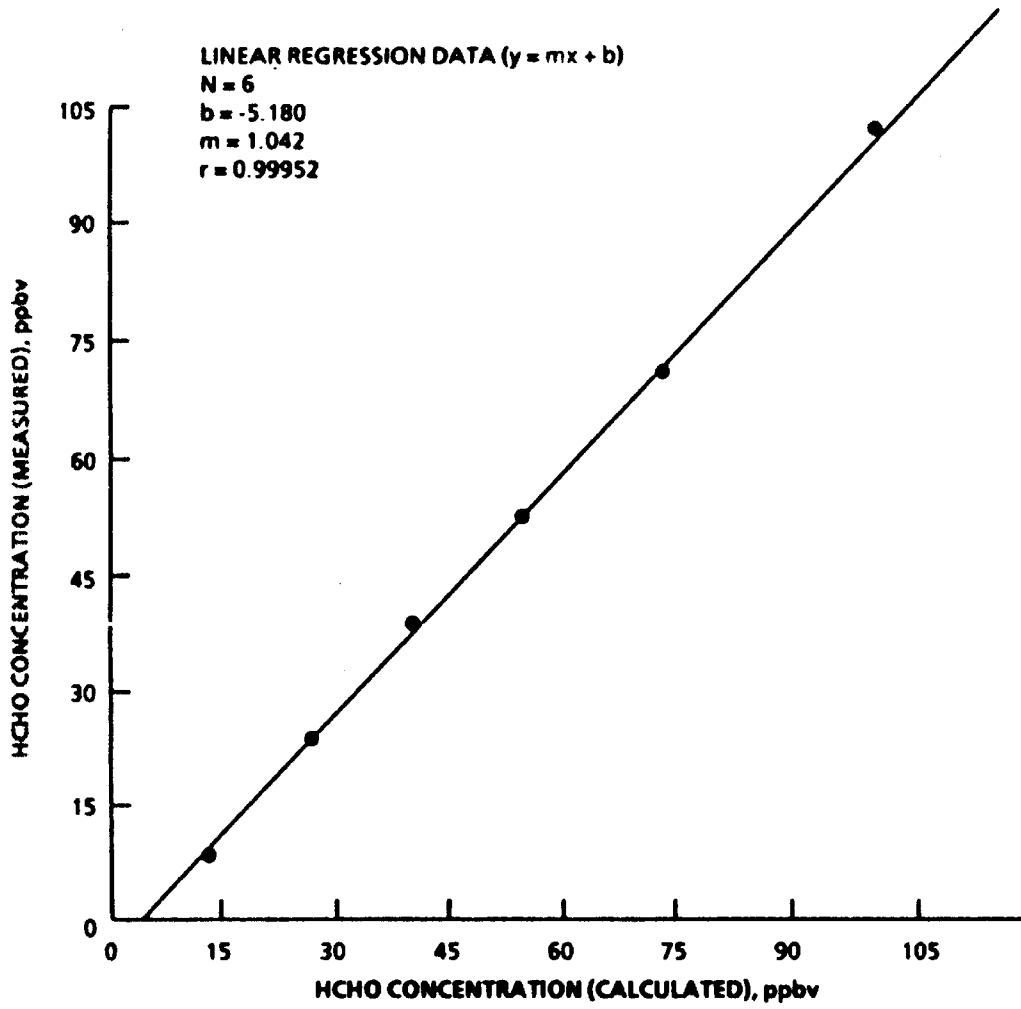
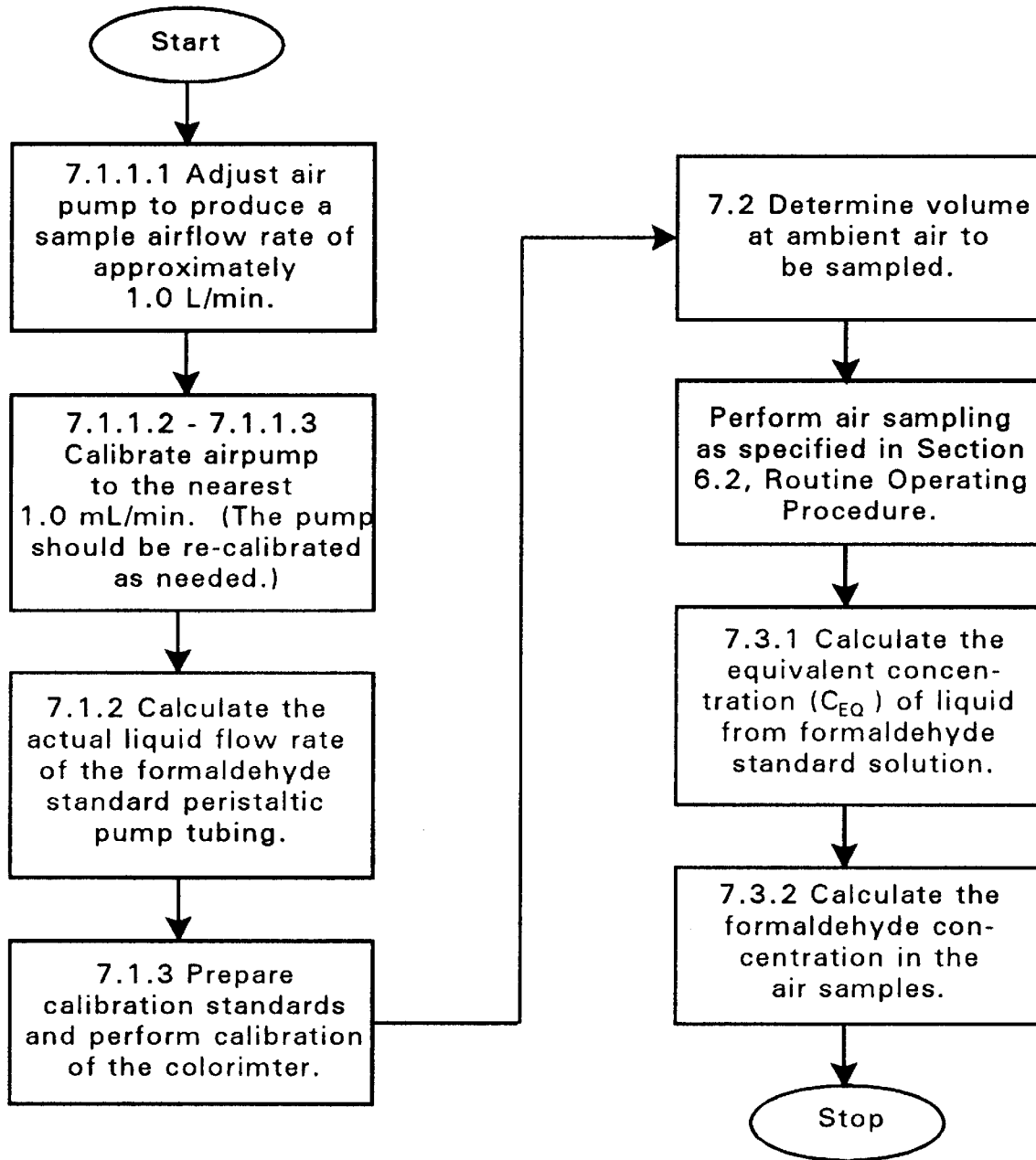

FIGURE 2.

CEA MONITOR DILUTION MANIFOLD MEASUREMENTS



CONTINUOUS MEASUREMENT OF FORMALDEHYDE IN AMBIENT AIR



APPENDIX A

FORMALDEHYDE VAPOR STANDARD GENERATOR

A.1 A laboratory apparatus may be constructed to produce a continuous, steady-state mixture of formaldehyde vapor at part-per-billion-by-volume (ppbv) concentrations. The apparatus consists of a clean air generator system, a gas dilution system, and a formaldehyde vapor generator. These three components are shown in Figures 1A, 2A, and 3A, respectively.

A.2 Primary Dilution Air Supply

A.2.1 An in-house compressed air supply is connected to a dual silica-gel cartridge assembly for moisture removal (Figure 1A). Use of the appropriate valves and tube fittings permits easy replenishment of spent cartridges while maintaining continuous operation of the system.

A.2.2 The flow of dry air to the dilution manifold is regulated by a mass flow controller (Tylan Model FC 260 or equivalent) calibrated for a 0-5.0 L/min operating range.

A.2.3 The dry air is purified with a 400 cm³ capacity gas purifier (Alltech Assoc. or equivalent). The front half of the purifier is filled with activated charcoal to remove organic vapors, and the back half is filled with 13X molecular sieve to remove any remaining moisture and formaldehyde vapor.

A.2.4 The primary dilution air from this system enters the three-stage gas dilution manifold (Figure 2A) at point (A).

A.3 Three-Stage Dynamic Gas Dilution Manifold

A.3.1 Construction of Manifold

A.3.1.1 The manifold may be constructed by connecting three sections made from high-purity quartz, each of 10 mm ID and about 50 cm length. All connection ports are 1/4 in. OD to permit the use of standard compression fittings (PTFE) to assemble the components.

A.3.1.2 All tubing used throughout the system is FEP (Cole-Parmer or equivalent). The 1/4 in. union fitting used to connect the first and second stages of the manifold may be modified by snugly fitting a short length of 2 mm ID PTFE tubing into the union. This restriction decreases the size of the air passage by about one-half, which increases the air velocity significantly at this point to minimize any potential back-flushing of the secondary dilution air. The manifold assembly was wrapped over its entire length with a resistive wire connected to a variable transformer (output setting = 10%).

A.3.1.3 A K-type thermocouple may be attached to the surface of the third stage of the manifold, and the entire assembly is wrapped with a 1/2 in. thick foam insulation material. The temperature of the manifold should remain constant at 30°C, varying by no more than ±1°C with changes in the room temperature.

A.3.1.4 The exit end of the third-stage distribution manifold is connected to a 4.0 L/min rotameter to permit easy visual determination of the approximate exit flow

velocity. The excess gas flow is continuously vented to the fume hood through the exhaust manifold.

A.3.2 Gas Flow Rates - Gas flow rates into and out of the manifold are regulated by four calibrated mass flow controllers (Tylan Model FC 260 or equivalent) selected in various flow ranges up to 5.0 L·min⁻¹ to suit each requirement. Flow rates are selected and monitored by using a Tylan Model RO-28, or equivalent, readout/control unit. Four 120 cm³ capacity gas purifiers (Alltech Assoc. or equivalent) and four on/off valves (Swagelock, 316 ss, or equivalent) are positioned on either side of the flow controllers.

A.3.3 Formaldehyde Dilution Scheme - The following serial dilution scheme is versatile and responds quickly to adjustments of the flow systems; that is, equilibration is achieved within 1-3 min after adjustments are made. More importantly, this design permits the generation of a tenfold-more-dilute dynamic mixture than a single-stage method using the same volume of gas.

A.3.3.1 A continuous stream of formaldehyde in N₂ (200 cm³/cm) enters the first stage of the manifold at point (B)(Figure 2A), where it is mixed with the primary dilution air (up to 5.0 L/min).

A.3.3.2 Near the end of the first stage, up to 90% of the primary gas mixture may be removed by adjusting the flow controller to the desired second stage of the dilution manifold, secondary dilution of the gas mixture with zero air (\leq 5.0 L/min) may be performed in an analogous manner.

A.3.3.3 The third stage of the dilution manifold is designed with multiple sampling ports, where the fully diluted sample gas stream (generally flowing at 3.0-5.0 L/min) is available for test purposes. The second mass flow controller/purifier assembly connected to the house vacuum line is available for use with an optional extractive sampling method at flow rates less than or equal to 2.0 L/min.

A.3.4 The dilution manifold is connected to the formaldehyde vapor generator and gas dilution system shown in Figure 3A.

A.4 Low-Concentration Formaldehyde Vapor Generator/Gas Dilution System

A.4.1 The formaldehyde vapor generator (Figure 3A) may be fabricated mostly from available spare components and some custom-made glass, quartz, and machined PTFE parts.

A.4.2 A solid aluminum heater block (10.7 cm diameter x 25.4 cm height) is drilled to house the permeation tube holder. An adjacent thermowell is drilled to house a K-type thermocouple and a ceramic insulated RDT sensor for the temperature controller. The aluminum block is wrapped with a heavy-duty (silicone rubber-coated) heat tape, several coils of 1/8 in. copper tubing (to preheat the N₂ carrier gas), and a blanket of foam insulation. This assembly is mounted inside an insulated metal box (29 cm length x 30 cm 18 cm width x 30 cm height). A small opening is cut in the hinged lid to permit removal of the permeation tube holder without opening the box.

A.4.3 The temperature controller (RFL Industries or equivalent) is mounted to the wall inside the insulated compartment to decrease the variability in the set point temperature fluctuations. The externally adjustable controller is set to maintain a set point temperature of 55°C (as measured by the heater block thermocouple).

A.5 Permeation Tube and Holder - The permeation tube holder was constructed from a borosilicate glass vial (2.5 cm ID x 12.5 cm height) with a threaded opening. A threaded closure with a Viton O-ring seal was custom-machined from a solid piece of PTFE. The cap has two openings, each fitted with a 1/8 in. tube fitting. Preheated N₂ enters the holder, passes through a 10.0 cm length of 1/8 in. OD FEP tubing, and sweeps the trioxane vapor from the permeating tubeholder into the phosphoric acid converter. A permeation tube (5.0 cm active length) containing trioxane (mp 64°C) was purchased (Vici Metronics, part No. 100-050-3520, or equivalent). The nominal permeation rate for this device is 680 ng/min cm (±15%) at 90°C. Periodic gravimetric determinations of weight loss over a period of 36 days with this system resulted in a measured rate of about 56 ng/min cm at 55°C.

A.6 Converter

A.6.1 The high-temperature converter for depolymerizing the trioxane vapor may be constructed from an 8.0 cm section of 1.0 cm ID quartz tubing tapered at each end to 1/4 in OD for tubing connections. A 7 mm diameter indentation 2 mm deep was made at the center of the tube for attaching a temperature sensor and thermocouple wire.

A.6.2 The converter catalyst is prepared by saturating 14-mesh silicon carbide boiling chips with 85% phosphoric acid; saturation was ensured by heating for 1 hour and soaking overnight. The quartz tube is packed tightly with catalyst material, and small portions of quartz wool (Refrasil, or equivalent) were used to plug each end.

A.6.3 The converter tube is wrapped with a nickel-chromium heater wire, a layer of high-temperature fiberglass tape, and a double layer of fiberglass insulation wrap. The leads of the heater wire were connected to a variable transformer (output setting = 16%) that is wired to a temperature controller (Omega Engineering, Model 6102-J, or equivalent). The ceramic insulated J-type sensor from the controller and an exposed-junction K-type thermocouple are attached to the converter tube at the same point by using a silicon sealant. The temperature controller set point is adjusted to maintain the catalyst temperature at 160°C.

A.6.4 The outlet end of the converter assembly is connected by a short length of 1/8 in. tubing to the first stage of the dilution manifold; see Figure 2A, point (B).

A.7 Operation - The formaldehyde vapor generator/gas dilution system is maintained in continuous operation. The primary dilution air is normally set at 3.8 L/min and the N₂ carrier gas at 200 cm³/min for a continuous total flow of 4.0 L/min. A digital thermocouple meter with a 10-position selector switch (Omega Engineering, Model DSS-650, or equivalent) is used to monitor the three elevated temperature zones in the system, the CEA monitor analytical module, and the ambient air temperature. A matched set of five exposed-junction K-type thermocouple wires with PFA teflon insulation (Omega Engineering, or equivalent) are used.

FIGURE 1A
PRIMARY DILUTION AIR SUPPLY

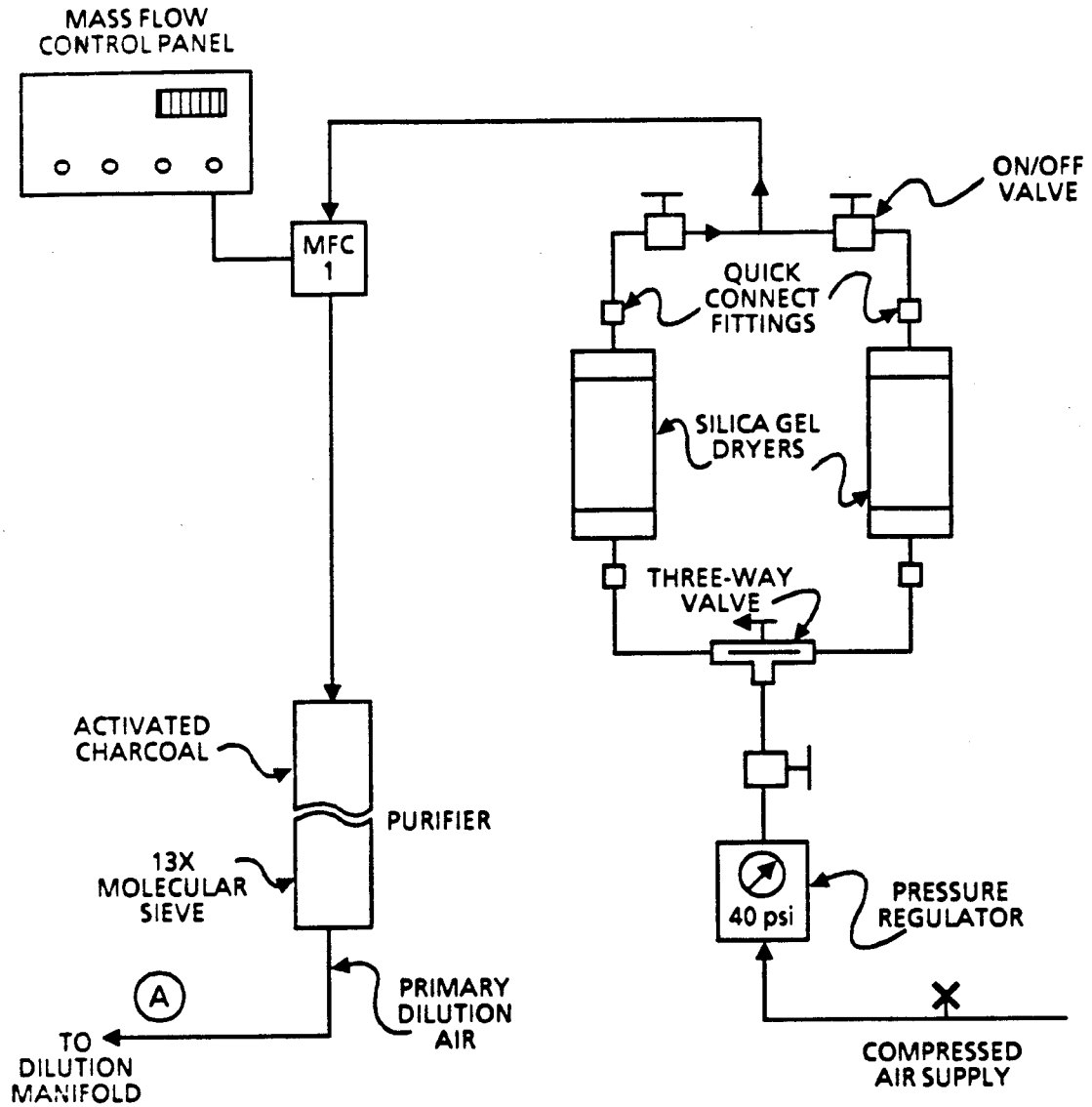

FIGURE 2A

THREE-STAGE DYNAMIC GAS DILUTION MANIFOLD

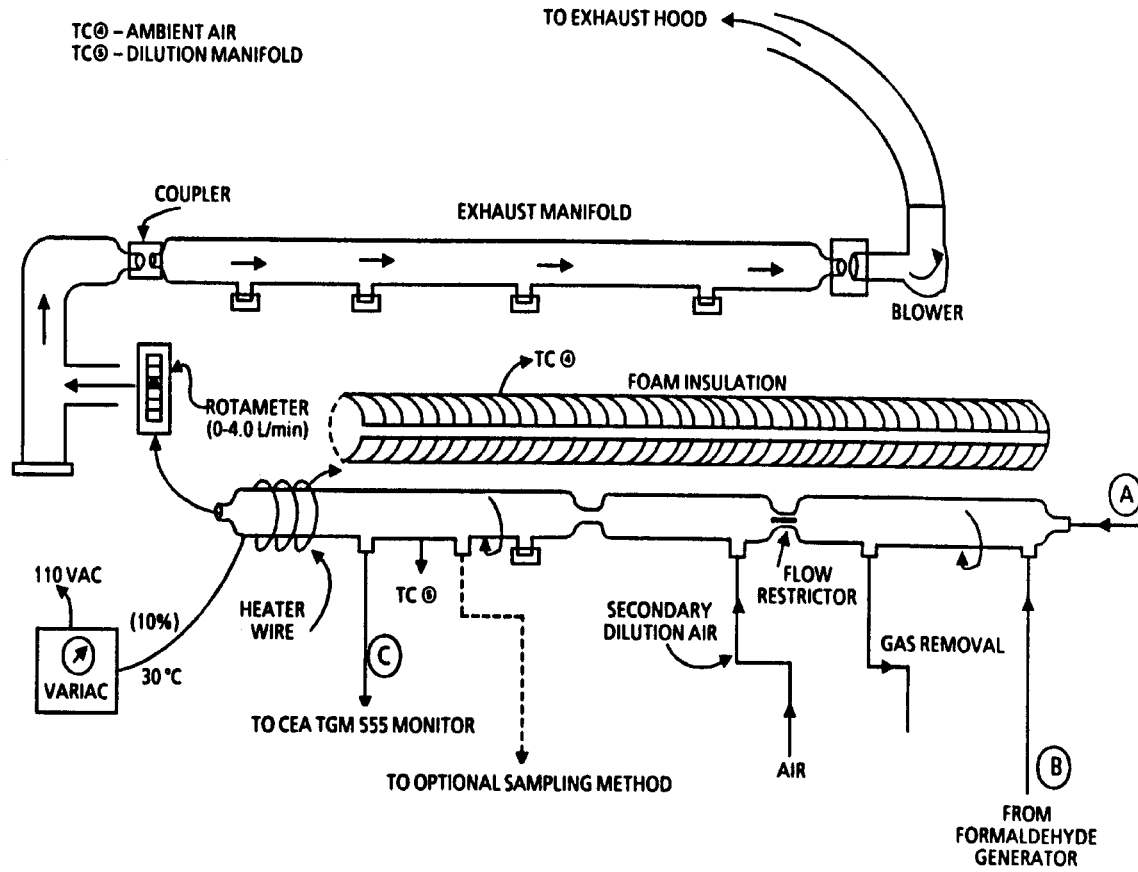

FIGURE 3A

LOW-CONCENTRATION FORMALDEHYDE VAPOR GENERATOR/GAS DILUTION SYSTEM

