



Federal Register

**Monday,
December 20, 2004**

Part IV

Department of Transportation

**National Highway and Traffic Safety
Administration**

**49 CFR Part 571
Federal Motor Vehicle Safety Standards;
Brake Hoses; Final Rule**

DEPARTMENT OF TRANSPORTATION**National Highway Traffic Safety Administration****49 CFR Part 571****[Docket No. NHTSA-2003-14483]****RIN 2127-AH79****Federal Motor Vehicle Safety Standards; Brake Hoses**

AGENCY: National Highway Traffic Safety Administration (NHTSA), Department of Transportation (DOT).

ACTION: Final rule.

SUMMARY: This rule updates the Federal motor vehicle safety standard on brake hoses to incorporate the substantive specifications of several Society of Automotive Engineers (SAE) Recommended Practices relating to hydraulic brake hoses, vacuum brake hoses, air brake hoses, plastic air brake tubing, and end fittings. The agency initiated this rulemaking in response to a joint petition from several brake hose and tubing manufacturers.

DATES: This final rule becomes effective December 20, 2006. The incorporation by reference of certain publications listed in the regulations is approved by the Director of the Federal Register as of December 20, 2006.

Optional early compliance is permitted as of February 18, 2005.

Any petitions for reconsideration of today's final rule must be received by NHTSA not later than February 3, 2005.

ADDRESSES: Petitions for reconsideration should refer to the docket number for this action and be submitted to: Administrator, National Highway Traffic Safety Administration, 400 Seventh Street, SW., Washington, DC 20590.

FOR FURTHER INFORMATION CONTACT:

For non-legal issues, Mr. Jeff Woods, Vehicle Dynamics Division, Office of Vehicle Safety Standards (Telephone: (202) 366-6206) (Fax: (202) 366-4921).

For legal issues, Ms. Dorothy Nakama, Office of the Chief Counsel (Telephone: (202) 366-2992) (Fax: (202) 366-3820).

You may send mail to both of these officials at: National Highway Traffic Safety Administration, 400 Seventh St., SW., Washington, DC 20590.

SUPPLEMENTARY INFORMATION:**Table of Contents**

- I. Background
- II. Notice of Proposed Rulemaking
- III. Summary of Comments
- IV. Agency Decision to Issue a Final Rule
- V. Issues Raised by Commenters and NHTSA's Responses

A. Issues Relating to All Types of Brake Hose

1. Use of the term "burst"
 2. Use of the term "any"
 3. Constriction test method
 4. Specification of ozone concentration
- B. Hydraulic Brake Hoses
1. General hydraulic brake hose comments in response to the NPRM
 2. Hydraulic brake hose manufacturer identification requirements
 3. Expansion and burst strength (volumetric expansion) test
 4. Tensile strength
 5. Water absorption and pressure test, tensile strength, and whip resistance
 6. Low temperature resistance test
 7. Brake fluid compatibility, constriction, and burst strength
 8. End fitting corrosion resistance
 9. High temperature impulse test
- C. Air Brake Hoses
1. Construction and labeling
 2. High temperature resistance
 3. Low temperature resistance
 4. Ozone resistance
 5. Adhesion
 6. Air pressure (leakage)
 7. Tensile strength
 8. Minimum bend radius
- D. Vacuum Brake Hoses
1. Swell (fuel resistance)
- E. Plastic Air Brake Tubing
1. General comments
 2. Construction
 3. Labeling
 4. Dimensions and tolerances
 5. One hundred percent leak test
 6. Burst test
 7. Moisture absorption
 8. Ultraviolet resistance
 9. Resistance to zinc chloride and methyl alcohol
 10. Stiffness
 11. Heat aging adhesion
 12. Collapse resistance
 13. Oil resistance
 14. Ozone resistance
- F. Plastic Air Brake Tubing Assemblies and End Fittings
1. General comments
 2. Tensile strength
 3. Hot tensile strength
 4. Vibration leak test
 5. Proof and burst test (end fitting retention)
 6. Serviceability test
 7. End fitting dimensional requirements
 8. End fitting corrosion resistance
- G. New Types of Brake Hose
- H. Metallic Tubing and Pipe
- VI. Statutory Bases for the Final Rule
- VII. Effective Date
- VIII. Rulemaking Analyses and Notices
- A. Executive Order 12866 and DOT Regulatory Policies and Procedures
- B. Regulatory Flexibility Act
- C. National Environmental Policy Act
- D. Executive Order 13132 (Federalism)
- E. Civil Justice Reform
- F. Paperwork Reduction Act
- G. National Technology Transfer and Advancement Act
- H. Unfunded Mandates Reform Act
- I. Plain Language
- J. Regulation Identifier Number

Final Rule Regulatory Text

I. Background

On October 30, 1998, three brake hose manufacturers, Elf Atochem North America, Inc., Mark IV Industrial/Dayco Eastman, and Parker Hannifin Corporation,¹ filed a joint petition for rulemaking with NHTSA. The petitioners requested that certain requirements relating to brake hoses, brake hose tubing, and brake hose end fittings that are presently administered by the Federal Motor Carrier Safety Administration (FMCSA) be incorporated into the brake hose standard that is administered by NHTSA. The Federal Motor Carrier Safety Regulations (FMCSR) requirements for brake hoses at 49 CFR 393.45 (Brake tubing and hose, adequacy) and 49 CFR 393.46 (Brake tubing and hose connections) reference several Society of Automotive Engineers (SAE) standards that describe the dimensions and performance requirements for brake hoses and end fittings for hydraulic, vacuum, and air brake hoses, and also metal and plastic tubing and end fittings used in brake systems. Specifically, the petitioners requested that the SAE standards referenced in the FMCSRs be incorporated into 49 CFR 571.106 (Brake hoses) of the Federal Motor Vehicle Safety Standards (FMVSS) that are administered by NHTSA.

The petitioners requested that the application of these SAE specifications be limited to hose, tubing, and fittings used on trucks, truck-trailer combinations, and buses with either a GVWR greater than 10,000 pounds or which are designed to transport 16 or more people, including the driver. In addition, the petitioners requested that the current versions of the SAE specifications be adopted instead of the older versions cited in the FMCSRs.

The joint petition was submitted in light of a 1997 proposal by the Federal Highway Administration (FHWA), which then administered the FMCSRs, to delete these provisions. The FHWA stated that because it has no statutory authority to regulate vehicle manufacturers or manufacturers of brake hose, tubing, or fittings, all such regulations should be included in NHTSA's FMVSS rather than in the FMCSRs. The FHWA proposed adopting a requirement that commercial motor vehicles be maintained in compliance

¹ Since the petition was filed, Mark IV Industrial/Dayco Eastman has been acquired by Parker Hannifin Corporation. Elf Atochem North American, Inc. was integrated into Atofina Chemical, Inc. The successor petitioning companies are referred to as Parker/Atofina.

with FMVSS No. 106. However, many of the provisions included in the FMCSRs in this subject area were not included in FMVSS No. 106.

In a 1998 public meeting on the subject, representatives from NHTSA and FHWA said that they favored consolidating all requirements for brake hose, brake tubing, and fittings in FMVSS No. 106, instead of maintaining separate requirements under the jurisdiction of two different agencies. They explained that consolidation of the requirements would, among other things, make them more enforceable. Some of the brake component manufacturers stated their opposition to deleting the SAE specifications for their products. FHWA and NHTSA indicated that anyone opposed to FHWA's proposal was welcome to file a petition for rulemaking requesting that the SAE specifications proposed for deletion from the FMCSRs be incorporated into FMVSS No. 106.

For details about FMCSR's brake hose requirements and additional background behind the joint petitions, please see NHTSA's notice of proposed rulemaking (NPRM) of May 15, 2003 (68 FR 26384, at pages 26384 to 26385).

II. Notice of Proposed Rulemaking

In an NPRM published on May 15, 2003 (68 FR 26384) [DOT Docket No. 03-14483] NHTSA announced that it had granted the joint petition for rulemaking to amend FMVSS No. 106. The agency agreed with the petitioners that there was a safety need to transfer the brake hose, tubing, and fitting requirements in Sections 393.45 and 393.46 of the FMCSRs to FMVSS No. 106, before those requirements were removed. NHTSA tentatively concluded that to ensure the continued safety of commercial motor vehicle braking systems, the substantive specifications of the SAE Recommended Practices should be incorporated into FMVSS No. 106, with a few exceptions. This would involve, among other changes, establishing a new category in FMVSS No. 106 for plastic air brake tubing, end fittings, and tubing assemblies.

NHTSA's decision to grant the petition was also based on the fact that FMVSS No. 106 had not been substantially updated in many years. The agency noted that most of the substantive requirements currently in FMVSS No. 106 were originally based on SAE standards and American Society for Testing and Materials (ASTM) standards referenced therein. While the SAE and ASTM standards have been modified over time to keep pace with technological developments in the industry, the substantive requirements

of FMVSS No. 106 have remained relatively unchanged. Therefore, NHTSA's proposed changes to FMVSS No. 106 took into account the substantial technological developments that have occurred and sought to align the standard's requirements with standard industry practices. Incorporating many of the SAE standards' performance requirements is consistent with Office of Management and Budget (OMB) Circular A-119, which directs federal agencies to use and/or develop voluntary consensus industry standards, in accordance with Pub. L. 104-113, the "National Technology Transfer and Advancement Act of 1995."

The agency's proposal differed as follows from the petition:

First, instead of simply incorporating complete SAE standards by reference as the FMCSRs currently do, NHTSA proposed to incorporate only the specific requirements/specifications of the SAE standards that are either more rigorous than those in FMVSS No. 106 or are not present at all in FMVSS No. 106.

Second, the agency did not propose to limit the application of those SAE requirements/specifications to brake hose, tubing, and fittings used on commercial motor vehicles. NHTSA tentatively concluded that all brake hose, tubing, and fittings can and should meet the SAE requirements/specifications, regardless of their end use.

Third, although NHTSA agreed with the petitioners that proposed changes to FMVSS No. 106 should be based on the most recent versions of the SAE standards instead of the older versions cited in the FMCSRs, the agency noted that a number of SAE's standards had been updated since the joint petition was filed. Accordingly, NHTSA proposed to rely on the most recent versions of the SAE standards.

Fourth, the agency did not propose to incorporate SAE standards relating to copper tubing, galvanized steel pipe, or end fittings used with metallic or non-metallic tubing. These materials are occasionally used in chassis plumbing and since these products are not considered to be brake hoses, NHTSA stated its belief that they are inappropriate for inclusion in FMVSS No. 106.

Fifth, NHTSA did not propose to incorporate the material and construction specifications for Type A and Type B tubing contained in SAE J844, *Nonmetallic Air Brake System Tubing*, and SAE J1394, *Metric Nonmetallic Air Brake System Tubing* because the agency tentatively

concluded that incorporating those material specifications would be design-restrictive.

Sixth, NHTSA did not propose to incorporate the manufacturer identification requirements in SAE J1401, *Hydraulic Brake Hose Assemblies for Use with Nonpetroleum-Base Hydraulic Fluids*, because it tentatively concluded that the manufacturer identification requirements already present in FMVSS No. 106 are sufficient.

III. Summary of Comments

In response to the May 15, 2003 NPRM, NHTSA received comments from the following eleven organizations and companies: SAE International (SAE) and ASTM International (ASTM), which are automotive and industrial standards organizations; Intertek Testing Services (Intertek), a company that tests brake hoses and other products; and the following manufacturers of brake hose products; Goodyear Engineered Products (Goodyear), Dana Coupled Products (Dana), Saint-Gobain Performance Plastics (SGPPL), Degussa High Performance Polymers (HPP), Parker Hanifin Corporation and Atofina Chemical, Inc. (Parker/Atofina), SMC Corporation of America (SMC), and DuPont Engineered Polymers (DuPont).

Parker/Atofina submitted joint comments to the NPRM and are the successor companies to the parties to the joint petition for rulemaking submitted to NHTSA in 1998. Intertek Testing Services conducts laboratory testing of various products, including brake hoses, and also contracts with NHTSA to perform compliance testing of brake hoses. DuPont submitted comments on June 16, 2004, after the NPRM's comment closing date of July 14, 2003. However, NHTSA has fully considered DuPont's comments.

The commenters generally supported NHTSA's proposal to amend FMVSS No. 106 to include the latest requirements in the SAE brake hose standards for hydraulic, vacuum, and air brake hose and tubing. The commenters raised numerous technical issues, however. For many of proposed tests, commenters provided detailed information on test methods and procedures. The comments also generally supported NHTSA's proposal to specify requirements for plastic brake tubing, and plastic air brake tubing assemblies and end fittings.

IV. Agency Decision To Issue a Final Rule

In this document, NHTSA announces that it has decided to issue a final rule. We have made this decision after we

have thoroughly reviewed the public comments. We have made a number of changes in response to the comments. In the few instances where we did not adopt a comment, we explain why, in light of the need for safety.

We believe that the updated brake hose standard, which combines the most rigorous requirements of the latest SAE standards, and of FMVSS No. 106, meets the need for safety. Significant changes have been made to existing brake hose standards, with the effect of upgrading the performance requirements and test procedures relating to: (a) Hydraulic brake hose; (b) air brake hose; and (c) vacuum brake hose. In addition, we are establishing requirements more specifically tailored for plastic air brake tubing, plastic air brake tubing assemblies and end fittings. NHTSA seeks to ensure safe plastic air brake tubing, and plastic air brake tubing assemblies and end fittings.

In the following sections, we discuss the public comments to the NPRM, our response to the comments, and how (if this is the case) the proposed language in the NPRM has been amended in response to the comments.

V. Issues Raised by Commenters and NHTSA's Responses

A. Issues Relating to All Types of Brake Hose

1. Use of the Term "Burst"

Intertek stated that several proposed requirements in the NPRM referred to the word "burst" and noted that "burst" was not defined in the proposed regulatory text. Intertek cited SAE J1401, stating that leaks or burst is "loss of test fluid from the brake hose assembly other than by designated inlet(s) and outlet(s)." NHTSA notes that in S4 of FMVSS No. 106, "rupture" is defined as any failure that results in separation of a brake hose from its end fitting or in leakage. In this final rule, NHTSA retains "burst" as a term that is presently used in FMVSS No. 106 to describe a required test or test pressures (as in, for example, a table of burst pressures). Whenever the performance requirement of a brake hose is specified, the word "rupture" has been substituted. This is consistent with existing FMVSS No. 106 text and avoids the need to add a definition of "burst" to S4.

2. Use of the Term "Any"

SMC Corporation commented that S11.3 Test requirements (for plastic air brake tubing, plastic air brake tubing assemblies, and plastic air brake tubing end fittings) stating "* * * capable of

meeting *any* of the requirements" should be changed to "*all* of the requirements." [Emphasis added.] NHTSA is not making this recommended change. The term "any" has a very specific meaning in the Federal motor vehicle safety standards, including FMVSS No. 106. 49 CFR Part 571.4 specifies that "(t)he word *any*, used in connection with a range of values or set of items in the requirements, conditions, and procedures of the standards or regulations in this chapter, means generally the totality of the items or values, any of which may be selected by the Administration for testing. * * * Thus, use of the term "any" has the effect of including all of the requirements.

3. Constriction Test Method

The constriction test is conducted to ensure the opening in the brake hose is large enough for the medium (*i.e.*, brake fluid or air) to flow through unimpeded. In the NPRM, NHTSA noted that while the existing FMVSS No. 106 includes constriction requirements, *i.e.*, requirements for minimum pass-through diameter, it does not specify a test procedure. The agency noted that two different constriction test procedures are available: A drop-ball test and a plug gauge test. The agency proposed to use a plug gauge method, similar to that in SAE J1401, that consists of a spherical end (sized at 64 percent of the brake hose nominal inside diameter for hydraulic brake hose and 66 percent of nominal inside diameter for air brake hose) with a shank and handle that can be inserted into the brake hose end fitting. The weight of the gauge is specified as two ounces, and this weight assists the passage of the spherical end through the fitting. The agency stated that it welcomed comments both on its proposal to specify a plug gauge test instead of a drop-ball test and on the differences between the plug gauge test specified in SAE J1401 and the one the agency proposed.

Goodyear commented on the proposed constriction test method for air brake hoses, and Dana similarly commented on the constriction testing for hydraulic brake hoses.

Goodyear stated that air brake hose manufacturing may result in curvature in the hose that could impede the gauge from fully entering the brake hose. The agency notes that the proposed regulatory text at S6.12 provided that the brake hose is held in a straight position to overcome such a problem. Holding the brake hose in a straight position allows the gauge to fully enter the brake hose. Goodyear stated that the

general practice is to use the rolling ball test (also described in the NPRM, but not proposed as a test method), and recommended that the constriction test method be left to the discretion of the hose/assembly manufacturer. NHTSA notes that the rolling ball test is similar but not identical to the drop ball test. The drop ball test relies on the force of gravity for the ball to drop vertically through the hose; the rolling ball test relies on a side-to-side motion by the tester to go through the hose.

Dana agreed with the plug gauge test but recommended including the option of a drop ball test or an extended plug gauge for hose assembly end fittings that by design do not offer a passage through which a plug gauge can be readily inserted. Dana stated that either the extended plug gauge or the rolling ball would permit constriction inspection without cutting the hose.

In response to the comments about the drop ball test vs. the extended plug gauge test, NHTSA begins by noting that S5.3 *Test requirements* in both the existing FMVSS No. 106 and proposed regulatory text for FMVSS No. 106 indicate that a hydraulic brake hose is only subjected to one of the test conditions in S5.3.2 through S5.3.11 (existing text) or through S5.3.13 (proposed text) after having met the constriction test requirement in S5.3.1. There is a similar provision for air brake hoses in S7.3 *Test requirements*. Thus, each brake hose tested to any of the conditions in FMVSS No. 106 would first be inspected for constriction test compliance. If the end fittings or other features of the brake hose do not permit the plug gauge to be used, or would require cutting of the brake hose or end fitting to do so, then constriction testing cannot be conducted prior to one of the other performance tests. Therefore, NHTSA is including the drop ball test in the final rule to provide NHTSA and the manufacturers an alternative to the plug gauge test. In addition, the use of an extended length plug gauge is also included for similar reasons. This will provide some flexibility in the constriction test method for the variety of end fittings likely to be encountered in compliance testing. None of these provisions would preclude a brake manufacturer or assembler from using other means to perform constriction testing, since the purpose of the constriction test is to verify the final inside diameter of a brake hose assembly in a pass-fail manner.

4. Specification of Ozone Concentration

Many commenters noted an incorrect specification of ozone concentration in the preamble to the NPRM, where the

units “parts per million” were stated, rather than the correct “parts per hundred million.” The agency agrees that this was an oversight, and notes that a change to the regulatory text is not needed, as the proposed text specified the correct units.

B. Hydraulic Brake Hoses

1. General Hydraulic Brake Hose Comments in Response to the NPRM

In general, the commenters agreed with the agency’s proposal to upgrade the hydraulic brake hose requirements in FMVSS No. 106 to those requirements in SAE J1401. In the NPRM, the agency proposed to keep all hydraulic brake hose requirements in one section, rather than creating separate categories of brake hoses for commercial vehicles and non-commercial vehicles. Dana stated that it agrees with this position, and does not see this as burdensome to the industry as a whole, as most brake hose manufacturers and light vehicle original equipment manufacturers (OEM) requirements currently exceed the SAE specifications. Goodyear stated that it currently brands, tests, and certifies its brake hoses to both FMVSS No. 106 and SAE requirements.

Parker/Atofina was the only commenter to oppose the upgrade in performance standards for all hydraulic brake hoses, stating that hydraulic brake hoses used on recreational boat trailers, motorcycles, all-terrain vehicles (ATVs), snowmobiles, and off-road tractors/trailers and farm implements do not require the same level of severe service performance requirements. NHTSA notes that of the vehicle types listed by Parker/Atofina, the upgraded requirements would only apply to “motor vehicles,” (*i.e.*, boat trailers and on-road motorcycles). The other vehicle types are not “motor vehicles” regulated by NHTSA. Parker/Atofina also asserted that the FMVSS No. 106 upgrade for all hydraulic brake hoses is unnecessarily cost prohibitive, but provided no cost data for the agency to evaluate.

NHTSA is not adopting Parker/Atofina’s recommendation because NHTSA does not wish to create separate categories of hydraulic brake hose (*e.g.*, “commercial” and “non-commercial.”) To avoid brake system failures caused by brake hose ruptures, we believe there is a safety need for all motor vehicle brake hose to meet rigorous performance requirements.

2. Hydraulic Brake Hose Manufacturer Identification Requirements

Parker/Atofina requested that the agency incorporate into FMVSS No. 106

the full manufacturer identification requirements as provided in SAE J1401. Parker/Atofina states that the agency may not realize that hydraulic brake hoses as defined in SAE J1401 more clearly describe the performance, markings, and requirements for hydraulic brake hose compared with those currently existing in FMVSS No. 106.

In response, NHTSA notes that the requirements for hose manufacturer identification in SAE J1401 are that the hose shall be either embossed or imprinted (three-dimensional) on the brake hose cover with the manufacturer’s name, or employ the market yarn color scheme (Appendix A) as registered with the Rubber Manufacturers Association. In addition, the marker yarn color scheme or name trademark on the brake hose cover shall be registered with the SAE. SAE J1401 does not include any provision for a brake hose assembler to add identifying markings to the end fittings or by means of a band placed around the brake hose assembly; only requirements for the manufacturer of the brake hose material are specified.

NHTSA further notes that the FMVSS No. 106 requirements for hydraulic brake hose manufacturer or assembler identification are specified in S5.2 *Labeling*. The brake hose manufacturer’s designation (symbol, text, *etc.*) is registered with NHTSA and labeled on the outside of the hose. The brake hose assembler’s designation is included on a band placed around the brake hose assembly, or may be stamped into an end fitting. Labeling exceptions are provided for brake hose assemblies included as part of a newly-manufactured vehicle. For these reasons, NHTSA determines that the current labeling requirements fully meet the agency’s needs for identifying the manufacturers of brake hose or brake hose assemblers. Therefore, in this final rule, NHTSA will not require any additional labeling or manufacturer identification requirements for hydraulic brake hoses.

3. Expansion and Burst Strength (Volumetric Expansion) Test

NPRM—The expansion test is conducted at test pressures of 1,000 psi and 1,500 psi and is followed by a burst strength test. NHTSA proposed to add language to S5.3.2 specifying that after the hydraulic brake hose assembly withstands water pressure of 4,000 psi for two minutes without rupture, it must “not rupture at less than 7,000 psi for 1/8 inch, 3 mm, or smaller diameter hose, or at less than 5,000 psi for a hose

with a diameter larger than 1/8 inch or 3mm (S6).”

Public Comments and NHTSA Response—Goodyear indicated that in addition to the expansion test pressures of 1,000 psi and 1,500 psi, SAE J1401 includes a third test at a higher pressure of 2,900 psi, and recommended that it be added to FMVSS No. 106.

In considering this issue, we note that it was an oversight not to include the third pressure in the NPRM. We did, however, explain that we were generally proposing to incorporate those SAE J1401 requirements that are more rigorous than FMVSS No. 106. We therefore believe it is reasonable to add this pressure for the final rule. We are therefore adding the third test at 2,900 psi to S5.3.2 and to Table 1.

We note, however, that SAE J1401 does not include any expansion requirements for the larger, 3/4 inch and 6 mm brake hose sizes that are included in FMVSS No. 106. Further, the agency is not able to extrapolate the existing values in FMVSS No. 106, Table 1, *Maximum Expansion of Free Length Brake Hose*, to determine what expansion limits would be appropriate for the larger brake hose sizes tested at the 2,900 psi expansion test. We are therefore not including at this time expansion requirements for the larger brake hose sizes tested at the 2,900 psi expansion test.

Intertek stated that for the final burst strength requirement in the expansion and burst strength tests, the proposed regulatory text included a 7,000 psi burst strength for 1/8 inch, 3 mm or smaller diameter brake hoses, and a 5,000 psi burst strength for 3/16 inch, 4 mm, or larger diameter brake hoses. Intertek noted that this does not include a defined specification for those brake hoses with diameters falling between 1/8 inch and 3/16 inch, or between 3 mm and 4 mm. To clarify this issue, in the final rule, the agency has changed the regulatory text to state that brake hoses with diameters greater than 1/8 inch or 3 mm shall not rupture at less than 5,000 psi.

4. Tensile Strength

NPRM—NHTSA proposed that the SAE J1401 fast-pull test and 370 pound strength requirement be incorporated into FMVSS No. 106. The agency also proposed to update the ASTM reference for tension testing machines to the latest version of the standard practice.

The agency notes that in the NPRM, the water absorption and tensile strength requirements were labeled as S5.3.5. However, S5.3.5 as currently specified in FMVSS No. 106 are the water absorption and burst strength

requirement test. In this final rule, NHTSA corrects the error. The water absorption and tensile strength requirements are at S5.3.6.

Public Comment and NHTSA's Response—At S6.4 of FMVSS No. 106, the tensile strength test procedures are specified. ASTM commented that the latest version of ASTM standard E 4 *Standard Practices for Force Verification of Testing Machines* was E 4–02. In preparing this final rule, NHTSA determined that E 4 has been revised to E 4–03. NHTSA is therefore incorporating by reference ASTM standard E 4–03 into FMVSS No. 106 at S6.4.

5. Water Absorption and Pressure Test, Tensile Strength, and Whip Resistance

NPRM—NHTSA did not propose any changes to the existing water absorption requirements of FMVSS No. 106 but did propose to incorporate SAE J1401's fast-pull test and 370-pound strength requirement into Standard No. 106's tensile strength test procedure. Accordingly, after being conditioned in water for 70 hours, hydraulic brake hose assembly would be required to meet these heightened tensile strength requirements.

The agency stated that the immersion of the brake hose in water for 70 hours as specified in S6.5 of FMVSS No. 106 is the same as that specified in SAE J1401. However, while the time specification of 70 hours is the same, the preparation of the brake hose specimen and the water soak method are different between the two standards. The preparation in FMVSS No. 106 specifies removal of 1 1/8 inches of outer brake hose cover (if present) at the center of the brake hose, without damage to any reinforcing material. Brake hoses tested to SAE J1401 do not have any cutting of the hose. Another difference between SAE J1401 and FMVSS No. 106 is that FMVSS No. 106 specifies soaking the brake hose in distilled water at room temperature (75 degrees Fahrenheit) while J1401 specifies an elevated water temperature of 185 degrees Fahrenheit.

Public Comments and NHTSA Response—Intertek commented that water temperature is not a great factor regarding the degradation of brake hoses, but that removal of the outer cover may influence the test results because of the possibility of damage to the reinforcing braid when the cover is cut. Goodyear stated that the SAE J1401 procedure was developed to eliminate the potential of yarn damage that may occur when the outer cover of the brake hose is removed by cutting. Goodyear recommended that the water soak

procedure in SAE J1401 be used in FMVSS No. 106. Dana noted the discrepancies in the two standards, and stated that it prefers the SAE procedure because it is easier for the technician to perform and has less risk of inadvertent damage to the brake hose. Further, Dana stated its belief that the results of the SAE J1401 and FMVSS No. 106 test methods are similar although the comparison data is about a decade old.

NHTSA agrees with the commenters that by using the SAE J1401 water soak procedure, the likelihood of unintended damage to the brake hose during the process of removing the cover will be eliminated. Thus, in the final regulatory text, NHTSA adopts the water soak procedure in SAE J1401.

6. Low Temperature Resistance Test

NPRM—NHTSA did not propose any changes in Standard No. 106's low temperature resistance requirements/procedures.

Public Comments and NHTSA's Response—Dana and Goodyear stated that while FMVSS No. 106 specifies a temperature of minus 40 degrees Celsius, SAE J1401 specifies a lower temperature range of minus 45 degrees Celsius to minus 48 degrees Celsius. Both Dana and Goodyear recommended the use of the lower test temperature as better reflecting the capabilities of the materials used in current day brake hoses.

In the final rule, NHTSA adopts the lower temperature specification recommended by Dana and Goodyear and as provided in SAE J1401.

7. Brake Fluid Compatibility, Constriction, and Burst Strength

NPRM—In the NPRM, NHTSA proposed to use the latest SAE reference RM brake fluid for the brake fluid compatibility test. Because the RM–66–05 fluid has superseded the RM–66–03 fluid, NHTSA did not propose any change in the type of fluid specified for conditioning the hose. NHTSA proposed, however, to increase the conditioning temperature in FMVSS No. 106 to 248 degrees Fahrenheit.

Public Comments and NHTSA's Responses—Goodyear indicated in its comments that the NPRM language regarding compatibility fluid was incorrect with respect to the version of the SAE compatibility fluid referenced in the existing FMVSS No. 106 and SAE J1401. NHTSA notes that SAE RM–66–04 is currently referenced in FMVSS No. 106, and SAE RM–66–05 is referenced in SAE J1401 (June 2003). The agency correctly identified the compatibility fluid in the proposed regulatory text as

SAE RM–66–05 and therefore will make no change in the final rule.

Goodyear recommended that FMVSS No. 106 reference the latest or current SAE fluid and not cite the specific version (e.g., –04 or –05). NHTSA will not adopt this recommendation. NHTSA will maintain the current system of referencing a specific version of the compatibility fluid, and perform periodic rulemaking as new versions of the test fluid are developed. In this way, the public will have an opportunity to comment on new versions of the compatibility fluid before it is incorporated by reference into FMVSS No. 106.

8. End Fitting Corrosion Resistance

NPRM—Instead of referencing either ASTM B117–64 or ASTM B 117 Appendix B, both of which are outdated, NHTSA proposed to change the reference in FMVSS No. 106 to the most recent set of ASTM specifications for salt spray chambers, which are found in ASTM B117–97. NHTSA did not propose any other changes to the end fitting corrosion resistance requirements/procedures in FMVSS No. 106.

Public Comment and NHTSA Response—ASTM commented that the latest revision of ASTM standard B 117 *Standard Practice for Operating Salt Spray (Fog) Apparatus* is B 117–02. In preparing this final rule, the agency determined that B 117 has been revised to B 117–03, and is incorporating B 117–03 in FMVSS No. 106 at a new S6.11, *End fitting corrosion test*. There are no substantive differences between B 117–02 and B 117–03.

9. High Temperature Impulse Test

NPRM—NHTSA proposed incorporating the high temperature impulse test from SAE J1401 into FMVSS No. 106.

Public Comment and NHTSA Response—Goodyear noted that in the NPRM's preamble, the text incorrectly stated that the impulse test is conducted in an air chamber at 259 degrees Fahrenheit, while the correct specification is 295 degrees Fahrenheit. No change is needed to the final rule regulatory text, as the correct temperature was specified in the NPRM's draft regulatory text.

C. Air Brake Hoses

1. Construction and Labeling

NPRM—NHTSA proposed that plastic air brake tubing be regulated in its own section in FMVSS No. 106 since it differs significantly in construction and material properties from elastomeric

rubber hoses. Therefore, NHTSA proposed that any references to synthetic or natural elastomeric rubber be deleted from *S7 Requirements—Air brake hose, brake hose assemblies, and brake hose end fittings* of FMVSS No. 106 since it will no longer be necessary to differentiate rubber hoses from plastic tubing in S7 and S8. The proposed text in the NPRM also removed references to “outside diameter (OD)” from S7 and S8 of FMVSS No. 106 since OD measurements are generally only applicable to tubing, which NHTSA proposed to address in the new section for plastic tubing.

NHTSA also proposed to specify in S7.2.1(e) of FMVSS No. 106 the labeling scheme that is to be used for air brake hose that meets the dimensional requirements of more than one type of end fitting (A, AI, or AII). The proper labeling of such hose has been addressed in several of the agency’s legal interpretation letters, and including this language in FMVSS No. 106 would serve to minimize confusion on this issue. The proposed text also stated that a hose intended for use with more than one type of end fitting may be labeled as such, but is not required to be so labeled. This provides flexibility for hose manufacturers to determine how they intend their hoses to be used, and would not require them to label hoses for multiple end fitting designations unless they so desire.

Public Comments and NHTSA’s Response—The SAE and Parker/Atofina stated that it is necessary to keep the references to synthetic or natural rubber in order to clearly indicate that the fittings intended for use with rubber air brake hose are not to be used with any type of plastic hose (which is similar to plastic tubing but is sized by inside diameter rather than outside diameter). Based upon the comments received, the agency determines that retaining the references to rubber provides beneficial information regarding the use of these brake hoses, and is retaining the existing FMVSS No. 106 language in the final rule.

Comments from the SAE and Parker/Atofina describe the differences in the three types of air brake hose designated as Type A, Type AI, and Type AII. The SAE suggested notes for Table III describing the application of reusable and permanent crimped fittings to each type of hose. The SAE also recommended that the dimensional requirements for Type A hose for use with both reusable and permanent fittings be included in Table III. Parker/Atofina also recommended that the correct dimensions for Type A, AI, and AII hose be included in FMVSS No. 106,

and that FMVSS No. 106 should conform to the specifications in SAE J1402 for these dimensions.

Historically, NHTSA has declined to specify dimensions of end fittings, as there are too many different end fitting thicknesses and too many different types. NHTSA notes that the industry has standardized brake hose end fittings. Therefore, on the issue of dimensional requirements for air brake hose intended for use with permanently attached fittings, NHTSA has stated its belief in the May 15, 2003 NPRM and in other rulemaking documents that it was not necessary to include those dimensional requirements in FMVSS No. 106. In the May 15, 2003 NPRM, NHTSA also stated that it believes that many of the brake hose assemblers are truck repair facilities that may be assembling brake hoses with permanently attached end fittings. It follows that these truck repair facilities must pay attention to the type of air brake hose being assembled, to ensure that the hose and end fitting are compatible. In the NPRM, NHTSA stated that it believes that air brake hose conforming to SAE J1402 is presently in use because of FMCSR requirements at 49 CFR 393.45.

Regarding metric sizes of air brake hose, in the NPRM, NHTSA noted that dimensions for metric air brake hoses are not included in FMVSS No. 106, and solicited comments on the dimensions for metric air brake hose (for use with permanently attached, or reusable end fittings) that may be appropriate to include in FMVSS No. 106. Since it received no comments on this subject, NHTSA will not include metric air brake hoses in Table III.

In the final rule, the agency is adopting the dimensional requirements for Type A air brake hose in Table III, as recommended by the SAE and Parker/Atofina, and is including the suggested notes for Table III. Table III’s title, and its reference in S7.1, *Construction*, are changed to no longer reference “reusable” end fittings because, as the SAE indicates, the air brake hose in the table may be used with either reusable or permanent fittings. The agency concludes that it is also appropriate to slightly revise the regulatory text for S7.2.1(e) in *Labeling* to indicate that the markings on the air brake hose directly relate to its type as specified in Table III. As metric air brake hose is not included in Table III, the agency is specifying that it continue to be designated with the letter “A.”

NHTSA proposed in the brake hose labeling requirements in S7.2.1(e), a labeling provision for brake hoses manufactured for use with more than

one type of end fitting, e.g., AI and AII. Upon further review and in light of the comments from the SAE and Parker/Atofina, NHTSA now believes that no such applications exist, because of the large differences in outside diameters between, for example, Type AI and Type AII brake hose. For these reasons, the multiple labeling provisions proposed in the NPRM are removed in the final rule.

2. High Temperature Resistance

NPRM—The high temperature resistance test for air brake hose ensures that there are no cracks or disintegration due to proximity to high temperatures of vehicle components such as engines and transmissions. NHTSA proposed that FMVSS No. 106 adopt the smaller radii test cylinders from SAE J1402 and, for 1/8 inch and 3 mm, 4 mm, and 5 mm hose, NHTSA proposed that the test cylinder radius of 1 inch as specified in SAE J1402 for 3/16 inch hose also be used for these hose sizes. As currently indicated in Table IV of FMVSS No. 106, the larger metric sizes of hose (6 mm and above) numerically correspond closely to inch sizes of hose, for example, 6 mm (0.236 inch) is very close to 1/4 inch (0.250 inch).

Accordingly, NHTSA proposed to apply the test cylinder values from SAE J1402 to metric sizes of hose as currently specified in Table IV of FMVSS No. 106. As to SAE J1402’s exclusion of fabric-covered air brake hose from the external inspection requirement, NHTSA disagreed that external inspection of such hose is impractical and, therefore, did not propose to incorporate SAE J1402’s exclusion.

Public Comments and NHTSA’s Response—The SAE and Parker/Atofina provided similar comments regarding the proposed test cylinder radii that NHTSA raised in the NPRM. The test cylinder radii were proposed to be decreased from the current values in FMVSS No. 106, Table IV, to smaller values from SAE J1402, Table 4—*Radius for High Temperature Resistance Test (small radius)*. For example, the test cylinder radius for a 3/8-inch air brake hose in existing FMVSS No. 106 is 3 1/2 inches while the test cylinder radius in SAE J1401 for the high temperature resistance test is 1 3/4 inches, or one-half the size.

The SAE and Parker/Atofina stated that SAE J1402 is going to be revised to remove the small radius test cylinders from the high temperature resistance test. However, in this final rule, the agency is making FMVSS No. 106 consistent with the current version of SAE J1402, but will be willing to

consider future alignments between the two standards in future rulemaking.

The agency also notes that in the NPRM, the incorrect value of 3 inches for the large test cylinder was specified for $\frac{3}{8}$ inch hose. NHTSA has corrected the value to $3\frac{1}{2}$ inches in this final rule.

NHTSA notes that in the NPRM, incorrect test cylinders were included in the proposed Table IV for the adhesion test of wire-reinforced hose. The agency stated that the values from SAE J1402, Table 4, should be used (small radius), while in fact SAE J1402 references the radii in Table 1 for this test (large radius). In the final rule, NHTSA retains the correct test cylinder values without change.

Comments from the SAE and Parker/Atofina note that the $\frac{1}{8}$ inch size of air brake hose is not produced, therefore, the test cylinder specification for that size hose is not needed in Table IV of FMVSS No. 106. The agency agrees and in the final rule, removes references to $\frac{1}{8}$ inch size of air brake hose from Table IV.

As currently stated in FMVSS No. 106, the required performance of a brake hose after being subjected to the test requirements in the high temperature test is that the brake hose shall not show external or internal cracks, charring, or disintegration visible without magnification. Under the high temperature resistance requirements in SAE J1402, the external surface of fabric-covered hoses is excluded from this inspection, stating that visual inspection is not practical. The agency proposed in the NPRM to keep the requirements in FMVSS No. 106 for external inspection and not include the SAE J1402 exclusion. Both the SAE and Parker/Atofina commented that the SAE J1402 exclusion be kept in place. SAE commented that for hoses covered with a textile braid (fabric-covered), this braid does not show cracks from exposure to ozone nor does it crack due to the high temperature test.

NHTSA does not understand the need to exclude external inspection of the hose if, as Parker/Atofina and the SAE comments indicate, those hoses with textile braid covering will not crack. The inspection is visual, and does not require special equipment or magnification, nor does it require removal of the fabric covering to inspect the hose beneath it. By having such an exclusion, conceivably, a fabric-covered brake hose that did show external cracks would be considered to have passed the test. NHTSA does not believe there is any reason to add the exclusion for external inspection. Further, the agency is specifying only the larger test cylinder sizes for this test, and this

should further minimize the likelihood of failure compared to the requirements currently in SAE J1402.

3. Low Temperature Resistance

NPRM—NHTSA proposed that the internal surface inspection of air brake hose, as specified in SAE J1402, be incorporated into FMVSS No. 106. However, the agency did not propose to incorporate SAE J1402's exclusion of fabric-covered air brake hose from external inspection.

Public Comments and NHTSA's Response—The SAE and Parker/Atofina commented that the $\frac{1}{8}$ inch size of brake hose does not need to be included in Table IV of FMVSS No. 106. NHTSA agrees and has removed the $\frac{1}{8}$ inch size of brake hose from Table IV in the final rule. Both SAE and Parker/Atofina also asked that the external inspection of the hose for cracks excluded fabric-covered hoses, but for the same reasons as described in the discussion on high temperature test requirements, NHTSA does not include this exemption in the final rule.

4. Ozone Resistance

NPRM—Since NHTSA proposed that the ozone concentration for hydraulic brake hose be changed from 50 pphm to 100 pphm, NHTSA proposed to specify the higher ozone concentration (100 pphm) for air brake hose as well. The agency tentatively concluded it is appropriate to specify the same concentration of ozone for testing all types of brake hoses.

Public Comments and NHTSA's Response—SAE, Parker/Atofina, and Goodyear correctly indicated that the proposed ozone concentration should be specified as 100 parts per hundred million, not by parts per million. The correct concentration (100 parts per hundred million) is specified in this final rule.

NHTSA notes that in the NPRM, the ozone test for air brake hose was incorrectly identified as S8.14. A new section of FMVSS No. 106 for the ozone resistance test is not needed since the ozone test is already included in S8.4. In this final rule, the ozone test is correctly identified as S8.4. Thus, the constriction requirements that were proposed to be in S8.15 are now in S8.14.

5. Adhesion

NPRM—NHTSA proposed to incorporate the SAE J1402 adhesion test for wire-reinforced air brake hose into FMVSS No. 106, with the exception of the steel ball sizes as discussed below. Also, to incorporate SAE J1402's specifications into FMVSS No. 106,

NHTSA proposed that rather than specifying steel ball diameters for each hose size, the steel ball should be specified as having a diameter that is 75 percent of the nominal inside diameter of the hose. This would allow for testing of any and all sizes of hose.

The agency also proposed to specify use of a plug gauge rather than a steel ball for constriction testing of other types of hose to which FMVSS No. 106 applies. For the adhesion test, however, it would not be possible to use a plug gauge because the hose is closed off at both ends during the test. Accordingly, NHTSA proposed to specify the use of a steel ball to test air brake hose for adhesion. Finally, the agency proposed to update the ASTM tension testing machine reference in S8.9 from the 1964 version currently in FMVSS No. 106 to the latest revision of that standard, *Standard Practices for Force Verification of Testing Machines*, Designation E4-99.

Public Comments and NHTSA's Response—The SAE and Parker/Atofina commented that they prefer the 73 percent of nominal inside diameter specification, which would allow the use of standard size test balls. Also, the size difference between a 73 and 75 percent ball size is small (0.008 inches for a $1\frac{3}{32}$ -inch brake hose). NHTSA agrees that the difference is not significant and adopts the 73 percent requirement in the final rule.

NHTSA also notes that the incorrect test cylinder radii were proposed for the adhesion test of wire-reinforced air brake hose. The small test cylinders from SAE J1402 Table 4 were proposed in the NPRM, but the correct radii from SAE J1402 Table 1 are included in this final rule.

6. Air Pressure (Leakage)

NPRM—The SAE J1402 specifications for hose leakage are more severe than those presently in FMVSS No. 106. NHTSA proposed incorporating the flexure/pressure test from SAE J1402 into FMVSS No. 106, with some modifications. NHTSA noted that the test procedure in SAE J1402 includes tolerances on the pressure requirements for determining whether the hose leakage rate is acceptable upon completion of the flexure test. The agency described how, if these tolerances were applied in various manners, it may not be possible to determine the pass/fail performance of a brake hose during a test.

Therefore, in the NPRM, we proposed an alternative, to modify the requirements to ensure there would be a pass or fail criterion. NHTSA also proposed to modify SAE J1402's test

procedures by specifying the thickness of the orifice during the final leak check. The thickness of the orifice, and not only the diameter of the orifice, affects the rate at which air can be supplied to the hose. The rate at which air is supplied to the hose would be critical if a small amount of hose leakage is present during the final leakage test. NHTSA proposed specifying an orifice thickness of 0.032 inches ($\frac{1}{32}$ inch), which is the same thickness specified for the orifice in FMVSS No. 121 at S5.3.5, *Control signal pressure differential for converter dollies and trailers designed to tow another vehicle equipped with air brakes*. NHTSA tentatively concluded that this proposed orifice dimension would supply air at a greater rate than any thicker orifice while still providing sufficient mechanical strength to withstand the test conditions.

The agency proposed to adopt the lowest test pressure (140 psi) in the brake hose during the leakage test from the range provided in SAE J1402 (140 to 160 psi). The applied supply pressure to a restrictive orifice was proposed to be at the midpoint of the pressure range, 150 psi. Thus, the supply pressure exceeds the required pressure that is to be maintained in the brake hose, allowing a small amount of leakage to be present, but not permitting excessive leakage to be present.

Public Comments and NHTSA's Responses—The SAE and Parker/Atofina both stated that the agency is proposing to change the SAE test, creating a new requirement. The commenters stated that it does not reflect good test methodology to require 150 psi supply pressure with no tolerance, or 140 psi with no tolerance in the brake hose within the two minute period. However, neither commenter recommended an alternative to NHTSA's proposal, other than to adopt the exact procedure in SAE J1402. Both commenters stated that the agency's proposal to adopt a thickness requirement for the orifice has some technical value.

While the agency has considered the comments, the commenters did not provide recommendations as to test pressures that the agency could adopt in the final rule. The agency believes that by specifying the minimum required pressure of 140 psi in the brake hose, while supplying air at the mid-point pressure of 150 psi through an orifice of minimal thickness that is least restrictive to air flow, a reasonable balance in test conditions is achieved. Therefore, NHTSA is making final the air pressure (leakage) test that it proposed in the NPRM.

NHTSA believes that measuring the leakage using a mass flow meter, as is done for test leaks of plastic air brake tubing, may be preferable to the method in this final rule. NHTSA may consider raising this issue in a future rulemaking.

7. Tensile Strength

NPRM—As currently in effect, FMVSS No. 106 includes different tensile strength requirements for air brake hoses if those hoses are used: (a) Between the vehicle frame and axle, or between a towing and towed unit; or (b) in any other application. The tensile strength requirements for brake hose assemblies in the former case are significantly higher than those requirements in the latter case. Because the agency proposed separate requirements for plastic tubing in a new section of FMVSS No. 106, NHTSA proposed to delete the lower tensile strength limits for hoses that are used for purposes other than connections between a frame and axle or between a towed and towing unit, and require the higher tensile strength requirements for all brake hoses. SAE J1402 only includes the higher tensile strength requirements.

The agency proposed that all rubber brake hoses meet the requirements for a hose that is used between a frame and an axle or between a towed and a towing unit. NHTSA tentatively concluded that rubber hoses are no longer used extensively for other purposes on heavy vehicles, as plastic tubing is used for most chassis plumbing of air systems. NHTSA tentatively concluded that these rubber hoses are of sufficient diameter to have the mechanical strength to meet the higher, frame-to-axle tensile strength requirements. NHTSA also solicited comments on any alternate tensile strength requirements that might be appropriate for rubber hoses.

Public Comments and NHTSA's Response—The SAE recommended that the SAE J1402 tensile strength testing be adopted. SAE did not elaborate on its recommendation. Parker/Atofina recommended keeping the current FMVSS No. 106 requirements with the high and low tensile strength requirements depending on application of the hose assembly. Parker/Atofina stated that the lower tensile strength requirements are still used in applications other than connections between a towed and a towing unit, and to raise these requirements to the higher tensile strength would add significantly to hose cost. No cost data was provided for the agency to evaluate.

In evaluating the tensile strength test requirements, NHTSA notes that it

proposed different tensile strength requirements for plastic air brake tubing depending on the application of the product (*e.g.*, between towing and towed unit, or in chassis plumbing applications), based on the current tensile strength requirements for air brake hoses in S7.3.10 of FMVSS No. 106. The reason for the different strength requirements is to accommodate different styles of end fittings. Thus, the end fittings for a brake hose or plastic tubing used between a towing and towed vehicle provide the highest tensile strength possible to prevent separation of the end fittings. In other applications, such as chassis plumbing, lower tensile strength requirements apply that permit the use of fittings designed for ease of assembly on chassis plumbing (such as push-to-connect fittings used with plastic tubing).

NHTSA did not believe that air brake hose is for chassis plumbing (having been replaced by plastic tubing) and therefore proposed to delete the lower tensile strength requirements for this type of brake hose. Parker/Atofina however, states that this is not the case, and the agency believes that Parker/Atofina is referring to the higher cost of high-strength end fittings and/or the longer assembly time required for these fittings. Therefore, in this final rule, the agency is not deleting the lower tensile strength requirements for end fitting retention for air brake hose, to avoid changes to vehicle manufacturing in situations where this type of air brake hose is used for chassis plumbing. The end fitting tensile strength requirements will therefore be similar for air brake hose and plastic air brake tubing.

8. Minimum Bend Radius

NPRM—NHTSA tentatively concluded it would not be appropriate to add SAE J1402 requirements for minimum bend radius to FMVSS No. 106 because FMVSS No. 106 regulates the properties of brake hoses as stand-alone motor vehicle equipment rather than use requirements. NHTSA did not propose to include a reference to the minimum bend radii from Table 1 in SAE J1402 as the minimum installation bend radii for brake hose as installed on vehicles.

Public Comments and NHTSA's Response—Both the SAE and Parker/Atofina asked that the minimum bend radii from Table 1 in SAE J1402 as the minimum installation bend radii for brake hose installed on vehicles be included to benefit users (installers) of the brake hose. The agency notes that in Section 3.3.1 of J1402, smaller installation radii may be appropriate for

some brake hoses. Therefore, in the final rule, NHTSA is not specifying installation bend radii. NHTSA believes individual brake hose manufacturers are in the best position to determine minimum bend radii for hose to be installed in motor vehicles.

D. Vacuum Brake Hoses

1. Swell (Fuel Resistance)

NPRM—NHTSA proposed that Reference Fuel B as specified in SAE J1403 be used for the swell test in FMVSS No. 106. NHTSA also proposed that the plug gauge method (in lieu of the steel drop-ball method) be kept in place in TP-106 for swell testing of vacuum brake hoses.

NHTSA proposed that the specifications of FMVSS No. 106 and SAE J1403 be combined as follows. Following the fuel conditioning using Reference Fuel B and the constriction test, each vacuum hose would be subjected to a vacuum of 26 inches of Hg for ten minutes, with no visible collapse or leakage of the hose permitted (as currently specified by FMVSS No. 106). Then, for hoses constructed of two layers or more, a layer adhesion test would be conducted with a specified performance of 8 pounds-per-inch minimum separation force (as specified by SAE J1403). NHTSA proposed that this adhesion test only be applied to multi-layer hoses for two reasons. First, the agency tentatively concluded that single layer hose cannot be tested easily. Second, NHTSA tentatively concluded that single layer hose that have lost mechanical integrity would not be able to pass the visual collapse or no leakage specification during the vacuum test and, as such, failure would already be detected prior to completion of the vacuum test.

NHTSA also proposed to update the ASTM test procedure referenced in S10.7 for the swell test to the current revision, D471-98e1.

Public Comments and NHTSA's Response—Goodyear supported the current SAE J1403 test sequence consisting of fuel soak, restriction (constriction) ball test, vacuum collapse test, and layer adhesion test with a minimum separation strength of 6 pounds per inch. Goodyear commented that the agency's proposed plug gauge for constriction testing, shown as Figure 4, has only three inches of length and would not be able to pass through a test sample of vacuum hose that is 12 inches in length. Further, the vacuum brake hose may have some curvature that would not permit a straight gauge to pass through it. For these reasons,

Goodyear recommended that a rolling ball be used to verify the internal dimensions of vacuum brake hose during the swell test.

In responding, the agency begins by noting that pre-formed vacuum brake hoses would have significant curvature molded into them, and standard vacuum brake hose may also have some natural curvature as described by Goodyear. NHTSA also notes that in the existing and proposed FMVSS No. 106 regulatory text, the method of verifying the inside diameter of the vacuum brake hose is not provided. As noted in the *NPRM*, the method is identified as a plug gauge in the agency's current test procedure, TP-106. For the final rule, the agency has decided to provide the option of using a drop ball for both constriction tests and verification of the inside diameter during the swell test, and to also permit the use of a standard plug gauge or an extended length plug gauge. The fact that several options are provided to brake hose manufacturers is consistent with constriction testing for other types of brake hoses in FMVSS No. 106, where more than one method may be employed (by NHTSA and brake hose manufacturers) due to the variety of end fitting designs that may preclude the use of the plug gauge. In this final rule, NHTSA is incorporating into FMVSS No. 106 the three constriction test methods to be used in the swell test.

In the *NPRM*, NHTSA proposed an adhesion strength test requirement of 8 pounds per inch. Goodyear stated that the value should be 6 pounds per inch, as stated in SAE J1403. The correct value of 6 pounds per inch adhesion strength requirement is in this final rule.

E. Plastic Air Brake Tubing

1. General Comments

In the *NPRM*, NHTSA stated that plastic air brake tubing is generally manufactured from nylon but the generic term, "plastic" is used to account for other types of plastic that may be used for air brake tubing. The comments on the proposal for requirements for plastic air brake tubing, plastic air brake tubing assemblies, and plastic air brake tubing end fittings fell into two groups: (a) Manufacturers currently manufacturing air brake tubing from polyamide (nylon) requesting that this material specification be included in FMVSS No. 106; and (b) manufacturers that may be considering manufacturing air brake tubing from materials other than nylon, that did not support including this material specification (plastic) in FMVSS No. 106.

Parker/Atofina stated that by not including additional material property tests into FMVSS No. 106, there would be insufficient safeguards for the performance of alternate tubing made from unproven and unspecified polymers that would create a significant product design risk. It also stated that the material specification of generic nylon is not design restrictive, but offers thermoplastic tubing manufacturers great latitude in product design options.

SMC stated that not including the material specification in FMVSS No. 106 leads to an issue that is being addressed in the SAE committee that is responsible for SAE J2547, *Alternate Nonmetallic Air Brake System Tubing*. Namely, the test should be application specific and not a material validation test like the burst pressure test in SAE J844. Different tube material may affect the retention of the tubing in the fitting per the SAE J1131 requirements. Until further evaluation is conducted on the new tubing materials with all fitting supplied in the industry, leaving the material open to the tubing manufacturers' discretion may lead to problems with the tube connection.

HPP stated that SAE J844 takes into account that the materials are polyamides. To exclude this requirement, additional tests would need to be introduced to ensure that long-term properties of tubing made from other materials meet the in-use requirements. HPP cited, for example, that there is no requirement for a high-temperature burst test at elevated pressures, while polyamides are known to possess the long-term properties for this requirement.

DuPont stated that the agency correctly points out in the *NPRM* that a material and construction specification is design restrictive. It notes that while polyamides used under SAE J844 have performed with an admirable safety record, it has a negative impact on innovation and commerce. DuPont also encouraged the elimination of any reference to specific types of construction, specifically regarding Type A (unreinforced) and Type B (reinforced) tubing. DuPont stated that any style of construction that passes the rigorous test procedures and dimensional requirements set forth in the proposal should be permissible.

In this final rule, NHTSA has decided to keep the generic terminology of plastic air brake tubing, rather than adopt the specification for nylon (polyamide) material. Regarding concerns that materials other than nylon might be inferior when used in air brake tubing, NHTSA notes that it proposed 24 performance test requirements

(proposed S11.3.1 through proposed S11.3.24), and is adopting twenty-two of those requirements in the final rule. NHTSA believes that these extensive requirements will ensure that alternative air brake tubing materials are subjected to rigorous testing to provide safe service in air brake systems.

HPP stated that if the requirements in SAE J844 are performed on air brake tubing made from materials other than nylon, additional tests might be appropriate, such as a high-temperature burst test. However, HPP did not provide any test parameters that the agency could evaluate. NHTSA notes in the section below that high-temperature conditioning requirements for plastic air brake tubing have been included for adoption in FMVSS No. 106.

With regard to the agency's statements in the NPRM that air brake tubing must be either Type A, single layer, unreinforced construction, or Type B, two layer, reinforced construction, the agency has reviewed the comments on this subject and has decided not to adopt these requirements in the final rule. Additional details that formed the agency's decision on this subject are included in the sections below.

2. Construction

NPRM—The NPRM solicited comments on whether air brake tubing should be designated as Type A—a non-reinforced, single-layer tubing (designated for small diameter tubing in SAE J844), or as Type B—constructed from two layers of material with a reinforcing braid at the interface of the two layers (designated for large diameter tubing in SAE J844).

Public Comments and NHTSA's Response—SMC cited the SAE J2547 as a standard currently in draft that will not restrict the tubing to have either a single wall or two walls with a reinforcement braid, but SMC did not provide any additional details on the SAE effort that the agency could consider regarding the final rule. SMC stated that Europe is currently using single wall tubing for all sizes used in the trucking industry. SGPPL proposed that if references to nylon are not included for air brake tubing, one solution would be to also eliminate references to reinforced, unreinforced, and single- or multi-layer tubing construction, but retain dimensional values including inside diameter, outside diameter and/or wall thickness.

HPP stated that single layer tubing with an outside diameter of 10, 12 and 16 millimeters, or $\frac{3}{8}$, $\frac{1}{2}$, $\frac{5}{8}$ and $\frac{3}{4}$ inches, can meet SAE J844 requirements and should be permitted in FMVSS No. 106. HPP stated that from technical and

safety standpoints, there is no need for reinforced tubing for the larger diameter applications.

As earlier noted, DuPont believed that there was no need to include references to specific types of construction in FMVSS No. 106, because any style of construction that passes the rigorous test procedures and dimensional requirements as described in the NPRM should be permissible.

The agency agrees with the comments from SMC, SGPPL, HPP, and DuPont that construction and reinforcement requirements do not need to be included in FMVSS No. 106. NHTSA believes that the safety of plastic air brake tubing will be ensured by the 22 tests specified in this final rule.

Parker/Atofina stated that the NHTSA proposal not to include the construction and material specifications for Type A and Type B tubing as specified in SAE J844 is inappropriate and potentially unsafe to users. It stated that by not including additional material property tests into FMVSS No. 106 to safeguard the performance of alternate tubing made from unproven and unspecified polymers creates a significant product design risk. It suggested including test requirements for battery acid resistance, high temperature burst, high temperature heat aging, and moisture absorption to help prevent the use of unsuitable materials. HPP made similar comments regarding the need for additional tests such as an elevated temperature burst test if nylon is not specified as the tubing material. HPP stated that air brake tubing can be exposed to temperatures in the 80 to 100 degree Celsius (176 to 212 degrees Fahrenheit) range.

NHTSA notes that the NPRM proposed to amend FMVSS No. 106 by including, for plastic air brake tubing, tests for moisture absorption, high temperature resistance, high temperature conditioning with low temperature impact resistance, boiling water conditioning with low temperature impact resistance, and high temperature conditioning and collapse resistance. All of these test requirements have been incorporated into the final rule. Parker/Atofina did not identify the parameters of the suggested battery resistance test, nor did they indicate why the test conditions proposed in NPRM involving, for example, high temperature conditioning of plastic air brake tubing, are insufficient for materials other than nylon. HPP indicated that temperatures up to 100 degrees Celsius (212 degrees Fahrenheit) can be experienced by plastic air brake tubing in use, and the agency has included high temperature conditioning

tests for tubing in the 100 to 110 degrees Celsius (212 to 230 degrees Fahrenheit) temperature range.

NHTSA believes that the extensive series of test requirements that it is adopting in the final rule will be sufficient to ensure the safe performance of plastic air brake tubing made from materials other than nylon, and, as discussed in the section below on zinc chloride and methyl alcohol resistance, the agency may consider additional chemical resistance tests for plastic air brake tubing in the future. For example, DuPont cited the use of copolyester elastomer in air brake tubing. Therefore, in this final rule, the agency is not specifying that air brake tubing must be manufactured from nylon.

NHTSA believes that although materials other than nylon, possibly constructed as unreinforced, single-layer tubing, have been developed and used (for example, in Europe), it does not automatically mean that these other materials or constructions (such as alternate plastic/non-nylon tubing) can be applied to FMVSS No. 106 without careful consideration. One of the main purposes of the agency's undertaking rulemaking on FMVSS No. 106 is to implement dimensional specifications for air brake tubing that currently do not exist in the standard, to preclude the sale or use of tubing that is not compatible with existing SAE J844 (or SAE J1394) tubing and end fittings used extensively in the United States. Alternate air brake tubing products that are developed will have to meet the extensive performance requirements for air brake tubing that are included in this final rule, and will also have to do so within the dimensional specifications that are also being adopted. NHTSA does not expect that inferior products of any type or size will meet these extensive requirements.

3. Labeling

NPRM—NHTSA proposed to require air brake tubing to be labeled with the manufacturer identifying information at intervals of not more than 6 inches, from the end of one legend to the beginning of the next. This represented no change from the FMVSS No. 106 labeling method already specified for brake tubing.

Public Comments and NHTSA's Response—Parker/Atofina commented that based on their experience, the vast majority of plastic air brake tubing assembly lengths are greater than 15 inches. The tubing would be sufficiently marked for product tracking if the text marking repeat interval is not more than 15 inches. NHTSA believes that to facilitate identification of the hose

manufacturer, all brake hoses must be labeled to identify the manufacturer. To increase the labeling interval to 15 inches may increase the likelihood that a particular brake hose may not include the labeling information. Therefore, NHTSA will not adopt the suggestion of a 15-inch repeat interval for brake hose labeling.

Parker/Atofina commented that the agency's proposal is too restrictive on manufacturers in order to maintain complete marking context and text liability on small diameter plastic tubing. Presumably, Parker/Atofina is referring to the requirement that the height of the labeling information be at least one-eighth of an inch. NHTSA notes the one-eighth inch height requirement has been in FMVSS No. 106 for many years. Further, Parker/Atofina did not suggest an appropriate lettering height for small diameters of air brake tubing. NHTSA is not changing the lettering height requirements in this final rule.

4. Dimensions and Tolerances

NPRM—NHTSA proposed to incorporate into FMVSS No. 106 the dimension and tolerance requirements contained in SAE J844, and also SAE J1394 covering metric sizes of tubing, as Table VII of FMVSS No. 106.

Public Comments and NHTSA's Response—Parker/Atofina provided several recommendations for changes to Table VII, stating that for example, the tolerance for wall thickness should be similar for metric tubing that is close in size to that of an inch-sized tubing. The recommended changes are for the dimensional specifications of 10, 12, and 16 millimeter brake tubing. Parker/Atofina stated that these revisions are currently in process by the SAE under project S4-J844-01-01. The agency has reviewed the recommended changes and notes in general that they serve to tighten the tolerances, compared to the values published in the NPRM. The agency is adopting Parker/Atofina's recommended changes.

Parker/Atofina also noted that in Table VII, the outside diameter of the 3/8-inch brake tubing is specified as 9.69 millimeters, but the value should be 9.63 millimeters (as it appears in SAE J844). The agency notes this correction and includes it in the final rule.

5. One Hundred Percent Leak Test

NPRM—NHTSA did not propose to incorporate the requirement in SAE J844 that requires tubing manufacturers to subject all air brake tubing to a 200-psi leak test. The agency stated its belief that this is a quality control test and not

a measure appropriate to include in FMVSS No. 106.

Public Comments and NHTSA's Response—Parker/Atofina commented that it believes that unless this requirement is mandated in FMVSS No. 106, manufacturers will not continue to perform the current quality inspections and controls, since the procedures represent added cost and require additional resources. NHTSA does not agree with this view. Manufacturers are required to take whatever steps are necessary to ensure that all of their plastic air brake tubing meets the full burst strength requirements in the standard ranging from 800 to 1,400 psi. NHTSA sees no additional safety need is met by requiring a 200 psi leak test in addition to a full strength burst test.

6. Burst Test

NPRM—NHTSA noted that in the existing FMVSS No. 106 test procedures, water is specified as a test medium, but that SAE J844 does not specify a medium. NHTSA considered air to be the more appropriate test medium for plastic air brake tubing rather than water. NHTSA proposed changing the burst strength requirements in FMVSS No. 106 to the higher values in SAE J844, and specifying air as the test medium rather than water. NHTSA proposed that the pressure in the tubing be increased in a period of 5 seconds because using the range of 3 to 15 seconds in SAE J844 would specify testing at both 3 and 15 seconds and therefore would be too broad of a specification for use in FMVSS No. 106.

Public Comments and NHTSA's Response—HPP, SMC, Parker/Atofina and SGPPL all recommended water (HPP recommended water or oil) as the preferred test medium because of concerns for the safety for the person conducting the test and cost factors. After considering this concern, NHTSA has decided to specify water as a test medium in all burst tests in this final rule, except for one test where oil is specified due to very low test temperatures.

SGPPL believes that FMVSS No. 106 should include a provision to prevent any conditioning of the air brake tubing sample prior to testing. SGPPL stated that polyamide material is hygroscopic and over time, will absorb water that will decrease the burst strength of the tubing. SGPPL recommended that the samples of tubing for the burst test be conducted on tubing as it is extruded from the production line.

NHTSA does not agree that samples of tubing should be tested to burst strength requirement only at the point of

production. Typically, the agency or test laboratories contracted to do testing for the agency will purchase samples of brake hose at a retail point of sale and those samples are required to meet the requirements in FMVSS No. 106. This is also reflective of the condition of brake hose when it is sold to and used by the public. The agency notes that this may require some diligence by the brake hose manufacturer to ensure that the manufacturer's distribution methods do not permit excessive degradation of brake hose products between manufacture and retail sale. NHTSA retains the existing FMVSS No. 106 requirement under S11 *Test conditions* (S13 in the NPRM) that brake hoses and brake hose assemblies must be at least 24 hours old, and unused.

In the NPRM, NHTSA proposed to apply the test pressure in the brake tubing in 5 seconds during a burst test, instead of within the range of 3 to 15 seconds as specified in SAE J844. NHTSA stated that if it were to adopt such a range, when NHTSA conducts the testing, the brake tubing would be required to meet the burst test at 3 seconds, at 15 seconds, and at any point in between 3 and 15 seconds. NHTSA stated that the specification "would be too broad of a specification for use in FMVSS No. 106." (See May 15, 2003 NPRM at page 26,398.) SGPPL stated that it does not exactly understand the agency's reasoning, but finds a range of 10 to 12 seconds to yield reliable, consistent results. SMC stated that instead of a timing requirement, a fixed flow rate should be specified rather than a time constraint, so that variable flow rates would not have to be used. However, SMC did not provide any details on what a suitable flow rate might be. Parker/Atofina stated that thermoplastic tubing possesses strain rate dependent properties such that if a tubing burst pressure is achieved under 3 seconds, a higher burst strength without failure can be achieved. It further stated that there is no one standard burst test apparatus that manufacturers could use, and specifying an exact 5 second timing requirement would require most costly and higher precision test equipment.

NHTSA believes that based on the comments, it may be difficult to achieve the 5-second timing with the existing test equipment in use. The agency notes that in the case of the burst strength test for a hydraulic brake hose as specified in FMVSS No. 106 at S6.2, the pressure in the brake hose is increased at a constant rate of 15,000 psi per minute. The precedent here is that a constant pressure increase rate is specified. Due to the costs and difficulty of achieving

the 5-second timing, in this final rule, NHTSA is going from a time increment to a pressure rate specification, as follows.

The burst strength pressures proposed for plastic air brake tubing are specified in Table VIII, and the specified burst strength pressures range from a low of 800 psi for 3/4-inch outside diameter tubing, to a high of 1,400 psi for 3/8-inch outside diameter tubing. To achieve an 800 psi pressure in 15 seconds, the application rate would be 3,200 psi per minute. To achieve a 1,400 psi pressure in 15 seconds, the application rate would be 5,600 psi per minute. NHTSA agrees with Parker/Atofina's comment that faster pressure application rates can affect the outcome of the test results. Therefore, in the final rule, the agency is adopting a test pressure application rate of 3,000 psi per minute (3,200 psi per minute rounded down to 3,000 psi). The test pressure application rate of 3,000 psi per minute is consistent with SMC's stated preference for a fixed flow rate, and should not result in manufacturers' having to purchase new test equipment, as 3,000 psi per minute is a relatively slow pressure increase rate.

7. Moisture Absorption

NPRM—NHTSA proposed incorporating the moisture absorption specification from SAE J844 into FMVSS No. 106. SAE J844 specifies a sample of air brake tubing is conditioned in a humidity chamber for 100 hours, and the required performance is that the sample cannot exceed a two percent weight gain of absorbed moisture.

Public Comments and NHTSA's Response—SGPPL stated that it believes the moisture absorption test is designed around polyamide (nylon) material and is design restrictive. SGPPL stated that the moisture absorption test is not performance-based and does not indicate failure. SGPPL also believed that the heat aging test, cold impact test, boiling water stabilization and burst tests would be satisfactory for evaluating the effects of moisture exposure on the properties of tubing. DuPont stated that although it has no objections to the moisture absorption test, it believed that it may be redundant to both the heat aged burst pressure test and the dimensional specifications test (boiling water conditioning and dimensional stability).

Based on the information it received, NHTSA does not agree that this proposed requirement is design restrictive in favor of nylon tubing. NHTSA agrees, however, that as SGPPL states, failure of the moisture absorption

test (excessive weight gain) does not directly indicate that the tubing has failed (*e.g.*, ruptured). In its prior comments regarding burst strength testing, SGPPL indicated that moisture absorption can affect burst strength. While DuPont believes that the moisture absorption test is redundant to other proposed test requirements, NHTSA notes that these tests involve soaking the tubing in boiling water for 2 hours, whereas the moisture absorption test involves a humidity soak of 100 hours. The outcome of these soakings would be affected if there were a difference in the water or moisture absorption rate of different materials.

NHTSA notes that in FMVSS No. 106 for hydraulic brakes, there are three performance requirements for hydraulic brake hose related to water absorption. After the hose is immersed in hot water for 70 hours (as specified in this final rule), brake hoses must pass a burst strength test, a tensile strength test, and a whip resistance test (separate tests, not conducted on the same hose).

If a sample of plastic air brake tubing were to fail the proposed moisture absorption test, the agency would then be able to show how that failure relates to a lessening of motor vehicle safety. If the agency could demonstrate a corresponding reduction in one or more mechanical properties of the tubing, NHTSA would be better able to demonstrate a relationship to motor vehicle safety. Therefore, in this final rule, NHTSA adopts a burst pressure strength requirement, rather than a weight gain limit, as the required performance criteria for this test requirement. NHTSA is using the same burst pressure requirement as for other tests that involve conditioning of the tubing, which is 80 percent of the burst strength in Table VIII.

8. Ultraviolet Resistance

NPRM—NHTSA tentatively concluded that the plastic material used in nylon air brake tubing is significantly different from the materials used in rubber air brake hoses, and that plastic is susceptible to deterioration that can cause embrittlement due to exposure to ultraviolet light. NHTSA proposed to incorporate SAE J844's ultraviolet resistance test into FMVSS No. 106. SAE J844 includes an ultraviolet (UV) resistance test using an accelerated weathering device specified as the Q-Panel QUV test apparatus equipped with Phillips lamps, type UVS-340. NHTSA did not refer to any brand name of equipment in the proposed regulatory text of FMVSS No. 106. Presumably this test equipment, except for the special UV lamps, can be custom manufactured

or purchased from a company such as Q-Panel.

The agency proposed to reference the apparatus specified in ASTM G154-00, *Standard Practice for Operating Fluorescent Light Apparatus for UV Exposure of Nonmetallic Materials*, rather than the one specified in ASTM G53 because ASTM G154-00 is an updated version of ASTM G53. NHTSA also proposed to reference two additional ASTM standards: ASTM D4329-99, *Standard Practice for Fluorescent UV Exposure of Plastics*, which is currently referenced in SAE J844, and ASTM G151-97, *Standard Practice for Exposing Nonmetallic Materials in Accelerated Test Devices that Use Laboratory Light Sources*, which is not currently referenced in SAE J844, but may provide useful guidance for conducting UV testing.

Public Comments and NHTSA's Response—SMC stated that the cost of purchasing a new system and performing the validation test on all sizes and configurations will need to be considered. SMC did not specify whether it has an older system that would need to be updated, or whether it has UV testing equipment. Parker/Atofina stated that the agency's proposal to require ASTM G-154-00 equipment will mandate that manufacturers will have to purchase a Q-Panel test apparatus with the Solar Eye irradiance measurement device. Parker/Atofina stated that this optional measurement device is not significantly relevant to the outcome or testing procedures required in the UV test for plastic tubing. Parker/Atofina stated that the alternate procedures in ASTM G53 and in SAE J844 are sufficient to display compliance with the current SAE J844 specification.

NHTSA disagrees that manufacturers will have to purchase new equipment that has the automatic irradiance control device. The requirement for the automatic irradiance control device is added to FMVSS No. 106 because the agency believes the device will provide the best available control of the UV irradiance level during the testing and reduce the likelihood of overexposure to UV light, compared to the alternate method of not using automatic irradiance control and rotating the lamps every 400 hours, discarding them after 1600 hours, and the other specified steps. NHTSA believes inclusion of automatic irradiance control will reduce variability in test results.

NHTSA believes that air brake tubing manufacturers will be able to use their existing UV test equipment if they are able to maintain the minimum specified irradiance level of 0.85 watts per square

meter. It is possible that equipment without irradiance measurement and control would result in higher irradiance levels and thus be more severe than the agency's required UV exposure requirement.

SMC commented that in the NPRM's section on *Rulemaking Analyses and Notices*, the capital cost to purchase a new ultraviolet test apparatus should be taken into consideration. SMC cited Executive Order 12866 for its position. In the NPRM, NHTSA discussed the cost issues resulting from the brake hose rulemaking and estimated the cost of upgrading brake hoses to meet with proposals in the NPRM to be in the range of zero dollars to \$1.6 million annually. Further, the agency stated that it did not believe that the rulemaking would have a significant economic impact on a substantial number of small entities. Regarding SMC's comments on the cost of purchasing new test equipment, NHTSA believes that the cost of such equipment may be on the order of \$5,000 to \$10,000, a sum that would not have a significant effect on NHTSA's estimated cost of this rulemaking.

Parker/Atofina stated that it believes NHTSA's proposed inclusion of ASTM D4329-99 and G 151-97 offer education to the reader, but do not add significantly to the testing procedure or to the requirements specified in SAE J844. Parker/Atofina recommended that references to ASTM G 53, as referenced in SAE J844, are sufficient. As NHTSA noted in the NPRM, G 53 has been replaced by G 154. NHTSA believes that it should reference the most current of these two ASTM standards, since a goal of the agency's rulemaking is to update FMVSS No. 106 and remove obsolete references.

The NPRM referred to three ASTM standards: G 154-00, which provides information on the spectral output of the UVA-340 lamps; G 151-97, which provides practices to maintain control of irradiance within a test device; and D 4329-99, which provides guidance on preparation of test samples, positioning in the test device, and interpreting test results. NHTSA believes that because these three ASTM standards are interrelated, they should all be included in FMVSS No. 106. Therefore, in the final rule, the agency is keeping references to all three ASTM standards.

ASTM commented that the latest revision of ASTM standard G 151 *Standard Practice for Exposing Nonmetallic Materials in Accelerated Test Devices that Use Laboratory Light Sources* was G 151-00. NHTSA agrees that ASTM G 151-00 is the latest revision and probatively tests plastic

tubing for ultraviolet resistance. In this final rule, NHTSA is incorporating ASTM G 151-00 in S12.7 *Ultraviolet light resistance test*.

9. Resistance to Zinc Chloride and Methyl Alcohol

NPRM—NHTSA proposed to incorporate the zinc chloride and methyl alcohol resistance requirements and test procedures from SAE J844 into FMVSS No. 106.

Public Comments and NHTSA's Response—DuPont stated that the agency's proposed test proposal was marginally adequate for FMVSS No. 106. It suggested considering adopting the requirements of ISO 7628 at S7.9.2, that includes resistance testing to zinc chloride, copper chloride, sodium chloride, and potassium chloride. In addition, testing discrete samples of brake tubing may be appropriate to evaluate all layers of the tubing, as may be found with cut ends of tubing or if an outer layer of the tubing is compromised. SGPPL also referenced the test in ISO 7628 and suggested that the agency may wish to review the test requirements. SGPPL stated that SAE is currently reviewing the ISO 7628 requirements and the ISO 7628 test may be needed, given the various chemicals used on roads today.

SGPPL requested a clarification that in the agency's proposed zinc chloride test, only the outside of the tubing is to be exposed during the test. SGPPL stated that the outside is the only part of the tubing that is exposed to zinc chloride while in operation on a motor vehicle. NHTSA agrees with this comment, and provides additional text in the final rule to clarify that the zinc chloride test is only conducted on the exterior of the tubing.

Regarding the incorporation of additional chemical resistance tests into FMVSS No. 106, the agency does not have sufficient information to include such incorporation in the final rule. NHTSA would also provide the public with an opportunity for comment before adopting additional chemical resistance tests.

HPP stated that the bend radius for the zinc chloride and methyl alcohol resistance tests (and also the high temperature flexibility tests) should be the test bend radius as specified in Table 2 of SAE J844, rather than two times the nominal outside diameter of the tubing as specified in the NPRM. This was also noted by Parker/Atofina. NHTSA has concluded that the commenters are correct and for the zinc chloride, methyl alcohol resistance, and high temperature flexibility tests, is

referencing the bend radii from FMVSS No. 106's Table VIII in the final rule.

10. Stiffness

NPRM—Because FMVSS No. 106 does not contain a similar set of procedures/requirements, NHTSA proposed to incorporate the stiffness procedures/requirements from SAE J844 into FMVSS No. 106. The stiffness test requires that a section of tubing is conditioned in a straight position at 230 degrees Fahrenheit for 24 hours, and after cooling and by using a special test fixture, the force required to deflect the tubing 2 inches at its ends is measured. The resulting force may not exceed a specified amount that ranges between one pound and 80 pounds depending on the diameter of the tubing. In the NPRM, the agency stated its belief that this test would ensure that the flexibility of the tubing is not reduced when the tubing is subjected to elevated temperatures.

Public Comments and NHTSA Response—SGPPL commented that it sees reasons to both include and exclude this test requirement from FMVSS No. 106. It believes that the stiffness test is not a true performance criterion for the tubing, and that stiffness is not linked to any failure mode. Stiffness also does not gauge form, fit, or function of the product. Historically, thermoplastic air brake tubing has replaced traditional steel and copper tubing air lines, and although much less stiff, plastic tubing stiffness does not affect the end functionality of the tubing. SGPPL stated that this test could be considered design restrictive and written around the use of plasticized polyamide material. SGPPL stated that the stiffness test does serve a purpose from the perspective of a truck original equipment manufacturer (OEM) in that overly stiff tubing would be too difficult to route during truck assembly.

SGPPL noted that the stiffness test as proposed in the NPRM did not include a pull rate specification that can affect the results of the test. It stated that it consistently uses a pull rate of one inch per minute.

NHTSA has considered SGPPL's comments and agrees that it would be difficult to identify how failures of the stiffness test would be detrimental to motor vehicle safety. The agency agrees that the stiffness test may serve a purpose for vehicle manufacturers that desire to specify a particular stiffness in their specifications for its airbrake tubing. NHTSA also believes that specific stiffness characteristics may be desirable for tubing used in applications such as when long runs of tubing are used on semitrailers versus tubing used

to plumb tractors. Therefore, NHTSA is not including the stiffness test in this final rule. In lieu of the stiffness test, NHTSA specifies a test for collapse resistance as a measure of brake tubing performance when subjected to elevated temperatures.

11. Heat Aging Adhesion

NPRM—NHTSA proposed to incorporate the heat aging adhesion test procedures from SAE J844. NHTSA also proposed that the minimum adhesion performance requirement for Type B tubing be changed from the SAE requirement of “no separation” to 25 pounds per linear inch. NHTSA described several problems in directly applying the SAE J844 requirements. Foremost is that during the adhesion test, in which air brake tubing made of two layers is separated at the layer interface by cutting it apart and then subject to being pulled apart at this juncture, SAE J844 states that no separation at the layer interface is permitted. NHTSA pointed out that this could not be adopted because the tubing will ultimately fail at some point during the test. NHTSA proposed a metric of 25 pounds minimum separation force per linear inch, based in part on a similar test that is contained in FMVSS No. 106 to measure the layer separation performance of elastomeric air brake hoses.

The agency proposed that rather than having a stand-alone adhesion test, the adhesion test would only be performed as specified in SAE J844 that includes a heat aging conditioning test. This would eliminate the need to run an adhesion test, and also a heat aging and adhesion test.

The agency also deviated from SAE J844 in that rather than preparing a test sample from a helical section of hose, with the cut line following one of the reinforcing braids in the tubing, NHTSA proposed that the sample be prepared from an inch-long sample of tubing cut through one side along its longitudinal centerline.

Public Comments and NHTSA's Response—SMC commented that the agency's proposal to include a process that generates numerical data is superior to what it used in SAE J844. SAE noted that the separation requirement for elastomeric air brake hose is 8 pounds per linear inch, and stated that the separation requirement in SAE J2547 (a draft document in committee) is 4.4 pounds per linear inch. SMC stated that the reason that air brake tubing layers would separate would be relative motion between the connections (end fittings). NHTSA notes that plastic air brake tubing is used in applications that

involve relative motion between components (e.g., the connections between tractors and trailers), but in those applications the tubing is in coiled form that generally distributes torsional and bending stresses over a great length of tubing. SMC also stated that the method of performing adhesion testing in SAE J2547 is still being drafted, and it did not provide any details as to what it might include.

DuPont stated that it agrees with the agency's proposed adhesion strength of 25 pounds per linear inch. It also stated that it believed the adhesion test to be potentially redundant since the performance in both the low temperature impact and heat age burst pressure tests would presuppose adequate bond strength.

SGPPL wrote in favor of adopting the 25 pounds per linear inch bond strength. It noted the difference between the sample preparation in SAE J844 which requires the cutting of a strip of tubing into a 6 millimeter wide helical coil (and other requirements) versus the NPRM proposal to cut a one-inch length of tubing cut lengthwise and cutting two flaps of material using a sharp knife to permit the test sample to be clamped in a tensile testing machine. SGPPL noted that if what is now a Type B tubing consisting of two layers were made as a single layer tubing, the bond strength test might not be needed. In addition, it posed the questions that if tubing were to be manufactured from several layers of different material bonded together, how would the adhesion levels be evaluated, and would it only be required at the bond interface of reinforcing material? SGPPL stated that it would be even more difficult to test between unreinforced layers of plastic than between a reinforced inner and outer layer.

HPP stated that there is no technical reason for a higher requirement for plastic tubing compared to elastomeric hoses. HPP has developed a method to determine the adhesion between layers of tubing, and references a ballot version of SAE J2260. However, HPP did not describe their test method, nor did it provide any further information about SAE J2260 that the agency could evaluate.

Parker/Atofina stated that the performance strength of Type B tubing is historically predicated on maintaining an inseparable bond between polymer layers across the yarn reinforcement interstitial areas within the tubing. Permitted separation between these tube and cover layers at the bond interface will result in tubing which kinks easily under mechanical stress. It states that the agency's

proposal of 25 pounds per linear inch is insufficient to ensure consistent plastic tubing and assembly performance. According to Parker/Atofina, the SAE J844-mandated inseparable bond test is intended to evaluate the integrity and manufactured quality of the Type B thermoplastic air brake tubing construction.

Regarding the agency's proposed test sample preparation method, Parker/Atofina stated that the preparation of an inch-long specimen is impractical and impossible with properly manufactured and inseparably bonded Type B tubing. It stated that the test sample must be cut through the entire tubing wall in a helical path nearly parallel to the reinforcement yarn lay pattern in order to gain access to the layer interface and allow physical and visual evaluation of the bond between the polyamide layers in the interstitial areas formed away from where the yarn lay patterns cross. The agency notes by examination of a typical 1/2 inch O.D. Type B air brake tube, the sample size defined in SAE J844 for this size tubing would be 0.25 inches by 7.85 inches. The agency does not know if this sample size would be large enough to mount in a tensile testing machine for evaluation. Under the agency's NPRM, the sample size would be approximately 1 inch by 1 1/2 inches for 1/2 inch O.D. air brake tubing.

Parker/Atofina stated that the SAE J844 adhesion test does not require a force measurement because the criterion for passing is an intimate bond as if the two layers were one. The need to specify a load is replaced by the visual examination between the two layers of contrasting colors.

The agency has reviewed all of the comments regarding adhesion testing and decided not to include the heat aging and adhesion test requirement in the final rule. It appears that the actual strength of the bond between layers of plastic tubing falls somewhere between 4.4 pounds per linear inch and something larger than 25 pounds per linear inch. The agency's proposed test method seemed acceptable to some commenters, but there were wide ranging viewpoints on what the acceptable adhesion strength should be. The SAE J844 test method appears unenforceable to NHTSA because it does not have any objective pass/fail metrics, such as a pounds force per linear inch strength requirement. The “no separation” specification in SAE J844, confirmed by visual inspection and not by a force measurement, does not seem to be a useful metric to determine the strength of the bond between tubing layers. In addition, as noted by SGPPL, alternate methods for

producing air brake tubing may include significantly different construction methods (more than two layers, or constructed without reinforcing braid) that would not be able to be easily tested to the procedure in SAE J844. It appears to NHTSA that the SAE committee working on SAE J2547 may be able to develop an alternate adhesion test method that the agency may be able to consider using in future rulemaking.

12. Collapse Resistance

NPRM—NHTSA proposed to incorporate the collapse resistance test procedures/performance requirements from SAE J844 into FMVSS No. 106, with two changes. First, the length of the pins that are used to attach the tubing in a bent position to the test fixture were specified as 1-inch or 50 millimeters in length, rather than left unspecified as in SAE J844. Second, the bend radii from Table 2 of SAE J844 were proposed to be adopted rather than the bend radii from SAE J844 Table 3, in order to have just one table of bend radii in FMVSS No. 106. The differences in the radii tables are slight, for example, for a ½ inch O.D. tube, Table 2 specified 2.00 inches versus 2.50 inches in Table 3, although for some other sizes of tubing, the radii in the two tables are the same. This made the proposal in FMVSS No. 106 slightly more rigorous than SAE J844, because in the collapse resistance test the tubing is bent without being supported by a test cylinder, and the bend radii in Table 2 are for bends that use a test cylinder for support as the tubing is bent around the cylinder.

Public Comments and NHTSA's Response—SMC stated that it find the agency's proposal acceptable. Parker/Atofina stated that the tubing sample length formulas specified in FMVSS No. 106 at S12.17(b) are less severe than in SAE J844. The diameter measurements in SAE J844 to validate the collapse resistance of tubing have been replaced with nominal diameters, lessening the severity of the bend test. NHTSA has carefully compared the requirements in SAE J844 with the NPRM, and cannot verify Parker/Atofina's statements. The diameter collapse measurement procedures proposed in Standard No. 106 at S12.15(c) *Calculation* are in fact the same calculation as used in SAE J844 at S9.14.5, and do not refer to a nominal diameter specification. The tubing samples specified in FMVSS No. 106 at S12.15(b) are the same as those in SAE J844. However, in FMVSS No. 106, the length of the supporting pins is specified while in SAE J844, the length of the supporting pins is not specified. For both FMVSS No. 106 and SAE J844,

the length of the supporting pins is considered in the length of the prepared tubing sample. NHTSA used different wording in the NPRM to amend FMVSS No. 106 than in SAE J844, partly to better describe the test procedure, and to avoid having to adopt Figures 3 and 4 from SAE J844 into FMVSS No. 106. NHTSA determined only that the collapse resistance proposed in FMVSS No. 106 is slightly more rigorous than in SAE J844 because of minor reductions in the bend radii used during the evaluation of collapse resistance for a few particular sizes of tubing.

Parker/Atofina also commented that the minimum kink radii from Table 3 of SAE J844 should be used for the collapse resistance test, and that Table VIII should be labeled "minimum kink radius" rather than "bend radius" as proposed in the NPRM.

For this final rule, after reviewing the proposed collapse resistance test and the comments provided, NHTSA has decided to amend the requirements from those proposed in the NPRM. Table VIII has been modified to include both sets of bend radii from SAE J844 (Table 2, Mechanical Properties, Test Bend Radius adopted into Table VIII of FMVSS No. 106 as "Supported Bend Radius," and Table 3, Minimum Kink Radius adopted into Table VIII of FMVSS as "Unsupported Bend Radius."). The supported bend radius values for metric sizes of brake tubing in Table VIII are taken directly from Table 2 in SAE J1394, but there are no values provided for Minimum Kink Radius in SAE J1394 that can be used for unsupported bend radius values in Table VIII in FMVSS No. 106.

NHTSA used the following approach to determine the unsupported bend radius values for metric sizes of air brake tubing for Table VIII:

1. The nominal diameter of 6 mm tubing is 0.236 inches, and is closer to ¼ inch tubing (0.250 inches), so the 1.00 inch unsupported bend radius for ¼ inch tubing was adopted.
2. The nominal diameter of 8 mm O.D. tubing is 0.315 inches, and is close to ⅝ inch tubing (0.313 inches), so the 1.50 inch unsupported bend radius for ⅝ inch tubing was adopted.
3. The nominal diameter of 10 mm O.D. tubing is 0.393 inches, and is close to ⅜ inch tubing (0.375 inches), so the 1.50 inch unsupported bend radius for ⅜ inch tubing was adopted.
4. The nominal diameter of 12 mm O.D. tubing is 0.472 inches, and is close to ½ inch tubing (0.500 inches), so the 2.5 inch unsupported bend radius for ½ inch tubing was adopted.
5. The nominal diameter of 16 mm O.D. tubing is 0.629 inches, and is close

to ⅝ inch tubing (0.625 inches), so the 3.00 inch unsupported bend radius for ⅝ inch tubing was adopted.

The agency adopts the term "unsupported bend radius" rather than Parker/Atofina's recommended "minimum kink radius" because during the collapse resistance test, the tubing is not permitted to kink. To use the term "kink" in FMVSS No. 106 may prove to be confusing.

The regulatory text of the test procedure in S12.15 has been modified in three respects from that proposed in the NPRM. First, the two supporting pins of the test fixture are not required to be adjustable, since pins only need to be set at a specified spacing as shown in Figure 5—Bend Test Fixture of SAE J844. The pin spacing requirement is now defined as twice the unsupported bend radius plus the nominal O.D. of the tubing, consistent with what is depicted in Figure 5 of SAE J844. In the NPRM, the pins were to be adjusted until the approximate bend radius was achieved on the brake tubing. The language in the final rule is simpler and has less opportunity for introducing variability. Second, a provision is added that the tubing should be bent in the direction of its natural curvature, consistent with SAE J844. Third, the term "elliptical minor diameter" is used rather than "minor diameter" to better indicate in geometric terminology where the initial and final diameter measurements of the tubing are to be taken.

13. Oil resistance

NPRM—NHTSA tentatively concluded that in the case of plastic air brake tubing, it would be more appropriate to evaluate a mechanical property of the tubing such as the ability to pass a burst test after conditioning in oil. NHTSA also concluded it is critical that plastic air brake tubing be resistant to oil exposure. Therefore, NHTSA proposed a test procedure for plastic tubing that combines existing FMVSS No. 106 oil conditioning criteria with the burst strength requirements of SAE J844. The proposed test procedure involved preparation of a tubing assembly, conditioning it in ASTM IRM 903 oil (which supercedes ASTM No. 3 oil as described in ASTM D471-98e1, *Standard Test Method for Rubber Property-Effect of Liquids*), and then subjecting the tubing to the burst test specified in SAE J844. NHTSA proposed that the tubing not burst at less than 80 percent of the burst pressure listed in Table 2 of SAE J844.

Public Comments and NHTSA's Response—HPP stated that the proposed oil resistance test should apply to

elastomeric brake hoses in addition to air brake tubing. SMC stated that the burst pressure of SAE J844 is more suited to testing tubing, and that the oil needs to be changed to stay consistent with the ASTM changes. SGPPL agreed that it is critical that plastic air brake tubing is resistant to oil, but stated that it has not performed any such testing as proposed in the NPRM. SGPPL asked if both the inner diameter and the outer diameter of the tubing were to be submerged in oil, and questioned whether the oil resistance requirements would be more suitable to brake hose assemblies as described in Section E, *Plastic Air Brake Tubing Assemblies and End Fittings*, of the NPRM. It stated that as proposed in the NPRM, it is a tubing material test, rather than a test for the mechanical properties of end fittings.

DuPont agreed with the addition of an oil resistance test to FMVSS No. 106. Parker/Atofina asked that its previous comments relating to the burst test (water used as the test medium and timing of pressure rise be measured) be considered for the oil resistance test as well.

After reviewing the comments, NHTSA also reviewed the proposed requirements for the end fitting retention test in S11.3.23, which was adopted from SAE J1131. This test evaluates the retention of end fittings that are used with plastic air brake tubing. A sample air brake tubing assembly is prepared, filled with hydraulic fluid and then pressurized to 50 percent of the burst strength pressure. This pressure is held for 30 seconds, and then the pressure is increased to 100 percent of the burst strength pressure. No leakage or separation is permitted.

The agency also reviewed the proposed thermal conditioning and end fitting retention test in S11.3.24 that was proposed to be adopted from SAE J1131. In this test, an air brake tubing assembly is prepared with end fittings, filled with hydraulic oil, and connected to a source of hydraulic pressure. The assembly is then conditioned in air at 200 degrees Fahrenheit for 25 hours with atmospheric pressure inside the tubing. The pressure is then increased to 450 psi while still at the elevated temperature, and held for five minutes. The pressure is reduced to atmospheric and the temperature reduced to 75 degrees Fahrenheit for one hour, and then the temperature is decreased to minus 40 degrees Fahrenheit for 24 hours. While at that temperature, the pressure is increased to 450 psi and held for five minutes, and the required performance is that no leakage or

separation from the end fittings is permitted.

Parker/Atofina's only recommendation for the thermal conditioning and end fitting retention test was to increase the pressure within 5 to 30 seconds during the pressure cycles to not hydraulically shock the system.

NHTSA evaluated all of the comments, reviewed the proposed test requirements, and reached the following conclusions. NHTSA has determined that the oil resistance test is intended to evaluate the properties of the tubing (S11.3.18 specifies that the air brake tubing shall not rupture or burst) although it may also evaluate the oil resistance properties of the end fittings, since end fittings must be installed to attach the tubing to the pressure test machine. Whether those end fittings are the same as the end fittings used on a vehicle, or are fittings designed to adapt the tubing to the pressure test device, is a decision to be made by the test sponsor. Both oil and water are non-compressible and will provide the same measure of performance. Therefore, the oil resistance test will be made final in this rule, but the pressure test medium (after the conditioning by soaking in oil) can be either water as suggested by Parker/Atofina for the final burst test, or oil at the manufacturer's option if cross-contamination of the water pressure source for the burst testing specified in S12.5 is a concern of the manufacturer.

The thermal conditioning and end fitting retention test is kept in the final rule for the purpose of evaluating end fitting retention when subject to thermal and pressure cycling. Water cannot be used in the thermal conditioning and end fitting retention test because of the low temperatures (minus 40 degrees Fahrenheit (minus 40 degrees Celsius)) involved. NHTSA noted in the NPRM that the hydraulic fluid in SAE J1131 did not have any particular specifications. NHTSA believes that if it changed the specification in the thermal conditioning and end fitting retention test to the ASTM IRM 903 oil, the test would be more suited towards ensuring that the end fitting retention test also provides a measure of oil resistance as well. The conditioning at 200 degrees Fahrenheit for 70 hours is similar to the requirements proposed for the oil resistance test except that a slightly higher oil soak temperature of 212 degrees Fahrenheit was proposed for the oil resistance test.

NHTSA adopts a constant pressure application and reduction rate of 3,000 psi per minute for all burst tests and pressure increases or decreases, to eliminate variability in the time of the

pressure application. NHTSA believes it has thus addressed Parker/Atofina's suggestion of a longer time limit for the pressure increases in the thermal conditioning and end fitting retention test.

NHTSA believes that with these changes, the plastic air brake tubing material and the end fittings of tubing assemblies will be able to be evaluated for oil resistance. NHTSA believes that both the outside and inside sections of brake hose tubing should be oil resistant, and includes this requirement in the oil resistance test. The thermal conditioning and end fitting test will only evaluate the oil resistance of those portions of the end fittings that are exposed to internal pressure in the tubing.

Finally, NHTSA notes that it may revisit the issue of the oil resistance test in a future rulemaking if this should become necessary.

NHTSA proposed that ASTM IRM 903 be the test medium for gauging air brake tubing and assemblies for oil resistance properties. NHTSA has reviewed the oil compatibility test in S3.7 of SAE J2494-3 *Performance Requirements for SAE J844 Non-Metallic Air Brake Tubing and Push-to-Connect Tube Fittings, with SAE J844 Air Brake Tubing as Used in Vehicular Air Brake Systems*, (described in more detail below), and notes that it is conducted using a mixture of 11 parts SAE 15W40CD type oil and one part SOFTC-2A contaminant. No commenter made note of this different reference oil specification. NHTSA is therefore keeping the ASTM oil specification in this final rule.

Regarding the end fitting retention test that was proposed as S12.24 in the NPRM (designated as S12.22 in this final rule), NHTSA is adopting Parker/Atofina's suggestion that water be used as the test medium rather than oil. Parker/Atofina stated that water is a cleaner test medium than hydraulic oil, and the agency believes that there are no special temperature requirements that preclude the use of water in this test. The pressure increase rate is being specified as 3,000 psi per minute as it is for all other test requirements relating to pressure tests for air brake tubing.

NHTSA is not adopting HPP's suggestion to subject elastomeric air brake hoses to the oil resistance test in this final rule. NHTSA notes that these types of brake hoses are subjected to a different type of oil resistance performance test that appears to be effective in ensuring adequate safety of these brake hoses.

14. Ozone resistance

NPRM—NHTSA proposed an ozone test for plastic air brake tubing in which a sample of tubing is bent around a test cylinder and exposed to ozone at a concentration of 100 parts ozone per hundred million parts of air, for 70 hours at a temperature of 104 degrees Fahrenheit. The required performance is that no cracks are visible when the tubing is viewed under 7x magnification.

Public Comments and NHTSA's Response—Parker/Atofina stated that thermoplastic air brake tubing does not require ozone testing because polyamide nylon is not affected by ozone. HPP stated that it supports the ozone test for plastic tubing, but it recommended that for tubing used with barbed end fittings, a test of the tubing with the end fittings attached should be conducted with a longer exposure time of 500 hours. DuPont acknowledged the importance of having an ozone resistance test in FMVSS No. 106. Several commenters noted that the agency had incorrectly stated the proposed ozone concentration in parts per million rather than parts per hundred million (pphm). The correct ozone concentration level of 100 pphm is included in this final rule.

NHTSA notes that for all types of brake hoses in FMVSS No. 106, the ozone concentration is being increased from 50 to 100 pphm in accordance with the latest SAE standards. As such, this represents an increase in the severity of the test condition. NHTSA does not believe that it would be appropriate to increase the exposure time from 70 to 500 hours at this time, as recommended by HPP. NHTSA believes that there is little or no use of barbed hose fittings on air braked vehicles in the United States, as the most common styles are push-to-connect and flanged sleeve compression fittings.

F. Plastic Air Brake Tubing Assemblies and End Fittings

1. General Comments

In the *NPRM*, NHTSA proposed to incorporate the substantive requirements of SAE J1131 *Performance Requirements for SAE J844 Nonmetallic Tubing and Fitting Assemblies Used in Automotive Air Brake Systems* into FMVSS No. 106. NHTSA noted that the petitioners did not ask NHTSA to adopt the requirements of this SAE standard into FMVSS No. 106. The petitioners had instead asked that NHTSA adopt the requirements of SAE J512 *Automotive Tube Fittings and SAE J246 Spherical and Flanged Sleeve (Compression) Tube Fittings*. These two

latter standards include specific dimensional requirements for the end fittings and components of fittings. The agency tentatively determined that rather than specifying the dimensions of the fittings, it would be more appropriate to specify the performance of the fittings per SAE J1131, to assure that the end fittings used along with air brake tubing work properly as an assembly.

Parker/Atofina stated that it believes that end fitting dimensional, material, performance and safety requirements referenced in SAE J246 and SAE J512 specifications should be retained, so that the components of end fittings from different manufacturers would continue to be compatible. As stated in the *NPRM*, the agency does not desire to include these dimensional specifications (which are in effect design specifications), but proposed instead to adopt the performance requirements for these fittings when used with plastic air brake tubing.

SMC, SGPPL, and Parker/Atofina made reference to three SAE Standards: J2494-1 *Push-to-Connect Tube Fittings for Use in the Piping of Vehicular Air Brake*, Rev. May 2000; J2494-2 *Dimensional Specifications for Non-Metallic Body Push-to-Connect Fittings Used on a Vehicular Air Brake System*, Rev. October 2002; and J2494-3 *Performance Requirements for SAE J844 Non-Metallic Air Brake Tubing and Push-to-Connect Fitting Assemblies Used in Vehicular Air Brake Systems*, Rev. July 2002. SMC stated that incorporation of SAE J2494-3 would benefit the evaluation of the FMVSS No. 106 revision. SGPPL stated that since push-to-connect fittings are widely used in both preformed air brake tubing assemblies and in routing bulk air brake tubing lines in trucks, NHTSA should consider the use of both push-to-connect and compression fittings. Parker/Atofina recommended that FMVSS No. 106 include the sample size requirements of SAE J2494-3 and the performance requirements of SAE J1131. Regarding Parker/Atofina's issue with sample sizes for testing, the agency has already described that sampling as an issue for manufacturers to use for quality control methods, but that every brake hose that is DOT certified must meet the requirements of FMVSS No. 106.

The agency was not aware of the SAE J2494 series of standards for push-to-connect fittings when it published its *NPRM*. After reviewing these standards, NHTSA believes that adding the substantive end fitting performance requirements of SAE J2494-3 to FMVSS No. 106 would help ensure safety.

However, NHTSA notes that incorporating SAE J2494-3 requirements into FMVSS would encompass an extensive series of test procedures including a tensile test (with high temperature, boiling water, and water absorption conditioning); thermal and pressure cycling and air leakage; vibration test; fitting pressure test; frozen water retention test; reassembly test; oil compatibility test; corrosion resistance test; side load leakage; moisture absorption; ultraviolet light resistance; zinc chloride and methyl alcohol resistance; and cold temperature impact. NHTSA would not issue a final rule amending FMVSS No. 106 by incorporating these tests without first putting forth a notice soliciting public comments on its proposal to include the tests. Some of the performance requirements included in the *NPRM* and this final rule provide similar coverage of the SAE J2494 requirements. Therefore, NHTSA will first complete its May 15, 2003 proposed rulemaking by issuing this final rule. At future date, NHTSA may consider proposing to add the outstanding requirements from SAE J2494.

2. Tensile Strength

NPRM—NHTSA proposed adopting similar tensile strength requirements for plastic air brake tubing as FMVSS No. 106 currently specifies for elastomeric air brake hose. The *NPRM* included slight reductions in tensile strength for the smallest sizes of plastic air brake tubing, proposing 35 pounds for 1/8 inch and 40 pounds for 5/32 inch tubing, in applications that are not between the frame and axle of a vehicle or between a towing and towed vehicle. The lowest specification for elastomeric brake hoses in the same application is 50 pounds if it is 1/4 inch or less nominal inside diameter.

NHTSA developed its proposed requirements for small diameters of plastic air brake tubing based in part on a comparison of brake hose and tubing. Air brake tubing is sized by outside diameter rather than inside diameter (as brake hose is sized), and therefore, the sizes are not directly comparable. A 1/4 inch outside diameter brake tube would be smaller than a 1/4 inch inside diameter brake hose, and therefore would not be expected to have the same tensile strength.

NHTSA noted that in the text on page 26403 of the *NPRM* that it correctly stated its intentions of a 35-pound strength for 1/8 inch tubing and 40 pounds for 3/32 inch tubing. However, Table VIII on page 26417 included incorrect values of 15 pounds for 1/8 inch tubing (which should have been 35

pounds) and of 40 pounds for $\frac{3}{16}$ inch tubing (it should have been 50 pounds). These are corrected in the final rule. The values in Table VIII for $\frac{3}{32}$ inch tubing were correct in the NPRM.

Public Comments and NHTSA's Response—SGPPL stated in its comments that it agrees with NHTSA's proposed reduction in tensile strength for $\frac{1}{8}$ inch and $\frac{5}{32}$ inch tubing. SGPPL stated that the 50-pound value used by SAE for $\frac{1}{8}$ inch tubing and $\frac{5}{32}$ inch tubing are not achievable using current products in the market place, as the tubing yields and breaks before a 50-pound value is attained in testing. SGPPL stated that the proposed values of 35 pounds and 40 pounds respectively are achievable using current tubing constructions.

SMC stated that the values in SAE J1131 (15 pounds for $\frac{1}{8}$ inch, 40 pounds for $\frac{5}{32}$ inch) reflect the tensile strength of current tubing material, and that higher values in SAE J2494 (50 pounds for $\frac{3}{32}$ through $\frac{1}{4}$ inch) is intended to meet the requirements are currently stated in FMVSS No. 106 and may be higher than the application requires and also may be design restrictive. SMC stated that the agency's proposal for reduced tensile strength requirements reflects the current capability of nylon tubing. However, NHTSA notes that SMC shows in its table of tensile strength the incorrect values that were included in the NPRM (15 pounds for $\frac{1}{8}$ inch and 40 pounds for $\frac{3}{16}$ inch). SMC also noted another error in Table VIII of the NPRM, where the correct tensile strength values for $\frac{3}{8}$ inch tubing should be 667 N or 150 pounds. The correct values are stated in the final rule.

Parker/Atofina stated that the present plastic tubing sizes and constructions specified in SAE J844 can meet the tensile strength requirements in FMVSS No. 106 and it did not see a basis for lowering these requirements. Parker/Atofina also asserted that the agency provided no engineering basis for its decision. NHTSA notes that it described in detail the reasons for lowering the tensile strength requirements for small diameters of tubing, including the fact that small diameters of air brake tubing are smaller than equivalent sizes of elastomeric air brake hose. Parker/Atofina did not describe how it views the requirements in SAE J1131, where the tensile strength requirements are specified for tubing assemblies that are lower than the values that NHTSA proposed in the preamble of the NPRM.

Based on the available information and comments received, NHTSA believes that the proposed tensile strength values for small diameters of

plastic air brake tubing are attainable by current plastic air brake tubing and therefore will incorporate these tensile strength values in this final rule.

Several commenters indicated that the proposed regulatory text for the plastic air brake tubing in S12.20 incorrectly referred to the procedure in S6.9 *Dynamic Ozone Test* instead of S6.4 *Tensile Strength Test*. The correct procedure is referred to in this final rule, except that the tensile strength test procedure for air brake hoses in S8.9 is referenced (S6.4 is for testing hydraulic brake hose) since it only includes a slow-pull test. SMC commented that the fixtures for holding the test specimen should be arranged so that the tubing and fittings have a straight centerline corresponding to the direction of the machine pull, and that the fitting should be mounted in the test machine using the same method as is used to mount the fitting on a vehicle. SMC suggested that non-threaded fittings would need further evaluation. NHTSA is adding a provision to S8.9 to include that a tubing assembly (or air brake hose) is to be arranged in a straight line when installed on the tension testing machine.

Parker/Atofina stated that it would be difficult to conduct the tensile test on coiled air brake tubing with the fixtures and procedures specified in SAE J1131 and proposed for FMVSS No. 106. Parker/Atofina requested that coiled air brake tubing be exempted from tensile testing requirements. As NHTSA stated in the NPRM, coiled air lines are commonly used for the connections between tractors and trailers, and normally function so that tensile loads on them are spread out over the long length of the coiled tubing. However, these coiled lines can get tangled among themselves, among various components (springs and poles) that are used to support the lines above the truck frame, or with the electrical cable. Further, NHTSA noted that these air lines are completely exposed to the elements, are frequently connected and disconnected, and may be subjected to various amounts of stretching depending on the physical dimensions of the trailers that are towed. The agency does not believe therefore that these air brake tubing assemblies should be exempted from tensile strength requirements. The tensile tests evaluate the connection of the plastic air brake tubing to the end fitting, and these portions of a coiled assembly can be evaluated by cutting off each end to a short length and testing each of these samples to the tensile strength requirements. Also, FMVSS No. 106 allows test samples to be made for such evaluations, by using the actual end fittings from the coiled assembly

coupled to a straight section of air brake tubing if a coiled section of tubing cannot be easily straightened to fit on the test machine. The end fittings are to be attached according to the end fitting manufacturer's instructions. NHTSA assumes that both coiled and straight air brake tubing have the same dimensional specifications and would perform similarly at the point of connection to the end fittings.

3. Hot tensile strength

NPRM—NHTSA proposed that the hot tensile strength requirement from SAE J1131 be incorporated into FMVSS No. 106. Considering that SAE J1131 does not include tensile loads for metric sized plastic brake tubing, however, the agency proposed to specify tensile load values for metric sized plastic brake tubing.

Public Comments and NHTSA's Response—Many of the comments regarding unconditioned tensile strength discussed in the above section "Tensile Strength," also apply to this test requirement. The agency is adopting the corrected, proposed tensile strength requirements in Table VIII of FMVSS No. 106 in this final rule.

SMC commented that a straight pull should be indicated as in the section on "Tensile Strength." NHTSA agrees. In this final rule, NHTSA adds the provision on straight pull to the regulatory text.

SGPPL stated that the test conditions in SAE J1131, upon which the agency based its proposal, may be inadequately defined. SGPPL stated that variations in hot tensile test results may be introduced by the vessel size and rate of boiling water evaporation, and the agency should consider more stringently-specified variables such as air flow over the exposed length of tubing. Further, it would want to review any proposed values for metric-sized plastic tubing before they are incorporated into FMVSS No. 106. The agency agrees that there could be very slight variations since the heat application rate, type of vessel, and other variables are not specified, but in general NHTSA believes the variables would not affect the test results since water will boil at 212 degrees Fahrenheit (100 degrees Celsius) at standard atmospheric pressure, and cannot get hotter. NHTSA believes that as a minimum performance test, the vessel must be large enough so that at all times, four inches of tubing is submerged, as the water is brought to a boil and during the five minutes of conditioning at the boiling point. As to the rate of heating the water, the agency believes that the amount of heat and the

method of applying the heat must be considered so that the water is brought to a boil without excessively heating the end fitting of the brake tubing assembly placed in the vessel. Therefore, in the final rule, when NHTSA performs the test, it will bring the water to a boil without the brake hose in place. The hose is placed after the water comes to a boil.

NHTSA reviewed the changes between the March 1997 and August 1998 revisions of SAE J1131 and notes that in the March 1997 revision, the water is brought to a boil and then allowed to continue boiling for five minutes. In the August 1998 revision, it is stated that the tubing is placed in the boiling water for 5 minutes. In the final rule, NHTSA is changing the regulatory text so that the water is first brought to a boil and then the tubing assembly is placed in it. Placing the tubing assembly after the water is brought to a boil will minimize the heating of the end fitting during the time the water is brought up to boil, but will require a rapid method of connecting the brake tubing assembly to the tensile testing machine while the water is boiling. Presumably, this would not be too difficult. The heat input required, mass of the vessel, and other variables must be at a minimum sufficient to keep the water boiling as the tubing assembly is placed in the water, and as it is conditioned for five minutes in the water.

Parker/Atofina stated that the hot tensile strength requirements for metric plastic air brake tubing must be consistent with those proposed by SAE in revisions of SAE J1394. However, Parker/Atofina does not indicate what those values are, as the agency finds that the tensile strength requirements are in SAE J1131 and not SAE J1394 or SAE J844. SAE J1131 does not include metric sizes of air brake tubing and therefore there is no specified tensile strength for these sizes. In a previous comment, Parker/Atofina stated, concerning tensile strength requirements, that the present plastic tubing sizes specified in SAE J844 and SAE J1394 can meet the tensile strength requirements specified in FMVSS No. 106. In the absence of any information to the contrary, in this final rule, NHTSA is keeping the proposed tensile strength values in FMVSS No. 106 Table VIII.

Parker/Atofina stated that the correct column heading for the tensile strength values should be "conditioned tensile load" to prevent confusion with the tensile strength requirements in S11.3.19. NHTSA agrees, and has made this change in the final rule.

NHTSA's proposed description of measuring free length at the end fittings

for air brake tubing assemblies (in several tests for air brake tubing) was: "The free length is measured from the innermost crimp, ferrule, taper, or other mechanical joint that secures the fitting to the tubing and spring guards and other appurtenances are disregarded for measurement purposes."

Parker/Atofina recommended that "free length" be defined simply as the exposed tubing between two end fittings. NHTSA has considered this change and agrees that the simpler definition would suffice. This final rule includes the simplified definition in the regulatory text of FMVSS No. 106 for all free length measurements of plastic air brake tubing assemblies.

4. Vibration Leak Test

NPRM—NHTSA stated its belief that the SAE J1131 performance requirements/test procedures ensure adequate end fitting performance to resist vibration and temperature cycling. NHTSA proposed to adopt the requirements from SAE J1131 in which an 18-inch long brake hose assembly is subjected to 1,000,000 vibration cycles while being thermally cycled between 220 degrees Fahrenheit and minus 40 degrees Fahrenheit. The low temperature leakage rate just prior to completion of the test is not to exceed 50 cubic centimeters per minute, and at room temperature, the leakage is not to exceed 25 cubic centimeters per minute.

Public Comments and NHTSA's Response—SGPPL commented that similar testing is in SAE J2494 covering push-to-connect fittings and may warrant review. SMC commented that the leakage rate in SAE J2494-3 is 7 cubic centimeters per minute at minus 40 degrees Celsius and 5 cubic centimeters per minute at 24 degrees Celsius, and that the vehicle manufacturers requested a lower leakage rate to reduce overall system leakage.

NHTSA agrees that while a lower leakage rate would be better for air leak reduction on vehicles, it was not aware of the SAE activity on J2494. Before adopting lower leakage values, the agency would first need to publish them for public comment. Therefore, in this final rule, NHTSA is adopting the values as proposed in the NPRM. In the future, NHTSA may propose adopting the lower leakage rates, and solicit public comment on the lower rates.

5. Proof and Burst Test (End Fitting Retention)

NPRM—NHTSA proposed to incorporate the proof and burst test from SAE J1131 into FMVSS No. 106 so that there will be a specific test to evaluate the performance of end fittings used

with plastic tubing. NHTSA proposed that this test be conducted using water, as this is the test fluid used for the burst strength test for air hoses in FMVSS No. 106. The tubing assembly is pressurized to one-half of burst strength pressure and held at that pressure at 30 seconds, and then the pressure is increased to burst pressure. The end fitting is not permitted to leak or separate from the tubing.

Public Comments and NHTSA's Response—SGPPL and Parker/Atofina noted some discrepancies between the preambular language in the NPRM and the proposed regulatory text. These problems have been corrected in the final rule, as they have for other burst tests in FMVSS No. 106. Water is specified as the test medium, and the regulatory text is changed to a constant 3,000 psi per minute pressure increase rate at each stage of pressure increase in the test.

Parker/Atofina notes that a visual inspection for leakage is only to be conducted at the one-half burst pressure point as it would not be safe to visually inspect the tubing assembly at the full burst pressure. Parker/Atofina states that visual inspection of the assembly at full burst pressure should not be conducted. In the final rule, NHTSA is removing references to visual inspection for the proof and burst test and also the thermal conditioning and end fitting retention test. The required performance specification continues to remain that the assembly shall not rupture.

SMC stated that common practice is for the proof pressure to be 50 percent of the burst pressure or 375 psi for end fittings, and the agency notes that this is covered in the first pressure hold of the proposed proof and burst test. SMC stated that the failure mode of end fitting tests is typically in the tubing. An additional test of the fitting can be conducted by plugging the tube end and then pressurizing the threaded connection to failure or 1,500 psi. However, NHTSA is most concerned about the performance of end fittings when they are connected to the brake tubing. NHTSA may consider stand-alone pressure tests of end fittings in a future rulemaking.

6. Serviceability Test

NPRM—NHTSA proposed that the serviceability test be included in Standard No. 106 for those fittings that use a threaded retaining nut. NHTSA proposed to adopt the serviceability test from SAE J1131 in which the fitting is assembled and disassembled four times. After a fifth reassembly, the fitting is subjected to a 120 psi pressure test. The permitted leakage is not to exceed 25

cubic centimeters per minute when measured with a mass flow meter.

NHTSA stated its belief that the serviceability test will ensure that the fittings can be separated and reused during servicing of brake system components with minimal likelihood of leakage upon reassembly. NHTSA stated it did not believe the serviceability test could be consistently applied to push-to-connect fittings and therefore did not propose to include them in the serviceability test.

Public Comments and NHTSA's Response—SGPPL referenced SAE J2494-3 requirements for a similar reassembly test for push-to-connect fittings contained in S3.6 of that standard. Under those requirements, a push-to-connect fitting is connected to a section of air brake tubing, and then pressurized to 120 psi and held at that pressure for five minutes. The assembly is depressurized and disconnected, and the sequence repeated. After the sixth assembly and pressurization, the leakage is measured with a mass flow meter and is not permitted to exceed 5 cubic centimeters per minute. No trimming of the tubing end is permitted during the test sequence.

Parker/Atofina correctly stated that in the NPRM, the test method was identified as 12.26, but that the corresponding test requirements were not included in S11. The agency notes that although not included in S11, the preamble on page 26,404 presented and discussed the proposed test requirements that would be adopted from SAE J1131.

In this final rule, the agency is adopting its original proposal to include this test for threaded fittings only. As stated in the NPRM, the serviceability test is used to evaluate end fitting performance for reusable fittings after repeated assembly and disassembly. No specifications for push-to-connect fittings will be specified in the serviceability test. The agency believes that push-to-connect fittings should be included, but the test procedure for them in SAE J2494 is different from the agency's proposal because the tubing assembly is pressurized and then depressurized during each reassembly cycle. Further, the leakage rates in SAE J2494 are significantly lower than those proposed to be adopted from SAE J1131, and NHTSA believes that an opportunity for public comment would be needed before adopting the more stringent requirement. NHTSA may revisit these issues in a future rulemaking.

No comments were received on the proposed pressure increase time in S12.26(c) in which the tubing assembly

is pressured to 120 psi in a period of two seconds. In the final rule, the agency is specifying the pressure increase as 3,000 psi per minute in order to be consistent with other performance requirements involving pressure increases for air brake tubing. This would yield an elapsed time of 2.4 seconds from zero to 120 psi and this is consistent with the 2-second time interval that was proposed in the NPRM.

7. End Fitting Dimensional Requirements

NPRM—NHTSA provided an extensive discussion of why it did not propose to incorporate the dimensional requirements for end fittings as specified in SAE J246 and SAE J512 into FMVSS No. 106. For example, SAE J246 and SAE J512 do not include any metric-sized tubing end fittings that the agency could adopt into FMVSS No. 106. Other types of brake hoses, including hydraulic, vacuum, and air, do not have end fitting dimensional requirements in FMVSS No. 106 and these brake hoses have not shown any field problems due to the end fitting dimensional specifications. There is also an SAE J246 provision stating that it is not intended to restrict or preclude other designs of a tube fitting for use with SAE J844 brake tubing. NHTSA tentatively concluded that the performance tests for end fittings as specified in SAE J1131 were appropriate to adopt into FMVSS No. 106, as various end fittings can be used in meeting these requirements.

Public Comments and NHTSA's Response—Parker/Atofina, whose predecessor companies were parties to the petition for rulemaking to include these requirements in FMVSS No. 106, stated that the agency's proposal not to retain end fitting specifications from SAE J246 and SAE J512 creates significant safety issues related to form, fit, function and component assembly compatibility. Parker/Atofina stated that without the dimensional and geometric requirements defined in those SAE standards, end fitting components from one manufacturer will not connect, fit and function properly when mated together.

NHTSA believes that end fitting manufacturers will continue to use the SAE standards for end fittings, but is not convinced of the need to incorporate them into FMVSS No. 106. NHTSA believes that the minimum need to ensure the safety of air brake tubing and assemblies is met through adopting the proposed performance specifications and dimensional requirements for the tubing so that replacement tubing will

be compatible with the end fittings. This is what has been done for many years for air brake hose. NHTSA is not aware of noted safety problems resulting from this practice.

8. End Fitting Corrosion Resistance

NPRM—NHTSA tentatively concluded that the existing corrosion resistance requirements in FMVSS No. 106 assure adequate integrity of end fittings, and in one respect is more strenuous than the SAE standards. NHTSA proposed to use the existing end-fitting corrosion resistance tests in FMVSS No. 106 that includes a 24-hour exposure to salt spray in the new section for plastic air brake tubing assemblies. NHTSA noted that SAE J246 and SAE J512 specify a longer, 72-hour exposure to salt spray for end fittings made from carbon steel, but the corrosion resistance test is performed on an end-fitting without attaching it to a brake hose. NHTSA proposed to keep the existing 24-hour exposure and test end fittings as they are attached to the brake hose, that is representative of how brake hose assemblies are installed on motor vehicles.

Public Comments and NHTSA's Response—Parker/Atofina stated that it agreed with NHTSA's proposal to include the 72-hour duration for the salt spray exposure. NHTSA in fact had asked for comments on increasing the exposure to 72 hours, but proposed that 24 hours of exposure be kept in FMVSS No. 106. Parker/Atofina provided no additional discussion on this subject.

SMC recommended that the corrosion resistance test also apply to plastic tubing in addition to the end fitting. NHTSA noted in the section discussing zinc chloride and methyl alcohol resistance that it may consider additional chemical resistance tests for air brake tubing, but it would first need to gather more information in this subject. After reviewing the comments, NHTSA is adopting the end fitting corrosion resistance test as proposed in the NPRM.

G. New Types of Brake Hose

The commenters brought to NHTSA's attention the following new types of brake hose. New hydraulic brake hose configurations have been developed in recent years that deviate from the conventional configuration of a length of hose with a fitting at each end. Intertek indicated that many brake hose assemblies are made of multiple-part sections (e.g., three sections of hose and two sections of metal tubing), that make determination of free hose length and conducting the whip test difficult. Dana indicated that wire-reinforced hydraulic

brake hose is being used on leisure vehicles, motorcycles, and as a performance option for light vehicles and as an aftermarket product, and stated that it might be best to provide a separate section in FMVSS No. 106 for wire-reinforced hydraulic brake hose. Intertek noted that stainless steel braided brake hoses have properties that differ significantly from traditional synthetic rubber brake hoses. HPP indicated that plastic vacuum brake booster lines are being used, in lieu of traditional rubber vacuum brake hose, and recommended that a suitable industry standard be developed in cooperation with end users and tubing suppliers.

NHTSA agrees that new developments in brake hoses may warrant additional consideration for FMVSS No. 106 rulemaking. However, NHTSA believes it is appropriate to first complete the initial updating of FMVSS No. 106 before considering further upgrades.

H. Metallic Tubing and Pipe

Parker/Atofina recommended that requirements be adopted for metallic brake tubing and pipe as specified in SAE J1149 June 1991 *Metallic Air Brake System Tubing and Pipe*. It disagreed with NHTSA's NPRM statement that such materials were no longer widely used in air brake systems. However, as NHTSA noted in the NPRM (68 FR 26386), it did not propose to adopt SAE standards relating to copper tubing, galvanized steel pipe, or end fittings used with metallic tubing because even though these materials are occasionally used in chassis plumbing, they are not considered to be brake hoses. It would therefore not be appropriate to incorporate the substantial requirements of SAE J1149 into FMVSS No. 106. There were no other comments on this issue, and in this final rule, NHTSA is not including requirements for metal air brake tubing and pipe into FMVSS No. 106.

VI. Statutory Bases for the Final Rule

We have issued this final rule pursuant to our statutory authority. Under 49 U.S.C. Chapter 301, *Motor Vehicle Safety* (49 U.S.C. 30101 *et seq.*), the Secretary of Transportation is responsible for prescribing motor vehicle safety standards that are practicable, meet the need for motor vehicle safety, and are stated in objective terms. 49 U.S.C. 30111(a). When prescribing such standards, the Secretary must consider all relevant, available motor vehicle safety information. 49 U.S.C. 30111(b). The Secretary must also consider whether a

proposed standard is reasonable, practicable, and appropriate for the type of motor vehicle or motor vehicle equipment for which it is prescribed and the extent to which the standard will further the statutory purpose of reducing traffic accidents and deaths and injuries resulting from traffic accidents. *Id.* Responsibility for promulgation of Federal motor vehicle safety standards was subsequently delegated to NHTSA. 49 U.S.C. 105 and 322; delegation of authority at 49 CFR 1.50.

As a Federal agency, before promulgating changes to a Federal motor vehicle safety standard, NHTSA also has a statutory responsibility to follow the informal rulemaking procedures mandated in the *Administrative Procedure Act* at 5 U.S.C. 553. Among these requirements are **Federal Register** publication of a general notice of proposed rulemaking, and giving interested persons an opportunity to participate in the rulemaking through submission of written data, views or arguments. After consideration of the public comments, we must incorporate into the rules adopted, a concise general statement of the rule's basis and purpose.

The agency has carefully considered these statutory requirements in promulgating this final rule to amend FMVSS No. 106. As previously discussed in detail, we have solicited public comment in an NPRM and have carefully considered the public comments before issuing this final rule. As a result, we believe that this final rule reflects consideration of all relevant available motor vehicle safety information. Consideration of all these statutory factors has resulted in the following decisions in this final rule.

This rulemaking began with NHTSA's proposal to adopt certain requirements relating to brake hoses, brake hose tubing, and brake hose fittings that are presently administered by the Federal Motor Carrier Safety Administration (FMCSA) into FMVSS No. 106. Since FMCSA proposed to remove brake hose provisions from its regulations, NHTSA believed it would meet the need for safety to incorporate the FMCSA requirements into FMVSS No. 106. In this way, NHTSA could continue to ensure the safety of commercial motor vehicle braking systems. NHTSA responded to an industry petition to include the FMCSA provisions into the FMVSSs.

In the NPRM, NHTSA also sought to update FMVSS No. 106, which has not been substantially updated in many years. Thus, in the NPRM, NHTSA compared SAE standards with FMVSS

No. 106 provisions, and proposed to include the provisions that it believed were the more rigorous. When SAE standards are used, NHTSA proposed to use the most current SAE standards. NHTSA also believed that it would better meet the need for safety to require that all brake hoses, not only those to be used on commercial vehicles, meet the new, upgraded FMVSS No. 106 requirements.

Using this reasoning, NHTSA proposed to amend FMVSS No. 106's performance requirements and test procedures relating to: (a) Hydraulic brake hose; (b) air brake hose; (c) vacuum brake hose; (d) plastic air brake tubing; and (e) plastic air brake tubing assemblies and end fittings.

In response to the NPRM, NHTSA received public comments from 11 organizations and companies. The public commenters generally supported NHTSA's proposal to amend FMVSS No. 106 to include the latest requirements in the SAE brake hose standards. For many of the test conditions, the commenters provided detailed information on test methods and procedures.

We have thoroughly reviewed the public comments and amended the final rule to reflect the comments. In a few instances where we did not adopt a comment, we explain why we believed it would not meet the need for safety to adopt the comment. We believe that this final rule, which combines the most rigorous requirements of the latest SAE standards, and of FMVSS No. 106, meets the need for safety.

VII. Effective Date

In the NPRM, the agency proposed an effective date of two years after publication of a final rule (68 FR 35354). NHTSA received one comment on the effective date issue. SGPPL stated that it believes that two years to meet with the published changes would be sufficient. Accordingly, as proposed in the NPRM, this final rule will take effect two years after publication in today's edition of the **Federal Register**. At each manufacturer's discretion, optional early compliance will be permitted 60 days from the date this final rule is published in the **Federal Register**.

VIII. Rulemaking Analyses and Notices

A. Executive Order 12866 and DOT Regulatory Policies and Procedures

Executive Order 12866, "Regulatory Planning and Review" (58 FR 51735, October 4, 1993), provides for making determinations whether a regulatory action is "significant" and therefore subject to Office of Management and

Budget (OMB) review and to the requirements of the Executive Order. The Order defines a "significant regulatory action" as one that is likely to result in a rule that may:

(1) Have an annual effect on the economy of \$100 million or more or adversely affect in a material way the economy, a sector of the economy, productivity, competition, jobs, the environment, public health or safety, or State, local, or Tribal governments or communities;

(2) Create a serious inconsistency or otherwise interfere with an action taken or planned by another agency;

(3) Materially alter the budgetary impact of entitlements, grants, user fees, or loan programs or the rights and obligations or recipients thereof; or

(4) Raise novel legal or policy issues arising out of legal mandates, the President's priorities, or the principles set forth in the Executive Order.

This notice was not reviewed under Executive Order 12866. Further, this notice was determined not to be significant within the meaning of the DOT Regulatory Policies and Procedures.

In this document, NHTSA incorporates performance requirements and test procedures that are currently contained and/or referenced in the Federal Motor Carrier Safety Regulations. Those performance requirements/test procedures are based on voluntary standards adopted by the Society of Automotive Engineers. Although NHTSA incorporates the most recent versions of these SAE requirements/procedures and to apply them to brake hoses, tubing, and fittings for all motor vehicles, not just commercial motor vehicles, the agency concludes that most, if not all, such hoses, tubing, and fittings are already designed to meet the SAE requirements/procedures. However, in the event that there are some brake hose products that would need to be modified to comply with the proposed regulations, the agency (1) estimates that it is a small proportion of brake hose products that would need modification, as most are believed to already comply; and (2) concludes that the manufacturers of the components used in producing such products are not small businesses.

For air brake hoses, both rubber hose and plastic tubing products, and hydraulic and vacuum brake hoses installed on vehicles that are typically used as commercial motor vehicles such as medium duty trucks, the agency concludes that all of the brake hose products already comply with the proposed regulations. The largest effect of the proposed regulations would be on

the light vehicle sector including passenger cars and light trucks, of which approximately 16 million vehicles are produced each year. As the typical light vehicle is equipped with three to four brake hoses, 48 to 64 million hydraulic brake hose assemblies as installed in new vehicles would be affected, as well as an unknown quantity of replacement brake hoses for light vehicles, but probably a few million. In addition, the agency estimates that approximately 15.5 million vacuum brake hoses and/or assemblies are installed on these vehicles.

Since large quantities of brake hose material are needed to manufacture these brake hoses, the agency believes that there are large manufacturers that produce both hydraulic and vacuum brake hoses in such large quantities. There are many small companies that use the brake hose material and end fitting components to produce brake hose assemblies, but NHTSA does not anticipate that they would be affected by the proposed changes because they simply assemble already-compliant components supplied by the large manufacturers.

The agency does not have data on the number of hydraulic and vacuum brake hose assemblies that must be modified to meet the final rule. Based on an informal survey of available hydraulic and vacuum brake hose assemblies, the agency estimates that perhaps as many as 20 percent may need to be modified in some manner to comply with the final rule. Likewise, the agency does not know the cost to modify the manufacturing processes of the brake hose materials to comply with the final rule, but can assume that it would be for improved additives to elastomeric compounds or improved synthetic fibers used as reinforcing materials. Again, the agency does not have any data on the cost of manufacturing such materials, but estimates that the modification of such manufacturing processes would add not more than ten cents to the cost of each brake hose assembly.

The highest-cost estimate of the final rule is based on production of 64 million new and replacement hydraulic brake hose assemblies, plus 16 million new and replacement vacuum brake hoses/assemblies, for a total of 80 million total affected brake hoses. If 20 percent of these need to be modified to meet the final rule, at a cost of ten cents per hose, the total cost would be \$1.6M.

In response to the NPRM, a brake hose manufacturer commented on the cost of purchasing new test equipment for the ultraviolet resistance test for plastic air brake tubing. NHTSA believes that if it

is necessary to purchase new test equipment (which NHTSA questions), the cost of such equipment may be on the order of \$5,000 to \$10,000, a sum that would not have a significant effect on NHTSA's estimated cost of this rulemaking.

Therefore, the agency estimates the cost of complying with the changes resulting from the final rule to amend FMVSS No. 106 to be between zero and \$1.6 million. This potential additional cost would not, however, be expected to have any impact on small businesses, but only on large manufacturers of brake hose materials that are produced in large quantities. Accordingly, the agency does not believe that this final rule would have any significant economic effects.

The DOT's regulatory policies and procedures require the preparation of a full regulatory evaluation, unless the agency finds that the impacts of a rulemaking are so minimal as not to warrant the preparation of a full regulatory evaluation. Since anecdotal evidence suggests that most, if not all, of these hose, tubing, and fittings are already compliant with the minimum performance requirements that the agency is applying in this final rule, the agency believes that the impacts of this rulemaking would be minimal. Thus, it has not prepared a full regulatory evaluation.

B. Regulatory Flexibility Act

Pursuant to the Regulatory Flexibility Act (5 U.S.C. 601 *et seq.*, as amended by the Small Business Regulatory Enforcement Fairness Act (SBREFA) of 1996), whenever an agency is required to publish a notice of rulemaking for any proposed or final rule, it must prepare and make available for public comment a regulatory flexibility analysis that describes the effect of the rule on small entities (*i.e.*, small businesses, small organizations, and small governmental jurisdictions). The Small Business Administration's regulations at 13 CFR Part 121 define a small business, in part, as a business entity "which operates primarily within the United States." (13 CFR § 121.105(a)). No regulatory flexibility analysis is required if the head of an agency certifies that the rule will not have a significant economic impact on a substantial number of small entities. The SBREFA amended the Regulatory Flexibility Act to require Federal agencies to provide a statement of the factual basis for certifying that a rule will not have a significant economic impact on a substantial number of small entities.

NHTSA has considered the effects of this rulemaking action under the Regulatory Flexibility Act. As explained above, NHTSA is incorporating performance requirements and test procedures that are currently contained or referenced in the Federal Motor Carrier Safety Regulations. Those performance requirements/test procedures are based on voluntary standards adopted by the Society of Automotive Engineers. Although NHTSA incorporates the most recent versions of these SAE requirements/procedures and to apply them to brake hoses, tubing, and fittings for all motor vehicles, not just commercial motor vehicles, the agency believes that most, if not all, such hoses, tubing, and fittings are already designed to meet the most recent SAE requirements/procedures.

For the remaining hoses, tubing, and fittings, estimated at up to 20 percent of all hydraulic and vacuum brake hoses manufactured each year, the agency estimates the cost of complying with these requirements to be \$1.6 million. Considering that the total number of hydraulic brake hose assemblies and vacuum brake hose/assemblies that would be subject to the requirements in this final rule is estimated to be approximately 80 million units annually, the agency estimates that the total annual effect of this final rule would be between zero and \$1.6 million. Accordingly, I hereby certify that this final rule will not have a significant economic impact on a substantial number of small entities.

C. National Environmental Policy Act

NHTSA has analyzed this rulemaking action for the purposes of the National Environmental Policy Act. The agency has determined that implementation of this action would not have any significant impact on the quality of the human environment.

D. Executive Order 13132 (Federalism)

Executive Order 13132 requires NHTSA to develop an accountable process to ensure "meaningful and timely input by State and local officials in the development of regulatory policies that have federalism implications." The Executive Order defines "policies that have federalism implications" to include regulations that have "substantial direct effects on the States, on the relationship between the national government and the States, or on the distribution of power and responsibilities among the various levels of government." Under Executive Order 13132, NHTSA may not issue a regulation with Federalism

implications, that imposes substantial direct compliance costs, and that is not required by statute, unless the Federal government provides the funds necessary to pay the direct compliance costs incurred by State and local governments, the agency consults with State and local governments, or the agency consults with State and local officials early in the process of developing the proposed regulation. NHTSA also may not issue a regulation with Federalism implications and that preempts State law unless the agency consults with State and local officials early in the process of developing the proposed regulation.

NHTSA has analyzed this rulemaking action in accordance with the principles and criteria set forth in Executive Order 13132. The agency has determined that this final rule will not have sufficient federalism implications to warrant consultation with State and local officials or the preparation of a federalism summary impact statement. The final rule will not have any substantial effects on the States, or on the current Federal-State relationship, or on the current distribution of power and responsibilities among the various local officials.

E. Civil Justice Reform

This final rule will not have any retroactive effect. Under 49 U.S.C. 30103, whenever a Federal motor vehicle safety standard is in effect, a State may not adopt or maintain a safety standard applicable to the same aspect of performance which is not identical to the Federal standard, except to the extent that the state requirement imposes a higher level of performance and applies only to vehicles procured for the State's use. 49 U.S.C. 30161 sets forth a procedure for judicial review of final rules establishing, amending, or revoking Federal motor vehicle safety standards. That section does not require submission of a petition for reconsideration or other administrative proceedings before parties may file suit in court.

F. Paperwork Reduction Act

Under the Paperwork Reduction Act of 1995, a person is not required to respond to a collection of information by a Federal agency unless the collection displays a valid Office of Management and Budget (OMB) control number. This final rule includes no new "collections of information" as that term is defined by the OMB in 5 CFR Part 1320.

G. National Technology Transfer and Advancement Act

Section 12(d) of the National Technology Transfer and Advancement Act of 1995 (NTTAA), Public Law 104-113, section 12(d) (15 U.S.C. 272) directs NHTSA to use voluntary consensus standards in its regulatory activities unless doing so would be inconsistent with applicable law or otherwise impractical. Voluntary consensus standards are technical standards (e.g., materials specifications, test methods, sampling procedures, and business practices) that are developed or adopted by voluntary consensus standards bodies, such as the Society of Automotive Engineers (SAE). The NTTAA directs the agency to provide Congress, through the OMB, explanations when we decide not to use available and applicable voluntary consensus standards.

The changes that NHTSA makes in this final rule are, for the most part, based on voluntary consensus standards adopted by the Society of Automotive Engineers. Accordingly, this final rule is in compliance with Section 12(d) of NTTAA.

H. Unfunded Mandates Reform Act

Section 202 of the Unfunded Mandates Reform Act of 1995 (UMRA) requires Federal agencies to prepare a written assessment of the costs, benefits, and other effects of proposed or final rules that include a Federal mandate likely to result in the expenditure by State, local or tribal governments, in the aggregate, or by the private sector, of more than \$100 million in any one year (adjusted for inflation with base year of 1995). Before promulgating a rule for which a written statement is needed, section 205 of the UMRA generally requires NHTSA to identify and consider a reasonable number of regulatory alternatives and adopt the least costly, most cost-effective, or least burdensome alternative that achieves the objectives of the rule. The provisions of section 205 do not apply when they are inconsistent with applicable law. Moreover, section 205 allows NHTSA to adopt an alternative other than the least costly, most cost-effective or least burdensome alternative if the agency publishes with the final rule an explanation why that alternative was not adopted.

This final rule would not result in the expenditure by State, local, or tribal governments, in the aggregate, or by the private sector of more than \$100 million annually. The cost of complying with the requirements in this final rule is estimated to be between zero and \$1.6M

annually. Accordingly, the agency has not prepared an Unfunded Mandates assessment.

I. Plain Language

Executive Order 12866 requires each agency to write all rules in plain language. Application of the principles of plain language includes consideration of the following questions:

- Have we organized the material to suit the public's needs?
- Are the requirements in the rule clearly stated?
- Does the rule contain technical language or jargon that is not clear?
- Would a different format (grouping and order of sections, use of headings, paragraphing) make the rule easier to understand?
- Would more (but shorter) sections be better?
- Could we improve clarity by adding tables, lists, or diagrams?
- What else could we do to make this rulemaking easier to understand?

If you have any responses to these questions, please include them in your comments to the agency.

J. Regulation Identifier Number (RIN)

The Department of Transportation assigns a regulation identifier number (RIN) to each regulatory action listed in the Unified Agenda of Federal Regulations. The Regulatory Information Service Center publishes the Unified Agenda in April and October of each year. You may use the RIN contained in the heading at the beginning of this document to find this action in the Unified Agenda.

List of Subjects in 49 CFR Part 571

Imports, Incorporation by Reference, Motor vehicle safety, Motor vehicles, Rubber and rubber products, and Tires.

■ In consideration of the foregoing, NHTSA amends 49 CFR part 571 as follows:

PART 571—FEDERAL MOTOR VEHICLE SAFETY STANDARDS

■ 1. The authority for part 571 continues to read as follows:

Authority: 49 U.S.C. 322, 30111, 30115, 30166, and 30177; delegation of authority at 49 CFR 1.50.

■ 2. Section 571.106 is amended by:

- a. Adding in S4 the definition of "Preformed" in the appropriate alphabetical order;
- b. Revising the first sentence of paragraph (b) of S5.2.2;
- c. Revising the first sentence of paragraph (b) of S5.2.4;
- d. Revising S5.3 through S5.3.2;

- e. Revising Table I;
- f. Revising S5.3.4;
- g. Revising S5.3.6;
- h. Revising S5.3.8 and S5.3.9;
- i. Revising S5.3.11;
- j. Adding S5.3.12 and S5.3.13;
- k. Revising paragraph (b) of S6.1.3;
- l. Revising paragraph (c) of S6.2;
- m. Revising S6.4;
- n. Revising S6.4.2;
- o. Revising S6.5;
- p. Removing S6.5.1 and S6.5.2;
- q. Revising paragraphs (a) and (b) of S6.6.1;
- r. Revising paragraph (b) of S6.8.2;
- s. Revising S6.9;
- t. Revising paragraphs (a) and (b) in S6.9.1;
- u. Removing S6.9.1(c) through (f);
- v. Adding Figure 3 following S6.9.1(b);
- w. Revising S6.9.2;
- x. Removing S6.9.3;
- y. Adding S6.10 through S6.12;
- z. Adding Figure 4 following S6.12.2;
- aa. Revising S7.1;
- bb. Revising the first sentence in paragraph (b), and paragraphs (d), and (e) of S7.2.1;
- cc. Revising Table III;
- dd. Revising the first sentence in paragraph (b) and paragraph (d) of S7.2.2;
- ee. Revising S7.3, S7.3.1, S7.3.2, and S7.3.3;
- ff. Revising Table IV;
- gg. Revising S7.3.5 through S7.3.11;
- hh. Revising paragraphs (a) and (b) of S8.1;
- ii. Revising paragraphs (a) and (c) in S8.2;
- jj. Adding paragraph (d) in S8.2;
- kk. Revising paragraph (b) in S8.3.2;
- ll. Revising S8.4;
- mm. Revising the heading of S8.6;
- nn. Revising S8.7;
- oo. Adding S8.7.1 and S8.7.2;
- pp. Adding Figure 5 and the table accompanying Figure 5, following S8.7.1;
- qq. Revising S8.8;
- rr. Revising in S8.9 the introductory sentence and paragraph (a);
- ss. Adding S8.13 and S8.14;
- tt. Revising S9.2 and S9.2.1 through S9.2.3;
- uu. Revising S9.2.7 through S9.2.10;
- vv. Removing S9.2.11;
- ww. Revising S10.1 and S10.2;
- xx. Revising paragraph (a) of S10.6;
- yy. Redesignating Figure 3 as Figure 6, following S10.6;
- zz. Revising S10.7;
- aaa. Removing and reserving S10.8;
- bbb. Revising paragraph (b) in S10.9.2;
- ccc. Redesignating Figure 4 as Figure 7, following S10.9.2(b);
- ddd. Revising S10.10;
- eee. Revising S11 and S11.1;
- fff. Adding Table VII, following S11.1;

- ggg. Revising S11.2;
- hhh. Adding S11.2.1 through S11.2.3.1;
- iii. Revising S11.3;
- jjj. Adding S11.3.1 through S11.3.5;
- kkk. Adding Table VIII, following S11.3.5;
- lll. Adding S11.3.6 through S11.3.24;
- mmm. Adding S12;
- nnn. Adding S12.1 through S12.7;
- ooo. Adding Figure 8, and the table accompanying Figure 8, following S12.7;
- ppp. Adding S12.8 through S12.25;
- qq. Adding S13; and
- rrr. Adding S13.1 through S13.3.

The additions and revisions read as follows:

§ 571.106 Standard No. 106; Brake hoses.

* * * * *

S4. Definitions.

* * * * *

Preformed means a brake hose that is manufactured with permanent bends and is shaped to fit a specific vehicle without further bending.

* * * * *

S5. Requirements—*Hydraulic brake hose, brake hose assemblies, and brake hose end fittings.*

* * * * *

S5.2.2 * * *

* * * * *

(b) A designation that identifies the manufacturer of the hose, which shall be filed in writing with: Office of Vehicle Safety Compliance, Equipment Division NVS-222, National Highway Traffic Safety Administration, 400 Seventh St. SW., Washington, DC 20590. * * *

* * * * *

S5.2.4 * * *

* * * * *

(b) A designation that identifies the manufacturer of the hose assembly, which shall be filed in writing with: Office of Vehicle Safety Compliance, Equipment Division NVS-222, National Highway Traffic Safety Administration, 400 Seventh St. SW., Washington, DC 20590. * * *

* * * * *

S5.3 *Test requirements.* A hydraulic brake hose assembly or appropriate part thereof shall be capable of meeting any of the requirements set forth under this heading, when tested under the conditions of S13 and the applicable procedures of S6. However, a particular hose assembly or appropriate part thereof need not meet further requirements after having been subjected to and having met the constriction requirement (S5.3.1) and any one of the requirements specified in S5.3.2 through S5.3.13.

S5.3.1 *Constriction.* Except for that part of an end fitting which does not contain hose, every inside diameter of any section of a hydraulic brake hose assembly shall be not less than 64 percent of the nominal inside diameter of the brake hose (S6.12).

S5.3.2 *Expansion and burst strength.* The maximum expansion of a hydraulic brake hose assembly at 1,000 psi, 1,500 psi and 2,900 psi shall not exceed the values specified in Table I (S6.1), except that a brake hose larger than 3/16 inch or 5 mm is not subject to the 2,900 psi expansion test requirements. The

hydraulic brake hose assembly shall then withstand water pressure of 4,000 psi for 2 minutes without rupture, and then shall not rupture at less than 7,000 psi for a 1/8 inch, 3 mm, or smaller diameter hose, or at less than 5,000 psi for a hose with a diameter larger than 1/8 inch or 3 mm (S6.2).

TABLE I.—MAXIMUM EXPANSION OF FREE LENGTH BRAKE HOSE, CC/FT

Hydraulic brake hose, inside diameter	Test pressure					
	1,000 psi		1,500 psi		2,900 psi	
	Regular expansion hose	Low expansion hose	Regular expansion hose	Low expansion hose	Regular expansion hose	Low expansion hose
1/8 inch, or 3 mm, or less	0.66	0.33	0.79	0.42	1.21	0.61
3/16 inch, or 4 to 5 mm	0.86	0.55	1.02	0.72	1.67	0.91
1/4 inch, or 6 mm, or more	1.04	0.82	1.30	1.17	*	*

*Not applicable.

* * * * *

S5.3.4 *Tensile strength.* A hydraulic brake hose assembly shall withstand a pull of 325 pounds without separation of the hose from its end fittings during a slow pull test, and shall withstand a pull of 370 pounds without separation of the hose from its end fittings during a fast pull test (S6.4).

* * * * *

S5.3.6 *Water absorption and tensile strength.* A hydraulic brake hose assembly, after immersion in water for 70 hours (S6.5), shall withstand a pull of 325 pounds without separation of the hose from its end fittings during a slow pull test, and shall withstand a pull of 370 pounds without separation of the hose from its end fittings during a fast pull test (S6.4).

* * * * *

S5.3.8 *Low-temperature resistance.* A hydraulic brake hose conditioned at a temperature between minus 49 degrees Fahrenheit (minus 45 degrees Celsius) and minus 54 degrees Fahrenheit (minus 48 degrees Celsius) for 70 hours shall not show cracks visible without magnification when bent around a cylinder as specified in S6.6 (S6.6).

S5.3.9 *Brake fluid compatibility, constriction, and burst strength.* Except for brake hose assemblies designed for use with mineral or petroleum-based brake fluids, a hydraulic brake hose assembly shall meet the constriction requirement of S5.3.1 after having been subjected to a temperature of 248 degrees Fahrenheit (120 degrees Celsius) for 70 hours while filled with SAE RM-66-04 "Compatibility Fluid," as described in Appendix B of SAE Standard J1703, revised JAN 1995, "Motor Vehicle Brake Fluid." This

incorporation by reference was approved by the Director of the Federal Register in accordance with 5 U.S.C. 552(a) and 1 CFR Part 51. Copies may be obtained from the Society of Automotive Engineers, Inc., 400 Commonwealth Drive, Warrendale, PA 15096-0001. Copies may be inspected at the National Highway Traffic Safety Administration, Technical Information Services, 400 Seventh Street, SW., Plaza Level, Room 403, Washington, DC 20590, or at the National Archives and Records Administration (NARA). For information on the availability of this material at NARA, call 202-741-6030, or go to: http://www.archives.gov/federal_register/code_of_federal_regulations/ibr_locations.html. It shall then withstand water pressure of 4,000 psi for 2 minutes and thereafter shall not rupture at less than 5,000 psi (S6.2 except all sizes of hose are tested at 5,000 psi).

* * * * *

S5.3.11 *Dynamic ozone test.* A hydraulic brake hose shall not show cracks visible without magnification after having been subjected to a 48-hour dynamic ozone test (S6.9).

S5.3.12 *High temperature impulse test.* A brake hose assembly tested under the conditions in S6.10:

(a) Shall withstand pressure cycling for 150 cycles, at 295 degrees Fahrenheit (146 degrees Celsius) without leakage;

(b) Shall not rupture during a 2-minute, 4,000 psi pressure hold test, and;

(c) Shall not burst at a pressure less than 5,000 psi.

S5.3.13 *End fitting corrosion resistance.* After 24 hours of exposure to salt spray, a hydraulic brake hose end fitting shall show no base metal

corrosion on the end fitting surface except where crimping or the application of labeling information has caused displacement of the protective coating (S6.11).

S6. *Test procedures—Hydraulic brake hose, brake hose assemblies, and brake hose end fittings.*

* * * * *

S6.1.3 *Calculation of expansion at 1,000 psi, 1,500 psi and 2,900 psi.*

* * * * *

(b) Close the valve to the burette, apply pressure at the rate of 1,500 psi per minute, and seal 1,000 psi in the hose (1,500 in second series, and 2,900 psi in third series).

* * * * *

S6.2 *Burst strength test.*

* * * * *

(c) After 2 minutes at 4,000 psi, increase the pressure at the rate of 15,000 psi per minute until the pressure exceeds 5,000 psi for a brake hose larger than 1/8 inch or 3 mm diameter, or until the pressure exceeds 7,000 psi for a brake hose of 1/8 inch, 3 mm, or smaller diameter.

* * * * *

S6.4 *Tensile strength test.* Utilize a tension testing machine conforming to the requirements of American Society for Testing and Materials (ASTM) E4-03, "Standard Practices for Force Verification of Testing Machines," and provided with a recording device to measure the force applied. This incorporation by reference was approved by the Director of the Federal Register in accordance with 5 U.S.C. 552(a) and 1 CFR Part 51. Copies may be obtained from the American Society for Testing and Materials (ASTM) International, 100 Barr Harbor Drive,

P.O. Box C700, West Conshohocken, PA 19428-2959. Copies may be inspected at the National Highway Traffic Safety Administration, Technical Information Services, 400 Seventh St., S.W., Plaza Level, Room 403, Washington, D.C. 20590, or at the National Archives and Records Administration (NARA). For information on the availability of this material at NARA, call 202-741-6030, or go to: http://www.archives.gov/federal_register/code_of_federal_regulations/ibr_locations.html.

* * * * *

S6.4.2 *Operation.* (a) Conduct the slow pull test by applying tension at a rate of 1 inch per minute travel of the moving head until separation occurs.

(b) Conduct the fast pull test by applying tension at a rate of 2 inches per minute travel of the moving head until separation occurs.

* * * * *

S6.5 *Water absorption sequence tests.* (a) Prepare three brake hose assemblies and measure the free length of the hose assemblies.

(b) Immerse the brake hose assemblies in distilled water at 185 degrees Fahrenheit (85 degrees Celsius) for 70 hours. Remove the brake hose

assemblies from the water and condition in air at room temperature for 30 minutes.

(c) Conduct the tests in S6.2, S6.3, and S6.4, using a different hose for each sequence.

S6.6 *Low temperature resistance test.*

S6.6.1 *Preparation.* (a) Remove hose armor, if any, and condition the hose in a straight position in air at a temperature between minus 49 degrees Fahrenheit and minus 54 degrees Fahrenheit (minus 45 degrees Celsius and minus 48 degrees Celsius) for 70 hours.

(b) Condition a cylinder in air at a temperature between minus 49 degrees Fahrenheit and minus 54 degrees Fahrenheit (minus 45 degrees Celsius and minus 48 degrees Celsius) for 70 hours, using a cylinder of 2½ inches in diameter for tests of hose less than ⅛ inch or 3mm, 3 inches in diameter for tests of ⅛ inch or 3 mm hose, 3½ inches in diameter for tests of ⅜ to ¼ inch hose or 4 mm to 6 mm hose, and 4 inches in diameter for tests of hose greater than ¼ inch or 6 mm in diameter.

* * * * *

S6.8.2 *Exposure to ozone.*

* * * * *

(b) Immediately thereafter, condition the hose on the cylinder for 70 hours in an exposure chamber having an ambient air temperature of 104 degrees Fahrenheit (40 degrees Celsius) during the test and containing air mixed with ozone in the proportion of 100 parts of ozone per 100 million parts of air by volume.

* * * * *

S6.9 *Dynamic ozone test.*

S6.9.1 *Apparatus.* Utilize a test apparatus shown in Figure 3 which is constructed so that:

(a) It has a fixed pin with a vertical orientation over which one end of the brake hose is installed.

(b) It has a movable pin that is oriented 30 degrees from vertical, with the top of the movable pin angled towards the fixed pin. The movable pin maintains its orientation to the fixed pin throughout its travel in the horizontal plane. The other end of the brake hose is installed on the movable pin.

BILLING CODE 4910-59-P

Figure 3. Dynamic Ozone Test Apparatus

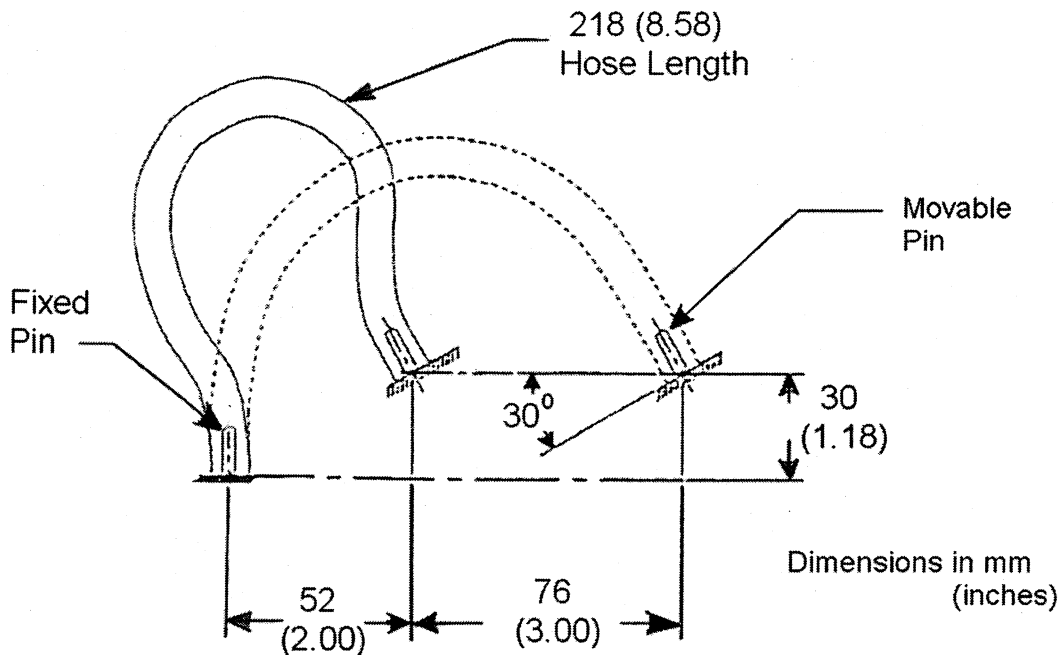

S6.9.2 *Preparation.* (a) Precondition the hose assembly by laying it on a flat surface in an unstressed condition, at room temperature, for 24 hours.

(b) Cut the brake hose assembly to a length of 8.6 inches (218 mm), such that no end fittings remain on the cut hose.

(c) Mount the brake hose onto the test fixture by fully inserting the fixture pins into each end of the hose. Secure the hose to the fixture pins using a band clamp at each end of the hose.

(d) Place the test fixture into an ozone chamber

(e) Stabilize the atmosphere in the ozone chamber so that the ambient temperature is 104 °F (40 degrees Celsius) and the air mixture contains air mixed with ozone in the proportion of 100 parts of ozone per 100 million parts of air by volume. This atmosphere is to remain stable throughout the remainder of the test.

(f) Begin cycling the movable pin at a rate of 0.3 Hz. Continue the cycling for 48 hours.

(g) At the completion of 48 hours of cycling, remove the test fixture from the ozone chamber. Without removing the hose from the test fixture, visually examine the hose for cracks without magnification, ignoring areas immediately adjacent to or within the area covered by the band clamps. Examine the hose with the movable pin at any point along its travel.

S6.10 *High temperature impulse test.*

S6.10.1 *Apparatus.* (a) A pressure cycling machine to which one end of the brake hose assembly can be attached, with the entire hose assembly installed vertically inside of a circulating air oven. The machine shall be capable of increasing the pressure in the hose from zero psi to 1600 psi, and decreasing the pressure in the hose from 1600 psi to zero psi, within 2 seconds.

(b) A circulating air oven that can reach a temperature of 295 degrees Fahrenheit (146 degrees Celsius) within 30 minutes, and that can maintain a constant 295 degrees F (146 degrees Celsius) thereafter, with the brake hose assembly inside of the oven and attached to the pressure cycling machine.

(c) A burst test apparatus to conduct testing specified in S6.2

S6.10.2 *Preparation.* (a) Connect one end of the hose assembly to the pressure cycling machine and plug the other end of the hose. Fill the pressure cycling machine and hose assembly with SAE RM-66-04 "Compatibility Fluid," as described in Appendix B of SAE Standard J1703, revised JAN 1995 "Motor Vehicle Brake Fluid," and bleed all gases from the system.

(b) Place the brake hose assembly inside of the circulating air oven in a vertical position. Increase the oven temperature to 295 degrees F (146 degrees Celsius) and maintain this temperature throughout the pressure cycling test.

(c) During each pressure cycle, the pressure in the hose is increased from zero psi to 1600 psi and held constant for 1 minute, then the pressure is decreased from 1600 psi to zero psi and held constant for 1 minute. Perform 150 pressure cycles on the brake hose assembly.

(d) Remove the brake hose assembly from the oven, disconnect it from the pressure cycling machine, and drain the fluid from the hose. Cool the brake hose assembly at room temperature for 45 minutes.

(e) Wipe the brake hose using acetone to remove residual Compatibility Fluid. Conduct the burst strength test in S6.2, except all sizes of hose are tested at 5,000 psi.

S6.11 *End fitting corrosion test.* Utilize the apparatus described in ASTM B117-03, "Standard Practice for Operating Salt Spray (Fog) Apparatus". This incorporation by reference was approved by the Director of the Federal Register in accordance with 5 U.S.C. 552(a) and 1 CFR Part 51. Copies may be obtained from the American Society for Testing and Materials (ASTM) International, 100 Barr Harbor Drive, P.O. Box C700, West Conshohocken, PA 19428-2959. Copies may be inspected at the National Highway Traffic Safety Administration, Technical Information Services, 400 Seventh St., SW., Plaza Level, Room 403, Washington, DC 20590, or at the National Archives and Records Administration (NARA). For information on the availability of this material at NARA, call (202) 741-6030, or go to: http://www.archives.gov/federal_register/code_of_federal_regulations/ibr_locations.html.

S6.11.1 *Construction. Construct the salt spray chamber so that:*

(a) The construction material does not affect the corrosiveness of the fog.

(b) The hose assembly is supported or suspended 30 degrees from the vertical and parallel to the principal direction of the horizontal flow of fog through the chamber.

(c) The hose assembly does not contact any metallic material or any material capable of acting as a wick

(d) Condensation which falls from the assembly does not return to the solution reservoir for respraying.

(e) Condensation from any source does not fall on the brake hose assemblies or the solution collectors.

(f) Spray from the nozzles is not directed onto the hose assembly.

S6.11.2 *Preparation.* (a) Plug each end of the hose assembly.

(b) Mix a salt solution five parts by weight of sodium chloride to 95 parts of distilled water, using sodium chloride substantially free of nickel and copper, and containing on a dry basis not more than 0.1 percent of sodium iodide and not more than 0.3 percent total impurities. Ensure that the solution is free of suspended solids before the solution is atomized.

(c) After atomization at 95 degrees Fahrenheit (35 degrees Celsius), ensure that the collected solution is in the PH range of 6.5 to 7.2. Make the PH measurements at 77 degrees Fahrenheit (28 degrees Celsius).

(d) Maintain a compressed air supply to the nozzle or nozzles free of oil and dirt and between 10 and 25 psi.

S6.11.3 *Operation.* Subject the brake hose assembly to the salt spray continuously for 24 hours.

(a) Regulate the mixture so that each collector will collect from 1 to 2 milliliters of solution per hour for each 80 square centimeters of horizontal collecting area.

(b) Maintain exposure zone temperature at 95 degrees Fahrenheit (35 degrees Celsius).

(c) Upon completion, remove the salt deposit from the surface of the hose by washing gently or dipping in clean running water not warmer than 100 degrees Fahrenheit (38 degrees Celsius) and then drying immediately.

S6.12 *Constriction test.* Brake hose constriction test requirements shall be met using at least one of the methods specified in S6.12.1, S6.12.2, or S6.12.3.

S6.12.1 *Plug gauge.* (a) Utilize a plug gauge as shown in Figure 4. Diameter "A" is equal to 64 percent of the nominal inside diameter of the hydraulic brake hose being tested.

(b) Brake hose assemblies that are to be used for additional testing have constriction testing only at each end fitting. Other brake hose assemblies may be cut into 3-inch lengths to permit constriction testing of the entire assembly. Hose assemblies with end fittings that do not permit entry of the gauge (e.g., restrictive orifice or banjo fitting) are cut 3 inches from the point at which the hose terminates in the end fitting and then tested from the cut end.

(c) Hold the brake hose in a straight position and vertical orientation.

(d) Place the spherical end of the plug gauge just inside the hose or end fitting. If the spherical end will not enter the hose or end fitting using no more force than gravity acting on the plug gauge,

this constitutes failure of the constriction test.

(e) Release the plug gauge. Within 3 seconds, the plug gauge shall fall under the force of gravity alone up to the handle of the gauge. If the plug gauge does not fully enter the hose up to the handle of the gauge within three seconds, this constitutes failure of the constriction test.

S6.12.2 *Extended plug gauge.* (a) The test in 6.12.1 may be conducted with an extended plug gauge to enable

testing of the entire brake hose from one end fitting, without cutting the brake hose. The extended plug gauge weight and spherical diameter specifications are as shown in Figure 4, but the handle portion of the gauge may be deleted and the gauge length may be greater than 3 inches.

(b) The required performance of the extended plug gauge in S6.12.1(e) is that after the plug gauge is released, the extended plug gauge shall fall under the

force of gravity alone at an average rate of 1 inch per second until the spherical diameter of the extended gauge passes through all portions of the brake hose assembly containing hose. If the extended plug gauge does not pass through all portions of the brake hose assembly containing hose at an average rate of 1 inch per second, this constitutes failure of the constriction test.

BILLING CODE 4910-59-P

FIGURE 4. CONSTRICTION TEST PLUG GAUGE

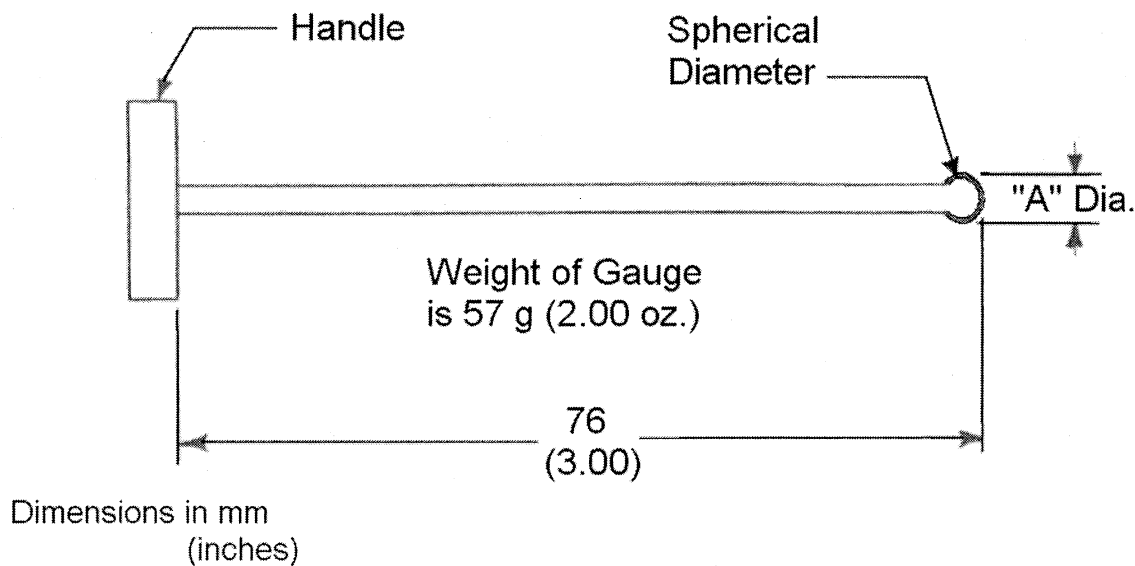

S6.12.3 *Drop ball test.* (a) Utilize a rigid spherical ball with a diameter equal to 64 percent of the nominal inside diameter of the hydraulic brake hose being tested. The weight of the spherical ball shall not exceed 2 ounces (57 grams).

(b) Hold the brake hose in a straight position and vertical orientation.

(c) Hold the ball just above the end fitting.

(d) Release the ball. The ball shall fall under the force of gravity alone completely through all portions of the brake hose assembly containing hose, at an average rate of 1 inch per second. Failure of the ball to pass completely through all portions of the brake hose assembly containing hose, at an average

rate of 1 inch per second, constitutes failure of the constriction test.

* * * * *

S7.1 *Construction.* Each air brake hose assembly shall be equipped with permanently attached brake hose end fittings or reusable brake hose end fittings. Each air brake hose constructed of synthetic or natural elastomeric rubber shall conform to the dimensional requirements specified in Table III, except for brake hose manufactured in metric sizes.

* * * * *

S7.2.1 *Hose.* * * *

* * * * *

(b) A designation that identifies the manufacturer of the hose, which shall be filed in writing with: Office of Vehicle Safety Compliance, Equipment Division NVS-222, National Highway

Traffic Safety Administration, 400 Seventh St. SW., Washington, DC 20590.* * *

* * * * *

(d) The nominal inside diameter of the hose expressed in inches or fractions of inches or in millimeters. The abbreviation "mm" shall follow hose sizes that are expressed in millimeters. (Examples: 3/8, 1/2 (1/2SP in the case of 1/2 inch special air brake hose), 4mm, 6mm.)

(e) The type designation corresponding to the brake hose dimensions in Table III. Type A shall be labeled with the letter "A", Type AI shall be labeled with the letters "AI", and type AII shall be labeled with the letters "AII". Metric air brake hose shall be labeled with the letter "A."

TABLE III.—AIR BRAKE HOSE DIMENSIONS. INSIDE DIAMETER (ID) AND OUTSIDE DIAMETER (OD) DIMENSIONS IN INCHES (MILLIMETERS)

TYPE A—HOSE SIZE—NOMINAL INSIDE DIAMETER						
	1/4	5/16	3/8(1)	7/16(1)	1/2 SP(1)	5/8
Min.	0.277	0.289	0.352	0.407	0.469	0.594
I.D.	(5.8)	(7.3)	(8.9)	(10.3)	(11.9)	(15.1)
Max.	0.273	0.335	0.398	0.469	0.531	0.656
I.D.	(6.9)	(8.5)	(10.1)	(11.9)	(13.5)	(16.7)
Min.	0.594	0.656	0.719	0.781	0.844	1.031
O.D.	(15.1)	(16.7)	(18.3)	(19.8)	(21.4)	(26.2)
Max.	0.656	0.719	0.781	0.843	0.906	1.094
O.D.	(16.7)	(18.3)	(19.8)	(21.4)	(23.0)	(27.8)

TYPE AI(2)—HOSE SIZE—NOMINAL INSIDE DIAMETER						
	3/16	1/4	5/16	13/32	1/2	5/8
Min.	0.188	0.250	0.312	0.406	0.500	0.625
I.D.	(4.8)	(6.4)	(7.9)	(10.3)	(12.7)	(15.9)
Max.	0.214	0.281	0.343	0.437	0.539	0.667
I.D.	(5.4)	(7.1)	(8.7)	(11.1)	(13.7)	(16.9)
Min.	0.472	0.535	0.598	0.714	0.808	0.933
O.D.	(12.0)	(13.6)	(15.1)	(18.1)	(20.5)	(23.7)
Max.	0.510	0.573	0.636	0.760	0.854	0.979
O.D.	(13.0)	(14.6)	(16.2)	(19.3)	(21.7)	(24.9)

TYPE AII(2)—HOSE SIZE—NOMINAL INSIDE DIAMETER						
	3/16	1/4	5/16	13/32	1/2	5/8
Min.	0.188	0.250	0.312	0.406	0.500	0.625
I.D.	(4.8)	(6.4)	(7.9)	(10.3)	(12.7)	(15.9)
Max.	0.214	0.281	0.343	0.437	0.539	0.667
I.D.	(5.4)	(7.1)	(8.7)	(11.1)	(13.7)	(16.9)
Min.	0.500	0.562	0.656	0.742	0.898	1.054
O.D.	(12.7)	(14.3)	(16.7)	(18.8)	(22.8)	(26.8)
Max.	0.539	0.602	0.695	0.789	0.945	1.101
O.D.	(13.7)	(15.3)	(17.7)	(20.1)	(24.0)	(27.9)

Notes:
 (1) Type A, sizes 3/8, 7/16, and 1/2 Special can be assembled with reusable end fittings. All sizes can be assembled using permanently-attached (crimped) end fittings.
 (2) Types AI and AII, all sizes, can be assembled with reusable or permanently-attached (crimped) end fittings.

S7.2.2 End fittings. * * *

(b) A designation that identifies the manufacturer of that component of the fitting, which shall be filed in writing with: Office of Vehicle Safety Compliance, Equipment Division NVS-222, National Highway Traffic Safety Administration, 400 Seventh St. S.W., Washington, DC 20590. * * *

(d) The nominal inside diameter of the hose to which the fitting is properly attached expressed in inches or fractions of inches or in millimeters. (See examples in S7.2.1 (d).) The abbreviation "mm" shall follow hose sizes that are expressed in millimeters. * * *

S7.3 Test requirements. Each air brake hose assembly or appropriate part thereof shall be capable of meeting any of the requirements set forth under this heading, when tested under the conditions of S13 and the applicable procedures of S8. However, a particular hose assembly or appropriate part thereof need not meet further requirements after having met the constriction requirement (S7.3.1) and then having been subjected to any one of the requirements specified in S7.3.2 through S7.3.14.

S7.3.1 Constriction. Every inside diameter of any section of an air brake hose assembly shall not be less than 66 percent of the nominal inside diameter of the brake hose. (S8.14)

S7.3.2 High temperature resistance. An air brake hose shall not show external or internal cracks, charring, or disintegration visible without magnification when straightened after being bent for 70 hours at 212 degrees Fahrenheit (100 degrees Celsius) over a small test cylinder having the radius specified in Table IV for the size of hose tested. (S8.1)

S7.3.3 Low temperature resistance. The inside and outside surfaces of an air brake hose shall not show cracks as a result of conditioning at minus 40 degrees Fahrenheit (minus 40 degrees Celsius) for 70 hours when bent around a large test cylinder having the radius specified in Table IV for the size of hose tested (S8.2).

TABLE IV.—AIR BRAKE HOSE DIAMETERS AND TEST CYLINDER RADII

Nominal hose inside diameter, inches ¹	3/16	1/4	5/16	3/8	13/32	7/16, 1/2	5/8
Nominal hose inside diameter, millimeters ¹	4, 5	6	8	10	12	16
Small test cylinder, radius in inches (millimeters) ²	1 (25)	1 1/2 (38)	1 3/4 (45)	1 3/4 (45)	1 7/8 (48)	2 (51)	2 1/2 (64)

TABLE IV.—AIR BRAKE HOSE DIAMETERS AND TEST CYLINDER RADII—Continued

Large test cylinder, radius in inches (millimeters) ³	2 (51)	2½ (64)	3 (76)	3½ (89)	3½ (89)	4 (102)	4½ (114)
------------------------------------------------------------------------	--------	---------	--------	---------	---------	---------	----------

Notes:

¹ These sizes are listed to provide test cylinder radii for brake hoses manufactured in these sizes. They do not represent conversions.

² Small test cylinders are used for the high temperature resistance test.

³ Large test cylinders are used for the low temperature resistance, ozone resistance, and adhesion of wire-reinforced hose tests.

* * * * *

S7.3.5 *Ozone resistance.* An air brake hose assembly shall not show cracks visible under 7-power magnification after exposure to ozone for 70 hours at 104 degrees Fahrenheit (49 degrees Celsius) when bent around a test cylinder of the radius specified in Table IV for the size of hose tested (S8.4).

S7.3.6 *Length change.* An air brake hose shall not contract in length more than 7 percent nor elongate more than 5 percent when subjected to air pressure of 200 psi (S8.5).

S7.3.7 *Adhesion.* (a) Except for hose reinforced by wire, an air brake hose shall withstand a tensile force of 8 pounds per inch of length before separation of adjacent layers (S8.6).

(b) An air brake hose reinforced by wire shall permit a steel ball to roll freely along the entire length of the inside of the hose when the hose is subjected to a vacuum of 25 inches of Hg and bent around a test cylinder (S8.13).

S7.3.8 *Flex strength and air pressure leakage.* An air brake hose assembly of the length specified in the table accompanying Figure 5, when subjected to a flex test and internal pressure cycling, shall be capable of having its internal pressure increased from zero to 140 psi within 2 minutes with pressurized air supplied through an orifice (S8.7).

S7.3.9 *Corrosion resistance and burst strength.* An air brake hose assembly exposed to salt spray shall not rupture when exposed to hydrostatic pressure of 900 psi (S8.8).

S7.3.10 *Tensile strength.* An air brake hose assembly designed for use between a frame and axle or between a towed and towing vehicle shall withstand, without separation of the hose from its end fittings, a pull of 250 pounds if it is ¼ inch, 6 mm, or less in nominal inside diameter, or a pull of 325 pounds if it is larger than ¼ inch or 6 mm in nominal inside diameter. An air brake hose assembly designed for use in any other application shall withstand, without separation of the

hose from its end fittings, a pull of 50 pounds if it is ¼ inch, 6 mm, or less in nominal inside diameter, 150 pounds if it is larger than ¼ inch or 6 mm and equal to or smaller than ½ inch or 12 mm in nominal inside diameter, or 325 pounds if it is larger than ½ inch or 12 mm in nominal inside diameter (S8.9).

S7.3.11 *Water absorption and tensile strength.* After immersion in distilled water for 70 hours, an air brake hose assembly designed for use between a frame and axle or between a towed and a towing vehicle shall withstand, without separation of the hose from its end fittings, a pull of 250 pounds if it is ¼ inch or less or 6 mm or less in nominal inside diameter, or a pull of 325 pounds if it is larger than ¼ inch or 6 mm in nominal inside diameter. After immersion in distilled water for 70 hours, an air brake hose assembly designed for use in any other application shall withstand, without separation of the hose from its end fittings, a pull of 50 pounds if it is ¼ inch or 6 mm or less in nominal inside diameter, 150 pounds if it is larger than ¼ inch or 6 mm and equal to or smaller than ½ inch or 12 mm in nominal inside diameter, or 325 pounds if it is larger than ½ inch or 12 mm in nominal inside diameter. (S8.10)

S8.1 *High temperature resistance test.*

(a) Utilize a small test cylinder with a radius specified in Table IV for the size of hose tested.

(b) Bind the hose around the cylinder and condition it in an air oven for 70 hours at 212 degrees Fahrenheit (100 degrees Celsius).

* * * * *

S8.2 *Low temperature resistance test.* (a) Utilize a large test cylinder with a radius specified in Table IV for the size of hose tested.

* * * * *

(c) With the hose and cylinder at minus 40 degrees Fahrenheit (minus 40 degrees Celsius), bend the hose 180 degrees around the cylinder at a steady rate in a period of 3 to 5 seconds. Remove the hose from the test cylinder

and visibly examine the exterior of the hose for cracks without magnification.

(d) Allow the hose to warm at room temperature for 2 hours. All reusable end fittings are removed from the hose. All permanently-attached end fittings are cut away from the hose. Cut through one wall of the hose longitudinally along its entire length. Unfold the hose to permit examination of the interior surface. Visibly examine the interior of the hose for cracks without magnification.

* * * * *

S8.3.2 *Measurement.*

* * * * *

(b) Immerse each specimen in ASTM IRM 903 oil for 70 hours at 212 degrees Fahrenheit (100 degrees Celsius) and then cool in ASTM IRM 903 oil at room temperature for 30 to 60 minutes.

* * * * *

S8.4 *Ozone resistance test.* Conduct the test specified in S6.8, using air brake hose, except use the large test cylinder specified in Table IV for the size of hose tested.

* * * * *

S8.6 *Adhesion test for air brake hose not reinforced by wire.*

* * * * *

S8.7 *Flex strength and air pressure test.*

S8.7.1 *Apparatus.* A flex testing machine with a fixed hose assembly attachment point and a movable hose assembly attachment point, which meets the dimensional requirements of Figure 5 for the size of hose being tested. The attachment points connect to the end fittings on the hose assembly without leakage and, after the hose assembly has been installed for the flex test, are restrained from rotation. The movable end has a linear travel of 6 inches and a cycle rate of 100 cycles per minute. The machine is capable of increasing the air pressure in the hose assembly from zero to 150 psi within 2 seconds, and decreasing the air pressure in the hose assembly from 150 to zero psi within 2 seconds.

BILLING CODE 4910-59-P

FIGURE 5. FLEX TEST APPARATUS

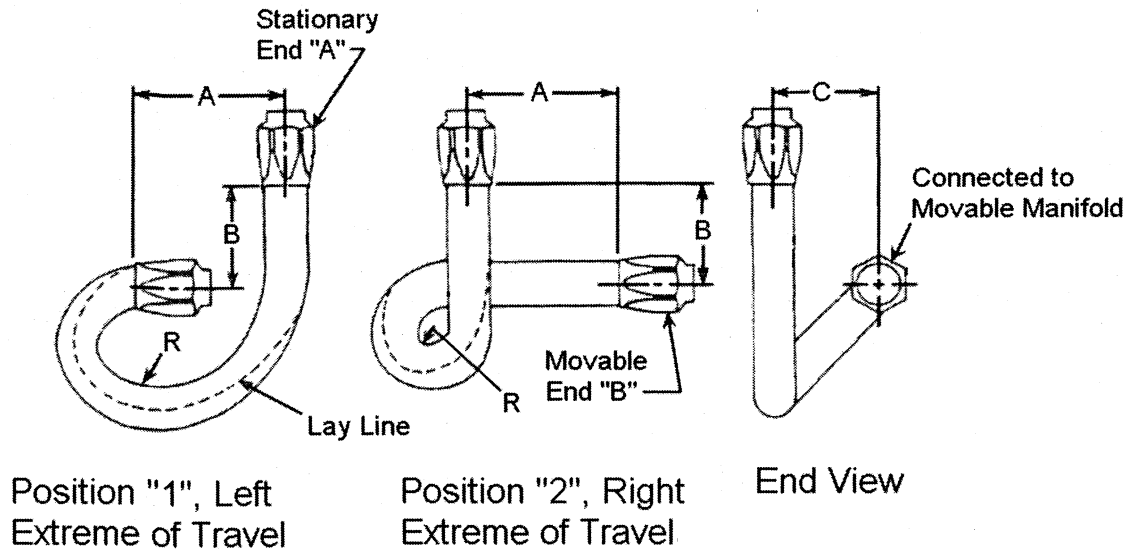

TABLE ACCOMPANYING FIGURE 5.—DIMENSIONS IN INCHES (MILLIMETERS)

Free hose length	Nominal hose inside diameter	Dimensions							
		Position "1"				Position "2"			
		A	B	C	R ⁽¹⁾	A	B	C	R ⁽¹⁾
10.00 (254)	3/16, 1/4	3.00 (76)	2.75 (70)	3.75 (95)	1.40 (34)	3.00 (76)	2.75 (70)	3.75 (95)	1.20 (30)
11.00 (279)	5/16, 3/8, 13/32	3.00 (76)	3.50 (89)	4.50 (114)	1.70 (43)	3.00 (76)	3.50 (89)	4.50 (114)	1.30 (33)
14.00 (355)	7/16, 1/2, 5/8	3.00 (76)	4.00 (102)	5.00 (127)	2.20 (56)	3.00 (76)	4.00 (102)	5.00 (127)	1.80 (46)

Note (1) This is an approximate average radius.

S8.7.2 *Preparation.* (a) Lay the hose material on a flat surface in an unstressed condition. Apply a permanent marking line along the centerline of the hose on the uppermost surface.

(b) Prepare the hose assembly with a free length as shown in the table accompanying Figure 5. The end fittings shall be attached according to the end fitting manufacturer's instructions.

(c) Plug the ends of the hose assembly and conduct the salt spray test in S6.11 using an air brake hose assembly. Remove the plugs from the end fittings.

(d) Within 168 hours of completion of the salt spray test, expose the hose assembly to an air temperature of 212 degrees Fahrenheit (100 degrees Celsius) for 70 hours, with the hose in a straight

position. Remove the hose and cool it at room temperature for 2 hours. Within 166 hours, subject the hose to the flexure test in S8.7.2(e).

(e) Install the hose assembly on the flex testing machine as follows. With the movable hose attachment point at the mid point of its travel, attach one end of the hose to the movable attachment point with the marked line on the hose in the uppermost position. Attach the other end of the hose to the fixed attachment point allowing the hose to follow its natural curvature.

(f) Cycle the air pressure in the hose by increasing the pressure in the hose from zero psi to 150 psi and holding constant for one minute, then decreasing the pressure from 150 psi to zero psi and holding constant for one

minute. Continue the pressure cycling for the duration of the flex testing. Begin the flex testing by cycling the movable attachment point through 6 inches of travel at a rate of 100 cycles per minute. Stop the flex testing and pressure cycling after one million flex cycles have been completed.

(g) Install an orifice with a hole diameter of 0.0625 inches and a thickness of 0.032 inches in the air pressure supply line to the hose assembly. Provide a gauge or other means to measure air pressure in the hose assembly. Regulate the supply air pressure to the orifice to 150 psi.

(h) Apply 150 psi air pressure to the orifice. After 2 minutes have elapsed, measure the air pressure in the brake hose assembly, while pressurized air

continues to be supplied through the orifice.

S8.8 Corrosion resistance and burst strength test. (a) Conduct the test specified in S6.11 using an air brake hose assembly. Remove the plugs from the ends of the hose assembly.

(b) Fill the hose assembly with water, allowing all gases to escape. Apply water pressure at a uniform rate of increase of approximately 1,000 psi per minute until the hose ruptures.

S8.9 Tensile strength test. Utilize a tension testing machine conforming to the requirements of American Society for Testing and Materials (ASTM) E4-03 "Standard Practices for Force Verification of Testing Machines," and provided with a recording device to measure the force applied.

(a) Attach an air brake hose assembly to the testing machine to permit straight, even, machine pull on the hose. Use adapters to mount hose assemblies equipped with angled end fittings so that the hose is in a straight position when installed on the machine.

* * * * *

S8.13 Adhesion test for air brake hose reinforced by wire. (a) Place a steel ball with a diameter equal to 73 percent of the nominal inside diameter of the hose being tested inside of the hose. Plug one end of the hose. Attach the other end of the hose to a source of vacuum.

(b) Subject the hose to a vacuum of 25 inches of Hg for five minutes. With the vacuum still applied to the hose, bend the hose 180 degrees around a large test cylinder with a radius specified in Table IV for the size of hose tested. At the location of this bend, bend the hose 180 degrees around the test cylinder in the opposite direction.

(c) With the vacuum still applied to the hose, return the hose to a straight position. Attempt to roll the ball inside the hose using gravity from one end of the hose to the other end.

S8.14 Constriction test. Perform the constriction test in S6.12 using an air brake hose, except that the spherical diameter "A" of the plug gauge in Figure 4, or the diameter of the rigid spherical ball in S6.12.3(a), shall be 66 percent of the nominal inside diameter of the air brake hose being tested.

* * * * *

S9.2 Test requirements. Each vacuum brake hose assembly or appropriate part thereof shall be capable of meeting any of the requirements set forth under this heading, when tested under the conditions of S13 and the applicable procedures of S10. However, a particular hose assembly or appropriate part thereof need not meet

further requirements after having met the constriction requirement (S9.2.1) and then having been subjected to any one of the requirements specified in S9.2.2 through S9.2.10.

S9.2.1 Constriction. Except for that part of an end fitting which does not contain hose, every inside diameter of any section of a vacuum brake hose assembly shall be not less than 75 percent of the nominal inside diameter of the hose if for heavy duty, or 70 percent of the nominal inside diameter of hose if for light duty (S10.10).

S9.2.2 High temperature resistance. A vacuum brake hose tested under the conditions specified in S10.1:

(a) Shall not have collapse of the outside diameter exceeding 10 percent of the initial outside diameter for a heavy-duty vacuum brake hose, or exceeding 15 percent of the initial outside diameter for a light-duty vacuum brake hose;

(b) Shall not show external cracks, charring, or disintegration visible without magnification, and;

(c) Shall not leak when subjected to a hydrostatic pressure test.

S9.2.3 Low temperature resistance. A vacuum brake hose tested under the conditions specified in S10.2 shall:

(a) Not show cracks visible without magnification after conditioning at minus 40 degrees Fahrenheit (minus 40 degrees Celsius) for 70 hours when bent around a cylinder having the radius specified in Table V for the size hose tested; and

(b) Not leak when subjected to a hydrostatic pressure test (S10.6).

* * * * *

S9.2.7 Bend. The collapse of the outside diameter of a vacuum brake hose, other than a preformed vacuum brake hose, at the middle point of the test length when bent until the ends touch shall not exceed the values given in Table V for the size of hose tested (S10.6).

S9.2.8 Swell and adhesion.

Following exposure to Reference Fuel B, every inside diameter of any section of a vacuum brake hose shall not be less than 75 percent of the nominal inside diameter of the hose if for heavy duty, or 70 percent of the nominal inside diameter of the hose if for light duty. The vacuum brake hose shall show no leakage in a vacuum test of 26 inches of Hg for 10 minutes. A vacuum hose that is constructed of two or more layers shall withstand a force of 6 pounds per inch of length before separation of adjacent layers. (S10.7).

S9.2.9 Deformation. A vacuum brake hose shall return to 90 percent of its original outside diameter within 60

seconds after five applications of force as specified in S10.8, except that a wire-reinforced hose need only return to 85 percent of its original outside diameter. In the case of a heavy duty hose, the first application of force shall not exceed a peak value of 70 pounds, and the fifth application of force shall reach a peak value of at least 40 pounds. In the case of light duty hose the first application of force shall not exceed a peak value of 50 pounds, and the fifth application of force shall reach a peak value of at least 20 pounds (S10.9).

S9.2.10 End fitting corrosion resistance. After 24 hours of exposure to salt spray, vacuum brake hose end fittings shall show no base metal corrosion of the end fitting surface except where crimping or the application of labeling information has caused displacement of the protective coating. (S10.10).

* * * * *

S10. Test procedures—Vacuum brake hose, brake hose assemblies, and brake hose end fittings.

S10.1 High temperature resistance test. (a) Measure the initial outside diameter of the hose.

(b) Subject the hose to an internal vacuum of 26 inches of Hg at an ambient temperature of 257 degrees Fahrenheit (125 degrees Celsius) for a period of 96 hours. Remove the hose to room temperature and atmospheric pressure.

(c) Within 5 minutes of completion of the conditioning in S10.1(b), measure the outside diameter at the point of greatest collapse and calculate the percentage collapse based on the initial outside diameter.

(d) Cool the hose at room temperature for 5 hours. Bend the hose around a mandrel with a diameter equal to five times the initial outside diameter of the hose. Examine the exterior of the hose for cracks, charring, or disintegration visible without magnification. Remove the hose from the mandrel.

(e) Fill the hose assembly with water, allowing all gases to escape. Apply water pressure in the hose of 175 psi within 10 seconds. Maintain an internal hydrostatic pressure of 175 psi for one minute and examine the hose for visible leakage.

S10.2 Low temperature resistance test. (a) Conduct the test specified in S8.2(a) through (c) using vacuum brake hose with the cylinder radius specified in Table V for the size of hose tested.

(b) Remove the hose from the test cylinder, warm the hose at room temperature for 5 hours, and conduct the hydrostatic pressure test in S10.1(e).

* * * * *

S10.6 *Bend test.* (a) Bend a vacuum brake hose, of the length prescribed in Table V, in the direction of its normal curvature until the ends just touch as shown in Figure 6.

* * * * *

S10.7 *Swell and adhesion test.* (a) Fill a specimen of vacuum brake hose 12 inches long with ASTM Reference Fuel B as described in ASTM D471-98 ϵ 1 Standard Test Method for Rubber Property—Effect of Liquids. This incorporation by reference was approved by the Director of the Federal Register in accordance with 5 U.S.C. 552(a) and 1 CFR part 51. Copies may be obtained from the American Society for Testing and Materials (ASTM) International, 100 Barr Harbor Drive, P.O. Box C700, West Conshohocken, PA 19428-2959. Copies may be inspected at the National Highway Traffic Safety Administration, Technical Information Services, 400 Seventh St., SW., Plaza Level, Room 403, Washington, DC 20590, or at the National Archives and

Records Administration (NARA). For information on the availability of this material at NARA, call 202-741-6030, or go to: http://www.archives.gov/federal_register/code_of_federalregulations/ibr_locations.html.

(b) Maintain reference fuel in the hose under atmospheric pressure at room temperature for 48 hours.

(c) Remove fuel and conduct the constriction test in S10.10.

(d) Attach the hose to a source of vacuum and subject it to a vacuum of 26 inches of Hg for 10 minutes. Remove the hose from the vacuum source.

(e) For a vacuum brake hose constructed of two or more layers, conduct the test specified in S8.6 using the vacuum brake hose.

S10.8 [Reserved]

* * * * *

S10.9.2 *Operation.*

* * * * *

(b) Apply gradually increasing force to the test specimen to compress its

inside diameter to that specified in Table VI (dimension D of Figure 7) for the size of hose tested.

* * * * *

S10.10 *Constriction test.* Perform the constriction test in S6.12 using a vacuum brake hose, except that the spherical diameter “A” of the plug gauge in Figure 4, or the diameter of the rigid spherical ball in S6.12.3(a), shall be 75 percent of the nominal inside diameter of the vacuum brake hose if it is heavy duty, or 70 percent of the nominal inside diameter of the vacuum brake hose if it is light duty.

S11. *Requirements—Plastic air brake tubing, plastic air brake tubing assemblies, and plastic air brake tubing end fittings.*

11.1 *Construction.* Each plastic air brake tubing assembly shall be equipped with permanently attached end fittings or reusable end fittings. Plastic air brake tubing shall conform to the dimensional requirements specified in Table VII. (S12.1)

TABLE VII.—PLASTIC AIR BRAKE TUBING DIMENSIONS

Nominal tubing outside diameter	Maximum outside diameter		Minimum outside diameter		Nominal inside diameter		Nominal wall thickness		Wall thickness tolerance	
	mm	inches	mm	inches	mm	inches	mm	inches	mm	inches
1/8 inch	3.25	0.128	3.10	0.122	2.01	0.079	0.58	0.023	0.08	0.003
5/32 inch	4.04	0.159	3.89	0.153	2.34	0.092	0.81	0.032	0.08	0.003
3/16 inch	4.83	0.190	4.67	0.184	2.97	0.117	0.89	0.035	0.08	0.003
1/4 inch	6.43	0.253	6.27	0.247	4.32	0.170	1.02	0.040	0.08	0.003
5/16 inch	8.03	0.316	7.82	0.308	5.89	0.232	1.02	0.040	0.10	0.004
3/8 inch	9.63	0.379	9.42	0.371	6.38	0.251	1.57	0.062	0.10	0.004
1/2 inch	12.83	0.505	12.57	0.495	9.55	0.376	1.57	0.062	0.10	0.004
5/8 inch	16.00	0.630	15.75	0.620	11.20	0.441	2.34	0.092	0.13	0.005
3/4 inch	19.18	0.755	18.92	0.745	14.38	0.566	2.34	0.092	0.13	0.005
6 mm	6.10	0.240	5.90	0.232	4.00	0.157	1.00	0.039	0.10	0.004
8 mm	8.10	0.319	7.90	0.311	6.00	0.236	1.00	0.039	0.10	0.004
10 mm	10.13	0.399	9.87	0.389	7.00	0.276	1.50	0.059	0.10	0.004
12 mm	12.13	0.478	11.87	0.467	9.00	0.354	1.50	0.059	0.10	0.004
16 mm	16.13	0.635	15.87	0.625	12.00	0.472	2.00	0.079	0.13	0.005

S11.2 *Labeling.*

S11.2.1 *Plastic air brake tubing.* Plastic air brake tubing shall be labeled, or cut from bulk tubing that is labeled, at intervals of not more than 6 inches, measured from the end of one legend to the beginning of the next, in block capital letters and numerals at least one-eighth of an inch high, with the information listed in paragraphs (a) through (e) of this section. The information need not be present on tubing that is sold as part of a motor vehicle.

(a) The symbol DOT, constituting a certification by the hose manufacturer that the hose conforms to all applicable motor vehicle safety standards.

(b) A designation that identifies the manufacturer of the tubing, which shall

be filed in writing with: Office of Vehicle Safety Compliance, Equipment Division NVS-222, National Highway Traffic Safety Administration, 400 Seventh St. SW., Washington, DC 20590. The designation may consist of block capital letters, numerals, or a symbol.

(c) The month, day, and year, or the month and year, of manufacture, expressed in numerals. For example, 10/1/96 means October 1, 1996.

(d) The nominal outside diameter expressed in inches or fractions of inches or in millimeters followed by the letters OD. The abbreviation “mm” shall follow tubing sizes that are expressed in millimeters. (Examples: 3/8 OD, 6 mm OD.)

(e) The letter “A” shall indicate intended use in air brake systems.

S11.2.2 *End fittings.* Except for an end fitting that is attached by deformation of the fitting about the tubing by crimping or swaging, at least one component of each plastic air brake tubing end fitting shall be etched, embossed, or stamped in block capital letters and numerals at least one-sixteenth of an inch high with the following information:

(a) The symbol DOT, constituting a certification by the manufacturer that the end fitting conforms to all applicable motor vehicle safety standards.

(b) A designation that identifies the manufacturer of the end fitting, which shall be filed in writing with: Office of

Vehicle Safety Compliance, Equipment Division NVS-222, National Highway Traffic Safety Administration, 400 Seventh St. SW., Washington, DC 20590. The designation may consist of block capital letters, numerals, or a symbol.

(c) The letter "A" shall indicate intended use in air brake systems.

(d) The nominal outside diameter of the plastic tubing to which the fitting is properly attached expressed in inches or fractions of inches or in millimeters followed by the letters OD. The abbreviation "mm" shall follow tubing sizes that are expressed in millimeters. (Examples: 3/8 OD, 6 mm OD)

S11.2.3. *Assemblies.* Each plastic air brake tubing assembly made with end fittings that are attached by crimping or swaging, except those sold as part of a motor vehicle, shall be labeled by means of a band around the brake tubing assembly as specified in this paragraph or, at the option of the manufacturer, by means of labeling as specified in S11.2.3.1. The band may at the manufacturer's option be attached so as to move freely along the length of the assembly, as long as it is retained by the end fittings. The band shall be etched, embossed, or stamped in block capital letters, numerals or symbols at least one-eighth of an inch high, with the following information:

(a) The symbol DOT, constituting certification by the tubing assembler

that the tubing assembly conforms to all applicable motor vehicle safety standards.

(b) A designation that identifies the manufacturer of the hose assembly, which shall be filed in writing with: Office of Vehicle Safety Compliance, Equipment Division NVS-222, National Highway Traffic Safety Administration, 400 Seventh St. SW., Washington, DC 20590. The designation may consist of block capital letters, numerals, or a symbol.

S11.2.3.1 At least one end fitting of a plastic air brake tubing assembly made with end fittings that are attached by crimping or swaging shall be etched, stamped, or embossed with a designation at least one-sixteenth of an inch high that identifies the manufacturer of the tubing assembly and is filed in accordance with S11.2.3(b).

S11.3 *Test requirements.* Each plastic air brake tubing assembly or appropriate part thereof shall be capable of meeting any of the requirements set forth under this heading, when tested under the conditions of S13 and the applicable procedures of S12. However, a particular tubing assembly or appropriate part thereof need not meet further requirements after having met the constriction requirement (S11.3.1) and then having been subjected to any one of the requirements specified in

S11.3.2 through S11.3.22. Unless otherwise specified, testing is conducted on a sample of tubing 12 inches in length.

S11.3.1 *Constriction.* Every inside diameter of any section of a plastic air brake tubing assembly shall not be less than 66 percent of the nominal inside diameter of the brake tubing. (S12.2)

S11.3.2 *High temperature conditioning and dimensional stability.* Plastic air brake tubing shall conform to the dimensions in Table VII after conditioning in air at 230 degrees Fahrenheit (110 degrees Celsius) for four hours. (S12.3)

S11.3.3 *Boiling water conditioning and dimensional stability.* Plastic air brake tubing shall conform to the dimensions in Table VII after conditioning in boiling water for two hours. (S12.4)

S11.3.4 *Burst Strength.* Plastic air brake tubing shall not rupture when subjected to the burst strength pressure in Table VIII for the size of tubing being tested. (S12.5)

S11.3.5 *Moisture absorption and burst strength.* Plastic air brake tubing shall not rupture when subjected to 80 percent of the burst strength pressure in Table VIII, after the tubing has been dried in an oven and then conditioned in a 100 percent relative humidity atmosphere at 75 degrees Fahrenheit (24 degrees Celsius) for 100 hours. (S12.6)

TABLE VIII.—PLASTIC AIR BRAKE TUBING MECHANICAL PROPERTIES

Nominal tubing OD	Burst strength pressure		Supported bend radius ¹		Unsupported bend radius ²		Conditioned tensile load	
	kPa	Psi	Mm	inches	mm	inches	N	lbf
1/8 inch	6900	1000	9.4	0.37	9.4	0.37	156	35
5/32 inch	8300	1200	12.7	0.50	12.7	0.50	178	40
3/16 inch	8300	1200	19.1	0.75	19.1	0.75	222	50
1/4 inch	8300	1200	25.4	1.00	25.4	1.00	222	50
5/16 inch	6900	1000	31.8	1.25	38.1	1.50	334	75
3/8 inch	9700	1400	38.1	1.50	38.1	1.50	667	150
1/2 inch	6600	950	50.8	2.00	63.5	2.50	890	200
5/8 inch	6200	900	63.5	2.50	76.2	3.00	1446	325
3/4 inch	5500	800	76.2	3.00	88.9	3.50	1557	350
6 mm	7600	1100	20.0	0.75	25.4	1.00	222	50
8 mm	6200	900	31.8	1.25	38.1	1.50	334	75
10 mm	8200	1200	38.1	1.50	38.1	1.50	667	150
12 mm	6900	1000	44.5	1.75	63.5	2.50	890	200
16 mm	6000	875	69.9	2.75	76.2	3.00	1446	325

Notes: (1) Supported bend radius for tests specifying cylinders around which the tubing is bent. (2) Unsupported bend radius for the collapse resistance test in which the tubing is not supported by a cylinder during bending.

S11.3.6 *Ultraviolet light resistance.* Plastic air brake tubing shall not rupture when subjected to 80 percent of the burst strength pressure in Table VIII for the size of tubing being tested, after being exposed to ultraviolet light for 300 hours and then impacted with a one

pound weight dropped from a height of 12 inches. (S12.7)

S11.3.7 *Low temperature flexibility.* The outer surface of plastic air brake tubing shall not show cracks visible without magnification as a result of conditioning in air at 230 degrees Fahrenheit (110 degrees Celsius) for 24

hours, and then conditioning in air at minus 40 degrees Fahrenheit (minus 40 degrees Celsius) for four hours, and then bending the tubing 180 degrees around a test cylinder having a radius equal to six times the nominal outside diameter of the tubing. (S12.8)

S11.3.8 *High temperature flexibility.* Plastic air brake tubing shall not rupture or burst when subjected to 80 percent of the burst strength pressure in Table VIII for the size of tubing being tested, after the tubing has been:

(a) Conditioned in air at 230 degrees Fahrenheit (110 degrees Celsius) for 72 hours while bent 180 degrees around a cylinder having a radius equal to the supported bend radius in Table VIII for the size of tubing being tested; and

(b) Cooled to room temperature while remaining on the cylinder, then straightened; and

(c) Bent 180 degrees around the cylinder in the opposite direction of the first bending. (S12.9)

S11.3.9 *High temperature resistance.* Plastic air brake tubing shall not rupture or burst when subjected to 80 percent of the burst strength pressure in Table VIII for the size of tubing being tested, after the tubing has been conditioned in air at 230 degrees Fahrenheit (110 degrees Celsius) for 72 hours. (S12.10)

S11.3.10 *High temperature conditioning, low temperature impact resistance.* Plastic air brake tubing shall not rupture or burst when subjected to 80 percent of the burst strength pressure in Table VIII for the size of tubing being tested, after the tubing has been conditioned in air at 230 degrees Fahrenheit (110 degrees Celsius) for 24 hours, then conditioned in air at minus 40 degrees Fahrenheit (minus 40 degrees Celsius) for 4 hours and impacted with a one pound weight dropped from a height of 12 inches. (S12.11)

S11.3.11 *Boiling water conditioning, low temperature impact resistance.* Plastic air brake tubing shall not rupture when subjected to 80 percent of the burst strength pressure in Table VIII for the size of tubing being tested, after the tubing has been conditioned in boiling water for two hours, then conditioned in air at minus 40 degrees Fahrenheit (minus 40 degrees Celsius) for 4 hours, and then impacted with a one pound weight dropped from a height of 12 inches. (S12.12)

S11.3.12 *Zinc chloride resistance.* The outer surface of plastic air brake tubing shall not show cracks visible under 7-power magnification after immersion in a 50 percent zinc chloride aqueous solution for 200 hours while bent around a cylinder having a radius equal to the supported bend radius in Table VIII for the size of tubing tested. (S12.13)

S11.3.13 *Methyl alcohol resistance.* The outer surface of plastic air brake tubing shall not show cracks visible under 7-power magnification after immersion in a 95 percent methyl

alcohol aqueous solution for 200 hours while bent around a cylinder having a radius equal to the supported bend radius in Table VIII for the size of tubing tested. (S12.14)

S11.3.14 *High temperature conditioning and collapse resistance.* The collapse of the outside diameter of plastic air brake tubing shall not exceed twenty percent of the original outside diameter when bent 180 degrees on a holding fixture to the unsupported bend radius specified in Table VIII and conditioned in air at 200 degrees Fahrenheit (93 degrees Celsius) for 24 hours. (S12.15)

S11.3.15 *Ozone resistance.* The outer surface of plastic air brake tubing shall not show cracks visible under 7-power magnification after exposure to ozone for 70 hours at 104 degrees Fahrenheit (40 degrees Celsius). (S12.16)

S11.3.16 *Oil resistance.* Plastic air brake tubing shall not rupture when subjected to 80 percent of the burst strength pressure in Table VIII for the size of tubing being tested, after the tubing has been conditioned in ASTM IRM 903 oil at 212 degrees Fahrenheit (100 degrees Celsius) for 70 hours. (S12.17)

S11.3.17 *Tensile strength.* A plastic air brake tubing assembly designed for use between frame and axle or between a towed and a towing vehicle shall withstand, without separation of the tubing from its end fittings, a pull of 250 pounds if it is $\frac{3}{8}$ inch, 10 mm, or less in nominal outside diameter, or a pull of 325 pounds if it is larger than $\frac{3}{8}$ inch or 10 mm in nominal outside diameter. A plastic air brake tubing assembly designed for use in any other application shall withstand, without separation of the hose from its end fittings, a pull of 35 pounds if it is $\frac{1}{8}$ inch, 3 mm, or less in nominal outside diameter, 40 pounds if it is $\frac{5}{32}$ inch or 4 mm in nominal outside diameter, 50 pounds if it is $\frac{3}{16}$ to $\frac{3}{8}$ inch or 5 mm to 10 mm in nominal outside diameter, 150 pounds if it is $\frac{1}{2}$ to $\frac{5}{8}$ inch or 11 mm to 16 mm in nominal outside diameter, or 325 pounds if it is larger than $\frac{5}{8}$ inch or 16 mm in nominal outside diameter. (S12.18)

S11.3.18 *Boiling water conditioning and tensile strength.* A plastic air brake tubing assembly when subjected to a tensile pull test shall either elongate 50 percent or withstand the conditioned tensile load in Table VIII without separation from its end fittings, with one end of the assembly conditioned in boiling water for 5 minutes. (S12.19)

S11.3.19 *Thermal conditioning and tensile strength.* A plastic air brake tubing assembly when subjected to a

tensile pull test shall either elongate 50 percent or withstand the conditioned tensile load in Table VIII without separation from its end fittings after the assembly has been subjected to four cycles of conditioning in air at minus 40 degrees Fahrenheit (minus 40 degrees Celsius) for thirty minutes, normalizing at room temperature, conditioning in boiling water for 15 minutes, and normalizing at room temperature. (S12.20)

S11.3.20 *Vibration resistance.* A plastic air brake tubing assembly with an internal air pressure of 120 psig shall not rupture or leak more than 50 cm³ per minute at a temperature of minus 40 degrees Fahrenheit (minus 40 degrees Celsius) and 25 cm³ per minute at a temperature of 75 degrees Fahrenheit (24 degrees Celsius), after the assembly has been subjected to 1,000,000 cycles of vibration testing with one end of the assembly fixed and the other end stroked $\frac{1}{2}$ -inch at 600 cycles per minute. In addition, end fittings that use a threaded retention nut shall retain at least 20 percent of the original retention nut tightening torque upon completion of the vibration testing. The vibration test shall be conducted in an environmental chamber and the air temperature shall be cycled between minus 40 degrees Fahrenheit (minus 40 degrees Celsius) and 220 degrees Fahrenheit (104 degrees Celsius) during the test. (S12.21)

S11.3.21 *End fitting retention.* The end fittings of a plastic air brake tubing assembly shall not rupture when the assembly is filled with water and pressurized to the burst strength pressure in Table VIII. (S12.22)

S11.3.22 *Thermal conditioning and end fitting retention.* The end fittings of a plastic air brake tubing assembly shall not rupture when the tubing assembly is filled with ASTM IRM 903 oil and:

(a) Conditioning in air at 200 degrees Fahrenheit (93 degrees Celsius) for 24 hours with atmospheric pressure inside the tubing assembly; and

(b) Increasing the pressure inside the tubing assembly to 450 psi, and holding this pressure for five minutes while maintaining an air temperature of 200 degrees Fahrenheit (93 degrees Celsius); and

(c) Reducing the pressure inside the tubing assembly to atmospheric and permitting the tubing assembly to cool at 75 degrees Fahrenheit (24 degrees Celsius) for 1 hour; and

(d) Conditioning the tubing assembly in air at minus 40 degrees Fahrenheit (minus 40 degrees Celsius) for 24 hours with atmospheric pressure inside the tubing assembly; and

(e) Increasing the pressure inside the tubing assembly to 450 psi, and holding this pressure for five minutes while maintaining an air temperature of minus 40 degrees Fahrenheit (minus 40 degrees Celsius). (S12.23)

S11.3.23 *End fitting serviceability.* A plastic air brake end fitting that uses a threaded retention nut shall not rupture or leak more than 25 cm³ per minute when pressurized to 120 psi after five assembly cycles. (S12.24)

S11.3.24 *End fitting corrosion resistance.* After 24 hours of exposure to salt spray, air brake hose end fittings shall show no base metal corrosion on the end fitting surface except where crimping or the application of labeling information causes a displacement of the protective coating. (S12.25)

S12. *Test procedures—Plastic air brake tubing, plastic air brake tubing assemblies, plastic air brake tubing end fittings.*

S12.1 *Air brake tubing dimensions.* Measure the tubing dimensions including wall thickness, inside diameter, and outside diameter, using appropriate metrology apparatus such as micrometers, dial indicators and gauges, or optical comparators. To account for slight out-of-round conditions, diameter measurements may be calculated using the average of the major and minor diameters.

S12.2 *Constriction test.* Perform the constriction test in S6.12 using an air brake tubing assembly, except that the spherical diameter "A" of the plug gauge in Figure 4, or the diameter of the rigid spherical ball in S6.12.3(a), shall be 66 percent of the nominal inside diameter of the tubing as specified in Table VII.

S12.3 *High temperature conditioning and dimensional stability test.* (a) Condition the tubing at 230 degrees Fahrenheit (110 degrees Celsius) for 4 hours in an air oven.

(b) Remove the tubing from the oven and allow to cool at room temperature for 30 minutes.

(c) Measure the dimensions of the tubing using the procedure in S12.1.

S12.4 *Boiling water conditioning and dimensional stability test.* (a) Utilize a container constructed of a non-reactive material large enough so that the tubing to be tested does not touch any surface of the container. Fill container with distilled water.

(b) Slip the tubing over a stainless steel wire for positioning it in the pot.

(c) Bring the water to a boil. Place the tubing in the water and position it so that it does not touch the container. Boil the tubing for two hours. Replenish the water as necessary, adding it slowly so

that the water in the pot boils continuously.

(d) Remove the tubing from the water and allow to cool at room temperature for 30 minutes. Wipe off any water that remains on the tubing.

(e) Measure the dimensions of the tubing using the procedure in S12.1.

S12.5 *Burst strength test.* (a) Utilize an air brake tubing assembly or prepare a 12 inch length of tubing and install end fittings according to the end fitting manufacturer's instructions.

(b) Plug one end of the assembly, fill it with water, and connect the other end to a source of water pressure. Bleed any air from the assembly and water pressure system.

(c) Increase the water pressure inside the tubing assembly at a rate of 3,000 psi per minute to the burst strength pressure for the size of tubing being tested as specified in Table VIII.

S12.6 *Moisture absorption and burst strength.* (a) Prepare a sample of tubing twelve inches in length.

(b) Condition the tubing at 230 degrees Fahrenheit (110 degrees Celsius) for 24 hours in an air oven. Remove the tubing from the oven and within 30 seconds, and weigh it to establish the initial weight. The weight shall be measured with a resolution of 0.01 gram; if the scale has a higher resolution, then values of 0.005 gram and above shall be rounded to the nearest 0.01 gram and values below 0.005 gram shall be truncated.

(c) Place the tubing in an environmental chamber and condition it for 100 hours at 100 percent relative humidity and a temperature of 75 degrees Fahrenheit (24 degrees Celsius).

(d) Remove the tubing from the chamber and within a period of 5 minutes, remove all surface moisture from the tubing using cloth and weigh the tubing to establish the conditioned weight. Weight shall be measured to the nearest 0.01 gram as in S12.6(b).

(e) Calculate percentage of moisture absorption as follows:
((Conditioned Weight – Initial Weight) / [Initial Weight] × 100)

(f) Install end fittings according to the end fitting manufacturers instructions.

(g) Conduct the burst strength test in 12.5 except use 80 percent of the burst strength pressure for the size of tubing being tested as specified in Table VIII.

S12.7 *Ultraviolet light resistance test.* (a) *Apparatus.* An accelerated weathering test machine for ultraviolet light conditioning of plastic air brake tubing. The machine shall be equipped with fluorescent UVA–340 light bulbs and automatic irradiance control. Also utilize an impact test apparatus as shown in Figure 8.

(b) *Test standards.* The testing is in accordance with American Society for Testing and Materials (ASTM) G154–00 "Standard Practice for Operating Fluorescent Light Apparatus for UV Exposure of Nonmetallic Materials;" ASTM G151–97 "Standard Practice for Exposing Nonmetallic Materials in Accelerated Test Devices that Use Laboratory Light Sources," and; ASTM D4329–99 "Standard Practice for Fluorescent UV Exposure of Plastics." These incorporations by reference were approved by the Director of the Federal Register in accordance with 5 U.S.C. 552(a) and 1 CFR Part 51. Copies may be obtained from the American Society for Testing and Materials (ASTM) International, 100 Barr Harbor Drive, P.O. Box C700, West Conshohocken, PA 19428–2959. Copies may be inspected at the National Highway Traffic Safety Administration, Technical Information Services, 400 Seventh St., SW., Plaza Level, Room 403, Washington, DC 20590, or at the National Archives and Records Administration (NARA). For information on the availability of this material at NARA, call (202) 741–6030, or go to: http://www.archives.gov/federal_register/code_of_federal_regulations/ibr_locations.html.

(c) *Preparation.* (1) Utilize a 12 inch length of plastic air brake tubing. Mask 1 inch of each end of the tubing where end fittings will be attached using opaque tape.

(2) Attach the tubing to the test rack of the machine, securing it at the ends along the masked sections. Wipe the outside surface of the tubing with acetone to remove any surface contaminants. Place the tubing and rack in the accelerated weathering test machine so that the center of the tubing assembly is approximately in the center of the UV light exposure area of the test machine. (If multiple plastic brake tubing assemblies are tested, then their position in the machine should be rotated according to ASTM D4329–99 S7.4.1, except the rotation shall be each 96 hours instead of weekly.) The distance from the light bulb to the tubing shall be approximately 2 inches. Set the UV irradiance to 0.85 watts per square meter at 340 nm and maintain this level during the testing. Maintain a temperature inside the test chamber of 113 degrees Fahrenheit (45 degrees Celsius), and use only atmospheric humidity. Expose the tubing at this UV irradiance level for 300 hours continuously. Remove the tubing from the test chamber.

(3) Place the tubing inside the impact test apparatus, and drop the impactor onto the tubing from a height of 12 inches.

(4) Remove the masking material from the ends of the tubing. Install end fittings according to the end fitting

manufacturer's instructions. Conduct the burst strength test in S12.5 except use 80 percent of the burst strength

pressure for the size of tubing being tested as specified in Table VIII.
BILLING CODE 4910-59-P

FIGURE 8. IMPACT TEST APPARATUS

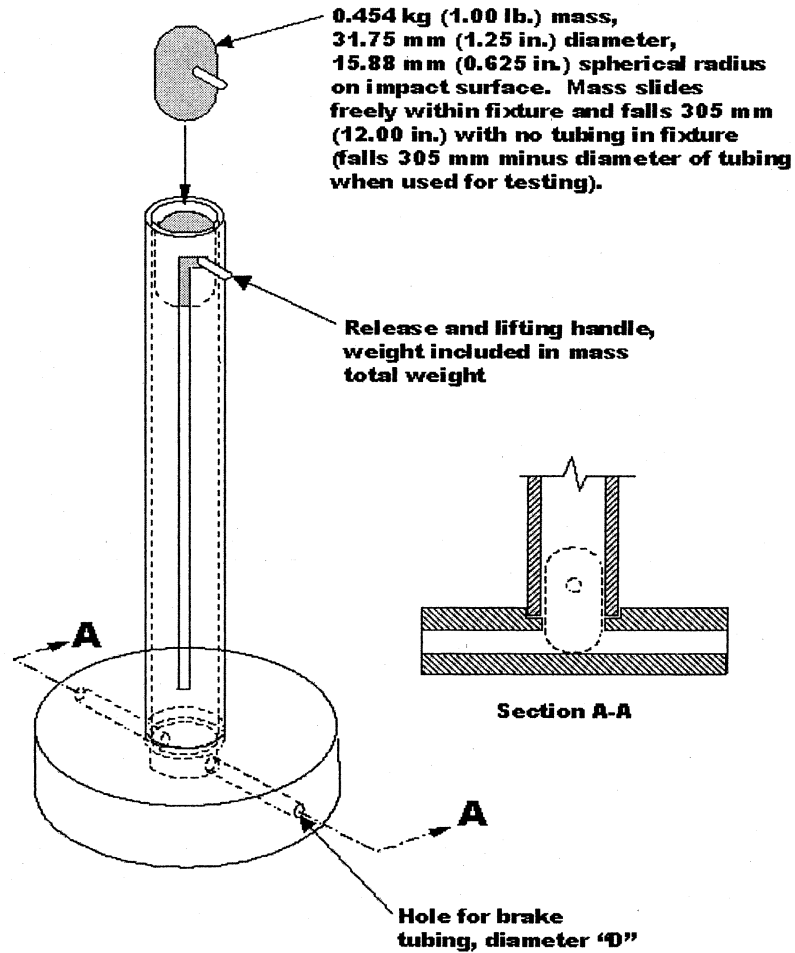

TABLE ACCOMPANYING FIGURE 8

Nominal tubing outside diameter	Hole diameter "D"	
	mm	Inches
1/8 inch	3.96	0.156
5/32 inch	4.75	0.187
3/16 inch	5.54	0.218
1/4 inch	7.14	0.281
5/16 inch	8.71	0.343
3/8 inch	10.31	0.406
1/2 inch	13.49	0.531
5/8 inch	16.66	0.656
3/4 inch	20.32	0.800
6 mm	6.80	0.268
8 mm	8.80	0.346
10 mm	10.80	0.425

TABLE ACCOMPANYING FIGURE 8—Continued

Nominal tubing outside diameter	Hole diameter "D"	
	mm	Inches
12 mm	12.80	0.504
16 mm	16.80	0.661

S12.8 Low temperature flexibility test. (a) Utilize a cylinder having a radius of six times the nominal outside diameter of the tubing.
(b) Condition the tubing in an air oven at 230 degrees Fahrenheit (110 degrees Celsius) for 24 hours. Remove from the

oven and cool at room temperature for 30 minutes.

(c) Condition the cylinder and the tubing in an environmental chamber at minus 40 degrees Fahrenheit (minus 40 degrees Celsius) for four hours.

(d) With the tubing and test cylinder at minus 40 degrees Fahrenheit (minus 40 degrees Celsius), bend the tubing 180 degrees around the cylinder at a steady rate in a period of 4 to 8 seconds.

S12.9 High temperature flexibility test. (a) Utilize a cylinder having a radius equal to the supported bend radius in Table VIII for the size of tubing being tested.

(b) Bend the tubing 180 degrees around the cylinder and hold in place with a clamp or other suitable support, applying only enough force on the tubing to hold it in position.

(c) Condition the tubing and cylinder in an air oven at 230 degrees Fahrenheit (110 degrees Celsius) for 72 hours. Remove the tubing and cylinder from the oven and cool at room temperature for two hours.

(d) Remove the clamps or supports from the tubing and straighten the tubing at a steady rate in a period of 4 to 8 seconds.

(e) Rebend the tubing 180 degrees around the cylinder, at the same point but in the opposite direction of the bending in S12.9(b), at a steady rate in a period of 4 to 8 seconds.

(f) Conduct the burst strength test in S12.5 except use 80 percent of the burst strength pressure for the size of tubing being tested as specified in Table VIII.

S12.10 High temperature resistance test. Condition the tubing in an air oven at 230 degrees Fahrenheit for 72 hours. Remove the tubing and allow to cool at room temperature for 30 minutes. Conduct the burst strength test in S12.5 except use 80 percent of the burst strength pressure for the size of tubing being tested as specified in Table VIII.

S12.11 High temperature conditioning, low temperature impact resistance test. (a) *Apparatus.* Utilize an impact test apparatus as shown in Figure 8.

(b) Condition the tubing in an air oven at 230 degrees Fahrenheit (110 degrees Celsius) for 72 hours. Remove the tubing and allow to cool at room temperature for 30 minutes.

(c) Condition the tubing and the impact test apparatus in an environmental chamber at minus 40 degrees Fahrenheit (minus 40 degrees Celsius) for 4 hours.

(d) With the tubing and impact test apparatus at minus 40 degrees Fahrenheit (minus 40 degrees Celsius), place the tubing inside the apparatus and drop the impacter onto the tubing from a height of 12 inches. Remove the tubing from the chamber and allow to warm at room temperature for one hour.

(e) Conduct the burst strength test in S12.5 except use 80 percent of the burst strength pressure for the size of tubing being tested as specified in Table VIII.

S12.12 Boiling water conditioning, low temperature impact resistance test. (a) *Apparatus.* Utilize an impact test apparatus as shown in Figure 8.

(b) Condition the tubing in boiling water using the test in S12.4 (a) through (d), except that the length of tubing shall be 12 inches.

(c) Condition the tubing and the impact test apparatus in an environmental chamber at minus 40 degrees Fahrenheit (minus 40 degrees Celsius) for 4 hours.

(d) With the tubing and impact test apparatus at minus 40 degrees Fahrenheit (minus 40 degrees Celsius), place the tubing inside the apparatus and drop the impacter onto the tubing from a height of 12 inches. Remove the tubing from the chamber and allow to warm at room temperature for one hour.

(e) Conduct the burst strength test in S12.5 except use 80 percent of the burst strength pressure for the size of tubing being tested as specified in Table VIII.

S12.13 Zinc chloride resistance test.

(a) Utilize a cylinder having a radius equal to the supported bend radius in Table VIII for the size of tubing being tested. The cylinder is constructed of a non-reactive material or coated to prevent chemical reaction with zinc chloride. The length of the tubing sample is long enough so that its ends will not be submerged during the immersion in zinc chloride, or the ends of the tubing are plugged to keep the zinc chloride from entering the tubing.

(b) Bend the tubing 180 degrees around the cylinder and hold in place with a clamp or other suitable support constructed of non-reactive materials, applying only enough force on the tubing to hold it in position.

(c) Immerse the tubing and cylinder in a 50 percent zinc chloride aqueous solution at room temperature for 200 hours.

(d) Remove the tubing and cylinder from the solution. While still on the test cylinder, inspect the tubing under 7-power magnification for cracks.

S12.14 Methyl alcohol resistance. (a) Utilize a cylinder having a radius equal to the supported bend radius in Table VIII for the size of tubing being tested. The cylinder is constructed of a non-reactive material or coated to prevent chemical reaction with methyl alcohol.

(b) Bend the tubing 180 degrees around the cylinder and hold in place with a clamp or other suitable support constructed of non-reactive materials, applying only enough force on the tubing to hold it in position. The ends of the tubing may be shortened so that they will be fully submerged in the methyl alcohol.

(c) Immerse the tubing and cylinder in a 95 percent methyl alcohol aqueous solution at room temperature for 200 hours.

(d) Remove the tubing and cylinder from the solution. While still on the test cylinder, inspect the tubing under 7-power magnification for cracks.

S12.15 High temperature conditioning and collapse resistance test. (a) *Apparatus.* A holding device consisting of two vertical pins affixed to a flat, horizontal plate. Each pin projects 1 inch above the top surface of the plate. The diameter of each pin is approximately equal to the inside diameter of the tubing being tested. Using the unsupported bend radius for the size of tubing being tested from Table VIII, the distance between the pin centerlines is equal to:

$$[2 \times \text{unsupported bend radius}] + [\text{nominal OD of tubing}]$$

(b) *Preparation.* (1) Use the unsupported bend radius for the size of tubing being tested from Table VIII and cut the tubing to the following length:

$$[3.14 \times [\text{unsupported bend radius}] + [10 \times [\text{nominal tubing OD}]] + 2 \text{ inches}$$

$$\text{or}$$

$$[3.14 \times [\text{unsupported bend radius}] + [10 \times [\text{nominal tubing OD}]] + 50 \text{ mm}$$

(2) Place a reference mark at the center of the sample. At this mark, measure the initial outside diameter of the tubing. If the tubing is slightly out-of-round, use the elliptical minor diameter as the initial outside diameter.

(3) Install the tubing completely over the pins of the holding device so that the tubing is bent 180 degrees. If the tubing has a natural curvature, the tubing shall be bent in the direction of the natural curvature.

(4) Condition the holding device and tubing in an air oven at 230 degrees Fahrenheit (110 degrees Celsius) for 24 hours. Remove the holding device and tubing and allow to cool at room temperature for thirty minutes.

(5) With the tubing still mounted to the holding device, measure the elliptical minor diameter of the tubing at the reference mark to determine the final outside diameter.

(c) *Calculation.* Calculate the percentage collapse of the outside diameter of the tubing as follows:

$$[(\text{Initial Outside Diameter} - \text{Final Outside Diameter}) / \text{Initial Outside Diameter}] \times 100$$

S12.16 Ozone resistance test.

Conduct the test specified in S6.8 using plastic air brake tubing.

S12.17 Oil resistance test. (a) Utilize a plastic air brake tubing assembly or prepare a 12 inch length of tubing and install end fittings according to the end fitting manufacturer's instructions.

(b) Immerse the tubing assembly in ASTM 903 oil at 212 degrees Fahrenheit (100 degrees Celsius) for 70 hours. Remove and allow to cool at room temperature for 30 minutes. Wipe any excess oil from the tubing assembly.

(c) Conduct the burst strength test in S12.5 except use 80 percent of the burst strength pressure for the size of tubing being tested as specified in Table VIII and, at the manufacturer's option, oil may be used as the test medium instead of water.

S12.18 Tensile strength test. Conduct the test in S8.9 using a plastic air brake tubing assembly or an assembly prepared from a 12 inch length of air brake tubing with end fittings installed according to the end fitting manufacturer's instructions.

S12.19 Boiling water conditioning and tensile strength. (a) *Apparatus.* Use a tension testing machine as specified in S8.9. The lower attachment point of the machine is equipped with a heated, open-top container that is water tight. The inside of the container (lower attachment point) and upper attachment point of the machine have provisions to quickly attach a brake hose assembly for tensile testing.

(b) *Preparation.* Prepare an air brake tubing assembly with a free length of 6 inches (six inches of exposed tubing between the end fittings), with the end fittings installed in accordance with the end fitting manufacturer's instructions. If necessary install adapters on the end fittings to permit quick attachment to the machine, to keep water from entering the tubing assembly, and to ensure that the tubing assembly is in a straight position when installed on the machine. Fill the container with distilled water such that the lower 4 inches of exposed tubing will be submerged when the brake tubing assembly is installed on the machine. Heat the water until it boils. Then quickly install the plastic air brake tubing assembly on the machine with the lower end of the tubing assembly in the boiling water. After the water has boiled continuously for 5 minutes, apply tension to the tubing assembly at a rate of 1 inch per minute travel of the moving head until either the conditioned tensile load in Table VIII for the size of tubing being tested is reached or the free length of the tubing assembly reaches 9 inches, whichever occurs first.

S12.20 Thermal conditioning and tensile strength. (a) *Apparatus.* Use a tension testing machine as specified in S8.9.

(b) *Preparation.* Prepare an air brake tubing assembly with a free length of 6 inches (six inches of exposed tubing between the end fittings), with the end fittings installed in accordance with the end fitting manufacturer's instructions. If necessary install adapters on the end fittings to permit attachment to the machine, to keep water from entering

the tubing assembly, and/or to ensure that the tubing assembly is in a straight position when installed on the machine. Subject the tubing assembly to four complete cycles of the following sequence:

(1) Condition the tubing assembly in an environmental chamber at minus 40 degrees Fahrenheit (minus 40 degrees Celsius) for 30 minutes. Remove from the chamber and allow to warm at room temperature for 30 minutes.

(2) Condition the tubing assembly by submerging it in boiling water for 15 minutes. Remove and allow to cool at room temperature for 30 minutes. Install the tubing assembly on the tension testing machine and apply tension to the tubing assembly at a rate of one inch per minute travel of the moving head until either the conditioned tensile load in Table VIII for the size of tubing being tested is reached or the free length of the tubing assembly reaches 9 inches, whichever occurs first.

S12.21 Vibration resistance test. (a) *Apparatus.* A vibration testing machine that supports a brake tubing assembly by its end fittings in approximately a straight line and includes the following features:

(1) One tubing assembly attachment point is fixed and the other moves in a plane perpendicular to a line projected between the attachment points. The movable attachment point moves in a linear direction and travels 1/2 inch total and at its midpoint of travel falls on a line projected between the attachment points. The movable attachment point has a cycle rate of 600 cycles per minute.

(2) The distance between the attachment points is adjustable to compensate for varying lengths of brake tubing assemblies.

(3) The actuating mechanism for the movable attachment point is balanced to prevent introduction of machine vibration into the brake tubing assembly.

(4) The machine has a compressed air supply system that pressurizes the air brake tubing assembly through one fitting while the other fitting is plugged. The machine's compressed air supply system includes a pressure gauge or monitoring system and an air flow meter.

(5) The machine is constructed so that an air brake tubing assembly mounted on it can be conditioned in an environmental test chamber.

(b) *Preparation.* (1) Prepare an air brake tubing assembly with a free length of 18 inches (18 inches of exposed tubing between the end fittings), with the end fittings installed in accordance with the end fitting manufacturer's

instructions. Record the initial tightening torque for an end fitting that uses a threaded retaining nut.

(2) Install the air brake tubing assembly on the vibration testing machine and, with the movable attachment point at the midpoint of its travel, adjust the distance between the attachment points so that they are 1/2 inch closer together than the distance at which the tubing assembly is taut.

(3) With the tubing assembly inside the environmental chamber, apply compressed air to the tubing assembly at a regulated pressure of 120 psi and maintain the supply of air to the tubing assembly for the duration of the test. Set the temperature of the environmental chamber to 220 degrees Fahrenheit (104 degrees Celsius) and initiate cycling of the movable attachment point. After 250,000 cycles, set the temperature of the environmental chamber to minus 40 degrees Fahrenheit (minus 40 degrees Celsius). After 500,000 cycles, set the temperature of the environmental chamber to 220 degrees Fahrenheit (104 degrees Celsius). After 750,000 cycles, set the temperature of the environmental chamber to minus 40 degrees Fahrenheit (minus 40 degrees Celsius). Measure the air flow rate just prior to 1,000,000 cycles and if the compressed air flow rate supplied to the air brake tubing assembly exceeds 50 cubic centimeters per minute this constitutes failure of the test. Stop the cycling at 1,000,000 cycles and set the environmental chamber temperature to 75 degrees Fahrenheit (24 degrees Celsius), while air pressure is still supplied to the air brake tubing assembly. After one hour, measure the compressed air flow rate supplied to the air brake tubing assembly and if the rate exceeds 25 cubic centimeters per minute this constitutes failure of the test.

(4) For end fittings that use a threaded retaining nut, apply 20 percent of the original tightening torque as recorded in S12.21(b)(1). If the retention nut visibly moves, this constitutes a failure of the test.

S12.22 End fitting retention test. (a) Utilize an air brake tubing assembly or prepare a 12 inch length of tubing and install end fittings according to the end fitting manufacturer's instructions.

(b) Plug one end of the assembly, fill it with water, and connect the other end to a source of water pressure. Bleed any air from the assembly and water pressure system.

(c) Increase the pressure inside the tubing assembly at a rate of 3,000 psi per minute to 50 percent of the burst strength pressure for the size of tubing being tested as specified in Table VIII.

Hold the pressure constant for 30 seconds.

(d) Increase the pressure inside the tubing assembly at a rate of 3,000 psi per minute to the burst strength pressure for the size of tubing being tested as specified in Table VIII.

S12.23 Thermal conditioning and end fitting retention test. (a) *Apparatus.* A source of hydraulic pressure that includes a pressure gauge or monitoring system, uses ASTM IBM 903 oil, and is constructed so that an air brake tubing assembly mounted to it can be conditioned in an environmental test chamber.

(b) *Preparation.* Utilize an air brake tubing assembly or prepare a 12 inch length of tubing and install end fittings according to the end fitting manufacturer's instructions. Attach one end of the assembly to the hydraulic pressure supply and plug the other end of the assembly, fill the assembly with ASTM IRM 903 oil and bleed any air from the assembly, and place the tubing assembly inside an environmental chamber. Conduct the following tests:

(1) With atmospheric pressure applied to the oil inside the tubing assembly, set the environmental chamber temperature to 200 degrees Fahrenheit (93 degrees Celsius) and condition the tubing assembly for 24 hours.

(2) With the temperature maintained at 200 degrees Fahrenheit (93 degrees Celsius), increase the oil pressure inside

the tubing assembly at a rate of 3,000 psi per minute to 450 psi, and hold this pressure for 5 minutes.

(3) Decrease the oil pressure inside the tubing assembly at a rate of 3,000 psi per minute to atmospheric pressure and set the temperature of the environmental chamber to 75 degrees Fahrenheit (24 degrees Celsius). Condition the tubing assembly at this temperature for 1 hour.

(4) Set the temperature of the environmental chamber to minus 40 degrees Fahrenheit (minus 40 degrees Celsius) and condition the tubing assembly for 24 hours.

(5) With the temperature maintained at minus 40 degrees Fahrenheit (minus 40 degrees Celsius), increase the hydraulic pressure inside the tubing assembly at a rate of 3,000 psi per minute to 450 psi, and hold this pressure for 5 minutes.

S12.24 End fitting serviceability. (a) *Apparatus.* A source of air pressure that includes a pressure gauge or monitoring system and is equipped with a mass air flow meter.

(b) *Preparation.* Prepare a 12-inch length of tubing and plug one end. Assemble the end fitting with the threaded retention nut on the other end of the tubing according to the end fitting manufacturer's instructions, then disassemble the fitting. Repeat the assembly and disassembly sequence three more times, and then reassemble

the end fitting (five total assembly steps).

(c) Attach the end fitting with the threaded retention nut to the source of air pressure. Pressurize the tubing at a rate of 3,000 psi per minute to a pressure of 120 psi. If the end fitting leaks, measure and record the leakage rate using the mass air flow meter.

S12.25 End fitting corrosion resistance. Utilize an air brake tubing assembly or prepare a 12-inch length of tubing and install end fittings according to the end fitting manufacturer's instructions. Conduct the test specified in S6.11 using a plastic air brake tubing assembly.

S13. Test Conditions. Each hose assembly or appropriate part thereof shall be able to meet the requirements of S5, S7, S9, and S11, under the following conditions.

S13.1 The temperature of the testing room is 75 degrees Fahrenheit (24 degrees Celsius).

S13.2 The brake hoses and brake hose assemblies are at least 24 hours old, and unused.

S13.3 Specified test pressures are gauge pressures (psig).

Issued on: December 3, 2004.

Jeffrey W. Runge,
Administrator.

[FR Doc. 04-27088 Filed 12-17-04; 8:45 am]

BILLING CODE 4910-59-P