

STANDARD ARROW DETAILS

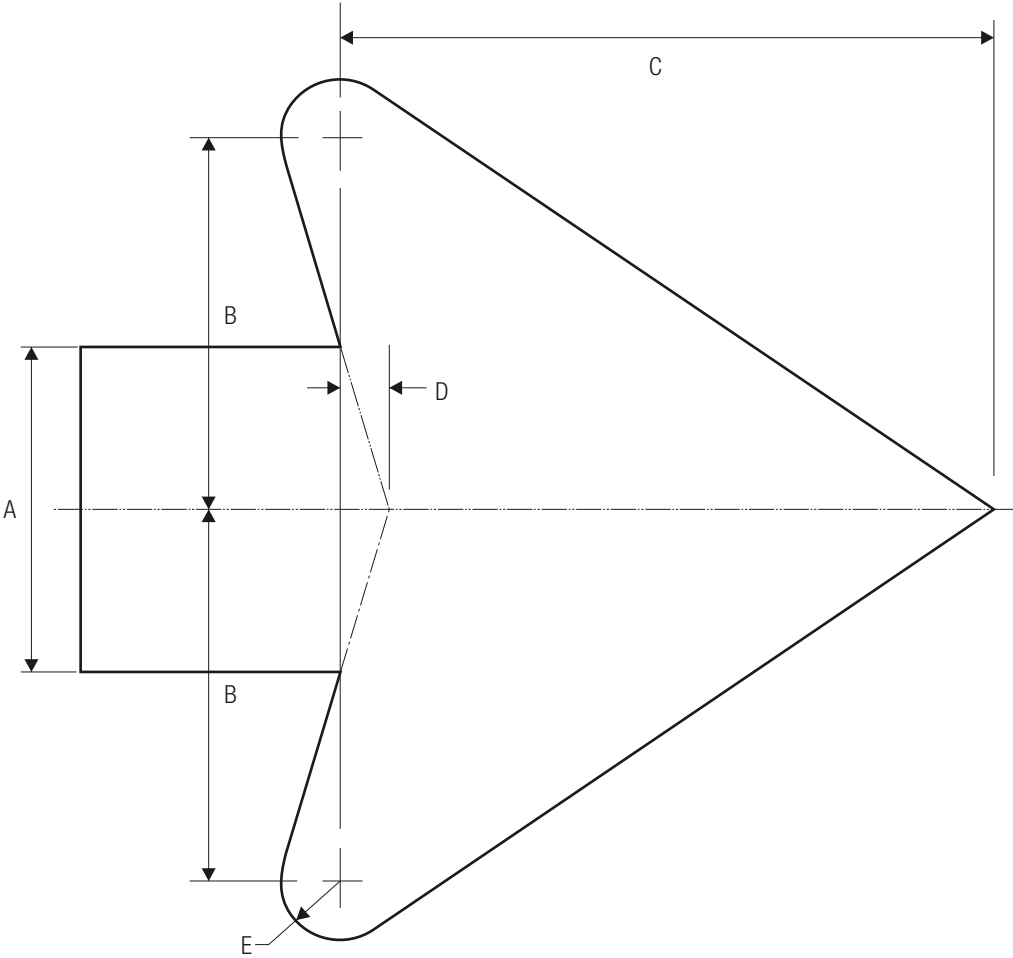

| A | B | C | D | E |
|-------|-------|-------|------|------|
| 2 | 2.313 | 4.313 | .313 | .375 |
| 2.25 | 2.625 | 4.5 | .375 | .438 |
| 2.5 | 2.875 | 5.063 | .375 | .5 |
| 2.625 | 3 | 5.25 | .375 | .5 |
| 2.75 | 3 | 5.563 | .438 | .563 |
| 3 | 3.5 | 6.125 | .438 | .563 |
| 3.125 | 3.625 | 6.375 | .5 | .625 |
| 3.25 | 3.75 | 6.625 | .5 | .625 |
| 3.313 | 3.813 | 6.688 | .5 | .688 |
| 3.5 | 4 | 7.125 | .563 | .688 |
| 3.75 | 4.313 | 7.625 | .563 | .75 |
| 4 | 4.625 | 8.125 | .625 | .813 |
| 4.063 | 4.75 | 8.25 | .625 | .813 |
| 4.25 | 4.875 | 8.625 | .625 | .813 |
| 4.375 | 5 | 8.875 | .688 | .875 |
| 4.5 | 5.188 | 9.125 | .688 | .875 |

| A | B | C | D | E |
|-------|-------|--------|-------|-------|
| 4.75 | 5.438 | 9.625 | .75 | 1 |
| 4.875 | 5.625 | 9.875 | .75 | 1 |
| 5 | 5.75 | 10.125 | .75 | 1 |
| 5.25 | 6 | 10.625 | .813 | 1.063 |
| 5.5 | 6.375 | 11.125 | .875 | 1.125 |
| 5.75 | 6.625 | 11.688 | .875 | 1.125 |
| 6 | 6.875 | 12.188 | .938 | 1.188 |
| 6.5 | 7.5 | 13.188 | 1 | 1.625 |
| 7 | 8 | 14.188 | 1.063 | 1.375 |
| 7.5 | 8.625 | 15.188 | 1.125 | 1.5 |
| 8 | 9.188 | 16.25 | 1.25 | 1.625 |

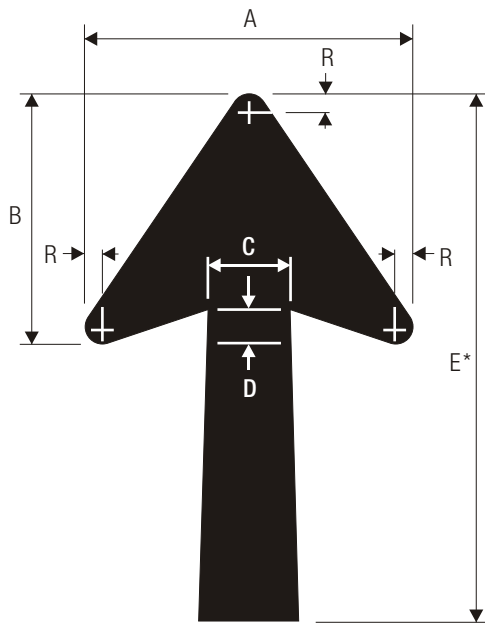

UP ARROW

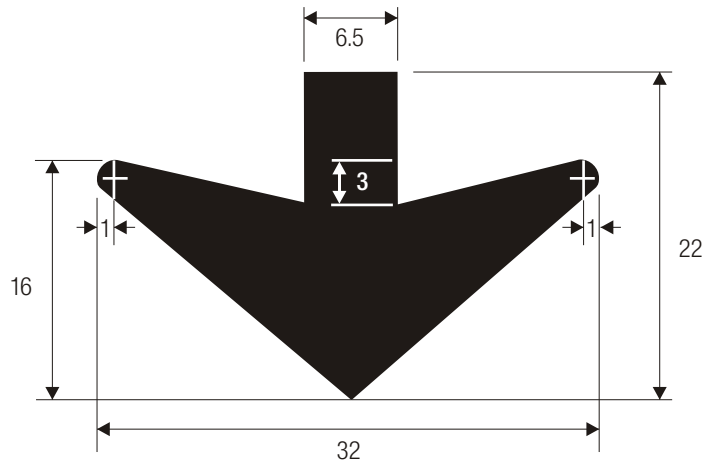

DOWN ARROW

ARROWS FOR GUIDE SIGNS

Dimensions of Arrow When Used With Various Letter Cap Heights.

| Letter Size | A | B | C | D | E* | R |
|-------------|--------|--------|-------|-------|-------|------|
| 8 | 15.125 | 11.563 | 3.75 | 1.313 | 17-25 | .813 |
| 10-13.3 | 18.25 | 14 | 4.5 | 1.5 | 20-30 | .75 |
| 16 | 22.25 | 17 | 5.375 | 1.75 | 25-35 | 1 |

*Taper of .5" per ft. should be held constant for longer or shorter shaft lengths.

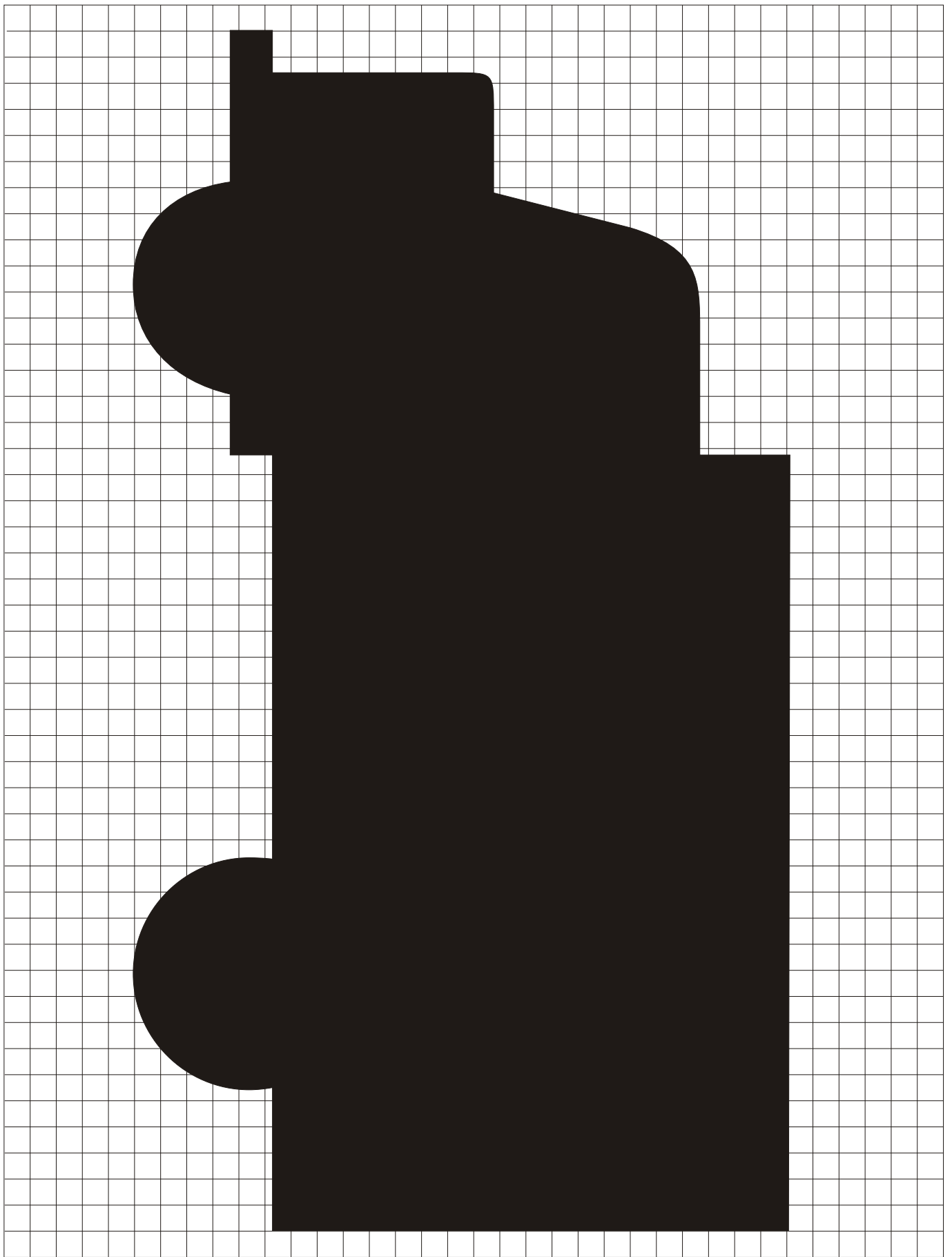

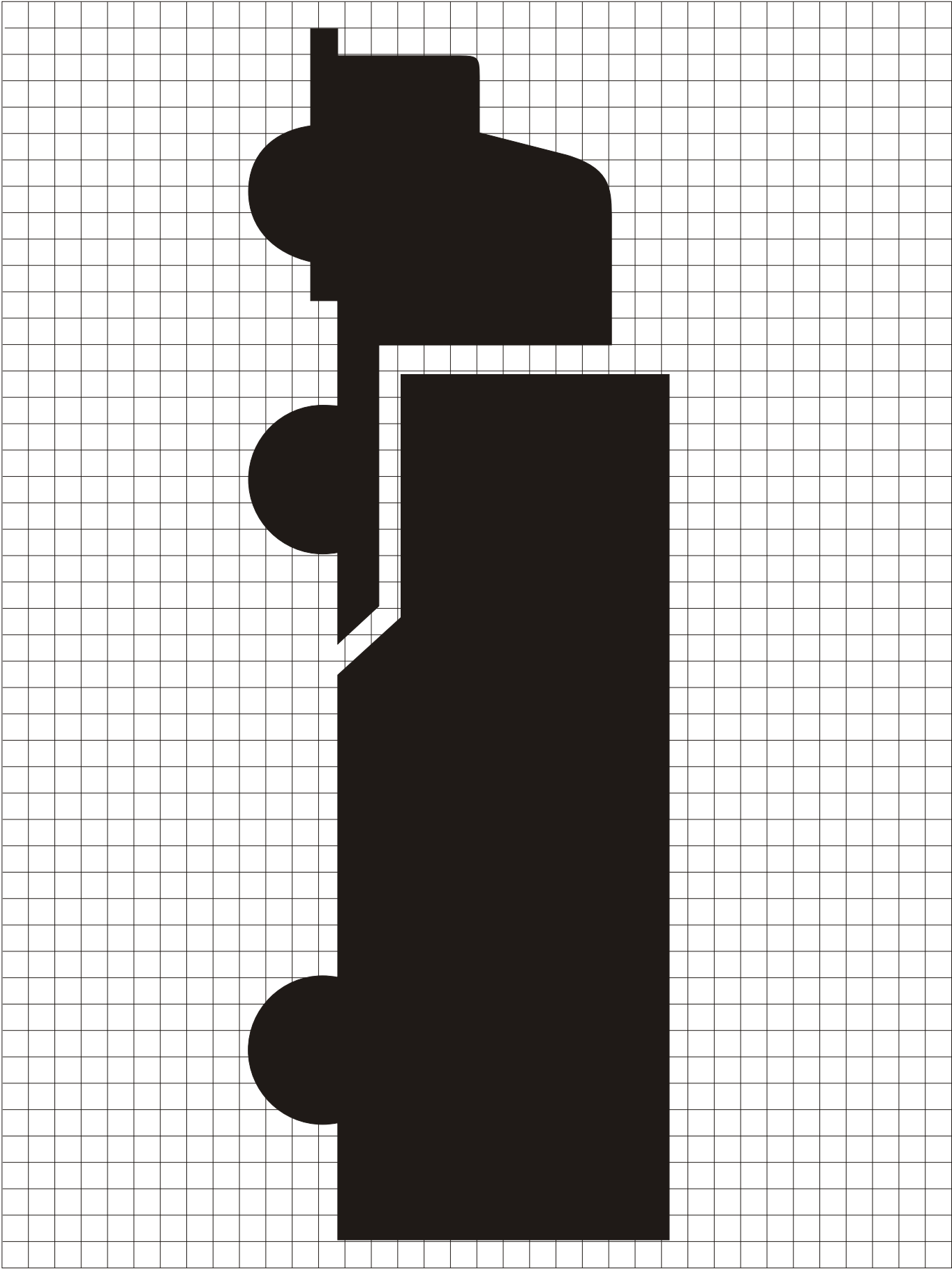

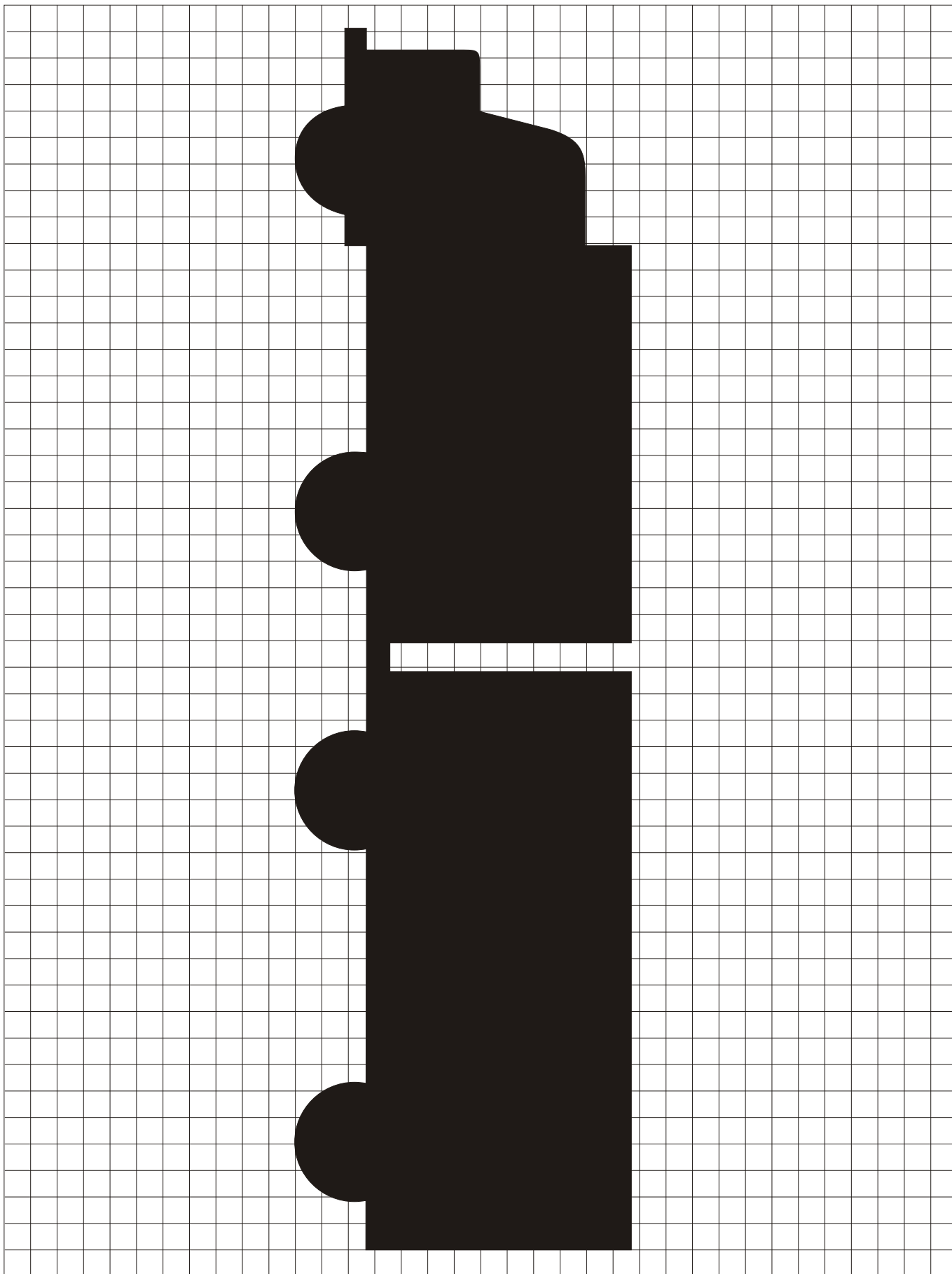

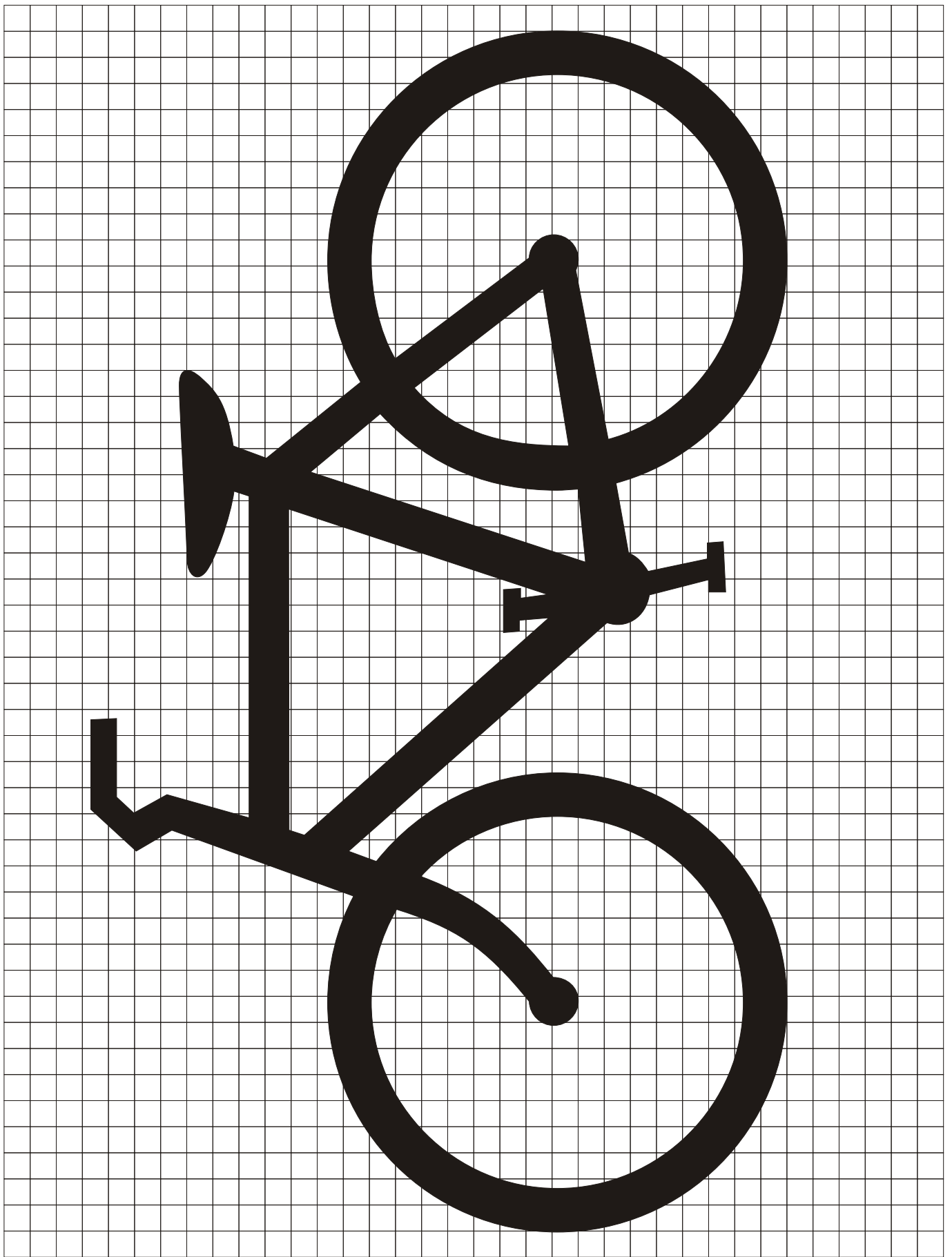

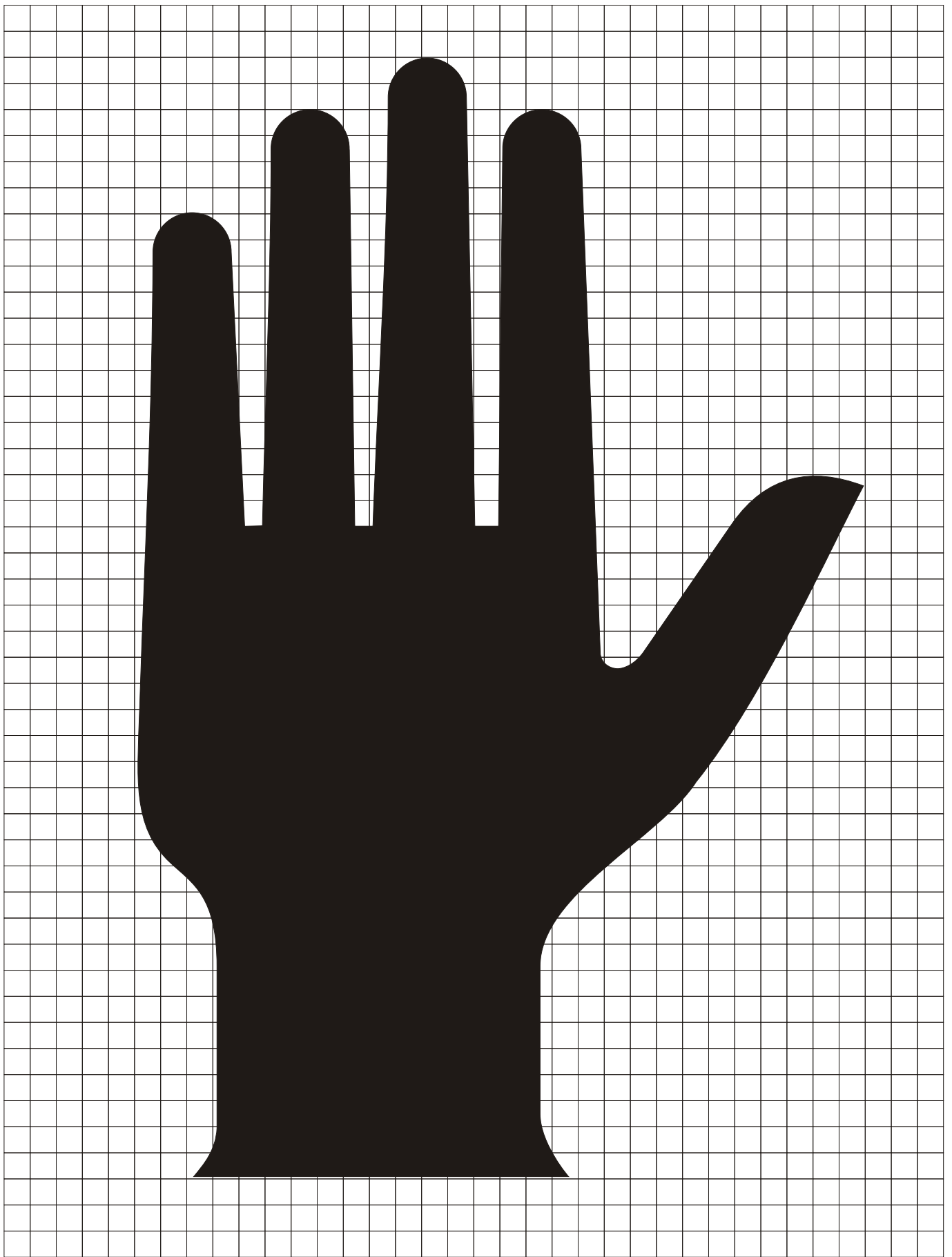

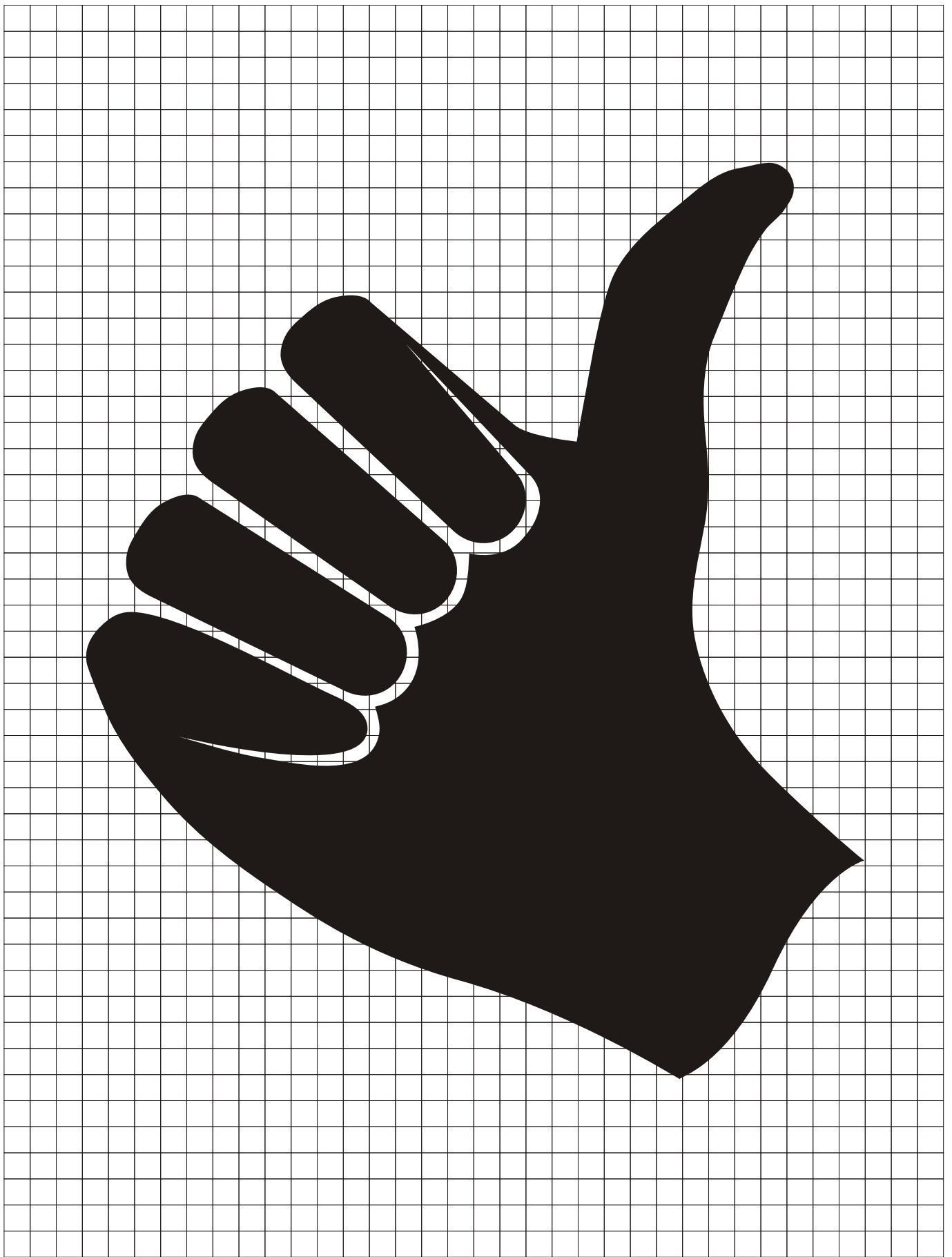

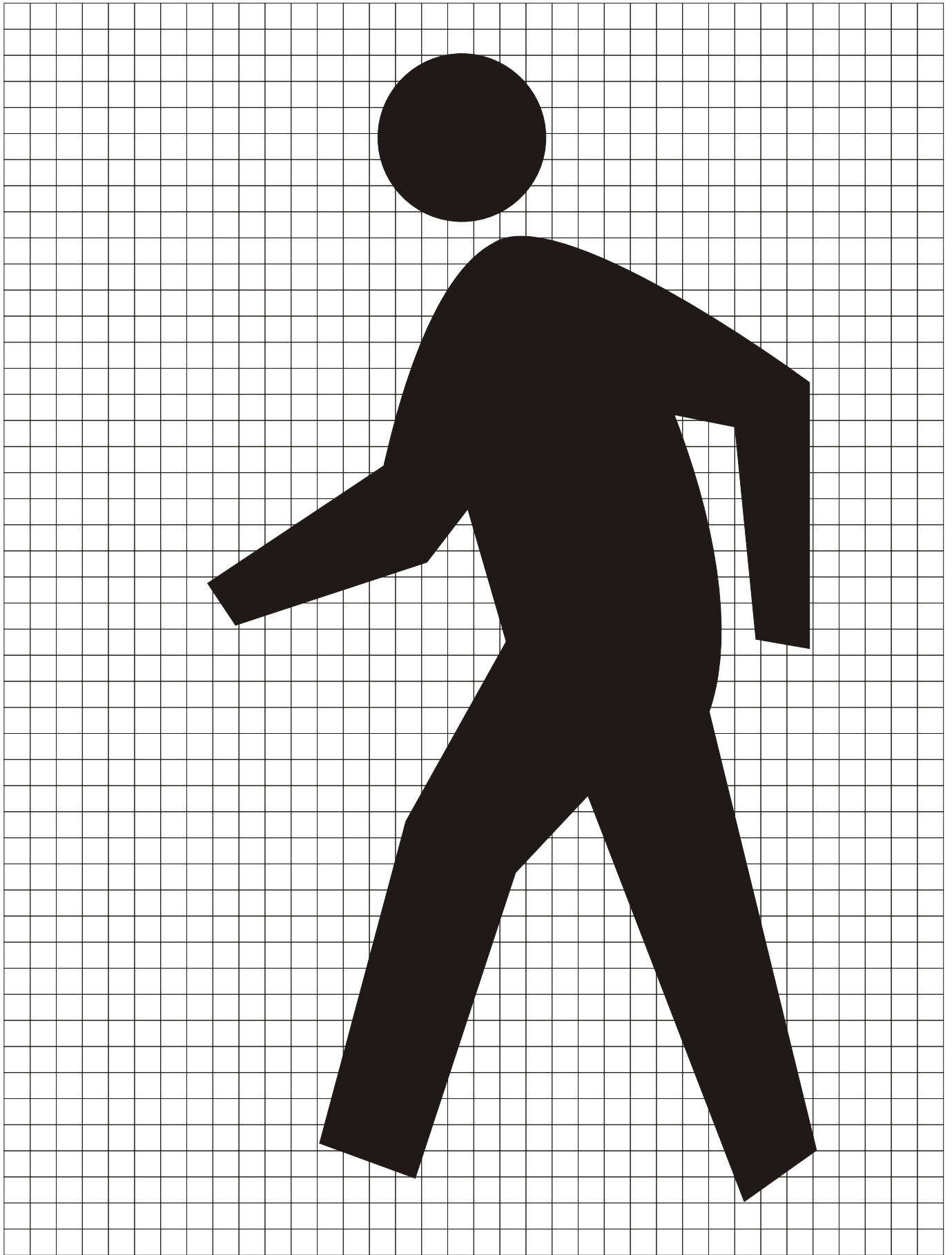

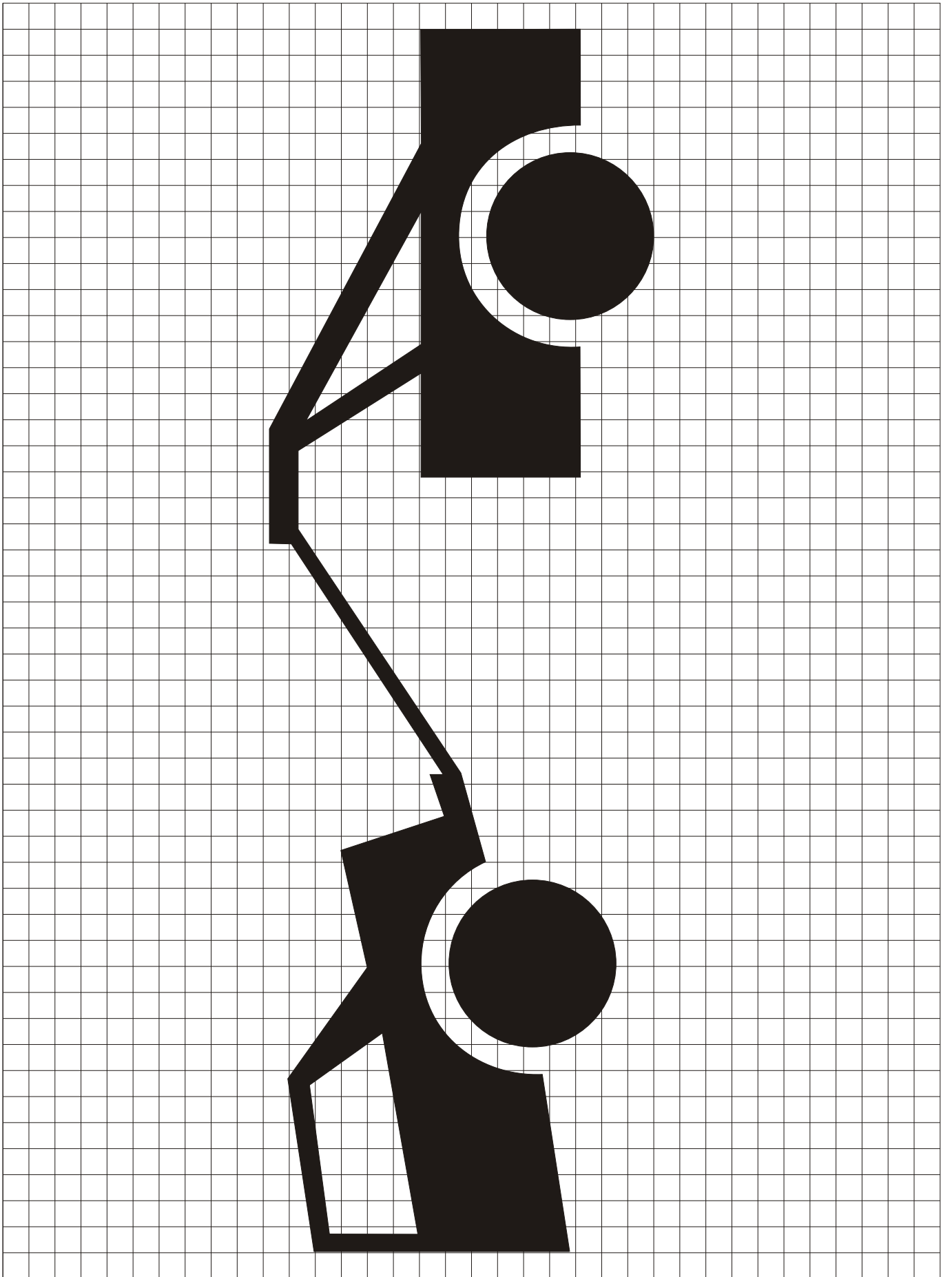

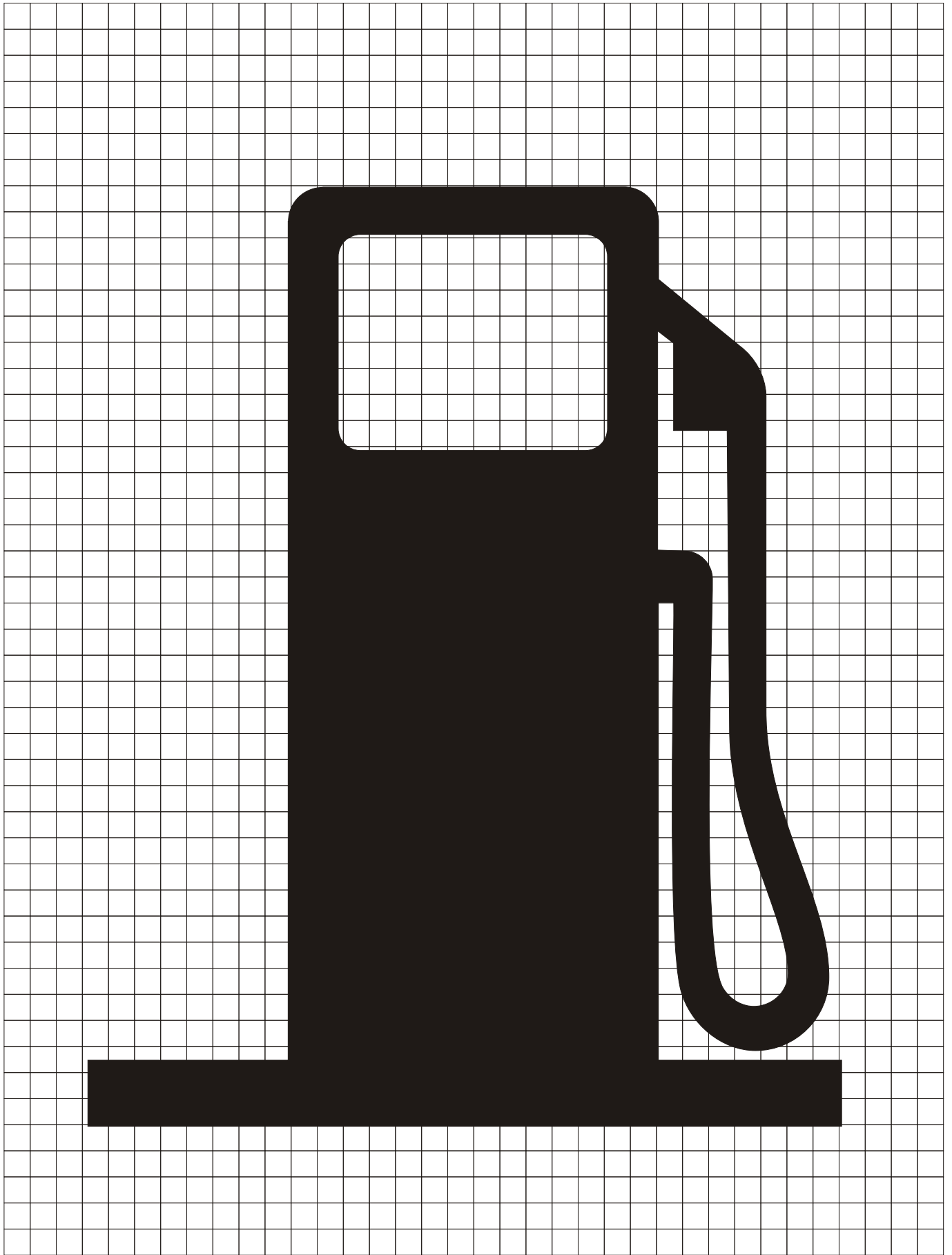

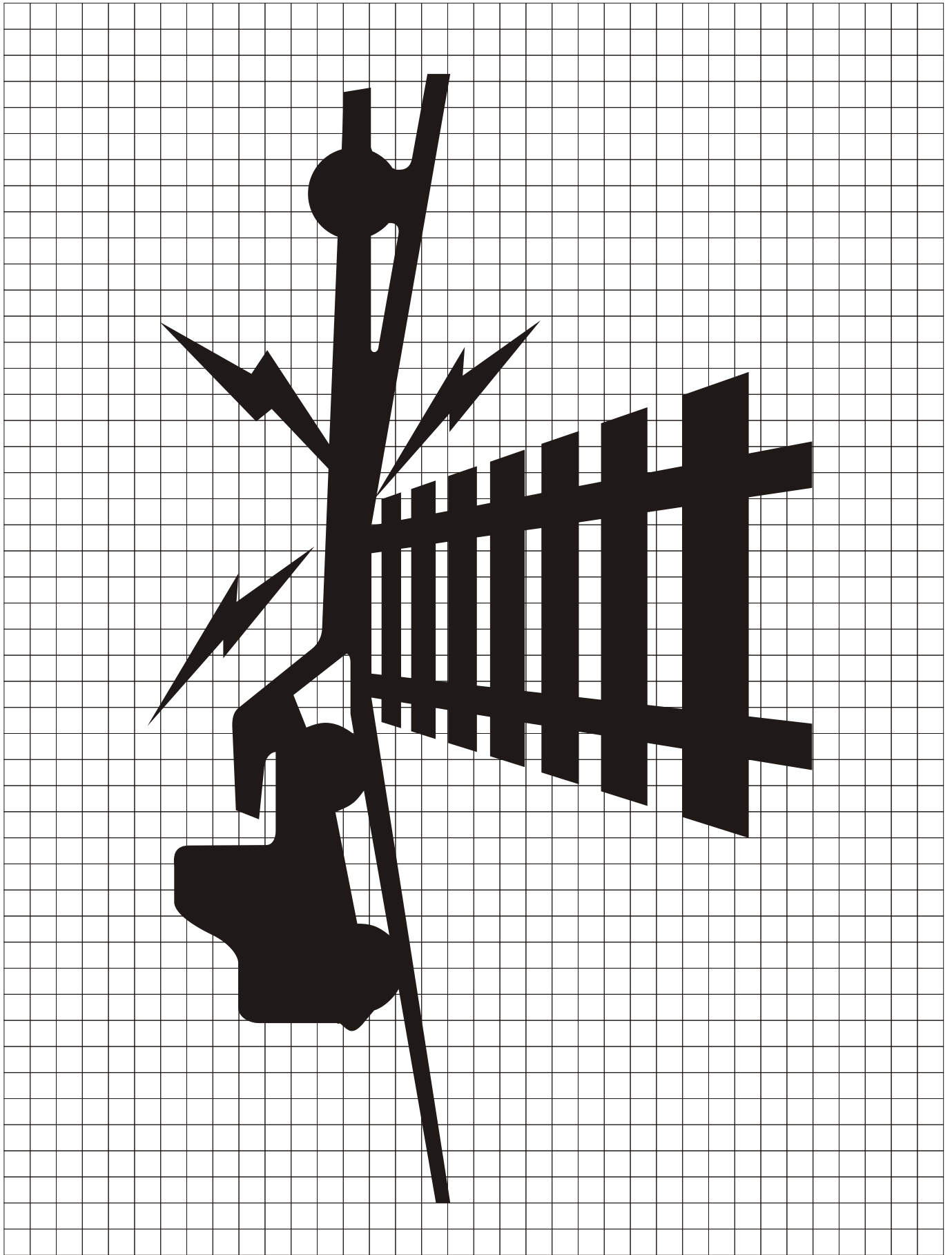

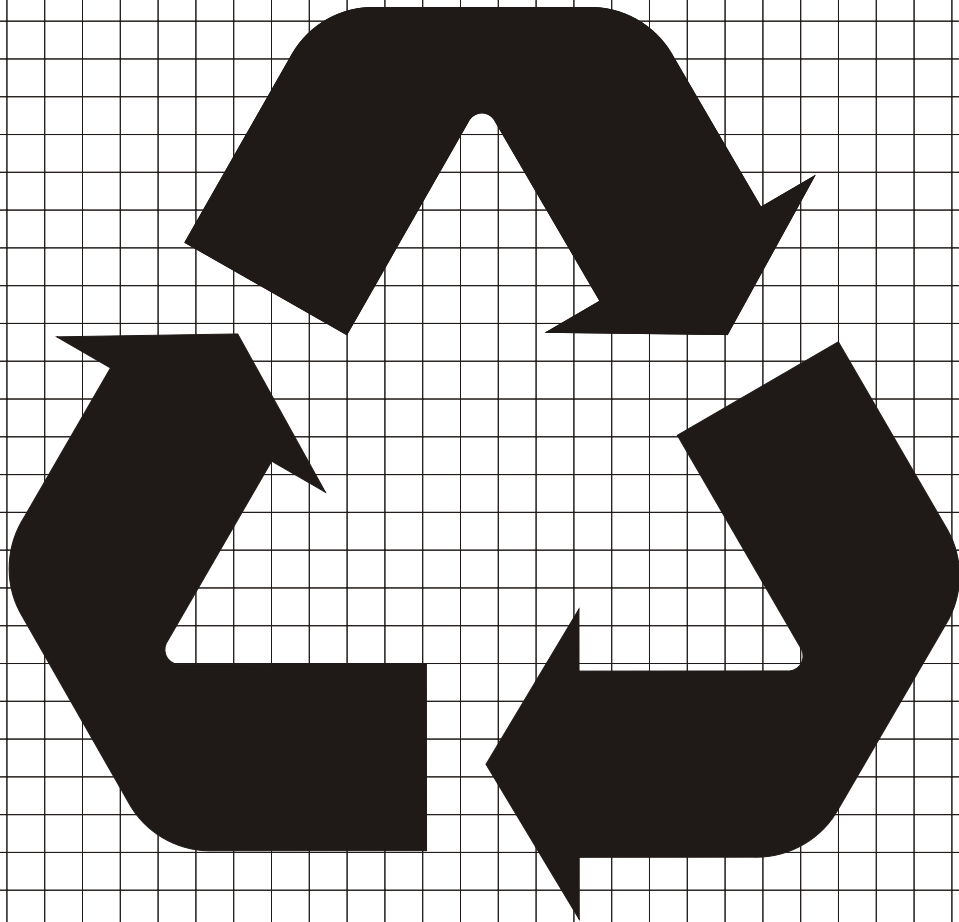



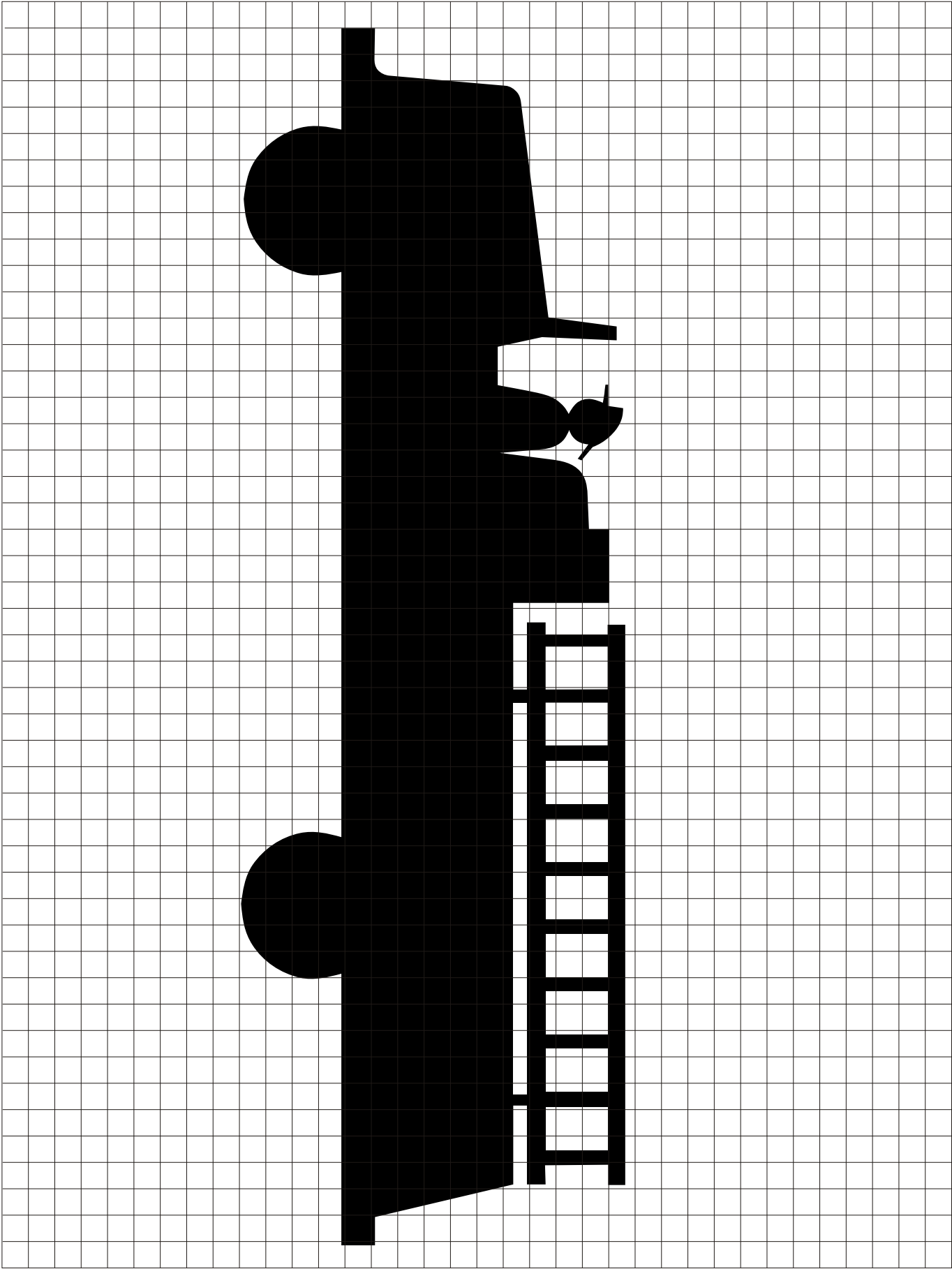

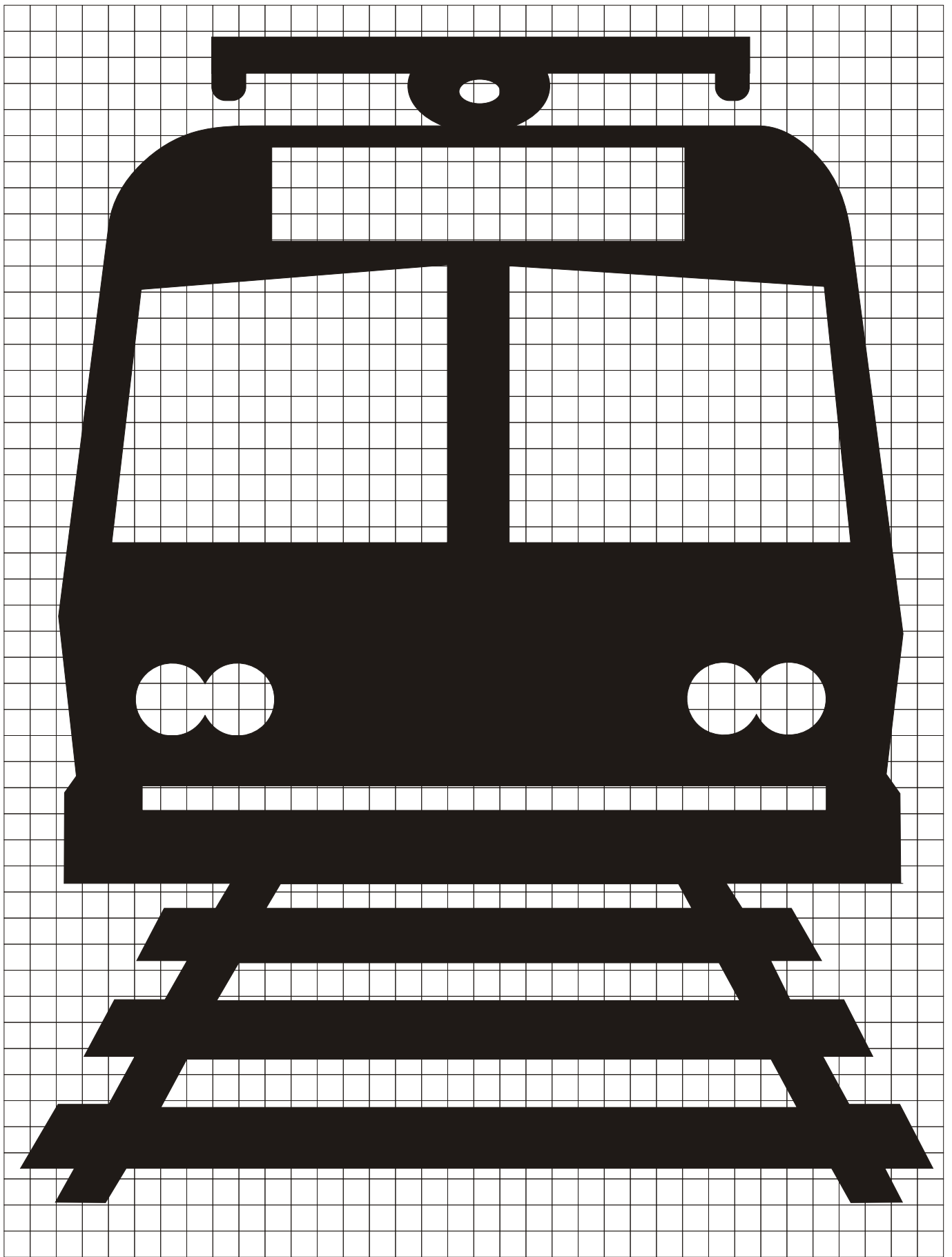

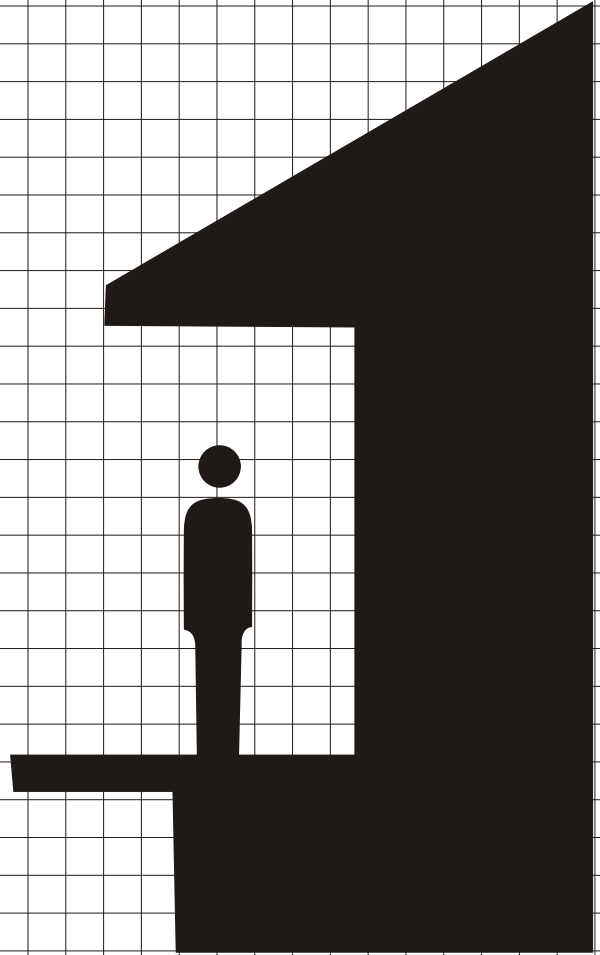
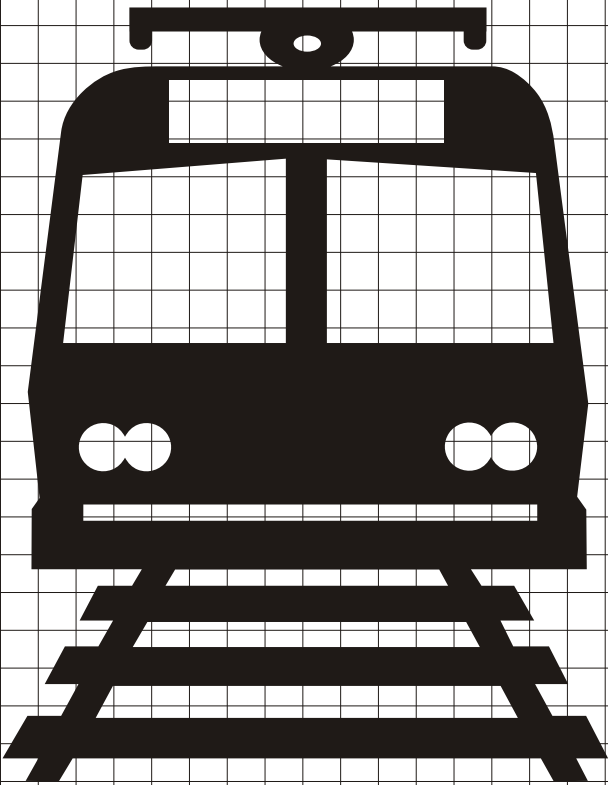

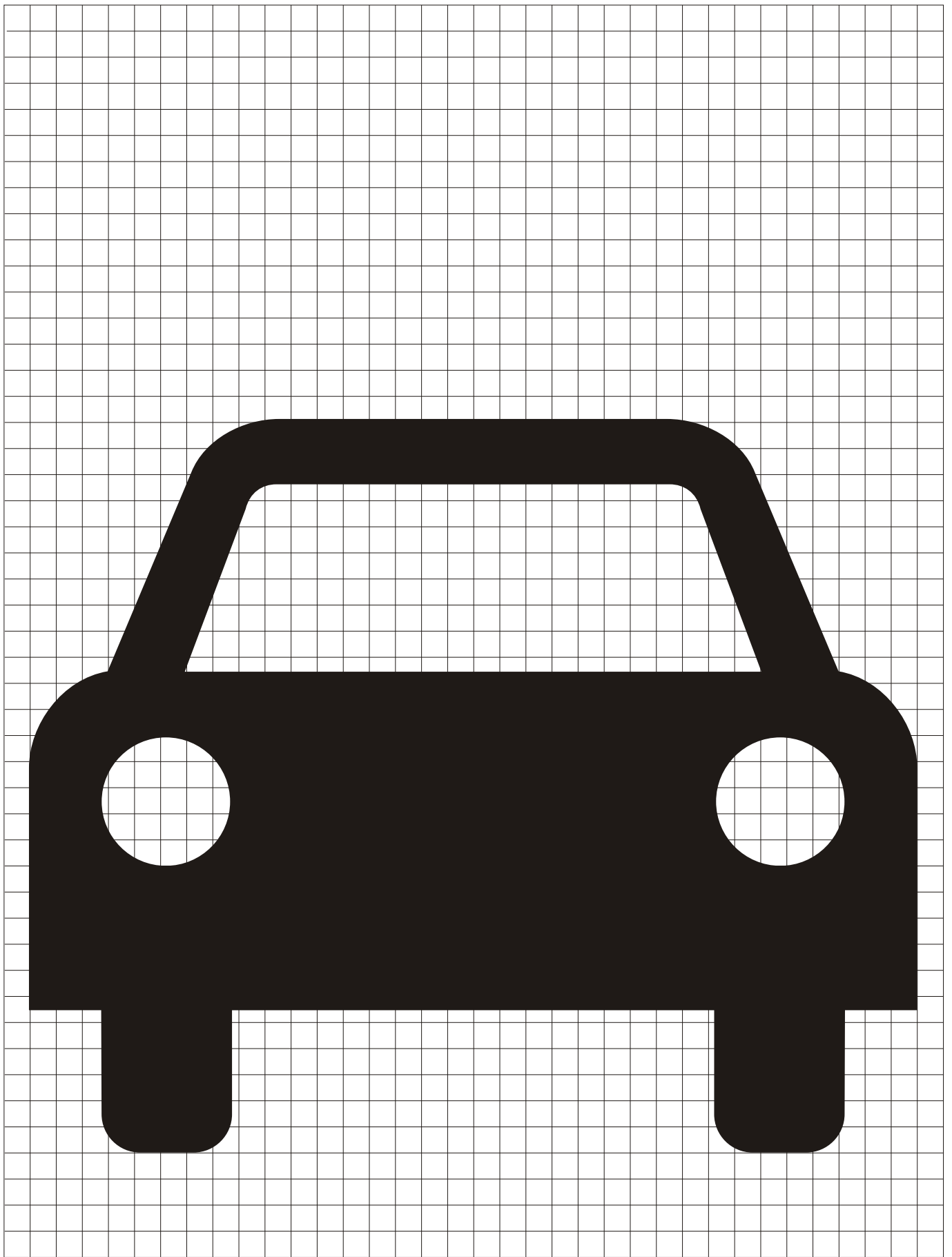

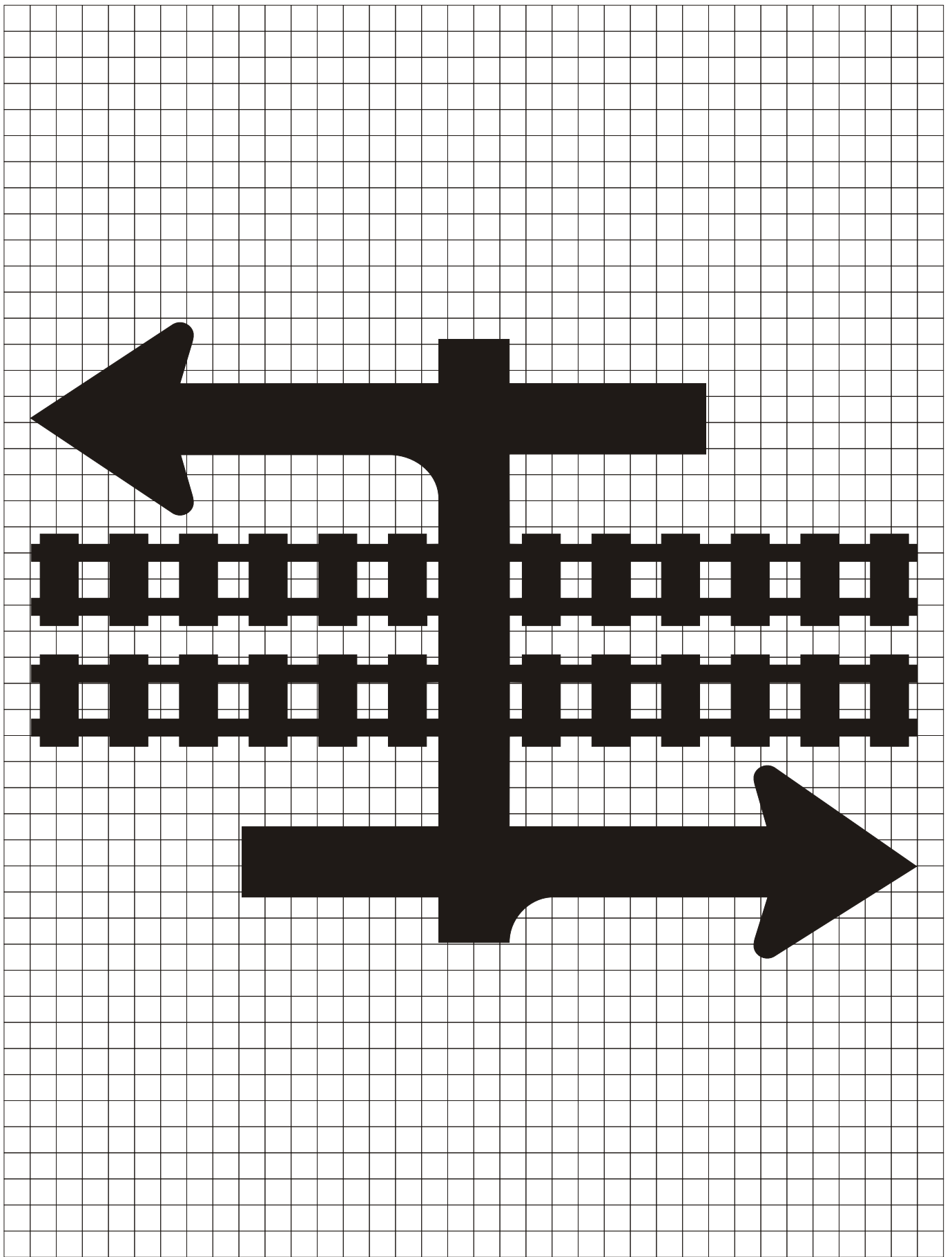

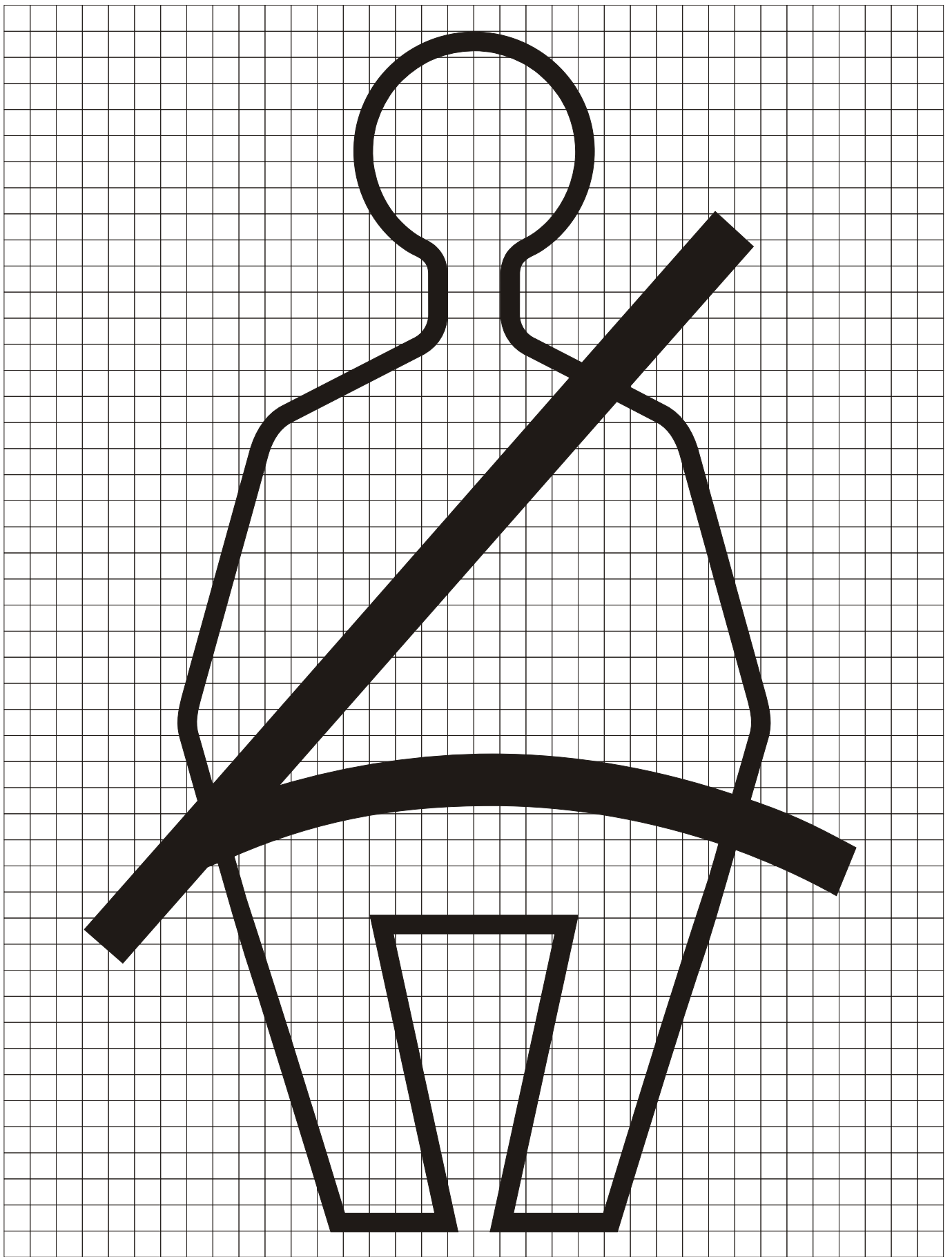

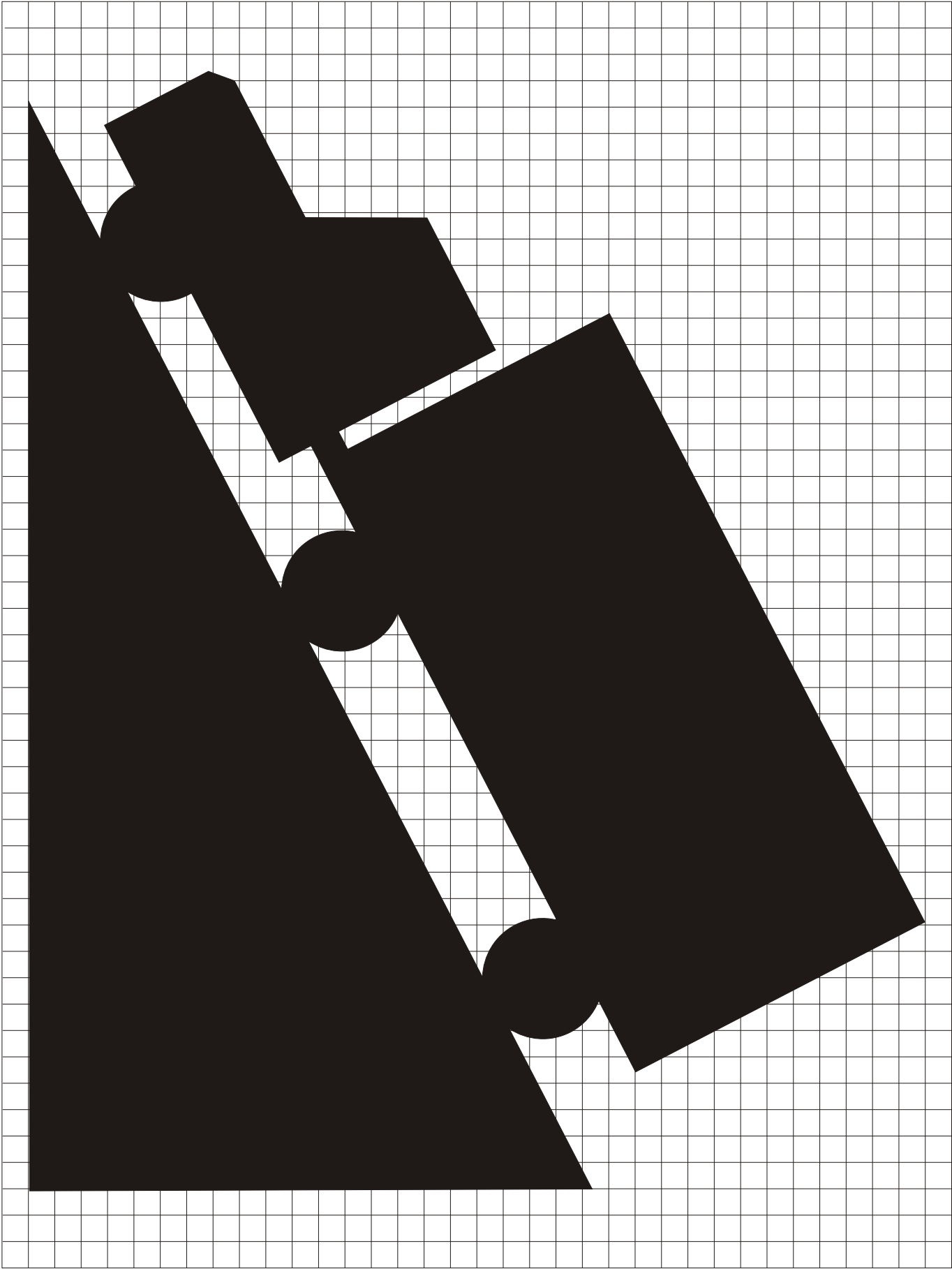

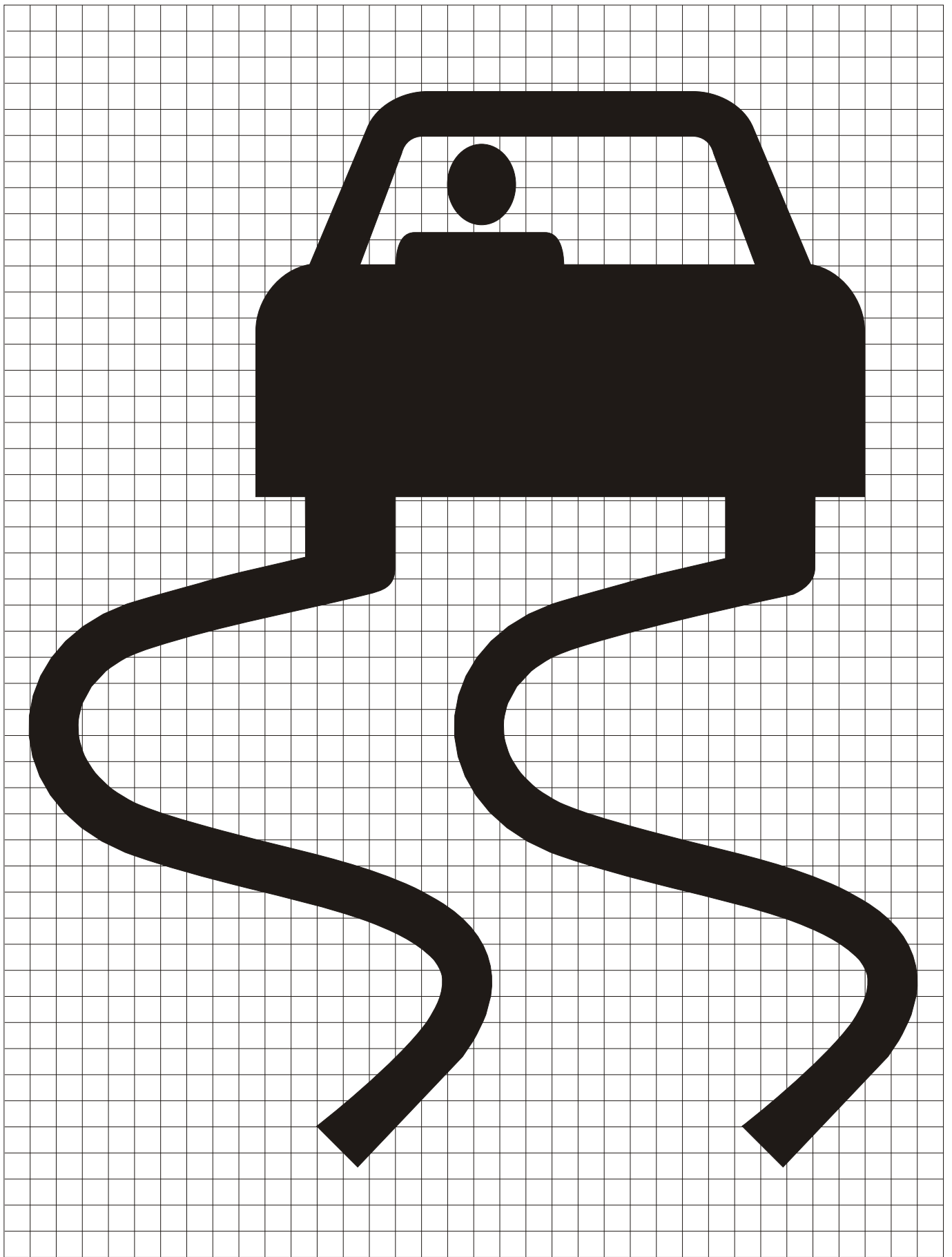

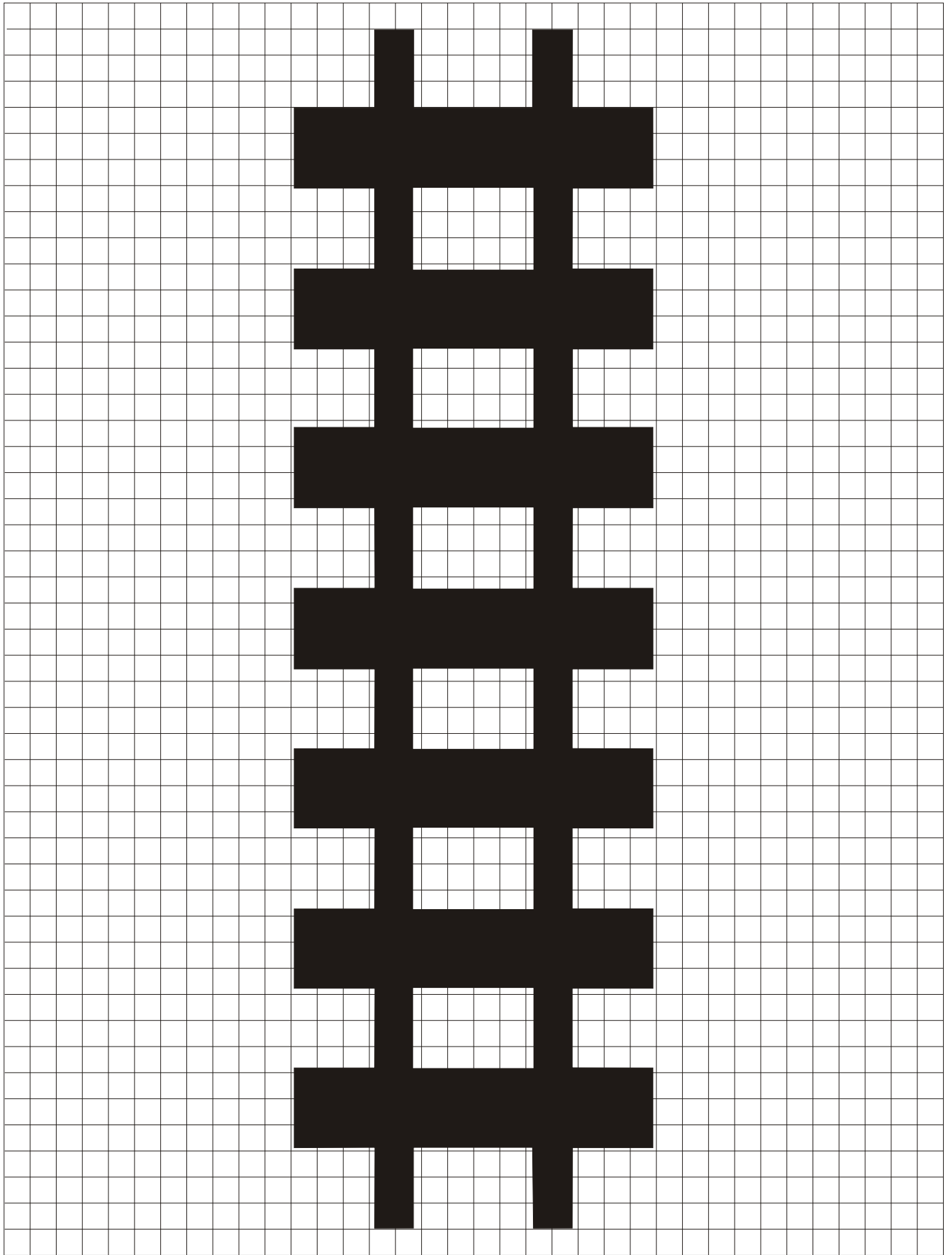

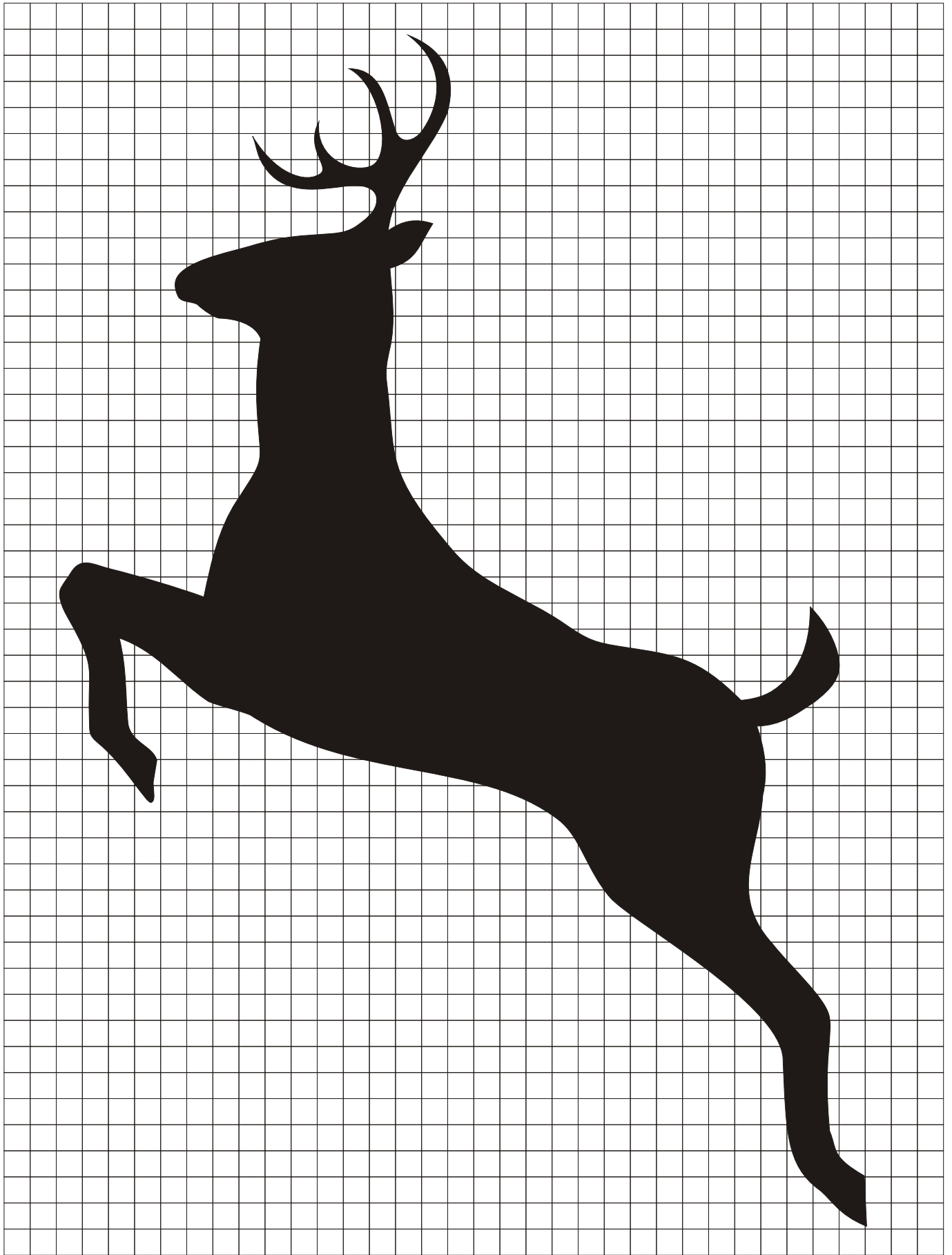

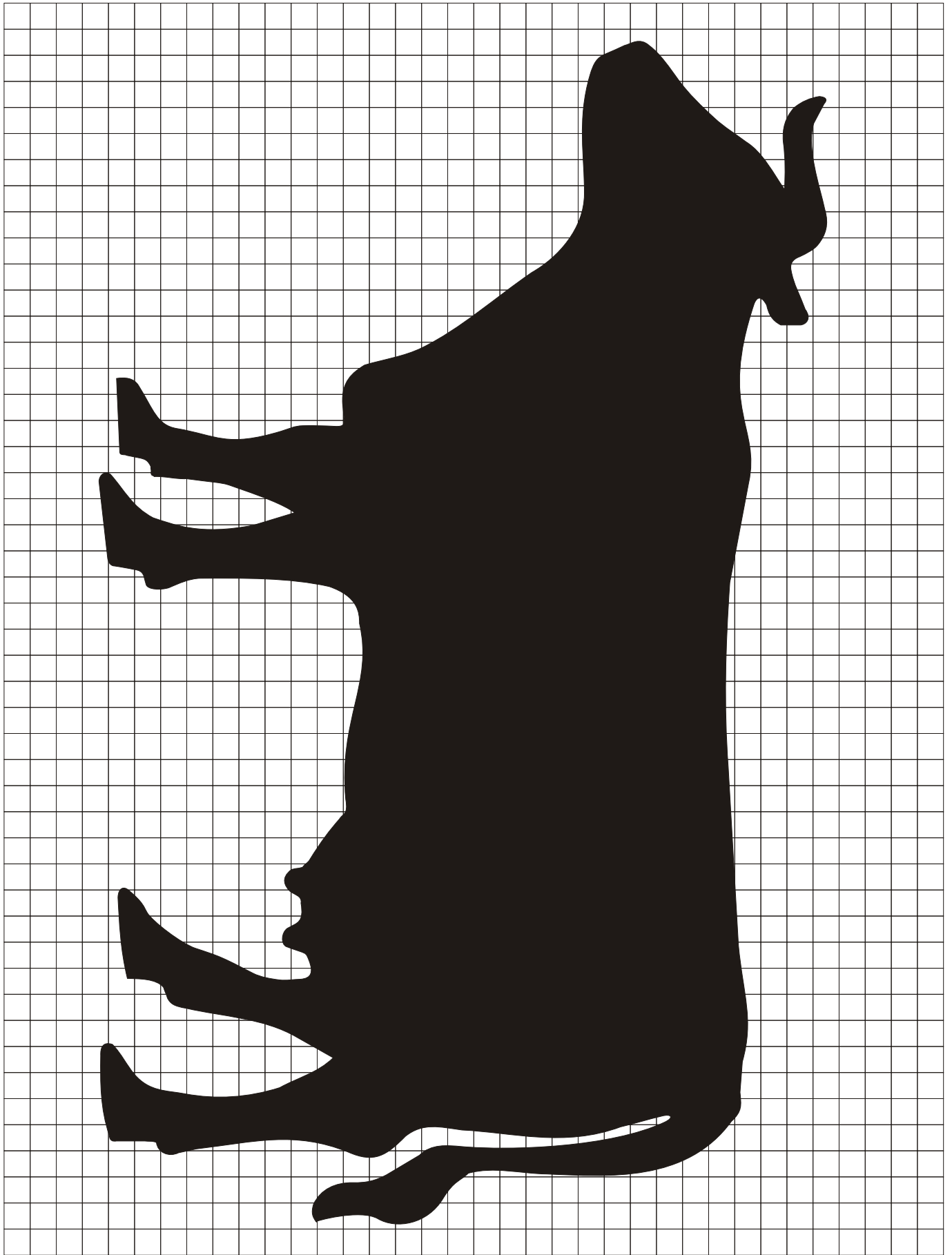

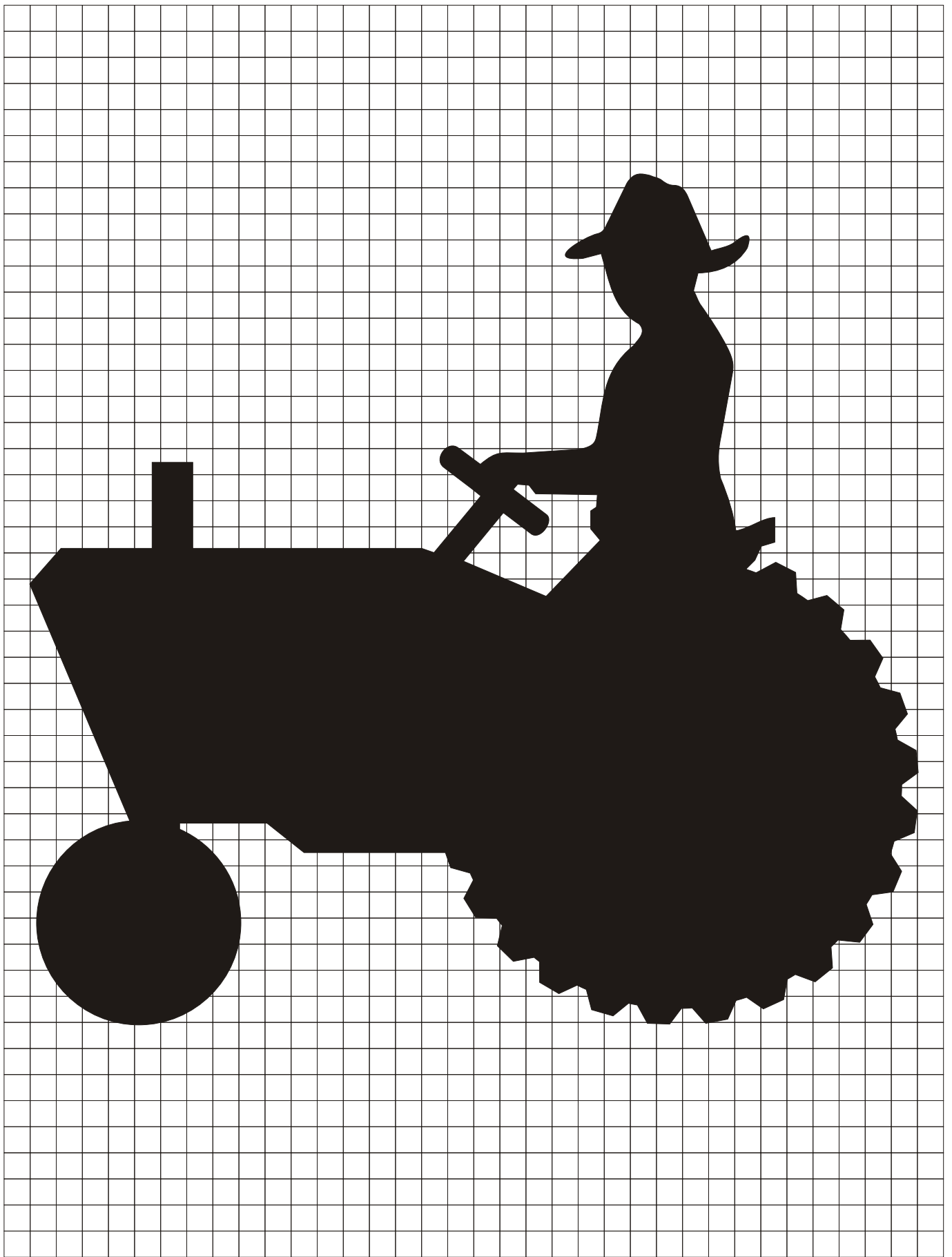

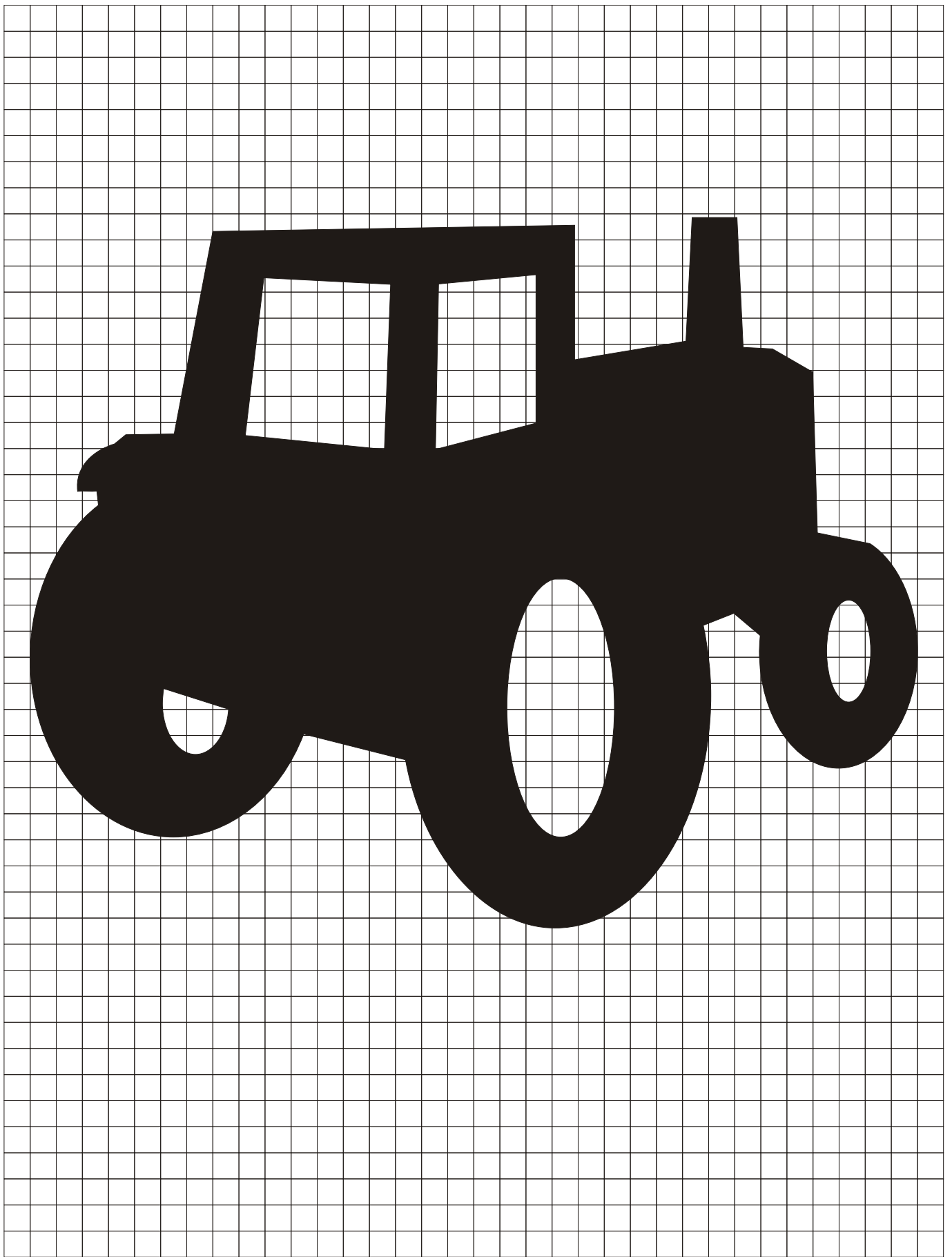

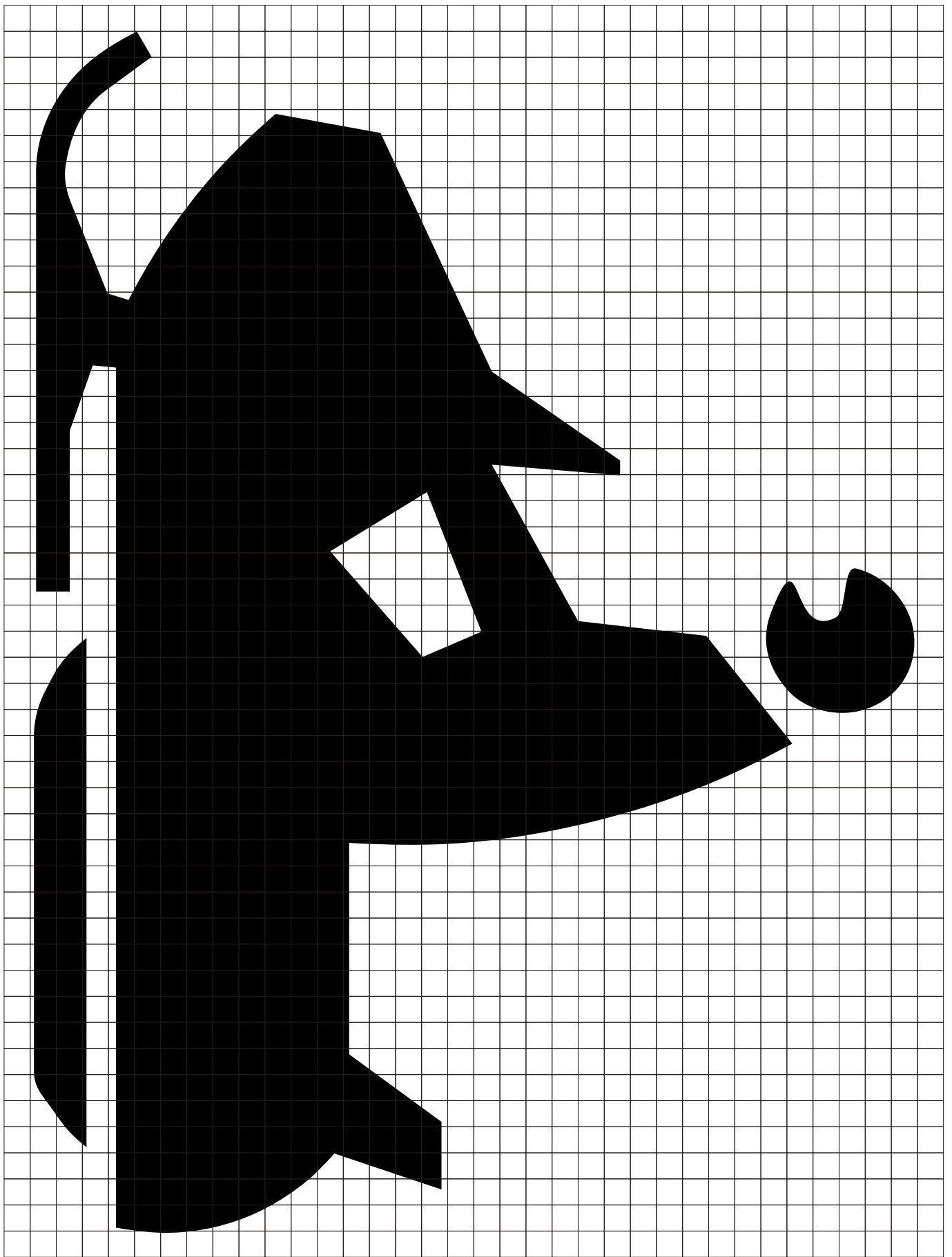

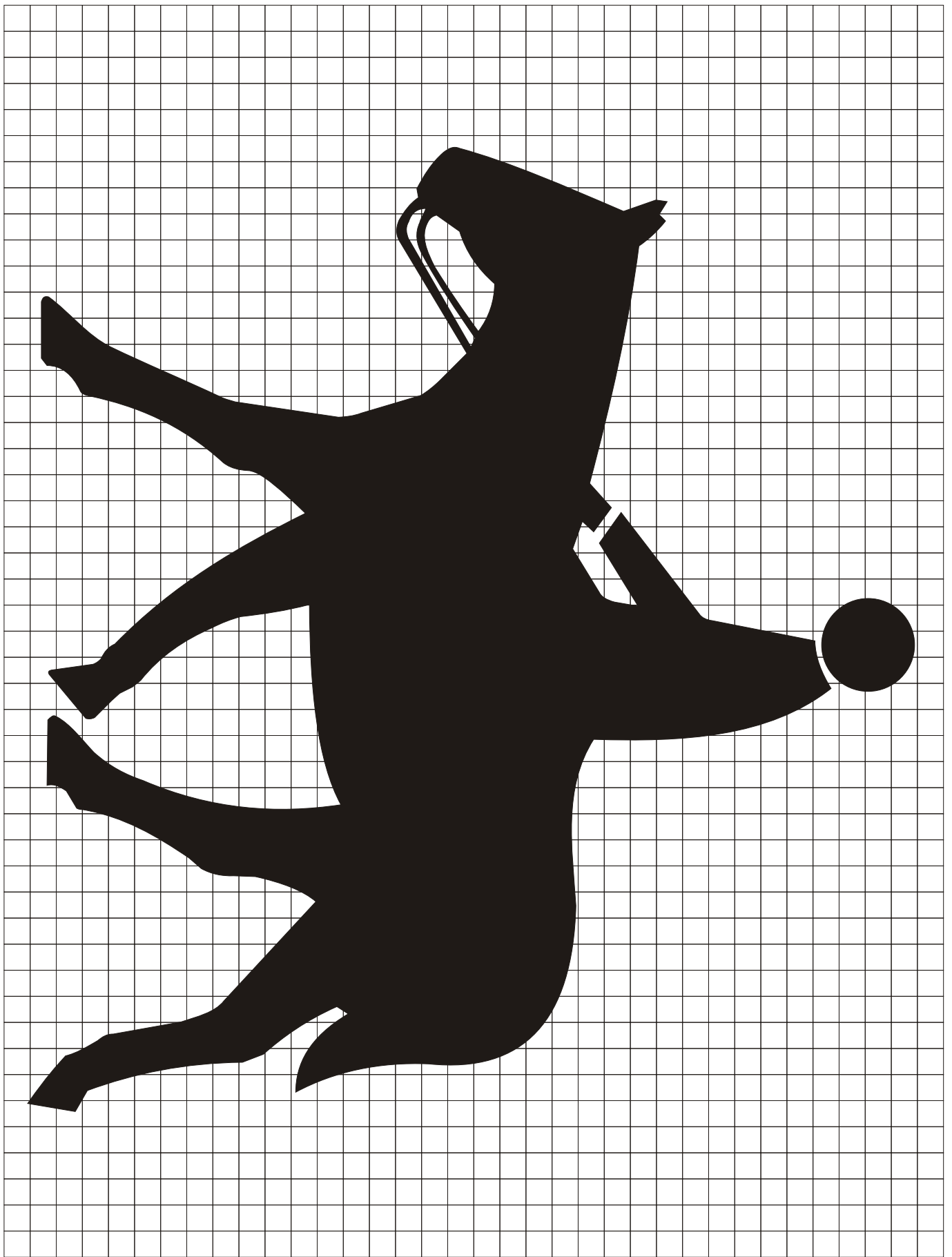

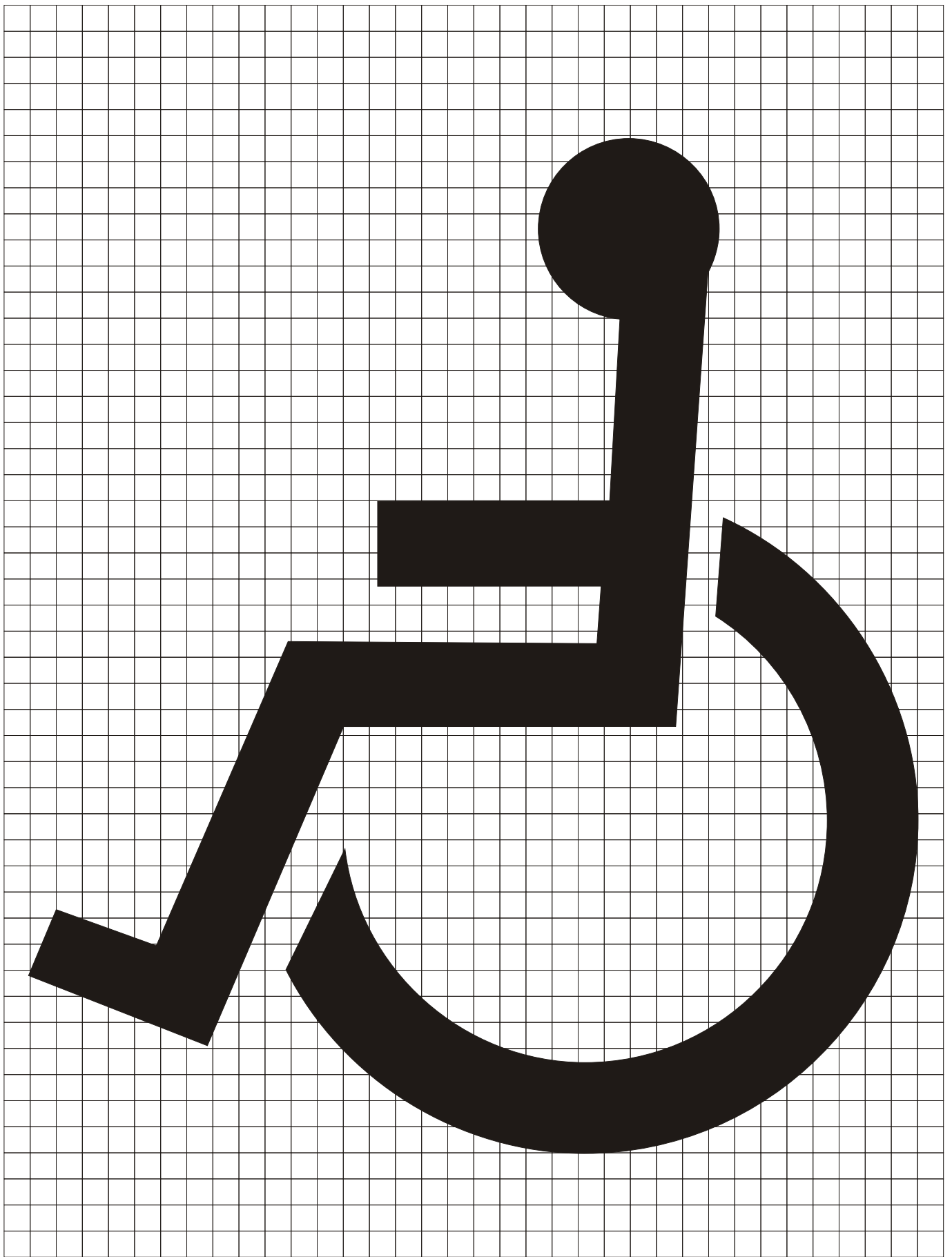

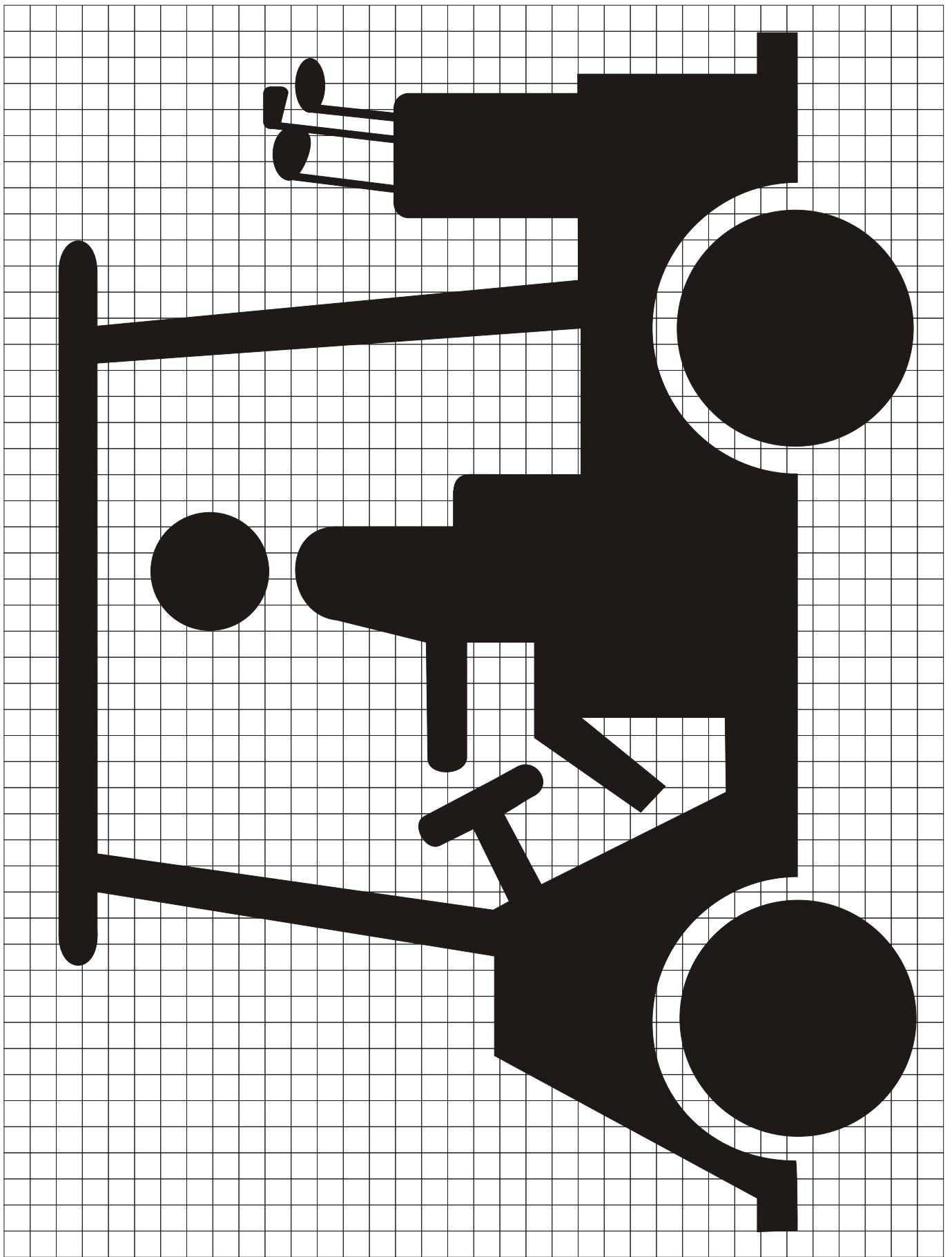

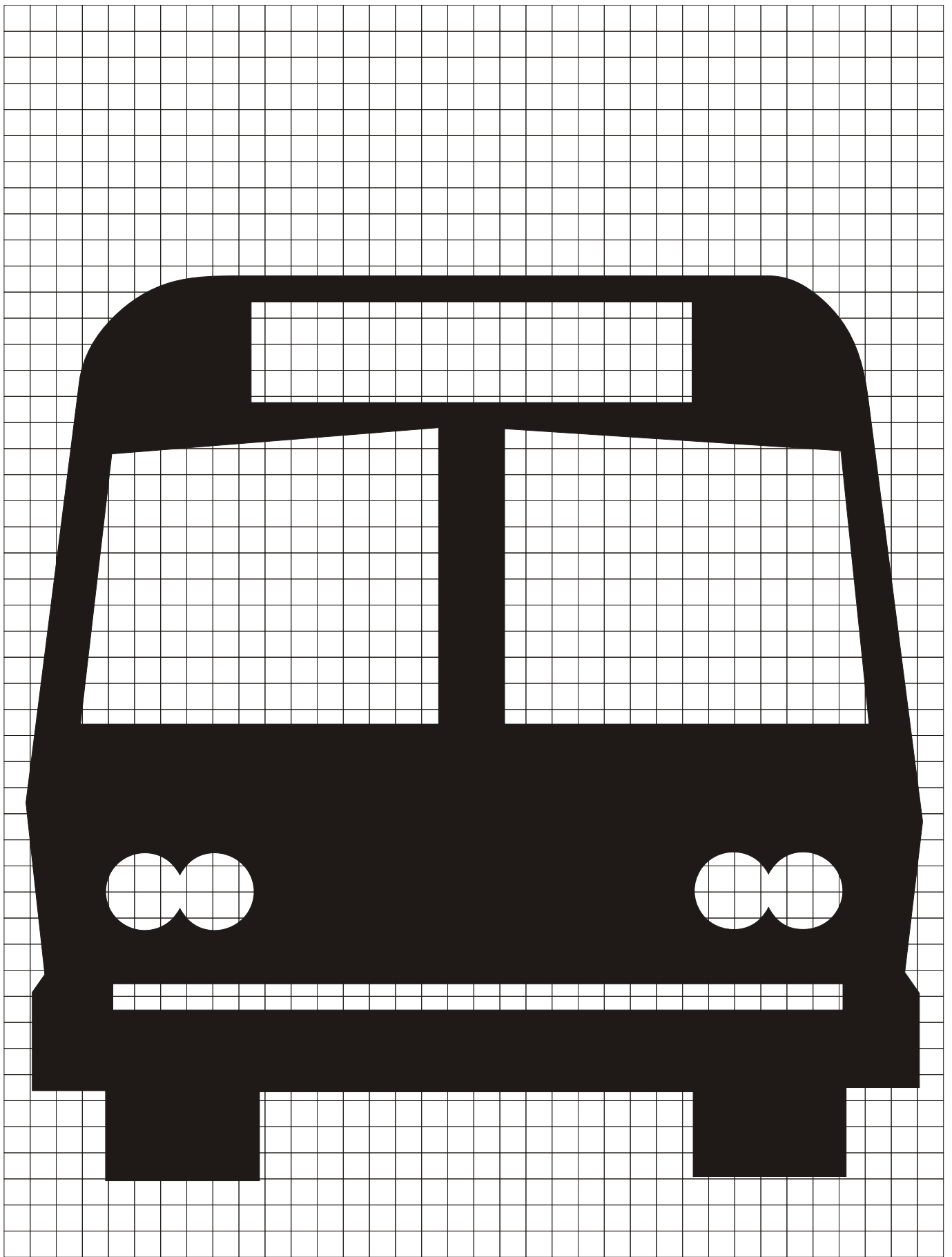

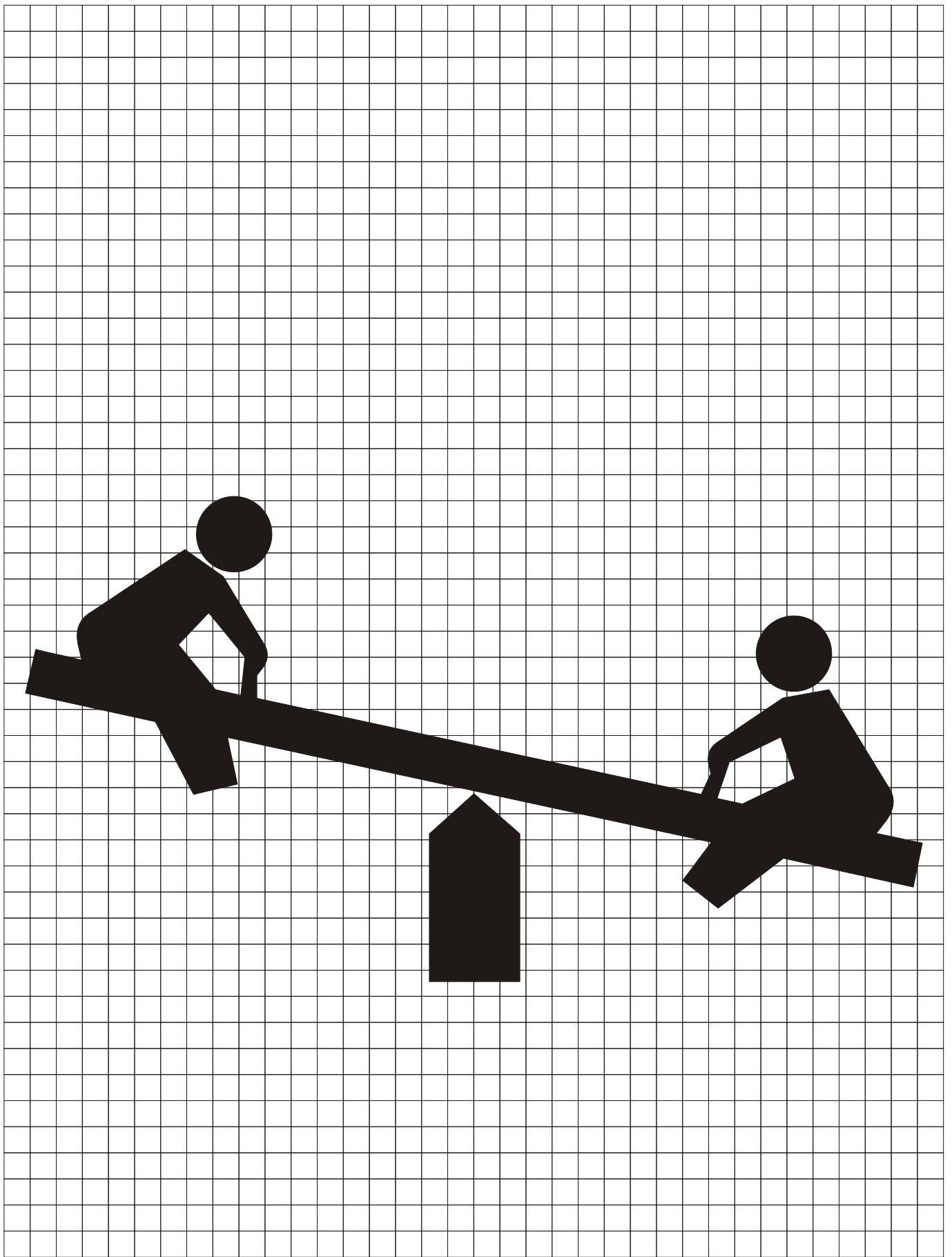

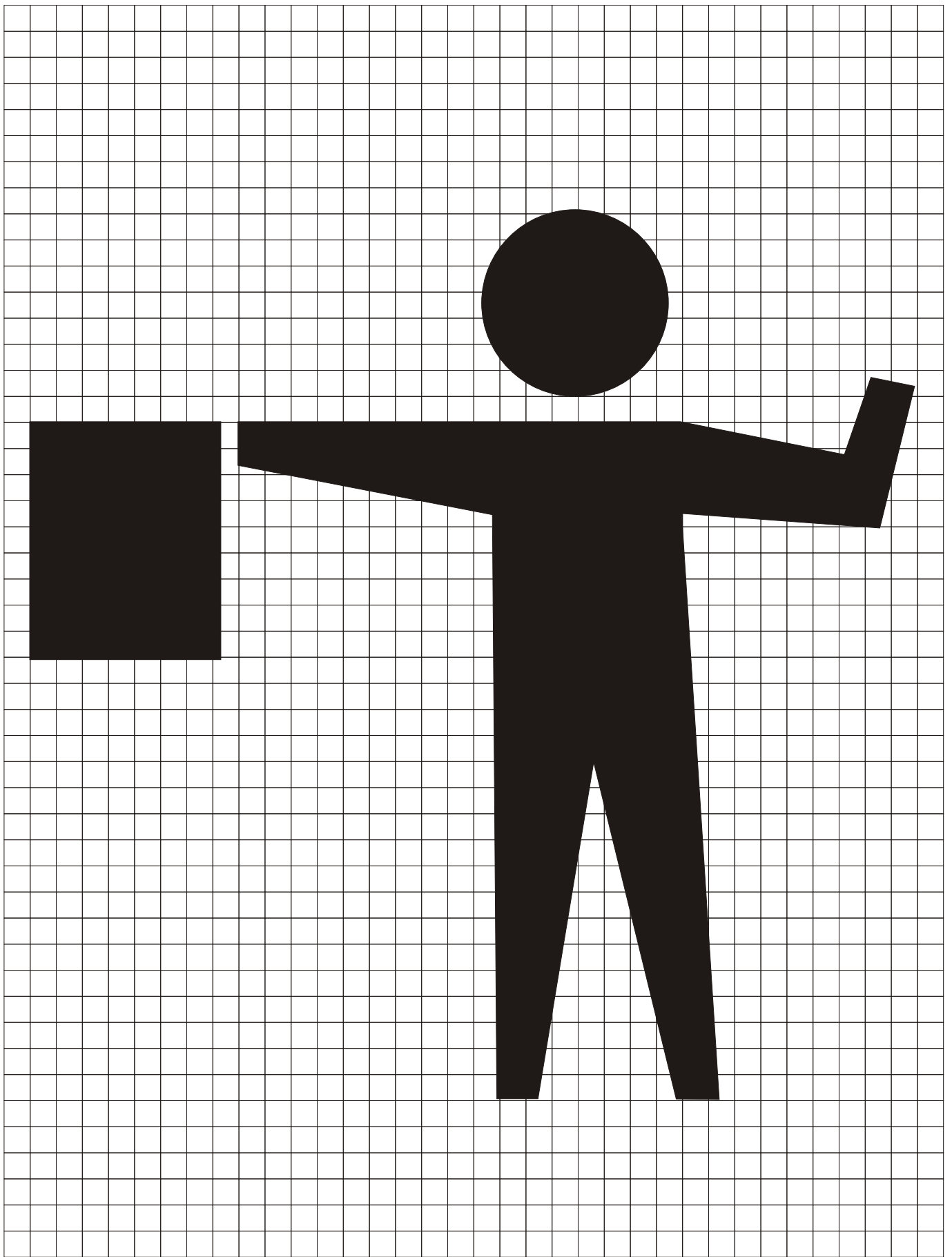

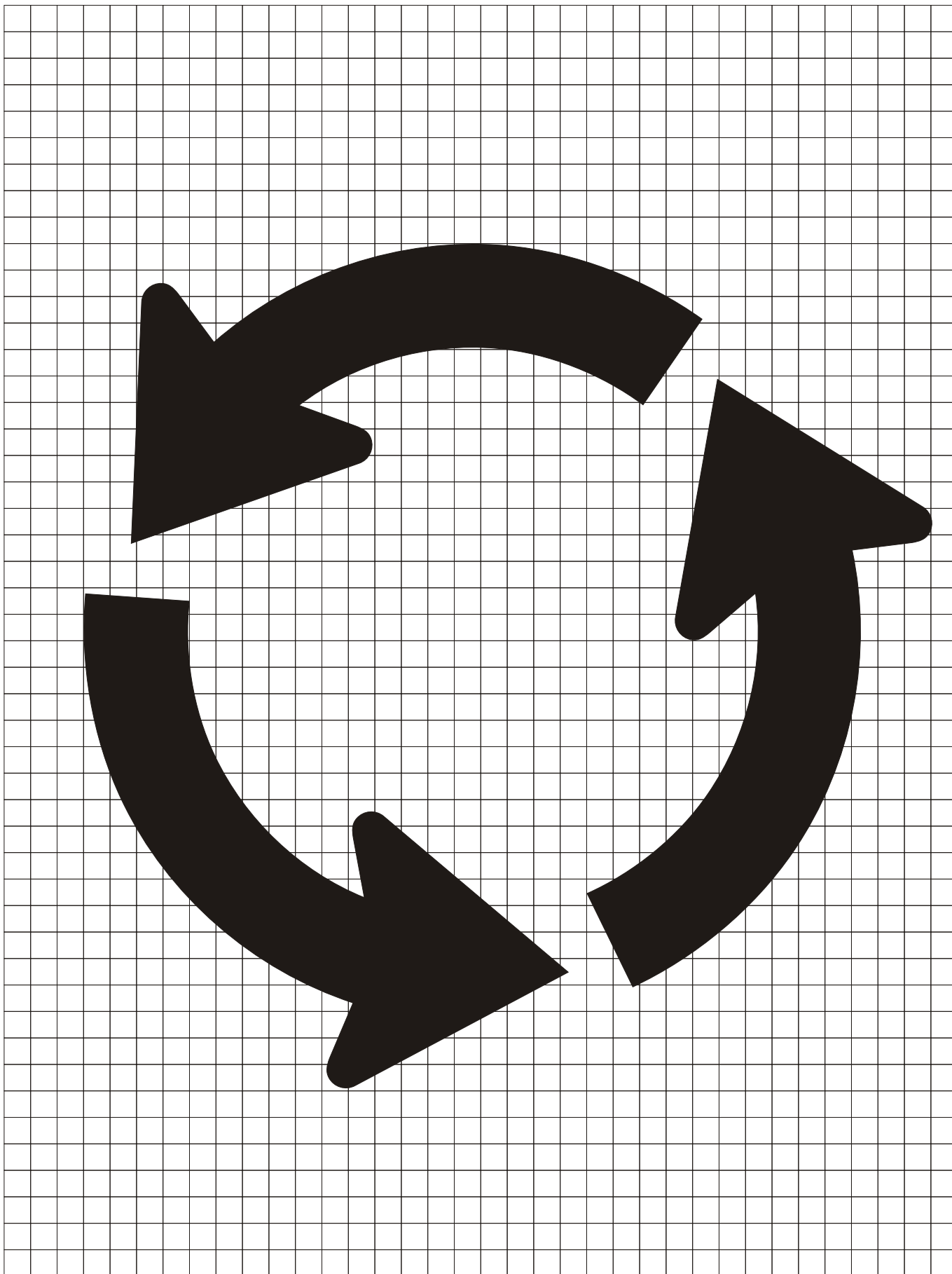

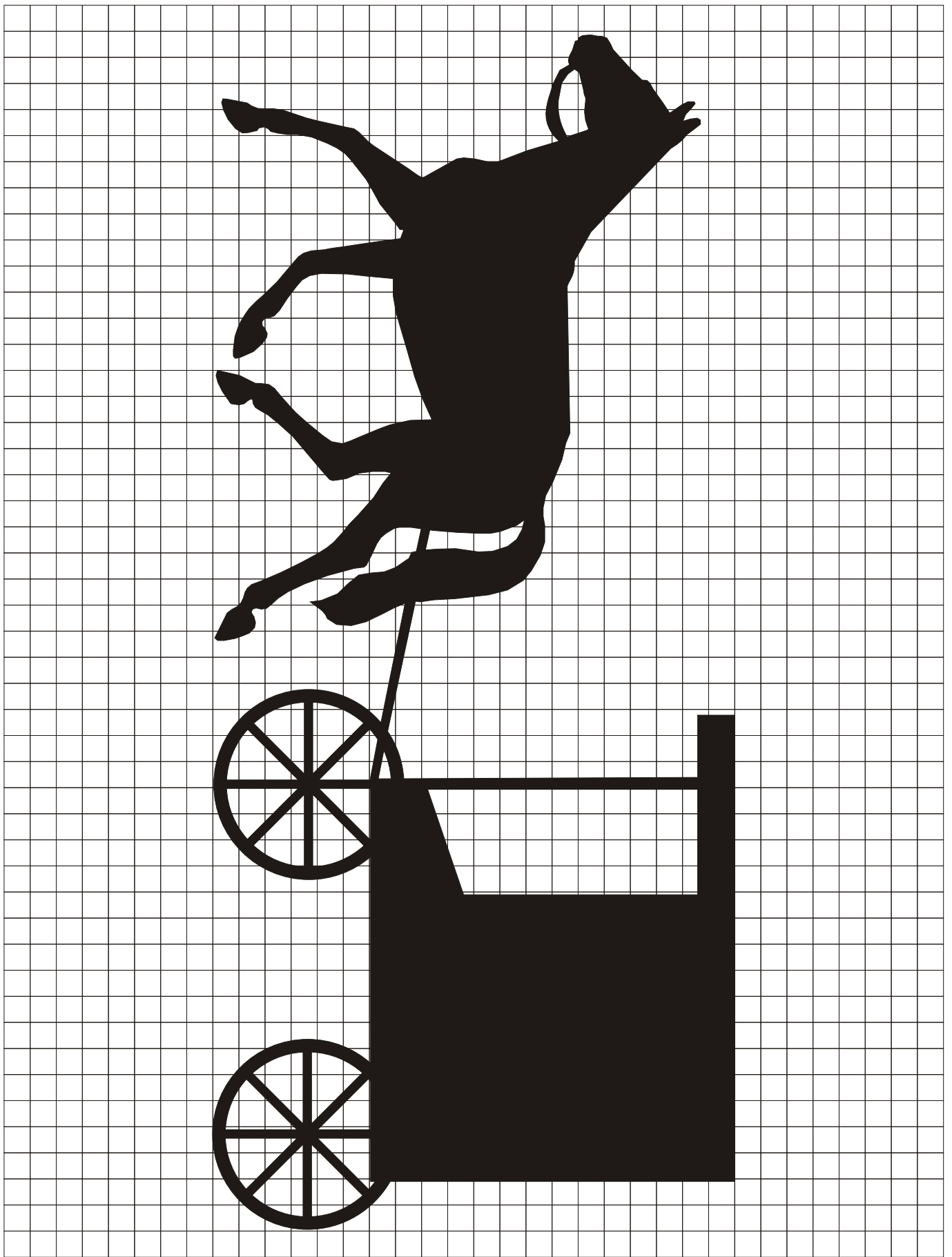

**National
Forests**

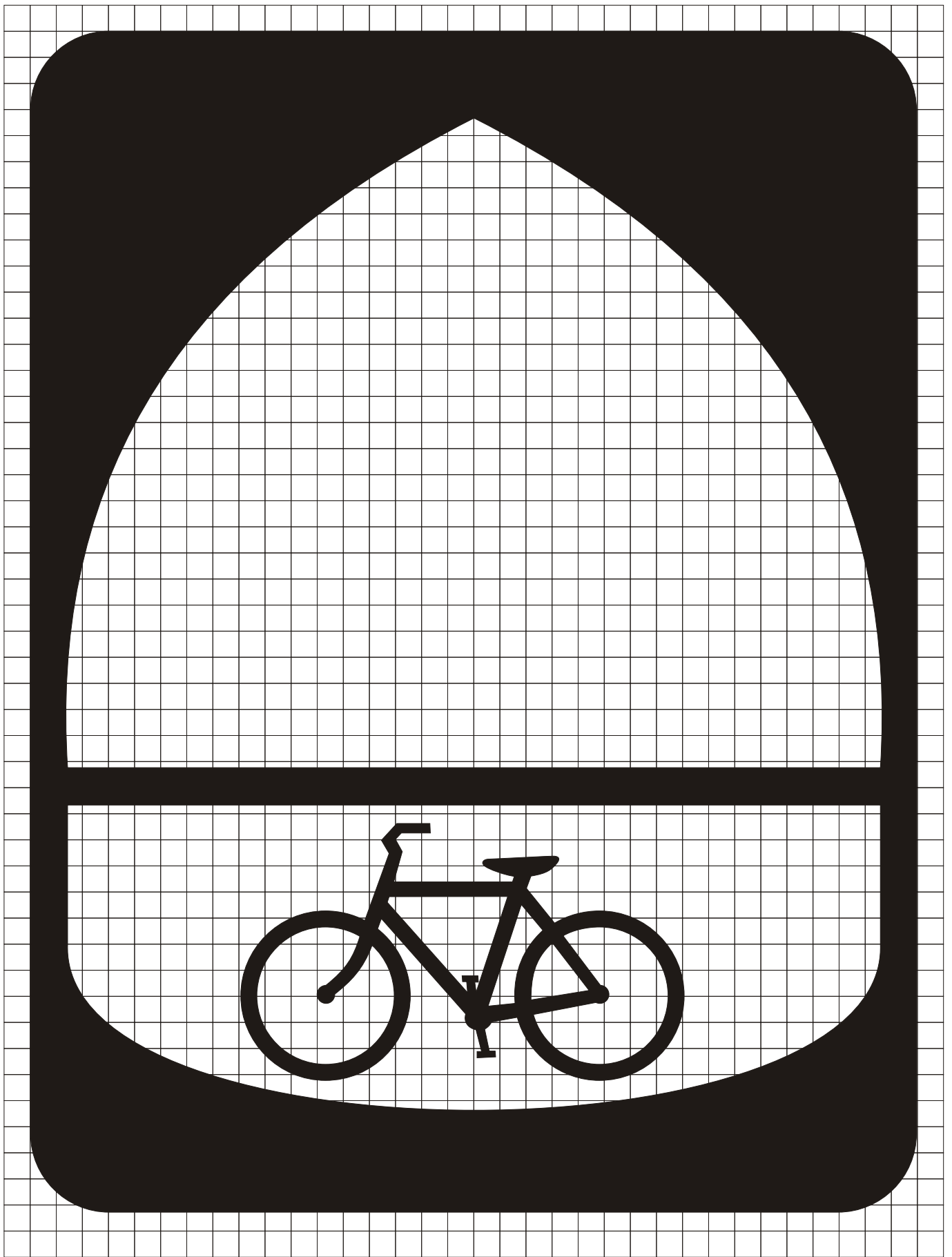

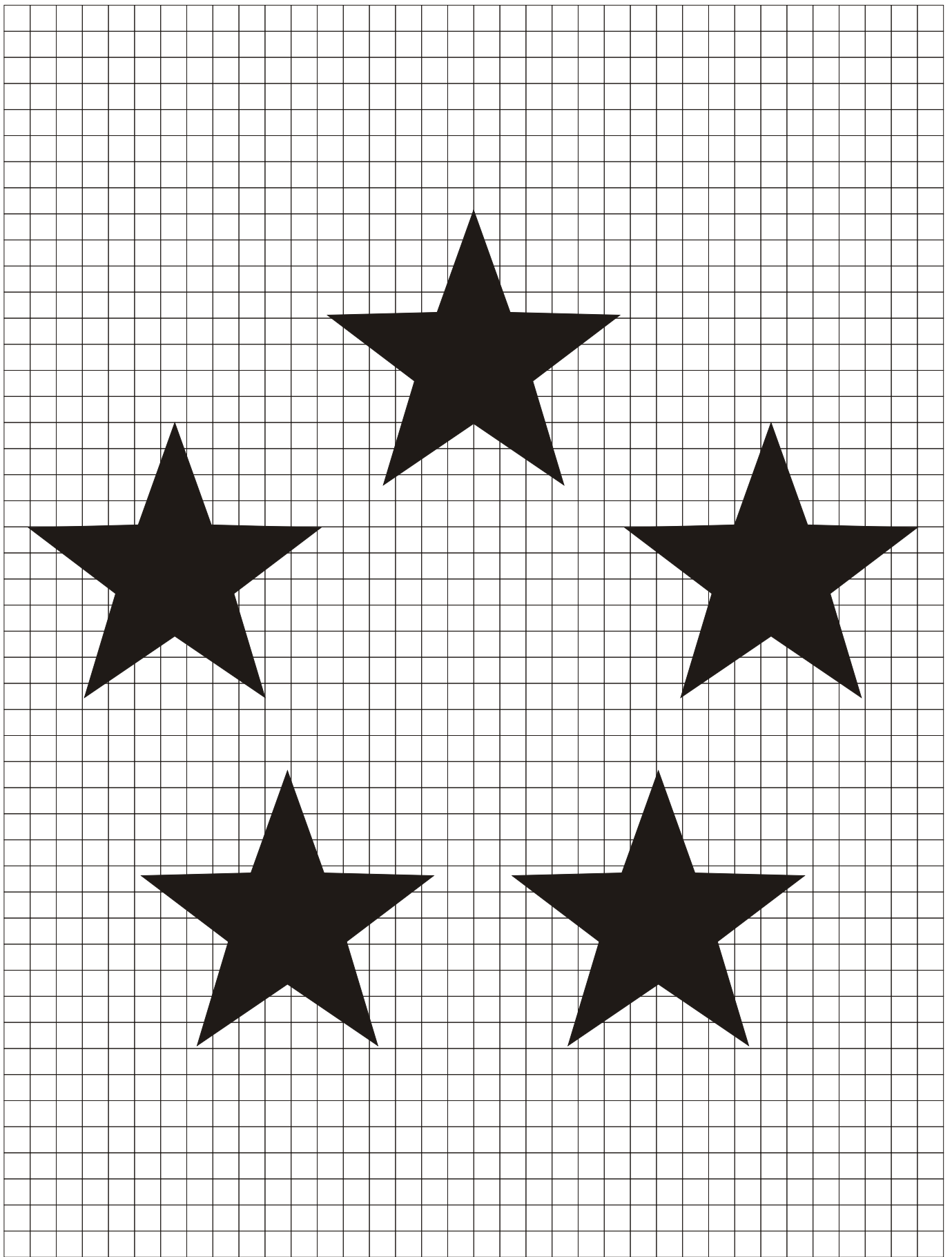

ESSENTIAL INTELLIGENCE SYSTEM

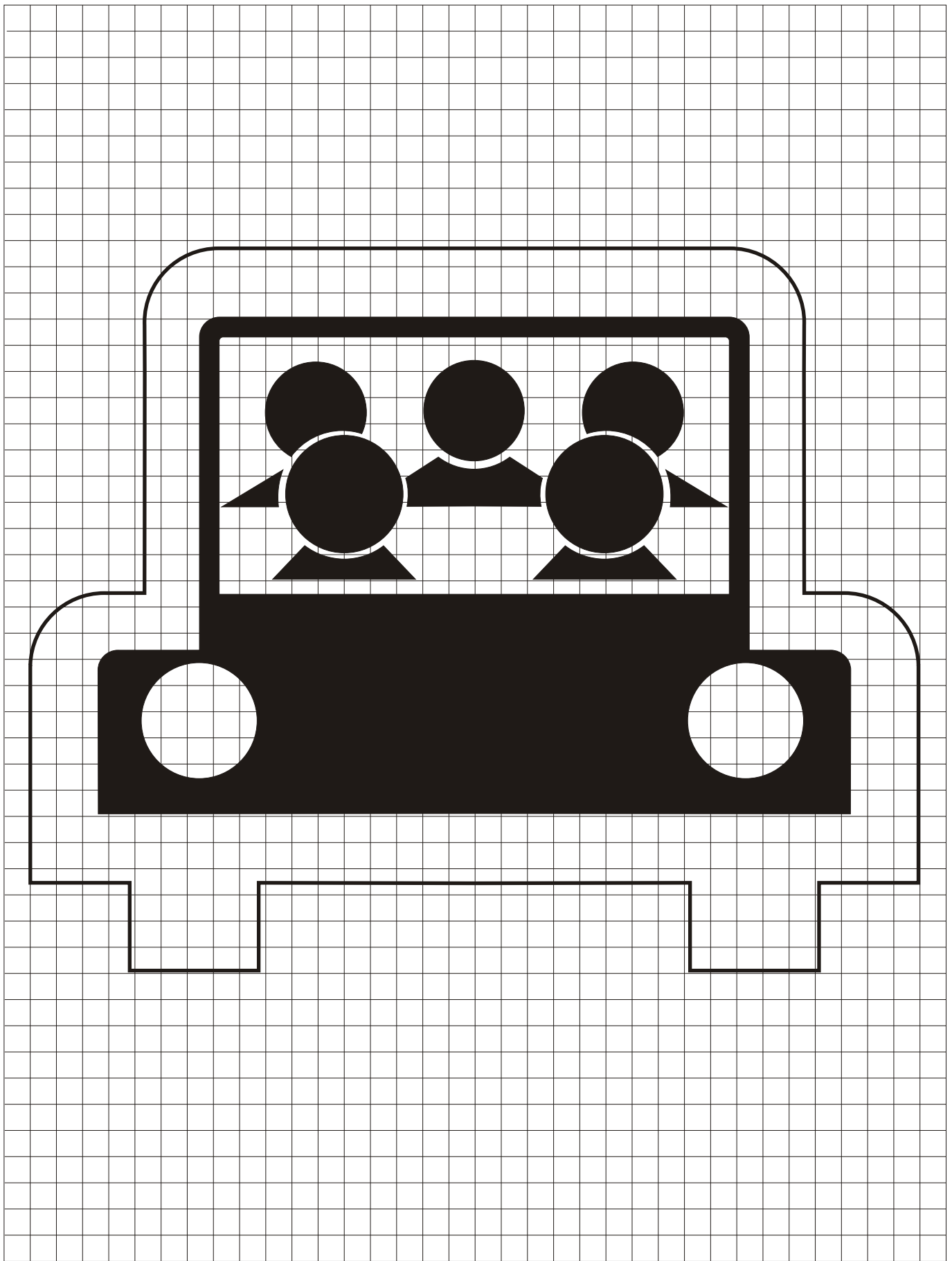

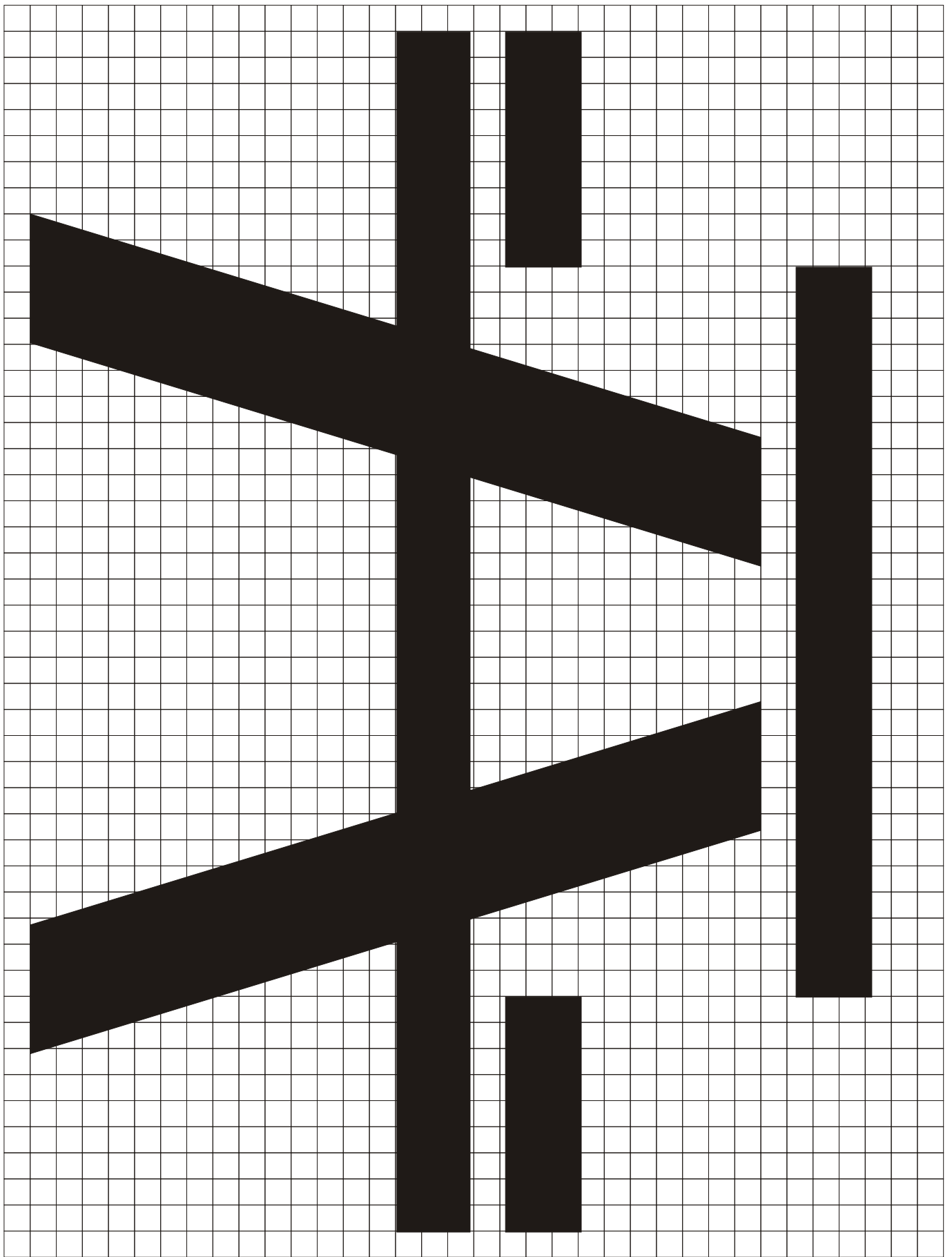

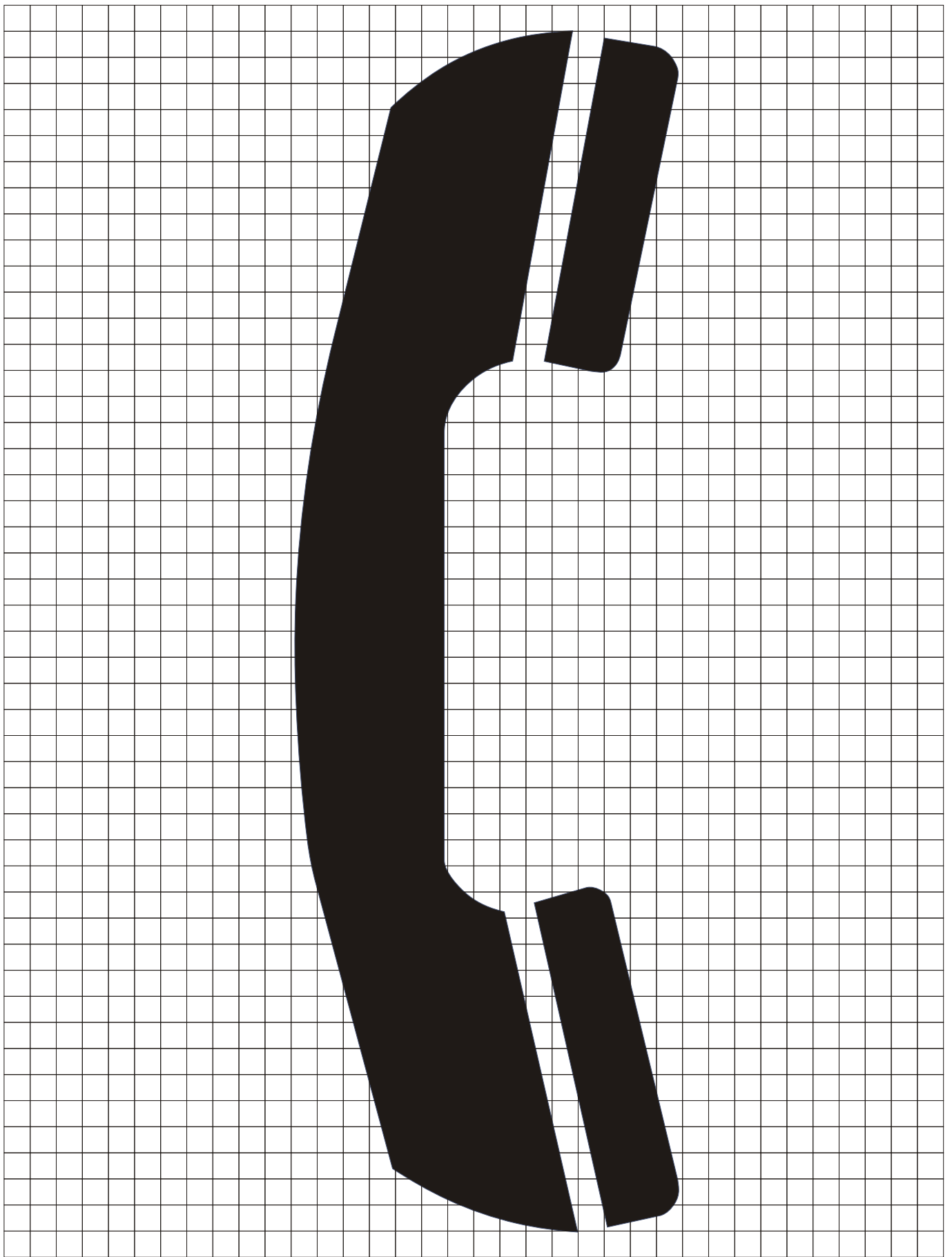

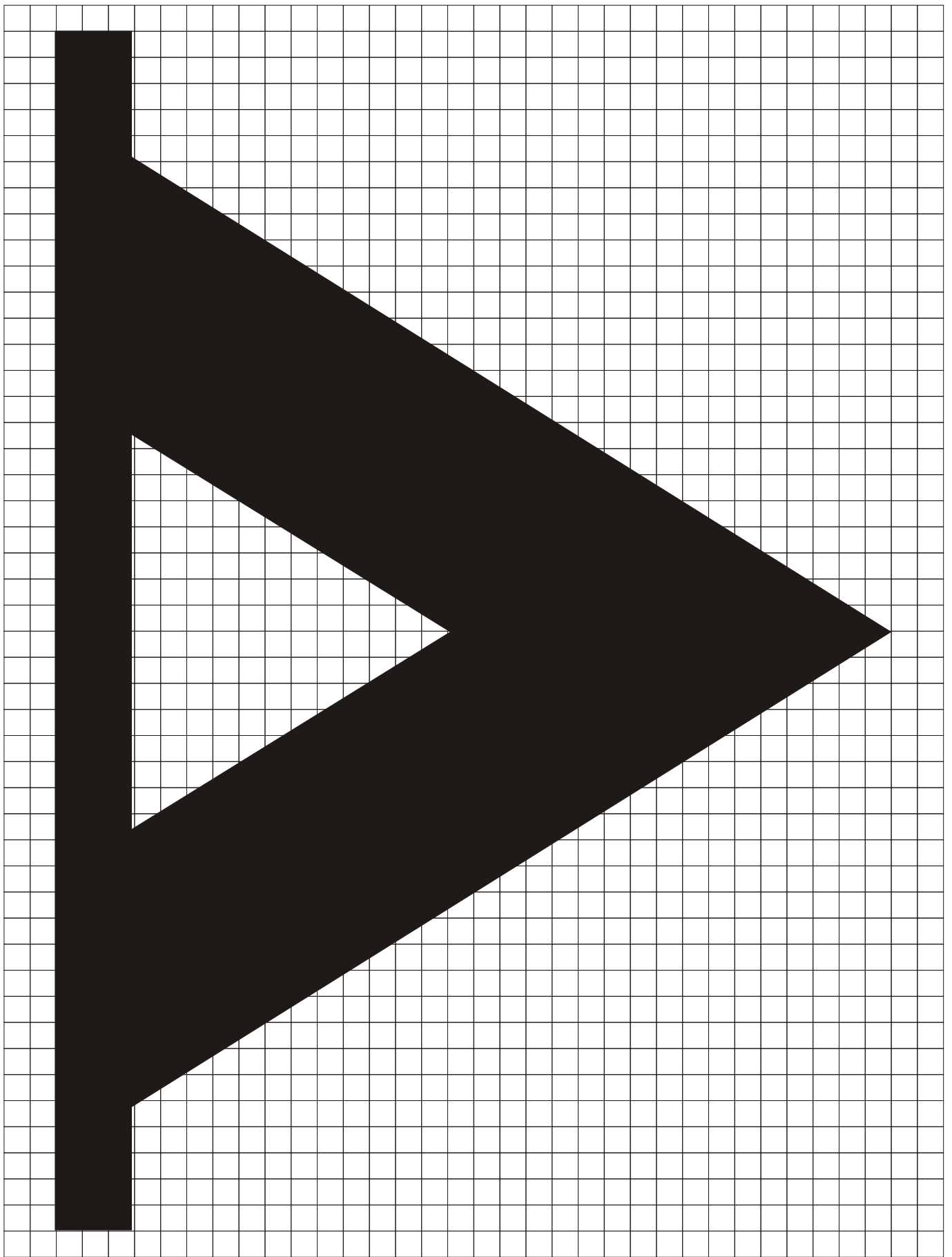

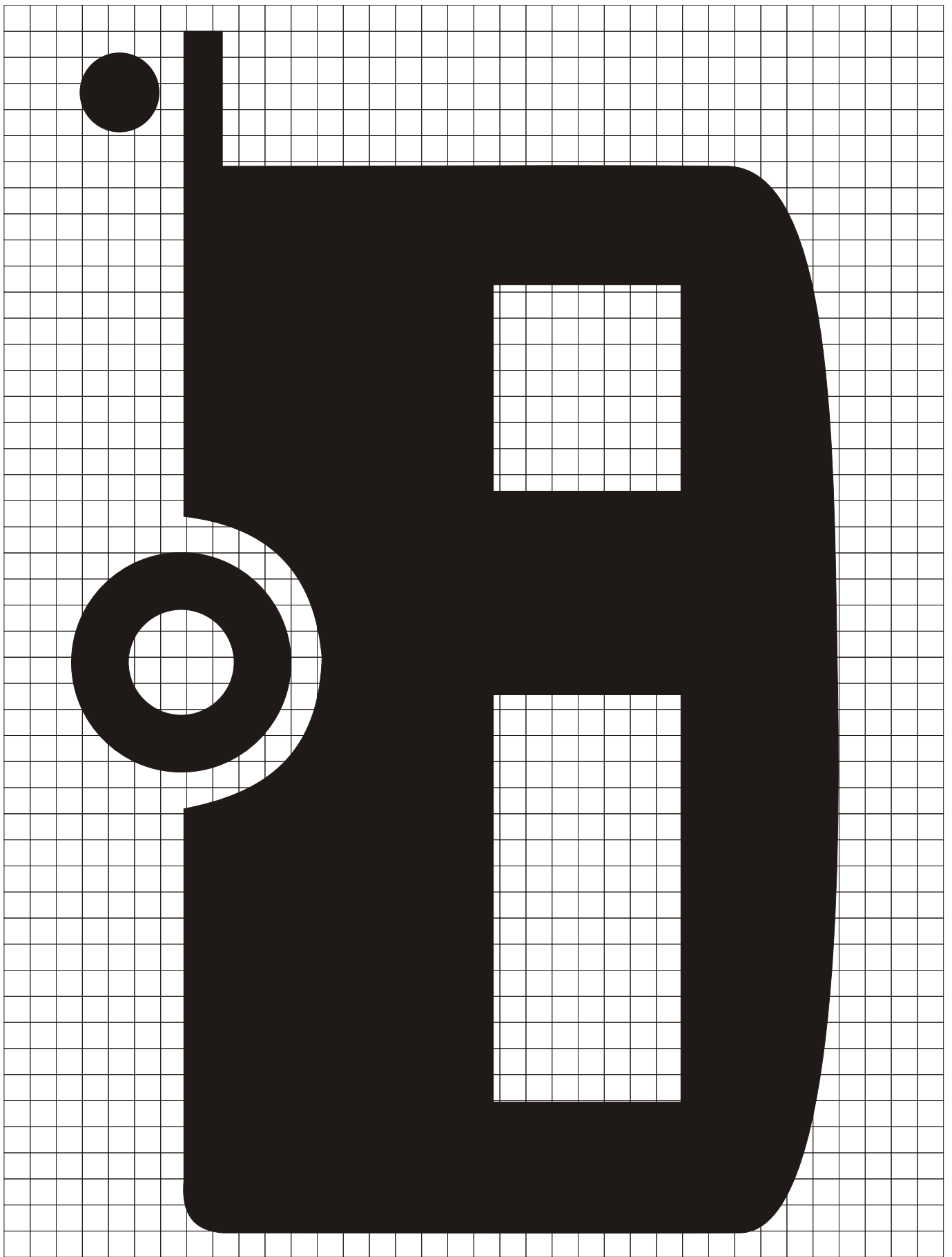

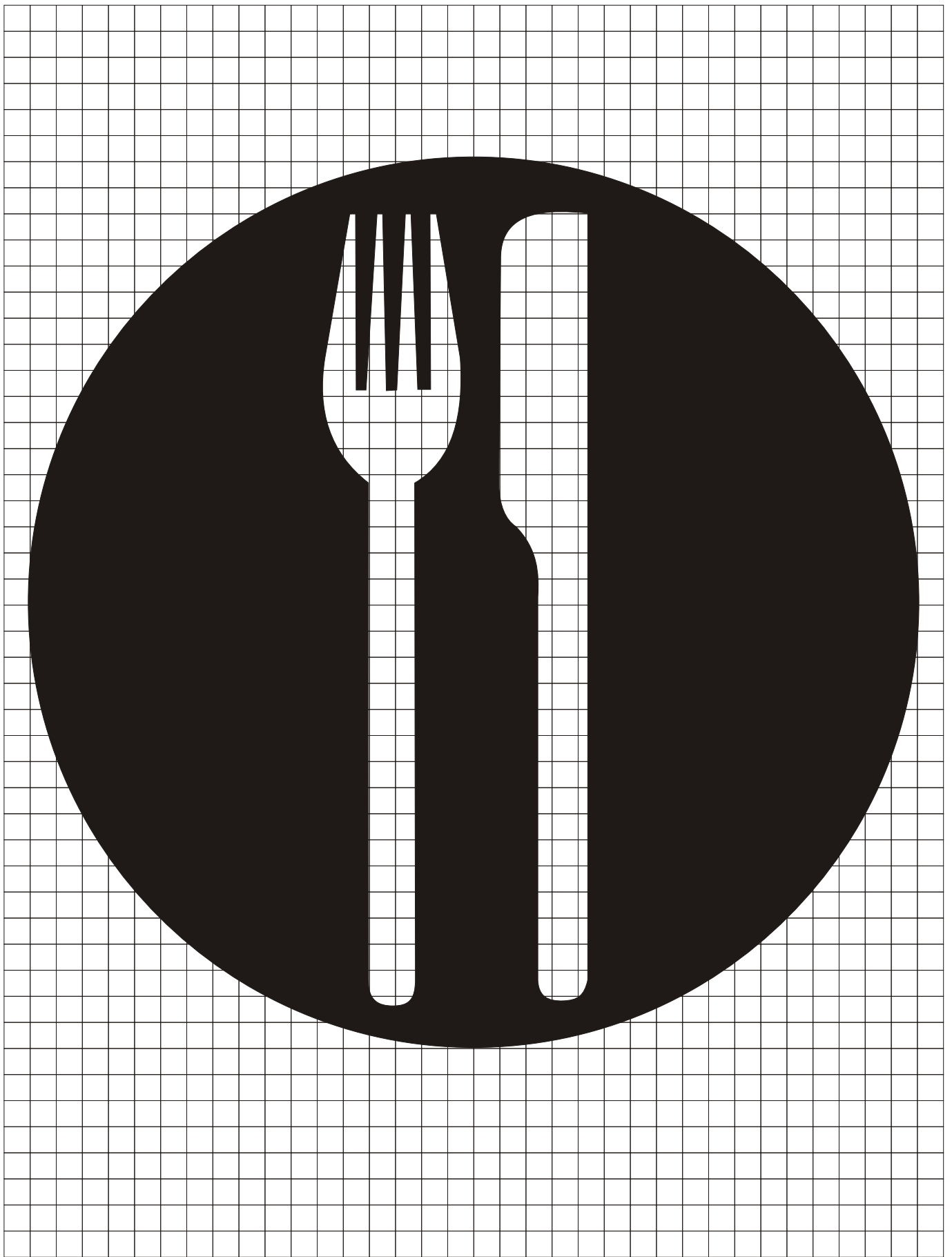

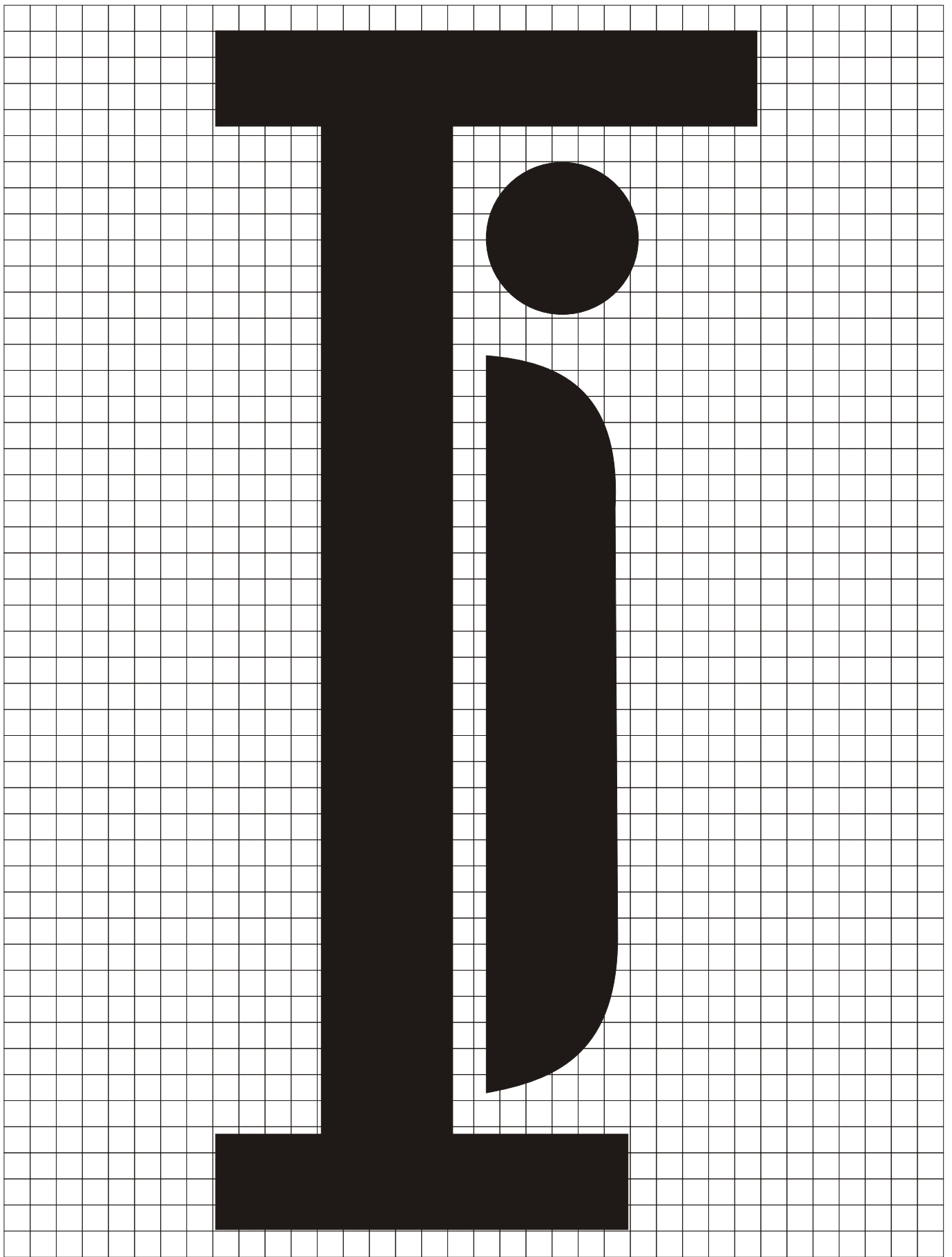

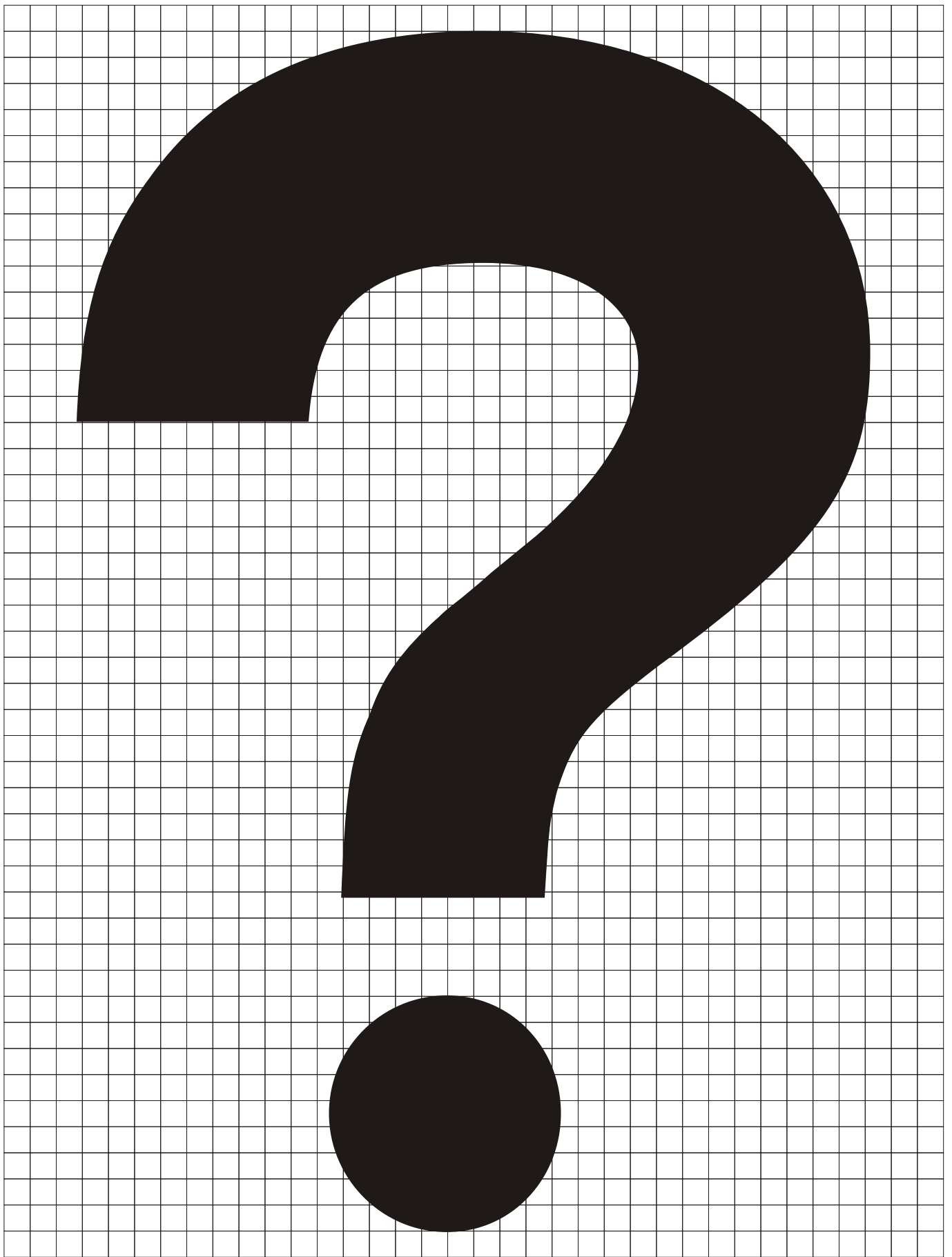

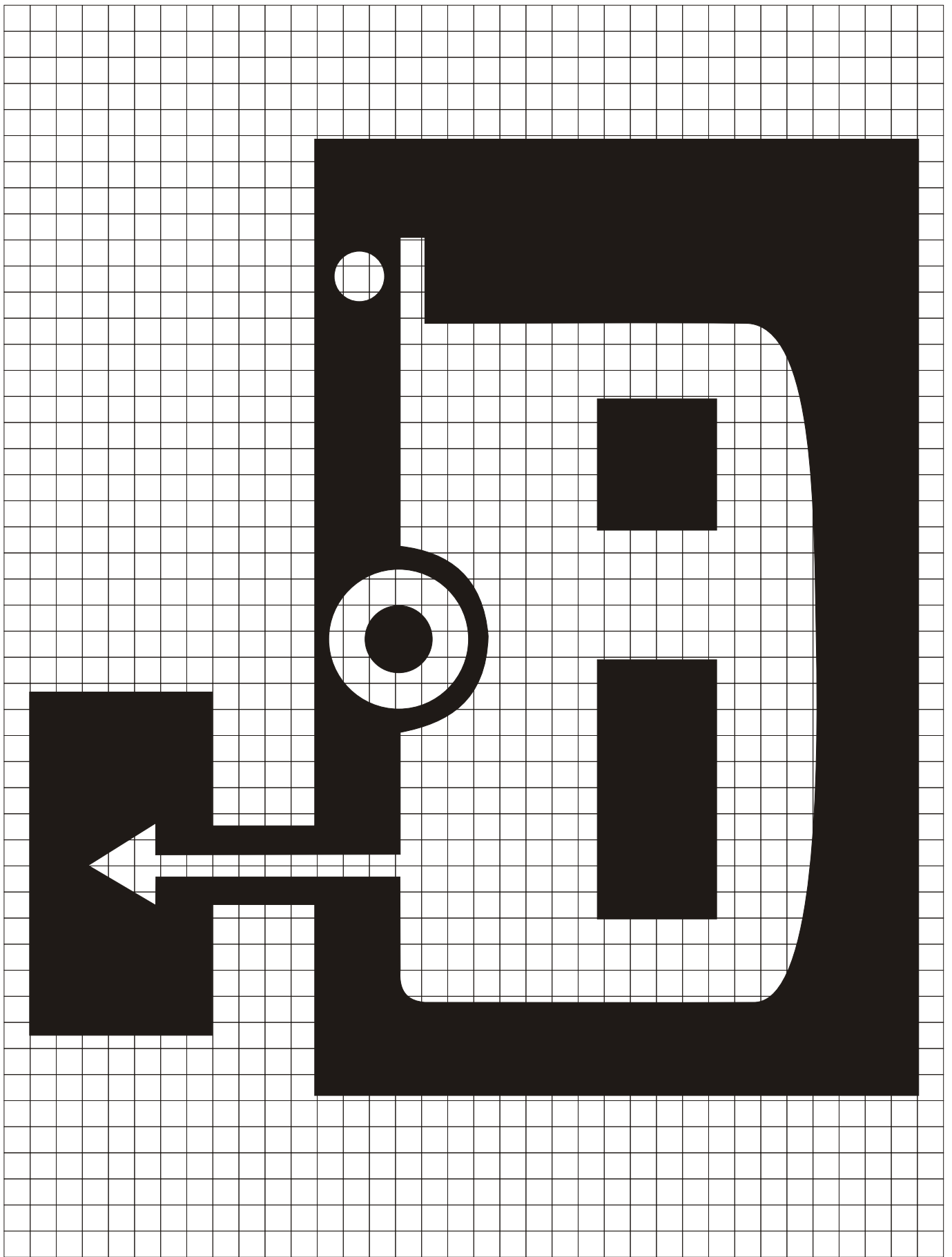

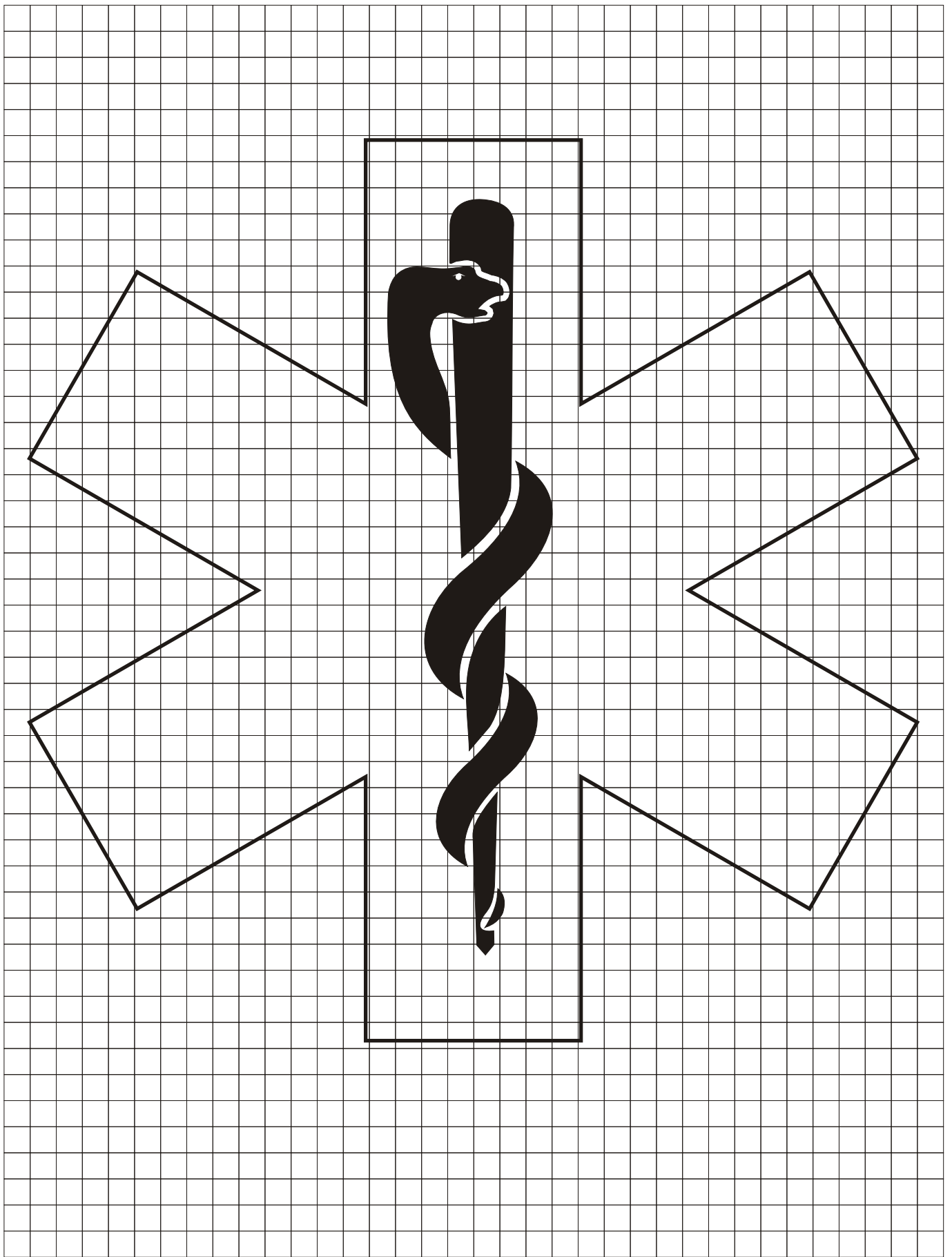

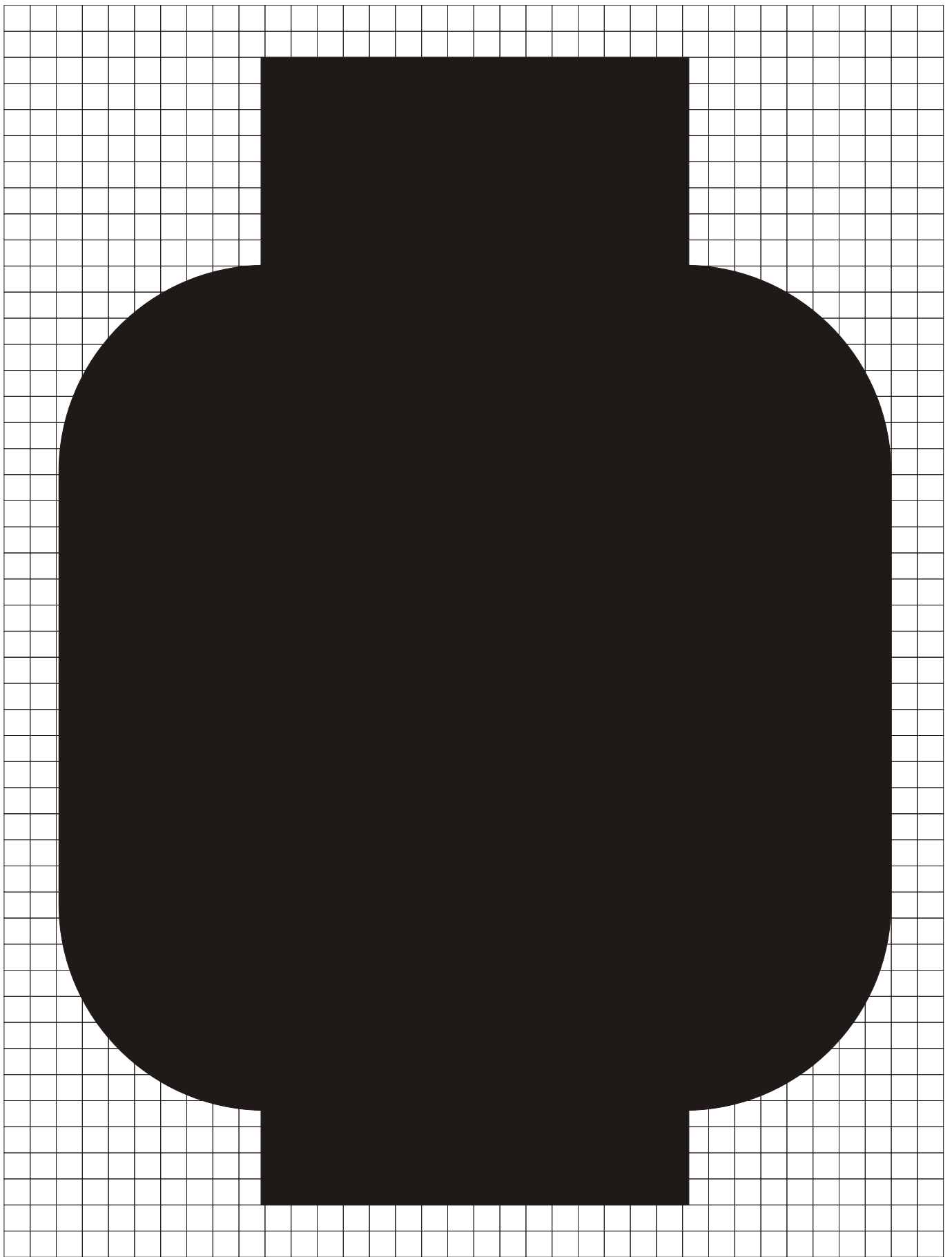

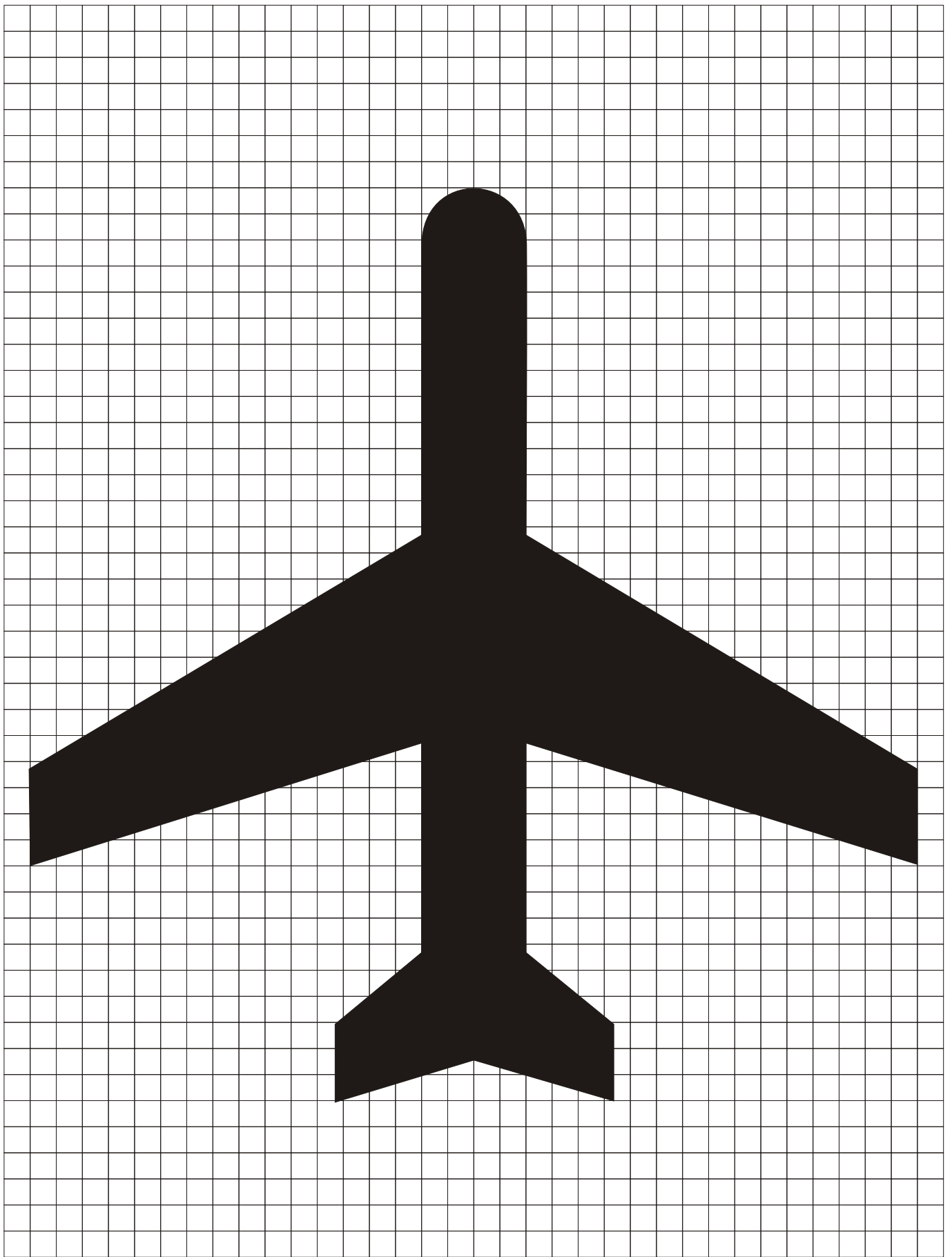

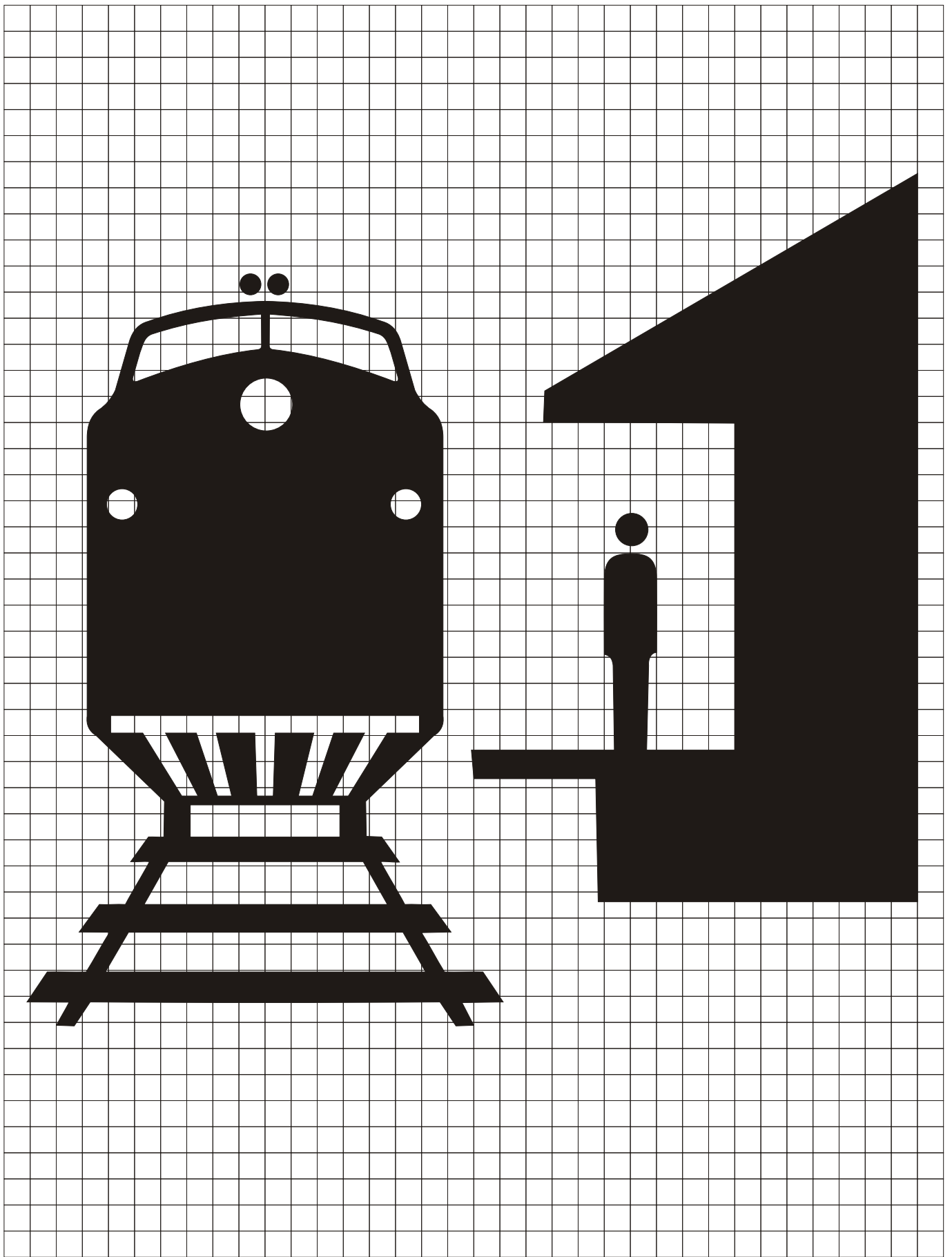

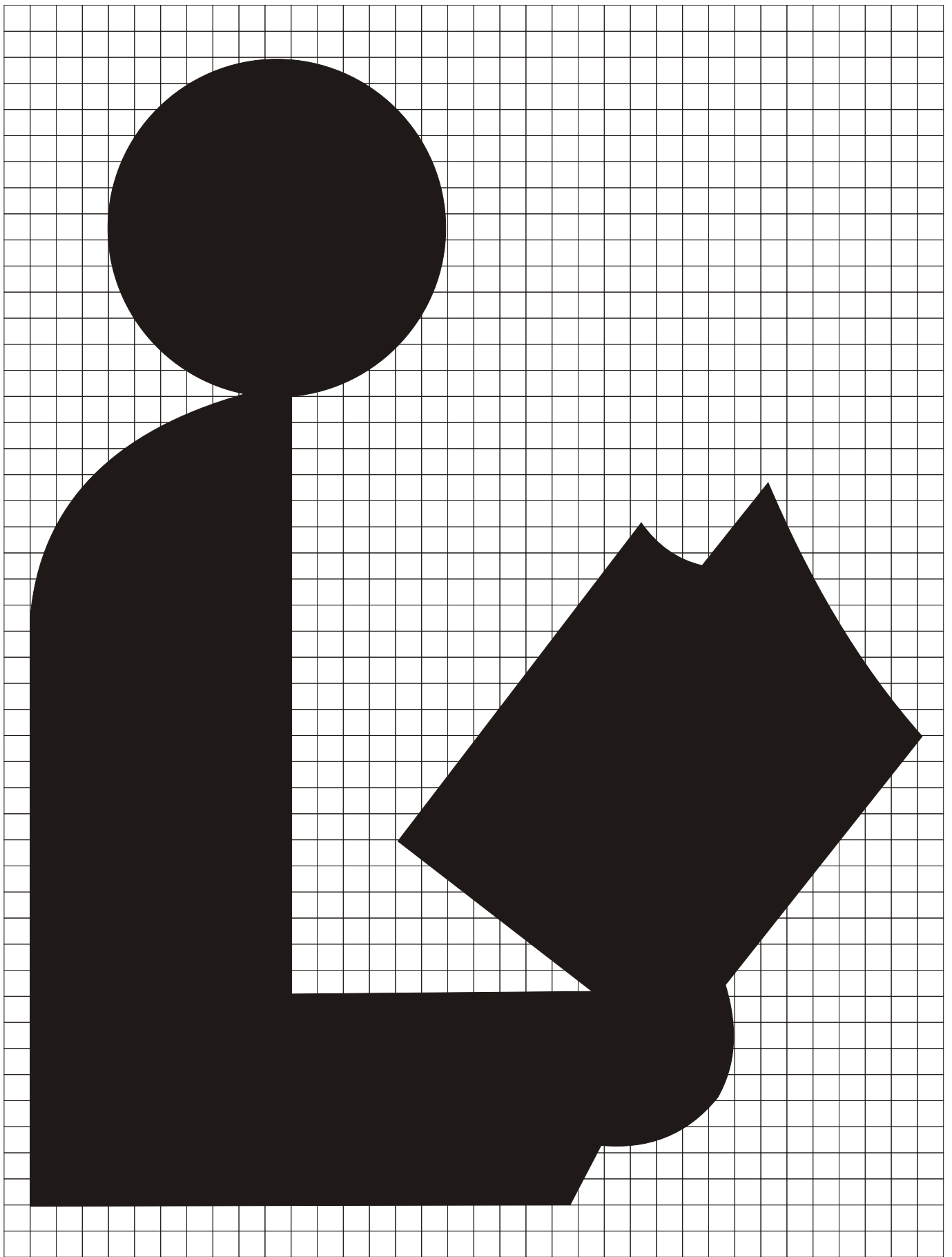

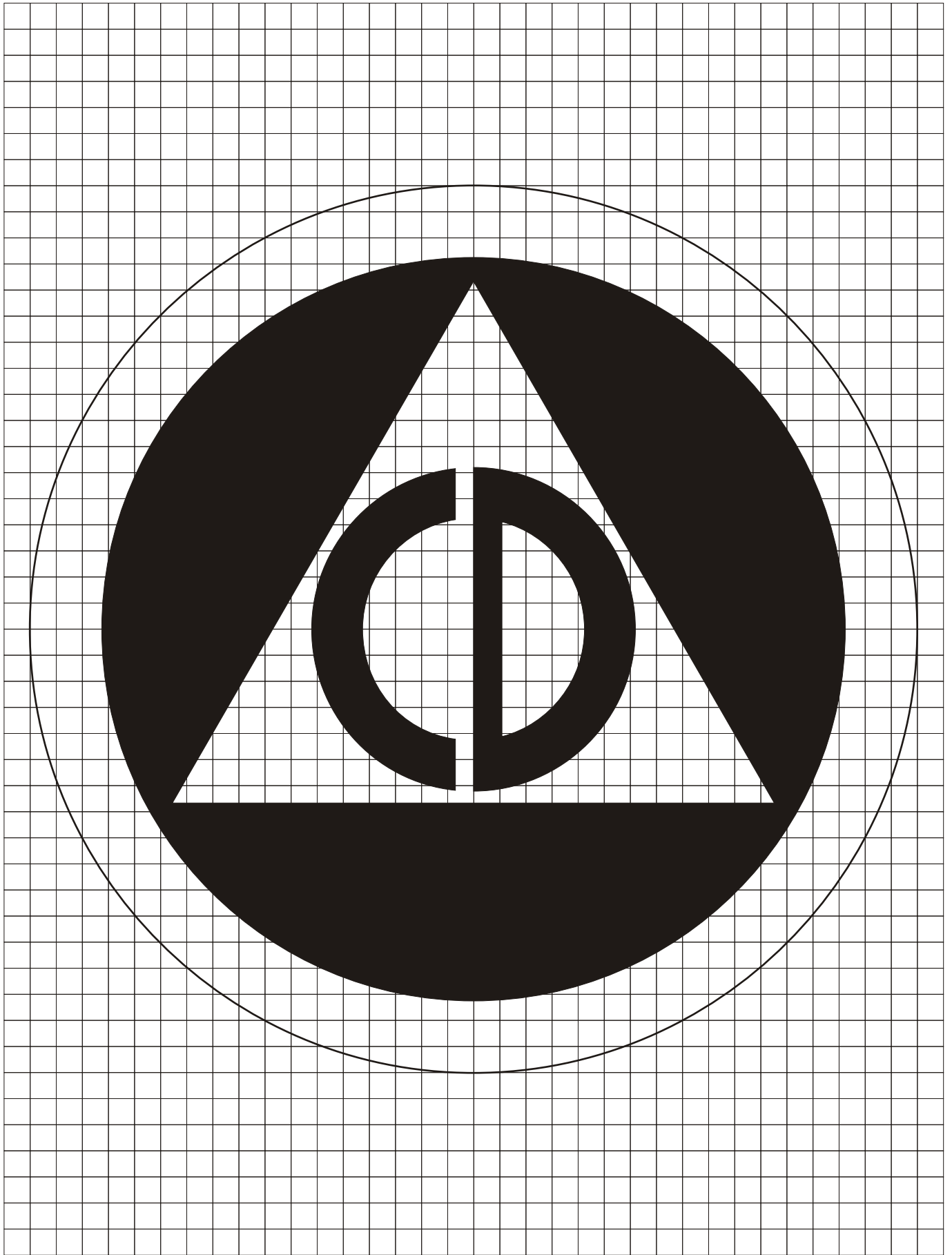

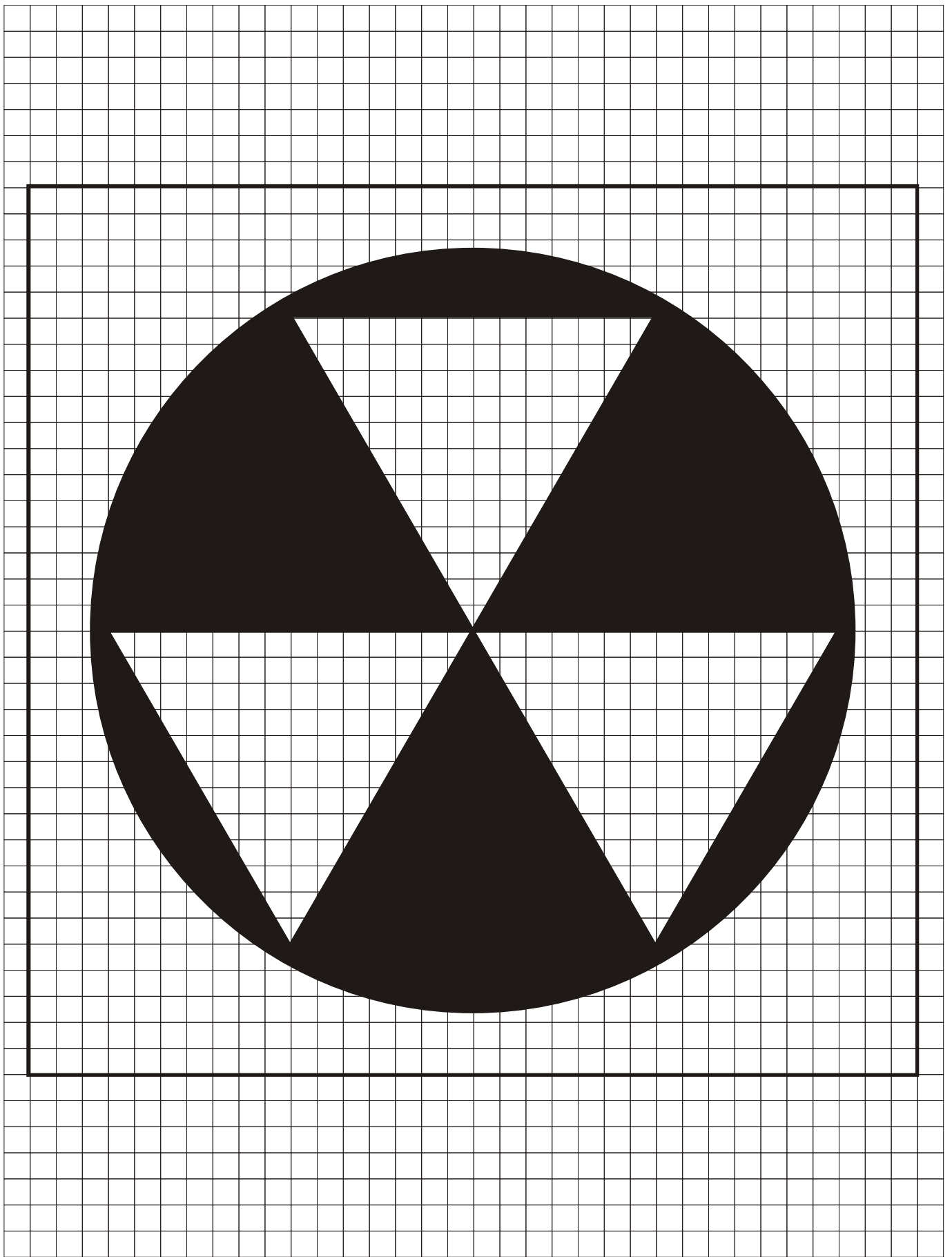

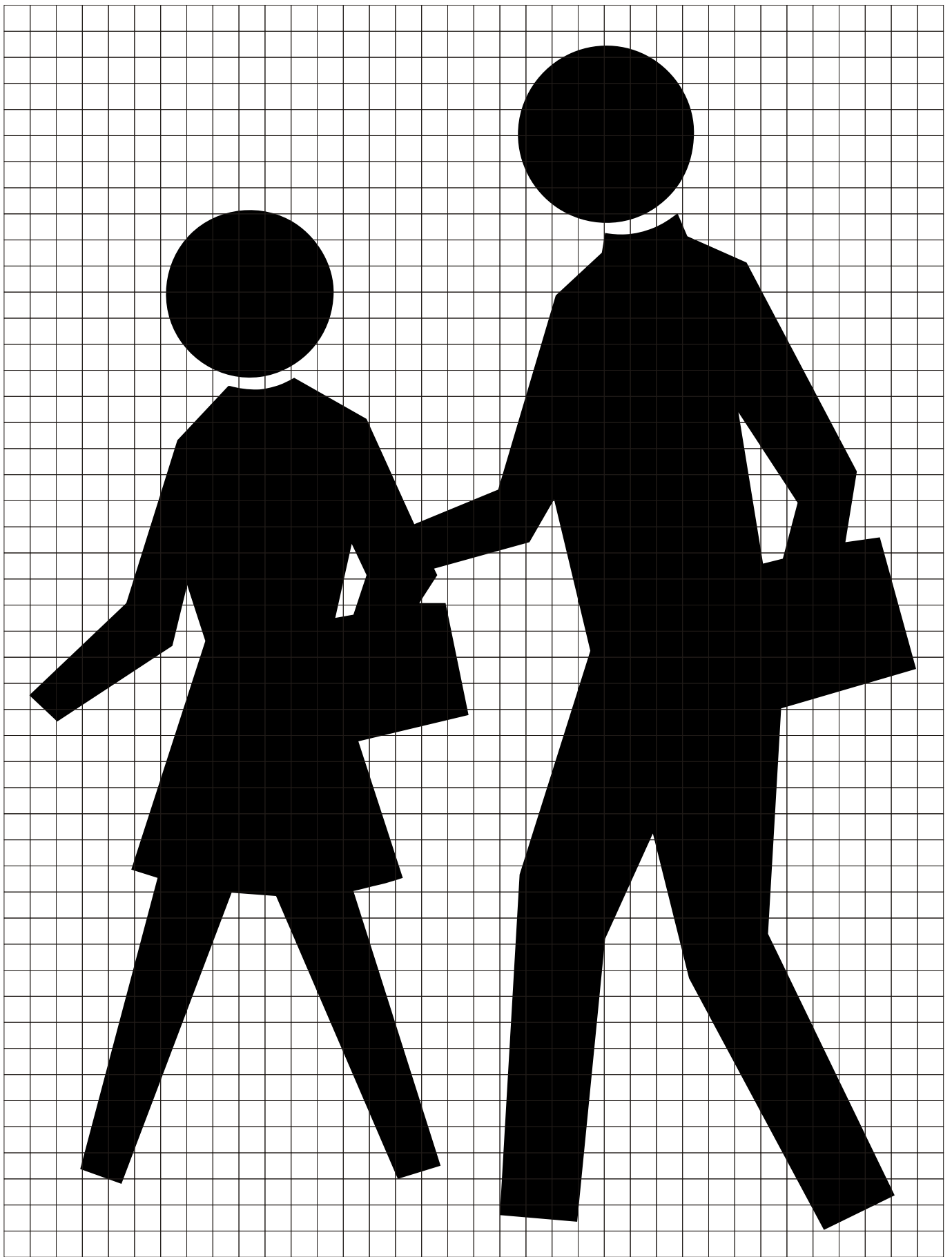

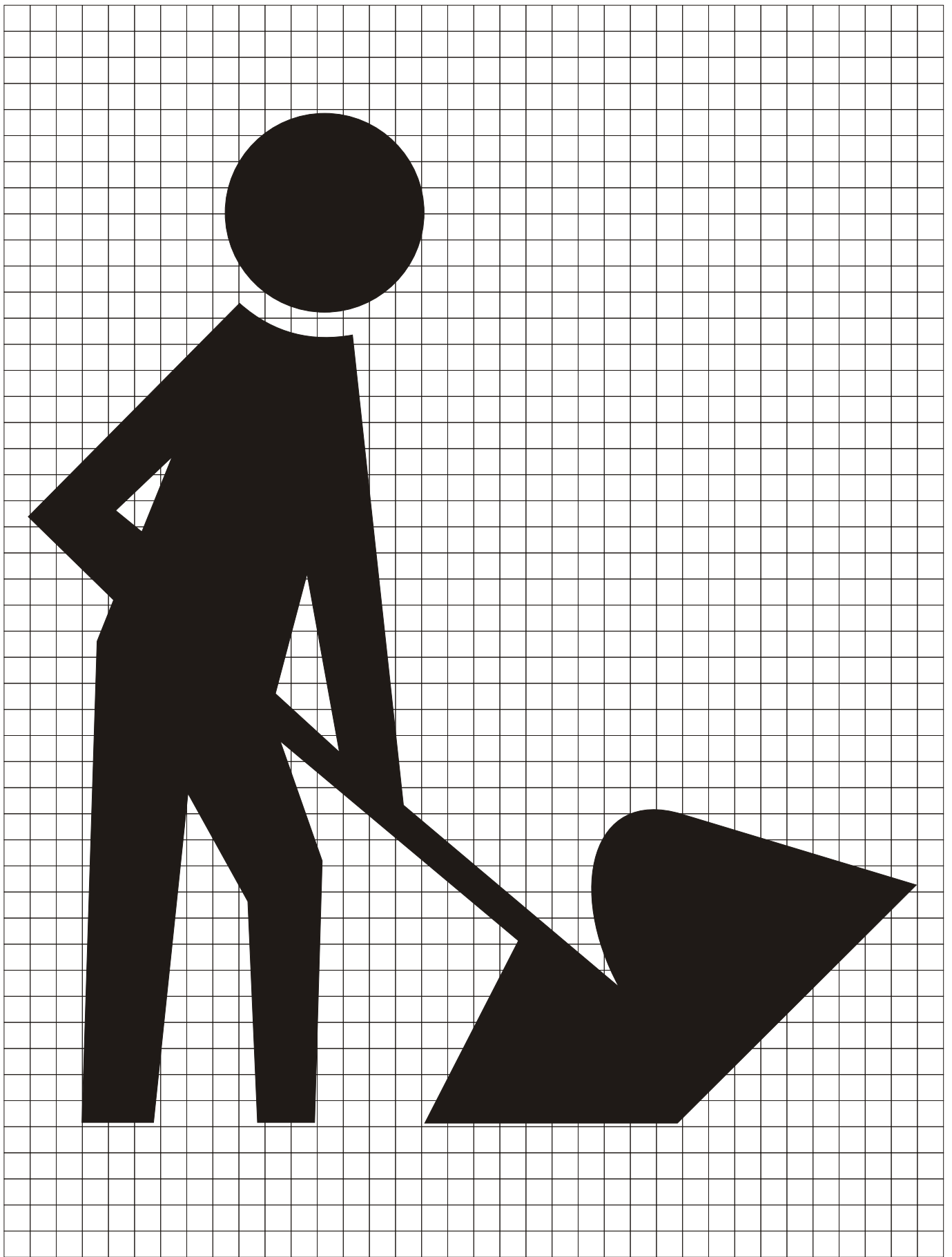

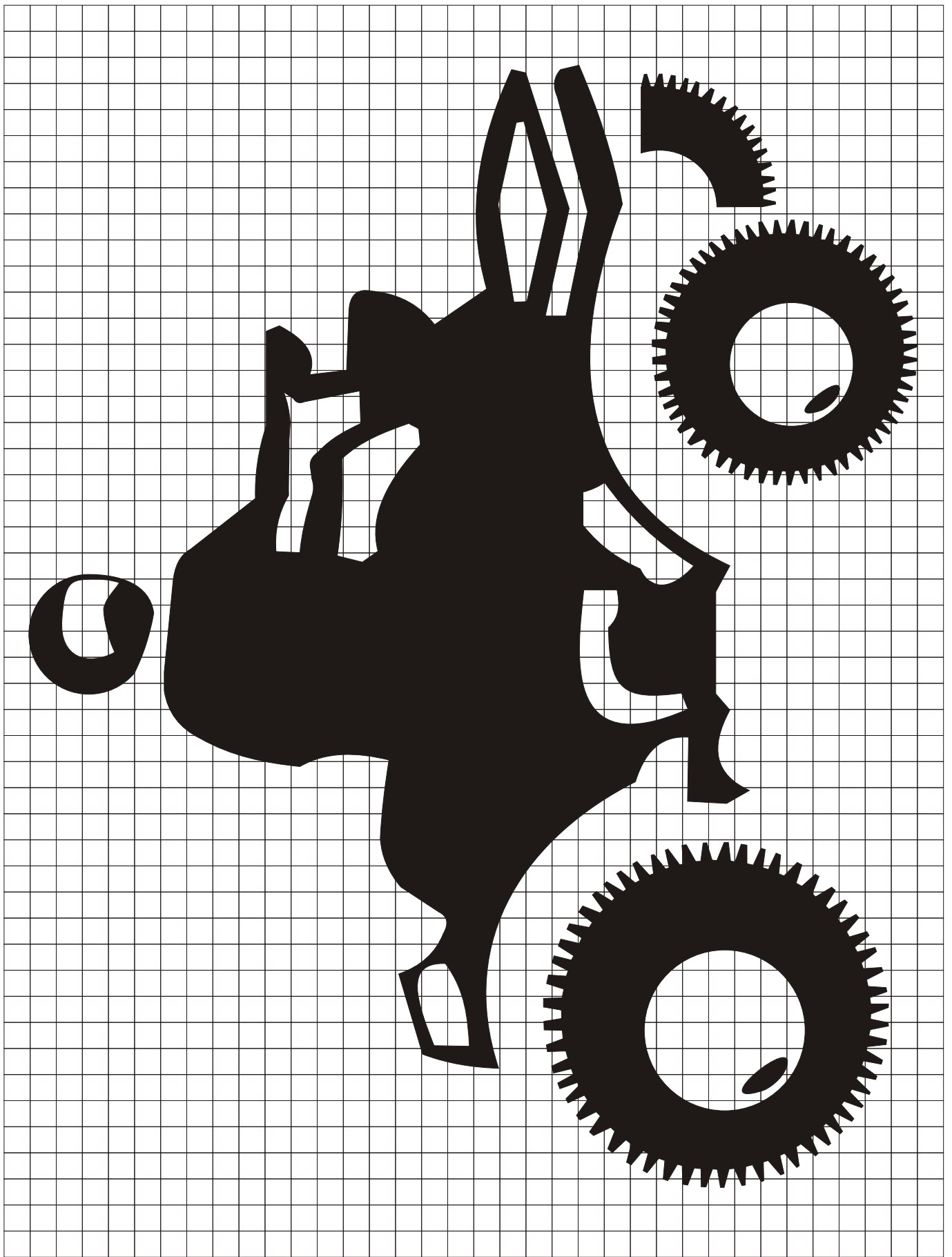

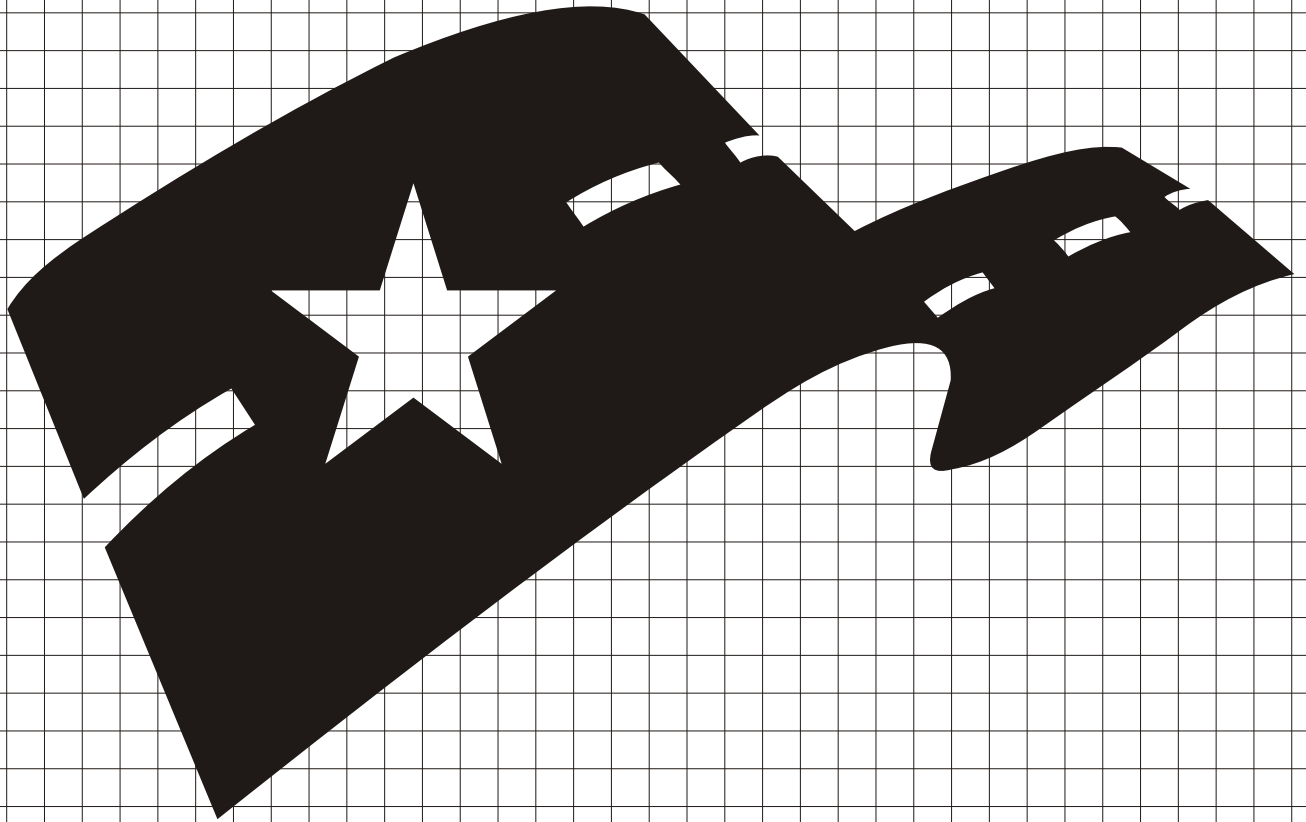

**AMERICA'S
BYWAYS**

