

CADBE

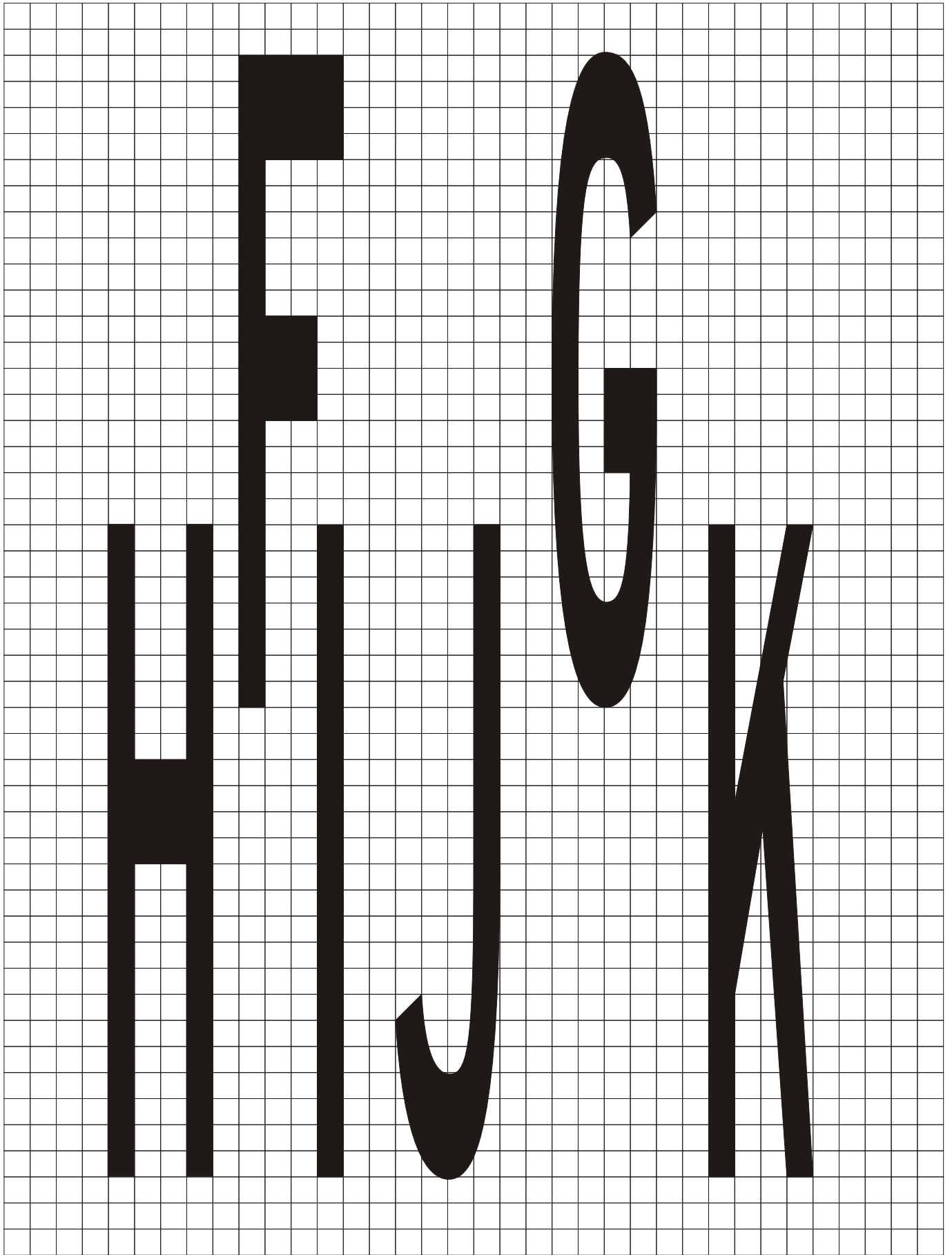

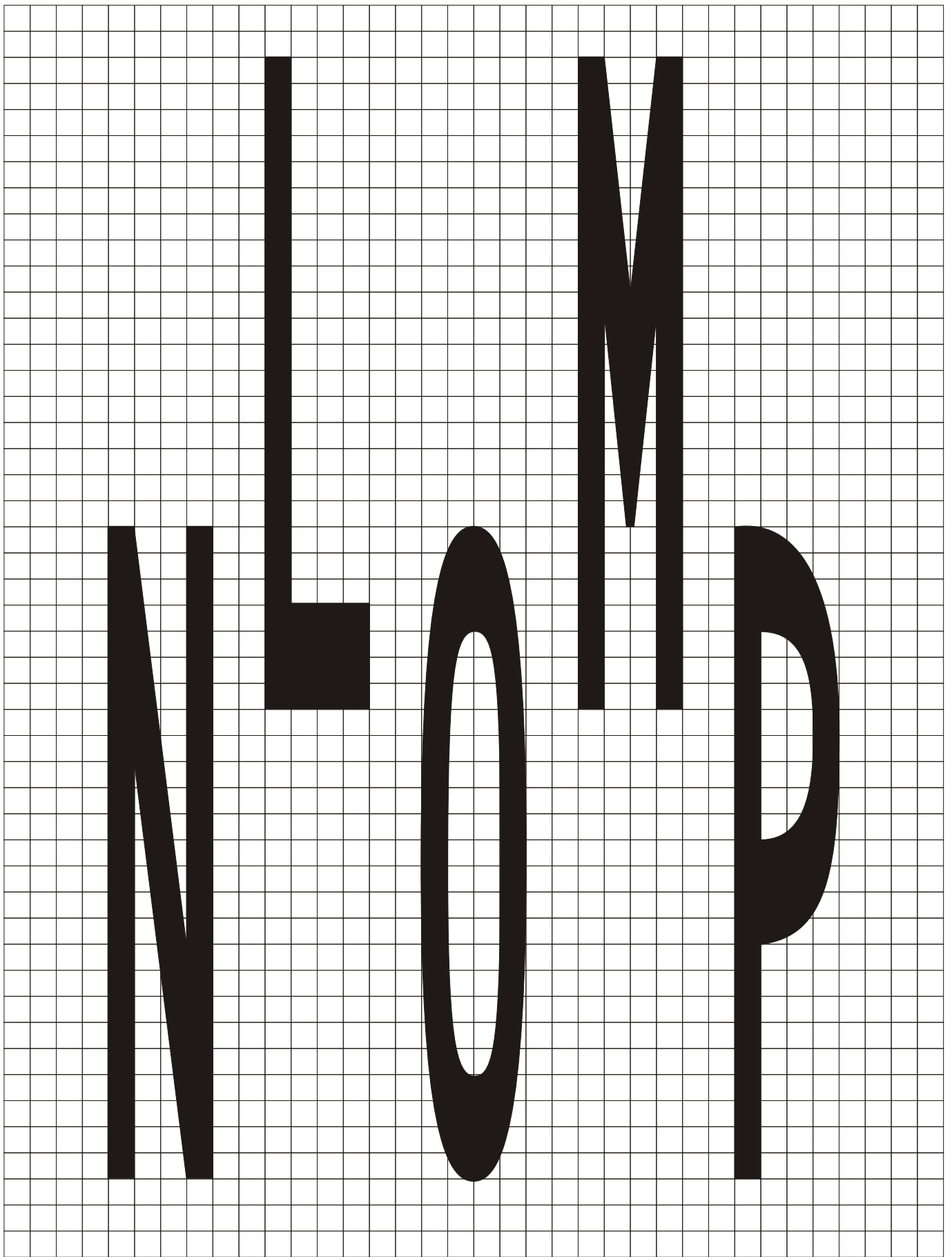

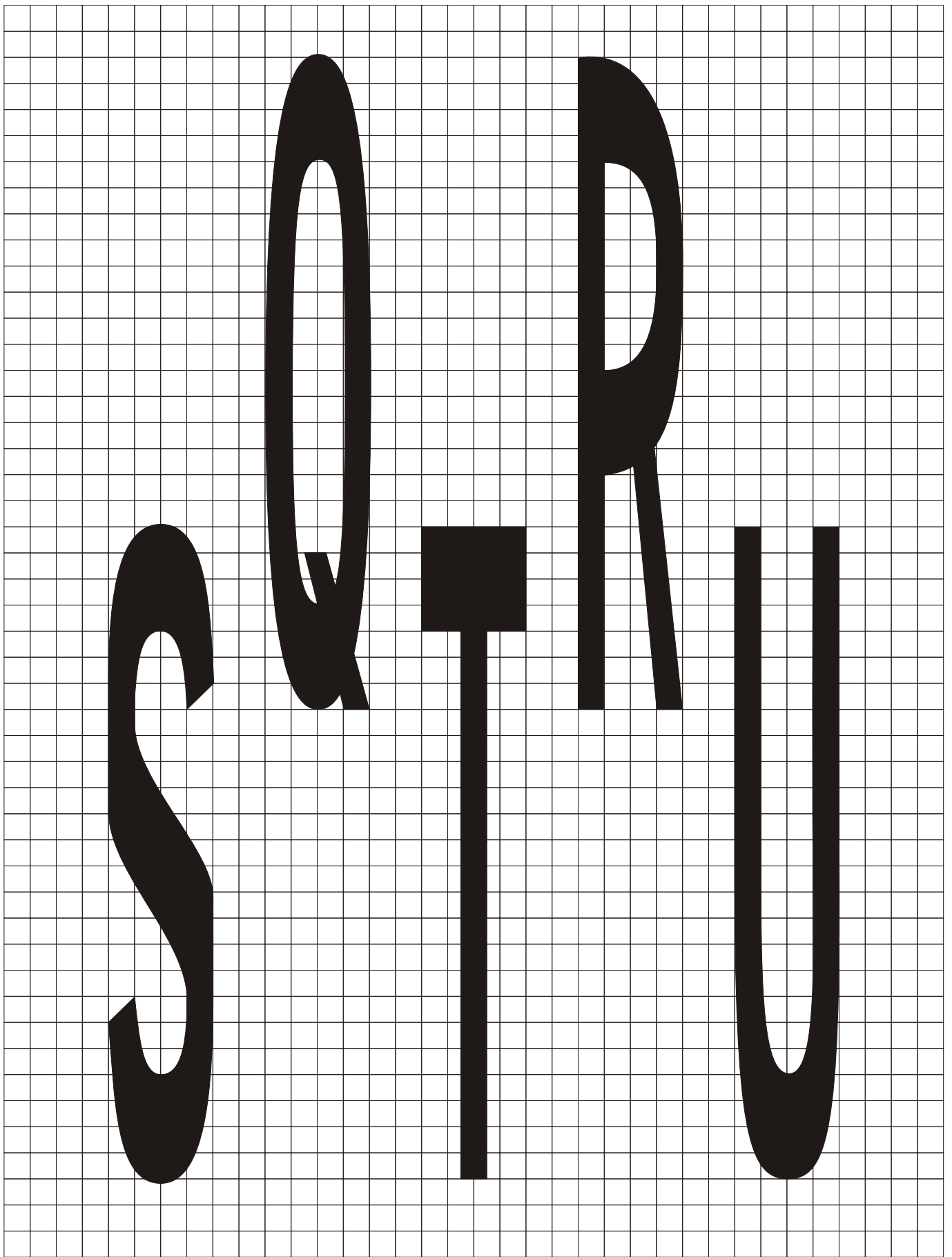

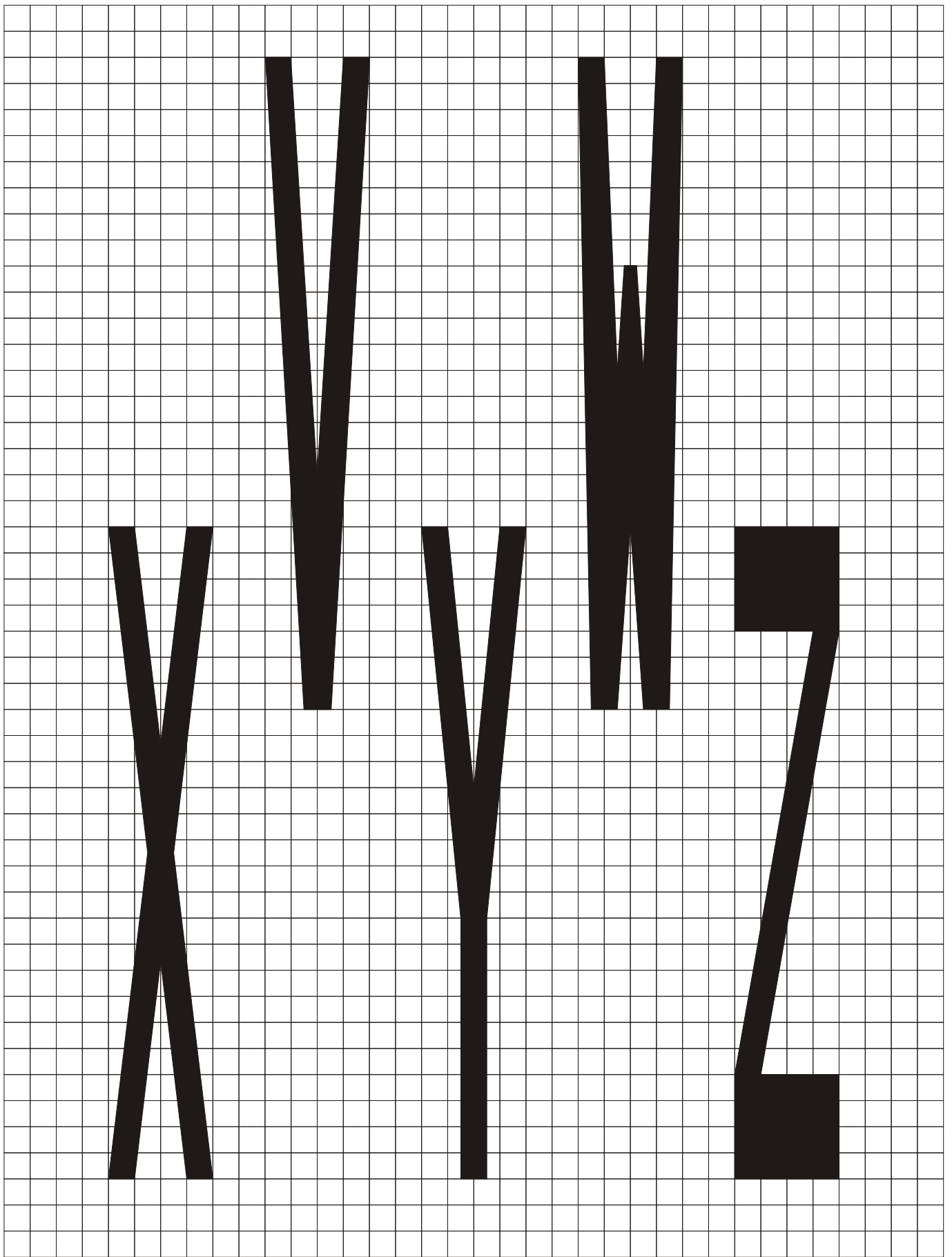

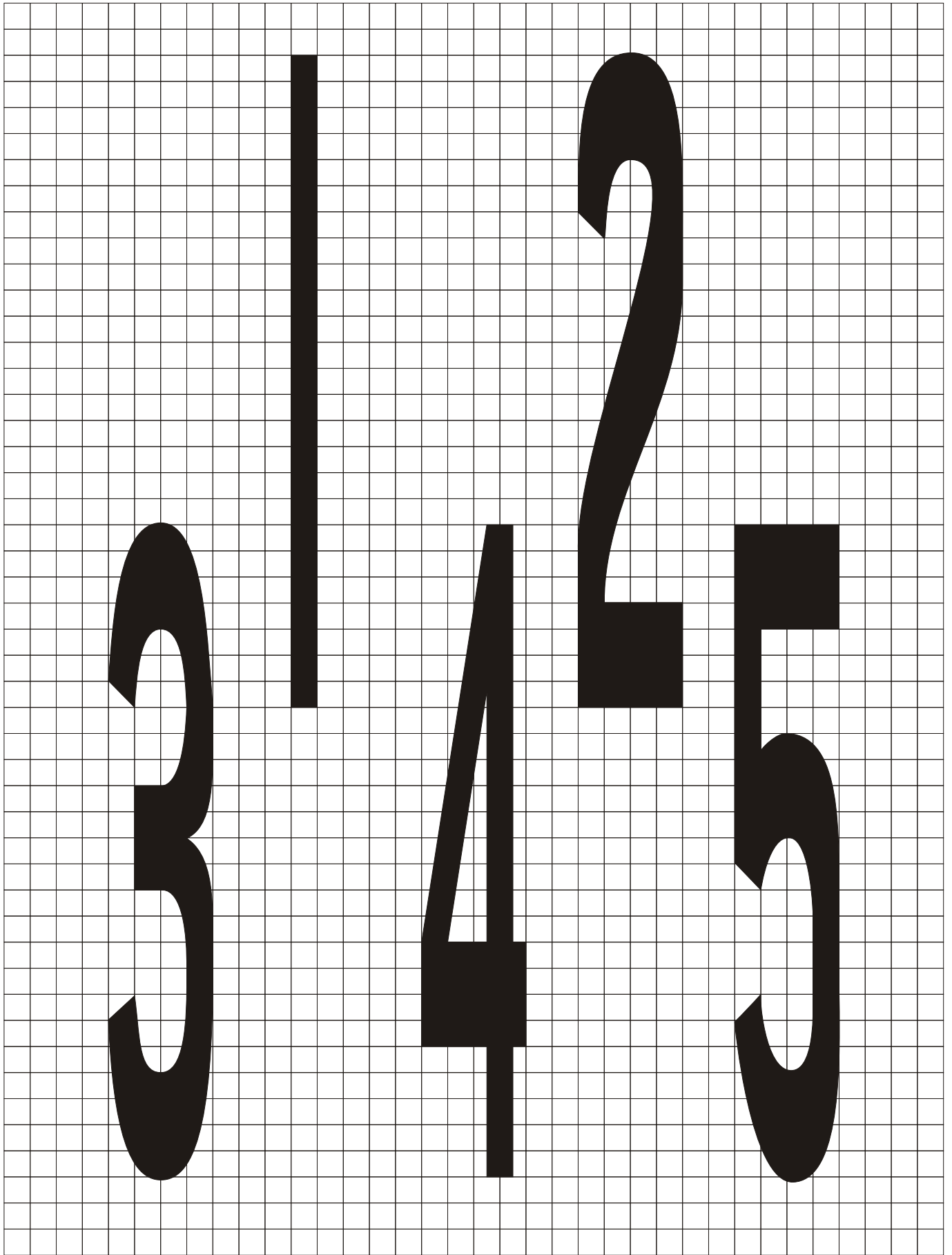

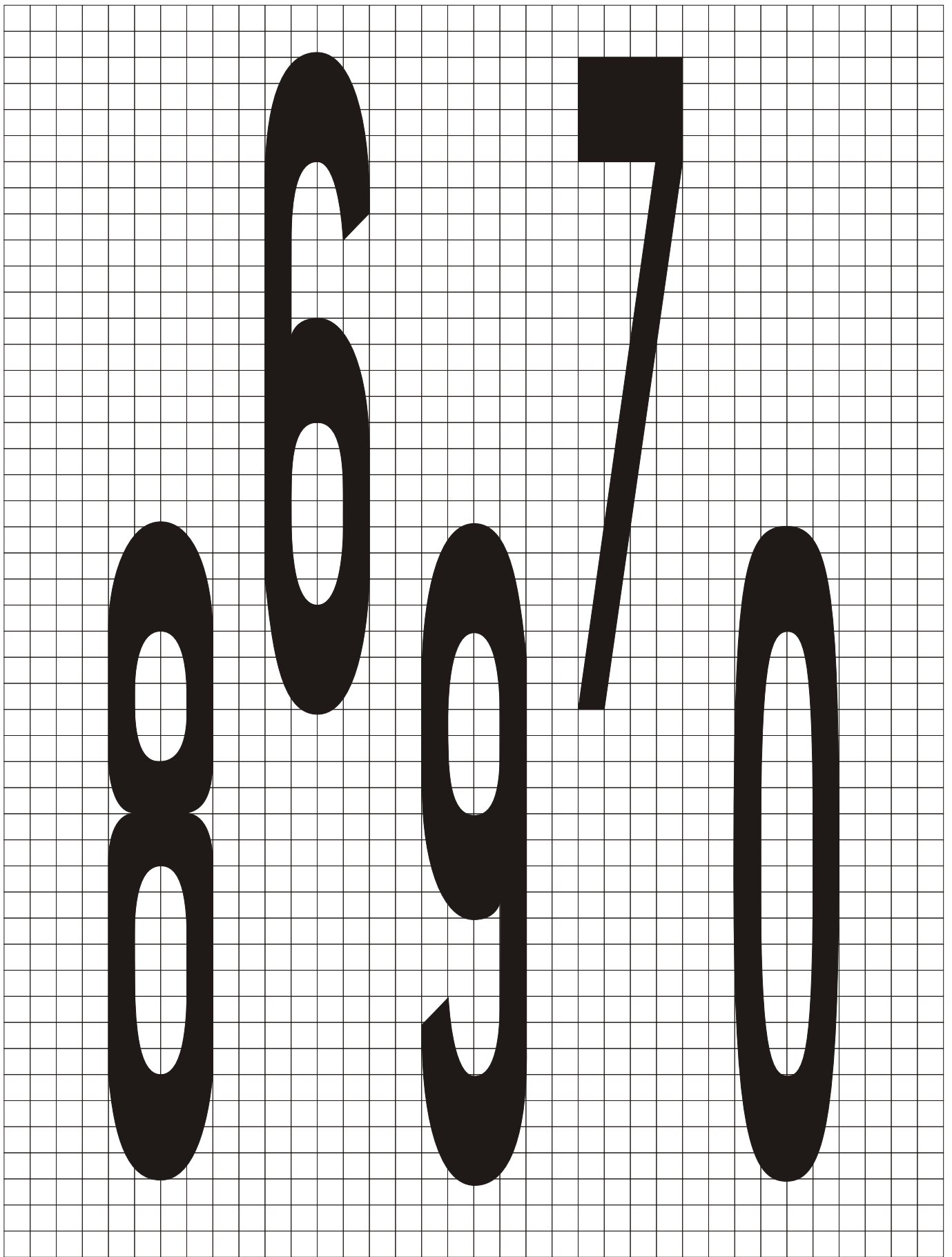

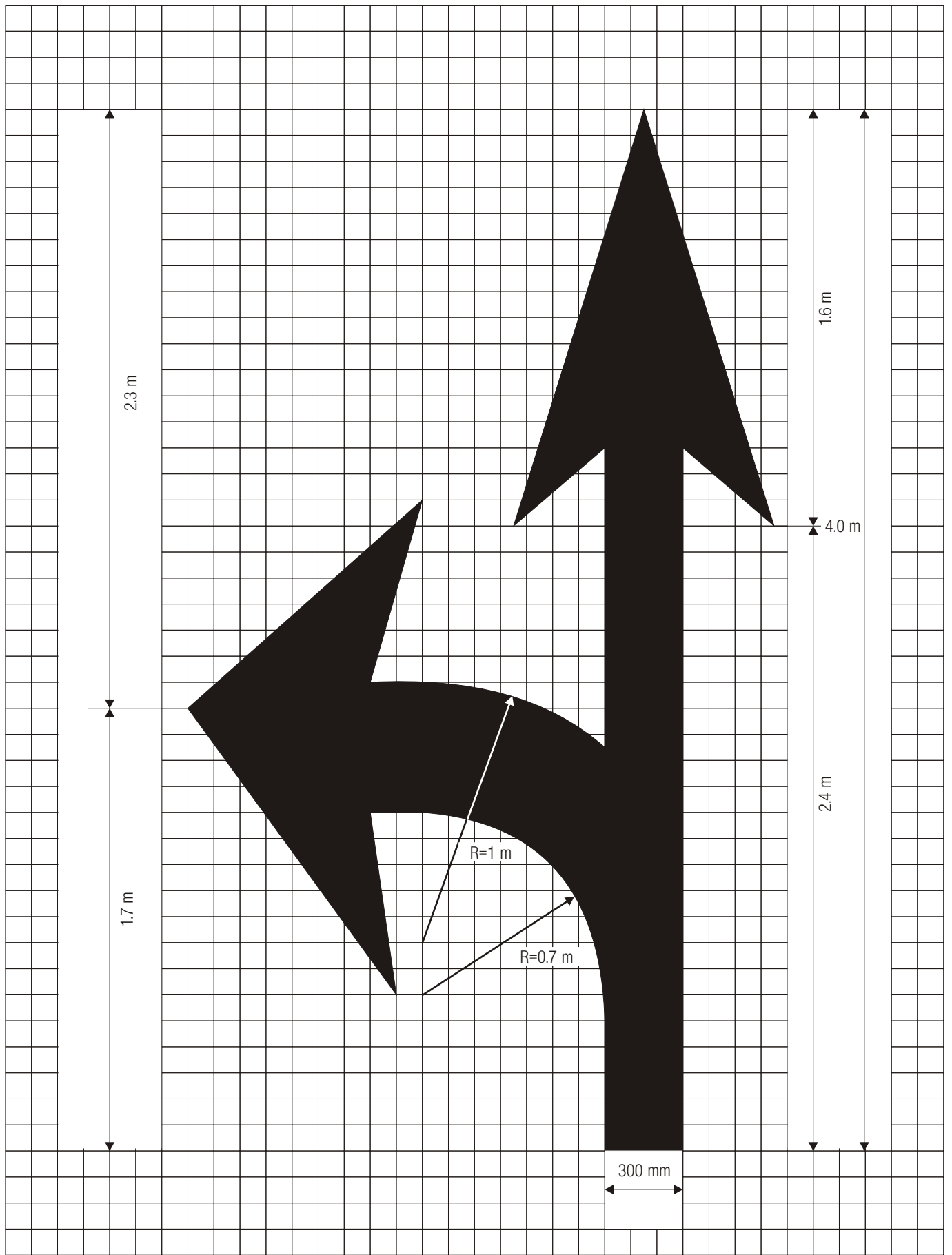

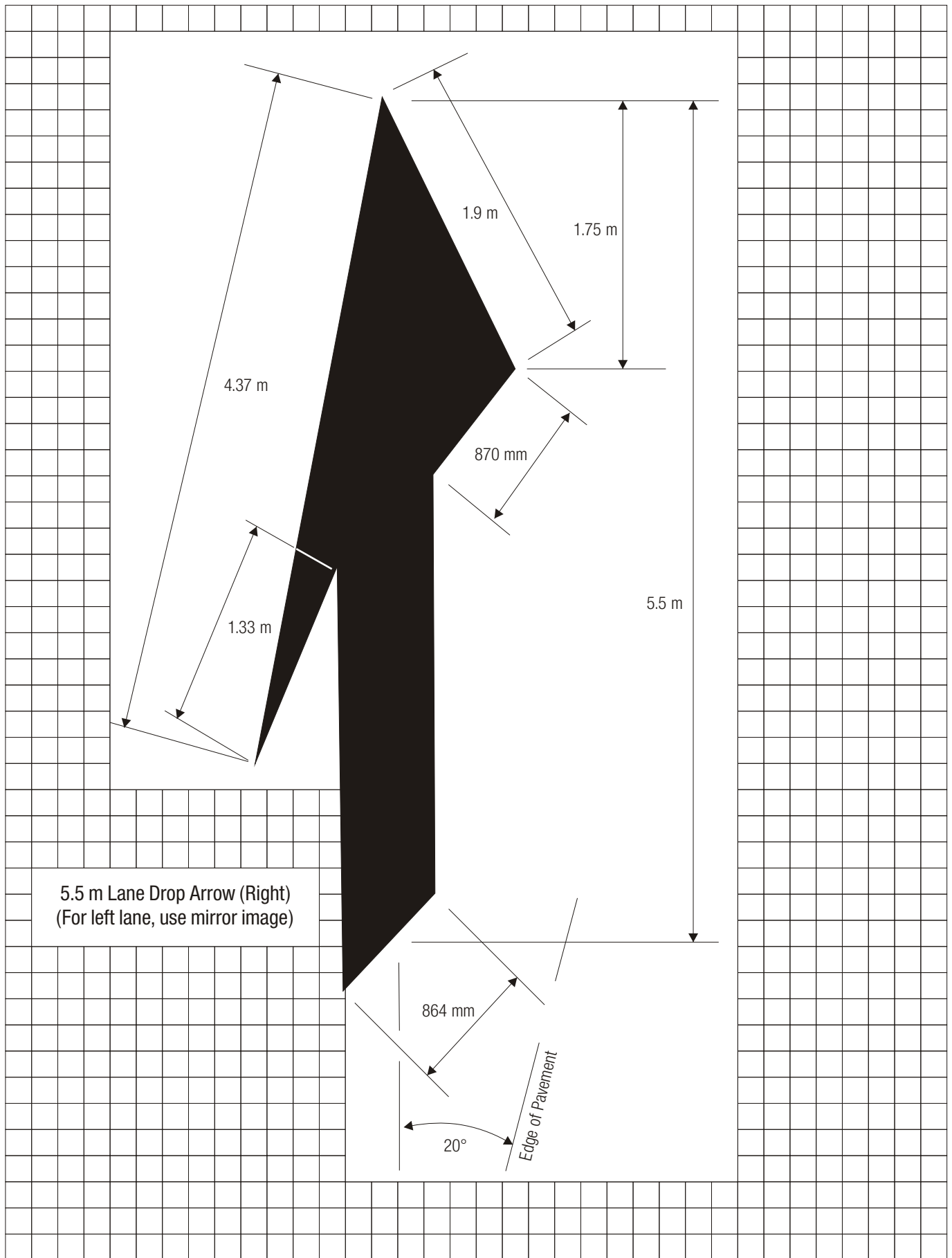

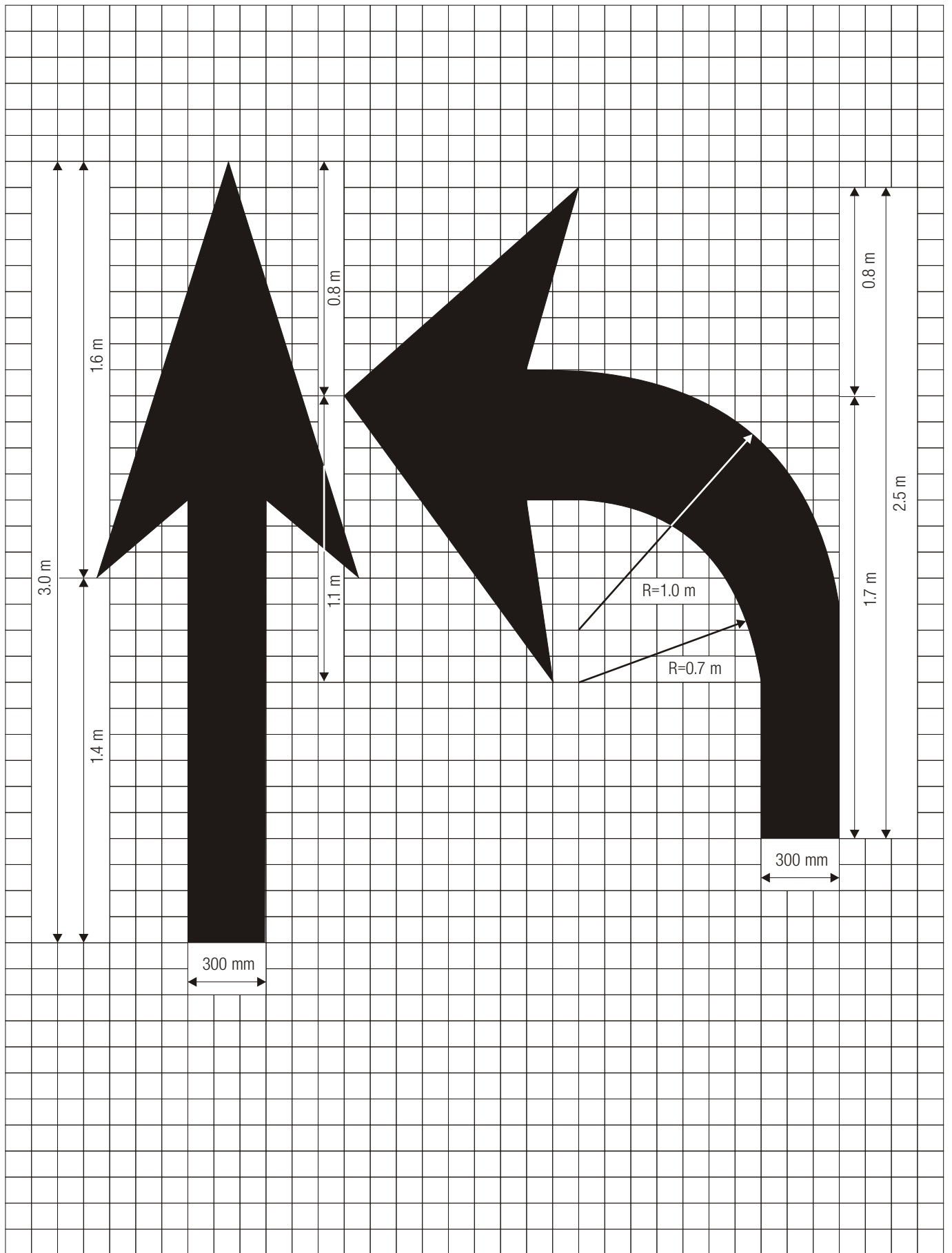

Optional Narrow Elongated Arrows

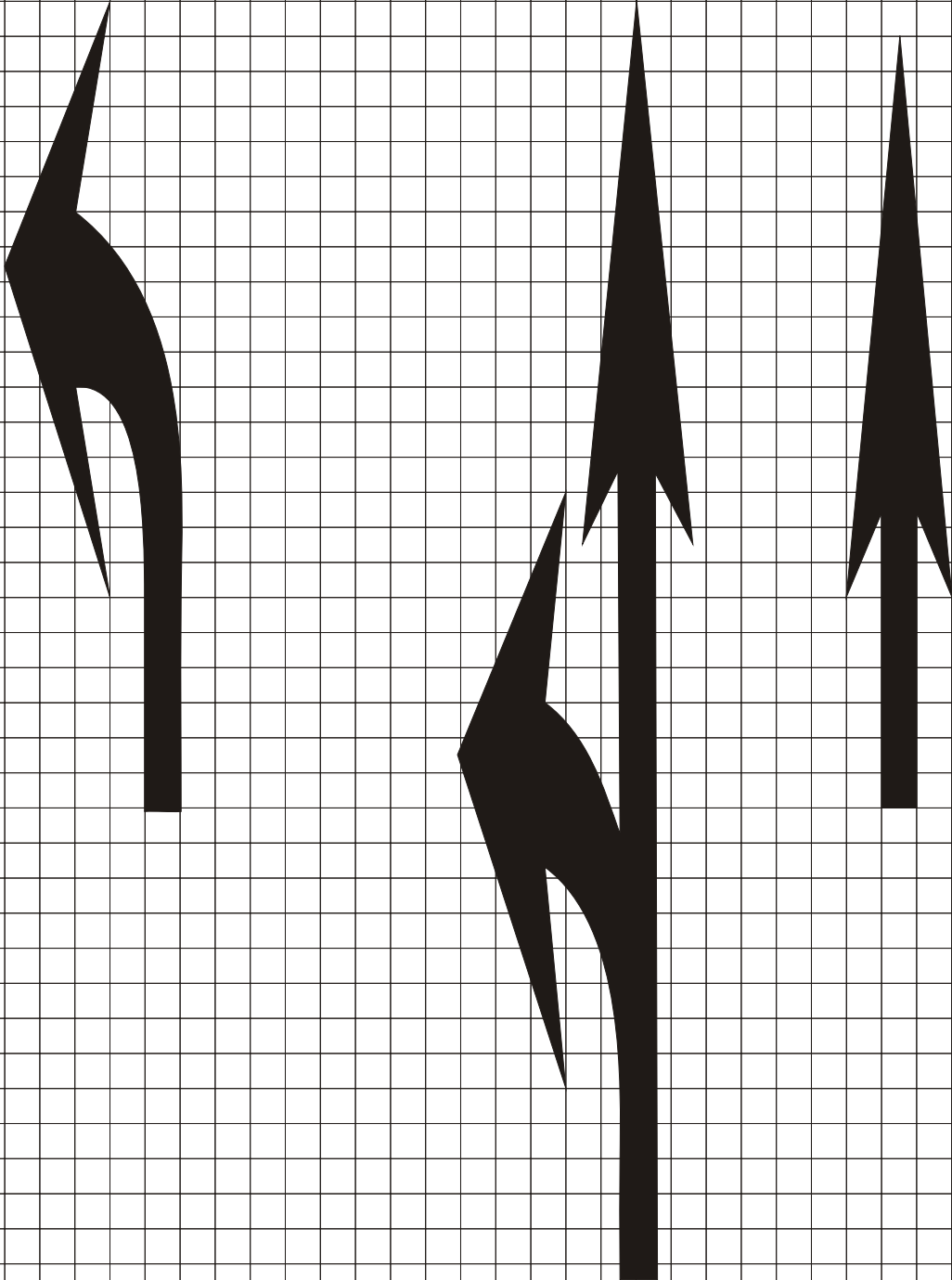

Freeway, Expressway and Ramp Pavement Arrow

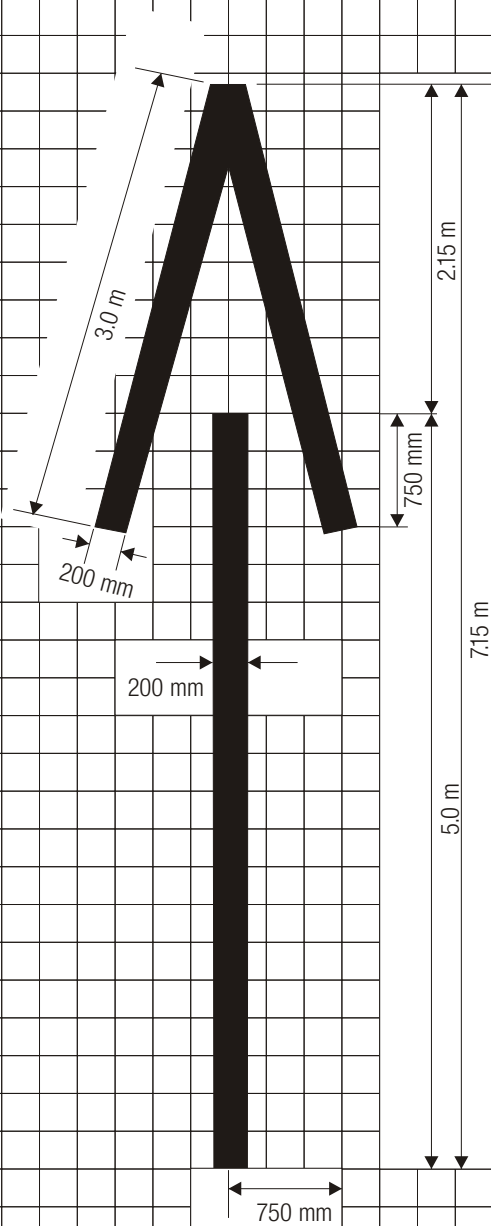

Preferential Lane Symbol

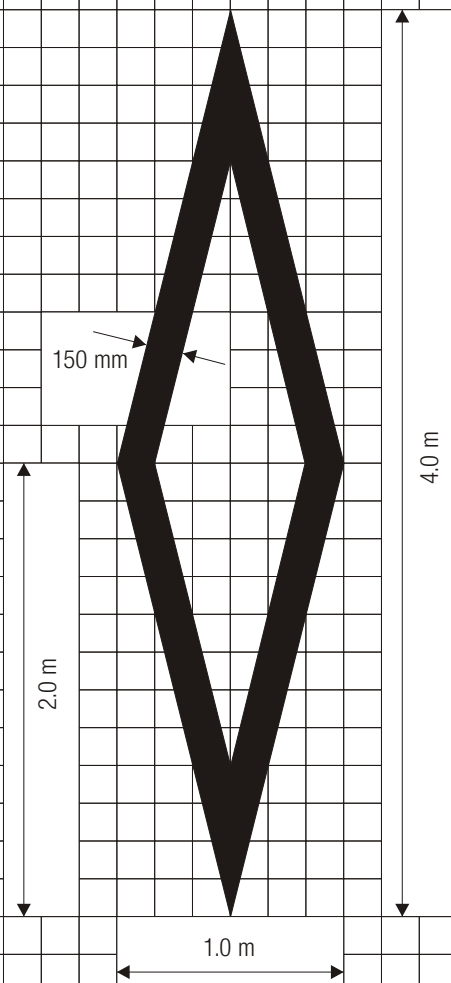

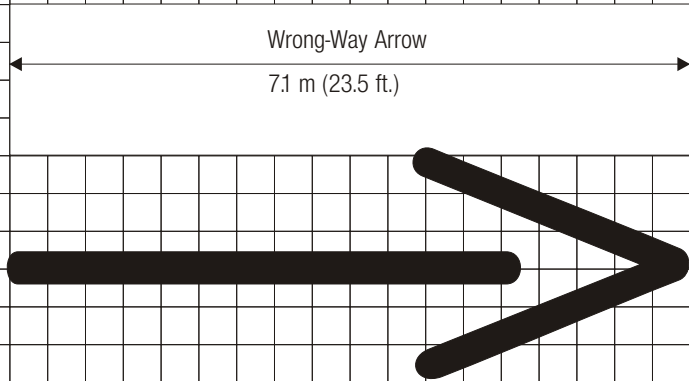

Wrong-Way Arrow Using Retroreflective Raised Pavement Markers

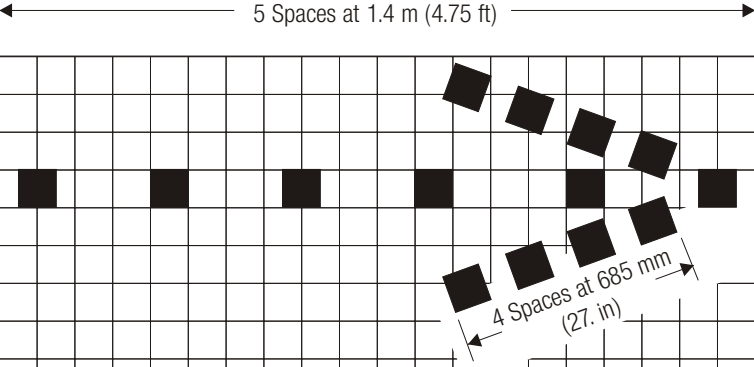

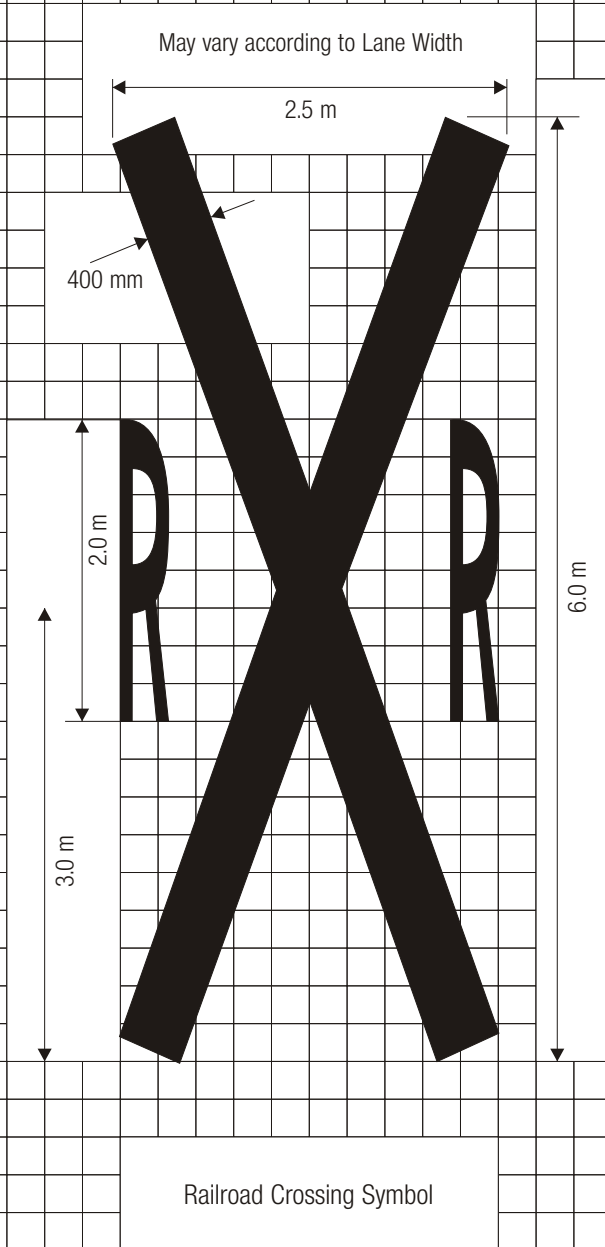

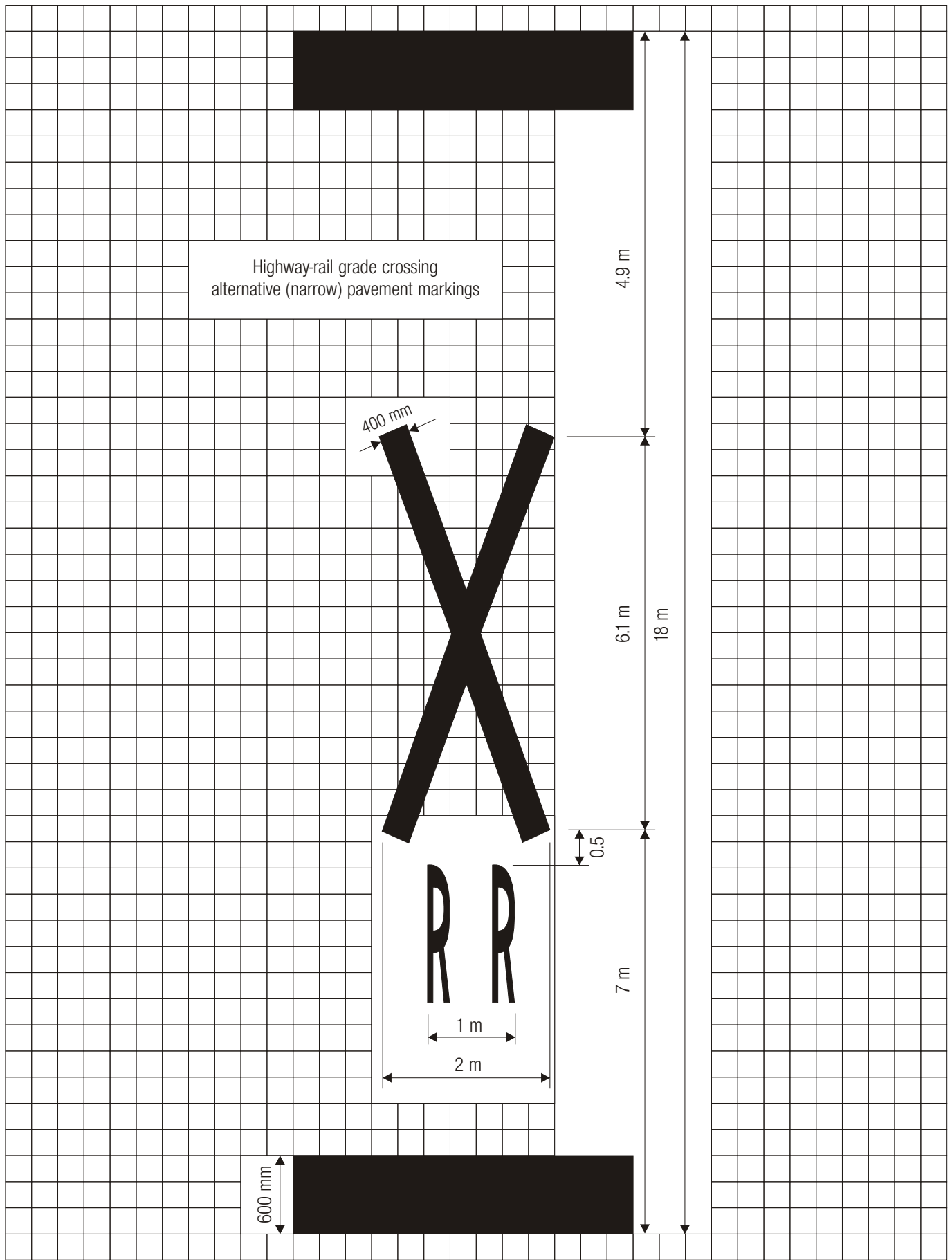

Bicycle Symbols

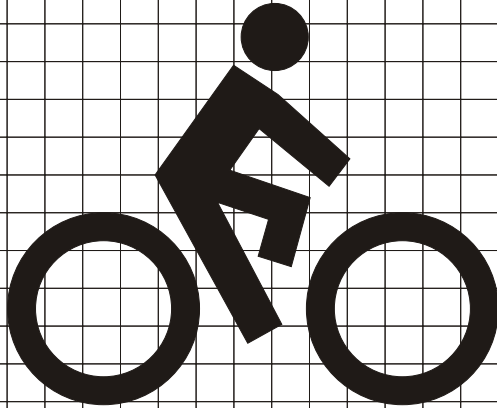

Bicycle Trail

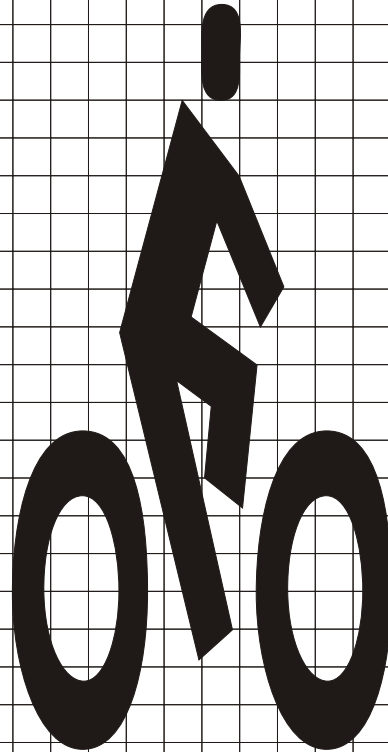

Designated Bicycle Lane

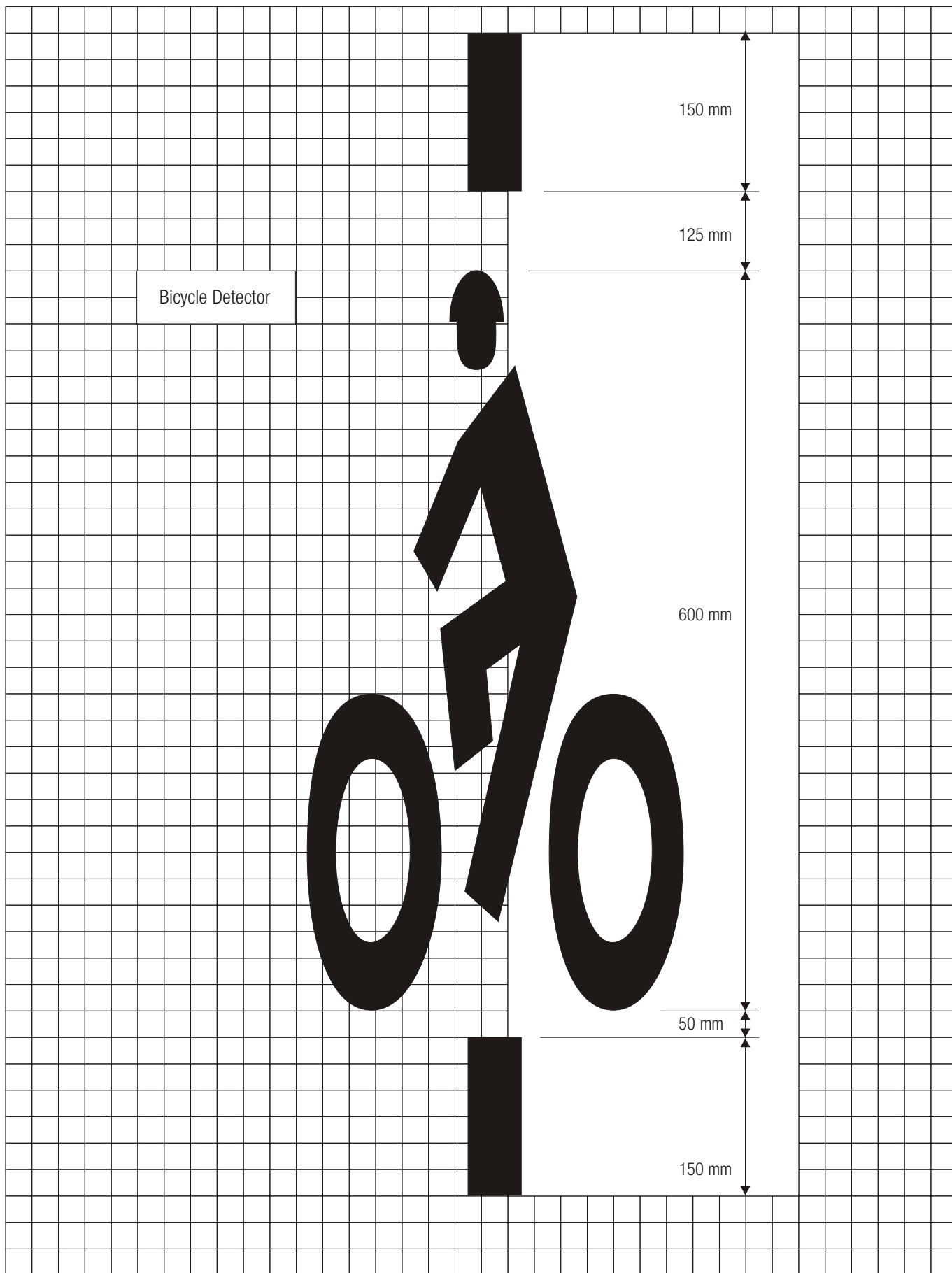

SCHOOL

3,480 mm

3,000 mm

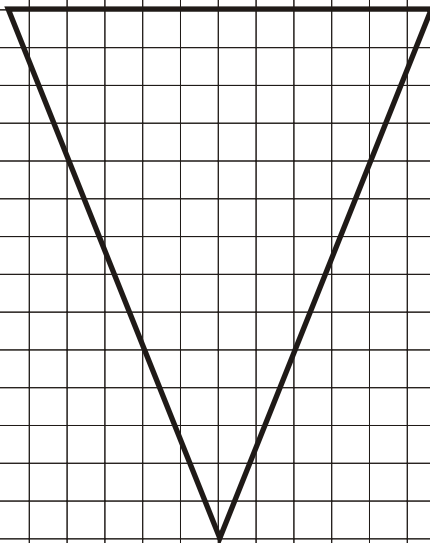
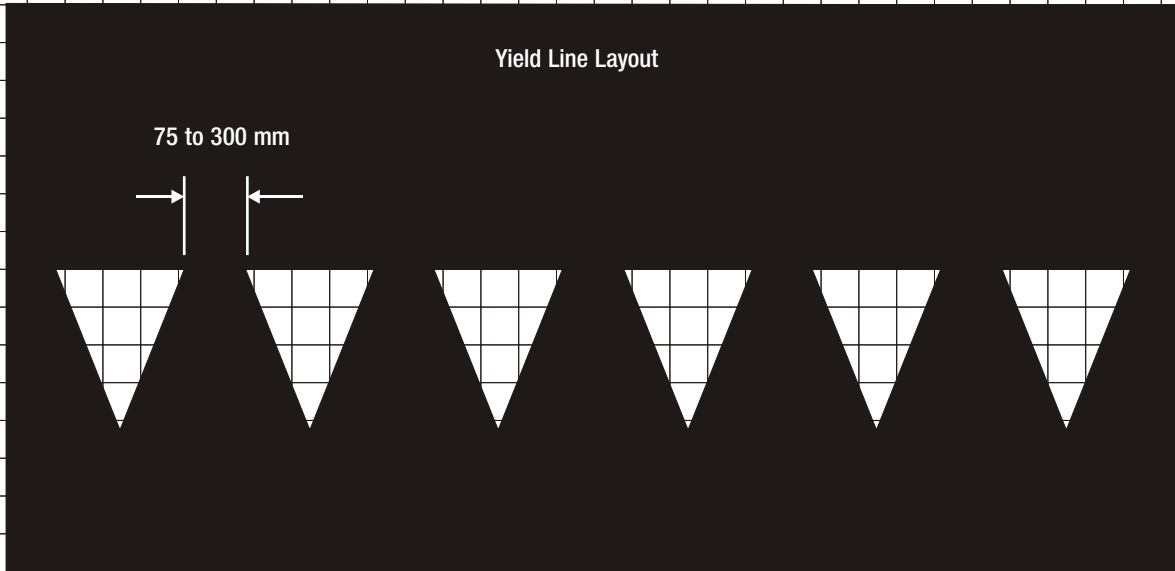

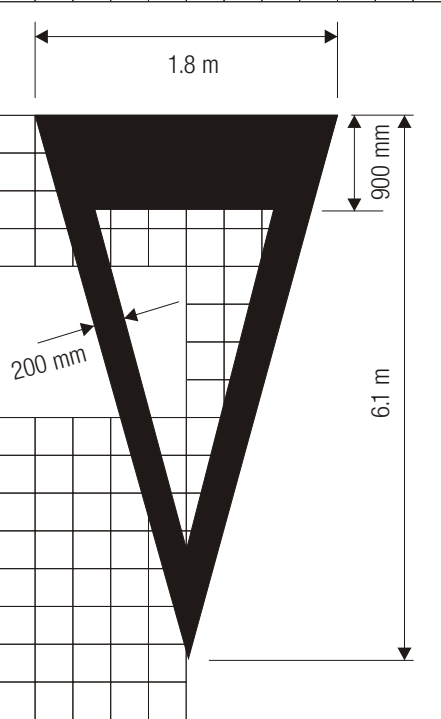

Yield Ahead Triangle

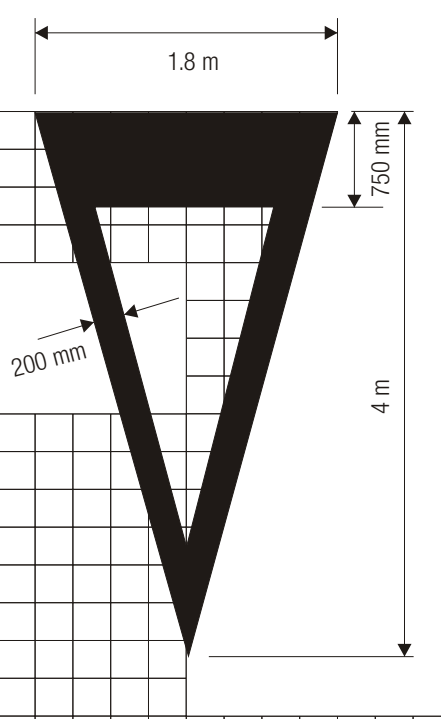

Speed Hump Markings

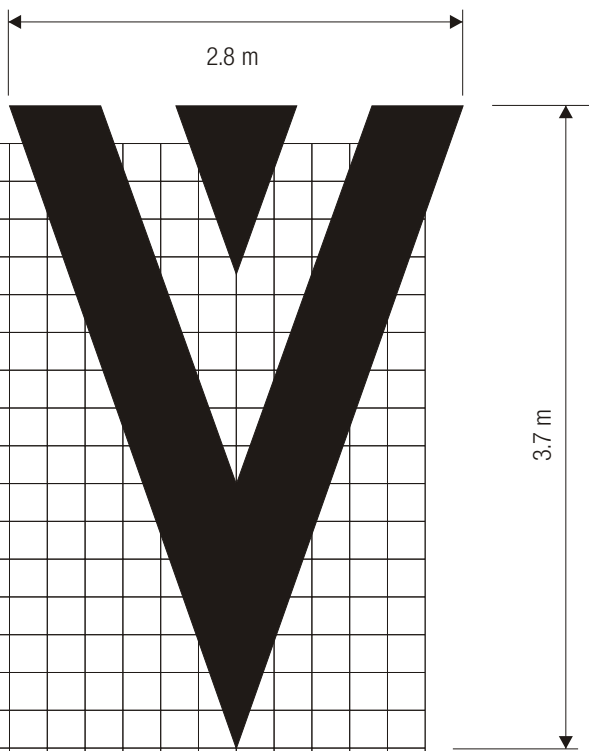
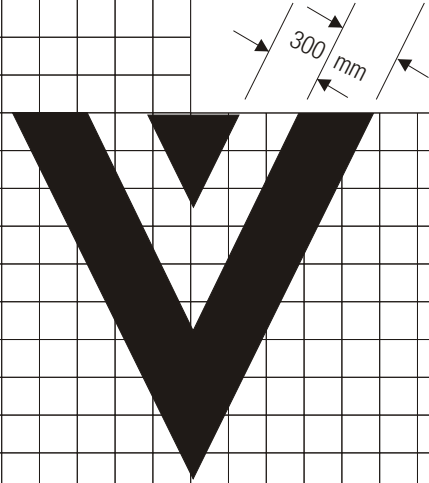
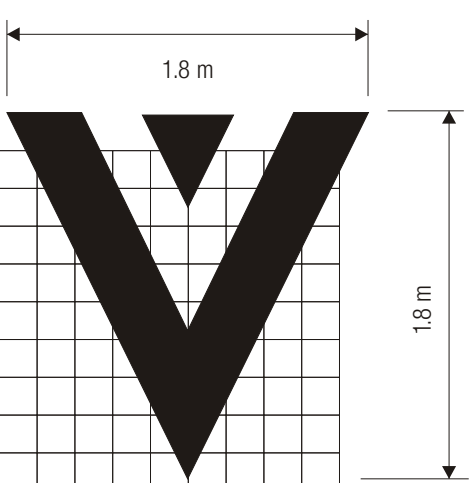

International Symbol of Accessibility Parking Space Marking
with Blue Background and White Border Options

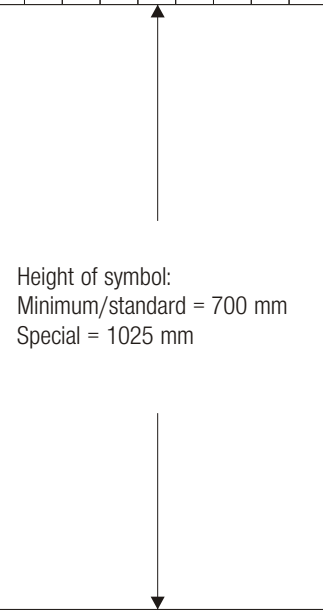

Height of symbol:
Minimum/standard = 700 mm
Special = 1025 mm



Width of symbol:
Minimum/standard = 600 mm
Special = 900 mm

*Stroke width:
Minimum/standard = 75 mm
Special = 100 mm

