

THE CRESCENT EVALUATION

APPENDIX A: ON-SITE ANALYSIS OF HELP TECHNOLOGIES AND OPERATIONS, EVALUATION REPORT

NOTE TO READER:

THIS IS A LARGE DOCUMENT

Due to its large size, this document has been segmented into multiple files. All files separate from this main document file are accessible from links ([blue type](#)) in the [table of contents](#) or the body of the document.

Appendix A:
On-Site Analysis of HELP
Technologies and Operations

Evaluation Report

by

Castle Rock Consultants

February 1994

CONTENTS

	<u>Page</u>
1. CONTENT OF THE REPORT	1-1
2. STATE PROFILES	2-1
2.1 OVERVIEW	2-1
2.2 WASHINGTON	2-2
2.3 OREGON	2-3
2.4 CALIFORNIA	2-7
2.5 ARIZONA	2-11
2.6 NEW MEXICO	2-15
2.7 TEXAS	2-17
3. EVALUATION APPROACH	3-1
3.1 OVERVIEW	3-1
3.2 WEIGHSTATION SITES	3-2
3.3 MAINLINE SITES	3-11
4. DATA ANALYSIS	4-1
4.1 OVERVIEW	4-1
4.2 EQUIPMENT ANALYSIS	4-1
4.3 OPERATIONAL ANALYSIS	4-12
5. EVALUATION RESULTS	5-1
5.1 INTRODUCTION	5-1
5.2 EQUIPMENT ANALYSIS	5-1
5.3 OPERATIONAL ANALYSIS	5-22
5.4 ON-SITE PERSONNEL INTERVIEWS	5-37
6. AVI EVALUATION	6-1
6.1 INTRODUCTION	6-1
6.2 AVI TESTS AND RESULTS	6-2
6.3 CONCLUSIONS	6-12

CONTENTS (continued)

	Page
7. COST-BENEFIT ANALYSIS	7-1
7.1 OVERVIEW	7-1
7.2 UNIT COSTS	7-2
8. CONCLUSIONS AND RECOMMENDATIONS	8-1
8.1 CONCLUSIONS	8-1
8.2 RECOMMENDATIONS	8-3
REFERENCES	
ANNEX A. STATISTICAL TESTS	A-1
ANNEX B. EVALUATION RESULTS	B-1

LIST OF FIGURES

	Page
2-1 Bow Hill: Location and Layout	2-4
2-2 Woodburn: Location and Layout	2-6
2-3 Ashland: Location and Layout	2-8
2-4 Santa Nella: Location and Layout	2-10
2-5 Banning: Location and Layout	2-12
2-6 San Simon: Location and Layout	2-14
2-7 Lordsburg: Location and Layout	2-16
6-1 Lateral Position Numbering System	6-3
6-2 Saline Solution Trough Used June 27, 1991	6-9
6-3 Saline Solution Trough Used October 1991	6-11
6-4 Tag Read Distances at Belt Heights for Santa Nella Site	6-14

LIST OF TABLES

		<u>Page</u>
4-1	HELP Specification Accuracies for WIM Equipment	4-4
4-2	IRD Bending Plate WIM Specification Accuracies	4-5
4-3	PAT DAW200 Specification Functional Requirements	4-6
5-1	Observed WIM Accuracies for Axle Weights	5-3
5-2	Observed WIM Accuracies for Vehicle Weights	5-4
5-3	Average WIM Accuracies	5-5
5-4	Specification WIM Accuracies at Weighstations	5-7
5-5	Specification WIM Accuracies at Mainline Sites	5-7
5-6	Accuracies for Comparison to the HELP WIM Specification	5-8
5-7	Percentage Proportions of Overweight Trucks	5-13
5-8	Effects of Different Screening Weight Limits	5-14
5-9	Weight Screening Analysis for Woodburn May 20, 1993	5-15
5-10	AVC Classification Accuracy	5-16
5-11	Screened Classification Accuracies	5-18
5-12	Screened Modified Classification Accuracies	5-19
5-13	Wheelbase Measurement Accuracy	5-20
5-14	Axle Spacing Accuracy	5-20
5-15	Accuracies Compared to the IRD Specification	5-22
5-16	Truck Volumes Through Sites	5-23
5-17	Truck Proportions Using Local System Routes	
5-18	Proportion of Trucks Statically Weighed	5-24 5-26
5-19	Truck Transit Times Through Sites	
5-20	Average Time Delays to Legally-Laden Trucks	5-28 5-29
5-21	Queues at Weighstations	5-30
5-22	Average Delay Times with AVI Bypass Usage	5-31
5-23	Proportion of Trucks Inspected	5-34
5-24	Proportion of Trucks Cited	5-37

LIST OF TABLES (continued)

	Page	
6-1	Placement Test Results	6-4
6-2	Speed Test Results	6-4
6-3	Multi-Lane Test Results	6-5
6-4	Multi-Tag Test Results	6-6
6-5	External Interference Test Results	6-7
6-6	Environmental Test Results	6-10
6-7	Additional Environmental Test Results	6-12
7-1	Equipment Unit Costs	7-3
7-2	Components of Regional Computer System	7-5
7-3	Components of State Computer System	7-10
7-4	Estimated Cost of Manual Data Collection	7-17
7-5	Estimated Yearly Costs of Hazardous Material Accidents	7-20
7-6	Estimated Value of Reduced Hazardous Material Accident Costs Over a 20-Year Period	7-21
7-7	Estimated Value of Reduced Tax Evasion Over a 20-Year Period (low case)	7-23
7-8	Estimated Value of Reduced Tax Evasion Over a 20-Year Period (medium case)	7-24
7-9	Estimated Value of Reduced Tax Evasion Over a 20-Year Period (high case)	7-25
7-10	Estimated Savings from Reduced Road Damage Over a 20-Year Period (low case)	7-27
7-11	Estimated Savings from Reduced Road Damage Over a 20-Year Period (medium case)	7-27
7-12	Estimated Savings from Reduced Road Damage Over a 20-Year Period (high case)	7-29
7-13	Estimated Reduced Weighstation Operating Costs (low case)	7-31
7-14	Estimated Reduced Weighstation Operating Costs (medium case)	7-32
7-15	Estimated Reduced Weighstation Operating Costs (high case)	7-33
7-16	Average Savings Due to Automated Credentials Checking (low case)	7-35

LIST OF TABLES (continued)

	Page
7-17 Average Savings Due to Automated Credentials Checking (medium case)	7-36
7-18 Average Savings Due to Automated Credentials Checking (high case)	7-37
7-19 Washington State Highway Accidents Involving Trucks Over 10K with Defects	7-39
7-20 Savings Due to Automated Safety Inspection Schedules (low case)	7-41
7-21 Savings Due to Automated Safety Inspection Schedules (medium case)	7-42
7-22 Savings Due to Automated Safety Inspection Schedules (high case)	7-43
7-23 Average Weighstation Transit Delay Time for Statically Weighed Vehicles	7-45
7-24 Estimated Savings from Mainline Bypass	7-46
7-25 Estimated Savings from In-Station Bypass	7-47
7-26 Estimated Value of Fleet Management	7-50
7-27 Benefits and Costs of a Type I Configuration	7-53
7-28 Benefits and Costs of a Type II Configuration	7-54
7-29 Benefits and Costs of a Type III Configuration	7-56
7-30 Benefits and Costs of a Type IV Configuration	7-57
7-31 Benefits and Costs of a Type V Configuration	7-59
7-32 Benefits and Costs of a Type VI Configuration	7-60
7-33 Benefits and Costs of a Type VII Configuration	7-61
7-34 Benefits and Costs of a Type VIII Configuration	7-63
7-35 Benefits and Costs of a Type IX Configuration	7-64
7-36 Benefits and Costs of a Type X Configuration	7-66
7-37 Benefits and Costs of a Type XI Configuration	7-67

Forward

The Crescent Project element of the HELP Program is a bi-national multi-jurisdictional cooperative research and demonstration initiative involving the public and private sectors in an application of advanced technologies for the creation of an integrated heavy vehicle management system. This initiative is a leading example of the commercial vehicle operations (CVO) aspect of the Intelligent Vehicle Highway Systems (IVHS) concept. Some of the advanced technologies demonstrated in this project include: (1) automatic vehicle identification (AVI); (2) weigh-in-motion (WIM); (3) automatic vehicle classification (AVC); and (4) data communications networks and systems integration.

The HELP program, initiated in the early 1980s, consisted of three phases which included assessing the feasibility of the concept, technical studies involving laboratory and field tests, and lastly, a demonstration phase. Perhaps the most significant activity of this project centered on the subject of institutional arrangements, associated with the integration of emerging technologies with current operational policies and practices, within both government and industry sectors.

The demonstration element of the program, referred to as the Crescent Demonstration Project, began in 1991 and involved six U.S. states and one Canadian province. This project was phased into full scale operation over a three year period.

This document is one of several cited below which comprise the evaluation of the Crescent Project. The complete evaluation is reported in the following list of documents:

The Crescent Project: An Evaluation of an Element of the HELP Program: Executive Summary

Appendices:

- A. On-Site Analysis of HELP Technologies and Operations Evaluation Report***
- B. State Case Study Evaluation Report***
- c. Motor Carrier Case Study Evaluation Report***
- D. Crescent Computer System Components Evaluation Report***
- E. Crescent Demonstration Office Evaluation Report***
- F. State Line Beacon Project User Case Studies***

The Evaluation team consisted of the following groups:

WHM Transportation Engineering Consultants, Inc. (lead group)

Castle Rock Consultants

Western Highway Institute, ATA Foundation

In addition, the evaluation team was supported in this effort by:

Lockheed Information Management Systems

Booz-Allen & Hamilton Inc.

The team members wish to acknowledge the participation and support of the many individuals and organizations who provided guidance, assistance and encouragement during the evaluation process. While the team members are solely responsible for the content accuracy of these evaluation documents, the process would have been greatly impaired without the recognition of the importance of this effort by all who contributed and their desire to promote efficiency and productivity in future freight systems. To all we are greatly appreciative and indebted.

C. Michael Walton

Chairman, Evaluation Team

DISCLAIMER

The contents of this report reflect the views of Castle Rock Consultants, who are responsible for the facts and the accuracy of the data presented herein. The contents do not necessarily reflect the official views or policies of the State of Arizona or the Federal Highway Administration. This report does not constitute a standard, specification, or regulation. The United States Government and the State of Arizona do not endorse products or manufacturers. Trade or manufacturers' names which may appear herein are cited only because they are considered essential to the objective of this report.

ACKNOWLEDGEMENTS

This report has been prepared in cooperation with the U.S. Department of Transportation, Federal Highway Administration.

Castle Rock Consultants also wishes to acknowledge the support of the other Crescent Evaluation Team members: WHM Transportation Engineering Consultants; the Western Highway Institute; and Booz-Allen and Hamilton, Inc. In particular, we are grateful for the leadership provided by Dr. C. Michael Walton. CRC also acknowledges the input of the HELP program's Evaluation Committee under the co-chairmanship of Mr. Walt Keeney and Mr. Alvin Luedecke. Finally, CRC wishes to thank the personnel in each of the Crescent states who supported the field data collection activities. Without these dedicated individuals it would have been impossible to complete this study.

1. CONTENT OF THE REPORT

This report describes the data collection procedures, the data analysis methods, and the results gained from the on-site evaluations. The content of the report is as follows:

Chapter 2 - State Profiles. This chapter includes descriptions of the organizational structure of personnel at each of the test sites, the site layouts, the Crescent equipment configurations, and the operational procedures used. These procedures and configurations are key to the emphasis of this evaluation and the potential applications of the system.

Chapter 3 - Evaluation Approach. The approaches used for the on-site operational and equipment analyses are described for each site. These descriptions include the general methodology that was employed for weighstation and mainline sites, together with site-specific variations that affected these general procedures.

Chapter 4 - Data Analysis Approach. The approaches used in the analysis of the on-site evaluation data are described. These descriptions cover all aspects of the on-site evaluation including equipment accuracy assessments and operational analysis at weighstations.

Chapter 5 - Evaluation Results. The results gained from the on-site evaluations are presented in this chapter. The description includes the significance of the results and highlights other factors of interest. The results are presented in three sections covering the equipment accuracy assessments, the operational analysis and the interviews undertaken with on-site personnel.

Chapter 6 - AVI Testing. As explained in Chapter 3, a limited scope of testing of the AVI equipment was possible within the on-site evaluation. This was primarily due to the limited number of AVI-equipped vehicles and observational difficulties. Chapter 6 presents results from acceptance testing that was undertaken outside the Crescent Evaluation project. These results reflect the operational accuracies that are achieved by the AVI equipment used within the Crescent system.

Chapter 7 - Cost-Benefit Analysis Model. A cost-benefit analysis framework has been developed and is utilized to determine the potential costs and benefits available from the Crescent system. Sensitivity analyses have been performed on a number of key factors within the cost-benefit model. This chapter describes the model and the assumptions used.

Chapter 8 - Conclusions and Recommendations. The conclusions drawn from both the on-site evaluation and the cost-benefit analysis model are presented in this chapter. From these conclusions and incorporating the findings of the other Crescent Evaluation studies, a series of recommendations have been developed. These are also presented in Chapter 8.

To complement the main report there are two annexes, Annex A describes the statistical tests that have been undertaken. Annex B presents more detailed results from the on-site evaluation. These have been summarized in Chapter 5, and include observed equipment accuracies for AVC, WIM and automatic axle spacing measurement equipment, and the operational **analysis** that was performed.

2. STATE PROFILES

2.1 OVERVIEW

The Crescent Demonstration has integrated the HELP technologies into weighstation and mainline highway sites in six U.S. states and the Canadian province of British Columbia. However, at each of the weighstations the operational procedures and site configurations vary. This chapter describes the operations and site configurations for those Crescent sites visited during the on-site testing. This on-site testing included six mainline sites and seven weighstations. The mainline sites were:

- * Kelso, Washington;
- * Jefferson, Oregon;
- * Ashland, Oregon;
- * Bakersfield, California;
- * South Phoenix (Tempe), Arizona; and
- * Seguin, Texas.

. The weighstation sites were:

- * Bow Hill, Washington;
- * Woodburn, Oregon;
- * Ashland, Oregon;
- * Santa Nella, California;
- * Banning, California;
- * San Simon, Arizona; and
- * Lordsburg, New Mexico.

The mainline site installations are located at strategic points on the highway. Mainline weigh-in-motion (WIM) and automatic vehicle classification (AVC) equipment provides state agencies with classified traffic counts, vehicle speeds and vehicle weights. These data are currently used for highway and transportation planning.

The mainline automatic vehicle identification (AVI) equipment identifies vehicles equipped with transponders. These data can be used by carriers to track individual vehicles and generate reports on fleet movements. As more sites are brought into the Crescent system, the AVI network potentially enables more efficient tracking, including hazardous material shipment movements. In addition, the AVI network could improve the efficiency of collecting or auditing vehicle-mile taxes.

Weighstation applications for the Crescent system vary greatly depending upon the configuration of the equipment. Weighstations equipped with only AVI equipment, without WIM, can use the system to preclear vehicles on permit checks, tax collection or safety inspections. The AVI, in conjunction with the WIM and AVC, can preclear, screen and bypass vehicles from weight enforcement, as well as performing other weighstation operations.

In the Crescent Evaluation, several site and equipment configurations were tested. The Crescent on-site evaluation examined the utility of each of these site configurations. This chapter outlines the characteristics of each site. The physical parameters of each site, as well as the operational activities at each weighstation site, are discussed in detail. These sites are described by state. An illustration for each of the weighstation sites visited during the on-site evaluation displays the site configuration and position of the Crescent equipment installed.

Additionally, for each of the Crescent states, a brief overview of the organizational structure of states authorities in relation to the weighstations and mainline sites is provided. A more complete survey of the organizational structure for each state may be found in the State Case Study Evaluation Report.

2.2 WASHINGTON

Organizational Structure The State of Washington has provided one weighstation and four mainline sites for the Crescent Demonstration. As part of the Crescent Evaluation, two sites were reviewed, the Bow Hill weighstation and the mainline installation near the City of Kelso.

Weighstations throughout the state are operated by the Washington State Patrol (WSP) Commercial Vehicle Division and supported by the Washington Utilities and Transportation Commission (WUTC). Mainline installations are under the authority of the Washington Department of Transportation's (WSDOT) Planning Division.

WSP is the lead agency at weighstation sites, and is responsible for the enforcement of size and weight regulations, insurance checks, and the performance of Commercial Vehicle Safety Alliance (CVSA) safety inspections. The WUTC issues cab cards, trip permits, CVSA decals and correction notices to vehicles. The WSDOT Planning Division maintains and operates all mainline installations. WSDOT uses the gathered data for highway and transportation planning needs.

Bow Hill

Site Configuration The Bow Hill weighstation is located along Interstate Highway I-5 between Mount Vernon and the Washington-Canada border. The weighstation operates 24-hours-a-day, 7-days-per-week and under normal conditions is staffed by four representatives from the agencies stated above. The site is equipped with IRD WIM/AVC and Mark IV AVI equipment, which has been installed in the weighstation entrance ramp. The current site configuration is illustrated in Figure 2-1.

The weighstation has a single entrance ramp that separates into two static scale lanes. The two lanes merge beyond the scale house for re-entry to the interstate. A recirculation lane is provided to permit access to the two inspection stations. In addition, an in-station bypass lane has been proposed for the site.

Operational Procedures Current operational procedures require all trucks to enter the weighstation, cross the WIM installation and proceed to the static scales. Vehicles are weighed on the static scales using a rollover weighing. Overweight trucks are statically reweighed for enforcement. Trucks are randomly selected for inspection based upon the availability of an inspection station.

The operational procedures for the proposed bypass lane would allow vehicles satisfying the screening criteria to be directed to the bypass lane. It is anticipated that some of the bypassed vehicles will be randomly selected for static weighing and inspection. The screening criteria have not yet been identified for bypass procedures.

Kelso

Site Configuration The Kelso site is located on I-5 near the City of Longview. The site is a mainline installation with partial lane coverage. I-5 is a six-lane divided highway at this Crescent installation. The two outside lanes of both the northbound and southbound roadway are equipped with IRD WIM/AVC and Mark IV AVI. The installation is located approximately 200 feet north of the Kelso weighstation. The deployed Crescent equipment is currently not being used by the weighstation for weight screening. The data gathered from the site are being stored in the WSDOT database for future use.

2.3 OREGON

Organizational Structure The Weighmaster Unit of the Oregon Department of Transportation (ODOT) is responsible for the installation and maintenance of Crescent sites in Oregon. The State of Oregon has six sites in the Crescent Demonstration, of which four are included in the evaluation study.

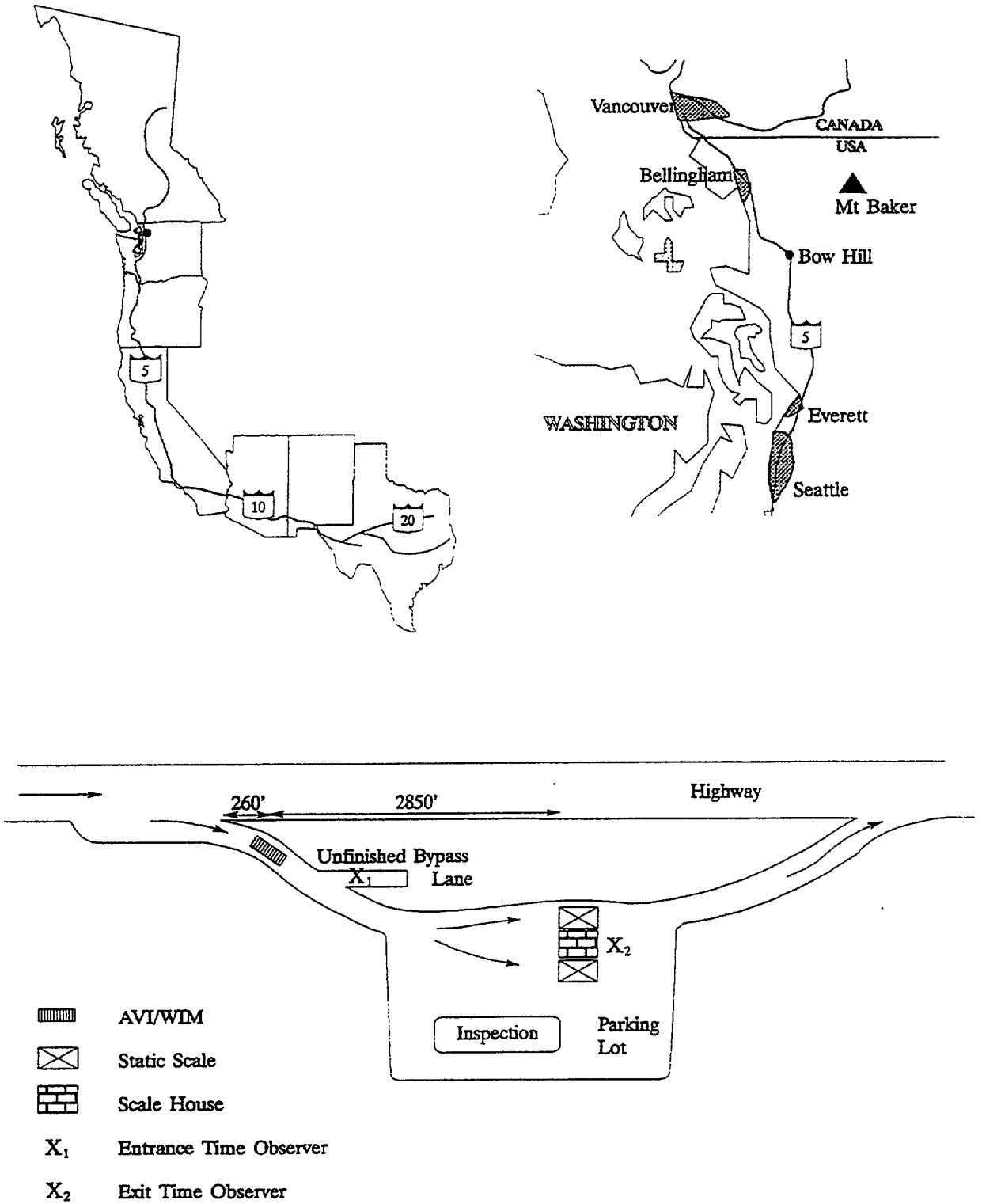

Figure 2-1. Bow Hill: Location and Layout

Weighstation operations are administered by the ODOT Weighmaster Unit, which enforces weight and size regulations and conduct safety inspections. Weighstation operations are supported by the Oregon Public Utility Commission (PUC) and the Oregon State Police (OSP). The PUC collects permit fees, taxes and applicable penalties, and issues plates and permits to vehicles and operators. The OSP provides enforcement assistance when necessary. All data gathered from mainline installations are managed by the Transportation Development Division of ODOT for use in highway and transportation planning.

Woodburn

Site Configuration The Woodburn facility is a port-of-entry weighstation located on I-5 between the Cities of Salem and Portland. The weighstation has a normal operating staff of three officers and one supervisor. Two additional officers are on duty when inspections are scheduled. The weighstation operates 24-hours-a-day, 7-days-per-week. The Woodburn site has a single lane entrance where IRD WIM/AVC equipment and a Mark IV AVI system are installed approximately 200 feet from the entrance threshold. The entrance lane separates into a bypass lane and a pair of static scale lanes. A signal system, installed along the entrance ramp, directs the vehicles to the appropriate lane. A schematic diagram of the site configuration is shown in Figure 2-2.

Operational Procedures Current procedures at the site call for weight screening and in-station bypassing of the static scales. All vehicles are required to enter the weighstation and are screened by the WIM positioned in the entrance ramp. Trucks meeting the weight threshold criteria are directed to the bypass lane. Random trucks are selected from the bypass lane and directed to the static scale for credential checks or inspections. All vehicles not meeting the weight threshold criteria are directed to the static scale and weighed using rollover weighing. If the rolling weight method indicates that a truck is overweight, the truck is reweighed statically for weight enforcement.

All trucks directed to the static scales have their credentials checked via their PUC number. Vehicles that do not have a PUC plate, except for some agricultural vehicles, are detained until proper permits are obtained from the PUC office. The weighstation has a maximum capacity of 400 trucks per hour and an average daily traffic of 3,500 trucks.

Ashland

Site Configuration The Ashland site is a port-of-entry weighstation positioned on I-5 between the City of Medford and the Oregon-California state line. The facility operates 24-hours-a-day, 7-days-per-week and has a normal operating staff of two officers. The site has a capacity of approximately 300 trucks per hour.

The weighstation is currently not equipped with Crescent equipment. However, a mainline installation is located approximately five miles upstream of the weighstation and Crescent equipment is scheduled to be installed to provide mainline bypass. Once the installation is complete, trucks equipped with the Mark IV type 3 transponder will be bypassed from the weighstation via an in-vehicle display attached to the transponder. Equipped trucks will be

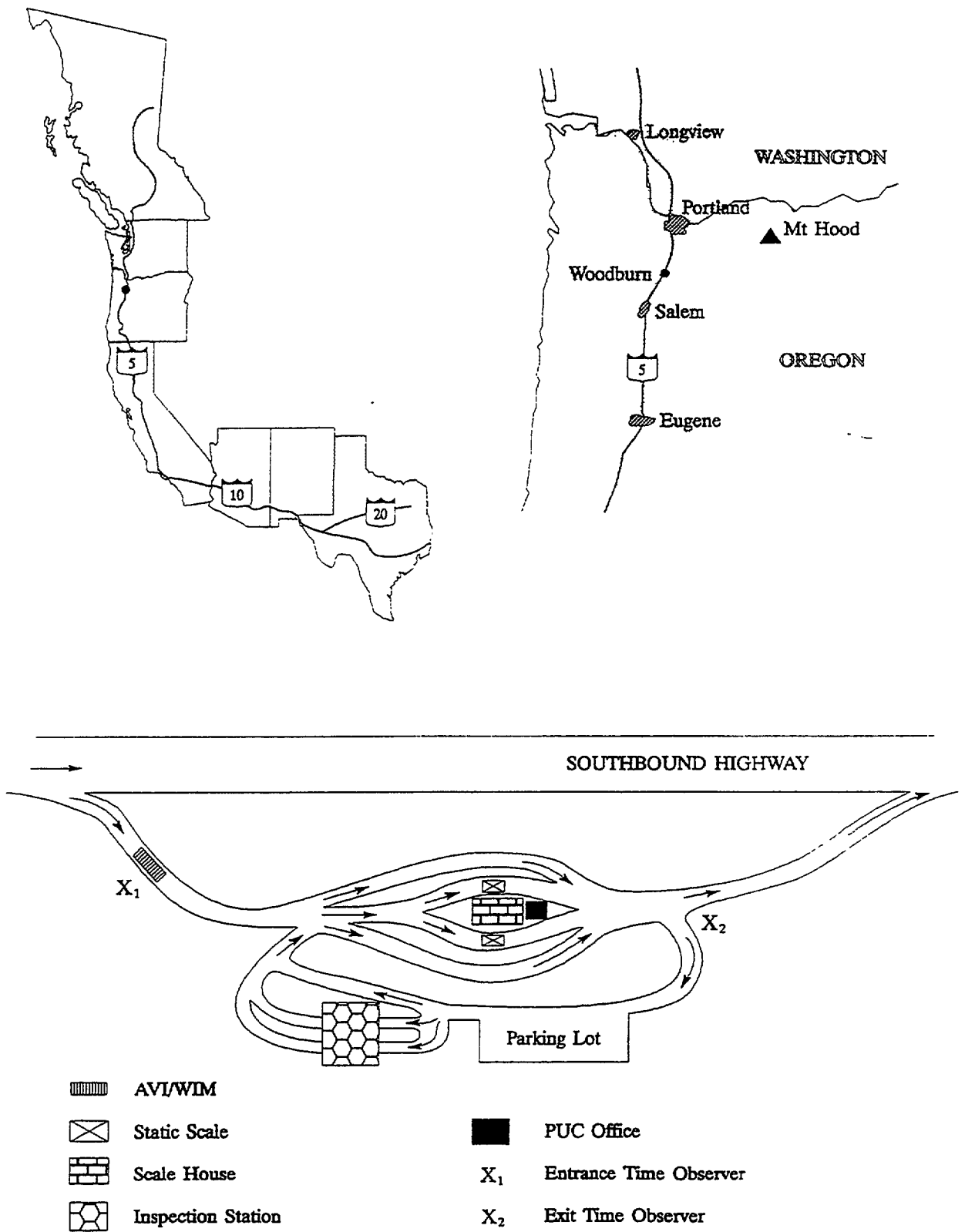

Figure 2-2. Woodburn: Location and Layout

identified from the first AVI communication and the system will conduct a credentials check based on the tag identification. When the truck reaches the second AVI antenna, the truck will be directed to bypass the weighstation or to enter the weighstation for a manual check of credentials or inspection. The driver is notified of the bypass status by a green or red light indicator located on the dashboard of the truck. If a truck bypasses the weighstation without approval, an alarm will sound in the weighstation and a highway patrolman will be dispatched.

The mainline installation is equipped with IRD WIM/AVC and a Mark IV AVI for two-way roadside-to-vehicle communications. The weighstation will be equipped with IRD WIM/AVC and Mark IV AVI system with roadside-to-vehicle communications to enable mainline bypassing. The Ashland weighstation consists of a single lane entrance which separates into two static scale lanes. The static lanes merge approximately 500 feet beyond the scale house for re-entry to the interstate. A recirculation lane is provided for routing trucks to the two safety inspection stations. Figure 2-3 illustrates the Ashland weighstation site configuration.

Operational Procedures. Current operational procedures allow vehicles to enter the weighstation and be prescreened on the static scales using rollover weighing. If a truck is determined to be overweight using the rollover methodology, it is statically reweighed. Credentials are checked by the weighmaster keying the vehicle PUC number into the on-site computer, which accesses state database records for the vehicle. If a truck does not have a PUC license plate, the driver is detained until the appropriate permits are purchased from the PUC. Random inspections are conducted by weighstation officials based on the availability of an inspection stall and date of last inspection.

Proposed site operations will allow for mainline weight screening. AVI-equipped vehicles that are PUC registered will be identified for weighstation bypass if WIM weights are within specified thresholds. Trucks that bypass the weighstation without preclearance will trigger an alarm in the scale house and enforcement personnel will be dispatched.

Jefferson

Site Configuration The Jefferson site is a mainline installation located along I-5 between the Cities of Salem and Corvallis, 28 miles south of the Woodburn weighstation. The installation encompasses both north- and southbound lanes. IRD WIM/AVC and Mark IV AVI are installed on the southbound lanes of the site. IRD piezoelectric WIM/AVC and Mark IV AVI are installed on the northbound lanes of the site.

2.4 CALIFORNIA

Organizational Structure The California Department of Transportation (Caltrans) administers the HELP program statewide and is responsible for installing and maintaining Crescent sites. The State of California has eight sites in the Crescent Demonstration, including two weighstations and six mainline installations. Two weighstation sites and one mainline site were evaluated during the demonstration.

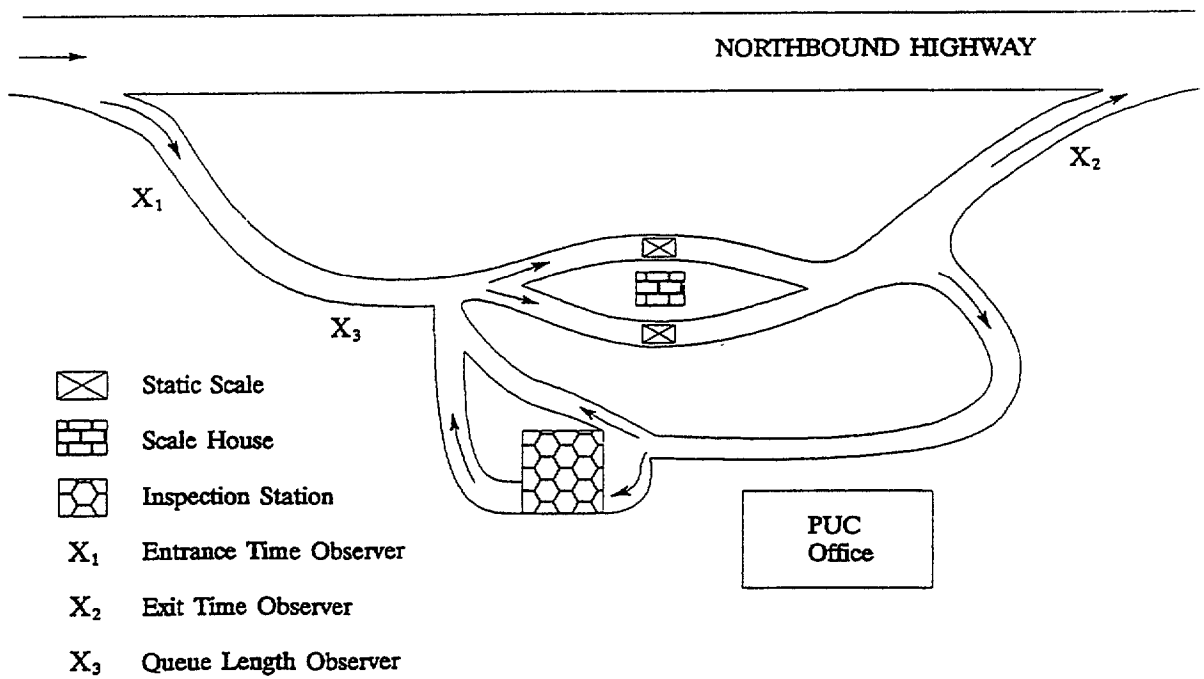
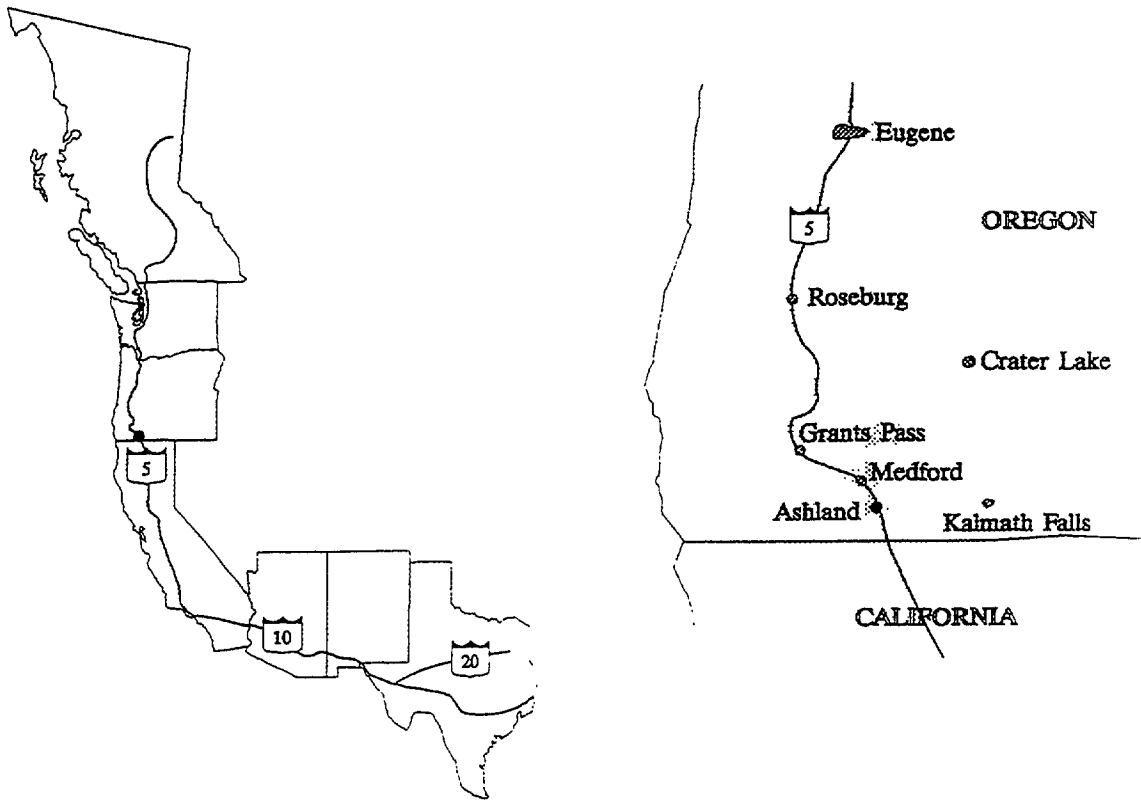

Figure 2-3. Ashland: Location and Layout

Weighstation operations are under the authority of the California Highway Patrol (CHP), whose primary functions are to enforce weight and size regulations, provide safety inspections and enforce safety guidelines issued by the state. Additional regulatory agencies present at some weighstations are the State Board of Equalization (BOE), the PUC, the California Air Resources Board (CARB) and Caltrans.

The BOE is responsible for issuing state permits and registrations, the PUC is responsible for monitoring tax compliance, and Caltrans installs and maintains all WIM and AVC equipment associated with the Crescent Demonstration. CARB conducts emissions test for all vehicles in excess of 8,500 pounds.

Santa Nella

Site Configuration Located along I-5 between Sacramento and Los Banos, the Santa Nella weighstation is designed to provide both mainline bypass and in-station static scale bypass.

The mainline installation is equipped with two PAT bending plate WIM/AVC systems located approximately one-half mile from the weighstation entrance. The mainline installation is also equipped with Mark IV AVI and a Lockheed roadside-to-vehicle communications system that enables two-way communication to equipped vehicles of their bypass status.

The weighstation entrance ramp separates into two lanes. The right lane contains the static scale, while the left lane contains a PAT WIM/AVC and Mark IV AVI system located approximately 100 feet from the scale house. The left lane is a bypass lane which is used for in-station weight screening of trucks at approximately 10 mph. This is effectively high-speed rollover weighing. The two lanes merge about 100 feet beyond the scale house for re-entry to the interstate. A recirculation lane is provided for vehicles that have been screened by the WIM and identified as being potentially overweight. This lane allows access to the static scale from the bypass lane. The Santa Nella weighstation is illustrated in Figure 2-4.

Operational Procedures Trucks equipped with AVI transponders and Lockheed Express receivers are prescreened at the mainline WIM installation. Provided that the AVI-equipped trucks are within weight requirements, the in-vehicle display signals the driver to bypass the weighstation. The vehicle is re-examined by the mainline AVI to verify the truck's bypass status. If a vehicle bypassing the weighstation was not precleared, an alarm is activated in the weighstation scale house and a CHP officer is dispatched for enforcement. This mainline bypass system was not operational at the time of the on-site evaluation studies.

Weighstation procedures at the site for nonequipped vehicles require the trucks to proceed to the WIM-equipped lane in the weighstation for screening purposes. Vehicles identified by the in-station WIM to be within specified weight requirements are permitted to proceed to the interstate. Vehicles identified as being potentially overweight are directed to the recirculation lane for reweighing at the static scale. Vehicles are visually inspected for safety violations by the weighmaster.

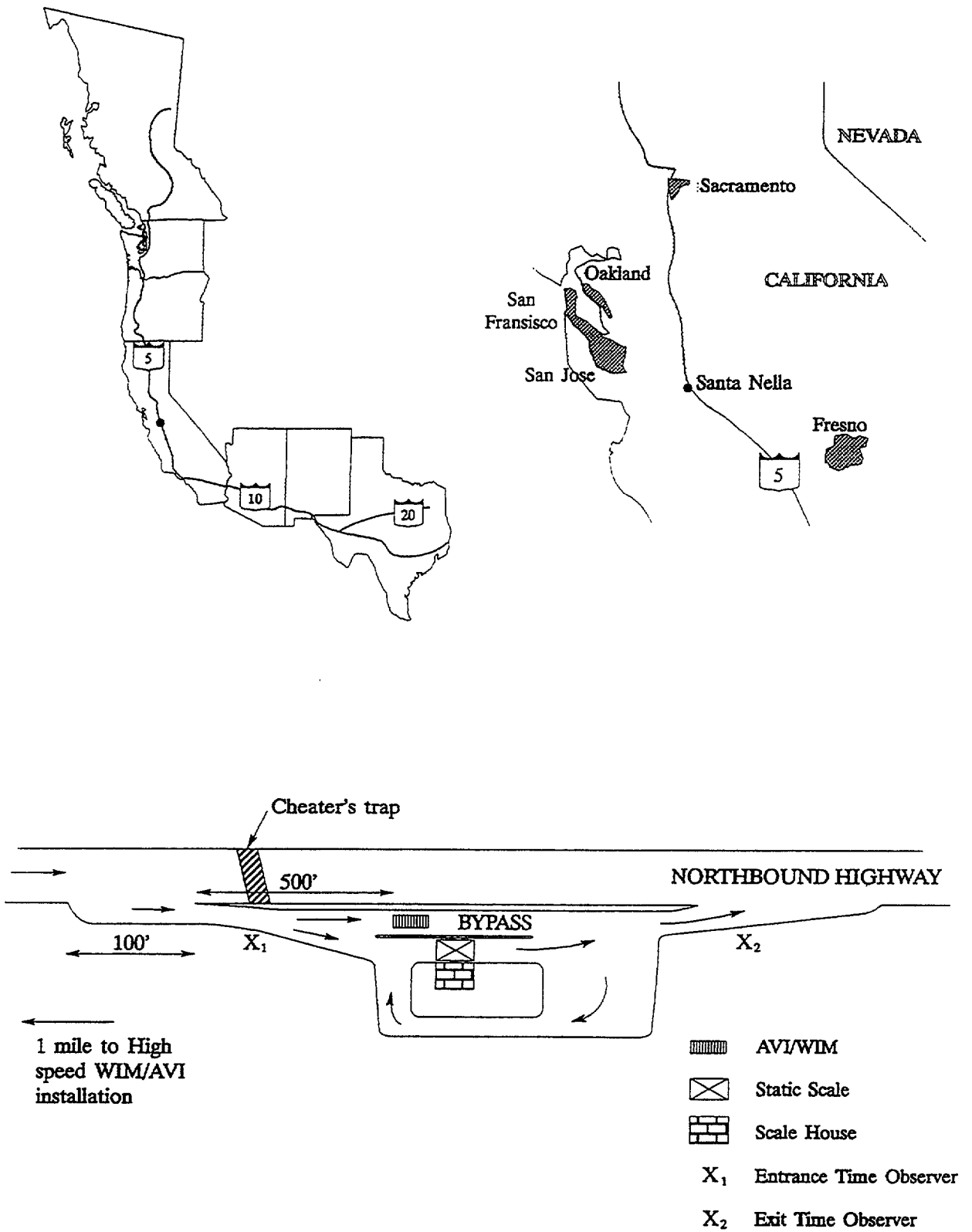

Figure 2-4. Santa Nella: Location and Layout

Banning

Site Configuration In addition to the standard weight screening operations, the Banning weighstation serves as an inspection station and registration office for trucks traveling through California. The site is located along I-10 between San Bernardino and Palm Springs and operates 24-hours-a-day, 6-days-per-week. The station is closed on Saturdays.

The weighstation is staffed by two CHP officers who manage the operations of the station, monitor the static scale and select trucks for safety inspection. Six CHP officers conduct safety inspections. The Banning facility is equipped with a Mark IV AVI system, installed approximately 100 feet from the static scale. This site is configured with a bypass lane for use by vehicles whose weight does not exceed 20,000 pounds and a static lane for other vehicles. The bypass lane is primarily used by unladen trucks. However, trucks are not directed to use the bypass lane and may choose to do so at the driver's discretion. No weighing equipment is installed in the bypass lane. The current large vehicle volume passing through the site has necessitated the use of both lanes for processing purposes and few vehicles using the bypass lane are recalled for static weighing. The site layout is illustrated in Figure 2-5.

Operational Procedures Trucks entering the Banning weighstation may select either the bypass lane or the static scale. Signage indicates that vehicles under 20,000 pounds should use the bypass lane. Carriers are instructed to drive through the station at 5 mph. The scale operator in the weighstation visually inspects trucks for any flagrant violations as they pass the scale house. Trucks passing in the scale lane are weighed using rollover weighing and are stopped and reweighed if weight violations are detected.

Safety inspections are conducted based upon the availability of the inspection stalls, as well as the current status of the vehicle's 90-day inspection sticker. Upon successful completion of the inspection process, a sticker is presented which releases the vehicle from being inspected for three months, unless a violation is observed by the officer at the scale. The weighstation has the capacity to process 125 trucks per hour and has an average daily traffic of approximately 3,500 trucks per day.

Bakersfield

Site Configuration The Bakersfield facility is a mainline installation located on I-5 northeast of Los Angeles. The site is equipped with PAT bending plate WIM/AVC and Mark IV AVI. Data gathered from this site are used to supplement road data used in statewide highway and transportation planning.

2.5 ARIZONA

Organizational Structure The State of Arizona has four Crescent sites: two mainline installations and two weighstation installations. Two sites have been included in the on-site evaluation of the Crescent Demonstration.

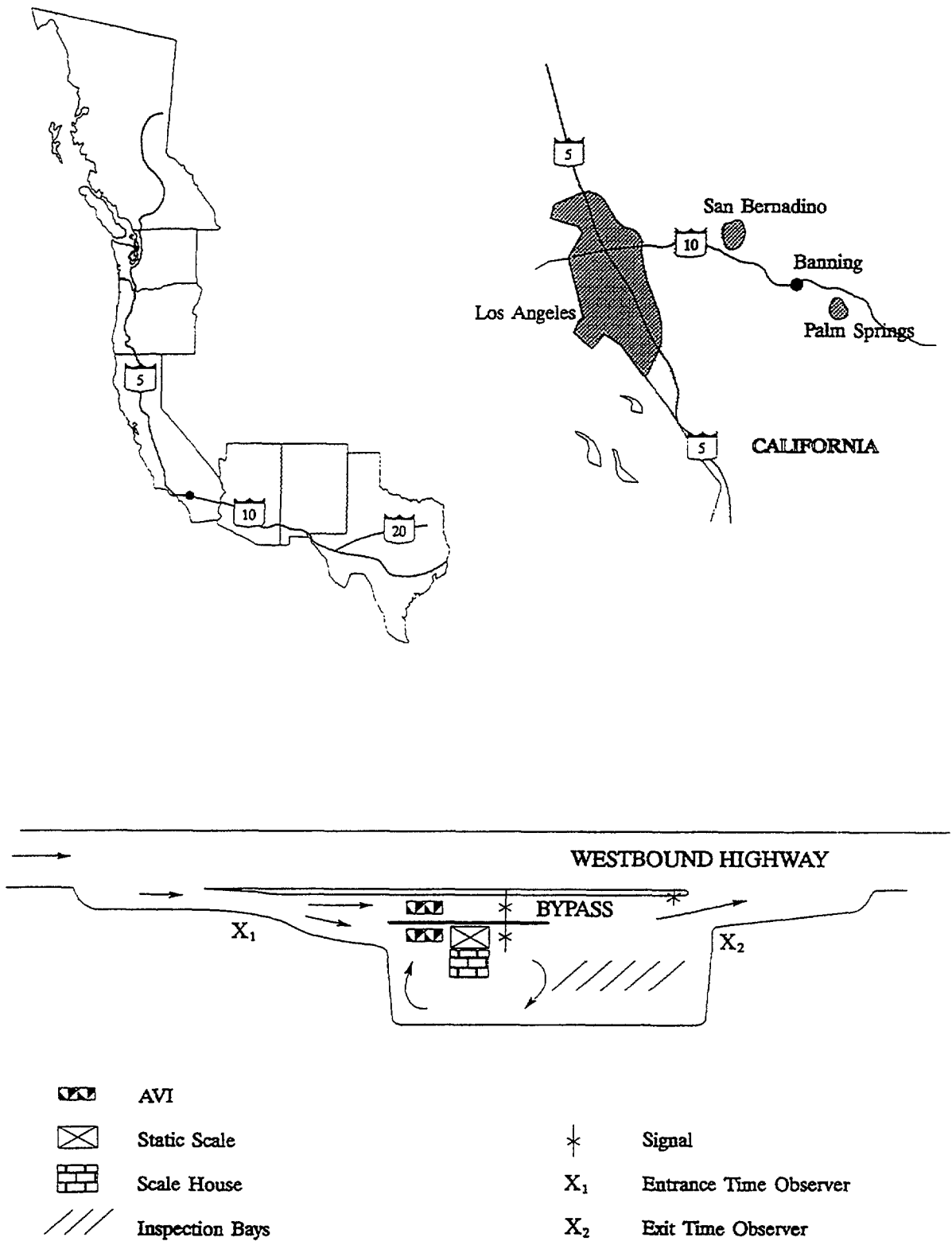

Figure 2-5. Banning: Location and Layout

Crescent equipment installation is managed by the Transportation Planning Division (TPD) of the Arizona Department of Transportation (ADOT). Weighstation operations are conducted by the Motor Vehicle Division of ADOT in association with the Arizona Department of Agriculture, Arizona Department of Public Safety (DPS) and local county sheriffs. Primary functions of weighstations include enforcing weight and size restrictions, collecting commercial vehicle taxes and issuing permits. The Arizona weighstations have the authority to hold vehicles for safety violations. However, DPS enforces heavy vehicle safety regulations in the state.

San Simon

Site Configuration The San Simon weighstation is a port-of-entry (POE) located along I-10 near the Arizona-New Mexico state line. The POE operates 24-hours-a-day, 7-days-per-week with a staff ranging from four to seven agency representatives (depending upon the time of day). The weighstation operations are divided into three shifts. The daytime shift requires one officer to operate the scale and five officers to issue permits. During the night shift, one officer operates the scale **and** three officers issue permits. The “graveyard” shift, through the early hours of the morning, consists of one officer operating the scale and three officers issuing permits. A supervisor is on duty for both day and night shifts.

The facility has a single entrance lane, equipped with PAT WIM/AVC and Mark IV AVI equipment, located 600 feet from the scale house. The entrance lane divides into a bypass lane and a static scale lane approximately 330 feet before the scale house. A signal, located approximately 400 feet from the bypass intersection, directs traffic to one of the respective lanes for examination. The signal does not have an automatic inductive loop switch and must be operated manually from a power locker situated near the signal. The site also has an additional bypass lane that was previously utilized as an entrance to an agricultural inspection station. The agricultural inspection station is no longer used. Figure 2-6 illustrates the site configuration.

Operational Procedures Current operating procedures omit the use of the bypass lane and direct all vehicles to the static scale. All commercial vehicles entering the station are weighed and classified by the WIM while queuing for the static scale. Upon reaching the static scale, the vehicles are reweighed, registration and permits are checked and a state weight-distance tax is assessed. Carriers that maintain an account with the state are logged into a statewide commercial vehicle database through a magnetically coded card containing all pertinent tax and permit information. This allows all relevant information to be quickly examined for more efficient processing of the vehicles. Carriers not maintaining an account with the state are motioned into the weighstation parking area for credential checks and payment of assessed taxes.

During periods of high truck volumes, the queue extends to the full length of the entrance ramp. In such instances, vehicles possessing valid magnetic cards are instructed to bypass the station. This process is continued until the queue has been adequately reduced. The San Simon weighstation has a capacity of approximately 150 trucks per hour with an average daily traffic of approximately 2,000 trucks a day.

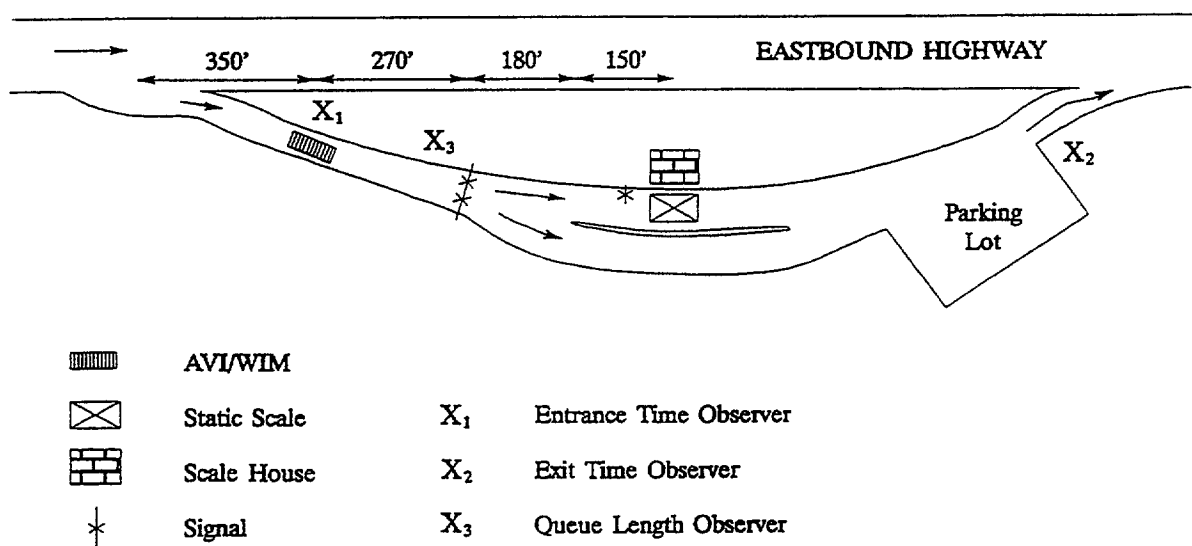
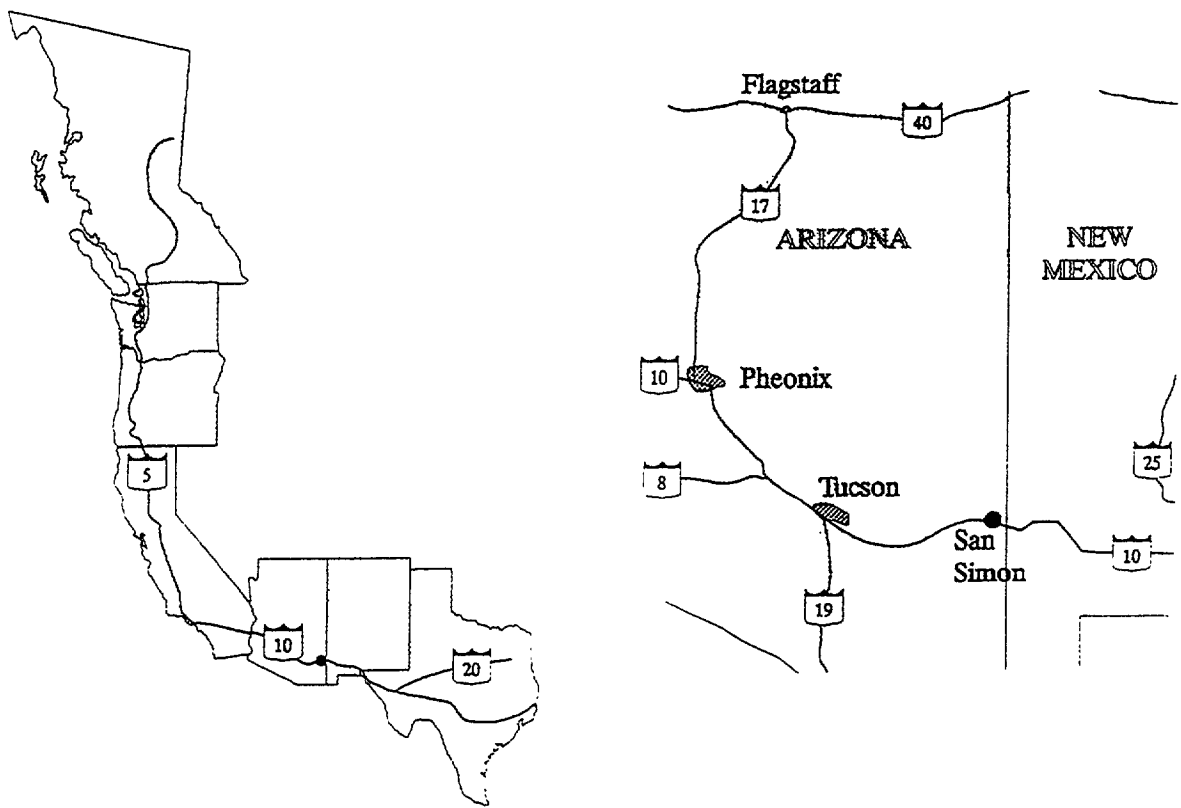

Figure 2-6. San Simon: Location and Layout

South Phoenix (Tempe)

Site Configuration The Tempe facility is a ten-lane, mainline installation on I-10 in Tempe, a suburb south of Phoenix. The site is operated and maintained by ADOT TPD. The site currently provides traffic counts and road use statistics for highway planning. The site is equipped with IRD WIM/AVC and Mark IV AVI equipment.

2.6 NEW MEXICO

Organizational Structure The Transportation Planning Division of the New Mexico State Highway and Transportation Department (NMSHTD) manages the HELP program in the state and is responsible for the installation and maintenance of Crescent sites. New Mexico has two POE weighstation sites in the demonstration, one of which was assessed during the on-site evaluation of the Crescent demonstration.

Management of weighstations is the responsibility of the Motor Transportation Division (MTD) of the Taxation and Revenue Department. The MTD enforces vehicle registration and tax laws and performs CVSA inspections. Joining the MTD statewide at weighstations is the State Corporation Commission, whose main function is to inspect intrastate wreckers and ambulances.

Lordsburg

Site Configuration The Lordsburg weighstation is located on I-10 near the New Mexico-Arizona state line. The site operates 24-hours-a-day, 7 days-per-week with an average staff of five officers. On an average day, one officer operates the static scale, three officers handle permits and one supervisor is on duty. The facility is equipped with Mark IV AVI, which is installed on the site entrance ramp 400 feet from the static scale. The site layout is illustrated in Figure 2-7.

Operational Procedures Commercial vehicles enter the Lordsburg weighstation and queue to the static scale. Standard procedures include weighing vehicles at the static scale, examining registration and permits and assessing weight-distance tax. Heavy vehicle operators are requested to present an identification card at the static scale. Using the identification card, the weighmaster checks the credentials and assesses the tax to the carrier's account. When the operator is not in possession of a valid card, the driver is detained at the weighstation while credentials are checked and taxes paid.

During periods where queue length extends to the highway, drivers who present state-issued identification cards are motioned through the weighstation, while those without identification cards are detained until credentials can be inspected. The Lordsburg weighstation has the capacity to process approximately 120 trucks per hour.

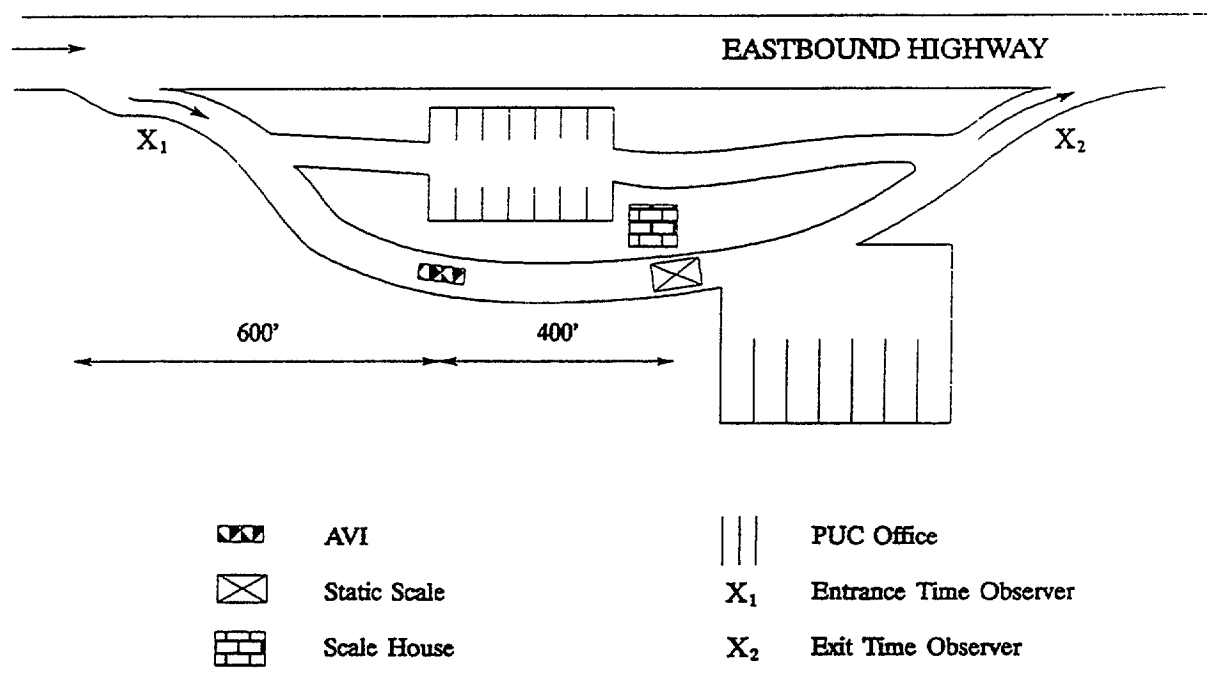
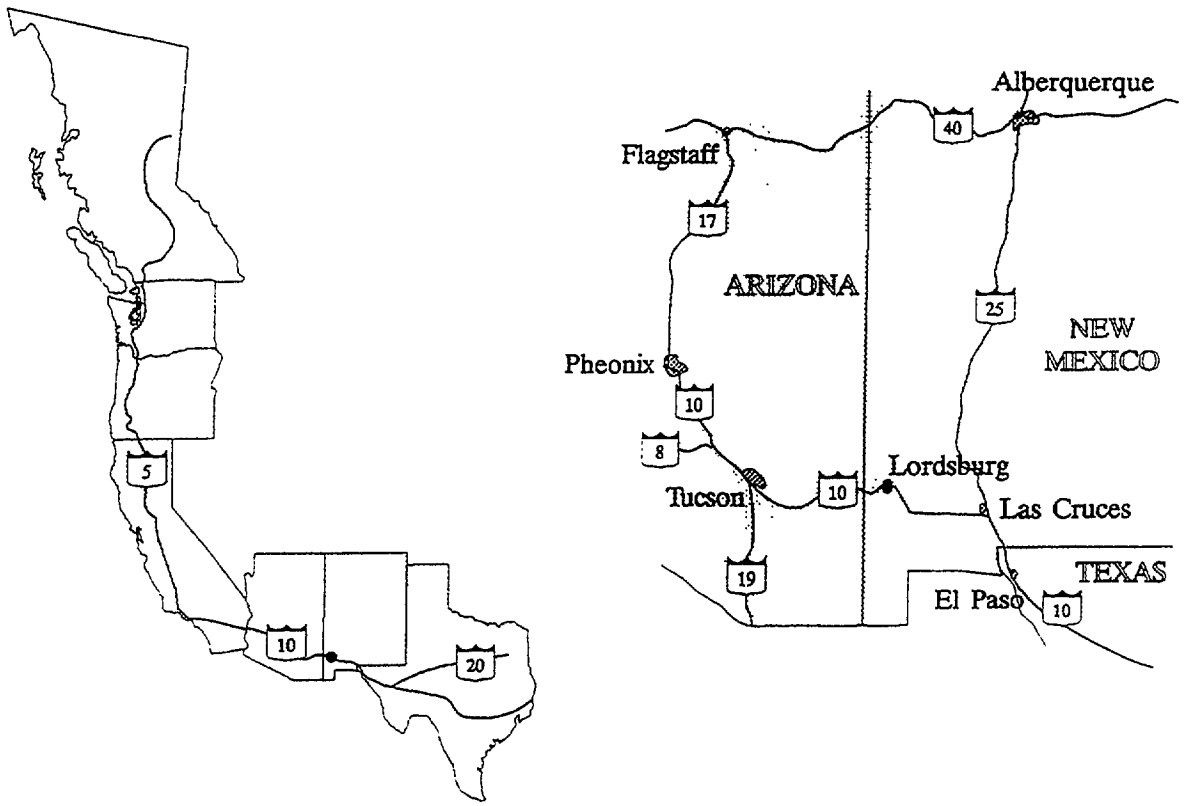

Figure 2-7. Lordsburg: Location and Layout

2.7 TEXAS

Organizational Structure The State of Texas has four sites participating in the Crescent Demonstration. These sites are maintained by the Transportation Planning Division of the Texas Department of Transportation (TXDOT). Weight enforcement activities are directed by the DPS. This agency employs License and Weight troopers to conduct safety inspections and enforce weight and size regulations. The State of Texas is unlike any other state in the Crescent Demonstration in that it does not have any permanently-manned weighstations. DPS officers conduct random inspections along the roadside or at temporary facilities.

Seguin

Site Configuration The Seguin site is a mainline installation on I-10 between San Antonio and Houston. The site is equipped with bending plate PAT WIM, Peak Traffic AVC and Mark IV AVI. Data collected from the Seguin site are currently utilized for transportation and highway planning.

3. EVALUATION APPROACH

3.1 OVERVIEW

The site analysis and data collection activities for the on-site Crescent evaluation were designed to provide the information required to assess the utility and operational accuracy of the Crescent system equipment for each site visited. This chapter provides a description of the general approach toward data collection activities and describes any site-specific modifications to the general evaluation plan.

The on-site evaluation considered the individual characteristics at each site, such as the layout of the site, the configuration of Crescent equipment and the different operational procedures used by each state within the Crescent Demonstration. A description of the data collection procedures at each site is provided.

The sites have been divided into weighstations and highway mainline sites. The evaluations performed at these two types of sites have different emphases. At mainline sites, the operational accuracy of the Crescent equipment was assessed, whereas at weighstations the evaluation considered both the operational accuracy and the utility of the Crescent system.

Most of the weighstation sites in the Crescent Demonstration were designed and constructed before HELP was conceived. Crescent equipment has been installed at sites with previously-established operating procedures. The full implementation and integration of the HELP technologies with these established procedures was not complete at the time of this evaluation. The original evaluation concept aimed to consider sites “before” and “after” the implementation and integration of the HELP technologies. However, due to the limited implementation and the lack of significant integration into the normal operating procedures, each evaluation plan has been adapted to suit the circumstances present at each of the sites. These evaluation plans consider the following factors:

1. the layout of the site and the configuration of the Crescent equipment installed;
2. the operational procedures at the site; and
3. the extent to which the Crescent system was being utilized by the site personnel.

The data collection procedures were prepared with a certain level of assistance anticipated from state personnel. The state agencies for the most part were very cooperative. However, circumstances arose that resulted in less assistance than expected. *This* required modifications to be made to the evaluation plans to enable a suitable evaluation to be undertaken. Additionally, certain data collection procedures were affected by safety considerations. Protecting the safety of data collection personnel during the study was of paramount importance. Therefore, the location and data collection methods used by personnel during the study were altered when required to ensure safe working conditions.

The overall objective of the on-site evaluation was to assess the effects of the Crescent equipment on the functions of a site. At sites where the Crescent system was not being fully utilized during the evaluation period, it was necessary to make assumptions about potential benefits to be drawn from use of the system, given the physical constraints of the site. The design of the data collection activities reflects these site constraints. For example, if a particular site layout could facilitate the bypassing of trucks from the static scale lane by prescreening using the Crescent system, but the equipment was not being used, the data collection effort would focus on the current operating conditions with a goal of identifying the changes that would result from use of the Crescent system. This involves recording truck volumes through the weighstation, truck transit times through the weighstation, processing times at the weighstation, and the truck queue lengths to the static scale, particularly those beyond the point of bypass.

Alternatively, sites which had integrated the Crescent equipment into their operating procedures before the study period generally had done so through necessity to relieve congestion and reduce truck queues. With high truck volumes passing through the site, safe operation could not be maintained without use of the HELP equipment. Weighmasters at such sites were unable to permit the site to be returned to non-HELP usage for the purposes of the study. Therefore, it was necessary to design the data collection to enable assessment of both HELP and non-HELP based operations. For example, if a site operated with WIM/AVC weight screening of trucks enabling bypassing from the static scale lane, then data would be collected on the average processing time of statically-weighed trucks and of bypassing trucks within the site, and the overall truck volume at the station. These data can be used in combination with the average queue length for trucks entering the site and the overall length of the entrance ramp to estimate the formation of queues if the screening and bypassing functions were not in operation.

This chapter describes the general evaluation approaches used at weighstations and mainline sites. Alterations made to these general evaluation approaches are described in the site-specific test descriptions.

3.2 WEIGHSTATION SITES

Although the weighstation evaluations varied by site, the basic evaluation approach and goals were consistent. The data collection activities at each site were designed to assess the operations of the site and identify the site parameters affected by the integration of the Crescent system. The on-site data collection for weighstation sites was divided into the following components:

1. assessment of the site operations;
2. assessment of the Crescent equipment installation;
3. manual collection of truck weight, axle spacing and classification data to assess Crescent equipment accuracy;
4. collection of truck transit times and delay time data, in conjunction with inspection and citation data, to assess the utility or potential utility of the Crescent system; and

5. interviews with the weighstation personnel.

Assessment of the site operations included an initial inspection of the site activities and equipment functionality. The evaluation team performed checks to ensure the Crescent equipment was operational and talked to weighstation personnel about the site operating procedures and how the Crescent and other equipment was used. The evaluation team observed site operations over a period of time to determine whether the original site evaluation plan was appropriate for the site configuration and operational activities. Although the preprepared evaluation plans were based on detailed telephone conversations with weighstation personnel, it was necessary to adjust some of the evaluation plans after observing the site operations and layout. In particular, after observing the site operations, it was sometimes possible to develop more efficient means of data collection.

The initial site assessment included a safety review of the evaluation plan, to ensure that the data collection activities would not cause any unsafe conditions for either the evaluation team or the truck drivers. The evaluation plans were reviewed in detail with the weighstation manager or supervisor. All safety concerns or operational interruptions were discussed and a final data collection plan was agreed.

The equipment installation was assessed. This included an evaluation of the physical characteristics of the site that could affect the performance of the WIM or AVC equipment. The surface condition of the pavement within fifty feet of the installation was inspected. The presence of any potholes, cracks or erosion of the pavement surface around the AVC loops or WIM sensors was recorded. Wherever possible, state authorities performed profilometer tests to provide better representation of the physical characteristics of the site. Profilometer tests determine the gradient of the pavement surface adjacent to the installation and the depth and size of any potholes or irregularities in the pavement surface.

The data collection procedures used to determine WIM and AVC accuracy were dependent on the site layout and the amount of automated data that could be provided during the evaluation period at the weighstation. The overall design of this data collection exercise was to manually classify, measure and statically weigh trucks, and to match these manual data with the data provided by the WIM and AVC equipment.

The data collection procedure for the equipment analysis was as follows. Manual and automatic data collected were synchronized by matching the internal clocks of the Crescent system site computer and the portable data collection computers. Two members of the evaluation team were positioned near the Crescent equipment installation, which generally was on the highway close to the approaches to the weighstation or in the entrance ramp to the weighstation. These two observers recorded license plate numbers and classified vehicles passing over the Crescent equipment. Each record entered was time-stamped automatically by the portable data collection computer. A third evaluation team member was positioned in the scale house and recorded the license plate numbers and individual axle weights and gross weights for each vehicle statically weighed. It was noted that many weighmasters weigh tandem axles together rather than dividing the pair into individual axles. The data analysis was adjusted to make provision for this method of weighing.

AVC equipment accuracy was assessed by comparing automatic to manual vehicle classifications on a vehicle-by-vehicle basis. As stated above, manual classifications were recorded and time-stamped on the portable data collection computers. Manual and automatic classifications for vehicles were matched through time synchronization of records.

The accuracy of WIM equipment was determined by static/dynamic weight comparisons for individual vehicles. The static and dynamic weight comparisons required matching vehicle license plate numbers recorded at the WIM equipment to those recorded at the static scales. This was followed by time synchronization of these manually-recorded, time-stamped truck records observed at the WIM to those automatically recorded by the Crescent equipment. These comparisons were undertaken on a vehicle-by-vehicle basis for axle weights and gross vehicle weights.

The accuracy of automated axle spacing measurement equipment was assessed by comparing automatic and manually-observed measurements on a vehicle-by-vehicle basis. This comparison procedure was as follows. Details of the automatically measured axle spacing were recorded from the Crescent system CRT monitor in the scale house by an evaluation team member. Two other team members manually measured and recorded the axle spacings for these same vehicles. Vehicles were directed to the parking lot, for manual measurement when the site had such facilities. At sites with no parking lot, the axle spacings were measured while the vehicle was on the static scale. Axle spacing comparison was only performed when the weighmaster thought the disruption to the site operations would be acceptably limited and the collection of manual measurements would not create unsafe working conditions.

The evaluation plan stated that AVI equipment testing would be undertaken to check unique codes transmitted from vehicles routinely passing AVI reader sites during all the on-site evaluation sessions. This process would be facilitated by the Crescent decals on AVI-equipped trucks. Visual recognition of these decals would indicate when an AVI read should be received.

In practice, it was discovered that limited use of the decals occurred. Thus observers at the side of the highway or in weighstations had no method of identifying AVI-equipped trucks other than to stop each truck to inspect it for a transponder. This clearly was an unacceptable option. Without the ability to visually identify AVI-equipped trucks, no testing could be undertaken to determine the level of AVI passes that were being detected from a random sample of AVI-equipped trucks. Results from earlier acceptance testing of the HELP AVI system are included in the Chapter 5 for completeness.

The second major aspect of the evaluation was to assess the operational procedures at the site to determine the effectiveness or potential effectiveness of the Crescent system. The data collected included:

1. entrance times, exit times and license plate numbers for trucks passing through the weighstation;
2. delay times for credential checks and inspections;
3. the number of trucks bypassing the weighstation completely; and

4. the license plate numbers for vehicles bypassing the static scale lane within the weighstation.

The procedures for these data collection tasks vary for each weighstation. A detailed description for each of the sites is included later in this chapter. However, the general methodology used for this data collection was similar at all weighstation sites and is described below. The activities of the evaluation team were dependent on both the site conditions and the level of support gained from the state authorities. All vehicle timings and license plate numbers were recorded on two portable computers. These computers were time synchronized at the start of each day of the study period.

The entrance and exit times for individual vehicles were recorded by two members of the evaluation team positioned at the site entrance and site exit. These team members were located where they were able to record vehicle license plate numbers from a position of safety. The data recorded on the data collection computers were automatically time-stamped. By matching the vehicle license plates recorded at the site entrance and exit, the vehicle's entrance and exit times were identified. This enabled the transit time for vehicles to pass through the site to be calculated.

When in-station truck bypassing was undertaken, the volume of trucks using each route through the weighstations was recorded, as well as the identity of the individual trucks being bypassed. This enabled calculation of the transit times through the weighstation for trucks using these different routes, which in turn provided an important indicator of the benefits to be gained from use of the Crescent system. Two approaches to recording these data were used. Either the observer at the site entrance recorded the route taken by each truck upon entry to the site in combination with the vehicle's license plate number, or, when available, data from state authorities were utilized. Such state data were recorded at a limited number of sites. These sites are identified in the site-specific evaluation descriptions.

To assess the effect of different truck volumes through the weighstations, the length of the queue waiting to pass over the static scales was recorded. This was performed by either the evaluation team member at the site entrance or by a third team member if assistance was available. In addition, all inspections performed and violations issued during the study period were recorded by either a member of the evaluation team or the weighmaster.

The final aspect of the evaluation activities was to interview site personnel about the structure of their organization and their opinions of the Crescent system. A questionnaire was developed which sought information on the user's experience and opinions of the system. This was issued to weighstation operators, who filled in the replies before the evaluation team left the site. In instances where the operators had no experience or knowledge of the Crescent system, an informal interview process was undertaken, which included explanations of the HELP program, Crescent equipment and database. The replies received in these interviews have been incorporated into the findings of this study and are presented in Chapter 5.

Evaluations undertaken at specific sites are described below. Alterations made to the general evaluation approach are identified and described. The weighstations evaluated, listed from north to south, were as follows:

1. Bow Hill, Washington;
2. Woodburn, Oregon;
3. Ashland, Oregon;
4. Santa Nella, California;
5. Banning, California;
6. San Simon, Arizona; and
7. Lordsburg, New Mexico.

Bow Hill Weighstation, Washington

At the time of the evaluation, the Bow Hill weighstation in Washington was a two-scale station with a single entrance ramp. However, the installation of a weight screening and bypass system around the static scales had begun during the evaluation study period. The Bow Hill site was evaluated twice during the study, with the first visit on April 13-14, 1993 and the second visit on June 24-25, 1993. A diagram of the site's layout and location is provided in Figure 2-1.

The focus of the evaluation was to determine the accuracy of the Crescent equipment and to assess the potential for bypassing trucks. The transit times of trucks through the station were determined to quantify the benefits to be gained from screening and bypassing.

Equipment Accuracy Evaluation The general evaluation plan for the equipment accuracy assessment was followed during both visits.

Operational Evaluation At the time of the visits, the Bow Hill weighstation had not fully integrated the Crescent equipment into its operations. The general evaluation plan for the operational analysis was followed at this site. The data collected represented the current operating characteristics. The potential benefits of the Crescent system have been determined using the proposed operating procedures with the observed truck volumes and operating delays. Inspection records, recorded by the weighmaster, were used to determine the delays caused by safety inspections.

Woodburn Weighstation, Oregon

The Woodburn weighstation was visited twice during the study, with the first visit on March 8-9, 1993 and the second on May 20-21, 1993. A diagram of the site layout and location is given in Figure 2-2.

This site is equipped with Crescent WIM, AVC and AVI equipment on the entrance ramp. Trucks with a dynamic weight under 50,000 lbs are bypassed through the weighstation to avoid the static scale without being statically weighed or checked for credentials.

This site has a high volume of traffic, and even with the prescreening and bypass operations, trucks must be weighed using a rolling weight method to prevent large queues from forming. The evaluation aimed to determine the accuracy of the Crescent equipment and assess the transit times through the weighstation.

The initial evaluation plan was intended to determine the delays that would occur from not bypassing any trucks. However, the weighstation supervisor felt that this would cause a traffic hazard at the station due to the formation of large queues. The evaluation plan was amended accordingly.

Equipment Accuracy Evaluation The general evaluation plan for equipment accuracy was used. The only alteration to the evaluation plan was that there was no requirement to collect data on static weights or vehicle license plate numbers in the scale house. Vehicle PUC plate numbers for all statically-weighed vehicles are entered by the weighmaster into the state database for commercial vehicle management and taxation. These data are automatically stored with the static axle and gross weights for each vehicle for later retrieval. The state authority made this information available for the days of the evaluation study.

The state information was utilized for the data analysis of the static and dynamic weights and to enable calculation of the routes taken by trucks through the weighstation. Those vehicles appearing in the state records passed over the static scales. Those trucks appearing on the record of the site entrance observer but not in the state records were assumed to have bypassed the static scales.

Operational Evaluation The general operational analysis plan was followed at this site. As site operations could not be altered to temporarily prevent the prescreening and bypassing of trucks, the data collected represent the current Crescent-assisted operational practices. An evaluation team member recorded the PUC number and delay time of each truck detained at the station for violations. The delays for the trucks called in for inspection were extrapolated from the entrance and exit times.

Ashland Weighstation, Oregon

The Ashland weighstation in Oregon was targeted for mainline bypass implementation during the course of the evaluation. However, the installation of the bypass system was not completed during the study.

The evaluation included one visit to the site, on May 15, 1993, as a “before” study to the implementation of mainline bypass to the site. A follow-up “after” study with the bypass system operational was not possible in the timeframe of the evaluation. The Ashland site operates two static scales with a single entrance ramp. A diagram of the site layout and location is given in Figure 2-3.

The focus of the evaluation was on assessing the time delays resulting from the processing procedures at the weighstation and determining the benefits of mainline bypassing. As no equipment installation had been undertaken, no equipment analysis was possible.

Operational Evaluation The general evaluation plan for the operational analysis was followed,

Santa Nella Weighstation, California

The Santa Nella weighstation in California is a proposed mainline bypass site. The site is equipped with Crescent high-speed WIM/AVC and AVI equipment on the highway less than one mile from the site, and Crescent low-speed WIM/AVC and AVI equipment in the weighstation's bypass lane. The proposed operations of the site will allow legally-laden trucks equipped with AVI-transponders to bypass the weighstation along the highway.

The evaluation team visited the site on May 6-7, 1993 and on June 28-30, 1993. The evaluation was designed to provide "before" and "after" analyses of site operations. However, during the second visit the weighstation bypass was not yet operational. Additionally, during both visits to the site, Lockheed was testing the AVI and mainline bypass system. A diagram of the site layout and location is provided in Figure 2-4.

Assessment of normal site operations during these visits was difficult, since disruptions were inevitable due to the installation and testing of the mainline bypass system. Current operations allow the slow-speed WIM in the station to screen truck weights. Therefore, only those trucks close to or above weight limits were directed to the static scale. This screening process was performed manually by the weighstation operator who observed the Crescent system CRT monitor and directed overweight trucks to the static scale. It was also the responsibility of the operator to visually inspect trucks for safety violations.

Due to the mainline bypass being nonoperational during the second site visit and a lack of sufficient data due to interruptions during the initial site visit, both visits consisted of evaluating equipment accuracies and observing the time delays encountered during normal operations.

Equipment Accuracy Evaluation The slow-speed WIM installed in the weighstation's bypass lane does not download data to the regional Crescent system computer and therefore does not provide a permanent record of vehicles' dynamic weights and classifications. As a result of this complication, the data collection effort was adapted for the low-speed WIM.

During the first visit, the low-speed WIM was assessed by the following method. WIM records were manually copied from the CRT monitor onto data sheets, as the system's printer was not operational. Each time a new truck crossed the WIM, a new record was displayed on the CRT. To maintain the screen record for sufficient time to record the data, a time delay was introduced between trucks. This time delay was accomplished through the following procedure: the weighstation was opened allowing trucks to enter; after a short time the weighstation was closed again; the last truck to enter the weighstation was directed to the static scale having already passed over the WIM system; the dynamic and static weights were recorded; the weighstation was reopened to repeat the cycle.

During the first visit, the initial evaluation plan for the high-speed WIM anticipated one evaluation team member recording license plate numbers and Crescent system clock time at the WIM installation. A second team member, positioned at the static scale, would identify by their license numbers those trucks to be statically weighed. As the mainline WIM is located one-half mile from the scale house, this plan required communications to be available between the WIM installation and the weighstation. The telephone line between the WIM installation and the scale house had not been installed at the time of the evaluation; therefore the evaluation plan required modification.

To identify trucks to be statically weighed and to correlate the WIM and static weights, trucks were visually identified with binoculars from the scale house and the Crescent clock time recorded from the CRT as they passed the WIM installation. Due to the inherent difficulties of recording these times from a distance, only those trucks traveling singly were used.

On the second visit to this site, the evaluation procedure for the slow-speed equipment was the same as for the first visit. The evaluation plan for the mainline WIM was altered since the telephone lines had been installed. Trucks to be statically weighed were identified at the mainline installation and license plate numbers were communicated to the weighstation operator, who directed these vehicles for static weighing. The evaluation team member at the WIM installation linked the data collection computer into the Crescent system and maintained a log of both the truck record number and the system's clock time for each truck to be statically weighed.

The mainline AVC was evaluated separately by manually classifying trucks at the installation and maintaining a compatible time record with the system clock. The slow-speed AVC system was evaluated by manually classifying the trucks as they crossed the installation and verifying the classification on the CRT inside the scale house.

Operational Evaluation The general evaluation plan for the operational analysis was followed at this site during both visits.

Banning Weighstation, California

The Banning site in California, which is one of the busiest weighstations on the Crescent route, was evaluated on May 13, 1993. This site is equipped with AVI and is configured with a bypass lane around the static scale. Figure 2-5 shows the site layout and location.

With the absence of weight screening equipment at Banning, trucks are allowed to bypass the scale if their weight is below 20,000 lbs. Due to the large truck volume entering the site, a high proportion of trucks bypass the static scale. The queue entering the weighstation often extends to the highway and, therefore, trucks are frequently bypassed around the weighstation entirely.

The evaluation data collection activities focused on the delay times and number of trucks bypassing the static scales both through the weighstation and along the highway.

Operational Evaluation The operational evaluation plan was revised on **site** as **no** state representatives were available to support data collection activities. The observer at the site

entrance recorded vehicle license plates, the queue length and the lane used by each vehicle. All of these records were time-stamped on a data collection computer. Another observer recorded vehicle exit times at the site exit. From these site entrance and exit times, the transit times for vehicles traveling by different routes through the weighstation were calculated. The delay times for processing violations and safety inspections were obtained directly from records maintained by the California Highway Patrol.

San Simon Weighstation, Arizona

The San Simon weighstation in Arizona was visited twice during the study, with the first visit on February 2-3, 1993 and the second on May 10-11, 1993. A diagram of the site layout and location is provided in Figure 2-6. During both site visits, although the Crescent system was operational, it was not being used in any weighstation operations. Prior to the first visit the system had not been operational. Lockheed continued debugging the system software during both site visits. The data collection activities were designed to represent the current operating procedures and would allow for an analysis to evaluate the potential for screening and bypassing when the system became fully operational.

In the pre-evaluation assessment of the San Simon site for the February 2-3 visit, the system was nonoperational. During the week preceding the visit, Lockheed dispatched a systems engineer to troubleshoot the problems. However, throughout the evaluation period the system was found to be unreliable. Lockheed was able to remotely restart the system following each failure. The delay between trucks crossing the Crescent equipment and the associated records being displayed on the CRT monitor varied widely, averaging between 10 and 20 seconds. Confidence in identifying particular truck WIM records was limited.

The San Simon weighstation was equipped with a bypass lane which began 200 feet prior to the static scale. The typical queue length recorded at this site was approximately 500 feet from the static scale, offering little opportunity for trucks to bypass without stopping. The weighstation has an additional bypass lane to a redundant agricultural inspection station which could potentially be used to bypass transponder-equipped trucks. The current operating procedures allow trucks to completely bypass the weighstation, without being charged weight/distance taxes, when the queue is backed to the highway.

Equipment Accuracy Evaluation The general evaluation plan for equipment accuracy assessment was followed during both visits.

Operational Evaluation During the operational assessment, the Crescent equipment was not being used by weighstation staff. An assumption was made that once bugs in the software were corrected and the site signal control system updated, the equipment would be used for screening and bypassing trucks with state tax accounts and valid permits. The potential for bypassing with the existing site and equipment configuration was assessed.

The processing times for trucks in which the driver had a magnetic card for automated tax collection were not individually recorded. The process of entering the magnetic ID code into the

state taxation database and keying in the destination of the truck was completed in the time taken to perform a static weighing and therefore created no additional time delay.

At the initial site visit, exit times were recorded as the vehicle left the static scale. An average time for trucks to travel from the static scale and re-enter the highway was estimated using a sample of fifteen trucks. This time from the static scales to the site exit was added to the transit time from the site entrance to leaving the static scales. This composite time is directly comparable with the other transit times recorded. On the second visit the general approach to the operational analysis was used.

Lordsburg Weighstation. New Mexico

The Lordsburg weighstation was visited on March 5, 1993. A scheduled second visit to the site was cancelled after the destruction of the weighstation in a traffic accident. The Lordsburg site was equipped with AVI only and did not have a bypass lane. A diagram of the site layout and location is given in Figure 2-7. The focus of the evaluation was the queue length and time delays at the weighstation.

The AVI system was operational and the site operating procedures were consistent with the team's pre-evaluation review. The AVI equipment at the site had not been integrated into the normal operational procedures at the time of the evaluation. The Crescent database was not used by the weighstation personnel.

Operational Evaluation The general evaluation plan for the operational analysis was followed at this site.

3.3 MAINLINE SITES

The mainline Crescent installations are used primarily to collect road use data for highway planning activities. The objective of the on-site evaluation data collection activities was to assess the accuracy of Crescent equipment. The logistics of the data collection were more complicated than for the weighstation sites as the static scales, which are required for weight comparisons, were rarely in the proximity of the Crescent system installation. This made the matching of the vehicle dynamic and static weights more difficult.

The on-site data collection procedures were prepared according to a particular installation's proximity to a static scale and by the weight records maintained by the state. If the test site was not **near** the weighstation, typically the Highway Patrol or Department of Public Safety (DPS) assisted by utilizing a portable scale to take static weights. Communications between the Crescent installation and the static scale were maintained via a cellular telephone or two-way radio. This enabled identification of those trucks to **be** statically weighed. A detailed description of each site's data collection activities is outlined below. The site-specific details of the mainline evaluations are described in the following order:

1. Kelso, Washington;
2. Jefferson, Oregon;
3. Ashland, Oregon;
4. Bakersfield, California;
5. South Phoenix (Tempe), Arizona; and
6. Seguin, Texas.

Kelso Mainline Site, Washington

The Kelso mainline site, which is situated close to the Kelso weighstation on I-5 in Washington, was evaluated twice, with the first visit on June 22, 1993 and the second visit on July 29, 1993.

The Kelso installation is less than 100 feet from the Kelso weighstation. This weighstation is operated by the Highway Patrol and is opened randomly dependent on the schedule of the Highway Patrol. The Highway Patrol made arrangements to have the station open on the evaluation days. This site was evaluated twice, due to the loss of most of the data from the first visit resulting from a power failure at the site.

Equipment Accuracy Evaluation During the first site visit, the method of matching truck license plate numbers at the Crescent installation and the static scale could not be used due to reduced visibility in inclement weather. The data were obtained by maintaining continuous communications with the team member at the static scale. A team member at the Crescent installation would identify by visual characteristics the trucks to be statically weighed to the observer at the static scale. A second observer at the Crescent installation classified the trucks and recorded the time-stamped data on a data collection computer. Data analysis was performed using the time synchronization of manual and automatic records as explained previously.

On the second visit to the Kelso site, the trucks to be statically weighed were identified by the observer at the Crescent installation and communicated to the observer at the static scale by telephone. Static weights, vehicle license plate numbers and the time of traversing the Crescent equipment were recorded. This enabled the comparison of static/dynamic weights by time synchronization and license plate matching as described above.

Jefferson Mainline Site, Oregon

The Jefferson site, which is located approximately fifteen miles south of the Woodburn weighstation, was visited on April 7, 1993. The Jefferson site was added to the evaluation after it was determined impractical to test the I-205 Portland site. The I-205 site was on a heavily-traveled section of roadway and not in the proximity of a weighstation.

The databases maintained by the State of Oregon made it possible to perform the evaluation at this site with only minor assistance from state personnel. The state representative met the evaluation team at the site and logged into the Crescent system's internal clock to synchronize the timing of computer records.

Equipment Accuracy Evaluation. The WIM and AVC data were collected simultaneously at this site. One observer recorded the PUC number of each truck passing in the outside lane, using binoculars, and the other observer classified the same truck as it crossed the Crescent installation. Both records were time-stamped on data collection computers. The PUC numbers were used to match the static and dynamic weights at the site and the time records were used to enable synchronization of the manual records with the automated data. Static weight data were available from the state database at the Woodburn weighstation. The manually-recorded PUC numbers were matched with the manual classification records by collating the two truck counts.

Ashland Mainline Site, Oregon

The Ashland site, which is located approximately five miles from the Ashland weighstation, was evaluated on April 5, 1993. The site has WIM and AVC equipment installed.

The Crescent equipment is installed in a section of highway with a number of steep inclines. The WIM is installed at the apex of one of the hills but an incline in the pavement exists at the site.

The data collection for this site was aimed at assessing the equipment accuracy. Although the State of Oregon was able to provide personnel to assist with the data collection, no one at the weighstation was familiar with the Crescent software and, therefore, synchronization of the Crescent system clock with the internal clocks of the data collection computers was not possible. The data collection approach was revised to overcome this problem.

Equipment Accuracy Evaluation The static weight data were coordinated with the WIM weight records by maintaining a record of the PUC number as trucks crossed the Crescent equipment. These records were time-stamped on a data collection computer. The vehicle PUC numbers enabled matching of the dynamic weight records with the static weight data stored in the state database for the Ashland weighstation site for the same day. The PUC number was obtained at the equipment installation by one observer reading the PUC plate with binoculars and another observer entering that identification into the database at the precise time the truck crossed the WIM.

The AVC was evaluated by manually classifying each truck and maintaining a time record as the truck crossed the WIM. The time record was used to synchronize the manual record and the automated record.

Bakersfield Mainline Site, California

The Bakersfield site, which is situated on I-5 north of Los Angeles, was evaluated on April 16, 1993. The State of California was unable to provide assistance for this site evaluation, so the data collection activities were completed by the two-member evaluation team.

The Bakersfield site is located approximately three miles south of the Bakersfield weighstation. The inaccessibility of the Crescent system clock was the only obstacle to conducting the tests without assistance from the state. This was overcome by changing the data collection procedures.

Equipment Accuracy Evaluation The static weights and manual classification data were recorded separately. The static weight data were obtained with one team member at the Crescent installation identifying trucks to be weighed to the other team member at the Bakersfield weighstation by cellular telephone. The team member at the Crescent installation maintained a record of the vehicles crossing the equipment and the vehicle's classification. These records were time-stamped on a data collection computer. The time record was later used to synchronize the WIM records with the manual records.

South Phoenix (Tempe) Mainline Site, Arizona

The South Phoenix site is a ten-lane installation on a heavily travelled section of I-10. This site was visited on March 25-26, 1993. As there was no weighstation available near the site, the DPS assisted by setting up a portable scale near the site to collect static weights.

The South Phoenix site was a difficult test site due to the high volume of traffic along this section of I-10 and the number of traffic lanes in one direction. The scheduling for the site evaluation was coordinated with the DPS and had to be completed between morning and afternoon peak hours (9:00 am - 4:00 pm). DPS agreed to be available for the evaluation from 9:00 am to 1:00 pm on March 26, 1993.

On the eve of the evaluation, it was discovered that there was no power to the WIM or AVC equipment. The power company was unable to restore power before the evaluation. A portable generator was used to power the equipment during the evaluation.

Major safety concerns were expressed associated with pulling trucks off the highway for static weighing in heavy traffic and with vehicles parking on the shoulder of the roadway near the WIM installation.

Equipment Accuracy Evaluation To address the safety concerns of pulling over all trucks on the highway, DPS used motorcycle officers to prescreen trucks about a mile from the portable scale setup. The motorcycle officers would pull over a truck and instruct the driver to stop at the portable scale. In the interest of time, the officers were requested not issue any citations, except in cases of flagrant safety violation. Statically-weighed trucks were marked with reflective stickers to enable identification by the evaluation team member positioned near the WIM.

The safety issue of positioning a team member on the shoulder of the highway for an extended period of time was resolved by taking observations from an access road running parallel to the highway. Two-way communications between the team member at the WIM and the DPS officer were maintained throughout the evaluation, so that the officer could describe the physical characteristics of the statically-weighed trucks. The WIM records were matched to the static weight records by correlating the time and lane data.

The classification data were collected after the weight data collection was completed. The team members maintained a time and classification record of trucks as they passed the AVC installation. The time record was used to match the manual data with the automated data.

Seguin Mainline Site. Texas

The Seguin mainline site is located on a four-lane section of I-10 between Houston and San Antonio. The site is equipped with PAT bending plate WIM and AVC. There is a DPS pull-off ramp approximately six miles east of the site. An access road runs parallel to the main highway.

Equipment Accuracy Evaluation The manual classification data were recorded from a parked vehicle on an elevated section of the access road at a distance of approximately 50 feet from the Crescent installation. The data were time-stamped on a data collection computer. Manual and automatic classification records were synchronized using the recorded time.

Static weight data were obtained with the assistance of DPS officers. The DPS officers pulled all trucks into the inspection ramp and weighed selected trucks on a calibrated portable scale. The DPS officers recorded the vehicle license plate numbers and classification for statically-weighed vehicles at the static scale. A time-stamped record of the vehicles crossing the Crescent installation was compiled. Time synchronization and matching plate numbers enabled the matching of dynamic and static axle and gross vehicle weights.

A computer failure at the end of the testing period resulted in the loss of the manually-observed times for vehicles crossing the Crescent installation. This affected the records for the truck weight comparison, therefore no truck weight comparison was undertaken at the Seguin site.

4. DATA ANALYSIS

4.1 OVERVIEW

The evaluation of the Crescent Demonstration project was undertaken to examine many aspects of the introduction and implementation of a large-scale commercial vehicle monitoring system. As described in Chapters 1 and 3, this evaluation consisted of five different evaluation tasks. Each of these examined different aspects of the introduction and operation of the system. One task, the on-site evaluation, was performed by CRC. The objectives of this task were:

1. to determine the accuracy of the on-site vehicle monitoring technologies of the Crescent system; and
2. to examine the impact of various operational procedures, site layouts and equipment configurations with respect to the Crescent system.

This chapter describes the data analysis procedures performed on the data collected during the on-site evaluations. The two forms of analysis as indicated by the above objectives are examined separately below.

4.2 EQUIPMENT ANALYSIS

The equipment analysis section of the on-site evaluation examines the accuracy observed for each of the major component technologies used within the data collection processes in the Crescent system. These technologies enable the unique identification, measurement and weighing of vehicles without the need for costly and time-consuming delays at weighstations. The three technologies comprise:

1. **WIM;**
2. **AVC;** and
3. **AVI.**

The data analysis procedures for the assessment of each of these technologies are described below. This description contains the objectives of the analysis being performed, the determination of the required sample size to achieve the desired statistical confidence in the results, the statistical tests that have been performed and the general methodology used in the data analysis.

Weigh-in-Motion

The accuracy of WIM equipment was determined by comparing both dynamic axle weights and gross vehicle weights automatically recorded by the WIM against the equivalent axle or vehicle weight measured by static weighing of identifiable vehicles. The preferred sample size used for this comparison was 200 axles or approximately 70 trucks. The determination of this sample size is described in Annex A.

As explained in the description of the testing procedures for mainline sites positioned at some distance from a weighstation, the use of portable scales, operated by state Highway Patrols, enabled the comparison of static/dynamic weights. For these mainline sites, difficulty in achieving the necessary sample sizes resulted from the use of portable scales and the practical difficulties of pulling over vehicles on the highway. Therefore, at mainline sites, smaller sample sizes were collected, generating lower levels of confidence for the results gained. Occasions when a reduced sample size was collected are indicated in the presentation of the results.

WIM Data Analysis Procedures For each axle, combination of axles or vehicle observed, an analysis was undertaken to compare the static weight to a corresponding dynamic WIM weight. The two measures used in this analysis were the absolute difference and the percentage difference between the static and dynamic weights. The absolute difference for individual axles, axle groupings or gross vehicle weights is given by equation 4-1 and is expressed in pounds (lbs). A negative value for the absolute difference indicates that the WIM is under-weighing vehicles relative to the static scale.

$$\text{Absolute difference} = \text{WIM weight} - \text{Static weight} \quad (4-1)$$

The percentage difference for individual axles, axle groupings or gross vehicle weights is given by equation 4-2 and is expressed as a percentage.

$$\text{Percentage difference} = \frac{(\text{WIM weight} - \text{static weight}) \times 100\%}{\text{static weight}} \quad (4-2)$$

Determination of the absolute and percentage differences in static/dynamic weights enabled estimation of the systematic and random errors present in the WIM equipment measurements at the test sites. The systematic error is given by the mean of the percentage difference distribution or the mean of the absolute difference distribution for static/dynamic weight comparisons. The systematic error indicates the degree of calibration between the static scales measuring the static weights and the WIM system recording the dynamic weights.

During the calibration of WIM equipment, a large sample size of axle weights should be used to reduce the systematic error to close to zero. The required size of this calibration sample (400 axles) is calculated in Annex A. An actual systematic error of zero could only be achieved by a perfect calibration between the static scale and the WIM, which would require the sampling of the entire truck population to be weighed for calibration of the WIM. This clearly is an

impracticable situation. The methodology for calibrating WIM systems is not considered in this report since the WIM calibration was due to be performed by state authorities prior to the on-site evaluation.

The random errors inherent in the WIM equipment measurements are estimated by the standard deviation of either the percentage difference distribution or the absolute difference distribution. Random errors occur for any form of measurement. These can be reduced by the use of more accurate equipment or a more highly-controlled measurement environment.

The systematic and random errors determined for each WIM system are compared to two forms of specification accuracy. These are the specifications laid down for HELP system equipment and those issued by the WIM system manufacturers for the equipment involved in the evaluation study. These two forms of specifications are described below.

The first of these specifications is the HELP WIM performance specification [I] which was developed by Cunagin at the Texas A&M Research Foundation for ADOT. This specification was adopted by the HELP WIM Performance Specification Subcommittee. An extract from this specification is given in Table 4-1.

Table 4-1 shows the HELP WIM specification accuracy for two types of sites. These site types perform separate roles and have different functional requirements. Type I sites are POE sites, defined as those located “on state lines where truck traffic enters a state and therefore comes under a different jurisdiction with respect to permits, taxation, and size and weight limits” [1]. At POEs, the HELP system components required are AVI, AVC and a high-precision WIM.

Type II sites are permanent sites for weight enforcement purposes. These sites require AVI, AVC, and lower-precision accuracy WIM for weight enforcement screening. In addition, two further site classifications exist. Type III sites are AVC/AVI-only equipped fixed sites that are used primarily for highway data collection. Type IV sites are portable sites utilizing AVC, AVI and WIM.

Each site type is provided with specification accuracies for the random and systematic errors in terms of both the percentage and absolute difference for static/dynamic weights. The assessment of the WIM accuracy is based on the “funnel” concept, which also has been adopted by the HELP WIM Performance Specification Subcommittee. The goal of defining a specification accuracy for the WIM is to attain a consistent weight accuracy irrespective of the magnitude of the vehicle weight. For assessing WIM equipment accuracy, the use of percentage and absolute differences exclusively is found to be deficient. The funnel concept is intended to remove these deficiencies, as described below.

Table 4-1. HELP Specification Accuracies for WIM Equipment

Site Type	Error Type	Percentage Difference	Absolute Difference
Gross vehicle weights, single and tandem axles, speed between 20 mph and 40 mph			
I	Systematic	±4%	±400 lbs
	Random	±4%	±400 lbs
II	Systematic	±5%	±500 lbs
	Random	±12%	±1200 lbs
Gross vehicle weights, speed more than 40 mph			
I	Systematic	±4%	±400 lbs
	Random	±8%	±800 lbs
II	Systematic	±5%	±500 lbs
	Random	±12%	±1200 lbs
Single axles, speed more than 40 mph			
I	Systematic	±5%	±500 lbs
	Random	±10%	±1000 lbs
II	Systematic	±5%	±500 lbs
	Random	±12%	±1200 lbs
Tandem axles, speed more than 40 mph			
I	Systematic	±4%	±400 lbs
	Random	±10%	±1000 lbs
II	Systematic	±5%	±400 lbs
	Random	±12%	±1000 lbs

The absolute difference provides a good measure of WIM accuracy for low vehicle or axle weights, but has less significance at higher truck weights. For example, an error of 500 lbs in weighing a truck of 5,000 lbs equates to a 10% percentage difference, whereas with an 80,000 lb truck the same error in weighing gives a percentage difference of less than 1%. Conversely, percentage difference provides a good measure of WIM accuracy at higher truck weights but is a less reliable measure at lower truck weights. Thus at low weights, the absolute difference is perceived to be more significant than the percentage difference, whereas the reverse is true at higher weights.

The funnel concept utilizes both the percentage and absolute differences depending upon the weight of the truck or axle being weighed. For trucks below 10,000 lbs, the absolute difference is used as a measure of the WIM accuracy and, above 10,000 lbs, the percentage difference is used. The point of intersection between these two specifications, at 10,000 lbs, is known as the pivot point.

The specifications issued by WIM system manufacturers in respect to their own equipment are the second form of specification considered. The following equipment specifications were made available by manufacturers whose equipment was assessed during the Crescent Demonstration:

1. IRD Bending Plate WIM; and
2. PAT DAW200 WIM.

The IRD bending plate WIM specification contains the following extract:

“The system must meet the following accuracy criteria, as shown below (in Table 4-2):

Table 4-2. IRD Bending Plate WIM Specification Accuracies

Requirement	Mean Error	Standard Deviation
Steering Axles	±3%	8%
Single Axles	±3%	8%
Tandem Axles	±3%	6%
Gross Vehicle Weight	±2%	5%
Axle Spacing	±2 inches	3 inches
Vehicle Length	±12 inches	18 inches
Speed	±1 mph	2 mph

The above accuracy specifications are to be based on a minimum sample of 50 vehicles, loaded to within 75% of the legal allowable limit. Vehicles that traverse the scale with more than a 10% speed variation shall not be considered. The accuracies will be based on a one standard deviation confidence level. This assumes that the errors are normally distributed, and subsequently, 68% of all samples fall within the above quoted limits. The above accuracies are contingent upon specific site conditions.”

The specification continues on to provide guidelines on the choice of site installation including the acceptable pavement roughness and gradient.

As a result of equipment limitations, no vehicle speed measurements were recorded during the on-site evaluation. A general comparison was undertaken to indicate the qualitative compliance of WIM accuracies with manufacturers’ specifications for highway speeds and speeds typical of weighstations. Therefore, it was not possible to make a direct comparison of observed WIM accuracies with the specifications displayed in Table 4-2.

The PAT DAW200 WIM specification is based upon the American Society for Testing and Materials (ASTM) specification for WIM systems [2]. The ASTM specification defines four types of WIM system. The PAT DAW200 is a type 1 WIM. The specification defines the functional performance requirements for this type of WIM in terms of a tolerance for a 95% probability of conformity. These requirements are shown in Table 4-3.

Table 4-3. PAT DAW200 Specification Functional Requirements

Requirement	Tolerance
Axle load	±20%
Axle-group load	±15%
Gross vehicle weight	±10%
Speed	±1 mph
Axle Spacing	±0.5 ft

Assuming that the measurements recorded by the WIM are normally distributed, a 95% probability of conformity contains all measurements within two standard deviations of the mean. Therefore, to enable comparison of the observed accuracies and these specification accuracies, at one standard deviation, the tolerances shown in Table 4-3 have to be halved.

There is no indication in this specification as to the acceptable limits of deviation between the mean values of the static and dynamic weight distributions, or the required sample size to assess the WIM accuracy.

Weight Range Analysis To test the WIM accuracy across different weight ranges, the weight readings were segregated into weight ranges, based on their static weights. Analyses were undertaken to compare the accuracies attained for each of these ranges to determine any trends present with increasing weight. In general, the weight ranges were:

1. less than 10,000 lbs;
2. 10,000 - 19,999 lbs;
3. 20,000 - 29,999 lbs;
4. 30,000 - 39,999 lbs;
5. 40,000 - 49,999 lbs;
6. 50,000 - 59,999 lbs;
7. 60,000 - 69,999 lbs;
8. 70,000 - 79,999 lbs; and
9. 80,000 lbs or greater.

However, the weight ranges used were changed if the sample sizes falling into each range were not sufficient, or if a range contained a large number of samples. This segregation process was undertaken for both single/combination axles and gross vehicle weights. For each of these weight ranges, the absolute differences and percentage differences were calculated. In addition, the standard deviations of each of these measures were determined.

Two forms of comparative analysis were undertaken to identify trends in the WIM accuracy at different weight levels. F tests were performed to identify significant differences between the mean percentage differences of each weight range. If significant differences were found between the means of each weight range, it was concluded that a change in calibration between the WIM and static scale occurs with a changing vehicle weight. The statistical basis of F tests is described in Annex A.

The second form of comparison undertaken was a t-test to examine whether pairs of weight range mean percentage differences were significantly different. This test enabled the nature of differences between weight range accuracies to be established. The t-tests are also described in Annex A.

Screening Tolerance Procedures One of the major considerations of the WIM accuracy is the ability to perform preclearance weight screening. Under this preclearance scenario, an AVI-equipped truck approaching a weighstation is automatically weighed, classified and its credentials checked by the Crescent system database. Within the weight screening only those trucks at or above a specified screening weight limit would be directed for weighing at the static scale.

Ideally in a WIM system with no errors, this screening limit would be set at the legal weight limit. Only overweight vehicles would be directed for static weighing. In practice, the accuracy with which the WIM can determine a vehicle's axle and gross weights is an important factor in determining this screening weight limit given the variations present within the weight measurement. The approach adopted is based on a probabilistic analysis of a normal distribution for the WIM weight measurements. This approach is explained below.

For a range of screening tolerances the proportion of overweight trucks avoiding detection and the proportion of legally-laden trucks unnecessarily stopped have been calculated. These calculations have been undertaken for weight screening based on gross vehicle weights, front axle weights, other single axles which do not contain the individual axles within tandem axle pairs, and tandem axles.

The probability of a truck with a specific static weight escaping detection at a particular screening weight limit was determined using the following procedure. The z-value for the screening weight limit's position relative to the mean in the WIM weight measurement distribution is given by equation 4-3.

$$z = \frac{\text{Absolute (WL - } W_s)}{(W_s \times \sigma_{\text{observed}})} \quad (4-3)$$

where W_s is the static weight of the truck, WL is the screening weight limit and σ_{observed} is the standard deviation of the percentage difference distribution for the static/dynamic comparisons. This z-value enables a probability of the WIM weight of this truck being under the screening weight limit to be obtained using statistical tables for the normal distribution. For a truck determined to be overweight from a static measurement, a WIM weight measured below the screening weight limit enables the truck to avoid detection as an overweight vehicle.

An example of these calculations illustrates the approach. For a truck of 82,000 lbs static weight, a screening weight limit of 60,000 lbs and a standard deviation for the percentage difference observed in the comparison of static and dynamic weights of 10%, the resulting z-value is given by equation 4-4. This z-value represents the number of standard deviations of the distribution that the screening weight limit is from the mean of the distribution - the vehicle's actual static weight.

$$z = \frac{\text{Absolute (82,000-60,000)}}{(82,000 \times 10\%)} = 2.68 \quad (4-4)$$

The screening weight limit (the z-value) lies 2.68 standard deviations from the distribution mean. Therefore, the proportion of WIM weight observations of this truck that will generate a resultant WIM weight under the screening weight limit is given by the integral $A(z)$ of the normal distribution function from z to zero. These are all instances where the WIM weight of the vehicle is found to be below the screening weight limit. This value can be gained from statistical tables for the normal distribution. For a z-value of 2.68, $A(z) = 0.0037$ or 0.37%.

This analysis provides the probability of a truck of a specified static weight avoiding detection at a specified screening weight limit. The analysis is expanded to include trucks of all weights above the designated legal overweight limit. The proportion of overweight trucks avoiding detection is given by equation 4-5:

$$\text{Proportion of overweight trucks avoiding defection} = E A(z) \times P(z_o) \quad (4-5)$$

where $P(z_o)$ is the proportion of overweight trucks from the overweight truck population that occurs in a defined narrow weight range and $A(z)$ is the probability that a truck of the specified weight range will avoid detection. The frequency of observations falling into a series of narrow weight ranges is utilized for the values of $P(z_o)$ between the overweight limit and the heaviest weight recorded for the required form of observations, whether this observation is the gross weight, front axle, single axle or combination axle weight.

The distribution of trucks by weight range has been calculated using static truck weights both from the observed sample and from a 24-hour sample recorded by the WIM which contains the evaluation sample. Determination of this distribution enables the calculation of $P(z)$, the proportion of overweight trucks on a specific narrow weight range, for any weight range.

A similar form of analysis is undertaken to calculate the proportion of legally-laden trucks that will be unnecessarily stopped because their WIM weight is greater than the screening weight limit. The proportion of legally-laden trucks unnecessarily stopped is given by equation 4-6:

$$\text{Proportion of overweight trucks avoiding detection} = E A(z) \times P(z_l) \quad (4-6)$$

where $P(z_l)$ is the proportion of legally-laden trucks that occurs in a narrow specified weight range and $A(z)$ is the probability that trucks in the specified weight range will avoid detection. The frequency of observations falling into a series of narrow weight ranges is utilized for the values of $P(z_o)$ between the overweight limit and the zero weight recorded for the required form of observations, whether this is gross weights, single axle weight or combination axle weights.

These analyses indicate the effects of selecting weight screening limits with respect to the WIM accuracy observed at each test site.

Automatic Vehicle Classification

The assessment of the accuracy of the AVC equipment was based upon a comparison of AVC to manually-observed vehicle classifications for specific vehicles. As a result of this process, it is possible to identify not only the manual and automatic classifications for vehicles, but also those observations where either the observer or the AVC system has failed to record a vehicle. These misses are tabulated in Chapter 5. The significance of certain missed observations is described later in this section.

Two measures are used for assessment of the AVC equipment accuracy. These are the absolute accuracy and the compensated accuracy. The absolute accuracy measures the proportion of observations that are correctly classified by the AVC system. The absolute accuracy for any class of vehicles or for any group of classes is given by equation 4-7. The absolute accuracy is expressed as a percentage.

$$\text{Absolute accuracy} = \frac{\text{Number of vehicles correctly classified} \times 100\%}{\text{Manual total observed for that group}} \quad (4-7)$$

The compensated accuracy provides a more useful measure for highway planning applications, as it measures the accuracy of the class totals rather than the accuracy of individual observations. During the classification of vehicles some errors will occur. However, if these errors are compensated by mistaken classifications of an opposite nature, the resultant class totals will remain correct. The compensated accuracy, therefore, considers compensation and cancellation. The compensated accuracy for a vehicle class is given by equation 4-8 and for any group of vehicle classes by equation 4-9. The compensated accuracy is expressed as a percentage.

$$\text{Compensated accuracy} = \frac{\text{Absolute (manual - automatic class totals)}}{\text{Manual class total}} \times 100\% \quad (4-8)$$

$$\text{Compensated accuracy} = \frac{E (\text{Absolute (manual - automatic class totals)})}{\text{Total manual count}} \times 100\% \quad (4-9)$$

As well as determining the absolute and compensated accuracies for the AVC system, a number of additional factors require consideration. To reduce the required data storage volume, the AVC system undergoes some automatic screening of vehicle records before storage. The HELP system is primarily aimed towards commercial vehicle operations, so this screening process removes all passenger cars, motorcycle and several classes of small truck. Specifically, the screening removes all vehicles of class 6 or under in the FHWA Scheme F Classification schedule. Consequently, vehicles falling into these classes will have been manually observed but apparently not observed by the AVC system. In the subsequent data analysis, these vehicles will be registered as misses by the AVC system. A further analysis has been performed to make an allowance for these screened-out vehicles. The absolute and compensated accuracies have been calculated for these screened data.

In addition, where consistent errors have occurred between the automatic and manually-observed classifications, further analysis has been undertaken. This analysis has considered both the AVC accuracy following modifications of the system to remove such errors and the source of the errors. The FHWA Scheme F Classification schedule was developed for visually-observed classifications and AVC systems attempt to emulate Scheme F through classifications based on the vehicle's wheelbase, number of axles and axle spacings. Inconsistencies in the two forms of classification occur. These are examined in Chapter 5.

A comparison of actual system accuracies with the HELP AVC specification accuracies has been undertaken. Two measures of accuracy are specified for AVC classification [1]. The overall vehicle type classification accuracy states that at least 90% of all vehicles sampled must be correctly classified. Individual vehicle type classification accuracy states that the AVC must correctly classify at least 90% of each vehicle type that contains at least 30 vehicles in the sample size.

Axle Spacings Measurement Accuracy

The algorithms utilized by the AVC equipment to determine vehicle classifications are based on the vehicle's wheelbase, number of axles and axle spacing. Therefore, the accuracy achieved by the automatic axle spacing measurement has a direct impact on the accuracy of the AVC classification.

The accuracy of axle spacing and wheelbase measurement for vehicles is determined by comparing automatic and manual measurement observations for specific vehicles. The measures used for this comparison are the absolute difference and the percentage difference between the manual and automatic axle spacings and wheelbase measurements. The absolute difference is given by equation 4-10 and is expressed in feet and decimal feet. The percentage difference is given by equation 4-11 and is expressed as a percentage.

$$\text{Absolute difference} = \text{Manual axle spacing} - \text{AVC axle spacing} \quad (4-10)$$

$$\text{Percentage difference} = \frac{(\text{Automatic} - \text{Manual axle spacing})}{\text{Manual axle spacing}} \times 100\% \quad (4-11)$$

The systematic error is given by the mean absolute difference or the mean percentage difference observed between automatic and manual axle spacing measurements. The random error is approximated by the standard deviation of the absolute difference distribution or the standard deviation of the percentage difference distribution.

As with the WIM accuracy assessment, the automatic axle spacing measurement accuracy observed is compared with two forms of specification accuracy. These are the HELP WIM/AVC specification and the manufacturers' specification relating to their own equipment.

The HELP WIM/AVC specification for axle spacing accuracy utilizes the funnel concept. A systematic error of no greater than 0.5 feet is permitted in measurements below 8 feet or 5% in measurements greater than 8 feet. A random error of no greater than 1.0 foot is permitted in measurements below 8 feet or 5% in measurements greater than 8 feet.

The manufacturers' specifications for axle spacing measurements are illustrated in Tables 4-2 and 4-3. For the IRD bending plate WIM system, axle spacings measurements have specified accuracies of a mean error of ± 2 inches with a standard deviation of ± 3 inches. Similarly, for

the measurement of the vehicle's wheelbase the specified accuracies are a mean error of 1 foot with a standard deviation of 18 inches. For the PAT DAW200 WIM axle spacing measurements are permitted a tolerance of ± 0.25 feet or ± 4 inches.

Automatic Vehicle Identification

The determination of AVI accuracy is based on the comparison of manual observations of AVI-equipped trucks to the automatic records for these trucks. As explained in Chapter 3, the evaluation plan aimed to use the Crescent decals that were to be placed on each AVI-equipped vehicle. However, it was discovered that many of the AVI-equipped vehicles did not display these decals and therefore there was no practical method of identifying these trucks without the detailed inspection of each vehicle. This was clearly not a practical screening option. Therefore, it was not possible to perform a widespread testing of the AVI-based tracking abilities of the Crescent system.

Results from earlier AVI system testing have been included in this report. This acceptance testing on the Mark IV AVI transponder showed the AVI met all except one of the specification requirements. These acceptance tests cover transponder placement, speed tests, multi-lane and multi-tag tests, external interference tests, power supply tests, emitted radiation tests and attenuation tests.

4.3 OPERATIONAL ANALYSIS

The operational analysis considers a number of measures affected by the specific site layout, the operational procedures used, and the equipment configuration at different test sites. The operational analysis is only performed at weighstation sites. A number of different statistical measures are calculated for operational analysis. These comprise:

1. time delays for legally-laden vehicles;
2. proportion of vehicles checked and unchecked;
3. proportion of vehicles weighed and unweighed;
4. selection efficiency of the weight screening procedures;
5. proportion of overweight vehicles avoiding detection;
6. average truck queue length;
7. frequency of queue backing up to the highway;
8. proportion of vehicles cited;

9. truck volumes through weighstations; and
10. mean transit time through the site.

For clarity, these statistical measures are divided into two categories as follows (however, it should be noted that because of the interaction between the different aspects of a site's operation, all features should be considered collectively):

1. truck flows, queues and weight enforcement; and
2. safety and other inspections.

The data analysis procedures used for these categories are described below. This description contains the objectives of the analysis being performed and a description of the *analysis*.

Truck Volumes/Queues/Weight Enforcement

This section considers the truck flows observed following each path through a weighstation or bypassing a weighstation. Three general situations are considered, as follows:

1. weighstations not using the Crescent system;
2. weighstations using off-ramp screening; and
3. weighstations using mainline screening.

It must be noted that throughout the course of the on-site evaluation it was apparent that each site was significantly different due to the site layout, operational procedures used and the equipment configuration at each site. The effects of these factors will be discussed.

Weighstations not using: the Crescent system For weighstation sites not utilizing the Crescent system, no vehicle weight information is available prior to static scale weighing. When the truck volume on the highway exceeds the processing capacity of the weighstation, queues develop. For safety considerations, it may be necessary to allow a number of trucks to bypass the weighstation without weighing. The proportion of trucks pulled into the weighstation is given by (A) and the proportion of trucks permitted to bypass the site without weight screening is given by (B).

Different weighstation operating procedures and site layouts enable some sites to undertake in-station bypassing of vehicles without weighing. The selection of trucks for bypassing is a voluntary decision by the truck driver, based on a weight limit sign at the site entrance, that the vehicle is running empty and that the necessary credentials are in order. No check other than a quick visual inspection by weighstation personnel is performed on these bypassing vehicles. On entering the weighstation, the proportion of vehicles bypassing the static scales within the site is given by (C) and the proportion of vehicles being statically weighed is given by (D). For the vehicles statically weighed, a proportion will be overweight (D1) and a proportion will be legally laden (D).

For weighstations that operate in-station bypassing of the static scales, and with the assumption that there are no overweight trucks utilizing the bypass lane, the proportion of overweight trucks in the whole truck population can be estimated to be (D_1/A) and the proportion of legally-laden trucks in the whole truck population can be estimated to be $(C+D_2)/A$. The proportion of vehicles that are unweighed is given by $(B+C)$.

For weighstations that have no in-site bypassing of vehicles, the proportion of overweight trucks in the total truck population can be estimated to be (D_1/A) . The proportion of legally-laden trucks in the total truck population can be estimated to be (D_2/A) .

Having established the proportions of overweight and legally-laden trucks in the total population, it is possible to estimate the number of overloaded trucks and legally-laden trucks being allowed to pass unchecked. For trucks bypassing the weighstation, these proportions are determined through a simple multiplicative process, such that the proportion of overweight trucks bypassing is given by B_1 , which equals $(D_1 \times B)/A$, and the proportion for the legally-laden trucks bypassing the site is given by B_2 , which equals $((C+D_2) \times B)/A$.

The definition of time delay used in this assessment is the delay caused by the weight enforcement procedure. The average time delay (T) for each legally-laden truck is calculated from the average time for a truck to bypass the site at highway speed (T_1), the time taken for a truck to pass from the site entrance to the site exit passing over the static scales (T_2), and the time taken to pass through the site using the bypass lane (T_3). The average time delay for all legally-laden trucks caused by the weight enforcement procedures is given by equation 4-12.

$$T = \frac{(D_2 \times (T_2 - T_1) + (C \times (T_3 - T_1)))}{(A + B)} \quad (4-12)$$

Transit times through the weighstation are screened to remove abnormally long time delays which can be attributed to the issuing of citations or to the truck driver parking in the weighstation. The division between normal transit times and abnormally long transit times is defined as those transit times one standard deviation over the mean transit time. Assuming a normal distribution, this is expected to comprise approximately 16% of the trucks passing through the site.

Since no weight information is obtained prior to enforcement weighing, the proportion of undetected overweight vehicles should be represented by the proportion of vehicles allowed to pass unchecked $B/(A+B)$. The selection efficiency of the weight screening process is defined in equation 4-13.

$$\text{Selection efficiency} = \frac{\text{Number of overweight trucks statically weighed}}{\text{Number of trucks statically weighed}} \times 100\% \quad (4-13)$$

Weighstations Using Off-Ramp Screening At weighstation sites utilizing the Crescent system, all vehicles entering the weighstation are weighed, and AVI-equipped trucks are checked for the necessary credentials and safety inspections. As with non-Crescent weighstations, when the truck volume on the highway exceeds the processing capacity of the weighstation, trucks may be allowed to bypass the weighstation. The proportion of trucks pulled into the weighstation is given by (A) and the proportion of trucks permitted to bypass the site is given by (B).

In-station screening and bypassing of trucks may be performed under one of two scenarios, affected by the operational procedures chosen at the site. The first scenario is the bypassing of AVI-equipped trucks that are found to be legally laden and have current permits and safety inspections. This applies at weighstations that perform rigorous credential checking. The second scenario applies to sites that operate a largely weight-only enforcement policy. All trucks entering the weighstation are weighed, and only those at or above a prescribed weight screening limit are directed for static weighing.

As for non-Crescent weighstations, on entering the site, the proportion of vehicles bypassing the static scales is given by (C) and the proportion of vehicles being statically weighed is given by (D). For the vehicles statically weighed, a proportion will be overweight (D₁) and a proportion will be legally laden (D₂).

For weighstations that operate in-station screening and bypassing of the static scales, the proportion of overweight trucks can be estimated to be (D₁/A) and the proportion of legally-laden trucks can be estimated to be (C+D₂)/A.

Having established the proportions of overweight and legally-laden trucks in the total population, it is possible to estimate the number of overloaded trucks and legally-laden trucks being allowed to pass unchecked. For trucks bypassing the weighstation, these proportions are determined through a simple multiplicative process, such that the proportion of overweight trucks bypassing the site is given by B₁, which equals (D₁ x B)/A, and the proportion of legally-laden trucks bypassing the site is given by B₂, which equals ((C+D₂) x B)/A.

The analysis of the time delay for legally-laden trucks is similar to that used for non-Crescent sites, and is given by equation 4-12. Since no weight information is obtained before entry into the site, the proportion of undetected overweight vehicles will be represented by the proportion of vehicles allowed to pass the site unchecked B/(A+B).

Weighstations Using Mainline Screening Mainline screening sites weigh and identify trucks as they pass along the highway prior to entering a weighstation. AVI-equipped trucks with the appropriate credentials and a WIM weight under their permitted limit are notified by means of a communications link into the truck cab that everything is in order, and may bypass the weighstation. All other vehicles are required to enter the weighstation, unless they are waived due to an excessive queue. The proportion of trucks pulled into the weighstation is given by (A) and the proportion of trucks permitted to bypass the site without weight screening is given by (B).

At low levels of AVI penetration, the truck flow into the site will not be greatly reduced from present levels, and therefore the need for in-station bypassing may still exist. As described earlier, the selection of trucks for bypassing may be based on a voluntary decision by the truck driver based on a sign at the site entrance that the vehicle is running empty and that their credentials are in order. No check other than a visual inspection by weighstation personnel is performed on these bypassing vehicles. On entering the weighstation, the proportion of vehicles bypassing the static scales within the site is given by (C) and the proportion of vehicles being statically weighed is given by (D). For the vehicles statically weighed, a proportion will be found to be overweight (D,) and a proportion will be legally laden (D2).

For weighstations that operate in-station bypassing of the static scales, with the assumption that there are no overweight trucks utilizing the bypass lane, the proportion of overweight trucks can be estimated to be $(D1/(A+B))$ and the proportion of legally-laden trucks can be estimated to be $(A+B-D2)/(A+B)$.

The assessment for the time delay is similar to the other situations, except that there are no in-site bypassing trucks; therefore equation 4-12 simplifies to equation 4-14.

$$T = \frac{(D2 \times (T2 - T1))}{(A + B)} \quad (4-14)$$

Since no weight information is obtained prior to enforcement weighing, the proportion of undetected overweight vehicles should be represented by the proportion of vehicles allowed to pass unchecked, $B/(A+B)$. The selection efficiency of the weight screening process is defined in equation 4-13.

Truck Volume and Queue Analysis The effects of queues developing at the entrance to weighstations have been considered in the earlier analyses. The average queue length, both in number of trucks and length in feet, together with the various truck volumes through the weighstations, have been calculated for each observation period and have been divided into 5- and 15-minute segments.

Variations in the queue length have been examined in association with the truck flow volume through the site to assess the relationship between these two factors. Similarly, variations in the truck volume through weighstations and the transit times taken for those vehicles have been assessed to determine the relationship between these factors. This analysis has been undertaken to determine the impact of reducing the truck volume passing over the static scales by use of truck bypassing using the KELP concept. This has considered bypassing both around the static scales through the weighstation, and directly along the highway.

Additionally, all instances of the queue backing up to the highway and the proportion of the total observed time that this occurred have been recorded.

Safety and Other Inspections

The policies on performing vehicle inspections adopted by participating Crescent states vary considerably in terms of both the physical condition of the vehicle and the required documentation. This section describes the analyses of the inspection effort and the proportion of vehicles cited for violations.

The statistical measures considered are the proportion of vehicles inspected, the proportion of vehicles not inspected, the proportion of vehicles cited, and the nominal efficiency of the selection process for inspecting vehicles.

It is recognized that different states and individual sites have different approaches to dealing with violators. Therefore, the efficiency of the selection process for inspecting a vehicle based upon a comparison of the number of inspections and the number of citations issued must be considered in light of the normal policy adopted at the sites.

As described earlier, the total vehicle count passing through or bypassing a site during a sampling period is known. In addition, weighstation personnel were requested to record every inspection undertaken and the citations issued during the sampling period. The proportion of vehicles inspected within the site is given by equation 4-15.

$$\textit{Proportion inspected} = \frac{\textit{Number of trucks inspected}}{\textit{Truck flow through site}} \times 100\% \quad (4-15)$$

The proportion of vehicles inspected is expressed as a percentage. The proportion of vehicles inspected from the total truck population is given by equation 4-16.

$$\textit{Proportion inspected} = \frac{\textit{Number of trucks inspected} \times 100\%}{\textit{Total observed truck flow}} \quad (4-16)$$

The proportion of vehicles not inspected is the percentage given after subtraction of the proportion inspected from the total truck flow. The proportion of vehicles cited from the vehicles passing through the site is given by equation 4-17 and from the total truck flow by equation 4-18.

$$\textit{Proportion cited} = \frac{\textit{Number of trucks cited} \times 100\%}{\textit{Truck flow through site}} \quad (4-17)$$

$$\textit{Proportion cited} = \frac{\textit{Number of truck cited} \times 100\%}{\textit{Total truck flow}} \quad (4-18)$$

The selection efficiency of the inspection process is given by equation 4-19. Again, the different policies and approaches used at weighstations are recognized. Therefore, the selection efficiency may not indicate the true proportion of vehicles inspected that are either cited or receive a cautionary warning.

$$\textit{Selection efficiency} = \frac{\textit{Number of trucks cited}}{\textit{Number of trucks inspected}} \times 100\% \quad (4-19)$$

In addition to these proportions of vehicles that are inspected and cited, the nature of the inspections and citations has been examined. Utilization of the HELP concept enables AVI-equipped trucks to have automatic verification of their credentials. At some weighstations, this would enable an increased throughput of vehicles by the use of truck bypassing. However, those sites that concentrate on safety inspection enforcement may gain reduced benefits from use of the HELP concept. Such perceived costs and benefits are assessed in Chapter 7.

5. EVALUATION RESULTS

5.1 INTRODUCTION

This chapter presents the results gained from the on-site evaluation of the Crescent system. During the study period, from January through July 1993, twelve Crescent sites were evaluated. The results are presented in a similar format to the layout of Chapter 4, which describes the data analysis procedures undertaken for the on-site evaluation. The accuracy assessment of different forms of Crescent equipment are presented first, followed by the assessment of operational factors at weighstation sites. The results gained from the on-site interviews with weighstation personnel are also presented. A discussion of the implications of the results gained from this evaluation is presented in Chapter 7.

As described in the Crescent Evaluation plan, each mainline site was to be visited once to enable assessment of the equipment accuracy. Additionally, each weighstation was to be visited twice to enable both the equipment accuracy assessment and the evaluation of the operational factors that would be affected by the introduction of the HELP system. The second visit was primarily to enable a second evaluation of the operations to reduce the possibilities of non-typical conditions being recorded on the first visit. However, a further assessment of equipment accuracy was also performed where possible.

Some additional on-site evaluations were performed to gain more significant sample sizes where difficulties had been encountered on previous visits. Two weighstation sites were only visited on one occasion: at Lordsburg the weighstation was destroyed after the first visit; and at Banning the weighstation had a limited Crescent installation which reduced the evaluation to considering the operational aspects only.

For brevity, the results presented in this chapter summarize more comprehensive results which may be found in Annex B. Descriptions of the statistical tests used in the data analysis are given in Annex A.

5.2 EQUIPMENT ANALYSIS

The utility of the HELP concept is reliant on the accuracy of the information that is generated. There are three major on-site vehicle monitoring technologies utilized within the HELP system. Each of these has been evaluated to assess the operational accuracies and abilities to satisfy established specifications, such as those adopted by the HELP WIM Performance Specification Subcommittee. These three technologies are as follows:

- * weigh-in-motion (WIM);
- * automatic vehicle classification (AVC); and

* automatic vehicle identification (AVI).

The results and any relevant points of discussion arising from the on-site evaluation tests performed on each of these component technologies are presented below.

Weigh-in-Motion Equipment Analysis

The accuracy of WIM equipment affects the effectiveness and efficiency of a number of the Crescent applications, including weight enforcement screening, automated tax collection policies and highway planning data collection. An estimate of WIM accuracy was determined by comparing static and dynamic weights for axles and vehicles on a vehicle-by-vehicle basis, as explained in Chapter 4.

The two measures used to determine the WIM accuracy are the absolute and the percentage differences observed between the static and dynamic weights for individual axles or vehicles. Table 5-1 shows the mean values and standard deviations for the percentage and absolute differences for static/dynamic comparisons of individual axles and combinations of axles at sites visited during the evaluation. Table 5-2 shows the corresponding results for static/dynamic weight comparisons for gross vehicle weights.

As shown in Annex A, the required sample size for a WIM accuracy evaluation with 95 percent confidence limit and an assumed standard deviation of 10 percent is approximately 200 axles or 70 trucks. The on-site evaluations aimed to gain samples larger than the required size within the constraints of the on-site studies. Any difficulties experienced in data collection, such as gaining the required sample size, or in the subsequent data analysis are described in this chapter.

Tables 5-1 and 5-2 list the sites evaluated from north to south, weighstations first followed by the mainline sites. This sequence is used for the presentation of results throughout this chapter.

All of the sites listed in Tables 5-1 and 5-2, except Ashland, Bow Hill and Woodburn; are type II sites as defined by the HELP WIM Performance Specification [1]. This type of site is used primarily for weight enforcement procedures and for data collection for highway planning purposes, although some tax collection functions are performed by some states as described in Chapter 2. Ashland, Bow Hill and Woodburn are POE sites that are nominated type I in the HELP WIM specification. The specification accuracies for these two types of sites are described in Chapter 4.

In Tables 5-1 and 5-2, the evaluation results from the two WIM systems at the Santa Nella site are shown separately. The mainline high-speed WIM system at Santa Nella is denoted by (HS) and the low-speed in-station WIM system by (LS). This notation is continued throughout this chapter. In addition, at the Ashland site, it should be noted that all equipment analysis relates to the mainline installation, as no Crescent equipment had been installed at the weighstation during the period of the on-site evaluation.

Table 5-1. Observed WIM Accuracies for Axle Weights

Site	Date Visited	Sample Size	Percentage Difference (%)		Absolute Difference (x 1000 lbs)	
			Mean	S.D.	Mean	SD.
Bow Hill	April 93	181	1.9	12.6	0.0	2.1
Bow Hill	June 93	400	-1.9	16.5	-0.3	1.8
Woodburn	March 93	582	1.9	13.0	0.1	1.7
Woodburn	May 93	395	2.5	10.8	0.4	1.8
Santa Nella (HS)	May 93	52	1.7	8.7	0.3	1.3
Santa Nella (LS)	May 93	30	-3.4	3.0	-0.6	0.5
Santa Nella (HS)	June 93	71	1.8	2.9	0.3	0.5
Santa Nella (LS)	June 93	92	1.5	2.8	0.3	0.5
Kelso	July 93	229	-16.2	14.7	-2.9	5.0
Jefferson	April 93	107	6.8	15.2	1.7	3.3
Ashland	April 93	159	1.7	9.8	0.4	1.5
Bakersfield	April 93	55	-1.9	12.0	-0.4	1.9
S. Phoenix	March 93	92	-8.2	13.2	-1.4	2.1

Of the sites evaluated, only three have mean percentage differences for axle weight comparisons of greater than ± 5 percent. These are Kelso, Washington; Jefferson, Oregon; and South Phoenix, Arizona. These sites also show mean percentage differences for gross vehicle weights of greater than ± 5 percent. The mean standard deviation of the percentage difference distributions for axle weight comparisons is 10.4 percent, with two sites above 15 percent and three sites at or below 3 percent.

These mean percentage differences indicate that most of the systems have been calibrated, but the random error, which is estimated by the standard deviation of the percentage difference, is close to the HELP WIM specification limits for type I and II sites. Direct comparison of the observed accuracies with the HELP WIM specification and manufacturer's WIM specifications are shown later in this chapter.

Table 5-2. Observed WIM Accuracies for Vehicle Weights

Site	Date Visited	Sample Size	Percentage Difference (%)		Absolute Difference (x 1000 lbs)	
			Mean	S.D.	Mean	S.D.
Bow Hill	June 93	60	0.7	12.1	0.0	4.6
Bow Hill	April 93	128	-1.3	15.2	-0.8	3.9
Woodburn	March 93	172	0.4	3.4	0.4	2.4
Woodburn	May 93	117	1.7	7.7	1.1	4.4
Santa Nella (HS)	May 93	15	1.7	4.6	0.9	2.1
Santa Nella (LS)	May 93	10	-2.5	2.4	-1.2	1.6
Santa Nella (HS)	June 93	21	2.4	2.2	1.1	1.1
Santa Nella (LS)	June 93	25	1.6	1.7	1.1	1.3
Kelso	July 93	71	-15.4	11.4	-8.8	10.6
Jefferson	April 93	33	8.2	12.0	5.6	8.1
Ashland	April 93	45	1.9	5.3	1.2	3.0
Bakersfield	April 93	16	-2.5	5.6	-1.3	3.5
S. Phoenix	March 93	31	-8.0	10.3	-4.3	5.4

The average WIM accuracy observed for mainline and weighstation installations is shown in Table 5-3. These results show the weighstation WIM systems to have greater accuracy than mainline screening sites. These differences in accuracy are probably due to the greater variation in truck operating speeds for the mainline WIM and the more controlled measurement environment, such as better lane discipline, that is achieved within weighstations.

Table 5-3. Average WIM Accuracies

Site Type	Absolute difference below 10,000 lbs (x 1000 lbs)		Percentage difference above 10,000 lbs (%)	
	Mean	S.D.	Mean	S.D.
Mainline sites	0.6	1.1	5.0	10.1
Weighstations	0.2	0.9	2.0	7.4

Data collection difficulties for WIM equipment analysis. For three sites, on-site WIM equipment accuracy assessments were undertaken but no results were available due to difficulties encountered after the on-site evaluations. These sites were:

- * Kelso (June);
- * San Simon (February and May); and
- * Seguin (January).

The evaluation at the Kelso site was affected by difficulties during the on-site evaluation in June 1993. The on-site evaluation was undertaken as described in Chapter 3. Unbeknown to CRC or WSDOT, a power loss to the Crescent system equipment occurred during a large part of the evaluation period. This power loss remained undiscovered until CRC's receipt of the WIM data. The system had been operating normally at both the start and end of the evaluation period. CRC scheduled an additional on-site visit to gather further data. This was performed in July 1993.

At the San Simon site, two WIM accuracy assessments were performed in February and May 1993, however, the automatically-recorded Crescent WIM data were lost. The WIM data that were required for these static/dynamic weight comparisons within these accuracy analyses were purged by Lockheed before the data analyses were undertaken. This resulted from a lack of communication between participating partners.

The participating states' DOTs agreed a policy that CRC should request all the required Crescent WIM data after all on-site evaluations in the individual states had been completed, rather than after each on-site evaluation. This reduced the data retrieval effort for the DOTs and enabled easier coordination of the data by CRC. Due to Lockheed's difficulty in storing and archiving all the recorded Crescent data, a purge of the data was undertaken without the knowledge of the state DOTs or CRC. Therefore, only at the completion of evaluation schedules in individual states was it apparent that Lockheed no longer held the data required for the evaluation.

Additionally, manually-observed data collected at the Seguin site were lost due to a software failure on one of the portable data collection computers. This failure was recognized following

the completion of the evaluation at the Seguin site. No additional opportunity to perform a second evaluation and complete an analysis of the data has been possible.

Small sample sizes were recorded at a number of mainline sites where this difficulty had been anticipated due to operational conditions. The only weighstation with a small sample size was Santa Nella. This was due to the weighmaster's opinion that such evaluation created a dangerous traffic condition and would cause discontent among the truck drivers.

There were three sites evaluated that did not have Crescent WIM equipment installed at the time of the evaluation study. These were the weighstation installations at Ashland, Banning and Lordsburg.

WIM accuracy compared to the HELP WIM specification. The observed accuracies for WIM systems has been assessed against two forms of specification accuracy. The first is the HELP WIM Performance Specification, developed by Cunagin of the Texas A&M Research Foundation for ADOT [1]. This specification utilizes the funnel concept, as explained in Chapter 4.

The second form of specification used is the manufacturers' own specifications for their installed WIM equipment. Comparison of observed WIM system accuracies to the HELP WIM specification are presented first.

The HELP WIM specification accuracies are defined in terms of the systematic and random errors for static/dynamic weight comparisons. These definitions utilize the absolute difference in static/dynamic weight comparisons below 10,000 pounds and in the percentage difference above 10,000 pounds, for specific types of sites, ranges of truck speeds and weight groups. These weight groups include such classes as single axle loads, tandem axle loads or gross vehicle weights.

Comparison of the observed accuracies with those in the specification requires some assumptions to be made. As no speed measurements were recorded during the on-site evaluations, it was assumed that mainline WIM systems operate with truck speeds above 40 mph and in-station WIM systems operate with trucks between 20 and 40 mph. These assumptions were confirmed by observation of truck speeds automatically measured by the WIM system.

The HELP WIM specification accuracies used for comparison against the observed accuracies have been separated into vehicle weights and axle weight comparisons. The specification limits for weighstation installations are shown in Table 5-4. Similar specification limits are shown in Table 5-5 for mainline installations.

As the HELP WIM specification defines limits for single axle and tandem axle load independently, the most stringent of these limits has been used for the axle load comparison. The on-site evaluation examining WIM accuracies considered all axle weights, i.e., single axle or tandem axles, together.

Table 5-4. Specification WIM Accuracies at Weighstations

Site Type	Error Type	Percentage Difference	Absolute Difference
I	Systematic	±4%	±400 lbs
	Random	±4%	±400 lbs
II	Systematic	±5%	±500 lbs
	Random	±2%	±1200 lbs

Table 5-5. Specification WIM Accuracies at Mainline Sites

Site Type	Error Type	Percentage Difference	Absolute Difference
I	Systematic	±4%	±400 lbs
	Random	±8% (Vehicle Weight) ±10% (Axle Weight)	±800 lbs (Vehicle Weight) ±1000 lbs (Axle Weight)
II	Systematic	±5%	±500 lbs
	Random	±12%	±1200 lbs

Table 5-6 shows the mean value and standard deviation for the observed absolute differences below 10,000 pounds and the percentage difference above 10,000 pounds for static/dynamic axle weight comparisons. The mean of these difference distributions approximates to the systematic error present in the system and the standard deviation to the random error.

Comparing the observed WIM accuracies to the HELP WIM specification limits shows that the Bakersfield and both of the Santa Nella WIM systems were within specification for all weight types. All the other sites evaluated illustrated some form of deficiency outside the specification limits. However, it is recognized that the limited sample sizes in some cases reduce confidence in these results.

Table 5-6. Accuracies for Comparison to the HELP WIM Specification

Site	Site Types	Date Visited	Absolute difference below 10,000 lbs (x 1000 lbs)		Percentage difference above 10,000 lbs (%)	
			Mean	S.D.	Mean	S.D.
Bow Hill	I	April 93	0.2	0.9	0.4	12.5
Bow Hill	I	June 93	-0.1	1.3	-2.8	11.4
Woodburn	I	March 93	0.5	1.7	1.5	10.3
Woodburn	I	May 93	0.5	1.5	2.2	9.8
Santa Nella (HS)	II	May 93	0.1	0.5	1.4	9.0
Santa Nella (IS)	II	May 93	-0.2	0.2	-4.2	2.0
Santa Nella (HS)	II	June 93	0.1	0.3	1.8	2.9
Santa Nella (LS)	II	June 93	0.2	0.3	1.4	2.6
Kelso	II	July 93	-1.5	1.2	-15.8	14.7
Jefferson	II	April 93	1.4	2.3	6.1	13.5
Ashland	I	April 93	0.0	1.5	1.9	8.7
Bakersfield	II	April 93	-0.4	1.1	-1.0	11.8
S. Phoenix	II	March 93	-0.6	1.2	-8.7	12.7

For the sites that did not satisfy the HELP WIM specification accuracy requirements, the weighing inaccuracies were attributable as follows:

- * The Bow Hill WIM system was within specification for the systematic errors given by the mean absolute or percentage differences. This indicates that the WIM system has been calibrated to the static scale. However, the random errors given by the standard deviation of the absolute or percentage difference distribution are unacceptably large.
- * The Woodburn site WIM failed to meet the specification limits on three measures. The mean absolute difference for axle weights below 10,000 pounds was observed as 500 pounds, which exceeds the systematic error limit of ± 400 pounds. Additionally, the random errors for both the absolute difference below 10,000 pounds and the

percentage difference above 10,000 pounds for axle weights exceed the permissible limits used in the funnel concept.

- * The WIM system at the Kelso site underweighed both vehicles and axles, producing dynamic weights which were less than the corresponding static weight. The mean percentage differences were -16.2 percent for axles and -15.4 percent for trucks for all samples observed. Additionally, excessive random errors were identified for the percentage difference of both axle and vehicle weights.
- * At the Jefferson site, the WIM system was found to be overweighing the trucks (with an 8.2 percent mean percentage difference) and axles (with a 6.8 percent mean percentage difference for all axles) relative to their static weights. Additionally, large variations for static/dynamic comparisons were seen at low weights, particularly for axle weights.
- * The Ashland mainline WIM system showed excessive random errors for axle weights. Both the absolute difference below 10,000 pounds (1,500 pounds) and the percentage difference above 10,000 pounds (8.7 percent) failed to meet the specification limits for this type I POE site.
- * At the South Phoenix site, the WIM system underweighed both vehicles and axles, producing dynamic weights less than the corresponding static weight. The mean percentage differences were -8.2 percent for all axle weight comparisons and -8.0 percent for gross vehicle weight comparisons for all samples observed.

WIM accuracy compared to the IRD WIM specifications. Three manufacturers' makes of WIM system have been evaluated. The WIM manufacturers were:

- * IRD;
- * PAT; and
- * W/W.

Two sets of specifications have been obtained from IRD and PAT that relate directly to the equipment evaluated.

At some sites, neither the state agency or the WIM manufacturer had recorded the exact model number of the WIM system. Therefore, the comparison to the specification compares the WIM against a specification for the same generic type of WIM, for example, an IRD bending plate WIM. Five sites evaluated have IRD WIM systems installed, as follows:

- * Bow Hill;
- * Woodburn;
- * Kelso;

- * Jefferson; and
- * South Phoenix.

As described in Chapter 4, due to the nature and requirements of the IRD specification, it is not possible to firmly state whether the systems evaluated are within the specification limits. Therefore, these results may only be considered as comparative.

As with the HELP WIM specification, different types of axle weight groups have various permissible accuracy limits within the IRD bending plate WIM specification (see Chapter 4). For the purposes of this analysis, all of the axle weights have been combined and the most stringent specification from the weight groups included have been applied. Therefore, axle weight static/dynamic comparisons have limiting accuracies of a ± 3 percent mean error with a 6 percent standard deviation. The equivalent accuracies for gross vehicle weight comparison is a ± 2 percent mean error with a 5 percent standard deviation. The funnel concept is not used in this specification.

Four sites have IRD bending plate WIM systems. All of these fail to meet the specification accuracies from the observations made. These specification failures are as follows:

- * The Bow Hill WIM showed large standard deviations in the percentage difference for both axle (12.6 percent and 16.5 percent) and gross vehicle weights (12.1 percent and 15.2 percent).
- * At the Woodburn site, the WIM system presented large standard deviations in the percentage difference for axle weights (13.0 percent and 10.8 percent).
- * The Kelso WIM was found to underweigh both vehicles and axles and displayed large standard deviations in the percentage difference for both axle (14.7 percent) and vehicle weights (11.4 percent).
- * At the South Phoenix site, the WIM was found to underweigh both vehicles and axles, and displayed large standard deviations in the percentage difference for both axle (13.2 percent) and vehicle weights (10.3 percent).

The fifth site utilizing an IRD WIM system was the mainline installation at Jefferson. This site has a bending plate WIM in the southbound direction and a piezoelectric WIM in the northbound direction. The northbound side was evaluated.

The IRD specification for the piezoelectric WIM has a similar format to the specification for the bending plate WIM. For the purposes of this analysis, all of the axle weights have been combined and the most stringent specification from the included weight groups have been applied. Therefore, axle weight static/dynamic comparisons have limiting accuracies of a ± 3 percent mean error with a 10 percent standard deviation. The equivalent accuracies for gross vehicle weight comparison are a ± 2 percent mean error with an 8 percent standard deviation. As with the IRD bending plate specification, the funnel concept is not used in this specification.

This site also failed to meet the specification accuracies from the observations made. The specification failure is as follows:

- * The Jefferson WIM was found to overweigh both vehicles (with a mean percentage difference of 8.2 percent) and axles (with a mean percentage difference of 6.8 percent). The WIM system also displayed large standard deviations in the percentage difference for both axle (14.7 percent) and vehicle weights (11.4 percent).

WIM accuracy compared to the PAT WIM specification. The comparison of observed accuracies against the PAT specification supplied has been made using the specification for the PAT DAW200 WIM system. As with the IRD WIM specifications, the different types of axle weight groups are each provided with acceptable accuracies. However, the groups are not the same as those used in the IRD specifications. A similar form of analysis has been undertaken using two categories of weight types, that is, axle weights and vehicle weights. Three sites evaluated were equipped with the PAT bending plate WIM, as follows:

- * Santa Nella, high-speed mainline WIM;
- * Ashland, mainline; and
- * Bakersfield.

The PAT specification provides an acceptable accuracy tolerance in terms of a 95 percent confidence level for each weight grouping (see Table 4-3). As all the analyses have been performed on the basis of one standard deviation these values have been halved. For the purposes of this analysis, all of the axle weights have been combined and the most stringent specification accuracy from the different axle weight groups applied. Therefore, the acceptable tolerance accuracy for axle weights is ± 7.5 percent and for vehicle weights is ± 5 percent for one standard deviation. This specification does not differentiate between random and systematic errors.

All three sites were found to be deficient in some area of the specification accuracies. These were as follows:

- * The mainline, high-speed WIM at Santa Nella showed an unacceptably high standard deviation for the percentage difference comparison of axle weights (8.7 percent).
- * The Ashland WIM displayed an unacceptably high standard deviation for the percentage difference comparison of axle weights (9.8 percent).
- * The Bakersfield site displayed an unacceptably high value of the standard deviation for the percentage difference comparison of axle weights (12.0 percent).

Screening tolerance procedures. Tests were performed to determine the effectiveness and efficiency of weight screening policies at weighstations given the observed operational accuracies of the HELP WIM systems. The tests determine the proportion of overweight vehicles that escape detection and the proportion of legally-laden vehicles that are unnecessarily stopped during

weight enforcement screening. These proportions are affected by the distribution of gross vehicle weights and axle weights throughout the truck population and the operational accuracy of WIM systems.

With the sample size used for the accuracy evaluation of the WIM systems (approximately 70 trucks), it was felt that although the sample was randomly selected, it could not provide a realistic distribution of truck or axle weights passing over the equipment being tested. Therefore, the proportion of overweight trucks in the total truck population has been estimated from the truck and axle weight WIM data available for each site on the day of testing.

The observed systematic errors determined in the static/dynamic weight comparison are used to normalize the dynamic weights. This process utilized the mean percentage difference between the static and dynamic weights for either gross vehicle weights or axle weights depending on the type of weight groupings being considered. The choice to use the percentage difference rather than the absolute difference was dictated by the wider ranging effect of the percentage difference-based normalization over all truck and axle weights. This is illustrated by the proportion of truck and axle weights that rest above and below the 10,000-pound pivot point, as shown in Annex B.

Due to the inherent variation in the accuracy of WIM and static weight measurements, this normalization process does not produce a true truck weight distribution. This analysis is therefore indicative. From the resultant truck and axle weight distributions, the proportion of overweight vehicles was calculated for the following criteria:

- * gross vehicle weights;
- * front axle weights;
- * other single axle weights;
- * tandem axle weights; and
- * the federal bridge formula.

In each instance, the state legal weight limits applying at each site have been used to calculate the overweight proportions. The bridge formula calculations, due to their complexity, have been performed only on those trucks that have been found legally laden under the four preceding criteria. No overweight violations on the bridge formula alone were detected. Some vehicles were identified as a overweight under more than one screening criteria.

The proportion of overweight vehicles determined for each test site is provided in Table 5-7.

Table 5-7. Percentage Proportions of Overweight Trucks

Site	Date Visited	Sample Size	Gross Weight (%)	Front Axle (%)	Single Axle (%)	Tandem Axles (%)	Bridge Formula (%)	Total (%)
Bow Hill	April 93	1762	16.7	0.9	11.1	2.6	0.0	20.5
Bow Hill	June 93	1679	13.8	3.1	1.8	7.4	0.0	17.2
Woodburn	March 93	3304	16.8	3.5	4.8	10.0	0.0	23.7
Woodburn	May 93	3423	15.8	2.7	5.8	5.6	0.0	20.7
Kelso	July 93	3306	18.7	15.2	23.8	6.1	0.0	37.3
Jefferson	April 93	3199	27.4	4.9	6.8	18.4	0.0	32.4
Ashland	April 93	1268	9.8	0.8	1.4	15.1	0.0	17.4
Bakersfield	April 93	2266	6.1	3.1	4.8	24.8	0.0	26.3
S. Phoenix	March 93	4979	1.9	9.1	0.9	6.3	0.0	12.6

Table 5-7 shows the total proportions of overweight vehicles to range between approximately 10 and 40 percent with a mean of 23.1 percent. Mainline sites display, on average, higher proportions of overweight vehicles than the weighstation sites, with mean total proportions of 25.2 and 20.5 percent, respectively. This may indicate a higher level of illegally-laden vehicles operating on sections of the interstate at locations that are remote from weighstations.

Within the breakdown of the individual weight criteria, it can be seen that the largest proportions of overweight vehicles, in general, are found under the gross vehicle weight and tandem axle criteria. This is particularly true for the Washington and Oregon sites shown (Bow Hill, Woodburn, Kelso, Jefferson and Ashland). This may reflect the policy in these states enabling the legal operation of vehicles exceeding normal legal limits when in possession of a valid overweight permit. The weight distributions for each site and each type of weight grouping are shown in full in Annex B.

With the truck and axle weight distributions and an observed WIM accuracy available the proportion of overweight vehicles that escape detection and the proportion of legally-laden vehicles unnecessarily stopped during weight enforcement screening has been determined. This data analysis procedure is described in Chapter 4.

A range of screening weight limits has been utilized to illustrate the effects of adopting different screening policies. For gross vehicle weights, a range of screening weight limits from 50,000 to 100,000 pounds was used. For steering axles the screening weight limit ranges varied by state, but in general were from 10,000 to 16,000 pounds. Similarly, the other single axle and tandem axle screening weight ranges varied by state, but in general were from 14,000 to 24,000 pounds and from 28,000 to 38,000 pounds, respectively.

Table 5-8 shows an example of these truck proportions for gross vehicle weights at screening weight limits of 60,000 pounds and 80,000 pounds. The results from these screening tolerance analyses are presented for each site and weighing criterion in Annex B. For all sites, as the screening weight limit is increased, the proportion of overweight trucks escaping detection increases, while the proportion of legally-laden trucks being unnecessarily stopped decreases. The proportions calculated depend upon the truck weight distribution, and therefore will change on a daily basis as the truck weight distribution varies by day of the week and season of the year,

Table 5-8. Effects of Different Screening Weight Limits

Site	Date Visited	60,000 lbs Limit		80,000 lbs Limit	
		Overweight Escaping (%)	Legal Stopped (%)	Overweight Escaping (%)	Legal Stopped (%)
Bow Hill	April 93	0.6	26.3	20.6	7.3
Bow Hill	June 93	2.2	25.8	26.4	7.5
Woodburn	March 93	0.0	32.2	10.9	2.7
Woodburn	May 93	0.0	27.4	12.1	4.7
Kelso	July 93	0.3	27.8	16.8	5.3
Jefferson	April 93	0.5	28.2	20.4	5.7
Ashland	April 93	0.0	35.0	31.0	3.5
Bakersfield	April 93	0.0	41.8	35.6	5.0
S. Phoenix	March 93	0.4	12.9	32.2	2.1

For the sites which have had a weight analysis performed and WIM data are available for the days of the on-site evaluations, the screening weight analyses have been undertaken. The results of these analyses enable the weighstation operating authorities to examine their potential screening policies using the Crescent system. An example of this may be seen in operation at the Woodburn weighstation, where weight-only prescreening is used to reduce the volume of trucks passing over the static scales.

Table 5-9 presents the proportions of legal (underweight) trucks that are unnecessarily stopped for static weighing and illegal (overweight) trucks that escape detection bypassing the static scales. These figures are based on the gross vehicle weight distribution, which can be seen in Graph B.J.4.17 in Annex B, and the selected weight screening limit. The weight screening limit ranges have been shown in 10,000-pound intervals from 50,000 to 100,000 pounds.

Table 5-9. Weight Screening Analysis for Woodburn May 20, 1993

Screening Weight Limit (x 1000 lbs)	Unnecessary Legal Stops (%)	Illegal Escapes (%)
50	36.0	0.0
60	27.4	0.0
70	17.2	0.9
80	4.7	12.1
90	0.2	38.6
100	0.0	66.0

Graphs of these two truck proportions for each on-site evaluation with the suitable data set are provided in Annex B. Additionally, graphs showing the proportion of illegal trucks escaping detection plotted against the proportion of legally-laden vehicles unnecessarily stopped for static weighing are given.

The selection of a suitable screening weight limit is determined by the screening policy adopted, the operational accuracy of the WIM system, the truck volume through the weighstations, the weighstation capacity and the truck weight distribution.

Automatic Vehicle Classification Equipment Accuracy

Tests were undertaken to determine the accuracy of the vehicle classifications achieved automatically by the Crescent equipment. Vehicles were classified manually and data were analyzed on a vehicle-by-vehicle basis using a comparison of the automatic and manual classifications.

The results of the classification study by site are summarized in Table 5-10. The data shown in Table 5-10 represent the complete data collected during the study period. However, two additional factors affecting the AVC accuracy have also been considered in the study.

Table 5-10. AVC Classification Accuracy

Site	Date Visited	Manual Total	WIM Total	Absolute Accuracy (%)	Compensated Accuracy (%)
Bow Hill	June 93	336	310	78.0	67.6
Bow Hill	April 93	57	52	73.7	59.6
Woodburn	May 93	637	637	72.2	68.1
Kelso	July 93	75	71	84.0	73.3
Jefferson	April 93	362	193	47.5	42.8
Ashland	April 93	90	84	75.6	60.0
Bakersfield	April 93	227	196	73.1	65.2
S. Phoenix	March 93	202	136	45.5	33.7
Seguin (3)	Jan. 93	136	131	64.7	52.2
Seguin (4)	Jan. 93	706	589	63.0	55.1

Table 5-10 contains separate data for both of the two lanes at the Seguin site. Lane 3, which is denoted (3), is the median lane, which accounts for the relatively low truck count observed in comparison to lane 4, which is the outside lane and is denoted by (4).

From Table 5-10 it can be seen that the AVC absolute accuracies observed ranged between 45.5 and 84.0 percent, with a mean value of 67.7 percent. The compensated accuracies observed ranged between 33.7 and 73.3 percent, with a mean value of 57.8 percent. In all cases, the compensated accuracy is smaller than the associated absolute accuracy. This results from a lack of compensation between the different classifications of vehicles, indicating that the AVC systems are biased in relation to the manual observations.

Also, in all cases, the manually observed total number of vehicles equals or exceeds the AVC total. This arises from the automated screening of some vehicle classifications from the WIM records. This screening process is outlined below. Detailed breakdowns of these results may be found in Annex B.

Automated screening of AVC vehicle observations. Two significant factors have been considered in the analysis of the AVC accuracy. The first factor is the automatic screening of small trucks and other vehicles from the WIM records by the Crescent system. This reduces the computer storage capacity required to store WIM and AVC data recorded continuously from all of the sites in the Crescent Demonstration.

The second factor considers consistent errors that have been identified between the vehicle classifications recorded manually and automatically. This is examined later in this chapter.

This section addresses the automated screening of some classifications of vehicles from the WIM records. Generally, the records of those vehicles that are class 6 or under in the FHWA Scheme F Classification schedule are discarded. This classification scheme is also known as FHWA 13, as it contains 13 classification types. Consequently, all vehicles falling into these classification types will be manually observed but are apparently missed in the WIM records.

This screening process was recognized during the on-site evaluations and observers did not record noncommercial light vehicles passing over the Crescent equipment. An analysis has been undertaken to make an allowance for this vehicle screening. The AVC accuracies gained from the screened analysis are shown in Table 5-11.

Following the analysis removing all manual observations of vehicles under class 6 that were not recorded by the AVC system, both the compensated and absolute accuracies are found to increase.

From Table 5-11, it can be seen that the AVC absolute accuracies observed ranged between 54.1 and 89.1 percent, with a mean value of 77.3 percent. The compensated accuracies observed ranged between 40.0 and 83.2 percent, with a mean value of 67.5 percent. In both cases the mean accuracies are just less than 10 percent greater than the accuracies for the raw data. Again, in all cases, the compensated accuracy is smaller than the associated absolute accuracy.

The AVC system at the South Phoenix (Tempe) site shows low accuracies. The analysis indicates that the system failed to classify 38.6 percent of the vehicles within the raw data set and, even after allowing for the automated screening, the AVC failed to provide any classification on 27.1 percent of the vehicles observed. This large proportion of nonclassified vehicles may result from a number of sources, such as poor lane discipline or a defective installation.

Data collection difficulties for AVC equipment analysis. For four sites, on-site AVC equipment accuracy assessments were undertaken but no results are available due to difficulties encountered after the on-site evaluations. These sites were:

- * Kelso (June);
- * Woodburn (March);
- * Santa Nella (HS) (May and June); and
- * San Simon (February and May).

Table 5-11. Screened Classification Accuracies

Site	Date Visited	Absolute Accuracy (%)	Compensated Accuracy (%)
Bow Hill	June 93	84.0	72.8
Bow Hill	April 93	82.4	66.7
Woodburn	May 93	72.2	83.2
Kelso	July 93	85.1	74.3
Jefferson	April 93	89.1	80.3
Ashland	April 93	80.0	63.5
Bakersfield	April 93	83.4	74.4
S. Phoenix	March 93	54.1	40.0
Seguin (3)	Jan. 93	71.0	57.3
Seguin (4)	Jan. 93	71.3	62.3

At the Kelso site, a power failure to the AVC equipment enabled no automated data collection for a majority of the on-site evaluation period during the June 1993 visit. This has been described in the WIM accuracy evaluation results section. An additional on-site visit was scheduled by CRC to replace these lost data. This visit was performed in July 1993.

At Woodburn, Santa Nella and San Simon, the AVC data were lost due to purging of the WIM data records, as explained in the WIM accuracy evaluation results section. Therefore, no results are available for these on-site evaluations. At the Bow Hill, Kelso and Ashland sites, small sample sizes resulted from operational difficulties encountered during the evaluations. These sample sizes reduce confidence in the results gained for these AVC systems.

Three weighstation sites visited during the on-site evaluations had no AVC system in place. These weighstations were Ashland, Banning and Lordsburg.

AVC accuracy compared to the HELP AVC specification. A comparison of the accuracies observed for AVC systems has been made to the HELP AVC accuracy specification. The HELP specification contains two conditions relating to accuracy that require satisfaction. The first condition is the overall vehicle type classification accuracy should correctly classify at least 90 percent of vehicles. The second condition is that vehicle classes containing at least 30 vehicles should correctly classify at least 90 percent accurately.

None of the observed accuracies, after allowance for the automated screening of the smaller vehicle classifications, met the HELP AVC specification accuracy conditions.

Identification of consistent classification errors. On a number of separate occasions, the AVC systems recorded vehicles from one classification consistently into a second different classification. Most commonly this occurred with vehicles that were manually observed as class 3 being recorded by the AVC system as class 5 vehicles. Specific details of the adjustments that have been performed are given in the classification tables in Annex B.

These misclassifications probably relate to the nature of identifying classes of vehicle used by the WIM/AVC system. Such automated systems utilize algorithms to define the classification based upon the number of axles, axle spacings and overall wheelbase of vehicles. This does not ideally correlate with the FHWA classification scheme which was developed for manual visual observations of vehicles.

The results in Table 5-12 combine the effects of the automated screening adjustment with the rectification of these recurrent misclassifications. The resultant mean AVC absolute accuracy for all sites following this adjustment is 82.7 percent and the mean compensated accuracy is 77.8 percent. Both of these forms of adjustments increase the observed accuracy of the AVC classifications.

Table 5-12. Screened Modified Classification Accuracies

Site	Date Visited	Absolute Accuracy (%)	Compensated Accuracy (%)
Bow Hill	June 93	93.6	92.0
Bow Hill	April 93	90.2	82.4
Kelso	July 93	91.9	87.8
S. Phoenix	March 93	63.5	58.8
Seguin (3)	Jan. 93	81.5	73.4
Seguin (4)	Jan. 93	81.4	82.5

Axle Spacing Measurement Accuracy

Tests were undertaken to determine the accuracy of axle spacing measurements made automatically by the Crescent equipment. A random sample of vehicles was manually measured using a tape measure, and the data were analyzed on a vehicle-by-vehicle basis to enable a comparison of the manual and automatic axle spacing measurements.

The results of the axle spacing study are summarized in Tables 5-13 and 5-14. Table 5-13 shows the accuracy of wheelbase measurements for vehicles, which are generated by accumulating the individual axle spacings for a vehicle. Table 5-14 shows the accuracy of individual axle spacing measurements.

Table 5-13. Wheelbase Measurement Accuracy

Site	Sample Size	Absolute Difference (feet)		Percentage Difference (%)	
		Mean	S.D.	Mean	S.D.
Bow Hill	10	0.7	0.4	-1.2	1.0
Bow Hill	6	0.3	0.4	0.5	0.8
Woodburn	12	-0.2	1.2	-0.4	1.9
Santa Nella (LS)	15	0.8	0.6	1.5	1.1
Santa Nella (LS)	20	-0.5	2.8	-1.0	4.9
Santa Nella (LS)	25	-0.9	3.4	-1.1	8.2
Kelso	5	1.2	0.4	2.2	0.6

Table 5-14. Axle Spacing Accuracy

Site	Sample Size	Absolute Difference Below 8 ft (feet)		Sample Size	Percentage Difference Above 8 ft (%)	
		Mean	S.D.		Mean	S.D.
Bow Hill	15	0.0	0.1	24	-1.4	1.0
Bow Hill	11	0.0	0.1	13	0.7	1.0
Woodburn	24	-0.1	0.1	27	0.0	2.1
Santa Nella (LS)	21	0.0	0.1	36	1.5	1.5
Santa Nella (LS)	32	-0.2	0.1	48	-0.2	6.0
Santa Nella (LS)	26	-0.1	0.2	67	-1.8	9.0
Kelso	11	0.1	0.1	12	2.1	0.9

Data collection difficulties for axle spacing equipment analysis. Difficulties were encountered at the following sites during the axle spacing equipment evaluations:

- * Kelso (June); and
- * San Simon (May).

A power loss to the Crescent equipment at the Kelso site during the June on-site evaluation, as explained previously, permitted no further data analysis to be undertaken. Purging of WIM data by Lockheed meant that no further data analysis could be performed following the May on-site evaluation at the San Simon site.

At a number of sites, no data collection was permitted as the weighmasters felt that the disruption to the normal flow of trucks constituted a hazardous traffic situation.

Comparison to the HELP axle spacing specification Comparison of the accuracies observed with specification accuracies was undertaken with two forms of specification. As with the WIM accuracy measurements, these observed accuracies are compared to the HELP specification and specifications from the manufacturers for the individual systems in place. Two makes of WIM system were examined for axle spacing accuracy. The IRD specification was made available.

Comparison of the observed accuracies of axle spacing measurements with the HELP WIM specification accuracy shows all of the sites examined, except Santa Nella (low speed), to be within the acceptable limits for axle spacing measurements. Table 5-14 shows the results in the format required by the HELP WIM specification accuracy for axle spacing measurement.

The HELP WIM specification accuracy for the axle spacing measurement permits a systematic error of no more than ± 0.5 ft for axle spacing with lengths less than 8 ft with a random error of 1.0 ft. Above 8 ft, the percentage difference is used with a maximum permissible systematic error of ± 5 percent with a random error of 5 percent. This specification follows the funnel concept with the pivot point at 8 ft.

Comparison to the IRD system axle spacing specification. The IRD systems were assessed for their specification compliance. Three sites have IRD systems installed, as follows:

- * Bow Hill;
- * Woodburn; and
- * Kelso.

The IRD specification defines acceptable limits for vehicle wheelbase measurement and axle spacing measurement. A mean error of 12 inches (1.0 ft) with a standard deviation of 18 inches (1.5 ft) exists for vehicle wheelbase measurements. Similarly, a mean error of 2 inches (0.17 ft) with a standard deviation of 3 inches (0.25 ft) exists for axle spacing measurements. This specification does not use the funnel concept.

Table 5-15 shows the absolute accuracies for all measurements of wheelbase and axle spacing.

Table 5-15. Accuracies Compared to the IRD Specification

Site	Wheelbase			Axle Spacings		
	Sample Size	Mean (ft)	S.D. (ft)	Sample Size	Mean (ft)	S.D. (ft)
Bow Hill	10	0.7	0.4	39	-0.2	0.2
Bow Hill	6	0.3	0.4	24	0.1	0.1
Woodburn	12	-0.2	1.2	51	-0.1	0.4
Kelso	5	1.2	0.4	23	0.3	0.3

The only system that fails to meet the IRD specification is at the Kelso site. Large mean errors can be seen for both the wheelbase (1.2 ft) and axle spacing (0.3 ft) measurements.

5.3 OPERATIONAL ANALYSIS

Tests were performed to evaluate the normal operating procedures of weighstation sites in order to determine the possible impacts of use of the HELP system. These tests consider the weight enforcement process at each site as well as the types of inspections performed.

As explained in Chapter 4, weighstations in all participating states undertake weight screening of trucks for enforcement purposes. In addition, some states collect commercial vehicle taxes at the weighstations. The different functions of weighstations in each state are illustrated through the results presented in this section.

This section is divided into three elements. As stated before, these elements are not independent and are separated only for ease of reading. These elements are:

- * truck volumes through weighstations;
- * truck transit times and delays at weighstations; and
- * analysis of inspections and citations.

Truck Volumes Through Weighstations

This element of the operational analysis addresses the truck flows through the weighstation sites, the routes used by trucks in the weighstations and the proportion of trucks that were statically weighed at each site.

The volume of truck traffic passing through each weighstation is shown in Table 5-16. The results shown are the mean truck flow and the standard deviation of the distribution for fifteen-minute periods during the study. The standard deviation is given to show the order of the change in the truck flow that occurred during the study period.

Table 5-16. Truck Volumes Through Sites

Site	Date Visited	Trucks passing through site	
		Mean	S.D.
Bow Hill	April 93	31	7
Bow Hill	June 93	30	6
Woodburn	March 93	58	8
Woodburn	May 93	56	6
Ashland	April 93	8	2
Ashland	May 93	29	6
Santa Nella	May 93	23	4
Santa Nella	July 93	31	6
Banning	May 93	69	10
San Simon	Feb. 93	23	6
San Simon	May 93	21	6
Lordsburg	March 93	26	5

From Table 5-16, it can be seen that the truck flows varied from the lowest volume levels of about 20 trucks per 15 minutes (approximately **1.3** trucks arriving per minute) to higher volume sites up to 70 trucks per 15 minutes (approximately 4.7 trucks arriving per minute). The Ashland site showed a notably low truck volume during the April 1993 evaluation, however, this was not repeated during the May 1993 evaluation. All of these on-site evaluations

are considered separately throughout this operational analysis. However, the low truck flow at Ashland may indicate that it is an abnormal traffic day.

For the sites with the higher truck flows, the arrival rate of trucks sporadically exceeded the processing rate at the site. This temporary overloading of the operational system caused significant queues to develop. These truck flows have been combined with queue length and truck transit time information to create a model of the truck flow through each site. This is explained later in this chapter.

Not all of the trucks entering a weighstation pass over the static scales. Table 5-17 illustrates the proportion of trucks using each travel path within the weighstation local system. The three paths available through or around weighstations are:

- * passing over the static scale;
- * bypassing within the weighstation; and
- * bypassing the weighstation along the highway.

Table 5-17. Truck Proportions Using Local System Routes

Site	Date Visited	Trucks Passing Over Scales (%)	Bypassing	
			Site (%)	In Station (%)
Bow Hill	April 93	99.3	0.7	
Bow Hill	June 93	100.0		
Woodburn	March 93	41.1		58.9
Woodburn	May 93	100.0		
Ashland	April 93	100.0		
Ashland	May 93	96.1		3.9
Santa Nella	May 93	100.0		
Santa Nella	July 93	100.0		
Banning	May 93	44.2	27.3	28.5
San Simon	Feb. 93	96.5		3.5
San Simon	May 93	99.3		0.7
Lordsburg	March 93	100.0	-	

For most of the weighstations evaluated, a significant majority of the trucks followed the route passing over the static scales. However, this does not necessarily mean that these trucks were statically weighed as some trucks were waived through the site, passing over the static scales without being weighed if a large queue had developed.

Two sites showed significant usage levels of routes other than over the static scale, in the form of in-station bypassing or total bypassing of the weighstation. At Woodburn, the WIM, which is located in the entrance ramp, is used to provide an automatic weight screening bypass system. Unladen trucks dynamically weighed under a chosen limit were given a signal to bypass the static scales. This increased the truck capacity of the site and limited the growth of queues to the static scales.

The two on-site evaluations at Woodburn show different levels of use of this weight-only in-station bypassing. On the first occasion (March 1993), the screening weight limit was set at 50,000 pounds and 58.9 percent of trucks used the in-station bypass. On the second occasion (May 1993), the limit was 80,000 lbs and no trucks used the in-station bypass. This provides a good illustration of the weight screening process described in the equipment analysis section of these results.

At Banning, in particular, the processing rate limit was exceeded regularly during the evaluation study period. Large queues developed on a number of occasions and the queue backed up beyond the off-ramp for 58 percent of the study period. To reduce the queues, the weighstation would be temporarily closed and trucks allowed to bypass the station along the highway. It was observed on a number of such occasions that trucks reversed along the off-ramp to gain access back to the highway without the need to pass through the weighstation. This created a highly hazardous traffic situation.

In addition, the Banning weighstation operates a bypass lane within the site that enables trucks to bypass the static scale. Use of this bypass lane is a voluntary decision by the truck driver that his/her vehicle is under the prescribed 20,000 pounds weight limit. No checking is performed on these vehicles.

As explained above, not all vehicles passing over the static scales are weighed. The proportion of trucks that are statically weighed at each site is given in Table 5-18.

These results in conjunction with the proportion of trucks using the path that passed over the static scales as shown in Table 5-17, indicates the proportion of trucks following that path that were not weighed. Most noticeably, at Woodburn (March 93) 6.1 percent of the truck population passed over the scales without being weighed. This tends to indicate sites which operate near to capacity. The waiving through of trucks reduces the queue length and enables faster processing of trucks.

Table 5-18. Proportion of Trucks Statically Weighed

Site	Date	Statically Weighed (%)
Bow Hill	April 93	93.9
Bow Hill	June 93	99.3
Woodburn	March 93	35.0
Woodburn	May 93	100.0
Ashland	April 93	100.0
Ashland	May 93	96.1
Santa Nella	May 93	100.0
Santa Nella	July 93	100.0
Banning	May 93	44.2
San Simon	Feb. 93	93.9
San Simon	May 93	99.3
Lordsburg	March 93	100.0

Truck Transit Times and Delays at Weighstations

The time taken for a truck to pass through each weighstation was determined by vehicle registration plate matching at the site entrance and exit. For the vehicles that were clearly identifiable, transit times were calculated. The entrance times would be logged for vehicles either as the vehicle passed a point denoting the entrance to the site or when the vehicle joined the end of the queue to the static scales, if this was outside the site and beyond the site entrance marker. At the site exit, trucks were timed and recorded as they left the boundary limit of the weighstation. Therefore, the transit times for trucks through weighstations may be considered an underestimate as no provision is made for deceleration into the site or acceleration away from the site that occurs on the off-ramp and on-ramp.

A number of longer duration times were recorded within the distribution of truck transit times determined at each site. These indicate trucks that have stopped to obtain a required permit or that have simply parked in the station. To provide a measure of the normal transit time through a site these longer transit times have been rejected.

To form a consistent definition of an abnormally long transit time for all sites, only vehicles whose transit time was greater than the mean transit time plus one standard deviation of the transit times distribution would be highlighted as abnormally long durations. This should encompass approximately 16 percent of trucks passing through the site, if the truck transit times follow a normal distribution. Table 5-19 shows the nonstop normal truck transit times for the sites evaluated.

In Table 5-19 it can be seen that the mean transit times range from the longest of 765 seconds (at Lordsburg) to the shortest of 73 and 74 seconds (at Woodburn and Bow Hill, respectively). The Lordsburg transit times are distorted by the relatively large number of vehicles that had exceptionally long transit times. This results in some vehicles that have parked being included in the normal transit times. The dividing point between abnormal and normal times for Lordsburg, calculated by the standard method, is 29 minutes. The five identified abnormal vehicles had a mean transit time of over 53 minutes. Therefore, the true “normal” transit time for vehicles passing through the Lordsburg weighstation without unnecessary delays is somewhat shorter than indicated.

In general, weighstations that require some form of interaction with the truck drivers at the static scale display longer mean transit times than stations with no interactions at the scale. A notable exception to this is Banning, where the congestion and lengthy queues are reflected in a long mean transit time. At Santa Nella and Bow Hill, the two pairs of mean transit times for each site are significantly different. Further investigation has revealed no identifiable reasons for these differences.

In addition to the normal transit times for vehicles using the path passing over the static scales, as shown in Table 5-19, transit times were also determined for in-station bypassing. This has only been calculated where significant sample sizes for in-site bypassing were recorded. These in-station bypass transit times were as follows:

- * Woodburn (March 93) - mean 54 seconds, standard deviation 15 seconds; and
- * Banning (May 93) - mean 219 seconds, standard deviation 77 seconds.

Given the normal transit times for vehicles to pass through each weighstation, the average delay to legally-laden trucks has been calculated. This combines the transit time for each path around the weighstation with the proportions of trucks using this path. These delays indicate the time lost in the weighstation, as an allowance has been made for the time taken to pass directly along the highway. This time allowance is based on the distance from the site entrance to the site exit measured along the highway and an assumed truck speed of 55 mph. The resulting average time delays are given for each site in Table 5-20.

Table 5-19. Truck Transit Times Through Sites

Site	Date Visited	Sample Size	Normal transit time		
			Proportion of trucks (%)	Mean (s)	S.D. (s)
Bow Hill	April 93	116	100.0	74	29
Bow Hill	June 93	419	97.1	137	53
Woodburn	March 93	340	91.8	99	21
Woodburn	May 93	524	98.9	73	32
Ashland	May 93	369	91.3	158	81
Santa Nella	May 93	268	100.0	170	23
Santa Nella	July 93	227	98.2	80	18
Banning	May 93	259	96.5	390	124
San Simon	Feb 93	313	82.1	204	49
San Simon	May 93	238	89.1	168	120
Lordsburg	March 93	66	92.4	765	345

Table 5-20. Average lime Delays to Legally-Laden Trucks

Site	Date Visited	Delay Time (s)
Bow Hill	April 93	49
Bow Hill	June 93	92
Woodburn	March 93	66
Woodburn	May 93	53
Ashland	May 93	142
Santa Nella	May 93	145
Santa Nella	June 93	55
Banning	May 93	216
San Simon	February 93	176
San Simon	May 93	147
Lordsburg	March 93	102

The figures shown in Table 5-20 are the average delay times for all vehicles passing through the weighstation without unnecessary stops or being detained for inspection purposes. This includes vehicles bypassing within the weighstation. These figures, in conjunction with the queue lengths and truck volumes, were used to create a model for the flow of trucks around the sites.

The average queue length for each site is presented in Table 5-21. The queue lengths are shown in terms of the average number of trucks in the queue and the queue length in feet. Queue lengths were recorded every minute during the operational analysis study period. However, due to the limited assistance from state authorities on some sites, the queue length monitoring was restricted to recording either the number of trucks in the queue or the queue length in feet. These difficulties applied to the evaluations at Ashland and Banning.

Two of these sites have two static scales. The queue lengths shown for Woodburn are for the left and right scale, respectively. No queue length in feet was recorded, as the observer was required to record the activity in the two queues simultaneously. At Bow Hill, although there are two static scales, only one is operated at any time. The queue lengths given are for the first and second scale, respectively. Bow Hill operates roll-over weighing, which reduces the average time taken to statically weigh vehicles.

Table 5-21. Queues at Weighstations

Site	Date Visited	Queue Length (Trucks)		Queue Length (feet)	
		Mean	S.D.	Mean	SD.
Bow Hill	June 93	2/3	1/2	103	115
Woodburn	March 93	1.3 / 1.0	0.4 / 0.3		
Ashland	May 93	3	.	-	
Santa Nella	May 93	2	1	55	37
Banning	May 93			602	160
San Simon	Feb 93	4	2	66	66
San Simon	May 93	2	2	63	65
Lordsburg	March 93	10	4	457	207

Analysis of the queuing data in conjunction with the truck volumes and rate of arrival of trucks at weighstations was undertaken. This analysis attempted to identify relationships between the rate of arrival of trucks at the site and their transit times through the site. Graphs illustrating the results are given in Annex B.

From this analysis, it was not possible to generate any clear relationship between longer queues and longer transit times for vehicles to pass through the site. Therefore, the time savings determined for different levels of AVI-equipped trucks have been calculated by the reduced transit times gained from bypassing legal AVI-equipped trucks. These are assumed to be mainline bypasses with the trucks not entering the weighstation.

The bypassing of trucks has an impact on the queue length to the static scale, which, in turn, logically reduces the transit times for non-AVI-equipped vehicles passing through the site. However, without a queue-length-to-transit-time relationship, this time savings cannot be estimated with any certainty, and therefore it has been omitted from the delay time calculations. The time savings generated by the bypassing of legal AVI-equipped trucks therefore must be considered as low estimates.

The relationship between different levels of AVI-equipped trucks and the average delay times for trucks passing weighstations, either through it or along the highway, is linear. An example is shown for the San Simon site (February 1993) in Table 5-22.

Table 5-22. Average Delay Times with AVI Bypass Usage

Proportion of AVI Equipped Trucks (%)	Average Time Delay (s)
0	176
1	174
5	167
10	158
20	141
30	123
50	88

A more complex situation exists at the Banning weighstation. As the proportion of trucks completely bypassing the site increases, there will not necessarily be a reduction in the average delay time experienced at the site. This results from a replacement of those vehicles removed from the weighstation queue by vehicles that currently escape having to enter the weighstation. These escaping vehicles are released when the queues grow to a point that the weighstation has to be temporarily closed.

Analysis of Inspections and Citations

The different levels of enforcement effort at each site have been measured by the proportion of trucks that undergo some form of inspection. The nature and frequency of these inspections affected the operational capacity of the site. Table 5-23 presents the proportion of trucks inspected within the truck population captured in the study sample. This represents the proportion of vehicle entering the weighstations that are checked.

From Table 5-23, it is not difficult to identify weighstations that perform some form of inspection of documentation when the vehicle is on the static scale. This is reflected in the graphs showing the different forms of inspection undertaken. Weighstations that do not undertake any documentation check of vehicles on the static scale tend to visually select vehicles to check.

The different forms of inspection are illustrated in Graphs 5-1 through 5-5. These inspections are not mutually exclusive, as the full-vehicle inspection contains most of the checks performed.

A number of sites undertook occasional checks on bills of loading, agriculture permits, medical cards, fuel permits and insurance documentation. Where these types of inspection have not been specifically identified, they have been included in the “others” category.

GRAPH 5-1 - INSPECTIONS

Lordsburg, NM March 5, 1993



 Data A

Sample size - 556

GRAPH 5-2 - INSPECTIONS

San Simon, AZ February 3, 1993

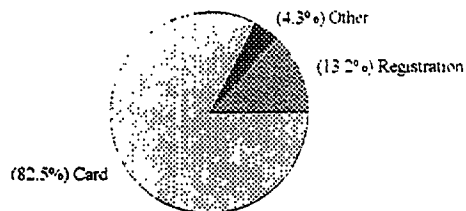

Sample size - 606

GRAPH 5-3 - INSPECTIONS

Woodburn, OR March 9, 1993

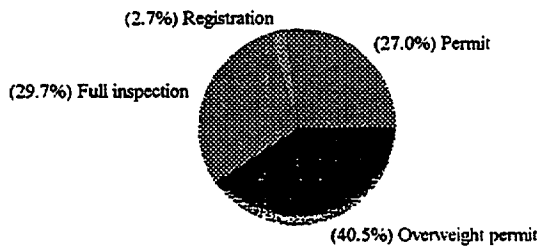

GRAPH 5-4 - INSPECTIONS

San Simon, AZ May 10, 1993

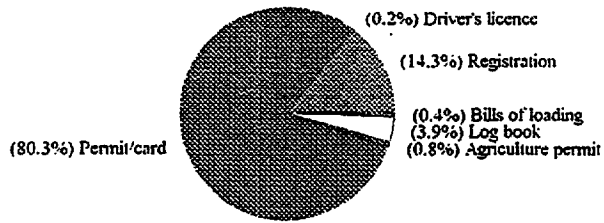

Sample size - 483

GRAPH 5-5 - INSPECTIONS

Bow Hill, WA April 14, 1993

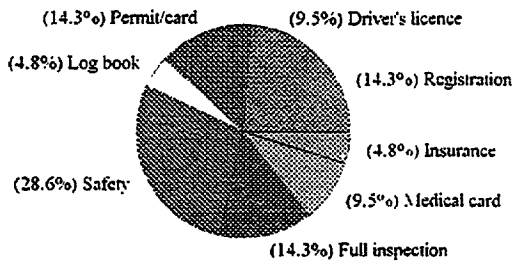

Sample size - 23

Table 5-23. Proportion of Trucks Inspected

Site	Date	Vehicles Inspected	Vehicles Checked (%)
Bow Hill	April 93	23	2.8
Woodburn	March 93	29	2.9
Santa Nella	May 93	3	0.9
Santa Nella	July 93	0	0.0
Banning	May 93	28	4.5
San Simon	Feb. 93	606	93.9
San Simon	May 93	483	99.3
Lordsburg	March 93	556	93.5

In addition to the sites shown in Graphs 5-1 through 5-5, two other sites undertook inspections. At Banning, 28 full-vehicle inspections were made, and at Santa Nella one check on registration documentation and two safety inspections of vehicles were undertaken.

From Graphs 5-1 through 5-5, it can be seen that the Lordsburg and San Simon sites concentrated on permit and registration documents. The Woodburn site primarily concentrated on permit, overweight permit and full inspections, which included documentation and a vehicle safety check. The Bow Hill site undertook a wide range of inspections, with safety inspections being the largest category.

From the inspections undertaken some citations were issued as shown in Graphs 5-6 through 5-10. Table 5-24 gives the proportion of trucks that passed through each site that were cited during the study period. In addition to the citations issued, weighmasters frequently issue verbal warnings to truck drivers. However, these are more difficult to document and the data received from the weighstation staff were considered unreliable.

GRAPH 5-6 - VIOLATIONS

Lordsburg, NM March 5, 1993

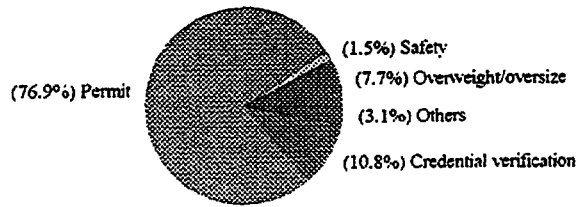

■ Data A

Sample size - 61

GRAPH 5-7 - VIOLATIONS

San Simon, AZ February 3, 1993

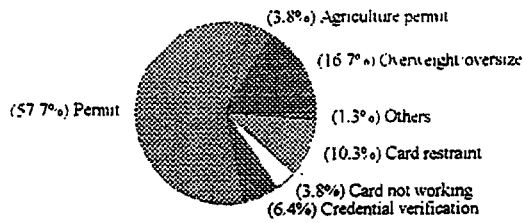

■ Data A ■ Data B

Sample size - 78

GRAPH 5-8 - VIOLATIONS

Woodburn, OR March 9, 1993

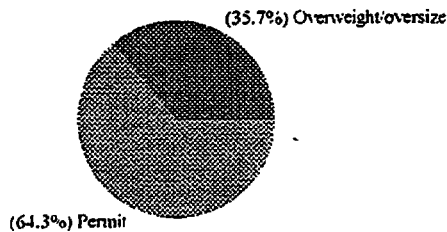

■ Data A

Graph 5-9 Violations

San Simon, AZ May 10, 1993

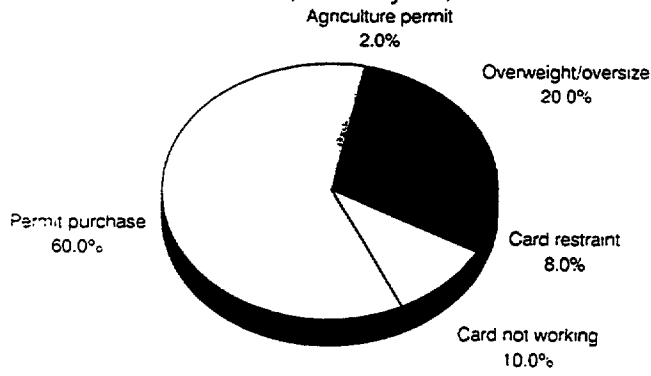

Sample size 50

Graph 5-10 Violations

Bow Hill, WA May 10, 1993

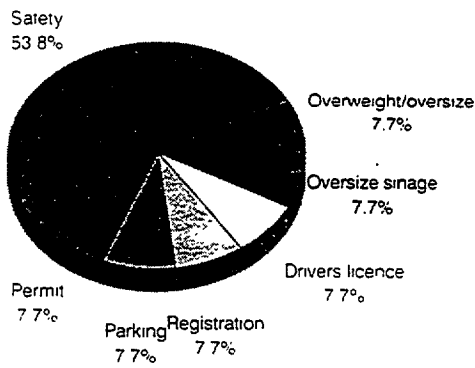

Sample size 13

Table 5-24. Propotion of Trucks Cited

Site	Date	Number of Citations Issued	Proportion Cited (%)
Bow Hill	April 93	13	2.1
Woodburn	March 93	14	1.7
Santa Nella	May 93	0	0.0
Santa Nella	July 93	0	0.0
Banning	May 93	13	2.1
San Simon	Feb. 93	78	12.3
San Simon	May 93	49	12.0
Lordsburg	March 93	65	11.4

Table 5-24 presents a breakdown of the different forms of citations issued during the study period. States operating vehicle ton-mile tax collection procedures at weighstations recorded higher levels of citations than states undertaking weight enforcement and safety checks only. However, the citations issued by these states were biased towards violations for invalid permits or overweight trucks travelling without the necessary overweight permits.

5.4 ON-SJTE PERSONNEL INTERVIEWS

At the weighstations visited, personnel were asked to complete a questionnaire which considered their views on various aspects of the HELP concept and the Crescent Demonstration. The purpose of the on-site interviews was to obtain the impressions and attitudes of the weighstation personnel on the performance and effectiveness of the Crescent equipment and system. Weighstation personnel were asked questions examining the following areas:

- * the extent to which the Crescent system was being used at the weighstation;
- * the level of theoretical and practical training received;
- * the ease of operation of the system;
- * their impression of the accuracy and reliability of the system;
- * the effect of the system on the efficiency of operations at the weighstation; and
- * their recommendations for improvements in system operations.

The general impressions of the Crescent system varied between sites depending on the extent to which the system was being used at the weighstation. It should also be noted that at the time of the site interviews, the Crescent system was not fully operational at many of the sites. A summary outlining the main points arising from each interview is given below.

Bow Hill, Washington

The Bow Hill weighstation is currently equipped with AVI and WIM on the entrance ramp to the weighstation but did not have weighstation bypass capabilities at the time of the evaluation. WSDOT is planning to install a bypass lane at the weighstation during 1994.

The on-site interviews recorded that the current site operations are not affected by the Crescent equipment. The weighstation operators believed they received sufficient practical training to use the system and also some theoretical training. They reported that the Crescent system was easy to use. Beyond those comments, their attitudes towards the system were neutral and no suggestions for improvements were provided.

Woodburn, Oregon

The Woodburn weighstation uses the Crescent system to bypass trucks from the static scale to a bypass lane within the weighstation. The weighstation officers reported that they received sufficient practical training to operate the system but did not receive enough theoretical training indicating the potential applications of the system to weighstation operations. They found the system easy to use, but thought the data provided by the system were inaccurate and unreliable.

The site officers felt that using the system made no difference to the level of paperwork undertaken at the weighstation, but significantly reduced the staff work load while increasing the vehicle processing rate, violation detection rate and general site operations. The weighstation officers did not provide any recommendations or comments on improvements to the system.

A PUC officer expressed concern that there was no identification of the trucks bypassing the static scales using the weight-only preclearance of trucks. This has an impact on the auditing process.

Santa Nella, California

The Santa Nella weighstation was designed and configured for the use of the Crescent system and related equipment. At the time of the on-site interviews, the Crescent system was becoming operational and the full effects and impacts of the system could not be determined. The CHP officer operating the weighstation felt that he had received sufficient practical and theoretical training on the system and that the system was easy to use. He had no opinion of the accuracy

and reliability of the system, and felt that at the present time the system had no effect on the paperwork, workload, vehicle processing or violation detection. However, he did feel that the system improved the general operation of the site.

The officer suggested the system should be upgraded to show tandem axle weights and that the site configuration be changed. This reconfiguration would position the slow-speed WIM in the lane closest to the scale house where the static scale is currently positioned. Such a configuration would remove the need to order trucks to circle around the scale house in order to gain access to the static scale for reweighing.

Banning, California

The Banning weighstation was only equipped with AVI, and the system was not being used. The site officers reported that they had received some practical training on operating the system when it had been installed, but because the system was not being used no one at the weighstation was familiar with the equipment. This was considered to be a major hindrance to future use of the system. The weighstation officers had no opinion on the ease of operation, or the accuracy and reliability of the system.

The sergeant in charge of the weighstation believed that the entire weighstation needed to be reconfigured and that these technologies may have a place in a site layout designed to utilize the system. This reconfiguration was considered to be more important than installation of further Crescent equipment.

San Simon, Arizona

The San Simon weighstation was not using the Crescent system at the time of the on-site evaluation, the system had been nonoperational for months before the first on-site evaluation and Lockheed was still debugging the system during both on-site evaluations.

The weighstation personnel reported that they received sufficient practical training to operate the system but had received no theoretical training to demonstrate the applications of the system to weighstation operations. The weighstation officers felt the system was not reliable or accurate. Furthermore, as the Crescent system was not in use, it had no effect on site operations. The weighstation manager felt that the weighstation would be better served by extending the entrance ramp rather than the installation of further Crescent equipment.

Lordsburg, New Mexico

The Lordsburg weighstation had not yet integrated the Crescent system into site operations. The weighstation operators were provided with some practical training when the AVI system was first installed but received no theoretical training relating to the potential applications of the technology. The weighstation personnel had no opinions on the accuracy or reliability of the equipment and had no recommendations or comments on integrating the system into site operations.

6. AVI EVALUATION

6.1 INTRODUCTION

The evaluation approach used to assess the HELP technology used in the Crescent Demonstration called for real-world performance tests of the HELP equipment at each of the installations included in the study. The original AVI evaluation plan called for AVI-equipped trucks to be identified visually by a Crescent Demonstration decal that was to be attached to the windshield of participating trucks. However, this approach was discontinued as the reliability of observations was low due to the large proportion of participating trucks that did not use the decal. These observational difficulties were magnified by the low number of AVI equipped-trucks in some states.

An alternative approach was developed which called for a comparison of truck logs against the AVI records for identifiable vehicles. This approach was also disregarded when the fleet operator could not provide the required truck logs. A further attempt at evaluation was made by matching the truck routes traveled with the AVI records for trucks passing along the same routes. However, reports of weighstation site closing times were found not to be accurate and there was no method of verifying the trucks' compliance with the route plan.

The Mark IV AVI equipment used in the Crescent Demonstration has undergone rigorous testing within the HELP program, including specific tests conducted by CRC for the Crescent Demonstration. Due to the difficulties encountered with the AVI evaluation in the study, it was decided that the Crescent Demonstration AVI tests conducted by CRC on June 24-27, 1991 and October 15-16, 1991 would serve as the AVI equipment assessment section of the overall on-site evaluation. These tests do not examine the AVI equipment accuracy over a series of installations or enable an assessment of the truck location monitoring capabilities of the Crescent system. This chapter presents a brief outline of each of the tests performed and the results gained from these tests.

The tests were performed to verify the Mark IV AVI system's compliance with the HELP program specifications. Seven categories of operational test were undertaken, as follows:

- * placement tests;
- * speed tests;
- * multi-lane tests;
- * multi-tag tests;
- * external interference tests;
- * environmental or adverse weather condition tests; and

- * radio frequency emissions measurements.

Tests were carried out with a variety of AVI transponder mounting positions to replicate real-life scenarios.

The first test location was the Wheeler Ridge, California Crescent mainline site on I-5. The equipment is installed in a bypass lane used by all I-5 southbound trucks to avoid the intersection of I-5 and State Route 99. AVI antennas are installed in both lanes of this bypass facility.

The second test site used was the Santa Nella weighstation on I-5. This site consists of a single antenna in a static weighscale bypass lane. A schematic diagram of the site layouts is presented in Figure 6-1.

A portable computer was used to display data generated by the AVI reader unit. This computer was connected to the AVI reader diagnostics port enabling the direct downloading of data. Each AVI read made by the system was displayed on the screen, giving the time of the read, the tag number, the lane number and the number of reads (or handshakes) made as the transponder passed through the antenna field. The system configuration allowed for a maximum of 40 handshakes to be recorded.

At the Wheeler Ridge site, vehicles used the shoulder to return to the start position for subsequent runs after each test pass. At the Santa Nella site, vehicle repositioning after each pass was achieved via the recirculation road around the weighstation office or by reversing the vehicle over the antenna. The system software forces a thirty-second delay between subsequent reads of the same transponder, after it has left the antenna field. This function prevents slow-moving vehicles from generating multiple AVI records. This factor was taken into account between runs, particularly when reversing over the antenna was required to reposition the vehicle.

6.2 AVI TESTS AND RESULTS

Each of the tests listed above are presented here. A brief description and the results gained from these tests are given.

Placement Tests

Placement tests were carried out to determine AVI tag read performance at five lateral positions across the lane as defined in Figure 6-1. These tests also check for correct operation of the system when the AVI tag passes directly between two adjacent antenna elements. A single automobile was used for all passes forming the complete set of placement tests. The vehicle was driven across the antenna read zone such that the tag was centered to the extent practical on the lateral position under test. Five passes were made at each of the lateral positions. The vehicle speed varied between 30 and 65 mph. The results of these tests are presented in Table 6-1.

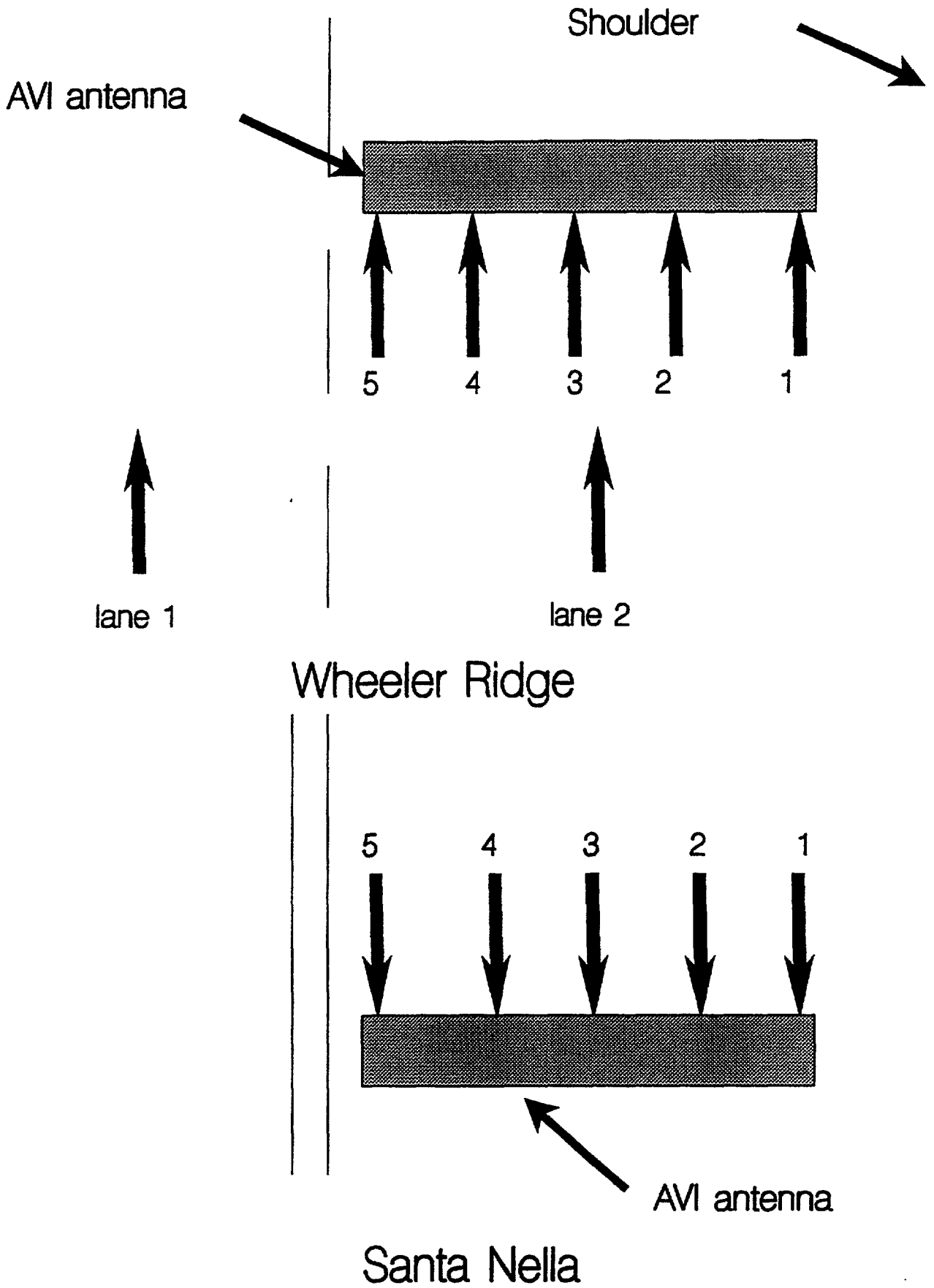

Figure 6-1. Lateral Position Numbering System

Table 6-1. Placement Test Results

Lateral Position	Vehicle Speed (mph)	Number of Correct Reads	Number of Handshakes	Number of Incorrect or Missed Reads	Read Accuracy (%)
1	35-45	6	21-28	0	100
2	30-40	5	21-27	0	100
3	25	5	29-38	0	100
4	45-60	5	8-12	0	100
5	50-65	5	6-13	0	100

Speed Tests

The speed tests were performed to verify correct operation of the AVI system at high speed. These tests used two different lateral positions: the center of a lane (running directly over the AVI antenna); and straddling two lanes. Five passes were made for each position. The CHP provided a vehicle and driver for the test. Vehicle speeds between 95 and 119 mph were achieved. The results of these tests are presented in Table 6-2.

Table 6-2. Speed Test Results

Vehicle Speed (mph)	Lateral Position	Number of Correct Reads	Number of Handshakes	Number of Incorrect or Missed Reads	Read Accuracy (%)
100-119	Straddling lanes	6	5-8	0	100
95-102	Center of lane	5	7-9	0	100

Multi-Lane Tests

This series of tests utilized two automobiles to explore the effects of vehicles passing over the reader site in multi-lane situations. So far as practicable, the two cars passed over the reader antennas simultaneously. These tests were performed under the following scenarios:

- * two vehicles traveling in adjacent lanes in the same direction at equal speeds of approximately 45 mph;
- * two vehicles traveling in adjacent lanes in the same direction simultaneously rolling to a stop over the reader antennas; and
- * two vehicles traveling in adjacent lanes in the same direction at different speeds.

The AVI tags were mounted on the two vehicles such that each would pass over the antenna read zone for the respective lane of travel of the vehicle. The results of these tests are presented in Table 6-3.

Table 6-3. Multi-Lane Test Results

First Vehicle Speed (mph)	Second Vehicle Speed (mph)	Number of Correct Reads	Number of Handshakes	Number of Incorrect or Missed Reads	Read Accuracy (%)
45	45	10	13-21	0	100
0	0	10	>40	0	100
55	40	10	1 1-26	0	100

Multi-Tag Tests

The multi-tag tests were used to verify correct system operation with multiple tags fitted to the same vehicle. These tests were carried out at the Wheeler Ridge site and utilized a single vehicle with transponders fitted to the front and rear license plates. Tests were carried out at speeds of approximately 35 and 50 mph, with five runs being made at each speed. The results of these tests are presented in Table 6-4.

Table 6-4. Multi-Tag Test Results

Vehicle Speed (mph)	Number of Correct Reads	Number of Handshakes	Number of Incorrect or Missed Reads	Read Accuracy (%)
35-40	10	20-28	0	100
50-55	10	14-19	0	100

External Interference Tests

These tests were performed at the Santa Nella site and examined the effect of external radio and electrical interference on the AVI system's operation. The effect of the AVI system on other radio frequency-based equipment was also ascertained. This was achieved by operating radio/electrical sources adjacent to the AVI reader cabinet and in the area of the antennas. The tests examined the following effects:

- * the effect of an electrical generator operated on the shoulder of the reader site as the vehicle passed the reader site;
- * the effect of the use of a cellular telephone at the reader site as the vehicle passed;
- * the effect of operating a two-way radio at the reader site as the vehicle passed; and
- * the effect of the AVI system on a pager unit.

For the generator tests, five runs were made at speeds between 30 and 55 mph over the end of the antenna. The pager tests were conducted by placing the pager within the antenna field and telephoning the pager number. Two tags were then repeatedly swept through the antenna zone until the pager had been paged. The use of two tags prevented the thirty-second delay between reads of the same tag discussed earlier (subsequent reads of a different tag will clear the time delay). This test was repeated five times.

A police two-way radio was utilized for the two-way radio tests. A portable unit operated beside the reader cabinet was used to broadcast to a receiver mounted in a police vehicle approximately 100 yards away. Test broadcasts were made as each of two vehicles passed through the read zone. One vehicle had the tag mounted so that it would pass through the read zone at the center of the antenna (position 3), with the other vehicle carrying the tag over the end of the antenna (position 5). Each vehicle made five passes.

A portable telephone was operated at the reader site while ten passes were made, five at each of the lateral positions 1 and 3. The conversation was recorded on tape to permit identification of AVI-induced interference at the receiving end of the conversation.

The results were recorded on the relevant data recording sheet along with any observed effects of the AVI system on the external source under consideration. The results of these tests are presented in Table 6-5.

Table 6.5 External Interference Test Results

Source of Interference	Vehicle Speeds (mph)	Lateral Placement	Number of Correct Reads	Number of Handshakes	Number of Incorrect or Missed Reads	Read Accuracy (%)
Generator	30-55	1	5	>40	0	100
Cellular telephone	40 40	3 5	5 5	>40 >40	0 0	100 100
Two-way radio at site	30 30	5 3	5 5	>40 =40	0 0	100 100
Pager at site	N/A	N/A	5	>40	0	100

Environmental Tests

These tests were designed to assess the effect on system operation of various substances placed over the antenna. The tests were carried out at the Santa Nella site.. The substances investigated were: saline solution at 0.1 molar concentration; saline slush; and highway sand, which is used by Caltrans in the prevention of slick road surfaces. The tests were modified once practical limits were identified both in the testing methodology and in the operation of the AVI equipment.

Sand

The effects of a sand layer of 1-inch depth covering the antenna were determined. The tag was mounted on a wooden boom protruding sideways from the back of a Caltrans truck. This allowed the tag to be mounted to the side of the vehicle and pass over the antenna while the vehicle was driven in the adjacent lane to avoid disturbance to the sand layer. Five runs were made at lateral positions 4 and 5 at the maximum practical speed of approximately 50 mph.

Saline slush

The effect of a 2-inch depth of saline slush/ice placed over the antenna array was tested. The salt/slush mix was calculated to give a 0.1 molar solution on melting. Table salt containing an anti-caking agent was used for these tests. The wooden boom was again used for these tests, for which five runs were made at lateral positions 3 and 5 at approximately 40 mph.

Saline solution

For tests conducted on June 26, a single dam lined with plastic sheeting was constructed to contain the saline solution around the antenna. The tag was again mounted on the boom for these initial tests. Due to the slope of the road, the depth of the saline solution was measured at the point below the center of the passage of the tag. Degradation of the antenna field highlighted inadequacies and unknown variables in the initial testing method. These primarily consisted of a large amount of tag oscillation due to the boom mounting method; and inadequate position control over the lateral passage of the tag, particularly noticeable when attempting passages at the end of the antenna.

No reliable results were obtained from these initial tests; they were therefore repeated on June 27. For these repeat tests, a compartmentalized trough **was** constructed using a stiffer plastic tarpaulin sheet as shown in Figure 6-2. Timber was used to support the sheet at various lateral positions across the antenna, forming five individual pools. This allowed a more even depth of saline solution across the antenna and permitted the truck to drive directly over the antenna. The troughs were refilled between runs. Five runs were made utilizing this method, with the tag passing over the center of the antenna at the maximum practical speed of approximately 40 mph.

A rigid boom was also constructed from steel pipe, allowing further test passes to be made with the tag passing over the end of the antenna. Five runs at each of the speeds 40 and 60 mph were made using this arrangement. For the higher speeds, the lateral position of the vehicle was controlled utilizing carefully-positioned traffic cones after an initial positioning problem had been identified.

These final tests highlighted an additional phenomenon. This phenomenon was concerned with the total coverage of the antenna field by the saline solution. Better read results could be obtained if the trough positioning did not extend past the end of the antenna. For this reason, five more test passes were made at 60 mph with the trough covering the full length of the antenna plus approximately 12 inches of the road past the antenna end. The lateral baffles were removed for this test and therefore water depth varied from 0 to 2 inches across the trough. The tag passed over a point at which the solution depth was 1.75 inches. The results of these tests are presented in Table 6-6.

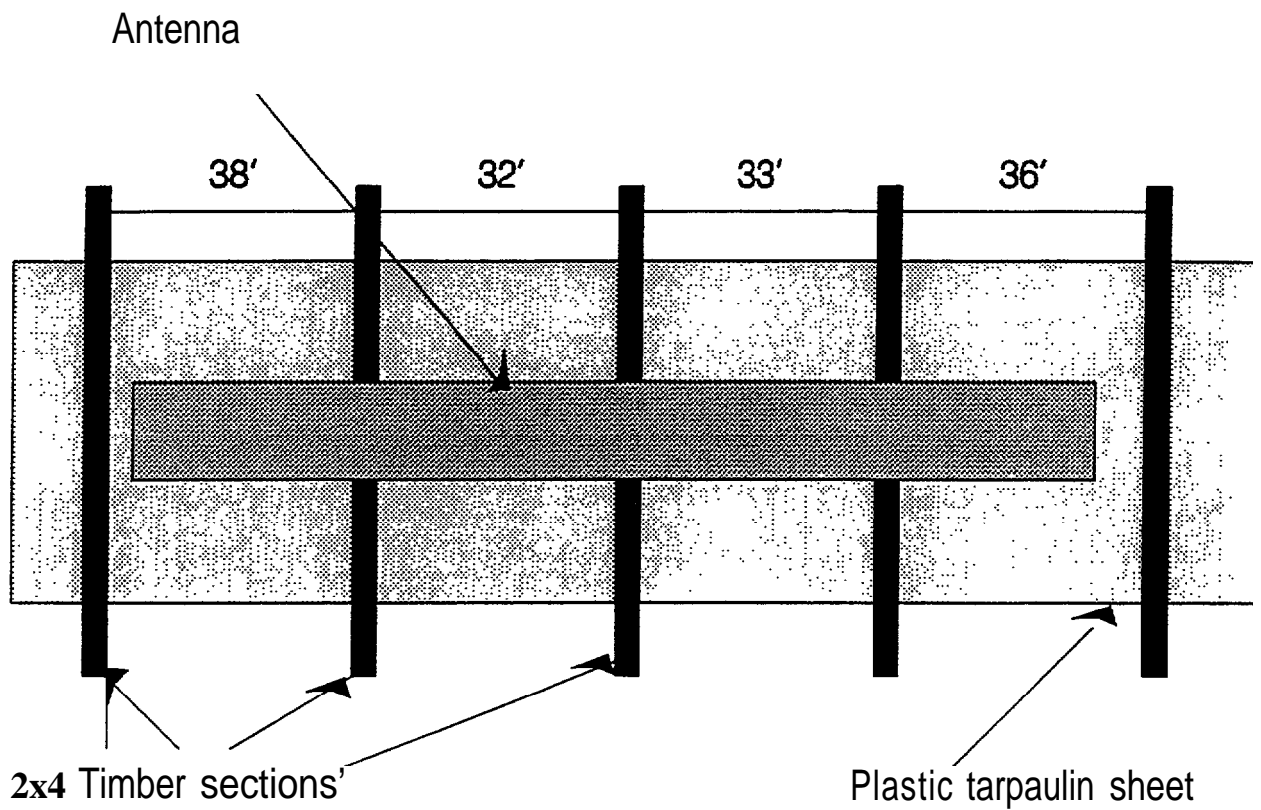

Top view

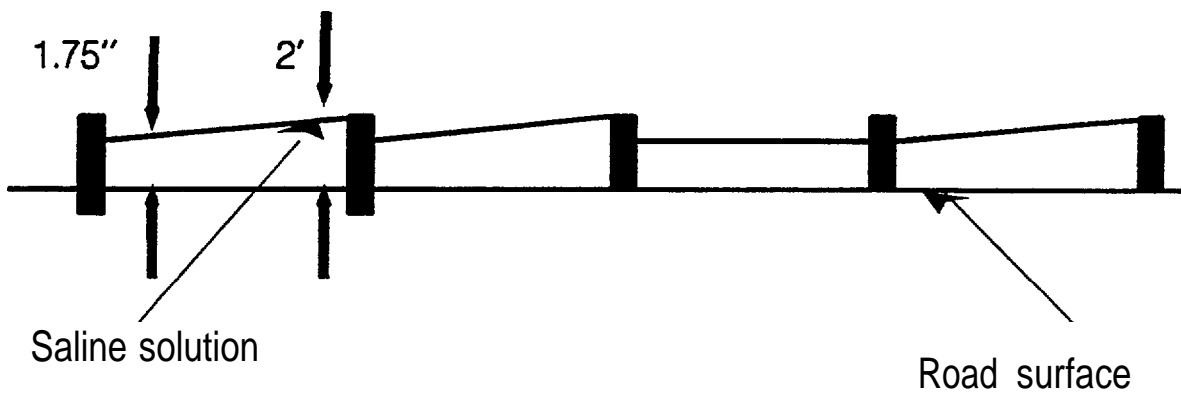

Side view

Figure 6-2. Saline Solution Trough Used June 27, 1991

Table 6-6. Environmental Test Results

Obstruction	Vehicle Speed (mph)	Lateral Position	Number of Correct Reads	Number of Handshakes	Number of Missed Reads	Read Accuracy (%)
1" sand	50	4	5	>40	0	100
	50	5	5	>40	0	100
2" saline ice/slush	40	3	5	>40	0	100
	40	5	5	>40	0	100
2" saline solution over antenna only	40	3	5	24-31	0	100
	40	5	5	27-32	0	100
	60	5	5	13-30	0	100
Saline solution covering antenna plus 12" past antenna	60	5	5	16-20	0	100

A further round of saline solution tests was carried out on October 16 after completion of the RF measurements detailed below. These tests attempted to replicate and confirm the results of those conducted earlier. The tests utilized the tag mounted on the vehicle to remove any affects resulting from use of the boom. The troughs containing the saline solution were constructed without the use of timber cross supports. The resulting trough dimensions are shown in Figure 6-3. A number of vehicle runs and hand tag-swipes were carried out for saline depths of between 1 and 2 inches. The results of these additional environmental tests are presented in Table 6-7.

Radio Frequency Emissions Measurements

These tests were conducted to ascertain conformance of the AVI reader and antenna with ANSI C95.1- 1982 requirements. An external consultant, EMACO of San Diego, was contracted to perform this work. The results of these tests concluded that the Mark IV AVI system was in compliance with ANSI C95.1-1982 requirements for RF emissions.

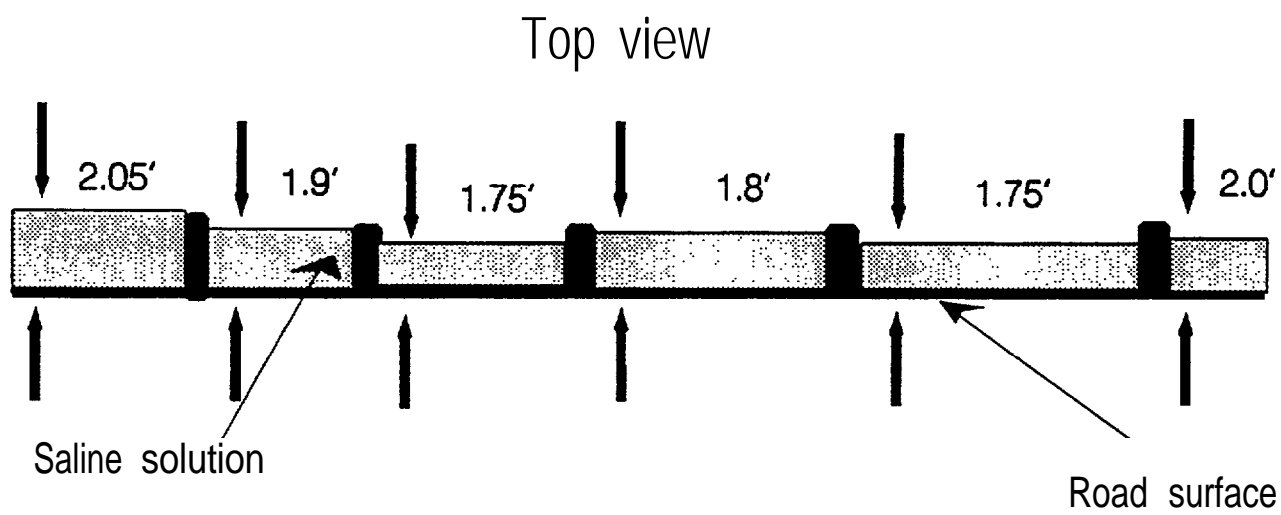
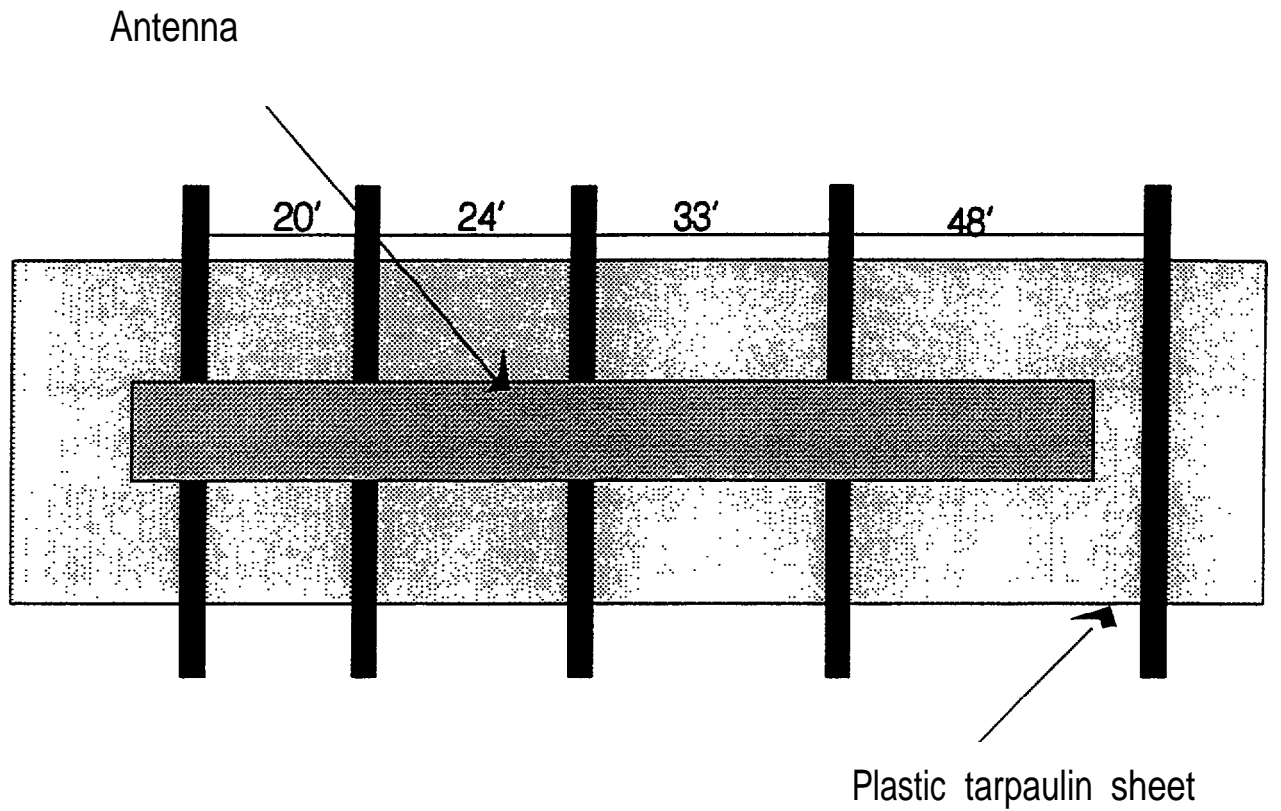

Side view

Figure 6-3. Saline Solution Tough Used October 1991

Table 6-7. Additional Environmental Test Results

Obstruction	Vehicle Speed (mph)	Lateral Position	Number of Correct Reads	Number of Handshakes	Number of Missed Reads	Read Accuracy (%)
2" saline as per Figure 6-4	40	3	0	0	1	0
	<5	3	0	0	1	0
	0	3	1	>40	0	100
1.5" saline	0	3	1	>40	0	100
1.25" saline	0	4	1	>40	0	100
	5	3	1	>40	0	100
	10	3	0	0	1	0
1" saline	40	3	5	5-7	0	100
	40	5	3	0-3	2	60
	0	5	2	7-40	0	100

Note: speed of zero indicates that the tag was waved across or held above the antenna by hand.

6.3 CONCLUSIONS

The series of tests described in this document were designed to test for conformance of the Mark IV AVI system to the performance requirements of the HELP AVI specification under a number of simulated real-life conditions. The percent read accuracy described in the following conclusions represents the ratio of correct reads to total reads.

The following conclusions may be drawn from the test results:

- * the system achieved 100 percent read accuracy with transponders passing over the antenna at all feasible lateral positions at speeds of between 25 and 65 mph under good conditions;
- * the system achieved 100 percent read accuracy with transponders passing over the antenna at speeds of up to 119 mph in good conditions;
- * the system achieved 100 percent read accuracy in the multi-lane scenarios evaluated with vehicles traveling up to 55 mph under good conditions;

- * the system achieved 100 percent read accuracy in the multi-tagged vehicle tests with vehicles passing at the speed of 55 mph in good conditions;
- * none of the various positions used for tag mounting had any noticeable affect on system operation;
- * the system achieved 100 percent read accuracy at speeds of up to 55 mph with various interference sources operating adjacent to the reader site;
- * the system did not noticeably affect the operation of various RF communication devices being operated adjacent to the reader site;
- * the system achieved 100 percent read accuracy through 1 inch of sand with vehicle speeds of 50 mph;
- * the system achieved 100 percent read accuracy through 2 inches of saline slush/ice. Due to the warm air temperature and limited availability of ice, testing the system through 3 inches of saline slush was not practical. However, no noticeable degradation in system performance (number of handshakes) was noted through 2 inches of saline slush;
- * in initial tests, the system achieved 100 percent read accuracy through 2 inches of 0.1 molar saline solution with vehicles traveling at 60 mph. The system performance was degraded by the saline solution as can be seen from the reduced number of handshakes. These initial 100 percent accuracy results were not repeated in the subsequent saline solution tests;
- * the system used at the Santa Nella site was considerably more sensitive/powerful than that used at the Wheeler Ridge site. This can be deduced from the number of handshakes recorded for similar speeds at each site. When considering this factor, the following points should be borne in mind: system performance will vary from site to site due to variables such as site condition and antenna matching; and the Wheeler Ridge AVI reader was operating two antennas while the Santa Nella reader operated a single antenna. For these reasons, variations in system performance may be experienced at different sites;
- * to allow comparison with results from different sites, basic field geometry measurements were made at Santa Nella. These are presented in Figure 6-4. The field geometry measured in October was approximately equal to that measured in June; and
- * the radio frequency emission levels of the system comply with the requirements of ANSI C95.1-1982.

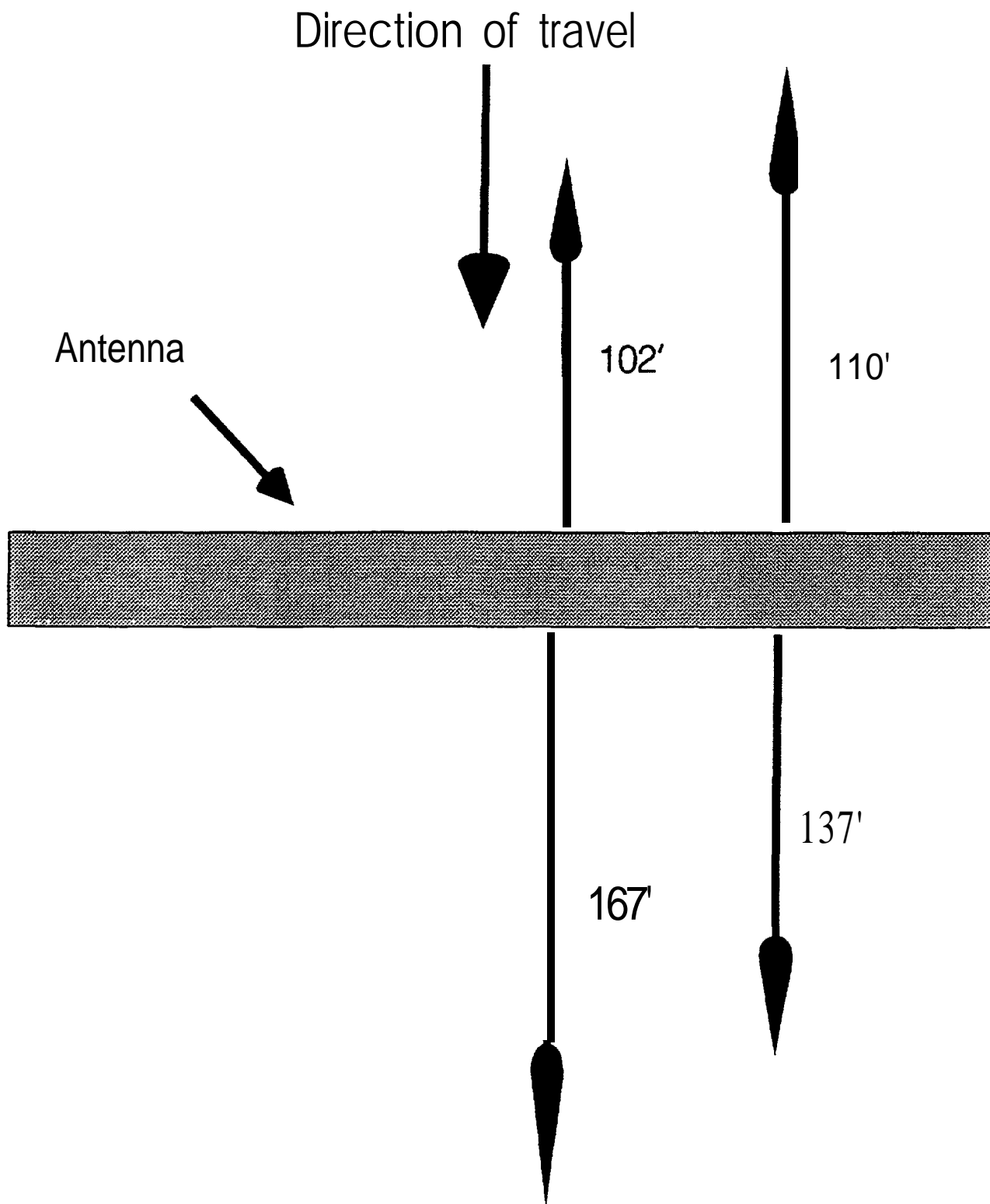

Figure 6-4. Tag Read Distances at Belt Heights for Santa Nella Site