

EDUCATION & TECHNICAL ASSISTANCE PROGRAM

A MOTOR CARRIER'S
GUIDE TO

IMPROVING HIGHWAY SAFETY

JULY 2008



U.S. Department of Transportation
Federal Motor Carrier Safety Administration

EDUCATION & TECHNICAL ASSISTANCE PROGRAM

A Motor Carrier's Guide to Improving Highway Safety

Federal Motor Carrier Safety Administration
Outreach Division
1200 New Jersey Avenue, SE, MC-ESO
Washington, DC 20590
www.fmcsa.dot.gov

While every effort has been made to assure that the information provided here is complete and accurate; it is not intended to take the place of published agency regulations. The document paraphrases the Federal Motor Carrier Safety Regulations published in Title 49 of the U.S. Code of Federal Regulations. The contents may not be relied upon as a substitute for the most current official text. The regulations issued by the U.S. Department of Transportation and its Operating Administrations are published in the Federal Register and compiled in the U.S. Code of Federal Regulations (CFR).

The Agency cannot assume any responsibility for omissions, errors, misprinting, or ambiguity contained within this publication and shall not be held liable in any degree for any loss or injury caused by such omission, error, misprinting, or ambiguity presented in this publication. This publication is designed to provide reasonably accurate and authoritative information in regard to the subject matter covered. It is sold with the understanding that the Publisher is not engaged in rendering legal or other professional service. If legal advice or other expert assistance is required, the services of a competent professional person should be sought.

This publication is distributed by the U.S. Department of Transportation, Federal Motor Carrier Safety Administration (FMCSA), in the interest of information exchange. The United States Government assumes no liability for its contents or use thereof. If trade or manufacturers' names or products are mentioned, it is only because they are considered essential to the object of the publication and should not be construed as an endorsement. The United States Government does not endorse products or manufacturers.

DRIVER QUICK-REFERENCE

What are the commercial driving qualifications to become certified?

Requirements and Responsibilities.....	45
Physical Requirements	47
Checklist	48
Applying for Exemptions	70
Disqualifying Offenses	71

What are the driving laws and regulations?

Illness or Fatigue	72
Drugs	72
Alcohol	72
Safe Loading.....	72
Operating Authority	72
Railroad Crossing/Stopping.....	73
Seat Belts	73
Emergency Signals	73
Placement of Warning Devices.....	73
Radar Detectors	73

What requirements are needed for a CDL driver besides the license?

Certificate of Road Test	59
Fitness Determination and Physical Qualifications	60
Instructions to Medical Examiner and Certificate	64
Drug Testing Policy	14

Are there additional tests for specialized commercial vehicles?

Groups and Endorsements.....	21
Application to Carry Hazardous Materials.....	23

What if I am convicted of a State or local traffic violation?

Notification Requirements.....	18
License Disqualification Offenses	19

What do I need to have displayed on my vehicle?

Identification Requirements.....	43
----------------------------------	----

What parts and accessories are required for safe operation?

Lamps	74
Lighting Devices and Reflectors	74
Retroreflective Sheeting and Reflex Reflectors	74
Brake Systems	74
Breakaway and Emergency Braking	75
Brake Components and Slack Adjustors	75
Brake Warning Devices	76
Automatic and Antilock Systems	76
Windshield.....	76
Fuel System	76
Coupling Devices	76
Tires	77
Sleeper Berths.....	78
Exhaust Systems.....	78
Rear End Protection.....	78
Seat Belts	78
Emergency Equipment	78
Fire Extinguisher	78
Cargo Securement.....	79
Frames	79
Cab and Body Components.....	79
Wheels	79
Suspension Systems.....	79
Steering Wheel Systems	79

What must I know and complete for required vehicle maintenance?

Recordkeeping	85
Roadside Inspection.....	85
Post-Trip Inspection.....	85
Driver Inspection	85
Periodic Inspection	86
Forms:	
Levels of Inspection	88
Annual Vehicle Inspection Report	89
Driver's Vehicle Inspection Report	90
Vehicle Service Due Status Report	91
North American Standard Inspection Procedure.....	92
Inspection, Repair, and Maintenance Record.....	94
Bus Emergency Exits Inspection	97
Brake Adjustment.....	98

How can I help prevent accidents?

Non-Preventable vs. Preventable Accidents.....	116
Accident Countermeasures: Success Stories	119
Forms:	
Accident Register	125
Revenue Worksheet.....	126

EMPLOYER QUICK-REFERENCE

How do I apply for new entrant registration and a U.S. DOT number?

Application Package and Requirements	27
Safety Audits	27

Who can certify drivers?

Classroom Instructors	10
Skills Instructors	10

What qualifications must drivers meet?

Exemptions	45
Requirements and Checklist	45
Physical Requirements	47
Qualification Forms	48
Employment Application	49
Request From Previous Employer	51
Multiple-Employer Drivers	69
Inquiry to State Agency	56
Annual Driving Record Review	57
Traffic Violations	58
Road Test Certificate	59
Medical Examiner's Report	60
Medical Examiner's Certificate	68
Applying for Exemptions	70
Skill Performance Evaluations	70
Disqualification	71
Driving Laws and Regulations	72

What endorsements do drivers need for specialized vehicles?

CMV Groups	21
Hazardous Materials	23
HM Safety Permit Program	28
Applying and Maintaining an HMSP	29

What information do I need to keep on file?

Recordkeeping Requirements	11
Drug and Alcohol Testing Requirements	13
Length of Record Retention	15
DOT Alcohol Testing Form	17
Driver Qualification File Checklist	48
Proof of Insurance	32
Maintenance Records	85
Inspector Qualifications	86

What actions do I take if substance abuse is suspected?

Testing and Procedures	13
Drivers Who Test Positive	15

What actions do I take if a driver commits a traffic offense?

Disqualification of Drivers	19
Suspension Timelines	20

How is the company reviewed and rated for safety?

Review and Audit	25
Ratings	25
Safety Standards and Notification of Rating	26
New Entrant Application and Requirements	27
Safety Permits	28

What insurance coverage is required by law?

Minimum Levels of Financial Responsibility	38
DOT Forms and Endorsements	32

What are the general FMCSA regulations?

Exceptions	41
Accident Registers	42
Motor Carrier Identification Reports	43
Vehicle Identification	43
Emergencies	43

What parts and accessories are required to comply with safe operation?

Lamps	74
Lighting Devices and Reflectors	74
Retroreflective Sheeting and Reflex Reflectors	74
Brake Systems	74
Breakaway and Emergency Braking	75
Brake Components and Slack Adjustors	75
Brake Warning Devices	76
Automatic and Antilock Systems	76
Windshield	76
Fuel Systems	76
Coupling Devices	76
Tires	77
Sleeper Berths	78
Exhaust Systems	78
Rear End Protection	78
Seat Belts	78
Emergency Equipment	78
Fire Extinguisher	78
Cargo Securement	79
Frames	79
Cab and Body Components	79
Wheels	79
Suspension Systems	79
Steering Wheel Systems	79

What are the rules for drivers' hours of service?

100 Air-Mile Radius Exemption.....	80
CMVs Exempt From Daily Logs	80
Sleeper Berth Provision.....	81
Property-Carrying Rules.....	81
Passenger-Carrying Rules.....	81
Record of Duty (Driver's Log).....	81
Off-Duty Authorization	82
Out of Service.....	82
On-board Recording Devices	82
Forms:	
Hours of Service Record for First-Time or Intermittent Drivers.....	83
Letter of Off-Duty Authorization	84

What is required for vehicle maintenance?

Recordkeeping.....	85
Roadside Inspection.....	85
Post-Trip Inspection.....	85
Driver Inspection.....	85
Periodic Inspection	86
Inspector Qualification	86
Inspector Training or Experience	86
Brake Inspectors	86
Forms:	
Levels of Inspection	88
Annual Vehicle Inspection Report	89
Driver's Vehicle Inspection Report.....	90
Vehicle Service Due Status Report	91
North American Standard Inspection Procedure.....	92
Inspection, Repair, and Maintenance Record.....	94
Inspector Qualifications	95
Brake Inspector Qualifications.....	96
Bus Emergency Exits Inspection	97
Brake Adjustment	98

What are the regulations for transporting hazardous materials?

Who Is Regulated	101
What Materials Are Hazardous	101
Pre-Transportation Functions	102
DOT Registration	103
Hazmat Security Plans.....	103
Security and Training	104
Penalties for Failing to Comply.....	104
Definitions	105

What are the regulations for passenger-carriers?

Who Is Regulated	109
For-Hire Motor Carriers of Passengers	109
Private Motor Carriers of Passengers	110
Business and Non-Business.....	110
Frequently Asked Questions.....	111
School Bus Transportation	112
Small Passenger Carriers.....	112
Financial Responsibility	112
Financial Responsibility Exemptions.....	112

How can I help prevent accidents?

Non-Preventable vs. Preventable Accidents.....	116
Accident Countermeasures: Success Stories	119
Forms:	
Accident Register.....	125
Revenue Worksheet.....	126

What data am I required to report to the Bureau of Transportation Statistics?

Requirements	127
Exceptions	127
Forms:	
Form M (Motor Carriers of Property and Household Goods Annual Report)	128
Form QFR (Motor Carriers of Property and Household Goods Quarterly Report).....	136
Form MP-1 (Motor Carriers of Passengers Quarterly and Annual Report).....	138

What is required for Mexico-domiciled carriers?

Application Process for Certificate of Registration.....	141
Proof of Insurance	142
Approval	143
Safety Audit.....	143
Safety-Monitoring System.....	144
Roadside Performance.....	144
Permanent Certificate of Registration	145

Introduction	6
Federal Motor Carrier Safety Administration Field Office Directory	7
Section 1	
Part 380: LCV Driver-Training and Driver-Instructor Requirements	10
Part 382: Controlled Substances and Alcohol Use and Testing	13
Part 383: Commercial Driver’s License Standards: Requirements and Penalties	18
Part 385: Safety Fitness Procedures	25
Part 387: Minimum Levels of Financial Responsibility for Motor Carriers	31
Part 390: Federal Motor Carrier Safety Regulations: General	41
Part 391: Qualification of Drivers	45
Part 392: Driving of Motor Vehicles	72
Part 393: Parts and Accessories Necessary for Safe Operation	74
Part 395: Hours of Service of Drivers	80
Part 396: Inspection, Repair, and Maintenance	85
Section 2	
Overview: Transportation of Hazardous Materials	100
Section 3	
Motor Carriers of Passengers	109
Section 4	
Accident Countermeasures	115
Part 1420: Motor Carrier Financial and Operation Statistics	127
Certificate For Mexico-Domiciled Carriers to Operate in the U.S. Commercial Zones	141

The Federal Motor Carrier Safety Administration (FMCSA) was established as a separate administration within the U.S. Department of Transportation on January 1, 2000, as a result of the Motor Carrier Safety Improvement Act of 1999. FMCSA's primary mission is to reduce crashes, injuries, and fatalities involving large trucks and buses on our Nation's highways. We accomplish this through a coordinated effort of Federal, State, and industry organizations to reduce fatalities, injuries, property damage and hazardous materials incidents. We implement our safety and compliance program through a national network of fifty-two field offices, including the District of Columbia and Puerto Rico.

FMCSA has produced "A Motor Carrier's Guide to Improving Highway Safety". This guide is intended to provide educational and technical assistance to the motor carrier industry and provide basic guidance on the Federal Motor Carrier Safety Regulations (FMCSRs). It is not intended to be a substitute for the regulations. To purchase a complete copy of the FMCSRs, Parts 300-399, contact the Superintendent of Documents, U.S. Government Printing Office, Washington, DC 20402, telephone number: (866) 512-1800 (in the Washington, DC Metro area (202) 512-1800) or at www.access.gpo.gov.

This guide is comprised of eleven parts, each containing a specific safety regulation topic that is covered in the FMCSRs. These parts are listed in the Table of Contents. Each part contains information sheets that cover the highlights of that section. Some sections contain sample forms and we encourage you to reproduce any or all material in this package and to distribute copies as needed. You may also obtain this information on our website at www.fmcsa.dot.gov.

It is the responsibility of motor carrier operators and drivers to know and comply with all applicable FMCSRs. Safety compliance and safe operations translate into saved lives and property. We believe the information in this package, when effectively applied, will contribute to safer motor carrier operations and highways.



Headquarters

Federal Motor Carrier Safety Administration

1200 New Jersey Avenue, SE

Washington, DC 20590

Western Service Center

Golden Hills Office Centre
12600 West Colfax Avenue, Suite B-300
Lakewood, CO 80215
Phone: (303) 407-2350
Fax: (303) 407-2339

American Samoa, AK, AZ, CA, CO,
Guam, HI, ID, Mariana Islands, MT,
ND, NM, NV, OR, SD, UT, WA, WY

Midwestern Service Center

19900 Governors Drive, Suite 210
Olympia Fields, IL 60461
Phone: (708) 283-3577
Fax: (708) 283-3579
IA, IL, IN, KS, MI, MO,
MN, NE, OH, WI

Eastern Service Center

802 Cromwell Park Drive, Suite N
Glen Burnie, MD 21061
Phone: (443) 703-2240
Fax: (443) 703-2253
CT, DC, DE, MA, MD, ME,
NJ, NH, NY,
PA, PR, RI,
VA, VT, WV

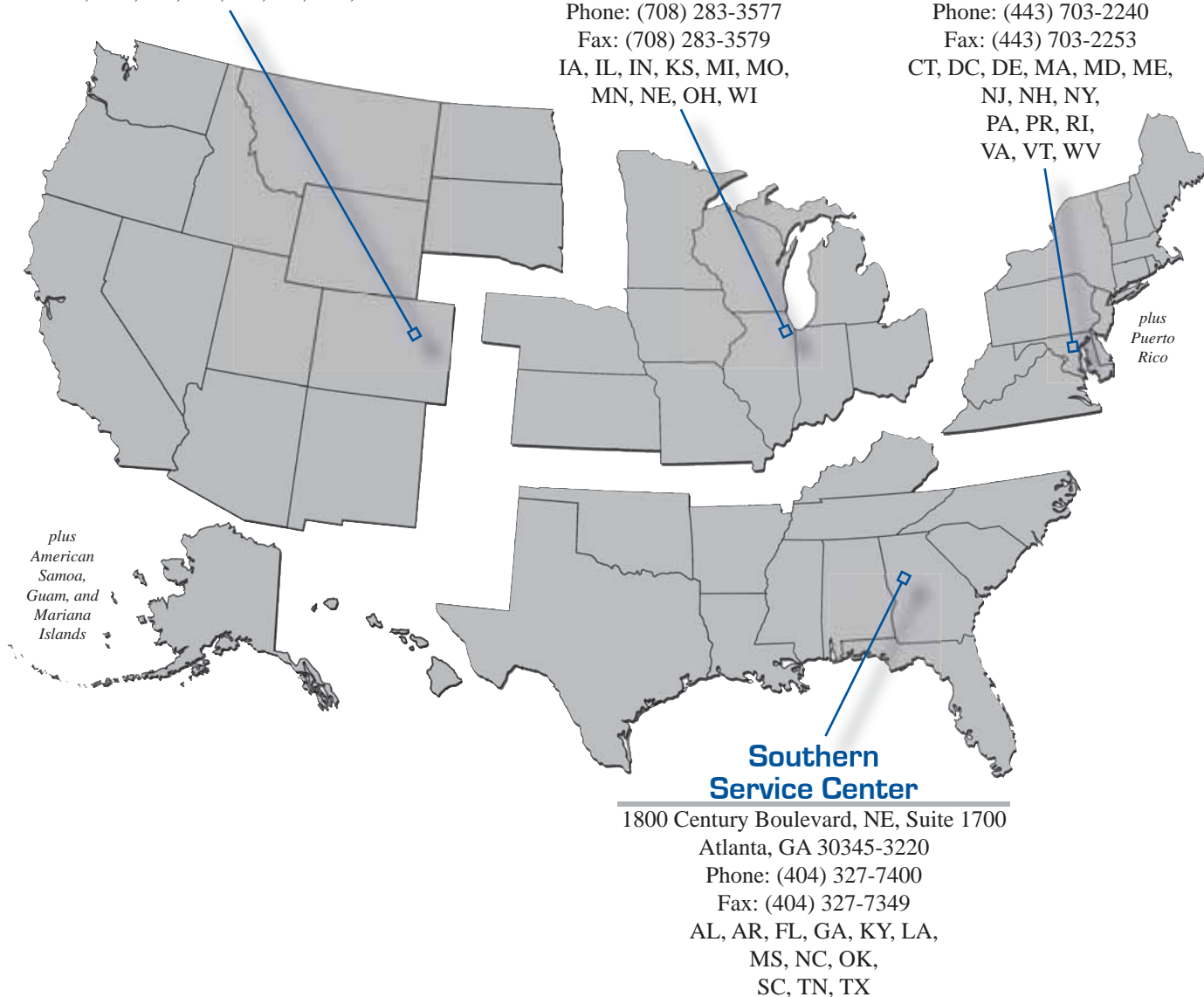

Southern Service Center

1800 Century Boulevard, NE, Suite 1700
Atlanta, GA 30345-3220
Phone: (404) 327-7400
Fax: (404) 327-7349
AL, AR, FL, GA, KY, LA,
MS, NC, OK,
SC, TN, TX

Alabama Division

500 Eastern Boulevard, Suite 200
 Montgomery, AL 36117
 Phone: (334) 223-7244
 Fax: (334) 223-7700

Alaska Division

Frontier Building, Suite 260
 3601 C Street
 Anchorage, AK 99503
 Phone: (907) 271-4068
 Fax: (907) 271-4069

Arizona Division

One Arizona Center
 400 East Van Buren Street, Suite 401
 Phoenix, AZ 85004-2223
 Phone: (602) 379-6851
 Fax: (602) 379-3627

Arkansas Division

2527 Federal Building
 700 W. Capitol Avenue
 Little Rock, AR 72201
 Phone: (501) 324-5050
 Fax: (501) 324-6562

California Division

1325 J Street, Suite 1540
 Sacramento, CA 95814
 Phone: (916) 930-2760
 Fax: (916) 930-2778

Colorado Division

12300 West Dakota Avenue, Suite 130
 Lakewood, CO 80228
 Phone: (720) 963-3130
 Fax: (720) 963-3131

Connecticut Division

628-2 Hebron Avenue, Suite 302
 Glastonbury, CT 06033
 Phone: (860) 659-6700
 Fax: (860) 659-6725

Delaware Division

J. Allen Frear Federal Building
 300 South New Street, Suite 1105
 Dover, DE 19904-6726
 Phone: (302) 734-8173
 Fax: (302) 734-5380

District of Columbia Division

1990 K Street, NW, Suite 510
 Washington, DC 20006
 Phone: (202) 219-3553
 Fax: (202) 219-3546

Florida Division

545 John Knox Road, Room 102
 Tallahassee, FL 32303
 Phone: (850) 942-9338
 Fax: (850) 942-9680

Georgia Division

Two Crown Center
 1745 Phoenix Boulevard, Suite 380
 Atlanta, GA 30349
 Phone: (678) 284-5130
 Fax: (678) 284-5146

Hawaii Division

300 Ala Moana Boulevard,
 Room 3-243
 Box 50226
 Honolulu, HI 96850
 Phone: (808) 541-2790
 Fax: (808) 541-2702

Idaho Division

3200 North LakeHarbor Lane,
 Suite 161
 Boise, ID 83703
 Phone: (208) 334-1842
 Fax: (208) 334-1046

Illinois Division

3250 Executive Park Drive
 Springfield, IL 62703-4514
 Phone: (217) 492-4608
 Fax: (217) 492-4986

Indiana Division

575 North Pennsylvania Street,
 Room 261
 Indianapolis, IN 46204
 Phone: (317) 226-7474
 Fax: (317) 226-5657

Iowa Division

105 6th Street
 Ames, IA 50010-6337
 Phone: (515) 233-7400
 Fax: (515) 233-7494

Kansas Division

1303 SW First American Place,
 Suite 200
 Topeka, KS 66604-4040
 Phone: (785) 271-1260
 Fax: (785) 228-9725

Kentucky Division

330 West Broadway, Room 124
 Frankfort, KY 40601
 Phone: (502) 223-6779
 Fax: (502) 223-6767

Louisiana Division

5304 Flanders Drive, Suite A
 Baton Rouge, LA 70808
 Phone: (225) 757-7640
 Fax: (225) 757-7636

Maine Division

Edmund S. Muskie Federal Building
 40 Western Avenue, Room 411
 Augusta, ME 04330
 Phone: (207) 622-8358
 Fax: (207) 622-8477

Maryland Division

City Crescent Building
 10 South Howard Street, Suite 2710
 Baltimore, MD 21201
 Phone: (410) 962-2889
 Fax: (410) 962-3916

Massachusetts Division

55 Broadway, Bldg 3, Room 1-35
 Cambridge, MA 02142
 Phone: (617) 494-2770
 Fax: (617) 494-2783

Michigan Division

315 West Allegan, Room 219
 Lansing, MI 48933
 Phone: (517) 853-5990
 Fax: (517) 377-1868

Minnesota Division

380 Jackson Street
 Galtier Plaza, Suite 500
 St. Paul, MN 55101
 Phone: (651) 291-6150
 Fax: (651) 291-6001

Mississippi Division

666 North Street, Suite 103
 Jackson, MS 39202-3199
 Phone: (601) 965-4219
 Fax: (601) 965-4674

Missouri Division

3219 Emerald Lane, Suite 500
 Jefferson City, MO 65109
 Phone: (573) 636-3246
 Fax: (573) 636-8901

Montana Division

2880 Skyway Drive
 Helena, MT 59602
 Phone: (406) 449-5304
 Fax: (406) 449-5318

Nebraska Division

100 Centennial Mall North, Room 406
Lincoln, NE 68508
Phone: (402) 437-5986
Fax: (402) 437-5837

Nevada Division

705 North Plaza Street, Suite 204
Carson City, NV 89701
Phone: (775) 687-5335
Fax: (775) 687-8353

New Hampshire Division

70 Commercial Street, Suite 102
Concord, NH 03301
Phone: (603) 228-3112
Fax: (603) 223-0390

New Jersey Division

840 Bear Tavern Road, Suite 310
West Trenton, NJ 08628
Phone: (609) 637-4222
Fax: (609) 538-4913

New Mexico Division

2400 Louisiana Boulevard NE,
Suite 520 AFC-5
Albuquerque, NM 87110
Phone: (505) 346-7858
Fax: (505) 346-7859

New York Division

Leo W. O'Brien Federal Building,
Room 816
Clinton Avenue & North Pearl Street
Albany, NY 12207
Phone: (518) 431-4145
Fax: (518) 431-4140

North Carolina Division

310 New Bern Avenue, Suite 468
Raleigh, NC 27601
Phone: (919) 856-4378
Fax: (919) 856-4369

North Dakota Division

1471 Interstate Loop
Bismarck, ND 58503
Phone: (701) 250-4346
Fax: (701) 250-4389

Ohio Division

200 North High Street, Room 609
Columbus, OH 43215
Phone: (614) 280-5657
Fax: (614) 280-6875

Oklahoma Division

300 North Meridian, Suite 106 South
Oklahoma City, OK 73107
Phone: (405) 605-6047
Fax: (405) 605-6176

Oregon Division

The Equitable Center
530 Center Street, NE, Suite 100
Salem, OR 97301-3740
Phone: (503) 399-5775
Fax: (503) 399-5838

Pennsylvania Division

228 Walnut Street, Room 560
Harrisburg, PA 17101
Phone: (717) 221-4443
Fax: (717) 221-4552

Puerto Rico Division

Torre Chardón
350 Chardón Street, Suite 207
Hato Rey, PR 00918
Phone: (787) 766-5985
Fax: (787) 766-5015

Rhode Island Division

20 Risho Avenue, Suite E
East Providence, RI 02914
Phone: (401) 431-6010
Fax: (401) 431-6019

South Carolina Division

1835 Assembly Street, Suite 1253
Columbia, SC 29201-2430
Phone: (803) 765-5414
Fax: (803) 765-5413

South Dakota Division

116 East Dakota Avenue, Suite B
Pierre, SD 57501
Phone: (605) 224-8202
Fax: (605) 224-1766

Tennessee Division

640 Grassmere Park, Suite 111
Nashville, TN 37211
Phone: (615) 781-5781
Fax: (615) 781-5780

Texas Division

903 San Jacinto Boulevard,
Suite 101
Austin, TX 78701
Phone: (512) 916-5440
Fax: (512) 916-5482

Utah Division

2520 West 4700 South, Suite 9B
Salt Lake City, UT 84118-1847
Phone: (801) 963-0096
Fax: (801) 963-0086

Vermont Division

87 State Street, Room 305
P.O. Box 338
Montpelier, VT 05601
Phone: (802) 828-4480
Fax: (802) 828-4581

Virginia Division

400 North 8th Street, Suite 780
Richmond, VA 23219-4827
Phone: (804) 771-8585
Fax: (804) 771-8670

Washington Division

2424 Heritage Drive SW, Suite 302
Olympia, WA 98502-6031
Phone: (360) 753-9875
Fax: (360) 753-9024

West Virginia Division

700 Washington Street East
Geary Plaza, Suite 205
Charleston, WV 25301
Phone: (304) 347-5935
Fax: (304) 347-5617

Wisconsin Division

Highpoint Office Park
567 D'Onofrio Drive, Suite 101
Madison, WI 53719-2844
Phone: (608) 829-7530
Fax: (608) 829-7540

Wyoming Division

1637 Stillwater Avenue, Suite F
Cheyenne, WY 82009
Phone: (307) 772-2305
Fax: (307) 772-2905

Section 1

PART 380

Longer Combination Vehicle (LCV) Driver-Training and Driver-Instructor Requirements

Applicability (380.103)

The rules in Part 380, Subpart A through Subpart D apply to all operators of LCVs in interstate commerce, employers of such persons, and LCV driver-instructors.

Definition (380.105)

Longer combination vehicle (LCV) means any combination of a truck tractor and two or more trailers or semi trailers which operate on the National System of Interstate and Defense Highways with a gross vehicle weight of more than 80,000 pounds (36,288 kilograms).

General LCV Driver Training Requirements (380.107)

A driver who wishes to operate a Longer Combination Vehicle (LCV) shall first take and successfully complete a LCV driver-training program that provides the knowledge and skills necessary to operate an LCV.

Before a driver receives training, the driver shall present evidence to the LCV driver-instructor showing that they successfully completed the Driver Training Program requirements, set forth in subpart B of Part 380 in the Federal Motor Carrier Safety Regulations, for the specific type of LCV training required. Also, before a driver receives training, the LCV driver-instructor shall verify that each LCV trainee-driver applicant meets the general requirements for the specific type of LCV training to be completed.

Employer Requirements (380.113)

Employers are prohibited from allowing drivers to operate LCVs unless those drivers can produce either:

- An LCV Driver-Training Certificate as evidence of successful completion of an LCV driver training course; or

- An LCV Driver-Training Certificate of **Grandfathering**, showing that the driver is exempt from the training requirements based on experience. As a note, drivers may be grandfathered June 01, 2004 to May 01, 2005 only.

Driver-Instructor Qualification Requirements (380.301)

There are two types of LCV driver-instructors: classroom instructors and skills instructors.

To qualify as a LCV **Classroom** Instructor, a person shall have audited the driver-training course they intend to instruct and if employed at a training institution, meet **all State** requirements for a vocational instructor.

To qualify as a LCV **Skills** Instructor, a person shall

- provide evidence of successful completion of the Driver Training Program requirements, set forth in subpart B of Part 380 in the Federal Motor Carrier Safety Regulations, during a compliance review;
- meet **all State** requirements for a vocational instructor if employed by a training institution;
- possess a valid CDL with all applicable endorsements necessary to operate the CMVs applicable to the subject matter being taught; and
- have a minimum of 2 years of CMV driving experience in a vehicle representative of the type of LCV training to be provided.

Part 380.303 of 49 CFR notes the provisions to substitute the instructor requirements.

Recordkeeping Requirements (380.401)

A driver who successfully completes the LCV training or has met the requirements of 49 CFR section

380.111 concerning the grandfathering clause must be issued a Driver-Training Certificate or Certificate of Grandfathering. A copy of the certificate must be maintained in the driver's qualification file.

■ Entry-Level Driver Training Requirements

Applicability (380.501)

All entry-level drivers who drive in interstate commerce and are subject to the Commercial drivers license (CDL) requirements of 49 CFR Part 383 must comply with the rules of Entry-Level Driver Training Requirements of 49 CFR Part 380, except drivers who are subject to the jurisdiction of the Federal Transit Administration or who are otherwise exempt under 49 CFR section 390.3(f).

Definition (380.502)

An entry-level driver is a driver who has less than one year of experience operating a Commercial Motor Vehicle (CMV) with a CDL in interstate commerce.

Entry-Level Driver Training Requirements (380.503)

A driver or potential driver, with less than one-year experience, must receive training before operating a CMV (as defined in 383.5) in interstate commerce.

■ Training required for CDL drivers, in addition to passing the CDL test.

A. Driver Qualification Requirements

- Medical certification
- Medical examination procedures
- General qualifications
- Responsibilities
- Disqualifications

B. Hours of Service of Drivers

- Driving hours limitations
- Off-duty requirements
- Record of duty status preparation
- Part 395 exceptions
- Fatigue countermeasures

C. Driver Wellness

Basic health maintenance, including diet and exercise; the importance of avoiding excessive alcohol use.

D. Whistleblower Protection

Employee's right to question safety practices without risk of losing their job or become subject to any reprisals.

Employer Requirement (380.509)

Each employer must ensure each entry-level driver who first began operating a CMV requiring a CDL in interstate commerce after July 20, 2003, receives the required training as noted in 49 CFR section 380.503.

Recordkeeping Requirements (380.513, 380.509, 380.111)

- The training provider must provide a certificate/diploma to an entry-level driver upon completion of training. (380.513)
- A certificate/diploma must be placed in the driver's personnel/qualification file. (380.509)
- The employer must keep these records for as long as the driver is employed and for one year thereafter. (380.111)

(Sample certificate shown on next page)



Certificate of Training for Entry Level Commercial Drivers

Driver's First name, middle initial, last name

I certify that the above named driver has completed the training requirements set forth in the Federal Motor Carrier Safety Regulations for entry level driver training in accordance with 49 CFR 380.503

- Driver Qualification Requirements (49 CFR 391)
- Hours of Service of Drivers (49 CFR 395)
- Driver Wellness
- Whistleblower Protection (29 CFR 1978)

Name of Director of Safety

Certificate Issuance Date

Organization Name

Organization Address

PART 382

Controlled Substances and Alcohol Use and Testing

Applicability (382.103)

Drivers required to have a commercial drivers license (CDL), who operate a CMV as defined in Part 382 are subject to the controlled substance and alcohol testing rules. This requirement extends to those drivers currently covered by the rule, including interstate and intrastate truck and motor coach operations. This includes commercial motor vehicles operated by:

- For-hire and private companies
- Federal, State, local, and tribal governments
- Church and civic organizations
- Apiarian (bee) industries

Exemptions (382.103)

- Drivers who are required to comply with the Federal Transit Administration's (FTA) alcohol and controlled substance testing (49 CFR Parts 653 and 654)
- Drivers exempt from commercial driver's license requirements by their issuing State
- Active duty military personnel

Definitions (382.107)

Commercial motor vehicle means a motor vehicle or combination of motor vehicles used in interstate, intrastate, or foreign commerce to transport passengers or property if the vehicle:

- Has a gross combination weight rating of 26,001 pounds or more (11,794 kilograms or more) inclusive of a towed unit(s) with a gross vehicle weight rating of more than 10,000 pounds (4,536 kilograms); or
- Has a gross vehicle weight rating of 26,001 pounds or more (11,794 kilograms or more); or
- Is designed to transport 16 or more passengers, including the driver; or
- Is of any size and is used in the transportation of hazardous materials requiring placarding.

Safety-sensitive function means all time from the time a driver begins to work or is required to be in readiness to work until the time he/she is relieved from work and all responsibility for performing work.

Alcohol means the intoxicating agent in beverage alcohol, ethyl alcohol, or other low molecular weight alcohols including methyl and isopropyl alcohol.

■ Types of Controlled Substances and Alcohol Tests (Part 382, Subpart C-Tests Required)

Pre-Employment (382.301 – Controlled Substances Only)

No employer shall allow a driver to perform a safety-sensitive function until they have received the negative controlled substance test result.

Post-Accident (382.303)

As soon as practicable following an accident involving a commercial motor vehicle operating on a public road in commerce, each employer shall test for alcohol (within 8 hours) and controlled substances (within 32 hours) for each of its surviving drivers:

- Who was performing safety-sensitive functions with respect to the vehicle, if the accident involved the loss of human life; or
- Who receives a citation within 8 hours of the occurrence under State or local law for a moving traffic violation arising from the accident, if the accident involved:
 - Bodily injury to any person who, as a result of the injury, immediately receives medical treatment away from the scene of the accident; or
 - One or more motor vehicles incurring disabling damage as a result of the accident, requiring the motor vehicle to be transported away from the scene by a tow truck or other motor vehicle.

**Post-Accident:
Table for §382.303(a) and (b)**

Type of accident involved	Citation issued to the CMV driver	Test must be performed by employer
Human fatality	Yes	Yes
	No	Yes
Bodily injury with immediate medical treatment away from the scene	Yes	Yes
	No	No
Disabling damage to any motor vehicle requiring tow away	Yes	Yes
	No	No

Random (382.305)

Companies are to randomly test drivers at a minimum annual percentage rate of 10% of the number of drivers for alcohol testing, and 50% for controlled substances testing. The random alcohol tests must be performed immediately prior, during or immediately after a driver has performed a safety-sensitive function as defined in 49 CFR section 382.107. All drivers must have an equal chance of being tested.

Reasonable Suspicion (382.307)

An employer shall require a driver to submit to an alcohol and/or controlled substance test when the employer has reasonable suspicion to believe that the driver has violated the prohibitions concerning alcohol and/or controlled substances. The employer's determination that reasonable suspicion exists to require the driver to undergo an alcohol and/or controlled substances test must be based on specific, coincidental, articulable observations concerning the appearance, behavior, speech or body odors of the driver. The required observations shall be made by a supervisor or company official who is trained in accordance with 49 CFR section 382.603.

Return-to-Duty (382.309)

Each employer shall ensure that before a driver returns to duty requiring the performance of a safety-sensitive function after engaging in conduct prohibited by Subpart B (Prohibitions) of Part 382 concerning alcohol or controlled substances, the driver shall undergo a return-to-duty alcohol test with a result

indicating an alcohol concentration of less than 0.02 and/or the driver shall undergo a return-to-duty controlled substances test with a result indicating a verified negative result for controlled substances use.

Follow-Up (382.311)

The Substance Abuse Professional (SAP) will establish a follow-up testing plan. The employer must ensure that the follow-up testing plan is carried out. A minimum of six tests must be conducted in the first 12 months, and the driver may also be subject to follow-up tests during the 48 months of safety-sensitive duty following the first 12-month period.

Driver Awareness (382.601)

Every motor carrier shall provide educational materials explaining the requirements of the regulations as well as the employer's policies regarding alcohol misuse and controlled substances abuse. At a minimum, detailed discussions should include:

- The identity of the person designated to answer drug and alcohol questions.
- Which drivers are subject to these requirements, what behavior is prohibited, and clarification of what a "safety-sensitive function" is.
- The circumstances under which a driver will be tested, and the procedures that will be used for testing.
- Explanations of the requirement that a driver submit to the testing, as well as what constitutes a driver's refusal to submit to testing.

- The consequences for drivers who have violated the testing requirements.
- Information concerning the effects of alcohol misuse, and controlled substances abuse on health, work, and personal life.

■ What is required of the Motor Carrier if a driver tests positive?

Controlled Substance (382.501, 40.23)

When an employer receives notification of a verified positive controlled substance test result or a verified adulterated or substituted controlled substance test result, the employer must **immediately** remove the employee involved from any safety-sensitive functions. Do not wait to receive written verification confirming the test results or the result of a split specimen test.

Alcohol (382.501, 40.23)

When an employer receives an alcohol test result of 0.04 or higher alcohol concentration, the employer must **immediately** remove the employee involved from any safety-sensitive functions. Do not wait to receive written verification confirming the test results.

When the motor carrier receives an employee's alcohol test result showing an alcohol concentration of .02 to .039, the employer must **immediately** remove the employee from any safety-sensitive functions until the start of the employee's next regularly scheduled duty period; but not less than 24 hours following administration of the test.

General (382.309, 40.305)

Before an employer allows a driver to return to duty to perform a safety-sensitive function following certain prohibited conduct such as:

- a verified positive controlled substances test result;
- an alcohol result of 0.04 or greater;
- a refusal to submit to a test; or
- any other activity that violates provisions of the Prohibitions (Part 382, Subpart B) that driver must first be evaluated by a SAP, participate in any treatment program prescribed, and pass a controlled substances and/or alcohol return-to-duty test.

It is the motor carrier's responsibility to provide to the employee a list, including the names,

addresses, and telephone numbers, of qualified SAPs as required by 49 CFR section 40.287.

As an employer, you may not alter a drug or alcohol test result transmitted to you by a Medical Review Officer (MRO), Breath Alcohol Technician (BAT), or Consortium/Third Party Administrator (C/TPA) as noted in 49 CFR section 40.23.

Drug and Alcohol Convictions While Operating a Noncommercial Vehicle (391.51)

Drivers should be made aware that certain drug and alcohol convictions in a noncommercial vehicle may affect their commercial driver's license status. See Part 383 of this CD-ROM or review 49 CFR section 383.51.

Recordkeeping Requirements (382.401)

■ General requirements.

Each employer must maintain records of its alcohol misuse and controlled substances use prevention programs in a secure location with controlled access. When requested by an authorized representative of FMCSA, the records must be made available at the principal place of business within two business days. See 49 CFR section 383.51.

If a record is required to be prepared, it must be retained. The following records must be maintained for a minimum of:

Five Years

- Records of alcohol test results indicating an alcohol concentration of 0.02 or greater;
- Records of verified positive controlled substances test results;
- Documentation of refusals to take required alcohol and/or controlled substances tests;
- Driver evaluation and referrals; or
- Calibration documentation of Evidential Breath Testing (EBT) devices;
- Records related to the administration of the alcohol and controlled substances testing program; and
- A copy of each annual calendar year summary if required by 49 CFR section 382.403.

Two Years

Records related to the alcohol and controlled substances collection process (except calibration of evidential breath testing devices) including:

- Random selection process records;
- Reasonable suspicion testing documentation;
- Post accident testing documentation; and
- Medical explanation for a driver's inability to provide adequate sample.

One Year

- Records of negative and cancelled substances test results; and
- Alcohol test results with a concentration of less than 0.02.

Indefinite Period

Records must be maintained by the employer while the individual performs the functions which require the training and for **two years** after ceasing to perform those functions.

- All records related to the training and education of drivers, supervisors, breath alcohol technicians, and screening technicians;
- Employer's testing policy; and
- Driver's signed receipt for educational materials and policy received.

For more information, reference: "Implementation Guidelines for Alcohol and Drug Regulations in Highway Transportation" at <http://www.fmcsa.dot.gov/safety-security/safety-initiatives/drugs/drug-guidelines.htm>.



Form to Use

- 17 U.S. Department of Transportation (DOT) Alcohol Testing Form



U.S. Department of Transportation (DOT) Alcohol Testing Form

(The instructions for completing this form are on the back of Copy 3)

Step 1: TO BE COMPLETED BY ALCOHOL TECHNICIAN

A: Employee Name _____
(Print) (First, M.I., Last)

B: SSN or Employee ID No. _____

C: Employer Name _____
Street _____
City, ST ZIP _____

DER Name and Telephone No. _____ (____)
DER Name _____ DER Phone Number _____

D: Reason for Test: Random Reasonable Susp Post-Accident Return to Duty Follow-up Pre-employment

*Affix
Or
Print
Screening Results
Here*

*Affix
With
Tamper-Evident
Tape*

STEP 2: TO BE COMPLETED BY EMPLOYEE

I certify that I am about to submit to alcohol testing required by US Department of Transportation regulations and that the identifying information provided on the form is true and correct.

_____/_____/_____
Signature of Employee Date Month Day Year

*Affix
Or
Print
Confirmation Results
Here*

STEP 3: TO BE COMPLETED BY ALCOHOL TECHNICIAN

(If the technician conducting the screening test is not the same technician who will be conducting the confirmation test, each technician must complete their own form.) I certify that I have conducted alcohol testing on the above named individual in accordance with the procedures established in the US Department of Transportation regulation, 49 CFR Part 40, that I am qualified to operate the testing device(s) identified, and that the results are as recorded.

TECHNICIAN: BAT STT DEVICE: SALIVA BREATH* 15-Minute Wait: Yes No

SCREENING TEST: (For BREATH DEVICE* write in the space below only if the testing device is not designed to print.)

Test #	Testing Device Name	Device Serial # <u>OR</u> Lot # & Exp Date	Activation Time	Reading Time	Result
--------	---------------------	--	-----------------	--------------	--------

CONFIRMATION TEST: Results MUST be affixed to each copy of this form or printed directly onto the form.

REMARKS:

Alcohol Technician's Company _____ Company Street Address _____ (____)

(PRINT) Alcohol Technician's Name (First, M.I., Last) _____ Company City, State, Zip _____ Phone Number _____

_____/_____/_____
Signature of Alcohol Technician Date Month Day Year

*Affix
With
Tamper-Evident
Tape*

*Affix
Or
Print
Additional Results
Here*

*Affix
With
Tamper-Evident
Tape*

STEP 4: TO BE COMPLETED BY EMPLOYEE IF TEST RESULT IS 0.02 OR HIGHER

I certify that I have submitted to the alcohol test, the results of which are accurately recorded on this form. I understand that I must not drive, perform safety-sensitive duties, or operate heavy equipment because the results are 0.02 or greater.

_____/_____/_____
Signature of Employee Date Month Day Year

OMB No. 2105-0529

PART 383

Commercial Driver's License Standards: Requirements and Penalties

The licensing provisions in Part 383 are intended to help reduce accidents by setting standards that:

- Require commercial drivers to be properly qualified and to hold a single valid commercial driver's license (CDL); and
- Disqualify drivers who do not operate commercial motor vehicles (CMVs) safely.

Because the CDL is a State-issued license, you should check with appropriate State officials regarding particular license classes and specific exemptions. Drivers must hold CDLs if they operate in interstate, intrastate, or foreign *commerce* and drive a CMV.

Applicability (383.3)

The rules in 49 CFR Part 383 apply to every person who operates a commercial motor vehicle (CMV), as defined below, in interstate, foreign, or intrastate commerce, to all employers of such persons, and to all States. Exceptions and Restrictions are stated in 49 CFR section 383.3.

Definitions (383.5)

Commercial Driver's License Information System (CDLIS) means the CDLIS established by FMCSA pursuant to section 12007 of the Commercial Motor Vehicle Safety Act of 1986. CDLIS enables the States to exchange information about the driving records and driver's licenses of CMV drivers. This helps ensure that only one license is issued to a driver and that drivers currently disqualified are prevented from obtaining a CDL.

Commercial motor vehicle (CMV) means a motor vehicle or combination of motor vehicles used in commerce to transport passengers or property if the motor vehicle:

- Has a gross combination weight rating of 26,001 pounds or more (11,794 kilograms or more) inclusive of a towed unit(s) with a gross vehicle weight rating of more than 10,000 pounds (4,536 kilograms); or
- Has a gross vehicle weight rating of 26,001 pounds or more (11,794 kilograms or more); or
- Is designed to transport 16 or more passengers, including the driver; or
- Is of any size and is used in the transportation of hazardous materials requiring placarding.

Disqualification means any of the following three actions:

- The suspension, revocation, or cancellation of a CDL by the State or jurisdiction of issuance.
- Any withdrawal of a person's privileges to drive a CMV by a State or other jurisdiction as the result of a violation of State or local law relating to motor vehicle traffic control (other than parking, vehicle weight, or vehicle defect violations).
- A determination by the FMCSA that a person is not qualified to operate a commercial motor vehicle under 49 CFR Part 391.

Notification to Employer and Licensing State (383.31)

Upon *conviction* for *any* State or local traffic violation, a driver must notify his/her employer(s) within 30 days. This notification must be in writing and must include the following information:

- Driver's full name;
- Driver's license number;
- Date of conviction;
- Details about the offense, including any resulting suspension, revocation, or cancellation of driving privileges;
- Indication of whether the violation happened in a CMV;
- Location of offense; and
- Driver's signature.

Disqualification of Drivers (383.51)

No employer shall knowingly allow, require, permit, or authorize a disqualified driver to drive a CMV. The period of time which a driver must be disqualified depends on the offense and the type of vehicle the driver is operating at the time of the violation.

Recent changes in driver's license regulations require driver disqualification for some violations that occur while driving non-commercial vehicles. See 49 CFR section 383.51 for details.

Disqualifying Offenses Include:

- Driving a CMV while *under the influence of alcohol*.
- Driving a CMV while *under the influence of a disqualifying drug or other controlled substance*.
- Leaving the scene of an accident that involves a CMV.
- Using a CMV to commit a *felony*.
- Using a CMV to commit *serious traffic violations*.
- Using a CMV to violate an *Out-of-Service Order*.
- Using a CMV to violate *the Railroad-Highway Grade Crossing rule*.

■ Suspensions for traffic violations:

60-Day Suspension

A 60-day suspension will be imposed following conviction for a *second serious traffic violation* in a separate incident within three years while driving a CMV.

These violations include:

- Excessive speeding (15 miles per hour or more above the posted speed limit in a single offense);
- Reckless driving, improper or erratic lane changes, or following the vehicle ahead too closely;
- Traffic offenses involving a fatal accident; and
- Driving a CMV without a CDL, proper class of CDL, and/or proper endorsement.

120-Day Suspension

A 120-day suspension will be imposed following three convictions of any serious violations within three years.

Disqualification for Major Offenses:

A driver will be disqualified for 1 year to life if convicted of the offenses contained in Table 1 of 49 CFR section 383.51. These violations include:

- Being under the influence of alcohol
- Being under the influence of a controlled substance
- Having an alcohol concentration of 0.04 or greater while operating a CMV
- Refusing to take an alcohol test
- Leaving the scene of an accident
- Using a CMV to commit a felony
- Driving a CMV when, as a result of prior violations committed operating a CMV, the driver's CDL is revoked, suspended, or canceled, or the driver is disqualified from operating a CMV
- Causing a fatality through the negligent operation of a CMV
- Using the vehicle in the commission of a felony involving manufacturing, distributing, or dispensing a controlled substance

Implied Consent (383.72)

Any CDL holder is automatically considered to have consented to alcohol testing by any State or jurisdiction.

Disqualification for serious traffic violations.

Table on page 20 contains a list of the offenses and the periods for which a driver must be disqualified, depending upon the type of vehicle the driver is operating at the time of the violation, as follows:

If the driver operates a motor vehicle and is convicted of:	For a second conviction of any combination of offenses in this Table in a separate incident within a 3 year period while operating a CMV, a person required to have a CDL and a CDL holder must be disqualified from operating a CMV for:	For a second conviction of any combination of offenses in this Table in a separate incident within a 3 year period while operating a non CMV, a CDL holder must be disqualified from operating a CMV, if the conviction results in the revocation, cancellation or suspension of the CDL holder's license for non CMV driving privileges, for:	For a third or subsequent conviction of any combination of offenses in this Table in a separate incident within a 3 year period while operating a CMV, a person required to have a CDL and a CDL holder must be disqualified from operating a CMV for:	For a third or subsequent conviction of any combination of offenses in this Table in a separate incident within a 3 year period while operating a non CMV, a CDL holder must be disqualified from operating a CMV, if the conviction results in the revocation, cancellation or suspension of the CDL holder's license for non CMV driving privileges, for:
1) Speeding excessively, involving any speed of 24.1 kmph (15 mph) or more above the posted speed limit.	60 days	60 days	120 days	120 days
2) Driving recklessly, as defined by State or local law or regulation, including but, not limited to, offenses of driving a motor vehicle in willful or wanton disregard for the safety of persons or property.	60 days	60 days	120 days	120 days
3) Making improper or erratic traffic lane changes.	60 days	60 days	120 days	120 days
4) Following the vehicle ahead too closely.	60 days	60 days	120 days	120 days
5) Violating State or local law relating to motor vehicle traffic control (other than a parking violation) arising in connection with a fatal accident.	60 days	60 days	120 days	120 days
6) Driving a CMV without obtaining a CDL.	60 days	Not applicable	120 days	Not applicable
7) Driving a CMV without a CDL in the driver's possession.	60 days	Not applicable	120 days	Not applicable
8) Driving a CMV without the proper class of CDL and/or endorsements for the specific vehicle group being operated or for the passengers or type of cargo being transported.	60 days	Not applicable	120 days	Not applicable

Commercial motor vehicle groups (383.91)

Commercial Driver's License (CDL)

COMMERCIAL MOTOR VEHICLE GROUPS

Group A (Combination Vehicle)

Any combination of vehicles with a gross combination weight rating (GCWR) of 26,001 pounds or more, provided the gross vehicle weight rating (GVWR) of the vehicle(s) being towed is in excess of 10,000 pounds.



Group B (Heavy Straight Vehicle)

Any single vehicle with a GVWR of 26,001 pounds or more, or any such vehicle towing a vehicle not in excess of 10,000 pounds GVWR.



Group C (Small Vehicle)

Any single vehicle, or combination of vehicles, that meets neither the definition of Group A nor Group B, but is designed to transport 16 or more passengers including the driver, or is used in the transportation of materials found to be hazardous which require the motor vehicle to be placarded. This includes any quantity of chemical or biological material or agent posing a threat to national security, including toxins.



Revised 01/06

Endorsements (383.93)

In addition to general knowledge and skills tests, drivers who operate specialized commercial motor vehicles must pass additional tests and obtain endorsements on their CDLs, as follows:

- T** — Double/triple trailers (knowledge test only)
- P** — Passenger (knowledge and skills tests)
- N** — Tank vehicle (knowledge test only)
- H** — Hazardous materials (knowledge test only)
- X** — Combination of tank vehicle and hazardous materials (knowledge tests)
- S** — School Bus (knowledge and skills test)

Commercial Driver's License (CDL)

CDL ENDORSEMENTS

Double/Triple Trailers (T)



Passenger Vehicles (P)



Tank Vehicles (N)



Hazardous Materials (H) (any size vehicle)



School Buses (S)



Tank & Hazardous Materials (X)



Federal Motor Carrier
Safety Administration

U.S. Department of Transportation
www.fmcsa.dot.gov

Air Brake Restrictions (383.95)

If an applicant fails the air brake section of the knowledge test, or performs the skills test in a vehicle not equipped with air brakes, his/her CDL, if issued, will indicate that the license holder may not operate any CMV (requiring a CDL) equipped with air brakes.

***NOTE:** For the purposes of the skills test and the license restriction, air brakes include any braking system that operates fully or partially on the air brake principle.*

Hazardous Materials Endorsement Requirements (383.141)

- ▶ A State may not issue, renew, upgrade, or transfer a HM endorsement for a CDL to any individual unless the Transportation Security Administration (TSA) has determined that the individual does not pose a security risk warranting denial of the endorsement.
- ▶ At least 60 days prior to the expiration date of the CDL or HM endorsement, a State must notify the holder of a CDL with an HM endorsement that the individual must pass a TSA security threat assessment. An individual who does not successfully complete the TSA security assessment process may not be issued a HM endorsement.
- ▶ Each State must require that HM endorsements be renewed every 5 years or less.

(Sample application shown on next page)





**Transportation
Security
Administration**

**APPLICATION FOR A
HAZARDOUS MATERIALS
ENDORSEMENT**

For Department Use Only
CDL #: _____
Type of Endorsement (H or X): _____

NAME (Last, First, Middle, Suffix)				SOCIAL SECURITY NUMBER	
PREVIOUS NAMES USED (Last, First, Middle, Suffix)				DRIVER LICENSE NUMBER	
SEX (Check one) <input type="checkbox"/> Male <input type="checkbox"/> Female	DOB (mm/dd/yyyy)	HEIGHT	WEIGHT	HAIR COLOR	EYE COLOR
CURRENT RESIDENTIAL ADDRESS					
CITY		STATE	ZIP		
CURRENT MAILING ADDRESS (If different than residential)					
CITY		STATE	ZIP		
PREVIOUS RESIDENTIAL ADDRESS					
CITY		STATE	ZIP		
RESIDENCY STATUS I comply with the immigration requirements described in Section 2 of the back of this form <input type="checkbox"/> True <input type="checkbox"/> False					
COUNTRY OF CITIZENSHIP		NATURALIZATION DATE		ALIEN REGISTRATION NUMBER	
CITY OF BIRTH		STATE OF BIRTH		COUNTRY OF BIRTH	
MILITARY SERVICE I have served in the United States military <input type="checkbox"/> Yes <input type="checkbox"/> No			BRANCH	DISCHARGE (mm/dd/yy)	TYPE OF DISCHARGE
CURRENT EMPLOYER NAME				CURRENT EMPLOYER PHONE (include area code)	
CURRENT EMPLOYER ADDRESS					
CITY		STATE	ZIP		
CURRENT EMPLOYER NAME (If More than One)				CURRENT EMPLOYER PHONE (include area code)	
CURRENT EMPLOYER ADDRESS (If more than one)					
CITY		STATE	ZIP		
1. I have not been convicted, or found not guilty by reason of insanity, of any disqualifying crime listed in Section 1, Part A, in any jurisdiction, military or civilian, during the 7 years before the date of this application.....					<input type="checkbox"/> True <input type="checkbox"/> False
2. I have not been released from incarceration in any jurisdiction, military or civilian, for committing any disqualifying crime listed in Section 1, Part A, in during the 5 years before the date of this application.....					<input type="checkbox"/> True <input type="checkbox"/> False
3. I have not been convicted, or found not guilty by reason of insanity, of any disqualifying crime listed in Section 1, Part B, in any jurisdiction, military or civilian.....					<input type="checkbox"/> True <input type="checkbox"/> False
4. I am not wanted or under indictment for any disqualifying crime listed in Section 1, Part C.....					<input type="checkbox"/> True <input type="checkbox"/> False
5. I have not been adjudicated as lacking mental capacity or involuntary committed to a mental institution.....					<input type="checkbox"/> True <input type="checkbox"/> False

I have disclosed any and all information with this application related to disqualifying crimes committed and as required by Federal regulation 49 CFR 1572.5(b) I understand my continuing obligation to disclose to TSA within 24 hours if I am convicted or found not guilty by reason of insanity of any disqualifying crime, or adjudicated as a mental defective or committed to a mental institution, while I have a hazardous materials endorsement for a CDL.

The information I have provided on this application is true, complete, and correct to the best of my knowledge and belief and is provided in good faith. I understand that a knowing and willful false statement, or an omission of a material fact, on this application can be punished by fine or imprisonment or both (see section 1001 of Title 18 United States Code), and may be grounds for denial of a hazardous materials endorsement.

Applicant Signature: _____

Date: _____

Applicant: Review Notices on Second Page prior to Signature

OMB No. 1652-0027
(Exp. 01/31/2008)

Section 1. List of Disqualifying Criminal Offenses for Hazardous Materials Endorsement

Part A: Interim Disqualifying Offenses

A driver will be disqualified from holding a hazmat endorsement on a CDL if he or she was convicted or found not guilty by reason of insanity within the previous seven years or was released from prison in the last five years for any of the following crimes:

- a) Assault with intent to murder
- b) Kidnapping or hostage taking
- c) Rape or aggravated sexual abuse
- d) Unlawful possession, use, sale, manufacture, purchase, distribution, receipt, transfer, shipping, transporting, delivery, import, export of, or dealing in a firearm or other weapon
- e) Extortion
- f) Dishonesty, fraud, or misrepresentation, including identity fraud
- g) Bribery
- h) Smuggling
- i) Immigration violations
- j) Violations of the Racketeer Influenced and Corrupt Organizations Act, 18 U.S.C. 1961, et seq., or a State law that is comparable, other than the violations listed in paragraph (j) of Part B: Permanently Disqualifying Criminal Offenses
- k) Robbery
- l) Distribution of, intent to distribute, or importation of a controlled substance
- m) Arson
- n) Conspiracy or attempt to commit the any of these crimes

Part B: Permanently Disqualifying Criminal Offenses:

A driver will be permanently disqualified from holding a hazmat endorsement on a CDL if he or she was convicted or found not guilty by reason of insanity for any of the following crimes:

- a) Espionage
- b) Sedition
- c) Treason
- d) A crime listed in 18 U.S.C. Chapter 113B—Terrorism, or a State law that is comparable
- e) A crime involving a transportation security incident
- f) Improper transportation of a hazardous material under 49 U.S.C. 5124 or a State law that is comparable
- g) Unlawful possession, use, sale, distribution, manufacture, purchase, receipt, transfer, shipping, transporting, import, export, storage of, or dealing in an explosive or explosive device
- h) Murder
- i) Conspiracy or attempt to commit any of these crimes
- j) Violations of the Racketeer Influenced and Corrupt Organizations Act, 18 U.S.C. 1961, et seq., or a State law that is comparable, where one of the predicate acts found by a jury or admitted by the defendant, consists of one of the offenses listed in paragraphs (d) or (h) of this section

Part C: Under Want or Warrant:

A driver will be disqualified from holding a hazmat endorsement on a CDL if he or she is wanted or under indictment in any civilian or military jurisdiction for a felony listed under Part A or Part B until the want or warrant is released.

Section 2: Permissible Immigration Status to Hold Hazardous Materials Endorsement

An applicant for an HME must be one of the following:

- a) A citizen of the U.S. who has not renounced his/her U.S. citizenship
- b) A lawful permanent resident of the U.S. as defined in section 101(a)(20) of the Immigration and Nationality Act
- c) A lawful nonimmigrant in possession of valid, unrestricted employment authorization
- d) A refugee admitted under section 8 U.S.C. 1157 in possession of valid, unrestricted employment authorization
- e) In asylum status under section 8 U.S.C. 1158 in possession of valid, unrestricted employment authorization

Section 3: Privacy Act and Paperwork Reduction Act Notices

Authority: The authority for collecting this information is 49 U.S.C. 114, 40113, and 49 U.S.C. 5103a.

Purpose: This information is needed to verify your identity and to conduct a security threat assessment to evaluate your suitability for a hazardous materials endorsement for a commercial drivers license. Furnishing this information, including your SSN or alien registration number, is voluntary; however, failure to provide it will prevent the completion of your security threat assessment, without which you cannot be granted a hazardous materials endorsement.

Routine Uses: Routine uses of this information include disclosure to the FBI to retrieve your criminal history record; to TSA contractors or other agents who are providing services relating to the security threat assessments; to appropriate governmental agencies for licensing, law enforcement, or security purposes, or in the interests of national security; and to foreign and international governmental authorities in accordance with law and international agreement. For additional details, see TSA's system of records notice for DHS/TSA 002, published in the Federal Register at 69 Fed. Reg. 57348 (September 24, 2004).

Public Burden: It is estimated that the time to complete this form is approximately 30 minutes. An agency may not conduct or sponsor, and a person is not required to respond to, a collection of information unless it displays a valid OMB control number. The control number for this collection is OMB 1652-0027.

PART 385

Safety Fitness Procedures

Purpose and Scope (385.1)

49 CFR Part 385 establishes the FMCSA's procedures to determine:

- Safety fitness of motor carriers, to assign safety ratings, to direct motor carriers to take remedial action when required, and to prohibit motor carriers receiving a safety rating of "unsatisfactory" from operating a CMV;
- Safety assurance program for a new entrant motor carrier initially seeking to register with FMCSA to conduct interstate operations. It also describes the consequences that will occur if the new entrant fails to maintain adequate basic safety management controls; and
- Safety permit program for a motor carrier to transport the types and quantities of hazardous materials listed in 49 CFR section 385.403.

Definitions (385.3)

Compliance review means an on-site examination of motor carrier operations, such as drivers' hours of service, maintenance and inspection, driver qualification, commercial drivers license requirements, financial responsibility, accidents, hazardous materials, and other safety and transportation records to determine whether a motor carrier meets the safety fitness standard. A compliance review may be conducted in response to a request to change a safety rating, to investigate potential violations of safety regulations by motor carriers, or to investigate complaints, or other evidence of safety violations. The compliance review may result in the initiation of an enforcement action.

Safety Audit means an examination of a motor carrier's operations to provide educational and technical assistance on safety and the operational requirements of the FMCSRs and applicable HMRs and to gather critical safety data needed to make an assessment of the carrier's safety performance and basic safety management controls. Safety audits do not result in safety ratings.

Safety management controls means the systems, policy programs, practices, and procedures used by a motor carrier to ensure compliance

with applicable safety and hazardous materials regulations, which ensure the safe movement of products and passengers through the transportation system, and to reduce the risk of highway accidents and hazardous materials incidents resulting in fatalities, injuries, and property damage.

■ Safety ratings:

Satisfactory safety rating means that a motor carrier has in place and functioning adequate safety management controls to meet the safety fitness standard prescribed in 49 CFR section 385.5. Safety management controls are adequate if they are appropriate for the size and type of operation of the particular motor carrier.

Conditional safety rating means a motor carrier does not have adequate safety management controls in place to ensure compliance with the safety fitness standard that could result in occurrences listed in 49 CFR sections 385.5(a) through (k).

Unsatisfactory safety rating means a motor carrier does not have adequate safety management controls in place to ensure compliance with the safety fitness standard which **has** resulted in occurrences listed in 49 CFR sections 385.5(a) through (k).

Safety Fitness Standard (385.5 (a) - (k))

The satisfactory safety rating is based on the degree of compliance with the safety fitness standard for motor carriers. To meet the safety fitness standard, the motor carrier shall demonstrate that it has adequate safety management controls in place that function effectively to ensure acceptable compliance with applicable safety requirements to reduce the risk associated with:

- a. Commercial driver's license standard violations (Part 383)
- b. Inadequate levels of financial responsibility (Part 387)
- c. The use of unqualified drivers (Part 391)
- d. Improper use and driving of motor vehicles (Part 392)
- e. Unsafe vehicles operating on the highways (Part 393)

- f. Failure to maintain accident registers and copies of accident reports (Part 390)
- g. The use of fatigued drivers (Part 395)
- h. Inadequate inspection, repair, and maintenance of vehicles (Part 396)
- i. Transportation of hazardous materials, driving and parking rule violations (Part 397)
- j. Violation of hazardous materials regulations (Parts 170 through 177), and
- k. Motor vehicle accidents and hazardous materials incidents.

Notification of Safety Fitness Determination (385.11)

The motor carrier will receive written notice of the safety rating from FMCSA within 30 days after the review.

A motor carrier transporting placardable quantities of hazardous materials, or operating a vehicle designed to transport more than 15 passengers including the driver that has received an “unsatisfactory” safety rating from FMCSA will have 45 calendar days from the effective date of that rating, or from the date of the notice, whichever is later, to improve the safety rating to “conditional” or “satisfactory”. Other motor carriers that have received an “unsatisfactory” safety rating will have 60 days to improve the safety rating to “conditional” or “satisfactory”. If this improvement does not occur, the carrier is prohibited from operating commercial motor vehicles in interstate commerce. Also, a motor carrier with an “unsatisfactory” safety rating is ineligible to contract or subcontract transportation services with Federal agencies.

Change of Safety Rating Based Upon Corrective Action (385.17)

A motor carrier that has taken action to correct the deficiencies that resulted in a proposed or final rating of “conditional” or “unsatisfactory” may request a rating change at any time.

Safety Monitoring System for Mexico-Domiciled Carriers

Definitions (385.101)

Provisional operating authority means the registration under 49 CFR section 365.507 that the FMCSA

grants to a Mexico-domiciled motor carrier to provide interstate transportation within the United States beyond the municipalities along the United States-Mexico border and the commercial zones of such municipalities. It is provisional because it will be revoked if the registrant is not assigned a satisfactory safety rating following a compliance review conducted during the safety monitoring period.

Provisional certificate of registration means the registration under 49 CFR section 368.6 that the FMCSA grants to a Mexico-domiciled motor carrier to provide interstate transportation of property within the United States solely within the municipalities along the United States-Mexico border and the commercial zones of such municipalities. It is provisional because it will be revoked if the registrant does not demonstrate that it is exercising basic safety management controls during the safety monitoring period.

Safety Monitoring System (385.103)

- ▶ Each Mexico-domiciled carrier operating in the United States will be subject to an oversight program to monitor its compliance with applicable Federal Motor Carrier Safety Regulations (FMCSRs), Federal Motor Vehicle Safety Standards (FMVSSs), and Hazardous Materials Regulations (HMRs).
- ▶ Each Mexico-domiciled carrier granted provisional operating authority must have on every commercial motor vehicle it operates in the United States a current decal attesting to a satisfactory inspection by a Commercial Vehicle Safety Alliance (CVSA) inspector.
- ▶ The FMCSA will conduct a safety audit on a Mexico-domiciled carrier within 18 months after the FMCSA issues the carrier a provisional Certificate of Registration.
- ▶ The FMCSA will conduct a compliance review on a Mexico-domiciled carrier within 18 months after the FMCSA issues the carrier provisional operating authority.

Each Mexico-domiciled carrier that receives provisional operating authority or a provisional Certificate of Registration will be subject to intensified monitoring through frequent roadside inspections.

Expedited Action (385.105)

A Mexico-domiciled motor carrier committing any 49 CFR section 385.105 violations identified through roadside inspections or by any other means, may be subjected to an expedited safety audit or compliance review, or may be required to submit a written response demonstrating corrective action:

Failure to respond to an agency demand for a written response demonstrating corrective action within 30 days will result in the suspension of the carrier's provisional operating authority or provisional Certificate of Registration until the required showing of corrective action is submitted to the FMCSA.

A satisfactory response to a written demand for corrective action does not excuse a carrier from the requirement that it undergo a safety audit or compliance review, as appropriate, during the provisional registration period.

■ New Entrant Safety Assurance Program

Beginning January 1, 2003, all new motor carriers (private and for-hire) domiciled in the United States and Canada **and** operating in interstate commerce must apply for registration (U.S. DOT Number) as a "new entrant".

Non-business private motor carriers of passengers are not subject to the new entrant program requirements.

New Entrant Program Requirements (385.301)

All new entrant motor carriers must complete an application package consisting of a MCS-150 and a MCS-150A. This application may be completed online at <http://safer.fmcsa.dot.gov> or by contacting our headquarters office at (800) 832-5660 and requesting an application by mail. For-hire motor carriers must complete an OP-1, or OP-1(P), the BOC-3, and pay a \$300.00 filing fee to obtain operating authority. A motor carrier may not transport for-hire loads before being granted operating authority. Private and exempt for-hire carriers will not be required to pay any fee. Once the application package is completed, the carrier will be granted new entrant registration (U.S. DOT number).

New Entrant Pre-Operational Requirements (385.307)

After a new entrant satisfies all applicable pre-operational requirements, it will be subject to the new entrant safety monitoring procedures for a period of 18 months. During this 18-month period:

- The new entrant's roadside safety performance will be closely monitored to ensure the new entrant has basic safety management controls that are operating effectively. An accident rate or driver or vehicle violation rate that is higher than the industry average for similar motor carrier operations may cause the FMCSA to conduct an expedited safety audit or compliance review at any time.
- A safety audit will be conducted on the new entrant, once it has been in operation for enough time to have sufficient records to allow the agency to evaluate the adequacy of its basic safety management controls.
- Failure to demonstrate basic safety management controls may result in the carrier having their new entrant registration revoked.

Purpose of the Safety Audit (385.309)

The purpose of the safety audit is to provide the new entrant motor carrier with educational and technical assistance and to gather safety data needed to make an assessment of the motor carrier's safety performance and adequacy of your basic safety management controls.

Safety Audit (385.311)

An individual certified under the FMCSA regulations to perform safety audits will conduct the safety audit.

The safety audit will consist of a review of the carrier's safety management system. The areas of review include, but are not limited to, the following:

- Driver Qualifications;
- Driver Duty Status;
- Vehicle Maintenance;
- Accident Register;
- Controlled Substances and Alcohol Use and Testing Requirements; and
- Hazardous Materials.

Completion of Safety Audit (385.319)

Upon completion of the audit, the auditor will review the findings with the motor carrier. This discussion will be followed up within 45 days with an official letter from the agency advising the motor carrier whether FMCSA has determined that you have adequate basic safety management controls.

After The 18-month New Entrant Safety Monitoring Period (383.333)

The carrier will be notified in writing that the “new entrant” registration designation will be removed and their registration has become permanent at the end of the 18-month safety-monitoring period, if the carrier meets the following requirements:

- The new entrant has passed a safety audit, or has not been deemed “unfit” following a compliance review;
- The new entrant is not currently under an order placing its operations out of service; and
- The new entrant does not have any outstanding civil penalties.

■ Hazardous Materials Safety Permits Program

Applicability (385.401)

No one may transport the materials listed in 49 CFR section 385.403 without a safety permit.

Definitions (385.402)

HM safety permit means a document issued by FMCSA that contains a permit number and confers authority to transport in commerce the hazardous materials listed in 49 CFR section 385.403.

Carrier’s HM Safety Permit Program (385.403)

On January 1, 2005, the FMCSA began to phase in the Federal Hazardous Materials Safety (HMSP) Program for intrastate, interstate, and foreign motor carriers transporting certain types and amounts of hazardous materials. These carriers must maintain a certain level of safety in their operations and certify they have programs in place as required by the Hazardous Materials Regulations and the HMSP regulations.

Motor carriers will be required to apply for an HMSP by completing Form MCS-150B. HMSPs remain valid for up to two years and must be renewed according to the schedule in 49 CFR section 390.19.

The following hazardous materials carried in these quantity amounts will require an HMSP:

- Radioactive Materials: A highway route-controlled quantity of Class 7 material, as defined in 49 CFR section 173.403.
- Explosives: More than 25kg (55 pounds) of a Division 1.1, 1.2 or 1.3 material, or an amount of a Division 1.5 material requiring a placard under 49 CFR Part 172, subpart F.
- Material Poisonous by Inhalation:
 - *Hazard Zone A*: More than one liter (1.08 quarts) per package of a “material poisonous by inhalation,” as defined in 49 CFR section 171.8, that meets the criteria for “hazard zone A,” as specified in 49 CFR section 173.116(a) or 173.133(a).
 - *Hazard Zone B*: A “material poisonous by inhalation,” as defined in 171.8 of this title, that meets the criteria for “hazard zone B,” as specified in 49 CFR section 173.116(a) or 173.133(a) in a bulk packaging (capacity greater than 450 L [119 gallons]).
 - *Hazard Zone C & D*: A “material poisonous by inhalation,” as defined in 171.8 of this title, that meets the criteria for “hazard zone C,” or “hazard zone D,” as specified in 173.116(a) of this title, in a packaging having a capacity equal to or greater than 13,248 L (3,500 gallons).
- Methane: A shipment of compressed or refrigerated liquefied methane or liquefied natural gas or other liquefied gas with a methane content of at least 85% in a bulk packaging having a capacity equal to or greater than 13,248 L (3,500 gallons) for liquids or gases.

Carrier's Requirement to Obtain and Maintain an HMSP

The detailed requirements for obtaining and maintaining a permit are found in 49 CFR Part 385.

These requirements include:

- ▶ Maintain a “satisfactory” safety rating in order to obtain and hold a safety permit.
- ▶ Maintain their crash rating, and their driver, vehicle, hazardous materials or out-of service rating so they are not in the worse 30 percent of the national average as indicated in FMCSA’s Motor Carrier Management Information System (MCMIS). For calendar years 2007 and 2008, the HMSP OOS and crash rate thresholds are:
 - a. HMSP Crash Rate Threshold – 0.125%
 - b. HMSP Driver OOS Threshold – 9.52%
 - c. HMSP Vehicle OOS Threshold – 33.3%
 - d. HMSP Hazardous Materials OOS Threshold – 6.06%
- ▶ Have a satisfactory security program (and associated training) according to 49 CFR section 172.800 in place.
- ▶ Maintain registration with Pipeline and Hazardous Materials Safety Administration.
- ▶ Develop a system of communication that will enable the vehicle operator to contact the motor carrier during the course of transportation and maintain records of these communications.
- ▶ Have written route plan required for radioactive materials set forth in 49 CFR section 397.101 and for explosives in 49 CFR section 397.19 (currently required).
- ▶ Perform a pre-trip inspection (North American Standard (NAS) Level VI Inspection for Radioactive Shipments) for shipments containing highway route controlled Class 7 (radioactive) materials.
- ▶ Provide proof of adequate financial responsibility in the form of a properly executed copy of Form MCS-90 (Endorsement) or Form MCS-82 (Surety Bond).

If a carrier meets all the above criteria, but does not have a safety rating, FMCSA may issue a Temporary Hazardous Materials Safety Permit (THMSP). The THMSP is valid for 6 months in which time a FMCSA compliance review will be conducted and a safety rating issued to the carrier.

The HMSP program continually monitors the safety performance of HMSP carriers. Violations to the HMSP regulations may lead to suspension or revocation of the carrier’s HMSP laid out in 49 CFR section 385.421. Denials, suspensions and revocations of the HM Safety Permit may be appealed through the process laid out in 49 CFR section 385.423.

Applying for an HMSP (385.405)

The forms and instructions for completing the forms may be obtained on the internet at http://li-public.fmcsa.dot.gov/liview/pkg_registration or by contacting FMCSA at Federal Motor Carrier Safety Administration, MC-RIS, Room W65-206, 1200 New Jersey Avenue SE, Washington, DC 20590, Telephone: 1-800-832-5660.

(A list of frequently cited violations on next page)



List of Frequently Cited Violations

VIOLATION DESCRIPTION	SECTION OR CITE	BASELINE ASSESSMENT
General Requirements		
A. Registration Requirements: Failure to register as an offeror or carrier of hazardous material and pay registration fee.	107.608 107.612	\$1,000 + \$500 each additional year.
B. Training Requirements:	172.702	\$450 and up each area \$500 and up or \$800 and up
C. Security Plans	172.704	\$3,000 and up
D. Notification to a Foreign Shipper: Failure to provide information of HMR requirements applicable to a shipment of hazardous materials within the United States, to a foreign offeror or forwarding agent at the place of entry into the U.S.	171.12(a)	\$1,500 to \$7,500 (corresponding to violations by foreign offeror or forwarding agent).
E. Expired Exemption or Special Permit: Offering or transporting a hazardous material, or otherwise performing a function covered by an exemption or special permit, after expiration of the exemption or special permit	171.2(a), (b), (c), Various	\$1,000 + \$500 each additional year.
Offeror Requirements—All hazardous materials		
A. Undeclared Shipment:		
Offering for transportation a hazardous material without shipping papers, package markings, labels, or placards	172.200, 172.300, 172.400 172.500	\$15,000 and up
B. Shipping Papers:	172.201 172.201(a)(1) 172.201(e), 172.202 172.202(c) 172.203(a) 172.203(b) 172.203(k) 172.203(c)(2) 172.204 174.24(b), 175.30(a), 176.24(b), 177.817(f)	\$500-\$6,000
C. Emergency Response Information Requirements:	172.602 172.604	\$800-\$6,000
D. Package Marking Requirements:	172.301(a) 172.303(a) 172.301(c) 172.304(a)(4) 172.312 172.324(b)	\$500-\$6,000
E. Package Labeling Requirements:	172.400 172.401(a) 172.402 172.406(a) 172.407(c) 172.407(d) 172.411	\$800-\$5,000
F. Placarding Requirements:	172.504	\$800-\$9,000
G. Packaging Requirements:	178.503(a) 178.601 173.22(a)(4) 173.24(b) 171.14 173.25(a)(4) 173.32(a), 180.352, 180.605 173.32(f)(6) 173.471(a). 173.416 Various	\$2,000-\$12,000
12. Offering any Type B, Type B(U), Type B(M) packaging that failed to meet the approved DOT, NRC or DOE design, as applicable		\$9,000.
a. Failure to have the required radiation survey record		\$5,000.

PART 387

Minimum Levels of Financial Responsibility for Motor Carriers

Applicability (387.3)

49 CFR Part 387 applies to for hire motor carriers operating motor vehicles transporting property or passengers in interstate or foreign commerce as well as motor carriers operating motor vehicles transporting hazardous materials, hazardous substances, or hazardous wastes in interstate, foreign, or intrastate commerce.

Definitions (387.5)

Financial responsibility means having insurance policies or surety bonds sufficient to satisfy the minimum public liability requirements.

For hire carriage means the business of transporting, for compensation, the goods or property of another.

Freight forwarder means a person holding itself out to the general public (other than as an express, pipeline, rail, sleeping car, motor, or water carrier) to provide transportation of property for compensation in interstate commerce, and in the ordinary course of its business:

- Performs or provides for assembling, consolidating, break-bulk, and distribution of shipments;
- Assumes responsibility for transportation

Household goods freight forwarder (HHGFF) means a freight forwarder of household goods, unaccompanied baggage, or used automobiles.

Motor carrier means a for hire motor carrier or a private motor carrier. The term includes, but is not limited to, a motor carrier's agent, officer, or representative; an employee responsible for hiring, supervising, training, assigning, or dispatching a driver; or an employee concerned with the installation, inspection, and maintenance of motor vehicle equipment and/or accessories.

Motor vehicle means any vehicle, machine, tractor, trailer, or semitrailer propelled or drawn by mechanical power and used to transport property, but does not include any vehicle, locomotive, or car operated exclusively on a rail or rails. The following combinations will be regarded as one motor vehicle:

- A tractor that draws a trailer or semitrailer; and
- A truck and trailer bearing a single load.

Public liability means liability for bodily injury, property damage, and environmental restoration.



Requirements for Financial Responsibility (387.7)

Motor carriers of property operating commercial motor vehicles in interstate, foreign, or intrastate commerce, and for hire carriers of passengers operating in interstate or foreign commerce must have at least the minimum amount of insurance required by law.

On the following pages is the Schedule of Limits for minimum levels of financial responsibility.

■ Proof

The motor carrier must have proof of the minimum level of insurance at the company's principal place of business. Proof may be shown by any of the following:

- Endorsements for Motor Carriers policies of insurance for public liability under sections 29 and 30 of the Motor Carrier Act of 1980 (Form MCS-90) issued by an insurer.
- Endorsements for Motor Carriers of Passengers policies of insurance for public liability under section 18 of the Bus Regulatory Reform Act of 1982 (Form MCS-90B) issued by an insurer.
- A Motor Carrier Surety Bond for public liability under section 30 of the Motor Carrier Act of 1980 (Form MCS-82) issued by an insurer.
- A Motor Carrier of Passengers Surety Bond for public liability under section 18 of the Bus Regulatory Reform Act of 1982 (Form MCS-82B) issued by an insurer.
- A written decision, order or authorization of the Federal Motor Carrier Safety Administration authorizing the motor carrier to self-insure under 49 CFR section 387.309.



Forms to Use

Shown on following pages and available at Web address: http://www.fmcsa.dot.gov/documents/forms/part_387.pdf

- 33**MCS-82 –
Motor Carrier Public Liability Surety Bond Under Sections 29 and 30 of the Motor Carrier Act of 1980.
- 34**MCS-82B –
Motor Carrier Public Liability Surety Bond Under Section 18 of the Bus Regulatory Reform Act of 1982.
- 35**BMC-90 –
Endorsement For Motor Carrier Policies of Insurance For Automobile Bodily Injury and Property Damage Liability Under Section 13906, Title 49 of the United States Code.
- 36, 37**MCS-90B –
Endorsement for Motor Carrier Policies of Insurance for Public Liability Under Section 18 of the Bus Regulatory reform Act of 1982.

A Federal Agency may not conduct or sponsor, and a person is not required to respond to, nor shall a person be subject to a penalty for failure to comply with a collection of information subject to the requirements of the Paperwork Reduction Act unless that collection of information displays a current valid OMB Control Number. The OMB Control Number for this information collection is 2126-0008. Public reporting for this collection of information is estimated to be approximately 2 minutes per response, including the time for reviewing instructions, gathering the data needed, and completing and reviewing the collection of information. All responses to this collection of information are mandatory. Send comments regarding this burden estimate or any other aspect of this collection of information, including suggestions for reducing this burden to: Information Collection Clearance Officer, Federal Motor Carrier Safety Administration, MC-101, Washington, D.C. 20590.



**MOTOR CARRIER PUBLIC LIABILITY SURETY BOND
UNDER SECTIONS 29 AND 30 OF THE MOTOR CARRIER ACT OF 1980**

<u>PARTIES</u>	Surety Company and Principal <u>Place of Business Address</u>	Motor Carrier Principal, FMCSA Docket No., <u>And Principal Place of Business Address</u>
	_____	_____
	_____	_____
	_____	_____

PURPOSE This is an agreement between the Surety and the Principal under which the Surety, its successors and assignees, agree to be responsible for the payment of any final judgment or judgments against the Principal for public liability, property damage, and environmental restoration liability claims in the sums prescribed herein; subject to the governing provisions, and the following conditions.

- GOVERNING PROVISIONS**
- (1) Sections 29 and 30 of the Motor Carrier Act of 1980 (49 U.S.C. 31139).
 - (2) Rules and regulations of the Federal Motor Carrier Safety Administration (FMCSA)

CONDITIONS The Principal is or intends to become a motor carrier of property subject to the applicable governing provisions relating to financial responsibility for the protection of the public.

This bond assures compliance by the Principal with the applicable governing provisions, and shall insure to the benefit of any person or persons who shall recover a final judgment or judgments against the Principal for public liability, property damage, or environmental restoration liability claims (excluding injury to or death of the Principal's employees while engaged in the course of their employment, and loss of or damage to property of the principal, and the cargo transported by the Principal). If every final judgment shall be paid for such claims resulting from the negligent operation, maintenance, or use of motor vehicles in transportation subject to the applicable governing provisions, then this obligation shall be void, otherwise it will remain in full effect.

Within the limits described herein, the Surety extends to such losses regardless of whether such motor vehicles are specifically described herein and whether occurring on the route or in the territory authorized to be served by the Principal or elsewhere.

The liability of the Surety on each motor vehicle subject to the financial responsibility requirements of Section's 29 and 30 of the Motor Carrier Act of 1980 for each accident shall not exceed \$ _____, and shall be a continuing one notwithstanding any recovery hereunder.

The surety agrees, upon telephone request by an authorized representative of the FMCSA, to verify that the surety bond is in force as of a particular date. The telephone number to call is: _____

This bond is effective from _____ (12:01 a.m., standard time, at the address of the Principal as stated herein) and shall continue in force until terminated as described herein. The principal or the Surety may at any time terminate this bond by giving (1) thirty (30) days notice in writing to the other party (said 30 day notice to commence from the date the notice is mailed, proof of mailing shall be sufficient proof of notice), and (2) if the Principal is subject to the FMCSA's registration requirements, by providing thirty (30) days notice to the FMCSA (said 30 days notice to commence from the date notice is received by the FMCSA at its office in Washington, D.C.). The Surety shall not be liable for the payment of any judgment or judgments against the Principal for public liability, property damage, or environmental restoration claims resulting from accidents which occur after the termination of this bond as described herein, but such termination shall not affect the liability of the Surety for the payment of any such judgment or judgments resulting from accidents which occur during the time the bond is in effect.

_____ Date

(AFFIX CORPORATE SEAL)

_____ Surety

_____ City

_____ State

By _____

ACKNOWLEDGMENT OF SURETY

STATE OF _____ COUNTY OF _____

On this _____ day of _____, 20____, before me personally came _____, who, being by me duly sworn, did depose and say that he resides in _____; that he/she is the _____ of the _____, the corporation described in and which executed the foregoing instrument; that he knows the seal of said corporation; that the seal affixed to said instrument is such corporate seal; that it was so affixed by order of the board of directors of said corporation; that he/she signed his/her name thereto by like order, and he/she duly acknowledged to me that he/she executed the same for and on behalf of said corporation.

_____ Title of official administering oath

(OFFICIAL SEAL)

Surety Company File No. _____

Burden Statement

OMB NO: 2126-0008
Expiration Date:

and Agency may not conduct or sponsor, and a person is not required to respond to, nor shall a person be subject to a penalty for failure to comply with a collection of information subject to the requirements of the Paperwork Reduction Act unless that collection of information displays a current valid OMB Control Number. MB Control Number for this information collection is 2126-0008. Public reporting burden for this collection of information is estimated to average 2 minutes per response, including the time for reviewing instructions, gathering the data needed, and completing and reviewing the collection of information. All responses to this collection of information are mandatory. Send comments regarding this burden estimate or any other aspect of this collection of information, including suggestions for reducing this burden to: Information Collection Clearance Officer, Federal Motor Carrier Safety Administration, MC-MMI, Washington, D.C. 20590.



U.S. Department
of Transportation
Federal Motor Carrier
Safety Administration

**MOTOR CARRIER PUBLIC LIABILITY SURETY BOND
UNDER SECTION 18 OF THE BUS REGULATORY REFORM ACT OF 1982**

PARTIES

Surety Company and Principal
Place of Business Address

Motor Carrier Principal, FMCSA Docket No.,
And Principal Place of Business Address

PURPOSE

This is an agreement between the Surety and the Principal under which the Surety, its successors and assigns, agree to be responsible for the payment of any final judgment or judgments against the Principal for public liability and property damage claims in the sums prescribed herein, subject to the governing provisions and following conditions.

GOVERNING PROVISIONS

- (1) Section 18 of the Bus Regulatory Reform Act of 1982
- (2) Rules and regulations of the Federal Motor Carrier Safety Administration (FMCSA)

CONDITIONS

The Principal is or intends to become a motor carrier of passengers subject to the applicable governing provisions relating to financial responsibility for the protection of the public.

This bond assures compliance by the Principal with the applicable governing provisions, and shall inure to the benefit of any person or persons who shall recover a final judgment or judgments against the Principal for public liability or property damage claims (excluding injury to or death of the Principal's employees while engaged in the course of their employment, and loss of or damage to property of the Principal, and the cargo transported by the Principal). If every final judgment shall be paid for such claims resulting from the negligent operation, maintenance, or use of motor vehicles in transportation subject to the applicable governing provisions, then this obligation shall be void, otherwise it will remain in full effect.

Within the limits described herein, the Surety extends to such losses regardless of whether such motor vehicles are specifically described herein and whether occurring on the route or in the territory authorized to be served by the Principal or elsewhere.

The liability of the Surety for each motor vehicle subject to the applicable governing provisions for each accident shall not exceed \$ _____, and shall be a continuing one notwithstanding any recovery thereunder.

The surety agrees, upon telephone request by an authorized representative of the FMCSA, to verify that the surety bond is in force as of a particular date. The telephone number to call is _____.

This bond is effective from _____ (12:01 a.m., standard time, at the address of the Principal as stated herein) and shall continue in force until terminated as described herein. The Principal or the Surety may at any time terminate this bond by giving (1) thirty-five (35) days notice in writing to the other party (said 35 days notice to commence from the date the notice is mailed, proof of mailing shall be sufficient proof of notice), and (2) if the Principal is subject to the FMCSA's registration requirements, by providing thirty (30) days notice to the FMCSA (said 30 days notice to commence from the date notice is received by the FMCSA at its office in Washington, D.C.). The Surety shall not be liable for the payment of any judgment or judgments against the Principal for public liability or property damage claims resulting from accidents which occur after the termination of this bond as described herein, but such termination shall not affect the liability of the Surety from the payment of any such judgment or judgments resulting from accidents which occur during the time the bond is in effect.

Date

Surety

City

State

By _____

(AFFIX CORPORATE SEAL)

ACKNOWLEDGMENT OF SURETY

STATE OF _____ COUNTY OF _____

On this _____ day of _____, 20____, before me personally came _____, who, being by me duly sworn, did depose and say that he resides in _____; that he/she is _____ of the _____, the corporation described in and which executed the foregoing instrument; that he knows the seal of said corporation; that the seal affixed to said instrument is such corporate seal; that it was so affixed by order of the board of directors of said corporation; that he signed his name thereto by like order, and he duly acknowledged to me that he executed the same for and on behalf of said corporation.

Title of official administering oath

(OFFICIAL SEAL)

Surety Company File No. _____

According to the Paperwork Reduction Act of 1995, no persons are required to respond to a collection of information unless it displays a valid OMB control number. It is estimated that an average of 10 minutes per response is required to complete this collection of information. This estimate includes time for reviewing instructions, searching existing data sources, gathering and maintaining the data needed, and completing and reviewing the collection of information. Comments concerning the accuracy of this burden estimate or suggestions for reducing this burden should be directed to the Federal Motor Carrier Safety Administration, 400 7th St., SW, Washington, DC 20590

Form BMC-90

Approved by OMB

2126-0017

Expires: 02/28/2009

**ENDORSEMENT FOR MOTOR CARRIER POLICIES OF INSURANCE FOR
AUTOMOBILE BODILY INJURY AND PROPERTY DAMAGE LIABILITY UNDER
SECTION 13906, TITLE 49 OF THE UNITED STATES CODE**

The policy to which this endorsement is attached is an automobile bodily injury and property damage liability policy and is amended to assure compliance by the insured as a motor carrier of passengers or property, with Section 13906, Title 49 of the United States Code and the pertinent rules and regulations of the Federal Motor Carrier Safety Administration.

In consideration of the premium stated in the policy to which this endorsement is attached, the Company agrees to pay, within the limits of liability prescribed herein, any final judgment recovered against the insured for bodily injury to or death of any person, or loss of or damage to property of others (excluding injury to or death of the insured's employees while engaged in the course of their employment, and property transported by the insured, designated as cargo), resulting from negligence in the operation, maintenance, or use of motor vehicles under certificate or permit issued to the insured by the Federal Motor Carrier Safety Administration, or otherwise in interstate or foreign commerce subject to Chapter 139 of Title 49 of the United States Code, regardless of whether or not such motor vehicles are specifically described in the policy and whether or not such negligence occurs on any route or in any territory authorized by the Federal Motor Carrier Safety Administration to be served by the insured or elsewhere.

It is understood and agreed that no condition, provision, stipulation, or limitation contained in the policy, or any other endorsement thereon or violation thereof, or of this endorsement, by the insured, shall relieve the Company from liability or from the payment of any final judgment, irrespective of the financial responsibility or lack thereof or insolvency or bankruptcy of the insured. However, all terms, conditions, and limitations in the policy to which this endorsement is attached are to remain in full force and effect as binding between the insured and the Company, and the insured agrees to reimburse the Company for any payment made by the Company on account of any accident, claim, or suit involving a breach of the terms of the policy, and for any payment that the Company would not have been obligated to make under the provisions of the policy except for the agreement contained in this endorsement.

It is understood and agreed that, upon failure of the Company to pay any final judgment recovered against the insured as prescribed herein, the judgment creditor may maintain an action in any court of competent jurisdiction against the Company to compel such payment.

The Company's liability for the amounts provided in this endorsement apply separately to each accident and any payment under the policy because of any one accident shall not operate to reduce the liability of the Company for the payment of final judgments resulting from any other accident.

The liability of the Company on each motor vehicle shall be the limits prescribed in 49 CFR 387.303(b)(1), governing minimum amounts of insurance.

This endorsement may not be canceled without notification to the Federal Motor Carrier Safety Administration. Such cancellation may be effected by the Company or the insured giving thirty (30) days notice in writing to the Federal Motor Carrier Safety Administration at its office in Washington, D.C., said thirty (30) days notice commencing from the date notice is received by the FMCSA.

Issued to: _____ of _____

Dated at _____ this _____ day of _____, _____

Amending Policy No. _____ Effective Date _____

Name of Insurance Company _____

Countersigned by _____

Authorized Company Representative

Public Burden Statement

A Federal Agency may not conduct or sponsor, and a person is not required to respond to, nor shall a person be subject to a penalty for failure to comply with a collection of information subject to the requirements of the Paperwork Reduction Act unless that collection of information displays a current valid OMB Control Number. The OMB Control Number for this information collection is 2126-0008. Public reporting for this collection of information is estimated to average approximately 2 minutes per response, including the time for reviewing instructions, gathering the data needed, and completing and reviewing the collection of information. All responses to this collection of information are mandatory. Send comments regarding this burden estimate or any other aspect of this collection of information, including suggestions for reducing this burden to: Information Collection Clearance Officer, Federal Motor Carrier Safety Administration, MC-AMM, Washington, D.C. 20590.



U.S. Department
of Transportation

Federal Motor Carrier
Safety Administration

**ENDORSEMENT FOR
MOTOR CARRIER POLICIES OF INSURANCE FOR PUBLIC LIABILITY
UNDER SECTION 18 OF THE BUS REGULATORY REFORM ACT OF 1982**

Issued to _____ of _____

Dated at _____ this _____ day of _____, 20____

Amending Policy No. _____ Effective Date _____

Name of Insurance Company _____

Countersigned by _____

Authorized Company Representative

The policy to which this endorsement is attached provides primary or excess insurance, as indicated by "[X]" for the limits shown:

This insurance is primary and the company shall not be liable for amounts in excess of \$ _____ for each accident.

This insurance is excess and the company shall not be liable for amounts in excess of \$ _____ for each accident in excess of the underlying limit of \$ _____ for each accident.

Whenever required by the Federal Motor Carrier Safety Administration (FMCSA) the company agrees to furnish the FMCSA a duplicate of said policy and all its endorsements. The company also agrees, upon telephone request by an authorized representative of the FMCSA, to verify that the policy is in force as of a particular date. The telephone number to call is: _____

Cancellation of this endorsement may be effected by the company of the insured by giving (1) thirty-five (35) days notice in writing to the other party (said 35 days notice to commence from the date the notice is mailed, proof of mailing shall be sufficient proof of notice), and (2) if the insured is subject to the FMCSA's registration requirements, by providing thirty (30) days notice to the FMCSA (said 30 days notice to commence from the date the notice is received by the FMCSA at its office in Washington, D.C.)

DEFINITIONS AS USED IN THIS ENDORSEMENT

Accident includes continuous or repeated exposure to conditions which result in Public Liability which the insured neither expected nor intended.
Bodily Injury means injury to the body, sickness, or disease to any person, including death resulting from any of these.

Motor Carrier means a for-hire carrier of passengers by motor vehicle.
Property Damage means damage to or loss of use of tangible property
Public Liability means liability for bodily injury or property damage.

The insurance policy to which this endorsement is attached provides automobile liability insurance and is amended to assure compliance by the insured, within the limits stated herein, as a for-hire motor carrier of passengers with Section 18 of the Bus Regulatory Reform Act of 1982 and the rules and regulations of the Federal Motor Carrier Safety Administration.

However, all terms, conditions, and limitations in the policy to which the endorsement is attached shall remain in full force and effect as binding between the insured and the company. The insured agrees to reimburse the company for any payment made by the company on account of any accident, claim, or suit involving a breach of the terms of the policy, and for any payment that the company would not have been obligated to make under the provisions of the policy except for the agreement contained in this endorsement.

In consideration of the premium stated in the policy to which this endorsement is attached, the insurer (the company) agrees to pay, within the limits of liability described herein, any final judgment received against the insured for public liability resulting from negligence in the operation, maintenance or use of motor vehicles subject to financial responsibility requirements of Section 18 of the Bus Regulatory Reform Act of 1982 regardless of whether or not each motor vehicle is specifically described in the policy and whether or not such negligence occurs on any route or in any territory authorized to be served by the insured or elsewhere. Such insurance as is afforded, for public liability, does not apply to injury to or death of the insured's employees while engaged in the course of their employment, or property transported by the insured, designated as cargo. It is understood and agreed that no condition, provision, stipulation, or limitation contained in the policy, this endorsement, or any other endorsement thereon, or violation thereof, shall relieve the company from liability or from the payment of any final judgment, within the limits of liability herein described, irrespective of the financial condition, insolvency or bankruptcy of the insured.

It is further understood and agreed that, upon failure of the company to pay any final judgment recovered against the insured as provided herein, the judgment creditor may maintain an action in any court of competent jurisdiction against the company to compel such payment.

The limits of the company's liability for the amounts prescribed in this endorsement apply separately to each accident and any payment under the policy because of any one accident shall not operate to reduce the liability of the company for the payment of final judgments resulting from any other accident.

The Bus Regulatory Reform Act of 1982 requires limits of financial responsibility according to vehicle seating capacity. It is the MOTOR CARRIER'S obligation to obtain the required limits of financial responsibility. THE SCHEDULE OF LIMITS SHOWN ON THE REVERSE SIDE DOES NOT PROVIDE COVERAGE. The limits shown in the schedule are for information purposes only.

SCHEDULE OF LIMITS--PUBLIC LIABILITY
For-hire motor carriers of passengers operating in interstate or foreign commerce

Vehicle Seating Capacity	Effective Dates	
	Nov. 19, 1983	Nov. 19, 1985
(1) Any vehicle with a seating capacity of 16 passengers or more.	\$2,500,000	\$5,000,000
(2) Any vehicle with a seating capacity of 15 passengers or less.	\$ 750,000	\$1,500,000

SAMPLE

Financial Responsibility, Minimum Levels (387.9)

SCHEDULE OF LIMITS PUBLIC LIABILITY		
Type of carriage	Commodity transported	Jan. 1, 1985
(1) For-hire (In interstate or foreign commerce, with a gross vehicle weight rating of 10,000 or more pounds).	Property (nonhazardous).	\$ 750,000
(2) For-hire and Private (In interstate, foreign, or intrastate commerce, with a gross vehicle weight rating of 10,000 or more pounds).	Hazardous substances, as defined in 49 CFR section 171.8, transported in cargo tanks, portable tanks, or hopper-type vehicles with capacities in excess of 3,500 water gallons; or in bulk Division 1.1, 1.2, and 1.3 materials, Division 2.3, Hazard Zone A, or Division 6.1, Packing Group I, Hazard Zone A material; in bulk Division 2.1 or 2.2; or highway route controlled quantities of a Class 7 material, as defined in 49 CFR section 173.403.	\$5,000,000
(3) For-hire and Private (In interstate or foreign commerce, in any quantity; or in intrastate commerce, in bulk only; with a gross vehicle weight rating of 10,000 or more pounds).	Oil listed in 49 CFR section 172.101; hazardous waste, hazardous materials, and hazardous substances defined in 49 CFR section 171.8 and listed in 49 CFR section 172.101, but not mentioned in (2) above or (4) below.	\$1,000,000
(4) For-hire and Private (In interstate or foreign commerce, with a gross vehicle weight rating of less than 10,000 pounds).	Any quantity of Division 1.1, 1.2, or 1.3 material; any quantity of a Division 2.3, Hazard Zone A, or Division 6.1, Packing Group I, Hazard Zone A material; or highway route controlled quantities of a Class 7 material as defined in 49 CFR section 173.403.	\$5,000,000

Financial Responsibility, Minimum Levels (387.33)

SCHEDULE OF LIMITS PUBLIC LIABILITY		
For-hire motor carriers of passengers operating in interstate or foreign commerce		
Vehicle Seating Capacity	Effective Dates	
	Nov. 19, 1983	Nov. 19, 1985
(1) Any vehicle with a seating capacity of 16 passengers or more.	\$2,500,000	\$5,000,000
(2) Any vehicle with a seating capacity of 15 passengers or less. (see note)	\$750,000	\$1,500,000

NOTE: Except as provided in 49 CFR section 387.27(b).

As noted in 49 CFR section 387.27(b), the above schedule of limits does not apply to:

- A motor vehicle transporting only school children and teachers to or from school;
- A motor vehicle providing taxicab service and having a seating capacity of less than 7 passengers and not operated on a regular basis;
- A motor vehicle carrying less than 16 individuals in a single daily round trip to commute to and from work; and
- A motor vehicle operated by a motor carrier under contract providing transportation of preprimary, primary, and secondary students for extracurricular trips organized, sponsored, and paid by a school district.



PART 390

Federal Motor Carrier Safety Regulations: General

General Applicability (390.3)

The Federal Motor Carrier Safety Regulations (FMCSRs) apply to all employers, employees, and commercial motor vehicles transporting property or passengers in interstate commerce.

Every employer shall be knowledgeable of and comply with all regulations contained in the FMCSRs which are applicable to that motor carrier's operations.

Every driver and employee shall be instructed regarding, and shall comply with, all applicable regulations contained in the FMCSRs.

All motor vehicle equipment and accessories required by the FMCSRs shall be maintained in compliance with all applicable performance and design criteria set forth in the FMCSRs.

General Applicability: Exceptions (390.3)

Unless specifically stated, the rules in the FMCSRs do not apply to:

- School bus operations as defined in 49 CFR section 390.5;
- Transportation provided by Federal, State, local governments, or an agency established under a compact between States that has been approved by the Congress of the United States;
- Occasional transportation of personal property by individuals not for compensation nor for commercial purposes;
- Transportation of human corpses or sick and injured people;
- The operation of fire trucks and rescue vehicles while involved in emergency and related operations;
- Transportation provided by commercial motor vehicles transporting between 9 and 15 passengers (including the driver), **not for compensation**, except for the requirements to file the Motor Carrier Identification Report (MCS-150), maintain an accident register, and mark the vehicles with the motor carrier identification number;
- Transportation provided by commercial motor vehicles transporting between 9 and 15 passengers (including the driver), **for compensation**, provided the vehicle is not being operated beyond a 75 air-mile radius (86.3 statute miles or 138.9 kilometers) from the driver's normal work-reporting location, except for the requirements to file the Motor Carrier Identification Report (MCS-150), maintain an accident register, and mark the vehicles with the motor carrier identification number.

General Applicability: Carriers that Transport HMs in Intrastate Commerce (390.3)

Motor carriers that transport hazardous materials in intrastate commerce must comply with specific sections/parts of the FMCSRs as noted below:

- Subparts A (General) and E (Hazardous Materials Safety Permits) of 49 CFR Part 385 of the FMCSRs for carriers subject to the requirements Hazardous Materials Safety Permit concerning 49 CFR section 385.403 of the FMCSRs.
- Part 386 of 49 CFR, Rules of practice for motor carrier, broker, freight forwarder, and hazardous materials proceedings of the FMCSRs.
- Part 387 of 49 CFR, Minimum Levels of Financial Responsibility for Motor Carriers, to the extent provided in 387.3 of the FMCSRs.
- Section 390.19 of 49 CFR concerning Motor carrier identification report and 49 CFR section 390.21 concerning Marking of CMVs, for carriers subject to the Hazardous Materials Safety Permit requirements of 49 CFR section 385.403 of the FMCSRs.

Definitions (390.5)

Accident is an occurrence involving a commercial motor vehicle operating on a public road that results in at least one of the following:

- A fatality;
- Bodily injury to a person who, as a result of the injury, immediately receives medical treatment away from the scene of the accident; or
- Disabling damage to one or more motor vehicles, requiring the vehicle(s) to be towed or otherwise transported from the scene by a tow truck or other vehicle.

Commercial Motor Vehicle means any self-propelled or towed motor vehicle used on a highway in interstate commerce to transport passengers or property when the vehicle:

- Has a gross vehicle weight rating or gross combination weight rating, or gross vehicle weight or gross combination weight, of 10,001 pounds (4,536 kg) or more, whichever is greater; or
- Is designed or used to transport more than 8 passengers (including the driver) for compensation; or
- Is designed or used to transport more than 15 passengers, including the driver, and is not used to transport passengers for compensation; or
- Is used in transporting a quantity of hazardous material requiring placarding.

NOTE: The general definition for commercial motor vehicle is noted above and in 49 CFR section 390.5. The above commercial motor vehicle definition refers to a vehicle used on highways, in interstate commerce, that meets at least one of the four above criteria. The regulations in 49 CFR Parts 390 through 396 apply to drivers of vehicles meeting the above definition.

Also, a different definition of “commercial motor vehicle” is used for 49 CFR Parts 382 and 383. These parts regulate the commercial driver’s license (CDL) (49 CFR Part 382) and alcohol and drug testing (49 CFR Part 383). This definition, as noted in 49 CFR section 383.5 and below, refers to a vehicle used in commerce, whether **interstate or intrastate** that meets one of the following criteria:

- Has a gross combination weight rating of 26,001 or more pounds inclusive of a towed unit with a gross vehicle weight rating of more than 10,000 pounds;
- Has a gross vehicle weight rating of 26,001 or more pounds;
- Is designed to transport 16 or more passengers, including the driver; or
- Is of any size and is used in the transportation of hazardous materials.

Interstate commerce means trade, traffic, or transportation in the United States—

- Between a place in a State and a place outside of such State (including a place outside of the United States);
- Between two places in a State through another State or a place outside of the United States; or
- Between two places in a State as part of trade, traffic, or transportation originating or terminating outside the State or the United States.

Intrastate commerce means any trade, traffic, or transportation in any State which is not described in the term “interstate commerce.”

Accident Register (390.15)

(See form on page 44)

For a period of three years after an accident (as defined above) occurs, motor carriers are required to maintain an accident register containing the following information:

- Date and place of accident
- Driver’s name
- Number of injuries and fatalities

Whether hazardous materials (other than fuel spilled from the fuel tanks of motor vehicle involved in the accident) were released. If the accident involves the release of hazardous materials cargo, see the hazmat incident reporting section of this guide for further requirements.

Motor carriers are also required to maintain copies of all accident reports required by State or other governmental entities or insurers for a period of three years after an accident occurs.



Filing the MCS-150 Report (390.19)

The Motor Carrier Identification Report (MCS-150) is a one-page form that must be filed with the FMCSA by all motor carriers operating in interstate commerce. The MCS-150 report must be processed by the FMCSA before the motor carrier begins operations. After processing the MCS-150, FMCSA will issue the motor carrier a U.S. DOT number (identification number).

Certain carriers of hazardous materials must obtain an FMCSA Hazardous Materials Safety Permit. Carriers qualifying for this permit file the MCS-150B “Combined Motor Carrier Identification Report and HM Permit Application” in lieu of the MCS-150.

The below websites provide more information concerning filing the MCS-150 report and to electronically submit the MCS-150 form over the internet:

<http://www.fmcsa.dot.gov/about/other/faq/faqs.asp>

<http://www.fmcsa.dot.gov/registration-licensing/registration-licensing.htm>

If you do not have access to the internet, you can call FMCSA’s toll-free number at 1-800-832-5660 for assistance.

All motor carriers, except as provided in 49 CFR section 390.19(g) with reference to the Performance and Registration Information Systems Management (PRISM) program, are required to file a MCS-150 once every 24 months after beginning its operations. The schedule for updating the MCS-150 information is listed below:

U.S. DOT Number ending in:	Must file by last day of:
1	January
2	February
3	March
4	April
5	May
6	June
7	July
8	August
9	September
0	October

If the next-to-last digit of its U.S. DOT number is odd, the motor carrier shall file its update in every odd-numbered calendar year. If the next-to-last digit of the U.S. DOT number is even, the motor carrier shall file its update in every even-numbered calendar year.

Vehicle Identification (390.21)

Every commercial motor vehicle operated by a motor carrier in interstate commerce must be marked, on BOTH sides of vehicle, with the following:

- The motor carrier’s name or trade name
- The motor carrier’s identification number, preceded by “US DOT”
- The size, shape and color markings must be in letters that contrast sharply in color with the background on which the letters are placed
- The lettering must be readily legible during daylight hours, from a distance of 50 feet

Relief from Regulations During Emergencies (390.23)

Relief from Parts 390 – 399 of the FMCSRs may be granted during declared emergencies to any motor carrier who provides emergency assistance.

PART 391

Qualification of Drivers

Applicability (391.1)

Persons who drive commercial motor vehicles are subject to minimum qualification as specified in 49 CFR Part 391. The rules in this part also establish minimum duties of motor carriers with respect to the qualifications of their drivers. As well, a motor carrier who employs himself/herself as a driver must comply with both the rules in this part that apply to motor carriers and the rules in this part that apply to drivers (i.e. owner operators with authority).

General Exemptions (391.2)

■ Farm custom operation

The rules in 49 CFR Part 391 do not apply to a driver who drives a commercial motor vehicle controlled and operated by a person engaged in custom-harvesting operations, as specified in 49 CFR section 391.2(a), if the commercial motor vehicle is used to—

- Transport farm machinery, supplies, or both, to or from a farm for custom harvesting operations on a farm; or
- Transport custom harvested crops to storage or market.

■ Apiarian industries

The rules in 49 CFR Part 391 do not apply to a driver who is operating a commercial motor vehicle controlled and operated by a beekeeper engaged in the seasonal transportation of bees as specified in 49 CFR section 391.2(b).

■ Certain farm vehicle drivers

As specified in 49 CFR section 391.2(c), the rules in 49 CFR Part 391 do not apply to a farm vehicle driver except a farm vehicle driver who drives an articulated (combination) commercial motor vehicle as defined in 49 CFR section 390.5. (For limited exemptions for farm vehicle drivers of articulated commercial motor vehicles reference 49 CFR section 391.67.)

Driver Requirements/Responsibilities (391.11 & 391.13)

A driver must meet the following requirements and responsibilities:

- Be at least 21 years of age;
- Speak and read English well enough to converse with the general public, understand highway traffic signals, respond to official questions, and be able to make legible entries on reports and records;
- Be able to drive the vehicle safely;
- Be in good health and physically able to perform all duties of a driver;
- Possess a valid medical certificate;
- Have only one valid commercial motor vehicle operator's license;
- Provide an employing motor carrier with a list of all motor vehicle violations or a signed statement that driver has not been convicted of any motor vehicle violations during the past 12 months. A disqualified driver must not be allowed to drive a commercial motor vehicle for any reason;
- Qualified to drive a CMV;
- Pass a driver's road test or equivalent; and,
- Know how to safely load and properly block, brace, and secure the cargo.

Driver Qualification File Checklist (391.51)

Every motor carrier must have a qualification file for each regularly employed driver.

The file must include:



DRIVER'S APPLICATION FOR EMPLOYMENT (391.21)

A person will not be allowed to drive a commercial motor vehicle unless he/she has completed and signed an application for employment.



DRIVING RECORD FROM STATE AGENCY (INQUIRY) – 3 YEARS (391.23(a)(1) & (b))

The driver's driving record for the preceding three years.

DRIVER'S ROAD TEST CERTIFICATE (391.31) OR EQUIVALENT (391.33)

A person must not be allowed to drive a commercial motor vehicle until he/she has successfully completed a road test and has been issued a certificate, or a copy of the license or certificate which the motor carrier accepted as equivalent to the driver's road test pursuant to CFR section 391.33.

INQUIRY TO STATE AGENCIES FOR DRIVING RECORD (391.25(c)(1))

Request driving record annually for each driver.

ANNUAL REVIEW OF DRIVING RECORD (391.25(c)(2))

The motor carrier must annually review/certify the driving records for all drivers operating a commercial vehicle to determine whether or not they meet the minimum requirements for safe driving and have no disqualifying offenses pursuant to 49 CFR section 391.15. A note stating the results of this review shall be included in the Driver's Qualification File.

ANNUAL DRIVER'S CERTIFICATION OF VIOLATIONS (391.27)

At least once every 12 months, a motor carrier must require each driver that it employs to prepare and furnish a list of all violations of motor vehicle traffic laws and ordinances during the previous 12 months.

NOTE: Drivers who have provided information required by 49 CFR section 383.31 need not repeat that information in this annual list of violations.

MEDICAL EXAMINER'S CERTIFICATE (391.43)

The driver must pass a medical examination conducted by a licensed medical examiner as defined in 49 CFR section 390.5. A driver must be issued a Medical Examiner's Certificate, which must be carried at all times and must be renewed every two years unless the medical examiner specifies a date of less than two years on the certificate.

○ SKILL PERFORMANCE EVALUATION (SPE) CERTIFICATE (391.49)

If applicable, drivers with Impairment or amputation of a limb must maintain SPE certificate.

○ ENTRY - LEVEL DRIVER TRAINING CERTIFICATE (380.509(b))

○ LONGER COMBINATION VEHICLE DRIVER TRAINING CERTIFICATE (380.401) OR CERTIFICATE OF GRANDFATHERING (if applicable) (380.111)

Driver Investigation History File Checklist (391.53)

Each motor carrier must maintain files relating to the investigation into the safety performance history of a new or perspective driver. This data must only be used for the hiring decision. This file must be maintained in a secure location with controlled access and must include:

INQUIRY TO PREVIOUS EMPLOYERS – 3 YEARS

An investigation of the driver's:

- Employment record during the preceding three years. (49 CFR section 391.23(d)(1))
- Accident history during the preceding three years. (49 CFR section 391.23(d)(2))
- Alcohol and Control Substance testing records during the preceding three years. (49 CFR section 391.23(e))

○ CONTROLLED SUBSTANCE AND ALCOHOL TESTING DRIVER RELEASE FORM IF APPLICABLE (391.53(b)(1))

○ NOTES OF RESPONSES RECEIVED FROM THE ABOVE INVESTIGATIONS (391.3(b)(2))

Examples of Physical Requirements (391.41)

- Has no loss of a foot, a leg, a hand, or an arm, or has been granted a skill performance evaluation certificate pursuant to 49 CFR section 391.49.
- Has no impairment of a hand or finger which interferes with prehension or power grasping or has been granted a skill performance evaluation certificate pursuant to 49 CFR section 391.49.
- Has no impairment of an arm, foot, or leg which interferes with the ability to perform normal tasks associated with operating a CMV or has been granted a skill performance evaluation certificate pursuant to 49 CFR section 391.49.
- Has no established medical history or clinical diagnosis of diabetes mellitus currently requiring insulin for control or has been issued a diabetic or vision exemption.
- Has no current clinical diagnosis or any disqualifying heart disease.
- Has no established medical history or clinical diagnosis of a respiratory dysfunction.
- Has no current clinical diagnosis of high blood pressure.
- Has no established medical history or clinical diagnosis of arthritis.
- Has no clinical diagnosis or clinical history of epilepsy.
- Has no mental, nervous, organic, or functional disease or psychiatric disorder.
- Has 20/40 vision or better with or without corrective lenses.
- Has distant binocular acuity of at least 20/40 in both eyes with or without corrective lenses.
- Has the ability to recognize the colors (red, green and amber) of traffic signals.
- Has hearing to perceive a forced whisper voiced equals to or greater than 5 feet with or without hearing aid or average hearing loss in the better ear equals or less than 40 dB.
- Has no history of drug use or any other substance identified in Schedule 1.
- Has no clinical diagnosis of alcoholism.



Forms to Use

Shown on following pages and available at Web address as shown:

- 48**.....Driver Qualification File Checklist:
<http://www.fmcsa.dot.gov/documents/eta/drqualif.pdf>
- 49-50**.....Application for Employment:
<http://www.fmcsa.dot.gov/documents/eta/application.pdf>
- 51-55**Request for Information from Previous Employer:
<http://www.fmcsa.dot.gov/documents/eta/requestforinfo.pdf>
- 56**.....3 Years' Inquiry to State Agency for Driver's Record: <http://www.fmcsa.dot.gov/documents/eta/inquirystateagency.pdf>
- 56**.....Annual Inquiry to State Agency for Driver's Record: <http://www.fmcsa.dot.gov/documents/eta/inquirystateagency.pdf>
- 57**Annual Review of Driving Record:
<http://www.fmcsa.dot.gov/documents/eta/annualreview.pdf>
- 58**.....Driver's Certification of Violations:
<http://www.fmcsa.dot.gov/documents/eta/drcertviolat.pdf>
- 59**.....Driver's Road Test Examination:
<http://www.fmcsa.dot.gov/documents/eta/drrdtestexam3.pdf>
- 60-68**.....Medical Examination Report and Medical Examiner's Certificate:
<http://www.fmcsa.dot.gov/documents/safetyprograms/Medical-Report.pdf>
- 69**.....Multiple-Employer Drivers:
<http://www.fmcsa.dot.gov/documents/eta/multipleemployerdr.pdf>

DRIVER QUALIFICATION FILE CHECKLIST

- Driver's Application For Employment
(49 CFR 391.21)**

- Inquiry To Previous Employers – 3 Years
(49 CFR 391.23(A) (2) & (C))**

- Inquiry To State Agencies – 3 Years
(49 CFR 391.23(A) (1) & (B))**

- Inquiry To State Agencies – Annual
(49 CFR 391.25(A) & (C))**

- Annual Review Of Driving Record
(49 CFR 391.25)**

- Annual Driver's Certification Of Violations
(49 CFR 391.27)**

- Driver's Road Test Certificate or Equivalent
(49 CFR 391.31)**

- Medical Examiner's Certificate
(49 CFR 391.43)**

- Multiple-Employer Drivers
(49 CFR 391.63)**

EMPLOYMENT RECORD
(ATTACH SHEET IF MORE SPACE IS NEEDED)

Applicants that desire to drive in intrastate/interstate commerce must provide the following information on all employers during the previous three years. You must give the same information for all employers you have driven a commercial motor vehicle for the seven years prior to the initial three years (total of ten years employment record).

Must list the complete mailing address: street number and name, city, state and zip code.

LAST EMPLOYER: NAME _____

ADDRESS _____ PHONE _____

POSITION HELD _____ FROM _____ TO _____ SALARY _____

REASONS FOR LEAVING _____

ANY GAPS IN EMPLOYMENT AND/OR UNEMPLOYMENT MUST BE EXPLAINED. INCLUDE DATES (MONTH/YEAR) AND REASON. _____

Were you subject to the Federal Motor Carrier Safety Regulations (FMCSRs) while employed by the previous employer? Yes No

Was the previous job position designated as a safety sensitive function in any DOT regulated mode, subject to alcohol and controlled substances testing requirements as required by 49 CFR Part 40? Yes No

SECOND LAST EMPLOYER: NAME _____

ADDRESS _____ PHONE _____

POSITION HELD _____ FROM _____ TO _____ SALARY _____

REASONS FOR LEAVING _____

ANY GAPS IN EMPLOYMENT AND/OR UNEMPLOYMENT MUST BE EXPLAINED. INCLUDE DATES (MONTH/YEAR) AND REASON. _____

Were you subject to the Federal Motor Carrier Safety Regulations (FMCSRs) while employed by the previous employer? Yes No

Was the previous job position designated as a safety sensitive function in any DOT regulated mode, subject to alcohol and controlled substances testing requirements as required by 49 CFR Part 40? Yes No

THIRD LAST EMPLOYER: NAME _____

ADDRESS _____ PHONE _____

POSITION HELD _____ FROM _____ TO _____ SALARY _____

REASONS FOR LEAVING _____

ANY GAPS IN EMPLOYMENT AND/OR UNEMPLOYMENT MUST BE EXPLAINED. INCLUDE DATES (MONTH/YEAR) AND REASON. _____

Were you subject to the Federal Motor Carrier Safety Regulations (FMCSRs) while employed by the previous employer? Yes No

Was the previous job position designated as a safety sensitive function in any DOT regulated mode, subject to alcohol and controlled substances testing requirements as required by 49 CFR Part 40? Yes No

TO BE READ AND SIGNED BY APPLICANT

I authorize you to make sure investigations and inquiries to my personal, employment, financial or medical history and other related matters as may be necessary in arriving at an employment decision. (Generally, inquiries regarding medical history will be made only if and after a conditional offer of employment has been extended.) I hereby release employers, schools, health care providers and other persons from all liability in responding to inquiries and releasing information in connection with my application.

In the event of employment, I understand that false or misleading information given in my application or interview(s) may result in discharge. I understand, also, that I am required to abide by all rules and regulations of the Company.

"I understand that information I provide regarding current and/or previous employers may be used, and those employer(s) will be contacted, for the purpose of investigating my safety performance history as required by 49 CFR 391.23(d) and (e). I understand that I have the right to:

- Review information provided by current/previous employers;
- Have errors in the information corrected by previous employers and for those previous employers to re-send the corrected information to the prospective employer; and
- Have a rebuttal statement attached to the alleged erroneous information, if the previous employer(s) and I cannot agree on the accuracy of the information."

DATE

APPLICANT'S SIGNATURE

This certifies that I completed this application, and that all entries on it and information in it are true and complete to the best of my knowledge.

DATE

APPLICANT'S SIGNATURE

Note: A motor carrier may require an applicant to provide information in addition to the information required by the Federal Motor Carrier Safety Regulations.

SAFETY PERFORMANCE HISTORY RECORDS REQUEST

PART 1:	TO BE COMPLETED BY PROSPECTIVE EMPLOYEE
I, (Print Name) _____	
<div style="display: flex; justify-content: space-between; border-bottom: 1px solid black;"> First M.I. Last Social Security Number </div>	
Hereby authorize: _____	
<div style="display: flex; justify-content: space-between; border-bottom: 1px solid black;"> Previous Employer: _____ Email: _____ </div>	
<div style="display: flex; justify-content: space-between; border-bottom: 1px solid black;"> Street: _____ Telephone: _____ </div>	
<div style="display: flex; justify-content: space-between; border-bottom: 1px solid black;"> City, State, Zip: _____ Fax No.: _____ </div>	
To release and forward the information requested by section 3 of this document concerning my Alcohol and Controlled Substances Testing records within the previous 3 years from _____.	
(employment application date)	
To: Prospective Employer: _____	
Attention: _____ Telephone: _____	
Street: _____	
City, State, Zip: _____	
In compliance with §40.25(g) and 391.23(h), release of this information must be made in a written form that ensures confidentiality, such as fax, email, or letter.	
Prospective employer's fax number: _____	
Prospective employer's email address: _____	
<div style="display: flex; justify-content: space-between;"> Applicant's Signature Date </div>	
This information is being requested in compliance with §40.25(g) and 391.23.	

PART 2:	TO BE COMPLETED BY PREVIOUS EMPLOYER																								
ACCIDENT HISTORY																									
The applicant named above was employed by us. Yes <input type="checkbox"/> No <input type="checkbox"/>																									
Employed as _____ from (m/y) _____ to (m/y) _____																									
1. Did he/she drive motor vehicle for you? Yes <input type="checkbox"/> No <input type="checkbox"/> If yes, what type? Straight Truck <input type="checkbox"/> Tractor-Semitrailer <input type="checkbox"/> Bus <input type="checkbox"/> Cargo Tank <input type="checkbox"/> Doubles/Triples <input type="checkbox"/> Other (Specify) _____																									
2. Reason for leaving your employ: Discharged <input type="checkbox"/> Resignation <input type="checkbox"/> Lay Off <input type="checkbox"/> Military Duty <input type="checkbox"/>																									
If there is no safety performance history to report, check here <input type="checkbox"/> , sign below and return.																									
ACCIDENTS: Complete the following for any accidents included on your accident register (§390.15(b)) that involved the applicant in the 3 years prior to the application date shown above, or check <input type="checkbox"/> here if there is no accident register data for this driver.																									
<table style="width: 100%; border-collapse: collapse;"> <thead> <tr> <th style="width: 15%;"></th> <th style="width: 20%;">Date</th> <th style="width: 20%;">Location</th> <th style="width: 15%;"># Injuries</th> <th style="width: 15%;"># Fatalities</th> <th style="width: 15%;">Hazmat Spill</th> </tr> </thead> <tbody> <tr> <td>1.</td> <td>_____</td> <td>_____</td> <td>_____</td> <td>_____</td> <td>_____</td> </tr> <tr> <td>2.</td> <td>_____</td> <td>_____</td> <td>_____</td> <td>_____</td> <td>_____</td> </tr> <tr> <td>3.</td> <td>_____</td> <td>_____</td> <td>_____</td> <td>_____</td> <td>_____</td> </tr> </tbody> </table>			Date	Location	# Injuries	# Fatalities	Hazmat Spill	1.	_____	_____	_____	_____	_____	2.	_____	_____	_____	_____	_____	3.	_____	_____	_____	_____	_____
	Date	Location	# Injuries	# Fatalities	Hazmat Spill																				
1.	_____	_____	_____	_____	_____																				
2.	_____	_____	_____	_____	_____																				
3.	_____	_____	_____	_____	_____																				
Please provide information concerning any other accidents involving the applicant that were reported to government agencies or insurers or retained under internal company policies: _____																									

Any other remarks: _____																									

Signature: _____																									
Title: _____ Date: _____																									

PREVIOUS EMPLOYER – COMPLETE PAGE 2 PART 3

PART 3:	TO BE COMPLETED BY PREVIOUS EMPLOYER
DRUG AND ALCOHOL HISTORY	
<p>If driver was not subject to Department of Transportation testing requirements while employed by this employer, please check here <input type="checkbox"/>, fill in the dates of employment from _____ to _____, complete bottom of Part 3, sign, and return.</p> <p>Driver was subject to Department of Transportation testing requirements from _____ to _____.</p>	
<ol style="list-style-type: none"> Has this person had an alcohol test with the result of 0.04 or higher alcohol concentration? YES <input type="checkbox"/> NO <input type="checkbox"/> Has this person tested positive or adulterated or substituted a test specimen for controlled substances? YES <input type="checkbox"/> NO <input type="checkbox"/> Has this person refused to submit to a post-accident, random, reasonable suspicion, or follow-up alcohol or controlled substance test? YES <input type="checkbox"/> NO <input type="checkbox"/> Has this person committed other violations of Subpart B of Part 382, or Part 40? YES <input type="checkbox"/> NO <input type="checkbox"/> If this person has violated a DOT drug and alcohol regulation, did this person complete a SAP-prescribed rehabilitation program in your employ, including return-to-duty and follow-up tests? If yes, please send documentation back with this form. YES <input type="checkbox"/> NO <input type="checkbox"/> For a driver who successfully completed a SAP's rehabilitation referral and remained in your employ, did this driver subsequently have an alcohol test result of 0.04 or greater, a verified positive drug test, or refuse to be tested? YES <input type="checkbox"/> NO <input type="checkbox"/> 	
<p>In answering these questions, include any required DOT drug or alcohol testing information obtained from prior previous employers in the previous 3 years prior to the application date shown on page 1.</p> <p>Name: _____</p> <p>Company: _____</p> <p>Street: _____</p> <p>City, State, Zip: _____ Telephone: _____</p> <p>Part 3 Completed by (Signature): _____ Date: _____</p>	

PART 4a:	TO BE COMPLETED BY PROSPECTIVE EMPLOYER
<p>This form was (check one) <input type="checkbox"/> Faxed to previous employer <input type="checkbox"/> Mailed <input type="checkbox"/> Emailed <input type="checkbox"/> Other _____</p> <p>By: _____ Date: _____</p>	

PART 4b:	TO BE COMPLETED BY PROSPECTIVE EMPLOYER
<p>Complete below when information is obtained.</p> <p>Information received from: _____</p> <p>Recorded by: _____ Method: <input type="checkbox"/> Fax <input type="checkbox"/> Mail <input type="checkbox"/> Email <input type="checkbox"/> Telephone</p> <p>Date: _____ <input type="checkbox"/> Other _____</p>	

INSTRUCTIONS TO COMPLETE THE SAFETY PERFORMANCE HISTORY RECORDS REQUEST

PAGE 1 PART 1: Prospective Employee

- Complete the information required in this section
- Sign and date
- Submit to the Prospective Employer

PAGE 2 PART 4a: Prospective Employer

- Complete the information
- Send to Previous Employer

PAGE 1 PART 2: Previous Employer

- Complete the information required in this section
- Sign and date
- Turn form over to complete SIDE 2 SECTION 3

PAGE 2 PART 3: Previous Employer

- Complete the information required in this section
- Sign and date
- Return to Prospective Employer

PAGE 2 PART 4b: Prospective Employer

- Record receipt of the information
- Retain the form

**RECORDS REQUEST FOR
DRIVER/APPLICANT SAFETY PERFORMANCE HISTORY**

This request is made by the driver/applicant in compliance with the Department of Transportation regulations.

§391.23(i)(2) Drivers who have previous Department of Transportation regulated employment history in the preceding three years, and wish to review previous employer-provided investigative information must submit a written request to the prospective employer, which may be done at any time, including when applying, or as late as thirty (30) days after being employed or being notified of denial of employment. The prospective employer must provide this information to the applicant within five (5) business days of receiving the written request. If the prospective employer has not yet received the requested information from the previous employer(s), then the five-business-days deadline will begin when the prospective employer receives the requested safety-performance history information. If the driver has not arranged to pick up or receive the requested records within thirty (30) days of the prospective employer making them available, the prospective motor carrier may consider the driver to have waived his/her request to review the records.

PART 1:	COMPLETED BY THE DRIVER/APPLICANT
TO:	
Prospective Employer: _____	
Street/P.O. Box: _____	
City, State, Zip: _____ Telephone # _____	
FROM:	
Driver/Applicant: _____ Social Security/I.D. # _____	
Street: _____	
City, State, Zip: _____ Telephone # _____	
<p>I am submitting this written request to obtain copies of my Department of Transportation Safety Performance History for the preceding three years. I understand, for records requested from a prospective employer, that I must arrange to pick up or receive the requested records within thirty (30) days of the records being made available or I have waived my request to review the records.</p> <p>This information should be: <input type="checkbox"/> sent to me at the above address. <input type="checkbox"/> I will arrange to pick up.</p> <p>Driver/Applicant Signature: _____ Date: _____ / _____ / _____ M D Y</p>	

PART 2:	COMPLETED BY THE PROSPECTIVE EMPLOYER
<p>The information must be provided to the applicant within five (5) business days of receiving the written request. If the prospective employer has not yet received the requested information from the previous employer(s), then the five-business-days deadline will begin when the prospective employer receives the requested safety performance history information.</p> <p>Information supplied to:</p> <p>Name: _____</p> <p>Street: _____</p> <p>City, State, Zip: _____</p> <p>Comments: _____</p> <p>_____</p> <p>By:</p> <p>_____ Release Date: _____ / _____ / _____ Signature/person providing information Telephone # M D Y</p>	

COPY 1 PROSPECTIVE EMPLOYER

**SAFETY PERFORMANCE HISTORY INFORMATION
DRIVER/APPLICANT REBUTTAL**

This rebuttal is made by the driver/applicant in compliance with the Department of Transportation regulations.

§391.23(j)(3) Drivers wishing to rebut information in records received pursuant to paragraph (i) of this section must send the rebuttal to the previous employer with instructions to include the rebuttal in that driver's safety performance history.
§391.23(j)(4) After October 29, 2004, within five business days of receiving a rebuttal from a driver, the previous employer must:
 (i) Forward a copy of the rebuttal to the prospective motor carrier employer;
 (ii) Append the rebuttal to the driver's information in the carrier's appropriate file, to be included as part of the response for any subsequent investigating prospective employers for the duration of the three-year data retention requirements.

PART 1: COMPLETED BY THE DRIVER/APPLICANT

TO:
 Previous Employer: _____
 Street/P.O. Box: _____
 City, State, Zip: _____
 Telephone: _____ Fax: _____

FROM:
 Driver/Applicant: _____ Social Security # _____
 Street: _____
 City, State, Zip: _____ Telephone No.: _____

I have submitted this rebuttal to my previous employer requesting that it be attached to my Safety Performance History and provided to subsequent prospective employers.

Reason for the rebuttal (attach documents as necessary): _____

I request that this rebuttal be sent to the attached list of motor carriers.

Driver/Applicant Signature: _____ Date: ____/____/____
M D Y

PART 2: COMPLETED BY THE PREVIOUS EMPLOYER

Received by:
 Signature: _____ Date: ____/____/____
M D Y

**CORRECTION REQUEST
OF
ERRONEOUS SAFETY PERFORMANCE HISTORY INFORMATION**

This request is made by the driver/applicant in compliance with the Department of Transportation regulations, §391.23, investigations and inquiries, paragraphs (j)(1) and (2) as printed below.

§391.23(j)(1) Driver wishing to request correction of erroneous information in records received pursuant to paragraph (i) of this section must send the request for the correction to the previous employer that provided the records to the prospective employer.

§391.23(j)(2) After October 29, 2004, the previous employer must either correct and forward the information to the prospective motor carrier employer, or notify the driver within 15 days of receiving a driver's request to correct the data that it does not agree to correct the data. If the previous employer corrects and forwards the data as requested, that employer must also retain the corrected information as part of the driver's safety performance history record and provide it to subsequent prospective employers when requests for this information are received. If the previous employer corrects the data and forwards it to the prospective motor carrier employer, there is no need to notify the driver.

PART 1:	COMPLETED BY THE DRIVER/APPLICANT
TO:	Prospective Employer: _____ Street/P.O. Box: _____ City, State, Zip: _____ Telephone # _____
FROM:	Driver/Applicant: _____ Social Security/I.D. # _____ Street: _____ City, State, Zip: _____ Telephone # _____
I request correction of erroneous information in my Safety Performance History. Please forward to the following prospective employer: Company Name: _____ Attention: _____ Street: _____ City, State, Zip: _____	
Explanation of desired correction (attach documents as necessary) _____ _____ _____	
Driver/Applicant Signature: _____ Date: ____/____/____ M D Y	
Driver: Retain COPY 4 DRIVER RECORD for your files, Submit copies 1, 2, and 3 to your previous employer.	

PART 2:	COMPLETED BY THE PREVIOUS EMPLOYER
Disposition of the requested information:	
<input type="checkbox"/> Information was corrected and forwarded to the prospective motor carrier employer.	
<input type="checkbox"/> The driver was notified on ____/____/____ that the previous employer does not agree to correct the data. Return copy 3 to the driver.	
Information sent to: Company Name: _____ Attention: _____ Street: _____ City, State, Zip: _____	
Comments: _____ _____	
By: _____ Release Date: ____/____/____ Signature/person providing information Telephone # M D Y	

PART 3:	COMPLETED BY THE PROSPECTIVE MOTOR CARRIER EMPLOYER
The corrected information was received on ____/____/____	
Prospective Employer: _____ Location: _____	
Received by: _____ Signature Title	

COPY 1 PROSPECTIVE EMPLOYER

**U.S. DEPARTMENT OF TRANSPORTATION
MOTOR CARRIER SAFETY PROGRAM
INQUIRY TO STATE AGENCY FOR
DRIVER'S RECORD
391.23**

(Driver's Name)

(Driver's Operator's Lic. No.)

(Driver's Social Sec. No.)

Dear _____,

The above listed individual has made application with us for employment as a driver. Applicant has indicated that the above numbered operator's license or permit has been issued by your State to applicant and it is in good standing.

In accordance with Section 391.23(a)(1) and (b) of the Federal Motor Carrier Safety Regulations, we are required to make inquiry into the driving record during the preceding 3 years of every State in which an applicant-driver has held a motor vehicle operator's license or permit during those 3 years.

Therefore, please certify to us what the individual's driving record is for the preceding 3 years, or certify that no record exists if that be the case.

In the event that this inquiry does not satisfy your requirements for making such inquiries, please send us such forms of yours as are necessary for us to complete our inquiry into the driving record of this individual.

Respectfully yours,

Signature of individual making inquiry

(printed) Name of person making inquiry

Title of person making inquiry

Motor Carrier Name

Street Address

City

State

Zip

**U.S. DEPARTMENT OF TRANSPORTATION
MOTOR CARRIER SAFETY PROGRAM
ANNUAL REVIEW OF DRIVING RECORD
391.25**

Name (Last,

First,

M.I.)

(Soc. Sec. No.)

This day I reviewed the driving record of the above named driver in accordance with 391.25 of the Federal Motor Carrier Safety Regulations. I considered any evidence that the driver has violated applicable provisions of the Federal Motor Carrier Safety Regulations and the Hazardous Materials Regulations. I considered the driver's accident record and any evidence that he/she violated laws governing the operation of motor vehicles, and gave great weight to violations, such as speeding, reckless driving and operation while under the influence of alcohol or drugs, that indicate that the driver has exhibited a disregard for the safety of the public. Having done the above, I find that:

the driver meets the minimum requirements for safe driving, or

the driver is disqualified to drive a motor vehicle pursuant to 391.15

Date of Review

Motor Carrier's Name

Reviewed by: Signature and title

Date of Review

Motor Carrier's Name

Reviewed by: Signature and title

Date of Review

Motor Carrier's Name

Reviewed by: Signature and title

**MOTOR VEHICLE
DRIVER'S CERTIFICATION
OF VIOLATORS
391.27**

I certify that the following is a true and complete list of traffic violations (other than parking violations) for which I have been convicted or forfeited bond or collateral during the past 12 months.

Date	Offense	Location	Type of Vehicle Operated
_____	_____	_____	_____
_____	_____	_____	_____
_____	_____	_____	_____
_____	_____	_____	_____
_____	_____	_____	_____
_____	_____	_____	_____
_____	_____	_____	_____
_____	_____	_____	_____
_____	_____	_____	_____
_____	_____	_____	_____
_____	_____	_____	_____
_____	_____	_____	_____
_____	_____	_____	_____
_____	_____	_____	_____
_____	_____	_____	_____
_____	_____	_____	_____
_____	_____	_____	_____
_____	_____	_____	_____
_____	_____	_____	_____
_____	_____	_____	_____
_____	_____	_____	_____

If no violations are listed above, I certify that I have not been convicted or forfeited bond or collateral on account of any violation required to be listed during the past 12 months.

(Date of Certification)

(Driver's Signature)

(Motor Carrier's Name)

(Motor Carrier's Address)

(Reviewed by: Signature)

(Title)

CERTIFICATE OF DRIVER'S ROAD TEST

Instructions: If the road test is successfully completed, the person who gave it shall complete a certificate of the driver's road test. The original or copy of the certificate shall be retained in the employing motor carrier's driver qualification file of the person examined and a copy given to the person who was examined.
(49 CFR 391.31(e)(f)(g))

CERTIFICATION OF ROAD TEST

Driver's Name _____

Social Security Number _____

Operator's or Chauffeur's License Number _____

State _____

Type of Power Unit _____

Type of Trailer(s) _____

If passenger carrier, type of bus _____

This is to certify that the above-named driver was given a road test under my supervision on _____, 20____, consisting of approximately _____ miles of driving.

It is my considered opinion that this driver possesses sufficient driving skill to operate safely the type of commercial motor vehicle listed above.

(Signature of Examiner)

(Title)

(Organization and Address of Examiner)

Medical Examination Report FOR COMMERCIAL DRIVER FITNESS DETERMINATION

649-F (6045)

1. DRIVER'S INFORMATION					
Driver completes this section					
Driver's Name (Last, First, Middle)	Social Security No.	Birthdate M / D / Y	Age	Sex <input type="checkbox"/> M <input type="checkbox"/> F	New Certification Recertification Follow-up <input type="checkbox"/> <input type="checkbox"/> <input type="checkbox"/>
Address	City, State, Zip Code	Work Tel: ()	Driver License No.	License Class <input type="checkbox"/> A <input type="checkbox"/> C <input type="checkbox"/> B <input type="checkbox"/> D <input type="checkbox"/> Other	Date of Exam
2.					

Driver completes this section, but medical examiner is encouraged to discuss with driver.

<p>Yes <input type="checkbox"/> No <input type="checkbox"/></p> <p><input type="checkbox"/> Any illness or injury in the last 5 years? <input type="checkbox"/> Head/Brain injuries, disorders or illnesses <input type="checkbox"/> Seizures, epilepsy <input type="checkbox"/> medication</p> <p><input type="checkbox"/> Eye disorders or impaired vision (except corrective lenses) <input type="checkbox"/> Ear disorders, loss of hearing or balance <input type="checkbox"/> Heart disease or heart attack; other cardiovascular condition <input type="checkbox"/> medication</p> <p><input type="checkbox"/> Heart surgery (valve replacement/bypass, angioplasty, pacemaker) <input type="checkbox"/> High blood pressure <input type="checkbox"/> Muscular disease <input type="checkbox"/> Shortness of breath</p>	<p>Yes <input type="checkbox"/> No <input type="checkbox"/></p> <p><input type="checkbox"/> Lung disease, emphysema, asthma, chronic bronchitis <input type="checkbox"/> Kidney disease, dialysis <input type="checkbox"/> Liver disease <input type="checkbox"/> Digestive problems <input type="checkbox"/> Diabetes or elevated blood sugar controlled by: <input type="checkbox"/> diet <input type="checkbox"/> pills <input type="checkbox"/> insulin <input type="checkbox"/> Nervous or psychiatric disorders, e.g., severe depression <input type="checkbox"/> medication</p> <p><input type="checkbox"/> Loss of, or altered consciousness</p>	<p>Yes <input type="checkbox"/> No <input type="checkbox"/></p> <p><input type="checkbox"/> Fainting, dizziness <input type="checkbox"/> Sleep disorders, pauses in breathing while asleep, daytime sleepiness, loud snoring <input type="checkbox"/> Stroke or paralysis <input type="checkbox"/> Missing or impaired hand, arm, foot, leg, finger, toe <input type="checkbox"/> Spinal injury or disease <input type="checkbox"/> Chronic low back pain <input type="checkbox"/> Regular, frequent alcohol use <input type="checkbox"/> Narcotic or habit forming drug use</p>
---	---	---

For any YES answer, indicate onset date, diagnosis, treating physician's name and address, and any current limitation. List all medications (including over-the-counter medications) used regularly or recently.

I certify that the above information is complete and true. I understand that inaccurate, false or missing information may invalidate the examination and my Medical Examiner's Certificate.

Driver's Signature _____ Date _____

Medical Examiner's Comments on Health History (The medical examiner must review and discuss with the driver any "yes" answers and potential hazards of medications, including over-the-counter medications, while driving. This discussion must be documented below.)

TESTING (Medical Examiner completes Section 3 through 7) Name: Last, First, Middle,

3. VISION

Standard: At least 20/40 acuity (Snellen) in each eye with or without correction. At least 70 degrees peripheral in horizontal meridian measured in each eye. The use of corrective lenses should be noted on the Medical Examiner's Certificate.

INSTRUCTIONS: When other than the Snellen chart is used, give test results in Snellen-comparable values. In recording distance vision, use 20 feet as normal. Report visual acuity as a ratio with 20 as numerator and the smallest type read at 20 feet as denominator. If the applicant wears corrective lenses, these should be worn while visual acuity is being tested. If the driver habitually wears contact lenses, or intends to do so while driving, sufficient evidence of good tolerance and adaptation to their use must be obvious. **Monocular drivers are not qualified.**

Numerical readings must be provided.

ACUITY	UNCORRECTED	CORRECTED	HORIZONTAL FIELD OF VISION
Right Eye	20/	20/	Right Eye <input type="radio"/>
Left Eye	20/	20/	Left Eye <input type="radio"/>
Both Eyes	20/	20/	

Complete next line only if vision testing is done by an ophthalmologist or optometrist

Date of Examination _____ Name of Ophthalmologist or Optometrist (print) _____ Tel. No. _____ License No./ State of Issue _____ Signature _____

4. [Redacted] **Standard: a) Must first perceive forced whispered voice ≥ 5 ft., with or without hearing aid, or b) average hearing loss in better ear ≤ 40 dB**
 Check if hearing aid used for tests. Check if hearing aid required to meet standard.

INSTRUCTIONS: To convert audiometric test results from ISO to ANSI, -14 dB from ISO for 500Hz, -10dB for 1,000 Hz, -8.5 dB for 2000 Hz. To average, add the readings for 3 frequencies tested and divide by 3.

Numerical readings must be recorded.

a) Record distance from individual at which forced whispered voice can first be heard.

Right ear \ Feet	Left Ear \ Feet
------------------	-----------------

b) If audiometer is used, record hearing loss in decibels. (acc. to ANSI Z24.5-1951)	Right Ear		Left Ear	
	500 Hz	1000 Hz	2000 Hz	500 Hz
	Average:			

5. [Redacted] **Numerical readings must be recorded. Medical Examiner should take at least two readings to confirm BP.**

Blood Pressure	Systolic	Diastolic
----------------	----------	-----------

Driver qualified if ≤140/90.

Pulse Rate: Regular Irregular

Record Pulse Rate: _____

Reading	Category	Expiration Date	Recertification
140-159/90-99	Stage 1	1 year	1 year if ≤140/90. One-time certificate for 3 months if 141-159/91-99.
160-179/100-109	Stage 2	One-time certificate for 3 months.	1 year from date of exam if ≤140/90
≥180/110	Stage 3	6 months from date of exam if ≤140/90	6 months if ≤ 140/90

6. [Redacted] **Numerical readings must be recorded.**

URINE SPECIMEN	SP. GR.	PROTEIN	BLOOD	SUGAR
----------------	---------	---------	-------	-------

Urinalysis is required. Protein, blood or sugar in the urine may be an indication for further testing to rule out any underlying medical problem.

Other Testing (Describe and record) _____

7. PHYSICAL EXAMINATION Height: _____ (in.) Weight: _____ (lbs.)

Name: Last, First, Middle,

The presence of a certain condition may not necessarily disqualify a driver, particularly if the condition is controlled adequately, is not likely to worsen or is readily amenable to treatment. Even if a condition does not disqualify a driver, the medical examiner may consider deferring the driver temporarily. Also, the driver should be advised to take the necessary steps to correct the condition as soon as possible particularly if the condition, if neglected, could result in more serious illness that might affect driving.

Check YES if there are any abnormalities. Check NO if the body system is normal. Discuss any YES answers in detail in the space below, and indicate whether it would affect the driver's ability to operate a commercial motor vehicle safely. Enter applicable item number before each comment. If organic disease is present, note that it has been compensated for. See *Instructions to the Medical Examiner* for guidance.

BODY SYSTEM	CHECK FOR:	YES*	NO	BODY SYSTEM	CHECK FOR:	YES*	NO
1. General Appearance	Marked overweight, tremor, signs of alcoholism, problem drinking, or drug abuse.			7. Abdomen and Viscera	Enlarged liver, enlarged spleen, masses, bruits, hernia, significant abdominal wall muscle weakness.		
2. Eyes	Pupillary equality, reaction to light, accommodation, ocular motility, ocular muscle imbalance, extraocular movement, nystagmus, exophthalmos. Ask about retinopathy, cataracts, aphakia, glaucoma, macular degeneration and refer to a specialist if appropriate.			8. Vascular System	Abnormal pulse and amplitude, carotid or arterial bruits, varicose veins.		
3. Ears	Scarring of tympanic membrane, occlusion of external canal, perforated eardrums.			9. Genito-urinary System	Hernias.		
4. Mouth and Throat	Irremediable deformities likely to interfere with breathing or swallowing.			10. Extremities- Limb impaired. Driver may be subject to SPE certificate if otherwise qualified.	Loss or impairment of leg, foot, toe, arm, hand, finger, Perceptible limp, deformities, atrophy, weakness, paralysis, clubbing, edema, hypotonia. Insufficient grasp and prehension in upper limb to maintain steering wheel grip. Insufficient mobility and strength in lower limb to operate pedals properly.		
5. Heart	Murmurs, extra sounds, enlarged heart, pacemaker, implantable defibrillator.			11. Spine, other musculoskeletal	Previous surgery, deformities, limitation of motion, tenderness.		
6. Lungs and chest, not including breast examination	Abnormal chest wall expansion, abnormal respiratory rate, abnormal breath sounds including wheezes or alveolar rales, impaired respiratory function, cyanosis. Abnormal findings on physical exam may require further testing such as pulmonary tests and/ or xray of chest.			12. Neurological	Impaired equilibrium, coordination or speech pattern; asymmetric deep tendon reflexes, sensory or positional abnormalities, abnormal patellar and Babinski's reflexes, ataxia.		

***COMMENTS:**

Note certification status here. See Instructions to the Medical Examiner for guidance.

- Meets standards in 49 CFR 391.41; qualifies for 2 year certificate
- Does not meet standards
- Meets standards, but periodic monitoring required due to _____
 Driver qualified only for: 3 months 6 months 1 year Other

- Wearing corrective lenses
- Wearing hearing aid
- Accompanied by a _____ waiver/ exemption. Driver must present exemption at time of certification.
- Skill Performance Evaluation (SPE) Certificate
- Driving within an exempt intracity zone (See 49 CFR 391.62)
- Qualified by operation of 49 CFR 391.64

Medical Examiner's signature _____
 Medical Examiner's name _____
 Address _____
 Telephone Number _____

Temporarily disqualified due to (condition or medication): _____
 Return to medical examiner's office for follow up on _____

If meets standards, complete a Medical Examiner's Certificate as stated in 49 CFR 391.43(f). (Driver must carry certificate when operating a commercial vehicle.)

49 CFR 391.41 Physical Qualifications for Drivers

THE DRIVER'S ROLE

Responsibilities, work schedules, physical and emotional demands, and lifestyles among commercial drivers vary by the type of driving that they do. Some of the main types of drivers include the following: turn around or short relay (drivers return to their home base each evening); long relay (drivers drive 9-11 hours and then have at least a 10-hour off-duty period), straight through haul (cross country drivers); and team drivers (drivers share the driving by alternating their 5-hour driving periods and 5-hour rest periods.)

The following factors may be involved in a driver's performance of duties: abrupt schedule changes and rotating work schedules, which may result in irregular sleep patterns and a driver beginning a trip in a fatigued condition; long hours; extended time away from family and friends, which may result in lack of social support; tight pickup and delivery schedules, with irregularity in work, rest, and eating patterns, adverse road, weather and traffic conditions, which may cause delays and lead to hurriedly loading or unloading cargo in order to compensate for the lost time; and environmental conditions such as excessive vibration, noise, and extremes in temperature. Transporting passengers or hazardous materials may add to the demands on the commercial driver.

There may be duties in addition to the driving task for which a driver is responsible and needs to be fit. Some of these responsibilities are: coupling and uncoupling trailer(s) from the tractor, loading and unloading trailer(s) (sometimes a driver may lift a heavy load or unload as much as 50,000 lbs. of freight after sitting for a long period of time without any stretching period); inspecting the operating condition of tractor and/or trailer(s) before, during and after delivery of cargo; lifting, installing, and removing heavy tire chains; and, lifting heavy tarpaulins to cover open top trailers. The above tasks demand agility, the ability to bend and stoop, the ability to maintain a crouching position to inspect the underside of the vehicle, frequent entering and exiting of the cab, and the ability to climb ladders on the tractor and/or trailer(s).

In addition, a driver must have the perceptual skills to monitor a sometimes complex driving situation, the judgment skills to make quick decisions, when necessary, and the manipulative skills to control an oversize steering wheel, shift gears using a manual transmission, and maneuver a vehicle in crowded areas.

\$391.45 PHYSICAL QUALIFICATIONS FOR DRIVERS

(a) A person shall not drive a commercial motor vehicle unless he is physically qualified to do so and, except as provided in §391.67, has on his person the original, or a photographic copy, of a medical examiner's certificate that he is physically qualified to drive a commercial motor vehicle.

(b) A person is physically qualified to drive a motor vehicle if that person:

(1) Has no loss of a foot, a leg, a hand, or an arm, or has been granted a Skill Performance Evaluation (SPE) Certificate (formerly Limb Waiver Program) pursuant to §391.49.

(2) Has no impairment of: (i) A hand or finger which interferes with prehension or power grasping; or (ii) An arm, foot, or leg which interferes with the ability to perform normal tasks associated with operating a commercial motor vehicle; or any other significant limb defect or limitation which interferes with the ability to perform normal tasks associated with operating a commercial motor vehicle; or has been granted a SPE Certificate pursuant to §391.49.

(3) Has no established medical history or clinical diagnosis of diabetes mellitus currently requiring insulin for control;

(4) Has no current clinical diagnosis of myocardial infarction, angina pectoris, coronary insufficiency, thrombosis, or any other cardiovascular disease of a variety known to be accompanied by syncope, dyspnea, collapse, or congestive cardiac failure.

(5) Has no established medical history or clinical diagnosis of a respiratory dysfunction likely to interfere with his ability to control and drive a commercial motor vehicle safely.

(6) Has no current clinical diagnosis of high blood pressure likely to interfere with his ability to operate a commercial motor vehicle safely.

(7) Has no established medical history or clinical diagnosis of rheumatic, arthritic, orthopedic, muscular, neuromuscular, or vascular disease which interferes with his ability to control and operate a commercial motor vehicle safely.

(8) Has no established medical history or clinical diagnosis of epilepsy or any other condition which is likely to cause loss of consciousness or any loss of ability to control a commercial motor vehicle;

(9) Has no mental, nervous, organic, or functional disease or psychiatric disorder likely to interfere with his ability to drive a commercial motor vehicle safely;

(10) Has distant visual acuity of at least 20/40 (Snellen) in each eye without corrective lenses or visual acuity separately corrected to 20/40 (Snellen) or better with corrective lenses, distant binocular acuity of at least 20/40 (Snellen) in both eyes with or without corrective lenses, field of vision of at least 70 degrees in the horizontal meridian in each eye, and the ability to recognize the colors of traffic signals and devices showing standard red, green and amber;

(11) First perceives a forced whispered voice in the better ear not less than 5 feet with or without the use of a hearing aid, or, if tested by use of an audiometric device, does not have an average hearing loss in the better ear greater than 40 decibels at 500 Hz, 1,000 Hz and 2,000 Hz with or without a hearing device when the audiometric device is calibrated to the American National Standard (formerly ASA Standard) Z24.5-1951;

(12) (i) Does not use a controlled substance identified in 21 CFR 1308.11 Schedule I, an amphetamine, a narcotic, or any other habit-forming drug. (ii) Exception: A driver may use such a substance or drug, if the substance or drug is prescribed by a licensed medical practitioner who: (A) Is familiar with the driver's medical history and assigned duties; and (B) Has advised the driver that the prescribed substance or drug will not adversely affect the driver's ability to safely operate a commercial motor vehicle; and (13) Has no current clinical diagnosis of alcoholism.

General Information

The purpose of this examination is to determine a driver's physical qualification to operate a commercial motor vehicle (CMV) in interstate commerce according to the requirements in 49 CFR 391.41-49. Therefore, the medical examiner must be knowledgeable of these requirements and guidelines developed by the FMCSA to assist the medical examiner in making the qualification determination. The medical examiner should be familiar with the driver's responsibilities and work environment and is referred to the section on the form, **The Driver's Role**.

In addition to reviewing the **Health History** section with the driver and conducting the physical examination, the medical examiner should discuss common prescriptions and over-the-counter medications relative to the side effects and hazards of these medications while driving. Educate the driver to read warning labels on all medications. History of certain conditions may be cause for rejection, particularly if required by regulation, or may indicate the need for additional laboratory tests or more stringent examination perhaps by a medical specialist. These decisions are usually made by the medical examiner in light of the driver's job responsibilities, work schedule and potential for the conditions to render the driver unsafe.

Medical conditions should be recorded even if they are not cause for denial, and they should be discussed with the driver to encourage appropriate remedial care. This advice is especially needed when a condition, if neglected, could develop into a serious illness that could affect driving.

If the medical examiner determines that the driver is fit to drive and is also able to perform non-driving responsibilities as may be required, the medical examiner signs the medical certificate which the driver must carry with his/her license. The certificate must be dated. **Under current regulations, the certificate is valid for two years, unless the driver has a medical condition that does not prohibit driving but does require more frequent monitoring.** In such situations, the medical certificate should be issued for a shorter length of time. The physical examination should be done carefully and at least as complete as is indicated by the attached form. Contact the FMCSA at (202) 366-1790 for further information (a vision exemption, qualifying drivers under 49 CFR 391.64, etc.).

Interpretation of Medical Standards

Since the issuance of the regulations for physical qualifications of commercial drivers, the Federal Motor Carrier Safety Administration (FMCSA) has published recommendations called Advisory Criteria to help medical examiners in determining whether a driver meets the physical qualifications for commercial driving. These recommendations have been condensed to provide information to medical examiners that (1) is directly relevant to the physical examination and (2) is not already included in the medical examination form. The specific regulation is printed in italics and its reference by section is highlighted.

Federal Motor Carrier Safety Regulations -Advisory Criteria-

Loss of Limb:

§391.41(b)(1)
A person is physically qualified to drive a commercial motor vehicle if that person:
Has no loss of a foot, leg, hand or an arm, or has been granted a Skill Performance Evaluation (SPE) Certificate pursuant to Section 391.49.

Limb Impairment:

§391.41(b)(2)
A person is physically qualified to drive a commercial motor vehicle if that person:
Has no impairment of: (i) A hand or finger which interferes with prehension or power grasping; or (ii) An arm, foot, or leg which interferes with the ability to perform normal tasks associated with operating a commercial motor vehicle; or (iii) Any other significant limb defect or limitation which interferes with the ability to perform normal tasks associated with operating a commercial motor vehicle; or (iv) Has been granted a Skill Performance Evaluation (SPE) Certificate pursuant to Section 391.49.

A person who suffers loss of a foot, leg, hand or arm or whose limb impairment in any way interferes with the safe performance of normal tasks associated with operating a commercial motor vehicle is subject to the Skill Performance Evaluation Certification Program pursuant to section 391.49, assuming the person is otherwise qualified.

With the advancement of technology, medical aids and equipment modifications have been developed to compensate for certain disabilities. The SPE Certification Program (formerly the Limb Waiver Program) was designed to allow persons with the loss of a foot or limb or with functional impairment to qualify under the Federal Motor Carrier Safety Regulations (FMCSRs) by use of prosthetic devices or equipment modifications which enable them to safely operate a commercial motor vehicle. Since there are no medical aids equivalent to the original body or limb, certain risks are still present, and thus restrictions may be included on individual SPE certificates when a State Director for the FMCSA determines they are necessary to be consistent with safety and public interest.

If the driver is found otherwise medically qualified (391.41(b)(3) through (13)), the medical examiner must check on the medical certificate that the driver is qualified only if accompanied by a SPE certificate. The driver and the employing motor carrier are subject to appropriate penalty if the driver operates a motor vehicle in interstate or foreign commerce without a current SPE certificate for his/her physical disability.

Diabetes

§391.41(b)(3)

A person is physically qualified to drive a commercial motor vehicle if that person:

Has no established medical history or clinical diagnosis of diabetes mellitus currently requiring insulin for control.

Diabetes mellitus is a disease which, on occasion, can result in a loss of consciousness or disorientation in time and space. Individuals who require insulin for control have conditions which can get out of control by the use of too much or too little insulin, or food intake not consistent with the insulin dosage. Incapacitation may occur from symptoms of hyperglycemic or hypoglycemic reactions (drowsiness, semiconsciousness, diabetic coma or insulin shock).

The administration of insulin is, within itself, a complicated process requiring insulin, syringe, needle, alcohol sponge and a sterile technique. Factors related to long-haul commercial motor vehicle operations, such as fatigue, lack of sleep, poor diet, emotional conditions, stress, and concomitant illness, compound the dangers, the FMCSA has consistently held that a diabetic who uses insulin for control does not meet the minimum physical requirements of the FMCSRs.

Hypoglycemic drugs, taken orally, are sometimes prescribed for diabetic individuals to help stimulate natural body production of insulin. If the condition can be controlled by the use of oral medication and diet, then an individual may be qualified under the present rule. CMV drivers who do not meet the Federal diabetes standard may call (202) 366-1790 for an application for a diabetes exemption.

(See Conference Report on Diabetic Disorders and Commercial Drivers and Insulin-Using Commercial Motor Vehicle Drivers at:

<http://www.fmcsa.dot.gov/rulesregs/medreports.htm>)

Cardiovascular Condition

§391.41(b)(4)

A person is physically qualified to drive a commercial motor vehicle if that person:

Has no current clinical diagnosis of myocardial infarction, angina pectoris, coronary insufficiency, thrombosis or any other cardiovascular disease of a variety known to be accompanied by syncope, dyspnea, collapse or congestive cardiac failure.

The term "has no current clinical diagnosis of" is specifically designed to encompass: "a clinical diagnosis of" (1) a current cardiovascular condition, or (2) a cardiovascular condition which has not fully stabilized regardless of the time limit. The term "known to be

accompanied by" is designed to include a clinical diagnosis of a cardiovascular disease (1) which is accompanied by symptoms of syncope, dyspnea, collapse or congestive cardiac failure; and/or (2) which is likely to cause syncope, dyspnea, collapse or congestive cardiac failure.

It is the intent of the FMCSRs to render unqualified, a driver who has a current cardiovascular disease which is accompanied by and/or likely to cause symptoms of syncope, dyspnea, collapse, or congestive cardiac failure. However, the subjective decision of whether the nature and severity of an individual's condition will likely cause symptoms of cardiovascular insufficiency is on an individual basis and qualification rests with the medical examiner and the motor carrier. In those cases where there is an occurrence of cardiovascular insufficiency (myocardial infarction, thrombosis, etc.), it is suggested before a driver is certified that he or she have a normal resting and stress electrocardiogram (ECG), no residual complications and no physical limitations, and is taking no medication likely to interfere with safe driving.

Coronary artery bypass surgery and pacemaker implantation are remedial procedures and thus, not unqualifying. Implantable cardioverter defibrillators are disqualifying due to risk of syncope. Coumadin is a medical treatment which can improve the health and safety of the driver and should not, by its use, medically disqualify the commercial driver. The emphasis should be on the underlying medical condition(s) which require treatment and the general health of the driver. The FMCSA should be contacted at (202) 366-1790 for additional recommendations regarding the physical qualification of drivers on coumadin.

(See Cardiovascular Advisory Panel Guidelines for the Medical Examination of Commercial Motor Vehicle Drivers at: <http://www.fmcsa.dot.gov/rulesregs/medreports.htm>)

Respiratory Dysfunction

\$391.41(b)(5)
A person is physically qualified to drive a commercial motor vehicle if that person:

Has no established medical history or clinical diagnosis of a respiratory dysfunction likely to interfere with ability to control and drive a commercial motor vehicle safely.

Since a driver must be alert at all times, any change in his or her mental state is in direct conflict with highway safety. Even the slightest impairment in respiratory function under emergency conditions (when greater oxygen supply is necessary for performance) may be detrimental to safe driving.

There are many conditions that interfere with oxygen exchange and may result in incapacitation, including emphysema, chronic asthma, carcinoma, tuberculosis, chronic bronchitis and sleep apnea. If the medical examiner detects a respiratory dysfunction, that in any way is likely to interfere with the driver's ability to safely control and drive a commercial motor vehicle, the driver must be referred to a specialist for further evaluation and therapy. Anticoagulation therapy for deep vein thrombosis and/or pulmonary thromboembolism is not unqualifying once optimum dose is achieved, provided lower extremity venous examinations remain normal and the treating physician gives a favorable recommendation.

(See Conference on Pulmonary/Respiratory Disorders and Commercial Drivers at: <http://www.fmcsa.dot.gov/rulesregs/medreports.htm>)

Hypertension

\$391.41(b)(6)
A person is physically qualified to drive a commercial motor vehicle if that person:

Has no current clinical diagnosis of high blood pressure likely to interfere with ability to operate a commercial motor vehicle safely.

Hypertension alone is unlikely to cause sudden collapse; however, the likelihood increases when target organ damage, particularly cerebral vascular disease, is present. This regulatory criteria is based on FMCSA's Cardiovascular Advisory Guidelines for the Examination of CMV Drivers, which used the Sixth Report of the Joint National Committee on Detection, Evaluation, and Treatment of High Blood Pressure (1997).

Stage 1 hypertension corresponds to a systolic BP of 140-159 mmHg and/or a diastolic BP of 90-99 mmHg. The driver with a BP in this range is at low risk for hypertension-related acute incapacitation and may be medically certified to drive for a one-year period. Certification examinations should be done annually thereafter and should be at or less than 140/90. If less than 160/100, certification may be extended one time for 3 months.

A blood pressure of 160-179 systolic and/or 100-109 diastolic is considered Stage 2 hypertension, and the driver is not necessarily unqualified during evaluation and institution of treatment. The driver is given a one time certification of three months to reduce his or her blood pressure to less than or equal to 140/90. A blood pressure in this range is an absolute indication for anti-hypertensive drug therapy. Provided treatment is well tolerated and the driver demonstrates a BP value of 140/90 or less, he or she may be certified for one year from date of the initial exam. The driver is certified annually thereafter.

A blood pressure at or greater than 180 (systolic) and 110 (diastolic) is considered Stage 3, high risk for an acute BP-related event. The driver may not be qualified, even temporarily, until reduced to 140/90 or less and treatment is well tolerated. The driver may be certified for 6 months and biannually (every 6 months) thereafter if at recheck BP is 140/90 or less.

Annual recertification is recommended if the medical examiner does not know the severity of hypertension prior to treatment.

An elevated blood pressure finding should be confirmed by at least two subsequent measurements on different days.

Treatment includes nonpharmacologic and pharmacologic modalities as well as counseling to reduce other risk factors. Most antihypertensive medications also have side effects, the importance of which must be judged on an individual basis. Individuals must be alerted to the hazards of these medications while driving. Side effects of somnolence or syncope are particularly undesirable in commercial drivers.

Secondary hypertension is based on the above stages. Evaluation is warranted if patient is persistently hypertensive

on maximal or near-maximal doses of 2-3 pharmacologic agents. Some causes of secondary hypertension may be amenable to surgical intervention or specific pharmacologic disease.

(See Cardiovascular Advisory Panel Guidelines for the Medical Examination of Commercial Motor Vehicle Drivers at: <http://www.fmcsa.dot.gov/rulesregs/medreports.htm>)

Rheumatic, Arthritic, Orthopedic, Muscular, Neuromuscular or Vascular Disease \$391.41(b)(7)

A person is physically qualified to drive a commercial motor vehicle if that person:

Has no established medical history or clinical diagnosis of rheumatic, arthritic, orthopedic, muscular, neuromuscular or vascular disease which interferes with the ability to control and operate a commercial motor vehicle safely.

Certain diseases are known to have acute episodes of transient muscle weakness, poor muscular coordination (ataxia), abnormal sensations (paresthesia), decreased muscular tone (hypotonia), visual disturbances and pain which may be suddenly incapacitating. With each recurring episode, these symptoms may become more pronounced and remain for longer periods of time. Other diseases have more insidious onsets and display symptoms of muscle wasting (atrophy), swelling and paresthesia which may not suddenly incapacitate a person but may restrict his/her movements and eventually interfere with the ability to safely operate a motor vehicle. In many instances these diseases are degenerative in nature or may result in deterioration of the involved area.

Once the individual has been diagnosed as having a rheumatic, arthritic, orthopedic, muscular, neuromuscular or vascular disease, then he/she has an established history of that disease. The physician, when examining an individual, should consider the following: (1) the nature and severity of the individual's condition (such as sensory loss or loss of strength); (2) the degree of limitation present (such as range of motion); (3) the likelihood of progressive limitation (not always present initially but may manifest itself over time); and (4) the likelihood of sudden incapacitation. If severe functional impairment exists, the driver does not qualify. In cases where more frequent monitoring is required, a certificate for a shorter period of time may be issued. (See Conference on Neurological Disorders and Commercial Drivers at: <http://www.fmcsa.dot.gov/rulesregs/medreports.htm>)

Epilepsy

§391.41(b)(8)

A person is physically qualified to drive a commercial motor vehicle if that person:

Has no established medical history or clinical diagnosis of epilepsy or any other condition which is likely to cause loss of consciousness or any loss of ability to control a motor vehicle.

Epilepsy is a chronic functional disease characterized by seizures or episodes that occur without warning, resulting in loss of voluntary control which may lead to loss of consciousness and/or seizures. Therefore, the following drivers cannot be qualified: (1) a driver who has a medical history of epilepsy; (2) a driver who has a current clinical diagnosis of epilepsy; or (3) a driver who is taking antiseizure medication.

If an individual has had a sudden episode of a nonepileptic seizure or loss of consciousness of unknown cause which did not require antiseizure medication, the decision as to whether that person's condition will likely cause loss of consciousness or loss of ability to control a motor vehicle is made on an individual basis by the medical examiner in consultation with the treating physician. Before certification is considered, it is suggested that a 6 month waiting period elapse from the time of the episode. Following the waiting period, it is suggested that the individual have a complete neurological examination. If the results of the examination are negative and antiseizure medication is not required, then the driver may be qualified.

In those individual cases where a driver has a seizure or an episode of loss of consciousness that resulted from a known medical condition (e.g., drug reaction, high temperature, acute infectious disease, dehydration or acute metabolic disturbance), certification should be deferred until the driver has fully recovered from that condition and has no existing residual complications, and not taking antiseizure medication.

Drivers with a history of epilepsy/seizures off antiseizure medication **and** seizure-free for 10 years may be qualified to drive a CMV in interstate commerce. Interstate drivers with a history of a single unprovoked seizure may be qualified to drive a CMV in interstate commerce if seizure-free **and** off antiseizure medication for a 5-year period or more.

(See Conference on Neurological Disorders and Commercial

Drivers at:

<http://www.fmcsa.dot.gov/rulesregs/medreports.htm>)

Mental Disorders

§391.41(b)(9)

A person is physically qualified to drive a commercial motor vehicle if that person:

Has no mental, nervous, organic or functional disease or psychiatric disorder likely to interfere with ability to drive a motor vehicle safely.

Emotional or adjustment problems contribute directly to an individual's level of memory, reasoning, attention, and judgment. These problems often underlie physical disorders. A variety of functional disorders can cause drowsiness, dizziness, confusion, weakness or paralysis that may lead to incoordination, inattention, loss of functional control and susceptibility to accidents while driving. Physical fatigue, headache, impaired coordination, recurring physical ailments and chronic "nagging" pain may be present to such a degree that certification for commercial driving is inadvisable. Somatic and psychosomatic complaints should be thoroughly examined when determining an individual's overall fitness to drive. Disorders of a periodically incapacitating nature, even in the early stages of development, may warrant disqualification.

Many bus and truck drivers have documented that "nervous trouble" related to neurotic, personality, or emotional or adjustment problems is responsible for a significant fraction of their preventable accidents. The degree to which an individual is able to appreciate, evaluate and adequately respond to environmental strain and emotional stress is critical when assessing an individual's mental alertness and flexibility to cope with the stresses of commercial motor vehicle driving.

When examining the driver, it should be kept in mind that individuals who live under chronic emotional upsets may have deeply ingrained maladaptive or erratic behavior patterns.

Excessively antagonistic, instinctive, impulsive, openly aggressive, paranoid or severely depressed behavior greatly interfere with the driver's ability to drive safely. Those individuals who are highly susceptible to frequent states of emotional instability (schizophrenia, affective psychoses, paranoia, anxiety or depressive neuroses) may warrant disqualification. Careful consideration should be given to the side effects and interactions of medications in the overall qualification determination. See Psychiatric Conference Report for specific recommendations on the use of medications and potential hazards for driving.

(See Conference on Psychiatric Disorders and Commercial Drivers at:

<http://www.fmcsa.dot.gov/rulesregs/medreports.htm>)

Vision

§391.41(b)(10)

A person is physically qualified to drive a commercial motor vehicle if that person:

Has distant visual acuity of at least 20/40 (Snellen) in each eye with or without corrective lenses or visual acuity separately corrected to 20/40 (Snellen) or better with corrective lenses, distant binocular acuity of at least 20/40 (Snellen) in both eyes with or without corrective lenses, field of vision of at least 70 degrees in the horizontal meridian in each eye, and the ability to recognize the colors of traffic signals and devices showing standard red, green, and amber.

The term "ability to recognize the colors of" is interpreted to mean if a person can recognize and distinguish among traffic control signals and devices showing standard red, green and amber, he or she meets the minimum standard, even though he or she may have some type of color perception deficiency. If certain color perception tests are administered, (such as Ishihara, Pseudoisochromatic, Yarn) and doubtful findings are discovered, a controlled test using signal red, green and amber may be employed to determine the driver's ability to recognize these colors.

Contact lenses are permissible if there is sufficient evidence to indicate that the driver has good tolerance and is well adapted to their use. Use of a contact lens in one eye for distance visual acuity and another lens in the other eye for near vision is not acceptable, nor telescopic lenses acceptable for the driving of commercial motor vehicles.

If an individual meets the criteria by the use of glasses or contact lenses, the following statement shall appear on the Medical Examiner's Certificate: "Qualified only if wearing corrective lenses."

CMV drivers who do not meet the Federal vision standard may call (202) 366-1790 for an application for a vision exemption.

(See Visual Disorders and Commercial Drivers at:

<http://www.fmcsa.dot.gov/rulesregs/medreports.htm>)

Hearing

§391.41(b)(11)

A person is physically qualified to drive a commercial motor vehicle if that person:

First perceives a forced whispered voice in the better ear at not less than 5 feet with or without the use of a hearing aid, or, if tested by use of an audiometric device, does not have an average hearing loss in the better ear greater than 40 decibels at 500 Hz, 1,000 Hz, and 2,000 Hz with or without a hearing aid when the audiometric device is calibrated to American National Standard (formerly ADA Standard) Z24.5-1951.

Since the prescribed standard under the FMCSRs is the American Standards Association (ANSI), it may be necessary to convert the audiometric results from the ISO standard to the ANSI standard. Instructions are included on the Medical Examination report form.

If an individual meets the criteria by using a hearing aid, the driver must wear that hearing aid and have it in operation at all times while driving. Also, the driver must be in possession of a spare power source for the hearing aid.

For the whispered voice test, the individual should be stationed at least 5 feet from the examiner with the ear being tested turned toward the examiner. The other ear is covered. Using the breath which remains after a normal expiration, the examiner whispers words or random numbers such as 66, 18,

23, etc. The examiner should not use only sibilants (s sounding materials). The opposite ear should be tested in the same manner. If the individual fails the whispered voice test, the audiometric test should be administered.

If an individual meets the criteria by the use of a hearing aid, the following statement must appear on the Medical Examiner's Certificate "Qualified only when wearing a hearing aid."

(See Hearing Disorders and Commercial Motor Vehicle Drivers at: <http://www.fmcsa.dot.gov/rulestregs/medreports.htm>)

Drug Use

§391.41(b)(12)

A person is physically qualified to drive a commercial motor vehicle if that person:

Does not use a controlled substance identified in 21 CFR 1308.11.

Exception: A driver may use such a substance or drug, if the substance or drug is prescribed by a licensed medical practitioner who is familiar with the driver's medical history and assigned duties; and has advised the driver that the prescribed substance or drug will not adversely affect the driver's ability to safely operate a commercial motor vehicle.

This exception does not apply to methadone. The intent of the medical certification process is to medically evaluate a driver to ensure that the driver has no medical condition which interferes with the safe performance of driving tasks on a public road. If a driver uses a Schedule I drug or other substance, an amphetamine, a narcotic, or any other habit-forming drug, it may be cause for the driver to be found medically unqualified.

Motor carriers are encouraged to obtain a practitioner's written statement about the effects on transportation safety of the use of a particular drug.

A test for controlled substances is not required as part of this biennial certification process. The FMCSA or the driver's employer should be contacted directly for information on controlled substances and alcohol testing under Part 382 of the FMCSRs.

The term "uses" is designed to encompass instances of prohibited drug use determined by a physician through established medical means. This may or may not involve body fluid testing. If body fluid testing takes place, positive test results should be confirmed by a second test of greater specificity. The term "habit-forming" is intended to include any drug or medication generally recognized as capable of becoming habitual, and which may impair the user's ability to operate a commercial motor vehicle safely.

The driver is medically unqualified for the duration of the prohibited drug(s) use and until a second examination shows the driver is free from the prohibited drug(s) use. Recertification may involve a substance abuse evaluation, the successful completion of a drug rehabilitation program, and a negative drug test result. Additionally, given that the certification period is normally two years, the examiner has the option to certify for a period of less than 2 years if this examiner determines more frequent monitoring is required.

(See Conference on Neurological Disorders and Commercial Drivers and Conference on Psychiatric Disorders and Commercial Drivers at: <http://www.fmcsa.dot.gov/rulestregs/medreports.htm>)

Alcoholism

§391.41(b)(13)

A person is physically qualified to drive a commercial motor vehicle if that person:

Has no current clinical diagnosis of alcoholism

The term "current clinical diagnosis of" is specifically designed to encompass a current alcoholic illness or those instances where the individual's physical condition has not fully stabilized, regardless of the time element. If an individual shows signs of having an alcohol-use problem, he or she should be referred to a specialist. After counseling and/or treatment, he or she may be considered for certification.

MEDICAL EXAMINER'S CERTIFICATE

I certify that I have examined _____ In accordance with the Federal Motor Car-
rier Safety Regulations (49 CFR 391.41-391.49) and with knowledge of the driving duties, I find this person is qualified; and, if applicable, only when:

- wearing corrective lenses driving within an exempt intracity zone (49 CFR 391.62)
- wearing hearing aid accompanied by a Skill Performance Evaluation Certificate (SPE)
- accompanied by a _____ waiver exemption Qualified by operation of 49 CFR 391.64

The information I have provided regarding this physical examination is true and complete. A complete examination form with any attachment embodies my findings completely and correctly, and is on file in my office.

SIGNATURE OF MEDICAL EXAMINER		TELEPHONE	DATE
MEDICAL EXAMINER'S NAME (PRINT)		<input type="checkbox"/> MD <input type="checkbox"/> DO <input type="checkbox"/> Chiropractor <input type="checkbox"/> Physician Assistant <input type="checkbox"/> Advanced Practice Nurse	
MEDICAL EXAMINER'S LICENSE OR CERTIFICATE NO./ISSUING STATE			
SIGNATURE OF DRIVER		DRIVER'S LICENSE NO. STATE	
ADDRESS OF DRIVER			
MEDICAL CERTIFICATE EXPIRATION DATE			

MULTIPLE-EMPLOYER DRIVERS

Instructions: If a motor carrier employs a person as a multiple-employer driver (as defined in 49 CFR 390.5), the motor carrier shall comply with all requirements of Part 391, except the carrier need not—

- (1) Require the person to furnish an application for employment (391.21);
- (2) Make an inquiry into the person's driving record during the preceding three years to the appropriate State agency(s) and an investigation of the person's employment record during the preceding three years (391.23);
- (3) Perform annual review of the person's driving record (391.25); or
- (4) Require the person to furnish a record of violations or a certificate (391.27).

The checklist below may be helpful to ensure that required documents are obtained.

DRIVER QUALIFICATION FILE CHECKLIST

Name _____

Social Security Number _____

Driver's License Number _____

Type of License _____ State _____

In addition to the above information, copies of the following must be obtained.

- Medical Examiner's Certificate
- Road Test (or equivalent)
- Certificate of Road Test
- Controlled Substances Test

Diabetes and Vision Exemptions (Part 381, Subpart C)

An individual may apply for an exemption from the diabetes, 49 CFR section 391.41(b)(3), and vision standard, 49 CFR 391.41(b)(10). If you do not currently meet the diabetes and/or the vision standard and are unable to obtain a medical card, you may be an eligible candidate.

See link for exemption packages:

<http://www.fmcsa.dot.gov/rules-regulations/topics/medical/exemptions.htm>

Skill Performance Evaluation (SPE) Certificate Program for Drivers with Missing or Impaired Arms, Hands, Fingers, Legs or Feet [391.49]

Drivers with physical impairments which affect their ability to safely operate CMVs according to their medical examiners, or with missing limbs (e.g., a hand or finger, an arm, foot or leg), are required to obtain SPE certificates.

SPE certificate application packets can be downloaded from the below site, or obtained by contacting FMCSA's Service Center (below) which is responsible for the territory in which the driver is a legal resident.

New Driver Application Package: <http://www.fmcsa.dot.gov/documents/safetyprograms/spe-certificate-package.pdf>

Renewal Package: <http://www.fmcsa.dot.gov/documents/safetyprograms/spe-certificate-renew-package.pdf>

For questions regarding the SPE certificate application packets and/or medical requirements, please contact:

Location	Address	Territory Included
Eastern Service Center	802 Cromwell Park Drive, Suite N Glen Burnie, MD 21061 Phone: (443) 703-2240	CT, DC, DE, MA, MD, ME, NJ, NH, NY, PA, PR, RI, VA, VT, WV
Midwestern Service Center	19900 Governors Drive, Suite 210 Olympia Fields, IL 60461 Phone: (708) 283-3577 • FAX: (708) 283-3579	IA, IL, IN, KS, MI, MO, MN, NE, OH, WI
Southern Service Center	1800 Century Boulevard, N.E., Suite 1700 Atlanta, GA 30345-3220 Phone: (404) 327-7371 • FAX: (404) 327-7359	AL, AR, FL, GA, KY, LA, MS, NC, OK, SC, TN, TX
Western Service Center	1800 Century Boulevard, N.E., Suite 1700 Atlanta, GA 30345-3220 Phone: (404) 327-7370 • FAX: (404) 327-7359 (SPE inquiries for Western States are handled by the Southern Service Center)	American Samoa, AK, AZ, CA, CO, Guam, HI, ID, Mariana Islands, MT, ND, NM, NV, OR, SD, UT, WA, WY

Limited Exemptions (391.61-391.69)

391.61	Drivers who were regularly employed before January 1, 1971
391.62	Limited exemptions for intra-city zone drivers
391.63	Multiple-employer drivers
391.64	Grandfathering for certain drivers participating in vision and diabetes waiver study programs
391.65	Drivers furnished by other motor carriers
391.67	Farm vehicle drivers of articulated commercial motor vehicles
391.68	Private motor carrier of passengers (nonbusiness)
391.69	Private motor carrier of passengers (business)

Disqualifying Offenses (391.15)

A driver is disqualified from operating a commercial motor vehicle (CMV) on public highways for the following offenses:

- Revocation, suspension, or withdrawal of an operator's license.
- Conviction or forfeiture of bond for the following criminal offenses while driving a commercial motor vehicle:
 - Driving a CMV while under the influence of alcohol.
 - Driving a CMV while under the influence of a disqualifying drug or other controlled substance.
 - Transporting or possessing a disqualifying drug or controlled substance.
 - Leaving the scene of an accident that involves a CMV.
 - Using a CMV to commit a felony.
 - Using a CMV to violate an Out-of-Service Order.

Disqualifying Offense Penalties (391.15)

- A first offender is disqualified for one year following conviction or forfeiture (6 months for possession of a controlled substance).
- For a second offense within three years, a driver is disqualified for three years.

Additional Requirements

For additional requirements see:

Part 380 – Entry-Level Driver Training and Longer Combination Vehicle Driver Training (*page 10*)

Part 382 – Controlled Substance and Alcohol Use and Testing (*page 13*)

Part 383 – Commercial Driver's License Standards (*page 18*)



PART 392

Driving of Motor Vehicles

Applicability (392.2)

Every commercial motor vehicle must be operated in accordance with the laws, ordinances, and regulations of the jurisdiction in which it is being operated. However, if a regulation of the Federal Motor Carrier Safety Administration imposes a higher standard of care than that law, ordinance or regulation, the Federal Motor Carrier Safety Regulation must be complied with.

Illness or Fatigue (392.3)

No driver is permitted to operate a motor vehicle when their ability and/or alertness is impaired by fatigue, illness, or any other cause that makes it unsafe to begin (or continue) to drive the vehicle.

Drugs (392.4)

No driver may be on duty and possess, be under the influence of, or use:

- Any 21 CFR section 1308.11 Schedule I substance
- Any amphetamine or formulation of an amphetamine (including pep pills and bennies)
- Narcotics or derivatives
- Any other substance that makes driving unsafe

NOTE: Schedule I can be retrieved at <http://frwebgate.access.gpo.gov/cgi-bin/get-cfr.cgi>

Alcohol (392.5)

A driver is forbidden to consume or be under the influence of alcohol within four hours of going on duty, while on duty, or while driving. A driver is forbidden to possess any alcoholic beverage while on duty, or while driving, unless it is a manifested part of the shipment.

Safe Loading (392.9)

No one may drive or require anyone to drive a commercial motor vehicle unless the cargo is properly distributed and adequately secured.

Operating Authority (392.9a)

A motor vehicle may not be operated without the required registration or operated beyond the scope of its registration.

Information on the application process for obtaining operating authority may be obtained at http://www.fmcsa.dot.gov/rules-regulations/administration/fmcsr/fmcsrguidedetails.asp?rule_toc=735§ion_toc=735

Who must register for operating authority.

- U.S. and Canada-domiciled Motor Carriers
 - All for-hire motor carriers that want to operate in interstate transportation of regulated property, household goods, and passengers, and all brokers and freight forwarders of property and household goods
- Mexico-domiciled Motor Carriers
 - All carriers of private operations (except private motor carriers of passengers)
 - All for-hire carriers that want to operate in foreign transportation of property (exempt & regulated), household goods and passengers

The web sites below provide information concerning the operating authority application process:

<http://www.fmcsa.dot.gov/about/other/faq/faqs.asp>

<http://www.fmcsa.dot.gov/registration-licensing/online-registration/onlineregdescription.htm>

If you do not have access to the internet, you can call FMCSA's toll-free number at 1-800-832-5660 for assistance.

Railroad Crossing/Stopping (392.10)

Motor vehicles transporting certain types and quantities of hazardous materials, as specified in 49 CFR section 392.10(a)(2) through (a)(6), and most vehicles transporting passengers are forbidden to cross railroad tracks without first stopping, listening, and looking both ways. Additionally, the driver must not shift gears while crossing the track.

Seat Belts (392.16)

A driver must not drive a commercial motor vehicle before correctly restraining himself or herself with seat belt assembly.

Emergency Signals for Stopped Vehicles (392.22(a))

If a vehicle is stopped on a highway or shoulder, the driver must activate the vehicle's hazard warning flashers immediately. The driver must leave the flashers on until warning devices are activated. The flashers must again be used while the warning devices are being picked up before the vehicle moves on.

Placement of Warning Devices (392.22(b))

The warning devices must be placed as follows (except where special rules apply – see 49 CFR section 392.22(b)(2)):

- ▶ One warning device must be placed on the traffic side of the vehicle, within ten feet, in the direction of approaching traffic.
- ▶ A second device must be placed facing the direction of approaching traffic approximately 100 feet away and in the center of the lane or shoulder where the vehicle is stopped.
- ▶ The third device must be placed about 100 feet away from the stopped vehicle, in the direction away from approaching traffic.

Radar Detectors (392.71)

Radar detectors shall not be used by a driver in a commercial motor vehicle or operate a commercial motor vehicle that is equipped with or contains a radar detector.

Motor carriers shall not require or permit a driver to violate the radar detector provisions.



PART 393

Parts and Accessories Necessary for Safe Operation

Applicability (393.1)

49 CFR Part 393 establishes the minimum standards for commercial motor vehicles as defined in 49 CFR section 390.5. Only motor vehicles (as defined in section 390.5) and combinations of motor vehicles which meet the definition of a commercial motor vehicle are subject to the requirements of this part. All requirements that refer to motor vehicles with a GVWR below 10,001 pounds (4,536 kg) are applicable only when the motor vehicle or combination of motor vehicles meets the definition of a commercial motor vehicle.

Every employer and employee shall comply and be knowledgeable of the requirements and specifications of 49 CFR Part 393. No employer shall operate a commercial motor vehicle, or cause or permit it to be operated, unless it is equipped in accordance with the requirements and specifications of 49 CFR Part 393.

Additional Equipment and Accessories (393.3)

Every commercial motor vehicle must be equipped with certain standard equipment. Additional equipment or accessories are permitted only if these items do not decrease the operational safety of the vehicle.

Lamps Operable (393.9)

All required lamps must be capable of being operated at all times.

Lighting Devices and Reflectors (393.11)

49 CFR section 393.11 specifies the required color, position, and types of lamps and reflectors for commercial motor vehicles. All lamps and reflectors for commercial motor vehicles manufactured after December 25, 1968 must meet the requirements of Federal Motor Vehicle Safety Standard (FMVSS) No. 108 (49 CFR 571.108) in effect on the date of manufacture. Lamps and reflectors on commercial motor vehicles manufactured on or prior to December 25, 1968 must meet either the

requirements of 49 CFR Part 393 or of FMVSS No. 108 that were in effect on the date of manufacture.

Retroreflective Sheeting and Reflex Reflectors (393.13)

Certain trailers manufactured on or after December 1, 1993, must have retroreflective sheeting or additional reflex reflectors to make them more visible to other motorists at night and under other conditions of reduced visibility. Trailers manufactured before December 1, 1993, must be retrofitted with retroreflective sheeting or additional reflectors.

Requirements for Lamps Other Than Head Lamps (393.25)

Mounting. All lamps must be permanently and securely mounted on a permanent part of the vehicle. The exceptions are temporary lamps on motor vehicles being transported in driveaway-towaway operations and temporary electric lamps on projecting loads. Temporary lamps must be securely attached.

Stop lamps. All stop lamps on a commercial motor vehicle must activate when the service brakes are applied.

Required Brake Systems (393.40)

Each commercial motor vehicle must meet the applicable service, parking, and emergency brake system requirements as provided in 49 CFR section 393.40.

Brakes Required on All Wheels (393.42)

Every commercial motor vehicle must be equipped with brakes acting on all wheels, with the following exceptions:

- ▶ Trucks and truck tractors with three or more axles, manufactured before July 25, 1980, are not required to have steering axle brakes. However, these vehicles must meet the requirements of 49 CFR section 393.52.

- Vehicles being towed in a driveaway-towaway operation are not required to have operative brakes provided the combination of vehicles meet the requirements of 49 CFR section 393.52. This exception is not applicable to:
 - Any motor vehicle towed by means of a tow-bar when another motor vehicle is full-mounted on the towed vehicle; or
 - Any combination of motor vehicles utilizing three or more saddle-mounts.
- Any semitrailer or pole trailer (laden or unladen) with a gross weight of 3,000 pounds or less, provided the axle weight of the towed vehicle does not exceed 40 percent of the sum of the axle weights of the towing vehicle.
- Any full trailer or four-wheel pole trailer (laden or unladen) with a gross weight of 3,000 pounds or less, provided the sum of the axle weights of the towed vehicle does not exceed 40 percent of the sum of the axle weights of the towing vehicle.
- A three-axle dolly on the steering axle which is steered by a co-driver.
- Loaded housemoving dollies, specialized trailers and dollies used to transport industrial furnaces, reactors, and similar motor vehicles, provided the speed at which the combination of vehicles will be operated does not exceed 20 mph and brakes on the combination of vehicles are capable of stopping the combination within 40 feet from the speed at which the vehicle is being operated or 20 mph, whichever is less.

Breakaway and Emergency Braking (393.43)

Every truck or truck tractor equipped with air brakes, when used to tow other vehicles equipped with air brakes, must be capable of activating (manually and automatically) the emergency features of the trailer brakes. The brakes must apply automatically when the towing vehicle air supply pressure is between 20 and 45 psi. The manual control must be operable by the driver from the driver's seat, with seat belt in use. These requirements do not apply to vehicles in driveaway-towaway operations.

Every trailer is required to be equipped with brakes that apply automatically if the trailer breaks away from the towing vehicle. The brakes must remain in the applied position for at least 15 minutes. These requirements do not apply to vehicles in driveaway-towaway operations.

Brake Tubing and Hose (393.45)

Safe and reliable operation of a vehicle's brakes depends upon adequate protection of the tubing and hoses from mechanical and other damage.

All brake tubing and hoses, brake hose assemblies, and brake hose end fittings must meet the applicable requirements of FMVSS No. 106 (49 CFR section 571.106).

- Length and flexibility must accommodate all normal motions of the parts to which the hose is attached.
- Protection against mechanical damage must include protection against chafing, kinking, and mechanical damage.
- Protection from high temperature must include protection from or location away from exhaust pipes and other sources of high temperatures.

Brake Actuators, Slack Adjusters, Linings/Pads, and Drums/Rotors (393.47)

Brake components must be constructed, installed and maintained to prevent excessive fading and grabbing. The means of attachment and physical characteristics must provide for safe and reliable stopping of the commercial motor vehicle.

The effective length of the slack adjuster on each end of an axle must be the same.

Brakes to be Operative (393.48)

All brakes with which a commercial motor vehicle is equipped must be operable at all times.

Section 393.48(c) of 49 CFR provides an exception to the requirement that brakes be operable at all times. This exception covers disabled vehicles being towed and vehicles towed in a driveaway-towaway operation.

The driveway-towaway exception in 49 CFR section 393.48(c) is contingent upon the conditions outlined in 49 CFR section 393.42(b)(2). Towed vehicles must have brakes as may be necessary to ensure compliance with the performance requirements of 49 CFR section 393.52. A motor vehicle towed by means of a tow-bar when any other vehicle is full-mounted on the towed vehicle, or any combination of motor vehicles utilizing 3 or more saddle-mounts, would not be covered under the exception found at 49 CFR section 393.48(c).

With regard to the disabled-vehicle provision of 49 CFR section 393.48(c)(1), the combination vehicle would have to meet the applicable performance requirements of 49 CFR section 393.52.

Brake Warning Devices (393.51)

Buses, trucks, and truck tractors must be equipped with a signal that provides a warning to the driver when a failure occurs in the vehicle's service brake system. This signal requirement covers hydraulic brake systems, air brake systems, vacuum brake systems, and hydraulic brakes applied or assisted by air or vacuum.

The brake warning device rules concerning (1) air brakes, (2) vacuum brakes, and (3) hydraulic brakes applied or assisted by air or vacuum of 49 CFR 391.51 do not apply to property carrying commercial motor vehicles which have less than three axles and (1) were manufactured before July 1, 1973, and (2) have a manufacturer's gross vehicle weight rating less than 10,001 pounds (4,536 kg).

Automatic Brake Adjusters and Brake Adjustment Indicators (393.53)

- Each commercial motor vehicle manufactured on or after October 20, 1993, and equipped with a hydraulic brake system, must be equipped with an automatic brake adjustment system that meets the requirements of FMVSS No. 105.
- Each commercial motor vehicle manufactured on or after October 20, 1994, and equipped with an air brake system, must be equipped with an automatic brake adjustment system that meets the requirements of FMVSS No. 121.
- Air-braked vehicles manufactured on or after October 20, 1994, and equipped with an external automatic adjustment mechanism, must be equipped with an automatic

brake adjustment indicator that meets the requirements of FMVSS No. 121.

Antilock Brake Systems (393.55)

Certain commercial motor vehicles are required to be equipped with antilock braking systems that meet the requirements of FMVSS No. 105 (49 CFR 571.105) concerning hydraulic brake systems, and FMVSS No. 121 (49 CFR 571.121) concerning air brake systems. The rules apply to:

- Truck tractors manufactured on or after March 1, 1997;
- Air-braked single-unit trucks, buses, and trailers (including converter dollies) manufactured on or after March 1, 1998; and
- Hydraulic-braked trucks and buses manufactured on or after March 1, 1999.

Windshield Condition (393.60)

A vehicle's windshield must be free of discoloration and cracks in the area extending from the top of the steering wheel to within two inches of the top of the windshield.

Fuel Systems (393.65)

Fuel systems used for the operation of commercial motor vehicles and of auxiliary equipment installed on or used in connection with commercial motor vehicles must meet the following requirements.

Each fuel system must be located so that:

- No part of the system extends beyond the widest part of the vehicle.
- No part of a fuel tank is forward of the front axle or a power unit.
- Fuel lines do not extend between a towed vehicle and the towing unit while the combination is in motion.
- No part of the fuel system of a bus manufactured on or after January 1, 1973, is located within or above the passenger compartment.

Coupling Devices (393.70 and 393.71)

Sections 393.70 and 393.71 of 49 CFR provide requirements for the attachment and location of the fifth wheel and requirements for the towing of full trailers. In addition, requirements for saddle mount operations are provided.



Tires (393.75)

Tires used on commercial motor vehicles must meet specific safety rules. No tire that is in use on a commercial motor vehicle may have any of the following defects:

- Body ply or belt material exposed through the tread or sidewall
- Tread or sidewall separation
- Audible leak (or flat)
- A cut exposing the ply or belt material
- A tread groove pattern depth of less than $\frac{4}{32}$ of an inch (front tires) or $\frac{2}{32}$ of an inch (other tires)
- regrooved tires on front wheels of trucks or truck tractors which have a load carrying capacity equal to or greater than 4,920 pounds (2,232 kg)
- Regrooved, recapped, or retreaded tires on the front wheels of buses are prohibited

Sleeper Berths (393.76)

Sleeper berths must meet minimum dimensions. A sleeper berth must not be installed on a trailer and must be located in or adjacent to the cab. An exit door at least 18" high by 36" wide must lead directly into the cab. Section 393.76 of 49 CFR contains special provisions for sleeper berths installed before 1975. Sleeper berths must be equipped with adequate sheets and blankets, and a mattress and springs or innerspring mattress. They must be adequately ventilated, and located so as to protect occupants against exhaust heat and fumes and fuel leaks. A mandatory restraint system must withstand at least 6,000 lbs. of force applied toward the front of the vehicle.

Exhaust Systems (393.83)

Exhaust systems must meet the following requirements:

- The exhaust system and discharge must be located where it is not likely to burn or damage the electrical wiring, the fuel supply, nor any combustible part of the vehicle.
- The discharge from the exhaust system must not be located immediately below the fuel tank or the fuel tank filler pipe.
- The exhaust system may not be temporarily repaired with patch or wrap material.
- The exhaust pipe and mufflers must be securely fastened to the vehicle.
- The exhaust system may not leak or discharge at any point forward of or directly below the driver or sleeper compartment.

For trucks and truck tractors, the exhaust system must discharge at a location to the rear of the cab, or above and near the rear of the cab.

For a bus powered by a *gasoline* engine, the exhaust pipe must discharge at a point no farther forward than six inches forward of the rearmost part of the bus.

For a bus powered by *diesel or other fuel* (not gasoline), the exhaust pipe must discharge either:

- At a point no farther forward than 15 inches forward of the rearmost part of the bus, or
- To the rear of all doors or windows designed to be open (not including emergency exits).

Rear End Protection (393.86)

Every commercial motor vehicle must be equipped with either bumpers or other devices that prevent the under ride of another vehicle. Tractors, pole trailers, and driveaway-towaway vehicles are exempt. Certain trailers manufactured on or after January 26, 1998 must have rear impact guards that meet FMVSS Nos. 223 & 224.

Seat Belts (393.93)

Commercial motor vehicle must be equipped with seats, seat belt assemblies, and seat belt anchorages as specified in the FMVSS.

Emergency Equipment (393.95)

Commercial motor vehicles must carry the following emergency equipment:

- Fire extinguisher (not required for driveaway-towaway operations)
- Spare fuses
- Warning devices for stopped vehicles

Fire Extinguisher (393.95)

Fire extinguishers must be securely mounted and readily accessible for use. Each extinguisher must have a gauge or other indicator that shows whether the extinguisher is fully charged, and a label showing its Underwriters' Laboratories (UL) rating.

The fire extinguisher(s) must meet one of the following standards:

- One extinguisher with a UL rating of 5 B:C or more;
- Two extinguishers each with a UL rating of 4 B:C or more; or
- One extinguisher with a UL rating of 10 B:C or more, if the vehicle is transporting placardable quantities of hazardous material.

Cargo Securement (393.100 – 393.136)

Each commercial motor vehicle must, when transporting cargo on public roads, be loaded and equipped, with the cargo secured, in accordance with Subpart I of 49 CFR section 393 to prevent the cargo from leaking, spilling, blowing, or falling from the motor vehicle.

Cargo is required to be loaded and secured so that it will not shift or fall off the vehicle. The cargo securement regulations include minimum strength requirements for securement devices and requirements for protection against longitudinal and lateral movement of the cargo. Rules for securing specific types of commodities are included.

The requirements for securing specific types of commodities cover logs, dressed lumber or similar building products, metal coils, paper rolls, concrete pipe, intermodal containers, automobiles, light trucks, vans, heavy vehicles, equipment and machinery, flattened or crushed vehicles, roll-on/roll-off or hook lift containers, and large boulders.

Frames (393.201)

The frame or chassis of each commercial motor vehicle shall not be cracked, loose, sagging or broken. Parts and accessories shall not be welded to the frame or chassis of a commercial motor vehicle except in accordance with the vehicle manufacturer's recommendations. Any welded repair of the frame must also be in accordance with the vehicle manufacturer's recommendations.

Cab and Body Components (393.203)

The cab compartment doors or door parts used as an entrance or exit shall not be missing or broken. Doors shall not sag so that they cannot be properly opened or closed. No door shall be wired shut or otherwise secured in the closed position so that it cannot be readily opened.

Wheels (393.205)

Wheels and rims shall not be cracked or broken. Stud or bolt holes on the wheels shall not be elongated (out of round). Nuts or bolts shall not be missing or loose.

Suspension Systems (393.207)

Suspension systems are required to be structurally sound and in safe working order, including the following:

- Axles must be in proper alignment, and no positioning part can be cracked, broken, loose, or missing.
- Adjustable axles must have locking pins in place.
- Leaf springs must not be cracked, broken, missing, or shifted out of position.
- Coil springs must not be cracked or broken.
- Torsion bars must not be cracked or broken.
- Air suspensions must support the vehicle in a level position and must not leak.
- Air suspension exhaust controls must not have the capability to exhaust air from the suspension system of one axle of a two-axle air suspension trailer unless the controls are either located on the trailer, or the power unit and trailer combination are not capable of traveling at a speed greater than 10 miles per hour while the air is exhausted from the suspension system. This paragraph shall not be construed to prohibit.
 - Devices that could exhaust air from both axle systems simultaneously; or
 - Lift axles on multi-axle units.

Steering Wheel Systems (393.209)

Steering system must be in proper working order, which includes the following:

- Steering wheel must be properly secured and no cracked or missing spokes.
- Steering wheel lash must meet the requirements of 49 CFR section 393.209.
- Steering column must be securely fastened.
- Steering system must not have worn or welded universal joints and ball and socket joints; loose or missing mounting bolts or cracks in the steering gear box or mounting brackets; or a loose pitman arm on the steering gear output shaft.
- Power steering unit must not have loose or broken parts; frayed, cracked, or slipping belts; leaks; or insufficient fluid in reservoir.

PART 395

Hours of Service of Drivers

Applicability (395.1)

The hours of service rules apply to all motor carriers and drivers, with exceptions found in paragraphs (b) through (o) of 49 CFR section 395.1.

■ Short-haul provision (395.1(e))

100 Air-Mile Radius Exemption (395.1(e)(1))

A driver is exempt from maintaining the driver's daily log requirements of 49 CFR section 395.8 if all of the following is true:

- ▶ The driver operates within a 100 air-mile radius of the normal work reporting location.
- ▶ The driver returns to the work reporting location and is released from work within 12 consecutive hours.
- ▶ Each 12 hours on duty are separated by at least 10 consecutive hours of off duty for property-carrying drivers or 8 consecutive hours off duty for passenger-carrying drivers.
- ▶ The driver does not exceed a maximum of 11 hours driving time following 10 consecutive hours off duty for property-carrying drivers, or 10 hours driving time following 8 consecutive hours off duty for passenger-carrying drivers.
- ▶ The motor carrier that employs the driver maintains and retains for a period of six months accurate and true time records that show:
 - The total number of hours the driver is on duty each day
 - The time the driver reports for duty each day
 - The time the driver is released from duty each day
 - The total time for the preceding seven days for first-time or intermittent drivers

Operators of Property-Carrying Commercial Motor Vehicles Not Requiring a Commercial Driver's License (CDL). (395.1(E)(2))

A driver is exempt from maintaining the driver's daily log requirements of section 395.8 if all the following are true:

- ▶ The driver operates a property-carrying commercial motor vehicle (CMV) which does not require a CDL for operation.
- ▶ The driver operates within a 150 air-mile radius of the normal work reporting location.
- ▶ The driver returns to the normal work reporting location at the end of each duty tour.
- ▶ The driver has at least 10 consecutive hours off duty separating each on-duty period.
- ▶ The driver does not exceed a maximum of 11 hours driving time following 10 consecutive hours off duty.
- ▶ The driver does not exceed a maximum of 14 hours after coming on duty 5 days a week of any period of 7 consecutive days or after the 16th hour after coming on duty 2 days a week of any period of 7 consecutive days.
- ▶ The driver does not drive after having been on duty for 60 hours in 7 days or 70 hours in 8 days.
- ▶ The 7 or 8 day period may end with the beginning of any off-duty period of 34 or more consecutive hours.
- ▶ The motor carrier that employs the driver maintains and retains for a period of six months accurate and true time records that show:
 - The total number of hours the driver is on duty each day
 - The time the driver reports for duty each day
 - The time the driver is released from duty each day
 - The total time for the preceding seven days for first-time or intermittent drivers

Drivers who use the above-described short-haul provision are not eligible to use the 100 air-mile provision in 49 CFR section 395.1(e), sleeper berth provision in 49 CFR section 395.1(g), or the current 16-hour exception in 49 CFR section 395.1(o).

Sleeper Berth Provision (395.1(G))

CMV drivers using the sleeper berth provision must take at least 8 consecutive hours in the sleeper berth, plus 2 consecutive hours either in the sleeper berth, off duty, or any combination of the two.

Property-Carrying Operation (395.3)

11-hour rule

Drivers are allowed to drive for 11 hours following 10 consecutive hours off duty.

14-hour rule

A motor carrier cannot permit or require a driver to drive after the 14th hour after coming on duty following 10 consecutive hours off duty.

16-hour exception

An exception, commonly called the short-haul exception, is available to drivers who normally return to their work reporting location. A property-carrying CMV driver may extend the 14-hour on-duty period by 2 additional hours once every 7 days if he or she:

- Has been released from duty at their normal work reporting location for the previous 5 duty tours;
- Is released from duty at his or her normal work reporting location within 16 hours after coming on duty following 10 consecutive hours off duty; and
- Has not taken this exemption within the previous 6 days, except following a 34-hour restart of a 7/8-day period.

60 and 70-hour rules

A motor carrier must not permit or require a driver to drive after a total of:

- 60 hours on duty in 7 consecutive days, or
- 70 hours on duty in 8 consecutive days, and
- An off duty period of 34 or more consecutive hours may restart a driver's 7 or 8 consecutive day period as long as the driver has not exceeded 60 or 70 hours on duty.

NOTE: If a driver of a property-carrying vehicle works more than one job of any kind, that time must also be included as On-Duty Time.

Passenger-Carrying Operations (395.5)

10-hour rule

Drivers are allowed to drive for 10 hours following 8 consecutive hours off duty.

15-hour rule

A motor carrier cannot permit or require a driver to drive after 15 hours are spent on duty following 8 consecutive hours off duty.

60 and 70-hour rules

A motor carrier must not permit or require a driver to drive after a total of:

- 60 hours on duty in 7 consecutive days (carrier does not operate CMVs every day of the week).
- 70 hours on duty in 8 consecutive days (carrier operates CMVs every day of the week).

NOTE: If a driver of a passenger-carrying vehicle works more than one job of any kind, that time must also be included as On-Duty Time.

Driver's Record of Duty Status (395.8)

Every driver shall prepare a record of duty status (driver's daily log) in his or her own handwriting for each 24-hour period, unless operating under the 100 air-mile radius exemption or drivers of property-carrying CMVs who do not require a CDL for operation and who operate within a 150-air-mile radius of their normal work reporting location.

Failure to complete or retain the log, or knowingly falsifying logs or other reports, makes the driver and/or carrier liable to prosecution.

Every driver must keep his/her activities current by showing each change in duty status. The time zone used on a driver's daily log should be the time standard of that driver's home terminal.

Submitting/Retaining Duty Status Log (395.8(I)-(K))

The driver must submit the original log sheet to the employing carrier within 13 days after completion. When a motor carrier uses a driver initially or intermittently, that carrier must obtain from its driver a signed statement giving the total time on duty during the immediately preceding 7 days and the time at which he or she was last relieved of duty. Records of duty status must be maintained, with all supporting documents, for a minimum of six months.

Driver Off Duty Authorization (395.8)

A driver may log meal breaks as Off Duty instead of On Duty not driving with a permission letter from the motor carrier if:

- The vehicle is parked in a safe and secure place that is not obstructing traffic;
- The meal break is at least 30 minutes but no more than an hour; and
- While off duty, the driver is relieved of vehicle and cargo responsibility; and
- If the driver is free to leave the premises on which the vehicle is parked to pursue other activities as long as the ability to safely operate the vehicle is not impaired as required by Part 392, "Driving of Vehicles, of the Federal Motor Carrier Safety Regulations.

Drivers Declared Out Of Service (395.13)

No driver shall drive after being on duty in excess of the maximum periods permitted.

No motor carrier shall require or permit a driver who has been declared out of service to operate a CMV until the driver may lawfully do so.

Automatic On-Board Recording Devices (395.15)

Alternatively, motor carriers may require a driver to use an *automatic on-board recording device* to record duty status. The driver must still have in his/her possession records of duty status in automated or written form, for the previous seven consecutive days. All hard copies of the driver's record of duty status must be signed by the driver.



LETTER OF OFF-DUTY AUTHORIZATION

This letter authorizes our driver _____
to be Off-Duty during meal and other routine stops.

The purpose of the Federal Department of Transportation Hours of Service Regulations (Part 395) is to keep tired drivers from operating vehicles. Under certain circumstances, however, it appears that enroute stops for meals or other routine purposes may serve to lessen a driver's fatigue.

Therefore, this letter is authorization for you to record your meal or other routine stops on your logs as Off-Duty, rather than On-Duty Not Driving as would normally be the case. However, this may be done only under all of the following circumstances.

1. Your vehicle must be parked in a safe and secure manner so as to prevent obstruction of traffic and theft or damage to the vehicle and cargo.
2. The off-duty period must be no less than 30 minutes and no longer than 60 minutes.
3. During the off-duty period, you are relieved from responsibility from your vehicle and cargo.
4. During the off-duty period, you are free to leave the premises on which your vehicle is parked and to pursue activities of your choosing, as long as your ability to safely operate your vehicle is not impaired as required by part 392, "Driving of Vehicles", of the Federal Motor Carrier Safety Regulations.

Driver Supervisor

Date

PART 396

Inspection, Repair, and Maintenance

Applicability (396.1)

Every motor carrier, its officers, drivers, agents, representatives, and employees directly concerned with inspection or maintenance of commercial motor vehicles must comply and be knowledgeable of these rules.

General Requirements (396.3)

Every carrier shall systematically inspect, repair, and maintain all commercial motor vehicles under its control.

Recordkeeping Requirements (396.3)

Motor carriers must maintain the following information for every vehicle they have controlled for 30 days or more:

- Identifying information, including company number, make, serial number, year, and tire size
- A schedule of inspections to be performed, including type and due date
- Inspection, repair, and maintenance records
- Records of tests conducted on buses with push-out windows, emergency doors, and marking lights

These records must be retained for one year at the location where the vehicle is garaged and maintained for six months after the vehicle leaves the carrier's control (e.g., sale, trade-in, scrap).

Roadside Inspection Reports (396.9)

Any driver who receives a roadside inspection report must deliver it to the motor carrier.

Certification of Roadside Inspection Reports (396.9)

An official of the motor carrier is to examine the roadside inspection report and ensure that any violations or defects noted on the report are corrected. Within 15 days after the inspection, the carrier must sign the completed roadside inspection report to certify that all violations have been corrected and

then return it to the indicated address. A copy must be retained for 12 months from the date of inspection.

Post-Trip Inspection Report (396.11)

Every carrier must require its drivers to prepare a daily written post-trip inspection report at the end of each driving day. Every driver is responsible for preparing such a report for each vehicle driven. This report must cover *at least* the following parts and accessories:

- Service brakes (including trailer brake connections)
- Parking (hand) brake
- Steering mechanism
- Lighting devices and reflectors
- Tires
- Horn
- Windshield wipers
- Rearview mirrors
- Coupling devices
- Wheels and rims
- Emergency equipment

The report must list any condition that the driver either found or had reported to him/her that would affect safety of operation or cause a breakdown. If no defect or deficiency is reported or found, the report should state this. The driver must sign the report in all cases.

Before dispatching the vehicle again, a carrier shall ensure that a certification has been made as to any defect or deficiency, that they have been corrected, or state those deficiencies that do not require immediate correction. Carriers must keep the original post-trip inspection report and the certification of repairs for at least three months from the date of preparation.

Driver Inspection (396.13)

Before starting out, the driver must be satisfied that the motor vehicle is in safe operating condition. If the last vehicle inspection report notes any deficiencies, the driver must review and sign to acknowledge that necessary repairs have been completed.

Periodic Inspection (396.17)

Every commercial vehicle, including each segment of a combination vehicle requires periodic inspection that must be performed at least once every 12 months. At a minimum, inspections must include all items listed in the Minimum Periodic Inspection Standards, Appendix G to Subchapter B. Carriers may perform required annual inspections themselves. The original or a copy of the periodic inspection report must be retained by the motor carrier for 14 months from the report date.

Documentation (report, sticker, or decal) of the most recent periodic inspection must be kept on the vehicle.

Inspector Qualification (396.19)

Motor carriers must ensure that persons performing annual inspections are qualified. Inspectors must:

- Understand the inspection standards of Part 393 and Appendix G;
- Be able to identify defective components; and
- Have knowledge and proficiency in methods, procedures, and tools.

Inspector Training or Experience (396.19)

Inspectors may have gained experience or training by:

- Completing a State or Federal training program, or earning a State or Canadian Province qualifying certificate in commercial motor vehicle safety inspections.
- A combination of other training or experience totaling at least a year.

Evidence of Qualifications (396.19)

Motor carriers must retain evidence of an inspector's qualifications until one year after the inspector ceases to perform inspections for the carrier.

Equivalent to Periodic Inspection (396.23)

The motor carrier may meet periodic inspection requirements through:

- State or other jurisdiction's roadside inspection program;
- Self-inspection by qualified employee; or
- Third party inspection by qualified individual.

Qualifications for Brake Inspectors (396.25)

The motor carrier is responsible for ensuring that all inspections, maintenance, repairs, and service to brakes of commercial motor vehicles comply with these regulations. The carrier must ensure that the employees responsible for brake inspection, maintenance, service, or repairs meet minimum brake inspector qualifications.

The brake inspector must:

- Understand and be able to perform the brake service and inspection;
- Know the methods, procedures, tools and equipment needed; and
- Be qualified to perform brake service or inspection by training and/or experience.

Qualifying brake training or experience (396.25)

Qualifying brake training or experience includes successful completion of:

- A State, Canadian Province, Federal agency, or union training program;
- A State-approved training program;
- Training that led to attainment of a State or Canadian Province qualifying certificate to perform assigned brake service or inspection tasks, including passage of CDL air brake test in the case of a brake inspection; or
- One year of brake-related training, experience, or combination of both.

Maintaining Evidence of Brake Inspector Qualifications (396.25)

Motor carriers must maintain evidence of brake inspector qualification at the principal place of business or the location where the inspector works. Evidence must be retained for the period during which the brake inspector is employed in that capacity, and for one year thereafter.



Forms to Use

Shown on following pages and available at Web address as shown:

- | | |
|---|---|
| <p>88Inspection Items: (combined)
Differences in the Levels of Inspection:
http://www.fmcsa.dot.gov/documents/forms/part_396form4.pdf</p> <p>89Annual Vehicle Inspection Report:
http://www.fmcsa.dot.gov/forms/print/irm.htm</p> <p>90Drivers Vehicle Inspection Report:
http://www.fmcsa.dot.gov/documents/forms/sec396_form1.pdf</p> <p>91Vehicle Service Status Report:
http://www.fmcsa.dot.gov/documents/forms/sec396_form2.pdf</p> <p>92, 93North American
Standard Inspection Procedure:
http://www.fmcsa.dot.gov/documents/forms/sec396_form3.pdf</p> | <p>94Inspection, Repair and Maintenance Record:
http://www.fmcsa.dot.gov/documents/forms/sec396_form5.pdf</p> <p>95Inspector Qualifications:
http://www.fmcsa.dot.gov/documents/forms/sec396_form7.pdf</p> <p>96Brake Inspectors Qualifications:
http://www.fmcsa.dot.gov/documents/forms/sec396_form8.pdf</p> <p>97Bus Emergency Exits Inspection:
http://www.fmcsa.dot.gov/documents/forms/sec396_form9.pdf</p> <p>98On Guard:
http://www.fmcsa.dot.gov/documents/forms/sec396_form10.pdf</p> |
|---|---|

DIFFERENCES IN THE LEVELS OF INSPECTION

Inspection Items	Level I	Level II*	Level III	Level IV	Level V**
1. Driver's License	✓	✓	✓		
2. Medical examiner's certificate and waiver (if applicable)	✓	✓	✓		
3. Alcohol and drugs	✓	✓	✓		
4. Driver's log (hours-of-service and duty status)	✓	✓	✓		
5. Seatbelt system	✓	✓	✓		✓
6. Periodic inspection documentation	✓	✓	✓		✓
7. Brake system	✓	✓			✓
8. Coupling devices	✓	✓			✓
9. Exhaust system	✓	✓			✓
10. Frame	✓	✓			✓
11. Fuel system	✓	✓			✓
12. Brake, head, tail lamps, turn signals, and lamps on projecting loads	✓	✓			✓
13. Safe loading of cargo	✓	✓			✓
14. Steering mechanism	✓	✓			✓
15. Suspension	✓	✓			✓
16. Tires	✓	✓			✓
17. Wheels, rims and hubs	✓	✓			✓
18. Van and open-top trailer bodies	✓	✓			✓
19. Windshield wipers	✓	✓			✓
20. Emergency exits (for buses)	✓	✓			✓
21. Hazardous materials requirements (if applicable)	✓	✓	✓		✓
22. One-time special inspection of a particular item				✓	
CVSA decal issued for "Pass" inspection (no violations/defects found in items 7-20)	✓				✓

Notes:

* Level II inspections only include those items that can be inspected without physically getting under the vehicle

** Level V inspections are conducted without a driver present

ANNUAL VEHICLE INSPECTION REPORT

VEHICLE HISTORY RECORD

REPORT NUMBER	FLEET UNIT NUMBER
DATE	

MOTOR CARRIER OPERATOR	INSPECTOR'S NAME (PRINT OR TYPE)
ADDRESS	THIS INSPECTOR MEETS THE QUALIFICATION REQUIREMENTS IN SECTION 396.19. <input type="checkbox"/> YES
CITY, STATE, ZIP CODE	VEHICLE IDENTIFICATION (✓) AND COMPLETE <input type="checkbox"/> LIC. PLATE NO. <input type="checkbox"/> VIN <input type="checkbox"/> OTHER
VEHICLE TYPE <input type="checkbox"/> TRACTOR <input type="checkbox"/> TRAILER <input type="checkbox"/> TRUCK <input type="checkbox"/> (OTHER)	INSPECTION AGENCY/LOCATION (OPTIONAL)

VEHICLE COMPONENTS INSPECTED

ITEM	OK	NEEDS REPAIR	REPAIRED DATE	ITEM	OK	NEEDS REPAIR	REPAIRED DATE
1. BRAKE SYSTEM				7. STEERING MECHANISM			
a. Service Brakes				a. Steering Wheel Free Play			
b. Parking Brake System				b. Steering Column			
c. Brake Drums or Rotors				c. Front Axle Beam and All Steering Components Other Than Steering Column			
d. Brake Hose				d. Steering Gear Box			
e. Brake Tubing				e. Pitman Arm			
f. Low Pressure Warning Device				f. Power Steering			
g. Tractor Protection Valve				g. Ball and Socket Joints			
h. Air Compressor				h. Tie Rods and Drag Links			
i. Electric Brakes				i. Nuts			
j. Hydraulic Brakes				j. Steering System			
k. Vacuum Systems							
2. COUPLING DEVICES				8. SUSPENSION			
a. Fifth Wheels				a. Any U-bolt(s), spring hanger(s), or other axle positioning part(s) cracked, broken, loose or missing resulting in shifting of an axle from its normal position.			
b. Pintle Hooks				b. Spring Assembly			
c. Drawbar/Towbar Eye				c. Torque, Radius or Tracking Components.			
d. Drawbar/Towbar Tongue							
e. Safety Devices				9. FRAME			
f. Saddle-Mounts				a. Frame Members			
3. EXHAUST SYSTEM				b. Tire and Wheel Clearance			
a. Any exhaust system determined to be leaking at a point forward of or directly below the driver/sleeper compartment.				c. Adjustable Axle Assemblies (Sliding Subframes)			
b. A bus exhaust system leaking or discharging to the atmosphere in violation of standards (1), (2) or (3).				10. TIRES			
c. No part of the exhaust system of any motor vehicle shall be so located as would be likely to result in burning, charring, or damaging the electrical wiring, the fuel supply, or any combustible part of the motor vehicle.				a. Tires on any steering axle of a power unit.			
4. FUEL SYSTEM				b. All other tires.			
a. Visible leak				11. WHEELS AND RIMS			
b. Fuel tank filler cap missing				a. Lock or Side Ring			
c. Fuel tank securely attached				b. Wheels and Rims			
5. LIGHTING DEVICES				c. Fasteners			
All lighting devices and reflectors required by Section 393 shall be operable.				d. Welds			
6. SAFE LOADING				12. WINDSHIELD GLAZING			
a. Part(s) of vehicle or condition of loading such that the spare tire or any part of the load or dunnage can fall onto the roadway.				Requirements and exceptions as stated pertaining to any crack, discoloration or vision reducing matter (reference 393.60 for exceptions)			
b. Protection against shifting cargo				13. WINDSHIELD WIPERS			
				Any power unit that has an inoperative wiper, or missing or damaged parts that render it ineffective.			
				List any other condition which may prevent safe operation of this vehicle.			

INSTRUCTIONS: MARK COLUMN ENTRIES TO VERIFY INSPECTION: X OK, X NEEDS REPAIR, NA IF ITEMS DO NOT APPLY, _____ REPAIRED DATE

CERTIFICATION: THIS VEHICLE HAS PASSED ALL THE INSPECTION ITEMS FOR THE ANNUAL VEHICLE INSPECTION REPORT IN ACCORDANCE WITH 49 CFR 396.

Driver's Vehicle Inspection Report

Check ANY Defective Item and Give Details under "Remarks."

DATE: _____

TRUCK/TRACTOR NO. _____

- | | | |
|--|--|--|
| <input type="checkbox"/> Air Compressor | <input type="checkbox"/> Horn | <input type="checkbox"/> Springs |
| <input type="checkbox"/> Air Lines | <input type="checkbox"/> Lights | <input type="checkbox"/> Starter |
| <input type="checkbox"/> Battery | Head – Stop | <input type="checkbox"/> Steering |
| <input type="checkbox"/> Brake Accessories | Tail – Dash | <input type="checkbox"/> Tachograph |
| <input type="checkbox"/> Brakes | Turn Indicators | <input type="checkbox"/> Tires |
| <input type="checkbox"/> Carburetor | <input type="checkbox"/> Mirrors | <input type="checkbox"/> Transmission |
| <input type="checkbox"/> Clutch | <input type="checkbox"/> Muffler | <input type="checkbox"/> Wheels |
| <input type="checkbox"/> Defroster | <input type="checkbox"/> Oil Pressure | <input type="checkbox"/> Windows |
| <input type="checkbox"/> Drive Line | <input type="checkbox"/> On-Board Recorder | <input type="checkbox"/> Windshield Wipers |
| <input type="checkbox"/> Engine | <input type="checkbox"/> Radiator | <input type="checkbox"/> Other |
| <input type="checkbox"/> Fifth Wheel | <input type="checkbox"/> Rear End | |
| <input type="checkbox"/> Front Axle | <input type="checkbox"/> Reflectors | |
| <input type="checkbox"/> Fuel Tanks | <input type="checkbox"/> Safety Equipment | |
| <input type="checkbox"/> Heater | Fire Extinguisher | |
| | Flags – Flares – Fuses | |
| | Spare Bulbs & Fuses | |
| | Spare Seal Beam | |

TRAILER(S) NO (S). _____

- | | | |
|--|---------------------------------------|------------------------------------|
| <input type="checkbox"/> Brake Connections | <input type="checkbox"/> Hitch | <input type="checkbox"/> Tarpaulin |
| <input type="checkbox"/> Brakes | <input type="checkbox"/> Landing Gear | <input type="checkbox"/> Tires |
| <input type="checkbox"/> Coupling Chains | <input type="checkbox"/> Lights – All | <input type="checkbox"/> Wheels |
| <input type="checkbox"/> Coupling (King) Pin | <input type="checkbox"/> Roof | <input type="checkbox"/> Other |
| <input type="checkbox"/> Doors | <input type="checkbox"/> Springs | |

Remarks: _____

- Condition of the above vehicle is satisfactory

Driver's Signature _____

- Above Defects Corrected

- Above Defects Need NOT Be Corrected For Safe Operation Of Vehicle

Mechanic's Signature _____ Date _____

Driver's Signature _____ Date _____

Vehicle Service Due Status Report

VEHICLE IDENTIFICATION

MAKE

SERIAL NUMBER

YEAR

TIRE SIZE

COMPANY NUMBER/OTHER I.D.

OWNER, IF LEASED

DATE OF INSPECTION	TYPE OF INSPECTION	MILEAGE AT TIME OF INSPECTION	DATE NEXT INSPECTION DUE	MILEAGE TYPE OF INSPECTION DUE	INSPECTION DUE

NORTH AMERICAN STANDARD INSPECTION PROCEDURE

1. PREPARE THE VEHICLE AND DRIVER

Instruct the driver to remain at the controls, and turn the engine off. (Allow cool down time for turbo-charged engines.) Place chock blocks in position beginning on the driver's side, one in front, and one behind the driver axle tires or between the axles, and advise the driver that the wheels have been chocked.

Have the driver place the transmission in neutral and release all brakes.

Advise the driver in the use of hand signals. (Lamps and brakes.)

2. CHECK DRIVER'S REQUIREMENTS

- **DRIVER LICENSE (391.11)**
Check for expiration date, birth date, status check.
- **MEDICAL CERTIFICATE (391.41)**
Check for expiration date, corrective lenses, hearing aid, signatures. Canadian driver license services as medical certificate.
- **MEDICAL WAIVER (if applicable) (391.49)**
Check for expiration date, and make sure form is completed. Note the stated physical limitations.
- **RECORD OF DUTY STATUS (395.8) (395.3)**
Updated to last change of duty status, today's date, legible handwriting, past 7 days recorded, mileage, driving time, on duty time, vehicle numbers, carrier name, signature.
"Remarks" section may include locations of duty status change, unusual circumstances that delay the trip, and shipping document numbers or the name of the shipper. Check for written authorization for interactive electronic recording devices, if applicable.
- **DRIVER VEHICLE INSPECTION REPORT (396.11)**
Check for I.D. number of vehicle(s) inspected, record of defects found (if any), and signatures.
- **SHIPPING PAPERS/BILL OF LADING**
Check for listings of hazardous materials indicated by the first entry, an "X" in the H.M. column, or a contrasting color. Papers must be within arm's reach and visible.
- **SEAT BELT (392.16)**
Check for condition and usage
- **ALCOHOL AND DRUGS (392.4) (392.5)**
Check for violations

3. CHECK FOR PRESENCE OF HAZARDOUS MATERIALS

- **PLACARDS**
Check for the presence of placards, but use caution even if none are posted.
- **LEAKS, SPILLS, UNSECURE CARGO**
When hazardous materials are present, be **ESPECIALLY** careful with leaks, spills, or unsecure cargo.
- **MARKINGS**
Cargo tanks and portable tanks will display markings on an orange panel or placard. They indicate the I.D. number of the hazardous materials. There are exceptions to this rule.
- **LABELS**
When containers are visible, labels will identify the hazardous materials. There are exceptions to this rule.

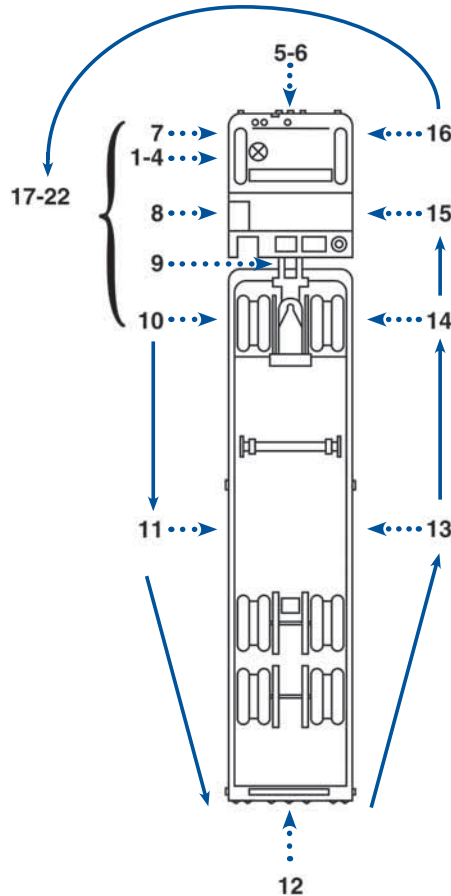

4. INSIDE CAB

- **STEERING LASH**
Measure amount of steering lash and compare with Out-of-Service Criteria.
- **STEERING COLUMN**
Check for unsecure attachment.

5. FRONT OF TRACTOR

- **HEAD LAMPS, TURN SIGNALS, EMERGENCY FLASHERS (393.25)**
Check for improper color and operation.
- **WINDSHIELD WIPERS (393.78)**
Check for improper operation. Two wipers are required unless one can clean the driver's field of vision.
- **WINDSHIELD (393.60)**
Check for cracks or other damage. Check for decals or stickers in field of vision.

6. STEERING AXLE

- INFORM THE DRIVER THAT YOU ARE GOING UNDER THE VEHICLE, AND TO LISTEN FOR YOUR INSTRUCTIONS.**
- **STEERING SYSTEM (BOTH SIDES) (393.209)**
Check for loose, worn, bent, damaged or missing parts. Instruct the driver to rock the steering wheel, and check key components: front axle beam, gear box, pitman arm, drag link, tie rod, tie rod ends.
 - **FRONT SUSPENSION (BOTH SIDES) (393.207)**
Check for indications of misaligned, shifted, or cracked springs, loosened shackles, missing bolts, springhangers unsecure at frame, and cracked or loose U-bolts. Also, check for

unsecure axle positioning parts and signs of axle misalignment.

- **FRONT BRAKES (BOTH SIDES) (393.48)**
Check for missing, nonfunctioning, loose, contaminated, or cracked parts on the brake system, such as brake drum, shoes, rotors, pads, linings, brake chamber, chamber mounting push rods, slack adjusters.
Check for "S" cam flip over. Be alert for audible air leaks around brake components and lines.
With the brakes released, mark the brake chamber push rod at a point where the push rod exits the brake chamber. Mark the push rods on both sides at this time; all push rods will be measured in ITEM 10.
- **FRONT AXLE**
Check for cracks, welds, and obvious misalignment.
- **FRAME and FRAME ASSEMBLY**
Check for cracks, or any defect that may lead to the collapse of the frame.

7. LEFT FRONT SIDE OF TRACTOR (393.205)

- **LEFT FRONT WHEEL & RIM**
Check for cracks, unseated locking rings, broken or missing lugs, studs or clamps. Bent or cracked rims, "bleeding" rust stains, loose or damaged lug nuts and elongated stud holes.
- **LEFT FRONT TIRE (393.75)**
Check for improper inflation, serious cuts, bulges.
Check tread wear and measure major tread groove depth.
Inspect sidewall for defects.
Check for exposed fabric or cord.
Radial and bias tires should not be mixed on the steering axle.

8. LEFT SADDLE TANK AREA

- **LEFT FUEL TANK(S) (393.65)**
Check for unsecure mounting, leaks, or other damage. Verify that the fuel cross-over line is secure. Check for unsecure cap(s).
Check ground below tank for signs of leaking fuel.
- **TRACTOR FRAME (393.201)**
Check frame rails and cross members on the tractor just behind the cab, looking for cracks, bends, or excessive corrosion.
- **EXHAUST SYSTEM (393.83)**
Check for unsecure mounting, leaks (under the cab), exhaust contacted by fuel or air lines or electrical wires.

9. TRAILER FRONT

- **AIR & ELECTRICAL LINES (393.28)**
Lines between tractor and trailer should be suspended and free of tangles and crimps. They should have sufficient slack to allow the vehicle to turn. Inspect line connections for proper seating. Listen for audible air leaks.
- **FRONT END PROTECTION (393.106)**
Check for height requirements. (Note exceptions.)

10. LEFT REAR TRACTOR AREA (393.205)

- **WHEELS, RIMS & TIRES**
Inspect as described in ITEM 7.
Check inside tire of dual for inflation and general condition.
Tires should be evenly matched (same

circumference) on dual wheels.

Without placing yourself between the tires on tandem axles, check for debris between the tires.

- **LOWER FIFTH WHEEL (393.70)**
Check for unsecure mounting to the frame or any missing or damaged parts. Check for any visible space between the upper and lower fifth wheel plates. Verify that the locking jaws are around the shank and not the head of the kingpin. Verify that the release lever is sealed properly, and that the safety latch is engaged.
- **UPPER FIFTH WHEEL (393.70)**
Check for any damage to the weight bearing plate and its supports on the trailer. Check kingpin condition.
- **SLIDING FIFTH WHEEL**
Check for proper engagement of locking mechanism (teeth fully engaged on rail). Check for worn or missing parts, making sure that the position does not allow the tractor frame rails to contact the landing gear during turns.

INFORM THE DRIVER THAT YOU ARE GOING UNDER THE VEHICLE. ENTER THE UNDERCARRIAGE IN VIEW OF THE DRIVER.

- **SUSPENSION (BOTH SIDES) (393.207)**
Inspect as described in ITEM 6. Check for deflated or leading air suspension systems.
- **BRAKES (BOTH SIDES) (393.48)**
Inspect brakes as described in ITEM 6. With brakes released, mark the push rods.

11. LEFT SIDE OF TRAILER

- **FRAME AND BODY (393.20, 393.203)**
Check for cracks and any indication leading to collapse of the frame.
- **CARGO SECUREMENT (393.100)**
Check for improper blocking or bracing, and unsecure chains or straps. Verify end gates are secured in stake pockets. Check tarp or canvas.
- **WHEELS, RIMS, & TIRES (393.205)**
Inspect as described in ITEM 7.
- **SLIDING TANDEM (393.70)**
Check for misalignment and position. Look for damaged, worn, or missing parts. Check locking mechanism; teeth of locking mechanism must fully mesh with those of the rail secured to the frame.

INFORM THE DRIVER THAT YOU ARE GOING UNDER THE VEHICLE. ENTER THE UNDERCARRIAGE IN VIEW OF THE DRIVER.

- **SUSPENSION (BOTH SIDES) (393.207)**
Inspect as described in ITEM 6
- **BRAKES (BOTH SIDES) (393.48)**
Inspect as described in ITEM 6. With brakes released, mark push rods.

12. REAR OF TRAILER

- **TAIL, STOP & TURN LAMPS & EMERGENCY FLASHERS (393.11)**
Check for improper color and operation.
- **CARGO SECUREMENT (393.100)**
Inspect as described in ITEM 11. Also check tailboard security. Verify end gates are secured in stake pockets, and rear doors are closed. Check both sides of trailer to insure protection of cargo from shifting or falling.

13. RIGHT SIDE OF TRAILER

- CHECK ALL ITEMS AS ON LEFT SIDE.

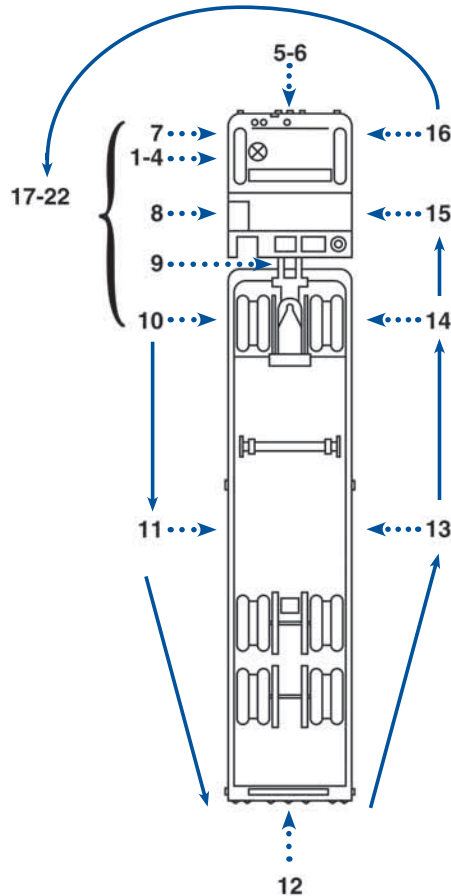

14. RIGHT REAR TRACTOR AREA

- CHECK ALL ITEMS AS ON LEFT SIDE.

15. RIGHT SADDLE TANK AREA

- CHECK ALL ITEMS AS ON LEFT SIDE.

16. RIGHT FRONT SIDE OF TRACTOR

- CHECK ALL ITEMS AS ON LEFT SIDE.

17. BRAKE ADJUSTMENT CHECK

INFORM THE DRIVER THAT YOU ARE GOING UNDER THE VEHICLE. ENTER THE UNDERCARRIAGE IN VIEW OF THE DRIVER.

- **MEASURE PUSH ROD TRAVEL (ALL BRAKES) (393.48)**
While the brakes are applied, move around the vehicle and measure the distance of push rod travel at each chamber. Write down each push rod measurement, and compare them to the Out-of-Service Criteria for the appropriate size and type of brake chamber. Again, listen for leaks as you move around the vehicle.

18. FIFTH WHEEL MOVEMENT CHECK (393.70)

- **USE CAUTION**
If conducted improperly, this method of checking for fifth wheel movement can result in serious damage to the vehicle. Use caution and instruct the driver carefully.
- **PREPARE THE VEHICLE AND DRIVER**
Have the driver put the vehicle in gear, release the service brakes, and apply the trailer brakes. Remove the wheel chocks and have the driver start the vehicle. Carefully explain the procedure to the driver. Tell the driver to GENTLY rock the tractor as you watch the fifth wheel.

• CONDUCT THE PROCEDURE

As the tractor rocks, watch for movement between the mounting components and frame, pivot pin and bracket, and the upper and lower fifth wheel halves.

19. AIR LOSS RATE (393.50)

- **WHEN TO CONDUCT THE TEST**
If you heard an air leak at any point in the inspection, you should now check the vehicle's air loss rate.
- **CONDUCT THE PROCEDURE**
Have the driver run the engine at idle, then apply and hold the service brake. Observe the air reservoir pressure gauge on the dash. Have driver pump the pressure down to 80 psi. Compressors do not activate until system pressure drops below a certain level. At about 80 lbs most compressors should be operating. Air pressure should be maintained or increase. A drop in pressure indicates a serious air leak in the brake system, and the vehicle should be placed out of service.

20. LOW AIR PRESSURE WARNING DEVICE (393.51)

- **TEST THE WARNING DEVICE**
Instruct the driver to pump the air down until the low air pressure warning device activates. Observe the gauges on the dash. The low air pressure warning must activate at a minimum of 1/2 the compressor governor cut out pressure, approximately 55 psi.

21. TRACTOR PROTECTION VALVE

This procedure will test both the tractor protection valve and the trailer emergency brakes.

- **CONDUCT THE TEST**
Instruct the driver to release the emergency brakes by pushing in the dash valves. Break the supply emergency line at the hose couplers between the tractor and the trailer. When the line is disconnected, a blast of air will be noticed. At this point, the emergency brakes on the trailer should set up.
- **OBSERVE THE DASH GAUGE**
Air will leak from the tractor side of the line until the pressure in the tractor's system drops to the 20-45 psi range. At that point, the air loss should stop, isolating the tractor air system. A loss of air in the tractor system below the 20-45 psi range indicates a malfunctioning tractor protection valve. If the trailer brakes do not set up when the line is disconnected, there is a problem with the trailer emergency brakes.

22. COMPLETE THE INSPECTION

- **COMPLETE PAPER WORK**
Complete inspection forms and other paperwork, as required.
- **CONCLUDE WITH THE DRIVER**
Explain any violations or warnings to the driver. Take appropriate enforcement action, if necessary.
- **APPLY C.V.S.A. DECAL**
Apply a C.V.S.A. decal on all vehicles that qualify.

Inspection, Repair & Maintenance Record

VEHICLE IDENTIFICATION

MAKE

SERIAL NUMBER

YEAR

TIRE SIZE

COMPANY NUMBER/OTHER I.D.

OWNER, IF LEASED

DATE	OPERATION PERFORMED, INSPECTION AND/OR REPAIR

INSPECTOR QUALIFICATIONS

Certification — 49 CFR — Part 396.19

Motor carriers are responsible for ensuring that individual(s) performing an annual inspection under 396.19 are qualified as follows:

- Understands the inspection criteria set forth in Part 393 and Appendix G and can identify defective components
- Is knowledgeable of and has mastered the methods, procedures, tools and equipment used when performing an inspection
- Is capable of performing an inspection by reason of experience, training, or both, and qualifies in one of the following categories (check all that apply):
 - I. Successfully completed a State or Federal training program or has certificate from a State or Canadian Province which qualifies the person to perform commercial vehicle safety inspections. Specify:

or

- II. Have a combination of training or experience totaling at least one year as follows (check all that apply):
 - A. Participation in a truck manufacturer-sponsored training program or similar commercial training program designed to train students in truck operation and maintenance. Where and Date:

- B. ____ (years) experience as a mechanic or inspector in a motor carrier maintenance program. Name and Date:

- C. ____ (years) experience as a mechanic or inspector in truck maintenance at a commercial garage, fleet leasing company, or similar facility. Name of Facility and Dates:

- D. ____ (years) experience as a commercial vehicle inspector for a State, Provincial, or Federal Government. Where and Dates:

I certify the above information is true and accurate to the best of my knowledge.

Employee _____
Signature of Mechanic/Inspector Date

Motor Carrier/Company _____
Signature of Employer/Supervisor Date

Evidence of Inspector Qualifications are on file at:

BRAKE INSPECTOR QUALIFICATIONS

Certification — 49 CFR — Part 396.25

“Brake Inspector” means any employee of a motor carrier who is responsible for ensuring all brake inspections, maintenance, service, or repairs to any commercial motor vehicle, subject to the motor carrier’s control, meet the applicable Federal standards.

No motor carrier shall require or permit any employee who does not meet minimum brake inspector qualifications to be responsible for the inspection, maintenance, service or repairs of any brakes on its commercial motor vehicles.

Minimum Qualifications

- Understands and can perform brake service and inspection
- Is knowledgeable of and has mastered the methods, procedures, tools and equipment necessary to perform brake service and inspection
- Is capable of performing brake service or inspection by reason of experience, training, or both, and qualifies in one of the following categories (check all that apply):

I. Has successfully completed an apprenticeship program sponsored or approved by a State, Canadian Province, a Federal agency or labor union, or has a certificate from a State or Canadian Province which qualifies the person to perform brake service or inspections.
Specify:

or

II. Has brake-related training or experience or a combination thereof totaling at least one year as follows (check all that apply):

A. Participation in a brake maintenance or inspection training program sponsored by a brake or vehicle manufacturer or similar commercial training program. Where and Date:

B. ____ (years) experience performing brake maintenance or inspection in a motor carrier maintenance program. Name and Date:

C. ____ (years) experience performing brake maintenance or inspection at a commercial garage, fleet leasing company, or similar facility. Name of Facility and Dates:

I certify the above information is true and accurate to the best of my knowledge.

Employee _____
Signature of Mechanic/Inspector Date

Motor Carrier/Company _____
Signature of Employer/Supervisor Date

Evidence of Inspector Qualifications are on file at:

Bus Emergency Exits Inspection

VEHICLE IDENTIFICATION	
MAKE	SERIAL NUMBER
YEAR	TIRE SIZE
COMPANY NUMBER/OTHER I.D.	OWNER, IF LEASED

	Dates – Inspection Due Every 90 Days										
CHECK PUSHOUT WINDOWS											
EMERGENCY DOORS											
EMERGENCY DOOR LIGHTS											

WITHIN AN INCH OF YOUR LIFE

IF BRAKE SLACK EXCEEDS ONE INCH, YOU COULD BE DRIVING A "KILLER TRUCK."

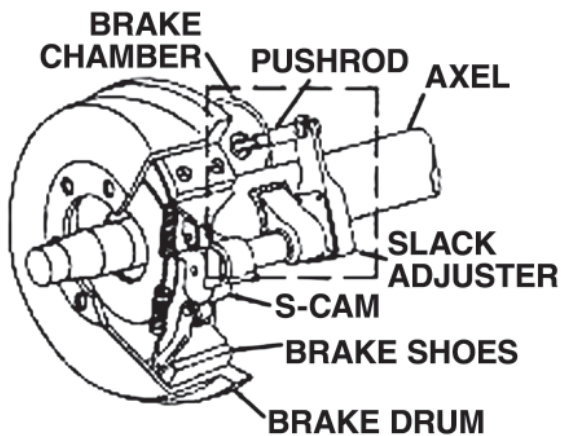

THIS IS THE MOST IMPORTANT INCH OF YOUR LIFE.

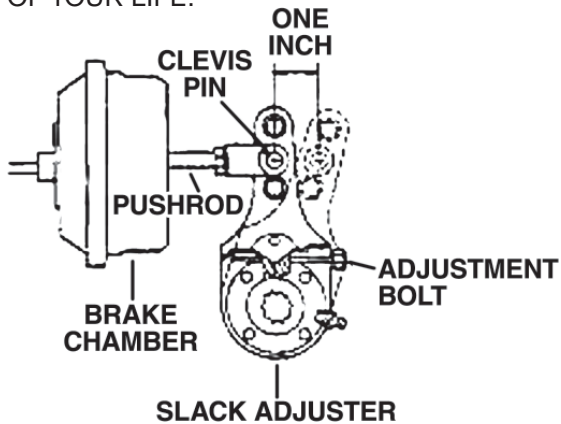

BRAKES SHOULD BE CHECKED BEFORE EACH TRIP AND MORE FREQUENTLY IN HILLY AREAS.

On Guard



U.S. Department of Transportation

TRUCKERS! Poorly adjusted brakes could cost you time and money with out-of-service violations, jeopardize your safety and that of others due to impaired stopping ability, and even cost you your life. The only way to be sure that your vehicle's brakes are properly adjusted is to physically check each wheel on a regular schedule. It is difficult for you to sense, simply from pedal feel, that your brakes are out of adjustment. Under normal braking conditions, your brakes may respond satisfactorily, but under a *hard* or *panic* stop you may find that you are unable to stop in time.

HOW TO CHECK

Before checking or making adjustments, be sure that your vehicle is parked on a level surface with the wheels blocked, spring brakes released, and the engine shut off. The following measurements are for *Type 30 air chamber brakes only*. For other types, check with your mechanic, supervisor, or manufacturer.

One person method: (1) Pull the chamber pushrod to its limit by hand or by prying with a short pry bar. (2) Measure from the clevis pin to the chamber face at both full retraction and at full extension. The difference between these measurements is the pushrod travel or slack. One-half inch is correct, and the *MAXIMUM ALLOWABLE TRAVEL IS ONE INCH* (one-person method).

Two-person method: Make the same measurements described in the one-person method, but with brakes fully applied and with brakes released. Because of the considerable stretching and bending of various parts when using the two-person method, the *MAXIMUM ALLOWABLE TRAVEL IS TWO INCHES* for Type 30 air chamber brakes.

HOW TO ADJUST

Brake adjustment, or "taking up the slack," is done by first making sure the brakes are released, then turning the adjusting bolt on the slack adjuster arm: (1) Depress the spring locking sleeve with a wrench. (2) Tighten the bolt until solid resistance is met. This indicates that the brake linings are touching the drum.

NOTE: Most adjusting bolts require a normal clockwise turn to "set up" the brakes, but some require a counter-clockwise turn. Be alert for any outward movement of the chamber pushrod and slack adjuster arm while the adjustment bolt is being turned. This movement means you are turning in the wrong direction.

(3) Restore running clearance by backing off the adjustment between one-quarter and one-half a turn. Re-check the pushrod travel. Proper adjustment leaves one-half an inch. (4) Check each brake drum or rotor for excessive heat soon after the brakes have been adjusted. An extra-hot brake drum means that you have adjusted the brakes too tightly.

For both this type and other types of brake systems, always check with the manufacturer for proper maintenance and adjustment procedures. If you are not comfortable with these procedures, ask your mechanic or supervisor.

Section 2

OVERVIEW

Transportation Of Hazardous Materials

The last few years has witnessed significant changes to the regulations for the Transportation of hazardous materials. These changes were first introduced under Docket HM-181. Docket HM-181 provided for a phased transition of the hazardous materials regulations which would to the maximum extent possible, be compatible with international standards, in order to facilitate foreign trade and maintain the competitiveness of U.S. goods.

Since October 1, 1997, applicability of the hazardous materials regulations was extended to all intrastate shipments of hazardous materials by highway as published in the final rule, Docket HM-200 dated January 8, 1997. This final rule also provided exceptions for “materials of trade,” “agricultural operations” and certain nonspecification packaging used in commerce.

The SECRETARY of the Department Of Transportation receives the authority to regulate the transportation of hazardous materials from the Hazardous Materials Act (HMTA), as amended and codified in 49 U.S.C. 5101 et seq. The Secretary is authorized to issue regulations to implement the requirements of 49 U.S.C. The Pipeline and Hazardous Materials Safety Administration (PHMSA) is delegated the responsibility to write the hazardous materials regulations, which are contained in 49 CFR Parts 100-180. In order to accomplish responsibilities under the HMTA, the Secretary “...may authorize any officer, employee, or agent to enter upon, inspect, and examine, at reasonable times and in a reasonable manner, the records and properties of persons to the extent such records and properties relate to (1) The manufacture, fabrication, marking, maintenance, reconditioning, repair, testing, or distribution of packages or containers for use by any “person” in the transportation of hazardous materials in commerce; or (2) the transportation or shipment by any “person” of hazardous materials in “commerce.”



In regards to commercial or governmental activities, Special Agents of the Department of Transportation can not be denied reasonable access to those areas that fall within the official scope of their duties. The Secretary has delegated this authority to the Federal Aviation Administration, (FAA); Federal Motor Carrier Safety Administration, (FMCSA); Federal Railway Administration, (FRA); Pipeline and Hazardous Materials Safety Administration (PHMSA); and the United States Coast Guard, (USCG).

The hazardous materials regulations are constantly changing. These changes may be the result of changes to the international regulations, Congressional, mandates, and/or advances in technology. The challenge facing shippers and transporters is to keep current.

The Government Printing Office has made the Federal Registers and 49 CFR available on the internet. The website for the Federal Registers is <http://www.gpoaccess.gov/fr/index.html>. The website address for 49 CFR is <http://www.gpoaccess.gov/cfr/index.html>. Clarifications of the requirements contained in the Federal Hazardous Materials Regulations and the Motor Carrier Safety Regulations may be found at <http://hazmat.dot.gov> and <http://www.fmcsa.dot.gov>, respectively.

Who do the regulations apply to?

No person shall offer or accept a Hazardous Material for transportation in commerce unless that person is registered as a hazmat shipper or carrier as required by 49 CFR section 107, subpart G, and the hazardous material is properly classed, described, packaged, marked, labeled, and in condition for transport as required or authorized by the Federal Hazardous Materials Transportation Regulations (HMR). The hazardous materials regulations apply to all persons operating in intrastate, interstate, and foreign commerce.

Who is a person under these regulations? – §171.8

A *person* means an individual, corporation, company, association, firm, partnership, society, joint stock company; a government or Indian tribe or authority of a government offering a hazardous material for transportation in commerce, or transporting a hazardous material to support a commercial enterprise.

What is a Hazardous Material? – Definition §171.8

Hazardous material means a substance or material that the Secretary of Transportation has determined is capable of posing an unreasonable risk to health, safety, and property when transported in commerce, and has been designated as hazardous by federal hazardous materials law. The term includes hazardous substances, hazardous wastes, marine pollutants, elevated temperature materials, materials designated as hazardous in the hazardous materials table in 49 CFR 172. 101, and materials that meet the defining criteria for hazard classes and divisions in 49 CFR section 173.

Who do the Hazardous Materials Regulations apply to?

The Federal Hazardous Materials Transportation Regulations (HMR) apply to persons that transport hazardous materials, or perform pre-transportation functions to assure the safe transportation of hazmat, including persons who ship, offer, cause or are responsible for hazardous materials transported in commerce. The HMR also apply to persons who manufacture, maintain, mark, or certify hazardous materials packages.

The following activities require adherence to HMR:

1. Determining the hazard class of a hazardous material.
2. Selecting a hazardous materials packaging.
3. Filling a hazardous materials packaging, including bulk packaging.
4. Transloading hazmat at intermodal transfer facilities from one bulk packaging to another.
5. Securing the closure on a filled, partially filled, or residue containing package.
6. Marking a package to indicate it contains hazardous material.
7. Labeling a package to indicate it contains hazardous material.
8. Preparing a shipping paper.
9. Providing and maintaining emergency response information.
10. Reviewing a shipping paper to verify compliance with the HMR.
11. For importers of hazardous materials, providing the shipper with timely and complete information on the requirements of the HMR that will apply to that shipment in the United States.
12. Certifying that a hazardous material in condition for transport in conformance with the requirements of the HMR.

13. Loading, blocking, and bracing a hazmat package in a freight container or transport vehicle.
14. Segregating a hazardous materials package in a freight container or transport vehicle from incompatible cargo.
15. Selecting, providing, or affixing placards for a transport vehicle or freight container to indicate it contains hazardous materials.

■ What is a Pre-Transportation Function?

These Pre-Transportation functions are activities regulated by the HMR because they are actions that prepare hazardous materials for transportation.

Transportation in Commerce begins when a carrier takes possession of the hazmat for the purpose of transporting it and continues until the hazmat package arrives at its intended location. For private carriers, transportation in commerce begins when the driver takes possession of the hazardous material for the purpose of transport, and continues until the driver relinquishes possession of the package at its destination. Transportation in Commerce includes:

1. Movement of hazmat by highway, railroad, aircraft, or vessel.
2. Loading incidental to movement, including the loading of packaged hazardous materials into a transport vehicle, blocking, bracing and securing a package in the vehicle, and segregating the hazardous materials from incompatible materials in the transport unit. For bulk packages like cargo tanks or portable tanks, loading incidental to movement is filling the bulk packaging with the hazmat for the purpose of transporting it when performed by the carrier or in the presence of the carrier.
3. Unloading incidental to movement, is removing packaged or containerized hazmat from a transport vehicle, or for bulk packaging, emptying the cargo tank or other packaging after the packaging has been delivered to the consignee, and prior to the carrier leaving the delivery location.

4. Storage incidental to movement is the temporary storage of hazmat between the time the carrier takes possession and its delivery to the location indicated on the shipping paper or package marking. An example is hazmat packages dropped at a freight terminal by original driver or carrier, to be picked up by another driver or carrier for delivery to the consignee.

■ What functions or activities are not subject to the Hazardous Materials Regulations? – (49 CFR 171.1)

All aspects of Transportation in Commerce are regulated activities. The following items do not fall into the definition of hazardous materials in commerce:

1. Storage of hazmat containers, vehicles or packages at a shipper or offeror facility prior to a carrier taking possession of the hazardous materials for transportation in commerce.
2. Unloading of transport vehicles or bulk packages by the consignee after the departure of the carrier from the consignee location. For private carriers, unloading of the hazmat after the driver leaves the delivery area.
3. Storage of the container, vehicle, or package containing the hazardous material after delivery by the carrier to the destination listed on the shipping document.
4. Motor vehicle movements of hazardous materials exclusively within the contiguous facility boundary where public access is limited, except for movements that cross a public road.
5. Transport of hazmat by motor vehicles operated by a government agency.
6. Transportation of hazmat by an individual for non-commercial purposes in a private motor vehicle.
7. Any shipment subject to the U.S. Post Office laws or regulations.



Who has to Register as a Hazardous Materials Shipper or Carrier with U.S. DOT?

Any person who offers or transports hazardous materials in one of the following categories must annually register with the U.S. DOT as a shipper or carrier:

1. Any quantity of a Class 7 highway route controlled radioactive material.
2. More than 25 kg of 1.1, 1.2, or 1.3 explosives.
3. More than 1 liter per package of materials extremely toxic by inhalation that meet the criteria of a “hazard zone A” material.
4. Shipments of hazardous materials in bulk pages having a capacity equal to or greater than 3,500 gallons (13,248 liters) for liquids or gases, or more than 13.24 cubic meters (468 cubic feet) for solids.
5. A shipment in non-bulk packagings of 5,000 pounds (2,268 kg) gross weight or more on one class of hazmat for which placarding of the transport unit would be required.
6. A quantity of hazardous material that would require placarding under the provisions of Subpart F of Part 172.

If one time a year, you ship, offer, or transport a type, form, or quantity of hazardous materials that would

require the transport vehicle to be placarded, you must be registered with the U.S. DOT. Limited exceptions from the registration requirements are available for farmers and operations by government agencies. Registration can be done on-line at: <http://hazmat.dot.gov/regs/register/register.htm> or by calling (617) 494-2545.

Hazmat security plans (49 CFR 172.800 through 172.804)

The U.S. DOT Pipeline and Hazardous Material Administration issued a final rule on March 25, 2003, that establishes new requirements aimed at enhancing the security of hazardous materials transportation. This new rule requires some hazmat offerors and transporters to develop and implement security plans. It requires all hazmat employers to provide security training to their employees as part of their regular hazmat training.

This rule creates a new Subpart I, *Security Plans*, in Part 172 of the regulations. This new regulation requires persons subject to the security plan requirements to perform an assessment of the risks associated with the materials they ship or carry. 49 CFR 172.800 requires each person who offers or transports certain categories of hazardous materials to develop and adhere to a security plan that conforms to the new requirements of Subpart I. **Hazmat Security Plans must be developed and in effect.**

Security plans must include:

- An assessment of possible security risks for shipments of covered materials;
- Appropriate measures to address these security risks;
- Personnel security, including measures taken to confirm background information provided by employees hired for positions that have access to hazardous materials covered by the security plan;
- Unauthorized access procedures, including measures to address the risk that unauthorized persons could gain access to facilities or vehicles used to transport hazardous materials covered by this rule; and
- En Route security, including assessment by the shipper and carrier of security risks associated with hazmat transportation from origin to final destination, including temporary storage incident to transportation.

The security plan must be in writing and retained as long as it remains in effect. Copies of the plan, or portions thereof, must be available to employees responsible for implementing the plan, in a manner consistent with security clearances and a demonstrated need to know. The U.S. DOT has published a security template on its website at <http://hazmat.dot.gov/riskmgmt/rmsef/rmsef.htm> that can be used to identify points in the transportation process where security measures can be enhanced.

■ Hazmat security training (49 CFR 172.704 (a)(4))

The hazardous materials transportation regulations have been revised to include the new requirements for security awareness training and in-depth security training. Many hazardous materials transported in commerce may potentially be used as weapons of mass destruction or weapons of convenience, and it is critical that training for persons that ship or transport hazardous materials include a security component.

■ Security awareness training

At the next scheduled recurrent hazmat training, each hazmat employee must receive training that provides awareness of security risks associated with hazmat transport, and methods designed to enhance transportation security. Training must include a

component covering how to recognize and respond to a security threat. New hazmat employees must receive security training within 90 days of employment. Hazmat employers are strongly encouraged to provide security awareness training to employees on an accelerated schedule whenever possible.

■ In-depth security training

All hazmat employees of a person required to have a security plan by Part 172, Subpart I, must be trained concerning the security plan and its implementation. This training must include:

- Company Security Objectives
- Specific Security Procedures
- Employee Responsibilities
- Actions in case of a Security Breach
- Organizational Security Structure

Security training conducted to comply with the requirements of other federal or international agencies may be used to satisfy this DOT requirement to the extent it complies with the training components required in 49 CFR 172.704 (a).

The U.S. DOT Office of Hazardous Materials Safety has prepared a Hazmat Transportation Security Awareness Training Module, which is available from them at no cost. You can order it from their Web site at <http://hazmat.dot.gov> or by calling (202) 366-4900, or (800) 467-4922 ext. 3.

■ Are there penalties for failing to comply with the Hazardous Materials Regulations?

The Federal Motor Carrier Safety Administration, its State Government partners, and the other Modal Agencies have established enforcement programs to prioritize their inspection of activities of shippers and transporters of hazardous materials. These include investigations of complaints, compliance reviews, roadside inspections, and spill and incident reports.

In the event that an inspection of your hazmat operations disclose violations of the HMR, you may be subject to civil and/or criminal penalties. Civil penalties of not more than \$50,000 and not less than \$270 per day and per violation may be assessed. Criminal penalties of not more than \$105,000 and not less than \$270 per day

and per violation may be assessed. A list of violations and guidelines for civil penalties can be found in Appendix A to Subpart D in Part 107 of the HMR.

This Motor Carrier Fact Sheet is intended as a resource. It is not intended to explain all requirements of Federal law. The actual regulations in 49 CFR (Code of Federal Regulations) are recommended as a resource. For additional assistance, contact the Federal Motor Carrier Safety Administration at (800) 832-5660.

■ Agricultural Product

An agricultural product means a hazardous material, other than a hazardous waste, whose end use directly supports the production of an agricultural commodity including, but not limited to a fertilizer, pesticide, soil amendment or fuel. An agricultural product is limited to a material in Class 3, 8, or 9, Division 2.1, 2.2, 5.1, or 6.1, or an ORM-D material.

■ Commerce

The term *commerce* means trade, traffic, commerce, or transportation in the jurisdiction of the United States:

- (A) between a place in a State and any place outside of such State; or
- (B) which affects trade, traffic, commerce, or transportation described in subparagraph (A). 49 U.S.C. 5101 et seq.

■ Government NOT engaged in commerce

- (1) The Government service or activity benefits the community as a whole and is available to the public at little or no direct expense.
- (2) The service or activity is undertaken for the purpose of public service rather than for monetary gain.
- (3) Government is the principal provider of activity.
- (4) Government is particularly suited to provide the service or perform the activity.
- (5) The activity is supported through general tax revenues.

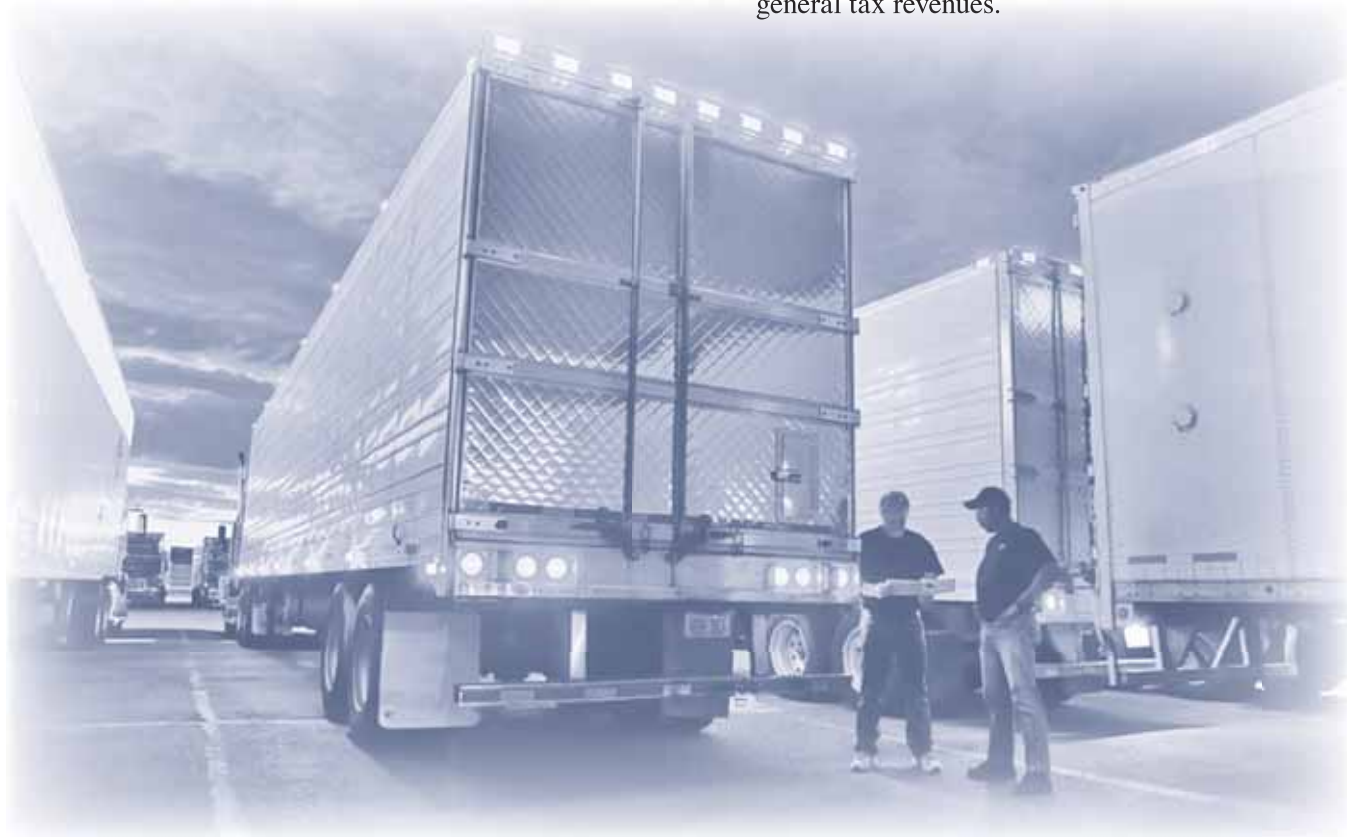

■ Government IS engaged in commerce

- (1) When it engages in activities contrary to the previously mentioned circumstances.
- (2) When the government “offers” material into commerce.

■ Contractors

Any person who, under contract with any department, agency, or instrumentality of the executive, legislative, or judicial branch of the Federal Government, transports, or causes to be transported or shipped, a hazardous material or manufactures, fabricates, marks, maintains, reconditions, repairs, or tests a package or container which is represented, marked, certified, or sold by such person as qualified for use in transportation of hazardous materials shall be subject to and comply with all provisions of the Federal Hazardous Material Transportation Law, or the regulations issued thereunder.

■ Hazmat Employee

A person who is employed by a hazmat employer and who in the course of employment directly affects hazardous materials transportation safety. This term includes an owner-operator of a motor vehicle which transports hazardous materials in commerce. This term includes an individual, including a self-employed individual, employed by a hazmat employer who, in the course of employment:

- (1) Loads, unloads, or handles hazardous materials;
- (2) Manufactures, tests, reconditions, or repairs, modifies, marks, or otherwise represents containers, drums, or packages as qualified for use in the transportation of hazardous materials;
- (3) Prepares hazardous materials for transportation;
- (4) Is responsible for safety of transporting hazardous materials; or
- (5) Operates a vehicle used to transport hazardous materials.

■ Hazmat Employer

A person who uses one or more of its employees in connection with; transporting hazardous materials in commerce; causing hazardous materials to be transported or shipped in commerce; or representing, marking, certifying, selling, offering, manufacturing, reconditioning, testing, repairing, or modifying containers, drums, or packaging as qualified in the transportation of hazardous materials. This term includes an owner-operator of a motor vehicle which transports hazardous materials in commerce. This term includes any department, agency, or instrumentality of the United States, a State, a political subdivision of a State, or an Indian tribe engaged in the first sentence of this definition.

■ Materials of Trade

Materials of Trade means a hazardous material, other than a hazardous waste, that is carried on a motor vehicle—(1) For the purpose of protecting the health and safety of the vehicle operator or passengers; (2) For the purpose of supporting the operation of a motor vehicle (including its auxiliary equipment); or (3) By a private motor carrier (including vehicles operated by a rail carrier) in direct support of a principal business other than transportation by a motor vehicle.

■ Person

Person means an individual, corporation, company, association, firm, partnership, society, joint stock company; or a government, Indian tribe, or authority of a government or tribe offering a hazardous material for transportation in commerce or transporting a hazardous material to support a commercial enterprise. This term does not include the United States Postal Service or for purposes of 49 U.S.C. 5123 and 5124, a Department, agency, or instrumentality of the government.

■ Offeror

Any person who performs, attempts to perform or, under the circumstances involved, is contractually or otherwise responsible to perform, any of the functions assigned to the offeror or shipper by the HMR is legally responsible under the HMR for their proper performance. Performance or attempted performance of any offeror or shipper function may be evidence of responsibility under the HMR for performance of other offeror or shipper functions. No shipper

commercial act, such as a sale or transfer of ownership, is necessarily determinative of that responsibility.

NOTE: In actuality there may be one or more offerors, jointly and severally responsible for compliance with the HMR, in any transportation scenario depending upon the details of the scenario.

■ Shipper

The word “shipper” is not specifically defined in the HMR (49 CFR Parts 170-179), due primarily to the fact that it is not possible for the Department to account for the numerous commercial arrangements that may exist under that concept, although the word “shipper” does appear, it is used in an ordinary layman’s manner rather than a specific, technical term of art. Consequently, responsibilities generally are placed on “offerors” for performance of the functions associated with “offering” hazardous materials for transportation (e.g., see the general duty and applicability provisions in 49 CFR section 171.1, 171.2, 172.3, and 173.1).

■ Transports

The term *transports* or *transportation* means any movement of property by any mode, and any loading, unloading, or storage incident thereto.

■ Transportation in commerce on a public highway

Transportation on (across or along) roads outside of Government properties generally is transportation in commerce. If a road is used by members of the general public (including dependents of Government employees) without their having to gain access through a controlled access point, transportation on (across or along) a road on Government properties is in commerce. On the other hand if access to a road is controlled at all times through the use of gates and guards, transportation on that road is not in commerce.

The Commercial Motor Vehicle Safety Act of 1986 required DOT to establish Federal standards for States to test and license truck and bus drivers, establish uniform penalty provisions, and establish a data system containing data on drivers.

■ Commercial driver’s license

The commercial driver’s license (CDL) regulations apply to drivers of motor vehicles used in commerce to transport hazardous materials in a quantity requiring the vehicle to be placarded. The CDL regulations do not apply to active duty military drivers, but do apply to government civilian employees.

■ Safety ratings

Motor carriers transporting hazardous materials in quantities requiring placards are prohibited from operating commercial motor vehicles beginning on the 46th day after receiving a proposed unsatisfactory rating. Federal agencies can not use a motor carrier to transport hazardous materials requiring placards if the motor carrier has an unsatisfactory rating.

Safety Ratings and Carrier Profiles are public information and may be obtained on the internet on a system called SAFER (Safety and Fitness Electronic Record) at <http://www.safer.org/>.



Section 3

Motor Carriers of Passengers

Definitions

Commercial motor vehicle means any self-propelled or towed motor vehicle used on a highway in interstate commerce to transport passengers or property when the vehicle:

- Has a gross vehicle weight rating or gross combination weight rating, or gross vehicle weight, or gross combination weight of 10,001 pounds (4,536 kg) or more, whichever is greater;
- Is designed or used to transport more than 8 passengers, including the driver, for compensation;
- Is designed or used to transport more than 15 passengers, including the driver, and is not used to transport passengers for compensation; or
- Is used in transporting material found by the Secretary of Transportation to be hazardous under 49 U.S.C. 5103 and transported in a quantity requiring placarding under regulations prescribed by the Secretary under 49 CFR, subtitle B, chapter 1, subchapter C.

Direct compensation means payment made to the motor carrier by the passengers or a person acting on behalf of the passengers for the transportation services provided and not included in a total package charge or other assessment for highway transportation services.

PASSENGER CARRIER OPERATIONS

■ For-hire Motor Carriers of Passengers

For-hire motor carriers of passengers provide transportation of passengers for compensation. Examples of for-hire transportation of passengers include intercity bus service, charter bus service, canoe rental company bus service, and hotel bus service. Three factors must be present before a motor carrier of passengers is classified as a for-hire carrier:

- The motor carrier provides interstate transportation of passengers for a commercial purpose;
- The motor carrier is compensated, either directly or indirectly, for the transportation service provided; and
- The transportation service is generally available to the public at large.

The chart below summarizes the applicability of the Federal Motor Carrier Safety Regulations (FMCSRs) to for-hire motor carriers of passengers.

PART	REGULATORY TOPIC	APPLICABLE
380	Special Training Requirements	Partial
382	Controlled Substances and Alcohol Use and Testing	Yes
383	Commercial Driver's License	Yes
387	Financial Responsibility (Insurance/Surety)	Yes
390	General Applicability and Definitions	Yes
391	Qualification of Drivers	Partial
392	Driving of Commercial Motor Vehicles	Yes
393	Parts and Accessories	Yes
395	Hours of Service of Drivers	Yes
396	Inspection, Repair, and Maintenance	Yes

Private Motor Carriers of Passengers (PMCPs)

Private motor carriers of passengers (PMCPs) became subject to the FMCSRs on January 1, 1995. They are separated into two groups -- business or non-business.

Private Motor Carriers of Passengers (PMCPs): Business

Business PMCPs provide private transportation of passengers in the furtherance of a commercial purpose. Examples include companies that use buses to transport their own employees and professional musicians who use buses for concert tours.

Commercial businesses that provide transportation to the general public are not business PMCPs.

The chart below summarizes the applicability of the Federal Motor Carrier Safety Regulations (FMCSRs) to business private motor carriers of passengers (PMCPs).

PART	REGULATORY TOPIC	APPLICABLE
380	Special Training Requirements	Partial
382	Controlled Substances and Alcohol Use and Testing	Yes
383	Commercial Driver's License	Yes
387	Financial Responsibility (Insurance/Surety)	Yes
390	General Applicability and Definitions	Yes
391	Qualification of Drivers	Partial
392	Driving of Commercial Motor Vehicles	Yes
393	Parts and Accessories	Yes
395	Hours of Service of Drivers	Yes
396	Inspection, Repair, and Maintenance	Yes

Business PMCPs are **not** subject to:

- Minimum levels of financial responsibility
- Road test requirements of Part 391 if they meet the requirements of 391.69

Private Motor Carriers of Passengers (PMCPs): Non-business

Non-business PMCPs provide private transportation of passengers that is not in the furtherance of a commercial purpose. Examples of non-business PMCPs include churches, private schools, civic organization, scout groups, and other organizations that may purchase or lease buses for the private transportation of their respective groups.

The chart below summarizes the applicability of the FMCSRs to non-business private motor carriers of passengers.

PART	REGULATORY TOPIC	APPLICABLE
380	Special Training Requirements	Partial
382	Controlled Substances and Alcohol Use and Testing	Yes
383	Commercial Driver's License	Yes
387	Financial Responsibility (Insurance/Surety)	Yes
390	General Applicability and Definitions	Yes
391	Qualification of Drivers	Partial
392	Driving of Commercial Motor Vehicles	Yes
393	Parts and Accessories	Yes
395	Hours of Service of Drivers	Partial
396	Inspection, Repair, and Maintenance	Partial

Non-business PMCPs are **not** subject to:

- Minimum levels of financial responsibility
- Subpart C of Part 391
- Subpart D of Part 391
- Subpart F of Part 391
- Most paperwork and recordkeeping requirements of Parts 390, 391, 395, and 396

Frequently Asked Questions Regarding the Applicability of the FMCSRs to PMCPs.

Q1: Are PMCPs required to register and mark their vehicles as required by 49 CFR section 390.21?

A1: Yes. All PMCPs must register with the FMCSA as required by 49 CFR section 390.19 and mark their vehicles according to 390.21 with their name and U.S. DOT number.

Q2: Are non-business PMCP drivers required to be medically examined?

A2: No. Section 391.68 (a)(4) specifically states that much of sections 391.41 and 391.45, which require a driver to be medically examined and to have a medical examiner's certificate on his/her person, do not apply to non-business PMCPs. However, non-business PMCP drivers are subject to the minimum physical qualification standards found in section 391.41(b)(1)-(13).

Non-business PMCPs should become familiar with the minimum physical qualification standards found in section 391.41 and the driver waiver conditions of section 391.49.

Non-business PMCP drivers may be placed out-of-service during terminal, en route, or destination inspections if they are required by section 391.41 to have a waiver and do not possess one.

Q3: Are non-business PMCP drivers subject to the driver's hours of service regulations?

A3: Yes. However, they are not required to prepare or maintain records of duty status. Non-business PMCP driver's hours of service will be evaluated by enforcement officers during terminal, en route, and destination inspections based on evidence available at the inspection location.

It is recognized that some individuals who volunteer to drive for non-business PMCPs may also drive for other motor carriers and in that capacity are required to maintain a record of duty status. All on-duty time performed for a non-business PMCP must be recorded on the records of duty status submitted to that driver's regularly employing motor carrier.

Q4: Are non-business PMCPs required to have their vehicles inspected?

A4: Yes. Section 396.17 requires that commercial motor vehicles be inspected at least once annually. The inspection must be completed by a qualified inspector and must include all components identified in Appendix G of the FMCSRs. Documentation of this inspection must be kept on the vehicle.

School Bus Transportation

The chart below summarizes the applicability of the FMCSRs to school bus transportation.

School Bus Transportation	School to Home/ Home to School	Extracurricular School Activities
Public School Transporting Students	Not Subject	Not Subject
Private School Transporting Pre-primary, Primary, and Secondary Students	Not Subject	Subject as Non-business PMCPs
Private School Transporting Post-Secondary Students	Subject as Non-business PMCPs	Subject as Non-business PMCPs
"For-hire" Contractors Transporting Pre-primary, Primary, and Secondary Students	Not Subject	Subject as "For-hire" Carriers
"For-hire" Contractors Transporting Post-secondary Students	Subject as "For-hire" Carriers	Subject as "For-hire" Carriers

Small Passenger Carriers

The FMCSA regulates for-hire carriers that transport 9 to 15 passengers in interstate commerce for compensation.

For-hire operators of vehicles designed or used to transport 9 to 15 passengers, including the driver, for compensation provided the vehicle is not being operated beyond a 75 air mile radius (86.3 statute miles) from the driver's normal work reporting location and provided the vehicle does not otherwise meet the definition of a commercial motor vehicle are subject to all of the safety regulations in Part 385 and Parts 390 through 396.

For-hire operators of vehicles designed or used to transport 9 to 15 passengers, including the driver, that are not directly compensated but operate within a 74 air-mile radius (86.3 statute miles), provided the vehicle does not otherwise meet the definition of a commercial motor vehicle, are subject to the Motor Carrier Identification Report (MCS-150) filing requirements of section 390.19, the commercial motor vehicle marking requirements of 390.21, and the accident register recordkeeping requirements of section 390.15.

APPLICABILITY OF MINIMUM FINANCIAL RESPONSIBILITY ON PASSENGER CARRIER OPERATIONS

Regulations covering the minimum levels of financial responsibility (insurance) are found in 49 CFR Part 387, subpart B. These regulations are only applicable to for-hire carriers transporting passengers in interstate commerce.

For-hire Motor Carriers of Passengers

The chart below summarizes the applicability of the minimum levels of financial responsibility regulations to for-hire passenger carriers.

Vehicle	For-hire Passenger Carriers	Business PMCPs	Non business PMCPs
Vehicle with a Seating Capacity of 16 or More	\$5,000,000 insurance required	Not Subject	Not Subject
Vehicle with a Seating Capacity of 15 or Less	\$1,500,000 insurance required	Not Subject	Not Subject

School Bus Transportation

The chart below summarizes the applicability of the minimum levels of financial responsibility regulations for school bus transportation.

"For hire" Contractors	School to Home/ Home to School	Extracurricular School Activities Organized, Sponsored, and Paid by the School	Extracurricular School Activities Organized and Paid by an Independent Group (e.g., Athletic Boosters Club)
"For-hire" Contractors Transporting Pre-primary, Primary, and Secondary Students, and Accompanying Teachers	Not Subject	Not Subject	Bus seating capacity of 16 or more: \$5,000,000 insurance required Bus seating capacity of 15 or less: \$1,500,00 insurance required
"For-hire" Contractors Transporting Post-secondary Students	Bus seating capacity of 16 or more: \$5,000,000 insurance required Bus seating capacity of 15 or less: \$1,500,00 insurance required	Bus seating capacity of 16 or more: \$5,000,000 insurance required Bus seating capacity of 15 or less: \$1,500,00 insurance required	Bus seating capacity of 16 or more: \$5,000,000 insurance required Bus seating capacity of 15 or less: \$1,500,00 insurance required

Minimum financial responsibility regulations do not apply to:

- A motor vehicle transporting only school children and teachers to and from school;
- A motor vehicle providing taxicab service, having a seating capacity of less than 7 passengers, and not operating on a regular route or between specified points;
- A motor vehicle carrying less than 16 individuals in a single daily round trip to commute to and from work; and
- A motor vehicle operated by a motor carrier under contract providing transportation of pre-primary, primary, and secondary students for extracurricular trips organized, sponsored, and paid by a school district.



Section 4

Accident Countermeasures

Background

As part of the ongoing FMCSA safety management effort to reduce the number of vehicle accidents on highways, assistance by safety specialists in accident analysis and countermeasures planning is now an integral part of compliance reviews conducted by the FMCSA. Accident countermeasures are examples of defensive strategies designed to reduce preventable accidents.

Purpose

This section is designed to provide motor carriers and drivers with an introduction to the concepts of preventability analysis and accident countermeasures. The material suggests practical measures that can be taken now to prevent accidents, though its main intent goes further. The core of the presentation is a series of case histories of successful countermeasures. These are true stories of industry successes in promoting highway safety. The case histories are presented, together with a guide called Determining Preventability of Accidents, to help readers analyze accidents and create strategies to keep similar accidents from happening in the future.

The FMCSA intends to stimulate thinking and discussion about accident prevention within the motor carrier industry. The preventability guide

and the Accident Countermeasures cases are not rating sheets nor orders from above to be followed exactly. They are guidelines and discussion tools to help carriers and drivers look at their unique operations and practices with an eye to identifying opportunities to make safety improvements.

■ Determining preventability

No two accidents or carriers are exactly alike and the FMCSA recognizes that not all accidents are preventable. Some types of accidents, however, can be prevented by drivers, while others require changes in motor carrier practices and policies or equipment. The new FMCSA method for determining preventability is based on examination of the facts in accident records.

■ Cases and countermeasures

The countermeasures cases in this file actually occurred. They are true success stories that show how relatively modest improvements led to significant reductions in accident rates.

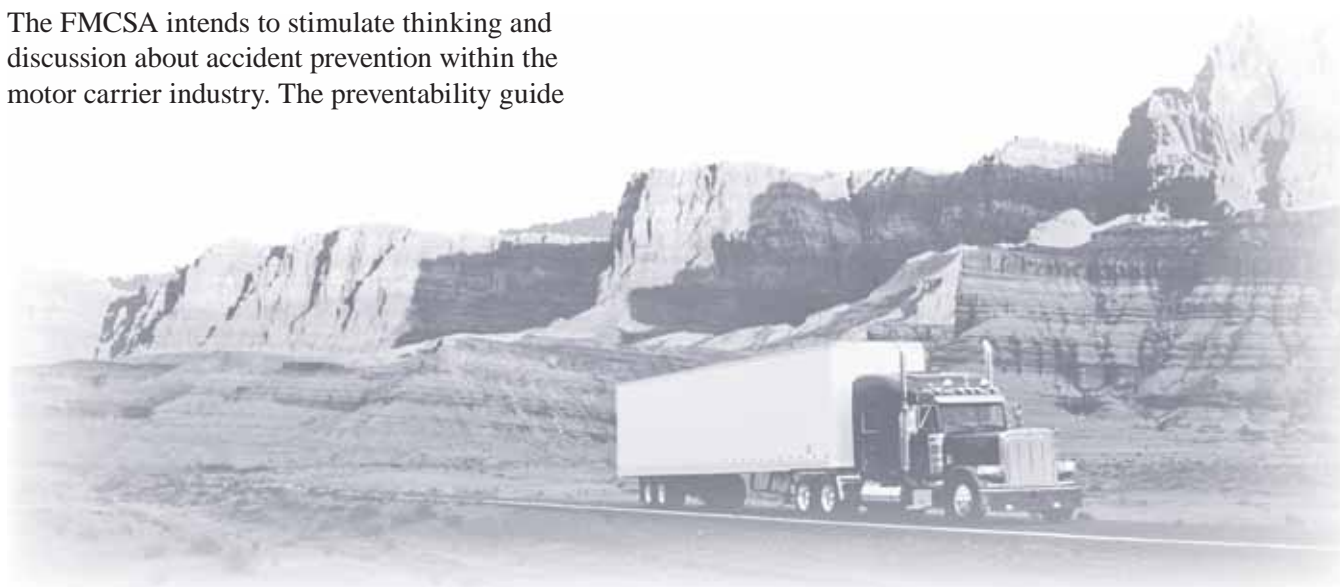

■ Contents and attachments

This section contains A Guide to Determining Preventability of Accidents and Accident Countermeasures: Success Stories. Attachments include an Accident Register form and a chart, Revenue Necessary to Pay for Accident Losses.

You are welcome to reproduce and distribute any of the materials in this booklet.

■ A Guide to Determining Preventability of Accidents

The heart of accident analysis is the determination of preventability, based on the facts furnished in the motor carrier's recordable accident register, and from various other sources. These sources of information must be evaluated in light of all available facts that are pertinent to the cause of the accident. Digging out these facts from the information on these reports can be difficult in practice due to the limited data contained in some reports. But the information can be obtained in many instances by a detailed analysis and reconstruction of the accident sequence.

Each accident must be judged individually. Certain types will generally fall in the non-preventable category, and certain others, in the absence of extenuating circumstances and conditions, fall in the preventable category. The types of accidents listed below do not cover every accident that may occur, but they are intended to provide general guidance to assist in determining preventability.

Non-Preventable Accidents

Struck in Rear by Other Vehicle

Preventable if:

- Driver's vehicle was legally and properly parked
- Driver was proceeding in his/her own lane of traffic at a safe and lawful speed
- Driver was stopped in traffic due to existing conditions or was stopped in compliance with traffic sign or signal or the directions of a police officer or other person legitimately controlling traffic
- Driver was in proper lane waiting to make turn
- Struck while parked

Non-preventable if:

- Driver was properly parked in a location where parking was permitted:
- Vehicle was stopped, parked, or left standing in accordance with Sections 392.21 and 392.22 of the Federal Motor Carrier Safety Regulations

Preventable Accidents

Accidents at Intersections

Preventable if:

- Driver failed to control speed so that he/she could stop within available sight distance
- Driver failed to check cross-traffic and wait for it to clear before entering intersection
- Driver pulled out from side street in the face of oncoming traffic
- Driver collided with person, vehicle, or object while making right or left turn
- Driver collided with vehicle making turn in front of him/her

■ Striking Other Vehicle in Rear

Preventable if:

- Driver failed to maintain safe following distance and have his/her vehicle under control
- Driver failed to keep track of traffic conditions and did not slow down
- Driver failed to ascertain whether vehicle ahead was moving slowly, stopped, or slowing down for any reason
- Driver misjudged rate of overtaking
- Driver came too close before pulling out to pass
- Driver failed to wait for vehicle ahead to move into the clear before starting up
- Driver failed to leave sufficient room for passing vehicle to get safely back in line

■ Sideswipe and Head-on Collisions

Preventable if:

- Driver was not entirely in his/her proper lane of travel
- Driver did not pull to right and slow down or stop for vehicle encroaching on his/her lane of travel when such action could have been taken without additional danger

■ Struck in Rear by Other Vehicle

Preventable if:

- Driver was passing slower traffic near an intersection and had to make sudden stop
- Driver made sudden stop to park, load, or unload
- Vehicle was improperly parked
- Driver rolled back into vehicle behind them while starting on grade

■ Squeeze Plays and Shutouts

Preventable if:

- Driver failed to yield right-of-way when necessary to avoid accident

■ Backing Accidents

Preventable if:

- Driver backed up when backing could have been avoided by better planning of his/her route
- Driver backed into traffic stream when such backing could have been avoided
- Driver failed to get out of cab and check proposed path of backward travel
- Driver depended solely on mirrors when it was practicable to look back
- Driver failed to get out of cab periodically and recheck conditions when backing a long distance
- Driver failed to check behind vehicle parked at curb before attempting to leave parking space
- Driver relied solely on a guide to help him/her back
- Driver backed from blind side when he/she could have made a sight-side approach

■ Accident Involving Rail Operated Vehicles

Preventable if:

- Driver attempted to cross tracks directly ahead of train or streetcar
- Driver ran into side of train or streetcar
- Driver stopped or parked on or too close to tracks

■ Accidents While Passing

Preventable if:

- Driver passed where view of road ahead was obstructed by hill, curve, vegetation, traffic, adverse weather conditions, etc.
- Driver attempted to pass in the face of closely approaching traffic
- Driver failed to warn driver of vehicle being passed
- Driver failed to signal change of lanes
- Driver pulled out in front of other traffic overtaking from rear
- Driver cut in too short while returning to right lane

■ Accidents While Being Passed

Preventable if:

- Driver failed to stay in his own lane and hold speed or reduce it to permit safe passing

■ Accidents While Entering Traffic Stream

Preventable if:

- Driver failed to signal when pulling out from curb
- Driver failed to check traffic before pulling out from curb
- Driver failed to look back to check traffic if he/she was in position where mirrors did not show traffic conditions
- Driver attempted to pull out in a manner that forced other vehicle(s) to change speed or direction
- Driver failed to make full stop before entering from side street, alley, or driveway
- Driver failed to make full stop before crossing sidewalk
- Driver failed to yield right of way to approaching traffic

■ Pedestrian Accidents

Preventable if:

- Driver did not reduce speed in area of heavy pedestrian traffic
- Driver was not prepared to stop
- Driver failed to yield right of way to pedestrian

■ Mechanical Defects Accidents

Preventable if:

- Defect was of a type that driver should have detected in making pre-trip or enroute inspection of vehicle
- Defect was of a type that driver should have detected during the normal operation of the vehicle
- Defect was caused by driver's abusive handling of the vehicle
- Defect was known to driver, but ignored
- Driver was instructed to operate with known defect

■ All Types of Accidents

Preventable if:

- Driver was not operating at a speed suitable for the existing conditions of road, weather, and traffic
- Driver failed to control speed so that he/she could stop within assured clear distance
- Driver misjudged available clearance
- Driver failed to yield right-of-way to avoid accident
- Driver failed to accurately observe existing conditions
- Driver was in violation of company operating rules or special instructions, the regulations of any Federal or State regulatory agency, or any applicable traffic laws or ordinances.



Accident Countermeasures: Success Stories

References in parentheses are to cases in the Commercial Vehicle Preventable Accident Manual (Countermeasures Manual).

COUNTERMEASURE:

The Safety Specialist discussed the findings with management and recommended the carrier's vehicles be rerouted until the construction was complete.

(Countermeasures Manual Case No. A11-Planning Schedules, Loads and Routes)

The carrier realized that it could not continue with the increased level of accidents for another six months and agreed with the recommendation. Although the new route was approximately 30 miles more each way, the benefit of reducing accidents outweighed this.

■ CASE # 1.

An Oregon-based carrier transporting wood chips from the coast to the Eugene area began to have an unusual number of accidents. An analysis by the Safety Specialist revealed that the majority of the accidents occurred on a three-mile stretch of the route being used. This two-lane road was narrow, winding, and frequented by tourists in summer; and plagued with fog, ice, and snow in winter. Further investigation revealed that for the past eight months construction had been underway along the three-mile stretch - about the same time the accidents had been happening. The highway department indicated that construction would continue for another six months.

■ CASE # 2.

An Illinois-based produce hauler was experiencing a high number of driver injuries resulting in a large number of workman compensation claims. A Safety Specialist's review of the accidents revealed that drivers were wrenching their necks inside their cabovers (vs. conventional cabs) when passing over bumps in the road. The drivers were being thrown unexpectedly out of their seats and into the windshield or ceiling of their tractors. The cabovers were identified as being the primary source of these incidents - the driver's seat is located directly over the front wheels and provides little resistance or cushion to reduce the impact of bumps in the road to the driver.

COUNTERMEASURE:

The Safety Specialist reminds the carrier that a commercial motor vehicle which has a seat belt assembly installed at the driver's seat shall not be driven unless the driver has properly restrained himself/herself with the seat belt assembly. Failure to do so could result in a citation.

(Countermeasures Manual Case No. A8-Company Driver Manuals)

The carrier agreed and, in addition, instructed guards at each terminal gate to check drivers before leaving to ensure they were complying with the company's policy. This simple solution, which had been overlooked by everyone, turned out to be the key in reducing this type of injury to zero.

COUNTERMEASURE:

The Safety Specialist recommended to the carrier that it should begin holding safety meetings sometime in April and provide each driver with a one-page handout in the period prior to the start of these meetings to keep them alert.

(Countermeasures Manual Case No. A7-Fleet Safety Program and Supervision)

This simple solution turned out to be the key in reducing these accidents to zero. When the Safety Director was asked why he had never noticed this problem, he replied “This was right there in front of me, but I just never had the time to sit down and look at it in this manner!”

■ CASE # 3.

An Indiana-based school bus contractor was experiencing a high number of accidents caused by driver inattention. After examining all of the carrier’s accidents, the Safety Specialist determined that they all were occurring during the month of June. The Safety Specialist also came to the conclusion that no specific driver or vehicle was responsible for the accidents. It seemed that the drivers, in general, were becoming inattentive because summer was near and they were anticipating the end of the school year. Further analysis revealed that the Safety Director held two safety meetings a year with the drivers, one in September and another in February.

■ CASE # 4.

A Utah-based carrier, which conducts the majority of its business west of the Mississippi River, was experiencing a high number of accidents.

After discussion with some drivers and management officials, an analysis by the Safety Specialist revealed that a high number of accidents occurred during the same time of day on a three-to-five mile section of a certain interstate, heading west. Apparently, drivers were being blinded as they came over the crest of a very large hill at sunset.

COUNTERMEASURE:

The Safety Specialist discussed the situation with management and recommended that the carrier change the time its drivers were being dispatched. The carrier agreed with the recommendation and immediately began to dispatch drivers an hour earlier or an hour later in order to avoid driving over the hill at sunset. This change eliminated the accidents.

■ CASE # 5.

During a review of a large Indiana-based household goods carrier that operates over 5,000 tractor-trailers, a Safety Specialist discovered that the carrier was experiencing a high number of rear-end collisions. Some of these accidents caused damage to the extent that they were reportable to the DOT. Most, however, were of a lesser amount but still added to the carrier's cost of operation.

COUNTERMEASURE:

The Safety Specialist recommended the installation of brake and turn signal lights at the top of the carrier's trailers.

(Countermeasures Manual Case No. B6-Turning Left and Right)

(Countermeasures Manual Case No. C10-Vehicle lighting and Conspicuity)

This reduced accidents almost immediately.

COUNTERMEASURE:

The Safety Specialist discussed the findings with the carrier and recommended the installation of turn signals at a higher level on trailers.

(Countermeasures Manual Case No. B6-Turning Left and Right)

(Countermeasures Manual Case No. C10-Vehicle Lighting and Conspicuity)

■ CASE # 6.

During a review of a Washington-based grocery company, operating over 100 tractor trailers primarily in urban areas, the Safety Specialist discovered an accident pattern - an inordinate number of right turn accidents. Some of the accidents caused damage to the extent that they were reportable to DOT. Most, however, caused damages in a lesser amount but still added to the carrier's cost of operation.

■ CASE # 7.

During a recent review, a Washington-based carrier that operates over 2,400 tractor trailers west of the Mississippi River was found to have a high number of loss-of-control accidents during adverse driving conditions.

COUNTERMEASURE:

The Safety Specialist recommended the carrier require drivers to attend a safety meeting.

(Countermeasures Manual Case No. A7-Fleet Safety Program and Supervision)

(Countermeasures Manual Case No. A9-Driver Training Aids)

To promote attendance, the carrier scheduled ten Saturday meetings in various locations and required all drivers to attend one. Drivers were paid to attend the meetings and coffee and doughnuts were provided. The safety meeting consisted of approximately four hours of training on the Federal Motor Carrier Safety Regulations, driving in adverse conditions, and other general safety information. Within a short period of time, the company records indicated a 60 percent reduction in accidents.

COUNTERMEASURE:

The Safety Specialist recommended that each driver attend a safety meeting, and that a safety notice be distributed to all drivers requiring them to assist each other during backing maneuvers.

(Countermeasures Manual Case No. A7-Fleet Safety Program and Supervision)

(Countermeasures Manual Case No. A9-Driving Training Aid)

(Countermeasures Manual Case No. B3-Start-Up/Back-Up)

The carrier agreed with the suggestion and required every driver to attend a safety meeting (meetings were held on several Saturdays to allow attendance by all). Drivers were paid overtime and coffee and donuts were furnished. The meeting contained about four hours of training on proper procedures for backing. In addition, a safety notice was distributed in driver's paychecks instructing them to assist each other during backing maneuvers. Backing accidents dropped quickly, and because of increased driver awareness, there was a reduction in other types of accidents as well.

CASE # 8.

An Oregon-based produce hauler, generally running from Portland to Los Angeles was having a very high number of backing accidents. Considering the areas in which they were required to load and unload, the carrier had not found the number of accidents unusual. An analysis by the Safety Specialist revealed that the carrier was using qualified but relatively inexperienced drivers in sleeper teams. They were paid for load/unload time whether they actually had to do the work or not. Although most of the backing accidents involved damage costing less than \$1,000, one dock worker had been crushed between a trailer and the dock, which emphasized the danger inherent in backing accidents.

CASE # 9.

A Missouri-based farm commodity and hazardous material transporter was experiencing a high number of accidents. Examination of all its accidents revealed that they occurred during bad weather and that the majority of them were caused by drivers who were not paying attention to the road conditions (that is, they were driving too fast for the weather).

COUNTERMEASURE:

The Safety Specialist recommended that the carrier implement a safe driver recognition/incentive program and a driver training program geared to avoiding accident situations and to driving in adverse weather conditions.

(Countermeasures Manual Case No. A3-Safe Driving Recognition)

(Countermeasures Manual Case No. A4-Driver Safety Infractions)

(Countermeasures Manual Case No. A7-Fleet Safety Program and Supervision)

(Countermeasures Manual Case No. B11-Driving in Adverse Conditions)

The carrier agreed with the recommendations, and now holds quarterly safety meetings with 95 percent driver participation. Any driver who attended the previous meeting and was accident free during the quarter receives a \$150 U.S. Savings Bond. The carrier also, implemented a driver training program and classroom instruction on accident situations and driving in adverse weather conditions. After the carrier took this proactive stance, its accident rate improved from 0.88 to 0.37 over 12 months.

COUNTERMEASURE:

After further discussion with management officials, the Safety Specialist recommended that the carrier change the time the drivers were being paid. The carrier agreed with the recommendation and began paying the drivers at the end of the day. The change forced drivers to cash their paychecks after work while off-duty, and eliminated the accidents.

■ CASE # 10.

A city-based carrier that operates over 30 delivery trucks was experiencing a high number of accidents.

An analysis by the Safety Specialist revealed that a majority of accidents occurred within a two to three block area downtown every Thursday between nine and ten in the morning. The analysis also revealed that drivers were paid every Thursday morning, and that a number of banks are located within the problem area. Apparently, after they were paid in the morning, drivers would stop at the banks while on-duty to cash their paychecks.

Driving in this highly congested area during rush hour placed both the driver and vehicle in extremely unfavorable conditions. Cashing the checks during the morning rush hour traffic was placing both the driver and vehicle in the worst possible place at the busiest time of the day and led to the high number of accidents.

■ CASE # 11.

An Illinois-based carrier that operates over 200 tractor trailers was experiencing a high number of accidents. An analysis by the carrier's Safety Director revealed that the majority of these accidents fell into three main categories. The carrier was experiencing:

- ▶ too many right turn accidents
- ▶ too many backing accidents
- ▶ too many right lane change accidents

COUNTERMEASURE:

After further discussion among management officials, the carrier developed a program that was based on the three accident types that were occurring most frequently. Each accident type was assigned a different color dot sticker: red, blue, and yellow. The number one accident situation (right turns) was assigned a red dot sticker. The number two accident situation (backing) was assigned a blue dot sticker. The number three accident (right lane change) was assigned a yellow dot sticker. The dots were placed on the right side mirror of the motor carrier's vehicle as a safety reminder to drivers who had accidents.

The carrier also placed a large red sticker halfway back on the side of trailers to aid drivers when making right turns. If a driver could not see the colored sticker in the right side mirror, then he/she had not pulled far enough out to execute the turn.

After implementing the program, the carrier began to see accident numbers starting to decrease considerably.

After a few months, however, the carrier became lax in seeing that the dots remained affixed. Accident rates started to rise again. The Safety Director states that the carrier now makes sure that when a unit comes through the shop, the safety dots are checked and replaced if needed. Other carriers could easily copy this program to meet their own company's most frequent accident situations.

CASE # 12.

Motor carriers in California and Tennessee have recently experienced accidents involving the driver's inability to see other vehicles because of poor visibility (specifically, in fog or dust storms).

COUNTERMEASURE:

According to researchers here and in Europe, use of front and rear running lights during daylight hours would save lives and prevent injuries, since many crashes are caused by poor visibility. These running lights can be:

- special additional lights;
- reduced-intensity headlights for daytime use; or
- high-intensity parking lights.

In Finland, researchers found that, during a six-year period, the use of daytime running lights in winter reduced daytime crashes by 21 percent. In Sweden, results were similar: crashes decreased by 11 percent. Finland, Sweden, and Denmark now require all drivers to use daytime running lights. In 1989, Canada passed legislation requiring that all new cars, trucks, vans, and buses be equipped with front lights that turn on whenever the engine is running. According to James White of Transport Canada, about 20 percent of all drivers voluntarily use running lights in the daytime. By 1994, he said, enough new vehicles will be on the road to bring the total to two in five vehicles with lights on in the daytime.

Of course, all of these countries are in the north where it can be relatively dark much of the day in the winter. What about here in the United States? Some States already require the use of headlights just after sunrise, before sunset, or whenever visibility is poor. New York recently passed a law requiring the use of low-beam headlights whenever it rains, snows, sleets, or hails. Any time one has windshield wipers on in New York, headlights must be switched on or the driver risks being ticketed for an equipment violation (a \$100 fine).

In one study, the Insurance Institute of Highway Safety (a research organization supported in part by the insurance industry) equipped 2,000 trucks and vans with automatic daytime running lights for a year. Crashes decreased by 13 percent in bad weather

and 7 percent at other times - less than the reduction shown in several European studies but enough to lend support to the use of daytime running lights.

A government study completed in April 1990 showed that, in light levels equivalent to early morning or twilight, drivers were able to see vehicles with running lights sooner than those with no lights. The lights improved visibility and provided drivers going 55 miles per hour with about three extra seconds to brake or take other action to prevent a crash. Several car makers, including General Motors, Chrysler, Ford, and Volvo, voiced support for daytime running lights as a way to decrease highway deaths and injuries. General Motors has filed a petition with the National Highway Traffic Safety Administration for clearance to install daytime running lights.

Daytime running lights won't affect gas mileage by much: for every \$10 spent on gas, they would cost an extra nickel (0.5 percent, according to a study by the Canadian government). Some people may object that these daytime lights can be blinding for other drivers, especially when reflected in rearview mirrors and for older drivers. One government study indicated that glare in the rearview mirror during daytime could be a problem, though the age of the driver was not a significant factor. The right intensity for running lights under different conditions "should be considered" in recommending lamp design, the study concluded.

Meanwhile, it makes good safety sense to switch on low-beam headlights in adverse weather conditions, at daybreak, dusk, and on dark and overcast winter afternoons.



Forms to Use

Shown on following pages and available at Web address as shown:

125Accident Register:
http://www.fmcsa.dot.gov/documents/forms/form_1.pdf

126Revenue Necessary
 To Pay For Accident Losses:
http://www.fmcsa.dot.gov/documents/forms/revenue_necessary.pdf

REVENUE NECESSARY TO PAY FOR ACCIDENT LOSSES

This table shows the dollars of revenue required to pay for different amounts of costs for accidents.

It is necessary for a motor carrier to generate an additional \$1,250,000 of revenue to pay the cost of a \$25,000 accident, assuming an average profit of 2%. The amount of revenue required to pay for losses will vary with the profit margin (as shown in chart below).

REVENUE REQUIRED TO COVER LOSSES

YEARLY ACCIDENT COSTS	VS. PROFIT MARGIN				
	1%	2%	3%	4%	5%
\$1,000	\$100,000	\$50,000	\$33,000	\$25,000	\$20,000
5,000	500,000	250,000	167,000	125,000	100,000
10,000	1,000,000	500,000	333,000	250,000	200,000
25,000	2,500,000	1,250,000	833,000	625,000	500,000
50,000	5,000,000	2,500,000	1,667,000	1,250,000	1,000,000
100,000	10,000,000	5,000,000	3,333,000	2,500,000	2,000,000
150,000	15,000,000	7,500,000	5,000,000	3,750,000	3,000,000
200,000	20,000,000	10,000,000	6,666,000	5,000,000	4,000,000

Accident costs consist of any /or all of the following:

- Vehicle Damage
- Loss of Revenue
- Administrative Costs
- Police Reports
- Cargo Damage
- Possible Effects on Cost of Insurance
- Possible Effect on Cost of Workmen's Compensation Insurance
- Towing
- Storage of Damaged Vehicle
- Damage to Customer Relationships
- Legal Fees
- Customer's Loss of Revenue Directly Attributable to Accident

PART 1420

Motor Carrier Financial and Operation Statistics

The Bureau of Transportation Statistics' Motor Carrier Financial and Operating Statistics (F&OS) Program collects annual and quarterly data from motor carriers of property and passengers that meet the applicability requirements listed in the table below. The program collects balance sheet and income statement data along with information on tonnage, mileage, employees, transportation equipment, and other related items, but there are no explicit safety data items. The Motor Carrier F&OS forms are not currently a part of the FMCSA compliance review process. The F&OS data are used by the U.S. Department of Transportation, other government agencies, trucking associations, insurance companies, consultants, law firms, academia, trade publications, and others. Under 49 CFR 1420.10, unless otherwise provided by law, "the data contained in the report[s]...shall be made publicly available."

■ Applicability

Any motor carrier of property, household goods, or passengers engaged in interstate, intrastate, and/or foreign operations and with annual revenues of \$3 million dollars or more must file annual and/or quarterly reports with the Bureau of Transportation Statistics, as required by 49 CFR 1420.

■ Requirements

As listed under 49 CFR 1420.

Class I, Property	\$10 million or greater	Form M, annual	March 31
		Form QFR, quarterly	30 days after the end of each quarter
Class II, Property	\$3 - \$10 million	Form M, annual	March 31
Class I, Passenger	\$5 million or greater	Form MP-1, annual and quarterly	March 31st and 30 days after the end of each quarter

■ Exceptions

Motor Carriers that:

- are below the Class I or Class II revenue thresholds (see the worksheet for calculating carrier classification);
- are a private motor carrier;
- are outside DOT jurisdiction;
- do not hold DOT or ICC operating authority or have leased their operating authority to another carrier;
- are in bankruptcy; or
- have received an exemption from filing (see 49 CFR 1420.8 and 1420.9).

Please contact the Office of Motor Carrier Information, Bureau of Transportation Statistics at 202-366-2984 or 202-366-4023 for additional information about the Motor Carrier Financial and Operating Statistics Program.



Forms to Use

Shown on following pages and available at Web address as shown:

128-135 ...Quarterly and Annual:

http://www.fmcsa.dot.gov/forms/reporting/InformationForFilers/FormM_FMCSA_11_19_04.htm

136, 137 ..QFR: Class I - Motor Carriers of Property and Household Goods - Quarterly Report:

http://www.fmcsa.dot.gov/forms/reporting/InformationForFilers/FormQFR_FMCSA_11_19_04.htm

138, 139 ..MP-1: Quarterly and Annual Report - Motor Carriers of Passengers:

http://www.fmcsa.dot.gov/forms/reporting/InformationForFilers/FormMPI_FMCSA_11_19_04.htm

140Online Registration Options:

https://li-public.fmcsa.dot.gov/LIVIEW/PKG_REGISTRATION.prc_option

Class I & II — Motor Carriers of Property and Household Goods

2001 Annual Report

IDENTIFICATION

MOTOR CARRIER NO. <input type="text"/>		U.S. DOT NO. <input type="text"/>	
BASE STATE* (see instructions) <input type="text"/>		BASE STATE REGISTRATION NO.* (see instructions) <input type="text"/>	
Name of Company <input type="text"/>			
Trade or Doing Business As: <input type="text"/>			
Street Address <input type="text"/>			
City <input type="text"/>	State <input type="text"/>	ZIP Code <input type="text"/>	Telephone No. (Include Area code) (<input type="text"/>) <input type="text"/>

CONTACT (for purposes of this report)

Contact name <input type="text"/>	Title <input type="text"/>	Telephone No. (Include Area code) (<input type="text"/>) <input type="text"/>
--------------------------------------	-------------------------------	---

MAILING ADDRESS (if different from above)

Mailing Address <input type="text"/>		
City <input type="text"/>	State <input type="text"/>	ZIP Code <input type="text"/>

AFFILIATED COMPANIES: Name(s)	MC number (if any)	U.S. DOT number (if any)
Parent <input type="text"/>	<input type="text"/>	<input type="text"/>
Affiliates <input type="text"/>	<input type="text"/>	<input type="text"/>
<input type="text"/>	<input type="text"/>	<input type="text"/>
<input type="text"/>	<input type="text"/>	<input type="text"/>

Revenue Commodity Group

MOTOR CARRIER NO.

Indicate which type of carriage makes up the majority of your revenues.

Parcel: Includes expedited and courier service.

Tank motor carriers: Included in liquid petroleum/liquid chemical products or refrigerated liquids.

GENERAL FREIGHT

- Less than truckload
- Truckload
- Parcel
- Container

HOUSEHOLD GOODS

SPECIALTY FREIGHT (mark up to 3)

- Heavy equipment
- Liquid petroleum or chemical products
- Bulk chemicals
- Refrigerated liquids
- Refrigerated solids
- Dump trucking
- Agricultural commodities
- Motor vehicles
- Armored truck services
- Building materials
- Film and associated products
- Forest products
- Mine ore (not coal)
- Retail store delivery
- Explosives or dangerous products
- Other - *Specify*

— GENERAL INSTRUCTIONS —

- Use Generally Accepted Accounting Principles (GAAP)
- Report dollar values in whole dollars.
- Respond to each item. Use "0," "none," or "not applicable" as appropriate.
- Explain any unusual items, such as large differences between figures reported in the current report and those for the preceding report.
- Use parentheses to indicate negative numbers.

Schedule 100 — Balance Sheet

Current Assets		Balance close of 2001 (a)	Balance start of 2001 (b)
101	Cash and equivalents – available on demand by company (cash and working funds, special deposits, temporary cash investments, etc.).		
102	Accounts receivable – Accounts owed to the business by customers or affiliates who have bought "on credit". Include all accounts receivable regardless of source. Exclude long-term accounts receivable.		
103	Notes receivable – Money owed by customers or affiliates who have signed a written promise to pay within one year. Include all notes receivable regardless of source.		
104	Other current assets – Include all assets not considered long-term which were not included above (materials and supplies, prepayments, deferred charges, etc.).		
105	Total current assets – Sum of lines 101 through 104 →		
Long-term Assets			
106	Net carrier operating property – Depreciated book value of all tangible operating property (revenue and other operating equipment, land, buildings, garage, furniture and office equipment, carrier owned operating property used by others in motor carrier operations, etc.).		
107	Other long-term assets – Include depreciated book value of nonoperating property, long-term notes and accounts receivable, receivables from affiliates, deferred income tax debits, and other deferred debits. Include intangible assets.		
108	Total long-term assets – Sum of lines 106 and 107 →		
109	TOTAL ASSETS – Sum of lines 105 and 108 →		

MOTOR CARRIER NO.

Current Liabilities		Balance close of 2001 (a)	Balance start of 2001 (b)
110	Accounts payable – Accounts payable within one year. Accounts owed to others for goods and services bought on credit.		
111	Notes payable – Promissory notes payable within one year. Include payables to affiliated companies and matured obligations.		
112	Taxes payable – Taxes payable within one year (accrued taxes, deferred income tax credits).		
113	Current portion of long-term debt – Long term debt that is due within one year (bonds, equipment obligations, lease obligations, etc.).		
114	Other current liabilities – Report all other liabilities due within one year not included above (unclaimed wages, accrued bonuses, vacation pay, etc.).		
115	Total current liabilities – Sum of lines 110 through 114 →		

Long-term Liabilities

116	Long-term debt – All debt and advances payable due after one year (all types of bonds, mortgages, notes, advances, etc., outstanding with more than one year of payments remaining).		
117	Other long-term liabilities – Include deferred tax credits and any other deferred credits or liabilities of more than one year in duration.		
118	Total long-term liabilities – Sum of lines 116 and 117 →		
119	TOTAL LIABILITIES – Sum of lines 115 and 118 →		

Owners' Equity or Capital

120	Retained earnings (if corporation) – That part of net profit that is kept for use in the business (instead of distributed to the owners).		
121	Equity and other capital (if corporation) – Include common and preferred capital stock plus additional paid-in capital. Subtract Treasury Stock.		
122	Proprietary or partnership capital (if not a corporation) – Investments of a sole proprietor or partners in an unincorporated entity.		
123	Total owners' equity or capital Sum of lines 120 through 122 →		
124	TOTAL LIABILITIES AND EQUITY Sum of lines 119 and 123 →		

Schedule 200 — Income Statement

MOTOR CARRIER NO.

Operating Revenues		Amount for 2001
201	Freight operating revenue – intercity – Revenue from the transportation of property by motor vehicles. Include revenue from common and contract carriage. Include revenue from your portion of interline shipments. Exclude revenue from household goods, compensated intercorporate hauling, and private carriage.	
202	Freight operating revenue – local – Revenue from local freight carriage. Exclude revenue from Household Goods operations.	
203	Household goods carrier operating revenue – Revenue from intercity common and contract carriage of household goods. Include local household goods revenue. Exclude revenue from noncarrier activities such as packing and warehousing.	
204	Other operating revenue – Operating revenue not shown above. Include revenue from furnishing vehicles with drivers to other common or contract carriers under lease or similar arrangement. Include revenue received from the lease of your operating rights. Include compensated intercorporate hauling and private carriage. Include commissions for brokerage services, commissions for making payroll deductions, operations of lunch rooms, restaurants, etc.	
205	Total operating revenue – Sum of lines 201 through 204 →	

Wages and Salaries

Report gross earnings paid to employees prior to such deductions as employees' Social Security contributions, withholding taxes, group insurance premiums, union dues, savings bonds, etc. Include all miscellaneous paid time off, etc.

206	Driver and helper wages (W-2 employees) – Exclude 1099 owner-operator driver compensation, which are included in equipment rentals with drivers (line 226).	
207	Cargo handler wages	
208	Officer, supervisor, administrative, and clerical wages and salaries	
209	Other wages and salaries	
210	Fringe benefits – Include Federal, state, and local payroll taxes, workers' compensation, group insurance, pension and retirement plans, and other fringe benefits. Include all fringe benefits, whether required by law or not.	
211	Commission agent fees (HHG only) – Booking commissions paid to agents.	
212	Total wages, salaries, and fringe benefits – Sum of lines 206 through 211 →	

Operating Supplies

213	Fuel, oil, and lubricants – Include cost of gas, propane, diesel, motor oil, grease, lubricants, and coolants used by revenue vehicles, terminal vehicles, and maintenance vehicles. Exclude taxes for fuel, which are reported separately.	
214	Outside maintenance – Maintenance performed by outside vendors. Include total amount paid on invoice – with taxes.	
215	Vehicle parts – Cost of parts used to repair vehicles. Exclude tires and tubes.	
216	Tires and tubes – Cost of tires and tubes for vehicles. (Retread charges and taxes, etc.)	
217	Other operating supplies – Other operating supplies and expenses used in the operations of vehicles, terminals, and shops.	
218	Total operating supplies – Sum of lines 213 through 217 →	

MOTOR CARRIER NO.

Amount for
2001

Insurance Expenses

219	Cargo loss and damage premiums and claims paid – Net cost of commercial insurance to protect the carrier against liability for claims resulting from loss or damage to, or delay of, property being moved or stored by carrier. Include claims paid.	
220	Liability and property damage premiums and claims paid – Cost of commercial insurance to protect carrier from liability due to deaths or injuries to non-employees and damage to other property caused by carrier's equipment. Include claims paid.	
221	Other insurance expenses – Commercial insurance for fire, theft, floods, etc. Include insurance for buildings, offices, structures, machinery, etc. Exclude any insurance cost included in fringe benefits, such as worker's compensation.	
222	Total insurance expenses – Sum of lines 219 through 221 →	

Miscellaneous Expenses

223	Fuel taxes – Federal and state taxes on gas, diesel, and oil consumed by revenue vehicles and terminal or maintenance activities.	
224	Operating taxes and licenses (except fuel taxes) – Include Federal, state, and local operating taxes, license and registration fees, tolls, other vehicle use taxes, and real estate and personal property taxes. Exclude income, payroll, sales and other taxes collected from customers.	
225	Depreciation and amortization charges – Depreciation and amortization expenses of revenue equipment, building and improvements, and all other property. Include depreciation on assets rented or leased to others by you under an operating lease agreement. Include depreciation on assets owned and used by your firm within leaseholds, and assets obtained through capital lease agreements. Exclude depreciation on intangible assets and assets leased to others by you under a capital lease agreement.	
226	Equipment rentals – with drivers – Amounts payable to others for the use of revenue vehicles where vehicle and driver are under control of carrier. Include monies paid to 1099 independent contractors. Exclude wages paid to W-2 drivers which are reported separately.	
227	Equipment rentals – without drivers – Amounts payable to others for the use of revenue vehicles where vehicle is under control of carrier. Include compensation for use of owner operator vehicles when driver services are paid separately.	
228	Equipment rentals – agents (HHG Only) – Amounts payable to agents for moving and transportation costs related to household goods operations. Exclude commission agent fees, which are reported separately.	
229	Purchased transportation – Cost of purchased transportation when the hauling carrier retains control of the vehicle and driver. Include payments for the transportation of individual shipments and partial loads in the vehicles of another carrier (interlining), and payments to railroads, water carriers, airline, and others for the transportation of your company's loaded or empty motor vehicles and containers. Include payments for the delivery of small shipments by parcel, courier, or expedited services. Exclude 1099 independent contractor compensation which is reported separately.	
230	Communications and utilities – Cost of communications services plus taxes (long distance communications, fax services, telephone equipment, etc.).	
231	Other operating expenses – Include building rents and office equipment rents, gain (loss) on disposal of operating assets, etc. Exclude interest on loans, sales taxes, and other taxes collected directly from customers and paid directly to a taxing authority.	
232	Total miscellaneous expenses – Sum of lines 223 through 231 →	
233	TOTAL OPERATING EXPENSES – Sum of lines 212, 218, 222, and 232 →	

MOTOR CARRIER NO.

**Amount for
2001**

Net Income (Loss) Calculation

234	Net operating income (loss) – Line 205 minus 233	
235	Non-operating revenue – Revenue from non-carrier operations. Include revenue from the lease of a distinct operating unit and household goods packing and warehousing revenue. Include gains on sale, trade in, retiring of equipment. Include interest and dividend income.	
236	Non-operating expenses – Expenses from non-carrier operations. Include household goods packing and warehousing expenses. Include losses on sale, trade in, retiring of equipment.	
237	Interest expenses – Interest and amortization of debt discount expense and premium.	
238	Ordinary income (loss) before taxes – Line 234 plus (lines 235 minus 236 minus 237) →	
239	Total provision for income taxes – Accruals for Federal, state, or other income taxes applicable to ordinary income.	
240	Ordinary income (loss) after taxes – Line 238 minus 239 →	
241	Extraordinary items, effect of accounting changes, and other items – Include items that are unusual in nature and infrequent in occurrence.	
242	NET INCOME (LOSS) Line 240 minus 241 →	

Schedule 300 — Operating Statistics

Operating Statistics (all carriers) –
Report statistics for carrier’s owned and leased power units, equipment rentals with and without drivers, equipment rentals – agents, and purchased transportation. Include statistics from common and contract carriage and your portion of interline shipments. Exclude statistics from local, compensated intercorporate, and private carriage.

		General Freight Only		Total (c)
		(LTL) up to 10,000 lbs. (a)	(TL) 10,000 lbs. and over (b)	
301	Miles – intercity – Report total miles operated, both loaded and empty, in intercity service. This line should equal the sum of lines 302 and 303.			
302	Miles: highway			
303	Miles: rail, water, and air			
304	Tons – intercity – Use estimates if necessary.			
305	Total shipment carried - intercity			
306	Revenue – intercity (including HHG) – This line will equal line 201 plus the intercity portion of line 203.			
307	*Ton-miles – intercity			

***How to calculate ton-miles:** **Method 1** – Multiply the distance of each movement by the weight in tons to get ton-miles for individual shipments. Sum all ton-miles for individual shipments to get total ton-miles.
Method 2 – Compute the average length of haul (total miles/total shipments) for your operations. Then multiply this average haul by the total number of actual tons transported in intercity service. (Multiplying the total tons of all movements by the total miles of all movements produces an erroneous result and should not be used.)

MOTOR CARRIER NO.

**Operating Statistics
(household goods carriers only)**

		Revenue (intercity common & contract carriage) (a)	Tons (actual weight) (b)	Number of shipments (c)
308	Personal effects and property used or to be used in a dwelling			
309	Furniture, fixtures, equipment, and the property of stores, offices, etc.			
310	Articles of an unusual nature or value (objects of art, etc.)			
311	Total →			

Schedule 400 — Revenue Equipment

Report all operating equipment owned or leased under a capital lease. Exclude rented vehicles. Include vehicles used in terminals, maintenance facilities, intercity highway, & storage.

	Number of units at start of year (a)	Units acquired during the year		Number of units retired/ disposed of during the year (d)	Number of units at end of year (e)
		Number (b)	Cost (c)		
401	Straight trucks - owned				
402	Straight trucks - leased				
403	Truck-tractors - owned				
404	Truck-tractors - leased				
405	Trailers and semi-trailers - owned				
406	Trailers and semi-trailers - leased				
407	Other revenue equipment				
408	Total revenue equipment →				

MOTOR CARRIER NO.

Schedule 500 — Employment Information

Include W-2 employees. Exclude 1099 independent contractors.

Average: (number at beginning of year + number at end of the year) divided by 2, or use an average Full Time Equivalent calculation.

Total compensation: Include all wages, salaries, and miscellaneous paid time off. Exclude fringe benefits. Should equal figures in lines 206 through 209.

Hours earned/miles operated: Estimate the total hours/miles included in total compensation.

		Average number of employees (a)	Total compensation (b)	Hours earned or miles operated (c)
501	Drivers and Helpers – hourly basis			Hours
502	Drivers and Helpers – mileage basis			Miles
503	Drivers and Helpers – other basis – Drivers and Helpers not reported above.			
504	Cargo handlers			Hours
505	Officers, supervisors, administrative, and clerical			
506	Other labor – Average number of other employees (include vehicle repair, etc.)			
507	Total employment – <i>Sum of lines 501 through 506</i> →			

Drivers

Number at close of 2001

508	CDL drivers – All drivers that hold a valid CDL license.	
509	Non-CDL drivers – Indicate the number of non-CDL drivers on payroll.	
510	Total drivers – <i>Sum of lines 508 and 509</i> →	

Certification – I hereby certify that this report was prepared by me or under my supervision, that I have examined it, and that the items herein reported on the basis of my knowledge are correctly shown.

Name	Signature
Title	Date

Return the completed form to:

BUREAU OF TRANSPORTATION STATISTICS
U.S. DEPARTMENT OF TRANSPORTATION
c/o VISTRONIX, INC.
1970 CHAIN BRIDGE ROAD, SUITE 1200
MCLEAN, VA 22102

Phone: (202) 366-4383
Fax: (703) 749-8480
Email: mcs@bts.gov
Web site: www.bts.gov/mcs

U.S. Department of Transportation
Bureau of Transportation Statistics**Class I — Motor Carriers of
Property and Household Goods****2002
Quarterly Report**QUARTER – *Mark (X) ONE*1 2 3 4

IDENTIFICATION

MOTOR CARRIER NO.		U.S. DOT NO.	
<input type="text"/>		<input type="text"/>	
Name of Company			
Trade or Doing Business As:			
Street Address			
City	State	ZIP Code	Telephone No. (Include Area code) ()

CONTACT (for purposes of this report)

Contact name	Title	Telephone No. (Include Area code) ()
--------------	-------	---

MAILING ADDRESS (if different from above)

Mailing Address		
City	State	ZIP Code

AFFILIATED
COMPANIES:

Name	MC number (if any)	U.S. DOT number (if any)
Parent		
Affiliates		

— GENERAL INSTRUCTIONS —

- Use Generally Accepted Accounting Principles (GAAP)
- Report dollar values in whole dollars.
- Respond to each item. Use "0," "none," or "not applicable" as appropriate.
- Explain any unusual items, such as large differences between figures reported in the current report and those for the preceding report.
- Use parentheses to indicate negative numbers.

Operating Revenues

1. Freight operating revenue – intercity	\$
2. Household goods carrier operating revenue	\$
3. Other operating revenue	\$
4. Total Operating Revenue (Sum of lines 1 through 3)	\$

Operating Expenses

5. Freight operating expenses	\$
6. Household goods carrier operating expenses	\$
7. Total Operating Expenses (Sum of lines 5 and 6)	\$

Net Income (Loss) Calculation

8. Net Operating Income (Loss) (Line 4 minus line 7)	\$
9. Net Non-Operating Income (Loss)	\$
10. Interest expenses - show as a positive number	\$
11. Ordinary income (loss) before taxes (Sum of lines 8 and 9 minus line 10)	\$
12. Total provision for income taxes, extraordinary items, effect of accounting changes, and other items	\$
13. Net Income (Loss) (Line 11 minus line 12)	\$

Operating Statistics (all carriers)

14. Miles – intercity: highway	
15. Miles – intercity: rail, water, and air	
16. Tons – intercity	
17. Total freight bills (shipments and/or loads) – intercity	

Certification – I hereby certify that this report was prepared by me or under my supervision, that I have examined it, and that the items herein reported on the basis of my knowledge are correctly shown.

Name	Signature
Title	Date

Return the completed form to:

BUREAU OF TRANSPORTATION STATISTICS
 U.S. DEPARTMENT OF TRANSPORTATION
 OFFICE OF MOTOR CARRIER INFORMATION
 c/o VISTRONIX, INC.
 1970 CHAIN BRIDGE ROAD SUITE 1200
 MCLEAN, VA 22102

Phone: (202) 366-4383
 Fax: (703) 749-8480
 Email: mcs@bts.gov
 Web site: www.bts.gov/mcs

MP-1

Quarterly and annual report to the
Federal Motor Carrier Safety Administration

Approved by OMB: 2126-0031
Expires: 9-30-2009

Quarterly and Annual Report Form Motor Carriers of Passengers

Calendar / Fiscal Year

Carrier name and address

MC Number: _____

1. _____ Period covered (check one):

- | | | | | |
|-----------------------|-----------------------|-----------------------|-----------------------|-----------------------|
| 1 | 2 | 3 | 4 | A |
| <input type="radio"/> | <input type="radio"/> | <input type="radio"/> | <input type="radio"/> | <input type="radio"/> |

2. Type of operation based on major sources of revenues (check one):

- Regular route service
- Charter service

3. If respondent is a consolidated group, list and describe all entities making up the consolidation.

4. If a merger, consolidation, or change in the company or consolidated group occurred during the year, please describe.

Instructions - please see the following page for instructions and footnotes on individual items.

Respondent only

Consolidated

5. Number of Passengers:

(a) Intercity regular route

_____	_____
-------	-------

(b) Charter or special

_____	_____
-------	-------

(c) Local or commuter

_____	_____
-------	-------

(d) Total passengers

_____	_____
-------	-------

6. Revenue:

(a) Intercity regular route	_____	_____
(b) Charter or special	_____	_____
(c) Local or suburban	_____	_____
(d) Express and other revenue	_____	_____
(e) Total operating revenue	_____	_____
7. Total Operating Expenses	_____	_____
8. Net Operating Income (Loss)	_____	_____
9. Other Income (Deductions)	_____	_____
10. Extraordinary Items, Net of Taxes	_____	_____
11. Total Provision for Income Taxes	_____	_____
12. Net Income (Loss)	_____	_____
13. Total Assets	_____	_____
14. Total Liabilities	_____	_____
15. Shareholders' Equity	_____	_____
16. Operating Ratio	_____	_____

Certification:

I certify that this form was prepared by me or under my supervision, that I have examined it, and that the items reported on the basis of my knowledge and belief are correctly shown.

Your name (print or type)

Official title

Address

City, State, Zip

Telephone No. (including area code)

Signature

Date



FMCSA

Federal Motor Carrier
Safety Administration

Registration Options

Welcome to the online site for making sure that your Motor Carrier operation (truck and passenger carrier) is properly registered with the Federal Motor Carrier Safety Administration. Whether you need to register with us or make an update to an existing record, this site will help you get the job done.

All electronic transactions will require a valid credit card (American Express, Discover, Master Card, Visa.)

New or Additional Registration



I think I need to register with the FMCSA to get a USDOT number, Operating Authority (MC/FF/MX number), or CT number (Cargo Tank Facility).
(If you're not sure, select this option, then "Continue" and the system will let you know).

Continue Filling Out Registration



Use your registration tracking number and Personal Identifier (PIN) to continue filling in your registration (one of the following forms: MCS-150, MCS-150A, MCS-150B, OP-1, OP-1(P), OP-1(FF), CT Registration, or update Operating Authority (MC/FF/MX number)).



Use your registration tracking number and Personal Identifier (PIN) to continue filling in your Form OP-2 application (commercial zone, Mexico domiciled).

Existing Registration Updates



I need to update my USDOT number registration information or file my biennial update.



I need to update my MCS-150B / HM Safety Permit.

I was registered with the FMCSA and now want to restart my business by:



a. Reapplying for a USDOT number after revocation



b. Requesting that my Operating Authority (MC/FF/MX number) be reinstated



I want to update my Cargo Tank Facility registration statement information.

I want to notify the FMCSA that I am no longer in business



Inactivate my USDOT number

Other



I want to request a copy of a document.

The following Existing Registration Update transactions cannot be made using this system:

- Operating Authority (MC/FF/MX number) Name changes
- Operating Authority (MC/FF/MX number) Address changes
- Operating Authority (MC/FF/MX number) Transfers
- Operating Authority (MC/FF/MX number) Voluntary Revocations

Please contact FMCSA <http://www.safersys.org/POCs.aspx> if you need additional information or help.

Continue

Certificate For Mexico-Domiciled Carriers To Operate In the U.S. Commercial Zones

Mexico-Domiciled Motor Carrier Operations within U.S. Municipalities and Commercial Zones on the U.S./Mexico Border

Provisional certificate of registration means the registration under 49 CFR section 368.6 that the FMCSA grants to a Mexico-domiciled motor carrier to provide interstate transportation of property within the United States solely within the municipalities along the United States-Mexico border and the commercial zones of such municipalities. It is provisional because it will be revoked if the registrant does not demonstrate that it is exercising basic safety management controls during the safety monitoring period.

Provisional operating authority means the registration under 49 CFR section 365.507 that the FMCSA grants to a Mexico-domiciled motor carrier to provide interstate transportation within the United States beyond the municipalities along the United States-Mexico border and the commercial zones of such municipalities. It is provisional because it will be revoked if the registrant is not assigned a satisfactory safety rating following a compliance review conducted during the safety monitoring period.

Process for Obtaining a Certificate of Registration

This process applies to Mexico-domiciled motor carriers who wish to register to operate only in the municipalities in the United States on the U.S./Mexico border or within the commercial zones of such municipalities. It also applies to Mexico-domiciled motor carriers that currently hold a Certificate of Registration from the former Interstate Commerce Commission, the Federal Highway Administration, the Office of Motor Carrier Safety or the FMCSA.

■ The process for obtaining a Certificate of Registration is comprised of three sub-processes:

- The application process
- The safety audit
- The performance monitoring

Application Process

The application process represents the first phase in a carrier's efforts to obtain a Certificate of Registration to operate within the border commercial zones. To successfully complete the application process, a carrier must correctly complete and file the OP-2 application package, accompanied by an application fee.

An OP-2 Application package can be obtained by:

- Calling FMCSA's information line at (800) 832-5660 to have an application mailed
- Visiting the FMCSA web site at www.fmcsa.dot.gov/registration-licensing/print-forms/print-forms.htm

Completing the Application

- The application package is printed in English and Spanish, but the carrier's response must be written in English. It is very important that the carrier provides all required information and completes the application in its entirety before mailing it back. Applications with missing information or fees will be returned to the carrier. Information provided on the application will be checked against a variety of U.S. and Mexican databases to ensure that the carrier is eligible for a Certificate of Registration.



Filing the Application:

- ▶ Motor Carrier Identification Report (MCS-150) – A completed and signed Form MCS-150. The MCS-150 provides basic information about the carrier's operation necessary to maintain FMCSA's carrier census database.
- ▶ Designation of Agents for Process (Form BOC-3) – A carrier must provide a signed and dated Form BOC-3, Designation of Agents for Service of Process, or use a process service agent who will electronically file the BOC-3 within 90 days. The BOC-3 form must show the street addresses for the person(s) designated as the agent(s) for serving notices of enforcement action. A process agent must be designated in each state in which the applicant may operate. The applicant may not begin operations unless the Form BOC-3 has been filed with the FMCSA.
- ▶ Filing Fee – Except for those carriers that have already paid the fee, a filing fee of \$300 for each type of registration requested (e.g. contract, common or household goods) payable in U.S. dollars on a U.S. bank to the FMCSA by means of check, money order, or credit card must accompany the application.

- The completed application, fee, and above mentioned documents should be sent to:

Federal Motor Carrier Safety Administration
MC-RIO
1200 New Jersey Avenue, SE
Washington, DC 20590

Proof of Insurance

The applicant does not have to submit evidence of insurance with the application. However, if the applicant is issued a Certificate of Registration, the following must be on each of its vehicles when crossing the border:

- ▶ A current DOT Form MCS-90
- ▶ Evidence of Insurance: The evidence of insurance must show either trip insurance coverage (24 hours or more coverage), or evidence of continuing insurance

Approval

Applicants that have fully met the requirements for completing their OP-2 applications will be notified in writing by FMCSA that their application has been approved. The Carrier will also receive:

- A provisional certificate of Registration that allows the carrier to operate in the commercial zones for a period of 18 months
- A U.S. DOT number

■ Operating with a Provisional Certificate of Registration

FMCSA has implemented a safety monitoring system to help determine whether Mexico-domiciled carriers conducting operations between points in Mexico and the border commercial zones comply with the applicable safety regulations and conduct safe operations. The safety audit and performance monitoring are the primary components of safety monitoring.

Safety Audit

All Mexico-domiciled carriers seeking a permanent Certificate of Registration to operate in the border commercial zones must undergo and pass an FMCSA-conducted safety audit. The safety audit consists of a review of the carrier's safety data, a review of requested motor carrier documents, and an interview session with the motor carrier's safety official by a trained safety auditor. The following steps describe this aspect of the application process.

Preparing for the Safety Audit

Mexico-domiciled carriers seeking a permanent Certificate of Registration to operate in the border commercial zones must receive and pass an FMCSA Safety Audit within the 18-month provisional period. FMCSA recommends that a Mexico-domiciled carrier obtain FMCSA's Educational and Technical Assistance package on the internet at: <http://www.fmcsa.dot.gov/safety-security/eta/index.htm> (English) or www.fmcsa.dot.gov/espanol/english/eta_index.htm (Spanish).



Objective of Safety Audit

The objective of the safety audit is to both educate the carrier on compliance with the FMCSRs and HMRs and to determine areas where the carrier might be deficient in terms of compliance. The safety auditor will use a series of questions regarding the carrier's safety management practices and safety performance to ensure that all applicable acute and critical areas of the FMCSRs and HMRs are addressed. Areas covered include the qualification of drivers, driving a motor vehicle, hours of service, inspection, repair, and maintenance, transporting and marking hazardous materials, controlled substance and alcohol use and testing, commercial driver's license standards, and financial responsibility. At the end of the audit, the carrier will receive a report listing any deficiencies that may have been found along with recommendations for correcting those deficiencies. FMCSA will notify the carrier of the results of the audit (Pass or Fail) within 45 days after completion of the audit.

Passing the Audit

If the safety audit reveals that the carrier is in compliance with the FMCSRs and has basic safety management controls in place that are functioning adequately, the carrier will receive a passing score. The Mexico-domiciled carrier's provisional Certificate of Registration will remain in place and its performance will be closely monitored by the FMCSA until the end of the 18-month period.

Failing the Audit

If a carrier fails the audit due to severe safety problems, the lack of adequate safety management controls, and/or non-compliance with the FMCSRs, FMCSA will notify the carrier that it will suspend its registration effective 15 days after the service date of the notice unless the carrier demonstrates, within 10 days, that the safety audit contained material error. If the carrier fails to show a material error in the safety audit, FMCSA will then issue an Order suspending the carrier's provisional Certificate of Registration and notify the carrier that unless it presents evidence of necessary corrective action within 30 days from the service date of the Order, the carrier's provisional Certificate of Registration would be revoked.

■ Safety Monitoring System for Mexico-Domiciled Carriers

Safety Monitoring System (385.103)

- Each Mexico-domiciled carrier operating in the United States will be subject to an oversight program to monitor its compliance with applicable Federal Motor Carrier Safety Regulations (FMCSRs), Federal Motor Vehicle Safety Standards (FMVSSs), and Hazardous Materials Regulations (HMRs).
- Each Mexico-domiciled carrier granted provisional operating authority must have on every commercial motor vehicle it operates in the United States a current decal attesting to a satisfactory inspection by a Commercial Vehicle Safety Alliance (CVSA) inspector.
- The FMCSA will conduct a safety audit on a Mexico-domiciled carrier within 18 months after the FMCSA issues the carrier a provisional Certificate of Registration.
- The FMCSA will conduct a compliance review on a Mexico-domiciled carrier within 18 months after the FMCSA issues the carrier provisional operating authority.

Each Mexico-domiciled carrier that receives provisional operating authority or a provisional Certificate of Registration will be subject to intensified monitoring through frequent roadside inspections.

Roadside Performance Monitoring

During the 18-month period following issuance of a provisional Certificate of Registration or provisional Operating Authority, the FMCSA will track and assess the safety performance of Mexico-domiciled carriers on U.S. highways through a comprehensive roadside performance monitoring system. The major aspects of that system are presented below.

Expedited Action (385.105)

A Mexico-domiciled motor carrier committing any 49 CFR section 385.105 violations identified through roadside inspections or by any other means, may be subjected to an expedited safety audit or compliance review, or may be required to submit a written response demonstrating corrective action:

- Using drivers not possessing, or operating without a valid Commercial Driver's License (CDL) or Licencia Federal de Conductor (LF);
- Operating vehicles that have been placed out-of-service (OOS) for Commercial Vehicle Safety Alliance (CVSA) OOS violations without making the required repairs;
- Involvement in, due to carrier act or omission, a hazardous materials (HM) incident within the U.S. involving highway route controlled quantity of certain HM;
- Involvement in, due to carrier act or omission, two or more hazardous materials incidents within the U.S.;
- Using a driver who tests positive for drugs or alcohol or who refuses to submit to required drug or alcohol tests;
- Operating within the U.S. a motor vehicle that is not insured as required by 49 CFR Part 387;
- Having a driver or vehicle OOS rate of at least 50% based upon three inspections within a consecutive 90-day period.

Failure to respond to an agency demand for a written response demonstrating corrective action within 30 days will result in the suspension of the carrier's provisional operating authority or provisional Certificate of Registration until the required showing of corrective action is submitted to the FMCSA.

A satisfactory response to a written demand for corrective action does not excuse a carrier from the requirement that it undergo a safety audit or compliance review, as appropriate, during the provisional registration period.

Operating With a Permanent Operating Authority or a Permanent Certificate of Registration

Mexico-domiciled carriers that demonstrate acceptable levels of safety performance and pass the safety audit will be notified that their operating authority or Certificate of Registration has become permanent at the end of the 18-month provisional period. Once Mexico-domiciled carriers have been issued their operating authority or permanent Certificates of Registration, they will be subject to the same safety requirements and operational procedures applied to U.S. and Canadian carriers.

