



Inside IAQ

EPA's Indoor Air Quality Research Update

COST ANALYSIS OF VOC AIR CLEANERS: ACTIVATED CARBON VS. PHOTOCATALYTIC OXIDATION

Historically, gaseous air cleaners for removing volatile organic compounds (VOCs) from indoor air have been utilized only infrequently. In such cases, the most common technology is adsorption on granular activated carbon (GAC). Common concerns about GAC air cleaners are: 1) they are generally not designed and operated to handle spikes in the airborne VOC concentrations, so that they become overloaded by spikes and may thus serve to shave the peaks rather than to actually reduce cumulative occupant exposure; and 2) the sorbed organics remain on the carbon, and thus still must be disposed of in some manner.

Photocatalytic oxidation (PCO) might be considered an alternative to GAC for VOC air cleaners. PCO should destroy the organics, so that the need for subsequent disposal would be eliminated. However, PCO is a developmental process, with insufficient kinetic data to demonstrate its ability to completely and economically destroy the full range of organic compounds that can be found in the indoor environment at relatively low concentrations, without producing organic intermediates in the off-gas. There are no successful commercial demonstrations of PCO reactors for this application, and only limited consideration of practical reactor designs.

To assess the economic potential of PCO, a comparison was made of the capital and annual costs for two indoor air cleaners based on GAC vs. PCO technology. Both air cleaners were assumed to be challenged with a steady inlet VOC concentration of 1 ppmv.

The GAC estimates are based on one commercially available unit (see Figure 1). Equipment and carbon replacement costs were obtained from the manufacturer. Installation and incremental air handler costs were derived using R. S. Means Mechanical Cost Data. Energy cost impacts were computed using the DOE-2 building energy model. Carbon replacement frequency (every 2 months) was estimated based upon independent data.

The PCO estimates were based on one possible generic reactor configuration (see Figure 2). The reactor is assumed to be a packed bed with an enhanced titanium dioxide (TiO₂) photocatalyst deposited on suitable supports [transparent to ultraviolet (UV) radiation], irradiated by

COMING!
July 21-23, 1997
Engineering Solutions to Indoor Air Quality Problems Symposium
(See page 12 for announcement)

In This Issue	Page
Cost Analysis of VOC Air Cleaners: Activated Carbon vs. Photocatalytic Oxidation	1
Evaluation of VOC Emissions from an Alkyd Paint	4
Glossary of Acronyms	5
Reducing Solvent and Propellant Emissions from Consumer Products	6
Possible Role of Radon Reduction Systems in Combustion Product Spillage	8
Summaries of Recent Publications	9
Symposium Announcement	12

Inside IAQ is distributed twice a year and highlights indoor air quality (IAQ) research conducted by EPA's National Risk Management Laboratory's (NRMRL) Indoor Environment Management Branch (IEMB). If you would like to be added to or removed from the mailing list, please mail, fax, or e-mail your name and address to:

Inside IAQ
Att. Kelly Leovic (MD-54)
U.S. EPA
Research Triangle Park, NC 27711
Fax: 919-541-2157
E-mail: kleovic@engineer.aeerl.epa.gov

a suitable UV source. This is one of several generic reactor designs considered in the literature. The reactor is assumed to operate at 40°C, necessitating the recuperative heat exchanger configuration shown in the Figure 2.

Best-case assumptions were used for the PCO reactor design and operation to provide what might be an optimistic estimate of PCO costs. The reaction rate for oxidation of the range of VOCs present in the inlet was assumed to be 4×10^6 g of catalyst per gmol/sec of VOC feed. This represents perhaps the fastest kinetics for the most reactive individual organic compounds reported in the literature with effective irradiation. In practice, with the range of (probably less reactive) organics that will be present, the kinetics would be poorer. Also, it was assumed (based on essentially no data) that the catalyst bed will have to be regenerated every 4 months, and replaced every 5 years. These assumptions are probably optimistic, especially at the relatively low operating temperature.

The equipment and installation costs for the reactor and other components in Figure 2 – also including the costs of a larger air handler – were judiciously estimated using the Means data, the W. W. Grainger Catalog, and heating, ventilating, and air-conditioning (HVAC) texts. Catalyst costs were developed based upon contacts with specialty catalyst manufacturers (including Degussa Corp., a major TiO₂ photocatalyst vendor), and are felt to be reasonably good. System pressure drops were estimated using Perry's Chemical Engineers' Handbook. Total building energy cost impacts were computed using the DOE-2 model.

The results of this cost analysis are presented in Table 1, in terms of \$ (or \$/year) per 1,000 ft³/min (MCFM) of air throughput. As shown, the installed cost of the PCO system is about 10 times that of the GAC. This due to the high costs of the PCO reactor (about three-quarters of which is associated with the UV-related electrical equipment), the initial catalyst charge, the recuperative heat exchanger, and the added ducting.

But the annual cost of the PCO system is only about 2 times that of the GAC. The difference is reduced to a factor of 2 because the GAC carbon is assumed to have to be replaced 6 times per year, whereas the PCO catalyst is optimistically assumed to be replaced only once every 5 years.

(Continued on Page 3)

Table 1. Summary Cost Comparison of GAC Versus PCO for VOC Control in Indoor Air

Cost Item Equipment and Installation Costs (\$/MCFM)	Cost (\$/MCFM or \$/yr/MCFM)	
	Activated Carbon	Photo- catalytic
Reactor (excluding carbon/catalyst)	\$ 530	\$ 3,300
Initial carbon/catalyst charge	240	3,400
Duct heater and controls	--	600
Air-to-air heat exchanger	--	2,600
Enlarged central air handler (increased static pressure)	40	150
Additional ducting, elbows, dampers, etc.	370	2,000
TOTAL INCREMENTAL INSTALLED COSTS	\$ 1,180	\$ 12,050
Total Annual Costs (\$/yr/MCFM)		
<i>Operating</i> Electricity cost (increased HVAC cooling load and fan static pressure, power for photocatalytic reactor)	\$ 50	\$ 1,150
<i>Maintenance</i> Regeneration of catalyst	--	650
Replacement of UV bulbs	--	500
Replacement of carbon	2,170	--
<i>Capital Charges</i> Catalyst depreciation (5 yr straight)	--	750
Equipment depreciation (10 yr straight)	120	850
Interest, taxes, insurance	70	750
TOTAL INCREMENTAL ANNUAL COST	\$ 2,410	\$ 4,650

Even with the optimistic assumptions used for the PCO system, the PCO reactor configuration used here is estimated to cost significantly more than GAC for this application. To reduce costs, the developers of photocatalytic processes must: 1) demonstrate improved catalysts offering faster reaction rates and longer lifetimes at ambient reaction temperatures; and 2) develop improved reactor designs that provide greater exposed catalyst surface per unit volume, improved catalyst irradiation, and reduced pressure drop.

If PCO systems are more expensive to install and operate than GAC systems, it is critical that commercial-scale PCO reactors be demonstrated to reliably achieve consistently high destruction of a wide array of organic compounds without the appearance of intermediate oxidation products in the off-gas. To justify the higher cost, PCO units must be able to handle the VOC spikes that cause overloading of GAC units. (EPA Contact: Bruce Henschel, 919-541-4112, bhenschel@engineer.aeeri.epa.gov)

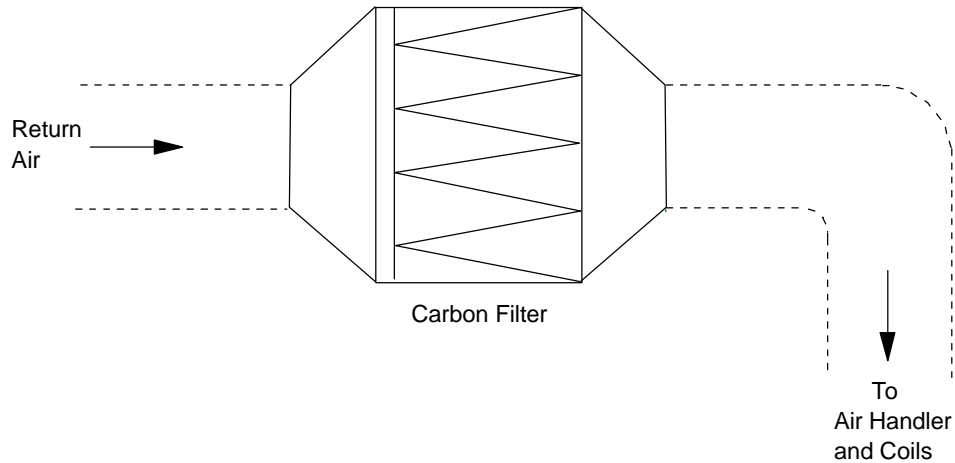

Figure 1. Granular Activated Carbon VOC Air Cleaner
(Equipment added as part of VOC air cleaner shown with solid lines)

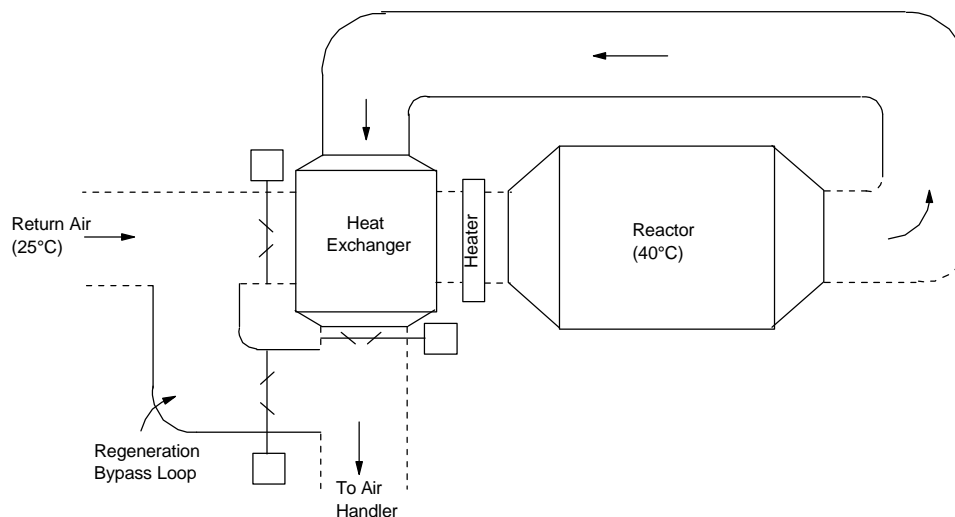

Figure 2. Photocatalytic Oxidation VOC Air Cleaner
(Equipment added as part of VOC air cleaner shown with solid lines)

EVALUATION OF VOC EMISSIONS FROM AN ALKYD PAINT

Despite increased use of latex paints indoors in the past few decades, large quantities of alkyd paints continue to be used. Alkyd paints are of concern because they normally contain high percentages of organic solvents. As a result, use of alkyd paints in indoor environments may result in exposure of building occupants to volatile organic compounds (VOCs) emitted as the paint dries.

A primer and an alkyd semigloss paint produced by a major U.S. paint manufacturer were selected for IEMB's current source characterization research. The objectives of the research include: 1) determining VOC emission rates and patterns; 2) measuring specific emission profiles and peak concentrations of C-9 aromatics, alkanes, and other major VOCs emitted; 3) developing source emission models, with emphasis on the fundamental mass transfer models; 4) determining the effects of indoor sinks on exposure risk to alkyd paint VOCs; 5) comparing total VOC (TVOC) emission profiles measured in small chambers, a large chamber, and the EPA test house; and 6) evaluating source management options and demonstrating the effectiveness of selected options.

Table 2 shows the volatile contents and densities of the primer and the alkyd paint as determined by EPA Method 24, "Determination of Volatile Matter Content, Water Content, Density, Volume of Solids, and Weight of Solids of Surface Coatings." Table 3 shows the content of VOCs in the test products determined by the proposed EPA Method 311, "Analysis of Hazardous Air Pollutant Compounds in Paints and Coatings by Direct Injection into a Gas Chromatograph." Decane and undecane are the most abundant components in the primer and paint, respectively, indicating that the primer is more volatile than the paint.

For this study, small chamber tests were conducted using a yellow pine board as the substrate to characterize VOC emissions. The pine board was purchased locally and cut into 16 by 16 cm pieces. The exposed edges of the board were sealed with sodium silicate solution. The primer was applied to one side of the board with a 10 cm paint roller, and then the board was placed in the chamber for VOC emission measurements. After 1.14 hours, the board was taken out of the chamber and 2.67 g of the alkyd paint was applied as a topcoat to the side of the board already painted with the primer. The painted board was returned to the chamber for additional VOC emission measurements.

The measured TVOC concentration profiles are shown in Figure 3. A mass balance indicated that almost all the VOCs were emitted within the 20 hour test period. The measured TVOC concentration profiles were simulated by using a mass transfer model developed by EPA:

$$dC/dt = L \cdot k \cdot (C_v \cdot M/M_o - C) \cdot N \cdot C$$

$$dM/dt = -k \cdot (C_v \cdot M/M_o - C)$$

where

C = chamber concentration, mg/m³;

t = time, h;

L = loading factor (0.48), m⁻¹;

k = mass transfer coefficient, m/h;

C_v = total concentration for TVOC, mg/m³;

M = TVOC mass remaining in the source, mg/m²;

M_o = TVOC mass applied, mg/m²; and

N = air exchange rate (0.525), h⁻¹.

The initial condition was t=0, C = 0, and M = M_o. The value of mass transfer coefficient, k, was 6 m/h as determined previously in the 53-L chamber. The total vapor pressure, C_v, was estimated by the following model based on the formulation data (i.e., all identified compounds): C_v = Σ(C_{vi} · x_i). The estimated total vapor pressure was 28.2 g/m³ for the primer and 11.1 g/m³ for the paint.

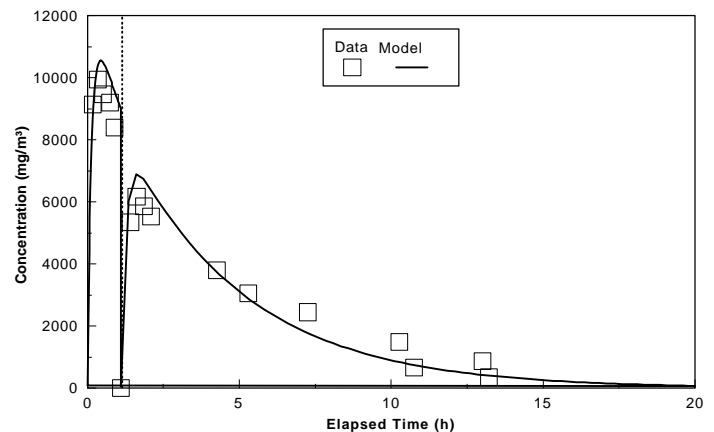

Figure 3. TVOC Concentrations Predicted by the Model and Measured in a Small Chamber with a Primer and Alkyd Paint on a Pine Board. (Primer applied at time = 0. Alkyd paint applied at time = 1.14; i.e., vertical line)

(Continued on Page 5)

A comparison of the predicted chamber concentrations and the measured concentration profiles is shown in Figure 3. The mass transfer model predictions are in good agreement with the experimental data. Since the model was developed based on the assumption that the emissions were controlled only by gas-phase mass transfer, the results in Figure 3 indicate that VOC emissions from the primer and the alkyd paint are governed by a gas-film-diffusion-controlled and fast evaporation-like process. This was also confirmed by the mass balance results which indicated that almost 100% of the VOCs were emitted within 20 hours after the painting. (EPA Contact: John Chang, 919-541-3747, jchang@engineer.aeerl.epa.gov)

GLOSSARY OF ACRONYMS

AARST-American Association of Radon Scientists and Technicians
 ASD-Active Soil Depressurization
 DOT-Department of Transportation
 ELA-Effective Leakage Area
 GAC-Granular Activated Carbon
 HVAC-Heating, Ventilating, and Air-Conditioning
 IAQ-Indoor Air Quality
 IEMB-Indoor Environment Management Branch
 NRMRL-National Risk Management Research Laboratory
 NTIS-National Technical Information Service
 PCO-Photocatalytic Oxidation
 SOG-Slab-on-Grade
 TVOC-Total Volatile Organic Compound
 UV-Ultraviolet
 VOC-Volatile Organic Compound

Table 2. Volatile Contents and Densities of the Primer and the Alkyd Paint Determined by EPA Method 24

Parameter	Primer	Alkyd Paint
Volatile Contents, %	33.3	33.1
Density, g/cm ³	1.33	1.26

Table 3. Content of Selected VOCs Determined by EPA Method 311

Compound	Primer, mg/g	Alkyd Paint, mg/g
undecane	7.42	37
decane	33.0	15.1
dodecane	ND*	11.6
p-xylene	1.82	6.33
o-ethyltoluene	ND	21.0
trans-decahydronaphthalene	2.55	4.92
nonane	19.4	3.79
propylcyclohexane	4.34	2.04
methyl ethyl ketoxime	ND	2.28
p-ethyltoluene	0.21	0.79
ethylbenzene	0.27	1.26
1,2,4-trimethylbenzene	0.16	1.06
o-xylene	0.23	0.91
1,2,3-trimethylbenzene	ND	0.33
1,3,5-trimethylbenzene	ND	0.31
toluene	0.34	0.26
n-propylbenzene	0.01	ND
octane	12.2	ND
TVOC	352	408

* ND = Not Detected

REDUCING SOLVENT AND PROPELLANT EMISSIONS FROM CONSUMER PRODUCTS

Consumer products typically contain an active agent, a solvent, and a propellant. For example, hair styling products are made up of a polymer, alcohol, and isobutane, all contained in a precharged package. The polymer, as the active ingredient, holds the hair strands in place. Alcohol is added for two reasons. The first is to reduce product viscosity while it is flowing out of the dispenser. Without the alcohol solvent, the polymer would plug the dispenser orifice and refuse to leave the package. The second reason for the alcohol is to reduce the product viscosity and surface tension during the spray formation process - a number of researchers have shown that lower viscosity and surface tension fluids are easier to form into the sprays desired by customers.

The propellant, isobutane, is used to force the product out of the can and to direct it at the intended target. Isobutane, or another hydrocarbon, is usually employed because it resides in the can as a liquid which rapidly evaporates when the dispenser is activated. The large volume change that occurs when a liquid vaporizes to a gas allows only a small volume of isobutane to be used when spraying a large volume of product. The small volume of stored isobutane reduces package size.

To minimize indoor exposures from consumer products, the objective of this project is to develop a mechanism for removing the need for VOC solvents and hydrocarbon propellants in consumer products, replacing them with water and air, respectively. There are two barriers to be surmounted before this goal can be achieved: product efficacy and spray formation.

Product efficacy involves the ability of the product active ingredient to perform its assigned task; e.g., linking strands of hair together in the case of a hair styling product. Some active ingredients lose their linking ability when dissolved in water. Such concerns are best left to the product formulators.

However, when active ingredients can be dissolved in water without losing their effectiveness, they must still be formed into a spray. This requires the dispenser designer to overcome the increase in both viscosity and surface tension that results from replacing alcohol with water. In addition, the quantity of propellant must be substantially reduced when replacing isobutane with a more environmentally friendly gas such as air, nitrogen, or carbon dioxide. The spray formation problem has been the focus of this research project at Purdue University.

The project has accomplished two things thus far: 1) development of a dispenser (Figure 4) whose performance is nearly independent of product viscosity and surface tension, and 2) demonstration of markedly reduced propellant consumption so that isobutane, or other hydrocarbon propellants, can be replaced by an inert gas such as air, nitrogen, or carbon dioxide. These accomplishments were achieved through the two unique dispenser features discussed below.

The first feature is the manner in which the product is formed into sprays. Conventional dispensers use the "scrubbing action" of the propellant, a process termed "aerodynamic shear," to break up large liquid globules into much smaller drops. Conventional aerodynamic shear is inefficient because only a small fraction of the propellant actually contributes to the scrubbing process. Consequently, a substantial fraction of the propellant is wasted. In contrast, the effervescent atomizer dispenser developed in this project intimately mixes the product and propellant during the spray formation process, thereby involving a much larger fraction in the scrubbing process. As a result, there is less waste so that less propellant needs to be stored in the package (in fact a reduction factor of about 100, by mass, can be obtained). This reduction in propellant consumption facilitates replacement of hydrocarbon propellants by gases.

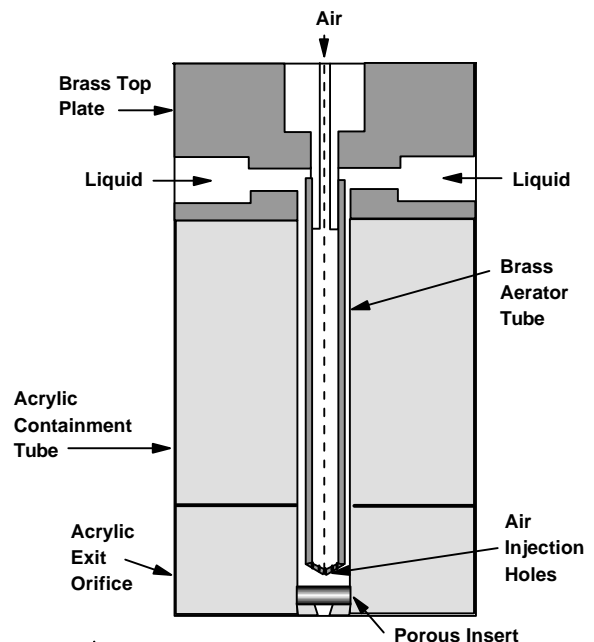

Figure 4. Prototype of New Spray Dispenser Developed by Purdue University

The second feature of the dispenser developed at Purdue is the method used to prepare the product for spray formation. Conventional dispensers (and even early effervescent atomizers) simply routed the product to a circular exit orifice and let the propellant do the rest. This approach worked well as long as there was sufficient propellant available to keep the liquid flowing around the edges of the exit orifice and gaseous propellant down the center, an arrangement termed "annular flow." The annular flow configuration resulted in the breakup process proceeding through two steps: filament (or ligament) formation and the subsequent breakup of filaments into drops. Unfortunately, reductions in propellant consumption always lead to the collapse of the annular flow resulting in large chunks of liquid exiting the dispenser, producing large drops. The Purdue research has shown that the annular flow can be preserved at very low propellant consumption rates by replacing the conventional circular exit orifice with a small porous disk. These disks are commercially available and made of sintered plastics with a wide variety of pore diameters.

The research at Purdue has demonstrated several important advantages of ligament-controlled effervescent atomizers. First, that products having viscosities many times that of current consumer products can be successfully formed into sprays. This means that these dispensers can be expected to meet both future needs and current demands. Second, that acceptable sprays are formed from water-based products so it is possible to replace alcohols with water. Finally, that propellant consumption is low enough that current package sizes can be used without exceeding Department of Transportation (DOT) pressurization restrictions or deceptive packaging guidelines, while replacing hydrocarbon propellants with air.

The design guidelines for the new dispenser will be available in late 1997. (EPA Contact: Kelly Leovic, 919-541-7717, kleovic@engineer.aeerl.epa.gov)

THE INDOOR AIR QUALITY INFORMATION CLEARINGHOUSE (IAQ INFO)

IAQ INFO is an easily accessible, central source of information on IAQ. It is supported by EPA's Office of Air and Radiation's Indoor Environment Division.

IAQ INFO can provide information on many aspects of IAQ:

- ◆ Indoor air pollutants and their sources
- ◆ Health effects of indoor air pollution
- ◆ Testing and measuring indoor air pollution
- ◆ Controlling indoor air pollutants
- ◆ Constructing and maintaining homes and commercial buildings to minimize IAQ problems
- ◆ Existing standards and guidelines related to IAQ
- ◆ General information on IAQ-related federal and state legislation

IAQ INFO contains:

- ◆ Citations and abstracts on more than 2,000 books, reports, newsletters, and journal articles
- ◆ An inventory of publications prepared by the federal government, including fact sheets, pamphlets, directories, training materials, and reports
- ◆ Information on more than 150 government research, public interest, and private sector organizations in the IAQ field

You may call a toll-free number to speak to an information specialist Monday through Friday, 9:00 a.m. to 5:00 p.m. EST. After hours, you may leave a voice message. You may inquire by fax or mail anytime.

IAQ INFO 1-800-438-4318
P.O. Box 37133 202-484-1307
Washington, DC 20013-7133 Fax: 202-484-1510

POSSIBLE ROLE OF RADON REDUCTION SYSTEMS IN COMBUSTION PRODUCT SPILLAGE

EPA's Radon Mitigation Standards currently require that back-draft testing be conducted following the installation of active soil depressurization (ASD) systems for residential reduction. This testing is specified to ensure that the ASD system is not causing sufficient additional depressurization of the house to create or exacerbate spillage of combustion products from natural draft combustion appliances.

A computational sensitivity analysis was conducted to assess whether there are conditions where it can safely be assumed that serious spillage will not be caused by the ASD system. If so, it might be possible to relax the requirement for back-draft testing under such conditions.

The parameters varied in conducting this sensitivity analysis included: house floor area (from 100 to 280 m²); normalized shell leakage area (0.7 to 9.0 cm² at 4 Pa per m² of floor area); the rate at which the ASD system is exhausting house air (5 to 35 L/s); and the combined exhaust rate of appliances other than the ASD system (50 to 140 L/s). The ranges selected for each parameter cover typical ranges that would be encountered in the U.S. housing stock.

The results of these computations are summarized in Tables 4 and 5, for two cases:

- 1) Conditions representative of the spillage test specified in a recent standard issued by the Canadian General Standards Board (Standard CAN/CGSB-51.71-95). These conditions assume that a potential threat of serious spillage exists when house depressurizations are greater than 5 Pa with the ASD and all exhaust appliances (except bathroom fans) operating. Results are shown in Table 4.
- 2) More conservative (stringent) conditions. These conditions assume that a potentially serious spillage threat can exist when house depressurization reaches 3.5 Pa with all exhausts (including bathroom fans) operating. See Table 5.

Tables 4 and 5 show the normalized house leakage areas that would be required to avoid exceeding these depressurizations (5 and 3.5 Pa), as a function of floor area and ASD exhaust rate. The values assume an exhaust rate for the non-ASD exhaust appliances (not shown in the tables), dependent on house size.

Table 5 shows that – even with the smallest house (100 m²) and the highest ASD exhaust flows – the ASD system would not be predicted to create or exacerbate serious spillage, even under conservative assumptions reflected by the table, as long as the normalized leakage area is greater than about 4 cm²/m². For a reference point, one data set containing over 12,000 houses suggests that the mean leakage area for U.S. houses

might be as high as 10 cm²/m². Thus, it would appear that ASD systems should not create or exacerbate serious spillage in most of the housing stock. On the other hand, Table 4 shows that – even with the largest house (280 m²) and the lowest ASD exhaust flows – the ASD system could contribute to spillage even under the more lenient assumptions reflected by that table, if the normalized leakage area is less than about 2 cm²/m². Some fraction of the U.S. housing stock does have leakage areas below this amount, especially in colder climates. Thus, ASD can contribute to spillage in some portion of the housing stock.

These results indicate that, in the absence of data on the leakiness of the house shell, it is not possible to use the house size and ASD system flow rate to reliably estimate the risk that an ASD installation might contribute to spillage in a given house. Consequently, spillage testing would be needed for essentially all ASD installations. (EPA Contact: Bruce Henschel, 919-541-4112, bhenschel@engineer.aeeri.epa.gov)

Table 4. Maximum Allowable Depressurization=5 Pa, Bathroom Fans Excluded (ELA=Effective Leakage Area)

ASD exhaust out of house/ (approx. total ASD system flow) (L/s)	Minimum ELA @ 4 Pa, per unit floor area (cm ² /m ²), to ensure house depressuriza- tion < 5 Pa for various house floor areas		
	100 m ²	190 m ²	280 m ²
0 / (0) (ASD off)	1.6	1.7	1.2
5 / (10)	1.8	1.8	1.2
12 / (24)	2.0	1.9	1.3
20 / (40)	2.3	2.1	1.4
35 / (70)	2.8	2.3	1.6

Table 5. Maximum Allowable Depressurization=3.5 Pa, Bathroom Fans Included

ASD exhaust out of house/ (approx. total ASD flow) (L/s)	Minimum ELA @ 4 Pa, per unit floor area (cm ² /m ²), to ensure house depressuriza- tion < 3.5 Pa for various house floor areas		
	100 m ²	190 m ²	280 m ²
0 / (0) (ASD off)	2.9	2.6	2.1
5 / (10)	3.1	2.7	2.1
12 / (24)	3.4	2.9	2.2
20 / (40)	3.7	3.1	2.4
35 / (70)	4.4	3.4	2.6

This section provides summaries of recent publications on EPA's indoor air research. The source of the publication is listed after each summary. Publications with NTIS numbers are available (prepaid) from the National Technical Information Service (NTIS) at: 5285 Port Royal Road, Springfield, VA 22161, 703-487-4650 or 800-553-6847.

A Method for Testing the Diffusion Coefficient of Polymer Films

-This paper discusses the development and evaluation of a method to measure the diffusion of radon through thin polymer films. The system was designed so that a simple, one-dimensional transport model could be used. The system uses radium-bearing rock as a high level radon source. The test film is sealed in the system with the high concentration radon gas on one side and an alpha detector sealed on the other side. Three polymer films with published values of the radon diffusion coefficient (polyethylene, polyester, and latex) were tested in duplicate to evaluate the method and determine its comparability to values in published literature. The results show good repeatability (10%) and some comparability to similar published data (20 to 200%). Source: "Proceedings of the American Association of Radon Scientists and Technicians' (AARST) 1996 International Radon Symposium," Sept. 29 - Oct. 2, 1996. (Lead Author and EPA Contact: Richard B. Perry, 919-541-2721, rperry@engineer.aeerl.epa.gov)

An Evaluation of Indoor Radon Reductions Possible with the Use of Diffusion-Resistant Flexible Construction Membranes

-This paper provides a modeling assessment of the indoor radon reductions possible through the use of "improved" radon resistant

membranes. The evaluation considers the application of radon resistant membranes to slab-on-grade (SOG) construction, source strengths, and site conditions typical of Florida. Guidance for non-Florida construction and site conditions is provided. Conclusions from the paper show: 1) Placement of an integral impermeable flexible membrane (vapor barrier) under SOG construction can produce significant (100x) reductions in indoor radon concentration from the no barrier case; 2) In most cases, even for floating SOG construction, on moderately high radon potential (10 pCi g^{-1} , ^{226}Ra) sites, currently available diffusion resistant membranes can keep indoor radon concentrations below 4 pCi L^{-1} ; 3) Enhanced diffusion limiting membranes (e.g., going from 1×10^{-11} to $1 \times 10^{-13} \text{ m}^2 \text{ s}^{-1}$ diffusion coefficients) may become cost effective on high radon potential sites (e.g., sites greater than 20 pCi g^{-1} ^{226}Ra); 4) The placement of a completely intact vapor barrier is critical to limiting radon entry into new and existing structures even at the well-balanced indoor/outdoor pressure differential condition (-2.4 Pa) used in this analysis; and 5) Comparison of the performance of new house evaluation study results with model predictions indicates the potential for enhanced radon entry limiting performance of vapor barriers, perhaps through enhanced placement practices. Source: "Proceedings of the AARST 1996 International Radon Symposium," Sept. 29 - Oct. 2, 1996. (Lead Author and EPA Contact: David C. Sanchez, 919-541-2979, dsanchez@engineer.aeerl.epa.gov)

Assessment of Fungal (Penicillium chrysogenum) Growth on Three HVAC Duct Materials

-This paper summarizes experimental results evaluating the susceptibility of three types of duct materials: fibrous glass ductboard, galvanized steel, and insulated flexible

duct. The results indicate that, of newly purchased duct materials, only the flexible duct supported moderate growth of *P. chrysogenum*. No fungal growth was detected on the fibrous glass and galvanized steel. Wetting the clean duct samples with sterile water did not increase amplification of the *P. chrysogenum* over levels without wetting. Soiling the samples with dust collected from residential heating and air-conditioning systems enhanced the susceptibility of all three duct materials to fungal growth. The results suggest that dust accumulation and/or high humidity should be properly controlled in any HVAC duct to prevent fungal growth. Source: *Environment International*, 22,4, 425-431, 1996. (Lead Author and EPA Contact: John C. S. Chang, 919-541-3747, jchang@engineer.aeerl.epa.gov)

Characterization of Manufacturing Processes and Emissions and Pollution Prevention Options for the Composite Wood Panel Industry

-This report summarizes information in the literature on emissions from the composite wood industry and potential pollution prevention options. Little information exists in the literature pertaining to pollution prevention. Most of the available literature focuses on ways to reduce raw material consumption and improve manufacturing processes. Potential pollution prevention options presented in this report include: conveyor belt drying; low temperature drying; high moisture bonding adhesives; foam extrusion; variable glue application rate; use of alternative fiber sources such as agricultural fiber and recycled wood waste; and naturally derived adhesives. Source: EPA Report, EPA-600/R-96-066 (NTIS PB96-183892), June 1996. (Lead Author: Cybele Martin; EPA Contact: Elizabeth M. Howard, 919-541-7915, bhoward@engineer.aeerl.epa.gov)

Description of a Method for Measuring the Diffusion Coefficient of Thin Films to ²²²Rn Using a Total Alpha Detector-This paper describes a method for using a total alpha detector to measure the diffusion coefficient of a thin film by monitoring the accumulation of radon that penetrates the film. Results show that a virtual steady state condition exists in the thin film during the early stages of accumulation that allows reliable measurements of the diffusion coefficient without having to wait for the final condition of equilibrium or having to analyze the complex transient solutions. Source: "Proceedings of AARST 1996 International Radon Symposium," Sept. 29 - Oct. 2, 1996. (Lead Author and EPA Contact: Ronald B. Mosley, 919-541-7865, rmosley@engineer.aeerl.epa.gov)

Development of a Radon Protection Map for Large Buildings in Florida-This report discusses a radon protection map that uses soil and geologic features to show areas of Florida that require different levels of radon protection for large building construction. The map was proposed as a basis for implementing radon-protective construction standards in areas of high radon risk and avoiding unnecessary regulations in areas of low radon risk. Separate model analyses estimated the effectiveness of different building construction features. The map was compared with over 275,000 measurements in 20,156 large buildings. A statewide bias of only -0.004 ±1.067 standard deviations suggests excellent average agreement. Observations of 306 buildings with the greatest bias showed that, with crawl spaces, 89% measured low and only 11% measured high. Source: EPA Report, EPA-600/R-96-028 (NTIS PB96-168216), March 1996. (Lead Author: Kirk K. Nielson; EPA Contact: David C. Sanchez, 919-541-2979, dsanchez@engineer.aeerl.epa.gov)

Effectiveness of Radon Control Features in New House Construction, South Central Florida-This report gives results of a study to evaluate the effectiveness of two slab types (monolithic and slab-in-stem wall) in retarding radon entry in new houses built in accordance with the State of Florida's proposed radon standard for new construction over high radon potential soils. Fourteen houses were monitored during their construction on sites whose soil gas radon concentrations were screened to be >1000 pCi/L. Slab integrity was monitored over time, and post-construction ventilation and radon entry were measured in all the houses. The houses with slab-in-stem wall foundations exhibited more slab cracking than those with monolithic slabs and also had higher average radon entry rates, radon entry velocities, and concentration ratios. However, both slab types proved to be effective in retarding radon entry, especially when penetrations were properly sealed. Source: EPA Report, EPA-600/R-96-044 (NTIS PB96-177761), April 1996. (Lead Author: Charles S. Fowler; EPA Contact: David C. Sanchez, 919-541-2979, dsanchez@engineer.aeerl.epa.gov)

Indoor Environment Management Branch-This pamphlet describes IEMB's in-house and extramural programs. In-house research studies are conducted on a variety of bench-, pilot-, and full-scale test facilities in Research Triangle Park, NC. Test facilities include eight small environmental chambers, a large environmental chamber, an IAQ test house, 24 biological static chambers, a biological dynamic chamber, a large soil chamber, and a pilot scale ventilation test facility. A three-phase research approach [chamber(s)-model-test house] forms the core of IEMB's in-house research program. This approach ensures that test methods, emission factors, and source/sink models developed are validated in a full scale environment.

Source: EPA Report, EPA-600/F-96-004, March 1996. (EPA Contact: John Chang, 919-541-3747, jchang@engineer.aeerl.epa.gov)

Large Building HVAC Simulation-This report gives the results from a project that established the potential for using models to analyze radon levels in large buildings. This was done by applying modeling tools developed in earlier work to analyze pressures, airflows, and indoor radon levels in a school building monitored by IEMB and Southern Research Institute. Source: EPA Report, EPA-600/R-96-116 (NTIS PB97-104715), September 1996. (Lead Author: Lixing Gu; EPA Contact: Marc Y. Menetrez, 919-541-7981, mmenetrez@engineer.aeerl.epa.gov)

Research Agenda on Air Duct Cleaning-Duct cleaning practices currently include: removal of dust and dirt from the ducts and other HVAC system components; application of antimicrobial agents to kill bacteria and fungi; encapsulants and sealants to contain imbedded contaminants; and the introduction of ozone to mask odors and kill microbiological organisms. All have the potential to affect IAQ. Four priority research areas are discussed to reduce exposure to indoor pollutants: 1) contaminant control techniques, 2) application and use of antimicrobial agents, 3) HVAC system sealants/encapsulants, and 4) use of ozone in ventilation systems. Source: Accepted for publication in *Indoor Air*. (Lead Author: Marie S. O'Neill; EPA Contact: R. N. Kulp, 919-541-7980, rkulp@engineer.aeerl.epa.gov)

Site-specific Protocol for Measuring Soil Radon Potentials for Florida Houses-This report describes a protocol for site-specific measurement of radon potentials for Florida houses that is consistent with existing residential radon protection maps. The protocol gives further guidance on the possible need for radon-protective house construction features. Sensitivity analyses identified radium concentration, soil layer depth, soil density, soil texture, and water table depth as the independent parameters dominating indoor radon. Radium concentration and water table depth were most important. Soils up to 2.4 m deep contributed to indoor radon in uniform-radium scenarios, and soil layers about 0.6 m thick significantly affected radon in cases of non-uniform radium distributions. Source: EPA Report, EPA-600/R-96-045 (NTIS PB96-175260), April 1996. (Lead Author: Kirk K. Nielson; EPA Contact, David C. Sanchez, 919-541-2979, dsanchez@engineer.aeeri.epa.gov)

Sources and Factors Affecting Indoor Emissions from Engineered Wood Products: Summary and Evaluation of Current Literature-Engineered wood components (e.g., particleboard and medium-density fiberboard) are common to several types of consumer wood products (e.g., residential and ready-to-assemble furniture and kitchen cabinets). The resins used to bind the wood, the wood itself, coatings, and laminates applied to the components all affect emissions of formaldehyde and other VOCs from the products to the indoor environment. This report evaluates existing data and testing methodologies. Information in the report was used to select engineered wood components with various finishing and resin systems for a cooperative research project between IEMB, Research Triangle Institute, and industry. The research objectives are to characterize indoor air emissions from engineered wood products and to identify and evaluate pollution prevention approaches for reducing indoor air emissions from these products. Source: EPA Report, EPA-600/R-96-067 (NTIS PB96-183876), June 1996. (Lead Author: Sonji Turner; EPA Contact: Elizabeth M. Howard, 919-541-7915, bhoward@engineer.aeeri.epa.gov)

Technical Basis for a Candidate Building Materials Radium Standard-This report summarizes the technical basis for a candidate building materials radium standard. It contains the standard and a summary of the technical basis for the standard. Source: EPA Report, EPA-600/R-96-022 (NTIS PB96-157565), March 1996. (Lead Author: Vern C. Rogers; EPA Contact: David C. Sanchez, 919-541-2979, dsanchez@engineer.aeeri.epa.gov)

SYMPOSIUM ANNOUNCEMENT

Engineering Solutions to Indoor Air Quality Problems

The second biennial *Engineering Solutions to Indoor Air Quality Problems* Symposium, an international symposium cosponsored by EPA's National Risk Management Research Laboratory and the Air & Waste Management Association, will be held **July 21-23, 1997**, at the Sheraton Imperial Hotel and Conference Center in Research Triangle Park, NC.

Topics will include:

- ! Managing the Risk of Indoor Air Pollution
- ! Indoor Air Source Characterization Methods
- ! Indoor Air Source Management
- ! Low Emitting/Low Impact Materials Development (Pollution Prevention)
- ! Biocontaminant Prevention and Control
- ! Indoor Air Cleaning Methods
- ! Ventilation for Indoor Air Quality
- ! HVAC Systems as Sources of Indoor Air Pollution
- ! Air Duct Cleaning
- ! Particles in Indoor Air
- ! Indoor Air Quality Modeling
- ! Costs of Managing Indoor Air Quality

For registration information, please contact the Registrar, Air & Waste Management Association, phone: (412) 232-3445 or (412) 232-3444 ext. 3142.

For information on exhibition opportunities, please contact David Randall, phone: (919) 677-0249, ext. 5139# or fax: (919) 677-0065.

United States
Environmental Protection Agency
Indoor Environment Management Branch
MD-54
Research Triangle Park, NC 27711

Official Business
Penalty for Private Use
\$300

EPA/600/N-97/001, Fall/Winter 1996

An Equal Opportunity Employer

FIRST CLASS MAIL
POSTAGE AND FEES PAID
EPA
PERMIT No. G-35