

- NOTE:**
1. Use the Type A, blocked-out, system or the Type B, non-blocked-out, system as specified.
 2. Use the weathering steel for all structural steel and fastener hardware.
 3. Furnish shop bent splice plates. Use the minimum bend angle shown in the table below.
 4. See Sheet 2 of 2 for Plan View Layout.
 5. Furnish hardware in the metric sizes shown. Equivalent US Customary sizes may be used when metric sizes are not available.
 6. Dimensions without units are millimeters.

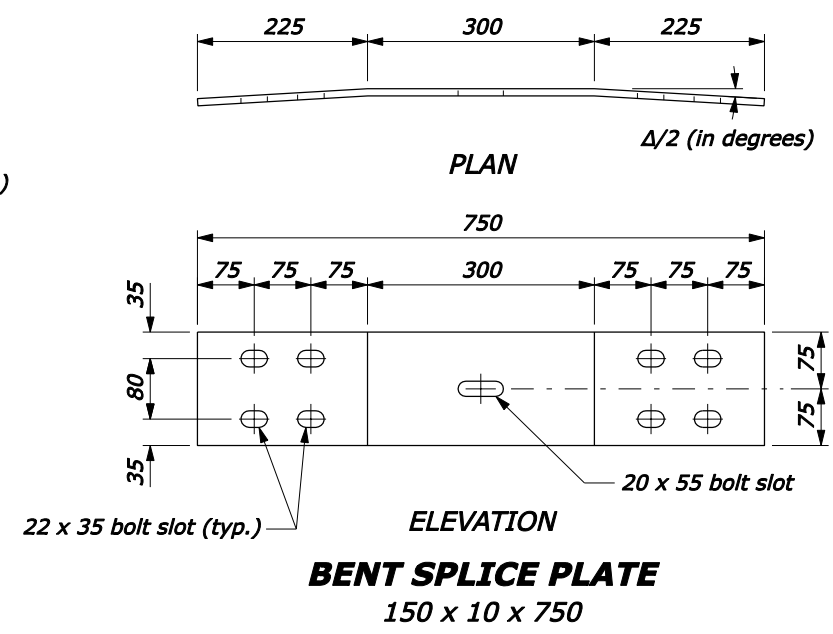

Radius R meters	Δ/2 degrees	d mm
5	8.63	23
6	7.18	19
8	5.38	14
10	4.30	11
12	3.58	9
14	3.07	8
16	2.69	7
18	2.39	6
20	2.15	6
22	1.95	5
over 22	flat	0

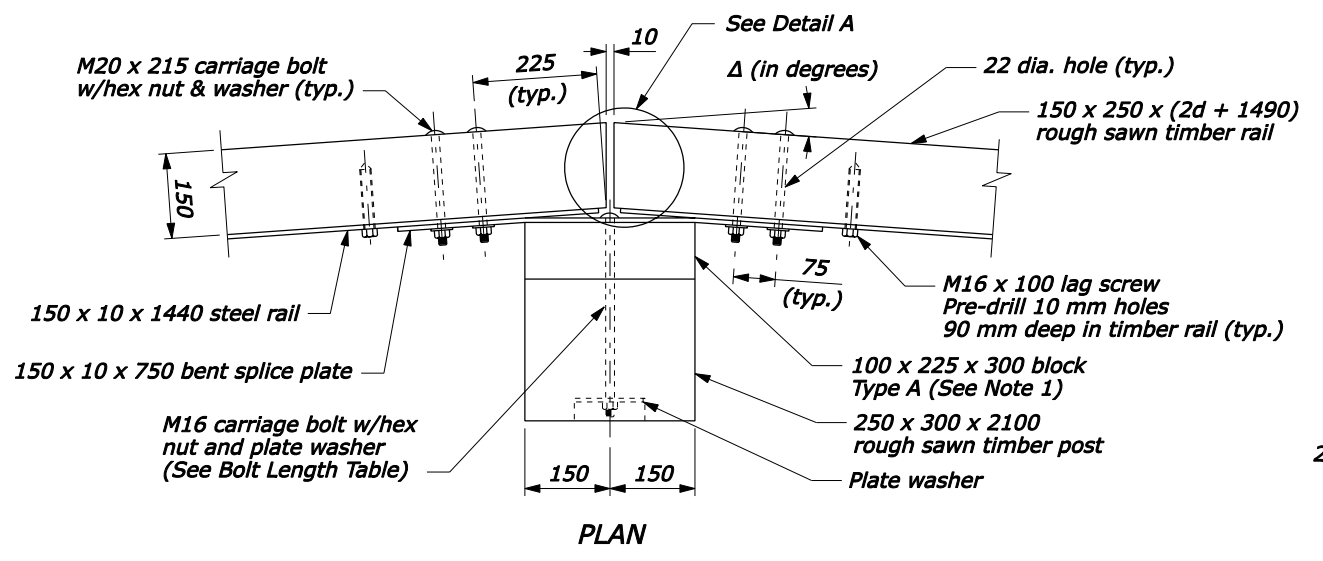
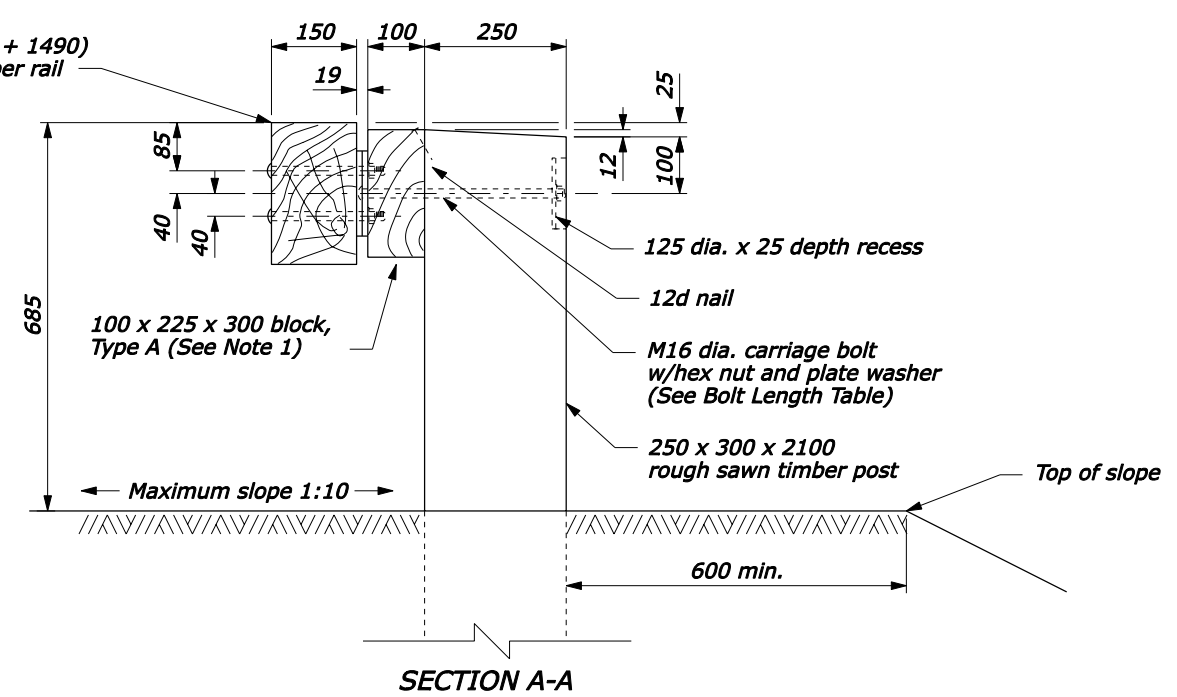
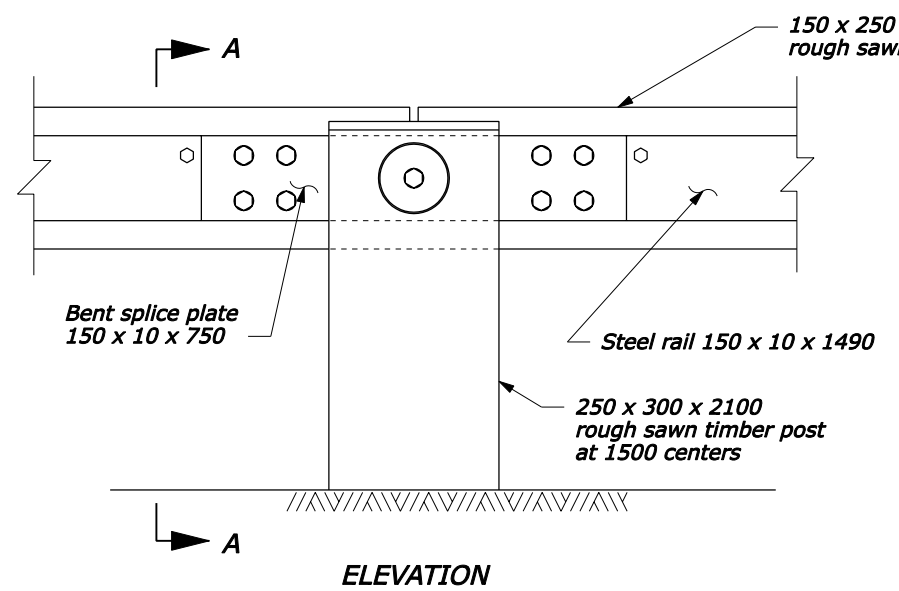

Type A (Block-out)	Type B (No Block-out)
375	275

U.S. DEPARTMENT OF TRANSPORTATION
FEDERAL HIGHWAY ADMINISTRATION
FEDERAL LANDS HIGHWAY

METRIC STANDARD
**STEEL-BACKED TIMBER GUARDRAIL
AROUND CIRCULAR CURVES
22 m RADIUS AND BELOW**
Sheet 1 of 2

STANDARD APPROVED FOR USE 3/1996
REVISED: 6/2005

STANDARD
M617-63

NO SCALE

16-Jun-2005 04:25 PM F:\StandDraw\std61763.dgn [Metric]

- NOTE:**
1. Δ is the central angle which subtends a 1500 mm chord.
 2. R is measured from the center of the circle to the back surface of the rough sawn timber rail.
 3. Dimensions without units are millimeters.

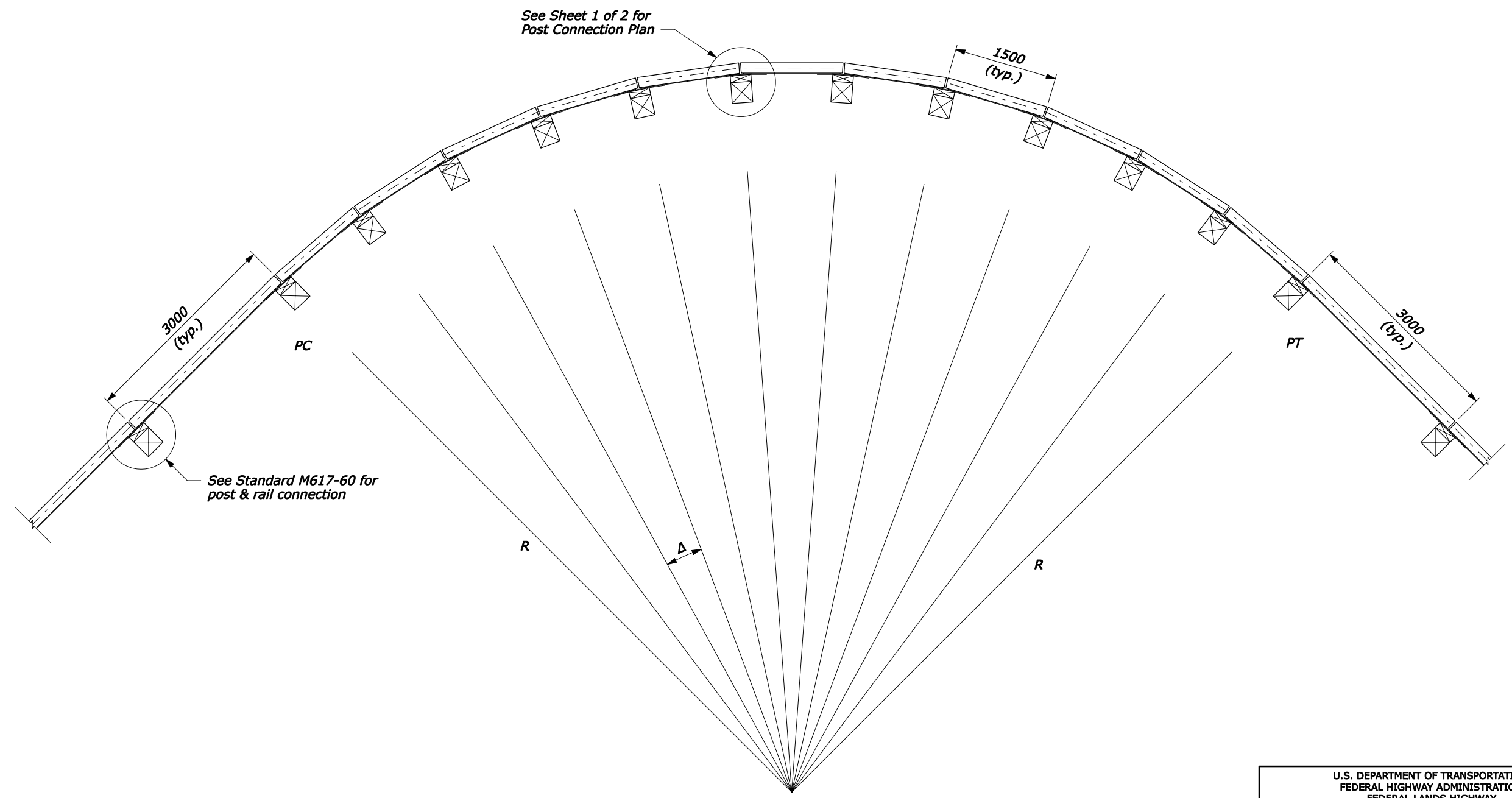

PLAN VIEW LAYOUT

NO SCALE

U.S. DEPARTMENT OF TRANSPORTATION FEDERAL HIGHWAY ADMINISTRATION FEDERAL LANDS HIGHWAY	
METRIC STANDARD	
STEEL-BACKED TIMBER GUARDRAIL AROUND CIRCULAR CURVES 22 m RADIUS AND BELOW	
Sheet 2 of 2	
STANDARD APPROVED FOR USE 3/1996	STANDARD
REVISED: 6/2005	M617-63

F:\StandDraw\std61763.dgn [Metric] 16-Jun-2005 04:26 PM