

PLAN

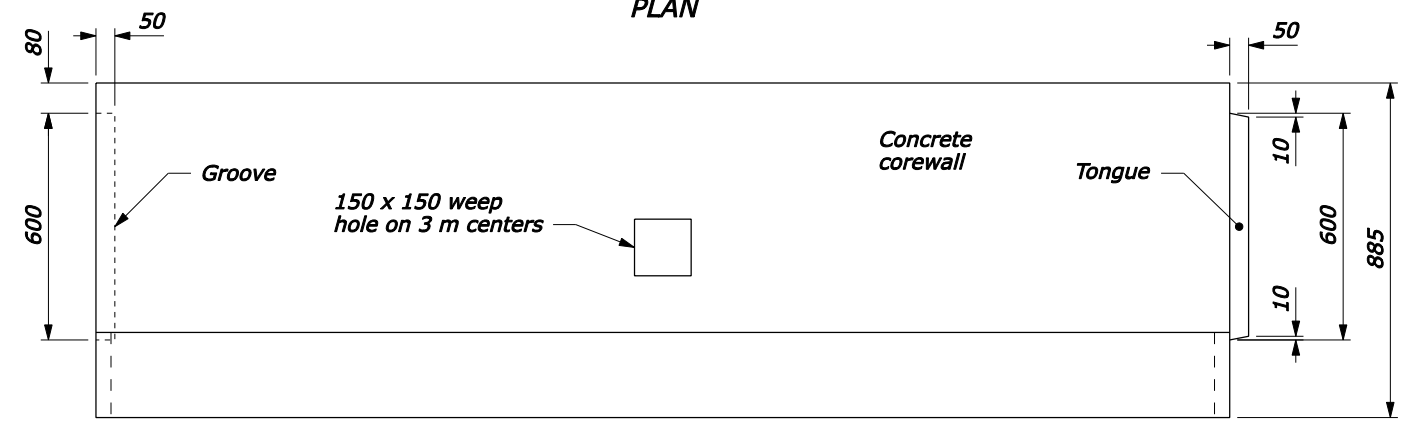

ELEVATION

**PRECAST CONCRETE COREWALL**

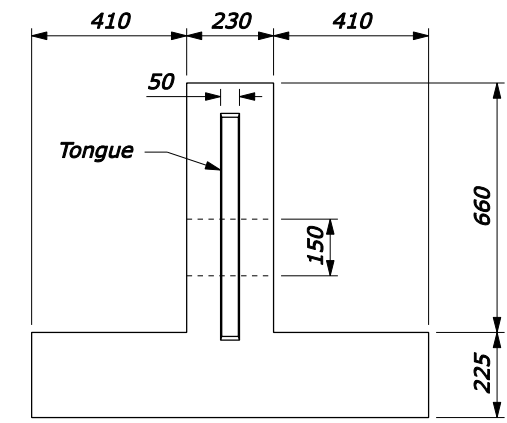

END VIEW

**NOTE:**

1. Form construction joints in the corewall at 9 m intervals or, at the option of the Contractor, the corewall may be constructed of precast concrete units.
2. On curves with radius less than 50 m, the corewall is to be cast-in-place.
3. The depth of base may be less than 150 mm as directed by the CO, when the foundation is on either rock fill or solid rock.
4. Set galvanized metal slots with anchors for the stone work or other approved type of metal anchors in the concrete. Equivalent attachment systems are allowed with the approval of the CO.
5. Dimensions without units are millimeters

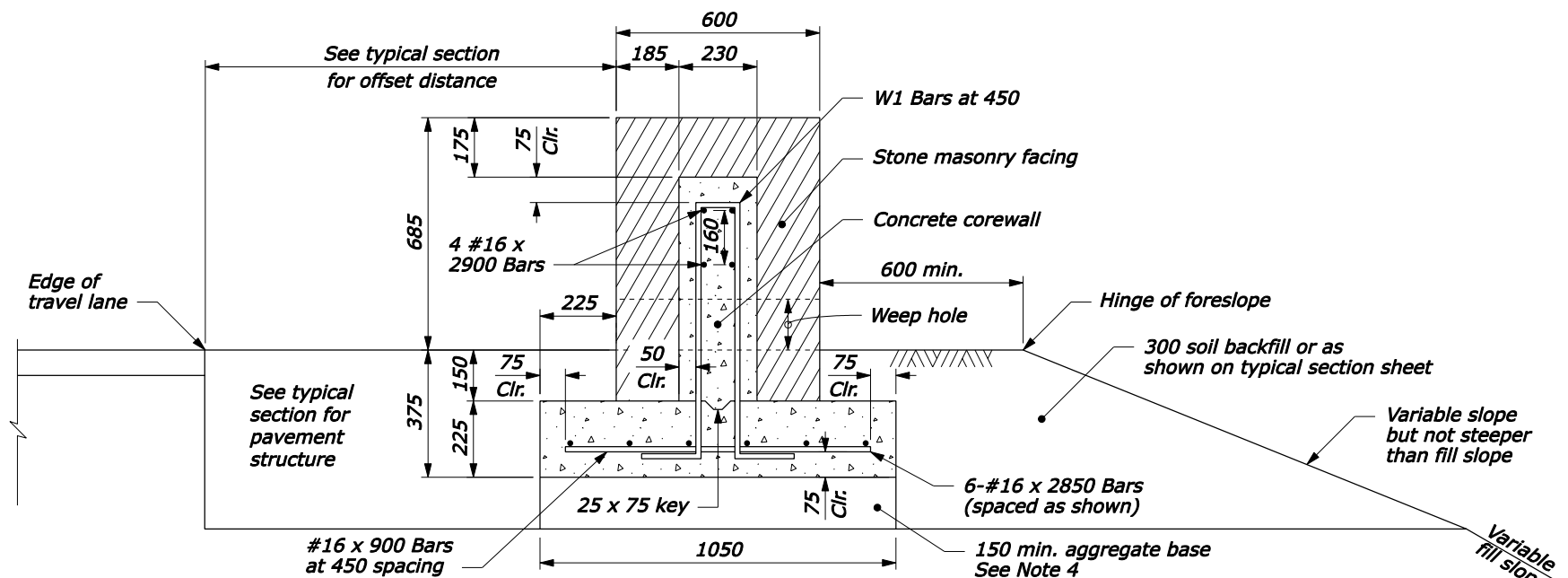

**TYPICAL GUARDWALL CROSS SECTION (DOUBLE FACE)**

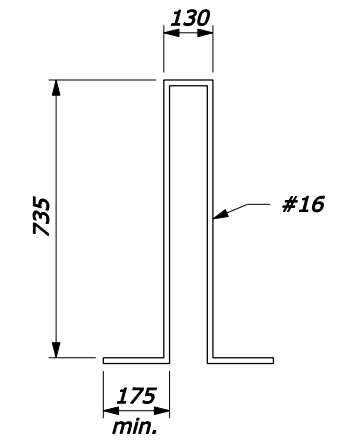

**W1 BAR BENDING DIAGRAM**

U.S. DEPARTMENT OF TRANSPORTATION FEDERAL HIGHWAY ADMINISTRATION FEDERAL LANDS HIGHWAY	
METRIC STANDARD	
<b>STONE MASONRY GUARDWALL (DOUBLE FACE)</b>	
STANDARD APPROVED FOR USE 3/1996	STANDARD
REVISED: 5/1997 6/2005	M620-2

NO SCALE

F:\StanDraw\st62002.dgn [Metric] 16-Jun-2005 06:43 AM