



U.S. Department  
of Transportation  
**National Highway  
Traffic Safety  
Administration**



---

**DOT HS 808 849**

**May 1998**

**Final Report  
Volume I: Technical Report**

# **Intelligent Cruise Control Field Operational Test**

This publication is distributed by the U.S. Department of Transportation, National Highway Traffic Safety Administration, in the interest of information exchange. The opinion, findings, and conclusions expressed in this publication are those of the author(s) and not necessarily those of the Department of Transportation or the National Highway Traffic Safety Administration. The United States Government assumes no liability for its contents or use therefore. If trade or manufacturer's name or products are mentioned, it is because they are considered essential to the object of the publication and should not be construed as an endorsement. The United States Government does not endorsement products or manufacturers.

1. Report No. DOT HS 808 849		2. Government Accession No.		3. Recipient's Catalog No.	
4. Title and Subtitle <b>Intelligent Cruise Control Field Operational Test (Final Report)</b>				5. Report Date May 1998	
				6. Performing Organization Code	
7. Author(s) P. Fancher, R. Ervin, J. Sayer, M. Hagan, S. Bogard, Z. Bareket, M. Mefford, J. Haugen				8. Performing Organization Report No. UMTRI-98-17	
9. Performing Organization Name and Address The University of Michigan Transportation Research Institute 2901 Baxter Road, Ann Arbor, MI 48109-2150				10. Work Unit No. (TRAIS)	
				11. Contract or Grant No. DTNH22-95-H-07428	
12. Sponsoring Agency Name and Address National Highway Traffic Safety Administration U.S. Department of Transportation 400 7th Street S.W. Washington, D.C. 20590				13. Type of Report and Period Covered Final Report Sept. 1995 to July 1998	
				14. Sponsoring Agency Code	
15. Supplementary Notes UMTRI's partners in the FOT are Automotive Distance Control Systems (ADC) GmbH, Haugen Associates, and the Michigan Department of Transportation. The Volpe National Transportation Systems Center is to produce a separate report as the independent evaluator.					
16. Abstract This document reports on a cooperative agreement between NHTSA and UMTRI entitled Intelligent Cruise Control (ICC) Field Operational Test (FOT). The main goal of the work is to characterize safety and comfort issues that are fundamental to human interactions with an automatic, but driver-supervised, headway-keeping system. Volumes I and II of this report describe the work done to prepare and instrument a fleet of 10 passenger cars with infrared ranging sensors, headway-control algorithms, and driver interface units as needed to provide an adaptive-cruise-control (ACC) functionality, and these volumes present results and findings deriving from operational testing lasting from July 1996 to September 1997. The vehicles were given to 108 volunteer drivers to use for two or five weeks as their personal cars. An extensive data base covering objective and subjective results has been assembled and analyzed. The central finding presented here is that ACC is remarkably attractive to most drivers. The research indicates that, because ACC is so pleasing, people tend to utilize it over a broad range of conditions and to adopt tactics that prolong the time span of each continuous engagement. Notwithstanding having some concerns, field test participants were completely successful at operating ACC over some 35,000 miles of system engagement. In examining the results, the researchers observe that the role played by the driver as the supervisor of ACC entails subtle issues whose long-term safety and traffic impacts are unknown. These issues pertain to the shared-control nature of ACC driving requiring a fine match to the perceptual and cognitive behavior of drivers in a safety-central task that affects others driving nearby. Thus, while offering great promise for improving the quality of the driving experience, ACC implies an inherent necessity for human-centered design. Volume III of the report covers the operation of a serial string or dense cluster of passenger cars equipped with an ACC system (see separate documentation page in Volume III).					
17. Key Words Adaptive or Intelligent Cruise Control, Headway or Longitudinal Control, Crash Avoidance, ACC, ICC, Platoon, String, Cluster, Field Operational Test			18. Distribution Statement Unrestricted		
19. Security Classif. (of this report) None		20. Security Classif. (of this page) None		21. No. of Pages 530	22. Price

## SI\* (MODERN METRIC) CONVERSION FACTORS

APPROXIMATE CONVERSIONS TO SI UNITS					APPROXIMATE CONVERSIONS FROM SI UNITS				
Symbol	When You Know	Multiply By	To Find	Symbol	Symbol	When You Know	Multiply By	To Find	Symbol
<b>LENGTH</b>					<b>LENGTH</b>				
in	inches	25.4	millimeters	mm	mm	millimeters	0.039	inches	in
ft	feet	0.305	meters	m	m	meters	3.28	feet	ft
yd	yards	0.914	meters	m	m	meters	1.09	yards	yd
mi	miles	1.61	kilometers	km	km	kilometers	0.621	miles	mi
<b>AREA</b>					<b>AREA</b>				
in <sup>2</sup>	square inches	645.2	square millimeters	mm <sup>2</sup>	mm <sup>2</sup>	square millimeters	0.0016	square inches	in <sup>2</sup>
ft <sup>2</sup>	square feet	0.093	square meters	m <sup>2</sup>	m <sup>2</sup>	square meters	10.764	square feet	ft <sup>2</sup>
yd <sup>2</sup>	square yards	0.836	square meters	m <sup>2</sup>	m <sup>2</sup>	square meters	1.195	square yards	yd <sup>2</sup>
ac	acres	0.405	hectares	ha	ha	hectares	2.47	acres	ac
mi <sup>2</sup>	square miles	2.59	square kilometers	km <sup>2</sup>	km <sup>2</sup>	square kilometers	0.386	square miles	mi <sup>2</sup>
<b>VOLUME</b>					<b>VOLUME</b>				
fl oz	fluid ounces	29.57	milliliters	mL	mL	milliliters	0.034	fluid ounces	fl oz
gal	gallons	3.785	liters	L	L	liters	0.264	gallons	gal
ft <sup>3</sup>	cubic feet	0.028	cubic meters	m <sup>3</sup>	m <sup>3</sup>	cubic meters	35.71	cubic feet	ft <sup>3</sup>
yd <sup>3</sup>	cubic yards	0.765	cubic meters	m <sup>3</sup>	m <sup>3</sup>	cubic meters	1.307	cubic yards	yd <sup>3</sup>
<b>MASS</b>					<b>MASS</b>				
oz	ounces	28.35	grams	g	g	grams	0.035	ounces	oz
lb	pounds	0.454	kilograms	kg	kg	kilograms	2.202	pounds	lb
T	short tons (2000 lb)	0.907	megagrams (or "metric ton")	Mg (or "t")	Mg (or "t")	megagrams (or "metric ton")	1.103	short tons (2000 lb)	T
<b>TEMPERATURE (exact)</b>					<b>TEMPERATURE (exact)</b>				
°F	Fahrenheit temperature	5(F-32)/9 or (F-32)/1.8	Celsius temperature	°C	°C	Celsius temperature	1.8C + 32	Fahrenheit temperature	°F
<b>ILLUMINATION</b>					<b>ILLUMINATION</b>				
fc	foot-candles	10.76	lux	lx	lx	lux	0.0929	foot-candles	fc
fl	foot-Lamberts	3.426	candela/m <sup>2</sup>	cd/m <sup>2</sup>	cd/m <sup>2</sup>	candela/m <sup>2</sup>	0.2919	foot-Lamberts	fl
<b>FORCE and PRESSURE or STRESS</b>					<b>FORCE and PRESSURE or STRESS</b>				
lbf	poundforce	4.45	newtons	N	N	newtons	0.225	poundforce	lbf
lbf/in <sup>2</sup>	poundforce per square inch	6.89	kilopascals	kPa	kPa	kilopascals	0.145	poundforce per square inch	lbf/in <sup>2</sup>

\* SI is the symbol for the International System of Units. Appropriate rounding should be made to comply with Section 4 of ASTM E380.

(Revised September 1993)

# Table of Contents

## VOLUME I

EXECUTIVE SUMMARY .....	12
1.0 INTRODUCTION TO THE REPORT.....	17
2.0 BACKGROUND, OBJECTIVES, AND INTENT .....	20
2.1 PROJECT BASIS.....	20
2.2 PROJECT OBJECTIVES .....	20
2.3 RETROSPECTIVE SUMMARY OF THE PROJECT APPROACH .....	21
3.0 THE TEST METHOD.....	24
3.1 THE ACC SYSTEM.....	25
3.1.1 ADC ODIN-4 System.....	26
3.1.2 ACC Control Algorithm .....	30
3.1.3 Sensor Calibration and Alignment.....	38
3.1.4 Human-Machine Interface.....	39
3.2 THE VEHICULAR TEST PLATFORM .....	42
3.2.1 The Base Vehicle .....	43
3.2.2 Provisions for the Integration of the ACC System.....	44
3.2.3 Preparation of Each Vehicle for Use in Field Data Collection .....	47
3.2.4 System Characterization Procedure and Results .....	49
3.3 THE DATA-ACQUISITION SYSTEM .....	50
3.3.1 The DAS Package.....	51
3.3.2 The Collected Variables .....	57
3.3.3 Automatic Recovery of Trip Data via Cellular Modem.....	64
3.3.4 Recovery of All Data From One Driver From the Hard Disk.....	67
3.3.5 The Quality of GPS-Derived Range Versus Sensor Range .....	68
3.4 THE EXPERIMENTAL DESIGN .....	69
3.4.1 Power Analysis .....	70
3.4.2 Sampling Frame.....	70
3.5 MANAGEMENT OF TEST PARTICIPANTS.....	71
3.5.1 The Basis For Human Use Approval and Pilot Testing .....	71
3.5.2 Participant Recruitment and Screening.....	72
3.5.3 Participant Orientation.....	73
3.6 MANAGEMENT OF TEST VEHICLES .....	74
3.6.1 Data Downloading .....	75
3.6.2 Sensors Check.....	76
3.6.3 Functionality Check.....	79
3.6.4 Vehicle Maintenance .....	83
3.6.5 Preparation for the Next Driver.....	84

3.7 OPERATIONAL ISSUES LEADING TO MODIFICATIONS .....	84
3.7.1 System Modifications .....	84
3.7.2 Wintertime Issues .....	85
4.0 CONTENTS OF THE DATA SET .....	87
4.1 ARCHIVED DATABASE .....	87
4.1.1 Subjects.mdb Database .....	87
4.1.2 DriverXXX.mdb Database .....	87
4.1.3 ICCXXX.mdb Database .....	91
4.2 REORGANIZED & AUGMENTED DATABASES .....	93
4.2.1 Database Reorganization .....	93
4.2.2 Database Additions .....	94
4.3 INVALID DATA AND KNOWN ANOMALIES .....	94
4.4 DRIVER RELATED DATA .....	96
4.4.1 Summary of Driver Biographic Data .....	96
4.4.2 The Myers-Briggs Type Inventory .....	102
4.4.3 Driving Style Questionnaire Results .....	106
5.0 DATA-PROCESSING METHODS .....	114
5.1 HISTOGRAMMING .....	114
5.1.1 Histograms Collected On-Board the FOT Vehicles .....	117
5.1.2 Additional Histograms .....	118
5.1.3 Methodology of Approximating Probability From Histograms .....	119
5.2 TIME HISTORY PROCESSING .....	121
5.2.1 Capturing of Nontarget-Related Time-History Events .....	122
5.2.2 Subsetting the Time-History Record .....	122
5.2.3 Capturing of Target-Related Time-History Events .....	124
5.2.4 Data Cleansing and Target Identification .....	124
5.3 PHASE SPACE PRESENTATION .....	126
5.4 SUBJECTIVE INFORMATION FROM QUESTIONNAIRES, DEBRIEFING AND FOCUS GROUPS .....	128
5.4.1 Detailed ACC System Questionnaire .....	128
5.4.2 Participant Debriefing .....	128
5.4.3 Focus Group Activities .....	129
5.5 PROCESSING DATA ASSOCIATED WITH TRANSITION EVENTS .....	129
5.6 DRIVER CHARACTERIZATION METHODS .....	130
5.7 PROCESSING DATA ASSOCIATED WITH GPS .....	135
6.0 BEHAVIORAL CHARACTERISTICS OF INDIVIDUAL DRIVERS .....	136
7.0 SUMMARY STATISTICS OF THE DRIVING EXPOSURE .....	144
7.1 EXPOSURE BY TIME AND MILEAGE FOR DIFFERENT DRIVER GROUPS .....	145
7.1.1 Driving Mode Exposure Time as Depends Upon Speed Range and Driver Age .....	149
7.1.2 The ACC and CCC Exposure Time of Nonusers Versus Users .....	149

7.1.3 Exposure Distance .....	152
7.2 EXPOSURE BY TIME AND MILEAGE FOR INDIVIDUAL DRIVERS .....	156
7.3 EXPOSURE BY ROAD TYPE.....	160
7.3.1 Exposure by Road Type and Velocity .....	160
7.3.2 Exposure By Road Type And Driving Mode .....	163
7.4 SUMMARY OF TRIP AND TRIP DURATION FOR THE FOT DRIVERS.....	164
8.0 BASIC RELATIONSHIPS ILLUSTRATING DRIVING PERFORMANCE.....	167
8.1 OBSERVATIONS PERTINENT TO MANUAL DRIVING .....	167
8.1.1 Observations on Manual Throttle Modulation .....	167
8.1.2 Observation and Theory on Manual Headway Modulation.....	170
8.1.3 Influence of Age, CCC Usage, and Gender on Manual Driving Style.....	182
8.1.4 Distributions of Manual Braking Behavior .....	188
8.2 ACC PERFORMANCE IN DRIVING SCENARIOS .....	201
8.2.1 Observations pertaining to ACC headway modulation.....	207
8.2.2 Driving style during ACC driving.....	209
8.2.3 Headway Time (Th) Selection .....	212
8.2.4 Observations pertaining to ACC braking events .....	215
8.3 BASIC COMPARISONS OF ACC OPERATION WITH MANUAL.....	220
8.3.1 Comparison Based Upon Headway Time Margins .....	220
8.3.2 The Influence of ACC on Driving Style.....	224
8.3.3 Observations Pertaining to Braking Events .....	232
8.3.4 Observations and Comparisons Concerning Following and Closing Situations.....	234
8.4 BASIC RESULTS FROM QUESTIONNAIRES.....	244
8.4.1 Questionnaire Results Showing Overall Satisfaction and Utility .....	244
8.4.2 Statistically Significant Differences Related to Age, CCC Usage, and Exposure to ACC.....	251
8.5 BASIC RESULTS FROM FOCUS GROUPS.....	257
9.0 PRESENTATION OF RESULTS BY ISSUE .....	263
9.1 IMPACT OF CONTROL MODE ON UTILIZATION CHOICES.....	263
9.1.1 Utilization Levels in ACC Versus CCC Modes of Control .....	263
9.1.2 The Basic Determinants of ACC Utilization Level.....	266
9.1.3 Trends in ACC Utilization Level With Tenure of Use .....	270
9.1.4 Relationship Between Utilization Level and Driver Opinions .....	271
9.2 ISSUES OF SYSTEM OPERATION ENCOUNTERED BY THE ACC DRIVER .....	274
9.2.1 Operating Experience While Establishing and Maintaining Engagement .....	274
9.2.2 Conditions Prompting Driver Intervention on ACC Control.....	282
9.2.3 Cut-In Behavior of Other Drivers as a Function of ACC Headway Time .....	294
9.2.4 Speeding Behavior in ACC Versus Manual Control.....	300

9.3	SUBJECT APPRAISAL OF COMFORT AND CONVENIENCE.....	304
9.3.1	Comfort as Associated With the Time of Exposure to ACC .....	305
9.3.2	System Characteristics Possibly Contributing to Ease of Use.....	306
9.3.3	Comfort as Associated With the Relief of Certain Driving Stresses .....	307
9.3.4	High Comfort Ratings Notwithstanding Certain Nuisances .....	307
9.4	SUBJECTS CRITIQUE OF SYSTEM FEATURES.....	308
9.4.1	No ACC Response to Stopped Objects.....	309
9.4.2	Target Loss (or Late-Acquire) on Curves.....	313
9.4.3	Deceleration Due to a False Detection.....	313
9.4.4	Delayed, Weak Acceleration Back Toward Set Speed .....	314
9.4.5	Minimum Speed of Retained Engagement While Tracking .....	315
9.4.6	Performance in Bad Weather .....	316
9.4.7	Driver's Use of Set Speed .....	317
9.4.8	Use of Headway Adjustments .....	318
9.4.9	Traffic Environment in Which ACC Was Utilized .....	321
9.4.10	Limited Level of (Throttle + Downshift) Deceleration Authority .....	322
9.4.11	ACC-Applied Deceleration as an Attention Prompt (or Cue).....	324
9.4.12	Requirement For ACC Controls and Displays.....	324
9.4.13	Driver's Vigilance With ACC .....	325
9.5	IMPLICATIONS OF IMPACT ON SAFETY .....	327
9.5.1	Objective Results Having Possible Safety Implications .....	328
9.5.2	Subjective Results Having Possible Safety Implications.....	334
9.6	RESULTS HAVING IMPLICATIONS FOR TRAFFIC FLOW .....	337
9.7	IMPLICATIONS FOR FUEL USAGE.....	342
10.0	SUMMARY OF FINDINGS AND OBSERVATIONS .....	345
10.1	UTILIZATION CHOICES .....	346
10.1.1	Versus Length of Exposure.....	346
10.1.2	Versus Type of Trip .....	346
10.1.3	Versus Traffic Environment.....	347
10.1.4	Versus Type of Road.....	347
10.1.5	Versus Driver's Aggressiveness .....	347
10.2	IMPACT OF ACC ON INDIVIDUAL'S DRIVING TASKS .....	348
10.2.1	Closing In.....	348
10.2.2	Following.....	349
10.2.3	Cut-In Reaction .....	349
10.3	IMPLIED COLLECTIVE TRAFFIC IMPACT .....	350
10.3.1	Safety .....	350
10.3.2	Traffic Flow .....	353
10.3.3	Energy Use.....	354



10.4 SYSTEM FUNCTIONALITY REACTION .....	354
10.4.1 Headway Adjustment .....	355
10.4.2 False Alarms .....	355
10.4.3 Missed Targets.....	355
10.4.4 Acceleration Level .....	356
10.4.5 Deceleration Level .....	356
10.4.6 Weather.....	357
10.5 COMFORT AND CONVENIENCE REACTION.....	357
10.5.1 Ease of Learning.....	358
10.5.2 Ease of Use .....	358
10.5.3 Utility Versus CCC and Manual.....	358
10.5.4 Driving Alertness .....	358
10.5.5 Product Purchase Appeal .....	359
11.0 CONCLUDING REMARKS AND RECOMMENDATIONS .....	360
11.1 THE CENTRAL FINDING.....	360
11.2 RECOMMENDATIONS.....	361
11.2.1 On studying the Collected FOT Data Further .....	361
11.2.2 On the Need for Fundamental Understanding on Driver Supervision of ACC .....	362
11.2.3 On the Need for Direct Measurement of ACC’s Energy Impact .....	362
11.2.4 On the Need to Explore the Traffic Impacts of ACC in Greater Detail.....	363
11.2.5 On Examining the Naturalistic Use of ACC-With-Braking .....	363
11.3 CONCLUDING COMMENT .....	365
REFERENCES .....	366

**VOLUME II**

APPENDIX A —	
DESCRIPTION OF THE DATA ARCHIVE AS A PERMANENT RESOURCE.....	372
A.1 DRIVER DATABASE DOCUMENTATION .....	372
A.2 ICC DATABASE DOCUMENTATION.....	373
A.3 SUBJECT DATABASE DOCUMENTATION .....	414
APPENDIX B — SUMMARY OF ACC SYSTEM QUESTIONNAIRE RESPONSES .....	417
APPENDIX C — SUMMARY OF EXPOSURE MEASUREMENTS FOR ALL DRIVERS AND DRIVER GROUPS .....	451
APPENDIX D — FORMS USED IN RECRUITING PARTICIPANTS.....	505
D.1 INFORMATION LETTER - ACC FIELD OPERATIONAL TEST.....	505
D.2 INFORMED CONSENT FORM -ACC FIELD OPERATIONAL TEST.....	507

APPENDIX E — SYSTEM CHARACTERIZATION PROCEDURE.....	511
E.1 TEST 1: CLOSING-IN ON A PRECEDING VEHICLE .....	512
E.2 TEST 2: CHANGING TO A NEW HEADWAY.....	514
E.3 TEST 3: MANUALLY ACCELERATING.....	517
APPENDIX F — CHRONOLOGY OF DRIVERS, VEHICLES, SYSTEMS, AND EVENTS.....	520
F.1 ALGORITHM'S VERSION HISTORY .....	520
F.2 SENSOR'S SOFTWARE VERSIONS.....	521
F.3 FAR OFF SENSORS .....	522
F.4 ASSIGNMENT SUMMARY .....	522

**VOLUME III**

EXECUTIVE SUMMARY.....	534
1.0 BACKGROUND.....	535
2.0 DESCRIPTION OF THE VEHICLE OPERATIONS AND PROCEDURES .....	536
2.1 LONGITUDINAL STRING TESTS.....	536
2.2 CLUSTER TESTS .....	537
3.0 OBSERVATIONS AND OBJECTIVE RESULTS FOR THE FOUR-VEHICLE STRING TESTS.....	538
3.1 DRIVER OBSERVATIONS .....	538
3.1.1 Naturalistic occurrence of vehicle strings.....	538
3.1.2 Harmonic nature of FOT vehicles in a string.....	538
3.1.3 Effect of a four-vehicle string on other traffic .....	539
3.2 OBJECTIVE RESULTS.....	539
4.0 OBSERVATIONS AND OBJECTIVE RESULTS FOR THE EIGHT-VEHICLE STRING TESTS .....	543
4.1 TWO-LANE INTERSTATE HIGHWAY .....	543
4.2 DRIVER OBSERVATIONS .....	543
4.2.1 Formation concerns.....	543
4.2.2 Harmonic nature of FOT vehicles in a string.....	544
4.2.3 Effect of an eight-vehicle string on other traffic.....	544
4.3 THREE-LANE INTERSTATE HIGHWAY .....	545
4.4 DRIVER OBSERVATIONS .....	545
4.4.1 Formation concerns.....	545
4.4.2 Harmonic nature of FOT vehicles in a string.....	545
4.4.3 Effect of an eight-vehicle string on other traffic.....	545
4.5 OBJECTIVE RESULTS.....	546
5.0 OBSERVATIONS AND OBJECTIVE RESULTS FOR THE EIGHT-VEHICLE CLUSTER TESTS .....	549

5.1 DRIVER OBSERVATIONS FOR CLUSTER TEST 1 .....	549
5.2 OBJECTIVE RESULTS .....	550
5.3 DRIVER OBSERVATIONS FOR CLUSTER TEST 2 .....	551
6.0 CONCLUSIONS .....	552
6.1 TEST METHODOLOGY .....	552
6.2 INTERACTIONS BETWEEN MULTIPLE ACC VEHICLES AND NEARBY TRAFFIC.....	553
6.3 FUTURE TEST POSSIBILITIES .....	554
REFERENCES .....	555

## Executive Summary

A field operational test was conducted in which a group of 108 volunteers drove, as their personal car, a passenger vehicle equipped with an adaptive cruise control (ACC) system. The ACC system was incorporated into a fleet of ten passenger cars, each employing a grille-mounted sensor that detects vehicles ahead and controls both the speed and headway of the test vehicle so that the driver can proceed through moderate freeway traffic without adjusting cruise buttons or touching the throttle or brake.

The field test placed the ACC-equipped vehicles in the hands of 108 randomly-invited citizens for use as their personal car for two weeks for 84 of the driver/participants and, during the later stages of the project, 24 drivers were given the vehicle for a total of five weeks. In this manner, the vehicles were put into naturalistic use, without constraining where the person drives, or when, or how. Each driver was also free to choose between operating manually or with conventional cruise control during the first week and between manual or ACC driving during the second (or subsequent) weeks. The table below summarizes the scope of usage covered by these drivers (“CCC” in this table and through the report refers to the usage of conventional cruise control). Approximately 35,033 of the mileage was covered with ACC control actually engaged out of a total of 114,044 miles representing 11,092 individual driving trips. (ACC was used in 2,364 of the 11,092 trips.) No crashes occurred during ACC driving. Persons drove primarily in Michigan but some also undertook long trips within the United States.

No. of Drivers: 108	All Trips		CCC Used	ACC Used	Manual
Distance, miles	114,044		10,764	35,033	68,247
Duration, hours	3,049		165	534	2350

The ACC system under study here can be described in terms of the sensor, the commander/controller, and the driver's interface. The sensor is an infrared device that measures distance and the rate of closure to vehicles in the lane ahead, steering its sensing beam to the right or left as needed to follow lane curvature. The commander/controller acts on the sensory data to modulate the throttle and also downshift the transmission as required to satisfy the driver-selected minimum for headway or spacing to a vehicle ahead. Since brakes are not incorporated into this ACC system, the vehicle has only modest deceleration available for controlling headway — a characteristic that is believed to figure strongly in the field experience reported here. The driver selects among three minimum

headway buttons ranging from “closer” to “farther” and otherwise operates the ACC system through the normal cruise control buttons located on the face of the steering wheel.

The results of the field test, as drawn from instrumented measurements on-board each vehicle and from questionnaires answered by each participant, allow comparison of the ACC driving experience with those of both manual and CCC forms of control. The results also support detailed study of how drivers interact with ACC and how their driving tactics adapt to it. For the most part, the findings follow from one central observation. That is, because people are remarkably attracted to ACC and to its relief of driving stress, they choose to engage the system under as broad a set of driving conditions as possible and they seek to prolong each episode of system engagement. Four aspects of this central observation are summarized below.

### **ACC Comfort and Attractiveness**

The overwhelming majority of participants were comfortable with ACC and were very attracted to this mode of driving. ACC’s appeal derives partly from the relief of a sort of “throttle stress” that otherwise comes from the surprisingly busy and inefficient motions of the throttle pedal that are applied during manual driving. Evidence also supports the view that constraints on human ability to perceive range and relative velocity during manual headway control impose a form of “headway stress” that is also greatly reduced by ACC. Since ACC automatically manages most headway conflicts, it also substantially reduces the interruptions that commonly burden CCC driving. The field test shows that virtually all drivers learn to use ACC comfortably within hours or, at most, a few days and have settled into fairly stable patterns of system usage within a few weeks.

### **Utilization of ACC**

A surprisingly significant, but perhaps obvious, point influencing all of the collected data on ACC driving is that the driver chooses when to use the system. Since driving conditions become judged by the individual as either favorable or unfavorable for ACC usage, all ACC test results derive from the *combination* of a) the driving conditions that prevail once the ACC choice is made and, b) the outcome of driver/system interactions under those conditions. Although the total group of 108 drivers utilized ACC in more than 50% of all miles traveled at speeds above the 35 mph minimum for ACC control, the utilization rates for individual drivers ranged from less than 20% to almost 100% under comparable conditions. That is, very individualized choices are being made about when to use ACC. While freeway environments tended to dominate the observed usage pattern,

participants used ACC twice as much on non-freeway roads as they had used CCC on the same kinds of roads.

The higher rate of ACC usage on surface streets and local highways may be quite significant since these driving environments are more laden with traffic conflict and complexity for the overall driving task. The test data support an hypothesis that pending ACC products that employ automatic braking will experience higher levels of utilization and more non-freeway usage than was seen here with an ACC system that did not incorporate braking. (Clearly, the rates of utilization will be so high, regardless of the braking feature, that motor vehicle travel in the United States will some day be massively exposed to ACC operations if such products reach high levels of penetration in the vehicle population.)

### **The Driver in an ACC-Supervisory Role**

Once the driver has engaged the ACC system, the abiding tactic is to just “let ACC do it,” for as long as seems prudent given the prevailing traffic condition. Throughout the engagement period, then, the driver serves as a “supervisor” over ACC, continually monitoring its limited-authority control activity to determine when manual intervention is needed. Because ACC automatically manages most headway conflicts that do arise, the driver learns to withhold such intervention when conflicts first develop so as to let the ACC controller resolve the situation, if possible. As an apparent result of this tactic for prolonging ACC engagement, relatively higher deceleration levels are observed when the driver does intervene by braking. ACC disengagements were seen to occur, for example, at twice the deceleration levels of disengagements from conventional cruise control, when the driver braked to resolve a headway conflict.

Many participants reported that they especially valued the deceleration cue that can be felt immediately when the ACC controller begins to slow down. While this cue is beneficial for drawing attention to an arising conflict (should the driver be delayed in observing it) evidence suggests that some persons may be relaxing their overall vigilance in some way that adapts to this apparently reliable cue. Future research should strive to determine whether ACC drivers are reducing their visual surveillance of the overall driving scene, perhaps on the misperception that the automatic deceleration cue offers some kind of general-purpose alerting mechanism (which in reality it does not since ACC sensing coverage is narrowly limited).

## **Manual Driving Behavior as the Baseline for Interpreting ACC**

The inherent manual driving style of the individual serves to predispose many aspects of interaction with ACC. A method for classifying the longitudinal control style of individuals was developed in this study, showing that the “tailgater” style, for example, is largely foiled under ACC control. Such persons thus either become “converted” to a more relaxed mode of headway-keeping or choose to turn the system off when it simply impedes their rapid progress through the traffic stream. While all drivers tended toward substantially longer headways under ACC relative to manual control, younger people generally preferred the shortest headway selection available while older persons preferred the longest. Persons in their sixties tended to utilize ACC the most, apparently having found that the properties of this particular system meshed quite well with their more-typically conservative driving style. Significant differences also existed between persons who had previously been users of CCC and those who had not. The CCC users tended to more readily adapt and broadly utilize ACC, although the majority of non users nevertheless rated ACC as an attractive feature that they would also wish to buy. On the flip side, some 5% of participants described themselves as “very uncomfortable” with ACC and unlikely to use it in the future.

## **Conclusion**

Certain conclusions from this field test can be stated quite definitely. It is obvious that the ACC system worked very well, that people learned to use it quickly, and that its great appeal caused it to be heavily utilized. ACC usage definitely serves to lengthen typical headway clearances and even cultivates a less aggressive driving style in many persons. Thus it is easy to argue that ACC will become a highly successful automotive product, if attractively marketed.

The data also show surprisingly high levels of deceleration that prevail when the brake is used to disengage ACC. Less definite results that probably link with this observation relate to subtle aspects of human interaction with this system. Certain safety issues appear to be embedded within these subtleties, but their net effect cannot be predicted. What can be said is that product versions of ACC that incorporate braking are likely to amplify the significance of these subtleties beyond what was seen here.

Moreover, the “shared-control” nature of ACC driving seems to require that system designs be finely matched to the perceptual and cognitive behavior of drivers. Headway control is, after all, a safety-central task that intimately involves the driver in a way that also affects others operating nearby. While offering great promise for improving the

quality of the driving experience, ACC poses an inherent necessity for human-centered design and does not fit a “business as usual” outlook for either automotive product development or highway operations.



## 1.0 Introduction to the Report

This document constitutes the final report on a cooperative agreement between NHTSA and UMTRI concerning a field operational test (FOT) of intelligent cruise control (ICC). The ICC systems employed in this study are known as and referred to as *adaptive cruise control* (ACC) by the partners in the FOT. UMTRI's partners in the FOT are Automotive Distance Control Systems (ADC) GmbH (a joint business venture of Leica and Temic to develop and market advanced distance-control technology), Haugen Associates, and the Michigan Department of Transportation.

This FOT is part of the U.S. DOT's Intelligent Transportation Systems (ITS) program. In general terms, the purpose of this type of FOT is to help to bridge the gap between research and development and the deployment of ITS technology. The tests permit an evaluation of how well newly developed ITS technologies work under real operating conditions, and they assess the benefits and public support for the product or system. Accordingly, this FOT has been conducted in naturalistic transportation service using volunteer drivers. The study is unlike traditional research experiments in which the test conditions are deliberately bounded. Rather the FOT may be compared to a drug test in which the goal is to see if the product is effective in actual usage and if there are any unanticipated side effects. In this study the goals are (1) to see how effective an ACC system may be in providing safer following distances and the convenience of less stressful driving and (2) to determine if any unforeseen difficulties appear to warrant further study.

Per the U.S. DOT's requirements for FOTs, the program involves an independent evaluation, which in this case was led by personnel from U.S. DOT's Volpe National Transportation Systems Center (VNTSC). Volpe is aided in their evaluation effort by their subcontractor, Science Applications International Corporation (SAIC). Although there is an open exchange of test data, plans, and ideas between the partner's group and the independent evaluator's group, this report is entirely the responsibility of UMTRI and its partners.

The material presented here has been prepared by UMTRI to provide NHTSA with an understanding of the conduct and findings of the field operational test (FOT). To that end, this report summarizes the approach and methods used in the FOT and presents results and findings deriving from the testing activities now completed.

Although a particular ACC system was utilized in this project, it is intended that this report characterize issues that, to the maximum extent possible, are fundamental to

human interaction with an automatic driver-selected headway-keeping system. Nevertheless it is clear that specific features of the fielded system have directly determined various details in the human use of these ACC vehicles.

The field-test vehicles are ten 1996 Chrysler Concorde sedans that were purchased and modified to incorporate an ACC functionality. The vehicles were equipped with Leica ODIN 4 infrared ranging sensors. These prototype sensors are part of an electronics package that provides range and range-rate information in a form that is convenient for use in assembling and evaluating an ACC system. Based upon this framework developed by Leica/ADC, a headway control algorithm was created by UMTRI and installed in the vehicles.

A communication network was developed so that the conventional cruise-control system existing on the vehicle could be used as a velocity controller that responds to commands from the headway control unit (“commander” unit). This network also included communication with the transmission controller in the vehicle so that a transmission downshift from fourth to third gear could be used to extend the control authority of the ACC system, thereby increasing the deceleration capability of the system without using the vehicle’s braking system. In addition, the vehicles were extensively instrumented to collect data on driving performance and the driving environment. All of these systems and features functioned in the field operational tests that began in July 1996 and ended in September 1997.

The results presented here portray the driving experience of 108 volunteer driver/participants who operated one of the ten ACC-equipped passenger cars. A total of 84 drivers operated a vehicle for one week without ACC and the next week with ACC available. In addition, 24 drivers had one week without ACC and the next four weeks with ACC available in order to examine the effects of longer exposure to ACC driving. All driving took place within the driver/participants’ natural driving environment.

The results and findings presented in this report use the set of data from the 108 driver/participants to address questions associated with the following operational issues:

- the nature of speed and headway keeping behavior of drivers with and without an ACC system
- when, where, and how drivers use ACC
- driver's ability to adapt to different driving situations while using ACC
- concerns with ACC operation
- the levels of comfort and convenience and safety drivers associate with ACC
- the performance of a current state-of-the-art ACC system

After brief remarks in section 2 covering background information on the ACC project, the main body of the report starts by describing the FOT methodology including considerable detail on the ACC system, the vehicle platform, the data-acquisition system, the experimental design, and the management of the driver/participants and the vehicle systems. Section 4 presents information on the structure of the objective data set that has also been archived for future use. The section includes data related to the characteristics of the drivers. Methods for processing data are discussed briefly in section 5. Measures describing the manual driving behavior of each driver participant are presented in section 6. The driving exposure obtained in the project is quantified in section 7. Sections 8 and 9 presents results and findings concerning driving performance and ACC system issues. A summary of findings is given in section 10 and concluding statements and recommendations are presented in section 11.

## **2.0 Background, Objectives, and Intent**

### **2.1 Project Basis**

Intelligent, or adaptive, cruise control systems (ICC or ACC) are under active development by car companies and their suppliers throughout the world. Such systems, which automatically control headway or range to a vehicle in front, are intended to become the next logical upgrade of conventional cruise control (CCC). However, validation of the comfort, convenience, and safety implications (positive and negative) of such systems has heretofore not been undertaken using normal consumers as test subjects.

This project constituted a field operational test (FOT), which has involved more than a hundred such test subjects. The FOT was intended to serve as the transition between research and development and the full-scale deployment of ACC technologies. The test permitted an evaluation of how well a newly developed ACC technology would work under real operating conditions and an assessment of the benefits and public acceptance of this ACC system.

### **2.2 Project Objectives**

The general goal of this project was to characterize issues that are fundamental to human interaction with an automatic headway-keeping system. The extent to which this goal is realized clearly depends upon the extent to which results from using this particular ACC system can be generalized to other ACC systems.

In addressing this overall goal, the field operational test strives to:

- evaluate the extent to which ACC systems will be safe and satisfying when used by the public
- consider the influences of key system properties such that the results can help in finalizing the design of production systems
- identify design and performance issues that call for further development, market research, industry recommended practices, or public policy
- contribute to the evolutionary process leading to the deployment of ACC systems as a user service
- develop an understanding of how the functionality provided by ACC systems contributes to the safety and comfort of real driving

- qualify how drivers use and appraise the functional properties provided by ACC systems
- develop an appreciation for the public issues and societal benefits to transportation associated with ACC systems

### 2.3 Retrospective Summary of the Project Approach

Figure 1 provides a conceptual overview of the FOT. As illustrated in the figure, the work in the project has involved (1) designing a field test using ideas concerning an analysis structure and an experimental design, (2) collecting exposure information using the testing methodology developed in the project, and (3) processing the resulting large database of field test data to address pertinent issues and their associated items as listed at the bottom of Figure 1. As evidenced in this report, the project has addressed, discovered, and reported important aspects and findings pertaining to all of the items listed in Figure 1.

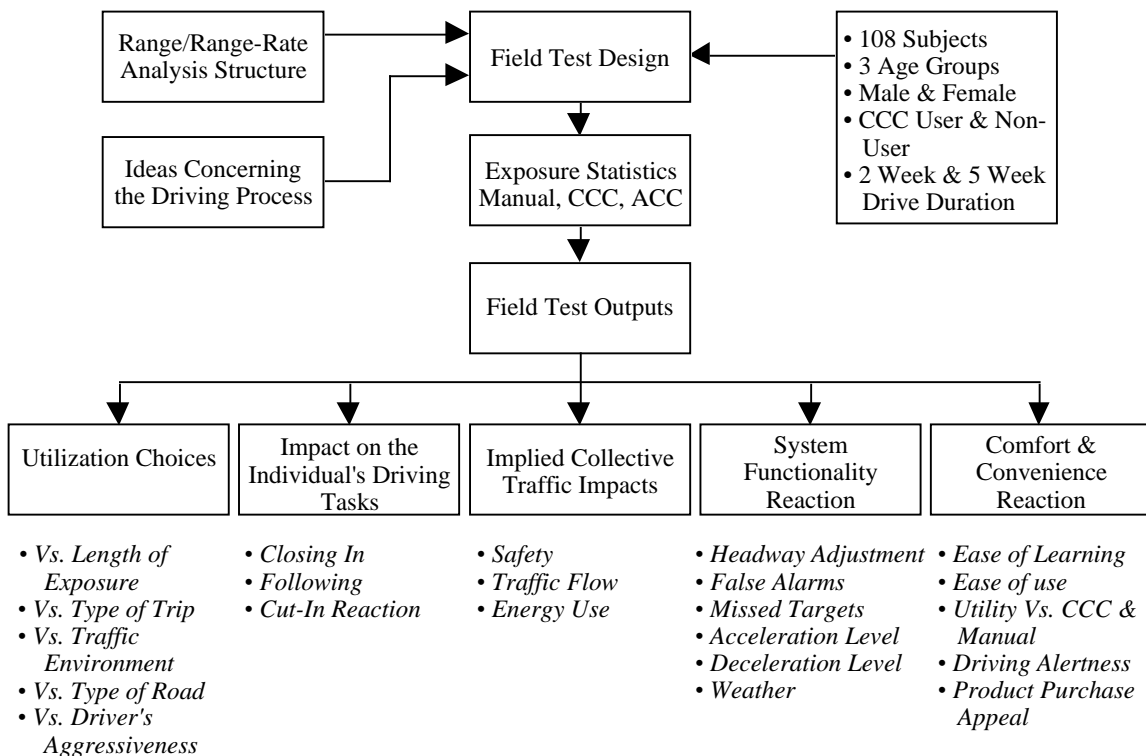

Figure 1. An overview of this field operational test

When operating in a naturalistic environment, it is not easy to answer questions concerning why a particular event happened, but the approach used in this project involved expending considerable effort in attempting to account for why drivers made the

choices they did and why they behaved the way they did. It is believed that such efforts are fundamental to the evolution of a science of driving suitable for use in evaluating the influences of advanced technology.

The findings from this FOT range from almost philosophical considerations concerning the purposes of field tests to specific results and observations concerning ACC functionality, comfort and convenience, utilization, manual driving, and the driver as the supervisor of the ACC system. The following discussion provides philosophical insights on the FOT. The remainder of the report addresses ACC systems per se.

The experience of conducting this field operational test has led to an increased appreciation and understanding of the incredible complexity of driving in a naturalistic environment. This point follows from the observation that, in a typical experiment, the number and scope of choices available to the driver/participant is intentionally limited and well defined. In contrast, in a naturalistic field test the driver/participants choose when, where, and how to drive. This means that, due to the almost unlimited variations of choice and the complexity of the driving environment, certain events may appear to be similar to others but there are always some differences between them.

Even so, the naturalistic features of this FOT have provided the opportunity to investigate and create mental images (models) of how the driver's cognitive skills, rules, and knowledge processes influence manual, CCC, and ACC driving. However, there is no direct method for measuring how a driver's cognitive processes are functioning —at best one can only infer what drivers are thinking by examining objective data revealing what the drivers did and by interpreting subjective data covering driver opinions.

Based upon the experience of having conducted this FOT, the following retrospective view of the purposes of FOTs is offered:

An FOT serves to provide

1. information indicating whether the system under study functions as expected in naturalistic use, whether drivers will use the system in actual transportation service, and whether people will like the system
2. discoveries that are answers to questions no one thought or knew how to ask, other than to ask generic open-ended questions, such as: Could there be any undesirable side effects? or, Are there any surprising benefits?

The researchers conducting an FOT are faced with a dilemma regarding the scope of the study. On the one hand, issues pertaining to safety, traffic flow, and the like call for gathering huge amounts of data for very many samples of the system, almost to the point

of full deployment. On the other hand, practical considerations limit the scope of the study in size and period of time. The net result is that the researchers feel comfortable answering questions pertaining to item 1 on how the system functions, how it is utilized, and liked (even though they could be misled, given the enormity and complexity of the undertaking), but they have reservations about doing more than pointing out observations pertaining to the discoveries alluded to in item 2 above.

### 3.0 The test method

Figure 2 provides a conceptual overview of the FOT methodology. As illustrated in the figure, the work done to provide a test system has involved acquiring system elements, assembling ACC systems and installing them in the test vehicles, designing and building a data-acquisition system, and arranging for a pool of drivers.

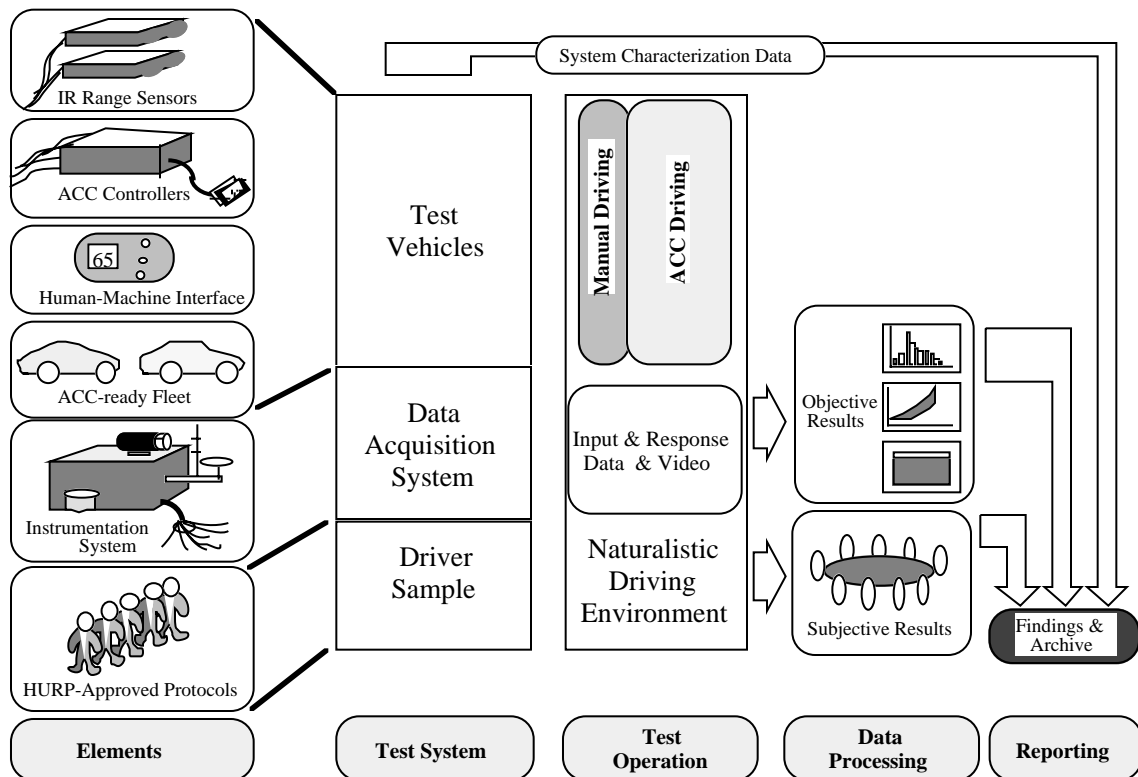

Figure 2. FOT Methodology overview

Key elements of the project approach are:

- use of infrared-based ACC sensors and associated electronic systems, which are engineering prototypes designed by Leica of Switzerland and have been provided under contract by ADC, a joint venture of Leica and TEMIC
- development and installation of headway-control algorithms and communication links as needed to provide ACC functionality in the 10 test vehicles
- development and installation of human-machine interfaces as needed to provide ACC functionality in the 10 test vehicles



- development and installation of a data-acquisition system (DAS) providing quantitative data regarding various driving performance measures along with measures of the driving environment (including video and GPS data)
- selection of test subjects through cooperation with the Michigan Secretary of State office, filling specific cells of subjects for age and CCC system level of familiarity. The basis for use of test subjects entailed meeting requirements of the NHTSA Human Use Review Panel (HURP) protocols
- familiarization training whereby drivers undergo training with UMTRI human factors personnel and then drive the test cars unaccompanied for periods of either two or five weeks (the first week of test car use is restricted to manual driving to provide a basis for comparison with the later ACC driving)
- data acquisition providing quantitative data regarding various driver-performance parameters both at the end of each trip via cellular phone and when the vehicle is returned to UMTRI to change drivers
- driver qualitative data, obtained through survey questionnaires, debriefings and focus group meetings

### **3.1 The ACC System**

The ACC system provides headway-control functionality by adapting the speed of the host vehicle. The driver is provided with the capability to set some of the system's parameters, so as to tailor its operation to individual preferences. The system performs the following functional operations:

- establish and maintain a desired range if there is a preceding target vehicle present, with reference to one of three driver-selectable headway settings — nominally 1.0, 1.4 or 2.0 seconds
- automatically accelerate and decelerate smoothly to maintain desired headway; automatically accelerate to the driver-selected set speed when a target disappears
- establish and maintain a desired speed (set speed) if there is no preceding target
- inform the driver of the detection of a target ahead and of the operating status of the ACC
- decelerate the car when necessary, using throttle reduction; provide added deceleration by transmission downshifting if needed

- ignore targets that have a velocity less than 0.3 of the speed of the ACC vehicle to eliminate false alarms from fixed objects
- minimize any failure to detect targets that have poor reflective characteristics or unusual geometry.

An overview of the layout of the ACC system, with its connections to other components in the vehicle is provided in Figure 3. The various elements in the figure and their functionality are discussed in detail in this section through section 3.3.

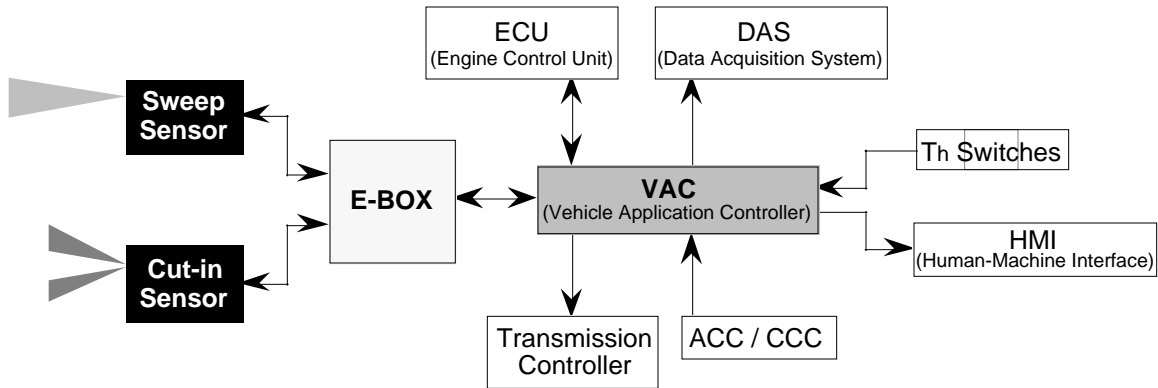

Figure 3. The ACC system layout and its connections

### 3.1.1 ADC ODIN-4 System

The ACC system includes headway sensors, an E-BOX and a VAC, each of which is described below. The headway sensor is a two-sensor combination which includes a main sweep sensor and a cut-in sensor. The E-BOX provides the electrical interface to the sensors, power supply, and the solid-state gyro. The VAC is the hardware/software unit that provides serial interface to the vehicle, data-acquisition system, and to the human-machine interface (HMI).

#### ODIN4 Headway Sensors

The ODIN-4 headway-sensing system as implemented in the FOT is composed of two separate sensors: a sweep sensor and a cut-in sensor. The pair of sensors is being used to maximize target detection performance in near- and far-field ranges. The sensor respective coverage areas are illustrated in Figure 4.

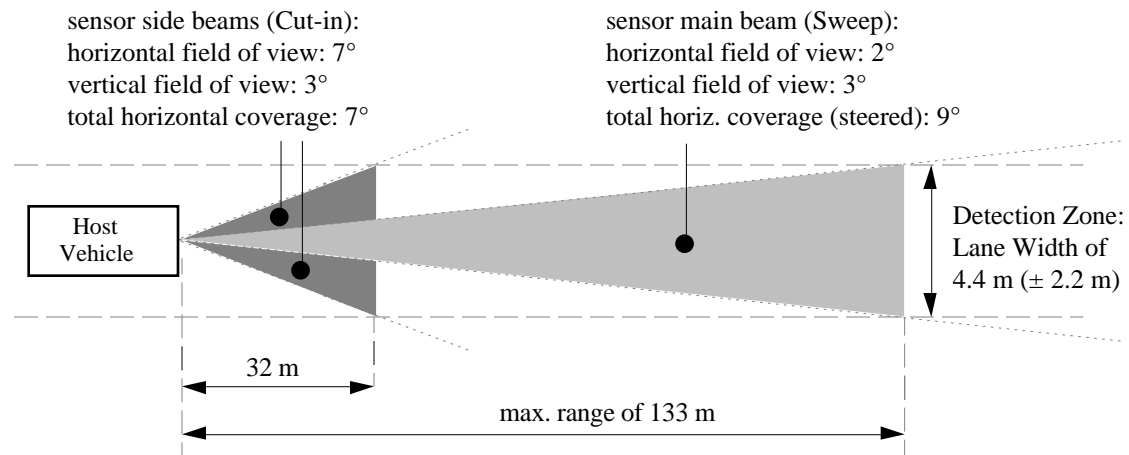

Figure 4. ODIN4 sensors coverage areas

The sweep sensor is a steered laser beam, which is directed left or right using data from a solid-state gyro, which dynamically responds to path curvature. This sensor detects targets in the far field (6 to 150 meters). The considered range, however, of the sweep sensor caused to be limited when the vehicle is on curves, as a function of curve radius. The gyro sends instantaneous curve-radius data to the sensor to steer the beam in the direction of the curve radius. The gyro does not have the capability to predict the road geometry in front of the vehicle. The sensor may lose a target in its lane or acquire a false target in adjacent lanes when the curve radius of the road is  $\pm 500$  meters or less. This may also occur during transition to or from a curved segment of the road, since the sweep sensor is steered only in response to the instantaneous path curvature of the host vehicle. Clearly, any target lying outside of the beam covered geometry will not be detected.

The gyro provided with the ODIN4 sensors requires a maximum reset time of 1.7 seconds. If high yaw rate is produced by the vehicle before the gyro is stabilized, it may establish a “false zero,” so that when the vehicle is driven straight forward, the sensor will be “looking” sideways. It takes 300 milliseconds to direct the beam from its far-right to the far-left position across the 9-degrees field of view.

The cut-in sensor has a fixed beam and limited range. The primary function of this sensor is to detect vehicles that might cut in close to the front of a test vehicle (0 to 30 meters).

Both sensors operate by transmitting pulses of infrared light energy at a wavelength of 850 nanometers. The time of flight for an echo pulse to be received is used to determine range and range rate to a target vehicle.

The sensors are connected in a token ring configuration, and they report one single target. Safety is built into this configuration so that if one sensor fails both sensors would shut down. Outputs from the sensors system include range and range-rate information for the most relevant target. A relevant target is a target whose speed is at least 30% of the speed of the equipped vehicle. This means that stationary targets and targets otherwise traveling less than 30% of the speed of the host vehicle will be ignored. Two update rates are utilized depending on the distance to the target. The minimum update rate is 10 Hz, and the maximum is 100 Hz.

There are several conditions that limit the sensor's ability to detect vehicles at the maximum detection range.

The infrared sensor's performance has been specified based on measurements of a standard target with a reflective surface. Though vehicle regulations require some reflective surfaces such as license plates and warning lights, if these reflective surfaces of target vehicles are missing or obstructed (by mud, luggage, or objects being transported, etc.), these vehicles could be detected at a reduced range.

The wavelength of the infrared laser is 850 nanometers which is close to visible light. Atmospheric conditions (rain, snow, road spray) that obscure human vision also limit the Infrared sensor as well. The infrared sensor does not have the ability to see through what the eye cannot. The sensor's front glass must therefore be kept clean if performance is to be assured. Contaminants such as road spray, snow, mud, etc. inhibit the sensor's ability to transmit and receive laser energy.

In addition to target-related information, the sensors also provide a measure that is indicative of weather-based observation. This measure takes on a numerical value called *backscatter*. As the name implies, backscatter is a measure indicating the relative amount of transmitted laser energy scattered back by the ambient conditions, and that is received by the sensor. Road spray, rain, snow, and fog are examples of ambient conditions that will cause the infrared beam to scatter and to reflect back into the sensor's receiver. Since Infrared laser technology is based on vision, it was assumed that this backscatter information might be used to deduce the prevailing visibility.

Leica performed in 1995 extensive experiments to correlate maximum visibility and maximum detection range as a function of backscatter index (BSI). The results of these tests are installation-dependent: mounting the sensors behind the windshield, mounting them at the grill, and mounting them below the grill. As one might expect, the variance of these tests is high: The higher the mounting is, the less susceptible the sensors are to road-

level spray and contaminants, and therefore similar visibility conditions will result in a lower BSI reading than if the sensors are mounted in the grill or below it. Clearly, below-the-grill mounting will produce the highest BSI reading for given visibility conditions. These tests result in curve-fit expressions that established empirical relationships between visibility distance and backscatter values for each installation. A qualitative illustration of these empirical relationships is provided in Figure 5. In this figure, the empirical relationships are bounded by a maximum range value that is determined by the sensor's ranging limits, and by some maximum backscatter value that represents ambient conditions beyond which the sensor's reading are not acceptable at any range.

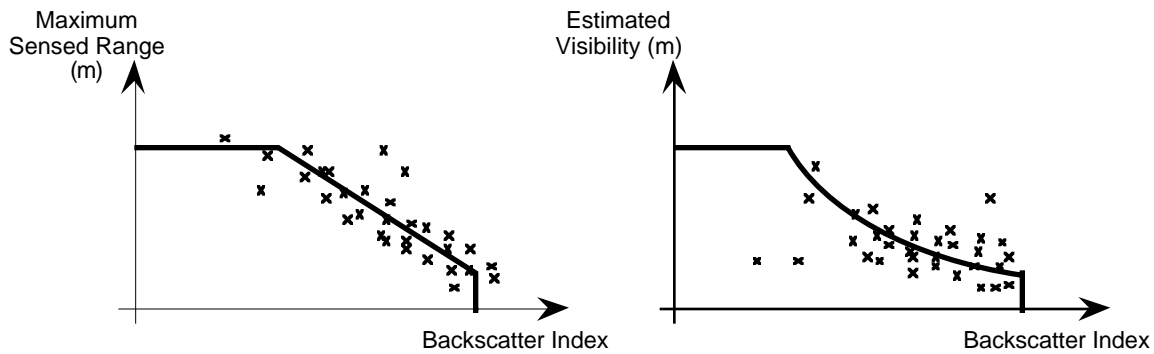

Figure 5. Empirical relationships based on backscatter index

During the design stages of the FOT, we tried to verify these relationships, so that they could be used in the control algorithm. However, only a limited application was eventually made of the backscatter index employing it as a feature in the ACC control algorithm (see sections 3.1.2 and 3.7.2).

### **E-Box**

The E-Box contains the solid-state gyro, the system power supply, electrical interfaces to the sensors and to the VAC, and an external power supply. It features CAN Bus and RS232 serial interface connections that are used for system diagnostic and troubleshooting when the need arises.

### **Vehicle Application Controller (VAC)**

The VAC contains software code and algorithms, including the UMTRI code and algorithms, used to provide the ACC control functions.

The following functions and algorithms are provided via the VAC:

- compute desired speed to achieve ACC functionality
- compute when added deceleration by means of downshift is needed

- communicate with the original equipment (OEM) engine controller unit (ECU) to command the desired speed, receive cruise switch activity, read actual vehicle speed, get throttle position and brake pedal activity
- provide hardware interface to the transmission controller for activating downshift
- read driver's setting of headway switches
- read hardware input establishing the cruise operation mode (ACC or CCC)
- send data to data-acquisition system
- communicate with the E-Box
- activate and control the driver's display

### 3.1.2 ACC Control Algorithm

In this project an approach that uses speed to control headway is employed. The ACC control algorithm has three main conceptual features: (1) it will maintain the speed desired by the driver if no impeding traffic prevails, (2) it will adjust speed as needed to maintain headway with respect to slower traffic, and (3) it will autonomously switch back and forth between the above two operational modes. Figure 6 illustrates this concept.

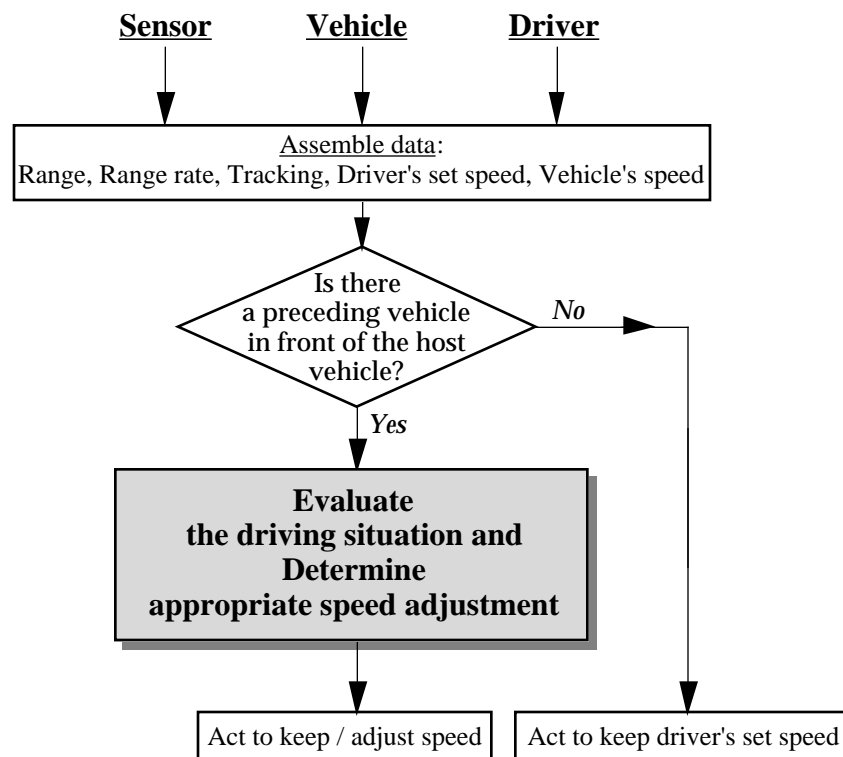

Figure 6. Employing speed to control headway

In the figure, the shaded block entitled “Evaluate the driving situation and Determine appropriate speed adjustment” hosts the control algorithm. The logic of that control

algorithm is based on several premises which constitute the system's characteristics from the standpoint of function and operation:

- Driver's actions always take precedence over the system's.
- The system will never attempt to reach a speed higher than the driver's set speed.
- If the driver brakes — the system does not automatically reengage thereafter.
- If the driver accelerates — the system automatically reengages thereafter (using the previous set speed and headway parameters).
- When speed change is required, it is executed in a controlled and smooth way.
- System's authority is applied gradually:
  - acceleration: from partial throttle application to full throttle application
  - deceleration: from no-throttle coast down to downshifting of the transmission
- Targets that are not a preceding vehicle are ignored.
- Preceding vehicles beyond 525 ft are ignored.
- Preceding vehicles slower than 0.3 of host vehicle's speed are ignored.

### Fundamental Quantities

Figure 7 provides a sketch showing the basic motion variables that are used in the headway controller.

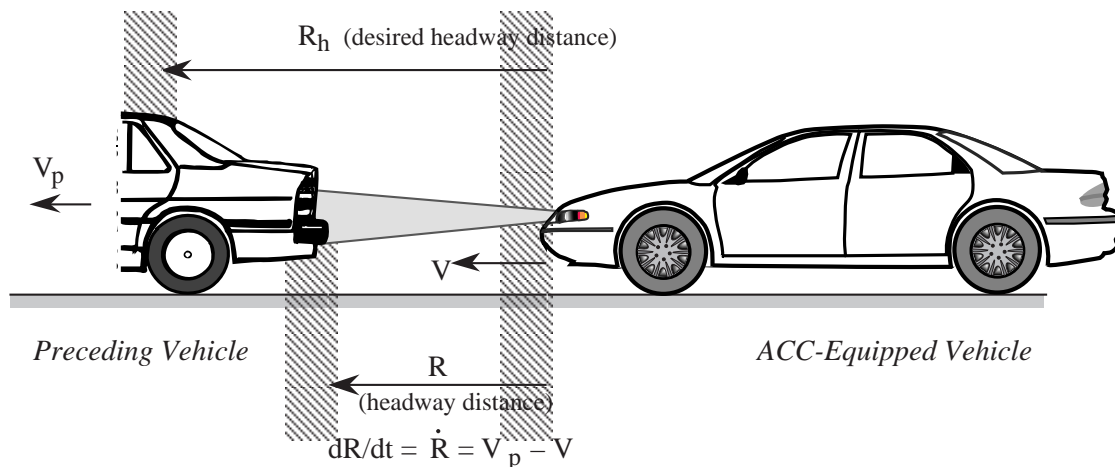

Figure 7. Headway control

The following fundamental quantities are needed to describe headway and speed control:

- $V_p$  — velocity of the preceding vehicle
- $V$  — velocity of the ACC-equipped vehicle
- $R$  — range from the ACC-equipped vehicle to the preceding vehicle

$R_h$  — desired range from the ACC-equipped vehicle to the preceding vehicle (In the situation shown in Figure 7, the ACC-equipped vehicle is closer to the preceding vehicle than the desired range.)

$dR/dt$  — range-rate, the relative velocity between the vehicles (Range rate is also denoted by  $R_{Dot}$  in this report.)

Knowledge of these quantities plus the accelerations of these vehicles allows a complete kinematic analysis of the relative motion between the following and preceding vehicles.

### Algorithm Design

The range-versus-range-rate diagram (Figure 8) is useful for explaining the concepts behind the headway control algorithm employed in the ACC system used in the FOT. Conceptually, the control objective is to perform headway control in accordance with the following equation:

$$T \cdot \frac{dR}{dt} + R - R_h = 0 \quad (1)$$

where the coefficient  $T$  determines the closing rate and serves as a control-design parameter. The equation for the control objective appears as a straight line in the range-rate/range diagram, and the slope of that line is  $-T$ . See the line labeled “Dynamics line for headway control” in Figure 8.

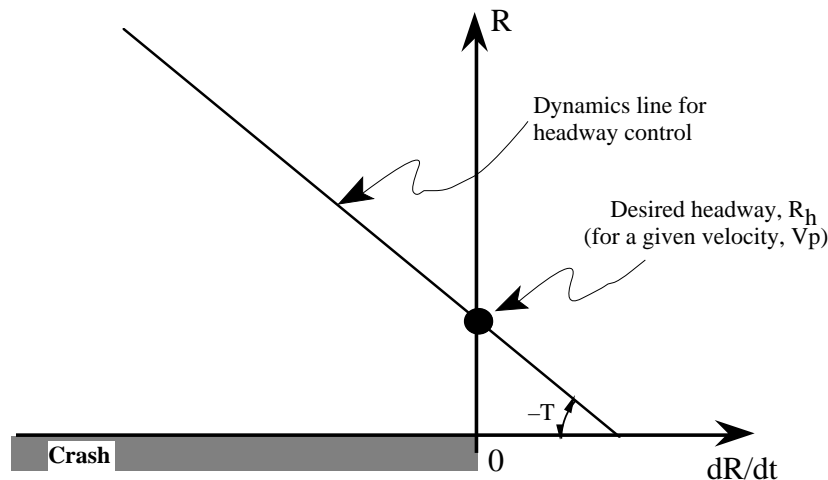

Figure 8. Range rate versus range

For the system to follow the control objective and to perform satisfactorily, the value of the parameter  $T$  should correspond to the dynamic properties of the vehicle, and it cannot be selected too arbitrarily. A small value (i.e., the line in Figure 8 appears more horizontal) will represent a vehicle that can respond quickly with either high deceleration



values (in the  $dR/dt < 0$  side of the plot) or high acceleration values (in the  $dR/dt > 0$  side). Similarly, a large value (i.e., the line in Figure 8 appears steeper) will represent a vehicle with limited deceleration and acceleration capabilities. If too small a value is selected for  $T$ , the resultant commanded speed will call for decelerations (or accelerations) that exceed the available control authority. Selecting a high value for  $T$  will not challenge the control authority, but it will cause the speed-adaptation process of the ACC vehicle to be objectionably long and unnatural. The availability of control authority in the FOT vehicles is bounded by the coastdown-with-downshift deceleration on one hand, and on the other hand by the response of the OEM engine controller to speed commands. Following characterization and optimization tests, the value of  $T = 11$  sec. was used in the design of the particular system employed in the FOT.

The point at  $R = R_h$  and  $dR/dt = 0$  is the ultimate objective for the ACC equipped vehicle. The desired headway at steady following is a linear function of  $V_p$ , the velocity of the preceding vehicle, viz.,

$$R_h = V_p \cdot T_h \quad (2)$$

where  $T_h$  is the desired headway time, which is a control-system parameter. (In the ACC system used in the FOT, the driver can change  $T_h$ . See section 3.1.4.)

The headway distance varies with velocity, thereby providing a fixed margin in time for the system or the driver to react to changes in the speed of the preceding vehicle. The underlying concept here is similar to that which is behind the commonly used advice, "Allow one car length for each ten miles per hour of speed."

The speed of the preceding vehicle is given by:

$$V_p = dR/dt + V \quad (3)$$

using equation (3), measurements of  $V$ ,  $R$ , and  $dR/dt$  are sufficient to evaluate the terms in equations (1) and (2). This means that the difference between the desired control state and our current situation, expressed as an error ( $e$ ) in velocity is as follows:

$$e = dR/dt + \frac{(R - R_h)}{T} \quad (4)$$

where the quantities on the right side of the equation are evaluated using inputs from the sensors and the values of the control parameters,  $T$  and  $T_h$ .

For a vehicle with a cruise-control system, there is already an existing velocity-control system. To make a headway and speed control, one needs to send a velocity command ( $V_c$ ) to the cruise-control unit, so that the desired headway will be attained and maintained. The general idea is that if the preceding vehicle is too close, one must slow

down. If the preceding vehicle is far away, one speeds up (but does not exceed the driver's set speed).

As in sliding control methodology [1], equation (1) may be considered as a "sliding surface" towards which the controller attempts to converge, while equation (4) describes the prevailing error at any given time. Considering equations (3) and (4) together, the error is minimized to zero when the vehicle speed becomes:

$$V = V_p + \frac{(R - R_h)}{T} \quad (5)$$

This velocity value can be viewed as the desired speed for the ACC-equipped vehicle, or the velocity command ( $V_c$ ) to achieve the desired headway ( $R_h$ ), viz.,

$$V_c = V_p + \frac{(R - R_h)}{T} \quad (6)$$

Equation (6) is the basis for a simple design method for extending (or adapting) a speed controller to include an outer control loop that achieves a headway-control function.

A major consideration with such an approach is the amount of control authority (also discussed earlier in the context of the parameter  $T$ ). If, for example, the ACC-equipped vehicle travels at 70 mph and the prevailing conditions call for a commanded speed ( $V_c$ ) of 60 mph, the vehicle can only decelerate so fast before the control authority saturates (its coast-down deceleration). During the time that  $V \neq V_c$  the error is also not zero, and the expression given by equation (1) is not satisfied. In graphical terms, we cannot follow the straight line (the control objective) in Figure 8 when the deceleration (or acceleration) has been saturated at the system's maximum control authority. The further we get from the control objective line, the more critical our situation becomes from a headway-keeping standpoint, and hence the more urgent our response should be.

From the discussion above, it appears that one might divide the range-versus-range-rate space portrayed in Figure 8 into zones based on response urgency, or in other words, based on deceleration levels that are required to attain certain headway clearances (and to avoid a crash).

A trajectory of constant relative deceleration ( $a$ ) in the range-versus-range-rate space is described by:

$$R = R_a + \frac{\left(\frac{dR}{dt}\right)^2}{2 \cdot a} \quad (7)$$

Equation (7) describes a parabola that intersects the vertical axis (range) at some point  $R_a$  (see Figure 9). This point can be viewed as a design factor which may vary from some arbitrary headway threshold all the way down to zero, when crash avoidance is the objective. The higher the parabola's deceleration rate is, the more "flat" the parabola becomes.

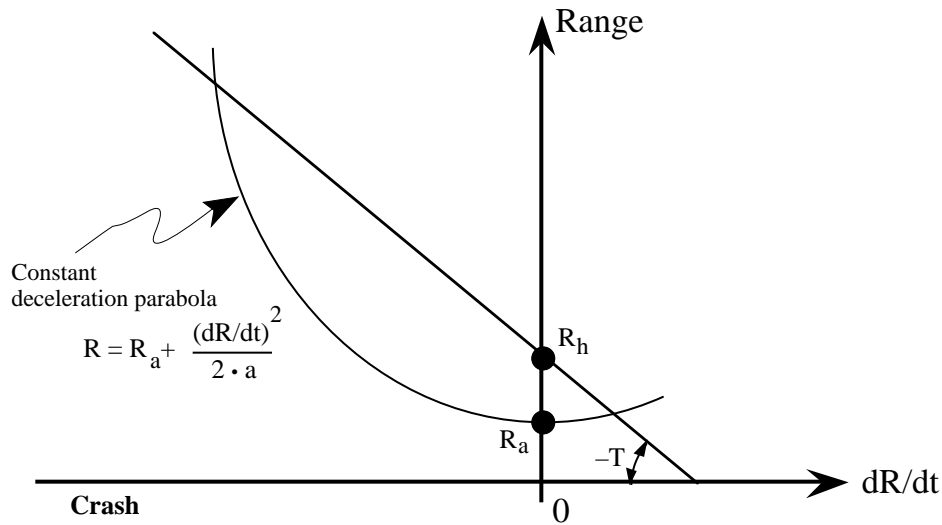

Figure 9. Constant deceleration parabola

With regards to the particular control algorithm employed in the FOT vehicles, the design value of constant deceleration ( $a$ ) used was 0.05 g. This value corresponds to the Concorde's coast-down deceleration on a flat road at highway speeds. As long as the range and range-rate data from the sensors are above the parabola, the vehicle uses only coast down to decelerate. However, if the sensor data are below the parabola, then even with full coast-down authority the ACC-equipped vehicle will end up closer than  $R_a$  to the preceding vehicle. In order to avoid that situation, higher deceleration rate (that is, control authority) is needed.

The software of the electronic transmission controllers in the ten test vehicles has been modified in cooperation with the Chrysler Corporation. This modification allows the control algorithm to command a single transmission downshift. By downshifting, a deceleration rate of about 0.07 g can be obtained. This added deceleration (compared to 0.05 g by coast down only) provides for a higher control authority. With the more flat parabola that is associated with higher deceleration, the range/range-rate trajectory might get back above the parabola and eventually achieve a headway range that is above  $R_a$ , or even closer to the objective  $R_h$ .

## Low-Visibility Function

The overall performance level of this, or any similar ACC system mainly depends upon the ability of the sensors to properly provide information about preceding vehicles. The infrared sensors used in the field test were susceptible to visibility conditions (see discussion in section 3.1.1). For the high-seated driver the visibility may seem acceptable, but because the sensors were mounted in the grill, they could be “blinded” by lower-level road-spray. If the system was engaged and operating, and the prevailing visibility conditions changed so as to cause degradation in the performance of the sensor (without the driver being aware of it), the driver could be placed in a potentially unsafe situation where the system did not respond to what he might have thought was a normal scenario. It was determined that the algorithm must incorporate a function that, under conditions that may inhibit the ability of the sensor to perform, the driver will be notified, and the system will disengage.

Using the backscatter index information reported by the sensors, a threshold value of 50 was established. Once the threshold was crossed for more than 2 continuous seconds, the low-visibility function was triggered. The outcome of triggering the low-visibility function depends upon the status of the ACC system, and is outlined in Table 1.

Table 1. Low-Visibility function

<b>System Status Prior to Trigger</b>	<b>Outcome of Trigger</b>
<i>Engaged</i> (system is actively controlling the speed of the vehicle)	<ul style="list-style-type: none"><li>• Coast down</li><li>• Illuminate low-visibility light (Figure 14)</li><li>• Sound buzzer for 2 seconds</li></ul>
<i>Standby</i> (system is turned on, but not actively controlling the speed of the vehicle)	<ul style="list-style-type: none"><li>• Illuminate low-visibility light</li></ul>

Once the function was triggered during a system engagement, the driver had to take action (i.e., disengage the system manually) before being able to reengage it. From the driver’s perspective, the system had simply issued a warning that visibility is bad, whereupon the vehicle started slowing down. When the weather constraint dissipated, the “low-visibility” lamp would go out, thereupon permitting manual reengagement of ACC.

## Control Architecture

A depiction of the architecture of this ACC system that uses throttle and transmission algorithms to control speed and headway is shown in Figure 10. The figure shows the sensor's range and range-rate signals as inputs to the control system. The velocity of the ACC-equipped vehicle serves as the feedback signal used in an outer control loop and in two inner loops: one inner loop for throttle actuation and the other inner loop for transmission downshift actuation.

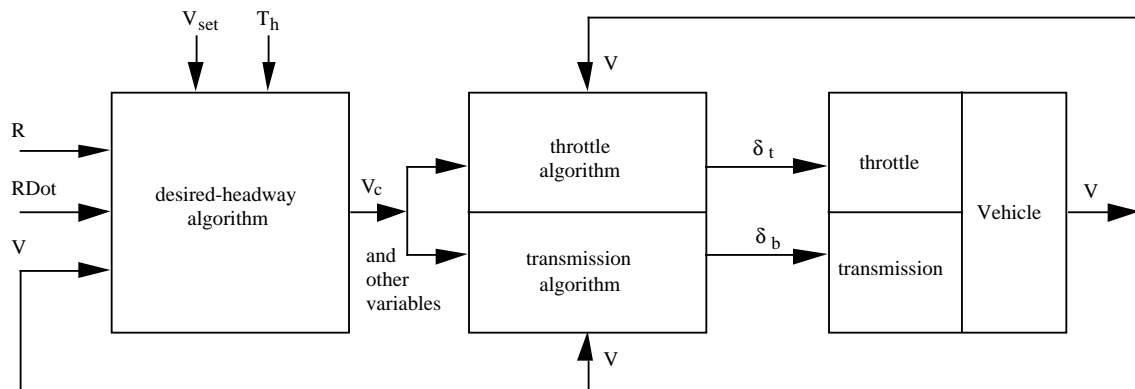

Figure 10. Control architecture for FOT ACC system

The control concept is based upon an overall goal for the ACC system. This goal is expressed by equation (1). At any given time, the system's state relative to that goal is given by the error in equation (4). When the goal is obtained, the error becomes zero.

In order to better explain the control idea, its basic generalized form is illustrated in Figure 11.

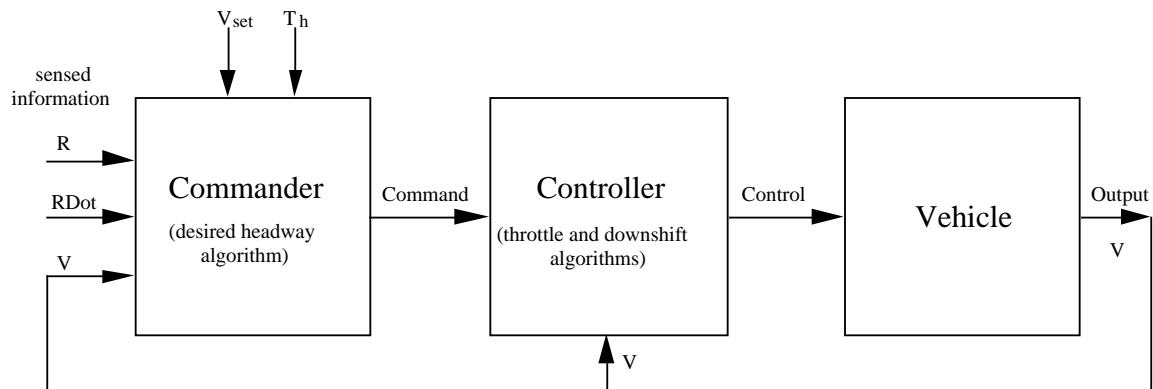

Figure 11. Control architecture with a commander

The outer loop (which includes the inner loop as a special actuation loop) involves a “commander” element that looks at the sensed information, including the velocity of the

vehicle and the external quantities  $R$  and  $R\dot{D}$  and decides what “command” to give to the “controller.” The controller uses this command to generate control signals that cause the vehicle to respond in a manner that is consistent with the goal.

Throughout the above discussion, the variable  $T_h$ , which is the desired headway time for following, has been shown to hold a prime importance. Clearly, it is a variable whose value greatly depends upon individual preferences. The design of the ACC system employed in this FOT allows the driver to select one of three possible values for that variable. The functional structure of the system is depicted in a block-diagram form in Figure 12.

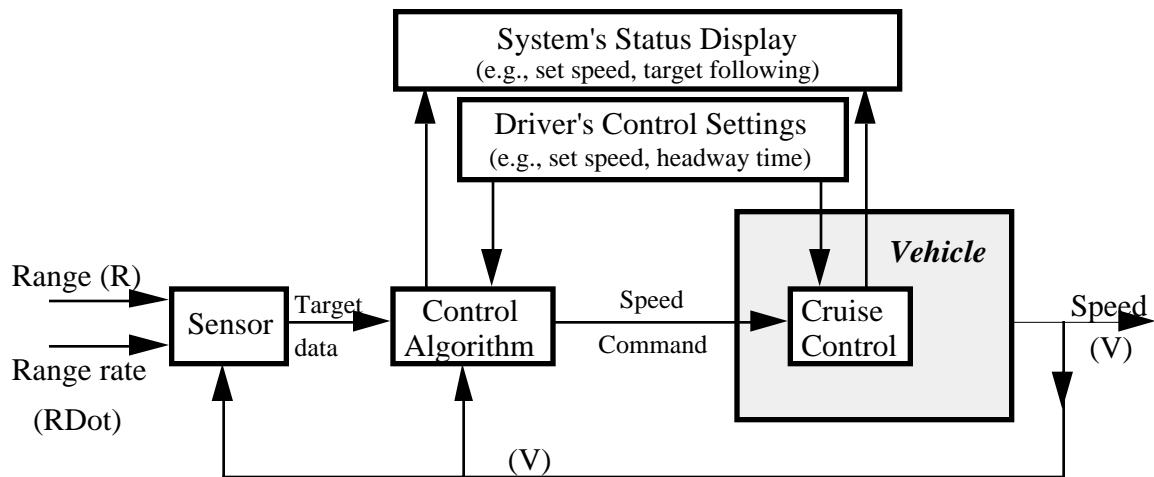

Figure 12. ACC System structure

In this design the driver can also provide other inputs that are essential to the operation of the ACC system: engaging/disengaging the system, setting speed, or pressing the brake. At the same time the system provides the driver with feedback about its operating status: what the set speed is, what its activation state is, and whether targets are tracked.

### 3.1.3 Sensor Calibration and Alignment

Both the sweep and cut-in sensors need to be aligned when installed on a vehicle. When properly aligned, the beam of the sweep sensor will be tilted in azimuth at an angle  $\alpha$  relative to the vehicle’s true-running centerline, so that at a range of 120m, the beam’s center will overlap with the center of the lane. Similarly, the aligned cut-in sensor is tilted in azimuth at an angle  $\beta$ , and the beam’s center coincides with the center of the lane at a range of 30m. These range values (120m and 30m) are determined by the maximum range of the sweep and cut-in sensors respectively. A top-view depiction of the alignment objective is provided in Figure 13. In addition, the sensors must also be aligned in terms

of elevation, so as to avoid energy reflections from the ground. Azimuth and elevation adjustments are made using set screws in the installation kits.

Loading of the vehicle (weight in trunk) without load stabilization may impact the vertical alignment of the sensor in that the front end of the vehicle would be higher. No means of self stabilization was provided in this installation.

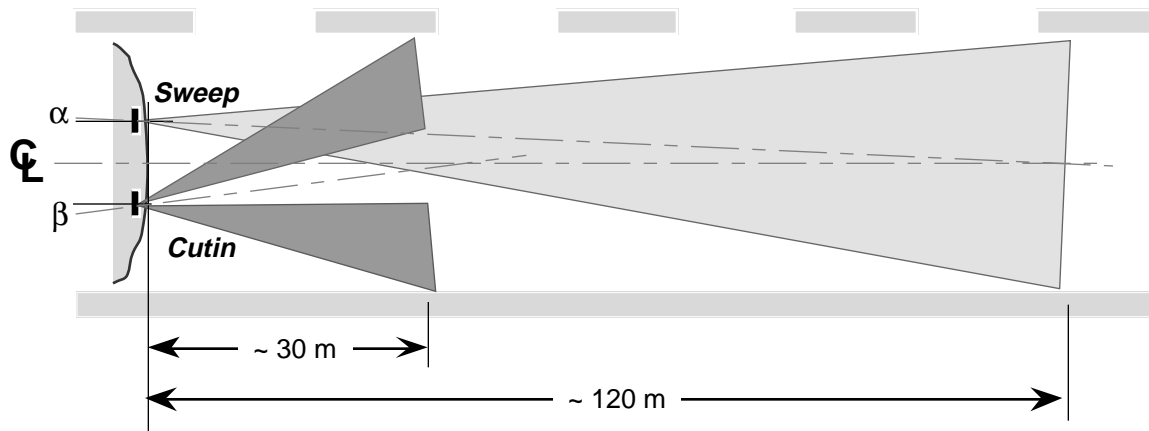

Figure 13. Top view of aligned sensor beams

### 3.1.4 Human-Machine Interface

An integral part of the ACC system was the driver interface. The interface used for conventional cruise control was maintained in its OEM configuration and incorporated into the control of the ACC system. However, several new elements were added in order to accommodate use of ACC. The driver interface is illustrated in Figure 14.

The items in the headway controller's driver interface included a display for presenting the set speed to the driver, a light accompanied by an audible tone for indicating when visibility was poor, and a light for indicating when the ACC system had recognized a preceding vehicle. In addition there was a set of switches for the driver to use in selecting headway time (labeled as "HEADWAY" in Figure 14). The right-most button was labeled "Farther," the left-most button was labeled "Closer," and the center button was unlabeled. By pushing one of these buttons the driver could select nominal headway times of 2.0, 1.0, and 1.4 seconds, respectively.

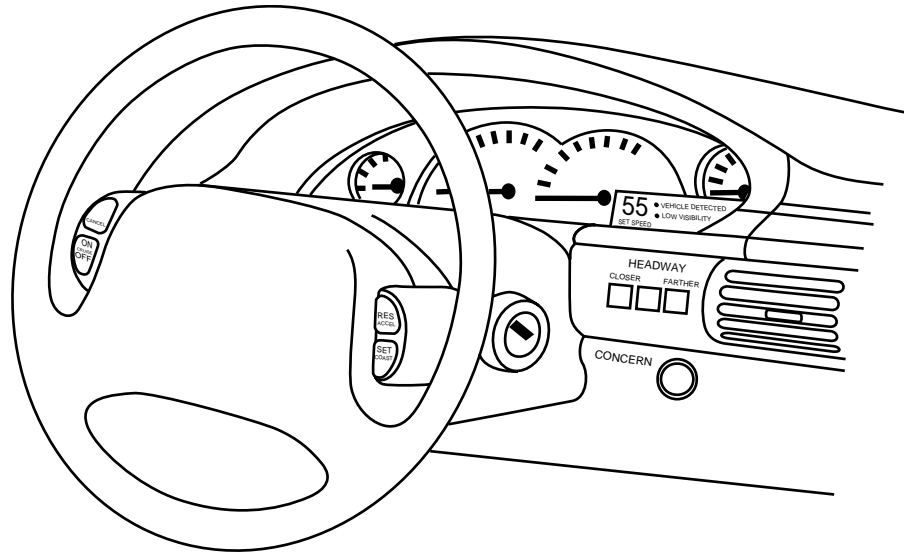

Figure 14. Chrysler Concorde instrument panel with ACC controls and displays

### **Headway Adjustment Control**

The control for adjusting headway was composed of three buttons (Switchcraft® Series 6700 Multi-station Switches). These buttons were interlocked with lock-out such that a solenoid release would prevent more than one button from being depressed. The buttons for headway adjustment were white in color and illuminated only when the vehicle headlamps are on. The face of each button was 16 mm square and had a travel of 4.75 mm. Positive identification was achieved through snap feel and back illumination. Barriers were installed between buttons to guide fingertips away from adjacent buttons and prevent inadvertent actuation. The headway adjustment control was located on the driver's right-hand side (see Figure 14). The location of the control relative to the line of sight was down and to the right not more than 36 degrees of visual angle. The labeling for the control was composed of white lettering on a black background. The subtended visual angle of the characters was not less than 17 minutes of arc.

### **Concern Button**

The so-called concern button was a device that allowed the participants to mark in the data stream an event in time at which they had become concerned or dissatisfied with the performance of the ACC system. The button was an illuminated flush-mounted momentary-contact pushbutton, with the button face flush with the button bezel. The button face was 12.5 mm in diameter and had a travel of 3 mm. The button was yellow in color, and illuminated only when the vehicle headlamps were on. The concern button was located at the top of the knee bolster, on the driver's right-hand side (see Figure 14). The



location of the button relative to the line of sight was down and to the right not more than 34 degrees of visual angle. The labeling for the control was composed of white lettering on a black background, where the subtended visual angle was not less than 17 minutes of arc.

### **Conventional Cruise Control Interface**

The switches for operating the conventional cruise-control system were also used in the operation of the ACC system. The vehicle's manufacturer established this interface. The switches for turning the cruise control on, off, canceling, setting, resuming, accelerating, and coasting were all located on the face of the steering wheel (see Figure 14). These controls consisted of two three-position rocker switches (on-none-on configuration) located on either the left or right side of the steering wheel hub. The switch surfaces were approximately rectangular, measuring 54 mm in length and 17.5 mm in width. The location of the switches relative to the line of sight was down and to the right or left not more than 38 degrees of visual angle. The labels were white capital characters on a black background. The subtended visual angle of the characters was not less than 17 minutes of arc. These buttons were not back illuminated. During ACC operation, each tap on the rocker side labeled "ACCEL" increased the set speed by 2 mph, and each tap on the side labeled "SET" decreased the set speed by 2 mph.

### **Set Speed Display**

Two seven-segment light-emitting-diode (LED) digits displayed the vehicle's set speed. These digits were green in color, and illuminated to approximately 75 cd/m<sup>2</sup> in daytime conditions (headlamps off) and 5 cd/m<sup>2</sup> in nighttime conditions (headlamps on). The subtended visual angle of the digits was not less than 25 minutes of arc. The set speed display was located in the rightmost portion of the instrumentation cluster (see Figure 14). The location of the set speed display relative to the line of sight was down and to the right not more than 29 degrees of visual angle. The labeling for the display was composed of white lettering on a black background. The subtended visual angle of the characters was not less than 17 minutes of arc.

### **Sensor Status Displays**

Two LEDs were used to display the ACC sensor status. The first display, indicating a "vehicle detected" condition, was a green LED that indicated that the ACC system had a valid target in its path. This LED would only illuminate when a valid target was present. The display was illuminated to approximately 75 cd/m<sup>2</sup> in daytime conditions (headlamps off) and 5 cd/m<sup>2</sup> in nighttime conditions (headlamps on). The subtended visual angle of

the vehicle-detected display was not less than 11 minutes of arc. The vehicle-detected display was located in the rightmost portion of the instrumentation cluster, and to the immediate right of the set speed display (see Figure 14). The location of the vehicle-detected display relative to the line of sight was down and to the right not more than 32 degrees of visual angle. The labeling for the display was white lettering on a black background. The subtended visual angle of the characters was not less than 17 minutes of arc.

The second display, low visibility, was a series of red LEDs that indicated that the ACC system could not properly function due to reduced visibility or system failure. This display would only illuminate when reduced visibility or system failure existed. The display was illuminated to approximately  $75 \text{ cd/m}^2$  in daytime conditions (headlamps off) and  $5 \text{ cd/m}^2$  in nighttime conditions (headlamps on). The subtended visual angle of the low visibility display was not less than 11 minutes of arc. The low visibility display was located in the rightmost portion of the instrumentation cluster, and to the immediate right of the set speed display (see Figure 14). The location of the low-visibility display relative to the line of sight was down and to the right not more than 32 degrees of visual angle. The labeling for the display comprised black lettering on a clear background. The subtended visual angle of the characters was not less than 17 minutes of arc. When on, the red LEDs back illuminated a label stating “Low Visibility.”

The low-visibility display also included an auditory component that was provided to the driver whenever the ACC system could not properly function due to reduced visibility or system failure. The auditory component of the low visibility display was characterized as a warble tone with a center frequency of  $2400 \pm 500 \text{ Hz}$ . The intensity of the auditory component was not more than 80 dB at the position of the driver’s ear, with a duration of 2 seconds. The auditory component of the display was only provided at the initial onset of the low visibility criteria.

### **3.2 The Vehicular Test Platform**

The test platform refers to the complete, integrated ACC and data-acquisition packages on-board the vehicle, in a “ready-to-roll” configuration. It includes the instrumented vehicle with ACC functionality, and all the necessary driver interface elements to enable ACC operation. This section describes the base vehicle which served as the automotive platform in the field test, the provisions that had to be made for the integration of the ACC system, and the activities that took place to ensure a proper, safe functionality of the test platform each time it was delivered to a participant.

### 3.2.1 The Base Vehicle

The vehicles procured for this project were '96 Chrysler Concordes. The Chrysler Concorde is a five-passenger sedan which belongs to the family of Chrysler LH-platform cars. This family also includes the Dodge Intrepid, Eagle Vision, Chrysler New Yorker and Chrysler LHS. The New Yorker and LHS have bigger trunks and C-shaped C-pillars, but other than these features they are mechanically similar to the other cars.



Figure 15. Chrysler Concorde

The primary motivation for using the Chrysler Concorde as the FOT vehicle platform was based on ADC's prior experience with integrating an ACC system onto the Chrysler LH platform. Early experience indicated that a careful tailoring of the ACC application to the selected vehicle must be made if good performance is to be ensured. Tailoring requires suitability of the electronics interface and matching of the control system parameters to the longitudinal response properties of the vehicle. ADC's earlier integration experience with the Chrysler LH platform was found to be most helpful during the pretesting task of designing the system's installation.

The following are highlights from the vehicle's specification, which also served as guidelines when procuring the cars:

1. Model — 1996 Chrysler Concorde LX, option package 26C
2. Engine — 3.5-liter (215 CID) 24-valve V6, 214 hp, 221 lb-ft
3. Transmission — four-speed automatic transaxle with overdrive, electronically controlled
4. Brakes — power-assisted, 4-wheel disc antilock system.

5. Steering — variable assist, speed-sensitive rack-and-pinion power steering with tilt steering column
6. Suspensions — front: Independent system with gas-charged (MacPherson-type) struts and double ball-joint stabilizer bar; rear: independent multilink suspension
7. Mirrors — inside mirror has a power antiglare system; both external mirrors are remotely controlled and heated
8. Dual Air Bags — driver and front-seat passenger are both protected by an air bag supplemental restraint system
9. Rear Defroster — electric heating elements fused to the glass of the rear window
10. Trunk — low-liftover edge of open trunk, and large cargo space to accommodate both luggage and data-collection equipment
11. Other equipment — factory installed seat belts for all passengers, cruise control, power windows and locks, and air conditioning; antitheft alarm installed separately

### **3.2.2 Provisions for the Integration of the ACC System**

Within the framework of this field operational test, one of UMTRI's functions was to be the system integrator. ADC provided the sensors and control modules as parts, the vehicle was delivered in its standard configuration off the dealer's lot, and the specially designed human-machine interface (HMI) was assembled separately. The components of the ACC system had to be installed in the vehicle, communication links with some of its electronic control units (ECU) had to be provided, and installation of the HMI was to be made in a way that would ensure an integrated, functional ACC system that could be field tested. These activities for all the ten vehicles in the FOT fleet were performed by UMTRI, and they are described in this section.

In addition to the vehicle-wide wiring work, the integration task of the ACC system was focused in four main areas of activity: (1) sensors at front grill and bumper, (2) transmission controller and power supply in the engine compartment, (3) HMI and ECU interface in the dashboard area, and (4) VAC and E-BOX in the trunk. Figure 16 on the next page shows these areas, and also a list of the activities related to the integration of the ACC system. Many of the subsystems shown involved substantial preassembly before they could be installed. Also of significance was the installation and routing of a wire harness that provided power and data connectivity between the different systems. The sequence of the tasks was optimized to help avoid repeated disassembly and modification of the vehicle components and existing subsystems.

- 1. Fabricate instrumentation chassis
- 2. Install VAC and E-Box in instrumentation chassis
- 3. Assemble & check instrumentation chassis
- 4. Modify grill and front bumper cover
- 5. Install sensors and mounting brackets
- 6. Fabricate board & box for brake lamp mod
- 7. Fabricate HMI circuit board
- 8. Modify ADC's HMI controller box
- 9. Stuff & assemble HMI display
- 10. Remove dashboard, center console, and rear seats
- 11. Fabricate sensors Plexiglas covers
- 12. Fabricate sensor foam inserts

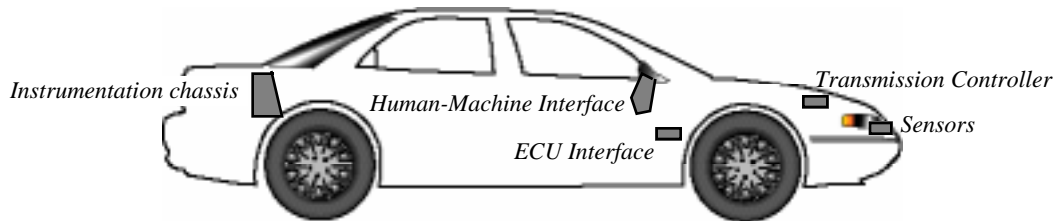

- 13. Add vehicle-wide supplemental wiring
- 14. Install connectors on wiring
- 15. Dress wiring
- 16. Install brake lamp mod box
- 17. Install & connect instrumentation chassis
- 18. Re-install seat belts & back seat
- 19. Modify trunk carpet
- 20. Install HMI controller
- 21. Install HMI display and hood
- 22. Install HMI cover & labels
- 23. Install buzzer
- 24. Fuse and attach battery connections
- 25. Fabricate and mount ECU interface connector
- 26. Connect and verify communication to the ECU
- 27. Modify Chrysler's transmission connector
- 28. Modify Chrysler's transmission software
- 29. Install wire to Chrysler's transmission controller
- 30. Shrink-wrap sensor connectors
- 31. Align sensors; modify mounting as needed
- 32. Install sensor foam inserts
- 33. Install cut-in Plexiglas cover

Figure 16. ACC System installation checklist

## Sensors

With the sensors, ADC provided an installation kit, which includes an adjustable mounting. Once the sensor is installed into this mounting, it is possible to adjust its orientation using several adjustment means. Installing the sensors in the vehicle involved modifying the adjustable mounting, affixing it to the vehicle's front bumper, and modifying the grill to accommodate the sensors.

The adjustable mounting includes a subframe onto which the sensor is attached. This subframe can be slid up or down, and it can also be rotated in azimuth and elevation. To accommodate installation in the grill between the bumper and the cooling radiator, it was necessary to modify some parts of the adjustable mounting. Special brackets were fabricated and welded to the bumper frame, and the modified adjustable mountings were bolted onto these brackets.

Special openings were cut in the grill to accommodate the sensors. Also, provisions were made to allow access to the adjustment screws of the mountings without any parts removal. The installed sensors are shown in Figure 17. The transmitter and receiver of the

sweep sensor are shown on the driver's side of the grill; those of the cut-in sensor are shown on the passenger's side of the grill.

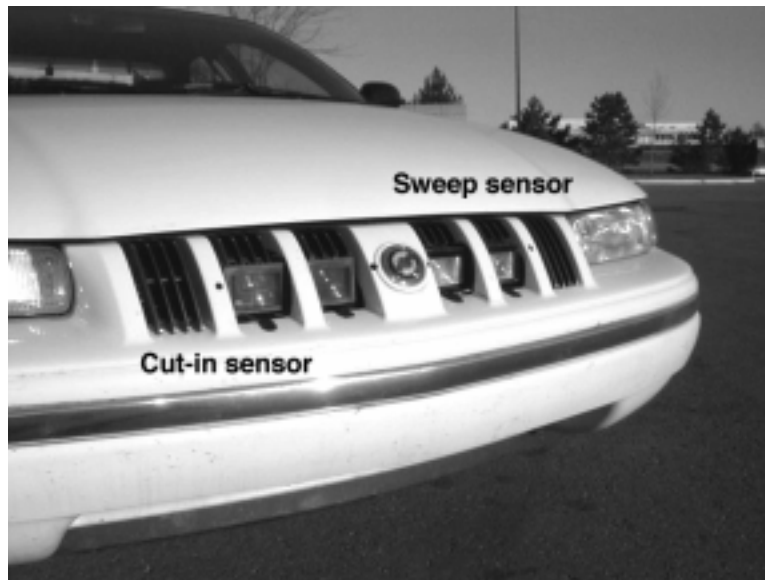

Figure 17. Sensors installed in the grill

Item number 33 in Figure 16 is “Install cut-in Plexiglas cover.” During the early stages of the field test it became evident that the glass lenses of the cut-in sensor were quite fragile. That fact, combined with the forward, low mounting introduced a problem of the glass lens breaking quite often. The sweep sensor did not have this problem, since it had a lens that was made of a much thicker glass. ADC provided a solution for the problem in the form of protective Plexiglas covers that were glued to the lenses. As a preemptive measure, a Plexiglas cover was installed onto the sweep sensor as well. These covers were proven effective in the course of the FOT.

### **Transmission Controller**

Using a special-purpose communication tool (DRB-2) provided by Chrysler, UMTRI personnel modified the software of the electronic transmission controllers in the ten test vehicles. This modification was needed to allow the transmission to downshift by command from the control algorithm (see discussion under “ACC Control Algorithm”).

### **VAC and E-Box**

The VAC and the E-Box are housed together with the data-acquisition system (DAS) module. Though not necessary for the operation of the ACC system, the DAS installation had to be completed for the VAC / E-Box to be mounted and connected.

The DAS housing is mounted in the vehicle's trunk compartment adjacent to the rear surface of the rear passenger seat. An enclosing structure of Dow blue Styrofoam (R-10.8) with cover was provided to contain the electronics package within a thermally stabilized environment. This covering was modified to suit the particular demands of each temperature season. The covering also protected the equipment from damage or tampering by the participants. The structure consumed about a third of the trunk, however it did not interfere with access to the spare tire. Figure 18 shows the VAC and E-BOX mounted in the DAS housing in the trunk (without the covering).

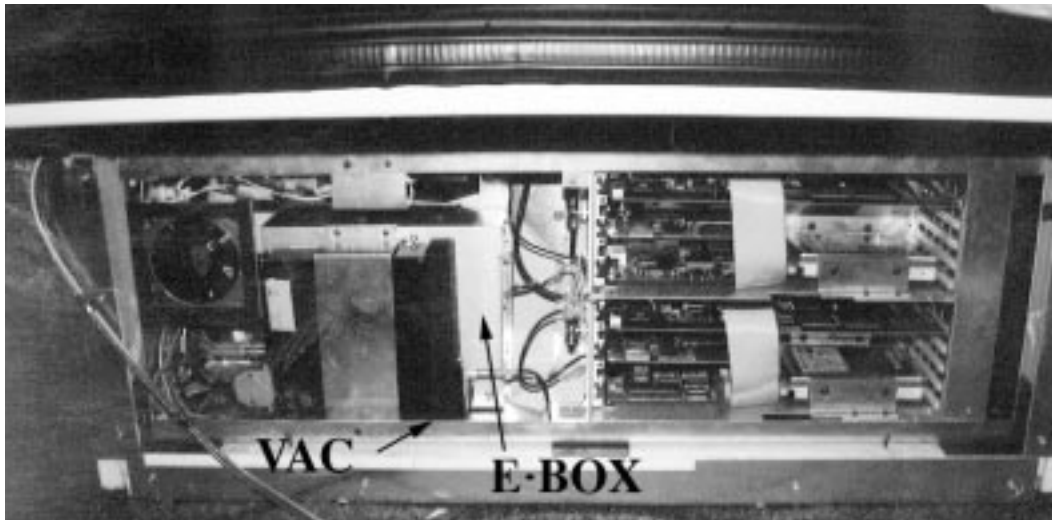

Figure 18. VAC / E-Box in the DAS housing

### 3.2.3 Preparation of Each Vehicle for Use in Field Data Collection

Data were collected in the FOT vehicles from four sources: (1) VAC – data from the ACC system and from the vehicle, (2) GPS system – geographic location data, (3) HMI – driver input data, and (4) video camera – visual samples of the forward scene. Provisions had to be made to store the data and to transmit selected data summaries back to UMTRI via a cellular modem. Figure 19 shows these data sources, and also a list of the activities related to the installation of the DAS system.

A general view of the data acquisition chassis as it is mounted in its insulated box in the trunk is provided in Figure 18. The primary DAS components that were mounted within the chassis are a data processor subsystem, a video processor subsystem (subsystems include disk drives, power supplies, and I/O support cards, shown as the racks on the right of Figure 18), the GPS receiver, cellular modem transceiver, environmental controller, 12V batteries, and the power delivery system.

- |  |  |
|--|--|
| <input type="checkbox"/> 1. Fabricate instrumentation chassis                | <input type="checkbox"/> 6. Build up camera assembly     |
| <input type="checkbox"/> 2. Install VAC and E-Box in instrumentation chassis | <input type="checkbox"/> 7. Add supplemental wiring      |
| <input type="checkbox"/> 3. Assemble & check instrumentation chassis         | <input type="checkbox"/> 8. Install connectors on wiring |
| <input type="checkbox"/> 4. Fabricate cover plate attachment                 | <input type="checkbox"/> 9. Dress wiring                 |
| <input type="checkbox"/> 5. Fabricate GPS antenna backplate                  | <input type="checkbox"/> 10. Mount cellular antenna      |

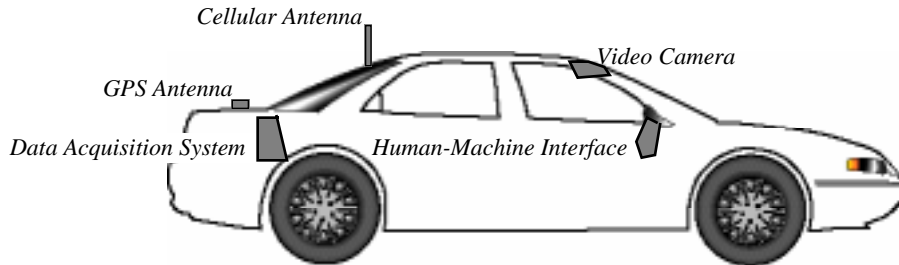

- |  |  |
|--|--|
| <input type="checkbox"/> 11. Mount GPS antenna                         | <input type="checkbox"/> 16. Defeat "Rec" air button             |
| <input type="checkbox"/> 12. Install & connect instrumentation chassis | <input type="checkbox"/> 17. Reinstall seat belts & back seat    |
| <input type="checkbox"/> 13. Remove dashboard                          | <input type="checkbox"/> 18. Modify trunk carpet                 |
| <input type="checkbox"/> 14. Install concern button                    | <input type="checkbox"/> 19. Position and install video camera   |
| <input type="checkbox"/> 15. Wire concern button                       | <input type="checkbox"/> 20. Fuse and attach battery connections |

Figure 19. DAS System installation checklist

Following the installation and preparation, each vehicle was given a final verification checkout. This checkout consisted of the following tasks:

- power-up check
- ACC communications check
- HMI communication check (LED & buttons algorithm)
- ACC functional check
- cellular data transfer
- alarm installed and functioning
- verify equipment tracking sheet
- mileage run-in

## GPS

The GPS system uses a Trimble six-channel receiver model SVeeSix-CM3. The receiver is mounted inside the DAS insulated housing in the trunk, and the active antenna is mounted on the center of the trunk lid. The original mounting of the antenna was modified, and a backplate was added to allow screwing the antenna to the lid (instead of a magnetic attachment). Also, the antenna wire was reconnected to provide a more protected route.



## **Human-Machine Interface**

The “Concern” button, which allows the driver to provide some input regarding his or her observation of the ACC functionality, is part of the HMI. It is mounted on the dashboard (see Figure 14), and it is wired to the DAS in the trunk.

## **Video Camera**

The CCD video camera is mounted on the inside of the windshield, behind the rear-view mirror (see Figure 20). It has a wide-angle forward view, and it continuously digitizes and stores captured video to internal buffers in the video computer of the DAS.



Figure 20. Forward-looking CCD camera

## **Cellular Communication**

The cellular communications system consists of an AT&T KeepInTouch 14.4-Kbps cellular modem, a Motorola 3-watt transceiver, and an antenna. The modem and the transceiver are located within the DAS chassis, and the antenna is mounted at the top of the rear windshield.

### **3.2.4 System Characterization Procedure and Results**

Tests to characterize the performance of the overall system were conducted by UMTRI engineers on public roads covering a broad set of operating scenarios. Each test elicited a certain response that served as a meaningful description of system properties. Data were collected using the same data-acquisition package as was installed in each car for operational testing. Test variables that were controlled include the host vehicle speed, lead vehicle speed, state of the control system, and relatively simple steering and braking maneuvers. In each test, the properties of the system were characterized independent of human behavioral variables. A comprehensive description of the characterization-tests procedure is provided in appendix E, which also includes example plots of test results.

Each of the test measurements was conducted with negligible road grade and head wind. Further, some of the tests required that a *co-op vehicle* be engaged to execute preplanned interactive movements between the host vehicle and a preceding vehicle. In these cases, the co-op vehicle was simply another passenger car driven by a collaborating staff member.

### 3.3 The Data-Acquisition System

The data-acquisition system installed in the ACC-equipped vehicles was designed to collect, process, and store both numerical and video data files using two on-board computers to quantify aspects of the driving process that are pertinent to the control of speed and the headway gap relative to the closest preceding vehicle. The data were collected and stored on a trip-per-trip basis. Once a trip was completed, an on-board computer sent summary data via cellular phone to a server at the base station. These data were mainly in the form of histograms and trip summary numerics computed on-line to describe features of the trip. After two to five weeks in typical transportation service in the field operational test, the ACC vehicles were returned to the base station and time histories of pertinent variables such as range, range-rate, and velocity plus GPS and video data were downloaded.

Figure 21 shows the general flow of the numerical and video data. This section focuses on the acquisition and transfer of the data (the left side of the figure). Sections 4 and 5 provide a detailed discussion of the processing and the permanent storage of the data on CD-ROM.

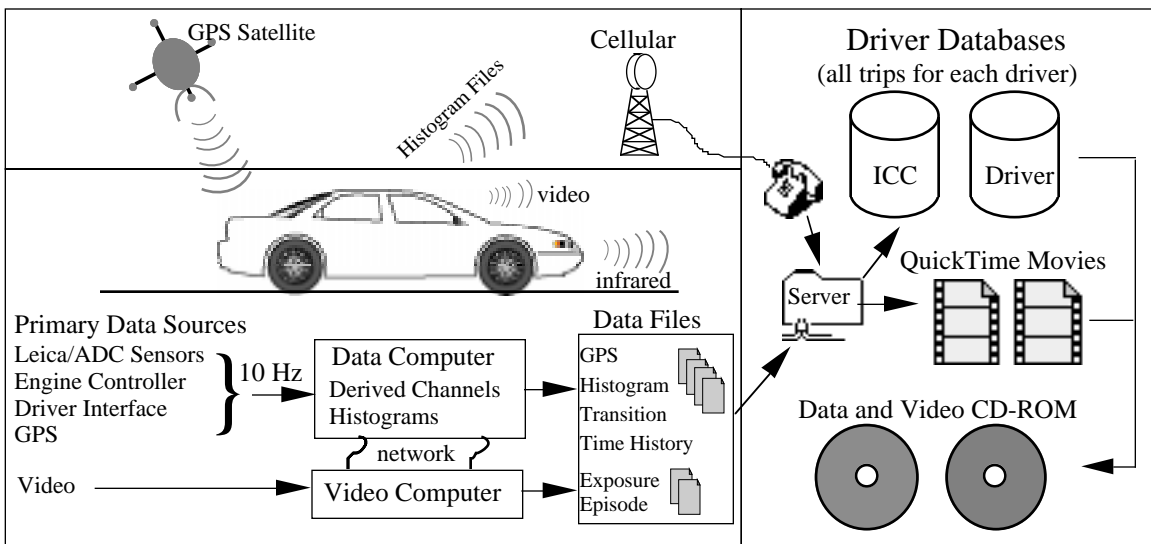

Figure 21. Data flow for the field operational test

The main part of the DAS was located in the insulated chassis in the trunk (see Figure 18), containing the processing, storage, and transceiving elements of the system. A depiction of the data sources and the location of the DAS elements in the vehicle is provided in Figure 19. This overall section describes the set of measurement techniques employed in collecting, online processing, and transferring of the data. Details of the design of the data-acquisition package and the many forms of data that were collected are also provided.

### 3.3.1 The DAS Package

The data-acquisition system consists of five subsystems (see Figure 22 for a block diagram of the system):

- power, interface, and control
- main computer
- GPS
- cellular communications
- video computer

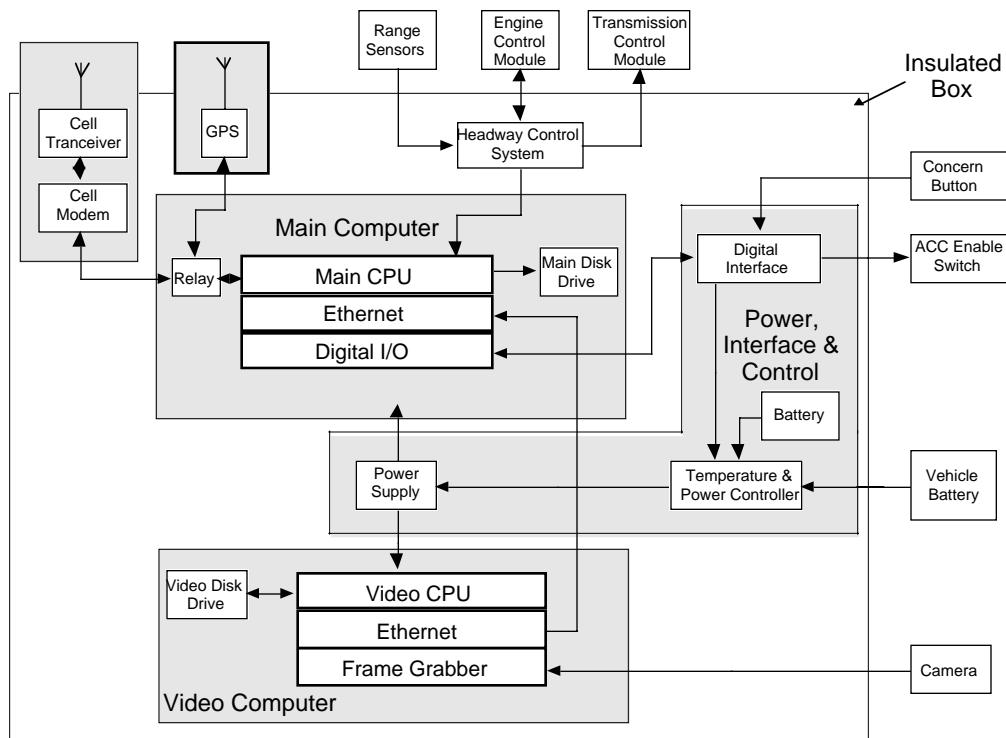

Figure 22. Data-acquisition system hardware

## **Power, Interface, And Control**

The power, interface, and control subsystem provides power sequencing of the various components and closed-loop heating or cooling of the chassis. It includes:

- two triple-output (5, +-12 volt) ac-dc converters for the computers
- 9-volt regulator for camera power
- 3-volt lithium battery for the GPS battery-backup RAM
- three 12-volt 17.5 amp-hour lead acid batteries
- microcontroller with 11 channel 10-bit A/D and 12 digital inputs/outputs
- circulation and exhaust fans
- 50-watt heater
- three temperature sensors

The microcontroller continuously monitors the chassis and camera temperatures, battery voltages, and state of the ignition switch and updates histograms of these variables in nonvolatile memory (EEPROM). The histograms are downloaded and inspected via an RS232 serial line when the participant returns the vehicle.

The vehicle power system and the chassis batteries are connected only when the ignition is on. Power for heating and cooling of the system comes from the three chassis batteries. The camera temperature is maintained above -5 degrees C by turning it on (self-heating). If the temperature of the chassis goes below 4 degrees C, a 50-watt heating element and a circulation fan are activated. The microcontroller ceases closed-loop heating when the battery voltage drops below 10.0 volts. This assures that the chassis can be powered up when the next ignition-on event occurs. If the chassis temperature is out of operating range (2 degrees to 50 degrees C), the microcontroller does not turn the computers on and logs a missed trip in its EEPROM.

## **Main Computer**

The main computer system collects and records data from the headway-control system, the vehicle (via the headway-control system), and the GPS system. The data are organized by trip (ignition-on to ignition-off). The main computer system also performs on-line data processing to generate derived channels, histograms, summary counts, and video episode triggers. The main computer includes:

- a five-slot passive backplane and chassis
- an IBM-AT compatible CPU card with 90 MHz Pentium processor, 16 MB RAM, two serial ports, printer port, and hard disk controller
- 1.6 GB hard disk drive

- Ethernet network adapter
- digital I/O expansion card

Figure 23 shows how the system operates. When the vehicle is started, the interface and control system activates the main system, which turns on the GPS and video systems. The GPS system sends (via an RS-232 serial line) encoded position and velocity packets every time it computes a new position. The main system decodes these packets, calculates grade and heading from the velocity information, and stores the time, latitude, longitude, altitude, grade, and heading to a position file. The GPS time at power-up is used to set the main and video computer clocks.

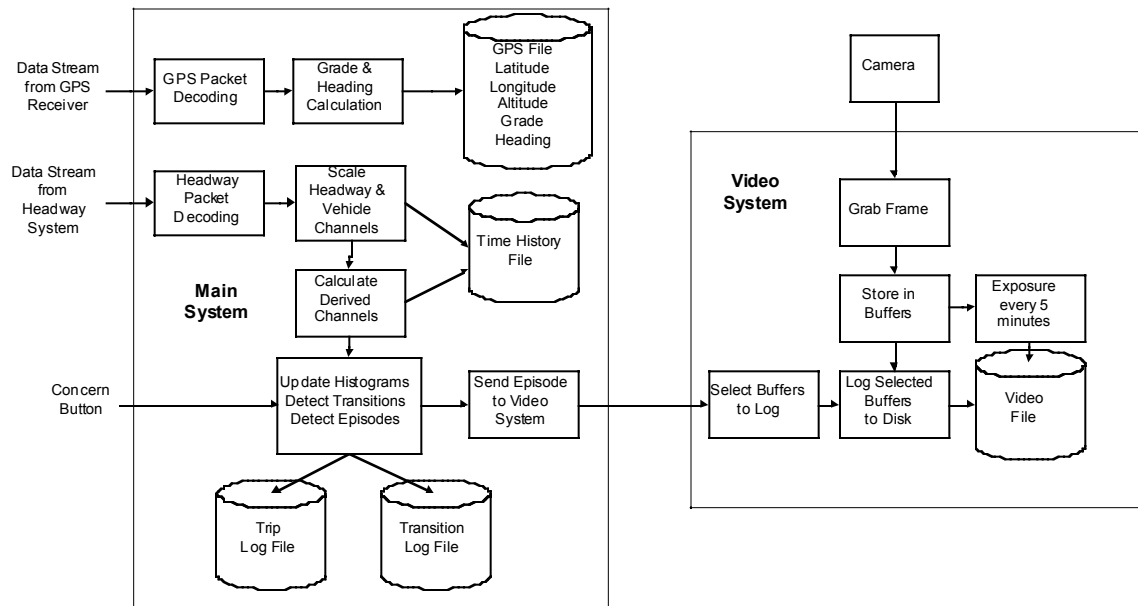

Figure 23. Data acquisition system operation

The headway controller sends (via a second RS-232 serial line) an encoded packet of information every 0.1 seconds. The main system decodes this packet and extracts the appropriate sensor and vehicle information channels. Derived channels are then calculated and selected information is logged to a time-history file. The next section describes the data channels and the derived channels. Some logical channels are logged to a transition file. Each transition-file record indicates a channel number, the time of the false-to-true transition, and the duration that the signal was true.

An episode-processing task monitors the incoming primary and calculated channels for the occurrence of significant episodes (e.g., ACC overrides, near encounters, concern button presses, etc.). When an episode is detected, the main system logs it to the transition file and sends a message (via Ethernet network) to the video system. The time

of each episode is used as a pointer into the time history files for further investigation of the driving environment. Transition counts, histograms, errors, and other trip summary information are logged to a trip log at the end of each trip.

When a trip ends, the main system turns off the GPS and video systems and activates the cellular system to transfer data to UMTRI. Once the transfer is completed (or fails, see section 3.3.3), the main computer signals the microcontroller, which turns the computer off.

## Video Computer

The video computer system continuously samples output from a windshield-mounted camera. It saves 2.5-second exposures every 5 or 10 minutes and 30-second episodes when triggered by the main system. The video computer includes:

- a five-slot passive backplane and chassis
- an IBM-AT compatible CPU card with 90 MHz Pentium processor, 32 MB RAM, two serial ports, printer port, and hard disk controller
- 2.1GB disk drive
- Ethernet network adapter
- CX100 Frame Grabber

The CX100 frame grabber is programmed to capture an image of 486 rows by 512 pixels in NTSC high-resolution mode. Each image frame contains two interlaced fields (243 rows by 512 pixels) as shown in Figure 24.

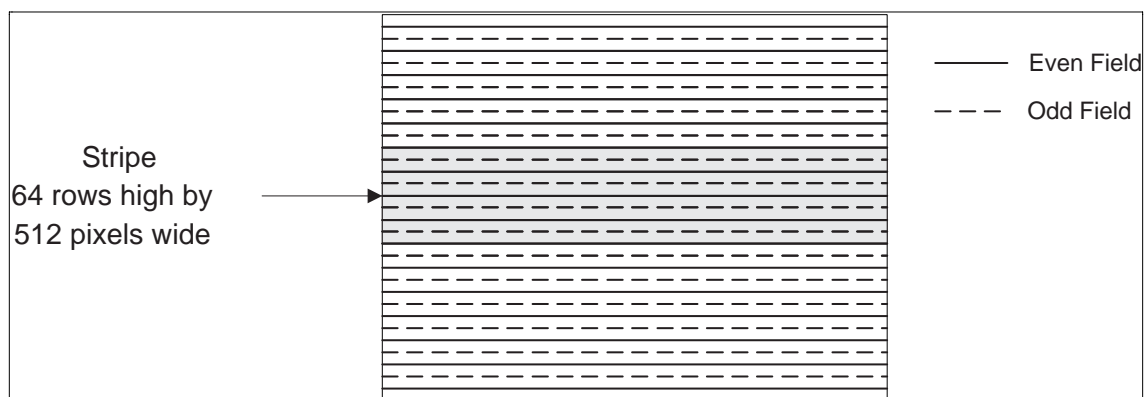

Figure 24. Video image frame structure

The video software samples a stripe from the even field, which is 64 rows by 512 pixels, every six frames, or 0.1 seconds. The stripe is marked with a date/time stamp derived from the system clock, which reflects the time the stripe was copied into a stripe

buffer (not the time the frame grabber digitized the field) and stored in a stripe buffer selected from a pool of 600 buffers.

The system maintains a circular list of the last 300 stripes. At 5-minute intervals, an exposure task wakes up and saves the last 25 stripes (2.5 seconds) to a file (819,200 bytes). The system hard disk contains 420 contiguous preallocated exposure files labeled from “1.exp” to “420.exp.” The files are created once and never deleted, which minimizes write time and prevents the disk from becoming fragmented. They are overwritten in sequential order, and a current list of file and driver-trip information is stored in a directory file called “director.exp.”

When the main system detects an episode, it sends a message that contains the episode type, driver number, trip number, date/time stamp, and the importance of the episode (a number between 0.0 and 1.0). The video system copies the list of the last 300 buffers and increments the buffer-use counts so they will not be returned to the “available” or “free” pool until they are written to disk. The episode is scheduled to be recorded after a 15-second wait period. If another more important episode occurs during this period, the previously scheduled one is deleted and the new one is scheduled. Thus cascaded triggers that are close in time generate only one video episode. The system hard disk contains 160 contiguous preallocated episode files (9,830,400 bytes each) labeled from “1.epi” to “160.epi.” Table 2 shows the nine types of episodes that vie for this file space.

Table 2. Episode types

<b>Episode Type</b>	<b>Minimum</b>	<b>Maximum</b>
Concern button	50	50
Manual Brake Intervention - 1 <sup>st</sup> week	10	50
Manual Near Encounter - 1 <sup>st</sup> week	10	50
Cruise Brake Intervention	10	50
Cruise Near Encounter	10	50
Manual Brake Intervention - 2nd week	20	50
Manual Near Encounter - 2nd week	20	50
ACC Brake Intervention	20	50
ACC Near Encounter	20	50

The episodes files are filled in order from 1 to 160 as long as the number of each type is less than its maximum. Once all of the files are filled, a set of preemption rules applies. The current list of episodes is stored in a directory file called “director.epi.”

The exposures and episode binary files are converted to “QuickTime movies,” which can be played on Macintoshes or PCs running Windows (3.1, 95, or NT). The images are doubled in height to recapture the original aspect ratio (only the even rows are contained in the sample) and compressed. The resulting exposure movies are 200 to 350 K bytes in size. The longer episodes are from 3.5 to 4 Megabytes. The first frame of each movie is a title frame showing the driver number, trip number, date/time of the trigger or exposure, and the importance. Subsequent frames display the frame number and frame timestamp at the bottom. Figure 25 shows a frame from an episode movie.



Figure 25. Snapshot from an episode movie

## GPS

The GPS system uses a six-channel receiver (which tracks up to eight satellites) with real-time clock and active antenna that is mounted on the center of the trunk lid [2]. The receiver stores the almanac, ephemeris, and configuration data in battery-backup RAM. This minimizes the time from power-up to first computed position. If the receiver has been powered down for less than four hours, the saved data are considered valid and the acquisition time is typically less than 30 seconds. If more than four hours, the time to first fix is around 40 seconds.

The main computer communicates with the receiver via a 9600 baud RS232 serial line using a binary packet protocol that permits full control of the receiver’s operating parameters and output format. Table 3 on the next page shows the packets that are automatically sent by the receiver and processed by the data-acquisition software.



Table 3. GPS Packet information

Packet Type	Description
Health	Satellite tracking status and operational health of the receiver
Time	GPS time reported in weeks since January 6, 1980 and seconds since Sunday morning at midnight of the current week
Position	Single precision position in Latitude-Longitude-Altitude (LLA) coordinates
Velocity	Single precision velocity in East-North-Up (ENU) coordinates

The main computer causes the receiver to operate in 3D-manual and over-determined modes. Position and velocity packets are sent twice a second as long as at least four satellites are visible. Reacquisition time for a momentary satellite loss is typically under 2 seconds. The over-determined 3D solution (which smoothes the position output and minimizes discontinuities caused by constellation changes) requires five or six visible satellites.

## **Cellular Communications**

The cellular communications system consists of an AT&T KeepInTouch 14.4-Kbps cellular modem that uses the Enhanced Throughput Cellular protocol, a 3-watt transceiver, and a window-mounted antenna. The main data acquisition and communications programs maintain a list of trip files to be transmitted to the UMTRI server. When a trip is completed, the data are transferred to UMTRI (see discussion in section 3.3.3). The system then executes a disconnect script and turns itself off.

### **3.3.2 The Collected Variables**

#### **Primary and Derived Channel**

The numerical data flow starts with the collection of 38 primary signals at a rate of 10Hz from various sources on-board each FOT vehicle. These sources are shown on the left in Figure 21 and include ADC's infrared sensors, the vehicle's engine control unit, the video camera, the GPS, and the driver/vehicle interface. A list of the 38 primary signals is given in Table 4. This table shows the name, type, description, and units of each signal. It also has a column called Logged. This column indicates if the signal is permanently stored on disk. Some of the logical signals are stored in a more compact format than that used for time histories. This format is explained later in this section under Transition Files. The following nomenclature is used in the column "Logged" to indicate which file the data is logged into: "H" – time history; "G" – GPS history, "T" – transition table.

Table 4. Primary channels

Name	Type	Description	Units	Logged
AccMode	Integer	0=off, 1=standby, 2=Not Operating On a Target (NOOT), 3= Operating On a Target (OOT)		H
Accel	Logical	True if accel button is pressed		T
AccEnable	Logical	True after 1st week		
Altitude	Float	Altitude	m	G
Backscatter	Float	Backscatter (0 to 1023)		H
Blinded	Logical	True if ODIN 4 blinded bit is on		
Brake	Logical	True if brake pedal is pressed		H
Cancel	Logical	True if cancel button is pressed		T
AccOn	Logical	True if cruise or ACC switch is on		
Cleaning	Logical	True if ODIN 4 cleaning bit is on		
Coast	Logical	True if coast button is pressed		T
Concern	Logical	True if concern button is pressed		T
CurveRadius	Float	Curve radius	ft	
Date/Time	Double	UTC Days since 12/30/1899 + fraction of day	days	H
Downshift	Logical	True if controller requests downshift		T
EastVelocity	Float	East velocity, + for east	m/sec	
EcuError	Logical	True when a VAC to ECU communication error occurs		
HeadwayTime	Float	Selected headway time	sec	
HeadwaySwitch	Integer	headway switches , 1,2, or 4		
Latitude	Float	Latitude, + for north	radians	G
Longitude	Float	Longitude, + for east	radians	G
NetworkError	Logical	True when a DAS to Video communication error occurs		
NewTarget	Logical	True for .3 sec with new target		H
NorthVelocity	Float	North velocity, + for north	m/sec	
Range	Float	Distance to target	ft	H
RDot	Float	Rate of change of range	ft/sec	H
ReducedRange	Logical	True if ODIN 4 reduced range bit is on		
Resume	Logical	True if resume button is pressed		T
Set	Logical	True if set button is pressed		T
Throttle	Float	Throttle percent		H
Tracking	Logical	True when tracking a target		H
UpVelocity	Float	Up velocity, + for up	m/sec	
VacError	Logical	True when a VAC to DAS communication error occurs		
VacTime	Float	Time since ignition switch was turned on (based on VAC system clock)	min	H
ValidTarget	Logical	Tracking AND Velocity > 25mph		H
VCommand	Float	Velocity commanded by controller	ft/sec	H
Velocity	Float	Vehicle velocity	ft/sec	H
VSet	Float	Cruise speed set by driver	ft/sec	H

The numerical data processing begins as these primary channels are read into the memory of the DAS. The computer then calculates what are called *derived channels*. These channels are combinations and manipulations of the primary signals. Examples of derived channels include:  $V_p$  (velocity of the preceding vehicle), road grade, distance, near, following, etc. There are 67 derived channels. The 31 floating-point derived channels are given in Table 5. The remaining 36 are logical channels and are listed in Table 6. Both tables show the name of the derived signal, a description (which includes its derivation), units, and whether it is logged to disk.

Table 5. Floating point derived channels

Name	Description	Units	Logged
AverageBackscatter	20 second moving average of Backscatter		
AverageDNearEncounter	4 second moving average of DNearEncounter	g's	H
AverageVDot	4 second moving average of -VDot	g's	H
CDot	Derivative of DegreeOfCurvature	deg/sec	H
D	$R\dot{D}ot^2 / (2 \cdot (Range - 0.7 \cdot Vp) \cdot 32.2)$	g's	
DecelAvoid	$R\dot{D}ot^2 / (2 \cdot Range \cdot 32.2)$	g's	H
DegreeOfCurvature	$5728.996 / CurveRadius$	deg	H
Distance	Integral of velocity	miles	H
DistanceEngaged	Integral of velocity while engaged	miles	
DNearEncounter	$R\dot{D}ot^2 / (2 \cdot (Range - 0.3 \cdot Vp) \cdot 32.2)$	g's	H
DScore	if DScoreRegion then DScore = $(D - 0.03) / 0.47$ ; if TScoreRegion then DScore = 1		H
EngMaxAvgDNear	Maximum value of AverageDNearEncounter while EngNearEncounter is true	g's	
EngMaxAvgVDot	Maximum value of AverageVDot while EngBrakeIntervention is true	g's	
Flow	Velocity / (Range + L)	veh/sec	
Grade(GPS)	$UpVelocity / \sqrt{(NorthVelocity^2 + EastVelocity^2)}$		G
Heading	Heading angle calculated from NorthVelocity and EastVelocity	deg	G
HeadwayTimeMargin	Range / Velocity	sec	H
Hinderance	Velocity / Vset		
ManMaxAvgDNear	Maximum value of AverageDNearEncounter while ManNearEncounter is true	g's	
ManMaxAvgVDot	Maximum value of AverageVDot while ManBrakeIntervention is true	g's	
RangeCheck	$0.7 \cdot Vp + R\dot{D}ot^2 / (2 \cdot 0.5 \cdot 32.2)$	ft	
RangeNear	$0.5 \cdot Vp + R\dot{D}ot^2 / (2 \cdot 0.1 \cdot 32.2)$	ft	
Rpt03	$Range - R\dot{D}ot^2 / (2 \cdot 0.03 \cdot 32.2)$	ft	
Thpt03	$Rpt03/Vp$ if $R\dot{D}ot < 0$ or $Range/Vp$ if $R\dot{D}ot \geq 0$	sec	H
TimeToImpact	$-Range / R\dot{d}ot$	sec	H
TrackingError	$TimeConstant \cdot R\dot{d}ot + Range - Th \cdot Vp$	ft	
TScore	if TScoreRegion then TScore = $(0.7 - Th0) / 0.7$		H
VDot	Derivative of Velocity / 32.2	g's	H
VehicleResp	VCommand - Velocity	fps	
Vp	Velocity + RDot	fps	H
VpDot	Derivative of Vp / 32.2	g's	H

Table 6. Logical derived channels (Velocity, V, is in mph in Tables 6,7, and 8)

Name	Description	Logged
AccBi	15-sec oneshot - AccEnable AND EngBrakeIntervention	T
AccFollowing	Following AND $0.9Rh < Range < 1.1Rh$	H
AccNe	15-sec oneshot - AccEnable AND EngNearEncounter	T
AccTracking	AccMode > 2	
AlwaysTrue	Always True	
BackscatterWarn	Backscatter > 50	H
CccBi	15-sec oneshot - NOT(AccEnable) AND EngBrakeIntervention	T
CccNe	15-sec oneshot - NOT(AccEnable) AND EngNearEncounter	T
Closing	NOT(Near ) AND $RDot < -5$	H
Cutin	$Range < RangeNear$ AND $RDot > 0$	H
DScoreRegion	ValidTargetVgt35 AND $RDot \leq 0$ AND $Range > RangeCheck$	
Engaged	AccMode > 1	T
EngBrakeIntervention	15-sec oneshot - Brake AND Vgt40 AND AverageVDot > 0.05 AND WasEngaged	
EngNearEncounter	15-sec oneshot – ValidTargetVgt40 AND AverageBackscatter <10 AND AverageDNearEncounter > 0.05 AND WasEngaged	
Following	NOT(Near OR Cutin) AND $-5 \leq RDot \leq 5$	H
HeadwayLong	True if long headway switch is pressed	T
HeadwayMedium	True if medium headway switch is pressed	T
HeadwayShort	True if short headway switch is pressed	T
LDegOfCurvature	$  DegreeOfCurvature   > 3$ AND $V > 50$	
LVpDot	$VpDot < -0.05g's$ AND $V > 35$	
Man1Bi	15-sec oneshot - NOT(AccEnable) AND ManBrakeIntervention	T
Man1Ne	15-sec oneshot - NOT(AccEnable) AND ManNearEncounter	T
Man2Bi	15-sec oneshot - AccEnable AND ManBrakeIntervention	T
Man2Ne	15-sec oneshot - AccEnable AND ManNearEncounter	T
ManBrakeIntervention	15-sec oneshot - Brake AND Vgt40 AND AverageVDot > 0.05 AND NOT WasEngaged	
ManNearEncounter	15-sec oneshot – ValidTargetVgt40 AND AverageBackscatter <10 AND AverageDNearEncounter > 0.05 AND NOT WasEngaged	
Near	$Range < RangeNear$ AND $RDot < 0$	H
Separating	NOT(Cutin) AND $RDot > 5$	H
Stopped	Velocity <3	
TScoreRegion	ValidTargetVgt35 AND $RDot \leq 0$ AND $Range \leq RangeCheck$	
ValidTargetVgt35	ValidTarget AND $V > 35$	
ValidTargetVgt50	ValidTarget AND $V > 50$	
Vgt35	Velocity > 35	
Vgt40	Velocity > 40	
Vgt50	Velocity > 50	
WasEngaged	True if engaged within the last 15 seconds	

## Floating-Point Histograms

During each trip some of the primary and derived floating-point channels are made into histograms by the on-board computer. The counting and binning for the histograms is done “on-the-fly” as the signals are derived and processed. Table 7 shows the twenty-seven floating-point histograms that were being made and permanently stored. If data for a particular histogram are collected continuously during a trip, its enabling channel is listed as “Always True.” For other histograms the enabling channel is either a primary or derived logical channel and it must be true in order for counting to occur in that particular histogram. For example, the throttle histogram is only loaded when the enabling channel, Velocity > 35 mph, is true.

Table 7. Floating-point histograms

Name	Source Channel	Enabling Channel	Sorting Channel
BackScatterFhist	Backscatter	Vgt35	None
CDotFhist	CDot	Vgt35	Engaged
DecelAvoidFhist	DecelAvoid	ValidTargetVgt35	Engaged
DegOfCurvatureFhist	DegreeOfCurvature	Vgt35	Engaged
DScoreFhist	DScore	DScoreRegion	Engaged
FlowFhist	Flow	ValidTargetVgt50	Engaged
HindranceFhist	Hindrance	Engaged	None
HtmFhist	HeadwayTimeMargin	Following	Engaged
RangeFhist	Range	ValidTarget	Vgt35
RangeFollowingFhist	Range	Following	Engaged
RangeVgt35FhistV	Range	ValidTargetVgt35	Engaged
RDotFhist	RDot	ValidTarget	Vgt35
RDotVgt35Fhist	RDot	ValidTargetVgt35	Engaged
Thpt03Fhist	Thpt03	ValidTargetVgt35	Engaged
ThrottleFhist	Throttle	Vgt35	Engaged
TimeToImpactFhist	TimeToImpact	ValidTargetVgt35	Engaged
TrackingErrorFhist	TrackingError	AccTracking	None
TScoreFhist	TScore	TScoreRegion	Engaged
VCommandFhist	VCommand	Vgt35	Engaged
VDotFhist	VDot	Always True	Vgt35
VDotVgt35Fhist	VDot	Vgt35	Engaged
VehnessFhist	VehicleResp	Engaged	AccTracking
VelocityFhist	Velocity	Always True	None
VelocityVgt35Fhist	Velocity	Vgt35	Engaged
VpDotVgt35Fhist	VpDot	ValidTargetVgt35	Engaged
VpFhist	Vp	ValidTargetVgt35	Engaged
VSetFhist	VSet	Engaged	None

As shown in Table 7, most histograms have a sorting channel. The sorting channel separates the counts into two histograms depending on the state of the sorting channel variable. For example, the sorting channel for the Throttle histogram is the Engaged logical channel. When this channel is true, that is, the velocity of the test vehicle is being controlled by either conventional or adaptive cruise control, one set of bins for the throttle histogram is filled. If the driver turns the cruise control off, then engaged is false, and the other set of bins for the throttle histogram is filled. (Of course, in this example the vehicle must maintain a speed greater than 35 mph for either set of bins to be filled because the enabling channel is  $Velocity > 35$  mph). In short, there are really two histograms when a sorting channel is used.

One two-dimensional histogram is processed by the DAS. This is a normalized range, range-rate histogram. The normalizing channel is the speed of the preceding vehicle ( $V_p$ ). The histogram is enabled by the ValidTargetVgt50 logical channel and is sorted by the Engaged channel.

Besides creating histograms, the DAS also calculates three statistical figures for each histogram. These figures are the most likely value (which histogram bin has the greatest number of counts), the mean and the variance, where the later two are defined as follows:

$$mean = \bar{x} = \frac{\sum_{i=1}^{nbins} x_i \cdot n_i}{\sum_{i=1}^{nbins} n_i} \quad (8)$$

and

$$variance = \frac{\sum_{i=1}^{nbins} (\bar{x} - x_i)^2 \cdot n_i}{\sum_{i=1}^{nbins} n_i - 1} \quad (9)$$

where:

- $\bar{x}$  = mean,
- $nbins$  = number of bins,
- $n_i$  = count in each bin, and
- $x_i$  = value of the bin center

## Logical Histograms

There are twenty logical histograms recorded by the DAS for each trip of each test vehicle. Table 8 shows the names, source channels, enabling channels and sorting channels for these histograms. Unlike the floating-point histograms, the logical histograms all have five bins. The first bin records the number of transitions (count of false-to-true changes) for the logical source channel. The second and third bins contain

the number of counts that the source channel was true and false, respectively. The fourth and fifth bins contain the number of counts that corresponds to the longest consecutive time that the source channel was true and false, respectively. The enabling and sorting channels have the same meaning as in the floating-point histograms.

Table 8. Logical histograms

Name	Source Channel	Enabling Channel	Sorting Channel
AccFollowingLhist	AccFollowing	ValidTargetVgt35	Engaged
AccTrackingLhist	AccTracking	Engaged	None
BackscatterWarnLhist	BackscatterWarn	Vgt35	Vgt35
BlindedLhist	Blinded	Vgt35	Engaged
BrakeLhist	Brake	Vgt35	WasEngaged
CleaningLhist	Cleaning	Vgt35	Engaged
ClosingLhist	Closing	ValidTargetVgt35	Engaged
CutinLhist	Cutin	ValidTargetVgt35	Engaged
DScoreRegionLhist	DScoreRegion	ValidTargetVgt35	Engaged
FollowingLhist	Following	ValidTargetVgt35	Engaged
LVpDotLhist	LVpDot	ValidTargetVgt35	Engaged
NearLhist	Near	ValidTargetVgt35	Engaged
NewTargetLhist	NewTarget	Vgt35	Engaged
ReducedRangeLhist	ReducedRange	Vgt35	Engaged
SeparatingLhist	Separating	ValidTargetVgt35	Engaged
TrackingLhist	Tracking	Vgt35	Engaged
TScoreRegionLhist	TScoreRegion	ValidTargetVgt35	Engaged
ValidTargetLhist	ValidTarget	AlwaysTrue	Engaged
ValidTargetVgt35Lhist	ValidTarget	Vgt35	Engaged
ValidTargetVgt50Lhist	ValidTarget	Vgt50	Engaged

### 3.3.3 Automatic Recovery of Trip Data via Cellular Modem

When a trip ends and the ignition switch is turned off, the main system turns off the GPS and video systems and activates the cellular system. The trip-data files are then transferred to the UMTRI server using standard Internet protocols (FTP, TCP/IP, and PPP) over cellular communication.

The system executes a connection script that initializes the modem (which usually connects at rates of 4800, 7200, or 9600 baud), dials the phone, and logs in to the server with a PPP account name and password. If the call is not answered (busy cellular system or server) a second attempt is made. Files are transferred using FTP until either all the files in the list have been sent or 5 minutes has lapsed since the driver turned off the ignition.



The primary motive for incorporating such automatic data recovery is twofold: diagnostic information concerning the system's operation, and a certain level of monitoring of how the vehicle is being operated. Continual monitoring of the remotely collected data permits tracking the ACC usage and determination of the possible need for administrative intervention (for example, if the ACC system is not being used by the subject at all).

The files sent via the phone lines contain histogram, trip summary, and diagnostic information that allows different levels of remote surveillance of the components of the DAS. Table 8 shows the trip summary information. Error flags provide a quick summary of the major components of the DAS and the ACC system, while more detailed histograms can be used to find problems that manifest themselves within the various data streams. For example, a sensor that continually reports the same range would be detected by plotting the range histogram as is shown in the top of Figure 26, whereas a sensor that functions properly will report a more evenly distributed histogram (bottom of Figure 26). The data in the figure are histogrammed as a frequency distribution function.

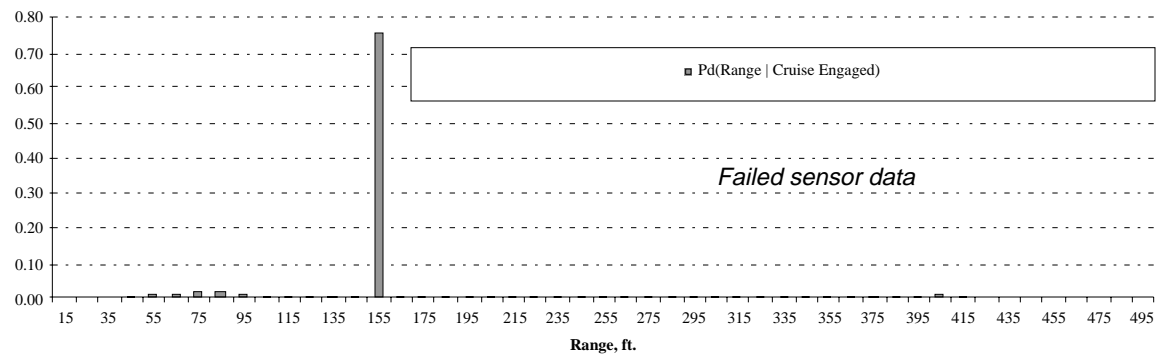

Pd(Range | Cruise Engaged); 0.9 Hrs; 1 Trips; 155.0 Most Likely Value; 168.7 Mean; 64.0 SDev.

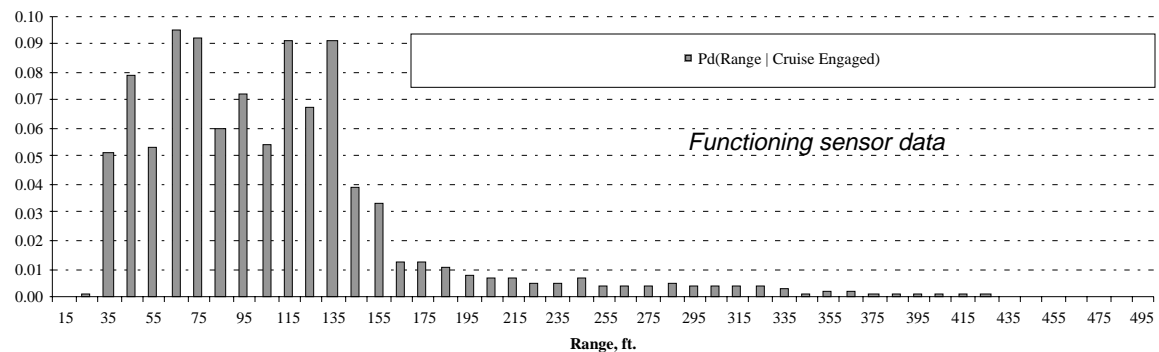

Pd(Range | Cruise Engaged); 0.2 Hrs; 1 Trips; 65.0 Most Likely Value; 110.7 Mean; 64.1 SDev.

Figure 26. Data samples from a failed and from a functioning sensors

Table 9. Trip Summary Information

Field Name	Description
AccBi	Count of brake interventions while ACC is engaged
Accel	Count of Accel button hits
AccEnable	Switch indicating if ACC or CCC is enabled
AccNe	Count of near encounters while ACC is engaged
AccOn	Count of ACC button hits
Blinded	Count of blinded transitions
Brake	Count of brake pedal applications
Cancel	Count of cancel button hits
CccBi	Count of brake interventions while CCC is engaged
CccNe	Count of near encounters while CCC is engaged
Cleaning	Count of cleaning transitions
Coast	Count of coast button hits
Concern	Count of concern button hits
Distance	Distance traveled during the trip, miles
DistanceEngaged	Distance traveled with the cruise control is engaged, miles
Downshift	Count of down shift transitions
DriverID	Driver identification number
Duration	Duration of the trip, minutes
EcuError	Count of ECU error transitions
EndAltitude	Altitude of the end of the trip
EndLatitude	Geographical latitude of the end of the trip
EndLongitude	Geographical longitude of the end of the trip
EndTime	End time of trip, days since 12/30/1899 + fraction of day
Engaged	Count of ACC engaged transitions
FileError	Count of file system error transitions
GpsError	Count of GPS error transitions
Man1Bi	Count of manual brake interventions while CCC is enabled
Man1Ne	Count of near encounters while CCC is enabled
Man2Bi	Count of manual brake interventions while ACC is enabled
Man2Ne	Count of near encounters while ACC is enabled
NetworkError	Count of network error transitions
NewTarget	Count of new target transitions
OdinError	Count of Odin error transitions
ReducedRange	Count of reduced range transitions
Resume	Count of resume button hits
Set	Count of set button hits
StartAltitude	Altitude of the start of the trip
StartLatitude	Geographical latitude of the start of the trip
StartLongitude	Geographical longitude of the start of the trip
StartTime	Start time of trip, days since 12/30/1899 + fraction of day
Stopped	Count of vehicle stops transitions
SystemError	Count of system error transitions
Tracking	Count of tracking transitions
TripID	Trip identification number
VacError	Count of VAC error transitions
ValidTarget	Count of valid target transitions
Version	DAS software version number
Vgt50	Count of velocity greater than 50 mph transitions

### 3.3.4 Recovery of All Data From One Driver From the Hard Disk

When a car returns to UMTRI, the on-board Ethernet network is connected to the building network and the data are transferred to the project server from both the main and the video computers.

#### Data Files Formats

For each trip, the DAS records and saves ten different file formats. Four of these files contain the numerical information for the trip and the other six contain the video information.

The numerical files are named using the template : Mode D D D T T T File Type.bin Where the first character is the mode, the next three indicate the driver, next three indicate the trip number, and the last is the file type. Table 10 defines the mode and file type characters. For example, a time-history file for a first week trip (trip 15) by driver 88 would be labeled M088015H.bin.

Table 10. Mode and file type descriptions

<i>Mode</i>	<i>Description</i>	<i>File Type</i>	<i>Description</i>
M	1 <sup>st</sup> week -ACC disabled	H	Time-History Files
A	2 <sup>nd</sup> -5 <sup>th</sup> week -ACC enabled	G	GPS Files
		T	Transition files
		E	Histogram files

A short description of each file formats follows.

- *GPS Files* - The GPS data are written in a time-history format to the DAS hard disk. The channels of this file include time, latitude, longitude, altitude, grade, and heading. These data are written to the file at 0.5 Hz. Typically, these files are 60KB in size. In addition to logging a complete record of the test vehicle's position, start and end latitude, longitude, and altitude, GPS coordinates for each trip are saved in a more accessible format within the histogram file type.
- *Histogram files* - The data for all the floating-point and derived histograms are saved in the histogram files. These files are between 11 and 15 KB. The histogram files also contains a trip summary table. Unlike the other DAS files, the histogram files are also transferred to UMTRI at the end of each trip via the cellular phone that is built into the DAS system. These files are then monitored as they are received to

- identify problems with the test equipment or anomalous results. Test drivers can then be contacted and appropriate measures taken to correct the problem.
- *Transition files* - The transition file format is a concise way of tracking logical events that occur relatively infrequently, such as cruise-control button pushes by the driver. Instead of recording these events in a time-history format (which can consume large amounts of disk storage space) a table containing the event name, its start time, and duration is constructed. Using this information, a time-history of the logical variable can be recreated if necessary. Transition files are typically less than 1 KB in size. (These variables are denoted by a “T” in the logged column of the tables above.)
  - *Time-History files* - With the exception of the video files, the time-history files constitute the bulk of the data storage and archive. There are thirty-six channels in each time history file (denoted by an “H” in the logged column of the tables above). For an average trip a time history file is 1.3 MB.
  - *Video files* - There are two types of video files: exposure and episode. Episodes are the capture of event-related video of 30 seconds duration. There can be from 0 to 160 episode files per driver. These files are named “0.epi” – “159.epi” and are 9.8 MB in size. Exposure files provide a brief video sample (2.5 seconds) recorded every 5 to 10 minutes<sup>1</sup> regardless of the operational state. This information is used to derive a regular spot-record of the highway and traffic conditions. There can be up to 420 exposure files per driver. These files are named “0.exp” – “419.exp” and are 0.8 MB in size. The episode and exposure files are never erased but their contents are overwritten. The files “director.epi” and “director.exp” are directories for these files. Finally, the “episode.log” and “exposure.log” files record a text message describing each video as it is written.

### **3.3.5 The Quality of GPS-Derived Range Versus Sensor Range**

To demonstrate the GPS system, data were collected using two FOT vehicles driven together on the same route. The range-sensor data collected by the DAS on the following FOT vehicle was used together with the geometric distance based on the GPS latitude, longitude, altitude signals between the two vehicles to produce a “new” three-

---

<sup>1</sup> The sampling interval was eventually lowered to 5 minutes following an analysis of the trip-summary information from the first group of drivers. This approach gave a more complete picture of the driving environment for each trip and made better use of the storage capability of the hard disk on the video DAS.

dimensional, intra vehicle range signal. These two range vectors indicated very close agreement as shown in time histories of each in Figure 27.

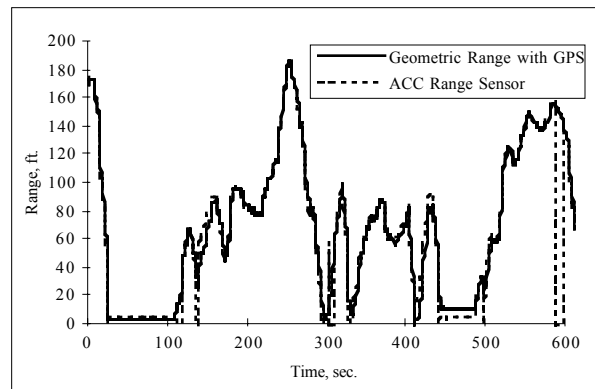

Figure 27. GPS Time history example

### 3.4 The Experimental Design

Following a detailed ACC orientation and instruction, accompanied by a research professional, each driver/participant first operated the assigned vehicle in the manual or conventional cruise-control modes for one week (approximately 5.5 days). While driving in either the manual or conventional cruise-control modes data from the range sensor and other transducers were collected continuously to capture the individual's normal car-following behavior, but ACC was initially disabled. The same participant then operated the vehicle for a period of one week (approximately 6.5 days) to one month (approximately 26.5 days) under manual control or using the ACC system (note, then, that conventional cruise control was not available to drivers after the first week). Use of the test vehicles by anyone other than the trained participant was strictly prohibited.

Consenting drivers operated the test vehicle in an unsupervised manner, simply pursuing their normal trip-taking behavior using our test vehicle as a substitute for their personal vehicle. Objective data in digital form were recovered periodically throughout the day from each test vehicle using cellular modem. Qualitative (subjective) information was recovered using questionnaires, exit interviews, and focus groups.

Continual monitoring of the remotely collected data permitted tracking the ACC usage and determination of the possible need for administrative intervention (for example, if the vehicle was not being used by the subject at all.) The objective data were processed to derive suitable measures of the convenience and safety-related aspects of ACC operation, relative to the manual and conventional cruise-control driving behavior of each test participant. The primary emphasis in the experimental design was on

relatively long exposures of individual lay drivers and upon a sampling scheme that roughly mirrored the population of registered drivers, but with simple stratification that reflected variables previously seen to interact with the manual-versus-ACC driving paradigm.

#### **3.4.1 Power Analysis**

The experimental design was based in part on findings from the FOCAS project [3], [4], and a series of two power analyses performed by the Center for Statistical Consultation and Research at the University of Michigan. Specifically, the independent variables of participant age and conventional-cruise-control usage were previously found to influence both objective and subjective dependent measures. Using data first from the FOCAS project (the within-class variance associated with driver age and cruise usage), the dependent measures range, range rate and velocity were used to perform a power analysis in order to estimate the number of participants (sample size) that may be required in the FOT. Power analysis determines an experiment's ability to detect treatment effects, the ability to demonstrate that a phenomenon exists if it truly does exist. The level of significance selected for the power analysis was 0.05. The initial power analysis that was based on the FOCAS data estimated that just over 180 participants would be required in the FOT.

Once the FOT began, a second power analysis was performed using data collected from the first 38 participants. In the second analysis the three modes of driving (manual, conventional cruise control, and adaptive cruise control) were added to the two previously determined independent variables (driver age and cruise usage). The dependent measures used in the analysis were range, range rate and velocity. The level of significance selected for the second power analysis was again 0.05. While the initial power analysis estimated that 180 participants would be required, the second analysis estimated that slightly more than 100 participants were required. The difference in the two estimates was associated with several differences between the first and second analyses. Specifically, the second analysis concentrated on velocities greater than 35 mph, where the first analysis considered all velocity ranges. Furthermore, the data used in the second analysis was a larger sample than the first, thereby reducing the influence of any outlying data.

#### **3.4.2 Sampling Frame**

Using the estimate from the second power analysis, the total number of participants and the experimental design were defined. Only the independent variables associated with driver characteristic (age, conventional-cruise-control usage, and duration of exposure to ACC)

were treated in the context of a controlled experimental design. Other variables such as weather, road type, and time-of-day were uncontrolled in the sense that they represented whatever situations the driver encountered in his or her normal driving pattern.

The controlled independent variables included three levels of participant age (20 to 30, 40 to 50, 60 to 70 years) two levels of conventional-cruise-control usage (rarely/never use, frequently use), and two levels associated with the duration of participation (2 weeks or 5 weeks). The gender of participants was balanced in each cell. Because giving a participant a research vehicle for 5 weeks represented a significant investment of resources, and the novelty effect associated with first-time cruise-control users was to be avoided in this duration of exposure, only participants who reported themselves a priori as being frequent cruise-control users were included in the 5-week sample. Figure 28 shows a graphical representation of this experimental design.

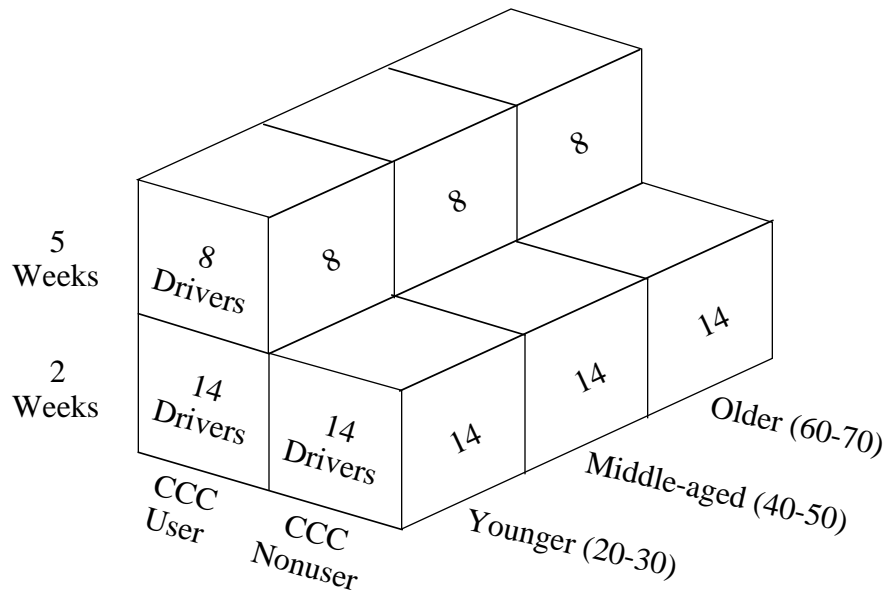

Figure 28. Graphical representation of the experimental design

### 3.5 Management of Test Participants

#### 3.5.1 The Basis For Human Use Approval and Pilot Testing

Since ACC has not yet reached the maturity of a commercial product, the systems were treated as engineering prototypes. Thus, the ACC implementation in our test vehicles, and the protocols for its use, were subjected to careful preliminary testing before operational testing began.

Two phases of pilot testing were performed covering both supervised and unsupervised driving. Six volunteer drivers were included in each of the two pilot testing phases. In the supervised testing phase, participants received the standard instruction and were accompanied on a 2.5-hour route through metropolitan Detroit on interstate and state highways. During supervised testing ACC was always available to the participants. The overall scope of issues for full operational testing was scrutinized, including the performance of the ACC system, functioning of the instrumentation and remote data-recovery system, the quality of the recovered data, and details of participant recruitment and orientation methods.

The application by which approval was sought for the use of human participants in supervised pilot testing was submitted early in the contract period. Approval was received from the Human Use Review Panel (HURP), NHTSA, USDOT on the 27th of February, 1996. An application seeking additional approval from the University of Michigan was submitted to the Human Subjects in Research Review Committee (HSRRC), Institutional Review Board Behavioral Sciences Committee. Approval from the University was also received in late February 1996.

The second phase of pilot testing (unsupervised) was similar to the operational test condition in that six participants were not accompanied by a researcher. Each participant in this phase of pilot testing possessed the research vehicle for a 2-day period. Again, participants received the standard instruction. The Human Use Review Panel (HURP), NHTSA, USDOT approved the application that sought approval for the use of human participants in unsupervised pilot testing in April, 1996. An application seeking additional approval from the University of Michigan was submitted to the Human Subjects in Research Review Committee (HSRRC), Institutional Review Board Behavioral Sciences Committee. Approval from the University was received May 14, 1996. This approval also addressed full scale operational testing on the basis of the first pilot test.

### **3.5.2 Participant Recruitment and Screening**

Participants were recruited with the assistance of the Michigan Secretary of State (Michigan's driving license bureau). A random sample of 6,000 driving records was drawn from the population of licensed drivers in eight counties in South Eastern Michigan. These eight counties included major metropolitan areas, as well as rural areas of the state (all within approximately a 1-hour drive of UMTRI).



All information obtained through the Department of State records was treated with strict confidentiality. An initial screening of driver records excluded persons on the basis of the following criteria: a) they possessed more than four (citation) points on their total driving record, b) they had more than two crashes, c) they had one crash resulting in a serious injury or fatality, and d) they had been convicted of either driving while intoxicated or under the influence of alcohol or a controlled substance.

Potential participants identified from the Department of State records were contacted through U.S. mail to solicit their participation in the field operational test. The initial contact, via postcard, did not mention the nature of the study but indicated only that participants would be asked to drive a car and would receive financial compensation for their time. Interested persons were asked to call UMTRI. A total of 443 individuals contacted UMTRI with an interest in participating. Each individual was screened by a research assistant to ensure that they met the predetermined qualifications for participation. Screening questions included the individual's age, conventional-cruise-control usage, and an estimate of the miles driven in the previous 12 months. An 8,000-mile minimum annual mileage threshold was required for a driver to qualify, with some modification of this requirement for older drivers. Individuals who met the qualifications and were needed to satisfy the experimental design, received a brief overview of the field test. The final selection of participants was dependent upon the match of an individual with a cell in the experimental design, and upon the subject's availability for taking and returning a test vehicle per the test schedule. Potential participants were further informed of any benefits or risks associated with participation. If individuals found the conditions of participation to be generally agreeable, and after a series of screening questions were answered, a specific date and time was arranged for the participant to visit UMTRI for orientation and training.

### **3.5.3 Participant Orientation**

Each participant was required to read an information letter that outlined the study procedures, protocol, risks, and benefits (appendix D). Furthermore, participants were required to acknowledge their awareness and acceptance of these conditions by signing an informed-consent form (appendix D). Participant orientation and training began with an introduction to the research vehicle provided in an 18-minute instructional video, which was followed by a briefing provided by a researcher. The instructional video covered the three principle areas: the location of standard controls and displays on the Chrysler Concord including use of the vehicle's safety equipment (air bag, seat belt, ABS, etc), use of the vehicle's conventional cruise control, and use of the ACC system

and the field operational test. This video included comprehensive information regarding the use of both conventional and adaptive cruise-control systems.

Participants received hands-on instruction for the research vehicle and ACC system. The experimental apparatus are identified and purposes explained. Accompanied by a researcher, each participant experienced the ACC operation during the orientation drive. This was done to ensure the participant's understanding of the research vehicle and ACC-system use. The orientation drive lasted approximately 25 minutes and was conducted on a local section of state highway (in normal midday traffic). The researcher that provided the orientation was thereafter the primary point of contact for the participant should any questions or concerns arise regarding the research vehicle or ACC system. Each research vehicle was equipped with a cellular telephone that could be used by participants to contact researchers as necessary. Two researchers carried pagers, having one common number, at all times. Participants were assured of contacting a researcher, if the need arose, on a 24-hour-a-day basis.

Once participants completed the orientation and were comfortable with their understanding of the ACC system, they left with the ACC-equipped research vehicle. The scheduled date and time the vehicle was to be returned was included in materials located in the glove compartment. These materials included a copy of the instructional videotape so that participants could review the instructions for ACC-system use (as well a manual outlining all the material included in the video for persons without access to videotape players), a map of Michigan, a log book in which to make comments, emergency contact information, and a copy of the informed-consent form.

### **3.6 Management Of Test Vehicles**

Maintenance and monitoring of the test fleet, from both the automotive and the system operation aspects, were vital to the success and safety of the field operational test. The likelihood that some drivers would treat the vehicles in less than a conservative manner, combined with the complexity of the on-board system, made the maintenance task challenging.

To have a successful study with as few unexpected problems as possible, a fairly rigorous "punch list" of items needed to be processed before a new test subject was given an FOT vehicle. The overall procedure UMTRI followed between drivers is given in Table 11. (This list is specific to the "turnaround" of each test vehicle and does not include procedures for orienting the FOT drivers.) This list also includes an estimate of the time of each task.

Table 11. General list of vehicle handling between FOT drivers

Task description	Time est., hrs.
<ul style="list-style-type: none"> <li>• Download temperature and voltage histograms</li> </ul>	0.50
<ul style="list-style-type: none"> <li>• Copy and backup all driver data (time history and video) from the vehicle DAS and load driver databases.</li> </ul>	4.00
<ul style="list-style-type: none"> <li>• Record current sensor alignment (noting any misalignment that may have occurred during usage by last driver.) and realign sensors if necessary</li> </ul>	0.75
<ul style="list-style-type: none"> <li>• Assess the quality of the sensor signal to anticipate sensor failures.</li> </ul>	0.75
<ul style="list-style-type: none"> <li>• Replace sensors or related equipment if necessary</li> </ul>	1.00
<ul style="list-style-type: none"> <li>• Perform periodic maintenance on the vehicle if necessary</li> </ul>	1.00
<ul style="list-style-type: none"> <li>• Prepare and clean the vehicle for the next subject.</li> </ul>	0.75
<ul style="list-style-type: none"> <li>• Verify the functionality of the ACC system and create a permanent record of the system behavior using a predefined set of driving maneuvers.</li> </ul>	0.75
<ul style="list-style-type: none"> <li>• Verify that the DAS system is working correctly and reinitialize the system for the next driver</li> </ul>	0.75

The order of tasks shown in Table 11 was followed as closely as possible. In some cases scheduling problems made this difficult, but the goal was to do the characterization and functionality driving test last. This was done to reduce the likelihood of possible failures at the start of and during a subject’s test period. However, this did not eliminate all surprises, such as dead vehicle batteries or sudden sensor failures, and in these situations the practice was to have at least one FOT vehicle as a backup.

### 3.6.1 Data Downloading

The DAS and video systems were programmed to operate as FTP servers when commanded via plugging in a switch box to the configuration connector (accessible in the trunk). The dedicated Ethernet line to the project server was connected to the on-board network allowing remote download control. Table 12 summarizes the data recovery tasks.

Table 12. Data Recovery and Validation

Task	Description
Data File Transfer	Transfer the time history, GPS, transition, and histogram files
Database Loading	Load the time history, GPS, and transition files into tables within the driver database. Load any histogram files not transferred over the phone into the database.
Data Audit	Run validation queries on loaded databases. Look for missing files or trips. Compare miles driven from odometer readings to the distance traveled from the trip table.
Video File Transfer	Inspect the “log” files to determine which episode and exposure files to transfer (i.e., only those filled by this driver). Transfer the raw video episodes and exposures, directory files, and log files.
Video Renaming	Run the rename program that uses the directory files to rename the episode and exposure files (e.g., 1.epi or 123.exp) using the template DDDTTTNN.mov where “DDD” is the driver number, “TTT” is the trip number and “NN” is the episode or exposure number.
Tape Backup	Copy the raw video files to tape and archive. Copy the raw data files and the database to tape and archive.
QuickTime Movies	Run a program from networked Macintosh computers to transform the raw frame-grabbed images into QuickTime movies. This was usually an overnight procedure.
Data CD	Burn data CD with the binary files, the video directory and log files, the driver database, and the “Icc” database.
Video CD	Burn video CD(s) with movie files.
Transfer to Evaluator	Inform evaluator’s representative of any known problems with the data from this driver. Provide copies of video and data CDs

### 3.6.2 Sensors Check

The headway sensors used in this project are prototype sensors. As such, certain inspections and maintenance activities were required to be performed periodically to maintain the sensors’ operative status. Part of the routine maintenance activities was dedicated to the sensors. These activities included sensor alignment and sensor inspection

(by means of both software and hardware). As a result of sensor inspection, additional maintenance activities often ensued.

The laser beams from the sensors are well defined by the optical cone on the front end of the sensor. The shape of the beam is rectangular and the beam is visible using a special infrared scope. Being able to see the signature of the laser beam as it illuminated a “target” positioned in front of the vehicle, is very useful when conducting sensor alignment.

The geometry that prescribes the required orientation of the sensors is outlined in section 3.1.3. A dedicated area for sensor alignment was prepared in UMTRI, and special-purpose items were fabricated, namely,

- a quick-attachment jig with a laser-beam pointer to accurately mark the vehicle’s centerline
- a board with adjustable “targets” that could be accurately positioned (within 1 mm) both vertically and horizontally

When properly aligned, the beam signatures of the sweep and the cut-in sensors would be centered on their respective targets. Because of deviations in the exact location of the sensors across the fleet of ten cars, the targets on the aligning board had to be specially set for each vehicle. An *aligning template sheet* was prepared for each vehicle, in which the calculated position of the targets was based on the accurate location of the sensors as they were installed in the particular vehicle. Figures 29 and 30 show the signatures of the sweep and the cut-in sensors respectively (these pictures were taken using special infrared film).

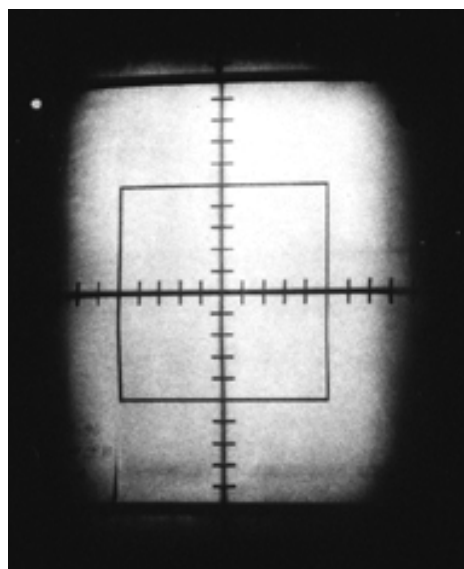

Figure 29. The sweep sensor beam centered on its target

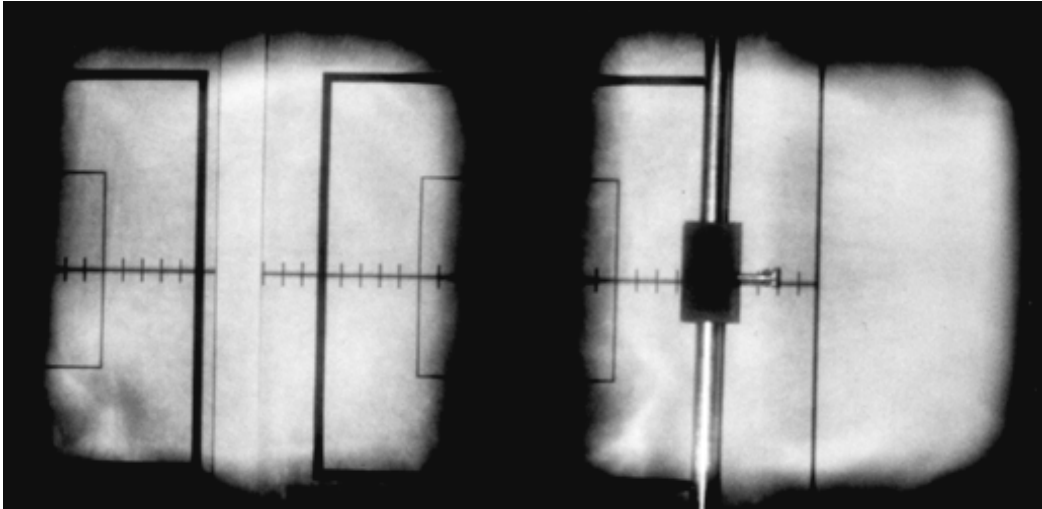

Figure 30. The cut-in sensor twin beams illuminate the aligning target

Each time a sensor was replaced, and also periodically every two months, the information on the aligning template sheets was verified by repeating the measurement of the installation geometry.

Being prototype sensors that were still in a development stage, the sensors' operative status had to be evaluated periodically by means of software diagnostic tools. The infrared beam is modulated using a mechanical component within the sensor called the *chopper*. As the test progressed it was found that, since the sensors were mounted externally, the cold temperatures of Michigan's winter affected the operation of the chopper to a point that it could cease functioning. To address this situation, ADC provided UMTRI with diagnostic tools to assess the "health" status of the chopper and help identifying those choppers whose performance might be deteriorating. The graphic display in the top part of Figure 31 on the next page shows the signature of a healthy chopper, and the bottom part depicts a chopper that failed shortly thereafter. Furthermore, the system was capable of self-detecting a failed sensor, in which case the HMI would display an error code to driver.

In addition, the sensor's software employs over 40 parameters which had to be verified periodically, and the overall sensor performance characteristics had to be ascertained. For that purpose an *acceptance protocol* was established by ADC which included a list of about 30 measures, with pass/fail values for each measure.

During each predelivery procedure (see Table 11 on page 60), sensor-related activities were performed. These activities included checking the alignment, recording the results, and correcting as needed. Almost each time that the alignment was checked,

the 30 measures of the acceptance protocol and the 40 sensor parameters were also validated.

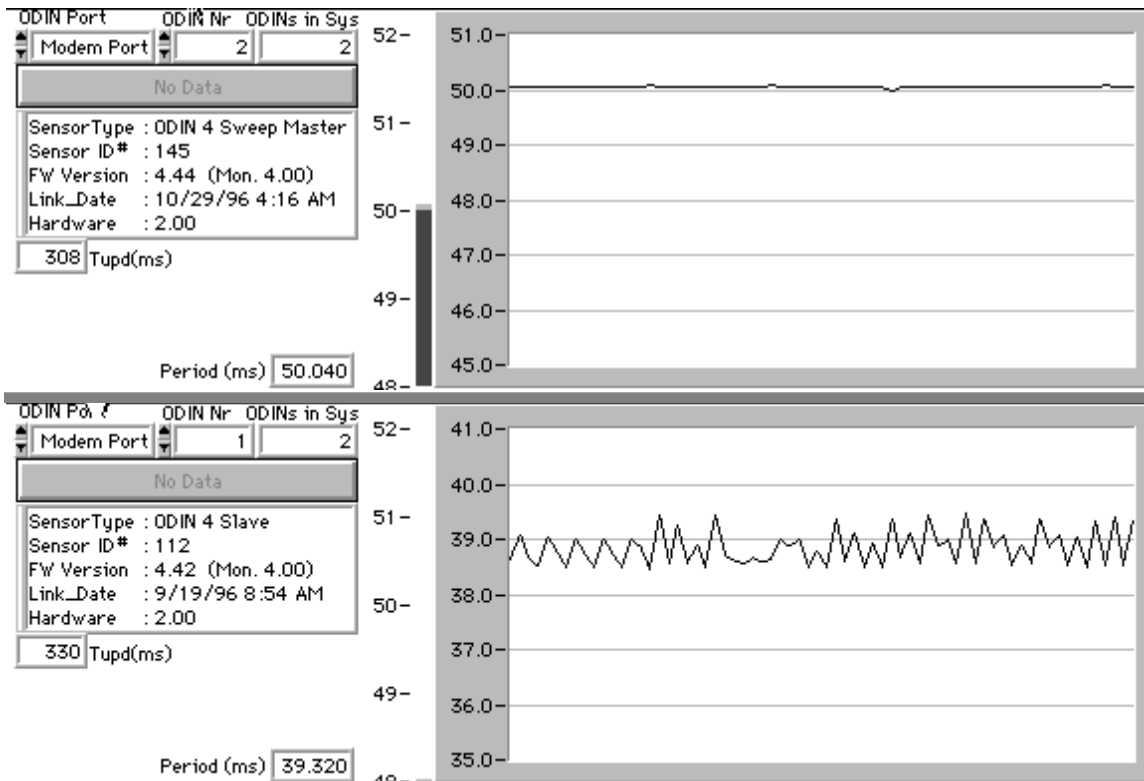

Figure 31. Chopper data analysis

### 3.6.3 Functionality Check

The functionality check consisted of more than driving the FOT vehicle. A check list of pre- and posttest tasks helped ensure that each FOT vehicle went into the field in a suitable state of readiness. Table 13 below summarizes all the checks done to each FOT vehicle before and after the driving test was performed. The driving test is outlined below. For a complete analysis of the vehicle and ACC system characterization see section 3.2.4, appendix E, and also [5], [6].

Table 13. Pre- and postfunction test check list.

<b>Pretest</b>	
Video Software	Update exposure video software. Exposures for 5-week drivers were taken every 10 minutes; 2-week drivers every 5 minutes.
Download Verification	Verify that the previous driver's electronic data (both time history and video) has been downloaded from the vehicle.
DAS Inspection	Inspect the DAS to ensure that it has been properly enclosed within its thermally stabilized chassis.
Vehicle Inspection	Walk-around inspection of the vehicle and its undercarriage.
System Countdown	Start the vehicle and verify the startup 10-second countdown. The countdown allowed more time for the system's yaw-rate gyro to stabilize and also any temporary sensor or communication errors to be cleaned up. <sup>2</sup> .
<b>Posttest</b>	
download data	Connect the DAS to the network server and download all files created during the functionality test.
re-initialize the video	Download an episode video and delete all video directory files.
driver number and fuse date	Enter the next driver number and set the fuse date that indicates when to switch from CCC to ACC during the test.
exposure time	Verify that the exposure videos are being taken at the correct time interval.
load database	Load the time history, GPS, transition, and histograms files into tables within that vehicles characterization database.
verify data	Inspect the tables to verify that the main computer of the DAS is recording all the test results.
verify video	Transfer a 30-second episode video to a QuickTime movie and view for image quality, focus, exposure, and camera direction.
clean-up video drive	Delete the video logs and directory files.
clean-up data drive	Verify that data from the previous driver has been copied and backed up before deleting data files from the main computer to free up storage space for the next driver.
re-build video directories	Run the vehicle for at least five minutes to allow video directory files to be rebuilt.
test cell-phone	Turn off vehicle and verify cell phone connection and data transfer.
Label Vehicle with driver number and fuse date	Put a sign in the vehicle's window indicating that the vehicle is now ready for the indicated driver and should not be driven until the test subject is ready to take the vehicle.

<sup>2</sup> Early in the study it was found that temporary errors would display on the human-machine interface. It was felt that these may confuse drivers and cause unnecessary restarts so a countdown was introduced to reduce the display of these errors and provide additional time for the yaw-rate gyro to stabilize and the DAS to initialize.



The driving test took place on a 15-mile route that included an arterial and an interstate highway near UMTRI. The purpose of the test was a) to verify that the ACC system worked correctly, and b) document the performance of the vehicle for future reference. Figure 32 shows a GPS map of the route used for this test. This is an actual plot of the GPS longitude and latitude coordinates from one of the tests. (To keep the figure as simple as possible the axis labels have been eliminated.) In general the legend indicates the type of road and the type of test that was done before an FOT vehicle was given to a subject.

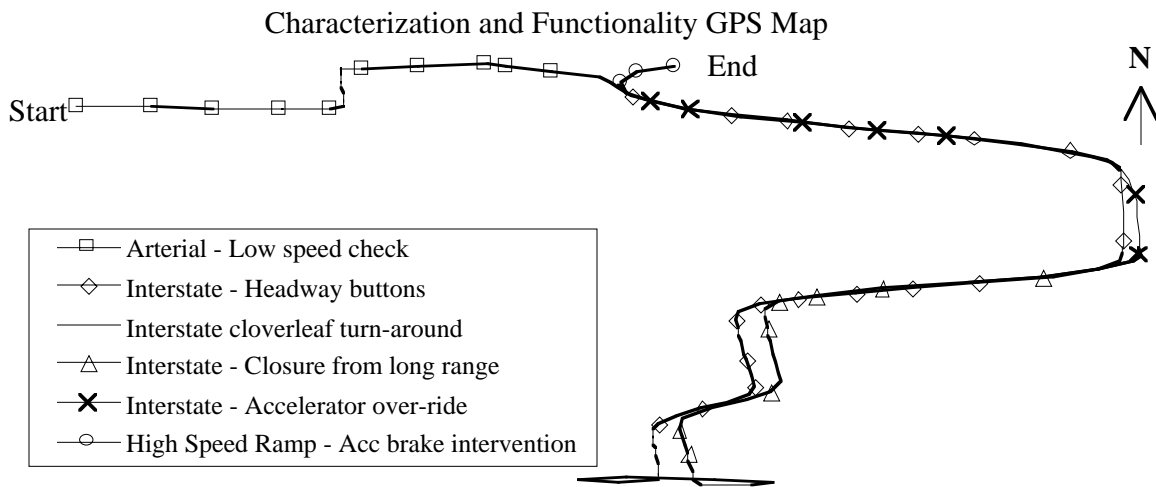

Figure 32. GPS route for functionality driving test

Some of the tests outlined below involve a second, confederate vehicle. Typically, the best candidate for this vehicle was a heavy truck. Trucks made good targets not because of their larger size but due to other characteristics, such as: a) they travel at consistent speeds, b) they tend to not change lanes and, c) they are not likely to exit on the local ramps (thus prematurely interrupting a test).

The tests were performed during light traffic times (i.e., avoiding early morning and late afternoon rush hour) and when weather conditions were good and roads were dry.

### Low-speed check

The first test took place on an arterial road leading to the highway near UMTRI. This test, called a low-speed check, simply made sure that the system would automatically disengage when the vehicle speed went below the cut-off velocity (approximately 25 mph). It also verified that the system would not engage (using both the set and resume buttons) below the cut-off velocity.

## **Headway buttons**

This test involved switching between the three user-selected headway buttons. The test was performed on the southbound portion of the interstate and required the most time and distance of all the tests. After finding a confederate vehicle, the ACC was engaged using a set-speed well above the speed of the target vehicle. The test started by selecting either a 1.0- or 2.0-second headway and allowing the vehicle to reach a steady-state condition. After approximately 15 seconds of steady-state following, the middle, 1.4-second, button was selected. Then after the vehicle reached a steady-state following condition at this headway time, the remaining headway button was selected and a steady-state condition maintained. Finally, the driver selects the button used at the beginning of the test and allows the vehicle to return to the original headway time.

## **Closure from long range**

The closure from long range test was difficult to perform on all driving tests. It required a long stretch of open highway and a relatively slow moving target. (In some cases an open stretch of highway could be found but excessive speeds were required to close in on a distant target within the time and distance of the test route. At other times there was just too much traffic. In these cases, the test was not performed.) Also complicating this test was the entering and exiting of local traffic along the test route. However, there was one section of northbound interstate where the conditions for this test were more likely. For this test a 1.4-second headway button was selected and the ACC system was engaged with a relatively high set-speed (typically 70 to 76 mph). The test starts with the target vehicle beyond the maximum range (approx. 400 ft) of the ACC sensor. The FOT vehicle was then allowed to acquire, close in, and reach a steady-state following condition behind a target vehicle. The steady-state condition was maintained for approximately 15 seconds before the test finished.

## **Manual override**

In the manual override test, the driver engaged the ACC system using the 1.4-second headway button and reached a steady-state following condition behind an impending vehicle. Then using the accelerator pedal the driver slowly closed in on the target until the ACC system commanded a transmission downshift at which point the accelerator pedal was released. The FOT vehicle was then allowed to separate from the target and return to a steady-state following condition.

## **ACC brake Intervention**

The ACC brake intervention helped verify the video capture and triggering mechanisms. At the end of the functionality test the driver simply did an aggressive ACC brake intervention on the interstate exit ramp. The level of deceleration caused a video episode event to be triggered such that a 30-second video was taken. This video was then viewed in the posttest checkout to verify that the DAS and video system were operating satisfactorily.

## **Other activities**

In addition to the maneuvers outlined above, the driving test also verified other aspects of ACC system functionality. Namely, all the standard cruise-control buttons were pressed and ACC-commanded transmission downshift and activation of the brake lights were tested. Finally, during the test an effort was made to assess the quality of the sensor alignment by passing other vehicles and moving laterally within the driving lane in an effort to acquire vehicles in the adjacent lane.

### **3.6.4 Vehicle Maintenance**

Vehicle maintenance encompassed efforts by UMTRI staff and work performed by an authorized Chrysler service shop. The maintenance task was carried out through three subtasks, as follows:

- home-base inspection — Each time a test vehicle was brought back to UMTRI between subjects, it was thoroughly checked. A comprehensive checklist was prepared and evaluated to ensure the safety, readiness, and functionality of all automotive systems
- OEM maintenance — Needed repairs and periodic maintenance per the manufacturer-recommended schedule were to be performed by an authorized Chrysler service shop in Ann Arbor, Michigan. From the standpoint of service, the test fleet was quite unique. That is, expensive equipment items and new wiring had been installed throughout the vehicle, and OEM equipment had been modified (e.g., wired access to the engine controller, new transmission software, etc.). For these reasons, one dedicated point of Chrysler service was selected—a dealer who agreed to assign dedicated maintenance personnel who were acquainted with the special nature of our vehicles. The intention was that the fleet would be serviced only by the selected dealer unless road emergencies necessitated other arrangements.

### **3.6.5 Preparation for the Next Driver**

Upon the return of an FOT vehicle to UMTRI, each car was thoroughly inspected and prepped prior to being sent out with another participant. Log-in mileage was recorded and any personal effects that the driver left in the car were collected and the driver was promptly notified. Fluid levels were checked and filled as needed. The exterior and the interior of the car were cleaned. The trunk was checked for the cellular phone and phone manual. The following items were checked and replaced if they were found to be missing from the glove compartment: the car's owner's manual, the FOT instructional video and written supplement, a log book and pen, and a Michigan map. Finally, the tire air pressure was checked and adjusted if necessary.

## **3.7 Operational Issues Leading To Modifications**

The field operational test was conducted over a period of 14 months, which were preceded by 10 months of intensive preparation. Given the time, the amount of the precursory tasks, and the nature of the test, it became clear that all operational issues could not be forecasted, and that modifications would become inevitable. Appendix F lists the various versions of the different system components, and also the corresponding implementation dates and the drivers affected. This section describes the operational issues that surfaced during testing, and the modifications that ensued.

### **3.7.1 System Modifications**

System modifications included changes to the sensor software, the control algorithm, and the data-acquisition system. The sensor software involves proprietary code that was provided by ADC. The algorithm and the data acquisition were developed by UMTRI, the details of whose modifications are provided herein.

#### **Control Algorithm and Sensor Software Changes**

A detailed list of the algorithm versions is provided in appendix F. Versions prior to 9.17 were used only in the pilot testing and the development stages. Version 9.18 through version 9.27 were developed primarily to address the following issues:

- ensure better startup sequence of the system
- minimize premature downshifting and slowdown beginning at excessive range
- correct for potential confusion of the driver regarding the engagement state of the system
- improve fidelity of the data signals that the algorithm sends to the DAS
- minimize unexplained disengagements of the system

- provide better feedback to driver when system failure occurs

The sensor software was modified by ADC to correct for false target detections under certain peculiar conditions, and to improve the reliability of the chopper.

### Data-Acquisition Software Changes

Table 14 summarizes the changes made to the data-acquisition software. The trip table contains a field called “Version” that documents the version of the DAS software used for each trip.

Table 14. DAS Software Changes

Version 1 to 2	Changed Source of velocity channel to new filtered velocity (created in VAC to prevent system dropouts).
Version 2 to 3	Removed 1.6 second error in synchronization of video computer. Added distance channel to time history. Added 20-second moving average of backscatter to get rid of near encounter episodes caused by “spray targets.” Changed video exposure interval from 10 minutes to 5 minutes. Fixed reporting of network error problem in “e” file.
Version 3 to 4	Changed maximum number of exposures from 400 to 420. Fixed problem with episode prioritization when disk is full (the most severe episodes were not always saved). Created two versions of video software: 5-min exposure intervals for 2-week drivers and 10-min exposure intervals for 5-week drivers.

### 3.7.2 Wintertime Issues

It was known from the beginning that snow, rain, and ambient moisture could inhibit the sensor’s ability to perform (see discussion in section 3.1.1). The initial design incorporated a feature for disabling the system in rain and fog based on backscatter information from the sensor. However, shortly after winter started and operation under snowy conditions commenced, it became evident that snow-related issues could not be addressed by backscatter.

The sensors were mounted outside, in the vehicle’s grill (see Figure 17). Under snowy conditions, they would become covered with snow, sleet, and ice quite rapidly. This type of opaque cover, however, would seldom make the backscatter reading go high enough to trigger system shutdown such as occurs under strong rain or fog conditions. It

is possible that a different installation method or location would have enabled a better automatic identification of snow- or ice-covered sensors. A different design of the protective Plexiglas cover, for example, could contribute to such automatic detection. That type of activity, however, was beyond the scope of the field test and, hence, was not fully explored.

The outcome of a blinded, snow-covered sensor would often be an ACC-equipped vehicle that acts just like a standard CCC-equipped car: It does not respond to slower-moving vehicles. The driver then needs to realize the situation and act accordingly by taking control and disengaging the system. Once the problem has been identified by the research team, drivers were warned and instructed not to operate the system under snow or ice conditions. An amendment to the participant instruction for wintertime use of the ACC system stated the following:

*Because snow and salt-spray “blind” the sensors, we do not want you to drive with Adaptive Cruise Control if it is actively snowing OR if the temperature is below 45 F AND the roads are predominantly wet. The sensors will be unable to track vehicles and the system will not decelerate in response to slower moving vehicles. The car is safe to drive in the snow and when the roads are wet or slushy. We just do not want you to drive using Adaptive Cruise Control under these conditions. Please remember the following:*

- *Again, do not drive using Adaptive Cruise Control if it is snowing or if the temperature is below 45F and the roads are predominantly wet.*
- *The sensors are cleaned whenever you clean the windshield. Please clean the windshield each time that you start the car and before driving away. A good time to do this is during the system countdown.*
- *Under no circumstances do we want you to pull off the road to clean the sensors. If the system is not performing properly, and you suspect that the sensors are dirty, try cleaning the windshield. If this does not resolve the problem, wait until you are at a gas station or until you arrive at your destination to check the sensors.*
- *Adaptive Cruise Control is a convenience feature and not a collision avoidance system. You are to be in control of the vehicle at all times.*

At the same time we sought to fix the problem.

After consulting with ADC and conducting various measurements under snowy conditions, we concluded that the backscatter signal could not be used to indicate with any degree of certainty that the sensor is covered with snow or ice. A solution for removing the blocking layer (ice or snow) from the sensors, however, was successfully devised. Jet sprays similar to those used in windshield washers were installed, together with specially fabricated containers for storing a quantity of washer fluid, and drivers were instructed about washer activation.

## 4.0 Contents of the Data Set

To facilitate the exchange, validation, and analysis of the FOT data, all nonvideo information on vehicles and participants was loaded into a commercial database format (Microsoft Access). The term “Archived ACC FOT Database” refers to a logical or conceptual data set, not to a single database file. The database files for each individual driver were burned on CDROM and delivered to the evaluator’s on-site representative usually within a week of each car’s return. A second “UMTRI ACC FOT Database” was developed from the same files by reorganizing and recombining the original database files to optimize query development and execution. Finally, this reorganized database has been augmented with new tables as new processing methods have been developed.

### 4.1 Archived Database

The archived data base consists of one “subjects.mdb” database, 108 “driverxxx.mdb” database files, and 108 “Iccxxx.mdb” database files. “xxx” is a placeholder for the driver number (i.e., driver001.mdb). These databases are fully described in appendix A.

#### 4.1.1 Subjects.mdb Database

All subject information is contained in the “Subjects.mdb” database. The four main tables are listed in Table 15. All tables are keyed by the “DriverID” field (a unique number assigned in chronological order from 1 to 117). (Please note that 117 individuals became engaged as drivers in this field test, although the data from only 108 of them was finally identified as the valid test sample.) The information in these tables comes from the questionnaires described later in Section 4.4.

Table 15. Subject Database Tables

DriversMain	Sanitized version of driver biographical information
DrivingStyleQuestionnaire	Driving style questionnaire results
MBti	Meyers-Briggs Type Inventory
PQv2p0	ACC System Questionnaire

#### 4.1.2 DriverXXX.mdb Database

The bulk of the FOT data is contained in the 108 driver databases. Figure 33 on the next page shows a block diagram of the conversion from binary files to tables in the

database. Each binary file (e.g., A002055H.bin) is written to a table (A002055H) with the same name. The driver database contains three tables (G, H, and T) for each trip.

An Access form (including embedded VisualBasic code to read the binaries) as shown in Figure 34 was used to load the driver databases. The driver databases average 154 Mbytes in size and vary from 38 Mbytes for a 2-week driver who drove 234 miles to 596 Mbytes for a 5-week driver who drove 5,572 miles.

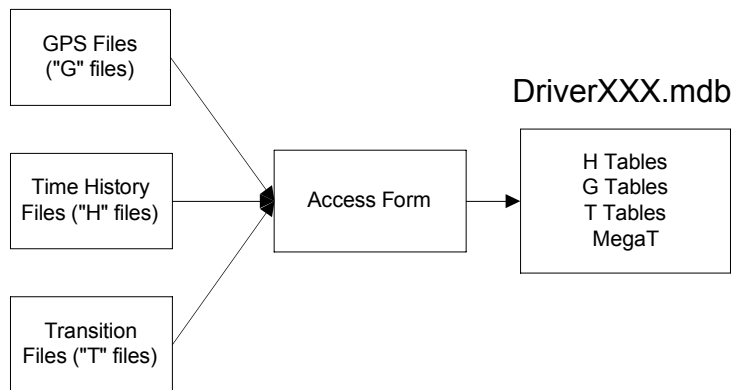

Figure 33. Driver Database Loading



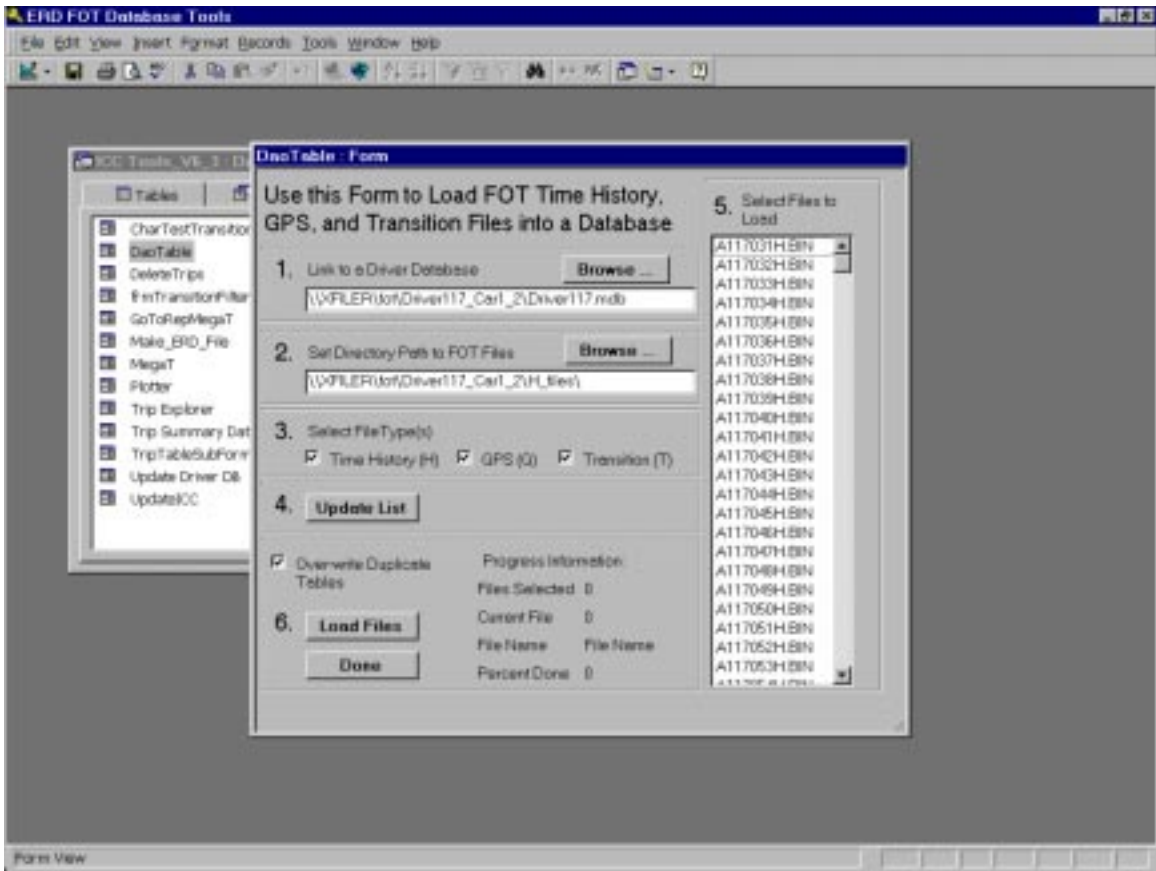

Figure 34. Driver database form

Table 16 lists the fields in the “H” tables. These tables are indexed by the “Time” field (for drivers 39-117). They are loaded in chronological order at a nominal sampling rate of 10 records per second. These channels were defined in section 3.3.2.

Table 16. “H” Table Channels

AccFollowing	AccMode	AverageDNearEncounter
AverageVDot	Backscatter	BackscatterWarn
Brake	CDot	Closing
Cutin	Date/Time	DecelAvoid
DegreeOfCurvature	Distance	DNearEncounter
DScore	Following	HeadwayTimeMargin
Near	NewTarget	Range

RDot	Separating	Thpt03
Throttle	TimeToImpact	Tracking
TScore	VacTime	ValidTarget
VCommand	VDot	Velocity
Vp	VpDot	VSet

Table 17 lists the fields in the “G” tables. These tables are indexed by the “GpsTime” field (for drivers 39-117). They are loaded in chronological order at a nominal sampling rate of two records per second.

Table 17. “G” Table Channels

Grade
Heading
Latitude
Longitude
GpsTime

The transition, or “T”, tables are organized to record state transitions of logical variables. A channel appears in the table only on a false-to-true transition. Table 18 shows an example “T” table for an ACC trip. Table 19 lists the names corresponding to the values in the “ChannelID” field. The “Time” value used in all of the FOT tables is a double precision real number where the number to the left of the decimal point is the number of days since December 31, 1989 (i.e., 1 is January 1, 1990) and the fractional part is the fraction of the day (e.g., .5 is noon). The time is not local but UTC or Coordinated Universal Time. The first time in Table 18, 35697.8788800926, corresponds to **September 24 1997 21:05**. For ChannelIDs from 200 to 210 the third column is the duration that the channel was true (e.g., the third row shows the ACC turned on for 730.68 seconds). Channels 300 to 308 are by definition, 15 seconds long and so the third column records the importance of the event (e.g., the second row shows a manual second-week brake intervention with a peak AverageVDot of .176 g’s).

Table 18. Example transition table

Time	ChannelID	Duration or Importance
35697.8788800926	209	2088.98
35697.8888925926	304	0.1758168
35697.8903489583	200	730.68
35697.8924773148	308	0.3242722
35697.8938149306	304	0.2884986
35697.8942534722	207	260.63
35697.8942534722	201	0.1099999
35697.8985337963	304	0.2090617

Table 19. “T” Table Channels

ChannelID	Name	ChannelID	Name
200	AccOn	210	HeadwayLong
201	Set	300	Concern
202	Coast	301	AccBi
203	Resume	302	CccBi
204	Accel	303	Man1Bi
205	Cancel	304	Man2Bi
206	Downshift	305	AccNe
207	Engaged	306	CccNe
208	HeadwayShort	307	Man1Ne
209	HeadwayMedium	308	Man2Ne

After all the “T” tables were loaded, a new “MegaT” table was constructed by adding “DriverID” and “TripID” information to each transition and appending all transitions into one table.

#### 4.1.3 ICCXXX.mdb Database

Figure 35 shows the process of loading the “E” files into an “ICC” database. The “E” files include the trip summary information and histograms that were sent to the server via cellular phone. About four times a day, the program illustrated in Figure 36 was run to load the files into their appropriate “ICC” database. These new data were then examined to check for proper operation of the DAS and ACC subsystems.

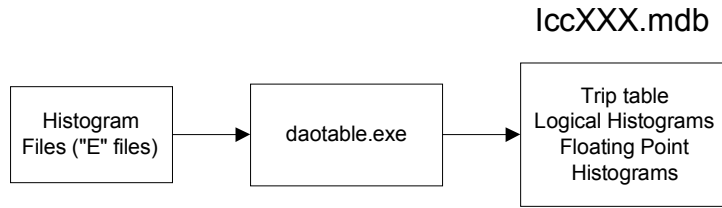

Figure 35. ICC Database Loading

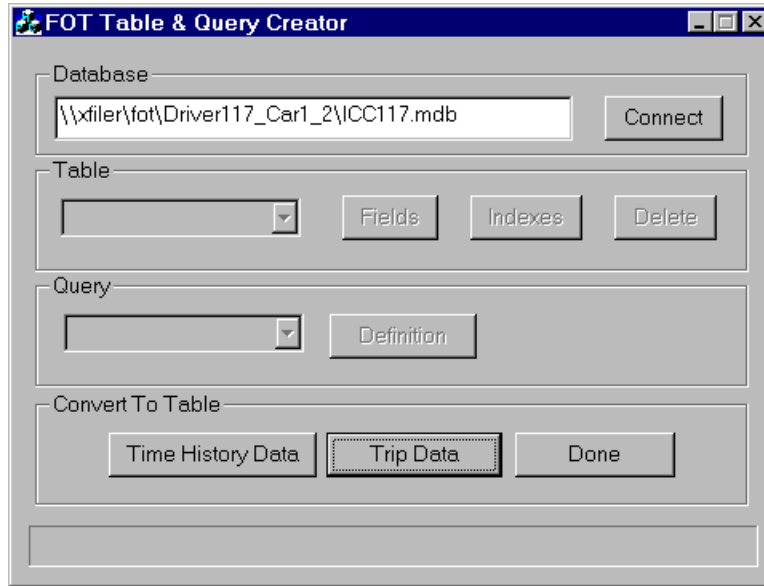

Figure 36. ICC Loading program

Tables 20 and 21 on the next page list the floating point and logical-histogram table names. The histogram tables with a sorting channel are keyed by “DriverID”, “TripID”, and sorting channel (e.g., “Engaged”). The remaining tables are keyed by the “DriverID” and “TripID” fields. The “ICC” databases average 2.5 Mbytes in size.

Table 20. Floating Point Histogram Tables

BackScatterFhist	CDotFhist	DecelAvoidFhist
DegOfCurvatureFhist	DScoreFhist	FlowFhist
HindranceFhist	HtmFhist	RangeFhist
RangeFollowingFhist	RangeVgt35FhistV	RDotFhist
RDotVgt35Fhist	Thpt03Fhist	ThrottleFhist
TimeToImpactFhist	TrackingErrorFhist	TScoreFhist
VCommandFhist	VDotFhist	VDotVgt35Fhist
VehnessFhist	VelocityFhist	VelocityVgt35Fhist
VpDotVgt35Fhist	VpFhist	VSetFhist

Table 21. Logical Histogram Tables

AccFollowingLhist	AccTrackingLhist	BackscatterWarnLhist
BlindedLhist	BrakeLhist	CleaningLhist
ClosingLhist	CutinLhist	DScoreRegionLhist
FollowingLhist	LVpDotLhist	NearLhist
NewTargetLhist	ReducedRangeLhist	SeparatingLhist
TrackingLhist	TScoreRegionLhist	ValidTargetLhist
ValidTargetVgt35Lhist	ValidTargetVgt50Lhist	

## 4.2 Reorganized & Augmented Databases

The database design of the archived data described above was optimized for prompt delivery and not for ease of analysis. Section 4.2.1 describes how the data were reorganized and placed on the FOT server to enable all team members to access and query the same data set. Section 4.2.2 describes some of the new data derived from additional processing.

### 4.2.1 Database Reorganization

All of the ICCXXX.mdb database information for each driver was combined into a master database called IccMaster.mdb. A master transition table for all drivers was created and called MegaT.mdb. In addition, the H tables and G tables were combined into

master tables. New values of  $V_{dot}$  and  $V_{pDot}$  were computed using differentiation algorithms that employ future as well as past values of stored data.

#### 4.2.2 Database Additions

The reorganized database was processed to provide new information as indicated in Table 22.

Table 22. Database additions

Database	Description
Brake	table of braking events
Button	accel, decel, and headway time records
Disengagements	type and condition of disengagement circumstances
Engagements	type and condition of engagement circumstances
Gps	home and work coordinates.
Streams	driving situations, e.g., closing, cut-in, following, etc.
Video	episode and exposure tables

#### 4.3 Invalid Data and Known Anomalies

The InvalidTrips table in the IccMaster database contains at least one record for each trip reported by the DAS via the cellular phone. If no problems were reported for the trip, an InvalidCode of “0” is recorded. Table 23 on the next page shows the codes and corresponding trip information. The codes are not mutually exclusive. For example, a trip with a sensor error could have two entries in the invalid trips table: one with a value of “4” and one with a value of “8.”

Figure 37 on the next page illustrates a sensor anomaly commonly found when an ACC car is following a vehicle on a wet road. The lead car is approximately 110 feet ahead of the ACC car. Some of the time the sensor reads the correct range but often the spray becomes a “target” and the sensor reports a range of about 15 feet. For the first 38 drivers, this anomaly would have generated a near encounter video. A moving average (20 seconds) of backscatter threshold of 10 was added to the triggering logic to prevent videos of these events. Trips with many of these false near encounters were marked with the invalid code of “6” as shown in Table 23.

Table 23. Invalid data summary

<b>InValid Code</b>	<b>Description</b>	<b>Number of Trips</b>	<b>Hours</b>	<b>Miles</b>
0	Valid Trip	11,092	3050.9	114,083.6
1	EcuError	384	54.7	1,037.2
2	Phantom target	1	1.8	119.9
3	Invalid counts in a histogram	1	0.3	5.1
4	Driver had a sensor error	86	36.7	2,006.7
5	Malfunction of the headlight switch	68	18.5	678.0
6	More than 10 near encounters and BS >60	73	130.1	7,786.6
7	Cancel button counts during manual driving	1	0.2	4.8
8	OdinError	86	38.8	1770.9
9	Zero length trip	56	0	0
10	Negative duration	7	0	0
11	Nondesignated driver trip	3	9.2	426.5
12	Valid trip but computer malfunction	2	4.6	265.9
13	Invalid trip due to computer malfunction	35	0.3	4.5
14	Backscatter > 1023 per form in BS database	26	5.5	189.7
15	E-Box error	47	12.9	458.6
16	Removed due to inactivity	81	21.7	846.2
17	Removed due to too many drivers in cell	151	46.3	1665.0
18	VpDot has excessive negative counts	2	1.91	98.3

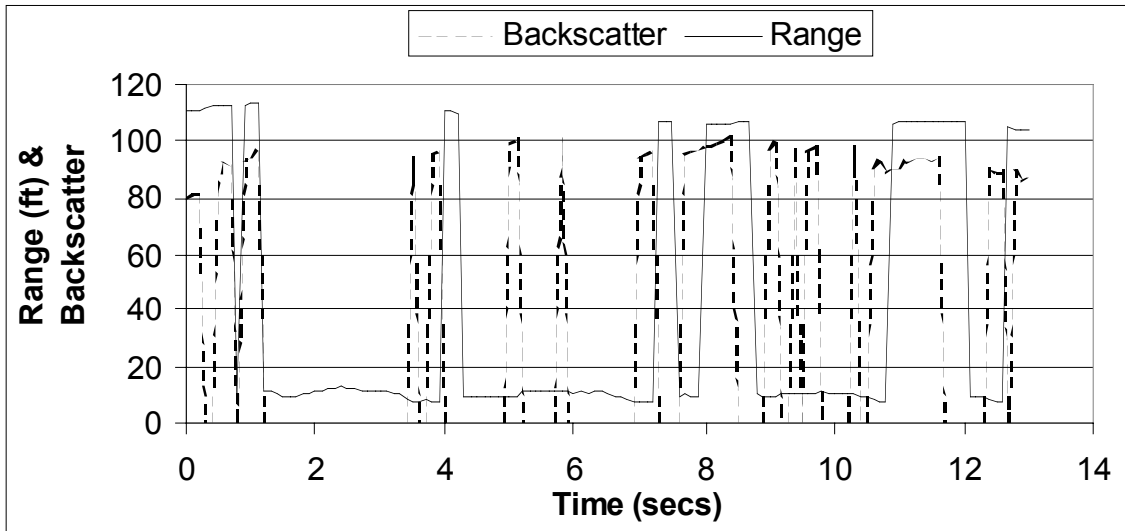

Figure 37. Spray targets

## 4.4 Driver Related Data

### 4.4.1 Summary of Driver Biographic Data

Biographical (background) information was collected from each of the participants (see Table 24 on the next page). This information, in addition to the participant's complete driving record as provided by the Michigan Department of State, Secretary of State's Office, was cataloged in the subject.mdb database according to participant number. Table 25, which spans the next few pages, provides some summary information for each of the 108 participants, including their age, gender, conventional-cruise-control usage, the duration of their participation, miles driven in the 12 months prior to participation, and city in which they lived. A visual depiction of the geographic distribution of the participants is provided in Figure 38 below. The mean and standard deviation of participant age for each of the three age groups are provided in Table 26. Table 27 provides the mean miles driven in the 12 months prior to participating in the ACC FOT by participant group.





Figure 38. Geographic distribution of the participants

Table 24. Biographical information form

**Background Questionnaire**

First Name \_\_\_\_\_ Last Name \_\_\_\_\_

Home Address \_\_\_\_\_

Work City \_\_\_\_\_ State \_\_\_\_\_ Zip \_\_\_\_\_

Home Phone \_\_\_\_\_ Best time to reach you at home \_\_\_\_\_

Work Address \_\_\_\_\_

Work City \_\_\_\_\_ State \_\_\_\_\_ Zip \_\_\_\_\_

Work Phone \_\_\_\_\_ Times at work \_\_\_\_\_

Occupation \_\_\_\_\_ Date of Birth \_\_\_\_\_

Social Security Number \_\_\_\_\_ Driver's License Number \_\_\_\_\_

How long have you been driving? \_\_\_\_\_

Year/Make/Model of the vehicle that you are currently driving \_\_\_\_\_

Your average highway speed \_\_\_\_\_

The average miles per trip (Please consider all of the driving that you do. A trip is defined from when you start you car until you turn off your car at your destination i.e. not a round trip) \_\_\_\_\_

The total number of miles that you drove last year \_\_\_\_\_

Of the miles that you drove last year, what percentage of the miles were traveled on:

rural roads? \_\_\_\_\_

city roads? \_\_\_\_\_

highways? \_\_\_\_\_

100%

The number of moving violations that you have had in the past 12 months? \_\_\_\_\_

Gender        \_\_\_ Male        \_\_\_ Female

Smoker \_\_\_ Yes        \_\_\_ No

Do you wear contacts or glasses?    \_\_\_ Yes        \_\_\_ No

When you drive on the highway, how would you describe your cruise control usage? Would you say that you use cruise control;

\_\_\_ Never or rarely        \_\_\_ Frequently

Table 25. Summary of Driver Data

Sort Count	Driver ID #	Age	Gender	Cruise Usage	5 week?	Miles Traveled Last Year	Home City
1	27	20-30	Female	Nonuser	FALSE	20000	Novi
2	31	20-30	Female	Nonuser	FALSE	15000	Detroit
3	38	20-30	Female	Nonuser	FALSE	10000	Ann Arbor
4	39	20-30	Female	Nonuser	FALSE	15000	Trenton
5	44	20-30	Female	Nonuser	FALSE	20000	Westland
6	45	20-30	Female	Nonuser	FALSE	12000	Grosse Pointe
7	49	20-30	Female	Nonuser	FALSE	10000	Fowlerville
8	4	20-30	Male	Nonuser	FALSE	10000	Ypsilanti
9	41	20-30	Male	Nonuser	FALSE	30000	Detroit
10	63	20-30	Male	Nonuser	FALSE	20000	Beverly Hills
11	93	20-30	Male	Nonuser	FALSE	3000	Ann Arbor
12	98	20-30	Male	Nonuser	FALSE	30000	Farmington Hills
13	109	20-30	Male	Nonuser	FALSE	20000	Southfield
14	114	20-30	Male	Nonuser	FALSE	15000	Ypsilanti
15	10	20-30	Female	User	FALSE	15000	Redford
16	15	20-30	Female	User	FALSE	16000	Farmington Hills
17	30	20-30	Female	User	FALSE	9000	Leslie
18	42	20-30	Female	User	FALSE	15000	Ann Arbor
19	50	20-30	Female	User	FALSE	17000	Detroit
20	51	20-30	Female	User	FALSE	30000	Ann Arbor
21	52	20-30	Female	User	FALSE	13000	Troy
22	33	20-30	Male	User	FALSE	40000	Dexter
23	37	20-30	Male	User	FALSE	17000	Dearborn Heights
24	54	20-30	Male	User	FALSE	18000	Jackson
25	59	20-30	Male	User	FALSE	15000	Northville
26	60	20-30	Male	User	FALSE	16000	Ann Arbor
27	61	20-30	Male	User	FALSE	30000	Pontiac
28	64	20-30	Male	User	FALSE	15000	Northville

29	1	40-50	Female	Nonuser	FALSE	375	Pontiac
30	23	40-50	Female	Nonuser	FALSE	7000	Grass Lake
31	25	40-50	Female	Nonuser	FALSE	8000	Detroit
32	26	40-50	Female	Nonuser	FALSE	10000	Bloomfield Hills
33	29	40-50	Female	Nonuser	FALSE	12000	Grosse Pointe Woods
34	80	40-50	Female	Nonuser	FALSE	18000	Novi
35	84	40-50	Female	Nonuser	FALSE	12000	Temperance
36	34	40-50	Male	Nonuser	FALSE	15000	Grosse Pointe Park
37	75	40-50	Male	Nonuser	FALSE	23000	Saline
38	94	40-50	Male	Nonuser	FALSE	10000	Royal Oak
39	102	40-50	Male	Nonuser	FALSE	19000	Berkley
Sort Count	Driver ID #	Age	Gender	Cruise Usage	5 week?	Miles Traveled Last Year	Home City
40	111	40-50	Male	Nonuser	FALSE	30000	Macomb
41	112	40-50	Male	Nonuser	FALSE	20000	Brighton
42	117	40-50	Male	Nonuser	FALSE	18000	Plymouth
43	5	40-50	Female	User	FALSE	15000	Ann Arbor
44	6	40-50	Female	User	FALSE	20000	Brighton
45	8	40-50	Female	User	FALSE	25000	Brighton
46	9	40-50	Female	User	FALSE	40000	Howell
47	12	40-50	Female	User	FALSE	25000	Canton
48	21	40-50	Female	User	FALSE	49999	Grosse Pointe Farms
49	24	40-50	Female	User	FALSE	20000	Jackson
50	3	40-50	Male	User	FALSE	10000	Saline
51	14	40-50	Male	User	FALSE	16000	Clinton Township
52	17	40-50	Male	User	FALSE	16000	Trenton
53	22	40-50	Male	User	FALSE	15000	Royal Oak
54	35	40-50	Male	User	FALSE	19000	Troy
55	74	40-50	Male	User	FALSE	12000	Lincoln Park
56	105	40-50	Male	User	FALSE	35000	Saline
57	43	60-70	Female	Nonuser	FALSE	5000	Lake Orion
58	46	60-70	Female	Nonuser	FALSE	5300	Oak Park
59	82	60-70	Female	Nonuser	FALSE	4000	Madison Heights
60	83	60-70	Female	Nonuser	FALSE	5000	Birmingham
61	91	60-70	Female	Nonuser	FALSE	12000	Rochester Hills
62	95	60-70	Female	Nonuser	FALSE	7000	West Bloomfield
63	106	60-70	Female	Nonuser	FALSE	10000	Northville
64	103	60-70	Male	Nonuser	FALSE	30000	Ann Arbor
65	107	60-70	Male	Nonuser	FALSE	20000	Ann Arbor
66	108	60-70	Male	Nonuser	FALSE	8000	Ann Arbor
67	110	60-70	Male	Nonuser	FALSE	20000	Clarkston

68	113	60-70	Male	Nonuser	FALSE	20000	Sterling Heights
69	115	60-70	Male	Nonuser	FALSE	20000	Rochester Hills
70	116	60-70	Male	Nonuser	FALSE	15000	Oak Park
71	13	60-70	Female	User	FALSE	15000	Lansing
72	48	60-70	Female	User	FALSE	32000	Livonia
73	57	60-70	Female	User	FALSE	15000	Brighton
74	65	60-70	Female	User	FALSE	5000	Monroe
75	67	60-70	Female	User	FALSE	20000	Ann Arbor
76	69	60-70	Female	User	FALSE	12000	Dearborn Heights
77	72	60-70	Female	User	FALSE	10000	West Bloomfield
78	7	60-70	Male	User	FALSE	24000	Brighton
79	11	60-70	Male	User	FALSE	18000	Livonia
Sort Count	Driver ID #	Age	Gender	Cruise Usage	5 week?	Miles Traveled Last Year	Home City
80	18	60-70	Male	User	FALSE	15000	Northville
81	19	60-70	Male	User	FALSE	15000	Temperance
82	20	60-70	Male	User	FALSE	15000	Southgate
83	32	60-70	Male	User	FALSE	25000	Ann Arbor
84	47	60-70	Male	User	FALSE	15000	Brooklyn
85	56	20-30	Female	User	TRUE	30000	Holt
86	73	20-30	Female	User	TRUE	15000	Lansing
87	79	20-30	Female	User	TRUE	12000	Monroe
88	87	20-30	Female	User	TRUE	20000	Ypsilanti
89	55	20-30	Male	User	TRUE	10000	Livonia
90	68	20-30	Male	User	TRUE	40000	Birmingham
91	76	20-30	Male	User	TRUE	20000	East Lansing
92	89	20-30	Male	User	TRUE	25000	Allen Park
93	88	40-50	Female	User	TRUE	45000	St. Clair
94	96	40-50	Female	User	TRUE	25000	Grosse Pointe Farms
95	99	40-50	Female	User	TRUE	20000	Troy
96	104	40-50	Female	User	TRUE	20000	Farmington Hills
97	78	40-50	Male	User	TRUE	25000	Ann Arbor
98	81	40-50	Male	User	TRUE	23000	MI
99	92	40-50	Male	User	TRUE	36000	Brighton
100	100	40-50	Male	User	TRUE	30000	Canton
101	70	60-70	Female	User	TRUE	20000	Whitmore Lake
102	77	60-70	Female	User	TRUE	12000	Southfield
103	90	60-70	Female	User	TRUE	18000	Howell
104	97	60-70	Female	User	TRUE	25000	Ann Arbor
105	40	60-70	Male	User	TRUE	12000	Northville
106	62	60-70	Male	User	TRUE	19000	Redford

107	66	60-70	Male	User	TRUE	25000	Oxford
108	85	60-70	Male	User	TRUE	36000	Beverly Hills

Table 26. Mean and standard deviation of participant age, by age group

<b>Age Group</b>	<b>Mean Age</b>	<b>Standard Deviation of Age</b>
20 – 30 years old	24.42	2.81
40 – 50 years old	44.17	3.17
60 – 70 years old	64.75	2.98

Table 27. Mean and standard deviation of miles driven in the previous 12 months by group

<b>Group</b>	<b>Mean Miles Driven</b>	<b>Standard Deviation of Miles Driven</b>
<i>Age:</i>		
20-30	18555.55	8436.127
40-50	20677.05	10709.91
60-70	16230.55	7891.363
<i>Cruise Usage:</i>		
Nonuser	14611.30	7653.526
User	20954.53	9287.547
<i>Duration:</i>		
2 week	19523.78	9192.275
5 week	23458.33	9103.172
<i>Gender:</i>		
Females	16642.11	9833.805
Males	20333.33	8181.894

#### 4.4.2 The Myers-Briggs Type Inventory

Additional background information collected from each participant included a Myers-Briggs Type Inventory. The Myers-Briggs Type Inventory, or MBTI, was created in the 1940s based on Carl Jung’s theories about personality categories and the differences in personality type. The test is used to analyze eight personality preferences that people use to determine a distinct pattern of behavioral preference. The purpose of the MBTI is not to predict behavior but to classify individuals according to preferences — how people

prefer to express themselves, evaluate others, act on feelings, etc. Applications of MBTI range from career counseling to organizational restructuring to communication and management training. The MBTI has also been highly correlated with scales of aggression, self confidence, and management skills. It was thought that this tool might provide insight into personality variables and how they correlate with recorded variables of driving behavior.

Each participant completed an MBTI consisting of about 125 questions. The four scales measured by the MBTI are as follows: Extraversion-Introversion (coded with either E or an I), Sensing-Intuition (coded with either S or an N), Thinking-Feeling (coded with either T or an F), and Judging-Perceiving (coded with either J or a P). The eight preferences combine to produce one of sixteen personality types. Each participant's MBTI was scored, and these scores are listed in Table 28. For a complete description of the sixteen personality types, and details regarding the MBTI, see *Type* by Isabel Briggs Meyers, Consulting Psychologists Press, Inc., 1987.

Table 28. Myers-Briggs Type scores for each participant

Sort Count	Driver ID #	Age	Gender	MBTI
1	27	20-30	Female	ISFJ
2	31	20-30	Female	ESTJ
3	38	20-30	Female	ISTJ
4	39	20-30	Female	ESFJ
5	44	20-30	Female	ISTP
6	45	20-30	Female	INFJ
7	49	20-30	Female	ESFP
8	4	20-30	Male	INTJ
9	41	20-30	Male	ESTJ
10	63	20-30	Male	INTJ
11	93	20-30	Male	ENTJ
12	98	20-30	Male	ISTP
13	109	20-30	Male	ISTP
14	114	20-30	Male	ENFP
15	10	20-30	Female	ESFP
16	15	20-30	Female	INTJ
17	30	20-30	Female	ESFP
18	42	20-30	Female	ESTJ
19	50	20-30	Female	INFJ
20	51	20-30	Female	INFP
21	52	20-30	Female	ESFJ

Sort Count	Driver ID #	Age	Gender	MBTI
22	33	20-30	Male	ISTJ
23	37	20-30	Male	ENTJ
24	54	20-30	Male	ENFP
25	59	20-30	Male	ENTP
26	60	20-30	Male	ESTP
27	61	20-30	Male	ENTP
28	64	20-30	Male	ISTJ
29	1	40-50	Female	ESTJ
30	23	40-50	Female	INFP
31	25	40-50	Female	ISTJ
32	26	40-50	Female	ESFP
33	29	40-50	Female	ISTJ
34	80	40-50	Female	ESTJ
35	84	40-50	Female	ESFJ
36	34	40-50	Male	ISFJ
37	75	40-50	Male	INTJ
38	94	40-50	Male	ENFP
39	102	40-50	Male	ISTJ
40	111	40-50	Male	ESTJ
41	112	40-50	Male	ISTP
42	117	40-50	Male	ISTJ
43	5	40-50	Female	ISTJ
44	6	40-50	Female	ISFJ
45	8	40-50	Female	ESTJ
46	9	40-50	Female	ISTJ
47	12	40-50	Female	ENFJ
48	21	40-50	Female	INFP
49	24	40-50	Female	ISFJ
50	3	40-50	Male	INTJ
51	14	40-50	Male	INTP
52	17	40-50	Male	ISTJ
53	22	40-50	Male	ESTJ
54	35	40-50	Male	ISTJ
55	74	40-50	Male	ESTJ
56	105	40-50	Male	ISTJ
57	43	60-70	Female	ISFJ
58	46	60-70	Female	INFP
59	82	60-70	Female	ISTP
60	83	60-70	Female	ENTJ
61	91	60-70	Female	ISTJ
62	95	60-70	Female	ESFJ
63	106	60-70	Female	ESTJ



Sort Count	Driver ID #	Age	Gender	MBTI
64	103	60-70	Male	ISFP
65	107	60-70	Male	INFJ
66	108	60-70	Male	INTJ
67	110	60-70	Male	ENFP
68	113	60-70	Male	ENFP
69	115	60-70	Male	ESTJ
70	116	60-70	Male	ISTJ
71	13	60-70	Female	ISFJ
72	48	60-70	Female	ESTJ
73	57	60-70	Female	ESFJ
74	65	60-70	Female	ISTJ
75	67	60-70	Female	ENFJ
76	69	60-70	Female	ESTJ
77	72	60-70	Female	ESTJ
78	7	60-70	Male	ESTJ
79	11	60-70	Male	ESTJ
80	18	60-70	Male	ESTJ
81	19	60-70	Male	ESTJ
82	20	60-70	Male	ESFP
83	32	60-70	Male	INFP
84	47	60-70	Male	ESFJ
85	56	20-30	Female	ISTJ
86	73	20-30	Female	INTP
87	79	20-30	Female	ESTJ
88	87	20-30	Female	ESFJ
89	55	20-30	Male	ISFJ
90	68	20-30	Male	INFJ
91	76	20-30	Male	ISTJ
92	89	20-30	Male	ISTJ
93	88	40-50	Female	ENFP
94	96	40-50	Female	ISTP
95	99	40-50	Female	ESFJ
96	104	40-50	Female	ESFJ
97	78	40-50	Male	ISTJ
98	81	40-50	Male	ISTJ
99	92	40-50	Male	ENTP
100	100	40-50	Male	ENFJ
101	70	60-70	Female	INTJ
102	77	60-70	Female	ESTJ
103	90	60-70	Female	ISTP
104	97	60-70	Female	ESFJ
105	40	60-70	Male	ENFP

Sort Count	Driver ID #	Age	Gender	MBTI
106	62	60-70	Male	ESTJ
107	66	60-70	Male	ISFJ
108	85	60-70	Male	ESTP

#### **4.4.3 Driving Style Questionnaire Results**

Prior to and just after participating in the FOT, each participant completed a driving style questionnaire. These questionnaires were developed specifically for the FOT as a means for participants to self-report their level of aggressive driving behavior, and have not been validated as data-collection instruments elsewhere. The two questionnaires, pre-FOT and post-FOT, contained almost identical questions. However, the questionnaire that participants completed prior to driving the ACC vehicle was only concerned with manual driving behavior. The post-FOT questionnaire was only concerned with the participant's driving behavior while using ACC. The questions asked included an assessment of speed traveled relative to other traffic, passing habits, and headway keeping. The complete pre- and post-FOT driving style questionnaires are listed in Tables 29 and 30.

Table 29. Pre-FOT, manual driving style questionnaire

### Driving Style Questionnaire

Please complete the following questionnaire and **circle only one answer** for each question. The answers you provide will in no way affect your participation so answer as freely as you can.

When driving, do you generally travel: (Circle one answer)

- a. faster than the surrounding traffic
- b. at a speed similar to the surrounding traffic
- c. slower than the surrounding traffic

When driving, do you find yourself: (Circle one answer)

- a. passing other vehicles more often than you were passed
- b. passing other vehicles just as often as you were passed
- c. being passed by other vehicles more often than you passed

Do you pass other vehicles on their passenger side (i.e., use a lane designated for slower traffic in order to pass): (Circle one answer)

- a. frequently
- b. occasionally
- c. rarely

When following another vehicle, the distance you maintain between your vehicle and the preceding vehicle is: (Circle one answer)

- a. a distance which was shorter than that maintained by surrounding traffic
- b. a distance similar to that maintained by surrounding traffic
- c. a distance which was longer than that maintained by surrounding traffic

When driving, which is most likely to affect the distance you maintain between your vehicle and the preceding vehicle: (Circle one answer)

- a. your speed
- b. traffic density

c. your schedule

Do you ever avoid traveling in conditions where you might encounter heavy traffic: (Circle one answer)

- a. frequently
- b. occasionally
- c. rarely

Table 30. Post-FOT, manual driving style questionnaire

### Driving Style Questionnaire

Please complete the following questionnaire and **circle only one answer** for each question. The answers you provide will in no way affect your participation so answer as freely as you can.

When driving the ACC vehicle, did you generally travel: (Circle one answer)

- a. faster than the surrounding traffic
- b. at a speed similar to the surrounding traffic
- c. slower than the surrounding traffic

When driving the ACC vehicle, did you find yourself: (Circle one answer)

- a. passing other vehicles more often than you were passed
- b. passing other vehicles just as often as you were passed
- c. being passed by other vehicles more often than you passed

When driving the ACC vehicle, did you pass other vehicles on their passenger side (i.e., use a lane designated for slower traffic in order to pass): (Circle one answer)

- a. frequently
- b. occasionally
- c. rarely

When following another vehicle in the ACC vehicle, the distance you maintained between your vehicle and the preceding vehicle was: (Circle one answer)

- a. a distance which was shorter than that maintained by surrounding traffic

- b. a distance similar to that maintained by surrounding traffic
- c. a distance which was longer than that maintained by surrounding traffic

When driving in the ACC vehicle, which was most likely to affect the distance you maintained between your vehicle and the preceding vehicle: (Circle one answer)

- a. your speed
- b. traffic density
- c. your schedule

Did you ever avoid traveling in conditions where you might encounter heavy traffic while driving the ACC vehicle: (Circle one answer)

- a. frequently
- b. occasionally
- c. rarely

The design of both questionnaires was of the multiple-choice type. Each possible answer was assigned a score such that the sum of the answers could be computed per driver, and the sum scores potentially used in a classification scheme of driver behavior, or to examine the score relationship with observed/recorded dependent measures of performance. Driver scores could range from six to eighteen, where the lower the driver's score, the less aggressive their driving habits were considered to be. Below is an example of one of the questions, and the score methodology.

*Do you pass other vehicles on their passenger side (i.e. use a lane designated for slower traffic in order to pass): (Circle one answer)*

- a. frequently*
- b. occasionally*
- c. rarely*

For this question, answer *a* was assigned a value of 3, answer *b* was assigned a value of 2 and answer *c* was assigned a value of 1. These scores are broken down for the three independent variables of the experimental design (participant age, conventional cruise control usage, and duration of participation in the operational test) as well as participant gender in Table 31. A summary of individual participant driving style scores is provided in Table 32.

Table 31. Summary of driving style questionnaire results by independent variable<sup>1</sup>

<b>Group</b>	<b>No Change in score from Pre to Post</b>	<b>Increased score Pre to Post (more aggressive)</b>	<b>Decreased score Pre to Post (less aggressive)</b>
<i>Age:</i>			
20-30	8	17	11
40-50	12	11	13
60-70	12	10	14
<i>Cruise Usage:</i>			
Nonuser	13	15	14
User	19	23	24
<i>Duration<sup>2</sup>:</i>			
2 week	12	18	12
5 week	7	5	12
<i>Gender:</i>			
Females	19	14	21
Males	13	24	17

Table 32. Individual participant driving-style scores, pre- and post-FOT

Sort Count	Driver ID #	Age	Cruise Usage	5 week?	Gender	Difference
1	27	20-30	Nonuser	FALSE	Female	Less Aggressive
2	31	20-30	Nonuser	FALSE	Female	Less Aggressive
3	38	20-30	Nonuser	FALSE	Female	No Change
4	39	20-30	Nonuser	FALSE	Female	No Change
5	44	20-30	Nonuser	FALSE	Female	Less Aggressive
6	45	20-30	Nonuser	FALSE	Female	No Change
7	49	20-30	Nonuser	FALSE	Female	Less Aggressive
8	4	20-30	Nonuser	FALSE	Male	Less Aggressive
9	41	20-30	Nonuser	FALSE	Male	More Aggressive
10	63	20-30	Nonuser	FALSE	Male	More Aggressive
11	93	20-30	Nonuser	FALSE	Male	Less Aggressive
12	98	20-30	Nonuser	FALSE	Male	More Aggressive
13	109	20-30	Nonuser	FALSE	Male	Less Aggressive

<sup>1</sup> Values in the table represent the number of participants falling under the three possible categories (no change in aggressivity, increased aggressivity, and decreased aggressivity).

<sup>2</sup> For the “2 weekers,” only the “Users” are listed (by design, all 5 weekers were Users).

Sort Count	Driver ID #	Age	Cruise Usage	5 week?	Gender	Difference
14	114	20-30	Nonuser	FALSE	Male	More Aggressive
15	10	20-30	User	FALSE	Female	More Aggressive
16	15	20-30	User	FALSE	Female	More Aggressive
17	30	20-30	User	FALSE	Female	No Change
18	42	20-30	User	FALSE	Female	Less Aggressive
19	50	20-30	User	FALSE	Female	No Change
20	51	20-30	User	FALSE	Female	More Aggressive
21	52	20-30	User	FALSE	Female	Less Aggressive
22	33	20-30	User	FALSE	Male	More Aggressive
23	37	20-30	User	FALSE	Male	More Aggressive
24	54	20-30	User	FALSE	Male	No Change
25	59	20-30	User	FALSE	Male	More Aggressive
26	60	20-30	User	FALSE	Male	More Aggressive
27	61	20-30	User	FALSE	Male	More Aggressive
28	64	20-30	User	FALSE	Male	More Aggressive
29	1	40-50	Nonuser	FALSE	Female	More Aggressive
30	23	40-50	Nonuser	FALSE	Female	No Change
31	25	40-50	Nonuser	FALSE	Female	Less Aggressive
32	26	40-50	Nonuser	FALSE	Female	No Change
33	29	40-50	Nonuser	FALSE	Female	Less Aggressive
34	80	40-50	Nonuser	FALSE	Female	Less Aggressive
35	84	40-50	Nonuser	FALSE	Female	More Aggressive
36	34	40-50	Nonuser	FALSE	Male	No Change
37	75	40-50	Nonuser	FALSE	Male	No Change
38	94	40-50	Nonuser	FALSE	Male	More Aggressive
39	102	40-50	Nonuser	FALSE	Male	No Change
40	111	40-50	Nonuser	FALSE	Male	No Change
41	112	40-50	Nonuser	FALSE	Male	More Aggressive
42	117	40-50	Nonuser	FALSE	Male	More Aggressive
43	5	40-50	User	FALSE	Female	No Change
44	6	40-50	User	FALSE	Female	More Aggressive
45	8	40-50	User	FALSE	Female	Less Aggressive
46	9	40-50	User	FALSE	Female	No Change
47	12	40-50	User	FALSE	Female	No Change
48	21	40-50	User	FALSE	Female	Less Aggressive

Sort Count	Driver ID #	Age	Cruise Usage	5 week?	Gender	Difference
49	24	40-50	User	FALSE	Female	More Aggressive
50	3	40-50	User	FALSE	Male	No Change
51	14	40-50	User	FALSE	Male	Less Aggressive
52	17	40-50	User	FALSE	Male	More Aggressive
53	22	40-50	User	FALSE	Male	More Aggressive
54	35	40-50	User	FALSE	Male	More Aggressive
55	74	40-50	User	FALSE	Male	Less Aggressive
56	105	40-50	User	FALSE	Male	No Change
57	43	60-70	Nonuser	FALSE	Female	More Aggressive
58	46	60-70	Nonuser	FALSE	Female	More Aggressive
59	82	60-70	Nonuser	FALSE	Female	No Change
60	83	60-70	Nonuser	FALSE	Female	No Change
61	91	60-70	Nonuser	FALSE	Female	More Aggressive
62	95	60-70	Nonuser	FALSE	Female	Less Aggressive
63	106	60-70	Nonuser	FALSE	Female	Less Aggressive
64	103	60-70	Nonuser	FALSE	Male	No Change
65	107	60-70	Nonuser	FALSE	Male	More Aggressive
66	108	60-70	Nonuser	FALSE	Male	Less Aggressive
67	110	60-70	Nonuser	FALSE	Male	Less Aggressive
68	113	60-70	Nonuser	FALSE	Male	More Aggressive
69	115	60-70	Nonuser	FALSE	Male	No Change
70	116	60-70	Nonuser	FALSE	Male	More Aggressive
71	13	60-70	User	FALSE	Female	No Change
72	48	60-70	User	FALSE	Female	Less Aggressive
73	57	60-70	User	FALSE	Female	Less Aggressive
74	65	60-70	User	FALSE	Female	More Aggressive
75	67	60-70	User	FALSE	Female	No Change
76	69	60-70	User	FALSE	Female	Less Aggressive
77	72	60-70	User	FALSE	Female	More Aggressive
78	7	60-70	User	FALSE	Male	More Aggressive
79	11	60-70	User	FALSE	Male	More Aggressive
80	18	60-70	User	FALSE	Male	Less Aggressive
81	19	60-70	User	FALSE	Male	No Change
82	20	60-70	User	FALSE	Male	Less Aggressive
83	32	60-70	User	FALSE	Male	No Change



Sort Count	Driver ID #	Age	Cruise Usage	5 week?	Gender	Difference
84	47	60-70	User	FALSE	Male	Less Aggressive
85	56	20-30	User	TRUE	Female	Less Aggressive
86	73	20-30	User	TRUE	Female	More Aggressive
87	79	20-30	User	TRUE	Female	No Change
88	87	20-30	User	TRUE	Female	No Change
89	55	20-30	User	TRUE	Male	More Aggressive
90	68	20-30	User	TRUE	Male	More Aggressive
91	76	20-30	User	TRUE	Male	Less Aggressive
92	89	20-30	User	TRUE	Male	More Aggressive
93	88	40-50	User	TRUE	Female	Less Aggressive
94	96	40-50	User	TRUE	Female	Less Aggressive
95	99	40-50	User	TRUE	Female	More Aggressive
96	104	40-50	User	TRUE	Female	Less Aggressive
97	78	40-50	User	TRUE	Male	No Change
98	81	40-50	User	TRUE	Male	Less Aggressive
99	92	40-50	User	TRUE	Male	Less Aggressive
100	100	40-50	User	TRUE	Male	Less Aggressive
101	70	60-70	User	TRUE	Female	Less Aggressive
102	77	60-70	User	TRUE	Female	No Change
103	90	60-70	User	TRUE	Female	No Change
104	97	60-70	User	TRUE	Female	No Change
105	40	60-70	User	TRUE	Male	No Change
106	62	60-70	User	TRUE	Male	Less Aggressive
107	66	60-70	User	TRUE	Male	Less Aggressive
108	85	60-70	User	TRUE	Male	Less Aggressive

## 5.0 Data-Processing Methods

A goal of this FOT was to assess the influence of ACC on the driving task. A variety of data-processing procedures were employed to make this assessment. These procedures ranged from examining signals derived in real time by the DAS installed in the FOT vehicles to investigating time-indexed records (i.e., time histories) stored in a database format for enabling flexible query generation and data interconnectedness. The data processing fell into two general processes. The first involved the real-time, on-board processing of the primary and derived signals into histograms. The second was the cleansing, manipulating, and reduction of time-history signals such as velocity, range, and their derivatives. Histograms were created both on-board the FOT vehicles as the data were collected and also generated after the fact using the stored time-history records. The time-history data were processed to find certain types of driving patterns such as closing, separating, following, and braking. These patterns or events were found using rule-based methods and were processed to provide quantitative measures of the influences of driver characteristics, control-system properties, and vehicle characteristics on driving performance. This section describes the prominent data-processing methods used in this FOT.

### 5.1 Histogramming

A large part of the data analyses and processing for this FOT involved the creation and display of histograms. (See section 5.1.3.) The reasons for the extensive use of histograms in this study are the following:

- Histograms are compact in terms of computer memory and data file size (an important consideration for files being transferred over cellular phone in the FOT vehicles) and require a fixed amount of memory for storage.
- Histograms can easily be combined to aggregate data across trips or drivers.
- Histograms contain counts that are directly proportional to the driving time represented by the histogram.
- Histograms can be used to approximate certain statistics such as mean, median, and standard deviation.

The last observation in the above list is important because summary statistics are a useful and common means for characterizing the differences between individual drivers and groups of drivers.

To demonstrate the last point in the list above, Table 33 shows the difference between the mean, standard deviation, and median values for the headway-time-margin measure,  $H_{tm}$ , for two drivers using their histograms and time-history data. The table shows that the mean and standard deviation values are nearly identical for both drivers, while the histogram median values show the largest difference, as they are limited by the bin width resolution of the histogram.

Table 33. Example of  $H_{tm}$  statistics generated by histogram and time-history data

	Driver	Count	Mean	Std. Dev.	Median	25 <sup>th</sup> Percentile	75 <sup>th</sup> Percentile
Histogram	10	74839	1.127861	0.6812	0.900	0.600	1.400
Time-history	10	74839	1.127863	0.6813	0.898	0.601	1.469
Histogram	55	16123	1.723944	0.7382	1.700	1.100	2.300
Time-history	55	16123	1.723839	0.7378	1.722	1.151	2.377

To probe the histograms created during the FOT, a special computer tool called the *trip explorer* was developed. The main purpose of the tool was to produce graphic displays of the histogram data. The tool is based on the idea that histograms can be combined for different drivers and groups of drivers, as long as they are combined using the raw counts within the common bins of the histograms. This tool takes advantage of Structured Query Language (SQL) to calculate the aggregate histograms. It also has a built-in filtering option that allows any value of an existing histogram to serve as a filter for selecting a subset of trips or drivers. An example of this approach was used in the interim FOT report where in various histograms that were shown for all trips, the mean velocity was above 44 ft/sec [6]. The main input screen for the trip explorer is shown in Figure 39.

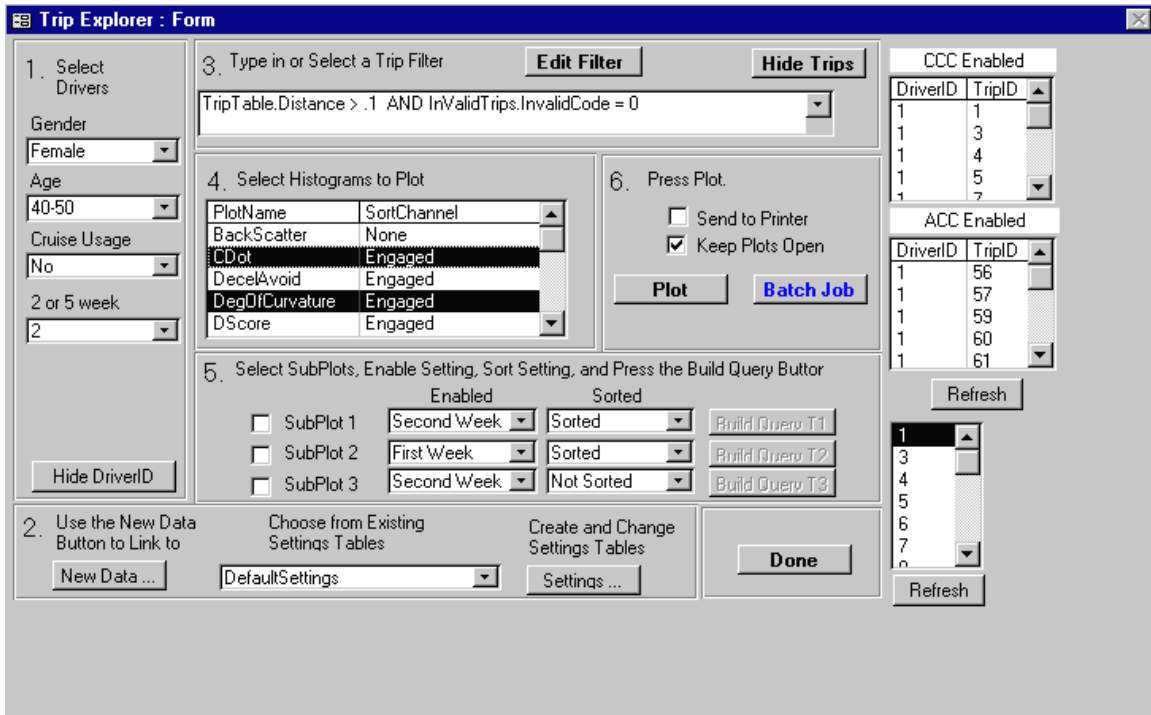

Figure 39. FOT trip explorer tool for displaying histograms

Figure 40 shows an example plot generated using the trip explorer tool. The plot shows the ACC engaged headway-time-margin for cruise users in all three age groups. The histogram is shown as a frequency distribution, which means that each bin of the histogram has been normalized by the total count of all bins.

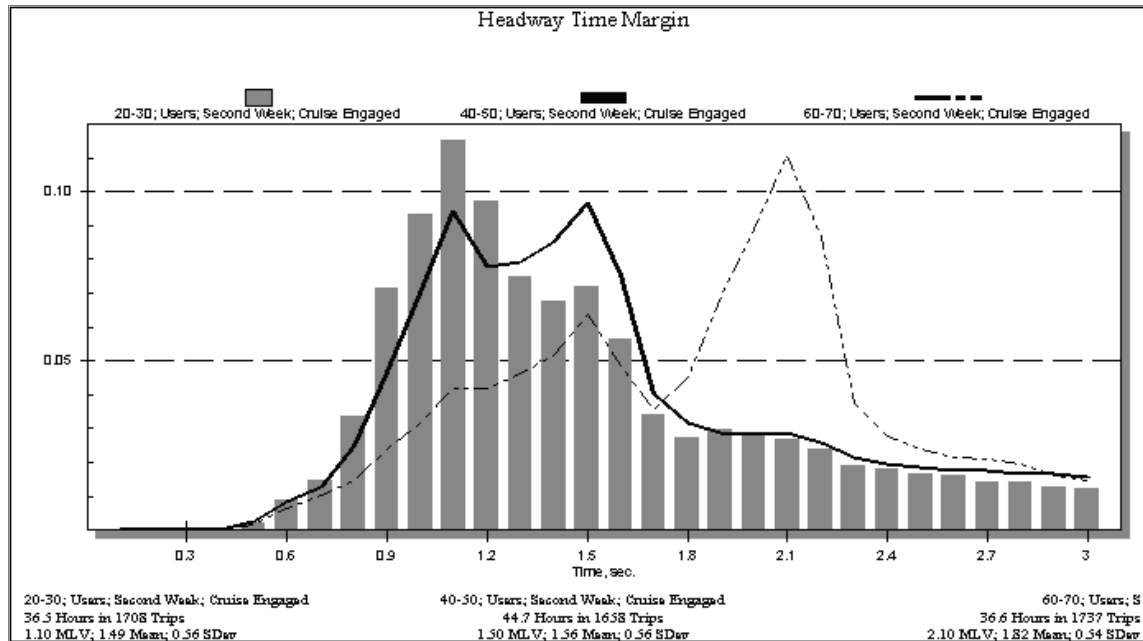

Figure 40. Example headway-time-margin histogram for cruise users

### 5.1.1 Histograms Collected On-Board the FOT Vehicles

In total there were 27 floating-point histograms, 20 logical histograms, and one two-dimensional histogram created on-board the FOT vehicles as they were being driven by the test subjects. These histograms are listed in section 3.3.2. A majority of these histograms are velocity-dependent in that they were only collected at velocities above a certain threshold (most often 35 mph, the enabling velocity for cruise control). However, it was soon learned that velocity has a large influence on cruise usage, thereby prompting the development of more histograms that were, themselves, a function of velocity.

All the floating-point histograms created during the FOT needed to be defined in terms of their bin characteristics. These characteristics include the number of bins, the starting bin center value, and most importantly the bin width. The bin width value is critical because a poor choice can result in artificially large counts or a bias in a particular bin or set of bins. Binning errors were generally avoided in the FOT by setting the bin width of a given signal to an integer multiple of the resolution of that signal. For example, all histograms of velocity had a bin width of 4.4 ft/sec which is an integer multiple (6, in this case) of the velocity signal resolution of 0.73 ft/sec. In addition to defining the number of bins, start bin center, and bin width, each histogram had unbounded end bins to capture counts that fell outside of the defined bin range.

### 5.1.2 Additional Histograms

Ten additional histograms were created using the time-history records from the 108 FOT test subjects. These histograms were like those generated on the vehicles, in that they used the same bin values and spacing, except that they were made with an additional dimension, which typically was velocity. A list of these newly created histograms is given in Table 34. Figure 41 is an example of a two-dimensional histogram.

Table 34. Two-dimensional histograms

Name	1st Source Channel	2nd Source Channel	Enabling Channel	Sorting Channel
Rdot/VVHist	Rdot/Velocity	Velocity	ValidTarget	Engaged
RRdotFhist	Range/Velocity	Rdot/Velocity	ValidTarget	Engaged
RRdotSFhist	Range/Velocity	Rdot/Velocity	Eng., ValTgt, 1.0 sec. Th	None
RRdotMFhist	Range/Velocity	Rdot/Velocity	Eng., ValTgt, 1.4 sec Th	None
RRdotLFhist	Range/Velocity	Rdot/Velocity	Eng., ValTgt, 2.0 sec Th	None
HtmVHist	Range/Velocity	Velocity	ValidTarget	Engaged
TtiVHist	TimeToImpact	Velocity	ValidTarget	Engaged
RangeVHist	Range	Velocity	ValidTarget	Engaged
DecAvdVHist	DecelAvoid	Velocity	ValidTarget	Engaged
Rdot/RVHist	Rdot/Range	Velocity	ValidTarget	Engaged

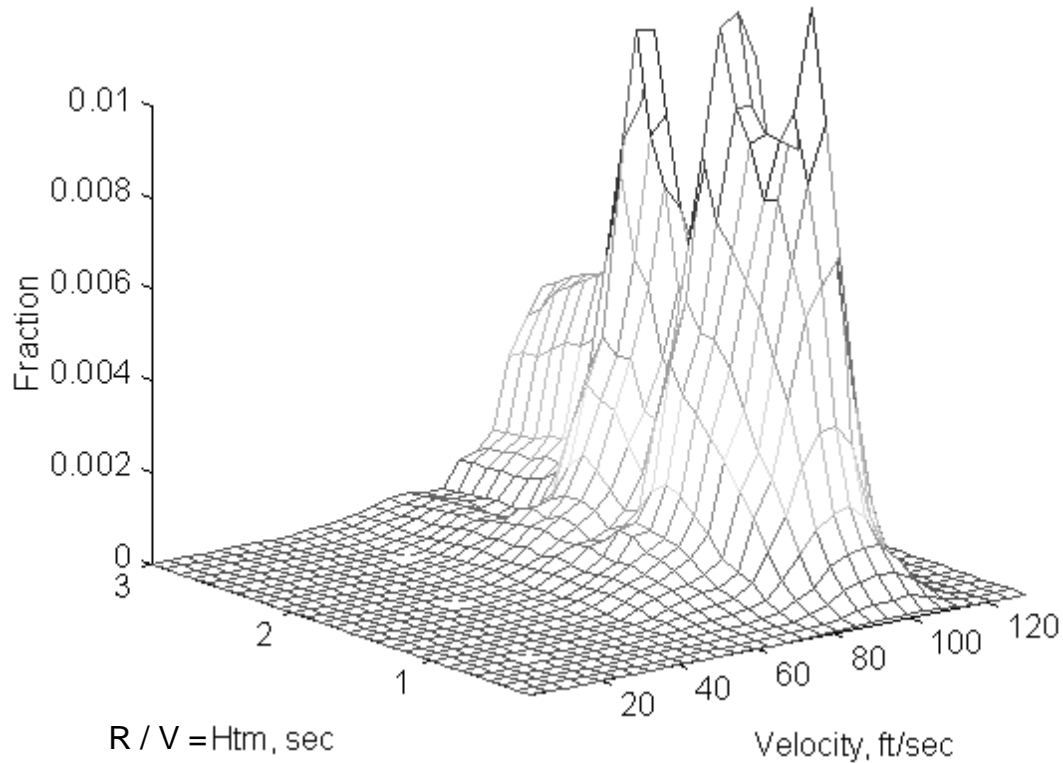

Figure 41. Two-dimensional histogram of velocity and Htm for ACC driving mode

### 5.1.3 Creation and Interpretation of Histograms

This section discusses how the data have been processed to create histograms. It also presents certain symbols associated with that process.

Although histograms are used in many applications, they are not commonly used to display results from vehicle dynamics and control studies. It is common practice to use time-histories to display the time sequence of events in vehicle dynamics studies. However, due to the quantity of data gathered in this study, histograms have been employed as a means of collapsing the time dimension so as to present large sets of data in a compact form. This approach results in the loss of time dependent relationships but it does provide a means for communicating and examining features of huge amounts of raw data to aid in identify interesting and illuminating patterns. The goal is the discovery of new knowledge about the phenomena involved in driving even if the process involves using unusual approaches or interpretations to penetrate the data. (In this context for example, the use of histograms to condense time-histories of dynamic variables may appear as an unconventional approach to some practitioners in the area of vehicle dynamics.)

The basic information portrayed in the histograms are counts of how often the data fall within a defined subset (sometimes referred to as a bin) of a larger, parent set of data made up of two or more bins (subsets). The ratio of the counts within a particular bin to the total number of counts in all of the bins corresponding to a given variable can be viewed as an approximation to the chance, likelihood, or probability that the variable takes on a value that falls within that particular bin. In a sense, this ratio (the fraction of the number of members of the parent set falling within the subset) represents the observed frequency of occurrence, and a complete set of these ratios for a single variable describes a one-dimensional distribution of observed frequencies for that variable.

One use of the histograms, common in this study, is to compare results based upon whether a logical variable (as opposed to a floating-point variable) is true or false. An example of a logical variable is whether the adaptive cruise control is engaged or not. In another example, the driver's age variable has been assigned three discrete levels (older, middle age, and younger) rather than being treated as a continuous variable. In this case, the data have been organized and presented to compare three histograms—one for each age group as shown in Figure 40. (In this figure bars are used to represent the younger drivers, while line segments indicative of middle aged and older drivers are used to connect the observed frequencies of occurrence assigned at the bin centers employed in the histograms.)

In the context of this discussion, the symbol “ $Fb(\cdot | \cdot)$ ” is introduced to represent a descriptive operator acting on two pieces of information. For example, the result from  $Fb(ACC | V_i)$  represents the observed frequency that the driver is using ACC given that the velocity lies within a particular range of velocities.  $V_i$  serves to identify this range of velocities where  $V_i$  equals the value of the center of the bin in question. Inequalities are also used to define the conditional constraints on velocity in certain cases where the bins have broad widths.

Usually bar charts and graphs of lines connecting the observed frequencies (plotted at bin centers) are presented for a number of bins. In these cases the result of using the  $Fb(\cdot | \cdot)$  operator repeatedly over a number of bins or subsets of data is symbolized as  $Pd(\cdot | \cdot)$ . For example,  $Pd(ACC | V)$  represents the set of observed frequencies of occurrence of the use of ACC for a number of velocity bins. The reverse expression  $Pd(V | ACC)$  also has meaning. It represents the distribution of the observed chance (frequency) that the driver is operating within various velocity ranges (bins) under the condition that the driver is using the ACC system. Although it is not a statistically rigorous and conventional interpretation, both  $Pd(ACC | V)$  and  $Pd(V | ACC)$  are seen as



possible indications of the shape or pattern of an underlying conditional probability density function, although the underlying analytic form for each distribution is unknown and unexplored here. However, the main use of the Pd graphical presentation is to provide an orderly labeling scheme for the descriptive results that are obtained by the normalized processing of sets and subsets of data. This type of labeling appears in many figures. For examples, see figures 63, 72, 99, 100, 108, etc.

These concepts for labeling the results of data processing can be extended to multiple dimensions and conditions but it is difficult to envision how to make plots when more than two variables are involved. There are however some two-dimensional histograms presented and in these cases the third “vertical” axis is the observed frequency (fraction of the parent set) for each bin defined by subsets of data for the two variables involved. See figure 41 for an example. The results shown in Figure 41 could be further processed to make a one-dimensional histogram for Htm simply by accumulating (adding) the values for the cells of the velocity variable corresponding to each value of Htm. In this manner higher dimensional histograms can be reduced to lower dimensional histograms.

From a certain perspective the whole database covering each 0.1 second of information could be condensed to a giant n-dimensional array of the counts in each cell or bin of the array—essentially eliminating the time dimension (variable) from the data. Then lower dimensional arrays could be built by combining counts pertaining to the variables removed. Various conditions defining pertinent subsets of the data set could also be used in establishing special arrays of data for use in examining interesting situations. However, using graphical methods to examine and compare the patterns involved means reducing the data to various combinations of one- and two-dimensional histograms. This is what has been done in this study to address matters and issues that are pertinent to the study. However, there could well be important relationships, requiring more than one or two dimensions for their description, which cannot be viewed directly using the histogramming techniques employed in this study.

## **5.2 Time History Processing**

The data-acquisition system on each FOT vehicle collected and permanently stored a time-history file (identified by an “H” appended to the file name) for all time during a trip. The time-history file contains 35 channels (described earlier in section 3.3). These data were logged to the file at 10 Hz and were stored in individual files for each trip taken by a FOT driver.

The size of the time-history files varies depending upon the length of the trip and can be computed by multiplying the length of each record in the file (113 bytes) by the length of the trip in tenths of a second. In the FOT the 108 drivers accumulated a total of over 3000 hours of trip time, which translates into approximately 12.2 gigabytes of time-history data. (This does not include the GPS, transition and histogram files collected for each trip.) As of this writing, 12.2 gigabytes is considered to be a rather large data set for processing on desktop computers, and therefore, inquiring of these data in a timely manner required careful planning and implementation of modern data-handling software. This section will discuss the different methods used to query the time-history data set. These inquiries fall into two general categories: those that are related to having and tracking a valid impeding (or “target”) vehicle and those that are independent of the target state.

### **5.2.1 Capturing of Nontarget-Related Time-History Events**

The time-history records for all the FOT drivers were processed to identify the start, end, and intermediate conditions for several types of events. These events were brake-pedal application, engagement of the cruise-control system, headway-button selection during ACC engagement, and selection of the various cruise-control input buttons (set, resume, coast, and acceleration). All of these events have identifiable start and end times in the time-history record and in some cases (engagements and button selections) these times (or their start time and duration) have been captured and stored in the transition file for the event.

These events are classified as nontarget related because they are primarily identified in the time history record by their start and end times and are independent of an impeding vehicle. For example, a driver can apply the brake pedal at any time during a trip regardless of other vehicles (at their own peril, of course). However, identifying time-history segments that are characterized as “following” or “closing” are defined by and can only occur in the presence of an impeding vehicle. This is not to say that targets are not important during nontarget-related events, but that such events are not dependent upon them.

### **5.2.2 Subsetting the Time-History Record**

The approach to processing of the time-history data involved building independent database tables of events that could be related and joined with other database tables. In general there were three distinct event tables for each event type. The first consisted of a start time-history record for the event. The second consisted of an end time-history record

for the event, and the third consisted of calculated or summary values that characterize the time between the start and end of the event.

The start or end time-history tables contained the complete record — all 35 channels for the instant in time that marks the start or end of the event. The third table contained calculated values that characterize the different signals between the start and end times. The contents of the third table can vary depending upon the type of event. The braking event table, for example, is rather simple and contains a maximum deceleration value, a 2-second filtered maximum deceleration value, and a target flag indicating whether there was a change in targets during the brake application.

Common among all three-event tables are fields that allow them to be joined together. Typically, these are the driver identification number, trip number, and an event number. The combination of these three fields creates a unique reference to each event and allows them to be joined together creating the equivalent of one large table. Numerical operations can then be done to calculate other summary statistics or to create a list of values across all events that then can be made into a histogram. An example of this type of operation is the calculation of average deceleration for a braking event. In this case, the change in velocity during the event is divided by the duration of the event. All of these values are easily accessed from the start and end event tables.

There are some exceptions to having three tables characterizing these event types. In some cases, particularly with cruise-control button pushes, a single record in the time-history table may describe the event. Events like button taps are simply captured in the time-history record by a value changing from one record to the next. In these cases only one table may be sufficient for further analysis or characterization. Regardless of the number of tables needed to capture the events, each event continues to be uniquely identified within the table allowing it to be joined with other database tables. Similarly, if the start and end tables of an event have been defined, any number of other tables that describe the event can be created. For example, consider that a table already exists containing the average velocity during a cruise-control engagement and that there is a need for the maximum velocity for each engagement. Then instead of changing the table containing the average value, a new table is created with the maximum values. The proper identification fields are added to this new table allowing it to form a one-to-one alignment with the other tables describing this event. Using the methods described here the database continues to grow with “value-added” tables that characterize in some way the FOT experience.

### **5.2.3 Capturing of Target-Related Time-History Events**

To analyze and process events related to the presence of an impeding vehicle, a set of tables were created for each driver that identified the segments of the time-history record where a valid target was present. The events in these tables, called streams, are primarily defined by GPS time values indicating the start and end of the stream along with summary statistics that describe how some of the primary signals varied during the stream. Creation of the streams tables decreases processing time because it allows direct access to the records in the time-history table that correspond to times when an impeding vehicle is present. Other efficiencies resulted by using a subset of the stream table to identify stream events within certain velocity ranges or with initial and final range values that meet the criteria of a driving conflict scenario. Specific driving scenarios that used the streams table are discussed in sections 8.2 and 9.2.3. Derivation of the streams tables, which included cleansing of the range and range-rate signals, is discussed in the next section.

### **5.2.4 Data Cleansing and Target Identification**

There are many reasons why the range data coming from the sensor may have dropouts or large instantaneous jumps. Some of these drastic changes are real and reflect the sensors inability to “see” completely around curves or to detect a target lying out near the extreme distance threshold of the sensor. Still other glitches are just momentary target losses which occur for no apparent reason. When these range and range-rate signals are plotted, it is clear that the target was temporarily lost (or that a false target was picked up) and that the range values are inaccurate during these large breaks in the signal.

When the streams tables were created, a simple set of rules was used to identify, document, and ultimately remove these large changes in the range and range-rate signals. Figure 42 shows a 120-second snapshot of an original and corrected range signal. In this example, the original signal shows six large dropouts where the signal is lost and a zero range value is recorded in the time-history file. It is clear that the loss of the range signal resulted from some anomaly and undoubtedly the range value should simply have continued during these short lapses. It is also fairly certain that the FOT vehicle was following the same target throughout this 2-minute time period.

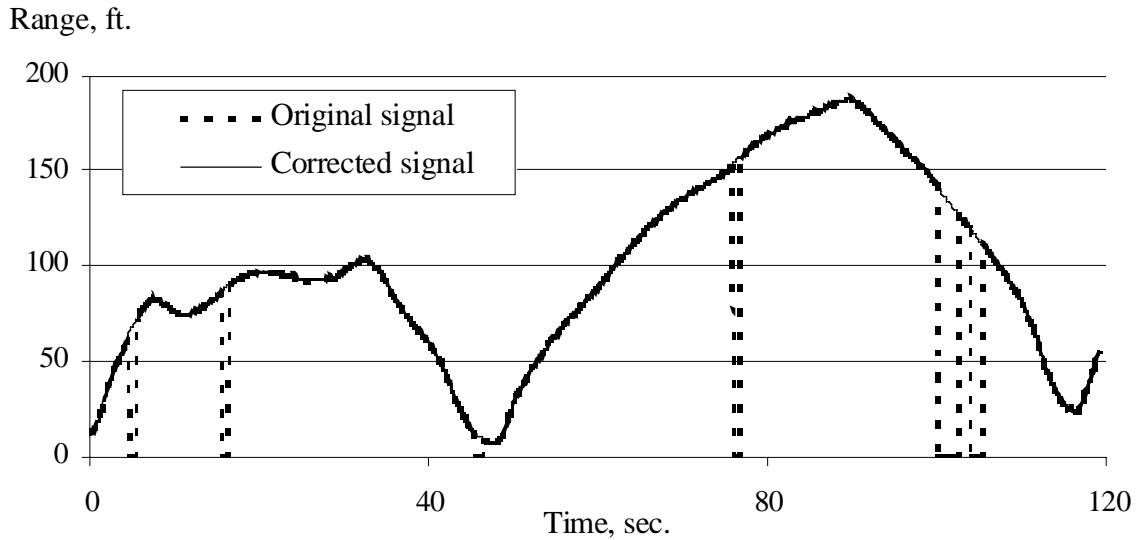

Figure 42. Original and corrected range signal

To identify temporary dropouts and false targets a two-step approach was used in the data processing of the stream tables. Both steps were incorporated into a computer program that would analyze, on a trip-by-trip basis, the range and range-rate values recorded in the time-history tables for each FOT driver. The first step in the program verified that once a stream was initiated, the next set of range and range-rate values were within reasonable thresholds. Given the following:

$R_t$	is range at time t
$R_{t+1}$	is range at the next time step
$\dot{R}_t$	is range-rate at time t
$\dot{R}_{t+1}$	is range-rate at the next time step
$R_{threshold}$	is range threshold (5 ft)
$\dot{R}_{threshold}$	is the range-rate threshold (3.2 ft/sec)
$R_{maxthreshold}$	is maximum range threshold value (20 ft)
$\dot{R}_{maxthreshold}$	is the maximum range-rate threshold value (24 ft/sec)

The next range and range-rate points became part of the stream if the following two relationships were true:

$$|\dot{R}_t - \dot{R}_{t+1}| < \dot{R}_{threshold}$$

$$|(R_t + \dot{R}_t \cdot 0.1) - R_{t+1}| < R_{threshold}$$

If either one of these relationships failed then the program began to “look ahead” in range and range-rate for values that were likely a continuation of the original stream. The

look-ahead time was limited to 3.0 seconds and the reference for comparing the new points within this time period was always the range and range-rate values that prevailed just prior to the failure to satisfy either one of the inequalities given above. The stream continued if all of the conditional statements below were satisfied:

$$\begin{aligned} \left| \dot{R}_t - \dot{R}_{t+i} \right| &< \dot{R}_{\max threshold} \\ \left| R_t - R_{t+i} \right| &< R_{\max threshold} \\ \left| R_t + \left( \left( \left( \dot{R}_t + \dot{R}_{t+i} \right) / 2 \right) \cdot (0.1 \cdot i) \right) - R_{t+i} \right| &< R_{threshold} \end{aligned}$$

If these conditions are met, then the range or range-rate deviation is marked in the streams table as a discontinuity and classified depending on the relative magnitude of the range deviation. The different types of range deviations or “blips” are given in Table 35. The table shows two fields. The first is an identification number that is used for sorting and searching for the different types of streams. The second field is a description. The different types of range blips have identification numbers equal to or larger than 610.

Table 35. Stream identification numbers

Identification Number	Description
600	Range stream
601	Zero range stream
610	Zero range dropout
611	Range blip up
612	Range blip down
613	Range blip (up and down)

To account for all time in the trip files, a zero range stream (identification number of 601) has been defined. This type of stream accounts for all time when not in a range stream (identification number 600) and there is no target. In summary, all driving time is accounted for by either a range stream or a zero range stream and blips or dropouts occur only during a range stream.

### 5.3 Phase Space Presentation

The study of driver control of headway is facilitated by the use of range-versus-range-rate diagrams. There is a considerable body of literature, particularly with regard to nonlinear systems, in which a time-varying quantity (such as range) is plotted versus its derivative with respect to time (such as range rate). This approach has already been used in section

3.1.2 to explain the headway control algorithm used in this ACC system. The information presented there provides an exemplar case of a phase-space presentation using R versus Rdot (dR/dt).

This same type of presentation is used in explaining driver control of headway and in comparing ACC to manual control in section 8.0. Furthermore, lines having special properties for dividing the driving situation into different types are readily displayed using the R versus Rdot phase space. For example, constant deceleration lines and lines that represent human perceptual thresholds on the rate of change of visual angle are useful constructs for interpreting data. Also, the closing, following, separating, near, and cut-in driving situations can be defined using boundaries selected in the R-versus-Rdot phase space.

As observed in [7], the R-versus-Rdot phase diagram has the following generic properties (which apply as well to all phase spaces such as V versus Vdot or  $\Theta$  versus  $\Theta$ dot, where V is velocity and  $\Theta$  is visual angle) as demonstrated in Figure 43:

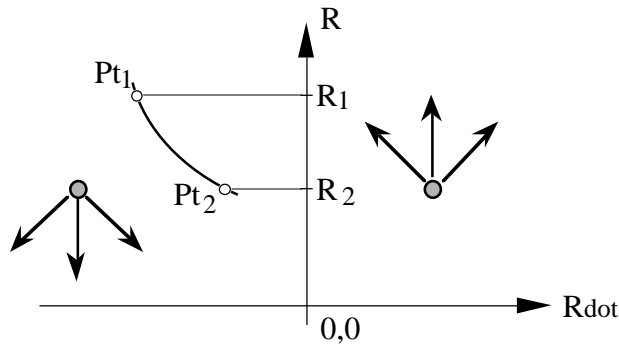

Figure 43. Trajectories in the R-versus-Rdot space

- Trajectories in the left-hand side must go down towards smaller R because Rdot is negative.
- Trajectories in the right-hand side must go up towards larger R.
- The time to go from Pt1 to Pt2 along a trajectory (defined by a relationship presenting Rdot as a function of R) is given by equation (10). This means that trajectories with small values of |Rdot| take a long time to traverse and, vice versa, large |Rdot| values correspond to short time periods.

$$\Delta t = \int_{R_1}^{R_2} \frac{dR}{Rdot} \quad (10)$$

## **5.4 Subjective Information from Questionnaires, Debriefing and Focus Groups**

Subjective data were obtained following the participant's use of an ACC-equipped research vehicle. All subjective information collected from participants (questionnaire data, debriefing comments, and focus group transcriptions) was cataloged in the "Subjects.mdb" database (see section 4.1.1) according to participant number and question number, for questionnaire and focus-group data.

### **5.4.1 Detailed ACC System Questionnaire**

Upon return of the ACC-equipped vehicle, each participant was required to complete a detailed questionnaire that included 44 questions. Four questions were open ended, allowing the participant to provide written comment; eight questions were rank order for preference (mostly addressing the use of manual control, conventional cruise control, or ACC in various scenarios); and the remaining questions were anchored, Likert-type, scale questions with numbers ranging from 1 to 7. A complete copy of the detailed questionnaire and descriptive statistics associated with the observed responses is provided in appendix B. A summary of the results is presented in section 8.4.

For each of the rank order and Likert-type questions, the overall mean and standard deviation of responses were calculated. In addition, means and standard deviations were calculated according to the three independent variables of the experimental design (participant age, conventional-cruise-control usage, and duration of participation in the operational test). For each of the rank-order questions, the mean and standard deviation of rank were similarly reported.

### **5.4.2 Participant Debriefing**

Once participants had completed all of the subjective questionnaires, at least one researcher spent 10 to 30 minutes with each participant in order to review their questionnaire responses and examine entries made in the vehicle's log book. The researcher(s) often posed questions to participants in order to clarify responses to certain questionnaire items, requests for a more complete description of events that were recorded in the vehicle's log book, and general questions regarding their overall experience with ACC. It was common during debriefings that participants provided anecdotal evidence of the conditions under which they used ACC, their likes and dislikes of the system, and posed questions of the researchers concerning things such as system



costs and availability. All comments, often in an abbreviated form, were entered into the representational database along with all other subjective information.

### **5.4.3 Focus Group Activities**

The purpose of the focus groups was to gain additional information from the participants about their experiences with the ACC research vehicle. Attending a focus group gave participants the opportunity to expand on their answers to the detailed questionnaire, as well as on any other feedback they provided during the debriefing. Furthermore, the interaction between focus group participants sparked conversation that frequently reminded participants of previously unreported experiences, thereby providing additional insight into the participants' opinions, reasoning and perhaps even their driving behavior.

Each focus group typically lasted approximately 2 hours. During this time, a series of seventeen questions were asked. The same questions were asked in each of the 10 focus groups. All seventeen questions are provided in section 8.5, and are followed there by a brief summary of participant responses.

## **5.5 Processing Data Associated With Transition Events**

During the FOT there were over 100,000 transition events logged by the DAS on the test vehicles. These events included button pushes, transmission down-shifting, video capture flags, cruise engagements, and headway button selections. They are classified as transition events due to their on-off or boolean nature. A transition event is defined by a start time for the event, an identification number, and a duration. This simple record of information creates a complete time history for these events without the repetition and data-storage requirements needed if they were stored in the continuous time-history record captured on the FOT vehicles.

Aside from the computer memory and storage advantages of defining events in this manner, there is also a computational efficiency to having all these events stored in one FOT database. By combining all transition events for all drivers, summary counts and queries could be generated across all test subjects with one statement (as opposed to time-history processing, which required a query for each driver in the test). This allows quick and efficient processing of these types of events. Furthermore, transition events, when stored this way, contain the necessary information to efficiently go to the corresponding time in the time-history records for further processing of signals stored in a time-history format. (In essence, the transition table acts as a bookmark table for direct access to other data that help describe the driving environment during the transition period.)

The transition tables also provided the basic outline for processing of other events such as cut-in, road-type, and braking. These events were defined and saved in separate database tables with their start time, duration and a unique identifier. Then further processing of the other FOT data during this event time could be done by simply using the transition bookmarks as a pointer into the corresponding time-history database for each FOT driver.

## 5.6 Driver Characterization Methods

This section presents two methods used in this report to rate drivers and their driving style. (One could imagine and select many other methods but these are the ones employed herein to classify driving behavior.)

The ultimate purpose of examining manual driving style is to compare manual driving with ACC driving. However, another purpose of rating driving style is to classify the manual driving behavior of the 108 drivers who participated in the FOT. In an individual sense, there have been 108 different driver behaviors involved in a test activity that employed ten identical vehicles equipped with identical sensors. Earlier sections of this report have described in considerable detail those vehicles and the testing procedures associated with their use. In keeping with the thrust of those earlier sections, a methodology for rating drivers is described here. (The results of applying these methods for describing each driver are presented later in section 6.)

One simple measure of driving style is the percentage of time, expressed as a frequency, for a driver to be in the near region of the range-versus-range-rate space. Figure 44 provides a graphical definition of the near region. The near region is defined by the following boundaries:

$$Rdot < 0 \text{ and } R < 0.5 Vp + [(Rdot)^2/2(0.1g)] \quad (11)$$

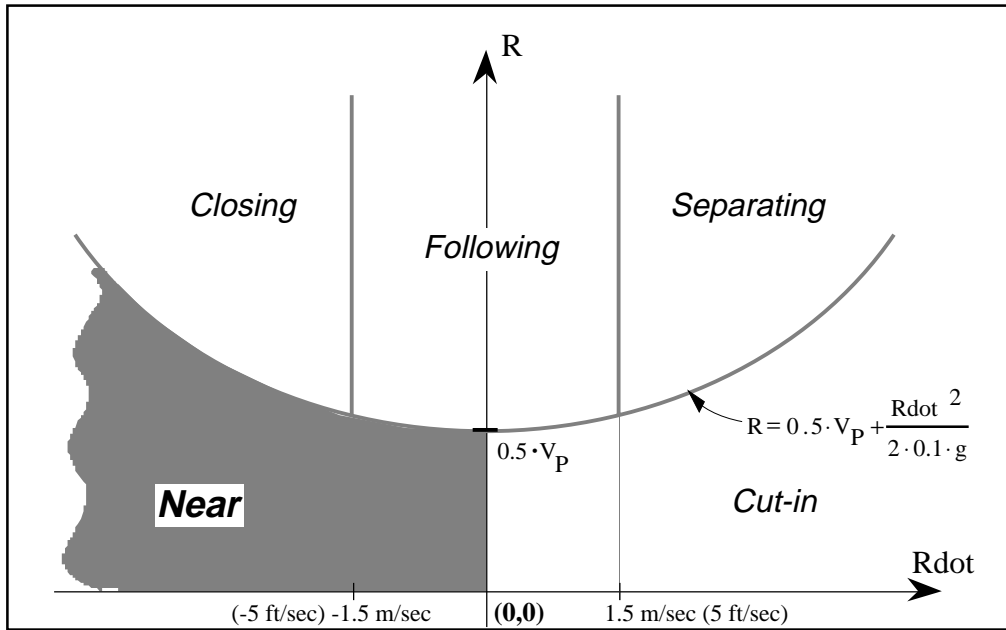

Figure 44. Near region in the range-versus-range-rate space

The frequency of being in the near region is called *confliction* in this report. For example, the confliction value averaged over all drivers operating manually at speeds above 35 mph is 0.024. However (for example), driver number 25 (the driver with identification number 25) had a confliction of 0.005. This means that the likelihood that driver number 25 will have a near-region conflict is much smaller than the likelihood of a near-region conflict as determined for all drivers.

Although confliction is a useful numeric for studying driver tendencies to have near encounters with other vehicles, it does not provide a detailed understanding of the driving style of each individual. Previously, FOT data had been used to develop driver classifications called *hunters*, *gliders*, and *followers*. [8] Based on those initial ideas, an expanded classification scheme has been developed. The tails of the R/V and Rdot/V distributions for each driver are now used in classifying driving style.

The new classification scheme quantifies driving styles at highway speeds above 55 mph (80.7 ft/sec, 24.5 m/sec) using the following boundaries, which are displayed in the normalized range-versus-range-rate diagram presented in Figure 45:

$$R/V \leq 0.65 \text{ sec}, R/V \geq 2.25 \text{ sec}, Rdot/V \leq -0.075, \text{ and } Rdot/V \geq 0.075. \quad (12)$$

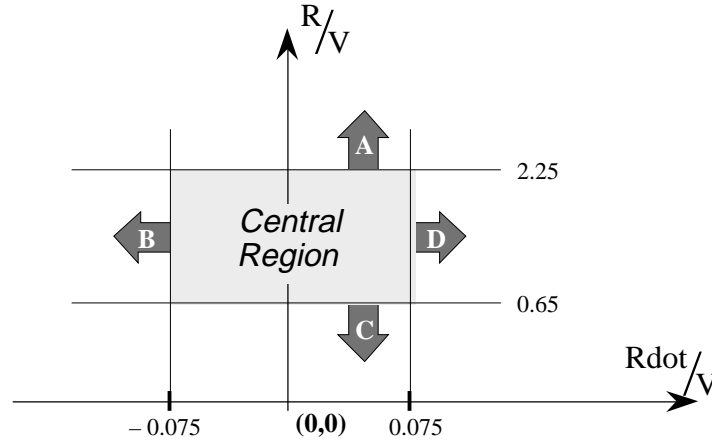

Figure 45. Boundaries used in defining driving styles

These boundaries and the data associated with a given driver are used to evaluate certain frequencies symbolized as A, B, C, and D:

$$A = P(R/V > 2.25) \quad (13)$$

$$B = P(Rdot/V < -0.075) \quad (14)$$

$$C = P(R/V < 0.65) \quad (15)$$

$$D = P(Rdot/V > 0.075) \quad (16)$$

where  $P(\dots)$  means the frequency of the event enclosed in the parentheses.

The quantity A is a measure of the “far” tendency of a driver; B represents the “fast” tendency; C represents “close”; and D represents “slow.”

In order to use a technique known as “small multiples” [9] to display and compare driving styles between individual drivers, the frequencies A, B, C, and D for a given driver are displayed as illustrated in Figure 46.

Seven items appearing in Figure 46 are used in classifying driving style. The items used are A, B, C, and D plus the products AB, BC, and AD. These products are proportional to the areas of three of the four triangles shaded in Figure 46. For example, the triangle associated with AD is characterized by the labels “far” and “slow” in Figure 46. The area of this triangle provides a graphical indication of the amount of driving that

is characterized by the tendency to drive slower and farther away than other drivers. If A and D are large, then the area AD/2 of the AD triangle will be large. In a similar manner, the triangles AB and BC are related to “far” and “fast” and “fast” and “close” respectively.

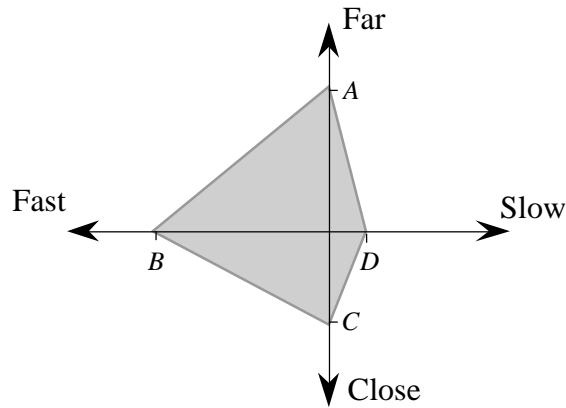

Figure 46. Plotting the quantities that define driving styles

The triangle CD, if it were to be used, would be related to driving at close range while traveling slower than the preceding vehicle. Since this is a physically difficult situation to maintain, it has not been used in rating driving style.

The 75th percentiles for values of the seven items defined above are determined by examining the data for all 108 drivers. This information is used to classify drivers using the following names to provide a descriptive portrayal of five types of driving styles:

1. “Ultraconservative” means that AD or D is greater than the 75th percentile.  
Ultraconservative means an unusual tendency towards far and/or slow driving.
2. “Planner” means that AB or B or A is greater than the 75th percentile. Planner means an unusual tendency towards far and/or fast driving.
3. “Hunter/tailgater” means that BC or C is greater than the 75th percentile.  
Hunter/tailgater means an unusual tendency towards fast and/or close driving.
4. “Extremist” means that the driver satisfies more than one of the above tendencies.  
This means that types 1, 2, and 3 are not resolved until the extremist designation has been considered.
5. “Flow conformist” means that the driver satisfies none of the above. A flow conformist tends to travel at the same speed as other cars and at approximately the median headway time gap.

The process of classifying drivers starts with determining the 75th percentile as illustrated by the example portrayed in Figure 47. Once the drivers with tendencies to operate in the tails of the distributions are determined, they are classified into one of the five classifications listed above. For example, driver number 55 is classified as a planner, which means the tendency to travel relatively fast while somehow planning ahead to be able to remain far away from the vehicle ahead. Figure 48 shows how driver number 55 is represented using the frequencies of far, fast, close, and slow driving.

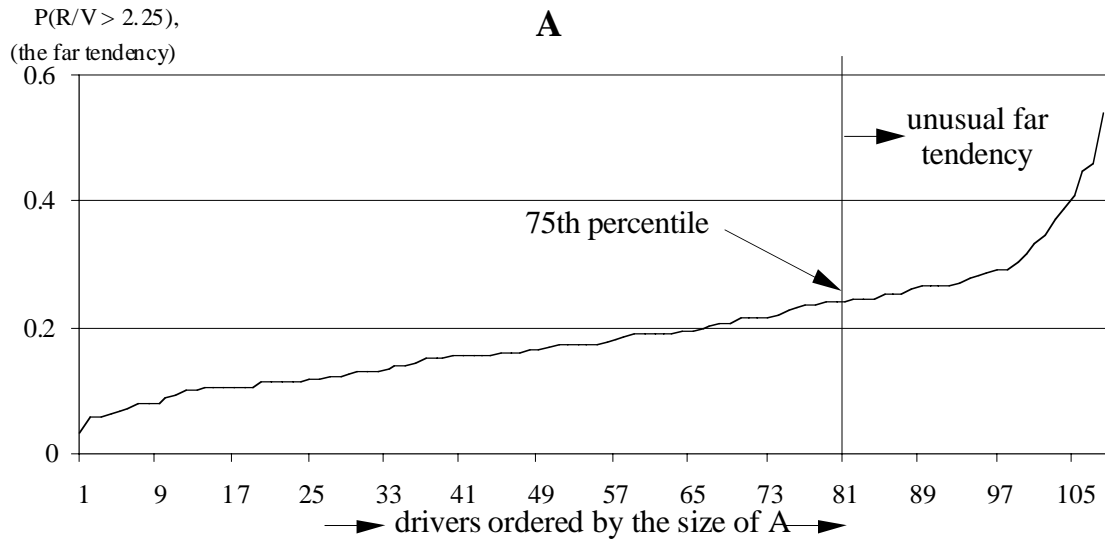

Figure 47. Example showing 75th percentile of  $P(R/V > 2.25$  seconds)

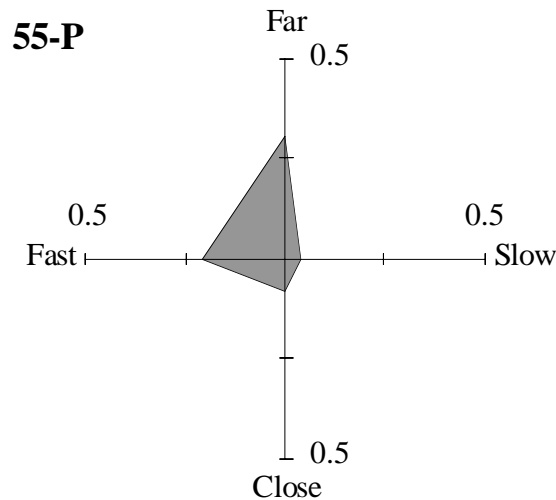

Figure 48. Example of a planner (driver number 55)

Representations like Figure 48, displayed as “small multiples” or “miniatures,” are used in section 6 to compare driving styles.

## 5.7 Processing Data Associated With GPS

The GPS data collected in the FOT served three general purposes. The primary purpose was to determine the type of roads traveled during the test. This task was handled by the FOT’s independent evaluator. Using a database of road class, location, and names, the GPS data from the vehicles were mapped into the road database to determine the most likely road being used by the FOT driver. The road mapping data was limited to southeast Michigan, so trips by FOT drivers that went outside of the mapping region were not identified by the mapping program. These data served as the primary source of road-type information presented in this report and also served as supporting evidence that speed may serve as a reasonable surrogate for some road types.

The GPS data were also used to identify trip types and to diagnose DAS problems. By knowing the GPS location of a driver's home and work a subset of trips was labeled as work commutes. The GPS data also served as a way to document where the vehicle traveled during the test and aided in the diagnosis of some of the problems encountered during the test. (For example, the files transferred over the phone for one FOT driver showed some premature restarts of the DAS related to excessive temperatures. The GPS information showed the driver was in one of the southern states during this period and weather reports confirmed relatively high ambient temperatures.)

Finally, the GPS did serve as another means of measuring the distance between two FOT vehicles. This information was used early in the study as a means of verifying the range sensors on the vehicles. Figure 49 shows the distance between two FOT vehicles as measured by the range sensor and by the differential GPS signal logged by both vehicles.

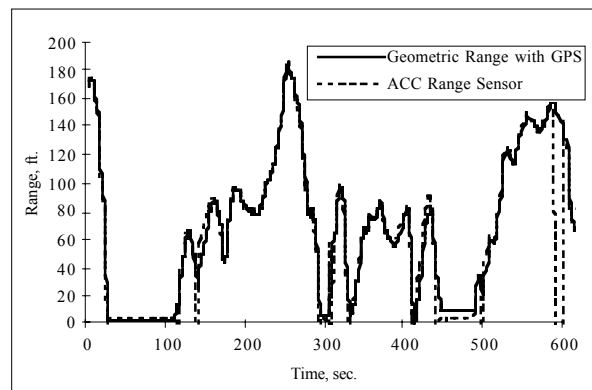

Figure 49. GPS Time history example

## 6.0 Behavioral Characteristics of Individual Drivers

This section presents descriptive results for individual drivers using the methods presented in section 5.6. These results include confliction ratings and driving style classifications for each driver.

Confliction is a measure of the driver's tendency to close in on another vehicle in a manner that results in a relatively short range, given the rate of closure. The confliction numeric chosen for this study is the observed frequency of operating in the near region of the range-versus-range-rate space. Table 36 lists the confliction values for each of the 108 drivers along with other characteristics of these drivers. The driver's identification number is given in the third column of the table. Pertinent driver characteristics as well as pertinent driving exposure numerics are also given in the table. Confliction values (as given in the next to last column) are seen to cover the range of frequencies from 0.002 to 0.121. Apparently there is a wide range of behavior extending from drivers who are very unlikely to have a near encounter with another vehicle to those who tend to travel in the near region quite frequently. Even without considering the implications with respect to safety, traveler comfort, or traffic flow, a high or low value of confliction appears to be a measure that discriminates between drivers.

Table 36. Confliction and driving style by driver (ordered in increasing confliction)

Measure	Mode	ID	Test Time	Age	Cruise Usage	Gender	Trips	Transitions	Time True	Time False	Prob.	Style
----- 0th percentile -----												
Near	Manual	116	2	60-70	Nonuser	Male	12	22	99	49317	0.002	Ultra
Near	Manual	104	5	40-50	User	Female	64	196	978	439905	0.002	Flow C
Near	Manual	48	2	60-70	User	Female	21	46	219	93121	0.002	Ultra
Near	Manual	82	2	60-70	Nonuser	Female	13	35	232	70030	0.003	Plan
Near	Manual	35	2	40-50	User	Male	38	87	477	141642	0.003	Extrem
Near	Manual	67	2	60-70	User	Female	18	27	120	33837	0.004	Ultra
Near	Manual	20	2	60-70	User	Male	13	45	260	70345	0.004	Extrem
Near	Manual	45	2	20-30	Nonuser	Female	22	55	356	88128	0.004	Ultra
Near	Manual	95	2	60-70	Nonuser	Female	13	28	121	29758	0.004	Ultra
Near	Manual	6	2	40-50	User	Female	24	43	206	50336	0.004	Plan
Near	Manual	113	2	60-70	Nonuser	Male	28	78	653	157186	0.004	Ultra
Near	Manual	115	2	60-70	Nonuser	Male	27	47	286	66837	0.004	Ultra
Near	Manual	102	2	40-50	Nonuser	Male	40	349	2423	529291	0.005	Ultra
Near	Manual	106	2	60-70	Nonuser	Female	22	38	294	63788	0.005	Ultra
Near	Manual	25	2	40-50	Nonuser	Female	25	55	390	84181	0.005	Ultra
Near	Manual	72	2	60-70	User	Female	13	46	279	56242	0.005	Flow C
Near	Manual	46	2	60-70	Nonuser	Female	20	37	165	31592	0.005	Ultra
Near	Manual	83	2	60-70	Nonuser	Female	7	40	158	29482	0.005	Ultra
Near	Manual	40	5	60-70	User	Male	40	112	888	163726	0.005	Plan
Near	Manual	49	2	20-30	Nonuser	Female	32	169	1506	276308	0.005	Flow C
Near	Manual	22	2	40-50	User	Male	16	25	245	44399	0.005	Ultra
Near	Manual	96	5	40-50	User	Female	66	229	1722	256894	0.007	Flow C
Near	Manual	69	2	60-70	User	Female	27	77	567	83987	0.007	Flow C



Measure	Mode	ID	Test Time	Age	Cruise Usage	Gender	Trips	Transitions	Time True	Time False	Prob.	Style
Near	Manual	107	2	60-70	Nonuser	Male	17	80	792	117114	0.007	Extrem
Near	Manual	38	2	20-30	Nonuser	Female	6	10	52	7342	0.007	Ultra
Near	Manual	108	2	60-70	Nonuser	Male	15	39	199	27603	0.007	Ultra
Near	Manual	92	5	40-50	User	Male	32	97	779	106336	0.007	Flow C
<b>----- 25th percentile -----</b>												
Near	Manual	13	2	60-70	User	Female	19	56	257	34787	0.007	Extrem
Near	Manual	66	5	60-70	User	Male	65	138	1079	145869	0.007	Plan
Near	Manual	9	2	40-50	User	Female	36	109	1049	134431	0.008	Extrem
Near	Manual	93	2	20-30	Nonuser	Male	37	117	700	87600	0.008	Plan
Near	Manual	110	2	60-70	Nonuser	Male	46	247	1821	223787	0.008	Flow C
Near	Manual	34	2	40-50	Nonuser	Male	37	161	1720	206780	0.008	Flow C
Near	Manual	23	2	40-50	Nonuser	Female	19	43	232	27246	0.008	Ultra
Near	Manual	65	2	60-70	User	Female	21	110	1357	138207	0.010	Flow C
Near	Manual	30	2	20-30	User	Female	32	67	420	42065	0.010	Plan
Near	Manual	47	2	60-70	User	Male	19	46	513	49726	0.010	Plan
Near	Manual	68	5	20-30	User	Male	78	809	9269	834892	0.011	Flow C
Near	Manual	5	2	40-50	User	Female	38	138	1504	134299	0.011	Plan
Near	Manual	15	2	20-30	User	Female	20	134	1162	96630	0.012	Flow C
Near	Manual	18	2	60-70	User	Male	30	64	491	40696	0.012	Flow C
Near	Manual	11	2	60-70	User	Male	28	62	507	40778	0.012	Plan
Near	Manual	94	2	40-50	Nonuser	Male	28	150	1634	128871	0.013	Flow C
Near	Manual	61	2	20-30	User	Male	46	317	3755	283013	0.013	Plan
Near	Manual	63	2	20-30	Nonuser	Male	92	239	2270	170890	0.013	Plan
Near	Manual	79	5	20-30	User	Female	74	222	2009	148376	0.013	Plan
Near	Manual	54	2	20-30	User	Male	41	192	1281	93088	0.014	Flow C
Near	Manual	57	2	60-70	User	Female	18	63	417	30276	0.014	Ultra
Near	Manual	75	2	40-50	Nonuser	Male	49	219	1785	128167	0.014	Plan
Near	Manual	91	2	60-70	Nonuser	Female	20	36	300	20722	0.014	Ultra
Near	Manual	8	2	40-50	User	Female	33	106	2068	142566	0.014	Ultra
Near	Manual	81	5	40-50	User	Male	91	349	4010	256295	0.015	Flow C
Near	Manual	44	2	20-30	Nonuser	Female	91	469	3201	200003	0.016	Extrem
Near	Manual	97	5	60-70	User	Female	80	457	2332	142662	0.016	Flow C
<b>----- 50th percentile -----</b>												
Near	Manual	105	2	40-50	User	Male	28	202	2343	139061	0.017	Flow C
Near	Manual	37	2	20-30	User	Male	44	178	1720	101476	0.017	Hunter
Near	Manual	90	5	60-70	User	Female	36	169	2176	121079	0.018	Flow C
Near	Manual	62	5	60-70	User	Male	100	220	2062	113803	0.018	Extrem
Near	Manual	55	5	20-30	User	Male	101	259	3093	164305	0.018	Plan
Near	Manual	7	2	60-70	User	Male	28	270	5905	301283	0.019	Plan
Near	Manual	77	5	60-70	User	Female	107	369	4692	235545	0.020	Flow C
Near	Manual	56	5	20-30	User	Female	75	371	5823	280963	0.020	Flow C
Near	Manual	21	2	40-50	User	Female	30	141	1708	81609	0.021	Hunter
Near	Manual	43	2	60-70	Nonuser	Female	26	83	716	33516	0.021	Extrem
Near	Manual	70	5	60-70	User	Female	47	391	1900	88377	0.021	Ultra
Near	Manual	117	2	40-50	Nonuser	Male	42	406	4865	218734	0.022	Flow C
Near	Manual	98	2	20-30	Nonuser	Male	23	252	2925	130525	0.022	Extrem
Near	Manual	24	2	40-50	User	Female	13	43	471	20835	0.022	Extrem
Near	Manual	88	5	40-50	User	Female	48	499	6704	294114	0.022	Hunter
Near	Manual	29	2	40-50	Nonuser	Female	28	146	2708	114568	0.023	Plan
Near	Manual	111	2	40-50	Nonuser	Male	45	521	7279	302328	0.024	Hunter
Near	Manual	89	5	20-30	User	Male	101	830	9911	406198	0.024	Plan
Near	Manual	3	2	40-50	User	Male	21	94	1162	44891	0.025	Extrem
Near	Manual	100	5	40-50	User	Male	115	647	9596	367584	0.025	Flow C
Near	Manual	12	2	40-50	User	Female	39	168	2326	87355	0.026	Hunter
Near	Manual	39	2	20-30	Nonuser	Female	28	295	1956	71830	0.027	Flow C
Near	Manual	33	2	20-30	User	Male	37	485	2454	89699	0.027	Flow C
Near	Manual	99	5	40-50	User	Female	110	632	8487	302048	0.027	Hunter
Near	Manual	1	2	40-50	Nonuser	Female	34	136	3469	119256	0.028	Hunter
Near	Manual	17	2	40-50	User	Male	26	146	913	30088	0.029	Flow C

Measure	Mode	ID	Test Time	Age	Cruise Usage	Gender	Trips	Transitions	Time True	Time False	Prob.	Style
Near	Manual	84	2	40-50	Nonuser	Female	20	460	3031	98931	0.030	Flow C
<b>----- 75th percentile -----</b>												
Near	Manual	78	5	40-50	User	Male	74	714	4505	146629	0.030	Plan
Near	Manual	32	2	60-70	User	Male	40	194	2621	85209	0.030	Flow C
Near	Manual	74	2	40-50	User	Male	20	84	925	29437	0.030	Hunter
Near	Manual	19	2	60-70	User	Male	34	113	1649	47931	0.033	Hunter
Near	Manual	4	2	20-30	Nonuser	Male	47	377	8652	250152	0.033	Hunter
Near	Manual	76	5	20-30	User	Male	85	677	9831	274788	0.035	Hunter
Near	Manual	112	2	40-50	Nonuser	Male	45	376	4889	135643	0.035	Flow C
Near	Manual	103	2	60-70	Nonuser	Male	15	243	1910	52011	0.035	Extrem
Near	Manual	50	2	20-30	User	Female	80	470	7151	175416	0.039	Extrem
Near	Manual	80	2	40-50	Nonuser	Female	31	458	7006	169141	0.040	Hunter
Near	Manual	27	2	20-30	Nonuser	Female	17	94	2817	61714	0.044	Plan
Near	Manual	31	2	20-30	Nonuser	Female	33	446	6165	126521	0.046	Hunter
Near	Manual	109	2	20-30	Nonuser	Male	32	466	7497	147901	0.048	Hunter
Near	Manual	10	2	20-30	User	Female	33	233	6525	124573	0.050	Hunter
Near	Manual	52	2	20-30	User	Female	49	850	1252	207605	0.057	Hunter
Near	Manual	85	5	60-70	User	Male	132	1691	2796	436229	0.060	Hunter
Near	Manual	73	5	20-30	User	Female	100	1050	1979	307515	0.060	Hunter
Near	Manual	42	2	20-30	User	Female	14	186	4043	62639	0.061	Hunter
Near	Manual	14	2	40-50	User	Male	35	282	5866	89051	0.062	Hunter
Near	Manual	59	2	20-30	User	Male	46	658	1074	161924	0.062	Hunter
Near	Manual	51	2	20-30	User	Female	15	195	1987	29399	0.063	Extrem
Near	Manual	26	2	40-50	Nonuser	Female	20	411	4945	72878	0.064	Flow C
Near	Manual	64	2	20-30	User	Male	41	481	9562	139327	0.064	Hunter
Near	Manual	87	5	20-30	User	Female	125	1193	2237	318814	0.066	Hunter
Near	Manual	60	2	20-30	User	Male	25	177	3088	35312	0.080	Hunter
Near	Manual	41	2	20-30	Nonuser	Male	27	274	5156	52455	0.089	Extrem
Near	Manual	114	2	20-30	Nonuser	Male	41	1088	1659	120257	0.121	Hunter
<b>----- 100th percentile -----</b>												

The confliction information given in Table 36 is plotted in Figure 50. This figure shows that there is a gradual increase in confliction up to about the 81st driver in the order of increasing confliction (that is, up to the 75th percentile where the drivers in places 82 to 108 are in the last quartile in this plot of 108 drivers).

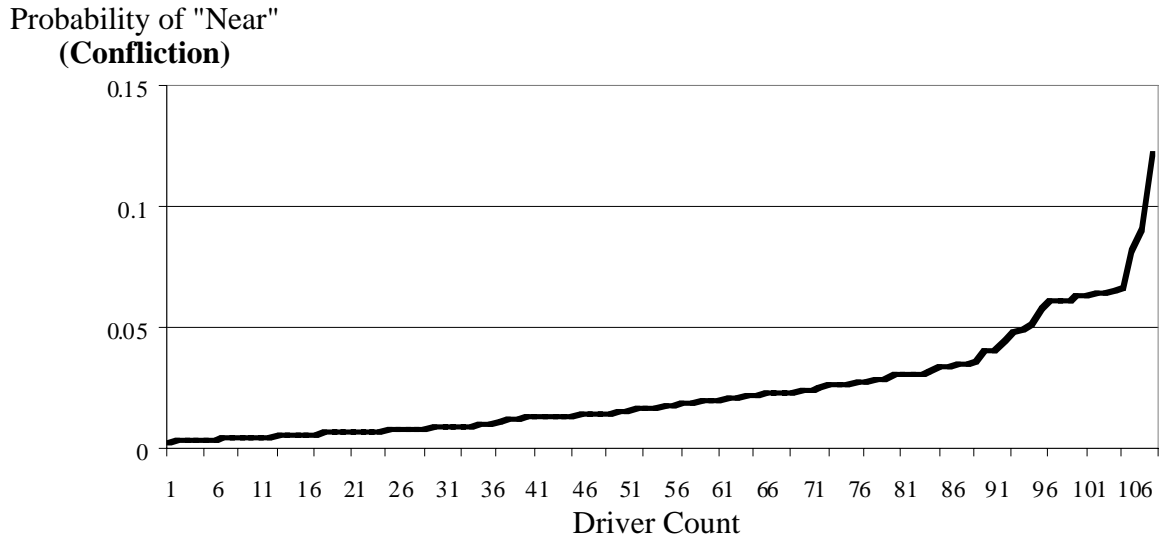

Figure 50. Confliction values from lowest to highest

The last three drivers in the plot have extraordinarily large values of confliction with frequencies of 0.08, 0.089, and 0.121 as listed in the table. The extreme confliction-related performance of these drivers could be due to chance (poor luck) but nevertheless the prospect of spending 8 to 12 percent of the time in the near region is reason to wonder how uncomfortable one would be when riding with these drivers.

Further insight into driver behavior can be obtained from results for the driving style classifications described in section 5.6. The last column of Table 36 provides a list specifying the driving style of each driver. Inspection of this table indicates that flow conformists (Flow C), planners (Plan), and extremists (Extrem) are fairly well spread out over the range of confliction. The ultraconservatives (Ultra) tend to be in the lowest quartile (below the 25th) with only one ultraconservative above the 50th percentile of confliction. The hunter/tailgaters (Hunter) tend to be above the 75th percentile with none of them below the 50th percentile of confliction. Apparently confliction level is strongly related to ultraconservative and hunter/tailgater tendencies as one might expect.

In order to allow the reader's eye to inspect the style of many drivers quickly, the small multiples technique has been used to create Figure 51. Each multiple appearing in the figure is based on the discussion accompanying Figure 46 in section 5.6. The multiples are arranged in an order determined by the driver's driving style first and then by the area of the "diamond" corresponding to the frequencies of A, B, C, and D representing far, fast, close, and slow as indicated in the key to Figure 51.

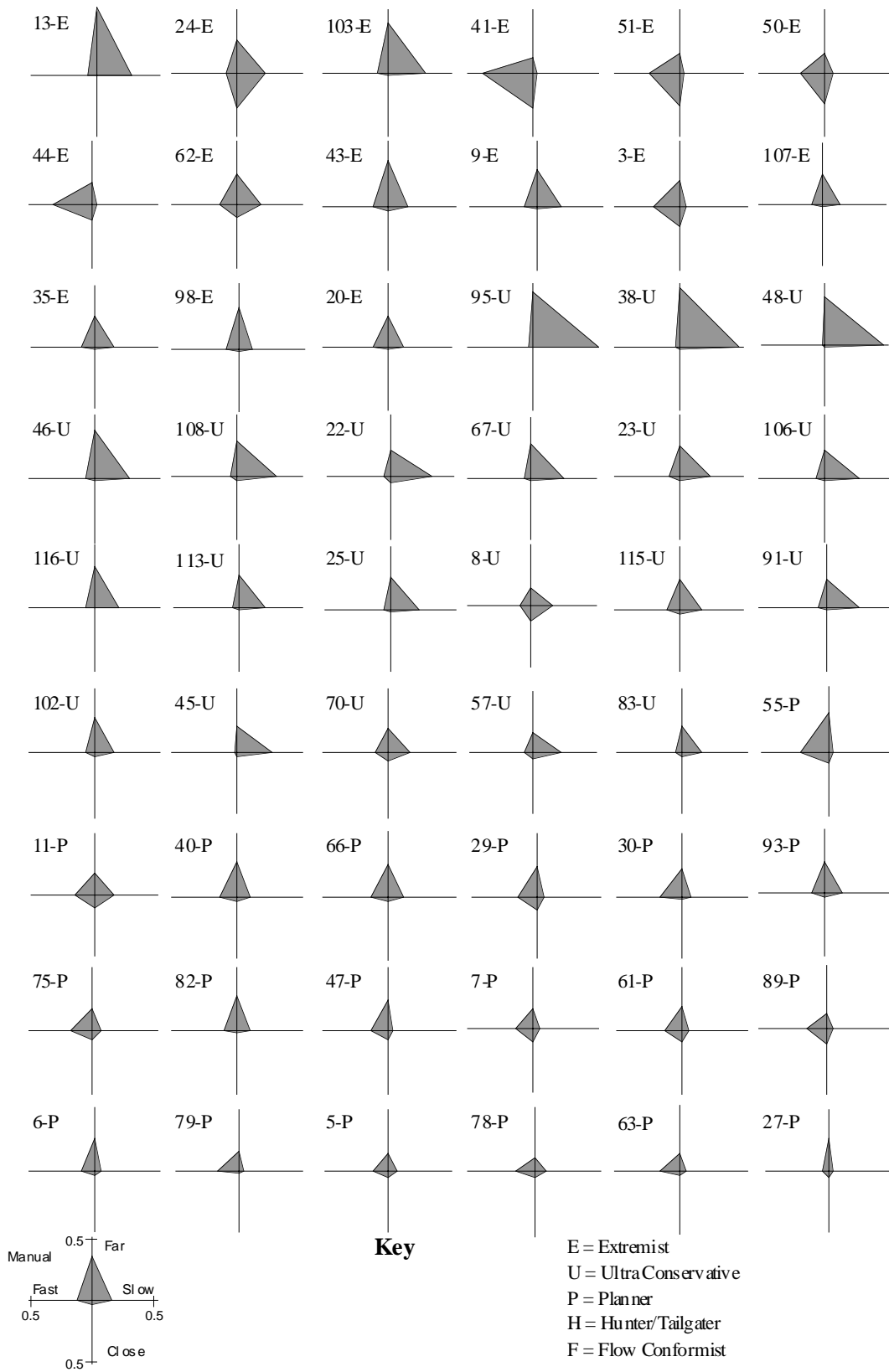
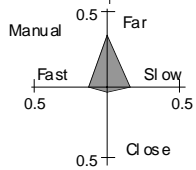
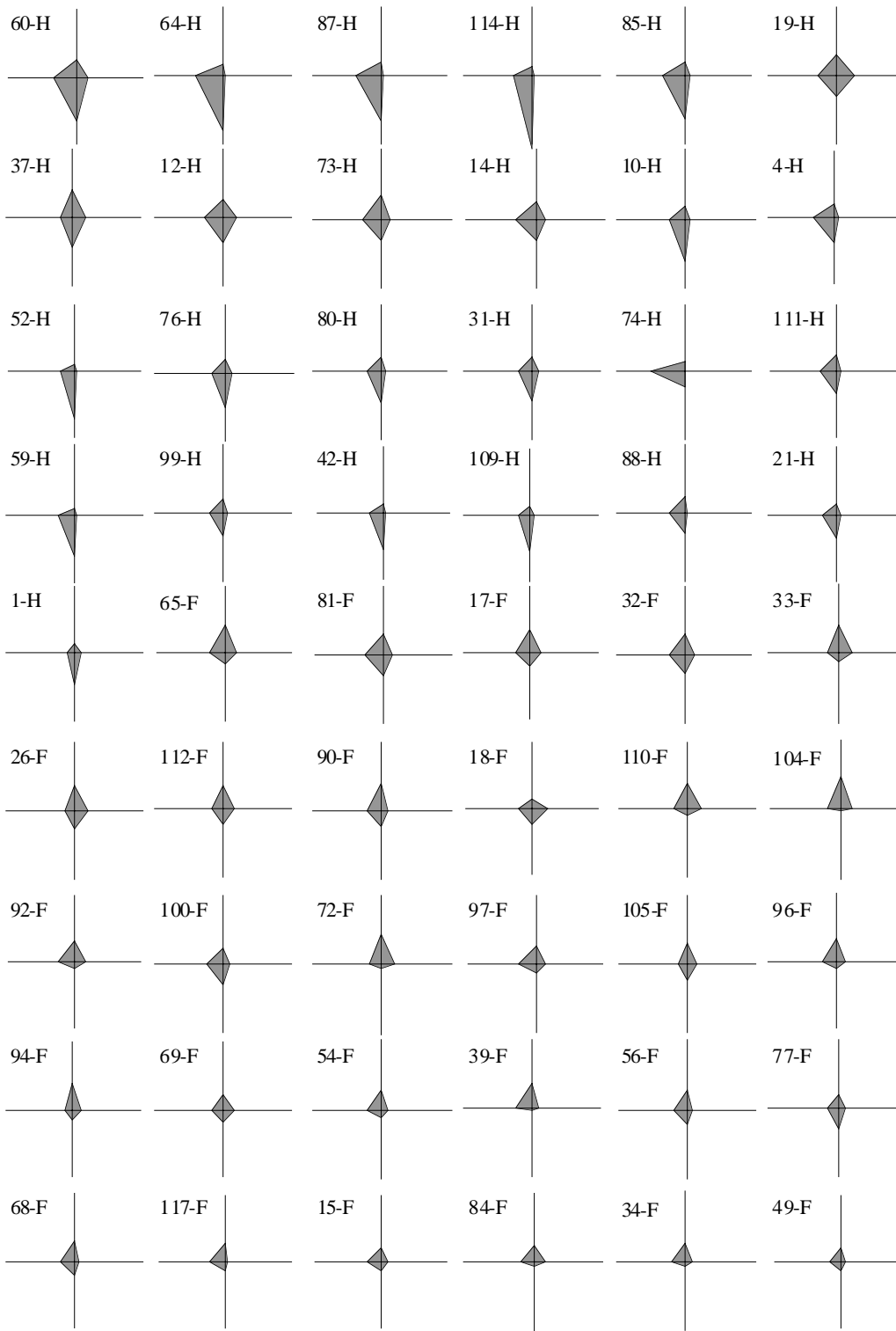

Figure 51. Manual driving behavior for individual drivers (velocity > 55 mph)



**Key**

- E = Extremist
- U = Ultra Conservative
- P = Planner
- H = Hunter/Tailgater
- F = Flow Conformist

Figure 51. Manual driving behavior for individual drivers (velocity > 55 mph) (*Cont.*)

The first fifteen drivers displayed in Figure 51 are extremists, which means that these drivers have more than one tendency to operate above the 75th percentile in some type of driving behavior. It can be seen that there are different types of shapes depending upon which driving factors (far, fast, close, or slow) contributed to the extremist rating.

Next are the ultraconservatives. There are 20 of them. The areas of some of these multiples are relatively large because there is ample opportunity to operate with slow and/or far properties in most driving situations. Clearly the miniatures for ultraconservatives tend to emphasize the slow and far factors. Many of these multiples are practically triangular in shape.

The 19 planners come next. The extremists, ultraconservatives, and planners make up one-half (54) of the drivers. The miniatures for the planners are distinguished by fast and far tendencies (note that the miniature for driver 55 is provided in an enlarged format in Figure 48 in section 5.6). It is interesting to note that there are many drivers who are able to work their way through traffic and remain far from the car ahead. Apparently going fast alone does not mean the driver is a hunter/tailgater. Being a planner means that the driver does not travel close to the car ahead. Somehow, either by the selection of roads and travel times or by very careful execution of driving tactics, the planner succeeds in traveling faster than the other vehicles nearby without getting close to them—the best of all worlds in some sense.

There are 25 hunter/tailgaters. Inspections of the corresponding miniatures shows that many of the hunter/tailgaters seem to be primarily tailgaters in the sense that they have a propensity for close travel even though they tend to go approximately at the speed of the car ahead of them. Driver number 114, who is a hunter and has the highest confliction rating, has a close factor that goes off of the scale allotted to the close dimension in these multiples. This means that the observed frequency of being closer than 0.65 seconds is more than 0.5 (that is, more than 50 percent of the time). It is interesting to note that hunter/tailgaters are the second most prevalent class of drivers according to the methods used here for classifying drivers.

The classification containing the most drivers is the flow conformist class. There are 29 flow conformists. The areas of the miniatures for the flow conformists tend to be smaller than those for the other classifications because these drivers have lower frequencies of being far, fast, close, or slow. Consequently, the miniatures for the last few flow conformists are remarkably small.

Although section 8 tends to emphasize combined descriptive statistics for groups of drivers, there is a need to remember that there are 108 different stories here. When it comes to issues such as those treated in section 9, the experiences and properties of particular individuals may be as important as the combined experience of groups of people.

## 7.0 Summary Statistics of the Driving Exposure

During the field test, from July 1996 through September 1997, a total of 117 subjects met the requirements of the driver screening process and were given a test vehicle. For these drivers, the on-board data-acquisition system (DAS) logged a total of 12,199 trips, 131,378 miles, and 3,432 hours of driving. However, not all drivers were used to constitute the sample of 108 that were needed to meet the requirements of the study's experimental design. Nine drivers were excluded from the study for reasons ranging from an accident to lack of use of the test vehicle. The driver number, vehicle number and the reason for excluding the nine deleted drivers are shown in Table 37. A more comprehensive discussion of problems known to exist in the data set and with the vehicles can be found in section 4.5.

Table 37. Drivers removed from the study

Driver	Car No.	Comments
2	3	No video capability – the car was struck from behind
16	8	Vehicle returned with sensor error
28	9	Bad fuse & headlight switch
36	4	Too many participants in Cell
53	0	Too many participants in Cell
58	1	E-box failure
71	9	Recalled - intended 5wk but subject stopped driving
86	5	Recalled - fuse & over temp
101	5	Headlight switch failure

For the remaining portion of this report, the results and findings will be based on the information collected from the set of 108 drivers. These data were also screened to remove any trips that were identified to contain problems and/or anomalies. For the entire set of 108 drivers, the *valid* data show a total of 11,092 trips, over 114,044 miles and a duration of 3,049 hours. The 108 drivers accumulated a total of 45,797 miles of engaged driving in both ACC and CCC, which results in an overall utilization (distance engaged / total distance) for both ACC and CCC modes of control of 40 percent. These statistics are shown in Table 38 along with per-driver average values for each exposure measure.



Table 38. Exposure summary for all drivers and for the individual average driver

Exposure	All Drivers	Average per Driver
Trips	11,092	102.7
Distance, miles	114,044	1,056
Manual distance	68,247	632
Engaged distance	45,797	424
Time, hours	3,049	28.2

Note: these average values are for all drivers taken as a group. The numbers are not corrected for different driver exposure times, more specifically two- and five-week test periods. A more comprehensive exposure summary that accounts for the different cells of the experimental design, along with road type and driving style is covered below.

### 7.1 Exposure by Time and Mileage for Different Driver Groups

Of the 3,051 hours driven in the FOT, manual driving comprised the largest component of the total time with 2350 hours (77 percent) in this mode while ACC and CCC engagement time constituted only 534 and 165 hours (17.5 and 5.4 percent), respectively. These numbers are shown in Figure 52. Certainly when considering the time spent on short trips and at low speed, (e.g., zero speed while waiting at traffic signals, stop signs, etc.) it is not too surprising that much of the time accumulated in the vehicles is in the manual mode.



Figure 52. Exposure time for all drivers as function of driving mode

If exposure is measured in terms of distance, the relative percentages between modes change. Shown in Figure 53 are the distances traveled in each of the three driving modes. As the figure shows, of the 114,044 miles, 68,247 (59.8 percent) were driven in the manual mode, while 35,033 and 10,764 miles (30.7 and 9.5 percent) were driven with ACC or CCC engaged, respectively.

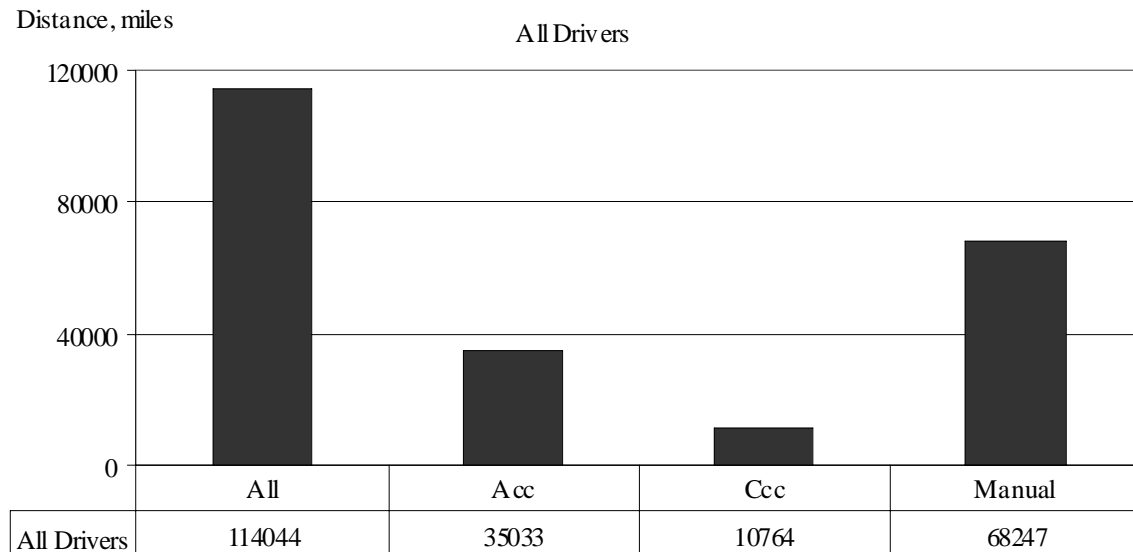

Figure 53. Exposure distance for all drivers as function of driving mode

However, to more fairly compare the manual experience with that of ACC (and CCC), the speed of the vehicle must be considered when accumulating time and distance in each mode. The cruise control in the FOT vehicles had a low speed cut-off velocity of approximately 30 mph. Hence, any time or distance accumulated at or below this speed only contributes to exposure in the manual mode. Furthermore, it was observed in the FOT that drivers are much more likely to use ACC or CCC on high-speed roads such as highways and interstates (see section 7.3 for details) and, therefore, at velocities that are typically above 55 mph. Given these observations, the exposure time and distance results have been further subdivided into two velocity ranges. The first range covers speeds between 35 and 55 mph, while the high-speed segment covers speeds from 55 to 85 mph.

An upper speed limit of 85 mph is used here since this is the highest set-speed value allowed by the ACC system. Data were collected above this velocity for both manual and engaged driving modes (the latter of which required manually overriding the ACC system in order to exceed 85 mph) but the time and mileages are insignificant relative to the exposure at speeds between 35 and 85 mph. In some figures, the 55-to-85-mph range is simply shown as 55 mph and above.

The following subsections (7.1.1 through 7.1.3) discuss exposure in terms of time and distance under the different driving modes, for all driver groups. The accompanying figures used to illustrate the exposure share the same format. Each figure is divided into three graphs showing different driver groups. For example, Figure 54 shows exposure time for three different velocity ranges. The top part (bar graph and table) of Figure 54 shows exposure time for all velocities and all drivers as a function of the different cells in the experimental design. The middle part (bar graph and table) of this figure, shows the exposure for only two-week drivers while the bottom part details the exposure for only five-week drivers. (Note: all five week drivers were “cruise users” by selection.)

Care must be exercised when comparing the different experimental design cells shown in these figures. For example, the left-most cells of the exposure time representing all drivers at all speeds (i.e., in the top graph and table of Figure 54) shows the amount of time in each driving mode for five-week and two-week drivers. The five-week and two-week drivers showed a total of 274 and 259 hours, respectively, with ACC engaged. Although it is true that in the aggregate the five-week drivers spent more time in ACC, this result is not true when normalized on a per-driver-week basis. There were 24 five-week drivers who each had an ACC-enabled time period of four weeks. Therefore, on average, each five-week driver used the ACC system for 2.85 hours per week. However, there were 84 two-week drivers who each had ACC enabled for a one-week period. Therefore, the average two-week driver had an ACC exposure of 3.1 hours per week. Having expressed this concern, it is clear that comparing exposure differences between the experimental design cells has to account for the underlying choices in the design of the FOT. The observations made in subsections 7.1.1 through 7.1.3 are based on exposure numbers that have a similar basis in terms of driver count and test period.

The driver groups shown in Figure 54 (and in the following figures) do not cover all the possible combinations. The reader should note, however, that appendix C presents a grand summary of exposures for all combinations of driver groups along with each of the possible driving modes and sample periods. The word “All” in appendix C refers to grouping of all possibilities for a given category. For example, “All” under the mode category aggregates across all driving modes, whereas, “All” in the gender category groups both male and female drivers together. In addition to the time and mileage summaries appendix C also provides a count field to indicate the number of drivers that constitute each grouping.

Time, hours

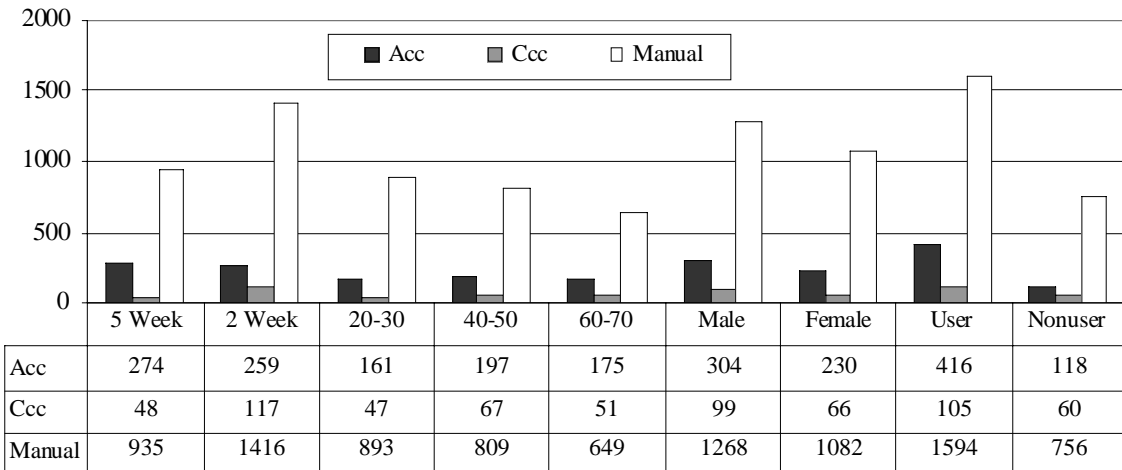

Time for 2 Week Drivers, hours

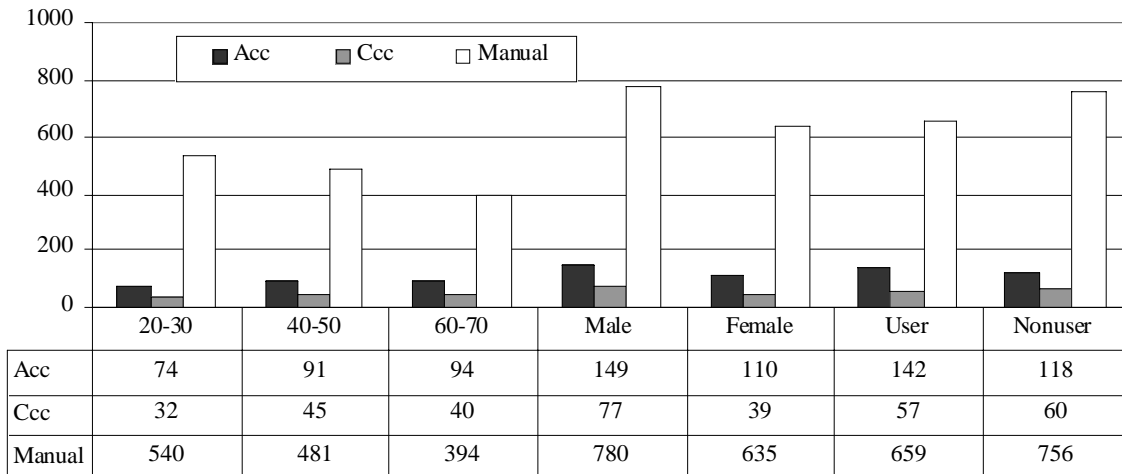

Time for 5 Week Drivers, hours

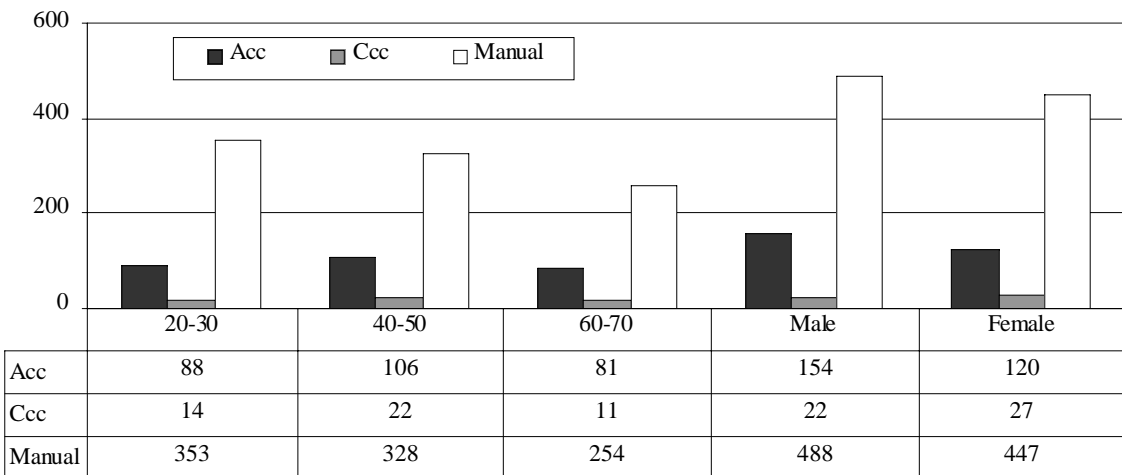

Figure 54. Exposure time for all velocities

### **7.1.1 Driving Mode Exposure Time as Depends Upon Speed Range and Driver Age**

Overall, Figures 55 and 56 clearly show that driving-mode exposure time is dependent on speed. Figure 55 shows that for velocities between 35 and 55 mph, the time spent in the manual mode is clearly dominant. Figure 56, covering velocities above 55 mph, shows that the exposure time while in a cruise-engaged mode is larger than the manual-driving exposure. Furthermore, in many of the driver groupings (e.g., all five-week driver groups) exposure time in the ACC mode alone is larger than that of the manual mode for this velocity range.

In general, for the 35 to 55 mph velocity range shown in Figure 55, the 60-to-70-year-old group (both the two-week and five-week variety) shows more exposure to both ACC and CCC than any other age group or driver category. As a percentage of all driving, this group used a cruise mode approximately 20 percent of the time, while other driver groups averaged around 11 percent. This relatively high rate of exposure for the 60 to 70 year olds is also true at speeds above 55 mph. Although the relationship is not as striking at the high speed, it is still relevant and supports the general observation that choice of driving mode does have an age dependency and that 60 to 70 year old drivers are more likely than other age groups to use either CCC or ACC at all enabled velocities.

### **7.1.2 The ACC and CCC Exposure Time of Nonusers Versus Users**

To compare nonuser and users, only the two-week data have an equal representation in terms of drivers and test time. Interestingly, for the 35 to 55 mph velocity range there is little difference in the amount of exposure time for drivers who classified themselves as users and nonusers. As shown in Figure 55 both groups used ACC for 17 hours at the lower speed range. When considering the higher speed range of Figure 56, however, the users do show more exposure to ACC but less to CCC.

Time, hours (35 mph <= Velocity < 55 mph)

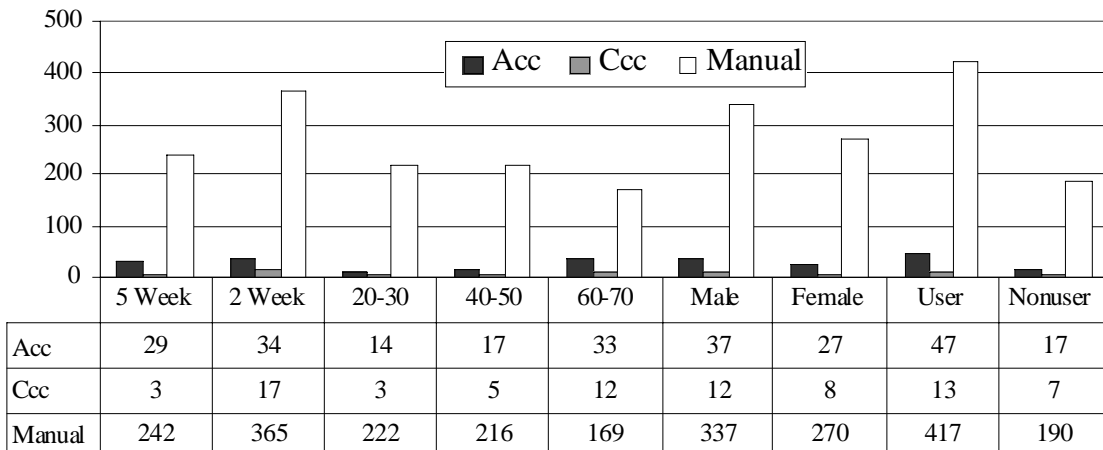

Time for 2 Week Drivers, hours (35 mph <= Velocity < 55 mph)

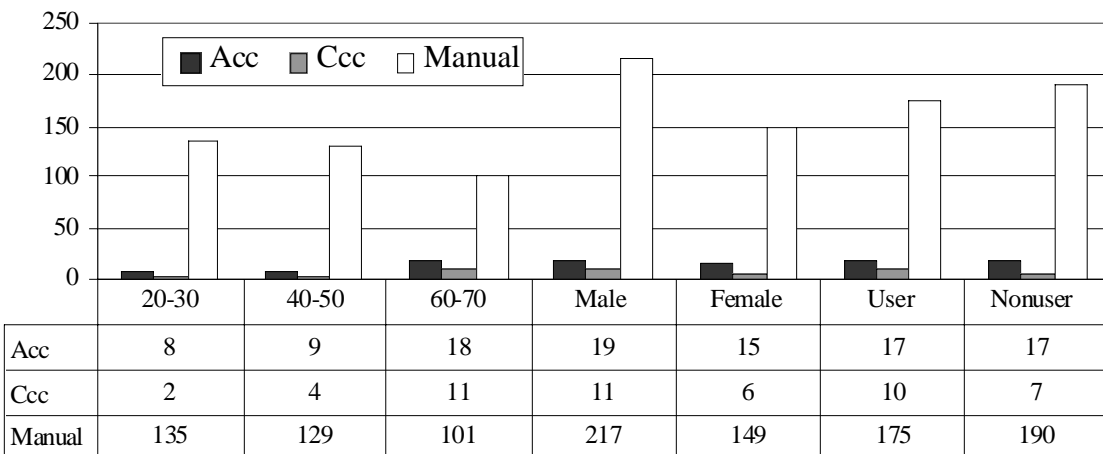

Time for 5 Week Drivers, hours (35 mph <= Velocity < 55 mph)

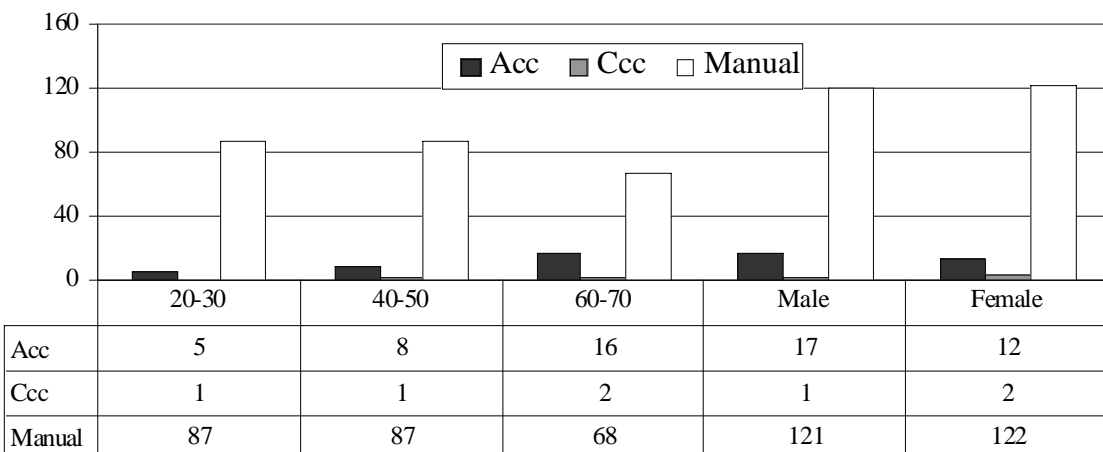
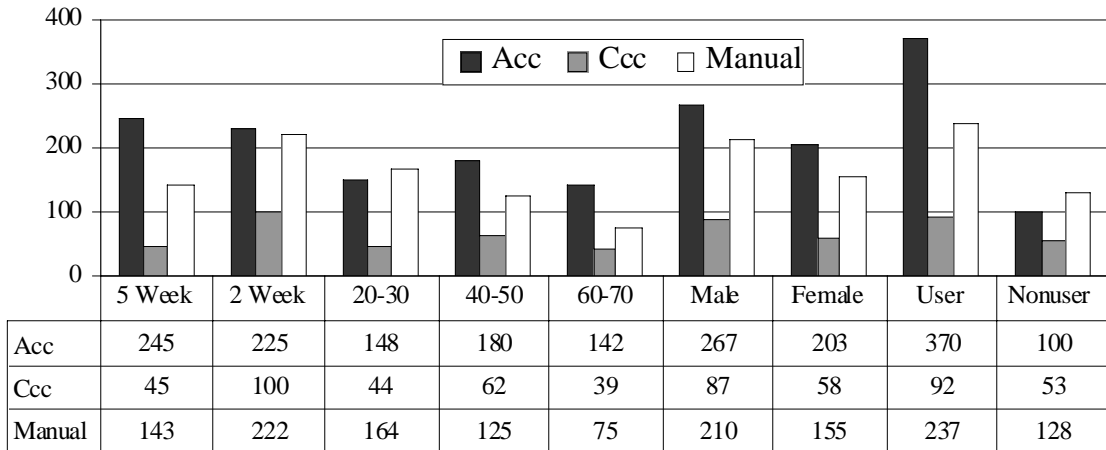
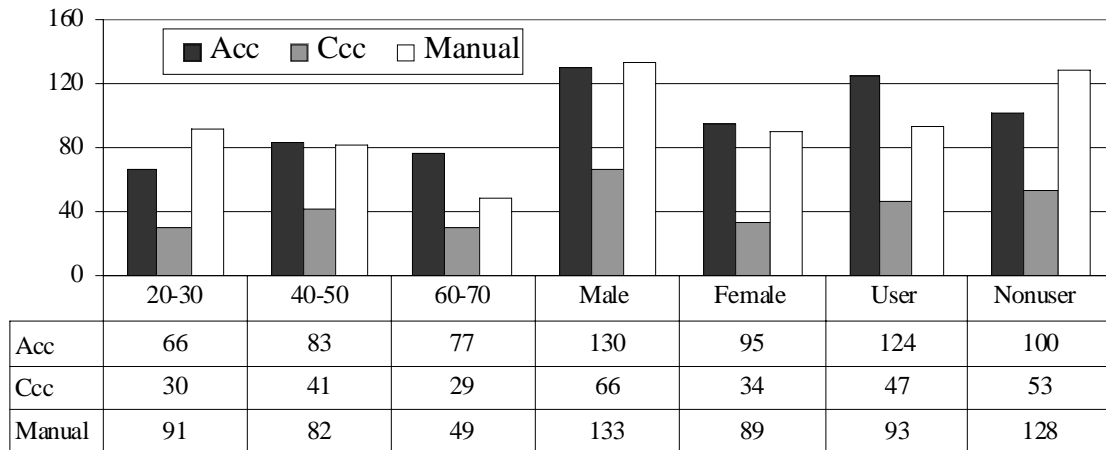

Figure 55. Exposure time for velocities between 35 and 55 mph.

Time, hours (Velocity > 55 mph)



Time for 2 Week Drivers, hours (Velocity > 55 mph)



Time for 5 Week Drivers, hours (Velocity > 55 mph)

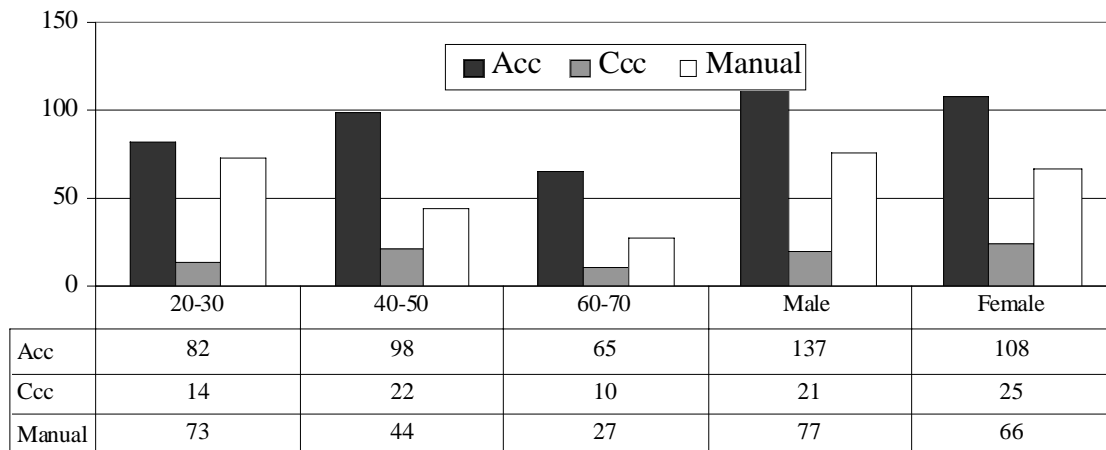

Figure 56. Exposure time for velocities above 55 mph

### **7.1.3 Exposure Distance**

Exposure distances for the different driver groups and velocity ranges are shown in Figures 57 through 59. The trends and relationships observed in the exposure time can also be seen in the exposure distance results.

The largest differences between the exposure time and distance results can be observed when comparing Figures 54 and 57, which summarize the exposures over all velocities. Since time will accumulate faster than distance at slower speeds, large differences in the exposure contrast across the three driving modes for the various driver groups can be observed between these two figures. Figure 57 shows the larger representation of ACC and CCC exposure distance relative to that of manual driving than is seen in the time data of Figure 54.



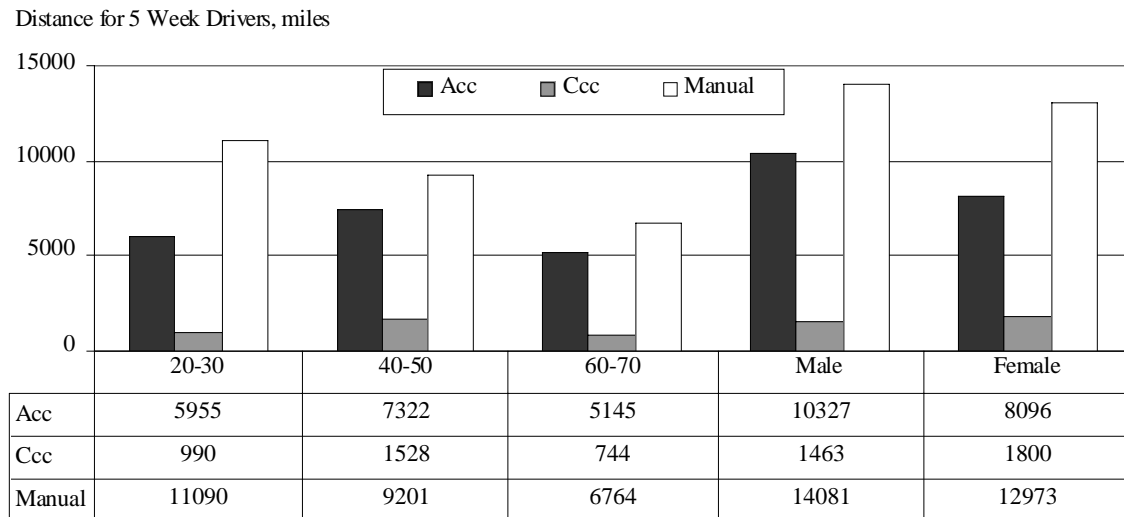
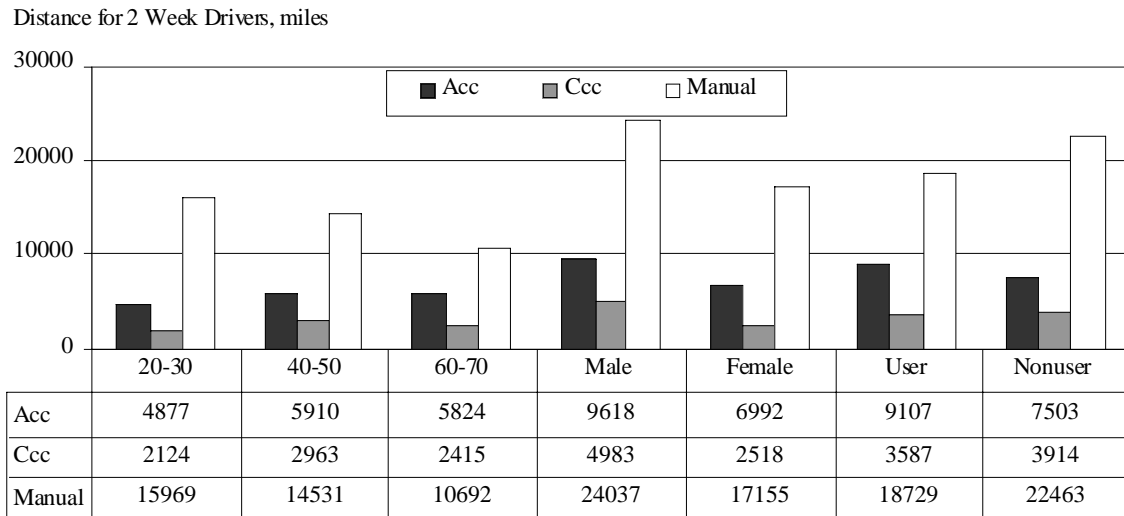
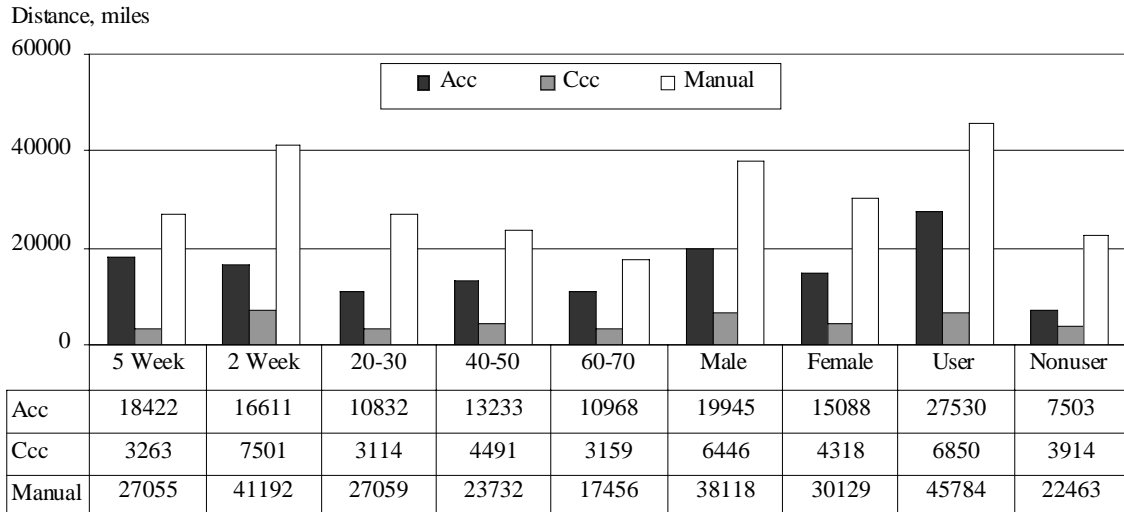
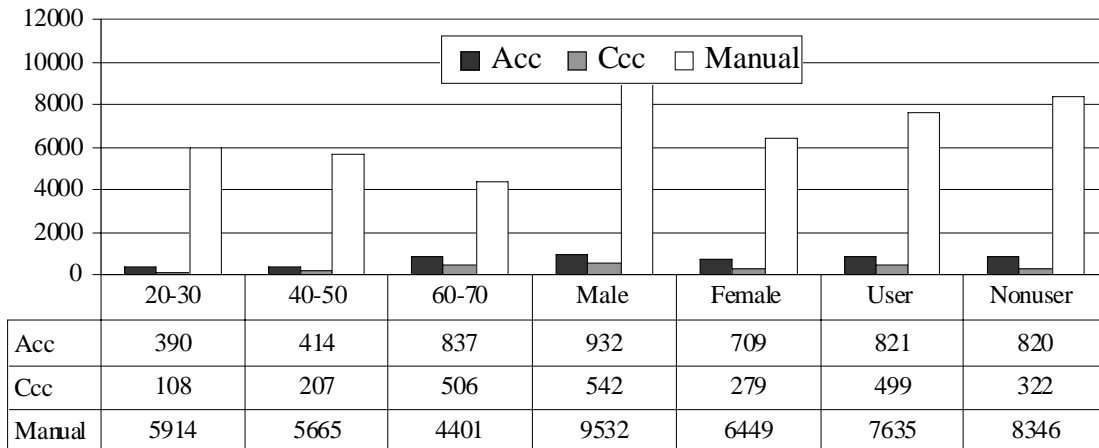
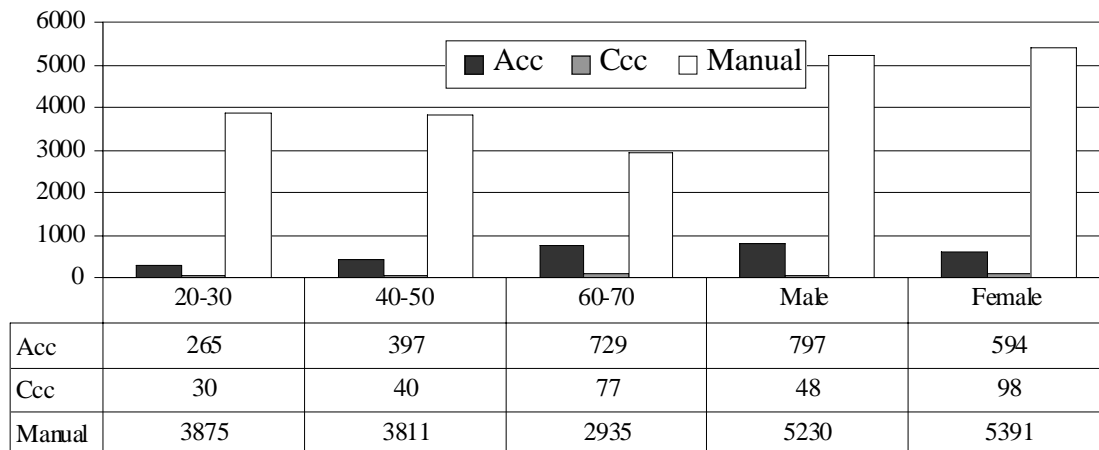

Figure 57. Exposure distance for all velocities

Distance for 2 Week Drivers, miles (35 mph <= Velocity < 55 mph)



Distance for 5 Week Drivers, miles (35 mph <= Velocity < 55 mph)



Distance, miles (35 mph <= Velocity < 55 mph)

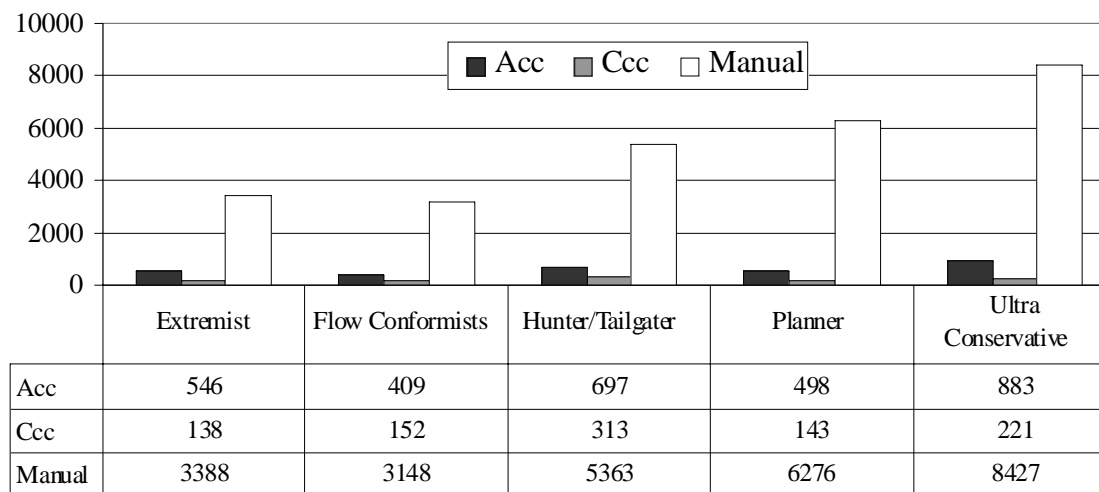
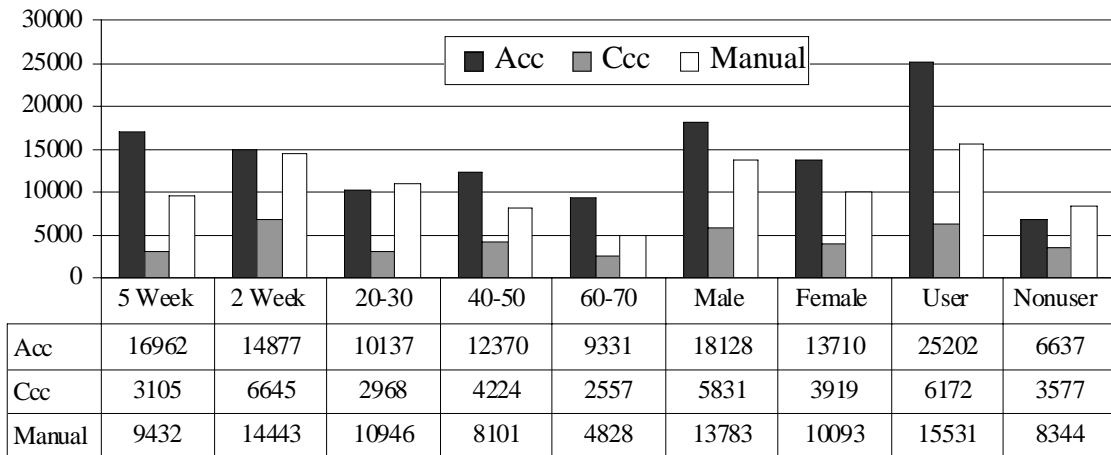
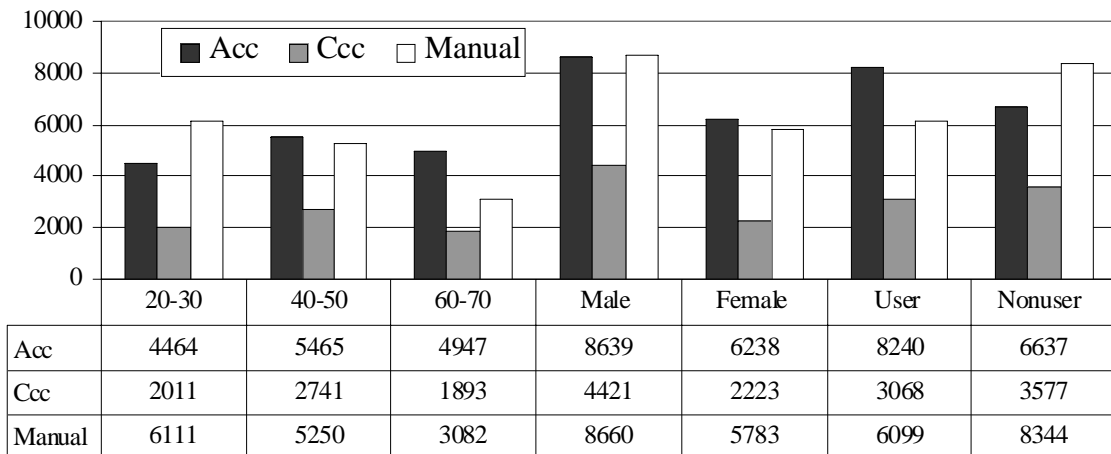

Figure 58. Exposure distance for velocities between 35 and 55 mph

Distance, miles (Velocity > 55 mph)



Distance for 2 Week Drivers, miles (Velocity > 55 mph)



Distance for 5 Week Drivers, miles (Velocity > 55 mph)

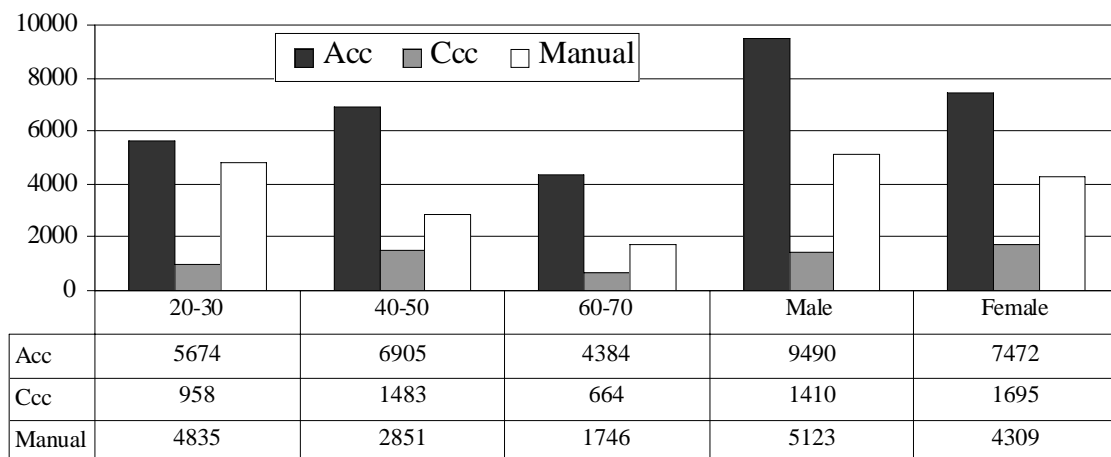

Figure 59. Exposure distance for velocities above 55 mph

## 7.2 Exposure by Time and Mileage for individual drivers

Exposure varied considerably across individuals during the FOT. In one case a five-week driver traveled a total of 3975 miles during the test period. At the other extreme a different driver logged only 227.7 miles. The five drivers that logged the most miles in all three driving modes are shown in Table 39. (Note that one of these is a two-week driver who traveled a total of 2829.4 miles in only twelve days.) Shown in the table is the general driver profile information along with the total number of miles traveled in ACC and CCC. Three out of five drivers in the table belong to the 20-to-30-year-old category. Of the five drivers, these three also had the least number of ACC miles. A female in the 40-to-50-year-old group who traveled 2339 out of a total of 3847 miles in ACC logged the most ACC miles. Only one driver had an unusually high exposure to CCC, traveling a total of 662.7 miles with CCC engaged.

Table 39. The five highest mileage drivers

ID	Test time	Age	Usage	Gender	Total, miles	MANUAL	ACC	CCC
68	5 Weeks	20-30	User	Male	3975.4	2766.9	1036.6	171.9
99	5 Weeks	40-50	User	Female	3847.5	1288.4	2339.5	219.6
89	5 Weeks	20-30	User	Male	3197.3	1702	1378.6	116.7
40	5 Weeks	60-70	User	Male	2977.0	877.5	2072.9	26.6
98	2 Weeks	20-30	Nonuser	Male	2829.4	1320.6	846.1	662.7

Table 40 shows the five drivers who accumulated the lowest total mileages during the FOT. All these drivers had the vehicle for two weeks. A 60-to-70-year-old nonuser female drove the shortest distance logging only 227.7 miles of which 63 and 9 were engaged in ACC and CCC, respectively. Of this group, driver 41, a male in the 20-to-30-year-old group drove the least distance in ACC. (It should be noted that five other drivers in the field test drove less than the indicated 36.8 miles in the ACC mode, ranging from 15.5 to 32.7 miles of ACC engagement. Of these drivers, four of them fell into the 20-to-30-year-old age category. For a complete list of miles driven in the different modalities see the tables of appendix C.)

Table 40. The five lowest mileage drivers

ID	Test time	Age	Usage	Gender	Total, miles	MANUAL	ACC	CCC
83	2 Weeks	60-70	Nonuser	Female	227.7	155.7	62.7	9.3
74	2 Weeks	40-50	User	Male	270.8	151.3	71.7	47.8
41	2 Weeks	20-30	Nonuser	Male	287.7	250.9	36.8	0.0
57	2 Weeks	60-70	User	Female	308.0	199.8	69.7	38.5
60	2 Weeks	20-30	User	Male	313.6	193.4	71.3	48.9

Figures 60 and 61 show ordered distributions, from lowest to highest, of distances driven in all three modes across the full 108-driver count for two-week and five-week drivers in the 35 to 55 mph and 55 to 85 mph speed ranges, respectively. Overall, the distributions are similar for both five- and two-week drivers. In both cases, a majority of the drivers traveled greater distances in the 35 to 55 mph speed range. Tables 41 and 42 below show the quartile values for the distributions shown in Figures 60 and 61.

Table 41. Minimum, maximum, and quartile distances for two-week drivers

Percentile	ACC, miles		CCC, miles		Manual, miles	
	35 to 55	55 to 85	35 to 55	55 to 85	35 to 55	55 to 85
Min.	0.0	15.5	0.0	0.0	47.3	11.0
25th	3.2	57.6	0.0	11.7	120.7	44.8
50th	14.0	98.4	1.4	39.3	166.1	113.1
75th	26.1	278.7	10.0	84.5	222.3	211.7
Max.	91.8	843.1	186.7	661.7	511.0	908.0

Table 42. Minimum, maximum, and quartile distances for five-week drivers

Percentile	ACC, miles		CCC, miles		Manual, miles	
	35 to 55	55 to 85	35 to 55	55 to 85	35 to 55	55 to 85
Min.	0.0	91.4	0.0	26.5	189.2	42.7
25th	18.1	236.1	0.1	64.1	372.5	127.0
50th	40.4	578.1	1.6	96.6	451.7	248.1
75th	80.0	982.6	9.9	171.5	498.8	453.2
Max.	184.0	2305.1	19.2	427.2	684.4	1900.1

Distance, miles

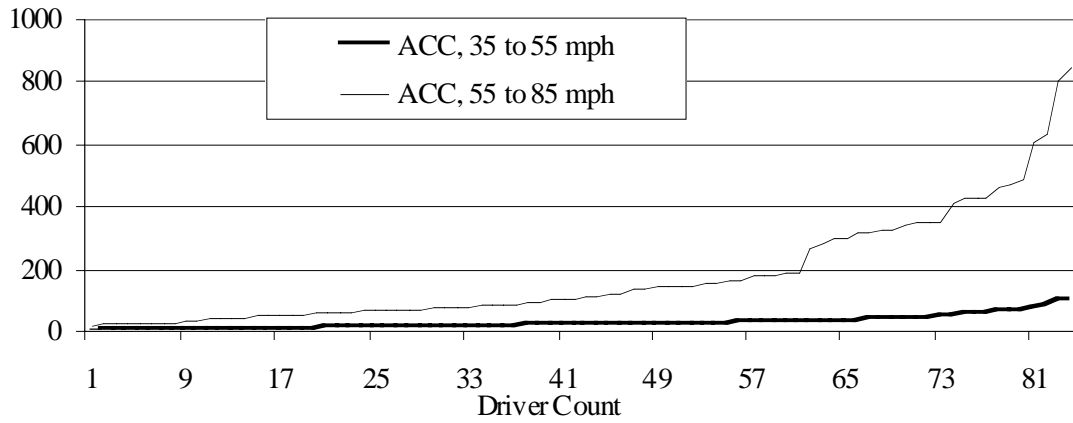

Distance, miles

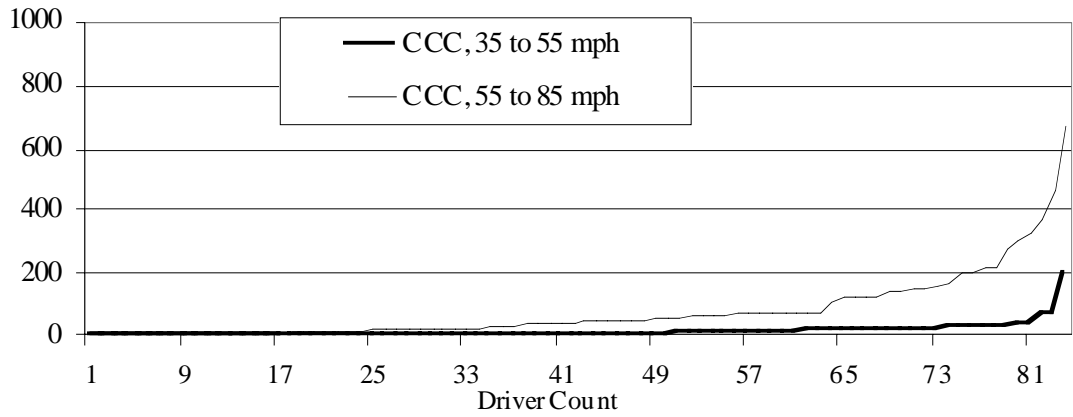

Distance, miles

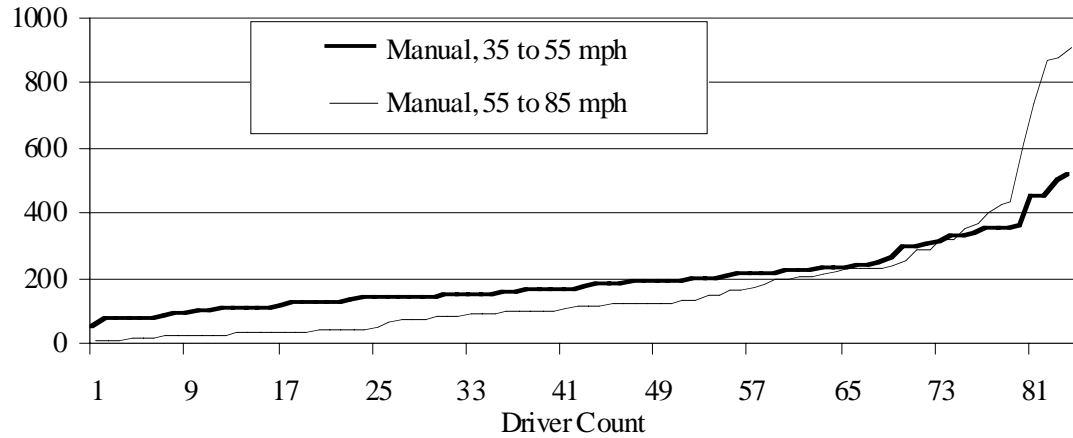
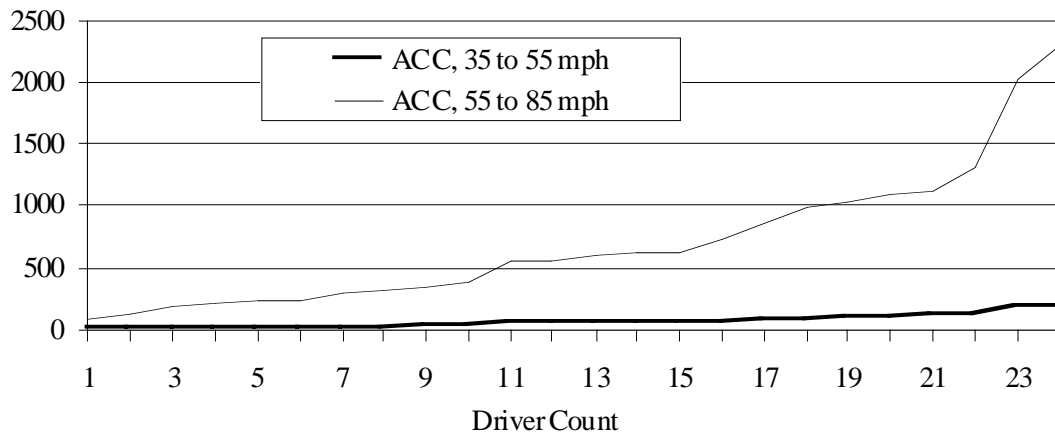
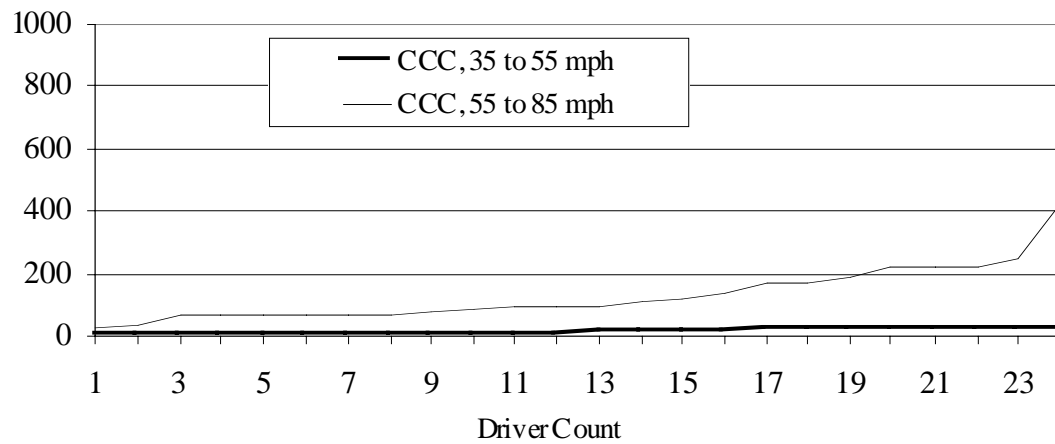

Figure 60. Distribution of distance traveled by all two-week drivers

Distance, miles



Distance, miles



Distance, miles

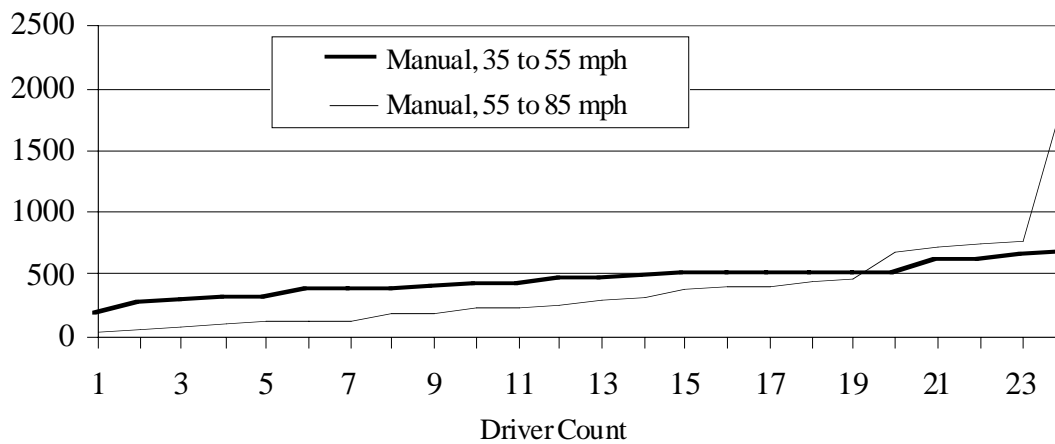

Figure 61. Distribution of distance traveled by five-week drivers

### 7.3 Exposure by Road Type

One application of the GPS data collected during the FOT was to track the types of roads that the subjects used during their test period. Using the latitude and longitude mapping coordinates that were saved by the DAS it was possible to use a database of roads and their GPS-mapped locations to identify the roads driven by each FOT subject. Processing of the GPS data and road-type database was done by the independent evaluator, Volpe, and their subcontractor SAIC. The different road types considered by the mapping algorithm are shown in Table 43. For the exposure presentation in this section, class 0 and classes 5 through 9 were all aggregated and labeled “Other.” The map-matching database was limited and only contained the latitudinal and longitudinal data for roads in SE Michigan. When a driver left the map coverage area the GPS coordinates recorded during those times were logged as being outside the mapping area and labeled “No Mapping Point.” The road-type exposure figures and tables presented in this section were generated using the results of this mapping process.

Table 43. FOT road classes

Road Type
Class0 - HighSpeedRamp
Class1 - Interstate
Class2 - StateHighway
Class3 - Arterial
Class4 - Collector
Class5 - LightDuty
Class6 - AlleyorUnpaved
Class8 - Unknown
Class9 - LowSpeedRamp
No Mapping Point

#### 7.3.1 Exposure by Road Type and Velocity

Road-type exposure can be presented in terms of time spent on a particular road type or by the distance traveled on a road type. The exposure to road type described in this section covers both approaches.



Figure 62 shows the frequency distribution of operating on various road classes as a function of time and distance. The time and distance covered outside the mapping area is not shown in Figure 62, but it constituted a total of 40,346 miles and 805 hours of driving. This is approximately 40 percent of all mapped miles and 33 percent of all mapped time. If the NMP (no mapping point) data are added to that within the coverage area, approximately 79 percent of all time and 93 percent of all miles were accounted for with the mapping algorithm.<sup>1</sup> Figure 62 shows that over half of the distance and nearly 40 percent of the time was traveled on an interstate road within the mapping region. Arterial roads accounted for the next largest percentage of distance and time.

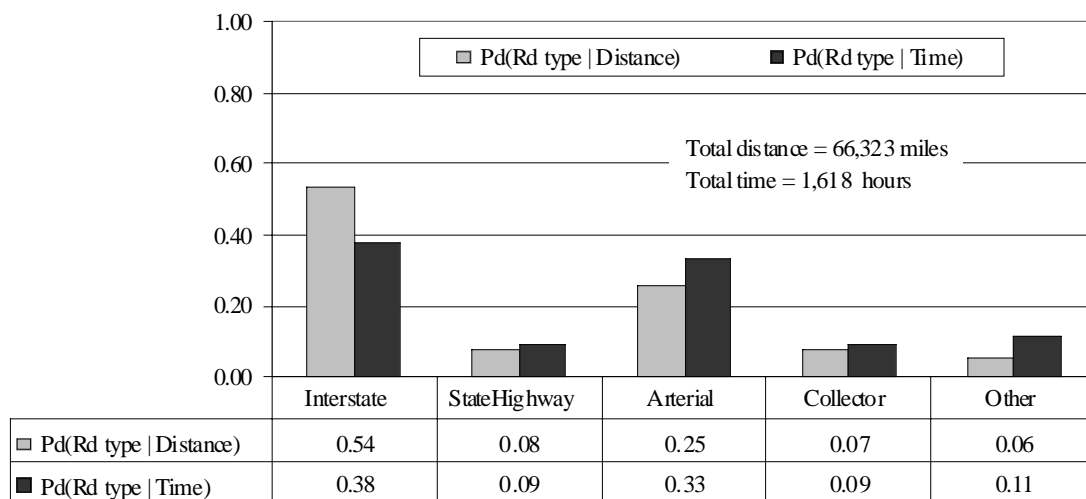

Figure 62. Frequency distribution of operating on various road types as a function of distance and time

The rest of the figures in this section will show only distributions based on the distance information collected in the road-type database.

Figure 63 shows the frequency distribution of operating on various road types for three velocity ranges. The most striking aspect of this figure is the large (91 percent) frequency of being on an interstate road if travelling at speeds above 55 mph. This finding is particularly useful because it indicates that velocity can serve as a reasonable

<sup>1</sup> These numbers are not closer to 100 percent for the following reasons: a) the GPS information was “lost” for some drivers due to problems with the acquisition hardware, b) the GPS data were temporarily not logged due to switching between available satellites, c) terrain obstruction, and d) initialization delays (“cold and warm startup”).

surrogate for road type. (This is exactly what is done later in this report, where the analysis of ACC, CCC, and manual driving is done for velocities above 55 mph or in speed ranges that include 55 mph and above.) Figure 63 also shows that operating on arterial roads is most probable at velocities below 55 mph.

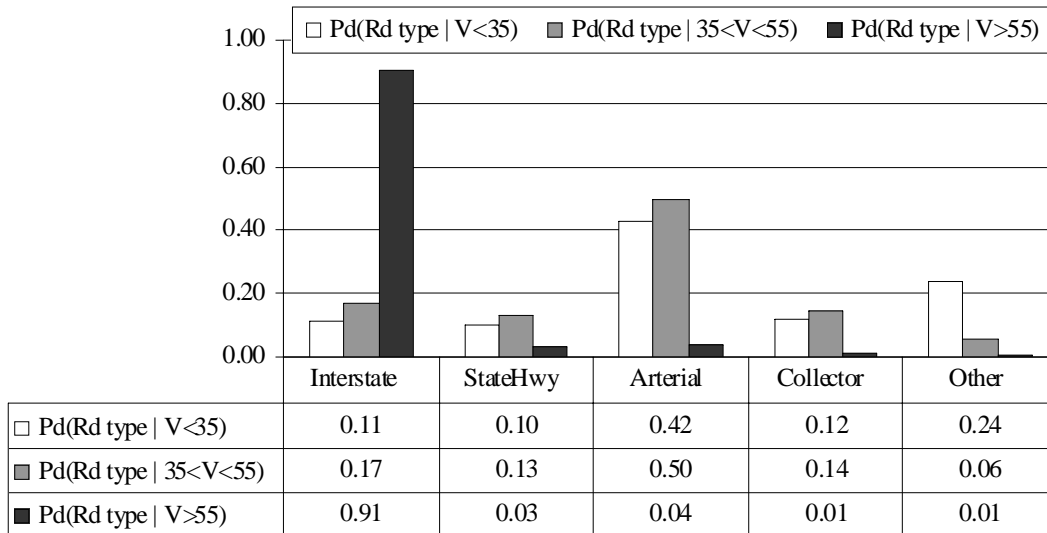

Figure 63. Frequency distribution of operating on various road-types for three velocity ranges

Figure 64 shows the frequency distribution of the same three velocity ranges when outside of the mapping region. Here 74 percent of the distance traveled outside the mapping area was done at speeds above 55 mph. It is likely that most of these miles were done on interstate road types based both on Figure 63 and upon the fact that most of these miles were accumulated during long trips taken by FOT drivers.



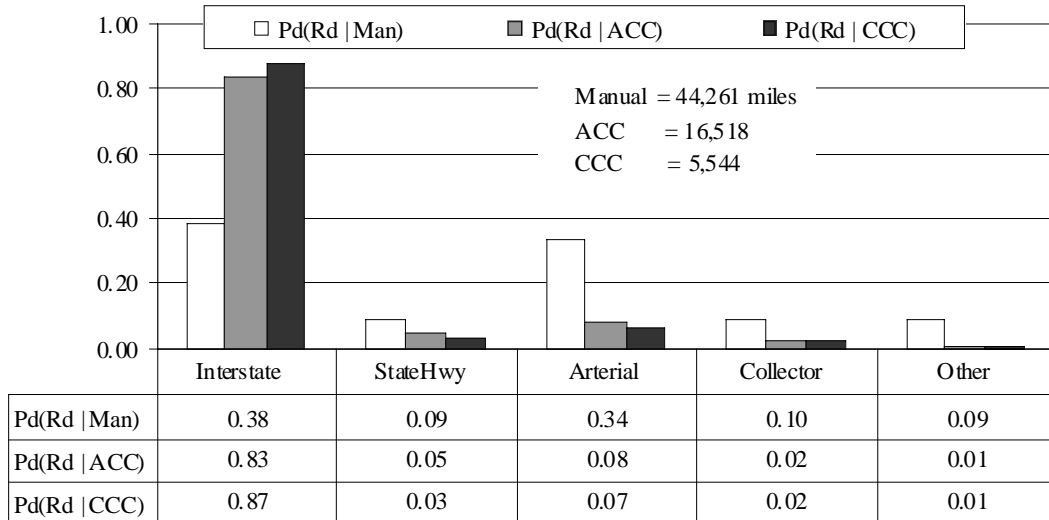

Figure 66. Frequency of road type for the three different driving modes

The figure clearly shows that most of the miles in all three modes occurred on interstate roads. This was particularly true for the cruise modes of driving where 83 percent of ACC miles and 87 percent of CCC miles were driven on interstate roads. Most of the manual driving (72 percent) was distributed between interstate and arterial road types.

Table 44 shows a summary of mapped and unmapped distance traveled for each driving mode during the study. The column named “Sum” in Table 44 shows the total for all mapped and unmapped distances and is based on the GPS data, whereas, the “Total dist.” column shows the total of all distance traveled in each mode based on the integration of the velocity time history records. The difference between these totals is shown as a percentage in the far right column of Table 44 indicating that over 90 percent of all distance traveled was accounted for by the GPS mapping algorithm.

Table 44. Summary of mapped and unmapped distance by driving mode

<i>Mode</i>	<i>Mapped</i>	<i>Not Mapped</i>	<i>Sum</i>	<i>Total dist.</i>	<i>Percent</i>
Manual	44,261	19,249	63,510	68,314	0.93
ACC	16,518	16,908	33,426	35,017	0.95
CCC	5,544	4,190	9,734	10,753	0.91

## 7.4 Summary of trip and trip duration for the FOT Drivers

Of the 11,092 trips logged during the study, 54 percent (5,950) had a duration of less than 10 minutes and 96 percent were less than 60 minutes long. The longest trip during the study was 905 minutes (over 15 hours) and was nearly three times longer than the next

longest trip<sup>2</sup>. In all there were a total of 111 trips that were longer than 120 minutes. Figure 67 shows the distribution of trips as a function of duration for the entire study.

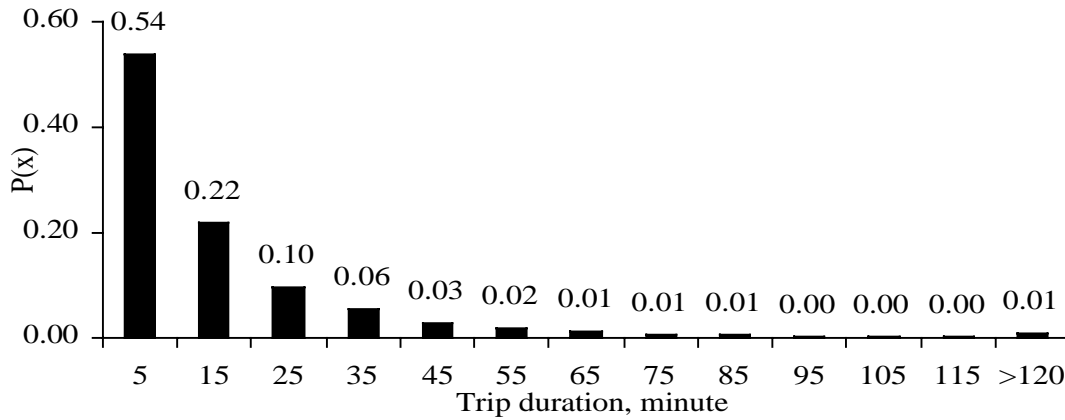

Figure 67. Distribution of trips as a function of trip length in minutes

Shown in Figure 68 is the distribution of trips as a function of day of the week, based on the start times of each trip. Friday and Saturday are the most popular days for FOT trips while Wednesday and Thursday are the least. This latter observation is probably a result of the experimental design, since two-week drivers were scheduled such that they would pick up a vehicle late on a Wednesday or Thursday and return it on Monday or Tuesday, thus being one or two days short of a full two weeks of vehicle usage.

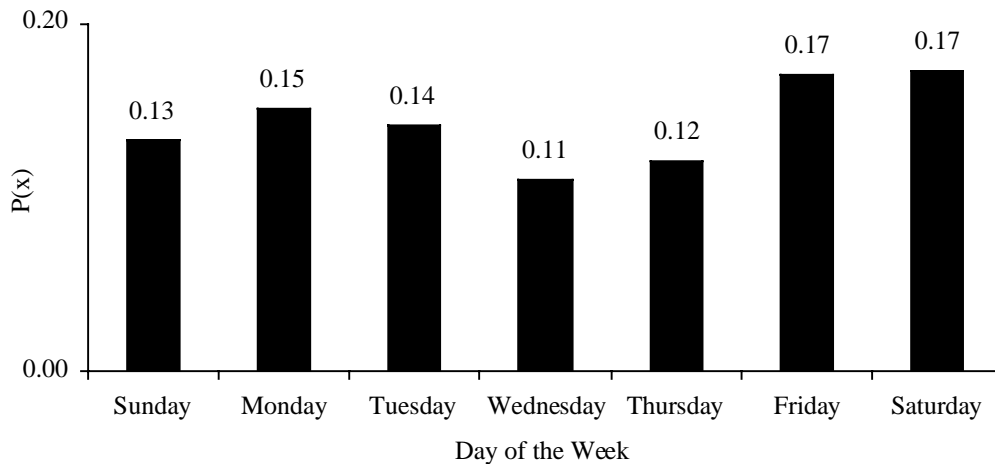

Figure 68. Distribution of trips as a function of day of the week

---

<sup>2</sup> Obviously the driver in this vehicle did not turn off the ignition while it was being re-fueled.

Similarly, a distribution of trip start times as a function of time of day is shown in Figure 69 using one-hour bins. (Data have been corrected for day-light-savings time changes.)

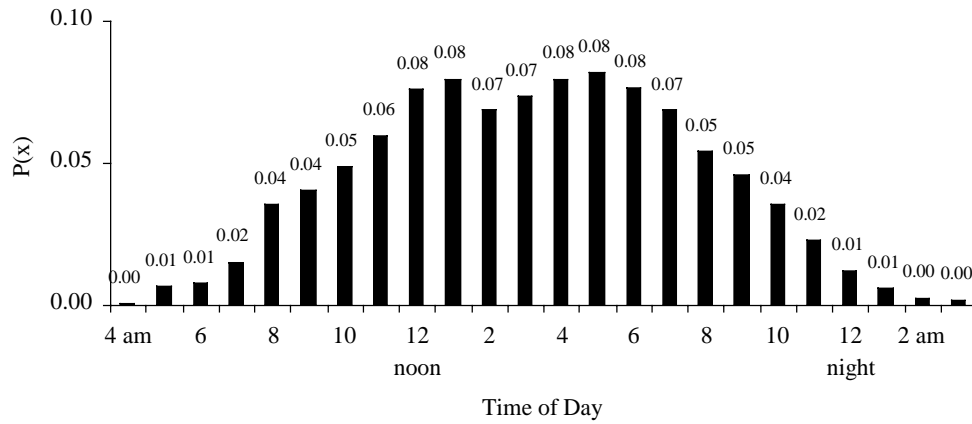

Figure 69. Distribution of trips as a function of time of day

Based on this distribution the most common time of trip starting is approximately 5 P.M. Not surprisingly, the least common time to start a trip was between 12 midnight and 6 in the morning. If it is assumed that there is daylight from 7 A.M. until 7 P.M. on average over the course of the study, then approximately 80 percent of the trips began while it was light outside.

## **8.0 Basic Relationships Illustrating Driving Performance**

Section 8.0 develops basic aspects of a theory of driving. Both manual and ACC driving are examined using measurements, subjective ratings, theoretical structures, and mental models. The material presented here expands the basis for understanding why ACC is such an appealing function and why individuals may have used it in the way they did. Although much of the data analysis has revealed that personalized driving style is of central importance, results do support the proposition that, in comparison to manual driving, this ACC system provides longer following distance and the comfort of less stressful driving.

### **8.1 Observations Pertinent to Manual Driving**

A basic conceptual feature of the approach employed in guiding this FOT has been the desire to compare ACC driving to manual driving. Although not fully appreciated at the beginning of this project, this implies that the researchers need to develop a useful understanding of how people drive manually. In this regard, a particularly pertinent question is: How do people control headway? Although this has turned out to be a challenging question, results and ideas pertaining to a concept of manual driving have been generated in this study. Some of the results are simply observations of driving behavior—what the drivers actually did. However, the interpretation of these observations has led to ideas that could potentially contribute to a broader theory of driving. These interpretations involve considering certain aspects of the cognitive processes through which drivers use skills, rules, and knowledge in choosing the plans (perhaps better described as “templates”) to use and the steps to take in controlling headway and vehicle speed. The intention of this section is to present these results and ideas in a manner that is conducive to later comparisons between ACC driving and manual driving.

#### **8.1.1 Observations on Manual Throttle Modulation**

In controlling speed and headway it has been observed that drivers tend to move the accelerator pedal (throttle) frequently resulting in relatively large-amplitude excursions of throttle motion having a period of approximately 3 to 4 seconds [3].

Figure 70 shows a typical example of throttle modulation measured during manual driving in this FOT. Instead of simply putting the throttle to the fixed position needed for the speed desired, the driver is commonly seen to modulate the throttle over a wide band of variations. Throttle excursions range from complete (or nearly complete) release, to actuations whose peak values are double that needed for steady state.

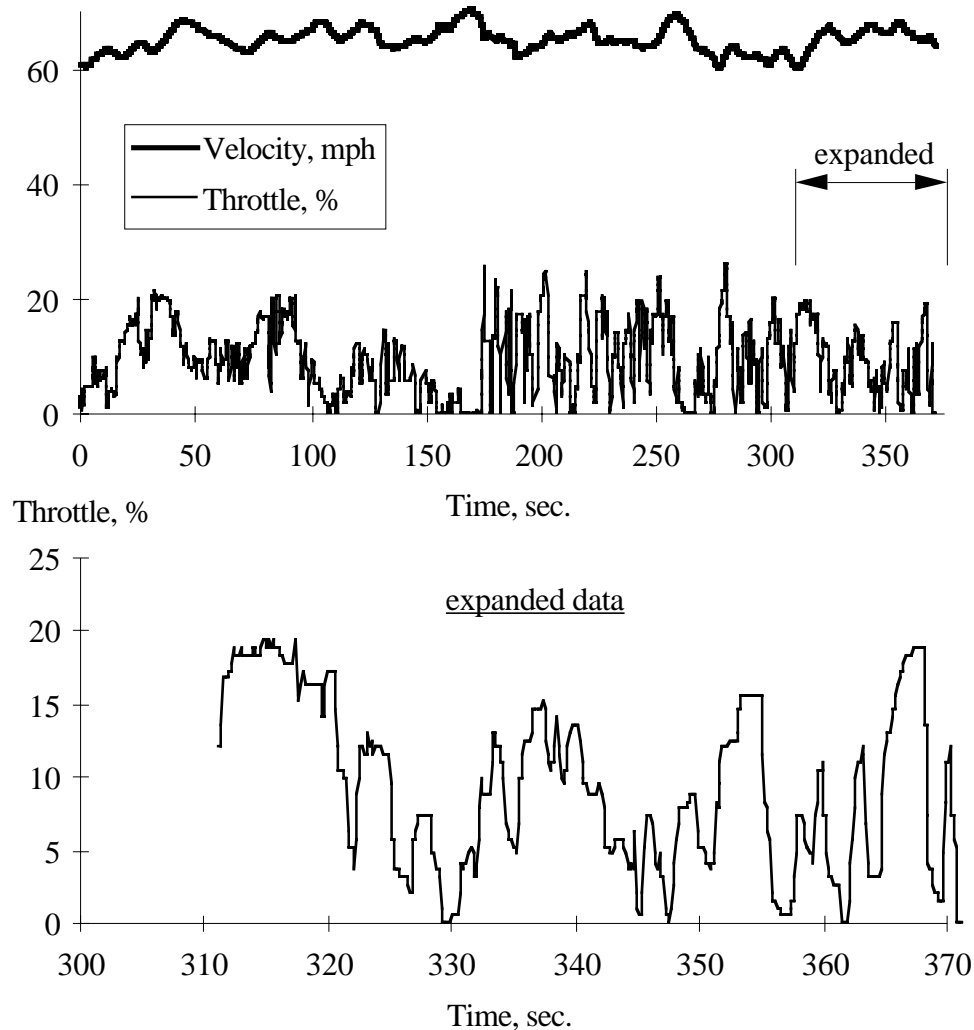

Figure 70. Typical throttle modulation in manual driving

For example, during manual driving at speeds above 35 mph, the standard deviation of throttle setting in percentage of full throttle movement is approximately equal to the mean. Figure 71 shows an ordered distribution of these measures across the entire sample of 108 drivers. For manual driving (as strange as it may sound) the most likely value of throttle setting is seen to be between 0 and 1 percent for all but two of the drivers. This



means that, if we histogram the data at bin widths greater than 1%, zero is the most likely value of throttle setting (even though vehicle speed is more than 35 mph).

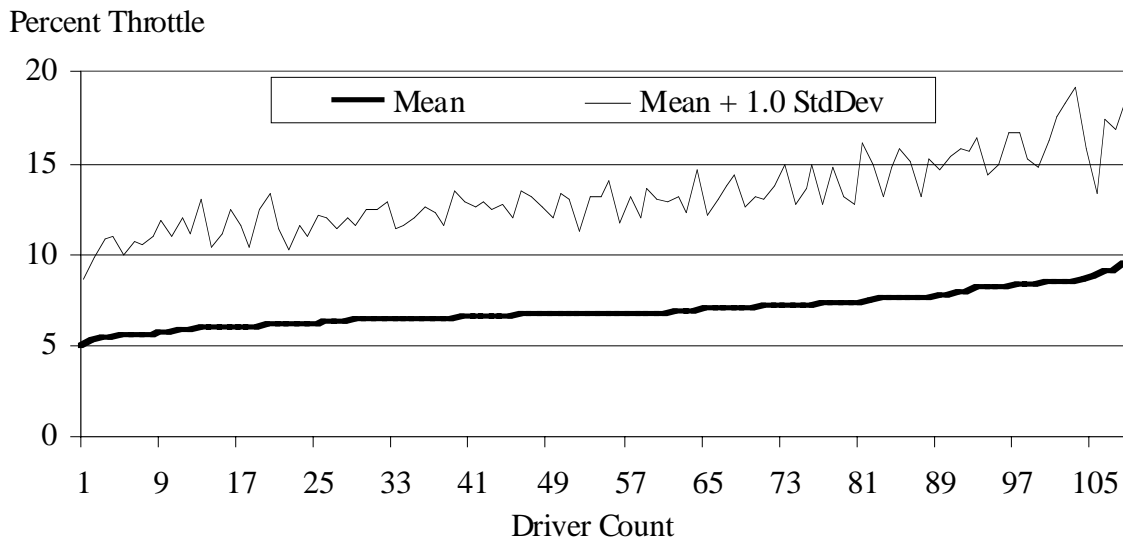

Figure 71. Mean and standard deviation of throttle setting by driver

The point is that all drivers are very active in moving the throttle. They typically move the throttle up and down by an important amount about 1000 times during an hour of driving. (This activity will be referred to as “throttle stress” herein.) Throttle stress not only includes the physical activity in modulating the throttle but more importantly it includes the mental activity (mental workload) involved in all of the choices associated with deciding to increase or decrease the throttle setting. Fortunately for vehicle manufacturers and users, drivers are not consciously aware of this activity. Throttle modulation is believed to be part of the learned skill associated with controlling headway and speed, and it occurs without the driver having to think about it.

Throttle stress is very important in this project because it is associated with an obviously direct benefit of both conventional and adaptive cruise control. Although most people may feel that they can drive manually with little effort, the popularity of conventional cruise control appears to indicate that relief from throttle stress is valuable to many people. As in conventional cruise control, adaptive cruise control provides the relief associated with not having to move the throttle. Compared with conventional cruise control, ACC also appears to relieve some of the tension associated with checking to see whether speed needs to be adjusted to avoid overrunning an impeding vehicle. One reason why ACC driving is expected to be less stressful than manual driving is because

throttle stress is eliminated or greatly reduced over rather prolonged episodes of ACC engagements.

### 8.1.2 Observation and Theory on Manual Headway Modulation

An important observational measure is the headway time margin (Htm) between a preceding vehicle and the driver/participant's vehicle. Headway time margin, which is defined as  $R/V$ , represents a measure of the time available to react to sudden speed changes of a preceding vehicle. It also represents the driver's instantaneous performance characteristic in controlling the headway time to a preceding vehicle. Different drivers chose different headway time margins to fit their desires and their driving situations. A wide range of Htm values is seen in the data that were collected during manual driving in this FOT. Figure 72 indicates that, for all speeds greater than 55 mph, the aggregated most-likely value of Htm for all of the drivers is 0.8 seconds. As can be seen, the Htm distribution (i.e., the observed density) is skewed towards short times with a long tail extending out past values that are expected to be of much concern in the task of manual headway control. As indicated in the figure, the observed frequency of a short Htm that is less than 0.65 seconds is fairly large —greater than 0.1 if the values plotted for 0.3 to 0.6 seconds are summed together.

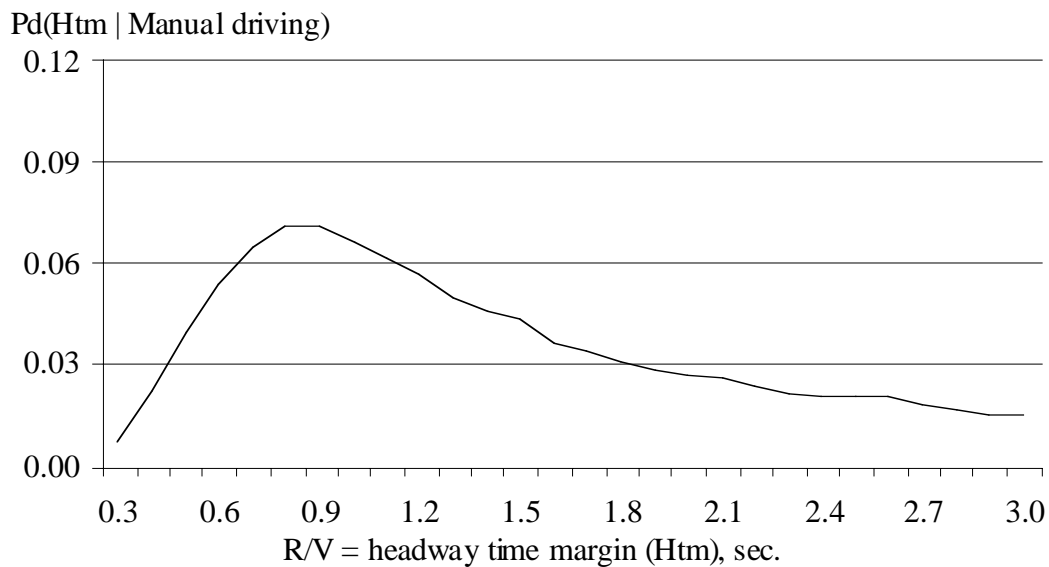

Figure 72. Htm for manual driving with  $V > 55$  mph

People who have measured reaction times might wonder why drivers choose to travel at such small headways and how they avoid collisions given that they drive at headway times that are often shorter than the value of generally accepted reaction times. One way

to answer this is to suggest that drivers are very good at judging when or if the preceding vehicle is about to slow down rapidly. Another response to these questions is to try to develop an organized approach for explaining manual headway control. The approach employed here draws ideas from vehicle dynamics, control system philosophy, and human factors (i.e., psychological) considerations to try to organize a conceptual foundation for a theory that is at least useful for discussing headway control.

Figure 73 is a block diagram that provides a conceptual overview of the driving process by dividing that process into two parts —one for executing the driver’s plan and the other for causing the actual motion of the vehicle plant to track such motion commands. The diagram is quite generic and it may seem too mechanical to represent the behavior of a person. Nevertheless, it can be used to guide the examination of how people sense information, process it, decide on commands, and perform control actions.

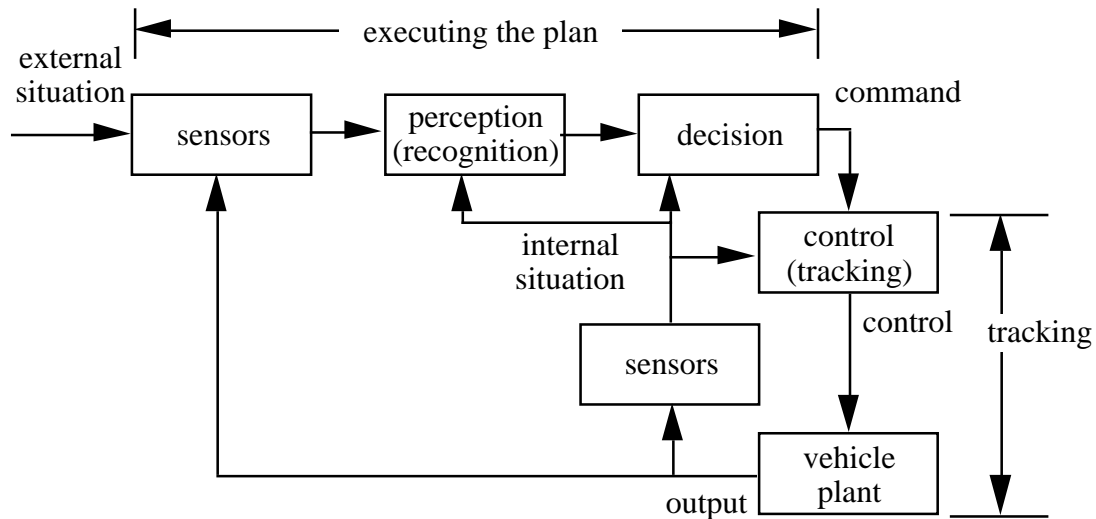

Figure 73. Conceptual portrayal of the elements of the driving process

The driver behavior theory presented here has its origins in ideas about human performance models as published by Rasmussen in 1983 [10]. The underlying model for this theory involves three levels of behavior — skill, rule, and knowledge-based behavior.

Figure 74 illustrates a hierarchy of considerations and actions going from those requiring knowledge, through those based on rules, and finally to skills that are mainly automatic. The skilled driver has developed sets of rules through experience and has learned skills for executing those rules with very little conscious effort. The driver is envisioned as being able through experience to recognize signs in the basic raw signals

that guide the selection of alternative rules (plans or templates) as needed to adapt to changing situations.

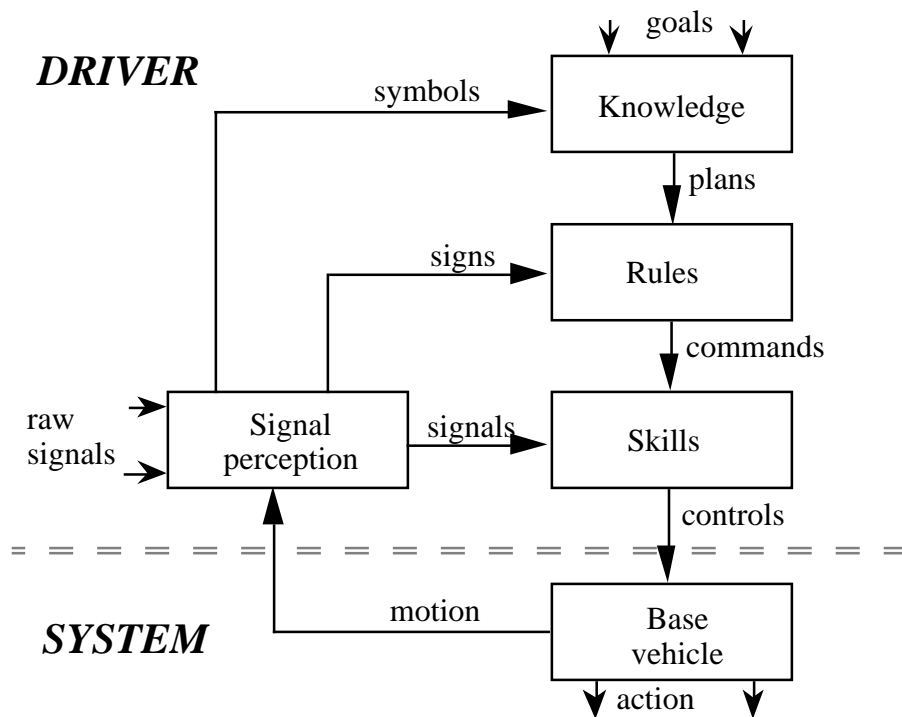

Figure 74. Skills, rules and knowledge associated with the driving process

When a situation develops that is unfamiliar or if something is going wrong, the driver is expected to use knowledge of how the driving process works to formulate another plan (rule) that is suitable for this new situation. Unfortunately, this higher-level knowledge-based process tends to be slow compared with the time available in an emergency. In emergency situations one hopes that the driver picks a good rule to use but the time constraints may simply prevent development of an appropriate plan.

Clearly this approach to modeling the driver represents a simplified method for dealing with something that is extraordinarily complex. The intention in this discussion is to use aggregation, abstraction, and analogy to cope with complexity.

The framework for modeling the driver as presented in Figure 74 is related to Figure 73 through the use of the labels “plan(s),” “command(s),” and “control(s).” These labels stand for the outputs of the knowledge, rule, and skill processes shown in Figure 74. Figure 73 shows “command” as the output of an activity called “executing the plan,” and “control” as part of an activity called “tracking.” The existence of a “plan” is tacitly assumed in Figure 73, which emphasizes operational aspects of the driving process.

Nevertheless, the control system and human factors aspects of the concepts and associations attributed to the terms “plan,” “command,” and “control” are essential parts of this theory.

The tracking activity as described here involves vehicle dynamics as well as control and human-factors considerations. The goal of the tracking part of the driver model is to achieve suitable agreement between the vehicle motion the driver wants (the “command”) and the vehicle motion the driver obtains. The elements of the tracking activity are portrayed in Figure 75. According to this model, the driver is skilled at moving the controls (accelerator  $\delta t$  and brake  $P_b$ ) to quickly get a selected vehicle motion. (In the case of headway control the desired motion is a velocity that is appropriate for the current driving situation.) In order to accomplish the tracking goal, the driver needs to become skilled at determining how to move the controls in a manner that will achieve the objective of satisfactory tracking. In a sense, the driver eliminates the vehicle’s dynamic properties in the process of obtaining the desired vehicle motion. (Clearly, the limits on the vehicle’s dynamic capabilities still constrain what the driver can achieve.)

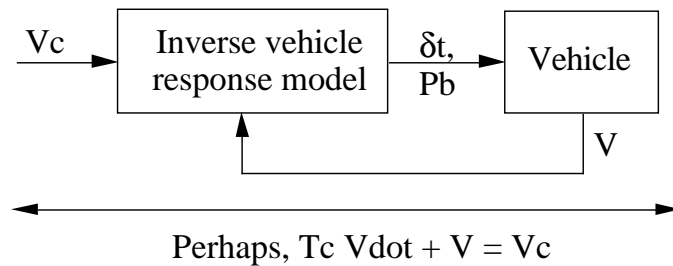
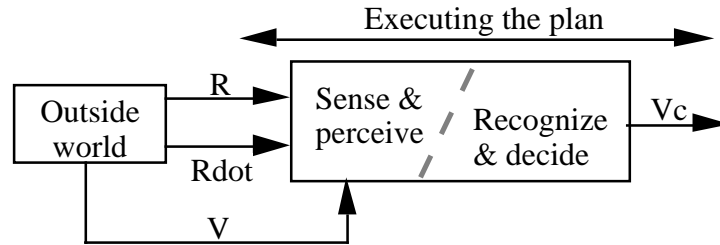

Figure 75. The operational elements of a tracking activity

To complete the description of the driving process as portrayed in Figure 73, there needs to be a means for executing a plan. Figure 76 presents a conceptual model of a set of elements that are intended to represent how a driver executes a plan (i.e., uses a rule or template).



Note: 12 % Range Resolution,  $\Delta R = \pm 0.12 R$   
 $R\dot{d}$  threshold, e.g.,  $R\dot{d} < -0.0005 R^2$  (feet)

Figure 76. Model of commander and perceptual limits

The driver is envisioned as sensing the driving situation, perceiving what is happening, recognizing any signs that would call for a change in control tactics (rules), and deciding what command to issue to the skill-based tracking activity. In order to reduce the verbiage involved, the set of elements that selects a plan and determines the command is called a “commander” just as the set of control elements that determines the control is called a “controller.” In summary, the driving process is envisioned as consisting of a tight inner-control loop employing a controller for tracking purposes and a broader, more objective-oriented outer control loop using a commander for executing a plan (with the help of the controller of course).

Just as there are limits on what the controller can achieve, there are limits on what the commander can achieve. In the case of the controller, some of these limits are set externally by what the vehicle can do. In the case of the commander, there are limits on what the human can sense. In particular, human factors experiments indicate that people perceive range to within approximately 12 percent. Also, there exists a threshold on range-rate perception that corresponds to a minimum discernible rate of change of visual angle of approximately 0.003 radians per second [11]. At typical highway speeds and ranges, this means that the commander does not have a very accurate perception of either range or range rate —two of the critical variables in controlling headway.

From an overall perspective on this type of driver model/theory, note that, regardless of the terminology, the form of the model consists of a part that looks at the input and determines some intermediate quantities that are communicated to another part that sends an output to the plant to be controlled. This is the same form as that used in neural networks, fuzzy logic, and other modern control concepts. The main differences here are that (1) there is a specified inner feedback loop in this model and (2) the outer loop is directly related to goals and objectives.

(The type of model described above has evolved from observations of driving behavior as obtained during this FOT and from the FOCAS project [4]. Two papers that provide further insight into this type of driver model are presented in references [12] and [13].)

Given the framework provided by a driver model, one can discuss and interpret results in a structured manner referring to concepts that have been defined with some degree of rigor with regard to the phenomena involved. For example, the observation and discussion of throttle stress (as presented in section 8.1), can now be interpreted in terms of the tracking part of the driver model. Examination of Figure 75 indicates that the throttle plays a role of an amplified error signal in a simple velocity-control loop. The difference between the commanded velocity and the actual velocity is used to determine the throttle setting in this model. This difference is amplified (and possibly differentiated to use some preview or lead) in order to respond quickly relative to the dynamics of the outer loop involving the commander. Every bit of noise and other sources of error variation appear in the throttle response. The vehicle (with its rotating engine inertia, torque response dynamics, etc.) acts as a low pass filter so that the velocity of the vehicle is fairly smooth even though the throttle fluctuates rapidly. It might be said that the driver's control of the throttle is quick but not accurate at going to an appropriate value and staying there.

The observation that drivers tend to use short headway times appears to be puzzling, although a clue to this preference can be gained by noting the characteristic human threshold on detection of the rate of change of visual angle. The visual angle subtended by an object at range  $R$  with maximum edge boundaries separated by a distance  $W$  is illustrated in Figure 77. The following relationship between the visual angle  $\theta$  and range  $R$  represents the connection between the longitudinal world represented by  $R$  and the vertical-plane world view that is projected on the driver's eye:

$$W = R\theta$$

(17)

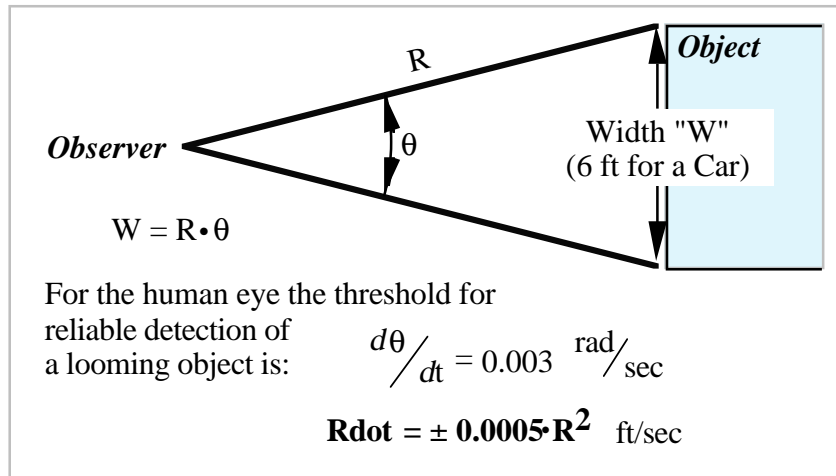

Figure 77. The visual angle,  $\theta$

There is an interesting type of symmetry associated with this relationship, as shown here:

$$R = W/\theta \quad \text{and} \quad \theta = W/R$$

(18)

Differentiating the expressions for  $R$  and  $\theta$  yields:

$$Rdot = - \theta dot / \theta^2 \quad \text{and} \quad \theta dot = - Rdot / R^2$$

(19)

So far in this report, considerations pertaining to headway control have centered mainly on the range-versus-range-rate space, however the above equations can be used to transform from the vehicle dynamics perspective expressed in terms of range and range rate to the driver's perspective defined by visual angle  $\theta$  and its time rate of change  $\theta dot$ . The phase space defined by  $\theta$  versus  $\theta dot$  is considered to be a mind's eye representation of the headway situation as the driver sees it.

As a direct result of this transformation, a threshold on  $\theta dot$  can be transformed from the mind's eye to a perception boundary in the range versus range rate diagram. The following expression, which is also listed in Figure 77, is a direct result of transforming the perceptual threshold given by  $\theta dot = \pm 0.003$  radians/sec as suggested in reference [11] into the range-versus-range-rate phase space:

$$Rdot = \pm 0.0005 R^2 \quad (\text{where } R \text{ and } Rdot \text{ are in ft and ft/sec})$$

(20)



This expression has been used in a driver model to aid in developing bounds on the vehicle following capability of a driver [13]. The idea is that, if the driver's perceptual ability is limited, the driver's ability to develop useful commands is correspondingly limited. As will be shown later, observations of driver following behavior show that driver performance is characterized by a type of hunting behavior about a point defined by the apparent desired range at  $R\dot{=} 0$ . The hypothesized theory is that the driver has only a limited ability to determine range as well as a threshold limiting the ability to measure range rate. In a sense, the driver is not able to do perfect following because the driver does not have the resolution capability needed to follow perfectly.

Another interesting observation is that drivers do not appear to be sensitive to large changes in range rate if the range is large. Equation (19) provides an explanation of this observation. It indicates that  $\theta\dot{}$  is inversely proportional to  $R^2$ . Even if  $R\dot{}$  is relatively large at long range,  $\theta\dot{}$  is not large because of the  $R^2$  effect. This shows up dramatically in transforming  $R$  and  $R\dot{}$  data into the mind's eye space. It also aids in understanding how drivers can be insensitive to speed differentials at long range.

The data shown in Figure 78 illustrates this point. The figure shows, at the top, a time history of the velocities of two successive vehicles during a closure sequence, measuring from an initial range of 350 ft. The middle and lower groups express the same closure sequence in terms of the  $R$ -versus- $R\dot{}$  and  $\theta$ -versus- $\theta\dot{}$  relationships, respectively.

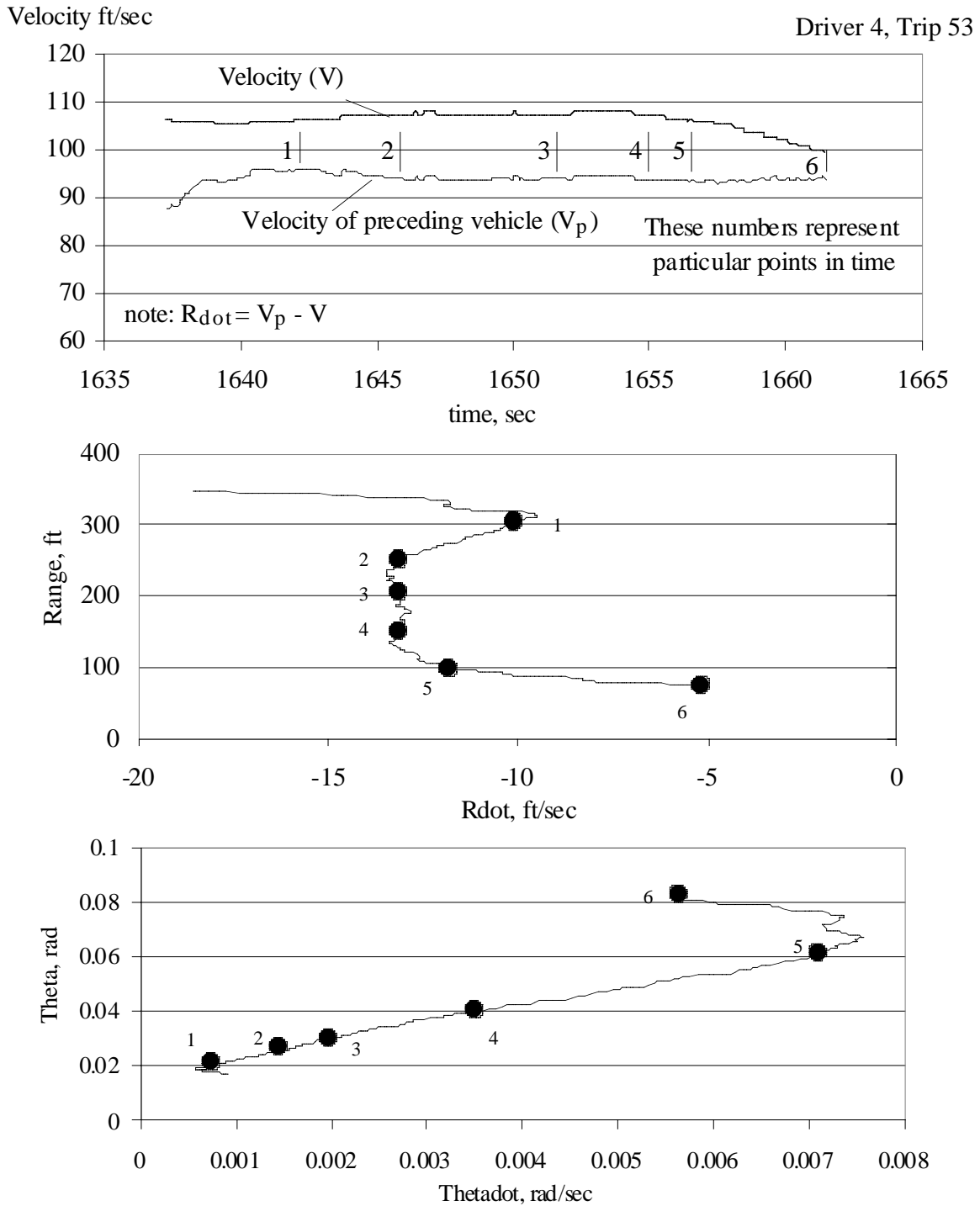

Figure 78. Example points in time displayed in R-vs.- $R_{dot}$  and  $\theta$ -vs.- $\theta_{dot}$  spaces

We see, for example, that the 0.003 radians/sec detection threshold in  $\theta_{dot}$  is reached in this sequence when the range value, R, is around 120 ft.

There is in all of this theory an implied hypothesis explaining why drivers may employ relatively short values of Htm (headway time margin). The hypothesis is that drivers close in on an impeding vehicle until they can readily sense the rate of change of the visual angle subtended by the impeding vehicle. At this point, the driver gains a much better means of assessing the headway situation. In a sense, at longer ranges, drivers are almost unaware of how rapidly a conflict situation may be developing. But if they are at least somewhat aware of the situation, they expect to be able to handle it when they get close enough to judge it. Fortunately, this is the way it almost always works out, together with supplemental tactics of cautious approach that help ensure a low absolute rate of crashes.

A pertinent issue in headway control involves the preferential range value or its equivalent image size (visual angle) which the driver chooses in particular driving situations. Examination of preferential range values requires that we first select a speed domain within which to be comparing manual versus ACC driving. The results plotted in Figure 79 indicate that the speed domain above 55 mph constitutes the zone (dominated by freeway travel) in which the ACC system is most utilized. Conversely, this ACC system is not used for many miles at speeds below 55 mph.

ACC utilization (Distance engaged / total distance)  
 Man2 utilization = 1 - ACC utilization

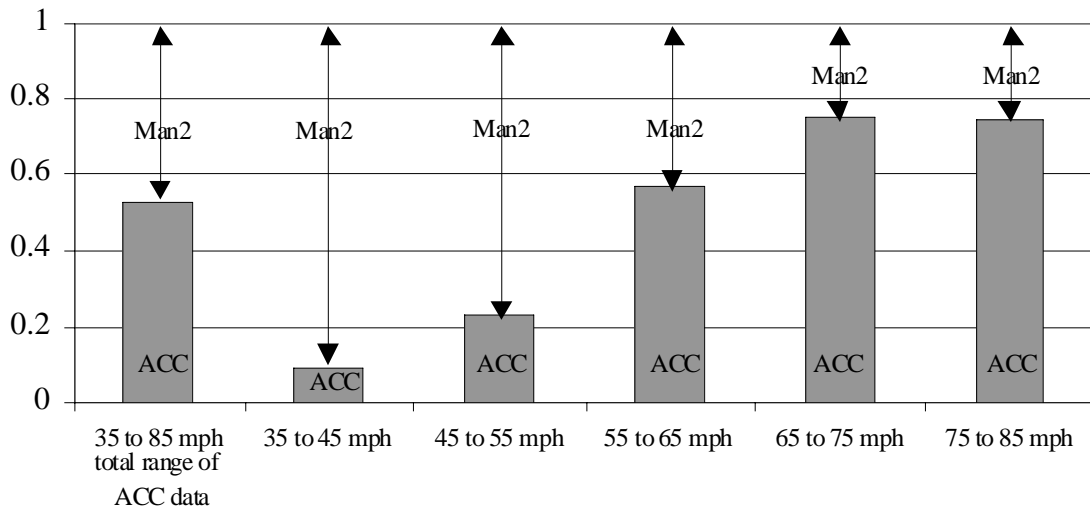

Figure 79. ACC and manual (MAN2) utilization vs. velocity

Figure 80 shows aggregated results for all drivers indicating a fairly constant result for the most likely value of range at velocities above 81 ft/sec (55 mph). (There is an underlying belief here that it is, by the way, reasonable to associate the most likely value

of a variable with what the driver wants or chooses most frequently.) The data suggests that at speeds above 55 mph, drivers have a favored visual image size that represents their desired headway position.

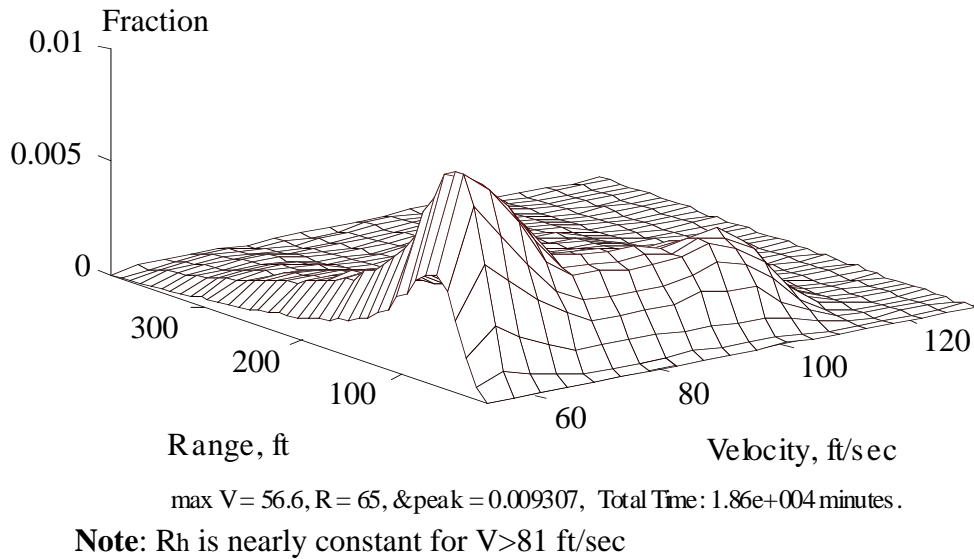

Figure 80. Observed frequency of range vs. velocity for manual driving

The result of further investigation of this matter is shown in Figure 81, which reveals that the most likely range value has an extraordinarily flat sensitivity to travel speed over the speed range between approximately 61 and 114 ft/sec (42 to 78 mph).

Most likely value of range, ft

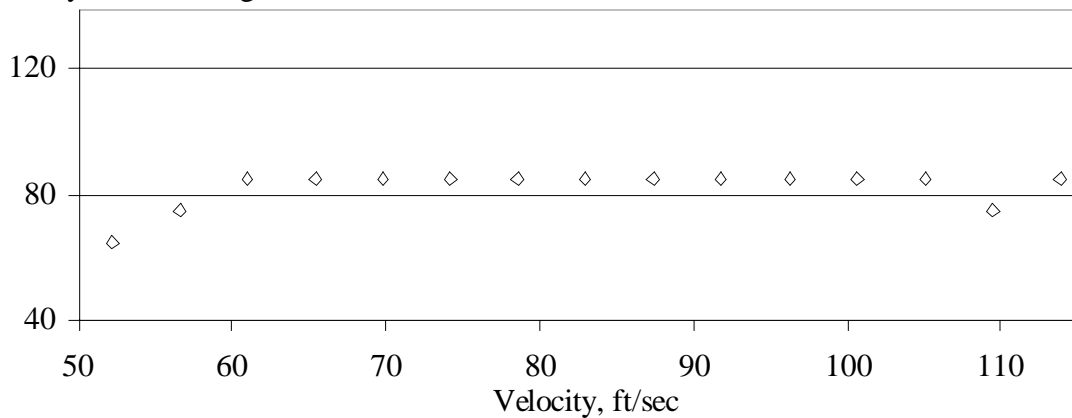

Figure 81. Most likely value of range vs. velocity for manual driving

A brief examination of the figure suggests that 85 ft is a sort of magic number which, for a 6-foot-wide object would transform into a visual angle  $\theta = 6/85 = 0.07$  radians.

On the other hand, the 85-ft value may not be all that “magic” insofar as the resolution of range used in assembling the data for Figure 81 is between 80 and 90 feet and, furthermore, these data represent an aggregate of 108 people. Clearly, each person behaves differently and does not necessarily choose 85 ft. Nevertheless, it is instructive to consider 85 ft as a representative number for a typical desired headway distance for manual driving at highway speeds. (Note, also that the use of a constant 85-ft value for representing manual driving means that the most likely value of Htm decreases as speed increases.)

The following analytical results indicate interesting relationships between  $\theta$  and  $\dot{\theta}$  for both constant deceleration and exponential approaches (parabolic and straight-line approaches in the R-versus-Rdot space) to the desired image size  $\theta_h$  for car-following. Figure 82 shows examples of various trajectories applicable to closing in on an impeding vehicle. An important feature indicated in these diagrams relates to the maximum value of  $\dot{\theta}$ . Because of the  $R^2$  effect,  $\dot{\theta}$  starts at zero for small values of  $\theta$ . Then  $\dot{\theta}$  increases up to a maximum value and finally returns to zero at the value  $\theta_h$ .

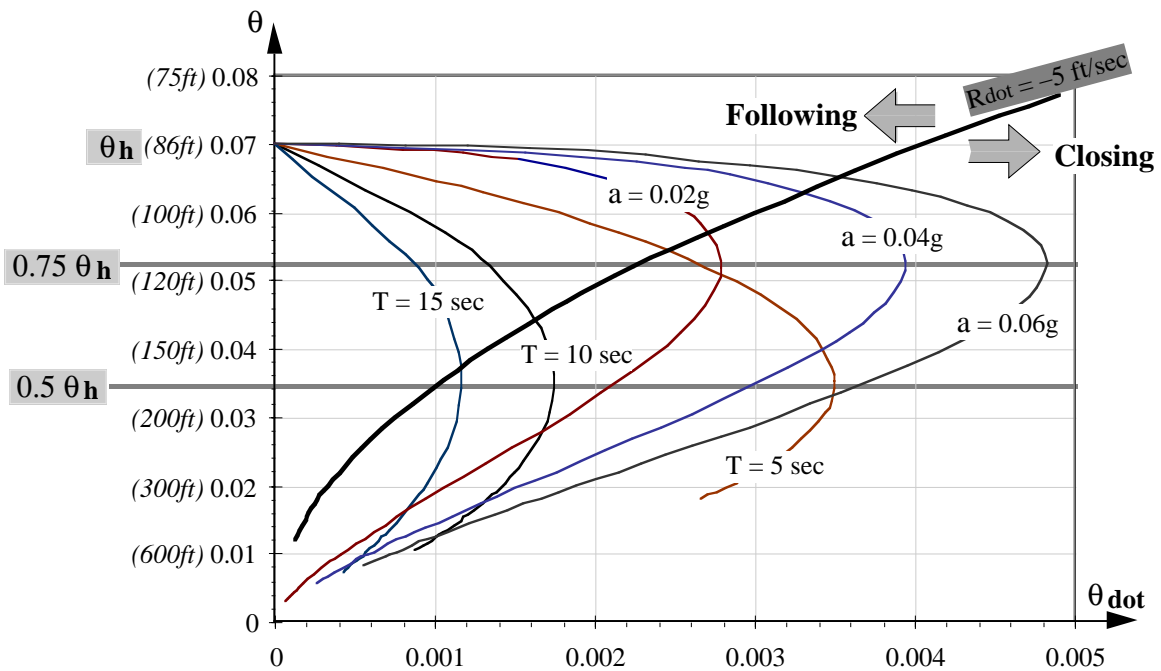

Figure 82. Idealized closing trajectories in  $\theta$  vs.  $\dot{\theta}$  space

The expressions for the constant deceleration lines and the exponential lines having constant values of the time constant,  $T$ , have been analyzed to find the maximums where  $\partial\dot{\theta}/\partial\theta = 0$ . The analysis shows that for lines of constant deceleration:

$$\dot{\theta}(\text{maximum}) \text{ occurs at } (0.75) \theta h \quad (21)$$

and for lines of constant exponential time constant:

$$\dot{\theta}(\text{maximum}) \text{ occurs at } (0.5) \theta h \quad (22)$$

The relationships given by equations (21) and (22) apply regardless of the value of constant deceleration or exponential time constant, as shown in Figure 82.

Figure 82 provides a reference mental model (or image) of what to expect when examining data pertaining to closing situations. The line labeled “ $\dot{R} = -5\text{ft/sec}$ ” is the boundary separating the closing and following regions defined in terms of the R-versus- $\dot{R}$  diagram of figure 44 in section 5.6. To the left of this boundary, real data shows the hunting phenomenon which is typical of the following behavior of drivers. Nevertheless, this idealized model is useful for evaluating closing situations before the hunting associated with following develops. It provides a basis for comparing ACC with manual driving in section 8.3.

### **8.1.3 Influence of Age, CCC Usage, and Gender on Manual Driving Style**

The definitions of driving style were presented in section 5.6. Small miniatures for portraying driving style were then presented for each of the 108 drivers in section 6.0. That work has been extended here to consider the manual driving of groups of drivers falling into various categories of age, CCC usage, and gender. The results are presented in a summary fashion in Figure 83.

As can be seen by examining the figure, the miniatures for these groups of drivers are quite similar. They show nowhere near the variation displayed in figure 51 in section 6.0. However, careful examination of Figure 83 illustrates certain differences.

For example a comparison of the miniature labeled “ONA” in the lower left region of the figure is quite different from the miniature labeled “AAA” in the center region of the figure. The designation ONA stands for the set of drivers that are Older, Nonusers of CCC, and of All (i.e., both) genders; AAA stands for all drivers aggregated into one group. The older, nonusers show the form of the ultraconservative driving style. The size of this miniature is approximately in the middle of the sizes displayed for the individual ultraconservatives in figure 51 in section 6.0. The other distinctions seen in Figure 83 are more subtle than this one, but it can be seen that the set OAF has a shape similar to ONA and that the young-driver sets with Y (YAA, YNA, YUA, YAF, and YAM) tend to have less of the slow property than the other sets in the figure.

Even so, as might be expected, the miniatures for these sets of drivers tend to become much like the set for all drivers.

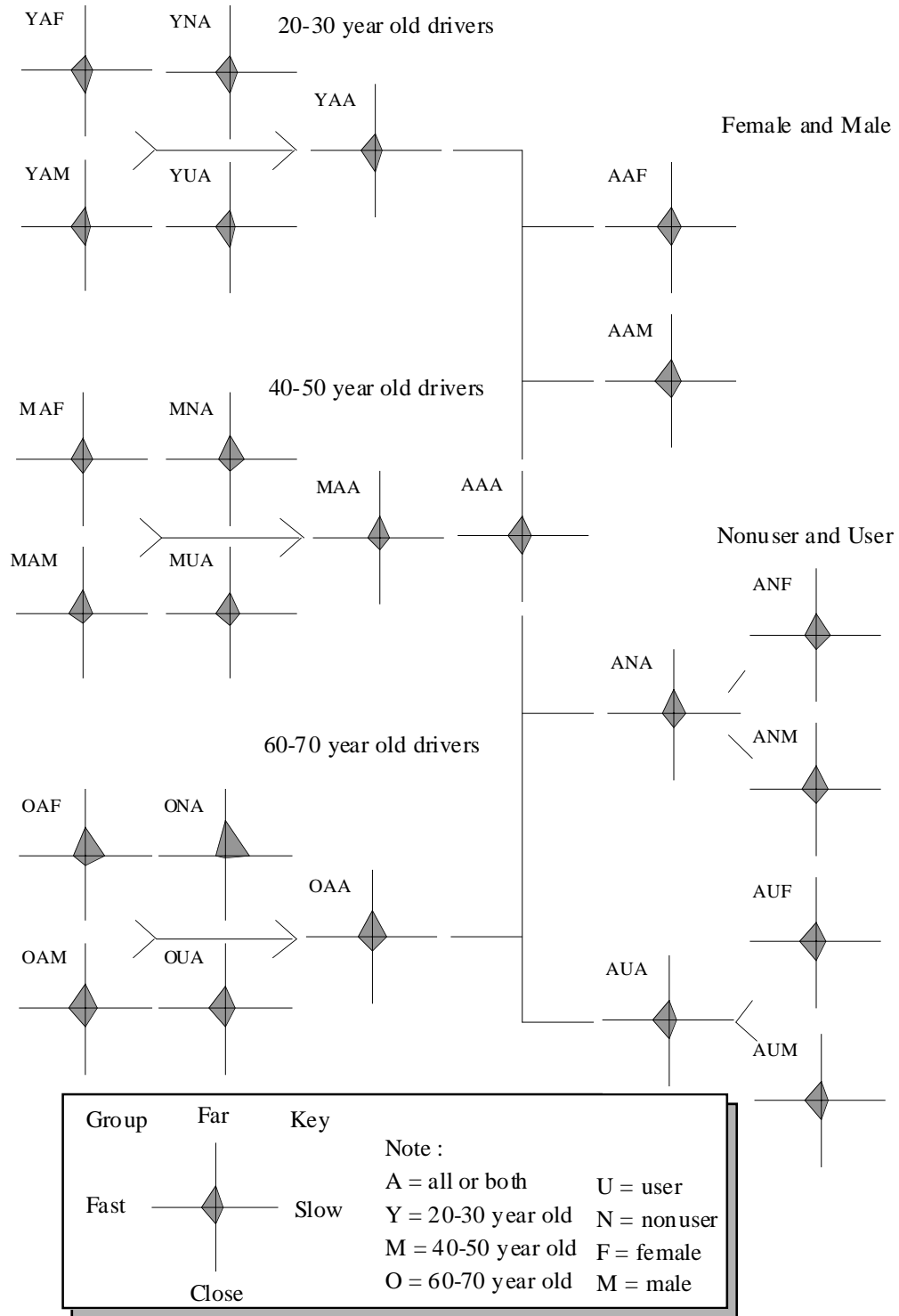

Figure 83. Driving style by age, gender, and CCC usage

Another approach to seeing the effect of age, usage, and gender is to examine the results aggregated first by driving style. Figure 84 shows miniatures for each of the five driving styles. These miniatures have distortions in each of their diamond shapes typical of their style, even though they present the aggregates of many drivers.

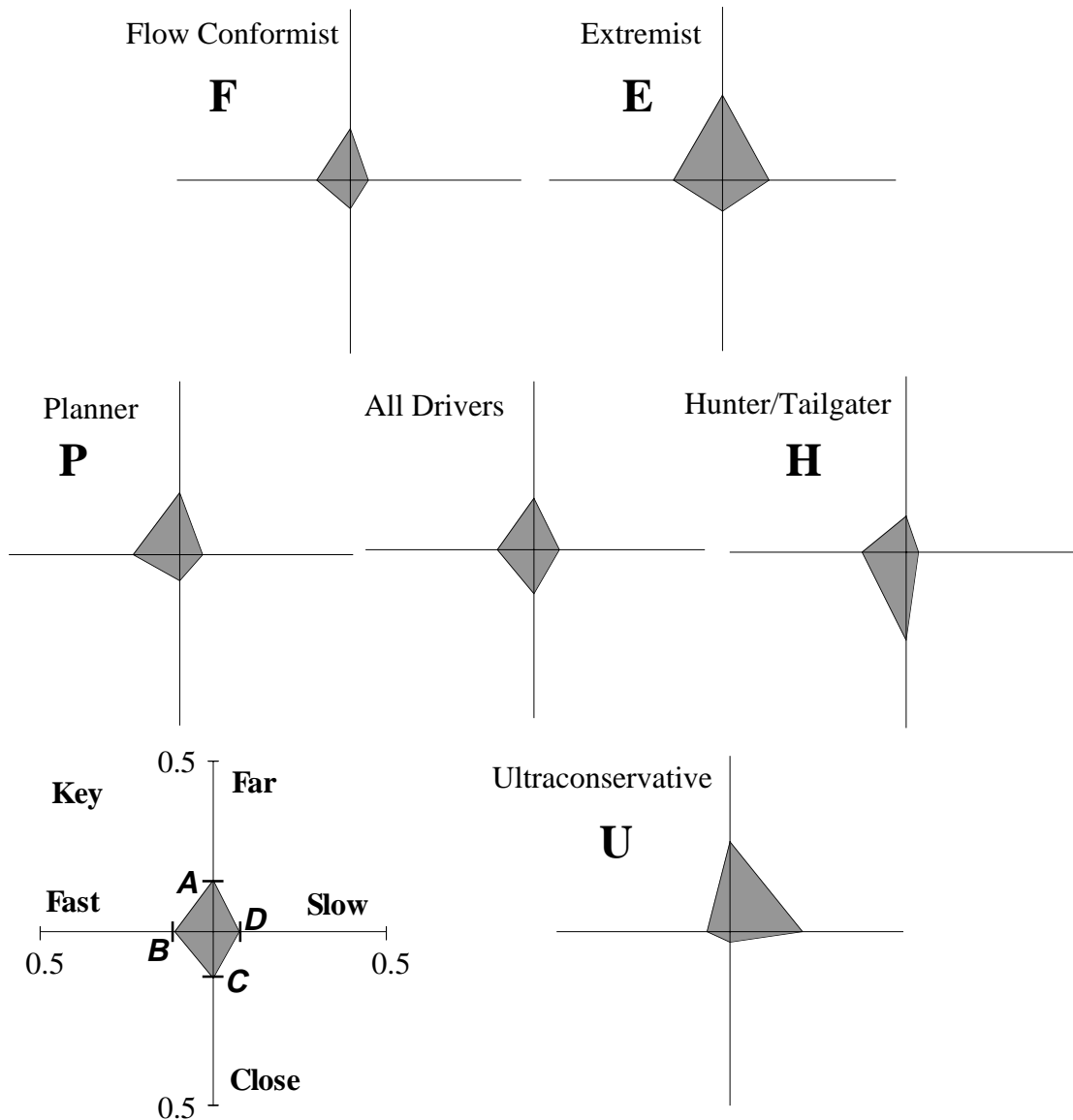

Figure 84. Miniatures created from the processing of all manual driving data, aggregated by driving style

Examination of the influence of age, usage, and gender within each driving style provides interesting information for identifying the subgroup that tend to drive in a particular style.



Figures 85 through 89 illustrate the composition of each driving style in terms of age, usage, and gender.

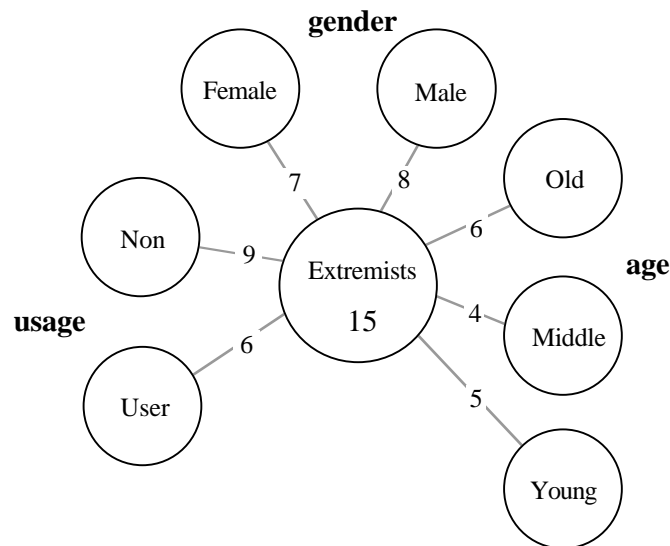

Figure 85. Extremists by age, usage, and gender

As shown in Figure 85, the extremists are fairly uniformly distributed with respect to gender and age. There are 9 non-users of CCC versus 6 users. This is a stronger effect in the “user” variable than the numbers first indicate because there are 66 users and 42 nonusers in the overall test sample. (Recall that all the five-week drivers were cruise-users.) If users and nonusers were equally likely, the ratio should be proportional to 66/42 or 11 users for each 7 nonusers. Other than a small overrepresentation of nonusers, the results indicate that extremists are not prone to be associated with age or gender. The planners (as shown in Figure 86) tend to be male more often than female, and young is more prevalent than the other age groups. There is a slight tendency towards users—slightly more than the 11 versus 7 odds. In this case there are 9 male users out of the 12 male planners.

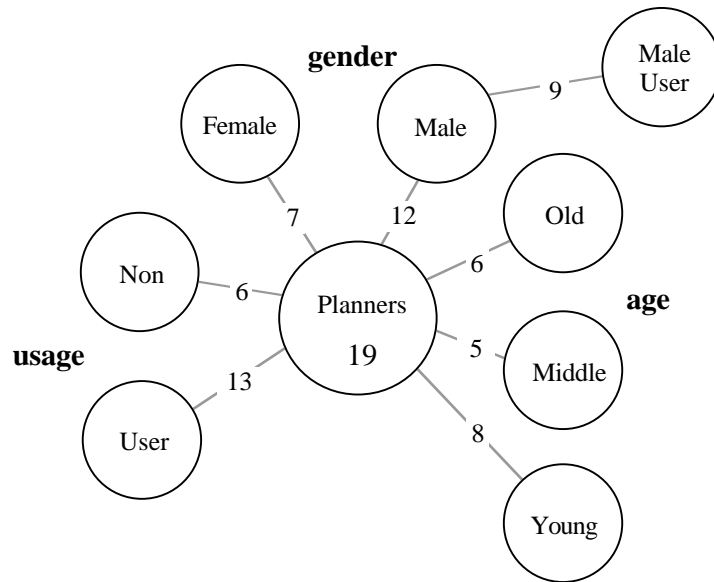

Figure 86. Planners by age, usage, and gender

As indicated in Figure 87, ultraconservatives are likely to be old, nonuser, and female.

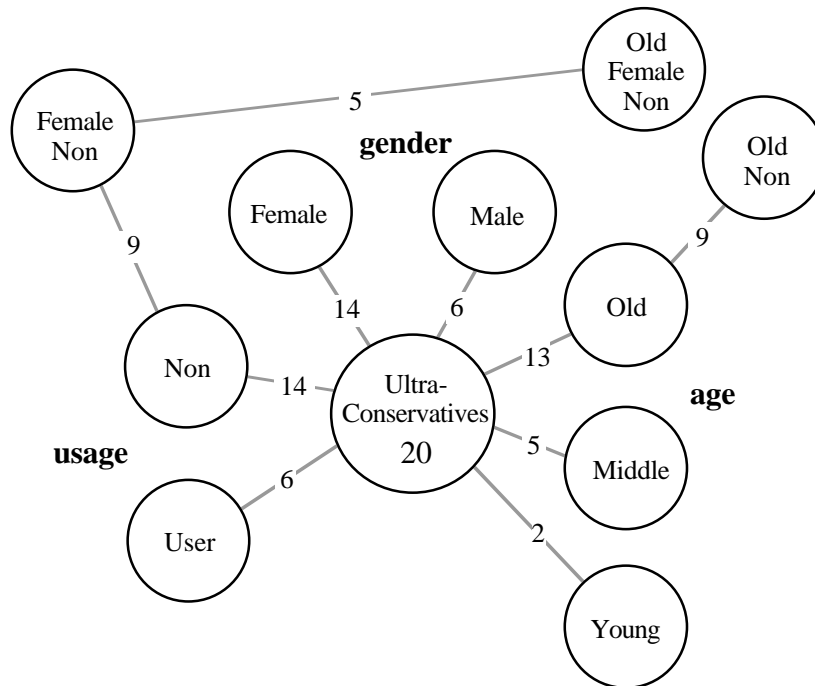

Figure 87. Ultraconservatives by age, usage, and gender

At the other extreme from ultraconservatives, Figure 88 shows that hunter/tailgaters are likely to be young and users. Gender is evenly divided —12 female versus 13 male. Out of 25 hunters 10 of them are both young and CCC users.

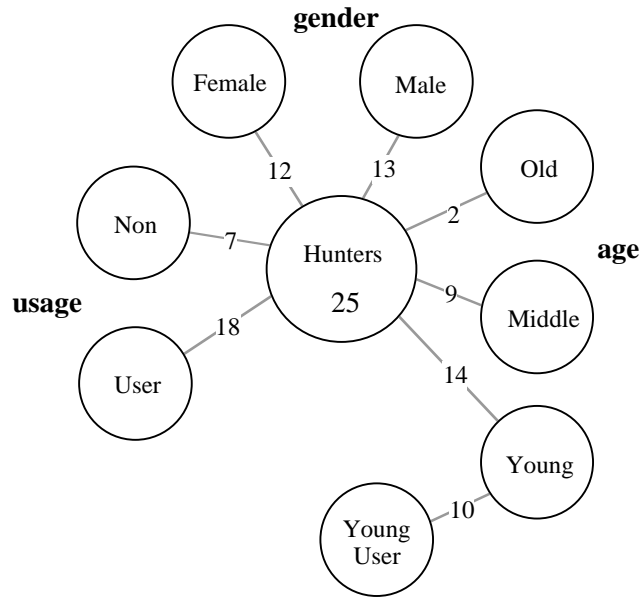

Figure 88. Hunters by age, usage, and gender

In Figure 89 we see that flow conformists have tendencies to be users and middle aged with gender being well balanced. The age effect is not large, noting 7 young, 13 middle age, and 9 older drivers in this style. Interestingly all 9 of the older drivers are also users.

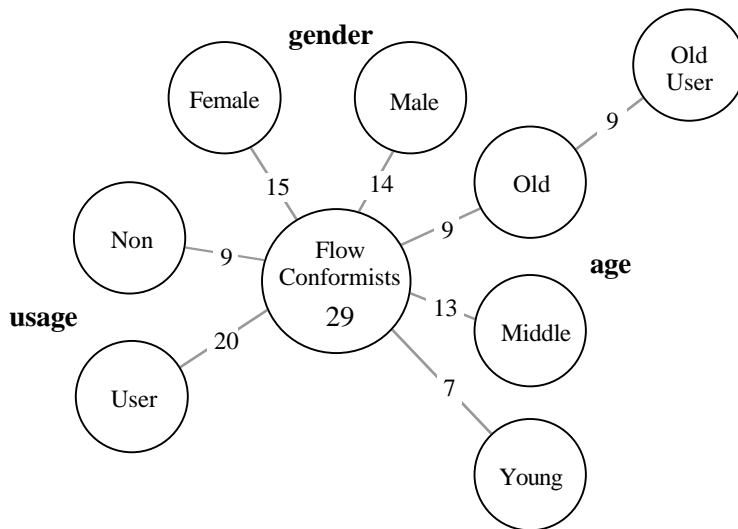

Figure 89. Flow conformists by age, usage, and gender

In summary there is some evidence to link hunters with younger people, flow conformists with middle aged drivers, and ultraconservatives with older people. There is some association of nonusers with extremists and ultraconservatives. Gender differences are associated with planners and ultraconservatives in that planners are more likely to be males and ultraconservatives more likely to be females. Although one may conceive of contexts where each of these findings are assigned importance, the main findings appear to be that only 2 out of 36 younger drivers were ultraconservative and only 2 out of 36 older drivers exhibited the hunter/tailgater driving style.

#### **8.1.4 Distributions of Manual Braking Behavior**

Braking behavior is difficult to examine because the reasons for braking are not always self evident in the data. Braking represents a change in the rules (as portrayed in Figure 74 in section 8.1.2). The driver recognizes certain signs in the outside information signals indicating that it is time to change from throttle modulation to braking in order to reduce speed more abruptly. The driver essentially adopts a new template that represents the rule for operating the brake pedal skillfully.

There are many “signs” that evoke braking. For example, a slower-moving vehicle may be impeding the path of the driver’s vehicle, thus constituting a sign for driver recognition. To investigate such a case, the researcher can use the data for  $V$  and  $V_p$  to identify the situation. However, signs like the illumination of the brake lights of the preceding vehicle may induce braking well before range, range rate, or velocity have changed appreciably. Clearly, traffic signs and signals can also cause a driver to brake. The desire to adjust vehicle position and speed relative to merging or passing vehicles can cause the driver to brake. Besides, drivers brake for reasons that derive from high-level goals, such as “this is where I turn off to go home,” “my passenger told me to slow down,” “I am afraid I might get a ticket,” “I want to read a sign or admire the view,” etc. The point is that the driver can have reasons for braking that are not clear to the researcher examining driving data. This means that it is difficult to extract episodes from unstructured, naturalistic driving data in order to put braking behavior into neat, well defined classes of braking activity.

Regardless of the reasons for braking, Figure 90 presents the aggregated deceleration data for all drivers for each braking event that occurred during manual driving and lasted for more than 0.3 seconds. The figure shows the average value of deceleration for the braking event. The observed levels of frequency are per braking event — not per second of brake application — thus, short applications count equally with longer brake

applications. The influence of driving speed, at the time the brake was applied, is indicated by different lines in this graph.

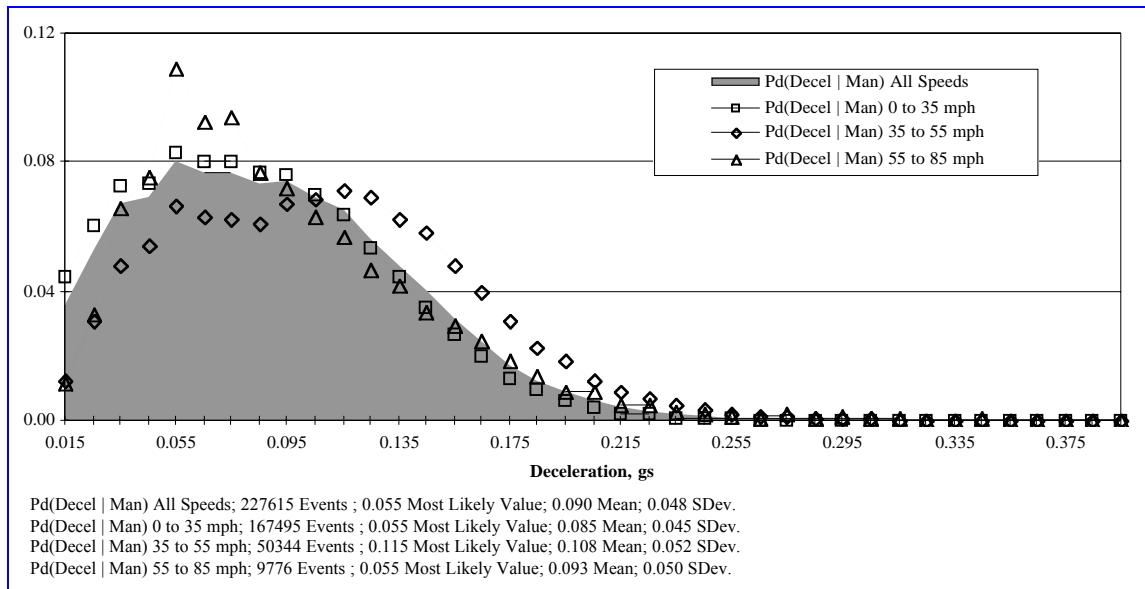

Figure 90. Average deceleration in manual braking events (duration > 0.3 seconds)

The data show that at speeds above 55 mph (88 kph), the frequency of low level braking is relatively high in the range of braking events from .05 to .08g. Interestingly, in the speed range from 35 mph (56 kph) to 55mph (88 kph) there is a definite tendency towards relatively higher frequencies for higher levels of braking above approximately 0.11g of braking. Perhaps this explains why drivers choose to use ACC (and CCC too) at speeds above 55 mph and to reduce ACC utilization at speeds between 35 and 55 mph. Also, speeds above 55 mph mainly represent driving on limited-access freeways where frequent braking is not expected. In summary, ACC utilization behavior (presented in detail in section 9.1) relates closely to the braking decelerations that otherwise describe the ambient traffic environment. That is, there appears to be a strong tendency for drivers to opt for manual control when it appears to them that considerable braking is likely to be required.

Figure 91 shows the distribution of maximum (as compared with average) deceleration levels per manual braking event. Maximum braking levels appear to be around twice those of the average decelerations. The distribution of maximum braking level may seem more like data presented elsewhere in available literature than the data that were shown in Figure 90. It may be that braking data are often measured under a particular set of circumstances, such as at a particular set of stop signs, rather than under

all driving circumstances. In any event, these maximum deceleration data also show that braking in the 35-to-55-mph range is more severe than it is in higher or lower speed ranges.

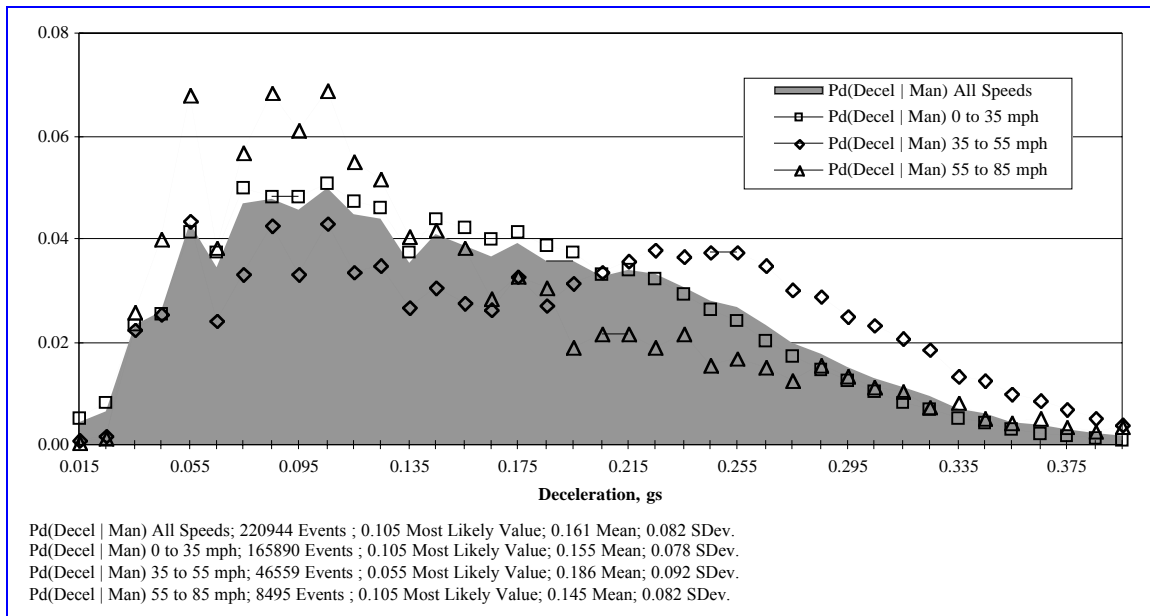

Figure 91. Maximum deceleration in manual braking events (duration > 1.0 seconds)

Examination of the notes at the bottom of Figures 90 and 91 indicates that these data are based upon over 220,000 braking events of which approximately 166,000 are at speeds from 0 to 35 mph, 50,000 are at speeds from 35 to 55 mph, and 10,000 are at speeds above 55 mph. Thus above 55 mph, both the amount of braking and the frequency distributions for braking levels are largely different from those observed in the speed range from 35 to 55 mph.

For use in comparisons with ACC driving, the amount of braking per mile is also a pertinent consideration. Figure 92 shows the number of miles traveled per braking episode that passed the criteria for being a candidate for recording as a video.

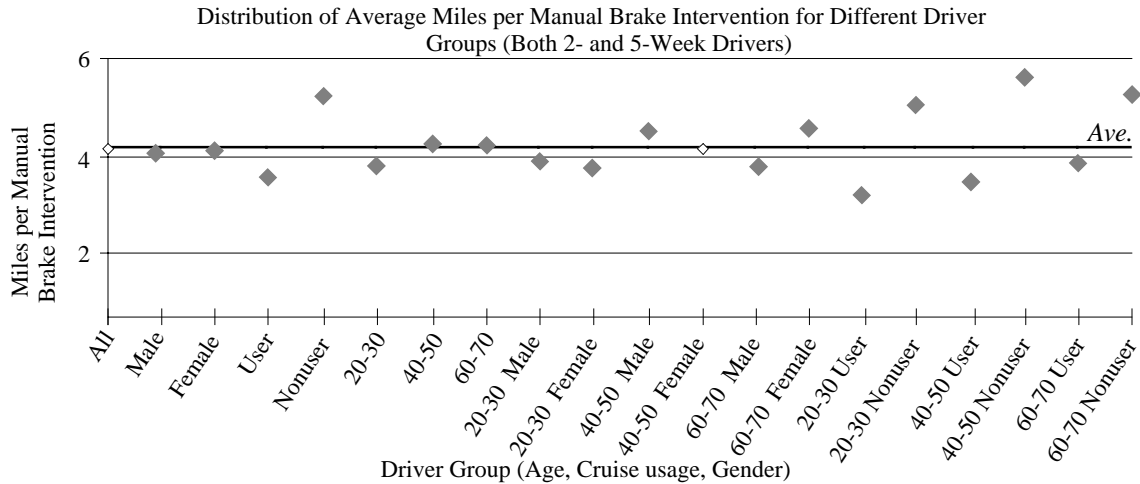

Figure 92. Manual braking per mile (V > 50mph)

In general these are braking episodes that last long enough and have a deceleration level large enough to be more than a momentary or minor braking activity. (Not all such episodes actually become stored on video because data collection was limited to the most severe episodes per driver, based upon each driver’s propensity to have episodes worthy of storage. See section 3.3 for more information.) As seen in Figure 92, the results for all of the various groups of drivers fall between 3 and 6 miles per brake intervention. The solid line at 4.1 miles per brake intervention is the average for all manual driving above 35 mph.

Figure 93 presents similar results for so-called near encounters with an impeding vehicle as defined in section 3.3, for the collection of video segments containing certain episodic events. During all manual driving the average distance traveled per near encounter is approximately 13 miles. (In general terms, “near encounters” are episodes in which it appears the driver was close enough to have been very ready to brake but chose to ride out the situation rather than brake.)

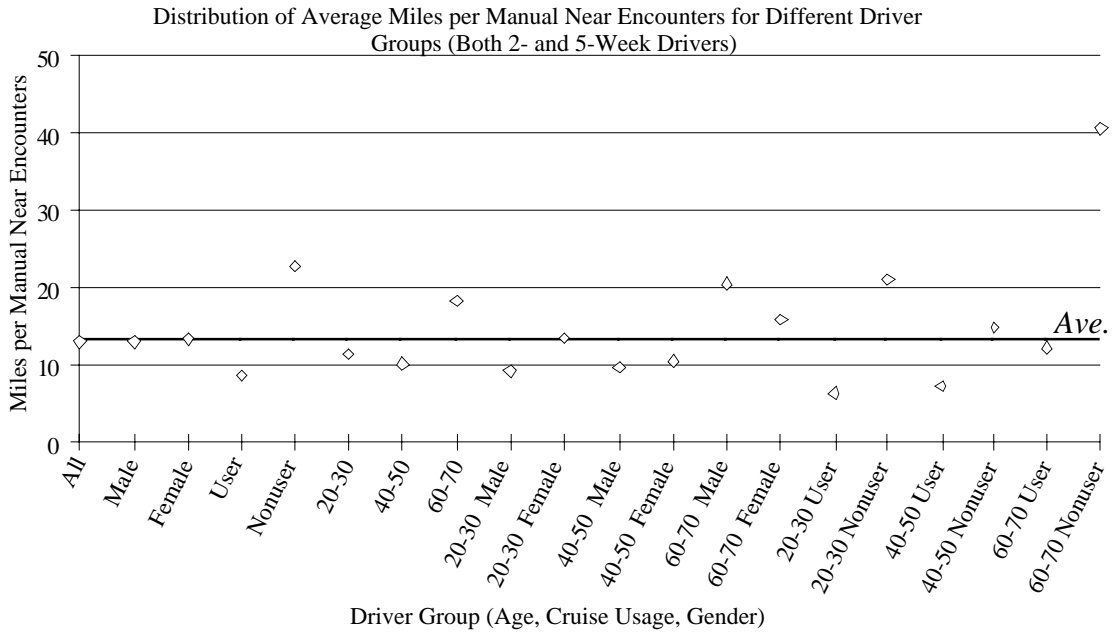

Figure 93. Near encounters per mile of manual driving

To gain insight into the conditions that prompt braking and the brake applications that ensue, the data were organized into brake tables —one for each driver. These tables could be examined electronically to select situations prescribed by the researchers. The total set of brake tables is very long even if speeds are restricted to the set of initial velocities above 55 mph —approximately 10,000 manual braking events as noted earlier. To examine events that might be considered relevant to crash avoidance, braking events with average decelerations greater than 0.25 g were selected. Including manual, CCC, and ACC operation, there were 145 braking events that lasted for more than 0.3 seconds with initial velocities above 55 mph and average deceleration levels above 0.25 g.

It is of interest to examine these 145 relatively heavy braking situations. Even though Table 46 is fairly long, it is presented to provide an idea of the type of information that can be assembled using a relational database. The content of each column in the table is listed in Table 45 below.

Table 45. Description of the data presented in Table 46

Column	[..]	Description/formula of column
Driver	—	Driver ID number
Trip	—	Trip number
Event	—	Event sequential number
DeltaT	sec	Duration of braking event



St.V	ft/sec	Velocity at start of braking event
End.V	ft/sec	Velocity at end of braking event
DeltaV	ft/sec	Velocity differential between St.V and End.V
St.R	ft	Range at start of braking event
End.R	ft	Range at end of braking event
St.Vp	ft/sec	Vp at start of braking event
VpEnd	ft/sec	Vp at end of braking event
$\Delta V_p$	ft/sec	Vp differential between St.Vp and VpEnd
St.Tti	sec	Time to impact at start of braking event
St.DA	g	Deceleration to avoid rear-end crash at start of brake event
St. $\Theta$	rad	$\Theta$ at start of braking event { $\Theta = 6/R$ }
St. $\Theta$ dot	rad/sec	$\Theta$ dot at start of braking event { $\Theta$ dot = $(-6 * Rdot) / R^2$ }
St.Htm	sec	Htm at start of braking event
Dist	ft	Distance covered during braking event
Target	—	1 = Same Target for entire brake event
ACC Enable	—	0 = CCC enabled; 1 = ACC enabled
Mode	—	0 = Manual; 1 = Manual (Standby); 2 = Engaged but not acting on target; 3 = Engaged and acting on a target
Max Ax	g	Maximum deceleration during brake event
Avg Ax	g	Average deceleration during brake event

Table 46. Braking events with Ax average > 0.25g and St.V > 55mph

Driver	Trip	Event	DeltaT sec.	St.V ft/sec	End.V ft/sec	DeltaV ft/sec	St.R ft	End.R ft	St.Vp ft/sec	VpEnd ft/sec	ΔVp ft/sec	St.Tti sec	St.DA g	St.Θ Θdot	St. sec	St.Htm sec	Dist ft	Target	ACC Enable	Mode	Max Ax, g	Avg Ax, g
1	111	30	9.3	82.1	0.0	82.1	74	5	82.5	0.0	82.5	50.0	0.000	0.081	0.000	0.899	312	1	1	0	0.556	0.274
4	49	29	4.9	98.2	41.0	57.2	64	45	96.6	45.8	50.8	38.8	0.001	0.094	0.002	0.648	329	1	0	0	0.628	0.363
4	100	39	4.5	101.2	52.0	49.1	171	0	66.7	0.0	66.7	5.0	0.108	0.035	0.007	1.693	349	0	1	1	0.526	0.339
4	99	34	10.1	87.9	5.8	82.1	0	0	0.0	0.0	0.0	50.0	0.000	0.000	0.000	0.000	542	0	1	1	0.403	0.252
4	61	4	4.5	104.8	52.8	52.0	277	139	41.6	39.6	2.1	4.4	0.223	0.022	0.005	2.645	348	0	1	2	0.644	0.359
4	60	7	3.1	105.5	79.9	25.6	0	192	0.0	82.3	-82.3	50.0	0.000	0.000	0.000	0.000	283	0	1	2	0.396	0.257
4	97	36	3.6	82.8	35.2	47.7	49	17	66.3	31.3	35.1	2.9	0.087	0.124	0.042	0.586	201	1	1	3	0.641	0.411
7	77	16	3.5	91.6	60.8	30.8	0	0	0.0	0.0	0.0	50.0	0.000	0.000	0.000	0.000	266	0	1	0	0.463	0.273
7	55	54	6.8	81.4	17.6	63.8	0	0	0.0	0.0	0.0	50.0	0.000	0.000	0.000	0.000	374	0	1	1	0.465	0.291
7	55	53	3.0	90.1	64.5	25.6	0	0	0.0	0.0	0.0	50.0	0.000	0.000	0.000	0.000	235	0	1	1	0.338	0.265
14	22	39	3.3	86.5	50.6	35.9	51	37	72.5	46.8	25.6	3.6	0.061	0.119	0.033	0.584	230	0	1	3	0.523	0.338
15	56	29	2.1	85.8	68.2	17.6	106	89	77.5	64.4	13.0	12.8	0.010	0.057	0.004	1.236	162	1	1	0	0.341	0.260
21	70	17	2.9	82.1	57.9	24.2	100	84	73.5	60.5	13.0	11.6	0.011	0.060	0.005	1.215	202	1	1	3	0.414	0.260
26	62	16	5.9	116.6	52.8	63.8	303	114	40.8	49.0	-8.2	4.0	0.293	0.020	0.005	2.604	489	0	1	2	0.572	0.336
30	20	46	2.6	99.7	75.5	24.2	70	0	97.6	0.0	97.6	33.2	0.001	0.086	0.003	0.698	233	0	0	3	0.417	0.290
32	62	17	8.1	89.4	0.0	89.4	0	0	0.0	0.0	0.0	50.0	0.000	0.000	0.000	0.000	416	0	1	0	0.593	0.343
34	82	126	4.0	92.3	56.4	35.9	56	39	81.8	60.7	21.1	5.4	0.030	0.106	0.020	0.611	302	1	1	0	0.537	0.279
41	20	19	2.9	123.9	96.8	27.2	0	302	0.0	88.4	-88.4	50.0	0.000	0.000	0.000	0.000	325	0	0	0	0.393	0.291
41	19	33	9.3	87.9	2.2	85.8	0	10	0.0	0.0	0.0	50.0	0.000	0.000	0.000	0.000	406	0	0	0	0.464	0.286
41	2	33	11.3	93.1	0.0	93.1	0	0	0.0	0.0	0.0	50.0	0.000	0.000	0.000	0.000	563	0	0	0	0.404	0.256
41	56	9	6.9	85.8	0.0	85.8	225	0	65.3	0.0	65.3	11.0	0.029	0.027	0.002	2.621	292	0	1	0	0.632	0.386
41	55	25	7.2	84.3	8.7	75.6	0	0	0.0	0.0	0.0	50.0	0.000	0.000	0.000	0.000	344	0	1	0	0.542	0.326
41	61	23	8.8	82.1	0.0	82.1	71	0	87.4	0.0	87.4	50.0	0.000	0.085	-0.006	0.859	349	0	1	0	0.473	0.290
41	54	68	6.0	85.0	34.4	50.6	0	0	0.0	0.0	0.0	50.0	0.000	0.000	0.000	0.000	373	0	1	0	0.379	0.262
43	74	40	6.7	81.4	13.1	68.3	0	112	0.0	0.0	0.0	50.0	0.000	0.000	0.000	0.000	312	0	1	2	0.426	0.316
43	31	10	9.5	82.8	0.0	82.8	0	187	0.0	0.0	0.0	50.0	0.000	0.000	0.000	0.000	392	0	1	3	0.395	0.271
44	161	12	9.4	83.6	0.0	83.6	0	0	0.0	0.0	0.0	50.0	0.000	0.000	0.000	0.000	342	0	1	0	0.424	0.276
44	134	49	10.1	81.4	0.0	81.4	0	0	0.0	0.0	0.0	50.0	0.000	0.000	0.000	0.000	435	0	1	0	0.467	0.250
44	157	10	9.0	87.9	0.0	87.9	346	0	70.9	0.0	70.9	20.3	0.013	0.017	0.001	3.932	395	0	1	1	0.444	0.303
44	149	9	8.8	84.3	8.0	76.3	184	22	61.9	2.2	59.7	8.2	0.042	0.033	0.004	2.183	393	1	1	3	0.462	0.269
50	173	43	5.8	107.0	51.3	55.7	0	0	0.0	0.0	0.0	50.0	0.000	0.000	0.000	0.000	485	0	1	1	0.483	0.298
51	57	21	2.6	85.8	52.8	33.0	0	0	0.0	0.0	0.0	50.0	0.000	0.000	0.000	0.000	180	0	1	0	0.574	0.394
51	54	64	2.3	101.2	78.5	22.7	0	0	0.0	0.0	0.0	50.0	0.000	0.000	0.000	0.000	209	0	1	0	0.402	0.306
51	56	18	7.8	84.3	13.9	70.4	0	0	0.0	0.0	0.0	50.0	0.000	0.000	0.000	0.000	418	0	1	0	0.405	0.280
51	28	49	8.6	104.1	9.5	94.6	151	0	106.5	0.0	106.5	50.0	0.000	0.040	-0.001	1.447	481	0	1	2	0.528	0.342
51	28	32	4.9	94.6	50.6	44.0	68	33	80.2	51.9	28.3	4.7	0.047	0.088	0.019	0.721	345	1	1	3	0.454	0.279

Table 46. Braking events with Ax average > 0.25g and St.V > 55mph (Cont.)

Driver	Trip	Event	DeltaT sec.	St.V ft/sec	End.V ft/sec	DeltaV ft/sec	St.R ft	End.R ft	St.Vp ft/sec	VpEnd ft/sec	ΔVp ft/sec	St.Tti sec	St.DA g	St.Θ Θdot	St. sec	St.Htm ft	Dist ft	Target	ACC Enable	Mode	Max Ax, g	Avg Ax, g
52	11	26	2.7	85.8	54.2	31.5	36	42	84.8	63.5	21.3	40.0	0.000	0.165	0.004	0.425	187	1	0	0	0.562	0.363
52	11	37	1.2	82.8	71.1	11.8	36	37	78.5	73.5	5.0	8.3	0.008	0.165	0.020	0.440	91	1	0	0	0.344	0.304
52	15	26	6.2	96.8	41.0	55.8	99	61	87.9	41.7	46.2	11.2	0.012	0.061	0.005	1.020	422	1	0	0	0.443	0.279
52	15	29	1.9	104.1	87.2	16.9	60	60	95.9	90.4	5.5	7.3	0.017	0.100	0.014	0.577	180	1	0	0	0.385	0.276
52	53	24	1.2	91.6	79.9	11.7	36	31	86.1	76.9	9.2	6.6	0.013	0.166	0.025	0.394	105	1	1	0	0.348	0.302
52	53	13	1.5	102.6	88.7	13.9	40	37	94.2	90.8	3.5	4.8	0.027	0.149	0.031	0.393	144	1	1	0	0.368	0.289
52	47	22	2.8	95.3	71.8	23.5	29	34	93.5	76.9	16.6	15.8	0.002	0.208	0.013	0.303	235	1	1	0	0.323	0.261
52	41	6	3.5	96.1	49.1	46.9	97	0	96.4	0.0	96.4	50.0	0.000	0.062	0.000	1.011	256	0	1	3	0.657	0.416
54	6	63	8.6	88.7	13.9	74.8	0	0	0.0	0.0	0.0	50.0	0.000	0.000	0.000	0.000	470	0	0	0	0.383	0.270
55	61	17	3.1	88.7	60.8	27.9	0	0	0.0	0.0	0.0	50.0	0.000	0.000	0.000	0.000	238	0	1	0	0.452	0.279
55	179	14	3.6	90.9	58.6	32.3	105	51	73.3	55.0	18.3	6.0	0.046	0.057	0.010	1.159	280	1	1	3	0.365	0.278
56	71	37	12.5	101.2	0.0	101.2	0	177	0.0	32.6	-32.6	50.0	0.000	0.000	0.000	0.000	614	0	1	2	0.425	0.251
56	108	13	4.0	96.8	60.1	36.7	170	75	51.4	52.1	-0.7	3.7	0.189	0.035	0.009	1.752	312	1	1	3	0.415	0.285
59	58	20	3.5	99.0	63.8	35.2	72	50	94.1	66.1	28.0	14.5	0.005	0.084	0.006	0.723	284	1	0	0	0.562	0.312
59	27	9	4.1	107.0	68.9	38.1	0	0	0.0	0.0	0.0	50.0	0.000	0.000	0.000	0.000	373	0	0	0	0.394	0.289
59	61	24	3.7	82.1	49.9	32.3	38	29	79.3	50.5	28.8	13.5	0.003	0.158	0.012	0.463	241	1	0	0	0.376	0.271
59	69	2	3.9	87.9	48.4	39.6	0	0	0.0	0.0	0.0	50.0	0.000	0.000	0.000	0.000	283	0	1	0	0.494	0.315
59	88	63	4.6	82.1	38.8	43.3	0	0	0.0	0.0	0.0	50.0	0.000	0.000	0.000	0.000	286	0	1	0	0.417	0.292
59	62	2	5.4	93.1	46.1	47.0	0	0	0.0	0.0	0.0	50.0	0.000	0.000	0.000	0.000	394	0	1	0	0.407	0.270
59	68	10	4.8	87.9	48.4	39.6	0	48	0.0	17.5	-17.5	50.0	0.000	0.000	0.000	0.000	349	0	1	0	0.393	0.256
59	62	5	2.0	87.2	65.3	22.0	0	0	0.0	0.0	0.0	50.0	0.000	0.000	0.000	0.000	155	0	1	1	0.544	0.341
59	66	54	4.6	82.1	38.8	43.3	0	0	0.0	0.0	0.0	50.0	0.000	0.000	0.000	0.000	284	0	1	1	0.450	0.292
59	69	17	12.4	106.3	5.8	100.4	0	0	0.0	0.0	0.0	50.0	0.000	0.000	0.000	0.000	737	0	1	1	0.430	0.252
59	66	21	3.7	83.6	40.3	43.3	54	17	71.7	34.3	37.5	4.6	0.040	0.111	0.024	0.648	237	1	1	3	0.465	0.363
59	67	14	6.7	99.7	38.8	60.9	105	27	88.6	37.0	51.6	9.5	0.018	0.057	0.006	1.056	436	1	1	3	0.570	0.282
65	53	55	5.0	85.0	37.4	47.7	192	78	60.2	22.6	37.6	7.8	0.050	0.031	0.004	2.261	303	1	1	0	0.425	0.296
65	66	7	4.1	95.3	49.9	45.5	225	121	50.3	39.3	11.0	5.0	0.140	0.027	0.005	2.357	288	1	1	2	0.586	0.344
66	162	2	7.0	82.1	12.4	69.7	0	39	0.0	8.8	-8.8	50.0	0.000	0.000	0.000	0.000	324	0	1	1	0.408	0.309
66	157	15	3.4	94.6	60.8	33.8	90	53	78.6	71.5	7.1	5.6	0.044	0.067	0.012	0.950	263	1	1	1	0.541	0.309
66	254	7	4.4	84.3	24.9	59.4	0	49	0.0	16.5	-16.5	50.0	0.000	0.000	0.000	0.000	217	0	1	2	0.635	0.419
66	93	10	9.7	91.6	0.0	91.6	0	181	0.0	0.0	0.0	50.0	0.000	0.000	0.000	0.000	421	0	1	2	0.399	0.293
66	254	6	2.2	83.6	63.1	20.5	0	0	0.0	0.0	0.0	50.0	0.000	0.000	0.000	0.000	165	0	1	2	0.356	0.289
66	104	5	7.4	81.4	14.6	66.8	257	59	34.7	10.3	24.4	5.5	0.132	0.023	0.004	3.152	349	0	1	2	0.389	0.280
66	336	10	10.0	87.9	0.0	87.9	0	0	0.0	0.0	0.0	50.0	0.000	0.000	0.000	0.000	427	0	1	2	0.463	0.273
66	130	36	6.3	85.8	28.5	57.2	196	73	43.1	0.0	43.1	4.6	0.144	0.031	0.007	2.288	335	1	1	3	0.468	0.282
66	322	4	4.3	81.4	46.1	35.3	200	89	48.9	34.0	14.9	6.2	0.082	0.030	0.005	2.459	272	1	1	3	0.315	0.255

Table 46. Braking events with Ax average > 0.25g and St.V > 55mph (Cont.)

Driver	Trip	Event	DeltaT sec.	St.V ft/sec	End.V ft/sec	DeltaV ft/sec	St.R ft	End.R ft	St.Vp ft/sec	VpEnd ft/sec	ΔVp ft/sec	St.Tti sec	St.DA g	St.Θ Θdot	St. sec	St.Htm ft	Dist ft	Target	ACC Enable	Mode	Max Ax, g	Avg Ax, g
68	125	29	4.2	96.1	60.8	35.3	56	35	91.3	60.8	30.5	11.9	0.006	0.106	0.009	0.587	330	1	1	0	0.459	0.261
70	107	27	4.3	87.9	40.3	47.7	0	0	0.0	0.0	0.0	50.0	0.000	0.000	0.000	0.000	276	0	1	0	0.475	0.344
73	66	24	5.0	103.3	55.7	47.7	0	88	0.0	38.3	-38.3	50.0	0.000	0.000	0.000	0.000	403	0	1	0	0.421	0.296
73	90	10	10.0	90.9	0.0	90.9	160	0	104.7	0.0	104.7	50.0	0.000	0.037	-0.003	1.762	442	0	1	0	0.399	0.282
73	167	55	9.5	85.8	0.0	85.8	202	0	85.8	0.0	85.8	50.0	0.000	0.030	0.000	2.360	365	0	1	0	0.497	0.280
73	31	3	7.7	84.3	21.2	63.1	0	0	0.0	0.0	0.0	50.0	0.000	0.000	0.000	0.000	423	0	1	0	0.371	0.254
75	44	5	8.4	82.1	0.0	82.1	0	0	0.0	0.0	0.0	50.0	0.000	0.000	0.000	0.000	334	0	0	0	0.417	0.304
75	32	4	1.6	85.8	71.1	14.7	202	0	28.2	0.0	28.2	3.5	0.254	0.030	0.008	2.360	124	0	0	0	0.366	0.285
75	51	8	9.4	84.3	0.0	84.3	0	106	0.0	0.0	0.0	50.0	0.000	0.000	0.000	0.000	402	0	1	0	0.381	0.279
76	25	21	5.0	104.1	59.3	44.7	0	0	0.0	0.0	0.0	50.0	0.000	0.000	0.000	0.000	409	0	0	1	0.423	0.278
76	76	11	4.0	90.9	57.9	33.0	199	0	83.7	0.0	83.7	30.8	0.003	0.030	0.001	2.194	300	0	1	1	0.388	0.256
76	155	16	4.3	89.4	47.7	41.7	222	109	51.0	34.5	16.5	5.8	0.103	0.027	0.005	2.488	282	1	1	2	0.487	0.301
76	121	18	6.1	92.3	41.7	50.6	309	0	57.6	0.0	57.6	8.9	0.061	0.019	0.002	3.351	428	0	1	2	0.348	0.258
76	154	6	3.9	93.9	46.9	46.9	130	112	44.4	28.8	15.6	2.6	0.293	0.046	0.018	1.384	268	0	1	3	0.599	0.374
76	158	19	1.5	99.0	85.0	13.9	122	124	90.9	91.1	-0.3	15.1	0.008	0.049	0.003	1.236	139	1	1	3	0.391	0.289
77	1	19	3.8	82.1	51.3	30.8	100	70	71.5	50.9	20.5	9.4	0.018	0.060	0.006	1.219	254	1	0	0	0.310	0.252
77	106	16	3.9	92.3	60.1	32.3	191	146	76.2	52.5	23.7	11.8	0.021	0.031	0.003	2.068	297	1	1	3	0.387	0.257
80	5	131	7.6	105.5	43.9	61.6	0	160	0.0	35.2	-35.2	50.0	0.000	0.000	0.000	0.000	553	0	0	1	0.441	0.252
81	91	54	3.8	83.6	47.7	35.9	122	94	64.9	51.2	13.7	6.5	0.044	0.049	0.008	1.460	243	1	1	0	0.403	0.293
81	105	8	5.8	81.4	29.3	52.1	95	0	86.1	0.0	86.1	50.0	0.000	0.063	-0.003	1.173	319	0	1	0	0.469	0.279
81	163	15	4.5	87.9	49.1	38.8	106	60	75.8	47.8	28.1	8.8	0.021	0.056	0.006	1.209	294	1	1	1	0.556	0.268
81	174	22	6.5	100.4	43.9	56.5	139	57	77.3	41.1	36.2	6.0	0.060	0.043	0.007	1.382	436	1	1	3	0.568	0.270
81	185	8	3.0	86.5	60.8	25.7	46	41	75.5	67.8	7.7	4.1	0.041	0.132	0.032	0.527	221	1	1	3	0.347	0.266
82	72	20	10.5	90.9	0.0	90.9	0	0	0.0	0.0	0.0	50.0	0.000	0.000	0.000	0.000	487	0	1	2	0.420	0.269
82	30	18	10.9	93.9	0.7	93.1	58	14	90.0	3.9	86.0	14.9	0.004	0.103	0.007	0.622	482	1	1	3	0.385	0.265
84	17	35	3.2	87.9	58.6	29.3	0	0	0.0	0.0	0.0	50.0	0.000	0.000	0.000	0.000	237	0	0	2	0.372	0.285
84	32	33	8.2	84.3	0.0	84.3	0	245	0.0	0.0	0.0	50.0	0.000	0.000	0.000	0.000	306	0	1	1	0.474	0.319
85	34	153	8.2	87.2	16.9	70.4	346	0	73.6	0.0	73.6	25.5	0.008	0.017	0.001	3.965	491	0	0	1	0.457	0.266
85	100	136	6.5	96.1	30.0	66.1	220	108	88.7	24.9	63.8	29.8	0.004	0.027	0.001	2.288	433	0	1	0	0.504	0.316
85	282	106	4.5	93.9	50.6	43.3	52	25	91.1	50.9	40.3	18.8	0.002	0.116	0.006	0.549	300	0	1	0	0.523	0.299
85	282	110	4.6	96.8	57.1	39.6	81	53	82.8	54.0	28.8	5.8	0.037	0.074	0.013	0.834	342	1	1	0	0.432	0.268
85	288	31	8.5	94.6	13.9	80.7	91	45	77.1	14.6	62.5	5.2	0.052	0.066	0.013	0.961	455	0	1	1	0.494	0.295
85	143	75	9.7	95.3	16.1	79.2	0	0	0.0	0.0	0.0	50.0	0.000	0.000	0.000	0.000	595	0	1	1	0.391	0.254
85	66	10	6.2	90.1	30.7	59.4	81	27	69.8	29.7	40.1	4.0	0.079	0.074	0.018	0.903	352	1	1	3	0.500	0.298
87	15	33	2.4	98.2	71.8	26.4	61	35	83.4	67.9	15.5	4.1	0.056	0.099	0.024	0.618	203	1	0	0	0.445	0.342
87	21	28	5.8	82.8	24.2	58.7	276	0	89.0	0.0	89.0	50.0	0.000	0.022	0.000	3.327	279	0	0	1	0.469	0.314

Table 46. Braking events with Ax average > 0.25g and St.V > 55mph (Cont.)

Driver	Trip	Event	DeltaT sec.	St.V ft/sec	End.V ft/sec	DeltaV ft/sec	St.R ft	End.R ft	St.Vp ft/sec	VpEnd ft/sec	ΔVp ft/sec	St.Tti sec	St.DA g	St.Θ Θdot	St. sec	St.Htm ft	Dist ft	Target	ACC Enable	Mode	Max Ax, g	Avg Ax, g
87	140	25	6.4	84.3	14.6	69.7	90	20	72.9	10.0	62.9	7.9	0.022	0.067	0.009	1.062	298	0	1	1	0.647	0.338
88	1	383	7.5	99.0	24.2	74.8	0	0	0.0	0.0	0.0	50.0	0.000	0.000	0.000	0.000	502	0	0	0	0.466	0.310
88	1	184	6.0	87.2	38.8	48.4	106	57	79.5	40.4	39.1	13.7	0.009	0.056	0.004	1.219	365	1	0	0	0.435	0.250
88	45	44	9.0	81.4	2.2	79.2	0	0	0.0	0.0	0.0	50.0	0.000	0.000	0.000	0.000	426	0	0	2	0.471	0.273
88	177	105	2.3	99.7	70.4	29.3	64	56	93.1	72.3	20.8	9.6	0.011	0.094	0.010	0.642	202	1	1	1	0.532	0.396
88	161	93	3.5	99.0	63.8	35.2	64	121	101.4	99.6	1.8	50.0	0.000	0.094	-0.004	0.646	304	0	1	1	0.588	0.312
88	185	11	9.8	87.2	8.0	79.2	0	0	0.0	0.0	0.0	50.0	0.000	0.000	0.000	0.000	531	0	1	1	0.383	0.251
88	103	26	7.6	85.8	22.0	63.8	143	0	85.0	0.0	85.0	50.0	0.000	0.042	0.000	1.668	430	0	1	2	0.407	0.261
89	153	23	1.6	94.6	76.9	17.7	32	0	77.6	0.0	77.6	1.9	0.140	0.187	0.099	0.340	139	0	1	0	0.461	0.343
89	212	98	2.3	106.3	82.8	23.4	138	141	96.4	92.9	3.5	14.1	0.011	0.043	0.003	1.303	220	1	1	0	0.476	0.316
89	272	9	4.6	91.6	46.1	45.5	116	72	83.5	43.2	40.3	14.3	0.009	0.052	0.004	1.264	295	1	1	0	0.580	0.307
89	259	8	8.9	81.4	0.0	81.4	0	0	0.0	0.0	0.0	50.0	0.000	0.000	0.000	0.000	306	0	1	0	0.449	0.284
89	114	156	3.1	94.6	68.2	26.4	51	36	87.5	70.4	17.0	7.2	0.015	0.117	0.016	0.541	249	1	1	0	0.430	0.265
89	99	38	2.5	82.1	56.4	25.7	0	0	0.0	0.0	0.0	50.0	0.000	0.000	0.000	0.000	173	0	1	1	0.408	0.319
89	212	93	4.9	97.5	52.0	45.5	240	148	52.6	53.7	-1.1	5.4	0.130	0.025	0.005	2.466	360	1	1	2	0.525	0.288
89	254	56	5.0	96.1	50.6	45.5	228	147	67.2	48.9	18.2	7.9	0.057	0.026	0.003	2.374	365	1	1	2	0.449	0.282
91	63	5	8.7	81.4	0.0	81.4	270	15	35.7	0.0	35.7	5.9	0.120	0.022	0.004	3.322	331	0	1	2	0.444	0.291
96	157	30	3.6	90.1	60.1	30.1	0	0	0.0	0.0	0.0	50.0	0.000	0.000	0.000	0.000	268	0	1	0	0.356	0.259
96	172	16	1.8	107.0	90.9	16.1	0	0	0.0	0.0	0.0	50.0	0.000	0.000	0.000	0.000	178	0	1	2	0.321	0.278
99	205	1	12.5	107.7	0.0	107.7	0	0	0.0	0.0	0.0	50.0	0.000	0.000	0.000	0.000	668	0	1	2	0.440	0.268
99	129	9	4.0	103.3	68.2	35.2	77	59	97.2	73.2	24.1	12.6	0.008	0.078	0.006	0.743	341	1	1	3	0.459	0.273
99	194	56	2.3	96.1	76.2	19.9	41	33	92.5	75.7	16.8	11.6	0.005	0.145	0.012	0.430	199	1	1	3	0.345	0.268
100	15	10	2.8	87.9	61.5	26.4	26	17	83.6	63.3	20.2	5.8	0.012	0.234	0.040	0.291	200	1	0	0	0.630	0.293
100	192	12	9.0	93.9	7.3	86.6	0	0	0.0	0.0	0.0	50.0	0.000	0.000	0.000	0.000	471	0	1	1	0.467	0.299
100	117	11	9.3	86.5	6.6	79.9	0	0	0.0	0.0	0.0	50.0	0.000	0.000	0.000	0.000	489	0	1	1	0.380	0.267
107	10	26	9.3	90.1	5.1	85.0	90	36	74.2	7.5	66.7	5.6	0.044	0.067	0.012	0.997	301	1	0	1	0.706	0.284
109	53	8	9.7	86.5	0.0	86.5	98	6	83.9	0.0	83.9	38.4	0.001	0.061	0.002	1.134	417	0	1	0	0.417	0.277
110	59	38	3.4	95.3	67.4	27.9	0	80	0.0	48.3	-48.3	50.0	0.000	0.000	0.000	0.000	265	0	1	0	0.494	0.255
110	46	17	10.5	96.8	5.1	91.7	0	0	0.0	0.0	0.0	50.0	0.000	0.000	0.000	0.000	530	0	1	2	0.412	0.271
112	34	7	10.6	87.2	0.0	87.2	413	0	71.8	0.0	71.8	26.8	0.009	0.015	0.001	4.732	458	0	0	0	0.402	0.256
114	14	89	6.4	104.1	52.0	52.0	0	46	0.0	40.9	-40.9	50.0	0.000	0.000	0.000	0.000	525	0	0	0	0.584	0.253
114	51	10	3.7	88.7	30.0	58.7	0	0	0.0	0.0	0.0	50.0	0.000	0.000	0.000	0.000	230	0	1	0	0.706	0.493
114	46	22	9.5	86.5	0.0	86.5	0	65	0.0	9.0	-9.0	50.0	0.000	0.000	0.000	0.000	464	0	1	0	0.449	0.283
115	42	51	5.8	86.5	39.6	46.9	0	0	0.0	0.0	0.0	50.0	0.000	0.000	0.000	0.000	361	0	1	2	0.358	0.251
117	33	42	6.9	88.7	28.5	60.2	0	0	0.0	0.0	0.0	50.0	0.000	0.000	0.000	0.000	442	0	1	1	0.448	0.271

Examination of Table 46 reveals that some drivers were much more conspicuously involved in braking activity than others. In fact, 61 of the 108 drivers had no braking episodes in the set of 145 heavy-braking events with start velocities over 55 mph and average decelerations greater than 0.25 g. On the other hand 20 of the drivers had more than two such braking events while 27 had one or two braking events satisfying the heavy-braking criteria. Table 47 lists the number of episodes and the driving properties of the 20 drivers who were most prominent in terms of heavy-braking behavior.

Table 47. Drivers exhibiting more than two heavy-braking episodes at  $V_{\text{start}} > 55\text{mph}$

Driver ID	No. Episodes	No. Weeks	Confliction	Driving Style
4	6	2	0.033	H
7	3	2	0.019	P
41	7	2	0.089	E
44	4	2	0.016	E
51	5	2	0.063	E
52	8	2	0.057	H
59	12	2	0.062	H
66	9	5	0.007	P
73	4	5	0.060	H
75	3	2	0.014	P
76	6	5	0.035	H
81	5	5	0.015	F
85	7	5	0.060	H
87	3	5	0.066	H
88	7	5	0.022	H
89	8	5	0.024	P
99	3	5	0.027	H
100	3	5	0.025	F
114	3	2	0.121	H
117	3	2	0.022	F

Examination of Table 47 indicates that driver 59 had the most episodes—an extraordinary total of 12 heavy-braking episodes. Ten of the drivers in this table had the car for two weeks (including driver number 59) and ten had the car for 5 weeks. One might expect the 5-weekers to have more opportunity to utilize heavy braking. On the

other hand there were 84 drivers who had a car for 2 weeks and 24 drivers who had a car for 5 weeks. Since the possibility of finding a heavy-braking individual is greater for the 2-weekers, a 10-to-10 even split between 2-weekers and 5-weekers appears plausible. For the most part the confliction ratings seem reasonable, with higher confliction levels being an indicator of the likelihood of being a heavy braker. However driver number 66 seems to represent the odd combination of both low confliction and yet a rather high total number of heavy-braking episodes. It turns out that driver number 66 is something of a special case in that this driver had 7 heavy-braking episodes while operating with ACC. (This will be discussed further later.) There are no members of the heavy-braking set that are in the 0 to 25th percentile of confliction. Since the 50th percentile of confliction occurs at 0.017 and the 75th percentile starts at 0.030, it can be seen that many of the 20 heavy brakers are in the higher percentiles of confliction. The distribution of driving style is also interesting in that 10 of the heavy brakers were hunter/tailgaters. There were 4 planners, 3 extremists, and 3 flow conformists. There were no ultraconservatives in the set of heavy brakers. Although the data do not show a perfect correspondence, confliction and driving style relate to the tendency for heavy braking in a manner that one might expect—high confliction and a tendency to travel close and/or fast are associated with heavy braking.

Further insight into the characteristics of the 20 heavy brakers is illustrated in Figure 94. The results indicate that the most prevalent driver properties are male (13), young (11), or users of CCC (14).

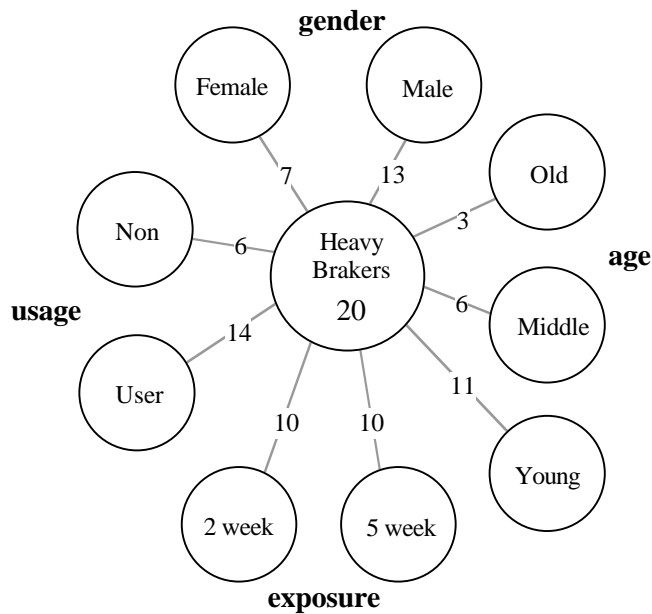

Figure 94. Sampling variables associated with the 20 drivers who braked heavily

Ninety-seven of these heavy braking situations occurred above 55 mph during manual driving. Three occurred during CCC driving and 45 occurred during ACC driving. Given that there are different driving conditions associated with the selection among manual, CCC, and ACC driving modes, it is not straightforward to arrive at a fair comparison between control modes. Although there were more miles traveled using ACC at speeds above 55 mph than there were using manual driving, it is believed that drivers choose the manual mode when the need for moderate braking is large.

With regard to the 97 relatively heavy, manual-braking episodes (whose duration begins with brake switch on and concludes with brake switch off), examination of Table 46 indicates that there was a decelerating, or slower-moving vehicle present in 43 of these episodes. However, there are 54 cases in which the presence of an impeding vehicle is not clearly indicated. Perhaps many of these cases are on exit ramps as confirmable only by examination of video data. In any event, the presence of a rapidly decelerating impeding vehicle does not account for all of the heavy braking cases. Another possibility for the cause for heavy braking is a stopped or very slowly moving impeding vehicle such that the range sensor would not report the data. Nevertheless it seems likely that there are diverse reasons for stopping quickly. For example, the video for one case shows that the driver pulled over onto the shoulder and then decelerated rapidly even though there was no obstruction on the shoulder. Without further study of video information, the main conclusion to be derived from these data is that in approximately 45 percent of the cases hard braking was caused by a decelerating preceding vehicle.

The next section of this report goes into ACC driving. The discussion of the 45 ACC heavy-braking cases will be presented there.

Finally, consider the following observations. The data show that drivers will quit braking even though they may be very close to the vehicle ahead. They often quit braking when it is clear to them that the vehicle ahead is going (ever so slightly) faster than their vehicle and the vehicle ahead is not decelerating. In other words, as soon as the aggressive driver discerns that the preceding vehicle is going faster than they are, braking ceases.

Another observation has to do with the possibility for using manual-driving data to develop and evaluate driver-warning systems. One could examine the data to find the circumstances in which drivers tend to brake manually above some threshold of braking intensity. Then, it is not clear how to proceed using the results presented here because some of the manual braking could have been due to undetermined circumstances for



which drivers do not want warnings. On the other hand, although it seems unlikely to be accepted, one could argue that the data presented here show no braking episodes that actually warranted a warning. From the standpoint of the driver model presented in the beginning of this section, there appears to be a dilemma concerning how much time a driver needs to recognize the meaning of a warning and how much time remains for correcting the situation if the driver was not already aware of the need for braking when the warning was given. Perhaps it is reasonable to say that warnings are not the focus of this study and that the results of this study have not yet been processed in a manner that resolves issues associated with warning systems.

## **8.2 ACC Performance in Driving Scenarios**

ACC control puts the driver into a supervisory role with respect to headway control. The driver no longer participates directly in controlling the throttle. The driver tells the ACC system what to do through selection of the set speed  $V_{set}$  and the desired headway time  $T_h$ . After engagement the driver's role is to monitor the headway-control process and intervene when necessary.

When ACC is in operation, the driver supervises an assistance feature whose automated performance of certain routine driving tasks has been exchanged for the intimacy of manual driving. By way of exploring the supervisory role of the driver, we begin with Figure 95 which represents the ACC/vehicle system only —the driver is not part of this figure but the designer of the ACC system is.

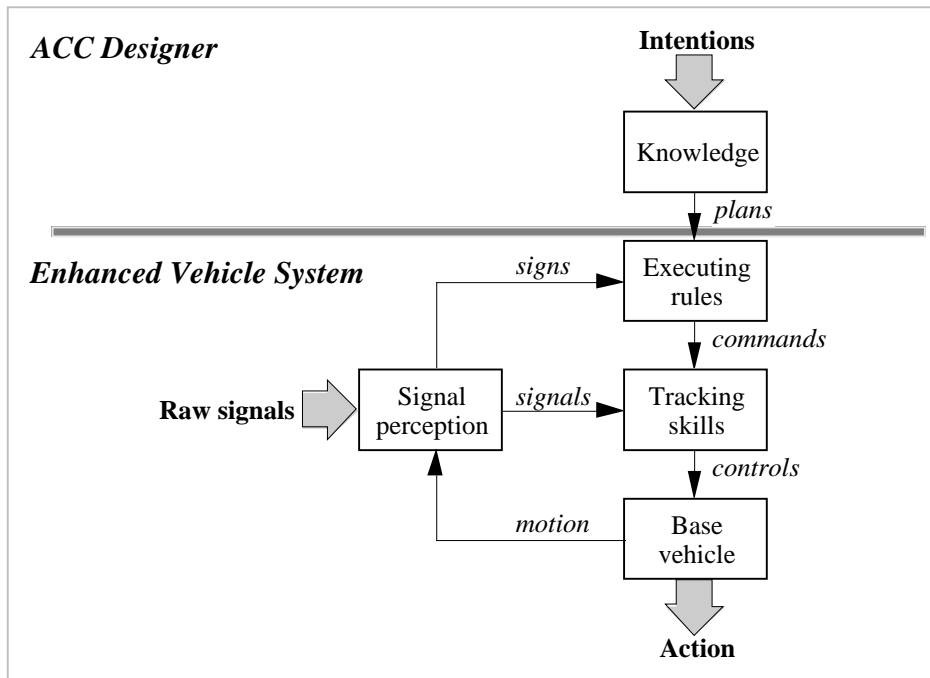

Figure 95. The system that the driver supervises during ACC driving

The figure presents a mental image (i.e., a model) in which the knowledge of the ACC designer has been used to configure (or program) a set of rules for controlling headway. These rules have some limited ability to adapt or change in response to certain features of the information received from the sensor. Based upon the rule in effect, the system controls the basic vehicle in conformance with what the commander commands it to do. Although this system involves ideas associated with the knowledge, rules, and skills concepts used in describing manual driving (as illustrated previously in Figure 76 in section 8.1.2), control is done in a mechanical manner. The system can adapt by responding to an impeding vehicle, but it is not “intelligent” in the lay sense of the word. (In fact, driver/participants in earlier studies have been so distracted by the name “intelligent cruise control” that it was deemed wise to use the name “adaptive cruise control” in dealing with the participants in this FOT.)

It is interesting to recognize that the driver of the ACC vehicle is relying to some extent upon the knowledge that had been supplied by the ACC designer (who is, of course, not present in the vehicle and is not aware of the instantaneous situation). To the extent that the actual driver can learn the intentions of the ACC designer through operation of the system, the driver’s ability to supervise the system may be improved. In operation, the driver needs to bring knowledge-based intelligence in managing the headway-control process. After enough experience the driver may develop a new layer of

rules and skills for dealing with ACC-equipped vehicles. Fortunately, drivers can use analogies to past experience in manual driving to quickly resolve situations that develop during ACC operation. Subjective results presented in section 8.4 indicate that most drivers felt that they learned how to use the ACC system employed in this FOT in no more than one day.

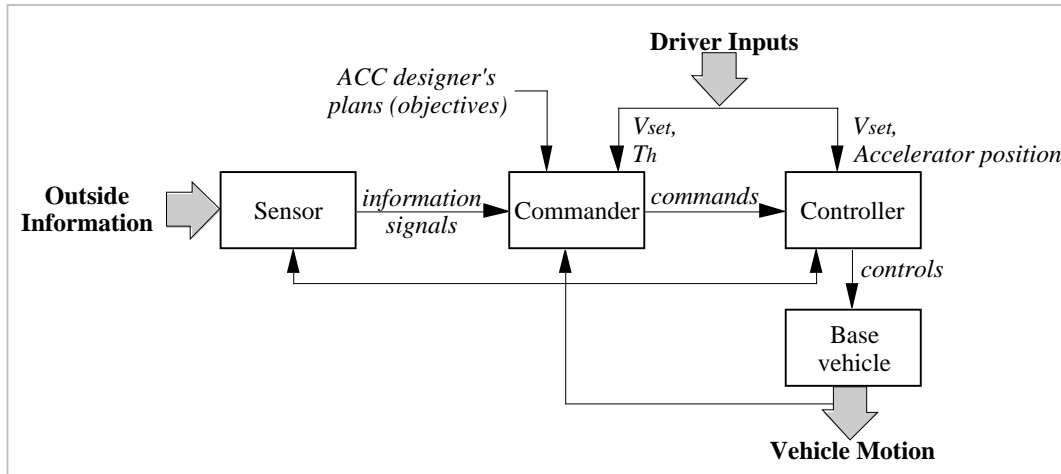

Figure 96. Diagram of the controlled system during ACC operation

Figure 96 shows the ACC vehicle as a system consisting of a sensor, a commander, a controller, and a base vehicle. This diagram represents the situation when the ACC system is engaged by the driver to perform headway and speed control. In this ACC system the commander has been programmed by the designer to generate speed control and transmission downshift commands. The controller uses the vehicle's cruise control system (which is part of the engine controller) and its transmission controller to modulate the throttle and to downshift from fourth to third gear when commanded by the ACC commander. The driver selects a desired headway time  $T_h$  and a set speed  $V_{set}$ . The system asks for a velocity command equal to  $V_{set}$  if there is no impeding vehicle. (This state is known as "NOOT" which is very much like operating in conventional cruise control.) If the system is operating on a sensed target (a control state known as "OOT"),  $T_h$  determines the desired headway time that the system will try to achieve and maintain by means of speed commands. At any time the driver can apply the throttle manually to seek an acceleration greater than that provided by the ACC system without disengaging ACC control — again very much as with conventional cruise control.

One should realize that this ACC system operates on a few deterministic rules. Compared with manual driving, the data for ACC driving are much more consistent and, in that sense, not as interesting. In addition, this means that knowledge of the rules used

by the ACC system provides considerable insight into what happens during ACC driving. Figure 97 illustrates the main rules involved in this ACC system.

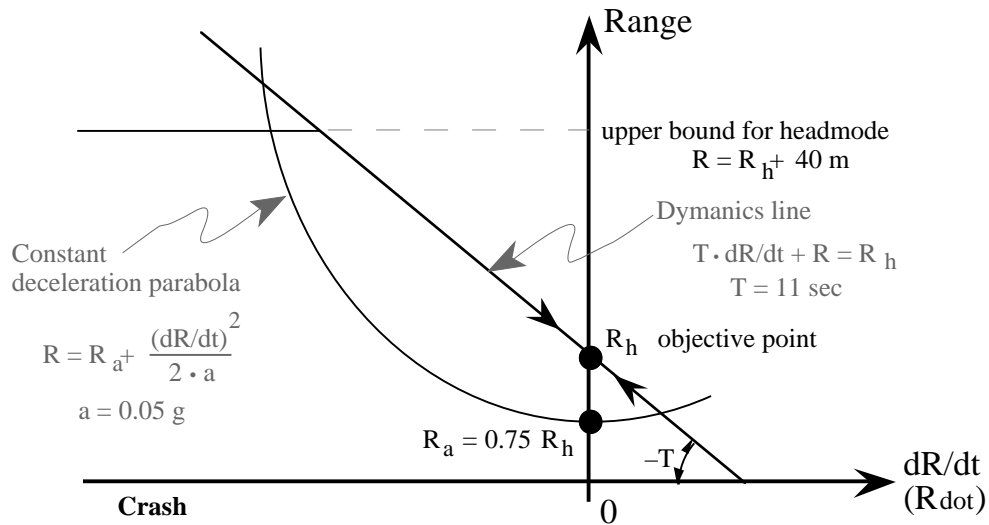

Figure 97. ACC rules built into the commander

The commander unit determines the speed command based upon the indicated “dynamics line” passing through the objective point  $R_h$ . The objective point depends upon the velocity of the preceding vehicle ( $V_p$ ) and the desired headway time ( $T_h$ ) set by the driver per the following equation:

$$R_h = T_h V_p$$

(23)

The dynamics line is given by the following first order linear differential equation:

$$T \dot{R} + R = R_h$$

(24)

Experience using this type of ACC system has led the ACC designers to choose a value of the time constant  $T$  equal to approximately 10 seconds. This design provides a velocity command given by the following equation when the system is operating on a target:

$$V_c = V_p + (R - R_h)/10$$

(25)

A constant-deceleration parabola like the one shown in Figure 97 is used to determine the values of  $R$  and  $Rdot$  that will cause a downshift command to be generated and to turn on the brake lights during downshift.

As illustrated, there is an upper bound to the region (known as “headmode”) where the ACC system will start to operate on the range and range-rate signals from a preceding vehicle. Experience, especially in the pilot testing activity, has shown that drivers will complain if the system starts to slow the vehicle at what seems like an exceptionally long range. It can be very disconcerting if the ACC system starts to slow the vehicle at about the same point at which the driver commences to pass a preceding vehicle. To alleviate these difficulties, this ACC system does not start operating on a target until  $R$  is below the dynamics line and  $R$  is less than the headway boundary at  $R_h$  plus 40 m.

The system quits operating on a target when the computed velocity command exceeds  $V_{set}$  or when there is no target reported by the sensor. This means that the headmode criteria becomes false and the velocity command becomes  $V_{set}$ . Consequently, the commander never asks for a velocity greater than  $V_{set}$ .

Although drivers almost never override with the accelerator pedal, they could reach velocities greater than  $V_{set}$  by pushing the accelerator pedal. On the other hand application of the brake pedal disengages the ACC system to the standby state, and the driver proceeds under manual control until such time as ACC operation is reset or resumed. After braking, the vehicle will simply coast until the driver reapplies the accelerator or reengages the ACC.

An overview of the driver’s supervisory role may be obtained by examining Figure 98. The driver is always responsible for the position of the mode-control switch shown in concept in Figure 98. The driver always decides whether to use the ACC system’s rules (i.e., its template) or the driver’s own rules. The driver receives situational information from the driver/ACC interface and transmits information to the ACC system through the use of the cruise control’s methods for changing  $V_{set}$  and by means of pressing headway time buttons for selecting either the closer, middle, or farther headway time values. (As will be shown later, these settings correspond to desired headway times of 1.1, 1.5, and 2.1 seconds.)

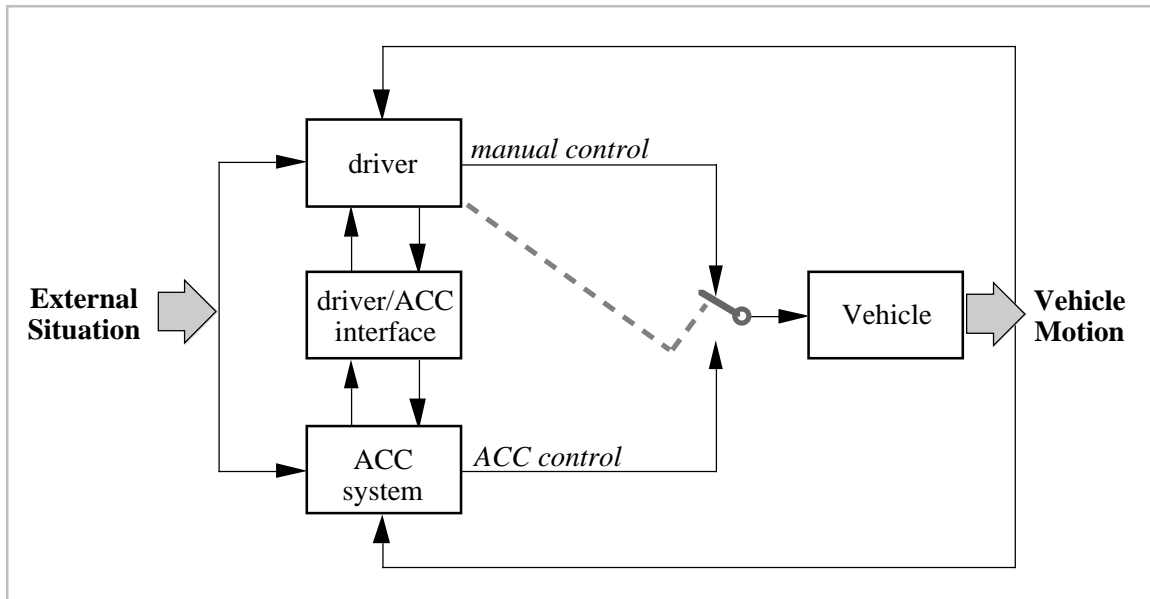

Figure 98. Overview of control supervision in ACC driving

In the prototype ACC system employed in this FOT, the speed controller was not specifically designed for ACC. Rather it utilized the CCC system designed for the Chrysler Concorde. This means that the speed controller and its incorporation within the headway control system has not been optimized for this application. Nevertheless the tracking properties of this controller arrangement proved to be satisfactory for controlling headway. From the driver's standpoint, the main problem encountered with this arrangement was that the vehicle exhibited sluggish acceleration when the driver pulled out to pass. It seems that if the drivers had been intimately involved in driving the vehicle they would have applied the accelerator as they saw fit to perform passing operations. Under ACC control, however, they expect the system to do that for them even though they could have pushed on the accelerator without disengaging the system. It is anticipated that future ACC systems will be arranged to have more acceleration capability for passing than this controller provided. Nevertheless, it is interesting that drivers expect the system to serve them such that even the modest form of supplementary human control is avoided in order to simply let the system do it for them.

One property of the sensor is important to keep in mind. The system does not operate on targets that are going less than 0.3 times the ACC vehicle's speed. In this system the sensor is arranged so that range and range-rate signals are not received by the commander if the speed of the preceding vehicle is below this minimum value. Consequently, the driver is responsible for slow or stopped obstacles. This arrangement cuts down on the number of false alarms that could be triggered by roadway features. It also means that if

the driver feels that braking is needed, only the driver's action will meet that need. In this system the decision as to when to brake is easier than that for ACC systems that employ the foundation brakes. In this case, if there is any doubt, the driver knows and learns to put on the brakes because the ACC system will not do it.

### 8.2.1 Observations pertaining to ACC headway modulation

The observed frequencies for different values of headway time margin ( $H_{tm}$ ) aggregated for all drivers during ACC driving are shown in Figure 99. There are three curves—one for each of the three possible settings for  $T_h$  (closer, middle, and farther desired headway times) chosen by the drivers.

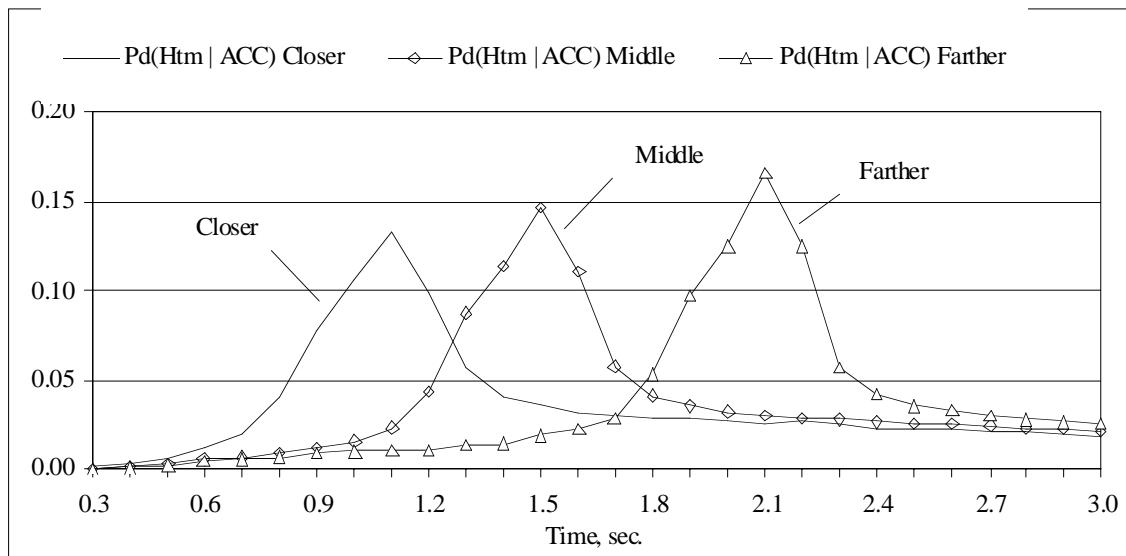

Figure 99.  $H_{tm}$  for ACC driving with  $V > 55$  mph

As seen in the figure, the closer setting peaks at 1.1 seconds of headway time. The width of this peak reflects driving situations that are encountered during system operation at this setting of headway time. The probability of being greatly removed from the peak is small, but of course, time is spent away from the peak during episodes of closing on an impeding vehicle or during maneuvers of other vehicles such as those involving cutting in and/or decelerating. Similar results occur for the middle and farther headway time settings whose histogram peaks are seen at 1.5 and 2.1 seconds respectively. These results show that the ACC system works (functions) as expected when operated in real traffic by typical drivers.

Furthermore, the test data also show a distinct influence of age on headway time margin. As shown in Figure 100 during ACC engagements, younger drivers tend to operate near the 1.1-second value for headway ( $T_h = 1.1$ ), middle-age drivers near 1.5 seconds, and older drivers at 2.1 seconds. These results show that age is strongly associated with the selection of headway time ( $T_h$ ) while otherwise revealing the distribution of  $H_{tm}$  values obtained in ACC driving.

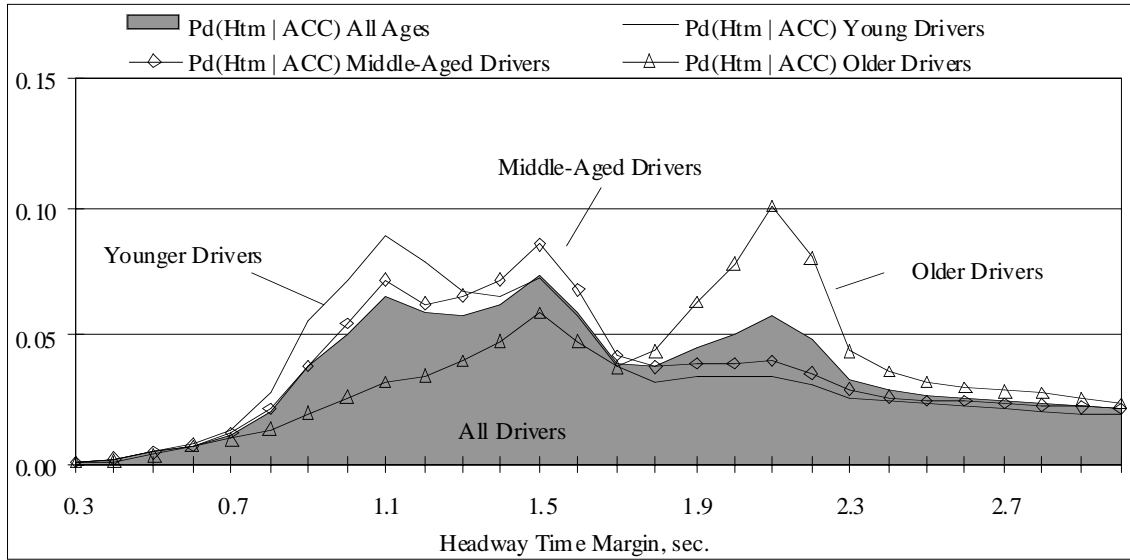

Figure 100. Distribution of headway time margin under ACC by driver age group



In addition, there is a strong influence of gender on the headway time margin obtained in ACC driving. Figure 101 shows that the female drivers are not as likely to use 2.1 second headways as are male drivers.

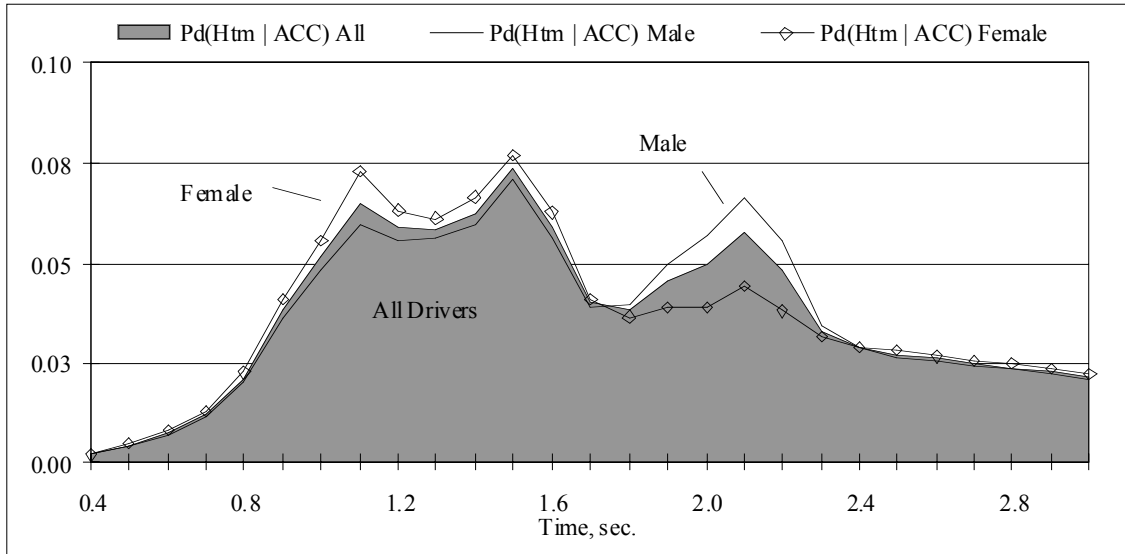

Figure 101. Distribution of headway time margin under ACC by driver gender

### 8.2.2 Driving style during ACC driving

Now consider classifying the ACC-driving data for individuals according to the driving styles developed earlier for categorizing manual-driving behavior. Figure 102 (spread over the next two pages) shows the result of processing each driver's ACC driving using the rules for driving style derived earlier. The results are presented in the same order as that used for manual driving in figure 51 of section 6. The ACC results and the manual-driving results will be compared in the next section. However, with regard to ACC driving itself, note that no driver was rated within the hunter/tailgater style when driving with ACC engaged. Since the minimum headway-time setting was 1.1 seconds in ACC, drivers did not get as close as needed to be rated as a hunter/tailgater. To do so, they would have had to use the accelerator pedal, which they chose not to do and did not learn to do. (In a sense they chose not to fight the system. It is presumed that if a shorter value of  $T_h$  had been available some drivers, especially hunter/tailgaters, would have used it.)

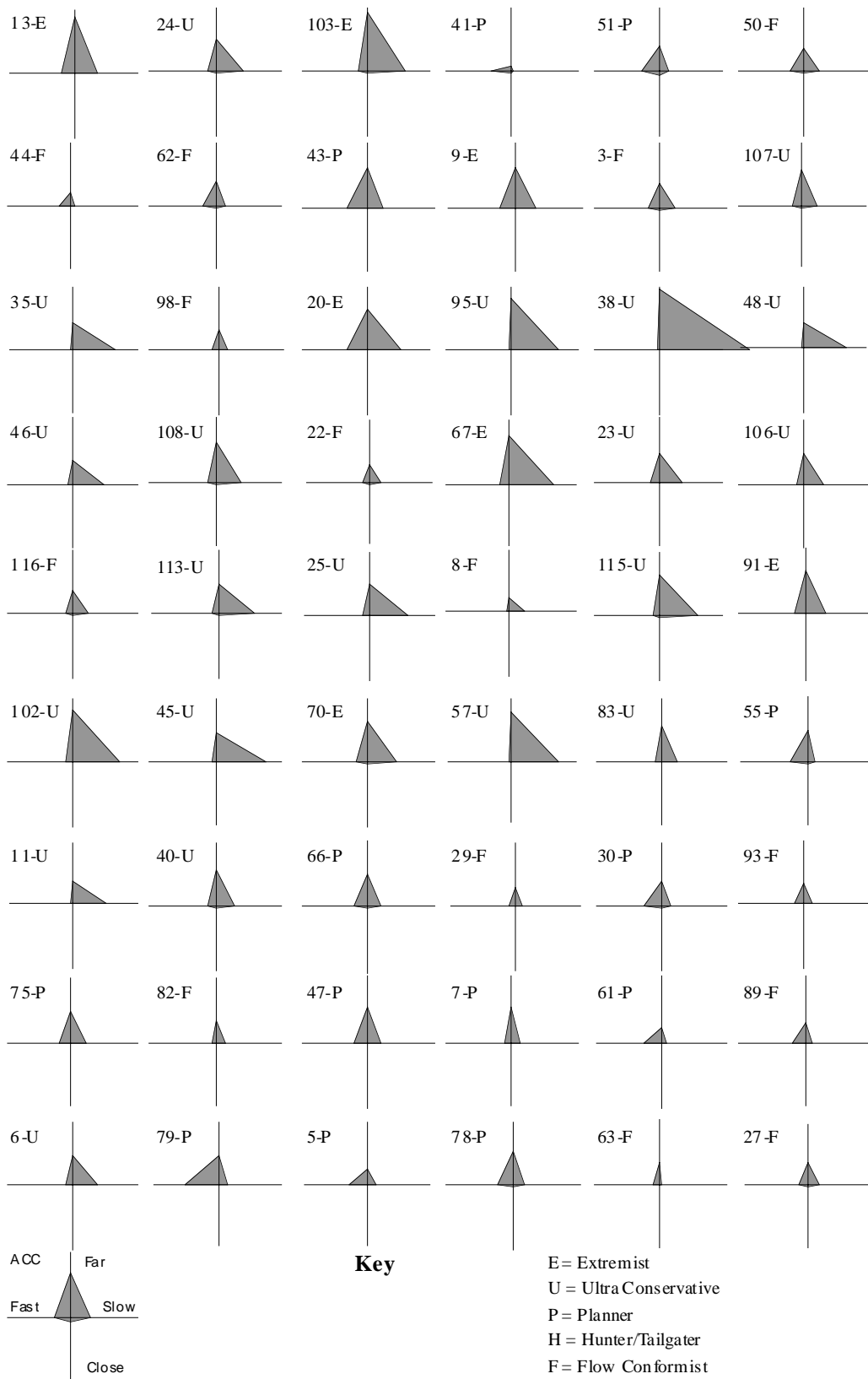

Figure 102. ACC driving behavior for individual drivers ( $V > 55$  mph)

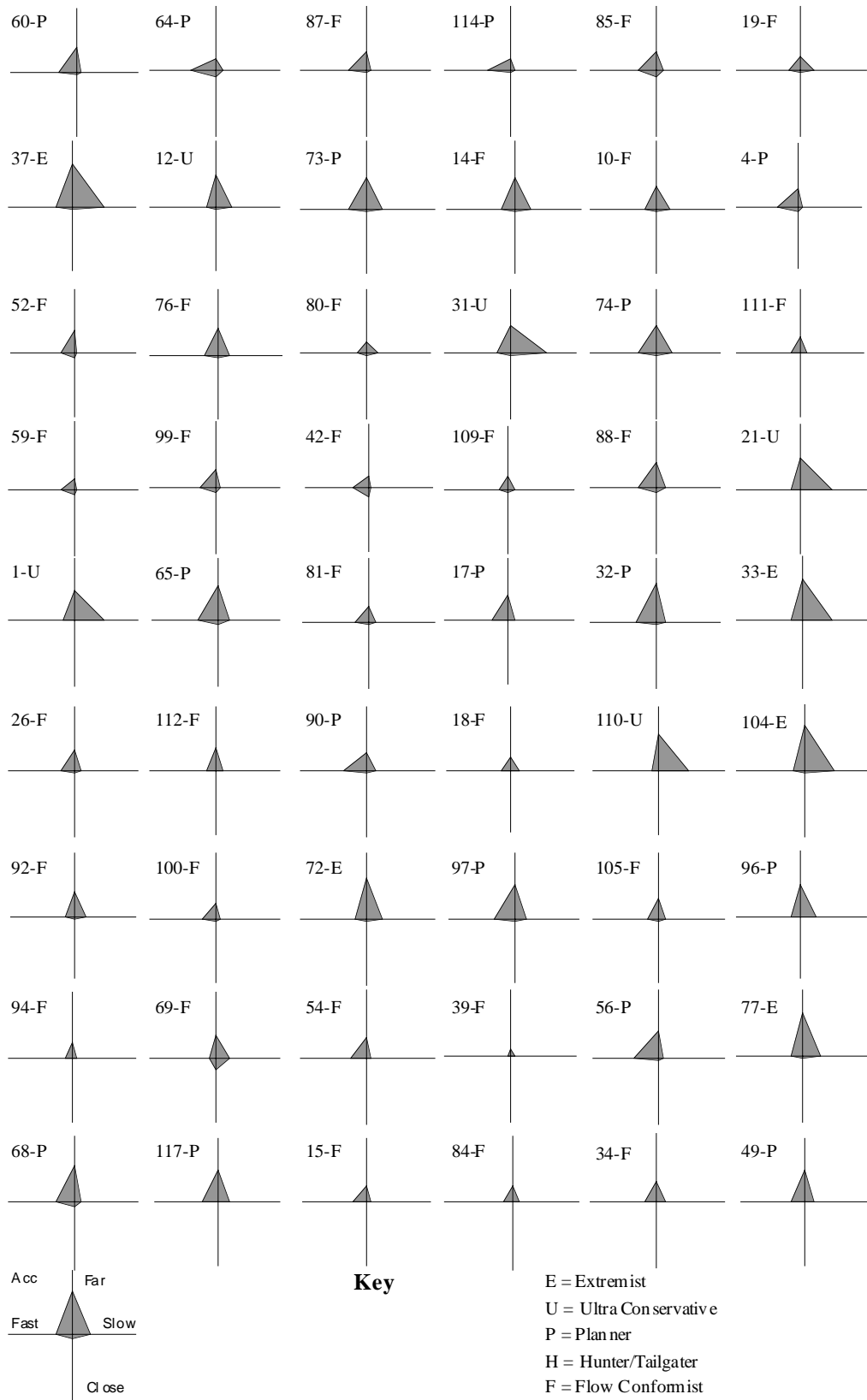

Figure 102. ACC driving behavior for individual drivers ( $V > 55$  mph) (Cont.)

### 8.2.3 Headway Time (Th) Selection

The results presented in section 8.2.1 have already shown that age and gender are associated with the selection of headway time (and the resulting observations of headway time margin  $H_m$ ). In addition, the influence of ACC on driving style was considered in section 8.2.2. Further examination of the association between driving style and ACC operation is presented in this section. The results in Table 48 show that extremists favor the middle and farther Th settings (buttons); the flow conformists favor closer or middle; the hunter/tailgaters have a strong propensity for the closer button; the planners have a propensity for the farther button; and the ultraconservatives tend to use middle or farther headway settings as well as having the fewest ACC miles.

Table 48. Th Button selections (miles)

Driving Styles	Th Settings					
	V > 55 mph			V < 55 mph		
	Closer	Middle	Farther	Closer	Middle	Farther
Extremist	665.8	1743.3	1166.8	112.1	291.1	109.5
Flow Conformist	4160.8	4404.7	933.5	175.8	496.4	131.3
Hunter/Tailgater	5814.9	1924.2	403.2	181.6	212.5	63.2
Planner	2046.7	2081.2	4619.0	88.1	173.1	326.0
Ultraconservative	172.4	1208.0	848.7	44.9	139.9	206.1
<i>Totals</i>	<i>12860.6</i>	<i>11361.4</i>	<i>7971.2</i>	<i>602.5</i>	<i>1313.0</i>	<i>836.1</i>
	Long trips with V > 55 mph					
Extremist	370.1	1024.7	1075.0			
Flow Conformist	2908.3	2983.5	595.5			
Hunter/Tailgater	4082.3	1024.7	253.0			
Planner	1573.7	1241.2	3879.2			
Ultraconservative	70.8	524.9	638.5			
<i>Totals</i>	<i>9005.2</i>	<i>6799.0</i>	<i>6441.2</i>			

Although these results appear to make sense in general, it is somewhat noteworthy that persons from each driving style except the planners have a Th setting they do not favor. The hunter/tailgaters have one setting they definitely prefer — the closer selection. The planners did a large amount of ACC driving with a preference for the farther button but they also accumulated over 2000 miles using the closer and middle buttons. Apparently one needs to plan ahead and use different tactics in order to succeed at traveling relatively fast while staying relatively far away from other vehicles.

Table 49 indicates how the Th selection results vary from driver to driver. Clearly, there are wide differences in mileage between individual drivers. Nevertheless many individual drivers have one Th button that they almost never use. Interestingly it is the

ultraconservatives who tend to do relatively little ACC driving. Although 10 of the hunter/tailgaters did very little ACC driving (less than 100 miles), the others accumulated many ACC miles. These results tend to indicate that, even though there are recognizable tendencies for each driving style, the choices of Th vary considerably among the individual drivers without regard to driving style.

Table 49. Th Buttons selection by driver

DriverID	Style	V > 55 mph			V < 55 mph		
		Closer	Middle	Farther	Closer	Middle	Farther
41	Extremist	33.6	3.1	0.0			
50	Extremist	72.8	40.5	0.2	0.6	15.4	0.0
13	Extremist	9.3	101.0	214.8	2.7	16.8	
98	Extremist	37.6	262.2	522.2	1.3	1.0	21.5
35	Extremist	0.0	75.4	11.7	17.1	2.1	
103	Extremist	0.0	21.3	66.4	0.0	2.1	33.6
20	Extremist	0.0	69.6	232.5	17.2		
9	Extremist	2.4	597.5	12.8	13.8		
24	Extremist	32.3	304.9	0.0	8.5		
107	Extremist	36.7	28.1	88.0	6.3	15.4	1.3
62	Extremist	93.4	144.0	3.1	77.3	107.3	0.1
43	Extremist	2.8	68.6	15.1	0.1	73.7	11.5
44	Extremist	19.5	2.7	31.7	3.0		
3	Extremist	45.9	7.8	0.0	7.8	2.4	2.5
51	Extremist	298.9	16.1				
45	Ultraconservative	18.1	45.8	0.0	1.7	20.0	0.0
57	Ultraconservative	10.1	44.2	5.9	4.6	2.5	2.3
38	Ultraconservative	71.3	41.2				
70	Ultraconservative	307.9	55.9				
46	Ultraconservative	20.0	30.3	12.7	5.0	2.2	9.0
25	Ultraconservative	21.3	10.4	0.0	0.2	0.8	
48	Ultraconservative	92.6	3.0				
23	Ultraconservative	21.3	74.9	0.7	1.3	4.9	
22	Ultraconservative	49.2	0.3	0.0	28.6	5.2	0.5
67	Ultraconservative	142.1	18.0				
95	Ultraconservative	8.9	52.5	30.0	0.0	1.5	0.2
102	Ultraconservative	0.0	79.4	1.2	0.6		
91	Ultraconservative	0.0	12.1	95.7	101.0		
83	Ultraconservative	37.5	25.2				
8	Ultraconservative	16.6	165.0	0.0			
106	Ultraconservative	347.8	1.2				
113	Ultraconservative	6.8	12.7	95.5	3.5	1.0	42.2
108	Ultraconservative	157.1					
115	Ultraconservative	0.0	5.4	79.7	0.0	0.1	6.4
116	Ultraconservative	0.2	45.9	0.0	0.9		

DriverID	Style	V > 55 mph			V < 55 mph		
		Closer	Middle	Farther	Closer	Middle	Farther
5	Planner	30.2	16.3	2.5	0.5	0.0	0.2
63	Planner	19.1	0.2	3.2	1.0	0.5	
11	Planner	159.5	105.9	176.6	36.0	32.0	4.7
40	Planner	87.1	13.0	1946.1	4.3	0.0	21.1
7	Planner	0.0	0.8	401.0	0.6	4.6	65.7
66	Planner	0.0	39.2	592.8	3.2	11.4	157.2
6	Planner	4.0	134.2	0.0			
30	Planner	101.5	0.6	4.9	0.5	0.1	0.7
29	Planner	13.7	60.3	0.0	0.1		
78	Planner	1064.6	25.3	13.5			
79	Planner	97.3	0.0	15.4	0.1		
27	Planner	59.3	13.4	5.9	0.3		
55	Planner	34.0	131.2	37.3	31.2	24.4	21.8
82	Planner	245.4	102.8	0.0	60.3	0.2	
47	Planner	10.0	23.8	122.8	0.0	2.1	30.0
61	Planner	171.8	2.9	2.5	1.9	1.2	1.0
93	Planner	9.0	442.9	22.6	2.7	1.1	
89	Planner	244.4	661.1	449.8	6.3	10.7	6.2
75	Planner	38.3	67.5	737.6	7.0	15.6	
4	Hunter/Tailgater	392.6	29.4	68.6			
42	Hunter/Tailgater	33.9	0.1	0.1	6.5	0.7	0.0
37	Hunter/Tailgater	22.1	31.6	12.0	8.2	7.2	1.2
31	Hunter/Tailgater	1.8	18.3	0.0	1.8		
12	Hunter/Tailgater	36.4	147.4	4.8	3.0	2.9	2.0
14	Hunter/Tailgater	4.3	109.8	75.3	2.1	21.7	1.2
21	Hunter/Tailgater	123.0	266.1	38.1	14.8	5.9	0.3
19	Hunter/Tailgater	35.9	73.4	26.0	12.6	14.1	35.6
10	Hunter/Tailgater	47.6	14.9	0.0	4.1	0.3	
73	Hunter/Tailgater	425.6	165.2	5.2	18.7	13.8	
88	Hunter/Tailgater	60.2	546.5	11.2	3.0	95.7	6.7
87	Hunter/Tailgater	543.3	64.2	0.9	13.2	4.4	0.9
85	Hunter/Tailgater	353.6	0.4	0.1	2.3		
59	Hunter/Tailgater	149.7	2.7	0.4	30.2	0.2	0.1
80	Hunter/Tailgater	42.8	0.7	0.0	2.9	5.3	0.0
76	Hunter/Tailgater	689.9	292.8	2.0	23.7	15.3	2.6
74	Hunter/Tailgater	7.2	14.5	26.8	1.8	12.9	7.7
99	Hunter/Tailgater	2111.1	113.7	92.3	9.6	7.3	4.0
64	Hunter/Tailgater	15.2	0.3	0.0			
52	Hunter/Tailgater	452.7	5.0	0.0	0.2		
114	Hunter/Tailgater	16.5	3.2	0.0	5.5	0.0	0.0
1	Hunter/Tailgater	22.8	9.8	4.6	1.5	2.1	0.5
60	Hunter/Tailgater	61.9	0.1	0.7	8.4	0.0	0.2
111	Hunter/Tailgater	109.8	13.9	33.9	3.5	0.1	0.0
109	Hunter/Tailgater	55.0	0.1	0.0	5.9	0.6	0.3

DriverID	Style	V > 55 mph			V < 55 mph		
		Closer	Middle	Farther	Closer	Middle	Farther
96	Flow Conformists	313.9	584.2	233.1	10.6		
18	Flow Conformists	90.0	270.1	0.0	18.7	27.4	1.8
110	Flow Conformists	32.0	83.8	178.6	3.7	7.5	7.4
97	Flow Conformists	208.3	24.1	0.0	15.7	2.9	
26	Flow Conformists	23.4	125.9	1.8	0.6	4.0	0.6
15	Flow Conformists	21.6	116.1	0.0	0.2	3.4	
17	Flow Conformists	47.1	16.9	9.3	10.7	0.4	16.5
100	Flow Conformists	502.1	233.6	0.0	10.9	65.0	0.0
112	Flow Conformists	2.0	1.2	15.7	1.7	5.3	14.9
104	Flow Conformists	94.0	32.3	6.2	13.2	18.4	3.7
105	Flow Conformists	45.7	588.1	11.3	0.0	15.8	2.1
94	Flow Conformists	31.3	321.5	0.5	0.6		
34	Flow Conformists	1.5	82.2	0.2			
54	Flow Conformists	37.8	140.4	132.2	0.0	7.9	14.1
56	Flow Conformists	862.7					
117	Flow Conformists	141.7	136.7	35.7	11.6	4.0	5.7
65	Flow Conformists	25.2	0.0	21.6	3.4		
68	Flow Conformists	939.4	95.9	0.0			
39	Flow Conformists	23.0	0.2	2.2	26.9	2.8	24.5
84	Flow Conformists	45.7	125.4	0.0	0.4	12.9	0.1
72	Flow Conformists	256.2	164.8	0.0			
92	Flow Conformists	20.7	523.2	18.3	90.3		
33	Flow Conformists	0.0	44.0	227.3	0.2	5.3	12.6
32	Flow Conformists	22.6	35.4	0.0	1.0		
77	Flow Conformists	53.7	174.7	0.1	39.7	78.7	1.4
49	Flow Conformists	2.1	12.2	37.2	0.0		
81	Flow Conformists	291.1	40.5	2.7	19.1	9.8	11.6
90	Flow Conformists	37.3	375.3	0.0	0.7	105.7	0.1
69	Flow Conformists	13.9	31.0	21.1	0.7	6.8	0.0

#### 8.2.4 Observations pertaining to ACC braking events

The aggregated data on average deceleration for all ACC braking events above 55 mph are shown in Figure 103. These data indicate that braking in the range from 0.045 to 0.095 g occurs with a frequency of approximately 0.08. This means that approximately 40 percent of the ACC braking events lie within this range. It appears that less than 10 percent of the braking events are above 0.185 g when ACC is in operation at the start of the braking event.

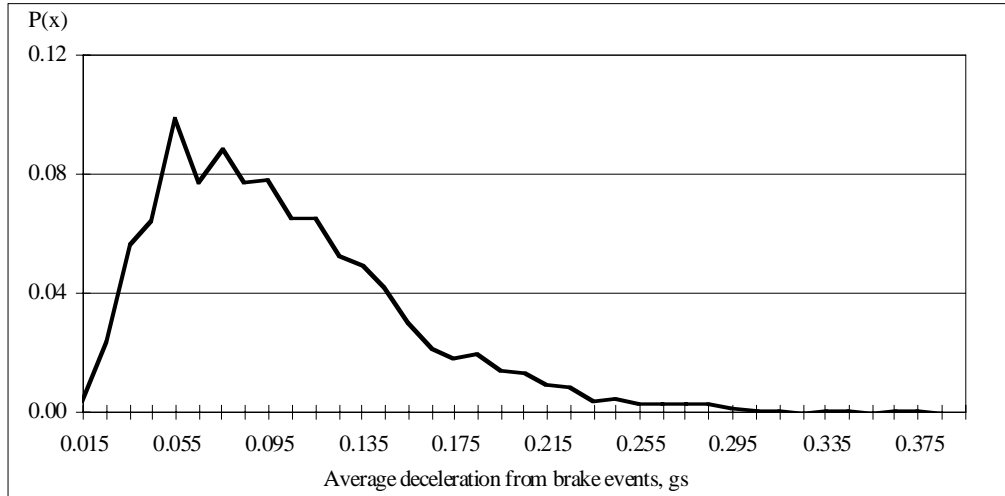

Figure 103. Average deceleration for all ACC braking events at  $V_{start} > 55$  mph

Figure 104 shows the number of miles traveled per ACC braking event that passed the criteria for a video episode. The figure also shows results for when CCC was in operation. On average (as indicated by the solid and broken lines) the ACC and CCC results are much alike. As indicated by the solid line for ACC, there are on average 20 miles between brake interventions when ACC is in use.

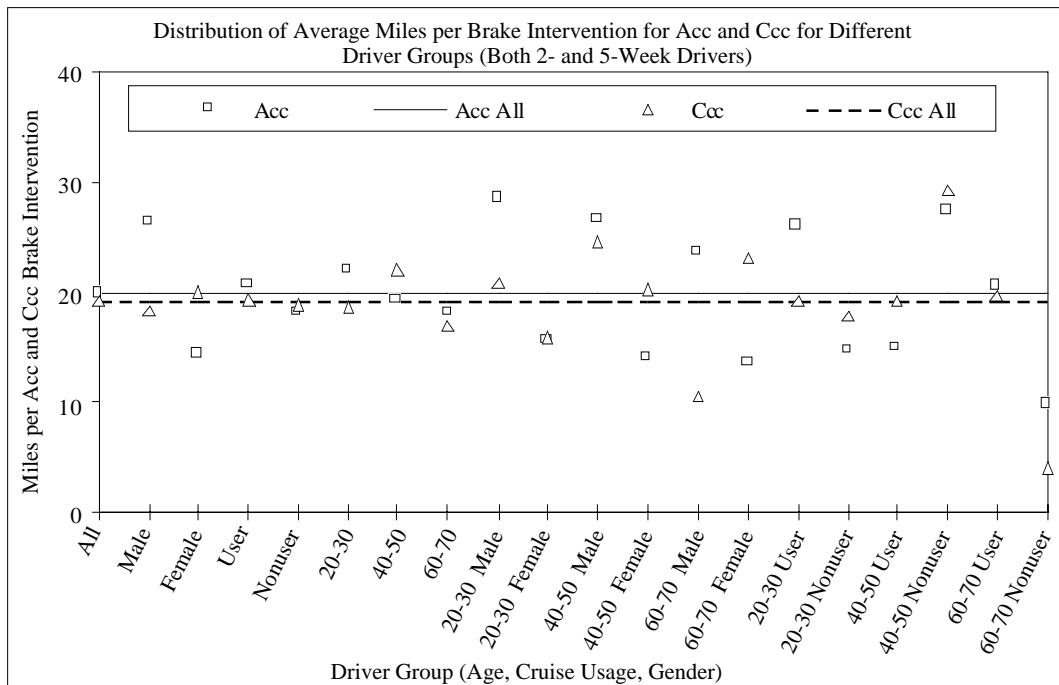

Figure 104. ACC braking per mile



The companion measure pertaining to ACC near encounters per mile is plotted in Figure 105. It shows that ACC and CCC are again much alike and that there are 32 miles between ACC near encounters.

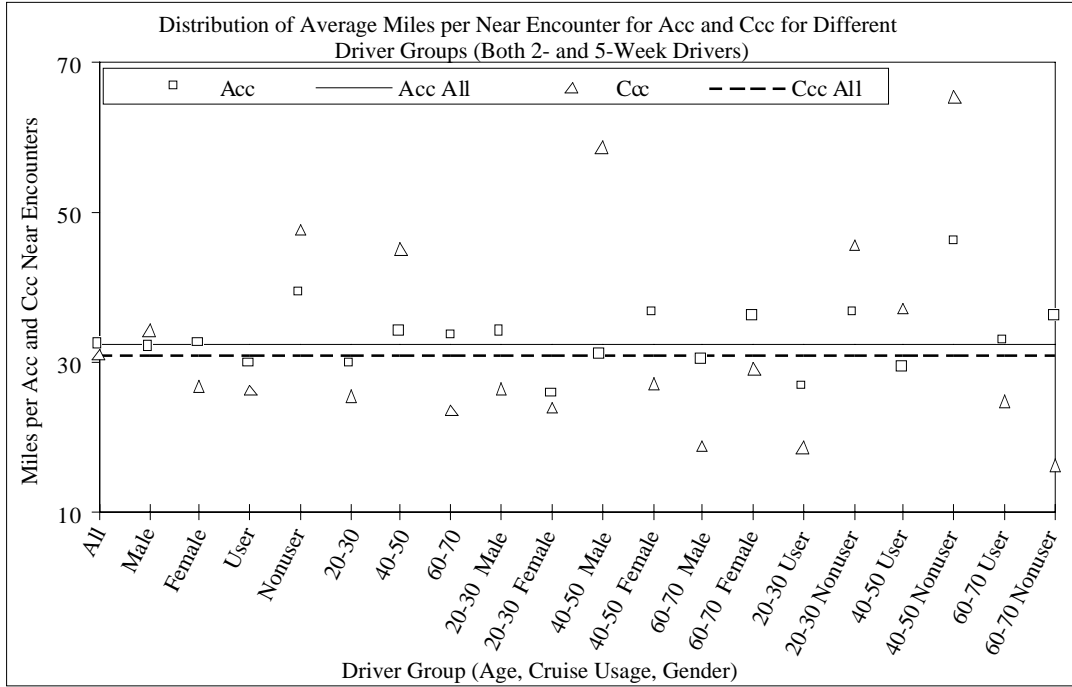

Figure 105. ACC near encounters per mile

Returning to the brake table for the 145 braking events with an average deceleration greater than 0.25 g, recall that 45 of these started with ACC in operation. (See table 1 in section 8.1.4.) The data for these 45 braking episodes have been further processed to separate those that occurred when the system was operating on a target (OOT) and when it was not (NOOT). The results show that there are 22 episodes in which relatively heavy braking was started when there was a target vehicle present as compared with 23 episodes during a NOOT period when the system did not have a valid target.

Table 50 presents results for the 22 heavy-braking episodes that started in the OOT condition. Examination of the table indicates that in 16 of these 22 cases, there is clear evidence that the impeding vehicle was decelerating, sometimes rapidly.

Table 50. Braking above 0.25g with ACC operating on a target, Vstart>55mph

Driver	Trip	Event	Ave. Axp	Comments
--------	------	-------	----------	----------

99	194	56	0.09	
99	129	9	0.19	
85	66	10	0.20	
82	30	18	0.25	
81	185	8	0.08	
81	174	22	0.17	
77	106	16	0.19	
76	158	19	—	1.5 sec., $\Delta V=13.9$
76	154	6	—	Very slow vehicle ahead, $V_p = 44\text{ft/sec}$
66	322	4	0.11	
66	130	36	?	Probably a slow vehicle, endR=13, startR=196
59	67	14	0.24	
59	66	21	0.31	
56	108	13	—	Very slow vehicle ahead, $V_p = 52\text{ft/sec}$
55	179	14	0.16	
52	41	6	—	Vehicle ahead decelerated rapidly, startR=97
51	28	32	0.18	
44	149	9	0.21	
43	31	10	—	Might have been classified as NOOT
21	70	17	0.14	
14	22	39	0.24	
4	97	36	0.30	

In one of the other 6 cases driver number 56 overtook a relatively slowly moving vehicle going about 0.5 times the speed of the ACC vehicle. In another case driver number 52 apparently slowed very rapidly for a vehicle that decelerated very rapidly but somehow was no longer a target at the end of the braking episode. (See table 1 in section 8.1.4.) Driver number 76 had two cases in which range information was available at the beginning and the end of the braking episode. In trip 154 for driver number 76, there was a change in target vehicle during the braking episode. (See table 1 in section 8.1.4.) Examination of the video for this event indicates that there were five vehicles involved here. There was a slow vehicle in the lead, then three vehicles, and then the ACC vehicle. The ACC vehicle started to head for the shoulder while braking heavily but just then the immediately preceding van changed lanes, which revealed another impeding vehicle which shortly changed lanes. All the time there were vehicles streaming by in the other lane such that it was not easy for driver number 76 to find a usable gap. In any event, driver number 76 responded “yes” to the question, “Did you ever come close to having a crash?”

Driver number 76 also braked fairly aggressively but only for 1.5 seconds in another case where there was a preceding vehicle going slightly slower than the ACC vehicle. The final OOT case (for driver number 43) might have been classified as NOOT because

the mode switched from OOT within 1 second of the brake event. Nevertheless the driver braked aggressively to a complete stop in this case. In summary, aggressive braking from the OOT state of ACC driving could usually be attributed to deceleration of the preceding vehicle or sometimes to encountering a very slowly moving, impeding vehicle.

Table 51 presents results for 23 heavy-braking episodes that started in the NOOT condition of the ACC system.

Table 51. Braking above 0.25g with ACC NOOT

Driver	Trip	Event	startVp (ft/sec) (0 means no target)	Estimated range for <i>headmode</i>	startR (ft)	Target at end	Comments
4	61	4	41.6	173	277	Yes	Change
4	60	7	0	–	0	Yes	Change, merge
26	62	16	40.8	172	303	Yes	Change, flashers
43	74	40	0	–	0	Yes	Change, complete stop
51	28	49	106.5	Rdot > 0	151	No	Change
56	71	37	0	–	0	Yes	No change
65	66	7	50.3	181	255	Yes	Change
66	254	7	0	–	0	Yes	Change
66	93	10	0	–	0	Yes	Change
66	254	6	0	–	0	No	Change
66	104	5	34.7	166	257	Yes	Change
66	336	10	0	–	0	No	Traffic light
76	155	16	51.0	182	222	Yes	No change, left turn
76	121	18	57.6	188	309	No	Change
82	72	20	0	–	0	No	Change
88	103	26	85.0	–	143	No	Change, left turn
89	212	93	52.6	184	240	Yes	No change
89	254	56	67.2	198	228	Yes	No change
91	63	5	35.7	167	270	Yes	Change
96	172	16	0	–	0	No	Change
99	205	1	0	–	0	No	Change
110	46	17	0	–	0	No	Change, exit
115	42	51	0	–	0	No	Change

The rows in the table having zero entries for both Start V<sub>p</sub> and Start R represent situations in which there is no valid target in the sensor’s view at the start of the braking event. There are 12 of these cases. They represent situations in which the driver probably observed something like a stop light or an exit or a merging vehicle. (Examination of the video might render detailed understanding in such cases.) The driver chose to brake at a relatively high level in many of these cases even though there was no real emergency—it just suited the driver’s purposes to slow down rapidly. In nine other cases the ACC system was NOOT because the driver chose to brake at long range. As explained earlier,

this ACC system did not start operating on targets that were far away. This design feature was in response to driver complaints over premature deceleration during closing episodes. Nevertheless, there are cases in which the driver chooses to brake relatively heavily even though the impeding vehicle is far away. In each of these cases the impeding vehicle is traveling very slowly compared with the ACC vehicle. For example, in one case the impeding vehicle had its flashers going. In a second case, driver number 51 chose to brake when there was a vehicle ahead that was traveling faster than the ACC vehicle. A third case involved both vehicles going close to the same speed.

Examination of Table 51 indicates that driver number 66 had an exceptional number of heavy braking events in NOOT — specifically, five. Examination of the corresponding video clips indicates that this driver tends to operate on non-limited-access roads at just over 55 mph. As conflicts develop, even while still at long range, the driver responds with relatively heavy braking. Further examination indicates that this driver is a 60-to-70 year old male who is classified as a planner. At least as a partial elaboration on this individual's behavior, he achieves the planner driving style by going fast but braking aggressively for impeding situations such as other vehicles, traffic lights, etc.

### **8.3 Basic Comparisons of ACC Operation With Manual**

Sections 8.1 and 8.2 have considered manual and ACC driving separately. This section examines the results simultaneously in order to compare ACC and manual driving and as a means for evaluating differences between ACC and manual driving.

Condensations and elaborations pertaining to headway time margin ( $R/V$ ), normalized relative velocity ( $Rdot/V$ ), driving styles, brake interventions, following performance, and closing situations are presented in this section.

#### **8.3.1 Comparison Based Upon Headway Time Margins**

A graphical image of the difference between manual and ACC driving can be obtained by examining Figures 106 and 107 showing three-dimensional illustrations of the observed frequency of various levels of headway time margin and velocity.

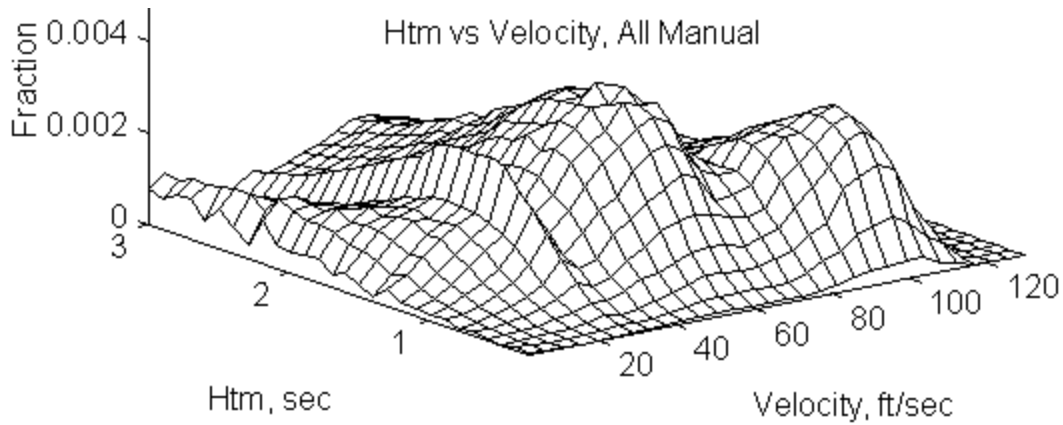

Figure 106. Observed frequencies of headway time margin versus velocity, manual driving

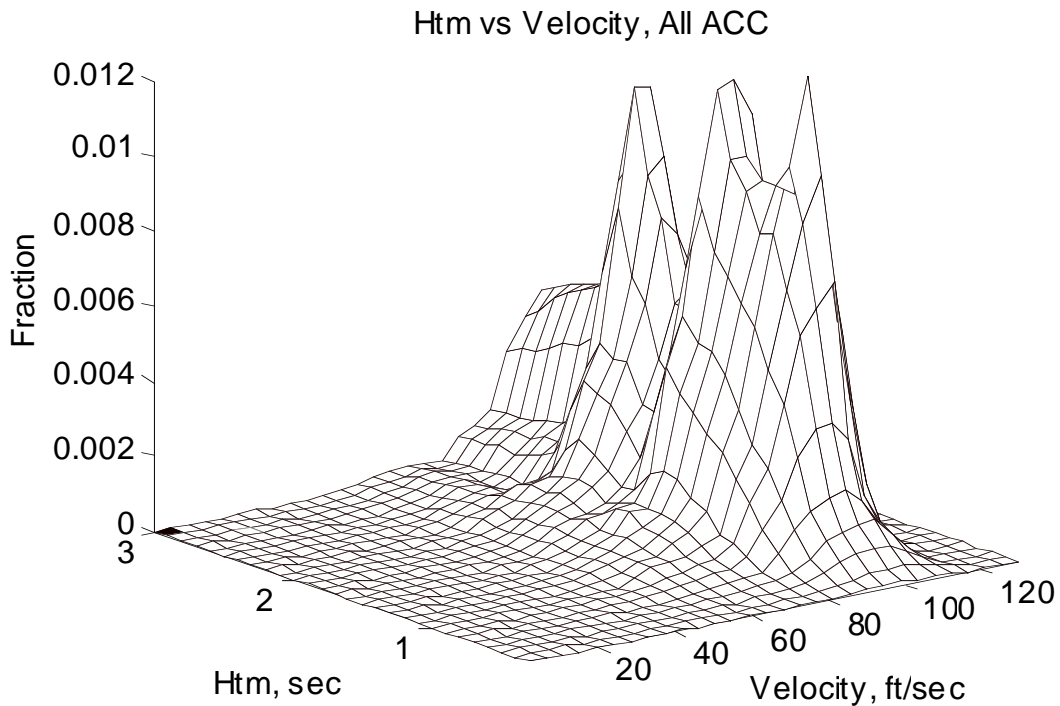

Figure 107. Observed frequencies of headway time margin versus velocity, ACC driving

The figures look entirely different from one another because ACC is seldom used at speeds less than 60 ft/sec. Also, during ACC driving, the driver has only three choices of headway time corresponding to the peaks at Htm equal to 1.1, 1.5, and 2.1 seconds. In contrast, manual driving is done at all speed ranges and the choice of headway time is continuous. This means that the plot for manual driving appears to be relatively flat with a few rolling hills and ridges, while the plot for ACC driving has much higher values and steeper slopes occurring predominantly at higher speeds.

The velocity data for manual driving has three ridges in Figure 106. One ridge appears at about the 25 ft/sec value at which the automatic transmission shifts from second to third gear. The next ridge or hill is around 60 ft/sec which represents the bulk of nonfreeway driving. The higher velocity crest appearing at about 100 ft/sec corresponds to the travel domain that is also most likely for ACC driving, as shown in Figure 107. Since manual driving has a valley at about 80 ft/sec and the amount of ACC driving starts to increase rapidly at this speed, data for driving above 55mph (81ft/sec) are often used in comparing manual and ACC driving.

The difference between headway control modes as measured by Htm is presented in Figure 108. The results for ACC are presented as three individual curves (one for each headway time setting) to expose the results associated with each headway setting by itself.

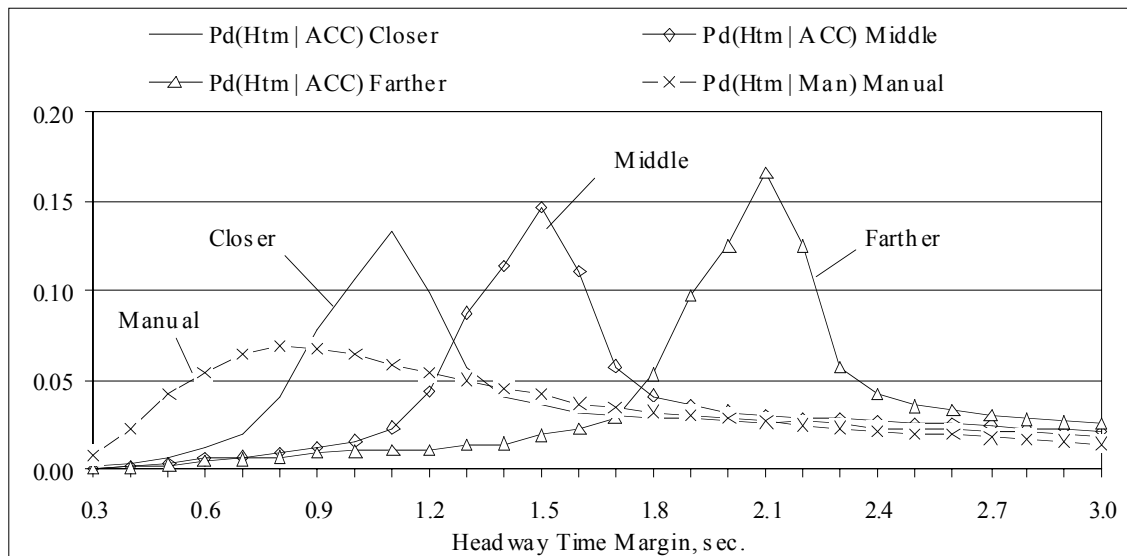

Figure 108. Comparison of ACC to manual driving using headway time margin,  $V > 55$  mph

The manual driving curve is concentrated in the short headway domain with a most likely value of 0.8 seconds, that is, considerably below the most likely value of 1.1 seconds for the closer ACC setting. Driving with  $T_h$  equal to 1.5 or 2.1 seconds corresponding to the middle and farther settings results in a very low observed frequency of having Htm less than 0.9 seconds for this ACC system. As illustrated by these results for Htm, this ACC system provides the driver with longer headway times and more time and distance in which to react to changes in the longitudinal motion of the preceding vehicle.

Earlier results were presented showing that driver age and gender are associated with the selection of headway time when ACC was in use. Figure 109 describes the influence of age when comparing these ACC results with manual driving results. As shown in the figure, younger drivers have a propensity for shorter headways in manual driving just as they do in ACC driving, but in manual driving younger drivers are most likely to chose to travel at 0.8 seconds of Htm — well below the 1.1-second peak for ACC driving.

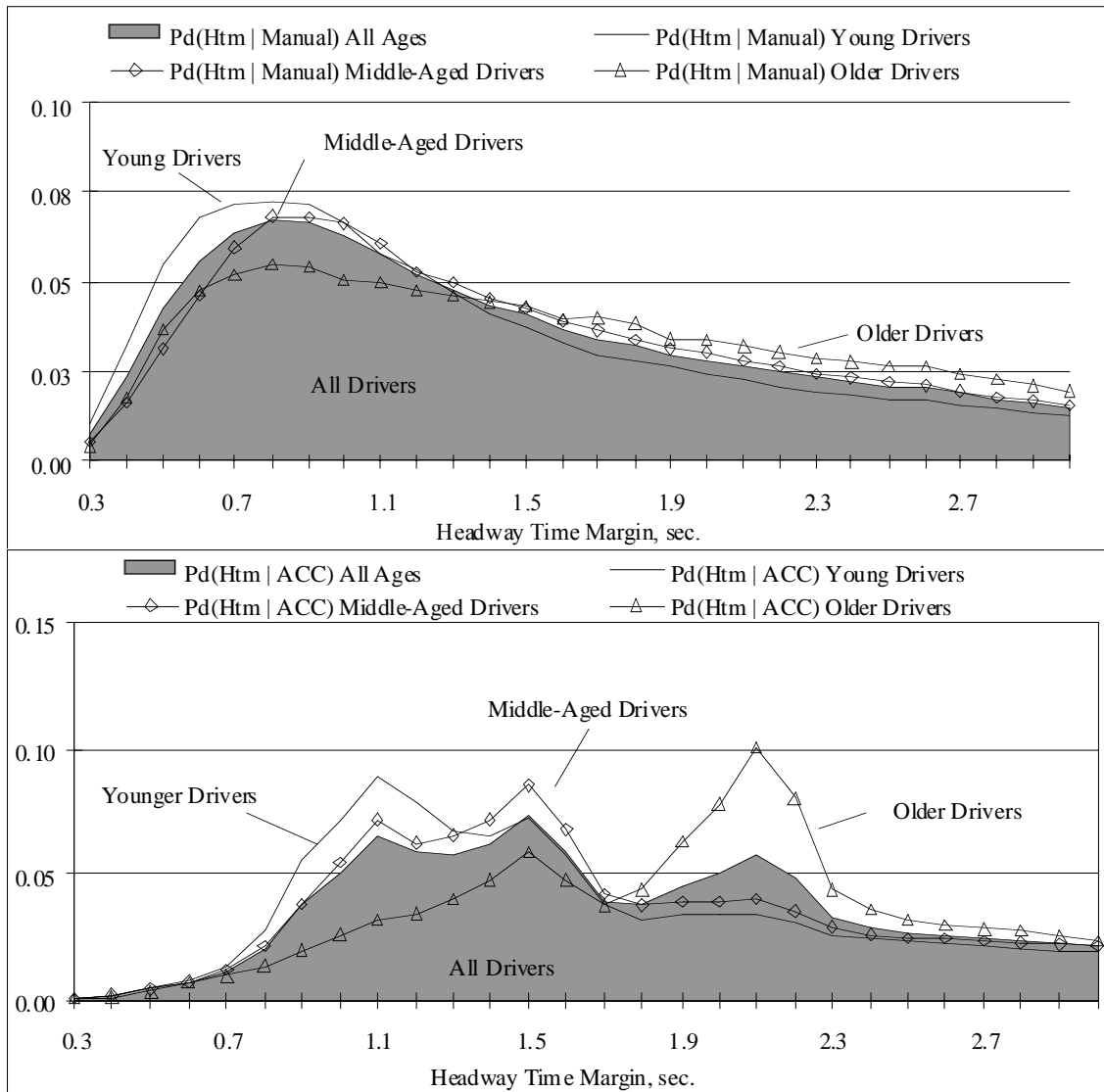

Figure 109. Influence of age on headway time margin under ACC and manual control

Figure 110 describes the influence of gender when comparing ACC results with manual driving results. The differences in Htm between the male and female participants in the FOT are fairly large for ACC driving and not so large for manual driving. In previous studies the differences between male and female drivers turned out to be not

significant, but these results show modest but important differences between male and female drivers with respect to their choice of headway settings.

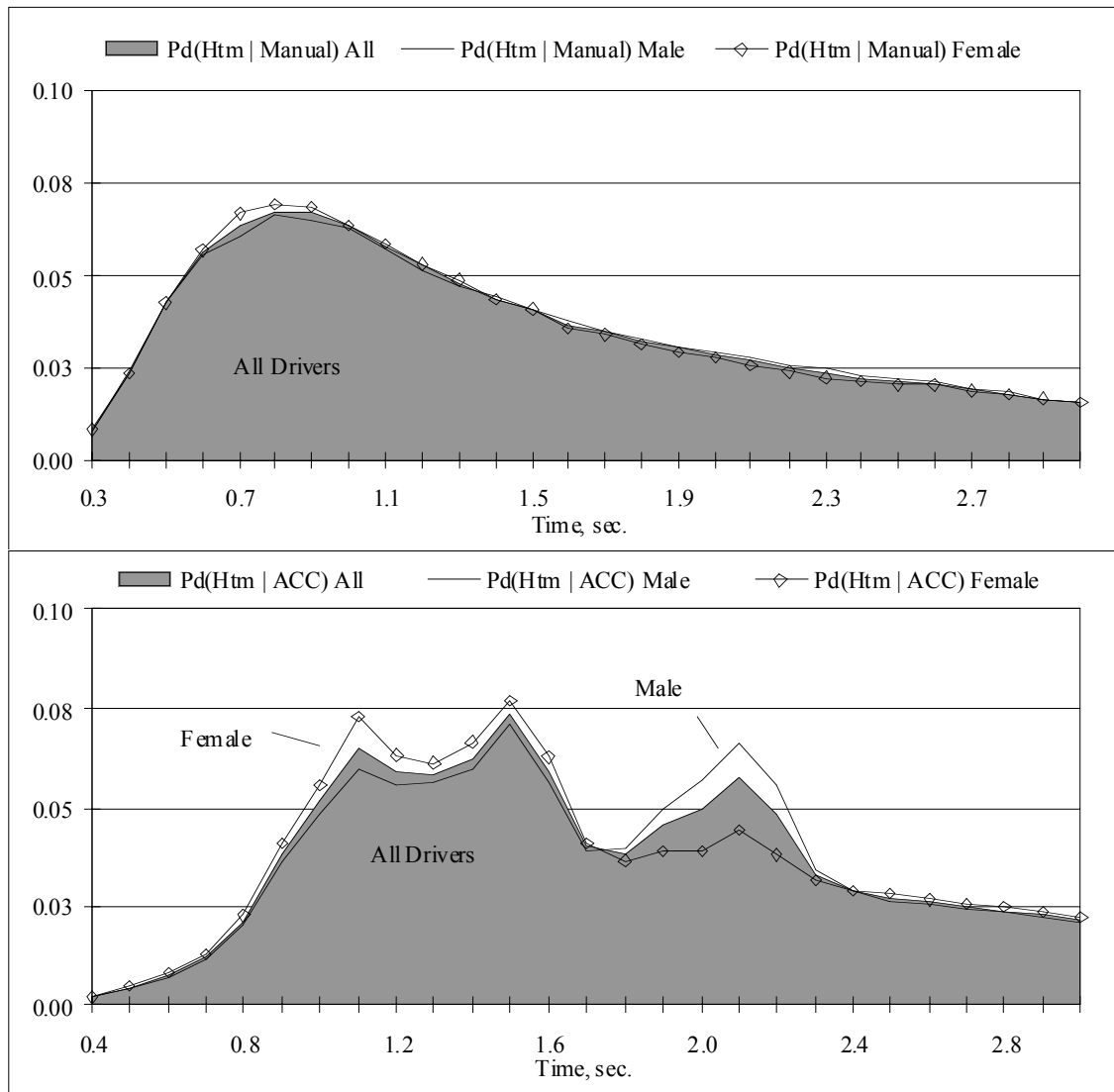

Figure 110. Influence of gender on headway time margin under ACC and manual control

### 8.3.2 The Influence of ACC on Driving Style

The one-dimensional, normalized histograms for Htm (R/V) can be expanded to illustrate the influence of normalized range rate. (Actually the data processing goes from more dimensions to fewer dimensions in condensing the results —just the opposite of the tendency to expand the complexity of the discussion by going from one to two dimensions.) Figures 111 through 114 show three dimensional perspectives portraying the likelihood of various combinations of R/V and Rdot/V.



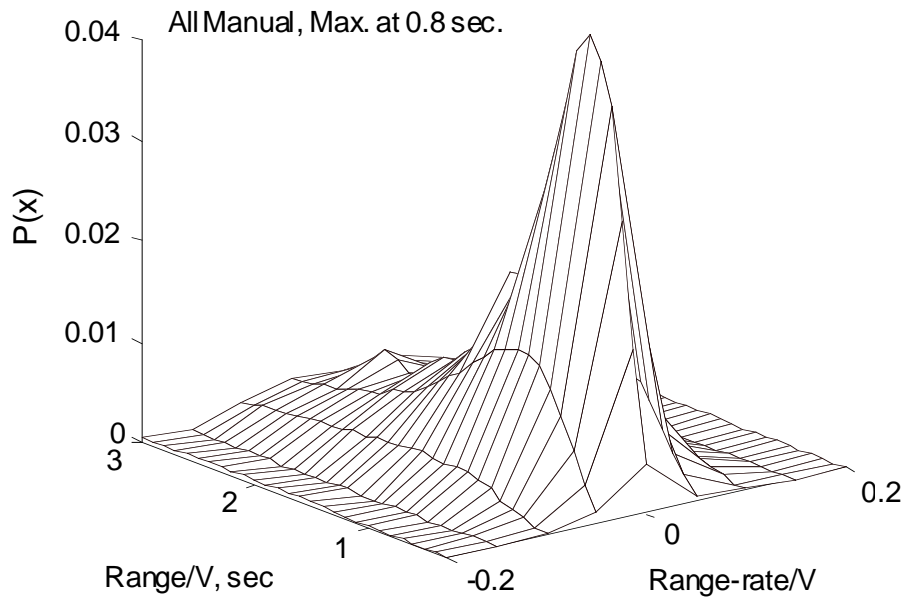

Figure 111. R/V versus Rdot/V for manual driving ( $V > 55$  mph)

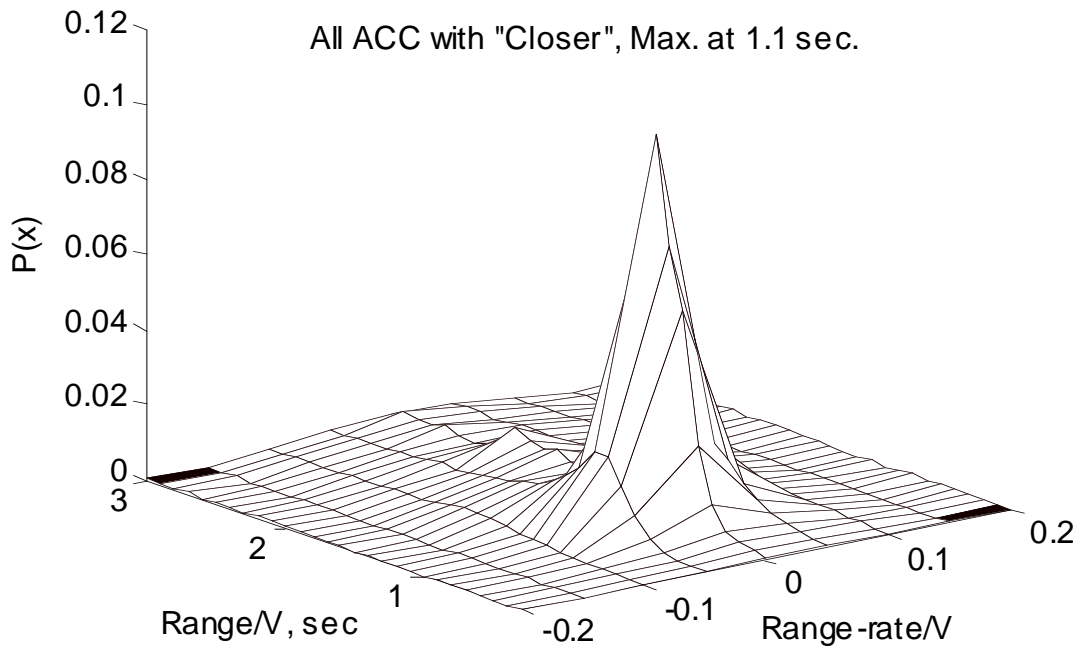

Figure 112. R/V versus Rdot/V for ACC driving with  $T_h = 1.1$  sec. ( $V > 55$  mph)

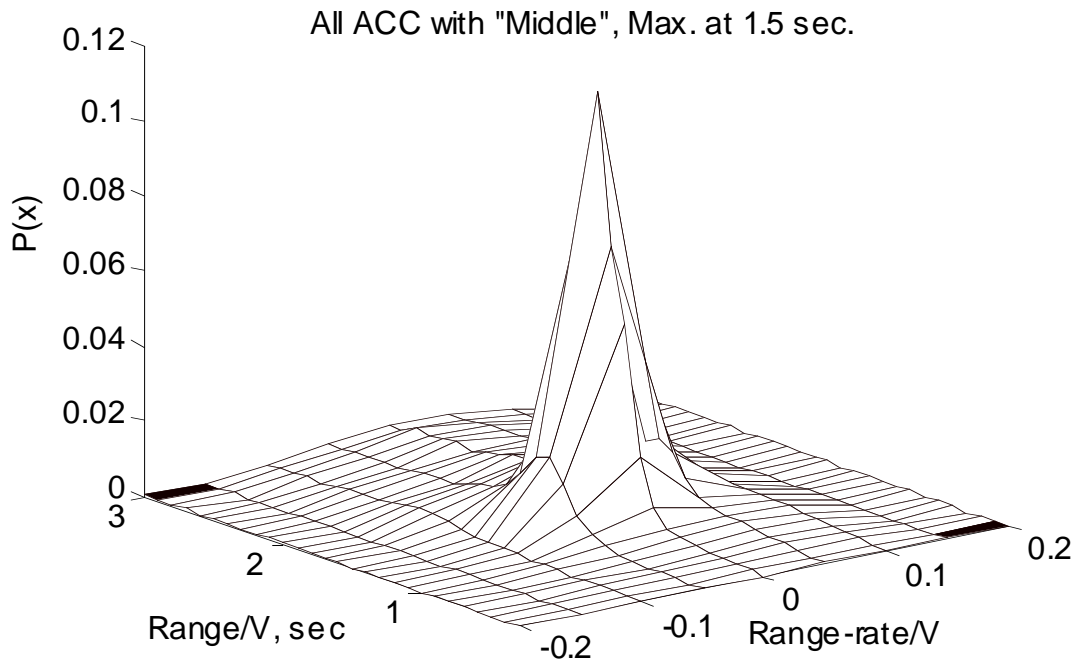

Figure 113. R/V versus Rdot/V for ACC driving with  $T_h = 1.5$  sec. ( $V > 55$  mph)

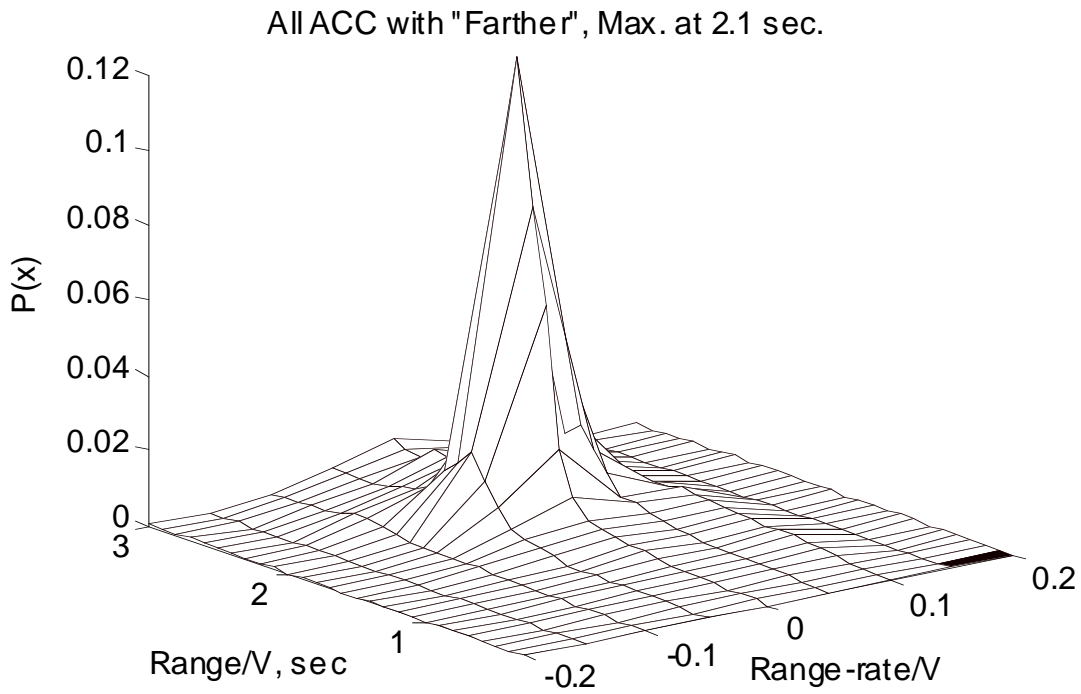

Figure 114. R/V versus Rdot/V for ACC driving with  $T_h = 2.1$  sec. ( $V > 55$  mph)

In these figures, manual driving is characterized by shorter headways and higher negative values of  $Rdot/V$  at short headways. This means that smaller values of time to impact ( $-R/Rdot$ ) are more likely for manual driving. With the 1.1-second headway setting, the ACC data is dominated by a peak at  $Htm (R/V)$  equal to 1.1 seconds and the normalized relative velocity ( $Rdot/V$ ) equal to zero. These data also show little chance of headway times below 0.3 seconds or  $Rdot/V$  less than -0.05 for small values of  $R/V$ . The figures for the longer headway time settings of 1.5 and 2.1 seconds look similar to that shown for 1.1 seconds except that the peak is further from  $R$  equal zero, and the chance of short ranges occurring is even less.

Interestingly, in Figure 114, one can perceive a very slight ridge in the neighborhood of  $Rdot/V$  equal to 0.1 and  $R/V$  equal to and above a value of 0.9 seconds. This slight rise is caused by vehicles traveling faster than the ACC vehicle and cutting in front of it. Although this does not happen very often in the big picture of driving time, it can be disconcerting to some drivers. Perhaps the sudden change in image size of a closer vehicle is disrupting to the driver's skill and rule-based processes. In any event, the tendency for cut-ins is especially observable in the data for the longer headway setting, at  $T_h = 2.1$  seconds.

Previously, driving style was characterized using the tails of the  $R/V$  versus  $Rdot/V$  distribution for manual driving—the distribution shown in Figure 111. This process resulted in driving-style classifications for all 108 drivers. Those results have been combined to produce Figure 115 (span over the next four pages) showing driving style miniatures for all 108 drivers in both manual and ACC driving. Clearly, the style that emerges under ACC control is determined by the driver's choices of  $T_h$  and  $V_{set}$  (and the road and traffic conditions in which the individual travels). Obviously, this ACC system has strongly modified the driving style of many drivers.

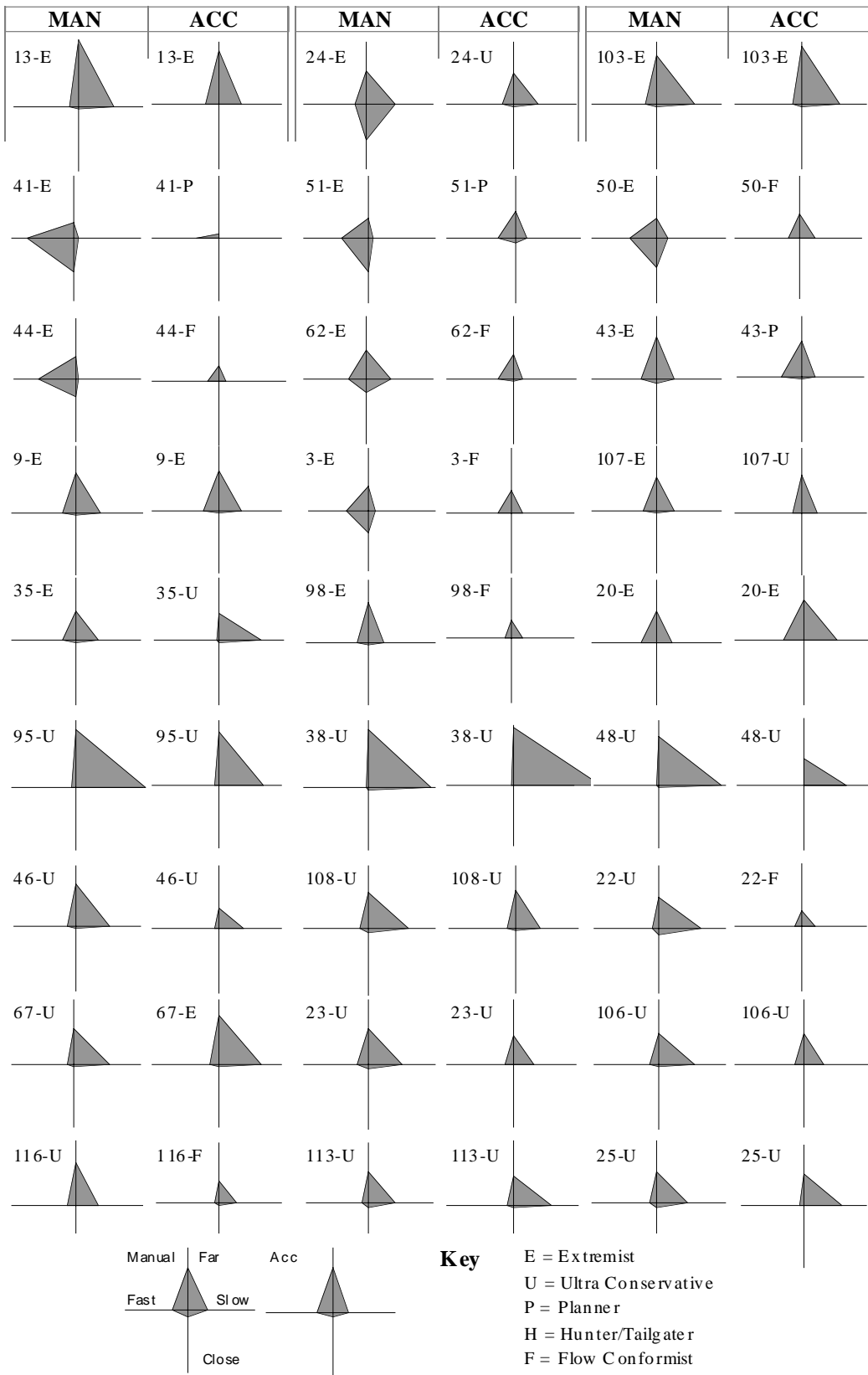

Figure 115. Comparison of manual versus ACC driving style for all drivers

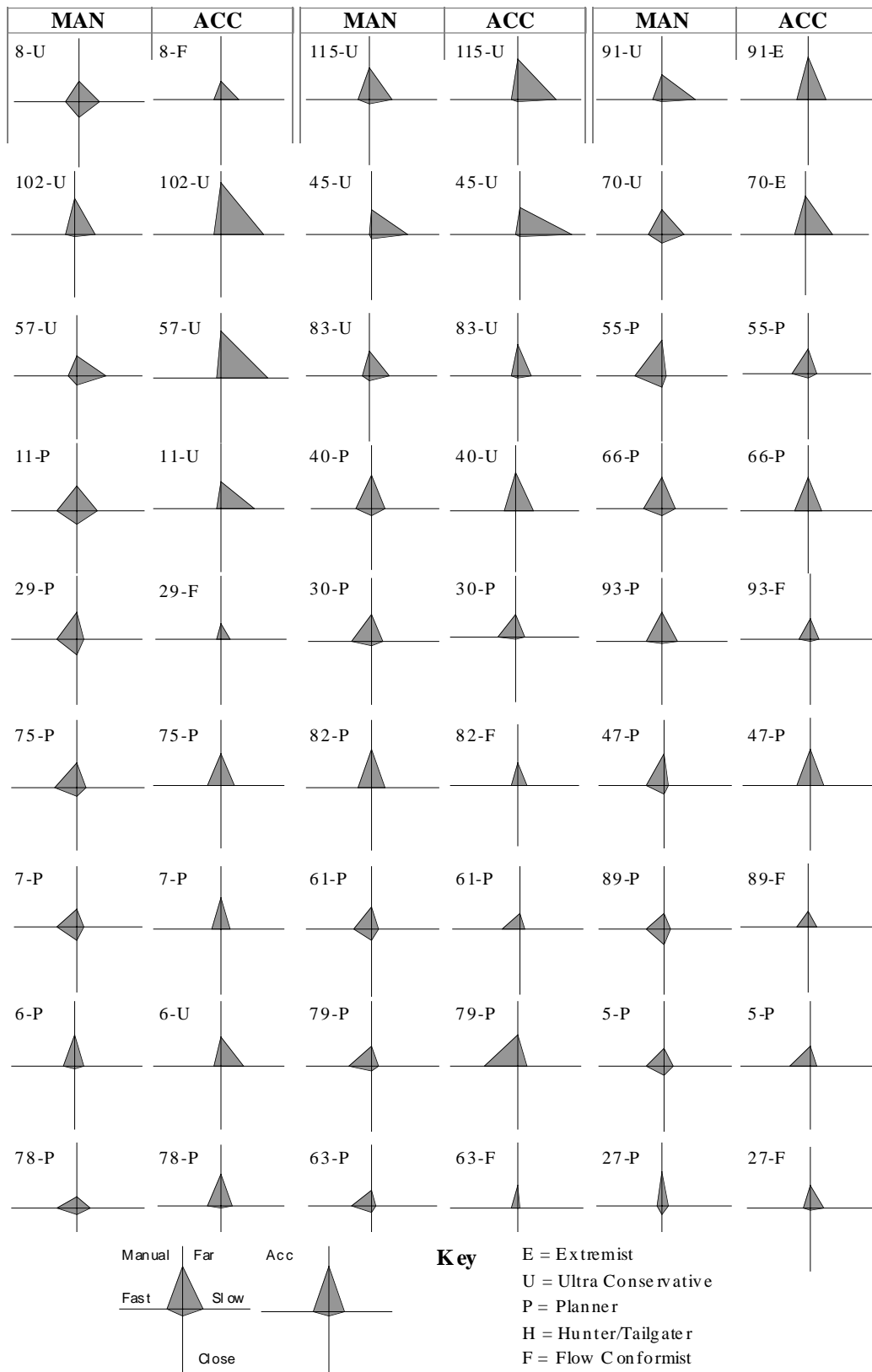

Figure 115. Comparison of manual versus ACC driving style for all drivers (Cont.)

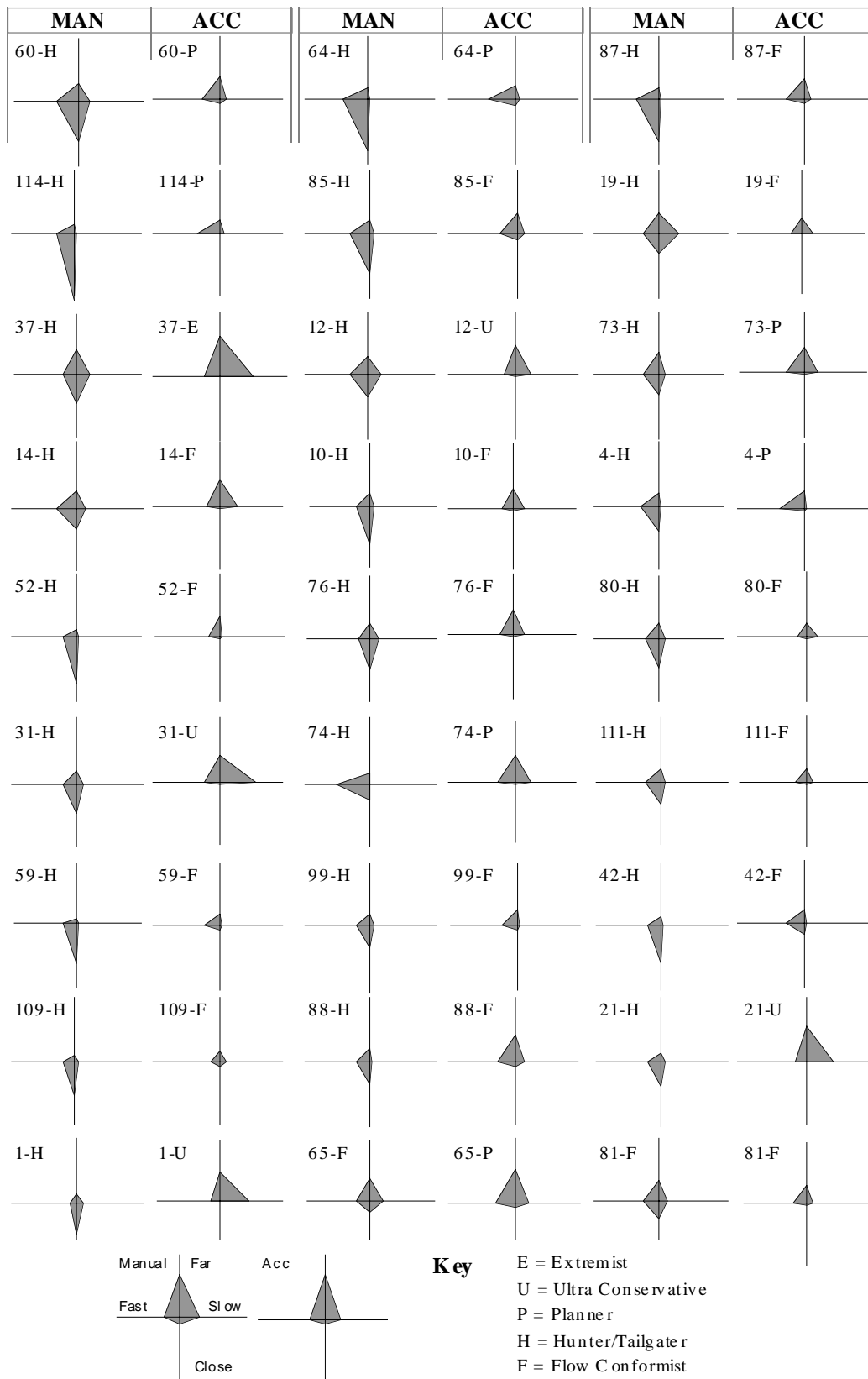

Figure 115. Comparison of manual versus ACC driving style for all drivers (Cont.)

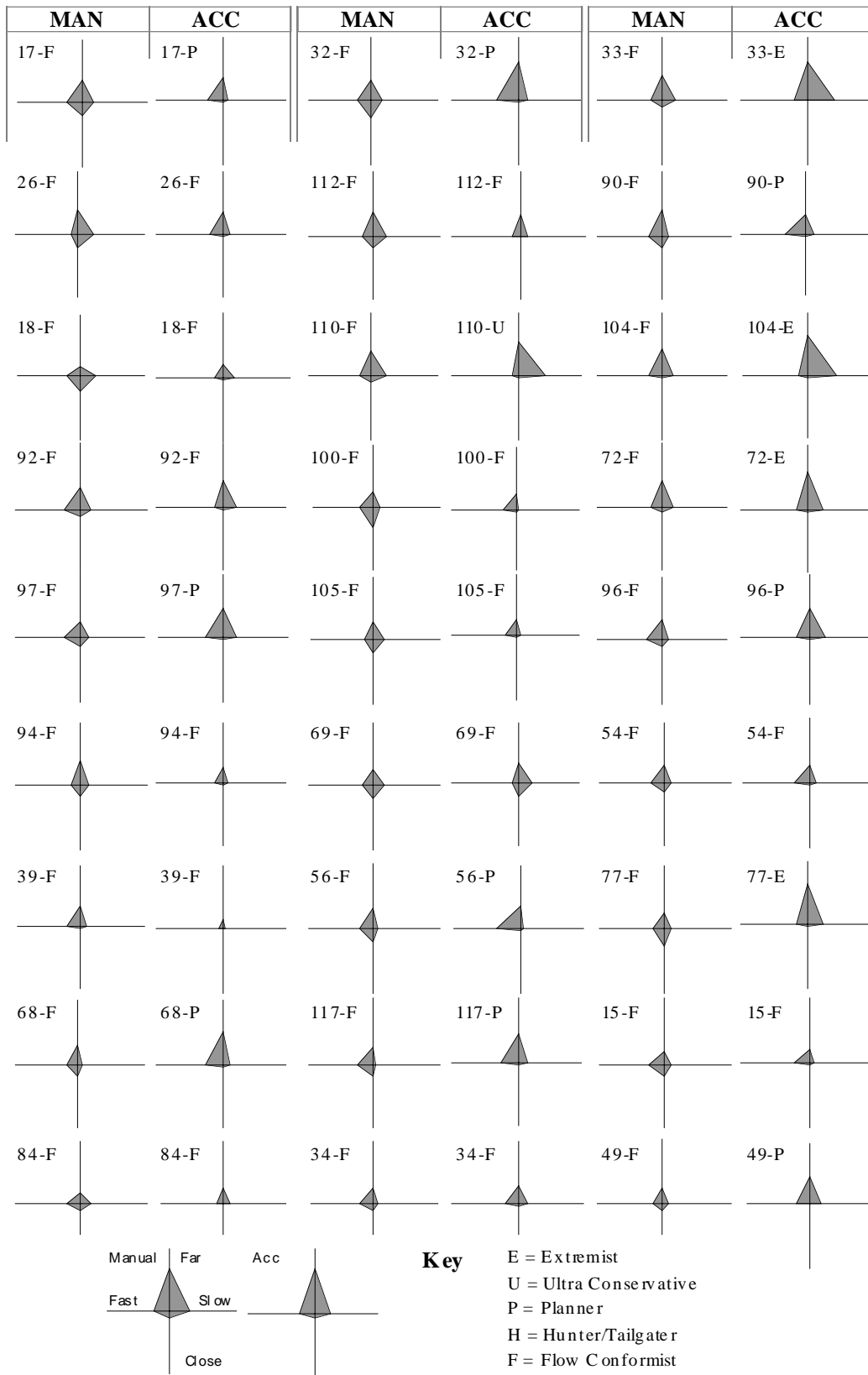

Figure 115. Comparison of manual versus ACC driving style for all drivers (Cont.)

In order to be more specific, Figure 116 was created to quantify the differences between manual and ACC driving as portrayed in Figure 115. Figure 116 shows that none of the drivers operated as hunter/tailgaters under ACC control. Of the 25 drivers that were seen to be hunter/tailgaters under manual control, 14 of them became flow conformists and 6 of them became planners as shown in Figure 116. As can also be seen, the extremists divide up nearly equally into the other four remaining categories of ACC driving styles. However, some of the other drivers became extremists when using ACC. The other three styles of drivers (ultraconservatives, planners, and flow conformist) often had the same style in both ACC and manual driving, but some switching is observed. The net effect of this ACC system was to convert 15 extremists, 20 ultraconservatives, 19 planners, 25 hunter/tailgaters, and 29 flow conformists in manual driving to an ACC distribution of driving styles consisting of 12 extremists, 25 ultraconservatives, 29 planners, zero hunter/tailgaters, and 42 flow conformists.

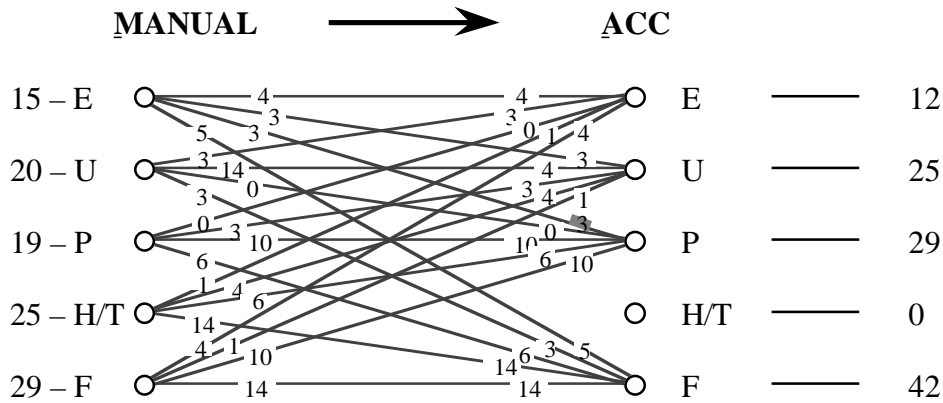

Figure 116. The influence of ACC on driving style

### 8.3.3 Observations Pertaining to Braking Events

Table 52 shows a direct comparison between ACC and manual driving. Manual driving has approximately five times as many braking events per mile at speeds above 35 mph, and about 2.5 times as many near encounters as ACC driving. The combination of system properties and driver's choice of conditions under which to use ACC, appears to result in less demanding driving when this ACC system is in use.



Table 52. Comparison of miles between brake interventions and near encounters (V>35mph)

Miles between:	Driving mode	
	Manual	ACC
Brake interventions	4	20
Near encounters	13	32

With regard to the distribution of average deceleration levels used in ACC and Manual driving, the results shown in Figure 117 indicate that the distributions are quite similar. Manual driving is characterized by slightly lower frequency of decelerations for most of the range from 0.08 g to 0.3 g. However, this means that the probability is greater for lower levels of deceleration, since the total area of the frequency distribution equals 1.0. Conversely, since the ACC system takes care of many of the low-level conflicts without brake actuation, braking at a low level during an ACC intervention is not as likely. This also implies that, for ACC, higher levels of braking are more likely.

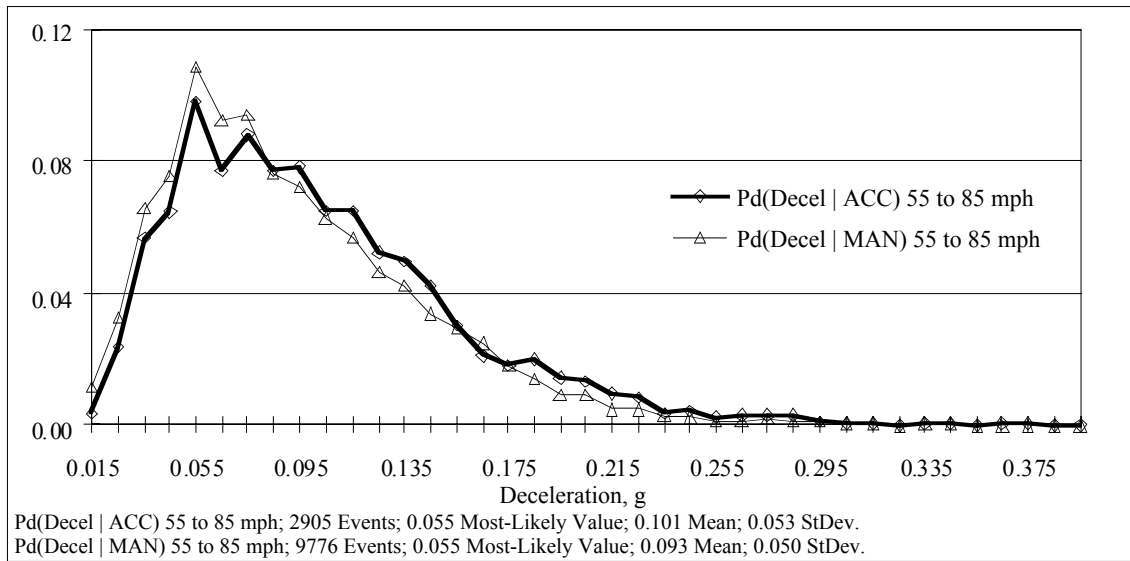

Figure 117. Distribution of average deceleration in braking events for ACC and manual driving (V > 55 mph)

As shown in the figure, there are about 2,900 ACC braking events and almost 10,000 manual braking events in this speed range. Also in this speed range there are more ACC miles than manual miles in the data from the FOT. The net result is that, in an absolute sense, there are many more braking events at all levels during manual driving than there are with ACC driving.

### 8.3.4 Observations and Comparisons Concerning Following and Closing Situations

ACC systems are designed to close in on a slower moving vehicle until the desired headway is attained. Then the ACC vehicle is expected to follow the preceding vehicle at the desired headway gap. The quality of the performance of this ACC system in this fundamental sequence of closing and following will be evaluated here by comparing ACC performance with that of manual driving in closing and following situations.

In order to find representative closing and following situations, a large table called the "streams" table was constructed. The streams table accounts for every time period in all of the time history data. There are periods without a target vehicle present and periods during which the ACC sensor reports R and Rdot information for the same target vehicle. The latter streams, which apply to one target, are called "target" streams. They can be short or long in duration. They can include operation in all regions of the range-versus-range-rate space as long as the same target vehicle is detected by the sensor. There are hundreds of thousands of target streams in the full data set. Each of them has been "cleansed" so that momentary dropouts of the sensor signal (such as those that tend to happen at long range) are filled in to maintain a continuous stream of time history data pertaining to a particular target. Target streams can be further examined to select portions that are in the closing or following regions of the R-versus-Rdot space.

Figure 118 presents time histories for an example of a target stream having both closing and following sections. As can be seen in the figure, the ACC vehicle is traveling about 15 ft/sec faster than the target vehicle at the beginning of the time history. The sensor initially detects the impeding vehicle at a range of nearly 450 ft. At approximately a third of the 80 seconds shown, Rdot rises above the -5 ft/sec value at which the situation has changed from closing to following per the definitions given in section 5.6. Once following has commenced, the driver modulates the throttle to hold Rdot in the neighborhood of zero with a range approaching about 150 ft.

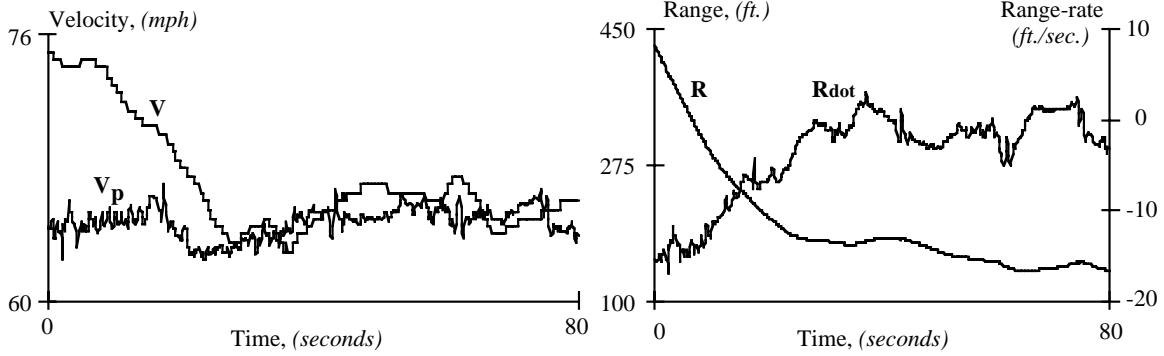

Figure 118. An example target stream illustrating closing and following operation during manual driving

When plotted in the R-versus-Rdot space this same stream sequence appears as shown in Figure 119. Note that the first 25 seconds or so of the time history data represent the closing portion going from about 450 ft and Rdot equal to -15 ft/sec to the following part, which starts at Rdot equal to -5 ft/sec. The following part, which lasts for about 55 seconds, is characterized by small hunting cycles in which the driver is trying to maintain a suitable range with Rdot approximately equal to zero. These small cycles are believed to be the consequence of the driver's visual limitations in detecting range and range rate as discussed in section 8.1.2.

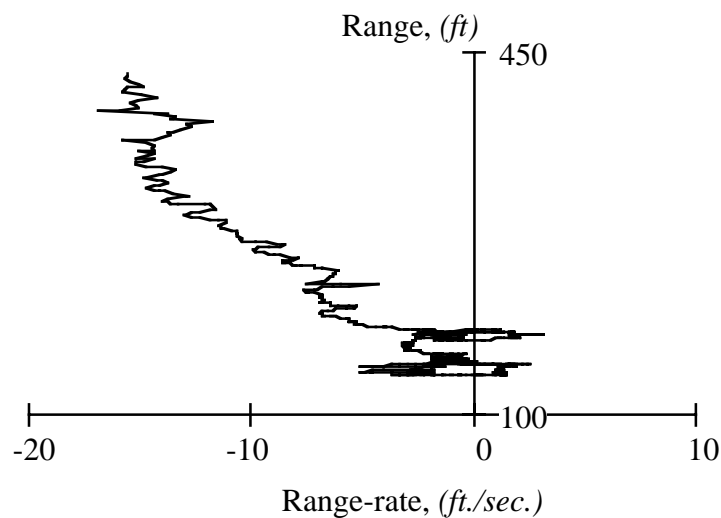

Figure 119. Range vs. range rate during the closing and following sequence of Figure 118

The stream illustrated in Figures 120 and 121 on the next page is an example of data gathered during ACC driving. In this case, the impeding vehicle as well as the ACC vehicle are changing speed appreciably. This sequence is not unusual since drivers rarely hold speed (or following distance) relatively constant. Their ability to do so is limited. Consequently, it is difficult to find data where  $V_p$  is nearly constant. Nevertheless, this stream indicates that this ACC system appears to operate in a manner that is not entirely unlike manual driving performance. There is a closing section followed by hunting for a stable following situation (though in this case the preceding vehicle does not cooperate by maintaining a relatively steady speed).

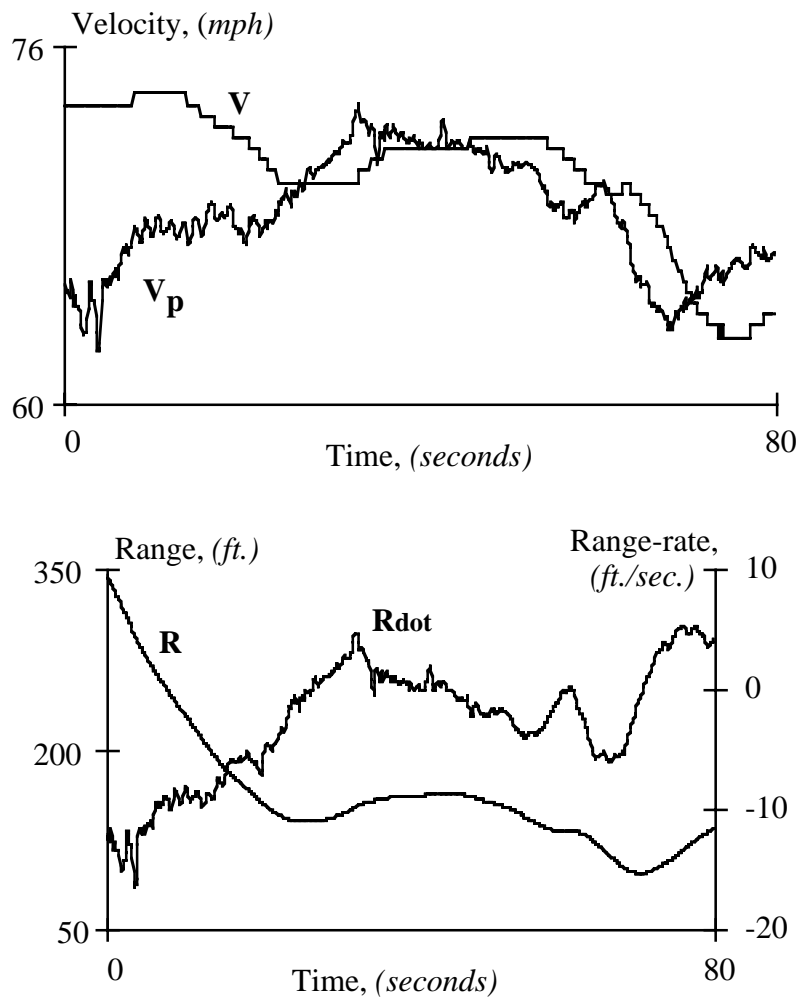

Figure 120. An example target stream illustrating closing and following operation during ACC driving

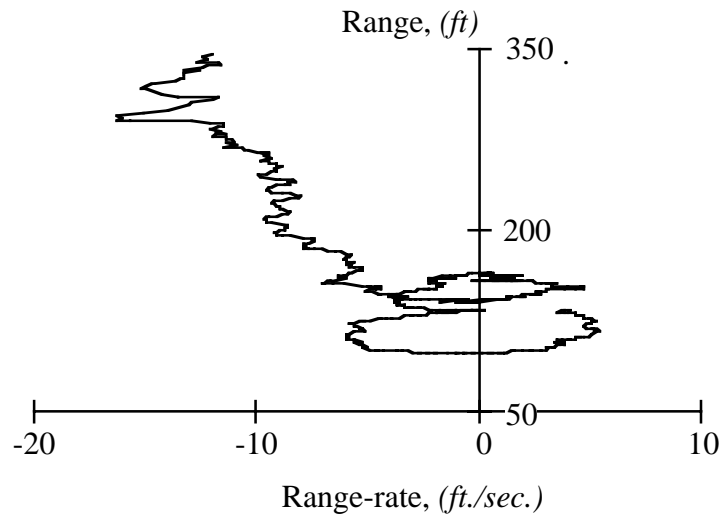

Figure 121. Range vs. range rate during the closing and following sequence of Figure 120

Since the world of driving is complex and situations are seldom as tidy as those arranged on a test facility, the evaluation and comparison of ACC and manual driving performance is not as simple as it might seem. In order to make comparisons between ACC and manual driving in a naturalistic setting, special data-processing procedures have been developed.

In order to broadly characterize driving in the following region, RMS values of R and Rdot were computed during the hunting cycles by which following is maintained. (In general the hunting cycles are erratic enough that it is difficult to treat them as limit cycles.) Reasonable “pure” following cases were selected having a duration of at least 60 seconds and speeds above 55 mph. (Note that stream duration is important here since a single hunting loop in R and Rdot often takes about 15 seconds of following to complete.)

Figure 122 shows RMS values of range deviations during the hunting control of headway for manual driving. In this plot the data from some 235 “following” streams are arranged in order going from lowest to highest values of the RMS value of R deviations. As indicated in Table 53, the median (50th percentile) RMS value of the R deviation for these data is 10.37 ft, while the 75th percentile value is 14.02 ft, and the 25th percentile value is 8.28 ft. These values appear to correspond reasonably well to human-factors results indicating that people can resolve range to within approximately  $\pm 12$  percent.

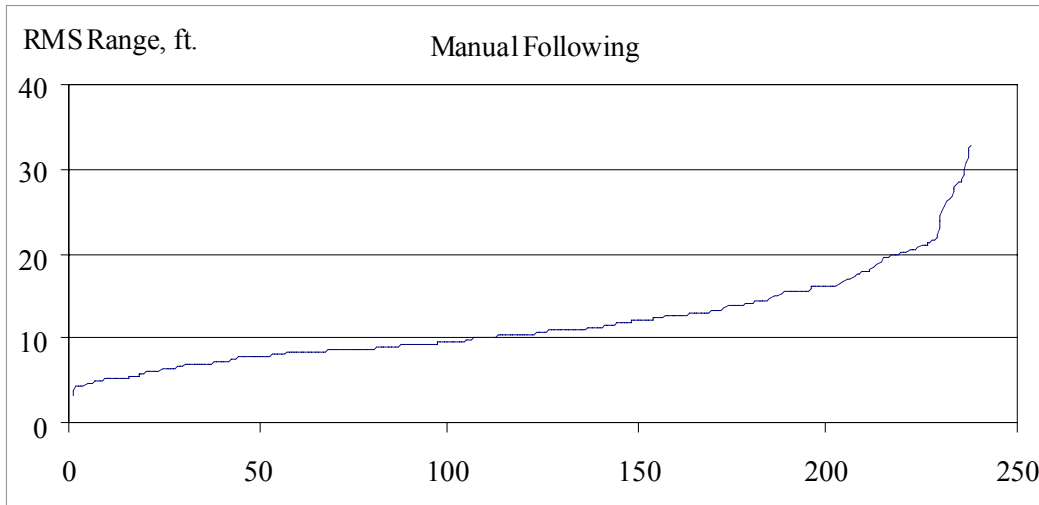

Figure 122. Root-mean-square deviation in range during manual following

Table 53 also gives RMS values for Rdot and the mind's eye coordinates, Theta ( $\theta$ ) and ThetaDot ( $\theta$ dot), as well as average values for R and  $\theta$ . The average value of R is in agreement with the magic number of 85 ft shown previously in Figure 81 in connection with the desired headway during manual driving. Also the average value of  $\theta$  is close to 0.07 radians as used previously in describing manual driving per the mind's eye coordinates.

Table 53. Following performance in manual and ACC driving

<b>Following Manual:</b>						
	AvgRange	rmsRange	rmsRDot	rmsTheta	rmsThetaDot	AvgTheta
Min. Value:	45.173331	3.255031	0.978925	0.000903	0.000126	0.017639
25th Percentile:	70.010860	8.277937	1.562074	0.005950	0.001077	0.059973
50th Percentile:	82.796556	10.369487	1.761377	0.009432	0.001701	0.074340
75th Percentile:	101.965220	14.020153	1.953844	0.013309	0.002222	0.087408
Max. Value:	341.019693	32.691080	2.617573	0.025772	0.004789	0.134572
<b>Following ACC:</b>						
	AvgRange	rmsRange	rmsRDot	rmsTheta	rmsThetaDot	AvgTheta
Min. Value:	58.982444	0.236695	0.235928	0.000062	0.000049	0.017787
25th Percentile:	112.856495	9.151298	1.294505	0.002305	0.000325	0.035193
50th Percentile:	138.034616	11.612990	1.698612	0.003877	0.000543	0.043764
75th Percentile:	172.694464	15.153612	1.934713	0.005820	0.000820	0.053769
Max. Value:	338.352918	37.111363	2.547771	0.019390	0.002684	0.102892

Returning to Figure 122, note that these data for manual driving are based upon 235 streams only. The explanation for this relatively small data sample is that the drivers did

not follow manually very often. The data imply that following is an activity that drivers tend to avoid if they can when driving manually. One might say that many drivers would not consider following for a full minute's duration. In fact the data comprising these 235 manual following situations were obtained from only 59 different drivers, meaning that there were 49 drivers in our overall test sample who did not follow any single vehicle for a full minute while driving manually at speeds above 55 mph.

In addition, Table 53 contains comparable results for ACC driving. Examination of the results for ACC and manual driving shows that the RMS values for range and range rate are very nearly the same for ACC and manual driving. This means that with respect to range and range rate, this ACC system has resolution and control qualities that are approximately equivalent to those of drivers.

These results could provide a basis for specifying ACC performance. One might specify that in order for an ACC system to be acceptable its RMS values of range deviations and  $\dot{R}$  should conform to, or be smaller than, those obtained here for manual driving. The idea behind this requirement is that an ACC system, which is expected to have better sensing of  $R$  and  $\dot{R}$  than the human driver, should be able to control  $R$  and  $\dot{R}$  at least as well as humans. If this is accomplished, the system is expected to perform well enough that people will not notice headway-control deviations during following and that the system will control headway at least as accurately as manual drivers do.

The results for this ACC system indicate that the system's headway control not only is comparable in control accuracy to the manual controller but it does it at a longer median range. The median ranges given in Table 53 are 82.80 ft for manual driving and 138.03 ft for ACC driving. Furthermore, greater range has a large effect on the mind's eye coordinates,  $\theta$  and  $\dot{\theta}$ , since  $\theta$  varies inversely to range and  $\dot{\theta}$  varies inversely as the square of range. As can be seen in Table 53, the RMS values for  $\theta$  deviations and  $\dot{\theta}$  are considerably smaller for ACC driving than for manual driving. This means that drivers (on the average) see smaller images and feel less looming during ACC driving. Perhaps this feature contributes to the driver's perception of comfort with this ACC system. (See section 8.4 for subjective comfort ratings.) Although each driver has differing perceptions and driving preferences, these results help to understand comments made in one of the focus group sessions. One driver thought the system was like magic. How could the system know and do what the driver wanted even before the driver knew?

In summary, this ACC system performs the following operation within the bounds of manual-driving accuracy but at longer ranges than those that drivers tend to use in

manual driving. It is thought that drivers would be less accurate and would experience difficulty in trying to modulate the throttle for controlling headway at the ranges used by the ACC system.

The process of closing is clearly different from following. Rather than attempting to hold range constant, closing (as the name implies) is characterized by decreasing values of range. Two main features of closing situations are the range at which driving speed starts to decrease in adjusting to the speed of the impeding vehicle and the rate of this decrease in speed.

A general rule, indicating when manual driving enters a mode that is the equivalent of operating on a target (OOT), is not easy to deduce from the data. This difficulty has been resolved by studying the last part of the closing operation. This is done by working backwards in time from the point at which following began (i.e., at  $R_{dot}$  equal to -5 ft/sec). The closing stream is thus defined backward in time from the start of following (the end of closing) to a previous point in time at which the range has increased by 50 ft into the closing process region. The reason for choosing only the last 50 ft for studying the closing is that drivers often start adjusting speed manually just prior to reaching this point. The ACC system is already operating on a target at this starting point for defining a closing stream.

The duration of the time to close the last 50 feet and the average deceleration (change in velocity divided by the duration) are used here as characterizing measures for examining closing performance. There were nearly 600 suitable manual-closing events found in the streams table. This number is also relatively low because preceding vehicles do not often hold speed constant for long enough to satisfy the search criteria for closing on a constant velocity target. The results for duration and average deceleration for manual driving are shown in Figures 123 and 124. Comparable results covering over 700 suitable closing sequences during ACC driving are shown in Figures 125 and 126.



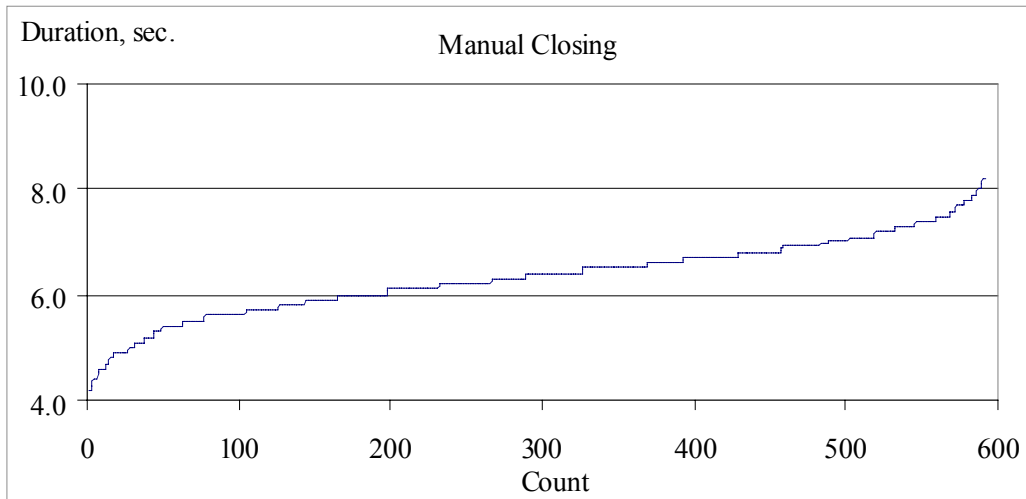

Figure 123. Duration of time for the last 50ft of manual closing

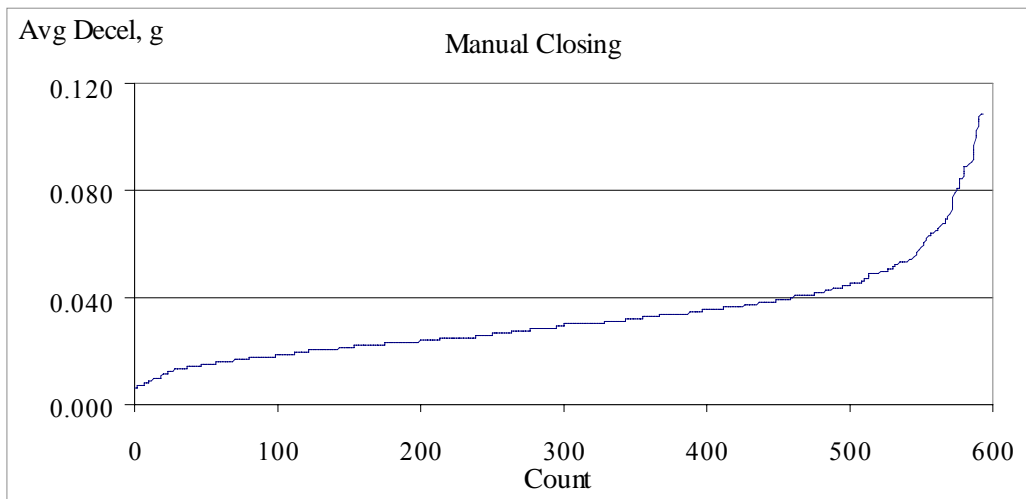

Figure 124. Average deceleration during the last 50ft of manual closing

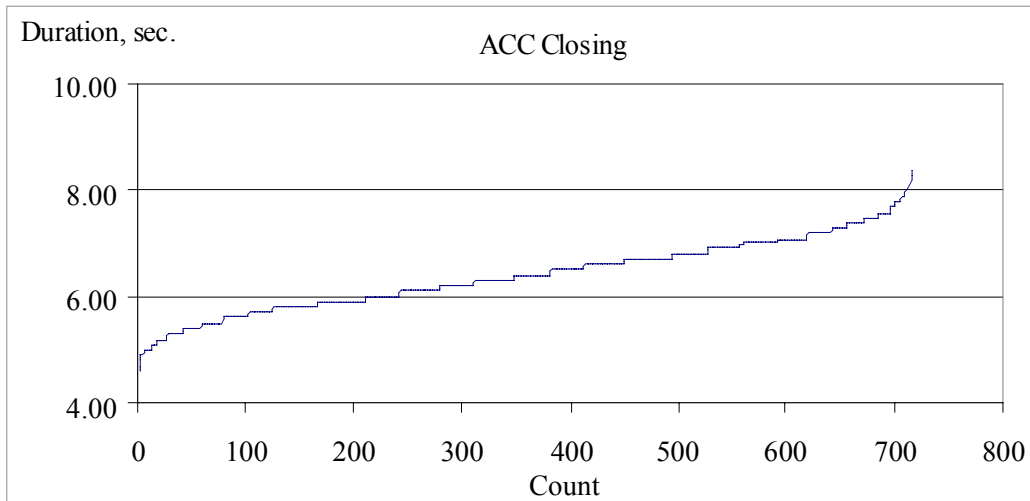

Figure 125. Duration of time for the last 50ft of ACC closing

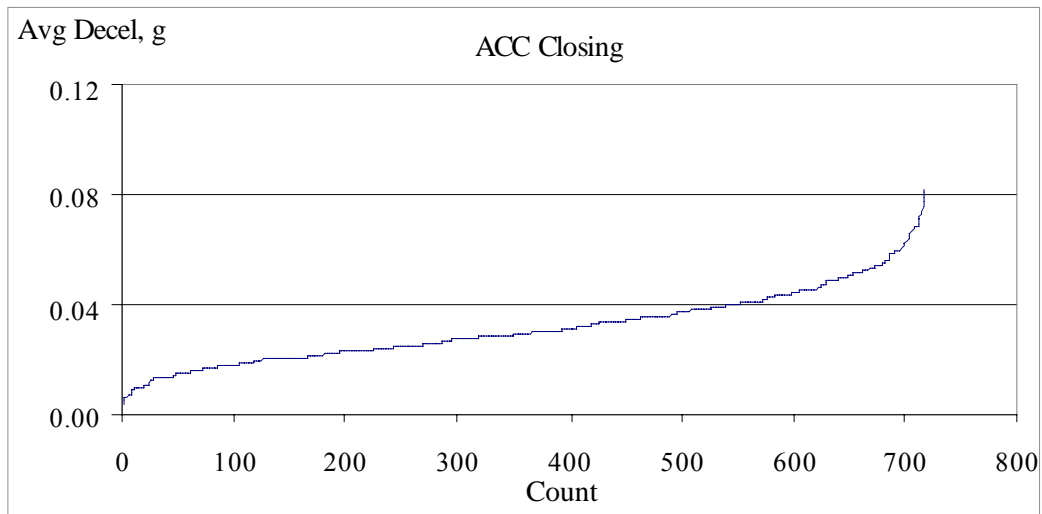

Figure 126. Average deceleration during the last 50ft of ACC closing

The values portrayed in these four figures have been processed to obtain the percentile values for duration and average deceleration contained in Table 54 on the next page. Examination of the table shows that according to these measures ACC closing is very similar to that of manual closing—at least for the 25<sup>th</sup> to 75<sup>th</sup> percentile values for the last 50 ft of the operation.

Table 54. Comparison of manual and ACC driving

<b>Manual Closing (During)</b>			
	Duration, sec.	Avg Decel, g	Avg Vp, ft/sec
Min. Value:	4.2000	0.0057	57.4608
25th Percentile:	5.9000	0.0212	85.5671
50th Percentile:	6.4000	0.0292	91.0355
75th Percentile:	6.8000	0.0382	97.7437
Max. Value:	8.2004	0.1087	117.1097
<b>ACC Closing (During)</b>			
	Duration, sec.	Avg Decel, g	Avg Vp, ft/sec
Min. Value:	4.6001	0.0031	68.9310
25th Percentile:	5.9000	0.0214	86.2861
50th Percentile:	6.4000	0.0292	91.4607
75th Percentile:	6.9000	0.0392	96.4214
Max. Value:	8.4001	0.0821	110.6298

Although the average decelerations are nearly the same, ACC closing happens at longer range than manual closing—as is consistent with the results for the following region. For example the 50th percentile value of range for the start of the closing analysis is 160 ft for manual closing and 185 ft for ACC closing.

An interesting feature of the closing results has to do with the average velocity of the impeding vehicle. Results show that 50 percent of them are traveling between 86 and 98 ft/sec for manual driving and 86 to 96 ft/sec for ACC driving—around 105 kph. These results indicate that drivers tend to operate the ACC system at speeds such that they encounter preceding vehicles at nearly the same values of range rate as those they encounter when driving manually.

The results for closing situations might be used in developing an ACC specification for closing situations. An initial attempt at this is as follows: The duration of the last 50 ft of closing before Rdot equals -5 ft/sec should have a 25th to 75th percentile spread falling between 5.8 to 7.0 seconds, and the average deceleration should have a 25th to 75th percentile spread falling between 0.02 g to 0.04 g at highway speeds above 55 mph. Even though one could argue that this approach is too complicated and restrictive to be acceptable as a standard, it provides a starting point for examining and comparing the performance of ACC systems in closing situations. Until more is understood about the science of driving, this specification might provide a means for comparing ACC systems with how people drive manually in closing situations. This specification and the one suggested earlier for the following type of sequence provide means for comparing ACC

systems in general with a particular ACC system that received the generally good subjective ratings presented in the next section.

## **8.4 Basic Results From Questionnaires**

The detailed ACC system questionnaire was composed of 44 questions. Four questions were open ended, requiring the participant to provide written comments. Appendix B includes a detailed summary of all the responses to the questions, including those that were open ended. Statistical analyses were performed on the responses to the remaining 40 questions that involved numbered ratings and rate values.

Eight of the 40 questions were questions in which the participant was asked to rank order their preference in using manual control, conventional cruise control, or ACC under various scenarios. The results of the rank order questions were analyzed using the Friedman two-way analysis of variance-by-ranks test.

The remaining 32 questions used Likert-type scales ranging from 1 to 7, and were anchored on both ends with terms appropriate for the question. Analyses of variance were performed on the results to all of the Likert-type scale questions. For the purpose of these analyses it was assumed that the underlying assumptions of analysis of variance were not violated such that the data were considered to be normally distributed, that the variances associated with different treatment populations were equal, and that there was independence between error components. Null responses (0's) were not included in these analyses.

### **8.4.1 Questionnaire Results Showing Overall Satisfaction and Utility**

The subjective results presented here pertain to issues concerning (1) the levels of comfort (convenience) and safety drivers associate with ACC, (2) reactions to driving with this ACC system, (3) the driver's ability to adapt to different road, traffic, and weather situations while using this ACC system, and (4) willingness to purchase.

Statistics regarding the participants' answers to each question are provided in appendix B. This section of the report includes excerpts from the appendix, grouped by topics that the questionnaire addresses. The results given in this section are for all drivers. Results for various groups of drivers are given in the appendix.

#### **Comfort and Convenience (in General)**

The participants gave high ratings to the ACC system with relation to driving comfort. Most participants, 91 of 108, reported feeling comfortable using the system in one day or

less. The remaining 17 participants reported feeling comfortable using the system after a few days (see questions 1 and 2 in Table 55 on the next page).

However, participants reported that they would become more comfortable with the system were they given additional time to use it (see questions 3, 5, and 10 in Table 55). The ACC system was also favorably rated on several other dimensions (see questions 6 through 10 in Table 55). When asked to rank the three possible modes of operation on the basis of comfort, participants ranked ACC as their first choice, followed by conventional cruise control and manual control (see question 11 in Table 55). Similar results were observed when participants were asked to rank the three modes of operation on the basis of convenience or driving enjoyment (see two items of question 11 in Table 55).

Table 55. Summary of general comfort and convenience questions

Question	Answer	
1. How comfortable did you feel driving the car using the ACC system?	<b>Rating</b>	1 to 7 (most comfortable)
	<b>Mean</b>	5.8 (s = 1.4)
2. How long did it take you to be comfortable using the ACC system?	91 after the first day or less 15 needed more than a day 2 were never comfortable	
3. How easy was it to drive using the ACC system?	<b>Rating</b>	1 to 7 (most likely)
	<b>Mean</b>	6.0 (s = 1.0)
4. How likely is it that you would have become more comfortable using the ACC system given more time?	<b>Rating</b>	1 to 7 (most comfortable.)
	<b>Mean</b>	5.0 (s = 2.4)
5. How comfortable were you physically driving the ACC system in comparison to your usual mode of driving ?	<b>Rating</b>	1 to 7 (most comfortable.)
	<b>Mean</b>	5.4 (s = 1.4)
10. How comfortable would you feel if your child, spouse, parents or other loved ones drove a vehicle equipped with ACC?	<b>Rating</b>	1 to 7 (most comfortable)
	<b>Mean</b>	5.7 (s = 1.6)
11. Compare three operation modes (Manual, Conventional Cruise, ACC) for comfort	<b>Rank</b>	1 to 3 (least comfort)
	<b>Mean</b>	2.6 (Manual, s=.7)
		2.1 (Conv. Cruise, s=.5) 1.3 (ACC, s=.6)
Compare three operation modes (Manual, Conventional Cruise, ACC) for convenience	<b>Rank</b>	1 to 3 (least convenient)
	<b>Mean</b>	2.6 (Manual, s=.8) 2.1 (Conv. Cruise, s=.5)

Question	Answer	
		1.3 (ACC, s=.6)
Compare three operation modes (Manual, Conventional Cruise, ACC) for driving enjoyment	<b>Rank</b>	1 to 3 (least convenient)
	<b>Mean</b>	2.6 (Manual, s=.8)
		2.1 (Conv. Cruise, s=.5)
		1.3 (ACC, s=.6)

### Safety (in General)

With regards to safety, participants have reported the ACC system to be safe to use (see question 28 in Table 56), and that use of the system may actually increase driving safety (question 29 in Table 56). When asked to rank the three possible modes of operation on the basis of safety participants ranked the use of manual control first, followed by ACC (question 11 in Table 56). Participants also reported driving most cautiously when using ACC relative to conventional cruise control and manual control (question 14 in Table 56), without experiencing “unsafe” following distances (question 21 and 25 in Table 56). In addition, very few system failures were reported (questions 34 and 35 in Table 56). Finally, participants reported being both aware of and responsive to surrounding traffic when using the ACC system (questions 18 and 19 in Table 56).

Table 56. Summary of general safety questions

Question	Answer	
11. Compare safety under the three operating modes (Manual, Conventional Cruise, ACC)	<b>Rank</b>	1 to 3 (least safety)
	<b>Mean</b>	1.4 (Manual, s=.7)
		2.6 (Conv. Cruise, s=.6) 2.0 (ACC, s=.6)
14. Under which mode of operation do you drive most cautiously?	<b>Rank</b>	1 to 3 (least cautious)
	<b>Mean</b>	2.2 (Manual, s=.9)
		2.1 (Conv. Cruise, s=.7) 1.7 (ACC, s=.8)
18. Driving the ACC system, compared to manual driving, did you find yourself more or less aware of the actions of vehicles around you?	<b>Rating</b>	1 to 7 (most aware)
	<b>Mean</b>	5.5 (s = 1.4)
19. Driving the ACC system, compared to manual driving, did you find yourself more or less responsive to actions of vehicles around you?	<b>Rating</b>	1 to 7 (most responsive)
	<b>Mean</b>	5.3 (s = 1.3)
21. How easy or difficult did you find it to maintain a safe distances to the preceding	<b>Rating</b>	1 to 7 (very easy)
	<b>Mean</b>	5.4 (Manual, s=1.9)

<b>Question</b>	<b>Answer</b>	
vehicle using each of the following modes of operation?		3.6 (Conv. Cruise, s=1.7) 5.9 (ACC, s=1.2)
25. How often, if ever, did you experience “unsafe” following distances when using the ACC system?	<b>Rating</b>	1 to 7 (least frequent)
	<b>Mean</b>	5.7 (s = 1.5)
28. How safe did you feel using the ACC system?	<b>Rating</b>	1 to 7 (very safe)
	<b>Mean</b>	6.0 (s = 1.1)
29. Do you think ACC is going to increase driving safety?	<b>Rating</b>	1 to 7 (strongly agree)
	<b>Mean</b>	5.4 (s = 1.4)
34. While using the ACC system, how often, if ever, did the system fail to detect a preceding vehicle?	<b>Rating</b>	1 to 7 (never)
	<b>Mean</b>	6.0 (s = 1.3)
35. While using the ACC system, how often, if ever, did the system produce false alarms (i.e., detect a vehicle when none existed)?	<b>Rating</b>	1 to 7 (never)
	<b>Mean</b>	6.0 (s = 1.4)

### **Willingness to Purchase**

When asked to provide an overall ranking of the three modes of operation for personal use, participants ranked ACC first with conventional cruise control a distant third (see question 38 in Table 57). Participants also reported being very willing to purchase an ACC system in their next new car (question 39), but were frequently reluctant to provide an amount they would be willing to pay (question 40). Participants were also willing to rent an ACC-equipped vehicle (question 41). They also felt that ACC would be easy to market and could replace CCC (questions 36 and 37 in Table 57).

Table 57. Summary of questions regarding willingness to purchase

<b>Question</b>	<b>Answer</b>	
36. How easy or difficult do you feel it will be to market a vehicle equipped with an ACC System?	<b>Rating</b>	1 to 7 (very easy)
	<b>Mean</b>	5.7 (s = 1.4)
37. How comfortable would you feel if ACC systems replaced conventional cruise control?	<b>Rating</b>	1 to 7 (very comfortable)
	<b>Mean</b>	6.2 (s = 1.3)
38. Rank, in order of preference, the following modes of operation for personal use	<b>Rank</b>	1 to 3 (least desirable)
	<b>Mean</b>	1.9 (Manual, s=.9)
	<b>Mean</b>	2.5 (Conv. Cruise, s=.6) 1.6 (ACC, s=.6)
39. Would you be willing buy an ACC system in your next new vehicle?	<b>Rating</b>	1 to 7 (very willing)
	<b>Mean</b>	5.8 (s = 1.6)

40. Approximately how much would you be willing to spend for this feature in a new vehicle? (24 did not answer)		Answer range from \$0 to \$2,500
		Median approximately \$450
41. Would you be willing to rent a vehicle equipped with an ACC system when you travel?	<b>Rating</b>	1 to 7 (very willing)
	<b>Mean</b>	6.4 (s = 1.2)

### Roads, traffic, and weather

The ratings and rankings given in Table 58 reflect the reluctance of drivers to use ACC under conditions that make them uncomfortable for any reason, including safety, ease of control, and mental workload.

The ratings and rankings are generally lower in more demanding driving situations. Furthermore, the number of drivers that chose not to use the ACC system increases as the difficulty of the driving situation increases. Many drivers did not wish to use this ACC system in bad weather, on hilly roads, on winding roads, on two-lane rural roads, on arterial streets, or in heavy traffic (see Table 58).

Table 58. Summary of questions pertaining to roads, traffic, and weather

Question	Answer	
6. How comfortable were you using the ACC system in the rain or snow?	<b>Rating</b>	1 to 7 (very comfortable)
	<b>Mean</b>	4.5 (s = 1.7) Did not experience: 29 drivers
7. How comfortable are you using conventional cruise control in rain or snow?	<b>Rating</b>	1 to 7 (very comfortable)
	<b>Mean</b>	4.6 (s = 1.8) Did not experience: 16 drivers
8. How comfortable were you using the ACC system on hilly roads?	<b>Rank</b>	1 to 7 (very comfortable)
	<b>Mean</b>	5.25 (s = 1.6) Did not experience: 32 drivers
9. How comfortable were you using the ACC system on winding roads?	<b>Rank</b>	1 to 7 (very comfortable)
	<b>Mean</b>	4.8 (s = 1.6) Did not experience: 16 drivers
23. How did using the ACC system affect your speed, relative to neighboring vehicles, when driving in the following traffic environments?	<b>Rank</b>	1 to 7 (faster)
	<b>Mean</b>	4.6 ( <u>Freeways</u> , s=1.4) Did not use: 0 drivers 4.1 ( <u>2-lane rural hwy</u> , s=1.2) Did not use: 27 drivers 3.8 ( <u>Arterial streets</u> , s=1.0) Did not use: 37 drivers



Question	Answer	
		3.3 ( <u>Heavy traffic</u> , s=1.3) Did not use: 39 drivers 4.2 ( <u>Medium traffic</u> , s=1.0) Did not use: 3 drivers 5.1 ( <u>Light traffic</u> , s=1.1) Did not use: 1 drivers
24. How did using the ACC system affect your headway (following distance), as compared to manual control, when driving in the following traffic environments?	<b>Rank</b> <b>Mean</b>	1 to 7 (farther) 4.9 ( <u>Freeways</u> , s=1.5) Did not use: 0 drivers 4.8 ( <u>2-lane rural hwy</u> , s=1.5) Did not use: 24 drivers 4.7 ( <u>Arterial streets</u> , s=1.4) Did not use: 35 drivers 5.4 ( <u>Heavy traffic</u> , s=1.7) Did not use: 38 drivers 4.7 ( <u>Medium traffic</u> , s=1.3) Did not use: 6 drivers 4.5 ( <u>Light traffic</u> , s=1.5) Did not use: 1 drivers
27. Compare operation modes (manual, CCC, ACC) you are most likely to drive on the following road types	<b>Rank</b> <b>Mean</b>	1 to 3 (least likely) <u>Freeway:</u> 2.64 (Manual, s=.7) 2.2 (Conv. Cruise, s=.5) 1.2 (ACC, s=.4) <u>2-lane rural road:</u> 1.9 (Manual, s=.9) 2.5 (Conv. Cruise, s=.6) 1.7 (ACC, s=.7) <u>Arterial streets:</u> 1.2 (Manual, s=.5) 2.7 (Conv. Cruise, s=.5) 2.1 (ACC, s=.6)

### ACC Driving

Table 59 summarizes reactions aggregated to all 108 drivers. These questions are aimed at understanding how drivers felt about the performance of this ACC system.

Questions 12, 13, 30, and 31 are comparative in form and/or provide an overall perception of the system in general. In contrast, questions 15 through 26, 32, and 33 are more readily associated with specific design features of the ACC system.

In general, the subjective ratings reflect rather favorable judgements concerning the performance of this ACC system. Although there is room for improvement, the system's performance appears to have acceptable utility to many drivers.

Table 59. Summary of questions concerning performance features of this ACC system

Question	Answer	
12. In general, under what mode of operation did you feel like you drove fastest?	<b>Rank</b>	1 to 3 (slowest)
	<b>Mean</b>	1.5 (Manual, s=.8) 2.3 (Conv. Cruise, s=.6) 2.2 (ACC, s=.7)
13. Which mode of operation required you to apply the brakes most often?	<b>Rank</b>	1 to 3 (most braking)
	<b>Mean</b>	2.1 (Manual, s=.9) 2.3 (Conv. Cruise, s=.6) 1.6 (ACC, s=.8)
15. What did you think of the deceleration rate provided by the ACC system when following other vehicles?	<b>Rating</b>	1 to 7 (too fast)
	<b>Mean</b>	3.64 (s = 1.2)
16. What did you think of the acceleration provided by the ACC system when pulling into an adjacent lane to pass other vehicles?	<b>Rating</b>	1 to 7 (too fast)
	<b>Mean</b>	3.2 (s = 1.5)
17. How consistent did you maintain your speed when using the ACC system, as compared to driving manually?	<b>Rating</b>	1 to 7 (very consistent)
	<b>Mean</b>	5.82 (s = 1.5)
20. When using the ACC system, did you ever feel you didn't understand what the system was doing, what was taking place, or how the ACC system might behave?	<b>Rating</b>	1 to 7 (very infrequently)
	<b>Mean</b>	5.52 (s = 1.5)
26. Do you feel the headway adjustment feature useful?	<b>Rating</b>	1 to 7 (strongly agree)
	<b>Mean</b>	5.87 (s = 1.5)
30. While driving using ACC, did you ever feel overly confident?	<b>Rating</b>	1 to 7 (strongly agree)
	<b>Mean</b>	3.2 (s = 1.8)
31. Did you feel more comfortable performing additional tasks, (e.g., adjusting the heater or the radio) while using the ACC system as compared to driving under manual control?	<b>Rating</b>	1 to 7 (strongly agree)
	<b>Mean</b>	4.4 (s = 1.9)

Question	Answer	
32. Did you find the ACC system functions distracting (e.g., automatic acceleration and deceleration)?	<b>Rating</b>	1 to 7 (not at all distracting)
	<b>Mean</b>	5.6 (s = 1.6)
33. Did you find the ACC system components distracting (e.g., status lights, control buttons)?	<b>Rating</b>	1 to 7 (not at all distracting)
	<b>Mean</b>	5.7 (s = 1.6)

#### 8.4.2 Statistically Significant Differences Related to Age, CCC Usage, and Exposure to ACC

Because the experimental design was not a full-factorial design (see Figure 28 in Section 3.4.2 for a graphical representation of the experimental design), two analyses of variance tests were performed on each of the Likert-type scale questions. The two separate analyses treated the results as though they were derived from two full-factorial designs. The first being a two-factor-by-three-factor design that included conventional cruise-control usage (user, nonuser) and participant age group (20-to-30, 40-to-50, and 60-to-70 years). The second analyses were also performed as a two-factor-by-three-factor design that included duration participation (2 weeks, 5 weeks) and participant age group (20-to-30, 40-to-50, and 60-to-70 years).

Listed below are the questions in which a statistically significant main effect or two-way interaction was observed, using either the analysis-of-variance techniques described above or the Friedman two-way, analysis-of-variance-by-ranks test. When a significant main effect or interaction resulted from the analysis of variance, and there were more than two levels of the variable, the results of a Newman-Keuls post-hoc analysis of differences between means are presented. The Newman-Keuls post-hoc analyses allow for individual differences between means to be assessed for statistical significance (denoted in the following tables through use of different letters).

1. *How comfortable did you feel driving the car using the ACC system?*

1	2	3	4	5	6	7
<i>Very Uncomfortable</i>					<i>Very Comfortable</i>	

The statistically significant main effect was driving exposure time,  $F(1, 60) = 5.65$ ,  $p = 0.02$

	Mean
2 weeks	5.71







Middle-aged 5 weeks	7.00			C
---------------------	------	--	--	---

Means with the same letter are not significantly different from one another.

25. How often, if ever, did you experience “unsafe” following distances when using the ACC system?

1	2	3	4	5	6	7	
<i>Very Frequently</i>					<i>Very Infrequently</i>		

The statistically significant main effect was usage,  $F(1, 78) = 7.56, p = 0.007$

	Mean
Nonuser	5.24
User	6.14

26. Do you feel the headway adjustment feature useful?

1	2	3	4	5	6	7	
<i>Strongly Disagree</i>					<i>Strongly Agree</i>		

The statistically significant main effect was age,  $F(2, 78) = 3.40, p = 0.04$

	Mean		
20-30	5.11	A	
40-50	5.86	A	B
60-70	6.21		B

Means with the same letter are not significantly different from one another.

30. While driving using ACC, did you ever feel overly confident?

1	2	3	4	5	6	7	
<i>Strongly Disagree</i>					<i>Strongly Agree</i>		

The statistically significant main effect was usage,  $F(1, 78) = 4.49, p = 0.04$ . There also was a significant interaction between age and usage,  $F(2, 78) = 7.43, p = 0.001$ .

**Usage**

	Mean
Nonuser	2.71
User	3.48

**Age and Usage**

	Mean				
Older Nonuser	1.71	A			
Younger User	2.93		B		
Younger Nonuser	3.00		B		
Middle-aged User	3.07		B		
Middle-aged Nonuser	3.43			C	
Older User	4.43				D

Means with the same letter are not significantly different from one another.

35. While using the ACC system, how often, if ever, did the system produce false alarms (i.e., reported the presence of a vehicle when none existed)?

1      2      3      4      5      6      7

*Always*

*Never*

The statistically significant main effects were age,  $F(2, 78) = 5.39, p = 0.006$  and exposure,  $F(1, 60) = 9.62, p = 0.003$

#### Age

	Mean		
20-30	5.64	A	
40-50	6.50		B
60-70	6.64		B

Means with the same letter are not significantly different from one another.

#### Exposure

	Mean
2 weeks	6.14
5 weeks	5.04

36. How easy or difficult do you feel it were to market a vehicle equipped with an Adaptive Cruise Control (ACC) System?

1      2      3      4      5      6      7

*Very*

*Very*

*Difficult*

*Easy*

The statistically significant main effect was usage,  $F(1, 77) = 6.43, p = 0.01$ .

	Mean
Nonuser	5.29
User	6.02





moderator. A total of 51 participants attended a focus group, and of these 23 were female and 28 were male. Twenty-one of the participants traditionally did not use conventional cruise control on their own cars (non-users) while the remaining 30 regularly used conventional cruise control (users). Forty-three of the participants had driven an ACC vehicle for two weeks, while 8 had driven it for five weeks. Thirteen of the participants ranged in age from 20 to 30, 14 ranged in age from 40 to 50, and 24 ranged in age from 60 to 70 years old.

During each of the ten focus group meetings, a particular series of seventeen questions were asked. All seventeen questions are listed below, followed by a brief summary of the responses. Responses are not exclusive (i.e., the same participant may have accounted for more than one response per question).

### *Question 1*

#### ***In what situations was adaptive cruise control most useful?***

- Consider traffic density, road type, and weather conditions.
- What features of adaptive cruise control did you find most beneficial?

Twenty participants found it useful on expressways.
---

Nine participants liked the ability to select headway.
--

Eight participants liked it best in light to moderate traffic.
--

Six participants found it most useful in heavy traffic.
---

### *Question 2*

#### ***When was the adaptive cruise control system least useful?***

- Consider traffic density, road type, and weather conditions.
- What additional features would you like to have with adaptive cruise control?

Eleven participants found it least useful in the rain.
--

Eighteen participants found it least useful in heavy traffic.
---

Eight participants found it least useful on surface streets.
--

Seven participants found it least useful in stop and go traffic.
--

Twelve participants found it least useful in bad weather.
---

### *Question 3*

#### ***How convenient did you find using adaptive cruise control?***

- Was it difficult to learn to operate?

Twenty-seven participants found it convenient and easy to learn.
--

Six participants said it took a while to get used to it.

*Question 4*

***How similar to your own driving behavior do you think the adaptive cruise control system operated?***

- If the system was different, how did it differ from your driving behavior?

Eight participants said it made them tailgate less.

Six participants reported speeding less/keeping a steadier pace.

*Question 5*

***Did you feel comfortable with the headway distances available for use?***

- Should they have been longer or shorter?
- Should there have been more levels?

Fourteen participants liked present headway options.

Eight participants preferred the closest setting.

Eleven participants preferred the middle setting.

Twelve participants preferred the farthest setting.

Eight participants didn't like the closest/thought it unsafe.

Ten participants thought settings needed improvement .

Seven participants would like continuous headway adjustment.

*Question 6*

***Were the controls and display for the ACC system easy to use and easy to see.***

- Were there other types of information you would like displayed?
- Where else might you place the controls/display?

Eleven participants want both speed displays close together and digital.

Eleven participants want ACC controls on the steering wheel.

Eight participants would like better lighting of the CCC/ACC controls at night

Eight participants liked the vehicle-detected light.

*Question 7*

***What impact did adaptive cruise control have on your sense of comfort?***

- Consider traffic density, road type, and weather conditions.

Twenty-five participants were more comfortable using ACC.

Nine participants were less comfortable.

*Question 8*

***Did the system ever make you feel too comfortable?***

- Did you feel that you might fall asleep easily?

Nineteen participants could be too comfortable/fall asleep because of the system.

Twelve participants didn't think they would become too comfortable.

*Question 9*

***Did the system ever track false targets (i.e. cars in adjacent lanes)?***

- Briefly explain the conditions under which this occurred.

Forty-one participants reported having false targets.

*Question 10*

***Did the system ever track phantom targets (i.e. vehicles that did not exist)?***

- Briefly explain the conditions under which this occurred.

Nine participants reported having phantom targets.

*Question 11*

***Was there ever a situation when you didn't understand whether or not the system was working properly?***

- Briefly explain.
- If so, what was your strategy?

Twenty-four participants experienced situations they didn't understand.

*Question 12*

***What do you think of the adaptive cruise control system's rate of acceleration:***

- When passing?
- When closing a gap?

Nine participants thought it was slow to close gaps.

Twenty-four participants thought it was slow to pass.

Five participants thought the acceleration was adequate.

Eight participants reported overriding to accelerate.

Twelve participants thought the onset of acceleration was slow.

*Question 13*

***What do you think of the adaptive cruise control system's rate of deceleration:***

- In response to slower moving vehicles?
- In response to “cut-ins”?

Seven participants thought it decelerated too slowly.
---

Eighteen participants thought the deceleration was adequate.
--

Six participants thought the onset of deceleration was slow.
--

*Question 14*

***When a difference in vehicle speeds required you to use the brake, was it difficult to learn when braking was required?***

- Would an audible tone (warning) be useful?

Eleven participants would like an audible tone.
---

Twenty-one participants do not want a tone.
---

Sixteen participants thought it was easy to learn when to brake
---

*Question 15*

***What impact did adaptive cruise control have on your sense of safety?***

- Consider traffic density, road type, and weather conditions.
- Did you feel more or less safe driving with ACC as compared to manual driving?

Twenty-three participants thought it was safer than manual.
---

Eleven participants thought it was not as safe as manual.
---

*Question 16*

***When driving with ACC engaged, were you ever disturbed by an event involving a stopped vehicle due to the fact that the ACC system does not respond to stopped objects?***

- Do you feel the system should respond to stopped objects?

Twenty participants thought it should respond to stopped objects.
---

Thirteen participants didn't think it should respond to stopped objects.
--

*Question 17*

***Would a greater degree of ACC deceleration, using the brake system, have been helpful for dealing with a wider range of traffic situations?***

Twenty participants wanted brakes involved in deceleration.
---

Ten participants didn't think brakes were necessary.

In some way, this tabulation of results from the focus group sessions is less satisfying than observing the actual sessions. Direct observation provides the opportunity to assess the conviction and understanding developed by each participant. Nevertheless, the responses to these 17 questions indicate the same generally-positive response to ACC as that presented in section 8.4 pertaining to the results from the questionnaire.

## **9.0 Presentation of Results by Issue**

In this section, portions of the test data will be presented to address various issues posed by the ACC application. In general, these issues deal with impacts that may attend the general use of ACC products. While ACC will have certain fundamental impacts on the driving experience of the individual, as discussed in various presentations in section 8, this section strives to generalize on the issues that may have some macro impact on the highway environment. Lacking comprehensive models for headway control and its interaction with safety, traffic flow, and energy-usage, results are presented here in a more-or-less piecemeal fashion. That is, since understanding of the driving process is limited, observations must be simply amassed without the benefit of relationships that tie them together in a cohesive way.

### **9.1 Impact of Control Mode on Utilization Choices**

Utilization of ACC is defined as the percentage of ACC-engaged miles out of some total miles traveled when ACC could have been used. For example, the ratio of ACC-engaged miles to all miles traveled at speeds between 50 and 70 mph may be regarded as “utilization between 50 and 70 mph”, but doing the same for a speed range such as 15 to 40 mph will not result in a valid utilization, because in this case ACC could not have been used all the time (below minimum speed). A similar definition applies to CCC utilization. Noting in section 8 that ACC engagement rises strongly with velocity, it is valuable to distinguish certain aspects of utilization according to the speed range that is in question. In this section, various apparent relationships between utilization and condition variables are presented. The presentation covers 1) the utilization levels seen in ACC versus CCC operations, 2) basic determinants of ACC utilization level, 3) trends in ACC utilization with the tenure of usage by individual drivers, and 4) the relationship between utilization and the subjective evaluation of ACC acceptability by individuals.

#### **9.1.1 Utilization Levels in ACC Versus CCC Modes of Control**

Shown in Figure 127 is a comparison of the total utilization rates for ACC and CCC for speeds between 35 and 85 mph. We see that ACC was utilized over 53% of all travel in this speed range while CCC (during its single of week of availability to each participant) was utilized over 35% of miles in the same speed range. Thus, utilization of this ACC system is seen to be higher than that of CCC by half. Although certain patterns of driving activity were noted suggesting that “novelty usage” of ACC played some role in this elevated level of utilization, scrutiny of the data taken with “five-week” drivers shows

utilization rate declining only 2% from the second to the fifth week. (Note that section 9.1.3 specifically addresses utilization as a function of tenure of use.)

Utilization (Distance engaged/total distance)

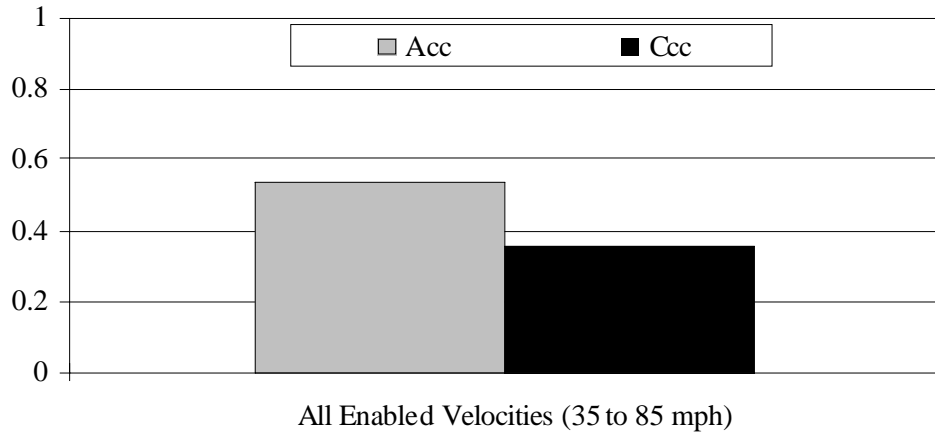

Figure 127. Comparison of total utilization rates for ACC and CCC control

Figure 128 presents, from left to right, an ordered sequence of comparative ACC and CCC utilization levels exhibited by all 108 individuals in the study, beginning with the lowest percentages at the left.

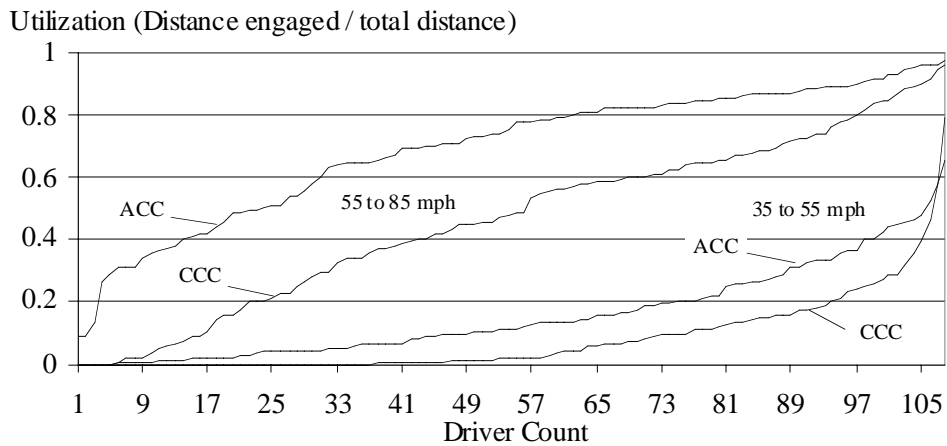

Figure 128. Utilization rate of ACC and CCC control at low and high speed

The figure contains separate sets of curves pertaining to the ordered utilizations obtained in the 35-to-55 mph and 55-to-85 mph speed ranges, respectively. We see that utilization levels varied tremendously across the driver sample, from essentially zero to above 97%. Because the upper ACC curve is distinctly convex, the utilization level adopted by the median participant lies high in the range, at 77%—with half of the participants exhibiting utilizations between 8% to 77% and the other half lying between



77% and 98%. In the corresponding CCC curve pertaining to higher speeds, the utilization levels span the range from 0% to 97%, with the median individual (not the same person as the median individual in the ACC data) lying almost exactly at the center value, 49%. Thus, while the highest utilization rates in either curve are essentially the same for ACC and CCC, a large number of drivers (particularly, those lying toward the left side of the curve) adopted a much higher rate of utilization with ACC than with CCC. One could say that this ACC system succeeded in attracting a substantial new cadre of users from among those who, at least in these data, selected rather low rates of CCC utilization.

The corresponding concavity of the lower-speed curves places the median drivers rather near the bottom of the data range, at a 17% utilization level with ACC and a 4% value with CCC. Thus, half the population of drivers in the low-speed regime of ACC usage lie between 0% and 17% and other half between 17% and 81%. Among the drivers utilizing CCC, half lie between 0% and 4% and the other half lie between 4% and 74%. Clearly, ACC has yielded a more-than-double increase in cruise utilization, over that of CCC, in the speed regime between 35 and 55 mph. This outcome is thought to be highly significant since the low-speed regime is also typified by nonfreeway road designs presenting a more complex environment for conflict plus the interesting phenomenon of traffic signals as an additional factor in longitudinal control. Figure 129 provides the simplest summary of ACC versus CCC utilization results in terms of the contrasting usage by nominal road conditions.

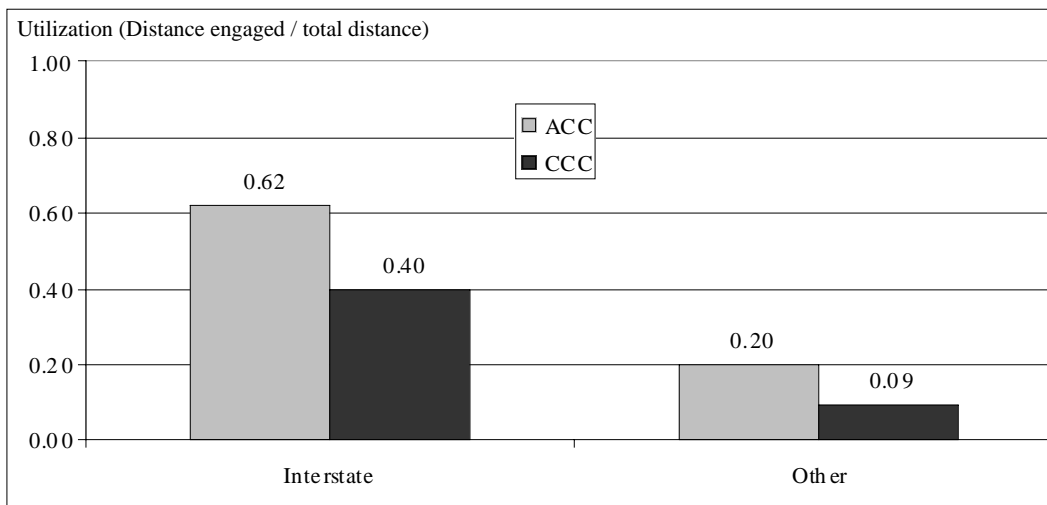

Figure 129. ACC and CCC utilization influenced by road type

The figure shows that while ACC utilization was 55% higher than that of CCC on interstate-quality roads, it was 122% higher on all “other” road types. (The influence of road type per se, on utilization is treated more completely in the next section.)

Another tangent question that was addressable through the data, because of continuous GPS tracking of each vehicle, involved the utilization of ACC and CCC on commute trips. It was possible to isolate commute-only trips by means of having logged each subject’s home and workplace addresses, together with the ability to convert addresses into lat/long coordinates which could then be matched up with GPS tracking coordinates. The results of this exercise showed, as expected, that the denser traffic prevailing during commuting periods resulted in significantly reduced utilization of both ACC and CCC. Compared with overall utilizations in all trips at 53% for ACC and 35% for CCC, the corresponding values in commuting trips were 37% and 25%, respectively. Thus, the ratio of utilization rates seen with ACC versus CCC in commuting trips was almost identical to that seen in all trips (i.e., approximately 1.5). Interestingly, the rate of both cruise-mode utilization levels was about one-fifth lower in the work-to-home leg of the commute cycle than in the home-to-work leg.

### **9.1.2 The Basic Determinants of ACC Utilization Level**

The drivers’ choice of engaging the ACC controller, or not, appears to be influenced by a number of factors. In this section, example variables influencing utilization level are reviewed. While it is recognized that this multivariate problem would be more properly treated by dealing with all of the influential variables acting in concert, the presentation given below shows only the individual influences that are observable in one variable at a time.

Shown in Figure 130 is a histogram of ACC utilization fraction versus velocity. As was indicated on a driver-by-driver basis earlier, we see that ACC is utilized primarily in the higher speed range. Indeed, when the vehicle’s speed is above 65 mph, ACC is seen to be engaged over approximately 77% of all miles traveled, given our sample of 108 subjects. Presumably, the driver’s perception of traffic density and the potential for conflicts requiring intervention is instrumental in the driver’s judgment to engage ACC at any speed.

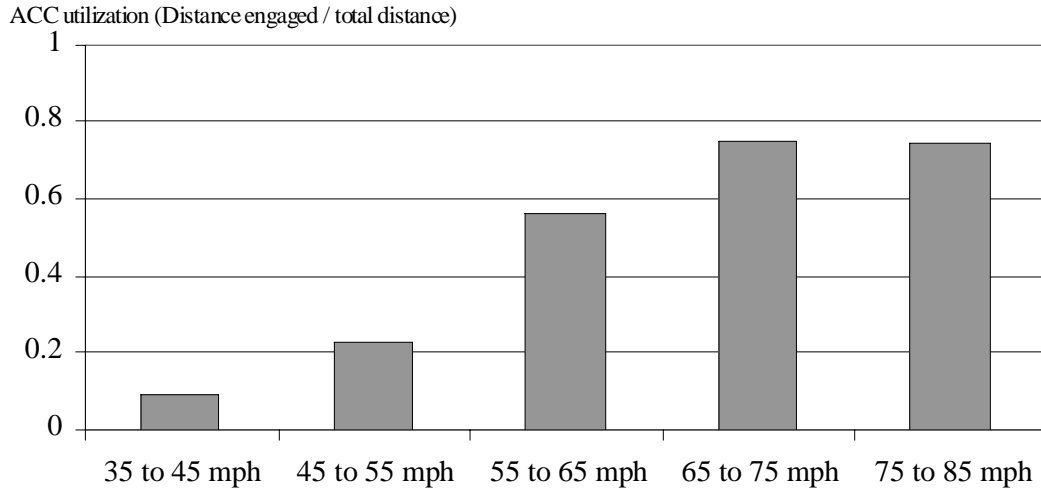

Figure 130. ACC utilization at various speeds

In Figure 131, the influence of driver age on ACC utilization is presented. The data show that the utilization fraction tends to grow with age for both the low and higher speed bands of vehicle operation. Other information gathered through subjective questionnaires appears to indicate that the correlation of utilization level with age probably derives strongly from the relationship between age and driving style. That is, younger drivers are seen to prefer shorter headways and often a higher value of average speed than that of the ambient traffic such that ACC utilization presents more of a hindrance than a help. In such situations, it appears that the driver is less apt to choose ACC engagement.

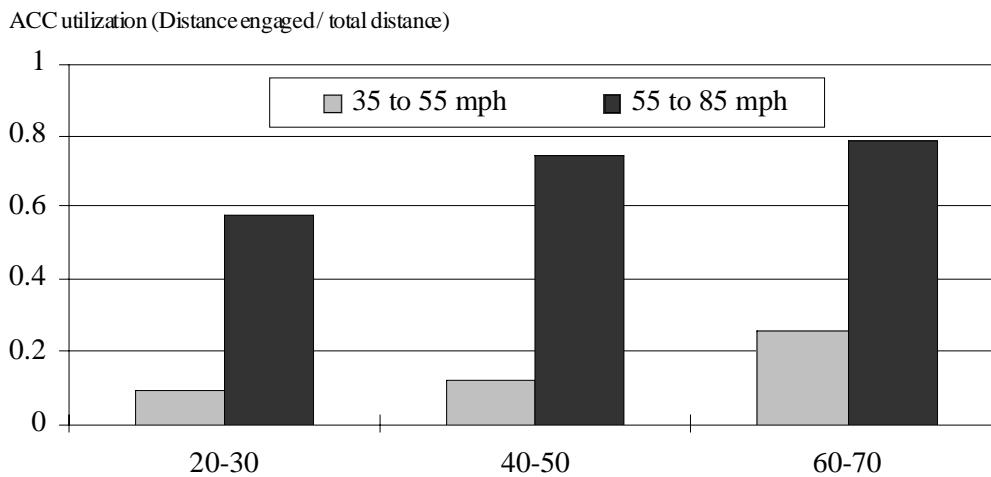

Figure 131. Influence of driver age on ACC utilization

Shown in Figure 132 is an illustration of the influence of the CCC user/nonuser self-characterization on the level of ACC utilization that was exhibited. We see that the CCC users were substantially more likely to utilize ACC, especially in the higher range of operating speeds. In the 55-to-85-mph speed range, users exhibited a 77% utilization level compared with 63% for the nonusers.

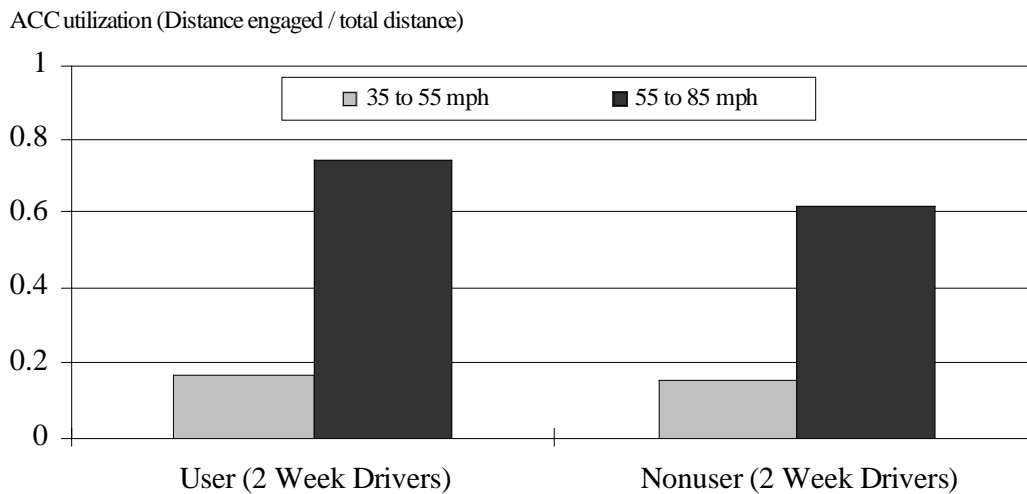

Figure 132. ACC utilization for users and nonusers

Shown in Figure 133 are the utilization levels observed on each of four respective classes of roadway. Insofar as the road type designations were derived through processing of GPS data using map-based road coding, a certain bias in the data presentation must be acknowledged. That is, since the road-type identifier preferentially coded the higher-design type whenever the lat/long coordinates fell within the placement of two differing road types, the mileages used in computing utilization tended to be over-inflated for, say, freeways and state highways. Accordingly, the actual contrast in utilization on high versus low volume is somewhat greater than illustrated. It is expected, for example, that ACC utilization at higher speeds on interstate highways is actually greater than the 68% value shown in the Figure while the corresponding higher-speed utilization level seen on Collector streets is lower than the 39% value shown.

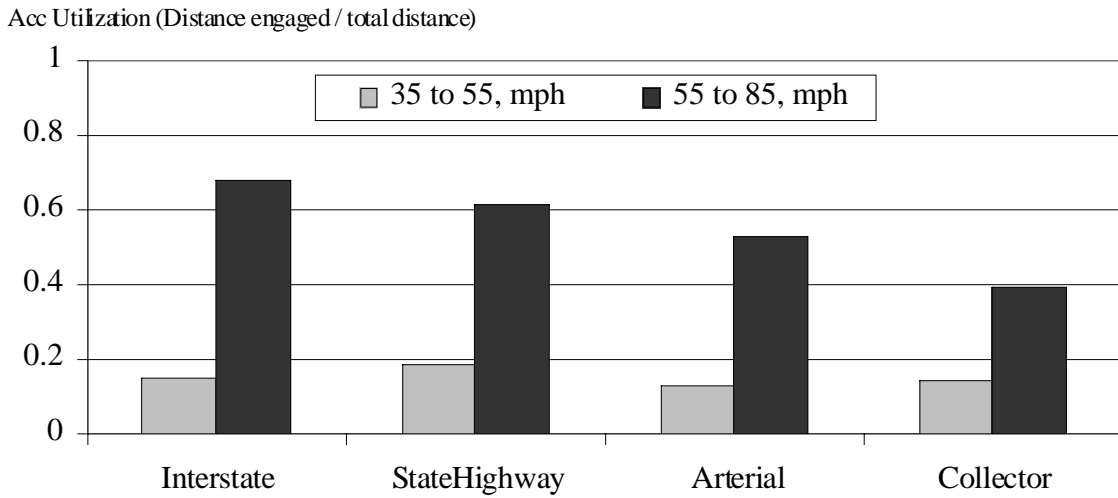

Figure 133. ACC utilization for different road type

The driver-style designations first introduced in section 6 are employed for presentation of utilization results shown in Figure 134. We see that each of the five driving styles differ from one another in terms of utilization, although not in a manner which captures any of the individual extremes seen earlier in Figure 128. That is, while the individual data showed ACC utilizations for at least fifteen persons below the 40% level in the 55-to-85-mph speed range, the data in Figure 134 indicate no driver styles, as a group, utilizing ACC at a level below 60% in the same speed range.

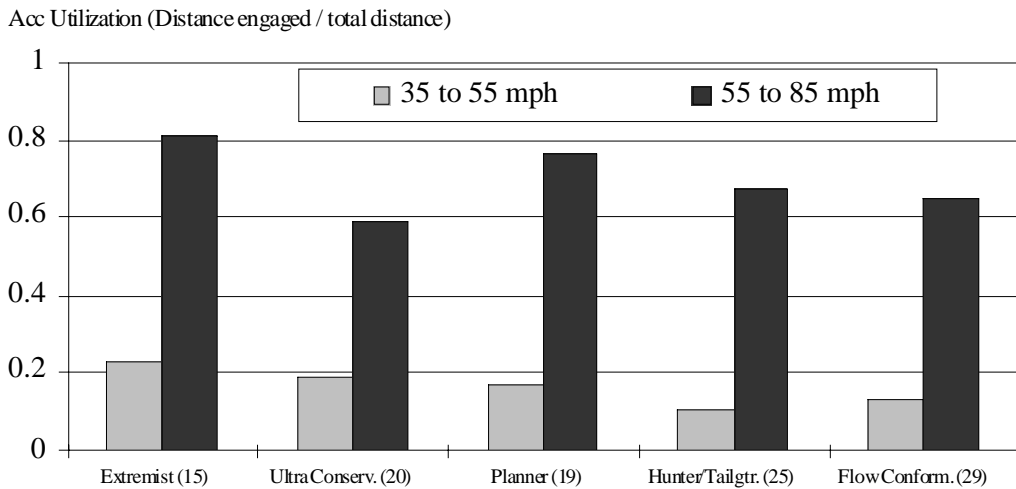

Figure 134. ACC utilization for different driving styles

Thus, it would appear that the style distinctions that were derived from range and velocity attributes seen in manual driving behavior tend to group drivers rather broadly from across the spectrum of utilization levels and, therefore, do not constitute any simple surrogate for predicting utilization, per se.

### **9.1.3 Trends in ACC Utilization Level With Tenure of Use**

The operational test was designed to permit some degree of exploration of changes in a driver's ACC-usage behavior with increasing time (or "the tenure") of usage experience. If, for example, anything about the continued ACC experience of a driver tended to make ACC operation more or less attractive as a control-mode option, presumably it would show up as a change in utilization level as time went by. Changes in ACC utilization level with tenure of use were evaluated only for five-week drivers. Since all five-week drivers were CCC users, the results reported here apply to users only. The question of whether four weeks of continuous ACC availability is sufficient for meaningful measurement of such changes is, of course, an issue that the field test itself is unable to resolve.

It was reported earlier that the aggregate utilization data taken across all five-week drivers and across the entire ACC-relevant speed range (from 35 to 85 mph) showed only a modest decline from 56% in the second week of participation (when ACC was first available as a mode choice) to 54% utilization in the fifth week of participation.

Shown in Figures 135 and 136, this relatively low sensitivity to usage tenure is presented for each of the two respective speed ranges and for each of the three classes of driver age.

While these two Figures are dominated by the rather strong influence of age on utilization, the trend across all four successive weeks of ACC availability shows no strong and distinctive patterns. One can observe a peculiar diminishment in utilization, especially for the younger drivers, in the week 3 and week 4 stages of participation, but utilization in week 5 rises back up to within 5% of the value seen at the beginning, in week 2. Also, the low-speed utilization by the older group of drivers is seen to decline steadily over the 4-week period from 25% to 19%. This same group dropped its high-speed utilization level from 84% in week 2 to 75 (+/-1)% for each of the final 3 weeks.

Moreover, these data indicate that if ACC utilizations will change markedly as usage experience grows, such a result is not predictable through only a 4-week term of exposure.

ACCUtilization (Distance engaged / total distance) for 35 to 55 mph

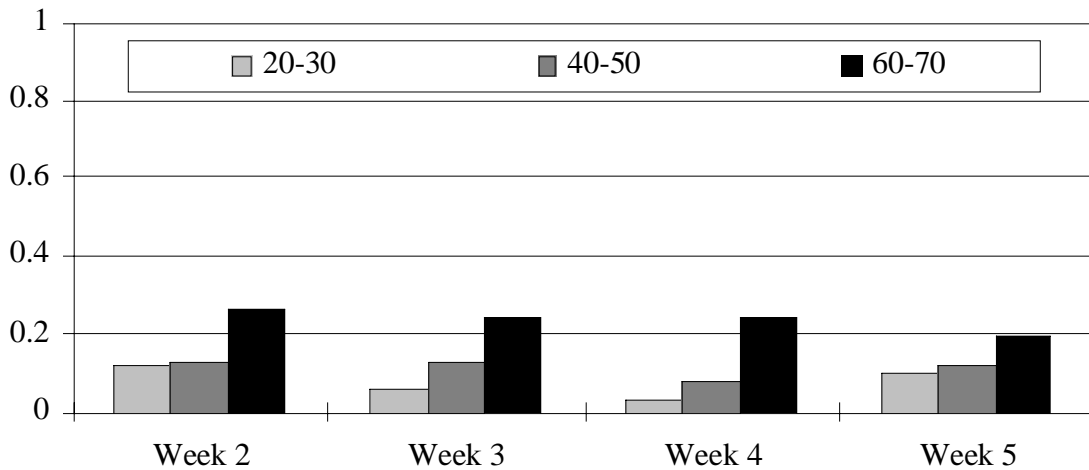

Figure 135. ACC utilization in the 35-to-55-mph speed range for different age categories as a function of week for five-week drivers

ACCUtilization (Distance engaged / total distance) for 55 to 85 mph

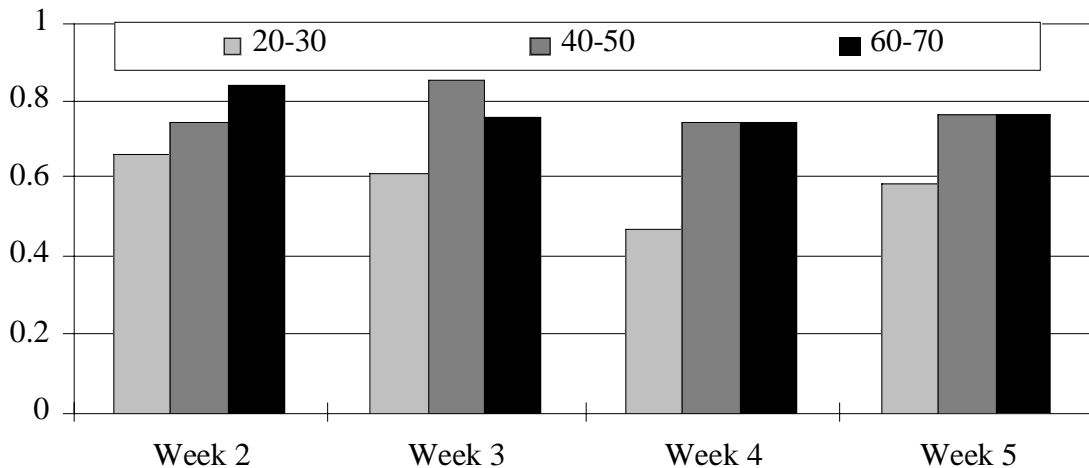

Figure 136. ACC utilization in the 55-to-85-mph speed range for different age categories as a function of week for five-week drivers

#### 9.1.4 Relationship Between Utilization Level and Driver Opinions

It was supposed that there would be some relationship between the subjective evaluation of the ACC system performance and the actual degree of utilization that a driver exhibited with the system. Although no rigor has been placed on the statistical evaluation

of such relationships, the raw data make it clear that any such relationships are exceedingly low in confidence level.

For example, the subjective responses to the question “How comfortable did you feel driving the car with the ACC system?” yielded ratings from 1 (very uncomfortable) to 7 (very comfortable). A summary of the responses to this question is shown in Figure 137, plotted against the overall utilization level observed for each individual in the high-speed range of system operation. The Figure shows that, while the great majority of the subjects selected quite high rating scores (the mean value was 5.75), those selecting considerably lower scores are not generally described as “low utilizers.” Moreover, no meaningful relationship appears to be expressed in these results.

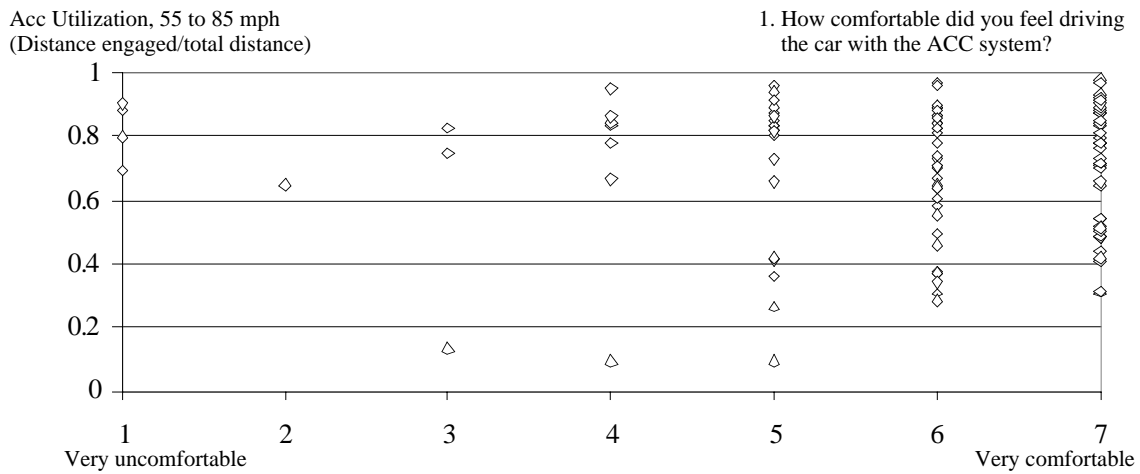

Figure 137. ACC utilization and driver comfort

Similarly, Figure 138 shows that no apparent relationship exists between the measured utilization and the subject’s answer to the question “How long did it take you to become comfortable with using the ACC system?”



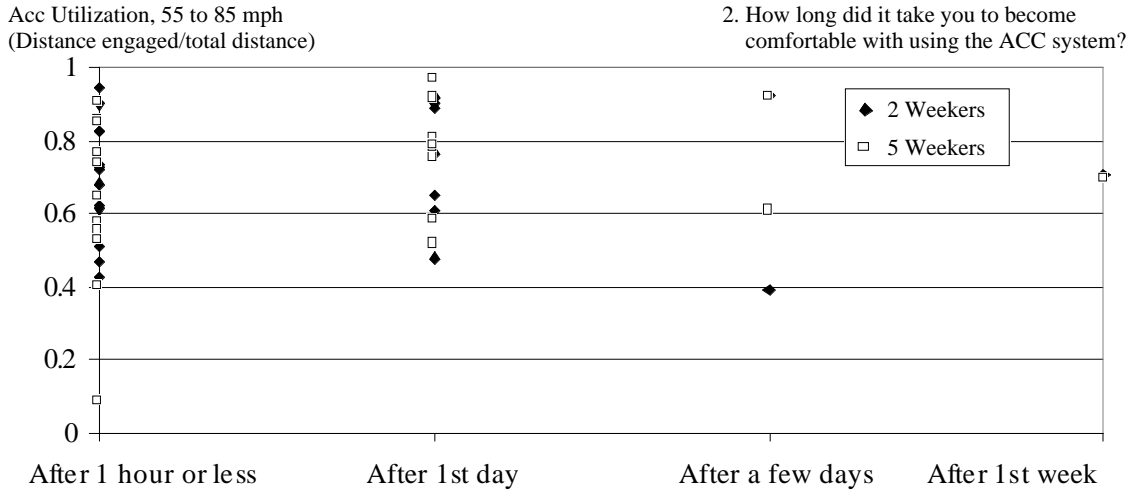

Figure 138. ACC utilization and length of time to become comfortable with the ACC system

In this case, the mean response across all participants was a rating of 1.81, which indicated that most drivers became comfortable using ACC within the first day of operation.

Figure 139 shows, again, that no clear relationship exists between utilization level and the subject's response to the question, "What do you think of the rate of deceleration provided by the ACC system when following other vehicles?" Although this subjective result was more widely spread across the driver population than most other responses in the questionnaire, it does not appear to relate meaningfully to the utilization level actually adopted by individual drivers.

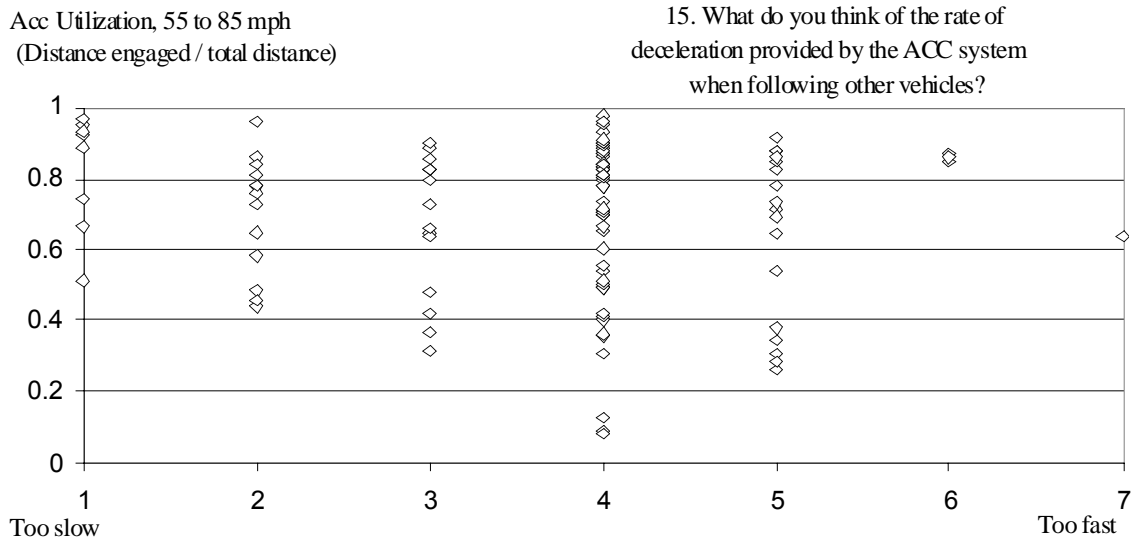

Figure 139. ACC utilization and rate of deceleration provided by the ACC system

## 9.2 Issues of System Operation Encountered by the ACC Driver

This section addresses differing aspects of ACC system operation that are encountered by the driver when using the ACC function. While these operational activities would not, perhaps, properly be called “issues” by themselves, the observed behaviors seem to have implications that weave broadly into issues of safety, customer satisfaction, and overall traffic flow. As mentioned in the beginning of this section, the lack of a general scientific structure for explaining the driving process leaves us with the pragmatic and rather untidy approach of lumping data into little groups that have no clear distinctiveness of their own and yet speak to important observations. In the four subsections that follow, results are presented addressing 1) the driver’s use of buttons for adjusting set speed, 2) the conditions prompting, and driver’s behavior when undertaking, intervention on ACC control, 3) the cut-in behavior of others who move into the gap being controlled by the ACC vehicle, and 4) the question of whether drivers with ACC are traveling faster than they would have otherwise.

### 9.2.1 Operating Experience While Establishing and Maintaining Engagement

In much of the driving process, with a cruise mode engaged, the driver interacts with an ACC system differently than is seen with CCC. These differences are manifest in both the duration of engagements (i.e., an outcome of the driver’s judgement on the conditions

that support comfortable engagement) and in the driver’s use of the “coast” and “accel” buttons by which the SET Speed value is adjusted down or up, respectively, during an engagement.

In terms of the overall engagement experience, the field test captured 7,256 ACC engagements and 3,199 CCC engagements. Because the nominal speed regime heavily determines the traffic conflict environment, which in turn influences the engagement duration, it is important first to acknowledge the differences in engaged-average-speed histograms for ACC and CCC operation, as shown in Figure 140. Here we note that the ACC data are distributed distinctly more toward the left, into the lower speed regime, than is CCC—even though both systems are predominantly employed toward the high-speed end of the driving spectrum.

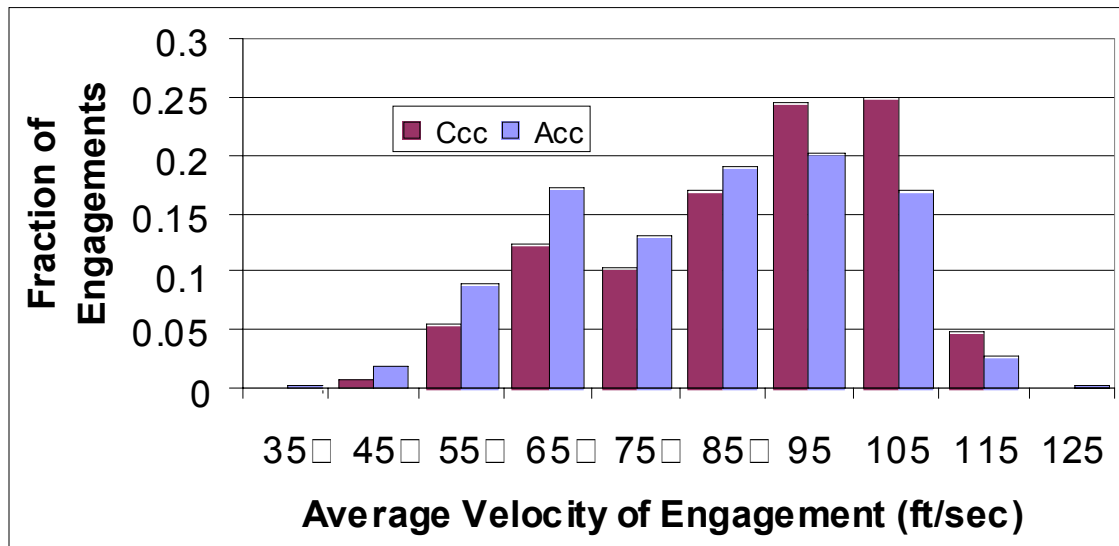

Figure 140. Average engaged velocities

Noting the differing speed distribution between ACC and CCC, we will see that this point of comparison figures strongly in the measure of average miles traveled per engagement, at differing ends of the speed range. The miles-per-engagement measure is of obvious interest as one simple means of validating the marketing concept of ACC that purports to relieve the driver of intervention stresses, presumably with the outcome of longer periods of continuous engagement in addition to qualitative improvement in the driver’s perception of comfort and convenience. Shown in Table 60, is a listing of the miles-per-engagement averages observed in ACC and CCC usage, for regimes of average engagement speed lying above and below 55 mph, and for all engagements.

Table 60. Average engagement miles

	<b>V &lt; 55</b>	<b>V &gt; 55</b>	<b>All</b>
<b>ACC</b>	0.90	7.68	4.82
<b>CCC</b>	0.97	4.38	3.35

The entire set of ACC engagements is divided approximately 58% above an average speed of 55 mph and 42% below 55 mph. From a mileage point of view, however, approximately 90% of all engagement miles were accrued in the regime above 55 mph. Thus, in Table 60, it is perhaps most significant to the total driving experience of individuals that ACC affords a 75% increase over CCC in the typical distance covered in a continuous engagement above 55 mph. Conversely, in the lower-speed regime, where Figure 140 showed ACC usage distributed more deeply than that of CCC into the lower portion of this speed range, we see that ACC yields even shorter engagement lengths than CCC. Clearly, since ACC invited more utilization in the lower speed regime, which is also more burdened with conflicts that tend to shorten engagement durations, the comparison of all engaged distances does not appear as favorable to ACC as does the same measure computed only for speeds above 55 mph. The next figure provides a means of scaling the sensitivity of engagement distance to average velocity over the engagement episode.

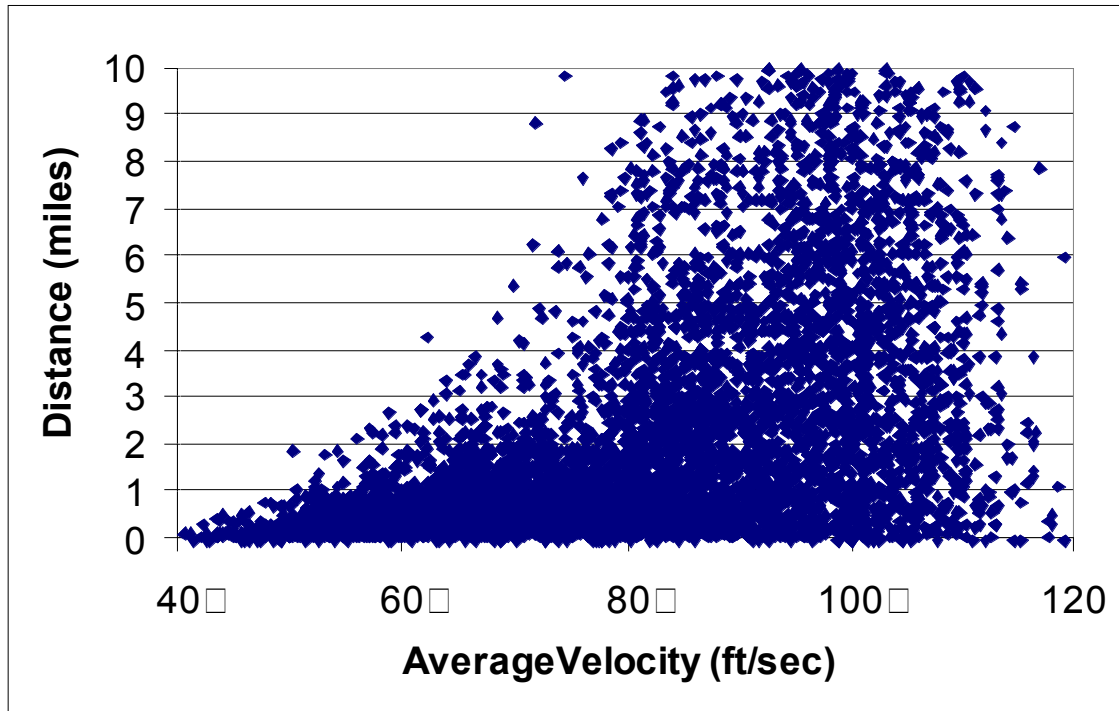

Figure 141. ACC Distance engaged vs. average velocity over the engagement

Figure 141 shows a scatter plot from all ACC engagements (eight of which registered continuous operation at highway speeds, without intervention, for longer than 100 miles.) These data show that typical engagement lengths will dwindle down to less than half a mile when average velocity approaches 40 mph.

Moreover, it is fair to summarize that for comparable traffic environments this ACC system should support sustained engagements that are typically half to three-quarters longer in duration than would CCC.

Figure 142 presents the engagement data in a manner that appears to refute the “longer durations” observation just made above for ACC. That is, the Figure shows that the number of ACC and CCC engagements per individual trip are distributed almost exactly alike, across the full population of trips made under each mode of cruise control.

The hidden correlate that makes this presentation somewhat misleading is that the typical ACC trip is considerably longer than the typical CCC trip. Thus, as shown in Figure 143, we see that ACC is differentiated meaningfully from CCC, in terms of the average engagement length plotted against the length of the trip, itself. Here, we note that ACC engagement length is growing at a faster rate, as trip length grows, than is CCC. On

very short trips, however, the distinctions in engagement duration are more or less inconsequential.

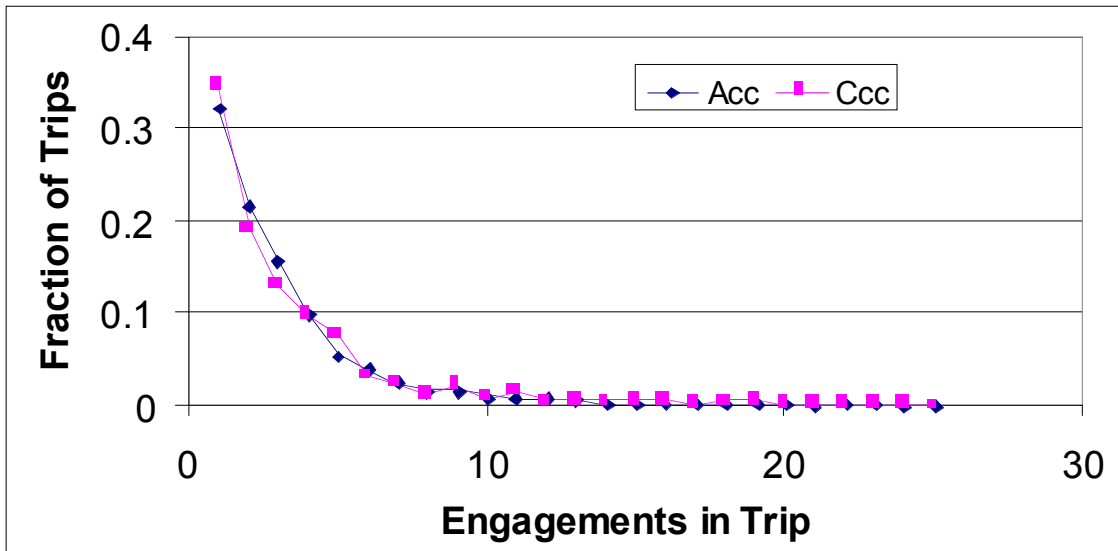

Figure 142. Engagements per trip

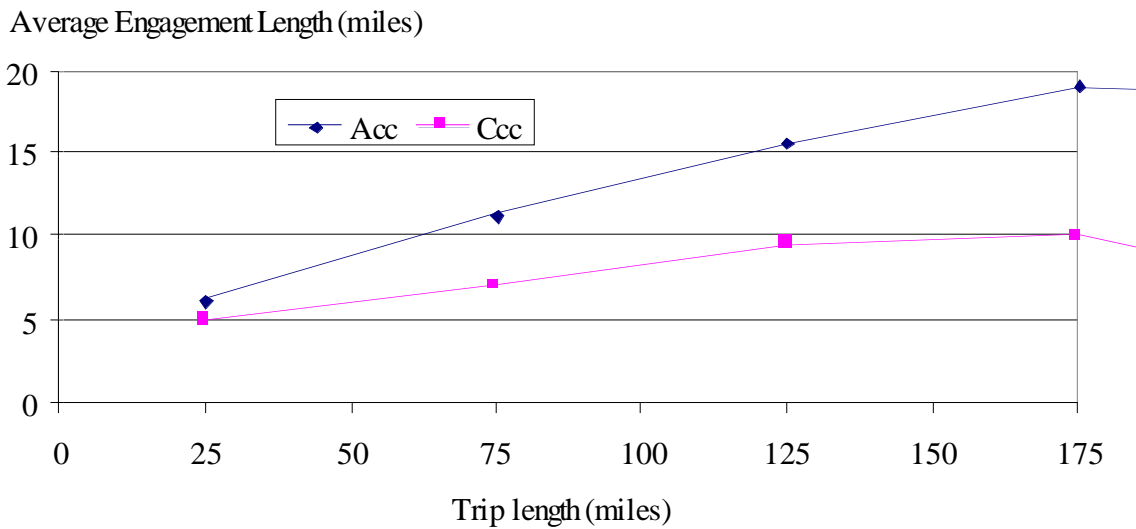

Figure 143. Average engaged length ( $V_{ave}>55\text{mph}$ )

Interesting differences are also observed in the pattern of button-presses during ACC versus CCC engagements. Tables 61 and 62 present summary figures for the use of coast and accel buttons during the start, middle, and end of engagement periods with ACC and CCC systems, respectively. The buttons function somewhat differently between ACC and

CCC engagements: tapping the coast in CCC would not cause any noticeable or systematic deceleration, whereas doing so under ACC would decrement the set-speed value by 2 mph for each tap (see section 3.1.4).

Table 61. ACC – Coast & Accel Buttons for Engagements > 60 secs long,  $V_{ave} > 55\text{mph}$

3359 Engagements 2793 Coasts & 5869 Accels										
470.4 hours										
31764.4 miles										
<b>ACC</b>										
		<i>Count</i>	<i>Valid Target</i>	<i>% Valid</i>	<i>Average V</i>	<i>Near</i>	<i>Cut-in</i>	<i>Following</i>	<i>Closing</i>	<i>Separating</i>
<b>Start</b>	<i>Coast</i>	487	193	39.6%	94.2	0	4	114	23	52
	<i>Accel</i>	2612	1272	48.7%	89.9	2	24	617	96	533
<b>Middle</b>	<i>Coast</i>	1969	750	38.1%	98.2	4	9	402	251	84
	<i>Accel</i>	3194	1309	41.0%	94.9	8	37	640	84	540
<b>End</b>	<i>Coast</i>	337	138	40.9%	92.9	3	0	65	67	3
	<i>Accel</i>	63	32	50.8%	97.5	1	0	19	2	10

Table 62. CCC – Coast & Accel Buttons for Engagements >60 secs long,  $V_{ave} > 55\text{mph}$

1490 Engagements 2033 Coasts & 1522 Accels										
140.9 hours										
9470.6 miles										
<b>CCC</b>										
		<i>Count</i>	<i>Valid Target</i>	<i>% Valid</i>	<i>Average V</i>	<i>Near</i>	<i>Cut-in</i>	<i>Following</i>	<i>Closing</i>	<i>Separating</i>
<b>Start</b>	<i>Coast</i>	482	221	45.9%	99.9	7	1	128	60	25
	<i>Accel</i>	364	179	49.2%	91.9	0	6	80	4	89
<b>Middle</b>	<i>Coast</i>	1243	742	59.7%	99.6	41	15	384	268	34
	<i>Accel</i>	1108	546	49.3%	95.5	7	26	249	27	237

<b>End</b>	<i>Coast</i>	308	214	69.5%	98.1	8	3	58	138	7
	<i>Accel</i>	50	32	64.0%	98.9	0	1	13	6	12

The “start” segment is defined as the first 30-second portion of engagement and the “end” is defined as the last 15 seconds. For each segment, the tables list: 1) the total count of coast and accel-button press events, 2) the number of press events in which a valid target was present ahead of the vehicle, 3) the percentage of button presses in which a valid target was present, 4) the average value of velocity prevailing over the indicated set of button press events in each cell, and 5) the respective counts of press events in which the vehicle’s R and Rdot state placed it within the Near, Cut-in, Following, Closing, or Separating domains of operation vis-a-vis a valid target.

The most obvious contrast in these data during the start segment of engagement appears in the fact that drivers initiate ACC at an instantaneous speed value that is well below the SET speed value that the driver ultimately intends. Thus, the initial phase of ACC engagement is dominated by a very high incidence of accel-button presses relative to coast presses (see Table 61). This practice appears to indicate a strategy of “engaging ACC as early as possible” following, say, a transition onto a freeway. ACC becomes engaged while the vehicle is still well below the intended set speed, presumably so that the driver can accrue the utility of the ACC control function even while climbing (through use of the accel button) into the higher speed range. By comparison, the rate of accel-button presses in the initial phase of CCC engagement is much lower and nearly balanced with coast presses, apparently revealing a common practice of CCC users to initiate an engagement cycle while travelling rather near to the intended cruise speed. Thus, even though the buttons have an identical function in both ACC and CCC applications, the driver has adopted an entirely different strategy for their use during the process of initiating engagement.

Other subtleties also play themselves out in the usage of the buttons. We note, for example, that in the “middle” segment of engagement in either mode of cruise usage, the driver employs the coast button on the “closing” side of zero Rdot and the accel button on the “separating” side of zero Rdot. This interesting result indicates a behavior that was observed in other contexts as well. Namely, it is apparent that many drivers tend, at least early in their ACC experience, to employ the coast and accel buttons as a supplementary means of closing the control loop on headway (which, of course, is the central utility offered by the ACC system, itself.) It is as if some drivers choose to interact in the same manner when operating ACC as they did when operating CCC.



Also, although the absolute numbers are not large, drivers in the middle portion of CCC engagement do show a significant exercise of coast-button presses while coping with a “near” type conflict.

Shown in Figure 144 is an illustration of the more-or-less rational pattern of ACC-button presses that appears when approaching the termination (or “end”) of an engagement. We see that a substantial rise in the rate of coast-button presses appears over the last few seconds of engagement, while the rate of accel usage declines toward zero.

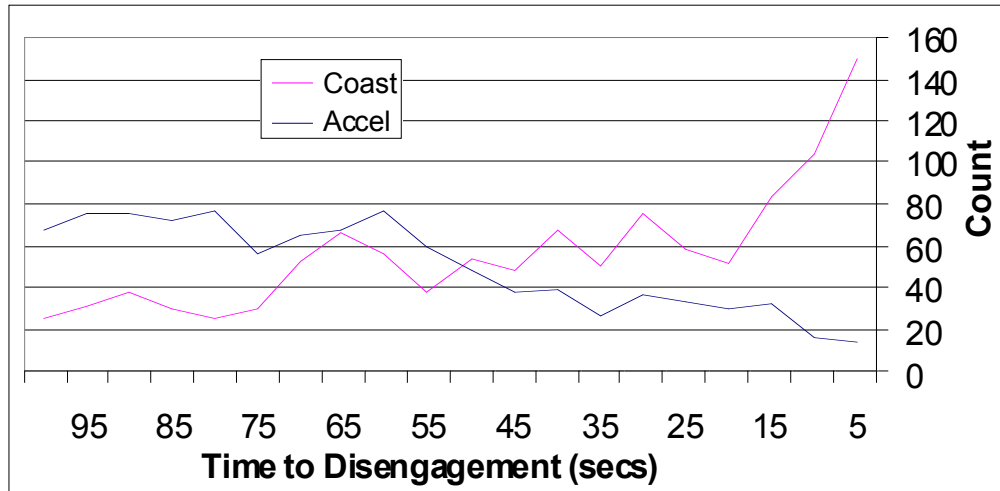

Figure 144. Button presses at end of ACC disengagement (AveEngV>55mph & Duration>60sec)

Inspection of individual time-history records reveals that a substantial number of drivers chose to retain ACC in engagement even while traversing some distance onto a freeway exit ramp, choosing to successively adjust down their set speed using the coast button rather than simply terminating engagement. Of course, some other fraction of end-transition coast presses also accompany closure conflicts that are finally terminated by braking or cancel functions.

Overall, a great diversity of cruise-button usage behaviors was observed across the population of test subjects. Even in the very frequency of button usage, the population ranged from those who applied the coast or accel buttons less than once in every thirty miles to those who pressed one of these buttons more than two or three times in each mile. It was also clear that non-users of CCC exhibited markedly more exercise of the coast and decel buttons, even when driving with ACC engaged, than did users.

### **9.2.2 Conditions Prompting Driver Intervention on ACC Control**

Shown in Figures 145 and 146 are logical trees accounting for the entire set of ACC and CCC disengagements, respectively. The diagrams break down disengagements according to speed regimes (< 55 mph on the left, > 55 mph on the right) and thence into subsets differentiated by the conditions of disengagement, itself.

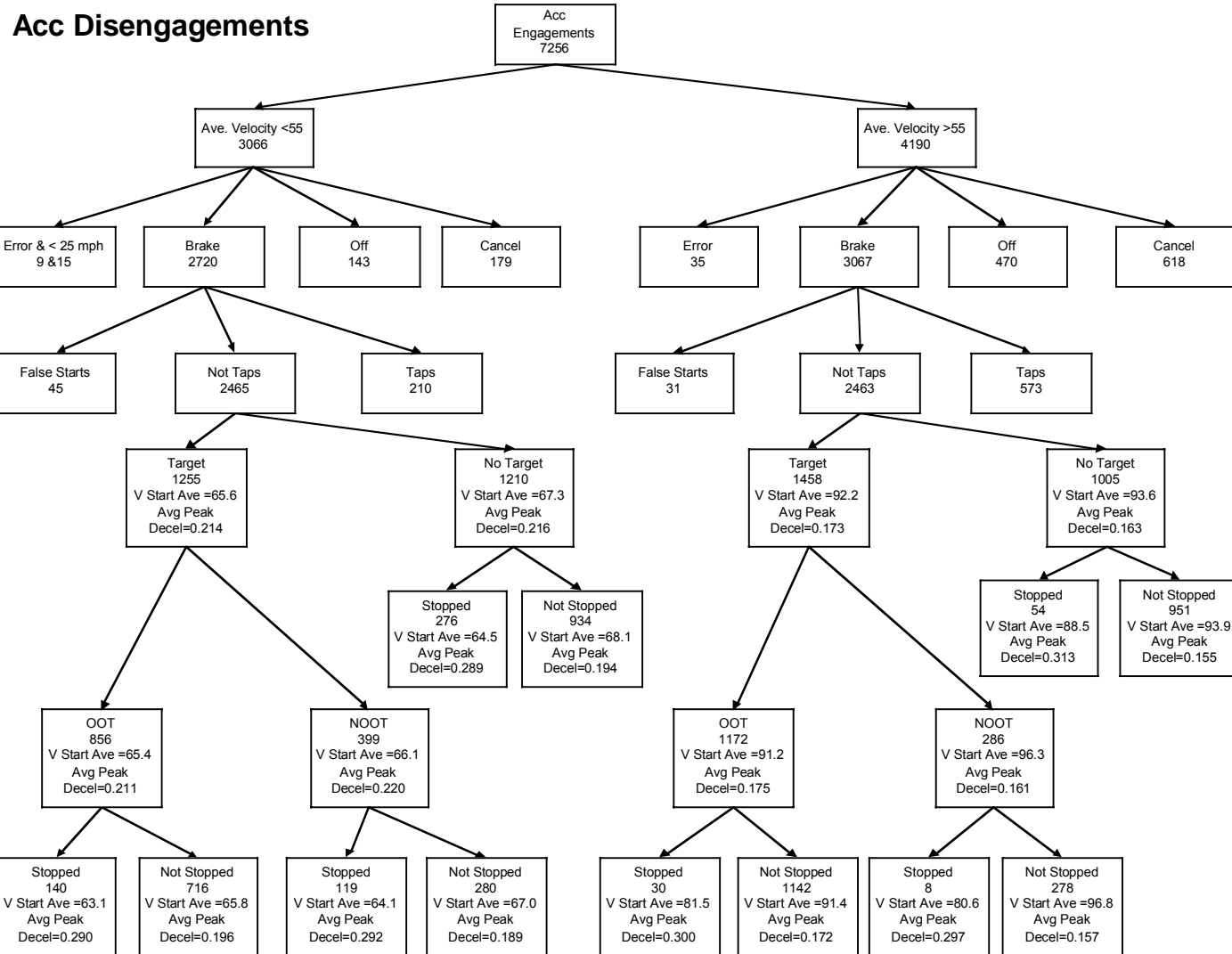

Figure 145. ACC disengagements breakdown

# Ccc Disengagements

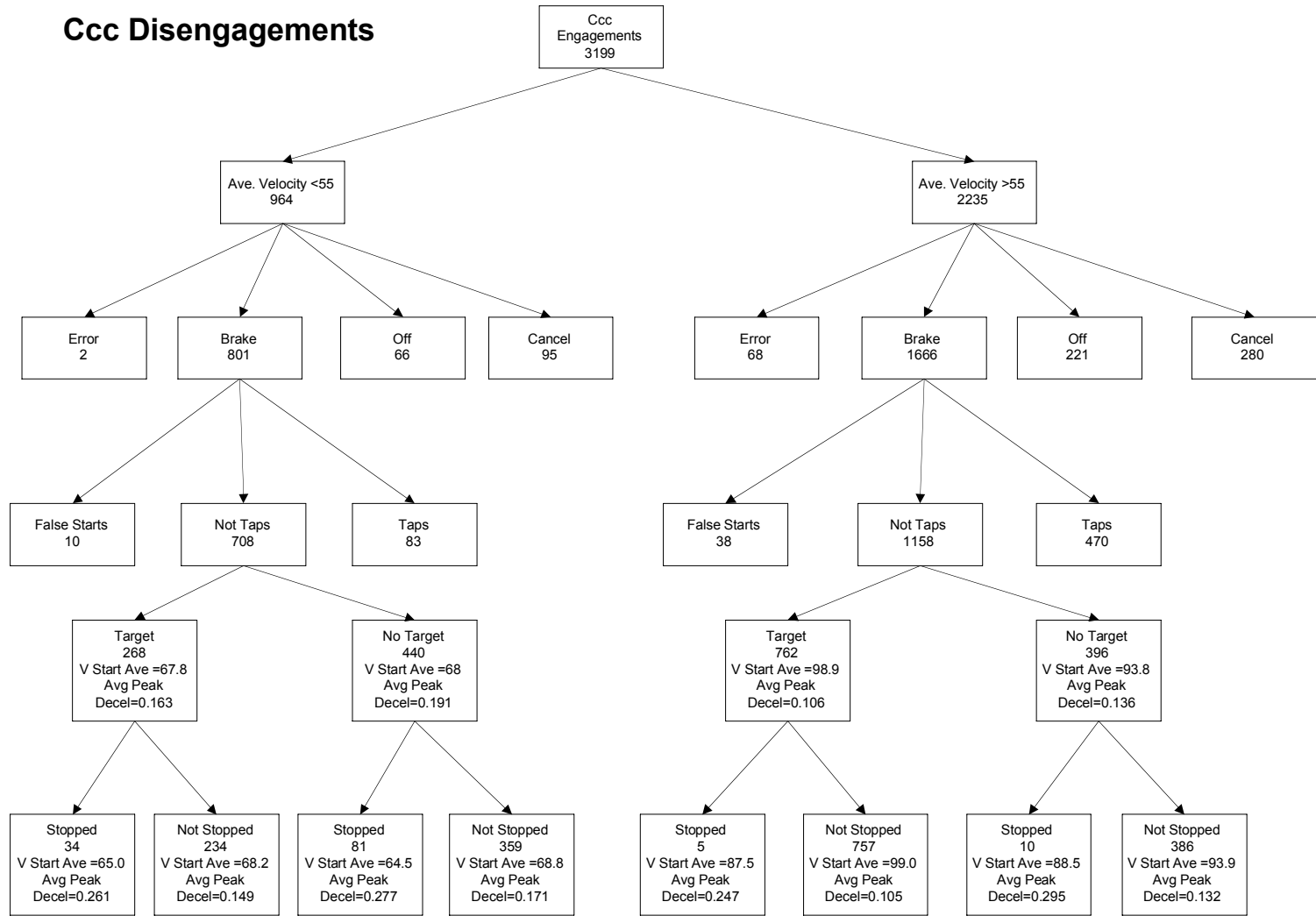

Figure 146. CCC disengagements

Following down the successive layers of disengagement conditions, from top to bottom, Figures 145 and 146 distinguish four differing means of disengagement, namely, error signals causing cruise to drop out, brake application, use of the OFF button, and use of the CANCEL button.

Since our primary interest here is in conditions for which braking was used as a deliberate means of cruise intervention, brake applications are then broken down further into “taps,” whereby very light momentary braking was employed apparently for nondecelerating disengagement; “not taps,” which include all disengagements involving a substantive brake application, and “false starts,” whereby cruise was engaged only momentarily with the driver’s foot on the brake at the same time. Pursuing the “not tap” braking events as the central interest, results are split into “target” and “no-target” situations to differentiate between disengagements that may have been prompted by a target conflict ahead and disengagements that were likely derived from other causes (e.g., an exit ramp transition). In the “no-target” cases of ACC and both the “no-target” and “target” cases of CCC, the results are further differentiated by whether the braking episode proceeded continuously to a full stop, or not.

Proceeding from the “target” cases of ACC, results are further broken into the “operating on target,” or OOT, case (i.e., the state in which ACC control of headway to the target vehicle is actually being invoked) or “not operating on target,” or NOOT, (i.e., the state in which ACC continues to control speed toward the SET value, although a valid target has been detected within range of the sensor.) In all the braking cases above the level of a “tap,” an average value of the peak deceleration level reached across all the involved subset of events is shown on the diagram.

The combined data of the two figures shows the following:

- Although braking is used as the preferred means of disengagement more frequently in the lower—rather than higher—speed cases, with both ACC and CCC, no substantive difference exists in the frequency of braking for disengaging ACC versus CCC.
- Braking above the tap level of application is used approximately 10% more often for disengaging ACC than it is for disengaging CCC.
- Brake-induced disengagement that proceeds all the way to a stop, with a target acquired ahead, occurs approximately 1.6 times as often with ACC than CCC in the lower speed regime and approximately 4.3 times as often in the higher-speed regime.

- Braking to a stop typically entails a deceleration peak that is 50 to 100% greater in magnitude than it is for nonstopping brake applications.
- Braking-induced disengagements with a target ahead do not yield deceleration peaks that are substantially different from those exhibited when disengaging with no target ahead.
- Braking to disengage ACC from its OOT mode of control does not yield deceleration peaks which are substantially different from those exhibited when disengaging from the NOOT mode.
- The individual deceleration levels are seen to be generally higher with ACC than with CCC—an issue that will be expanded upon further in the presentation below.

Shown in Figures 147 and 148 are average- and maximum-deceleration histograms, respectively, of all nontap braking disengagements of ACC and CCC for the higher-speed range above 55 mph. The data show that drivers tend to employ substantially higher deceleration levels when disengaging ACC in this operating range than when disengaging CCC. To first order, it is assumed that this difference is largely attributed to the stereotypical scenario by which the ACC driver only intervenes via braking when the deceleration levels available through ACC throttle and downshift control have been (or are about to be) inadequate for resolving conflicts developing ahead. However explained, ACC disengagement by braking in this speed range yields about twice the incidence of average decelerations registered above 0.125 g's and maximum decelerations registered above 0.175 g's.

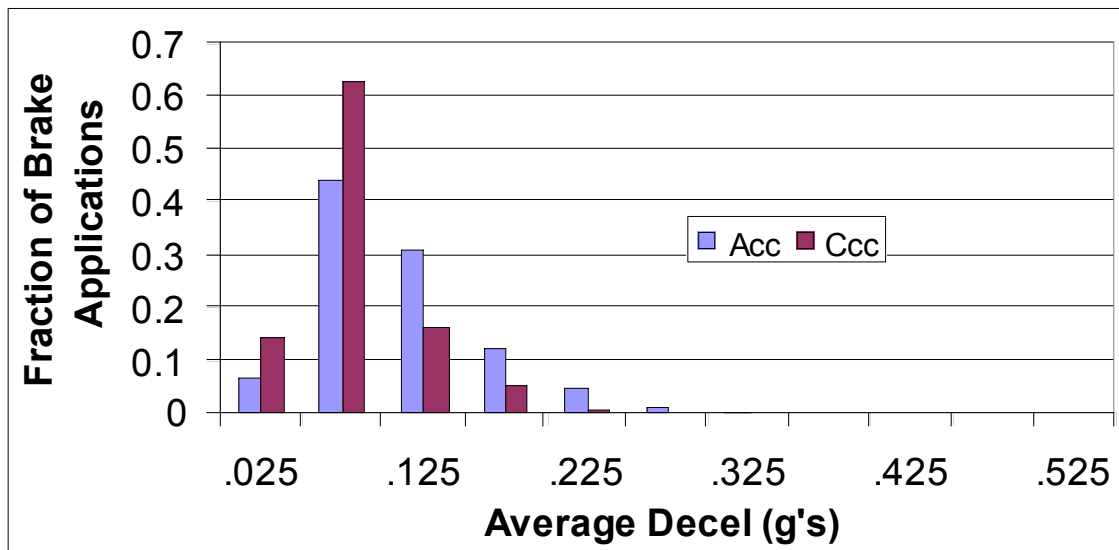

Figure 147. Average deceleration during braking (V>55mph)

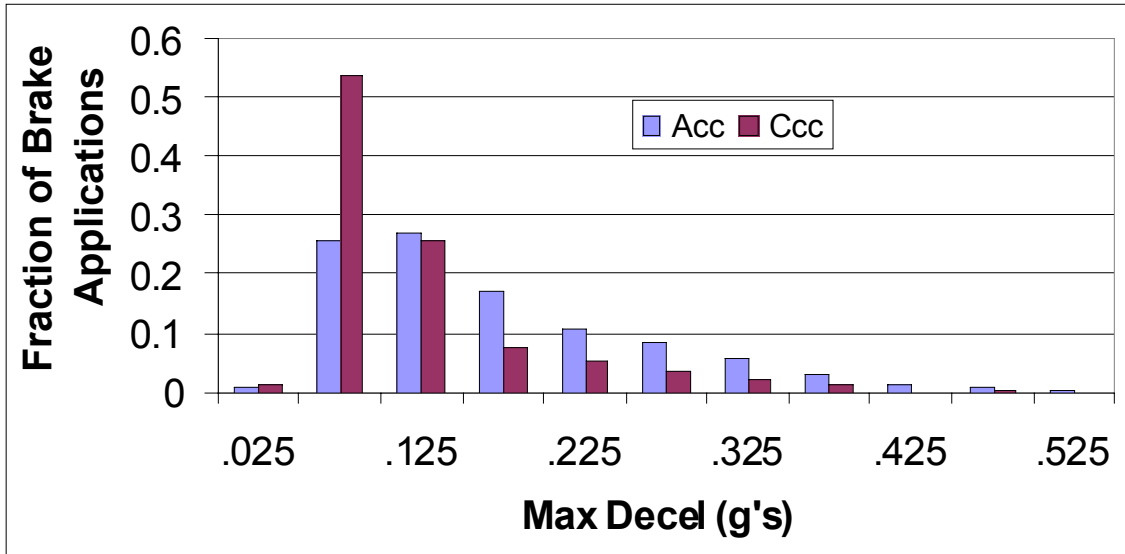

Figure 148. Maximum deceleration during braking (V>55mph)

It is not known how disengagement decelerations may vary as a function of pavement friction level—an ambient condition, which, if immaterial to cruise-usage behavior, could affect the frequency of antilock brake cycling according to the differences in upward distribution of deceleration peaks under ACC and CCC modes of control.

Using maximum deceleration as the presentation measure, Figures 149 and 150 cover cases of brake-induced disengagement in the high speed regime in which, respectively, either a valid target (VT) or no target (NT) is present at the time of disengagement.

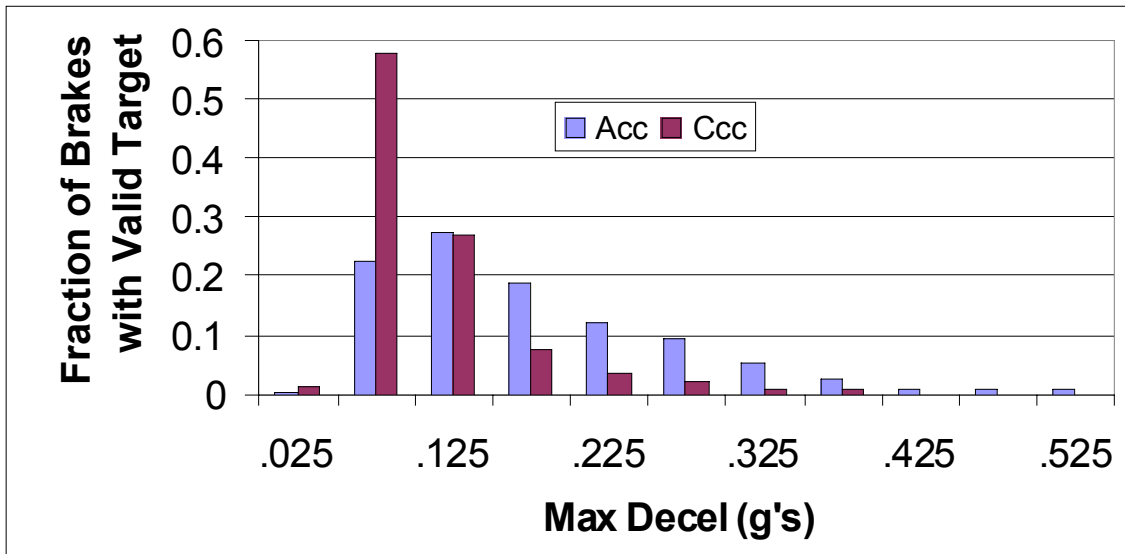

Figure 149. Maximum deceleration during braking, target present (V>55mph)

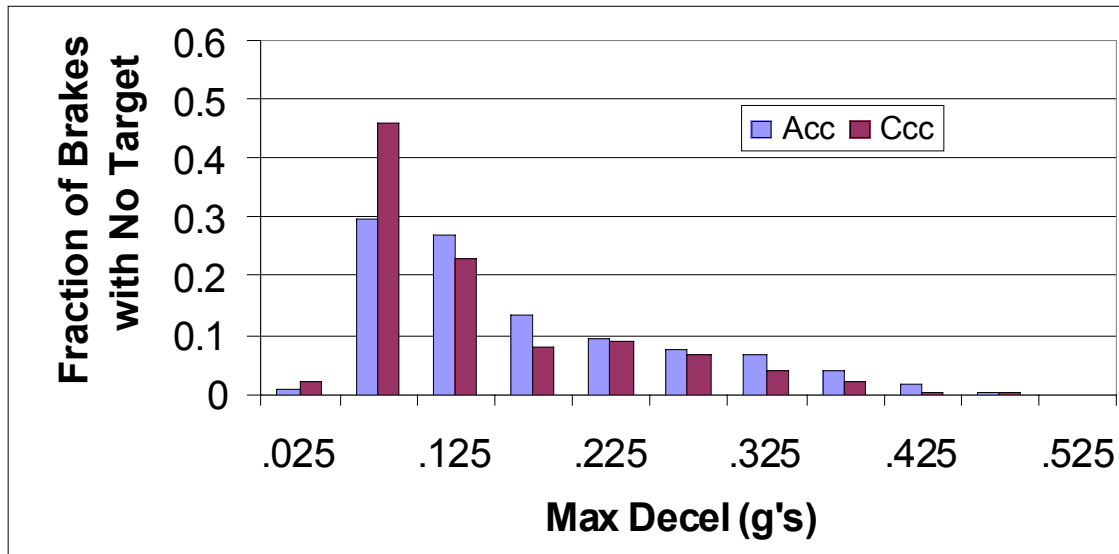

Figure 150. Maximum deceleration during braking, no target present ( $V > 55$ mph)

Figure 149 shows that disengagements with a target present involve a deceleration histogram that looks much like the data shown above in Figure 148 for all braking disengagements at high speed, except that the ACC dominance in the higher end of the deceleration range is even more pronounced. That is, disengagements at maximum deceleration levels above  $0.175 \text{ g's}$  are almost five times as frequent with ACC as with CCC when a valid target is present ahead. Put another way, disengagements of CCC are, by nature, more anticipatory events since the driver is quite aware that headway conflicts are resolved only by human intervention and never by the automatic—albeit limited authority—mechanism afforded by ACC.

By contrast in Figure 150, braking disengagements with no target present are much less distinctive in differentiating between ACC and CCC modes of control. In the no-target case, ACC disengagements above  $0.175 \text{ g's}$  are only about 1.25 times more prevalent than the same high-deceleration disengagements from CCC.

Figures 151 and 152 show the corresponding braking disengagement results for the low-speed regime below 55 mph. Clearly, the lower-speed environment is characterized by a much more rightward distribution of the histograms, toward higher rates of deceleration.



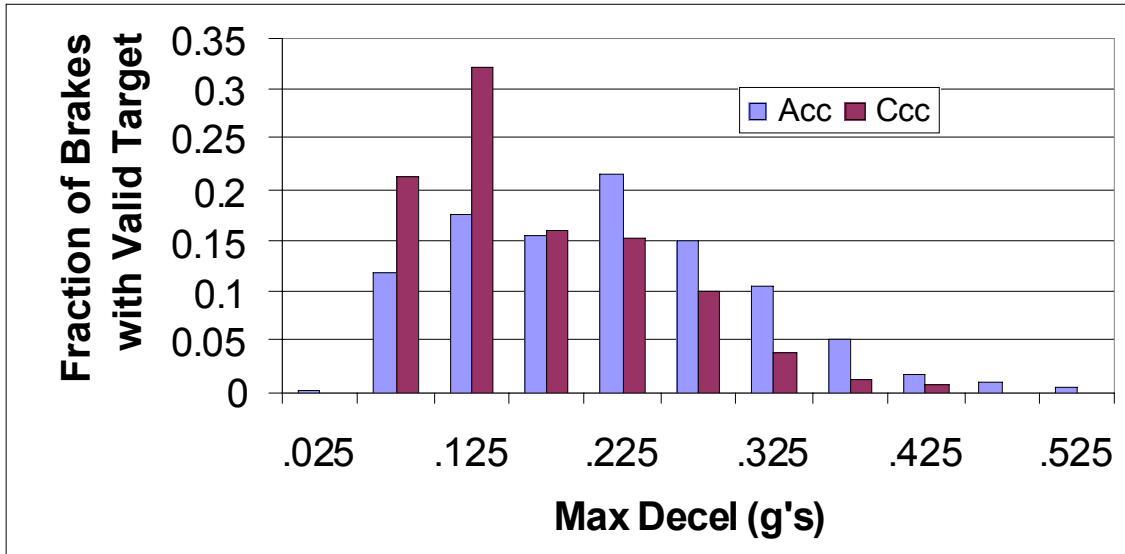

Figure 151. Maximum deceleration during braking, target present (V<55mph)

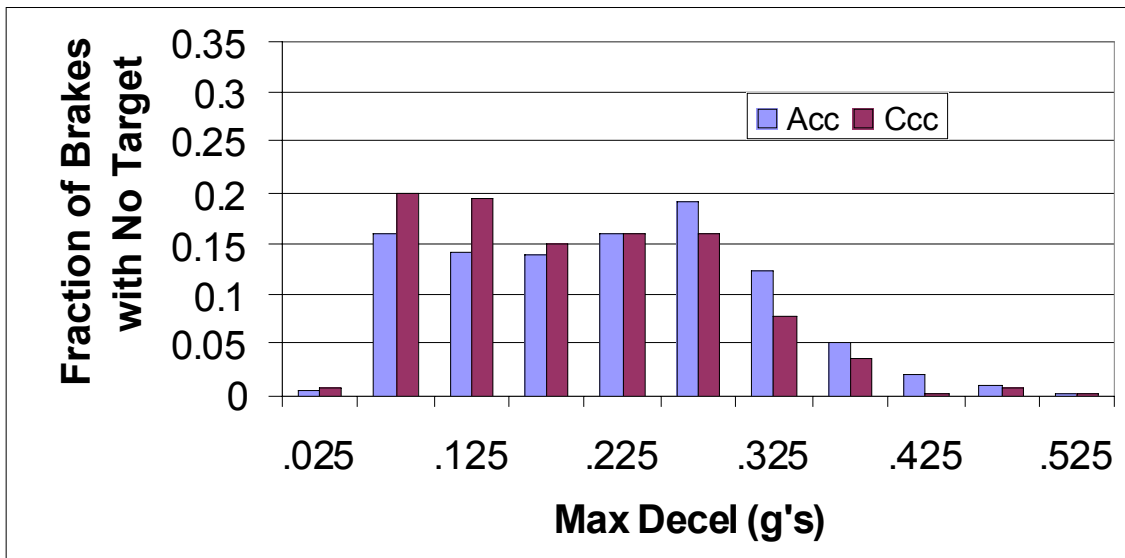

Figure 152. Maximum deceleration during braking, no target present (V<55mph)

Again, ACC disengagements tend toward the higher deceleration values, but not with the degree of contrast against the CCC data as was seen in the higher-speed range.

Considering the extent of headway conflict prevailing at the moment a braking disengagement begins, Figures 153 and 154 present the histogram of time to impact (TTI), in seconds, for ACC versus CCC in the respective higher- and lower-speed regimes (only the lower portion of the entire computed range of TTI values is being shown).

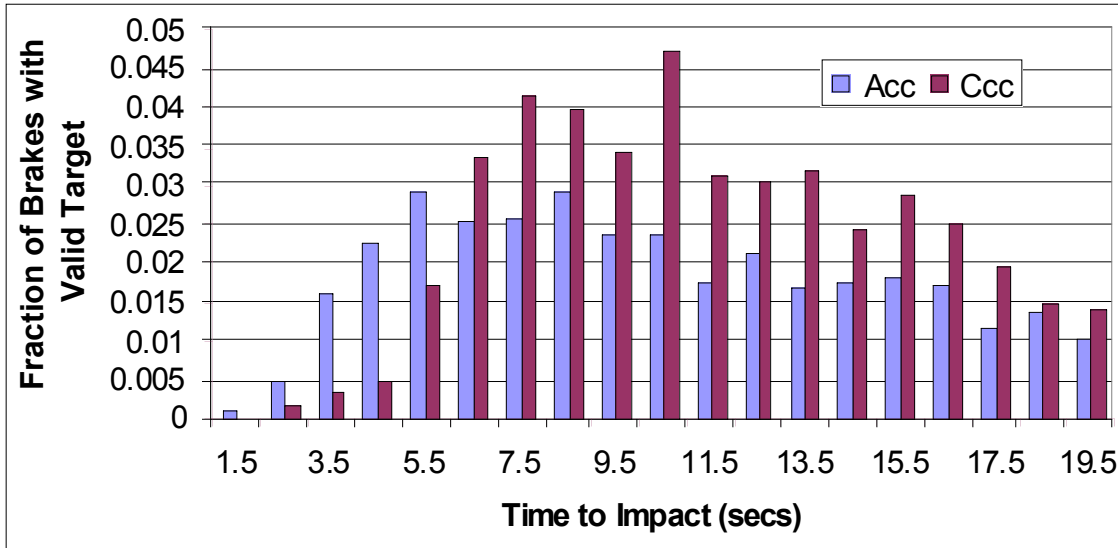

Figure 153. Time to Impact during braking (V>55mph)

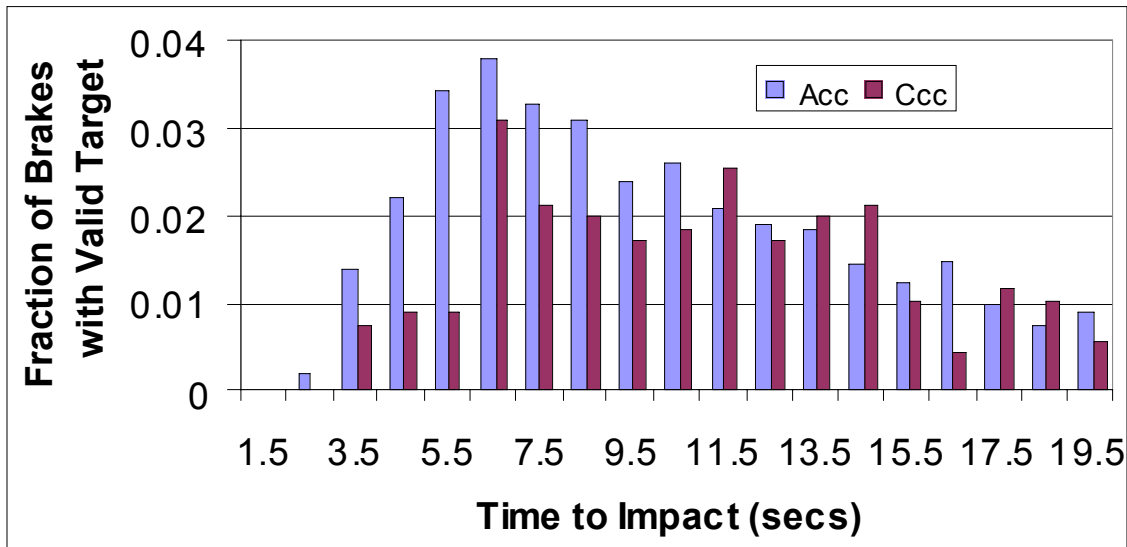

Figure 154. Time-To-Impact during braking (V<55mph)

We see generally that, when compared to CCC, ACC disengagements are characterized by a considerably higher occurrence of low TTI values, below 6 seconds or so.

Interestingly, the nominal frequency of TTI values in the 1 to 6 second range is largely unaffected by the speed range of operation.

Figures 155 and 156 present the relationship, in scatter plots, of the TTI value at the moment of ACC and CCC disengagements, respectively, plotted against the individual maximum deceleration levels that were achieved during each disengagement-braking process.

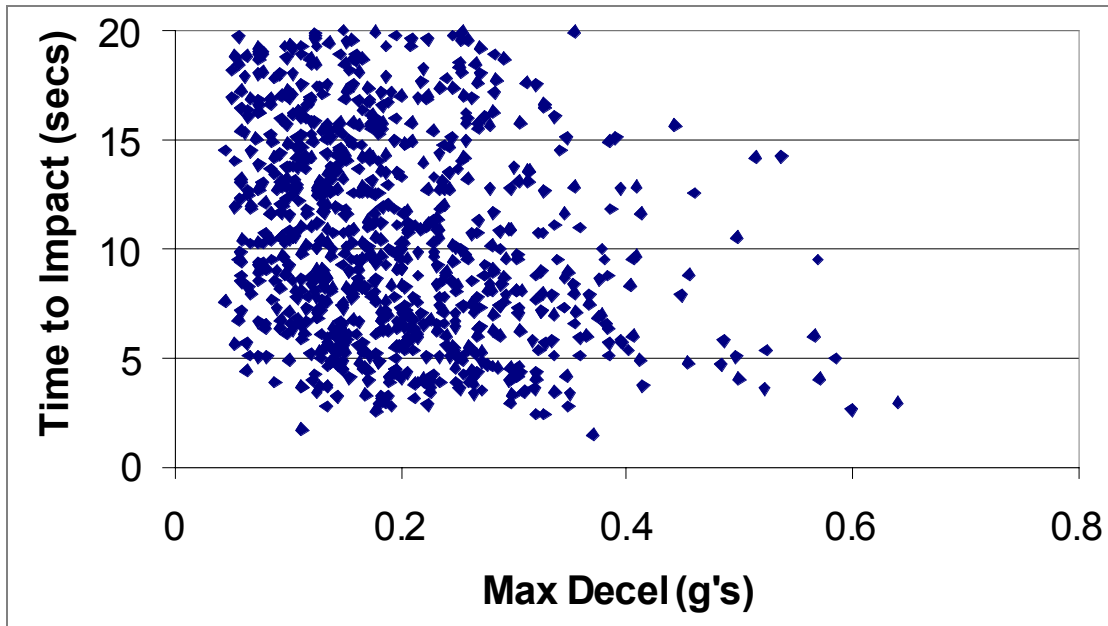

Figure 155. Time to Impact and maximum deceleration during ACC braking ( $V > 55\text{mph}$ )

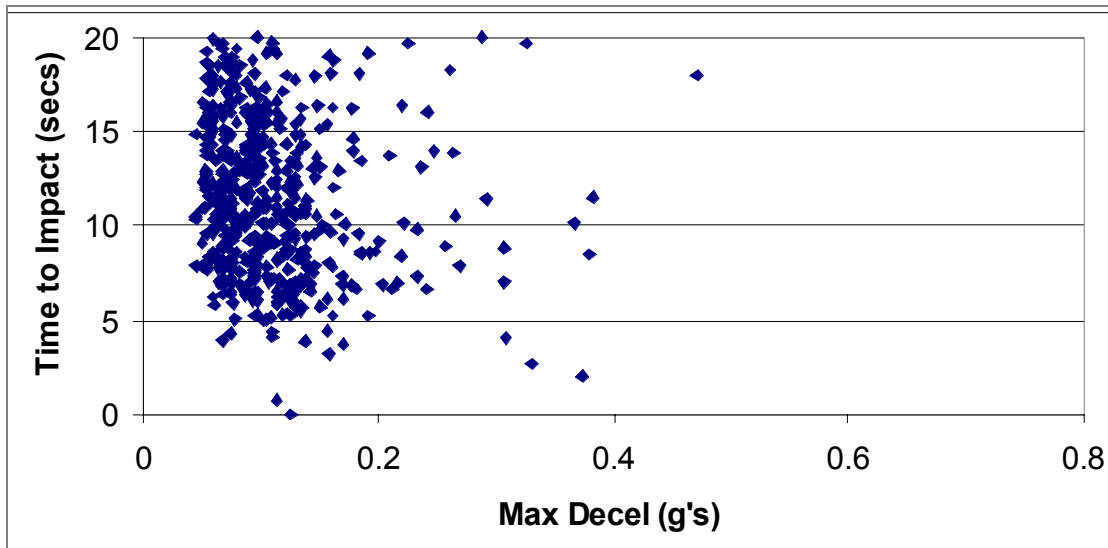

Figure 156. Time to Impact and maximum deceleration during CCC braking ( $V > 55\text{mph}$ )

The scatter-plot format is useful in this case since it allows the consideration of the thin tails of a distribution in which the sparsity of points causes data to more or less vanish from a histogram but still appear as singular elements in the scatter plot. The two figures present the maximum value of deceleration in cases of braking (without taps) disengagement in the higher-speed regime.

To first order, it seems fair to observe that there is only a very subtle relationship between time-to-impact and the level of deceleration that is achieved, for either the ACC or CCC disengagement data. In both figures, most drivers are resolving the shorter-TTI conflicts with approximately the same levels of braking as had been applied at much longer values of TTI. Nevertheless, although a great preponderance of ACC braking is at maximum deceleration values below approximately 0.3 g's, an increasing incidence of braking levels above 0.4 begin to appear within about 14 seconds-to-impact. Also, the one or two highest- deceleration data points on the ACC chart appear at very short TTI values, within 4 seconds-to-impact. No corresponding observation in the CCC data seems obvious.

The scatter plot results give a good visual image depicting the contrast between ACC and CCC disengagement via braking, above 55 mph. Indeed, it is puzzling that drivers would have typically employed about twice the level of deceleration in disengaging ACC compared with CCC, even at rather large values of time to impact. In fact, the relative tendency to employ higher decelerations in ACC disengagement seems to apply rather uniformly across the entire indicated range of TTI values. With plenty of reason to worry about lurking correlates in any of the relationships drawn from this field test, it may be that drivers showing dominant use of CCC differed from those using ACC or that other contrasts in road type, traffic conditions, etc. that are exposed to ACC versus CCC usage tended to bloom the ACC deceleration distributions into the higher magnitude values than those seen with CCC. Nevertheless, the marked contrasts in disengagement braking seen here seem to warrant further study. A plausible hypothesis is that drivers know that while CCC does not address the headway conditions, one can simply wait to see if ACC will resolve the current headway conflict — with the consequent need for harder braking if intervention is needed.

Shown in paired Figures 157 and 158 the issue of headway-time undershoot during ACC disengagement is addressed. That is, the two figures present, for the respective high- and low-speed ranges, histograms of the ratio of the value of headway-time margin (Htm) prevailing at the moment of ACC disengagement to the driver's selected value of headway time (Th). (In order to compute an Htm value, of course, these data are

addressable only for the case when a valid target is present.) By way of example, then, if disengagement had occurred when the instantaneous value of headway time was exactly equal to the driver's  $T_h$  selection, the histogram would have counted an event at 1.0 on the horizontal axis labeled ( $H_t m/T_h$ ).

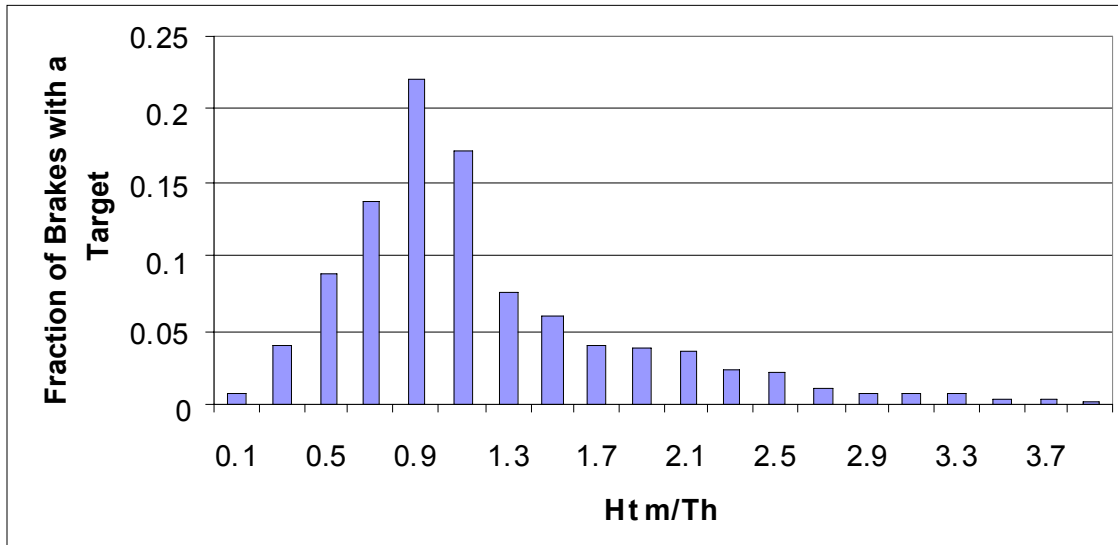

Figure 157. Normalized prevailing headway time during braking ( $V > 55$  mph)

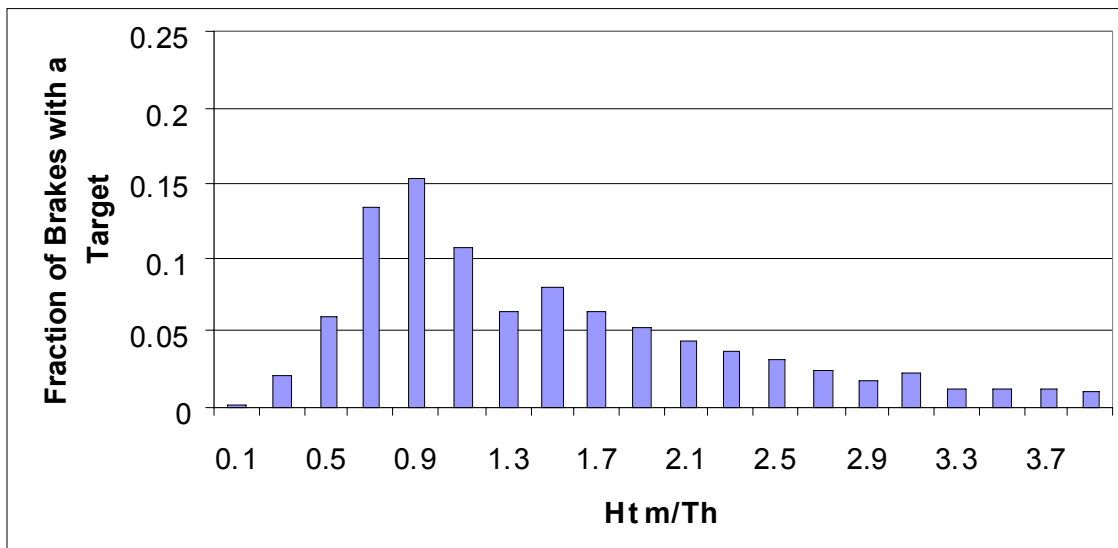

Figure 158. Normalized prevailing headway time during braking ( $V < 55$  mph)

The data show that, at speeds above 55 mph (in Figure 157) disengagement via braking typically occurs at an  $H_t m$  value that is typically near or inside of the targeted  $T_h$  value. Indeed, fully half of all disengagements developed at less than a ratio of 1.0 and another 16% occurred around 1.1— where the controller tends to dwell as its most likely

value relative to a given setting (due to asymmetric system dynamics and other factors.) Further, a substantial number of the disengagements occurred with the degree of undershoot penetrating down below half of the selected headway time. On the high end of the scale, it is fair to say that the driver is relatively unlikely to disengage ACC using the brake while at relatively long range from a target ahead—whether closing or separating in absolute headway—in the higher-speed regime of operation.

Perhaps, if the ACC system had higher deceleration authority there would be fewer incidents in which  $H_{tm}/T_h$  was less than 1.0. Conversely, there could be more such incidents if the increased deceleration authority were to make the driver wait longer to intervene. A favorable resolution to this matter depends upon how well human-centered engineering will be applied in developing ACC systems with braking.

Although qualitatively similar, the data in Figure 158 show that in the lower-speed regime, braking disengagement of ACC more commonly occurs at ( $H_{tm}/T_h$ ) ratios well above 1.0. We see that only 36% of the disengagements occurred at ratio values that fell below 1.0. Since the absolute range available for a given headway time obviously declines with speed, it may be that drivers' enhanced visual capability to detect looming images causes them to intervene more readily in the shorter-range, lower-speed environment (a result that is also supported by the engagement-duration data shown earlier in Figure 141.) Of course, the low-speed environment is also more laden with inter-vehicular conflicts per se, and with the prevalence of nonheadway phenomenon (such as traffic lights) which pose other mechanisms that prompt disengagement.

### **9.2.3 Cut-In Behavior of Other Drivers as a Function of ACC Headway Time**

A substantial ACC-design issue that ultimately blends both safety and customer acceptance concerns is the constraint placed on the minimum set-able headway time value. The principal factor arguing for a relatively short value of this minimum setting is the likely rate of cut-ins experienced by the ACC driver, especially when operated in fairly dense traffic. Further, the overall experience of cut-in events seems likely to affect an ACC driver's level of satisfaction, presumably with declining sensitivity as the absolute value of the selected  $T_h$  setting increases.

A cut-in event is described as one in which, over a very brief time interval (such as the 0.1 second time increment of data collection) an initial target at known headway time is displaced by a new target at a shorter value of measured headway time. (Note that in the context of this section of the report, cut-in refers to a driving phenomenon and not to

the cut-in region of the range, range-rate space described earlier by Figure 44 in section 5.6). A central flaw in this definition, however, can arise from the possibility of a “cut-out” maneuver executed by the ACC driver. In a cut-out scenario, the initial target that was being followed in the initial lane would be succeeded immediately by a second, nearer, target which is actually encountered during the ACC driver’s maneuver into an adjacent lane. It was determined that cut-out cases would be screened from consideration, rather harshly, by selecting only those cut-in sequences wherein the ACC vehicle proceeded virtually in a straight line. Although it is believed that this approach removes virtually all cut-out sequences, it should be recognized that a few could still appear in the data presented below for cases in which the ACC driver executes a cut-out by changing lanes along a tangent trajectory precisely at a point in which the roadway has otherwise transitioned into a curve.

How close do other drivers cut-in in front of us? Is the answer different for low- and high-speed driving? Shown in Figure 159 is a scatter plot indicating the combined values of the initial headway time,  $Htm_1$  and the subsequent, or cut-in-presented headway time,  $Htm_2$ , for all cases which satisfied the defined constraint, while ACC was engaged at speeds below 55 mph. Note that some 425 cut-in cases were captured in the low-speed regime.

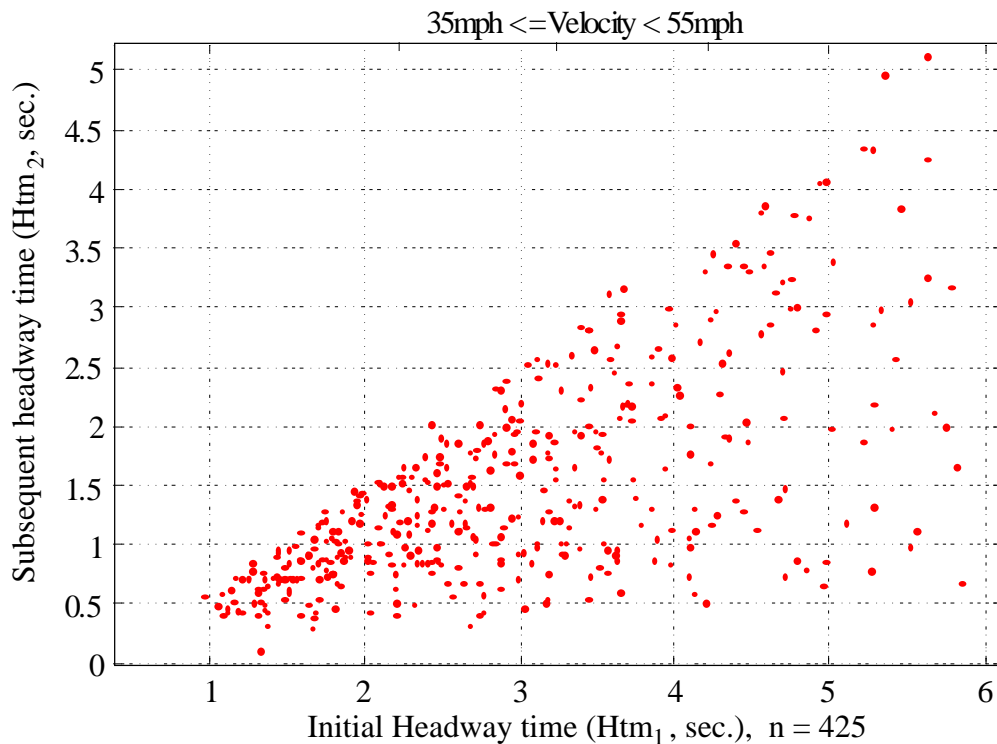

Figure 159. Htm<sub>2</sub> at cut-in vs. Htm<sub>1</sub> prior to cut-in, low speed

Figure 160 shows a similar scatter plot of the initial and the subsequent headway times, for all cut-ins while ACC was engaged at speeds above 55 mph. In the case of the high-speed group, 1198 cut-ins were found. The scatter plots indicate that cut-in occurred over a very broad range of combined headway values, including many cases in which the  $Htm_2$  value was either very close to zero (i.e., just barely ahead of the host vehicle) or very nearly equal to  $Htm_1$ , (i.e., virtually on top of the initial preceding vehicle).

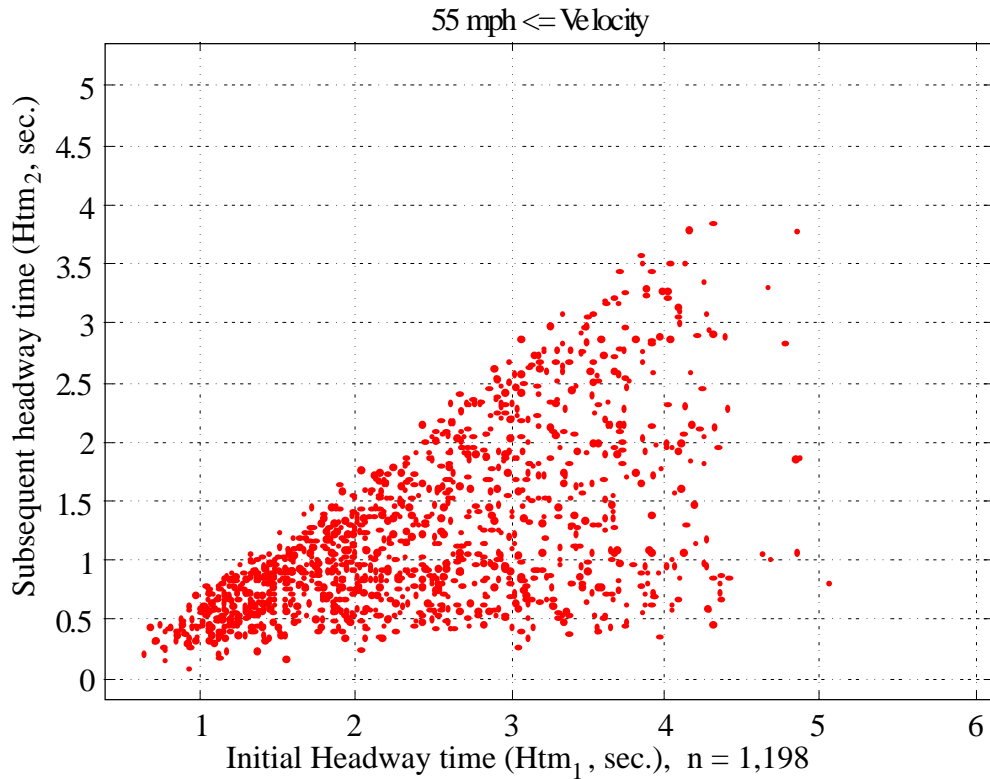

Figure 160.  $Htm_2$  at cut-in vs.  $Htm_1$  prior to cut-in, high speed

Figures 161 and 162 present the corresponding low- and high-speed simplifications of the preceding scatter plots, showing the average values of  $Htm_2$  that prevailed within the indicated bin values of  $Htm_1$ . Clearly, the average values reveal the rational expectation that drivers tend to cut-in on others by arriving in the middle of the space available — that is with the average value of  $Htm_2 = Htm_1/2$ . Thus, the typical cut-in maneuver is tailored to more or less bisect the available headway space that initially prevailed, but with a great deal of scatter in the result, as shown above.



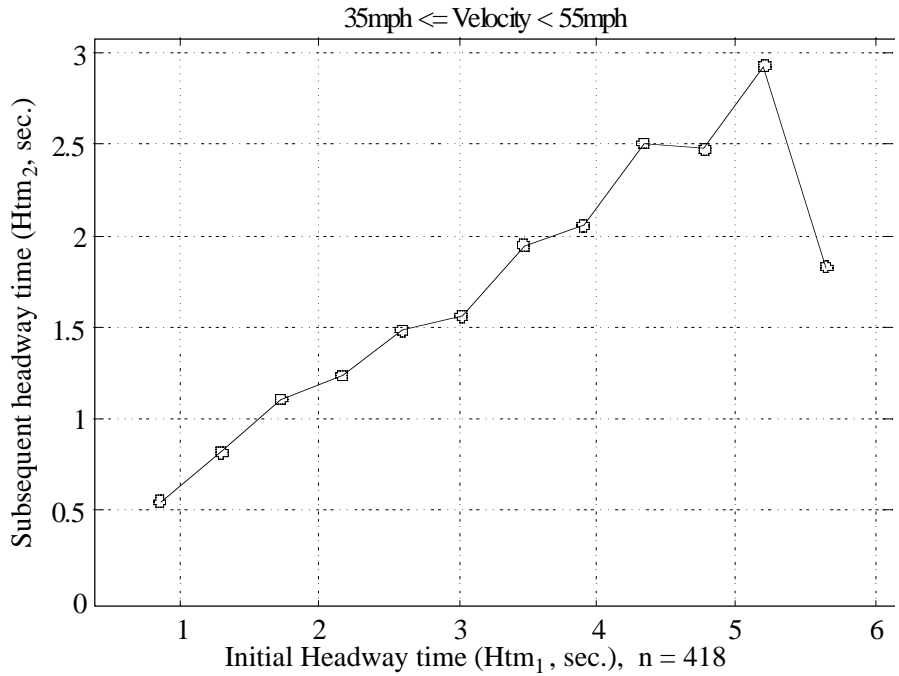

Figure 161. Average Htm<sub>2</sub> at cut-in vs. Htm<sub>1</sub> prior to cut-in, low speed

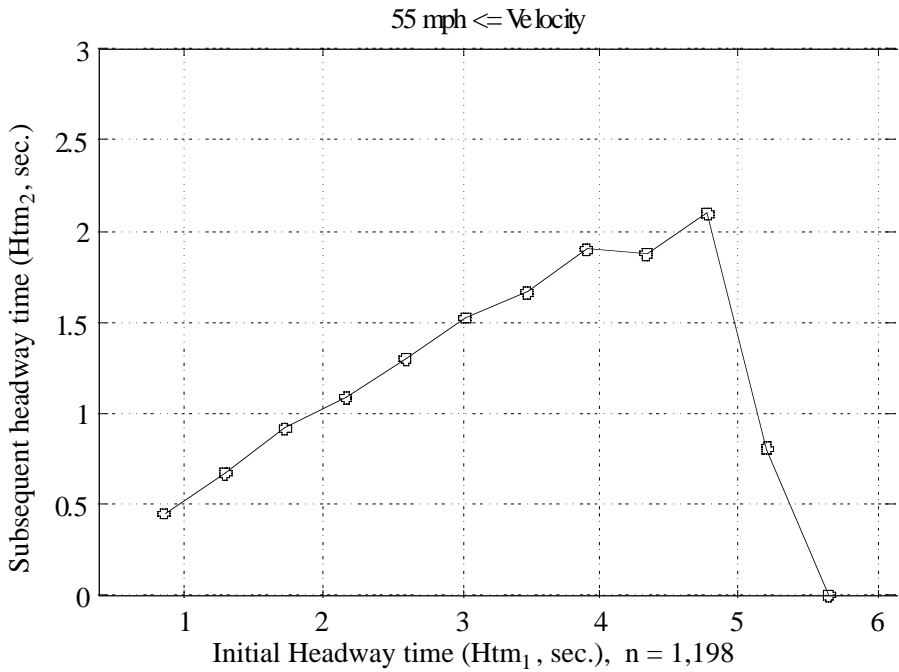

Figure 162. Average Htm<sub>2</sub> at cut-in vs. Htm<sub>1</sub> prior to cut-in, high speed

It was assumed that an associated factor that would also influence the cut-in behavior of other drivers would be the initially prevailing value of Rdot. Shown in Figure 163 and

Figure 164 are the respective low- and high-speed regime data relating histograms of cut-in events by the  $Htm_1$  value, for cases of  $Rdot < 0$  and  $Rdot > 0$ .

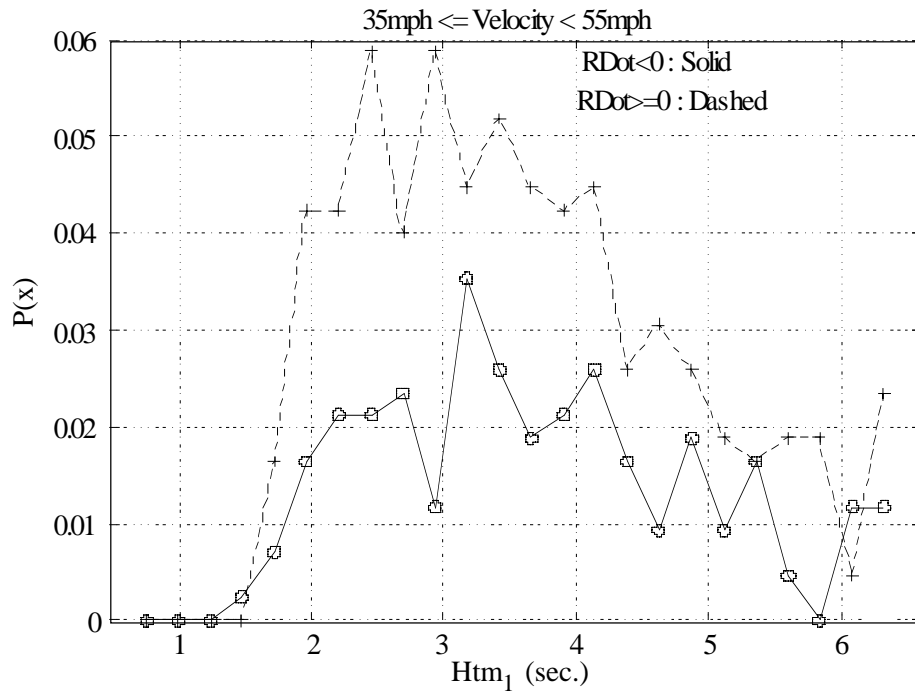

Figure 163. Frequency of cut-in, low speed

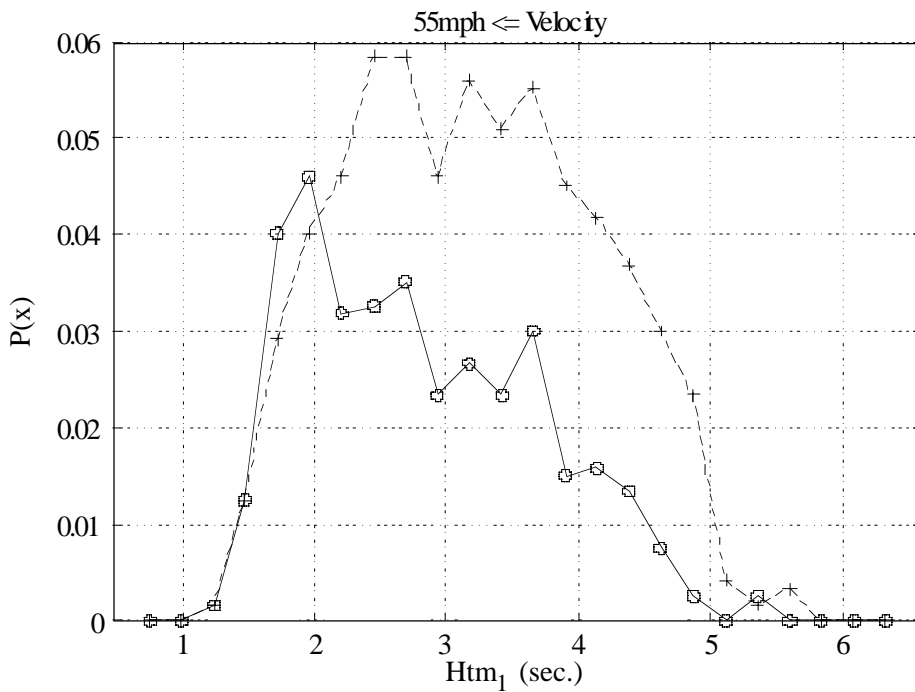

Figure 164. Frequency of cut-in, high speed

We see in both speed regimes that the other drivers markedly prefer to execute a cut-in when Rdot is greater than zero—that is, when the size of the available space is growing. The extent of this preference, however, tends to disappear at both ends of the Htm range. At high values of initial headway time, for example—where it is probably difficult for the cut-in driver to ascertain a reasonable impression of Rdot between two widely spread vehicles—the frequency of cut-in at positive versus negative values of Rdot tends to be indistinguishable. The frequency also becomes muddled at very low values of headway time, where it is presumed that the absolute values of Rdot are typically so low that they become inconsequential to the cut-in decision.

The bottom line of the cut-in experience for an ACC operator may, ultimately, involve the overall rate at which cut-in is encountered per unit driving exposure. To roughly scale this rate, the histogram data relating cut-in frequency to the value of  $Htm_1$  was supplemented with the full set of ACC-engagement data giving nominal mileage exposure according to headway time. For any given bin of initial headway time, then, a rate could be computed of the frequency of cut-ins per mile of exposure. These data are shown in Figures 165 and 166.

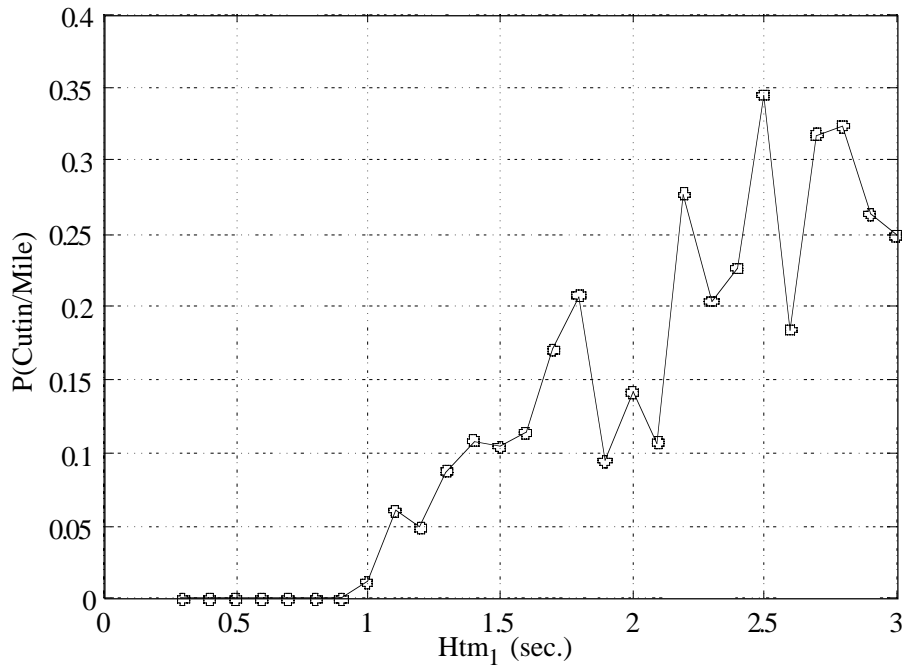

Figure 165. Frequency of cut-in rate per mile, low speed

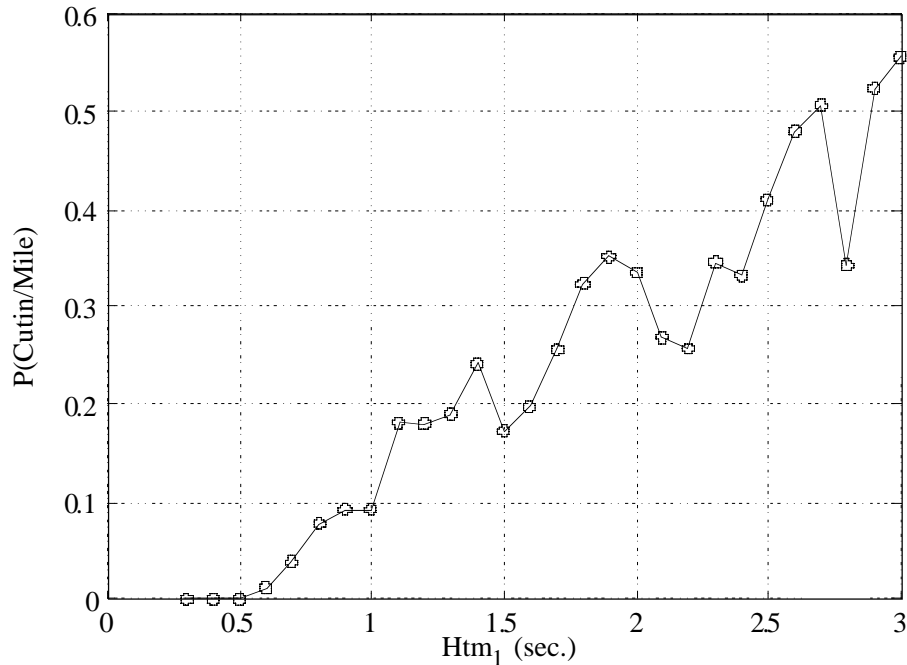

Figure 166. Frequency of cut-in rate per mile, high speed

For the low-speed regime covered in Figure 165, we see that the cut-in rate rises noisily from an effective zero value at an initial headway time of 1.0 seconds to a rate of approximately 0.3 cut-ins per mile in the vicinity of  $Htm_1=3$  seconds. The data for the high-speed regime of operation, in Figure 166, show that a substantial rate of cut-in behavior is observed well below an  $Htm_1$  value of 1.0 seconds. Presumably, the differences in cut-in tolerance for headway time track more or less directly with the average velocities, themselves, such that the cut-in decision is predicated largely by the available range distance, or gap, which initially prevails. By this reasoning, one could say that headway range values below approximately the 50 foot dimension (such as prevails with  $Htm=0.5$  seconds at 70 mph and  $Htm=1.0$  seconds at 35 mph) provide too small a space for comfortable cut-in activity.

The data also suggest that drivers who abhor the experience of being cut-in upon will be certain to want a headway-time setting of less than 1.0 seconds, especially when they operate in the fast lane on high-speed freeways.

#### 9.2.4 Speeding Behavior in ACC Versus Manual Control

One can pose the simple and apparently significant question, “do drivers tend to drive faster with ACC than they do without it?” If all driving were done either a) with ACC engaged or b) without it, the question would be straightforward to answer. As it is,

however, ACC is engaged only under those ambient conditions (including at least the factors of road type and traffic density) in which the driver feels comfortable with ACC usage. Since it is apparent that a first-order relationship exists between road type, traffic density, and the nominal speed of the ambient traffic, it follows that choices for ACC engagement by individual drivers will closely weave the question of ACC usage speed with that of environments conducive to ACC use. Thus, one could answer the above question by saying, “drivers choose to use ACC only in conducive environments—and those environments are generally characterized by higher-than-mean overall driving speeds.”

For example, Figure 167 indicates that even in the higher-speed regime, itself, the histogram of velocity with ACC engaged is skewed to the higher end of the range, relative to that of manual driving. We note that the ACC distribution does not venture observably into speed values falling above those ever encountered in manual driving, but it does show the driver’s predilection for selecting ACC engagement at higher speeds.

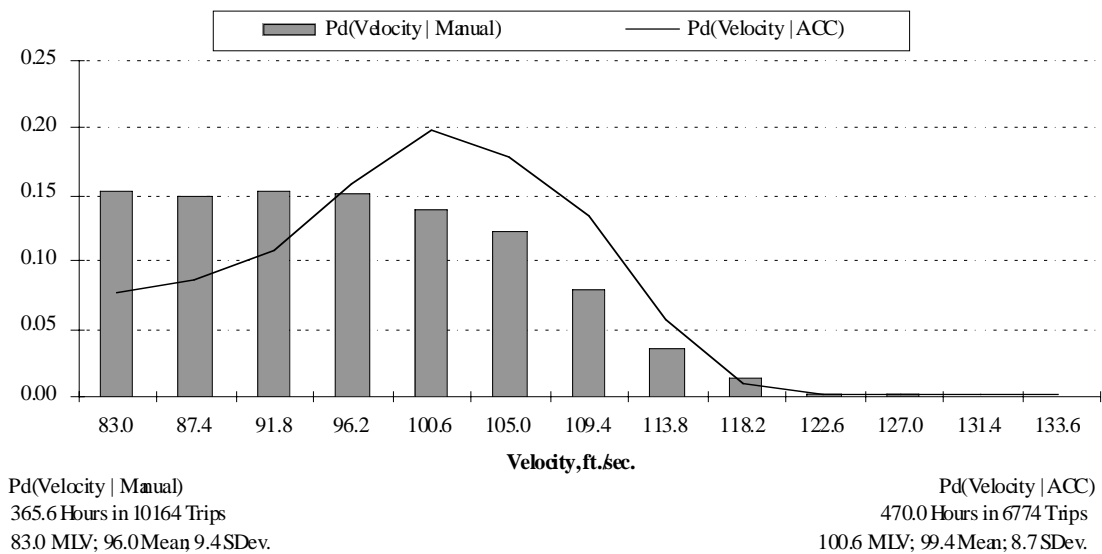

Figure 167. Velocity histogram of manual and ACC driving for all FOT drivers

A somewhat tighter means of examining the question of whether ACC actually induces higher speeds for the same driving environments, however, is provided in the next three figures.

These figures show the velocity histograms of five-week drivers during their first week of participation (i.e., without ACC even being available as an optional control mode) and during their fifth week of participation (when ACC was available, and

presumably after some degree of the novelty of ACC had worn off—an issue that might otherwise tend to skew overall trip-taking habits with additional freeway travel by drivers seeking to “try ACC out” in deliberate little trips that tended to favor the engagement-conducive, high-speed road environment. Some evidence of such deliberate trip-taking was apparent in the field test.)

Figure 168 shows that the velocity histogram from all driving is distributed somewhat more towards higher speeds in the fifth week than in the first-week. (Note, again, that the choice here of presenting the result for “all” rather than for ACC driving, separately, is rationalized to avoid the selectivity toward high-speed environments that is associated with the ACC engagement choice. The assumption in using the format of Figure 168 is that any observed redistribution of the speed histogram is entirely attributable to the ACC (versus CCC) cruise mode feature if the participants engage in the same nominal trip-taking behavior and route selections with ACC available during the fifth week as without it during the first week. A data set of approximately 8,000 miles, each, is seen in the respective results shown here for fifth- and first-week driving.)

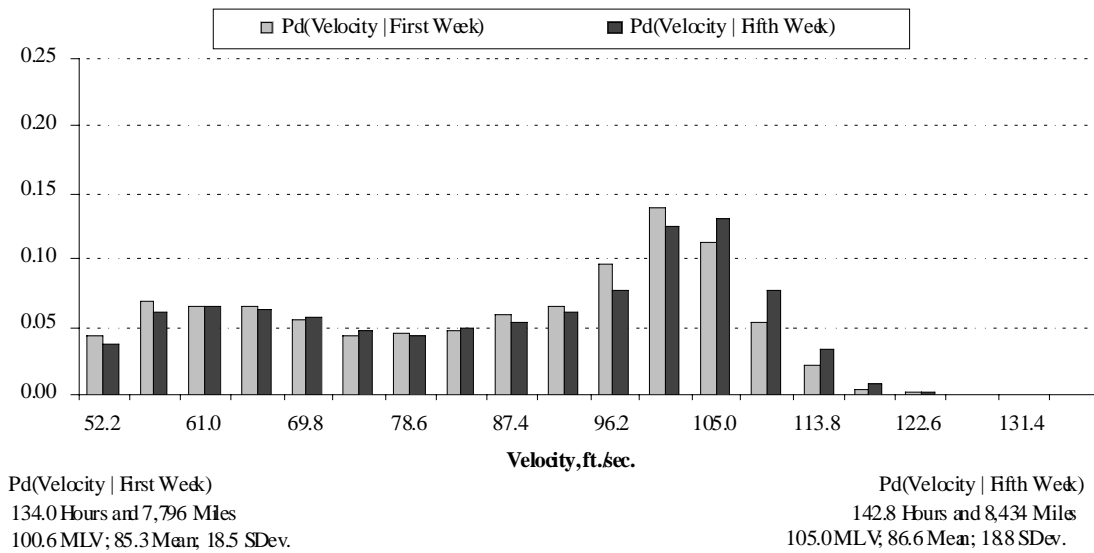

Figure 168. Velocity histogram for the first week and fifth week of five-week drivers

Figure 169 presents the fifth versus first week total speed distributions for travel on interstate highways, only. Here, we see an even more substantial skewing of the fifth-week speed data toward high-speed values, relative to the freeway travel observed during the first week. In this case, the result is drawn from data sets of approximately 3,000 miles, each, for fifth- and first-week driving on freeways.)

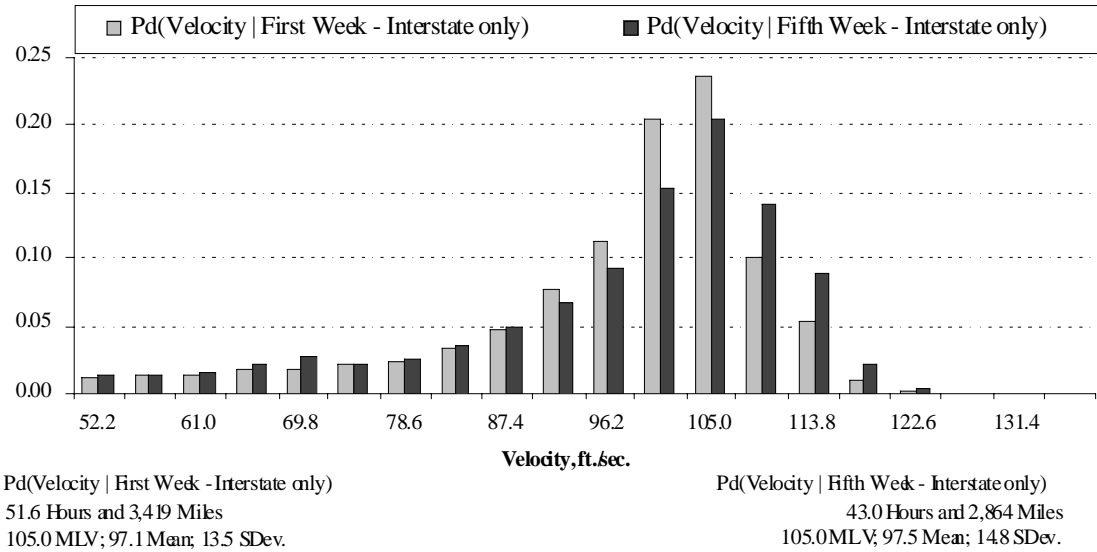

Figure 169. Velocity histogram for the first week and fifth week of five-week drivers on interstate roads

In order to tighten the logic that the redistribution towards higher speeds seen in Figure 168 is probably explained by faster travel in the ACC mode on freeways, Figure 170 addresses the corresponding regime of arterial streets.

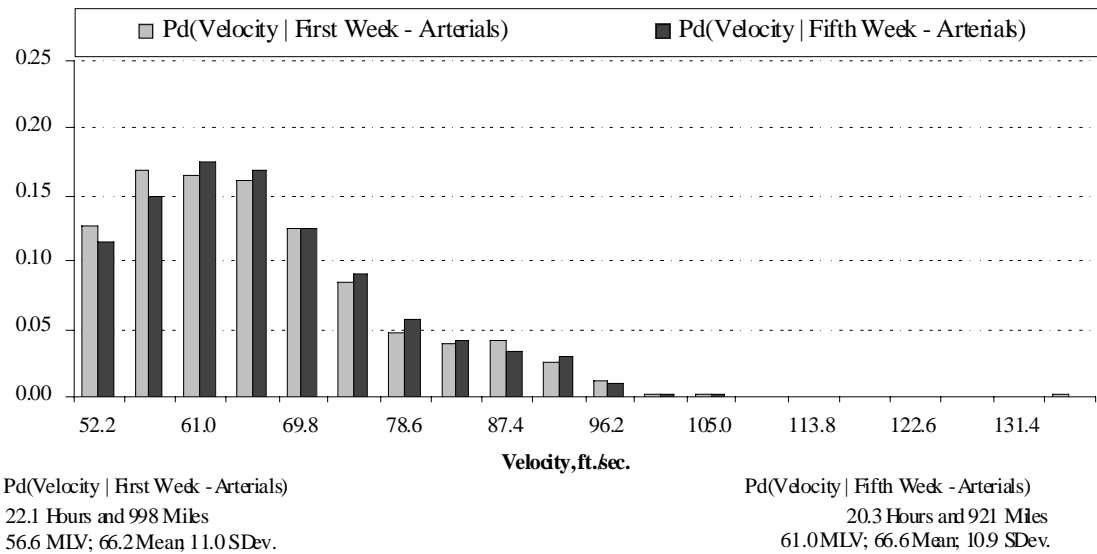

Figure 170. Velocity histogram for the first week and fifth week of five-week drivers on arterial roads

It is suggested that the low rate of ACC usage on arterial streets should render these data more indicative of the fifth versus first week comparison, lacking an ACC influence in either. The data show that although a very modest rightward redistribution of velocity in

these relatively low-speed roads occurred in the fifth week relative to the first week, speed behavior in the two respective driving periods are largely unaffected in this “ACC-sparse” road domain. Since mileages covered on arterial streets totaled only about 900 miles for each of the considered weeks, one also observes that the modest rightward skew in arterial speeds had minimal impact on the net elevation in speeds seen in the aggregate data of Figure 168.

Moreover, these results suggest that ACC usage has induced some elevation in the speeds that would otherwise prevail in conventional (i.e., manual and CCC) driving. This effect is observed primarily on freeways and could conceivably relate to ACC efficiencies in the process of speed maintenance during resolution of headway conflicts, as well as to a mechanism of driver preference — that is, deliberately seeking faster travel while in ACC engagement.

### **9.3 Subject Appraisal of Comfort and Convenience**

One overarching observation from the field operational test is that the ACC system was found to be rather easy to use, quick to learn, satisfying in its use, and more or less straightforward to supervise in the hands of most lay drivers. Subjective results, summarized earlier as obtained from the 108 drivers (and included, in total, as Appendix B) generally express a high level of acceptance of this headway control functionality. In this section the subjectively reported ratings of comfort and convenience are examined in more detail, as if the overall perception of comfortable operation were a system-design issue.

Post-driving questionnaires yielded responses such as those shown in Table 63 (summarizing answers to questions 1 and 3). ACC driving received high ratings with regard to the comfort and ease of driving. That is, where such questionnaire responses yielded a rating near 6 on a 7-point scale expressing ease of use and comfort perceptions, a great majority of drivers expressed nominal compatibility with the ACC system. Noting that the skew in ratings towards the high end makes it difficult to generalize on the tails of the distribution, it may be useful to also recognize that four individuals registered a feeling of “very uncomfortable” to question (1), above, by indicating a rating of “1” and another four persons responded with ratings of 2 or 3, indicating some relative degree of discomfort.



Table 63. Subjective ratings

a. How comfortable did you feel driving the car using the ACC system?						
<b>1</b>	<b>2</b>	<b>3</b>	<b>4</b>	<b>5</b>	<b>6</b>	<b>7</b>
<b>Very uncomfortable</b>					<b>Very comfortable</b>	
<i>Statistics</i>			<i>Mean</i>		<i>Std Dev</i>	
for all drivers:			5.75		1.44	
b. How easy did you find it was to drive using the ACC system?						
<b>1</b>	<b>2</b>	<b>3</b>	<b>4</b>	<b>5</b>	<b>6</b>	<b>7</b>
<b>Very difficult</b>					<b>Very Easy</b>	
<i>Statistics</i>			<i>Mean</i>		<i>Std Dev</i>	
for all drivers:			6.08		1.02	

Each driver was also asked (in question 11) to rank their preference (1st, 2nd, 3rd) for driving under the manual, CCC, or ACC modes of control, as alternative means of realizing differing qualities within the driving experience. When the qualities in question were either “enjoyment,” “convenience,” or “comfort,” the mean rankings of ACC were between 1.29 and 1.31 compared to either 2.1 or 2.6, respectively, as the nominal ranks given to CCC and manual driving (implying that ACC was the clear first choice for a large majority of drivers, in accruing any of the three qualities.)

### 9.3.1 Comfort as Associated With the Time of Exposure to ACC

The five-week drivers (all of whom had identified themselves as cruise “users”) rated their comfort level (in question 1) at 6.50 compared to 5.71 for those two-week drivers who were also cruise users—appearing to indicate that longer exposure to ACC usage tends to boost comfort rather than degrade it. This result addresses, at least to some degree, the concern that some uncomfortable discoveries in ACC operation might appear only when lower-probability types of conflict tended to manifest themselves over longer exposure periods.

In response to question 2 asking “how long did it take to become comfortable using ACC?” 60% of the 108 participants indicated that they became comfortable within the first single day of driving and more than 95% felt comfortable within the first week. When asked (in question 4) how likely it is that the person would become more comfortable with ACC given more time, the two-week users showed a mean response of 5.07 on a 7-point scale while the five-week users gave a mean response of 3.71. Thus, two additional observations can be made. Firstly, drivers complied with the debriefing by responding to questions in the sequence of their presentation, thus indicating a

comfortable use of ACC within a mean time period of approximately one day. Yet, in response to the later question re: the likelihood of becoming more comfortable given more time, we must infer that a further process of ACC adjustment and accommodation was actually anticipated. Secondly, this further process is loosely quantified in noting the contrast in five-weeker versus two-weeker responses. We see that the addition of three more weeks of exposure to ACC usage (recall that two-weekers had ACC available for only one week and the five-weekers had it available for four weeks) substantially reduced the driver's expectation that more exposure time would further improve the comfort of ACC use.

### **9.3.2 System Characteristics Possibly Contributing to Ease of Use**

Anecdotal testimony by many drivers during focus group discussions also seems to imply that the sensation of the deceleration cue that arises from the normal, appropriate action of the ACC controller is a primary factor determining the driver's relative ease in learning to use the system. In another free-form question asking drivers to compare ACC driving with that of CCC, six drivers alluded to the ACC deceleration cue by way of explaining their perception of being relatively more aware of other vehicles in their near proximity. When asked specifically to rate their degree of awareness of other vehicles during ACC use (in question 18), the full set of 108 participants indicated a mean response of 5.53 on a scale from 1.0 (very unaware) to 7.0 (very aware).

Histograms shown previously in section 8 have indicated that headway times, or Htm values, associated with manual driving tend to exhibit a more low-biased distribution, with plenty of driving below the one-second mark, than is seen in ACC driving. Clearly, the contrast derives primarily from the fact that the ACC controller offered a value of 1 second as the minimum on headway time adjustment. Thus, the typical ACC driver experienced longer-than-usual spacings. This practical aspect of the described ACC controller is believed to have played a significant role in the high overall ratings of comfort and ease of use since it resulted in more relaxed margins for responding with an unfamiliar functionality to headway conflicts arising from vehicle braking ahead, cut-ins, overtaking from long range, and so on. As one participant put it, "ACC almost forces you to maintain a safe distance from the car in front of you" perhaps also partially explaining the high ratings for ease of use.

### **9.3.3 Comfort as Associated With the Relief of Certain Driving Stresses**

The other, perhaps primary, dimension of the comfort and convenience subject pertains not so much to the ease with which a driver manages to supervise the ACC mode of control but rather to the very nature of the benefit which driver's perceive as arising from the ACC function. Part of that benefit is believed to trace to the relief of what was called throttle stress in section 8.1.1. ACC, itself, further extends the accrual of throttle stress relief over that generally realized under CCC control by lengthening the typical time period of continuous cruise engagement without intervention by approximately 75%—in the dominant, high-speed, regime of usage. Also, during ACC engagement, the driver can typically forego the additional stress of CCC driving that derives from using the coast and accel buttons for adjusting speed to manage a headway conflict (recognizing, as discussed in section 9.2.1 that a substantial number of new ACC users continue to attempt crude headway maintenance by use of the buttons, even though ACC is serving to control headway, automatically.)

### **9.3.4 High Comfort Ratings Notwithstanding Certain Nuisances**

High overall ratings for comfort and ease of use were reported notwithstanding certain system characteristics that tended to disfavor ACC usage. Some drivers, for example, tended to find that the one-second minimum on headway time setting and the tendency of ACC to interrupt their preferred rhythm by beginning a slow-down response while pulling out to pass a slower-moving vehicle, “on-the-fly,” served to impede convenient driving, presumably to the detriment of their overall satisfaction and utilization levels. As a case in point, the younger group of drivers gave a statistically lower rating of the usefulness of the headway time adjustment feature (in question 26) than did middle-aged and older drivers. This same group also showed distinctly lower levels of ACC utilization at all speeds (see section 9.1) and their rating of “ability to change lanes” (per question 22) in ACC versus manual modes of control showed the largest dis-preference for ACC of any age group. Nevertheless, it must be acknowledged that whatever is the nuisance content of such individualized mismatches with this younger age group in particular, the ACC system was rated by them at a mean comfort level that was identical to that obtained (in response to question 1) from the aggregated sample of all drivers.

Many drivers also commented negatively on certain operational flaws of the prototype ACC system that had been provided to them. The system in question was not a production item and, although rather refined in many respects, still contained certain

performance features that would not be expected in a finished, commercial product. In particular, many if not most drivers had some experience with occasional false detection—and subsequent deceleration—responses in the ACC mode of control, especially when passing long trucks. The ACC system would at least drop the throttle momentarily in such circumstances, and often undertake a transmission downshift as well, even if no impeding vehicle had presented itself ahead.

Also, all drivers encountered a relatively sluggish reacceleration response each time the ACC control mode switched from that of managing headway behind a preceding vehicle to that of recovering the SET speed condition. This characteristic called for either more anticipatory action when pulling out to pass or for manual intervention on the throttle to boost acceleration during the transition in speed back up toward the SET value.

In responding to the free-form questions on the questionnaire and in spontaneous comments during focus group sessions, it was clear that many drivers did, indeed, perceive these anomalies and felt that they needed improvement. (In response to question 43 which invited suggestions for improvement, for example, one participant said, “maybe [provide] a device [allowing for] greater acceleration that you would push prior to merging into another lane.” This response—in overlooking that the throttle pedal is precisely such a “device”—perhaps helps reveal the novel frame of mind that a new driver may adopt when allowing a driver-assistance control to take over a routine driving function.) Nevertheless, the bottom-line opinions on comfort and ease of use tended toward high levels of approval of the ACC function, notwithstanding system flaws.

One partial explanation of this outcome, of course, is that participants tended to give the university research group some license for suboptimal system performance, even though such drivers might be unlikely to tolerate the same flaws in a future automotive product of their own purchase. Nevertheless, broadly consistent ratings on comfort and convenience questions, plus high observed levels of actual ACC utilization and strongly supportive commentary in focus group discussions, all point to a remarkably positive appraisal of this ACC system. It would appear that no more than approximately 15% of the participants would be properly characterized as either uncomfortable with ACC or inconvenienced in its usage. This minority would include approximately 5% who found the system to be wholly uncomfortable.

## **9.4 Subjects Critique of System Features**

Item 43 in the postdriving questionnaire asked the free-form question, “can you suggest changes for improving ACC?” Shown in Table 64 is a listing of the responses, as

roughly grouped into sixteen types of statements. The list includes a broad set of items which, for the most part, are recognized among automotive developers of ACC as relatively significant requirements.

Table 64. Summary of the subjects' critique of the system

Can you suggest changes for improving ACC?	
None	21
Higher acceleration (for passing)	17
Fewer false decelerations	14
Better-appointed and more complete ACC display	11
Better performance in bad weather	9
Illumination of the (cruise) buttons	7
Higher deceleration authority (i.e., braking via ACC)	6
Better tracking on curves	6
Better headway control (crisper, smoother)	4
Provide an intervention prompt (warning)	3
Better agreement between set speed and speedometer	3
Shorter headway settings	3
Longer headway settings	2
More reliable ACC functioning	2
Signal the car behind you to anticipate slowdown	2
Provide ACC response to stopped traffic ahead	2

The overall question of system features as perceived by the participants in the field test will be reviewed in this section by weaving the responses shown in the table, above, together with a few example cases of individual behaviors, for each of a set of thirteen issues whose importance in ACC system design have been previously recognized (see, e.g., [14], [12]). Subsections, 9.4.1 through 9.4.13, below, present and discuss each of these issues.

#### **9.4.1 No ACC Response to Stopped Objects**

The issue of ACC response to stopped objects is known to be of key concern to ACC developers, although in this field test the implemented ACC system did not respond to

any targets (i.e., vehicles detected ahead) whose forward velocity was less than 30% of the speed of the host vehicle. Thus, a field test vehicle under ACC control that was approaching at, say, 50 mph behind another vehicle traveling below 15 mph would proceed ahead without any automatic attempt to manage the shrinking headway distance between them. The subject responses pertinent to this system issue are tabulated below according to the number of pertinent reportings:

- One possible near-miss reported.

In responding to question 44— “did you come close to having any accidents that you feel were related to using the ACC system?” subject number 76 said, “Yes, vehicle traveling significantly slower than the system can compensate for”. Since no individual event in the recorded time histories can be located in order to confirm an incident in hard data, it is not possible to comment on whether the loose statement above, in fact, pertains to the “stopped object” issue or at least to the less-than-30%-of-host-speed class of conflicts.

Although the aggregated data on participant number 76 does not address the specific incident to which he refers, Figure 171, serves to roughly profile this driver (a male in his 20s) in terms of his velocity, Htm, and time-to-impact (TTI) histograms when driving with ACC engaged. These data show a driver preferring relatively high-speed ACC engagements whose Htm histogram is narrow relative to that of the overall subject sample and whose TTI histogram is wholly unremarkable.

Moreover, while the cited experience of the individual could have constituted a “stopped object” class of event, it may also be that this subject’s comment reflects simply a colloquial variant on the common issue of overtaking a slower moving vehicle, at relatively high Rdot, thus calling for a braking intervention even though the preceding vehicle is at a speed exceeding 30% of host speed and the ACC controller is operating on the target.

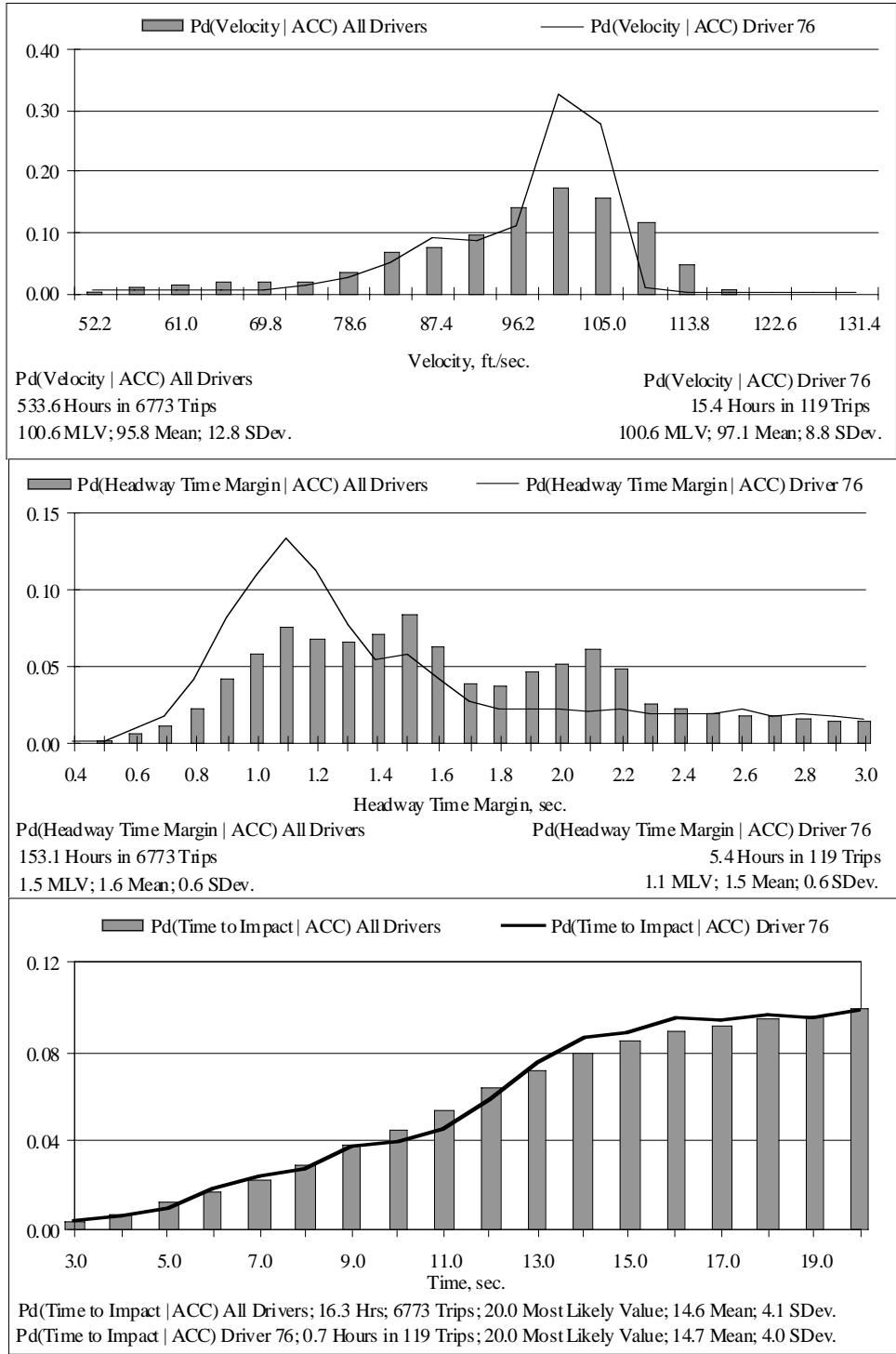

Figure 171. Velocity, Htm, and TTI histograms under ACC for driver 76

- Two other subjects mentioned a concern over striking stopped vehicles, in their free-form responses to question 44, even though they were not reporting a specific

near-miss kind of an incident. One subject said “...had I not been aware of very slow or stopped traffic, I could have struck the vehicle in front.” This person, driver number 113, presents an interesting case of ACC utilization. Shown in Figure 172 are the velocity and time-to-impact histograms for this nonuser male in his sixties.

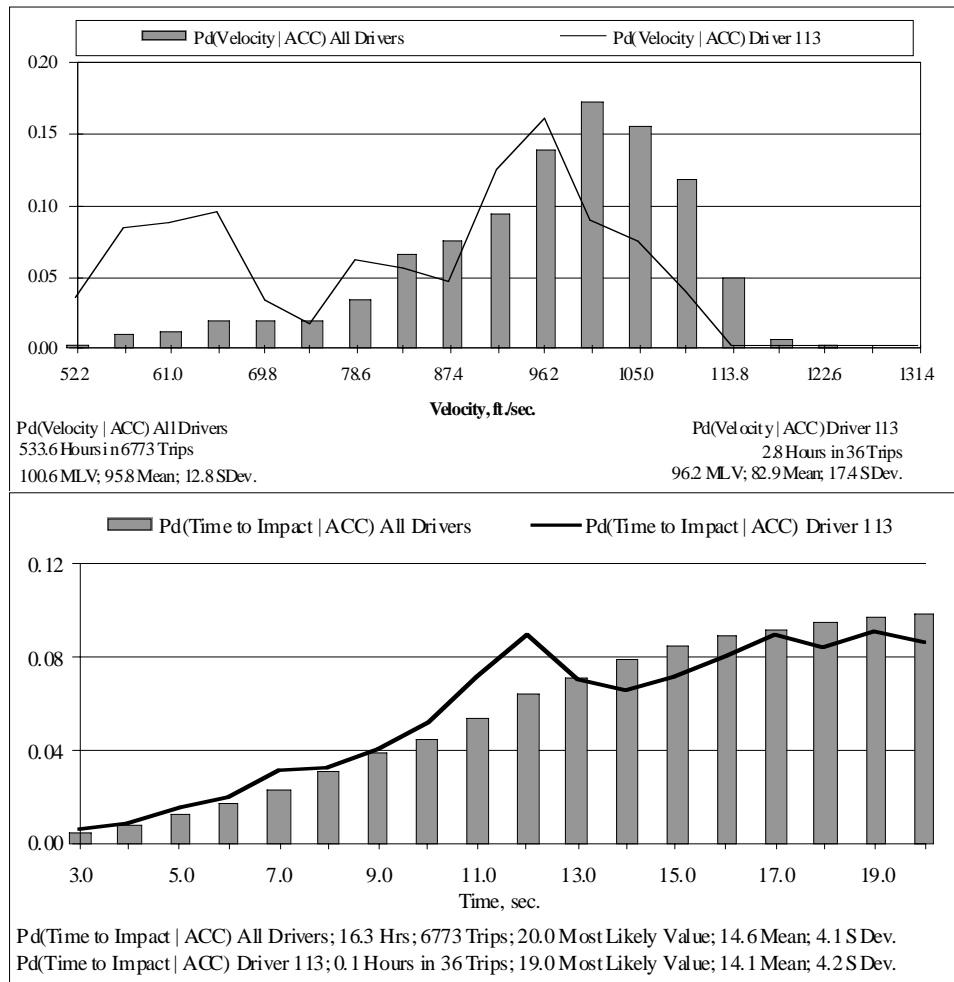

Figure 172. Velocity and time-to-impact histograms for driver 113

The profile is that of a person who used ACC for a total of only 2.2 hours of engagement, with much of the usage at speeds below 50 mph. The tendency for low-speed usage of ACC implies traffic environments which are typically more laden with conflict due to slowing and perhaps turning vehicles. The time-to-impact data, on the other hand, show a histogram that is not too distinguishable from that produced by all ACC driving. Thus, it would appear that this individual chose to employ ACC in traffic environments that tended to heighten his



expressed concern over “slow or stopped” traffic but apparently did not persuade him to reserve ACC utilization to other more conducive environments—at least not within the limited term of his field test participation.

- Two drivers suggested changing the system to handle stopped vehicles, in their response to question 43. The specific phraseology of comments from the two individuals was, respectively, that the ACC system should ...”be able to adjust to stopped traffic” and “respond more quickly to stopped or decelerating-to-stop vehicles.”

#### **9.4.2 Target Loss (or Late-Acquire) on Curves**

This issue pertains to the system’s ability to either continue the detection of a once-acquired target, even while traversing a curved section of the road, or to readily detect another vehicle even if it is first encountered within a curve. The ADC Odin-4 system utilized in this field test did provide a feature for tracking through curves, by which the long-range sensor beam was optically steered in azimuth according to continuous measurements of vehicle yaw rate and forward speed. The feature provided a rather effective means of beam deflection within steady state curves but, of course, could temporarily lose a target at relatively long range during transitions between tangent and curved sections of roadway. Responses indicated that:

- Zero near misses associated with this issue were reported
- Six persons cited in their recommended ACC improvements (in response to question 43) that better tracking on curves was desirable. Drivers cited the issue using terms such as the “problem of curves, not seeing car ahead” and “problem of sensor reading adjacent-lane vehicles on winding (roads)”.

#### **9.4.3 Deceleration Due to a False Detection**

As was indicated earlier, the ACC controller would occasionally decelerate the vehicle in response to detection of an inappropriate vehicle, most commonly a long semitrailer in the adjacent lane. Questionnaire responses included the following:

- One near miss was reported in response to question 44 which asked whether the subject was ever “close to having any accidents... (with ACC).” One participant responded, “Yes, when a driver followed me very closely, the car slowed down due to a car ahead detected, and I was sure he was going to hit me. I was going 68 mph, then the car slowed down to 62 but the driver behind me was still going 68. Need something to alert the driver behind you that your car is slowing down.”

This specific incident has not been located in hard data. The comment, itself, does not directly point to a false detection situation and may simply pertain to the ACC operating normally on a valid target ahead. Further, the subject's final comment reflects a failure to recall that the ACC system in this field test did, indeed, illuminate the brake lamps whenever the transmission was downshifted under ACC control. Nevertheless, the comments roughly align with a fundamental concern arising from false ACC detections. Namely, one can speculate on a possible risk of collision from the rear, especially when a following driver has a good view of empty space ahead of the ACC vehicle and then chooses to crowd the ACC vehicle at an unusually short headway with the implication that passing is intended. In such a scenario, the following driver might be postured at too short a headway value for comfortably managing an unanticipated deceleration by the ACC vehicle if such is triggered by a false detection. The crux of the conflict centers on the expectancies of the fairly aggressive driver in the rear who is assuming that no abrupt deceleration will be engendered by a leading vehicle that has no impediments ahead.

- Two participants expressed concern for a crash from behind during a false-deceleration episode, when responding to question 44, although they cited no specific events. One subject said there “could have been an accident, had traffic been heavy...when the vehicle slowed down as I was passing a large truck in the right lane.”
- Fourteen participants cited the false deceleration matter as an area for suggested improvement of the ACC system, in response to question 43. Subjects used the terminology, “false alarms,” “picking up big trucks when passing,” and “false detections (especially trucks)” in their free-form references to this issue.

#### **9.4.4 Delayed, Weak Acceleration Back Toward Set Speed**

The “weak acceleration” issue drew the largest number of free-form comments suggesting system improvement (in response to question 43). This performance issue arose because of a practicable constraint in integrating the ACC controller onto an otherwise original-equipment vehicle platform. Because the ACC's electronic speed command was presented via the diagnostic port directly to a RAM location in the engine's ECU, certain processing priorities within the ECU code resulted in a subdued rate of reacceleration that approximated 0.02g's at 60 mph compared to a value of approximately twice that amount under normal CCC operation. Although this specific

degree of sluggishness exhibited by the test vehicles does not speak to the general issue of reacceleration authority in a tidy way, the tailoring of ACC reacceleration behavior is recognized as an important aspect of ACC-system design, and one that has been widely explored by industry using ACC prototypes. Questionnaire responses indicated the following:

- Zero related near misses
- One expression of concern over an unsafe passing process associated with the low rate of reacceleration while ACC was engaged. Although the reference is somewhat obscure, the following comment may be to the point (from driver number 117): “The only disconcerting experiences were from moving into a passing lane right behind another vehicle, and the ACC car would slow down rapidly. If I had tried to squeeze between two vehicles, as I do manually, there’s a potential for things to happen. Potential for getting rear-ended.” Assuming that the subject’s reference to “another vehicle” does not imply a legitimate forward constraint on headway to a slower moving vehicle ahead (which would obviously call for the ACC system to “slow down rapidly”) this comment may be addressing the sensation that the slow rate of reacceleration (when moving from a headway-constrained lane into an open stretch of road) was occasionally perceived as a state of deceleration because of the thwarted desire for strong acceleration when joining higher-speed traffic in the passing lane of a freeway.
- Seventeen participants expressed the need for what they called “faster acceleration” when “changing lanes,” “lane clears,” “slower vehicle moves out of path,” “picking up speed,” etc.

#### **9.4.5 Minimum Speed of Retained Engagement While Tracking**

The test vehicles exhibited a characteristic by which the 30 mph minimum operating speed for retaining ACC engagement would cause the ACC vehicle, under conditions of downshift-assisted deceleration, to suddenly upshift again (while still coasting at zero throttle) if it had slowed to below a value of 30 mph while tracking behind an impeding vehicle, thereupon disengaging ACC. While there was no focussed analysis of test data directed at this specific issue, comments by a few subjects indicated that some found this transition to be unanticipated and thus somewhat unsettling. It is believed that this transition may have accounted for comments by two drivers who expressed concern over the way the ACC system responded to “stopped” or “slowing-to-stop” vehicles. Attributing these concerns to the “minimum-speed disengagement” transition invokes a

rather different mechanism from that of the earlier discussion, in section 9.4.1, pertaining to the absence of an ACC control response to targets whose forward speed is below 30% of that of the ACC vehicle. Nevertheless, by either mechanism the issue acknowledges the driver's expectation that an automatic ACC deceleration, once begun, will continue as long as the headway constraint prevails (perhaps all the way to a stop.) In this context:

- Two drivers expressed concern (in addressing question 43) over the ACC system's response to stopped or slowing moving vehicles ahead.

#### **9.4.6 Performance in Bad Weather**

The ACC system implemented a feature by which the so-called "backscatter" measurements made continually within the laser-ranging sensor could detect when a rainfall or fog condition would cause the range-measurement performance to fall off unacceptably. When a defined maximum threshold for the backscatter level was exceeded, the ACC system algorithm was configured to trip an audible warning and to display a "low visibility" lamp while also dropping the throttle into a sustained coasting condition until the driver manually disengaged ACC using the cancel button or the brake pedal. If the ambient condition then dispersed, the low-visibility lamp would go out such that the driver could detect that the ACC function was again available, whereupon manual reengagement could commence. Although the sensor was generally quite tolerant of normal rainfall and of traffic-induced spray from standing water on the roadway, many participants did have at least one experience with the low-visibility function.

Additionally, a condition of wet snowfall could cause the sensor's lenses to be coated with an obscuring layer of snow that could gradually diminish sensor performance such that target acquisition would not occur. While it is recognized that some design techniques might have enabled an automatic detection and disengagement sequence under the condition of an obscuring snow coating, such techniques were not available at the time of field testing. Thus, when this phenomenon was first observed during the early winter period of field testing, all subsequent drivers were advised to terminate ACC usage during any inclement weather in which snow-induced loss in sensing capability might prevail. Although a few participants may have actually encountered the snow-obscured condition, it is believed that virtually all participant comments pertaining to bad-weather issues arose from experiences with the low-visibility function triggered by backscatter detection, as described earlier.

Comments addressing weather-related performance issues included the following:

- Zero comments citing a near miss, specifically, although one subject indicated (in response to question 44) that the low visibility “alarm made me nearly jump out of my skin the first time it went off, and I was in fairly heavy traffic on a curve of the expressway.” Comments overall make it clear that some of the negative response to the weather-performance issue derived from the rather assertive volume of the low-visibility warning device, rather than simply to the loss of ACC availability in bad weather, per se.
- Nine comments (in response to question 43) expressed dissatisfaction with the system’s response to inclement weather and suggested that an improvement was needed. Three of these participants made the judgement that the low-visibility function was “too sensitive” and another three took the view that better performance in the rain was “necessary.”

#### **9.4.7 Driver’s Use of Set Speed**

Previous discussion (in section 9.2.1) showed that drivers under ACC control often employ the buttons labeled “coast” (i.e., decrease set speed) and “accel” (i.e., increase set speed) in a manner that reveals the same strategy of manual headway control as was exhibited under CCC control. While this behavioral anomaly would seem to diminish the level of convenience afforded by ACC, no related matter was raised as a point of dissatisfaction by test participants. Comments pertaining to set speed included:

- Zero that suggested any related near miss incident.
- Three responses to question 43 in which drivers complained that the numerically displayed value of set speed did not match the nominal speed value displayed on the speedometer. While this subject clearly tended to annoy a few drivers, it was not linked to any known operational difficulty in ACC usage. Nevertheless, UMTRI’s industrial partners acknowledged that such complaints are of concern to automakers since they might arise in real service as a warranty claim. The background issue is that anytime an instrument panel employs presentations that are overlapping or redundant in their content, the degree of correspondence between the multiple presentations will be picked up by some users. Of course, it may also be that some test participants were confused with a lack of correspondence between the numerically displayed set speed value and the speedometer, even when the ACC system was automatically controlling speed at a lower-than-set value due to a prevailing headway constraint.

#### 9.4.8 Use of Headway Adjustments

The fact that values for target headway time under ACC engagement were rendered adjustable in the tested system via the three alternative buttons, plus the fact that the buttons allowed the specific values of 1.1, 1.5, and 2.1 seconds as the only available selections, figured significantly into the experience of the test subjects.

In general, it is believed that any commercialized ACC system is likely to provide headway adjustment, in reflection of consumer demand for such a feature (especially given variations in individual driving style and, of course, traffic conditions). Further, current work on international standards for ACC suggests that no party is likely to offer an open-ended adjustment, with no constraint on the minimum headway value [15]. The experiences reported by individuals in connection with headway adjustment are summarized as follows:

- One near miss was reported by subject number 62 (a cruise-user male in his sixties) under the circumstance when a vehicle “cut in front of me when there was just a tiny gap between me and the car ahead. Considering speed—[the] sensor didn’t detect it—it happened too fast for me and the sensor.” While the headway setting under which this incident occurred is unknown, it is clear from data presented in section 9.2.3 that substantial cut-in activity occurs well within the 1 second minimum headway time setting of the ACC controller—particularly when operating in the higher-speed range at which longer absolute values of headway range are sustained. Accordingly, the reported incident seems just as inevitable under ACC engagement as when driving at the same headways under manual control, although a great deal of manual driving (in high-speed lanes) is done at substantially shorter than 1 second headway times such that cut-in behavior is largely prevented. If commercial ACC products do not allow headway times down into the range of 0.5 seconds at which cut-in activity is largely absent, one should expect that ACC drivers will experience larger-than-normal rates of cut-in and the resulting system responses that attend them.
- Seven persons reported (in response to question 41) that ACC-controlled headways seemed “more appropriate” or “safer” than normally prevailed under CCC control. The implication of many of the comments is that the continuous maintenance of headway by the ACC controller (even apart from the question of specific headway values) is the primary feature rendering a favorable judgement. Nevertheless, a few persons in the focus group settings indicated that ACC induced them to alter their driving habits such that they were pleased to take up a

station-keeping activity at relatively long-headway spacings in traffic for which they would, manually, have been disposed to pass rather continually.

Two five-week drivers (number 78, a cruise-user female in her twenties, and number 79, a cruise-user male in his forties) both cited ACC as helping them “maintain” safer following distances than with CCC. Shown in Figures 173 and 174 are a set of headway time histograms that add together the results for these two rather similar drivers.

Figure 173 compares the headway time histograms compiled by these two drivers over all of their (higher-speed) manual, CCC and 5th-week ACC driving. The data show that, while the subjects felt that ACC induced “safer following distances,” the characteristic ACC headway time seen at around one second was much shorter than characteristic values under CCC control and relatively similar to headway times under manual control (although manual driving did yield about twice the incidence of headway times in the range of 0.5 to 0.7 seconds, relative to ACC driving.)

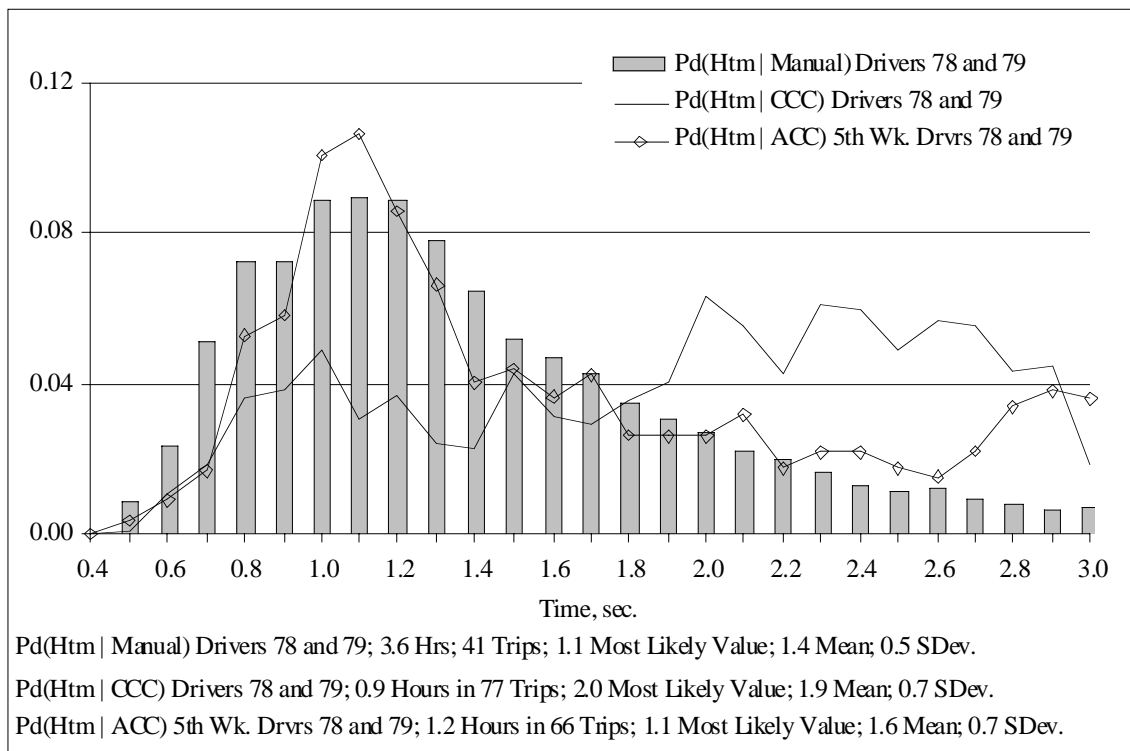

Figure 173. Headway time histograms for drivers 78 and 79 over all their fifth-week driving

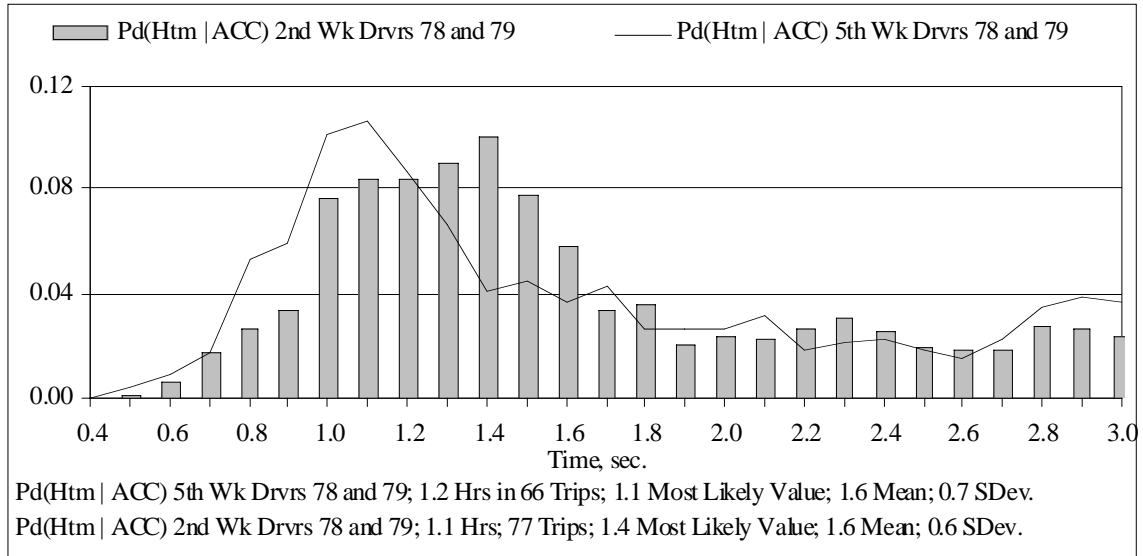

Figure 174. Headway time histograms for drivers 78 and 79 during their ACC driving

Figure 174 shows that from the second to the fifth week, the combined histogram for ACC driving by the two persons trended toward almost exclusive selection of the shortest headway time, 1.0 seconds. Thus, for these individuals to have said that “ACC helps me maintain the safest following distance” is not to say that ACC induces them to travel at longer headways as usage experience grows. One might surmise that a complex set of perceptions probably come together in the subjective comments by individual drivers reflecting on their own driving experience.

- Two drivers said (in response to question 43 on suggested system improvements) that a longer headway selection was needed. The headway time histogram for both of these individuals tends to look rather like that shown for one of them (driver number 91) in Figure 175. The figure confirms that the individual desiring longer than a 2.0 second headway selection under ACC control did, indeed, choose the 2.0-second button almost exclusively when driving in the field test.
- Three drivers said that a shorter headway selection was needed. The headway time histogram for each of these individuals tends to look rather like that shown for one of them (driver number 85) in Figure 176. The figure confirms that the individual desiring shorter than a 1.0 second headway selection under ACC control did, indeed, choose the 1.0-second button almost exclusively during the field test.



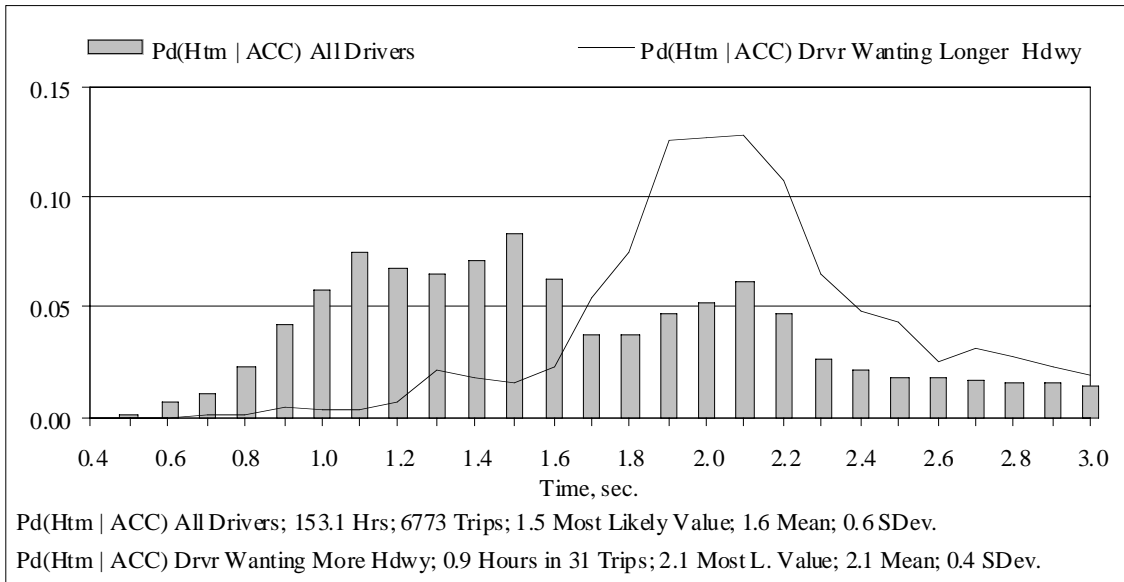

Figure 175. Headway time histogram for driver number 91

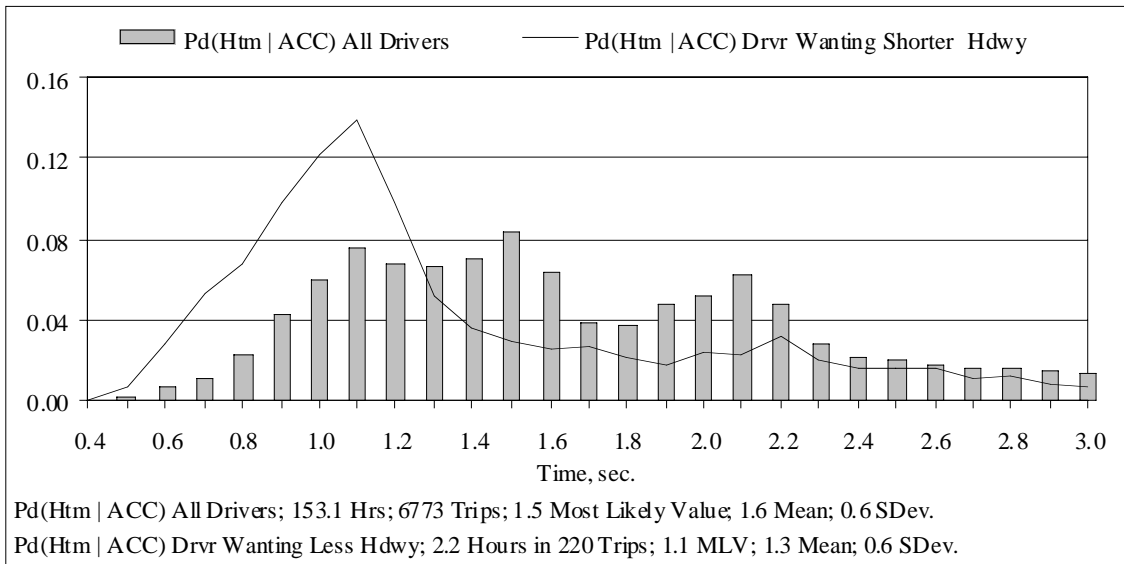

Figure 176. Headway time histogram for driver 85

#### 9.4.9 Traffic Environment in Which ACC Was Utilized

Data shown in section 9.1.2 showed that even though 90% of the total ACC-engagement miles were traveled on freeways, very substantial levels of utilization were exhibited on surface streets. The data showed, for example, that utilization on arterial streets, at speeds above 55 mph, was approximately 50% and, at speeds between 35 and 55 mph, utilization on arterials was near 14%. Further, data presented earlier in this section,

addressing the issue of ACC performance in the presence of stopped and slowing vehicles indicated that some individuals utilized ACC a good deal in the more conflict-laden traffic environments. In the various subjective statements made by participants, essentially every comment citing conflict arose from the presence of another vehicle—in contrast, say, to the stereotypical single-vehicle conflict that can arise with ACC when the system reaccelerates upon emerging from behind an impeding vehicle at the time of transitioning, alone, onto an exit ramp. Thus, we could summarize that:

- All of the few cited cases of a near-miss perception arose from the detailed context of the traffic environment.
- No comment among those responding to the “suggested improvements” question, 43, specifically complained that ACC was rendered low in utility in certain traffic environments, although such a conclusion can be drawn implicitly from comments indicating, for example, that the 1-second headway adjustment minimum was too long. This result rather clearly links to low utility since its principal proponents—the hunter/tailgater style of driver, usually among the twenties age group—exhibited the distinctly lowest level of overall ACC utilization within the driver sample (see section 9.1.2).
- Four persons responding to question 42, comparing ACC to CCC driving, indicated explicitly that ACC gave them a cruise utility for a broader array of traffic environments. Comments indicated that ACC was “much easier to drive in traffic of all types,” “better in urban areas, where there’s more traffic,” “greater ease of use for driving cruise in more dense traffic,” and that “I would rarely use normal cruise control on any road other than a divided highway, but ACC eliminated having to reset or make changes.”

#### **9.4.10 Limited Level of (Throttle + Downshift) Deceleration Authority**

The full range of deceleration authority on the ACC field test vehicles, measured at highway speeds, was approximately 0.07 g’s, achieved by means of both throttle release and transmission downshift from fourth gear to third. Since the deceleration authority determines, implicitly, the maximum severity of a headway conflict beyond which the driver must intervene via manual control, it clearly plays a central role in the perceived utility of ACC and in the experience of individuals in their fundamental role as ACC “supervisors.” Participant comments appearing to relate to the issue of ACC deceleration authority include the following:

- Zero comments citing a near miss experience can be related directly to the issue of deceleration authority. None was reported in response to question 44.
- Six participants suggested that ACC be improved by increasing the level of deceleration available under ACC control. Comments that were apparently referring to this feature used terms such as, “quicker slowing,” “slow down much faster to adjust to the car ahead,” “decelerate more quickly,” “better slowing-down distance,” and “better deceleration.” Perhaps the phraseology in the first suggestion—the one suggesting a “quicker slowing” characteristic—relates not so directly to the deceleration authority per se, but rather to the nature of the control algorithm which determines the range at which the deceleration process commences when closing on a slower vehicle from long range. Such an interpretation would then align closely with that of another participant who suggested that the system “[slow] down sooner if vehicle [ahead] is traveling much slower.” One additional suggestion for improvement that could be subject to a wide range of possible interpretations was to “make the changes in speed more accurate.” Another suggested the preference that “the transitions from acceleration to deceleration and vice versa would be smoother, not so abrupt.”

Clearly, the murky nature of comments pertaining to the system’s headway management performance reveals (1) the integrative nature of the issues to be addressed via the control algorithm, (2) the well-recognized sensitivities of human response to deceleration, and (3) the implicit desire for high utility which may roughly translate into (a) the frequency of intervention (or conversely the distance covered per continuous—non-intervened—engagement as quantified in section 9.2.1) and (b) the range of traffic environments which are judged to be conducive to (i.e., comfortably manageable under) ACC operation.

Whatever degree of dissatisfaction prevailed due to the modest level of ACC deceleration authority, it is instructive to also note that the free-form comments made by many individuals in response to question 42 (comparing ACC to CCC) were simply positive.

- Sixty-five participants chose to make a simple comment expressing satisfaction with ACC, using terms such as “comfortable,” “enjoyable,” “pleasing,” “better than CCC,” “relaxing,” “great,” and the like.

It is also pertinent to note the numerical ratings given in response to question 15, “what did you think of the rate of deceleration provided by the ACC system when

following other vehicles?” Participants responded with a mean rating of 3.64 over a range from 1 (too slow) to 7 (too fast). Since no subject ever expressed the observation that ACC control exhibited an excessive level of deceleration, it is not altogether clear why this response was not more skewed toward the low end of the scale (although the “too slow” and “too fast” lexicon may have failed to accrue uniform interpretations from this heterogeneous group of volunteer participants).

#### **9.4.11 ACC-Applied Deceleration as an Attention Prompt (or Cue)**

Participants occasionally referred to a greater sense of awareness of pending headway conflicts as a result of their physiological sensitivity to ACC-induced deceleration, as a cue. A related matter pertaining to the net impact upon the individual’s state of vigilance is addressed below, in subsection 9.4.13. Comments on awareness as appeared to arise from the deceleration cue included the following:

- Four persons responded to question 42 with comments that ACC , “helped to keep me aware of surrounding traffic”, “eliminates some of the stress, knowing it will alert you to other vehicles”, “provides a sense of awareness that CCC cannot”, “prompts attention to surrounding traffic changes.” When this subject was raised in the focus group discussions, rather complete concurrence among the participants revealed that the utility of deceleration as an attention cue was broadly realized, although not so often mentioned in responses to the free-form portion of the questionnaire. It might also be assumed that the apparent value of ACC deceleration as a cue figured to some degree in the perceptions of the (19) persons who cited ACC as “safer” than CCC, also in response to question 42. Further, the regularized character of this feedback cue may have figured significantly as an aid to the process of learning ACC operation (shown in the responses to question 2 as having reached the “comfort” level for most participants within the first day of usage.)

#### **9.4.12 Requirement For ACC Controls and Displays**

The nominal scope of controls and displays that specifically supported the driver’s operation of the ACC function included the conventional set of cruise-control buttons mounted onto the top face of the steering wheel plus the dashboard-mounted ACC display module and the headway-setting buttons described in section 3.1.4. By way of comment on the suitability of these provisions, participants made suggestions for improvement (under question 43) as follows:

- Three persons cited the need to illuminate the cruise buttons for easy operation at night. This suggestion apparently refers to Chrysler’s original-equipment switches mounted on the steering-wheel assembly for effecting on/off, set, resume, cancel, etc. (since the headway-setting buttons for ACC control were illuminated whenever the headlight switch was turned on). It seems reasonable to assume that the need for cruise-button illumination was unusually high because the drivers were unfamiliar with the vehicle platform.
- Eleven drivers cited various needs for improvements in the ACC control/display features, themselves, including suggestions to
  - show the current headway selection
  - quantify or graphically portray the distance to the current target ahead
  - provide a continuous headway adjustment (and/or, as discussed under subsection 9.4.8, extend the limits of adjustment both up and down beyond the minimum setting of one second and maximum of two seconds employed in the field test vehicles)
  - provide an audible intervention prompt that signals when the pending conflict calls for control action that exceeds the ACC’s deceleration authority

#### **9.4.13 Driver’s Vigilance With ACC**

Participant comments summarized above in subsection 9.4.11 indicated that the deceleration cue seemed to pose a mechanism that enhanced attentiveness of the driver in an ad hoc way, each time a developing headway conflict served to stimulate ACC control action whose deceleration component was discernible by the driver. Taking the broader view on the question of vigilance, however, it is clearly of interest to determine whether any significant adaptations in driver watchfulness might have occurred under ACC control. Clearly, the field test did not incorporate any means of directly characterizing vigilance behavior, per se. The only input on this issue obtainable from the test exercise derives either from anecdotes obtained during debriefing and focus-group discussions or from specific comments made by participants in response to the free-form questions.

Results indicate the following:

- Three persons cited concern over possible loss in vigilance due to ease of ACC driving (two persons in response to question 42 and one person in response to question 44.) These individuals commented that, “like anything automated, you grow to depend upon its judgement”, “ACC... may give false security, I’m sure,” and “the idea of ACC lulls you into thinking it will react to unsafe conditions.”

One might also infer an attitude of relaxed vigilance from statements of some other participants that were phrased, for example, as, “I can relax (with ACC) whereas the device adjusts to car ahead,” “(ACC) helps to relieve need for constant hovering of driver’s foot over accelerator and brake,” “you don’t have to constantly worry about braking when a car is in your lane ahead of you,” and “it promotes a feeling of security.”

Also, certain specific anecdotes that were conveyed by individuals appeared pertinent to the vigilance issue. For example, one young mother in her twenties indicated during a post-driving interview that, when traveling with her baby buckled into a back seat position, she had never been comfortable looking back to check on the child when driving manually on freeways. With ACC, however, she explicitly cited a growth in confidence from being able to feel the automatic deceleration response of ACC, revealing her perception that an additional layer of technological attentiveness to the forward scene had been provided by the ACC function. When asked what she might think if, right when she took a glance back at the baby, a condition might develop ahead that the ACC system is unable to detect and respond to, she seemed surprised at the thought. Of course, a fully balanced consideration of this anecdote is not possible—it is simply one comment from one real subject whose actual practices in driving vigilance are unknown. We do not know, for example, how much overall improvement in the individual’s attention to forward conflicts actually accrued from ACC, let alone its net balance against episodes of reduced attention due to back-seat glance-taking.

Another type of anecdote reported by a few subjects was the observation that ACC gave them more freedom to glance at the scenery, especially on long trips where unfamiliar vegetation attracted attention. No suggestion was made, in these reportings, that the adaptive glance-taking behavior may have posed a net increase in driving risk.

- Five persons said (in answering question 42) that ACC required more alertness to operate. Implying, perhaps, that ACC operation warrants a heightened state of vigilance simply for supervising its partial-control function, these individuals commented that with ACC “you have to be more alert,” “I was always under pressure because I wasn’t sure how close to the other car I could get before it would activate,” “I had to be more alert...constantly watching to see what would happen,” and “requires more attention.”

- Seven participants gave an almost opposite point of view to that cited just above. Namely, comments from this group implied (in response to question 42) that their driving vigilance, or perhaps some related quality of their safety attentiveness, improved when driving under ACC control, citing feelings of being, “more aware and alert to other motorists,” “more alert and cautious,” “more aware of surrounding traffic” under ACC control and that because it “eliminates some of the stress knowing it will alert you to other vehicles... (it therefore) allows you to concentrate more on the road ahead.”
- Nineteen persons offered the summary-type opinion (in response to question 42) that they were safer driving ACC, overall. Presumably the summary comments connote some reflection on the question of whether vigilance has been degraded as a side-effect of ACC usage. The aggregate question of safety impact is dealt with more in the next section.

## **9.5 Implications of Impact on Safety**

Determination of the safety impact of ACC usage was, of course, a key interest of all of the partners in this field operational test. Although deliberate care was taken to ensure the safety of the laypersons who operated under ACC control during this test, the lack of any crashes occurring during ACC engagement is notable. With only approximately 35,000 miles of ACC-engagement exposure logged during the project, however, one would have anticipated no more than a 10% chance that a police-reported crash would have occurred, if ACC crash risks simply matched the norm for conventional driving. Thus, the lack of any ACC crashes, while a welcome test outcome, serves as only a very crude data point, speaking to long-term crash potential for systems of this type. At the same time, the simple fact that participants chose to actually utilize ACC in more than 50% of all the driving miles in which the system was enabled tends to dramatically heighten the importance of any safety influences that do prevail. If ACC turns out to be safety-beneficial, its massive exposure will heighten the benefits. If ACC turns out to be used harmfully, it will be massively exposed for accruing the opposite effect.

In this section of the report, a variety of observations on safety implications will be summarized. In reviewing this material, the reader should note that the lack of a cohesive scientific structure for addressing the overall driving process severely handicaps the safety discussion. Thus, the following material presents a diverse collection of observations whose net implications for higher or lower crash risk is unknown. And yet, each is selected for presentation on the basis of some implied safety hypotheses, as if safety could be

forecast by looking at one factor at a time. While good arguments can be made for expecting either significantly positive or negative safety impacts from widespread use of this ACC system, a balanced reading of the safety “sketches” that follow will reveal a picture that is truly mixed.

The presentation covers results drawn from both objective and subjective results. The objective results have included histograms of ACC driving performance that may speak to global safety issues and measurements based upon the elevated braking responses arising when drivers chose to intervene upon ACC control. The subjective results include a set of observations that all appear to express global safety perceptions on ACC usage, plus opposing sets of specific views on whether the driver is either more or less vigilant when driving with ACC engaged.

### **9.5.1 Objective Results Having Possible Safety Implications**

Objective measurements of ACC versus manual and ACC versus CCC control have been presented in profusion in this report. Among the results presented earlier in sections 8 and 9, observations thought to have possible safety implications are reiterated below, referencing firstly certain issues associated with steady ACC engagement and, secondly, the peculiar issues associated with brake-induced disengagement of ACC.

## **Results Based Upon Data Aggregated Over Periods of ACC Engagement**

1. Longer values of headway time characteristically occur under ACC control than in manual driving. If headway time truly converts into lead time for emergency response to a headway conflict, a very simple safety hypothesis might be espoused. The data show that all Htm histograms from ACC driving are shifted further to the right than those from corresponding manual driving, as shown contrasted for each of the three respective age groups in Figure 177. The “stretched-headway” outcome with ACC has an obvious partial explanation in the fact that the shortest available value of headway-time adjustment in ACC, at one second, was well above the domain occupied in approximately one-third of all manual driving. Figure 177 further suggests that individuals also make personalized judgements in selecting suitable ACC-controlled headways relative to manually selected headways. The histograms show that older drivers have lengthened their ACC-headway preferences much farther beyond their corresponding manual distributions than did younger drivers. This curious phenomenon may well relate to physiological differences emerging beyond age 60 in visual range accommodation as well as in reaction delays. There may also



be more subtle changes in the respective headway tolerances based upon perceived risk in the driver's role as an ACC supervisor.

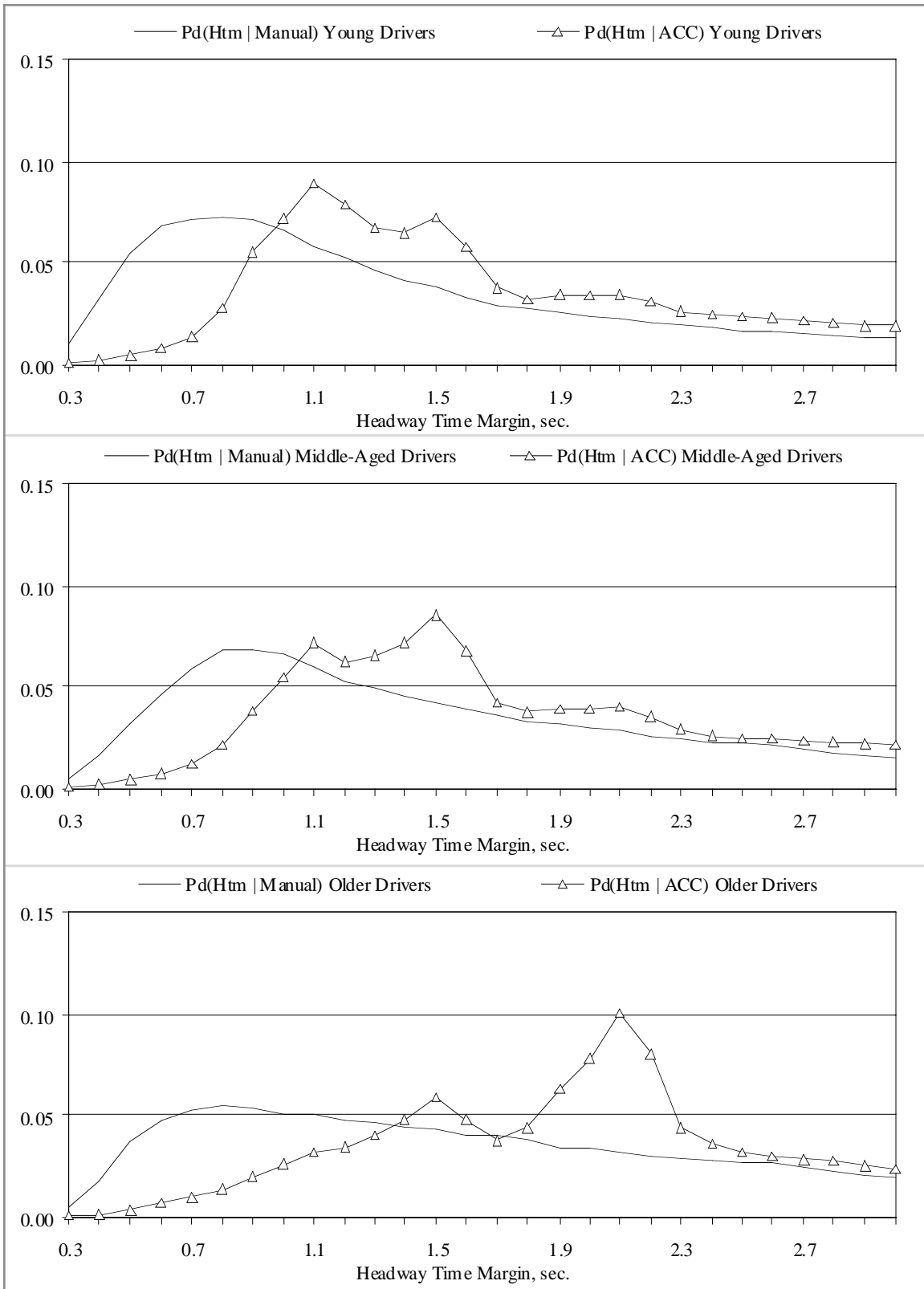

Figure 177. Htm shift between manual and ACC driving as a function of age

In any case, the objective measurements obtained through this field test definitely establishes that driving with this ACC controller involved a dramatic lengthening of typical headway times—perhaps to the effect of a safety benefit, although many other safety-interacting influences may also effect the net outcome.

2. Histograms of the time-to-impact (TTI) variable that were measured during ACC driving were seen to be skewed substantially upward relative to those seen in either manual or CCC driving. The data showed that ACC operation involved approximately half the accrued time of exposure at TTI values below 8 seconds than were seen in manual driving. ACC driving also showed approximately 10 to 15% lower exposure at TTI values below 12 seconds than were seen during CCC driving.
3. A modest skew toward higher velocities has been observed in the total driving data obtained during weeks with ACC available. On the one hand, it is not possible to differentiate between a) a “mechanistic” effect by which the ACC controller simply manages to sustain speed better than the human controller who may tend to overretard his speed in response to temporary traffic-imposed impediments, and b) a “behavioral” effect by which ACC somehow cultivates a driver preference for higher travel speeds, when the system is engaged. On the other hand, some will argue that any elevation in travel speeds, however achieved, is safety-detrimental due to its classical correlation with an increase in harm when crashes do occur.
4. ACC engagement is also distributed more significantly into the lower portion of the speed range than was seen under CCC control. The increased presence of cruise usage in “low-speed traffic environments,” in turn, appears to involve increased exposure to the more frequent and demanding conflicts arising from unstable traffic flow and from cross-lane movements by vehicles engaged in other-than-basic following scenarios.
5. Directly associated with item 4, above, the ACC utilization rate is also seen to be more than twice as high as that of CCC on off-freeway roads. Thus, the nature of conflicts by the ACC-supervising driver tends to include more situations with stopped and turning vehicles ahead, plus a variety of intervention situations occasioned by traffic lights and the phasing of light timing with the instantaneous placement of the ACC host vehicle relative to the intersection stop line and the other vehicles that may be preceding the host toward the intersection. In a

nutshell, the greater frequency of ACC usage on surface streets seems to cultivate more challenging intervention activities than are seen in CCC usage.

## **Results Involving Brake-Induced Disengagement of ACC Control**

Objective measurements associated with the disengagement of ACC tend to show that significantly elevated levels of control severity have been exercised by the driver, when intervening using the brakes. Indications along these lines include the following:

1. Deceleration levels reached during brake-induced disengagement of ACC were seen to be considerably higher than those used in disengaging CCC. The overall range of braking deceleration values accrued upon disengaging ACC and CCC modes of control were compared in a way that removed all “tap” braking (i.e., deceleration levels  $< 0.05$  g’s) from the data set. The comparisons showed that ACC disengagements occurred at approximately twice the deceleration magnitude as was seen in CCC disengagement. Shown in Figures 178 and 179 for example, ACC and CCC disengagements via braking are occurring over comparable, instantaneous values of headway time, but deceleration levels in ACC interventions are dramatically higher than those attained in CCC interventions. On the one hand, this result may simply confirm that the typical CCC disengagement is a more anticipatory control action that is initiated well before headway conflicts are allowed to build up to a level requiring a high deceleration input. On the other hand the occurrence of relatively frequent deceleration levels reaching above 0.2 g’s while traveling in the high-speed domain (i.e., with  $V > 55$ mph) raises the prospect that the ACC host vehicle may disturb vehicles travelling behind it in an unexpected way.
2. The question of how “unexpected” would be the disturbance potential of ACC-intervention braking was partially addressed through comparison of its deceleration distributions with those obtained simply during manual braking, in the high-speed domain of driving. Results showed that ACC-associated decelerations were distributed modestly more toward higher levels, even though the driver’s tendency to engage cruise control only under the more benign traffic conditions should have produced the opposite comparison, all things being equal.

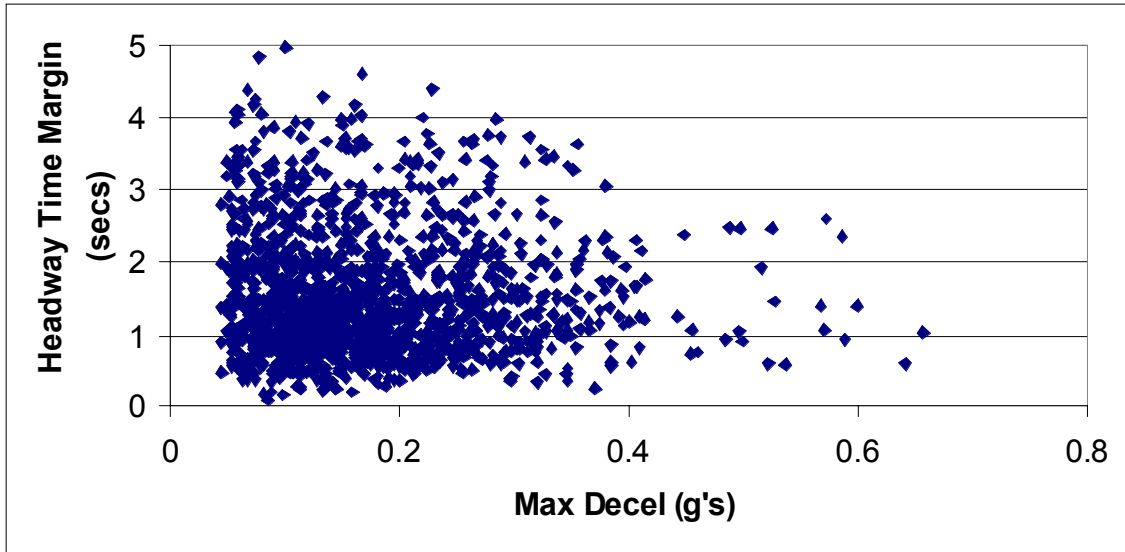

Figure 178. ACC disengagements via braking

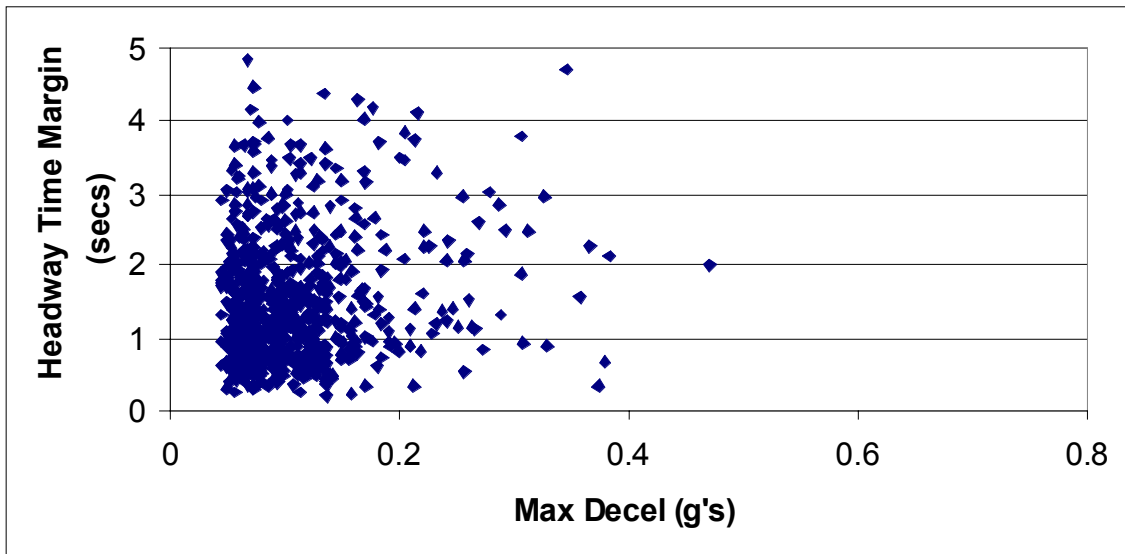

Figure 179. CCC disengagements via braking

That is, preferential engagement of ACC in mild traffic (thereby leaving high-conflict traffic for manual control) should have concentrated the manual braking distributions more toward the higher-deceleration responses. Carrying the implications of this logic to a conclusion, one would infer that ACC disengagement involved brake applications whose deceleration levels exceeded those of the ambient (manually controlled) vehicles operating in the same prevailing environments.

3. Measured at the moment of first pedal movement to disengage ACC, there is a substantial incidence of headway penetrations whose minimum clearances to the vehicle ahead lie well below the selected value of headway time. Results showed that in 10% to 15% (depending upon speed) of the cases in which ACC was disengaged using the brake, the headway time had fallen to half or less than the selected value of  $T_h$  by the time braking commenced. Lacking any reference paradigm for judging this result, one can only direct further study into the dynamics of ACC intervention, seeking to assimilate the headway-penetration data together with the associated braking levels that were invoked, all compared against what drivers do under manual control.
4. Notwithstanding results mentioned earlier that showed TTI values over all driving miles to be favorably longer under ACC control than under either manual or CCC control, the comparison of times-to-impact for ACC and CCC control modes at the moment of brake-induced disengagement shows a strongly reversed result. Namely, braking disengagements of ACC occur far more frequently than those of CCC in the range below approximately 6 seconds-to-impact. Again, while this phenomenon presumably derives from the proactive versus reactive distinction of the CCC versus ACC modes of cruise supervision, the ACC driver is nonetheless employed in approximately three times the incidence of short time-to-impact interventions.

### **9.5.2 Subjective Results Having Possible Safety Implications**

The fact that drivers were overwhelmingly positive in their subjective ratings of ACC comfort and convenience indicates that the fielded system constituted a basically human-friendly automotive feature. That is, the system was obviously found to be readily operable by virtually all 108 participants, although approximately 5% of the subjects indicated that they were relatively uncomfortable using ACC. Operability was found to be so high, overall, that participants saw fit to travel with ACC engaged more than 50% of all miles in the speed range of ACC's availability, once it was made available. Individuals manage to assimilate their own test experience so as to perceive the safety quality of ACC driving, and they provided a rather extensive set of subjective responses that appear to speak to this question. Nine different types of subjective ratings that were obtained through the debriefing questionnaire are presented below, as they appear to provide an overall, macro assessment of ACC usage. A second set of subjective

responses deal more specifically with the question of vigilance and, by implication, the drivers role as an ACC supervisor.

### **Subjective Responses Revealing Perceptions of the Overall Safety of ACC**

Items 1 through 3, below, address safety within the specific terminology of questions that were posed. Items 4 through 9 address perceptions of the broad acceptability of ACC—yielding results that presumably give indirect evidence of global safety judgements (assuming that people would not express enthusiasm for an automotive function that they perceived to be unsafe). Questionnaire results (with the specific question number referenced in parentheses) indicate the following:

1. Participants felt substantially safe when using ACC, giving a mean rating of 5.98 on a scale from 1 (“very unsafe”) to 7 (“very safe”). (Q 28)
2. Participants did not feel as safe under ACC control as under Manual control—a view expressed through ranking the three control modes according to their relative safety level. Manual driving was ranked at a mean of 1.38 (that is, it was ranked safest among the three modes, by most participants) compared with 1.98 for ACC and 2.63 for CCC. (Q 11)
3. Participants generally expect that ACC will increase driving safety (in the future), giving a mean rating of 5.35 on a scale from 1 (“strongly disagree”) (that ACC will increase safety) to 7 (“strongly agree”). (Q 29)
4. Participants would be relatively comfortable with their “child, spouse, parents, or other loved ones” driving an ACC vehicle, expressing a mean rating of 5.66 on a scale from 1 (“very uncomfortable”) to 7 (“very comfortable”) with this proposition. (Q 10)
5. Participants would be comfortable with ACC replacing CCC, indicating a mean rating of 6.18 on a scale from 1 (“very uncomfortable”) to 7 (“very comfortable”). (Q 37)
6. ACC was the “most desirable” form of control modality, ranking first among the choices between ACC (at a mean ranking of 1.59), manual (at 1.92), and CCC (at 2.50). (Q 38)
7. ACC was resoundingly the “most likely” choice of control modality for use on “highway, interstate, state route, or turnpike” roadways, ranking at a mean of 1.15 compared with CCC (at 2.20) and manual (at 2.64).

8. Participants would be broadly willing to buy an ACC system in their next new vehicle, expressing a mean rating of 5.79 on a scale from 1 (“very unwilling”) to 7 (“very willing”). (Q 39)
9. Participants would be even more willing to rent a vehicle with the ACC feature when they travel, giving a mean rating of 6.37 on a scale from 1 (“very unwilling”) to 7 (“very willing”). (Q 41).

### **Subjective Responses Addressing Specific Driver Perceptions on ACC Usage**

There appears to be a vague sense of concern over the retention of a vigilant, cautious driving style when operating ACC. This view appears to have been implied as a possible safety issue in certain of the questionnaire responses that follow:

1. Participants appear to have indicated some concern with their vigilance as ACC operators in having given a mean rating of 3.15, on a scale between 1 (“strongly disagree”) and 7 (“strongly agree”), in response to the question “While driving using ACC, did you ever feel overly confident?” That is, drivers only mildly disagreed with the suggestion that they might feel overly confident when using ACC. (Q 30)
2. Participants also may have implied some greater tendency to divide their visual attention when driving with ACC engaged, having given a mean rating of 4.44, on a scale between 1 (“strongly disagree”) and 7 (“strongly agree”), in response to the question, “Did you feel more comfortable performing additional tasks, (e.g., adjusting the heater or the radio) while using the ACC system as compared to driving under manual control?” That is, drivers modestly agreed that they may have felt more comfortable directing some additional attention to other than the main control tasks, while driving ACC. (Q 31)
3. Participants may have experienced some degree of uncertainty over the ACC function, as revealed in the mean rating of 5.52, on a scale between 1 (“very frequently”) and 7 (“very infrequently”), in response to the question, “When using the ACC system, did you ever feel you didn’t understand what the system was doing, what was taking place, or how the ACC system might behave?” Interestingly, five-week drivers gave a lower rating (5.22) than that of two-week drivers (5.76) perhaps indicating that the longer exposure durations provided a richer distribution of driving experiences within which to encounter an uncertain or confusing aspect of ACC control. Some evidence has been shown, however, that longer-duration usage may have also led to greater experimentation with



- ACC in the more highly conflict-laden traffic environments within which the complexity of supervisory demands probably rises. (Q 20)
4. ACC was ranked as the control mode resulting in the “most cautious” driving, comparing ACC (with a mean ranking of 1.72) with CCC (at 2.07) and manual (at 2.18). This result may imply either that supervision of the ACC control mode requires that the driver exercise greater caution or that inherent ACC features including automatic deceleration as a kinesthetic cue of pending headway conflicts and the typically longer headway times serve to naturally complement a more cautious mode of driving. Focus group responses, as well as written answers to question 42 reveal that both types of perceptions were made by differing individuals. (Q 14)
  5. Participants rated their awareness level under ACC control at a mean value of 5.53 on a scale from 1 (“very unaware”) to 7 (“very aware”). Again awareness could be boosted either as a deliberate driver response to the need imposed for ACC supervision or as a serendipitous outcome of the system’s behavior. One could readily argue, of course, that the former interpretation would not align very well with the very high levels of acceptance and perceived comfort of ACC usage that have been cited earlier. (Q 18)
  6. Participants felt that they were relatively “responsive” to the actions of vehicles around them, when under ACC control, giving a mean rating of 5.26 on a scale from 1 (“very unresponsive”) to 7 (“very responsive”). (Q 19)

## **9.6 Results Having Implications for Traffic Flow**

In this section, test results are examined for their apparent implications on the performance of the traffic system as a whole. Since test data were taken from one ACC-equipped vehicle at a time, however, and since there was virtually never a case in which a number of the equipped vehicles happened to operate nearby one another for any period of time, the field test constitutes a very ineffective way of deducing a system-level impact such as the future influence of many ACC vehicles on traffic flow. Accordingly, it is only possible to crudely explore various traffic-related inferences using piecemeal observations of phenomena measured during the ACC engagement of individual vehicles.

It is assumed that the primary concern over ACC impact on traffic flow pertains to throughput on freeways when traffic volume is in the vicinity of the capacity of the road. At levels of traffic density falling well below capacity limits, freeway traffic will be expected to move at rated (regulated) speeds, or above, notwithstanding the presence or

absence of ACC-equipped vehicles. At the other, very congested, end of the spectrum, the tested type of ACC system is not likely to impact traffic flow because the high levels of conflict accompanying congested operations strongly discourage the usage of this system, whereupon manual-only control will prevail. Clearly it is the near-capacity case that is pertinent—a condition for which the nominal headway selections and the quality of their modulation may indeed impact on freeway throughput if ACC were to be present in large numbers.

Shown in Figure 180 is a macro characterization of the flow implications of headway keeping by individual vehicles operating in the indicated manual, CCC, and ACC modes of control. The figure presents the so-called Flow variable computed continuously whenever the vehicle is operating above 50 mph and is acquiring range data from a target vehicle ahead. The Flow variable is defined as the ratio,  $V/(R + L)$ , where V and R represent the host velocity and range variables and L represents the nominal length of the passenger car. The Flow measure expresses the number of vehicles per second that would pass a given point on the highway if the entire traffic stream employed the same headway/speed relationship as was measured here using one pair of vehicles at a time (i.e., where the “pair” in question comprises the sensor-equipped vehicle and the detected vehicle ahead).

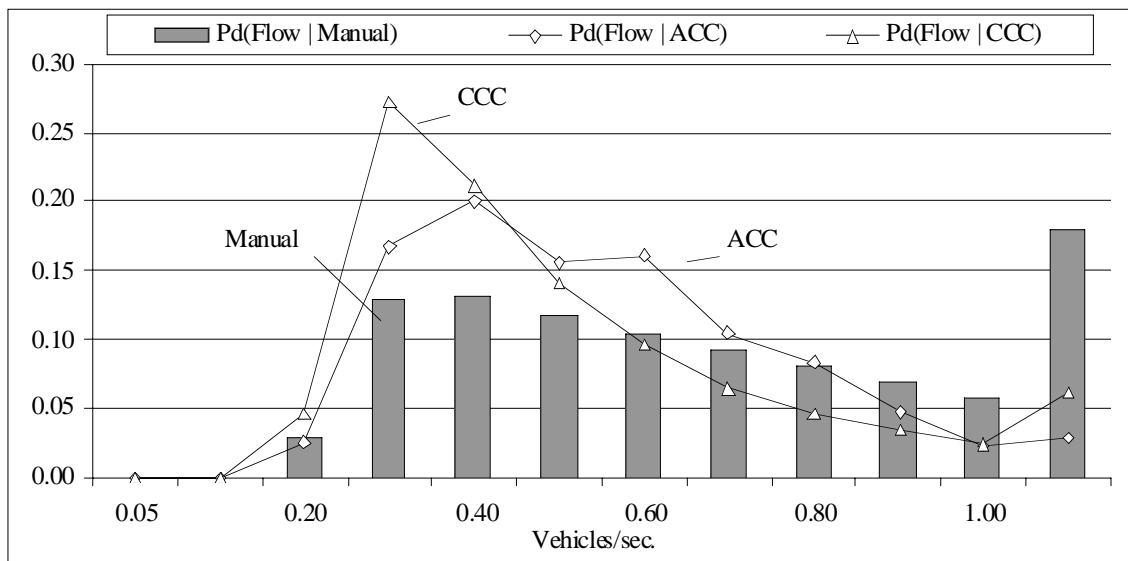

Figure 180. Frequency distribution of Flow in manual and ACC driving

Firstly, it must be recognized that the indicated data derive from a broad array of traffic conditions and road types, many of which conditions lie well away from the near-capacity traffic condition cited above as the nominal domain of our interest. Further, the

gross shape of the respective histogram envelopes speaks to the fact that cruise-type driving is preferentially matched up with lighter-traffic conditions.

The Figure shows that CCC and ACC control tend generally toward lower Flow values than are seen in manual driving, confirming the known fact that longer headways prevail when cruise is engaged. The CCC curve is skewed toward the left of the ACC data because a) ACC seems to be selected under heavier traffic conditions than can be managed under ACC control and b) drivers generally do not dwell for any period of time at relatively close headway behind other vehicles when operating in the CCC mode. The automatic headway control feature of ACC, on the other hand, provides a comfortable means of prolonged, proximate following if the driver chooses to dwell in such a scenario.

The manual mode of control shows a large “end-bin” at a Flow value of 1.05, indicating that some 18% of all manual driving, above 50 mph, is conducted at especially short headway values that are virtually never occupied in either of the two modalities of cruise control. For example, if the typical speed in the “above 50 mph” category is, say, 62 mph, the manually-driven vehicle exceeds a Flow value of 1.05 vehicles/second whenever it travels at a headway time of 0.88 seconds or less.

The mean values of Flow under the respective CCC, ACC and manual modes of control are seen to be 0.51, 0.55 and 0.66 vehicles per second. While these data appear at first blush to imply a negative impact of the ACC function on highway capacity, the known preference for ACC usage under traffic conditions that are rather free-flowing suggests that the impact on near-capacity traffic flow may be minimal because ACC would be turned off in such circumstances. Figure 181 illustrates the respective preferences for selecting ACC versus CCC versus Manual modes of control only on freeways, as a function of speed.

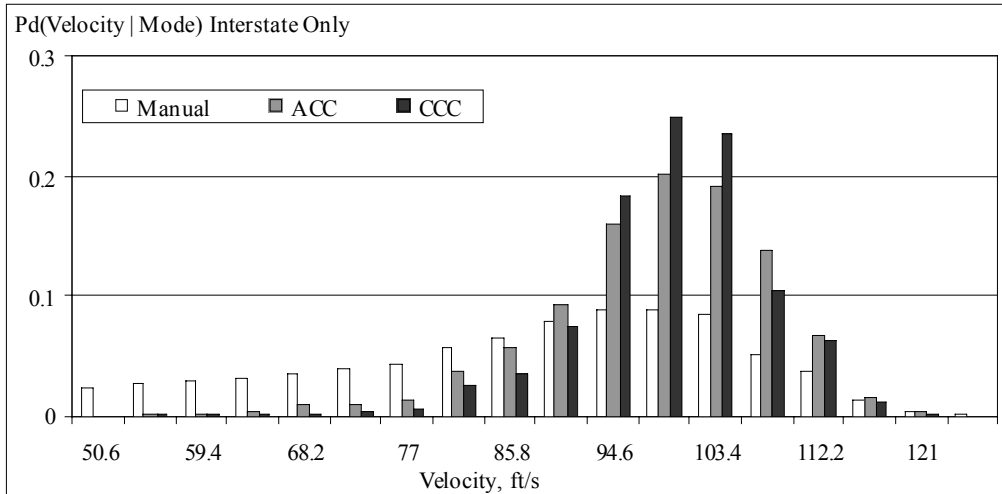

Figure 181. Frequency distribution of traffic speed ( $V_p$ ) in manual and ACC driving

As discussed earlier in the report, the data show that ACC is used on freeways almost exclusively when traffic speeds are higher, above 80 ft/sec or so. Thus, it would appear that the longer range values kept during ACC operation, as showing Figure 182 for all travel above 55 mph, are associated with high-speed, relatively free-flowing traffic for which the capacity limitations of the highway are more or less moot.

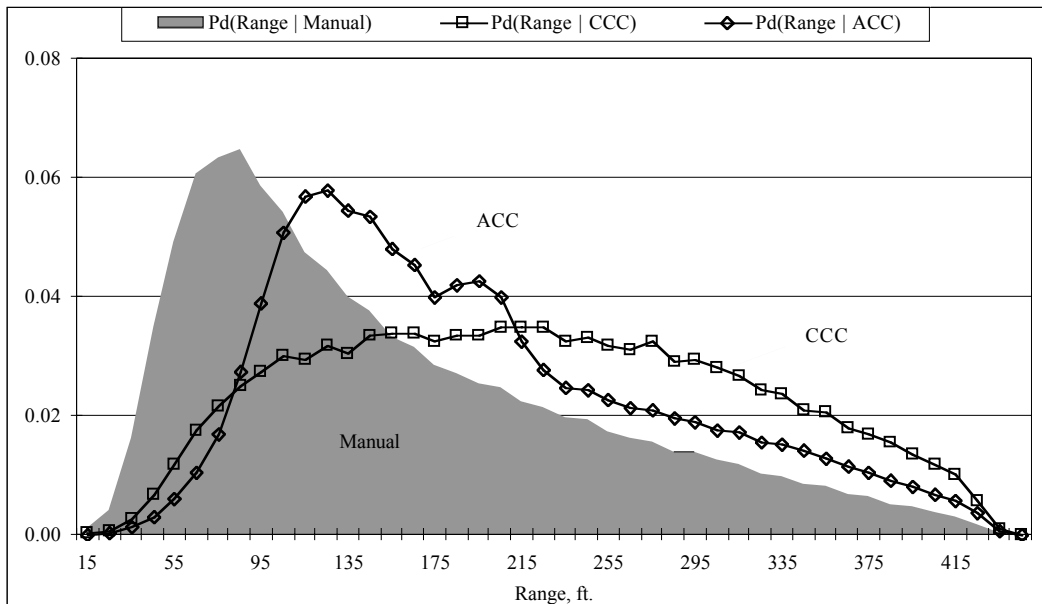

Figure 182. Frequency distribution of Range in manual and ACC driving

Manual control, on the other hand, tends to be preferentially selected when congestion causes travel speed to decline (as per Figure 181), thereupon also resulting in

the shorter range values (as seen in Figure 182) that appear commonly in congested traffic. Clearly, then, a net assessment of the ACC traffic-flow impact would require that the preferential selections implied in Figure 181 be factored together with the patterns of headway keeping that do prevail (as seen in Figure 182) when one or the other mode of control is invoked. While velocity serves as a crude surrogate for the nominal state of traffic, it is truly not a definitive means of capturing equivalent traffic conditions in which both ACC and manual control may have been exercised.

Another issue that expresses more of an impact of the ambient traffic on ACC operations, rather than the other way around, is the so-called Hindrance measure that is shown in Figure 183 for both CCC and ACC operations. This measure represents the ratio of the host vehicle velocity,  $V$ , to the set speed,  $V_{set}$ . With ACC engaged, the ratio of these values indicates how much the prevailing traffic conditions have impeded the driver from continuously travelling at the set speed value due to headway constraints.

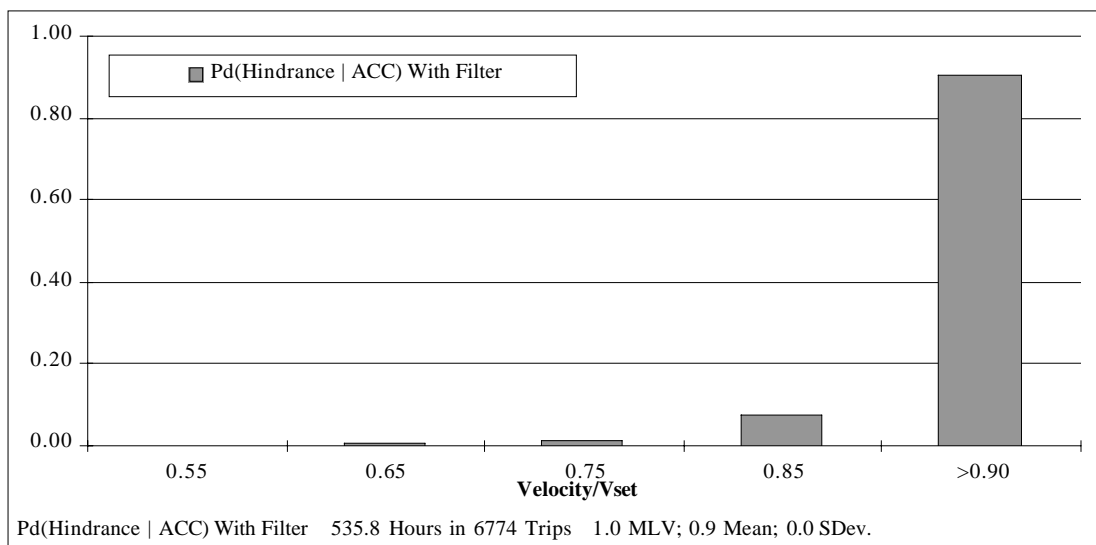

Figure 183. Frequency distribution of Hindrance in CCC and ACC driving

The Figure shows that approximately 8% of ACC driving time is spent at speeds between 80% and 90% of the set speed value and that 90% of the time is spent in the range between 90% and 100% of the set speed. This result speaks both to the extent of traffic-induced impediments that have slowed the ACC vehicle to below what is presumed to be the driver's desired  $V_{set}$  condition and partially to the preference of many participants to select  $V_{set}$  values rather near to the prevailing speed of traffic, thus not significantly falling below  $V_{set}$  even when they encounter a headway-control episode due to a vehicle ahead. Such a pattern of  $V_{set}$  selections essentially matches the learned

practice of selecting set speeds under CCC control—a practice by which CCC is maintained in the presence of other vehicles by adjusting the set speed value to virtually match that of nearby traffic.

## 9.7 Implications for Fuel Usage

No direct data were collected showing the relative fuel consumption rates under ACC versus other modes of control. Nevertheless, two simple observations can be provided which speak at least inferentially to the question of the ACC impact on fuel usage.

Shown in Figure 184 are histograms comparing the longitudinal acceleration response obtained during ACC engagement with two corresponding samples of manual-driving data. The most directly comparable manual data expresses a histogram of the  $V_{pDot}$  variable that represents the acceleration behavior of whatever vehicle happened to be traveling ahead of the ACC host vehicle, thus documenting a reference signature under precisely the coincident roadway and traffic conditions to which the ACC vehicle was subjected. In fact, the  $V_{pDot}$  data show the aggregated accelerations of the lead vehicle, to which the ACC  $V_{Dot}$  accelerations were responding as the ACC vehicle proceeded down the road.

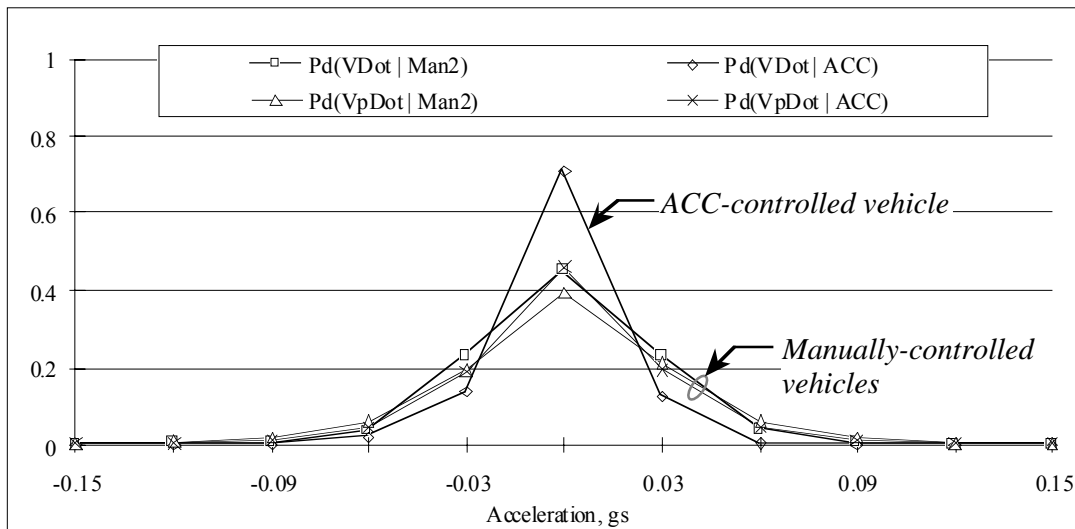

Figure 184. Frequency distribution of acceleration in manual and ACC driving

The results show that the ACC host vehicle exhibits much lower acceleration levels than the vehicles it followed and thus should yield favorable energy consumption compared with manual control in these ACC-utilized traffic environments.

The Figure also shows two other alternative reference sets of manual data covering the same  $V > 55$  mph speed range in which ACC usage is most popular, but without any provision for matching either the traffic mix or road type to the corresponding ACC conditions. The two additional cases involve the  $V_{Dot}$  accelerations of the FOT vehicle being driven manually and the  $V_{pDot}$  accelerations of preceding vehicles, as detected by the sensor during manual driving of the FOT vehicle. These data show that manual, high-speed driving, typically involves a much broader distribution of longitudinal accelerations, implying that poorer energy efficiencies would prevail in the broadly defined range of manual operations than in ACC driving. Of course, the lurking variable in these alternative presentations is the precise nature of the prevailing traffic. Given the observed preferences for relegating manual control to the more conflict-laden driving conditions, it is only fair to suggest that the tested ACC system is not about to displace the manual control option over the full set of conditions in which manual fuel efficiencies are expected to be worse.

Another illustration of ACC versus manual control that may have some implication for fuel consumption is simply that of the differences in throttle modulation as shown in Figure 185. The data show that the ACC throttle controller, during episodes of sustained modulation of headway behind a more or less steady-speed preceding vehicle, exercises many fewer cycles of throttle actuation and makes many fewer corrections down to the fully dropped throttle position. The rather frenetic character of manual throttle modulation was termed “throttle stress,” earlier—a stress whose relief is seen as one of the significant reasons behind the attractiveness of ACC to drivers. If manual throttle modulation, per se, is indeed detrimental to fuel consumption, then the data would support the hypothesis that the tendency of ACC to displace manual control over some portion of the driving spectrum will surely have an energy conservation benefit. For cases in which no impeding vehicle is causing throttle modulation to control headway, the ACC controller reverts to a throttle-control characteristic that matches that of CCC—a characteristic that outperforms the human throttle modulator even better than that shown in Figure 185.

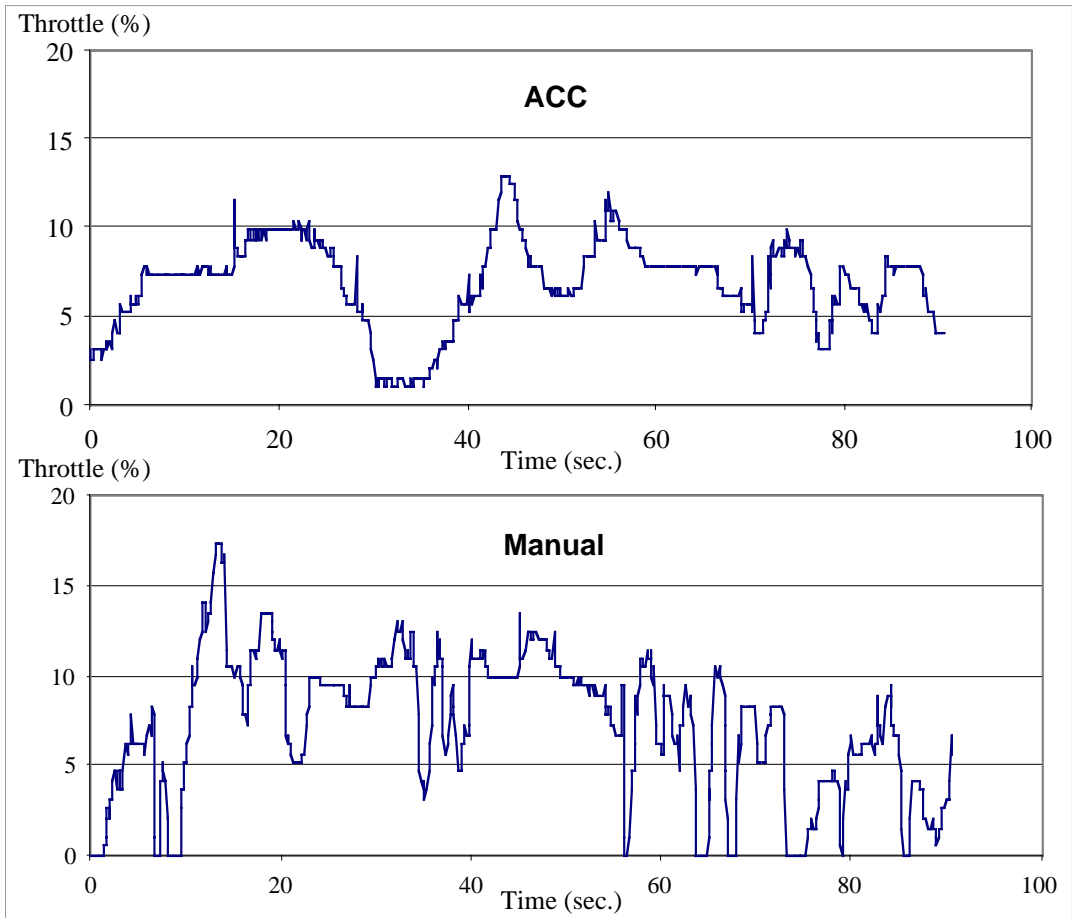

Figure 185. Throttle modulation under ACC and under manual control



## 10.0 Summary of Findings and Observations

This section summarizes findings and observations drawn from the results presented in sections 4 through 9. In a sense these findings might be viewed as an aid in explaining, and thereby simplifying, our understanding of certain processes involved in driving a passenger vehicle in typical transportation service.

Because this study was performed in a naturalistic environment in which individual drivers often made quick decisions in response to an ever changing panorama of conditions, there is considerable uncertainty as to whether any particular event is exactly the same as any other event, “Probably almost the same” is a fair representation of events that are classified as being the same. In addition, when the ACC system is engaged, the driver’s role changes from that of the primary controller who continually executes, say a tracking task to that of an agent who authorizes ACC execution of partial control and then continually supervises the outcome. Furthermore, hindsight makes it clear that ACC operation and manual operation differ from one another in an essential way. The driver switches ACC on and off while manual driving has fundamental continuity. For the most part drivers separate when they use ACC from when they drive manually, just as they do for CCC. In the context of this paragraph about uncertainty, one implicit general finding/observation can be stated as follows:

- Experienced drivers are very skilled at the tasks involved in driving, however there are no data here that rigorously and directly explain how the drivers’ skills, rules, or knowledge processes are functioning in each situation at each moment of either manual, CCC, or ACC driving. Consequently the observations presented here represent humble estimates of reality without really knowing what drivers are thinking while driving.

Another related general observation is:

- Researchers (as well as many others possibly) tend to underestimate the complexity of the driving task. Drivers learn to drive by developing their skills over time, but these learned skills do not reside in an area of the driver’s brain that is readily accessible for formulating verbal or written explanations of how driving is done. Although simplified models of the driving task may be useful for simulating the driving process, developing similar automatic control strategies, and explaining traffic situations, a comprehensive model of driving could well include tens of thousands of “If/then” statements unless someone discovers a

breakthrough for explaining how people can adapt to so many different situations without becoming fraught with indecision.

Even though the findings/observations presented here tend to be empirical as opposed to fitting a well-established theory, there is a need to organize them into a coherent structure. In the following material, the findings/observations are presented using the topic areas and items that were listed as field test outputs in Figure 1 in section 2.2 describing the project approach.

## **10.1 Utilization Choices**

This ACC system tends to be used when speeds above 55 mph can be readily maintained. For example, the system was used for 77% of the miles at speeds above 65 mph. It appears that drivers chose manual control when traffic conditions were demanding and there was competition for gaps. The results (in Figure 131, for example) indicate that older drivers would be expected to use this ACC system more than younger drivers would. Nevertheless, ACC driving is well accepted by lay drivers in general. People appear to be attracted to the ACC functionality and are not reluctant to assume the role of the system's supervisor. The results indicate that if ACC systems were available, drivers would use ACC more frequently and in more situations than they use conventional cruise control now. The main point here is that the results indicate that if drivers have ACC available they will use it for a considerable amount of their driving.

### **10.1.1 Versus Length of Exposure**

The five-week drivers tended to use ACC approximately as frequently in the fifth week as they did in earlier weeks. The use of ACC appears to be more sensitive to the type of driving required than it is to the length of exposure to ACC system availability. The five-week drivers did tend to do less ACC driving during the second week than that done by two-week drivers in their second week, but this result is attributed to opportunism on the part of the two-week drivers. It appears that the length of exposure to ACC does not have an important influence on the choice of control mode for this ACC system. However, this result could change if periods longer than 4 weeks of ACC exposure (such as 6 months or a year) were involved.

### **10.1.2 Versus Type of Trip**

Long trips nearly always involve ACC use. The driver's judgment of the difficulty of the speed-maintenance situation (as indicated in the basic finding above) appears to be the

primary factor determining whether to use ACC on a particular trip. Drivers engage ACC on low-speed trips, but seldom are they able to stay engaged for more than a mile when operating at speeds less than 55 mph. With regard to commuting trips, although the utilization rate is 1.5 times that of CCC, the ACC utilization rate is considerably less than that found for all trips. This is particularly true for the evening commute from work to home when denser traffic prevails.

### **10.1.3 Versus Traffic Environment**

The total traffic environment is not readily apparent from range and range-rate measurements other than to determine whether there is a preceding vehicle present or not. In addition, there is some evidence that drivers attempt to avoid following other vehicles when driving manually. In general it seems that speed, per se, serves as a useful, if crude, surrogate for the traffic condition. Thus, speeds below 55 mph are often characterized by the presence of traffic signals, incidents, and conflicts, which tend to discourage the use of this ACC system. Even though the evidence is somewhat indirect, the overall impression derived from the FOT results is that drivers tend to prefer manual control when the traffic environment is expected to be demanding.

### **10.1.4 Versus Type of Road**

There is a close association between the type of road, its level of service, and vehicle speed. Hence it is to be expected that 90% of the total ACC engaged miles were traveled on freeways. However, for speeds above 55 mph on arterial streets, the ACC utilization was approximately 50% of the miles even though at speeds between 35 and 55 mph the utilization rate was near 14%. Drivers chose to operate ACC more than twice as much in the off-freeway environment than they chose to use CCC in the off-freeway environment.

### **10.1.5 Versus Driver's Aggressiveness**

Driving style was classified into five categories based upon the driver's tendencies for following closely, traveling rapidly, or the opposites of those qualities. To the extent that close and fast represents aggressive driving, the driving styles, in order of aggressiveness, are hunter/tailgaters, extremists, planners, flow conformists, and ultraconservatives.

Within these groups, the hunter/tailgaters are the most aggressive and the ultraconservatives are the least aggressive, as the names imply. The planners drive fast but stay far away from other cars; the extremists are hard to predict, using many different extremes; and the flow conformists tend to drive like the vehicles around them.

Interestingly (in Figure 134), the extremists had the highest utilization rate of ACC, with over 80% for speeds above 55 mph. The ultraconservatives had the lowest ACC utilization rate — just under 60%. The ultraconservatives tended to be non-users of CCC as well as old and females. See Figure 87. Perhaps there is some relationship between the willingness to use CCC and the willingness to use ACC. The planners used the system in over 75% of the miles above 55 mph while the hunter/tailgaters and the flow conformists tended to use the system for about 65% of their miles above 55 mph. Hence, style distinctions appear to have a bearing on ACC utilization, but all styles of drivers used the system extensively.

Perhaps hunter/tailgaters showed relatively low utilization of this ACC system because its minimum headway time setting, at 1.1 sec, was too large for those whose style is to tailgate at 0.6 to 0.8 sec.

## **10.2 Impact of ACC on Individual's Driving Tasks**

This ACC system performs closing and following operations in much the same manner as are done in manual driving. The primary difference is that at freeway speeds the ACC system seeks longer range values than those used in manual driving. Given that similar results for ACC and manual driving were observed in (1) RMS values for changes in R and Rdot during following, (2) the average deceleration level, and (3) the length of time for the last 50 ft of closing to Rdot equal to -5 ft/sec, specific values of these measures of performance have been used to suggest the following preliminary specifications for the performance of an ACC system in following and closing situations:

- For following, with Rdot between -5 and +5 ft/sec, the RMS value of the difference,  $(R - R|_{\text{average}})$ , should be less than 12% of  $R|_{\text{average}}$  for speeds above 55 mph. The 75th percentile value of the RMS of Rdot should be less than 2 ft/sec. (This would apply to all values of headway time or desired range allowed by the ACC system.)
- For closing, during the last 50 ft of closing, the 25th to 75th percentile spread of the time duration should fall between 5.8 and 7.0 sec and the 25th to 75th percentile spread of the average deceleration should fall between 0.02 and 0.04 g on a level road.

### **10.2.1 Closing In**

As indicated above, ACC closing is similar to the process of manual closing. However, since drivers tend to use longer ACC headway time settings than their manual

preferences, the visual response in mind's-eye coordinates (image size or visual angle and its rate of change) is much lower on the scale of human acuity during ACC driving than it appears to be for manual driving. For aggressive drivers that have learned to enjoy relatively large image sizes in manual driving, the smaller image sizes and the corresponding perceptions of longer range in ACC driving could be disconcerting to them. Whether experience will cause younger drivers to accept ACC's longer characteristic headways before they reach middle age is problematic unless experience is combined with education and training.

### **10.2.2 Following**

With regard to the mind's-eye coordinates, the situation for the influence of ACC on following is much like that for closing. In addition, because of the limits on human ability to resolve visual angle and its rate of change, drivers have what might be considered a "dead zone" for the perception of range and range rate. This means that drivers tend to hunt around a desired range during following. This hunting is accompanied by considerable throttle activity as the driver drifts far enough either way to be able to recognize the need to correct the range and velocity situation. Perhaps a major part of the attraction of the ACC system is its capacity for relieving the driver from the stress associated with having to modulate the throttle in the presence of perceptual uncertainty.

### **10.2.3 Cut-In Reaction**

Drivers are concerned with cut-ins. There appears to be a human aversion to allowing intrusions that reduce the space in front. Clearly, people use the verbal part of their mind to think about, and to express feelings about cut-in behavior. The underlying cause for this aversion might be that it takes considerable effort for a driver to accept a headway gap and to become comfortable with it—only to have someone negate this effort by suddenly doubling the image size to the vehicle ahead. It is speculated that this is easier to accept if the ACC system is doing the driving but drivers still recognize and worry that they are losing ground and may need to take action when their space is violated.

The types of cut-ins that occur in merging situations can be a problem. In these cases the merging vehicle is often going slower than the ACC vehicle such that the ACC driver may need to intervene by braking. In many other situations an overtaking vehicle cuts in at short range but is typically going faster than the host vehicle such that the conflict is minimal. In a problematic case involving a small gap, the cut-in vehicle may slow to below the speed of the ACC vehicle. Since vehicles are picked up by the sensor only when they actually enter the path of the ACC vehicle, the ACC system has little

anticipation and a decreasing headway time margin to control, resulting in short headways and/or brake interventions by the driver. This problem can be accentuated by vehicles that merge onto a freeway at low speed and at a short distance ahead of a vehicle under ACC control.

Observed results indicate that drivers will not cut in into gaps that are less than approximately 50 ft long. However at high speeds (approximately 100 ft/sec), this translates into gaps with 0.5 sec of headway.

### **10.3 Implied Collective Traffic Impact**

The results obtained directly from FOT measurements show that ACC operation appears to be largely benign with regard to causing safety, traffic flow, or fuel usage problems — in fact there could be some benefits in these areas. Nevertheless it is difficult to extrapolate to future outcomes if ACC were to have high usage penetrations. The results of the FOT could provide a foundation for defining controlled (proving ground) test procedures and test measures for assessing certain aspects of ACC performance. These tests would tend to check the technical aspects of the system's functions but it seems difficult to arrange tests to ascertain whether drivers would become over reliant on the system or become less vigilant or take greater risks. It is the human influence on safety that is believed to be both crucial as well as very difficult to predict.

With regard to traffic flow it appears that ACC systems could yield smoother, more uniform traffic if people were willing to travel that way. Again, there is a human element that could determine whether ACC will improve the level of service without jeopardizing throughput.

Since throttle action and the resulting acceleration behavior is much smoother in ACC (as well as in CCC) than it is in manual driving, ACC driving is expected to promote fuel economy. However there is again a human element related to the speeds and headway times drivers choose.

The basic idea is that safety, traffic flow, and energy usage are all related to the speeds and headways people choose and to the circumstances under which they choose ACC as the means to control them.

#### **10.3.1 Safety**

As with manual driving, the main safety concern is whether drivers will make irreversible mistakes. People will make mistakes, but will they allow a margin for recovery? That is, will they be able to recover from their mistakes? To the extent that a mistake is a

misunderstanding involving a wrong action preceding from inadequate knowledge, faulty judgment, or inattention, one wonders whether ACC induces some drivers to make mistakes in certain circumstances. On the other hand, perhaps the headway margins and the deceleration cues afforded by ACC will reduce the importance of such mistakes.

The data gathered in the FOT could be used to argue both for and against safety benefits. More headway time and a deceleration type of warning, if the driver is inattentive, certainly appear to be safety benefits. The possibility of inattention due to over reliance and over confidence as well as the possibility of slower or delayed reactions certainly appear to pose dis-benefits. Given the limitations of presently available data, the net impacts on safety are unknown.

In order to try to make sense of these pros and cons, a model of the basic structure of a human operator may be helpful. Figure 186, which is a summary of the conceptual representation of the driving process presented in Figures 73 through 76 in section 8.1.2, provides a structure that captures many aspects of the driver in a single, simple representation.

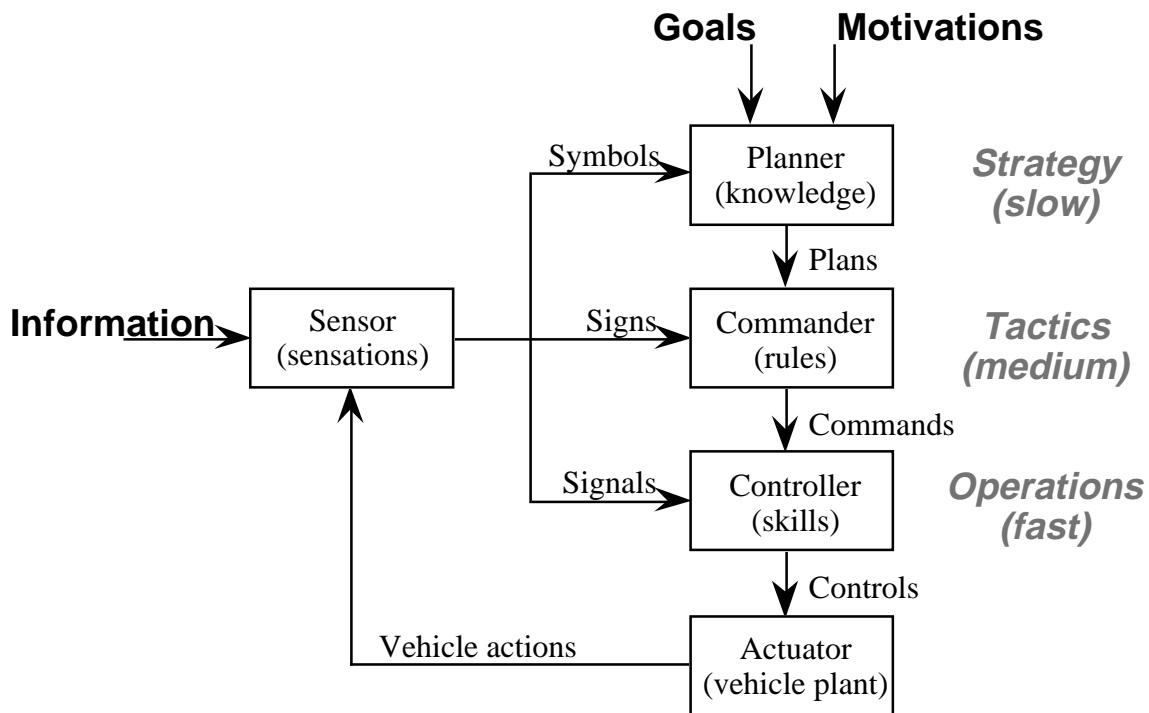

Figure 186. Simplified concept of driver-vehicle system

In this context the driving process involves three levels of cognition: knowledge (strategy), rules (tactics), and skills (operations). Learned skills and operations are fast. Tactics are somewhat slower but preconceived rules can be put into effect quickly once

they are selected, and plans and strategy can take long periods of time to derive and then execute. Given acceptance of this structure as a reasonable presentation of the overall system, one can conclude that symbols coming in at the planner level may not be actionable when faced with an emergency. There can even be concern with appeals at the tactics level if the driver is slow in selecting a rule to use. A need for quick action can mean a need for something like an emotional or reflex reaction at the most primitive level of cognition.

One can hope that safety does not come down to the need for quick action—that safety involves prudent plans and the development of wise rules built through a process of graduated experience, education, and training. However, when situations develop rapidly that are beyond the driver's skills and experience, quick reflex actions (i.e., “fight or flight” responses) may be the last resort—anything else is too slow. For ACC to be a safety success (even though that is not its actual reason for being), drivers need to adopt appropriate plans for using the system. The results indicate that the drivers in the FOT tended to adopt such plans, for the most part. Drivers need to develop an understanding of how the system works (its capabilities as well as limitations) and to develop both the appropriate rules and the recognition of signs that trigger those rules during ACC driving. The results of the FOT indicate that the drivers absorbed much information about the system during the brief orientation they were given. From short experience with ACC driving using analogies from manual driving experience, they were quick to learn how to operate the system comfortably. For the most part it appears that the drivers selected appropriate rules to use. It seems that the drivers did such a good job in strategy and tactics that they were rarely faced with an emergency situation that was beyond their skill and experience even though they were relatively inexperienced at operating an ACC vehicle. This means that the results do not provide much to go on in judging whether there will be problems in real emergencies. Fortunately, the results do not contain information pertaining to irreparable mistakes. On the other hand the occurrence of no crashes is less informative than would be a few crashes with plausible explanations. Given the infrequent occurrence of emergency events, it is difficult and perhaps unwise to say that ACC driving is benign just because there were no irrecoverable mistakes in this FOT. The supervisory behavior of the driver could reduce the safety of ACC control.

However, one can use the results pertaining to driving styles to point out that almost 25% of the drivers were hunter/tailgaters in their manual driving, but none retained that aggressive style when using this ACC system. Also, the number of flow conformists increased from 29 drivers during manual driving to 42 during ACC driving. To the extent



that safety is associated with longer headways and more uniform traffic, driving with this ACC system provides safety benefits.

### **10.3.2 Traffic Flow**

Although an objective of this work is to assess impacts on traffic flow, the results are not ideal for use in employing traditional traffic-flow methods. The sensor provides information only on the preceding vehicle and not on other vehicles in near proximity — much less on the whole traffic stream. Noting that the independent evaluator group has expertise in methods for studying traffic behavior, however, it is suggested that the evaluator's report should be a source of interesting findings. In addition, the FOT researchers will report on operational experience with a string of these ACC cars in a later report.

However, the results of this study have been used in the creation of a driver model for the headway control task [13]. This model contains provisions for representing the closing and following features measured during manual driving in this FOT. It also contains means for representing the limitations of drivers in assessing range and range rate. Recently the FOT researchers have discovered a driver model with apparently similar features [16]. This model was developed many years ago in Germany to simulate street traffic flow. There has been recent work in Europe adapting this model for studies of traffic flow as well as ACC control, but none in this country (to our knowledge).

In any event, the point is that the driver model developed in the FOT to represent driving styles for characterizing drivers can also be used to represent ACC systems with different headway time settings and set-speed provisions. Such models can also represent the control precision of expected ACC products. Hence, although this study does not provide predictions of what would happen if many vehicles were to be equipped with ACC systems, it does provide the operational data needed for determining parametric values covering a representative cross section of different driving styles and control modes. Parametric values corresponding to this realistic cross section could be employed in a microscopic simulation to predict the effect of ACC on traffic flow in various freeway environments.

Also, as with the safety discussion, one could use the information on driving styles to reason philosophically. For example, if the traffic stream had no hunter/tailgaters and 45% more flow conformists, one could argue that the level of service would seem much better to the lay person, at least until traffic density becomes so saturated that cut-in activity tends to swamp ACC headway-keeping. In any case, the results of the FOT hold

out the prospect for much smoother driving if ACC were to be extensively used on non saturated (perhaps ramp-metered) freeways.

### **10.3.3 Energy Use**

The FOT results for throttle variation indicate that the ACC system (in this case employing the OEM speed controller) had less throttle variation than that observed at comparable speeds during manual driving. In this sense ACC driving was smoother than manual driving. Perhaps a reasonable estimate of the fuel economy involved could be obtained by finding information showing the fuel economy, if any, attributed to the conventional cruise control.

Perhaps it would be of more value to use the results of the FOT to determine a duty cycle for setting up a test procedure that would be suitable for evaluating the fuel economy of various ACC (and CCC) systems in comparison with manual driving under the same circumstances. These procedures would be objective test procedures that were performed under controlled conditions on a test track.

## **10.4 System Functionality Reaction**

The basic finding is that drivers were surprisingly positive in their acceptance of this ACC system. Although various improvements were suggested, drivers broadly acknowledged the deceleration cue as a critical attribute of the system. Drivers appear to use deceleration as a cue in checking themselves and the ACC system. If for any reason the deceleration cue seemed unusual to the driver, the driver would quickly decide if immediate action was needed. In any case, the driver would go on alert if an acceleration/deceleration cue was felt. This is the reason for believing that a system-generated deceleration cue is a meaningful indication to the driver, and it elicits a quick response.

Even though the system is good at detecting moving targets, it is not perfect. From a safety standpoint it is good that drivers have considerable experience in evaluating the forward scene. They know what they want the scene to look like and they can decide when they need to intervene. Perhaps people tend to be optimistic, but the results of the FOT indicate that they quickly became comfortable with their ability to understand and work with the capabilities and limitations of this ACC system.

#### **10.4.1 Headway Adjustment**

Out of the 108 drivers three indicated that they would prefer a shorter headway time than the closest of settings (1.1 sec) available in the FOT system. Two drivers indicated that they would have liked a longer setting. Hence the range from 1.1 to 2.1 sec appears to cover most of the range of headway time settings that drivers will use in the range of environments examined.

With regard to the three discrete choices amounting to 1.1, 1.5, or 2.1 sec of headway time, some drivers had one setting they tended to use almost exclusively. Other drivers tended to have two settings that they used frequently. But few drivers chose to use all three settings frequently. There was an age trend by which younger drivers tended to choose 1.1 sec, middle age drivers chose 1.5 sec, and older drivers chose 2.1 sec. These results indicate that a range of settings is needed to satisfy the individual preferences of drivers in various driving conditions.

#### **10.4.2 False Alarms**

Drivers notice and remember whether or not the vehicle is decelerating, even to a minor level, when they do not think it is appropriate. False decelerations when passing a long tractor-semitrailer in an adjacent lane were rare but frequent enough to be noted by the drivers. Also, although the cause might not be apparent, drivers did feel that false alarms occurred when they were entering or exiting curves. This occurred because the system uses steady state path curvature to predict the path and steer the sensor beam. Nevertheless, the drivers' main concerns involved worries about being struck from behind if their vehicle slowed down at a time that might be unanticipated by others.

#### **10.4.3 Missed Targets**

Although it rarely happens in good weather, there can be a "phantom" vehicle that the sensor misses. In these rare situations, it is fortunate that this ACC system does not cause the ACC vehicle to accelerate rapidly. Perhaps it is a good idea in general to only increase acceleration gradually. (When the "accel" button is pushed in conventional cruise control, for example, the CCC system holds at low acceleration for a while and then it increases acceleration gradually.)

Target misses due to road curvature may occur at long ranges but as the target gets closer, it comes into the field of view of the sensor. Misses due to curvature on freeways and high-speed roads built to meet the design policies of the American Association of State Highway and Transportation Officials (AASHTO) for speeds, superelevations,

friction factors (lateral acceleration levels), and radii should occur only at long ranges with this system. However, vehicles traveling at high speeds on tight curves such as at some exit ramps may accelerate at a rate greater than the driver expects. Clearly the system does not slow down for targets that are outside of its field of view.

The system does not respond to stopped or slowly moving vehicles. This is not technically a miss, but drivers could mistake it for a miss. In this case the driver needs to take over control of headway. In any case involving an obstacle that the system is not responding to as the driver wants, the driver is expected to take control of headway. The driver's perception of the forward scene (and the driver's role as supervisor) is the backup for a missed target or obstacle.

#### **10.4.4 Acceleration Level**

Drivers judged that inadequate acceleration was available under ACC control when they pulled out to pass. On the other hand this same level of acceleration could seem too large if the driver had just pulled onto an exit ramp having tight curvature. It is interesting that although drivers were often dissatisfied with the ACC acceleration level when passing, they did not choose to manually move the accelerator pedal themselves. It appears that drivers want and expect acceleration characteristics that differ from those available to them in these FOT cars, although the scenario of automatic ACC re-acceleration on exit ramps or upon dropping a minimal-speed target is still troublesome. Clearly there are conflicting reasons for either increasing or decreasing ACC's acceleration level.

#### **10.4.5 Deceleration Level**

The maximum deceleration level of an ACC system determines its primary headway-control authority. In the FOT vehicles, the maximum control authority at highway speeds on a level road was about 0.07 g. This may not seem like much but it is adequate for normal closing and following operations. As shown even in the manual driving results, drivers on freeways seldom use their brakes. Even so it is believed that vehicle manufacturers will be producing ACC systems that employ the foundation brakes. Such systems are expected to provide the driver with greater functionality and utilization potential than this ACC system provides. The tradeoff here is related to whether a large false deceleration is likely to cause a safety problem (i.e., unexpected braking in response to a false alarm). Nevertheless, some of the FOT drivers commented that they would have liked more deceleration. An associated tradeoff will also involve the subtle changes in driver supervisory behavior when drivers find that the ACC's greater deceleration authority almost always resolves headway conflicts that arise.

#### **10.4.6 Weather**

This ACC system did have a provision for shutting down in bad weather. The sensor detected backscatter conditions, and when backscatter was above a level where human vision started to be obscured, the system was shut down, and the driver was notified with a loud audio signal. When this happened, drivers did not like it; they often felt that they could still see sufficiently to continue in ACC control. Besides, the alarm surprised them. The features of the bad weather system used in this FOT do not appear to be acceptable for use in a finished product. This is not to say that such a system may not be useful. The observation is only that the particular feature used in the FOT was not good enough.

Although expedient for launching the FOT fleet, the location of the sensors and the provision for protecting them from the weather was also less than ideal. The lower front region of the grill, where the sensors were installed, is a poor choice with respect to road spray and the accumulation of snow. These infrared sensors would have been better protected if they had been behind the windshield or built into the headlight assembly. In either case, washers and wipers could be used to provide the sensor with a clearer visual path. Since the research team was not able to find a quick fix for snow accumulation during the winter, driver/participants did not use the vehicles during several weeks during the winter.

It seems clear that driving performance during bad weather conditions needs study to aid in developing means for assisting the driver in choosing when to quit using the system. For now, the prudent advice appears to be: Do not use this system in weather that causes sensor performance to be excessively degraded.

### **10.5 Comfort and Convenience Reaction**

The subjective results (presented in sections 9.3 and 8.4.1) speak to the perception of high levels of comfort and convenience. The results showing high utilization also indicate that people are attracted to the use of ACC. In fact the lure of ACC control is somewhat of a worry. It appears that people will want to use ACC because it is easier than manual driving, and they experience high levels of comfort, convenience, and driving enjoyment when using ACC. Hence there needs to be every effort to ensure that there are not any subtle safety traps. On the other hand the comfort and convenience qualities of ACC might portend safety benefits in terms of alertness and safer following distance and even changes in driving style if clever ideas are used in structuring ACC system properties so that people will not misuse the systems in ways that reduce attention to the driving scene.

### **10.5.1 Ease of Learning**

The results indicate that most driver/participants felt that they learned to use this system in less than one day. The participants did have the benefit of brief training by an expert in using the system. In addition, the interface for the system used the CCC controls with which most U.S. drivers are familiar. The drivers could use their experience in manual driving to aid them in supervising the system. The supervision task was not difficult to explain, because this system definitely required braking intervention on a regular basis. The net effect of these items is that drivers started to utilize the system as soon as it became available to them, and although they felt that they had more to learn even after 4 weeks of exposure to the system, they were comfortable with high rates of usage almost immediately.

### **10.5.2 Ease of Use**

The system characteristics that appear to contribute to the high subjective ratings concerning ease of use are (1) acceleration/deceleration cues associated, with ACC system functions whose meanings are apparent to drivers and (2) longer than manual headway time margins (Htm) which allowed drivers to be more relaxed in responding to headway conflicts.

### **10.5.3 Utility Versus CCC and Manual**

ACC engagement rises strongly with velocity. This system is mainly used at speeds above 55 mph. In the speed range nominally covered by CCC (35 to 85 mph), the ACC system was chosen over manual driving for 53% of the miles traveled while CCC was chosen over manual driving for 35% of the miles traveled. ACC driving was even more popular for freeway driving above 55 mph than it was above 35 mph.

### **10.5.4 Driving Alertness**

There are results indicating ways in which drivers are more alert, and there are results indicating that some drivers used the extra time provided by ACC to engage in non-driving tasks. On the positive side, drivers reported being more aware of other vehicles and being less tired on long trips. On the other side, drivers reported doing things they would not have done without ACC. For example, one driver reported looking at cotton fields for long spells and another reported turning to look at her baby in a car seat in the back seat. Overall, it seems that drivers were somewhat more aware of the total driving situation when using ACC; but they would on occasion use the time provided by the reduced mental workload to perform auxiliary tasks.

### **10.5.5 Product Purchase Appeal**

Many driver/participants had difficulty estimating the dollar amount they would pay for ACC. Many of them did not have a feel for how much CCC costs. The estimates ran from 0 to \$2,500 with a quasi-median value of approximately \$450. The subjective ratings not involving price but pertaining to willingness to purchase were also high. For example, the question “Would you be willing to buy an ACC system in your next vehicle?” received a rating of 5.8 on a scale from 1 (unwilling) to 7 (very willing).

## 11.0 Concluding Remarks and Recommendations

In this section a concluding view on the overall field test experience is provided and recommendations are offered. Although the complexity of driving-related observations tempts one to list a great array of salient details, the attempt here is to take the most high-level view on what transpired. In the sense of a conclusion, we offer what we call the “central finding” followed by a simple summary of its main elements. The recommendations are intended to highlight research initiatives that will help ensure that ACC products and their potential derivatives turn out to be safe and satisfying in the hands of the public.

### 11.1 The Central Finding

ACC control is remarkably attractive to most drivers.

Because ACC is so pleasing, people tend to utilize it over a broad range of conditions and to adopt tactics that prolong the time span of each continuous engagement. Notwithstanding some concerns, field test subjects were completely successful at operating ACC over some 35,000 miles of system engagement.

One also observes that the role played by the driver as the “supervisor” of ACC control entails some subtle issues whose long-term safety and traffic impacts are unknown.

Thus ACC does not fit a “business as usual” outlook for either the auto industry or for highway operations. The “shared-control” nature of ACC requires a fine match to the perceptual and cognitive behavior of drivers, in a safety-central task that may affect others driving nearby. While offering great promise for improving the quality of the driving experience, ACC implies an inherent necessity for human-centered design.

The following summarizes the basis for the central finding:

1. The strong attraction of ACC seems to be explained by:
  - complete relief of the “throttle stress” that is believed to impose a palpable burden on manual driving
  - great relief of the “headway stress” believed to be embedded within the manual driving task due to human visual limitations in perceiving range and relative velocity to the vehicle ahead



- substantial relief from the frequency of interruption normally required under conventional cruise control
2. These relief mechanisms prevail only when the driver “lets ACC do it.”
  3. Certain observations confirm that people are rather strongly disposed to let ACC do it, namely:
    - high rates of ACC utilization that accrue over a broader range of speeds and road types than with CCC, thus posing a more complex environment within which the driver must judge when to manually interrupt system control
    - participant evaluations that indicated a high preference for the ACC mode of control across many different driving environments
    - a reluctance to even partially intervene upon ACC control by manually applying the throttle when re-accelerating back up to the set speed—even though most drivers clearly detected the need for such partial involvement when operating this ACC vehicle
    - stronger braking levels when ACC disengagement does occur, and at shorter times-to-collision (apparently since drivers delay a braking intervention in order to let ACC handle the conflict, if it can)
  4. The driver’s ability to retain a vigilant, cautious driving style when in ACC engagement is questioned by such observations as:
    - mixed responses among test subjects to certain debriefing questions, including some concern for overconfidence, divided visual attention, and incomplete understanding of the ACC response, at times
    - personalized anecdotes suggesting inattention to the full scope of the normal vigilance task, apparently due to the inadvertent reductive assumption that the ACC deceleration cue serves as a general- (rather than limited-) purpose alert that a conflict is developing ahead

## **11.2 Recommendations**

Recommendations are made spanning five areas of activity, as follows:

### **11.2.1 On Studying the Collected FOT Data Further**

The compiled archive of data from this field test is believed to be unique in the world in 1998. Noting that so many fundamental driving variables are addressable via relational database tools, much additional research can be meaningfully pursued using this resource. Investigations could serve to:

- better underpin standards for ACC and forward-crash-warning (FCW) systems, using the database as a source of quantitative information for addressing issues of concern to SAE and ISO committees
- guide ACC and FCW design decisions and/or the projection of benefits and other impacts of broad system usage within an environment of manually-driven vehicles
- advance understanding on the normal driving process. A very broad array of inquiry on manual driving is possible using the collected data. Because the data provide a plausibly representative estimate of distributions covering some 68,000 miles of manual driving, much can be done in understanding driving styles, control tactics, and the seemingly arbitrary individual travel preferences as exhibited across a rich sample of persons, trip-taking, and traffic-induced conflicts and conditions. The authors believe that a sound understanding of normal driving is imperative if driver assistance products are to have a hope of flourishing. Research on the driving process would also do well to build upon the driving theory that has been initiated herein.

### **11.2.2 On the Need for Fundamental Understanding on Driver Supervision of ACC**

Insofar as ACC poses subtle challenges for human performance due to the supervisory role that the driver must assume, research into the psychological dimensions of this machine-supervision task is needed. Principal among these are the cognitive aspects of performance including the means by which self-manifestation by the ACC system induces a mental model of system function in the mind of the driver. Ultimately at issue is the definition of features that should be embedded within ACC design for limiting the risks of irrecoverable mistakes in the supervision of the system, over a diverse population of drivers. Note that among these issues is the heretofore untouched question of ACC control by the altogether naive driver — that is, the first-time user who just climbs into the car and starts pushing buttons that invoke ACC control.

### **11.2.3 On the Need for Direct Measurement of ACC's Energy Impact**

Since this field test has served to define the utilization duty cycle for ACC operation, it should be straightforward to conduct a controlled experiment for quantifying the energy-consumption impact of ACC. One would simply measure fuel consumption over an

exemplar ACC-usage duty cycle comparing against an acknowledged benchmark cycle for manual driving.

#### **11.2.4 On the Need to Explore the Traffic Impacts of ACC in Greater Detail**

It is expected that ACC usage, at high levels of penetration into the vehicle population, will have a significant impact on traffic operations. Within this project, no significant analysis was performed for making such projections although it is apparent that 1) lengthened headway times under ACC control may tend to reduce highway capacity, 2) weaving movements on freeways may be impeded by serial strings of ACC vehicles operating near one-second headway times, but 3) the greater consistency of ACC controllers may tame the tendency for traffic flow instabilities. Serious exploration of traffic flow impacts is felt to be a mandatory part of any near-term program of public research on ACC.

#### **11.2.5 On Examining the Naturalistic Use of ACC With Braking**

It is recommended that naturalistic testing of braking-assisted ACC proceed at the earliest possible time, recognizing that most ACC products expected for sale in the United States within the next five years will employ electronically-controlled braking, up to approximately 0.20 g's, in contrast to the 0.07g throttle-and-downshift system employed here. This recommendation follows from the gist of the central finding, above, based upon the following hypotheses:

1. Brake-assisted ACC control will be considerably more attractive than the already very attractive system that was tested here (because all of the human-perceived "relief" mechanisms cited above will be even more fully and consistently realized when operating a polished version of brake-assisted ACC).
2. When braking is added, the ACC utilization domain will expand substantially beyond that seen in this study. One observes, for example, that a three-fold growth in deceleration authority (from the 0.07g level to that of 0.20g) will dramatically expand the number of conflicts that the ACC controller is capable of resolving. In high-speed freeway settings for example (using for estimation the average deceleration results reported earlier for manual braking) ACC with braking should be able to automatically resolve approximately 98% of the conflicts posed when the preceding vehicle is manually braked, whereas the tested system, at 0.07g's, could only manage about 50% of such conflicts. For the

advanced ACC system, then, it would seem almost certain that ACC utilization would climb from the 75% level measured here to nearly 100% of all freeway travel above 55 mph.

Perhaps much more significantly, the ACC utilization level reported here at 13% for all travel *on arterial streets* in the 30-to-55 mph range might easily rise to 30% or more when driving with a braking-assisted controller. Since surface streets pose a harsher, more complex array of conflicts, and since driver intervention will surely be postponed until deeper into each conflict sequence, (once the driver has learned that the 0.20g controller can handle most of them) the drama of ACC supervision is likely to rise if “local usage” of the system grows as expected. But it may be that drivers tend to realize the increasing risk after a few intervention experiences, such that compensatory strategies of utilization begin to appear. However these crucial issues play themselves out, we believe that minimal information exists in the public domain for predicting the outcomes, at present.

3. Driver vigilance and attentiveness to the full scope of potential driving hazards may be lower when operating a brake-assisted ACC controller compared with the low-authority system examined here. Since the ability to sense the onset of deceleration in the field-test cars was nearly universal across test subjects, minimal further benefit from the deceleration cue is expected to derive from any higher-g range of ACC control authority. On the other hand, even the simplest model of learning would imply that drivers will tend to gain greater confidence in a system that readily manages almost every headway conflict that comes along. Given the predominance of headway as a conflict mechanism calling for vigilance in all normal driving, a very high level of comfort with ACC control may cultivate the odd tendency in some persons to mentally underestimate the domain of all attentional demands, reducing it occasionally to that of the headway modality, alone.

If and when this occurs, attention may be allocated to less than the complete space over which visual surveillance is needed for safe driving. That is, the driver may more frequently devote visual attention to other interests either inside or outside of the vehicle while implicitly relying on ACC deceleration as some kind of general-purpose alerting mechanism (which it is not). European research reporting an unexplained inattention to traffic lights, when operating ACC on surface streets, may also be linked to the same hypothesized quirk in cognitive behavior.

### **11.3 Concluding Comment**

The suggestions for further research, listed above, have tended to focus on concerns that may or may not turn out to significantly challenge the development of fully acceptable ACC products. Putting such concerns in perspective, the authors must acknowledge that certain technology leaders in the auto industry have been studying ACC for almost fifteen years, presumably gaining proprietary knowledge that has resolved some issues through designed features of the system or has proven others to be insignificant. Indeed, the rapid pace of ACC marketing plans suggests the conviction within several OEM companies, especially those headquartered outside of the United States, that ACC will succeed as a popular automotive feature that appeals to almost any driver.

In considering safety concerns, we must also acknowledge the remarkable adaptability of the human operator who brings a primordial ability to manage risk while maximizing personal benefit, when the task is understood. Further, the few cautionary notes that question whether high-fidelity adaptation to ACC will be assured constitute rather tenuous observations within the overwhelmingly positive bulk of results produced here. Thus, the reader is asked to consider such cautions as a call for a fuller understanding that will guarantee the eventual success of ACC products in the hands of a driving population that will probably use them in the majority of all miles driven.

## References

1. Slotine, J.-J.E., and Li, W. *Applied Nonlinear Control*, Prentice Hall, Englewood Cliffs, New Jersey, 1991.
2. "SveeSix-CM3™ Embedded GPS Core Module System Designer Reference Guide," GPS System Manual, Part Number 27378-00 Rev. B, Trimble, Sunnyvale, California, 1995.
3. Fancher, P., Bareket, Z., Sayer, J., Johnson, G., Ervin, R., Mefford, M., *Fostering Development, Evaluation, and Deployment of Forward Crash Avoidance Systems (FOCAS)*, Annual Research Report ARR-5-15-95, NHTSA Contract No. DTNH22-94-Y-47016, The University of Michigan Transportation Research Institute, UMTRI-95-31, Ann Arbor, Michigan, May. 15, 1995.
4. Fancher, P., Bareket, Z., Sayer, J., MacAdam, C., Ervin, R., Mefford, M., Haugen, J., *Fostering Development, Evaluation, and Deployment of Forward Crash Avoidance Systems (FOCAS)*, Annual Research Report ARR-12-15-96, NHTSA Contract No. DTNH22-94-Y-47016, The University of Michigan Transportation Research Institute, UMTRI-96-44, Ann Arbor, Michigan Dec. 15, 1996.
5. Fancher, P.S., Bareket, Z., Bogard, S., MacAdam, C.C., and Ervin, R.D. *Tests Characterizing Performance of an Adaptive Cruise Control System*, Presented at the 1997 Society of Automotive Engineers International Congress and Exposition Detroit, Michigan, SAE Paper No. 970458.
6. Fancher, P., Ervin, R., Sayer, J., Hagan, M., Bogard, S., Bareket, Z., Mefford, M., Haugen, J., *Intelligent Cruise Control Field Operational Test (Interim Report)* Interim Report, NHTSA Contract No. DTNH22-95-H-07428, The University of Michigan Transportation Research Institute, UMTRI-97-11, Ann Arbor, Michigan March, 1997.
7. Fancher, P., Bareket, Z., "Evaluating Headway Control Using Range Versus Range-Rate Relationships," *Vehicle System Dynamics*, Vol. 28, No. 8, 1994, pp. 575-596.
8. Fancher, P., Sayer, J., Bareket, Z., *A Comparison of Manual Versus Automatic Control of Headway as a Function of Driver Characteristics*, 3rd Annual World Congress on Intelligent Transport System, Orlando, Florida, October 14-18, 1996.
9. Tufte, E.R., *The Visual Display of Quantitative Information*, Graphics Press, Cheshire, Connecticut, 1995.
10. Rasmussen, J., "Skills, Rules, and Knowledge; Signals, Signs, and Symbols, and Other Distinctions in Human Performance Modes," *IEEE Transactions on Systems, Man, and Cybernetics*, Vol. SMC-13, No. 3, May/June 1983, pp. 257-266.
11. Hoffman, E., and Mortimer, R., "Scaling of Relative Velocity Between Vehicles," *Accident Analysis and Prevention*, Vol. 28, No. 4, July 1996, pp. 415-421.

12. Fancher, P., Ervin, R., and Bogard, S., "A Field Operational test of Adaptive Cruise Control: System Operability in Naturalistic Use", Presented at the 1998 Society of Automotive Engineers International Congress and Exposition Detroit, Michigan, SAE Paper No. 980852.
13. Fancher, P., and Bareket, Z., "An Evolving Model For Studying Driver/Vehicle System Performance in the Longitudinal Control of Headway," to be published in the forthcoming Transportation Research Board (TRB) Record series *Driver and Vehicle Modeling*, 1998.
14. Ervin, R., Nagarajan, A., and Argalas, E., "Adaptive Cruise Control: An Industry Outlook on Product Features and Marketing", Final Report, Sponsored by US Department of Transportation, Washington, D.C., The University of Michigan Transportation Research Institute, UMTRI-97-38, Ann Arbor, Michigan, 1997.
15. "Road Vehicles — Adaptive Cruise Control Systems — Performance Requirements and Tests Procedure," Working Draft of the International Organization for Standardization (ISO), ISO/TC204/WG14/N143.8, Feb. 1998.
16. Wiedemann, R., "Simulation des Straßenverkehrsflusses," Schriftenreihe des Instituts für Verkehrswesen der Universität Karlsruhe, H. 8, 1974

2. “Test Definition and Project Plan,” delivered to NHTSA as part of the project entitled *Intelligent Cruise Control Field Operational Test*, DTNH22-95-H-07428, The University of Michigan Transportation Research Institute, Ann Arbor, Michigan Feb. 29, 1996.
3. “Operational Test Plan,” delivered to NHTSA as part of the project entitled *Intelligent Cruise Control Field Operational Test*, DTNH22-95-H-07428, The University of Michigan Transportation Research Institute, Ann Arbor, Michigan June, 1996.



**DOT HS 808 849**  
**May 1998**



U.S. Department  
of Transportation  
**National Highway  
Traffic Safety  
Administration**



---

**DOT HS 808 849**

**May 1998**

**Final Report  
Volume II: Appendices A-F**

# **Intelligent Cruise Control Field Operational Test**

# TABLE OF CONTENTS VOLUME II

## BACK TO VOLUME I

### APPENDIX A —

DESCRIPTION OF THE DATA ARCHIVE AS A PERMANENT RESOURCE.....372

A.1 DRIVER DATABASE DOCUMENTATION ..... 372

A.2 ICC DATABASE DOCUMENTATION..... 373

A.3 SUBJECT DATABASE DOCUMENTATION ..... 414

APPENDIX B - SUMMARY OF ACC SYSTEM QUESTIONNAIRE RESPONSES..... 417

APPENDIX C - SUMMARY OF EXPOSURE MEASUREMENTS FOR ALL DRIVERS  
AND DRIVER GROUPS..... 451

APPENDIX D — FORMS USED IN RECRUITING PARTICIPANTS ..... 505

D.1 INFORMATION LETTER - ACC FIELD OPERATIONAL TEST ..... 505

D.2 INFORMED CONSENT FORM -ACC FIELD OPERATIONAL TEST ..... 507

APPENDIX E — SYSTEM CHARACTERIZATION PROCEDURE..... 511

E.1 TEST 1: CLOSING-IN ON A PRECEDING VEHICLE ..... 512

E.2 TEST 2: CHANGING TO A NEW HEADWAY..... 514

E.3 TEST 3: MANUALLY ACCELERATING ..... 517

APPENDIX F — CHRONOLOGY OF DRIVERS, VEHICLES, SYSTEMS,  
AND EVENTS..... 520

F.1 ALGORITHM'S VERSION HISTORY ..... 520

F.2 SENSOR'S SOFTWARE VERSIONS..... 521

F.3 FAR OFF SENSORS..... 522

F.4 ASSIGNMENT SUMMARY..... 522

## VOLUME III

1. Report No. DOT HS 808 849		2. Government Accession No.		3. Recipient's Catalog No.	
4. Title and Subtitle <b>Intelligent Cruise Control Field Operational Test (Final Report)</b>				5. Report Date May 1998	
				6. Performing Organization Code	
7. Author(s) P. Fancher, R. Ervin, J. Sayer, M. Hagan, S. Bogard, Z. Bareket, M. Mefford, J. Haugen				8. Performing Organization Report No. UMTRI-98-17	
9. Performing Organization Name and Address The University of Michigan Transportation Research Institute 2901 Baxter Road, Ann Arbor, MI 48109-2150				10. Work Unit No. (TRAIS)	
				11. Contract or Grant No. DTNH22-95-H-07428	
12. Sponsoring Agency Name and Address National Highway Traffic Safety Administration U.S. Department of Transportation 400 7th Street S.W. Washington, D.C. 20590				13. Type of Report and Period Covered Final Report Sept. 1995 to July 1998	
				14. Sponsoring Agency Code	
15. Supplementary Notes UMTRI's partners in the FOT are Automotive Distance Control Systems (ADC) GmbH, Haugen Associates, and the Michigan Department of Transportation. The Volpe National Transportation Systems Center is to produce a separate report as the independent evaluator.					
16. Abstract This document reports on a cooperative agreement between NHTSA and UMTRI entitled Intelligent Cruise Control (ICC) Field Operational Test (FOT). The main goal of the work is to characterize safety and comfort issues that are fundamental to human interactions with an automatic, but driver-supervised, headway-keeping system. Volumes I and II of this report describe the work done to prepare and instrument a fleet of 10 passenger cars with infrared ranging sensors, headway-control algorithms, and driver interface units as needed to provide an adaptive-cruise-control (ACC) functionality, and these volumes present results and findings deriving from operational testing lasting from July 1996 to September 1997. The vehicles were given to 108 volunteer drivers to use for two or five weeks as their personal cars. An extensive data base covering objective and subjective results has been assembled and analyzed. The central finding presented here is that ACC is remarkably attractive to most drivers. The research indicates that, because ACC is so pleasing, people tend to utilize it over a broad range of conditions and to adopt tactics that prolong the time span of each continuous engagement. Notwithstanding having some concerns, field test participants were completely successful at operating ACC over some 35,000 miles of system engagement. In examining the results, the researchers observe that the role played by the driver as the supervisor of ACC entails subtle issues whose long-term safety and traffic impacts are unknown. These issues pertain to the shared-control nature of ACC driving requiring a fine match to the perceptual and cognitive behavior of drivers in a safety-central task that affects others driving nearby. Thus, while offering great promise for improving the quality of the driving experience, ACC implies an inherent necessity for human-centered design. Volume III of the report covers the operation of a serial string or dense cluster of passenger cars equipped with an ACC system (see separate documentation page in Volume III).					
17. Key Words Adaptive or Intelligent Cruise Control, Headway or Longitudinal Control, Crash Avoidance, ACC, ICC, Platoon, String, Cluster, Field Operational Test			18. Distribution Statement Unrestricted		
19. Security Classif. (of this report) None		20. Security Classif. (of this page) None		21. No. of Pages 530	22. Price

## SI\* (MODERN METRIC) CONVERSION FACTORS

APPROXIMATE CONVERSIONS TO SI UNITS					APPROXIMATE CONVERSIONS FROM SI UNITS				
Symbol	When You Know	Multiply By	To Find	Symbol	Symbol	When You Know	Multiply By	To Find	Symbol
<b>LENGTH</b>					<b>LENGTH</b>				
in	inches	25.4	millimeters	mm	mm	millimeters	0.039	inches	in
ft	feet	0.305	meters	m	m	meters	3.28	feet	ft
yd	yards	0.914	meters	m	m	meters	1.09	yards	yd
mi	miles	1.61	kilometers	km	km	kilometers	0.621	miles	mi
<b>AREA</b>					<b>AREA</b>				
in <sup>2</sup>	square inches	645.2	square millimeters	mm <sup>2</sup>	mm <sup>2</sup>	square millimeters	0.0016	square inches	in <sup>2</sup>
ft <sup>2</sup>	square feet	0.093	square meters	m <sup>2</sup>	m <sup>2</sup>	square meters	10.764	square feet	ft <sup>2</sup>
yd <sup>2</sup>	square yards	0.836	square meters	m <sup>2</sup>	m <sup>2</sup>	square meters	1.195	square yards	yd <sup>2</sup>
ac	acres	0.405	hectares	ha	ha	hectares	2.47	acres	ac
mi <sup>2</sup>	square miles	2.59	square kilometers	km <sup>2</sup>	km <sup>2</sup>	square kilometers	0.386	square miles	mi <sup>2</sup>
<b>VOLUME</b>					<b>VOLUME</b>				
fl oz	fluid ounces	29.57	milliliters	mL	mL	milliliters	0.034	fluid ounces	fl oz
gal	gallons	3.785	liters	L	L	liters	0.264	gallons	gal
ft <sup>3</sup>	cubic feet	0.028	cubic meters	m <sup>3</sup>	m <sup>3</sup>	cubic meters	35.71	cubic feet	ft <sup>3</sup>
yd <sup>3</sup>	cubic yards	0.765	cubic meters	m <sup>3</sup>	m <sup>3</sup>	cubic meters	1.307	cubic yards	yd <sup>3</sup>
<b>MASS</b>					<b>MASS</b>				
oz	ounces	28.35	grams	g	g	grams	0.035	ounces	oz
lb	pounds	0.454	kilograms	kg	kg	kilograms	2.202	pounds	lb
T	short tons (2000 lb)	0.907	megagrams (or "metric ton")	Mg (or "t")	Mg (or "t")	megagrams (or "metric ton")	1.103	short tons (2000 lb)	T
<b>TEMPERATURE (exact)</b>					<b>TEMPERATURE (exact)</b>				
°F	Fahrenheit temperature	5(F-32)/9 or (F-32)/1.8	Celcius temperature	°C	°C	Celcius temperature	1.8C + 32	Fahrenheit temperature	°F
<b>ILLUMINATION</b>					<b>ILLUMINATION</b>				
fc	foot-candles	10.76	lux	lx	lx	lux	0.0929	foot-candles	fc
fl	foot-Lamberts	3.426	candela/m <sup>2</sup>	cd/m <sup>2</sup>	cd/m <sup>2</sup>	candela/m <sup>2</sup>	0.2919	foot-Lamberts	fl
<b>FORCE and PRESSURE or STRESS</b>					<b>FORCE and PRESSURE or STRESS</b>				
lbf	poundforce	4.45	newtons	N	N	newtons	0.225	poundforce	lbf
lbf/in <sup>2</sup>	poundforce per square inch	6.89	kilopascals	kPa	kPa	kilopascals	0.145	poundforce per square inch	lbf/in <sup>2</sup>

\* SI is the symbol for the International System of Units. Appropriate rounding should be made to comply with Section 4 of ASTM E380.

(Revised September 1993)

## Appendix A

### Description of the data archive as a permanent resource

#### A.1 Driver Database Documentation

**Table: G**

Columns

<i>Name</i>	<i>Type</i>	<i>Size</i>
GpsTime	Number (Double)	8
Latitude	Number (Single)	4
Longitude	Number (Single)	4
Altitude	Number (Single)	4
Grade	Number (Single)	4
Heading	Number (Single)	4

Table Indexes

<i>Name</i>	<i>Number of Fields</i>
GpsTime	1

Fields: GpsTime, Ascending

**Table: H**

Columns

<i>Name</i>	<i>Type</i>	<i>Size</i>
Time	Number (Double)	8
VacTime	Number (Single)	4
Range	Number (Single)	4
RDot	Number (Single)	4
Velocity	Number (Single)	4
VSet	Number (Single)	4
VCommand	Number (Single)	4
Throttle	Number (Single)	4
Backscatter	Number (Single)	4
Vdot	Number (Single)	4
DegreeOfCurvature	Number (Single)	4
CDot	Number (Single)	4
Vp	Number (Single)	4
VpDot	Number (Single)	4
TimeToImpact	Number (Single)	4
DecelAvoid	Number (Single)	4
HeadwayTimeMargin	Number (Single)	4
Thpt30	Number (Single)	4
Dscore	Number (Single)	4
Tscore	Number (Single)	4
AccMode	Number (Integer)	2
Brake	Number (Byte)	1
Tracking	Number (Byte)	1
NewTarget	Number (Byte)	1
ValidTarget	Number (Byte)	1
BackScatterWarn	Number (Byte)	1
Near	Number (Byte)	1
Cutin	Number (Byte)	1
Following	Number (Byte)	1
Closing	Number (Byte)	1
Separating	Number (Byte)	1
AccFollowing	Number (Byte)	1
DNearEncounter	Number (Single)	4
AverageVdot	Number (Single)	4
AverageDNearEncounter	Number (Single)	4

Distance	Number (Single)	4
----------	-----------------	---

**Table Indexes**

<b>Name</b>	<b>Number of Fields</b>
Time	1
Fields:	Time, Ascending

**Table: T**

**Columns**

<b>Name</b>	<b>Type</b>	<b>Size</b>
Time	Number (Double)	8
ChannelID	Number (Long)	4
Duration	Number (Single)	4

**Table: MegaT**

**Columns**

<b>Name</b>	<b>Type</b>	<b>Size</b>
DriverID	Number (Integer)	2
TripID	Number (Integer)	2
Time	Number (Double)	8
ChannelID	Number (Long)	4
Duration	Number (Single)	4

**Table Indexes**

<b>Name</b>	<b>Number of Fields</b>
ChannelID	1
Fields:	ChannelID, Ascending
DriverID	1
Fields:	DriverID, Ascending
PrimaryKey	4
Fields:	DriverID, Ascending TripID, Ascending Time, Ascending ChannelID, Ascending
Time	1
Fields:	Time, Ascending
TripID	1
Fields:	TripID, Ascending

**A.2 ICC Database Documentation**

**Table: AccFollowingLhist**

**Columns**

<b>Name</b>	<b>Type</b>	<b>Size</b>
DriverID	Number (Integer)	2
TripID	Number (Integer)	2
Engaged	Number (Byte)	1
Transitions	Number (Long)	4
NotAccFollowing	Number (Long)	4
AccFollowing	Number (Long)	4
LongestTimeNotAccFollowing	Number (Long)	4
LongestTimeAccFollowing	Number (Long)	4

**Table Indexes**

<b>Name</b>	<b>Number of Fields</b>
UniqueID	3
Clustered:	False
Distinct Count:	0
Foreign:	False
Ignore Nulls:	False

Name:	UniqueID
Primary:	True
Required:	True
Unique:	True
Fields:	DriverID, Ascending TripID, Ascending Engaged, Ascending

## Table: AccTrackingLhist

### Columns

<i>Name</i>	<i>Type</i>	<i>Size</i>
DriverID	Number (Integer)	2
TripID	Number (Integer)	2
Transitions	Number (Long)	4
NotAccTracking	Number (Long)	4
AccTracking	Number (Long)	4
LongestTimeNotAccTracking	Number (Long)	4
LongestTimeAccTracking	Number (Long)	4

### Table Indexes

<i>Name</i>	<i>Number of Fields</i>
UniqueID	2
Clustered:	False
Distinct Count:	0
Foreign:	False
Ignore Nulls:	False
Name:	UniqueID
Primary:	True
Required:	True
Unique:	True
Fields:	DriverID, Ascending TripID, Ascending

## Table: BackScatterFhist

### Columns

<i>Name</i>	<i>Type</i>	<i>Size</i>
DriverID	Number (Integer)	2
TripID	Number (Integer)	2
Mean	Number (Single)	4
Variance	Number (Single)	4
MostLikelyValue	Number (Single)	4
TotalCount	Number (Long)	4
LTP30PT0	Number (Long)	4
P30PT5	Number (Long)	4
P31PT5	Number (Long)	4
P32PT5	Number (Long)	4
P33PT5	Number (Long)	4
P34PT5	Number (Long)	4
P35PT5	Number (Long)	4
P36PT5	Number (Long)	4
P37PT5	Number (Long)	4
P38PT5	Number (Long)	4
P39PT5	Number (Long)	4
P40PT5	Number (Long)	4
P41PT5	Number (Long)	4
P42PT5	Number (Long)	4
P43PT5	Number (Long)	4
P44PT5	Number (Long)	4
P45PT5	Number (Long)	4
P46PT5	Number (Long)	4
P47PT5	Number (Long)	4
P48PT5	Number (Long)	4
P49PT5	Number (Long)	4
P50PT5	Number (Long)	4
P51PT5	Number (Long)	4



P52PT5	Number (Long)	4
P53PT5	Number (Long)	4
P54PT5	Number (Long)	4
P55PT5	Number (Long)	4
P56PT5	Number (Long)	4
P57PT5	Number (Long)	4
P58PT5	Number (Long)	4
P59PT5	Number (Long)	4
P60PT5	Number (Long)	4
P61PT5	Number (Long)	4
P62PT5	Number (Long)	4
P63PT5	Number (Long)	4
P64PT5	Number (Long)	4
P65PT5	Number (Long)	4
P66PT5	Number (Long)	4
P67PT5	Number (Long)	4
P68PT5	Number (Long)	4
P69PT5	Number (Long)	4
P70PT5	Number (Long)	4
P71PT5	Number (Long)	4
P72PT5	Number (Long)	4
P73PT5	Number (Long)	4
P74PT5	Number (Long)	4
P75PT5	Number (Long)	4
P76PT5	Number (Long)	4
P77PT5	Number (Long)	4
P78PT5	Number (Long)	4
P79PT5	Number (Long)	4
P80PT5	Number (Long)	4
P81PT5	Number (Long)	4
P82PT5	Number (Long)	4
P83PT5	Number (Long)	4
P84PT5	Number (Long)	4
P85PT5	Number (Long)	4
P86PT5	Number (Long)	4
P87PT5	Number (Long)	4
P88PT5	Number (Long)	4
P89PT5	Number (Long)	4
GTP90PT0	Number (Long)	4

#### Table Indexes

<i>Name</i>	<i>Number of Fields</i>
UniqueID	2
Clustered:	False
Distinct Count:	0
Foreign:	False
Ignore Nulls:	False
Name:	UniqueID
Primary:	True
Required:	True
Unique:	True
Fields:	DriverID, Ascending TripID, Ascending

#### **Table: BackscatterWarnLhist**

##### Columns

<i>Name</i>	<i>Type</i>	<i>Size</i>
DriverID	Number (Integer)	2
TripID	Number (Integer)	2
Vgt35	Number (Byte)	1
Transitions	Number (Long)	4
NotBackscatterWarn	Number (Long)	4
BackscatterWarn	Number (Long)	4
LongestTimeNotBackscatterWarn	Number (Long)	4
LongestTimeBackscatterWarn	Number (Long)	4

### Table Indexes

<b>Name</b>	<b>Number of Fields</b>
UniqueID	3
Clustered:	False
Distinct Count:	0
Foreign:	False
Ignore Nulls:	False
Name:	UniqueID
Primary:	True
Required:	True
Unique:	True
Fields:	DriverID, Ascending TripID, Ascending Vgt35, Ascending

### Table: BlindedLhist

#### Columns

<b>Name</b>	<b>Type</b>	<b>Size</b>
DriverID	Number (Integer)	2
TripID	Number (Integer)	2
Engaged	Number (Byte)	1
Transitions	Number (Long)	4
NotBlinded	Number (Long)	4
Blinded	Number (Long)	4
LongestTimeNotBlinded	Number (Long)	4
LongestTimeBlinded	Number (Long)	4

#### Table Indexes

<b>Name</b>	<b>Number of Fields</b>
UniqueID	3
Clustered:	False
Distinct Count:	0
Foreign:	False
Ignore Nulls:	False
Name:	UniqueID
Primary:	True
Required:	True
Unique:	True
Fields:	DriverID, Ascending TripID, Ascending Engaged, Ascending

### Table: BrakeLhist

#### Columns

<b>Name</b>	<b>Type</b>	<b>Size</b>
DriverID	Number (Integer)	2
TripID	Number (Integer)	2
WasEngaged	Number (Byte)	1
Transitions	Number (Long)	4
NotBrake	Number (Long)	4
Brake	Number (Long)	4
LongestTimeNotBrake	Number (Long)	4
LongestTimeBrake	Number (Long)	4

#### Table Indexes

<b>Name</b>	<b>Number of Fields</b>
UniqueID	3
Clustered:	False
Distinct Count:	0
Foreign:	False
Ignore Nulls:	False
Name:	UniqueID
Primary:	True

Required:  
 Unique:  
 Fields:

True  
 True  
 DriverID, Ascending  
 TripID, Ascending  
 WasEngaged, Ascending

## Table: CDotFhist

### Columns

<i>Name</i>	<i>Type</i>	<i>Size</i>
DriverID	Number (Integer)	2
TripID	Number (Integer)	2
Engaged	Number (Byte)	1
Mean	Number (Single)	4
Variance	Number (Single)	4
MostLikelyValue	Number (Single)	4
TotalCount	Number (Long)	4
LTN2PT05	Number (Long)	4
N2PT00	Number (Long)	4
N1PT90	Number (Long)	4
N1PT80	Number (Long)	4
N1PT70	Number (Long)	4
N1PT60	Number (Long)	4
N1PT50	Number (Long)	4
N1PT40	Number (Long)	4
N1PT30	Number (Long)	4
N1PT20	Number (Long)	4
N1PT10	Number (Long)	4
N1PT00	Number (Long)	4
N0PT90	Number (Long)	4
N0PT80	Number (Long)	4
N0PT70	Number (Long)	4
N0PT60	Number (Long)	4
N0PT50	Number (Long)	4
N0PT40	Number (Long)	4
N0PT30	Number (Long)	4
N0PT20	Number (Long)	4
N0PT10	Number (Long)	4
P0PT00	Number (Long)	4
P0PT10	Number (Long)	4
P0PT20	Number (Long)	4
P0PT30	Number (Long)	4
P0PT40	Number (Long)	4
P0PT50	Number (Long)	4
P0PT60	Number (Long)	4
P0PT70	Number (Long)	4
P0PT80	Number (Long)	4
P0PT90	Number (Long)	4
P1PT00	Number (Long)	4
P1PT10	Number (Long)	4
P1PT20	Number (Long)	4
P1PT30	Number (Long)	4
P1PT40	Number (Long)	4
P1PT50	Number (Long)	4
P1PT60	Number (Long)	4
P1PT70	Number (Long)	4
P1PT80	Number (Long)	4
P1PT90	Number (Long)	4
P2PT00	Number (Long)	4
GTP2PT05	Number (Long)	4

### Table Indexes

<i>Name</i>	<i>Number of Fields</i>
UniqueID	3
Clustered:	False
Distinct Count:	0
Foreign:	False
Ignore Nulls:	False

Name:	UniqueID
Primary:	True
Required:	True
Unique:	True
Fields:	DriverID, Ascending TripID, Ascending Engaged, Ascending

## Table: CleaningLhist

### Columns

<b>Name</b>	<b>Type</b>	<b>Size</b>
DriverID	Number (Integer)	2
TripID	Number (Integer)	2
Engaged	Number (Byte)	1
Transitions	Number (Long)	4
NotCleaning	Number (Long)	4
Cleaning	Number (Long)	4
LongestTimeNotCleaning	Number (Long)	4
LongestTimeCleaning	Number (Long)	4

### Table Indexes

<b>Name</b>	<b>Number of Fields</b>
UniqueID	3
Clustered:	False
Distinct Count:	0
Foreign:	False
Ignore Nulls:	False
Name:	UniqueID
Primary:	True
Required:	True
Unique:	True
Fields:	DriverID, Ascending TripID, Ascending Engaged, Ascending

## Table: ClosingLhist

### Columns

<b>Name</b>	<b>Type</b>	<b>Size</b>
DriverID	Number (Integer)	2
TripID	Number (Integer)	2
Engaged	Number (Byte)	1
Transitions	Number (Long)	4
NotClosing	Number (Long)	4
Closing	Number (Long)	4
LongestTimeNotClosing	Number (Long)	4
LongestTimeClosing	Number (Long)	4

### Table Indexes

<b>Name</b>	<b>Number of Fields</b>
UniqueID	3
Clustered:	False
Distinct Count:	0
Foreign:	False
Ignore Nulls:	False
Name:	UniqueID
Primary:	True
Required:	True
Unique:	True
Fields:	DriverID, Ascending TripID, Ascending Engaged, Ascending

## Table: CutinLhist

### Columns

<i>Name</i>	<i>Type</i>	<i>Size</i>
DriverID	Number (Integer)	2
TripID	Number (Integer)	2
Engaged	Number (Byte)	1
Transitions	Number (Long)	4
NotCutin	Number (Long)	4
Cutin	Number (Long)	4
LongestTimeNotCutin	Number (Long)	4
LongestTimeCutin	Number (Long)	4

### Table Indexes

<i>Name</i>	<i>Number of Fields</i>
UniqueID	3
Clustered:	False
Distinct Count:	0
Foreign:	False
Ignore Nulls:	False
Name:	UniqueID
Primary:	True
Required:	True
Unique:	True
Fields:	DriverID, Ascending TripID, Ascending Engaged, Ascending

## Table: DecelAvoidFhist

### Columns

<i>Name</i>	<i>Type</i>	<i>Size</i>
DriverID	Number (Integer)	2
TripID	Number (Integer)	2
Engaged	Number (Byte)	1
Mean	Number (Single)	4
Variance	Number (Single)	4
MostLikelyValue	Number (Single)	4
TotalCount	Number (Long)	4
LTPOPT000	Number (Long)	4
P0PT005	Number (Long)	4
P0PT015	Number (Long)	4
P0PT025	Number (Long)	4
P0PT035	Number (Long)	4
P0PT045	Number (Long)	4
P0PT055	Number (Long)	4
P0PT065	Number (Long)	4
P0PT075	Number (Long)	4
P0PT085	Number (Long)	4
P0PT095	Number (Long)	4
P0PT105	Number (Long)	4
P0PT115	Number (Long)	4
P0PT125	Number (Long)	4
P0PT135	Number (Long)	4
P0PT145	Number (Long)	4
P0PT155	Number (Long)	4
P0PT165	Number (Long)	4
P0PT175	Number (Long)	4
P0PT185	Number (Long)	4
P0PT195	Number (Long)	4
P0PT205	Number (Long)	4
P0PT215	Number (Long)	4
P0PT225	Number (Long)	4
P0PT235	Number (Long)	4
P0PT245	Number (Long)	4
P0PT255	Number (Long)	4

P0PT265	Number (Long)	4
P0PT275	Number (Long)	4
P0PT285	Number (Long)	4
P0PT295	Number (Long)	4
P0PT305	Number (Long)	4
P0PT315	Number (Long)	4
P0PT325	Number (Long)	4
P0PT335	Number (Long)	4
P0PT345	Number (Long)	4
P0PT355	Number (Long)	4
P0PT365	Number (Long)	4
P0PT375	Number (Long)	4
P0PT385	Number (Long)	4
P0PT395	Number (Long)	4
P0PT405	Number (Long)	4
P0PT415	Number (Long)	4
P0PT425	Number (Long)	4
P0PT435	Number (Long)	4
P0PT445	Number (Long)	4
P0PT455	Number (Long)	4
P0PT465	Number (Long)	4
P0PT475	Number (Long)	4
P0PT485	Number (Long)	4
P0PT495	Number (Long)	4
GTP0PT500	Number (Long)	4

**Table Indexes**

<b>Name</b>	<b>Number of Fields</b>
UniqueID	3
Clustered:	False
Distinct Count:	0
Foreign:	False
Ignore Nulls:	False
Name:	UniqueID
Primary:	True
Required:	True
Unique:	True
Fields:	DriverID, Ascending TripID, Ascending Engaged, Ascending

**Table: DegOfCurvatureFhist**

**Columns**

<b>Name</b>	<b>Type</b>	<b>Size</b>
DriverID	Number (Integer)	2
TripID	Number (Integer)	2
Engaged	Number (Byte)	1
Mean	Number (Single)	4
Variance	Number (Single)	4
MostLikelyValue	Number (Single)	4
TotalCount	Number (Long)	4
LTN15PT5	Number (Long)	4
N15PT0	Number (Long)	4
N14PT0	Number (Long)	4
N13PT0	Number (Long)	4
N12PT0	Number (Long)	4
N11PT0	Number (Long)	4
N10PT0	Number (Long)	4
N9PT0	Number (Long)	4
N8PT0	Number (Long)	4
N7PT0	Number (Long)	4
N6PT0	Number (Long)	4
N5PT0	Number (Long)	4
N4PT0	Number (Long)	4
N3PT0	Number (Long)	4
N2PT0	Number (Long)	4
N1PT0	Number (Long)	4

P0PT0	Number (Long)	4
P1PT0	Number (Long)	4
P2PT0	Number (Long)	4
P3PT0	Number (Long)	4
P4PT0	Number (Long)	4
P5PT0	Number (Long)	4
P6PT0	Number (Long)	4
P7PT0	Number (Long)	4
P8PT0	Number (Long)	4
P9PT0	Number (Long)	4
P10PT0	Number (Long)	4
P11PT0	Number (Long)	4
P12PT0	Number (Long)	4
P13PT0	Number (Long)	4
P14PT0	Number (Long)	4
P15PT0	Number (Long)	4
GTP15PT5	Number (Long)	4

**Table Indexes**

<b>Name</b>	<b>Number of Fields</b>
UniqueID	3
Clustered:	False
Distinct Count:	0
Foreign:	False
Ignore Nulls:	False
Name:	UniqueID
Primary:	True
Required:	True
Unique:	True
Fields:	DriverID, Ascending TripID, Ascending Engaged, Ascending

**Table: DScoreFhist**

**Columns**

<b>Name</b>	<b>Type</b>	<b>Size</b>
DriverID	Number (Integer)	2
TripID	Number (Integer)	2
Engaged	Number (Byte)	1
Mean	Number (Single)	4
Variance	Number (Single)	4
MostLikelyValue	Number (Single)	4
TotalCount	Number (Long)	4
LTP0PT00	Number (Long)	4
P0PT05	Number (Long)	4
P0PT15	Number (Long)	4
P0PT25	Number (Long)	4
P0PT35	Number (Long)	4
P0PT45	Number (Long)	4
P0PT55	Number (Long)	4
P0PT65	Number (Long)	4
P0PT75	Number (Long)	4
P0PT85	Number (Long)	4
P0PT95	Number (Long)	4
GTP1PT00	Number (Long)	4

**Table Indexes**

<b>Name</b>	<b>Number of Fields</b>
UniqueID	3
Clustered:	False
Distinct Count:	0
Foreign:	False
Ignore Nulls:	False
Name:	UniqueID
Primary:	True
Required:	True
Unique:	True

Fields: DriverID, Ascending  
 TripID, Ascending  
 Engaged, Ascending

## Table: DScoreRegionLhist

### Columns

<i>Name</i>	<i>Type</i>	<i>Size</i>
DriverID	Number (Integer)	2
TripID	Number (Integer)	2
Engaged	Number (Byte)	1
Transitions	Number (Long)	4
NotDScoreRegion	Number (Long)	4
DScoreRegion	Number (Long)	4
LongestTimeNotDScoreRegion	Number (Long)	4
LongestTimeDScoreRegion	Number (Long)	4

### Table Indexes

<i>Name</i>	<i>Number of Fields</i>
UniquelD	3
Clustered:	False
Distinct Count:	0
Foreign:	False
Ignore Nulls:	False
Name:	UniquelD
Primary:	True
Required:	True
Unique:	True
Fields:	DriverID, Ascending TripID, Ascending Engaged, Ascending

## Table: FlowFhist

### Columns

<i>Name</i>	<i>Type</i>	<i>Size</i>
DriverID	Number (Integer)	2
TripID	Number (Integer)	2
Engaged	Number (Byte)	1
Mean	Number (Single)	4
Variance	Number (Single)	4
MostLikelyValue	Number (Single)	4
TotalCount	Number (Long)	4
LTP0PT05	Number (Long)	4
P0PT10	Number (Long)	4
P0PT20	Number (Long)	4
P0PT30	Number (Long)	4
P0PT40	Number (Long)	4
P0PT50	Number (Long)	4
P0PT60	Number (Long)	4
P0PT70	Number (Long)	4
P0PT80	Number (Long)	4
P0PT90	Number (Long)	4
P1PT00	Number (Long)	4
GTP1PT05	Number (Long)	4

### Table Indexes

<i>Name</i>	<i>Number of Fields</i>
UniquelD	3
Clustered:	False
Distinct Count:	0
Foreign:	False
Ignore Nulls:	False
Name:	UniquelD
Primary:	True
Required:	True



Unique:  
Fields:

True  
DriverID, Ascending  
TripID, Ascending  
Engaged, Ascending

## Table: Flthists

### Columns

<i>Name</i>	<i>Type</i>	<i>Size</i>
COUNT	Number (Long)	4
NAME	Text	20
SOURCE	Text	20
ENABLER	Text	20
CONDITION	Text	20
REFERENCE	Number (Double)	8
BIN_WIDTH	Number (Double)	8
MINIMUM	Number (Double)	8
MAXIMUM	Number (Double)	8
DIMENSIONS	Number (Double)	8

## Table: FollowingLhist

### Columns

<i>Name</i>	<i>Type</i>	<i>Size</i>
DriverID	Number (Integer)	2
TripID	Number (Integer)	2
Engaged	Number (Byte)	1
Transitions	Number (Long)	4
NotFollowing	Number (Long)	4
Following	Number (Long)	4
LongestTimeNotFollowing	Number (Long)	4
LongestTimeFollowing	Number (Long)	4

### Table Indexes

<i>Name</i>	<i>Number of Fields</i>
UniqueID	3
Clustered:	False
Distinct Count:	0
Foreign:	False
Ignore Nulls:	False
Name:	UniqueID
Primary:	True
Required:	True
Unique:	True
Fields:	DriverID, Ascending TripID, Ascending Engaged, Ascending

## Table: HindranceFhist

### Columns

<i>Name</i>	<i>Type</i>	<i>Size</i>
DriverID	Number (Integer)	2
TripID	Number (Integer)	2
Mean	Number (Single)	4
Variance	Number (Single)	4
MostLikelyValue	Number (Single)	4
TotalCount	Number (Long)	4
LTP0PT00	Number (Long)	4
P0PT05	Number (Long)	4
P0PT15	Number (Long)	4
P0PT25	Number (Long)	4
P0PT35	Number (Long)	4
P0PT45	Number (Long)	4
P0PT55	Number (Long)	4

P0PT65	Number (Long)	4
P0PT75	Number (Long)	4
P0PT85	Number (Long)	4
P0PT95	Number (Long)	4
GTP1PT00	Number (Long)	4

**Table Indexes**

<i>Name</i>	<i>Number of Fields</i>
UniqueID	2
Clustered:	False
Distinct Count:	0
Foreign:	False
Ignore Nulls:	False
Name:	UniqueID
Primary:	True
Required:	True
Unique:	True
Fields:	DriverID, Ascending TripID, Ascending

**Table: HtmFhist**

**Columns**

<i>Name</i>	<i>Type</i>	<i>Size</i>
DriverID	Number (Integer)	2
TripID	Number (Integer)	2
Engaged	Number (Byte)	1
Mean	Number (Single)	4
Variance	Number (Single)	4
MostLikelyValue	Number (Single)	4
TotalCount	Number (Long)	4
LTP0PT05	Number (Long)	4
P0PT10	Number (Long)	4
P0PT20	Number (Long)	4
P0PT30	Number (Long)	4
P0PT40	Number (Long)	4
P0PT50	Number (Long)	4
P0PT60	Number (Long)	4
P0PT70	Number (Long)	4
P0PT80	Number (Long)	4
P0PT90	Number (Long)	4
P1PT00	Number (Long)	4
P1PT10	Number (Long)	4
P1PT20	Number (Long)	4
P1PT30	Number (Long)	4
P1PT40	Number (Long)	4
P1PT50	Number (Long)	4
P1PT60	Number (Long)	4
P1PT70	Number (Long)	4
P1PT80	Number (Long)	4
P1PT90	Number (Long)	4
P2PT00	Number (Long)	4
P2PT10	Number (Long)	4
P2PT20	Number (Long)	4
P2PT30	Number (Long)	4
P2PT40	Number (Long)	4
P2PT50	Number (Long)	4
P2PT60	Number (Long)	4
P2PT70	Number (Long)	4
P2PT80	Number (Long)	4
P2PT90	Number (Long)	4
P3PT00	Number (Long)	4
GTP3PT05	Number (Long)	4

**Table Indexes**

<i>Name</i>	<i>Number of Fields</i>
UniqueID	3
Clustered:	False

Distinct Count:	0
Foreign:	False
Ignore Nulls:	False
Name:	UniqueID
Primary:	True
Required:	True
Unique:	True
Fields:	DriverID, Ascending TripID, Ascending Engaged, Ascending

## Table: Loghists

### Columns

<i>Name</i>	<i>Type</i>	<i>Size</i>
COUNT	Number (Long)	4
NAME	Text	24
SOURCE	Text	20
ENABLER	Text	20
CONDITION	Text	20
DIMENSIONS	Number (Double)	8

## Table: LVpDotLhist

### Columns

<i>Name</i>	<i>Type</i>	<i>Size</i>
DriverID	Number (Integer)	2
TripID	Number (Integer)	2
Engaged	Number (Byte)	1
Transitions	Number (Long)	4
NotLVpDot	Number (Long)	4
LVpDot	Number (Long)	4
LongestTimeNotLVpDot	Number (Long)	4
LongestTimeLVpDot	Number (Long)	4

### Table Indexes

<i>Name</i>	<i>Number of Fields</i>
UniqueID	3
Clustered:	False
Distinct Count:	0
Foreign:	False
Ignore Nulls:	False
Name:	UniqueID
Primary:	True
Required:	True
Unique:	True
Fields:	DriverID, Ascending TripID, Ascending Engaged, Ascending

## Table: NearLhist

### Columns

<i>Name</i>	<i>Type</i>	<i>Size</i>
DriverID	Number (Integer)	2
TripID	Number (Integer)	2
Engaged	Number (Byte)	1
Transitions	Number (Long)	4
NotNear	Number (Long)	4
Near	Number (Long)	4
LongestTimeNotNear	Number (Long)	4
LongestTimeNear	Number (Long)	4

### Table Indexes

<i>Name</i>	<i>Number of Fields</i>
-------------	-------------------------

UniqueID	3
Clustered:	False
Distinct Count:	0
Foreign:	False
Ignore Nulls:	False
Name:	UniqueID
Primary:	True
Required:	True
Unique:	True
Fields:	DriverID, Ascending TripID, Ascending Engaged, Ascending

## Table: NewTargetLhist

### Columns

<b>Name</b>	<b>Type</b>	<b>Size</b>
DriverID	Number (Integer)	2
TripID	Number (Integer)	2
Engaged	Number (Byte)	1
Transitions	Number (Long)	4
NotNewTarget	Number (Long)	4
NewTarget	Number (Long)	4
LongestTimeNotNewTarget	Number (Long)	4
LongestTimeNewTarget	Number (Long)	4

### Table Indexes

<b>Name</b>	<b>Number of Fields</b>
UniqueID	3
Clustered:	False
Distinct Count:	0
Foreign:	False
Ignore Nulls:	False
Name:	UniqueID
Primary:	True
Required:	True
Unique:	True
Fields:	DriverID, Ascending TripID, Ascending Engaged, Ascending

## Table: RangeFhist

### Columns

<b>Name</b>	<b>Type</b>	<b>Size</b>
DriverID	Number (Integer)	2
TripID	Number (Integer)	2
Vgt35	Number (Byte)	1
Mean	Number (Single)	4
Variance	Number (Single)	4
MostLikelyValue	Number (Single)	4
TotalCount	Number (Long)	4
LTP10PT0	Number (Long)	4
P15PT0	Number (Long)	4
P25PT0	Number (Long)	4
P35PT0	Number (Long)	4
P45PT0	Number (Long)	4
P55PT0	Number (Long)	4
P65PT0	Number (Long)	4
P75PT0	Number (Long)	4
P85PT0	Number (Long)	4
P95PT0	Number (Long)	4
P105PT0	Number (Long)	4
P115PT0	Number (Long)	4
P125PT0	Number (Long)	4
P135PT0	Number (Long)	4
P145PT0	Number (Long)	4

P155PT0	Number (Long)	4
P165PT0	Number (Long)	4
P175PT0	Number (Long)	4
P185PT0	Number (Long)	4
P195PT0	Number (Long)	4
P205PT0	Number (Long)	4
P215PT0	Number (Long)	4
P225PT0	Number (Long)	4
P235PT0	Number (Long)	4
P245PT0	Number (Long)	4
P255PT0	Number (Long)	4
P265PT0	Number (Long)	4
P275PT0	Number (Long)	4
P285PT0	Number (Long)	4
P295PT0	Number (Long)	4
P305PT0	Number (Long)	4
P315PT0	Number (Long)	4
P325PT0	Number (Long)	4
P335PT0	Number (Long)	4
P345PT0	Number (Long)	4
P355PT0	Number (Long)	4
P365PT0	Number (Long)	4
P375PT0	Number (Long)	4
P385PT0	Number (Long)	4
P395PT0	Number (Long)	4
P405PT0	Number (Long)	4
P415PT0	Number (Long)	4
P425PT0	Number (Long)	4
P435PT0	Number (Long)	4
P445PT0	Number (Long)	4
P455PT0	Number (Long)	4
P465PT0	Number (Long)	4
P475PT0	Number (Long)	4
P485PT0	Number (Long)	4
P495PT0	Number (Long)	4
GTP500PT0	Number (Long)	4

#### Table Indexes

<i>Name</i>	<i>Number of Fields</i>
UniqueID	3
Clustered:	False
Distinct Count:	0
Foreign:	False
Ignore Nulls:	False
Name:	UniqueID
Primary:	True
Required:	True
Unique:	True
Fields:	DriverID, Ascending TripID, Ascending Vgt35, Ascending

#### **Table: RangeFollowingFhist**

##### Columns

<i>Name</i>	<i>Type</i>	<i>Size</i>
DriverID	Number (Integer)	2
TripID	Number (Integer)	2
Engaged	Number (Byte)	1
Mean	Number (Single)	4
Variance	Number (Single)	4
MostLikelyValue	Number (Single)	4
TotalCount	Number (Long)	4
LTP30PT0	Number (Long)	4
P40PT0	Number (Long)	4
P60PT0	Number (Long)	4
P80PT0	Number (Long)	4
P100PT0	Number (Long)	4

P120PT0	Number (Long)	4
P140PT0	Number (Long)	4
P160PT0	Number (Long)	4
P180PT0	Number (Long)	4
P200PT0	Number (Long)	4
GTP210PT0	Number (Long)	4

**Table Indexes**

<b>Name</b>	<b>Number of Fields</b>
UniqueID	3
Clustered:	False
Distinct Count:	0
Foreign:	False
Ignore Nulls:	False
Name:	UniqueID
Primary:	True
Required:	True
Unique:	True
Fields:	DriverID, Ascending TripID, Ascending Engaged, Ascending

**Table: RangeVgt35Fhist**

**Columns**

<b>Name</b>	<b>Type</b>	<b>Size</b>
DriverID	Number (Integer)	2
TripID	Number (Integer)	2
Engaged	Number (Byte)	1
Mean	Number (Single)	4
Variance	Number (Single)	4
MostLikelyValue	Number (Single)	4
TotalCount	Number (Long)	4
LTP10PT0	Number (Long)	4
P15PT0	Number (Long)	4
P25PT0	Number (Long)	4
P35PT0	Number (Long)	4
P45PT0	Number (Long)	4
P55PT0	Number (Long)	4
P65PT0	Number (Long)	4
P75PT0	Number (Long)	4
P85PT0	Number (Long)	4
P95PT0	Number (Long)	4
P105PT0	Number (Long)	4
P115PT0	Number (Long)	4
P125PT0	Number (Long)	4
P135PT0	Number (Long)	4
P145PT0	Number (Long)	4
P155PT0	Number (Long)	4
P165PT0	Number (Long)	4
P175PT0	Number (Long)	4
P185PT0	Number (Long)	4
P195PT0	Number (Long)	4
P205PT0	Number (Long)	4
P215PT0	Number (Long)	4
P225PT0	Number (Long)	4
P235PT0	Number (Long)	4
P245PT0	Number (Long)	4
P255PT0	Number (Long)	4
P265PT0	Number (Long)	4
P275PT0	Number (Long)	4
P285PT0	Number (Long)	4
P295PT0	Number (Long)	4
P305PT0	Number (Long)	4
P315PT0	Number (Long)	4
P325PT0	Number (Long)	4
P335PT0	Number (Long)	4
P345PT0	Number (Long)	4

P355PT0	Number (Long)	4
P365PT0	Number (Long)	4
P375PT0	Number (Long)	4
P385PT0	Number (Long)	4
P395PT0	Number (Long)	4
P405PT0	Number (Long)	4
P415PT0	Number (Long)	4
P425PT0	Number (Long)	4
P435PT0	Number (Long)	4
P445PT0	Number (Long)	4
P455PT0	Number (Long)	4
P465PT0	Number (Long)	4
P475PT0	Number (Long)	4
P485PT0	Number (Long)	4
P495PT0	Number (Long)	4
GTP500PT0	Number (Long)	4

**Table Indexes**

<b>Name</b>	<b>Number of Fields</b>
UniquelD	3
Clustered:	False
Distinct Count:	0
Foreign:	False
Ignore Nulls:	False
Name:	UniquelD
Primary:	True
Required:	True
Unique:	True
Fields:	DriverID, Ascending TripID, Ascending Engaged, Ascending

**Table: RDotFhist**

**Columns**

<b>Name</b>	<b>Type</b>	<b>Size</b>
DriverID	Number (Integer)	2
TripID	Number (Integer)	2
Vgt35	Number (Byte)	1
Mean	Number (Single)	4
Variance	Number (Single)	4
MostLikelyValue	Number (Single)	4
TotalCount	Number (Long)	4
LTN121PT0	Number (Long)	4
N120PT0	Number (Long)	4
N118PT0	Number (Long)	4
N116PT0	Number (Long)	4
N114PT0	Number (Long)	4
N112PT0	Number (Long)	4
N110PT0	Number (Long)	4
N108PT0	Number (Long)	4
N106PT0	Number (Long)	4
N104PT0	Number (Long)	4
N102PT0	Number (Long)	4
N100PT0	Number (Long)	4
N98PT0	Number (Long)	4
N96PT0	Number (Long)	4
N94PT0	Number (Long)	4
N92PT0	Number (Long)	4
N90PT0	Number (Long)	4
N88PT0	Number (Long)	4
N86PT0	Number (Long)	4
N84PT0	Number (Long)	4
N82PT0	Number (Long)	4
N80PT0	Number (Long)	4
N78PT0	Number (Long)	4
N76PT0	Number (Long)	4
N74PT0	Number (Long)	4

N72PT0	Number (Long)	4
N70PT0	Number (Long)	4
N68PT0	Number (Long)	4
N66PT0	Number (Long)	4
N64PT0	Number (Long)	4
N62PT0	Number (Long)	4
N60PT0	Number (Long)	4
N58PT0	Number (Long)	4
N56PT0	Number (Long)	4
N54PT0	Number (Long)	4
N52PT0	Number (Long)	4
N50PT0	Number (Long)	4
N48PT0	Number (Long)	4
N46PT0	Number (Long)	4
N44PT0	Number (Long)	4
N42PT0	Number (Long)	4
N40PT0	Number (Long)	4
N38PT0	Number (Long)	4
N36PT0	Number (Long)	4
N34PT0	Number (Long)	4
N32PT0	Number (Long)	4
N30PT0	Number (Long)	4
N28PT0	Number (Long)	4
N26PT0	Number (Long)	4
N24PT0	Number (Long)	4
N22PT0	Number (Long)	4
N20PT0	Number (Long)	4
N18PT0	Number (Long)	4
N16PT0	Number (Long)	4
N14PT0	Number (Long)	4
N12PT0	Number (Long)	4
N10PT0	Number (Long)	4
N8PT0	Number (Long)	4
N6PT0	Number (Long)	4
N4PT0	Number (Long)	4
N2PT0	Number (Long)	4
P0PT0	Number (Long)	4
P2PT0	Number (Long)	4
P4PT0	Number (Long)	4
P6PT0	Number (Long)	4
P8PT0	Number (Long)	4
P10PT0	Number (Long)	4
P12PT0	Number (Long)	4
P14PT0	Number (Long)	4
P16PT0	Number (Long)	4
P18PT0	Number (Long)	4
P20PT0	Number (Long)	4
P22PT0	Number (Long)	4
P24PT0	Number (Long)	4
P26PT0	Number (Long)	4
P28PT0	Number (Long)	4
P30PT0	Number (Long)	4
P32PT0	Number (Long)	4
P34PT0	Number (Long)	4
P36PT0	Number (Long)	4
P38PT0	Number (Long)	4
P40PT0	Number (Long)	4
P42PT0	Number (Long)	4
P44PT0	Number (Long)	4
P46PT0	Number (Long)	4
P48PT0	Number (Long)	4
P50PT0	Number (Long)	4
P52PT0	Number (Long)	4
P54PT0	Number (Long)	4
P56PT0	Number (Long)	4
P58PT0	Number (Long)	4
P60PT0	Number (Long)	4
P62PT0	Number (Long)	4
P64PT0	Number (Long)	4
P66PT0	Number (Long)	4



P68PT0	Number (Long)	4
P70PT0	Number (Long)	4
P72PT0	Number (Long)	4
P74PT0	Number (Long)	4
P76PT0	Number (Long)	4
P78PT0	Number (Long)	4
P80PT0	Number (Long)	4
P82PT0	Number (Long)	4
P84PT0	Number (Long)	4
P86PT0	Number (Long)	4
P88PT0	Number (Long)	4
P90PT0	Number (Long)	4
P92PT0	Number (Long)	4
P94PT0	Number (Long)	4
P96PT0	Number (Long)	4
P98PT0	Number (Long)	4
P100PT0	Number (Long)	4
P102PT0	Number (Long)	4
P104PT0	Number (Long)	4
P106PT0	Number (Long)	4
P108PT0	Number (Long)	4
P110PT0	Number (Long)	4
P112PT0	Number (Long)	4
P114PT0	Number (Long)	4
P116PT0	Number (Long)	4
P118PT0	Number (Long)	4
P120PT0	Number (Long)	4
GTP121PT0	Number (Long)	4

#### Table Indexes

<b>Name</b>	<b>Number of Fields</b>
UniqueID	3
Clustered:	False
Distinct Count:	0
Foreign:	False
Ignore Nulls:	False
Name:	UniqueID
Primary:	True
Required:	True
Unique:	True
Fields:	DriverID, Ascending TripID, Ascending Vgt35, Ascending

### Table: RDotVgt35Fhist

#### Columns

<b>Name</b>	<b>Type</b>	<b>Size</b>
DriverID	Number (Integer)	2
TripID	Number (Integer)	2
Engaged	Number (Byte)	1
Mean	Number (Single)	4
Variance	Number (Single)	4
MostLikelyValue	Number (Single)	4
TotalCount	Number (Long)	4
LTN121PT0	Number (Long)	4
N120PT0	Number (Long)	4
N118PT0	Number (Long)	4
N116PT0	Number (Long)	4
N114PT0	Number (Long)	4
N112PT0	Number (Long)	4
N110PT0	Number (Long)	4
N108PT0	Number (Long)	4
N106PT0	Number (Long)	4
N104PT0	Number (Long)	4
N102PT0	Number (Long)	4
N100PT0	Number (Long)	4
N98PT0	Number (Long)	4

N96PT0	Number (Long)	4
N94PT0	Number (Long)	4
N92PT0	Number (Long)	4
N90PT0	Number (Long)	4
N88PT0	Number (Long)	4
N86PT0	Number (Long)	4
N84PT0	Number (Long)	4
N82PT0	Number (Long)	4
N80PT0	Number (Long)	4
N78PT0	Number (Long)	4
N76PT0	Number (Long)	4
N74PT0	Number (Long)	4
N72PT0	Number (Long)	4
N70PT0	Number (Long)	4
N68PT0	Number (Long)	4
N66PT0	Number (Long)	4
N64PT0	Number (Long)	4
N62PT0	Number (Long)	4
N60PT0	Number (Long)	4
N58PT0	Number (Long)	4
N56PT0	Number (Long)	4
N54PT0	Number (Long)	4
N52PT0	Number (Long)	4
N50PT0	Number (Long)	4
N48PT0	Number (Long)	4
N46PT0	Number (Long)	4
N44PT0	Number (Long)	4
N42PT0	Number (Long)	4
N40PT0	Number (Long)	4
N38PT0	Number (Long)	4
N36PT0	Number (Long)	4
N34PT0	Number (Long)	4
N32PT0	Number (Long)	4
N30PT0	Number (Long)	4
N28PT0	Number (Long)	4
N26PT0	Number (Long)	4
N24PT0	Number (Long)	4
N22PT0	Number (Long)	4
N20PT0	Number (Long)	4
N18PT0	Number (Long)	4
N16PT0	Number (Long)	4
N14PT0	Number (Long)	4
N12PT0	Number (Long)	4
N10PT0	Number (Long)	4
N8PT0	Number (Long)	4
N6PT0	Number (Long)	4
N4PT0	Number (Long)	4
N2PT0	Number (Long)	4
P0PT0	Number (Long)	4
P2PT0	Number (Long)	4
P4PT0	Number (Long)	4
P6PT0	Number (Long)	4
P8PT0	Number (Long)	4
P10PT0	Number (Long)	4
P12PT0	Number (Long)	4
P14PT0	Number (Long)	4
P16PT0	Number (Long)	4
P18PT0	Number (Long)	4
P20PT0	Number (Long)	4
P22PT0	Number (Long)	4
P24PT0	Number (Long)	4
P26PT0	Number (Long)	4
P28PT0	Number (Long)	4
P30PT0	Number (Long)	4
P32PT0	Number (Long)	4
P34PT0	Number (Long)	4
P36PT0	Number (Long)	4
P38PT0	Number (Long)	4
P40PT0	Number (Long)	4
P42PT0	Number (Long)	4

P44PT0	Number (Long)	4
P46PT0	Number (Long)	4
P48PT0	Number (Long)	4
P50PT0	Number (Long)	4
P52PT0	Number (Long)	4
P54PT0	Number (Long)	4
P56PT0	Number (Long)	4
P58PT0	Number (Long)	4
P60PT0	Number (Long)	4
P62PT0	Number (Long)	4
P64PT0	Number (Long)	4
P66PT0	Number (Long)	4
P68PT0	Number (Long)	4
P70PT0	Number (Long)	4
P72PT0	Number (Long)	4
P74PT0	Number (Long)	4
P76PT0	Number (Long)	4
P78PT0	Number (Long)	4
P80PT0	Number (Long)	4
P82PT0	Number (Long)	4
P84PT0	Number (Long)	4
P86PT0	Number (Long)	4
P88PT0	Number (Long)	4
P90PT0	Number (Long)	4
P92PT0	Number (Long)	4
P94PT0	Number (Long)	4
P96PT0	Number (Long)	4
P98PT0	Number (Long)	4
P100PT0	Number (Long)	4
P102PT0	Number (Long)	4
P104PT0	Number (Long)	4
P106PT0	Number (Long)	4
P108PT0	Number (Long)	4
P110PT0	Number (Long)	4
P112PT0	Number (Long)	4
P114PT0	Number (Long)	4
P116PT0	Number (Long)	4
P118PT0	Number (Long)	4
P120PT0	Number (Long)	4
GTP121PT0	Number (Long)	4

#### Table Indexes

<i>Name</i>	<i>Number of Fields</i>
UniqueID	3
Clustered:	False
Distinct Count:	0
Foreign:	False
Ignore Nulls:	False
Name:	UniqueID
Primary:	True
Required:	True
Unique:	True
Fields:	DriverID, Ascending TripID, Ascending Engaged, Ascending

### Table: ReducedRangeLhist

#### Columns

<i>Name</i>	<i>Type</i>	<i>Size</i>
DriverID	Number (Integer)	2
TripID	Number (Integer)	2
Engaged	Number (Byte)	1
Transitions	Number (Long)	4
NotReducedRange	Number (Long)	4
ReducedRange	Number (Long)	4
LongestTimeNotReducedRange	Number (Long)	4
LongestTimeReducedRange	Number (Long)	4

**Table Indexes**

<b>Name</b>	<b>Number of Fields</b>
UniqueID	3
Clustered:	False
Distinct Count:	0
Foreign:	False
Ignore Nulls:	False
Name:	UniqueID
Primary:	True
Required:	True
Unique:	True
Fields:	DriverID, Ascending TripID, Ascending Engaged, Ascending

**Table: RRDotFhist**

**Columns**

<b>Name</b>	<b>Type</b>	<b>Size</b>
DriverID	Number (Integer)	2
TripID	Number (Integer)	2
Engaged	Number (Byte)	1
RDotCenters	Number (Single)	4
P0PT30	Number (Long)	4
P0PT40	Number (Long)	4
P0PT50	Number (Long)	4
P0PT60	Number (Long)	4
P0PT70	Number (Long)	4
P0PT80	Number (Long)	4
P0PT90	Number (Long)	4
P1PT00	Number (Long)	4
P1PT10	Number (Long)	4
P1PT20	Number (Long)	4
P1PT30	Number (Long)	4
P1PT40	Number (Long)	4
P1PT50	Number (Long)	4
P1PT60	Number (Long)	4
P1PT70	Number (Long)	4
P1PT80	Number (Long)	4
P1PT90	Number (Long)	4
P2PT00	Number (Long)	4
P2PT10	Number (Long)	4
P2PT20	Number (Long)	4
P2PT30	Number (Long)	4
P2PT40	Number (Long)	4
P2PT50	Number (Long)	4
P2PT60	Number (Long)	4
P2PT70	Number (Long)	4
P2PT80	Number (Long)	4
P2PT90	Number (Long)	4
P3PT00	Number (Long)	4

**Table Indexes**

<b>Name</b>	<b>Number of Fields</b>
UniqueID	4
Clustered:	False
Distinct Count:	0
Foreign:	False
Ignore Nulls:	False
Name:	UniqueID
Primary:	True
Required:	True
Unique:	True
Fields:	DriverID, Ascending TripID, Ascending Engaged, Ascending RDotCenters, Ascending

## Table: RRDotPtsFhist

### Columns

<i>Name</i>	<i>Type</i>	<i>Size</i>
DriverID	Number (Integer)	2
TripID	Number (Integer)	2
Engaged	Number (Byte)	1
TotalCount	Number (Long)	4
TotalOutside	Number (Long)	4

### Table Indexes

<i>Name</i>	<i>Number of Fields</i>
UniqueID	3
Clustered:	False
Distinct Count:	0
Foreign:	False
Ignore Nulls:	False
Name:	UniqueID
Primary:	True
Required:	True
Unique:	True
Fields:	DriverID, Ascending TripID, Ascending Engaged, Ascending

## Table: SeparatingLhist

### Columns

<i>Name</i>	<i>Type</i>	<i>Size</i>
DriverID	Number (Integer)	2
TripID	Number (Integer)	2
Engaged	Number (Byte)	1
Transitions	Number (Long)	4
NotSeparating	Number (Long)	4
Separating	Number (Long)	4
LongestTimeNotSeparating	Number (Long)	4
LongestTimeSeparating	Number (Long)	4

### Table Indexes

<i>Name</i>	<i>Number of Fields</i>
UniqueID	3
Clustered:	False
Distinct Count:	0
Foreign:	False
Ignore Nulls:	False
Name:	UniqueID
Primary:	True
Required:	True
Unique:	True
Fields:	DriverID, Ascending TripID, Ascending Engaged, Ascending

## Table: Thpt03Fhist

### Columns

<i>Name</i>	<i>Type</i>	<i>Size</i>
DriverID	Number (Integer)	2
TripID	Number (Integer)	2
Engaged	Number (Byte)	1
Mean	Number (Single)	4
Variance	Number (Single)	4
MostLikelyValue	Number (Single)	4
TotalCount	Number (Long)	4
LTPOPT05	Number (Long)	4

P0PT10	Number (Long)	4
P0PT20	Number (Long)	4
P0PT30	Number (Long)	4
P0PT40	Number (Long)	4
P0PT50	Number (Long)	4
P0PT60	Number (Long)	4
P0PT70	Number (Long)	4
P0PT80	Number (Long)	4
P0PT90	Number (Long)	4
P1PT00	Number (Long)	4
P1PT10	Number (Long)	4
P1PT20	Number (Long)	4
P1PT30	Number (Long)	4
P1PT40	Number (Long)	4
P1PT50	Number (Long)	4
P1PT60	Number (Long)	4
P1PT70	Number (Long)	4
P1PT80	Number (Long)	4
P1PT90	Number (Long)	4
P2PT00	Number (Long)	4
P2PT10	Number (Long)	4
P2PT20	Number (Long)	4
P2PT30	Number (Long)	4
P2PT40	Number (Long)	4
P2PT50	Number (Long)	4
P2PT60	Number (Long)	4
P2PT70	Number (Long)	4
P2PT80	Number (Long)	4
P2PT90	Number (Long)	4
P3PT00	Number (Long)	4
GTP3PT05	Number (Long)	4

**Table Indexes**

<b>Name</b>	<b>Number of Fields</b>
UniquelD	3
Clustered:	False
Distinct Count:	0
Foreign:	False
Ignore Nulls:	False
Name:	UniquelD
Primary:	True
Required:	True
Unique:	True
Fields:	DriverID, Ascending TripID, Ascending Engaged, Ascending

**Table: ThrottleFhist**

**Columns**

<b>Name</b>	<b>Type</b>	<b>Size</b>
DriverID	Number (Integer)	2
TripID	Number (Integer)	2
Engaged	Number (Byte)	1
Mean	Number (Single)	4
Variance	Number (Single)	4
MostLikelyValue	Number (Single)	4
TotalCount	Number (Long)	4
LTP0PT0	Number (Long)	4
P0PT5	Number (Long)	4
P1PT5	Number (Long)	4
P2PT5	Number (Long)	4
P3PT5	Number (Long)	4
P4PT5	Number (Long)	4
P5PT5	Number (Long)	4
P6PT5	Number (Long)	4
P7PT5	Number (Long)	4
P8PT5	Number (Long)	4

P9PT5	Number (Long)	4
P10PT5	Number (Long)	4
P11PT5	Number (Long)	4
P12PT5	Number (Long)	4
P13PT5	Number (Long)	4
P14PT5	Number (Long)	4
P15PT5	Number (Long)	4
P16PT5	Number (Long)	4
P17PT5	Number (Long)	4
P18PT5	Number (Long)	4
P19PT5	Number (Long)	4
P20PT5	Number (Long)	4
P21PT5	Number (Long)	4
P22PT5	Number (Long)	4
P23PT5	Number (Long)	4
P24PT5	Number (Long)	4
P25PT5	Number (Long)	4
P26PT5	Number (Long)	4
P27PT5	Number (Long)	4
P28PT5	Number (Long)	4
P29PT5	Number (Long)	4
P30PT5	Number (Long)	4
P31PT5	Number (Long)	4
P32PT5	Number (Long)	4
P33PT5	Number (Long)	4
P34PT5	Number (Long)	4
P35PT5	Number (Long)	4
P36PT5	Number (Long)	4
P37PT5	Number (Long)	4
P38PT5	Number (Long)	4
P39PT5	Number (Long)	4
P40PT5	Number (Long)	4
P41PT5	Number (Long)	4
P42PT5	Number (Long)	4
P43PT5	Number (Long)	4
P44PT5	Number (Long)	4
P45PT5	Number (Long)	4
P46PT5	Number (Long)	4
P47PT5	Number (Long)	4
P48PT5	Number (Long)	4
P49PT5	Number (Long)	4
P50PT5	Number (Long)	4
P51PT5	Number (Long)	4
P52PT5	Number (Long)	4
P53PT5	Number (Long)	4
P54PT5	Number (Long)	4
P55PT5	Number (Long)	4
P56PT5	Number (Long)	4
P57PT5	Number (Long)	4
P58PT5	Number (Long)	4
P59PT5	Number (Long)	4
P60PT5	Number (Long)	4
P61PT5	Number (Long)	4
P62PT5	Number (Long)	4
P63PT5	Number (Long)	4
P64PT5	Number (Long)	4
P65PT5	Number (Long)	4
P66PT5	Number (Long)	4
P67PT5	Number (Long)	4
P68PT5	Number (Long)	4
P69PT5	Number (Long)	4
P70PT5	Number (Long)	4
P71PT5	Number (Long)	4
P72PT5	Number (Long)	4
P73PT5	Number (Long)	4
P74PT5	Number (Long)	4
P75PT5	Number (Long)	4
P76PT5	Number (Long)	4
P77PT5	Number (Long)	4
P78PT5	Number (Long)	4

P79PT5	Number (Long)	4
P80PT5	Number (Long)	4
P81PT5	Number (Long)	4
P82PT5	Number (Long)	4
P83PT5	Number (Long)	4
P84PT5	Number (Long)	4
P85PT5	Number (Long)	4
P86PT5	Number (Long)	4
P87PT5	Number (Long)	4
P88PT5	Number (Long)	4
P89PT5	Number (Long)	4
P90PT5	Number (Long)	4
P91PT5	Number (Long)	4
P92PT5	Number (Long)	4
P93PT5	Number (Long)	4
P94PT5	Number (Long)	4
P95PT5	Number (Long)	4
P96PT5	Number (Long)	4
P97PT5	Number (Long)	4
P98PT5	Number (Long)	4
P99PT5	Number (Long)	4
GTP100PT0	Number (Long)	4

### Table Indexes

<i>Name</i>	<i>Number of Fields</i>
UniqueID	3
Clustered:	False
Distinct Count:	0
Foreign:	False
Ignore Nulls:	False
Name:	UniqueID
Primary:	True
Required:	True
Unique:	True
Fields:	DriverID, Ascending TripID, Ascending Engaged, Ascending

### **Table: TimeToImpactFhist**

#### Columns

<i>Name</i>	<i>Type</i>	<i>Size</i>
DriverID	Number (Integer)	2
TripID	Number (Integer)	2
Engaged	Number (Byte)	1
Mean	Number (Single)	4
Variance	Number (Single)	4
MostLikelyValue	Number (Single)	4
TotalCount	Number (Long)	4
LTP2PT5	Number (Long)	4
P3PT0	Number (Long)	4
P4PT0	Number (Long)	4
P5PT0	Number (Long)	4
P6PT0	Number (Long)	4
P7PT0	Number (Long)	4
P8PT0	Number (Long)	4
P9PT0	Number (Long)	4
P10PT0	Number (Long)	4
P11PT0	Number (Long)	4
P12PT0	Number (Long)	4
P13PT0	Number (Long)	4
P14PT0	Number (Long)	4
P15PT0	Number (Long)	4
P16PT0	Number (Long)	4
P17PT0	Number (Long)	4
P18PT0	Number (Long)	4
P19PT0	Number (Long)	4
P20PT0	Number (Long)	4



GTP20PT5

Number (Long)

4

**Table Indexes**

<b>Name</b>	<b>Number of Fields</b>
UniqueID	3
Clustered:	False
Distinct Count:	0
Foreign:	False
Ignore Nulls:	False
Name:	UniqueID
Primary:	True
Required:	True
Unique:	True
Fields:	DriverID, Ascending TripID, Ascending Engaged, Ascending

**Table: TrackingErrorFhist**

**Columns**

<b>Name</b>	<b>Type</b>	<b>Size</b>
DriverID	Number (Integer)	2
TripID	Number (Integer)	2
Mean	Number (Single)	4
Variance	Number (Single)	4
MostLikelyValue	Number (Single)	4
TotalCount	Number (Long)	4
LTN35PT0	Number (Long)	4
N30PT0	Number (Long)	4
N20PT0	Number (Long)	4
N10PT0	Number (Long)	4
P0PT0	Number (Long)	4
P10PT0	Number (Long)	4
P20PT0	Number (Long)	4
P30PT0	Number (Long)	4
GTP35PT0	Number (Long)	4

**Table Indexes**

<b>Name</b>	<b>Number of Fields</b>
UniqueID	2
Clustered:	False
Distinct Count:	0
Foreign:	False
Ignore Nulls:	False
Name:	UniqueID
Primary:	True
Required:	True
Unique:	True
Fields:	DriverID, Ascending TripID, Ascending

**Table: TrackingLhist**

**Columns**

<b>Name</b>	<b>Type</b>	<b>Size</b>
DriverID	Number (Integer)	2
TripID	Number (Integer)	2
Engaged	Number (Byte)	1
Transitions	Number (Long)	4
NotTracking	Number (Long)	4
Tracking	Number (Long)	4
LongestTimeNotTracking	Number (Long)	4
LongestTimeTracking	Number (Long)	4

**Table Indexes**

<b>Name</b>	<b>Number of Fields</b>
-------------	-------------------------

UniqueID	3
Clustered:	False
Distinct Count:	0
Foreign:	False
Ignore Nulls:	False
Name:	UniqueID
Primary:	True
Required:	True
Unique:	True
Fields:	DriverID, Ascending TripID, Ascending Engaged, Ascending

## Table: TripTable

### Columns

<b>Name</b>	<b>Type</b>	<b>Size</b>
Version	Number (Integer)	2
DriverID	Number (Integer)	2
TripID	Number (Integer)	2
StartTime	Number (Double)	8
EndTime	Number (Double)	8
Duration	Number (Single)	4
StartLatitude	Number (Single)	4
StartLongitude	Number (Single)	4
StartAltitude	Number (Single)	4
EndLatitude	Number (Single)	4
EndLongitude	Number (Single)	4
EndAltitude	Number (Single)	4
Distance	Number (Single)	4
DistanceEngaged	Number (Single)	4
AccEnable	Number (Long)	4
AccOn	Number (Long)	4
Set	Number (Long)	4
Coast	Number (Long)	4
Resume	Number (Long)	4
Accel	Number (Long)	4
Brake	Number (Long)	4
Cancel	Number (Long)	4
Tracking	Number (Long)	4
ValidTarget	Number (Long)	4
NewTarget	Number (Long)	4
Cleaning	Number (Long)	4
Blinded	Number (Long)	4
ReducedRange	Number (Long)	4
DownShift	Number (Long)	4
Stopped	Number (Long)	4
Engaged	Number (Long)	4
Concern	Number (Long)	4
Vgt50	Number (Long)	4
AccBi	Number (Long)	4
CccBi	Number (Long)	4
Man1Bi	Number (Long)	4
Man2Bi	Number (Long)	4
AccNe	Number (Long)	4
CccNe	Number (Long)	4
Man1Ne	Number (Long)	4
Man2Ne	Number (Long)	4
EcuError	Number (Long)	4
OdinError	Number (Long)	4
VacError	Number (Long)	4
GpsError	Number (Long)	4
FileError	Number (Long)	4
NetworkError	Number (Long)	4
SystemError	Number (Long)	4

### Table Indexes

<b>Name</b>	<b>Number of Fields</b>
-------------	-------------------------

UniqueID	2
Clustered:	False
Distinct Count:	0
Foreign:	False
Ignore Nulls:	False
Name:	UniqueID
Primary:	True
Required:	True
Unique:	True
Fields:	DriverID, Ascending TripID, Ascending

## Table: TScoreFhist

### Columns

<b>Name</b>	<b>Type</b>	<b>Size</b>
DriverID	Number (Integer)	2
TripID	Number (Integer)	2
Engaged	Number (Byte)	1
Mean	Number (Single)	4
Variance	Number (Single)	4
MostLikelyValue	Number (Single)	4
TotalCount	Number (Long)	4
LTP0PT00	Number (Long)	4
P0PT05	Number (Long)	4
P0PT15	Number (Long)	4
P0PT25	Number (Long)	4
P0PT35	Number (Long)	4
P0PT45	Number (Long)	4
P0PT55	Number (Long)	4
P0PT65	Number (Long)	4
P0PT75	Number (Long)	4
P0PT85	Number (Long)	4
P0PT95	Number (Long)	4
GTP1PT00	Number (Long)	4

### Table Indexes

<b>Name</b>	<b>Number of Fields</b>
UniqueID	3
Clustered:	False
Distinct Count:	0
Foreign:	False
Ignore Nulls:	False
Name:	UniqueID
Primary:	True
Required:	True
Unique:	True
Fields:	DriverID, Ascending TripID, Ascending Engaged, Ascending

## Table: TScoreRegionLhist

### Columns

<b>Name</b>	<b>Type</b>	<b>Size</b>
DriverID	Number (Integer)	2
TripID	Number (Integer)	2
Engaged	Number (Byte)	1
Transitions	Number (Long)	4
NotTScoreRegion	Number (Long)	4
TScoreRegion	Number (Long)	4
LongestTimeNotTScoreRegion	Number (Long)	4
LongestTimeTScoreRegion	Number (Long)	4

### Table Indexes

<b>Name</b>	<b>Number of Fields</b>
-------------	-------------------------

UniqueID	3
Clustered:	False
Distinct Count:	0
Foreign:	False
Ignore Nulls:	False
Name:	UniqueID
Primary:	True
Required:	True
Unique:	True
Fields:	DriverID, Ascending TripID, Ascending Engaged, Ascending

## Table: UpdateLog

### Columns

<i>Name</i>	<i>Type</i>	<i>Size</i>
Date	Date/Time	8
Time	Date/Time	8
Table or Object Name	Text	255
Person or Form Name	Text	255
Form Version	Text	50
Description of Change	Text	255

## Table: ValidTargetLhist

### Columns

<i>Name</i>	<i>Type</i>	<i>Size</i>
DriverID	Number (Integer)	2
TripID	Number (Integer)	2
Engaged	Number (Byte)	1
Transitions	Number (Long)	4
NotValidTarget	Number (Long)	4
ValidTarget	Number (Long)	4
LongestTimeNotValidTarget	Number (Long)	4
LongestTimeValidTarget	Number (Long)	4

### Table Indexes

<i>Name</i>	<i>Number of Fields</i>
UniqueID	3
Clustered:	False
Distinct Count:	0
Foreign:	False
Ignore Nulls:	False
Name:	UniqueID
Primary:	True
Required:	True
Unique:	True
Fields:	DriverID, Ascending TripID, Ascending Engaged, Ascending

## Table: ValidTargetVgt35Lhist

### Columns

<i>Name</i>	<i>Type</i>	<i>Size</i>
DriverID	Number (Integer)	2
TripID	Number (Integer)	2
Engaged	Number (Byte)	1
Transitions	Number (Long)	4
NotValidTargetVgt35	Number (Long)	4
ValidTargetVgt35	Number (Long)	4
LongestTimeNotValidTargetVgt35	Number (Long)	4
LongestTimeValidTargetVgt35	Number (Long)	4

### Table Indexes

<b>Name</b>	<b>Number of Fields</b>
UniqueID	3
Clustered:	False
Distinct Count:	0
Foreign:	False
Ignore Nulls:	False
Name:	UniqueID
Primary:	True
Required:	True
Unique:	True
Fields:	DriverID, Ascending TripID, Ascending Engaged, Ascending

### Table: ValidTargetVgt50Lhist

#### Columns

<b>Name</b>	<b>Type</b>	<b>Size</b>
DriverID	Number (Integer)	2
TripID	Number (Integer)	2
Engaged	Number (Byte)	1
Transitions	Number (Long)	4
NotValidTargetVgt50	Number (Long)	4
ValidTargetVgt50	Number (Long)	4
LongestTimeNotValidTargetVgt50	Number (Long)	4
LongestTimeValidTargetVgt50	Number (Long)	4

#### Table Indexes

<b>Name</b>	<b>Number of Fields</b>
UniqueID	3
Clustered:	False
Distinct Count:	0
Foreign:	False
Ignore Nulls:	False
Name:	UniqueID
Primary:	True
Required:	True
Unique:	True
Fields:	DriverID, Ascending TripID, Ascending Engaged, Ascending

### Table: VCommandFhist

#### Columns

<b>Name</b>	<b>Type</b>	<b>Size</b>
DriverID	Number (Integer)	2
TripID	Number (Integer)	2
Engaged	Number (Byte)	1
Mean	Number (Single)	4
Variance	Number (Single)	4
MostLikelyValue	Number (Single)	4
TotalCount	Number (Long)	4
LTN2PT8	Number (Long)	4
N0PT6	Number (Long)	4
P3PT8	Number (Long)	4
P8PT2	Number (Long)	4
P12PT6	Number (Long)	4
P17PT0	Number (Long)	4
P21PT4	Number (Long)	4
P25PT8	Number (Long)	4
P30PT2	Number (Long)	4
P34PT6	Number (Long)	4
P39PT0	Number (Long)	4
P43PT4	Number (Long)	4

P47PT8	Number (Long)	4
P52PT2	Number (Long)	4
P56PT6	Number (Long)	4
P61PT0	Number (Long)	4
P65PT4	Number (Long)	4
P69PT8	Number (Long)	4
P74PT2	Number (Long)	4
P78PT6	Number (Long)	4
P83PT0	Number (Long)	4
P87PT4	Number (Long)	4
P91PT8	Number (Long)	4
P96PT2	Number (Long)	4
P100PT6	Number (Long)	4
P105PT0	Number (Long)	4
P109PT4	Number (Long)	4
P113PT8	Number (Long)	4
P118PT2	Number (Long)	4
P122PT6	Number (Long)	4
P127PT0	Number (Long)	4
P131PT4	Number (Long)	4
GTP133PT6	Number (Long)	4

**Table Indexes**

<b>Name</b>	<b>Number of Fields</b>
UniqueID	3
Clustered:	False
Distinct Count:	0
Foreign:	False
Ignore Nulls:	False
Name:	UniqueID
Primary:	True
Required:	True
Unique:	True
Fields:	DriverID, Ascending TripID, Ascending Engaged, Ascending

**Table: VDotFhist**

**Columns**

<b>Name</b>	<b>Type</b>	<b>Size</b>
DriverID	Number (Integer)	2
TripID	Number (Integer)	2
Vgt35	Number (Byte)	1
Mean	Number (Single)	4
Variance	Number (Single)	4
MostLikelyValue	Number (Single)	4
TotalCount	Number (Long)	4
LTNOPT505	Number (Long)	4
N0PT500	Number (Long)	4
N0PT490	Number (Long)	4
N0PT480	Number (Long)	4
N0PT470	Number (Long)	4
N0PT460	Number (Long)	4
N0PT450	Number (Long)	4
N0PT440	Number (Long)	4
N0PT430	Number (Long)	4
N0PT420	Number (Long)	4
N0PT410	Number (Long)	4
N0PT400	Number (Long)	4
N0PT390	Number (Long)	4
N0PT380	Number (Long)	4
N0PT370	Number (Long)	4
N0PT360	Number (Long)	4
N0PT350	Number (Long)	4
N0PT340	Number (Long)	4
N0PT330	Number (Long)	4
N0PT320	Number (Long)	4

N0PT310	Number (Long)	4
N0PT300	Number (Long)	4
N0PT290	Number (Long)	4
N0PT280	Number (Long)	4
N0PT270	Number (Long)	4
N0PT260	Number (Long)	4
N0PT250	Number (Long)	4
N0PT240	Number (Long)	4
N0PT230	Number (Long)	4
N0PT220	Number (Long)	4
N0PT210	Number (Long)	4
N0PT200	Number (Long)	4
N0PT190	Number (Long)	4
N0PT180	Number (Long)	4
N0PT170	Number (Long)	4
N0PT160	Number (Long)	4
N0PT150	Number (Long)	4
N0PT140	Number (Long)	4
N0PT130	Number (Long)	4
N0PT120	Number (Long)	4
N0PT110	Number (Long)	4
N0PT100	Number (Long)	4
N0PT090	Number (Long)	4
N0PT080	Number (Long)	4
N0PT070	Number (Long)	4
N0PT060	Number (Long)	4
N0PT050	Number (Long)	4
N0PT040	Number (Long)	4
N0PT030	Number (Long)	4
N0PT020	Number (Long)	4
N0PT010	Number (Long)	4
P0PT000	Number (Long)	4
P0PT010	Number (Long)	4
P0PT020	Number (Long)	4
P0PT030	Number (Long)	4
P0PT040	Number (Long)	4
P0PT050	Number (Long)	4
P0PT060	Number (Long)	4
P0PT070	Number (Long)	4
P0PT080	Number (Long)	4
P0PT090	Number (Long)	4
P0PT100	Number (Long)	4
P0PT110	Number (Long)	4
P0PT120	Number (Long)	4
P0PT130	Number (Long)	4
P0PT140	Number (Long)	4
P0PT150	Number (Long)	4
P0PT160	Number (Long)	4
P0PT170	Number (Long)	4
P0PT180	Number (Long)	4
P0PT190	Number (Long)	4
P0PT200	Number (Long)	4
P0PT210	Number (Long)	4
P0PT220	Number (Long)	4
P0PT230	Number (Long)	4
P0PT240	Number (Long)	4
P0PT250	Number (Long)	4
P0PT260	Number (Long)	4
P0PT270	Number (Long)	4
P0PT280	Number (Long)	4
P0PT290	Number (Long)	4
P0PT300	Number (Long)	4
P0PT310	Number (Long)	4
P0PT320	Number (Long)	4
P0PT330	Number (Long)	4
P0PT340	Number (Long)	4
P0PT350	Number (Long)	4
P0PT360	Number (Long)	4
P0PT370	Number (Long)	4
P0PT380	Number (Long)	4

P0PT390	Number (Long)	4
P0PT400	Number (Long)	4
P0PT410	Number (Long)	4
P0PT420	Number (Long)	4
P0PT430	Number (Long)	4
P0PT440	Number (Long)	4
P0PT450	Number (Long)	4
P0PT460	Number (Long)	4
P0PT470	Number (Long)	4
P0PT480	Number (Long)	4
P0PT490	Number (Long)	4
P0PT500	Number (Long)	4
GTP0PT505	Number (Long)	4

**Table Indexes**

<b>Name</b>	<b>Number of Fields</b>
UniqueID	3
Clustered:	False
Distinct Count:	0
Foreign:	False
Ignore Nulls:	False
Name:	UniqueID
Primary:	True
Required:	True
Unique:	True
Fields:	DriverID, Ascending TripID, Ascending Vgt35, Ascending

**Table: VDotVgt35Fhist**

**Columns**

<b>Name</b>	<b>Type</b>	<b>Size</b>
DriverID	Number (Integer)	2
TripID	Number (Integer)	2
Engaged	Number (Byte)	1
Mean	Number (Single)	4
Variance	Number (Single)	4
MostLikelyValue	Number (Single)	4
TotalCount	Number (Long)	4
LTN0PT505	Number (Long)	4
N0PT500	Number (Long)	4
N0PT490	Number (Long)	4
N0PT480	Number (Long)	4
N0PT470	Number (Long)	4
N0PT460	Number (Long)	4
N0PT450	Number (Long)	4
N0PT440	Number (Long)	4
N0PT430	Number (Long)	4
N0PT420	Number (Long)	4
N0PT410	Number (Long)	4
N0PT400	Number (Long)	4
N0PT390	Number (Long)	4
N0PT380	Number (Long)	4
N0PT370	Number (Long)	4
N0PT360	Number (Long)	4
N0PT350	Number (Long)	4
N0PT340	Number (Long)	4
N0PT330	Number (Long)	4
N0PT320	Number (Long)	4
N0PT310	Number (Long)	4
N0PT300	Number (Long)	4
N0PT290	Number (Long)	4
N0PT280	Number (Long)	4
N0PT270	Number (Long)	4
N0PT260	Number (Long)	4
N0PT250	Number (Long)	4
N0PT240	Number (Long)	4



N0PT230	Number (Long)	4
N0PT220	Number (Long)	4
N0PT210	Number (Long)	4
N0PT200	Number (Long)	4
N0PT190	Number (Long)	4
N0PT180	Number (Long)	4
N0PT170	Number (Long)	4
N0PT160	Number (Long)	4
N0PT150	Number (Long)	4
N0PT140	Number (Long)	4
N0PT130	Number (Long)	4
N0PT120	Number (Long)	4
N0PT110	Number (Long)	4
N0PT100	Number (Long)	4
N0PT090	Number (Long)	4
N0PT080	Number (Long)	4
N0PT070	Number (Long)	4
N0PT060	Number (Long)	4
N0PT050	Number (Long)	4
N0PT040	Number (Long)	4
N0PT030	Number (Long)	4
N0PT020	Number (Long)	4
N0PT010	Number (Long)	4
P0PT000	Number (Long)	4
P0PT010	Number (Long)	4
P0PT020	Number (Long)	4
P0PT030	Number (Long)	4
P0PT040	Number (Long)	4
P0PT050	Number (Long)	4
P0PT060	Number (Long)	4
P0PT070	Number (Long)	4
P0PT080	Number (Long)	4
P0PT090	Number (Long)	4
P0PT100	Number (Long)	4
P0PT110	Number (Long)	4
P0PT120	Number (Long)	4
P0PT130	Number (Long)	4
P0PT140	Number (Long)	4
P0PT150	Number (Long)	4
P0PT160	Number (Long)	4
P0PT170	Number (Long)	4
P0PT180	Number (Long)	4
P0PT190	Number (Long)	4
P0PT200	Number (Long)	4
P0PT210	Number (Long)	4
P0PT220	Number (Long)	4
P0PT230	Number (Long)	4
P0PT240	Number (Long)	4
P0PT250	Number (Long)	4
P0PT260	Number (Long)	4
P0PT270	Number (Long)	4
P0PT280	Number (Long)	4
P0PT290	Number (Long)	4
P0PT300	Number (Long)	4
P0PT310	Number (Long)	4
P0PT320	Number (Long)	4
P0PT330	Number (Long)	4
P0PT340	Number (Long)	4
P0PT350	Number (Long)	4
P0PT360	Number (Long)	4
P0PT370	Number (Long)	4
P0PT380	Number (Long)	4
P0PT390	Number (Long)	4
P0PT400	Number (Long)	4
P0PT410	Number (Long)	4
P0PT420	Number (Long)	4
P0PT430	Number (Long)	4
P0PT440	Number (Long)	4
P0PT450	Number (Long)	4
P0PT460	Number (Long)	4

P0PT470	Number (Long)	4
P0PT480	Number (Long)	4
P0PT490	Number (Long)	4
P0PT500	Number (Long)	4
GTP0PT505	Number (Long)	4

#### Table Indexes

<i>Name</i>	<i>Number of Fields</i>
UniqueID	3
Clustered:	False
Distinct Count:	0
Foreign:	False
Ignore Nulls:	False
Name:	UniqueID
Primary:	True
Required:	True
Unique:	True
Fields:	DriverID, Ascending TripID, Ascending Engaged, Ascending

### Table: VehnessFhist

#### Columns

<i>Name</i>	<i>Type</i>	<i>Size</i>
DriverID	Number (Integer)	2
TripID	Number (Integer)	2
AccTracking	Number (Byte)	1
Mean	Number (Single)	4
Variance	Number (Single)	4
MostLikelyValue	Number (Single)	4
TotalCount	Number (Long)	4
LTN27PT5	Number (Long)	4
N25PT0	Number (Long)	4
N20PT0	Number (Long)	4
N15PT0	Number (Long)	4
N10PT0	Number (Long)	4
N5PT0	Number (Long)	4
P0PT0	Number (Long)	4
P5PT0	Number (Long)	4
P10PT0	Number (Long)	4
P15PT0	Number (Long)	4
P20PT0	Number (Long)	4
P25PT0	Number (Long)	4
GTP27PT5	Number (Long)	4

#### Table Indexes

<i>Name</i>	<i>Number of Fields</i>
UniqueID	3
Clustered:	False
Distinct Count:	0
Foreign:	False
Ignore Nulls:	False
Name:	UniqueID
Primary:	True
Required:	True
Unique:	True
Fields:	DriverID, Ascending TripID, Ascending AccTracking, Ascending

### Table: VelocityFhist

#### Columns

<i>Name</i>	<i>Type</i>	<i>Size</i>
DriverID	Number (Integer)	2

TripID	Number (Integer)	2
Mean	Number (Single)	4
Variance	Number (Single)	4
MostLikelyValue	Number (Single)	4
TotalCount	Number (Long)	4
LTP0PT0	Number (Long)	4
P2PT2	Number (Long)	4
P6PT6	Number (Long)	4
P11PT0	Number (Long)	4
P15PT4	Number (Long)	4
P19PT8	Number (Long)	4
P24PT2	Number (Long)	4
P28PT6	Number (Long)	4
P33PT0	Number (Long)	4
P37PT4	Number (Long)	4
P41PT8	Number (Long)	4
P46PT2	Number (Long)	4
P50PT6	Number (Long)	4
P55PT0	Number (Long)	4
P59PT4	Number (Long)	4
P63PT8	Number (Long)	4
P68PT2	Number (Long)	4
P72PT6	Number (Long)	4
P77PT0	Number (Long)	4
P81PT4	Number (Long)	4
P85PT8	Number (Long)	4
P90PT2	Number (Long)	4
P94PT6	Number (Long)	4
P99PT0	Number (Long)	4
P103PT4	Number (Long)	4
P107PT8	Number (Long)	4
P112PT2	Number (Long)	4
P116PT6	Number (Long)	4
P121PT0	Number (Long)	4
P125PT4	Number (Long)	4
P129PT8	Number (Long)	4
GTP132PT0	Number (Long)	4

#### Table Indexes

<i>Name</i>	<i>Number of Fields</i>
UniqueID	2
Clustered:	False
Distinct Count:	0
Foreign:	False
Ignore Nulls:	False
Name:	UniqueID
Primary:	True
Required:	True
Unique:	True
Fields:	DriverID, Ascending TripID, Ascending

### Table: VelocityVgt35Fhist

#### Columns

<i>Name</i>	<i>Type</i>	<i>Size</i>
DriverID	Number (Integer)	2
TripID	Number (Integer)	2
Engaged	Number (Byte)	1
Mean	Number (Single)	4
Variance	Number (Single)	4
MostLikelyValue	Number (Single)	4
TotalCount	Number (Long)	4
LTP50PT0	Number (Long)	4
P52PT2	Number (Long)	4
P56PT6	Number (Long)	4
P61PT0	Number (Long)	4
P65PT4	Number (Long)	4

P69PT8	Number (Long)	4
P74PT2	Number (Long)	4
P78PT6	Number (Long)	4
P83PT0	Number (Long)	4
P87PT4	Number (Long)	4
P91PT8	Number (Long)	4
P96PT2	Number (Long)	4
P100PT6	Number (Long)	4
P105PT0	Number (Long)	4
P109PT4	Number (Long)	4
P113PT8	Number (Long)	4
P118PT2	Number (Long)	4
P122PT6	Number (Long)	4
P127PT0	Number (Long)	4
P131PT4	Number (Long)	4
GTP133PT6	Number (Long)	4

**Table Indexes**

<b>Name</b>	<b>Number of Fields</b>
UniquelD	3
Clustered:	False
Distinct Count:	0
Foreign:	False
Ignore Nulls:	False
Name:	UniquelD
Primary:	True
Required:	True
Unique:	True
Fields:	DriverID, Ascending TripID, Ascending Engaged, Ascending

**Table: VpDotVgt35Fhist**

**Columns**

<b>Name</b>	<b>Type</b>	<b>Size</b>
DriverID	Number (Integer)	2
TripID	Number (Integer)	2
Engaged	Number (Byte)	1
Mean	Number (Single)	4
Variance	Number (Single)	4
MostLikelyValue	Number (Single)	4
TotalCount	Number (Long)	4
LTNOPT505	Number (Long)	4
N0PT500	Number (Long)	4
N0PT490	Number (Long)	4
N0PT480	Number (Long)	4
N0PT470	Number (Long)	4
N0PT460	Number (Long)	4
N0PT450	Number (Long)	4
N0PT440	Number (Long)	4
N0PT430	Number (Long)	4
N0PT420	Number (Long)	4
N0PT410	Number (Long)	4
N0PT400	Number (Long)	4
N0PT390	Number (Long)	4
N0PT380	Number (Long)	4
N0PT370	Number (Long)	4
N0PT360	Number (Long)	4
N0PT350	Number (Long)	4
N0PT340	Number (Long)	4
N0PT330	Number (Long)	4
N0PT320	Number (Long)	4
N0PT310	Number (Long)	4
N0PT300	Number (Long)	4
N0PT290	Number (Long)	4
N0PT280	Number (Long)	4
N0PT270	Number (Long)	4

N0PT260	Number (Long)	4
N0PT250	Number (Long)	4
N0PT240	Number (Long)	4
N0PT230	Number (Long)	4
N0PT220	Number (Long)	4
N0PT210	Number (Long)	4
N0PT200	Number (Long)	4
N0PT190	Number (Long)	4
N0PT180	Number (Long)	4
N0PT170	Number (Long)	4
N0PT160	Number (Long)	4
N0PT150	Number (Long)	4
N0PT140	Number (Long)	4
N0PT130	Number (Long)	4
N0PT120	Number (Long)	4
N0PT110	Number (Long)	4
N0PT100	Number (Long)	4
N0PT090	Number (Long)	4
N0PT080	Number (Long)	4
N0PT070	Number (Long)	4
N0PT060	Number (Long)	4
N0PT050	Number (Long)	4
N0PT040	Number (Long)	4
N0PT030	Number (Long)	4
N0PT020	Number (Long)	4
N0PT010	Number (Long)	4
P0PT000	Number (Long)	4
P0PT010	Number (Long)	4
P0PT020	Number (Long)	4
P0PT030	Number (Long)	4
P0PT040	Number (Long)	4
P0PT050	Number (Long)	4
P0PT060	Number (Long)	4
P0PT070	Number (Long)	4
P0PT080	Number (Long)	4
P0PT090	Number (Long)	4
P0PT100	Number (Long)	4
P0PT110	Number (Long)	4
P0PT120	Number (Long)	4
P0PT130	Number (Long)	4
P0PT140	Number (Long)	4
P0PT150	Number (Long)	4
P0PT160	Number (Long)	4
P0PT170	Number (Long)	4
P0PT180	Number (Long)	4
P0PT190	Number (Long)	4
P0PT200	Number (Long)	4
P0PT210	Number (Long)	4
P0PT220	Number (Long)	4
P0PT230	Number (Long)	4
P0PT240	Number (Long)	4
P0PT250	Number (Long)	4
P0PT260	Number (Long)	4
P0PT270	Number (Long)	4
P0PT280	Number (Long)	4
P0PT290	Number (Long)	4
P0PT300	Number (Long)	4
P0PT310	Number (Long)	4
P0PT320	Number (Long)	4
P0PT330	Number (Long)	4
P0PT340	Number (Long)	4
P0PT350	Number (Long)	4
P0PT360	Number (Long)	4
P0PT370	Number (Long)	4
P0PT380	Number (Long)	4
P0PT390	Number (Long)	4
P0PT400	Number (Long)	4
P0PT410	Number (Long)	4
P0PT420	Number (Long)	4
P0PT430	Number (Long)	4

P0PT440	Number (Long)	4
P0PT450	Number (Long)	4
P0PT460	Number (Long)	4
P0PT470	Number (Long)	4
P0PT480	Number (Long)	4
P0PT490	Number (Long)	4
P0PT500	Number (Long)	4
GTP0PT505	Number (Long)	4

**Table Indexes**

<b>Name</b>	<b>Number of Fields</b>
UniqueID	3
Clustered:	False
Distinct Count:	0
Foreign:	False
Ignore Nulls:	False
Name:	UniqueID
Primary:	True
Required:	True
Unique:	True
Fields:	DriverID, Ascending TripID, Ascending Engaged, Ascending

**Table: VpFhist**

**Columns**

<b>Name</b>	<b>Type</b>	<b>Size</b>
DriverID	Number (Integer)	2
TripID	Number (Integer)	2
Engaged	Number (Byte)	1
Mean	Number (Single)	4
Variance	Number (Single)	4
MostLikelyValue	Number (Single)	4
TotalCount	Number (Long)	4
LTN2PT8	Number (Long)	4
N0PT6	Number (Long)	4
P3PT8	Number (Long)	4
P8PT2	Number (Long)	4
P12PT6	Number (Long)	4
P17PT0	Number (Long)	4
P21PT4	Number (Long)	4
P25PT8	Number (Long)	4
P30PT2	Number (Long)	4
P34PT6	Number (Long)	4
P39PT0	Number (Long)	4
P43PT4	Number (Long)	4
P47PT8	Number (Long)	4
P52PT2	Number (Long)	4
P56PT6	Number (Long)	4
P61PT0	Number (Long)	4
P65PT4	Number (Long)	4
P69PT8	Number (Long)	4
P74PT2	Number (Long)	4
P78PT6	Number (Long)	4
P83PT0	Number (Long)	4
P87PT4	Number (Long)	4
P91PT8	Number (Long)	4
P96PT2	Number (Long)	4
P100PT6	Number (Long)	4
P105PT0	Number (Long)	4
P109PT4	Number (Long)	4
P113PT8	Number (Long)	4
P118PT2	Number (Long)	4
P122PT6	Number (Long)	4
P127PT0	Number (Long)	4
P131PT4	Number (Long)	4
GTP133PT6	Number (Long)	4

**Table Indexes**

<b>Name</b>	<b>Number of Fields</b>
UniqueID	3
Clustered:	False
Distinct Count:	0
Foreign:	False
Ignore Nulls:	False
Name:	UniqueID
Primary:	True
Required:	True
Unique:	True
Fields:	DriverID, Ascending TripID, Ascending Engaged, Ascending

**Table: VSetFhist**

**Columns**

<b>Name</b>	<b>Type</b>	<b>Size</b>
DriverID	Number (Integer)	2
TripID	Number (Integer)	2
Mean	Number (Single)	4
Variance	Number (Single)	4
MostLikelyValue	Number (Single)	4
TotalCount	Number (Long)	4
LTP50PT0	Number (Long)	4
P52PT2	Number (Long)	4
P56PT6	Number (Long)	4
P61PT0	Number (Long)	4
P65PT4	Number (Long)	4
P69PT8	Number (Long)	4
P74PT2	Number (Long)	4
P78PT6	Number (Long)	4
P83PT0	Number (Long)	4
P87PT4	Number (Long)	4
P91PT8	Number (Long)	4
P96PT2	Number (Long)	4
P100PT6	Number (Long)	4
P105PT0	Number (Long)	4
P109PT4	Number (Long)	4
P113PT8	Number (Long)	4
P118PT2	Number (Long)	4
P122PT6	Number (Long)	4
P127PT0	Number (Long)	4
P131PT4	Number (Long)	4
GTP133PT6	Number (Long)	4

**Table Indexes**

<b>Name</b>	<b>Number of Fields</b>
UniqueID	2
Clustered:	False
Distinct Count:	0
Foreign:	False
Ignore Nulls:	False
Name:	UniqueID
Primary:	True
Required:	True
Unique:	True
Fields:	DriverID, Ascending TripID, Ascending

## A.3 Subject Database Documentation

**Table: DriversMain**

<u>Columns</u>		
<i>Name</i>	<i>Type</i>	<i>Size</i>
DriverID	Number (Integer)	2
FirstName	Text	50
HCity	Text	50
State	Text	20
Zip	Text	20
HomeTime	Text	50
WCity	Text	50
WZip	Text	20
WorkTime	Text	50
Birthdate	Date/Time	8
Gender	Text	50
Occupation	Text	50
Year	Number (Long)	4
VMake	Text	50
VModel	Text	50
YearsDriving	Number (Long)	4
Smoker	Text	50
CLenses	Text	50
Nature of Driving	Text	50
CruiseUsage	Text	50
AvgHWaySpeed	Number (Long)	4
AvgMilesTrip	Number (Long)	4
MilesLastYear	Number (Long)	4
PctTotalRural	Number (Long)	4
PctTotalCity	Number (Long)	4
PctTotalHWay	Number (Long)	4
Notes	Memo	-
FocusGroup	Text	50

<u>Table Indexes</u>	
<i>Name</i>	<i>Number of Fields</i>
PrimaryKey	1
Fields:	DriverID, Ascending

**Table: DrivingStyleQuestionnaire**

<u>Columns</u>		
<i>Name</i>	<i>Type</i>	<i>Size</i>
Driver ID	Number (Long)	4
M1	Text	1
M2	Text	1
M3	Text	1
M4	Text	1
M5	Text	1
M6	Text	1
A1	Text	1
A2	Text	1
A3	Text	1
A4	Text	1
A5	Text	1
A6	Text	1

<u>Table Indexes</u>	
<i>Name</i>	<i>Number of Fields</i>
PrimaryKey	1
Fields:	Driver ID, Ascending



## Table: MBti

### Columns

<i>Name</i>	<i>Type</i>	<i>Size</i>
DriverID	Number (Integer)	2
Mbti	Text	50

### Table Indexes

<i>Name</i>	<i>Number of Fields</i>
DriverID	1
Fields:	DriverID, Ascending
DriversMainMBti	1
Fields:	DriverID, Ascending
PrimaryKey	1
Fields:	DriverID, Ascending

## Table: PQv2p0

### Columns

<i>Name</i>	<i>Type</i>	<i>Size</i>
DriverID	Number (Integer)	2
q1	Number (Integer)	2
q2	Number (Integer)	2
q3	Number (Integer)	2
q3t	Text	255
q4	Number (Integer)	2
q5	Number (Integer)	2
q6	Number (Integer)	2
q7	Number (Integer)	2
q8	Number (Integer)	2
q9	Number (Integer)	2
q10	Number (Integer)	2
q11sm	Number (Integer)	2
q11sc	Number (Integer)	2
q11sa	Number (Integer)	2
q11fm	Number (Integer)	2
q11fc	Number (Integer)	2
q11fa	Number (Integer)	2
q11cm	Number (Integer)	2
q11cc	Number (Integer)	2
q11ca	Number (Integer)	2
q11dm	Number (Integer)	2
q11dc	Number (Integer)	2
q11da	Number (Integer)	2
q12m	Number (Integer)	2
q12c	Number (Integer)	2
q12a	Number (Integer)	2
q13m	Number (Integer)	2
q13c	Number (Integer)	2
q13a	Number (Integer)	2
q14m	Number (Integer)	2
q14c	Number (Integer)	2
q14a	Number (Integer)	2
q15	Number (Integer)	2
q16	Number (Integer)	2
q17	Number (Integer)	2
q18	Number (Integer)	2
q19	Number (Integer)	2
q20	Number (Integer)	2
q21m	Number (Integer)	2
q21c	Number (Integer)	2
q21a	Number (Integer)	2
q22m	Number (Integer)	2
q22c	Number (Integer)	2
q22a	Number (Integer)	2
q23p1	Number (Integer)	2
q23p2	Number (Integer)	2

q23p3	Number (Integer)	2
q23p4	Number (Integer)	2
q23p5	Number (Integer)	2
q23p6	Number (Integer)	2
q24p1	Number (Integer)	2
q24p2	Number (Integer)	2
q24p3	Number (Integer)	2
q24p4	Number (Integer)	2
q24p5	Number (Integer)	2
q24p6	Number (Integer)	2
q25a	Number (Integer)	2
q25b	Memo	-
q26a	Number (Integer)	2
q26b	Memo	-
q27am	Number (Single)	4
q27ac	Number (Single)	4
q27aa	Number (Single)	4
q27bm	Number (Single)	4
q27bc	Number (Single)	4
q27ba	Number (Single)	4
q27cm	Number (Single)	4
q27cc	Number (Single)	4
q27ca	Number (Single)	4
q28	Number (Integer)	2
q29	Number (Integer)	2
q30	Number (Integer)	2
q31	Number (Integer)	2
q32	Number (Integer)	2
q33	Number (Integer)	2
q34	Number (Integer)	2
q35	Number (Integer)	2
q36	Number (Integer)	2
q37	Number (Integer)	2
q38m	Number (Single)	4
q38c	Number (Single)	4
q38a	Number (Single)	4
q39	Number (Integer)	2
q40	Text	50
q41	Number (Integer)	2
q42	Memo	-
q43	Memo	-
q44	Memo	-

**Table Indexes**

**Name**

PrimaryKey

Fields:

**Number of Fields**

1

DriverID, Ascending

## Appendix B

### Summary of ACC System Questionnaire Responses

1. How comfortable did you feel driving the car using the ACC system?

1      2      3      4      5      6      7

*Very  
Uncomfortable*

*Very  
Comfortable*

	Mean	Std. Dev.
All Drivers	5.75	1.44
20-30	5.75	1.63
40-50	5.69	1.56
60-70	5.81	1.12
Users	6.00	1.35
Nonusers	5.36	1.51
2 week users	5.71	1.58
5 week users	6.50	0.51

2. How long did it take you to become comfortable using the ACC system?

*I was:*

- 1   *comfortable using the ACC system after one hour or less.*
- 2   *comfortable using the system after the first day.*
- 3   *comfortable using the system after a few days.*
- 4   *comfortable using the system after the first week.*
- 5   *never comfortable using the ACC system.*

	Mean	Std. Dev.
All Drivers	1.81	0.88
20-30	1.64	0.64
40-50	1.92	0.94
60-70	1.86	1.02

Users	1.68	0.81
Nonusers	2.00	0.96
2 week users	1.71	0.81
5 week users	1.63	0.82

3. How easy did you find it was to drive using the ACC system?

1 2 3 4 5 6 7

*Very  
Difficult*

*Very  
Easy*

	Mean	Std. Dev.
All Drivers	6.08	1.02
20-30	6.03	1.23
40-50	6.33	0.68
60-70	5.89	1.06
Users	6.21	0.98
Nonusers	5.88	1.06
2 week users	6.14	1.09
5 week users	6.33	0.76

4. How likely is it that you would have become more comfortable using the ACC system given more time?

1 2 3 4 5 6 7

*Very  
Unlikely*

*Very  
Likely*

	Mean	Std. Dev.
All Drivers	4.97	2.40

20-30	5.14	2.29
40-50	5.22	2.38
60-70	4.54	2.52
Users	4.57	2.54
Nonusers	5.60	2.04
2 week users	5.07	2.32
5 week users	3.71	2.71

5. How comfortable were you physically (your posture, legs, feet, etc.) when driving using the ACC system in comparison with your usual mode of driving?

1 2 3 4 5 6 7

*Less  
Comfortable*

*More  
Comfortable*

	Mean	Std. Dev.
All Drivers	5.41	1.39
20-30	5.25	1.38
40-50	5.44	1.50
60-70	5.53	1.32
Users	5.36	1.33
Nonusers	5.48	1.50
2 week users	5.45	1.38
5 week users	5.21	1.25

6. How comfortable were you using the ACC system in the rain or snow?

1 2 3 4 5 6 7 0

	<i>Very Uncomfortable</i>		<i>Very Comfortable</i>	<i>Did Not Experience</i>
			Mean	Std. Dev.
All Drivers			4.52	1.69
20-30			4.63	1.53
40-50			4.82	1.81
60-70			4.11	1.69
Users			4.51	1.79
Nonusers			4.55	1.44
2 week users			4.61	1.66
5 week users			4.38	2.00
Count of zeros:	29			

7. How comfortable are you using conventional cruise control in rain or snow?

	<i>1</i>	<i>2</i>	<i>3</i>	<i>4</i>	<i>5</i>	<i>6</i>	<i>7</i>	<i>0</i>
	<i>Very Uncomfortable</i>					<i>Very Comfortable</i>		<i>Did Not Experience</i>
						Mean	Std. Dev.	
All Drivers						4.60	1.76	
20-30						4.41	1.45	
40-50						4.80	1.95	
60-70						4.54	1.84	
Users						5.02	1.66	
Nonusers						3.64	1.64	
2 week users						4.88	1.72	
5 week users						5.26	1.54	

Count of zeros: 16

8. How comfortable were you using the ACC system on hilly roads?

	<i>1</i>	<i>2</i>	<i>3</i>	<i>4</i>	<i>5</i>	<i>6</i>	<i>7</i>	<i>0</i>		
	<i>Very Uncomfortable</i>							<i>Very Comfortable</i>		<i>Did Not Experience</i>
								<b>Mean</b>	<b>Std. Dev.</b>	
All Drivers								5.25	1.60	
20-30								4.86	1.70	
40-50								5.72	1.24	
60-70								5.14	1.76	
Users								5.24	1.70	
Nonusers								5.27	1.43	
2 week users								5.14	1.57	
5 week users								5.40	1.90	

Count of zeros: 32

9. How comfortable were you using the ACC system on winding roads?

	<i>1</i>	<i>2</i>	<i>3</i>	<i>4</i>	<i>5</i>	<i>6</i>	<i>7</i>	<i>0</i>		
	<i>Very Uncomfortable</i>							<i>Very Comfortable</i>		<i>Did Not Experience</i>
								<b>Mean</b>	<b>Std. Dev.</b>	
All Drivers								4.79	1.59	
20-30								4.31	1.63	
40-50								4.97	1.33	
60-70								5.06	1.73	

Users	4.98	1.64
Nonusers	4.50	1.48
2 week users	5.00	1.59
5 week users	4.96	1.74

Count of zeros: 16

10. How comfortable would you feel if your child, spouse, parents or other loved ones drove a vehicle equipped with ACC?

	<i>1</i>	<i>2</i>	<i>3</i>	<i>4</i>	<i>5</i>	<i>6</i>	<i>7</i>		
	<i>Very Uncomfortable</i>						<i>Very Comfortable</i>		
						<b>Mean</b>		<b>Std. Dev.</b>	
All Drivers						5.66		1.57	
20-30						5.94		1.29	
40-50						5.67		1.59	
60-70						5.36		1.78	
Users						5.67		1.61	
Nonusers						5.64		1.51	
2 week users						5.64		1.62	
5 week users						5.71		1.63	

11. For the following categories, please compare the three modes of operation (Manual control, Conventional Cruise Control, and ACC), and rank them based on your preference. Use (1) to indicate your most preferred and (3) to indicate your least preferred.

<i>Safety</i>	_____	<i>Manual Control</i>	_____	<i>Conventional Cruise</i>	_____	<i>ACC</i>			
		All Drivers		20-30		40-50		60-70	



	Mean	$\sigma$	Mean	$\sigma$	Mean	$\sigma$	Mean	$\sigma$
Manual	1.38	0.73	1.25	0.65	1.22	0.54	1.67	0.89
CC	2.63	0.57	2.72	0.57	2.75	0.44	2.42	0.65
ACC	1.98	0.60	2.03	0.45	2.00	0.59	1.92	0.73

	Users		Nonusers		2 week users		5 week users	
	Mean	$\sigma$	Mean	$\sigma$	Mean	$\sigma$	Mean	$\sigma$
Manual	1.53	0.83	1.14	0.47	1.40	0.73	1.75	0.94
CC	2.56	0.64	2.74	0.45	2.60	0.59	2.5	0.72
ACC	1.89	0.61	2.12	0.55	1.98	0.64	1.75	0.53

*Comfort*      \_\_\_\_\_ *Manual Control*      \_\_\_\_\_ *Conventional Cruise*      \_\_\_\_\_ *ACC*

	All Drivers		20-30		40-50		60-70	
	Mean	$\sigma$	Mean	$\sigma$	Mean	$\sigma$	Mean	$\sigma$
Manual	2.62	0.71	2.56	0.77	2.69	0.67	2.61	0.69
CC	2.06	0.53	2.22	0.42	2.06	0.47	1.92	0.65
ACC	1.31	0.61	1.22	0.54	1.25	0.55	1.47	0.70

	Users		Nonusers		2 week users		5 week users	
	Mean	$\sigma$	Mean	$\sigma$	Mean	$\sigma$	Mean	$\sigma$
Manual	2.76	0.58	2.40	0.83	2.69	0.64	2.88	0.45
CC	1.95	0.48	2.24	0.58	1.98	0.56	1.92	0.28
ACC	1.29	0.60	1.36	0.62	1.33	0.61	1.21	0.59

*Convenience*      \_\_\_\_\_ *Manual Control*      \_\_\_\_\_ *Conventional Cruise*      \_\_\_\_\_ *ACC*

	All Drivers		20-30		40-50		60-70	
	Mean	$\sigma$	Mean	$\sigma$	Mean	$\sigma$	Mean	$\sigma$
Manual	2.59	0.75	2.64	0.68	2.64	0.72	2.50	0.85
CC	2.12	0.49	2.19	0.47	2.11	0.46	2.06	0.53
ACC	1.29	0.58	1.17	0.45	1.25	0.55	1.44	0.69

	Users		Nonusers		2 week users		5 week users	
	Mean	$\sigma$	Mean	$\sigma$	Mean	$\sigma$	Mean	$\sigma$
Manual	2.70	0.68	2.43	0.83	2.76	0.58	2.58	0.83
CC	2.00	0.46	2.31	0.47	2.00	0.49	2	0.42
ACC	1.30	0.61	1.26	0.54	1.24	0.53	1.42	0.72

*Driving Enjoyment*      \_\_\_\_\_ *Manual Control*      \_\_\_\_\_ *Conventional Cruise*      \_\_\_\_\_ *ACC*

	All Drivers		20-30		40-50		60-70	
	Mean	$\sigma$	Mean	$\sigma$	Mean	$\sigma$	Mean	$\sigma$
Manual	2.56	0.75	2.39	0.87	2.61	0.69	2.67	0.68
CC	2.12	0.54	2.22	0.54	2.11	0.52	2.03	0.56
ACC	1.31	0.59	1.39	0.64	1.25	0.55	1.31	0.58

	Users		Nonusers		2 week users		5 week users	
	Mean	$\sigma$	Mean	$\sigma$	Mean	$\sigma$	Mean	$\sigma$
Manual	2.68	0.68	2.36	0.82	2.67	0.69	2.71	0.69
CC	1.98	0.48	2.33	0.57	2.00	0.49	1.96	0.46

ACC	1.32	0.61	1.31	0.56	1.31	0.60	1.33	0.64
-----	------	------	------	------	------	------	------	------

12. In general, under what mode of operation did you feel like you drove fastest?  
(1 = fastest, 3 = slowest)

	<i>Manual Control</i>		<i>Conventional Cruise Control</i>				<i>ACC</i>	
	All Drivers		20-30		40-50		60-70	
	Mean	Std.Dev	Mean	Std.Dev	Mean	Std.Dev	Mean	Std.Dev
Manual	1.45	0.78	1.42	0.81	1.39	0.77	1.56	0.77
CC	2.33	0.64	2.33	0.64	2.33	0.63	2.33	0.68
ACC	2.20	0.73	2.25	0.69	2.28	0.70	2.08	0.81

	Users		Nonusers		2 week users		5 week users	
	Mean	Std.Dev	Mean	Std.Dev	Mean	Std.Dev	Mean	Std.Dev
	Manual	1.53	0.81	1.33	0.72	1.40	0.66	1.75
CC	2.30	0.70	2.38	0.54	2.38	0.73	2.17	0.64
ACC	2.15	0.73	2.29	0.74	2.19	0.71	2.08	0.78

13. Which mode of operation required you to apply the brakes most often?  
(1 = least braking, 3 = most braking)

	<i>Manual Control</i>		<i>Conventional Cruise Control</i>				<i>ACC</i>	
	All Drivers		20-30		40-50		60-70	
	Mean	Std.Dev	Mean	Std.Dev	Mean	Std.Dev	Mean	Std.Dev
Manual	2.06	0.86	2.03	0.84	2.00	0.89	2.17	0.85
CC	2.31	0.64	2.33	0.68	2.42	0.60	2.19	0.62
ACC	1.61	0.78	1.61	0.77	1.58	0.73	1.64	0.87

	Users		Nonusers		2 week users		5 week users	
	Mean	Std.Dev	Mean	Std.De	Mean	Std.De	Mean	Std.De
Manual	2.12	0.85	1.98	0.87	1.98	0.87	2.38	0.77
CC	2.30	0.63	2.33	0.65	2.31	0.64	2.29	0.62
ACC	1.58	0.79	1.67	0.79	1.71	0.83	1.33	0.64

14. Under which mode of operation do you drive most cautiously? (1 = most cautiously, 3 = least cautiously)

\_\_\_\_\_ *Manual Control*      \_\_\_\_\_ *Conventional Cruise Control*      \_\_\_\_\_ *ACC*

	All Drivers		20-30		40-50		60-70	
	Mean	Std.Dev	Mean	Std.Dev	Mean	Std.Dev	Mean	Std.Dev
Manual	2.18	0.91	2.17	0.94	2.06	0.94	2.31	0.86
CC	2.07	0.69	1.94	0.75	2.06	0.64	2.19	0.67
ACC	1.72	0.77	1.81	0.75	1.86	0.85	1.50	0.70

	Users		Nonusers		2 week users		5 week users	
	Mean	Std.Dev	Mean	Std.Dev	Mean	Std.Dev	Mean	Std.Dev
Manual	2.12	0.94	2.26	0.86	2.12	0.93	2.13	0.99
CC	2.08	0.64	2.05	0.76	2.10	0.70	2.04	0.55
ACC	1.78	0.80	1.62	0.73	1.76	0.77	1.83	0.87

15. What did you think of the rate of deceleration provided by the ACC system when following other vehicles?

1      2      3      4      5      6      7

	<i>Too Slow</i>		<i>Too Fast</i>	
		Mean	Std. Dev.	
All Drivers		3.64	1.23	
20-30		3.58	1.16	
40-50		3.83	1.03	
60-70		3.50	1.48	
Users		3.59	1.24	
Nonusers		3.71	1.24	
2 week users		3.64	1.28	
5 week users		3.50	1.18	

16. What did you think of the acceleration provided by the ACC system when pulling into an adjacent lane to pass other vehicles?

	<i>1</i>	<i>2</i>	<i>3</i>	<i>4</i>	<i>5</i>	<i>6</i>	<i>7</i>	
	<i>Too Slow</i>					<i>Too Fast</i>		
					Mean		Std. Dev.	
All Drivers					3.22		1.47	
20-30					2.92		1.61	
40-50					3.19		1.47	
60-70					3.57		1.27	
Users					3.08		1.48	
Nonusers					3.45		1.43	
2 week users					3.32		1.42	
5 week users					2.67		1.52	

17. How consistent did you maintain your speed when using the ACC system, as compared to driving manually?

1 2 3 4 5 6 7

*Very  
Inconsistent*

*Very  
Consistent*

	Mean	Std. Dev.
All Drivers	5.82	1.50
20-30	5.67	1.35
40-50	5.81	1.47
60-70	6.00	1.67
Users	5.95	1.47
Nonusers	5.62	1.53
2 week users	5.90	1.53
5 week users	6.04	1.40

18. When using the ACC system, as compared to driving manually, did you find yourself more or less aware of the actions of vehicles around you?

1 2 3 4 5 6 7

*Very  
Unaware*

*Very  
Aware*

	Mean	Std. Dev.
All Drivers	5.53	1.44
20-30	5.11	1.35
40-50	5.64	1.42
60-70	5.83	1.48

Users	5.52	1.42
Nonusers	5.55	1.48
2 week users	5.64	1.41
5 week users	5.29	1.43

19. When using the ACC system, as compared to driving manually, did you find yourself more or less responsive to the actions of vehicles around you?

	<i>1</i>	<i>2</i>	<i>3</i>	<i>4</i>	<i>5</i>	<i>6</i>	<i>7</i>		
	<i>Very Unresponsive</i>						<i>Very Responsive</i>		
								<b>Mean</b>	<b>Std. Dev.</b>
All Drivers								5.26	1.34
20-30								4.81	1.19
40-50								5.36	1.48
60-70								5.61	1.25
Users								5.12	1.41
Nonusers								5.48	1.21
2 week users								5.24	1.43
5 week users								4.92	1.38

20. When using the ACC system, did you ever feel you didn't understand what the system was doing, what was taking place, or how the ACC system might behave?

	<i>1</i>	<i>2</i>	<i>3</i>	<i>4</i>	<i>5</i>	<i>6</i>	<i>7</i>		
	<i>Very Frequently</i>						<i>Very Infrequently</i>		
								<b>Mean</b>	<b>Std. Dev.</b>

All Drivers	5.52	1.51
20-30	5.14	1.50
40-50	6.00	1.28
60-70	5.44	1.65
Users	5.57	1.42
Nonusers	5.45	1.66
2 week users	5.76	1.23
5 week users	5.22	1.70

21. How easy or difficult did you find it to maintain a safe distance to the preceding vehicle using each of the following modes of operation?

	All Drivers		20-30		40-50		60-70	
	Mean	Std.Dev	Mean	Std.Dev	Mean	Std.Dev	Mean	Std.Dev
Manual	5.41	1.87	5.31	1.79	5.22	1.99	5.69	1.85
CC	3.57	1.69	3.19	1.45	3.28	1.50	4.25	1.90
ACC	5.87	1.22	5.69	1.09	6.22	0.76	5.69	1.62

	Users		Nonusers		2 week users		5 week users	
	Mean	Std.Dev	Mean	Std.Dev	Mean	Std.Dev	Mean	Std.Dev
Manual	5.17	1.98	5.79	1.63	5.07	2.05	5.33	1.88
CC	3.76	1.69	3.29	1.66	3.67	1.62	3.92	1.84
ACC	6.12	1.02	5.48	1.42	6.05	1.06	6.25	0.94

22. How comfortable did you feel with your ability to change lanes (to pass other cars) using each of the following modes of operation?



	All Drivers		20-30		40-50		60-70	
	Mean	Std.Dev	Mean	Std.Dev	Mean	Std.Dev	Mean	Std.Dev
Manual	6.36	1.29	6.56	0.73	6.44	1.18	6.08	1.75
CC	4.60	1.65	4.42	1.54	4.61	1.71	4.78	1.71
ACC	4.97	1.70	4.78	1.62	4.72	1.80	5.42	1.63

	Users		Nonusers		2 week users		5 week users	
	Mean	Std.Dev	Mean	Std.Dev	Mean	Std.Dev	Mean	Std.Dev
Manual	6.33	1.38	6.40	1.15	6.26	1.43	6.46	1.32
CC	4.83	1.65	4.24	1.59	4.74	1.80	5.00	1.38
ACC	4.98	1.77	4.95	1.61	5.26	1.75	4.50	1.72

23. How did using the ACC system affect your speed, relative to neighboring vehicles, when driving in the following traffic environments?

*When using ACC on freeways and expressways, I drove:*

	1	2	3	4	5	6	7	0	
	<i>Slower</i>						<i>Faster</i>		<i>Didn't Use</i>
								Mean	Std. Dev.
All Drivers								4.57	1.35
20-30								4.56	1.32
40-50								4.64	1.33
60-70								4.53	1.42
Users								4.76	1.40
Nonusers								4.29	1.22
2 week users								4.71	1.35
5 week users								4.83	1.52

Count of zeros: 0

*When using ACC on two-lane rural highways, I drove:*

	<i>1</i>	<i>2</i>	<i>3</i>	<i>4</i>	<i>5</i>	<i>6</i>	<i>7</i>	<i>0</i>	
	<i>Slower</i>				<i>Faster</i>			<i>Didn't Use</i>	
								Mean	Std. Dev.
All Drivers								4.14	1.22
20-30								4.50	1.10
40-50								4.29	1.12
60-70								3.63	1.31
Users								4.19	1.16
Nonusers								4.03	1.35
2 week users								4.10	1.16
5 week users								4.33	1.15

Count of zeros: 27

*When using ACC on major arterial streets, I drove:*

	<i>1</i>	<i>2</i>	<i>3</i>	<i>4</i>	<i>5</i>	<i>6</i>	<i>7</i>	<i>0</i>	
	<i>Slower</i>				<i>Faster</i>			<i>Didn't Use</i>	
								Mean	Std. Dev.
All Drivers								3.80	1.01
20-30								3.65	0.88
40-50								4.00	0.87
60-70								3.73	1.22







2 week users	4.47	1.16
5 week users	5.05	1.40

Count of zeros: 24

*When using ACC on major arterial streets, I drove:*

1 2 3 4 5 6 7 0

*Closer* *Farther* *Didn't Use*

	Mean	Std. Dev.
All Drivers	4.68	1.42
20-30	4.62	1.24
40-50	4.80	1.55
60-70	4.63	1.47
Users	4.77	1.51
Nonusers	4.55	1.30
2 week users	4.77	1.45
5 week users	4.78	1.63

Count of zeros: 35

*When using ACC in heavy traffic, I drove:*

1 2 3 4 5 6 7 0

*Closer* *Farther* *Didn't Use*

	Mean	Std. Dev.
All Drivers	5.37	1.74

20-30	5.48	1.60
40-50	5.54	2.02
60-70	5.09	1.53
Users	5.63	1.62
Nonusers	4.88	1.87
2 week users	5.52	1.67
5 week users	5.79	1.58

Count of zeros: 38

*When using ACC in medium traffic, I drove:*

1	2	3	4	5	6	7	0
<i>Closer</i>				<i>Farther</i>			<i>Didn't Use</i>

	Mean	Std. Dev.
All Drivers	4.72	1.31
20-30	4.85	0.97
40-50	4.80	1.47
60-70	4.50	1.42
Users	4.80	1.30
Nonusers	4.57	1.32
2 week users	4.61	1.28
5 week users	5.13	1.30

Count of zeros: 6

*When using ACC in light traffic, I drove:*

1	2	3	4	5	6	7	0
---	---	---	---	---	---	---	---

	<i>Closer</i>	<i>Farther</i>	<i>Didn't Use</i>
		Mean	Std. Dev.
All Drivers		4.47	1.54
20-30		4.63	1.21
40-50		4.44	1.71
60-70		4.33	1.66
Users		4.48	1.56
Nonusers		4.44	1.52
2 week users		4.29	1.50
5 week users		4.83	1.63
Count of zeros:	1		

25. How often, if ever, did you experience “unsafe” following distances when using the ACC system?

	<i>1</i>	<i>2</i>	<i>3</i>	<i>4</i>	<i>5</i>	<i>6</i>	<i>7</i>		
	<i>Very Frequently</i>			<i>Very Infrequently</i>					
								Mean	Std. Dev.
All Drivers								5.69	1.52
20-30								5.50	1.38
40-50								5.89	1.69
60-70								5.67	1.49
Users								5.97	1.25
Nonusers								5.24	1.79
2 week users								6.14	1.22



5 week users 5.67 1.27

26. Do you feel the headway adjustment feature useful?

	1	2	3	4	5	6	7			
	<i>Strongly Disagree</i>							<i>Strongly Agree</i>		
							Mean	Std. Dev.		
All Drivers							5.87	1.54		
20-30							5.28	1.70		
40-50							6.06	1.49		
60-70							6.28	1.23		
Users							6.06	1.30		
Nonusers							5.57	1.82		
2 week users							5.88	1.47		
5 week users							6.38	0.88		

27. For the following questions, please rank the mode of operation you are most likely to use. (1 = most likely to use, 3 = least likely to use.)

*In which mode of operation were you more likely to drive on the highway, interstate, state route, or turnpike? (1 = most likely to use, 3 = least likely to use.)*

\_\_\_\_\_ *Manual Control*      \_\_\_\_\_ *Conventional Cruise Control*      \_\_\_\_\_ *ACC*

	All Drivers		20-30		40-50		60-70	
	Mean	Std.Dev	Mean	Std.Dev	Mean	Std.Dev	Mean	Std.Dev
Manual	2.64	0.65	2.47	0.77	2.67	0.68	2.77	0.43
CC	2.20	0.51	2.28	0.57	2.14	0.49	2.20	0.47
ACC	1.15	0.41	1.22	0.48	1.19	0.47	1.03	0.17

	Users		Nonusers		2 week users		5 week users	
	Mean	Std.Dev	Mean	Std.Dev	Mean	Std.Dev	Mean	Std.Dev
Manual	2.72	0.57	2.50	0.74	2.74	0.54	2.71	0.62
CC	2.14	0.50	2.31	0.52	2.14	0.47	2.10	0.55
ACC	1.12	0.38	1.19	0.45	1.10	0.37	1.19	0.38

*In which mode of operation were you most likely to drive on two lane rural roads?  
(1 = most likely to use, 3 = least likely to use.)*

\_\_\_\_\_ *Manual Control*      \_\_\_\_\_ *Conventional Cruise Control*      \_\_\_\_\_ *ACC*

	All Drivers		20-30		40-50		60-70	
	Mean	Std.Dev	Mean	Std.Dev	Mean	Std.Dev	Mean	Std.Dev
Manual	1.86	0.87	1.81	0.89	2.06	0.86	1.67	0.82
CC	2.50	0.59	2.53	0.61	2.47	0.65	2.52	0.51
ACC	1.65	0.72	1.67	0.68	1.47	0.61	1.82	0.85

	Users		Nonusers		2 week users		5 week users	
	Mean	Std.Dev	Mean	Std.Dev	Mean	Std.Dev	Mean	Std.Dev
Manual	2.03	0.90	1.55	0.71	2.05	0.91	2.04	0.91
CC	2.43	0.59	2.63	0.59	2.36	0.62	2.54	0.51
ACC	1.54	0.69	1.83	0.75	1.60	0.73	1.42	0.58

*In which mode of operation were you most likely to drive on major arterial streets?  
(1 = most likely to use, 3 = least likely to use.)*

\_\_\_\_\_ *Manual Control*      \_\_\_\_\_ *Conventional Cruise Control*      \_\_\_\_\_ *ACC*

All Drivers	20-30	40-50	60-70
-------------	-------	-------	-------



	<i>1</i>	<i>2</i>	<i>3</i>	<i>4</i>	<i>5</i>	<i>6</i>	<i>7</i>			
	<i>Strongly Disagree</i>							<i>Strongly Agree</i>		
								Mean	Std. Dev.	
All Drivers								5.35	1.43	
20-30								5.08	1.52	
40-50								5.42	1.38	
60-70								5.56	1.38	
Users								5.56	1.45	
Nonusers								5.02	1.35	
2 week users								5.57	1.47	
5 week users								5.54	1.44	

30. While driving using ACC, did you ever feel overly confident?

	<i>1</i>	<i>2</i>	<i>3</i>	<i>4</i>	<i>5</i>	<i>6</i>	<i>7</i>			
	<i>Strongly Disagree</i>							<i>Strongly Agree</i>		
								Mean	Std. Dev.	
All Drivers								3.15	1.75	
20-30								3.19	1.75	
40-50								3.22	1.69	
60-70								3.03	1.84	
Users								3.42	1.84	
Nonusers								2.71	1.53	



20-30	5.78	1.51
40-50	5.25	1.90
60-70	5.83	1.42
Users	5.80	1.66
Nonusers	5.33	1.57
2 week users	5.98	1.57
5 week users	5.50	1.79

33. Did you find the ACC system components distracting (e.g., status lights, control buttons)?

1 2 3 4 5 6 7

*Very  
Distracting*

*Not At All  
Distracting*

	Mean	Std. Dev.
All Drivers	5.69	1.63
20-30	6.08	1.36
40-50	5.53	1.78
60-70	5.47	1.68
Users	5.74	1.62
Nonusers	5.62	1.65
2 week users	5.74	1.62
5 week users	5.75	1.65

34. While using the ACC system, how often, if ever, did the system fail to detect a preceding vehicle?

1 2 3 4 5 6 7

	<i>Always</i>	<i>Never</i>
	Mean	Std. Dev.
All Drivers	6.01	1.29
20-30	5.75	1.32
40-50	6.11	1.14
60-70	6.17	1.38
Users	6.00	1.25
Nonusers	6.02	1.35
2 week users	6.07	1.35
5 week users	5.88	1.08

35. While using the ACC system, how often, if ever, did the system produce false alarms (i.e., reported the presence of a vehicle when none existed)?

	<i>1</i>	<i>2</i>	<i>3</i>	<i>4</i>	<i>5</i>	<i>6</i>	<i>7</i>
	<i>Always</i>					<i>Never</i>	
						Mean	Std. Dev.
All Drivers						5.99	1.44
20-30						5.39	1.73
40-50						6.22	1.24
60-70						6.36	1.10
Users						5.74	1.49
Nonusers						6.38	1.27
2 week users						6.14	1.30
5 week users						5.04	1.57







20-30	5.64	1.29
40-50	6.31	1.26
60-70	5.42	1.96
Users	6.08	1.38
Nonusers	5.33	1.75
2 week users	6.10	1.45
5 week users	6.04	1.30

40. Approximately how much would you be willing to spend for this feature in a new vehicle?

Eighty-five participants answered this question. The range of responses was \$0 to \$2500 with a median value of \$438. Several participants expressed their answers based upon the price of conventional cruise control. For example, two drivers responded that for ACC they would be willing to pay the same price as they would pay for conventional cruise control. Another driver stated that he would be willing to spend 10% more than the price of conventional cruise control for ACC.

41. Would you be willing to rent a vehicle equipped with an ACC system when you travel?

	<i>1</i>	<i>2</i>	<i>3</i>	<i>4</i>	<i>5</i>	<i>6</i>	<i>7</i>		
	<i>Very Unwilling</i>						<i>Very Willing</i>		
						<b>Mean</b>	<b>Std. Dev.</b>		
All Drivers						6.37	1.15		
20-30						6.23	1.03		
40-50						6.69	1.04		
60-70						6.18	1.31		
Users						6.47	1.02		
Nonusers						6.22	1.31		

2 week users	6.33	1.21
5 week users	6.71	0.55

42. In general, how does driving using the ACC system compare to driving with conventional cruise control?

Participants cited two major advantages of driving with ACC as compared to driving with conventional cruise control: reduced workload (43%) and increased safety (19%). While most drivers became confident using the ACC system and learned to compensate for the system's limitations, several drivers reported that they had to be "more alert" while driving using ACC because they weren't sure if the system would function properly.

43. Can you suggest any changes or modifications to the ACC system that might improve it?

The types of things that the 108 drivers suggested for improving the system are listed in the table below. Although there were many positive comments on the ACC system, some drivers had specific concerns and noted the need for improvement. Areas identified most frequently for improvement include 1) delayed, weak acceleration back towards the set speed (17 drivers), 2) deceleration due to a false detection (14 drivers), 3) improved display and ACC control features (11 drivers), and 4) performance in bad weather (9 drivers).

None	21
Higher Acceleration (for passing)	17
Fewer false decelerations	14
Better-appointed and more complete ACC display	11
Better performance in bad weather	9
Illumination of the (cruise) buttons	7
Higher decel. authority (i.e., braking via ACC)	6
Better tracking on curves	6
Better headway control (crisper, smoother)	4
Provide an intervention prompt (warning)	3
Better agreement between set speed and speedometer	3

Shorter headway settings	3
Longer headway settings	2
More reliable ACC functioning	2
Signal the car behind you to anticipate slowdown	2
Provide ACC response to stopped traffic ahead	2

44. Did you come close to having any accidents that you feel were related to using the ACC system?

During the FOT there were no crashes as a result of using the ACC system. Four drivers reported that they came close to having an accident as a result of the ACC system. One driver feared being rear-ended as the driver following him failed to slow down as the ACC-equipped vehicle was decelerating. Another driver reported that she felt a crash was impending when she encountered a slowly moving vehicle and the ACC-equipped car failed to respond.

## Appendix C

### **Summary of Exposure Measurements for all Drivers and Driver Groups**

The tables below present summary time and distance statistics for different driver groups and individual drivers. The tables are sorted by mode (ACC, all modes, CCC, first week manual-Man1, not first week manual-Man2, and all manual). The column headings indicate the content of the different fields and the word All simply means the combination of all possibilities for that field. The tables showing time values show only time above 35 mph. The distance tables cover all velocity ranges. Time and distance for different driver groups present the tables first then by time and distance for individual drivers.

Table C-1. Time statistics summary table (1)

Count	Mode	Test Time	Age	Cruise Usage	Gender	Time (hours) for different velocity ranges		
						> 35mph	35 – 55 mph	> 55 mph
28	ACC	2 Weeks	20-30	All	All	73.6	8.1	65.5
14	ACC	2 Weeks	20-30	All	Female	27.2	4.5	22.7
14	ACC	2 Weeks	20-30	All	Male	46.4	3.6	42.8
14	ACC	2 Weeks	20-30	Nonuser	All	37.6	4.8	32.8
7	ACC	2 Weeks	20-30	Nonuser	Female	8.5	3.3	5.1
7	ACC	2 Weeks	20-30	Nonuser	Male	29.1	1.4	27.7
14	ACC	2 Weeks	20-30	User	All	36.1	3.4	32.7
7	ACC	2 Weeks	20-30	User	Female	18.8	1.2	17.6
7	ACC	2 Weeks	20-30	User	Male	17.3	2.2	15.1
28	ACC	2 Weeks	40-50	All	All	91.2	8.6	82.7
14	ACC	2 Weeks	40-50	All	Female	40.9	2.6	38.2
14	ACC	2 Weeks	40-50	All	Male	50.4	6.0	44.4
14	ACC	2 Weeks	40-50	Nonuser	All	40.0	3.4	36.6
7	ACC	2 Weeks	40-50	Nonuser	Female	10.1	1.1	9.0
7	ACC	2 Weeks	40-50	Nonuser	Male	29.8	2.2	27.6
14	ACC	2 Weeks	40-50	User	All	51.2	5.2	46.1
7	ACC	2 Weeks	40-50	User	Female	30.7	1.5	29.2
7	ACC	2 Weeks	40-50	User	Male	20.5	3.7	16.8
28	ACC	2 Weeks	60-70	All	All	94.3	17.6	76.7
14	ACC	2 Weeks	60-70	All	Female	41.7	7.8	33.9
14	ACC	2 Weeks	60-70	All	Male	52.6	9.8	42.8
14	ACC	2 Weeks	60-70	Nonuser	All	40.0	9.0	31.0
7	ACC	2 Weeks	60-70	Nonuser	Female	22.8	5.9	16.9
7	ACC	2 Weeks	60-70	Nonuser	Male	17.2	3.1	14.1
14	ACC	2 Weeks	60-70	User	All	54.3	8.6	45.7
7	ACC	2 Weeks	60-70	User	Female	18.9	1.9	17.0

Count	Mode	Test Time	Age	Cruise Usage	Gender	Time (hours) for different velocity ranges		
						> 35mph	35 – 55 mph	> 55 mph
7	ACC	2 Weeks	60-70	User	Male	35.4	6.7	28.7
84	ACC	2 Weeks	All	All	All	259.1	34.3	224.9
42	ACC	2 Weeks	All	All	Female	109.7	14.9	94.9
42	ACC	2 Weeks	All	All	Male	149.4	19.4	130.0
42	ACC	2 Weeks	All	Nonuser	All	117.6	17.2	100.4
21	ACC	2 Weeks	All	Nonuser	Female	41.4	10.3	31.0
21	ACC	2 Weeks	All	Nonuser	Male	76.2	6.8	69.4
42	ACC	2 Weeks	All	User	All	141.6	17.1	124.5
21	ACC	2 Weeks	All	User	Female	68.4	4.5	63.9
21	ACC	2 Weeks	All	User	Male	73.2	12.6	60.6
8	ACC	5 Weeks	20-30	All	All	87.6	5.4	82.2
4	ACC	5 Weeks	20-30	All	Female	32.8	1.8	31.0
4	ACC	5 Weeks	20-30	All	Male	54.8	3.6	51.2
8	ACC	5 Weeks	40-50	All	All	105.9	8.2	97.7
4	ACC	5 Weeks	40-50	All	Female	63.3	3.8	59.5
4	ACC	5 Weeks	40-50	All	Male	42.6	4.4	38.2
8	ACC	5 Weeks	60-70	All	All	81.0	15.8	65.2
4	ACC	5 Weeks	60-70	All	Female	24.0	6.6	17.3
4	ACC	5 Weeks	60-70	All	Male	57.0	9.1	47.8
24	ACC	5 Weeks	All	All	All	274.5	29.4	245.1
12	ACC	5 Weeks	All	All	Female	120.1	12.3	107.8
12	ACC	5 Weeks	All	All	Male	154.4	17.1	137.3
36	ACC	All	20-30	All	All	161.2	13.5	147.7
18	ACC	All	20-30	All	Female	60.0	6.3	53.7
18	ACC	All	20-30	All	Male	101.2	7.2	94.0
14	ACC	All	20-30	Nonuser	All	37.6	4.8	32.8
7	ACC	All	20-30	Nonuser	Female	8.5	3.3	5.1
7	ACC	All	20-30	Nonuser	Male	29.1	1.4	27.7
22	ACC	All	20-30	User	All	123.7	8.8	114.9
11	ACC	All	20-30	User	Female	51.6	3.0	48.6
11	ACC	All	20-30	User	Male	72.1	5.8	66.3
36	ACC	All	40-50	All	All	197.1	16.8	180.4
18	ACC	All	40-50	All	Female	104.2	6.4	97.8
18	ACC	All	40-50	All	Male	93.0	10.3	82.6
14	ACC	All	40-50	Nonuser	All	40.0	3.4	36.6
7	ACC	All	40-50	Nonuser	Female	10.1	1.1	9.0
7	ACC	All	40-50	Nonuser	Male	29.8	2.2	27.6
22	ACC	All	40-50	User	All	157.2	13.4	143.8
11	ACC	All	40-50	User	Female	94.1	5.3	88.8
11	ACC	All	40-50	User	Male	63.1	8.1	55.0
36	ACC	All	60-70	All	All	175.3	33.4	141.9
18	ACC	All	60-70	All	Female	65.6	14.4	51.2
18	ACC	All	60-70	All	Male	109.6	19.0	90.6
14	ACC	All	60-70	Nonuser	All	40.0	9.0	31.0

Count	Mode	Test Time	Age	Cruise Usage	Gender	Time (hours) for different velocity ranges		
						> 35mph	35 – 55 mph	> 55 mph
7	ACC	All	60-70	Nonuser	Female	22.8	5.9	16.9
7	ACC	All	60-70	Nonuser	Male	17.2	3.1	14.1
22	ACC	All	60-70	User	All	135.2	24.4	110.9
11	ACC	All	60-70	User	Female	42.9	8.5	34.3
11	ACC	All	60-70	User	Male	92.4	15.8	76.5
10	ACC	All	All	All	All	533.6	63.7	470.0
54	ACC	All	All	All	Female	229.9	27.1	202.7
54	ACC	All	All	All	Male	303.8	36.5	267.3
42	ACC	All	All	Nonuser	All	117.6	17.2	100.4
21	ACC	All	All	Nonuser	Female	41.4	10.3	31.0
21	ACC	All	All	Nonuser	Male	76.2	6.8	69.4
66	ACC	All	All	User	All	416.1	46.5	369.6
33	ACC	All	All	User	Female	188.5	16.8	171.7
33	ACC	All	All	User	Male	227.6	29.7	197.9
28	All	2 Weeks	20-30	All	All	331.7	145.1	186.6
14	All	2 Weeks	20-30	All	Female	130.0	60.3	69.7
14	All	2 Weeks	20-30	All	Male	201.7	84.8	116.9
14	All	2 Weeks	20-30	Nonuser	All	182.2	72.1	110.1
7	All	2 Weeks	20-30	Nonuser	Female	59.9	31.5	28.4
7	All	2 Weeks	20-30	Nonuser	Male	122.3	40.6	81.7
14	All	2 Weeks	20-30	User	All	149.5	73.0	76.5
7	All	2 Weeks	20-30	User	Female	70.1	28.8	41.3
7	All	2 Weeks	20-30	User	Male	79.4	44.2	35.2
28	All	2 Weeks	40-50	All	All	346.7	141.9	204.9
14	All	2 Weeks	40-50	All	Female	143.6	55.6	88.0
14	All	2 Weeks	40-50	All	Male	203.1	86.2	116.9
14	All	2 Weeks	40-50	Nonuser	All	192.2	82.6	109.6
7	All	2 Weeks	40-50	Nonuser	Female	57.4	26.3	31.1
7	All	2 Weeks	40-50	Nonuser	Male	134.8	56.3	78.5
14	All	2 Weeks	40-50	User	All	154.5	59.3	95.2
7	All	2 Weeks	40-50	User	Female	86.2	29.3	56.9
7	All	2 Weeks	40-50	User	Male	68.3	30.0	38.3
28	All	2 Weeks	60-70	All	All	284.1	129.6	154.6
14	All	2 Weeks	60-70	All	Female	112.9	53.3	59.5
14	All	2 Weeks	60-70	All	Male	171.3	76.3	95.0
14	All	2 Weeks	60-70	Nonuser	All	121.5	59.6	61.9
7	All	2 Weeks	60-70	Nonuser	Female	50.6	25.9	24.7
7	All	2 Weeks	60-70	Nonuser	Male	70.9	33.8	37.1
14	All	2 Weeks	60-70	User	All	162.6	70.0	92.7
7	All	2 Weeks	60-70	User	Female	62.3	27.5	34.8
7	All	2 Weeks	60-70	User	Male	100.4	42.5	57.9
84	All	2 Weeks	All	All	All	962.6	416.6	546.0
42	All	2 Weeks	All	All	Female	386.5	169.3	217.2
42	All	2 Weeks	All	All	Male	576.1	247.3	328.8

Count	Mode	Test Time	Age	Cruise Usage	Gender	Time (hours) for different velocity ranges		
						> 35mph	35 – 55 mph	> 55 mph
42	All	2 Weeks	All	Nonuser	All	495.9	214.3	281.6
21	All	2 Weeks	All	Nonuser	Female	167.9	83.7	84.2
21	All	2 Weeks	All	Nonuser	Male	328.0	130.7	197.4
42	All	2 Weeks	All	User	All	466.7	202.3	264.4
21	All	2 Weeks	All	User	Female	218.6	85.6	133.0
21	All	2 Weeks	All	User	Male	248.1	116.6	131.4
8	All	5 Weeks	20-30	All	All	262.3	93.3	169.0
4	All	5 Weeks	20-30	All	Female	108.5	45.5	63.0
4	All	5 Weeks	20-30	All	Male	153.8	47.8	105.9
8	All	5 Weeks	40-50	All	All	259.3	96.3	163.0
4	All	5 Weeks	40-50	All	Female	152.0	50.5	101.5
4	All	5 Weeks	40-50	All	Male	107.3	45.8	61.5
8	All	5 Weeks	60-70	All	All	186.7	85.0	101.7
4	All	5 Weeks	60-70	All	Female	74.2	40.0	34.2
4	All	5 Weeks	60-70	All	Male	112.5	45.0	67.5
24	All	5 Weeks	All	All	All	708.3	274.7	433.6
12	All	5 Weeks	All	All	Female	334.7	136.0	198.7
12	All	5 Weeks	All	All	Male	373.6	138.7	234.9
36	All	All	20-30	All	All	594.0	238.5	355.5
18	All	All	20-30	All	Female	238.5	105.8	132.7
18	All	All	20-30	All	Male	355.5	132.6	222.8
14	All	All	20-30	Nonuser	All	182.2	72.1	110.1
7	All	All	20-30	Nonuser	Female	59.9	31.5	28.4
7	All	All	20-30	Nonuser	Male	122.3	40.6	81.7
22	All	All	20-30	User	All	411.8	166.4	245.5
11	All	All	20-30	User	Female	178.7	74.3	104.4
11	All	All	20-30	User	Male	233.2	92.0	141.1
36	All	All	40-50	All	All	606.1	238.2	367.9
18	All	All	40-50	All	Female	295.6	106.1	189.5
18	All	All	40-50	All	Male	310.4	132.1	178.4
14	All	All	40-50	Nonuser	All	192.2	82.6	109.6
7	All	All	40-50	Nonuser	Female	57.4	26.3	31.1
7	All	All	40-50	Nonuser	Male	134.8	56.3	78.5
22	All	All	40-50	User	All	413.8	155.6	258.2
11	All	All	40-50	User	Female	238.2	79.8	158.4
11	All	All	40-50	User	Male	175.6	75.8	99.8
36	All	All	60-70	All	All	470.9	214.6	256.2
18	All	All	60-70	All	Female	187.1	93.3	93.7
18	All	All	60-70	All	Male	283.8	121.3	162.5
14	All	All	60-70	Nonuser	All	121.5	59.6	61.9
7	All	All	60-70	Nonuser	Female	50.6	25.9	24.7
7	All	All	60-70	Nonuser	Male	70.9	33.8	37.1
22	All	All	60-70	User	All	349.4	155.0	194.4
11	All	All	60-70	User	Female	136.5	67.5	69.0



Count	Mode	Test Time	Age	Cruise Usage	Gender	Time (hours) for different velocity ranges		
						> 35mph	35 – 55 mph	> 55 mph
11	All	All	60-70	User	Male	212.9	87.5	125.4
10	All	All	All	All	All	1670.9	691.3	979.6
54	All	All	All	All	Female	721.2	305.3	415.9
54	All	All	All	All	Male	949.7	386.0	563.7
42	All	All	All	Nonuser	All	495.9	214.3	281.6
21	All	All	All	Nonuser	Female	167.9	83.7	84.2
21	All	All	All	Nonuser	Male	328.0	130.7	197.4
66	All	All	All	User	All	1175.0	476.9	698.1
33	All	All	All	User	Female	553.4	221.6	331.7
33	All	All	All	User	Male	621.6	255.3	366.3
28	CCC	2 Weeks	20-30	All	All	32.1	2.3	29.8
14	CCC	2 Weeks	20-30	All	Female	7.9	0.8	7.1
14	CCC	2 Weeks	20-30	All	Male	24.2	1.5	22.7
14	CCC	2 Weeks	20-30	Nonuser	All	22.5	1.2	21.3
7	CCC	2 Weeks	20-30	Nonuser	Female	2.1	0.7	1.4
7	CCC	2 Weeks	20-30	Nonuser	Male	20.4	0.5	19.9
14	CCC	2 Weeks	20-30	User	All	9.6	1.1	8.4
7	CCC	2 Weeks	20-30	User	Female	5.8	0.1	5.7
7	CCC	2 Weeks	20-30	User	Male	3.8	1.0	2.8
28	CCC	2 Weeks	40-50	All	All	44.8	4.3	40.5
14	CCC	2 Weeks	40-50	All	Female	18.9	1.3	17.6
14	CCC	2 Weeks	40-50	All	Male	25.9	3.0	22.9
14	CCC	2 Weeks	40-50	Nonuser	All	23.1	1.9	21.1
7	CCC	2 Weeks	40-50	Nonuser	Female	9.1	0.3	8.8
7	CCC	2 Weeks	40-50	Nonuser	Male	14.0	1.6	12.4
14	CCC	2 Weeks	40-50	User	All	21.7	2.3	19.4
7	CCC	2 Weeks	40-50	User	Female	9.8	1.0	8.8
7	CCC	2 Weeks	40-50	User	Male	11.8	1.3	10.5
28	CCC	2 Weeks	60-70	All	All	39.9	10.6	29.3
14	CCC	2 Weeks	60-70	All	Female	12.6	3.7	8.9
14	CCC	2 Weeks	60-70	All	Male	27.3	6.9	20.5
14	CCC	2 Weeks	60-70	Nonuser	All	14.1	3.6	10.5
7	CCC	2 Weeks	60-70	Nonuser	Female	4.6	2.4	2.2
7	CCC	2 Weeks	60-70	Nonuser	Male	9.5	1.3	8.2
14	CCC	2 Weeks	60-70	User	All	25.8	6.9	18.8
7	CCC	2 Weeks	60-70	User	Female	8.0	1.3	6.6
7	CCC	2 Weeks	60-70	User	Male	17.8	5.6	12.2
84	CCC	2 Weeks	All	All	All	116.8	17.2	99.6
42	CCC	2 Weeks	All	All	Female	39.4	5.9	33.6
42	CCC	2 Weeks	All	All	Male	77.3	11.3	66.0
42	CCC	2 Weeks	All	Nonuser	All	59.7	6.8	52.9
21	CCC	2 Weeks	All	Nonuser	Female	15.8	3.4	12.4
21	CCC	2 Weeks	All	Nonuser	Male	43.9	3.3	40.6
42	CCC	2 Weeks	All	User	All	57.1	10.4	46.7

Count	Mode	Test Time	Age	Cruise Usage	Gender	Time (hours) for different velocity ranges		
						> 35mph	35 – 55 mph	> 55 mph
21	CCC	2 Weeks	All	User	Female	23.6	2.5	21.2
21	CCC	2 Weeks	All	User	Male	33.4	7.9	25.5
8	CCC	5 Weeks	20-30	All	All	14.4	0.6	13.9
4	CCC	5 Weeks	20-30	All	Female	5.4	0.4	5.0
4	CCC	5 Weeks	20-30	All	Male	9.0	0.2	8.8
8	CCC	5 Weeks	40-50	All	All	22.5	0.8	21.6
4	CCC	5 Weeks	40-50	All	Female	13.2	0.4	12.9
4	CCC	5 Weeks	40-50	All	Male	9.2	0.5	8.8
8	CCC	5 Weeks	60-70	All	All	11.4	1.7	9.8
4	CCC	5 Weeks	60-70	All	Female	8.1	1.3	6.8
4	CCC	5 Weeks	60-70	All	Male	3.3	0.3	2.9
24	CCC	5 Weeks	All	All	All	48.3	3.0	45.3
12	CCC	5 Weeks	All	All	Female	26.8	2.1	24.7
12	CCC	5 Weeks	All	All	Male	21.5	1.0	20.6
36	CCC	All	20-30	All	All	46.5	2.9	43.6
18	CCC	All	20-30	All	Female	13.3	1.2	12.1
18	CCC	All	20-30	All	Male	33.2	1.7	31.5
14	CCC	All	20-30	Nonuser	All	22.5	1.2	21.3
7	CCC	All	20-30	Nonuser	Female	2.1	0.7	1.4
7	CCC	All	20-30	Nonuser	Male	20.4	0.5	19.9
22	CCC	All	20-30	User	All	24.0	1.7	22.3
11	CCC	All	20-30	User	Female	11.2	0.5	10.7
11	CCC	All	20-30	User	Male	12.8	1.2	11.6
36	CCC	All	40-50	All	All	67.2	5.1	62.1
18	CCC	All	40-50	All	Female	32.2	1.7	30.5
18	CCC	All	40-50	All	Male	35.1	3.4	31.7
14	CCC	All	40-50	Nonuser	All	23.1	1.9	21.1
7	CCC	All	40-50	Nonuser	Female	9.1	0.3	8.8
7	CCC	All	40-50	Nonuser	Male	14.0	1.6	12.4
22	CCC	All	40-50	User	All	44.1	3.2	41.0
11	CCC	All	40-50	User	Female	23.1	1.4	21.7
11	CCC	All	40-50	User	Male	21.1	1.8	19.3
36	CCC	All	60-70	All	All	51.4	12.3	39.1
18	CCC	All	60-70	All	Female	20.8	5.0	15.7
18	CCC	All	60-70	All	Male	30.6	7.2	23.4
14	CCC	All	60-70	Nonuser	All	14.1	3.6	10.5
7	CCC	All	60-70	Nonuser	Female	4.6	2.4	2.2
7	CCC	All	60-70	Nonuser	Male	9.5	1.3	8.2
22	CCC	All	60-70	User	All	37.2	8.6	28.6
11	CCC	All	60-70	User	Female	16.1	2.6	13.5
11	CCC	All	60-70	User	Male	21.1	6.0	15.1
10	CCC	All	All	All	All	165.1	20.2	144.9
54	CCC	All	All	All	Female	66.2	7.9	58.3
54	CCC	All	All	All	Male	98.9	12.3	86.6

Count	Mode	Test Time	Age	Cruise Usage	Gender	Time (hours) for different velocity ranges		
						> 35mph	35 – 55 mph	> 55 mph
42	CCC	All	All	Nonuser	All	59.7	6.8	52.9
21	CCC	All	All	Nonuser	Female	15.8	3.4	12.4
21	CCC	All	All	Nonuser	Male	43.9	3.3	40.6
66	CCC	All	All	User	All	105.4	13.5	91.9
33	CCC	All	All	User	Female	50.4	4.5	45.9
33	CCC	All	All	User	Male	55.0	8.9	46.0
28	Man1	2 Weeks	20-30	All	All	102.7	60.4	42.3
14	Man1	2 Weeks	20-30	All	Female	37.7	21.7	16.0
14	Man1	2 Weeks	20-30	All	Male	65.1	38.7	26.3
14	Man1	2 Weeks	20-30	Nonuser	All	59.0	30.9	28.1
7	Man1	2 Weeks	20-30	Nonuser	Female	20.2	11.2	9.0
7	Man1	2 Weeks	20-30	Nonuser	Male	38.8	19.7	19.2
14	Man1	2 Weeks	20-30	User	All	43.7	29.6	14.2
7	Man1	2 Weeks	20-30	User	Female	17.5	10.5	7.0
7	Man1	2 Weeks	20-30	User	Male	26.2	19.1	7.2
28	Man1	2 Weeks	40-50	All	All	106.3	61.4	44.9
14	Man1	2 Weeks	40-50	All	Female	50.5	28.2	22.2
14	Man1	2 Weeks	40-50	All	Male	55.8	33.2	22.7
14	Man1	2 Weeks	40-50	Nonuser	All	58.9	34.1	24.8
7	Man1	2 Weeks	40-50	Nonuser	Female	23.1	13.5	9.6
7	Man1	2 Weeks	40-50	Nonuser	Male	35.8	20.6	15.2
14	Man1	2 Weeks	40-50	User	All	47.4	27.3	20.1
7	Man1	2 Weeks	40-50	User	Female	27.4	14.8	12.6
7	Man1	2 Weeks	40-50	User	Male	20.0	12.5	7.5
28	Man1	2 Weeks	60-70	All	All	75.8	48.8	27.0
14	Man1	2 Weeks	60-70	All	Female	28.3	18.7	9.6
14	Man1	2 Weeks	60-70	All	Male	47.5	30.0	17.4
14	Man1	2 Weeks	60-70	Nonuser	All	35.6	22.9	12.7
7	Man1	2 Weeks	60-70	Nonuser	Female	9.8	7.2	2.6
7	Man1	2 Weeks	60-70	Nonuser	Male	25.7	15.7	10.1
14	Man1	2 Weeks	60-70	User	All	40.2	25.9	14.4
7	Man1	2 Weeks	60-70	User	Female	18.5	11.5	7.0
7	Man1	2 Weeks	60-70	User	Male	21.7	14.3	7.4
84	Man1	2 Weeks	All	All	All	284.8	170.6	114.2
42	Man1	2 Weeks	All	All	Female	116.5	68.6	47.9
42	Man1	2 Weeks	All	All	Male	168.3	101.9	66.4
42	Man1	2 Weeks	All	Nonuser	All	153.4	87.8	65.6
21	Man1	2 Weeks	All	Nonuser	Female	53.1	31.9	21.2
21	Man1	2 Weeks	All	Nonuser	Male	100.4	56.0	44.4
42	Man1	2 Weeks	All	User	All	131.4	82.7	48.6
21	Man1	2 Weeks	All	User	Female	63.4	36.8	26.6
21	Man1	2 Weeks	All	User	Male	68.0	46.0	22.0
8	Man1	5 Weeks	20-30	All	All	32.0	18.4	13.6
4	Man1	5 Weeks	20-30	All	Female	15.1	8.5	6.6

Count	Mode	Test Time	Age	Cruise Usage	Gender	Time (hours) for different velocity ranges		
						> 35mph	35 – 55 mph	> 55 mph
4	Man1	5 Weeks	20-30	All	Male	16.9	9.8	7.1
8	Man1	5 Weeks	40-50	All	All	31.7	17.2	14.4
4	Man1	5 Weeks	40-50	All	Female	19.3	8.1	11.2
4	Man1	5 Weeks	40-50	All	Male	12.4	9.1	3.3
8	Man1	5 Weeks	60-70	All	All	21.9	13.9	8.1
4	Man1	5 Weeks	60-70	All	Female	10.7	7.5	3.2
4	Man1	5 Weeks	60-70	All	Male	11.3	6.4	4.9
24	Man1	5 Weeks	All	All	All	85.6	49.5	36.2
12	Man1	5 Weeks	All	All	Female	45.1	24.2	20.9
12	Man1	5 Weeks	All	All	Male	40.6	25.3	15.2
36	Man1	All	20-30	All	All	134.7	78.8	55.9
18	Man1	All	20-30	All	Female	52.8	30.2	22.6
18	Man1	All	20-30	All	Male	82.0	48.6	33.4
14	Man1	All	20-30	Nonuser	All	59.0	30.9	28.1
7	Man1	All	20-30	Nonuser	Female	20.2	11.2	9.0
7	Man1	All	20-30	Nonuser	Male	38.8	19.7	19.2
22	Man1	All	20-30	User	All	75.8	48.0	27.8
11	Man1	All	20-30	User	Female	32.6	19.0	13.6
11	Man1	All	20-30	User	Male	43.2	28.9	14.2
36	Man1	All	40-50	All	All	138.0	78.6	59.3
18	Man1	All	40-50	All	Female	69.8	36.4	33.4
18	Man1	All	40-50	All	Male	68.2	42.3	25.9
14	Man1	All	40-50	Nonuser	All	58.9	34.1	24.8
7	Man1	All	40-50	Nonuser	Female	23.1	13.5	9.6
7	Man1	All	40-50	Nonuser	Male	35.8	20.6	15.2
22	Man1	All	40-50	User	All	79.1	44.5	34.5
11	Man1	All	40-50	User	Female	46.7	22.9	23.8
11	Man1	All	40-50	User	Male	32.4	21.6	10.8
36	Man1	All	60-70	All	All	97.7	62.6	35.1
18	Man1	All	60-70	All	Female	39.0	26.2	12.8
18	Man1	All	60-70	All	Male	58.7	36.4	22.3
14	Man1	All	60-70	Nonuser	All	35.6	22.9	12.7
7	Man1	All	60-70	Nonuser	Female	9.8	7.2	2.6
7	Man1	All	60-70	Nonuser	Male	25.7	15.7	10.1
22	Man1	All	60-70	User	All	62.2	39.7	22.4
11	Man1	All	60-70	User	Female	29.2	19.0	10.2
11	Man1	All	60-70	User	Male	33.0	20.7	12.2
10	Man1	All	All	All	All	370.5	220.1	150.4
54	Man1	All	All	All	Female	161.6	92.8	68.8
54	Man1	All	All	All	Male	208.9	127.3	81.6
42	Man1	All	All	Nonuser	All	153.4	87.8	65.6
21	Man1	All	All	Nonuser	Female	53.1	31.9	21.2
21	Man1	All	All	Nonuser	Male	100.4	56.0	44.4
66	Man1	All	All	User	All	217.0	132.2	84.8

Count	Mode	Test Time	Age	Cruise Usage	Gender	Time (hours) for different velocity ranges		
						> 35mph	35 – 55 mph	> 55 mph
33	Man1	All	All	User	Female	108.5	60.9	47.6
33	Man1	All	All	User	Male	108.5	71.3	37.2
28	Man2	2 Weeks	20-30	All	All	123.3	74.3	49.0
14	Man2	2 Weeks	20-30	All	Female	57.2	33.3	23.9
14	Man2	2 Weeks	20-30	All	Male	66.1	41.0	25.1
14	Man2	2 Weeks	20-30	Nonuser	All	63.1	35.3	27.8
7	Man2	2 Weeks	20-30	Nonuser	Female	29.2	16.3	12.9
7	Man2	2 Weeks	20-30	Nonuser	Male	34.0	19.1	14.9
14	Man2	2 Weeks	20-30	User	All	60.2	39.0	21.2
7	Man2	2 Weeks	20-30	User	Female	28.1	17.1	11.0
7	Man2	2 Weeks	20-30	User	Male	32.1	21.9	10.2
28	Man2	2 Weeks	40-50	All	All	104.4	67.6	36.8
14	Man2	2 Weeks	40-50	All	Female	33.4	23.5	9.9
14	Man2	2 Weeks	40-50	All	Male	71.1	44.2	26.9
14	Man2	2 Weeks	40-50	Nonuser	All	70.3	43.2	27.1
7	Man2	2 Weeks	40-50	Nonuser	Female	15.1	11.4	3.7
7	Man2	2 Weeks	40-50	Nonuser	Male	55.2	31.8	23.4
14	Man2	2 Weeks	40-50	User	All	34.2	24.5	9.7
7	Man2	2 Weeks	40-50	User	Female	18.3	12.1	6.2
7	Man2	2 Weeks	40-50	User	Male	15.9	12.4	3.5
28	Man2	2 Weeks	60-70	All	All	74.1	52.7	21.5
14	Man2	2 Weeks	60-70	All	Female	30.2	23.1	7.1
14	Man2	2 Weeks	60-70	All	Male	43.9	29.5	14.4
14	Man2	2 Weeks	60-70	Nonuser	All	31.8	24.1	7.7
7	Man2	2 Weeks	60-70	Nonuser	Female	13.4	10.4	3.0
7	Man2	2 Weeks	60-70	Nonuser	Male	18.4	13.7	4.7
14	Man2	2 Weeks	60-70	User	All	42.3	28.6	13.8
7	Man2	2 Weeks	60-70	User	Female	16.9	12.7	4.2
7	Man2	2 Weeks	60-70	User	Male	25.5	15.8	9.6
84	Man2	2 Weeks	All	All	All	301.9	194.6	107.3
42	Man2	2 Weeks	All	All	Female	120.8	79.9	40.9
42	Man2	2 Weeks	All	All	Male	181.0	114.7	66.4
42	Man2	2 Weeks	All	Nonuser	All	165.2	102.6	62.6
21	Man2	2 Weeks	All	Nonuser	Female	57.6	38.1	19.6
21	Man2	2 Weeks	All	Nonuser	Male	107.6	64.5	43.0
42	Man2	2 Weeks	All	User	All	136.7	92.0	44.6
21	Man2	2 Weeks	All	User	Female	63.2	41.9	21.3
21	Man2	2 Weeks	All	User	Male	73.4	50.1	23.3
8	Man2	5 Weeks	20-30	All	All	128.2	68.9	59.3
4	Man2	5 Weeks	20-30	All	Female	55.2	34.7	20.5
4	Man2	5 Weeks	20-30	All	Male	73.0	34.2	38.8
8	Man2	5 Weeks	40-50	All	All	99.3	70.1	29.2
4	Man2	5 Weeks	40-50	All	Female	56.2	38.2	18.0
4	Man2	5 Weeks	40-50	All	Male	43.1	31.9	11.2

Count	Mode	Test Time	Age	Cruise Usage	Gender	Time (hours) for different velocity ranges		
						> 35mph	35 – 55 mph	> 55 mph
8	Man2	5 Weeks	60-70	All	All	72.4	53.7	18.7
4	Man2	5 Weeks	60-70	All	Female	31.4	24.6	6.8
4	Man2	5 Weeks	60-70	All	Male	41.0	29.2	11.8
24	Man2	5 Weeks	All	All	All	299.9	192.7	107.1
12	Man2	5 Weeks	All	All	Female	142.8	97.5	45.3
12	Man2	5 Weeks	All	All	Male	157.1	95.3	61.8
36	Man2	All	20-30	All	All	251.5	143.3	108.3
18	Man2	All	20-30	All	Female	112.4	68.1	44.4
18	Man2	All	20-30	All	Male	139.1	75.2	63.9
14	Man2	All	20-30	Nonuser	All	63.1	35.3	27.8
7	Man2	All	20-30	Nonuser	Female	29.2	16.3	12.9
7	Man2	All	20-30	Nonuser	Male	34.0	19.1	14.9
22	Man2	All	20-30	User	All	188.4	107.9	80.4
11	Man2	All	20-30	User	Female	83.2	51.8	31.5
11	Man2	All	20-30	User	Male	105.1	56.1	49.0
36	Man2	All	40-50	All	All	203.7	137.7	66.0
18	Man2	All	40-50	All	Female	89.5	61.7	27.9
18	Man2	All	40-50	All	Male	114.2	76.0	38.1
14	Man2	All	40-50	Nonuser	All	70.3	43.2	27.1
7	Man2	All	40-50	Nonuser	Female	15.1	11.4	3.7
7	Man2	All	40-50	Nonuser	Male	55.2	31.8	23.4
22	Man2	All	40-50	User	All	133.4	94.5	38.9
11	Man2	All	40-50	User	Female	74.4	50.3	24.2
11	Man2	All	40-50	User	Male	59.0	44.3	14.7
36	Man2	All	60-70	All	All	146.5	106.4	40.1
18	Man2	All	60-70	All	Female	61.7	47.7	14.0
18	Man2	All	60-70	All	Male	84.9	58.7	26.2
14	Man2	All	60-70	Nonuser	All	31.8	24.1	7.7
7	Man2	All	60-70	Nonuser	Female	13.4	10.4	3.0
7	Man2	All	60-70	Nonuser	Male	18.4	13.7	4.7
22	Man2	All	60-70	User	All	114.7	82.3	32.4
11	Man2	All	60-70	User	Female	48.3	37.3	11.0
11	Man2	All	60-70	User	Male	66.4	45.0	21.4
10	Man2	All	All	All	All	601.7	387.3	214.4
54	Man2	All	All	All	Female	263.6	177.4	86.2
54	Man2	All	All	All	Male	338.1	209.9	128.2
42	Man2	All	All	Nonuser	All	165.2	102.6	62.6
21	Man2	All	All	Nonuser	Female	57.6	38.1	19.6
21	Man2	All	All	Nonuser	Male	107.6	64.5	43.0
66	Man2	All	All	User	All	436.5	284.8	151.8
33	Man2	All	All	User	Female	206.0	139.3	66.6
33	Man2	All	All	User	Male	230.6	145.4	85.2
28	Manual	2 Weeks	20-30	All	All	226.0	134.7	91.3
14	Manual	2 Weeks	20-30	All	Female	94.9	55.0	39.9

Count	Mode	Test Time	Age	Cruise Usage	Gender	Time (hours) for different velocity ranges		
						> 35mph	35 – 55 mph	> 55 mph
14	Manual	2 Weeks	20-30	All	Male	131.1	79.7	51.4
14	Manual	2 Weeks	20-30	Nonuser	All	122.1	66.2	55.9
7	Manual	2 Weeks	20-30	Nonuser	Female	49.3	27.5	21.9
7	Manual	2 Weeks	20-30	Nonuser	Male	72.8	38.7	34.1
14	Manual	2 Weeks	20-30	User	All	103.9	68.5	35.4
7	Manual	2 Weeks	20-30	User	Female	45.6	27.5	18.0
7	Manual	2 Weeks	20-30	User	Male	58.3	41.0	17.3
28	Manual	2 Weeks	40-50	All	All	210.7	129.0	81.7
14	Manual	2 Weeks	40-50	All	Female	83.9	51.7	32.1
14	Manual	2 Weeks	40-50	All	Male	126.9	77.3	49.6
14	Manual	2 Weeks	40-50	Nonuser	All	129.2	77.3	51.9
7	Manual	2 Weeks	40-50	Nonuser	Female	38.2	24.9	13.3
7	Manual	2 Weeks	40-50	Nonuser	Male	91.0	52.4	38.6
14	Manual	2 Weeks	40-50	User	All	81.6	51.8	29.8
7	Manual	2 Weeks	40-50	User	Female	45.6	26.8	18.8
7	Manual	2 Weeks	40-50	User	Male	35.9	24.9	11.0
28	Manual	2 Weeks	60-70	All	All	149.9	101.4	48.5
14	Manual	2 Weeks	60-70	All	Female	58.6	41.8	16.7
14	Manual	2 Weeks	60-70	All	Male	91.3	59.6	31.8
14	Manual	2 Weeks	60-70	Nonuser	All	67.4	47.0	20.4
7	Manual	2 Weeks	60-70	Nonuser	Female	23.2	17.6	5.6
7	Manual	2 Weeks	60-70	Nonuser	Male	44.2	29.4	14.8
14	Manual	2 Weeks	60-70	User	All	82.6	54.4	28.1
7	Manual	2 Weeks	60-70	User	Female	35.4	24.2	11.2
7	Manual	2 Weeks	60-70	User	Male	47.2	30.2	17.0
84	Manual	2 Weeks	All	All	All	586.7	365.2	221.5
42	Manual	2 Weeks	All	All	Female	237.3	148.6	88.8
42	Manual	2 Weeks	All	All	Male	349.4	216.6	132.7
42	Manual	2 Weeks	All	Nonuser	All	318.7	190.4	128.2
21	Manual	2 Weeks	All	Nonuser	Female	110.7	69.9	40.8
21	Manual	2 Weeks	All	Nonuser	Male	207.9	120.5	87.4
42	Manual	2 Weeks	All	User	All	268.0	174.7	93.3
21	Manual	2 Weeks	All	User	Female	126.6	78.6	48.0
21	Manual	2 Weeks	All	User	Male	141.4	96.1	45.3
8	Manual	5 Weeks	20-30	All	All	160.2	87.3	72.9
4	Manual	5 Weeks	20-30	All	Female	70.3	43.3	27.0
4	Manual	5 Weeks	20-30	All	Male	89.9	44.1	45.9
8	Manual	5 Weeks	40-50	All	All	130.9	87.3	43.6
4	Manual	5 Weeks	40-50	All	Female	75.4	46.3	29.1
4	Manual	5 Weeks	40-50	All	Male	55.5	41.0	14.5
8	Manual	5 Weeks	60-70	All	All	94.3	67.6	26.7
4	Manual	5 Weeks	60-70	All	Female	42.1	32.1	10.0
4	Manual	5 Weeks	60-70	All	Male	52.2	35.5	16.7
24	Manual	5 Weeks	All	All	All	385.5	242.2	143.3

Count	Mode	Test Time	Age	Cruise Usage	Gender	Time (hours) for different velocity ranges		
						> 35mph	35 – 55 mph	> 55 mph
12	Manual	5 Weeks	All	All	Female	187.8	121.6	66.2
12	Manual	5 Weeks	All	All	Male	197.7	120.6	77.1
36	Manual	All	20-30	All	All	386.3	222.1	164.2
18	Manual	All	20-30	All	Female	165.2	98.3	66.9
18	Manual	All	20-30	All	Male	221.1	123.8	97.3
14	Manual	All	20-30	Nonuser	All	122.1	66.2	55.9
7	Manual	All	20-30	Nonuser	Female	49.3	27.5	21.9
7	Manual	All	20-30	Nonuser	Male	72.8	38.7	34.1
22	Manual	All	20-30	User	All	264.1	155.9	108.3
11	Manual	All	20-30	User	Female	115.9	70.8	45.0
11	Manual	All	20-30	User	Male	148.3	85.1	63.2
36	Manual	All	40-50	All	All	341.7	216.3	125.4
18	Manual	All	40-50	All	Female	159.3	98.0	61.3
18	Manual	All	40-50	All	Male	182.4	118.3	64.1
14	Manual	All	40-50	Nonuser	All	129.2	77.3	51.9
7	Manual	All	40-50	Nonuser	Female	38.2	24.9	13.3
7	Manual	All	40-50	Nonuser	Male	91.0	52.4	38.6
22	Manual	All	40-50	User	All	212.5	139.1	73.4
11	Manual	All	40-50	User	Female	121.1	73.2	47.9
11	Manual	All	40-50	User	Male	91.4	65.9	25.5
36	Manual	All	60-70	All	All	244.3	169.0	75.3
18	Manual	All	60-70	All	Female	100.7	73.9	26.8
18	Manual	All	60-70	All	Male	143.6	95.1	48.5
14	Manual	All	60-70	Nonuser	All	67.4	47.0	20.4
7	Manual	All	60-70	Nonuser	Female	23.2	17.6	5.6
7	Manual	All	60-70	Nonuser	Male	44.2	29.4	14.8
22	Manual	All	60-70	User	All	176.9	122.0	54.9
11	Manual	All	60-70	User	Female	77.5	56.3	21.2
11	Manual	All	60-70	User	Male	99.4	65.7	33.7
10	Manual	All	All	All	All	972.2	607.4	364.8
54	Manual	All	All	All	Female	425.2	270.2	155.0
54	Manual	All	All	All	Male	547.0	337.2	209.8
42	Manual	All	All	Nonuser	All	318.7	190.4	128.2
21	Manual	All	All	Nonuser	Female	110.7	69.9	40.8
21	Manual	All	All	Nonuser	Male	207.9	120.5	87.4
66	Manual	All	All	User	All	653.5	417.0	236.6
33	Manual	All	All	User	Female	314.5	200.3	114.2
33	Manual	All	All	User	Male	339.1	216.7	122.4

Table C-2. Distance statistics summary table (1)

Count	Mode	Test Time	Age	Cruise Usage	Gender	Distance (miles), for different velocities ranges			
						All	< 35 mph	35 – 55 mph	> 55 mph
28	ACC	2 Weeks	20-30	All	All	4876.9	22.7	390.3	4463.9



Count	Mode	Test Time	Age	Cruise Usage	Gender	Distance (miles), for different velocities ranges			
						All	< 35 mph	35 – 55 mph	> 55 mph
14	ACC	2 Weeks	20-30	All	Female	1758.0	9.5	214.6	1533.9
14	ACC	2 Weeks	20-30	All	Male	3118.9	13.2	175.7	2930.0
14	ACC	2 Weeks	20-30	Nonuser	All	2452.2	12.6	228.9	2210.7
7	ACC	2 Weeks	20-30	Nonuser	Female	489.1	4.5	157.7	326.9
7	ACC	2 Weeks	20-30	Nonuser	Male	1963.1	8.1	71.2	1883.8
14	ACC	2 Weeks	20-30	User	All	2424.6	10.1	161.3	2253.2
7	ACC	2 Weeks	20-30	User	Female	1268.8	5.0	56.9	1207.0
7	ACC	2 Weeks	20-30	User	Male	1155.8	5.1	104.4	1046.2
28	ACC	2 Weeks	40-50	All	All	5910.2	31.1	413.6	5465.5
14	ACC	2 Weeks	40-50	All	Female	2643.2	15.3	126.1	2501.8
14	ACC	2 Weeks	40-50	All	Male	3267.0	15.8	287.5	2963.6
14	ACC	2 Weeks	40-50	Nonuser	All	2603.9	9.3	166.7	2427.9
7	ACC	2 Weeks	40-50	Nonuser	Female	643.9	2.9	54.7	586.3
7	ACC	2 Weeks	40-50	Nonuser	Male	1960.0	6.4	112.0	1841.6
14	ACC	2 Weeks	40-50	User	All	3306.3	21.8	246.9	3037.5
7	ACC	2 Weeks	40-50	User	Female	1999.3	12.3	71.5	1915.5
7	ACC	2 Weeks	40-50	User	Male	1307.0	9.4	175.5	1122.0
28	ACC	2 Weeks	60-70	All	All	5823.6	39.9	836.5	4947.2
14	ACC	2 Weeks	60-70	All	Female	2591.0	20.7	368.1	2202.2
14	ACC	2 Weeks	60-70	All	Male	3232.6	19.2	468.4	2745.0
14	ACC	2 Weeks	60-70	Nonuser	All	2447.2	24.7	424.1	1998.4
7	ACC	2 Weeks	60-70	Nonuser	Female	1375.7	15.4	276.3	1084.0
7	ACC	2 Weeks	60-70	Nonuser	Male	1071.4	9.3	147.7	914.4
14	ACC	2 Weeks	60-70	User	All	3376.5	15.2	412.4	2948.8
7	ACC	2 Weeks	60-70	User	Female	1215.3	5.3	91.8	1118.2
7	ACC	2 Weeks	60-70	User	Male	2161.2	9.9	320.7	1830.6
84	ACC	2 Weeks	All	All	All	16610.7	93.7	1640.4	14876.0
42	ACC	2 Weeks	All	All	Female	6992.2	45.4	708.9	6237.9
42	ACC	2 Weeks	All	All	Male	9618.5	48.3	931.6	8638.7
42	ACC	2 Weeks	All	Nonuser	All	7503.3	46.6	819.7	6637.0
21	ACC	2 Weeks	All	Nonuser	Female	2508.8	22.8	488.7	1997.3
21	ACC	2 Weeks	All	Nonuser	Male	4994.5	23.8	331.0	4639.8
42	ACC	2 Weeks	All	User	All	9107.4	47.1	820.7	8239.5
21	ACC	2 Weeks	All	User	Female	4483.4	22.6	220.1	4240.6
21	ACC	2 Weeks	All	User	Male	4624.0	24.5	600.6	3998.9
8	ACC	5 Weeks	20-30	All	All	5955.1	16.7	265.0	5673.5
4	ACC	5 Weeks	20-30	All	Female	2232.8	5.8	92.0	2135.1
4	ACC	5 Weeks	20-30	All	Male	3722.3	10.9	173.0	3538.5
8	ACC	5 Weeks	40-50	All	All	7322.5	20.8	396.7	6905.0
4	ACC	5 Weeks	40-50	All	Female	4379.1	13.1	188.6	4177.4
4	ACC	5 Weeks	40-50	All	Male	2943.3	7.6	208.1	2727.6
8	ACC	5 Weeks	60-70	All	All	5144.5	31.5	729.5	4383.5
4	ACC	5 Weeks	60-70	All	Female	1483.6	10.2	313.6	1159.8
4	ACC	5 Weeks	60-70	All	Male	3660.9	21.3	415.9	3223.7

Count	Mode	Test Time	Age	Cruise Usage	Gender	Distance (miles), for different velocities ranges			
						All	< 35 mph	35 – 55 mph	> 55 mph
24	ACC	5 Weeks	All	All	All	18422.1	68.9	1391.2	16962.
12	ACC	5 Weeks	All	All	Female	8095.6	29.1	594.1	7472.3
12	ACC	5 Weeks	All	All	Male	10326.6	39.8	797.0	9489.7
36	ACC	All	20-30	All	All	10832.0	39.4	655.2	10137.
18	ACC	All	20-30	All	Female	3990.8	15.3	306.6	3668.9
18	ACC	All	20-30	All	Male	6841.2	24.1	348.7	6468.5
14	ACC	All	20-30	Nonuser	All	2452.2	12.6	228.9	2210.7
7	ACC	All	20-30	Nonuser	Female	489.1	4.5	157.7	326.9
7	ACC	All	20-30	Nonuser	Male	1963.1	8.1	71.2	1883.8
22	ACC	All	20-30	User	All	8379.8	26.8	426.3	7926.7
11	ACC	All	20-30	User	Female	3501.6	10.8	148.9	3342.0
11	ACC	All	20-30	User	Male	4878.1	16.0	277.4	4584.7
36	ACC	All	40-50	All	All	13232.7	51.9	810.3	12370.
18	ACC	All	40-50	All	Female	7022.4	28.4	314.7	6679.3
18	ACC	All	40-50	All	Male	6210.3	23.5	495.6	5691.2
14	ACC	All	40-50	Nonuser	All	2603.9	9.3	166.7	2427.9
7	ACC	All	40-50	Nonuser	Female	643.9	2.9	54.7	586.3
7	ACC	All	40-50	Nonuser	Male	1960.0	6.4	112.0	1841.6
22	ACC	All	40-50	User	All	10628.7	42.6	643.7	9942.5
11	ACC	All	40-50	User	Female	6378.4	25.5	260.0	6092.9
11	ACC	All	40-50	User	Male	4250.3	17.1	383.6	3849.6
36	ACC	All	60-70	All	All	10968.2	71.4	1566.0	9330.8
18	ACC	All	60-70	All	Female	4074.6	30.9	681.7	3362.0
18	ACC	All	60-70	All	Male	6893.5	40.5	884.3	5968.7
14	ACC	All	60-70	Nonuser	All	2447.2	24.7	424.1	1998.4
7	ACC	All	60-70	Nonuser	Female	1375.7	15.4	276.3	1084.0
7	ACC	All	60-70	Nonuser	Male	1071.4	9.3	147.7	914.4
22	ACC	All	60-70	User	All	8521.0	46.7	1141.9	7332.3
11	ACC	All	60-70	User	Female	2698.9	15.5	405.4	2278.0
11	ACC	All	60-70	User	Male	5822.1	31.2	736.6	5054.3
108	ACC	All	All	All	All	35032.8	162.6	3031.6	31838.
54	ACC	All	All	All	Female	15087.8	74.5	1303.0	13710.
54	ACC	All	All	All	Male	19945.0	88.1	1728.6	18128.
42	ACC	All	All	Nonuser	All	7503.3	46.6	819.7	6637.0
21	ACC	All	All	Nonuser	Female	2508.8	22.8	488.7	1997.3
21	ACC	All	All	Nonuser	Male	4994.5	23.8	331.0	4639.8
66	ACC	All	All	User	All	27529.5	116.0	2211.9	25201.
33	ACC	All	All	User	Female	12579.0	51.8	814.3	11713.
33	ACC	All	All	User	Male	14950.5	64.3	1397.6	13488.
28	All	2 Weeks	20-30	All	All	22969.8	3971.4	6412.7	12585.
14	All	2 Weeks	20-30	All	Female	9201.1	1897.6	2635.9	4667.6
14	All	2 Weeks	20-30	All	Male	13768.6	2073.8	3776.8	7918.1
14	All	2 Weeks	20-30	Nonuser	All	12629.7	2046.5	3199.2	7384.1
7	All	2 Weeks	20-30	Nonuser	Female	4233.2	980.5	1382.0	1870.7

Count	Mode	Test Time	Age	Cruise Usage	Gender	Distance (miles), for different velocities ranges			
						All	< 35 mph	35 – 55 mph	> 55 mph
7	All	2 Weeks	20-30	Nonuser	Male	8396.6	1066.0	1817.2	5513.4
14	All	2 Weeks	20-30	User	All	10340.1	1924.9	3213.5	5201.6
7	All	2 Weeks	20-30	User	Female	4968.0	917.1	1254.0	2796.9
7	All	2 Weeks	20-30	User	Male	5372.1	1007.8	1959.6	2404.7
28	All	2 Weeks	40-50	All	All	23404.0	3661.2	6285.6	13457.
14	All	2 Weeks	40-50	All	Female	9883.4	1695.8	2449.5	5738.2
14	All	2 Weeks	40-50	All	Male	13520.6	1965.4	3836.2	7718.9
14	All	2 Weeks	40-50	Nonuser	All	12964.5	2086.9	3668.7	7209.0
7	All	2 Weeks	40-50	Nonuser	Female	4046.5	859.3	1148.7	2038.6
7	All	2 Weeks	40-50	Nonuser	Male	8918.0	1227.6	2520.0	5170.4
14	All	2 Weeks	40-50	User	All	10439.4	1574.3	2617.0	6248.2
7	All	2 Weeks	40-50	User	Female	5836.9	836.5	1300.8	3699.6
7	All	2 Weeks	40-50	User	Male	4602.6	737.8	1316.2	2548.6
28	All	2 Weeks	60-70	All	All	18930.2	3264.1	5744.2	9921.9
14	All	2 Weeks	60-70	All	Female	7580.9	1390.3	2351.5	3839.0
14	All	2 Weeks	60-70	All	Male	11349.3	1873.7	3392.7	6082.9
14	All	2 Weeks	60-70	Nonuser	All	8286.3	1701.6	2619.7	3965.0
7	All	2 Weeks	60-70	Nonuser	Female	3412.8	700.3	1144.7	1567.8
7	All	2 Weeks	60-70	Nonuser	Male	4873.5	1001.3	1475.0	2397.2
14	All	2 Weeks	60-70	User	All	10643.9	1562.5	3124.5	5956.9
7	All	2 Weeks	60-70	User	Female	4168.1	690.1	1206.8	2271.2
7	All	2 Weeks	60-70	User	Male	6475.8	872.4	1917.7	3685.7
84	All	2 Weeks	All	All	All	65303.9	10896.	18442.	35964.
42	All	2 Weeks	All	All	Female	26665.4	4983.7	7436.9	14244.
42	All	2 Weeks	All	All	Male	38638.5	5912.9	11005.	21719.
42	All	2 Weeks	All	Nonuser	All	33880.6	5835.0	9487.5	18558.
21	All	2 Weeks	All	Nonuser	Female	11692.5	2540.1	3675.3	5477.1
21	All	2 Weeks	All	Nonuser	Male	22188.1	3294.9	5812.2	13080.
42	All	2 Weeks	All	User	All	31423.4	5061.6	8955.0	17406.
21	All	2 Weeks	All	User	Female	14973.0	2443.6	3761.6	8767.7
21	All	2 Weeks	All	User	Male	16450.4	2618.0	5193.4	8639.0
8	All	5 Weeks	20-30	All	All	18035.7	2400.4	4169.2	11466.
4	All	5 Weeks	20-30	All	Female	7370.8	1067.9	2054.6	4248.4
4	All	5 Weeks	20-30	All	Male	10664.8	1332.5	2114.6	7217.7
8	All	5 Weeks	40-50	All	All	18051.3	2564.5	4247.6	11239.
4	All	5 Weeks	40-50	All	Female	10518.5	1322.0	2252.1	6944.4
4	All	5 Weeks	40-50	All	Male	7532.8	1242.5	1995.5	4294.8
8	All	5 Weeks	60-70	All	All	12652.4	2118.1	3741.0	6793.3
4	All	5 Weeks	60-70	All	Female	4979.7	919.0	1776.8	2284.0
4	All	5 Weeks	60-70	All	Male	7672.7	1199.1	1964.3	4509.3
24	All	5 Weeks	All	All	All	48739.4	7083.0	12157.	29498.
12	All	5 Weeks	All	All	Female	22869.1	3308.9	6083.5	13476.
12	All	5 Weeks	All	All	Male	25870.4	3774.1	6074.4	16021.
36	All	All	20-30	All	All	41005.4	6371.8	10581.	24051.

Count	Mode	Test Time	Age	Cruise Usage	Gender	Distance (miles), for different velocities ranges			
						All	< 35 mph	35 – 55 mph	> 55 mph
18	All	All	20-30	All	Female	16572.0	2965.5	4690.5	8916.0
18	All	All	20-30	All	Male	24433.5	3406.3	5891.4	15135.
14	All	All	20-30	Nonuser	All	12629.7	2046.5	3199.2	7384.1
7	All	All	20-30	Nonuser	Female	4233.2	980.5	1382.0	1870.7
7	All	All	20-30	Nonuser	Male	8396.6	1066.0	1817.2	5513.4
22	All	All	20-30	User	All	28375.7	4325.3	7382.7	16667.
11	All	All	20-30	User	Female	12338.8	1985.0	3308.5	7045.3
11	All	All	20-30	User	Male	16036.9	2340.3	4074.2	9622.5
36	All	All	40-50	All	All	41455.3	6225.7	10533.	24696.
18	All	All	40-50	All	Female	20401.9	3017.7	4701.6	12682.
18	All	All	40-50	All	Male	21053.4	3207.9	5831.7	12013.
14	All	All	40-50	Nonuser	All	12964.5	2086.9	3668.7	7209.0
7	All	All	40-50	Nonuser	Female	4046.5	859.3	1148.7	2038.6
7	All	All	40-50	Nonuser	Male	8918.0	1227.6	2520.0	5170.4
22	All	All	40-50	User	All	28490.7	4138.8	6864.6	17487.
11	All	All	40-50	User	Female	16355.3	2158.5	3552.9	10644.
11	All	All	40-50	User	Male	12135.4	1980.3	3311.7	6843.4
36	All	All	60-70	All	All	31582.6	5382.2	9485.2	16715.
18	All	All	60-70	All	Female	12560.6	2309.3	4128.3	6123.0
18	All	All	60-70	All	Male	19022.0	3072.9	5356.9	10592.
14	All	All	60-70	Nonuser	All	8286.3	1701.6	2619.7	3965.0
7	All	All	60-70	Nonuser	Female	3412.8	700.3	1144.7	1567.8
7	All	All	60-70	Nonuser	Male	4873.5	1001.3	1475.0	2397.2
22	All	All	60-70	User	All	23296.3	3680.6	6865.5	12750.
11	All	All	60-70	User	Female	9147.8	1609.0	2983.6	4555.2
11	All	All	60-70	User	Male	14148.5	2071.5	3881.9	8195.0
108	All	All	All	All	All	114043.3	17979.	30600.	65463.
54	All	All	All	All	Female	49534.5	8292.6	13520.	27721.
54	All	All	All	All	Male	64508.8	9687.1	17080.	37741.
42	All	All	All	Nonuser	All	33880.6	5835.0	9487.5	18558.
21	All	All	All	Nonuser	Female	11692.5	2540.1	3675.3	5477.1
21	All	All	All	Nonuser	Male	22188.1	3294.9	5812.2	13080.
66	All	All	All	User	All	80162.8	12144.	21112.	46905.
33	All	All	All	User	Female	37842.0	5752.5	9845.1	22244.
33	All	All	All	User	Male	42320.8	6392.1	11267.	24660.
28	CCC	2 Weeks	20-30	All	All	2123.8	5.3	108.0	2010.6
14	CCC	2 Weeks	20-30	All	Female	524.2	1.9	40.0	482.3
14	CCC	2 Weeks	20-30	All	Male	1599.6	3.3	67.9	1528.3
14	CCC	2 Weeks	20-30	Nonuser	All	1489.1	2.4	55.2	1431.5
7	CCC	2 Weeks	20-30	Nonuser	Female	128.3	0.4	34.2	93.7
7	CCC	2 Weeks	20-30	Nonuser	Male	1360.8	2.1	21.0	1337.7
14	CCC	2 Weeks	20-30	User	All	634.7	2.8	52.8	579.1
7	CCC	2 Weeks	20-30	User	Female	395.9	1.5	5.8	388.5
7	CCC	2 Weeks	20-30	User	Male	238.8	1.3	47.0	190.6

Count	Mode	Test Time	Age	Cruise Usage	Gender	Distance (miles), for different velocities ranges			
						All	< 35 mph	35 – 55 mph	> 55 mph
28	CCC	2 Weeks	40-50	All	All	2962.5	14.3	207.0	2741.3
14	CCC	2 Weeks	40-50	All	Female	1242.8	6.9	64.5	1171.4
14	CCC	2 Weeks	40-50	All	Male	1719.8	7.4	142.5	1569.9
14	CCC	2 Weeks	40-50	Nonuser	All	1552.6	5.9	95.2	1451.5
7	CCC	2 Weeks	40-50	Nonuser	Female	613.9	1.9	15.6	596.4
7	CCC	2 Weeks	40-50	Nonuser	Male	938.7	4.0	79.6	855.1
14	CCC	2 Weeks	40-50	User	All	1410.0	8.4	111.8	1289.8
7	CCC	2 Weeks	40-50	User	Female	628.9	5.0	48.9	575.0
7	CCC	2 Weeks	40-50	User	Male	781.1	3.4	62.9	714.8
28	CCC	2 Weeks	60-70	All	All	2414.6	15.3	506.5	1892.8
14	CCC	2 Weeks	60-70	All	Female	750.9	6.6	174.6	569.8
14	CCC	2 Weeks	60-70	All	Male	1663.7	8.7	331.9	1323.0
14	CCC	2 Weeks	60-70	Nonuser	All	872.5	6.6	171.9	694.0
7	CCC	2 Weeks	60-70	Nonuser	Female	253.5	3.2	111.2	139.1
7	CCC	2 Weeks	60-70	Nonuser	Male	618.9	3.4	60.7	554.9
14	CCC	2 Weeks	60-70	User	All	1542.2	8.8	334.6	1198.8
7	CCC	2 Weeks	60-70	User	Female	497.4	3.4	63.3	430.7
7	CCC	2 Weeks	60-70	User	Male	1044.7	5.3	271.3	768.1
84	CCC	2 Weeks	All	All	All	7501.0	34.9	821.4	6644.7
42	CCC	2 Weeks	All	All	Female	2518.0	15.5	279.0	2223.5
42	CCC	2 Weeks	All	All	Male	4983.0	19.4	542.4	4421.3
42	CCC	2 Weeks	All	Nonuser	All	3914.1	14.9	322.3	3576.9
21	CCC	2 Weeks	All	Nonuser	Female	995.7	5.5	161.1	829.2
21	CCC	2 Weeks	All	Nonuser	Male	2918.4	9.4	161.2	2747.7
42	CCC	2 Weeks	All	User	All	3586.9	20.0	499.1	3067.8
21	CCC	2 Weeks	All	User	Female	1522.2	10.0	118.0	1394.3
21	CCC	2 Weeks	All	User	Male	2064.6	10.0	381.1	1673.5
8	CCC	5 Weeks	20-30	All	All	990.4	3.0	29.6	957.8
4	CCC	5 Weeks	20-30	All	Female	374.8	1.0	19.5	354.2
4	CCC	5 Weeks	20-30	All	Male	615.7	2.0	10.1	603.6
8	CCC	5 Weeks	40-50	All	All	1528.3	5.6	39.6	1483.1
4	CCC	5 Weeks	40-50	All	Female	893.7	3.6	18.6	871.5
4	CCC	5 Weeks	40-50	All	Male	634.6	2.0	21.0	611.6
8	CCC	5 Weeks	60-70	All	All	744.0	3.5	76.6	663.8
4	CCC	5 Weeks	60-70	All	Female	531.8	2.2	60.1	469.4
4	CCC	5 Weeks	60-70	All	Male	212.2	1.3	16.5	194.4
24	CCC	5 Weeks	All	All	All	3262.7	12.2	145.8	3104.7
12	CCC	5 Weeks	All	All	Female	1800.2	6.8	98.3	1695.1
12	CCC	5 Weeks	All	All	Male	1462.5	5.3	47.6	1409.6
36	CCC	All	20-30	All	All	3114.3	8.3	137.6	2968.4
18	CCC	All	20-30	All	Female	899.0	3.0	59.6	836.4
18	CCC	All	20-30	All	Male	2215.3	5.3	78.0	2132.0
14	CCC	All	20-30	Nonuser	All	1489.1	2.4	55.2	1431.5
7	CCC	All	20-30	Nonuser	Female	128.3	0.4	34.2	93.7

Count	Mode	Test Time	Age	Cruise Usage	Gender	Distance (miles), for different velocities ranges			
						All	< 35 mph	35 – 55 mph	> 55 mph
7	CCC	All	20-30	Nonuser	Male	1360.8	2.1	21.0	1337.7
22	CCC	All	20-30	User	All	1625.2	5.8	82.4	1536.9
11	CCC	All	20-30	User	Female	770.6	2.6	25.3	742.7
11	CCC	All	20-30	User	Male	854.5	3.2	57.1	794.2
36	CCC	All	40-50	All	All	4490.8	19.9	246.6	4224.4
18	CCC	All	40-50	All	Female	2136.5	10.5	83.1	2042.9
18	CCC	All	40-50	All	Male	2354.4	9.4	163.5	2181.5
14	CCC	All	40-50	Nonuser	All	1552.6	5.9	95.2	1451.5
7	CCC	All	40-50	Nonuser	Female	613.9	1.9	15.6	596.4
7	CCC	All	40-50	Nonuser	Male	938.7	4.0	79.6	855.1
22	CCC	All	40-50	User	All	2938.3	14.0	151.4	2772.9
11	CCC	All	40-50	User	Female	1522.6	8.6	67.5	1446.5
11	CCC	All	40-50	User	Male	1415.7	5.4	83.9	1326.4
36	CCC	All	60-70	All	All	3158.6	18.9	583.1	2556.6
18	CCC	All	60-70	All	Female	1282.7	8.8	234.7	1039.2
18	CCC	All	60-70	All	Male	1875.9	10.1	348.4	1517.4
14	CCC	All	60-70	Nonuser	All	872.5	6.6	171.9	694.0
7	CCC	All	60-70	Nonuser	Female	253.5	3.2	111.2	139.1
7	CCC	All	60-70	Nonuser	Male	618.9	3.4	60.7	554.9
22	CCC	All	60-70	User	All	2286.1	12.3	411.2	1862.7
11	CCC	All	60-70	User	Female	1029.2	5.6	123.4	900.1
11	CCC	All	60-70	User	Male	1256.9	6.7	287.7	962.5
108	CCC	All	All	All	All	10763.7	47.0	967.3	9749.4
54	CCC	All	All	All	Female	4318.2	22.3	377.3	3918.6
54	CCC	All	All	All	Male	6445.5	24.8	590.0	5830.8
42	CCC	All	All	Nonuser	All	3914.1	14.9	322.3	3576.9
21	CCC	All	All	Nonuser	Female	995.7	5.5	161.1	829.2
21	CCC	All	All	Nonuser	Male	2918.4	9.4	161.2	2747.7
66	CCC	All	All	User	All	6849.6	32.1	645.0	6172.5
33	CCC	All	All	User	Female	3322.4	16.8	216.3	3089.4
33	CCC	All	All	User	Male	3527.1	15.3	428.7	3083.1
28	Man1	2 Weeks	20-30	All	All	7216.7	1729.4	2650.3	2836.9
14	Man1	2 Weeks	20-30	All	Female	2685.1	684.8	944.6	1055.7
14	Man1	2 Weeks	20-30	All	Male	4531.5	1044.6	1705.7	1781.2
14	Man1	2 Weeks	20-30	Nonuser	All	4148.6	897.5	1361.6	1889.5
7	Man1	2 Weeks	20-30	Nonuser	Female	1453.7	372.3	486.7	594.6
7	Man1	2 Weeks	20-30	Nonuser	Male	2694.9	525.2	874.8	1294.9
14	Man1	2 Weeks	20-30	User	All	3068.0	831.9	1288.7	947.4
7	Man1	2 Weeks	20-30	User	Female	1231.4	312.5	457.9	461.0
7	Man1	2 Weeks	20-30	User	Male	1836.6	519.4	830.9	486.4
28	Man1	2 Weeks	40-50	All	All	7259.9	1638.9	2698.2	2922.9
14	Man1	2 Weeks	40-50	All	Female	3493.5	822.3	1240.2	1430.9
14	Man1	2 Weeks	40-50	All	Male	3766.5	816.5	1458.0	1491.9
14	Man1	2 Weeks	40-50	Nonuser	All	4014.0	891.8	1500.2	1622.0

Count	Mode	Test Time	Age	Cruise Usage	Gender	Distance (miles), for different velocities ranges			
						All	< 35 mph	35 – 55 mph	> 55 mph
7	Man1	2 Weeks	40-50	Nonuser	Female	1597.9	390.5	588.8	618.6
7	Man1	2 Weeks	40-50	Nonuser	Male	2416.1	501.3	911.4	1003.4
14	Man1	2 Weeks	40-50	User	All	3245.9	747.1	1198.0	1300.9
7	Man1	2 Weeks	40-50	User	Female	1895.6	431.8	651.4	812.4
7	Man1	2 Weeks	40-50	User	Male	1350.3	315.2	546.6	488.5
28	Man1	2 Weeks	60-70	All	All	5338.5	1488.7	2121.2	1728.6
14	Man1	2 Weeks	60-70	All	Female	2007.6	572.8	807.9	626.9
14	Man1	2 Weeks	60-70	All	Male	3330.8	915.8	1313.3	1101.7
14	Man1	2 Weeks	60-70	Nonuser	All	2566.0	783.6	988.9	793.5
7	Man1	2 Weeks	60-70	Nonuser	Female	747.7	279.2	306.0	162.6
7	Man1	2 Weeks	60-70	Nonuser	Male	1818.3	504.4	683.0	630.9
14	Man1	2 Weeks	60-70	User	All	2772.5	705.1	1132.2	935.1
7	Man1	2 Weeks	60-70	User	Female	1259.9	293.7	501.9	464.3
7	Man1	2 Weeks	60-70	User	Male	1512.6	411.4	630.3	470.8
84	Man1	2 Weeks	All	All	All	19815.0	4857.0	7469.6	7488.4
42	Man1	2 Weeks	All	All	Female	8186.2	2080.0	2992.7	3113.6
42	Man1	2 Weeks	All	All	Male	11628.8	2777.0	4477.0	4374.8
42	Man1	2 Weeks	All	Nonuser	All	10728.7	2572.9	3850.7	4305.0
21	Man1	2 Weeks	All	Nonuser	Female	3799.3	1042.0	1381.5	1375.8
21	Man1	2 Weeks	All	Nonuser	Male	6929.3	1531.0	2469.2	2929.2
42	Man1	2 Weeks	All	User	All	9086.4	2284.1	3618.9	3183.4
21	Man1	2 Weeks	All	User	Female	4386.9	1038.0	1611.1	1737.7
21	Man1	2 Weeks	All	User	Male	4699.5	1246.1	2007.8	1445.6
8	Man1	5 Weeks	20-30	All	All	2183.0	479.4	816.0	887.6
4	Man1	5 Weeks	20-30	All	Female	1024.9	207.1	387.1	430.7
4	Man1	5 Weeks	20-30	All	Male	1158.1	272.3	428.9	456.9
8	Man1	5 Weeks	40-50	All	All	2204.0	503.4	757.3	943.3
4	Man1	5 Weeks	40-50	All	Female	1353.1	260.9	361.8	730.3
4	Man1	5 Weeks	40-50	All	Male	850.9	242.4	395.5	213.0
8	Man1	5 Weeks	60-70	All	All	1515.0	376.0	601.5	537.5
4	Man1	5 Weeks	60-70	All	Female	720.7	185.9	329.3	205.5
4	Man1	5 Weeks	60-70	All	Male	794.3	190.2	272.2	332.0
24	Man1	5 Weeks	All	All	All	5902.0	1358.8	2174.8	2368.4
12	Man1	5 Weeks	All	All	Female	3098.7	653.9	1078.3	1366.5
12	Man1	5 Weeks	All	All	Male	2803.3	704.9	1096.5	1001.9
36	Man1	All	20-30	All	All	9399.7	2208.8	3466.3	3724.5
18	Man1	All	20-30	All	Female	3710.0	891.9	1331.8	1486.3
18	Man1	All	20-30	All	Male	5689.6	1316.9	2134.6	2238.1
14	Man1	All	20-30	Nonuser	All	4148.6	897.5	1361.6	1889.5
7	Man1	All	20-30	Nonuser	Female	1453.7	372.3	486.7	594.6
7	Man1	All	20-30	Nonuser	Male	2694.9	525.2	874.8	1294.9
22	Man1	All	20-30	User	All	5251.0	1311.3	2104.8	1835.0
11	Man1	All	20-30	User	Female	2256.3	519.6	845.0	891.7
11	Man1	All	20-30	User	Male	2994.7	791.7	1259.8	943.3

Count	Mode	Test Time	Age	Cruise Usage	Gender	Distance (miles), for different velocities ranges			
						All	< 35 mph	35 – 55 mph	> 55 mph
36	Man1	All	40-50	All	All	9463.9	2142.3	3455.5	3866.1
18	Man1	All	40-50	All	Female	4846.5	1083.3	1602.0	2161.2
18	Man1	All	40-50	All	Male	4617.4	1059.0	1853.5	1704.9
14	Man1	All	40-50	Nonuser	All	4014.0	891.8	1500.2	1622.0
7	Man1	All	40-50	Nonuser	Female	1597.9	390.5	588.8	618.6
7	Man1	All	40-50	Nonuser	Male	2416.1	501.3	911.4	1003.4
22	Man1	All	40-50	User	All	5449.9	1250.5	1955.3	2244.1
11	Man1	All	40-50	User	Female	3248.6	692.8	1013.2	1542.7
11	Man1	All	40-50	User	Male	2201.2	557.7	942.1	701.5
36	Man1	All	60-70	All	All	6853.5	1864.7	2722.6	2266.1
18	Man1	All	60-70	All	Female	2728.3	758.7	1137.2	832.4
18	Man1	All	60-70	All	Male	4125.1	1106.0	1585.5	1433.7
14	Man1	All	60-70	Nonuser	All	2566.0	783.6	988.9	793.5
7	Man1	All	60-70	Nonuser	Female	747.7	279.2	306.0	162.6
7	Man1	All	60-70	Nonuser	Male	1818.3	504.4	683.0	630.9
22	Man1	All	60-70	User	All	4287.5	1081.2	1733.7	1472.6
11	Man1	All	60-70	User	Female	1980.6	479.6	831.2	669.8
11	Man1	All	60-70	User	Male	2306.9	601.6	902.5	802.8
108	Man1	All	All	All	All	25717.0	6215.8	9644.4	9856.7
54	Man1	All	All	All	Female	11284.9	2733.9	4070.9	4480.0
54	Man1	All	All	All	Male	14432.1	3481.9	5573.5	5376.7
42	Man1	All	All	Nonuser	All	10728.7	2572.9	3850.7	4305.0
21	Man1	All	All	Nonuser	Female	3799.3	1042.0	1381.5	1375.8
21	Man1	All	All	Nonuser	Male	6929.3	1531.0	2469.2	2929.2
66	Man1	All	All	User	All	14988.4	3642.9	5793.7	5551.7
33	Man1	All	All	User	Female	7485.6	1691.9	2689.4	3104.2
33	Man1	All	All	User	Male	7502.8	1951.0	3104.3	2447.5
28	Man2	2 Weeks	20-30	All	All	8752.5	2214.0	3264.2	3274.3
14	Man2	2 Weeks	20-30	All	Female	4233.8	1201.4	1436.7	1595.8
14	Man2	2 Weeks	20-30	All	Male	4518.6	1012.6	1827.5	1678.5
14	Man2	2 Weeks	20-30	Nonuser	All	4539.7	1133.9	1553.5	1852.4
7	Man2	2 Weeks	20-30	Nonuser	Female	2162.0	603.3	703.3	855.4
7	Man2	2 Weeks	20-30	Nonuser	Male	2377.7	530.6	850.2	997.0
14	Man2	2 Weeks	20-30	User	All	4212.7	1080.1	1710.7	1421.9
7	Man2	2 Weeks	20-30	User	Female	2071.8	598.1	733.4	740.4
7	Man2	2 Weeks	20-30	User	Male	2140.9	482.0	977.3	681.5
28	Man2	2 Weeks	40-50	All	All	7271.3	1976.9	2966.9	2327.5
14	Man2	2 Weeks	40-50	All	Female	2503.9	851.2	1018.7	634.0
14	Man2	2 Weeks	40-50	All	Male	4767.4	1125.7	1948.2	1693.5
14	Man2	2 Weeks	40-50	Nonuser	All	4794.0	1179.9	1906.6	1707.6
7	Man2	2 Weeks	40-50	Nonuser	Female	1190.8	464.0	489.6	237.3
7	Man2	2 Weeks	40-50	Nonuser	Male	3603.2	715.9	1417.0	1470.3
14	Man2	2 Weeks	40-50	User	All	2477.3	797.0	1060.3	620.0
7	Man2	2 Weeks	40-50	User	Female	1313.1	387.3	529.1	396.7



Count	Mode	Test Time	Age	Cruise Usage	Gender	Distance (miles), for different velocities ranges			
						All	< 35 mph	35 – 55 mph	> 55 mph
7	Man2	2 Weeks	40-50	User	Male	1164.2	409.8	531.2	223.2
28	Man2	2 Weeks	60-70	All	All	5353.4	1720.2	2280.0	1353.2
14	Man2	2 Weeks	60-70	All	Female	2231.3	790.2	1001.0	440.1
14	Man2	2 Weeks	60-70	All	Male	3122.1	930.0	1279.0	913.1
14	Man2	2 Weeks	60-70	Nonuser	All	2400.7	886.8	1034.7	479.1
7	Man2	2 Weeks	60-70	Nonuser	Female	1035.8	402.5	451.1	182.1
7	Man2	2 Weeks	60-70	Nonuser	Male	1364.9	484.3	583.6	297.0
14	Man2	2 Weeks	60-70	User	All	2952.8	833.4	1245.3	874.1
7	Man2	2 Weeks	60-70	User	Female	1195.5	387.7	549.9	258.0
7	Man2	2 Weeks	60-70	User	Male	1757.2	445.7	695.4	616.1
84	Man2	2 Weeks	All	All	All	21377.2	5911.1	8511.1	6955.1
42	Man2	2 Weeks	All	All	Female	8969.1	2842.8	3456.4	2669.9
42	Man2	2 Weeks	All	All	Male	12408.1	3068.2	5054.7	4285.2
42	Man2	2 Weeks	All	Nonuser	All	11734.4	3200.6	4494.8	4039.1
21	Man2	2 Weeks	All	Nonuser	Female	4388.7	1469.8	1644.0	1274.8
21	Man2	2 Weeks	All	Nonuser	Male	7345.8	1730.8	2850.8	2764.3
42	Man2	2 Weeks	All	User	All	9642.8	2710.5	4016.3	2916.0
21	Man2	2 Weeks	All	User	Female	4580.4	1373.0	1812.3	1395.1
21	Man2	2 Weeks	All	User	Male	5062.3	1337.5	2203.9	1520.9
8	Man2	5 Weeks	20-30	All	All	8907.1	1901.3	3058.6	3947.2
4	Man2	5 Weeks	20-30	All	Female	3738.4	853.9	1556.0	1328.5
4	Man2	5 Weeks	20-30	All	Male	5168.7	1047.4	1502.6	2618.7
8	Man2	5 Weeks	40-50	All	All	6996.5	2034.7	3054.0	1907.8
4	Man2	5 Weeks	40-50	All	Female	3892.6	1044.3	1683.1	1165.2
4	Man2	5 Weeks	40-50	All	Male	3104.0	990.4	1370.9	742.7
8	Man2	5 Weeks	60-70	All	All	5249.0	1707.1	2333.5	1208.5
4	Man2	5 Weeks	60-70	All	Female	2243.6	720.7	1073.7	449.2
4	Man2	5 Weeks	60-70	All	Male	3005.3	986.3	1259.7	759.3
24	Man2	5 Weeks	All	All	All	21152.6	5643.1	8446.0	7063.5
12	Man2	5 Weeks	All	All	Female	9874.6	2619.0	4312.8	2942.8
12	Man2	5 Weeks	All	All	Male	11278.0	3024.1	4133.2	4120.7
36	Man2	All	20-30	All	All	17659.5	4115.3	6322.7	7221.5
18	Man2	All	20-30	All	Female	7972.2	2055.3	2992.6	2924.2
18	Man2	All	20-30	All	Male	9687.3	2060.0	3330.1	4297.3
14	Man2	All	20-30	Nonuser	All	4539.7	1133.9	1553.5	1852.4
7	Man2	All	20-30	Nonuser	Female	2162.0	603.3	703.3	855.4
7	Man2	All	20-30	Nonuser	Male	2377.7	530.6	850.2	997.0
22	Man2	All	20-30	User	All	13119.8	2981.4	4769.3	5369.1
11	Man2	All	20-30	User	Female	5810.2	1452.0	2289.3	2068.8
11	Man2	All	20-30	User	Male	7309.6	1529.4	2479.9	3300.3
36	Man2	All	40-50	All	All	14267.9	4011.6	6020.9	4235.4
18	Man2	All	40-50	All	Female	6396.5	1895.6	2701.8	1799.2
18	Man2	All	40-50	All	Male	7871.4	2116.1	3319.1	2436.2
14	Man2	All	40-50	Nonuser	All	4794.0	1179.9	1906.6	1707.6

Count	Mode	Test Time	Age	Cruise Usage	Gender	Distance (miles), for different velocities ranges			
						All	< 35 mph	35 – 55 mph	> 55 mph
7	Man2	All	40-50	Nonuser	Female	1190.8	464.0	489.6	237.3
7	Man2	All	40-50	Nonuser	Male	3603.2	715.9	1417.0	1470.3
22	Man2	All	40-50	User	All	9473.9	2831.8	4114.3	2527.8
11	Man2	All	40-50	User	Female	5205.7	1431.6	2212.2	1561.9
11	Man2	All	40-50	User	Male	4268.2	1400.2	1902.1	965.9
36	Man2	All	60-70	All	All	10602.4	3427.2	4613.5	2561.7
18	Man2	All	60-70	All	Female	4475.0	1511.0	2074.7	889.3
18	Man2	All	60-70	All	Male	6127.4	1916.3	2538.8	1672.4
14	Man2	All	60-70	Nonuser	All	2400.7	886.8	1034.7	479.1
7	Man2	All	60-70	Nonuser	Female	1035.8	402.5	451.1	182.1
7	Man2	All	60-70	Nonuser	Male	1364.9	484.3	583.6	297.0
22	Man2	All	60-70	User	All	8201.7	2540.4	3578.7	2082.6
11	Man2	All	60-70	User	Female	3439.1	1108.4	1623.6	707.2
11	Man2	All	60-70	User	Male	4762.6	1432.0	1955.2	1375.4
108	Man2	All	All	All	All	42529.8	11554.	16957.	14018.
54	Man2	All	All	All	Female	18843.7	5461.8	7769.1	5612.7
54	Man2	All	All	All	Male	23686.1	6092.4	9187.9	8405.8
42	Man2	All	All	Nonuser	All	11734.4	3200.6	4494.8	4039.1
21	Man2	All	All	Nonuser	Female	4388.7	1469.8	1644.0	1274.8
21	Man2	All	All	Nonuser	Male	7345.8	1730.8	2850.8	2764.3
66	Man2	All	All	User	All	30795.4	8353.6	12462.	9979.5
33	Man2	All	All	User	Female	14455.0	3992.0	6125.1	4337.9
33	Man2	All	All	User	Male	16340.3	4361.6	6337.2	5641.6
28	Manual	2 Weeks	20-30	All	All	15969.1	3943.4	5914.5	6111.2
14	Manual	2 Weeks	20-30	All	Female	6918.9	1886.2	2381.3	2651.5
14	Manual	2 Weeks	20-30	All	Male	9050.2	2057.2	3533.2	3459.8
14	Manual	2 Weeks	20-30	Nonuser	All	8688.4	2031.4	2915.0	3741.9
7	Manual	2 Weeks	20-30	Nonuser	Female	3615.7	975.6	1190.0	1450.0
7	Manual	2 Weeks	20-30	Nonuser	Male	5072.7	1055.8	1725.0	2291.9
14	Manual	2 Weeks	20-30	User	All	7280.7	1912.0	2999.4	2369.3
7	Manual	2 Weeks	20-30	User	Female	3303.2	910.6	1191.3	1201.4
7	Manual	2 Weeks	20-30	User	Male	3977.5	1001.4	1808.2	1167.9
28	Manual	2 Weeks	40-50	All	All	14531.2	3615.8	5665.0	5250.4
14	Manual	2 Weeks	40-50	All	Female	5997.4	1673.6	2258.9	2064.9
14	Manual	2 Weeks	40-50	All	Male	8533.8	1942.2	3406.2	3185.4
14	Manual	2 Weeks	40-50	Nonuser	All	8808.1	2071.7	3406.8	3329.6
7	Manual	2 Weeks	40-50	Nonuser	Female	2788.7	854.5	1078.4	855.8
7	Manual	2 Weeks	40-50	Nonuser	Male	6019.3	1217.2	2328.4	2473.7
14	Manual	2 Weeks	40-50	User	All	5723.2	1544.1	2258.2	1920.8
7	Manual	2 Weeks	40-50	User	Female	3208.7	819.1	1180.5	1209.1
7	Manual	2 Weeks	40-50	User	Male	2514.5	725.0	1077.8	711.7
28	Manual	2 Weeks	60-70	All	All	10691.9	3208.9	4401.2	3081.8
14	Manual	2 Weeks	60-70	All	Female	4239.0	1363.1	1808.9	1067.0
14	Manual	2 Weeks	60-70	All	Male	6452.9	1845.8	2592.3	2014.8

Count	Mode	Test Time	Age	Cruise Usage	Gender	Distance (miles), for different velocities ranges			
						All	< 35 mph	35 – 55 mph	> 55 mph
14	Manual	2 Weeks	60-70	Nonuser	All	4966.7	1670.4	2023.7	1272.6
7	Manual	2 Weeks	60-70	Nonuser	Female	1783.6	681.7	757.1	344.7
7	Manual	2 Weeks	60-70	Nonuser	Male	3183.1	988.7	1266.6	927.9
14	Manual	2 Weeks	60-70	User	All	5725.2	1538.5	2377.5	1809.2
7	Manual	2 Weeks	60-70	User	Female	2455.4	681.4	1051.8	722.3
7	Manual	2 Weeks	60-70	User	Male	3269.8	857.1	1325.7	1086.9
84	Manual	2 Weeks	All	All	All	41192.2	10768.	15980.	14443.
42	Manual	2 Weeks	All	All	Female	17155.3	4922.8	6449.0	5783.5
42	Manual	2 Weeks	All	All	Male	24036.9	5845.3	9531.7	8660.0
42	Manual	2 Weeks	All	Nonuser	All	22463.1	5773.5	8345.5	8344.1
21	Manual	2 Weeks	All	Nonuser	Female	8188.0	2511.8	3025.5	2650.6
21	Manual	2 Weeks	All	Nonuser	Male	14275.1	3261.7	5320.0	5693.4
42	Manual	2 Weeks	All	User	All	18729.1	4994.6	7635.2	6099.4
21	Manual	2 Weeks	All	User	Female	8967.3	2411.0	3423.5	3132.8
21	Manual	2 Weeks	All	User	Male	9761.8	2583.6	4211.7	2966.6
8	Manual	5 Weeks	20-30	All	All	11090.1	2380.7	3874.6	4834.8
4	Manual	5 Weeks	20-30	All	Female	4763.3	1061.1	1943.1	1759.1
4	Manual	5 Weeks	20-30	All	Male	6326.8	1319.7	1931.5	3075.6
8	Manual	5 Weeks	40-50	All	All	9200.5	2538.1	3811.3	2851.1
4	Manual	5 Weeks	40-50	All	Female	5245.7	1305.3	2044.9	1895.4
4	Manual	5 Weeks	40-50	All	Male	3954.9	1232.8	1766.4	955.7
8	Manual	5 Weeks	60-70	All	All	6764.0	2083.1	2934.9	1746.0
4	Manual	5 Weeks	60-70	All	Female	2964.3	906.6	1403.0	654.7
4	Manual	5 Weeks	60-70	All	Male	3799.6	1176.5	1531.9	1091.3
24	Manual	5 Weeks	All	All	All	27054.6	7001.9	10620.	9431.8
12	Manual	5 Weeks	All	All	Female	12973.3	3272.9	5391.0	4309.3
12	Manual	5 Weeks	All	All	Male	14081.3	3729.0	5229.8	5122.6
36	Manual	All	20-30	All	All	27059.2	6324.1	9789.1	10946.
18	Manual	All	20-30	All	Female	11682.2	2947.2	4324.4	4410.6
18	Manual	All	20-30	All	Male	15377.0	3376.9	5464.7	6535.4
14	Manual	All	20-30	Nonuser	All	8688.4	2031.4	2915.0	3741.9
7	Manual	All	20-30	Nonuser	Female	3615.7	975.6	1190.0	1450.0
7	Manual	All	20-30	Nonuser	Male	5072.7	1055.8	1725.0	2291.9
22	Manual	All	20-30	User	All	18370.8	4292.7	6874.0	7204.1
11	Manual	All	20-30	User	Female	8066.5	1971.6	3134.4	2960.5
11	Manual	All	20-30	User	Male	10304.3	2321.1	3739.7	4243.5
36	Manual	All	40-50	All	All	23731.8	6153.9	9476.3	8101.5
18	Manual	All	40-50	All	Female	11243.0	2978.9	4303.8	3960.4
18	Manual	All	40-50	All	Male	12488.7	3175.1	5172.6	4141.1
14	Manual	All	40-50	Nonuser	All	8808.1	2071.7	3406.8	3329.6
7	Manual	All	40-50	Nonuser	Female	2788.7	854.5	1078.4	855.8
7	Manual	All	40-50	Nonuser	Male	6019.3	1217.2	2328.4	2473.7
22	Manual	All	40-50	User	All	14923.7	4082.2	6069.5	4771.9
11	Manual	All	40-50	User	Female	8454.3	2124.4	3225.4	3104.5

Count	Mode	Test Time	Age	Cruise Usage	Gender	Distance (miles), for different velocities ranges			
						All	< 35 mph	35 – 55 mph	> 55 mph
11	Manual	All	40-50	User	Male	6469.4	1957.9	2844.1	1667.4
36	Manual	All	60-70	All	All	17455.9	5292.0	7336.1	4827.8
18	Manual	All	60-70	All	Female	7203.3	2269.7	3211.9	1721.7
18	Manual	All	60-70	All	Male	10252.6	3022.3	4124.2	3106.0
14	Manual	All	60-70	Nonuser	All	4966.7	1670.4	2023.7	1272.6
7	Manual	All	60-70	Nonuser	Female	1783.6	681.7	757.1	344.7
7	Manual	All	60-70	Nonuser	Male	3183.1	988.7	1266.6	927.9
22	Manual	All	60-70	User	All	12489.2	3621.6	5312.4	3555.2
11	Manual	All	60-70	User	Female	5419.7	1588.0	2454.8	1377.0
11	Manual	All	60-70	User	Male	7069.4	2033.6	2857.6	2178.2
108	Manual	All	All	All	All	68246.8	17770.	26601.	23875.
54	Manual	All	All	All	Female	30128.5	8195.8	11840.	10092.
54	Manual	All	All	All	Male	38118.3	9574.3	14761.	13782.
42	Manual	All	All	Nonuser	All	22463.1	5773.5	8345.5	8344.1
21	Manual	All	All	Nonuser	Female	8188.0	2511.8	3025.5	2650.6
21	Manual	All	All	Nonuser	Male	14275.1	3261.7	5320.0	5693.4
66	Manual	All	All	User	All	45783.7	11996.	18256.	15531.
33	Manual	All	All	User	Female	21940.6	5684.0	8814.5	7442.1
33	Manual	All	All	User	Male	23843.1	6312.6	9441.5	8089.1

Table C-3. Time statistics summary table (2)

No	Mode	ID	Test Time	Age	Cruise Usage	Gender	Time (minutes) for different velocity ranges		
							> 35mph	35-55mph	> 55mph
1	ACC	27	2 Weeks	20-30	Nonuser	Female	70.4	1.1	69.3
2	ACC	31	2 Weeks	20-30	Nonuser	Female	21.7	3.0	18.8
3	ACC	38	2 Weeks	20-30	Nonuser	Female	123.7	54.1	69.6
4	ACC	39	2 Weeks	20-30	Nonuser	Female	94.2	70.7	23.5
5	ACC	44	2 Weeks	20-30	Nonuser	Female	64.7	45.6	19.1
6	ACC	45	2 Weeks	20-30	Nonuser	Female	89.3	25.6	63.7
7	ACC	49	2 Weeks	20-30	Nonuser	Female	44.0	0.3	43.7
8	ACC	4	2 Weeks	20-30	Nonuser	Male	407.3	8.7	398.6
9	ACC	41	2 Weeks	20-30	Nonuser	Male	28.7	0.0	28.7
10	ACC	63	2 Weeks	20-30	Nonuser	Male	22.4	3.8	18.6
11	ACC	93	2 Weeks	20-30	Nonuser	Male	404.2	11.1	393.2
12	ACC	98	2 Weeks	20-30	Nonuser	Male	803.7	45.8	757.9
13	ACC	109	2 Weeks	20-30	Nonuser	Male	56.6	9.5	47.1
14	ACC	114	2 Weeks	20-30	Nonuser	Male	23.7	6.4	17.2
15	ACC	10	2 Weeks	20-30	User	Female	61.5	6.3	55.2
16	ACC	15	2 Weeks	20-30	User	Female	122.1	3.2	118.8
17	ACC	30	2 Weeks	20-30	User	Female	108.4	4.9	103.5
18	ACC	42	2 Weeks	20-30	User	Female	36.4	7.1	29.2
19	ACC	50	2 Weeks	20-30	User	Female	127.9	25.7	102.2
20	ACC	51	2 Weeks	20-30	User	Female	292.6	22.1	270.5
21	ACC	52	2 Weeks	20-30	User	Female	376.7	0.7	376.1
22	ACC	33	2 Weeks	20-30	User	Male	274.8	28.1	246.6
23	ACC	37	2 Weeks	20-30	User	Male	84.4	24.5	59.9
24	ACC	54	2 Weeks	20-30	User	Male	285.0	23.8	261.1
25	ACC	59	2 Weeks	20-30	User	Male	167.9	37.7	130.2
26	ACC	60	2 Weeks	20-30	User	Male	63.6	11.7	51.9
27	ACC	61	2 Weeks	20-30	User	Male	149.6	5.2	144.4
28	ACC	64	2 Weeks	20-30	User	Male	12.2	0.0	12.2
29	ACC	1	2 Weeks	40-50	Nonuser	Female	41.4	9.1	32.2
30	ACC	23	2 Weeks	40-50	Nonuser	Female	99.5	8.2	91.3
31	ACC	25	2 Weeks	40-50	Nonuser	Female	33.3	2.5	30.8
32	ACC	26	2 Weeks	40-50	Nonuser	Female	139.8	15.5	124.3
33	ACC	29	2 Weeks	40-50	Nonuser	Female	66.6	0.5	66.2
34	ACC	80	2 Weeks	40-50	Nonuser	Female	50.7	14.1	36.6
35	ACC	84	2 Weeks	40-50	Nonuser	Female	176.6	17.9	158.6
36	ACC	34	2 Weeks	40-50	Nonuser	Male	77.1	2.8	74.3
37	ACC	75	2 Weeks	40-50	Nonuser	Male	831.7	61.4	770.4
38	ACC	94	2 Weeks	40-50	Nonuser	Male	297.3	2.0	295.3
39	ACC	102	2 Weeks	40-50	Nonuser	Male	77.8	1.7	76.1
40	ACC	111	2 Weeks	40-50	Nonuser	Male	143.7	6.2	137.5
41	ACC	112	2 Weeks	40-50	Nonuser	Male	49.4	32.9	16.5
42	ACC	117	2 Weeks	40-50	Nonuser	Male	313.7	28.0	285.7
43	ACC	5	2 Weeks	40-50	User	Female	52.8	1.5	51.3

No	Mode	ID	Test Time	Age	Cruise Usage	Gender	Time (minutes) for different velocity ranges		
							> 35mph	35-55mph	> 55mph
44	ACC	6	2 Weeks	40-50	User	Female	128.9	1.9	127.0
45	ACC	8	2 Weeks	40-50	User	Female	173.2	2.3	170.9
46	ACC	9	2 Weeks	40-50	User	Female	557.6	21.6	536.0
47	ACC	12	2 Weeks	40-50	User	Female	187.5	15.6	171.8
48	ACC	21	2 Weeks	40-50	User	Female	412.8	24.8	388.1
49	ACC	24	2 Weeks	40-50	User	Female	330.4	20.8	309.6
50	ACC	3	2 Weeks	40-50	User	Male	66.6	17.2	49.4
51	ACC	14	2 Weeks	40-50	User	Male	203.2	31.8	171.4
52	ACC	17	2 Weeks	40-50	User	Male	102.4	37.6	64.7
53	ACC	22	2 Weeks	40-50	User	Male	92.4	46.6	45.8
54	ACC	35	2 Weeks	40-50	User	Male	106.9	23.0	84.0
55	ACC	74	2 Weeks	40-50	User	Male	73.4	33.2	40.2
56	ACC	105	2 Weeks	40-50	User	Male	586.8	33.4	553.4
57	ACC	43	2 Weeks	60-70	Nonuser	Female	185.3	99.5	85.8
58	ACC	46	2 Weeks	60-70	Nonuser	Female	80.0	19.6	60.3
59	ACC	82	2 Weeks	60-70	Nonuser	Female	394.7	67.6	327.2
60	ACC	83	2 Weeks	60-70	Nonuser	Female	65.5	31.5	34.0
61	ACC	91	2 Weeks	60-70	Nonuser	Female	231.0	122.1	108.9
62	ACC	95	2 Weeks	60-70	Nonuser	Female	88.5	2.9	85.6
63	ACC	106	2 Weeks	60-70	Nonuser	Female	321.0	8.9	312.1
64	ACC	103	2 Weeks	60-70	Nonuser	Male	124.6	32.6	92.0
65	ACC	107	2 Weeks	60-70	Nonuser	Male	165.0	31.6	133.4
66	ACC	108	2 Weeks	60-70	Nonuser	Male	138.6	0.0	138.6
67	ACC	110	2 Weeks	60-70	Nonuser	Male	300.7	40.0	260.8
68	ACC	113	2 Weeks	60-70	Nonuser	Male	167.4	68.8	98.5
69	ACC	115	2 Weeks	60-70	Nonuser	Male	91.7	11.0	80.8
70	ACC	116	2 Weeks	60-70	Nonuser	Male	46.3	4.7	41.6
71	ACC	13	2 Weeks	60-70	User	Female	335.1	30.5	304.6
72	ACC	48	2 Weeks	60-70	User	Female	91.9	3.9	88.0
73	ACC	57	2 Weeks	60-70	User	Female	68.3	14.5	53.8
74	ACC	65	2 Weeks	60-70	User	Female	53.5	29.2	24.3
75	ACC	67	2 Weeks	60-70	User	Female	155.2	23.3	131.9
76	ACC	69	2 Weeks	60-70	User	Female	69.4	10.9	58.5
77	ACC	72	2 Weeks	60-70	User	Female	360.6	0.8	359.8
78	ACC	7	2 Weeks	60-70	User	Male	461.1	73.3	387.8
79	ACC	11	2 Weeks	60-70	User	Male	523.0	108.6	414.4
80	ACC	18	2 Weeks	60-70	User	Male	387.8	73.7	314.0
81	ACC	19	2 Weeks	60-70	User	Male	204.3	77.3	127.0
82	ACC	20	2 Weeks	60-70	User	Male	305.5	27.9	277.6
83	ACC	32	2 Weeks	60-70	User	Male	51.6	1.4	50.1
84	ACC	47	2 Weeks	60-70	User	Male	190.1	38.8	151.3
85	ACC	56	5 Weeks	20-30	User	Female	731.3	4.2	727.1
86	ACC	73	5 Weeks	20-30	User	Female	581.8	59.1	522.7
87	ACC	79	5 Weeks	20-30	User	Female	110.5	24.3	86.2

No	Mode	ID	Test Time	Age	Cruise Usage	Gender	Time (minutes) for different velocity ranges		
							> 35mph	35-55mph	> 55mph
88	ACC	87	5 Weeks	20-30	User	Female	544.4	21.4	523.0
89	ACC	55	5 Weeks	20-30	User	Male	278.5	103.9	174.5
90	ACC	68	5 Weeks	20-30	User	Male	856.2	0.0	856.2
91	ACC	76	5 Weeks	20-30	User	Male	926.6	48.5	878.1
92	ACC	89	5 Weeks	20-30	User	Male	1227.0	62.9	1164.1
93	ACC	88	5 Weeks	40-50	User	Female	707.3	120.6	586.7
94	ACC	96	5 Weeks	40-50	User	Female	1000.7	27.9	972.8
95	ACC	99	5 Weeks	40-50	User	Female	1923.1	36.6	1886.6
96	ACC	104	5 Weeks	40-50	User	Female	168.7	44.4	124.3
97	ACC	78	5 Weeks	40-50	User	Male	915.0	0.0	915.0
98	ACC	81	5 Weeks	40-50	User	Male	328.2	55.7	272.5
99	ACC	92	5 Weeks	40-50	User	Male	599.5	108.4	491.2
100	ACC	100	5 Weeks	40-50	User	Male	712.6	98.4	614.1
101	ACC	70	5 Weeks	60-70	User	Female	351.4	79.2	272.2
102	ACC	77	5 Weeks	60-70	User	Female	354.9	159.0	195.9
103	ACC	90	5 Weeks	60-70	User	Female	507.8	137.4	370.4
104	ACC	97	5 Weeks	60-70	User	Female	224.5	23.1	201.5
105	ACC	40	5 Weeks	60-70	User	Male	1857.8	63.3	1794.5
106	ACC	62	5 Weeks	60-70	User	Male	469.1	256.9	212.2
107	ACC	66	5 Weeks	60-70	User	Male	784.7	224.3	560.4
108	ACC	85	5 Weeks	60-70	User	Male	307.0	4.3	302.7
1	All	27	2 Weeks	20-30	Nonuser	Female	286.9	172.5	114.5
2	All	31	2 Weeks	20-30	Nonuser	Female	356.0	144.1	211.9
3	All	38	2 Weeks	20-30	Nonuser	Female	250.0	166.1	83.9
4	All	39	2 Weeks	20-30	Nonuser	Female	396.9	326.8	70.1
5	All	44	2 Weeks	20-30	Nonuser	Female	771.0	663.5	107.5
6	All	45	2 Weeks	20-30	Nonuser	Female	469.5	222.6	246.9
7	All	49	2 Weeks	20-30	Nonuser	Female	1061.8	194.6	867.2
8	All	4	2 Weeks	20-30	Nonuser	Male	1634.4	298.8	1335.6
9	All	41	2 Weeks	20-30	Nonuser	Male	225.9	110.4	115.5
10	All	63	2 Weeks	20-30	Nonuser	Male	668.8	482.5	186.3
11	All	93	2 Weeks	20-30	Nonuser	Male	800.5	271.7	528.8
12	All	98	2 Weeks	20-30	Nonuser	Male	2668.8	707.7	1961.1
13	All	109	2 Weeks	20-30	Nonuser	Male	841.3	310.7	530.7
14	All	114	2 Weeks	20-30	Nonuser	Male	498.0	254.6	243.4
15	All	10	2 Weeks	20-30	User	Female	541.3	196.1	345.2
16	All	15	2 Weeks	20-30	User	Female	405.5	165.5	240.0
17	All	30	2 Weeks	20-30	User	Female	598.4	237.2	361.3
18	All	42	2 Weeks	20-30	User	Female	282.9	110.2	172.7
19	All	50	2 Weeks	20-30	User	Female	785.7	519.8	265.9
20	All	51	2 Weeks	20-30	User	Female	542.0	220.4	321.6
21	All	52	2 Weeks	20-30	User	Female	1052.9	281.2	771.7
22	All	33	2 Weeks	20-30	User	Male	909.0	485.4	423.6
23	All	37	2 Weeks	20-30	User	Male	507.0	416.1	90.9

No	Mode	ID	Test Time	Age	Cruise Usage	Gender	Time (minutes) for different velocity ranges		
							> 35mph	35-55mph	> 55mph
24	All	54	2 Weeks	20-30	User	Male	937.7	441.9	495.8
25	All	59	2 Weeks	20-30	User	Male	602.9	289.3	313.6
26	All	60	2 Weeks	20-30	User	Male	272.6	146.1	126.6
27	All	61	2 Weeks	20-30	User	Male	1113.3	608.8	504.5
28	All	64	2 Weeks	20-30	User	Male	421.4	264.5	156.9
29	All	1	2 Weeks	40-50	Nonuser	Female	455.7	323.9	131.9
30	All	23	2 Weeks	40-50	Nonuser	Female	305.3	72.4	232.9
31	All	25	2 Weeks	40-50	Nonuser	Female	310.8	169.7	141.1
32	All	26	2 Weeks	40-50	Nonuser	Female	551.0	278.8	272.2
33	All	29	2 Weeks	40-50	Nonuser	Female	400.1	212.9	187.3
34	All	80	2 Weeks	40-50	Nonuser	Female	702.5	228.0	474.5
35	All	84	2 Weeks	40-50	Nonuser	Female	719.3	292.8	426.5
36	All	34	2 Weeks	40-50	Nonuser	Male	1098.7	323.7	775.0
37	All	75	2 Weeks	40-50	Nonuser	Male	1572.0	628.4	943.7
38	All	94	2 Weeks	40-50	Nonuser	Male	1191.4	472.0	719.4
39	All	102	2 Weeks	40-50	Nonuser	Male	1614.1	667.0	947.0
40	All	111	2 Weeks	40-50	Nonuser	Male	1008.8	402.1	606.6
41	All	112	2 Weeks	40-50	Nonuser	Male	700.1	416.0	284.1
42	All	117	2 Weeks	40-50	Nonuser	Male	904.5	468.6	435.9
43	All	5	2 Weeks	40-50	User	Female	503.9	184.8	319.1
44	All	6	2 Weeks	40-50	User	Female	432.2	212.1	220.1
45	All	8	2 Weeks	40-50	User	Female	1027.7	301.2	726.5
46	All	9	2 Weeks	40-50	User	Female	1265.1	349.2	915.9
47	All	12	2 Weeks	40-50	User	Female	631.7	300.2	331.5
48	All	21	2 Weeks	40-50	User	Female	755.8	251.1	504.6
49	All	24	2 Weeks	40-50	User	Female	556.5	160.6	395.9
50	All	3	2 Weeks	40-50	User	Male	306.0	187.8	118.2
51	All	14	2 Weeks	40-50	User	Male	565.2	186.4	378.8
52	All	17	2 Weeks	40-50	User	Male	322.3	176.7	145.5
53	All	22	2 Weeks	40-50	User	Male	384.5	276.0	108.6
54	All	35	2 Weeks	40-50	User	Male	1025.5	486.6	539.0
55	All	74	2 Weeks	40-50	User	Male	242.6	165.3	77.3
56	All	105	2 Weeks	40-50	User	Male	1251.1	318.3	932.8
57	All	43	2 Weeks	60-70	Nonuser	Female	420.7	280.7	140.0
58	All	46	2 Weeks	60-70	Nonuser	Female	292.4	172.9	119.4
59	All	82	2 Weeks	60-70	Nonuser	Female	709.4	256.5	452.9
60	All	83	2 Weeks	60-70	Nonuser	Female	201.0	134.1	66.9
61	All	91	2 Weeks	60-70	Nonuser	Female	468.5	309.4	159.1
62	All	95	2 Weeks	60-70	Nonuser	Female	287.2	147.9	139.3
63	All	106	2 Weeks	60-70	Nonuser	Female	655.7	249.8	405.9
64	All	103	2 Weeks	60-70	Nonuser	Male	532.5	268.0	264.4
65	All	107	2 Weeks	60-70	Nonuser	Male	699.0	329.3	369.7
66	All	108	2 Weeks	60-70	Nonuser	Male	393.1	210.6	182.4
67	All	110	2 Weeks	60-70	Nonuser	Male	997.4	367.7	629.6



No	Mode	ID	Test Time	Age	Cruise Usage	Gender	Time (minutes) for different velocity ranges		
							> 35mph	35-55mph	> 55mph
68	All	113	2 Weeks	60-70	Nonuser	Male	835.9	335.9	500.0
69	All	115	2 Weeks	60-70	Nonuser	Male	445.7	306.4	139.3
70	All	116	2 Weeks	60-70	Nonuser	Male	351.6	208.6	143.0
71	All	13	2 Weeks	60-70	User	Female	905.8	346.5	559.3
72	All	48	2 Weeks	60-70	User	Female	479.6	267.0	212.6
73	All	57	2 Weeks	60-70	User	Female	275.4	164.5	110.9
74	All	65	2 Weeks	60-70	User	Female	685.5	282.8	402.7
75	All	67	2 Weeks	60-70	User	Female	462.2	209.7	252.5
76	All	69	2 Weeks	60-70	User	Female	334.2	231.9	102.4
77	All	72	2 Weeks	60-70	User	Female	593.7	146.0	447.6
78	All	7	2 Weeks	60-70	User	Male	1572.1	459.8	1112.3
79	All	11	2 Weeks	60-70	User	Male	1405.0	604.5	800.5
80	All	18	2 Weeks	60-70	User	Male	666.7	300.5	366.2
81	All	19	2 Weeks	60-70	User	Male	751.9	443.0	308.9
82	All	20	2 Weeks	60-70	User	Male	638.2	255.0	383.1
83	All	32	2 Weeks	60-70	User	Male	382.7	217.1	165.6
84	All	47	2 Weeks	60-70	User	Male	605.7	268.8	336.9
85	All	56	5 Weeks	20-30	User	Female	1890.2	631.5	1258.7
86	All	73	5 Weeks	20-30	User	Female	2014.7	743.3	1271.4
87	All	79	5 Weeks	20-30	User	Female	984.6	698.8	285.8
88	All	87	5 Weeks	20-30	User	Female	1621.5	654.6	966.9
89	All	55	5 Weeks	20-30	User	Male	1050.9	720.1	330.8
90	All	68	5 Weeks	20-30	User	Male	3351.3	692.8	2658.5
91	All	76	5 Weeks	20-30	User	Male	2113.2	721.0	1392.2
92	All	89	5 Weeks	20-30	User	Male	2711.4	736.8	1974.6
93	All	88	5 Weeks	40-50	User	Female	2045.8	657.9	1387.9
94	All	96	5 Weeks	40-50	User	Female	2009.0	602.9	1406.1
95	All	99	5 Weeks	40-50	User	Female	3265.7	904.3	2361.4
96	All	104	5 Weeks	40-50	User	Female	1799.6	865.3	934.3
97	All	78	5 Weeks	40-50	User	Male	1741.1	423.1	1318.0
98	All	81	5 Weeks	40-50	User	Male	1410.2	896.7	513.5
99	All	92	5 Weeks	40-50	User	Male	1109.7	379.8	729.8
100	All	100	5 Weeks	40-50	User	Male	2178.2	1049.7	1128.4
101	All	70	5 Weeks	60-70	User	Female	987.4	533.1	454.4
102	All	77	5 Weeks	60-70	User	Female	1233.0	768.7	464.3
103	All	90	5 Weeks	60-70	User	Female	1306.0	552.4	753.5
104	All	97	5 Weeks	60-70	User	Female	927.2	546.9	380.2
105	All	40	5 Weeks	60-70	User	Male	2641.2	589.0	2052.2
106	All	62	5 Weeks	60-70	User	Male	972.7	652.4	320.2
107	All	66	5 Weeks	60-70	User	Male	1522.9	787.7	735.1
108	All	85	5 Weeks	60-70	User	Male	1612.5	672.1	940.4
1	CCC	27	2 Weeks	20-30	Nonuser	Female	0.3	0.0	0.3
2	CCC	31	2 Weeks	20-30	Nonuser	Female	4.6	0.8	3.8
3	CCC	38	2 Weeks	20-30	Nonuser	Female	6.9	6.9	0.0

No	Mode	ID	Test Time	Age	Cruise Usage	Gender	Time (minutes) for different velocity ranges		
							> 35mph	35-55mph	> 55mph
4	CCC	39	2 Weeks	20-30	Nonuser	Female	51.6	33.9	17.8
5	CCC	44	2 Weeks	20-30	Nonuser	Female	1.1	0.7	0.3
6	CCC	45	2 Weeks	20-30	Nonuser	Female	2.6	0.0	2.6
7	CCC	49	2 Weeks	20-30	Nonuser	Female	57.5	0.0	57.5
8	CCC	4	2 Weeks	20-30	Nonuser	Male	180.4	0.0	180.4
9	CCC	41	2 Weeks	20-30	Nonuser	Male	0.0	0.0	0.0
10	CCC	63	2 Weeks	20-30	Nonuser	Male	32.0	0.0	32.0
11	CCC	93	2 Weeks	20-30	Nonuser	Male	62.2	26.7	35.6
12	CCC	98	2 Weeks	20-30	Nonuser	Male	636.2	0.6	635.6
13	CCC	109	2 Weeks	20-30	Nonuser	Male	276.5	0.1	276.5
14	CCC	114	2 Weeks	20-30	Nonuser	Male	36.6	0.0	36.6
15	CCC	10	2 Weeks	20-30	User	Female	117.2	3.3	113.9
16	CCC	15	2 Weeks	20-30	User	Female	9.2	0.0	9.2
17	CCC	30	2 Weeks	20-30	User	Female	124.7	0.5	124.1
18	CCC	42	2 Weeks	20-30	User	Female	13.9	2.0	11.9
19	CCC	50	2 Weeks	20-30	User	Female	13.1	0.9	12.3
20	CCC	51	2 Weeks	20-30	User	Female	0.0	0.0	0.0
21	CCC	52	2 Weeks	20-30	User	Female	71.4	1.4	70.0
22	CCC	33	2 Weeks	20-30	User	Male	82.3	26.8	55.5
23	CCC	37	2 Weeks	20-30	User	Male	42.8	24.2	18.6
24	CCC	54	2 Weeks	20-30	User	Male	29.9	0.0	29.9
25	CCC	59	2 Weeks	20-30	User	Male	13.5	5.9	7.6
26	CCC	60	2 Weeks	20-30	User	Male	41.2	0.9	40.3
27	CCC	61	2 Weeks	20-30	User	Male	8.1	2.9	5.2
28	CCC	64	2 Weeks	20-30	User	Male	8.4	0.0	8.4
29	CCC	1	2 Weeks	40-50	Nonuser	Female	0.0	0.0	0.0
30	CCC	23	2 Weeks	40-50	Nonuser	Female	41.5	0.0	41.5
31	CCC	25	2 Weeks	40-50	Nonuser	Female	2.0	0.1	1.9
32	CCC	26	2 Weeks	40-50	Nonuser	Female	75.2	3.2	72.0
33	CCC	29	2 Weeks	40-50	Nonuser	Female	18.9	0.7	18.1
34	CCC	80	2 Weeks	40-50	Nonuser	Female	248.0	0.1	247.9
35	CCC	84	2 Weeks	40-50	Nonuser	Female	159.1	14.4	144.7
36	CCC	34	2 Weeks	40-50	Nonuser	Male	407.8	4.2	403.6
37	CCC	75	2 Weeks	40-50	Nonuser	Male	137.6	92.9	44.7
38	CCC	94	2 Weeks	40-50	Nonuser	Male	126.8	0.0	126.8
39	CCC	102	2 Weeks	40-50	Nonuser	Male	0.1	0.0	0.1
40	CCC	111	2 Weeks	40-50	Nonuser	Male	90.6	0.0	90.6
41	CCC	112	2 Weeks	40-50	Nonuser	Male	51.1	0.4	50.7
42	CCC	117	2 Weeks	40-50	Nonuser	Male	26.4	0.8	25.6
43	CCC	5	2 Weeks	40-50	User	Female	39.0	0.0	39.0
44	CCC	6	2 Weeks	40-50	User	Female	24.4	0.4	23.9
45	CCC	8	2 Weeks	40-50	User	Female	163.5	13.7	149.8
46	CCC	9	2 Weeks	40-50	User	Female	134.5	17.9	116.6
47	CCC	12	2 Weeks	40-50	User	Female	73.7	10.6	63.0

No	Mode	ID	Test Time	Age	Cruise Usage	Gender	Time (minutes) for different velocity ranges		
							> 35mph	35-55mph	> 55mph
48	CCC	21	2 Weeks	40-50	User	Female	83.4	14.7	68.7
49	CCC	24	2 Weeks	40-50	User	Female	72.2	2.4	69.8
50	CCC	3	2 Weeks	40-50	User	Male	46.4	14.8	31.6
51	CCC	14	2 Weeks	40-50	User	Male	136.9	11.0	125.8
52	CCC	17	2 Weeks	40-50	User	Male	72.7	13.7	59.0
53	CCC	22	2 Weeks	40-50	User	Male	40.8	4.6	36.2
54	CCC	35	2 Weeks	40-50	User	Male	249.8	2.1	247.7
55	CCC	74	2 Weeks	40-50	User	Male	51.1	33.4	17.7
56	CCC	105	2 Weeks	40-50	User	Male	113.0	0.1	113.0
57	CCC	43	2 Weeks	60-70	Nonuser	Female	59.0	38.2	20.8
58	CCC	46	2 Weeks	60-70	Nonuser	Female	38.6	7.4	31.2
59	CCC	82	2 Weeks	60-70	Nonuser	Female	0.8	0.1	0.8
60	CCC	83	2 Weeks	60-70	Nonuser	Female	12.1	11.3	0.8
61	CCC	91	2 Weeks	60-70	Nonuser	Female	124.6	85.3	39.3
62	CCC	95	2 Weeks	60-70	Nonuser	Female	21.0	1.0	20.0
63	CCC	106	2 Weeks	60-70	Nonuser	Female	22.4	0.3	22.1
64	CCC	103	2 Weeks	60-70	Nonuser	Male	87.5	31.6	55.9
65	CCC	107	2 Weeks	60-70	Nonuser	Male	70.8	2.4	68.3
66	CCC	108	2 Weeks	60-70	Nonuser	Male	7.8	0.8	6.9
67	CCC	110	2 Weeks	60-70	Nonuser	Male	189.6	16.6	173.0
68	CCC	113	2 Weeks	60-70	Nonuser	Male	197.6	21.4	176.3
69	CCC	115	2 Weeks	60-70	Nonuser	Male	12.9	2.4	10.5
70	CCC	116	2 Weeks	60-70	Nonuser	Male	3.6	0.0	3.6
71	CCC	13	2 Weeks	60-70	User	Female	236.5	25.5	211.0
72	CCC	48	2 Weeks	60-70	User	Female	18.7	6.0	12.7
73	CCC	57	2 Weeks	60-70	User	Female	38.4	6.6	31.8
74	CCC	65	2 Weeks	60-70	User	Female	70.3	0.0	70.3
75	CCC	67	2 Weeks	60-70	User	Female	67.0	12.8	54.3
76	CCC	69	2 Weeks	60-70	User	Female	35.3	28.6	6.8
77	CCC	72	2 Weeks	60-70	User	Female	11.4	1.0	10.4
78	CCC	7	2 Weeks	60-70	User	Male	50.2	0.0	50.2
79	CCC	11	2 Weeks	60-70	User	Male	590.2	227.8	362.3
80	CCC	18	2 Weeks	60-70	User	Male	73.2	38.1	35.1
81	CCC	19	2 Weeks	60-70	User	Male	175.3	39.1	136.2
82	CCC	20	2 Weeks	60-70	User	Male	40.4	23.0	17.4
83	CCC	32	2 Weeks	60-70	User	Male	24.1	0.0	24.1
84	CCC	47	2 Weeks	60-70	User	Male	116.0	8.4	107.6
85	CCC	56	5 Weeks	20-30	User	Female	88.9	10.5	78.4
86	CCC	73	5 Weeks	20-30	User	Female	85.3	0.1	85.2
87	CCC	79	5 Weeks	20-30	User	Female	83.5	10.3	73.2
88	CCC	87	5 Weeks	20-30	User	Female	66.9	1.6	65.3
89	CCC	55	5 Weeks	20-30	User	Male	84.2	0.3	83.9
90	CCC	68	5 Weeks	20-30	User	Male	143.0	0.0	143.0
91	CCC	76	5 Weeks	20-30	User	Male	208.8	11.0	197.8

No	Mode	ID	Test Time	Age	Cruise Usage	Gender	Time (minutes) for different velocity ranges		
							> 35mph	35-55mph	> 55mph
92	CCC	89	5 Weeks	20-30	User	Male	106.3	0.2	106.1
93	CCC	88	5 Weeks	40-50	User	Female	169.1	21.8	147.3
94	CCC	96	5 Weeks	40-50	User	Female	55.9	0.0	55.9
95	CCC	99	5 Weeks	40-50	User	Female	187.4	0.7	186.7
96	CCC	104	5 Weeks	40-50	User	Female	381.2	0.0	381.2
97	CCC	78	5 Weeks	40-50	User	Male	193.0	0.0	193.0
98	CCC	81	5 Weeks	40-50	User	Male	63.4	10.3	53.1
99	CCC	92	5 Weeks	40-50	User	Male	139.3	15.0	124.3
100	CCC	100	5 Weeks	40-50	User	Male	157.8	1.8	156.0
101	CCC	70	5 Weeks	60-70	User	Female	104.5	15.8	88.6
102	CCC	77	5 Weeks	60-70	User	Female	78.6	22.1	56.5
103	CCC	90	5 Weeks	60-70	User	Female	234.7	24.6	210.1
104	CCC	97	5 Weeks	60-70	User	Female	71.1	16.0	55.2
105	CCC	40	5 Weeks	60-70	User	Male	24.8	0.1	24.7
106	CCC	62	5 Weeks	60-70	User	Male	74.9	8.3	66.6
107	CCC	66	5 Weeks	60-70	User	Male	71.7	12.4	59.3
108	CCC	85	5 Weeks	60-70	User	Male	25.5	0.0	25.5
1	Man1	27	2 Weeks	20-30	Nonuser	Female	70.4	56.7	13.7
2	Man1	31	2 Weeks	20-30	Nonuser	Female	123.8	53.9	69.9
3	Man1	38	2 Weeks	20-30	Nonuser	Female	14.6	14.6	0.0
4	Man1	39	2 Weeks	20-30	Nonuser	Female	147.7	122.0	25.7
5	Man1	44	2 Weeks	20-30	Nonuser	Female	357.2	287.3	69.9
6	Man1	45	2 Weeks	20-30	Nonuser	Female	87.5	41.9	45.6
7	Man1	49	2 Weeks	20-30	Nonuser	Female	408.7	95.2	313.5
8	Man1	4	2 Weeks	20-30	Nonuser	Male	352.5	127.5	225.0
9	Man1	41	2 Weeks	20-30	Nonuser	Male	122.0	68.4	53.5
10	Man1	63	2 Weeks	20-30	Nonuser	Male	296.1	214.0	82.1
11	Man1	93	2 Weeks	20-30	Nonuser	Male	192.1	122.3	69.8
12	Man1	98	2 Weeks	20-30	Nonuser	Male	761.2	377.1	384.1
13	Man1	109	2 Weeks	20-30	Nonuser	Male	337.7	159.2	178.5
14	Man1	114	2 Weeks	20-30	Nonuser	Male	267.1	111.1	156.0
15	Man1	10	2 Weeks	20-30	User	Female	170.3	89.3	81.0
16	Man1	15	2 Weeks	20-30	User	Female	151.0	91.1	59.9
17	Man1	30	2 Weeks	20-30	User	Female	183.1	110.7	72.4
18	Man1	42	2 Weeks	20-30	User	Female	108.5	46.2	62.3
19	Man1	50	2 Weeks	20-30	User	Female	201.7	154.5	47.3
20	Man1	51	2 Weeks	20-30	User	Female	2.5	2.5	0.0
21	Man1	52	2 Weeks	20-30	User	Female	232.9	134.5	98.4
22	Man1	33	2 Weeks	20-30	User	Male	222.0	183.1	38.9
23	Man1	37	2 Weeks	20-30	User	Male	206.4	202.8	3.6
24	Man1	54	2 Weeks	20-30	User	Male	274.3	176.6	97.8
25	Man1	59	2 Weeks	20-30	User	Male	177.3	100.6	76.7
26	Man1	60	2 Weeks	20-30	User	Male	82.2	61.7	20.5
27	Man1	61	2 Weeks	20-30	User	Male	373.6	285.0	88.5

No	Mode	ID	Test Time	Age	Cruise Usage	Gender	Time (minutes) for different velocity ranges		
							> 35mph	35-55mph	> 55mph
28	Man1	64	2 Weeks	20-30	User	Male	238.9	135.3	103.6
29	Man1	1	2 Weeks	40-50	Nonuser	Female	205.7	152.8	52.9
30	Man1	23	2 Weeks	40-50	Nonuser	Female	133.7	45.4	88.3
31	Man1	25	2 Weeks	40-50	Nonuser	Female	163.2	96.3	67.0
32	Man1	26	2 Weeks	40-50	Nonuser	Female	171.9	148.0	23.9
33	Man1	29	2 Weeks	40-50	Nonuser	Female	209.3	141.8	67.4
34	Man1	80	2 Weeks	40-50	Nonuser	Female	253.5	74.9	178.6
35	Man1	84	2 Weeks	40-50	Nonuser	Female	248.5	149.1	99.4
36	Man1	34	2 Weeks	40-50	Nonuser	Male	323.6	130.2	193.4
37	Man1	75	2 Weeks	40-50	Nonuser	Male	262.9	226.7	36.2
38	Man1	94	2 Weeks	40-50	Nonuser	Male	147.4	66.8	80.6
39	Man1	102	2 Weeks	40-50	Nonuser	Male	312.1	249.5	62.6
40	Man1	111	2 Weeks	40-50	Nonuser	Male	504.1	191.4	312.7
41	Man1	112	2 Weeks	40-50	Nonuser	Male	428.8	243.1	185.7
42	Man1	117	2 Weeks	40-50	Nonuser	Male	170.1	130.5	39.6
43	Man1	5	2 Weeks	40-50	User	Female	215.6	104.5	111.0
44	Man1	6	2 Weeks	40-50	User	Female	182.5	134.1	48.4
45	Man1	8	2 Weeks	40-50	User	Female	528.6	173.5	355.1
46	Man1	9	2 Weeks	40-50	User	Female	332.6	192.8	139.8
47	Man1	12	2 Weeks	40-50	User	Female	237.0	167.0	70.0
48	Man1	21	2 Weeks	40-50	User	Female	97.1	68.1	29.0
49	Man1	24	2 Weeks	40-50	User	Female	49.8	46.1	3.7
50	Man1	3	2 Weeks	40-50	User	Male	137.1	107.5	29.5
51	Man1	14	2 Weeks	40-50	User	Male	85.1	48.9	36.2
52	Man1	17	2 Weeks	40-50	User	Male	94.8	77.0	17.9
53	Man1	22	2 Weeks	40-50	User	Male	145.6	125.8	19.8
54	Man1	35	2 Weeks	40-50	User	Male	402.3	206.8	195.4
55	Man1	74	2 Weeks	40-50	User	Male	65.2	55.3	9.9
56	Man1	105	2 Weeks	40-50	User	Male	270.5	130.4	140.2
57	Man1	43	2 Weeks	60-70	Nonuser	Female	62.9	47.3	15.6
58	Man1	46	2 Weeks	60-70	Nonuser	Female	72.6	56.7	15.9
59	Man1	82	2 Weeks	60-70	Nonuser	Female	71.7	28.8	42.9
60	Man1	83	2 Weeks	60-70	Nonuser	Female	86.7	66.7	20.0
61	Man1	91	2 Weeks	60-70	Nonuser	Female	73.2	67.0	6.2
62	Man1	95	2 Weeks	60-70	Nonuser	Female	83.6	68.3	15.3
63	Man1	106	2 Weeks	60-70	Nonuser	Female	137.8	97.1	40.7
64	Man1	103	2 Weeks	60-70	Nonuser	Male	169.2	100.3	68.8
65	Man1	107	2 Weeks	60-70	Nonuser	Male	315.5	196.4	119.1
66	Man1	108	2 Weeks	60-70	Nonuser	Male	99.9	97.3	2.6
67	Man1	110	2 Weeks	60-70	Nonuser	Male	323.5	176.1	147.4
68	Man1	113	2 Weeks	60-70	Nonuser	Male	340.0	132.3	207.7
69	Man1	115	2 Weeks	60-70	Nonuser	Male	180.9	163.0	17.9
70	Man1	116	2 Weeks	60-70	Nonuser	Male	115.8	75.8	40.0
71	Man1	13	2 Weeks	60-70	User	Female	158.1	137.6	20.4

No	Mode	ID	Test Time	Age	Cruise Usage	Gender	Time (minutes) for different velocity ranges		
							> 35mph	35-55mph	> 55mph
72	Man1	48	2 Weeks	60-70	User	Female	166.9	147.0	19.9
73	Man1	57	2 Weeks	60-70	User	Female	66.6	53.0	13.5
74	Man1	65	2 Weeks	60-70	User	Female	478.1	180.1	298.0
75	Man1	67	2 Weeks	60-70	User	Female	83.2	41.7	41.6
76	Man1	69	2 Weeks	60-70	User	Female	94.3	80.7	13.6
77	Man1	72	2 Weeks	60-70	User	Female	64.7	51.1	13.6
78	Man1	7	2 Weeks	60-70	User	Male	441.6	169.9	271.7
79	Man1	11	2 Weeks	60-70	User	Male	146.2	133.4	12.8
80	Man1	18	2 Weeks	60-70	User	Male	104.3	100.2	4.2
81	Man1	19	2 Weeks	60-70	User	Male	190.2	156.5	33.6
82	Man1	20	2 Weeks	60-70	User	Male	84.2	79.5	4.6
83	Man1	32	2 Weeks	60-70	User	Male	159.7	97.6	62.1
84	Man1	47	2 Weeks	60-70	User	Male	176.3	123.9	52.4
85	Man1	56	5 Weeks	20-30	User	Female	222.6	132.1	90.5
86	Man1	73	5 Weeks	20-30	User	Female	272.4	112.6	159.9
87	Man1	79	5 Weeks	20-30	User	Female	179.7	139.8	40.0
88	Man1	87	5 Weeks	20-30	User	Female	232.3	128.3	104.0
89	Man1	55	5 Weeks	20-30	User	Male	236.0	184.4	51.5
90	Man1	68	5 Weeks	20-30	User	Male	352.2	162.2	189.9
91	Man1	76	5 Weeks	20-30	User	Male	288.2	157.4	130.7
92	Man1	89	5 Weeks	20-30	User	Male	138.1	86.6	51.5
93	Man1	88	5 Weeks	40-50	User	Female	391.8	185.9	205.9
94	Man1	96	5 Weeks	40-50	User	Female	167.5	82.1	85.3
95	Man1	99	5 Weeks	40-50	User	Female	172.6	100.4	72.2
96	Man1	104	5 Weeks	40-50	User	Female	425.1	119.2	305.9
97	Man1	78	5 Weeks	40-50	User	Male	113.6	90.4	23.1
98	Man1	81	5 Weeks	40-50	User	Male	192.2	165.3	26.9
99	Man1	92	5 Weeks	40-50	User	Male	66.4	41.0	25.4
100	Man1	100	5 Weeks	40-50	User	Male	371.5	249.8	121.7
101	Man1	70	5 Weeks	60-70	User	Female	126.8	94.3	32.5
102	Man1	77	5 Weeks	60-70	User	Female	158.6	116.2	42.4
103	Man1	90	5 Weeks	60-70	User	Female	207.7	122.6	85.0
104	Man1	97	5 Weeks	60-70	User	Female	147.9	116.4	31.5
105	Man1	40	5 Weeks	60-70	User	Male	71.2	68.0	3.2
106	Man1	62	5 Weeks	60-70	User	Male	79.1	66.1	13.0
107	Man1	66	5 Weeks	60-70	User	Male	175.3	128.8	46.6
108	Man1	85	5 Weeks	60-70	User	Male	349.8	119.1	230.7
1	Man2	27	2 Weeks	20-30	Nonuser	Female	145.8	114.6	31.2
2	Man2	31	2 Weeks	20-30	Nonuser	Female	205.9	86.5	119.4
3	Man2	38	2 Weeks	20-30	Nonuser	Female	104.9	90.6	14.3
4	Man2	39	2 Weeks	20-30	Nonuser	Female	103.4	100.2	3.2
5	Man2	44	2 Weeks	20-30	Nonuser	Female	348.1	329.8	18.3
6	Man2	45	2 Weeks	20-30	Nonuser	Female	290.2	155.2	135.0
7	Man2	49	2 Weeks	20-30	Nonuser	Female	551.6	99.1	452.6

No	Mode	ID	Test Time	Age	Cruise Usage	Gender	Time (minutes) for different velocity ranges		
							> 35mph	35-55mph	> 55mph
8	Man2	4	2 Weeks	20-30	Nonuser	Male	694.2	162.5	531.7
9	Man2	41	2 Weeks	20-30	Nonuser	Male	75.3	42.0	33.3
10	Man2	63	2 Weeks	20-30	Nonuser	Male	318.3	264.7	53.6
11	Man2	93	2 Weeks	20-30	Nonuser	Male	141.9	111.6	30.3
12	Man2	98	2 Weeks	20-30	Nonuser	Male	467.8	284.2	183.5
13	Man2	109	2 Weeks	20-30	Nonuser	Male	170.6	141.9	28.6
14	Man2	114	2 Weeks	20-30	Nonuser	Male	170.7	137.1	33.6
15	Man2	10	2 Weeks	20-30	User	Female	192.3	97.2	95.1
16	Man2	15	2 Weeks	20-30	User	Female	123.2	71.2	52.0
17	Man2	30	2 Weeks	20-30	User	Female	182.3	121.1	61.2
18	Man2	42	2 Weeks	20-30	User	Female	124.2	54.9	69.2
19	Man2	50	2 Weeks	20-30	User	Female	442.9	338.8	104.1
20	Man2	51	2 Weeks	20-30	User	Female	246.9	195.9	51.1
21	Man2	52	2 Weeks	20-30	User	Female	371.9	144.6	227.3
22	Man2	33	2 Weeks	20-30	User	Male	329.9	247.3	82.6
23	Man2	37	2 Weeks	20-30	User	Male	173.3	164.5	8.9
24	Man2	54	2 Weeks	20-30	User	Male	348.5	241.5	107.0
25	Man2	59	2 Weeks	20-30	User	Male	244.2	145.0	99.1
26	Man2	60	2 Weeks	20-30	User	Male	85.6	71.7	13.9
27	Man2	61	2 Weeks	20-30	User	Male	582.0	315.7	266.3
28	Man2	64	2 Weeks	20-30	User	Male	161.9	129.2	32.7
29	Man2	1	2 Weeks	40-50	Nonuser	Female	208.6	161.9	46.7
30	Man2	23	2 Weeks	40-50	Nonuser	Female	30.6	18.9	11.8
31	Man2	25	2 Weeks	40-50	Nonuser	Female	112.2	70.8	41.4
32	Man2	26	2 Weeks	40-50	Nonuser	Female	164.0	112.0	52.0
33	Man2	29	2 Weeks	40-50	Nonuser	Female	105.4	69.9	35.5
34	Man2	80	2 Weeks	40-50	Nonuser	Female	150.4	138.9	11.4
35	Man2	84	2 Weeks	40-50	Nonuser	Female	135.2	111.4	23.8
36	Man2	34	2 Weeks	40-50	Nonuser	Male	290.2	186.6	103.6
37	Man2	75	2 Weeks	40-50	Nonuser	Male	339.8	247.4	92.4
38	Man2	94	2 Weeks	40-50	Nonuser	Male	620.0	403.3	216.7
39	Man2	102	2 Weeks	40-50	Nonuser	Male	1224.0	415.8	808.3
40	Man2	111	2 Weeks	40-50	Nonuser	Male	270.4	204.6	65.9
41	Man2	112	2 Weeks	40-50	Nonuser	Male	170.8	139.5	31.3
42	Man2	117	2 Weeks	40-50	Nonuser	Male	394.3	309.2	85.1
43	Man2	5	2 Weeks	40-50	User	Female	196.6	78.8	117.7
44	Man2	6	2 Weeks	40-50	User	Female	96.4	75.6	20.8
45	Man2	8	2 Weeks	40-50	User	Female	162.3	111.7	50.6
46	Man2	9	2 Weeks	40-50	User	Female	240.4	116.8	123.6
47	Man2	12	2 Weeks	40-50	User	Female	133.5	106.9	26.6
48	Man2	21	2 Weeks	40-50	User	Female	162.5	143.6	18.9
49	Man2	24	2 Weeks	40-50	User	Female	104.0	91.3	12.7
50	Man2	3	2 Weeks	40-50	User	Male	55.9	48.3	7.6
51	Man2	14	2 Weeks	40-50	User	Male	140.1	94.7	45.4

No	Mode	ID	Test Time	Age	Cruise Usage	Gender	Time (minutes) for different velocity ranges		
							> 35mph	35-55mph	> 55mph
52	Man2	17	2 Weeks	40-50	User	Male	52.4	48.4	4.0
53	Man2	22	2 Weeks	40-50	User	Male	105.7	98.9	6.8
54	Man2	35	2 Weeks	40-50	User	Male	266.5	254.7	11.8
55	Man2	74	2 Weeks	40-50	User	Male	52.9	43.4	9.5
56	Man2	105	2 Weeks	40-50	User	Male	280.7	154.5	126.1
57	Man2	43	2 Weeks	60-70	Nonuser	Female	113.6	95.8	17.8
58	Man2	46	2 Weeks	60-70	Nonuser	Female	101.2	89.3	11.9
59	Man2	82	2 Weeks	60-70	Nonuser	Female	242.1	160.1	82.0
60	Man2	83	2 Weeks	60-70	Nonuser	Female	36.7	24.5	12.1
61	Man2	91	2 Weeks	60-70	Nonuser	Female	39.6	34.9	4.8
62	Man2	95	2 Weeks	60-70	Nonuser	Female	94.2	75.7	18.5
63	Man2	106	2 Weeks	60-70	Nonuser	Female	174.4	143.5	31.0
64	Man2	103	2 Weeks	60-70	Nonuser	Male	151.2	103.5	47.7
65	Man2	107	2 Weeks	60-70	Nonuser	Male	147.7	98.9	48.9
66	Man2	108	2 Weeks	60-70	Nonuser	Male	146.7	112.5	34.3
67	Man2	110	2 Weeks	60-70	Nonuser	Male	183.6	135.1	48.5
68	Man2	113	2 Weeks	60-70	Nonuser	Male	130.9	113.4	17.5
69	Man2	115	2 Weeks	60-70	Nonuser	Male	160.1	130.0	30.1
70	Man2	116	2 Weeks	60-70	Nonuser	Male	185.9	128.0	57.9
71	Man2	13	2 Weeks	60-70	User	Female	176.1	152.9	23.2
72	Man2	48	2 Weeks	60-70	User	Female	202.1	110.0	92.1
73	Man2	57	2 Weeks	60-70	User	Female	102.1	90.4	11.7
74	Man2	65	2 Weeks	60-70	User	Female	83.6	73.5	10.1
75	Man2	67	2 Weeks	60-70	User	Female	156.7	131.9	24.8
76	Man2	69	2 Weeks	60-70	User	Female	135.2	111.7	23.5
77	Man2	72	2 Weeks	60-70	User	Female	157.0	93.2	63.8
78	Man2	7	2 Weeks	60-70	User	Male	619.3	216.7	402.7
79	Man2	11	2 Weeks	60-70	User	Male	145.7	134.8	10.9
80	Man2	18	2 Weeks	60-70	User	Male	101.3	88.5	12.8
81	Man2	19	2 Weeks	60-70	User	Male	182.1	170.0	12.1
82	Man2	20	2 Weeks	60-70	User	Male	208.0	124.6	83.5
83	Man2	32	2 Weeks	60-70	User	Male	147.3	118.1	29.2
84	Man2	47	2 Weeks	60-70	User	Male	123.4	97.8	25.6
85	Man2	56	5 Weeks	20-30	User	Female	847.4	484.6	362.7
86	Man2	73	5 Weeks	20-30	User	Female	1075.1	571.5	503.6
87	Man2	79	5 Weeks	20-30	User	Female	610.9	524.4	86.4
88	Man2	87	5 Weeks	20-30	User	Female	777.9	503.2	274.6
89	Man2	55	5 Weeks	20-30	User	Male	452.3	431.4	20.8
90	Man2	68	5 Weeks	20-30	User	Male	2000.0	530.6	1469.4
91	Man2	76	5 Weeks	20-30	User	Male	689.6	504.1	185.6
92	Man2	89	5 Weeks	20-30	User	Male	1240.0	587.0	652.9
93	Man2	88	5 Weeks	40-50	User	Female	777.5	329.5	447.9
94	Man2	96	5 Weeks	40-50	User	Female	784.9	492.8	292.1
95	Man2	99	5 Weeks	40-50	User	Female	982.5	766.6	215.9



No	Mode	ID	Test Time	Age	Cruise Usage	Gender	Time (minutes) for different velocity ranges		
							> 35mph	35-55mph	> 55mph
96	Man2	104	5 Weeks	40-50	User	Female	824.5	701.7	122.8
97	Man2	78	5 Weeks	40-50	User	Male	519.5	332.7	186.8
98	Man2	81	5 Weeks	40-50	User	Male	826.4	665.4	161.0
99	Man2	92	5 Weeks	40-50	User	Male	304.5	215.5	89.0
100	Man2	100	5 Weeks	40-50	User	Male	936.2	699.6	236.6
101	Man2	70	5 Weeks	60-70	User	Female	404.7	343.7	61.0
102	Man2	77	5 Weeks	60-70	User	Female	641.0	471.4	169.5
103	Man2	90	5 Weeks	60-70	User	Female	355.7	267.8	87.9
104	Man2	97	5 Weeks	60-70	User	Female	483.6	391.5	92.1
105	Man2	40	5 Weeks	60-70	User	Male	687.4	457.6	229.8
106	Man2	62	5 Weeks	60-70	User	Male	349.6	321.1	28.5
107	Man2	66	5 Weeks	60-70	User	Male	491.1	422.3	68.8
108	Man2	85	5 Weeks	60-70	User	Male	930.3	548.7	381.6
1	Manual	27	2 Weeks	20-30	Nonuser	Female	216.2	171.4	44.9
2	Manual	31	2 Weeks	20-30	Nonuser	Female	329.7	140.4	189.3
3	Manual	38	2 Weeks	20-30	Nonuser	Female	119.5	105.1	14.3
4	Manual	39	2 Weeks	20-30	Nonuser	Female	251.1	222.2	28.8
5	Manual	44	2 Weeks	20-30	Nonuser	Female	705.3	617.1	88.1
6	Manual	45	2 Weeks	20-30	Nonuser	Female	377.6	197.1	180.6
7	Manual	49	2 Weeks	20-30	Nonuser	Female	960.3	194.3	766.0
8	Manual	4	2 Weeks	20-30	Nonuser	Male	1046.7	290.0	756.6
9	Manual	41	2 Weeks	20-30	Nonuser	Male	197.2	110.4	86.8
10	Manual	63	2 Weeks	20-30	Nonuser	Male	614.5	478.7	135.8
11	Manual	93	2 Weeks	20-30	Nonuser	Male	334.0	233.9	100.1
12	Manual	98	2 Weeks	20-30	Nonuser	Male	1229.0	661.3	567.7
13	Manual	109	2 Weeks	20-30	Nonuser	Male	508.2	301.1	207.1
14	Manual	114	2 Weeks	20-30	Nonuser	Male	437.8	248.2	189.6
15	Manual	10	2 Weeks	20-30	User	Female	362.6	186.5	176.1
16	Manual	15	2 Weeks	20-30	User	Female	274.2	162.3	111.9
17	Manual	30	2 Weeks	20-30	User	Female	365.4	231.8	133.6
18	Manual	42	2 Weeks	20-30	User	Female	232.6	101.2	131.5
19	Manual	50	2 Weeks	20-30	User	Female	644.6	493.3	151.4
20	Manual	51	2 Weeks	20-30	User	Female	249.4	198.3	51.1
21	Manual	52	2 Weeks	20-30	User	Female	604.8	279.1	325.7
22	Manual	33	2 Weeks	20-30	User	Male	551.9	430.4	121.5
23	Manual	37	2 Weeks	20-30	User	Male	379.7	367.3	12.4
24	Manual	54	2 Weeks	20-30	User	Male	622.8	418.1	204.8
25	Manual	59	2 Weeks	20-30	User	Male	421.5	245.6	175.8
26	Manual	60	2 Weeks	20-30	User	Male	167.9	133.5	34.4
27	Manual	61	2 Weeks	20-30	User	Male	955.6	600.7	354.9
28	Manual	64	2 Weeks	20-30	User	Male	400.8	264.5	136.3
29	Manual	1	2 Weeks	40-50	Nonuser	Female	414.4	314.7	99.6
30	Manual	23	2 Weeks	40-50	Nonuser	Female	164.3	64.3	100.0
31	Manual	25	2 Weeks	40-50	Nonuser	Female	275.5	167.1	108.4

No	Mode	ID	Test Time	Age	Cruise Usage	Gender	Time (minutes) for different velocity ranges		
							> 35mph	35-55mph	> 55mph
32	Manual	26	2 Weeks	40-50	Nonuser	Female	336.0	260.0	76.0
33	Manual	29	2 Weeks	40-50	Nonuser	Female	314.7	211.7	102.9
34	Manual	80	2 Weeks	40-50	Nonuser	Female	403.9	213.8	190.0
35	Manual	84	2 Weeks	40-50	Nonuser	Female	383.6	260.5	123.1
36	Manual	34	2 Weeks	40-50	Nonuser	Male	613.8	316.8	297.0
37	Manual	75	2 Weeks	40-50	Nonuser	Male	602.7	474.1	128.6
38	Manual	94	2 Weeks	40-50	Nonuser	Male	767.4	470.0	297.3
39	Manual	102	2 Weeks	40-50	Nonuser	Male	1536.1	665.3	870.9
40	Manual	111	2 Weeks	40-50	Nonuser	Male	774.6	395.9	378.6
41	Manual	112	2 Weeks	40-50	Nonuser	Male	599.6	382.6	217.0
42	Manual	117	2 Weeks	40-50	Nonuser	Male	564.4	439.8	124.6
43	Manual	5	2 Weeks	40-50	User	Female	412.1	183.4	228.8
44	Manual	6	2 Weeks	40-50	User	Female	278.9	209.7	69.2
45	Manual	8	2 Weeks	40-50	User	Female	690.9	285.2	405.7
46	Manual	9	2 Weeks	40-50	User	Female	573.0	309.6	263.4
47	Manual	12	2 Weeks	40-50	User	Female	370.6	273.9	96.6
48	Manual	21	2 Weeks	40-50	User	Female	259.5	211.7	47.9
49	Manual	24	2 Weeks	40-50	User	Female	153.8	137.4	16.5
50	Manual	3	2 Weeks	40-50	User	Male	192.9	155.8	37.2
51	Manual	14	2 Weeks	40-50	User	Male	225.2	143.6	81.6
52	Manual	17	2 Weeks	40-50	User	Male	147.3	125.4	21.8
53	Manual	22	2 Weeks	40-50	User	Male	251.3	224.8	26.6
54	Manual	35	2 Weeks	40-50	User	Male	668.8	461.5	207.3
55	Manual	74	2 Weeks	40-50	User	Male	118.1	98.7	19.4
56	Manual	105	2 Weeks	40-50	User	Male	551.2	284.9	266.3
57	Manual	43	2 Weeks	60-70	Nonuser	Female	176.5	143.1	33.4
58	Manual	46	2 Weeks	60-70	Nonuser	Female	173.8	146.0	27.8
59	Manual	82	2 Weeks	60-70	Nonuser	Female	313.8	188.9	124.9
60	Manual	83	2 Weeks	60-70	Nonuser	Female	123.4	91.3	32.1
61	Manual	91	2 Weeks	60-70	Nonuser	Female	112.9	101.9	11.0
62	Manual	95	2 Weeks	60-70	Nonuser	Female	177.8	144.0	33.7
63	Manual	106	2 Weeks	60-70	Nonuser	Female	312.3	240.6	71.7
64	Manual	103	2 Weeks	60-70	Nonuser	Male	320.4	203.8	116.5
65	Manual	107	2 Weeks	60-70	Nonuser	Male	463.3	295.3	167.9
66	Manual	108	2 Weeks	60-70	Nonuser	Male	246.7	209.8	36.9
67	Manual	110	2 Weeks	60-70	Nonuser	Male	507.1	311.2	195.9
68	Manual	113	2 Weeks	60-70	Nonuser	Male	470.9	245.7	225.3
69	Manual	115	2 Weeks	60-70	Nonuser	Male	341.0	293.0	48.0
70	Manual	116	2 Weeks	60-70	Nonuser	Male	301.8	203.8	97.9
71	Manual	13	2 Weeks	60-70	User	Female	334.1	290.5	43.6
72	Manual	48	2 Weeks	60-70	User	Female	369.0	257.0	112.0
73	Manual	57	2 Weeks	60-70	User	Female	168.7	143.4	25.3
74	Manual	65	2 Weeks	60-70	User	Female	561.7	253.6	308.1
75	Manual	67	2 Weeks	60-70	User	Female	240.0	173.6	66.4

No	Mode	ID	Test Time	Age	Cruise Usage	Gender	Time (minutes) for different velocity ranges		
							> 35mph	35-55mph	> 55mph
76	Manual	69	2 Weeks	60-70	User	Female	229.5	192.4	37.1
77	Manual	72	2 Weeks	60-70	User	Female	221.7	144.3	77.4
78	Manual	7	2 Weeks	60-70	User	Male	1060.9	386.5	674.4
79	Manual	11	2 Weeks	60-70	User	Male	291.8	268.1	23.7
80	Manual	18	2 Weeks	60-70	User	Male	205.6	188.6	17.0
81	Manual	19	2 Weeks	60-70	User	Male	372.2	326.6	45.7
82	Manual	20	2 Weeks	60-70	User	Male	292.2	204.1	88.1
83	Manual	32	2 Weeks	60-70	User	Male	307.0	215.6	91.4
84	Manual	47	2 Weeks	60-70	User	Male	299.6	221.7	78.0
85	Manual	56	5 Weeks	20-30	User	Female	1069.9	616.7	453.2
86	Manual	73	5 Weeks	20-30	User	Female	1347.5	684.1	663.4
87	Manual	79	5 Weeks	20-30	User	Female	790.6	664.2	126.4
88	Manual	87	5 Weeks	20-30	User	Female	1010.1	631.5	378.7
89	Manual	55	5 Weeks	20-30	User	Male	688.2	615.9	72.3
90	Manual	68	5 Weeks	20-30	User	Male	2352.1	692.8	1659.3
91	Manual	76	5 Weeks	20-30	User	Male	977.8	661.5	316.3
92	Manual	89	5 Weeks	20-30	User	Male	1378.1	673.6	704.4
93	Manual	88	5 Weeks	40-50	User	Female	1169.3	515.4	653.9
94	Manual	96	5 Weeks	40-50	User	Female	952.4	574.9	377.5
95	Manual	99	5 Weeks	40-50	User	Female	1155.1	867.0	288.1
96	Manual	104	5 Weeks	40-50	User	Female	1249.6	820.9	428.7
97	Manual	78	5 Weeks	40-50	User	Male	633.0	423.1	210.0
98	Manual	81	5 Weeks	40-50	User	Male	1018.6	830.7	187.9
99	Manual	92	5 Weeks	40-50	User	Male	370.9	256.5	114.4
100	Manual	100	5 Weeks	40-50	User	Male	1307.8	949.4	358.3
101	Manual	70	5 Weeks	60-70	User	Female	531.6	438.0	93.5
102	Manual	77	5 Weeks	60-70	User	Female	799.5	587.7	211.9
103	Manual	90	5 Weeks	60-70	User	Female	563.4	390.5	173.0
104	Manual	97	5 Weeks	60-70	User	Female	631.5	507.9	123.6
105	Manual	40	5 Weeks	60-70	User	Male	758.6	525.6	233.0
106	Manual	62	5 Weeks	60-70	User	Male	428.7	387.2	41.5
107	Manual	66	5 Weeks	60-70	User	Male	666.5	551.0	115.4
108	Manual	85	5 Weeks	60-70	User	Male	1280.1	667.8	612.2

Table C-4. Distance statistics summary table (2)

No	Mode	ID	Test Time	Age	Cruise Usage	Gender	Distance (miles) for different velocity ranges			
							All	< 35mph	35-55mph	> 55mph
1	ACC	27	2 Weeks	20-30	Nonuser	Female	79.1	0.4	0.8	77.9
2	ACC	31	2 Weeks	20-30	Nonuser	Female	21.9	0.1	2.5	19.3
3	ACC	38	2 Weeks	20-30	Nonuser	Female	112.6	1.9	41.7	69.0
4	ACC	39	2 Weeks	20-30	Nonuser	Female	81.5	1.2	55.2	25.1
5	ACC	44	2 Weeks	20-30	Nonuser	Female	56.8	0.5	35.0	21.2

No	Mode	ID	Test Time	Age	Cruise Usage	Gender	Distance (miles) for different velocity ranges			
							All	< 35mph	35-55mph	> 55mph
							6	ACC	45	2 Weeks
7	ACC	49	2 Weeks	20-30	Nonuser	Female	51.5	0.2	0.3	51.1
8	ACC	4	2 Weeks	20-30	Nonuser	Male	490.7	1.3	7.0	482.4
9	ACC	41	2 Weeks	20-30	Nonuser	Male	36.8	0.1	0.0	36.7
10	ACC	63	2 Weeks	20-30	Nonuser	Male	24.0	0.0	3.2	20.7
11	ACC	93	2 Weeks	20-30	Nonuser	Male	478.3	2.6	8.9	466.8
12	ACC	98	2 Weeks	20-30	Nonuser	Male	846.1	3.7	39.7	802.8
13	ACC	109	2 Weeks	20-30	Nonuser	Male	61.9	0.3	7.3	54.3
14	ACC	114	2 Weeks	20-30	Nonuser	Male	25.3	0.1	5.1	20.0
15	ACC	10	2 Weeks	20-30	User	Female	66.9	0.5	4.8	61.6
16	ACC	15	2 Weeks	20-30	User	Female	141.3	0.4	2.6	138.2
17	ACC	30	2 Weeks	20-30	User	Female	116.5	0.2	4.3	112.0
18	ACC	42	2 Weeks	20-30	User	Female	41.3	0.8	4.6	35.8
19	ACC	50	2 Weeks	20-30	User	Female	129.6	0.8	20.6	108.1
20	ACC	51	2 Weeks	20-30	User	Female	315.0	0.5	19.4	295.2
21	ACC	52	2 Weeks	20-30	User	Female	458.3	1.8	0.6	456.0
22	ACC	33	2 Weeks	20-30	User	Male	289.4	1.4	24.2	263.8
23	ACC	37	2 Weeks	20-30	User	Male	82.5	0.1	19.2	63.2
24	ACC	54	2 Weeks	20-30	User	Male	332.5	0.6	19.9	312.0
25	ACC	59	2 Weeks	20-30	User	Male	183.2	1.3	28.9	153.0
26	ACC	60	2 Weeks	20-30	User	Male	71.3	0.6	8.4	62.4
27	ACC	61	2 Weeks	20-30	User	Male	181.3	1.1	3.9	176.3
28	ACC	64	2 Weeks	20-30	User	Male	15.5	0.0	0.0	15.5
29	ACC	1	2 Weeks	40-50	Nonuser	Female	41.4	0.2	8.0	33.1
30	ACC	23	2 Weeks	40-50	Nonuser	Female	103.1	0.4	6.8	95.9
31	ACC	25	2 Weeks	40-50	Nonuser	Female	32.7	0.4	1.9	30.3
32	ACC	26	2 Weeks	40-50	Nonuser	Female	156.3	1.1	12.0	143.1
33	ACC	29	2 Weeks	40-50	Nonuser	Female	74.2	0.4	0.4	73.4
34	ACC	80	2 Weeks	40-50	Nonuser	Female	51.7	0.2	10.9	40.6
35	ACC	84	2 Weeks	40-50	Nonuser	Female	184.6	0.2	14.7	169.7
36	ACC	34	2 Weeks	40-50	Nonuser	Male	83.8	0.2	2.3	81.3
37	ACC	75	2 Weeks	40-50	Nonuser	Male	897.2	3.5	50.7	843.1
38	ACC	94	2 Weeks	40-50	Nonuser	Male	354.1	0.6	1.5	352.0
39	ACC	102	2 Weeks	40-50	Nonuser	Male	81.3	0.3	1.3	79.7
40	ACC	111	2 Weeks	40-50	Nonuser	Male	161.6	0.4	4.8	156.4
41	ACC	112	2 Weeks	40-50	Nonuser	Male	46.1	1.1	26.9	18.1
42	ACC	117	2 Weeks	40-50	Nonuser	Male	335.8	0.4	24.4	311.0
43	ACC	5	2 Weeks	40-50	User	Female	60.0	0.5	1.2	58.4
44	ACC	6	2 Weeks	40-50	User	Female	138.2	0.3	1.7	136.3
45	ACC	8	2 Weeks	40-50	User	Female	181.6	0.6	2.1	178.8
46	ACC	9	2 Weeks	40-50	User	Female	626.8	2.3	17.2	607.3
47	ACC	12	2 Weeks	40-50	User	Female	196.8	0.6	12.6	183.5
48	ACC	21	2 Weeks	40-50	User	Female	450.1	7.4	18.4	424.3
49	ACC	24	2 Weeks	40-50	User	Female	345.7	0.7	18.3	326.8

No	Mode	ID	Test Time	Age	Cruise Usage	Gender	Distance (miles) for different velocity ranges			
							All	< 35mph	35-55mph	> 55mph
							50	ACC	3	2 Weeks
51	ACC	14	2 Weeks	40-50	User	Male	214.5	1.9	25.4	187.2
52	ACC	17	2 Weeks	40-50	User	Male	101.0	1.0	28.8	71.2
53	ACC	22	2 Weeks	40-50	User	Male	83.9	2.5	34.0	47.3
54	ACC	35	2 Weeks	40-50	User	Male	106.3	0.7	19.7	85.9
55	ACC	74	2 Weeks	40-50	User	Male	71.7	0.9	25.7	45.1
56	ACC	105	2 Weeks	40-50	User	Male	663.2	2.3	27.4	633.5
57	ACC	43	2 Weeks	60-70	Nonuser	Female	171.8	3.9	78.5	89.5
58	ACC	46	2 Weeks	60-70	Nonuser	Female	79.4	1.8	14.0	63.7
59	ACC	82	2 Weeks	60-70	Nonuser	Female	408.9	1.5	57.9	349.5
60	ACC	83	2 Weeks	60-70	Nonuser	Female	62.7	1.9	24.4	36.4
61	ACC	91	2 Weeks	60-70	Nonuser	Female	209.5	3.5	91.8	114.2
62	ACC	95	2 Weeks	60-70	Nonuser	Female	93.3	0.1	2.4	90.8
63	ACC	106	2 Weeks	60-70	Nonuser	Female	350.2	2.7	7.5	340.0
64	ACC	103	2 Weeks	60-70	Nonuser	Male	124.9	0.5	26.1	98.4
65	ACC	107	2 Weeks	60-70	Nonuser	Male	176.0	2.5	25.1	148.4
66	ACC	108	2 Weeks	60-70	Nonuser	Male	157.1	0.6	0.0	156.4
67	ACC	110	2 Weeks	60-70	Nonuser	Male	313.0	1.3	33.0	278.7
68	ACC	113	2 Weeks	60-70	Nonuser	Male	161.8	4.1	50.2	107.5
69	ACC	115	2 Weeks	60-70	Nonuser	Male	91.6	0.2	9.3	82.2
70	ACC	116	2 Weeks	60-70	Nonuser	Male	47.0	0.1	4.1	42.8
71	ACC	13	2 Weeks	60-70	User	Female	345.0	1.1	26.5	317.4
72	ACC	48	2 Weeks	60-70	User	Female	95.7	0.6	2.7	92.4
73	ACC	57	2 Weeks	60-70	User	Female	69.7	0.8	10.4	58.5
74	ACC	65	2 Weeks	60-70	User	Female	50.2	0.3	23.6	26.4
75	ACC	67	2 Weeks	60-70	User	Female	160.1	0.4	19.9	139.7
76	ACC	69	2 Weeks	60-70	User	Female	73.6	0.4	8.0	65.2
77	ACC	72	2 Weeks	60-70	User	Female	421.0	1.7	0.7	418.5
78	ACC	7	2 Weeks	60-70	User	Male	472.9	2.7	59.8	410.4
79	ACC	11	2 Weeks	60-70	User	Male	514.9	2.0	89.1	423.7
80	ACC	18	2 Weeks	60-70	User	Male	408.3	2.1	53.4	352.7
81	ACC	19	2 Weeks	60-70	User	Male	197.6	1.0	63.1	133.5
82	ACC	20	2 Weeks	60-70	User	Male	319.5	1.3	21.2	297.1
83	ACC	32	2 Weeks	60-70	User	Male	59.0	0.2	1.2	57.6
84	ACC	47	2 Weeks	60-70	User	Male	188.9	0.5	32.9	155.6
85	ACC	56	5 Weeks	20-30	User	Female	863.1	2.8	3.7	856.6
86	ACC	73	5 Weeks	20-30	User	Female	628.5	1.3	49.2	578.1
87	ACC	79	5 Weeks	20-30	User	Female	112.8	0.4	21.0	91.4
88	ACC	87	5 Weeks	20-30	User	Female	628.4	1.4	18.1	608.9
89	ACC	55	5 Weeks	20-30	User	Male	280.2	1.2	80.0	199.0
90	ACC	68	5 Weeks	20-30	User	Male	1036.6	1.2	0.0	1035.4
91	ACC	76	5 Weeks	20-30	User	Male	1026.8	3.9	40.4	982.6
92	ACC	89	5 Weeks	20-30	User	Male	1378.7	4.6	52.6	1321.5
93	ACC	88	5 Weeks	40-50	User	Female	729.6	3.4	100.3	625.9

No	Mode	ID	Test Time	Age	Cruise Usage	Gender	Distance (miles) for different velocity ranges			
							All	< 35mph	35-55mph	> 55mph
94	ACC	96	5 Weeks	40-50	User	Female	1142.1	2.5	23.8	1115.8
95	ACC	99	5 Weeks	40-50	User	Female	2339.6	5.3	29.2	2305.1
96	ACC	104	5 Weeks	40-50	User	Female	167.9	1.9	35.3	130.7
97	ACC	78	5 Weeks	40-50	User	Male	1103.7	1.2	0.0	1102.6
98	ACC	81	5 Weeks	40-50	User	Male	375.0	1.5	40.2	333.3
99	ACC	92	5 Weeks	40-50	User	Male	652.7	1.6	90.2	560.8
100	ACC	100	5 Weeks	40-50	User	Male	811.9	3.3	77.7	730.9
101	ACC	70	5 Weeks	60-70	User	Female	363.9	2.5	62.0	299.4
102	ACC	77	5 Weeks	60-70	User	Female	348.9	3.9	117.4	227.6
103	ACC	90	5 Weeks	60-70	User	Female	519.5	3.3	116.1	400.1
104	ACC	97	5 Weeks	60-70	User	Female	251.4	0.6	18.1	232.7
105	ACC	40	5 Weeks	60-70	User	Male	2073.0	5.6	51.9	2015.6
106	ACC	62	5 Weeks	60-70	User	Male	427.1	7.0	184.0	236.1
107	ACC	66	5 Weeks	60-70	User	Male	804.2	7.9	176.5	619.8
108	ACC	85	5 Weeks	60-70	User	Male	356.6	0.8	3.5	352.3
1	All	27	2 Weeks	20-30	Nonuser	Female	338.3	90.2	121.5	126.6
2	All	31	2 Weeks	20-30	Nonuser	Female	441.6	112.4	102.1	227.1
3	All	38	2 Weeks	20-30	Nonuser	Female	317.0	114.1	119.7	83.2
4	All	39	2 Weeks	20-30	Nonuser	Female	394.4	73.8	246.5	74.2
5	All	44	2 Weeks	20-30	Nonuser	Female	806.6	203.0	484.8	118.7
6	All	45	2 Weeks	20-30	Nonuser	Female	639.6	228.4	162.2	248.9
7	All	49	2 Weeks	20-30	Nonuser	Female	1295.7	158.5	145.1	992.1
8	All	4	2 Weeks	20-30	Nonuser	Male	1926.9	134.6	224.8	1567.5
9	All	41	2 Weeks	20-30	Nonuser	Male	287.7	68.1	81.1	138.5
10	All	63	2 Weeks	20-30	Nonuser	Male	860.6	301.6	348.2	210.7
11	All	93	2 Weeks	20-30	Nonuser	Male	996.8	185.5	195.5	615.8
12	All	98	2 Weeks	20-30	Nonuser	Male	2829.4	204.7	551.2	2073.6
13	All	109	2 Weeks	20-30	Nonuser	Male	942.5	103.5	226.0	613.0
14	All	114	2 Weeks	20-30	Nonuser	Male	552.6	67.9	190.5	294.3
15	All	10	2 Weeks	20-30	User	Female	619.0	84.2	142.6	392.2
16	All	15	2 Weeks	20-30	User	Female	486.0	90.8	122.3	273.0
17	All	30	2 Weeks	20-30	User	Female	653.0	93.3	179.2	380.5
18	All	42	2 Weeks	20-30	User	Female	350.7	70.0	76.9	203.8
19	All	50	2 Weeks	20-30	User	Female	1012.2	362.3	363.8	286.1
20	All	51	2 Weeks	20-30	User	Female	604.8	94.0	161.6	349.2
21	All	52	2 Weeks	20-30	User	Female	1242.2	122.6	207.5	912.1
22	All	33	2 Weeks	20-30	User	Male	971.2	152.2	373.2	445.8
23	All	37	2 Weeks	20-30	User	Male	553.7	160.2	297.2	96.3
24	All	54	2 Weeks	20-30	User	Male	1153.6	253.8	321.6	578.2
25	All	59	2 Weeks	20-30	User	Male	704.6	130.6	214.2	359.8
26	All	60	2 Weeks	20-30	User	Male	313.6	62.1	102.4	149.1
27	All	61	2 Weeks	20-30	User	Male	1192.0	152.7	456.9	582.4
28	All	64	2 Weeks	20-30	User	Male	483.3	96.1	194.1	193.1
29	All	1	2 Weeks	40-50	Nonuser	Female	559.6	185.7	236.2	137.7

No	Mode	ID	Test Time	Age	Cruise Usage	Gender	Distance (miles) for different velocity ranges			
							All	< 35mph	35-55mph	> 55mph
30	All	23	2 Weeks	40-50	Nonuser	Female	367.3	70.6	54.0	242.6
31	All	25	2 Weeks	40-50	Nonuser	Female	430.4	165.8	119.4	145.2
32	All	26	2 Weeks	40-50	Nonuser	Female	627.6	121.6	201.3	304.7
33	All	29	2 Weeks	40-50	Nonuser	Female	489.4	130.0	150.6	208.7
34	All	80	2 Weeks	40-50	Nonuser	Female	808.5	91.5	165.6	551.4
35	All	84	2 Weeks	40-50	Nonuser	Female	763.8	94.1	221.5	448.2
36	All	34	2 Weeks	40-50	Nonuser	Male	1302.9	210.2	231.5	861.2
37	All	75	2 Weeks	40-50	Nonuser	Male	1748.4	257.5	470.4	1020.5
38	All	94	2 Weeks	40-50	Nonuser	Male	1302.6	121.2	352.1	829.4
39	All	102	2 Weeks	40-50	Nonuser	Male	1691.3	213.1	490.4	987.8
40	All	111	2 Weeks	40-50	Nonuser	Male	1167.2	171.6	301.5	694.1
41	All	112	2 Weeks	40-50	Nonuser	Male	730.1	102.2	318.0	309.9
42	All	117	2 Weeks	40-50	Nonuser	Male	975.6	151.9	356.1	467.6
43	All	5	2 Weeks	40-50	User	Female	598.2	101.7	134.4	362.2
44	All	6	2 Weeks	40-50	User	Female	461.9	70.3	159.9	231.7
45	All	8	2 Weeks	40-50	User	Female	1112.4	99.2	236.6	776.7
46	All	9	2 Weeks	40-50	User	Female	1417.7	141.5	258.9	1017.4
47	All	12	2 Weeks	40-50	User	Female	706.6	136.4	220.7	349.5
48	All	21	2 Weeks	40-50	User	Female	897.5	176.3	174.8	546.4
49	All	24	2 Weeks	40-50	User	Female	642.5	111.1	115.6	415.7
50	All	3	2 Weeks	40-50	User	Male	318.2	47.1	146.6	124.5
51	All	14	2 Weeks	40-50	User	Male	658.9	110.4	137.0	411.5
52	All	17	2 Weeks	40-50	User	Male	349.1	62.0	130.4	156.7
53	All	22	2 Weeks	40-50	User	Male	436.4	131.8	194.2	110.5
54	All	35	2 Weeks	40-50	User	Male	1134.3	188.7	347.1	598.5
55	All	74	2 Weeks	40-50	User	Male	270.8	61.3	123.5	85.9
56	All	105	2 Weeks	40-50	User	Male	1434.8	136.5	237.3	1061.0
57	All	43	2 Weeks	60-70	Nonuser	Female	492.8	134.2	214.6	144.0
58	All	46	2 Weeks	60-70	Nonuser	Female	382.1	138.9	121.3	121.9
59	All	82	2 Weeks	60-70	Nonuser	Female	779.9	102.0	197.5	480.4
60	All	83	2 Weeks	60-70	Nonuser	Female	227.7	60.4	96.6	70.7
61	All	91	2 Weeks	60-70	Nonuser	Female	462.9	66.6	228.5	167.8
62	All	95	2 Weeks	60-70	Nonuser	Female	348.7	97.3	105.4	145.9
63	All	106	2 Weeks	60-70	Nonuser	Female	718.7	100.8	180.8	437.1
64	All	103	2 Weeks	60-70	Nonuser	Male	582.4	104.2	197.8	280.4
65	All	107	2 Weeks	60-70	Nonuser	Male	780.2	132.7	246.1	401.4
66	All	108	2 Weeks	60-70	Nonuser	Male	470.5	127.8	140.6	202.2
67	All	110	2 Weeks	60-70	Nonuser	Male	1090.9	137.0	279.1	674.8
68	All	113	2 Weeks	60-70	Nonuser	Male	957.5	170.3	240.5	546.6
69	All	115	2 Weeks	60-70	Nonuser	Male	533.8	167.1	222.3	144.4
70	All	116	2 Weeks	60-70	Nonuser	Male	458.1	162.3	148.5	147.4
71	All	13	2 Weeks	60-70	User	Female	953.7	112.7	261.0	580.0
72	All	48	2 Weeks	60-70	User	Female	503.7	88.9	192.4	222.4
73	All	57	2 Weeks	60-70	User	Female	308.0	74.1	117.0	116.9

No	Mode	ID	Test Time	Age	Cruise Usage	Gender	Distance (miles) for different velocity ranges			
							All	< 35mph	35-55mph	> 55mph
74	All	65	2 Weeks	60-70	User	Female	756.3	84.7	212.1	459.5
75	All	67	2 Weeks	60-70	User	Female	579.3	161.0	150.3	267.9
76	All	69	2 Weeks	60-70	User	Female	372.0	94.2	165.8	112.0
77	All	72	2 Weeks	60-70	User	Female	695.1	74.4	108.2	512.5
78	All	7	2 Weeks	60-70	User	Male	1733.1	186.0	351.5	1195.6
79	All	11	2 Weeks	60-70	User	Male	1391.9	108.3	469.3	814.2
80	All	18	2 Weeks	60-70	User	Male	797.1	179.5	210.0	407.6
81	All	19	2 Weeks	60-70	User	Male	738.4	73.5	339.6	325.2
82	All	20	2 Weeks	60-70	User	Male	703.7	112.7	186.0	405.0
83	All	32	2 Weeks	60-70	User	Male	462.3	123.3	153.4	185.6
84	All	47	2 Weeks	60-70	User	Male	649.3	89.2	207.7	352.4
85	All	56	5 Weeks	20-30	User	Female	2156.8	265.5	479.1	1412.3
86	All	73	5 Weeks	20-30	User	Female	2273.3	283.1	556.7	1433.5
87	All	79	5 Weeks	20-30	User	Female	1090.4	255.7	530.9	303.8
88	All	87	5 Weeks	20-30	User	Female	1850.3	263.7	487.9	1098.8
89	All	55	5 Weeks	20-30	User	Male	1112.7	208.6	531.9	372.2
90	All	68	5 Weeks	20-30	User	Male	3975.4	369.6	498.8	3107.0
91	All	76	5 Weeks	20-30	User	Male	2379.3	317.8	533.5	1528.1
92	All	89	5 Weeks	20-30	User	Male	3197.3	436.5	550.3	2210.5
93	All	88	5 Weeks	40-50	User	Female	2313.5	291.9	501.1	1520.5
94	All	96	5 Weeks	40-50	User	Female	2424.2	393.0	447.6	1583.5
95	All	99	5 Weeks	40-50	User	Female	3847.5	346.6	671.6	2829.3
96	All	104	5 Weeks	40-50	User	Female	1933.3	290.4	631.7	1011.1
97	All	78	5 Weeks	40-50	User	Male	2165.8	306.7	296.8	1562.3
98	All	81	5 Weeks	40-50	User	Male	1588.8	348.3	643.2	597.3
99	All	92	5 Weeks	40-50	User	Male	1259.6	149.5	291.8	818.3
100	All	100	5 Weeks	40-50	User	Male	2518.7	438.0	763.6	1317.0
101	All	70	5 Weeks	60-70	User	Female	1083.0	201.9	388.0	493.2
102	All	77	5 Weeks	60-70	User	Female	1323.9	233.4	559.1	531.4
103	All	90	5 Weeks	60-70	User	Female	1523.4	265.2	425.9	832.4
104	All	97	5 Weeks	60-70	User	Female	1049.4	218.5	403.8	427.0
105	All	40	5 Weeks	60-70	User	Male	2977.0	252.2	434.7	2290.1
106	All	62	5 Weeks	60-70	User	Male	1037.8	232.0	454.7	351.1
107	All	66	5 Weeks	60-70	User	Male	1710.5	323.3	585.4	801.8
108	All	85	5 Weeks	60-70	User	Male	1947.5	391.7	489.5	1066.3
1	CCC	27	2 Weeks	20-30	Nonuser	Female	0.3	0.0	0.0	0.3
2	CCC	31	2 Weeks	20-30	Nonuser	Female	4.7	0.0	0.7	4.0
3	CCC	38	2 Weeks	20-30	Nonuser	Female	5.7	0.0	5.6	0.0
4	CCC	39	2 Weeks	20-30	Nonuser	Female	46.8	0.1	27.4	19.4
5	CCC	44	2 Weeks	20-30	Nonuser	Female	0.9	0.0	0.6	0.3
6	CCC	45	2 Weeks	20-30	Nonuser	Female	2.6	0.0	0.0	2.6
7	CCC	49	2 Weeks	20-30	Nonuser	Female	67.3	0.2	0.0	67.1
8	CCC	4	2 Weeks	20-30	Nonuser	Male	216.4	0.3	0.0	216.1
9	CCC	41	2 Weeks	20-30	Nonuser	Male	0.0	0.0	0.0	0.0



No	Mode	ID	Test Time	Age	Cruise Usage	Gender	Distance (miles) for different velocity ranges			
							All	< 35mph	35-55mph	> 55mph
							10	CCC	63	2 Weeks
11	CCC	93	2 Weeks	20-30	Nonuser	Male	62.0	0.3	20.4	41.3
12	CCC	98	2 Weeks	20-30	Nonuser	Male	662.8	0.6	0.5	661.7
13	CCC	109	2 Weeks	20-30	Nonuser	Male	333.3	0.7	0.0	332.5
14	CCC	114	2 Weeks	20-30	Nonuser	Male	46.9	0.1	0.0	46.9
15	CCC	10	2 Weeks	20-30	User	Female	133.7	0.4	2.3	131.0
16	CCC	15	2 Weeks	20-30	User	Female	10.8	0.1	0.0	10.6
17	CCC	30	2 Weeks	20-30	User	Female	135.2	0.7	0.5	134.1
18	CCC	42	2 Weeks	20-30	User	Female	16.3	0.1	1.4	14.9
19	CCC	50	2 Weeks	20-30	User	Female	14.1	0.1	0.6	13.4
20	CCC	51	2 Weeks	20-30	User	Female	0.0	0.0	0.0	0.0
21	CCC	52	2 Weeks	20-30	User	Female	85.8	0.2	1.1	84.5
22	CCC	33	2 Weeks	20-30	User	Male	82.3	0.4	22.5	59.5
23	CCC	37	2 Weeks	20-30	User	Male	37.8	0.4	16.8	20.6
24	CCC	54	2 Weeks	20-30	User	Male	37.2	0.2	0.0	37.0
25	CCC	59	2 Weeks	20-30	User	Male	13.6	0.1	4.6	8.9
26	CCC	60	2 Weeks	20-30	User	Male	48.9	0.2	0.8	47.9
27	CCC	61	2 Weeks	20-30	User	Male	8.4	0.0	2.3	6.1
28	CCC	64	2 Weeks	20-30	User	Male	10.6	0.0	0.0	10.6
29	CCC	1	2 Weeks	40-50	Nonuser	Female	0.0	0.0	0.0	0.0
30	CCC	23	2 Weeks	40-50	Nonuser	Female	43.9	0.2	0.0	43.6
31	CCC	25	2 Weeks	40-50	Nonuser	Female	1.9	0.0	0.1	1.8
32	CCC	26	2 Weeks	40-50	Nonuser	Female	81.9	0.8	2.5	78.7
33	CCC	29	2 Weeks	40-50	Nonuser	Female	20.8	0.0	0.5	20.3
34	CCC	80	2 Weeks	40-50	Nonuser	Female	299.6	0.5	0.1	299.1
35	CCC	84	2 Weeks	40-50	Nonuser	Female	165.7	0.4	12.4	153.0
36	CCC	34	2 Weeks	40-50	Nonuser	Male	462.5	1.0	2.9	458.6
37	CCC	75	2 Weeks	40-50	Nonuser	Male	121.9	0.8	75.7	45.4
38	CCC	94	2 Weeks	40-50	Nonuser	Male	155.5	0.4	0.0	155.1
39	CCC	102	2 Weeks	40-50	Nonuser	Male	0.3	0.2	0.0	0.1
40	CCC	111	2 Weeks	40-50	Nonuser	Male	107.9	0.4	0.0	107.5
41	CCC	112	2 Weeks	40-50	Nonuser	Male	61.4	1.1	0.2	60.1
42	CCC	117	2 Weeks	40-50	Nonuser	Male	29.1	0.1	0.7	28.4
43	CCC	5	2 Weeks	40-50	User	Female	46.4	0.1	0.0	46.3
44	CCC	6	2 Weeks	40-50	User	Female	26.1	0.1	0.4	25.7
45	CCC	8	2 Weeks	40-50	User	Female	175.3	0.5	12.2	162.6
46	CCC	9	2 Weeks	40-50	User	Female	142.7	0.5	15.2	127.1
47	CCC	12	2 Weeks	40-50	User	Female	76.5	0.3	9.2	67.1
48	CCC	21	2 Weeks	40-50	User	Female	86.6	3.1	9.8	73.7
49	CCC	24	2 Weeks	40-50	User	Female	75.3	0.5	2.2	72.6
50	CCC	3	2 Weeks	40-50	User	Male	47.7	0.1	12.8	34.8
51	CCC	14	2 Weeks	40-50	User	Male	146.5	0.3	9.0	137.2
52	CCC	17	2 Weeks	40-50	User	Male	73.5	0.4	10.0	63.2
53	CCC	22	2 Weeks	40-50	User	Male	40.3	0.3	3.5	36.4

No	Mode	ID	Test Time	Age	Cruise Usage	Gender	Distance (miles) for different velocity ranges			
							All	< 35mph	35-55mph	> 55mph
54	CCC	35	2 Weeks	40-50	User	Male	287.1	0.8	1.5	284.7
55	CCC	74	2 Weeks	40-50	User	Male	47.8	1.2	26.0	20.6
56	CCC	105	2 Weeks	40-50	User	Male	138.2	0.2	0.0	137.9
57	CCC	43	2 Weeks	60-70	Nonuser	Female	52.2	0.4	30.9	21.0
58	CCC	46	2 Weeks	60-70	Nonuser	Female	36.3	0.5	5.5	30.3
59	CCC	82	2 Weeks	60-70	Nonuser	Female	0.8	0.0	0.1	0.8
60	CCC	83	2 Weeks	60-70	Nonuser	Female	9.3	0.3	8.2	0.8
61	CCC	91	2 Weeks	60-70	Nonuser	Female	109.4	1.3	65.5	42.6
62	CCC	95	2 Weeks	60-70	Nonuser	Female	22.4	0.5	0.9	21.0
63	CCC	106	2 Weeks	60-70	Nonuser	Female	23.1	0.2	0.2	22.7
64	CCC	103	2 Weeks	60-70	Nonuser	Male	86.1	1.0	24.8	60.4
65	CCC	107	2 Weeks	60-70	Nonuser	Male	79.2	0.6	1.8	76.8
66	CCC	108	2 Weeks	60-70	Nonuser	Male	7.7	0.0	0.8	6.9
67	CCC	110	2 Weeks	60-70	Nonuser	Male	207.1	0.7	13.9	192.4
68	CCC	113	2 Weeks	60-70	Nonuser	Male	222.3	1.0	17.6	203.7
69	CCC	115	2 Weeks	60-70	Nonuser	Male	12.9	0.0	1.8	11.0
70	CCC	116	2 Weeks	60-70	Nonuser	Male	3.8	0.0	0.0	3.8
71	CCC	13	2 Weeks	60-70	User	Female	243.5	1.0	22.7	219.8
72	CCC	48	2 Weeks	60-70	User	Female	18.4	0.4	4.6	13.4
73	CCC	57	2 Weeks	60-70	User	Female	38.5	0.8	4.9	32.8
74	CCC	65	2 Weeks	60-70	User	Female	84.6	0.2	0.0	84.5
75	CCC	67	2 Weeks	60-70	User	Female	71.0	1.0	9.2	60.8
76	CCC	69	2 Weeks	60-70	User	Female	28.9	0.0	21.2	7.7
77	CCC	72	2 Weeks	60-70	User	Female	12.4	0.0	0.8	11.7
78	CCC	7	2 Weeks	60-70	User	Male	54.7	0.0	0.0	54.7
79	CCC	11	2 Weeks	60-70	User	Male	555.9	2.6	186.7	366.7
80	CCC	18	2 Weeks	60-70	User	Male	66.4	1.4	27.5	37.5
81	CCC	19	2 Weeks	60-70	User	Male	179.7	0.8	32.0	146.8
82	CCC	20	2 Weeks	60-70	User	Male	36.5	0.1	17.8	18.6
83	CCC	32	2 Weeks	60-70	User	Male	27.2	0.0	0.0	27.1
84	CCC	47	2 Weeks	60-70	User	Male	124.4	0.5	7.2	116.7
85	CCC	56	5 Weeks	20-30	User	Female	97.5	0.2	9.4	87.9
86	CCC	73	5 Weeks	20-30	User	Female	107.4	0.3	0.1	107.0
87	CCC	79	5 Weeks	20-30	User	Female	94.4	0.3	8.7	85.4
88	CCC	87	5 Weeks	20-30	User	Female	75.4	0.2	1.4	73.9
89	CCC	55	5 Weeks	20-30	User	Male	97.3	0.5	0.2	96.6
90	CCC	68	5 Weeks	20-30	User	Male	171.9	0.4	0.0	171.5
91	CCC	76	5 Weeks	20-30	User	Male	229.7	0.9	9.7	219.1
92	CCC	89	5 Weeks	20-30	User	Male	116.8	0.1	0.2	116.5
93	CCC	88	5 Weeks	40-50	User	Female	183.1	1.1	18.0	164.0
94	CCC	96	5 Weeks	40-50	User	Female	61.9	0.1	0.0	61.8
95	CCC	99	5 Weeks	40-50	User	Female	219.6	0.5	0.6	218.6
96	CCC	104	5 Weeks	40-50	User	Female	429.0	1.9	0.0	427.2
97	CCC	78	5 Weeks	40-50	User	Male	225.9	0.1	0.0	225.8

No	Mode	ID	Test Time	Age	Cruise Usage	Gender	Distance (miles) for different velocity ranges			
							All	< 35mph	35-55mph	> 55mph
98	CCC	81	5 Weeks	40-50	User	Male	70.4	0.4	7.0	62.9
99	CCC	92	5 Weeks	40-50	User	Male	150.1	0.8	12.4	136.8
100	CCC	100	5 Weeks	40-50	User	Male	188.3	0.7	1.6	186.0
101	CCC	70	5 Weeks	60-70	User	Female	109.2	0.5	11.8	97.0
102	CCC	77	5 Weeks	60-70	User	Female	80.4	0.5	15.8	64.1
103	CCC	90	5 Weeks	60-70	User	Female	265.8	0.7	19.2	245.8
104	CCC	97	5 Weeks	60-70	User	Female	76.4	0.5	13.3	62.6
105	CCC	40	5 Weeks	60-70	User	Male	26.6	0.1	0.1	26.5
106	CCC	62	5 Weeks	60-70	User	Male	79.1	0.3	6.4	72.4
107	CCC	66	5 Weeks	60-70	User	Male	75.1	0.9	9.9	64.3
108	CCC	85	5 Weeks	60-70	User	Male	31.4	0.1	0.0	31.3
1	Man1	27	2 Weeks	20-30	Nonuser	Female	86.7	32.7	39.6	14.3
2	Man1	31	2 Weeks	20-30	Nonuser	Female	159.9	48.3	38.0	73.6
3	Man1	38	2 Weeks	20-30	Nonuser	Female	41.9	31.8	10.1	0.0
4	Man1	39	2 Weeks	20-30	Nonuser	Female	151.3	34.7	90.1	26.5
5	Man1	44	2 Weeks	20-30	Nonuser	Female	379.0	89.9	210.2	79.0
6	Man1	45	2 Weeks	20-30	Nonuser	Female	137.4	64.0	27.7	45.7
7	Man1	49	2 Weeks	20-30	Nonuser	Female	497.5	71.0	71.0	355.5
8	Man1	4	2 Weeks	20-30	Nonuser	Male	414.3	62.0	92.1	260.2
9	Man1	41	2 Weeks	20-30	Nonuser	Male	159.4	46.9	50.0	62.4
10	Man1	63	2 Weeks	20-30	Nonuser	Male	388.9	141.9	154.5	92.5
11	Man1	93	2 Weeks	20-30	Nonuser	Male	240.7	79.1	86.8	74.8
12	Man1	98	2 Weeks	20-30	Nonuser	Male	820.6	110.1	290.2	420.3
13	Man1	109	2 Weeks	20-30	Nonuser	Male	366.2	53.2	117.5	195.5
14	Man1	114	2 Weeks	20-30	Nonuser	Male	304.9	32.0	83.7	189.2
15	Man1	10	2 Weeks	20-30	User	Female	196.5	41.5	65.7	89.3
16	Man1	15	2 Weeks	20-30	User	Female	188.2	56.9	66.1	65.2
17	Man1	30	2 Weeks	20-30	User	Female	199.7	42.9	83.9	72.9
18	Man1	42	2 Weeks	20-30	User	Female	133.5	28.9	32.5	72.1
19	Man1	50	2 Weeks	20-30	User	Female	239.9	80.8	107.5	51.7
20	Man1	51	2 Weeks	20-30	User	Female	14.7	13.2	1.5	0.0
21	Man1	52	2 Weeks	20-30	User	Female	258.8	48.4	100.6	109.8
22	Man1	33	2 Weeks	20-30	User	Male	255.5	79.5	136.3	39.6
23	Man1	37	2 Weeks	20-30	User	Male	242.7	97.4	141.7	3.6
24	Man1	54	2 Weeks	20-30	User	Male	360.1	122.6	125.5	112.1
25	Man1	59	2 Weeks	20-30	User	Male	218.9	58.9	73.4	86.6
26	Man1	60	2 Weeks	20-30	User	Male	96.9	30.7	43.3	22.9
27	Man1	61	2 Weeks	20-30	User	Male	379.4	74.4	211.5	93.6
28	Man1	64	2 Weeks	20-30	User	Male	283.0	55.9	99.2	127.9
29	Man1	1	2 Weeks	40-50	Nonuser	Female	245.7	79.0	111.1	55.7
30	Man1	23	2 Weeks	40-50	Nonuser	Female	166.7	42.1	33.5	91.0
31	Man1	25	2 Weeks	40-50	Nonuser	Female	213.0	73.5	69.8	69.7
32	Man1	26	2 Weeks	40-50	Nonuser	Female	188.3	58.0	106.2	24.1
33	Man1	29	2 Weeks	40-50	Nonuser	Female	235.0	57.7	101.1	76.2

No	Mode	ID	Test Time	Age	Cruise Usage	Gender	Distance (miles) for different velocity ranges			
							All	< 35mph	35-55mph	> 55mph
							34	Man1	80	2 Weeks
35	Man1	84	2 Weeks	40-50	Nonuser	Female	264.4	50.7	112.1	101.7
36	Man1	34	2 Weeks	40-50	Nonuser	Male	386.4	83.9	94.7	207.7
37	Man1	75	2 Weeks	40-50	Nonuser	Male	322.9	123.0	162.8	37.1
38	Man1	94	2 Weeks	40-50	Nonuser	Male	165.4	25.6	49.1	90.6
39	Man1	102	2 Weeks	40-50	Nonuser	Male	317.1	73.1	178.7	65.3
40	Man1	111	2 Weeks	40-50	Nonuser	Male	581.2	77.3	143.5	360.4
41	Man1	112	2 Weeks	40-50	Nonuser	Male	453.4	67.3	185.2	200.9
42	Man1	117	2 Weeks	40-50	Nonuser	Male	189.9	51.0	97.4	41.5
43	Man1	5	2 Weeks	40-50	User	Female	253.4	52.7	75.5	125.2
44	Man1	6	2 Weeks	40-50	User	Female	192.8	42.8	101.0	49.1
45	Man1	8	2 Weeks	40-50	User	Female	580.5	61.2	135.2	384.1
46	Man1	9	2 Weeks	40-50	User	Female	366.6	76.9	139.9	149.8
47	Man1	12	2 Weeks	40-50	User	Female	265.5	72.5	121.6	71.5
48	Man1	21	2 Weeks	40-50	User	Female	150.0	73.8	47.2	29.0
49	Man1	24	2 Weeks	40-50	User	Female	86.7	52.0	31.0	3.8
50	Man1	3	2 Weeks	40-50	User	Male	141.9	28.8	82.7	30.4
51	Man1	14	2 Weeks	40-50	User	Male	114.3	41.0	34.9	38.4
52	Man1	17	2 Weeks	40-50	User	Male	105.7	31.5	55.8	18.4
53	Man1	22	2 Weeks	40-50	User	Male	168.2	58.6	89.7	19.9
54	Man1	35	2 Weeks	40-50	User	Male	437.0	73.5	147.4	216.1
55	Man1	74	2 Weeks	40-50	User	Male	85.4	35.2	39.5	10.7
56	Man1	105	2 Weeks	40-50	User	Male	297.7	46.5	96.5	154.7
57	Man1	43	2 Weeks	60-70	Nonuser	Female	94.9	44.2	35.0	15.8
58	Man1	46	2 Weeks	60-70	Nonuser	Female	100.8	44.1	40.8	15.8
59	Man1	82	2 Weeks	60-70	Nonuser	Female	89.1	23.6	20.3	45.2
60	Man1	83	2 Weeks	60-70	Nonuser	Female	108.6	41.3	46.3	21.1
61	Man1	91	2 Weeks	60-70	Nonuser	Female	77.6	23.9	47.4	6.3
62	Man1	95	2 Weeks	60-70	Nonuser	Female	120.4	57.3	47.7	15.4
63	Man1	106	2 Weeks	60-70	Nonuser	Female	156.2	44.8	68.4	42.9
64	Man1	103	2 Weeks	60-70	Nonuser	Male	201.0	57.8	71.3	71.9
65	Man1	107	2 Weeks	60-70	Nonuser	Male	329.8	57.9	147.9	124.0
66	Man1	108	2 Weeks	60-70	Nonuser	Male	131.7	64.7	64.3	2.6
67	Man1	110	2 Weeks	60-70	Nonuser	Male	359.0	71.9	132.4	154.7
68	Man1	113	2 Weeks	60-70	Nonuser	Male	398.4	83.8	96.9	217.7
69	Man1	115	2 Weeks	60-70	Nonuser	Male	219.7	83.6	117.6	18.6
70	Man1	116	2 Weeks	60-70	Nonuser	Male	178.7	84.6	52.6	41.5
71	Man1	13	2 Weeks	60-70	User	Female	169.1	47.3	102.0	19.7
72	Man1	48	2 Weeks	60-70	User	Female	172.7	47.1	104.7	21.0
73	Man1	57	2 Weeks	60-70	User	Female	82.7	31.6	37.4	13.6
74	Man1	65	2 Weeks	60-70	User	Female	525.0	51.4	135.4	338.2
75	Man1	67	2 Weeks	60-70	User	Female	121.7	50.3	28.7	42.7
76	Man1	69	2 Weeks	60-70	User	Female	110.9	39.7	56.4	14.8
77	Man1	72	2 Weeks	60-70	User	Female	77.8	26.4	37.2	14.2

No	Mode	ID	Test Time	Age	Cruise Usage	Gender	Distance (miles) for different velocity ranges			
							All	< 35mph	35-55mph	> 55mph
78	Man1	7	2 Weeks	60-70	User	Male	511.4	92.2	127.1	292.2
79	Man1	11	2 Weeks	60-70	User	Male	161.9	51.9	97.0	12.9
80	Man1	18	2 Weeks	60-70	User	Male	160.8	88.4	68.2	4.2
81	Man1	19	2 Weeks	60-70	User	Male	183.0	31.4	118.5	33.2
82	Man1	20	2 Weeks	60-70	User	Male	110.6	50.6	55.4	4.7
83	Man1	32	2 Weeks	60-70	User	Male	195.6	57.3	69.1	69.3
84	Man1	47	2 Weeks	60-70	User	Male	189.2	39.7	95.1	54.4
85	Man1	56	5 Weeks	20-30	User	Female	251.1	55.8	99.9	95.5
86	Man1	73	5 Weeks	20-30	User	Female	303.0	36.2	85.6	181.3
87	Man1	79	5 Weeks	20-30	User	Female	206.8	60.2	105.4	41.2
88	Man1	87	5 Weeks	20-30	User	Female	263.9	54.9	96.3	112.7
89	Man1	55	5 Weeks	20-30	User	Male	240.0	50.3	134.9	54.7
90	Man1	68	5 Weeks	20-30	User	Male	416.4	89.2	115.5	211.7
91	Man1	76	5 Weeks	20-30	User	Male	313.6	59.6	116.2	137.7
92	Man1	89	5 Weeks	20-30	User	Male	188.1	73.1	62.3	52.7
93	Man1	88	5 Weeks	40-50	User	Female	469.7	101.2	139.2	229.2
94	Man1	96	5 Weeks	40-50	User	Female	243.3	92.9	56.9	93.5
95	Man1	99	5 Weeks	40-50	User	Female	192.8	41.0	73.8	78.0
96	Man1	104	5 Weeks	40-50	User	Female	447.3	25.8	91.9	329.6
97	Man1	78	5 Weeks	40-50	User	Male	139.9	53.4	62.5	24.0
98	Man1	81	5 Weeks	40-50	User	Male	212.2	64.4	119.4	28.3
99	Man1	92	5 Weeks	40-50	User	Male	87.2	30.3	30.4	26.5
100	Man1	100	5 Weeks	40-50	User	Male	411.5	94.3	183.1	134.2
101	Man1	70	5 Weeks	60-70	User	Female	140.0	40.2	66.4	33.4
102	Man1	77	5 Weeks	60-70	User	Female	169.6	38.4	85.9	45.3
103	Man1	90	5 Weeks	60-70	User	Female	245.0	61.2	91.2	92.6
104	Man1	97	5 Weeks	60-70	User	Female	166.1	46.1	85.8	34.3
105	Man1	40	5 Weeks	60-70	User	Male	78.5	27.7	47.4	3.4
106	Man1	62	5 Weeks	60-70	User	Male	93.4	35.2	45.0	13.3
107	Man1	66	5 Weeks	60-70	User	Male	201.4	60.3	94.0	47.1
108	Man1	85	5 Weeks	60-70	User	Male	421.0	66.9	85.8	268.3
1	Man2	27	2 Weeks	20-30	Nonuser	Female	172.2	57.1	81.0	34.1
2	Man2	31	2 Weeks	20-30	Nonuser	Female	255.0	64.0	60.9	130.1
3	Man2	38	2 Weeks	20-30	Nonuser	Female	156.9	80.4	62.2	14.2
4	Man2	39	2 Weeks	20-30	Nonuser	Female	114.8	37.8	73.9	3.2
5	Man2	44	2 Weeks	20-30	Nonuser	Female	369.8	112.6	239.1	18.1
6	Man2	45	2 Weeks	20-30	Nonuser	Female	413.8	164.2	112.2	137.4
7	Man2	49	2 Weeks	20-30	Nonuser	Female	679.4	87.2	73.9	518.4
8	Man2	4	2 Weeks	20-30	Nonuser	Male	805.6	71.0	125.6	608.9
9	Man2	41	2 Weeks	20-30	Nonuser	Male	91.5	21.1	31.1	39.3
10	Man2	63	2 Weeks	20-30	Nonuser	Male	408.3	159.5	190.5	58.3
11	Man2	93	2 Weeks	20-30	Nonuser	Male	215.7	103.6	79.3	32.8
12	Man2	98	2 Weeks	20-30	Nonuser	Male	500.0	90.3	220.8	188.9
13	Man2	109	2 Weeks	20-30	Nonuser	Male	181.1	49.4	101.1	30.6

No	Mode	ID	Test Time	Age	Cruise Usage	Gender	Distance (miles) for different velocity ranges			
							All	< 35mph	35-55mph	> 55mph
14	Man2	114	2 Weeks	20-30	Nonuser	Male	175.5	35.7	101.7	38.2
15	Man2	10	2 Weeks	20-30	User	Female	221.9	41.7	69.8	110.3
16	Man2	15	2 Weeks	20-30	User	Female	145.7	33.3	53.5	58.8
17	Man2	30	2 Weeks	20-30	User	Female	201.6	49.5	90.6	61.5
18	Man2	42	2 Weeks	20-30	User	Female	159.7	40.2	38.4	81.0
19	Man2	50	2 Weeks	20-30	User	Female	628.6	280.6	235.1	112.8
20	Man2	51	2 Weeks	20-30	User	Female	275.1	80.4	140.7	54.1
21	Man2	52	2 Weeks	20-30	User	Female	439.3	72.3	105.3	261.8
22	Man2	33	2 Weeks	20-30	User	Male	344.0	70.9	190.2	82.9
23	Man2	37	2 Weeks	20-30	User	Male	190.7	62.3	119.5	8.9
24	Man2	54	2 Weeks	20-30	User	Male	423.8	130.5	176.2	117.1
25	Man2	59	2 Weeks	20-30	User	Male	288.9	70.3	107.4	111.2
26	Man2	60	2 Weeks	20-30	User	Male	96.5	30.6	50.0	15.9
27	Man2	61	2 Weeks	20-30	User	Male	622.9	77.2	239.2	306.5
28	Man2	64	2 Weeks	20-30	User	Male	174.1	40.1	94.9	39.1
29	Man2	1	2 Weeks	40-50	Nonuser	Female	272.5	106.5	117.2	48.9
30	Man2	23	2 Weeks	40-50	Nonuser	Female	53.6	27.8	13.7	12.0
31	Man2	25	2 Weeks	40-50	Nonuser	Female	182.8	91.9	47.6	43.4
32	Man2	26	2 Weeks	40-50	Nonuser	Female	201.1	61.7	80.6	58.8
33	Man2	29	2 Weeks	40-50	Nonuser	Female	159.4	72.0	48.6	38.8
34	Man2	80	2 Weeks	40-50	Nonuser	Female	172.3	61.2	99.6	11.5
35	Man2	84	2 Weeks	40-50	Nonuser	Female	149.1	42.9	82.4	23.8
36	Man2	34	2 Weeks	40-50	Nonuser	Male	370.3	125.1	131.6	113.6
37	Man2	75	2 Weeks	40-50	Nonuser	Male	406.3	130.2	181.2	94.9
38	Man2	94	2 Weeks	40-50	Nonuser	Male	627.7	94.6	301.4	231.7
39	Man2	102	2 Weeks	40-50	Nonuser	Male	1292.5	139.5	310.3	842.7
40	Man2	111	2 Weeks	40-50	Nonuser	Male	316.5	93.5	153.2	69.8
41	Man2	112	2 Weeks	40-50	Nonuser	Male	169.2	32.7	105.7	30.8
42	Man2	117	2 Weeks	40-50	Nonuser	Male	420.8	100.3	233.7	86.8
43	Man2	5	2 Weeks	40-50	User	Female	238.4	48.4	57.7	132.3
44	Man2	6	2 Weeks	40-50	User	Female	104.7	27.2	56.9	20.7
45	Man2	8	2 Weeks	40-50	User	Female	175.1	36.9	87.1	51.1
46	Man2	9	2 Weeks	40-50	User	Female	281.6	61.8	86.6	133.2
47	Man2	12	2 Weeks	40-50	User	Female	167.7	63.0	77.3	27.5
48	Man2	21	2 Weeks	40-50	User	Female	210.8	92.0	99.4	19.4
49	Man2	24	2 Weeks	40-50	User	Female	134.7	58.0	64.2	12.6
50	Man2	3	2 Weeks	40-50	User	Male	62.1	17.9	36.7	7.5
51	Man2	14	2 Weeks	40-50	User	Male	183.6	67.2	67.7	48.7
52	Man2	17	2 Weeks	40-50	User	Male	68.9	29.2	35.8	4.0
53	Man2	22	2 Weeks	40-50	User	Male	144.0	70.3	66.9	6.8
54	Man2	35	2 Weeks	40-50	User	Male	303.9	113.7	178.4	11.8
55	Man2	74	2 Weeks	40-50	User	Male	65.9	24.0	32.4	9.6
56	Man2	105	2 Weeks	40-50	User	Male	335.7	87.5	113.3	134.9
57	Man2	43	2 Weeks	60-70	Nonuser	Female	173.8	85.8	70.2	17.8

No	Mode	ID	Test Time	Age	Cruise Usage	Gender	Distance (miles) for different velocity ranges			
							All	< 35mph	35-55mph	> 55mph
58	Man2	46	2 Weeks	60-70	Nonuser	Female	165.6	92.5	61.0	12.1
59	Man2	82	2 Weeks	60-70	Nonuser	Female	281.1	77.0	119.3	84.9
60	Man2	83	2 Weeks	60-70	Nonuser	Female	47.0	16.9	17.7	12.4
61	Man2	91	2 Weeks	60-70	Nonuser	Female	66.5	37.9	23.8	4.7
62	Man2	95	2 Weeks	60-70	Nonuser	Female	112.6	39.5	54.4	18.7
63	Man2	106	2 Weeks	60-70	Nonuser	Female	189.1	53.0	104.7	31.5
64	Man2	103	2 Weeks	60-70	Nonuser	Male	170.4	45.0	75.6	49.7
65	Man2	107	2 Weeks	60-70	Nonuser	Male	195.3	71.7	71.3	52.3
66	Man2	108	2 Weeks	60-70	Nonuser	Male	174.1	62.4	75.6	36.2
67	Man2	110	2 Weeks	60-70	Nonuser	Male	211.9	63.0	99.8	49.1
68	Man2	113	2 Weeks	60-70	Nonuser	Male	175.0	81.4	75.8	17.8
69	Man2	115	2 Weeks	60-70	Nonuser	Male	209.6	83.2	93.7	32.7
70	Man2	116	2 Weeks	60-70	Nonuser	Male	228.7	77.5	91.8	59.3
71	Man2	13	2 Weeks	60-70	User	Female	196.1	63.4	109.8	22.9
72	Man2	48	2 Weeks	60-70	User	Female	216.8	40.9	80.4	95.6
73	Man2	57	2 Weeks	60-70	User	Female	117.1	40.8	64.2	12.0
74	Man2	65	2 Weeks	60-70	User	Female	96.4	32.9	53.1	10.5
75	Man2	67	2 Weeks	60-70	User	Female	226.5	109.3	92.5	24.7
76	Man2	69	2 Weeks	60-70	User	Female	158.7	54.0	80.4	24.3
77	Man2	72	2 Weeks	60-70	User	Female	183.9	46.3	69.5	68.1
78	Man2	7	2 Weeks	60-70	User	Male	694.1	91.0	164.7	438.4
79	Man2	11	2 Weeks	60-70	User	Male	159.2	51.8	96.5	10.9
80	Man2	18	2 Weeks	60-70	User	Male	161.6	87.5	60.9	13.1
81	Man2	19	2 Weeks	60-70	User	Male	178.0	40.3	126.1	11.7
82	Man2	20	2 Weeks	60-70	User	Male	237.1	60.8	91.7	84.7
83	Man2	32	2 Weeks	60-70	User	Male	180.4	65.8	83.0	31.6
84	Man2	47	2 Weeks	60-70	User	Male	146.8	48.5	72.6	25.7
85	Man2	56	5 Weeks	20-30	User	Female	945.1	206.6	366.2	372.2
86	Man2	73	5 Weeks	20-30	User	Female	1234.3	245.3	421.9	567.1
87	Man2	79	5 Weeks	20-30	User	Female	676.4	194.8	395.8	85.8
88	Man2	87	5 Weeks	20-30	User	Female	882.6	207.2	372.1	303.3
89	Man2	55	5 Weeks	20-30	User	Male	495.2	156.5	316.8	21.8
90	Man2	68	5 Weeks	20-30	User	Male	2350.5	278.8	383.3	1688.4
91	Man2	76	5 Weeks	20-30	User	Male	809.3	253.4	367.2	188.7
92	Man2	89	5 Weeks	20-30	User	Male	1513.8	358.7	435.2	719.8
93	Man2	88	5 Weeks	40-50	User	Female	931.1	186.1	243.6	501.4
94	Man2	96	5 Weeks	40-50	User	Female	976.9	297.5	366.9	312.5
95	Man2	99	5 Weeks	40-50	User	Female	1095.6	299.8	568.0	227.7
96	Man2	104	5 Weeks	40-50	User	Female	889.0	260.9	504.6	123.6
97	Man2	78	5 Weeks	40-50	User	Male	696.2	252.1	234.3	209.8
98	Man2	81	5 Weeks	40-50	User	Male	931.2	281.9	476.6	172.7
99	Man2	92	5 Weeks	40-50	User	Male	369.6	116.8	158.7	94.2
100	Man2	100	5 Weeks	40-50	User	Male	1106.9	339.7	501.3	266.0
101	Man2	70	5 Weeks	60-70	User	Female	470.0	158.8	247.8	63.4

No	Mode	ID	Test Time	Age	Cruise Usage	Gender	Distance (miles) for different velocity ranges			
							All	< 35mph	35-55mph	> 55mph
102	Man2	77	5 Weeks	60-70	User	Female	725.0	190.6	340.0	194.4
103	Man2	90	5 Weeks	60-70	User	Female	493.2	199.9	199.3	94.0
104	Man2	97	5 Weeks	60-70	User	Female	555.5	171.4	286.7	97.4
105	Man2	40	5 Weeks	60-70	User	Male	798.8	218.9	335.3	244.7
106	Man2	62	5 Weeks	60-70	User	Male	438.1	189.4	219.2	29.4
107	Man2	66	5 Weeks	60-70	User	Male	629.9	254.1	305.0	70.8
108	Man2	85	5 Weeks	60-70	User	Male	1138.5	323.9	400.2	414.4
1	Manual	27	2 Weeks	20-30	Nonuser	Female	258.9	89.8	120.7	48.4
2	Manual	31	2 Weeks	20-30	Nonuser	Female	414.9	112.3	99.0	203.7
3	Manual	38	2 Weeks	20-30	Nonuser	Female	198.7	112.2	72.3	14.2
4	Manual	39	2 Weeks	20-30	Nonuser	Female	266.1	72.5	164.0	29.7
5	Manual	44	2 Weeks	20-30	Nonuser	Female	748.9	202.5	449.3	97.2
6	Manual	45	2 Weeks	20-30	Nonuser	Female	551.2	228.2	140.0	183.0
7	Manual	49	2 Weeks	20-30	Nonuser	Female	1176.9	158.1	144.9	873.9
8	Manual	4	2 Weeks	20-30	Nonuser	Male	1219.9	133.1	217.8	869.0
9	Manual	41	2 Weeks	20-30	Nonuser	Male	250.9	68.0	81.1	101.8
10	Manual	63	2 Weeks	20-30	Nonuser	Male	797.2	301.4	345.0	150.8
11	Manual	93	2 Weeks	20-30	Nonuser	Male	456.4	182.7	166.1	107.6
12	Manual	98	2 Weeks	20-30	Nonuser	Male	1320.5	200.4	511.0	609.1
13	Manual	109	2 Weeks	20-30	Nonuser	Male	547.3	102.6	218.6	226.2
14	Manual	114	2 Weeks	20-30	Nonuser	Male	480.4	67.7	185.3	227.4
15	Manual	10	2 Weeks	20-30	User	Female	418.4	83.2	135.5	199.7
16	Manual	15	2 Weeks	20-30	User	Female	333.9	90.2	119.7	124.1
17	Manual	30	2 Weeks	20-30	User	Female	401.3	92.4	174.5	134.4
18	Manual	42	2 Weeks	20-30	User	Female	293.2	69.2	70.9	153.1
19	Manual	50	2 Weeks	20-30	User	Female	868.5	361.4	342.6	164.5
20	Manual	51	2 Weeks	20-30	User	Female	289.8	93.5	142.2	54.1
21	Manual	52	2 Weeks	20-30	User	Female	698.1	120.7	205.9	371.6
22	Manual	33	2 Weeks	20-30	User	Male	599.5	150.4	326.5	122.6
23	Manual	37	2 Weeks	20-30	User	Male	433.4	159.7	261.2	12.5
24	Manual	54	2 Weeks	20-30	User	Male	783.9	253.1	301.7	229.2
25	Manual	59	2 Weeks	20-30	User	Male	507.8	129.2	180.7	197.8
26	Manual	60	2 Weeks	20-30	User	Male	193.4	61.3	93.2	38.8
27	Manual	61	2 Weeks	20-30	User	Male	1002.3	151.6	450.7	400.0
28	Manual	64	2 Weeks	20-30	User	Male	457.1	96.0	194.1	167.0
29	Manual	1	2 Weeks	40-50	Nonuser	Female	518.2	185.5	228.2	104.6
30	Manual	23	2 Weeks	40-50	Nonuser	Female	220.3	70.0	47.3	103.0
31	Manual	25	2 Weeks	40-50	Nonuser	Female	395.8	165.4	117.4	113.1
32	Manual	26	2 Weeks	40-50	Nonuser	Female	389.4	119.7	186.8	82.9
33	Manual	29	2 Weeks	40-50	Nonuser	Female	394.4	129.6	149.7	115.0
34	Manual	80	2 Weeks	40-50	Nonuser	Female	457.2	90.8	154.6	211.7
35	Manual	84	2 Weeks	40-50	Nonuser	Female	413.5	93.6	194.4	125.5
36	Manual	34	2 Weeks	40-50	Nonuser	Male	756.6	209.0	226.3	321.3
37	Manual	75	2 Weeks	40-50	Nonuser	Male	729.2	253.2	344.0	132.0



No	Mode	ID	Test Time	Age	Cruise Usage	Gender	Distance (miles) for different velocity ranges			
							All	< 35mph	35-55mph	> 55mph
38	Manual	94	2 Weeks	40-50	Nonuser	Male	793.0	120.2	350.5	322.2
39	Manual	102	2 Weeks	40-50	Nonuser	Male	1609.7	212.6	489.1	908.0
40	Manual	111	2 Weeks	40-50	Nonuser	Male	897.7	170.8	296.7	430.2
41	Manual	112	2 Weeks	40-50	Nonuser	Male	622.6	100.1	290.8	231.7
42	Manual	117	2 Weeks	40-50	Nonuser	Male	610.6	151.3	331.0	128.2
43	Manual	5	2 Weeks	40-50	User	Female	491.8	101.1	133.2	257.5
44	Manual	6	2 Weeks	40-50	User	Female	297.5	69.9	157.9	69.7
45	Manual	8	2 Weeks	40-50	User	Female	755.6	98.1	222.3	435.2
46	Manual	9	2 Weeks	40-50	User	Female	648.2	138.7	226.5	283.0
47	Manual	12	2 Weeks	40-50	User	Female	433.3	135.5	198.8	98.9
48	Manual	21	2 Weeks	40-50	User	Female	360.8	165.8	146.6	48.4
49	Manual	24	2 Weeks	40-50	User	Female	221.5	110.0	95.1	16.4
50	Manual	3	2 Weeks	40-50	User	Male	204.0	46.7	119.4	37.9
51	Manual	14	2 Weeks	40-50	User	Male	297.9	108.2	102.6	87.1
52	Manual	17	2 Weeks	40-50	User	Male	174.7	60.7	91.6	22.4
53	Manual	22	2 Weeks	40-50	User	Male	312.2	128.9	156.6	26.7
54	Manual	35	2 Weeks	40-50	User	Male	740.9	187.2	325.9	227.9
55	Manual	74	2 Weeks	40-50	User	Male	151.4	59.3	71.9	20.2
56	Manual	105	2 Weeks	40-50	User	Male	633.4	134.0	209.8	289.5
57	Manual	43	2 Weeks	60-70	Nonuser	Female	268.7	129.9	105.2	33.6
58	Manual	46	2 Weeks	60-70	Nonuser	Female	266.4	136.6	101.9	27.9
59	Manual	82	2 Weeks	60-70	Nonuser	Female	370.2	100.6	139.5	130.1
60	Manual	83	2 Weeks	60-70	Nonuser	Female	155.6	58.2	64.0	33.5
61	Manual	91	2 Weeks	60-70	Nonuser	Female	144.1	61.8	71.2	11.0
62	Manual	95	2 Weeks	60-70	Nonuser	Female	233.1	96.7	102.1	34.2
63	Manual	106	2 Weeks	60-70	Nonuser	Female	345.3	97.8	173.1	74.4
64	Manual	103	2 Weeks	60-70	Nonuser	Male	371.4	102.8	146.9	121.7
65	Manual	107	2 Weeks	60-70	Nonuser	Male	525.0	129.6	219.2	176.2
66	Manual	108	2 Weeks	60-70	Nonuser	Male	305.8	127.1	139.9	38.8
67	Manual	110	2 Weeks	60-70	Nonuser	Male	570.8	134.9	232.2	203.7
68	Manual	113	2 Weeks	60-70	Nonuser	Male	573.4	165.2	172.8	235.4
69	Manual	115	2 Weeks	60-70	Nonuser	Male	429.3	166.8	211.2	51.2
70	Manual	116	2 Weeks	60-70	Nonuser	Male	407.4	162.2	144.5	100.8
71	Manual	13	2 Weeks	60-70	User	Female	365.2	110.7	211.8	42.7
72	Manual	48	2 Weeks	60-70	User	Female	389.6	87.9	185.1	116.6
73	Manual	57	2 Weeks	60-70	User	Female	199.8	72.5	101.7	25.6
74	Manual	65	2 Weeks	60-70	User	Female	621.4	84.2	188.5	348.7
75	Manual	67	2 Weeks	60-70	User	Female	348.3	159.6	121.3	67.4
76	Manual	69	2 Weeks	60-70	User	Female	269.5	93.7	136.7	39.1
77	Manual	72	2 Weeks	60-70	User	Female	261.7	72.7	106.7	82.3
78	Manual	7	2 Weeks	60-70	User	Male	1205.5	183.2	291.7	730.6
79	Manual	11	2 Weeks	60-70	User	Male	321.1	103.7	193.5	23.8
80	Manual	18	2 Weeks	60-70	User	Male	322.4	175.9	129.1	17.3
81	Manual	19	2 Weeks	60-70	User	Male	361.0	71.6	244.5	44.8

No	Mode	ID	Test Time	Age	Cruise Usage	Gender	Distance (miles) for different velocity ranges			
							All	< 35mph	35-55mph	> 55mph
82	Manual	20	2 Weeks	60-70	User	Male	347.7	111.3	147.1	89.3
83	Manual	32	2 Weeks	60-70	User	Male	376.1	123.1	152.1	100.9
84	Manual	47	2 Weeks	60-70	User	Male	336.0	88.2	167.7	80.1
85	Manual	56	5 Weeks	20-30	User	Female	1196.2	262.4	466.1	467.7
86	Manual	73	5 Weeks	20-30	User	Female	1537.4	281.5	507.4	748.4
87	Manual	79	5 Weeks	20-30	User	Female	883.2	255.0	501.2	127.0
88	Manual	87	5 Weeks	20-30	User	Female	1146.5	262.2	468.4	416.0
89	Manual	55	5 Weeks	20-30	User	Male	735.2	206.9	451.7	76.5
90	Manual	68	5 Weeks	20-30	User	Male	2766.9	368.0	498.8	1900.1
91	Manual	76	5 Weeks	20-30	User	Male	1122.9	313.0	483.5	326.4
92	Manual	89	5 Weeks	20-30	User	Male	1701.9	431.8	497.5	772.6
93	Manual	88	5 Weeks	40-50	User	Female	1400.8	287.3	382.8	730.7
94	Manual	96	5 Weeks	40-50	User	Female	1220.2	390.4	423.9	405.9
95	Manual	99	5 Weeks	40-50	User	Female	1288.3	340.8	641.8	305.6
96	Manual	104	5 Weeks	40-50	User	Female	1336.4	286.7	596.5	453.2
97	Manual	78	5 Weeks	40-50	User	Male	836.1	305.4	296.8	233.9
98	Manual	81	5 Weeks	40-50	User	Male	1143.4	346.4	596.0	201.0
99	Manual	92	5 Weeks	40-50	User	Male	456.9	147.1	189.2	120.6
100	Manual	100	5 Weeks	40-50	User	Male	1518.5	433.9	684.4	400.1
101	Manual	70	5 Weeks	60-70	User	Female	610.0	199.0	314.2	96.8
102	Manual	77	5 Weeks	60-70	User	Female	894.6	229.0	425.9	239.7
103	Manual	90	5 Weeks	60-70	User	Female	738.2	261.1	290.5	186.5
104	Manual	97	5 Weeks	60-70	User	Female	721.6	217.5	372.5	131.6
105	Manual	40	5 Weeks	60-70	User	Male	877.3	246.6	382.7	248.1
106	Manual	62	5 Weeks	60-70	User	Male	531.5	224.6	264.2	42.7
107	Manual	66	5 Weeks	60-70	User	Male	831.3	314.4	399.0	117.8
108	Manual	85	5 Weeks	60-70	User	Male	1559.5	390.8	486.0	682.7

## Appendix D

### **Forms Used in Recruiting Participants**

#### **D.1 Information Letter - ACC Field Operational Test**

The University of Michigan Transportation Research Institute and the National Highway Traffic Safety Administration are conducting a study of new cruise control devices for passenger vehicles, and one particular device referred to as “adaptive cruise control.” We are examining the impact of these devices on driving safety, comfort, and convenience. We are particularly interested in how the use of adaptive cruise control might modify driver behavior. We believe this is important research that will contribute to enhancing automobile safety and comfort, but we want to ensure that these devices are designed with the driver in mind.

You have been asked to participate in this study to evaluate adaptive cruise control in passenger cars. While participating in this study, you will be driving a car on local roadways that is equipped with this new form of cruise control. At no time during this study will you be asked to perform any unsafe driving actions. You must possess a valid, unrestricted, driver’s license. You must have a minimum of two years driving experience. You can not have been convicted of any felony involving a motor vehicle.

In addition, you must agree to the following:

- a. You, the participant, are the only person permitted to drive the research vehicle. The participant is defined as the one individual who agreed to, and received extensive instruction on, usage of the research vehicle and ACC system.
- b. The research vehicle can not be used to tow any form of trailer, or haul any material greater than what the vehicle was designed to accommodate.
- c. You may not, or allow others to, remove, modify, or tamper with any components of the research vehicle, ACC system, or data collection system. You must receive verbal permission from the experimenters prior to allowing any mechanical work to be performed on the research vehicle.
- d. The research vehicle can not be used to conduct illegal activities.
- e. The research vehicle cannot be used to transport flammable materials.
- f. You must agree to operate the research vehicle in accordance with all traffic laws.
- g. You cannot drive the research vehicle while impaired by alcohol or any controlled substances.

- h. You are the sole individual responsible for his/her conduct while driving the research vehicle.
- i. You are responsible for purchasing fuel for the research vehicle for the duration which it is assigned to you.
- j. The research vehicle can not be taken outside of the continental United States.
- k. You are the sole individual responsible for all tickets and violations for the duration which the research vehicle is assigned to you.
- l. You are responsible for reporting as early as possible to UMTRI any problems, mechanical malfunctions, or accidents with the research vehicle.
- m. If at any time, and for any reason, the experimenters deem it necessary that the research vehicle be returned to UMTRI, you must either return the vehicle or make arrangements for UMTRI personnel to retrieve it.
- n. You must return the research vehicle at the specified date and time your assignment ends.

**RISKS:** While participating in this study, you will be subject to all the risks that are normally present when driving a passenger car on public roadways. The use of the adaptive cruise control device being studied should not make driving any more hazardous than normal. However, caution should be used when operating a vehicle with which you are not familiar. The adaptive cruise control device you will be using will automatically accelerate and decelerate the research vehicle in order to maintain a constant distance (headway) separation between the research vehicle and any vehicle you are following. The level of deceleration you could experience is comparable to that of lightly applying the car's brakes. Be aware that accidents can happen at any time when driving, and that you can not rely on any device being studied to prevent an accident from occurring.

In the event that an accident occurs; you, any passengers, the research vehicle, as well as any other persons or property involved, will be covered under an insurance policy held by The University of Michigan Transportation Research Institute and The University of Michigan.

**BENEFITS:** The results of this study will provide valuable guidance for the development of cruise control devices for passenger cars. By participating in this study, you will be lending your experience and expertise to support highway safety research.

**PAYMENT:** You will be paid a total of \$150 for participating as a driver in this study. Your participation in the study will require approximately two (2) weeks.

**CONFIDENTIALITY:** The University of Michigan Transportation Research Institute and the National Highway Traffic Safety Administration are gathering information on the use of adaptive cruise control in passenger cars. We are not testing you or your skills. If you agree to participate in this study, your name will not be voluntarily released to anyone who does not work on this project. Your name will not appear in any reports or papers written about the project.

The University of Michigan Transportation Research Institute and the National Highway Traffic Safety Administration hope that you will agree to participate in this study. If you have any questions, please feel free at any time to ask the experimenter.

Once you have had your questions answered, please let the experimenter know whether you are interested in participating in this study. If you are willing to participate, the experimenter will ask you some questions to ensure that your skills and experience match our research needs. If it is determined that you qualify to participate, you will be asked to read and sign an Informed Consent Form before you can actually participate in the study.

## **D.2 Informed Consent Form -ACC Field Operational Test**

I, \_\_\_\_\_, agree to participate in the University of  
(Print your full name)

Michigan Transportation Research Institute's study of adaptive cruise control field operational test.

I understand that:

1. The purpose of this experiment is to investigate driver impressions and driving behavior concerning a new type of cruise control technology called adaptive cruise control.
2. As a participant, I will drive an instrumented car which is equipped with this new cruise control technology on public roadways.
3. At the conclusion of driving I will be asked to complete a questionnaire regarding my impressions of the adaptive cruise control system.
4. At no time in this study will I be asked to perform any unsafe driving actions.
5. I agree to obey all traffic laws while driving the research vehicle.
6. I must possess a valid, unrestricted, driver's license.
7. I must have a minimum of two years driving experience.
8. I cannot have been convicted of any felony involving a motor vehicle.

9. While driving in this study, I will be subject to all risks that are normally present while driving a passenger car. The use of adaptive cruise control is intended to make driving safer and more comfortable. However, caution should be exercised when operating a vehicle with equipment with which one is not familiar. I understand that the adaptive cruise control device will automatically accelerate and decelerate the research vehicle in order to maintain a constant distance (headway) separation between the research vehicle and any vehicle I am following, and that the level of deceleration is comparable to that of lightly applying the car's brakes. I will not become over reliant on the adaptive cruise control system, and I am aware that accidents can happen at any time while driving. I understand that the existence of an adaptive cruise control system on the research vehicle will not eliminate the possibility of an accident occurring.
10. In the event that an accident occurs; myself, any passengers, the research vehicle, as well as any other persons or property involved, will be covered under an insurance policy held by the University of Michigan Transportation Research Institute and the University of Michigan.
11. I also agree to the following conditions:
  - a. I, the participant, am the only person permitted to drive the research vehicle.
  - b. I will not use the research vehicle to tow any form of trailer, or haul any material greater than what the vehicle was designed to accommodate (heavy loading of the vehicle will negatively influence the operation of the ACC system).
  - c. I will not drive the research vehicle "off road", on any form of test or race track, nor will I use the vehicle in the performance of any form of stunt.
  - d. I will not, nor allow others to, remove, modify, or tamper with any components of the research vehicle, ACC system, or data collection system. I understand that I must receive verbal permission from an experimenter prior to allowing any mechanical work, other than changing a flat tire, to be performed on the research vehicle.
  - e. I will not use the research vehicle to conduct illegal activities.
  - f. I will not transport flammable materials in the research vehicle.
  - g. I cannot drive the research vehicle while impaired by alcohol or any controlled substances.
  - h. I am the sole individual responsible for his/her conduct while driving the research vehicle.

- i. I am responsible for the purchasing of fuel for the research vehicle for the duration which it is assigned to me.
  - j. I will not take the research vehicle outside of the continental United States (i.e., the research vehicle cannot enter Canada or Mexico).
  - k. I am the sole individual responsible for all tickets and violations for the duration which the research vehicle is assigned to me.
  - l. I am responsible for reporting as early as possible to UMTRI any problems, mechanical malfunctions, or accidents with the research vehicle.
  - m. If at any time, and for any reason, the experimenters deem it necessary that the research vehicle be returned to UMTRI prior to the end of the agreed term of my assignment, I must either return the vehicle or make arrangements for UMTRI personnel to retrieve it.
  - n. I must return the research vehicle at the specified date and time my assignment ends.
12. The results of this study will provide the University of Michigan Transportation Research Institute with information for the development of future adaptive cruise control devices. By participating in this study, I am lending my experience and expertise as a driver to support safety research regarding the future use of adaptive cruise control systems. I understand that I will not be informed as to the results of this study.
13. I will be paid a total of \$150 for participating in this testing. I understand that participation in this experiment will take approximately two (2) weeks, of which 3 hours time is spent at UMTRI.
14. The University of Michigan Transportation Research Institute is gathering information on adaptive cruise control devices, and not testing me. My name will not be released to anyone who is not working on the project. My name will not appear in any reports or papers written about the project. It is possible that, should the vehicle be involved in an accident or crime, that the University of Michigan Transportation Research Institute will have to release data on my driving in response to a court order. This information may include data related to driving performance and/or travel patterns.





## Appendix E

### **System Characterization Procedure**

The tests described in this appendix have been used to provide a preliminary checkout of the control functionality of the prototype ACC system being used in this field operational test. The purpose of these tests is not to measure the specific performance of the ACC sensors per se. Rather, it is to characterize the entire prototype system which includes the sensors, control algorithm, and vehicle platform.

The tests are controlled in reference to the speed of the preceding vehicle. It is desired that the speed of the preceding vehicle be approximately 66 mph or 60 mph in certain tests. In addition, other vehicles should not intervene between the ACC vehicle and the preceding vehicle. If the tests are done without a cooperative preceding vehicle (a confederate vehicle), it will be necessary to accept the speed of an arbitrarily picked preceding vehicle encountered on the highway.

The tests are intended to be useful even if they are performed on normal grades and curves as encountered on limited-access highways. However, curvature and grade will influence quantitative measures of performance to the extent that straight level sections of roadway are desired when consistent numerical results are needed.

The approach employed here for characterizing the ACC system is based upon identifying generic, fundamental tasks that the system may be expected to perform. These tasks are related to the following operational situations:

- closing-in on a preceding vehicle from a long range
- changing to a new headway in response to changing the system's headway setting
- responding to a close approach to a preceding vehicle

This set does not cover all aspects of ACC driving. However, it covers important situations and it provides a good basis for checking the performance of the existing ACC systems.

In order to check and evaluate system performance in these types of situations it is necessary to define (1) the input (essentially the behavior of the preceding vehicle), (2) the initial conditions for starting the test, (3) the conditions that apply during a test run, and (4) the performance signatures and measures used to characterize system performance.

The inputs to these tests are the speed of the preceding vehicle. The results of the tests are based upon measurements of range, range rate, velocity, transmission shift commands, and velocity commands resident within the ACC system. The primary data signals (and their

measured equivalents) that are used in performing and evaluating the test results were described in section 3.1.2, and illustrated in Figure xx15 in the main body of the report. Also, R versus Rdot plots are useful for interpreting results [xx4].

In addition, the computed quantity “Headway Time Margin”, symbolized as  $H_{tm}$ , is useful for interpreting results. The equation for  $H_{tm}$  is:

$$H_{tm} = \frac{R}{V}$$

(E-1)

In steady following with  $V = V_p$ ,  $H_{tm}$  should be equal to the headway time ( $T_h$ ) used in the headway controller.  $H_{tm}$  represents the reaction time within which the following driver would need to match any deceleration profile of the preceding vehicle in order to avoid a crash. The goal of the headway control system is viewed as trying to cause  $H_{tm}$  to approach  $T_h$ .

Sensor and velocity information is inherent and essential to the performance of this system. Therefore, these data are treated as “measured”, to emphasize the potential difference between the real data and that which the sensors report and the algorithm uses for calculations. (Symbols with a subscript “m” identify those variables.)

The following types of tests have been used to characterize basic functional aspects of the system.

## **E.1 Test 1: Closing-in on a Preceding Vehicle**

This test examines the transition from (a) operating in a manner similar to that of a conventional cruise control, to (b) operating in a headway-control mode. When the preceding vehicle is first detected, the ACC vehicle is using  $V_{set}$  and not range and range-rate to determine its speed. However, as the ACC vehicle closes in, the headway-control feature is automatically activated. The ACC system slows the vehicle to match the speed of the preceding vehicle and maintains a distance determined by the pre-selected headway time.

### Input

- $V_p = 60$  mph (88 ft/s, 26.8 m/s)

### Initial conditions for the ACC vehicle

- $V = 70$  mph (103 ft/s, 31.3 m/s)
- $V_{set} = 70$  mph
- $T_h = 1.4$  s (implies 123 ft at 60 mph, 37.5 m at 96.6 kph)
- $R >$  about 350 ft (107 m)

Run conditions: Starting from appropriate initial conditions operate the ACC system until a following condition ( $V = V_p$  and  $R = 1.4 V_p$ ) is established.

Example results: Typical results for this test are shown in Figure E-1 and Figure E-2. The process of slowing from the ACC vehicle's initial velocity to  $V_p$  is relatively long (30 to 60 seconds). Figure E-1 is a phase plane plot of range versus range rate for this test. Time is not directly shown in this plot, however the direction of increasing time is shown using arrowheads.

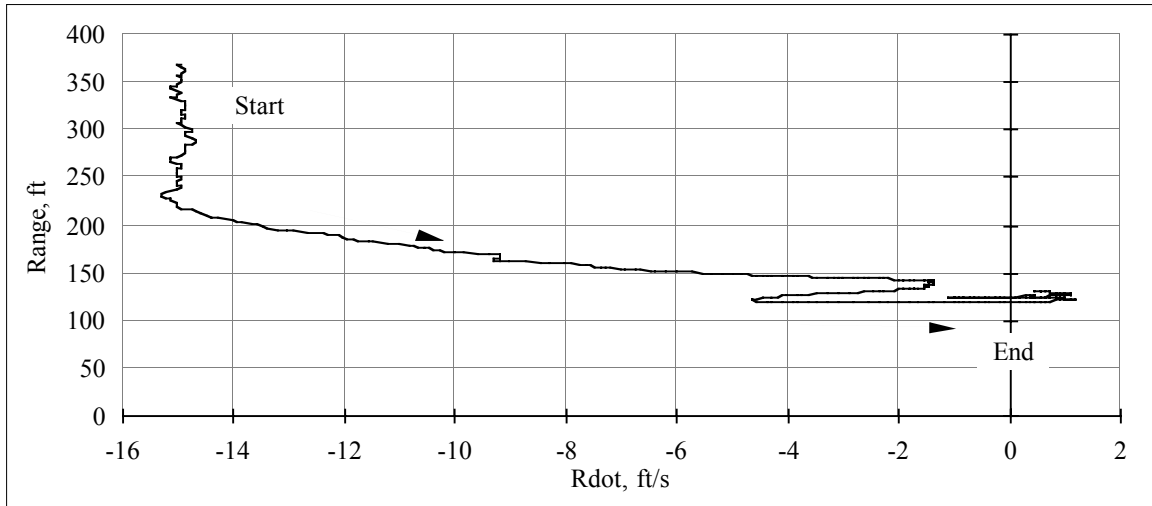

Figure E-1. Range versus Range-Rate, closing from long range

In closing from long range,  $R$  decreases as expected.  $Rdot$  is the derivative of  $R$ , and hence is negative for decreasing range. Figure E-2 is a plot of headway time margin,  $H_{tm}$ , versus time during this test.

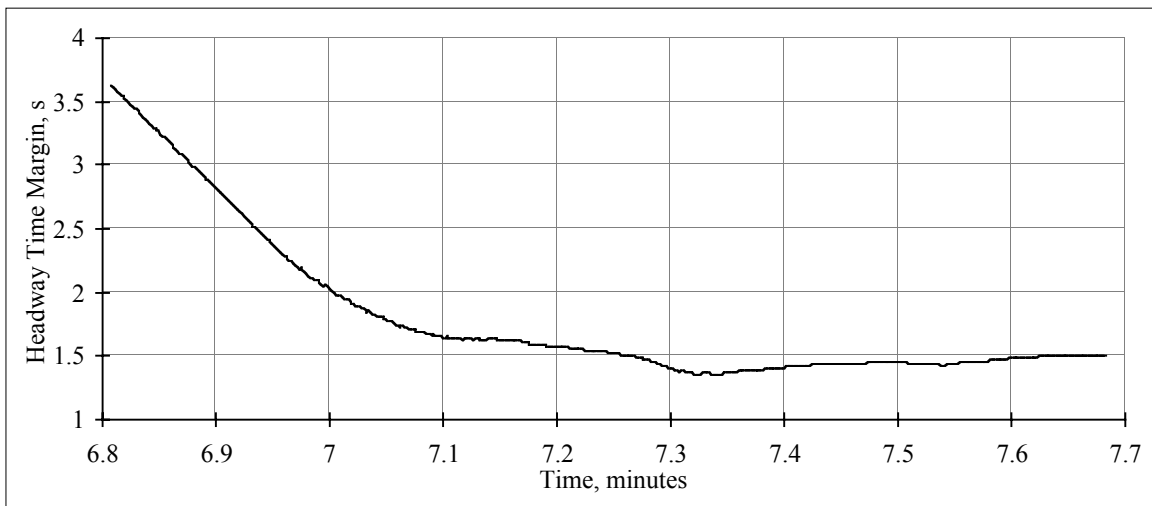

Figure E-2. Headway Time Margin ( $H_{tm}$ ) versus time, closing from long range

At the beginning of the sequence, before the system starts to respond to the preceding vehicle, the vehicles are separated by more than 3.5 seconds, and  $H_{tm}$  decreases linearly. At about  $H_{tm} = 2.3$  seconds, the time history of  $H_{tm}$  curves to approach somewhat exponentially to the selected headway time  $T_h = 1.4$  s. Typical variations in speed and grade will cause headway time margin  $H_{tm}$  to be within 10 percent of  $T_h$  when nominally steady following conditions are reached. Furthermore, the system tends to operate at 1.5 s rather than 1.4 s. (In practice, the actual headway times are best described as 1.1, 1.5, and 2.1 seconds.)

## E.2 Test 2: Changing to a new headway

The purpose of this test is to see how the ACC vehicle responds when headway is adjusted. The vehicle being tested has three settings for headway time: 1.0, 1.4, and 2.0 seconds (see section xx3.1.6 in the main body of the report). These settings cover the range of headway used by drivers who tend to travel at the speed of adjacent traffic [xx6]. The test cases (A through C below) pertain to changes between these levels of headway time.

### Case A

#### Input

- $V_p = 66$  mph (97 ft/s, 29.5 m/s)
- $T_h = 2.0$  s

#### Initial conditions

- $V = 66$  mph
- $V_{set} = 70$  mph (103 ft/s, 31.3 m/s)
- $R = T_h V_p = 194$  ft (59.2 m) for 66 mph

Run conditions: Follow the preceding vehicle for several seconds. (That is, with  $V = V_p$  and  $R = 2.0 V_p$ .) Change the  $T_h$  button setting from 2.0 to 1.0 s. This test should cause the vehicle to change to a shorter range of approximately 97 ft.

Example results: Figure E-3 is a plot of range versus range rate for this test. The range decreases to satisfy the lower  $T_h$  selection. Since the velocity of the preceding vehicle is nominally constant, the relative acceleration represents the acceleration of the following ACC vehicle. For this test, the highest closure rate is approximately -6 ft/s (-1.8 m/s) and the total change in range is approximately 120 ft (36m).

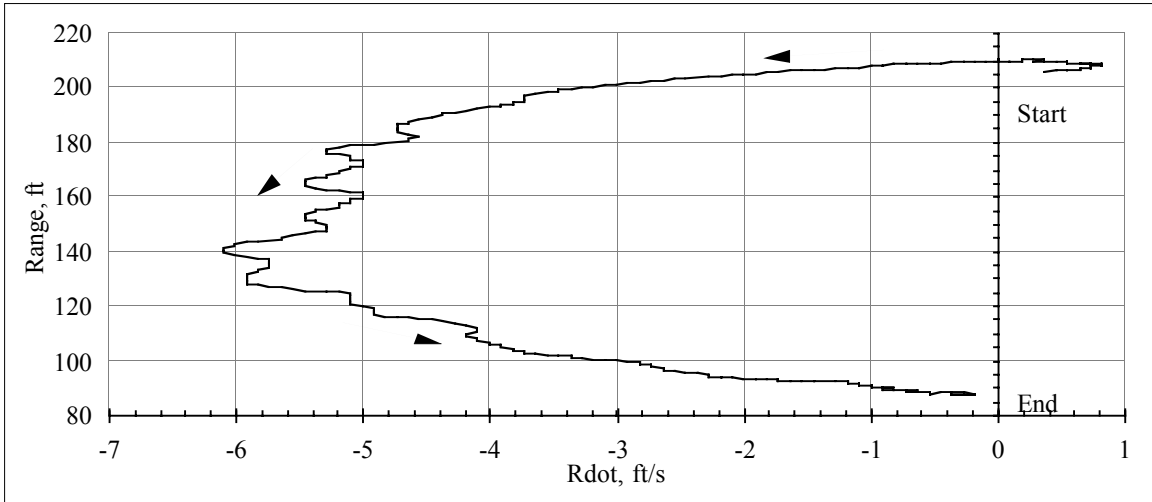

Figure E-3. Range versus Range-Rate, changing from  $T_h = 2.0$  to  $1.0$  s

Figure E-4 shows the headway time margin (see equation (E-1)). The headway time margin changes fairly linearly during the transient with a slope of approximately 3.14 s/minute for this test.

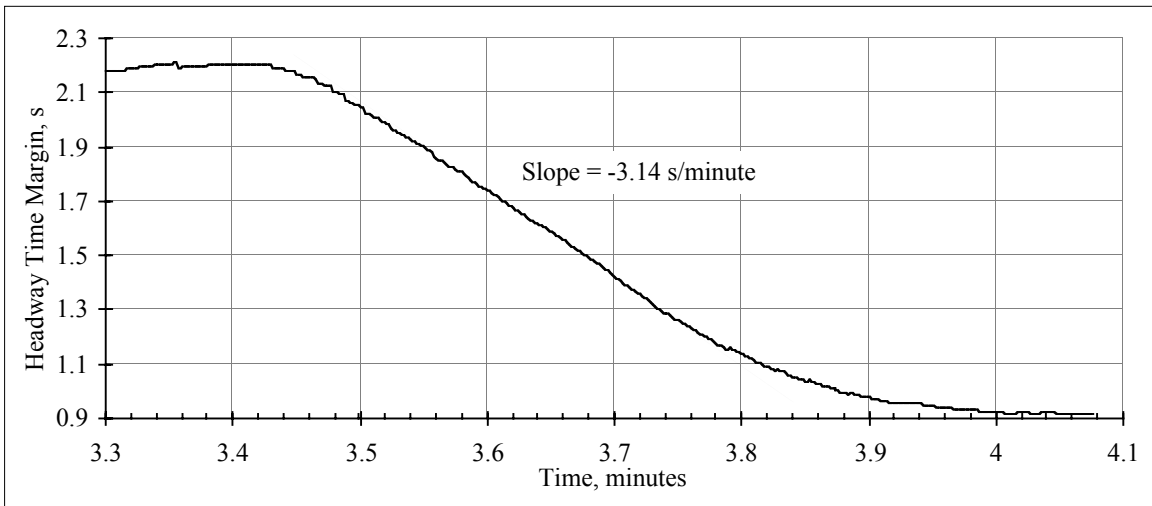

Figure E-4. Headway Time Margin ( $H_{tm}$ ) versus time, changing from  $T_h = 2.0$  to  $1.0$  s

### Case B

(This case is the inverse of case A: initial  $T_h$  is  $1.0$  s and final  $T_h$  is  $2.0$  s)

#### Input

- $V_p = 66$  mph (97 ft/s, 29.5 m/s)
- $T_h = 2.0$  s, from  $T_h = 1.0$  s initially

#### Initial conditions

- $V = 66$  mph

- $V_{\text{set}} = 70 \text{ mph (103 ft/s, 31.3 m/s)}$
- $R = T_h V_p = 97 \text{ ft (29.6 m)}$  for  $T_h = 1.0 \text{ s}$  initially

Run conditions: The same general idea as in case A, except this case causes the vehicle to change from a short to a longer range.

Example results: Figure E-5 presents the range versus range-rate diagram for this example. The maximum range-rate is 8 ft/sec. This means that the ACC vehicle slows down considerably as it widens the headway range by approximately 100 ft (30.5 m) in this case. Examination of the data for cases A and B indicates that this system increased headway (from  $T_h = 1.0$  to 2.0 s) in approximately 1/3 less time than it required to shorten headway by the same increment (compare Figure E-4 and Figure E-6 as well as Figure E-3 and Figure E-5).

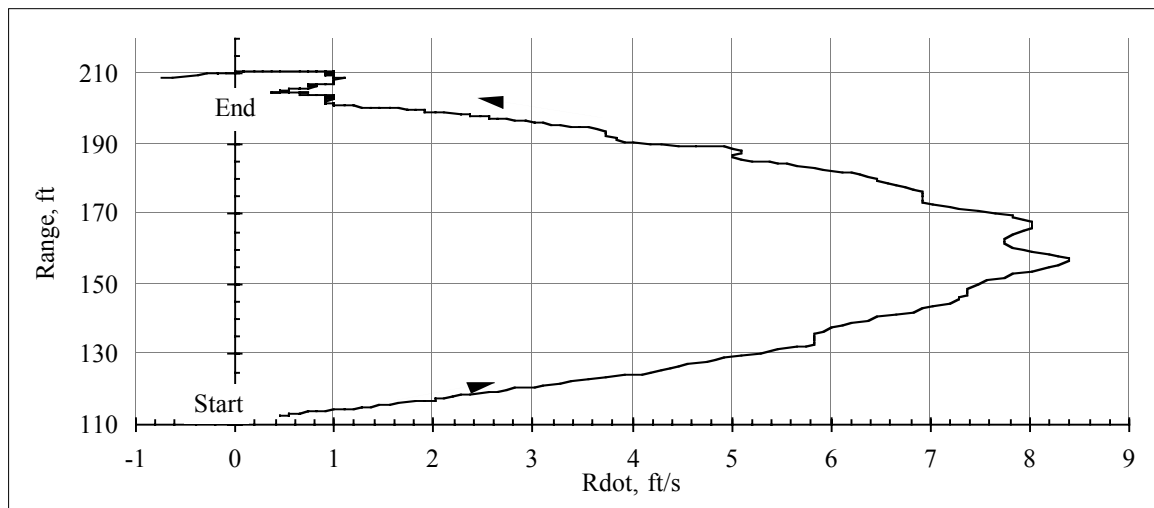

Figure E-5. Range versus Range-Rate, changing from  $T_h = 1.0$  to 2.0 s

Examination of Figure E-6 indicates that the maximum slope of the headway time margin is approximately 6.3 sec/minute, or in other words, the slew rate employed in increasing headway time is about twice as fast as that employed in decreasing headway time.

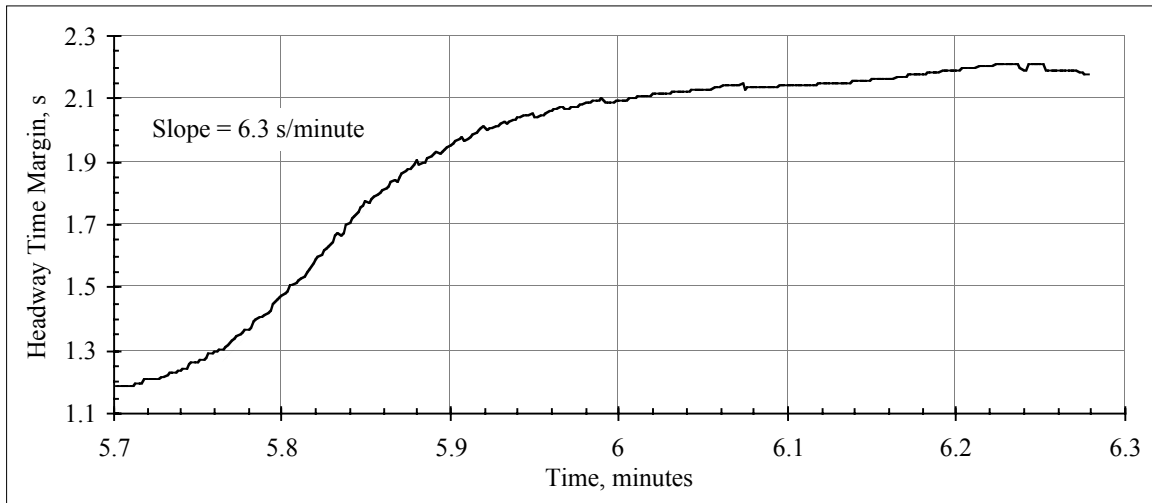

Figure E-6. Headway Time Margin ( $H_{tm}$ ) versus time, changing from  $T_h = 1.0$  to  $2.0$  s

### Case C

(This case is similar to case A, only that final  $T_h$  is 1.4 s)

### E.3 Test 3: Manually accelerating

The purpose of this test is to exercise the accelerator pedal override capability as well as to check the ability of the system to correct for a moderately-near encounter. This test may cause the control system to downshift the transmission while the driver is accelerating the ACC vehicle. Nevertheless, once the accelerator pedal is released by the driver, the ACC vehicle should slow down towards a proper following condition in a manner that is characteristic of the operation of this headway control system.

#### Input:

- $V_p = 60$  mph

#### Initial conditions for the ACC vehicle:

- $V = 60$  mph
- $V_{set} = 70$  mph
- $T_h = 1.4$  s ( implies  $T_h V_p = 123$  ft)
- The ACC vehicle should be following. ( $V = V_p$  and  $R = 1.4 V_p$ )

Run Conditions: The driver of the ACC vehicle is to accelerate and partially overtake the preceding vehicle. When the range gets to approximately 2/3 of the original gap, the driver of the following vehicle is to release the accelerator pedal. The test is continued until steady-state following is reestablished or until the driver brakes. (This test could be viewed as an aborted passing maneuver but it is probably better to view it as a means to simulate a near

encounter. In practical operation, near encounters can happen for many reasons including merges or other events that cause the sensor to pick up a preceding vehicle for the first time at close range.)

Example results: Data for range versus range-rate are presented in Figure E-7. These data show that the trajectory in the range versus range-rate space is nearly a closed loop. (Ideally it would be a closed loop.) The minimum  $R_{dot\_m}$  is approximately  $-12$  ft/s and the maximum is about  $8$  ft/s. The minimum range is close to  $50$  ft.

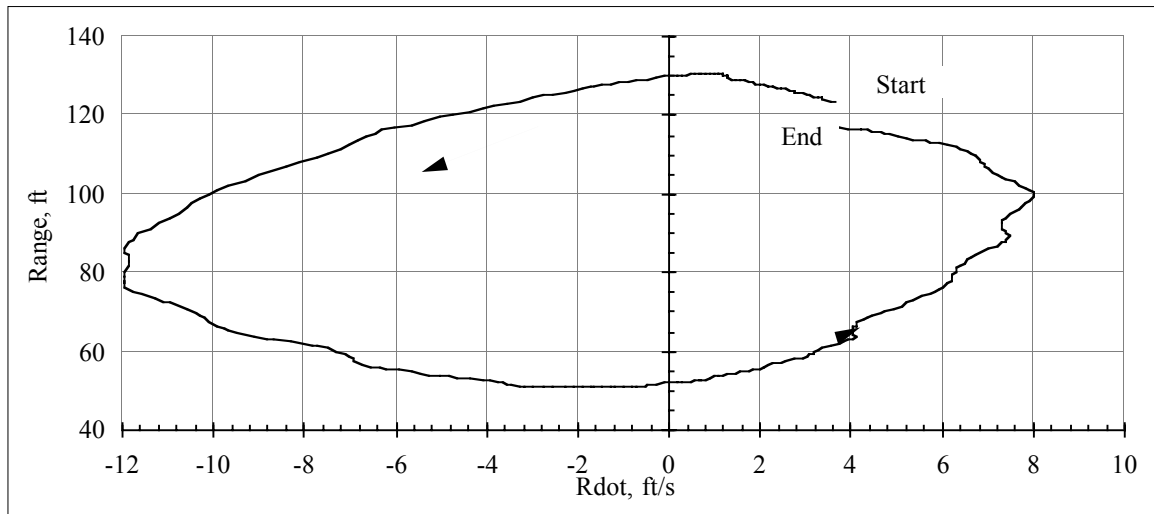

Figure E-7. Range versus Range-Rate, manually accelerating

Figure E-8 shows that the headway time margin goes from about  $1.5$  seconds to a low of about  $0.6$  seconds and then back to about  $1.4$  seconds in this test. This is all done in approximately  $0.45$  minutes ( $27$  seconds).

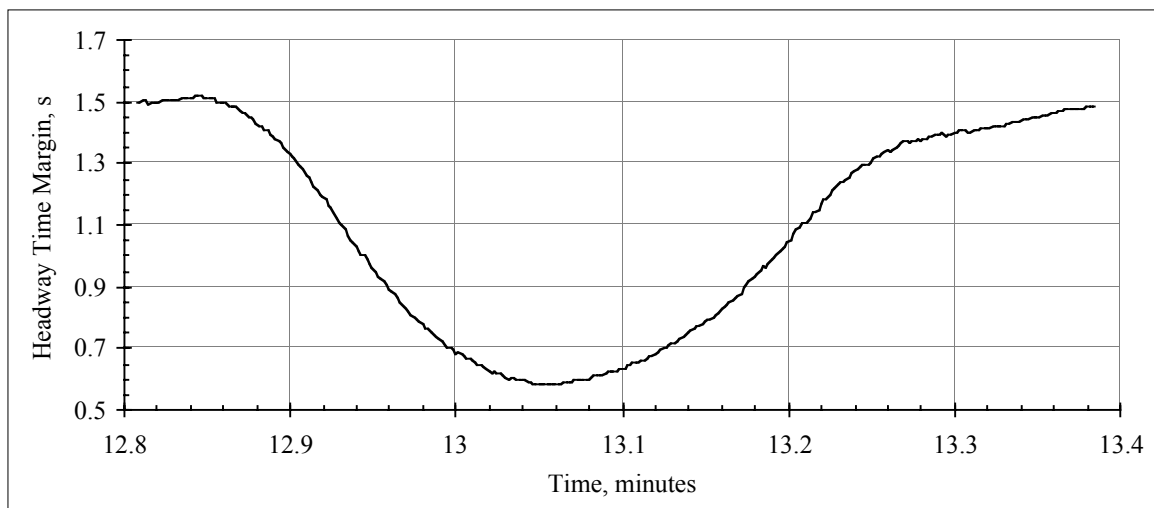

Figure E-8. Headway Time Margin versus time, manually accelerating



The test scenarios presented in this appendix serve as a practicable means for characterizing and periodically reconfirming the performance of the ACC vehicles in the field operational test. They provide performance signatures that can be examined to quantify features that serve as performance measures for ACC vehicles. Since the test conditions do not control for grade and traffic condition, the results will differ from time to time and place to place. Nevertheless, since the functionality of adaptive cruise control does not depend upon high levels of performance from a control system perspective, the results of these tests are sufficient to answer basic questions concerning the control algorithms such as: Does the vehicle slow down when it should? Does the vehicle speed up as it should? Does headway time adjust as it should?

From the characterization tests that were performed, it appears that this ACC system reaches selected headway times with a resolution of approximately ten percent. The system is able to correct for disturbances in speed or range-rate that cause range-rate to reach a closing rate of approximately 10 mph ( $-15$  ft/s,  $-4.5$  m/s). The system is also able to keep the headway time margin above 0.6 seconds in the sudden encounters involved in these tests. Changes in headway time are achieved smoothly with little overshoot or undershoot. When closing in from long range, the ACC system starts to adjust speed at 200 to 300 feet away. And finally, the ACC system downshifts when it needs to achieve a higher deceleration than that available from the natural retardation of the vehicle.

Clearly there are many driving situations that could be tested. The tests described here and an additional test that involves (1) a decelerating preceding vehicle, and (2) a preceding vehicle that suddenly appears in the path of the ACC vehicle, are presented in [xx7]. However, tests that involve braking or cut-in are difficult to perform, and could upset other drivers. Such tests were performed as part of the early characterization of the test vehicles, however, they are not part of the current routine checks. The 3 types of tests described in this appendix have been used routinely to check ACC functionality before a test vehicle is released to a participant driver.

## Appendix F

### Chronology of drivers, vehicles, systems, and events

#### F.1 Algorithm's Version History

The following versions were used after the official FOT started (subject #1 and after)

**9.17** - If the driver were to depress the brake pedal or press the “Off” button of the cruise control when the downshift command was active, it could have caused the transmission to be “stuck” in third gear. This version fixed the problem.

**9.18** - A ten-seconds countdown was displayed on the MMI to prompt the driver to wait between starting the car and driving, for the purpose of complete system initialization.

A more strict downshift requirement: the system had to be engaged and in a headway mode (a state where the commanded speed is lower than the set speed in order to accommodate a preceding vehicle); having just a “valid target” tracked by the sensor was not enough.

Provision to accommodate “flying passes”: an upper limit was established (desired range + 45 meters) above which the system would not respond to targets.

Shorter downshift delays: when downshift conditions prevail, the system will actually command downshift after only 200 mSec (used to be 500). Once downshift commenced, the system would keep it for at least 800 mSec (was 3 sec.)

In the face of sluggish acceleration, an attempt was made in previous versions to add more “oompf” under high-gap conditions by commanding a speed higher than what was computed. this feature was canceled in this version due to its ineffectiveness.

**9.19** - Fix error in low bound for “SetSpeed”: 30 mph to engage (was 35 mph), and 25 mph to resume (was 30 mph).

Modify downshift delays: when downshift conditions prevail, downshift commenced after only 200 mSec (used to be 200), and it was kept for at least 1 sec (was 800 mSec.)

**9.22** - Compute and collect in the data  $V_c$  (speed command to accommodate a preceding vehicle) even under CCC, when this  $V_c$  is not sent to the engine controller.

When coasting down, send (V-15) instead of Zero (could cause involuntary disengagement)

Initialize one of the “counting” variables to prevent premature indication of sensor error.,

Minimize the chance of a “false acceleration” when the algorithm “thinks” that the system is OFF by sending the current speed as a speed command (instead of a computed speed).

**9.23** - Further minimize the chance of a “false acceleration” when the algorithm “thinks” that the system is OFF or STANDBY by commanding “coastdown”.

**9.26** - Filter the speed input from the engine controller to avoid data “glitches” which might cause involuntary disengagement.

Allow for one-second glitches: above that period the system will accept the data as a valid speed information.

Send the filtered speed to the data collection (instead of the raw data from the engine).

**9.27** - Instead of a general display of “99” on the MMI for system’s failure, a more “decipherable” display was incorporated:

- 99 — invalid vehicle data (or failed communication with the ECU)
- 98 — failed communication with the sensors
- 97 — the bit “ready” from the sensors is not set; sensors are inoperative
- 96 — if the conditions leading to either “98” or to “97” persist for more than 500 mSec
- 95 — failed communication with the gyro.

The algorithm checks the errors “top-down” (starting with the “99”), and it displays the first one it encounters.

## **F.2 Sensor's Software Versions**

**4.41** - The original version that came with ODIN 4

**4.42** - Fixed the problem of “phantom” targets in 4.41. These phantom targets could appear if the sensor was to be powered-up with no target present. Also, this version had a new software driver for the chopper.

**4.44** - The original chopper driver from 4.41 was restored (the driver in 4.42 had problems), while keeping the fix for "phantom" targets from 4.42.

### **F.3 Far Off Sensors**

These were the inspection dates and the vehicle identifications for which the sensors were found excessively off alignment (more than 10 mm):

Car 0 —	3/17/97
	8/22/97
Car 1 —	6/23/97
Car 2 —	11/14/96
	5/21/97
	6/25/97
Car 3 —	5/29/97
Car 5 —	12/17/96
	8/20/97
Car 8 —	8/21/97
Car 9 —	3/12/97

### **F.4 Assignment Summary**

Table F-1 provides a summary of all the drivers in terms of what car they drove, when they drove, and what were the versions of the system's components.

Table F-1. Assignments summary

Driver	Vehicle	5 week?	Start Date	Start Mileage	End Date	End Mileage	Fuse Date	Sweep	Cut-in	Algorithm Version	Daq Version	Comments
1	0	0	7/31/96	0	8/12/96	0	8/6/96	4.41	4.41	9.17	1	No Video Capability
2	3	0	7/31/96	0	7/31/96	0	8/6/96	4.41	4.41	9.17	1	-no GPS Removed - No Video Capability - Rear End Accident
3	0	0	8/22/96	0	9/3/96	0	8/28/96	4.41	4.41	9.18	1	
4	1	0	8/23/96	0	9/3/96	0	8/29/96	4.41	4.41	9.18	1	
5	4	0	8/29/96	0	9/10/96	0	9/4/96	4.41	4.41	9.19	1	
6	2	0	8/30/96	0	9/11/96	0	9/5/96	4.41	4.41	9.19	1	
7	0	0	9/5/96	0	9/17/96	0	9/11/96	4.41	4.41	9.19	1	
8	1	0	9/6/96	0	9/18/96	0	9/12/96	4.41	4.41	9.19	1	
9	4	0	9/12/96	0	9/24/96	0	9/18/96	4.41	4.41	9.19	1	
10	2	0	9/13/96	0	9/25/96	0	9/19/96	4.41	4.41	9.19	1	
11	6	0	9/19/96	0	10/1/96	0	9/25/96	4.41	4.41	9.22	1	No Video - shorted camera cable
12	5	0	9/20/96	0	10/2/96	0	9/26/96	4.41	4.41	9.22	1	No Video - Camera power unplugged
13	0	0	9/20/96	0	10/2/96	0	9/26/96	4.41	4.41	9.22	1	
14	1	0	9/26/96	0	10/8/96	8175	10/2/96	4.42	4.42	9.22	1	V dropouts
15	2	0	9/27/96	0	10/9/96	4028	10/3/96	4.42	4.42	9.22	1	V dropouts
16	8	0	10/3/96	0	10/15/96	3380	10/9/96	4.42	4.42	9.23	1	Removed - Came in with sensor error

Table F-1. Assignments summary (Cont.)

Driver	Vehicle	5 week?	Start Date	Start Mileage	End Date	End Mileage	Fuse Date	Sweep	Cut-in	Algorithm Version	Daq Version	Comments
17	5	0	10/4/96	2389	10/16/96	2798	10/10/96	4.42	4.42	9.23	1	missing video - intermittent network?
18	0	0	10/4/96	12436	10/16/96	13253	10/10/96	4.42	4.42	9.23	1	
19	6	0	10/10/96	3126	10/22/96	3874	10/16/96	4.42	4.42	9.23	1	
20	1	0	10/17/96	8403	10/29/96	9111	10/23/96	4.41	4.42	9.26	2	
21	2	0	10/18/96	4448	10/30/96	5409	10/24/96	4.42	4.42	9.26	2	
22	8	0	10/18/96	3473	10/30/96	3936	10/24/96	4.41	4.42	9.26	2	
23	0	0	10/24/96	13312	11/5/96	13712	10/30/96	4.42	4.42	9.26	2	
24	6	0	10/25/96	3914	11/6/96	4600	10/31/96	4.42	4.42	9.26	2	
25	5	0	10/25/96	2868	11/6/96	3400	10/31/96	4.41	4.41	9.26	2	missing video - intermittent network?
26	4	0	10/31/96	5103	11/12/96	5733	11/6/96	4.41	4.41	9.26	2	
27	1	0	10/31/96	9145	11/12/96	9508	11/6/96	4.41	4.42	9.26	2	
28	9	0	11/1/96	3731		0	11/7/96	4.41	4.41	9.26	2	Removed - bad fuse & headlight switch
29	2	0	11/1/96	5443	11/13/96	5937	11/7/96	4.41	4.42	9.26	2	
30	0	0	11/7/96	13747	11/19/96	14701	11/13/96	4.44	4.42	9.27	2	
31	8	0	11/7/96	4196	11/19/96	4644	11/13/96	4.44	4.44	9.27	2	
32	6	0	11/8/96	4649	11/20/96	5148	11/14/96	4.44	4.44	9.27	2	
33	5	0	11/14/96	3711	11/26/96	4703	11/20/96	4.44	4.44	9.27	2	
34	1	0	11/15/96	9543	11/27/96	10846	11/21/96	4.44	4.44	9.27	2	
35	2	0	11/15/96	0	11/27/96	7152	11/21/96	4.44	4.44	9.27	2	
36	4	0	11/21/96	5783	12/3/96	6233	11/27/96	4.44	4.44	9.27	2	Removed - Too many in Cell
37	6	0	11/22/96	5175	12/4/96	5735	11/28/96	4.44	4.44	9.27	2	
38	5	0	11/29/96	4721	12/4/96	4993	11/28/96	4.44	4.44	9.27	2	

Table F-1. Assignments summary (Cont.)

Driver	Vehicle	5 week?	Start Date	Start Mileage	End Date	End Mileage	Fuse Date	Sweep	Cut-in	Algorithm Version	Daq Version	Comments
38	8	0	11/22/96	4691	11/29/96	4759	11/28/96	4.44	4.44	9.27	2	
39	1	0	1/21/97	13523	2/5/97	13968	1/27/97	4.44	4.44	9.27	3	
40	2	-1	1/28/97	7976	2/24/97	10905	1/28/97	4.44	4.44	9.27	3	
40	5	-1	1/22/97	5173	1/28/97	5360	1/28/97	4.44	4.44	9.27	3	Cold induced malfunction
41	6	0	1/29/97	5827	2/10/97	6598	2/4/97	4.44	4.44	9.27	3	
42	9	0	1/29/97	5088	2/10/97	5441	2/4/97	4.44	4.44	9.27	3	
43	5	0	2/10/97	6072	2/24/97	6614	2/16/97	4.44	4.44	9.27	3	
44	8	0	2/11/97	7164	2/25/97	8008	2/17/97	4.44	4.44	9.27	3	
45	1	0	2/15/97	14004	3/1/97	14670	2/21/97	4.44	4.44	9.27	3	
46	9	0	2/18/97	5497	3/5/97	5887	2/24/97	4.44	4.44	9.27	3	
47	6	0	2/26/97	6646	3/10/97	7331	3/4/97	4.44	4.44	9.27	3	
48	4	0	3/1/97	6866	3/15/97	7389	3/7/97	4.44	4.44	9.27	4	
49	2	0	3/3/97	10942	3/17/97	12243	3/9/97	4.44	4.44	9.27	4	
50	5	0	3/6/97	6665	3/18/97	7724	3/12/97	4.44	4.44	9.27	4	
51	8	0	3/13/97	8074	3/25/97	9549	3/19/97	4.44	4.44	9.27	4	ODIN Error trips 46-64
52	9	0	3/15/97	5920	3/29/97	7257	3/21/97	4.44	4.44	9.27	4	
53	0	0	3/20/97	15170	4/1/97	16713	3/26/97	4.44	4.44	9.27	4	Removed - Too many in Cell
54	1	0	3/20/97	14739	4/1/97	15898	3/26/97	4.44	4.44	9.27	4	
55	6	-1	3/21/97	7365	4/22/97	8508	3/27/97	4.44	4.44	9.27	4	
56	4	-1	3/28/97	7438	4/29/97	9830	4/3/97	4.44	4.44	9.27	4	
57	5	0	3/28/97	7819	4/9/97	8164	4/3/97	4.44	4.44	9.27	4	
58	1	0	4/3/97	15943	4/18/97	0	4/9/97	4.44	4.44	9.27	4	Removed - ebox error
59	9	0	4/3/97	7335	4/15/97	8129	4/9/97	4.44	4.44	9.27	4	
60	8	0	4/4/97	9586	4/16/97	9902	4/10/97	4.44	4.44	9.27	4	
61	2	0	4/4/97	13277	4/16/97	14484	4/10/97	4.44	4.44	9.27	4	

Table F-1. Assignments summary (Cont.)

Driver	Vehicle	5 week?	Start Date	Start Mileage	End Date	End Mileage	Fuse Date	Sweep	Cut-in	Algorithm Version	Daq Version	Comments
62	0	-1	4/11/97	16840	5/13/97	17975	4/17/97	4.44	4.44	9.27	4	
63	5	0	4/17/97	8212	4/29/97	9152	4/23/97	4.44	4.44	9.27	4	
64	9	0	4/17/97	8167	4/29/97	8686	4/23/97	4.44	4.44	9.27	4	
65	8	0	4/18/97	9939	4/30/97	10698	4/24/97	4.44	4.44	9.27	4	
66	2	-1	4/18/97	14519	5/20/97	16317	4/24/97	4.44	4.44	9.27	4	
67	1	0	4/25/97	16975	5/7/97	17569	5/1/97	4.44	4.44	9.27	4	
68	6	-1	4/25/97	8548	5/27/97	13002	5/1/97	4.44	4.44	9.27	4	
69	5	0	5/2/97	9192	5/14/97	9593	5/8/97	4.44	4.44	9.27	4	
70	4	-1	5/2/97	9865	6/3/97	10953	5/8/97	4.44	4.44	9.27	4	
71	9	0	5/2/97	8724	5/14/97	9574	5/8/97	4.44	4.44	9.27	4	Removed - recalled - intended 5wk but subject stopped driving
72	8	0	5/9/97	10948	5/21/97	11645	5/15/97	4.44	4.44	9.27	4	
73	1	-1	5/9/97	17613	6/10/97	23201	5/15/97	4.44	4.44	9.27	4	other driver on trips 64,66,121, 130,166,1 68,180(12 00 miles)
74	7	0	5/10/97	4965	5/23/97	5237	5/16/97	4.44	4.44	9.27	4	
75	3	0	5/16/97	3598	5/28/97	5369	5/22/97	4.44	4.44	9.27	4	
76	5	-1	5/16/97	9640	6/17/97	12170	5/22/97	4.44	4.44	9.27	4	
77	2	-1	5/22/97	16351	6/23/97	17997	5/28/97	4.44	4.44	9.27	4	
78	8	-1	5/23/97	11680	6/24/97	13865	5/29/97	4.44	4.44	9.27	4	
79	0	-1	5/29/97	18467	6/30/97	19676	6/4/97	4.44	4.44	9.27	4	
80	6	0	5/29/97	13039	6/10/97	13908	6/4/97	4.44	4.44	9.27	4	
81	7	-1	5/30/97	5273	7/1/97	6880	6/5/97	4.44	4.44	9.27	4	
82	9	0	6/6/97	9681	6/18/97	10470	6/12/97	4.44	4.44	9.27	4	
83	3	0	6/6/97	5482	6/18/97	5716	6/12/97	4.44	4.44	9.27	4	
84	4	0	6/13/97	10987	6/25/97	11753	6/19/97	4.44	4.44	9.27	4	



Table F-1. Assignments summary (Cont.)

Driver	Vehicle	5 week?	Start Date	Start Mileage	End Date	End Mileage	Fuse Date	Sweep	Cut-in	Algorithm Version	Daq Version	Comments
85	6	-1	6/19/97	0	7/21/97	16953	6/25/97	4.44	4.44	9.27	4	
86	5	0	6/20/97	12217		0	6/26/97	4.44	4.44	9.27	4	Removed - Recalled - fuse & over temp
87	3	-1	6/20/97	5761	7/20/97	7763	6/26/97	4.44	4.44	9.27	4	
88	9	-1	6/20/97	10505	7/22/97	13011	6/26/97	4.44	4.44	9.27	4	
89	1	-1	6/26/97	23316	7/15/97	25662	7/2/97	4.44	4.44	9.27	4	trips 1-190 (182-190 had E-box Failure) starting with trip 200
89	4	-1	7/15/97	12450	7/29/97	13355	7/2/97	4.44	4.44	9.27	4	
90	8	-1	6/27/97	13909	7/29/97	15438	7/3/97	4.44	4.44	9.27	4	
91	2	0	7/3/97	18040	7/15/97	18744	7/9/97	4.44	4.44	9.27	4	
92	4	-1	7/4/97	11824	7/9/97	12298	7/10/97	4.44	4.44	9.27	4	trips 1-30 (13-30 had Cutin Failure) trips 31-
92	7	-1	7/9/97	6942	8/5/97	7966	7/10/97	4.44	4.44	9.27	4	
93	0	0	7/3/97	19733	7/15/97	20733	7/9/97	4.44	4.44	9.27	4	
94	5	0	7/10/97	13908	7/22/97	15554	7/16/97	4.44	4.44	9.27	4	High Temp. caused CPU restarts in trips 85- 106, 113- 127
95	0	0	7/17/97	20788	7/29/97	21160	7/23/97	4.44	4.44	9.27	4	

Table F-1. Assignments summary (Cont.)

Driver	Vehicle	5 week?	Start Date	Start Mileage	End Date	End Mileage	Fuse Date	Sweep	Cut-in	Algorithm Version	Daq Version	Comments
96	1	-1	7/17/97	25735	8/11/97	28122	7/23/97	4.44	4.44	9.27	4	
96	6	-1	8/11/97	19825	8/18/97	20875	7/23/97	4.44	4.44	9.27	4	Odin Error: trips 129-139,143,146-157
97	3	-1	7/25/97	7800	8/26/97	8878	7/31/97	4.44	4.44	9.27	4	
98	6	0	7/25/97	16991	8/6/97	19821	7/31/97	4.44	4.44	9.27	4	
99	4	-1	8/1/97	13395	9/2/97	17408	8/7/97	4.44	4.44	9.27	4	
100	9	-1	8/7/97	13067	9/8/97	15681	8/13/97	4.44	4.44	9.27	4	
101	0	0	8/8/97	21225	8/14/97	21610	8/14/97	4.44	4.44	9.27	4	Key switch problems - replaced by car 5
101	5	0	8/14/97	15921		0		4.44	4.44	9.27	4	Removed - Headlight switch failure
102	8	0	8/8/97	15479	8/20/97	15479	8/14/97	4.44	4.44	9.27	4	
103	7	0	8/8/97	8023	8/20/97	8663	8/14/97	4.44	4.44	9.27	4	
104	1	-1	8/14/97	28168	9/15/97	30156	8/20/97	4.44	4.44	9.27	4	
105	6	0	8/21/97	20928	9/2/97	22372	8/27/97	4.44	4.44	9.27	4	
106	5	0	8/22/97	16640	9/3/97	17410	8/28/97	4.44	4.44	9.27	4	
107	8	0	8/28/97	17213	9/9/97	18005	9/3/97	4.44	4.44	9.27	4	
108	7	0	8/28/97	8718	9/9/97	8718	9/3/97	4.44	4.44	9.27	4	
109	0	0	8/29/97	21903	9/10/97	23337	9/4/97	4.44	4.44	9.27	4	
110	3	0	9/4/97	8937	9/16/97	10038	9/10/97	4.44	4.44	9.27	4	
111	4	0	9/4/97	17445	9/16/97	18733	9/10/97	4.44	4.44	9.27	4	
112	6	0	9/5/97	22409	9/17/97	23145	9/11/97	4.44	4.44	9.27	4	
113	5	0	9/11/97	17457	9/23/97	18504	9/17/97	4.44	4.44	9.27	4	
114	7	0	9/11/97	9251	9/23/97	9970	9/17/97	4.44	4.44	9.27	4	

Table F-1. Assignments summary (*Cont.*)

Driver	Vehicle	5 week?	Start Date	Start Mileage	End Date	End Mileage	Fuse Date	Sweep	Cut-in	Algorithm Version	Daq Version	Comments
115	8	0	9/12/97	18041	9/24/97	18574	9/18/97	4.44	4.44	9.27	4	
116	9	0	9/12/97	15689	9/24/97	16172	9/18/97	4.44	4.44	9.27	4	
117	1	0	9/18/98	30193	9/30/97	31219	9/24/97	4.44	4.44	9.27	4	

**DOT HS 808 849**  
**May 1998**



U.S. Department  
of Transportation  
**National Highway  
Traffic Safety  
Administration**



---

**DOT HS 808 849**

**July 1998**

**Final Report  
Volume III: Performance of a String or Cluster of ACC-Equipped Cars**

# **Intelligent Cruise Control Field Operational Test**

# Table of Contents for Volume 3

## RETURN TO VOLUME I

EXECUTIVE SUMMARY .....	1
1.0 BACKGROUND.....	3
2.0 DESCRIPTION OF THE VEHICLE OPERATIONS AND PROCEDURES .....	5
2.1 Longitudinal String Tests.....	5
2.2 Cluster Tests .....	6
3.0 OBSERVATIONS AND OBJECTIVE RESULTS FOR THE FOUR-VEHICLE STRING TESTS .....	7
3.1 Driver Observations .....	7
3.1.1 <i>Naturalistic occurrence of vehicle strings</i> .....	7
3.1.2 <i>Harmonic nature of FOT vehicles in a string</i> .....	7
3.1.3 <i>Effect of a four-vehicle string on other traffic</i> .....	8
3.2 Objective Results .....	8
4.0 OBSERVATIONS AND OBJECTIVE RESULTS FOR THE EIGHT-VEHICLE STRING TESTS .....	13
4.1 Two-Lane Interstate Highway.....	13
4.2 Driver Observations .....	13
4.2.1 <i>Formation concerns</i> .....	13
4.2.2 <i>Harmonic nature of FOT vehicles in a string</i> .....	14
4.2.3 <i>Effect of an eight-vehicle string on other traffic</i> .....	14
4.3 Three-Lane Interstate Highway.....	15
4.4 Driver Observations .....	15
4.4.1 <i>Formation concerns</i> .....	15
4.4.2 <i>Harmonic nature of FOT vehicles in a string</i> .....	15
4.4.3 <i>Effect of an eight-vehicle string on other traffic</i> .....	15
4.5 Objective Results .....	16
5.0 OBSERVATIONS AND OBJECTIVE RESULTS FOR THE EIGHT-VEHICLE CLUSTER TESTS .....	19
5.1 Driver Observations for Cluster Test 1 .....	19
5.2 Objective Results .....	20
5.3 Driver Observations for Cluster Test 2 .....	21
6.0 CONCLUSIONS .....	23
6.1 Test Methodology .....	23
6.2 Interactions between Multiple ACC Vehicles and Nearby Traffic .....	24
6.3 Future Test Possibilities .....	25
7.0 REFERENCES.....	27

## RETURN TO VOLUME II

<b>1. Report No.</b> DOT HS 808 849	<b>2. Government Accession No.</b>	<b>3. Recipient's Catalog No.</b>	
<b>4. Title and Subtitle</b> Intelligent Cruise Control Field Operational Test (Final Report) Vol. III: Performance of a String or Cluster of ACC-Equipped Cars		<b>5. Report Date</b> June 1998	
		<b>6. Performing Organization Code</b>	
<b>7. Author(s)</b> S. Bogard, P. Fancher, R. Ervin, M. Hagan, Z. Bareket		<b>8. Performing Organization Report No.</b> UMTRI-98-28	
<b>9. Performing Organization Name and Address</b> The University of Michigan Transportation Research Institute 2901 Baxter Road, Ann Arbor, MI 48109-2150		<b>10. Work Unit No. (TRAVIS)</b>	
		<b>11. Contract or Grant No.</b> DTNH22-95-H-07428	
<b>12. Sponsoring Agency Name and Address</b> National Highway Traffic Safety Administration U.S. Department of Transportation 400 7th Street S.W. Washington, D.C. 20590		<b>13. Type of Report and Period Covered</b> Final Report (Volume III) November 1997 to July 1998	
		<b>14. Sponsoring Agency Code</b>	
<b>15. Supplementary Notes</b> UMTRI's partners in the field operational test are Automotive Distance Control Systems (ADC) GmbH, Haugen Associates, and the Michigan Department of Transportation. The Volpe National Transportation Systems Center is to produce a separate report as the independent evaluator.			
<b>16. Abstract</b> <p>This report is one element of a cooperative agreement between NHTSA and UMTRI entitled Intelligent Cruise Control (ICC) Field Operational Test (FOT). It addresses the operation of a serial string or dense cluster of passenger cars equipped with a new automotive technology called adaptive cruise control (ACC). The string or cluster conditions are expected to arise commonly on public roadways in the future if ACC reaches high levels of penetration in the vehicle population. This report presents results derived from a very limited experimental study of string and cluster operations, as enabled by the availability of vehicles equipped with ACC systems after their use in an extensive field operational test (see volumes I and II of this report). The experiments involved a naturalistic traffic setting but a contrived procedure for inserting a dense grouping of ACC-equipped vehicles within the traffic stream. This work also served as a probing attempt to evaluate the impact of multiple ACC-equipped vehicles on such general issues as safety, traffic flow, and interference with unequipped vehicles. Conclusions from this activity pertain both to the issue of test methodology and to the long-term impacts of ACC on traffic operations.</p>			
<b>17. Key Words</b> Platoon, String, Cluster, Adaptive or Intelligent Cruise Control, Headway or Longitudinal Control, Crash Avoidance, ACC, ICC, Field Operational Test		<b>18. Distribution Statement</b> Unrestricted	
<b>19. Security Classif. (of this report)</b> None	<b>20. Security Classif. (of this page)</b> None	<b>21. No. of Pages</b> 31	<b>22. Price</b>

## Executive Summary

This report addresses the operation of a serial string or dense cluster of passenger cars equipped with a new automotive technology called adaptive cruise control (ACC). The string or cluster conditions are expected to arise commonly on public roadways in the future if ACC reaches high levels of penetration in the vehicle population. The report presents results derived from a very limited experimental study of string and cluster operations, as enabled by the availability of vehicles equipped with ACC systems after their use in an extensive field operational test (FOT) [1]. This work also served as a probing attempt to evaluate the impact of multiple ACC-equipped vehicles on such general issues as safety, traffic flow, and interference with unequipped vehicles. As with other automotive-control technologies in the early design stages, these broad issues may serve to influence product design and public policy.

The ACC function enhances conventional cruise control by automatically adjusting the speed of the host vehicle so as to maintain a driver-specified headway time between the host and an impeding (target) vehicle. The technology's primary component is a sensor<sup>1</sup> mounted on the front of the host vehicle that measures the distance between it and the impeding vehicle. This basic range information and its derivative, range-rate, are used by a control algorithm to perform the task of maintaining headway. Currently, ACC is not an available automotive feature in the U.S., however, all the major automobile manufacturers are considering the technology, and at least one European automobile manufacturer plans to have it available in the U.S. within the next few years. ACC is already available as an option on Mitsubishi and Toyota vehicles sold in Japan.

This report first comments briefly on prior studies addressing ACC string performance and then presents a summary of the test procedures used here to roughly explore operational issues. Results are then presented, followed by conclusions and recommendations.

---

<sup>1</sup> In some applications, more than one sensor is used. Current generation sensors use either infrared or radar beams to detect objects in the path of the host vehicle. The sensors used in this study were of the infrared type.



## 1.0 Background

There has been considerable effort by traffic flow analysts to studying the dynamics of streams of vehicles [2]. For example, there are results showing the development of shock waves in such vehicle streams, as generated by disturbances. One general idea is that, once a disturbance is started, if trailing vehicles have sufficiently delayed responses to the motions of preceding vehicles, eventually some vehicle back in the stream will need to brake to a stop or change lanes to avoid hitting the rear of the preceding vehicle.

In considering the development of automated highway systems, researchers have recently examined requirements for assuring that the headway gap does not go to zero. Results from such analyses have helped to quantify impacts of string size and separation showing that highway capacity could be greatly increased by means of automatically controlled string operations.

In the course of such research the conditions for string stability have been rigorously described in mathematical terms by Swaroop and Hedrick [3]. Although the application of these rigorous results would show that the FOT cars employed here would not exhibit string stability, the lack of such a stability quality is readily demonstrated using conceptually simpler approaches. For example, direct simulation of the problem using MATLAB/SIMULINK to create a string of 25 vehicles has shown the influence of disturbance size on the gap-keeping capability of a hypothetical string of ACC-equipped vehicles [4]. Based upon practical reasoning (or examining simulation results), it is straightforward to see that if each successive vehicle closes beyond (i.e., undershoots) a desired headway gap when the preceding vehicle slows down, the minimum headway gap will get smaller and smaller as one examines each vehicle back into the stream. Eventually, a driver needs to intervene suddenly or there will be a crash.

In this study, it was clear before testing that a string of cars equipped with the elementary ACC system used in the FOT would not have string stability in general. Hence, the purpose of operating a string of FOT cars was not to demonstrate the stability property per se, but rather to expose the broad practical issues that attend ACC string operations in normal freeway traffic. An important distinction in this context is the case in which drivers are free to proceed as they see fit, coming in and out of proximity to other vehicles equipped with ACC.

## 2.0 Description of the Vehicle Operations and Procedures

The study involved operating eight ACC-equipped vehicles on limited access freeways. These vehicles were driven by researchers having considerable experience in driving ACC systems in traffic on real roads. The reader is advised to consult reference [1] to obtain a technical description of the ACC system, itself, and of the data acquisition system by which vehicle responses and driver control input data were recorded.

Three distinct types of tests were performed with the FOT vehicles. These tests were performed on highways in southeast Michigan during a weekday at approximately mid-morning when traffic density is moderate to light and travel is at or near posted speed limits. The road surface for all tests was dry. Drivers were given simple instructions for each test scenario (detailed below) and were asked to drive in a safe, normal manner within the boundaries of the test and to continue the test only if there was no increased threat of an accident.

### 2.1 Longitudinal String Tests

The first procedure in this series of tests is best described as a longitudinal performance and traffic conflict test. In this scenario, the test vehicles formed strings of four or eight successive ACC cars in a string or platoon on a two-lane limited access-highway<sup>2</sup>. The eight-vehicle test was also performed on a three-lane highway of which approximately half the travel distance was designated as an express-configuration freeway, with no access ramps.

The primary purposes of operating the four-car strings was to evaluate a) how difficult the string is to maintain and b) to collect objective data on the longitudinal performance of the ACC-vehicles in this configuration (i.e., evaluate how longitudinal disturbances will affect the string.).

The purpose of the eight-vehicle string was to a) investigate a more exaggerated case than that posed by a four-vehicle stream on the same road type under similar traffic speeds and densities; b) evaluate how difficult the string is to maintain; c) make observations about its effect on the surrounding traffic; d) evaluate the likelihood of the

---

<sup>2</sup> The term platoon in this context is used to describe a line of vehicles travelling in series behind one another at headway times of 1.0 to 2.0 seconds.

formation of an eight-car string; and e) to collect objective data on the longitudinal performance of the ACC-vehicles in this configuration.

Additionally, the eight-vehicle test was performed on a three-lane highway to a) discover differences in ACC string operations that arise on multi-lane versus two-lane freeway segments; b) investigate if the presence of many tight headway controllers, in the lane adjacent to the right-most lane, might impede the cross-lane movements of vehicles intending to enter or exit the freeway; and c) investigate the effect of a 1.0 and 1.4-second headway time on the cross-lane movement of vehicles intending to enter or exit the freeway.

## **2.2 Cluster Tests**

Two tests were conducted to explore issues arising from the presence of multiple ACC-equipped vehicles that might appear in a cluster when traveling near each other (and, in some cases, passing each other) on a two-lane highway. In these tests the drivers were given specific set-speed and headway-time assignments and were instructed to simply engage the ACC-system and drive as they would normally toward the destination point. The purposes of these tests were to: a) experience ACC driving in which a substantial percentage of ACC-equipped vehicles appeared in the traffic stream without the anomalies introduced by deliberate string-formation instructions as had been followed in other tests; b) see if ACC cars might tend to form a spontaneous string; and c) determine if the presence of a cluster of ACC vehicles in a confined group disrupted the traffic stream in some way.

### **3.0 Observations and Objective Results for the Four-Vehicle String Tests**

The first test scenario consisted of a string of four ACC-equipped vehicles traveling on a two lane, class-1 interstate highway. The test was conducted two times by two groups of four vehicles. The distance traveled for each test was approximately 12 miles. The drivers were instructed to stay in the same order for the duration of each test and make a reasonable effort to maintain an uninterrupted series of four ACC-equipped vehicles. Each set of four vehicles performed the test using a set-speed value of 111 ft/sec (76 mph). With the exception of the lead vehicle, the drivers were instructed to use a headway time setting of 1.0 and 1.4 seconds for the two tests, respectively. The driver of the lead vehicle was instructed to vary speeds during the test (thus providing some longitudinal disturbance in the string) either by using the cruise control coast and acceleration buttons or by following slower-moving, non-ACC vehicles.

#### **3.1 Driver Observations**

Following the test the drivers were asked to record their observations. In general, observations fell into three categories, that is ease of string formation, harmonic nature of the string, and effect of the string on traffic. A summary of these observations follows.

##### **3.1.1 Naturalistic occurrence of vehicle strings**

Most drivers felt that driving in a four-vehicle string was tolerable but not completely natural. It took a conscious effort on each driver's part to maintain a deliberate string formation in real traffic.

##### **3.1.2 Harmonic nature of FOT vehicles in a string**

During most of the test, drivers observed that the control algorithm and deceleration authority of the FOT vehicles was sufficient to handle the speed changes of the lead vehicle. This was particularly true when these changes were within the normal range of acceleration and deceleration encountered during typical highway driving. (The driver of the lead car generally used the coast and acceleration buttons to change speed, which meant that the lead vehicle's level of acceleration and deceleration were within the control authority of the ACC system.) Drivers reported events (also verified in the electronic data collected on each vehicle) in which the ACC controller implemented a

transmission downshift to increase the level of deceleration.<sup>3</sup> In general, the longitudinal string showed fully stable responses in the sense that the control authority of the vehicles could handle routine disturbances by the first car in the string without causing the driver to intervene by either disengaging the ACC or changing lanes.

### **3.1.3 Effect of a four-vehicle string on other traffic**

On a two-lane freeway, much of the experience depends upon the choice of lane in which to form the string. If formed in the left-most, or high-speed lane, the string presents an unusual traffic impediment unless it is travelling at a speed that tends to satisfy the passing intentions of other motorists using that lane. If the string forms in the right-most, low-speed lane, the string becomes disrupted when encountering distinctly slower vehicles. If such vehicles must be passed, the string must proceed toward the left and then recover the right lane again. That is, the process of moving a string of vehicles through a passing and re-forming maneuver encounters the conundrum of a) impeding left-lane traffic while proceeding at a pace determined by the set-speed of the lead vehicle in the string and b) having difficulty forming again in the same order in the right lane if, upon recovery of the lane by the first few vehicles, other vehicles in the right lane move forward and close up the tail end of the string segment, leaving the remainder unable to resume position in the string. In the process of encountering conflict (b) the remaining string members must linger in the left lane, assuming the totally unnatural posture, of waiting for the adjacent spaces in the right lane to open up (precisely adjacent to their assigned spaces in the string). The response of motorists expecting to move ahead in the passing lane reveals their frustration with the decidedly odd behavior that is manifest ahead of them.

## **3.2 Objective Results**

A subset of the objective results for the four-vehicle string tests are shown in figures 1 through 3 below. These data present a case in which the drivers needed to intervene because of the amplitude of the speed change. Figure 1 shows the velocity of the four vehicles during and after a disturbance introduced by the first car in the string. (The 1.4-second headway-time value was selected during this test.) Figure 2 shows the

---

<sup>3</sup> Throttle-off deceleration at highway speed on a zero grade road is about 0.03g for the FOT vehicles. A transmission downshift from overdrive to third gear increases the deceleration level to approximately - 0.06 g.

corresponding range values for the following vehicles, and figure 3 shows a range, range-rate phase diagram for the same time segment.

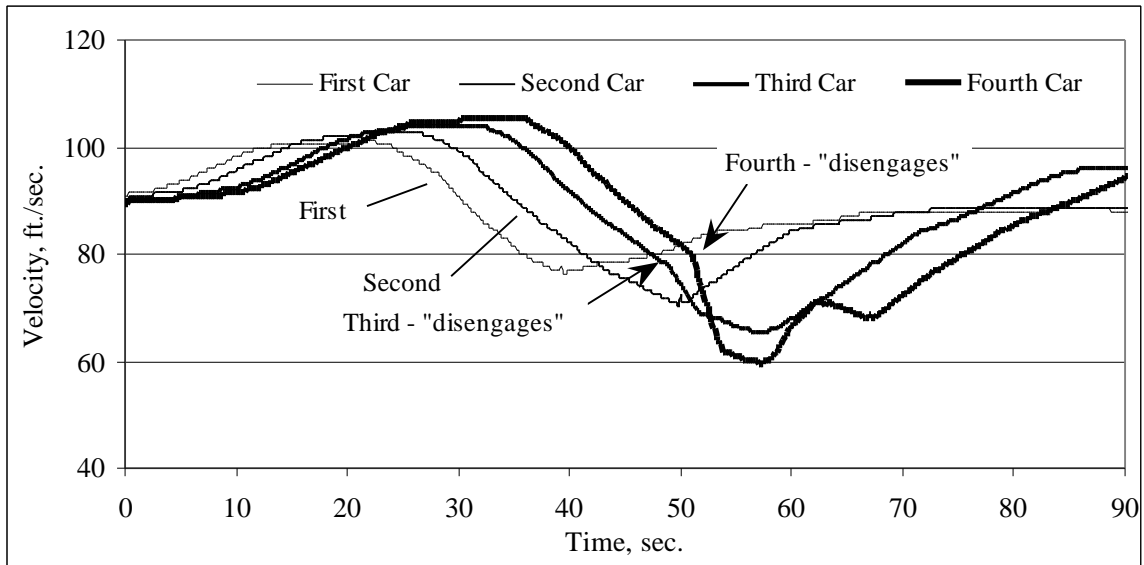

Figure 1. Velocity time history of four FOT vehicles in a string following a longitudinal disturbance

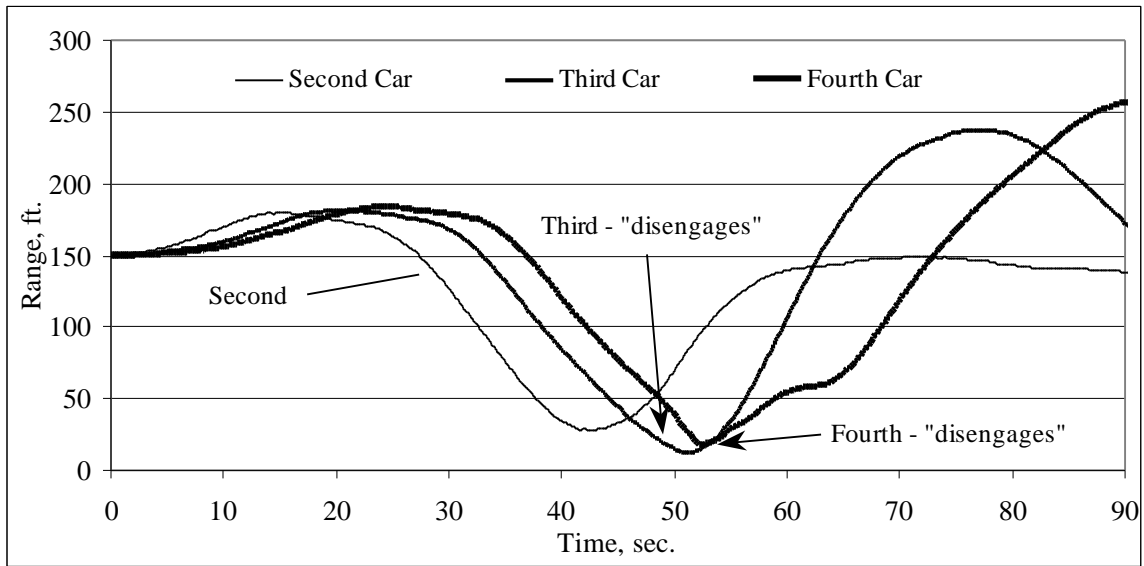

Figure 2. Range time history of three FOT vehicles in a string with a longitudinal disturbance

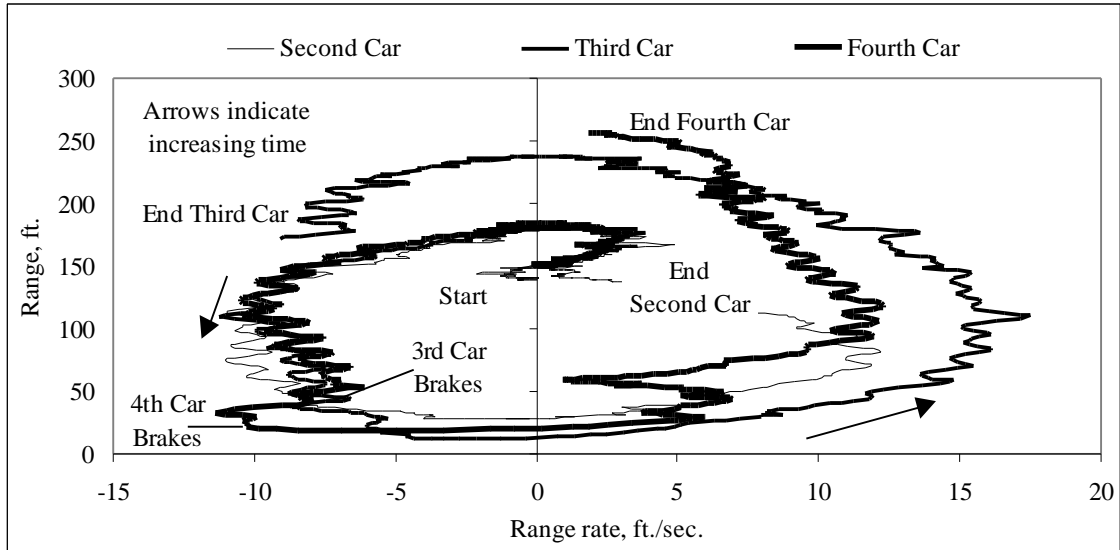

Figure 3. Range versus range-rate of three FOT vehicles in a string during a longitudinal disturbance

The disturbance consisted of a sinusoidal-like velocity change from an initial value of approximately 90 ft/sec. The lead vehicle reaches a maximum of 101 ft/sec and a minimum of 76 ft/sec in a total period of 60 seconds for the entire maneuver. (The maximum and minimum values corresponding to the response in figures 1 to 3 are shown in table 1.)

Table 1. Maximum and minimum values of velocity, range, and range-rate for a four-car string during a longitudinal disturbance

	First Car	Second Car	Third Car	Fourth Car
	Velocity, ft/sec			
Maximum	101.16	102.62	104.07	105.53
Minimum	76.19	70.35	65.25	59.33
	Range, ft			
Maximum	N/A	179.79	237.86	257.54
Minimum	N/A	28.21	12.46	18.70
	Range-rate, ft/sec			
Maximum	N/A	12.21	17.49	12.30
Minimum	N/A	-11.02	-11.20	-11.39

During the deceleration portion of this maneuver, from time = 20 to time = 40 seconds, the lead vehicle has an average deceleration of 0.04 gs. The responses of the other vehicles in the string are also shown in the figure. In this test, only the second car in the string has enough control authority to “handle” the disturbance of the first car without

driver intervention. The response of the second car shows that the vehicle does overshoot the velocity profile of the first vehicle and in this case the second vehicle reaches a maximum of 102 ft/sec and minimum of 70 ft/sec over a time span of 25 seconds. This represents an overall increase of 28 percent in velocity and a 25 percent increase in time to reach the extreme velocity values relative to the corresponding changes in the first car.

Of course, since the response of the second car constitutes the input for the third vehicle, we see further exaggerations in responses, with the third car reaching a maximum velocity of 104 ft/sec before beginning to decelerate. At a time of 50 seconds the driver of the third car is forced to intervene and use the service brakes to avoid a rear-end collision with car number two. Figure 2 shows the range as measured by the sensors of cars two, three and four during this disturbance. For car three, the figure shows a range of approximately 20 feet at the time of disengagement.

A similar scenario applies to the fourth vehicle of the string. This vehicle responds to the exaggerated changes of the third car, exhibiting an even greater overshoot early in its response and a driver intervention when range and range-rate reach uncomfortable levels. (The data show a range of 30 ft and a range-rate of -9 ft/sec when the driver applied the brakes in car four. The driver of car four applied the brakes 2.0 seconds after the commencement of braking by the driver of car three.)

Figure 3 below shows the range versus range-rate histories for cars two, three and four in response to this disturbance. The traces show the characteristic circular shape of response with large changes in range and range-rate. Because time is not shown in the plot, the start and end of the disturbance are indicated in the plot. (Time always progresses in a counter clockwise fashion in range range-rate diagrams.) During the initial segment of the maneuver, the vehicles are separating such that their range and range-rate values increase. This is shown in the figure as a small half circle starting at approximately 150 ft and zero range-rate and continues until the next zero range-rate value at a range of approximately 175 ft. At this point the vehicles have started to close on each other (crossing over to the negative range-rate side of the diagram) and, generally they tend to travel the same path in the range range-rate space until close range values are encountered. At this point, a clear deviation toward larger negative range-rate values is shown for the fourth car. This dramatic change is due to braking by the third car. Large changes in range-rate without a substantial change in range can only be achieved by large relative velocity changes between two vehicles over a short period of time. Such a relationship is reflected in the plot by the large horizontal change in the trace for the fourth car, caused when the driver of that vehicle reached a 0.2 g-peak deceleration level.



## **4.0 Observations and Objective Results for the Eight-Vehicle String Tests**

The eight-vehicle string tests were conducted on two-lane and multi lane interstate highway segments. Observations and objective results for these tests are discussed in the two sections below.

### **4.1 Two-Lane Interstate Highway**

The first eight-vehicle scenario consisted of a string of ACC-equipped vehicles traveling on a two-lane freeway. As in the four-vehicle scenario described above, this test was also conducted during the daytime when the road surface was dry. Traffic levels could be described as medium density. The drivers were all instructed to use a set-speed value of 76 mph. In the first half of the 30-mile test, drivers used a 1.4-second headway time. For the second half of the test, drivers used a 1.0-second headway time. As before, drivers were instructed to make a best effort to maintain an uninterrupted string of ACC-equipped vehicles.

### **4.2 Driver Observations**

Following the test, drivers were asked to record their observations. The observations fell into three categories, that is ease of string formation, harmonic nature of the string, and effect of the string on traffic.

#### **4.2.1 Formation concerns**

The task of following specific cars in a specific order became exceedingly difficult as the string got longer. Clearly the anomaly of following in an intentional order has virtually no relevance to any plausible routine driving scenario. The experience of proceeding through even moderate traffic as an eight-element string offers another odd case by which to observe that the behavior of drivers in traffic involves highly developed sociological expectations. In addition, the intentional-order-following string, per se, constitutes an oddity that violates many of those expectancies. The condition of steady-state with eight vehicles was probably never achieved on this road type. At a headway time of 1.4 seconds, the tendency for headway instability can be better absorbed, but other cars and trucks constantly interfere with the retention of the integral string of vehicles. At a uniform headway time of 1.0 sec, less interference is encountered but the string is rendered unstable merely by delays, grades, etc (no artificial disturbance had to be introduced to destabilize the string).

#### **4.2.2 Harmonic nature of FOT vehicles in a string**

Rearmost vehicles had large range and velocity changes in response to longitudinal disturbances initiated at the front of the string and the condition of steady-state with eight vehicles was probably never achieved on this road type. Cars at the rear of the string experienced continuous oscillations that is, strong acceleration followed by the need for manual brake interventions during this test condition.

#### **4.2.3 Effect of an eight-vehicle string on other traffic**

The deliberate retention of an eight-vehicle string seemed to annoy the truck drivers tremendously. When the string occupied the right lane one practicable issue that was observed, is the problem presented to tractor semitrailers, whose overall length is around 60 to 100 feet. When using a one-second headway time, the gap between ACC-vehicles is only 90 to 100 feet at normal highway speeds, thus posing a small gap that impedes the truck driver's attempts to resume the normal right-lane position after they have once taken a position in the left lane. Further drama would be added to this case, though it was not actually observed if the driver of a long truck simply needed to recover a spot in the right lane in anticipation of an upcoming exit. The simple observation is that spacing between vehicles in normal traffic is rather randomized—perhaps in part because the individual driver is not highly skilled as a headway controller. Thus, a substantial distribution of spacing exists in the normal traffic stream, presumably offering long trucks and others concerned about lane changing ample opportunities for their desired lateral movements.

An additional concern with heavy vehicles is raised by their low levels of acceleration and deceleration capability relative to that of passenger vehicles. When heavy vehicles need to interact with an eight-car string, which could be about 1000 feet long, substantial traffic delays can result. In a two-lane setting, if a truck driver decides to pass a string of vehicles, it takes time to make this maneuver and can result in a queue of traffic behind the truck.

As for the influence of ACC headway time on the sensitivity of other traffic to string operations, it was clear that many more cut-ins and pass-throughs of passenger vehicles occurred on the two-lane freeway, without any disrupting outcomes, when the string was operated at a common value of 1.4-second headway time.

### **4.3 Three-Lane Interstate Highway**

This scenario consisted of a string of eight ACC-equipped vehicles traveling in the center lane of a three-lane freeway, half of whose length incorporated no access ramps at all (i.e., an “express” segment of urban freeway). For this test, the set speed was not constant for each driver but was made dependent on each vehicle’s position within the string so as to ensure that any string gap, once opened, would be quickly reclosed, thereby keeping the string intact. The first vehicle used a set speed of 68 mph and each subsequent vehicle was assigned to increment the preceding vehicle’s set speed by 2 mph. (Thus, the last vehicle had a set speed of 82 mph.) For the first half of the 30-mile test, drivers were instructed to use a 1.4-second headway-time selection. During the second half of the test, drivers were instructed to use the 1.0-second headway-time selection.

### **4.4 Driver Observations**

Following the test, the drivers were asked to record their observations, as before, to address the ease of string formation, harmonic nature of the string, and effect of the string on the surrounding traffic.

#### **4.4.1 Formation concerns**

Efforts at string formation were more successful on a three-lane highway due to less interference (and less traffic congestion) with other vehicles cutting into the string.

#### **4.4.2 Harmonic nature of FOT vehicles in a string**

Because there was less interference from other vehicles, the string was able to stay in formation and in a steady-state condition much longer than in the two-lane test. However, when there was a disturbance or destabilizing pulse caused by the first vehicle, it did propagate down the string and caused the rearmost vehicles to slow down very significantly (to the point of driver intervention via braking). The most severe transients arose when a significant braking was imposed at the first vehicle.

#### **4.4.3 Effect of an eight-vehicle string on other traffic**

The experiment indicated that an ACC string running in the middle lane at uniform values of 1.4-second headway time, posed virtually no cross-lane impediment. (It should be cautioned, however, that very few tractor semitrailers were present in this traffic stream.) Even with 1.4-second headway time, however, the weaving movement of other cars traversing the string lane either toward the right or toward the left is common. (Please note, the term weaving will be used here in the traffic engineering sense by which

freeway drivers succeed in changing lanes over relatively short lengths of roadway as part of the entry/exiting process and the transitions thereto, as discussed for example in [1].) When a 1.0-second headway time was used, it was clear that the string constituted a significant impediment to traffic that intended cross-lane movement and that only rather aggressive drivers were still able to change lanes by penetrating the string. It was also observed that distinctly higher lateral-velocity cut-ins were apparent when drivers did cut through the string under these conditions. A number of these lateral-cross-lane maneuvers went all the way through the center lane in a single maneuver with no discernible pausing to check the left-side destination lane. Other more cautious drivers were seen to travel along next to the string for substantial distances after having merged on the freeway. They were seen to travel along in the right lane, making hesitant moves toward the center lane, and then retreating to wait a while longer, while apparently seeking a suitable gap for access to the left-most lane. Such behavior should be expected by the large majority of traffic that seeks to occupy higher-speed lanes, after merging onto the roadway, thereby avoiding the conflicts that recur in the right lane due to entering and exiting traffic. It is hypothesized that the cross-lane impediments, posed by ACC strings, such as observed here, would tend to maximize in medium-density traffic having a substantial number of trucks occupying the right lane and in areas for which high entry and exit flows are prevalent.

## **4.5 Objective Results**

A subset of the objective results for the eight-vehicle string tests are shown in figures 4 and 5. Figure 4 shows the velocity of the eight vehicles during and after a disturbance by the first car in the string. (The 1.0-second headway time value was selected during this test.) Figure 5 shows the corresponding range values for the following vehicles. For this set of results the drivers were able to stay in an uninterrupted string (with no intervention necessary) throughout the entire disturbance transient.

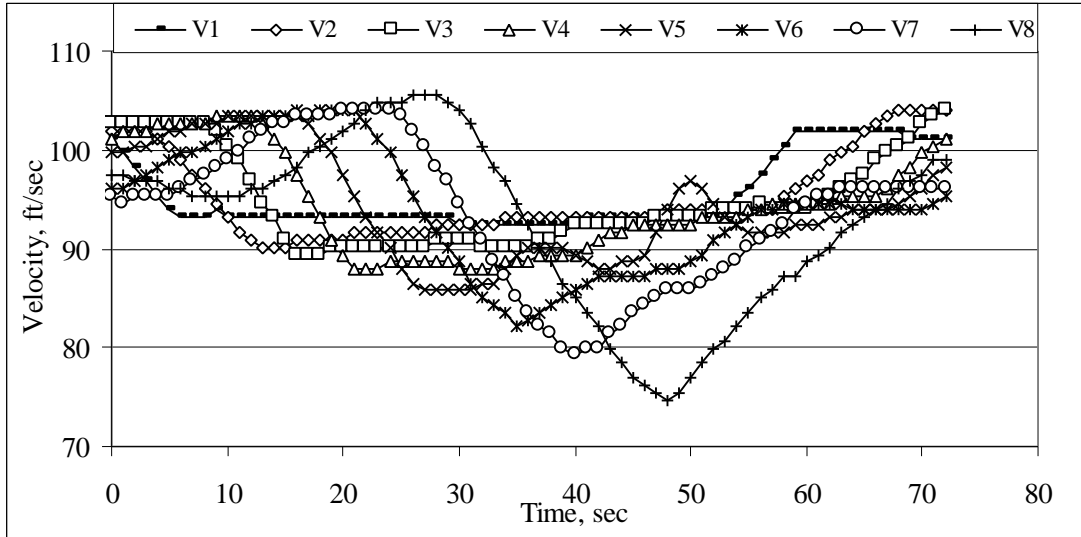

Figure 4. Velocity time history of eight FOT vehicles in a string with a longitudinal disturbance

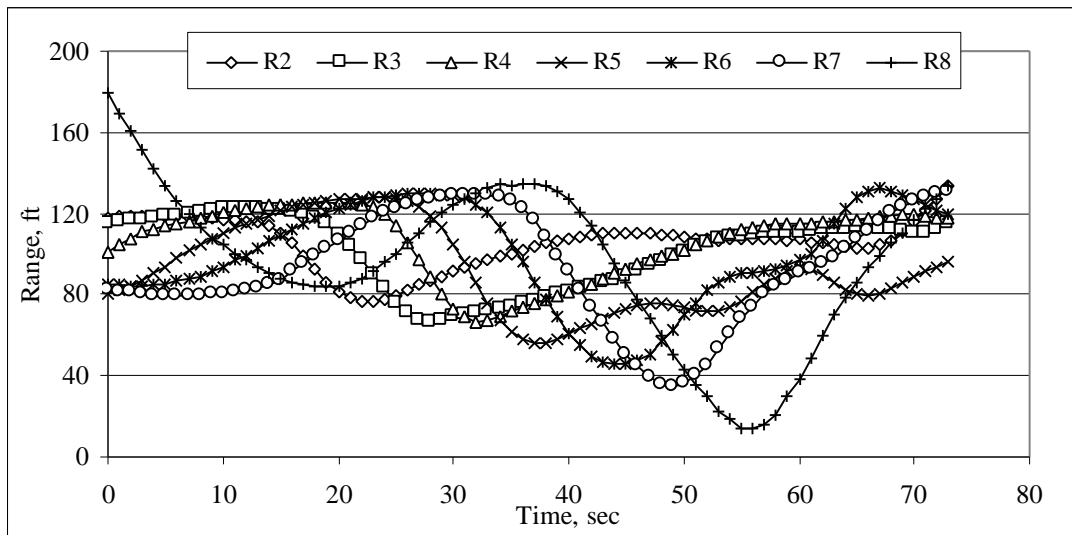

Figure 5. Range time history of seven FOT vehicles in a string, following a longitudinal disturbance

The lead vehicle disturbance for these results was a simple downward ramp/step in speed from 100 ft/sec to 93 ft/sec (a change of 5 mph) over a time of 8 seconds. The response of the other vehicles in the string is shown in the figure. Figure 4 clearly reveals the lag in response of each vehicle in the string. The effect of driving in a string with this ACC system is a more severe response by each successive vehicle as the overshoot propagates down the string. Table 2 shows the maximum and minimum values for

velocity, range and range-rate during this response sequence. For velocity, the minimum values range from 90 ft/sec in the second car to 75 ft/sec in the last car.

**Table 2.** Maximum and minimum values of velocity, range, and range-rate for a eight-car string during a longitudinal disturbance

	1st Car	2nd Car	3rd Car	4th Car	5th Car	6th Car	7th Car	8th Car
Velocity, ft/sec								
Maximum	101.9	104.1	104.1	103.3	103.3	104.1	104.1	105.5
Minimum	92.3	90.1	89.4	87.9	85.8	82.1	79.2	74.7
Range, ft								
Maximum	N/A	133.2	122.7	125.7	127.6	132.5	130.6	130.8
Minimum	N/A	76.4	66.6	66.6	56.4	45.9	34.8	13.8
Range-rate, ft/sec								
Maximum	N/A	5.6	2.6	3.4	4.2	8.2	8.4	9.8
Minimum	N/A	-7.1	-7.4	-9.2	-9.9	-9.5	-9.1	-12.8

Figure 5 shows the range values for the second through eighth car. These results are similar in shape and lag characteristics to those of velocity with the exception of more extreme values being reached by the rear most vehicles. Table 2 shows the minimum range going from 76 ft for the second car down to 14 ft for the last car. In the case of the eighth car, approximately 90 percent of the available headway range was used before it begins to separate from the seventh car.

## 5.0 Observations and Objective Results for the Eight-vehicle Cluster Tests

Two tests were conducted to see if the presence of multiple ACC-equipped vehicles would tend to form a cluster when traveling near each other on a two-lane suburban freeway. In both tests, the vehicles entered the highway at 5-second intervals and the drivers were instructed to simply engaged the ACC-system and drive as they would normally toward the destination point. Successive vehicles were dispatched at modestly incremented values of set speed, as shown in table 3. In the second test, all drivers used a set speed of 74 mph and a headway time of 1.4 seconds.

Table 3 Order, Set Speed, and Headway Time for Cluster Test 1

Highway Entry No.	Car Number	Set Speed, mph	Headway Time, sec
1	0	66	2.0
2	9	68	1.0
3	2	70	1.0
4	8	72	1.4
5	3	74	1.4
6	5	74	1.4
7	1	74	1.0
8	4	74	1.0

Following the test, the drivers were asked to record their observations, as discussed below.

### 5.1 Driver Observations for Cluster Test 1

The free-flowing cluster approach resulted in a concentration of the eight FOT vehicles within a group of approximately 20 vehicles during one segment of the trip. For this approximate 40 percent concentration of ACC cars (running at a 1.4-second headway) no discernible consequences were observed in terms of the freedom of other vehicles to proceed. The traffic during this leg was light. In some cases, the ACC equipped vehicles did follow each other, but when the road was clear, they did not get close enough to react to each other. Also, if one car got caught behind some slower traffic, other ACC cars

would just pass by rather than follow. For the most part, the cars with the higher set speeds simply passed the cars with the lower set speeds.

## 5.2 Objective Results

Objective results from the cluster test with initial conditions as described in table 3 are shown in figures 6 and 7. Figure 6 shows the relative distance between the eight vehicles as they traveled approximately 12 miles on a two-lane highway. The figure shows time along the abscissa and relative distance in feet along the ordinate axis. Car 1 is used as the zero-baseline for the results shown in figure 6. The figure shows that all vehicles started out “behind” the baseline vehicle. This negative gap increases during the first part of the test but as the rear most vehicles (i.e., those with higher set-speeds) enter the highway, they begin to close on the baseline vehicle and pass each other. At approximately 5.5 minutes into the test all but two of the eight vehicles have passed the baseline. The last vehicle, Car 8, passes the baseline between 7 and 7.5 minutes into the test. Overall, the figure does not suggest that the vehicles had a tendency to naturally cluster (except into two-car pairs such as vehicles numbered 1 and 2) and these results along with the driver’s comments suggest that multiple-ACC vehicles did not impede each other under these driving conditions.

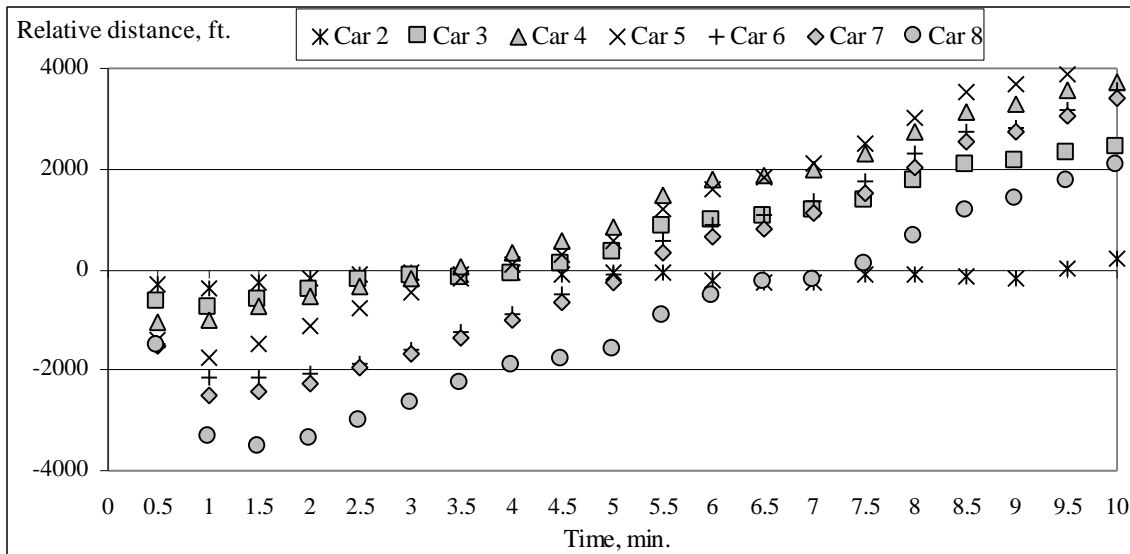

Figure 6. Relative distance during cluster test (Car 1 is baseline)

Figure 7 is a global position satellite (GPS) map of the route driven under the conditions outlined in table 3. (Note: Car 2 is missing from this list due to problems with



its GPS.) The figure reveals the nominal extent of clustering which did prevail, as expressed by the location and position of each vehicle at different snapshots taken each minute during the test.

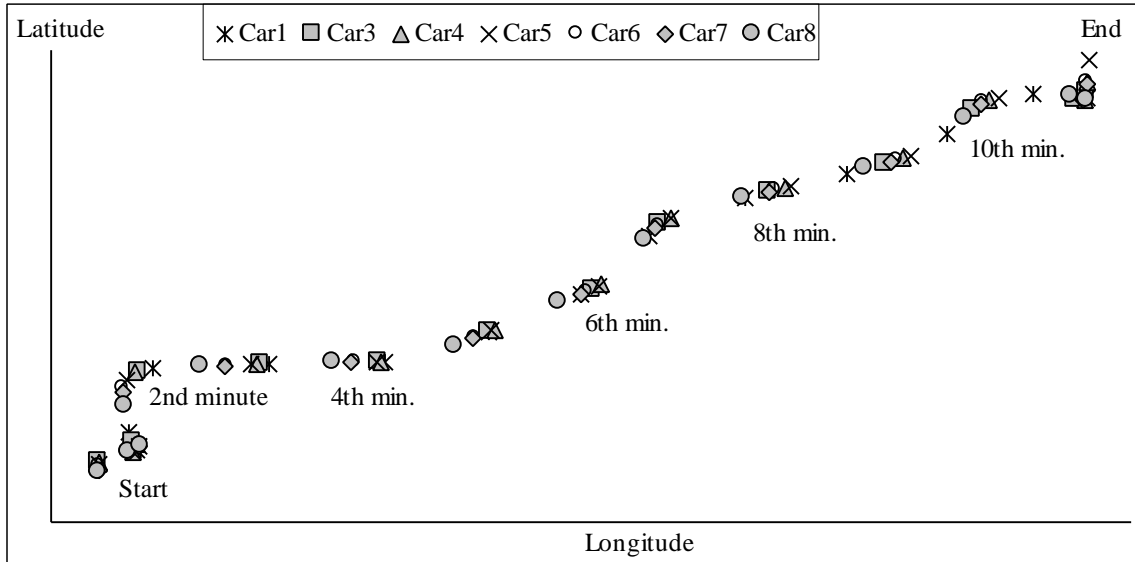

Figure 7. GPS map of FOT vehicles during cluster test

### 5.3 Driver Observations for Cluster Test 2

The second cluster test received a mixed response from drivers regarding the presence of cluster formation. Some of the drivers were able to avoid all impeding vehicles during the test and hence simply passed other vehicles (including FOT vehicles) that were travelling more slowly. However, when impeded by other vehicles some test drivers did report some clustering of the FOT. Nevertheless, it appears that any clustering occurred by driver choice rather than by necessity. This test implies that, for short urban distances, short strings might spontaneously occur from time to time and that during inter city trips, longer strings could occur, depending on the occurrence of vehicles having similar set speeds and depending on the degree of interference from other traffic, such as slower moving trucks.

## **6.0 Conclusions**

The experiments conducted here involved a naturalistic traffic setting but a contrived procedure for inserting a dense grouping of ACC-equipped vehicles within the traffic stream. Conclusions from this activity pertain both to the issue of test methodology and to the long-term impacts of ACC on traffic operations.

### **6.1 Test Methodology**

The principal research difficulties that arise when a group of confederated ACC drivers deliberately form an ACC string in traffic are the following: 1) merging and lane-changing movements of other vehicles tend to break up the string, 2) string-member drivers must occasionally undertake odd tactics to reposition themselves into strings that had become lost due to breakage, and 3) other drivers readily note the odd tactics of the string members and appear to become rather distracted by them. The outcome of these problems is that test productivity is low and questions of test validity arise from the “oddness” of the string-maintenance contrivance in a public traffic stream. On the latter point, it becomes difficult to discern which of the measured results is an artifact induced by the deliberately-intended formation and maintenance of the string and which is a true interaction such as would prevail in the future when ACC strings might form spontaneously.

A fully valid means of studying the interaction between multiple, proximate, ACC-equipped vehicles and other traffic would seem to require that ACC vehicles actually comprise a high fraction of the vehicle population in normal usage. If this were cultivated to occur, say through a massive localized field test, or if we simply waited until ACC had so penetrated the vehicle market that a high-population fraction had accrued over many years of ACC sales, the interactions between conventional traffic and naturally occurring strings or clusters of ACC-equipped vehicles could be observed directly. The limited results of the exercise described here suggest that fully instructive measurements will be very difficult to obtain, otherwise. Nevertheless, episodes of steady-state string operation do occur, even when the string is deliberately formed by confederate researchers. During these periods, certain apparently valid phenomena do manifest themselves.

## 6.2 Interactions between Multiple ACC Vehicles and Nearby Traffic

As implied above, it is assumed that high levels of ACC penetration into the vehicle population will cause extended strings of ACC-equipped vehicles to form spontaneously simply due to the probabilities of traffic mixing—even in the absence of any peculiar natural tendencies toward aggregation of vehicles under ACC control. Thus, the dynamic stability of ACC strings and their impact on the natural inter lane weaving movements of other traffic will constitute real issues if ACC becomes a successful product.

Observations from these tests have indicated that significant traffic impacts could arise from ACC strings. Firstly, considering simply the ACC system that was fielded here, (with its low deceleration authority and relatively sluggish re-acceleration response) a string of more than four of these vehicles will exhibit marginal stability levels, yielding exaggerated responses when longitudinally disturbed from the forward end of the string. With strings of eight vehicles equipped with this ACC controller, significant disruptions in the smooth movement of a traffic stream would ensue following modest disturbances.

Further to the string-stability issue, the authors of this report are not aware that this characteristic is being considered in the current design of automotive ACC products. In fact, an opposite approach has been apparent by which ACC control algorithms are “detuned” in some emerging products to render the controller unresponsive to brief misdetections by the range sensor. While string-stability problems would not manifest themselves as long as ACC-equipped vehicles are a rarity on the road, the issue will become highly important whenever the population density begins to precipitate long-string formation on a regular basis.

On the matter of cross-lane movements of other traffic, an important issue arises when an ACC string constitutes a sort of “moving wall” that impedes the natural weaving movement of other traffic. That is, due to ACC’s regularization of headway spacing, randomly extended gaps do not occur in the same manner as seen in manually-controlled traffic. Further, the ACC controller does not, by itself, respond to the “body language” of other drivers who maneuver alongside, in an adjacent lane, with the clear intention of weaving across into another destination lane. When headway time is in the vicinity of 1.0 second, at highway speed, it was seen that other motorists were basically thwarted in their attempts to change lanes through an eight-car string that occupied the next-to-right-most lane—occasionally exhibiting a fairly dramatic rate of penetrating the string in their apparent frustration to find a fully suitable gap in line with their exit/entrance transition

plans. (Note that, upon entering a freeway, some more aggressive drivers seek to occupy the “fast,” left-most lane as soon as possible—thus experiencing some frustration when they remain “stuck” in the rightmost lane while searching for a suitable gap.) When ACC headway times were uniformly set to 1.5 seconds, other drivers appeared to penetrate the string with minimal difficulty.

The string-penetration problem was seen to be most pronounced in the case of combination trucks whose great overall length made the gap-mismatch issue acute. Recognizing that many states legally require that heavy trucks use the right lane except when passing, the ability to readily recover the right-most lane position is fundamental to normal truck operations. Clearly, if an ACC string occupies the right lane, the ACC drivers simply must intervene upon the automatic-headway mode of control in order to create a suitable space for lane recovery by trucks. The readiness of ACC drivers to provide this courtesy, and indeed to recognize the need for it as a nuance of ACC control, has not been studied here.

When multiple-ACC vehicles appeared nearby one another in a noncontiguous, clustering type of distribution, no operational difficulties were noted. Even with a 40% density of ACC-equipped vehicles in a cluster of manually driven vehicles (but with no more than three ACC vehicles positioned in a continuous string at any one time) no disturbance of normal traffic movements was noted.

### **6.3 Future Test Possibilities**

Alternative testing conditions that would extend the results presented here are listed below:

- Eight-car string of vehicles equipped with updated ACC systems (higher resume accelerations) and more deceleration authority through the use of the foundation brakes.
- String operation at closer headway (less than a second) to understand safety implications
- String operation in the presence of dense commuter traffic to study the extent of longitudinal disturbance responses on the localized movement of near-capacity traffic.
- String operation at longer headway (2 seconds) to better understand cut-in implications.
- Longer test-drives, one hour or more, to represent inter-city operations; including nighttime operations. Start out in a string with equal  $V_{set}$  (set speed) and  $T_h$  (headway time) values. See if drivers stay in a string and like it or would rather operate independently.

## References

1. Fancher, P., Ervin, R., Sayer, J., Hagan, M., Bogard, S., Bareket, Z., Mefford, M., and Haugen, J. 1998. "Intelligent Cruise Control Field Operational Test. Final Report." University of Michigan, Ann Arbor, Transportation Research Institute, UMTRI-98-17. DOT HS-808-849 (Volumes I and II of this report).
2. Papageorgiou, M. and Ioannou, P. June 1993. "Traffic Flow Modeling and Control and Intelligent Highway Systems (IVHS)." Short course notes, SSC Systems, Los Angeles.
3. Swaroop, D., and Hedrick, J.K. 1994. "Direct Adaptive Longitudinal Control of Vehicle Platoons." IEEE Conference on Decision and Control. Proceedings. Vol. 1., IEEE Service center, Piscataway, NJ, pp. 684-689.
4. Fancher, P.S., and Bareket, Z. 1994. "The Influence of intelligent cruise control systems on traffic flow." International Symposium on Advanced Vehicle Control 1994. Proceedings. Tokyo, Society of Automotive Engineers of Japan, pp. 402-407. SAE 9438600.
5. "A Policy on Geometric Design of Highways and Streets." 1984. American Association of State Highway and Transportation Officials, Washington, D.C.

**DOT HS 808 849**  
**July 1998**