

# **GSA Advantage!** on-line shopping

To Place an Order

## Customer Log-in

Govt Purchase Card

- OR -

AAC

Password

**GO**

[Apply for an AAC](#)

[Apply for a Password](#)

**Welcome...** you've found the web's #1 Official Federal source for Government purchasing. **GSA Advantage!** offers the convenience of purchasing hundreds of thousands of products and services with the click of a button.

**GSA Advantage!** has been named one of the "Best Feds on the Web" and has received several prestigious awards including the Federal Technology Leadership Award which was presented by Government Executive Magazine and has also been recognized by the Computerworld Smithsonian Award Program for innovative technology in the workplace.



*There's a new search in GSA Advantage!  
Finding what you're looking for will be  
faster and easier.*

[click here for details](#)



(Image)

## Customer Tools

- ▶ [Quick Order](#)
- ▶ [FEDSTRIP Ordering](#)
- ▶ [Retrieve a Cart](#)
- ▶ [Requisition Status](#)
- ▶ [Report Order Problem](#)

### Available upon Log-In:

- [Order Status/History](#)
- [Reorder/Cancel](#)

## 2000 Calendars



[Click for details...](#)

## DIGITAL CAMERAS



[What's Available](#) | [Overseas Ordering](#) | [Mandatory Sources](#) | [Our Environment](#) | [FAQ](#) | [View](#)

Send questions or comments to [GSA.Advantage@gsa.gov](mailto:GSA.Advantage@gsa.gov) or contact

## GSA ADVANTAGE

"GSA *Advantage!* is the #1 Official Federal source for electronic purchasing of products and services. This internet based system, available at [www.fss.gsa.gov](http://www.fss.gsa.gov), contains almost one million products and services from more than 2,000 GSA schedule vendors and the Federal Supply Service. Recent enhancements make it possible for many vendors to offer services to Federal personnel through GSA *Advantage!*

The GSA *Advantage!* web site, which is available worldwide 7 days per week, 24 hours per day, receives almost one million web hits each business day. Sales through this internet based system were \$86 million for FY1999. The sales volume for FY2000 is 50% higher than for the same period in FY1999 and, we have customers

from every government agency located throughout the world. Customers can use the Government Purchase Card or their Activity Address Code to order products and services through GSA *Advantage!*

GSA *Advantage!* implemented a new search engine to make it easier and faster for our customers to find the products and services that they would like to buy. The power of this new search engine enables our customers to conduct one search every second throughout each business day. Our screens have been redesigned to make them more user friendly. We have also implemented new computer hardware to ensure that GSA *Advantage!* is always available for Federal customers whenever they choose to purchase our products and services."

## GSA ADVANTAGE! — ADVANCED SEARCH

GSA *Advantage!* also offers a special feature called "Advanced Search". Located immediately below the "Browse/Search" box (in the upper right hand corner of the of the GSA Advantage page), this feature will allow you to narrow your product search, for one example, to a specific environmental attribute.

In addition to environmentally oriented search options, such as: recycled, energy efficient, and Energy Star, there

are other options such as: UNICOR, NIB/NISH, and Small Business.

Next time you're in GSA *Advantage!*, try this special feature to help you comply with environmental and other requirements.

Address: <http://www.fss.gsa.gov/cgi-bin/advantage!737+0+++KPK4p2+1653110>

Channels / Favorites / History / Search

**GSA Advantage!** on-line shopping

**Advanced SEARCH**

SEARCH for:  [New Search Info](#)

Using: **All words** Display: **25**

Look in: **All fields** Sort by: **Most Relevant**

Limit Display To: (Check all that apply)

UNICOR Mandatory Items  Environmental Items

NIB/NISH Mandatory Items  Recycled Items

GSA Items  Energy Efficient Items

Small Business Items  Energy Star Items

Year 2000 (Y2K) Compliant Items

**SEARCH**

[> Search Tips <](#)

**MAIN MENU**

# New Items

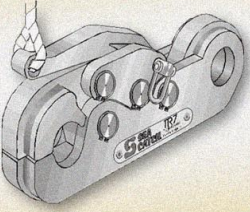

Now Available on GSA Schedule 79 I B

## CELLUTECH INC.

Cellutech manufactures absorbent products from recovered fibers discarded by paper mills, polypropylene absorbents from recovered fibers in synthetic industries, and a family of specialized super absorbents for water, acids, and biohazard liquids.

Our process used for the cellulose absorbents transforms the recovered fibers, originally destined for landfill, into a variety of absorbents that take advantage of the excellent absorbing characteristics of paper fibers. This recycled process benefits you, our customers, as well as the environment.

Our products are offered loose, in bags, or contained in socks, pillows, booms, pads, and kits. Additionally, we supply a full line of spill control products, cleaning products, filtration systems, disposal containers, personal safety wear, and a wide variety of accessories. Cellutech, Inc., is your one-stop source for complete spill solutions.

Order through GSA *Advantage!* or directly from the contractor:

CELLUTECH, INC.  
25 West Union Street, Suite 202  
Ashland, MA 01721  
Contact: Carol Dancer  
Phone: (800) 575-5945  
(508) 881-8925  
Fax: (508) 881-8932  
E-mail: [eperry@ma.ultranet.com](mailto:eperry@ma.ultranet.com)

Contract Number: GS-07F-0390J  
Special Item Numbers: 375-102, 375-351, 375-352,  
375-353, 375 -355

### C O N T A C T

Mark Brady  
Contracting Officer

### P H O N E

(817) 978-3711

### F A X

(817) 978-8634

### E - M A I L

[mark.brady@gsa.gov](mailto:mark.brady@gsa.gov)



**Now Available on GSA Schedule 19 Part I**

**Marine Craft and Equipment, Inboard/Outboard Engines, Towable Bladders, Floating Barriers and Buoys**

**SEA CATCH TOGGLE RELEASE**

McMillan Design, Inc., has developed the Sea Catch Toggle Release, a new quick release designed for safety during the release of a line under load.

It is an innovative design that offers multi-directional releasing capabilities and combines an old and proven toggle linkage principle with computer-generated parts precision-cut from aerospace-grade stainless steel plate. Proven in the field, it has become the release mechanism of choice to knowledgeable users within the military services, oceanographic research institutes, and general marine communities. It is extremely durable with a very simple design, using no springs or parts that can break under heavy marine wear. Due to its unique design, it has many applications and is far stronger and safer than pin shackles and leverage-type releases such as pelican hooks in use today.

The Sea Catch TR7 weighs only 4 pounds yet has a capacity of 7,042 pounds and a certified break load of 35,210 pounds. Since it is computer generated, the Sea Catch design offers several models and capacities and these can be easily modified to suit most user's needs. Selected models are available with remote release capability using squib-thrusters, air cylinders, or hydraulic rams. Call for details.

For more information or specifications contact:  
John McMillan at McMillan Design, Inc.,  
9816 Jacobsen Lane, Gig Harbor, WA 98332.  
Tel:(253)858-1985, Fax:(253)858-1986,  
Email: seacatch@compuserve.com,  
Website: www.seacatch.com.

Contract Number: GS-07F-0043K

**C O N T A C T**

Cheryl Goff  
Contracting Officer

**P H O N E**

(817) 978-8386

**F A X**

(817) 978-8672

**E - M A I L**

cheryl.goff@gsa.gov

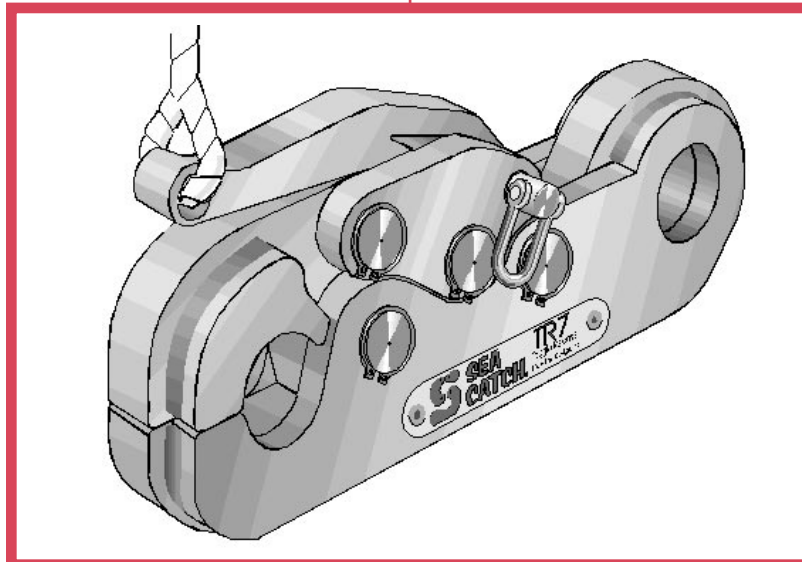

Now Available on Federal Supply Schedule 80 III A

## MAJOR RUST PREVENTION BREAKTHROUGH STAINLESS STEEL KOTE

### How a New Product Ends the Problem of Recurring Rust

**Rust.** It's a problem that won't go away. At the very least, it gives surfaces a worn, shabby and unattended appearance. Worse still, it shortens or ends the life of expensive equipment, such as urinal partitions, peeling toilet flushometers, salt spreaders, vehicle bodies, fuel tanks, snow plows, mufflers, pipes, lockers, pool equipment, bleachers, door kick plates, snow blowers, lawn mowers, cooling towers, iron railings and many, many other types of equipment. Your experience has shown you that no matter how you've treated it in the past, rust rapidly recurs.

The solution - Stainless Steel Kote - A remarkable breakthrough in rust treatment. Stainless Steel Kote is not paint, zinc or aluminum, nor is it simply a rust inhibitor. It is real stainless steel, 316 grade, in easy-to-use aerosol form. Once it is sprayed on and dries, you have a protective coating of attractive, non-rusting stainless steel that completely seals out moisture and oxygen - the main causes of rust. You have literally converted the surface to stainless steel - which does not rust. And, it's the only stainless steel product that can be painted over to accommodate your color scheme, if desired.

It is incredibly durable, able to resist acids, alkalis, salt damage, abrasion and other ravages of the natural elements. Sprayed on radiators, boilers, exhaust pipes, it withstands up to 1,200° Fahrenheit without blistering or peeling, with a final dry coat that is non-flammable. THERE'S JUST NOTHING LIKE IT.

Additional suggested areas of use include: chlorinator room railings and equipment, shelving, vents, vent fans, boilers, furnaces, plumbing fixtures, pumps, wheels, bumpers, trailer

hitches, fences, grills, water lines and feed areas, compactors, guard rails, fire hydrants, sign posts, dock areas, ladders, outdoor furniture, boxes and covers, hose bibs, chains, and storm drain covers.

Order using the Government Purchase Card.

Contract GS-06F-0019J  
Contact: Marvin Bratman  
Phone: (877) 397-3453 toll-free  
Or (973) 599-0444  
Fax: (973) 599-9191  
Rite Industries, Inc.  
375 State Route 10  
Whippany, NJ 07981

### C O N T A C T

Customer Service

### P H O N E

(816) 926-7315

### F A X

(816) 926-7971

### D S N

465-7315



**NEW Award Under Federal Supply Schedule 66 II J****NATIONAL INSTRUMENTS**

National Instruments manufactures hundreds of software and hardware products for computer-based measurement and automation. When combined with industry-standard computers, the products replace and/or communicate with traditional instruments to acquire, analyze, and display data for test, measurement, and industrial automation applications. Because National Instruments products are based on industry standards, engineers can build test and automation systems for significantly less money than when using traditional instruments.

National Instruments flagship product, LabVIEW™, is a highly productive graphical programming environment for building data acquisition and instrumentation systems. In addition to providing the software for test and measurement applications, National Instruments hardware, such as plug-in PCI and PXI™/CompactPCI data acquisition devices and strain gauge signal conditioning modules, work seamlessly with LabVIEW programs and give engineers and scientists more options when creating custom data acquisition solutions.

For more information about the wide range of their test and measurement products now available through the Federal Supply Schedules Program, contact National Instruments, 11500 N. Mopac Expwy, Austin, Texas 78759-3504. Call toll free in the U.S. and Canada at (800) 258-7022, fax (512) 683-9300, or e-mail [info@ni.com](mailto:info@ni.com). Readers also can access information through the company's Web site at <http://ni.com> Contract Number GS-24F-0007K. Federal Supply Schedule 66 II J

**C O N T A C T**

Stephanie Peat

**P H O N E**

(703) 305-6097

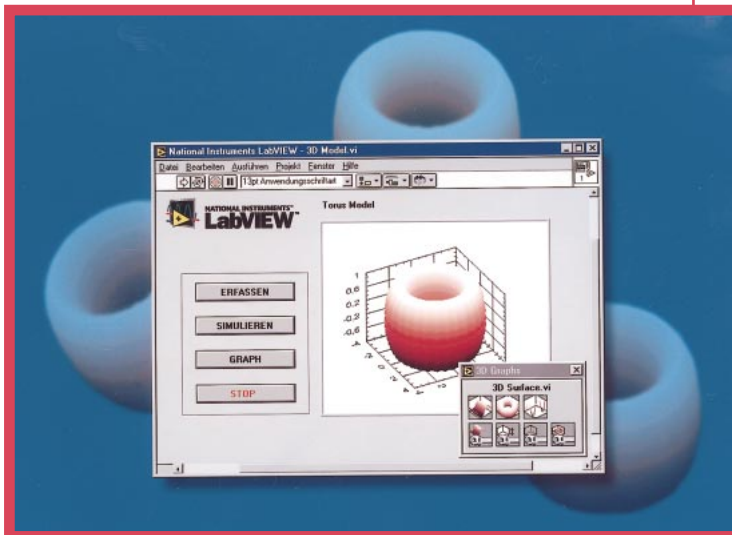
**E - M A I L**[stephanie.peat@gsa.gov](mailto:stephanie.peat@gsa.gov)

Introducing a New Product under Schedule 84 VI A  
Law Enforcement and Security Equipment

**MISTRAL BOMB CONTAINMENT WASTE RECEPTACLES  
AND EXPLOSIVE STORAGE UNITS**

Mail bombs, letter bombs, and pipe bombs are devices often used by terrorists. The two most common methods of delivering these mechanisms of destruction to an unsuspecting public are trash receptacles and the mail. Now, the Mistral Bomb Containment Waste Receptacles and Explosive Storage Units provide a means of preparing a facility against such unpredictable and life-threatening assaults.

When an explosive device is placed in a typical receptacle, the receptacle becomes part of the bomb. Detonation causes the components of the receptacle to fragment into thousands of pieces that can cause injury and death. Mistral Bomb Containment Waste Receptacles and Explosive Storage Units employ a two-layer system to absorb blast energy and fragments. The waste receptacles vent residual blast energy upward, keeping the receptacle intact and providing security, protection, and safety to the surrounding public. Storage units fully contain blast energy and fragmentation, providing safe storage for suspicious letters or packages until authorities can properly inspect them.

Mistral Bomb Containment Waste Receptacles and Explosive Storage Units are available in a variety of designs and sizes to fit a full range of protective and containment needs.

Order directly from the contractor:  
United Safety Container  
14 and Laurel Streets  
Pottsville, PA 17901-0870



Contact: John Knaut  
Phone: (800) 233-0314 Ext. 214  
Fax: (800) 847-8551  
E-mail: [usccinfo@unitedsafetycontainer.com](mailto:usccinfo@unitedsafetycontainer.com)  
GSA Contract No. GS-07F-03715

**C O N T A C T**

Leslie Cuevas  
Contracting Officer

**P H O N E**

(817) 978-8668

**F A X**

(817) 978-8661

**E - M A I L**

[leslie.cuevas@gsa.gov](mailto:leslie.cuevas@gsa.gov)

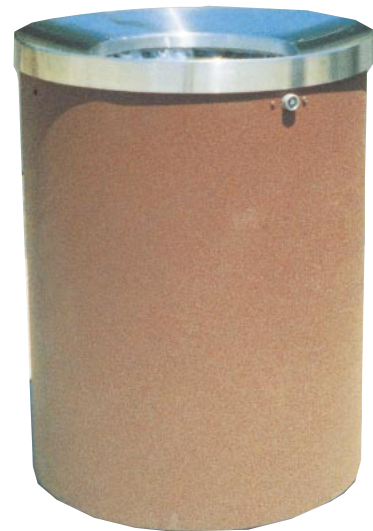



*Metal Buildings*  
Federal Supply Schedule 54 II B — Prefabricated Storage Buildings

**KELLY KLOSURE BUILDINGS**  
**"BEST VALUE" SOLUTIONS FOR SMALL OR LARGE SPAN METAL BUILDINGS**

Find out why first-time GSA Kelly building buyers become satisfied, repeat customers. Kelly's list of satisfied customers include repeat purchases by: Bureau of Land Management, USACOE, DOE, FAA, National Guards and Reserve Training Centers, TVA, U.S. Air Force, Army, and Navy installations, U.S. Border Patrol, U.S. Forest Service, USDA, and more.

Kelly buildings are simple and fast to construct—especially on short training exercises. They meet real property requirements, but can be considered "equipment". Kelly's unique pre-framed panel construction provides a permanent building that is truly relocatable.

There's no complicated contracting — it's so simple to order when you place a delivery order against GSA Contract GS-07F-7850C, Schedule 54, Part II, SINs 361-10, 11, 30, 32 and 98. Now you can use your government credit card as a form of payment. Place your order directly with:

KELLY INDUSTRIES, INC.  
220 North "H" Street  
P O Box 1058  
Fremont, Nebraska 68026-1058  
Phone: (800) 228-7230 or  
(402) 727-1344  
Fax: (402) 727-1363  
e-mail [inquire@kellyklosure.com](mailto:inquire@kellyklosure.com)  
web site <http://www.kellyklosure.com>

*3 Great Ways to obtain the KELLY "BEST VALUE" SOLUTION:*

1. Visit our website, input your questions, and download our literature
2. Call for Kelly Klosure's info and a GSA price list; or,
3. FAX your requirements and ideas – we're SOLUTION oriented!

**C O N T A C T**

Kori Bertino  
Contract Specialist

**P H O N E**

(817) 978-8376

**F A X**

(817) 978-8634

**E - M A I L**

[kori.bertino@gsa.gov](mailto:kori.bertino@gsa.gov)



# The Federal Acquisition On-Line University

In 1997, the Federal Acquisition Institute (FAI) embarked on a new and ambitious undertaking as it launched the On-Line University. When complete, the FAI On-Line University will bring to the Internet a comprehensive catalog of acquisition courses and research materials. It will provide training for new and experienced government acquisition personnel, helping those who support the ever-changing Federal Acquisition Regulations (FAR) gain and maintain competency. Located at <http://www.faionline.com>, the university will offer both self-paced and instructor-led courses as well as a library of print and audio resources.

FAI is responsible for assessing competencies of the entire acquisition work force and developing instructional materials for them. As access to the Internet grew, FAI explored ways to use the technology to deliver training and performance support tools to the acquisition community. FAI identified a need for on-line training, a library of references, student tracking, recordkeeping, and career management. Thus, the metaphor of a training university was born.

The purpose of the FAI On-Line University is to provide a site place where any official may go to obtain the necessary knowledge, skills, and abilities (KSAs), to perform acquisition-related assignments. KSAs would be presented for all four career development categories:

- ◆ The newly hired employee with no acquisition background
- ◆ The employee performing specific duties for the first time
- ◆ The employee solving more complex acquisition problems
- ◆ The experienced journeyman employee requiring training to remain current

Training and performance tool features of the FAI On-Line University include the following

- ◆ Courses: Certification Training – Self paced and Instructor Led

- ◆ Seminars and Training Games: Skills Update
- ◆ University features: Library, Career Management Center, Live Broadcasts, Announcements, Calendar of Events, Peer Networking

Available online FAI Courses and Seminars include:

- ◆ Contracting Orientation – This course is an introduction to the Federal acquisition process. It is designed for anyone with a role in the acquisition of supplies or services for the Federal Government and need just a general knowledge of the procurement process.
- ◆ Market Research for Acquisition Officers – Market Research is a self-paced course that consists of two duties focused on conducting market research. Although the course is designed for acquisition officials, it may be relevant to any personnel on market research teams or Integrated Product Team (IPTs) that conduct market research activities.
- ◆ COR Mentor – The Contracting Officer Representative (COR) Mentor provides self-paced learning for a total of 18

specific duties that may be assigned to a COR. This course has approximately 45 seat hours of courseware presented.

- ◆ Acquisition Planning for Commercial Items (AP) for Contract Specialists – The AP course contains eight lessons beginning with Determination of Need and ending with Solicitation Terms and Conditions. Each lesson takes approximately 4-6 hours to complete. Students are presented with a Pre and Post-test.
- ◆ Seminar – JWOD Training for Acquisition Professionals – This seminar was developed to provide all Acquisition Professionals with a better understanding of the Javits-Wagner-O'Day (JWOD) Program: basic program information, operations and processes, and best practices.

Contract Formation for Commercial Items is under development and will be available later this year. Future courses include Contract Administration of Commercial Items, Contracting for Non-commercial Items, Simplified Acquisition Procedures, and Contract by Sealed Bidding.

Training has become increasingly important to acquisition personnel who want to update their skills and keep current with the many recent changes in acquisition. On-line training is proving to be an efficient and cost-effective method for training the Federal Government's estimated 200,000 CORs and 28,000 Contract Specialists. No longer will the Government bear the costs of travel and per diem associated with attending classroom-based courses and seminars or have employees away from the office for weeks at a time.

Feedback from students has been very positive. FAI is averaging 1,000 new students a month. Now is the time for you to explore the FAI On-Line University. Internet training is the training vehicle of the new millennium.

