

MarkeTips

SPECIAL EDITION

Summer 1998

WHAT'S **INSIDE** THIS ISSUE?

2

EO12873: What Are the Standards?

3

Environmental Overview: Going for the Green

5

How You Can Avoid Copier Breakdowns

GSA Supports the President. Let Us Help You Do the Same.

GSA Will Offer Only Compliant Recycled Content Copier Paper

Effective immediately ... because it matters ... the Federal Supply Service is out of the non-compliant recycled content copier paper business.

FSS will fill existing orders for non-compliant recycled content copier paper until current stocks are depleted, at which time we will fill orders for copier paper only with compliant (min. 20%) recycled content copier paper.

NSNs for the non-compliant multi-purpose copier papers, soon to be phased out, are:

7530-00-181-7174 (8 1/2" x 11")

7530-00-181-7175 (8 1/2" x 14")

NSNs for the compliant multi-purpose copier papers are:

7530-01-335-2623 (8 1/2" x 11")

7530-01-334-7817 (8 1/2" x 14")

When stocks of non-compliant papers are depleted, their

NSNs will be retired.

This special edition of *MarkeTips* explains the FSS rationale in proactively supporting Executive Order 12873, "Recycling, Waste Prevention, and Environmentally-Preferable Acquisition."

It also provides some potentially helpful tips on how you can avoid copier paper problems that might arise in a typical office environment.

The general information about Federal environmental initiatives is included to give you an idea of how important these efforts can be, not only to the Nation, not only to us as

Federal professionals, but also to each one of us as an individual living on the planet.

We sincerely hope our customers will join us in support of EO12873 ... in support of the President and our environment.



Come join us on Planet GSA!



Photo courtesy White House Photo Office

Recycled Copier Paper and Executive Order 12873

What Are the Minimum Standards?

Ever since the signing of Executive Order 12873 (“Recycling, Waste Prevention, and Environmentally Preferable Acquisition”) in 1993, GSA has been working to help its customers comply with the order’s environmental guidelines, while still continuing to provide them with the quality products and services they can use to get the job done.

Almost as soon as the ink of the President’s signature had dried on the Executive Order, GSA was offering to its customers 20% postconsumer content paper at competitive prices, and agencies taking advantage of the offer could rest easy, knowing automatically that they were complying with EO12873.

Several years have passed since the signing of EO12873 and the standards established still hold. To meet the current minimum standard, Federal entities should be purchasing copier paper with at least 20% post-consumer content material, unless such paper is: a) not readily available; b) does not meet reasonable performance requirements; or c) is only available at an unreasonably inflated price.

The Truth About Performance

GSA buys its paper from the same mills that provide paper to all of the leading office supply wholesalers in the U.S. . . . and uses specs that are the same as those used by the U.S. Government Printing Office.

A LOT OF THINGS CAN HAPPEN TO A PIECE OF PAPER IN ITS TRAVELS THROUGH THE SYSTEM.

In fact, GSA’s performance requirements for compliant recycled copier paper are the same as for non-compliant recycled content paper: one jam per 5,000 copies.

So what’s the difference? From whence comes the perception that recycled content copier paper jams?

Our own experience indicates that a copier can jam for any number of reasons, such as: a bad batch of paper (yes, this can always happen, but it happens to non-recycled content paper as well as recycled content paper); poor maintenance of copier machine; improper storage of paper, (allowing moisture to affect sheets); improper handling of paper (not fanning paper out, not loading paper according to grain; not allowing paper to warm up (or cool down) to match the temperature of the copier room . . . etc. (And by the way, it’s been historically proven that dust in a copier room can be a killer.)

A lot of things can happen to a piece of paper in its travels through the system.

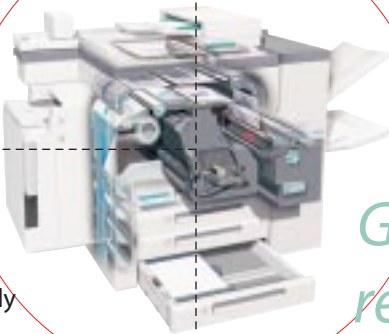

GSA’s performance requirements for compliant recycled copier paper are one jam per 5,000 copies.





Environmental Overview: GSA Helps Its Customers “Go For The Green”

In its attempt to help customers meet or exceed the requirements of a wide range of environmental laws and directives, especially including Executive Order 12873 (“Recycling, Waste Prevention, and Environmentally Preferable Acquisition”) GSA some time ago began the process of modifying its inventory to favor cleaner, less energy wasteful products.

The energy and focus generated by this “Go For The Green” effort has crossed all of GSA’s business lines, producing results that have often exceeded regulatory mandates. In FY97, for example, GSA offered its customers more than 3,000 environmental products, and more than 1,000 of those products were recycled content paper products. Total sales in environmentally oriented products topped \$400 million. Of that amount, \$300 million came from the sale of recycled content paper products.

Department of Defense Plays a Major Role

Department of Defense (DOD) has played a major role of leadership in the purchase of compliant recycled content copier paper items. In mid-FY97, following GSA’s unilateral, artificial price reduction of the compliant items, DOD mandated that 100% of its wholesale copier paper purchases through GSA would be the compliant recycled content items. As a result, DOD’s compliance rate shot up to 76.4% In just the first two quarters of FY98, DOD expenditures for recycled content copier paper reached \$11.8 million.

DOD’s strong show of support for EO12873 inspired other Federal entities to pledge their own increased support, including among them the U.S. Department of Energy, the U.S. Department of Justice, the U.S. Department of Labor, and the Department of Veterans Affairs. In each of these agencies, recycled content compliance improved through the 2nd quarter of FY98, sometimes dramatically. Department of Energy’s compliance rate improved from 69% to 95%. Department of Justice doubled their compliance rate to 51%. The Department of Veterans Affairs improved their compliance rate from 39% to 73%.

There were other Federal entities whose FY98 compliance rates improved. The U.S. Department of State went to 79% compliance; the Environmental Protection Agency reached 92%; and the compliance rate for the National Aeronautics and Space Administration reached 74%.

Recycled Content Copier Paper ... Yes! But There’s Also ...

In addition to recycled content copier paper, other examples of “green” paper products might include: calendars, planners, computer paper, graph paper, notebooks, file folders, index cards, envelopes, packing materials, boxes and cartons, paper towels, bathroom tissue ... and more.

Other items with recycled material (not paper) would include: latex paint, re-manufactured toner cartridges, recycling/waste containers, plastic desktop accessories, binders, trash bags, building insulation products, and even carpets ... and more.

You can find all of these items—plus an excellent overview of Federal environmental efforts—in the Spring 1998 edition of GSA’s

GSA PROVIDED CUSTOMERS WITH MORE THAN 2,000 ENERGY-SAVING COPIERS, WHICH WILL OVER THEIR LIFETIMES SAVE UNCLE SAM MILLIONS IN ENERGY COSTS.





Environmental Products Guide.

You can access the Guide on the Internet at: <http://www.fss.gsa.gov>. Or you can order a copy by faxing a request to our Centralized Mailing List Service (CMLS) at (817) 334-5227.

advances energy efficiency and helps protect the stratospheric ozone layer.



In Fact, We Can Cite 3 Categories of Environmental Initiatives

In the area of waste minimization, GSA offers recycled content products far in excess of the 36 categories of items designated by the Environmental Protection Agency (EPA). To help conserve this country's natural resources, GSA provides its customers with alternative fuel vehicles, along with energy efficient office equipment and household appliances. To help prevent/reduce pollution, GSA offers a wide variety of cleaning products, chemical items, and paints and coatings, that have been reformulated to be less damaging to the environment.

Working With Customers To Help Conserve Our Natural Resources

Since 1991, GSA has purchased for the Federal fleet nearly 15,000 alternative fuel vehicles, at an incalculable savings of fuel resources. By the close of FY98, GSA expects that number to rise to 18,500 ... and an electric-hybrid bus is also in the works.

Under the Energy Star Program, GSA provided customers with more than 2,000 energy-saving copiers, computers and printers which will over their lifetimes save Uncle Sam an estimated \$7 million in energy costs.

In a cooperative effort with Department of Energy (DOE), GSA established a Basic Ordering Agreement that not only simplifies the procurement of chillers, but also

Working To Help Prevent/Reduce Pollution

In recent years, GSA reformulated hundreds of paints and coatings to reduce harmful ingredients and help prevent pollution. In a recent pilot project with the Environmental Protection Agency (EPA) and with industry, GSA developed a matrix of characteristics for agencies to use when buying cleaning and degreasing products from GSA. Using the matrix, customers can select those products for purchase which best meet their needs, with the least environmental impact.

As an example of "environmentally preferable" purchasing practices, this "green" cleaning products initiative is just one recent example of GSA's continuing effort to help its customers comply with EO12873... not only with the letter of it, but also with its spirit.

We firmly believe that as Federal workers spearheading the national "green" effort, we can make a difference.

GSA has reformulated hundreds of paints and coatings to reduce harmful ingredients and help prevent pollution.

THREE QUARTERS OF GSA'S SALES OF ENVIRONMENTALLY ORIENTED PRODUCTS

CONSISTED OF RECYCLED CONTENT PAPER PRODUCTS





How You Can Avoid Paper Jams and Copier Breakdowns

The paper you buy from GSA is guaranteed to be 99.9% jam-free, and the copiers you buy or lease from GSA are top of the line machines with proven work horse credentials.

But if you don't perform the regularly scheduled maintenance on your copiers... and if you mistreat the paper stock in storage or in loading... your machines will inevitably break down, and the ratio of paper jams you encounter will increase.

All of that seems pretty clear, but it doesn't have to happen. In just a few simple steps, you can avoid paper jams and keep your copiers running. Here's how:

- Make sure the copier is fully serviced as per the manufacturers' maintenance schedule.
- After long print runs (especially of two-sided print jobs) allow the copier to cool off before using again.
- Add new toner when the warning light calls for it.
- Clean accessible areas where possible.
- If a paper jam does occur, and the paper is not readily removable, seek assistance from the designated service personnel.
- When removing paper jams, insure that the entire sheet of paper has been removed. Small pieces of paper remaining in the roller mechanisms can cause further jamming and result in costly service calls.
- Keep the copy room area clean and dust free. (Dust is a leading cause of copier jams.)

- Make sure the copier paper is stored at normal room temperature, in a dry place, preferably off the floor (especially if the floor is concrete).
- If the paper was stored in an area with a different temperature from that of the copier room, let it sit near the copier for several hours before use. This will acclimatize the paper to the copier room environment.
- Don't remove paper from wrapper until ready to use.
- Follow manufacturer's directions, and "fan" paper before use, checking for bent corners and ragged edges.
- Ensure paper is oriented correctly before loading into copier. Load paper according to the manufacturer's arrow on the ream label, if one is present.
- A special note: many copiers manufactured today are able to accommodate a variety of paper types and textures. However, the user must be sure to orient the curl of the paper in the correct direction. Should you encounter a jam, a good idea is to reverse the paper direction and attempt to copy again. If the machine continues to jam, call for service immediately.



Paper you buy from GSA is guaranteed to be 99.9% jam-free.

IF YOU DON'T PERFORM THE REGULARLY SCHEDULED MAINTENANCE ON YOUR COPIERS,

YOUR MACHINES WILL INEVITABLY BREAK DOWN.



For Questions or Assistance, Please Contact Your Customer Service Director

AZ	Phoenix	(602) 379-6619
CA	Bell San Diego San Francisco	(213) 526-7500 (619) 235-4706 (415) 522-2786
CO	Denver	(303) 236-7546 or 236-7543 or 236-7427
DC	Washington	(202) 619-8920
FL	Kennedy Space Center	(407) 867-2833
GA	Atlanta	(404) 331-3026
IL	Chicago	1-888-333-3477
MA	Boston	(617) 565-7302
MO	Kansas City	(816) 926-1620
MD	Baltimore	(410) 962-4422
NY	New York	(212) 264-3592
PA	Oakdale	(412) 644-4854
PA	Philadelphia	(215) 656-3868
TX	Ft Worth San Antonio	(817) 978-2892 (210) 472-6119
VA	Chesapeake	(757) 441-3115
WA	Auburn	(253) 931-7516

Overseas:

Europe, Northern Africa, and the Middle East — Frankfurt, Germany

DSN: 330-6085 or
330-7985

International Direct Dial

011-49-69-699-7985 or
011-49-69-699-6085

Pacific and Far East — Honolulu, Hawaii

(808) 541-1776
DSN 438-4960

U.S. GOVERNMENT
General Services Administration (7CPNL)
PO Box 6477
Ft Worth, TX 76115-6477

Official Business

Penalty for Private Use \$300

Address Corrections Requested

BULK RATE
POSTAGE & FEES
PAID
GSA
PERMIT No. G-30



U.S. General Services Administration
Federal Supply Service