

MarkeTips

Volume 11 Number 1
January/February, 1998



To acquire the professional services you need...

you can evaluate
your needs,
research vendors,
solicit offers,
evaluate proposals,
award contracts,
or do it the easy
way...

Call GSA's
Services
Acquisition Center

With today's emphasis on budget cuts, reengineering, and downsizing, it makes sense to look to the GSA's Services Acquisition Center for efficient solutions to all your professional services needs. Why spend time and money negotiating your own service contracts when GSA's Services Acquisition Center has already done all of the work; all you have to do is give us a call.

Our professional services cover a wide variety of areas. To assist you in easily locating the service programs that best fit your needs, we have divided our services into three basic areas:

- Travel and Transportation Services
- Organizational Management Services
- Financial Services

Several of our programs are being showcased in this edition of MarkeTips. Please take a few moments and look at the many professional service programs we offer. You'll be glad you did because the Services Acquisition Center has helped many agencies avoid procurement hassles, administrative burdens and delays in getting things done.

For more information on any of these programs, or to discuss the possibility of GSA developing other service programs, contact one of our customer service representatives on (703) 305-6658 or visit our website at www.services.fss.gsa.gov.

WHAT'S INSIDE THIS ISSUE?

17

Business Cards Available on Schedule

21

Postal Service Customers... We Have Your Paint

43

GSA Products and Services Expo

61

High Yield Toner Cartridges



Editorial Staff

**Paul Krysztoforski
Marguerite Prohaska**

A GSA Supply Catalog supplement
published by the
Office of Business Management
and Marketing
Federal Supply Service
General Services Administration
Washington, DC 20406-0001
(703) 308-4195
FAX: (703) 308-0190
Internet: <http://pub.fss.gsa.gov>

Published bi-monthly in the months of
January, March, May, July, September
and November

PUBLICATIONS

To request copies of FSS publications,
including the GSA Supply Catalog,
MarkeTips, Customer Assistance Guide
and all Federal Supply Schedules or to
request information concerning place-
ment of your activity on our publications
mailing list, contact:

**Centralized Mailing List Service
(CMLS)
(817) 334-5215
FAX: (817) 334-5227
Internet: cmls.gsa@gsa.gov**

INSIDE THIS ISSUE

Automotive	64
Customer Supply Centers	60
CSD Seminars	70
Defense Logistics Agency	68
Furniture & Furnishings	39
General Products	29
GSA Advantage	41
JWOD/NIB/NISH.....	66
National Customer Service Center	57
News and Information	54
Office & Scientific Equipment	58
Office Supplies & Paper Products	9
Paints & Chemicals	21
Property Management	38
Tools & Appliances	44
Travel & Transportation	56

**A warm hello to one of
our best customers...**

**... from the U.S.
Geological Survey,
Department of
Interior,
Raleigh, NC ...**

**Thanks, Tami, for the
Quality Control!**

**(Call us when you receive this
issue!)**

Travel and Transportation Services



Does your agency have a need to move people or things quickly and cost efficiently? If so, we have several programs that will get you where you want to go. Our Travel and Transportation Services include a broad range of programs from discounted airfares for Government Employees traveling on official duty to express delivery of letters and packages. Following are brief overviews of our most commonly used travel and transportation service contracts.

Airline City Pairs—The Only Way to Go . . . Save Up To 70% on Air Travel

GSA has developed an extremely successful Airline City Pair Program servicing approximately 6000 city pair combinations. The airfares offered under this program average a **70%** discount off comparable commercial fares; saving the Federal Government approximately \$2.65 billion annually. In addition to the tremendous price savings, the Airline City Pair Program has many features offering flexibility in planning official travel including:

- No advance purchase required,
- No minimum or maximum length of stay required,
- Fully refundable tickets,
- No charge for cancellations or changes,
- Last seat availability,
- No blackout periods,
- Fares are priced on one-way routes permitting agencies to plan multiple destinations, and
- Non-stop service was awarded in 99% of the markets where non-stop service was offered.

For more information on GSA's Airline City Pairs Program, call Ms. Anne Hasselbrack on (703) 305-7504.

Travel and Transportation Payment and Expense Control System—Do It the Easy Way . . . American Express Government Travel Card

Do you need help with your agency's payment and expense system for domestic and international official travel? If you answered yes, this program is for you! Here is how it works. American Express Government travel cards are issued to authorized Federal Employees for use on official travel. This card is accepted by all the common airline carriers, various car rental companies, Amtrak, numerous hotels, and 117,000 ATM locations worldwide. GSA's travel card program covers both domestic and international travel and includes both individual and centrally billed accounts. It provides access to travelers' checks in seven currencies and offers government-specific management reports. Some of the benefits of this program include:

- Individually billed and centrally billed accounts,
- Management reports,
- High rate of acceptance,
- Interest free accounts,
- Travelers Checks which are refunded at no cost to the traveler if lost or stolen,
- Dedicated 24 hour customer assistance,
- ATM and cash advance access,
- Automatic Business Travel Accident Insurance coverage, and

- Participating agencies receive .65% refund based on every dollar spent (excluding cash transactions).

For more information on GSA's Travel and Transportation Payment and Expense Control System, call Ms. Marion Williams on (703) 305-6906.

Prepayment Audit Services

Is your agency trying to get a handle on all the transportation billing documents it accumulates? Wouldn't it be nice to have all those transportation billing documents audited BEFORE they are paid to ensure accuracy and avoid paying excess charges? If you answered yes, we have just what you are looking for! GSA's Prepayment Auditing Services program helps agencies with a limited number of auditing staff, by establishing service contracts with contractors capable of auditing Government transportation billing documents. This program provides a means for auditing motor freight, air freight, rail freight, household goods (both foreign and domestic) and passenger government billing documents (air, rail, and steamship), to ensure accuracy prior to payment.

For more information on GSA's Prepayment Auditing Services please call Ms. Brenda Samuels on (703) 308-0805.

Try our DOMESTIC EXPRESS SMALL PACKAGE DELIVERY SERVICES . . .

"when it, absolutely, positively has to be there overnight."

Deadlines, Deadlines, and More Deadlines!

Do you need your package "there" yesterday? Let GSA help! We have a service program for desktop pickup and delivery of urgent letters and packages. If extremely urgent materials must be received by the next business day, use our next day delivery service which guarantees delivery by 10:30 a.m. If prompt delivery is needed, but next day service is not required, use our second business day service which guarantees delivery by 4:30 p.m. This program allows for prompt shipment of your materials at a lower price than next day delivery. Currently, our contract is with Federal Express and the geographic coverage includes the Continental United States, Alaska, Hawaii, and Puerto Rico. This program is loaded with extraordinary enhancements to meet your delivery needs. Some of the fabulous features this program offers are:

- Guaranteed next day delivery by 10:30 a.m.,
- Guaranteed 2nd day delivery by 4:30 p.m. second business day,
- Incredibly low rates,
- Automatic money-back guarantee (if shipments are even 60 seconds late),
- Agencies can request daily pick-up of packages or pick-up on an "as-needed basis"; and
- Packages can be tracked by Internet, FedEx Tracking Software, or by 1-800-GO-FEDEX.

If your agency would like to take advantage of these wonderful benefits, please call Mr. Ira Herman on (703) 305-6305. Let GSA help you get your package "there" yesterday!



Government Services that Relieve Stress?

If you think there's no such thing, then check us out!

Government Employee Relocation Services

As you may know, the process of marketing and selling a home while searching for a new residence can often lead to feelings of frustration and despair. We have a solution to that problem. Our Government Employee Relocation Services Program can make it easy. Employee relocation services are available for employees and their families being transferred to new duty stations anywhere within the continental United States and Puerto Rico. This program offers a multitude of flexible services to customize a solution that best meets your needs. Our program saves time and money and reduces stress by offering these features:

- Home Marketing Assistance,
- Home Sales Services,
- Destination Area Services,
- Management Reporting Services,
- Mortgage Counseling,
- Property Management Services, and
- Other Related Services.

Program features mentioned above include counseling, scheduling of viewing appointments, as well as information on schools, taxes, and commuting.

For more information on GSA's Employee Relocation Services, please call Ms. Brenda Samuels on (703) 308-0805.

Organizational Management Services



Have you thought about how you and your agency can maintain quality, value, and efficiency, with less people and resources?

We Have . . .

. . . By using the services offered under our Organizational Management Services area.

The services offered under our Organizational Management area provide access to expertise you may not have on staff. The contractor support provided will allow you to leverage your agencies' existing capabilities. Services range from Temporary Clerical Support to Quality Management Experts and EEO Counselors. Whether its Strategic Planning or Conference Planning, we have what you need to accomplish your agency's mission.

Management, Organizational, and Business Improvement Services (MOBIS)

If your agency needs help positioning themselves for the future, then GSA has the answer! MOBIS provides quick access to quality and performance improvement experts ready to assist you in this age of doing more with less. Agencies can obtain services in days rather than weeks or months and save resources. We have improved our MOBIS Schedule, offering more flexibility while providing a variety

of strategies and approaches for customer performance improvement needs. With MOBIS, all you have to do is place a task order with a contractor of your choice and your agency will take great strides towards improving performance, quality, timeliness, and efficiency. In addition, MOBIS assists agencies with meeting the mandates outlined in the Government Performance and Results Act (GPRA). Some of the programs most beneficial features include access to:

- Quality Management,
- Process and Systems Improvement,
- Business Process Re-engineering,
- Change Management,
- Change Implementation Strategies and Plans,
- Consulting Services,
- Facilitation Services,
- Strategic and Business Planning,
- Survey Services,
- Benchmarking,
- Performance Measurement, and
- Training Services (related to MOBIS).

For more information on MOBIS, please call Ms. Cynthia Claiborne on (703) 305-7423.

Equal Employment Opportunity (EEO) Services

Are you happy with all the requirements and restrictions imposed on your office's EEO procedures? We didn't think so. That's why we totally re-vamped GSA's old EEO schedule and started over with what you want.

You didn't want zonal restrictions. It was taken out! You didn't want to be locked into one contractor if you didn't like their performance, well now you are not. Our new EEO program offers agencies a choice in contractors. The flexibility of choice creates competition and encourages vendors to perform to YOUR standards.

Through this new program, agencies are provided with the full spectrum of EEO services which allows them to meet all the Federal Government's EEO regulations. The features of this program can be used to address existing EEO issues within your organization, or more importantly, this service can be used to create a healthier organizational culture and working environment. The new schedule features the following services:

- Investigations,
- Inquiries Regarding Notices of Intent to Sue under the Age Discrimination In Employment Act,
- Reference Materials,
- Final Agency Decisions,
- EEO Counseling,
- EEO Training and Consulting,
- Alternative Dispute Resolutions, and
- Analysis of Allegations of Non-Compliance with Settlement Agreements and their findings.

To find out more about eliminating the "Red-Tape" associated with the EEO process, take a look at our EEO Services Schedule or call Ms. Cindy Jones on (703) 308-0803.

Pilot Programs Flying High

The Services Acquisition Center currently has three pilot programs in the works. If these pilot programs prove to be as successful in saving time, money, and resources as our other programs, they will be made available on a much broader scale. The three pilot programs we are currently offering are **Temporary Clerical Support Services, Temporary Professional Support Services, and Conference Planning Services**. What is unique about the two temporary services is that they are available to all Federal agencies, but only in the Washington DC metropolitan area. If successful, the services will be expanded to other metropolitan areas across the United States. The Conference Planning Schedule offers the full gambit of conference services from the beginning stages of planning to the final thank you letters. Currently, this pilot program is only available to GSA, however, plans are in the works to expand this program to other Federal agencies. By incorporating pilot programs, we are able to identify and resolve implementation issues to ensure continued customer satisfaction. We like to think of this process as just another way we can provide you, our customer, with quality services. Below are brief descriptions of these programs.

Temporary Clerical and Temporary Professional Support Services

Have members of your administrative and professional staff been out sick when a critical project was due? Are events like jury duty always happening at the worst time? If so, let GSA come to the rescue with our two new Temporary Support Services Programs. Temporary Clerical and Temporary Professional Support Services both provide access to contractors, (100% small business set-asides), who are qualified to supply expert administrative, clerical, and professional support services to the Federal Government. Our Temporary Clerical schedule provides clerical, legal, and medical secretaries; receptionists;



general and administrative clerks; audit and accounting clerks; data entry operators; court reporters; stenotype operators; and transcribing machine operators. Our Temporary Professional Support schedule provides agencies with a wide range of professional services such as accountants, auditors, contract specialists, desktop publishers, environmental analysts, environmental technicians, graphic designers, lawyers, librarians, and market research analysts to name a few. Both schedules allow agencies to solve temporary staffing problems by providing for the short term assistance of clerical support and career professionals. These schedules offer many benefits such as:

- Orders for assistance can be filled within 24 hours,
- Quick response to changing staffing requirements,
- Temps can be used for up to 240 consecutive days,
- Choice of vendors, and
- Customers will be able to place orders on GSA Advantage!

These temporary Support Services are currently available to all Federal agencies in the Washington, DC metro area. If successful, the programs will be expanded to other major cities.

For more information on GSA's Temporary Clerical or Temporary Professional Support Services please call Mr. Guy Galloway on (703) 305-6000.

Conference Planning

Have you ever tried planning a conference? Have you experienced the stress associated with coordinating an out of town event? If so, then you know the amount of resources and time involved in conducting a conference from start to finish.

Enter GSA! We've experienced the same frustrations too! That's why we have created a multiple award schedule to provide comprehensive support for meetings and conferences of all sizes. Meeting sizes can range from 30 to 12,000 participants, and the contractor may be required to manage more than one conference at a time. This contract is a task order type contract and will provide savings in time, resources, and personnel needed to plan, coordinate and administer every phase of a conference or meeting. Key features of this schedule include:

- Pre-conference planning,
- Site selection,
- Reservations,
- On-site meeting support,
- Registration services,
- Mailings and other required correspondence,
- Post conference support,
- Travel support,
- Exhibit coordination and management,
- Computer support,
- Database creation and updating, and
- Overall management of the conference.

These conference planning services are currently being piloted and are only available to GSA. If the program proves successful, it will be offered to other Federal agencies.

For more information on this program, please call Ms. Brenda Samuels on (703) 308-0805.

Financial Services



Government-wide Purchase Card

This financial service provides commercial credit cards and associated services to support official government purchases. Use of the program greatly streamlines payment procedures and reduces the administrative costs associated with traditional and emergency purchases of supplies and services. Right now, more than 264,000 government employees are using the program and have an IMPAC card for "on-the-spot" purchasing that saves money, time, and paperwork. It is easy to enroll in the program and agencies can designate cardholders spending limits, appropriate purchase categories, and agency operating procedures. Below are additional benefits of using this program:

- Works like any commercial credit card
- Provides the ability to purchase supplies & services from a wide range of suppliers
- Improves agency cash management
- Can be used to purchase items from GSA Advantage!, GSA's Electronic Shopping Service

For more information on GSA's Government wide Purchase Card, please call Ms. Marion Williams on (703) 305 6906.

Consumer and Commercial Credit Reporting Services

This program provides easy access to information that is not readily available to the general public. Under this service, contractors collect, organize, and store financial and business information. Once

The Services Acquisition Center offers a wide variety of financial service programs to provide assistance with making purchases, tracing and controlling expenses, and reducing administrative costs. Do you or one of your co-workers have an International Merchant Purchase Authorization Card (IMPAC)? If so, you are already using one of the quality financial service programs provided by FSS.

the data is gathered, the contractors design reports to address agencies' requests. Agencies then use the information to conduct background checks to be used in hiring processes, loan evaluations, and contracting situations.

Sample reports include:

- Consumer and Commercial Credit Reports
- Domestic and International Business Profiles
- Mortgage Reports on Individuals and Businesses
- Written and Verbal Profiles
- Address Verification Reports
- Collection and Skip Locator Reports

For more information on this program, please contact Ms. Alexandra Walter on (703) 305-6747.

Auditing Services and Financial Management Services

Based on overwhelming requests from several customer agencies, the Services Acquisition Center is announcing the availability of new contracting services for Auditing and Financial Management

Support. This multiple award schedule provides the Federal Community direct access to commercially available auditing and financial management services to assist agencies in performing their duties. Government officials, policy makers, and managers need reliable financial and performance information in order to achieve the goal of developing a more responsive and effective government. This schedule will provide agencies with a wide choice of vendors, services and prices to meet all of your auditing and financial needs.

The key benefit of this program is the direct access to specialized expertise agencies need but do not have on staff. The second benefit is that agencies will be able use this specialized expertise to assist with meeting the requirements of the Chief Financial Officers Act, Government Performance and Results Act, and various Office of Management and Budget mandates, circulars, and bulletins. Available services include but are not limited to: Financial Audits, Performance Audits, Accounting Services, and Financial Consulting.

For more information on the Auditing and Financial Management Services, please contact Ms. Alexandra Walter on (703) 305-6747.

Health Care Cost Recovery (HCCR)

Federal Departments and Agencies that provide health care services to Government beneficiaries have the responsibility to recover the cost when other entities are also providing coverage. Under this program, qualified vendors assist Federal departments and agencies with the recovery process. The vendors review HCCR related processes and procedures, identify and verify third party health insurance coverage, perform preliminary recovery activities, and provide various support services. Agencies may purchase a single service or contract out the entire administrative process. This program assists with the collection of funds to which the government is entitled.

For more information on this service, please contact Mr. Alan Taylor on (703) 305-6133.

Third Party Payment Systems

This service makes money management easier and more efficient for customer agencies. Agencies are able to eliminate the use of petty cash, and better account for various expenditures, by making reimbursements and/or payments using a non-treasury check. The check is processed via standard commercial banking procedures, and upon being cleared for payment, the agency reimburses the vendor for the value of the check. The program is ideal for agencies that have representatives in remote locations where merchants may not accept the IMPAC as a form of payment. The program offers the following benefits:

- Improves management control by creating an audit trail
- Enhances cash management by minimizing the need for cash authorized transactions
- Universal acceptance
- Timely reconciliation of agency accounts

For more information on this program, please contact Mr. Alan Taylor on (703) 305-6133.

The Next Generation of Fleet, Travel, and Purchase Payment Systems

This program will replace the current Government-wide Commercial Purchase Card Program (IMPAC), the Travel and Transportation Payment and Expense Control System (AMEX), and the U.S. Government Fleet Services Card (Wright Express). The contracts will be effective November 30, 1998, and the base period will be for five years with one five year option. Agencies will place task orders against this contract, and FSS will provide assistance as needed.

Key Selling Points of the program include:

- Agency customization
- Choice of vendors
- Streamlined procurement processes
- Enhanced competition
- Continual access to advances in technology

This unique program is being awarded under a master contract approach for the first time. GSA has historically awarded these contracts separately with each program area being awarded to only one vendor. The master contract concept offers enormous benefits over the previous procurement method. The new approach recognizes that one size does not fit all. Agencies have varying financial requirements and it is impossible to design one system that meets everyone's needs. Under this new approach, agencies will have a selection of vendors and services to choose from and the flexibility to tailor a program to meet their unique needs. Agencies will also have the ability to change vendors if they wish during the contract period. The structure of the master contract concept allows for continual access to advances in technology, which encourages competition within industry to develop program improvements and share these best practices with the Government.

For more information on this program, please contact Ms. Rebecca Koses on (703) 305-6681



Financial Asset Management

GSA is in the process of developing a multiple award program for financial asset management. The program will provide a vehicle for all Government agencies to obtain the services of contractors with the qualifications, commitment, expertise, and experience required to assist the Government in the evaluation, management, maintenance, and disposal of various assets. The general types of contractual support for Government financial asset management covered by this program will include, but are not limited to:

- Transaction Financial Advisor Services
- Program Financial Advisor Services
- Due Diligence and Support Services
- Legal Support Services
- Credit Rating Services
- Loan Servicing
- Credit Reform and Federal Budget Analysis

We are just in the development stages of this program and invite potential users of this program to provide feedback regarding the types of financial asset management services your agency would find beneficial.

Please provide your suggestions and comments to Mr. Bill Toth on (703) 305-6670.

FSS**OFFICE SUPPLIES AND PAPER PRODUCTS**

Laser Printer Labels Are Available on Schedule

Specialty paper and specialty labels, including Laser Printer Labels are available at the lowest prices possible on Schedule 75, Part XI.

The prices are lower because we used our purchasing muscle to negotiate very attractive price structures. You save administrative and research costs, as well as time, because we have done all the legwork. You'll find:

Xerographic Paper (For special uses)

- Premium No. 4 White
- Three-hole drilled, edge reinforced
- 20 lb. Dual purpose
- 90 to 110 lb Index
- Watermarked, 25% cotton content
- 60 lb. white and gold parchment

Thermal Copy Paper

- Copier Machine Labels (Xerox and others)
- Laser Printer Labels (A wide variety of time-saving labels from Avery and other well-known brands)

You will find these paper and label bargains by contacting the following-named contractors:

Ansley Business Materials of Chicago

One ABM Center
413 N. Carpenter St.
Chicago, IL 60622
(312) 666-4070
Contact: James Fleming
Contract No. GS-15F-9507C

Federal Marketing Co.

10400 Eaton Place, Suite 305
Fairfax, VA 22030
(800) 706-9249
Fax: (703) 293-6490
Contact: Ed Hurley
Contract No. GS-15F-9505C

J. Jowdy Imaging Products

2370c Walsh Ave
Santa Clara, CA 95051
(408) 748-1115
Contact: Jeff Persin
Contract No. GS-15F-0036D

Xerox Corp.

Federal Contracts Div.
7900 Westpark Dr
Suite 4400
McLean, VA 22012
(800) 822-2200
Contact: Janet L. Gardner
Contract No. GS-15F9537C

When ordering be sure to identify yourself as a government purchaser and check the final invoice for government pricing. You can use your government I.M.P.A.C.® card, if you wish. Order copies of other schedules from:

Centralized Mailing List Service

P.O.Box 6477
Ft. Worth, TX 76115,
Phone (817) 334-5215
FAX (817) 334- 5227.

GSA Contact: Jeannette Faria, (212) 264-3503 (Contracting)

Order these fine products through:

FEDSTRIP/MILSTRIP or MUFFIN

Or Point, click and shop at GSA Advantage!™ on the Internet

<http://www.fss.gsa.gov>

Take A Look At Just A Few Of The Packaging Materials That -Are Available To You

Tape Dispensers

Reinforced filament tape should be used for light duty bundling and packaging when shipping conditions warrant. The hand-held Tape Dispenser makes sealing a neat and easy task as it dispenses the right amount of tape and cuts the tape cleanly. Light and portable. U/I - EA

60-yd roll of tape up to 1" wide with a 3" core.

NSN: 7520-00-579-9053

Price: \$3.42

Contact: Rodney Sally, (212) 264-4895 (Inventory)

For a 180' roll of tape up to 2" wide with a 3" core

NSN: 752001-424-4851

Price: \$20.15

Contact: Glen VaBoven (212) 264-8207

.....

Fully manual tear-off dispenser holds Kraft tape that is 3" wide and comes in 600 or 800' rolls. Requires moistening of tape with a brush or roller-type mechanism as it is manually fed under a serrated metal cutting edge. Features nonslip rubber feet or base.

NSN: 7520-00-550-7829

Price: \$25.41

.....

Sturdy, metal dispenser with holds a 72-yd roll of cellulose tape or a 60-yd roll of plastic-backed sealing tape. Outside tape diameter can be up to 5".

Accommodates rolls with a 3" core. Serrated tear-off cutting edge is guarded for user protection. For single or multiple rolls of tape up to 2" wide total. Nonslip feet.

NSN: 7520-00-285-1772

Price:

.....

Sturdy, metal dispenser with nonslip feet holds a 72-yd roll of cellulose tape or a 60-yd roll of plastic-backed sealing tape. Outside tape diameter can be up to 5". Accommodates rolls with a 3" core. Serrated tear-off cutting edge is guarded for user protection. For single or multiple rolls of tape up to 3" wide total.

NSN: 7520-00-634-6724

Price: \$15.47

Contact: Rodney Sally, (212) 264-4895 (Inventory)

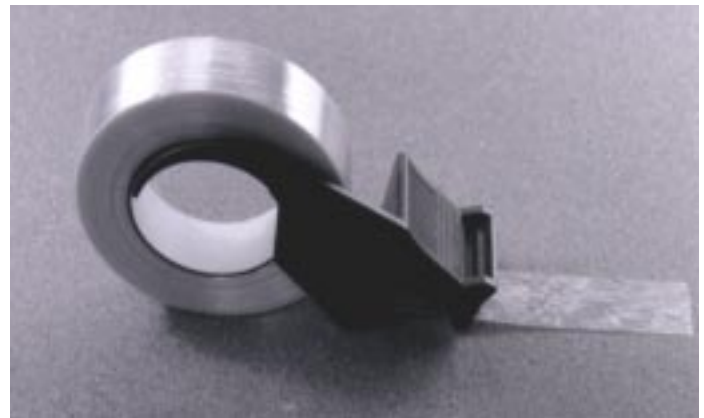

Manual gummed tape dispensers provide one-pull action that measures, moistens and cuts paper and reinforced tapes in lengths up to 500'. Holds tape widths of 1-1/2 to 3".

NSN: 7520-01-424-4869

Price: \$137.06

Contact: Glen VaBoven (212) 264-8207

Shipping Tags

Shipping Tags help assure deliver with clearly-marked Shipping Tags handy sizes for marking documentation in domestic shipping and transportation. Come with 12" metal wire ties. U/I - MX.

Printed on Manila paper with paper reinforced eyelet

Size: 1-5/8" x 3-1/4"

NSN: 8135-00-240-1388

Price: \$12.40

Contact: Rodney Sally, (212) 264-4895 (Inventory)

Storage and Shipping Boxes

<u>NSN</u>	<u>Stocking Indicator</u>	<u>Size</u>	<u>Style</u>	<u>U/I</u>	<u>Pkg.</u>	<u>Recycled Content</u>	<u>Slotting</u>	<u>Bursting Strength</u>	<u>Max.Wgt. Box and Contents</u>	<u>Price</u>
8115-00-079-8679*†	S	12" x 12" x 4"	RSC	BD	25 EA	40% PCM	Regular	275 psi	95 lbs.	\$14.37
8115-00-117-8249*	S	14-3/4" x 12" x 9.5"	LBC	BD	25 EA	40% PCM	Lock Bottom	275 psi	95 lbs.	\$41.42
8115-00-142-9594*	S	46-7/8" x 38-7/8" x 15-13/16"	HRSC	EA	EA	30% pcm	Half-Regular	N/A	N/A	\$28.07
8115-00-183-9498*†	S	8" x 8" x 8"	RSC	BD	25 EA	40% PCM	Regular	275 psi	95 lbs.	\$13.38
8115-00-183-9501*†	S	8" x 8" x 6"	RSC	BD	25 EA	40% PCM	Regular	275 psi	95 lbs.	\$13.87
8115-00-190-4950*†	S	9" x 6" x 6"	RSC	BD	25 EA	40% PCM	Regular	275 psi	95 lbs.	\$11.05
8115-00-190-5002*†	S	16" x 16" x 16"	RSC	BD	25 EA	30% PCM	Regular	400 psi	140 lbs.	\$68.06
8115-00-190-5012*†	S	20" x 8" x 9"	RSC	BD	15 EA	30% PCM	Regular	400 psi	140 lbs.	\$19.39
8115-00-190-5017*†	S	30" x 12" x 6"	RSC	BD	15 EA	30% PCM	Regular	400 psi	140 lbs.	\$31.00
8115-00-201-1123*†	S	20" x 20" x 3-1/2"	RSC	BD	15 EA	30% PCM	Regular	400 psi	140 lbs.	\$41.43
8115-00-290-3364*	S	6" x 5" x 7"	RSC	BD	25 EA	40% PCM	Regular	200 psi	65 lbs.	\$ 4.87
8115-00-290-3394*	S	25" x 20" x 5"	RSC	BD	15 EA	40% PCM	Regular	200 psi	65 lbs.	\$20.49
8115-00-527-2302*	S	10" x 6" x 4"	Lunch	BX	150 EA	None	fold-tuck	N/A	20 lbs.	\$54.54
8115-00-559-5516*	S	45" x 14" x 22"	RSC	BD	3 EA	30% PCM	Regular	‡	200 lbs.	\$31.12
8115-00-559-9998*	S	43" x 22" x 34"	RSC	BD	2 EA	30% PCM	Regular	‡	280 lbs.	\$37.42
8115-00-559-9999	S	45" x 22" x 22"	RSC	BD	2 EA	30% PCM	Regular	‡	280 lbs.	\$30.85
8115-00-579-8407*	S	23" x 23" x 23"	RSC	BD	3 EA	30% PCM	Regular	‡	280 lbs.	\$32.05
8115-00-598-5807*	S	21" x 21" x 20.5"	RSC	BD	15 EA	30% PCM	Regular	400 psi	140 lbs.	\$48.28
8115-00-616-9147*	S	27" x 19" x 14-3/4"	RSC	BD	4 EA	30% PCM	Regular	‡	280 lbs.	\$35.19
8115-00-616-9150*	S	21" x 19" x 14-3/4"	RSC	BD	4 EA	30% PCM	Regular	‡	280 lbs.	\$30.89
8115-00-616-9154*	S	43.5" x 18.5" x 13"	RSC	BD	3 EA	30% PCM	Regular	‡	280 lbs.	\$31.59
8115-00-774-6562	S	48" x 40" x 36"	RSC	EA	-----	30% PCM	Regular	‡	280 lbs.	\$26.49
8115-00-901-6435*	S	47.5" x 39.5" x 28"	RSC	EA	-----	30% PCM	Half-Regular with cover		280 lbs.	\$29.47
8115-00-935-5904*	S	86" x 31-3/4" x 35-1/4"	RSC	EA	-----	30% PCM	Regular	‡	280 lbs.	\$52.39
8115-00-935-5906	S	43" x 31-3/4" x 35-1/4"	RSC	EA	-----	30% PCM	Regular	‡	280 lbs.	\$27.51
8115-00-935-5907*	S	29" x 31-3/4" x 35-3/4"	RSC	EA	-----	30% PCM	Regular	‡	280 lbs.	\$21.59
8115-00-935-0276*	S	47.5" x 39.5" x 35.5"	RSC	EA	-----	30% PCM	Regular	‡	280 lbs.	\$33.17
8115-01-011-3619*	S	11-1/4" x 8-3/4" x 12"	RSC	BD	25	40% PCM	Regular	275 psi	95 lbs.	\$17.39

*Direct Delivery

†Manufactured under JWOD by non-profit agencies affiliated with NIB

‡1100 in-oz/inch

Contact: Jeff Fleisher (212) 264-5197 (Inventory)

GSA and The Federal Supply Service...

Listening to You and Offering More Choices Than Ever Before!!!

Cartridges and Ribbons For Your Office Equipment



7510-01-171-5856
7510-01-123-8973
7510-01-269-8364



7510-01-186-3987

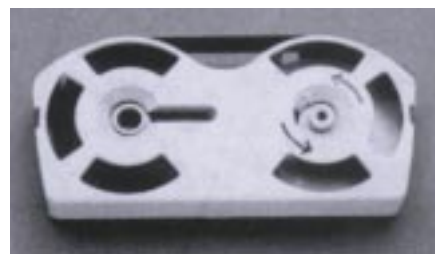

7510-01-095-2184

<u>Manufacturer</u>	<u>NSN</u>	<u>Description/Manufacturer's Part Number</u>	<u>Size</u>	<u>U/I</u>
Xerox/Diablo	7510-01-123-8973	Multi-strike plastic polyester film for use on nonportable electric Hytype II and Xerox Diablo 1750 printers P/N 24170/301980-04.	5/16" wide 390' long	EA
Data Products	7510-01-171-5856	Nylon continuous ribbon with weld skip over feature. Use in Data Products Crop. B-100 & B-300 printers.	1" wide 50 yd long	DZ
Burroughs	7510-00-162-3016	Cotton replacement ribbon for Burroughs portable electric and office adding machines.	7/16" wide 6 yd long	EA
Clary/Remington	7510-00-205-2245	Clary 150, 151 & 170 as well as Remington 102, 108, 40712-1040812-10, 50712-1050812-10, 51112-10 adding machines. Also for use in Clary and Remington cash registers 301 & 302, having dual spools.	12" wide, 6 yd long	EA
Olivetti	7510-00-965-2307	Olivetti adding and calculating machines and Audit 202 accounting machines.	1/2" wide, 9 yd long	EA
Genicom	7510-01-269-8364	Nylon & fabric cartridge for use in Genicom nonportable electric printer. Replacement for Genicom p/n 44A504287-G09, 10, 16 & 33.	3/4" wide, 75 yd long	DZ
IBM	7510-01-095-2184	IBM Correcting Selectric II & III, IBM Mag Card A and Mag Card II, IBM Model S101, SE100, SE1000C, SE1000CD, SE2000, 77C1830, 1850C, 5000CD and 6010, For use with Lift-Off/Cover-up Tape 7510-01-094-8418 or equal.	510' long	BX(6)

<u>Manufacturer</u>	<u>NSN</u>	<u>Description/Manufacturer's Part Number</u>	<u>Size</u>	<u>U/I</u>
Victor	7510-00-197-9193	Victor 1900, 3600 & 4000 printing calculators w/dual spools.	1/2" wide, 8 yd long	EA
Mannesman Tally	7510-01-119-5626	For use in M/T non-portable electric computer terminal. Features continuous mobius loop. Replacement for M/ T p/n 607014-10, Xerox p/n 8R1178 or equal.	3/8" wide, 20 yd long	DZ
Apple	7510-01-186-3987	Harmonica-shaped nylon ribbon for use in Apple I & II, Citizen MPS15 & MPS25, Epson RXFX100, FX286, MX100, RX100, and Victor 625, 6000 and 6025. Repl. for IBM p/n 6100261, Wang p/n 725-1291, PCPM and PCPM016 or equal.	1/2" wide, 75' long	EA
IBM	7510-00-083-3951	IBM Selectric II model 83 & 87, IBM Magnetic Card Selectric Model 935(MCST) & IBM Magnetic Card Executive Model 535 typewriters Use for preparing forms for OCR scanning.	3/4" wide, 405' long	EA
Adler	7510-00-285-2966	Adler Standard, Electric, Portable (OS Type-bar), SW3500, 5500, and 7500 & SE1000 fabric ribbon, Commodore Standard, Facit Standard, Electric & Portable.	1/2" wide, 16 yd long	EA
	--and--			
	7510-00-141-5556	(OS Typebar models), Oliver Standard, Olympia Report Deluxe, Splendid SG-1 & SG-2, Remington Travel Riter (OS), Roy al 5000 Fabric, Diana IC2000, 480, 642, Royalux 400, 424, 450.		DZ
	7510-00-141-5556	Portable Std Manual Models 6, 7, 8 & 9, SCM Portable Manuals above 5,500,000 & Portable Electrics above SN6, 100,000 & Underwood manuals & portables exc. Model 150 & Noiseless.		
Adler	7510-00-471-2890	Adler 21, 21C, 21D, 21F (NSNs under 7,770,000) J-5, MX, Contessa Deluxe, Meteor.	9/16"wide,	EA
		Special Applications, Satellite 2001 & Tippa U200TW, Citizen S-4 Royal 590, 690, 970-973 and 2000.	16 yd long black & red	Min. 20
RC Allen	7510-00-577-1162	RC Allen Standard & Electric 611, Lower Standard, Woodstock Standard & Electric Models.	1/2" wide, 16 yd long	EA
Commodore	7510-00-264-5987	Commodore 900, Remington Noiseless Portables (after SN1953 except Bantam, and Cadet, Pioneer, Remette, Scout and Streamline), Underwood (OS) and Noiseless.	1/2" wide, 16 yd long	EA
	7510-00-285-2967	150 (SNs below 7,881, 200).	black & red	EA



7510-01-170-8886



7510-01-219-5753



7510-01-219-2309

<u>Manufacturer</u>	<u>NSN</u>	<u>Description/Manufacturer's Part Number</u>	<u>Size</u>	<u>U/I</u>
Halda	7510-00-285-2969 7510-00-141-5560	Halda 5, 6, 7, Cicero & Star, Oliver 19, 20, 21 & Royal Electress, Noiseless, Princess and 440, 441, 470, 471, 550, 661, EB, FP, GA, HE and MC	1/2" wide, 16 yd long, black & red	EA
Olivetti	7510-00-181-7731	Olivetti multistrike fabric ribbon models except Documentor and Forum	1/2" wide, 16 yd long	EA
LC Smith	7510-00-285-2965	LC Smith Electric Portables (SNs below 6,100,000) and Smith Corona Manual Portables (SNs below 15,500,000).	1/2" wide, 6 yd long	EA
LC Smith	7510-00-285-2980	LC Smith Premier Noiseless II, 51, 61,71 and 91.	1/2" wide, 16 yd long	EA
IBM	7510-00-780-9894	Heavy inked nylon ribbon for multistrike models. IBM Selectric models. IBM Selectric 72, 721, 723 and 725, Selectric II models 84 and 88, MTST Model 775, MCST Model 975.	9/16" wide, 18 yd long	EA
RC Allen	7510-00-082-2615	RC Allen A-CR, B-CR, 711-CR, 811-CR, and Electrite, Adler 21C/D41C/D (serial no. above 7,770,000), Facit Electrics, Friden Flexowriter & Justowriter IBM A, B, C & D, Olympia CR (except 35CR) CRA, DR, DRD & M, Royal 565, 568, 595, 660,662, 665-1 & 970 Remington 25, 26, 250 & 300, Smith Corona (LCSmith) 62E, 72E, 2EE, 3EE, 400, 410 & 415 Underwood Documentor & Duplex (includes 153, Finger-Flite), Olivetti, except Editor 2 & Editor 3C, Olivetti-Underwood, Raphael, Forum & 702.	5/16" wide, 875' long	DZ
Data Royal	7510-01-170-8886	Medium-inked nylon ribbon for Data Royal nonportable electric & Facit 4528. Replaces Burroughs p/n B925201-1071-556 or equal.	1/2" wide, 15 yd long	EA

<u>Manufacturer</u>	<u>NSN</u>	<u>Description/Manufacturer's Part Number</u>	<u>Size</u>	<u>U/I</u>
Xerox/Diablo	7510-01-362-0088	Fits any of 766 daisy-wheel printers made by, or compatible with Xerox or Diablo, including all major brands.		EA
Swintec	7510-01-233-0033	Medium-inked nylon ribbon for use in Swintec Model No. 8014 and as replacement for Swintec p/n SWS1003 or equal.		PG (6)
IBM	7510-01-219-2309	Medium-inked nylon for IBM Selectric System 2000 and IBM Wheelwriter model 3, 5, 6 & 10. Serves as replacement for IBM p/n 1299845, 1337761, and 1380999 or equal. Use with lift-off/cover-up tape 7510-01-219-5753.	5/16" wide, 1390' long	PG (6)
Honeywell	7510-00-258-1477	Black nylon record ribbon for electric accounting machines and high-speed data processing printers. Honeywell 112, 222-7, 715 & 915 high-speed printers. Medium inked.	2" wide, 25 yd long	EA
IBM	7510-00-898-9290	IBM tabulating machines 402, 403, 404, 405, 413,416, 417, 418, 419 & 4557. Medium inked.	3/4" wide, 18 yd long	EA
IBM	7510-00-965-2445	IBM 1403 high-speed printer, medium-inked.	14-1/6" wide 20 yd long	EA
Sperry Rand	7510-00-926-9204	Sperry Rand Univac models 0752 & 1004/1005 printers. Medium inked.	14-1/6" wide 55 yd long	EA
Adler	7510-01-094-8418	Adler SE100CD, SE1000C, SE2000, SE2000C, E2000D, SE6000, SE6000D, Canon, Facit S1830, 1850, 1850C, 1885, 6452, IBM Correcting Selectric II & III, IBM Mag Card A & II, IBM Memory, IBM Correcting Selectric Right to Left 856, IBM Electric 50, 60 & 75, Mercury 6010, Olympia 77C, Remington SR101C, SE400 & S-101, Royal SE5000CE & SE6000, Silver Reed 8550, 8650, 8750, Swintec series 1146 & 1186, current Swintec models 7000/8000. Dry low tack.	19' long	PG (6)
IBM	7510-01-219-5753	Correctable tape for use in IBM Selectric Wheelwriter Model 3, 5 & 6. Replacement for IBM p/n1337765 (For use with Typewriter Ribbon 7510-01-219-2309.)	9/32" wide, 75' long	EA

Contact: Delores Turner (212) 264-3547



SKILCRAFT® Pen Refills Fit Three Popular Styles

Fill 'em up! SKILCRAFT® pen refills fit three popular styles. Saving budget dollars on writing instruments just got easier thanks to the introduction of the new SKILCRAFT®, ballpoint refills that are designed for use in the three new SKILCRAFT® Pens gaining popularity daily: Ergonomic, Cushion Grip and Rubberized Retractable Pens.

These are the same easy writing long-wearing pen points that write and write and write... sharply and clearly, with specially-designed cushion wearability. U/I-DZ.

These refills:

<u>NSN</u>	<u>Color</u>	<u>Point</u>	<u>Price</u>
7510-01-368-3500	Black	Medium	\$2.13
7510-01-368-3501	Blue	Medium	\$2.13
7510-01-381-7997	Black	Fine	\$2.13
7510-01-381-7998	Blue	Fine	\$2.13

...Fit these pens:

<u>NSN</u>	<u>Color</u>	<u>Point</u>	<u>Price</u>
ERGONOMIC Pens			
7520-01-424-4873	Blue	Fine	\$14.43
7520-01-424-4854	Blue	Medium	\$14.43
7520-01-424-4856	Black	Fine	\$14.43
7520-01-424-4876	Black	Medium	\$14.43

CUSHION GRIP Pens			
7520-01-424-4879	Blue	Medium	\$9.42
7520-01-424-4852	Blue	Fine	\$9.42
7520-01-424-4865	Black	Medium	\$9.42
7520-01-424-4857	Black	Fine	\$9.42

RUBBERIZED RETRACTABLE Pens			
7520-01-422-0327	Blue	Fine	\$5.66
7520-01-422-0323	Blue	Medium	\$5.66
7520-01-422-0315	Black	Fine	\$5.66
7520-01-422-0314	Black	Medium	\$5.66
7520-01-422-0324	Red	Fine	\$5.66
7520-01-422-0326	Red	Medium	\$5.66

For Refill information contact:

Andre Lovell (212) 264-8734 (Technical)
Vincent Cositore (212) 264-8214 (Inventory)

For Pen information, contact:

Andre Lovell (212) 264-8734 (Technical)
Dennis Steele (212) 264-4869 (Inventory)



Ergonomic



Cushion Grip



Retractable

Enhance and Preserve Your Award Certificates

Enhance the presentation of certificates and awards for achievement, commendation and recognition by enclosing them in special Award Certificate Binders identified by your agency or armed service.

Elegantly embossed on the front with either the military service's (Available in stock) or civilian agency's (Purchase through SOP) seal on the front, they provide safekeeping for a lifetime. The stock awards are listed below. The customized certificate binders can be purchased through the Special Order Program (SOP) at extremely attractive prices.

The SOP allows you to order customized binders through FSS, which will handle the transaction for your agency, although the finished products are shipped directly to you. To provide the binders at the low price, a minimum order of 200 binders is required. There is an additional charge for the die, but shipping costs are included in the price. Camera-ready art of the seal is required.

The handsome and stiff vinyl holders proudly display two 8-1/2" x 11" award certificates inside each cover, which are protected further by transparent protector sheets. Colors for armed service's binders are indicated below. Customized binders come in standard colors.

The binders are manufactured under JWOD by the Dallas Lighthouse for the Blind, Inc., an agency affiliated with NIB. Stock Binders (U/I-EA):



Award Certificate Binders for the armed services in stock. Now also available customized for all Federal agencies.

NSN: 7510-00-115-3250
Seal: Blue/Air Force
Overall Size: 9" x 11-5/8"
Price: \$1.93

NSN: 7510-00-482-2994
Seal: Blue/Navy
Overall Size: 9" x 11-5/8"
Price: \$1.93

NSN: 7510-00-755-7977
Seal: Green/Army
Overall Size: 8-1/2" x 11-1/8"
Price: \$1.85

NSN: 7510-01-056-1927
Seal: Red/Marine Corps
Overall Size: 9" x 11-5/8"
Price: \$1.93

Contact: Dennis Steele (212) 264-4869 (Inventory)

Customized Award Certificate Binders for civilian Federal agencies can be ordered through SOP. **Contact Bob Streeter (212)-264-1728 (Procurement).**



Business Cards Now Available Under Federal Supply Schedule 75 IIB

Handsome, yet inexpensive, custom-printed business cards enhance the image of all Federal agencies and military services are now available from the Lighthouse for the Blind, Seattle, WA., courtesy of GSA and a new ruling by the Department of Justice.

These quality printed customized, both plain and foil-stamped embossed cards, are printed on recycled paper using soy-based ink. Available in several attractive styles, the card designs will allow name, title and division, agency seal or logo, address, telephone and e-mail numbers. Delivery in only ten days after receipt of order and all required materials.

Made under JWOD by a non-profit agency affiliated with NIB and offered at prices far lower than any other source.

The Lighthouse will accept orders via fax or mail and payment via I.M.P.A.C.® card, check, money order, or on approved accounts. They will also accept orders from government employees who need to purchase cards with personal funds.

Contract #14F-0721G (11/ 97-9/02)

You may request a brochure and details by writing to:

The Lighthouse for the Blind, Inc.,
 2501 South Plum Street
 P.O.Box C1419
 Seattle, WA 98114

or by calling: 1-800-799-0402.

GSA Contact: Cassandra Spann (212) 264-0371 (Procurement)

They Are Classics, Try One of These Memorandum Books

A classic in its own way, in every sense of the word. Environmentally-beneficial, too: made of 50% recovered material, including 20% post consumer material. Often copied, but never equalled.

High quality: Sharply printed blue horizontal rules. White sulfite writing paper with protective covers (for field use).

Great Value:
Lots of pages (144 and 80), printed two sides.

Low price: The lowest anywhere. Compare.



Artificial leather cover, Green, U/I - DZ, 144 pages

NSN: 7530-00-222-0078

Size: 5.625" x 3.37"

Opens: Side

Price: \$6.55

NSN: 7530-00-060-7511

Size: 3-1/2" x 4-1/2"

Opens: End

Price: \$7.21

Hard, artificial leather cover, Black or green, U/I - EA, 80 pages

NSN: 7530-00-274-5494

Size: 5-5/8" x 9"

Opens: Side

Price: \$3.22

Stiff cloth cover, Olive drab or gray, U/I - DZ, 144 pages

NSN: 7530-00-243-9366

Size: 3-1/2" x 6"

Opens: End

Price: \$7.33

Contact: Charlie Joiner (212) 264-3539 (Inventory)

JWOD

Skilcraft® Facial Tissues...Soft and Absorbent

It's not news that curing the common cold is still an impossible dream, but preventing an infection from spreading throughout your office is not only do-able and practicable, it is really a necessity for managers who want productivity to stay high by keeping absenteeism low.

One important method is keeping an ample stock of tissues in the workplace. They'll prevent infections spreading, personnel happier and more of them at their jobs during coming cold wintry days.

There are no better tissues on the market at lower prices than SKILCRAFT® Facial Tissues from FSS. They're soft, absorbent, folded in white two-ply sheets and packed in attractive boxes. They're recycled, too, including 5% postconsumer material (PCM).

They are further society-beneficial because they are manufactured under JWOD by agencies affiliated with NIB.

Compare these low prices with any other source.



<u>NSN</u>	<u>Size</u> <u>Sq.in.</u>	<u>Tissues</u> <u>Per BX</u>	<u>U/I - PG</u> <u>(Contents)</u>	<u>Price</u>
Pop-up Dispenser				
8540-00-793-5425	66	100	12/BX	\$ 4.85
Regular Dispenser				
8540-00-281-8360	66	200	6/BX	\$ 4.89
8540-00-900-4891	40	50	200/BX	\$40.28

Contact: David St. Louis (212) 264-3537 (Inventory)

It's About Time...

Wrist watch

Waterproof, nonmagnetic watch has 15-jewel movement with a stainless steel casing and plastic crystal. Black face features both 12- and 24-hour dials, with luminous hands and minute markings, white numerals and a sweep second hand. Black nylon strap with buckle closure adjusts to most wrist sizes. Stem-winding mechanism has a 36-hour running time, is accurate to 30 seconds a day and carries a two-year guarantee.

NSN: 6645-00-066-4279

U/I: EA

Price: \$52.95

.....

Stopwatches

Push-button stopwatch with a minimum of seven jewel bearings ensures split-second accuracy over an extended period. It starts, stops or returns to zero with a single touch and times 30-minute intervals in increments as small as 1/5 second. Dustproof and shockproof stem-winding mechanism. Watch features a white metal dial with luminous hands and a rust-resistant case.

Adjusted for accurate operation in three positions: vertically with pendant up, horizontally with dial up or at a 45 degree angle with pendant and dial up.

NSN: 6645-00-250-4680

U/I: EA

Price: \$60.73

Digital stopwatches display minutes, seconds and 1/100th seconds, to a maximum of 59 minutes, 59.99 seconds. Water-resistant, hand-held instruments include an automatic rollover function. Powered by one or two 1.55v calculator/watch batteries (not included) (Rayovac Type 392 or equivalent recommended). Watches maintains accuracy for one full year of normal use.

Includes time-out mode and separate start/stop and rest controls.

NSN: 6645-01-106-4300

U/I: EA

Price: \$4.54

Designed with split-mode timing to freeze the split-time display while total timing continues. Has separate start/stop and reset controls.

NSN: 6645-01-106-4303

U/I: EA

Price: \$4.54

Alarm Clock

Be on time! Hand-wound, shelf-type alarm clock wakes or alerts you with a loud, 20-second alarm. Includes non-luminous Arabic numerals and minute marks, a metal or plastic case and a clear plastic dial cover. Spring-driven movement runs approximately 32 hours on one winding. Dustproof clock also features a regulator adjustment that allows for fast or slow operation. Dial size is as indicated. U/I -EA

Size: 4" diameter

NSN: 6645-00-268-4042

Price: \$5.72

Size: 3" diameter

NSN: 6645-00-151-5274

Price: \$7.12



.....

Reciprocating Counter

For counting people, vehicles, trees, packages, blood cells, bacteriological colonies and other visible objects. Hand-held instrument is actuated by the thumb; four-wheel mechanism registers to 9999. Heavy-duty unit will register up to 5,000,000 counts without failure. Features reset knob and clear window. Corrosion-resistant, dustproof case.

NSN: 6680-00-641-3206

U/I: EA

Price: \$6.36



Interval Timers

Use this hand-wound, spring-driven interval timer in photographic darkrooms. This accurate, rugged timer is corrosion- and chemical-resistant and has a regulator for fast or slow adjustment. Two hands and dials in contrasting colors are readable from a distance of 5'. Timer has two scales: a 10-minute outer scale in 15-second graduations and a 120-minute inner scale in 10-minute graduations. Alarm rings for five seconds and is audible up to 50'. Has a suspension ring, stable base and a clear crystal dial cover.

Size: 6 x 6 x 4"
NSN: 6645-00-880-8045
U/I: EA
Price: \$9.20



Keep track of time in photographic darkrooms and laboratories. Mechanically operated timer can time 1- to 60-minute intervals. Sturdy body, dial face and selector knob made of shatterproof, nonwarping plastic. Acid-resistant. Hands and dial in contrasting colors are readable from 5' in normal light. Bell alarm is audible up to 25'.

Size: 3 x 3 x 4-1/2"
NSN: 6645-00-732-7789
U/I: EA
Price: \$64.01

Contact: Charlie Joiner (212) 264-3539 (Inventory)

...CORRECTION...CORRECTION...

MarkeTips, November 1997, Page 24, please make the following phone number change:

**Independent Ink Company
 1-800-446-5538**

Our Art Supplies For Your Projects Can't Be Beat!

GSA Construction Paper is a heavyweight paper that's perfect for art projects, crafts and bulletin board mounting. The matte finish shows neither gloss nor glare. Size: 9" x 12" (A perfect background for 8-1/2" x 11" sheets) and a basis weight of 72 lb.

In compliance with the President's EO # 12873 on recycling, the paper is made of 50% post consumer material. U/I - HD

<u>NSN</u>	<u>Color</u>	<u>Price</u>
7530-00-285-2887	Green	\$1.27
7530-00-285-2879	Light Blue	\$1.27
7530-00-285-2876	Orange	\$1.27
7530-00-285-2901	Red	\$1.27
7530-00-285-2902	Violet	\$1.27
7530-00-285-2905	White	\$1.27
7530-00-285-2906	Yellow	\$1.27

Contact: Phyllis Rossi (212) 264-4320 (Inventory)

Life's a little on the grey side? Change all that, with multi-toned Uni-Paint Markers.

Fast-drying oil-based paint in pen-style markers give you permanence with maximum neatness and control, resulting in an opaque, glossy line in a medium width. With six- or twelve marker sets, you can mark and identify tools, equipment, vehicles, appliances, cabinets, or metal disks, and be confident that it will not wear off.

By using a spectrum assortment of six shades (black, blue, green, red, white, yellow) or twelve shades (black, blue, brown, gold, green, orange, pink, red, silver, violet, white, yellow), you can color code for quick identification. Also good for lettering, marking, and touch-ups on almost any surface: ironwork, wood, glass, paper, plastic, and numerous other porous and non-porous materials. Comes in convenient plastic see-through protector.

<u>NSN</u>	<u>U/I</u>	<u>Price</u>
7520-01-439-3409	Set (6)	\$7.08
7520-01-439-3410	Set (12)	\$13.98

Manufactured by Mark-Tex Corporation.

Supplied by Adams Marketing, a woman owned business.

<u>NSN</u>	<u>U/I</u>	<u>Price</u>
7520-01-207-4167	Set (6)	\$9.54
7520-01-207-4168	Set (12)	\$19.09

Manufactured by Eberhardt-Faber.

Contact: Andre Lovell (212) 264-8734 (Technical)
 Vince Cositore (212) 264-8214 (Inventory)

U.S. Postal Service Customers: We Have EPA 17 Free Paint!!

Federal specification TT-E-2784 is an acrylic enamel that is free of all EPA 17 chemicals. It is intended for use on exterior primed metal, concrete, masonry and wood, but may also be used for interior application. This paint provides a durable, long lasting coating when applied over properly prepared surfaces and is characterized by excellent gloss retention.

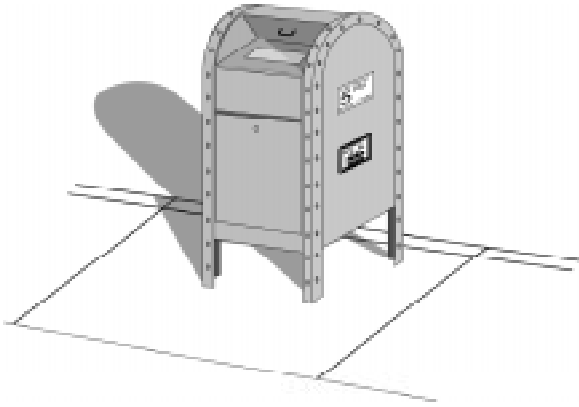

So it's the perfect product for indoor and outdoor collection boxes, and also for urks! It has a maximum VOC of 200 grams per liter and is available in over 150 colors. The NSN for Post Office Blue is 8010-01-333-9819 and comes in a 1 gallon can. For a complete listing of colors and sizes, please check the GSA Supply Catalog or visit us on-line at GSA *Advantage!*TM at: www.fss.gsa.gov for browsing and ordering.

Contact: Laura Davis (253) 931-7930

Correction!

Please make the following pen and ink changes to your 1997 GSA Supply Catalog, page 1028 for the "Big Squeeze" tube squeezer. The NSN should read 8030-01-424-4333. This device maximizes the use of sealants and adhesives by forcing contents from collapsible tubes forward and out. Minimum order is 12 EA. \$1.23 EA. Order through FEDSTRIP/MILSTRIP procedures.

Contact: Melissa Scarlett (253) 931-7487



Visit Us At Our Web Site:

www.northwest.gsa.gov/fss/pnt_chm.htm

100% Recyclable Sorbent Products Now Stocked

Executive Order 12873, Section 503, Federal Acquisition, Recycling & Waste Prevention, October 20, 1993.

In order to identify and show a preference for "environmentally preferable" products and services, President Clinton has called upon EPA to issue guidance for executive agencies to use when purchasing goods and services.

EPA recommends that each executive agency issue a policy directive that includes the following elements:

1) Commitment to increase the acquisition of environmentally preferable products.

2) Incentives and award programs for those who successfully promote or purchase environmentally preferable products.

3) Pilot projects which will generate more detailed guidance on purchasing environmentally preferable products and services. These pilots will also include development, training and education.

In accordance with EPA Guidelines, the Paints & Chemicals Center has decided to launch another Environmentally Preferable Products Pilot Program. The Center has chosen "Sorbent" products as our pilot. We have decided to put into our stock program sorbent products that are made from 100% recyclable products for use to absorb fuel, oil and paint.

Order using FEDSTRIP/MILSTRIP procedures.

NSN: 7930-01-418-1514
Description: 14"x24" single wt pads
U/I: BX (100 EA)
Price: \$30.46

NSN: 7930-01-436-7896
Description: 8" diam x 120" long Booms
U/I: BX (4 EA)
Price: \$95.85

NSN: 7930-01-436-7998
Description: Absorbent Sweep
U/I: BX (25 LBS)
Price: \$27.69

Contact: Carol McKenzie (253) 931-7887

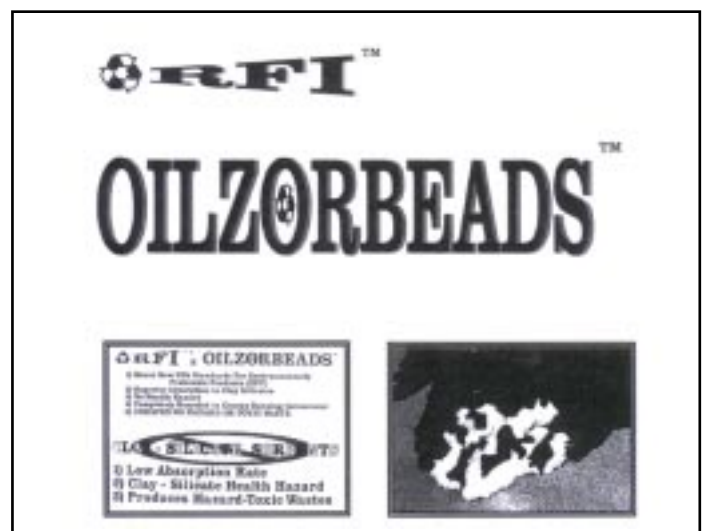

Multiple Award Schedule FSC 68 VI B Provides Wide Selection Of General Purpose and Special Use Deodorants

GSA's vendors under the Multiple Award Federal Supply Schedule FSC 68 VI B for Deodorants offer a full selection of bathroom deodorants, automatic deodorizing systems, general-purpose and special-use deodorizers to keep your workplace free of unpleasant odors. These deodorants can be used everywhere: offices, hotel and motel rooms, apartment buildings, barracks, locker rooms, hospitals, industrial facilities, refuse and compacting areas, sewage treatment plants, landfills and transfer stations, pit or vault toilets, or in every bathroom!

Check out the variety of deodorants and dispensers offered by the following vendors and see if they meet any of your requirements!

Contract #: GS-10F-8653D
***Airkem, Division of Ecolab Inc.
370 Wabasha St. N.
St. Paul, MN 55102
(612) 293-2570

Contract #: GS-10F-8651D
***American Sanitary Products, Inc
502 Wilson Road
Crownsville, MD 21032
(410) 987-5016

Contract #: GS-10F-6845D
***Chempace Corporation
P.O. Box 3484
45 Burbank Drive
Toledo, OH 43607
(800) 423-5350

Contract #: GS-10F-8663D
***Chemsearch, A Div. of NCH Corp.
P.O. Box 152170
Irving, TX 75015-2170
(214) 438-0188

Contract #: GS-10F-8808H
***Commonwealth Chemical International, Inc.
2619 Rockford Lane
Louisville, KY 40216
(502) 449-3322
Contract #: GS-10F-8811H

***Desert Microbial Products
2069 E. Carson
Tempe, AZ 85282-7405
(602) 375-3596

Contract #: GS-10F-8640D
***Hill Manufacturing Co., Inc.
1500 Jonesboro Road SE
Atlanta, GA 30315
(404) 522-8364

Contract #: GS-10F-8660D
Hygena
664-A Freeman Lane #236
Grass Valley, CA 95949
(800) 432-2719



Contract #: GS-10F-8664D
***Madison Bionics, A Div. of Systems
General Subsidiary of NCH Corp.
1630 E. Northgate
Irving, TX 75062
(214) 438-0603

Contract #: GS-10F-8658D
Nature Plus, Inc.
52 Lakeview Ave., Suite 20
New Canaan, CT 06840
(203) 972-1100

Contract #: GS-10F-8662D
***Navy Brand Manufacturing
511 Southwest Avenue
St. Louis, MO 63110-3496
(314) 865-5500

Contract #: GS-10F-8813H
***Neo Products
448 E. Oliver Street
Corunna, MI 48817
(888) 977-4848

Contract #: GS-10F-8661D
PN & PM Corporation
1189 Smallbrook Lane
York, PA 17403
(717) 845-7088

Contract #: GS-10F-8809H
***SeaTech, Inc.
2134 Espey Court, Ste. 18
Crofton, MD 21114
(301) 261-0052

Contract #: GS-10F-8812H
***Shola Enterprises
737 North LaSalle Street, Ste. 200
Chicago, IL 60610
(312) 649-8070

Contract #: GS-10F-8657D
***Walex Products Company, Inc.
P.O. Box 3785
Wilmington, NC 28406
(910) 371-2242

Contract #: GS-10F-8641D
***Zep Manufacturing, Inc.
1310 Seaboard Ind. Blvd. NW
Atlanta, GA 30315
(404) 352-1680

Contractors with the *** accept the Government Credit Card.

If you are interested in these items, contact the vendor(s) of your choice for specific product information and prices. Then don't forget you can use the Blanket Purchase Agreement (BPA) provisions to maximize your administrative and purchasing savings by setting up "accounts" to fill a "reoccurring requirement". Order directly from these vendors and use your I.M.P.A.C.® card today!

If you would like to receive a copy of this schedule (07SC 6822), contact:

GSA Centralized Mailing List Service (7CPNL)
PO Box 6477
Fort Worth, TX 76115

e:Mail: CMLS.gsa@gsa.gov

or on-line ordering at: <http://pub.fss.gsa.gov> or FAX your request to (817) 334-5227.

Contact: Trudy Metzler (253) 931-7098

Corrosion Preventives and Antiseize Compounds Are Available on FSS Schedule 80 Part III Section A

Now you can buy these brand name Armite products from our new Sealant, Adhesive and Corrosion Preventives Multiple Award Schedule.

-- 12/34 is a multiuse aerosol that removes moisture, prevents rust, loosens frozen rusty parts and lubricates. Non-flammable formula is recommended for electronic equipment, especially near salt water.

-- 12/12 provides a microscopic thin film which protects against rust for as long as 12 months on equipment stored outside.

-- LED-PLATE No. 250 or 250F Antiseize Compound for high temperature, high pressure corrosion proof antiseize with unequaled sealing for any threaded material. Contains lead.

Various sizes and quantity discounts are available. For pricing information and minimum quantities or to order contact Armite Laboratories, (213) 587-7744, reference FSS Schedule 80 Part III Section A Contract GS-10F 8807H. 7 day delivery.

Contact: Sandra Church (253) 931-7077

Inspecta-Shield A New Fire Retardant Coating

Inspecta-Shield reduces flammability on materials such as clothing, wall covering, upholstery, carpet, and draperies. It is easy to apply, non-toxic, non-allergenic, colorless, UV stable, and non-hardening. Product comes with application instructions and attachable spray nozzle.

Order using FEDSTRIP/MILSTRIP procedures.

NSN: 8030-01-389-1394

Part No: 6252-2

U/I: 1 QT

Price: \$17.56



Contact: Sandra Church (253) 931-7077
Melissa Scarlett (253) 931-7487

Price Reduction on Eureka Corrosion Preventives

Eureka Fluid Film anti-corrosive coatings are now available at lower prices. Fluid Film uses non-hazardous ingredients to protect metals from attack by moisture, salt water and industrial atmospheres. This non-drying formula can be used to coat the interior of ship rudders and ballast tanks, loosen frozen parts on metal equipment and lubricate chains or moving metal parts. Available in bulk, gel, pump spray and aerosol formulations as listed below.

NSN: 8030-01-386-3877
Item: Liquid A
U/I: GL
Size: 1 gal
Price: \$14.15
Minimum Order: 4
GSA Advantage!TM: Yes

NSN: 8030-01-387-1051
Item: Liquid A
U/I: CN
Size: 5 gal
Price: \$66.87
Minimum Order: 1
GSA Advantage!TM: No

NSN: 8030-01-381-1065
Item: Liquid A
U/I: DR
Size: 55 gal
Price: \$583.84
Minimum: 1
GSA Advantage!TM: No

NSN: 8030-01-381-7311
Item: Liquid AR
U/I: GL
Size: 1 gal
Price: \$14.15
Minimum: 4
GSA Advantage!TM: Yes

NSN: 8030-01-387-1131
Item: Aerosol
U/I: BX
Size: 12 12 oz.
Price: \$45.56
Minimum: 1
GSA Advantage!TM: No

NSN: 8030-01-381-6357
Item: Nonaerosol pump spray
U/I: BT
Size: 12 oz.
Price: \$4.68
Minimum Order: 12
GSA Advantage!TM: No

NSN: 8030-01-386-3871
Item: Spray Refill
U/I: GL
Size: 1 gal
Price: \$16.82
Minimum Order: 4
GSA Advantage!TM: Yes

NSN: 8030-01-387-1070
Item: Spray Refill
U/I: CN
Size: 5 gal
Price: \$76.90
Minimum Order: 1
GSA Advantage!TM: No

NSN: 8030-01-381-3160
Item: Gel
U/I: CN
Size: 5 gal
Price: \$120.29
Minimum Order: 1
GSA Advantage!TM: No

Order through FEDSTRIP/MILSTRIP or *Advantage!*TM where indicated above.

Contact: Lynn Springer (253) 931-7901

Have a Question?
**Help is just a toll-free phone call
 away...!**

**Paints and Chemicals
 Center Express Desk
 1-800-241-RAIN (7246)**

Schedule 80 Part III Section A Now Has Waterproof Coatings for Roofs, Decks and Masonry Surfaces

Sealoflex now offers a complete line of waterbased, VOC compliant primers and waterproof coatings for roofs, decks, walls, floors and below grade surfaces:

Rust-X-2020 5 gallons \$169.15
Non-hazardous coating transforms rust into a surface that can be painted.

Metal Etch Primer 5 gallons \$110.91
Waterborne acrylic primer with inorganic zinc for first coat on ferrous metals.

Sealobond Primer 5 gallons \$70.22
Deep penetrating primer for chalky or difficult surfaces.

Sealclear 5 gallons \$75.17
Siloxane based water repellent for concrete and masonry.

Wearcoat 5 gallons \$111.03
Aqueous abrasion resistant floor coating, smooth or nonskid formulas.

Levelcrete 50 pounds \$29.95
Powdered leveling, surfacing and grounding mortar.

Sealoment Plus 50 pounds \$55.00
Powdered concrete hardener, waterproofing and adhesion promoter.

Sealodeck 5 gallons \$67.58
Clear waterproofing, UV Protectant for decks.

Three part roofing system:

6" fabric (150 sq ft)	\$188.15
12" fabric (300 sq ft)	\$207.18
40" fabric (972 sq ft)	\$281.12

Flexible waterproof roofing system. UV resistant, for flat roofs, walls, decks, joints.

FSS Schedule 80 Part III Section A. Minimum order of \$100 for all items except roofing system. 7 day delivery. Order direct from Sealoflex Waterproofing Systems, (800) 318-6711 referencing contract GS-10F-8806H.

Contact: Patricia Finch (253) 931-7073



GSA and the Federal Supply Service...

Listening to You, and Offering More

Choices than Ever Before!!!

Several 1,1,1, Trichloroethane Products To Be Discontinued

1,1,1, Trichloroethane has been discontinued but alternatives for certain applications are available.

With the move to replace products that contain Ozone Depleting Substances (ODSs), the need to find replacements for 1,1,1, Trichloroethane has become critical. As a result, GSA has taken the initiative to find alternatives for the current 1,1,1, Trichloroethane NSNs through acquisition of new environmentally preferable products. With the multiple applications of 1,1,1, Trichloroethane, we feel that the alternatives listed below will give you the choice of product lines best suited to your needs. The products contain no halogenated solvents or suspected carcinogens, teratogens or metegens. These products are currently available through normal MILSTRIP/FEDSTRIP or MUFFIN procedures.

In view of the above, GSA will discontinue stocking the following 1,1,1, Trichloroethane NSNs. However, we will continue to fill requisitions until our present stock is exhausted. Requisitions received after our stock has been depleted, will be canceled CJ.

For technical information regarding a substitute for a specific need, contact **Daryl Jocoy (253) 931-7601**, e:mail daryl.jocoy@gsa.gov

Items To Be Discontinued

6810-00-292-9625	QT		
6810-00-664-1487	DR		
6810-00-664-0387	GL		
6810-00-664-0388	CN	(5 GL)	
6810-00-930-6311	CN	(12 OZ aerosol)	

Alternatives for certain 1,1,1, TRICHLOROETHANE applications

American Resource Safe-T-Solv

7930-01-398-0887	P/N 1054	CN5	GL	\$53.15
7930-01-398-0889	P/N 1054	DR55	GL	\$539.24

Chempace Citrusolv HF

7930-01-398-0852	P/N 32213	CO5	GL	\$37.49
7930-01-398-0853	P/N 32214	DR55	GL	\$379.66

National Chemical Laboratories Solvane

7930-01-393-6755	P/N 1406	DR55	GL	\$391.03
------------------	----------	------	----	----------

PCI of America

Hurrisafe 9030 Original Degreaser

7930-01-398-0902	BX	61-GL	\$68.23
7930-01-398-0903	CN	5 GL	\$55.15
7930-01-398-0906	DR	55 GL	\$490.69

Hurrisafe 9040 Special Formula Degreaser

7930-01-398-0909	BX	6 1-GL	\$68.21
7930-01-398-0911	CN	5 GL	\$58.52
7930-01-398-0914	DR	55 GL	\$504.57

P-T Technologies, Inc.

PF Electrical Cleaner Aerosol

7930-01-398-1026	P/N PF14AC	BX	12 14-OZ	\$50.48
------------------	------------	----	----------	---------

PF Degreaser

7930-01-328-5959	P/N PF16	BX	12 1-PT	\$32.52	squirt top bottle
7930-01-330-0187	P/N PF32	BX	12 1-QT	\$49.81	squirt top bottle
7930-01-328-5960	P/N PF01	BX	6 1-GL	\$73.28	
7930-01-398-1027	P/N PF03	CN	3-GL	\$38.62	
7930-01-328-2030	P/N PF05	CN	5-GL	\$55.12	
7930-01-328-4058	P/N PF55	DR	55-GL	\$523.71	

Puritan Churchill

Churchill L400 Ready-to-use Cleaner

7930-01-418-1123	P/N 38940055DR	55 GL	\$200.56
------------------	----------------	-------	----------

Space Chemical

Lift-Off 827

7930-01-418-1467	DR	55 GL	\$358.05
------------------	----	-------	----------

Zep Manufacturing

Zep ID Blue

7930-01-423-1313	P/N 056837	CN	7 GL	\$66.06
7930-01-423-1314	P/N 056850	DR	20 GL	\$185.05
7930-01-436-7825	P/N 056885	DR	55 GL	\$473.33

Zep ID Red (Aerosol)

7930-01-436-7887	P/N 009601	BX	12 24-OZ	\$34.26
7930-01-436-7890	P/N 009602	BX	24 24-OZ	\$67.78

Zep ID Red

7930-01-412-0996	P/N 057035	CN	5 GL	\$41.04
------------------	------------	----	------	---------

Zep ID Orange (Aerosol)

7930-01-436-7891	P/N 009701	BX	12 24-OZ	\$36.94
7930-01-436-7892	P/N 009702	BX	24 24-OZ	\$73.13

Zep ID Orange

7930-01-412-0997	P/N 057137	CN	7 GL	\$62.12
------------------	------------	----	------	---------

Contact: Lee Heydlauff (253) 931-7113

Multiple Award Schedule FSC 79, Part VII Environmentally Friendly Cleaning Products

An overall selection strategy for chemical cleaning products should be based around the 5 R's:

- 1) Re-evaluate: re-evaluate the entire cleaning process to determine if the procedure itself is necessary.
- 2) Reduction: reduce the quantity and toxicity of materials being used and packaging.
- 3) Reuse: purchase products which are durable, repairable, reusable or returnable.
- 4) Recycling: purchase for recyclability within your organizations recycling collection systems.
- 5) Renewable: select products that are derived from renewable feedstocks, such as detergents and solvents from cornstarch, coconut oils and orange peels.

In Federal Supply Service's effort to provide environmentally preferable products we have joined with EPA on several ventures. One of these ventures provided products derived from citrus fruits as a replacement for petroleum-based chemical solvents. The following highlights Rochester Midland's Enviro Care line of products found under Multiple Award Schedule FSC 79, Part VII for Chemical Dispensing Systems/Products. Enviro Care products are even more effective and economical using the push-button Chemizer Cleaning System that manages the mixing of cleaners and disinfectants for perfect dilution.

-- Chemizer can save up to 65% of product usage over non-portion control methods.

-- The concentration levels can be adjusted exactly.



The Enviro Care Program includes:

	All Purpose Cleaner			
7930-01-412-2417	1 GL	BX (4 EA)		\$ 43.66
	Tough Job Cleaner			
7930-01-412-2433	1 GL	BX (4 ES)		\$71.42
	Neutral Disinfectant			
7930-01-412-2423	1 GL	BX (4 EA)		\$51.75
	Washroom & Fixture Cleaner			
7930-01-412-2421	1 GL	BX (4 EA)		\$61.58
	Glass Cleaner			
7930-01-412-2418	1 GL	BX (4 EA)		\$29.96
	Carpet/Upholstery Cleaner			
7930-01-436-7953	1 GL	BX (4 EA)		\$37.26
	Chemizer Unit			
7930-01-412-2424		EA		\$377.76
	Chemizer Unit			
7930-01-436-7970		EA		\$217.35

Contact: Lee Heydlauff (253) 931-7113

Don't Forget To Mark Your Calendars...

**GSA Products and Services Expo
Washington State Convention and Trade Center
Seattle, Washington
July 8-9, 1998**

See Page 43

New Item

Wildland Firefighters Clothing

GSA is now stocking new larger size flame resistant shirts and jeans used by the wildland firefighters. These are high temperature resistant garments worn by wildland firefighters for protection and safety. Made of NOMEX material and meet the requirements of NFPA 1977-93.

NSN: 8415-01-421-3905
NFES No: 0569
Item Description: Shirt, Med-Long
U/I: EA
Price: \$43.32

NSN: 8415-01-421-3907
NFES No: 0570
Item Description: Shirt, XX-Large
U/I: EA
Price: \$43.32

NSN: 8415-01-434-0618
NFES No: 0511
Item Description: Shirt, Sm-Long
U/I: EA
Price: \$43.32

NSN: 8415-01-434-0626
NFES No: 0512
Item Description: Shirt, XX-Large-Long
U/I: EA
Price: \$43.32

NSN: 8415-01-434-0631
NFES No: 0503
Item Description: Jeans, 42 X 30
U/I: PR
Price: \$57.73

NSN: 8415-01-434-0637
NFES No: 0504
Item Description: Jeans, 42 X 34
U/I: PR
Price: \$57.73

NSN: 8415-01-434-0645
NFES No: 0505
Item Description: Jeans, 44 X 30`
U/I: PR
Price: \$57.73

NSN: 8415-01-434-0654
NFES No: 0506
Item Description: Jeans, 44 X 34
U/I: PR
Price: \$57.73

The above items are new to the GSA system and supplement the full line of fire clothing already in the program. For information on these or other sizes as well as other supplies and equipment that support the fire program, contact: Linda Schurg, (817) 978-3163 or Ray Balli, (817) 978-8637.

**GSA Contact: Linda Schurg (817) 978-3163,
 FAX (817) 978-8600 or E-Mail: linda.schurg@gsa.gov**

Visit Our Home Page!

We now have all of our individual Federal Supply Schedule program guides on line. Just click on Multiple Award Schedules at the site:

<http://www.gsa.gov/regions/7fss/7fx/index.htm>

A Special Sale For The Start Of A New Year

Attention MUFFIN users:

-- Sale items with a Y suffix NSN (e.g. 7530-00-123-4567Y) WILL NOT be found in the MUFFIN database.

-- Sale items without the Y suffix NSN (e.g., 7530-00-123-4567) WILL be found in the MUFFIN database, but will not reflect the sale price.

In both cases, you can place your orders through MUFFIN. You will automatically be billed at the reduced price.

GSA is offering the following items at 50 percent reduced selling price, effective until stock is depleted or for 90 days from the issuance of this publication. Please remember to use Advice Code "2J" when ordering these items. Items will no longer be available as GSA stock items.

Disposable Cups

<u>NSN</u>	<u>U/I</u>	<u>QTY</u>	<u>SALE PRICE</u>
7350-00-903-8141	BX	170	\$32.70

Tall-style cup without handle has a plastic coverall lid and is for cold liquids. White cup 6 oz capacity, 2500 each per BX.

Clearance Indicating Reflector

<u>NSN</u>	<u>U/I</u>	<u>QTY</u>	<u>SALE PRICE</u>
9905-00-182-5043	EA	3791	\$0.75

Reflector is intended for application directly to smooth, clear, nonporous, painted and corrosion- and weather-resistant surfaces. US Army Dwg No. 11614174, color - RED, size - 4-1/2 X 4-1/2".

GSA Contact: Jeff Fossmeyer, (817) 978-8674, FAX (817) 978-8600 or E-Mail: jeff.fossmeyer@gsa.gov

New Item

Lightweight, Compact Headlamp II Has Been Added To The Wildland Fire Supply System

A new, lightweight headlamp is now offered by GSA. NSN 6230-01-387-1399 (NFES #0713) has been added as a more compact alternative to the headlamp we have supplied firefighters for many years.

The new headlamp utilizes the same general design as the old one (NSN 6230-00-643-3562, NFES #0110), except that instead of the heavy 4 "D" batteries placed on the belt and connected to the headlamp by a cord that could catch branches or other objects, the new one uses 4 lightweight "AA" batteries attached to the back of the headband itself and rides on the helmet. In addition, the new one is weather tight and usable in the rain or other wet conditions.

The new cordless headlamp is supplied to GSA by Hartford Easter Seal, a NISH company, and GSA's price is \$23.80 each.



If you have any supply questions contact **Linda Schurg (817)978-3163, Fax (817)978-8600, E-Mail: linda.schurg@gsa.gov** or for technical questions contact **Dennis Davis (817)978-8628, Fax (817)978-8614, E-Mail: dennis.davis@gsa.gov.**

New...Heating Elements for Use with Insulated Vacuum Jugs On Military Aircraft

The CNU-2/C 2-gallon insulated jug (NSN 7330-00-532-5867) is a specialty product solely for use on various military aircraft including C-130's, C-17's, C-5's, and others. Originally, one NSN was

used for the replacement heating element, 7330-00-891-6077. However, this has caused some compatibility problems depending upon the manufacturer of the jug. We now have separate NSNs for heating elements for each of the three jug manufacturers and recommend that you order the heating element which matches each of your jugs. The heating element NSNs and manufacturers are listed below. For further technical assistance, contact Bill Hicks (817) 978-4428, fax (817) 978-8614.

<u>NSN</u>	<u>Manufacturer</u>
7330-00-891-6077	BE Aerospace (also Aircraft Products, Mansfield Aircraft Products, and Midland-Ross)
7330-01-406-8445	APW/Wyott Foodservice
7330-01-445-7611	Nash Metalware

GSA Contact: Bill Hicks (817)978-4428, FAX (817)978-8614 E-Mail: william.hicks@gsa.gov

New Item Program

Pressure Test Kit From Kappler

A user friendly pressure test kit that helps to ensure gas-tight protection and personnel safety. Level A Protective Suits should be pressure tested upon receipt from the manufacturer, upon removal from storage, after each use or annually, whichever is sooner. Kappler's innovative design allows testing according to ASTM F1052, "Practice for Pressure Testing of Totally Encapsulated Chemical Protective Suit."

**GSA Contact: Lyn DePriest (817) 978-2998,
FAX (817) 978-4366, or
E-mail: lyn.depriest@gsa.gov**



Order directly from:

GEOMET Technologies, Inc.
Tel.: (301) 428-9898, FAX (301)428-9482
Reference Special Item #F5410
under GSA Contract GS-07F-9770H

New Item Program

Responder[®] CSM[™] Chemical Warfare Protective Garment

Kappler, the world leader in protective apparel, and GEOMET Technologies, one of the largest commercial facilities certified by the U. S. Government to conduct testing with chemical warfare agents, joined forces to develop the Responder CSM protective garment. The Responder[®] CSM[™] is a totally encapsulating, front entry, expanded back, gas-tight Level A suit. Unlike many other suit manufacturers, the Kappler/GEOMET alliance ensures an extensive quality control and quality assurance program. Kappler provides 100% inspection and pressure testing, and GEOMET does pre-production roll testing of all suit material with Distilled Mustard (HD) and Sarin (GB) Nerve Chemical Warfare (CW) agents. In addition, one suit per fabricated lot is randomly selected for seam and material testing with the same two CW agents.

**GSA Contact: Lyn DePriest (817) 978-2998,
FAX (817) 978-4366 or
E-mail: lyn.depriest@gsa.gov**



Order directly from:

GEOMET Technologies, Inc.
Tel.: (301) 428-9898, FAX (301)428-9482
Reference Special Item #F5409
under GSA Contract GS-07F-9770H

New Item Program

Safety Is Just A Step Away With "Shure-Step"

Working in the engine compartment of trucks and larger vehicles can be dangerous and time consuming. Standing on milk crates or moving a small step around the vehicle is not the answer. Did you ever think "There has got to be a better way"? You bet there is... The Shure-Step!!!

The Shure-Step is an L-shaped platform made of high strength plastic. It lifts the technician(s) 10 inches off the ground while allowing him to move about the vehicle safely and efficiently. When two steps are butted together they surround the engine compartment with what amounts to a scaffold system. Got a truck so big you wonder how you'll ever work on it? No problem, the Shure-Step is a stackable unit which grows 7 inches with every step stacked. Because of the main unit's strength and stability, you can add steps to your heart's content. Now available through GSA under NSN 4910-01-440-4718 for only \$200 for quantities between 1 to 10 steps.

Order this items directly through GSA. Orders can be placed through automated FEDSTRIP/MILSTRIP, or MUFFIN. For more information, contact Requisition Management at (817) 978-2051. For technical assistance, contact the contract specialist.



GSA Contact:

Mary Ann Swearingen
GSA/FSS
General Products Center (7FXG-U5)
819 Taylor Street
Fort Worth, TX 76102

Phone: (817) 978-8377
Fax: (817) 978-8634

E-mail: maryann.swearingen@gsa.gov

New Item Program

We Have The Locks For Your Basic Security

Locks aren't everything, but they sure do help! Place your order for GSA's set of padlocks today.

We now have a new padlock set available for ordering. It consists of 6 padlocks (Brass or Bronze) that are all keyed alike. Included are two keys for each padlock. Conforms with ASTM F883. Padlocks are the same as NSN 5340-01-346-7462 except they are in sets of six and are all keyed alike. No key shall operate more than six (6) total padlocks per shipment.

PADLOCK Sets

NSN: 5340-01-412-7004

U/I: SE

Price: \$25.69

For stock availability, contact: **Virginia Skipwith (817) 978-8676 FAX: (817) 978-8600, or
E-Mail: virginia.skipwith@gsa.gov**

Correction!!!

**Please make the following
correction to page 36,
September 1997 issue
Marketips:**

NSN: 7920 01 383 7927

U/I: PG

Price: \$5.46

**Contact: Charles Hatch
(817) 978-2469 or FAX
(817) 978-8600**

FlexRope Tie-Downs Are Backed By A Lifetime Replacement Guarantee

No more rotting, cracking, fraying. Forget about tying knots due to memory loss. No more ugly black dirt that gets on everything. These products contain no rubber or cloth. They are made from a blend of polyurethanes - the tough stuff that stands up against the elements, salt water, oil, ozone and many chemicals.

These straps, cords and FlexRope are American Made with excel-

lent memory retention. Additionally they're backed by a Lifetime Replacement Guarantee against defects when used as directed.

Poly-Strap - If you're after excellent quality and your application requires "THE BEST", ask for them by name.

Poly-Strap®

Poly-Cord®

GSA Part No: F5386
Size: 12" Straps
U/I: 48 straps/96 Hooks
Price: \$68.43

GSA Part No: F5390
Size: 12" Cords
U/I: 48
Price: \$58.58

GSA Part No: F5387
Size: 18" Straps
U/I: 48 straps/96 Hooks
Price: \$82.94

GSA Part No: F5391
Size: 18" Cords
U/I: 48
Price: \$64.02

GSA Part No: F5388
Size: 24" Straps
U/I: 48 straps/96 Hooks
Price: \$98.24

GSA Part No: F5392
Size: 24" Cords
U/I: 48
Price: \$71.28

GSA Part No: F5389
Size: 31" Straps
U/I: 48 straps/96 Hooks
Price: \$134.00

- Hooks Are Made From Nylon and Glass Re-Enforced (No Metal)
- Hooks Are Molded Into the Cord
- 100% American Made
- No Rubber, No Cloth = No Rot
- Max Stretch 2 Times Original Length
- Unharmed by Salt Water, the Ozone, Oil and Many Chemicals

- Heavy duty stretch tie downs, max. stretch two (2) times original length
- Unharmed by salt water, oil, ozone and many chemicals
- 100% American Made
- Excellent memory retention
- Heavier gauged galvanized "S" hooks (.187 Wire)

NOTE: Please specify color when ordering: Black, Blue, Red, Yellow

NOTE: Please specify color when ordering: Black, Blue, Red, Yellow



Continued Next Page



Pro-Flex Rope:

GSA Part No: F3593
U/I: 1 spool
Price: \$37.11

- 5/16" Diameter, Black Elastomeric Rope
- 100' Spool, Color: Black
- Flexible To -40
- Cut Rope 2/3 Intended Stretch Distance
- 100% American made
- Unharmed by Salt Water, Oil, Ozone and Many Chemicals



Pro-Flex Rope



Flex Rope-Ends:

GSA Part No: F5394
U/I: 100
Price: \$67.50

Adjustable Hook with Removable Clip. This Hook can be used with FlexRope or other elasticized cordage.



Flex Rope-Ends

GSA Contact: Mary Ann Swearingen (817) 978-8377
FAX: (817) 987-8634
e-Mail: maryann.swearingen@gsa.gov

Order direct from the Contractor, referencing GSA Contract No. GS-07F-9743H:

Proflex Mfg./ Polyflex Inc
P.O. Box 3441
Macon, GA 31205-3441.
Phone: (800) 635-8021
FAX: (912) 781-6580
e-Mail: 105626.3653@compuserve.com

Govt. Credit Card Accepted

Plastic Mop Bucket and Wringer Set

These yellow, plastic floor mopping outfits have a wringer hopper with a sideward press mechanism, and accepts mops ranging in size from 12 oz. to 32 oz. The bucket holds up to 35 quarts, and comes with four, 3 inch casters. The outfit comes with corrosion-resistant metal handles and hardware. From heavy-duty mop buckets to wringers designed for effortless operation, this mop bucket and wringer will make the job of mopping floors easy and efficient.

Mail:

GSA, FSS, General Products Center
Requisition Processing Branch, 7FXMR
819 Taylor St., Rm 6A24
Ft. Worth, TX 76102-6114
Phone: (817) 978-2051
FAX: (817) 978-2605

Orders placed through the CSC's are shipped within 24 hrs. of their receipt and the price will be adjusted to \$49.63 for this service.

GSA Contact: Scheryl McBride (817) 978-2485
FAX (817) 978-8634
e:mail: scheryl.mcBride@gsa.gov



NSN: 7920-01-343-3776
U/I: QT
Price: \$44.31

**You're Invited To Attend the Largest
Professional Housing Management Association's
Trade Expo and Professional Development Seminar for
The Department of Defense Military Housing Personnel**

**February 22-27, 1998
Convention Center
Tulsa, Oklahoma**

The Professional Housing Management Association (PHMA) is a society devoted to the enhancement of housing services to military members and families of military members at installations throughout the Department of Defense. Memberships, both military and civilian, consists primarily of those decision makers who direct the use of over \$4 billion of housing funds for the operation, maintenance, furnishing, repair, improvement and leasing or construction facilities annually. Included in this context are over 375,000 family housing assets and more than 900,000 unaccompanied or bachelor accommodations.

This Trade Show has over 200 booths and more than 100 Exhibitors. You will be able to talk directly to suppliers and get a first hand look at the exhibitors' products. GSA's Household furnishings experts will be on hand to answer your questions such as:

What products can you buy through GSA?

What are your household furnishing product needs and how GSA may help you?

What contractors are under a GSA contract?

And much, much more!!!!

GSA product experts are responsible for many household furnishing items which include but are not limited to:

Bedding, Bed Linens, Blankets, Mattress Covers, Dishcloth, Dish Towels, Bath Mats, Cushions, Pillows, Hand Towels, Bed Spreads, Table Linens (tablecloths and napkins), Mattress Pads, Mattress Protectors, Pillow Protectors, Bath Towels, Sheets, Innerspring Mattress, Box Springs, Disposable Pillowcases, Shower Curtains, Shower Mats, Bath Mats, Shower Curtain Hooks, Pictures, Frames, Lamps, Room Furnishings, Clocks, Appliances, and much more...

If you are involved with housing operations in any way, do not miss this unique opportunity to gain vital exposure in this professional housing community.

GSA will be there, you can too!

For registration information please contact:

Marjorie Moore (703) 327-2505

OR

GSA Customer Relations (817) 978-4545

FAX (817) 978-3761

E-Mail: renata.drake@gsa.gov

Information Center Staff Provides More than Information...They Provide Solutions

The Federal Supply Service offers more than 4 million commercial products and services, but if a person doesn't know where to begin looking, then the frustration begins. Therefore these two pages are dedicated to demonstrate that we understand how to support our customers. We offer toll free numbers, fax, internet, telephone, e:mail and a variety of other ways to get to the information and assistance you seek. Here's the "solution" we know will quickly get you to your destination with a smile.

Federal Supply Service Information Center

For those of you new to the complex world of procurement you may come into contact with the term "schedule". You'll see advertisements and hear businesses proudly say "We are on GSA schedule". They should be proud because it's not easy to meet GSA's high standards. But what is a schedule? When you hear that term simply apply "government contract" in its place. And you are in luck, because you now have over four million products and services at your fingertips backed by the clout of the Federal Government. And what you will quickly discover is why GSA's Federal Supply Service is here... Our procurement process pros have negotiated the best prices and options on the planet. You choose the commercial products and services that meet your needs.

The Information Center is dedicated to helping you locate the products and services on GSA Schedule and then assist you on the many purchase options. Their schedules information library contains vast information on all the suppliers, their products and prices. We have products on display and people eager to assist you. If you are in the Washington area stop by and visit them in Arlington Virginia's convenient Crystal City, located at 1941 Jefferson Davis Highway, Crystal Mall Building 4 in the lobby, Room L-104. We are a 5 minute walk from the Crystal City Metro stop. Browse the library and have them assist you in finding the item(s) you need and then demonstrate how to order off the internet using the *GSA Advantage!*TM shopping mall. We are open from 8:00am to 4:30pm EST Monday through Friday. Photocopying is available too! But, if you're not in our vicinity please contact us using one of the options below. You'll be impressed that America's best businesses have teamed up with Uncle Sam to do their part in saving our taxpayers money by offering excellent selection and price.

Please call us on:

Commercial: (703) 305-6477

DSN: 327-1022

Toll Free: 1-888-FSS-0070

FAX: (703) 308-4168

National Customer Service Center (NCSC)

1-800-488-3111

DSN 465-1416

You've placed your supply order with GSA, but now you have more questions. With one call to the National Customer Service Center you will have a Customer Service Representative available to assist you Monday thru Friday from 7:00am to 5:30pm Central time. After hours please leave your name, telephone number and a brief message, and your representative will return your call the next working day. Representatives are ready to answer your questions about:

GSA *Advantage!*TM

Transportation

TTOS Status

MUFFIN Availability of products

FEDSTRIP/MILSTRIP

Customer Service Directors

Customer Supply Centers

FSS Publications

What if you have a problem with your order?

While we hate to hear they happen, occasional problems are the reality of a billion dollar business. Simply call the NCSC and talk with your Customer Service Representative about that problem. Shipping, billing, transportation or quality, if there is a problem or you are not satisfied with either the product or service you have received we want to hear from you. Our goal is to get the problem resolved quickly to your satisfaction.

Here we are!

1-800-488-3111

DSN: 465-1416

FAX: 816-926-6952

File your discrepancy report electronically by on the internet via GSA *Advantage!*TM at: **<http://www.fss.gsa.gov>**, click on *Advantage!*TM then select "Report Order Problems". Pretty neat!

It gets better! How about E-mail!

Civilian agencies: <http://www.rodsc.ncsc@gsa.gov>

Department of Defense: <http://www.rodsm.ncsc@gsa.gov>

All of us at GSA's Federal Supply Service sincerely appreciate serving you.

FSS

PROPERTY MANAGEMENT

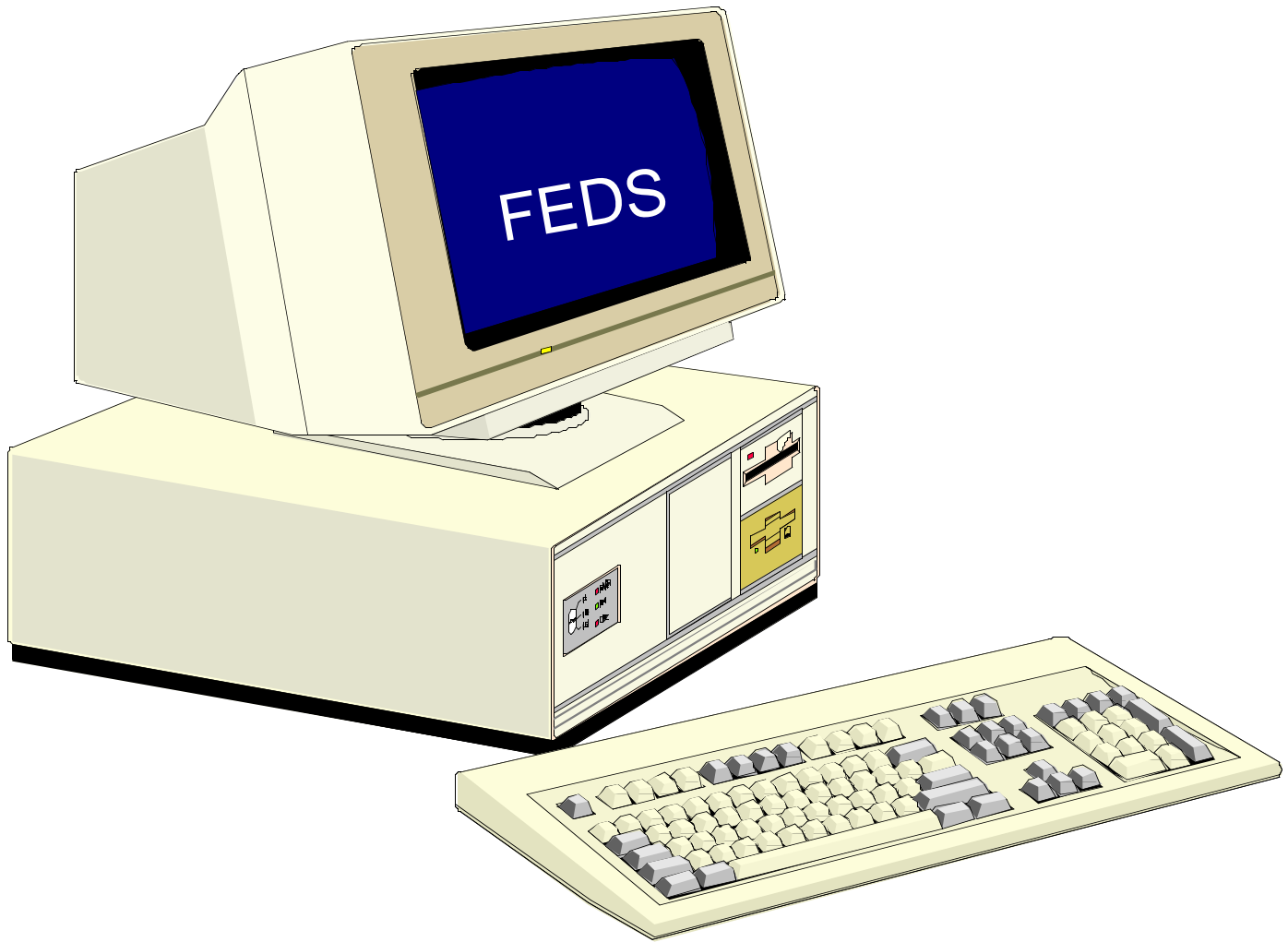

REMEMBER...Excess Is The First Source Of Supply

Get On-Line With "FEDS".

Tired of filling out hard copy reports of excess and traveling to remote locations to inspect property?? Contact your National Utilization Officer (NUO) today and get on-line with FEDS!!!

"FEDS," GSA Property Management Division's automated system, is an excellent tool for reporting and screening available federal excess property from a national perspective. Access to both REPADE, for reporting, and FEDS SCREEN, for screening, can be achieved by requesting that your agency's NUO obtain the proper access code and password from GSA Central Office (FBP)6 . A listing of agency NUOs can be found at the following internet address:

<http://pub.fss.gsa.gov/fbp/property.html>

FSS**FURNITURE AND FURNISHINGS**

**FOR THOSE TRULY FAMILY FRIENDLY ENVIRONMENTS,
GSA PRESENTS:
BABY CHANGING STATIONS AND PROTECTION SEATS**



The following items are available through GSA's New Item Program:

Baby Changing Station

7195-01-392-5192

Horizontal or Vertical Changing Station w/ lock

7195-01-392-5194

Horizontal or Vertical Changing Station w/o lock

Designed to be wall mounted for a safe and easy method of changing babies in public facilities. The unit is available in horizontal and vertical versions, with or without a factory installed lock to safeguard the unit from vandalism.

Child Protection Seat

This compact and efficient device attaches to the inside of a stall door, allowing parents to seat their young child safely in the stall with them.

7195-01-392-5193

Child Protection Seat

Sanitary Bed Liners

Biodegradable disposable bed liners provide a sanitary surface for changing diapers.

7195-01-392-5195

Sanitary Bed Liners

Quality Supplier: Koala Corp., Small Business

**For prices and additional info, contact:
Phil Richard (800) 724-7414**

For customer service or to place orders call: (800) 666-0363

Javits-Wagner-O'Day
JWOD

**Yes... FSS Has The
Picture Frame You
Need**

<u>NSN</u>	<u>Size</u>	<u>Price</u>
7105-01-419-5309*	5x7	\$42.19
7105-01-419-5318*	8x10	\$47.97
7105-01-419-5329*	8-1/2 x 11	\$53.13
7105-01-419-5339	9 x 12	\$78.62
7105-01-419-5350*	10 x 12	\$83.65
7105-01-419-5298	11 x 14	\$75.95

U/I: BX of 12

<u>NSN</u>	<u>Size</u>	<u>Price</u>
7105-01-419-5358	10 x 14	\$37.55
7105-01-419-5347	14 x 18	\$64.85
7105-01-419-5289	16 x 20	\$55.53
7105-01-419-5309	18 x 24	\$68.38
7105-01-419-5360	20 x 24	\$113.27

U/I: BX of 6

*Can be attached to office panels or easel style for desk top use.

Available in a wide variety of sizes through **GSA Advantage!**TM, FEDSTRIP/MILSTRIP or MUFFIN.

For additional information about these and other frames, contact a GSA Customer Service Representative at (703) 305-7003.



High Quality, Attractive, Hardwood Frames in Gold Finish by Kandu Industries, Inc.

Furniture FAQs

Q: Is it possible for you to expedite my order?

A: Yes! More often than not it is possible to expedite an order. GSA vendors "do what it takes" to satisfy our customers. If you need to expedite an order call our Customer Service Team on (703) 305-7003.

Q: May I cancel an order I have already placed?

A: Yes if the vendor has not started production on the item or it hasn't already shipped. To successfully process a cancellation we need the request in writing faxed to us ASAP at (703) 305-6032. We then notify the vendor and take the necessary steps to cancel the order.

Q: HELP! How do I make sense out of this SF344?

A: Our Customer Service Technicians will gladly talk you through the process of correctly filling out all required information on your SF344.

Q: The "Ship to" address on my order is incorrect. How do I get this corrected?

A: When you notice this error please contact the National Furniture Center immediately. We will contact the vendor and provide them with the correct shipping information for your order.

Q: I received twice the amount of what I ordered. What do I do with the overage?

A: You need to call the GSA National Customer Service Center (NCSC) in Kansas City, MO. On (800) 488-3111. The NCSC technician will take the information concerning your overage. In most cases your account will be adjusted and arrangements made to pick up the overage.

Q: I want to buy some chairs for the office. How do I get a copy of the GSA Schedule for chairs?

A: You may want to establish a small library of the schedules you anticipate purchasing from in the next year or two. To do this contact the Centralized Mailing List Service (CMLS). The CMLS can be reached by calling (817) 334-5215 or by fax at (817) 334-5227. If you have an urgent need for a particular furniture schedule one of our technicians will gladly fax it to you. Just call (703) 305-7003 to get your request moving.

Note: For customers in the Washington, DC., Metro area, our Customer Resource Center (CRC) maintains a library of all furniture and furnishing schedules. The CRC is located in the Washington Design Center at 300 D Street SW, Suite 632, Washington, DC., 20024. You can reach the CRC by calling (202) 245-0044 or faxing to (202) 245-0038.

New Item

GSA Contract GS-29F-0242G Offers Pocket Panel Doors for Systems Panels

Need a little privacy? Take ADVANTAGE of this! Advantage Office Systems was recently awarded a GSA contract on the New Item Introductory Schedule offering "Pocket Panel Doors."

This new item is an innovative design solution for enhancing open plan working environments.

The Pocket Panel Door is a panel, matching that of existing office systems panels. With a gentle pull, a divider slides out to close off the workstation or other opening. The door divider is housed inside the master panel and pulls out to a length of 36" locking into a receiver post on the other side. When the pocket panel is retracted it slides back into the master panel restoring the open plan decor.

In addition to offering privacy to open plan environments, the Pocket Panel Door is useful for blocking off duplicating, faxing, storage and conference areas.

For more information on the Pocket Panel Door (GSA contract GS-29F-0242G), contact **Natalie Simonson on (703) 305-5000** or Advantage Office Systems at (800) 642-3876 fax (415) 968-5565.

Multiple award Schedule 62 I Now Has Compact Fluorescent Lamps

Have you heard about the new, energy efficient Compact Fluorescent Lamps (CFL) now available through Multiple Award Schedule 62 I? No you say? Well, they use 1/3 the energy of a comparable incandescent lamp and last 10 times longer! As a matter of fact, these items are certified allies of the EPA "Green Lights" Program. What a wonderful way to support the Administration's objective for a more energy efficient country.

There are several styles available under the schedule. Read the next issue of MarkeTips for more details, or call **Monica L. Gormley at (215) 656-3839** for information now.

Using Order History/ Status in GSA Advantage!™

The Order History functions in GSA Advantage!™ have recently been enhanced to allow you to perform several different functions. You may obtain order/requisition status, report a problem, reorder, cancel an order, and/or view vendor and product detail. If you want to access Order History, we must first know who you are. Therefore, you must log on, the same way as you placed your original order i.e. .IM.P.A.C. credit card or Activity Address Code (AAC) + password. You must then go to the Main Menu and click on the Order History/Status button. Order History shows ALL the line items you ordered from GSA Advantage!™ regardless of method of supply IMMEDIATELY after your order is successfully placed by clicking on the Check Out button.

Searching:

You may search Order History by:

- Clicking on all Advantage! orders
- Entering the Advantage! session number
- Entering the purchase order number
- Entering the requisition number
- Entering a date range

Functions:

-- Cancel Item: provides the ability to cancel 7-14 day items, not yet shipped. If the item is a GSA National Stock Number (NSN) and has been shipped, the item may not be cancelled. Simply mark the item in the space provided and click on SUBMIT. You may also cancel schedule items; however, you are advised to call the vendor directly to determine shipment status since GSA does not receive status from vendors. The name and phone number of the schedule vendor is provided on the GSA Advantage!™ Order Summary and can also be obtained by clicking on the vendor name. Customer Supply Centers (CSC) 1-3 day items CANNOT BE CANCELLED because they are sent to the CSC for processing immediately after input.

-- Reorder: provides the option to immediately re-order the item (with refreshed pricing information). Simply indicate quantity in the space provided and click on SUBMIT.

-- Status: provides status for items purchased with status code explanations (See the status definitions referenced in this article)

-- Problem Reporting: provides users the ability to report a 7-14 day item problem to the National Customer Service Center (NCSC). 1-3 day order problems are reported directly to the supporting Customer Supply Center.

-- Product Details: Links are available which display vendor and product details.

Status:

If you place orders through GSA Advantage!™, you should only access status through ORDER HISTORY. This is the only source of status for 1-3 day (CSC) items.

There are several words used to provide status for items ordered through GSA Advantage!™. For NSN items, status is normally provided by the next day if the order was placed prior to 6 p.m. Eastern Time. Schedule items will always appear as "posted" or "canceled" since GSA does not receive any further status from the vendor.

Status Definitions:

-- Posted: Your order has been sent to the schedule vendor. Additional status must be obtained by contacting the vendor directly.

-- Pending: Each 7-14 day GSA Advantage!™ Advantage! requisition is uploaded daily to GSA's internal supply system for fulfillment and will display the status Pending until the requisition is processed. The same is true of 1-3 day items, except these are sent to the CSC within an hour after the order is successfully placed in GSA Advantage!™.

-- Waiting: The requisition/document number has been sent to GSA's internal supply system and Advantage!™ Advantage! is awaiting acknowledgment of receipt.

-- Normal: The 7-14 day requisition is being processed. Click on NORMAL to view expanded status information, which includes the estimated shipping date.

-- **Shipped:** The 7-14 day requisition has been fulfilled and shipped to you. Click on SHIPPED to view expanded status information, which includes the date the requisition was shipped and the mode of shipment.

-- **Rejected:** The 7-14 day requisition was rejected by GSA. Click on REJECTED to reveal why the requisition was rejected. The status codes explaining why the requisition was rejected are identical to the codes used in the FEDSTRIP process

-- **Canceled:** For 7-14 day delivery items, the requisition/purchase order has been canceled, either by you or GSA. To review why the requisition was canceled, click on CANCELED. The status codes explaining why the requisition was canceled are identical to the codes used in the FEDSTRIP process. For 1-3 day delivery items, CANCELED indicates that the CSC is out of stock and you should order at a later date. For Federal Supply Schedule purchase orders, CANCELED indicates that the purchase order has been canceled by you and the vendor has been notified.

-- **Confirmed:** The 1-3 day document number has been received by the CSC and the order is being shipped.

-- **Suspended:** The 7-14 day requisition was suspended by GSA. Click on SUSPENDED to reveal why. Reference the FEDSTRIP codes.

-- **Direct Ship:** The delivery order was issued by GSA to the vendor for direct shipment to you.

FEDSTRIP codes are available in the Fedstrip Operating Guide (FOG) and the Customer Assistance Guide. Call GSA's Centralized Mailing List Service (CMLS) at (817) 334-5215 to order these publications.

For information or additional questions, call the GSA *Advantage!*TM hotline at (703) 305-7359 or check the website out at <http://www.fss.gsa.gov>

I.M.P.A.C. Card Holders... Reconciling Your Statement Just Got Easier!

Starting with the IMPAC Card Statements for October 1, 1997, you will find a reference number beginning with GY or GZ. This is the applicable GSA Advantage requisition/document number for the charge.

Remember:

-- GSA *Advantage!*TM On-line Shopping orders for GSA Customer Supply Centers (CSC) (1-3 day items) have a Document Identifier.

-- GSA *Advantage!*TM On-line Shopping orders for GSA stock (7-14 day items) and direct delivery have a Requisition Number.

Simply match the GSA *Advantage!*TM Checkout Receipt or Order History with the Document Identifier or Requisition Numbers on your IMPAC Card Statement when reconciling.

For information on 7-14 day delivery item discrepancies, call the National Customer Service Center (NCSC) at (800) 488-3111. For information on 1-3 day delivery item discrepancies, call your local Customer Supply Center.

GSA *Advantage!*TM Tip: For status on all GSA Advantage! Orders, simply click on the Order History/Status button at the GSA Advantage! Main Menu. Don't forget, to access your Order

History/ Status you must sign on the way you ordered, i.e. credit card or Activity Address Code (AAC) and password.

For information or additional questions, call the GSA *Advantage!*TM hotline at (703) 305-7359 or check the website out at <http://www.fss.gsa.gov>

Advantage!TM 98.... Time For A Change

GSA *Advantage!*TM has begun an exciting transformation that will turn it into a state of the art on-line ordering system.

We have updated the look of *Advantage!*TM with an enticing new graphics presentation. We've added new graphics and lots of color. The new graphics will present GSA *Advantage!*TM in a contemporary, yet professional manner.

Initially, most of the changes will be graphic. However, in the coming months, you will notice significant changes in the functionality of GSA *Advantage!*TM Enhancements will be coming for product searches, site navigation, store drill-downs, the addition of frames, etc. These changes will help make shopping on GSA *Advantage!*TM a simple, yet enjoyable experience.

We invite you to stop by, take a look around, and maybe even buy something! You'll find GSA *Advantage!*TM, on the Internet, at <http://www.fss.gsa.gov>



GSA Products & Services Expo

Washington State Convention and Trade Center
Seattle, Washington
July 8-9, 1998

The GSA Federal Supply Service invites you to join us at the most important event you will attend in 1998.

Do you purchase for the Government? Then this is for you!

The Expo will feature:

- ☛ 36 **FREE** training sessions including: **GSA Advantage!**[™] on-line ordering, Government Purchase Card usage, JWOD mandatory sources, ordering from GSA Schedules, and much more!
- ☛ A Solutions Center featuring experts to assist you and answer questions on all forms of ordering from GSA.
- ☛ GSA Suppliers and Customer Service experts.
- ☛ New products and services available through GSA.

U.S. General Services Administration
Federal Supply Service

Expo Information: (888) 272-5565
Internet: www.northwest.gsa.gov/expo.htm



To be added to our Expo mail list, fill out this form and Fax it to (253) 931-7203. You will receive more information on this worthwhile event as it becomes available. You will also receive the registration package when it is mailed out.

Name _____ Title _____

Agency/Organization _____

Address _____

City _____ ST _____ Zip _____

Phone _____ Fax _____

E-mail _____

97-11-06

Self Adjusting, Angle Nose Robo-Grip Pliers

Pliers have a self-adjusting mechanism that is capable of automatically selecting the appropriate operating position by use of a single hand. Pliers automatically open for the next grip. Jaws are straight. Pliers are fabricated from four high carbon steel interlocking laminations and have cushion grip handles.

Pliers have 1-1/2 inches work capacity, 1-3/16 inches jaw length, nine operating positions and measures 9-1/2 inches long (nominal).



5120-01-354-6331
9" Self-Adjusting Pliers
\$22.37

Pliers have a self adjusting mechanism that is capable of automatically selecting the appropriate position by use of a single hand. Pliers automatically open for the next grip. Jaws are straight. Pliers are fabricated from four high carbon steel interlocking laminations and have cushion grip handles.

Pliers have a 1 inch work capacity, 7/8 inch jaw length, eight operating positions and measures 6 inches long (nominal).



5120-01-429-4952
6" Self-Adjusting Pliers
\$20.95

Contact: Nancy Graves (816) 926-2484, DSN: 465-2484, FAX (816) 926-7182, E-Mail: nancy.graves@gsa.gov

New Item

Leatherman Tool Adapter

The Tool Adapter from Leatherman, is a new product that permits a wide variety of screw bits to be used with any full-size Leatherman tool (Super Tool, PST II and Pocket Survival Tool). Any standard quarter-inch hex drive bit can be used with the new Tool Adapter, which slides easily over the plier jaws and attaches firmly to provide a safe, comfortable grip. The most significant advance provided by the Tool Adapter is its locking mechanism. The adapter drive locks in position at zero-, 45- and 90-degree angles to optimize accessibility and torque. No other multi-tool adapter on the market has this capability. The Tool Adapter is offered in a Standard Set that contains a leather belt sheath and six bits: #0 and #3 Phillips, #1 and #2 Robertson (square), #15 Torx and #8-10 Slotted.

Contact Point: Kathy Fjoser 816-926-3362, Fax 816-926-7182



Leatherman Tool Group Accessory Kit, Multi-Plier

NSN: 5110-01-445-2068
U/I: SE
Price: \$18.71
P/N: 65010101
Length: 3 1/4 inches/8.3 cm extended
Weight: 1.6 ounces/45 grams

GSA Now Has Gerber® Legendary Blades

Applegate®, Gator®, E-Z-Out™ and L.S.T.® Premium Lightweight Folding Knives

NSN 5110-01-436-1548	“Applegate” Premium Folding Knife Opens and closes easily with one hand. Stainless steel blade. Lock-back design. Heavy duty ballistic cloth belt sheath.	5-3/4 in.	4-1/2 in.	10-1/4 in.	5.5 oz.	05780	\$60.77
NSN 5110-01-395-0291	Gator® Folding Knife Comfortable soft textured handle. Stainless steel blade. Lock-back design. Heavy duty ballistic cloth belt sheath.	5 in.	3-3/4 in.	8-3/4 in.	5.0 oz	06069	\$29.18
NSN 5110-01-369-9340	Gator® Serrater Folding Knife Comfortable soft textured handle. Stainless steel half serrated blade. Lock-back design. Heavy duty ballistic cloth belt sheath.	5 in.	3-3/4 in.	8-3/4 in.	5.0 oz.	06079	\$29.18
NSN 5110-01-385-7392	Gator-Mate® Folding Knife Smaller version of Gator® . Comfortable soft textured handle. Stainless steel blade. Lock-back design. Heavy duty ballistic cloth belt sheath.	4-1/8 in.	2-3/4 in.	7-1/4 in.	3.2 oz.	06149	\$19.81
NSN 5110-01-385-7235	Gator-Mate® Serrater Folding Knife Smaller version of Gator® Serrater. Comfortable soft textured handle. Stainless steel half serrated blade. Lock-back design. Heavy duty ballistic cloth belt sheath.	4-1/8 in.	2-3/4 in.	7-1/4 in.	3.2 oz.	06151	\$19.81
NSN 5110-01-414-4918	E-Z-Out™ Folding Knife Opens and closes easily with one hand. Stainless steel blade. Lock-back design. Removable pocket/belt clip.	4-1/2 in.	3-1/2 in.	8 in.	3.0 oz.	06701	\$20.70
NSN 5110-01-414-4916	E-Z-Out™ Serrated Folding Knife Opens and closes easily with one hand. Stainless steel half serrated blade. Lock-back design. Removable pocket/belt clip.	4-1/2 in.	3-1/2 in.	8 in.	3.0 oz.	06751	\$20.70

continued next page

NSN 5110-01-414-4917	E-Z-Out™ Junior Folding Knife Smaller version of E-Z-Out™. Opens and closes easily with one hand. Stainless steel blade. Lock-back design. Removable pocket/belt clip.	3-1/8 in.	2-3/8 in.	5-1/2 in.	1.7 oz.	06501	\$17.46
NSN 5110-01-414-4920	E-Z-Out™ Junior Serrated Folding Knife Smaller version of E-Z-Out™ Serrated. Opens and closes easily with one hand. Stainless steel half serrated blade. Lock-back design. Removable pocket/belt clip.	3-1/8 in.	2-3/8 in.	5-1/2 in.	1.7 oz.	06551	\$17.46
NSN 5110-01-385-7328	Magnum L.S.T.® Folding Knife Comfortable finger notched hard Zytel, handle. Stainless steel blade. Lock-back design. Heavy duty ballistic cloth belt sheath.	4-5/8 in.	3-1/2 in.	8-1/8 in.	4.2 oz.	06038	\$23.41
NSN 5110-01-385-7236	L.S.T.® Drop Point Folding Knife Slim fiberglass filled nylon handle. Stainless steel blade. Lock-back design. Removable pocket/belt clip.	3-1/2 in.	2-5/8 in.	6-1/8 in.	1.3 oz.	06009	\$12.88

Lobster Claws Hold Your Work Firmly, Free Your Hands

This universal work-positioner clamp holds your work firmly and allows you to keep both hands free. Four 360 degree ball joints adjust work arms and jaws into a myriad of positions.

Vise clamp jaws adjust from 0" to 2-3/4" opening with a jaw depth of 2-1/2". Joints are treated to repel weld spatter. Heavy steel clamp is easily bolted onto your workbench or clamped in a vise.

NSN: 5120-01-426-3024
Part Number: 1502
Price: \$46.12
U/I: EA
Minimum Quantity: 6

Contact: TAC Customer Service (816) 926-6760



Manufacturer: Metalworking Services

Sabco "O" Ring Splice Kit

<u>Material</u>	<u>"O" Ring Sizes</u>	<u>Connector</u>	<u>Punches</u>	<u>Drill-Bits</u>	<u>Adhesives</u>	<u>Cutter</u>	<u>MSDS and Instructions</u>
Part #420 BUNA-N 70 ASTM D-2000 5 BG, -715, A14, B14, B014, E034 F17	1/8" 3/16" 1/4" 5/16" 3 ft. each size	1/16" 1/8" 4" each size	1-1/16" 1-1/8"	1-1/16" 101/8"	1-.07 ounce	Razor Blade 1 each	Yes
Part #420V VITON 75 ASTM D-2000 2 HK 715, B35, C12, F15	1/8" 3/16" 1/4" 5/16" 3 ft. each size	1/16" 1/8" 4" each size	1-1/16" 1-1/8"	1-1/16" 1-1/8"	1-.07 ounce	Razor Blade 1 each	Yes

Notice: Container included. Refill kits available

- Safety - Stops Leaks
- Protect Equipment
- Easily understood and assembled
- Reduce down time
- The Sabco "O" Ring Splice can, in many cases, be installed without disassembling equipment.

NSN: 5180-01-329-8736

SABCO P/N: #420 BUNA-N

NSN: 5180-01-329-8737

SABCO P/N: #420 VITON

Winter Is Here... Are You Prepared? You Will Be With These Shovels

Be prepared for the snow this year, order your snow shovels and have them ready!!

The Tools and Appliances Center offers the following shovels:

Medium-weight, knockdown-style shovel has a pusher-type, long handle. Blade is made of 16-gauge steel and measures 24" wide and 10" to 13" high. Shovel measures 55" to 72" overall length.

NSN: 5120-00-288-6529

Price: \$11.07

U/I: EA

Medium-weight, 18-gauge steel shovel has a D-style wooden handle. Blade measures 17" wide and 14" high. Handle measures 32" to 34" long. Weighs 7 lb.

NSN: 5120-00-494-1863

Price: \$8.69

U/I: EA

Lightweight, knockdown-type shovel has a D-style wooden handle. Ribbed aluminum blade measures 18" wide and 14" high. Handle measures 28" to 34" long.

NSN: 5120-00-892-5319

Price: \$9.58

U/I: EA

Prices are subject to change.

Contact: Jeani Ray (816) 926-7173 or FAX (816) 926-7182,

E-Mail: www.jeani.ray@gsa.gov

DELTA7 Pickup Truck Boxes Are Available From Delta Consolidated Industries, Inc.

DELTA, Aluminum Single Lid Crossover Truck Boxes

- Crossover style. Mounted across the side rails spanning the width of the truck bed just behind the cab.
- Treadplate aluminum with full weather stripping on lid.
- Single lid with beveled edges, reinforced, self-rising with gas spring lid lifts.
- Locks and unlocks from driver's side, opens from either side. Stainless steel paddle handles with lock.
- Includes heavy-duty sliding tray with three compartments.



NSN: 5140-01-439-8161
Delta P/N: 938000
Truck Size: Fullsize Ford, Chevrolet, Dodge, GMC short and long wheelbase wide bed trucks, 1967 to current.
Box Size: 70"W x 21"D x 14"H
 9.6 cu. ft. storage capacity
Price: \$255.01
U/I: EA

NSN: 5140-01-439-81609
Delta P/N: 939000
Truck Size: Compact Chevrolet S-10, Ford Ranger, GMC S-15 and Sonoma, Dodge D-50, Toyota, Nissan, Mazda and all compact long and short wheelbase trucks except Volkswagen. Also fits Dodge Sportsides and pre-1992 Ford Flaresides.
Box Size: 60"W x 21"D x 12"H
 7.5 cu. ft. storage capacity
Price: \$255.01
U/I: EA

DELTA, Aluminum Dual Lid Crossover Truck Boxes

- Crossover style. Mounted across the side rails spanning the width of the truck bed just behind the cab.
- Treadplate aluminum with full weather stripping on lid.
- Dual lids with beveled edges. Mid lid gull wing style. Center mounted self-rising lids with gas spring lid lifts open and lock from either side.
- End mounted stainless steel paddle handle locks.
- Includes heavy-duty sliding tray with three compartments.



NSN: 5140-01-440-2136
Delta P/N: 934000
Truck Size: Fullsize Ford, Chevrolet, Dodge, GMC short and long wheelbase wide bed trucks, 1967 to current.
Box Size: 70"W x 21"D x 14"H
 9.6 cu. ft. storage capacity
Price: \$255.01
U/I: EA

NSN: 5140-01-439-6909
Delta P/N: 935000
Truck Size: Compact Chevrolet S-10, Ford Ranger, GMC S-15 and Sonoma, Dodge D-50, Toyota, Nissan, Mazda and all compact long and short wheelbase trucks except Volkswagen. Also fits Dodge Sportsides and pre-1992 Ford Flaresides.
Box Size: 60"W x 21"D x 12"H
 7.5 cu. ft. storage capacity
Price: \$255.01
U/I: EA

DELTA, Steel Single Lid Crossover Truck Boxes

- Crossover style. Mounted across the side rails spanning the width of the truck bed just behind the cab.
- Tough steel construction with fully welded upper body seams and 4" channel ribs on bottom.
- Color: White.
 - Single lid, reinforced, self-rising with gas spring lid lift. Full weather stripping on lid.
- Locks and unlocks from driver's side, opens from either side.
- Includes sliding tray with three compartments.



NSN: 5140-01-440-1035
Delta P/N: 904000
Truck Size: Fullsize Ford, Chevrolet, Dodge, GMC short and long wheelbase wide bed trucks, 1967 to current.
Box Size: 70"W x 21"D x 14-1/2"H
 9.0 cu. ft. storage capacity
Price: \$193.00
U/I: EA

NSN: 5140-01-440-1036
Delta P/N: 905000
Truck Size: Compact Chevrolet S-10, Ford Ranger, GMC S-15 and Sonoma, Dodge D-50, Toyota, Nissan, Mazda and all compact long and short wheelbase trucks except Volkswagen. Also fits Dodge Sportsides and pre-1992 Ford Flaresides.
Box Size: 60"W x 21"D x 11-1/2"H
 5.8 cu. ft. storage capacity
Price: \$193.00
U/I: EA

NSN: 5140-01-440-1034
Delta P/N: 906000
Truck Size: Midsize Dodge Dakota, Chevrolet S-10, GMC S-15, GMC Sonoma, Toyota Tacoma, Toyota Compact and Isuzu trucks.
Box Size: 62"W x 21"D x 14-1/2"H
 7.8 cu. ft. storage capacity
Price: \$193.00
U/I: EA

DELTA, Steel Dual Lid Crossover Truck Boxes

- Crossover style. Mounted across the side rails spanning the width of the truck bed just behind the cab.
- Tough steel construction with fully welded upper body seams and 4" channel ribs on bottom.
- Color: White.
 - Dual lids. Gull wing style. Torsion bar lifts. Lids easily open and lock from either side. Full weather stripping on lids.
- End mounted locks.
- Includes sliding tray with three compartments.



NSN: 5140-01-440-1033
Delta P/N: 901000
Truck Size: Fullsize Ford, Chevrolet, Dodge, GMC short and long wheelbase wide bed trucks, 1967 to current.
Box Size: 70"W x 21"D x 14-1/2"H
 9.0 cu. ft. storage capacity
Price: \$151.35
U/I: EA

NSN: 5140-01-440-1032
Delta P/N: 902000
Truck Size: Compact Chevrolet S-10, Ford Ranger, GMC S-15 and Sonoma, Dodge D-50, Toyota, Nissan, Mazda and all compact long and short wheelbase trucks except Volkswagen. Also fits Dodge Sportsides and pre-1992 Ford Flaresides.
Box Size: 60"W x 21"D x 11-1/2"H
 5.8 cu. ft. storage capacity
Price: \$151.35
U/I: EA

**DELTA, Polyethylene Plastic Dual Lid
Crossover Truck Boxes**

- Crossover style. Mounted across the side rails spanning the width of the truck bed just behind the cab.
- Lightweight but sturdy polyethylene construction. Low maintenance exterior withstands sun, rain and snow. Reinforced stress points ensure strength and durability.
- Dual lids. Gull wing style. Spring operated lids easily open and lock from either side.
- End mounted self-adjusting locks ratchet down to tighten grip.
- Includes removable sliding tray.



NSN: 5140-01-440-8590
Delta P/N: 201000
Truck Size: Fullsize Ford, Chevrolet, Dodge, GMC short and long wheelbase wide bed trucks, 1967 to current.
Box Size: 71"W x 21"D x 14"H
8.5 cu. ft. storage capacity
Price: \$136.11
U/I: EA

.....

NSN: 5140-01-440-8584
Delta P/N: 202000
Truck Size: Compact Chevrolet S-10, Ford Ranger, GMC S-15, Dodge D-50 and Dakota, Toyota, Nissan, Mazda and all compact long and short wheelbase trucks except Volkswagen. Also fits Dodge Sportsides and pre-1992 Ford Sportsides.
Box Size: 61"W x 21"D x 14"H
6.5 cu. ft. storage capacity
Price: \$136.11

DELTA, Steel Single Lid Innerside Truck Box

- Innerside style designed to be mounted on the inside of one of the truck bed side rails.
- Ideal companion with crossovers to create total wrap around lockable storage areas.
- Tough steel construction with fully welded upper body seams.
- Color: White.
- Single lid, reinforced, with full weather stripping on lid.

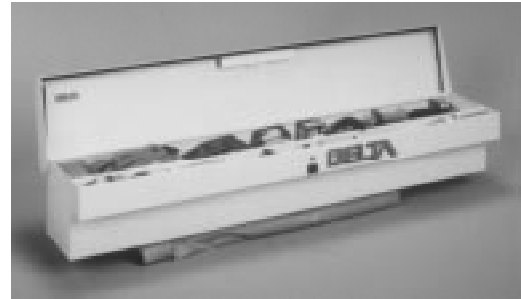

NSN: 5140-01-439-8159
Delta P/N: 821000
Truck Size: All fullsize, compact and mid-size long and short wheelbase pickup trucks.
Box Size: 65"W x 12"D x 11"H
3.5 cu. ft. storage capacity
Price: \$179.56
U/I: EA

**Visit The Tools and
Appliances Center
Homepage**

<http://www.r6.gsa.gov/tac>

DELTA, Heavy Duty Steel Chest

- Designed to sit on the truck bed floor flush against the bed wall.
- 16-gauge heavy duty steel construction for durability and heavy use.
- Color: White.
- Single lid, reinforced, with dual gas spring lid lifts for easy opening and closing.
- Recessed lid hinge allows lid to be fully opened when chest is flush against truck bed wall.
- Single stainless steel paddle handle lock.
- Bottom bolsters elevate chest above floor to keep contents out of standing water.
- Includes removable sliding tray for small tools or parts storage.



NSN: 5140-01-439-8162
Delta P/N: 807000
Truck Size: Fullsize Ford, Chevrolet, Dodge, GMC short and long wheelbase wide bed trucks.
Box Size: 59"W x 20-1/2"D x 19"H
10.2 cu. ft. storage capacity
Price: \$219.96
U/I: EA

PAYLOAD PLUS, by DELTA, Heavy Duty Aluminum Chest

- Designed to sit on the truck bed floor flush against the bed wall
- Treadplate aluminum .080 gauge
- Single lid, reinforced, with dual gas spring lid lifts for easy opening and closing.
- Recessed lid hinge allows lid to be fully opened when chest is flush against truck bed wall.
- Dual stainless steel paddle handles lock and unlock from driver's side and open from either side.
- Bottom bolsters elevate chest above floor to keep contents out of standing water.
- Includes sliding tray for small tools or parts storage.



NSN: 5140-01-440-8585
Delta P/N: 891980
Truck Size: Fullsize Ford, Chevrolet, Dodge, GMC short and long wheelbase wide bed trucks.
Box Size: 61"W x 21"D x 20"H
12.5 cu. ft. storage capacity
Price: \$366.14
U/I: EA

PAYLOAD PLUS, by DELTA, Steel Double Door Topside Truck Box

- Topside style. Sits on top of the truck bed side rail. Supported by the side rail and two support legs on the back of the box.
- Heavy duty steel construction with 14 gauge steel doors, center post and body ends.
- Color: White.
- Two extra large 12" high reinforced doors which open out. Provides flat working surface. Full weather stripping protects against dust and moisture.
- Two extra large 12" high reinforced doors which open out. Provides flat working surface. Full weather stripping protects against dust and moisture.
- Three point T-handle locks door at top and both sides.
- Includes steel storage shelf, mounting kit and steel support legs.



NSN: 5140-01-440-8124
Delta P/N: 879980
Truck Size: Chevrolet, Ford, Dodge and Dodge Dakota long wheelbase pickup trucks.
Box Size: 96"W x 13"D x 17"H
11.3 cu. ft. storage capacity
Price: \$329.84
U/I: EA

JOBOX7

Job Site Storage Boxes and Chests From Delta Consolidated Industries, Inc.

Available under the New Item Program (NIP) from GSA

JOBOX, Slope Lid Box

- Slope lid style. Large sloping lid with fold away supports. With the two lid supports extended, the top of the box serves as a large, flat work surface.
- Ideal height for use when standing.
- Heavy-duty 16 gauge reinforced steel construction.
- Color: Brown.
- Locking lid supports prevent fully opened lid from accidentally falling. Full length piano hinge on lid.
- Bolt cutter free locking system. Entire pad lock except key entry area is concealed.
- Full length built-in shelf with raised edge for storing smaller items.
- Two heavy-duty side handles.
- Extra high 3-3/8" skid bolsters accommodate larger forklift tines and are tapped for optional casters.
- Optional 4" and 6" casters are available.



NSN: 5140-01-440-8122
JOBOX P/N: 680990
Box Size: 61"W x 30"D x 37"H
Storage Capacity: 30.7 cu. ft
Weight: 216 lbs.
Price: \$395.42
U/I: EA

JOBOX, Piano Box

- Piano style. Double hinged cover folds up and out of the way. Allows easy access for storing and removing large items.
- Heavy-duty 16 gauge reinforced steel construction.
- Color: Brown.
- Dual gas spring lid lifts for easy opening and closing of door. Top rail designed to prevent door from falling.
- Bolt cutter free locking system. Entire pad lock except key entry area is concealed.
- Two full length built-in shelves with raised edges for storing smaller items.
- Two heavy-duty side handles.
- Extra high 3-3/8" skid bolsters accommodate larger forklift tines and are tapped for optional casters.
- Optional 4" and 6" casters are available.



NSN: 5140-01-440-8586
JOBOX P/N: 682990
Box Size: 61"W x 30"D x 50"H
Storage Capacity: 47.5 cu. ft.
Weight: 304 lbs.
Price: \$445.13
U/I: EA

JOBBOX, Chests

- Heavy-duty 16 gauge reinforced steel construction with full length corner reinforced welds and full mig welded hinges.
- Color: Brown.
- Locking lid support struts prevent accidental lid closings.
- Bolt cutter free locking system. Entire pad lock except key entry area is concealed.
- Extra high 3-3/8" skid bolsters accommodate larger forklift tines and are tapped for optional casters.
- Optional 4" and 6" casters are available.



NSN: 5140-01-440-8588
JOBBOX P/N: 654990
Box Size: 48"W x 24"D x 27"H
Storage Capacity: 15.0 cu. ft.
Weight: 132 lbs.
Price: \$268.50
U/I: EA

NSN: 5140-01-440-8587
JOBBOX P/N: 655990
Box Size: 60"W x 24"D x 27"H
Storage Capacity: 18.7 cu. ft.
Weight: 155 lbs.
Price: \$304.76
U/I: EA

NSN: 5140-01-440-8589
JOBBOX P/N: 656990
Box Size: 48"W x 30"D x 33"H
Storage Capacity: 23.7 cu. ft.
Weight: 169 lbs.
Price: \$304.76
U/I: EA

Contact: Arlene Tittle (816) 926-7588
DSN: 465-7588,
E-mail: arlene.tittle@gsa.gov

Enough Can't Be Said About This Base Housing Tool Kit!

This new General Mechanic's Tool Kit, ideal for minor repairs, consists of the following components: flashlight, plunger, industrial goggles, 16 ounce hammer, 10 piece socket head screw key set, craftsman knife, putty knife, level and plumb, mechanical finger, needle nose pliers, 2 slip joint pliers, nested saw set, glass scraper, razor blade, 2 cross tip screwdrivers, 2 flat tip screwdrivers, antiseizing tape, measuring tape, 10 piece nut driver style socket wrench set, open end adjustable wrench and plier wrench.

All components are supplied in a portable tool box step stool. Order today by contacting:

Gerald Holmes (816) 926-3498 or FAX: (816) 926-7182



Complete Set:
NSN 5180-01-423-6468
Price: \$200.37

Tool Box Only
NSN: 5140-01-424-9917
Price: \$44.05

Catalog Corrections

1997 SCIT KIT - Tool Cabinets & Chests Catalog

Page 11, Picture of Rollaway Cabinet Model KRL656.

NSN should read: 5140-01-358-5210

Spring 1997 Catalog

NSN 5120-01-004-2718 Hex Key Set (Ball End) - Catalog incorrectly states that the wrenches can be used at angles to 30 degrees instead of 25 degrees.

Corrected description should read:

Set consists of twelve L-shaped, long length hexagon keys ranging from key sizes from 0.050" to 5/16". The long arms are capable of being used at an angle of 25 degrees to the axis of the screw. The keys are made of alloy steel heat treated and hardened. The set comes in a case.

Energy Efficient Compact Fluorescent Lamps Are Now Available on Multiple Award Schedule 62 I

Have you heard about the new, energy efficient Compact Fluorescent Lamps (CFL) now available through Multiple Award Schedule 62 I? No you say? Well, they use 1/3 the energy of a comparable incandescent lamp and last 10 times longer! As a matter of fact, these items are certified allies of the EPA "Green Lights" Program. What a wonderful way to support the Administration's objective for a more energy efficient country.

There are several styles available under the schedule. Read the next issue of MarkeTips for more details or call **Monica L. Gormley** at (215) 656-3839 for information now.

Index of Federal Specifications, Standards and Commercial Item Descriptions Is Now On The FSS Home Page

The current "Index of Federal Specifications, Standards and Commercial Item Descriptions" is now available on the Federal Supply Service Internet home page. To reach it, access the GSA home page <http://www.gsa.gov>, then click on "Federal Supply Service", then on "FSS Home Page", then on "FSS Publications", and last on "Current Publications". Only the numeric lists (documents in order by document number) are posted now, but this is a work in progress. The alphabetic lists (documents in order by title), and the listing by Federal supply class will be added soon.

Contact: Joyce Williams, (703)305-5682.

Schedule Buys Can Now Count Towards Your Procurement Preference Goals!

In November 1997, the Administrator of the Small Business Administration (SBA) asked the heads of Federal agencies to partner with SBA in meeting the President's objective of expanding procurement opportunities for small businesses, including those owned by women and minorities. For FY 1998, SBA now allows agencies to include in their procurement base and goals, the dollar value of orders expected to be placed against GSA's Federal Supply Schedules and to report those accomplishments against those goals.

In FY 1999, agencies will include Schedule purchases as part of their procurement base and goals. This is a good opportunity to acquire commercial products and services from small business. The GSA Schedule also provides the ability for small businesses to participate in Teaming Arrangements and at the same time customers can report these accomplishments against their procurement goals.

Guidance on goal setting is available on the Internet at: <http://www.sba.gov/GC/goaling.html>

**MarkeTips is
Recyclable!**

**We Use Recycled Paper
and
Soy-based Inks!**

DuPont Tyvek[®] Envelopes in EPA's Recovered Materials Guidelines

Comprehensive Guideline for Procurement of Products Containing Recovered Materials (CPG).

The U.S. Environmental Protection Agency (EPA) has added envelopes of DuPont Tyvek[®] to its Comprehensive Procurement Guidelines and accompanying Recovered Materials Advisory Notice, known as the "CPG" and "RMAN," making them the best performing envelope in the plastic envelope category designated in the Environmental Purchase Preference Program of the Federal government.

The rule making published in the Federal Register November 13, 1997, specifically designates plastic envelopes manufactured from DuPont Tyvek[®] "or equal" as an item whose procurement will carry out the objectives of section 6002 of RCRA. All Tyvek[™] envelopes are made with 25 percent post-consumer-recycled content (PCR), are 100 percent recyclable. DuPont has put in place the infrastructure to recycle Tyvek[®] at more than 70 sites throughout North America that recycle flexible HDPE, identified with an HDPE resin code Number 2.

The post-consumer-recycle content program for DuPont Tyvek[®] won the National Recycling Coalition's first annual Buy Recycled Business Alliance Award for "Most Innovative Product" in September 1994. Since the introduction of 25 percent PCR Tyvek[®] in 1992, it has been specified by the U.S. Postal Service for their "Express Mail" and "Priority Mail" envelopes, as well as by Federal Express for their "FedEx Paks" and is also currently purchased by the General Services Administration (GSA) and Government Printing Office. Tyvek[®] envelopes meet the mailing criteria of many federal agencies, because they offer the performance characteristics of strength, durability, moisture resistance and tear/puncture resistance. At the same time they are cost-effective, because they are light-weight and come in a variety of sizes and shapes (including expansion envelopes for box replacement). Opportunities for cost savings include mail consolidation and cost savings from reduced postage, storage space, packaging, labor and inventory. Tyvek[®] envelopes also have a distinctive high quality appearance useful in reinforcing an image.

Tyvek[®] is a DuPont registered trademark for its brand of spun-bonded olefin. Only DuPont makes Tyvek[®].

The EPA's Comprehensive Guideline for Procurement of Products Containing Recovered Materials (CPG) is designed to foster markets for materials recovered from the solid waste stream by using government purchasing power -- as the nation's single larg-

est consumer of products and service -- to stimulate the use of these materials in the manufacture of new products.

The CPG implements a section of the Resource Conservation and Recovery Act (RCRA) that requires EPA to designate items that are produced with recovered materials and to recommend practices for the procurement of designated items by Federal or state procuring agencies. Once EPA designates an item, RCRA requires any procuring agency using Federally-appropriated funds to buy that item to purchase it with the highest percent of recovered materials practicable.

On November 7, 1996, the EPA proposed and published in the Federal Register to add 13 new items to its Comprehensive Guideline for Procurement of Products Containing Recovered Materials, which had been first issued May 1, 1995. The amended CPG, known as CPG II, and related Recovered Materials Advisory Notice (RMAN II) bring to 31 the total number of recovered content items designated for procurement in CPG I and CPG II. CPG I had designated 19 items in seven product categories containing recovered content that government procuring agencies are required to purchase.

Earlier, on October 20, 1993, President Clinton had issued Executive Order 12873, "Federal Acquisition, Recycling, and Waste Prevention," that directs federal agencies to give preferential purchase consideration to recycled and environmentally preferable products and services. Officials at the Office of the Federal Environmental Executive recently promulgated the goal of the Executive Order: "To establish the United States Government as a leader, both domestically and internationally, in waste reduction, source separation, and the procurement of recycled content products."

The EPA's proposed CPG II rule making issued in 1996 noted that the most common government use of Tyvek[®] envelopes was by "express mail, insurance, bank, legal, medical and international mail industries in heavy-duty, security-related and other specialized mailing applications." These and other new envelope designs and applications for Tyvek[®] were highlighted recently at the DuPont Tyvek[®] and several government booths at the National Marketplace for the Environment. Devoted to environmental products, programs and services for Federal, State and local governments, the conference was held in Washington, D.C. November 17-20, 1997.

If you have any questions, please call 1-800-44TYVEK (448-9845), Monday-Friday, 8:00 am - 6:00 pm EST or visit our web site:

www.dupont.com/Tyvek/envelopes

Inter-Agency Transportation Management System (ITMS)

In 1997, GSA implemented the Inter-Agency Transportation Management System (ITMS). ITMS replaced GSA's previous automated rate and routing system commonly referred to as Muffin or ARFARS. ITMS is a PC-based system using CD-ROM technology and will run on a user's own computer or from an office's Local Area Network (LAN). Federal agencies (for freight, only those offices/locations that have entered into funding agreements with GSA for the payment of freight services provided) can now access discounted rate offers and related accessorial service charges via cost comparisons for both freight (domestic, less-than-truckload and truckload shipments moving via closed van) and household goods (intrastate, interstate, and international) shipments via ITMS. In addition to rate and routing information, ITMS also provides users with reporting functions. Reports can be created for a specific carrier, combination of carriers, or all carriers by transportation and/or accessorial service offers for all general, alternating, and non-alternating rate offers by specific or all origins and destinations. For household goods, reports can also be created to show percentages offered for storage-in-transit, unaccompanied air baggage, and privately owned vehicles in addition to a carrier's approved scope of operations. All reports can be imported into a spreadsheet application for statistical studies. ITMS can also provide the user with the ability to view/print carrier information to include such things, if available, as carrier name, Standard Carrier Alpha Code (SCAC), mailing address, point of contact, phone/facsimile numbers, and an e-mail address. ITMS is distributed on a semi-annual basis and each distribution of ITMS is scheduled to contain increased functionality. Any questions regarding ITMS should be directed to the Agency's GSA National Account Manager.

Freight Management Program Standard Tender of Service (STOS)

GSA's Standard Tender of Service (STOS) for General Freight serves as the base document for the transportation of freight-all-kinds (FAK) shipments by those Federal civilian agencies that participate (have entered into funding agreements with GSA for the payment of services provided) in GSA's Freight Management Program.

The STOS comprises the following three parts:

- GSA General Freight Tender of Service No. 1-F (establishes such provisions as carrier approval requirements, solicitation and submission of rate offer procedures, performance requirements, service standards, and nonuse procedures).
- GSA National Rules Tender No. 100-D (replaces all carrier and bureau rules and accessorial tariffs).
- GSA Baseline Rate Publication No. 1000-D (replaces all carrier and bureau line haul tariffs).

The Freight Management Program has agreements with more than 300 carriers approved to haul government freight shipments. Rate offers for the transportation of FAK shipments solicited and accepted in accordance with the STOS provide participating Federal agencies with the most economical and responsive transportation rates and services. In addition to assisting participating Federal agencies with the transport of their FAK shipments, GSA will also help those agencies with all other freight-related shipments and/or questions. Federal agencies should contact their GSA National Account Manager for additional information on GSA's Freight Management Program.

Transportation Management Web Site

Visit the GSA Transportation Management Website at:

<http://www.kc.gsa.gov/fsstt>

for detailed information about these programs, participating Federal Agencies, and the GSA National Account Manager assigned to service them.

Centralized Household Goods Traffic Management Program

GSA/FSS Transportation Management Program Office has arrangements with more than 300 household goods common carriers both large and small for the shipment of household goods worldwide associated with work-required relocation of Federal employees. Federal agencies are provided a list of these carriers to use when selecting a carrier to handle its

employee relocations based on the level of past Federal customer satisfaction and the carrier's offered discount.

Basic carrier performance requirements and program standards are published in the GSA Household Goods Tender of Service (TOS) Agreement. Further information about arranging and managing a

household-goods move is contained in the GSA Publication 1993 Edition, Agency Guide: Shipping Your Household Goods. Relocating employees may also review the GSA Publication 1995 Edition, Employee Guide: Shipping Your Household Goods.



FSS

National Customer Service Center

1-800-488-3111

DSN 465-1416

Help us to help you!

Let us know how we are doing -

Are we providing the products you need?
Are these products easy to obtain, do they arrive on-time?
Are you aware of the services available through FSS?

Customer Service Representatives are available to answer your questions or provide any assistance you may require.

This includes every aspect of our relationship with you:

Products
 Delivery
 Service
 Personal Contacts

How are we doing?

1-800-488-3111

DSN 465-1416

E-Mail RODSM.NCSC@GSA.GOV

National Customer Service Center

Building 4

1500 East Bannister Road

Kansas City, MO 64131

Flight Data Recorders Added to The Multiple Award Schedules Program

Two New Technology items recently added to our Multiple Award Schedules Program which will be of interest to customers involved in aircraft operation are the "Black Box" (Flight Data Recorder) and Avionics Testing Equipment.

The Digital Flight Data/Voice Recorder, which is used to play back the events of a flight disaster, has been added to Federal Supply Schedule 66III. It is designed for use on military as well as commercial aircraft. Contract # GS-24F-3027G was awarded to Smiths Industries, under Special Item Number 602-1006, for the period February 1, 1997 to July 31, 1999. For more informa-

tion, you can call the company at (616)241-8135; Fax (616)241-7533 or write to them at Aerospace & Defense Systems, Inc, 4141 Eastern Ave., SE, Grand Rapids, MI 49518-8727.

In addition, under Federal Supply Schedule 66III, Special Item Number 627-1007, Advanced Testing Technologies, Inc (ATTI) has been awarded a contract for Avionics Test Equipment. This equipment is specially designed for testing the electronics of aircraft engines, generators, hydraulics, communication and navigational systems. ATTI's BRAT (Benchtop Reconfigurable Automatic Tester) system is designed to pinpoint faulty modules of an aircraft; once a faulty module has been identified, the BRAT system is capable of testing and identifying faulty circuit boards inside the module. For further information on this equipment, please write or call Advanced Testing Technologies, Inc, 110 Ricefield Lane, Hauppauge, NY 11788; (516)231-8777; Fax (516)231-8517 and cite Contract # GS-24F-3010G.

New Technology Awards Have Been Added to Scientific Schedules

Office and Scientific has made the following New Technology Awards:

(1) Ferrographic systems have been added to Schedule 66IIA. This system is used to analyze and test lubricants from helicopters, tractors, and other machinery to detect machine wear preceding component failure.

(2) Pressure calibration systems have been added to 66III. They are used to measure gas pressure, temperature and humidity.

(3) Resistivity Logger Concrete Surveying Instruments have been added to 66IIL. They are used to measure the resistance of concrete, masonry and other materials.

(4) Refrigerant Monitors have been added to 66IIR. They are used to detect refrigerant leaks in supermarkets and refrigerant storage locations, propellant filling operations, solvent cleaning stations and wherever else refrigerant leaks may occur.

In keeping with our customers' demands for the latest technologies, and to stay up-to-date with all the latest products, the Office and Scientific Equipment Center is able to make these products available to you when they become available to commercial cus-

tomers. If an item is truly new and has never been offered through the Federal Supply Schedules (FSS) Program, we will make every effort to make it available to you with the ease of schedule purchasing in an expedited manner. We can add these items under an "evergreen" provision with a continuous open season; we are not tied to a set schedule contract period. This is an ideal opportunity for you, our customer, to partner with both GSA and our contractors. If you see or hear of a product that is unlike anything else featured in our Schedules Program, will make your job easier and qualifies under our scope of products, please call **Patricia Miller, Director, Customer Service, Marketing and Business Development Division, (703)305-3044.**

Leasing of Scientific Equipment

The Office and Scientific Equipment Center is studying the feasibility of offering an option to lease scientific equipment. If you are interested in leasing any of the products on our Multiple Award scientific equipment schedules, please call one of the following individuals: Evangeline Turner-O'Neil on (703)305-6322; Dena Gross on (703)305-6630 or Leena Scott on (703)305-5124. Our technical representative on the project is Jawed Abdeljawad. He is available on (703)308-6532 to answer technical questions. We would be very interested in hearing from you and in communicating your needs to our contractors.

Electronic Copy Boards Are Now Available under Federal Supply Schedule 36, Part IV

Currently available under Federal Supply Schedule 36, Part IV, Electronic Copyboards are a terrific tool to add to your inventory of office equipment. Vital for meetings, presentations and training, electronic copyboards take your notes for you so that you can actively participate in the meeting or training session. After writing on the board, just push the copy button to electronically generate copies of everything written on, or attached to, the white board surface. Notes can be distributed instantly and everyone gets the same information. The board is an erasable, durable scratch-resistant surface. In addition, operation is almost effortless. There are no chemicals or toners involved; the process is all electronic. Check out these exciting new items by ordering a copy of Federal Supply Schedule 36, Part IV. You can write or call our Centralized Mailing List Service as follows:

General Services Administration
Centralized Mailing List Service
PO Box 6477
Fort Worth, TX 76115
Phone: (817)334-5215
Fax: (817)334-5227
Internet: cmls.gsa@gsa.gov

These items are listed under Special Item Number 51-103, Special Equipment, and are available from QuartetOvonic and Varitronic Systems.

Contact: Amanda Henderson (703)305-7427 or Linda Dogan (703)305-5994.

It's Here! Full Service Document Management Services

In response to growing Government requirements to provide a total reprographic solution that includes the copier, supplies, maintenance, and site management, Federal Supply Schedule Group 36, Part IV has been expanded to include these services. If you manage an agency reprographic program and have the need to provide service, you can meet your customers' needs by using document management services from the leaders in the reprographic industry and under GSA Federal Supply Schedule. The contracts allow the vendors to provide customized solutions that can be tailored to each customer's individual needs. If you are interested in these services, please contact **Walter Eckbreth on (703) 308-8281.**

Disposable Cameras Are Now Available on Schedule 67 II and III

Were you aware that GSA offers single-use, disposable cameras on one of our Multiple Award Schedules? FSS 67 II & III features these handy, convenient, reasonably priced items under Special Item Number 19-8. The following companies have been awarded contracts and offer a variety of types of these cameras. Call them directly to find out more about what they have to offer!!!

AGFA Div of Bayer, Inc; (508)658-5600, ext 5930
Contract No: GS-25F-6133D

Eastman Kodak Company; 800-828-6203
Contract No: GS-25F-6072D

FUJI Photo Film, U.S.A., Inc.; 703-925-3346
Contract No: GS-25F-6119D

Imation Enterprise Corp.; 612-704-3124
Contract No: GS-25F-6120D

Konica USA, Inc.; 800-285-6422
Contract No: GS-25F-6099D

Magnetic Stripe Encoded ID Cards Are Available on Federal Supply Schedule Group 74, Parts II and III

Does your office use magnetic stripe encoded ID cards? Are you looking to change your ID/security cards to a magnetic stripe encoded card system? Would you like to be able to make and issue the cards on-site, instantly? Look no further than GSA Federal Supply Schedule Group 74 Parts II & III and DataCard Corporation's GSA contract number GS-25F-5159C.

DataCard Corporation offers several affordable identification card systems that can make and issue attractive, durable identification cards on-site, instantly. The systems have the capability of including a configurable magnetic stripe encoding module. Other systems can encode cards with bar codes. Stay tuned!

Contact DataCard Corporation on 1-800-328-8623 for more details.

Contact: Frank Norman (703) 305-6425

FSS

CUSTOMER SUPPLY CENTERS

Welcome To GSA's Customer Supply Centers!

We have the office, business and industrial products to meet your needs from general office supplies, writing instruments and presentation aids, to mailing and packing supplies, computer accessories, cartridges for printers and copiers, tools, and lots more. With more than 15,000 products to choose

from, including many of your favorite brand names, it's easy to purchase whatever you need for your workplace - without ever leaving your desk. We'll also deliver right to your desk and do so to most locations within 1 to 3 days.

We care about our customers and want to ensure that you get the best value. It's important to us that you receive the best combination of service, quality and price, and we're continually striving to improve each of these. When you shop the CSC way, GSA provides not only the easy ordering system, products

and delivery, but also the acquisition, billing and payment services, all for a best value price. If we should ever fail you or if you have suggestions on how we can improve our service, please let your local CSC know or contact our National HELP desk by phone (1-800-865-4CSC) or e-mail (csc.desk@gsa.gov).

For information on setting up an account, obtaining a catalog or placing an order, please contact the Customer Supply Center nearest you at one of the numbers listed below. Thanks for shopping GSA!

Mission Essential Equipment featuring the Ultimate Organizer by Productivity Plus™

Credit Card Slots

Quality Crafted Binder

Bookmark/Calendar

Not Pictured

- Plastic Zip Pouch
- Business Card Holder

Pen Loop

Inside Pocket



A-Z File

Fast-Find Tabs

Daily Plans

Pen Loop

Monthly Calendar

1-5 Files (Tabbed)

Now Available at Your Customer Supply Centers

Travel Size (Zipper Binders)

Item #		
BCCZ	(Woodland Camo*)	(NSN 7530-01-332-3968)
BDDZ	(Desert Camo*)	(NSN 7530-01-207-4095)
BBLZ	(Black)	(NSN 7530-01-366-5856)
BBUZ	(Burgundy)	(NSN 7530-01-332-1560)

Soy Ink



Contract materials
are printed on
RECYCLED PAPER

Price **\$48⁵⁶**

Invest in
Your Productivity

The Customer Supply Centers Introduce:

High Yield Toner Cartridges

**FOR HP LASERJET II/III,
III/III/III PRINTERS**



**Yields 100% More Pages
than the Standard HP
92295A Cartridge!**

High Yield Toner Cartridge - 92295A
NSN# 7510-01-406-5389
Part # 670-GSX-5GB
Retail \$150.00
CSC PRICE/CTG \$86.88

**FOR HP LASERJET 4 & 5
SERIES PRINTERS**



**Produces 50% More Yield
than the Standard HP
92298A Cartridge.**

High Yield Toner Cartridge - 92298A
NSN# 7510-01-416-5208
Part # 670-GEX-09
Retail \$250.00
CSC PRICE/CTG \$113.69

**DOUBLE Your Output and REDUCE COST by 50%
Without Sacrificing Print Quality!**

Call Your Regional Supply Center to Place Your Order.

GSA Customer Supply Centers
make a visible difference
in quality pens & markers.

DRY ERASE MARKERS & CALENDAR PLANNERS



Kit for Dry Erase

Handsome case contains everything needed for an effective and colorful presentation on dry erase surfaces: Expo® Fine Point 4-Color Set, Expo® Chisel Tip 8-Color Set, Expo® Eraser, and Expo® Cleaner. Keep it in conference rooms, classrooms, and boardrooms, or carry it from presentation to presentation.

Expo® Dry Erase Kit
7520-01-365-6126 **\$13.45 each**

Organizer

Keeps six Expo® markers at your fingertips. Mounts easily to any smooth surface with double-stick tape (included) and comes with an Expo® Eraser and one each black, red, blue, green, brown, and orange Expo® Chisel Tip Markers (No. 83000 Series)

Expo® Organizer
7520-01-352-7321
\$8.24 each



Calendar Planner

Contemporary design with vinyl frame. Keep track of projects and appointments with this undated monthly calendar. (unit: Each)

12" x 18" White Board 7520-01-432-1644 **\$7.13 each**
18" x 24" White Board 7520-01-444-1175 **\$10.89 each**

We Welcome the I.M.P.A.C.® Visa Card

We'll gladly take your credit card for any purchase - no matter how small or big the order is!

To make it easier for you to do business with us, we've simplified the process for setting up accounts for our IMPAC credit card customers. If you're a new credit card customer and wish to set up an account, you can easily do so over the phone when placing your first order - without submitting any paperwork! All you'll need is your credit card number, expiration date, your address, and phone number.

If you have an Activity Address Code and Access Code, we would like to have them when you set up your account. Please remember that you can always use them to charge your orders to your Government account.

MONO CORRECTION TAPE

TOMBOW®

- Single line correction film in an ergonomic dispenser
- Sideways application permits placement of opaque film for quick, clean complete coverage
- No more messy fluids! Write or type over film instantly - no drying time!
- Fits any paper, including fan paper
- Leaves no copy shadows
- Acid-free 1/8" x 3/4", individually blister coated

\$2.49



Part# Description NSN
68620 MONO Tape, White 7510-01-599-0717

Now Available Through Your Regional Customer Supply Center:
HEWLETT-PACKARD TONER SUPPLY ITEMS

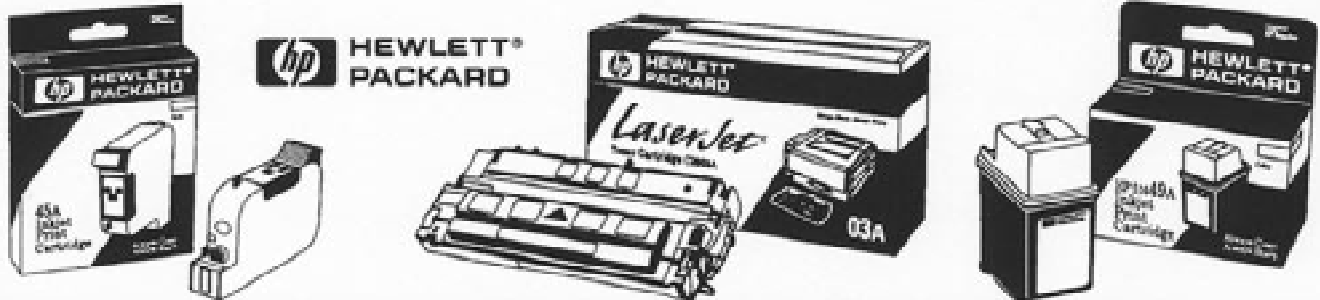

TONER CARTRIDGES	For Use In:	NSN#	Part #	CSC Price
	HP LaserJet 4L, 4P	6850-01-357-9991	92274A	\$68.70
	HP Color LaserJet, Color LaserJet 5	6850-01-424-8053	C3102A	35.96
	HP Color LaserJet, Color LaserJet 5	6850-01-424-8056	C3103A	35.96
	HP Color LaserJet, Color LaserJet 5	6850-01-424-8051	C3104A	35.96
	HP Color LaserJet, Color LaserJet 5	6850-01-424-8054	C3105A	7.33
	HP LaserJet 4V	6850-01-411-2657	C3900A	164.33
	HP LaserJet 5P & 6P	7045-01-422-9592	C3903A	89.76
	HP LaserJet 5L & 6L Series	6850-01-428-3583	C3906A	66.13
	HP LaserJet 5Si Series	7045-01-434-6753	C3909A	186.23

INKJET CARTRIDGES	For Use In:	Color	NSN#	Part #	CSC Price
	HP ThinkJet/QuietJet	Black	7510-01-394-3040	51604A	\$30.75
	HP DJ/DW 600 Series	Black	7510-01-422-1507	51629A	26.39
	HP DJ 800 Series	Tri-Chamber	7510-01-439-0430	51641A	30.79
	HP DJ 800/1600 Series	Black	7510-01-421-3346	51645A	31.39
	HP DJ/DW 600 Series	Tri-Chamber	7510-01-422-1560	51649A	30.23
	HP DesignJet 250/650	Cyan	7510-01-391-8844	51650C	35.45
	HP DesignJet 250/650	Magenta	7510-01-391-8843	51650M	35.45
	HP DesignJet 250/650	Yellow	7510-01-391-8842	51650Y	35.45
	HP DJ/DW 300/400 Series	Black	7510-01-428-3561	51633M	24.38

TO PLACE YOUR ORDER, CALL YOUR REGIONAL CSC.

NEW

Workstation Clocks!

MADE TO ADHERE TO YOUR
PARTITION'S FABRIC!!



PERFECT FOR
SMALL DESK AREAS!



(6" in diameter)

SAVES SPACE!
CONVENIENT!
ATTRACTIVE!
ACCURATE!

**ONLY
\$13.83**

AVAILABLE IN

Stone Gray
NSN-6645-01-421-6899

Taupe
NSN 6645-01-421-6900

AT YOUR LOCAL
CUSTOMER SUPPLY
CENTER

Customer Supply Center Opens in Yokosuka, Japan

In an effort to better serve customers and sustain readiness in the Pacific, GSA and FISC Yokosuka opened a Customer Supply Center (CSC) in Japan. When the store is in full operation, Navy customers will have a greater selection of items at very competitive prices. The new GSA CSC will provide improved supply support to fleet and shore based customers in Japan, Singapore and Diego Garcia.

Contact: Melinda Eyre or Maria Rodriquez (808) 541-1776

Next Day Delivery Service to Southern California Improves

Customers in Los Angeles, Orange, Ventura and San Diego Counties receive next day delivery from GSA at no extra charge. To take advantage of this value added service, call the Stockton CSC by 1:00 p.m. and place your order. The Stockton Customer Supply Center serves California, Nevada and Arizona.

Telephone: (800) 299-4129
 Fax: (800) 435-9475
 DSN: 466-7234
 DSN Fax: 466-7222

Now Available Through Your Regional Customer Supply Center:

SCHWAN-STABILO PENS

<p>STABILO point 88[®]</p>  <p>Economical fine line porous point pen for editing & multi-purpose writing.</p> <table border="1"> <thead> <tr> <th>NSMF</th> <th>Color</th> <th>Part #</th> </tr> </thead> <tbody> <tr> <td>7520-01-448-3070</td> <td>Green</td> <td>SWS883610</td> </tr> <tr> <td>7520-01-448-3073</td> <td>Red</td> <td>SWS884010</td> </tr> <tr> <td>7520-01-448-3067</td> <td>Blue</td> <td>SWS884110</td> </tr> <tr> <td>7520-01-448-3071</td> <td>Black</td> <td>SWS884610</td> </tr> <tr> <td>7520-01-448-3074</td> <td>Pink</td> <td>SWS885610</td> </tr> <tr> <td>7520-01-448-3075</td> <td>Lilac</td> <td>SWS885810</td> </tr> </tbody> </table>	NSMF	Color	Part #	7520-01-448-3070	Green	SWS883610	7520-01-448-3073	Red	SWS884010	7520-01-448-3067	Blue	SWS884110	7520-01-448-3071	Black	SWS884610	7520-01-448-3074	Pink	SWS885610	7520-01-448-3075	Lilac	SWS885810	<p>STABILO sensor[®]</p>  <p>Long-lasting porous point pen has vivid, quick-drying ink!</p> <table border="1"> <thead> <tr> <th>NSMF</th> <th>Color</th> <th>Part #</th> </tr> </thead> <tbody> <tr> <td>7520-01-436-2581</td> <td>Green</td> <td>SWS1893612</td> </tr> <tr> <td>7520-01-436-2572</td> <td>Blue</td> <td>SWS1894112</td> </tr> <tr> <td>7520-01-436-2576</td> <td>Black</td> <td>SWS1894612</td> </tr> <tr> <td>7520-01-436-2579</td> <td>Red</td> <td>SWS1894012</td> </tr> <tr> <td>7520-01-436-2574</td> <td>Pink</td> <td>SWS1895012</td> </tr> <tr> <td>7520-01-436-2578</td> <td>Lilac</td> <td>SWS1895612</td> </tr> <tr> <td>7520-01-436-2573</td> <td>6-Color Set</td> <td>SWS1896</td> </tr> </tbody> </table>	NSMF	Color	Part #	7520-01-436-2581	Green	SWS1893612	7520-01-436-2572	Blue	SWS1894112	7520-01-436-2576	Black	SWS1894612	7520-01-436-2579	Red	SWS1894012	7520-01-436-2574	Pink	SWS1895012	7520-01-436-2578	Lilac	SWS1895612	7520-01-436-2573	6-Color Set	SWS1896	<p>STABILO fluid 5[®]</p>  <p>High-quality visual ink system for extra-long writing distance & consistent line quality.</p> <table border="1"> <thead> <tr> <th>NSMF</th> <th>Color</th> <th>Part #</th> </tr> </thead> <tbody> <tr> <td>7520-01-448-3051</td> <td>Black</td> <td>SWS25894610</td> </tr> <tr> <td>7520-01-448-3054</td> <td>Blue</td> <td>SWS25894110</td> </tr> <tr> <td>7520-01-448-3055</td> <td>Red</td> <td>SWS25894010</td> </tr> <tr> <td>7520-01-448-3049</td> <td>Green</td> <td>SWS25893610</td> </tr> </tbody> </table>	NSMF	Color	Part #	7520-01-448-3051	Black	SWS25894610	7520-01-448-3054	Blue	SWS25894110	7520-01-448-3055	Red	SWS25894010	7520-01-448-3049	Green	SWS25893610	<p>STABILO Write-4-all[®]</p>  <p>Writes on Everything, Anytime, Anywhere! Ideal for glass, paper, plastic, metal & more.</p> <p>All Listed are 4-Color Sets.</p> <table border="1"> <thead> <tr> <th>NSMF</th> <th>Type</th> <th>Part #</th> </tr> </thead> <tbody> <tr> <td>7520-01-448-8300</td> <td>Fine</td> <td>SWS8324</td> </tr> <tr> <td>7520-01-448-8294</td> <td>Medium</td> <td>SWS8334</td> </tr> <tr> <td>7520-01-448-3058</td> <td>Supertine</td> <td>SWS8314</td> </tr> </tbody> </table> <p>Schwan STABILO</p>	NSMF	Type	Part #	7520-01-448-8300	Fine	SWS8324	7520-01-448-8294	Medium	SWS8334	7520-01-448-3058	Supertine	SWS8314
NSMF	Color	Part #																																																																									
7520-01-448-3070	Green	SWS883610																																																																									
7520-01-448-3073	Red	SWS884010																																																																									
7520-01-448-3067	Blue	SWS884110																																																																									
7520-01-448-3071	Black	SWS884610																																																																									
7520-01-448-3074	Pink	SWS885610																																																																									
7520-01-448-3075	Lilac	SWS885810																																																																									
NSMF	Color	Part #																																																																									
7520-01-436-2581	Green	SWS1893612																																																																									
7520-01-436-2572	Blue	SWS1894112																																																																									
7520-01-436-2576	Black	SWS1894612																																																																									
7520-01-436-2579	Red	SWS1894012																																																																									
7520-01-436-2574	Pink	SWS1895012																																																																									
7520-01-436-2578	Lilac	SWS1895612																																																																									
7520-01-436-2573	6-Color Set	SWS1896																																																																									
NSMF	Color	Part #																																																																									
7520-01-448-3051	Black	SWS25894610																																																																									
7520-01-448-3054	Blue	SWS25894110																																																																									
7520-01-448-3055	Red	SWS25894010																																																																									
7520-01-448-3049	Green	SWS25893610																																																																									
NSMF	Type	Part #																																																																									
7520-01-448-8300	Fine	SWS8324																																																																									
7520-01-448-8294	Medium	SWS8334																																																																									
7520-01-448-3058	Supertine	SWS8314																																																																									

To place an order, contact your regional Customer Supply Center*

<p>Franconia Virginia Phone: 1-800-848-8952 Fax: 1-800-848-9085</p>	<p>Palmetto Georgia Phone: 1-800-473-4484 Fax: 1-800-416-7065</p>	<p>Burlington New Jersey Phone: 1-800-788-7155 Fax: 1-800-814-2571</p>	<p>Worth Illinois Phone: 1-800-262-0570 Fax: 1-800-734-9575</p>	<p>Denver Colorado Phone: 303-236-1917 Fax: 303-236-5329</p>
<p>Stockton California Phone: 1-800-786-0258 Fax: 1-800-435-9475</p>	<p>Anchorage Alaska Phone: 1-800-472-5843 Fax: 1-800-660-3833</p>	<p>Auburn Washington Phone: 1-800-859-4377 Fax: 1-800-603-8357</p>	<p>Ft. Worth Texas Phone: 1-800-525-8027 Fax: 1-800-856-7057</p>	

Government I.M.P.A.C.[®] VISA Accepted

For more information about the Customer Supply Centers and the location nearest you, please visit our Home Page at www.fss.gsa.gov (click "Customer Assistance" and then "GSA Customer Supply Centers").

*Availability and prices of some items may vary outside of the continental United States. Availability may also be limited for customers using GSA Advantage or the ROCS system!

FSS

AUTOMOTIVE CENTER

Can We Schedule Something For You?

Like to have a choice of multiple vendors? Like to have a choice when selecting a product? Then look into the schedules provided by the Automotive Center. The Center provides an innovative approach to buying Tires, Mobile sound shell stage trailers, Digger/Derricks and Aerial Devices, Firetrucks, and Trash and Recycling Equipment.

Make it easier on yourself, save money and time, and get the product that best suits your needs. You can set up Blanket Purchase Agreements (BPA), and you may use the I.M.P.A.C.® card for convenience. Goodyear will also accept the Wright Express Card for new tires and retread services at no additional charge.

Look at our prices!: All contracts under Schedule 26 I have now been reduced by 3%.

Schedules available include:

- Schedule 38 II B Construction, Snow and Highway Maintenance Equipment Attachments
- Schedule 23 I A Enclosed Concession and Mobile Sound Shell Stage Trailers
- Schedule 23 II Trucks, Aerial Personnel Lifts, Digger/Derricks and Cable Placers
- Schedule 26 I Tires and Retread Services
- Schedule 42 IV Firetrucks, Trash and Recycling Equipment

If you would like to take advantage of these choices, and would like more information contact the Center's Customer Service Team on **703-308-CARS**.

Federal Supply Schedule
General Services Administration

Commodity Edition
November 10, 1997



Construction and Highway Maintenance Equipment
WORLDWIDE

FSC Class	38
Part	I
Class	A
FSC Class	2810, 2820, 2890, 2900, 3851, 4530, 1951

Multiple Award
For the period October 1, 1998 through September 30, 2000

Federal Supply Schedule
General Services Administration

Commodity Edition
June 10, 1997



Fire Fighting and Waste Disposal Vehicles

FSC Class	42
Part	III
FSC Class	2200, 2000, 4210

Multiple Award
For the period July 1, 1998 through June 30, 2000

Federal Supply Schedule
General Services Administration

Basic Edition
October 10, 1997



Tires, Pneumatic (New) for Passenger, Light Truck, Medium Truck, Bus, and Retread Services

FSC Class	28
Part	I
FSC Class	2810

Multiple Award
For the period October 1, 1998 through September 30, 2000

YOUR TICKET TO BIDE

VISIT OUR WEB SITE:

<http://www.fss.gsa.gov>



FREE SEMINAR FOR GOVERNMENT EMPLOYEES

"The YEAR 2000 PROBLEM IS ONE OF THE MOST SIGNIFICANT challenges facing the federal government today. Finding the RIGHT SOLUTION QUICKLY IS CRITICAL if we are to continue providing quality service to our fellow Americans".

—Frank Pugliese, Commissioner,
GSA's Federal Supply Service



FEBRUARY 4, 1998

OMNI SHOREHAM HOTEL

2500 CALVERT ST., N.W.

WASHINGTON, D.C.

PHONE 202.234.0700

Mark your calendar for the government sponsored conference dedicated to solving your Year 2000 problem. This one-day event will provide critical government-industry dialogue, and a look at the latest IT to analyze, assess, correct or migrate your systems.

See what the experts have to say...

FEATURING TWO KEYNOTE SPEAKERS:

Congressman Stephen Horn, Congressional Year 2000 Advocate

Dr. Kenneth Orr, Year 2000 Industry Expert and respected speaker

PLUS TRAINING SESSIONS ON:

How Agencies Can Fund Their Year 2000 Solutions

How GSA's Multiple Award Schedules Program Can Help

How Some Federal Agencies and Private Sector Firms Are Tackling Their Year 2000 Problems

PLUS MORE THAN TWO DOZEN EXHIBITORS:

See Dozens of Solutions all in one location

OPEN TO FEDERAL EMPLOYEES AT NO CHARGE!!!

To Register, or for more information, visit the Coalition For Government Procurement's Website at: <http://www.usassociations.com/cgpp>. If you still have questions call us at 202.331.0975.

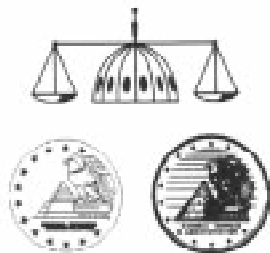

Sponsored by GSA's Federal Supply Service and the Coalition for Government Procurement.

Complete The Bathroom Tissue Line With SKILCRAFT® 2-Ply Toilet Tissue

New NIB Double Ply Toilet Paper Completes Bathroom Tissue Line...Offers Savings, Plus Environmental Rewards

The new SKILCRAFT®, Double Ply Toilet Paper from rounds out the FSS bathroom tissue offering and brings the user several benefits: Softer, stronger, and cheaper, than most private sector source.

It comes in uncompressed rolls of 500 perforated two-ply white sheets, 2250' long, wound around a cardboard core, and although containing more paper, it is no bigger than single roll paper. Each roll is individually wrapped.

More benefits: The tissue is made from 100% recycled paper, including a minimum of 20% post consumer material (PCM) and is septic system safe, impacting on landfill space and the environ-



ment and helping your agency comply with the President's Executive Order 12873 on recycling.

Another benefit: under JWOD, the toilet tissue comes from agencies associated with NIB.

<u>NSN</u>	<u>Type</u>	<u>U/I</u>	<u>Price</u>
8540-01-380-0690	Two-Ply	BX (96 RO)	\$40.77
8540-00-530-3770	One-Ply	BX (96 RO)	\$48.68
8540-01-055-6094*	One-Ply	BX (48 RO)	\$27.70

*(Packed in compressed water proof containers for U.S.Navy)

Contact: David St. Louis (212) 264-3537 (Inventory)

Make A Statement With These Bold Point Mechanical Pencils

It is a statement of fact that being progressive in today's government marketplace requires a continual evaluation of products and customer needs. We introduced the Twist In & Out Mechanical Pencil several years ago to meet our customers' needs for a high-quality writing pencil. In 1998, we have again reacted to changing customer needs to introduce the Bold Point Mechanical Pencil as an upgrade and replacement for the Twist In & Out pencil.

Your notes, jottings, and everyday writing will always make a bold statement when you use the Bold Point Mechanical Pencil. The enhanced push-action mechanism ejects the 1.1 mm lead. With a black graphite-based or red clay-based wide lead and state-of-the-art slimline design, the Bold Point Mechanical Pencil makes writing even your most hurried scribbles readable. Other features include a red or black barrel that indicates lead color, an eraser on the end of the retractor, and 3 leads.

The thick block lead makes a marked impression for photocopies and faxes, as well.

The SKILCRAFT® Bold Point Mechanical Pencil is manufactured by the San Antonio Lighthouse in San Antonio, Texas and meets the source requirements of the Javits-Wagner-O'Day Act. Your purchase of this and other SKILCRAFT® products supports employment opportunities for people who are blind.

The Bold Point Mechanical Pencil may be ordered using the following NSNs:

Price: \$5.49 a dozen (DZ)
7520-01-347-9581: Black Barrel, Black Lead (graphite based)
7520-01-354-2305: Red Barrel, Red Lead (clay based)

Please note: The above NSNs will replace the Twist In and Out Mechanical Pencil. The following NSNs for this product will be discontinued:

7520-00-164-8950
7520-00-268-9915
7520-00-268-9916

Contact: Peggy Bouyer (212) 264-4320

Use Your I.M.P.A.C.[®] Credit Card To Purchase JWOD Office Products

One of the many services that the GSA Service Acquisition Center administers on a daily basis is the I.M.P.A.C.[®] Credit Card. Office Products made under the Javits-Wagner-O'Day (JWOD) Program by nonprofit agencies affiliated with NISH (formerly National Industries for the Severely Handicapped) and National Industries for the Blind (NIB) can be ordered easily using your I.M.P.A.C.[®] Card. Your purchase of JWOD office products provides employment and training opportunities for people who are blind and have severe disabilities. The Program is administered by the Committee for Purchase From People Who Are Blind or Severely Disabled.

Hundreds of JWOD office products are available through GSA (and featured regularly in Marketips). As the primary distributor of JWOD office products, customers have two avenues to obtain products through GSA: GSA Customer Supply Centers (orders are shipped within 24 hours and usually arrive in 2-5 days); and, GSA *Advantage!*[™] On-line Shopping Service. This service allows you to browse, search for specific items, review prices, and place orders via the Internet. The customer selects the time and delivery schedule. Visit GSA *Advantage!*[™] when buying your JWOD Products at <http://www.gsa.gov>, or call (703) 305-7359.

While GSA remains the primary vendor, both the GSA and JWOD team realize there are some instances when a federal customer has special requirements. To provide an extra choice to the customer, GSA developed its Schedule 75 III A that allows federal customers to purchase JWOD Products from six national vendors and receive next-day, desktop delivery. Orders can be

placed by using by phone or by fax using your I.M.P.A.C.[®] Card. For more information, contact* the vendors:

Boise Cascade Office Products	(888) 505-FEDS (3337)
BT Office Supplies	(888) 862-8674
Corporate Express	(800) 706-9267
Innovative Sales Brokers	(800) 283-1903
Office Depot	(800) 263-9586
Staples National Advantage	(800) 538-2728

When contacting the vendors, be sure to request their "Government Catalog." Walk-in store purchases are not available at this time.

If you are a I.M.P.A.C.[®] Card Coordinator and would like copies of the BUYER'S Guide to the JWOD Program, and/or you would like a representative from the Committee, NISH or NIB to make a presentation to your card holders about the JWOD Program, please contact us at one of the numbers below. In addition to receiving top quality products, your purchase enables JWOD employees to lead more productive lives.

NISH National Office (703) 560-6800

National Industries for the Blind (703) 998-0770

Committee For Purchase From People Who Are Blind or Severely Disabled (703) 603-7740.

Check Out Our New Web Site

Need the JWOD Program's latest product list? Want to check our JWOD service capabilities? What about JWOD ordering information, or training materials? Its all on our web site:

www.jwod.gov

All Federal employees with purchasing authority (especially I.M.P.A.C.[®] credit card users) should be aware of the JWOD Program, a required source of supplies and services. This special procurement initiative creates jobs and training opportunities for people who are blind or who have other severe disabilities.

One way to familiarize yourself with the JWOD Program is to visit our web site, which includes supplies and services listings,

publications, procurement information, rehabilitation information and more. We have links to National Industries for the Blind (NIB) and NISH. For customers who are ready to place orders, a link to GSA *Advantage!*[™] On-Line Shopping Service. And a number of enhancements are in the works.

Not on-line yet? Call us or fax us for catalogs, flyers, videos or other information to aid you in spreading awareness of the JWOD Program.

Call: (703) 603-7740 or

FAX: (703) 603-0655

**DLA****DEFENSE LOGISTICS AGENCY**

1998 DLA Environmental Products (EP) Catalog

The fourth edition of DLA's Environmental Products catalog is now available to customers on the World Wide Web. DLA customers worldwide should you have received their hard copy version in December.

The 1998 catalog contains of over 850 national stock-numbered items in 19 product categories. New categories this year are reusable batteries (alkaline & NiCad) and alternative refrigerants (EPA SNAP-approved). Categories printed in earlier editions, such as petroleum, oils & lubricants and firefighting equipment, have been expanded by adding new items or additional National Stock Numbers (NSN).

The DLA EP catalog is a user-friendly publication which clearly suggests alternatives to previously used products or processes. These alternatives may be non-ozone-depleting, less toxic or promote recycling and waste minimization.

New technical data for the solvent categories in 1998 include flash point (if lower than 141 degrees Fahrenheit); class II ozone depleting chemical ingredients, if any; and toxicity data, such as LD 50, where available, for the blended product.

The catalog has an expanded points of contact section which will help customers request additional information from any of the DLA Supply Centers.

To be added to the mailing list for hard copies of the Environmental Products Catalog, call Defense Supply Center Richmond (DSCR) Product Marketing Division toll free at (800) 345-6333 or DSN 695-5699. Multiple copies for large organizations or for use as student handouts are also available.

Most catalogs published by DSCR are available on the Internet at <http://www.dscr.dla.mil>. You can view and download catalogs and actually place MILSTRIP requisitions for any DLA-managed NSN while on line.

If you have questions about the Environmental Products Catalog or DLA's environmental products, contact DSCR's Product Executive for Environmental Products, **Stephen Perez (804) 279-6054** or E-mail: sperez@dscr.dla.mil.

Grade 8 Cap Screw and Bolt Catalog's Are Now Available

FSC 5305 - Grade 8 Cap Screw Catalog

This first edition of a Grade 8 Hex Head Cap Screw catalog contains part numbers, NSN's, and characteristics of over 600 various size screws.

FSC 5306 - Bolt Catalog

Now in its second edition, this popular bolt catalog contains part numbers, NSN's and characteristics of Over 2,000 various size and material grade, hex head machine bolts.

To receive your free copy, fax your request to: **(215) 697-0909** or E-mail: eadamchick@disc.dla.mil.

Don't forget to visit our electronic catalog at:
http://www.disc.dla.mil/cbu/n/cbu_n.html

Food Service Equipment Sale

The Defense Industrial Supply Center has selected Food Service Equipment items on sale at a 50 percent reduction from the standard price. Items for sale include: ice makers, freezers, refrigeration units, dishwashers, deep fat fryers, mixers, accessories and much more! Just submit your requisition through normal channels, FEDSTRIP/MILSTRIP. Once an item is depleted, the sale is completed for that NSN. Substitutions will be not offered.

A listing of sale items can be viewed at the following site:
<http://www.disc.dla.mil/cbu/v/salecov.htm>. A listing is also available in FEDLOG under the Discounted Item Program.

If a hard copy listing is needed, call **S. McHale (215) 697-0649** or DSN 442-0649.

Visit our Web Site:

<http://www.supply.dla.mil>

and our Expanded Electronic mail:

<http://www.email.dla.mil>



**Don't Miss "The Total Solution" at FOSE!
Washington DC Convention Center
March 24 - 26, 1998**

FSS will showcase the broad range of commercial products and services supporting the Federal community's total information technology needs at the largest annual trade show serving the IT federal market – The Federal Office Systems Expo - FOSE 98!

The exhibit will spotlight:

- Demonstrations of *GSA Advantage!*TM - GSA's premiere on-line ordering system
- Live presentations by both GSA and GSA partners in industry
- Multi-media kiosks revealing the breadth of GSA/FSS schedule contracts
- Live product demonstrations, and more!

Visit us at booth # 728.

Join the 40,000+ federal employee attendees to see all that GSA has to offer. You will also be attending the largest Integrated Technology trade event serving all branches of the government. FOSE offers an array of products and services from over 500 leading IT companies, industry keynotes from leaders and information venues about the best solutions for government IT needs.

For detailed information on the benefits and scope of FOSE, visit the FOSE website at:
<http://fose.reedexpo.com>.

ALSO COMING SOON - FEDFacilities!

Following closely on the heels of the highly acclaimed FOSE 98 event, GSA's Federal Supply Service (FSS) and Public Building Service (PBS) will team together to co-sponsor the first annual FEDFacilities Expo, May 12-13, 1998. As co-sponsor, GSA will host several FREE educational conference tracks designed to benefit facilities managers, engineers, maintenance and purchasing officials who support federal facilities and installations. FSS & PBS experts will host an exhibit on the show floor spotlighting key GSA product and services of particular interest to federal facilities personnel. For more information about the show, contact: inquiry@fedfacilities.reedexpo.com

Customer Service Directors in the following regions will conduct FSS Information Seminars for local customers. While our target audience is new employees in supply and procurement/contracting, updated material will be presented that may be of use to experienced personnel. The following are tentative dates and locations. Exact dates and locations will be announced in regional mailings. Seminars are free; however, lodging and transportation, if required, are the responsibility of the attending agency.

MID-ATLANTIC REGION

**Delaware, Maryland, Pennsylvania, Virginia
Washington, DC and West Virginia**

Location	Dates
Washington, DC.....	February 1998
Washington, DC.....	March 1998
Washington, DC.....	May 1998
Washington, DC.....	August 1998
Washington, DC.....	September 1998

Contact: Cheryl Murray-Jackson, (202) 619-8920

Locations	Dates
Annapolis, MD	March 1998
Dover, DE	June 1998

Contact: Hazel Radford, (410) 962-4422

Locations	Dates
Petersburg, VA	April 1998
Lexington, VA.....	May 1998
Fredericksburg, VA	June 1998
Norfolk, VA	August 1998
Norfolk, VA	March 1998

Contact: John Engle, (757) 441-3115

Locations	Dates
York, PA.....	July 1998

Contact: Peter Carovillano (215) 656-3868

Philadelphia, PA	February 1998
------------------------	---------------

Contact: Richard Kostic, (215) 656-3882

EUROPE

Locations	Dates
Rota, Spain	February 1998
Stuttgart, Germany	March 1998
RAF Lakenheath, UK.....	April 1998
Heidelberg, Germany	May 1998

Contact: Peter Dallessandro, 011-49-69-699-7985

SOUTHEAST-SUNBELT REGION

**Kentucky, Tennessee, North Carolina, Mississippi,
Alabama, Georgia, South Carolina, Florida**

Location	Dates
Jacksonville, NC	February 19, 1998
Jacksonville, FL.....	March 12, 1998
Tampa, FL.....	March 17, 1998
Kennedy Space Center, FL	March 19, 1998
Biloxi, MS	March 19, 1998
Jackson, MS.....	April 8, 1998
Columbia, SC	April 16, 1998
Miami, FL.....	May 5, 1998
Columbus, MS	May 5, 1998
Ft. Lauderdale, FL	May 7, 1998
Tallahassee, FL	May 14, 1998
Charlotte, NC.....	May 14, 1998
Nashville, TN.....	May 19, 1998
Guantanamo Bay, Cuba	May 20, 1998
Memphis, TN.....	June 16, 1998
Savannah, GA	June 18, 1998
Pensacola, FL.....	June 25, 1998
Louisville, KY	July 21, 1998
Charleston, SC	July 23, 1998
Birmingham, AL.....	August 20, 1998
Lexington, KY	August 25, 1998
Knoxville, TN.....	September 22, 1998
Huntsville, AL	October 22, 1998

Contact: Adrian Finney (404) 331-3026

GREATER SOUTHWEST REGION

**Arkansas, Louisiana, New Mexico,
Oklahoma and Texas**

Locations	Dates
Corpus Christi, TX.....	February 1998
New Orleans, LA	March 1998
San Antonio, TX	April 1998
Albuquerque, NM	May 1998
Oklahoma City, OK	June 1998
Dallas/Ft. Worth, TX.....	August 1998
Little Rock, AR	October 1998
El Paso, TX	November 1998

**Contact: Betty Russell (817) 978-2892, FAX: (817) 978-2540
or e-mail: betty.russell@gsa.gov**

ROCKY MOUNTAIN REGION

Colorado, Montana, North Dakota, South Dakota,
Utah and Wyoming

Locations.....	Dates
Billings, MT	March 1998
Helena, MT.....	March 1998
Rapid City, SD.....	May 1998
Alberdeen, SD	May 1998
Denver, CO	June 1998
Colorado Springs, CO	June 1998
Grand Junction, CO	June 1998
Cheyenne, WY.....	September 1998
Sheridan, WY	September 1998
Bismark, ND.....	November 1998
Fargo, ND	November 1998

**Contact: Tony DelVecchio (303) 236-7546 or
E-mail: tony.delvecchio@gsa.gov**

NORTHWEST/ARCTIC REGION Alaska, Idaho, Oregon, Washington

FSS Seminars: a 2-day overview of FSS retail, stock, special order and schedule programs, as well as discussion of travel, traffic, fleet management and GSA *Advantage!*TM, GSA's on-line shopping service. Great for anyone new to procurement or needing a refresher on what GSA has to offer.

Symposiums: An interactive, 1 day update of what's new in the procurement area. Offers a half-day of GSA *Advantage!*TM training.

Made in GSA Day: A half day showcase of products and publications available through GSA Federal Supply Service.

Locations.....	Dates
2-day Seminar, Everett, WA	February 1998
1-day Symposium, Portland, OR.....	March 1998
Made in GSA Day, Portland, OR.....	March 1998
1-day Symposium, Newport, OR.....	March 1998
2-day Seminar, Boise, ID.....	April 1998
Made in GSA Day, Mtn, Home AFB, ID	April 1998
1-day Symposium, Bend, OR	April 1998
1-day Symposium, Wenatchee, WA.....	May 1998
1-day Symposium, Yakima, WA	May 1998
1-day Symposium, Anchorage, AK	May 1998
1-day Symposium, Fairbanks, AK.....	May 1998
Made in GSA Day, Ft. Wainwright, AK	May 1998
1-day Symposium, Pocatello, ID	June 1998
1-day Symposium, Salmon, ID.....	June 1998
1-day Seminar, Juneau, AK	July 1998
Made In GSA Day, Juneau, AK.....	July 1998
1-day Symposium, Coeur d' Alene, ID.....	August 1998
1-day Symposium, Lewiston, ID	August 1998
Made in GSA Day, Eugene, OR	September 1998

**Contact: Patti Lanzetti, Sharon Sciacqua or Bob Brown
(253) 931-7516, FAX: (253) 931-7203**

HEARTLAND REGION

Iowa, Nebraska, Kansas, Missouri

Locations.....	Dates
Springfield, MO	February 1998
Hays, KS	March 1998
North Platte, NE	March 1998
St. Louis, MO	March 1998
Topeka, KS	April 1998
Omaha, NE	April 1998
Grand Island, NE	April 1998

**Contact: Charlene Musick (816) 823-1240,
FAX: (816) 926-1661 or e-mail: charlene.musick@gsa.gov**

PACIFIC RIM REGION

California, Hawaii, Nevada, Pacific and Far East

Location.....	Dates
Flagstaff, AZ.....	April 1998
Phoenix, AZ.....	July 1998
Tucson, AZ.....	July 1998

Contact: Dilys Sunabe (213) 526-7500

Northern California and Northern Nevada

Location	Dates
Lemoore NAS	February 17, 1998
Fresno, CA.....	February 18, 1998
Travis AFB.....	March 18, 1998

Contact: Leslie Patterson (415) 522-2786

Southern California and Southern Nevada

Location.....	Dates
Vandenberg AFB, CA.....	February 1998
MCB Twenty-nine Palms, CA	March 1998
Oxnard, CA	March 1998
Los Angeles, CA	April 1998
San Diego, CA	April 1998
Long Beach, CA.....	June 1998
San Bernardino, CA	June 1998
Las Vegas, NV	September 1998

Contact: Dilys Sunabe (213) 526-7500

Pacific

Location.....	Dates
Fort Shafter, HI	February 1998
Honolulu, HI	February 1998
Kaneohe, HI	March 1998
Honolulu, HI	April 1998

Korea

Seoul	February 1998
.....	March 1998
.....	May 1998
.....	July 1998
.....	September 1998

Japan

.....	January 1998
-------	--------------

Contact: Melinda Eyre or Maria Rodriguez (808) 541-1776

Got a Problem? Need Help?...

Our Customer Service Directors (CSDs) stand ready to help you resolve your supply problems, explain the many GSA/FSS programs designed to save you time and money, and assist you in obtaining necessary service. They are as near as your phone and ready to support your needs. For your convenience, their numbers are listed below.

Region	Phone Number	Region	Phone Number
AZ - Phoenix	(602) 379-6619	MD - Baltimore	(410) 962-4422
CA - Bell	(213) 526-7500	MO - Kansas City	(816) 926-6485 or 926-5786
CA - San Diego	(619) 235-4706	NY - New York	(212) 264-3592
CA - San Francisco	(415) 522-2786	PA - Oakdale	(412) 644-4854
CO - Denver	(303) 236-7546/7543/7427	PA - Philadelphia	(215) 656-3868
DC - Washington	(202) 619-8920	TX - Ft Worth.....	(817) 978-2892
FL - Kennedy Space Center	(407) 867-2833	TX - San Antonio	(210) 472-6119
GA -Atlanta.....	(404) 331-3026	VA - Chesapeake	(757) 441-3115
IL - Chicago,	(312) 353-7549	WA - Auburn.....	(253) 931-7516
MA - Boston.....	(617) 565-7302		

Overseas:

Europe, Northern Africa, and the Middle East - Frankfurt, Germany DSN 330-6085/7985
 International Direct Dial. 011-49-69-699-7985/6085
 Pacific and Far East - Honolulu, Hawaii (808) 541-1776, DSN 438-4960

U.S. GOVERNMENT
 General Services Administration (7CAFL)
 PO Box 6477
 Ft Worth, TX 76115-6477

Official Business
 Penalty for Private Use \$300

Address Corrections Requested

BULK RATE
 POSTAGE & FEES PAID
 GSA
 PERMIT No. G-30

