

THE ECOLOGY OF POOLS 19 AND 20, UPPER MISSISSIPPI RIVER:

A Community Profile

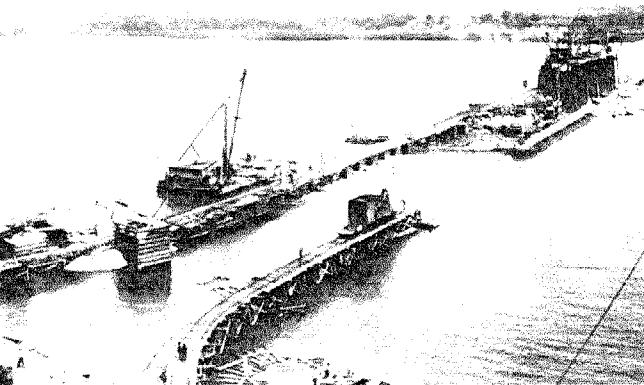

Biological Report 85(7.6)
September 1986

**THE ECOLOGY OF POOLS 19 AND 20, UPPER MISSISSIPPI RIVER:
A COMMUNITY PROFILE**

by

Larry A. Jahn

and

Richard V. Anderson

Department of Biological Sciences
Western Illinois University
Macomb, IL 61455

Project Officer

Walter G. Duffy
National Wetlands Research Center
U.S. Fish and Wildlife Service
1010 Gause Boulevard
Slidell, LA 70458

Prepared for
National Wetlands Research Center
Research and Development
U.S. Department of the Interior
Washington, DC 20240

Library of Congress Cataloging in Publication Data

Jahn, Lawrence A.

The ecology of pools 19 and 20, upper Mississippi River.

(Biological report ; 85 (7.6))

"September 1986."

Bibliography: p.

Supt. of Docs. no.: I 49.89/2:85(7.6)

1. Stream ecology--Mississippi River. I. Anderson, Richard V. II. National Wetlands Research Center (U.S.) III. Title. IV. Title: Ecology of pools nineteen and 20, upper Mississippi River. V. Title: Upper Mississippi River : a community profile. VI. Series: Biological report (Washington, D.C.) ; 85-7.6.

QH104.5.M5J34 1986 574.5'26323'0977 86-600373

This report may be referenced as follows:

Jahn, L.A., and R.V. Anderson. 1986. The ecology of Pools 19 and 20, Upper Mississippi River: a community profile. U.S. Fish Wildl. Serv. Biol. Rep. 85(7.6). 142 pp.

PREFACE

The Mississippi River is a resource that has multiple demands placed upon it for business and pleasure, recreation, commerce, and biotic and abiotic uses. We are becoming aware of the varied ecological relationships that govern the functioning of the river, but many details still need to be addressed. It is therefore of the utmost importance that those who use the river, for whatever purposes, have a better understanding of what is there and how the various components interact. It is imperative that increased efforts be made to better understand the riverine communities and, thus, to cope with multiple-use philosophy.

The information in this report will be beneficial to all those dealing either directly or indirectly with the Mississippi River or other large rivers. This report incorporates historical, recent, and on-going inquiries regarding the ecological mechanisms that govern life processes. It should serve as a reference for neophytes, as well as experienced river ecologists, for information about the river community and how the various segments affect one another. The report will also be helpful to those making budgetary decisions concerning riverine research because it not only points out what is known, but also indicates what needed knowledge is lacking.

Any questions or comments about or requests for publications should be directed to:

Information Transfer Specialist
National Wetlands Research Center
U.S Fish and Wildlife Service
NASA/Slidell Computer Complex
1010 Gause Boulevard
Slidell, LA 70458.

CONVERSION TABLE

Metric to U.S. Customary

<u>Multiply</u>	<u>By</u>	<u>To Obtain</u>
millimeters (mm)	0.03937	inches
centimeters (cm)	0.3937	inches
meters (m)	3.281	feet
kilometers (km)	0.6214	miles
square meters (m ²)	10.76	square feet
square kilometers (km ²)	0.3861	square miles
hectares (ha)	2.471	acres
liters (l)	0.2642	gallons
cubic meters (m ³)	35.31	cubic feet
cubic meters	0.0008110	acre-feet
milligrams (mg)	0.0003527	ounces
grams (g)	0.03527	ounces
kilograms (kg)	2.205	pounds
metric tons (t)	2205.0	pounds
metric tons	1.102	short tons
kilocalories (kcal)	3.968	British thermal units
Celsius degrees	1.8(°C) + 32	Fahrenheit degrees

U.S. Customary to Metric

inches	25.40	millimeters
inches	2.54	centimeters
feet (ft)	0.3048	meters
fathoms	1.829	meters
miles (mi)	1.609	kilometers
nautical miles (nmi)	1.852	kilometers
square feet (ft ²)	0.0929	square meters
acres	0.4047	hectares
square miles (mi ²)	2.590	square kilometers
gallons (gal)	3.785	liters
cubic feet (ft ³)	0.02831	cubic meters
acre-feet	1233.0	cubic meters
ounces (oz)	28.35	grams
pounds (lb)	0.4536	kilograms
short tons (ton)	0.9072	metric tons
British thermal units (Btu)	0.2520	kilocalories
Fahrenheit degrees	0.5556(°F - 32)	Celsius degrees

CONTENTS

	<u>Page</u>
PREFACE	iii
CONVERSION TABLE	iv
FIGURES	vi
TABLES	ix
ACKNOWLEDGMENTS	xii
CHAPTER 1. BACKGROUND AND CHARACTERISTICS OF POOLS	1
1.1 Pool and Dam Descriptions	1
1.2 Geologic History	2
1.3 History of Navigation	4
1.4 Classification of River Habitats	4
1.5 Significant Features and Uses	10
1.6 Structural Modifications	10
1.7 Limnological Considerations	13
1.8 Climatic Conditions	13
CHAPTER 2. COMMUNITY STRUCTURE	15
2.1 Succession and Habitat Development	15
2.2 Floodplain Vegetation	18
2.3 Macrophytes	20
2.4 Phytoplankton	29
2.5 Zooplankton	32
2.6 Meiofauna	44
2.7 Macroinvertebrates	45
2.8 Special Communities	57
2.9 Fishes	65
2.10 Amphibians and Reptiles	73
2.11 Birds	73
2.12 Mammals	78
2.13 Federal and State Endangered and Threatened Species	79
CHAPTER 3. COMMUNITY FUNCTION	87
3.1 Production and Biomass of Autotrophs	87
3.2 Production and Biomass of Heterotrophs	88
3.3 Trophic Relationships.....	92
3.4 Nutrient Cycling and Respiration	98
CHAPTER 4. HUMAN IMPACTS AND APPLIED ECOLOGY	103
4.1 The Community as a Resource	103
4.2 The Community as a Repository	117
4.3 The Community as a Highway	120
REFERENCES	129

FIGURES

<u>Number</u>		<u>Page</u>
1	The Upper Mississippi River navigation system includes all or parts of the Upper Mississippi, Illinois, Minnesota, St. Croix, Black, and Kaskaskia Rivers.....	2
2	Pool 19 map with cities and towns.....	3
3	Pool 20 map with cities and towns.....	3
4a	Sinking last cribs on upper leg of coffer dam, 22 July 1912.....	5
4b	Illinois view of dam from Iowa side showing progress on final section of coffer dam, 6 August 1912.....	5
5a	General view of work on ice fender to the right, 26 June 1912. Old canal is toward top of picture.....	7
5b	First boats to go through the new lock.....	7
6	Hypothetical section of the Upper Mississippi River showing habitat classes.....	8
7	Cross section of a rock and brush wing dam on the Upper Mississippi River.....	11
8	Bottom profile of the Mississippi River at RM 364.9, just above Lock and Dam 19.....	15
9	Changes in bottom profile, comparing the predicted profile to the actual profile produced because of a drought and development of macrophytes.....	16
10	The shift in invertebrate community composition and development of macrophyte beds as a result of a drought which increased water clarity.....	17
11	Plant succession on sand placed on existing floodplain forest or on newly created sand banks or islands.....	18
12	Plant succession on newly created rock banks and islands.....	19
13a	Island vegetation.....	20

<u>Number</u>		<u>Page</u>
13b	Undergrowth, including herb and vine vegetation of the floodplain forest.....	21
14	Growth forms and habitat relationships in aquatic macrophyte beds of Pool 19.....	26
15	Macrophyte bed, Nauvoo, Illinois, Pool 19, Mississippi River, American lotus in background.....	28
16	Seasonal distribution of phytoplankton by major growth forms in Pool 19, Mississippi River.....	33
17	Major phytoplankton taxa in various habitats in Pool 19, Mississippi River.....	34
18	Seasonal distribution of rotifers and crustacean zooplankton in various habitats of Pool 19, Mississippi River.....	43
19	Burrowing mayflies (<u>Hexagenia</u>) and fingernail clams (<u>Musculium</u>) in channel border substrate, Pool 19, Mississippi River.....	53
20	Seasonal distribution of size classes in finger-nail clam populations in Pool 19, Mississippi River.....	53
21	Effects of sampling techniques on distribution and density of insect and noninsect fauna down the length of Pool 19, Mississippi River.....	53
22a	Drift across the width of Pool 19, Mississippi River, showing effects of habitat.....	57
22b	Seasonal distribution of major drift taxa in Pool 20, Mississippi River.....	57
23	Sample containing high density of Asiatic clams and one mussel from area around Devil's Island, RM 378.0, Pool 19, Mississippi River.....	63
24	Duck migration corridors.....	76
25	Biomass production of arrowhead (<u>Sagittaria</u>) and lotus (<u>Nelumbo</u>) in a macrophyte bed near Nauvoo, Illinois, Pool 19, Mississippi River.....	89
26a	Diversity and biomass of benthic invertebrates down the length of Pool 19, Mississippi River.....	91
26b	Diversity and biomass of benthic invertebrates across the width of Pool 19, Mississippi River.....	91
27a	Diversity and biomass of benthic invertebrates down the length of Pool 20, Mississippi River.....	91
27b	Diversity and biomass of benthic invertebrates across the width of Pool 20, Mississippi River.....	91

<u>Number</u>		<u>Page</u>
28	Flow chart of trophic relationships of major components of a Mississippi River ecosystem.....	94
29	Seasonal change and distribution of biomass in major components of the channel border habitat, Pool 19, Mississippi River.....	95
30	Flow chart of nutrient transfers through major components of a Mississippi River ecosystem.....	101
31	Average pounds of all fish reported by commercial fishermen from Pools 19 and 20 of the Upper Mississippi River by 5-year increments.....	108
32	Average pounds of the four major fish species reported by commercial fishermen from Pools 19 and 20 of the Upper Mississippi River by 5-year increments.....	108
33	Best fishing areas and access sites on Pool 19.....	112
34	Best fishing areas and access sites on Pool 20.....	114
35	Bar and crowfoot dredge on boat for taking mussels.....	116
36	Sketch of a dredge fishing for mussels on the bottom of a river.....	116

TABLES

<u>Number</u>		<u>Page</u>
1	Features of Pools 19 and 20.....	4
2	Major events relating to navigational history of Pools 19 and 20.....	6
3	Pre- and post-aquatic conditions resulting from the 9-ft navigation channel, Upper Mississippi River, on Pools 19 and 20.....	11
4	Pre- and post-terrestrial conditions resulting from the 9-ft navigation channel, Upper Mississippi River, on Pools 19 and 20.....	12
5	Land ownership in terms of shoreline and islands.....	12
6	Ranges of variables for water year 1982 (Oct. 1981-Sept. 1982) taken at Station K04 (Keokuk) in tailwaters of Pool 19.....	14
7	Vegetation which may be found on islands and floodplains of Pools 19 and 20, Mississippi River.....	22
8	Relative distribution of major tree species in relation to elevation above normal pool level, Pools 19 and 20, Mississippi River.....	27
9	Relative contribution of major tree species to the canopy of the floodplain forest, Pools 19 and 20, Mississippi River.....	27
10	Distribution of vine species in relation to tree canopy density in floodplain forests, Pools 19 and 20, Mississippi River.....	27
11	Distribution of herbaceous species in relation to tree canopy density in floodplain forests, Pools 19 and 20, Mississippi River.....	28
12	Aquatic macrophytes from Pool 19.....	30
13	Phytoplankton reported in Pools 19 and 20, Mississippi River.....	35
14	Zooplankton taxa collected from Pools 19 and 20.....	42
15	Nematode taxa collected in various habitat types in Pool 19, Mississippi River.....	46
16	Macroinvertebrates collected from Pools 19 and 20, Upper Mississippi River.....	47

<u>Number</u>		<u>Page</u>
17	Number of macroinvertebrate taxa associated with particular habitat types in Pools 19 and 20, Upper Mississippi River.....	55
18	Number of macroinvertebrate taxa associated with particular substrate types in Pools 19 and 20, Upper Mississippi River.....	56
19	Macroinvertebrates found in the drift community of Pools 19 and 20, Mississippi River.....	58
20	Location of mussel beds in Pools 19 and 20, Upper Mississippi River...	61
21	Mussel taxa found in Pools 19 and 20 by various investigators over approximately 50 years.....	64
22	A checklist of parasites with number of fish species found infected by the parasites.....	66
23	Invertebrates which harbor cercariae, metacerciae, and larvae of various groups of parasites.....	67
24	Relative abundance of Upper Mississippi River fish species.....	70
25	Comparison of fish captured from several habitat types.....	72
26	Habitat study of the tailwaters below Locks and Dams 18 and 19.....	72
27	Amphibians and reptiles suspected or known to occur in the environs of Pools 19 and 20.....	74
28	Comparison of canvasback and scaup numbers and their use of Pools 19 and 20 from 1980 to 1983.....	77
29	Canvasback peak flights in the Illinois and Mississippi Valleys, 1950-1983.....	78
30	Comparison of nutritional values of the fingernail clam and Asiatic clam.....	79
31	Birds suspected and known from Pools 19 and 20 within 2 mi inland of the Mississippi River.....	80
32	Mammals suspected or known to occur in the environs of Pools 19 and 20.....	83
33	Federal and State endangered (E) or threatened (T) species, Pools 19 and 20.....	85
34	Seasonal mean phytoplankton density, biomass, and carbon in channel and channel border habitats, Pool 19, Mississippi River.....	88
35	Seasonal zooplankton density and biomass in two habitats, channel and channel border, Pool 19, Mississippi River.....	90

<u>Number</u>		<u>Page</u>
36	Biomass and rate of production of unionid mussels and clams found in Pools 19 and 20, Mississippi River.....	92
37	Caloric values of selected benthic organisms.....	93
38	Biomass and energy requirements of diving ducks on Pool 19, Mississippi River.....	93
39	Percent gut content of phytoplankton ingested by finger-nail clams.....	96
40	Frequency of occurrence of food items in fish taken above and below Lock and Dam 19, Mississippi River, during June and July.....	97
41	Frequency (percent occurrence) of food items in canvasback and lesser scaup taken on Pool 19, Mississippi River.....	99
42	Average values (mg/l) for nutrients, by habitat for August 1983 on Pool 19, Mississippi River.....	101
43	Seasonal gross productivity (mg O ₂ /l/hr) for channel border areas of Pool 19, Mississippi River.....	102
44	Percent reported harvest of fishes by type of gear from the Upper Mississippi River, 1953 through 1977.....	104
45	Total catch for Pools 19 and 20, 1980 and 1981, all gear combined.....	105
46	Reported catches in pounds of commercial fish caught in 1982 for Pools 19 and 20.....	106
47	Reported catches in pounds of commercial fish caught in 1983 for Pools 19 and 20.....	106
48	Dollar value of various commercial rough fishes, live condition, for 1980-81.....	107
49	Accepted common, scientific, and local names of fishes occurring in the Mississippi River.....	109
50	Recreational activities in Pools 19 and 20.....	117
51	Values regarding sediment loads and discharges, Pools 19 and 20.....	118
52	Tolerable uses for certain levels of turbidity.....	119
53	Analysis for Pools 19 and 20, using both constrained and unconstrained traffic projections.....	121
54	Response of Upper Mississippi River to construction of dikes and locks and dams.....	122
55	Major impacts of barge traffic related to various riverine components.....	125

ACKNOWLEDGMENTS

A treatise of this magnitude could not have been successfully produced without the help of many persons who kindly gave of their talents and time. We greatly appreciate their efforts and hope that we have not omitted anyone in our acknowledgments. The following persons and Federal agencies helped to supply information: Norman Benson and Walter Duffy, United States Fish and Wildlife Service (USFWS), project officers during the project; Frank Collins and Jon Duyvejonck, United States Army Corps of Engineers (USACE), Rock Island District, support and help; Fish and Wildlife Interagency Committee, review of drafts; National Science Foundation - Long Term Ecological Research Grant "Ecological Structure and Function of Major Rivers in Illinois" (BSR-8114563) awarded to the Illinois Natural History Survey with Richard V. Anderson, Western Illinois University (WIU), Nani G. Bhowmik, Illinois Water Survey (IWS), David L. Gross, Illinois Geological Survey (IGS), and Kenneth S. Lubinski, Illinois Natural History Survey (INHS) as principal investigators, for advice and much of the current information in the manuscript; Gail Peterson, USFWS, loan of material; Jerry Rasmussen, USFWS; Upper Mississippi River Conservation Committee (UMRCC), use of library and fish information; Rosalie Schnick, National Fishery Research Lab, loan of publications; Waterways Experiment Station, Vicksburg, MS, loan of publications.

A number of State agencies and their personnel also contributed to the project. They include from the Western Illinois University: David M. Day, Long Term Ecological Research technician, who produced most of the drafted figures and assisted in typing; Jan Hart, Research Office, typing and revisions; Edwin Franks, Biology Department, bird information; Michael Romano, Biology Department, herpetofauna verifications; Marla Vizdal, WIU Archives, photographs and printing; and John Warnock, Institute for Environmental Management, support of efforts. Assisting from the Illinois Natural History Survey's Havana Lab were Steve Havera, waterfowl information, and Richard E. Sparks, sharing and consulting. From the Illinois Department of Conservation we are grateful to Bill Fritz, fish data, and Vernon Kleen, bird information. Other helpful agencies and personnel were the Iowa Conservation Commission, Steve Waters, commercial fish data; Missouri Department of Conservation, Jack Robinson, commercial fish data; and Illinois Environmental Protection Agency (EPA), Bill Tucker, water quality information. Larry Weiman and Bill Vorhies of Union Electric Power Company provided photos of dam construction.

This report was prepared with funding from the Rock Island District Office of the U.S. Army Corps of Engineers.

CHAPTER 1

BACKGROUND AND CHARACTERISTICS OF POOLS

1.1 POOL AND DAM DESCRIPTIONS

The Upper Mississippi River was originally defined by the Upper Mississippi River Conservation Commission to extend from Hastings, Minnesota to Caruthersville, Missouri (Rasmussen 1979). It presently includes a series of navigation locks and dams constructed to permit navigation even during periods of low flow. Each dam, sequentially numbered from north to south, created a pool between it and the next dam, whose number applies to both the dam and the pool it impounds. The pooled portion extends from just upstream of St. Louis to Minnesota-St. Paul, a distance of 651 river miles (RM), with a resultant elevation change of 395 ft mean sea level to 723 ft mean sea level created by the series of dams. These dams significantly altered the Upper Mississippi River by reducing typical riverine characteristics (e.g., variable flows, productive river lakes, and side channels), while increasing lakelike characteristics for much of its length.

Two pools that lie in this area are Pools 19 and 20 (Figures 1,2,3). River mile distance is calculated from the mouth of the Ohio River going upstream. Some features of each pool are presented in Table 1 (data from Nord 1964; Wright 1970; U.S. Army Corps of Engineers, USACE, 1974a, 1974b; Rasmussen 1979).

The dams impounding water in Pools 19 and 20 are of different design and were constructed for different purposes. Dam 19 was built in 1913 by Union Electric Power Company (Figures 4a,b and 5a,b) for generation of hydroelectric power. It was, at the time, the second largest dam

in the country. By installing a lock, navigation traffic could more conveniently bypass the stretch of water from Keokuk to Montrose, Iowa, known originally as the Des Moines or Keokuk Rapids. The control section of Dam 19 consists of 119 lift gates (USACE 1974a) operated by the Union Electric Power Company. These gates are opened vertically to release excess river flow when the flow exceeds the capacity of turbines for power generation. The pool-controlling point (used to provide the established elevation for the theoretical flat pool stage) is located at the dam. A 110- x 1,200-ft lock along the Iowa shore was completed in 1957 to accommodate larger tows and currently is the only one in use. The original lock, 110 x 400 ft, and dry dock have not operated since the new lock became functional. A maximum vertical change of 19.4 to 38.2 ft between upriver and downriver sides of the dam is possible, depending on river stage.

Dam 20 consists of 3 roller gates and 40 tainter gates with a short 150-ft earthfill section tying to a levee on the Illinois shore (USACE 1974b). It was placed in operation on June 9, 1936. There are three controlling points--Dam 20, Gregory Landing gauge, and Dam 19--so that the established flat pool elevation of 480.0 MSL can be maintained. Gates are adjusted to maintain the minimum 9-ft pool and minimum channel depth for navigation (USACE 1974b). A maximum vertical change of 10.0 to 24.8 ft is possible on opposing sides of the dam. The lock, located along the Missouri shore, is 110 x 600 ft.

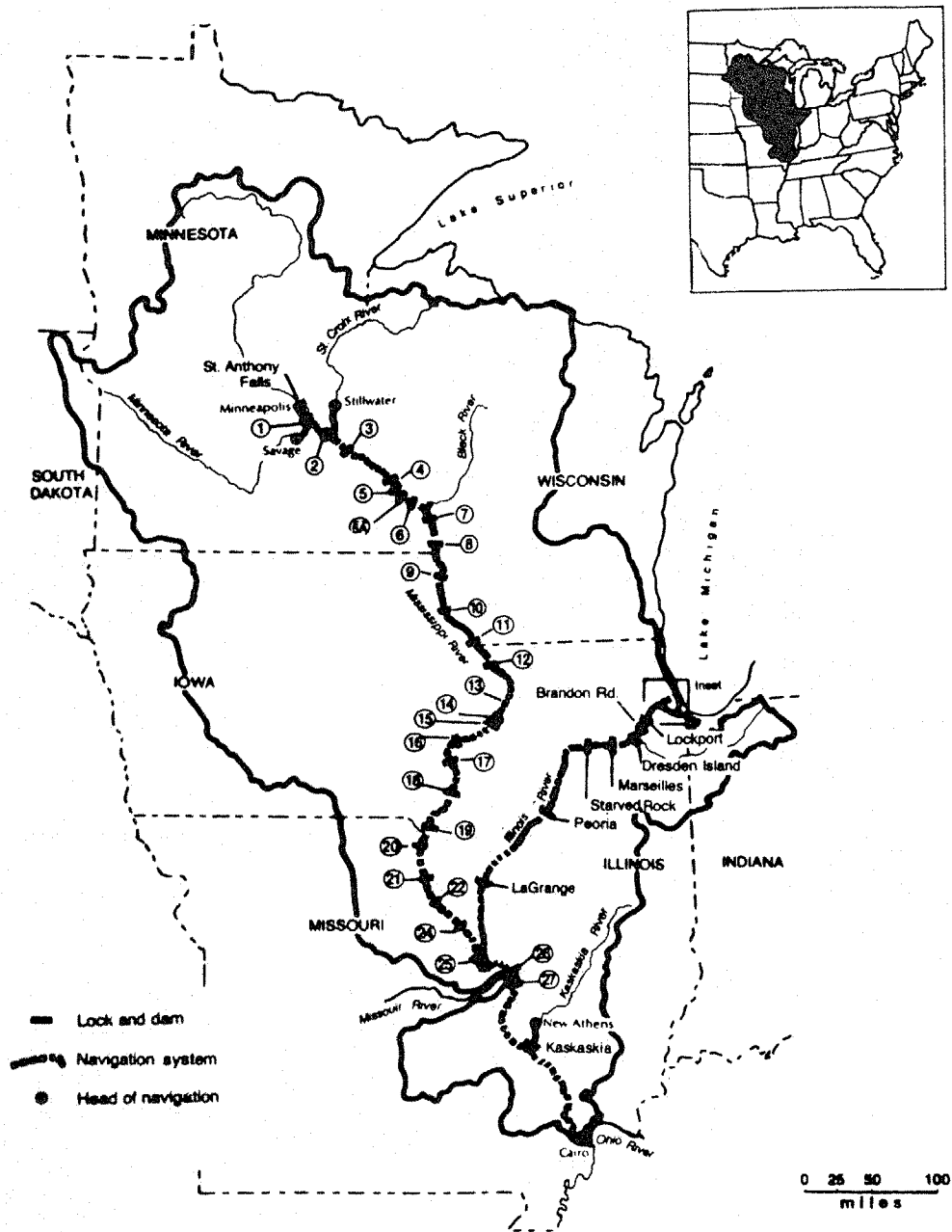

Figure 1. The Upper Mississippi River navigation system includes all or parts of the Upper Mississippi, Illinois, Minnesota, St. Croix, Black, and Kaskaskia Rivers.

GEOLOGIC HISTORY

There has been considerable change the river channel since its initial ation, much of the modification lting from glacial activity. The old floor in the valley at Fort Madison

is 120-125 ft below water (Leverett 1921). The valley was deepest in preglacial times. Near Fort Madison, pre-Kansan drift fills the old valley from the level of the rock floor to about 75 ft above the river, where a black soil marks the upper limit. From a few miles in the southeast

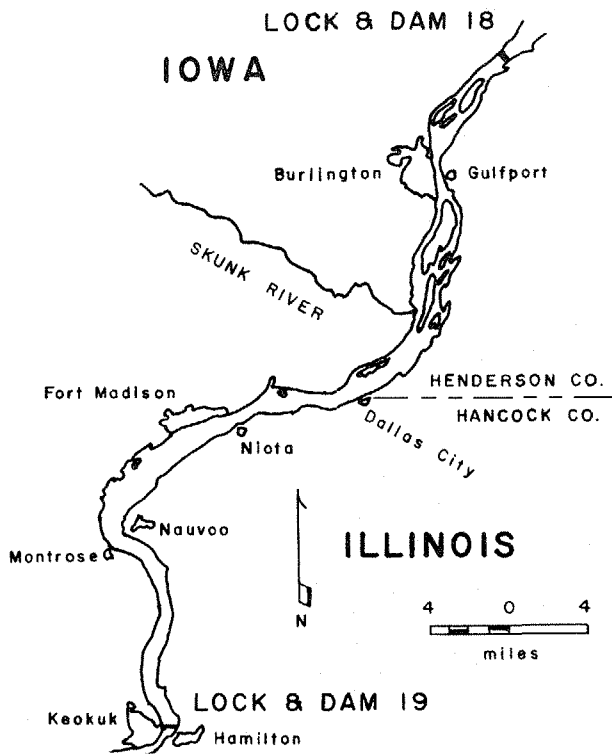

Figure 2. Pool 19 map with cities and towns.

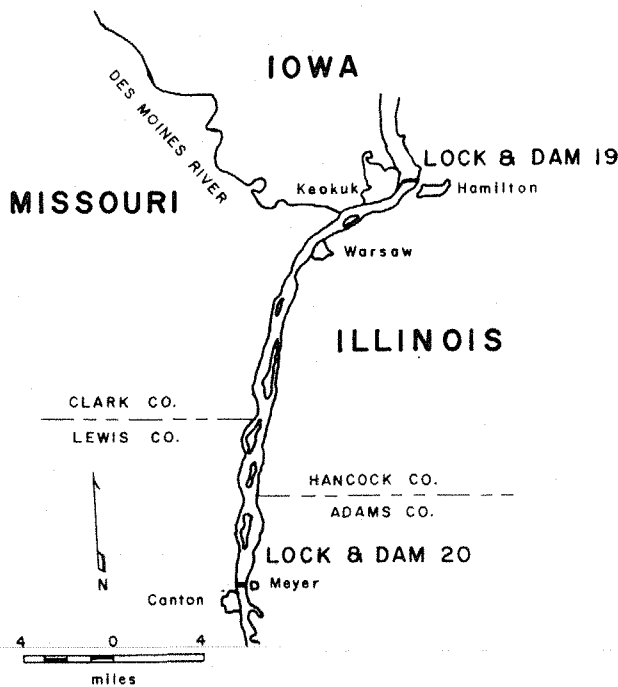

Figure 3. Pool 20 map with cities and towns.

corner of Iowa down to the Iowa-Missouri border, the channel near Keokuk was filled in completely with pre-Kansan (Nebraskan) and Kansan drift. The result was that the entire flow of glacial lake waters was diverted from the west side of Keokuk (where it flowed prior to this time) to the east side (present channel), or over what was the Des Moines or Keokuk Rapids. Below the mouth of the Des Moines River, the old valley was again occupied when ice from the Kansan stage melted. It is likely that nearly all erosion of the gorge at the Des Moines (Keokuk) Rapids has taken place since the Illinoian stage. The river at the head of the rapids is 50 to 60 ft lower than the surface of Wisconsin deposits of sandy gravel immediately above them.

The bedrock of Pool 19 consists of Keokuk and Burlington limestone of the Mississippian age (USACE 1974a). The riverbed deposits are primarily sand with lesser amounts of silt and clay and small amounts of gravel. Alluvial deposits in the floodplain are primarily silt and clay soils, and deposits above Dam 19 (some 30-35 ft deep above the old rapids) are also of these types.

The substratum below the dam in Pool 20 was not changed by construction (Coker 1929); rock and sand with a little gravel and clay remained near the banks and the rest was rock. The Des Moines Rapids has a solid rock bottom all the way across the river channel. The greatest depth of the rapids was 15 ft while most of the channel was 6 to 7 ft deep. From Montrose to Burlington there were some soundings of 26 ft, but the depth of the channel did not average over 12 to 15 ft. Once the dam was in place, the old rapids were 40 to 50 ft deep without any sediment. The old rapids descended gradually with a surface velocity of 2.88 ft/s and were seamed by a narrow crooked channel or several channels, with patches of sand gravel at the upper end. Until Burlington, the bottom was nearly all sand with some rock and gravel and scarcely any mud prior to the dam being built. By July, 1917 (4 years after the dam became operational) only mud was found 0.5 mi above dam, except in areas close to the banks (Coker 1929).

Table 1. Features of Pools 19 and 20.

Pool No.	Town closest to dam	Mile above Ohio River & lock bank	Length in miles	Estimated acreage	Flat pool elevation
19	Keokuk, IA	364.2R ^a	46.3	30,466	518.2
20	Canton, MO	343.2R	21.0	6,993	480.0

^aR is right bank, considering boats moving downriver.

1.3 HISTORY OF NAVIGATION

Navigation has always been of utmost importance on the Mississippi River. The history of navigation on the river has been described by Brunet (1977) and Tweet (1983) and is summarized in Table 2. Additional historical notes reveal that during the 1820's trading posts were established at the mouth of the Skunk River and at most major tributary mouths northward to collect furs. The shipping of lead was also important during the early 1800's. Between 1823 and 1848, 200 of 365 boats that sailed above the Des Moines Rapids were primarily in the lead trade and handled lead shipments from Galena, Illinois. However, by 1848 only 30 boats were shipping lead exclusively, and by 1859 the Galena and Chicago Railroad had taken over lead transportation, eliminating boat trafficking of this ore.

Railroads also competed for other goods and for passengers traveling the Mississippi River. In 1830, Joseph Throckmorton operated keel boats above and below the Des Moines Rapids, hauling both goods and passengers around the rapids. He attracted business by instituting well-maintained schedules. In 1842, the St. Louis and Keokuk Packet Line also began operating on a regular schedule, with a separate line to Quincy, Illinois in 1852. Several mergers took place until, in 1873, the Keokuk and Northern Line Packet Company running from St. Louis to St. Paul became known as the "tightest monopoly in the history of western steamboating." A year after this, however, the firm was bankrupt, because the railroads were expanding and competing effectively with riverboats.

Years of low water were especially important in kindling the idea of modifying the river for purposes of navigation. It was during low water years that the need to minimize annual water level fluctuations was dramatized.

During periods of low water in 1852, boats with drafts deeper than 24 inches could not pass the Des Moines Rapids. The channel along the Iowa shore had only a 10 to 12-inch depth so "lighters"--small horse-drawn boats--were used to transfer cargo from the packet boats. Lighters took 6 h to go from Keokuk to Montrose with "luck and eight horses." This extra inconvenience and cost prompted an interest in making the river more efficient for goods and people.

1.4 CLASSIFICATION OF RIVER HABITATS

The Fish Technical Committee of the Upper Mississippi River Conservation Commission has defined the various fish habitats in the Mississippi River according to (or on the basis of) an area's physical characteristics. These categories will help in understanding various ecological relationships discussed later. The following is taken directly from Nord (1967; Figure 6).

1.4.1 Main Channel

The main channel includes only the portion of the river through which large commercial craft can operate. It is defined by combinations of contraction works (wing dams and riprap), river banks, islands, and buoys and other markers. It

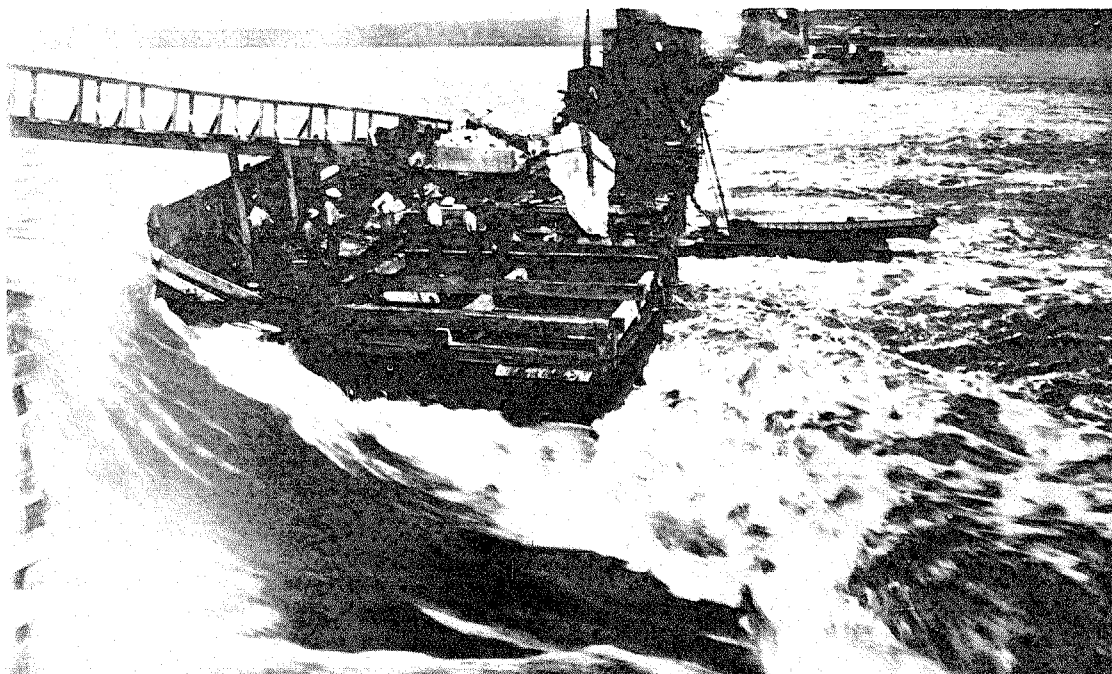

Figure 4a. Sinking last cribs on upper leg of coffer dam, 22 July 1912.

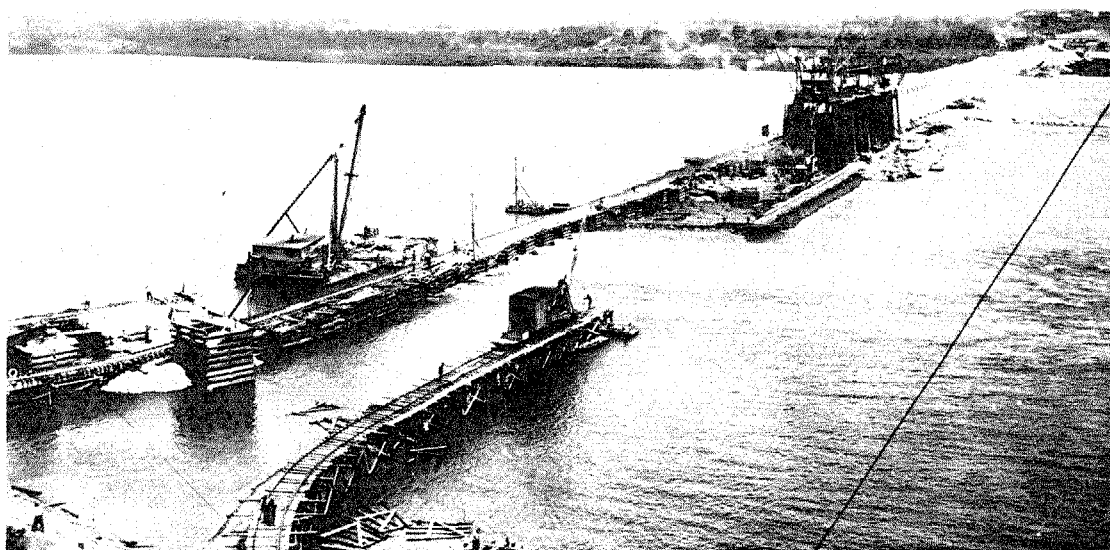

Figure 4b. Illinois view of dam from Iowa side showing progress on final section of coffer dam, 6 August 1912.

Table 2. Major events relating to navigational history of Pools 19 and 20 (Brunet 1977; Tweet 1983).

Year	Event
1820	First steamboat above St. Louis, <u>Western Engineer</u> , commanded by Major Long, reached Keokuk at foot of Des Moines Rapids.
1823	First steamboat above Keokuk, <u>Virginia</u> , carrying military supplies to Fort St. Anthony.
1828	Lt. Buford examined Des Moines Rapids with ice 12 ft thick to determine how the 11.25-mile stretch could be passed.
1829	First government survey of Des Moines Rapids.
1837	Robert E. Lee and M.C. Meigs surveyed and began improvements at Des Moines Rapids.
1839	During this low-water year a 50-ft by 4-ft deep cut was made through two chains of the lower rapids.
1843	Logs were floated to St. Louis from St. Croix, WI, through the area.
1852	Renewed attempts to improve Des Moines Rapids after St. Paul became the capital of the new Territory of Minnesota in 1849.
1864	All time low-water mark was reached; river traffic ceased for entire shipping season. Level became the mark by which subsequent measurements are still made.
1866	Beginning of the Rock Island District of Corps of Engineers. Concept of a 4-ft channel established.
1868	First channel markers, 5- to 6-ft ² white boards with large red cross in center, were established; first ridiculed, then much respected by river boatmen.
1868-72	Removal of over 1,700 snags, 700 stumps, and 3,000 trees that were leaning towards the channel.
1873-76	Only 81 snags and 13 stumps removed; of 3,300 trees removed, 80% were less than 8 inches in diameter.
1876	Lifts with chambers 78 by 291 ft established at Des Moines Rapids.
1877	Des Moines Rapids Canal was opened (also closed for short periods for repairs) to navigation.
1878-79	4.5-ft channel authorized by Congress to be created by dredging and wing and closing dams; wing dams constructed of willow and stone layers, with revetments on opposite shores.
1907	6-ft channel authorized using wing dam construction; new locks at Des Moines Rapids.
1913	Completion of Keokuk Dam and new 110 by 400 ft lock to replace 3 original locks in canal to provide a 40-ft lift.
1915	Last raft of white pine floated downriver.
1930	9-ft channel authorized on Upper Mississippi to be constructed by building a series of 27 locks and dams north of St. Louis.
1939	9-ft channel project completed.
1943	UMRCC ^a established based on "need for uniform regulation of the fisheries," "and the need for cooperative action on many problems affecting fish and wildlife of the river."
1957	New lock at Keokuk Dam, 110 by 1,200 ft, became operational.

^a UMRCC=Upper Mississippi River Conservation Commission.

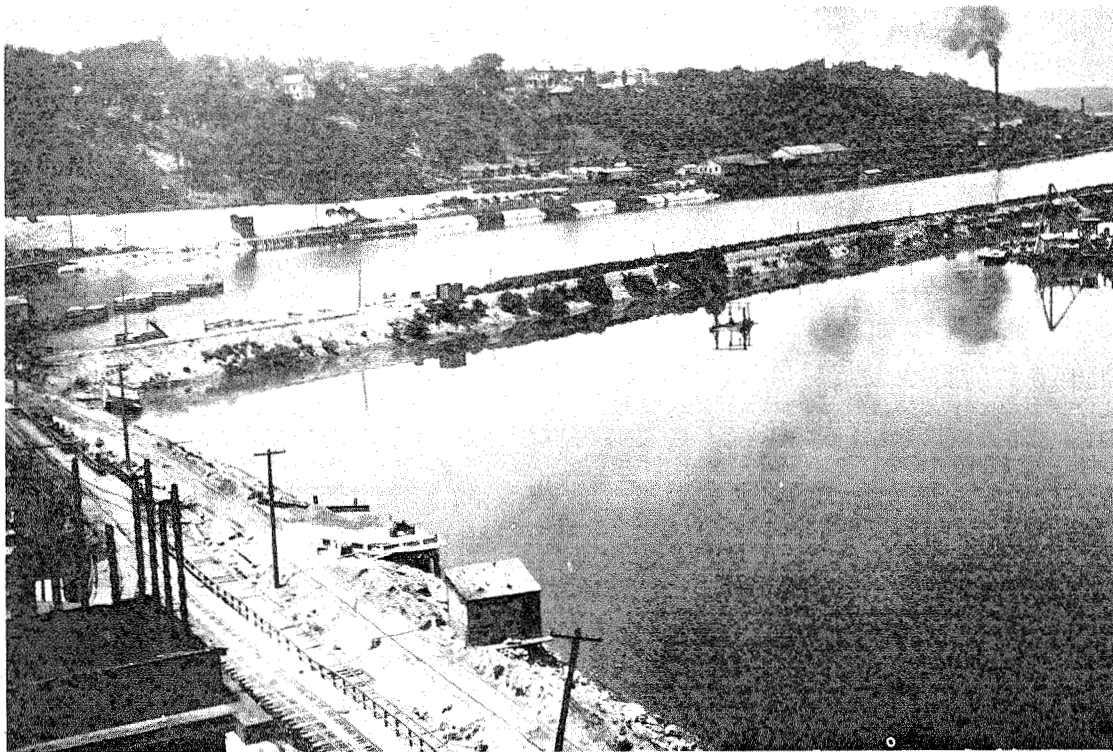

Figure 5a. General view of work on ice fender to the right, 26 June 1912. Old canal is toward top of picture.

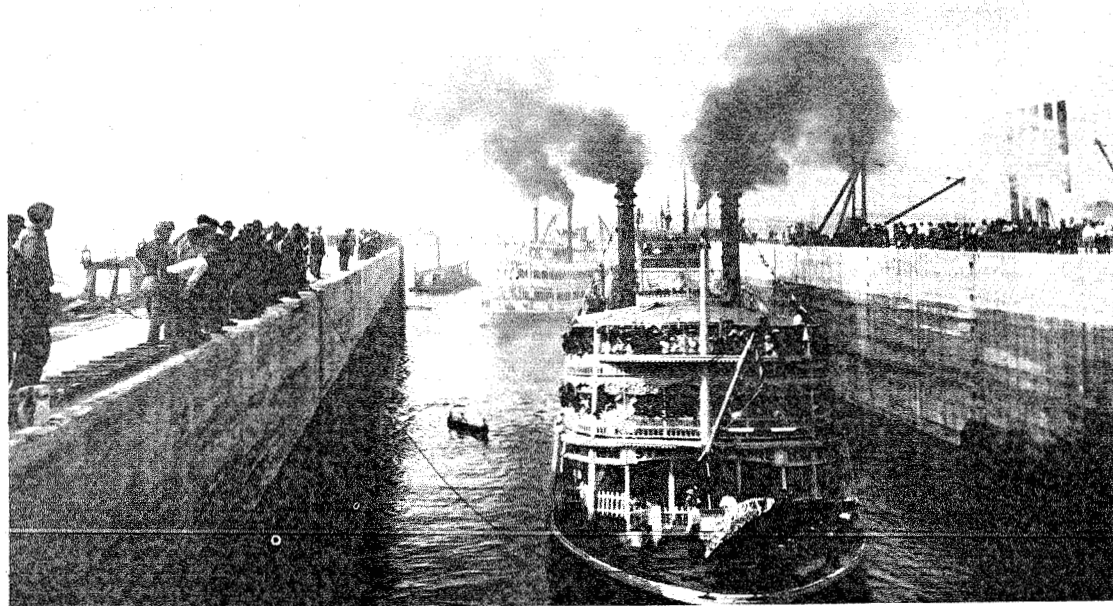

Figure 5b. First boats to go through the new lock.

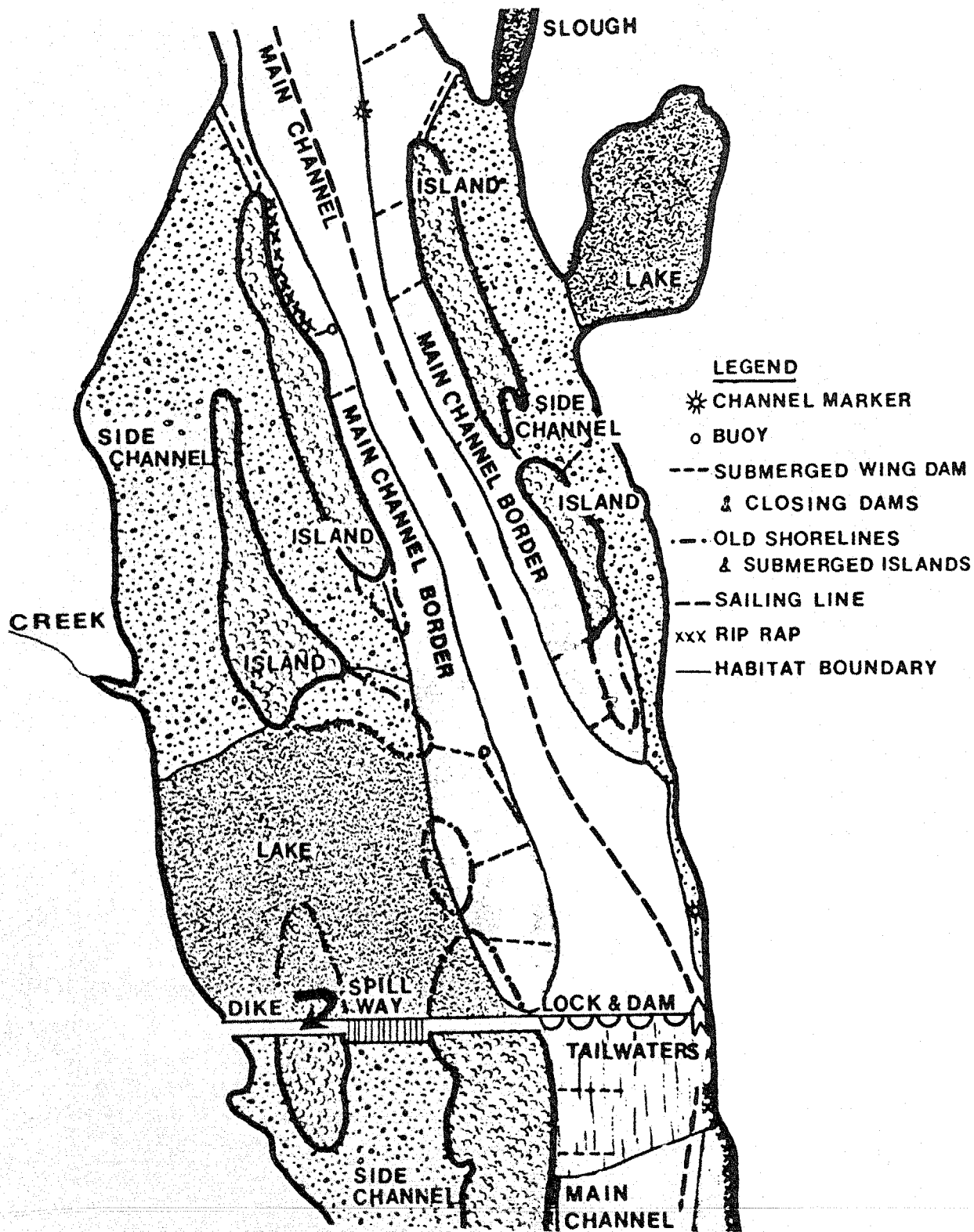

Figure 6. Hypothetical section of the Upper Mississippi River showing habitat classes (modified from Nord 1967).

has a minimum depth of 9 ft and a minimum width of 400 ft. The main channel always has a current, varying in velocity with water stages. The bottom type is mostly a function of the current. Within the upper section a pool usually has a sand bottom, changing to silt over sand in the lower section. A few areas have occasional patches of gravel. Most of the main channel is subject to scouring during periods of rapid water flow and when towboats pass in the shallower stretches. No rooted aquatic vegetation is present.

1.4.2 Main Channel Border

The main channel border is the zone between the 9-ft channel and the main river bank, islands, or submerged definitions of the old main river channel. It includes all areas in which wing dams occur along the main channel. This area is commonly thought of as part of the main channel, but for fishery purposes, it is considered a separate habitat. Buoys often mark the channel edge of this zone. Where the main channel is defined only by the bank, a narrow border still occurs, and often the banks have riprap and fair to good fish habitat. Dredge spoil has been placed in some sections of this zone and sometimes covers the wing dams. The bottom is mostly sand in the upper sections of the pool and silt in the lower. Little or no rooted aquatic vegetation is present. This zone provides some of the better fishing along the river at certain times of the year.

1.4.3 Tailwaters

Tailwaters include the main channel, main channel border, and the areas immediately below the dams that are affected by turbulence from the passage of water through the gates of the dams and out of the locks. Because these areas change in size according to water stage, an arbitrary lower boundary for fishery purposes has been set at a distance of 0.5 mi below the dams. The bottom is mostly sand and has no rooted aquatic vegetation.

1.4.4 Side Channels

Side channels include all departures from the main channel in which there is current during normal river stage. The

gradations in this category are widespread, ranging from fast-flowing watercourses with high banks to sluggish streams winding through marshy areas. Unless side channels are former main channels (a situation occurring in a few places on the Mississippi), the banks are usually unprotected. Undercut or eroded banks are common along side channels near their departure from the main channel. Such banks occur mainly in the upper sections of the pools where banks are highest and the current is swiftest. Closing, or diversion dams, are usually present where the side channel leaves the main channel and, infrequently, at other locations. In the river's impounded section, these dams are mostly submerged. The bottom type usually varies from sand in the upper reaches to silt in the lower. In waters with swift current there is no rooted aquatic vegetation, but vegetation is common in the shallower waters with silty bottoms and moderate to slight current.

Other terms that have been used for this habitat are sloughs, running sloughs, chutes, cuts, cutoffs, and canals.

1.4.5 River Lakes and Ponds

Most lakes and ponds in the Mississippi River bottoms are adequately defined in the literature. Within this category are waters formerly called "backwaters," a term no longer used for scientific purposes. Some backwaters are also included in the slough category. Following are types of lakes and ponds, their definitions, and examples found along the Mississippi.

Lakes of formation due to fluvial dams:

- Type 49 - Lakes of mature flood plains (Lake Pepin, between Minnesota and Wisconsin)
- Type 55 - Oxbows or isolated loops of meanders (possibly Spring Lake near Buffalo City, Wisconsin)
- Type 56 - Lakes in depressions formed on floodplains (Sturgeon Lake in Minnesota)

Type 57 - Lakes between natural levee and scarp (Goose Lake in Wisconsin).

Lakes due to behavior of higher organisms:

Type 73 - Dams built by humans (Keokuk Lake between Iowa and Illinois. Large, open areas, usually not named, off the main channel and main channel borders just above many of the dams).

In river studies on the Mississippi, only those lakes having some connection with the river during normal water stage are usually considered. River lakes and ponds may or may not have a current, depending on their location. Type 49, for example, has some current, especially in the upper and lower extremities. Most of the bottoms are mud or silt, 2 or more ft thick. Many of these waters have abundant rooted vegetation, both submerged and emergent. They are often surrounded by marshland.

1.4.6 Sloughs

Sloughs, also called "dead sloughs," include all of the remaining aquatic habitat found in the river. Sloughs often border on the "lake or pond" category on the one side and on the "side channel" category on the other. They may be former side channels that have been cut off or that have only intermittent flows. They may be relatively narrow branches or offshoots of other bodies of water. Sloughs are characterized by having no current at normal water stage, muck bottoms, and an abundance of submerged and emergent aquatic vegetation. The sloughs, and some of the ponds and smaller lakes, are often most representative of the ecological succession taking place in the river bottoms, from aquatic to marsh habitat.

1.5 SIGNIFICANT FEATURES AND USES

Habitat conditions before and after the construction of the 9-ft navigation channel, Upper Mississippi River, were examined by McDonald and Konefes (1977). Areal changes were expressed according to

UMRCC habitat categories (Table 3). Terrestrial changes in areas immediately adjacent to the river in floodplain areas were also evaluated (Table 4).

Overall, a net loss in aquatic habitat in Pool 19 has taken place; about two-thirds of the loss has been at the expense of main channel border areas. In Pool 20 a slight overall loss has occurred; losses in main channel borders have been nearly offset by additions of side channels and marshes.

Land ownership in general terms of shoreline and islands was identified in GREAT (1980a). There are no federally owned islands in either pool (Table 5). Floodplain land use acreages were identified in GREAT (1980a), which emphasized the influence land use may have on riverine communities.

1.6 STRUCTURAL MODIFICATIONS

Besides the modifications due to natural phenomena, several kinds of artificial structures have influenced the river, primarily in stabilizing banks, increasing water depths in the navigation channel, and reducing flooding in the floodplain. Wing dams (dike dams) constructed of rock and brush were built to direct water toward the main channel (Figure 7; Boland 1980). For those bordering Iowa on Pool 19, the mean depth is 8.8 ft below the surface with maximums of 13.8 to 19.5 ft, depending on configuration and placement (Boland 1980). Because of their orientation with respect to the current and shoreline, scouring may take place upstream and downstream from them, resulting in average maximum depths of 15.2 and 16.8 ft upstream and downstream, respectively. There is also the tendency for them to accumulate silt and debris. Of 39 wing dams originally constructed along the Iowa shore in Pool 19, 27 have either become covered or eroded and 1 has been removed. The total footage of wing and closing dams has been reduced by two-thirds from 34,033 (linear) ft to 11,300 ft in 1979. Silt and sand make up 85% of the substrate above and below the dams. The configuration of the dams affects deposition and thus these dams have

Table 3. Pre- and post-aquatic conditions resulting from the 9-ft navigation channel, Upper Mississippi River, on Pools 19 and 20 (McDonald and Konefes 1977).

Category	Pool	Acres		Difference
		1927	1975	
Main Channel	19	1,183.0	1,163.6	-19.4
	20	1,003.6	1,003.6	0
Main channel border	19	7,404.2	5,203.6	-2,200.6
	20	4,411.7	4,221.3	-100.4
Side channel	19	3,285.8	3,338.5	+52.7
	20	889.5	1,036.7	+147.2
Sloughs	19	960.0	346.8	-613.2
	20	48.0	35.0	-13.0
River lake, pond	19	17,866.7	17,675.4	-191.3
	20	196.0	120.5	-75.5
Tailwaters	19	0	124.3	+124.3
	20	223.5	237.1	+13.6
Marsh	19	1,965.5	1,664.6	-300.9
	20	26.3	46.8	+20.5
Total aquatic	19	32,665.2	29,516.8	-3,148.4
	20	6,798.6	6,701.0	-97.6

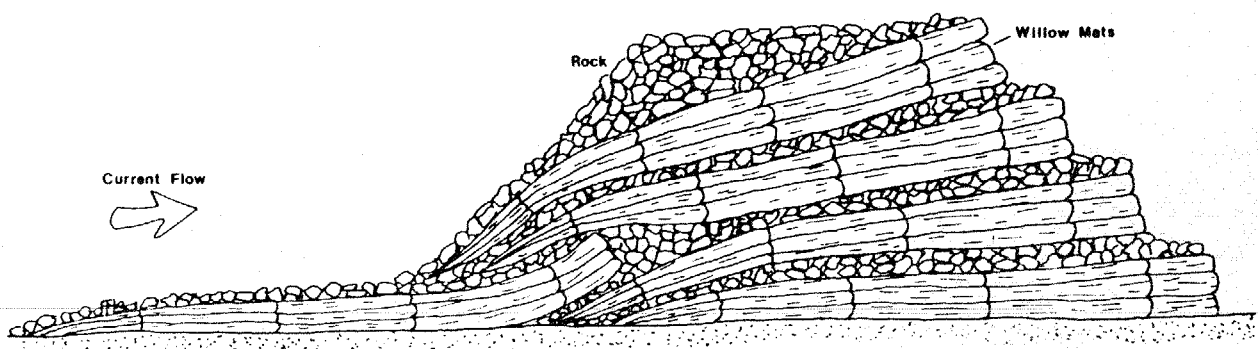

Figure 7. Cross section of a rock and brush wing dam on the Upper Mississippi River (from Boland 1980).

Table 4. Pre- and post-terrestrial conditions resulting from the 9-ft navigation channel, Upper Mississippi River, on Pools 19 and 20 (McDonald and Konefes 1977).

Category	Pool	Acres		
		1927	1975	Difference
Forest	19	4,593.4	9,410.5	+4,817.1
	20	1,878.7	2,635.4	+756.7
Brush	19	1,528.0	1,834.3	+306.3
	20	648.3	391.4	-256.9
Meadow	19	1,524.8	1,397.0	-127.8
	20	597.3	197.0	-400.3
Sand	19	29.0	106.3	+77.3
	20	917.0	97.7	-819.3
Mud flat	19	1.5	24.3	+22.8
	20	0	2.5	+2.5
Agriculture	19	25,297.8	20,423.4	-4,874.4
	20	3,498.7	2,823.9	-674.8
Developed	19	356.0	2,082.1	+1,736.1
	20	199.0	523.5	+324.5
Total terrestrial	19	33,320.5	35,277.9	+1,957.4
	20	7,739.0	6,671.4	-1,067.6

Table 5. Land ownership in terms of shoreline and islands (UMRCBS 1972).

Ownership	Pool	
	19	20
Shoreline		
Total miles	246	93
Federally owned	1	5.2
Non-federal	245	87.8
Islands (acres)		
Total	--	1,943
Non-federal	All	1,943
Mileage	364-410	343-364
Total acres	34,242	57,523
Crops and pasture	30,472	50,380
Other	3,770	7,143
Urban area subject to flooding	Burlington, Ft. Madison, IA; Dallas City, Pontoosoc, Nota, IL	Keokuk, IA

altered areas, especially those associated with islands and chutes, by reducing flows into river lakes. Rock revetments help restrict movement of the river channel by reducing bank erosion. Levees have markedly influenced the floodplain by preventing high water during flooding to expand into otherwise available river, lake, pond, and slough areas.

1.7 LIMNOLOGICAL CONSIDERATIONS

All biota in the Mississippi River, a 10th order stream (Cole 1983), depend on water quality for their survival, either directly or indirectly. Physical and chemical water quality variables are monitored by the USGS at bimonthly intervals 0.2 mi below Dam 19 and Keokuk. Records from the 104-year period up to water year 1982 (October 1981-September 1982) indicated discharge has averaged 62,880 f³/s, or 45,560 acre ft/yr during the period (USGS 1982). A maximum discharge of 344,000 f³/s, recorded on April 24, 1973, caused a river stage of 23.35 ft or 7 ft above the technical flood stage of 16.0 ft at the USGS stations. Minimum discharge during the period was 5,000 f³/s, recorded on December 27, 1933. Discharge apparently influences chemical parameters in the river. In a study of Pool 20, Heffelfinger (1973) noted that periods of increased stream discharge resulted in increases in current velocity, settleable solids, and carbon dioxide,

while dissolved oxygen and plankton numbers decreased. Air temperature was strongly linked with water temperature and water temperature varied little with depth, indicating thorough mixing of the water column in the three locations sampled in Pool 20. Ranges of values obtained by the USGS (1982) are given in Table 6 for the 1982 water year.

1.8 CLIMATIC CONDITIONS

Annual average precipitation during 1910-63 recorded at Burlington, Iowa, was 35.23 inches (Upper Mississippi River Comprehensive Basin Study 1970b) with a maximum record point rainfall for a 24-h period of 6.28 inches (June 1953) and 5.88 inches (June 1933) for Burlington and Keokuk, respectively. Average high and low monthly temperatures at Burlington over the 62 years of records were 87.7 °F (July) and 15.7 °F (January), resulting in an average annual temperature of 51.7 °F. Highest mile winds (73 mph) occur in April and August from the west and north, respectively; this figure integrates gusts and lulls during each mile of air which passes the recording station. The mean annual number of days of temperatures over 90 °F recorded from 1931 to 1952 was more than 30 while the mean annual number of days below 32 °F was more than 120. Mean fall frost date is October 20 and mean last spring frost date is April 22.

Table 6. Ranges of variables for water year 1982 (Oct. 1981-Sept. 1982) taken at Station K04 (Keokuk) in tailwaters of Pool 19 (USGS 1982).

Variable	Value range
Alkalinity, total, mg/l	137-190
Ammonia, mg/l	0.06-0.64
Chloride, mg/l	12-26
Conductivity, μ mhos	375-505
Copper, μ g/l recoverable	4-26
COD, mg/l	36-88
Coliforms (Millipore filter = 0.7 μ M-MF)	250-K11000/100 ml
Discharge, ft ³ /s	27,600-225,000
Hardness, (CaCO ₃) mg/l	182-235
Hardness, noncarbonate, mg/l	31-52
Iron, recoverable, μ g/l	180-6,798
Manganese, recoverable, μ g/l	90-368
Nitrate + nitrate, dissolved, mg/l	1.2-4.1
Oil & grease recoverable, mg/l	1-2
Oxygen, mg/l	6.7-13.3
pH	7.5-8.5
Phenols, μ g/l	5
Phosphate, total P, mg/l	0.100-0.360
Silica dissolved, mg/l	2.3-12
Sulfate dissolved, mg/l	9-34
Temperature, °F	32-81.5
Turbidity (NTU)	3-96
Suspended sediments discharged, ton/day	119-133,000

CHAPTER 2

COMMUNITY STRUCTURE

2.1 SUCCESSION AND HABITAT DEVELOPMENT

The normal process of succession and habitat development in a river system would involve the erosional and depositional zones along a continuum within the river course and its associated floodplain. The construction of the lock and dam system on the Upper Mississippi River interrupts this rapids-pool sequence, creating river lakes. These navigation pools can usually be divided into a lacustrine reach that occupies the lower end of the navigation pool and a riverine reach with island braiding and flow control structures in the upstream reach of the pool. Each lock and dam also has a tailwater area similar to a rapids type habitat. Successional processes within each of these broad areas have somewhat unique characteristics. The lacustrine areas of the pools are subject to sediment accumulation. Depending on the type of dam structure and the location of the navigation lock, the amount and rate of sediment and accumulation affect the types and succession of habitats in this area.

Lock and Dam 19, with surface lift gates, have produced a river lake that has acted as a sediment trap with the bottom profile becoming increasingly shallow over the past 70 years (Figure 8). Coker (1929) noted the water depth above Lock and Dam 19 was 7 ft; in 1985 the depth was 3 ft or less over much of the area above the lock and dam (Anderson et al., in prep.). The gradual accumulation of sediments produces distinct habitats. When the depth is shallow enough (1.5 m or less) a sequence of macrophytes develops. Extensive areas in the lacustrine reach

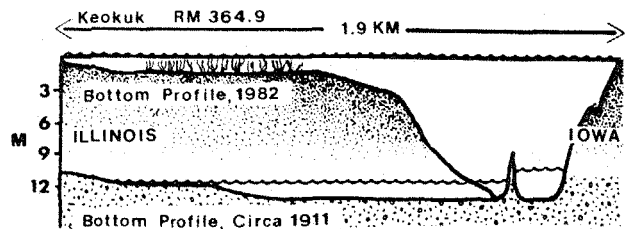

Figure 8. Bottom profile of the Mississippi River at RM 364.9, just above Lock and Dam 19.

of Pool 19 now have expanding macrophyte beds. The invertebrate community in areas of mud bottom channel border are distinctly different from those found in these macrophyte beds (Anderson and Day, in press, and Section 2.7). With a further decrease in depth, the macrophyte community also changes species composition from those plants with submerged growth forms to those which are emergent. The change in both invertebrates and macrophytes alters use by fish and other vertebrates, depending on the habitat preference of these organisms (Day 1984). Thus diving ducks feed in shallow mud-bottomed areas with some submerged vegetation, where they find preferred food items, and carp use areas between submerged and emergent vegetation for feeding and spawning. The species assemblages usually found in the lacustrine area of Pool 19 includes a depauperate mixed fauna in the main channel, sphaeriid-burrowing mayfly fauna in the mud-bottomed channel border, a transitional community of sphaerriids, gastropods, and insects in shallow areas with submerged vegetation, and a littoral annelid-crustacean-insect community

associated with emergent vegetation in areas with less than 1 m of water (see Sections 2.3 and 2.7 for specific species composition of these communities).

The rate of development of these habitats and associated communities is affected not only by sediment trapping characteristics of the lock and dam but also by annual flow regimes. Sparks and Anderson (in prep.) indicate that an event, such as a drought with low flow characteristics, increases water clarity and the development of macrophytes. Once established, the macrophytes further affect flow regimes by reducing current velocities and consequently increase sediment and organic matter accumulation. This accumulation produces a change in invertebrate communities and related habitat use by vertebrates and represents an increase in the rate of succession or habitat development (Figure 9; Sparks and Anderson, in prep.). Such an event occurred in 1975-76 and was reflected by a rapid expansion of macrophytes in Pool 19 (Figure 10). There was also an associated reduction in the *Sphaerium Musculium*-dominated benthic invertebrate community (Figure 10; Sparks and Anderson, in prep.) The invertebrate biomass did not recover after the drought and the plant beds continued to expand in most areas of Pool 19. The opposite of this accelerated succession can occur during extremely high flow and floods of record, when many or all of the gates on a dam--sometimes even the locks--are opened, resulting in substrate scouring. This occurs both above and below the dam. Under these conditions, the accumulated soft substrate behind the dam is resuspended and washed downstream, particularly in the spring or the late fall when macrophytes are not present to decrease current velocities. This is usually when extremely high flow periods occur. The scouring increases water depth, which inhibits the growth of macrophytes. These effects, however, are usually infrequent, since the pools act primarily as sediment traps to increase shallow area and expand macrophyte beds.

The upper end of the navigation pool is more riverine and not punctuated by these sharp, environmentally mediated habitat changes. While flooding may be more frequent in the riverine area, this

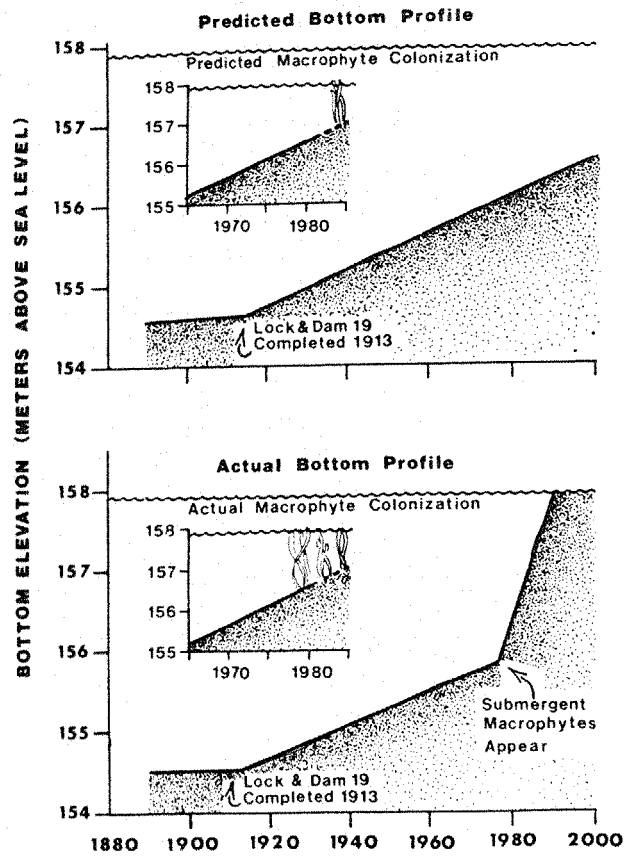

Figure 9. Changes in bottom profile, comparing the predicted profile to the actual profile produced because of drought and development of macrophytes.

area is adapted to this wetting-drying sequence. Consequently, habitat alteration and successional changes due to flooding or drought are not as marked as in the lower end of the pools. These reaches of both pools, however, are subject to human-induced habitat changes. The changes are a result of maintaining a 9-ft navigation channel, which requires the dredging of sand from the channel, construction of rock wing dams to direct water flow, rocky bank erosion protection, and, in the tailwaters of Lock and Dam 19, the blasting and removing of rock. These activities create sand or rock islands and banks that go through a primary successional process.

Howe (1979) studied these types of habitat in Pool 20 and found that three

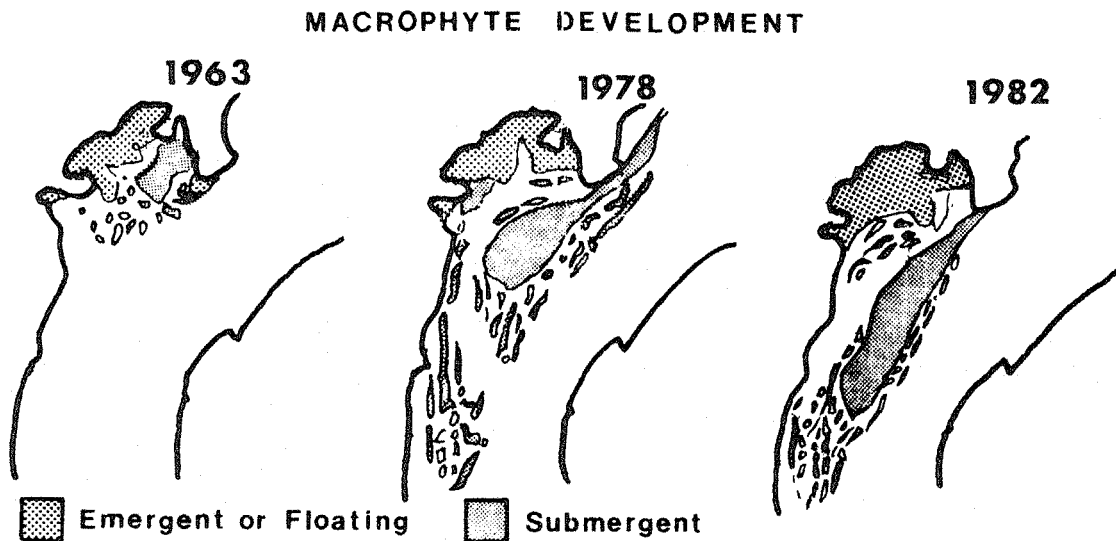
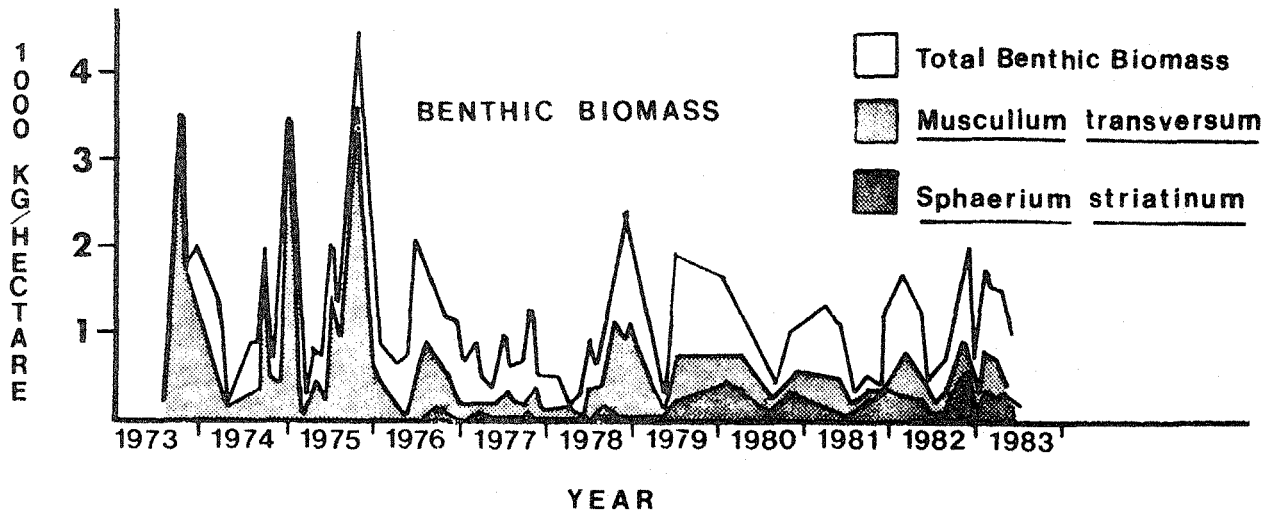

Figure 10. The shift in invertebrate community composition and development of macrophyte beds as a result of a drought which increased water clarity.

distinct plant communities developed. Dredge sand which had been placed on existing floodplain forest became covered with vines unless the canopy was killed. If the canopy was killed, herbaceous vegetation characterized the habitat (Figure 11). This vegetation developed rapidly and persisted for 25 years. New sand islands or banks were colonized by wet-soil species, particularly sandbar willow, with some herbaceous growth in drier areas (Figure 11). This successional sequence is dependent on depth of the sand soil. Floodplain forest is usually destroyed when spoil depth is

between 2 and 3 m; and unless flooding occurs to produce a silt lense, revegetation is much more slow (an order of magnitude) than shown in Figure 11. Most spoil sites (except those above Gulfport, Illinois, on Pools 19 and 20), are low sites inundated during flooding; thus plant succession usually occurs rapidly in these areas. Rock islands and banks were colonized by a variety of plant types, depending on the matrix material between the rocks. Areas with silt developed covers of forbs and graminoids. A sand matrix resulted in herbaceous species with community diversity (Figure 12),

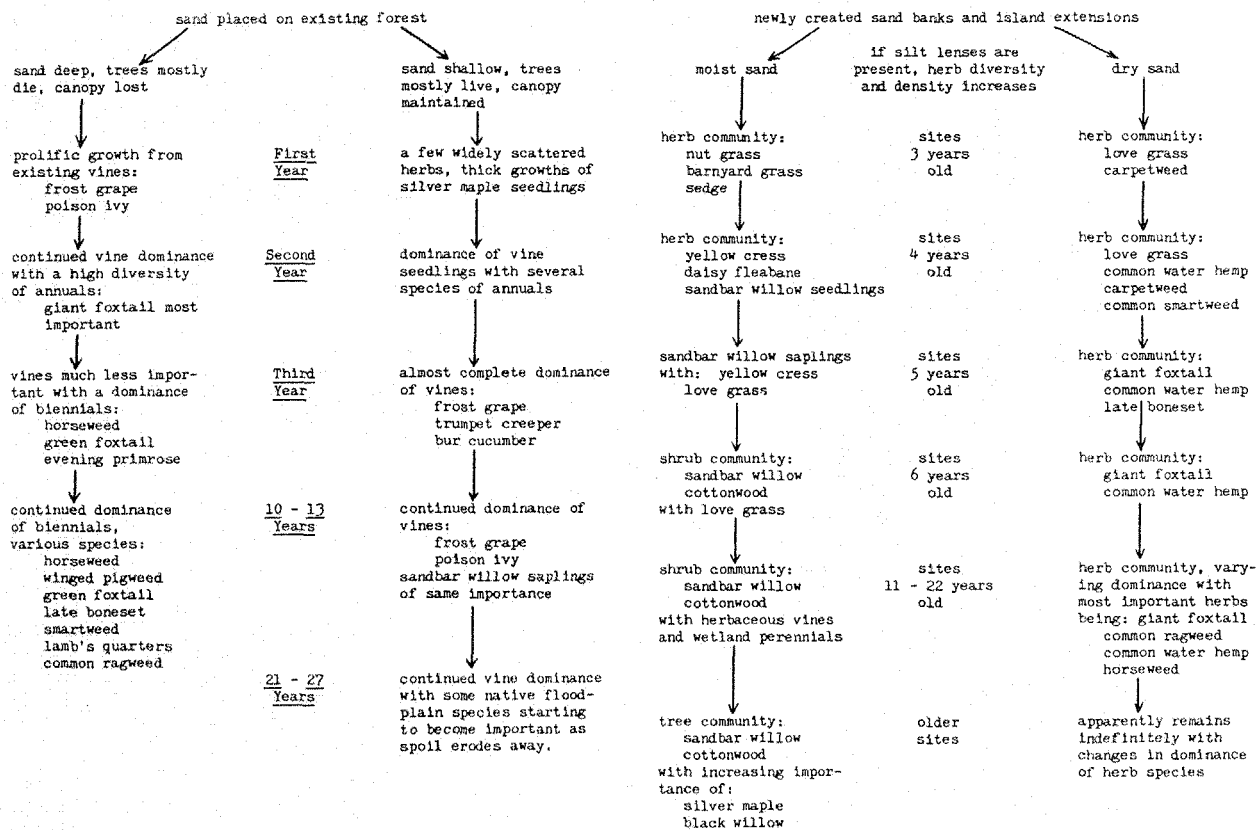

Figure 11. Plant succession on sand placed on existing floodplain forest or on newly created sand banks or islands (from Howe 1979).

increasing as moisture decreased. Sub-communities of plants dependent on soil moisture developed, but the initial colonizers in all communities persist for long periods (25 years).

2.2 FLOODPLAIN VEGETATION

The floodplain is a relatively flat expanse of land bordering the river and may occasionally be flooded. Along both pools the floodplain may be classified as palustrine forested wetland habitat (Cowardin et al. 1979). Much of the area, particularly along Pool 20 and the Iowa side of Pool 19, has been leveed and is now in agricultural use. There are 35 large islands scattered along the length of Pool 20 and about 60 large islands in Pool 19, all located in the upper island-braided reach of the pool. With few exceptions, these islands are covered with lowland woody vegetation. Though many of

the islands are large and elevated, none have tilled areas. Some logging has occurred on islands and the floodplain. General descriptions of island and floodplain vegetation of both pools are contained in the environmental impact statements for operation and maintenance of the 9-ft navigation channel (USACE 1974a, b) and in the long-term resource monitoring plan for the Upper Mississippi River (Jackson et al. 1981).

While local conditions or nutrients may cause some variation, soil type and water relationships primarily determine vegetation. Though there are few detailed studies of the floodplain vegetation in either Pools 19 and 20, those of Kunshek (1971) and Wells (1977) are probably applicable to most of these areas along both pools and are the sources for the following descriptions. In newly established lowlands where soils are usually poorly developed and wetted, a

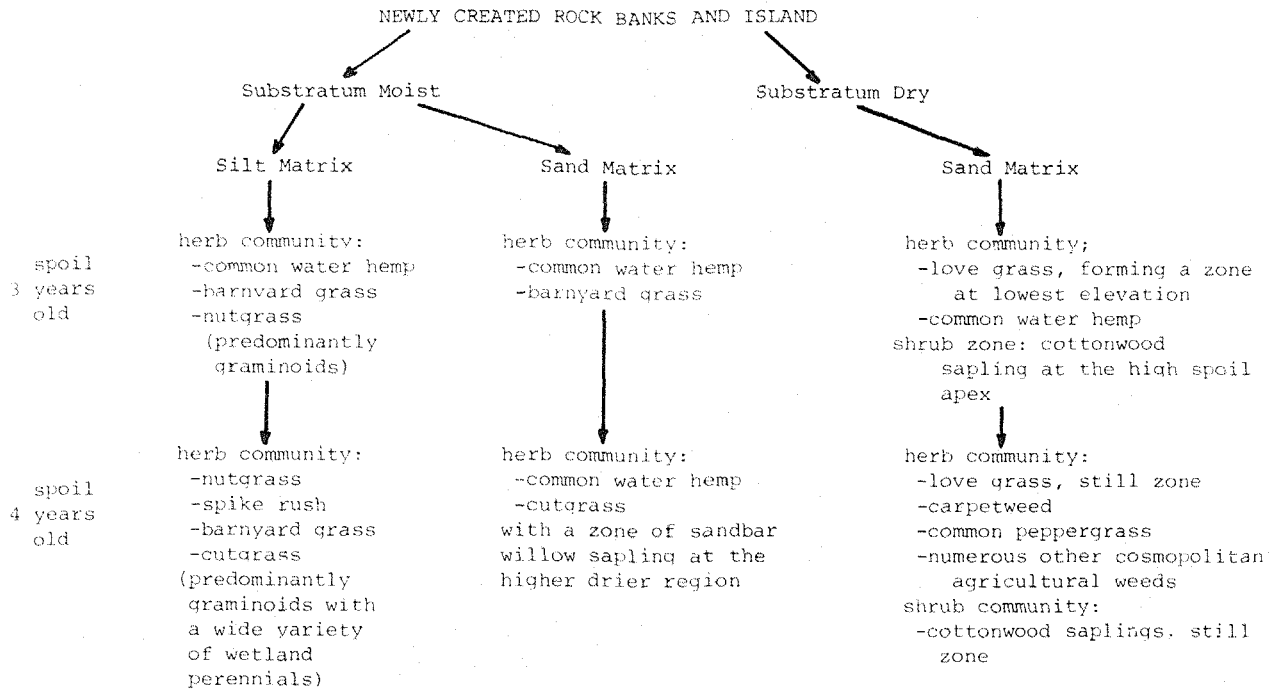

Figure 12. Plant succession on newly created rock banks and islands.

sandbar willow (*Salix interior*)-cottonwood (*Populus deltoids*)-black willow (*S. nigra*) pioneer community exists (Figure 13a,b); silver maple (*Acer saccharum*) becomes established and dominant after the willows and cottonwood stabilize the soils. The herbaceous layer in this area is dominated by the common cocklebur (*Xanthium*), hedge-hyssop (*Gratiola neglecta*), and a variety of grasses and moist soil plants. In areas where silver maple is abundant, wood nettle (*Laportea canadensis*), false nettle (*Boehmeria cylindrica*), and skullcap (*Scutellaria lateriflora*) begin to occur. Lianas, particularly grape (*Vitis* spp.) and American bindweed (*Convolvulus americanus*), are also present in some areas.

The willows and cottonwood seedlings are usually not shade tolerant; with the development of a silver maple canopy, mesic species with shade-tolerant seedlings begin to occur in the understory and to a limited degree in the canopy. Though occasionally flooded, these areas tend to be slightly higher and drier and have a more developed soil. These mesic tree species include slippery elm (*Ulmus rubo*),

white mulberry (*Morus alba*), red mulberry (*M. rubra*), hackberry (*Celtis occidentalis*), box elder (*Acer negundo*), green ash (*Fraxinus pennsylvanica*), and American elm (*Ulmus americanus*). The American elm once was abundant in this area, but as a result of Dutch elm disease, only a few individuals or small groves remain. The community does have a more diverse shrub and herbaceous layer, particularly when it occurs on islands, but it is still sparse because of scouring and burial resulting from flooding. Important vines and herbaceous species include bur-cucumber (*Sicyos angulatus*), riverbank grape (*Vitis riparia*), winter grape (*V. cinera*), poison ivy (*Rhus radicans*), creeper (*Parthenocissus quinquefolia*), dogbane (*Apocynum cannabinum*), tall goldenrod (*Solidago altissima*), aster (*Aster ontarionis*), swamp milkweed (*Asclepia incarnata*), common pigweed (*Amaranthus hybridus*), rough pigweed (*A. retroflexus*), stick-tight (*Bidens cernua*), rush (*Carex sartwelli*), and lady's thumb (*Polygonum persicaria*), as well as species found in willow-cottonwood areas. Many of these herbaceous species become more abundant along bank cuts of



Figure 13a. Island vegetation.

shores and head (or leading) edges of islands where more sunlight reaches this stratum.

A terrace community exists above the normal flood level (which is less mesic), and where more developed soil with litter layer is found. The tree community in this area is usually still dominated by silver maple; but hackberry, box elder, ash, and mulberry increase, and as conditions become drier, a few other species occur: black walnut (*Juglans nigra*), oaks (*Quercus* spp.), and hickory (*Carya* spp.). Even white oak (*Q. alba*) and pin oaks (*Q. macrocarpa*) have been reported on some mature islands. The climax for this region is an oak-hickory forest. With a more mature soil and less flood scouring, the shrub and herbaceous layers become more developed and variable depending on local nutrient, water, and shading (see Table 7 for a total list of species in terrace area).

In areas disturbed by logging, saplings of silver maple dominate small clusters of other mesic species. Lianas and herbaceous species become more evident in these areas because sunlight is able to penetrate to the forest floor. Grape, poison ivy, greenbriar (*Smilax hispida*), American bindweed, and bur-cucumber become so abundant that they cover the saplings. In the herbaceous layer grasses, nettles, clearweeds, and flowering species also occur frequently.

Species diversity in floodplain forests is usually high because of environmental heterogeneity and an overlap between the riparian and climax communities. As indicated in Table 7, stability is also a factor in increasing diversity. The terrace community, having fewer flood events and more mature soils, contains a much larger number of species. Distribution and density of tree species increases with land elevation above normal pool level (Table 8). This in turn affects canopy coverage (Table 9) and light penetration. These factors, in part, determine density and distribution of herbaceous and vine species. The vine community varies in species composition, and only grape occurs at all canopy densities (Table 10). Herbaceous diversity is greatest where canopy density is moderately high--50%-74% (Table 11), but is also high at very low canopy coverage. Thus, islands with only moderately developed tree communities or areas where the canopy has been removed through logging will also be diverse (Table 11).

2.3 MACROPHYTES

Aquatic plant beds are habitats dominated by vascular plants that grow principally on or below the water surface (Figure 14). The macrophytes included may be divided into major growth forms: (1) submerged plants, which may or may not be rooted and are usually submersed but may have floating leaves and aerial



Figure 13b. Undergrowth, including herb and vine vegetation of the floodplain forest.

reproductive structures; (2) floating plants that have true roots and leaves and occur on or in the water column; (3) emergent plants, whose roots and shoots are in shallow water, but whose foliage is above the water surface. These aerial parts, may be either persistent (though senescent), surviving to the next growing season, or nonpersistent, falling to the surface at the end of the growing season (Cowardin et al. 1979). Senescent emergents are often removed by ice movement during the winter.

Extensive beds of aquatic vegetation occupy about 25,000 ha of riverine habitat in Pools 2 to 26 (Minor et al. 1977). These macrophytes present a potentially important source of primary productivity in the Upper Mississippi River and serve as a direct (grazer pathway) food source for fish (King and Hunt, 1967; Gasaway and Drda 1977), migratory waterfowl (Thompson 1973; Paveglio and Steffek 1978) and other vertebrates (Clay 1983) and as an indirect (decomposer pathway) food source

for invertebrates (Cummins 1973; Anderson and Sedell 1979; Wallace and Merritt 1980; Rounick et al. 1982).

2.3.1 Pool 19

As a result of successional processes and sedimentation accompanying river impoundment by Lock and Dam 19, a large area of Pool 19 is occupied by aquatic macrophytes. According to aerial surveys in 1983 (Day 1984), about 6,800 ha of the total pool surface area have macrophytes. This area is more than 27% of the total estimated for the Upper Mississippi River system by Minor et al. (1977). This area also represents a substantial increase from earlier reports of Thompson (1973) and Paveglio and Steffek (1978) and is believed to be due to a decrease in water depth resulting from sediment accumulation. Turbidity in this area of the Mississippi River has been found to prevent development of macrophytes in water depths greater than about 1.5 m; most of the beds occur in less than 1 m of

Table 7. Vegetation which may be found on islands and floodplains of Pools 19 and 20, Mississippi River. Based primarily on data from Wells (1977) and Kunshek (1971).

Family	Species name	Common name	Probable occurrence		
			Island	Lowland	Terrace
Aceraceae	<i>Acer negundo</i>	Box elder	X	X	X
	<i>A. saccharinum</i>	Silver maple	X	X	X
Aizoaceae	<i>Mollugo verticillata</i>	Carpetweed	X		
Amaran Thaceae	<i>Acnida altissima</i>	Tall water hemp	X		
	<i>Amaranthus albus</i>	Tumbleweed	X	X	
	<i>A. hybridus</i>	Common pigweed	X		
	<i>A. Powellii</i>	Pigweed	X		
	<i>A. retroflexus</i>	Rough pigweed	X	X	X
Anacardiaceae	<i>Rhus radicans</i>	Poison ivy	X	X	X
Apocynaceae	<i>Apocynum cannabinum</i>	Dogbane	X		
	<i>A. medium</i>	Dogbane	X		
Araceae	<i>Arisaema dracontium</i>	Green dragon			X
Asclepiadaceae	<i>Asclepias incarnata</i>	Swamp milkweed	X		X
	<i>A. purpurascens</i>	Purple milkweed			X
	<i>A. verticillata</i>	Horsetail milkweed			X
					X
Balsaminaceae	<i>Impatiens biflora</i>	Spotted touch- me-nots			X
	<i>I. pallida</i>	Pale touch-me- nots			X
Bignoniaceae	<i>Campsis radicans</i>	Trumpet-creeper	X		
Boraginaceae	<i>Hackalia virginiana</i>	Beggar's lice			X
Campanulaceae	<i>Campanula americana</i>	Bellflower			X
Caprifoliaceae	<i>Sambucus canadensis</i>	Common elder		X	X
	<i>Symphoricarpos orbiculatus</i>	Coral berry			X
Chenopodiaceae	<i>Chenopodium album</i>	Lamb's quarters	X		X
Commelinaceae	<i>Commelina communis</i>	Dayflower			X
Compositae	<i>Ambrosia artemisiifolia</i>	Common ragweed			X
	<i>A. trifida</i>	Giant ragweed			X
	<i>Arctium minus</i>	Common burdock			X
	<i>Artemisia annua</i>	Annual wormwood	X		
	<i>Aster lateriflorus</i>		X		
	<i>A. ontarionis</i>			X	
	<i>A. pilosus</i>	White heath aster		X	
	<i>A. simplex</i>	Panicled aster			X
	<i>Bidens bipinnata</i>	Spanish needles			X
	<i>B. cernua</i>	Stick-tight	X	X	X
	<i>B. comosa</i>		X	X	
	<i>B. connata</i>	Swamp beggarticks	X	X	
	<i>B. frondosa</i>		X	X	

(continued)

Table 7. (Continued).

Family	Species name	Common name	Probable occurrence		
			Island	Lowland	Terrace
	<i>B. polyepis</i>	Tickseed-sunflower		X	
	<i>B. vulgata</i>	Common beggarticks		X	
	<i>Cirsium discolor</i>	Field thistle			X
	<i>Eclipta alba</i>	Yerba de Tajo	X		
	<i>Erigeron annuus</i>	Whitetop			X
	<i>E. canadensis</i>	Horseweed	X	X	
	<i>E. strigosus</i>	Daisy fleabane			X
	<i>Eupatorium</i>				
	<i>altissimum</i>	Tall thoroughwort			X
	<i>E. rugosum</i>	White snakeroot			X
	<i>E. serotinum</i>	Lateboneset			X
	<i>Galinsoga ciliata</i>	Quickweed			X
	<i>Helenium autumnale</i>	Thin-leaved sunflower			X
	<i>Lactuca floridana</i>	Woodland lettuce			X
	<i>Rudbeckia hirta</i>	Black-eyed Susan			X
	<i>R. triloba</i>	Brown-eyed Susan			X
	<i>Solidago altissima</i>	Tall goldenrod	X	X	X
	<i>S. gigantea</i>	Late goldenrod			X
	<i>S. ulmifolia</i>	Elm-leaved goldenrod			X
	<i>Vernonia altissima</i>	Ironweed			X
Convolvulaceae	<i>Convolvulus americanus</i>	American bindweed	X	X	
	<i>Ipomoea heberacea</i>	Ivy-leaved morning glory			X
Cornaceae	<i>Cornus drummondii</i>	Rough-leaved dogwood			X
Cruciferae	<i>Rorippa islandica</i>		X		
	<i>R. sessiliflora</i>	Yellow cress	X		X
Cucurbitaceae	<i>Sicyos angulatus</i>	Bur-cucumber	X	X	X
Cyperaceae	<i>Carex sartwellii</i>		X	X	X
	<i>Cyperus erythrorhizos</i>		X		
	<i>C. ferruginescens</i>		X		
	<i>Eleocharis calva</i>	Spike rush		X	
Dioscoreaceae	<i>Dioscorea villosa</i>	Yam			X
Euphorbiaceae	<i>Acalypha rhomboidea</i>	Common three-seeded mercury			X
	<i>Chamaesyce maculata</i>	Nodding spurge			X
Fagaceae	<i>Quercus macrocarpa</i>	Bur oak			X
Gramineae	<i>Digitaria ischaemum</i>		X	X	
	<i>D. sanguinalis</i>		X		
	<i>Echinochloa crusgalli</i>	Barnyard grass	X	X	X
	<i>Eragrostis frankii</i>				

(continued)

Table 7. (Continued).

Family	Species name	Common name	Probable occurrence		
			Island	Lowland	Terrace
	<i>E. hypnoides</i>	Pony grass	X	X	
	<i>Leersia oryzoides</i>	Cut grass	X	X	
	<i>Muhlenbergia frondosa</i>	Wirestem muhly			X
	<i>M. sulvatica</i>	Woodland muhly			X
	<i>Panicum agrostoides</i>	Munro grass	X	X	
	<i>P. capillare</i>	Witch grass		X	
	<i>P. depauperatum</i>		X	X	
	<i>P. dichotomiflorum</i>	Fall panicum	X	X	
	<i>Paspalum fluitans</i>			X	
	<i>Setaria faberii</i>	Giant foxtail	X	X	X
	<i>S. lutescens</i>	Yellow foxtail	X	X	X
Juglandaceae	<i>Juglans nigra</i>	Black walnut			X
Labiatae	<i>Agastache nepetoides</i>	Giant hyssop			X
	<i>Leonurus cardiaca</i>	Motherwort			X
	<i>Lycopus americanus</i>		X	X	
	<i>L. virginicus</i>		X	X	
	<i>Monarda fistulosa</i>	Wild bergamot			X
	<i>Neoeta cataria</i>	Catnip			X
	<i>Prunella vulgaris</i>	Carpenter-weed			X
	<i>Pycnanthemum pilosum</i>	Mountain mint			X
	<i>Scutellaria</i>				
	<i>lateriflora</i>	Mad-dog skullcap	X	X	X
	<i>Stachys tenuifolia</i>	Smooth hedge-nettle	X	X	X
	<i>Teucrium canadense</i>				X
Leguminosae	<i>Amorpha fruticosa</i>	Indigo bush			X
	<i>Amphicarpa comosa</i>	Hog-peanut			X
	<i>Desmodium glutinosum</i>	Tick-clover			X
	<i>D. longifolium</i>	Tick-clover			X
	<i>Gleditsia triacanthos</i>	Honey locust			X
	<i>Melilotus alba</i>	White sweet clover			X
Liliaceae	<i>Smilax hispida</i>	Greenbriar	X	X	X
	<i>S. lasioneura</i>	Carrion flower			X
Lythraceae	<i>Ammania coccinea</i>		X		X
	<i>Rotala ramosio</i>		X	X	
Menispermaceae	<i>Menispermum canadense</i>	Moonseed	X	X	X
Moraceae	<i>Maclura pomifera</i>	Osage orange			X
	<i>Morus alba</i>	White mulberry	X	X	X
	<i>M. rubra</i>	Red mulberry	X	X	X
Oleaceae	<i>Fraxinus americana</i>	White ash	X	X	X
	<i>F. pennsylvania</i>	Green ash	X	X	X
Onagraceae	<i>Circaea latifolia</i>	Enchanter's nightshade			X

(continued)

Table 7. (Continued).

Family	Species name	Common name	Probable occurrence		
			Island	Lowland	Terrace
	<i>Oenothera biennis</i>	Common evening-primrose			X
Oxalidaceae	<i>Oxalis stricta</i>	Upright wood-sorrel			X
Penthoraceae	<i>Penthorum sedoides</i>	Ditch stonecrop	X	X	
Phrymaceae	<i>Phryma leptostachya</i>	Lopseed			X
Phytolaccaceae	<i>Phytolacca americana</i>	Pokeweed			X
Plantaginaceae	<i>Plantago rugelii</i>	Common plantain			X
Platanaceae	<i>Platanus occidentalis</i>	Sycamore		X	
Polygonaceae	<i>Polygonum convolvulus</i>	Black bindweed			X
	<i>P. lapathifolium</i>	Pale smartweed	X		
	<i>P. pensylvanicum</i>	Pennsylvania smartweed	X	X	X
	<i>P. persicaria</i>	Lady's thumb			X
	<i>P. punctatum</i>	Dotted smartweed	X		
	<i>P. scandens</i>	Climbing false buckwheat			X
	<i>P. virginianum</i>	Virginia knotweed			X
Primulaceae	<i>Lysimachia ciliata</i>	Fringed loosestrife			X
	<i>L. nummularia</i>	Moneywort			X
Rosaceae	<i>Geum canadense</i>	White avens			X
	<i>Potentilla monspeliensis</i>	Rough cinquefoil			X
	<i>P. recta</i>	Upright cinquefoil			X
	<i>Rosa carolina</i>	Pasture rose			X
Rubiaceae	<i>Cephalanthus occidentalis</i>	Buttonbush	X	X	X
	<i>Galium aparine</i>	Goose-grass			X
Salicaceae	<i>Populus deltoides</i>	Eastern cottonwood	X	X	X
	<i>Salix interior</i>	Sandbar willow	X	X	
	<i>S. nigra</i>	Black willow	X	X	
Saxifragaceae	<i>Heuchera richardsonii</i>	Alumroot			X
Scrophulariaceae	<i>Geatiola neglecta</i>	Hedge-hyssop	X	X	
	<i>Mimulus ringens</i>	Monkey-flower		X	
	<i>Lindernia dubia</i>	False pimpernel		X	
	<i>Scrophularia marilandica</i>	Figwort			X
	<i>Verbascum thapsus</i>	Common mullein			X
Solanaceae	<i>Physalis heterophylla</i>	Ground cherry	X	X	
	<i>P. subglabrata</i>	Smooth ground cherry			X
	<i>Solanum nigrum</i>	Black nightshade	X	X	X

(continued)

Table 7. (Concluded).

Family	Species name	Common name	Probable occurrence		
			Island	Lowland	Terrace
Ulmaceae	<i>Celtis occidentalis</i>	Hackberry	X	X	X
	<i>Ulmus americanus</i>	American elm	X	X	X
	<i>U. rubra</i>	Slippery elm	X	X	X
Umbelliferae	<i>Daucus carota</i>	Wild carrot			X
Urticaceae	<i>Boehmira cylindrica</i>	False nettle	X	X	X
	<i>Laportea canadensis</i>	Wood nettle	X	X	X
	<i>Parietaria pennsylvanica</i>	Pellitory			X
	<i>Pilea pumila</i>	Clearweed	X	X	X
	<i>Urtica gracilis</i>	Common nettle	X	X	X
Verbenaceae	<i>Verbena stricta</i>	Hoary vervain			X
	<i>V. urticifolia</i>	White vervain			X
Violaceae	<i>Viola missouriensis</i>	Violet			X
	<i>V. papilionacea</i>	Butterfly violet			X
Vitaceae	<i>Ampelopsis cordata</i>	Raccoon-grape			X
	<i>Parthenocissus quinquefolia</i>	Virginia creeper		X	X
	<i>Vitis cinera</i>	Winter grape		X	X
	<i>V. riparia</i>	Riverbank grape	X	X	X
	<i>V. vulpina</i>	Frost grape			X

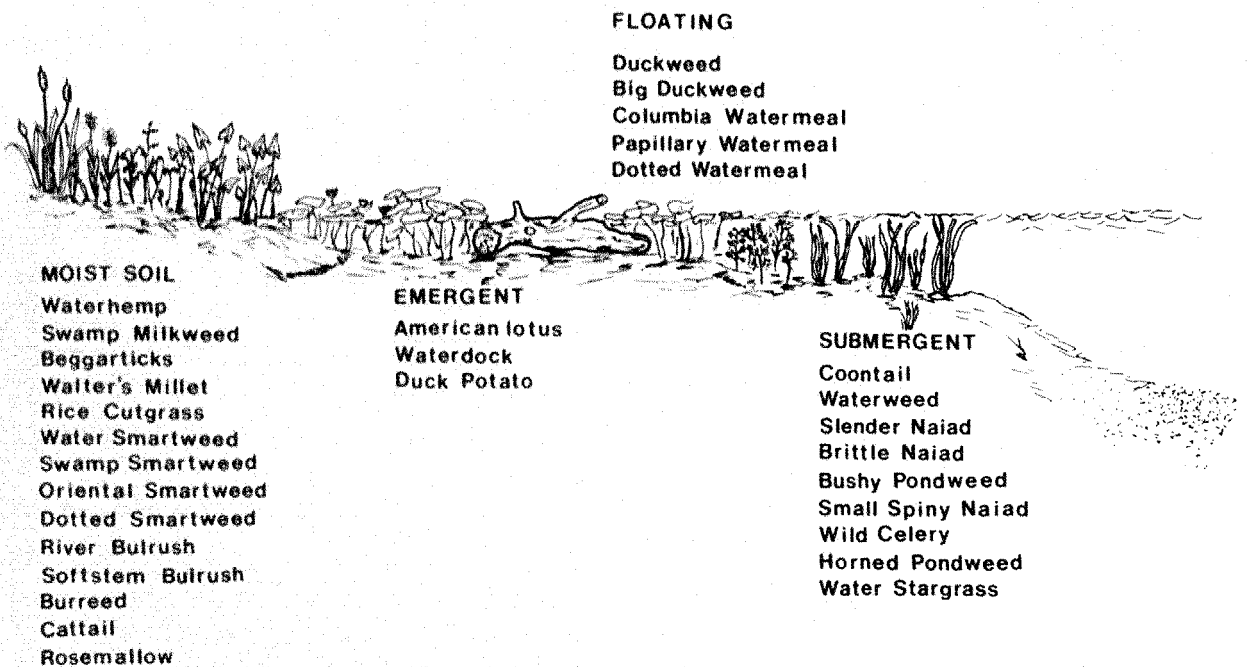

Figure 14. Growth forms and habitat relationships in aquatic macrophyte beds of Pool 19.

Table 8. Relative distribution of major tree species in relation to normal pool level (32-38 dm) Pools 19 and 20; dm=decimeters (adapted from Wells 1977).

Species	Below 32 dm	32-38 dm	Above 38 dm
Silver maple	44%	26%	30%
Red elm	-	38%	63%
White Mulberry	-	75%	25%
American elm	-	-	100%
Hackberry	50%	-	50%
Total, miscellaneous	7%	40%	53%

Table 9. Relative contribution of major tree species to the canopy of the floodplain forest, Pools 19 and 20, Mississippi River (adapted from Wells 1977).

Species	Tree canopy density			
	0-24%	25-49%	50-74%	75-100%
Silver maple	9%	13%	39%	39%
Red elm	13%	-	25%	63%
American elm	-	-	-	100%
White mulberry	-	-	-	100%
Hackberry	-	-	100%	-
Total, miscellaneous	7%	-	27%	67%

Table 10. Distribution of vine species in relation to tree canopy density in floodplain forests, Pools 19 and 20, Mississippi River (adapted from Wells 1977).

Species	Tree canopy density			
	0-24%	25-49%	50-74%	75-100%
Grape	31%	14%	9%	48%
Poison ivy	-	83%	17%	-
Greenbriar	-	33%	-	67%
Total, woody	14%	49%	12%	26%
American bindweed	98%	-	-	2%
Unidentified				
Convolvulaceae	100%	-	-	-
Total, herbaceous	98%	-	-	2%

Table 11. Distribution of herbaceous species in relation to tree canopy density in floodplain forests, Pools 19 and 20, Mississippi River (adapted from Wells 1977).

Species	Tree canopy density			
	0-24%	25-49%	50%-74%	75%-100%
Nettle family				
seedlings	9%	-	90%	1%
Wood nettle	53%	3%	16%	28%
False nettle	70%	6%	24%	-
Clearweed	7%	-	79%	14%
Total, nettle family	30%	1%	61%	7%
White grass	-	-	100%	-
Pony grass	-	-	100%	-
Unidentified grass, wide and smooth leaves	100%	-	-	-
Unidentified grass, wide and rough leaves	-	-	100%	-
Unidentified grass narrow leaves	43%	-	57%	-
Unidentified grass clumps	-	-	100%	-
Total, grass family	14%	-	86%	-
Hedge-hyssop	-	18%	82%	-
Skullcap	-	-	25%	75%

water. The 1976-77 drought and low water levels in 1983-84 are believed to have resulted in an increase of macrophytes which remain even after typical flow regimes return (Paveglia and Steffek 1978; Sparks and Anderson, in prep.). Aquatic vegetation had occurred in shallow backwater areas of Pool 19 for many years. However, the increased water clarity during the low flow years resulted in expansion of macrophytes in the lower lacustrine area of the pool. Three notable areas of expansion were just above Lock and Dam 19 and the areas of Nauvoo and Montrose flats (Figure 15). Two of these areas, above the Lock and Dam and at Montrose, are in open-water, shallow channel border areas not associated with shoreline. The macrophyte area has more than doubled in these beds; additionally, most shorelines are now vegetated and even small creek deltas have macrophytes. The submerged growth form has increased the

most through American lotus (*Nelumbo lutea*) and duck potato or arrowhead (*Sagittaria latifolia*), also expanded along shorelines and at Nauvoo flats.

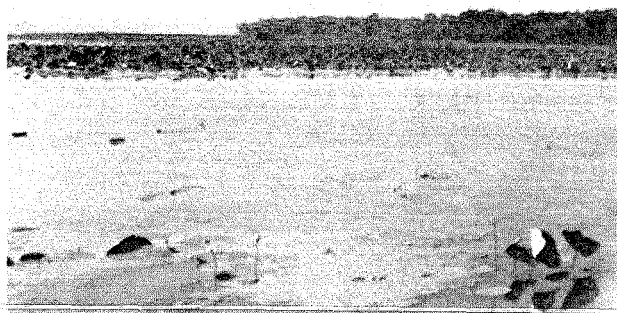

Figure 15. Macrophyte bed, Nauvoo, Illinois, Pool 19, Mississippi River, American lotus in background.

The morphometry of a pool is such that it can be divided into sections in relation to macrophytes (Figure 15). The upper reach of the river from Burlington Island north has almost no macrophytes. The island braiding, water level fluctuation, higher current velocity, and substrate are not conducive to the establishment of aquatic plants. From the head of Burlington Island to just below Fort Madison, Iowa, backwaters and intra-island pools have extensive macrophyte beds. These are the backwater areas that have had macrophytes for many years. Unlike the lower lacustrine reaches, however, these areas have decreased since 1977 (Schuyler 1980). The shallow channel border area of the lower lacustrine reach has developed extensive macrophyte beds similar to littoral areas of lakes both along the shore and in peninsulas or islands of vegetation which occur well out into the river.

Species lists compiled by Paveglio and Steffeck (1978), Schuyler (1980), and Henry (1982) appear in Table 12. Schuyler and Henry also indicated growth form. The submerged vegetation is dominated by sago pondweed (Potamogeton crispus) and water stargrass (Zosterella dubia); some coontail (Ceratophyllum demersum), wild celery (Vallisneria americana) and naiads (Najas spp.) are also present. The latter is sometimes locally abundant. Fewer submergents are present in the macrophyte beds of the middle section of the river. The submerged vegetation is usually the type which occurs first in a new macrophyte bed. It develops in clumps that increase in size as the bed matures. Because of the clumped growth pattern, coverage in these beds is often less, in some cases as much as 50% less, than in the area of the bed as defined from aerial photographs (Day 1984). The floating vegetation is dominated by duck weed (Lemna minor) and Columbia watermeal (Wolffia columbiana). Duckweed and watermeal may be found almost anywhere in the pool. They develop from early spring and last through fall but are usually most dense just after rooted macrophytes have become senescent. They then cover the water surface in the area of the beds. They also may be found in wind rows moving down the pool channel and nonvegetated channel border area. The

water fern (Azolla mexicana) occurs sporadically, primarily in the lower reaches of the pool where it may be abundant during some years.

The emergent vegetation usually develops in a sequence dependent on water depth. The American lotus, sometimes considered a floating form, grows in deeper water and is abundant in most of the macrophyte beds and along the shoreline throughout the pool. The two exceptions to its presence are the beds above Lock and Dam 19 and Montrose flats, both relatively recently developed beds dominated by submerged vegetation. Two small clumps of lotus were observed in the bed above Lock and Dam 19 during the summer of 1984. Thus it is likely that lotus will become a dominant part of this bed in the next few years. Duck potato is found in shallower areas along shorelines and marks the inner edge of the macrophyte beds. In low moist areas, there may be a variety of moist wetland plants (Schuyler 1980). Thus most macrophytic beds in this reach of the river can be defined as water stargrass-pondweed/lotus/duck potato beds in terms of the sequence from deep water (1.5 m) to the shoreline.

2.3.2 Pool 20

Compared to Pool 19, Pool 20 has few macrophytes. Fewer than 50 ha of aquatic vegetation have been defined from aerial photographs. Duckweed and watermeal are seasonally abundant, but whether these floating plants have developed in Pool 20 or are just washed downstream from Pool 19 is not known. It does appear that downstream movement of the plants may be the primary source in Pool 20. The backwater areas of this pool on both sides of the river have been leveed, thus limiting areas for development of macrophytes to shallow shorelines. Because few of these areas exist on the pool, few macrophytes are present. Most of the macrophytes present are of the submerged form, primarily sago pondweed. A few small areas of duck potato are present along some isolated shorelines where the banks are not eroded.

2.4 PHYTOPLANKTON

The potential significance of phytoplankton is substantial because of their

Table 12. Aquatic macrophytes from Pool 19. The list is a composite from Paveglio and Steffek (1978), Henry (1982), and Schuyler (1980). Only Henry and Schuyler include a few wetland plants; E=Emergent, F=Floating, S=Submergent, X=Present in sample. Designations are based on author's categories; thus some differences occur.

Species and common names	Sources		
	Paveglio & Steffek	Henry	Schuyler
<i>Amaranthus tuberculatus</i> - Waterhemp			(E)
<i>Asclepias incarnata</i> - Swamp milkweed			(E)
<i>Azolla mexicana</i> - Beggarticks		(F)	
<i>Bidens cernua</i> - Beggarticks			(E)
<i>Ceratophyllum demersum</i> - Coontail	X	(S)	(S)
<i>Echinochloa walteri</i> - Walter's millet			(E)
<i>Elodea canadensis</i> - American elodea		(S)	
<i>Elodea nuttallii</i> - Waterweed	X	(S)	
<i>Hibiscus militaris</i> - Rose mallow			(E)
<i>Leersia oryzoides</i> - Rice cutgrass			(E)
<i>Lemna minor</i> - Duckweed		(F)	(F)
<i>Najas flexilis</i> - Slender naiad		(S)	
<i>Najas gracillima</i> - Brittle naiad	X		
<i>Najas guadalupensis</i> - Bushy pondweed	X	(S)	(S)
<i>Najas minor</i> - Small spiny naiad		(S)	(S)
<i>Nelumbo lutea</i> - American lotus	X	(F)	(E)
<i>Polygonum amphibium</i> - Water smartweed			(E)
<i>Polygonum hydropiperoides</i> - Swamp smartweed			(E)
<i>Polygonum orientale</i> - Oriental smartweed			(E)
<i>Polygonum punctatum</i> - Dotted smartweed			(E)
<i>Potamogeton crispus</i> - Curlyleaf pondweed	X	(S)	(S)
<i>Potamogeton foliosus</i> - Leafy pondweed	X	(S)	
<i>Potamogeton nodosus</i> - Longleaf pondweed	X	(F)	(S)
<i>Potamogeton pectinatus</i> - Sago pondweed	X	(S)	(S)
<i>Potamogeton pusillus</i> - Small pondweed		(S)	
<i>Rumex verticillatus</i> - Waterduck			(E)
<i>Sagittaria latifolia</i> - Duck potato	X		(E)
<i>Scirpus fluviatilis</i> - River bulrush			(E)
<i>Scirpus tabernaemontanii</i> - Softstem bulrush			(E)
<i>Sparganium eurycarpum</i> - Burreed			(E)
<i>Spirodela polyrhiza</i> - Big duckweed		(F)	(F)
<i>Typha</i> spp. - Cattail			(E)
<i>Vallisneria americana</i> - Wild celery	X	(S)	(S)
<i>Wolffia columbiana</i> - Columbia watermeal		(F)	
<i>Wolffia papulifera</i> - Papillary watermeal		(F)	
<i>Wolffia punctata</i> - Dotted watermeal		(F)	
<i>Zannichellia palustris</i> - Horned pondweed		(S)	(S)
<i>Zosterella dubia</i> - Water stargrass	X	(S)	(S)

role as primary producers in aquatic systems. They may be the base of the food web in large river systems where phytoplankton production is theorized to be high (Vannote et al. 1980). Unlike small streams in which benthic algae constitute the major portion of the plankton (meroplankton or tychoplankton), large, slow-moving rivers have plankton communities dominated by true planktonic species (euoplankton). This is particularly true when dams impede the normal pattern of flow and create large pooled areas where dense plankton populations may develop. Large rivers in both North America and Europe have been found to be dominated by small centric diatoms, usually Cyclotella and Stephanodiscus (Swale 1969; Lack 1971; Williams 1972; Benson-Evans et al. 1975; Aykulu 1978; Baker and Baker 1979, 1981). Phytoplankton density has ranged from 10 to 1,000 organisms per milliliter in North American rivers. Densities in the Mississippi River tend toward the upper end of this range (Palmer 1964).

2.4.1 Pool 19

Most of the early records of phytoplankton in Pool 19, Mississippi River, are based on collections made by Galtsoff (1924) at several locations on the pool. These qualitative samples indicated that diatoms were the dominant algal groups more than 50 years ago, just 15 years after Dam 19 was completed. The diatom community was again examined in the early 1960's (Williams 1964, 1972) at Burlington, Iowa. Monthly samples were collected for 18 months. A seasonal shift in dominance was reported: the small centric diatom Stephanodiscus astraea var. minutula was abundant in spring, and Melosira amobia abundant in fall. Spring and fall seasonal peaks for total diatom densities were also reported. Plankton were also sampled in 1967-68 from an area of the river below Fort Madison, Iowa (Gale and Lowe 1971). These samples were taken as part of a study investigating feeding activities of fingernail clams at Devil's Island. Investigations found the diatom Stephanodiscus hantzchii to be the dominant species. A maximum of 38 phytoplankton genera was present in the water column during July and August, when diversity was the highest. These studies all indicated a seasonal shift

in phytoplankton community composition as well as some changes within the pool, possibly reflecting habitat associations.

The most comprehensive study on Pool 19 was conducted in 1982-83 by Engman (1984). Thirty-five sites along the entire length of the pool were sampled monthly or so between October 1982 and August 1983. Sites were located to evaluate effects of both habitat and longitudinal changes down the length of the pool. During this study 269 species of phytoplankton were collected in Pool 19 (Table 13). Mean densities ranged from a maximum of 20,180/ml in April to 2,213/ml in July. About 40% of these were diatoms and 33% green algae.

Distinct seasonal distribution patterns in these two groups and the other major group (blue-green algae 11%) were found (Figure 16) with spring and late summer maxima. An algal bloom of the blue-green algae Microcystis was frequently noted in September. Blue-greens were usually abundant in the summer and early fall. In addition to this seasonality, specific habitat associations were found in areas of macrophyte development, backwaters, and tributary confluences (Figure 17). In the vegetated areas pennate diatom densities (700/ml) and diversity were the highest, and the community was dominated by Achnanthes (Figure 17). The channel and channel border adjacent to these macrophyte beds had lower densities (270/ml) and diversity and were dominated by Cocconeis. Backwater also supported a higher diversity of plankton than did side channels or the main channel (Figure 17). Again, a unique assemblage of phytoplankton was found, with Ankistrodesmus, Euglena, and Nitzschia occurring at high densities (4950/ml) in the backwater habitat. Euglena and Trachelomonas found in this area are indicative of organically enriched conditions. Both the vegetated areas and the backwaters are more stable habitats with lower current velocities and lacustrine conditions which may favor the development of higher densities and diversities of phytoplankton. When tributary input was high, higher densities (770/ml versus 230/ml) of the benthic diatom Nitzschia occurred below the tributary confluence (Figure 17), reflecting

recruitment of algal species from those streams. Algal diversity tended to be highest in the spring and lowest in winter. In terms of longitudinal changes down the length of the pool, diversity was usually the highest in the upper reaches of the pool, possibly due to input from the lacustrine areas just above Lock and Dam 18, which drain into Pool 19. Though there were some seasonal changes, densities were also often higher in the upper end of the Pool.

2.4.2 Pool 20

Fewer studies of phytoplankton have been conducted in Pool 20. The major study was completed in 1973 by Heffelfinger (1973). During her study, weekly samples were collected at three sites, one just below Lock and Dam 19, a second 9 km above Lock and Dam 20, and a third 5 km above Lock and Dam 20. Organisms in the plankton were identified according to genus. Thirty-three of the 51 genera found were phytoplankton (Table 13). Again, diatoms were found to be the dominant phytoplankton, with Stephanodiscus and Cyclotella occurring abundantly in the spring and summer, and Asterionella, Fragillaria, and Synedra being abundant in the fall. Phytoplankton in other divisions which were seasonally abundant included Tribonema, Microcystis, Pediastrum, and Sunura. Variation in plankton abundance was found to correlate positively to oxygen but negatively to stream discharge, current velocity, and turbidity. These relationships are similar to those found by Galtsoff (1924), though he did report higher phytoplankton densities than Heffelfinger (1973).

2.4.3 Pool Comparisons

Both diversity and density of phytoplankton are higher in Pool 19 than Pool 20, not surprising since habitat diversity is much greater in Pool 19. Note, for example, the diversity which backwaters add to community composition (Figure 17). In addition, the more lacustrine nature of Pool 19, compared to the narrower more riverine conditions of Pool 20, may favor the development of high densities of phytoplankton. In both

pools the centric diatom Stephanodiscus, indicative of large rivers, was prevalent. However, species composition of dominant diatoms was different between the pools in the fall, Melosira occurring in Pool 19 and Fragillaria and Asterionella in Pool 20. This seasonal difference may again reflect important habitat influence and the different morphometric characteristics of the pools. These differences may become more pronounced during different seasons because of specific inputs from habitats.

2.5 ZOOPLANKTON

As one of the direct links to the trophic resource in phytoplankton and particulate organic matter, zooplankton communities are a dominant component of many freshwater ecosystems. Most studies of the species composition and density of zooplankton have dealt with lacustrine systems. The origin and composition of zooplankton in riverine systems are complex, and an apparent shift in organism composition occurs longitudinally down the river system (Cummins 1979). Plankton of smaller rivers originate in drainage basin lakes and ponds while large rivers have their own plankton communities (Lind 1979). Only a few studies of zooplankton in large rivers have been done. Notable among them are the studies of Forbes (1882) and Kofoid (1903, 1908), the latter of whom found rotifers to be the dominant zooplankton of the Illinois River. The dominance of rotifers is found in most riverine systems (Williams 1966). Galtsoff (1924), Wiebe (1927), and Reinhard (1931) described zooplankton on the Upper Mississippi, mostly for areas near Rock Island, Illinois. Colbert et al. (1975) in a U.S. Army Corps of Engineers study of Mississippi River Navigation Pools 24, 25, and 26 identified major zooplankton and indicated that densities were highest in late summer.

2.5.1 Pool 19

Although the common occurrence of rotifers was indicated in early studies of Pool 19, most of the work concentrated on the copepod and cladoceran crustaceans (Galtsoff 1924). Galtsoff's studies found much higher densities of crustaceans in

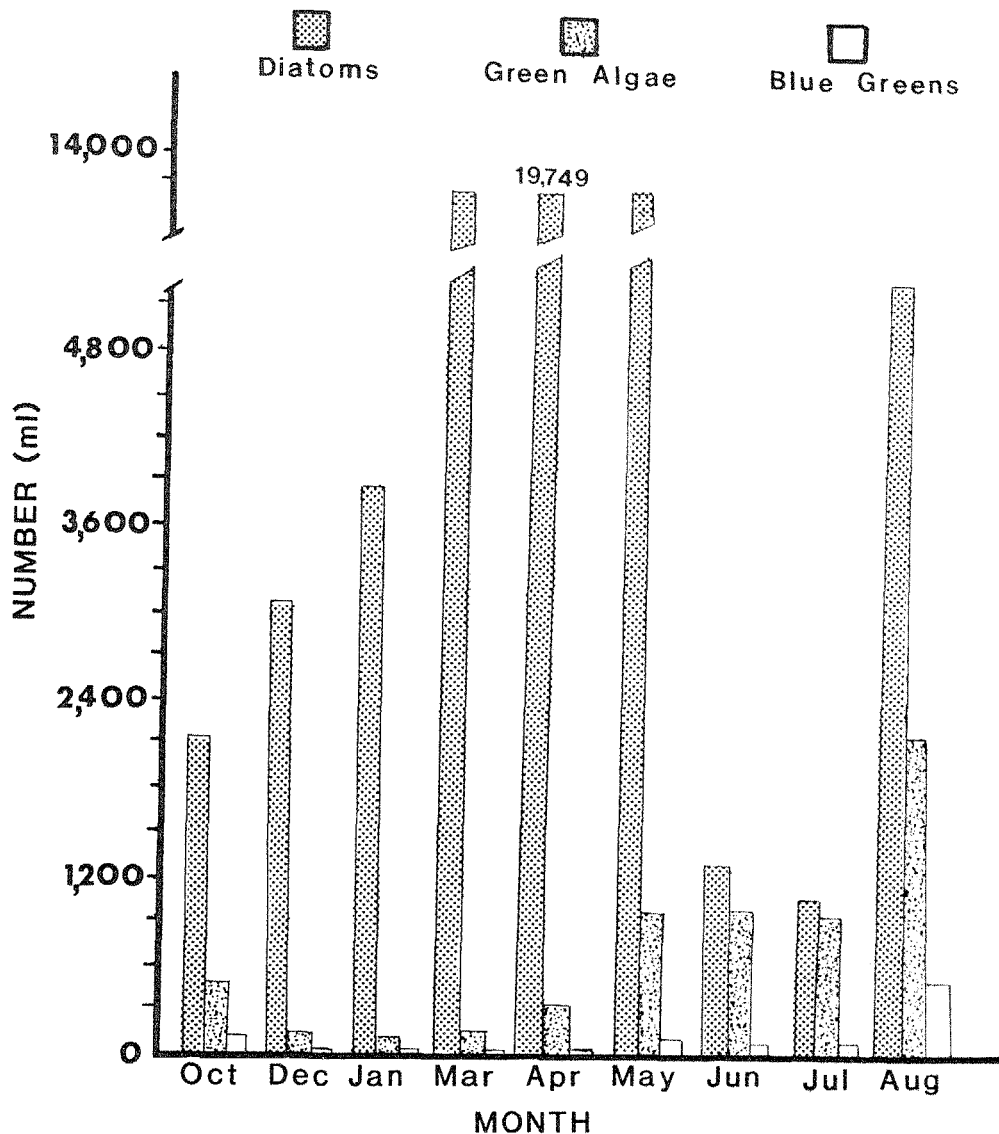

Figure 16. Seasonal distribution of phytoplankton by major growth forms in Pool 19, Mississippi River (Engman 1984).

the river reaches above Lock and Dam 19. In the river reach from Burlington, Iowa, to Nauvoo, Illinois, only 0-0.4 crustaceans/l occurred, while in the reach from Nauvoo, Illinois, to Keokuk, Iowa, 0.7-38 crustaceans/l were collected. Copepods, dominated by *Diaptomus* and *Cyclops*, were at least twice as abundant as cladocerans. In addition, Galtsoff indicated some vertical variability in crustacean densities throughout the sample which may be dependent on river stage and the "flushing" effects on the river lake.

In his investigation of rotifers in major U.S. waterways, Williams (1966) sampled in Pool 19 near Burlington, Iowa. Rotifers far outnumbered all other small planktonic invertebrates. *Keratella* was the most abundant genus with an average density of 47/l. Other abundant genera were *Brachionus*, *Polyarthra*, *Synchaeta*, and *Trichocerca* in order of decreasing average densities. The highest densities usually occurred in late summer or fall.

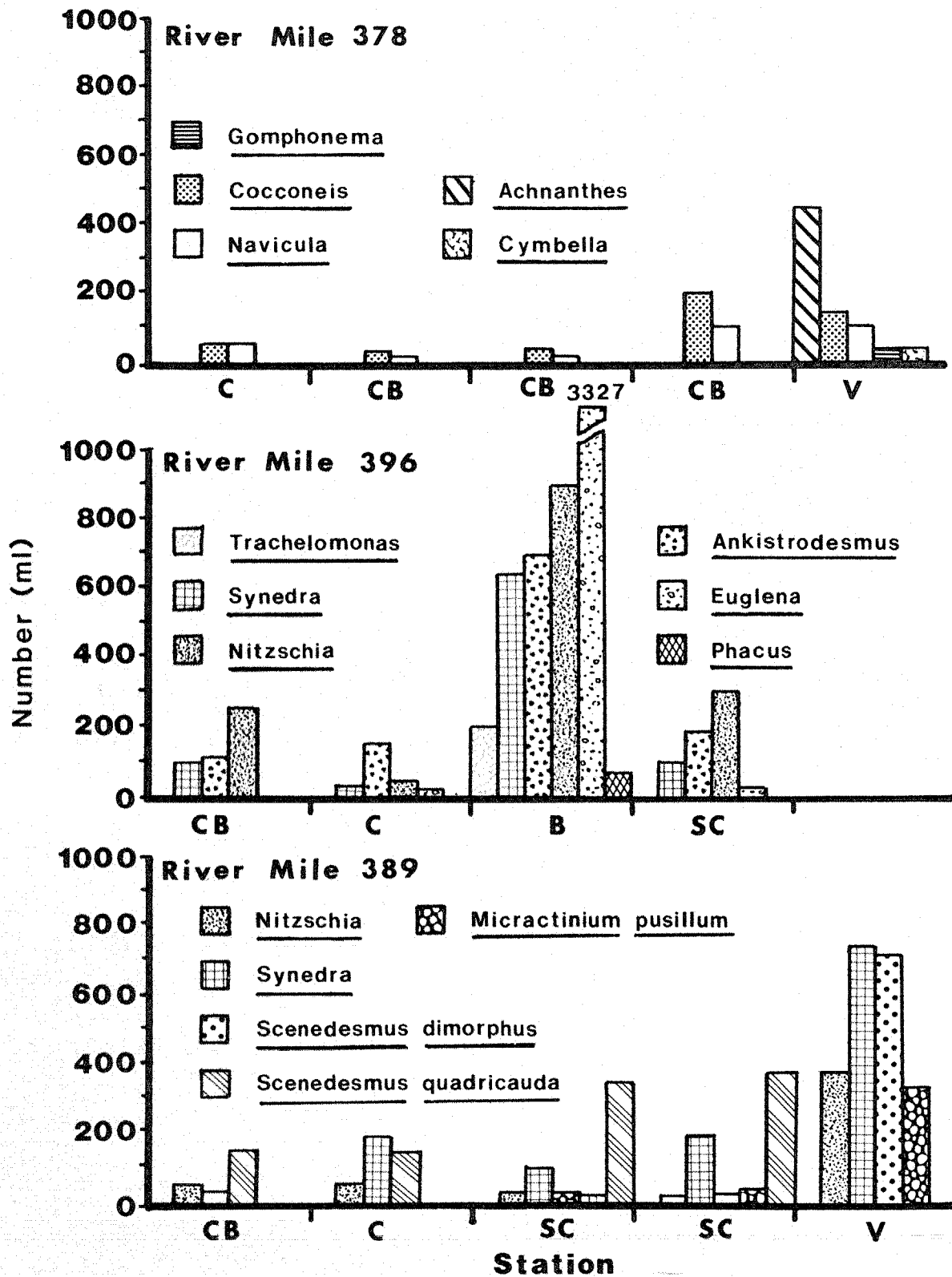

Figure 17. Major phytoplankton taxa in various habitats in Pool 19, Mississippi River.

Table 13. Phytoplankton reported in Pools 19 and 20, Mississippi River.

Species	Pool 19	Pool 20
BACILLARIOPHYCOPHYTA (<i>Diatoms</i>)		
<i>Achnanthes affinis</i> Grun.	X	
<i>Achnanthes exilis</i> Keutz.	X	
<i>Achnanthes lanceolata</i> (Breb.) Grun.	X	
<i>Achnanthes linearis</i> (Wm. Sm.) Grun.	X	
<i>Achnanthes minutissima</i> Keutz.	X	
<i>Achnanthes</i> sp.	X	
<i>Amphicampa mirabilis</i> Ehr. ex Ralfs	X	
<i>Amphora</i> sp.	X	
<i>Anomoeoneis follis</i> (Ehr.) Cl.	X	
<i>Anomoeoneis serians</i> (Breb.) Cl.	X	
<i>Anomoeoneis</i> sp.	X	
<i>Asterionella formosa</i> Hass.	X	X
<i>Asterionella formosa vargracillima</i> (Hantzsch) Grun.	X	
<i>Caloneis bacillaris</i> (Greg.) Cl.	X	
<i>Caloneis</i> sp.	X	
<i>Campylodiscus</i> sp.	X	
<i>Campylodiscus noricus</i> (Breb.) Wm. Sm.	X	
<i>Cocconeis pediculus</i> Ehr.	X	
<i>Cocconeis placentula</i> Ehr.	X	
<i>Cocconeis</i> sp.	X	
<i>Cyclotella chaetoceros</i> Lemm.	X	
<i>Cyclotella glomerata</i> Bachmann	X	
<i>Cyclotella Kuetzingiana</i> Thw.	X	
<i>Cyclotella melosiroides</i> (Kirchn.) Lemm.	X	
<i>Cyclotella meneghiniana</i> Keutz.	X	
<i>Cyclotella</i> sp.	X	X
<i>Cymbella affinis</i> Keutz.	X	
<i>Cymbella angustata</i> (Wm.Sm.) Cl.	X	
<i>Cymbella parva</i> (Wm.Sm.) Cl.	X	
<i>Cymbella tumida</i> Breb.	X	
<i>Cymbella</i> sp.	X	
<i>Cymatopleura eliptica</i> (Breg.) Wm.Sm.	X	
<i>Cymatopleura solea</i> (Breb.) Wm.Sm.	X	
<i>Diatoma vulgare</i> Bory	X	
<i>Diatoma</i> sp.	X	
<i>Eunotia pectinalis</i> var. minor (Keutz.) Rabh.	X	
<i>Eunotia rostellata</i> Hust. ex Patr.	X	
<i>Eunotia</i> sp.	X	
<i>Fragilaria capucina</i> Desm.	X	
<i>Fragilaria crotonensis</i> Kotton	X	
<i>Fragilaria</i> sp.	X	X
<i>Frustulia rhomboides</i> (Ehr.) DeT.	X	

(continued)

Table 13. (Continued).

Species	Pool 19	Pool 20
<i>Gomphonema</i> sp.	X	X
<i>Gomphonema acuminatum</i> Ehr.	X	
<i>Gomphonema constrictum</i> Ehr.	X	
<i>Gomphonema geminatum</i> (Lyngb.) C.A. Agardh	X	
<i>Gomphonema olivaceum</i> (Lyngb.) Keutz.	X	
<i>Gomphonema parvulum</i> (Keutz.) Grun.	X	
<i>Gomphonema truncatum</i> Ehr.	X	
<i>Gyrosigma acuminatum</i> Ehr.	X	
<i>Gyrosigma spencerii</i> (Gru.) Cl.	X	
<i>Gyrosigma scalproides</i> (Rabh.) Cl.	X	X
<i>Gyrosigma spencerii</i> (Querker.) Grigg & Henfr.	X	
<i>Gyrosigma wormleyi</i> (Sulliv.) Boyer	X	
<i>Hantzschia amphioxys</i> (Ehr.) Grun.	X	
<i>Hantzschia amphioxys</i> f. <i>capitata</i> Mull.	X	
<i>Melosira italica</i> (Ehr.) Keutz.	X	
<i>Melosira granulata</i> (Ehr.) Ralfs	X	
<i>Melosira varians</i> C.A. Agardh	X	
<i>Melosira</i> sp.	X	X
<i>Meridion circulare</i> (Grev.) C.A. Ag.	X	
<i>Navicula anglica</i> Ralfs.	X	
<i>Navicula cryptocephala</i> Keutz.	X	
<i>Navicula cuspidata</i> Keutz.	X	
<i>Navicula elginensis</i> (Greg.) Ralfs.	X	
<i>Navicula exigua</i> Gred. ex Grun.	X	
<i>Navicula tripunctata</i> (O.F. Mull.) Bory	X	
<i>Navicula protracta</i> Grun.	X	
<i>Navicula pupula</i> Keutz.	X	
<i>Navicula rhynchocephala</i> Keutz.	X	
<i>Navicula seminulum</i> Grun.	X	
<i>Navicula</i> sp. (in sheath)	X	
<i>Navicula</i> sp.	X	X
<i>Nitzschia acicularis</i> (Keutz.) Wm. Sm.	X	
<i>Nitzschia denticula</i> Grun.	X	
<i>Nitzschia linearis</i> (Ag.) Wm. Sm.	X	
<i>Nitzschia longissima</i> (Breb.) Ralfs	X	
<i>Nitzschia palea</i> (Keutz.) Wm. Sm.	X	
<i>Nitzschia sigmoidea</i> (Nitz.) Wm. Sm.	X	
<i>Nitzschia vermicularis</i> (Keutz.) Hantzsch	X	
<i>Nitzschia</i> sp. (radiate colony)	X	
<i>Nitzschia</i> sp.	X	
<i>Pinnularia appendiculata</i> (Agh.) Cl.	X	
<i>Pinnularia brebissonii</i> (Keutz.) Rabh.	X	
<i>Pinnularia</i> sp.	X	
<i>Rhoicosphenia curvata</i> (Keutz.) Grun.	X	
<i>Stauroneis anceps</i> Ehr.	X	

(continued)

Table 13. (Continued).

Species	Pool 19	Pool 20
<i>Stauroneis smithii</i> Grun.	X	
<i>Stauroneis</i> sp.	X	
<i>Stephanodiscus astraee</i> (Ehr.) Grun.	X	
<i>Stephanodiscus astraee</i> var. <i>minutula</i> (Keutz.) Grun.	X	
<i>Stephanodiscus hantzschii</i> Grun.	X	
<i>Stephanodiscus niagarae</i> Ehr.	X	
<i>Stephanodiscus</i> sp.	X	X
<i>Surirella angusta</i> Keutz.	X	
<i>Surirella didyma</i> Keutz.	X	
<i>Surirella linearis</i> Wm.Sm.	X	
<i>Surirella minuta</i> Breb.	X	
<i>Surirella ovata</i> Keutz.	X	
<i>Surirella</i> sp.	X	
<i>Synedra acus</i> Keutz.	X	
<i>Synedra delicatissima</i> Wm. Sm.	X	
<i>Synedra pulchella</i> Ralfs. ex. Keutz.	X	
<i>Synedra radians</i> Keutz.	X	
<i>Synedra rumpens</i> Keutz.	X	
<i>Synedra tenera</i> Wm.Sm.	X	
<i>Synedra ulna</i> (Nitz.) Ehr.	X	
<i>Synedra</i> sp.	X	X
<i>Tabellaria fenestrata</i> (Lyngb.) Keutz.	X	
<i>Tabellaria</i> sp.	X	X
CHLOROPHYTES (Green algae)		
<i>Actinastrum hantzschii</i> Lag.	X	X
<i>Actinastrum hantzschii</i> var. <i>fluviatile</i> Schroed	X	
<i>Ankistrodesmus braunii</i> (Naeg.) Brunn.	X	
<i>Ankistrodesmus convolutus</i> Corda	X	
<i>Ankistrodesmus falcatus</i> (Corda) Ralfs	X	X
<i>Ankistrodesmus spiralis</i> (Turn.) Lemm.	X	
<i>Ankyra judayi</i> (G.M. S.M.) Fott	X	
<i>Carteria multifilis</i> (Fresh.) Dill	X	
<i>Carteria</i> sp.	X	
<i>Chlamydomonas</i> sp.	X	X
<i>Chodatella ciliata</i> (Lag.) Chodat	X	
<i>Chodatella quadriseta</i> (Lemm.) G.M. S.M.	X	
<i>Closteriopsis longissima</i> Lemm.	X	
<i>Closterium diana</i> Ehr.	X	
<i>Closterium ehrenbergii</i> Meneth.	X	
<i>Closterium gracile</i> Breb.	X	
<i>Closterium intermedium</i> Ralfs.	X	
<i>Closterium</i> sp.	X	X

(continued)

Table 13. (Continued).

Species	Pool 19	Pool 20
<i>Coelastrum cambricum</i> Arch.	X	
<i>Coelastrum microporum</i> Naeg.	X	
<i>Cosmarium formulosum</i> Hoffm.	X	
<i>Cosmarium subcrenatum</i> Hantzsch	X	
<i>Cosmarium</i> sp.	X	
<i>Crucigenia quadrata</i> Morren	X	
<i>Crucigenia tetrapedia</i> (Kirchn.) West & West	X	
<i>Dictyosphaerium ehrenbergianum</i> Naeg.	X	
<i>Dictyosphaerium pulchellum</i> Wood	X	
<i>Dispora crucigenioides</i> Printz	X	
<i>Echinosphaerella limnetica</i> G.M. S.M.	X	
<i>Eudorina elegans</i> Ehr.	X	
<i>Gloeocystis gigas</i> (Keutz.) Lag.	X	
<i>Gloeocystis planctonica</i> (West & West) Lemm.	X	
<i>Gloeocystis</i> sp.	X	
<i>Golenkinia radiata</i> (Chod.) Wille	X	
<i>Gonium formosum</i> Pascher	X	
<i>Gonium pectorale</i> Mull.	X	
<i>Gonium sociale</i> (Duj.) Warm.	X	
<i>Kirchneriella elongata</i> G.M. S.M.	X	
<i>Kirchneriella lunaris</i> (Kirchn.) Moeb.	X	
<i>Kirchneriella</i> sp.	X	
<i>Micractinium pusillum</i> Fres.	X	
<i>Micractinium quadrisetum</i> (Lemm.) G.M. S.M.	X	
<i>Nephrocytium agardhianum</i> Naeg.	X	
<i>Nephrocytium</i> sp.	X	
<i>Oocystis borgei</i> Snow	X	
<i>Oocystis parva</i> West & West	X	
<i>Pandorina morum</i> Bory	X	X
<i>Pediastrum boryanum</i> (Turp.) Menegh.	X	
<i>Pediastrum boryanum</i> var. <i>longicorne</i> Raciborski	X	
<i>Pediastrum duplex</i> Meyen	X	X
<i>Pediastrum simplex</i> (Meyen) Lemm.	X	
<i>Pediastrum simplex</i> var. <i>duodenarium</i> (Bailey) Rabh.	X	
<i>Pediastrum tetras</i> (Ehr.) Ralfs	X	
<i>Pediastrum tetras</i> var. <i>tetraodon</i> (Corda) Hansg.	X	
<i>Phacotus lenticularis</i> (Ehr.) Stein	X	
<i>Pleurotaenium coronatum</i> (Breb.) Rabh.	X	
<i>Pleurotaenium</i> sp.	X	
<i>Polyedriopsis spinulosa</i> Schmidle	X	
<i>Pteromonas aculeata</i> Lemm.	X	
<i>Quadrigula</i> sp.	X	
<i>Scenedesmus armatus</i> (Chod.) G.M. S.M.	X	
<i>Scenedesmus arcuatus</i> Lemm.	X	

(continued)

Table 13. (Continued).

Species	Pool 19	Pool 20
<i>Scenedesmus bijuga</i> (Turp.) Lag.	X	
<i>Scenedesmus brasiliensis</i> Bohlin	X	
<i>Scenedesmus denticulatus</i> Lag.	X	
<i>Scenedesmus dimorphus</i> (Turp.) Keutz.	X	
<i>Scenedesmus opoliensis</i> P. Richter	X	
<i>Scenedesmus quadricauda</i> (Turp.) Breg.	X	X
<i>Schroederia setigera</i> (Schroed.) Lemm.	X	
<i>Selenastrum westii</i> G.M. S.J.	X	
<i>Selenastrum</i> sp.	X	
<i>Sphaerocystis schroeteri</i> Chod.	X	
<i>Staurastrum cuspidatum</i> Breb.	X	
<i>Staurastrum gracile</i> Ralfs	X	
<i>Staurastrum leptocladum</i> Nordst.	X	
<i>Staurastrum oxyacanthum</i> Archer	X	
<i>Staurastrum</i> sp.	X	
<i>Tetradesmus</i> sp.	X	
<i>Tetraedon caudatum</i> (Corda) Hansg.	X	
<i>Tetraedon minimum</i> (A. Br.) Hansg.	X	
<i>Tetraedon muticum</i> (A. Br.) Hansg.	X	
<i>Tetraedon pentaedricum</i> West & West	X	
<i>Tetraedon regulare</i> Keutz.	X	
<i>Tetraedon trigonum</i> (Naeg.) Hansg.	X	
<i>Tetraedon trigonum</i> var. <i>gracile</i> (Reinsch) DeT.	X	
<i>Tetrastrum staurogeniaforme</i> (Schroed.) Lemm.	X	
<i>Treubaria crassipina</i> G.M. S.M.	X	
<i>Treubaria setigerum</i> (Arch.) G.M. S.M.	X	
Unidentified branched filament		
CHRYSOPHYCOPHYTA		
<i>Centrित्रactus belanorplus</i> Lemm.	X	
<i>Dinobryon divergens</i> Imh.	X	
<i>Dinobryon sociale</i> Ehr.	X	
<i>Dinobryon sertularia</i> Ehr.	X	X
<i>Kybotion</i> sp.	X	
<i>Mallomonas acaroides</i> Perty	X	
<i>Synura</i> sp.	X	X
CRYPTOPHYCOPHYTA		
<i>Cryptomonas erosa</i> Ehr.	X	
<i>Cryptomonas</i> sp.	X	
<i>Rhodomonas</i> sp.	X	

(continued)

Table 13. (Continued).

Species	Pool 19	Pool 20
CYANOPHYCOPHYTA (Blue-green algae)		
<i>Anabaena circinalis</i> (Keutz.) Rabh.	X	
<i>Anabaena spiroides</i> Kleb.	X	
<i>Anabaena</i> sp.	X	X
<i>Anacystis incerta</i> Dr. & Daily	X	
<i>Anacystis marina</i> (Hansg.) Dr. & Daily	X	
<i>Anacystis montana</i> (Lightf.) Dr. & Daily	X	X
<i>Anacystis thermalis</i> (Menegh.) Dr. & Daily	X	
<i>Anacystis thermalis</i> f. <i>major</i> (Lagerh.) Dr. & Daily	X	
<i>Anacystis</i> sp.	X	
<i>Aphanizomenon flos-aquae</i> Born et. Flah.	X	
<i>Coccochloris stagnina</i> Spreng.	X	
<i>Coelosphaerium collinsii</i> Dr. & Daily	X	
<i>Gloeotheca rupestris</i> (Lyngb.) Bornet	X	
<i>Gloeotheca</i> sp.	X	
<i>Gloeocapsa</i> sp.	X	
<i>Gomphosphaeria lacustris</i> Chod.	X	
<i>Marssoniella elegans</i> Lemm.	X	
<i>Merismopedia glauca</i> (Ehrenb.) Naeg.	X	X
<i>Merismopedia gudruplicata</i> Trev.	X	
<i>Merismopedia</i> sp.	X	
<i>Microcoleus lyngbyaceus</i> (Keutz.) Crouan	X	
<i>Microcoleus</i> sp.	X	
<i>Microcystis</i> sp.	X	
<i>Raphidiopsis curvata</i> Fritsch & Rich	X	
<i>Oscillatoria curviceps</i> C.A. Agardh	X	
<i>Oscillatoria ornata</i> Keutz.	X	
<i>Oscillatoria</i> sp.	X	X
<i>Schizothrix calcicola</i> Gom.	X	
<i>Schizothrix</i> sp.	X	
<i>Spirulina subsala</i> Oerst.	X	X
<i>Synechocystis aquatilis</i> Sauv.	X	
EUGLENOPHYCOPHYTA (<i>Euglenoids</i>)		
<i>Euglena acus</i> Ehr.	X	
<i>Euglena acutissima</i> Lemm.	X	
<i>Euglena elastica</i> Prescott	X	
<i>Euglena</i> sp. (encysting)	X	
<i>Euglena</i> sp.	X	X
<i>Phacus acuminata</i> Stokes	X	
<i>Phacus angustatum</i> Lemm.	X	
<i>Phacus longicauda</i> (Ehr.) Duj.	X	
<i>Phacus pleuronectes</i> (Mull) Duj.	X	
<i>Phacus pyrum</i> (Ehr.) Stein	X	
<i>Phacus tortus</i> (Lemm.) Skvortzow	X	
<i>Phacus</i> sp.	X	X
<i>Trachelomonas creba</i> (Kell.) Defl.	X	
<i>Trachelomonas hispida</i> (Perty) Stein	X	
<i>Trachelomonas pulcherrima</i> Playfair	X	

(continued)

Table 13. (Concluded).

Species	Pool 19	Pool 20
<i>Trachelomonas schauinslandii</i> Lemm.	X	
<i>Trachelomonas similis</i> Stokes	X	
<i>Trachelomonas volvocina</i> Ehr.	X	
<i>Trachelomonas</i> sp. (smooth with neck)	X	
<i>Trachelomonas</i> sp. (spines)	X	
PYRRHOPHYCOPHYTA (<i>Dinoflagellates</i>)		
<i>Ceratium hirundinella</i> (O.F.M.) Shrank	X	X
<i>Glenodinium quadridens</i> (Stein) Schiller	X	
<i>Glenodinium</i> sp.	X	
<i>Gymnodinium</i> sp.	X	
<i>Peridinium cinctum</i> (Mull) Ehr.	X	
<i>Peridinium</i> sp.	X	X
XANTHOPHYCOPHYTA		
<i>Ophiocytium capitatum</i> Wolle	X	
<i>Ophiocytium capitatum</i> var. <i>longispinum</i> (Moeb.) Lemm.	X	
<i>Ophiocytium cochleare</i> (Eichw.) A. Br.	X	
<i>Tribonema</i> sp.	X	X

An extensive study of both rotifer and crustacean zooplankton in Pool 19 was done between May 1982 and January 1983 (Pillard 1983). Sites were selected so that all habitat types, including channel, side channel, nonvegetated channel border, vegetated channel border, and backwaters were sampled. These samples were quantitative and collected monthly.

Throughout the pool, a total of 36 taxa were identified (Table 14). Rotifers were usually dominant and included the greater diversity, 21 of the taxa. While copepods were seasonal or site specific in abundance, only 2 taxa were found, but 13 taxa of cladocerans were collected. Maximum densities of rotifer species ranged from 0.01/l (*Trichotria*) to 337.29/l (*Branchionus calyciflorus*) with greatest species peaks occurring in August (50%) and May (27%). Species peak densities also occurred in August (47%) for crustaceans and ranged from 0.01/l (*Polyphemus pediculus*) to 29.35/l (*Daphnia retrocurva*) for cladocera and 24.15/l for *Cyclops*.

Diversity, particularly for rotifers, was greatest in May-June and lowest in October-November. Periods of mean peak zooplankton density in the pool changed, however, depending on habitat (Figure 18). In the navigation channel and channel border, rotifer densities peaked in May-June and those of crustaceans in August (Figure 18). Rotifer densities were usually much higher than crustacean densities. The highest densities of both rotifers and crustaceans were found in the shallow nonvegetated channel border (Figure 18), where crustacean density was greater than rotifer density in August. Deviating from this pattern were zooplankton populations in side channels and backwaters. Densities in side channels were generally low (Figure 18), and crustaceans still peaked in December. Mean annual densities of rotifers and crustaceans in this habitat were about equal. In backwaters, zooplankton densities peaked in December, and crustacean densities (27.3/l) were higher than those of rotifers (7.3/l) (Figure 18). In general, density peaks and low levels in

Table 14. Zooplankton taxa collected from Pools 19 and 20. Relative maximum is abundance indicated. A=100/1, C=10-99/1, U=10/1.

Taxa	Pool 19	Pool 20
Rotifera		
<i>Asplanchna</i> spp.	U	U
<i>Brachionus angularis</i>	U	
<i>B. calyciforus</i>	A	
<i>B. caudatus</i>	U	U
<i>B. quadridentata</i>	C	U
<i>Conochiliodes</i> sp.	U	
<i>Euchlanis</i> spp.	C	
<i>Filinia longiseta</i>	U	
<i>Kellicottia longispina</i>	U	
<i>Keratella cochlearis</i>	C	
<i>K. quadrata</i>	U	
<i>Lecane</i> spp.	U	
<i>Mniobia</i> spp.	U	
<i>Notholca striata</i>	U	
<i>Platylabus patulus</i>	U	
<i>P. quadricornis</i>	U	U
<i>Polyarthra</i> spp.	U	
<i>Synchaeta</i> spp.	U	U
<i>Testudinella</i> spp.	U	U
<i>Trichocerca</i>	U	U
<i>Trichotria</i> spp.	U	
Arthropoda		
Crustacea		
Cladocera		
<i>Alona costata</i>	U	
<i>A. rectangula</i>	U	
<i>Bosmina longirostris</i>	C	U
<i>Ceriodaphnia reticulata</i>	U	U
<i>Daphnia parvula</i>	U	U
<i>D. pulex</i>	U	
<i>D. retrocurva</i>	C	U
<i>Diaphanosoma brachyurum</i>	U	U
<i>Eurycercus lamellatus</i>	U	
<i>Leptodora kindtii</i>	U	U
<i>Macrothrix</i> spp.	U	
<i>Polyphemus pediculus</i>	U	
Copepoda		
<i>Cyclops</i> spp.	C	C
<i>Diaptomus</i> spp.	U	U
Nauplii	U	U

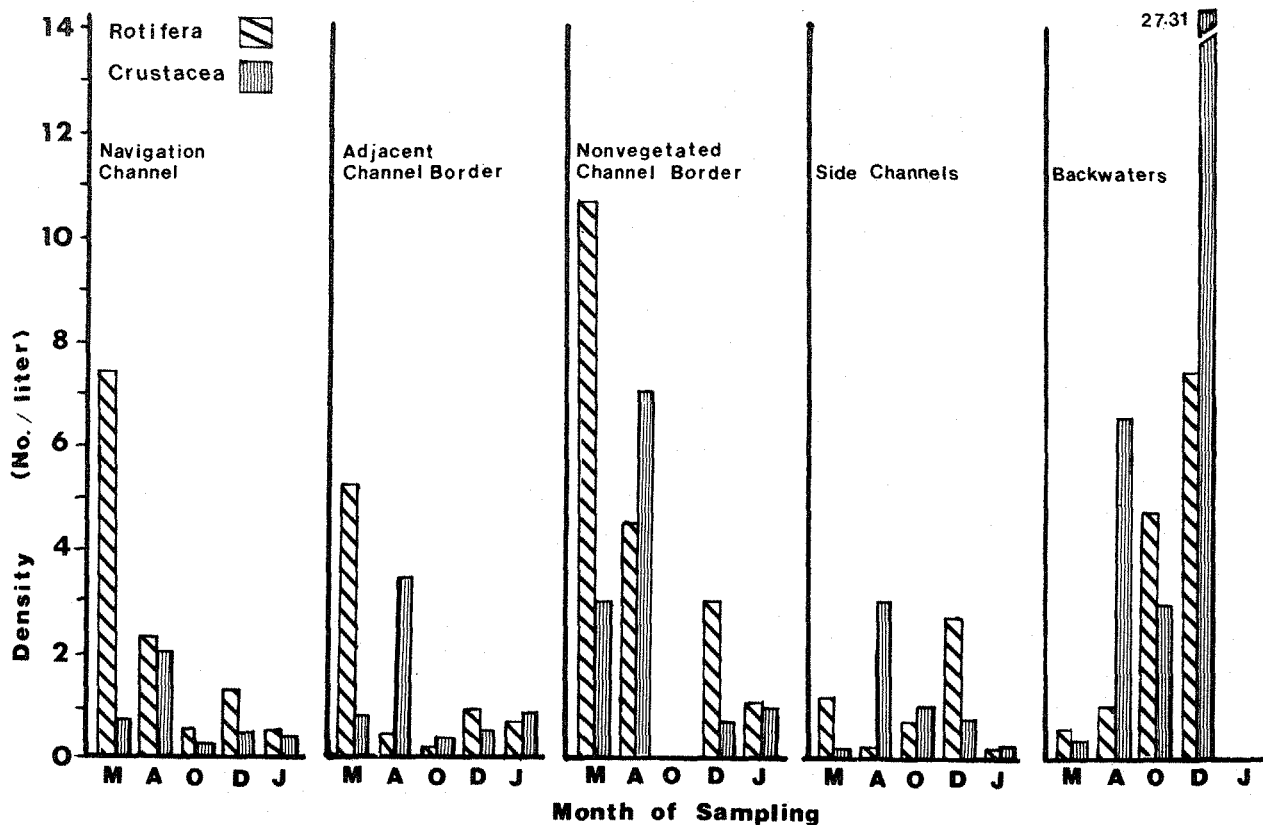

Figure 18. Seasonal distribution of rotifers and crustacean zooplankton in various habitats of Pool 19, Mississippi River (from Pillard 1983).

backwaters were just opposite of those found in channel and adjacent channel border habitats.

The generally high densities and diversity of rotifers and crustaceans from the channel and channel border areas in May-June samples correspond to the results of studies on other areas of the Mississippi River (Reinhard 1931) or other large rivers (Kofoid 1908). Areas of shallow water with lower current velocities tend to have an area of greater development of zooplankton populations. Galtsoff (1924) indicated higher crustacean densities in lower, lacustrinelike reaches of Pool 19. Similarly, in Pillard's study (1983), densities of zooplankton were high in backwater areas and shallow, sparsely vegetated channel borders where current velocities are low. These areas, as well as other upstream pools, contribute zooplankton to the main channel and adjacent channel border areas. Aquatic

macrophytes seem to limit zooplankton production; but the macrophyte growing season (June through August) is short and these shallow areas have abundant zooplankton populations in the fall after plant senescence.

2.5.2 Pool 20

Though a few samples of zooplankton from Pool 20 have been collected, only two systematic studies have been reported. In 1972-73, Heffelfinger (1973) collected zooplankton from three Pool 20 sites as part of an evaluation of plankton and water quality in this pool (see Section 2.4 for description of sample sites). Ten years later Pillard (1983) examined zooplankton communities in the upper reaches of Pool 20. In Pillard's study quantitative samples were collected at 19 sites in tailwater, channel, and channel border areas below Lock and Dam 19.

Between the two studies, 18 taxa were collected in Pool 20 (Table 14). Densities ranged from 7.59 zooplankton/l to 44.84/l, depending on location of sample sites. The zooplankton community was usually dominated by rotifers, particularly Brachionus calyciflorus in the upper end of the pool and Trichocera sp. in the lower reaches. The copepod Cyclops was also abundant, often equaling the density of the dominant rotifer. A decline in zooplankton density was noted down the length of the pool, with peak densities usually occurring in the tailwaters of Lock and Dam 19. Seasonally, densities of zooplankton were low in the winter with peak populations in the fall. Similar patterns were evident at all sampling stations down the length of the pool. With the exception of the tailwaters, little variation was observed between habitats in Pool 20. The tailwaters, though having lower densities than Pool 19, still had the highest diversity and density of samples from Pool 20. In the tailwaters, diversity and density were lower near the Iowa shore, with a progressive increase toward the Illinois shore.

Changes in diversity and density in the tailwaters may be due to feeding by fish or benthic invertebrates on zooplankton passing from the lacustrine habitat above Lock and Dam 19. The density distribution suggests this cause since densities decrease with downstream sampling stations. The lack of habitat diversity in Pool 20 is evidenced by the similarity in diversity and density of zooplankton communities at sites positioned across the pool at the same river mile. These trends are similar to those observed for phytoplankton in this pool.

2.5.3 Pool Comparisons

In both pools rotifers were found to be the dominant zooplankton, followed by copepods and cladocerans. The rotifer Brachionus calyciflorus was dominant in both pools and was the only abundant zooplankton (densities greater than 100/l) in Pool 19 (Table 14). These findings are a change from those of Williams (1966), who found the rotifer Keratella sp. to be the most abundant zooplankton in Pool 19.

Also, in Pool 20 Heffelfinger (1973) indicated that, at least in November, the rotifer Trichocerca was the most abundant. These differences, however, are usually only seasonal, and Brachionus is considered the dominant riverine species for these reaches of the Mississippi River.

The major differences between Pool 19 and Pool 20 are in species diversity and density. Pool 19 has a far higher diversity and density. As with phytoplankton, this difference apparently reflects the greater habitat diversity in Pool 19, which has extensive backwaters, vegetated channel borders, and island braiding with associated side channels. The high habitat diversity results in a variety of environmental conditions--e.g., lower current velocities, variable dissolved oxygen, and variable temperature--which stimulate or depress zooplankton populations and increase diversity. Diversity does decrease downstream on Pool 20 (Heffelfinger 1973; Pillard 1983). While greatest densities and diversity do occur in the lower reaches of Pool 19, Galtsoff (1924) indicated increased density in cladocerans and copepods in the upper reaches of the Mississippi River near Minneapolis, Minnesota. The areas examined by Galtsoff were more lacustrine, such as Lake Pepin, or were extensive backwaters with low current velocities.

2.6 MEIOFAUNA

Meiofauna include those benthic invertebrates that can pass through a 500-micron sieve. In most aquatic systems benthic meiofauna include rotifers, tardigrades, nematodes, and gastrotrichs. These organisms may occur in very high densities in some environments and they have been shown to be important in maintaining the dynamics of decomposer-based nutrient cycles. However, only one study has been conducted in the river reach from Lock and Dam 20 to Lock and Dam 18. Anderson (in prep.) used a corer to collect meiofauna from eight locations down the length of Pool 19. Three habitat types were sampled: main channel, unvegetated channel border, and vegetated channel border. The vegetated habitat was subdivided into emergent, floating, and submerged areas.

The most abundant meiofauna found were nematodes with densities ranging from 128,000/m² in emergent vegetation to about 11,000/m² in the main channel (Table 15). Diversity was greatest in habitats with floating vegetation in which 23 genera of nematodes sampled down the length of Pool 19 showed a longitudinal change in density. Densities in this habitat were highest in the lower lacustrine areas of the pool (90,000/m²) and declined at upstream stations (9,000/m²) with sandy substrates. The most common genera, in terms of both distribution between habitats and density was Trobilus (maximum density = 40,800/m²), a bacterial-feeding nematode. Other abundant genera include another bacterial feeder, Plectus (maximum density = 37,000/m²), and the stylet-bearing form, a plant feeder, Ironus (maximum density = 43,000/m²). Nematodes with stylets were usually more abundant in vegetated areas, where they constituted 50% or more of the taxa present in the habitat.

Benthic rotifers were reported to be about half as abundant as nematodes in all but the main channel habitat. In the channel, densities of both groups were very low for nematodes. Other types of meiofauna occurred only sporadically and never at levels of significant densities.

2.7 MACROINVERTEBRATES

Macroinvertebrates are usually defined by size and include those organisms that cannot pass through a U.S. standard No. 30 sieve (mesh size 500 µm). They are probably the most diverse group of animal biota found in the river, with representatives from at least 5 phyla and well over 100 genera present (Table 16). Not only are they a diverse group of organisms, but they also occur in very high densities and biomass in some habitats. While these high densities are sometimes considered a hinderance to human activity along the river (Fremling 1960b), they do represent the high productivity potential of the river and a vital trophic link for higher organisms in and along the river (see Section 3.3).

With the exception of the tail-water area of Pool 20, Pool 19 has been

evaluated the most for the macroinvertebrate taxa, partly, because of the link between invertebrate production and the use of the area by migratory water fowl (Thompson and Sparks 1978; Sparks 1984; Day 1984) and fish (Hoopes 1960; Jude 1973). In addition, the extreme densities of the mass emergences of caddisflies and burrowing mayflies have attracted continuing interest. Pool 19 was also designated as a long term ecological research site by the National Science Foundation through a grant to the Illinois Natural History Survey. As a result, intensive sampling of macroinvertebrates was started in 1980 and is expected to continue into the 21st century.

2.7.1 Pool 19

In Pool 19, 144 macroinvertebrate taxa have been reported (Table 16). The majority of these taxa are insects. Three insect orders contribute substantially to this diversity and include midge larvae (Chironomidae), mayfly nymphs (Ephemeroptera), and caddisfly larvae (Trichoptera). The diversity of mussels (Unionidae) and snails (Gastropoda) is also high in the pool. However, the greatest densities and biomass involve only a few species including the fingernail clam (Musculium transversum), caddisfly larva (Hydropsyche orris), and burrowing mayfly nymph (Hexagenia limbata). Because of the high density and production of these three organisms, their autecology in Pool 19 has been examined by several researchers (Fremling 1960b, 1964a, 1964b, 1973; Carlander et al. 1967; Gale 1969, 1971, 1973a, 1973b, 1976, 1977).

The community-dominating fingernail clam (M. transversum; Figure 19) lives in nonvegetated channel border areas having soft silt-sand substrates (Carlson 1968; Gale 1971, 1975; Butts and Sparks 1982; Anderson and Day, in press). Though densities of this species have been reported to exceed 100,000/m² (Gale 1969), their densities usually range between 100/m² and 10,000/m² (Butts and Sparks 1982; Anderson et al., in prep.). The clam's life cycle may be 3 to 12 months, depending on when an individual clam was produced. There are apparently two periods of peak reproductive activity in

Table 15. Abundance of nematodes by taxa collected in various habitat types in Pool 19, Mississippi River. A=abundant, 15,000/m²; C=common, 1,000-15,000/m²; and R=rare, 1,000/m². Habitat types include EV=emergent vegetation, FV=floating vegetation, SV=submerged vegetation, CB=nonvegetated channel border, and C=main channel.

Taxa	Habitat type				
	EV	FV	SV	CB	C
<i>Achromadora</i>	C	C	R	R	
<i>Acrobeloides</i>	C	C	V	R	R
<i>Alaimus</i>	R	R			
<i>Anonchus</i>		R	R	R	
<i>Aphanolaimus</i>	C	C	R	R	
<i>Aphelenchus</i>	C	C	R	R	
<i>Butlerius</i>		R	C	C	
<i>Chromadorita</i>	C	R	C	C	R
<i>Chronogaster</i>	C	C	C	R	
<i>Cryptonchus</i>	C	C	C	R	R
<i>Diplogaster</i>	C	C	C	C	
<i>Ditylenchus</i>	C	C	R		
<i>Dorylaimus</i>	C	C	C	C	
<i>Ethmolaimus</i>	C	C	R	C	R
<i>Ironus</i>	A	A	C	C	R
<i>Mesodorylaimus</i>	R	C	R	R	
<i>Monhystrella</i>	R	R	R	C	
<i>Paratylenchus</i>	C	C			
<i>Plectus</i>	C	C	A	C	C
<i>Rhabditis</i>	C	C			
<i>Rhabdolaimus</i>		C	C	R	
<i>Tobrilus</i>	A	A	A	A	C
<i>Tripyla</i>	R	R	C	C	R
Mean density, No./m ²	128,379	125,045	109,607	50,115	10,672

the population, one in late spring and one in mid fall (Gale 1969; Anderson et al., in prep.) (Figure 20). Clams produced in spring may mature to produce offspring in the fall. After production of young, the adult dies and the young may burrow as deep as 20 cm into the substrate (Gale 1971), in part, perhaps, to avoid predation and parasitism. In vegetated areas the species is replaced by *Sphaerium striatinum*, which never occurs at densities as high as *M. transversum*. In addition to the expansion or development of aquatic macrophyte beds, *M. transversum* may be limited by substrate (Gale 1971), ammonia (Sandusky and Sparks 1979), and burial caused by addition of coarse

substrates from dredging operations (Rogers 1976). The importance of this species in the trophic structure of the pool is discussed in Section 3.3.

Codominants of the fingernail clam in much of the channel border habitat are the burrowing mayflies *Hexagenia limbata* (Figure 19) and *H. bilineata*. Though these mayflies reach 2.5 billion in the pool (Carlson 1960), they have primarily been examined for their synchronized annual emergence (Carlson 1960; Fremling 1964a, 1973; Carlander et al. 1967). Most of the adults emerge from late June to early July though some emerge throughout the summer. The emergence results in a density

Table 16. Macroinvertebrates collected from Pools 19 and 20, Upper Mississippi River.

Taxa	Pool 20		Pool 19	
	Teska (1979)	Anderson (Unpubl.)	Carlson (1968)	Gale (1969) Anderson (Unpubl.)
Nematomorpha (Horsehair worms)				
<i>Gordius</i> sp.		X		X
Bryozoa (Moss animals)				
<i>Plumatella</i> spp.		X		X
Annelida				
Oligochaeta (Aquatic worms)				
<i>Aeolosoma</i> spp.				X
<i>Chaetogaster limnaei</i>			X	X
<i>Chaetogaster</i> sp.	X			X
<i>Dero</i> sp.	X			X
<i>Pristina</i> sp.				X
<i>Nais</i> spp.	X			X
<i>Branchiura sowerbyi</i>	X	X		X
<i>Limnodrilus</i> sp.	X			X
<i>Limnodrilus hoffmeisteri</i>		X	X	X
<i>Tubifex tubifex</i>	X			X
Hirudinea (Leeches)				
<i>Erpobdella punctata</i>		X	X	X
<i>Glossiphonia complanata</i>		X	X	X
<i>Haemopsis marmorata</i>				X
<i>Helobdella Fusca</i>			X	X
<i>H. nepheloidea</i>		X	X	
<i>H. stagnalis</i>	X	X	X	X
<i>Illinobdella</i> sp.	X	X		
<i>Nephelopsis obscura</i>				X
<i>Placobdella montifera</i>	X	X	X	X
<i>P. parasitica</i>			X	X
Arthropoda				
Isopoda (Aquatic sow bugs)				
<i>Asellus brevicaudus</i>		X		
<i>Asellus intermedius</i>	X		X	X
Amphipoda (Sideswimmers)				
<i>Hyalella azteca</i>	X	X	X	X
Decapoda (Crayfish & shrimp)				
<i>Palaemonetes Kadiakensis</i>				X
<i>Cambarus diogenes</i>				X
<i>Orconectes virilis</i>	X			X

(continued)

Table 16. (Continued).

Taxa	Pool 20		Pool 19	
	Teska (1979)	Anderson (Unpubl.)	Carlson (1968)	Gale (1969) Anderson (Unpubl.)
Insecta				
Collembola (Springtails)				
<i>Hypogastrura</i>				X
<i>Isotomurus palustris</i>	X			X
Plecoptera (Stoneflies)				
<i>Isoperla bilineata</i>	X	X		X
<i>Allocapnia</i> sp.	X			
Ephemeroptera (Mayflies)				
<i>Potamanthus verticis</i>	X			X
<i>Pentagenia vittigera</i>	X	X		X
<i>Hexagenia bilineata</i>	X	X	X	X
<i>H. limbata</i>	X	X	X	X
<i>Tricorythodes atratus</i>	X			X
<i>Caenis hilaris</i>	X	X	X	X
<i>C. simulans</i>				X
<i>Isonychia sicca</i>	X	X		X
<i>Baetis</i> spp.	X			X
<i>Ephoron album</i>	X			
<i>Pseudiron centralis</i>				X
<i>Stenacron interpunctatum</i>	X			X
<i>Stenonema integrum</i>	X		X	X
<i>S. bipunctatum</i>	X			X
<i>S. terminatum</i>	X			
<i>Heptagenia inconspicua</i>	X			X
<i>H. hebe</i>	X			
<i>H. maculipennis</i>	X			X
<i>Anepeorus simplex</i>	X			
Odonata				
Anisoptera (Dragonflies)				
<i>Gomphus</i> spp.	X	X		X
<i>Anax junius</i>				X
<i>Aeschna</i> sp.				X
<i>Macromia</i> sp.				X
<i>Somatochlora</i> spp.				X
<i>Libellula</i> sp.	X			X
<i>Sympetrum</i> sp.				X
<i>Pachydiplax</i> sp.				X
Zygoptera (Damselflies)				
<i>Agrion</i> sp.	X			X
<i>Lestes</i> sp.				X
<i>Argia</i> spp.				X
<i>Ischnura</i> sp.		X		X
<i>Enallagma</i> sp.				X
Hemiptera (True bugs)				
Heloridae (Velvet water bugs)				

(continued)

Table 16. (Continued).

Taxa	Pool 20		Pool 19	
	Teska (1979)	Anderson (Unpubl.)	Carlson (1968)	Gale (1969) Anderson (Unpubl.)
<i>Hebrus</i>				X
Mesoveliidae (Water treaders)				X
<i>Mesovelia</i>				X
Gerridae (Water strider)				X
<i>Gerris</i>	X			X
Veliidae (Broad-shouldered water strider)				X
<i>Microvelia</i>				X
Notonectidae (Backswimmers)				X
<i>Notonecta</i>				X
<i>Buena</i>				X
Pleidae (Pigmy backswimmers)				X
<i>Neoplea</i>				X
Nepidae (Water scorpions)				X
<i>Ranatra</i>				X
Belostomatidae (Giant water bugs)				X
<i>Belostoma Fluminea</i>				X
Corixidae (Water boatmen)				X
<i>Trichocorixa</i> sp.				X
<i>Palmacorixa</i> sp.				X
<i>Hesperocorixa</i> sp.				X
<i>Sigara</i> spp.				X
Megaloptera (Alderflies)				X
<i>Sialis</i> sp.				X
Trichoptera (Caddisflies)				X
<i>Cheumatopsyche</i> spp.	X		X	X
<i>C. Campyla</i>	X	X		X
<i>Hydropsyche bidens</i>	X			X
<i>H. orris</i>	X			X
<i>H. valanis</i>	X			X
<i>H. phalerata</i>	X			X
<i>Hydroptila ajax</i>				X
<i>H. waubesiana</i>				X
<i>Mayatrichia ayama</i>				X
<i>Orchotrichia</i> sp.	X			X
<i>O. tarsalis</i>			X	X
<i>Athripisodes falvus</i>				X
<i>A. transversus</i>				X
<i>Oecetis inconspicua</i>		X	X	X
<i>Nectopsyche</i> sp.	X			X
<i>Cynellus marginalis</i>	X			X
<i>Neureclipsis crepuscularis</i>				X
Lepidoptera (Aquatic caterpillars)				X
<i>Neocataclysta</i>				X
<i>Acentropus</i>				X

(continued)

Table 16. (Continued).

Taxa	Pool 20		Pool 19	
	Teska (1979)	Anderson (Unpubl.)	Carlson (1968)	Gale (1969) Anderson (Unpubl.)
Coleoptera (Beetles)				
Haliplidae (Crawling water beetles)				
<i>Peltodytes</i> sp.				X
<i>Haliphus</i> sp.	X			X
Dytiscidae (Predaceous diving beetles)				
<i>Hydroporus</i> sp.				X
<i>Laccophilus</i> sp.				X
<i>Agabus</i> sp.				X
<i>Dytiscus</i> sp.				X
<i>Cybister</i> sp.				X
Gyrinidae (Whirligig beetles)				
<i>Dineutus</i> sp.	X			X
<i>Gyrinus</i> sp.	X			X
Hydrophilidae (Water scavenger Beetles)				
<i>Helophorus</i> sp.				X
<i>Borosus</i> sp.				X
<i>Tropisternus</i> sp.				X
<i>Laccobius</i> sp.				X
Elmidae (Riffle beetles)				
<i>Stenelmis</i> sp.	X	X		X
Diptera (Flies)				
Tipulidae (Crane flies)				
<i>Helius</i> sp.				
<i>Tipula</i> sp.				
Culicidae (Mosquitoes)				
<i>Aedes</i> spp.	X			X
Chaoboridae (Phantom midge)				
<i>Chaoborus</i> sp.	X			X
Simuliidae (Black flies)				
<i>Prosimulium</i> sp.	X			X
Heleidae (Biting midges)				
<i>Palpomyia</i> sp.	X			X
<i>Bezzia</i> sp.				X
Stratiomyiidae (Soldier flies)				
<i>Odontomyia</i> sp.				X
Tabanidae (Horseflies)				
<i>Chrysops</i> sp.				X
<i>Tabanus</i> sp.				X
Anthomyiidae (Anthomyiids)				
<i>Limnophora</i> sp.				X
Chironomidae (Midges)				

(continued)

Table 16. (Continued).

Taxa	Pool 20		Pool 19	
	Teska (1979)	Anderson (Unpubl.)	Carlson (1968)	Gale (1969) Anderson (Unpubl.)
<i>Ablabesmyia</i>	X		X	X
<i>Anatopynia</i>			X	
<i>Clinotanypus</i>			X	X
<i>Coelotanypus</i>	X	X	X	X
<i>Pentaneura</i>		X		X
<i>Procladius</i>	X	X	X	X
<i>Tanypus</i>		X	X	X
<i>Chironomus</i>	X	X	X	X
<i>Cryptochironomus</i>	X	X	X	X
<i>Dicrotendipes</i>	X			X
<i>Microtendipes</i>	X	X		X
<i>Parachironomus</i>	X			X
<i>Paracladopelma</i>	X			X
<i>Paratendipes</i>	X			X
<i>Phaenospectra</i>	X			
<i>Polypedilum</i>	X	X	X	X
<i>Eukiefferiella</i>				X
<i>Cricotopus</i>				X
<i>Rheotanytarsus</i>	X			X
<i>Stenochironomus</i>	X	X		X
<i>Corynoneura</i>	X			
Mollusca				
Gastropoda (Snails)				
<i>Physa</i> sp.	X	X		X
<i>P. anatina</i>			X	X
<i>P. gyrina</i>			X	X
<i>Helisoma trivolvis</i>			X	X
<i>Laevapex</i> sp.	X			X
<i>L. Fuscus</i>			X	X
<i>Amnicola binneyana</i>		X		X
<i>A. lustrica</i>			X	X
<i>A. sayana</i>			X	X
<i>Fontigens nickliniana</i>			X	
<i>Somatogyrus depressus</i>		X		X
<i>S. isogonus</i>			X	X
<i>S. subglobosus</i>		X		
<i>Campeloma crassula</i>			X	
<i>C. decisum</i>	X	X		X
<i>Lioplax subcarinata</i>		X		
<i>L. subculosa</i>			X	
<i>Viviparus intertextus</i>		X		
<i>V. georgianus</i>	X		X	X
<i>Pleurocera acuta</i>	X	X	X	X

(continued)

Table 16. (Concluded).

Taxa	Pool 20		Pool 19	
	Teska (1979)	Anderson (Unpubl.)	Carlson (1968)	Gale (1969) Anderson (Unpubl.)
Pelecypoda (Clams and mussels)				
Sphaeriidae (Fingernail clams)				
<i>Pisidium</i> sp.	X			X
<i>P. compressum</i>			X	
<i>P. nitidum</i>			X	
<i>P. variabile</i>			X	
<i>Sphaerium lacustre</i>			X	
<i>S. simile</i>			X	
<i>S. striatinum</i>	X	X	X	X
<i>Musculium transversum</i>	X	X	X	X
Corbiculidae (Asiatic clam)				
<i>Corbicula fluminea</i>				X
Margaritiferidae (Mussels)				
<i>Cumberlandia monodonta</i>	X			X
Unionidae (Mussels)				
No. of species (see Section 2.8, Table 19 for species list)	20	10	22	26
Total no. of taxa	98	50	68	172

reduction of the nymphs by 80%-85% by mid-July. Populations recover in the fall when nymphs again begin to burrow and increase in size (Carlson 1960).

A similar situation is found with the caddisfly larvae. While several species of hydropsychiid caddisflies are found on hard substrates of the pool, *Hydropsyche orris* is the numerically dominant species, occurring at densities of 10,000/m². This species, as well as most hydropsychiid caddisflies, is most abundant in tailwaters but occurs as a dense mat on any solid substrate in flowing water. These mats, composed of larval retreats constructed of small pits of sand, may become so dense that they foul mooring lines and fish nets. The larvae are called sandworms by local fishermen and are considered a nuisance. Adult emergence, completing an annual life cycle, may

commence in May and continue to August (Fremling 1960b). In recent years the peak emergence is usually from early to mid June and constituted primarily of *H. orris* (Anderson et al., in prep.).

Besides the prevalence of these taxa in the pool, there is a distinct longitudinal and latitudinal gradient in the macroinvertebrate community's composition. Down the length of the pool the community shifts from one dominated by insects to one dominated by mollusks (Figure 21). In evaluating the longitudinal community structure, care must be taken in the choice of sampling method since some selectivity is present, depending on method used. Solid substrates, except those in areas of low current velocity that become fouled with silt, attract nonburrowing insects which attach to the surface or crawl along it (Figure 21,

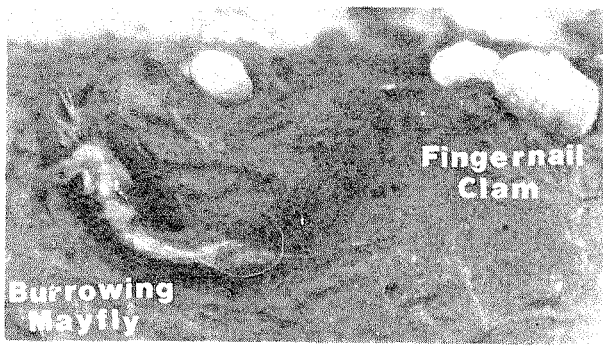

Figure 19. Burrowing mayflies (*Hexagenia*) and fingernail clams (*Musculium*) in channel border substrate, Pool 19, Mississippi River.

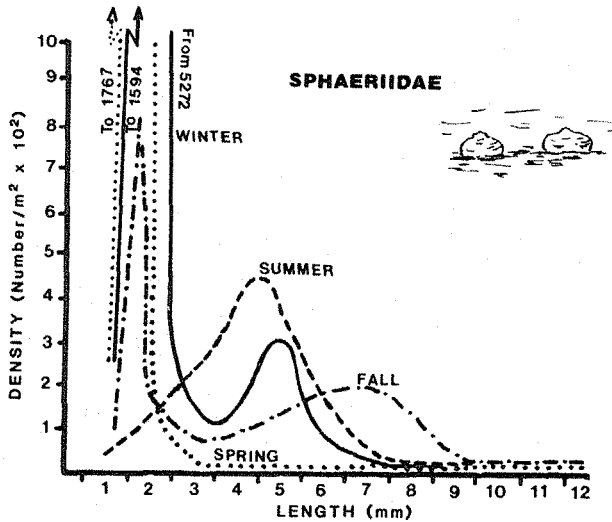

Figure 20. Seasonal distribution of size classes in fingernail clam populations in Pool 19, Mississippi River.

multiplates). Dredging does not adequately sample areas or habitats with solid substrates (Figure 21, dredge) because the dredge will not close around large solid substrates. Using a dredge to sample results in an underestimate of attached or surface-dwelling organisms. Thus, a combination of techniques such as implementing artificial substrates, diving, and dredging may be needed to examine longitudinal macroinvertebrate community structure as substrates and habitats change down the length of the pool.

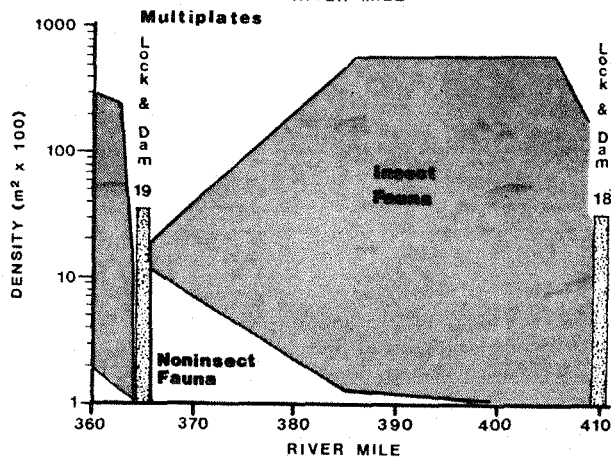
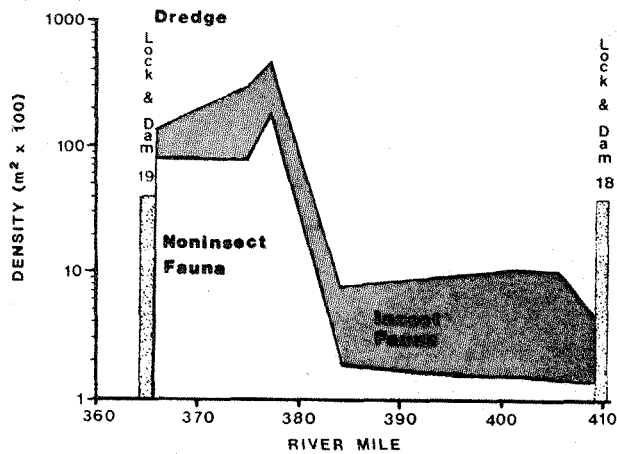

Figure 21. Effects of sampling technique on distribution and density of insect and noninsect fauna down the length of Pool 19, Mississippi River.

Latitudinally, macroinvertebrate community structure can be defined according to habitat (Table 17; Anderson and Day, in press). Most sections across the river have at least two distinct habitats and some may have as many as five. The main channel usually has a comparatively depauperate fauna composed principally of organisms washed into the channel. There are few resident species in this habitat. As mentioned previously, the channel border area is dominated by fingernail clams and burrowing mayflies, but as many as 84 other species are also found (Table 17). Habitats with the greatest number of taxa are areas with macrophytes. In these areas macroinvertebrate composition varies, depending on whether the habitat contains emergent,

floating, or submerged vegetation. The composition changes from a submerged vegetation, to one with searching predators (like damselflies) in floating vegetation, to litter-processing forms such as *Asellus* in areas of emergent vegetation (Anderson and Day, in press). Slough and backwater lakes have a similar but less diverse taxa than vegetated areas. This difference in diversity is probably due to an increase in organic matter in the sloughs and lakes and associated reduction in dissolved oxygen, factors which have been shown to reduce community diversity.

Superimposed on this habitat association is substrate preference. Many macroinvertebrate taxa have a specific substrate requirement (Table 18). The greatest number of taxa were associated with soft substrates and macrophytes. Both had a large variety of true flies (Diptera). Mud substrates also contained a diverse unionid mussel community. Hard substrates were dominated by caddisflies (Trichoptera) and mayflies (Ephemeroptera) but a species different from the burrowing form (Table 18). As a result of these associations, Anderson and Day (in press) described four distinct macroinvertebrate communities in Pool 19: (1) A community found in the channel with a low density and lacking key organisms, (2) communities in areas with hard substrates (tailwaters, riprap, riverine areas with coarse bed material) and characterized by hydro-psychiid caddisflies, (3) communities with high densities of fingernail clams and burrowing mayflies found in soft substrates of nonvegetated channel border areas, and (4) a mixed, highly diverse community of insects, crustaceans, and gastropods in habitats with macrophytes. The largest of these communities in Pool 19 is the fingernail clam-burrowing mayfly community which occurs in about 60% of the pool area.

2.7.2 Pool 20

Though macroinvertebrates are dispersed along much of the length of Pool 20, few studies have been conducted on them. Teska (1979) examined the macroinvertebrates of the tailwaters of Lock and Dam 19 and the upper portions of Pool

20. He found that hydro-psychiid caddisflies were the most abundant organisms in his study area, followed by nonburrowing mayflies and midges (Chironomidae). Channel border areas with soft substrates did have burrowing mayflies but no fingernail clams. Frendreis (1982) examined habitats with riprap (wing dams) and sand substrates adjacent to and just downstream of the mouth of the Des Moines River. The riprap was again dominated by hydro-psychiid caddisflies, and few organisms were found in the sand substrate. Neuswanger (1980) and Neuswanger et al. (1982) examined side channel habitats in the lower reaches of Pool 20. The mud substrates of these areas were dominated by burrowing mayflies and oligochaetes. When artificial substrates were introduced into the habitat, other mayflies and caddisflies colonized these solid substrates. These studies all indicated a strong association between macroinvertebrate community composition and substrate type in this pool (Table 18).

Ninety-eight taxa have been reported from Pool 20 (Table 16). Because of the presence of the unionid mussels there, the greatest number of different taxa was found in the channel (Table 17). Habitats with macrophytes were either not present or occupied such a small area that they were not examined. Channel borders and side channels often had soft substrates and burrowing macroinvertebrate communities.

2.7.3 Comparison of Pools 19 and 20

There are major differences between Pools 19 and 20 regarding macroinvertebrates. First, tailwater densities and diversity were much higher in Pool 20, in tailwaters of Lock and Dam 19, and in the tailwaters of Lock and Dam 18. Coarser substrates--rock and cobble--are found below Lock and Dam 19 than below Lock and Dam 18 where much of the substrate is sand. The more stable substrate is conducive to the development of higher densities and diversity. In addition, the production of particulate organic matter, phytoplankton and zooplankton, is higher in the large lacustrine area immediately above Lock and Dam 19. Drift of this material may provide an abundant food

Table 17. Number of macroinvertebrate taxa associated with particular habitat types (as defined in Section 1.4) in Pools 19 and 20, Upper Mississippi River. TW=tailwaters, C=channel, CB=channel border, SC=side channel, VCB=vegetated channel border, S-L=sloughs or lakes.

Taxa	Habitats in Pools 19 and 20											
	TW		C		CB		SC		VCB		S-L	
	19	20	19	20	19	20	19	20	19	20	19	20
Nematomorpha (1)							1	1				
Bryozoa (1)					1		1	1				
Annelida												
Oligochaeta (10)		1	2	2	8	4	3	1	6		7	
Hirudinea (10)			2		10	3	2	1	4		3	
Arthropoda												
Isopoda (1)							1	1	2			
Amphipoda (1)					1		1	1	1		1	
Decapoda (3)					1		1	1	2		1	
Insecta												
Collembola (2)								1	2		1	
Plecoptera (2)					1			1	1			
Ephemeroptera (19)	8	13	2	3	4	2	2	3	4		2	
Odonata												
Anisoptera (8)					2	1	2	1	6		4	
Zygoptera (5)					1	1	1	1	5		5	
Hemiptera (13)					2	1	3	1	13		11	
Megaloptera (1)									1			
Trichoptera (17)	6	8	5	6	10	2	2	1	2		1	
Lepidoptera (2)									2			
Coleoptera (14)	3	2	1	2	4		2		6		2	
Diptera (33)	8	11	10	13	7	9	6	3	14		16	
Mollusca												
Gastropoda (20)	2	1	3	2	5	3	2	2	11		9	
Pelecypoda												
Sphaeriidae (8)			2	1	2	1		1	8		4	
Corbiculidae (1)			1		1		1					
Unionidae (26)			17	18	24	7	21	14	5		1	
Totals	27	36	45	47	84	34	52	36	95		68	

source for filter-feeding macroinvertebrates attached to the substrates below the dam (Pillard 1983). Though tailwaters in Pool 20 support a high density of organisms, the channel border area of Pool 19 supports a much greater density and diversity than found anywhere in Pool 20. The complex habitats in Pool 19, abundance of potential food items, suitable substrates, and relatively stable pool levels all contribute to this high density and diversity. Additionally, the large macrophyte beds may provide an

abundant food source in Pool 19 during the summer, a period of peak growth for many organisms. By comparison, Pool 20 has neither the large shallow channel border areas nor the expansive macrophytic beds to provide habitat and food needed to support high population densities. Pool 20 also lacks extensive populations of fingernail clams, possibly the most dominant single species found in Pool 19. Again, this may be due to food availability.

Table 18. Number of macroinvertebrate taxa associated with particular substrate types in Pools 19 and 20, Upper Mississippi River.

Taxa	Substrate types							
	Rock	Rock-gravel	Gravel	Gravel sand	Sand	Sand-mud	Mud	Macrophytes
Nematomorpha (1)				1				
Bryozoa (1)	1							
Annelida								
Oligochaeta (10)	1	1	1	3	3	6	8	2
Hirudinea (10)						8	10	
Arthropoda								
Isopoda (1)							1	1
Amphipoda (1)						1	1	1
Decapoda (3)						1	2	1
Insecta								
Collembola (2)								2
Plecoptera (2)	1	1				1	1	
Ephemeroptera (19)	13	13	11	3	2	6	6	3
Odonata								
Anisoptera (8)						5	6	3
Zygoptera (5)								5
Hemiptera (13)								13
Megaloptera (1)								1
Trichoptera (17)	13	13	8	4			3	6
Lepidoptera (2)								2
Coleoptera (14)	3	3	3				4	10
Diptera (33)	9	10	6	6	6	11	18	21
Mollusca								
Gastropoda (20)	3	3	2		3	7	8	13
Pelecypoda								
Sphaeriidae (8)	1	1			1	2	2	6
Corbiculidae (1)					1	1	1	
Unionidae (26)			5	9	13	18	18	
Totals	45	45	37	26	29	67	90	89

Similarities between the pools do occur for some key species. Burrowing mayflies are present in both pools and are a dominant organism in areas with soft, mud-silt substrates. Hydropsychiid caddisflies, particularly *Hydropsyche orris*, are abundant on any solid substrate in the pools. Their similarities reflect the strong association between substrate and macroinvertebrates, while the generally lower densities in Pool 20 may reflect food availability or sequence of its availability. Similar unionid communities are found in both

pools and will be discussed in Section 2.8.

It is probable that many other species exist in both pools. Identification of several groups, aquatic worms (Oligochaeta) and midges (Chironomidae) in particular, is poorly known. Low densities of many species may be either widely distributed or restricted to specialized macrohabitats and thus not collected in the reported surveys. Increased research and study on these pools should produce an expanding taxa list.

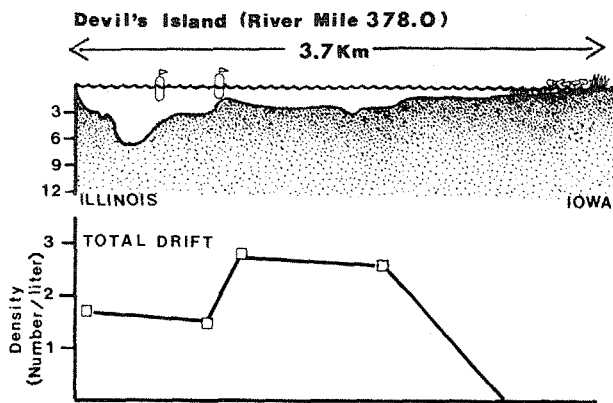

Figure 22a. Drift across the width of Pool 19, Mississippi River, showing effects of habitat.

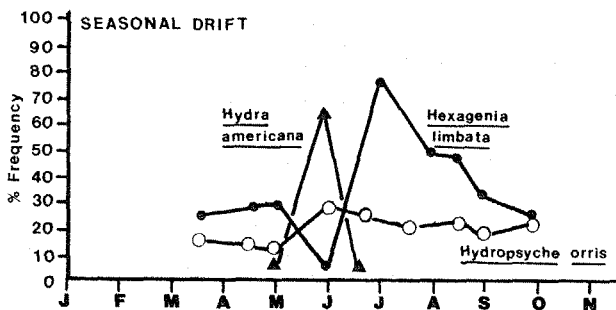

Figure 22b. Seasonal distribution of major drift taxa in Pool 20, Mississippi River.

2.8 SPECIAL COMMUNITIES

In addition to the invertebrate communities previously described, there are three specialized communities occurring in both Pools. These communities are macroinvertebrate drift, mussels, and parasites. They are important because of their effects on the community structure or economics of the pools. Several researchers have examined various aspects of these communities in relation to species composition, associations, and locations within the pool.

2.8.1 Macroinvertebrate Drift

The macroinvertebrate drift community is composed of macroinvertebrates--as

opposed to zooplankton--found suspended in and transported through the water column. Because of behavioral or catastrophic events, these organisms have become detached from the substrate on or in which they normally occur. Behavioral drift is often synchronous, resulting in diurnal and seasonal changes (Figure 22) in drift density. Catastrophic drift occurs as a result of abiotic events such as high current velocities due to flooding. These two types of drift may result in a relatively constant drift community in both Pools 19 and 20. In spite of low densities (0.001/l to 3/l) drift organisms have been shown to be a major food source for fish. Drift makes macroinvertebrates more available to fish and thus increases fish production.

The macroinvertebrate drift community is similar in species composition in both pools (Table 19). This composition generally reflects benthic macroinvertebrate communities often dominated by caddisfly larvae and mayfly nymphs. Some community elements not collected in benthic samples have been found, particularly members of the insect family Chironomidae (compare Tables 16 and 19). According to data presented by Frensdreis (1982), a more diverse community was found in Pool 20 than that reported from Pool 19. Most of the samples obtained from Pool 20 were collected just below the tailwaters of Lock and Dam 19. Consequently, drift samples contain species from both the hard substrates below the dam and the soft substrates immediately above the dam. Frensdreis (1982) noted little similarity between substrate samples from the immediate vicinity of drift samples and the species found in the drift. This indicates that drift organisms originate from the variety of upstream habitats.

Greater density of drift organisms were found in the channel border habitat as compared to other habitats (Figure 22, total drift). Little or no drift community was present in vegetated habitat. Current velocities in vegetated areas are extremely low and not conducive to production of a drift community. The higher density in the channel border area probably represents input from both invertebrates of the vegetated habitat and

Table 19. Macroinvertebrates found in the drift community of Pools 19 and 20, Mississippi River.

Taxa	Pool 19 Anderson (in prep.)	Pool 20 Frendreis (1982)
Coelenterata		
<i>Hydra americana</i>	X	X
Annelida		
Oligochaeta (Aquatic worms)		
<i>Branchiura sowerbyi</i>		X
<i>Limnodrilus</i> sp.	X	
<i>Naias</i> sp.	X	X
Hirudinea (Leeches)		
<i>Erpobdella punctata</i>	X	X
<i>Helobdella</i> sp.	X	
Arthropoda		
Amphipoda (Sideswimmers)		
<i>Hyalella azteca</i>	X	X
Insecta		
Plecoptera (Stone flies)		
<i>Isoperla bilineata</i>	X	X
Ephemeroptera (Mayflies)		
<i>Potamanthus verticis</i>		X
<i>Hexagenia limbata</i>	X	X
<i>H. bilineata</i>	X	X
<i>Ephoron</i> sp.		X
<i>Caenis</i> sp.	X	X
<i>Stenonema</i> sp.	X	X
<i>Baetis</i> sp.	X	X
Early instars	X	X
Odonata		
Zygoptera (Damselflies)		
<i>Lestes</i> sp.	X	X
Lepidoptera (Aquatic caterpillar)		
<i>Neocatoclystra</i> sp.		X
Trichoptera (Caddisflies)		
<i>Cheumatopsyche</i> sp.	X	X
<i>Hydropsyche</i> sp.	X	X
<i>Potamyia flava</i>	X	X
<i>Oecetis</i> sp.		X
<i>Hydroptila</i> sp.	X	X
Early instars	X	X
Coleoptera		
<i>Stenelmis</i>	X	

(continued)

Table 19. (Concluded).

Taxa	Pool 19 Anderson (in prep.)	Pool 20 Frendreis (1982)
Diptera		
Culicidae (Mosquitoes)		
Pupae	X	X
Chaoboridae (Phantom midge)		
<i>Chaoborus</i> sp.		X
Heleidae (Biting midge)		
<i>Bezzia</i> sp.		X
Chironomidae (Midges)		
<i>Ablabesmyia</i>	X	X
<i>Polypedilum</i>	X	X
<i>Cryptochironomus</i>		X
<i>Procladius</i>	X	X
<i>Eukiefferiella</i>		X
<i>Paracladopelma</i>	X	X
<i>Cricotopus</i>	X	
Pupae	X	X
Mollusca		
Gastropoda (Snails)		
<i>Campelema</i> sp.	X	X
Pelecypoda		
Sphaeriidae		
<i>Musculium transversum</i>	X	
Total	<u>29</u>	<u>33</u>

burrowing forms found in the channel border area. Though water movement is toward the channel, some organisms may settle out before reaching the channel or be eaten; such loss may reduce densities in the channel in conjunction with the diluting effect caused by the greater volume of water carried in the channel.

Marked seasonal trends exist in the community composition (Figure 22, seasonal drift) and density of drift in both pools. Much of this seasonality is a result of emergence patterns of particular insect species. Burrowing forms, such as *Hexagenia limbata*, occur most frequently in the drift just prior to and

following emergence. Apparently the nymphs leave the burrow just prior to ecdysis to adult forms and are subject to drift during that period. Once eggs of the mayfly hatch, the very small nymphs also occur frequently in the drift until they become established in the channel border substrate. Caddisfly larvae, such as the dominant *Hydropsyche orris*, occur at a comparatively constant frequency, though a slight increase does occur during emergence (Figure 22). These caddisflies are found on hard substrates in areas of higher current velocities and some individuals may be expected to be washed into the water column periodically. They also pupate on the hard substrate, and unlike the

burrowing mayflies, do not leave their larval retreats prior to this process. Consequently, the caddisflies are not as subject to drift.

Some organisms are very seasonal in their appearance in the drift. For example, the coelenterate Hydra americana was only present in late May or early June, when it was frequently found at high densities in samples. Most organisms, however, occurred sporadically in the invertebrate drift community.

2.8.2 Mussels

Mussels, often called clams, are found in both Pools 19 and 20. They are not true clams (subclass Heterodonta) but belong to the subclass Palaeoheterodonta. Mussels are a major segment of the benthic invertebrate community because of their size and mass. They are the largest invertebrates found in the pools and the only group commercially harvested. There is a long history of mussel fishing in the river reaches containing Pools 19 and 20 (See section 4.1.3). Use of harvested mussels has varied from a source of pearls to button material to cores for cultured pearls.

Special techniques are required to sample the mussel community. Because they are larger than other invertebrates, they cannot be quantitatively sampled by using small dredges or artificial substrates. The best quantitative method for sampling mussels is diving, but poor visibility and high current velocities in the Mississippi River make this technique available to only a few highly trained researchers.

The most common technique used is brailing, or the use of a crowfoot bar, which is inefficient, and collects only about 0.6% of available clams (Sparks and Blodgett 1983). Results are difficult to quantify in terms of area sampled. In addition, because of its low efficiency, brailing is only effective in areas where the mussels are dense.

Basket dredges and rakes tend to damage shells and may become snagged on bottom debris. Wading, while effective

and quantitative, is restricted to shallow areas where mussel densities are often low. While examination of fossil shells and middens may give some historic information, it does not provide information on density or present location and distribution. Effective sampling requires a combination of techniques tailored to individual habitats.

Mussels are important in the ecology of the river. They are a food source for many vertebrates and act as a link in the food web by consuming the primary producers (phytoplankton) of the system. Because of their size, relatively sessile life style, and ability to maintain specific orientation at the water-substrate interface, their shells serve as a stable, hard substrate in habitats with soft or shifting substrates (Anderson and Vinikour 1984). Several species of invertebrates attach to, and deposit eggs on, the exposed surface of mussel shells.

Mussel beds are areas identified as containing "large" numbers of mussels. Based just on the presence of live mussels, there are about 15 such beds in Pool 19 (Table 20) (Peterson 1984). These beds (locations identified by commercial mussel fishermen and scientific researchers) vary greatly in species diversity and in the type of habitat occupied. Reported diversity in the Pool 19 beds ranged from a low of 9 to a high of 22 species (Peterson 1984). The relative size of these beds also varies greatly and does not correspond to the species richness.

By comparison, only two beds were identified in Pool 20 (Table 20). The most diverse bed (20 species) is located just below the tailwaters of Lock and Dam 19 and has been identified by other investigators (Fuller 1978; Anderson et al., in prep.) as a dense, rich bed. The second bed in Pool 20 is in the lower reaches of the pool and has a lower diversity (9 species; Peterson 1984).

While these beds may represent the location of mussel communities of high density or commercial value, they do not represent the extent of mussel distribution within the pools. Several collections have been made in channel border

Table 20. Location of mussel beds in Pools 19 and 20, Upper Mississippi River (from Peterson 1984).

River miles on pool	Description of location	No. of species
<u>Pool 19</u>		
410.3-410.4	Located on the Iowa side of channel just Lock and Dam 18 and the head of Mercer Island	11
405.0-406.0	Located in O'Connell Slough on right bank	22
403.9-404.4	Located on the right side of the channel; this bed is commercially fished	15
399.8-400.0	Located on the Iowa shore; the bed is commercially fished	7
397.8-398.4	Located in Shokokon Slough on left side of river, commercial	14
396.3-398.2	Commercially valuable bed	18
393.0-393.7	Located on the left side of the channel	18
390.1-390.8	A high quality bed is along the left shore	
386.5-390.3	Located in the channel	22
386.0-387.0	Commercially fished bed in Lead Island Chute	
385.0-386.0	Located along the Iowa shore; this is a commercially fished bed	
383.5-384.5	Located along the left edge of the channel	20
382.2-382.6	Located along the Iowa shore	9
378.3-379.5	Located along the Illinois shore; commercially fished bed	
373.0-374.4	Commercially fished bed along the Iowa shore	
<u>Pool 20</u>		
360.0-363.0	Mussel bed located along the left side of the channel	20
349.0-349.7	Bed located along right side of channel	9

areas in both pools (Sparks and Blodgett 1983; Anderson and Vinikour 1984; Anderson et al., in prep.; Holm and Anderson, in prep.). These studies have found low densities, fewer than $10/m^2$, in the non-vegetated channel border areas throughout the pools. Habitats are also occupied by the highly productive fingernail clam-burrowing mayfly community. Frequently, these low density beds occur at the margins of macrophyte beds. Because of the size frequency distribution of mussel length and movement patterns, Anderson et al. (in prep.) have suggested that the shallow channel border areas may serve as nurseries for the mussel populations of the river. Juvenile mussels may burrow into the soft substrates of this area to avoid predation and adverse environmental factors until they mature enough to be less susceptible to these conditions. This is apparently what juvenile fingernail clams do when released from the female's marsupium (Gale 1969).

These channel border areas, however, do not contain as diverse a community as found in mussel beds along the channel thalweg. Some mussel species such as the butterfly (Ellipsaria lineolata), pocket-book (Lampsilis ovata ventricosa), and hickory nut (Obovaria olivaria) are restricted to areas with higher current velocities or coarser substrates. The mussel communities in the shallow channel border areas also differ from the bed communities in that they may be dominated by different species. In Pools 19 and 20 the three-ridge (Amblema plicata) is frequently one of the dominant species in both communities. However, the community in the shallow channel border usually has a codominant, the stout floater (Anodonta grandis corpulenta). In the channel beds, if there is a codominant, it is usually one of the Quadrula group, either the pimple back (Q. pustulosa) or the maple leaf (Q. quadrula).

In one of the few truly quantitative studies on a mussel bed in these pools, Sparks and Blodgett (1983; RM 386.5-390.3), using divers, found densities in the bed ranging from about $10.5/m^2$ to $60.5/m^2$. Mussel populations have been examined in Pools 19 and 20 for about 50 years (Table 21). Though densities were usually not reported, frequency of species

occurrence can be determined from number per sampling effort reported by investigators. Of the 30 species of mussels reported by either Ellis's 1930-31 study (van der Schalie and van der Schalie 1950) or Perry in 1975 (Rasmussen 1979), 26 were collected in Pool 19, and 20 in Pool 20 (Table 21). Fifty years ago the three-ridge was the most frequently collected species and it has remained so in all subsequent samples. The second most abundant species in the 1930-31 survey, the maple leaf, though still present in all subsequent surveys, was not as abundant as the conspecific pimple back. In recent studies in Pool 19, the stout floater has also been frequently collected (8.9%). Pool 20, primarily because of the mussel bed in the upper end of the pool, had a high frequency of the butterfly mussel in most samples.

Recent sampling in both pools, (Anderson and Sparks 1982-84) has revealed more taxa than the previous studies, probably because of the larger number of habitats and areas of the pools sampled in the recent surveys. With more intense sampling, other species may yet be found, however, it is apparent that some species occur only rarely in samples. Rare species in Pools 19 and 20 include the spectacle case (Cumberlandia monodonta), black sand shell (Ligumia recta), and monkey face (Quadrula metanevra).

Historical data indicate there is a trend toward reduction of the number of species present and reduction of density of mussels in the Mississippi River (Ellis 1936; Carlander 1954). Aside from overzealous commercial harvesters of mussels, several other factors have been implicated in this decline. They include burial due to erosion silt or dredge activity as well as chemical and organic pollutants. Both are suggested as possible causes for the reduction in mussel beds in Pool 20 below the confluence of the Des Moines River (Fuller 1978). In recent years the Asiatic clam (Corbicula fluminea) has invaded the pools, and, in some areas previously occupied by low density mussel communities, occurs at densities in excess of $100,000/m^2$ (Figure 23) (Holm and Anderson, in prep.). It is not known for certain whether the Asiatic

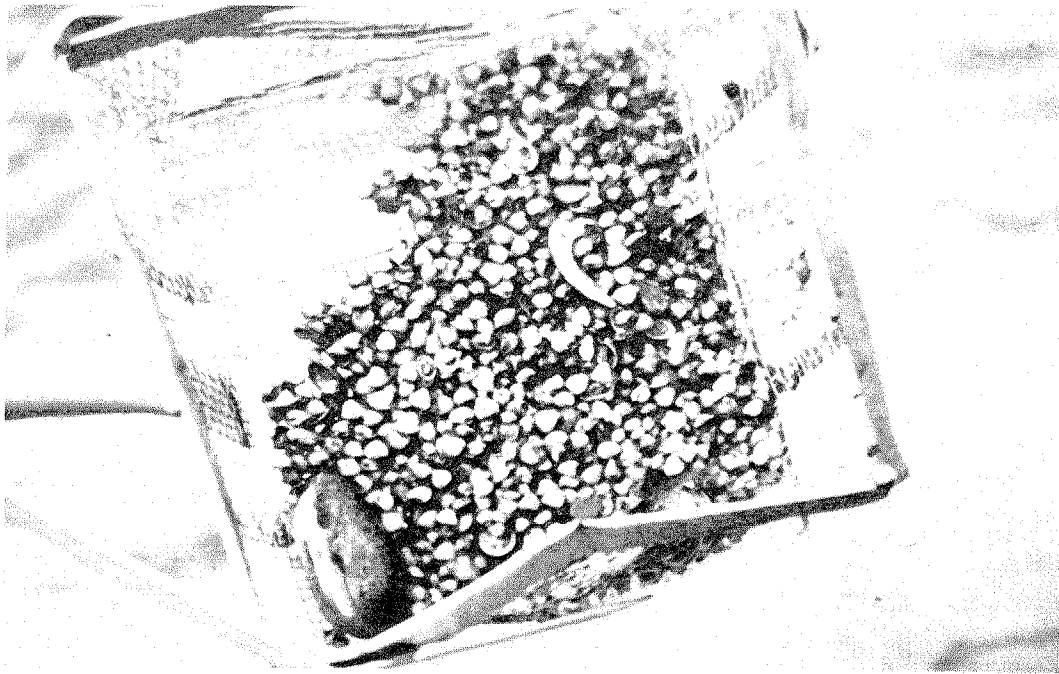

Figure 23. Sample containing high density of Asiatic clams and one mussel from area around Devil's Island, RM 378.0, Pool 19, Mississippi River.

clams compete directly with the mussels or occupy a niche vacated by mussels. Nevertheless, the presence of clams represents a potential decline in the mussel community. Mussels still present in the samples collected by Holm and Anderson (in prep.) were usually only larger individuals.

2.8.3 Parasites

Parasites are a special group of invertebrates that have been identified as potentially detrimental to many other groups of organisms in both pools (Meyer 1960; Wenke 1968; Gale 1973b; Robinson 1979; Robinson and Jahn 1980; Holm and Anderson, in prep.; Pillard and Anderson, in prep. b). When the density of a parasite is high, the host may die, and even at low densities, the host's growth and reproduction may be greatly decreased.

Molluscan parasites are the larval stage, glochidia, of many freshwater mussel species. The glochidia attach to

the gills, fins, and scales of fish, where they mature to a juvenile stage before detaching and dropping to the river bottom. While they are parasitic, they are also relatively host specific. Some common species are even known to infect only one species of fish. Examples from Pools 19 and 20 include the fragile paper shell (Leptodea fragilis), maple leaf, and pink heel splitter (Proptera alata) (Table 22). Others, such as the three-ridge, appear to be generalists known to infect 33 species of fish, at least 15 of which occur in Pools 19 and 20. This could account for the dominance of the three-ridge in the mussel community. The freshwater drum (Aplodinotus grunniens) harbors the most diverse glochidia taxa, 11 species, followed by bluegill (Lepomis macrochirus) and largemouth bass (Micropterus salmoides) with 9 and 7 species, respectively.

The occurrence of fish parasites has been studied in Pool 19 (Wenke 1968) and Pool 20 (Robinson 1979 and Robinson and

Table 21. Mussel taxa found in Pools 19 & 20 by various investigators over approximately 50 years.

Taxa	Ellis 1930-31 ^a Zones VIII & IX % of total	Perry 1975 ^b Presence		Ecological Analysis 1979-80 ^c % of total		Anderson-Sparks 1982-84 ^d % of total	
		Pool 19	Pool 20	Pool 19	Pool 20	Pool 19	Pool 20
<i>Actinonaias carinata</i> (Mucket)		x		0.3		0.8	0.8
<i>Ambiema plicata</i> (Three ridge)	21.0	x	x	20.5	53.2	16.8	19.5
<i>Anodonta grandis corpulenta</i> (Stout floater)	5.3	x		1.0	1.4	8.6	4.2
<i>A. imbecilis</i> (Paper pond shell)	2.9	x		1.3		3.1	
<i>A. suborbiculata</i> (Heel splitter)			x				
<i>Arcidens confragosus</i> (Rock pocketbook)		x		0.3		1.4	1.7
<i>Carunculina parvus</i> (Lilliput shell)						2.0	
<i>Cumberlandia monodonta</i> (Spectacle case)						0.3	0.8
<i>Ellipsaria lineolata</i> (Butterfly)		x		0.8		0.8	11.9
<i>Fusconaia ebena</i> (Ebony shell)	0.2		x				
<i>F. flava</i> (Pig toe)	5.8	x	x	6.6	8.6	1.4	4.2
<i>Lampsilis fallaciosa</i> (Slough sand shell)	0.7					2.0	
<i>L. ovata ventricosa</i> (Pocketbook)	3.4	x	x	9.6	0.7	3.4	6.8
<i>L. teres</i> (Yellow sand shell)	0.7		x			0.8	0.8
<i>Lasmigona complanata</i> (White heel splitter)	1.5						
<i>Leptodea fragilis</i> (Fragile paper shell)	11.6	x		3.0	0.7	4.5	3.4
<i>Ligumia recta</i> (Black sand shell)	0.5		x			0.3	0.8
<i>Megalonaias gigantea</i> (Washboard)	2.2	x		1.0		3.9	2.5
<i>Obovaria olivaria</i> (Hickory nut)	2.7	x	x	4.6	5.8	5.9	7.6
<i>Obliquaria reflexa</i> (Three-horned warty back)	6.3	x		4.6	2.9	4.5	4.2
<i>Proptera alata</i> (Pink heel splitter)	2.4	x		2.5	0.7	6.4	5.1
<i>P. laevissima</i> (Pink paper shell)	2.2	x		14.2	1.4	4.2	
<i>Quadrula metanevra</i> (Monkey face)				0.3		0.6	0.8
<i>Q. nodulata</i> (Warty back)	5.8	x	x	0.5	2.2	5.6	5.9
<i>Q. pustulosa</i> (Pimple back)	4.8	x	x	10.9	14.4	7.8	13.6
<i>Q. quadrula</i> (Maple leaf)	14.3	x	x	2.5	5.8	8.6	11.0
<i>Strophitus undulata</i> (Sqaw foot)	0.2					1.1	
<i>Truncilla donaciformis</i> (Fawn's foot)	5.6			12.7	1.4	3.6	2.5
<i>T. truncata</i> (Deer toe)		x		1.8	0.7	1.7	
No. of species 29	21	18	11	20	14	26	20

^a Ellis samples were not separated into pools, data from van der Schalie and van der Schalie (1952).

^b Data from tables found in Rasmussen (1979).

^c Data from Ecological Analysts, Inc. (1981).

^d Unpublished data from multiple samples over time period by R.V. Anderson and R.E. Sparks (1982-1984).

Jahn 1980). The latter study found nematodes to be the most common, with non-molluscan parasites occurring in over 50% of the infected hosts (Table 22). The nematode Camallanus oxycephalus occurred in the largest number of species (15). The river carpsucker (Carpiodes carpio) and goldeye (Hiodon alosoides) contained the largest variety of parasites, each with seven nonmolluscan parasite species. Parasite infestations were mostly moderate and did not appear to be affecting the fish.

Invertebrates are also affected by parasites. While some are parasitized specifically, e.g., infestation of the zooplankter, Brachionus calyciflorus by the protozoa Plistophora, (Pillard and Anderson, in prep. b), most are intermediate hosts for the immature stages of vertebrate parasites (Table 23). Gale (1973b) suggested that these secondary infestations may be severe enough to reduce the invertebrate host population, as in Crepidostomum cercaria infecting fingernail clams in Pool 19. Whether specific associations of some invertebrates are parasitic or inquilinistic has still not been determined. In Pool 19, the oligochaete Chaetogaster has been found in fingernail clams (Gale 1973b), Asiatic clams, and mussels (Holm and Anderson, in prep.). But whether the presence of this worm has caused the large reduction in mollusk populations is not clear and is an area for more research.

2.9 FISHES

The Mississippi River was important as a fishery resource well before the locks and dams were constructed. Even in the 1870's there was much concern over the disappearance of fishery resources in the United States and the Upper Mississippi River Valley (Carlander 1954). In 1872 the duties of the U.S. Commissioner of Fish and Fisheries included artificial propagation of fish. Stocking of American shad (Alosa sapidissima) was of high priority, as was Atlantic salmon (Salmo salar), because there were no dams to prevent the fish from running upstream great distances. Neither species was successful in establishing populations. But stocking of carp (Cyprinus carpio)

in 1879 was so successful that since 1900 this fish has exceeded all others in pounds landed. Many native fishes were also planted, including various centrarchids, freshwater drum (Aplodinotus grunniens), catfishes, buffalo fishes and others (Carlander 1954).

Along with stocking, a high priority was "fish-rescue" work from overflows into shallow areas during flooding. This was deemed cheaper than propagation and was done from 1876 to 1930. Fish were seined and returned to the river proper or taken by rail to other inland waters of other States. Such work was described as unhealthy, requiring men to work in a hot sun in mud holes and sleep in the river bottoms at night, which was said to produce malarial fevers. A report of the Missouri Fish Commission (1887) commented, "Good men cannot be hired to do such work for cheap wages" (cited by Carlander 1954, p.30). Rescue work was abandoned when the 9-ft channel was completed, resulting in more stable water levels.

Both stocking and rescue work probably did little to enhance the fish populations in the Mississippi River, except for carp. While sportsmen and conservationists did not like carp, those interested in food production thought it would be highly beneficial. A species shift due to carp introduction was evident in the early 1900's and buffalo decreases "probably were the result of competition from the introduced carp and of changes in the environment" (Carlander 1954).

Dams were felt by many to have had a major effect on the fishes in the river. Coker (1929, 1930) extensively studied the fish in the vicinity of Lock and Dam 19 after the dam was completed. He recognized that shallows were important for reproduction and stranding when water levels dropped. He determined that the dam was more of a barrier to fish passage upstream than downstream by setting a trammel net on the upper gate of the lock and counting the fish caught from each side of the net after 94 locking operations. He believed that the lock was not an effective fishway, but it did allow fish to pass through. The vertical pool change and the design of the Keokuk dam may produce a greater negative effect on

Table 22. A checklist of parasites with number of fish species found infected by the parasites.

Parasite	No.	Parasite	No.
NEMATODA:			
<i>Camallanus oxycephalus</i>	16	<i>Lampsilis ovata</i>	6
<i>Camallanus ancyloides</i>	5	<i>L. teres</i>	8
<i>Cystidicola stigmatura</i>	4	<i>Leptodea fragilis</i>	1
<i>Rhabdochona cascadilla</i>	7	<i>Ligumia recta</i>	5
<i>Contraecaecum spiculigerum</i>	1	<i>Megaloniaias gigantea</i>	16
<i>Spinitectus gracilis</i>	3	<i>Obovaria olivaria</i>	1
<i>Dacnitoidea spp.</i>	1	<i>Proptera alata</i>	1
		<i>P. laevissima</i>	2
		<i>Quadrula metanevra</i>	3
		<i>Q. nodulata</i>	6
		<i>Q. pustulosa</i>	6
		<i>Q. quadrula</i>	1
		<i>Truncilla donaciformis</i>	2
		<i>T. truncata</i>	1
TREMATODA: (Digenea)			
<i>Acetodextra ameiuri</i>	1		
<i>Azygia acuminata</i>	1		
<i>Allacanthochasmus varius</i>	2		
<i>Alloglossidium corti</i>	1		
<i>Caecincola parvulus</i>	1		
<i>Clinostomum marginatum</i>	1		
<i>Crepidostomum cooperi</i>	2		
<i>Lissorchis sp.</i>	1		
<i>P. minimum centrarchi</i>	4		
TREMATODA: (Monogenea)			
<i>Diclybothrium hamulatum</i>	1		
<i>Dactylogyrus sp.</i>	2		
<i>Cleidodiscus floridanus</i>	1		
<i>Mazocraeoides sp.</i>	1		
<i>Microcotyle spinicirrus</i>	1		
<i>Myzotrema cyclepti</i>	1		
<i>Octomacrum lanceatum</i>	1		
MOLLUSCA:			
UNIONIDAE (glochidia)			
<i>Amblema plicata</i>	15		
<i>Anodonta grandis corpulenta</i>	12		
<i>A. imbecilis</i>	8		
<i>Arcidens confragosa</i>	5		
<i>Carunculina parava</i>	5		
<i>Ellipsaria lineolata</i>	3		
<i>Fusconaia flava</i>	3		
		CESTODA:	
		<i>Bothriocephalus cuspidatus</i>	4
		<i>Corallobothrium fimbriatum</i>	1
		<i>Haplobothrium globuliforme</i>	1
		<i>Marsipometra hastata</i>	1
		<i>Proteocephalus macrocephalus</i>	
		<i>Proteocephalus larvae</i>	4
		<i>Proteocephalus pleurocercoids</i>	
		<i>Hypocaryophyllaeus paratarius</i>	
		<i>Khawia iowensis</i>	
		HIRUDINEA:	
		<i>Illinobdella moorei</i>	7
		<i>Placobdella sp.</i>	2
		<i>Placobdella sp.</i>	2

(continued)

Table 22. (Concluded).

Parasite	No.	Parasite	No.
COPEPODA:		ACANTHOCEPHALA:	
<i>Argulus</i> sp.	2	<i>Acanthocephalus</i> sp.	1
<i>Ergasilus arthrosis</i>	1	<i>Leptorhynchoides thecatum</i>	3
<i>Ergasilus</i> sp.	2	<i>Echinorhynchus</i> sp.	1
		Neoechinorhynchidae	1

Table 23. Invertebrates which harbor cercariae, metacerciae, and larvae of various groups of parasites.

Invertebrate host	Parasite taxa					
	Protozoa	Trematoda	Nematoda	Cestoda	Acanthocephala	Oligochaeta
Snails	X	X				
Fingernail clams		X				X
Large crustaceans				X	X	
Zooplankton	X		X	X		
Dragonfly nymphs		X	X			
Mayfly nymphs			X			
Caddisfly larvae			X			

fish passage than other dams such as Dam 20. He believed that the influence of the dam on the important groups of fishes were in some cases minimal, while in others it had a profound negative effect. Coker (1930) examined 60 species within 10 mi below the dam in Pool 20 and found the following:

paddlefish: Decline on the whole from 1888 to 1908 but somewhat inconsistent. Fishermen above the dam were unanimous in their opinion that the fish were becoming decidedly more numerous in the lake.

lake sturgeon: Declining at least 5 years before dam construction. However, 20 years before

the dam was completed, 40-50 sturgeon, each weighing 50-100 lb were caught; now (1930) at Alton only about 5 or 6 sturgeon weighing over 10 lb are seen. Humans are their main enemy and the chief cause for their decrease.

shovelnose sturgeon: More common between Keokuk and Warsaw after dam construction than before. Less abundant on Keokuk Lake now.

gar: No change noted.

mooneye, goldeye: Not affected by dam.

herring: Skipjack (river) herring much reduced above the dam after completion. Ohio shad seriously affected. Lake is favorable, but drainage districts with levees and reclamation are unfavorable for these fish.

eel: For at least 30 years they have been declining from the whole basin. perch: Decline in general due to changed environmental conditions throughout the country. Dam did not affect walleye or sauger, but sauger are not abundant. There are few yellow perch above the dam at this time.

blue catfish: Keokuk was about the normal northern range limit, so little effect noted.

channel catfish: No effect except local migration. temperate bass: White bass more common than yellow bass. It is not believed that the development of power plants caused injury to the bass because there has been an uninterrupted decline in these for 30 years.

flathead catfish (goujon): No effect caused by the dam because the fish is not migratory.

catfishes in general: No evidence of special abundance at Keokuk. It is probable that they tend to move upstream during warmer weather to compensate for downstream drifting in cold weather. drum: Appear to be holding their own; no serious injury to drum by the dam. Drum have not diminished over the past 30 years.

suckers: General decline between 1899 and 1903 that is continuing. Dam not responsible except possibly for the blue sucker. This fish declined in both the lower river (unimpounded) as well as above after dam construction. Barnickol and Starrett (1951) agreed that, while the blue sucker markedly declined in Pools 19 and 20 once the Des Moines Rapids were eliminated, they had also declined much farther south, below the impounded sections, thus indicating other causes. Carlander (1954) indicated the change in the river current probably had been more important in affecting the fish and fishing than had the increase and stabilization of the water area. It is difficult, however, to separate this effect from the effect of the dam as the causative agent for the reduction in current. It is probable that a whole series of factors, when taken together, (i.e., dam, current, snag removal, stabilization structures) have had important additive negative effects on the fish fauna as a whole. But it also seems clear that declines of a number of species were evident well before construction of the dams. The carp introduction and subsequent buildup coincided nicely with declines of buffalo and other fish and may have been one major influence on the fisheries. Development of civilization, removal of snags for commercial boat traffic, fishing pressure,

buffalo: Large (to 40 lb) now infrequent, probably due to intensive fishery or conditions affecting food supply. Drainage districts plus wave-action destroying nests on submerged islands may be affecting their numbers.

carp and minnows: The dam probably benefited the carp. Changing breeding conditions, not food supply, perhaps caused observed declines.

centrarchids: Dam not an obstructive factor for sunfish and bass.

and changes in the riverine environment were probably all working together and subjecting the fish to heretofore unknown pressures for survival and for maintaining their numbers.

The Mississippi river today supports a rich fish fauna and good populations of most of its native species (Smith et al. 1971). Fish lists indicating species by pool have been compiled (Nord 1967; Rasmussen 1979; Van Vooren 1983). Additional information comes from lists generated from class collections at the Kibbe Life Sciences Station operated by Western Illinois University, Ellis (1978), and Gutreuter (1980). Each pool contains about 65 species (Table 24), but some fish are strays from tributaries and others have not been collected since 1973. No indigenous fish in these pools have become extirpated in the past (Smith et al. 1971). However, where observable changes in numbers or distribution are seen, the causal agents have been drainage of marginal lakes and sloughs, erection of flood control dams, destruction or modification of habitats through efforts to maintain a navigable channel, and excessive siltation (Smith et al. 1971).

Different habitats are important for different species of fish, and one study aptly demonstrated this in Pool 19. Bertrand and Russell (1973) surveyed the population by using UMRCC habitat types as sampling areas and electrofishing and seining. Their data make an important point: a combination of habitat types (habitat diversity) is important to a diverse fishery.

Tailwater, slough, and lake habitats were most valuable to commercial fishery, as indicated by seines, while sport fishing was rated best in slough and tailwater habitats. Young-of-the-year sport and commercial fish were also caught most often in tailwaters and sloughs (Table 25).

Tailwaters below Locks and Dams 18 and 19 (Table 26) were an important habitat sampled by Dunham (1970, 1971). A summary of these two pools for the 2 years follows.

Gizzard shad, freshwater drum, and carp were most abundant; white bass and

bluegill were also well represented. Forage species comprised the greatest proportion of fishes in tailwater habitat below Dam 19 for both years. Commercial or forage species comprised the highest proportion below Dam 18. Tailwater areas probably are important due to their water current, contributing food from upriver pool areas, maintaining high dissolved oxygen, and keeping substrata relatively silt free.

Side channels were found to be of utmost importance in Missouri by Ellis et al. (1979) because of the lake of other kinds of backwaters for nursery areas for juvenile fishes. In examining a riverine, lacustrine, and transitional side channel in Pools 20 to 22, investigators found that different species were dominant, depending on the successional stage of the side channel. The authors indicated that artificial openings of transitional side channels may reduce losses of riverine side channels since there is no longer a natural gain and loss of side channels in the Upper Mississippi River. There is only a continued loss. Lack of any mitigation would result in the continued loss of riverine habitats and their fish communities.

Species composition may also be affected by revetted (sustained with large rocks) banks intended to stabilize shorelines. In comparing two natural and two revetted banks of the lower Mississippi, Pennington et al. (1983) found 24 species along natural banks, including greater abundance of freshwater drum, flathead catfish, bluegill, and skipjack herring. There were 27 species along revetted banks, including a greater abundance of shovelnose sturgeon, carp, channel catfish, sauger, blue sucker, and river carpsucker. Farabee (1984) concluded from a study in Pool 24 that loosely placed larger-diameter stone would be of superior value for fish habitat than tightly placed smaller-diameter stone. Large stone revetment yielded highest consistent catch per effort in almost all seasons.

There must be a variety of habitats present so that fish of a

Table 24. Relative abundance of Upper Mississippi River fish species (modified from Van Vooren 1983).

Species	Abundance in pools ^a	
	Pool 19	Pool 20
Chestnut lamprey (<i>Ichthyomyzon castaneus</i>)	U	O
Silver lamprey (<i>Ichthyomyzon unicuspis</i>)	O	U
Lake sturgeon (<i>Acipenser fulvescens</i>)	H	H
Pallid sturgeon (<i>Scaphirhynchus albus</i>)	--	R
Shovelnose sturgeon (<i>Scaphirhynchus platyrhynchus</i>)	O	O
Paddlefish (<i>Polyodon spathula</i>)	O	O
Longnose gar (<i>Lepisosteus osseus</i>)	C	C
Shortnose gar (<i>Lepisosteus platostomus</i>)	C	C
Bowfin (<i>Amia calva</i>)	C	C
Skipjack herring (<i>Alosa chrysochloris</i>)	H	O
Gizzard shad (<i>Dorosoma cepedianum</i>)	A	A
Threadfin shad (<i>Dorosoma petenense</i>)	A	A
Goldeye (<i>Hiodon alosoides</i>)	O	O
Mooneye (<i>Hiodon tergisus</i>)	C	O
Northern pike (<i>Esox lucius</i>)	O	O
Common carp (<i>Cyprinus carpio</i>)	A	A
Silvery minnow (<i>Hybognathus nuchalis</i>)	-	-
Speckled chub (<i>Hybopsis aestivalis</i>)	C	C
Silver chub (<i>Hybopsis storeriana</i>)	C	C
Golden shiner (<i>Notemigonus crysoleucus</i>)	O	H
Emerald shiner (<i>Notropis atherinoides</i>)	A	A
River shiner (<i>Notropis blennioides</i>)	A	A
Ghost shiner (<i>Notropis buchanani</i>)	C	C
Common shiner (<i>Notropis cornutus</i>)	-	-
Bigmouth shiner (<i>Notropis dorsalis</i>)	O	O
Pugnose minnow (<i>Notropis emiliae</i>)	-	-
Spottail shiner (<i>Notropis hudsonius</i>)	C	C
Red shiner (<i>Notropis lutrensis</i>)	C	C
Spotfin shiner (<i>Notropis spilopterus</i>)	O	O
Sand shiner (<i>Notropis stramineus</i>)	O	O
Weed shiner (<i>Notropis texanus</i>)	-	-
Mimic shiner (<i>Notropis volucellus</i>)	-	-
Bluntnose minnow (<i>Pimephales notatus</i>)	O	O
Fathead minnow (<i>Pimephales promelas</i>)	U	U
Bullhead minnow (<i>Pimephales vigilax</i>)	A	A
River carpsucker (<i>Carpiodes carpio</i>)	C	C
Quillback (<i>Carpiodes cyprinus</i>)	C	C
Highfin carpsucker (<i>Carpiodes velifer</i>)	U	U
White sucker (<i>Catostomus commersoni</i>)	X	X
Smallmouth buffalo (<i>Ictiobus bubalus</i>)	C	C
Bigmouth buffalo (<i>Ictiobus cyprinellus</i>)	C	C
Black buffalo (<i>Ictiobus niger</i>)	H	U
Spotted sucker (<i>Minytrema melanops</i>)	U	-
Silver redhorse (<i>Moxostoma anisurum</i>)	R	R
Golden redhorse (<i>Moxostoma erythrurum</i>)	R	R

(continued)

Table 24. (Concluded).

Species	Abundance in pools ^a	
	Pool 19	Pool 20
Shorthead redhorse (<i>Moxostoma macrolepidotum</i>)	O	O
Black bullhead (<i>Ictalurus melas</i>)	O	O
Yellow bullhead (<i>Ictalurus natalis</i>)	O	O
Brown bullhead (<i>Ictalurus nebulosus</i>)	R	-
Channel catfish (<i>Ictalurus punctatus</i>)	C	C
Flathead catfish (<i>Pylodictis olivaris</i>)	O	C
Pirate perch (<i>Aphredoderus sayanus</i>)	H	-
Trout perch (<i>Percopsis omiscomaycus</i>)	-	-
Burbot (<i>Lota lota</i>)	-	-
Blackstripe topminnow (<i>Fundulus notatus</i>)	U	O
Brook silverside (<i>Labidesthes sicculus</i>)	O	O
White bass (<i>Morone chrysops</i>)	C	C
Yellow bass (<i>Morone mississippiensis</i>)	O	U
Rock bass (<i>Ambloplites rupestris</i>)	R	R
Green sunfish (<i>Lepomis cyanellus</i>)	O	O
Pumpkinseed (<i>Lepomis gibbosus</i>)	U	-
Warmouth (<i>Lepomis gulosus</i>)	O	U
Orangespotted sunfish (<i>Lepomis humilis</i>)	C	C
Bluegill (<i>Lepomis macrochirus</i>)	A	A
Smallmouth bass (<i>Micropterus dolomieu</i>)	U	U
Largemouth bass (<i>Micropterus salmoides</i>)	C	C
White crappie (<i>Pomoxis annularis</i>)	C	C
Black crappie (<i>Pomoxis nigromaculatus</i>)	C	C
Western sand darter (<i>Ammocrypta clara</i>)	O	O
Mud darter (<i>Etheostoma asprigene</i>)	-	-
Johnny darter (<i>Etheostoma nigrum</i>)	U	U
Yellow perch (<i>Perca flavescens</i>)	C	-
Logperch (<i>Percina caprodes</i>)	O	O
River darter (<i>Percina shumhardi</i>)	C	C
Sauger (<i>Stizostedion canadense</i>)	C	C
Walleye (<i>Stizostedion vitreum</i>)	C	C
Freshwater drum (<i>Aplodinotus grunniens</i>)	C	A

- ^aX Probably occurs only as a stray from a tributary or inland stocking.
- H Records of occurrences are available, but no collections have been documented in the last 10 years.
- R Considered to be rare. Some species in this category may be on the verge of extirpation.
- U Uncommon, does not usually appear in sample collections, populations are small, but the species in this category do not appear to be on the verge of extirpation.
- O Occasionally collected, not generally distributed, but local concentrations may occur.
- C Commonly taken in most sample collections; can make up a large portion of some samples.
- A Abundantly taken in all river surveys.

Table 25. Comparison of fish captured from several habitat types.

	Tailwater	Border	Main channel	Side	
				Lake	Slough
Fish caught/h	174 (77-321)	85 (59-108)	79 (26-128)	95 (36-128)	142 (4-258)
Sport fish % ^a	39	23	25	36	54
Channel catfish %	10	--	--	27	--

^aexcluding drum, including catfish.

Table 26. Habitat study of the tailwaters below Locks and Dams 18 and 19 (Dunham 1970, 1971).

	1970		1971	
	Tailwaters below Lock and Dam		Tailwaters below Lock and Dam	
	18	19	18	19
No. of fish caught/h	164	141	321	174
No. species	15	14	14	18
% game	33.5	2.8	28.3	9.2
% Forage	17.7	78	41.7	71.8
% commercial	48.8	19.2	30	19
Depth, maximum (ft)	32	15	35	19
Depth, acreage (ft)	18	5	17	5

given species can find proper conditions to survive, grow, and reproduce. These habitats are not necessarily the same throughout a given species' life history. Non-nest builders may simply scatter eggs in the river, which upon hatching, become part of the plankton. The literature on ichthyoplankton has been examined by Holland and Huston (1983) for fishes common to the Upper Mississippi River. Studies are in progress on Pool 19 by Dr. Lubinski (Illinois Natural History Survey) but none are currently in progress for Pool 20. Studies of this type are essential to the understanding of fish populations; more work needs to be done, especially on identification and timing of collection. The latter is crucial in helping to identify spawning season and giving first estimates of year-class strengths.

Because of the variety of fishes in Pools 19 and 20, their foods vary widely as well. Many are predators, (gars, bowfin, temperate bass, some centrarchids, sauger, and walleye) consuming other fishes. Many others (suckers, carp, freshwater drum) rely on aquatic invertebrates and especially on bottom-dwelling immature insects during part, if not all, of their lifetimes. Mayflies and caddisflies are extremely important (especially *Hexagenia*). They constituted over 50% by volume of the food of channel catfish, freshwater drum, mooneyes, goldeyes, and white bass. They comprised over 40% of the food of paddlefish and white crappie (Hoopes 1960). A larval caddisfly (*Potamyia flava*) comprised over 60% of the food for shovelnose sturgeon. Fingernail clams provide food for a variety of fish, especially gizzard shad over 6 inches long in deeper water (Jude 1973), channel

catfish, and freshwater drum. Blue suckers rely heavily on caddisfly larvae and midge larvae (Rupprecht and Jahn 1980). A detailed ecological relationship of these organisms is presented in Chapter 3.

2.10 AMPHIBIANS AND REPTILES

The herpetofauna of Pools 19 and 20 have apparently not been intensively investigated. Table 27 lists those suspected or known to occur in the immediate area of the two pools. It is based on Smith (1961), USACE (1974c), and Morris et al. (1983) and lists made from observations since 1964 at the Kibbe Life Sciences Station, Western Illinois University (adjacent to Pool 20). Some herpetofauna are common while others are rare or only occasionally observed. At least 4 salamanders, 12 frogs and toads, 3 lizard or skinks, 14 turtles, and 22 snakes are possible residents in the immediate vicinity of the two pools. Amphibians are generally found in shallow water areas, while tailwaters, sloughs, lakes, ponds, main channels, and side channels have skinks, lizards, and box turtles. Marshy areas are important breeding ground for amphibians and offer greatest habitat diversity for reptiles and amphibians. Grassy areas are important to certain snakes and frogs.

The most severe disturbance to amphibians and reptiles is the destruction of marshes (USACE 1974c). Conversion of wet habitats to dry favors certain reptiles and adversely affects amphibians. Prolonged high water conditions have the opposite effect.

Herpetofauna play a valuable ecological role in warm months only, when they provide food for a variety of predators (birds of prey, wading birds, and some mammals). Some reptiles prey on other reptiles and amphibians, thus forming essential links in certain food webs.

Much more needs to be done in determining abundances, local habitats of importance, and the general ecology of the amphibians and reptiles.

2.11 BIRDS

2.11.1 Waterfowl

The Mississippi River is an important duck migration corridor (Bellrose 1976) along which at least 5 million ducks fly each year (Figure 24). Thompson (1973) estimated that 20 million diving duck days were spent on Keokuk Pool each of 3 years from 1966 to 1968. Thornberg (1973) stated that probably no other inland area in North America is more important to migrating diving ducks than is Keokuk Pool. Important species of diving ducks that use Pools 19 and 20 are lesser scaup, canvasback, ringnecks, goldeneye, ruddy ducks, common mergansers, and red-breasted mergansers. Of these, the scaup and canvasback are the most numerous. During the fall migration, Bellrose and Crompton conduct aerial censuses. Since 1950 they have tabulated peak numbers of ducks and used these as indicators of population trends. Unpublished data supplied by the Illinois Natural History Survey's Havana Laboratory show a comparison of the importance of Pools 19 and 20 (Table 28). Scaup numbers were higher in the mid-1970's, but fluctuations occur in continental population numbers because of varying food supplies and reproductive success.

Within Pool 19, the Burlington to Fort Madison stretch is more important to diving ducks. The Fort Madison to Keokuk stretch is more important to dabbling ducks. Dabblers are not as restricted to the river because adjacent habitats are available which they will use in preference to the main river.

An examination of canvasback peak numbers since 1950 reveals an interesting and spectacular change in their use of both the Illinois River Valley and Pool 19 (Table 29). Numbers of canvasbacks dramatically decreased during the mid-1960's, and these numbers have not fallen as low since. Apparently one important reason for the change was environmental degradation of certain critical areas in the Illinois River (Mills et al. 1966), especially in Peoria Lake, where a degradation in food supply caused these ducks to look elsewhere (i.e., Pool 19)

Table 27. Amphibians and reptiles suspected or known to occur in the environs of Pools 19 and 20 (revised from USACE 1974 a,b).

Common name	Scientific name
Mudpuppy	<i>Necturus maculosus</i>
Eastern tiger salamander	<i>Ambystoma tigrinum</i>
Smallmouth salamander	<i>Ambystoma texanum</i>
Western lesser siren	<i>Siren intermedia nettingi</i>
Northern Blanchard's cricket frog	<i>Acris crepitans blanchardi</i>
Spring peeper	<i>Hyla crucifer</i>
Gray treefrog	<i>Hyla versicolor</i>
Striped chorus frog	<i>Pseudacris triseriata triseriata</i>
Bullfrog	<i>Rana catesbeiana</i>
Green frog	<i>Rana clamitans melanota</i>
Northern leopard frog	<i>Rana pipiens</i>
Pickerel frog	<i>Rana palustris</i>
Northern crawfish frog	<i>Rana areolata circulosa</i>
American toad	<i>Bufo americanus</i>
Fowler's toad	<i>Bufo woodhousei fowleri</i>
Ornate box turtle	<i>Terrapene ornata ornata</i>
Eastern box turtle	<i>Terrapene carolina carolina</i>
Map turtle	<i>Graptemys geographica</i>
False map turtle	<i>Graptemys pseudogeographica</i>
Snapping turtle	<i>Chelydra serpentina</i>
Painted turtle	<i>Chrysemys picta</i>
Smooth softshell turtle	<i>Trionyx muticus</i>
Eastern spiny softshell turtle	<i>Trionyx spiniferus spiniferus</i>
Western spiny softshell turtle	<i>Trionyx spiniferus hartwegi</i>
Red eared slider	<i>Chrysemys scripta</i>
Stinkpot turtle	<i>Sternotherus odoratus</i>
Yellow mud turtle	<i>Kinosternon flavescens</i>
Alligator snapping turtle	<i>Macroclemys temmincki</i>
Six-lined racerunner	<i>Cnemidophorus sexlineatus sexlineatus</i>
Broadhead skink	<i>Eumeces laticeps</i>
Five-lined skink	<i>Eumeces fasciatus</i>
Graham's crayfish snake	<i>Regina grahami</i>
Eastern garter snake	<i>Thamnophis sirtalis sirtalis</i>
Eastern plains garter snake	<i>Thamnophis radix radix</i>
Red-sided garter snake	<i>Thamnophis sirtalis parietalis</i>
Eastern ribbon snake	<i>Thamnophis sauritus</i>
Eastern hognose snake	<i>Heterodon platyrhinos</i>
Prairie ringneck snake	<i>Diadophis punctatus arnyi</i>
Blue racer	<i>Coluber constrictor foxi</i>
Black rat snake	<i>Elaphe obsoleta obsoleta</i>
Bullsnake	<i>Pituophis melanoleucus sayi</i>
Eastern milk snake	<i>Lampropeltis triangulum triangulum</i>
Red milk snake	<i>Lampropeltis triangulum sypila</i>
Prairie kingsnake	<i>Lampropeltis calligaster calligaster</i>
Western worm snake	<i>Carphophis amoenus vermis</i>

(continued)

Table 27. (Concluded).

Common name	Scientific name
Western smooth green snake	<i>Opheodrys vernalis blanchardi</i>
Midland brown snake	<i>Storeria dekayi wrightorum</i>
Northern water snake	<i>Nerodia sipedon sipedon</i>
Diamondback water snake	<i>Nerodia rhombifera rhombifera</i>
Massasauga (swamp rattlesnake)	<i>Sistrurus catenatus catenatus</i>
Timber rattlesnake	<i>Crotalus horridus horridus</i>
Copperhead	<i>Agkistrodon contortrix</i>

for food. A recent study by Day (1984) summarized food habits of earlier studies. Canvasbacks' diets contained over 50% plant material (*Potamogeton* spp., pondweeds; *Vallisneria* spp., wild celery; and *Sagittaria* spp., duck potato) or a greater volume than animal material (*Ephemeroptera* spp., mayflies; and *Pelecypoda* spp., clams, especially *Musculium* and *Sphaerium*). More recent work, being conducted by personnel at the Illinois Natural History Survey Laboratory at Havana, indicates ducks now rely heavily on animal material (i.e., fingernail clams). Thompson (1973) indicated that heavy concentrations of diving ducks possibly harvest 25% of the benthic standing crop during fall. Scaup feed primarily on animal material (*Pelecypoda* spp., clams, as above) with less than 10% plant material. One reason why Pool 20 is used less by diving ducks than Pool 19 is its lack of suitable habitat.

Studies of distribution of ducks on Pool 19 (Thompson 1973; Thornberg 1973) showed that human disturbance (such as hunting, recreation, navigation) was a major factor inducing mass movements and governed the duck distribution. Without disturbance their distributions, in general, were correlated with the greatest abundance of benthic organisms. During the day, 60% of the diving ducks using the pool showed diurnal movements, loafing in less disturbed sections, and at dusk returning to choice feeding areas (Thornberg 1973) upriver from Niota, to Dallas City, Illinois (Figure 24).

Concern is growing among biologists familiar with the Mississippi River that an exotic species of Asiatic clam (*Corbicula manilensis*) may alter the web of life as it now exists, especially in Pool 19. One reason concerns the nutritional value of the Asiatic clam compared to that of the fingernail clam (*Musculium transversum*) (Table 30). Thompson and Sparks (1978) investigated these nutritional values and concluded there was no advantage to the heavier, shelled Asiatic clam since the ducks' calcium requirements are met anyway regardless of which is eaten. However, lesser scaup may have to spend more time and energy digesting *Corbicula* to obtain an equal amount of calories. If native clams are displaced by this introduced species, results could be catastrophic.

Since numbers of diving ducks can be expected to fluctuate, depending on weather patterns, food conditions, and the reproductive success or failure of continental populations, continued vigilance for the care of this and other natural resources is imperative to insuring that natural causes remain the lone controlling agents of population.

2.11.2 Other Birds

Colonial nesters (such as great blue heron and great egret) have been located on Pool 19 but not on Pool 20. Colonies at RM 396 near Lomax, Illinois, and RM 408 on Otter Island were examined by Kleen (1983). At the former, about 100 great blue heron nests and about 30 great egret

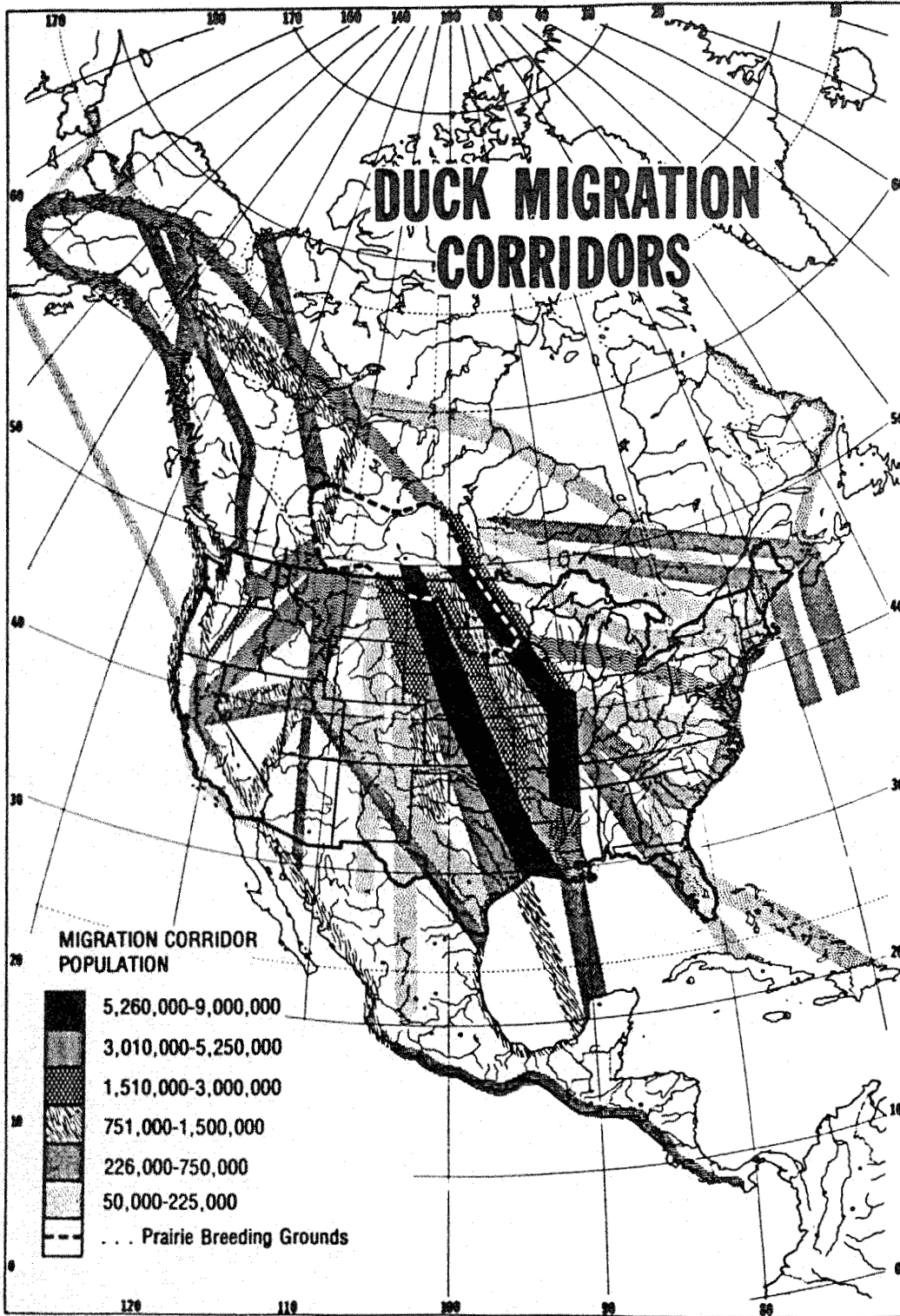

Figure 24. Duck migration corridors (Bellrose 1976).

Table 28. Comparison of canvasback and scaup numbers and their use of Pools 19 and 20 from 1980 to 1983.

Year	Canvasback Pools				Scaup Pools			
	19		20		19		20	
	Peak No.	Date	Peak No.	Date	Peak No.	Date	Peak No.	Date
1980	143,850	11/3	325	11/3	303,000	11/3	2,400	11/3
1981	112,500	12/1	115	11/16	235,000	10/26	550	11/16
1982	79,450	12/6	300	11/8	168,000	11/8	650	11/8
1983	65,200	11/29	175	11/1	121,000	11/14	675	11/1

nests were counted by aerial survey. Only the Otter Island colony was noted in May of 1977 by Thompson and Landin (1978). It included 40 pairs of great blue herons and 8 pairs of great egrets, with average numbers of young in June being 2.8 per successful nest. Nests located high in trees were later ground checked by using binoculars.

Thompson and Landin (1978) indicated 10 important factors influencing colony and nest site selection for these two species.

1. Preferred plant communities and nesting trees were silver maple (*Acer saccharinum*) and elm (*Ulmus americana*); sycamore (*Platanus occidentalis*) and cottonwood (*Populus deltoides*) were also used.
2. Preferred nesting height was usually within 10 ft of tallest trees.
3. Proximity to dams was within 10 mi downstream, where forests are best preserved and least flooded.
4. Proximity to feeding areas was mostly near shallow oxbow lakes and sloughs and also within several miles of extensive marshland.
5. Proximity to water was mostly within 100 yd.
6. Proximity to river junctions and dams within 2.5 mi, although colonies were not always associated with them.
7. Preferred side of navigation channel tended toward the east side.
8. Barriers to human disturbance varied with the colony, stage of breeding, and age. All colonies were over 175 yd from traveled roads. Birds may gradually move away from the

source of disturbance or relocate close by.

9. The need for protection from the wind was demonstrated by birds nesting neither on high bluffs nor on small islands surrounded by expanses of open water.
10. Interspecific associations showed that great blue herons arrived first at colonial sites followed by great egrets. Great egrets often selected sites where great blue herons were already nesting, but not always.

Thompson and Landin (1978) also indicated that both species were possibly declining overall. As stated before, habitat changes and human influences are in need of constant evaluation in order to maintain species integrity.

About 250 bird species (Table 31) have been sighted in areas of Pools 19 and 20 (E. Franks, Western Illinois University, pers. comm.; V. Kleen, Illinois Department of Conservation, pers. comm.). Many are migrants, but about 75 species have been identified as breeding.

One migrant residing in the area from October through March is the bald eagle. Fischer (1982) and Jonen (1973) described the bald eagle's winter activities in the vicinity of the Kibbe Life Sciences Station operated by Western Illinois University. At this location the Cedar Glen is heavily utilized by wintering eagles. Other studies concerning birds done near or at the Kibbe Station include those of Franks (1967), Baima (1971), Pace (1971), and Dunstan (1974, 1975, 1978, 1979).

Table 29. Canvasback peak flights in the Illinois and Mississippi Valleys, 1950-1983 (aerial census flights by Frank C. Bellrose and Robert Crompton).

Illinois Valley			Mississippi Valley		
Year	Peak	Date	Peak-Entire valley	Peak-Keokuk Pool ^a	Date
1950	81,090	11/13	2,710	2,675	11/21
1951	17,525	11/15	31,100	31,100	12/8
1952	106,350	10/29	15,160	15,050	11/5
1953	116,050	11/12	6,200	6,000	11/23
1954	65,425	10/25	23,970	23,900	11/15
1955	15,240	11/1	10,810	9,700	11/22
1956	2,500	11/14	16,390	15,700	11/23
1957	2,285	11/6	17,250	15,750	11/26
1958	1,960	10/29	14,775	11,000	11/29
1959	1,990	11/14	7,750	7,100	11/14
1960	2,320	11/23	22,075	21,100	12/1
1961	1,450	11/24	12,760	12,700	12/5
1962	2,760	11/30	18,175	17,700	11/29
1963	1,630	11/7	36,395	32,400	12/3
1964	1,975	11/17	36,300	32,500	11/24
1965	1,205	11/16	51,000	51,000	12/21
1966	925	11/15	74,840	74,700	11/23-24
1967	590	11/14	57,235	56,585	12/8
1968	300	11/4	56,035	55,760	12/3
1969	455	11/5	149,170	148,500	11/20
1970	770	11/5	168,335	168,000	12/2
1971	450	11/30	156,900	156,900	11/30
1972	589	10/30	84,200	83,800	11/20
1973	490	11/28 & 12/3	64,090	63,300	11/12
1974	870	11/19	75,478	75,045	11/5
1975	1,225	11/4	105,780	103,800	12/8-9
1976	1,005	11/8	54,225	43,400	11/15
1977	4,825	11/17	111,170	97,800	11/17
1978	5,285	11/7	153,895	134,400	11/20
1979	6,240	11/7	188,195	182,300	11/7
1980	2,895	10/28	147,190	143,850	11/3
1981	2,330	11/17	113,470	112,500	12/1
1982	2,290	12/13	81,410	79,450	12/6
1983	1,555	11/1	66,550	65,200	11/29

^a Keokuk Pool = Burlington to Keokuk.

2.12 MAMMALS

Investigations of mammals inhabiting specific areas in the vicinity of Pools 19 and 20 have not been exhaustive, particularly concerning nongame species. However, the following are the best extant sources of mammals suspected or known to occur in the immediate area: Schwartz and Schwartz (1964), Hoffmeister and Mohr (1972). USACE (1974), Bowles

(1975), and lists from the Kibbe Life Sciences Station near Warsaw, Illinois (Table 32).

Mammals in the study area may be herbivores, carnivores, or insectivores, representatives of which occupy nearly every terrestrial habitat. Some, especially the smaller species, may serve as prey for birds, reptiles, or other mammals and are thus important in converting

Table 30. Comparison of nutritional values of the fingernail clam and Asiatic clam (Thompson and Sparks 1978).

Nutritional Values	Fingernail clam (<i>Musculium transversum</i>)	Asiatic clam (<i>Corbicula manilensis</i>)
Fresh weight basis moisture	81.44	25.45
Crude protein (%)	2.46	2.35
Crude fat (%)	0.36	0.19
Crude fiber (%)	0.34	0.86
Ash (%)	11.94	66.62
Nitrogen-free extract %	3.46	4.53
Kcal/g	0.28	0.33
HCL and time for 95% digestion	1	2.5

vegetation or invertebrates into usable energy forms. High water conditions may adversely affect some prey species, but many have high reproductive rates that offset losses.

Marshes, lakes, and ponds are important to semi-aquatic species, such as muskrat and beaver. The latter often build lodges of sticks or excavate dens in the banks of the river but generally do not build dams. Population fluctuations of semi-aquatic mammals may be related more to flooding than trapping since little trapping is currently done. A single specimen of a seldom seen river otter, found caught and drowned in the net of a commercial fisherman about 1 mi north of Dam 19, is on display at Western Illinois University.

The bat species are insectivores and usually seek prey at night, preferring to be inactive during the day. Even though bats are relatively free from predators, removal of timber to create farmland or residential areas and human disturbances of cave areas

where the bats roost have adversely affected the bats and continue to threaten the remaining healthy and viable populations. Many bats migrate during winter, but some, including the endangered Indiana bat, *Myotis sodalis*, may hibernate in caves during cold weather.

2.13 FEDERAL AND STATE ENDANGERED AND THREATENED SPECIES

The Federal government and States bordering Pools 19 and 20 differ considerably on designating threatened and endangered species (Table 33). These differences probably are partly due to the more regional concerns of habitat loss associated with various species and the effect of that loss on specific species. In addition, some species have interstate distributions while others do not. Many of those listed are rarely seen, but some may be locally or seasonally abundant during migrations or during winter.

Table 31. Birds suspected and known from Pools 19 and 20 within 2 mi inland of the Mississippi River (E.C. Franks, Western Illinois University, pers. comm.; V.M. Kleen, Illinois Department of Conservation; pers. comm.).

Loons	Diving ducks
Red-throated loon	Barrows goldeneye
Common loon	Common goldeneye
Grebes	Black scoter
Pied-billed grebe	Surf scoter
Horned grebe	White-winged scoter
Red-necked grebe	Bufflehead
Eared grebe	Canvasback
Western grebe	Common merganser
Pelicans	Hooded merganser
American white pelican	Red-breasted merganser
Cormorants	Redhead
Double-crested cormorant	Greater scaup
Bitterns	Lesser scaup
American bittern	Harlequin duck
Least bittern	Oldsquaw
Egrets	Ruddy duck
Great egret	Vultures
Snowy egret	Black vulture
Cattle egret	Turkey vulture
Hérons	Eagles, kites, and osprey
Great blue heron	Bald eagle
Little blue heron	Golden eagle
Tricolored heron	Mississippi kite
Green-backed heron	Osprey
Night-Hérons	Hawks and falcons
Black-crowned night-heron	American kestrel
Yellow-crowned night-heron	Broad-winged hawk
Swans	Cooper's hawk
Tundra swan	Merlin
Mute swan	Northern harrier
Geese	Northern goshawk
Greater white-fronted goose	Peregrine falcon
Snow goose	Red-shouldered hawk
Canada goose	Red-tailed hawk
Puddle Ducks	Rough-legged hawk
American black duck	Sharp-shinned hawk
American wigeon	Swainson's hawk
Blue-winged teal	Pheasants, partridges, turkeys,
Cinnamon teal	and quail
Gadwall	Gray partridge
Green-winged teal	Greater prairie-chicken
Mallard	Northern bobwhite
Northern pintail	Ring-neck pheasant
Northern shoveler	Wild turkey
Ring-necked duck	Coots, gallinules, and rails
Wood duck	American coot

(continued)

Table 31. (Continued).

Common moorhen	Franklin's gull
Purple gallinule	Glaucous gull
Sora	Great black-backed gull
Yellow rail	Herring gull
Black rail	Iceland gull
King rail	Laughing gull
Virginia rail	Little gull
Cranes	Thayer's gull
Sandhill crane	Parasitic jaeger
Plovers, killdear, and avocets	Black tern
Black-bellied plover	Caspian tern
Lesser golden plover	Common tern
Piping plover	Forster's tern
Semipalmated plover	Least tern
Killdeer	Doves
American avocet	Rock dove
Sandpipers and allies	Mourning dove
Baird's sandpiper	Cuckoos
Buff-breasted sandpiper	Black-billed cuckoo
Least sandpiper	Yellow-billed cuckoo
Pectoral sandpiper	Owls
Purple sandpiper	Snowy owl
Semipalmated sandpiper	Barred owl
Solitary sandpiper	Long-eared owl
Spotted sandpiper	Short-eared owl
Stilt sandpiper	Saw-whet owl
Upland sandpiper	Nighthawks and nightjars
Western sandpiper	Common nighthawk
White-rumped sandpiper	Chuck-will's-widow
Short-billed dowitcher	Whip-poor-will
Long-billed dowitcher	Swifts and hummingbirds
Dunlin	Chimney swift
Hudsonian godwit	Ruby-throated hummingbird
Marbled godwit	Kingfishers
Red knot	Belted kingfisher
Wilson's phalarope	Woodpeckers and allies
Red-necked phalarope	Downy woodpecker
Ruff	Pileated woodpecker
Sanderling	Red-headed woodpecker
Common snipe	Red-bellied woodpecker
Ruddy turnstone	Northern flicker
Willet	Yellow-bellied sapsucker
American woodcock	Flycatchers
Greater yellowlegs	Acadian flycatcher
Lesser yellowlegs	Alder flycatcher
Skuas, jaegers, gulls, and terns	Eastern wood-pewee
Black-legged kittiwake	Olive-sided flycatcher
Bonaparte's gull	Yellow-bellied flycatcher

(continued)

Table 31. (Concluded).

Warblers	Yellow-headed blackbird
Bay-breasted warbler	Common grackle
Blackburnian warbler	Brown-headed cowbird
Blackpoll warbler	Eastern meadowlark
Black-and-white warbler	Western meadowlark
Black-throated blue warbler	Cardueline finches
Black-throated green warbler	Pine siskin
Canada warbler	Redpoll
Cape May warbler	Rufous-sided towhee
Chestnut-sided warbler	Dark-eyed junco
Connecticut warbler	Lapland longspur
Cerulean warbler	Smith's longspur
Hooded warbler	Snow bunting
Kentucky warbler	Bobolink
Magnolia warbler	Orchard oriole
Mourning warbler	Northern oriole
Palm warbler	Purple finch
Parula warbler	House finch
Pine warbler	Red crossbill
Prairie warbler	White-winged crossbill
Prothonotary warbler	American goldfinch
Swainson's warbler	Summer tanager
Wilson's warbler	Scarlet tanager
Worm-eating warbler	Sparrows
Yellow warbler	House sparrow
Yellow-rumped warbler	Eurasian tree sparrow
Yellow-throated warbler	Backman's sparrow
American redstart	American tree sparrow
Common yellowthroat	Chipping sparrow
Louisiana waterthrush	Clay-colored sparrow
Northern waterthrush	Field sparrow
Yellow-breasted chat	Vesper sparrow
Cardinals, grosbeaks, and allies	Lark sparrow
Evening grosbeak	Savannah sparrow
Pine grosbeak	Grasshopper sparrow
Northern cardinal	Henslow's sparrow
Rose-breasted grosbeak	Le Conte's sparrow
Blue grosbeak	Sharp-tailed sparrow
Dickcissel	Fox sparrow
Indigo bunting	Song sparrow
Blackbirds and allies	Lincoln's sparrow
Brewer's blackbird	Swamp sparrow
Red-winged blackbird	White-throated sparrow
Rusty blackbird	White-crowned sparrow
	Harris sparrow

Table 32. Mammals suspected or known to occur in the environs of Pools 19 and 20 Key: C=common; U=uncommon; R=rare; E=endangered. No letter indicates that a particular species had not been recorded.

Common name	Scientific name	Region	
		Pools 11-15	Pools 16-22
White-footed mouse	<i>Peromyscus leucopus</i>	C	
Southern bog lemming	<i>Synaptomys cooperi</i>		
Meadow vole	<i>Microtus pennsylvanicus</i>	C	
Prairie vole	<i>Microtus ochrogaster</i>	C	
Pine vole	<i>Microtus pinetorum</i>	C	
Muskrat	<i>Ondatra zibethicus</i>	C	
Norway rat	<i>Rattus norvegicus</i>	C	C
House mouse	<i>Mus musculus</i>	C	C
Meadow jumping mouse	<i>Zapus hudsonius</i>	C	R
Coyote	<i>Canis latrans</i>	R	R
Red fox	<i>Vulpes fulva</i>	C	C
Gray fox	<i>Urocyon cinereoargenteus</i>	C	C
Raccoon	<i>Procyon lotor</i>	C	C
Short-tailed weasel	<i>Mustela ermina</i>	U	
Mink	<i>Mustela vison</i>	U	U
Least weasel	<i>Mustela nivalis</i>		
Long-tailed weasel	<i>Mustela frenata</i>		
Badger	<i>Taxida taxus</i>	U	R
Spotted skunk	<i>Spilogale putorius</i>	C	R
Striped skunk	<i>Mephitis mephitis</i>	C	C
River otter	<i>Lutra canadensis</i>	C	R
Bobcat	<i>Lynx rufus</i>	R	R
White-tailed deer	<i>Dama Virginianus</i>	C	C
Virginia opossum	<i>Didelphis marsupialis</i>	C	C
Short-tailed shrew	<i>Blarina brevicauda</i>	C	C
Least shrew	<i>Cryptotis parva</i>	C	C
Southeastern shrew	<i>Sorex longirostris</i>		
Eastern mole	<i>Scalopus aquaticus</i>	C	C
Star-nosed mole	<i>Condylura cristata</i>	R	-
Little brown bat	<i>Myotis lucifugus</i>	C	C
Keen's bat	<i>Myotis keenii</i>	C	-
Silver-haired bat	<i>Lasionycteris noctivagans</i>		
Gray bat	<i>Myotis grisescens</i>		
Eastern pipistrel(bat)	<i>Pipistrellus subflavus</i>	U	U
Big brown bat	<i>Eptesicus fuscus</i>	C	C
Red bat	<i>Nycteris borealis</i>	C	C
Hoary bat	<i>Nycteris cinereus</i>	R	-
Indiana bat	<i>Myotis sodalis</i>	E	E
Evening bat	<i>Nycticeus humeralis</i>		
White-tailed jackrabbit	<i>Lepus townsendii</i>	R	-
Eastern cottontail rabbit	<i>Sylvilagus floridanus</i>	C	C
Woodchuck	<i>Marmota monax</i>	C	C

(continued)

Table 32. (Concluded).

Common name	Scientific name	Region	
		Pools 11-15	Pools 16-22
Thirteen-lined ground squirrel	<i>Spermophilis tridecemlineatus</i>	C	R
Franklin's ground squirrel	<i>Spermophilis franklinii</i>	R	R
Eastern chipmunk	<i>Tamias striatus</i>	C	C
Eastern gray squirrel	<i>Sciurus carolinensis</i>	C	C
Eastern fox squirrel	<i>Sciurus niger</i>	C	C
Southern flying squirrel	<i>Glaucomys volans</i>	C	R
Plains pocket gopher	<i>Geomys bursarius</i>	C	C
Beaver	<i>Castor canadensis</i>	C	C
Western harvest mouse	<i>Reithrodontomy megalotis</i>	U	U
Deer mouse	<i>Peromyscus maniculatus</i>	C	-

Table 33. Federal and State endangered (E) or threatened (T) species, Pools 19 and 20 (GREAT II 1980b).

	Federal	Iowa	Illinois
POOL 19			
Invertebrates	Higgins' eye pearly mussel (E)		
Fish		Western sand darter (T) Pallid sturgeon (E) Lake sturgeon (E)	Lake sturgeon (T)
Reptiles		Skipjack herring (T) Five-lined skink (T) Western slender glass lizard (E) Blanding's turtle (T) Red-eared turtle (T) Stinkpot (T) Ornate box turtle (T) Black rat snake (T) Graham's water snake (T) Diamondback water snake (T) Massasauga (T) Copperhead (E)	
Birds	Arctic peregrine falcon (E) American peregrine falcon (E) Bald eagle	Cooper's hawk (T) Red-shouldered hawk (E) Marsh hawk (E) Peregrine falcon (E) Broad-winged hawk (T) Long-eared owl (T) Upland sandpiper (E) Blue-winged warbler (T)	Cooper's hawk (E) Red-shouldered hawk (E) Marsh hawk (E) Peregrine falcon (E) Bald eagle (E) Osprey (E) Long-eared owl (E) Short-eared owl (E) Common gallinule (T) Yellow rail (E) Black rail (E) Black-crowned night-heron (E) Great egret (E) Double-crested cormorant (E) Upland sandpiper (E) Forster's tern (E) Veery (T) Brown creeper (E) Indiana bat (E) River otter (T)
Mammals	Indiana Bat (E)	Indiana bat (E) Keen's myotis (T) Evening bat (T) River otter (T) Woodland vole (E)	

(continued)

Table 33. (Concluded).

	Federal	Iowa	Illinois	Missouri
POOL 20				
Invertebrates	Higgins' eye pearly mussel (E)			
Fish		Western sand darter (T) Chestnut lamprey (T) Lake sturgeon (E) Skipjack herring (T) Five-lined skink (T) Western slender glass lizard (E) Red-eared turtle (T) Stinkpot (T) Ornate box turtle (T) Black rat snake (T) Speckled kingsnake (E) Graham's water snake (T) Massasauga (T) Copperhead (E)	Lake sturgeon (T)	Lake sturgeon (E)
Birds	Arctic peregrine falcon(E) American peregrine falcon (E) Bald eagle (E)	Cooper's hawk (T) Red-shouldered hawk (E) Marsh hawk (E) Peregrine falcon (E) Broad-winged hawk (T) Long-eared owl (T) Upland sandpiper (E) Least tern (E) Blue-winged warbler (T)	Cooper's hawk (E) Red-shouldered hawk (E) Marsh hawk (E) Peregrine falcon (E) Bald eagle (E) Osprey (E) Long-eared owl (E) Short-eared owl (E) Common gallinule (T) Yellow rail (E) Black rail (E) Black-crowned night-heron (E) Great egret (E) Double-crested cormorant (E) Upland sandpiper (E) Forster's tern (E) Veery (T) Brown creeper (E) Henslow's sparrow (T)	Cooper's hawk (E) Marsh hawk (E) Peregrine falcon (E) Osprey (E) Sharp-shinned hawk (E) Double-crested cormorant (E) Least tern (E)
Mammals	Indiana bat (E) Gray bat (E)	Indiana bat (E) Keen's myotis (T) Evening bat (T) River otter (T) Woodland vole (E)	Indiana Bat (E) Gray Bat (E) River Otter (T)	Indiana Bat (E) Gray Bat (E) River Otter (E)

CHAPTER 3

COMMUNITY FUNCTION

3.1 PRODUCTION AND BIOMASS OF AUTOTROPHS

In the pools the autotrophs include both algae and macrophytes. Phytoplankton, the major algal form, occurs in the water column throughout the pools. Other algal forms, for example periphyton, are not abundant since light does not penetrate to substrates in most habitats of the pools. The highest phytoplankton biomass occurs in the spring in channel habitat (Table 34). However, the highest standing crop occurs in late summer, 0.42 g dry weight (wt) $\times 10^{-8}$ /l/day compared to 0.37 g dry wt $\times 10^{-8}$ /l/day in the spring. Though production is about the same in the channel border habitat, biomass is generally lower. These biomass and production estimates are probably low in terms of energy fixed because of turnover and leakiness. These two factors may account for an underestimate of 25% to 80%. If these underestimates are considered, the annual biomass production by phytoplankton in Pool 19 would be approximately 11.9 million g of carbon and Pool 20 would contain about 20% of this amount. Even though phytoplankton are abundant (see Section 2.4) and productive in the Mississippi River relative to other aquatic systems, they still represent less than 1% of the carbon input to a navigation pool. Most of the carbon input comes from upstream pools and tributaries in the form of particulate organic carbon or dissolved organic carbon. The timing of peak phytoplankton biomass does correspond to periods of maximum growth in benthic invertebrate communities, but phytoplankton biomass is not sufficient to produce the very high mass of invertebrates in the channel border areas of pool.

Besides phytoplankton, a second autochthonous source of biomass in the pools is the aquatic macrophytes. Macrophytes occur seasonally in the pools from about June to November (Figure 25). Growth rates for the dominant species found in most pool beds is highest between July and August: 4.87 g ash free dry weight (AFDW)/ m^2 /day for lotus and 9.69 AFDW/ m^2 /day for arrowhead (Grubaugh et al. in prep.). Grubaugh et al. determined that annual net production for these species would be 724 g AFDW/ m^2 in arrowhead and 452 g AFDW/ m^2 for lotus. These values are higher than those of the natural vegetation of many terrestrial ecosystems and approach production value rates in some agroecosystems (Grubaugh et al. in prep.). As with phytoplankton, turnover may cause values to be underestimated. Sloughing of leaves throughout the growing season may result in as much as a 2- to 4-fold increase in production estimates. However, in spite of this potential sloughing, and even with the fall senescence, substrate concentrations of organic matter do not increase (Figure 25). This fact indicates that the organic matter is being either used in the beds or transported out of the macrophyte beds. Dense populations of benthic invertebrates occur in the soft substrates usually found adjacent to the macrophyte beds. These populations may develop because of food resource produced by the macrophytes and transported out of the plant beds by wind and current action. Peak macrophyte production does occur when algal densities are low and during periods of high macroinvertebrate production. Primary decomposing is also very high in the plant beds (Anderson et al. in prep.) and may account for much of the loss of organic matter produced by the plants.

Table 34. Seasonal mean phytoplankton density, biomass, and carbon in channel and channel border habitats, Pool 19, Mississippi River.

Date	Density $\times 10^6/l$ (Mean)	Biomass g Dry Weight $\times 10^{-8}/l$ (Mean)	Carbon grams $\times 10^{-8}/l$ (Mean)
<u>Channel</u>			
Jan.	4.56	4.78	2.25
March	10.53	10.38	4.88
April	21.74	21.44	10.08
May	14.13	16.93	7.96
June	2.14	3.57	1.68
July	2.00	3.19	1.50
Aug.	8.48	15.88	7.47
Oct.	2.88	6.42	3.02
Dec.	2.69	3.92	1.84
<u>Channel Border</u>			
Jan.	2.96	3.05	1.43
March	3.30	3.96	1.86
April	15.58	15.58	7.42
May	10.42	9.23	4.34
June	2.00	3.95	1.85
July	2.00	3.15	1.48
Aug.	6.62	22.31	5.32
Oct.	2.29	5.19	2.44
Dec.	2.03	3.57	1.21

3.2 PRODUCTION AND BIOMASS OF HETEROTROPHS

Heterotrophs include all organisms (microbes, zooplankton, macroinvertebrates, fishes and other vertebrates) not

able to photosynthesize. Representatives of this diverse group usually occupy all habitats in both Pool 19 and 20, though density and biomass may vary greatly. Little information on microbes found in these two pools is available. Preliminary

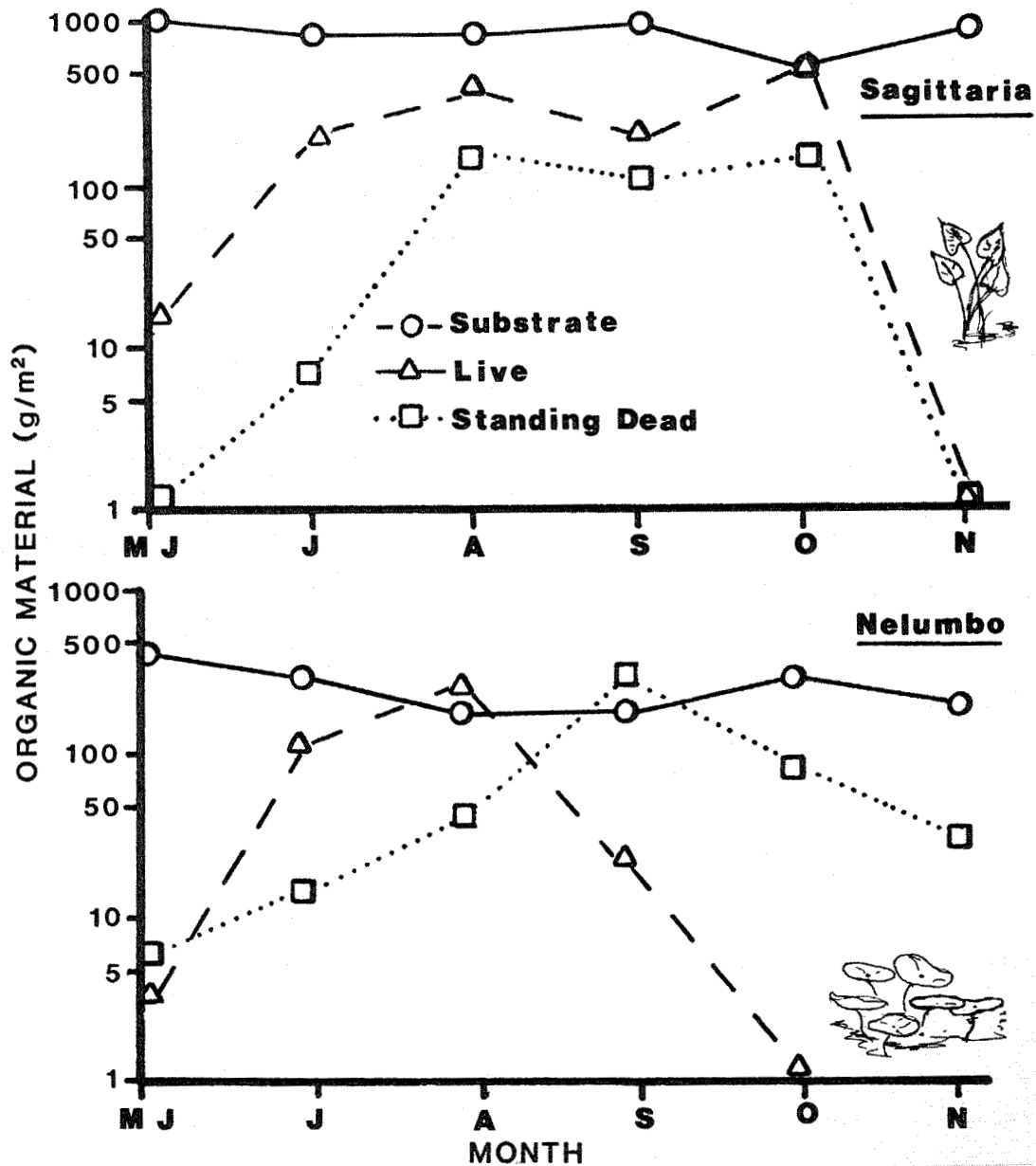

Figure 25. Biomass production of arrowhead (*Sagittaria*) and lotus (*Nelumbo*) in a macrophyte bed near Nauvoo, Illinois, Pool 19, Mississippi River (Grubaugh et al., submitted).

studies by Henebry and Gordon (in press) indicate about a 10-fold difference in density and estimated biomass between the water column and substrate communities. The microbial populations in the water column increase from the channel to the channel border to macrophytic beds. Peak biomass, about 0.6 g C/m³ in the channel and 0.7 g C/m³ in the channel border, occurs in late spring; there is a second peak in late summer that is about half the magnitude of the spring high. Low biomasses, from 0.07 to 0.10 g C/m³, occur in the winter. Substrate populations have smaller fluctuations.

Unlike phytoplankton or microbes, zooplankton populations usually exhibit a single biomass peak in the summer (Table 35). Higher biomasses are found in the main channel than in other habitats during periods of low density but the peak biomass, 13.66 g x 10⁻⁶/l, occurs in the channel border area in summer. This may reflect the lower current velocities found in this habitat and the availability of food items, phytoplankton, or particulate organic matter from macrophyte beds.

Just as macroinvertebrate density varies down the length of the pools and within habitats, so does biomass and diversity (Figures 26a,b and 27a,b). The highest macroinvertebrate biomass in Pool 19 occurs in the channel border area where the fingernail clam-burrowing mayfly community exists. Peak biomass of approximately 200 g/m² is found in these lacus-

trine areas of the lower third of the pool (Figure 26). During periods of highest productivity in this community, usually late summer and early fall, biomass changes may be as high as 1 g/m²/day. Upstream areas have significantly lower biomass though both biomass and diversity increase in the tailwaters of Lock and Dam 18 because of a diverse insect community dominated by dense populations of caddisflies. In Pool 20 the peak biomass occurs in the tailwaters of Lock and Dam 19, where mats of caddisfly larvae occur on the rocky substrates of the tailwaters (Figure 27). Again, this tailwater community is diverse because of the insect community. Both biomass and diversity decline rapidly in downstream samples as the substrate becomes less stable and available food resources decrease. The substrate association is again reflected in changes in biomass across the pool (Figure 27). Biomass is highest near shore where riprap or roots and fallen trees provide a solid substrate for organisms to cling to. Soft substrates in side channel and some channel border areas of Pool 20 do have a burrowing community but do not have the high densities of fingernail clams. Thus they usually have much lower biomass than the community in Pool 19.

Though the density of mussels may be low compared to other invertebrates, their large mass and commercial value make them important in the pools. Biomass and production have been estimated for several of

Table 35. Seasonal zooplankton density and biomass in two habitats, channel and channel border, of Pool 19, Mississippi River.

Season	Channel		Channel border	
	Density x 10 ³ /l	g dry weight x 10 ⁻⁶ /l	Density x 10 ³ /l	g dry weight x 10 ⁻⁶ /l
Spring	7.11	1.22	3.66	0.63
Summer	25.14	4.32	79.41	13.66
Fall	1.05	0.18	0.20	0.03
Winter	1.13	0.19	---	---

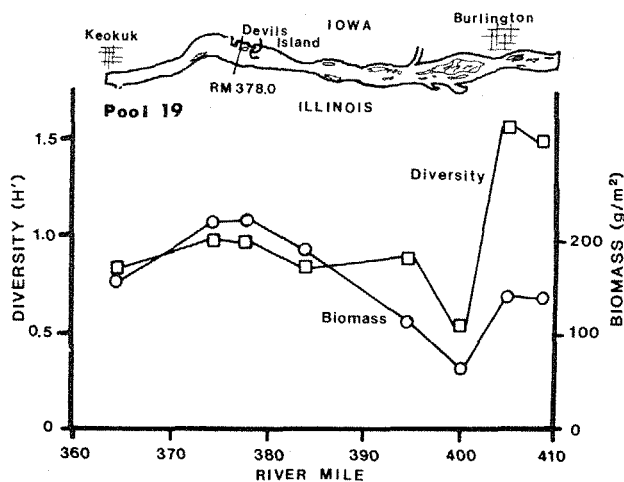

Figure 26a. Diversity and biomass of benthic invertebrates down the length of Pool 19, Mississippi River.

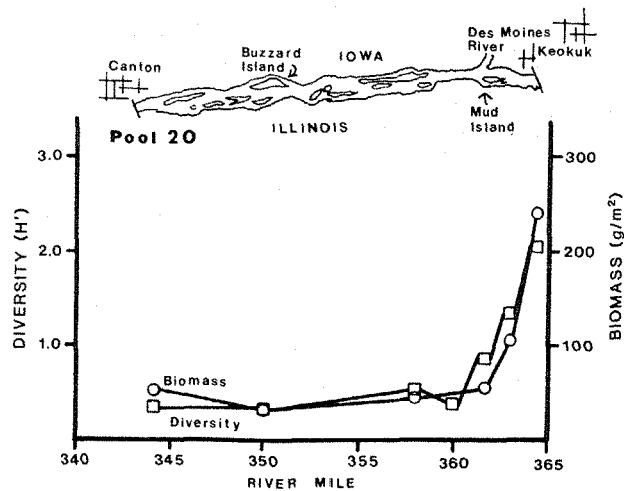

Figure 27a. Diversity and biomass of benthic invertebrates down the length of Pool 20, Mississippi River.

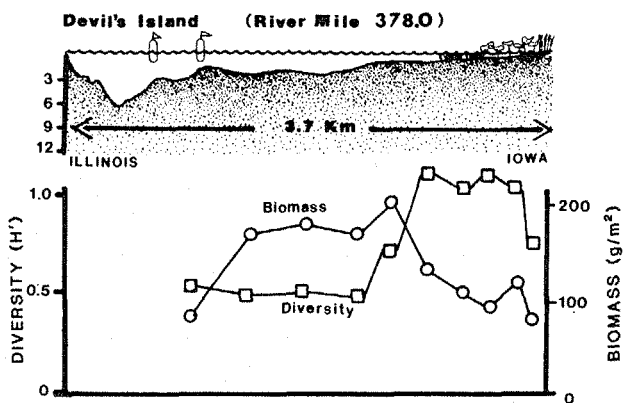

Figure 26b. Diversity and biomass of benthic invertebrates across the width of Pool 19, Mississippi River.

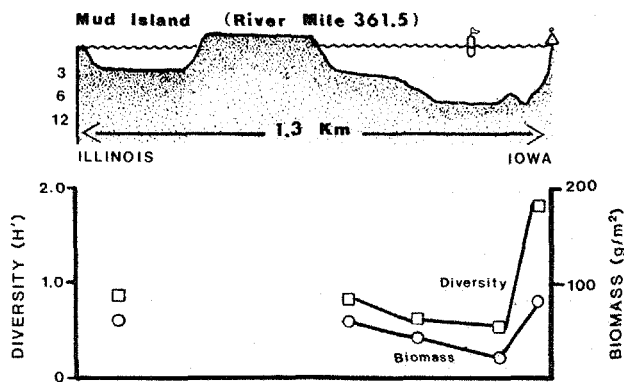

Figure 27b. Diversity and biomass of benthic invertebrates across the width of Pool 20, Mississippi River.

the common species in Pools 19 and 20 (Table 36). The commercially valuable three-ridge had the greatest mass in most mussel beds examined. It also had the highest net annual production, 0.003 g dry wt/individual/day (Table 36; Anderson et al. in prep.). The stout floater had the greatest mass in the channel border area, 24.47 g dry wt/m². This thin shelled species also had a high rate of production, 0.008 g dry wt/individual/day. Biomass of the *Quadrula* group (warty back,

pimple back, and maple leaf) in mussel beds and channel border areas varied by species but all had similar values for net annual production, 0.007 g dry wt/individual/day. Though few samples were available, the maple leaf was the only species that exhibited age specific growth: young individuals had a much higher change in mass than did older shells. Neither the three-ridge nor stout floater showed age specific growth; rather a constant change in mass was found in all individuals examined. More individuals, however, need to be examined before conclusive age-specific growth data is available

Table 36. Biomass and rate of production of unionid mussels and clams found in Pools 19 and 20, Mississippi River. Clam production values are peak net production, mussel values net annual production.

Species	Average biomass (shell) g dry wt/m ²		Rate of production g dry wt/day/indiv.
	Mussel bed	Channel border	
Mussels			
<i>Amblema plicata</i>	26.23	11.36	0.003
<i>Anodonta grandis corpulenta</i>	4.07	24.47	0.008
<i>Obliquaria reflexa</i>	1.38	0.19	0.0002
<i>Quadrula nodulata</i>	13.48		0.0007
<i>Q. pustulosa</i>	4.96	0.19	0.0007
<i>Q. quadrula</i>	18.80	1.13	0.0007
Clams			
<i>Corbicula fluminea</i>		212	0.0004
<i>Musculium transversum</i>		88	0.0001

for these species. Though the absolute value of production in clams is lower than in mussels, it represents a very high rate of growth since individual mass is comparatively much lower than that of mussels.

Specific estimates of vertebrate biomass production in Pools 19 and 20 are limited. Biomass of fishes is estimated to be approximately 100 kg/ha, but this probably varies greatly among seasons and habitats. Determination of energy requirements is more common than estimates of productivity and is limited by the relatively few estimates of energy content of food items (Table 37). Because of the extensive use of Pool 19 by diving ducks, specific information is available on this group of vertebrates (Table 38) (Bellrose 1976; Thompson and Sparks 1978; Day 1984; Day and Anderson, in prep.). The seasonal presence of large populations of canvasback and lesser scaup and associated energy requirements have been estimated for the spring and fall migration (Table 38). Spring and fall requirements for sexes within a species are not signifi-

cantly different. Energy requirements in canvasback, however, are higher than in lesser scaup. Thus canvasback may exert a greater impact on their food resources in the pool than do lesser scaup.

3.3 TROPHIC RELATIONSHIPS

In the previous sections and chapters many trophic relationships have been mentioned or suggested. The trophic interactions and food habits of organisms within the pools ultimately determine energy flow and productivity of these ecosystems. The high biomass of heterotrophs, particularly those near the top of a trophic pyramid or those that are present in the pools in very high densities for short periods of time, indicate the productivity of the habitats. Trophic interactions in the pools have been studied by a number of investigators (Hoopes 1960; Wenke 1965; Carlander et al. 1967; Jude 1968, 1973; Gale and Lowe 1971; Gale 1973b; Sparks 1984; Pillard and Anderson, in prep.).

Table 37. Caloric values of selected benthic organisms based on values from Cummins and Wuycheck (1971).

Taxa	Calories/ g dry wt	Calories/ g ash-free dry wt
Insects		
Mayflies		
<i>Baetis</i>		6409
<i>Caenis</i>		7130
		6985
Midge larvae		
Chironomidae	5516 \pm 260	
Caddisflies		
<i>Pycnopsyche</i>	3639.6 \pm 99.2	5195.9 \pm 912.1
<i>Hydropsyche</i>	5604.7 \pm 29.1	6375.0 \pm 842
<i>Macronema</i>	5167	
Clams		
<i>Sphaerium</i>	3422 \pm 812	4759 \pm 558
<i>Musculium</i>	5219	4230 ^a
<i>Corbicula</i>		4160 ^a
Snails		
<i>Viviparus</i>	1571	

^aData from Thompson and Sparks (1978).

Table 38. Biomass and energy requirements of diving ducks on Pool 19, Mississippi River (Day 1984; Day and Anderson, in prep.). S=spring; F=fall.

Species	Average mass (kg) (Bellrose 1976)	Estimated average seasonal mass on Pool 19 spring-fall (kg)	Daily energy requirement based on either daily energy or behavior			
			S ^a	F ^a	S ^b	F ^b
Canvasback						
Male	1.22	134,000	92.72	91.92	159.42	155.87
Female	1.16		90.16	88.34	158.56	155.99
Lesser Scaup						
Male	0.83	144,000	70.67	67.37	160.22	151.63
Female	0.75		66.34	63.50	158.95	161.67

^a Based on energy activity values in Wooley and Owen (1978).

^b Based on equations of Aschoff and Pohl (1970).

3.3.1 Tropic Dynamic models

Carlson (1968) proposed a trophic model of energy and nutrient flow in the channel border area of Pool 19. Another model of trophic interactions and energy flow as represented by carbon is being developed by the Illinois Natural History Survey under the NSF-LTER grant to Dr. R. Sparks (Figure 28). This model will be applicable to most navigational pools and requires data on biomass of dominant groups of organisms and organic inputs within a pool. The model has been developed and tested on the basis of data from Pool 19. The initial modeling runs indicate that the primary energy source in the pool is dissolved organic carbon (DOC) and particulate organic matter (POC). The DOC is derived from photosynthates leaked from phytoplankton and macrophytes and leached from POC. POC may be produced within the pool by phytoplankton and macrophytes or may be allochthonous material from the watershed and upstream pools. Production of other organisms within the pool is sen-

sitive to fluctuation in availability of DOC and POC and to the microbial organisms (decomposers) which transform this material into a usable food source for fauna in the pool. Some allochthonous input is necessary since phytoplankton and macrophytes within the pool cannot fix enough energy to support the high heterotrophic biomass and productivity found in Pool 19 (see Sections 3.1 and 3.2). Because of the seasonal nature of production peaks, macrophytes probably fuel the high summer productivity of benthic macroinvertebrates and zooplankton through leaked photosynthates and high turnover of leaves (Figure 29). Spring and fall population peaks of consumers result from phytoplankton production and higher inputs of allochthonous material due to flooding.

3.3.2 Invertebrate Relationships

Dr. Sparks' model predicts gross trophic controls within a pool; however, many specific interactions occur between producers and consumers and between

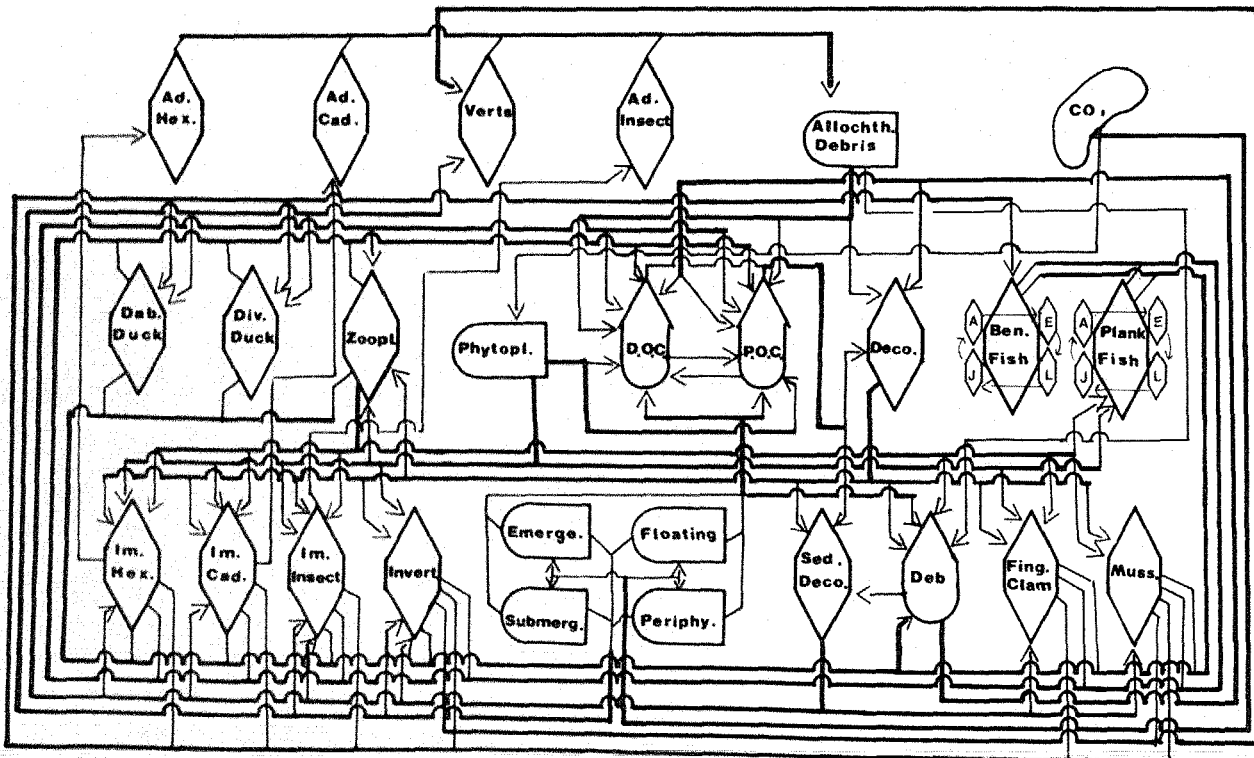

Figure 28. Flow chart of trophic relationships of major components of a Mississippi River ecosystem.

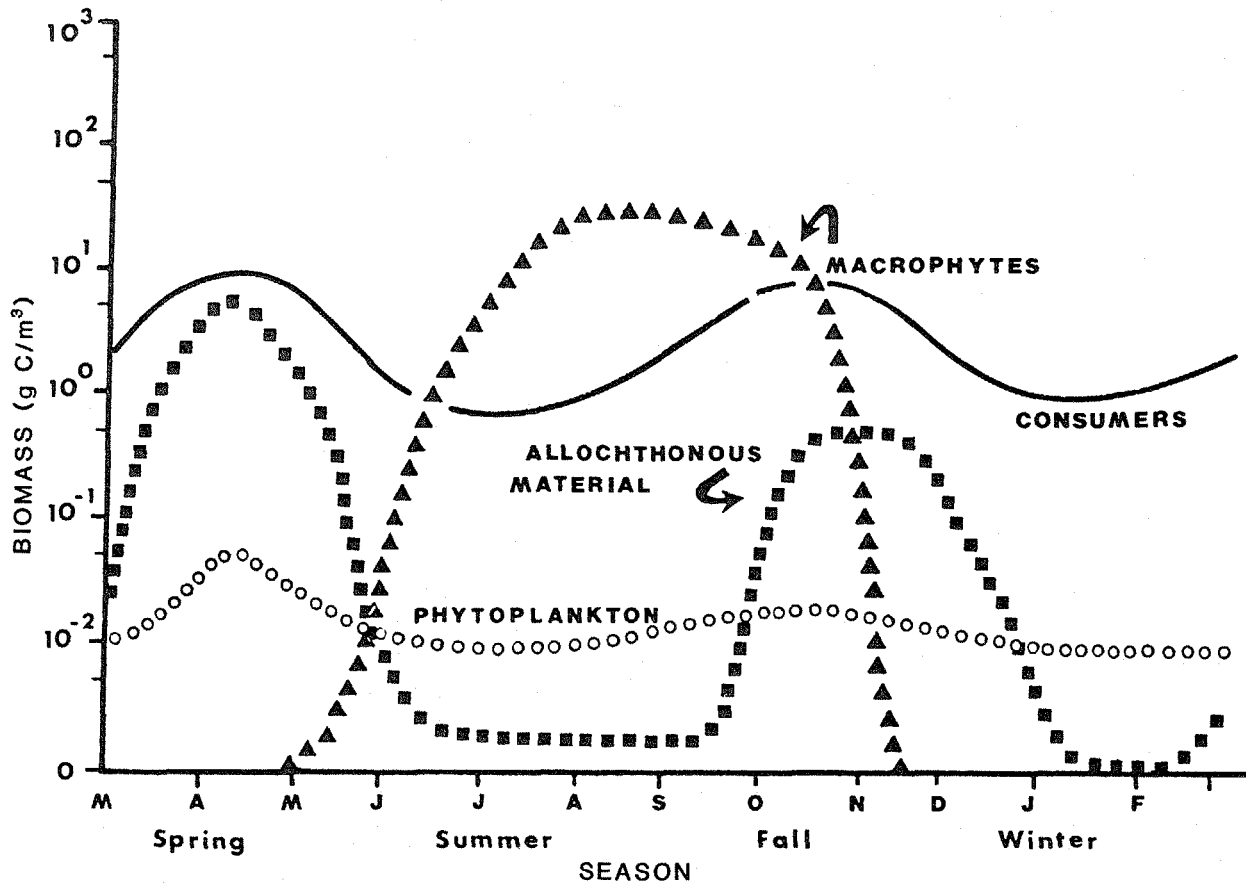

Figure 29. Seasonal change and distribution of biomass in major components of the channel border habitat, Pool 19, Mississippi River.

consumers. Carlson (1968) indicated that the most abundant organisms found in the channel border areas were detritus feeders and that relatively few strict herbivorous, carnivorous, or omnivorous organisms were present. This relationship, however, may be dependent on the habitat that the macroinvertebrates are found in as indicated by Anderson and Day (in press). Vegetated habitats have more carnivorous and herbivorous organisms than those in the channel or channel border areas. Whether filter feeders in the pools are detritus feeders or selectively feed on specific organisms in the water column has been evaluated for a few organisms in Pools 19 and 20. Gale and Lowe (1971) examined phytoplankton ingestions by the fingernail clam (*Musculium transversum*; Table 39). They found that clams non-selectively ingested phytoplankton, but were unable to determine if phytoplankton

served as a major food source in preference to other filtered material. The latter situation may be the major source of energy since most of the phytoplankton found in the lower gut of the clams appeared to be alive. Similar questions arise in terms of major food items of the filtering collector, *Hydropsyche orris*. This caddisfly, which dominates the hard substrates of both Pools 19 and 20, has a mesh on its filtering net that allows most phytoplankton to pass through, but catches POC and many zooplankton. In the upper end of Pool 19 there are few zooplankton, but there is considerable POC of a size that could be trapped. In the lower end of the pool and the trailwaters of Lock and Dam 19, most of the POC is small enough to pass through the net but many zooplankton are present. Thus, a shift in food resources may occur (Anderson et al., in prep.). Pillard (1983) found

Table 39. Percent^a gut content of phytoplankton ingested by fingernail clams (*Musculium transversum*) (adapted from Gale and Lowe 1971).

Taxa	Oct.	Nov.	Dec.	Feb.	March	April	June	July	Aug.
Chlorophyceae	61	80	16	5	6	35	57	48	55
Euglenophyceae	0	0	0	+	0	+	1	4	2
Bacillario- phyceae	31	20	78	92	95	61	16	37	21
Myxophyceae	9	2	2	4	2	0	1	26	13
Total genera	20	22	23	17	12	20	27	32	33

^a+ indicates values less than 0.5%.

zooplankton densities, particularly those of the larger species, were reduced when the zooplankton passed through the trailwaters of Lock and Dam 19. He suggested that the reduction of the zooplankton densities was possibly due to planktivorous fish and the dense caddisfly population in this area.

Many invertebrate predators occur in Pools 19 and 20, feeding primarily on other invertebrates. Carnivores, dipterans, fishflies, dragonflies, damselflies, beetles, and true bugs can be found in most habitats, but are most abundant in the submerged vegetation. In this ecotone between channel border habitat and dense macrophyte beds, more prey may be available, yet may find cover among the submerged plants to avoid larger predators. Thus, conditions for a diverse array of predators are present. These predators are often active swimmers and may be found throughout the vegetated habitat. However, increased current velocities in the channel border may restrict their occurrence in that area. Predators do occur in the channel border, but are either endobenthic or closely associated with the substrate. Gale (1973a) found that the major predators on fingernail clams in Pool 19 were leeches, several species of which occur in the channel border habitat. Leeches are probably important predators of most organisms in the channel border habitat since

densities frequently exceed 1,000/m².

3.3.3 Fish Relationships

Several fish species are also major predators on invertebrates in most pool habitats, according to Hoopes (1959, 1960), Wenke (1965), Jude (1968, 1973), and Gale (1973b). Though these authors reported different proportions of particular food items in the stomachs of various species of fish, they usually agreed on the principal food items. Mayflies were reported from 30 species of fish. The burrowing mayfly, by far the most common type of mayfly consumed, was found in 24 fish species. Some differences do occur in the use of adults and nymphs. In a study in which four species were collected at the same location and time from Pools 19 and 20, freshwater drum were found to eat more nymphs than adults, but the mooneye, white bass, and channel catfish preferred adults (Table 40). Caddisflies were found in 31 species of fish, thus contributing to a major portion of the stomach contents of fish in the tailwater habitat below Lock and Dam 19. Unlike the burrowing mayfly, however, adult caddisflies, when present, always constituted a larger part of the diet than did larvae (Table 40). Larval caddisflies occur in retreats and pupal cases which may be more difficult to remove from the substrates to which they are attached. Mayfly nymphs, which occupy soft

Table 40. Frequency of occurrence of food items in fish taken above and below Lock and Dam 19, Mississippi River, during June and July.

Gut content	Channel catfish		Mooneye		Drum		White bass	
	Above	Below	Above	Below	Above	Below	Above	Below
Plant debris & algae	1.00	0.65	0.25	0.10	0.27	0.15	--	0.10
Fingernail clams	0.30	0.05	--	--	0.43	--	--	--
Snails								
<i>Viviparus</i>	0.20	--	--	--	0.15	--	--	--
<i>Campeloma</i>	0.13	0.05	--	--	--	--	--	--
<i>Physa</i>	0.17	--	--	--	--	--	--	--
Mayflies								
<i>Hexagenia</i>								
(Adult)	0.63	0.27	0.93	--	0.21	0.05	1.00	--
(Nymph)	0.21	--	--	--	0.93	--	--	--
<i>Potamanthus</i>	0.05	0.25	--	--	--	0.15	--	0.07
<i>Stenonema</i>	--	0.33	--	--	--	0.05	--	--
Stoneflies								
Perlodidae	0.33	0.05	--	--	--	--	--	--
Caddisflies								
Hydropsychidae								
(Adult)	0.10	0.60	0.17	1.00	0.15	0.77	--	0.65
(Larva)	0.25	0.87	--	--	--	--	--	--
Dragonflies								
<i>Odonata</i>	0.15	--	0.07	--	0.47	--	--	--
Midges								
Chironomidae	0.67	0.60	0.17	0.10	0.11	--	0.10	0.10
Sowbugs								
<i>Asellus</i>	0.07	--	--	--	--	--	--	--
Fish	0.20	0.17	--	--	0.10	--	0.05	0.55

substrates or swim in the water column, may be easier to obtain. Many other species of invertebrates were also found in the stomachs of these fishes, though they usually were not as important as food items as the mayflies and caddisflies. Some species of fish are predators on fingernail clams. Gale (1973b) reported that channel catfish, carp, bullheads, and gizzard shad ate large numbers of the clams

and seemed to suppress clam population growth. In general, the channel catfish seemed to have the most diverse diet even during periods of insect emergences (Table 40).

Changes in diet with size or age of the fish have also been reported (Wenke 1965; Jude 1973). Zooplankton, crustaceans, and chironomids are frequently

eaten by small or young fish. Insects, clams, and fish are eaten by larger species and older fish. Gizzard shad, usually considered a planktivore (particularly when young), feed on bottom organisms and clams when older (Jude 1973). Some species such as buffalo and carpsucker are primarily herbivorous. Gar, crappie, sauger, and walleye are piscivorous; sauger and walleye are almost exclusively fisheating. Mussels, in spite of their relative abundance, are not a fish food, though small individuals may occasionally occur in gut contents.

3.3.4 Waterfowl

Other important, though seasonal, consumers, particularly in Pool 19, are waterfowl. Because they occur in very high densities (see Section 2.10), and their energy requirements are large (see Section 3.2), their feeding may affect the invertebrate and plant communities of the pools. Information about specific feeding has been based on gizzard content of waterfowl collected in Pool 19. Studies by Korschgen (1948), Rogers and Korschgen (1966), Thompson (1969), and Paveglio and Steffeck (1978), indicate the ducks have a diverse diet (Table 41). Foods include a variety of aquatic macrophytes and benthic invertebrates, proportions of which vary depending on season of migration and species. Pondweed and clams occur most frequently in canvasback ducks, but mayfly nymphs, snails, and other species of macrophytes are also frequently encountered in the gizzard contents. In general, however, animal material was a higher percentage of the total content than was plant material. Lesser scaup consumed similar food items, and the gizzard content was again dominated by animal material, primarily clams. Activity patterns of these diving ducks indicate they use Pool 19 as a feeding area and feed primarily in the channel border area dominated by a fingernail clam-burrowing mayfly community. Some estimates indicate the ducks may reduce fingernail clam populations by as much as 20% (Thompson 1969), probably a high value since some of the clam population is probably not available for use by the duck (Gale 1973b). Still, the abundance of fingernail clams in Pool 19 is apparently one reason the ducks extensively feed there. Pool 20, which has few

fingernail clams in its benthic community, receives only limited diving duck use.

Dabbling ducks, including mallards (*Anas platyrhynchos*) and wood duck (*Aix sponsa*), nest and feed in the vegetated channel border habitat and backwaters. Their dense growth of macrophytes and abundant invertebrates provide nutrient-rich food for egg production and the development of young ducks. Possibly the densest population of wood ducks is in the macrophyte bed below Nauvoo, Illinois (F. Bellrose, Illinois Natural History Survey; pers. comm.).

The importance of the channel border habitat and its fingernail clam-burrowing mayfly community is apparent from the numerous consumers using these resources. Invertebrates, fish, and waterfowl all feed on this community, yet little is known about specific food requirements of the benthic components of the food web. Though Gale (1971) found phytoplankton in the digestive systems of clams, they probably also use the microbially mediated POC from macrophyte beds and allochthonous sources, a more abundant food resource than phytoplankton.

3.4 NUTRIENT CYCLING AND RESPIRATION

The cycling of nutrients in the pools follows basic trophic and carbon pathways, requiring initial uptake and incorporation into plant or microbial biomass before use by other consumers in the system (Figure 30). Nutrient sources in the water column are available in all habitat types (Table 42). Nitrates are low in backwaters but ammonia-N and phosphate are high in this habitat. Concentrations of nitrates are highest in the channel and channel border areas. Not only are dissolved nutrients available, but some nitrogen-fixing blue-green algae are usually present in the phytoplankton (see Cyanophycophyta, Table 13 and Figure 16), and probably also provide some nitrogen to the system. Total nitrogen is usually highest in May, averaging about 10 mg/l throughout the pools, and lowest in August at about 2 mg/l. Tributaries apparently contribute a substantial amount of the total nitrogen. Inputs from the Skunk River and Henderson Creek on Pool 19, for example, exceed 12 mg/l during periods of high flow.

Table 41. Frequency (percent occurrence) of food items in canvasback and lesser scaup taken on Pool 19, Mississippi River. (Percent aggregate volume is given in parentheses; T=trace).

Food	Sources		
	Korschgen (1948)	Thompson ^a (1969)	Paveglio and Steffek (1978)
CANVASBACK			
Vegetation:	(7.3)		(25)
Pondweeds		37.3	
<i>Potamogeton</i> sp.	1.6		
<i>Potamogeton</i> seeds			11.7
Frogbit			
<i>Vallisneria</i> sp. winter buds			8.3
Smartweeds			
<i>Polygonus</i> sp.	T		
Bulrush		13.6	
<i>Scirpus</i> sp.	5.7		
Unidentified seeds		10.2	
Unidentified plants		13.6	5.0
Animal:	(92.7)		(75.0)
Gastropoda	65.3		T
<i>Somatogyrus</i> sp.		18.6	
<i>Campeloma</i> sp.		13.6	
<i>Pleurocera</i> sp.		5.1	
<i>Fontigens</i> sp.		5.1	
Unidentified snails		32.2	
Fingernail Clams			T
<i>Musculium</i> sp.	T		
<i>M. transversum</i>		30.5	
<i>Sphaerium striatinum</i>		25.4	
Unidentified clams		54.2	
Mussels			
Unionidae		15.2	
Unidentified Mollusca			75.0
Insects			
Ephemeroptera	27.4	45.8	
Caddisflies		10.2	
Midges		10.2	
Hymenoptera	T		
Unidentified insects	T		
LESSER SCAUP			
Vegetation:	(6.5)		(2.5)
Pondweeds			
<i>Potamogeton</i> sp.	27 (3.3) ^b	8.1	
<i>Potamogeton</i> sp. seeds	26 (2.9)		1.6
Smartweeds			

(continued)

Table 41. (Concluded).

Food	Sources		
	Korschgen (1948)	Thompson (1969) ^a	Paveglio and Steffek (1978)
LESSER SCAUP (continued)			
<i>Polygonum</i> sp.		6.3	
<i>Polygonum</i> sp. seeds			
Bulrush			T
<i>Scirpus</i> sp.			
<i>Scirpus</i> sp. seeds			T
<i>Sagittaria</i> sp. seeds			T
Unidentified seeds	26 (0.2)	5.9	
Unidentified plants			0.9 ^c
Animal:	(93.5)		(97.5)
Gastropoda			20.8
<i>Somatogyrus</i> sp.	8 (5.5)	33.3	
<i>Campeloma</i> sp.	22 (15.4)	21.1	
<i>Pleurocera</i> sp.	5 (2.5)		
<i>Fontigens</i> sp.		19.2	
<i>Amnicola</i> sp.	30 (13.7)		
<i>Lioplax</i> sp.	6 (4.1)	10.0	
<i>Polygyra</i> sp.	1 (0.1)		
Unidentified snails	46 (28.0)	68.1	
Fingernail clams			18.0
<i>Musculium</i> sp.			1.0
<i>M. transversum</i>		39.6	
<i>Sphaerium</i> sp.	33 (11.9)		
<i>Sphaerium</i> <i>striatinum</i>		75.9	
<i>Unio</i> sp.	3 (2.9)		
Unidentified clams	2 (0.1)	91.5	
Mussels			
Unionidae		9.6	0.1
Oligochaeta			T
Insects			
Ephemeroptera	15 (7.8)	13.3	
Caddisflies		7.0	55.1
Midges			T
Hymenoptera			
Other insects	5 (0.1)		
Unidentified insects	5 (0.1)		
Crustacea	1 (0.5)		

^a Items less than 5% not reported.

^b Values represent 1% volume of each group.

^c Several additional species in trace amounts.

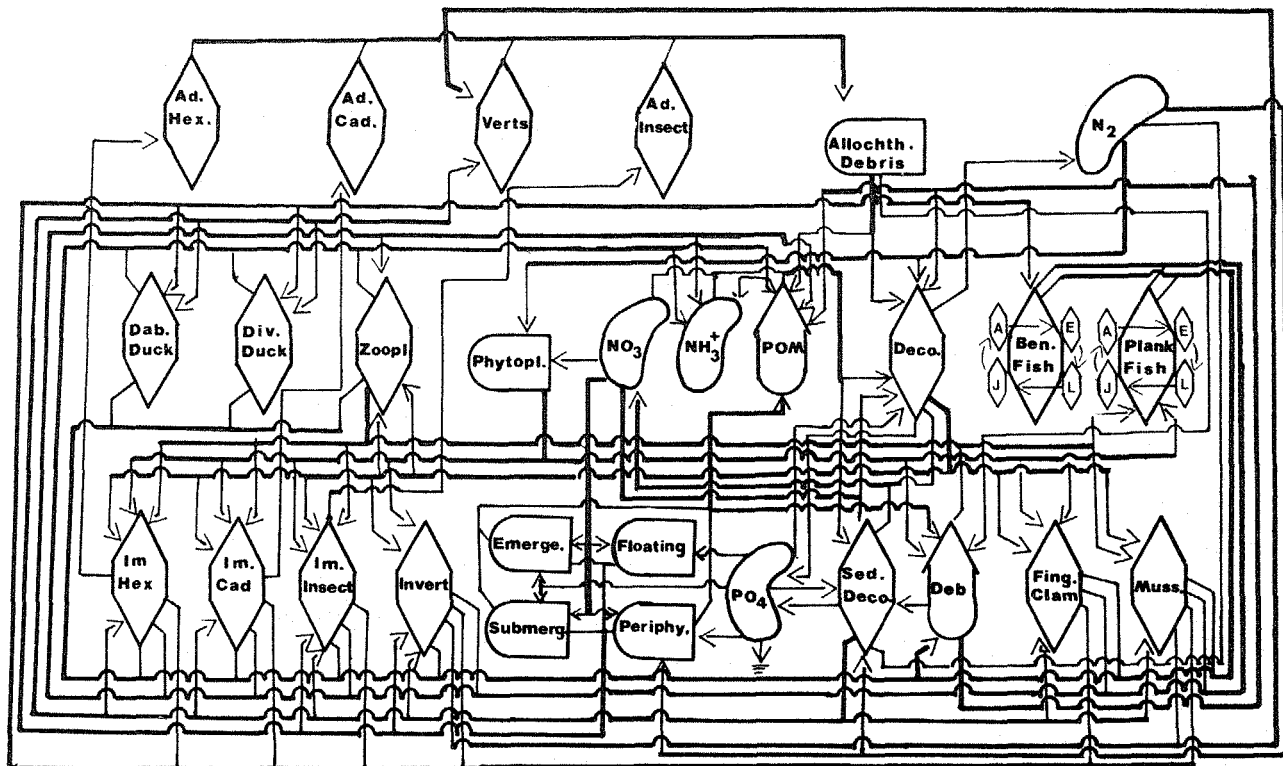

Figure 30. Flow chart of nutrient transfers through major components of a Mississippi River ecosystem.

Table 42. Average values (mg/l) for nutrients, by habitat, for August 1983 on Pool 19, Mississippi River.

Parameter	Habitat				
	Channel	Channel border	Side channel	Vegetated channel border	Backwater
Dissolved organic carbon	7.6	8.3	8.1	9.5	12.3
Nitrite	0.04	0.04	0.04	0.03	0.01
Nitrate	0.28	0.28	0.23	0.21	0.04
Ammonia	0.17	0.17	0.17	0.23	0.22
Soluble ortho-phosphate	0.08	0.08	0.09	0.11	0.22
Hardness	216	215	215	200	238

Tributaries flowing into Pools 19 and 20 drain agricultural lands which are frequently fertilized. Thus runoff may carry a significant amount of nitrogen and phosphorus into the river. During some periods of the year this runoff is sufficient to cause a nitrogen gradient across the river. The highest concentration occurs on the Iowa side of the river, where most of the agricultural-based drainage basin and largest urban areas occur. The substantial inputs of nutrients, at relatively high concentrations in the water column, indicate that nutrients are generally not limiting in this system.

Dissolved oxygen is also usually not limiting in either Pool though input from primary producers is usually low (Table 43) and may only slightly exceed respiratory demands. Thus the system usually has a production to respiration ratio of about 1:1. In macrophyte beds in the summer there is greater oxygen production than use compared to nonvegetated areas (Table 43). During the winter oxygen production is higher in open water than under ice, though in both of these cases gross productivity is low (Table 43).

Local demands for nutrients and oxygen may be high in some habitats or pool communities. Nutrient availability may be limited in macrophyte beds during peak growth periods. Oxygen demand from heterotrophic communities in the substrate, particularly dense communities, may be high and result in some oxygen stratification in the water column. Butts and Sparks (1982) examined sediment oxygen

demand (SOD) in channel habitats of Pool 19. In areas of high fingernail clam density (greater than 5000/m²), mean SOD was 7.07 g/m²/day compared to 5.52 g/m²/day in areas of lower clam density. In fact it was found the fingernail clams could account for as much as 45% of the SOD, though the primary cause of most of the SOD was microbial. SOD rates have been found to be significantly lower in the winter and higher in the summer. Additionally, the rates are higher in macrophyte beds where decomposition of organic matter is high (Anderson et al., in prep).

Table 43. Seasonal gross productivity (mg O₂/l/hr) for channel border areas of Pool 19, Mississippi River.

Season and area	Minimum	Maximum
Summer		
Nonvegetated	-0.005	0.025
Vegetated	0.050	0.065
Autumn		
Nonvegetated	-0.010	0.075
Winter		
Open	-0.005	0.020
Ice covered	-0.010	0.010
Spring		
Nonvegetated	-0.020	0.295

CHAPTER 4

HUMAN IMPACTS AND APPLIED ECOLOGY

4.1 THE COMMUNITY AS A RESOURCE

4.1.1 Commercial Fisheries

Fishing the Mississippi for food has long been important. From 1895 to 1899 commercial fishing prospered. Carp made up a sizable portion of the catch (Carlander 1954) and even today is sold in large metropolitan markets in Chicago and eastern cities. In 1942, inmates of the Fort Madison prison began commercially fishing Pool 19, which yielded catches of 18 to 22 tons of dressed fish per year. With carp introduction, a species shift occurred away from buffalo fish, "probably as a result of competition from the carp and changes in the environment" (Carlander 1954). Fluctuations in catches helped give impetus to the formation of the Upper Mississippi River Conservation Committee (UMRCC) in 1943. It provided for "uniform regulation of the fisheries" by various bordering States because of "the need for cooperative action on many problems affecting the fish and wildlife of the river . . ." (Carlander 1954).

Pool 19 ranks among those pools with the largest reported annual catches. Annual harvests ranging from 483,873 lb to 1,931,589 lb from 1953 to 1977 were reported. Pool 20 harvests were among the lowest reported, ranging from 69,569 lb to 329,517 lb for the same period (Rasmussen 1979). Various gear used included seines, trammel nets, basket traps, wing nets, hoop nets (either baited or unbaited), trap nets, and trot lines (Starret and Barnickol 1955). A summary of this 25-year period (Table 44) shows that traps were the major all-around gear and gill nets the least important. Traps were most effective for catfishes, carpsuckers,

buffalo, suckers, and Northern pike, and second most important for sturgeon and eel. Trammel nets were most effective for sturgeon, paddlefish, and gar and were the second most important for carp, freshwater drum, and mooneye. Trot lines were the second most important gear for harvest of bullhead and catfishes (Rasmussen 1979).

In comparing harvest sections, Rasmussen (1979) stated that Pools 16 to 20 made up one of four major fishing grounds in the Upper Mississippi River. Four major species in the catches are catfish, buffalo, carp, and freshwater drum. Catfish and buffalo lead in poundage dollar value (Tables 45, 46, 47, and 48). Unfortunately, prices paid to commercial fishermen remain low. Each year it is more difficult to show profits because costs of gear and fuel keep rising. Comparisons of 5-year catch averages from 1953 to 1977 (Figure 31) show a general decline for Pool 19 and a peak in 1963 for Pool 20 followed by a decline in harvest. Five-year averages for the four major species show a general downward trend in reported catches (Figure 32) of all species in recent years in Pool 19; the same is true for Pool 20 except for carp. This decline is partly due to a dwindling number of licensed commercial fishermen from Illinois and Missouri. Their decline is partially offset by an increase from Iowa, according to recent data (1973-77) (S. Waters, Iowa Conservation Commission; pers. comm.). Because all fishermen do not necessarily report all catches, data concerning harvests must be viewed as minimum.

Common names of fishes appear to be less standardized than those of other

Table 44. Percent reported harvest of fishes by type of gear from the Upper Mississippi River from 1953 through 1977 (Rasmussen 1979).

Species	Commercial gear					
	Setlines	Gill nets	Trammel nets	Seine	Trap	Unclassified
Carp	1.2	21.0	14.7	42.9	19.4	0.8
Buffalo	0.3	16.1	24.1	18.3	39.7	1.5
Drum	4.2	4.2	7.7	42.5	40.2	1.2
Catfish	27.4	1.7	3.0	3.3	62.6	2.0
Bullhead	36.0	0.8	1.1	3.4	55.1	2.6
Carp sucker	0.4	9.0	21.0	17.1	51.0	1.4
Sucker	2.1	5.4	5.2	32.0	51.7	3.6
Mooneye	0.9	3.2	5.5	76.6	13.3	0.5
Sturgeon	6.1	2.6	54.0	8.9	27.3	1.1
Paddlefish	0.6	10.9	40.2	35.6	11.9	0.8
Gar	6.4	12.8	31.7	29.1	19.0	1.0
Bowfin	35.6	5.5	6.6	29.7	20.5	2.1
Eel	48.0	2.4	3.3	0.7	43.6	2.0
Crappie ^a	0.0	0.0	3.2	1.7	95.1	0.0
Northern Pike ^b	0.2	0.0	1.0	7.7	90.1	1.0
Grass carp	0.0	1.9	72.6	0.0	19.8	5.7
Other	5.6	3.3	5.6	30.6	52.7	2.1

^a Not a commercial species since 1963.

^b Not a commercial species since 1959.

vertebrates, especially birds. The American Fisheries Society (1980) has standardized both common and scientific names for the scientific community. These common names have not been unanimously accepted by commercial fishermen, many of whom have learned fishes' names from their families or co-workers, and such traditions die hard. Therefore, locally used names of species caught are listed in Table 49.

Some commercial fishing takes place throughout the year. Interviewed fishermen who fished in winter indicated that they caught mostly carp and buffalo and fewer freshwater drum and catfish (ERT/Ecology Consultants, Inc. 1979a). In Pool 19, the total catch was 14% of the annual harvest and 17% of the annual value. No fishermen interviewed had fished Pool 20 in winter, and little, if any, fishing is done there.

4.1.2 Sport Fisheries

An underutilized resource of the Mississippi River is the sport fish (Bertrand 1983). For Pool 19, sportfishing provided 673,000 activity days, or 35% of the total recreational activity (GREAT II 1980). Fishermen generated about \$6 million (1975 dollars) to the economy. Most sought-after species were crappies, bluegill, channel catfish, and largemouth bass. For Pool 20, sportfishing provided 93,000 activity days, or 40% of the total recreational activity, and generated about \$840,000 (1975 dollars) for the economy. Species most actively sought were channel catfish, sauger, white bass, and walleye.

Bertrand (1983) wrote a fishing guide based on fishery biologists' data from 1980 to 1982 "to bring fish and fishermen together in the Upper Mississippi River." Best fishing areas and access areas were

Table 45. Total catch for Pools 19 and 20, 1980 and 1981, all gear combined (J. Rasmussen, Upper Mississippi River Conservation Committee; pers. comm.).

Species	1980			1981		
	Pool		Total of all pools	Pool		Total of all Pools
	19	20		19	20	
Carp	256,999	35,254	3,614,107	134,899	67,554	3,377,148
Buffalo	195,822	14,303	2,309,685	148,996	25,001	2,604,875
Drum	80,372	6,999	1,332,182	90,781	7,257	1,419,418
Catfish	367,595	8,644	1,619,634	257,636	13,421	1,458,391
Bullhead	441	5	88,959	6,185	45	91,645
Carp sucker	1,953	15,423	101,668	3,026	18,408	126,470
Redhorse/ sucker	4,844	900	116,917	2,937	2,350	124,544
Sturgeon	6,091	2,710	47,511	3,110	1,540	29,065
Paddlefish	22,510	2,119	106,588	1,402	2,550	33,895
Gar	106	92	30,617	150	295	45,302
Bowfin	184		12,418	267	50	13,331
American eel	34	28	1,731	26	112	2,552
Turtle			4,119			
Mooneye/goldeye	540		7,947	280	70	9,830
Grass carp		14	9,324	540	66	11,936
Other	570		20,183	10,565	7	65,724
Total	938,061	86,491	9,423,590	660,800	138,726	9,414,126

identified to help obtain this objective. Pools 19 and 20 (Figures 33 and 34) were identified, and hints on lures or baits, time of year, and specifics on habitats to try were included. On Pool 19, best areas included mouths of creeks on the Illinois side in the lower portion of the pool; sloughs and tailwaters of Dam 18 were considered best in the upper end of the pool. The tailwaters and side channel near Fox Island were considered best in Pool 20. Waters (1978) described fishing

in Iowa's waters of Pool 19 and, as did Bertrand, found tailwaters to be productive for walleye and sauger in early spring or fall. Wing dams, cut banks, stump fields, and other structures were good for catfish during the summer. The islands near Burlington in Pool 19 were listed as popular areas. Some of the best catches of panfish (i.e., sunfish) occur during the winter in the backwaters. Reciprocal agreements on licensing among Iowa, Illinois, and

Table 46. Reported catches in pounds of commercial fish caught in 1982 for Pools 19 and 20.

Species	Illinois		Iowa	Missouri
	Pool 19	Pool 20	Pool 19	Pool 20
Carp	50,438	946	57,538	20,060
Buffalo	55,485	561	60,132	8,284
Freshwater drum	42,457	220	34,854	6,732
Catfish	39,402	1,235	85,953	6,880
Bullhead	2,570	20	699	25
Sturgeon	154	12	374	1,205
Paddlefish	20,411	--	--	1,960
Carpsuckers	4,270	300	--	25,435
Suckers	615	6	6,120	935
Gar	3,235	34	--	2,650
Bowfin	1,480	12	--	--
Mooneye	520	12	--	--
Eel	71	62	--	20
Grass carp	90	--	--	125
Other			7,144 ^a	

^a Includes carpsuckers, mooneye, and eel.

Table 47. Reported catches in pounds of commercial fish caught in 1983 for Pools 19 and 20.

Species	Illinois		Iowa	Missouri
	Pool 19	Pool 20	Pool 19	Pool 20
Carp	64,762	31,665	41,492	49,888
Buffalo	106,756	15,925	42,451	22,546
Freshwater drum	24,804	6,510	21,988	12,209
Catfish	95,428	9,726	129,505	27,491
Bullhead	2,414	40	1,180	19
Sturgeon	1,750	730	5,436	1,820
Paddlefish	5,822	1,095	--	4,715
Carpsuckers	2,854	400	--	60,483
Suckers	1,156	35	3,528	4,910
Gar	1,726	40	--	6,485
Bowfin	575	--	--	--
Mooneye	1,079	2	--	--
Eel	60	--	--	4
Grass carp	196	--	--	130
Other			8,971 ^a	

^a Includes carpsuckers, mooneye, and eel.

Table 48. Dollar value of various commercial rough fishes, live condition, for 1980-81 (J. Rasmussen, Upper Mississippi River Conversation Committee; pers. comm.).

Kinds of fish	1980			1981		
	IL	MO	IA	IL	MO	IA
Carp	0.09	0.10	0.09	0.11	0.11	0.07
Buffalo	0.21	0.21	0.21	0.23	0.26	0.20
Drum	0.15	0.14	0.12	0.14	0.14	0.13
Catfish	0.64	0.62	0.61	0.58	0.61	0.60
Bullhead	0.30	0.30	0.35	0.27	0.27	0.23
Carp sucker	0.09	0.09		0.10	0.10	
Redhorse & sucker	0.09	0.09	0.09	0.07	0.05	0.05
Sturgeon	0.40	0.40	0.45	0.35	0.38	0.45
Paddlefish	0.24	0.20	0.19	0.20	0.20	
Gar	0.09	0.08		0.09	0.09	
Bowfin	0.09	0.08		0.08	0.08	
American eel	0.23	0.21		0.41	0.15	
Mooneye & goldeye	0.09			0.06		
Grass carp		0.30			0.25	

Missouri allow fishermen to use the entire channel between States without having to purchase a license from each State.

4.1.3 Commercial Harvesting of Mussels

Mussel fishing began on the river about 1889 (Carlander 1954). At that time mussels were important for making buttons. As beds were rapidly depleted near the first button factory at Muscatine, Iowa, musselmen moved to new beds, and in 1897, over 300 persons were engaged in mussel fishing between Burlington and Clinton, Iowa. In 1898 there were 1,000 musselmen between Fort Madison and Sabula, Iowa. Farmers found it difficult to keep hired hands because clamming was

more interesting and profitable. Not much equipment, capital, or experience was necessary, so many people began mussel fishing. Many thousands of pounds were harvested in a relatively short time. With such pressure, beds were depleted. In fact, Smith (1899) indicated that "the history of the fishery up to this time shows the disregard for the future which has come to be regarded as characteristic of fishermen." Fishing was done during the spawning season and winter. Small mussels were also kept. Because mussels grow slowly (a 2.5-inch long mussel may range from 5 to 16 years old), harvesting all sizes was disastrous and resources were rapidly depleted.

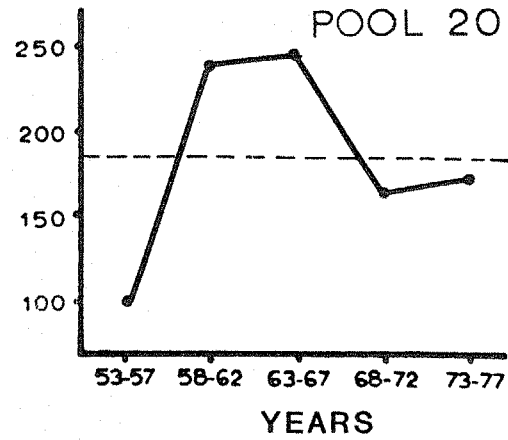
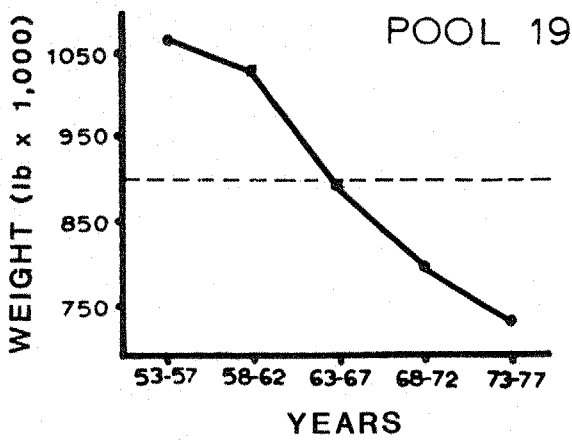

Figure 31. Average pounds of all fish reported by commercial fishermen from Pools 19 and 20 of the Upper Mississippi River by 5-year increments (Rasmussen 1979).

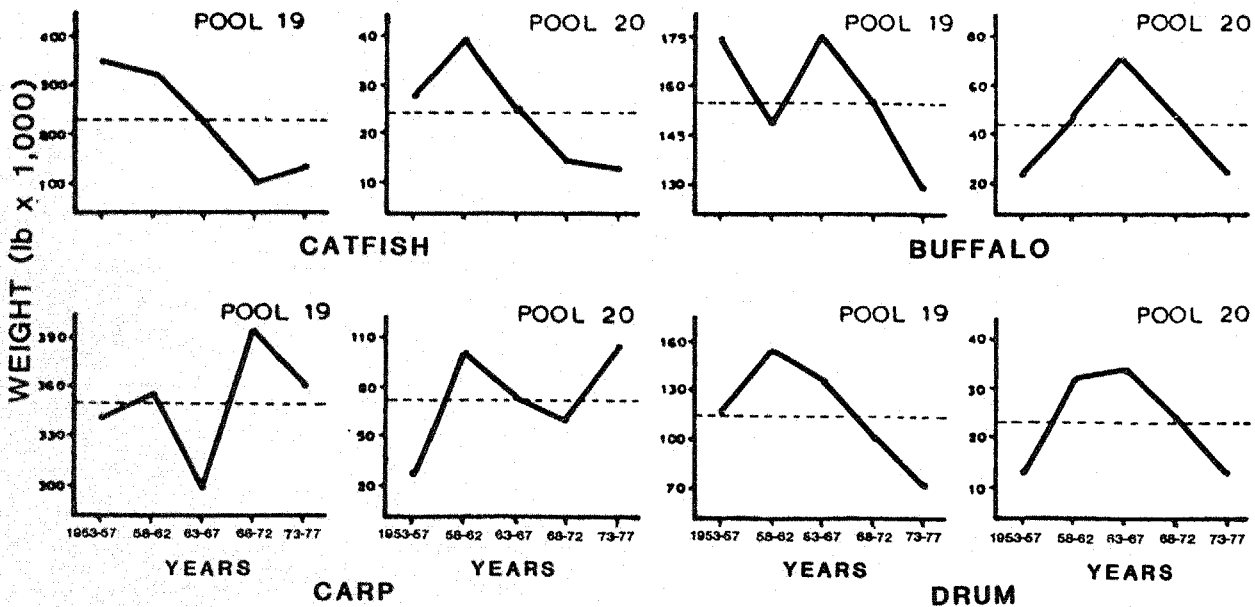

Figure 32. Average pounds of the four major fish species reported by commercial fishermen from Pools 19 and 20 of the Upper Mississippi River by 5-year increments.

Table 49. Accepted common, scientific, and local names of fishes occurring in the Mississippi River (modified from Barnickol and Starrett 1951).

Accepted common name	Scientific name	Local names
Shovelnose sturgeon	<i>Saphirhynchus platyrhynchus</i>	Hackleback, switchtail, sand sturgeon
Paddlefish	<i>Polyodon spathula</i>	Spoonbill cat, spoony
Longnose gar	<i>Lepisosteus osseus</i>	Garpike, billfish, billy gar
Shortnose gar	<i>Lepisosteus platostomus</i>	Duckbill gar
Bowfin	<i>Amia calva</i>	Dogfish, grindle, cypress trout, mudfish
Mooneye	<i>Hiodon tergisus</i>	Toothed herring, white shad
Goldeye	<i>Hiodon alosoides</i>	Mooneye
Skipjack	<i>Alosa chrysochloris</i>	Golden shad, river herring, blue herring
Gizzard shad	<i>Dorosoma cepedianum</i>	Hickory shad
American eel	<i>Anguilla rostrata</i>	Freshwater eel
Blue sucker	<i>Cycleptus elongatus</i>	Missouri sucker, blue fish, blackhorse, gourdseed sucker
Bigmouth buffalo	<i>Ictiobus cyprinellus</i>	Redmouth buffalo, stub-nose buffalo, roundhead buffalo, brown buffalo, goarhead, bullhead buffalo, bullmouth buffalo, bullnose buffalo, slough buffalo, trumpet buffalo
Black buffalo	<i>Ictiobus niger</i>	Mongrel buffalo, bugler, rooter, reefer, round buffalo, sheepshead buffalo, blue buffalo

(continued)

Table 49. (Continued).

Accepted common name	Scientific name	Local names
Smallmouth buffalo	<i>Ictiobus bubalus</i>	Razorback buffalo, roach-back buffalo, humpback buffalo, channel buffalo, liner buffalo, quillback buffalo
Quillback	<i>Carpiodes cyprinus</i>	Silver carp, carpsucker, coldwater carp
River carpsucker	<i>Carpiodes carpio</i>	Silver carp, carpsucker
Highfin sucker	<i>Carpiodes velifer</i>	Silver carp, river carp, carpsucker
White sucker	<i>Catostomus commersoni</i>	Common sucker, fine-scaled sucker
Spotted sucker	<i>Minytrema melanops</i>	Striped sucker
Silver redhorse	<i>Moxostoma anisurum</i>	Silver mullet
Northern redhorse	<i>Moxostoma macrolepidotum</i>	Des Moines plunger, mullet, common redhorse
Carp	<i>Cyprinus carpio</i>	German carp, European carp
Golden shiner	<i>Notemigonus crysoleucas</i>	American bream, roach
Channel catfish	<i>Ictalurus punctatus</i>	Fiddler, catfish, channel cat, spotted cat
Blue catfish	<i>Ictalurus furcatus</i>	Fulton cat, Mississippi cat, chucklehead cat, coal boater
Yellow bullhead	<i>Ictalurus natalis</i>	Yellow-bellied cat, greaser
Brown bullhead	<i>Ictalurus nebulosus</i>	Speckled bullhead
Black bullhead	<i>Ictalurus melas</i>	Bullhead

(continued)

Table 49. (Concluded).

Accepted common name	Scientific name	Local names
Flathead catfish	<i>Pylodictis olivaris</i>	Hoosier, goujon, shovel-nose cat, mudcat, yellow cat, Johnny cat, Morgan cat, flat belly
Pike	<i>Esox lucius</i>	Pickerel, great northern pike, northern pike, northern
Walleye	<i>Stizostedion vitreum</i>	Walleye, jack, jack salmon
Sauger	<i>Stizostedion canadense</i>	Sandpike, jack salmon
Smallmouth bass	<i>Micropterus dolomieu</i>	Smallmouth
Largemouth bass	<i>Micropterus salmoides</i>	Black bass, bigmouth bass, line side, green bass, green trout
Green sunfish	<i>Lepomis cyanellus</i>	Black perch
Organgespotted sunfish	<i>Lepomis humilis</i>	-----
Bluegill	<i>Lepomis macrochirus</i>	Bream, sunfish
Warmouth	<i>Lepomis gulosus</i>	Goggle-eye, warmouth bass
White crappie	<i>Pomoxis annularis</i>	Crappie, newlight
Black crappie bass	<i>Pomoxis nigromaculatus</i>	Calico bass, strawberry
White bass	<i>Morone chrysops</i>	Silver bass, striped bass, streaker
Yellow bass	<i>Morone mississippiensis</i>	Streaker, barfish
Freshwater drum	<i>Aplodinotus grunniens</i>	White perch, perch, sheephead, gaspergou, grunting perch, croaker

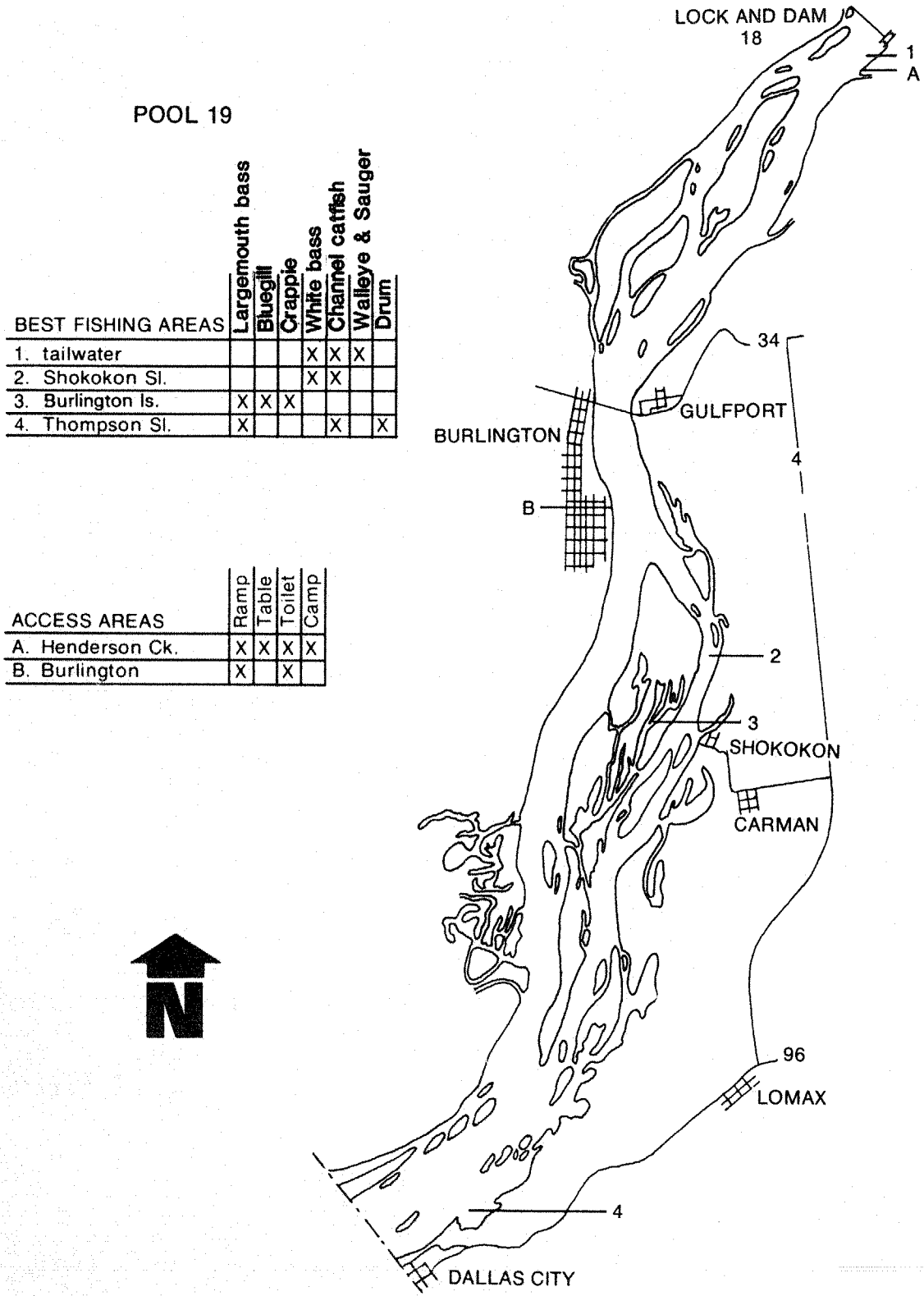

Figure 33. Best fishing areas and access sites on Pool 19 (Bertrand 1983).

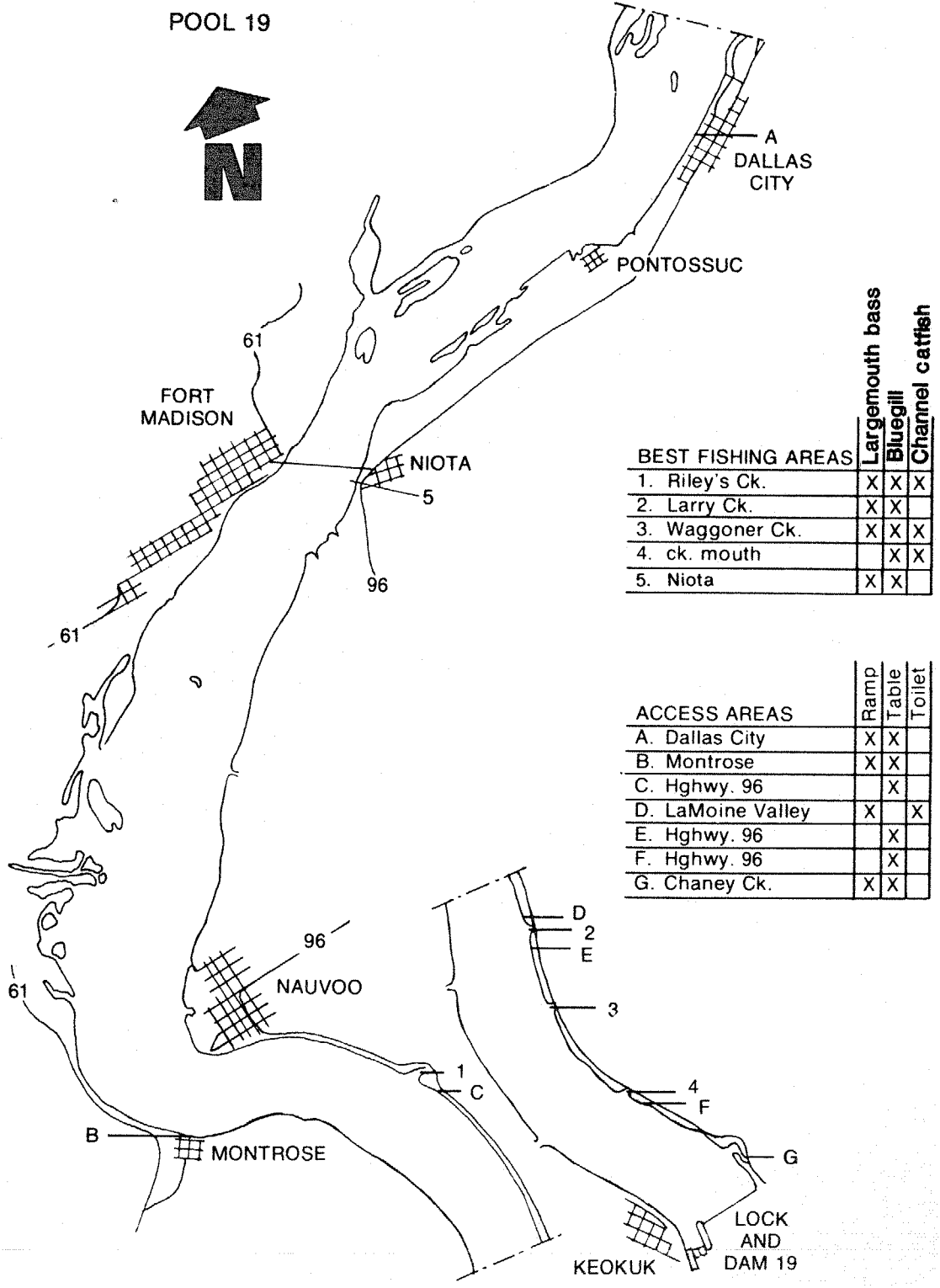

Figure 33. (Concluded).

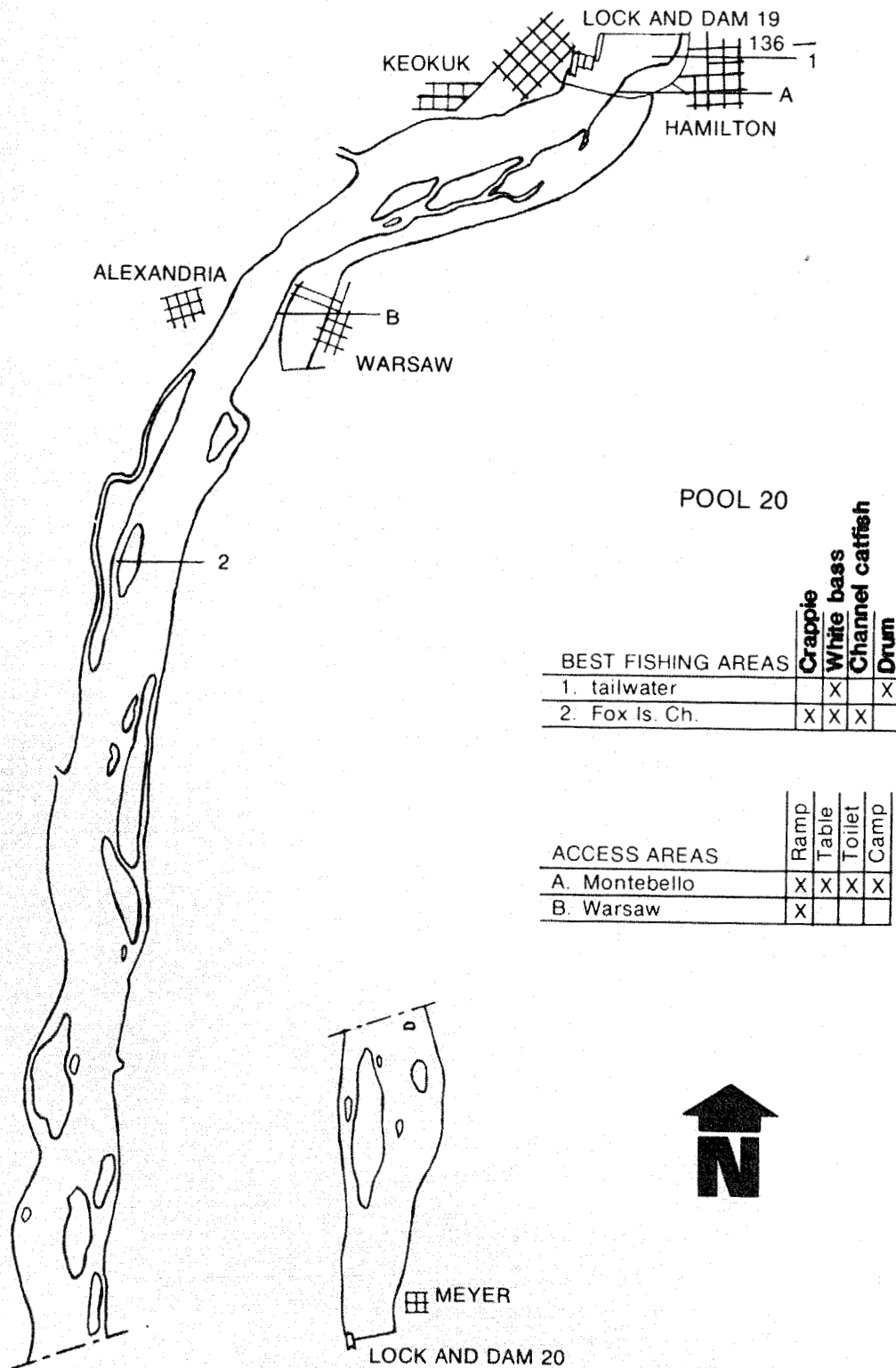

Figure 34. Best fishing areas and access sites on Pool 20 (Bertrand 1983).

Because of this concern, propagation attempts were made in the early 1900's and certain sections of the river were closed for 5-year intervals. Both actions had some success. However, one important factor working against replenishing the most important commercial species at that time (ebony shell) was construction of the Keokuk Dam. This prevented the skipjack herring, the host for the glochidia, from migrating above Pool 20; the herring was no longer present in any great number in Pool 19 by 1926. In addition, mussel spawn being produced were sensitive to the growing pollution levels, and young mussels were prevented from developing. The proposed 9-ft channel was also expected to make conditions worse for mussels (Carlander 1954). By 1946, there was no significant mussel fishing below Muscatine, Iowa (Pool 16).

A variety of gear, including basket dredges and hand rakes, has been used for harvesting mussel. Wading or "polliwogging" (grabbing mussels by hand) has also been done. The crowfoot bar (Figure 35), however, was the main device used because it was effective and simple to operate. It consisted of a wood or pine rod to which four-pronged hooks were attached at 6-inch intervals. As the hooks passed through a clam bed, the mussels would close their shells, pressing the hooks between their valves. Two crowfoot bars were usually used--one to fish with while the other was being picked. More recently, hand picking while wearing underwater diving gear has been successful.

Rather than being used for buttons, today's mussels are sold for the pearl culture industry in Japan. Shells are cut up and cubed before being polished and inserted into oysters. Harvest reports are made for the river as a whole and are not specifically recorded by pool. However, Robinson (Missouri Department of Conservation; pers. comm.) indicated there are no commercial clambers currently fishing in Pool 20 nor have there been any for a number of years. G. Ackerman (Iowa Conservation Commission; pers. comm.) indicated that only 2.15 tons were taken in Pool 19 in 1982 by Iowa musselmen, though more were taken in 1983. W. Fritz (Illinois Department of Conservation;

pers. comm.) doubted that a harvest of over 1,000 tons annually from the Mississippi River bordering Illinois can be maintained. He further stated that so little is known about the mussel populations, it may be impossible to manage them wisely to prevent a potential collapse due to overharvest. He stressed the need for additional study of mussel life history and ecology as they relate to harvest pressures and environmental changes.

Of the mussels captured, the most important species are the washboard and the three-ridge; maple leaf mixed with pigtoe, however, are of secondary importance. Prices paid per ton for green shells (meat not cooked out) ranged from \$175 to \$185 in 1981 (Fritz, unpubl. report), depending on the species and quality of the shells (size, thickness, clearness of nacre, and hardness). Cooked-out mussels can range from \$250 to \$750 per ton, depending on shell species and quality.

Of several methods currently used to harvest mussels, basket dredges (Figure 36) are destructive to mussels, damaging an average of 13.8 mussels and dislodging 35.3 for every harvestable mussel. Hand dredges may also damage mussels. Crowfoot bars are inefficient in capturing mussels; the capture rate is 0.6% to 2.5%, depending on mussel size (Sparks and Blodgett 1983). Divers can harvest up to 61.2% of mussels considered large enough by shell buyers' criteria; though harvesting this size is least harmful to the mussel population, it is probable that divers cannot remove all legal size mussels in deep rivers with zero visibilities. Because divers can, however, harvest more efficiently than those using standard gear, there is clearly a need for some regulation to prevent overharvest by divers.

Despite the low efficiency of the crowfoot bar techniques, catches reported by commercial musselmen in the late 1800's and early 1900's were large. Population densities then must have been phenomenally greater than today. Certainly the initial overharvest played an important role in the decline of mussels in the river. Also contributing to the reduction of mussel population, however, have been a decline in water quality, increases in sediment

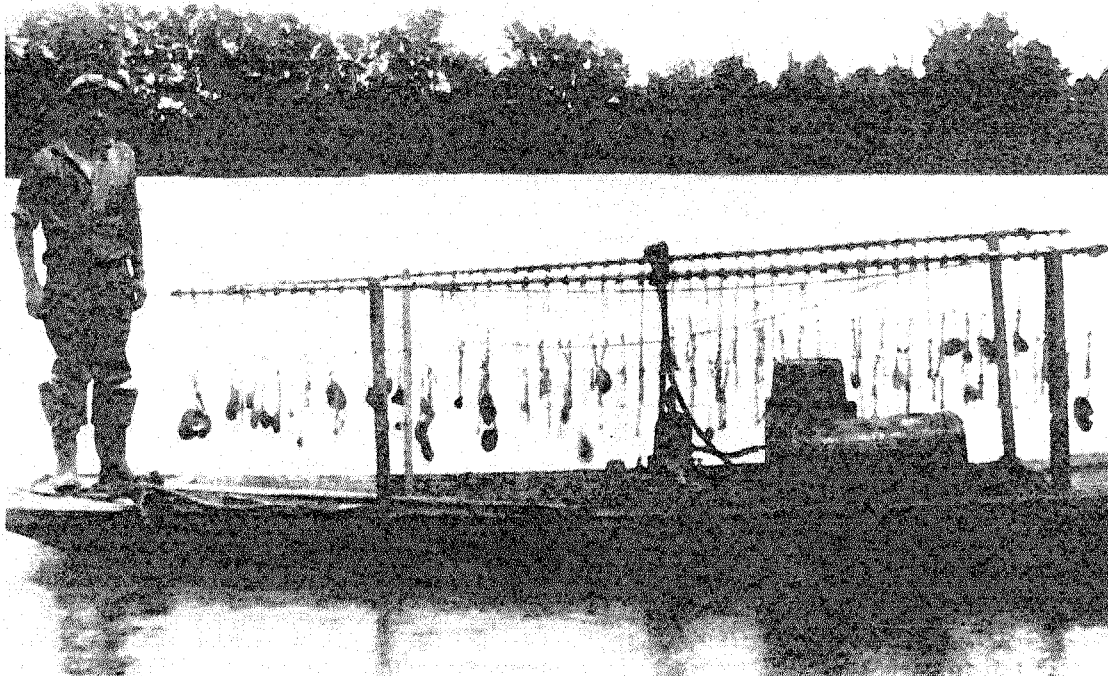

Figure 35. Bar and crowfoot dredge on boat for taking mussels (U.S. Fish and Wildlife photograph in Carlander 1954).

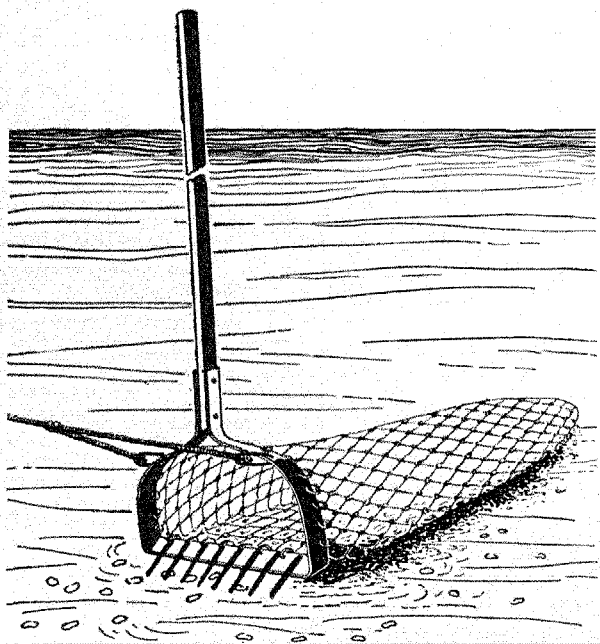

Figure 36. Sketch of a dredge fishing for mussels on the bottom of a river (from Danglade 1914, in Starrett 1971).

and chemical runoff, loss of fish glochidal hosts, and development of the sand and gravel industry (Ecological Analysts 1981). Dredging and channel maintenance, plus the 9-ft channel, may have caused species shifts, enhancing those more tolerant of silt and mud conditions while reducing those less tolerant. Coker et al. (1921) and Fuller (1974) stated that wing dams had destroyed mussels in areas where they had formerly thrived.

4.1.4 Recreation

Major recreational opportunities are provided in and along the Upper Mississippi River basin. Numerous aquatic and terrestrial activities are possible because of the proximity to water of variable topography and natural vegetation. The most popular recreational activities (Table 50) were listed by Jackson et al. (1981a). Specific recreational sites were delineated by Peterson (1984) on a series of maps for each of the pools for the Upper Mississippi River; types of recreation possible in each area also were given.

Table 50. Recreational activities in Pools 19 and 20 (Jackson et al. 1981)

Activity on the water	Shoreline activity
Sport fishing	Cottage use
Bank	Picnicking
Barge	Sightseeing
Boat	Cross country skiing
Set line	Snow shoeing
Ice fishing	Clamming
Commercial fishing	Snowmobiling
Hunting	Off road vehicles
Small game	Camping
Big game	On boat
Waterfowl	Off boat
Trapping	Photography
Passive leisure (loafing)	Dog training
Pleasure boating	Target shooting
Sail	Nature study
Houseboat	Gathering products
Cruiser	Hiking
Tubing	
Runabout	
Canoe	
Airboat	
Swimming	
Water-skiing	

Recreational use of an area can be measured in activity days, defined as the attendance of one person at the area for 1 day or fraction thereof, without regard to a specific number of hours (GREAT 1980f). Among Pools 11 through 22, Pool 19 had the highest use during 1978 while Pool 20 had the lowest (GREAT 1980f). Projections for the years 2000 and 2025 indicate nearly the same pattern of heavy use for Pool 19 and low use for Pool 20.

Activities most frequently engaged in for both pools were boating and fishing. Hunting, water-skiing, picnicking, swimming, and camping followed in decreasing order of use. Recreation in the GREAT II area is projected to increase 16% from the base (1977-78) to year 2000 and 21% to year 2025. Such increases could affect the quality of recreational experiences and also lead to overuse and safety problems. Increases could also lead to

disagreements between groups interested in river resources; without careful planning and interchange of ideas between various interest groups, there could be further negative impacts on the ecosystem.

Abuse through overuse could adversely affect certain biota. For example, human disturbance near colonial nesting birds may cause their reduction or elimination. Wildlife resources may be similarly affected. While use by large numbers of people at a given time is less along Pools 19 and 20 than near metropolitan areas such as St. Louis, there is no doubt that recreational uses will intensify, thus exerting additional pressures on the various resources through disturbance or reduction of usable habitat.

4.2 THE COMMUNITY AS A REPOSITORY

4.2.1 Sediment

Sediment has been classified as a pollutant (Stall 1972) because it interferes with many uses of water. The Side Channel Work Group (GREAT 1980e) called sedimentation "the number one problem facing the productive life of the backwaters of the river." They examined changes in open water surfaces of Pools 19 and 20 and found from 1956 to 1979 that 681 and 40 acres for Pools 19 and 20, respectively, had been lost to sediment deposition. Among the effects of sediment in aquatic systems are the reduction of photosynthesis, the filling of crevices and thereby the reduction of habitat for small organisms, the smothering of various bottom-dwelling organisms, the affecting of heat transfer, the lowering of the oxygen saturation point, and the filling in of channels.

Sediment sources include erosion from bare ground exposed by numerous activities such as farming, construction, logging, or dredging that prevent a ground cover of plants from holding soil in place.

In the areas of Pools 19 and 20, agriculture is of high priority. A cartoonist (J.N. Darling, Des Moines Register) referred to erosion from agricultural practices in this way: "beef steak and potatoes, roast duck, ham and eggs, and bread and butter with jam on it, are being

Table 51. Values regarding sediment loads and discharges, Pool 19 and 20 (Keown et al. 1977). RM=River mile.

Location	Estimated sediment loads, mean	Discharge (ft ³ /s)	
		Maximum	Minimum
Keokuk, Pool 20, RM 363.3	7,093 tons/day	34,400	5,000
Burlington, Pool 19, RM 403.1	30,000 tons/day	312,600	5,000

washed down our rivers each year in the form of good, rich farm topsoil" (Stall 1972). Within the Pool 19-20 region, soil loss from farming is classified as tolerable (loss not presently reducible) with 5-10 tons/acre/year being lost from farmlands (Stall 1972). In contrast, 100 tons/acre/year were lost from highway and subdivision construction.

Ellis (1936), using data from more than 700 stations along several large rivers, described erosion silt as a factor of concern in aquatic environments. He estimated that 429 million tons of silt were carried by the Mississippi in 1928. To help understand the effects of sediment, he used a variable termed the "millionth intensity depth" (m.i.d.), which was equal to that depth in which 99.9999% of the entering light was gone. From 392 samples taken between Davenport, Iowa, and Grafton, Illinois, from May to September 1932, an overall m.i.d. was less than 12 inches, but a maximum of 79 inches. At Keokuk, unfiltered samples had an average of 9 inches but filtering with a No. 40 Whatman filter paper changed the reading to 1.338 inches (111.5 ft). In addition, readings at Keokuk taken every 12 h from water surface to bottom showed that during July and August 1932 suspended silt was uniformly distributed from top to bottom in the non-thermally stratified water column. The m.i.d.'s were 3.4 to 61.0 inches; 47% of the surface and 54% of the near-bottom readings were less than 15.0 inches. Waters carrying larger silt loads transmitted more red light than shorter wave lengths, and maximum transmission was in the scarlet-orange range. Silt particles screened out non-selectively

regardless of their own color.

Keown et al. (1977) listed several important values regarding sediment for Pools 19 and 20 (Table 51). Both pools have 0.5 ft/mi channel gradients. As indicated, sediment loads at Burlington were not reaching Keokuk, mainly because of the dam just upstream from the observation point. Much sediment has indeed been deposited behind Dam 19. This is dramatically illustrated in Figure 9, which shows bottom profiles above Dam 19 for 1913, 1946, and 1983.

Major tributaries carry their silt loads into the main Mississippi channel, depositing considerable amounts as the gradient changes. Both the Skunk (Pool 19) and Des Moines (Pool 20) have steep gradients of 1.9 ft/mi and 1.1 ft/mi, respectively (Keown et al. 1977; Figure 8). Thus sediment buildup near their points of entry has caused physical changes, especially shoaling, in the river channel (Nakato and Kennedy 1977). Sediment data from the Des Moines River illustrate this effect. From 1974 to 1976, 141 to 99,200 tons/day of sediment were added to Pool 20 (Keown et al. 1977). Mean suspended sediment concentrations were generally higher near the right (west) bank during high river stages because of the abrupt deflection of the Des Moines and the slow rate of lateral mixing (Nakato and Kennedy 1977). During low stages, the Des Moines River penetrates farther across the Mississippi channel and becomes mixed with the flow more rapidly. While a recommendation to close off side channels in order to concentrate the flow of the Mississippi would reduce the sedimentation and shoaling at that location, such closure

would also reduce habitat variability so critical to maintaining a variety of habitats and thus riverine species (see Ellis et al. 1979).

Continuous turbidity from ambient sediment loads has been examined relative to barge traffic and subsequent potential resuspension or continued suspension. Johnson (1976a) stated that during normal pool conditions tow traffic does contribute to existing levels of suspended sediment measured as both suspended solids and turbidity. Those sediments resuspended from the main channel move laterally to shoreward areas, including potentially productive side channel areas. In the Mississippi River, however, tow-generated turbidity was extremely small compared to natural levels during flood stage. Multiple tows in succession did not add concentrations from previous tows. Oxygen was not reduced significantly in the main channel (less than 0.5 mg/l of surface concentration) and returned to ambient conditions 15 to 20 min following tow passage. Examination of recovery time for suspended solids showed that main channel levels recovered in 15-155 min after tow passage. As a result of wave action, however, values of suspended solids were higher than those of main channels or side channels.

Suspended solids may alter certain chemical variables. Delfino (1977) examined this relationship in an area of the Mississippi where land use was primarily agriculturally oriented with some food and chemical processing as well as wastewater treatment (an area similar to Pool 20 below Keokuk). An increase in suspended solids was responsible for higher levels of total phosphorus, chemical oxygen demand, iron, manganese, and copper. Variations in iron and manganese concentrations were strongly correlated with copper, lead, and zinc. About 90% of the total iron and manganese occurred in the suspended solid fraction. A low value of 5.1 ppm dissolved oxygen was encountered. Effects of such changes were not listed, but it could be surmised that because the phosphorus, iron, and manganese are all essential as nutrients for phytoplankton (Cole 1983), these may contribute to overall primary production, if light intensity levels are adequate. An excess

of turbidity, however, would lessen the benefit from the nutrients.

Stall (1972) indicated that certain levels of turbidity were tolerable for various uses (Table 52). Values for irrigation, livestock, aquatic life, navigation, hydropower, and waste assimilation were undetermined by Stall (1972), but lower values would probably be most beneficial.

Table 52. Tolerable levels of turbidity for certain uses (Stall 1972).

Use	Tolerable (mg/l)
Drinking	5
Industry	
Canning	10
Cooling	50
Dark paper	25
Light paper	5
Textiles	5
Swimming	10
Boating	20

The effects of sediment on river biota are several. One effect relates to heat transmission. Ellis (1936) showed in lab tests that, in comparing nonagitated to silt-laden river water, there was a skew lag in both warming and cooling but there was none with distilled water. Another effect concerns clam survival. Mussels (18 species) were unable to maintain themselves physiologically when subjected to between 0.25 and 1 inch of silt accumulation on either sand or gravel bottoms, while mussels suspended in lattice crates above the bottom were unharmed. Ellis also noted that organic matter in muds of Lake Keokuk (Pool 19) had 9.25% to 12.66% organic matter and 0.286% to 0.457% nitrogen (Kjeldahl dry weight), while erosion mud from surface runoff via streams usually carried less than 1% organic matter. There was low oxygen, high carbon dioxide, and often relatively high sulfur (as H₂S)

in water samples near the bottom, indicating a highly productive system. Though the silt did not materially alter the salt complex or amount of electrolytes in the water, there were high bacterial counts in erosion silts. These counts were much higher than in either the water above or the adjacent bottom areas of sand and gravel. Sediment also affects photosynthetic rates, fills in bottom areas to reduce habitat variability (and thus biotic variability), and favors certain silt tolerant species while reducing those not tolerant.

4.2.2 Point and Nonpoint Pollution

Although underlying rock formations and soil types initially determine water quality, pollution sources may dramatically modify that quality, either locally or for extensive areas downstream from the pollution source. Novotny (1981) stated that both sediment and pollution from nonpoint sources are the primary determinants of water quality in the Upper Mississippi River system. Point source effects are mainly localized to the mainstem reaches from metropolitan areas (e.g., Minneapolis-St. Paul and St. Louis) and below the confluence of the Illinois River. Major problems related to nonpoint pollution include turbidity, nutrient inputs, and PCB's from urban areas.

Jackson et al. (1981a, 1981b) listed 46 and 10 exact locations of point-source dischargers for Pools 19 and 20, respectively. Types of discharges include stormwater runoffs, sanitary wastes, thermal effluents, mobile home park effluents and a number of unspecified types. Jackson et al. (1981b) included river maps delineating discharge locations for each pool.

Contaminants in benthos, aquatic plants, and sediments were surveyed by Sparks and Smith (1979) for Pool 19. They found that metal and organic residue concentrations were relatively low. High levels of PCB's (nearly 1 ppm) were found in fingernail clams as was silver in clams and snails. These findings were thought to warrant further study. The U.S. Environmental Protection Agency's (USEPA) water quality standards for aquatic life have not been met in Pool 19 at Burlington

(RM 410.0) and Fort Madison (RM 384.0), Iowa (Simons et al. 1981a), and in Pool 20 at Keokuk, Iowa (RM 364.0) (Simons et al. 1981b). A number of point discharges are probably responsible for changing water quality in both pools. These discharges may all adversely impact the biota. Even though the reduced water quality may not directly kill larger organisms, it may have more subtle effects (such as predisposing the organism to other problems) that are reflected in the overall biotic integrity of the riverine community.

4.3 THE COMMUNITY AS A HIGHWAY

4.3.1 Navigation

Historical records show the Mississippi River has been and still is a major navigational artery. Modern barge tows comprise as many as 15 barges pushed by a towboat, the maximum number that can be locked through Lock 19 without the tow being broken apart. At Lock 20, nine barges can be locked at once. Increased tow traffic is projected, reflecting considerably higher growth in the years 1990-2010 than from 2010-2040 (UMRBC 1982). A detailed analysis for the earlier years has been done by using both constrained (no navigational improvements) and unconstrained (demand that could occur if there were no delays in the system such as lockage times) traffic projections. Projections for Pools 19 and 20 (UMRBC 1982), with 1980 as the base year, are given in Table 53.

The various modifications made over the years to enhance navigation have not been without effect. Schnick et al. (1982) discussed in detail the effects of major modifications, including clearing and snagging; channel enlargement, dredging, and disposal of dredged material; locks and dams; river training structures; bank stabilization; flood protection levees; and water level regulation.

Clearing and snagging removes vegetation, rocks, and other debris from channels and riverbanks to drain flood-plains for agriculture, to protect people from floods, or to create and maintain a navigable channel (Schnick et al. 1982). Impacts of clearing and snagging on certain physical and chemical characteristics

Table 53. Analysis for Pools 19 and 20 using both constrained (C) and unconstrained (U) traffic projections, with 1980 serving as base year (Upper Mississippi River Basin Commission 1982).

Lock	1980	Thousands of tons/year							
		1990		2000		2010		2040	
		C	U	C	U	C	U	C	U
19	29,074	41,113	42,959	40,527	58,377	40,020	68,523	39,655	78,911
20	29,698	41,507	43,353	41,015	58,925	40,554	69,181	40,245	79,673

include creating more uniform depths, increasing suspended solids due to unstable banks being eroded, increasing bed material movement if the armor layer of the bed is removed, and reducing light transmission when there is extensive removal of bank vegetation (Yorke 1978).

While data may not presently be adequate to predict quantitatively the biological effects of clearing and snagging, there are potential effects due to the reduction of physical habitat diversity and the subsequent decrease in hydraulic roughness of the channel including: (1) downstream movement of decomposing organic matter, (2) reduction of spawning and nursery habitat, (3) reduction in fish cover and shelter, (4) disruption of fish territoriality and orientation, and (5) reduction in plankton production because of the reduction of quiet water areas (Lubinski et al. 1981). Associated changes in river substrate can effect vegetation removal, causing reduced habitat for macroinvertebrates and reduced habitat for accumulation and decomposition of organic matter. The result is less food for macroinvertebrates, and reduced diversity and amount of fish food, reduced fish cover and spawning habitat, and disruption in fish territoriality and orientation (Marzolf 1978).

The impacts of locks and dams on certain physical (Table 54) and chemical characteristics include increasing and stabilizing water depths in the channel, increasing water surface area over that of the natural channel, making channel configuration more uniform, lowering water velocities except near locks and dams,

probably increasing temperature through area increases and clearing of the overstory, trapping suspended solids except silt and clay, decreasing movement of bed material by settling coarser materials at the head of each pool, leaving finer bed material (a poor substrate for aquatic organisms) elsewhere, reducing overall dissolved oxygen levels because of reduced aeration over longer stretches of river, and causing little effect on overall light transmission or flow variability (Yorke 1978). The number of islands following dam construction increased between 1929 and 1938 while the total area of these islands decreased. But between 1938 and 1973 the number of islands generally decreased while their area increased because of sedimentation and coalescence of small adjacent islands (Simons et al. 1981b) as shown by the islands between Warsaw and Keokuk in Pool 20. Because of sedimentation occurring behind dams, riverbeds have aggraded above and near primary control points. Extensive dredging has been required to maintain channel depth (Simons et al. 1981b).

Biological effects of locks and dams include selecting for certain lentic species while selecting against lotic species, changing fish migration patterns (depending on timing, magnitude, and duration of floods), changing distributions of certain mussels that have host-specific glochidia (e.g., ebony shell and skipjack herring), and changing aquatic plant communities whereby submergent plants are replaced by pondweeds after inundation. This last type of change has had effects on animals, increasing certain mammal species and

Table 54. Response of Upper Mississippi River to construction of dikes and locks and dams (Chen and Simons 1979).

Features	River response	
	Construction of dikes	Construction of locks and dams
Stage	Not significantly changed	Low stage was raised to the minimum pool level for navigation
Discharges	Not significantly changed	Not significantly changed
River position	Not appreciably changed	Not appreciably changed
River surface area	Reduced	Increased above lock and dam and decreased further upstream
Island area	Increased	Decreased above lock and dam and increased further upstream
Surface width	Reduced	Similar to river surface area change
Number of islands	Increased	Increased
Riverbed elevation	Low flow degradation	Degradation immediately below lock and dam and aggradation immediately above
Floodplain and backwater	Sediment deposition	Sediment deposition

waterfowl while reducing dry land fur-bearers and upland game birds (Lubinski et al. 1981).

River training structures of many kinds were built to increase water flow and scour the main channel to constrict the river by supplanting the natural meandering process (Schnick et al. 1982). Yorke (1978) described their effects related to certain physical and chemical characteristics. Channels are deepened and constricted while sedimentation accrues in slack water near the structures. River stages are thus lower during low flows because the center of the channel is degraded and are higher during floods because the conveyance capacity is reduced. Sediment accumulation over the years reduces the size of the channel. Suspended solids are reduced at downstream points while bed material, which is continually being scoured, is in a

constant state of change, providing poor substrate for aquatic organisms. With lower stages during low flows, increased drainage from adjacent agricultural land can occur and may increase movement of nutrients and pesticides into the waterway. Nutrients, however, during flooding may be used by floodplain vegetation as the river enters low-lying areas. Light transmission may decrease in the main channel but increase behind the structures as current and capacity to carry sediment drop. Because of a reduction in channel conveyance, overbank flooding and storage of water in the floodplain extend flood duration and reduce peak downstream discharges. The net result is lower peak flows, higher median flows, and lower low flows downstream from the controlled section of the river. Simons et al. (1981b) indicated that the average width of the river as a whole has been halved, similar to the findings given by Funk

and Robinson (1974) for the Missouri River. At Pool 19, however, a wider river was created due to the extent of the dam and subsequent rise in water from impounding.

Wing and closing dams can cause chemical changes in the river when flows are reduced in river lakes or side channels. Organic materials may collect in them with resultant high oxygen demands at night when photosynthesis of macrophytes and algae cannot offset them. Reduced oxygen at night can become critical or predispose fish to disease. Toxic materials may accumulate as well.

Other biological effects may be devastating to the river as a whole since these productive backwater areas are energy resource areas helping to drive the total biological system of the river (Lubinski et al. 1981). Some beneficial effects of wing and closing dams result from the addition of substrate and subsequent benthic diversity, at least as long as they exist. Structures not covered with sediment provide periphyton (if within the euphotic zone) and together with collected detritus attract certain fish species and may provide some with winter cover. However, other species (e.g., suckers and paddlefish) requiring main channel or main channel border habitats may be reduced or eliminated when gravel bars are eliminated for spawning.

Bank stabilization using revetments and bulkheads may affect certain physical and chemical characteristics. Yorke (1978) described these as follows. Constricting the channel with stabilizing structures results in reduced variability of water depth and a less variable habitat. The reduction of the total edge is a major contribution to a reduction in the diversity of riverine fauna. Removal of shoreline vegetation often occurs so that there is increased solar radiation and a rise in water temperature. Bank stabilization does reduce long-term suspended sediment discharge and sedimentation problems from bank erosion. But since energy loss from meandering is reduced, greater downcutting occurs, thus increasing bedload and reducing suitable substrate for organisms. Because much energy comes from streambank and

floodplain vegetation, their removal reduces a vital energy source. Light transmission may be increased because bank erosion and turbidity resulting from it are reduced. Lubinski et al. (1981) noted similar effects of revetments.

Flood protection levees consist of earth embankments or concrete walls parallel to the river so that flood waters are confined to a narrow area of the natural floodplain. Yorke (1978) gave, in general terms, the impacts levees have on selected physical and chemical characteristics. Levees, while protecting certain areas from flooding, reduce the flood conveyance and storage capacity of the floodplain, thus increasing flood stages, causing scouring, and creating a deeper channel. At the same time, containing flood discharges may cause streambank erosion and widening of the channel. Levees near the channel require overstory vegetation removal, thus allowing a greater diurnal temperature fluctuation; however, those levees set back from the channel do not affect temperature. Erosion of levees during floods may increase temporary sediment discharge, causing local sedimentation problems. Though levees have little direct effect on bed material, total dissolved solids may increase below levee projects because the areas of floodplain and vegetation available for assimilating dissolved substances usually are severely reduced. More crucial are the effects on the protected land by agricultural, residential, and industrial users since increased amounts of nutrients and pollutants may be released into the river when river stages are low, either by seepage or direct runoff. Toxicity or deficiencies of oxygen may result, thus adversely affecting aquatic organisms. Light transmission may be reduced as more sediment is transported by increased velocities. Flood waters are transmitted downstream faster because of decreased floodplain storage capacity and increased flood peaks, thus decreasing flood duration at downstream points. Though flood stages are higher now than in the past, flood protection by levees prevents flood damage in Pools 19 and 20 whenever the bank-full stage is exceeded. Before the levees were built, flood damage resulted whenever the river exceeded that stage.

Water level regulation to maintain sufficient depth for navigation even at low flows has biological consequences. Lubinski et al. (1981) noted that operational drawdowns concern both the upstream (from a dam) effects of decreasing water levels and downstream effects of increasing water levels. Fish may become stranded in pools isolated from the main channel when there is a sudden and drastic lowering of water levels. Winter drawdowns lead to oxygen depletion and fish kills and greater effects on game than nongame species. Fluctuating water levels prevent many bottom-dwelling organisms from establishing viable populations.

GREAT II (1980g) noted that either adverse or favorable effects on biota were possible when drawdowns or fluctuations occurred. Among the adverse effects were disturbances of spawning, nesting, feeding, migration, and other periods in the life cycles of fish. Wildlife and plants could be adversely affected due to inundation or drying of habitats used for nesting, food production, or cover. In contrast are the beneficial impacts of controlling vegetative growth, providing fish with access to spawning areas during appropriate times, limiting access of predators to prey, and maximizing littoral zone productivity. The key to balancing adverse and favorable effects is to decide what organisms specifically are to be managed and to understand what possible detrimental effects there would be (directly or indirectly) on those not managed.

Adverse effects of boat traffic are due not only to recreational boats but also to barges. Waves, drawdown effects, and effects related to pressure and velocity changes have been examined by Schnick et al. (1982). The Environmental Work Team summarized the major impacts of barge traffic in the Upper Mississippi River (Table 55). While the magnitude of these effects on the biota has not been determined, Lubinski et al. (1981) believed that barge traffic significantly contributes to increased levels of turbidity and resuspension. Johnson (1976a) indicated that a statistically significant greater amount of suspended sediment and turbidity were caused by barge traffic during normal pool conditions and that there was lateral movement of material from the main

channel to shoreward areas, including productive side channels. Main channels recovered their natural levels 15-155 min after tow passage (see Section 4.2.1).

Pollution problems due to barge traffic have already been discussed in the Pollution section (4.2.2). In addition, however, fuel and oil leakages may occur near marinas, docks, or fueling areas (Bhowmik et al. 1980). Oil leaks from cooling systems and contaminants from pleasure boat motor exhaust are present, depending on the amount of traffic. The more the traffic, the greater the potential for accidents.

There has been much recent attention given to winter navigation. Currently there is little navigation above the confluence of the Illinois and Mississippi Rivers. The mean number of days with minimum temperatures of 32 °F and below is 120 days (17 weeks) at Keokuk (USACE 1973), and the ice is usable in February. Ice conditions make for more difficult handling of barges. Problems associated with winter navigation may also affect winter commercial fishing. If the ice is broken, there could be loss of fishing equipment and additional hazards caused by open water and flowing ice, which produce unsafe shelf ice conditions (USACE 1973). Additional considerations are the hazards of fluctuating water levels and the dangers encountered by people crossing channels to get to fishing or hunting areas. Commercial fishermen interviewed by ERT/Ecology Consultants, Inc. (1979a), indicated both adverse and beneficial effects of winter navigation. Among the adverse effects were reduced access to fishing grounds, damage to fishing equipment and therefore loss of fishing opportunities and money. Beneficial effects included driving fish from the main channel to increase catch success. No winter fishing was reported in Pool 20, but in Pool 19 winter catches make up a substantial portion of the annual income. Little impact was perceived by those interviewed on fish or wildlife in general.

Certainly more data are needed concerning effects of winter navigation. Peterson (1983) attempted to determine winter species composition in Pool 18 of the Mississippi River but the task was

Table 55. Major impacts of barge traffic related to various riverine components (UMRBC Environmental Work Team 1981).

Component	Source of impact
Terrestrial vegetation and habitat	Bank erosion and runoff
Aquatic habitat	Total effect of the following factors: altered water velocities, directions, and levels; increased concentrations of suspended solids; high turbidity and sediment rates; and increased wave action.
Aquatic vegetation	Water quality degradation; water level changes; increased turbidity and sedimentation.
Plankton	Increased sedimentation, turbidity, and resuspended solids.
Benthos	Increased velocity and turbulence; scouring action causing dislodgment; burial by resuspended bottom sediments; species density and diversity altered; increased draw-down.
Fish	Changes in population of food organisms; increased suspended solids and associated turbidity and sedimentation that interfere with physiological functions and behavior; reduction in spawning habitat; direct damage from barge propellers and hulls; water level fluctuations.
Birds	Accelerated degradation of aquatic habitats resulting in reduction of food sources and nesting and resting areas; accumulative effects of wave wash, sediment resuspension, bank erosion, and general degradation of water quality.
Furbearers	Water level fluctuations; loss of denning areas due to bank erosion; loss of vegetation and cover.

difficult because ground truthing hydroacoustic gear was not feasible. A plan for further study was included in her report. Ashton (1974) did examine ice management problems at Pool 19 and pointed out that most ice production occurs during a small fraction of the ice cover period. Thus, removing ice from the channel by using special cutter barges should permit navigation during most of the season. Additional ice produced from continued cutting and clearing was found to be only a small part of the total ice production, so that wintertime navigation was not thought to be significant in increasing natural ice jamming. However, it could be theorized that ice broken by a tow could be forced laterally from the channel to eventually form an ice wall on either side of the channel. Such damming from surface ice to river bottom might create more severe jamming than without navigation.

Another recent concern is barge fleeting; i.e., barge shipping companies store loaded or empty barges along the navigation channel. Permits from the U.S. Army Corps of Engineers and some States are required, but "historical" fleeting areas are exempted. Environmental impacts in such areas have not been well documented, but damage to tie-up trees has been noted: stripped bark eventually causes the death of the tree. Because certain birds roost in tie-up trees, tying up to such trees should be stopped. Certainly, prop wash and wakes generated by boats may well make bottom areas unsuitable for maintaining stable communities. Barges that may break away from their moorings are potentially hazardous to aquatic communities, especially if they break and spill their contents. All approved fleeting areas should have strong, human-made mooring devices to minimize damage to shore-line areas and associated aquatic communities. To reduce impacts on the biota, there is a definite need to better regulate areas used for fleeting.

4.3.2 Dredging

The river channel is sometimes dredged to enhance navigation, especially during periods of low water. Several locations in Pools 19 and 20 require dredging as a result of sedimentation. Maintenance dredging has declined steadily

in Pool 19 from about 182,000 tons in 1938 to an average of about 65,000 tons in the 1970's but has increased in Pool 20 from about 52,000 tons in 1938 to an average of about 111,000 tons in the 1970's (USACE 1974a). Severe flooding brings in vast amounts of sediment, and it appears that considerable sediment in both pools comes from upstream (see Section 4.2.1). Problem areas requiring repeated dredging in recent years in Pool 19 are located at RM 406, 404, and 398 and in Pool 20 at RM 355, 351 and 349.

Yorke (1978) listed impacts of channel enlargement and dredging on selected physical and chemical characteristics of small rivers. Channel deepening leads to more uniformity, thus eliminating pools and riffles. Deepened channels and lower flows during dry periods promote drainage of adjacent low-lying wetlands. Concurrently, a more uniform surface area results and dredged spoil placed along the existing channel reduces the available floodplain. Bed material is disturbed during both spoil removal and deposition. Streamside vegetation may be altered either directly or indirectly by dredging, and sediment loads resulting from dredging may release certain nutrients. Light transmission is reduced during the actual dredging but may also be reduced over a long period as the spoils are eroded from their place of deposit. While release of polluted materials can result from dredging, adverse effects appear to be site specific and dependent on the materials deposited.

Lubinski et al. (1981) reported that dredging and spoil disposal create adverse impacts on the aquatic biota through habitat destruction, physical damage and burial of benthic organisms, increased exposure to toxic contaminants, and dissolved oxygen stress. Oxygen stress is caused by additional oxygen demand created by resuspended sediment and by the lowering of photosynthetic rates that result from increased turbidity. GREAT I and II determined that the most destructive impacts on the Upper Mississippi River are habitat destruction from disposal of spoils and movement of these materials into river lakes and ponds or side channels, perhaps even blocking flow into them. Thus, oxygen and removal of wastes

are often reduced while sedimentation increases. Thompson and Landin (1978) stated that no colonial nesting birds were located on dredged sites due to high recreational use (camping, picnicking, etc.) of dredged material and that only early successional stages of vegetation were present. The death of nearby trees from dredged materials could reduce screening and protection from the wind, perhaps forcing colonies to move.

Robinson (1970) determined the beneficial and detrimental effects of in-stream disposal. He evaluated present dredge spoil sites to assess current practices as they related to a proposed 12-ft channel project for the Mississippi River. He stated these spoils are harmful when they cause filling in of chutes and side channels or when they are placed

- in or near inlets or outlets between the river proper and sloughs and backwaters
- on submerged wing dams and closing structures
- at upstream ends of islands to be washed downstream again
- so that they cover aquatic vegetation
- without due consideration for established or contemplated public use areas.

He included maps of the river showing specific recommended locations for spoil sites. He recommended future disposal sites and uses of dredge spoil, including

placement on islands having low timber or wildlife value; creating sand islands in the lower ends of some pools; making beaches at State, county, or municipal properties; filling parking areas; creating dikes in large shallow areas for waterfowl and furbearers; and filling in lowland areas with little wildlife value and adjacent to communities needing land for industrial expansion or other uses. Robinson emphasized that various groups (e.g., State and Federal conservation agencies, municipal officials) should meet to plan the best use for spoil placement before it needs to be done.

GREAT (1980c) reinforced these points of view in developing channel maintenance plans to coordinate efforts concerning dredge spoil placement. In addition, specific site locations, site shaping, and vegetation considerations were outlined. Over 750 disposal sites in Pools 11 to 22 (59 and 37 sites, respectively for Pools 19 and 20) were reviewed and evaluated for habitat types, as well as for acceptable alternative disposal plans, mitigation, and stockpiling. Stockpiling would cause Pool 19 to suffer greater loss in habitat units than Pool 20, but without stockpiling Pool 20 would lose more habitat units than Pool 19. Revegetation and incorporation of organic matter in sites not stockpiled would help compensate for habitat unit losses, but placement of any solid waste in the floodplain is currently strictly prohibited.



REFERENCES

- Allen, F.R., and A.W. Garrison. 1972. Gas chromatography, mass spectrography identification of organic acids in the Mississippi River. *Bull. Ga. Acad. Sci.* 30(2):69.
- American Fisheries Society. 1980. A list of common and scientific names of fishes from the United States and Canada, 4th ed. *Am. Fish. Soc. Spec. Publ. No. 12.* 174 pp.
- Anderson, N.H., and J.R. Sedell. 1979. Detritus processing by macroinvertebrates in stream ecosystems. *Annu. Rev. Entomol.* 24:351-377.
- Anderson, R.V. (In prep.) Nematode and benthic rotifer associations with aquatic macrophyte beds, Mississippi River.
- Anderson, R.V., and D.M. Day. (In press) Predictive quality of macroinvertebrate habitat association in lower navigation pools of the Upper Mississippi River. In M.M. Smart, R.A. Schnick, and K.S. Lubinski, eds. *Ecology of the Upper Mississippi River.* Junk Publ., The Hague, Netherlands.
- Anderson, R.V., and W.S. Vinikour. 1984. Use of molluscs as pupation sites by *Oecetis inconspicua* (Trichoptera: Lep-troceridae). *J. Freshwater Ecol.* 2:417-422.
- Anderson, R.V., D. Day, D.A. Pillard, and J. Grubaugh. (In prep.) Temporal and habitat variation in benthic macroinvertebrates of a navigation pool, Upper Mississippi River.
- Anderson, R.V., R.E. Sparks, K.S. Lubinski, J.W. Grubaugh, and D.M. Day. (In prep.) Can autochthonous sources fuel a large river?
- Aschoff, J., and H. Pohl. 1970. Rhythmic variations in energy metabolism. *Fed. Proc.* 29:1541-1552.
- Ashton, G.D. 1974. Evaluation of ice management problems associated with operation of a mechanical ice cutter on the Mississippi River. Cold Regions Research and Engineering Laboratory, Hanover, N.H.; U.S. Coast Guard, Washington, D.C.
- Aykulu, G. 1978. A quantitative study of the phytoplankton of the River Avon, Bristol. *Brit. Phycol. J.* 13:91-102. 195 pp.
- Baima, S.F. 1971. The effects of habitat on starling (*Sturnus vulgaris*) breeding behavior. M.S. Thesis. Western Illinois University, Macomb. 46 pp.
- Baker, A.L., and K.K. Baker. 1979. Effects of temperature and current discharge on the concentration and photosynthetic activity of phytoplankton in the Upper Mississippi River. *Freshwater Biol.* 9:191-198.
- Baker, K.K., and A.L. Baker. 1981. Seasonal succession of the phytoplankton in the Upper Mississippi River. *Hydrobiologia* 83:295-301.
- Barnickol, P.G., and W.C. Starrett. 1951. Commercial and sport fishes of the Mississippi River between Caruthersville, Missouri and Dubuque, Iowa. *Ill. Nat. Hist. Surv. Bull.* 25(5):267-350.
- Bellrose, F.C. 1968. Waterfowl migration corridors east of the Rocky Mountains in the United States. *Ill. Nat. Hist. Surv. Biol. Notes No. 61.* 23 pp.

- Bellrose, F.C. 1976. Ducks, geese and swans of North America. Stockpole Books, Harrisburg, Pa. 544 pp.
- Benson-Evans, K., P.F. Williams, R.O. McLean, and N. Prance. 1975. Algal communities in polluted rivers of South Wales. Verh. Int. Verein. Limnol.
- Bertrand, B.A. 1983. Fishing the Mississippi. Illinois Department of Conservation, Division of Fisheries, Springfield.
- Bertrand, B.A., and K. Russell. 1973. Population survey of aquatic habitat types in Pool 19 of the Mississippi River. Illinois Department of Conservation, Division of Fisheries, Springfield.
- Bhowmik, N.G., R.L. Evans, J.R. Adams and M. Demissie. 1980. Identification and prioritization of study needs on the physical and chemical impacts of navigation. Draft report. Illinois Institute of Natural Resources, State Water Survey Division, Champaign. 26 pp.
- Boland, T. 1980. A classification of the wing and closing dams on the Upper Mississippi River bordering Iowa. Report to the Fish and Wildlife Management Work Group of GREAT II. Iowa Conservation Commission, Des Moines. 59 pp.
- Bowles, J.B. 1975. Distribution and biography of mammals at Iowa. Tex. Tech. Univ. Mus. (Lubbock) Spec. Publ. No. 9. 184 pp.
- Brannon, J.M. 1978. Evaluation of dredged material pollution potential. Synthesis report. U.S. Army Eng. Waterways Exp. Stn. Environ. Lab., Vicksburg, Miss. Tech. Rep. DS-78-6. 39 pp. NTIS No. ADA-059-724
- Brannon, J.M., R.H. Plumb, and I. Smith. 1978. Long-term release of contaminants from dredged material. U.S. Army Eng. Waterways Exp. Stn., Vicksburg, Miss. Tech. Rep. DS-78-49. 87 pp. NTIS No. ADA-060-814.
- Brunet, P.J. 1977. The Corps of Engineers and navigation improvement on the channel of Upper Mississippi River to 1939. M.A. Thesis. University of Texas, Austin. 195 pp.
- Butler, R.L. 1965. Freshwater drum, Aplodinotus grunniens, in the navigational impoundments of the Upper Mississippi River. Trans. Am. Fish. Soc. 94:339-349.
- Butts, T.A., and R.E. Sparks. 1982. Sediment oxygen demand: fingernail clam relationship in the Mississippi River Keokuk Pool. Trans. Ill. Acad. Sci. 75:29-39.
- Carlander, H.B. 1954. History of fish and fishing in the Upper Mississippi River. Prepared for Upper Mississippi River Conservation Committee, Rock Island, Ill. 96 pp.
- Carlander, K.D. 1969. Handbook of freshwater fishery biology, Vol. 1. Iowa State University Press, Ames. 752 pp.
- Carlander, K.D. 1977. Handbook of freshwater fishery biology, Vol. 2. Iowa State University Press, Ames. 431 pp.
- Carlander, K.D., C.A. Carlson, V. Gooch, and T.L. Wenke. 1967. Population of Hexagenia mayfly naiads in Pool 19, Mississippi River, 1959-1963. Ecology 48:873-878.
- Carlson, C.A. 1960. Abundance of mayfly naiads (Hexagenia spp.) in Pool 19, Upper Mississippi River. M.S. Thesis. Iowa State University, Ames. 90 pp.
- Carlson, C.A. 1966. Effects of three organophosphorus insecticides on immature Hexagenia and Hydropsyche of the Upper Mississippi River. Trans. Am. Fish. Soc. 95:1-5.
- Carlson, C.A. 1968. Summer bottom fauna of the Mississippi River, above Dam 19 Keokuk, Iowa. Ecology 49:162-169.
- Carter, N.E. 1968. Age and growth of sauger in Pool 19 of the Mississippi River. Proc. Iowa Acad. Sci. 75:179-183.

- Chen, Y.H., and D.B. Simons. 1979. Geomorphic study of Upper Mississippi River. J. Waterways, Port, Coastal Ocean Div. Am. Civil Eng. 105(WW3):313-328.
- Chesters, G., G.V. Simsiman, T. Danovich, V. Novotny, T. Lazewski, G. Stout, and V. Alavian. 1981. Resource description of the Upper Mississippi River system. Upper Mississippi River Basin Commission report. USACE, Rock Island, Ill. 266 pp.
- Chin, E.H., J. Skelton, and H.P. Guy. 1973. The 1973 Mississippi River basin flood: compilation and analysis of meteorologic, and stream flow and sediment data. U.S. Geol. Surv. Prof. Pap. 937.
- Clay, R.T. 1983. Population characteristics and habitat of muskrats on Pool Nine, Upper Mississippi River. M.S. Thesis. Iowa State University, Ames. 72 pp.
- Coker, R.E. 1929. Keokuk Dam and the fisheries of the Upper Mississippi River. Bull. U.S. Bur. Fish. Doc. No. 1063, 45:87-139.
- Coker, R.E. 1930. Studies of common fishes of the Mississippi River at Keokuk. Bull. U.S. Bur. Fish. 45:141-225.
- Coker, R.E., A.F. Shira, H.W. Clark, and A.D. Howard. 1921. Natural history and propagation of freshwater mussels. Bull. U.S. Bur. Fish. 37:75-181.
- Colbert, B.K., J.E. Scott, J.H. Johnson, and R.C. Soloman. 1975. Environmental inventory and assessment of navigation pools 24, 25 and 26. Upper Mississippi and Lower Illinois Rivers. An aquatic analysis. U.S. Army Corps of Engineers, St. Louis, Mo. 527 pp.
- Cole, G.A. 1983. Textbook of limnology. C.V. Mosby Co., St. Louis, Mo. 401 pp.
- Cowardin, L.M., V. Carter, F.C. Golet, and E.T. LaRoe. 1979. Classification of wetlands and deepwater habitats of the United States. U.S. Fish Wildl. Serv. Biol. Serv. Program FWS/OBS-79/31 103 pp.
- Crohurst, H.R. 1932. A study of the pollution and natural purification of the Upper Mississippi River. Pages 291-300 in Surveys and laboratory studies. Public Health Services, Washington, D.C.
- Culler, C.F. 1930. Depletion of the aquatic resources of the Upper Mississippi River and suggested remedial measures. Trans. Am. Fish. Soc. 60:279-283.
- Cummins, K.W. 1973. Trophic relations of aquatic insects. Annu. Rev. Entomol. 18:183-206.
- Cummins, K.W. 1979. The natural stream ecosystem. Pages 7-24 in J.V. Ward and J.A. Stanford, eds. The ecology of regulated streams. Plenum Press, New York.
- Cummins, K.W., and J.C. Wuycheck. 1971. Caloric equivalents for investigations in ecological energetics. Verh. Int. Ver. Limnol. 18:1-158.
- Day, D.M. 1984. Use of diving duck activity patterns to examine seasonal and habitat utilization of the lower reaches of Pool 19, Mississippi River. M.S. Thesis. Western Illinois University, Macomb. 147 pp.
- Day, D.M., and R.V. Anderson. (In prep.) Habitat use, behavior, and energy requirements of canvasbacks and lesser scaup on Pool 19, Mississippi River.
- Delfino, J.J. 1977. Effects of river discharge and suspected sediment on water quality in the Mississippi River. J. Environ. Sci. Health 12(3):79-95.
- Dunham, L.L. 1970. Fish sampling by electrofishing gear below ten navigation dams on the Mississippi River. Illinois Department of Conservation, Division of Fisheries. Mimeo, Springfield. 10 pp.
- Dunham, L.L. 1971. Fish sampling by electrofishing gear below navigation

- dams nos. 12-26 on the Mississippi River. Illinois Department of Conservation, Division of Fisheries, Mimeo, Springfield. 20 pp.
- Dunstan, T.C. 1974. The status and role of bald eagle winter studies in the midwest. Pages 62-67 in Proceedings of bald eagle days symposium, Keokuk, Ia.
- Dunstan, T.C. 1975. Cedar Glen eagle roost. Pages 7-11 in Proceedings of bald eagle days symposium. Bald eagle land: preservation and acquisition. Keokuk, Ia.
- Dunstan, T.C. 1978. Our bald eagle: freedom's symbol survives. Natl. Geogr. Mag. 152(2):186-199.
- Dunstan, T.C. 1979. Cedar Glen: land of wintering eagles. Nat. Conserv. News 29(5):32-33.
- Ecological Analysts, Inc. 1981. Survey of freshwater mussels (Pelecypoda: Unionacea) at selected sites in Pools 11 through 24 of the Mississippi River. U.S. Army Corps of Engineers, Rock Island, Ill. 188 pp.
- Ellis, J.M. 1978. Fish communities in three successional stages of side channels of the Upper Mississippi River. M.S. Thesis. University of Missouri, Columbia. 65 pp.
- Ellis, J.M., G.B. Farabee, and J.B. Reynolds. 1979. Fish communities in three successional stages of side channels in the Upper Mississippi River. Trans. Mo. Acad. Sci. 13:5-20.
- Ellis, M.M. 1936. Erosion silt as a factor in aquatic environments. Ecology 17(1):29-42.
- Engman, J.A. 1984. Phytoplankton distribution in Pool 19, Mississippi River. M.S. Thesis. Western Illinois University, Macomb. 184 pp.
- ERT/Ecology Consultants, Inc. 1979a. Environmental impacts study of Mississippi River year-round navigation. Vol. 1: Commercial fisheries and environmental observation; main report. ERT/Ecology Consultants, Inc., Fort Collins, Colo. 101 pp. + appendices.
- ERT/Ecology Consultants, Inc. 1979b. Evaluation of navigation effects of the biological components of the Mississippi River aquatic ecosystem. Prepared for Upper Mississippi River Basin Commission, Fort Snelling, Twin Cities, Minn. ERT/Ecology Consultants, Inc., Fort Collins, Colo.
- Farabee, G.B. 1984. Final report on electrofishing data collected from revetted and natural shoreline - Mississippi River. Mimeo report. Missouri Department of Conservation, Columbia. 20 pp.
- Federal Water Pollution Control Administration (FWPCA). 1969. Mississippi River reconnaissance, report of sampling in the vicinity of Dubuque, Iowa, and the tributaries from above Dubuque to below Keokuk, Iowa, in both Iowa and Illinois. Lake Michigan Basin Office, Chicago, Ill. 169 pp.
- Fischer, D.L. 1982. The seasonal abundance, habitat use and foraging behavior of wintering bald eagles, Haliaeetus leucocephalus, in west-central Illinois. M.S. Thesis. Western Illinois University, Macomb. 178 pp.
- Forbes, S.A. 1882. On some Entomostaca of Lake Michigan and adjacent waters. Am. Nat. 16:640-649.
- Franks, E.C. 1967. Breeding bird census of upland oak-hickory forest. Audubon Field Notes 21:615.
- Fremling, C.R. 1960a. Biology of a large mayfly, Hexagenia bilineata (Say), of the Upper Mississippi River. Iowa State Univ. Agric. Home Econ. Exp. Stn. Res. Bull. 483:842-853.
- Fremling, C.R. 1960b. Biology and possible control of nuisance caddisflies of the Upper Mississippi River. Iowa State Univ. Agric. Home Econ. Exp. Stn. Res. Bull. 483:856-879.
- Fremling, C.R. 1964a. Rhythmic Hexagenia mayfly emergences and the

- environmental factors which influence them. Verh. Int. Ver. Limnol. 15:912-916.
- Fremling, C.A. 1964b. Mayfly distribution indicates water quality on the Upper Mississippi River. Science 146:1164-1166.
- Fremling, C.R. 1968. Documentation of a mass emergence of Hexagenia mayflies from the Upper Mississippi River. Trans. Am. Fish. Soc. 97:278-280.
- Fremling, C.R. 1973. Environmental synchronization of mass Hexagenia bilineata (Ephemeroptera) emergences from the Mississippi River. Verh. Int. Ver. Limnol. 18:1521-1526.
- Fremling, C.R., and T.O. Claflin. 1984. The ecological history of the Upper Mississippi River. Pages 5-24 in J.G. Wiener, R.V. Anderson, and D.R. McConville, eds. Contaminants in the Upper Mississippi River. Butterworth Publ., Woburn, Mass.
- Freundreis, P.A. 1982. Benthic macroinvertebrates of Pool 20, Mississippi River and the possible effects of barge traffic on catastrophic drift. M.S. Thesis. Western Illinois University, Macomb. 114 pp.
- Fuller, S.L.H. 1974. Clams and mussels (Mollusca:Bivalvia). Pages 215-273 in C.W. Hart, Jr., and S.L.H. Fuller, eds. Pollution ecology of freshwater invertebrates. Academic Press, New York.
- Fuller, S.L.H. 1978. Freshwater mussels (Mollusca:Bivalvia:Unionidae) of the Upper Mississippi River: observations at selected sites within the 9-foot channel navigation project on behalf of the United States Army Corps of Engineers. Final report No. 78-33. The Academy of Natural Sciences of Philadelphia, Division of Limnology and Ecology, Philadelphia, Pa. 401 pp.
- Fuller, S.L.H. 1980. Historical and current distributions of freshwater mussels (Mollusca:Bivalvia:Unionidae) in the Upper Mississippi River. Pages 72-177 in J.L. Rasmussen, ed. Proceedings of the UMRCC symposium on Upper Mississippi River bivalve mollusks. Upper Mississippi River Conservation Committee, Rock Island, Ill.
- Funk, J.L., and J.W. Robinson. 1974. Changes in the channel of the Lower Mississippi River and effects on fish and wildlife. Mo. Dep. Conserv. (Jefferson City) Aquat. Ser. No. 11. 52 pp.
- Gakstatter, J.H., and R.L. Morris. 1970. Limnology of the Iowa reach of the Mississippi River. Paper presented at the American Public Health Association meeting in Houston, Tex. Oct. 27, 1970. 14 pp.
- Gale, W.F. 1969. Bottom fauna of Pool 19, Mississippi River with emphasis on the life history of the fingernail clam, Sphaerium transversum. Ph.D. Thesis. Iowa State University, Ames.
- Gale, W.F. 1971. An experiment to determine substrate preference of the fingernail clam, Sphaerium transversum (Say). Ecology 52:367-370.
- Gale, W.F. 1972. Seasonal variability in calyculism in Sphaerium transversum (Say). Nautilus 86:20-22.
- Gale, W.F. 1973a. Substrate preference of the fingernail clam, Sphaerium striatinum (Lamarck) (Sphaeriidae). Southwest. Nat. 18:31-37.
- Gale, W.F. 1973b. Predation and parasitism as factors affecting Sphaerium transversum (Say) populations in Pool 19, Mississippi River. Res. Popul. Ecol. (Kyoto). 14:169-187.
- Gale, W.F. 1975. Bottom fauna of a segment of Pool 19, Mississippi River, near Ft. Madison, Iowa, 1967-1969. Iowa State J. Res. 49:352-372.
- Gale, W.F. 1976. Vertical distribution and burrowing behavior of the fingernail clam, Sphaerium transversum. Malacologia 15:401-409.
- Gale, W.F. 1977. Growth of the fingernail clam, Sphaerium transversum (Say)

- in field and laboratory experiments. *Nautilus* 91:8-12.
- Gale, W.F., and R.L. Lowe. 1971. Phytoplankton ingestion by the fingernail clam, *Sphaerium transversum* (Say), in Pool 19, Mississippi River. *Ecology* 52:507-513.
- Gale, W.F., D.J. Jude, and R.G. Ranthum. 1969. Distribution of bottom fauna and its utilization by fish in the Fort Madison section of Pool 19, Mississippi River. Iowa Cooperative Fishery Unit Project No. 1373. Ames, Iowa.
- Garman, J. 1890. A preliminary report on the animals of the Mississippi bottoms near Quincy, Illinois in August, 1888. Part I. Ill. Nat. Hist. Bull. 3:123-184.
- Gasaway, R.D., and T.F. Drda. 1977. Effects of grass carp introduction on waterfowl habitat. *Trans. N. Am. Wildl. Nat. Resour. Conf.* 44:73-85.
- Galtsoff, P.S. 1924. Limnological observations in the Upper Mississippi, 1921. U.S. Bur. Fish. Bull. 39:347-438.
- Gould, N.W. 1889. Fifty years on the Mississippi. Nixon-Jones Printing Co., St. Louis, Mo. 750 pp.
- Great River Environmental Action Team (GREAT II). 1980a. Main report of GREAT II. Rock Island, Ill. 113 pp.
- Great River Environmental Action Team (GREAT II). 1980b. Fish and wildlife management work group appendix, GREAT II. Rock Island, Ill.
- Great River Environmental Action Team (GREAT II). 1980c. Channel maintenance handbook (supplement to Main Report, GREAT II). Rock Island, Ill. 35 pp. + exhibits.
- Great River Environmental Action Team (GREAT II). 1980d. Environmental report (supplement to Main Report, GREAT II). Rock Island, Ill. 191 pp.
- Great River Environmental Action Team (GREAT II). 1980e. Side channel work group appendix, GREAT II. Rock Island, Ill. 204 pp. + appendixes.
- Great River Environmental Action Team (GREAT II). 1980f. Recreation work group appendix, GREAT II. Rock Island, Ill. 470 pp.
- Great River Environmental Action Team (GREAT II). 1980g. Upper Mississippi River (Guttenberg, Iowa to Saverton, Mo.) Water quality work group appendix, GREAT II. Rock Island, Ill. 216 pp.
- Grubaugh, J.W., R.V. Anderson, D.M. Day, K.S. Lubinski, and R.E. Sparks. (In prep.) Production of *Sagittaria latifolia* and *Nelumbo lutea* on Pool 19 Mississippi River.
- Gutreuter, S.J. 1980. Factors affecting fish community structure and habitat preference in Mississippi River backwaters. M.S. Thesis. University of Missouri, Columbia. 126 pp.
- Hagen, R., L. Werth, and M. Meyer. 1977. Upper Mississippi River habitat inventory. Univ. Minn. Remote Sens. Lab. Res. Rep. 77-5, St. Paul. 18 pp. + appendixes.
- Harlan, J.R., and E.B. Speaker. 1956. Iowa fish and fishing. Iowa State Conservation Commission, Des Moines. 377 pp.
- Hazelton Environmental Sciences. 1979. GREAT II Fish and Wildlife Management Work Group annotated bibliography, Vols. 1-2, and Addendum. Report to U.S. Army Corps of Engineers, Rock Island District, Ill. 820 pp. + 276 pp. addendum.
- Hazelton Environmental Sciences. 1980. Literature review of fish and wildlife resources annotated bibliography. Report to Fish and Wildlife Management Work Group of GREAT II. 385 pp. + appendixes.
- Heffelfinger, J.A. 1973. A seasonal survey of certain physical and chemical factors and plankton at three locations in Pool 20 of the Mississippi River. M.S. Thesis. Western Illinois University, Macomb. 55 pp.

- Helms, D.R., and T.L. Boland. 1972. Upper Mississippi River natural resources bibliography. Upper Mississippi River Conservation Committee, Fish Technical Section. U.S. Army Corps of Engineers and Iowa Conservation Commission. 62 pp.
- Henebry, M.S., and R.W. Gordon. (In press.) The possible role of bacteria in the nutrition of benthic macroinvertebrates in Mississippi River Pool 19. *Hydrobiologia*.
- Henry, R.D. 1982. Floating and submerged vascular plants in the Hancock County, Illinois, section of the Mississippi River. West. Ill. Herb. Circ. No. 1. 11 pp.
- Hoffmeister, D.F., and C.O. Mohr. 1972. Field book of Illinois mammals. Dover Publications, New York. 233 pp.
- Holland, L.E., and M.L. Huston. 1983. A compilation of available literature on the larvae of fishes common to the Upper Mississippi River. U.S. Army Corps of Engineers, Rock Island District, Ill. 364 pp.
- Holland, L.E., and J.R. Sylvester. 1983a. Evaluation of simulated drawdown due to navigation traffic on eggs and larvae of two fish species of the Upper Mississippi River. U.S. Army Corps of Engineers, Rock Island District, Ill. 22 pp.
- Holland, L.E., and J.R. Sylvester. 1983b. Some effects of commercial barge traffic on young-of-the-year fishes of the Upper Mississippi River. U.S. Army Corps of Engineers, Rock Island District, Ill. 111 pp.
- Holland, L.E., and J.R. Sylvester. 1983c. Distribution of larval fishes related to potential navigation impacts on the Upper Mississippi River, Pool 7. *Trans. Am. Fish. Soc.* 112(2B):293-301.
- Holm, D.J., and R.V. Anderson. (In prep.) Chaetogaster limnaei (Oligochaeta: Naididae) infesting unionid mollusks (Pelecypoda: Unionidae) and Corbicula luminea (Pelecypoda: Corbiculidae) in Pool 19, Mississippi River.
- Hoopes, D.T. 1959. Utilization of mayflies and caddisflies by some Mississippi River fishes. M.S. Thesis. Iowa State University, Ames.
- Hoopes, D.T. 1960. Utilization of mayflies and caddisflies by some Mississippi River fishes. *Trans. Am. Fish. Soc.* 89:32-34.
- Howe, J.S. 1979. Vegetation characteristics of dredge spoils along the Mississippi River of west Illinois, southeast Iowa, and northeast Missouri. M.S. Thesis. Western Illinois University, Macomb. 137 pp.
- Iowa Conservation Commission. 1984. Resources inventory for the Mississippi River in Iowa. (In prep.)
- Jackson, G.A., C.E. Korschgen, P.A. Thiel, J.M. Besser, D.W. Steffek, and M.H. Bockenhauer. 1981a. A long-term resource monitoring plan for the Upper Mississippi River system. Technical report F, Vol. 1, Comprehensive master plan for the management of the Upper Mississippi River system. Upper Mississippi River Basin Commission, Bloomington, Minn. 384 pp.
- Jackson, G.A., C.E. Korschgen, P.A. Thiel, J.M. Besser, D.W. Steffek, and M.H. Bockenhauer. 1981b. A long-term resource monitoring plan for the Upper Mississippi River system. Technical report F, Vol. 2, Comprehensive master plan for the management of the Upper Mississippi River system. Upper Mississippi River Basin Commission, Bloomington, Minn. 966 pp. + appendixes.
- Johnson, J.H. 1976a. Effects of tow traffic on the resuspension of sediments and on dissolved oxygen concentrations in the Illinois and Upper Mississippi Rivers under normal pool conditions. U.S. Army Engineers Waterways Experiment Station, Vicksburg, Miss. 185 pp.
- Johnson, J.H. 1976b. Feasibility of using historic disposal areas, Upper Mississippi River, to evaluate effects of dredged material disposal on community structure of benthic

- organisms. U.S. Army Engineers Waterways Experiment Station, Vicksburg, Miss. 90 pp.
- Jonen, R.J. 1973. The winter ecology of the bald eagle in west-central Illinois. M.S. Thesis. Western Illinois University, Macomb. 84 pp.
- Jude, D.J. 1968. Bottom fauna utilization and distribution of 10 species of fish in Pool 19, Mississippi River. M.S. Thesis. Iowa State University, Ames. 238 pp.
- Jude, D.F. 1973. Food and feeding habits of gizzard shad in Pool 19, Mississippi River. Trans. Am. Fish. Soc. 102:378-383.
- Keown, M.P., E.A. Dardeau, and J.G. Kennedy. 1977. Inventory of sediment sample collection stations in the Mississippi River basin. U.S. Army Engineer Waterways Experiment Station, Vicksburg, Miss. 498 pp.
- King, D.R., and G.S. Hunt. 1967. Effect of carp on vegetation in a Lake Erie marsh. J. Wildl. Manage. 31: 181-188.
- Kleen, V.M. 1983. Survey of Illinois heron colonies, 1983. Ill. Dep. Conserv. Rep. 23. 9 pp.
- Kofoid, C.A. 1903. Plankton studies IV. The plankton of the Illinois River, 1894-1899, with introductory notes upon the hydrography of the Illinois River and its basin. Part 1. Quantitative investigation and general results. Ill. Nat. Hist. Surv. Bull. 6:95-635.
- Kofoid, C.A. 1908. Plankton studies V. The plankton of the Illinois River 1894-1899. Part 2. Constituent organisms and their seasonal distribution. Ill. Nat. Hist. Surv. Bull. 8:3-360.
- Korschgen, L.J. 1948. (In Pavaglio and Steffek, 1978, Unpubl. 34 pp.) Unpubl.
- Kunshek, R.J., Jr. 1971. Vegetational studies of two Mississippi River flood plains in west-central Illinois. M.S. Thesis. Western Illinois University, Macomb 129 pp.
- Lack, T.J. 1971. Quantitative studies on the phytoplankton of the River Thames and Kennet at Reading. Freshwater Biol. 1:213-224.
- Leverett, F. 1921. Outline of Pleistocene history of Mississippi valley. J. Geol. 29:615-626.
- Lind, O.T. 1979. Handbook of common methods in limnology. The C.V. Mosby Co., St. Louis. 199 pp.
- Lubinski, K.S., H.H. Seagle, Jr., N.G. Bhowmik, J.R. Adams, M.A. Sexton, J. Buhnerkempe, R.L. Allgire, D.K. Davie, and W. Fitzpatrick. 1981. Information summary of the physical, chemical and biological effects of navigation. Upper Mississippi River Basin Commission, Minneapolis, Minn. 132 pp.
- Lugn, A.L. 1927. Sedimentation in the Mississippi River below Davenport, Iowa and Cairo, Illinois. Ph.D. Thesis. University of Iowa, Iowa City. 104 pp.
- Marking, L., T.D. Bills, and V.K. Dawson. 1984. Evaluation of the acute effects of suspended sediment on fish in laboratory exposures. Prepared for U.S. Army Corps of Engineers, Rock Island District, Ill. Letter Order No. NCR-L0-83-C9. 61 pp.
- Marzolf, G.R. 1978. The potential effects of clearing and snagging on stream ecosystems. Kansas State University, Manhattan. U.S. Fish Wildl. Serv. Biol. Serv. Program FWS/OBS-78/14. 31 pp.
- McDonald, D.B. 1972. Characteristics of Mississippi River bordering Iowa. Am. Inst. Chem. Hydraul. Eng. Water Symp. Ser. 29. 380 pp.
- McDonald, D.B., and J.L. Konefes. 1977. Pre- and post-habitat conditions resulting from 9-foot navigation channel, Upper Mississippi River, Pools 11-22. University of Iowa, Institute of Hydraulic Research.
- Meyer, F.P. 1960. Life history of Marsipometra hastata and the biology of its host, Polyodon spathula. Ph.D. Dissertation. Iowa State University of

- Science and Technology, Ames, Ia. 113 pp.
- Mills, H.B., W.C. Starrett, and F.C. Bellrose. 1966. Man's effect on the fish and wildlife of the Illinois River. Ill. Nat. Hist. Surv. Biol. Notes No. 57. 24 pp.
- Minor, J.M., L.M. Carson, and D.P. Meyer. 1977. Upper Mississippi River habitat inventory. Univ. Minn., Remote Sens. Lab. Res. Rep. 77-7. St. Paul. 23 pp.
- Mississippi River Commission and U.S. Army Corps of Engineers. 1973. Mississippi River navigation. Vicksburg, Miss. 21 pp.
- Morris, M.A., R.S. Funk, and P.W. Smith. 1983. An annotated bibliography of the Illinois herpetological literature 1960-80, and an updated checklist of species of the State. Ill. Nat. Hist. Surv. Bull. 33(2):123-138.
- Morris, R.L., and L.G. Johnson. 1970. Pesticide levels in fish and bottom silt from Iowa streams. Iowa State Hygienic Lab. Rep. No. 71-10. Iowa City, Iowa.
- Mueller, A.J. 1977. Navigation effects in the open river. Pages 59-64 in Procedures 33rd Annual Upper Mississippi River Conservation Commission meeting, Rock Island, Ill.
- Nakato, T., and J.F. Kennedy. 1977. Field study of sediment transport characteristics of the Mississippi River near Fox Island (RM 355-6) and Buzzard Island (RM 349-50). Iowa Institute of Hydraulic Research, Iowa City. 95 pp.
- Nelson, D.A. 1977-80. Unique and sensitive areas within the Rock Island District Upper Mississippi River. U.S. Army Corps of Engineers, Rock Island, Ill.
- Neuswanger, D.J. 1980. Limnology of three backwaters in different seral stages in the Upper Mississippi River. M.S. Thesis. University of Missouri, Columbia. 135 pp.
- Neuswanger, D.J., W.W. Taylor, and J.B. Reynolds. 1982. Comparison of macro-invertebrate herpobenthos and haptobenthos in side channel and slough in the Upper Mississippi River. Freshwater Inverteb. Biol. 1:13-24.
- Nord, R.C. 1964. The 1962-1963 sport fishery survey of the Upper Mississippi River. Upper Miss. River Conserv. Comm. Spec. Publ. 231 pp.
- Nord, R.C. 1967. A compendium of fishery information on the Upper Mississippi River. Upper Mississippi River Conservation Committee, Rock Island, Ill. 238 pp.
- Novotny, V. 1981. Resource description of the Upper Mississippi River system. An annotated bibliography of non-point pollution: emphasis on the Upper Mississippi River system. (Appendix to Vol. 3: Water quantity and quality.) Upper Mississippi River Basin Commission, Minneapolis, Minn. 170 pp.
- Ostdiek, J.L., G.H. Schneider, and A.F. Pogge. 1978. Effects of winter navigation on Pool 21, Upper Mississippi River. Quincy College, Quincy, Illinois. Prepared for U.S. Army Corps of Engineers, Rock Island, Ill. 16 pp.
- Pace, J.L. 1971. Starling (*Sturnus vulgaris* L.) nesting in natural cavities and in two types of wood duck metal nest houses. M.S. Thesis. Western Illinois University, Macomb. 30 pp.
- Palmer, C.M. 1964. Algae in water supplies of the United States. Pages 239-261 in D.F. Jackson, ed. Algae and man. Plenum Press, New York. 262 pp.
- Paveglio, F.L., and D.W. Steffek. 1978. The relationship of aquatic plants and Mollusca to food habits and population levels of diving ducks on the Keokuk Pool (Pool 19), Mississippi River, 1977. (Unpubl. MS.) 41 pp.
- Pearson, R., and D.E. Cin. 1976. The Great River Study: a new perspective in river management. U.S. Army Corps of Engineers, St. Paul, Minn. 132 pp.

- Pelren, D.W. 1970. Age and growth of white bass from Pool 19 of the Mississippi River. Iowa State J. Sci. 44:471-479.
- Pennington, C.H., J.A. Baker, and M.E. Potter. 1983. Fish populations along natural and revetted banks on the Lower Mississippi River. N. Am. J. Fish. Manage. 3:204-211.
- Perry, E.W. 1975. A survey of Upper Mississippi River mussels. Pages 118-139 in J.L. Rasmussen, ed. A compendium of fishery information on the Upper Mississippi River, 2nd ed. Upper Mississippi Conservation Committee, Rock Island, Ill.
- Peterson, G.A., ed. 1983. A pilot study to evaluate the winter fishery biology of Pool 18 of the Upper Mississippi River. Summary report. U.S. Army Corps of Engineers, Rock Island, Ill. 110 pp.
- Peterson, G.A. 1984. Resources inventory for the Upper Mississippi River. Draft. U.S. Army Corps of Engineers, Rock Island, Ill. 136 pp.
- Pfleiger, W.L. 1975. The fishes of Missouri. Missouri Department of Conservation, Columbia. 343 pp.
- Pierce, R.B., D.W. Coble, and S. Corley. 1981. Fish catches in baited and unbaited hoop nets in the Upper Mississippi River. N. Am. J. Fish. Manage. 1:204-206.
- Pillard, D.A. 1983. An examination of the zooplankton of Pool 19, Mississippi River, and the effects of filtering collectors. M.S. Thesis. Western Illinois University, Macomb. 137 pp.
- Pillard, D.A., and R.V. Anderson. (In prep., a) The effects of aquatic macrophytes on zooplankton.
- Pillard, D.A., and R.V. Anderson. (In prep., b) A note on the parasitism of Rotifera by Plistophora (Protista: Sporozoa) in Pool 19, Mississippi River.
- Pillard, D.A., and R.V. Anderson. (In prep., c) A survey of the zooplankton of Pool 19, Upper Mississippi River.
- Ranthum, R.G. 1969. Distribution and food habits of several species of fish in Pool 19, Mississippi River. M.S. Thesis. Iowa State University, Ames. 207 pp.
- Rasmussen, J.L., ed. 1979. A compendium of fishery information on the Upper Mississippi River, 2nd ed. Upper Mississippi River Conservation Committee, Rock Island, Ill. 259 pp.
- Rasmussen, J.L. 1983. A summary of known navigation effects and a priority list of data gaps for the biological effects of navigation on the Upper Mississippi River. U.S. Army Corps of Engineers, Rock Island, Ill. 96 pp.
- Rasmussen, J.L., and J.G. Harber. 1981. Effects of navigation and operation/maintenance of the Upper Mississippi River system nine-foot channel on commercial fish and fishing. Upper Mississippi River Basin Commission, Environmental Work Team, Rock Island, Ill. 165 pp.
- Reinhard, E.G. 1931. The plankton ecology of the Upper Mississippi, Minneapolis to Winona. Ecol. Monogr. 1:395-464.
- Robinson, G.L. 1979. A survey of fish parasites in Pool 20, Mississippi River. M.S. Thesis. Western Illinois University, Macomb. 47 pp.
- Robinson, G.L., and L.A. Jahn. 1980. Some observations of fish parasites in Pool 20, Mississippi River. Trans. Am. Microsc. Soc. 99(2):206-212.
- Robinson, J.W. 1970. The 1969 Upper Mississippi River dredge spoil survey from Hastings, Minnesota to Cairo, Illinois. Upper Mississippi River Conservation Committee, Fish Technical Section, Columbia, Mo. 157 pp.
- Rogers, G.E. 1976. Vertical burrowing and survival of sphaeriid clams under

- added substrates in Pool 19, Mississippi River. Iowa State J. Res. 51:1-12.
- Rogers, J.P., and L.J. Korschgen. 1966. Foods of lesser scaup on breeding, migration and wintering areas. J. Wildl. Manage. 30:258-264.
- Rounick, J.S., M.J. Winterbourn, G.L. Lyon. 1982. Differential utilization of allochthonous and autochthonous inputs by aquatic invertebrates in some New Zealand streams: a stable carbon isotope study. Oikos 39:191-198.
- Rupprecht, R.J. 1979. Observations on the natural history of the blue sucker (*Cyprinus elongatus*). M.S. Thesis. Western Illinois University, Macomb. 62 pp.
- Rupprecht, R.J., and L.A. Jahn. 1980. Biological notes on blue suckers in the Mississippi River. Trans. Am. Fish. Soc. 109:323-326.
- Sandusky, M.J., and R.E. Sparks. 1979. Investigations of declines in fingernail clams (*Musculium transversum*) populations in the Illinois River and Pool 19 of the Mississippi River. Bull. Am. Malacol. Union 1979:11-15.
- Schnick, R.A., J.M. Morton, J.C. Mochalski, and J.T. Beall. 1982. Mitigation and enhancement techniques for the Upper Mississippi River system and other large river systems. U.S. Fish Wildl. Serv. Res. Publ. 149. 714 pp.
- Schuyler, A.E. 1980. Aquatic and wetland plants, Pool 19, Mississippi River. Academy of Natural Sciences of Philadelphia, Pa. 8 pp.
- Schwartz, C.W., and E.R. Schwartz. 1964. The wild mammals of Missouri. University of Missouri Press and Missouri Department of Conservation, Columbia. 341 pp.
- Serie, J.R., D.L. Trauger, and D.E. Sharp. 1983. Migration and winter distribution of canvasback staging on the Upper Mississippi River. J. Wildl. Manage. 47(3):741-753.
- Simons, D.B., R.M. Li, Y.H. Chen, and S.S. Ellis. 1981a. Water quality in the Upper Mississippi River system affected by sediment resuspension due to navigation activities. Upper Mississippi River Basin Commission, Minneapolis, Minn. 57 pp.
- Simons, D.B., R.M. Li, Y.H. Chen, and S.S. Ellis. 1981b. Working paper I for Task D: investigation of effects of navigation development and maintenance activities on hydrologic and geomorphic characteristics. Simons, Li, and Associates, Inc., Fort Collins, Colo. Submitted to the Upper Mississippi River Basin Commission, Minneapolis, Minn. 76 pp.
- Smith, H.M. 1899. The mussel fishery and pearl button industry of the Mississippi River. Bull. U.S. Fish Comm. 18(1898):289-314.
- Smith, P.W. 1961. The amphibians and reptiles of Illinois. Ill. Nat. Hist. Surv. Bull. 28(1):1-298.
- Smith, P.W. 1979. The fishes of Illinois. University of Illinois, Urbana. 314 pp.
- Smith, P.W., A.C. Lopinot, and W.L. Pflieger. 1971. A distributional atlas of Upper Mississippi River fishes. Ill. Nat. Hist. Surv. Biol. Notes No. 73. 20 pp.
- Sparks, R.E. 1984. The role of contaminants in the decline of the Illinois River: implications for the Upper Mississippi. Pages 25-66 in J.G. Wiener, R.V. Anderson, and D.R. McConville, eds. Contaminants in the Upper Mississippi River. Butterworth Publ., Woburn, Mass.
- Sparks, R.E. and K.D. Blodgett. 1983. Effects of three commercial harvesting methods on mussel beds. Final report, Project No. 3-327-R. Ill. Nat. Hist. Surv. Aquatic Biology Section, Havana, Ill. 43 pp.
- Sparks, R.E., and K.E. Smith. 1979. Contaminants in fish food organisms and duck food organisms from Keokuk Pool, Mississippi River. Illinois Natural

- History Survey, River Research Laboratory, Havana. Prepared for U.S. Fish and Wildlife Service, Environmental Contaminants Evaluation Program, Twin Cities, Minn. 39 pp.
- Sparks, R.E. and R.V. Anderson (In prep.). Effects of a short-term drought on long-term succession in a pooled reach of the Mississippi River. *Oecologia*.
- Stall, J.B. 1972. Effects of sediment on water quality. *J. Environ. Qual.* 1(4):353-360.
- Starrett, W.C., and P.G. Barnickol. 1955. Efficiency and selectivity of commercial fishing devices on the Mississippi River. *Ill. Nat. Hist. Surv. Bull.* 26(4):325-366.
- Sternberg, R.B. 1971. Upper Mississippi River habitat classification survey: Hastings, Minnesota to Alton, Illinois. Upper Mississippi River Conservation Committee, Fish Technical Section; U.S. Army Corps of Engineers; Minnesota Department of Natural Resources, St. Paul, Minn.
- Swale, E. 1969. Phytoplankton in two English rivers. *J. Ecol.* 57:1-23.
- Swecker, S.J., and K.S. Lubinski. (Submitted). Decomposition rates of sago pondweed, *Potamogeton pectinatus*, in Navigation Pool 19, Mississippi River.
- Sylvester, J.R., and J.D. Broughton. 1983. Distribution and relative abundance of fish in Pool 7 of the Upper Mississippi River. *N. Am. J. Fish. Manage.* 3:67-71.
- Teska, S.R. 1979. A survey of the macroinvertebrate bottom fauna of the upper portion of Pool 20, Mississippi River. M.S. Thesis. Western Illinois University, Macomb. 56 pp.
- Thompson, C.M., and R.E. Sparks. 1978. Comparative nutritional value of a native fingernail clam and the introduced asiatic clam. *J. Wildl. Manage.* 42:391-396.
- Thompson, D. 1973. Feeding behavior of diving ducks on Keokuk Pool, Mississippi River. *J. Wildl. Manage.* 37(3):367-381.
- Thompson, D.H., and M.C. Landin. 1978. An aerial survey of the waterbird colonies along the Upper Mississippi River and their relationship to dredged material disposal. U.S. Army Eng. Waterways Exp. Stn., Vicksburg, Miss., Rep. TR-D-78-13.
- Thompson, J.D. 1969. Feeding behavior of diving ducks on Keokuk Pool, Mississippi River. M.S. Thesis. Iowa State University, Ames.
- Thornberg, D.D. 1973. Diving duck movements on Keokuk Pool, Mississippi River. *J. Wildl. Manage.* 37:383-389.
- Tweet, A.D. 1983. History of transportation on the Upper Mississippi and Illinois rivers. National Waterways Study, U.S. Army Water Resources Support Center, Institute for Water Resources, Fairfax, Va. 124 pp.
- U.S. Army Corps of Engineers (USACE). 1958. Navigation charts. Middle and Upper Mississippi River. Cairo, Illinois to Minneapolis, Minn.
- U.S. Army Corps of Engineers (USACE). 1971. Navigation project, Mississippi River, Fort Madison, Iowa. Commercial boat harbor, Fort Madison, Iowa. Final environmental impact statement. Rock Island, Ill. 27 pp.
- U.S. Army Corps of Engineers (USACE). 1973. Phase 1 report: Mississippi River year-round navigation. Draft. Chicago, Ill. 93 pp.
- U.S. Army Corps of Engineers (USACE). 1974a. Final environmental impact statement, Pool 19, Mississippi River. Operations and maintenance, Upper Mississippi River 9-ft navigation channel. Rock Island, Ill.
- U.S. Army Corps of Engineers (USACE). 1974b. Final environmental impact statement, Pool 20, Mississippi River. Operations and maintenance, Upper Mississippi River 9-ft navigation channel. Rock Island, Ill.

- U.S. Army Corps of Engineers (USACE). 1974c. Final environmental impact statement, Pools 11 through 22. Operations and maintenance, Upper Mississippi River, 9-foot navigation channel. Rock Island, Ill.
- U.S. Army Corps of Engineers (USACE). 1981. Implementation report for GREAT II study, Upper Mississippi River. Final report. Rock Island, Ill. 29 pp.
- U.S. Department of Interior. 1969. Water quality standards conference State of Iowa. Iowa Interstate waters at the Mississippi River basin convening April 8, 1969, Davenport, Iowa. Federal Water Pollution Control Administration. Great Lakes Region, Chicago, Ill. 54 pp.
- U.S. Geological Survey. 1982. Water resources data, Illinois, Water Year, 1982. 1:239-242.
- Upper Mississippi River Basin Commission (UMRBC). Environmental Work Team. 1981. Comprehensive master plan for the management of the Upper Mississippi River system: draft executive summary to the environmental report. Data collection and synthesis. Hastings, Minn.
- Upper Mississippi River Basin Commission (UMRBC). 1981. Preliminary comprehensive master plan for the management of the Upper Mississippi River system. Minneapolis, Minn. 88 pp.
- Upper Mississippi River Basin Commission (UMRBC). 1982. Comprehensive master plan for the management of the Upper Mississippi River system. Minneapolis, Minn. 193 pp.
- Upper Mississippi River Basin Study (UMRBS). 1970a. Vol. 2. Appendix A: History of investigations. Appendix B: Aesthetic and cultural values. Coordinating Committee, Chicago, Ill. 193 pp.
- Upper Mississippi River Basin Study (UMRBS). 1970b. Vol. 3. Appendix C: Climatology and meteorology. Appendix D: Surface water hydrology. Appendix E: Ground water and geology. Appendix F: Mineral resources. Appendix G: Fluvial sediment. Coordinating Committee, Chicago, Ill. 310 pp.
- Upper Mississippi River Basin Study. 1970c. Vol. 6. Appendix K: Recreation. Appendix L: Fish and wildlife. Appendix M: Power. Appendix N: Agriculture. Coordinating Committee, Chicago, Ill. 555 pp.
- Upper Mississippi River Basin Study. 1972. Vol. 1. Main report. Coordinating Committee, Chicago, Ill. 133 pp.
- Upper Mississippi River Conservation Committee (UMRCC). n.d. Monitoring plan for the Upper Mississippi River system. Rock Island, Ill. 44 pp.
- van der Schalie, H., and A. van der Schalie. 1950. The mussels of the Mississippi River. *Am. Midl. Nat.* 44:448-466.
- Vannote, R.L., G.W. Minshall, K.W. Cummins, J.R. Sedell, and C.E. Cushing. 1980. The river continuum concept. *Can. J. Fish. Aquat. Sci.* 37:130-137.
- Van Vooren, A. 1983. Distribution and relative abundance of Upper Mississippi River fishes. Upper Mississippi River Conservation Committee, Fish Technical section. 20 pp.
- Wallace, J.B., and R.W. Merritt. 1980. Filter-feeding ecology of aquatic insects. *Annu. Rev. Entomol.* 25:103-132.
- Waters, S. 1978. Fishing Iowa's southern reach of the Mississippi River. *Iowa Conserv.* 37:18-19.
- Wells, F.R. 1977. Vegetational patterns of the Mississippi River island. Hancock County, Illinois. M.S. Thesis. Western Illinois University, Macomb. 1091 pp.
- Wenke, T.L. 1965. Some ecological relationships of mayflies, caddisflies, and fish in the Mississippi River near Keokuk, Iowa. Ph.D. Dissertation. Iowa State University, Ames. 180 pp.

- Wenke, T.L. 1968. Abundance of Crepidostomum and other intestinal helminths in fishes from Pool 19, Mississippi River. Iowa State J. Sci. 43:211-222.
- Wiebe, A.H. 1927. Biological survey of the Upper Mississippi River, with special reference to pollution. Bull. U.S. Fish. 43:137-167.
- Williams, L.G. 1964. Possible relationships between plankton diatom species numbers and water quality estimates. Ecology 45:809-823.
- Williams, L.G. 1966. Dominant planktonic rotifers of major waterways of the United States. Limnol. Oceanogr. 11:83-91.
- Williams, L.G. 1972. Plankton diatom species biomasses and the quality of American rivers and the Great Lakes. Ecology 53:1038-1050.
- Wooley, J.B., and R.B. Owen, Jr. 1978. Energy costs of activity and daily energy expenditure in the black duck. J. Wildl. Manage. 42(4):739-745.
- Wright, K.J. 1970. The 1967-1968 sport fishing survey of the Upper Mississippi River. Upper Miss. River Conserv. Comm. Spec. Publ. 116 pp.
- Yorke, T.H. 1978. Impact assessment of water resource development activities: a dual matrix approach. U.S. Fish Wildl. Serv. Biol. Serv. Program FWS/OBS-78/82. 27 pp.
- Zimmer, D.W. 1976. Observations of invertebrate drift in the Skunk River, Iowa. Proc. Iowa Acad. Sci. 82(3-4): 175-178.
- Zimmerman, B. 1979. Potential environmental impacts of Mississippi River year-round navigation on commercial fishing, Vol. 2. U.S. Army Corps of Engineers, Rock Island, Ill. 128 pp.

50272-101

REPORT DOCUMENTATION PAGE	1. REPORT NO. Biological Report 85(7.6)	2.	3. Recipient's Accession No.
4. Title and Subtitle The Ecology of Pools 19 and 20 of the Upper Mississippi River: A Community Profile			5. Report Date September 1986
7. Author(s) Larry A. Jahn and Richard V. Anderson*			6.
9. Performing Organization Name and Address			8. Performing Organization Rept. No.
12. Sponsoring Organization Name and Address National Wetlands Research Center U.S. Fish and Wildlife Service U.S. Department of the Interior Washington, DC 20240			10. Project/Task/Work Unit No.
U.S. Army Corps of Engineers Rock Island District Office Clock Tower Bldg. P.O. Box 2004 Rock Island, IL 61204			11. Contract(C) or Grant(G) No. (C) (G)
			13. Type of Report & Period Covered
			14.
15. Supplementary Notes *Affiliation: Western Illinois Univ., Dep. of Biol. Sci., Macomb, IL 67145			
16. Abstract (Limit: 200 words) To accommodate navigation, the Upper Mississippi River has been extensively modified by the dredging of navigation channels and the construction of a series of lock and dam structures. Each lock and dam creates a pool in the river. This document reviews ecological information and data on navigation pools 19 and 20 of the Upper Mississippi River extending from near Keokuk, IA, southward to Canton, MO, and Meyer, IL. This report reviews the geologic history and present physiographic conditions of the pools. Biological populations inhabiting or associated with the pools are described, followed by a section on community functions which includes a discussion of production and trophic interactions. The final chapter describes human impacts on this section of the river.			
17. Document Analysis a. Descriptors Rivers, wetlands, fishes, mammals, invertebrates, waterfowl, aquatic plants			
b. Identifiers/Open-Ended Terms Mississippi River, navigation, locks and dams, dredging, nutrient cycling, productivity			
c. COSATI Field/Group			
18. Availability Statement Unlimited	19. Security Class (This Report) Unclassified	21. No. of Pages 142	
	20. Security Class (This Page) Unclassified	22. Price	

(See ANSI-Z39.18)

OPTIONAL FORM 272 (4-77)
(Formerly NTIS-35)
Department of Commerce