

BUILDING DESIGN FOR HOMELAND SECURITY COOP T-t-T

Unit VIII

Chemical, Biological, and Radiological (CBR) Measures



FEMA

Unit Objectives

Explain the five possible protective actions for a building and its occupants.

Compare filtration system efficacy relative to the particles present in CBR agents.

Explain the key issues with CBR detection.

Identify the indications of CBR contamination.



FEMA

Unit VIII: CBR Measures

Units I-VI covered the Risk Assessment Process

Units VII and VIII explain Explosive Blast, CBR Agents, and their effects

Units IX and X demonstrate techniques for site layout and building design to counter or mitigate manmade threats and similar technological hazards



FEMA

CBR Measures: An Overview

FEMA 426, Chapter 5 is based on best practices for safeguarding building occupants from CBR threats. This module is organized into four sections :

- Protective Actions for Buildings and Occupants
- Air Filtration and Cleaning Principles and Technology
- CBR Detection and Current Technology
- Non-Technology CBR Contamination Indications



FEMA



SOURCE: SENSIR TECHNOLOGIES

CBR Terrorist Incidents Since 1970

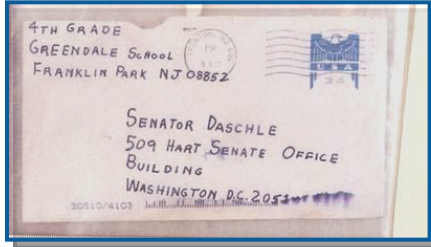

1972 Typhoid

70 75 80



1984 Salmonella
200 Injured

1984 Botulinum

1985 Cyanide

June 1994 Sarin
7 Dead, 200 Injured

1992 Cyanide
March 1995 Ricin

April 1995 Sarin

April-June 1995 Cyanide, Phosgene, Pepper Spray

March 1995 Sarin

May 1995 Plague

April 1997 U235

February 1997 Chlorine
14 Injured, 500 Evacuated

March 1998 Cesium-137

June 1996 Uranium

2001 Anthrax

December 1995 Ricin

November 1995 Radioactive Cesium



What is the CBR Threat Today?

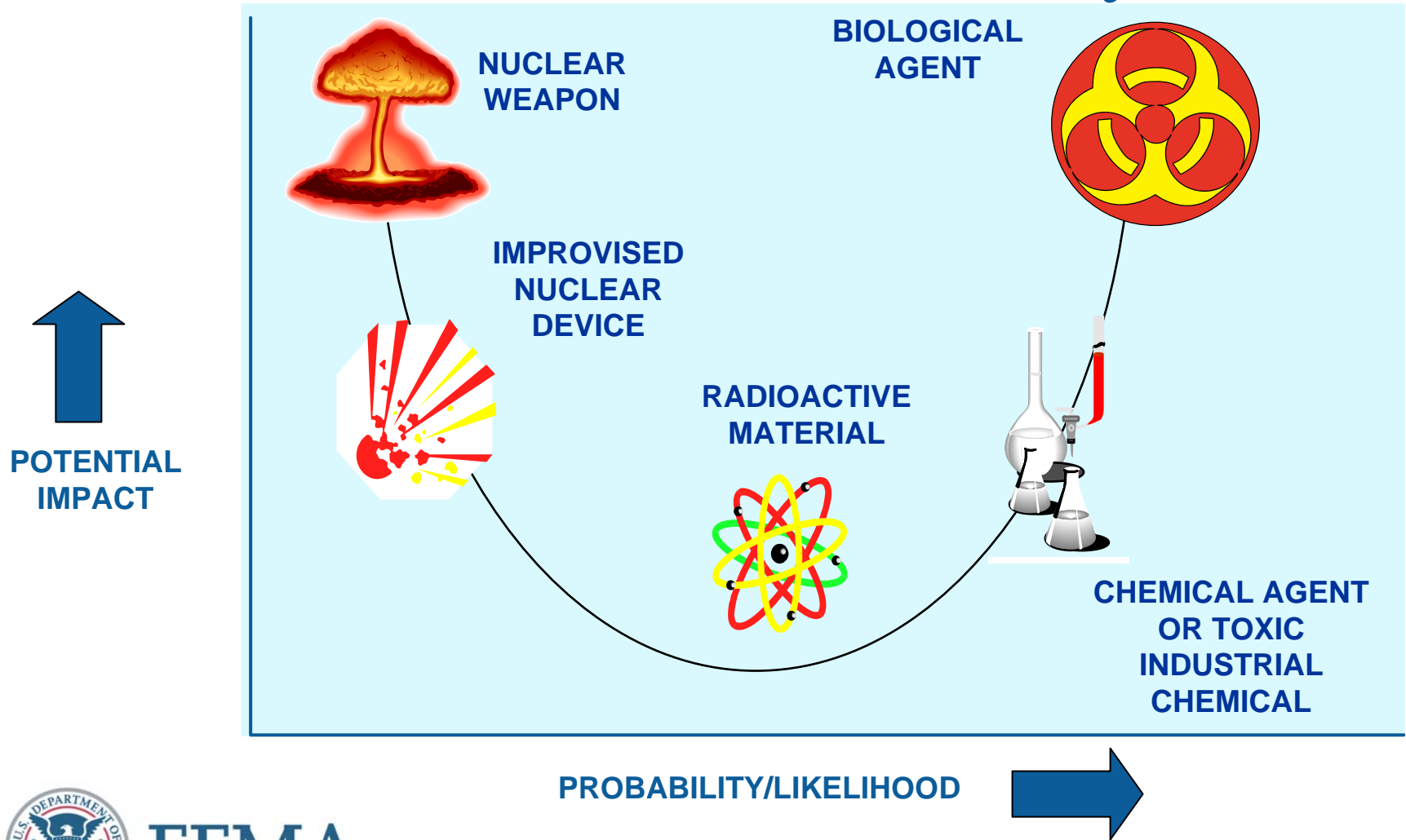

FEMA

Why Would Terrorists Use CBR?

- Available and relatively easy to manufacture
- Large amounts not needed in an enclosed space
- Easily spread over large areas
- Potential for mass casualties
 - Strong psychological impact
 - Overwhelms resources
 - Difficult to recognize (contagious or spread by victims)



FEMA

CBR Sources

- Laboratory/commercial
- Industrial facilities
- Foreign military sources
 - At least 26 countries possess chemical agents or weapons
 - 10 countries are suspected to possess biological agents or weapons
- Medical/university research facilities
- Nuclear facilities
- Home production

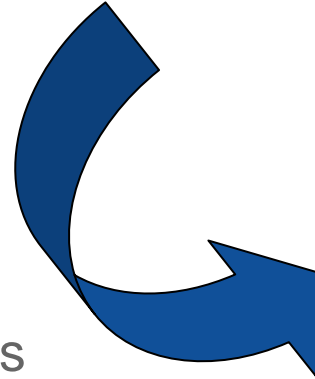

FEMA

Limitations of CBR Materials

- Targeted dissemination is difficult
- Delayed effects can detract from impact
- Counterproductive to terrorists' support
- Potentially hazardous to the terrorist
- Development and use require time and expertise

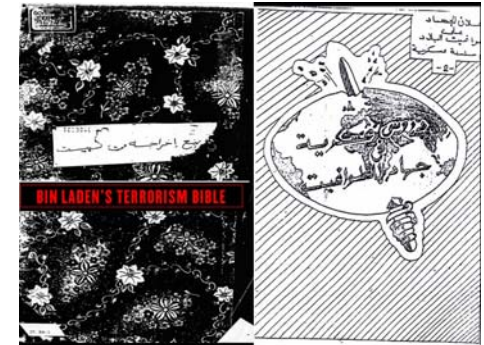
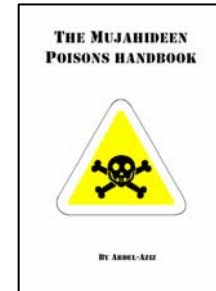

FEMA

Chemical Agents: Characteristics and Behavior

- Generally liquid (when containerized)
- Normally disseminated as aerosol or gas
- Present both a respiratory and skin contact hazard
- May be detectable by the senses (especially smell)
- Influenced by weather conditions



Subway riders injured in Aum Shinrikyo sarin gas attack, Tokyo, March 20, 1995.
(AP Photo/Chikumo Chiaki)



FEMA

Classes of Chemical Agents

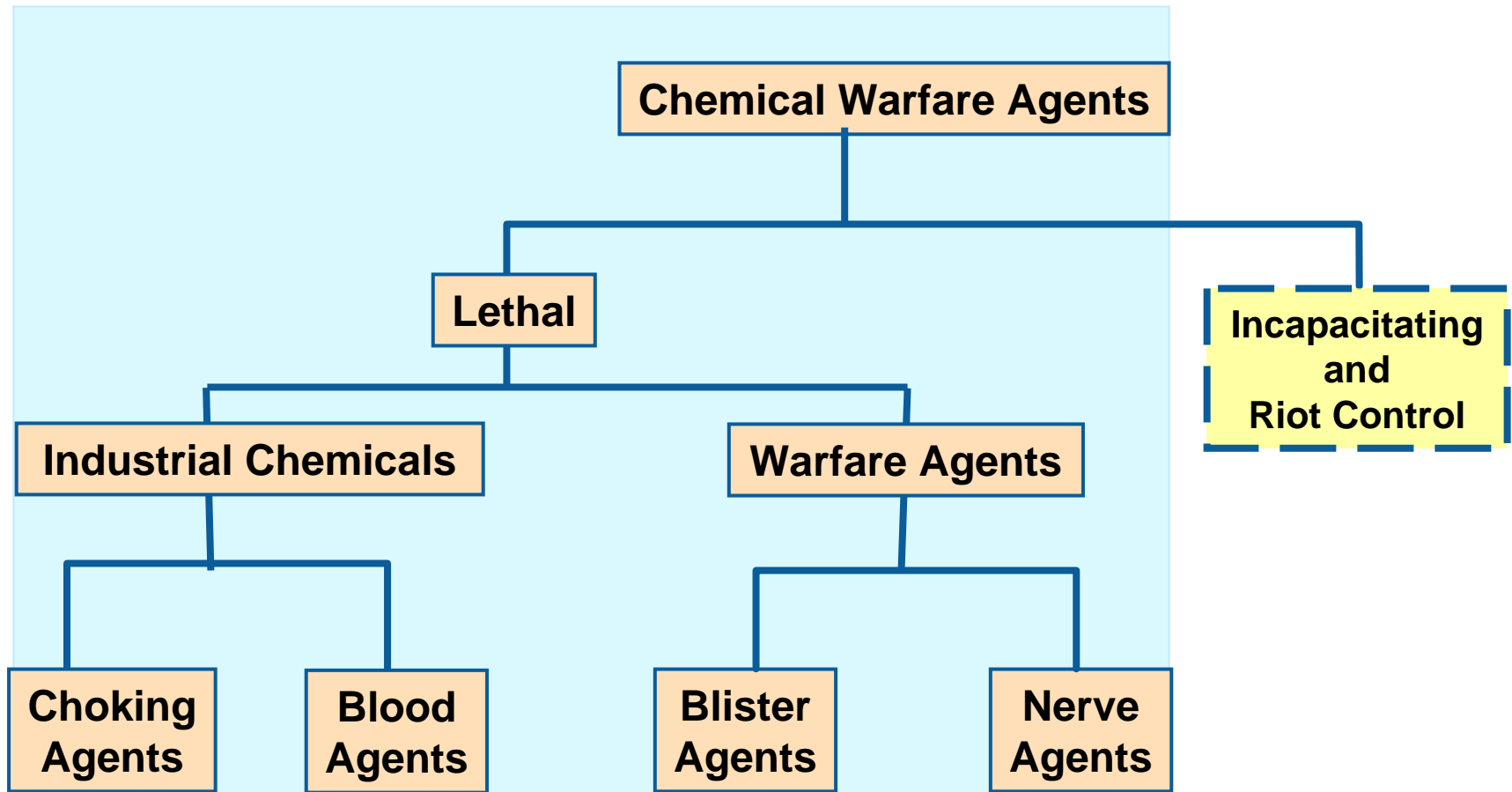

FEMA

Industrial Chemicals

Industrial chemicals previously used as chemical warfare agents

	Choking Agents Chlorine/Phosgene	Blood Agents Hydrogen Cyanide/ Cyanogen Chloride
Physical Appearance	Greenish-yellow vapor/ colorless vapor	Colorless vapor
Odor	Bleach/mown hay	Bitter almonds
Signs and Symptoms	Coughing, choking, tightness in chest	Gasping for air Red eyes, lips, skin
Protection	Respiratory	Respiratory
Treatment	Aeration	Aeration, cyanide kit

Four industrial chemicals previously used as chemical warfare agents



FEMA

Comparative Toxicity

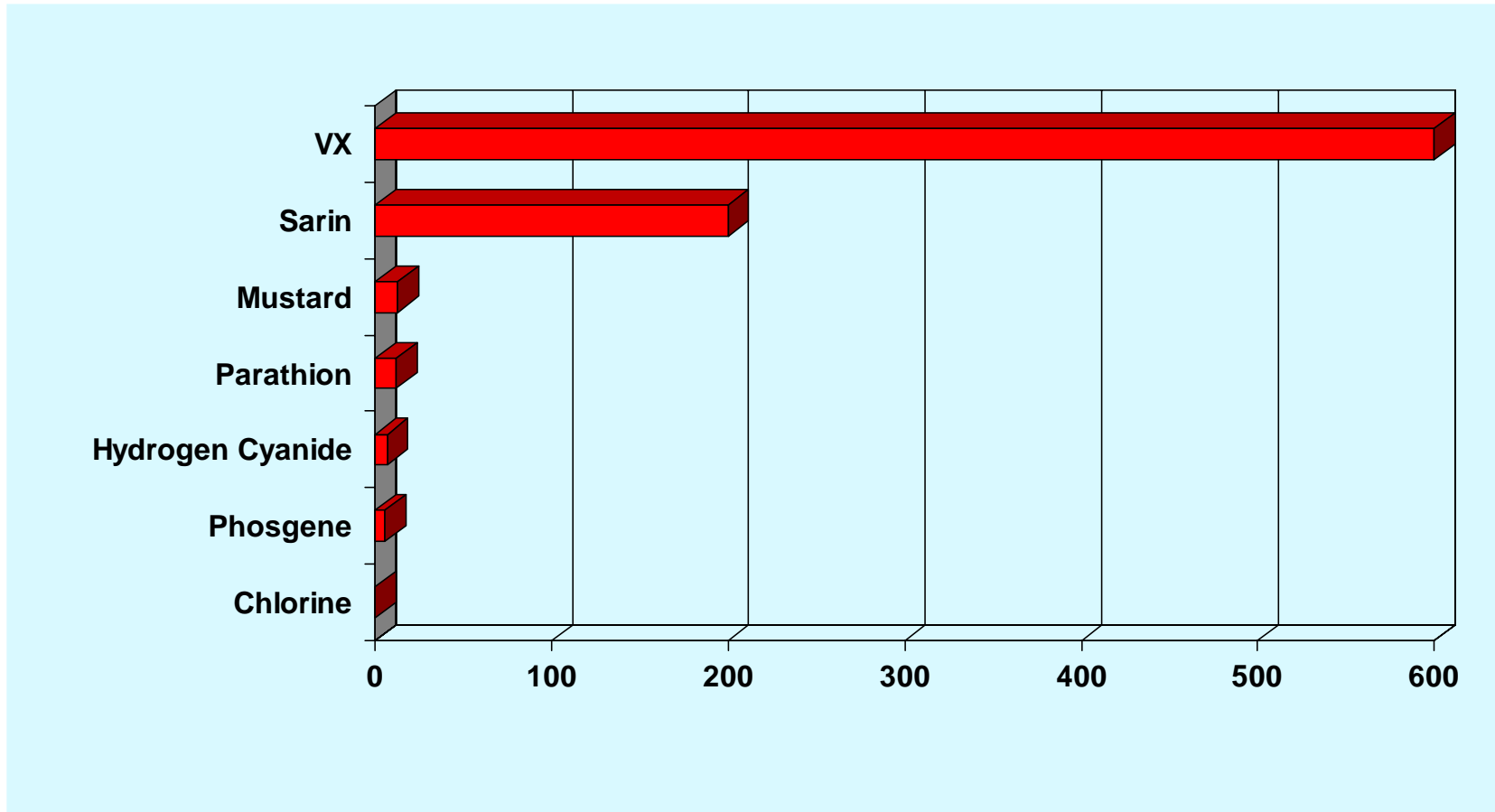

FEMA

How Much Sarin Does it Take?

Structure	Lethal Amount
Domed Stadium	107 kg (26 gals)
Movie Theater	1.2 kg (5 cups)
Auditorium	52 g (1/4 cup)
Conference Room (50-100 seating)	33 g (1 shot glass)

LD₅₀ amounts for 1 minute exposure to Sarin aerosol



FEMA

Chemical Agents Key Points

- Chemical agents are super toxic
- Relative toxicity: industrial chemicals < mustard < nerve
- Normal states are as a liquid or a vapor
- Inhalation hazard is of greatest concern



FEMA

Biological Warfare Agents

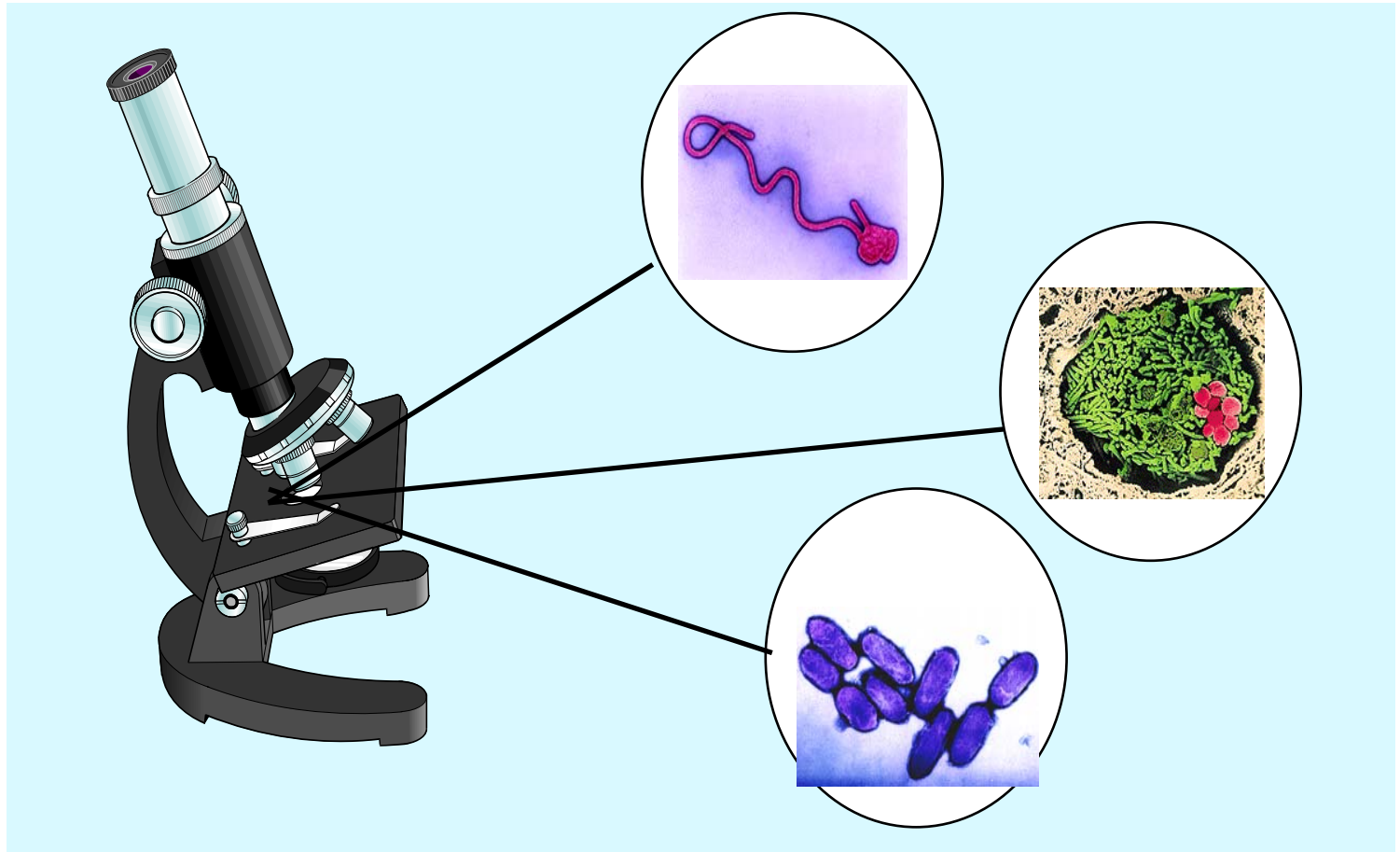

FEMA

Classes of Biological Agents

Bacteria

Viruses

Toxins

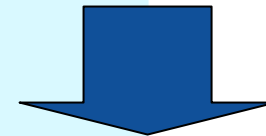
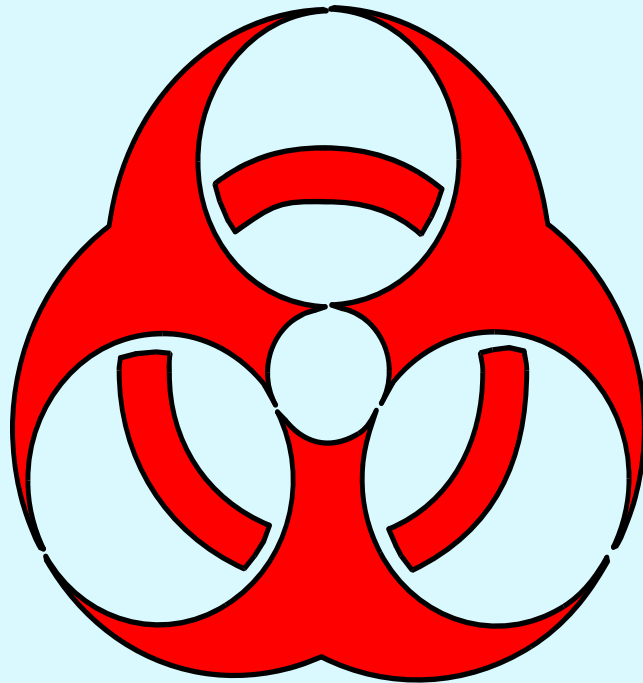

FEMA 426 - Appendix C contains a CBR glossary and characteristics of biological agents



FEMA

Bacteria

	Anthrax	Plague
Incubation Period	1 to 6 days	2 to 3 days for pneumonic 2 to 10 days for bubonic
Contagious	NO	YES (pneumonic) NO (bubonic)
Signs and Symptoms	Chills, fever, nausea, swollen lymph nodes	Chills, high fever, headache, spitting up blood, shortness of breath
Protection	Standard Precautions	Standard Precautions and Droplet Precautions
Treatment	Antibiotics and vaccines	Antibiotics and vaccines



FEMA

Viruses

	Smallpox	Viral Hemorrhagic Fevers
Contagious	YES	YES
Signs and Symptoms	Fever, rigors, vomiting, headache, pustules	Fever, vomiting, diarrhea, mottled/blotchy skin
Protection	Standard Precautions + Droplet + Airborne + Contact Precautions	Standard Precautions + Droplet + Airborne + Contact Precautions
Treatment	Vaccine, supportive therapy	Vaccines available for some



FEMA

Toxins

	Neurotoxin (Botulinum)	Cytotoxin (Ricin)
Onset of Symptoms	1 to 3 days	4-8 hours after ingestion 12-24 hours after inhalation
Contagious	NO	NO
Signs and Symptoms	Weakness, dizziness, dry mouth and throat, blurred vision, paralysis	Chills, high fever, headache, spitting up blood, shortness of breath
Protection	Standard Precautions	Standard Precautions
Treatment	Supportive care, antitoxins, and vaccines	Supportive oxygenation and hydration

Note: There are numerous naturally-occurring toxins. For our purposes, we will group them into two categories.



FEMA

Biological Agents Key Points

Onset of symptoms

Potentially contagious

Signs and symptoms

Protection

Treatment

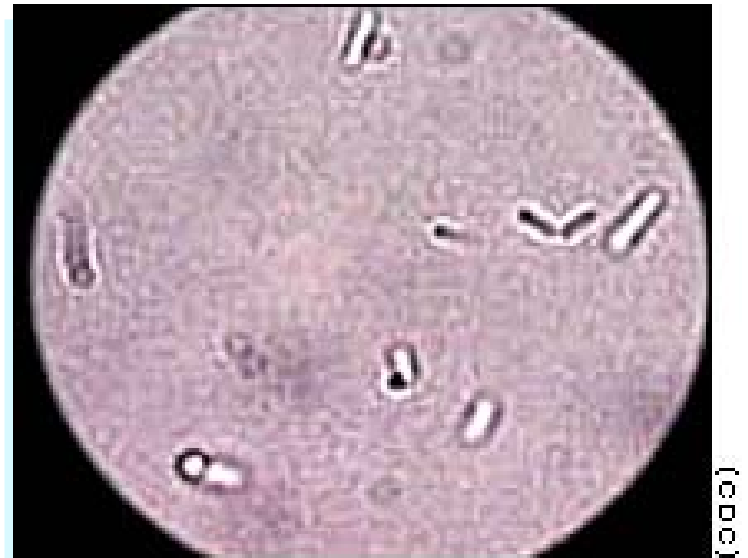
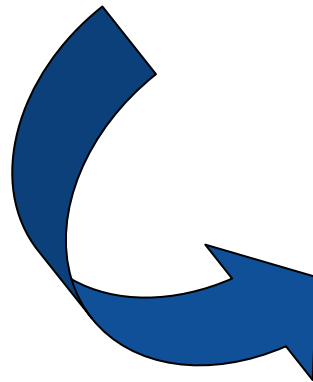

FEMA

Nuclear/Radiological Materials

Improvised Nuclear Devices

Nuclear Plants

Radiological Dispersal Device

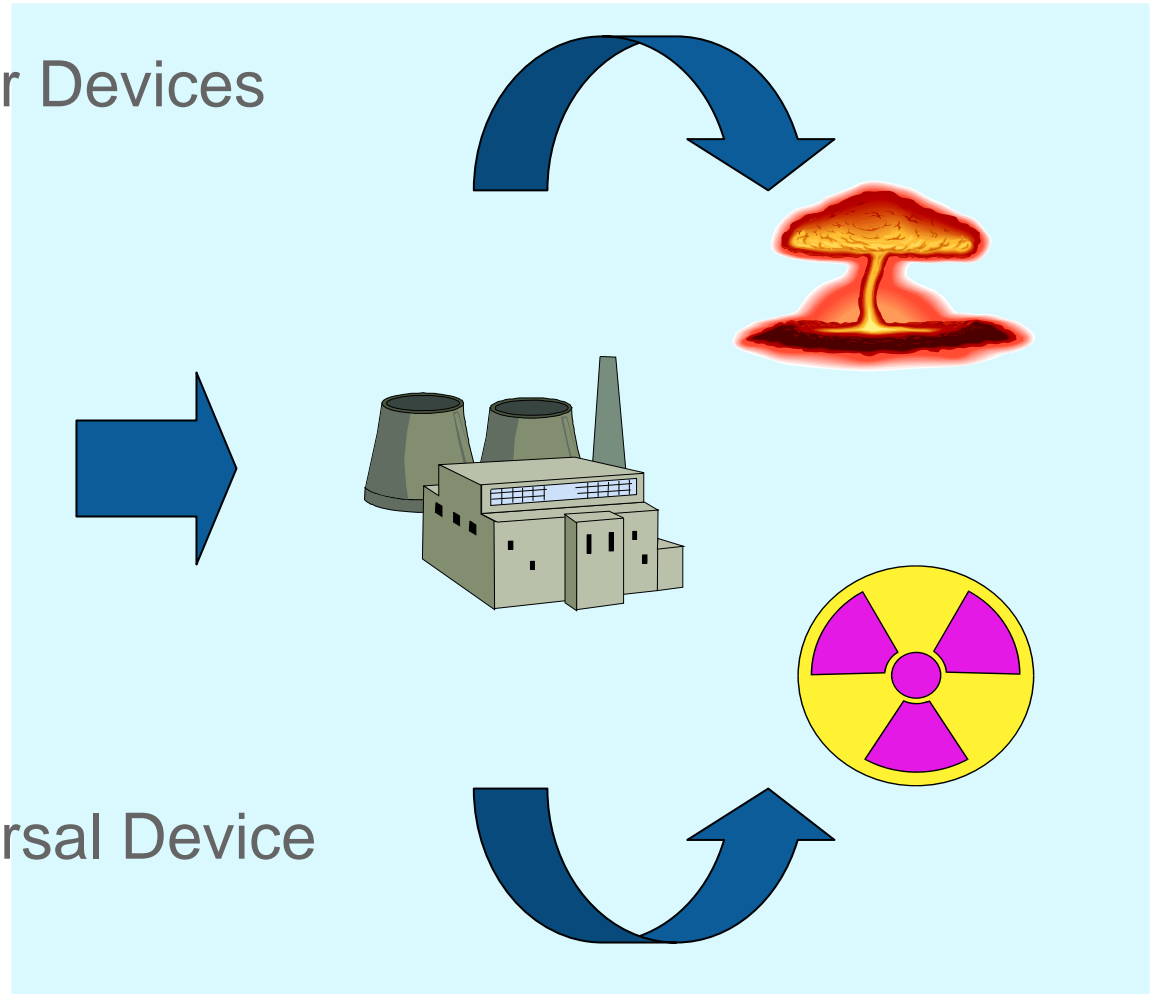

FEMA

Ionizing Radiation

Alpha particles

Beta particles

Gamma rays

Neutrons

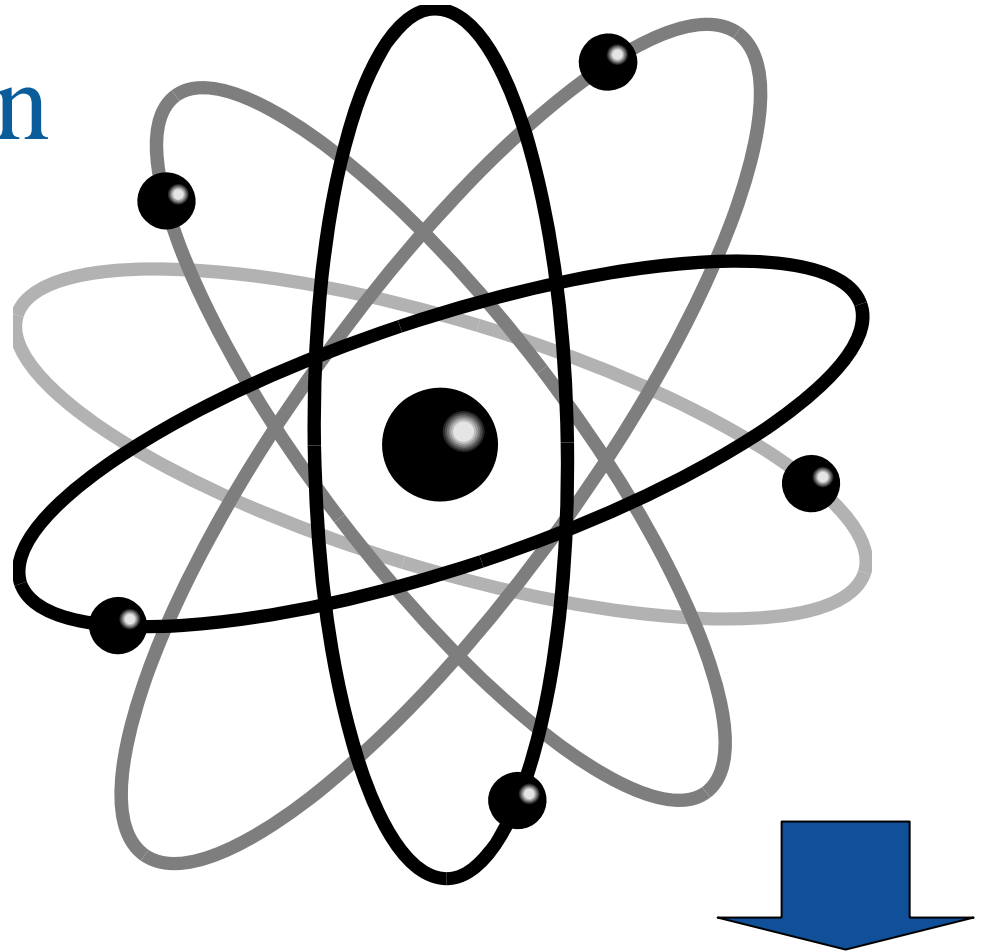

There are also non-ionizing types of radiation – fluorescent lights, lasers, and microwaves. In these examples, the radiation can cause burns, but it does not cause molecular change or ionization



FEMA

Common Radiation Exposures

Average annual exposure	360 mrem per year
Chest x-ray	10 to 30 mrem
Flight	0.5 mrem every hour
Smoking 1.5 packs per day	16,000 mrem per year

Chronic



Mild radiation sickness*	200,000 mrem
Lethal dose*	450,000 mrem

Acute



* single acute exposure



FEMA

Health Hazards in an Incident

- Exposure to radiation source (external)
- Contamination (possible internal and/or external)

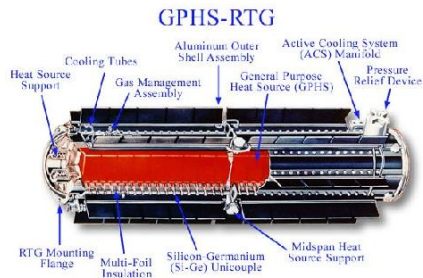

FEMA

Protection from Radiation Exposure

Time

Distance

Shielding

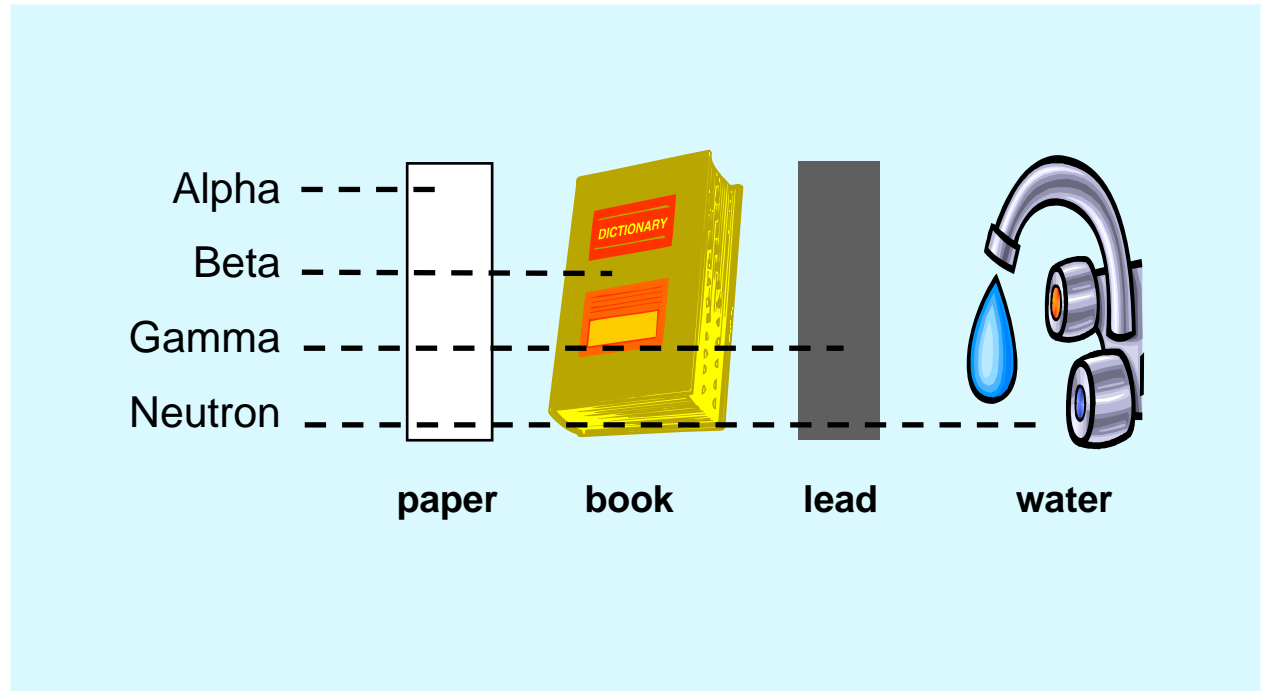

FEMA

CBR Detection

Radiological	✓
Chemical	✓
Biological	?



SOURCE: BAE SYSTEMS

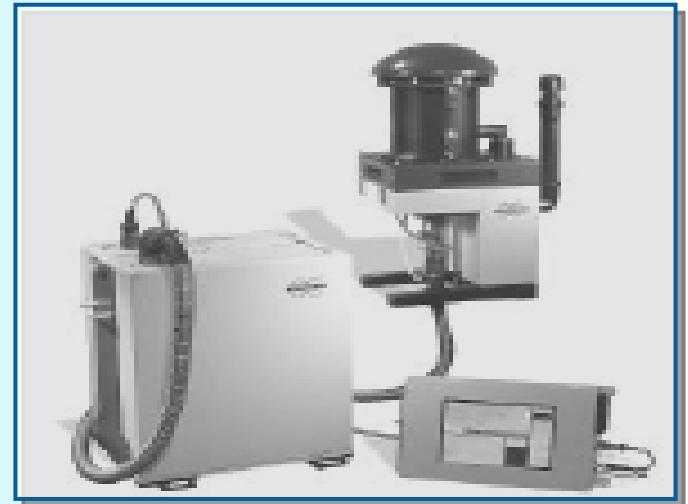

SOURCE: BRUKER DALTRONICS



FEMA

CBR Incident Indicators

Indicator	Chemical	Biological	Radiological
Dead Animals	✓		✓
Lack of Insect life	✓		
Physical Symptoms	✓	✓	✓
Mass Casualties	✓		✓
Unusual Liquids	✓		
Unexplained Odors	✓		
Unusual Metal Debris/Canisters	✓	✓	✓
Heat Emitting or Glowing			✓
Spray Mechanisms	✓	✓	



FEMA

CBR Protection Strategies

Protective Actions:

- Evacuation
- Sheltering in Place
- Personal Protective Equipment
- Air Filtration, Pressurization, and Ultraviolet Light
- Exhausting and Purging



FEMA

Evacuation

- Determine airborne hazard source -- internal or external
- Determine if evacuation will make things better or worse
- Assembly should be upwind, at least 1,000 feet away, and three different locations (A, B, C plan)
- In most cases, existing plans for fire evacuation apply – follow through - exercise

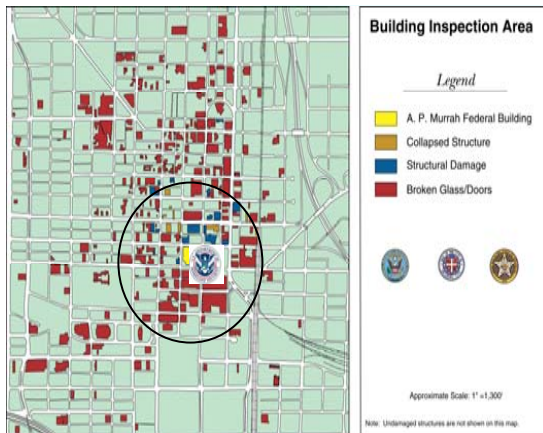

FEMA

Sheltering in Place

A building can provide substantial protection against agents released outside if uptake of contaminated air can be halted or reduced and/or if uptake of fresh/filtered air can be increased.

The amount of protection varies with:

- How tight the building is
- Level of exposure (dose x time)
- Purging or period of occupancy
- Natural filtering



FEMA

Personal Protective Equipment



SOURCE: BARDAS CHILD PROTECTIVE WRAP (ISRAEL)



SOURCE: MINE SAFETY APPLIANCES COMPANY (USA)



SOURCE: BROOKDALE INTERNATIONAL SYSTEMS INC (CANADA)



FEMA

Aftermath of Tragic Events



NMRT decontamination corridor.



Assembly should be to the upwind side of the building at least 1,000 feet away since any airborne hazard escaping the building during an internal release will be carried downwind.



FEMA

Air Filtration and Pressurization

- Requires modifications to HVAC and electrical systems – significant initial and life-cycle costs
- Introduces filtered air at a rate sufficient to produce an overpressure and create an outward flow through leaks and cracks

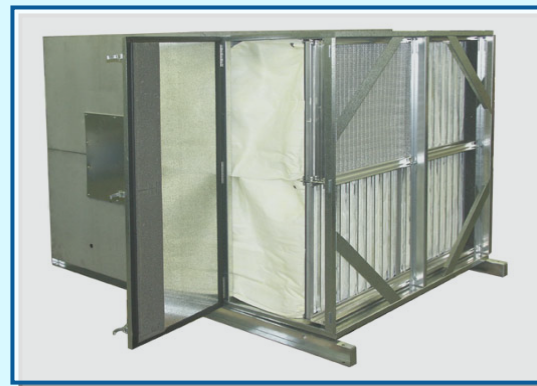
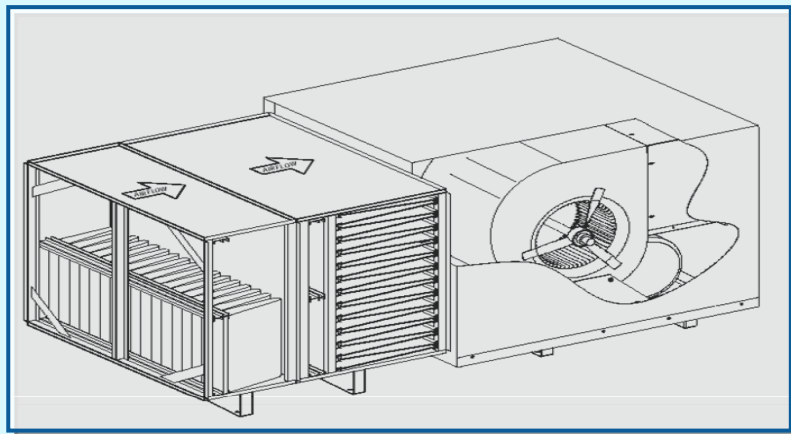

SOURCE: TRION INCORPORATED



FEMA

FEMA 426, Figures 5-5 and 5-12: Bag Filter and HEPA Filter; Commercial Air Filtration Unit, p. 5-12 and 5-22

Air Filtration and Cleaning

Two Types of Collection Systems:

- Particulate air filtration
 - Principles of collection
 - Types of particulate filters
 - Filter testing and efficiency ratings
- Gas-phase air filtration
 - Principles of collection
 - Types of gas-phase filters



FEMA

Air Contaminant Sizes

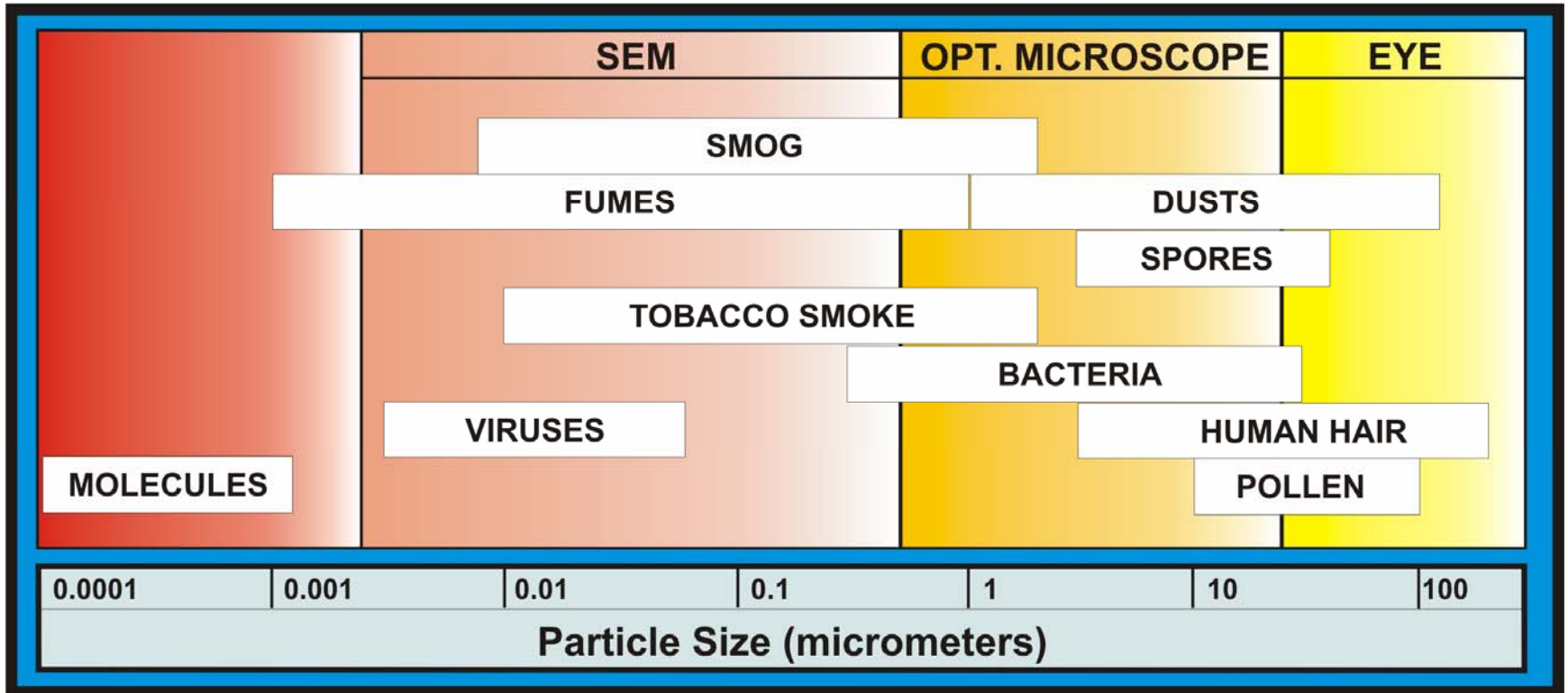

FEMA

Various Filter Types

HEPA Filters



SOURCE: FLANDERS CORPORATION

Pleated Panel Filters



SOURCE: AMERICAN FILTER

Carbon Filters



SOURCE: FLANDERS CORPORATION

FEMA 426, Figure 5-9: Charcoal Filter Beds (center), p. 5-17

BUILDING DESIGN FOR HOMELAND SECURITY COOP T-t-T Unit VIII-C-37



FEMA

ASHRAE Standards

ASHRAE 52.2				ASHRAE 52.1		Particle Size Range, μm	Applications
MERV	Particle Size Range			Test			
	3 to 10 μm	1 to 3 μm	.3 to 1 μm	Arrestance	Dust Spot		
1	< 20%	-	-	< 65%	< 20%	> 10	Residential, light, pollen, dust mites
2	< 20%	-	-	65 - 70%	< 20%		
3	< 20%	-	-	70 - 75%	< 20%		
4	< 20%	-	-	> 75%	< 20%		
5	20 - 35%	-	-	80 - 85%	< 20%	3.0 - 10	Industrial, Dust, Molds, Spores
6	35 - 50%	-	-	> 90%	< 20%		
7	50 - 70%	-	-	> 90%	20 - 25%		
8	> 70%	-	-	> 95%	25 - 30%		



FEMA

FEMA 426, Table 5-1: Comparison of ASHRAE Standards 52.1 and 52.2, p. 5-12

ASHRAE Standards

9	> 85%	< 50%	-	> 95%	40 - 45%	1.0 – 3.0	Industrial, Legionella, dust
10	> 85%	50 - 65%	-	> 95%	50 - 55%		
11	> 85%	65 - 80%	-	> 98%	60 - 65%		
12	> 90%	> 80%	-	> 98%	70 - 75%		
13	> 90%	> 90%	< 75%	> 98%	80 - 90%	0.3 – 1.0	Hospitals, Smoke removal, Bacteria
14	> 90%	> 90%	75 - 85%	> 98%	90 - 95%		
15	> 90%	> 90%	85 - 95%	> 98%	~95%		
16	> 95%	> 95%	> 95%	> 98%	> 95%		
17	-	-	≥ 99.97%	-	-	< 0.3	Clean rooms, Surgery, Chembio, Viruses
18	-	-	≥ 99.99%	-	-		
19	-	-	≥ 99.999%	-	-		
20	-	-	≥ 99.9999%	-	-		



FEMA

FEMA 426, Table 5-1: Comparison of ASHRAE Standards 52.1 and 52.2,
p. 5-12

Inside Versus Outside Releases

Outside Release

- Keep people inside building
- Reduce indoor/outdoor air exchange – close dampers
- Shut off air handling systems and equipment that moves air – HVAC, exhausts, combustion, computers, elevators
- Close all windows and doors
- Once the outdoor hazard has dissipated
 - Open all doors and windows
 - Turn on all fans, including purging systems



FEMA

Inside Versus Outside Releases

Inside Release

- Turn off all air handling equipment if no special stand-alone systems installed
- If special systems installed, i.e. mailroom
 - Place air handling system on full (or 100% outside air) to pressurize the space around release room
 - Turn off all air handling supplying release room
- Consider activating fire sprinklers in release room if toxic chemicals involved
- Evaluate evacuation routes for contamination
- Evacuate building in accordance with emergency plan



FEMA

Exhausting and Purging

Basic Principles:

- Use ventilation and smoke/purge fans to remove airborne hazards
 - Use primarily after an external release plume has passed
 - Selectively use for internal release – may spread contamination further
- Purging should be carefully applied
 - Primarily when agent has spread throughout building



FEMA

HVAC System Upgrade Issues

- What is the threat? Toxic Industrial Chemicals, particulate, gaseous, chemical, biological?
- How clean does the air need to be and what is the associated cost?
- What is the current system capacity?
- Is there filter bypass and how significant is air infiltration into the building envelope?
- Will improved indoor air quality offset upgrade costs?
- Is system maintenance addressed?



FEMA

Economic Issues to Consider

Initial Costs

- Filters, housing, blowers
- Factors including flow rate, contaminant concentration

Operating Costs

- Maintenance, replacement filters, utilities, waste disposal

Replacement Costs

- Filter life (factors include continued concentration and particle size distribution, flow rates, etc.)



FEMA

Access to Outdoor Intakes

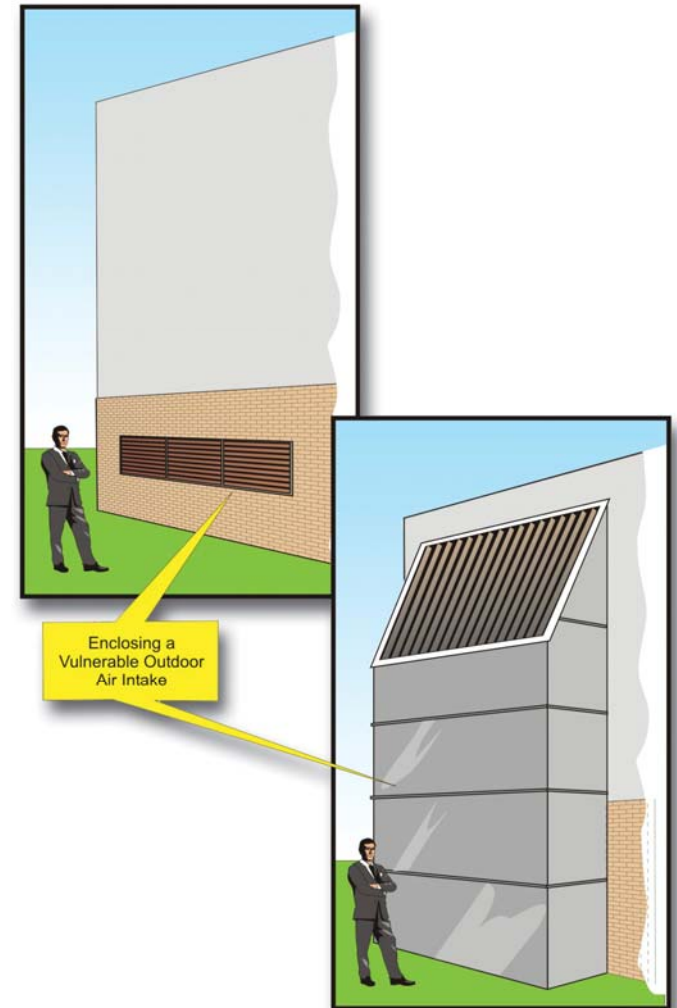
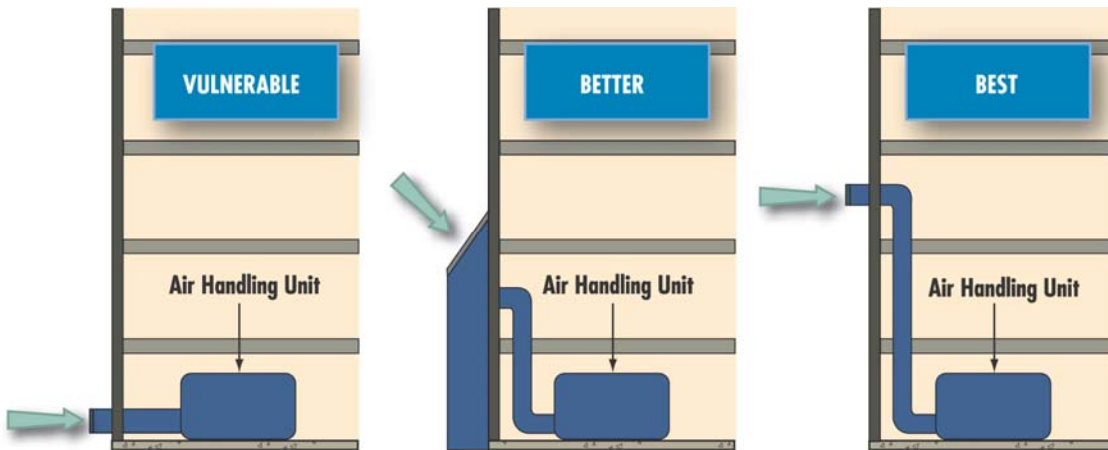

FEMA

FEMA 426, Figure 3-8, Example of Protecting Outdoor Air Intakes, p. 3-36 and Figure 3-11, Example of Enclosing Existing Vulnerable Air Intake, p.3-38

Ultraviolet Germicidal Irradiation

All viruses and almost all bacteria (excluding spores) are vulnerable to moderate levels of UVGI exposure

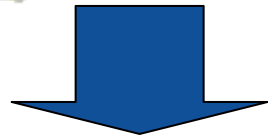
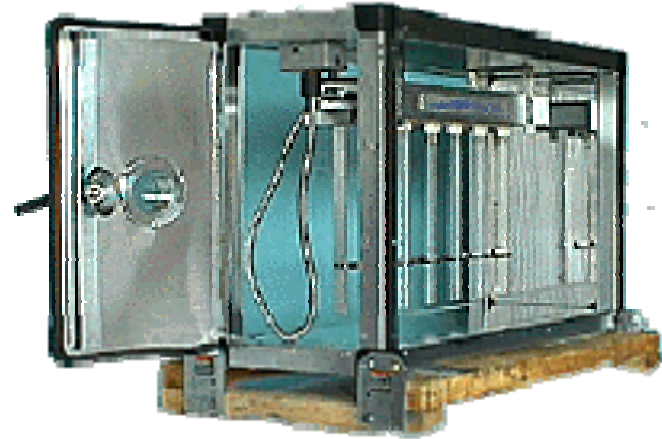

UV lamps resemble ordinary fluorescent lamps, but are designed to emit germicidal UV



FEMA

FEMA 426, Figure 5-10: UVGI Array with Reflective Surfaces, p. 5-19

Infiltration and Bypass

Infiltration

- Building envelope tightness and ventilation control are critical

Bypass

- Filters should be airtight
- Check gaskets and seals
- Periodically check

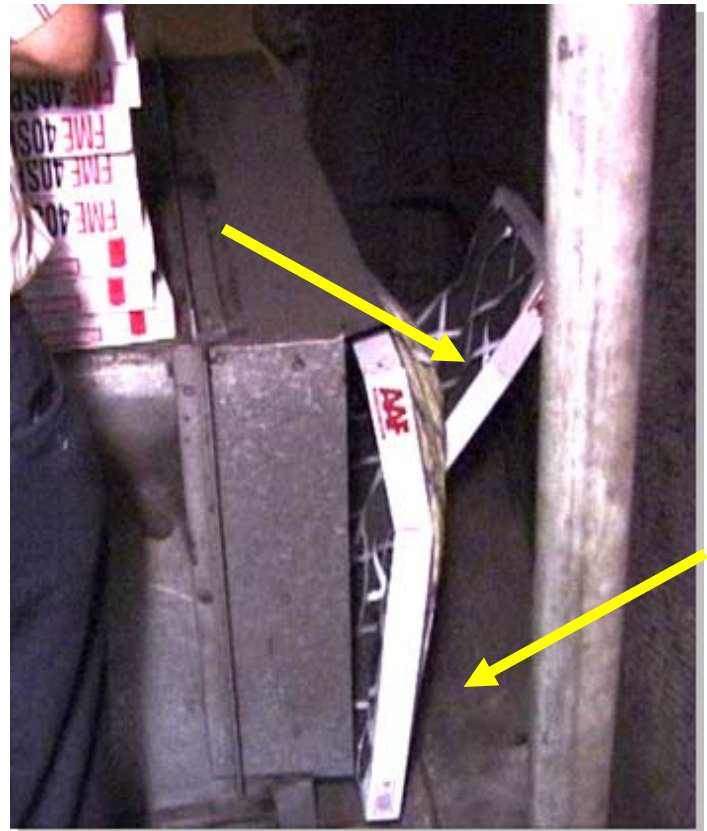

FEMA

Things Not to Do

- Outdoor air intakes should not be permanently sealed.
- HVAC systems (includes filter upgrades) should not be modified without understanding effects on building systems or occupants.
- Fire protection and life safety systems should only be modified after careful analysis and review.



FEMA

Things to Do

- Have a current emergency plan that addresses CBR concerns
 - Exercise plan
 - Revise plan based upon lessons learned
- Understand your HVAC building vulnerabilities
- Conduct periodic walk-through of system for evidence of irregularities or tampering
- Recognize that there are fundamental differences among various CBR events



FEMA

Summary

- CBR threats are real and growing.
- Industrial chemicals are readily available.
- Military chemicals require specialty expertise.
- Most buildings provide a reasonable level of protection.
- Inside versus outside building release determines evacuation and other reaction decisions.
- Develop an emergency plan and ensure it works.



FEMA

Unit VIII Case Study Activity

Chemical, Biological, and Radiological (CBR) Measures

Background

Purpose of activity: check on learning about the nature of chemical, biological, and radiological agents

Requirements

- Refer to Case Study and FEMA 426
- Answer worksheet questions



FEMA