



REGULATORY GUIDE

OFFICE OF NUCLEAR REGULATORY RESEARCH

REGULATORY GUIDE 1.52

(Draft was issued as DG-1102)

DESIGN, INSPECTION, AND TESTING CRITERIA FOR AIR FILTRATION AND ADSORPTION UNITS OF POST-ACCIDENT ENGINEERED-SAFETY-FEATURE ATMOSPHERE CLEANUP SYSTEMS IN LIGHT-WATER-COOLED NUCLEAR POWER PLANTS

A. INTRODUCTION

This guide provides guidance and criteria acceptable to the NRC staff for implementing the NRC's regulations in Appendix A to 10 CFR Part 50 with regard to the design, inspection, and testing of air filtration and iodine adsorption units of engineered-safety-feature (ESF) atmosphere cleanup systems in light-water-cooled nuclear power plants. For the purposes of this guide, ESF atmosphere cleanup systems are those systems that are credited in the licensee's current design basis accident analysis, as described in the Safety Analysis Report (SAR). This guide addresses ESF atmosphere cleanup systems, including the various components and ductwork, in the postulated design basis accident (DBA) environment.

In Appendix A, "General Design Criteria for Nuclear Power Plants," to 10 CFR Part 50, "Domestic Licensing of Production and Utilization Facilities," General Design Criteria 41, 42, and 43 require that containment atmosphere cleanup systems be provided as necessary to reduce the amount of radioactive material released to the environment following a postulated DBA. They also require that these

Regulatory guides are issued to describe and make available to the public such information as methods acceptable to the NRC staff for implementing specific parts of the NRC's regulations, techniques used by the staff in evaluating specific problems or postulated accidents, and data needed by the NRC staff in its review of applications for permits and licenses. Regulatory guides are not substitutes for regulations, and compliance with them is not required. Methods and solutions different from those set out in the guides will be acceptable if they provide a basis for the findings requisite to the issuance or continuance of a permit or license by the Commission.

This guide was issued after consideration of comments received from the public. Comments and suggestions for improvements in these guides are encouraged at all times, and guides will be revised, as appropriate, to accommodate comments and to reflect new information or experience. Written comments may be submitted to the Rules and Directives Branch, ADM, U.S. Nuclear Regulatory Commission, Washington, DC 20555-0001.

Regulatory guides are issued in ten broad divisions: 1, Power Reactors; 2, Research and Test Reactors; 3, Fuels and Materials Facilities; 4, Environmental and Siting; 5, Materials and Plant Protection; 6, Products; 7, Transportation; 8, Occupational Health; 9, Antitrust and Financial Review; and 10, General.

Single copies of regulatory guides (which may be reproduced) may be obtained free of charge by writing the Distribution Services Section, U.S. Nuclear Regulatory Commission, Washington, DC 20555-0001, or by fax to (301)415-2289, or by email to DISTRIBUTION@NRC.GOV. Electronic copies of this guide are available on the internet at NRC's home page at WWW.NRC.GOV in the Reference Library under Regulatory Guides and through the Electronic Reading Room, as Accession Number ML011710176, along with other recently issued guides, at the same web site.

systems be designed to permit appropriate periodic inspection and testing to ensure their integrity, capability, and operability.

General Design Criterion 61 of Appendix A to 10 CFR Part 50 requires that fuel storage and handling systems, radioactive waste systems, and other systems that may contain radioactivity be designed to ensure adequate safety under normal and postulated accident conditions and that they be designed with appropriate containment, confinement, and filtering systems. General Design Criterion 19 requires that adequate radiation protection be provided to permit access to and occupancy of the control room under accident conditions and for the duration of the accident without personnel radiation exposures in excess of 5 rem to the whole body, or its equivalent to any part of the body.

Nuclear power plants are required by 10 CFR Part 100, "Reactor Site Criteria," to be sited so that radiological doses from normal and postulated accidents are kept acceptably low. A footnote to 10 CFR 100.11 states that the fission product release assumed in the plant design should be based on a major accident involving substantial core damage with subsequent release of appreciable quantities of fission products. According to 10 CFR 50.67, an application to revise a licensee's current accident source term must contain an evaluation of the consequences of applicable design basis accidents previously analyzed in the Safety Analysis Report.

This guide does not apply to atmosphere cleanup systems designed to collect airborne radioactive materials during normal plant operation, including anticipated operational occurrences. Regulatory Guide 1.140, "Design, Inspection, and Testing Criteria for Air Filtration and Adsorption Units of Normal Atmosphere Cleanup Systems in Light-Water-Cooled Nuclear Power Plants," provides guidance for these systems.

The guidance and criteria presented in this guide are not mandatory and licensees may choose not to change their licensing basis. Methods and solutions different from those set out in this guide will be acceptable when an applicant or licensee proposes an acceptable alternative method for complying with the specified portions of the NRC's regulations.

The information collections contained in this regulatory guide are covered by the requirements of 10 CFR Part 50, which were approved by the Office of Management and Budget, approval number 3150-3011. If a means used to impose an information collection does not display a currently valid OMB control number, the NRC may not conduct or sponsor, and a person is not required to respond to, the information collection.

B. DISCUSSION

Atmosphere cleanup systems are included as ESFs in the design of light-water-cooled nuclear power plants to mitigate the radiological consequences of postulated accidents. The mitigating action of ESF atmosphere cleanup systems is limited to the removal of radioactive iodine (both elemental iodine and organic iodides) and particulate matter (aerosols) that may be released into the building or containment during and after the accident; the removal of fission product noble gases by ESF atmosphere cleanup systems is negligible. ESF atmosphere cleanup

systems should be designed to operate under the environmental conditions that would be generated during and after design basis accidents.

In this guide, ESF atmosphere cleanup systems that must operate under postulated DBA conditions inside the primary containment are designated as "primary systems." ESF systems required to operate outside the primary containment under postulated DBA conditions that are generally less severe are designated as "secondary systems." Secondary systems include such systems as the standby gas treatment system (SGTS) and the atmosphere cleanup systems for the spent fuel handling building, control room, shield or annulus building, secondary containment, as well as emergency core cooling system (ECCS) pump leakage. Figures 1 and 2 depict sample ESF atmosphere cleanup systems.

For most currently licensed plants, the characteristics of the fission product release from the core into the containment were set forth in Regulatory Guides 1.3 (Ref. 1) and 1.4 (Ref. 2) and were derived from Technical Information Document (TID) 14844, "Calculation of Distance Factors for Power and Test Reactor Sites" (Ref. 3). This source term has been used in the design basis applications for light-water-cooled nuclear power plants. Since the publication of TID-14844 in 1962, significant advances have been made in understanding the timing, magnitude, and chemical form of fission product releases from severe nuclear power plant accidents. In 1995, the NRC published NUREG-1465 (Ref. 4), which provides estimates of an alternative accident source term based on insights from severe accident research. The NRC enacted 10 CFR 50.67 to provide a means for operating reactors to change their design basis source terms. Regulatory Guide 1.183 (Ref. 5) was developed to provide guidance to licensees of operating power reactors on acceptable applications of alternative source terms. Regulatory Guide 1.183 establishes an acceptable alternative source term (AST) and identifies the significant attributes of other ASTs that may be found acceptable by the NRC staff. Regulatory Guide 1.183 also identifies acceptable radiological analysis assumptions for use in conjunction with the accepted AST. The NRC staff expects that future plants will use the alternative accident source term in support of safety analyses performed in accordance with 10 CFR 50.34 and 10 CFR 50.90.

The DBA environmental design conditions for a given ESF system (primary and secondary systems) should be determined for each plant. DBA radiological design conditions for typical primary and secondary systems should be based on the radiation source term specified in Regulatory Guides 1.3 (Ref. 1), 1.4 (Ref. 2), 1.25 (Ref. 6), or 1.183 (Ref. 5), as applicable. DBA environmental design conditions such as temperature, relative humidity, and pressure should also be considered. In addition, primary systems should be designed to withstand the radiation dose from water and plateout sources in the containment and the corrosive effects of chemical sprays (if such sprays are included in the plant design).

An ESF atmosphere cleanup system consists of housing, dampers, fans, and associated ductwork, motors, valves, and instrumentation. Typical components within the housing are moisture separators, heaters, prefilters, high-efficiency particulate air (HEPA) filters, medium-efficiency postfilters, and iodine adsorption units.

The housing is the portion of an ESF atmosphere cleanup system that encloses air cleaning components and provides connections to adjacent ductwork. Each of these components may be used for moving, cleaning, heating, cooling, humidifying, or dehumidifying the air stream.

The principal purpose of dampers in an ESF atmosphere cleanup system is to shut off or seal the system components from air flowing in a designated flow path. A typical unit has dampers both upstream and downstream from the "train" of components, i.e., upstream from the moisture separator and downstream from the last HEPA filter or iodine adsorber. The dampers prevent or isolate unwanted flow or circulation of the normal air stream through the system components in order to preserve or extend the useful service life of the filtration and iodine adsorption media. ESF system dampers may also serve secondary functions such as flow control, pressure control, balancing, pressure relief, or backflow prevention. This guide does not address the fire prevention aspect of dampers in ESF atmosphere cleanup systems.

The principal purpose of a moisture separator is to remove entrained water droplets from the inlet air stream, thereby protecting HEPA filters and iodine adsorbers from water damage and plugging. Moisture separators may also function as prefilters in some system designs.

Heaters normally follow the moisture separators in the cleanup train. They are designed to heat the incoming air stream to reduce the stream's relative humidity upstream from the HEPA filters and iodine adsorbers during system operation to minimize adsorption of water vapor from the air by the iodine adsorbers. As an added measure, some designs use heaters (or some other mechanism) to prevent condensation within the isolated components of the cleanup unit while the cleanup units are not in service.

Prefilters and HEPA filters are installed to remove particulate matter from the air stream. Prefilters remove the larger airborne particles from the air stream and prevent excessive loading of the HEPA filters. The HEPA filters remove the fine discrete particulate matter from the air stream. A HEPA filter or a medium efficiency postfilter (as defined in Section 5.3 of ASME N509-1989 (Ref. 7)) downstream from the adsorption units collects carbon fines and provides additional protection against particulate matter release in case of failure of the upstream HEPA filter bank. It is not necessary to perform in-place leak testing on postfilters or HEPA filters downstream from the carbon adsorbers. It is advantageous for the postfilters or HEPA filters downstream from the carbon adsorbers to be installed in separate housings or to be removed from the housing (for systems with a fan downstream from the housing) during in-place leak testing of the upstream HEPA filter. This will contribute to the accuracy of the test results for the upstream HEPA filter. The arrangement of the ductwork and the transitions between the separate housings can provide a torturous path that will aid in mixing the challenge agent. Removing the filters downstream from the carbon adsorbers will permit sampling downstream from the fan. The fan will provide the necessary mixing for an accurate test and the absence of the postfilters or HEPA filters downstream from the carbon adsorbers will prevent the challenge aerosol from being removed from the air stream.

The iodine adsorption units typically consist of impregnated activated carbon and are installed to remove gaseous radioactive elemental and organic forms of iodine from the air stream during design basis accidents.

The location of the fan, with respect to the overall system design and the individual ESF atmosphere cleanup unit, is important because of the imposed positive and negative pressure gradients the fan creates during operation. Consideration should be given to the impact of the ESF atmosphere cleanup unit's operating pressure with respect to surrounding areas in the system design. For example, when the ESF atmosphere cleanup system is located in a radioactively contaminated area and the air is supplied to a given radioactively clean area or exhausted to the environment, it is advantageous to locate the fan upstream from the ESF atmosphere cleanup unit. This minimizes the potential for unfiltered in-leakage into the radioactively clean area or inadvertent release of radioactive materials to the environment. When the ESF atmosphere cleanup system is located in a radioactively clean area, it is advantageous to locate the fan downstream from the ESF atmosphere cleanup unit. This minimizes the potential for outward leakage of radioactive materials into the radioactively clean area.

The environmental operating conditions preceding a postulated DBA may affect the performance of ESF atmosphere cleanup systems during and following a DBA. Industrial contaminants, pollutants, high temperature, and high relative humidity contribute to the aging and weathering of filters and adsorbers and may reduce their effective capability to perform their intended design functions. Therefore, aging and weathering, both of which will vary according to site-specific conditions, should be considered during design, operation, and maintenance. The potential for condensation of moisture inside ESF atmosphere cleanup systems when in a shutdown or standby mode of operation should also be given design consideration, e.g., provision for space heaters. The effects of these environmental factors on the performance of the ESF atmosphere cleanup system should be determined by scheduled periodic inspection and testing during operation.

All components of ESF atmosphere cleanup systems should be designed for reliable performance under accident conditions. Initial testing, periodic inspection and testing, and proper maintenance are primary factors in ensuring the reliability of the ESF atmosphere cleanup system. Careful attention to problems of ESF system maintenance during the design phase can contribute significantly to the reliability of the system by increasing the ease of such maintenance. A layout that provides accessibility and sufficient working space to safely and efficiently perform the required maintenance functions is of particular importance in the design. Periodic inspection and testing during operation of the components is another important means of ensuring reliability. It is important to perform periodic inspections and tests of the ESF atmosphere cleanup system in a manner that is consistent with the way the system was intended to operate during an accident. Built-in features that will facilitate convenient access for in-place testing are important in ESF system design.

Standards acceptable to the NRC staff for the design and testing of ESF atmosphere cleanup systems include those portions of ASME N509-1989, "Nuclear Power Plant Air-Cleaning Units and Components" (Ref. 7); ASME N510-1989, "Testing of Nuclear Air-Treatment Systems"

(Ref. 8); and ASME AG-1-1997, "Code on Nuclear Air and Gas Treatment" (Ref. 9) that are referenced in this guide, and ASTM D3803-1989, "Standard Test Methods for Nuclear-Grade Activated Carbon" (Ref. 10).

If a referenced standard has been incorporated separately into the NRC's regulations, licensees and applicants must comply with that standard as set forth in the regulation. If the referenced standard has been endorsed in a regulatory guide, the standard constitutes a method acceptable to the NRC staff for meeting a regulatory requirement as described in the regulatory guide. If a referenced standard has been neither incorporated into the NRC's regulations nor endorsed in a regulatory guide, licensees and applicants may consider and use the information in the referenced standard if appropriately justified, consistent with current regulatory practice.

C. REGULATORY POSITION

1. GENERAL DESIGN AND TESTING CRITERIA

ASME AG-1-1997, "Code on Nuclear Air and Gas Treatment" (Ref. 9), and ASME N509-1989, "Nuclear Power Plant Air-Cleaning Units and Components" (Ref. 7), provide criteria that are acceptable to the NRC staff for the performance, design, construction, acceptance testing, and quality assurance of equipment used as components in nuclear safety-related or engineered safety featured air and gas treatment systems in nuclear power plants. ESF atmosphere cleanup systems designed to ASME N509-1989 (or its earlier versions) and tested to ASME N510-1989 (or its earlier versions) (Ref. 8) are considered adequate to protect public health and safety.

2. ENVIRONMENTAL DESIGN CRITERIA

All parts and components of the ESF atmosphere cleanup system should be selected and designed to operate under the environmental conditions specified by the following guidelines.

2.1. In accordance with Section 4.4 of ASME N509-1989 (Ref. 7), the design of an ESF atmosphere cleanup system should be based on the anticipated range of operating parameters of temperature, pressure, relative humidity, radiation levels, and airborne iodine concentrations that are likely during and following the postulated DBA.

2.2. The location and layout of each ESF atmosphere cleanup system should consider the radiation dose to essential services and personnel in the vicinity, integrated over the 30-day period following the postulated DBA. The radiation source term should be consistent with the assumptions found in Regulatory Guides 1.3 (Ref. 1), 1.4 (Ref. 2), 1.25 (Ref. 6), or 1.183 (Ref. 5). Other ESFs, including pertinent components of essential services such as power, air, and control cables, should be adequately shielded from the ESF atmosphere cleanup systems.

2.3. The design of each adsorber should be based on the concentration and relative abundance of the iodine species (elemental, particulate, and organic) and should be consistent with

the assumptions found in Regulatory Guides 1.3 (Ref. 1), 1.4 (Ref. 2), 1.25 (Ref. 6), or 1.183 (Ref. 5).

2.4. The operation of any ESF atmosphere cleanup system should not degrade the operation of other ESFs such as containment spray systems, nor, conversely, should the operation of other ESFs such as containment spray systems, nor, conversely, should the operation of ESFs such as containment spray systems degrade the operation of any ESF atmosphere cleanup system.

2.5. Components of systems connected to compartments that are unheated during a postulated accident should be designed for the post-accident effects of both the lowest and highest predicted temperatures.

2.6. The design of an ESF atmosphere cleanup system should consider any significant contaminants that may occur during a DBA such as dusts, chemicals, excessive moisture, or other particulate matter that could degrade the cleanup system's operation.

3. SYSTEM DESIGN CRITERIA

ESF atmosphere cleanup systems should be designed in accordance with Section 4 of ASME N509-1989 (Ref. 7) as modified and supplemented by the following.

3.1. ESF atmosphere cleanup systems designed and installed for the purpose of mitigating accident doses should have redundant units (trains) to provide assurance that an operable unit will be available during the DBA. A typical unit is composed of the following components: (1) moisture separator, (2) prefilter (a moisture separator may serve this function), (3) heater, (4) HEPA filter before the adsorbers, (5) iodine adsorber (impregnated activated carbon), (6) HEPA filter or medium efficiency postfilter (as defined in Section 5.3 of ASME N509-1989) after the adsorbers, (7) fan, and (8) interspersed ducts, motors, dampers, valves, and related instrumentation.

3.2. The redundant ESF atmosphere cleanup units should be physically separated so that damage to one unit does not also cause damage to the other unit. The generation of missiles from high-pressure equipment rupture, rotating machinery failure, or natural phenomena should be considered in the design for separation and protection.

3.3. If the ESF atmosphere cleanup system is subject to pressure surges resulting from the postulated accident, the system should be protected from such surges. Each component should be protected with devices such as pressure relief valves¹ so that the overall system will perform its intended function during and after the passage of the pressure surge.

3.4. All components of an ESF atmosphere cleanup system whose failure would lead to the release of fission products that would exceed the regulatory limits should be designated as Seismic Category I (Regulatory Guide 1.29 (Ref. 11)).

¹ Surge protection devices such as pressure relief valves that have the potential to be an effluent discharge path should be monitored in accordance with General Design Criterion 64 of Appendix A to 10 CFR Part 50.

3.5. In the mechanical design of the ESF system, the high radiation levels that may be associated with buildup of radioactive materials on the ESF system components should be given particular consideration. ESF system construction materials should effectively maintain their intended function under the postulated radiation levels. The effects of radiation should be considered not only for moisture separators, heaters, HEPA filters, adsorbers, motors, and fans, but also for any electrical insulation, controls, joining compounds, dampers, gaskets, and other organic materials that are necessary for operation during and after a postulated DBA. In addition to the consideration of high radiation levels, the mechanical design of the ESF system should be based on consideration of other harsh conditions that may occur during a DBA such as high humidity, containment rain-out, chemical sprays, or high temperatures and pressures.

3.6. To ensure reliable in-place testing, the volumetric air-flow rate of each cleanup unit should be limited to approximately 30,000 cubic feet per minute. If a total system air flow in excess of this rate is required, multiple units should be used. For ease of maintenance, a filter layout three HEPA filters high and ten wide is preferred. Each ESF atmosphere cleanup system train should be designed such that at the maximum accident flow rate the adsorber residence time is not less than the design value (typically 0.25 seconds per 2 inches of activated carbon) as specified in Regulatory Position 4.11 of this guide. The residence time should be calculated in accordance with Article I-1000 of Sections FD and FE of ASME AG-1-1997 (Ref. 9).

3.7. The ESF atmosphere cleanup system should be instrumented to signal, alarm, and record pertinent pressure drops and flow rates at the control room in accordance with recommendations of Section 5.6 of ERDA 76-21 (Ref. 12) and Section 4.9 of ASME N509-1989 (Ref. 7).

3.8. The power supply and electrical distribution system for the ESF atmosphere cleanup system should be designed in accordance with Regulatory Guide 1.32 (Ref. 13). All instrumentation and equipment controls should be designed to IEEE Standard 603-1991 (Ref. 14). The ESF system should be qualified and tested under Regulatory Guide 1.89 (Ref. 15). To the extent applicable, Regulatory Guides 1.30 (Ref. 16), 1.100 (Ref. 17), and 1.118 (Ref. 18) and IEEE Standard 334 (Ref. 19) should be considered in the design.

3.9. Unless the applicable ESF atmosphere cleanup system operates continuously during all times that a DBA can be postulated to occur, the system should be automatically activated upon the occurrence of a DBA by (1) a redundant ESF actuation signal (e.g., temperature, pressure) or (2) a signal from redundant Seismic Category I radiation monitors.

3.10. To maintain radiation exposures to operating and maintenance personnel as low as is reasonably achievable (ALARA), ESF atmosphere cleanup systems and components should be designed to control leakage and facilitate maintenance, inspection, and testing in accordance with the guidance of Regulatory Guide 8.8 (Ref. 20). The ESF atmosphere cleanup unit should be totally enclosed. To minimize the potential contamination of the area when maintaining the ESF atmosphere cleanup system, the system should be designed and installed in a manner that permits replacement of an entire unit or a minimum number of segmented sections without removal of individual components.

3.11. Outdoor air intake openings should be equipped with louvers, grills, screens, or similar protective devices to minimize the effects of high winds, rain, snow, ice, trash, and other contaminants on the operation of the system. The outdoor air intake openings should be located to minimize the effects of possible onsite plant contaminants, such as the diesel generator exhaust. If the atmosphere surrounding the plant could contain significant environmental contaminants, such as dusts and residues from smoke cleanup systems from adjacent coal-burning power plants or industry, or is a salty environment near an ocean, the design of the system should consider these contaminants and prevent them from affecting the operation of any ESF atmosphere cleanup system.

3.12. ESF atmosphere cleanup system housings and ductwork should be designed to exhibit on test a maximum total leakage rate as defined in Section SA-4500 of ASME AG-1-1997 (Ref. 9). Duct and housing leak tests should be performed in accordance with Section TA of ASME AG-1-1997.

4. COMPONENT DESIGN CRITERIA AND QUALIFICATION TESTING

Components of ESF atmosphere cleanup systems should be designed, constructed, and tested in accordance with Division II of ASME AG-1-1997 (Ref. 9), as modified and supplemented by the following.²

4.1. Moisture separators should be designed, constructed, and tested in accordance with Section FA of ASME AG-1-1997.

4.2. Air heaters should be designed, constructed, and tested in accordance with Section CA of ASME AG-1-1997.

4.3. Materials used in the prefilters should withstand the radiation levels and environmental conditions prevalent during the postulated DBA. Prefilters should be designed, constructed, and tested in accordance with Section FB of ASME AG-1-1997.

4.4. HEPA filters used in ESF atmosphere cleanup systems should be designed, constructed, and tested in accordance with Section FC of ASME AG-1-1997. HEPA filters should be compatible with the chemical composition and physical conditions of the air stream.

Each HEPA filter should be tested by the manufacturer (or by a qualified filter test facility) for penetration of a challenge aerosol such as dioctyl phthalate (DOP) in accordance with the procedures of Section TA of ASME AG-1-1997. Testing and documentation should be in accordance with a quality assurance program consistent with Appendix B to 10 CFR Part 50.

4.5. The HEPA filter and Type II adsorber cell mounting frames should be constructed and designed in accordance with Section FG of ASME AG-1-1997.

² The pertinent quality assurance requirements of Appendix B, "Quality Assurance Criteria for Nuclear Power Plants and Fuel Reprocessing Plants," to 10 CFR Part 50 apply to all activities affecting the safety-related functions of all components of the ESF atmosphere cleanup system.

4.6. Filter and adsorber banks should be arranged in accordance with the recommendations of Section 4.4 of ERDA 76-21 (Ref. 12) and Section HA, "Housings," of ASME AG-1a-2000 (Ref. 21).

4.7. System filter housings, including floors and doors, should be constructed and designed in accordance with Section HA of ASME AG-1a-2000 (Ref. 21).

4.8. Water drains should be designed in accordance with the recommendations of Section 4.5.8 of ERDA 76-21 (Ref. 12) and Section HA of ASME AG-1a-2000 (Ref. 21). Special design features, such as water traps for each drain, should be incorporated into drain systems to prevent contaminated air bypassing filters or adsorbers through the drain system. Procedures should be in place to routinely verify the water level.

4.9. Adsorption units function most efficiently, with respect to retention of adsorbed iodine, at an input relative humidity of 70% or less. If the relative humidity of the air entering the ESF atmosphere cleanup system is expected to exceed 70% during accident situations, humidity control should be provided in the system design for controlling the relative humidity of the air entering the system.

Humidity control promotes the long-term retention of radioiodine in the iodine adsorbers (minimizing the potential for early desorption and release) by maintaining the relative humidity at less than or equal to 70%. For secondary systems, humidity control may be provided by either safety-related heaters or an analysis that demonstrates that the air entering the adsorbers is maintained at less than or equal to 70% relative humidity under all design basis accident conditions. For primary systems, an electric heater should not be provided because its use inside containment could result in a spark and possible hydrogen explosion in the event of an accident. Systems with humidity control can perform laboratory testing of representative samples of activated carbon at a relative humidity of 70%, and systems without humidity control should perform laboratory testing of representative samples of activated carbon at a relative humidity of 95% (see Table 1 of this guide).

4.10. Adsorbers should be designed, constructed, and tested in accordance with Section FD for Type II Adsorber cells or Section FE for Type III Adsorber cells of ASME AG-1-1997 (Ref. 9).

The design of the adsorber section should consider possible iodine desorption and adsorbent auto-ignition that may result from radioactivity-induced heat in the adsorbent and concomitant temperature rise. Acceptable designs include a low-flow air bleed system, cooling coils, water sprays for the adsorber section, or other cooling mechanisms. Any cooling mechanism should satisfy the single-failure criterion. A low-flow air bleed system should satisfy the single-failure criterion for providing low humidity (less than 70% relative humidity) cooling airflow.

When a water-based fire suppression or prevention (cooling) system is installed in the ESF atmosphere cleanup system housing, the fire system should be manually actuated unless there is a reasonable probability that the iodine desorption and adsorbent auto-ignition could occur in the housing, in which case the fire system should have both automatic and manual actuation. The fire

system should use open spray nozzles or devices of sufficient size, number, and location to provide complete coverage over the entire surface of the combustible filter media. The fire system should be hard piped and supplied with a reliable source of water at adequate pressure and volume. The location of the manual release (or valve) for the fire system should be remote from the cleanup system housing and should be consistent with the ALARA guidance in Regulatory Guide 8.8 (Ref. 20). Automatic fire systems should include a reliable means of detection³ to actuate the system. Cross-zoning of detectors is acceptable. Manual fire systems should include a reliable means of internal monitoring for determining when to manually actuate the fire systems. The monitoring indication should be remote from the cleanup system housing in accordance with ALARA practices.

4.11. The adsorber section of the ESF atmosphere cleanup system may contain any adsorbent material demonstrated to remove gaseous iodine (elemental iodine and organic iodides) from air at the required efficiency. However, since impregnated activated carbon⁴ is used almost exclusively, only impregnated activated carbon is discussed in this guide.

Each original or replacement batch or lot of impregnated activated carbon used in the adsorber section should meet Section FF-5000 of ASME AG-1-1997 (Ref. 9).^{5,6} A test performed as a "qualification test" should be interpreted to mean a test that establishes the suitability of a manufacturer's product for a generic application, normally a one-time test establishing typical performance of the product. Tests not specifically identified as being performed only for qualification purposes should be interpreted as "batch tests." Batch tests are tests to be made on each production batch of product to establish suitability for a specific application. Test conditions and acceptance criteria for batch tests should be the same as, or more stringent than, those specified in the plant's technical specifications for the specific application.

If impregnated activated carbon is used as the adsorbent, the adsorber system should be designed for an average atmosphere residence time of 0.25 seconds per 2 inches of adsorbent bed. Sections FD and FE of ASME AG-1-1997 should be used to determine the residence time. The adsorption unit should be designed for a maximum loading of 2.5 mg of total iodine (radioactive plus stable) per gram of activated carbon. No more than 5% of impregnant (50 mg of impregnant per gram of carbon) should be used. The radiation stability of the type of carbon specified should be demonstrated and certified (see Regulatory Position 2.2 of this guide for the design source term).

If an adsorbent other than impregnated activated carbon is proposed or if the mesh size distribution or other physical properties of the impregnated activated carbon are different from the

³ Detection can be accomplished by a mechanical or electrical device, including but not limited to, thermal, carbon monoxide, or smoke.

⁴ Activated carbon is typically impregnated with a chemical compound or compounds to enhance radioiodine retention, particularly under high temperatures and humidity conditions. Typical impregnants include iodides such as potassium iodide and triiodide, amines such as triethylenediamine (TEDA), and combinations thereof.

⁵ A "batch of activated carbon" or a "batch of impregnated activated carbon" is a quantity of adsorbent, not to exceed 10 cubic meters (or 350 cubic feet) in size, of the same grade or type that has been produced under the same manufacturer's production designation using a consistent manufacturing procedure and equipment, and that has been homogenized to exhibit the same physical properties and performance characteristics throughout the mass. (See Article FF-1130 of ASME AG-1-1997.)

⁶ A "lot of activated carbon" or a "lot of impregnated activated carbon" is that quantity of adsorbent consisting of one or more batches of adsorbent that constitute and satisfy a purchase order. (See Article FF-1130 of ASME AG-1-1997.)

specifications above, the proposed adsorbent should have the capability to perform as well as or better than activated carbon that satisfies the specifications in Article FF of ASME AG-1-1997.

If sample canisters are used, they should be designed in accordance with Appendix A of ASME N509-1989 (Ref. 7)

4.12. Ducts and filter housings should be laid out with a minimum of ledges, protrusions, and crevices that could collect dust and moisture and that could impede personnel or create a hazard to them in the performance of their work. Turning vanes or other air flow distribution devices should be installed where needed to ensure representative air flow measurement and uniform flow distribution through cleanup components.

4.13. Dampers should be designed, constructed, and tested in accordance with Section DA of ASME AG-1-1997.

4.14. The system fan, its mounting, and the ductwork connections should be designed, constructed, and tested in accordance with Section BA for Blowers and Section SA for Ducts in ASME AG-1-1997 (Ref. 9). The fan or blower used on the ESF atmosphere cleanup system should be capable of operating under the environmental conditions postulated, including radiation. Ductwork should be designed, constructed, and tested in accordance with Section SA of ASME AG-1-1997.

5. MAINTAINABILITY CRITERIA

Provisions for maintaining ESF atmosphere cleanup systems should be incorporated in the system design in accordance with Section 4.8 of ASME N509-1989 (Ref. 7) and Section HA of ASME AG-1a-2000 (Ref. 21) as supplemented by the following:

5.1. Accessibility of components for maintenance should be considered in the design of ESF atmosphere cleanup systems in accordance with Section 2.3.8 of ERDA 76-21 (Ref. 12) and Section HA of ASME AG-1a-2000 (Ref. 21). For ease of inspection and maintenance, the system design should provide for a minimum of 3 feet from mounting frame to mounting frame between banks of components. If components are to be replaced, the dimensions to be provided should be the maximum length of the component plus a minimum of 3 feet.

5.2. The cleanup components (i.e., HEPA filters, prefilters, and adsorbers) that are used during construction of the ventilation systems should be replaced before the system is declared operable.

6. IN-PLACE TESTING CRITERIA

Initial in-place acceptance testing of ESF atmosphere cleanup systems and components should be performed in accordance with Section TA of ASME AG-1-1997 (Ref. 9). Periodic,

in-place testing of ESF atmosphere cleanup systems and components should be performed in accordance with ASME N510-1989 (Ref. 8) as modified and supplemented by the following:

6.1. Each ESF atmosphere cleanup train should be operated continuously for at least 15 minutes each month, with the heaters on (if so equipped), to justify the operability of the system and all its components.

6.2. A visual inspection of the ESF atmosphere cleanup system and all associated components should be performed in accordance with Section 5 of ASME N510-1989 (Ref. 8).

6.3. In-place aerosol leak tests for HEPA filters upstream from the carbon adsorbers in ESF atmosphere cleanup systems should be performed (1) initially, (2) at least once each 24 months, (3) after each partial or complete replacement of a HEPA filter bank, (4) following detection of, or evidence of, penetration or intrusion of water or other material into any portion of an ESF atmosphere cleanup system that may have an adverse effect on the functional capability of the filters,⁷ and (5) following painting, fire, or chemical release in any ventilation zone communicating with the system that may have an adverse effect on the functional capability of the system.⁸ The test should be performed in accordance with Section 10 of ASME N510-1989. The leak test should confirm a combined penetration and leakage (or bypass)⁹ of the ESF atmosphere cleanup system of less than 0.05% of the challenge aerosol at rated flow $\pm 10\%$. To be credited with a 99% removal efficiency for particulate matter in accident dose evaluations, a HEPA filter bank in an ESF atmosphere cleanup system should demonstrate an aerosol leak test result of less than 0.05% of the challenge aerosol at rated flow $\pm 10\%$.

HEPA filter sections in ESF atmosphere cleanup systems that fail to satisfy the appropriate leak-test conditions should be examined to determine the location and cause of leaks. Repairs, such as alignment of filter frames and tightening of filter hold-down bolts, may be made; however, patching or caulking materials should not be used in the repair of defective, damaged, or torn filter media in ESF atmosphere cleanup systems; such filters should be replaced and not repaired. HEPA filters that fail to satisfy test conditions should be replaced with filters qualified pursuant to Regulatory Position 4.4 of this guide. After repairs or filter replacement, the ESF atmosphere cleanup system should be retested as described above in this Regulatory Position. The above

⁷ In 1998, the Department of Energy (DOE) presented the results of its HEPA filter deterioration research at the 25th DOE/NRC Nuclear Air Cleaning and Treatment Conference (Ref. 22). The results of this research demonstrated that wetting of the filter medium significantly reduces its tensile strength which is not fully recovered after drying. In addition, further water exposures resulted in additional losses in filter media tensile strength. (See NRC Information Notice 99-01, Reference 23.)

⁸ Painting, fire, or chemical release is “not communicating” with the HEPA filter or adsorber if the ESF atmosphere cleanup system is not in operation, the isolation dampers for the system are closed, and there is no pressure differential across the filter housing. This provides reasonable assurance that air is not passing through the filters and adsorbers. A program should be developed and consistently applied that defines the terms “painting,” “fire,” and “chemical release” in terms of the potential for degrading the HEPA filters and adsorbers. This program should be based on a well-documented, sound and conservative technical basis (i.e., the criteria should overestimate the potential damage to the filter and adsorber).

⁹ In Section FD-1130 of ASME AG-1-1997 (Ref. 9), penetration is defined as the exit concentration of a given gas from an air cleaning device, expressed as a percentage of inlet concentration. In Section 3 of ASME N509-1989 (Ref. 7), bypass is defined as a pathway through which contaminated air can escape treatment by the installed HEPA or adsorber banks. Examples are leaks in filters and filter mounting frames, defective or inefficient isolation dampers that result in uncontrolled flow through adjacent plenums, and unsealed penetrations for electrical conduits, pipes, floor drains, etc.

process should be repeated as necessary until combined penetration and leakage (bypass) of the system is less than the acceptance criteria described above in this Regulatory Position.

In accordance with ASME N510-1989 (Ref. 8) and Article TA-1000 of ASME AG-1-1997 (Ref. 9), the standard challenge aerosol used in the in-place leak testing of HEPA filters is polydisperse droplets of dioctyl phthalate (DOP), also known as di-2-ethylhexyl-phthalate (DEHP). The 0.3 micrometer monodisperse DOP aerosol is used for efficiency testing of individual HEPA filters by manufacturers and Filter Test stations. Alternative challenge agents¹⁰ may be used to perform in-place leak-testing of HEPA filters when their selection is based on the following.

1. The challenge aerosol has the approximate light scattering droplet size specified in Article TA-1130 of ASME AG-1-1997 (Ref. 9).
2. The challenge aerosol has the same in-place leak test results as DOP.
3. The challenge aerosol has a similar lower detection limit, sensitivity, and precision as DOP.
4. The challenge aerosol causes no degradation of the HEPA filter or the other ESF air cleaning system components under test conditions.
5. The challenge aerosol is listed in the Environmental Protection Agency's "Toxic Substance Control Act" (TSCA) (Ref. 25) inventory for commercial use.

6.4. In-place leak testing for adsorbers should be performed (1) initially, (2) at least once each 24 months, (3) following removal of an adsorber sample for laboratory testing if the integrity of the adsorber section is affected, (4) after each partial or complete replacement of carbon adsorber in an adsorber section, (5) following detection of, or evidence of, penetration or intrusion of water or other material into any portion of an ESF atmosphere cleanup system that may have an adverse effect on the functional capability of the adsorber, and (6) following painting, fire, or chemical release in any ventilation zone communicating with the system that may have an adverse effect on the functional capability of the system.⁸ The test should be performed in accordance with Section 11 of ASME N510-1989 (Ref. 8). The leak test should confirm a combined penetration and leakage (or bypass)⁹ of the adsorber section of 0.05% or less of the challenge gas at rated flow $\pm 10\%$.

Adsorber sections that fail to satisfy the appropriate leak-test conditions should be examined to determine the location and cause of leaks. Repairs, such as alignment of adsorber cells, tightening of adsorber cell holddown bolts, or tightening of test canister fixtures, may be made; however, the use of temporary patching material on adsorbers, filters, housings, mounting frames, or ducts should not be allowed. After repairs or adjustments have been made, the adsorber sections should be retested as described above in this Regulatory Position. The above process should be repeated as necessary until the combined penetration and leakage (bypass) of the adsorber section is less than the acceptance criteria described above in this Regulatory Position.

In accordance with ASME N510-1989 (Ref. 8) and Section TA of ASME AG-1-1997 (Ref. 9), the standard challenge gas used in the in-place leak testing of adsorbers is Refrigerant-11 (trichloromonofluoromethane). Alternative challenge gases may be used to perform in-place leak

¹⁰ Care should be taken to ensure that the aerosol generator is compatible with the selected alternative challenge agent (see NRC Information Notice 99-34 (Ref. 24)).

testing of adsorbers, when their selection is based on meeting the characteristics specified in Appendix TA-C of ASME AG-1-1997.

6.5. If any welding repairs are necessary on, within, or adjacent to the ducts, housing, or mounting frames, the HEPA filters and adsorbers should be removed from the housing (or otherwise protected) prior to performing such repairs. The repairs should be completed prior to re-installation of filters and adsorbers; the system should then be visually inspected and leak tested as in Regulatory Positions 6.2, 6.3, and 6.4.

7. LABORATORY TESTING CRITERIA FOR ACTIVATED CARBON

Laboratory testing of samples of activated carbon adsorber material from ESF atmosphere cleanup systems should be performed in accordance with ASTM D3803-1989 (Ref. 10) and Table 1 of this guide as supplemented by the following:

7.1. If an analysis of unused activated carbon has not been conducted within the past 5 years, representative¹¹ samples of the unused activated carbon should be collected at the time of installation or replacement of adsorber material and submitted for analysis. The analysis should be performed in accordance with Regulatory Position 4.11 or Table 1 of this guide, whichever is more restrictive. Carbon that is stored for future use should be stored in its original unopened and undamaged container and stored in a storage area that meets the specifications provided in Subpart 2.2 of ASME NQA-1-1997 (Ref. 26). Carbon that does not meet these specifications should not be used without performing an analysis demonstrating its current capability.

7.2. Sampling and analysis should be performed (1) after each 720 hours of system operation, or at least once each 24 months, whichever comes first, (2) following painting, fire, or chemical release in any ventilation zone communicating with the system that may have an adverse effect on the functional capability of the carbon media,⁸ and (3) following detection of, or evidence of, penetration or intrusion of water or other material into any portion of an ESF atmosphere cleanup system that may have an adverse effect on the functional capability of the carbon media.

7.3. For accident dose evaluation purposes, the activated carbon adsorber section of an ESF atmosphere cleanup system should be assigned the appropriate decontamination efficiency given in Table 1 for elemental iodine and organic iodides if the following conditions are met:

1. The adsorber section meets the leak-test conditions given in Regulatory Position 6.4 of this guide.
2. New activated carbon meets the performance and physical property specifications given in Regulatory Position 4.11 of this guide, and
3. Representative samples of new or used activated carbon pass the applicable laboratory tests specified in Table 1 of this guide.

¹¹ For the definition of "representative sample" and a description of sampling methods, see Appendix A of ASME N509-1989 (Ref. 7).

If the activated carbon fails to meet any of the above conditions, it should not be used in adsorbers in ESF atmosphere cleanup systems.

7.4. The activated carbon adsorber section should be replaced with new unused activated carbon that meets the performance and physical property specifications of Regulatory Position 4.11 of this guide if (1) testing in accordance with Regulatory Positions 7.1 and 7.2 results in a representative sample that fails to pass the applicable test in Table 1 of this guide or if (2) no representative sample is available for testing.

D. IMPLEMENTATION

The purpose of this section is to provide information to applicants and licensees regarding the NRC staff's plans for using this regulatory guide.

Except in those cases in which an applicant or licensee proposes an acceptable alternative method for complying with specified portions of the NRC's regulations, the methods described in this guide, which reflect public comments, will be used by the NRC staff in its evaluation of submittals in connection with the design, inspection, and testing of post-accident ESF atmosphere cleanup systems for the following light-water-cooled nuclear power plants:

1. Plants for which the construction permit or license application is docketed after the issue date of this guide;
2. Plants for which the licensee voluntarily commits to the provisions of this guide.

Table 1: Laboratory Tests For Activated Carbon

Activated Carbon ^a Total Bed Depth ^b	Maximum Assigned Credit for Activated Carbon Decontamination Efficiencies		Methyl Iodide Penetration Acceptance Criterion for Representative Sample
2 inches	Elemental iodine	95%	Penetration ≤2.5% when tested in accordance with ASTM D-3803- 1989 (Ref. 10)
	Organic iodide	95%	
4 inches or greater	Elemental iodine	99%	Penetration ≤0.5% when tested in accordance with ASTM D-3803- 1989 (Ref. 10)
	Organic iodide	99%	

^a The activated carbon, when new, should meet the specifications of Regulatory Position 4.11 of this guide.

^b Multiple beds, e.g., two 2-inch beds in series, should be treated as a single bed of aggregate depth. It is advantageous when series beds are located in separate housings and individually in-place leak tested. This aids in mixing the challenge agent and contributes to the accuracy of the test results.

NOTES:

(1) Credited decontamination efficiencies (a portion of which includes bypass leakage) are based on 0.25 second residence time per 2-inch bed depth.

(2) Organic iodide and elemental iodine are the forms of iodine that are expected to be absorbed by activated carbon during a design basis accident. Organic iodide is more difficult for activated carbon to adsorb than elemental iodine. Therefore, the laboratory test to determine the performance of the activated carbon adsorber is based on organic iodide. Methyl iodide is the organic form of iodine that is used in the laboratory test.

(3) This Table 1 provides acceptable decontamination efficiencies and methyl iodide test penetrations of used activated carbon samples for laboratory testing. Laboratory tests are conducted in accordance with ASTM D3803-1989 (Ref. 10). Tests are conducted at a temperature of 30°C and relative humidity of 95%, except a relative humidity of 70% is used when the air entering the carbon adsorber is maintained at less than or equal to 70% relative humidity.

(4) See Appendix A to ASME N509-1989 (Ref. 7) for the definition of a representative sample. Testing should be performed at the frequencies specified in Regulatory Position 7.2 of this guide. Testing should be performed in accordance with ASTM D3803-1989 (Ref. 10) at a temperature of 30°C and a relative humidity of 95% (or 70% with humidity control). Using the following equation from NRC Generic Letter 99-02 (Ref. 27), a safety factor of at least 2 should be applied when determining the appropriate methyl iodide penetration acceptance criterion in the Technical Specifications for the representative sample.

$$\text{Allowable Penetration} = \frac{[100\% - \text{Organic Iodide Efficiency for Activated Carbon Credited In Licensee's Accident Analysis}]}{\text{Safety Factor}}$$

Humidity control can be provided by heaters or an analysis that demonstrates that the air entering the activated carbon will be maintained less than or equal to 70% RH under design-basis conditions (e.g., worst-case relative humidity of system inlet air, maximum system design flow rate, normal and off-normal supply voltages).

FIGURE 1 Example of a Control Room ESF Atmosphere Cleanup Train^a

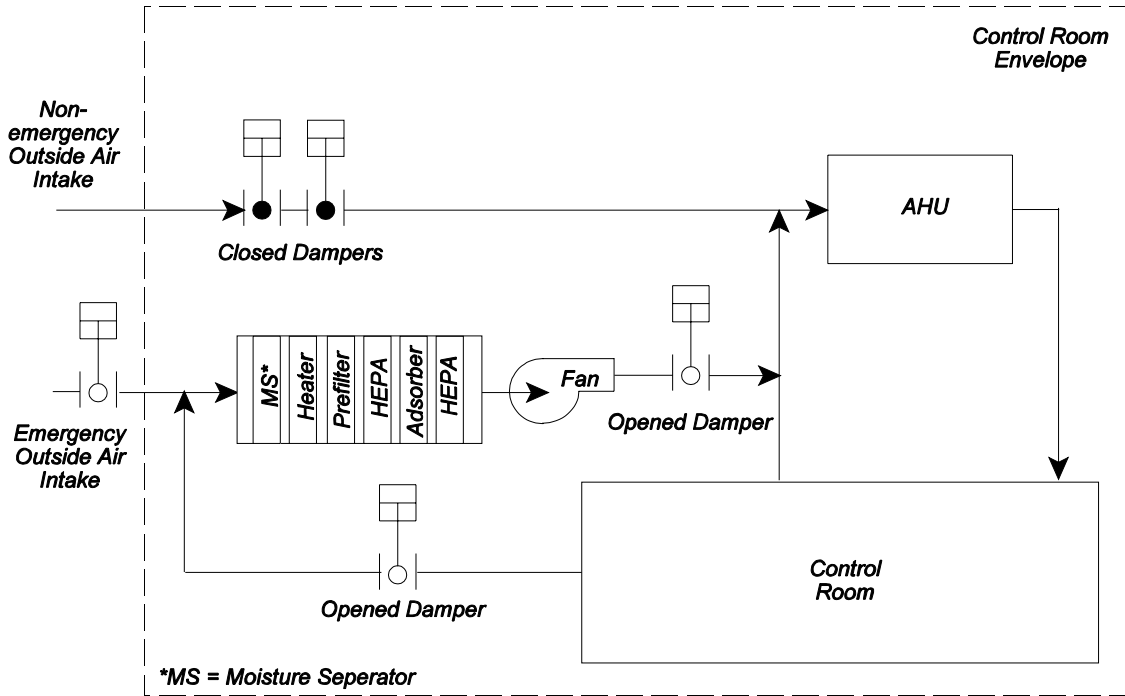
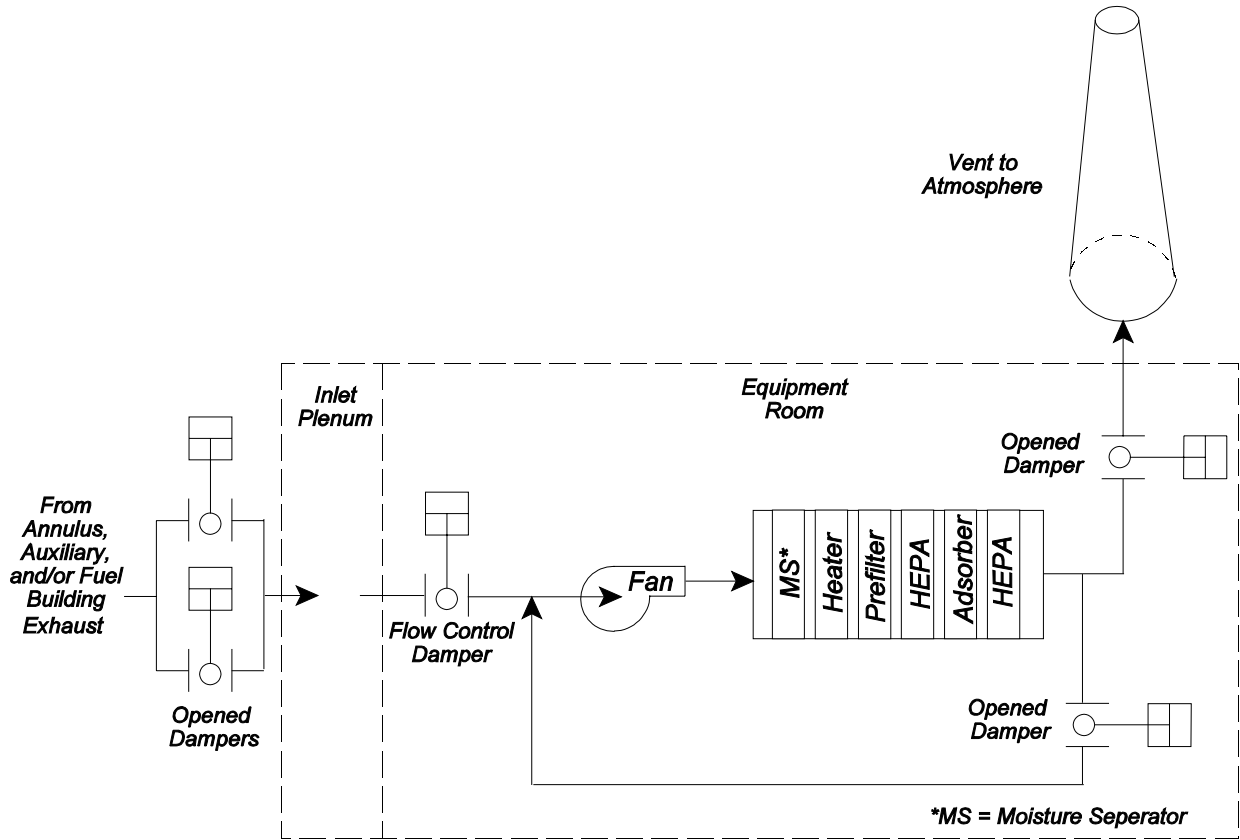

FIGURE 2 Example of a Shield, Annulus, and/or Fuel Building ESF Atmosphere Cleanup Train^a



^a Other acceptable configurations exist; these figures are only provided for conceptual purposes.

REFERENCES

1. USNRC, "Assumptions Used for Evaluating the Potential Radiological Consequences of a Loss of Coolant Accident for Boiling Water Reactors," Regulatory Guide 1.3, Revision 2, June 1974.¹
2. USNRC, "Assumptions Used for Evaluating the Potential Radiological Consequences of a Loss of Coolant Accident for Pressurized Water Reactors," Regulatory Guide 1.4, Revision 2, June 1974.¹
3. J.J. DiNunno et al., "Calculation of Distance Factors for Power and Test Reactor Sites," USAEC TID-14844, 1962.²
4. L. Soffer et al., "Accident Source Terms for Light-Water Nuclear Power Plants," NUREG-1465, February 1995.³
5. USNRC, "Alternative Radiological Source Terms for Evaluating Design Basis Accidents at Nuclear Power Reactors," Regulatory Guide 1.183, July 2000.¹
6. USNRC, "Assumptions Used for Evaluating the Potential Radiological Consequences of a Fuel Handling Accident in the Fuel Handling and Storage Facility for Boiling and Pressurized Water Reactors," Regulatory Guide 1.25 (AEC Safety Guide 25), March 1972.¹
7. American Society of Mechanical Engineers, "Nuclear Power Plant Air-Cleaning Units and Components," ASME N509-1989. Reaffirmed 1996.
8. American Society of Mechanical Engineers, "Testing of Nuclear Air-Treatment Systems," ASME N510-1989. Reaffirmed 1995.
9. American Society of Mechanical Engineers, "Code on Nuclear Air and Gas Treatment," ASME/ANSI AG-1-1997.

¹ Single copies of regulatory guides, both active and draft, and draft NUREG documents may be obtained free of charge by writing the Reproduction and Distribution Services Section, OClO, USNRC, Washington, DC 20555-0001, or by fax to (301)415-2289, or by email to <DISTRIBUTION@NRC.GOV>. Active guides may also be purchased from the National Technical Information Service on a standing order basis. Details on this service may be obtained by writing NTIS, 5285 Port Royal Road, Springfield, VA 22161; telephone (800)553-6847; online <<http://www.ntis.gov/ordernow>>. Copies of active and draft guides are available for inspection or copying for a fee from the NRC Public Document Room at 11555 Rockville Pike, Rockville, MD; the PDR's mailing address is USNRC PDR, Washington, DC 20555; telephone (301)415-4737 or (800)397-4209; fax (301)415-3548; email <PDR@NRC.GOV>.

² Copies are available for inspection or copying for a fee from the NRC Public Document Room at 11555 Rockville Pike, Rockville, MD; the PDR's mailing address is USNRC PDR, Washington, DC 20555; telephone (301)415-4737 or (800)397-4209; fax (301)415-3548; email <PDR@NRC.GOV>.

³ Copies are available at current rates from the U.S. Government Printing Office, P.O. Box 37082, Washington, DC 20402-9328 (telephone (202)512-1800); or from the National Technical Information Service at 5285 Port Royal Road, Springfield, VA 22161; telephone (800)553-6847; <<http://www.ntis.gov/ordernow>>. Copies are available for inspection or copying for a fee from the NRC Public Document Room at 11555 Rockville Pike, Rockville, MD; the PDR's mailing address is USNRC PDR, Washington, DC 20555; telephone (301)415-4737 or (800)397-4209; fax (301)415-3548; email is PDR@NRC.GOV.

10. American Society for Testing and Materials, "Standard Test Methods for Nuclear-Grade Activated Carbon," ASTM Standard D3803-1989. Reapproved 1995.
11. USNRC, "Seismic Design Classification," Regulatory Guide 1.29, Revision 3, September 1978.¹
12. C. A. Burchsted, J.E. Kahn, and A.B. Fuller, "Nuclear Air Cleaning Handbook," Oak Ridge National Laboratory, ERDA 76-21, March 31, 1976.⁴
13. USNRC, "Criteria for Safety-Related Electric Power Systems for Nuclear Power Plants," Regulatory Guide 1.32, Revision 2, February 1977.¹
14. Institute of Electrical and Electronics Engineers, "IEEE Standard Criteria for Safety Systems for Nuclear Power Generating Stations," IEEE Std 603-1991.
15. USNRC, "Environmental Qualification of Certain Electric Equipment Important to Safety for Nuclear Power Plants," Regulatory Guide 1.89, Revision 1, June 1984.¹
16. USNRC, "Quality Assurance Requirements for the Installation, Inspection, and Testing of Instrumentation and Electric Equipment," AEC Safety Guide 1.30, August 1972.¹
17. USNRC, "Seismic Qualification of Electric and Mechanical Equipment for Nuclear Power Plants," Regulatory Guide 1.100, Revision 2, June 1988.¹
18. USNRC, "Periodic Testing of Electric Power and Protection Systems," Regulatory Guide 1.118, Revision 3, April 1995.¹
19. Institute of Electrical and Electronics Engineers, "IEEE Standard for Type Tests of Continuous-Duty Class 1E Motors for Nuclear Power Generating Stations," IEEE Std 334-1974.
20. USNRC, "Information Relevant to Ensuring that Occupational Radiation Exposures at Nuclear Power Stations Will Be As Low As Is Reasonably Achievable," Regulatory Guide 8.8, Revision 3, June 1978.¹
21. American Society of Mechanical Engineers, "Code on Nuclear Air and Gas Treatment," Section HA, "Housings," ASME AG-1a-2000, Addenda to ASME AG-1-1997, December 2000.
22. J.K. Fretthold, "HEPA Service Life Tests-Effects-Recommendations at Department of Energy Rocky Flats Environmental Technology Site," Proceedings of the 25th DOE/NRC Nuclear Air Cleaning and Treatment Conference, NUREG/CP-0167, April 1999.³

⁴ Copies are available at current rates from the National Technical Information Service at 5285 Port Royal Road, Springfield, VA 22161; telephone (800)553-6847; <<http://www.ntis.gov/ordernow>>.

23. NRC Information Notice 99-01, "Deterioration of High-Efficiency Particulate Air Filters in a Pressurized Water Reactor Containment Fan Cooler Unit," January 20, 1999.²
24. NRC Information Notice 99-34, "Potential Fire Hazards in the Use of Polyalphaolefin in Testing of Air Filters," December 28, 1999.²
25. Environmental Protection Agency's "Toxic Substance Control Act" (TSCA), Inventory for Commercial Use.⁵
26. American Society of Mechanical Engineers, "Quality Assurance Requirements for Nuclear Facility Applications," ASME NQA-1-1997.
27. NRC Generic Letter 99-02, "Laboratory Testing of Nuclear-Grade Activated Charcoal," June 3, 1999.²

⁵ Copies are available at current rates from the U.S. Government Printing Office, P.O. Box 37082, Washington, DC 20402-9328 (telephone (202)512-1800).

VALUE/IMPACT STATEMENT

A value/impact statement was published with the draft of this guide when it was issued for public comment (Task DG-1102, October 2000). No changes were necessary, so a separate value/impact statement for this regulatory guide has not been prepared. This regulatory guide does not require a backfit analysis as described in 10 CFR 50.109(c) because it does not impose a new or amended provision in the NRC's rules and regulations. A copy of the value/impact statement (ADAMS Accession Number ML003756180) is available for inspection or copying for a fee in the NRC's Public Document Room at 11555 Rockville Pike, Rockville, MD; the PDR's mailing address is USNRC PDR, Washington, DC 20555; telephone (301)415-4737 or (800)397-4209; fax (301)415-3548; email is <PDR@NRC.GOV>.