

## Unit I-A

---

<b>COURSE TITLE</b>	Building Design for Homeland Security	<b>TIME</b>	90 minutes
---------------------	---------------------------------------	-------------	------------

---

<b>UNIT TITLE</b>	Introduction and Course Overview		
-------------------	----------------------------------	--	--

---

<b>OBJECTIVES</b>	<ol style="list-style-type: none"><li>1. Describe the goal, objectives, and agenda for the course</li><li>2. Describe and find material in the course reference manual and student activity handout</li></ol>		
-------------------	---	--	--

---

<b>SCOPE</b>	The following topics will be covered in this unit:  <ol style="list-style-type: none"><li>1. Welcome and Opening Remarks</li><li>2. Instructor Introductions</li><li>3. Administrative Information</li><li>4. Student Introductions</li><li>5. Course Overview</li><li>6. Course Materials</li><li>7. Activity: Refamiliarize with Case Study materials</li></ol>		
--------------	---	--	--

---

<b>REFERENCES</b>	<ol style="list-style-type: none"><li>1. Course Agenda</li><li>2. Course Goal and Objectives</li><li>3. EMI Evaluation Forms</li><li>4. FEMA 426, <i>Reference Manual to Mitigate Potential Terrorist Attacks Against Buildings</i></li><li>5. Case Study – Appendix S: Suburban, Hazardville Information Company</li><li>6. Student Manual, Unit I-A</li><li>7. Unit I-A visuals</li></ol>		
-------------------	---	--	--

---

<b>REQUIREMENTS</b>	<ol style="list-style-type: none"><li>1. FEMA 426, <i>Reference Manual to Mitigate Potential Terrorist Attacks Against Buildings</i> (one per student)</li><li>2. FEMA 452, <i>Risk Assessment - A How-To Guide to Mitigate Potential Terrorist Attacks Against Buildings</i> (one per student)</li><li>3. Instructor Guide, Unit I-A</li><li>4. Suburban Case Study Student Manual (A) (one per student)</li><li>5. Overhead projector or computer display unit</li><li>6. Unit I-A visuals</li><li>7. Risk Matrix poster and dry-erase markers (one per team)</li><li>8. Chart paper, easel, and markers (one per team)</li></ol>		
---------------------	---	--	--

---

<b>UNIT I-A OUTLINE</b>	<u>Time</u>	<u>Page</u>
I. Introduction and Course Overview	105 minutes	IG I-A-1
1. Welcome and Opening Remarks, Instructor Introductions, Administrative Information	10 minutes	IG I-A-5
2. Student Introductions	30 minutes	IG I-A-5
3. Course Overview	15 minutes	IG I-A-9
4. Course Materials	20 minutes	IG I-A-11
5. Summary and Transition	10 minutes	IG I-A-26
6. Student Activity: Introduction and Overview (Version (A) <b>Suburban</b> ) [20 minutes for students, 10 minutes for instructor review]	30 minutes	IG I-A-28

## **PREPARING TO TEACH THIS UNIT**

- **Tailoring Content to the Local Area:** This instruction unit has no linkages to the Local Area. The unit is a course overview and familiarization with the contents of the Urban Case Study.
- **Optional Activity:** There are no optional activities in this unit.
- **Activity:** The students will begin refamiliarizing themselves with the Case Study materials. The Case Study is a risk assessment and analysis of mitigation options and strategies for a typical commercial office building located in a mixed urban-suburban environment business park. The assessment will use the DoD Antiterrorism Standards and the GSA Interagency Security Criteria to determine Levels of Protection and identify specific vulnerabilities. Mitigation options and strategies will use the concepts provided in **FEMA 426** and other reference materials.
- Refer students to their Student Manual for worksheets and activities.
- Direct students to the appropriate page in the Student Manual.
- Instruct the students to read the activity instructions found in the Student Manual. Note that this Student Activity provides page numbers for each question to assist the students in their familiarization and answering of the questions.

- Tell students how long they have to work on the requirements.
- While students are working, all instructors should closely observe the groups' process and progress. If any groups are struggling, immediately assist them by clarifying the assignment and providing as much help as is necessary for the groups to complete the requirement in the allotted time. Also, monitor each group for full participation of all members. For example, ask any student who is not fully engaged a question that requires his/her viewpoint to be presented to the group. This latter point may not be evident in this first student activity.
- At the end of the working period, reconvene the class.
- After the students have completed the assignment, “walk through” the activity with the students during the plenary session. Call on different teams to provide the answer(s) for each question. Then simply ask if anyone disagrees. If the answer is correct and no one disagrees, state that the answer is correct and move on to the next requirement. If there is disagreement, allow some discussion of rationale, provide the “school solution” and move on.
- If time is short, simply provide the “school solution” and ask for questions. Do not end the activity without ensuring that students know if their answers are correct or at least on the right track.
- Ask for and answer questions.

INSTRUCTOR NOTES

CONTENT/ACTIVITY

VISUAL I-A (S)-11

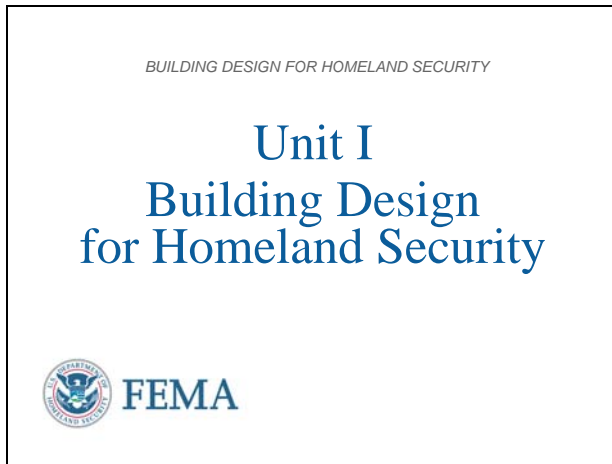

**Welcome and Opening Remarks**

Welcome the students to the Building Design for Homeland Security Course.

Introduce yourself and have the other instructors introduce themselves, using:

- Your name
- Your company or organization
- Brief statement of background and experience

Make the necessary administrative announcements, including:

- Housing, parking, and meals
- Attendance, start/stop times, breaks
- Restroom locations
- Messages and emergencies
- Fire exits

VISUAL I-A (S)-2

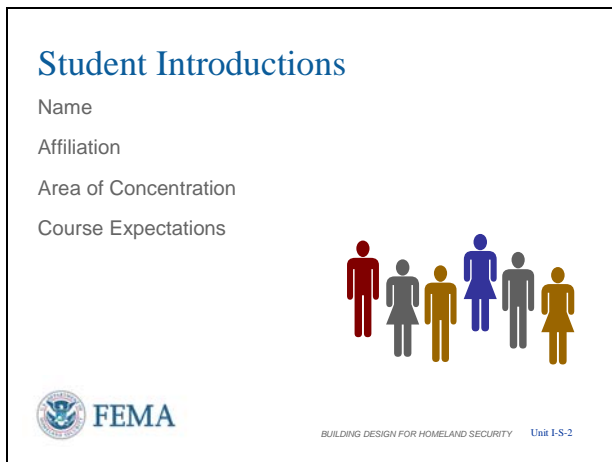

**Student Introductions**

Ask the students to introduce themselves, including:

- Name
- Affiliation
  - Brief statement of background and experience
  - Include any work done in course topic area
- Reasons they are attending course / course expectations. [These will be reviewed during Unit XIII, Course Wrap-Up.]

Recommend an instructor not presenting Unit I to collect Student Expectations on an easel tablet for reference throughout the course and review in Unit XIII.



VISUAL I-A (S)-3

**Purpose of Course and FEMA 426 Manual**

Provide guidance to building sciences community

Decision-makers determine which threats and mitigation measures

Mitigation Information

- Not mandatory
- Not applicable to all buildings
- Not applicable when it interferes with other hazards



BUILDING DESIGN FOR HOMELAND SECURITY Unit I-S-3

**Purpose**

The purpose of **FEMA 426** and this course is to provide guidance to the building sciences community working for public and private institutions. It presents tools to help decision-makers assess the performance of their buildings against terrorist threats and to rank recommendations. It is up to the decision-makers to decide which types of threats they wish to protect against and to determine their level of risk against each threat. Those decision-makers who consider their buildings to be at high risk can use this guidance as necessary.

The mitigation information in **FEMA 426** and this course is:

- Not mandatory
- Not applicable to all buildings
- Not applicable when it interferes with other hazards such as fire, seismic, or life safety requirements contained in building codes

VISUAL I-A (S)-4

**Course Goal**

To enhance student understanding of the measures and technology available to reduce risk from terrorist attack.



FEMA

U.S. AIR FORCE



BUILDING DESIGN FOR HOMELAND SECURITY Unit I-S-4

**Course Goal**

The goal of this course is to enhance student understanding of the measures and technology available to reduce risk from terrorist attack.

Included in this understanding is the process for assessing risk to focus upon which mitigation measures have the greatest applicability and benefit. The students will understand the design approaches to mitigate manmade hazards and comprehend the trade-offs needed to optimize various design requirements.

VISUAL I-A (S)-5

**Course Objectives**

Students will be able to:

1. **Explain** the basic components of the assessment methodology.
2. **Appreciate** the different assessment methodology approaches that can be used.
3. **Perform** an assessment for a building by identifying and prioritizing assets, threats, and vulnerabilities and calculating relative risk.



BUILDING DESIGN FOR HOMELAND SECURITY Unit I-S-5

**Course Objectives (1 of 3)**

The primary target audience for this course is engineers, architects, and state and local government and building officials with engineering and architectural backgrounds involved in mitigation planning and design to protect people and property against manmade hazards. Security personnel and first responders have also attended to understand the concerns of man-made hazards and the impact upon their areas of responsibility.

After attending the Building Design for Homeland Security course, the students should be able to:

1. Explain the basic components of the assessment methodology – threat/hazard, asset value, vulnerability, and risk, as applied to site, layout, and building.
2. Appreciate the different assessment methodology approaches being used by Federal agencies and comprehend which approach to use for a given organizational structure.
3. Perform an assessment for a given building by identifying the assessment components and prioritizing the asset-threat/hazard pairs by their relative risk to focus resources upon mitigation measures that reduce risk.

VISUAL I-A (S)-6

Course Objectives

- 4. **Identify** available mitigation measures applicable to the site and building envelope.
- 5. **Understand** the technology limitations and application details of mitigation measures for terrorist tactics and technological accidents.
- 6. **Perform** an assessment for a given building by identifying vulnerabilities using the Building Vulnerability Assessment Checklist in FEMA 426.



BUILDING DESIGN FOR HOMELAND SECURITY Unit I-S-6

Course Objectives (2 of 3)

- 4. Identify available mitigation measures either in-place or for new design and comprehend their applicability to a given situation.
- 5. Understand the technology limitations and application details of mitigation measures for terrorist tactics and technological accidents involving explosive blast and agent release (chemical, biological, and radiological) to achieve a desired level of protection.
- 6. Use the **Building Vulnerability Assessment Checklist in FEMA 426 (Table 1-22, pages 1-46 to 1-93)** and adjust the assessment relative risk based upon the identified vulnerabilities.

VISUAL I-A (S)-7

Course Objectives

- 7. **Select** applicable mitigation measures and prioritize them based upon the final assessment risk values.
- 8. **Appreciate** that designing a building to mitigate terrorist attacks can create conflicts with other design requirements.



BUILDING DESIGN FOR HOMELAND SECURITY Unit I-S-7

Course Objectives (3 of 3)

- 7. Select applicable mitigation measures and prioritize them based upon the final assessment relative risk values and associated estimated risk reduction provided so as to focus limited resources, all for a given situation.
- 8. Appreciate that designing to mitigate building vulnerabilities against terrorist attacks has conflicts with other design requirements, resulting in trade-offs to achieve acceptable compliance and levels of performance among the differing regulations, codes, programs, operational requirements, and owner desires within the resources available.

VISUAL I-A (S)-8

**Course Overview – Day 1**

<b>Unit I</b> – Introduction and Course Overview
<b>Unit II</b> – Asset Value Assessment
<b>Unit III</b> – Threat / Hazard Assessment
<b>Unit IV</b> – Vulnerability Assessment
<b>Unit V</b> – Risk Assessment / Risk Management

 BUILDING DESIGN FOR HOMELAND SECURITY Unit I-S-8

**Course Overview – Day 1**

This course is a full 3 days in length and includes 13 units of instruction. Most instruction blocks have an associated student activity using a Case Study to emphasize the concepts taught and apply what was just learned.

A detailed schedule is located in your Student Manuals. This is Unit I – Introduction and Course Overview. It will review the other blocks of instruction and the course materials.

For the rest of the first day, the course will introduce the components of risk and how to determine risk. Unit II – Asset Value Assessment will discuss how to identify assets – or things to be protected, and how to assign a relative value to them.

Unit III will examine the Threat/Hazard Assessment process and identify the threats and hazards that could impact a building or site, describe how to assess these threats and hazards, and provide a numerical rating for the threat or hazard.

Unit IV will cover Vulnerability Assessment, including what constitutes vulnerability and how to identify vulnerabilities using the **Building Vulnerability Assessment Checklist in FEMA 426 (Table 1-22, pages 1-46 to 1-93).**

Finally, the last Topic that will be covered on Day 1 is Unit V – Risk Assessment / Risk Management. Students will be taught what constitutes risk and how to determine a numerical value for risk and be introduced to the concept of the Design Basis Threat. This unit will be completed on Day 2.

VISUAL I-A (S)-9

**Course Overview – Day 2**

<b>Unit VI</b> – FEMA 452 Risk Assessment Database
<b>Unit VII</b> – Explosive Blast
<b>Unit VIII</b> – Chemical, Biological, and Radiological (CBR) Measures
<b>Exam and Exam Review</b>
<b>Unit IX</b> – Site and Layout Design Guidance

 BUILDING DESIGN FOR HOMELAND SECURITY Unit I-S-9

**Course Overview – Day 2**

Day 2 will start with Unit VI which presents the associated software database. The database is an electronic way of managing the information you collected manually yesterday to assess risk, make observations, and identify vulnerabilities and mitigation measures, track actions, and generate reports. The database presents an efficient way to manage the diverse information collected during a risk and vulnerability assessment.

[Options: If you brought a laptop, you can use the FEMA 452 Database CD to follow along the presentation, by installing and navigating the database. However, the demonstration / performance approach has not been fully successful for various reasons, so opportunity at lunch and at the end of the day will be made to assist in loading the database.]

Units VII and VIII will provide students with an understanding of some of the weapons commonly used by terrorists. Unit VI will cover explosive blast and Unit VII will cover chemical, biological, and radiological or CBR weapons.

No course would be complete without an exam – so there will be an open book multiple choice/short answer exam on Day 2. [This is the first component of the student evaluation for resident courses taught at the Emergency Management Institute (EMI). When taught as a traveling team away from EMI, the exam is not included.]

After the exam, the course will begin to explore mitigation options for reducing the risk and impact of terrorist attacks against buildings.

Unit IX – Site and Layout Design Guidance will cover things you can do to mitigate

VISUAL I-A (S)-10

**Course Overview – Day 3**

<b>Unit X</b> – Building Design Guidance
<b>Unit XI</b> – Electronic Security Systems
<b>Unit XII</b> – Finalization of Case Study Results
<b>Unit XIII</b> – Course Wrap-up

 **FEMA**

BUILDING DESIGN FOR HOMELAND SECURITY Unit I-S-10

terrorist attacks for the site – meaning from the property line up to the building.

**Course Overview – Day 3**

Unit X will explore mitigation options for the building envelope and inside the building.

Unit XI will introduce the basic concepts of electronic security systems.

As mentioned earlier – each block of instruction has an associated student activity using a Case Study to emphasize the concepts taught and apply what was just learned. In Unit XII, students will present the results of their work using the Case Study – highlighting their top three risks identified by the group, the vulnerabilities identified for these risks, and the top three mitigation measures to reduce vulnerability and risk. One member of the group will have about 5 minutes to brief their team’s results. [This is the second component of the grading system for resident courses at the Emergency Management Institute.]

Finally, Unit XIII will summarize the key points from the course and answer any final questions.

NO SLIDE – USE HARDCOPY

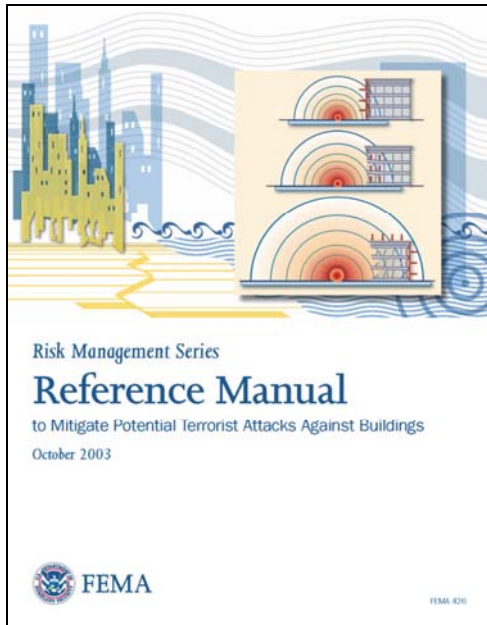

Display a copy of **FEMA 426**

NO SLIDE – USE HARDCOPY

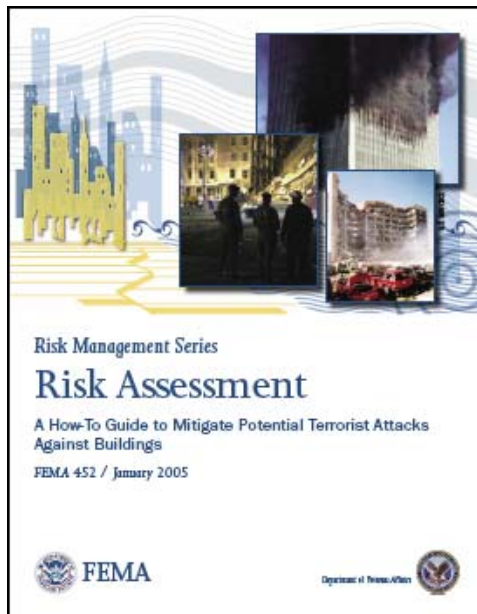

Display a copy of **FEMA 452**.

### FEMA 426

- This is the primary reference for this course
- Throughout the course, slides will contain references to figure and page number, as appropriate, in this document.
- There will be a comprehensive introduction to the document later in this unit.

### FEMA 452

- This is the “How-To” document that supplements FEMA 426 and expands the content of instruction units 2, 3, 4, and 5.
- It introduces the FEMA 452 Databases as the Risk Management tools to support the assessment and mitigation processes
- Similar to FEMA 426, the slides will contain reference to figure and page number taken from this document, as appropriate, as well as other publications



**Course Title: Building Design for Homeland Security**

Unit I-A: Introduction and Course Overview

**INSTRUCTOR NOTES**

**CONTENT/ACTIVITY**

NO SLIDE – USE HARDCOPY

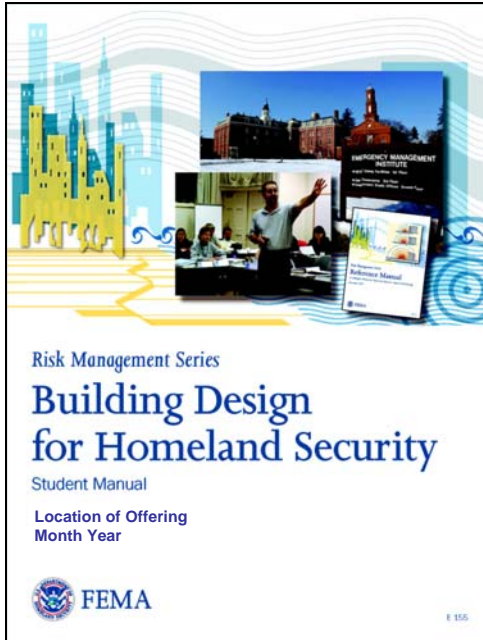

Display a copy of the **Student Manual** binder.

NO SLIDE – USE HARDCOPY

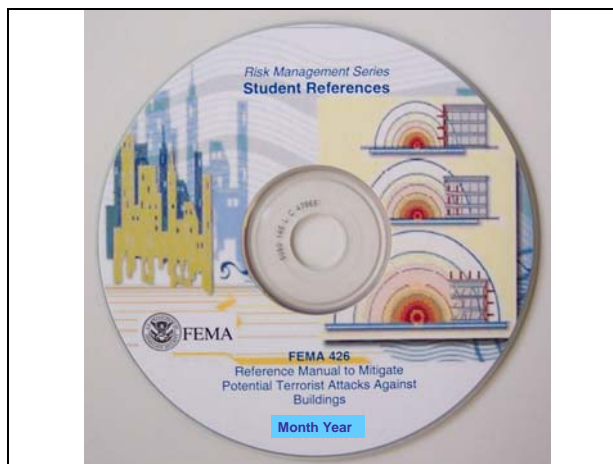

Show the double-sided media storage package containing the **Student Reference CD** and the **FEMA 452 Databases CD**.

**Student Manual**

- The Student Manual will be primarily used as a workbook for activities designed to apply major teaching points.
- Each unit contains worksheets that will be completed in the small group student activity sections of each unit.
- **Appendix S** of the Student Manual is the Suburban Case Study: Hazardville Information Company (HIC) that you were asked to read prior to beginning this course.

**Student References CD**

- The Student Reference CD contains electronic copies of various documents that will be referenced during this course and many that are contained in the Bibliography contained in FEMA 426.
- Tell students that they should have this CD in their handout packages at their seats.



**INSTRUCTOR NOTES**

**CONTENT/ACTIVITY**

NO SLIDE – USE HARDCOPY



Show the reverse side of the media storage package to show the **FEMA 452 Databases CD**.

NO SLIDE – USE HARDCOPY

Walk to a table and indicate the Risk Matrix poster (laminated with threats/hazards, critical functions, and critical infrastructure cells that the student will fill out with ratings for asset value, threat/hazard rating, vulnerability rating, and risk rating.

**FEMA 452 Databases CD**

- The FEMA 452 Databases CD contains the installation programs, User Guides, and files that will be used to demonstrate the features, capabilities, and operation of the databases.
- Tell students that they should have this CD in their handout packages at their seats.
- Point out to the students that the CD found inside the back cover of FEMA 452 is the enterprise version (Version 1.0) of the database as explained in the appendices at the end of that publication. The CD handed out is the latest version of the database. See the User Guide on this CD for installation and use instructions.
- Finally, tell the students that if they would like to have help loading the database on their laptop (if they brought one) to bring the laptop on Day 2 and we will assist in loading during lunch or at the end of the day.

**Risk Matrix Poster**

- The small group student activities are focused on the HIC Case Study (Suburban).
- In small groups, you will conduct a phased assessment of the HIC building after each step of the assessment process is introduced by the instructors.
- The final activity involves the development of possible mitigation actions to address identified risks.
- The Risk Matrix poster is provided for groups to keep a comprehensive record of their findings and for use in presenting these findings to the class.

VISUAL I-A (S)-11

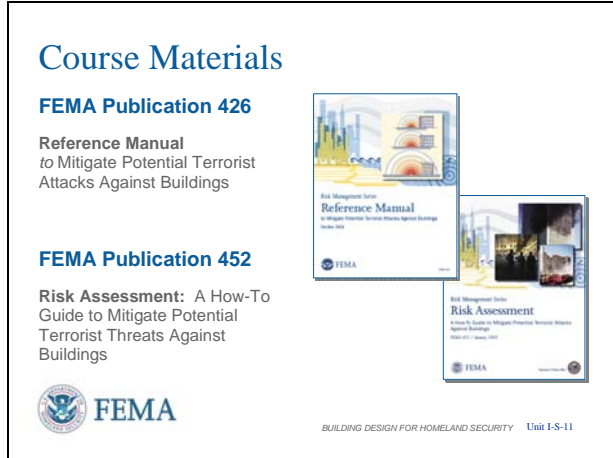

Confirm that each student has a copy of these materials.

Course Materials

At this point each student should have the following:

- **FEMA Publication 426**
- **FEMA Publication 452**
- Student Manual for the Case Study Version (**S – Suburban**) being used in this offering of the course.
- Risk Matrix Poster
- Multi-color dry-erase markers for use on the Risk Matrix Poster.
  - NOTE: The dry-erase markers are easy to erase, meaning that anything placed on top of the posters will erase the entries – so do not place anything on the posters once you start filling them in.

Now that we have confirmed the Course Materials you should have in your possession, we will **look further into the FEMA 426 and 452 publications.**

VISUAL I-A (S)-12

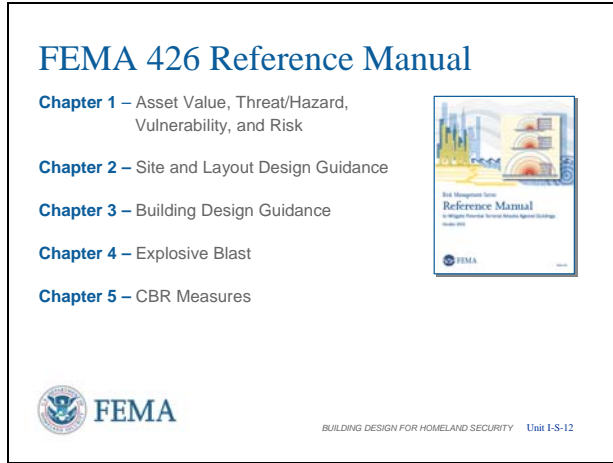

As you begin the following walk-through of **FEMA 426**:

Point out that the students will be following **FEMA 426** throughout the course and will use some sections heavily during exercises. The course visuals include **FEMA 426, FEMA 452, and other page references** for easy reference.

Encourage them to flag key pages and passages with Post-It® notes and highlighting.

Ask them to open **FEMA 426** and follow along as you preview the contents.

**FEMA 426 Reference Manual**

There are five chapters in the manual as listed here. This manual contains many how-to aspects based upon current information contained in FEMA, Department of Commerce, Department of Defense (including Army, Navy, and Air Force), Department of Justice, General Services Administration, Department of Veterans Affairs, Centers for Disease Control and Prevention/National Institute for Occupational Safety and Health, and other publications. It is intended to provide an understanding of the current methodologies for assessing asset value threat/hazard, vulnerability, and risk, and the design considerations needed to improve protection of new and existing buildings and the people occupying them. As needed, this manual should be supplemented with more extensive technical resources, as well as the use of experts when necessary.



Key concepts:

- Design Basis Threat
- Levels of Protection
- Layers of Defense

VISUAL I-A (S)-13

**FEMA 426 Reference Manual**

- Appendix A – Acronyms
- Appendix B – General Glossary
- Appendix C – CBR Glossary
- Appendix D – Electronic Security Systems
- Appendix E – Bibliography
- Appendix F – Associations and Organizations



BUILDING DESIGN FOR HOMELAND SECURITY Unit I-S-13

**FEMA 426 Appendices**



The manual also has six appendices to facilitate its use as a reference:

- Appendix A – Acronyms
- Appendix B – General Glossary
- Appendix C – CBR Glossary
- Appendix D – Electronic Security Systems
- Appendix E – Bibliography
- Appendix F – Associations and Organizations

VISUAL I-A (S)-14

**FEMA 426 – Chapter 1**

- Asset Value Assessment
- Threat/Hazard Assessment
- Vulnerability Assessment
- Risk Assessment
- Risk Management
- Building Vulnerability Assessment Checklist



FEMA 426, Figure 1-3: The Assessment Process Model, p. 1-5  
BUILDING DESIGN FOR HOMELAND SECURITY Unit I-S-14

**FEMA 426 - Chapter 1: Asset Value, Threat/ Hazard, Vulnerability, and Risk**

Chapter 1 presents selected methodologies to integrate threat/hazard, asset criticality, and vulnerability assessment information using applications such as the FEMA HAZUS-MH Geographic Information System (GIS) application to overlay imagery and maps to show access points, blast stand-off, and other site and building information.

The chapter also presents a risk matrix for the preparation of risk assessments. The topic areas of Chapter 1 are:

- Asset Value Assessment
- Threat/Hazard Assessment
- Vulnerability Assessment
- Risk Assessment
- Risk Management
- Building Vulnerability Assessment Checklist

For each of the following chapters, have the students flip through each chapter and highlight some of the key concepts, graphics, etc.

Finally, Chapter 1 provides an assessment checklist that compiles many best practices (based upon current technologies and scientific research) to consider during the

**INSTRUCTOR NOTES**

**CONTENT/ACTIVITY**

VISUAL I-A (S)-15

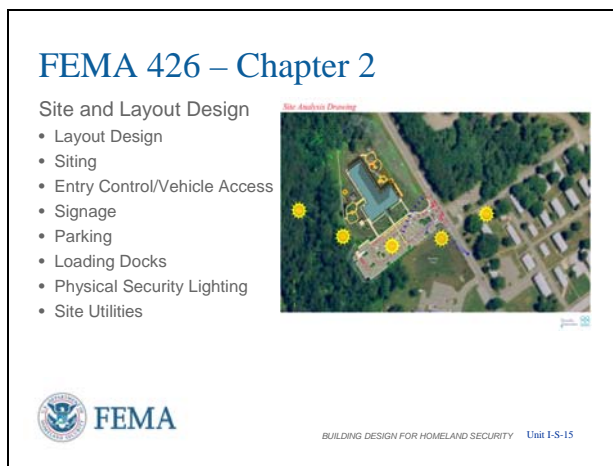

design of a new building or renovation of an existing building.

**Assessment Flow Chart**

The assessment flow chart illustrates the process you will follow in conducting the assessment.

**FEMA 426 - Chapter 2: Site Layout and Design Guidance**

Chapter 2 discusses architectural and engineering design considerations (mitigation measures), starting at the perimeter of the property line, and includes the orientation of the building on the site. Therefore, this chapter covers issues outside the building envelope.

Chapter 2 also discusses the following site layout and design topics:

- Layout Design
- Siting
- Entry Control/Vehicle Access
- Signage
- Parking
- Loading Docks
- Physical Security Lighting
- Site Utilities

VISUAL I-A (S)-16

**FEMA 426 – Chapter 3**

Building Design Guidance

- Architectural
- Building Structural and Nonstructural Considerations
- Building Envelope considerations
- Other Building Design Issues
- Building Mitigation Measures



FEMA 426, Figure 1-10: Non-Redundant Critical Functions Collocated Near Loading Dock, p. 1-41  
BUILDING DESIGN FOR HOMELAND SECURITY Unit I-S-16



**FEMA 426 - Chapter 3: Building Design Guidance**

Chapter 3 provides the same considerations for the building – its envelope, systems, and interior layout.

The topic areas in Chapter 3 include:



- Architectural
- Building Structural and Nonstructural Considerations
- Building Envelope Considerations
- Other Building Design Issues
- Building Mitigation Measures

VISUAL I-A (S)-17

**FEMA 426 – Chapter 4**

Explosive Blast

- Building Damage
- Blast Effects and Predictions
- Stand-off Distance
- Progressive Collapse



FEMA 426, Figure 1-11: Explosive Blast Effects, p. 1-42  
BUILDING DESIGN FOR HOMELAND SECURITY Unit I-S-17



**FEMA 426 - Chapter 4: Explosive Blast**

Chapter 4 provides a discussion of blast theory to understand the dynamics of the blast pressure wave, the response of building components, and a consistent approach to define levels of protection.

Some of the details you will address include:

- Building Damage
- Blast Effects and Predictions
- Stand-off Distance
- Progressive Collapse

**INSTRUCTOR NOTES**

**CONTENT/ACTIVITY**

**VISUAL I-A (S)-18**

**FEMA 426 – Chapter 5**

CBR Measures

- Evacuation
- Sheltering in Place
- Personal Protective Equipment
- Filtering and Pressurization
- Exhausting and Purging



 **FEMA**

BUILDING DESIGN FOR HOMELAND SECURITY Unit I-S-18

**FEMA 426 - Chapter 5: CBR Measures**

Chapter 5 presents chemical, biological, and radiological measures that can be taken to mitigate vulnerabilities and reduce associated risks for these terrorist tactics.

The concepts you should be familiar with at the end of the instruction include:

- Evacuation
- Sheltering in Place
- Personal Protective Equipment
- Filtering and Pressurization
- Exhausting and Purging

**VISUAL I-A (S)-19**

**FEMA 452 Risk Assessment How-To**

- Step 1** – Threat Identification and Rating
- Step 2** – Asset Value Assessment
- Step 3** – Vulnerability Assessment
- Step 4** – Risk Assessment
- Step 5** – Consider Mitigation Options



 **FEMA**

BUILDING DESIGN FOR HOMELAND SECURITY Unit I-S-19

**FEMA 452 Risk Assessment How-To**

This publication expands Chapter 1 of FEMA 426 going into greater detail in each step of the risk assessment process as indicated by Steps 1 through 4. Step 5 takes an overarching view of mitigation options, looking at cost, benefit, special considerations, and the like, rather than going into specific mitigation options as done in Chapters 2 through 5 of FEMA 426.



VISUAL I-A (S)-20

**FEMA 452 Risk Assessment How-To**

- Appendix A** – Building Vulnerability Assessment Checklist
- Appendix B1** – Risk Management Database v1.0: Assessor's User Guide
- Appendix B2** – Risk Management Database v1.0: Database Administrator's User Guide
- Appendix B3** – Risk Management Database v1.0: Manager's User Guide
- Appendix C** – Acronyms and Abbreviations



 **FEMA**

BUILDING DESIGN FOR HOMELAND SECURITY Unit I-S-20

**FEMA 452 Risk Assessment How-To Appendices**

The manual also has five appendices to facilitate its use as a reference:

- **Appendix A** – Building Vulnerability Assessment Checklist [This is the same checklist as found at the end of Chapter 1 in FEMA 426]
- **Appendices B1, B2, and B3** – Different User Guides to use the **Version 1.0** of the FEMA 452 Risk Assessment Database that comes with FEMA 452 on the inside back cover. [This is the large organization version of the database for use on servers to facilitate access by tens and hundreds of people.]
- **Appendix C** – Acronyms and Abbreviations

VISUAL I-A (S)-21

**Summary**

FEMA 426 and 452 are intended for building sciences professionals.

Manmade hazards risk assessments use a “Design Basis Threat.”

Site and building systems and infrastructure protection are provided by layers of defense.

Multiple mitigation options and techniques.

Use cost-effective multihazard analysis and design.

 **FEMA**

BUILDING DESIGN FOR HOMELAND SECURITY Unit I-S-21

**Summary**

- **FEMA 426 and 452** is intended for building sciences professionals, but can be used by anyone with basic understanding of the systems being assessed.
- Manmade hazards risk assessments use a “Design Basis Threat” and “Levels of Protection” for manmade disaster and loads versus building codes for natural disaster and loads.
- Site and building systems and infrastructure protection are provided by layers of defense.
- Multiple mitigation options and techniques to deter, detect, deny, and devalue.
- Use cost-effective multihazard analysis and design.



**INSTRUCTOR NOTES**

**CONTENT/ACTIVITY**

**VISUAL I-A (S)-22**

**Case Study Activities**

In small group settings, apply concepts introduced in the course.

Become conversant with contents and organization of FEMA 426.



 **FEMA**

BUILDING DESIGN FOR HOMELAND SECURITY Unit I-S-22

**Case Study Activities**

Through case studies in small group settings, students will become conversant with the contents and organization of **FEMA 426**.

- In small group settings, apply concepts introduced in the course
- Become conversant with contents and organization of FEMA 426

**VISUAL I-A (S)-23**

**HAZARDVILLE INFORMATION COMPANY (HIC)**

**Case Study**

Small IT / Communications / Data Center Company

- Occupies portion of building rented in Suburban Office Park
- Data center and communications for off-site clients

 **FEMA**

BUILDING DESIGN FOR HOMELAND SECURITY Unit I-S-23

**Introduction to the Case Study**

The Case Study activities throughout this course provide opportunities, in a small group setting, to apply concepts introduced in each unit.

These activities will enable students to become conversant with **FEMA 426**, *Reference Manual to Mitigate Potential Terrorist Attacks Against Buildings*.

Students will be able to use the document readily during the process of mitigating potential damage from terrorist attacks against buildings.

The activities are designed to “walk” students through the same assessment and design steps using a Case Study involving a hypothetical building and associated data about the threat environment.

**Hazardville Information Company (HIC)**

The Hazardville Information Company (HIC) is a fictional entity created for this course (see Appendix S of the Student Manual).

Divide students into small groups of 5 to 8, with 7 being the optimal. Greater than 8 leaves people out of the activity and tables are not usually large enough.

Students should work in these groups for the remainder of the small group sessions.

Refer students to the Unit I Case Study activity in the Student Manual.

Members of the instructor staff should be available to answer questions and assist groups

**INSTRUCTOR NOTES**

**CONTENT/ACTIVITY**

as needed.

- It is a composite of actual sites and buildings with actual systems typical of a number of commercial buildings.

The Case Study mainly addresses threat information related to manmade hazards:

- Explosive blast
- Chemical, biological, and radiological agents
- Armed attack
- Cyber attack

Each section of the Case Study activity includes:

- Examination of specific aspects of the Case Study data.
- Assessment of data and application to the Case Study of concepts and processes addressed in the unit.
- Completion of worksheets that demonstrate participant mastery of unit learning objectives.

VISUAL I-A (S)-24



**Hazardville Information Company**

**General Student Activity Requirements**

Each student is responsible for completion of his or her own worksheets.

In addition, the small groups will produce a completed worksheet for each unit's activity and post results as applicable on the Risk Matrix Poster.

Group members are encouraged to discuss activity requirements and collaborate on completion of the worksheets.

To facilitate this process, select a leader and a

**INSTRUCTOR NOTES**

**CONTENT/ACTIVITY**

**VISUAL I-A (S)-25**

**Mission**

**Regional Computer Center**

- Real-time IT support
- Backup services
- 24 x 7 operations

**Customers**

- Government and commercial
- Some classified work

**Layout**

- Downstairs: Computers, Communications, Staff
- Upstairs: Executive offices
- Loading dock, Storage



 **FEMA**

BUILDING DESIGN FOR HOMELAND SECURITY Unit I-S-25



**VISUAL I-A (S)-26**

**Threat Analysis**

**Terrorist Threat**

**Intelligence Threat**

**Criminal Threat**



 **FEMA**

FEMA 426, Figure 2-1: An Example of Using GIS to Identify Adjacent Hazards, p. 2-5  
BUILDING DESIGN FOR HOMELAND SECURITY Unit I-S-26

recorder.

- Turn to Appendix S, the Suburban Case Study materials in the Student Manual and briefly peruse the document.
- Use the Case Study data to answer worksheet questions, but feel free to ask questions based upon your experience.

**Hazardville Information Company**

The Hazardville Information Company supports approximately 1,000 users and 100 applications as a primary data center and as a disaster recovery backup site.

HIC has over 130 employees and approximately 80-100 employees are in the building at any given time.

**Threats/Hazards**

- Terrorism
- Intelligence
- Crime

Note the site location, terrain, parking, and other commercial buildings around HIC.

**INSTRUCTOR NOTES**

**CONTENT/ACTIVITY**

**VISUAL I-A (S)-27**

**Hazard Analysis**

HazMat

- Facilities
- Highway
- Rail

Liquid Fuels

Air Traffic

Natural Hazards



 FEMA

BUILDING DESIGN FOR HOMELAND SECURITY Unit I-S-27

**Threats/Hazards**

- HazMat
- Natural Hazards

Note the major interstate and rail lines near HIC.

**VISUAL I-A (S)-28**

**Computerized Elevation Looking Northwest**



 FEMA

BUILDING DESIGN FOR HOMELAND SECURITY Unit I-S-28

**Computerized Elevation Looking Northwest**

Note the elevation differences between the tank farm, the interstate, and the office park.

A tank leak overflowing the berm around the tank could flow down the interstate, but unlikely that it would flow into the office park.

VISUAL I-A (S)-29

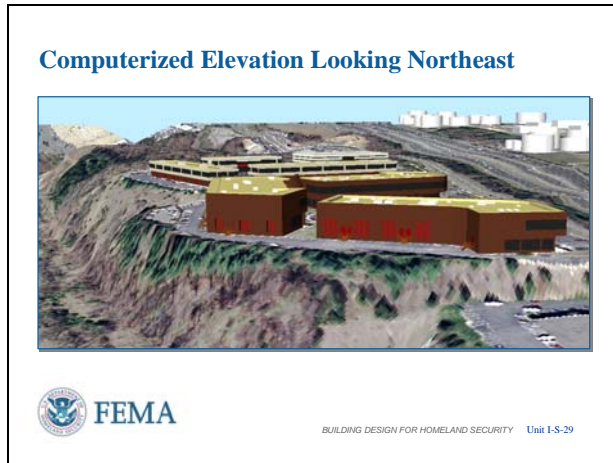

**Computerized Elevation Looking Northeast**

This slide shows the drop off behind the office complex which makes vehicle access very difficult from that direction.

VISUAL I-A (S)-30

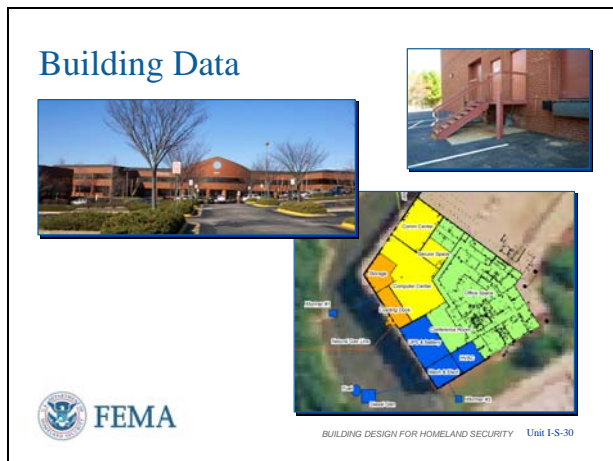

**HIC Building Data**

- Structural
- Mechanical
- Electrical
- IT
- Physical Security

Note the parking lot, building entry and exit access points, loading docks, building functions, and building infrastructure.

Also note that the interior columns have architectural standoff of about 4 inches per the graphic in the upper right corner.

VISUAL I-A (S)-31

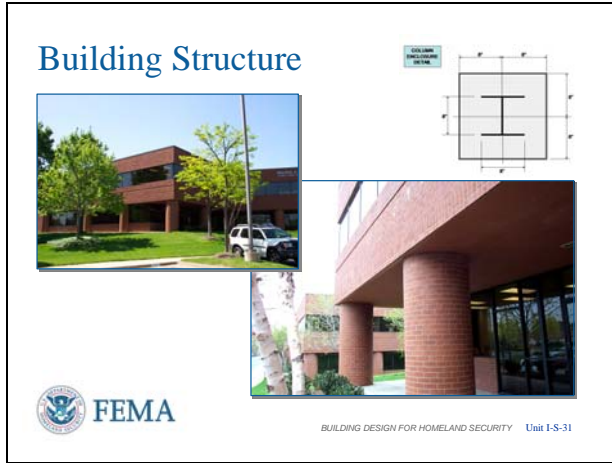

**HIC Building Structure**

The Case Study will review the building structure and envelope to identify vulnerabilities and mitigation options.

Note the percentage of glass on the exterior walls, overhangs, and type of construction.

Also note that the interior columns have architectural standoff of about 4 inches per the graphic in the upper right corner.

VISUAL I-A (S)-32



**HIC Mechanical Systems**

The Case Study will review mechanical systems, plumbing, and piping to identify vulnerabilities and mitigation options.

Note the exposed meter and ground level air intake.



VISUAL I-A (S)-33

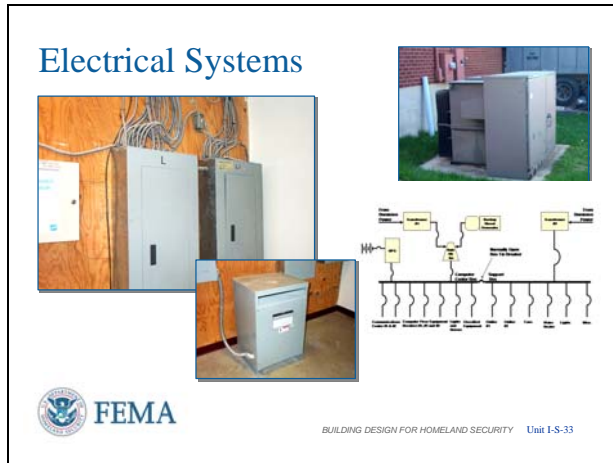

**HIC Electrical Systems**

The Case Study will review primary electrical utilities and backup power to identify vulnerabilities and mitigation options.

Note the exposed electrical transformers, critical utility entry points, and redundancies, especially the two buss system and the tie breaker.

VISUAL I-A (S)-34



**HIC Physical Security**

The Case Study will review physical security systems, equipment, and procedures to identify vulnerabilities and mitigation options.

Note the locations of sensors, lights, access points, and type of badges or card readers.

**INSTRUCTOR NOTES**

**CONTENT/ACTIVITY**

**VISUAL I-A (S)-35**



**HIC IT Systems**

The Case Study will review key IT systems to include the data center and communications to identify vulnerabilities and mitigation options.

Note the type of flooring, penetrations, mixed cable and fiber, racks.

**VISUAL I-A (S)-36**

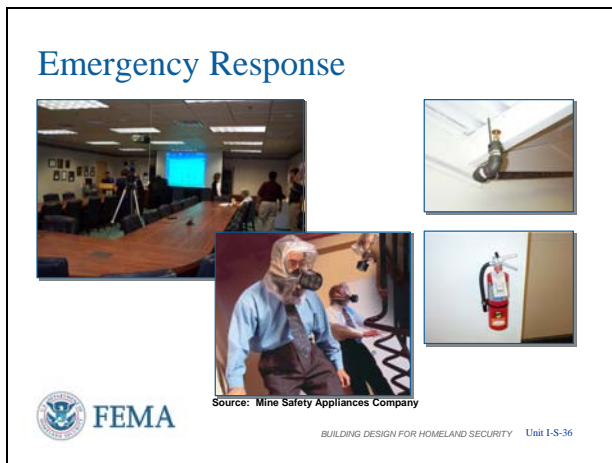

**HIC Emergency Response**

Determine the location, availability, and readiness condition of emergency response assets, and the state of training of building staff in their use.

Note the location and type of protective equipment, safe haven or shelter in place options, and mass notification capability.



INSTRUCTOR NOTES

CONTENT/ACTIVITY

VISUAL I-A (S)-37

**Design Basis Threat**

**Explosive Blast:** Car Bomb 250 lb TNT equivalent, Truck Bomb 5,000 lb TNT equivalent (Murrah Federal Building class weapon)

**Chemical:** Large quantity gasoline spill and toxic plume from the adjacent tank farm, small quantity (tanker truck and rail car size) spills of HazMat materials (chlorine)

**Biological:** Anthrax delivered by mail or in packages, smallpox distributed by spray mechanism mounted on truck or aircraft in metropolitan area

**Radiological:** Small “dirty” bomb detonation within the 10-mile radius of the HIC building



BUILDING DESIGN FOR HOMELAND SECURITY Unit I-S-37

**Design Basis Threat**

- Explosive Blast
- Chemical
- Biological
- Radiological (“dirty” bomb)

VISUAL I-A (S)-38

**Design Basis Threat**

**Criminal Activity/Armed Attack:** High powered rifle or handgun exterior shooting (sniper attack or direct assault on key staff, damage to infrastructure [e.g., transformers, chillers, etc.])

**Cyber Attack:** Focus on IT and building systems infrastructure (SCADA, alarms, etc.) accessible via Internet access



BUILDING DESIGN FOR HOMELAND SECURITY Unit I-S-38

**Design Basis Threat**

- Criminal Activity/Armed Attack
- Cyber Attack

INSTRUCTOR NOTES

CONTENT/ACTIVITY

VISUAL I-A (S)-39

**Levels of Protection and Layers of Defense**

Levels of Protection for Buildings

- GSA Interagency Security Criteria Level II Building
- DoD Low Inhabited Building

Elements of the Layers of Defense Strategy

- Deter
- Detect
- Deny
- Devalue



BUILDING DESIGN FOR HOMELAND SECURITY Unit I-S-39

**Levels of Protection and Layers of Defense**

The Case Study will use both the GSA and DoD Levels of Protection to evaluate vulnerabilities against and to develop mitigation options.

A key design strategy and concept is “Layers of Defense.” The elements of a layered system are:

- Deter
- Detect
- Deny
- Devalue

VISUAL I-A (S)-40

**Summary**

**FEMA Publication 426**

Reference Manual to Mitigate Potential Terrorist Attacks Against Buildings



**FEMA Publication 452**

Risk Assessment: A How-To Guide to Mitigate Potential Terrorist Threats Against Buildings



BUILDING DESIGN FOR HOMELAND SECURITY Unit I-S-40

**Summary**

The objective of this course is to provide a comprehensive approach to reducing the physical damage to structural and non-structural components of buildings and related infrastructure, focusing on six specific types of facilities:

- Commercial office facilities
- Retail commercial facilities
- Light industrial and manufacturing
- Health care
- Local schools
- Higher education

**Exam Questions #A18 and B17**

Most importantly, the course provide participants with a solid foundation on:

- Design Basis Threat
- Levels of Protection
- Layers of Defense

**INSTRUCTOR NOTES**

**CONTENT/ACTIVITY**

VISUAL I-A (S)-41

**Unit I Case Study Activity**  
**Introduction and Overview**  
**Background**  
Emphasis:

- Refamiliarize yourself with Appendix S, Case Study
- Get acquainted with FEMA 426

**Requirements**  
Refer to Case Study and, as a team, answer worksheet questions  
Use Case Study data to answer worksheet questions

- Ask instructors any clarifying questions based upon your experience



BUILDING DESIGN FOR HOMELAND SECURITY Unit I-S-41

At the end of 20 minutes, reconvene the class and facilitate group reporting in the plenary session.

**Unit I Case Study Activity**

**Requirements**

- Briefly refamiliarize yourself with CI/BC Case Study materials (Appendix C of the Student Manual)
- Read the questions on the Unit I Student Activity worksheet found in your Student Manual at the Unit 1 tab and, as a group, complete the worksheet.
- Use the Case Study data to answer worksheet questions, but feel free to ask clarifying questions from your experience.

**Transition**

In this course, you will learn how to perform a multihazard risk assessment of a building and become familiar with the key concepts to protect buildings from manmade threats and hazards:

- Asset Value
- Design Basis Threat
- Level of Protection
- Layers of Defense
- Vulnerability Assessment
- Risk Assessment
- Mitigation

Using the approach and guidance provided in **FEMA 426**, the majority of building owners should be able to complete a risk assessment of their building in a few days and identify the primary vulnerabilities, mitigation options, and make informed decisions on the ability of their building to survive, recover, and operate should an attack or event occur.

**Course Title: Building Design for Homeland Security**

Unit I-A: Introduction and Course Overview

**INSTRUCTOR NOTES**

**CONTENT/ACTIVITY**

For the rest of the first day, the course will introduce the components of risk and how to determine risk.

- Unit II – Asset Value Assessment
- Unit III – Threat/Hazard Assessment
- Unit IV – Vulnerability Assessment
- Unit V – Risk Assessment/Risk Management

**UNIT I-A CASE STUDY ACTIVITY:  
CASE STUDY OVERVIEW  
HAZARDVILLE INFORMATION COMPANY (HIC)  
(Suburban Version)**

**Requirements**

Turn to Appendix S, Case Study, and briefly peruse the document. Read the “familiarization” questions on the following worksheet and, as a group, complete the worksheet. Use only the Case Study data to answer worksheet questions. Information has been limited in an effort to focus the activity. However, feel free to ask questions of the instructors based upon your experience.

Students should read the case study before attending a course offering, but if not, recommending reading it as soon as possible on the first day of class. During the first day of class students realize that the general reading is a good start, but assessment requires a more in depth analysis of content and functional and spatial inter-relationships to perform the student activities.

The answer to the first question is filled-in as an example.

Question	Answer	Page # in Case Study
1. What are the major transportation modes in the surrounding area?	<p>A major interstate highway is located within ¼ mile of the HIC building.</p> <p>CSX Transportation and Norfolk-Southern Railway maintain a transportation corridor about ½ mile from HIC. There appear to be no restrictions on the material carried along these rail lines.</p> <p>Two airports are in the vicinity of HIC. One is a major international airport approximately 8 miles away. The other is a small, but busy general aviation airport less than 2 miles away.</p>	A-3, A-32 – A-35
2. What life safety/ emergency response assets are available, and what are their response times?	<ul style="list-style-type: none"> <li>• Wet pipe sprinkler system</li> <li>• 20 hand-held dry chemical fire extinguishers</li> <li>• Emergency generator for all functions</li> <li>• Fires station 2½ miles away. Seven others within 5 miles of the site. Response time: 8-10 minutes</li> <li>• Hospital 5 miles away</li> </ul>	A-17, A-18 – A-20, A-30

**Course Title: Building Design for Homeland Security**

Unit I-A: Introduction and Course Overview

3. What threats or hazards may affect HIC?	<ul style="list-style-type: none"><li>• Hazardous materials</li><li>• Liquid fuels</li><li>• Air traffic</li><li>• Natural disasters</li><li>• Manmade disasters (terrorist collateral damage or criminal threat)</li></ul>	A-6, A-31 – A-37
4. What are the prevalent weather/wind conditions at HIC?	The prevailing weather pattern for the area in the summer and fall is from the south Atlantic and the Gulf of Mexico. Warm, moist air brings thunderstorms and higher humidity. In the fall, cooler air from the north and west returns. Winter weather blasts across the state from the northern or central part of the continent. With no other weather activity, the prevailing wind is normally from the west-northwest.	A-6
5. What are the components of HIC's critical <u>utility</u> infrastructure ?	<ul style="list-style-type: none"><li>• Electrical systems (power to Computer Center)</li><li>• Communications systems (data and voice between HIC and clients)</li><li>• Gas supply (heat/humidity control to Computer Center)</li><li>• Mechanical systems (cooling to Computer Center)</li><li>• Water supply (cooling towers)</li><li>• Emergency response systems (backup generator, alternate communications, etc.)</li></ul>	A-13 – A-22
6. What are the components of HIC's critical <u>building</u> infrastructure ?	<ul style="list-style-type: none"><li>• Parking</li><li>• Entryways</li><li>• Exits</li><li>• Loading dock</li></ul>	A-4, A-5, A-11, A-12

<p>7. What personnel are key to the <u>operation</u> of HIC?</p>	<p>The critical functions of HIC are:</p> <ul style="list-style-type: none"><li>• Computer/data processing</li><li>• Wired/wireless networking</li><li>• Information Technology</li><li>• Communications</li></ul> <p>Of HIC's some 130 employees, the technical staff associated with Computer Center operations are the key personnel along with upper management/decision makers that provide the resources for these operations. Facility staff maintaining utilities that directly impact operations are also in this category.</p>	<p>A-23 – A-26</p>
--	--	--------------------

## Unit II

---

<b>COURSE TITLE</b>	Building Design for Homeland Security	<b>TIME</b>	75 minutes
---------------------	---------------------------------------	-------------	------------

---

<b>UNIT TITLE</b>	Asset Value Assessment
-------------------	------------------------

---

<b>OBJECTIVES</b>	<ol style="list-style-type: none"><li>1. Identify the assets of a building or site that can be affected by a threat or hazard</li><li>2. Explain the components used to determine the value of an asset</li><li>3. Determine the critical assets of a building or site</li><li>4. Provide a numerical rating for the asset and justify the basis for the rating</li></ol>
-------------------	---

---

<b>SCOPE</b>	<p>The following topics will be covered in this unit:</p> <ol style="list-style-type: none"><li>1. The core functions and critical infrastructure listed on the threat-vulnerability matrix.</li><li>2. Various approaches to determine asset value – FEMA, Department of Defense, Department of Justice, and Veterans Affairs.</li><li>3. A rating scale and how to use it to determine an asset value.</li><li>4. Activity: Identify the assets to consider in the Case Study and determine the asset value for each asset of interest.</li></ol>
--------------	---

---

<b>REFERENCES</b>	<ol style="list-style-type: none"><li>1. FEMA 426, <i>Reference Manual to Mitigate Potential Terrorist Attacks Against Buildings</i>, pages 1-10 to 1-14</li><li>2. FEMA 452, <i>Risk Assessment: A How-To Guide to Mitigate Potential Terrorist Attacks Against Buildings</i>, pages 2-1 to 2-26</li><li>3. Case Study – Appendix S: Suburban, Hazardville Information Company</li><li>4. Student Manual, Unit II (S) (info only – not in SM)</li><li>5. Unit II (S) visuals (info only – not in SM)</li></ol>
-------------------	---

---

<b>REQUIREMENTS</b>	<ol style="list-style-type: none"><li>1. FEMA 426, <i>Reference Manual to Mitigate Potential Terrorist Attacks Against Buildings</i> (one per student)</li><li>2. FEMA 452, <i>Risk Assessment: A How-To Guide to Mitigate Potential Terrorist Attacks Against Buildings</i> (one per student)</li><li>3. Instructor Guide, Unit II</li><li>4. Student Manual Suburban Case Study (one per student)</li><li>5. Overhead projector or computer display unit</li></ol>
---------------------	--

---



- 
6. Unit II visuals
  7. Risk Matrix poster and box of dry-erase markers (one per team)
  8. Chart paper, easel, and markers (one per team)

<b>UNIT II (S) OUTLINE</b>	<u>Time</u>	<u>Page</u>
II. Asset Value Assessment	75 minutes	IG II-1
1. Unit Objectives and Assessment Process	10 minutes	IG II-5
2. Identification of Assets	5 minutes	IG II-7
3. Asset Value Rating	10 minutes	IG II-8
4. Summary and Student Activity	5 minutes	IG II-11
5. Activity: Asset Value Ratings (Version <b>A Suburban</b> ) [35 minutes for students, 10 minutes for instructor review]	45 minutes	IG II-A-13
6. Activity: Asset Value Ratings (Version <b>B Urban</b> ) [35 minutes for students, 10 minutes for instructor review]	45 minutes	IG-II-B-19

## PREPARING TO TEACH THIS UNIT

- **Tailoring Content to the Local Area:** This is a generic instruction unit that does not have any specific capability for linking to the Local Area. However, Local Area discussion may be generated as students have specific situations for which they would like to determine asset value. Also, the determination of asset value rating is subjective because this course was designed for small organizations with few decision makers or levels of decision making. Large organizations would need a more objective approach to asset value rating so that the ratings of different people would be comparable, which does not occur in small organizations.
- **Optional Activity:** There are no optional activities in this unit.
- **Activity:** The students will apply the techniques of asset identification and asset value rating to the Case Study in order to identify and rate the assets found in the Case Study. The students will have to quickly scan the Case Study information with the specific intent of determining assets and their value to the organization. Reading the selected Case Study prior to the class greatly helps in performing this activity.
- Refer students to their Student Manuals for worksheets and activities.

- Direct students to the appropriate page (Unit #) in the Student Manual.
- Instruct the students to read the activity instructions found in the Student Manual. Note that this Student Activity provides asset value ratings that the students must determine agreement with and rationale for the given asset value rating.
- Explain that the asset value ratings determined by the team must be transferred to the Risk Matrix poster.
- Tell students how long they have to work on the requirements.
- While students are working, all instructors should closely observe the groups' process and progress. If any groups are struggling, immediately assist them by clarifying the assignment and providing as much help as is necessary for the groups to complete the requirement in the allotted time. Also, monitor each group for full participation of all members. For example, ask any student who is not fully engaged a question that requires his/her viewpoint to be presented to the group.
- At the end of the working period, reconvene the class.
- After the students have completed the assignment, “walk through” the activity with the students during the plenary session. Call on different teams to provide the answer(s) for each question. Then simply ask if anyone disagrees. If the answer is correct and no one disagrees, state that the answer is correct and move on to the next requirement. If there is disagreement, allow some discussion of rationale, provide the “school solution” and move on.
- If time is short, simply provide the “school solution” and ask for questions. Do not end the activity without ensuring that students know if their answers are correct or at least on the right track.
- Ask for and answer questions.

*This page intentionally left blank*

INSTRUCTOR NOTES

CONTENT/ACTIVITY

VISUAL II-1

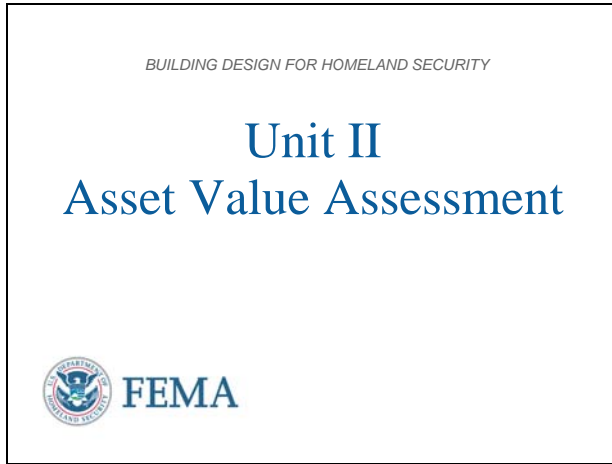

**Introduction and Unit Overview**

This is Unit II, Asset Value Assessment. This section will describe how to perform an asset value assessment (the first step in the assessment process), to identify people and asset values categorized as core functions and core infrastructure. Key to this process is interviewing stakeholders including owners, facility staff, and tenants.

VISUAL II-2



**Unit Objectives**

At the end of this unit, the students should be able to:

1. Identify the assets of a building or site that can be affected by a threat or hazard.
2. Explain the components used to determine the value of an asset.
3. Determine the critical assets of a building or site.
4. Provide a numerical rating for the asset and justify the basis for the rating.

VISUAL II-3

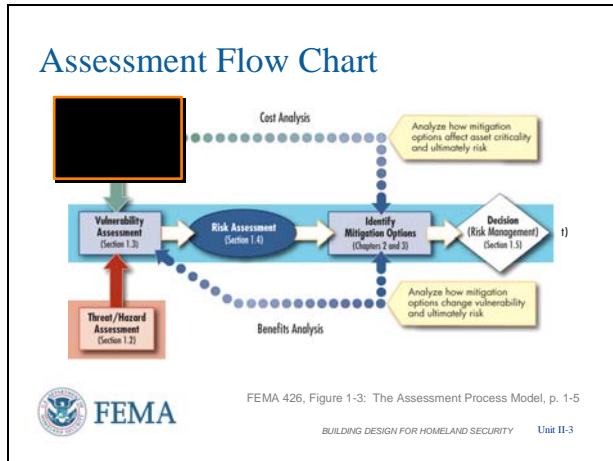

**Assessment Flow Chart**

Reviewing the Assessment Flow Chart, the first step in the risk assessment process is to determine asset value.

An asset is anything you want to protect because of its value, its need to maintain business continuity, and/or its difficulty in replacing within a required timeline.

VISUAL II-4

**Definition of Risk**

Risk is a combination of:

- The probability that an event will occur, and
- The consequences of its occurrence

**Asset** - A resource of value requiring protection. An asset can be tangible, such as buildings, facilities, equipment, activities, operations, and information; or intangible, such as processes or a company's information and reputation.

	Low Risk	Medium Risk	High Risk
Risk Factors Total	1-40	41-175	> 176

Risk = Asset Value x Threat Rating x Vulnerability Rating

Infrastructure	Function
Replacement/Repair	People
Loss of Use	

FEMA 426, Table 1-19: Total Risk Color Code, p. 1-38

FEMA logo and footer: BUILDING DESIGN FOR HOMELAND SECURITY Unit II-4

**Risk**

Risk can be defined as the potential for loss of or damage to an asset. It takes into account the **value of an asset**, the **threats or hazards** that potentially impact the asset, and the **vulnerability** of the asset to the threat or hazard.

Values can be assigned to these three components of risk to provide a risk rating.

In general terms, asset value can be considered the replacement cost for infrastructure and equipment. It can include lost profit to a business or lost capability to a mission that results in greater damage and loss to that asset and other assets.

VISUAL II-5

**People and Asset Value**

**Asset Value** - The degree of debilitating impact that would be caused by the incapacity or destruction of an asset.



 FEMA

BUILDING DESIGN FOR HOMELAND SECURITY Unit II-5

**People and Asset Value**

Understanding asset criticality is comparable to strategic planning in that the building owner should understand the mission of the organization, the resources that are used to perform that mission, how those resources interface with one another to achieve goals, and how the organization would cope or maintain business continuity if the asset(s) were lost.

People are a building's most critical asset.

**Exam Questions #A1 and B2**

VISUAL II-6

**Identification of a Building's Assets**

**Two Step Process**

**Step 1:** Define and understand a building's core functions and processes



**Step 2:** Identify site and building infrastructure and systems



 FEMA

BUILDING DESIGN FOR HOMELAND SECURITY Unit II-6

**Identification of a Building's Assets**

Identifying a building's critical assets is accomplished in a two-step process.

Step 1: Define and understand a building's core functions and processes.

Step 2: Identify site and building infrastructure and systems:

- Critical components/assets
- Critical information systems and data
- Life safety systems and safe haven areas
- Security areas

**Exam Questions #A2 and B1**

VISUAL II-7

### Asset Value

**Core Functions**

- Primary services or outputs
- Critical activities
- Identify customers
- Inputs from external organizations

**Critical Infrastructure**

- Injuries or deaths related to lifelines
- Effect on core functions
- Existence of backups
- Availability of replacements
- Critical support lifelines
- Critical or sensitive information



BUILDING DESIGN FOR HOMELAND SECURITY Unit II-7

**Asset Value**

The objective in the initial step is to determine the core functions for the building that will enable it to continue to operate or provide services after an attack. This focuses the assessment team on the key areas of the building. Factors include:

- What are the primary services?
- What critical activities take place at the building?
- Who are the building’s occupants and visitors?

To help evaluate and rank critical infrastructure, consider the following factors:

- Injuries or deaths related to critical infrastructure damage
- Effect on core functions
- Existence of backups, systems redundancy
- Availability of replacements
- Critical support lifelines
- Critical or sensitive information

VISUAL II-8

### Asset Value Rating

Asset Value		
Very High	10	Very High – Loss or damage of the building’s assets would have exceptionally grave consequences, such as extensive loss of life, widespread severe injuries, or total loss of primary services core processes, and functions.
High	8-9	High – Loss or damage of the building’s assets would have grave consequences, such as loss of life, severe injuries, loss primary services or major loss of core processes and functions for an extended period of time.
Medium High	7	Medium High – Loss or damage of the building’s assets would have serious consequences, such as serious injuries or impairment of core processes and functions for an extended period of time.

**Key elements**

- Loss of assets and/or people would have grave, serious, moderate, or negligible consequences or impact



FEMA 426, Adaptation of Table 1-1: Asset Value Scale, p. 1-13  
BUILDING DESIGN FOR HOMELAND SECURITY Unit II-8

**Quantifying Asset Value**

After a building’s assets requiring protection have been identified, they are assigned a value. The asset value is the degree of debilitating impact that would be caused by the incapacity or destruction of the building’s assets.

**FEMA 426** uses a combination of a seven-level linguistic scale and a ten-point numeric scale.

- **Very High** – Loss or damage of the asset would have exceptionally grave consequences, such as extensive loss of life, widespread severe injuries, or total loss of primary services, core processes, and functions.

VISUAL II-9

**Asset Value Rating (continued)**

Asset Value		
Medium	5-6	Medium – Loss or damage of the building’s assets would have moderate to serious consequences, such as injuries or impairment of core functions and processes.
Medium Low	4	Medium Low – Loss or damage of the building’s assets would have moderate consequences, such as minor injuries or minor impairment of core functions and processes
Low	2-3	Low – Loss or damage of the building’s assets would have minor consequences or impact, such as a slight impact on core functions and processes for a short period of time.
Very Low	1	Very Low – Loss or damage of the building’s assets would have negligible consequences or impact.

Key elements

- Loss of assets and/or people would have grave, serious, moderate, or negligible consequences or impact



FEMA 426, Adaptation of Table 1-1: Asset Value Scale, p. 1-13  
BUILDING DESIGN FOR HOMELAND SECURITY Unit II-9

- **High** – Loss or damage of the asset would have grave consequences, such as loss of life, severe injuries, and loss of primary services.
- **Medium High** – Loss or damage of the asset would have serious consequences, such as serious injuries, or impairment of core processes and functions for an extended period of time.

**Quantifying Asset Value (continued)**

At the other end of the scale we have:

- **Medium** – Loss or damage of the asset would have moderate to serious consequences.
- **Medium Low** – Loss or damage of the asset would have moderate consequences, such as minor injuries, or minor impairment of core functions and processes.
- **Low** – Loss or damage of the asset would have minor consequences or impact.
- **Very Low** – Loss or damage of the asset would have negligible consequences or impact.

VISUAL II-10

**Asset Value Notional Example**

Asset	Value	Numeric Value
Site	Medium Low	4
Architectural	Medium	5
Structural Systems	High	8
Envelope Systems	Medium High	7
Utility Systems	Medium High	7
Mechanical Systems	Medium High	7
Plumbing and Gas Systems	Medium	5
Electrical Systems	Medium High	7
Fire Alarm Systems	High	9
IT/Communications Systems	High	8



FEMA 426, Table 1-2: Nominal Building Asset Value Assessment, p. 1-14  
BUILDING DESIGN FOR HOMELAND SECURITY Unit II-10

**Asset Value Notional Example**

The key assets for this notional example by system are listed and an asset value rating is entered into the site critical infrastructures matrix.

HVAC mechanical systems in most buildings will likely be medium high (7).



VISUAL II-11

**Critical Functions**

Function	Cyber attack	Armed attack (single gunman)	Vehicle bomb	CBR attack
<b>Administration</b>				
Asset Value	5	5	5	5
Threat Rating				
Vulnerability Rating				
<b>Engineering</b>				
Asset Value	8	8	8	8
Threat Rating				
Vulnerability Rating				

 FEMA 426, Adaptation of Table 1-20: Site Functional Pre-Assessment Screening Matrix, p. 1-38  
BUILDING DESIGN FOR HOMELAND SECURITY Unit II-11

Note: The Asset Value under the Administration and Engineering functions is highlighted. A medium value rating (6) is assigned to the Administration function asset value because they are a small part of the total organization, but important to the organization for continuity of business and profit. A high Asset Value rating (8) was assigned for the Engineering Function as they account for over half of the organization and are considered the core of the business for the company.

VISUAL II-12

**Critical Infrastructure**

Infrastructure	Cyber attack	Armed attack (single gunman)	Vehicle bomb	CBR attack
<b>Site</b>				
Asset Value	4	4	4	4
Threat Rating				
Vulnerability Rating				
<b>Structural Systems</b>				
Asset Value	8	8	8	8
Threat Rating				
Vulnerability Rating				

 FEMA 426, Adaptation of Table 1-21: Site Infrastructure Systems Pre-Assessment Screening Matrix, p. 1-39  
BUILDING DESIGN FOR HOMELAND SECURITY Unit II-12

**Critical Functions Matrix**

List functions down the left side and threats across the top.

In general, the asset value for a given function is the same for all threats and the matrix helps to identify the primary functions in a quantitative form. The functions matrix is people oriented and is subjective, but the completed matrix should provide a guide to vulnerabilities and risks. An organization with few administrative staff, but with a large engineering group, is used in this example.

Note the value is the same for all threat pairs. It does not matter how the asset is lost. The asset value reflects the impact to the people and organization should the asset be lost, damaged, or degraded.

**Critical Infrastructure Matrix**

List infrastructure down the left side and threats across the top.

Note that the value is the same for all threat pairs to reflect the economic and organization impact losses that could occur over time should the critical infrastructure be lost, degraded, or damaged due to any threat tactic.

**INSTRUCTOR NOTES**

**CONTENT/ACTIVITY**

Note: The Asset Value rating under the Site and Structural Systems is highlighted. A medium low Asset Value rating (4) could be an initial value for a site infrastructure that has a well-defined and protected perimeter and economic replacement costs that are acceptable. A high Asset Value rating (8) could be an initial value for a Structural System in a multi-story that is subject to progressive collapse and cannot be replaced.

**VISUAL II-13**

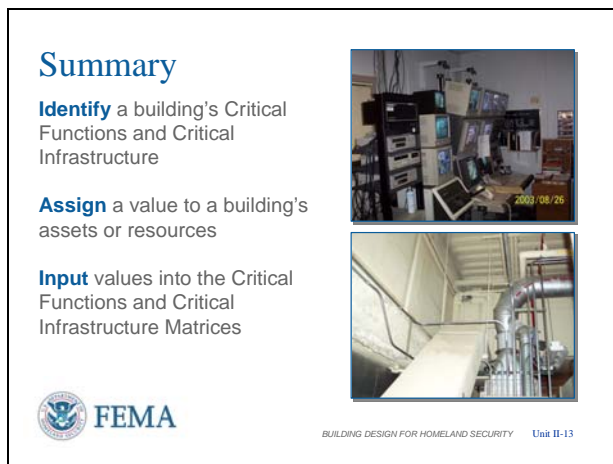

**Summary**

- Identify a building's Critical Functions and Critical Infrastructure
- Assign a value to a building's assets or resources
- Insert values into the Critical Functions and the Critical Infrastructure Matrices [Risk Matrix poster, manual spreadsheet, electronic spreadsheet, or risk assessment database]

**VISUAL II-14**

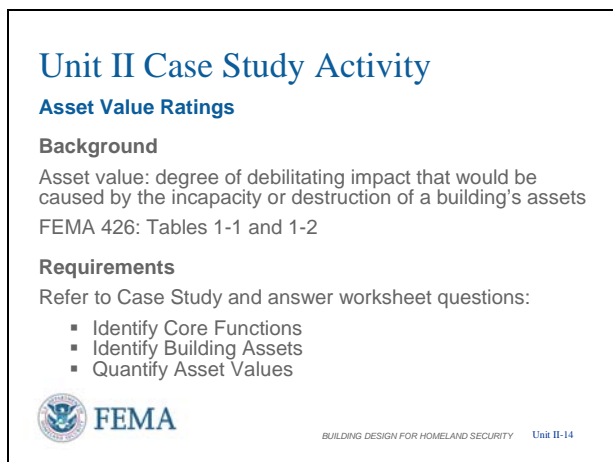

**Student Activity**

Asset value is the degree of debilitating impact that would be caused by the incapacity or destruction of a building's assets.

- **Table 1-1 on Page 1-13 of FEMA 426** provides an **Asset Value Scale** to quantify asset value, as well as definitions of the ratings.
- **Table 1-2 on page 1-14 of FEMA 426** provides a format to summarize the value of the major categories of a building's assets.

Refer participants to **FEMA 426** and the Unit

**Activity Requirements**

**INSTRUCTOR NOTES**

**CONTENT/ACTIVITY**

II Student Activity for the Selected Case Study (A or B) in the Student Manual.

Members of the instructor staff should be available to answer questions and assist groups as needed.

At the end of 35 minutes, reconvene the class and facilitate group reporting.

Allow 10 minutes for the plenary session.

Keep in mind that there are no incorrect answers. It is more important to be able to clearly explain and support the underlying rationale for the values that have been assigned. Also it has been proven that 7 people working effectively as a group can achieve genius level in their consensus response.

- Working in previously assigned small groups, refer to the Case Study Student Activity (Version A for Suburban or Version B for Urban) and answer the worksheet questions.

Take 35 minutes to complete this activity. Solutions will be reviewed in plenary group.

**Transition**

Unit III will cover Threat / Hazard Assessment and Unit IV will cover Vulnerability Assessment to continue the risk assessment process.

**UNIT II-A CASE STUDY ACTIVITY:  
ASSET VALUE RATINGS  
(Suburban Version)**

Asset value is the degree of debilitating impact that would be caused by the incapacity or destruction of a building's assets. **Page 1-13 of FEMA 426** provides an Asset Value Scale (**Table 1-1**) to quantify asset value, as well as definitions of the ratings. **Table 1-2 on page 1-14 of FEMA 426** provides a format to summarize the value of the major categories of a building's assets. **FEMA 452, pages 2-17 to 2-19** provide additional information.

**Requirements**

Refer to the Appendix S Case Study to determine answers to the following questions:

The first question below has the answer provided as an **example**. The other questions have the pages identified where the answers may be found.

**Identifying Building Core Functions**

1. What are Hazardville Information Company's (HIC) primary services or outputs? [Page A-1]

*IT services support for over 20 private and government organizations/clients. HIC supports over 1,000 users and over 100 applications as a primary data center and as a disaster recovery backup site to include field technicians and help desk. Many clients depend on HIC's ability to provide real time IT support, on a 24 x 7 basis. Others rely on the company's IT backup services.*

2. What critical functions/activities take place at HIC? [Page A-23 to Page A-26]

*Computer-based data processing, storage, and disaster recovery. Wired/wireless networking, information technology and communications.*

3. Who are the building's occupants and visitors? [Page A-1 to Page A-2]

*HIC employees and clients; business park neighbors are a mix of government and commercial organizations. HIC has over 130 employees and approximately 80 to 100 employees in the building at any given time. Visitors are vendors and clients. Clients include Fortune 500 companies, national and regional banks and credit unions, a major airline, large prime defense contractors, and government agencies, including one classified client.*

4. What inputs from external organizations are required for HIC's success? [Page A-1 to Page A-2 and Page A-11 to Page A-26]

*Utilities and communications supplies/vendors; hardware and software applications vendors; client data and support.*

### Identifying Building Assets and Quantifying Asset Value Ratings

Use the following process to complete the following tables -- HIC Critical Functions Asset Value Ratings and HIC Critical Infrastructure Asset Value Ratings

1. Refer to **Table 1-1 in FEMA 426** and the associated value descriptions for the ratings listed below
  - Very High (10)
  - High (8-9)
  - Medium High (7)
  - Medium (5-6)
  - Medium Low (4)
  - Low (2-3)
  - Very Low (1)
2. Consider the questions on **page 1-11 in FEMA 426** as you rate HIC's assets.
3. Refer to **Table 1-2 in FEMA 426, Nominal Building Asset Value Assessment** and use the descriptions of these asset categories as found in the Appendix S Case Study to focus the rating. Another approach is to use an asset value rating of 5 (mid-range) and do a pair-wise comparison to each asset category as the process continues, raising or lowering the rating from 5 as the team compares asset value inputs collected from the Appendix S Case Study.

**NOTE 1:** The first two rows in both tables are completed as **examples**. Nominal ratings are provided in all other asset categories.

1. Confirm the team's Asset Value Rating for each category [agree, raise, or lower the indicated rating]
2. Provide Rationale for each rating [whether changed or unchanged]
3. Enter asset value rating on the Risk Matrix

**NOTE 2:** Consult **Table 1-22, pages 1-46 to 1-92, in FEMA 426**. Look at the content of the questions to understand the various infrastructure asset categories.

For example, Utility Systems apply to all utilities outside the 3-foot drip line of the building (from the source to the building, but primarily on the site), while Mechanical, Plumbing, Gas, Electrical, Fire Alarm, Communications, and Information Technology Systems are inside the 3-foot drip line of the building.

**HIC Critical Functions Asset Value Ratings**

<b>Asset</b>	<b>Value</b>	<b>Numeric Value</b>	<b>Rationale</b>
1. Administration	<i>Medium-Low</i>	4	<i>Redundancy and staff skills that can be replaced. Senior managers and financial systems in the same area increase value. Low to medium economic cost to replace. Can impair in the long term core functions and processes.</i>
2. Engineering / IT Technicians	<i>High</i>	8	<i>Staff skills require specialized expertise, but can be replaced. Key equipment and resources needed for 24/7 ops. High economic cost to replace. Can impact core functions and processes for extended period of time.</i>
3. Loading Dock / Warehouse	<i>Medium-Low</i>	4	<i>Single point of entry into the interior for major shipping and receiving. Low to medium economic cost to replace. Can use other entryways in interim for most items. Minor impairment of core functions and processes.</i>
4. Data Center	<i>Very High</i>	10	<i>Primary function and organization critical. Many key staff and critical equipment. Very high economic cost to replace. Vital for 24/7 operation. Total loss of primary services, core processes, and functions possible.</i>
5. Communications	<i>High</i>	9	<i>Primary function and organization critical. A few key staff and critical equipment. High economic cost to replace. Needed for 24/7 operation. Major affect on primary services and core functions and processes for extended period of time.</i>
6. Security	<i>Medium High</i>	7	<i>Access and monitoring systems, security records, and location make the function critical to the organization. Needed due to client requirements. Medium economic cost to replace. Serious impairment of</i>

			<i>primary services, core processes, and functions for extended period of time.</i>
7. Housekeeping	<i>Very Low</i>	<i>1</i>	<i>Easily replaced, no critical skills or equipment. Minimal cost to replace. Many workarounds, thus negligible consequences or impact.</i>

**HIC Critical Infrastructure Asset Value Ratings**

<b>Asset</b>	<b>Value</b>	<b>Numeric Value</b>	<b>Rationale</b>
1. Site	<i>Medium-Low</i>	<i>4</i>	<i>HIC does not own building or site, but location is critical to access and support to clients. Cost is \$10 - \$20 per square foot which indicates other office complexes in area are competitive. Moderate consequences or minor impairment of core processes and functions if must move from site.</i>
2. Architectural	<i>Medium</i>	<i>5</i>	<i>Signage and business office information couple the building to other park tenants (geographically clustered, centralized). Nothing overly descriptive that requires the use of this building, but moderate to severe consequences or impairment if lost. Limited architectural flexibility either exterior or interior.</i>
3. Structural Systems	<i>Medium-Low</i>	<i>4</i>	<i>Relatively strong and flexible two-story building using standard construction will not experience progressive collapse. Building is small enough that anything affecting the structural system is affecting all other systems to a greater extent. Loss of structural systems will have moderate consequences or minor impairment of core functions and processes. Walls are capable of bearing load and workarounds available (shoring) if any structural problem occurs.</i>

4. Envelope Systems	<i>Medium</i>	5	<i>Fairly tight envelope, newer construction, CBR agents not likely to penetrate into interior through wall cracks or roof gaps without longer contact time. Over 50 percent of exterior surface is glazing on front and one-third of the side where glazing exists. Loss of any envelope system will have moderate to serious consequences or impairment of core functions and processes mainly due to environmental effects—weather entering building. Workarounds (plywood, plastic sheathing) possible.</i>
5. Utility Systems	<i>Medium</i>	5	<i>Well protected and buried, but single lines. Backups already planned or in-place makes loss of utility systems less important. Commercial utilities have high reliability in area.</i>
6. Mechanical Systems	<i>High</i>	8	<i>Single HVAC system supports multiple HVAC Air Handling Units and interior spaces. High economic cost to replace. Loss of business revenue. Limited workarounds due to location of HVAC load within building.</i>
7. Plumbing and Gas Systems	<i>Medium</i>	6	<i>Wet pipe sprinkler system and hand-held extinguishers are means of fire protection in this 24/7 operation. Natural gas provides some humidity control for core processes but workarounds (portable dehumidifiers) possible. Water for cooling tower makeup is critical to support core processes, but workaround (water tanker) possible. Moderate to serious consequences or impairment of core functions and processes if lost.</i>
8. Electrical Systems	<i>High</i>	8	<i>Single-point vulnerability and organization critical. High economic cost to replace. Loss of business revenue. Commercial utility with backup generator required to meet 24/7</i>



---

			<i>requirements.</i>
9. Fire Alarm Systems	<i>Medium</i>	5	<i>Wet pipe sprinkler system and hand-held extinguishers are only means of fire protection. Fire alarm system provides additional coverage – heat and smoke detectors. Nearby fire department has connection to alarm. Moderate to serious consequences or impairment of core functions or processes if lost. Workarounds (roving fire watchmen) possible.</i>
10. IT / Communications Systems	<i>High</i>	9	<i>Single-point vulnerability and organization critical. High economic cost to replace, <u>but replaceable</u>. Loss of business revenue. Loss of primary services or major loss of core processes and functions for an extended period.</i>

**UNIT II-B CASE STUDY ACTIVITY:  
ASSET VALUE RATING  
(Urban Version)**

Asset value is the degree of debilitating impact that would be caused by the incapacity or destruction of a building's assets. **Page 1-13 of FEMA 426** provides an Asset Value Scale (**Table 1-1**) to quantify asset value, as well as definitions of the ratings. **Table 1-2 on page 1-14 of FEMA 426** provides a format to summarize the value of the major categories of a building's assets. **FEMA 452, pages 2-17 to 2-19** provide additional information.

**Requirements**

Refer to the Appendix B Case Study to determine answers to the following questions:

The first question is answered below as an **example**.

**Identifying Building Core Functions**

1. What are HazardCorp (HZC) Building's primary services or outputs associated with its providing office rental space? [Pages B-3, B-10]

*Building Management provides security (access control and physical), coordination of emergency actions, operation and maintenance of emergency response / life safety systems, underground parking, loading dock security and coordination for supply trucks, vendors, and trash supporting the tenants. Inspection of mail, packages, and equipment using x-ray and other equipment before distributing to tenants within the building and to other agencies within 2 blocks. Utilities, along with emergency backups; and vertical transportation (elevators and stairs).*

2. What critical functions / activities take place at HZC to support the goals of the building management and goals of the building tenants? [Pages B-18 to B-26]

*Fire protection (water supply and fire detection), access control and physical security, emergency response, reliable utilities with backups, and secure / speedy movement of materials and supplies between loading dock and tenant locations.*

3. Who are the building's occupants and visitors? [Pages B-1, B-12]

*Building occupancy (tenants and staff) is estimated to be 8,000 people at any given moment. The tenants include Federal, State, and local agencies; along with financial, insurance, and banking companies. These agencies and companies have daily visitors to transact business. In addition, the first floor lobby and retail spaces can have an additional 1,000 people depending upon time of day, which includes meeting rooms that are available on the second and third floors. Building occupants / tenants use the*

*underground parking as well as the general public who may have no other link to the building.*

4. What inputs from external organizations are required for HZC's success?  
[Pages B-18 to B-26]

*Utilities and communications supplies/vendors; building systems hardware and software applications vendors; understanding of individual tenant requirements in regards to security and emergency response and coordination with local municipal emergency response. Also, armored cars/trucks for cash and valuables movement, messengers to and from to move packages, and the proverbial pizza delivery for late night work among tenants.*

### Identifying Building Assets and Quantifying Asset Values

Use the following process to complete the following tables -- HZC Critical Functions Asset Value Rating and HZC Critical Infrastructure Asset Value Rating

1. Refer to **Table 1-1 in FEMA 426** and the associated value descriptions for the ratings listed below
  - Very High (10)
  - High (8-9)
  - Medium High (7)
  - Medium (5-6)
  - Medium Low (4)
  - Low (2-3)
  - Very Low (1)
2. Consider the questions on **page 1-11 in FEMA 426** and as you rate HZC's assets.
3. Refer to **Table 1-2 in FEMA 426, Nominal Building Asset Value Assessment** and use the descriptions of these asset categories as found in the Appendix B Case Study to focus the rating. Another approach is to use an asset value rating of 5 (mid-range) and do a pair-wise comparison to each asset category as the process continues, raising or lowering the rating from 5 as the team compares asset value inputs collected from the Appendix B Case Study.

**NOTE 1:** The first rows in both tables are completed as **examples**. Nominal ratings are provided in all other asset categories. Confirm the team's Value and Numeric Value rating for each category and provide Rationale for each rating. Enter information on the following worksheets and on the Risk Matrix poster.

**NOTE 2:** Consult **Table 1-22, pages 1-46 to 1-92, in FEMA 426**. Look at the content of the questions to understand the various infrastructure asset categories. For example, Utility Systems apply to all utilities outside the 3-foot drip line of the building (from

the source to the building, but primarily on the site), while Mechanical, Plumbing, Gas, Electrical, Fire Alarm, Communications, and Information Technology Systems are inside the 3-foot drip line of the building.

**HZC Critical Functions Asset Value Ratings**

<b>Asset</b>	<b>Value</b>	<b>Numeric Value</b>	<b>Rationale</b>
1. Administration	Medium High	7	<i>While there may be some redundancy and staff skills that can be easily replaced, the Building Management administration keeps the building humming and loss of some or all administration staff would have serious consequences or impair core processes and functions for an extended period of time. Low to medium economic cost to replace, depending upon individual function.</i>
2. Engineering / IT Technicians	High	8	<i>Due to the complexity of building operations, including computer systems for Supervisory Control and Data Acquisition, Electronic Security Systems (CCTV and access control), Energy Management and Control Systems, etc., the loss of this function in whole or in part can result in severe loss of primary services or major loss of core processes and functions for an extended period of time. Interim workarounds include manufacturer's / technical service firms for each individual system. Moderately high economic cost to replace based upon skill sets sought.</i>
3. Loading Dock / Warehouse	Medium	5	Large amounts of mail, packages, supplies, furniture, materials, etc. are processed through the loading dock and adjoining mailroom. This single point of entry into the building cannot be handled easily through other entrances without moderate to serious consequences or impairment of core functions and processes -- Building Management support of tenants. Workarounds

			available which impact the first floor. Moderate economic cost to replace.
4. Data Center	High	8	For Building Management to support the tenants, the building data center must handle all building functions for the operations and maintenance of equipment, energy conservation, utilities, backup systems, etc. If these systems are lost for an extended period of time there will be grave consequences with loss of primary services or major loss of core processes and functions. Initial and future economic losses will far exceed the value of these systems, their maintenance, and replacement.
5. Communications	High	8	As with the Data Center, a 50-story building requires reliable communications to function, especially those associated with life safety. This is a core process of Building Management supporting tenants. Extended loss of communications, while workarounds (cell phones, alternate circuits) are available, result in large economic losses that may not be replaceable.
6. Security	Medium Low	4	The security provided by Building Management is limited to access control and criminal threat (alarms and CCTV monitoring), at least initially during this assessment. Tenants requiring higher levels of security provide it themselves. After assessment, security mitigation measures may increase the asset value of security systems due to increased support to tenants.
7. Housekeeping	Low	2	While this function can be easily replaced and requires no critical skills or equipment, the Building Management support to tenants requires an acceptable level of cleanliness due to the high number of visitors to the building. Much trash can be generated by 9,000 people

			over a day.
--	--	--	-------------

**HZC Critical Infrastructure Asset Value Ratings**

<b>Asset</b>	<b>Value</b>	<b>Numeric Value</b>	<b>Rationale</b>
1. Site	Medium	5	<i>Building owner has a large investment in the building and site. Loss of access to site by Building Management, but more so tenants, would have rippling economic impact. Because only parking and some fuel storage is underground, and site is relatively small, the building and its functions will have moderate to serious consequences and impairment of core functions and processes supporting the tenants.</i>
2. Architectural	Medium High	7	<i>Locations of functions within the building and their proximity to high risk areas, like the lobby, loading dock, and streets place a high value on where functions are placed in the building and how they can be protected. Architectural placement has serious consequences and impact upon core processes and functions over an extended period of time.</i>
3. Structural Systems	High	8	A 50-story building can exist only because of the structural system supports it. An incident affecting the structural systems on any floor can affect all other floors. Loss of even a small portion of the structural system can have grave consequences in this case, impacting everything in the building.
4. Envelope Systems	Medium High	7	The envelope system keeps the weather out and the conditioned air in. If the envelope was lost, there are workarounds to temporarily patch the situation, but depending upon the curtain wall design, the windows may have to be replaced from the <u>outside</u> on all floors which

			would be at great expense with minimal impact on tenants OR from the <u>inside</u> which would impact tenants to a greater extent or cost additional for working during non-business hours.
5. Utility Systems	High	8	For a 50-story high rise utilities are a necessity to make rentable office space inhabitable. While short term workarounds may allow some operations, loss of critical utilities usually results in the execution of COOP (Continuity of Operations Plans) for major tenants. The loss of business revenue for HZC would be very significant.
6. Mechanical Systems	High	8	For similar reasons as in Utility Systems above, Building Systems are equally important and necessary for occupancy. This is especially true for air conditioning of equipment and people.
7. Plumbing and Gas Systems	High	8	For similar reasons as in Utility Systems above, Building Systems are equally important and necessary for occupancy. Water Systems that support sanitation and fire protection are must haves when occupying a high rise.
8. Electrical Systems	High	8	For similar reasons as in Utility Systems above, Building Systems are equally important and necessary for occupancy. Electrical Systems for lights, equipment, environmental control, and elevators make inhabiting the upper floors of a high-rise possible.
9. Fire Alarm Systems	Medium Low	4	While necessary for occupancy of a high-rise, there are workarounds (manpower intensive) that can be done for weeks without requiring evacuation of building, especially since it has a water sprinkler system and 24/7 occupancy of the Security Operations Center / Fire Control Center.

**Course Title: Building Design for Homeland Security**

Unit II-B: Asset Value Assessment

---

10. IT / Communications Systems	High	8	For similar reasons as in Utility Systems above, Building Systems are equally important and necessary for occupancy. Data and Communications cannot be out of operation for short time periods, without resulting in significant economic impact.
---------------------------------------	------	---	---



*This page intentionally left blank*

## Unit III

---

<b>COURSE TITLE</b>	Building Design for Homeland Security	<b>TIME</b>	75 minutes
---------------------	---------------------------------------	-------------	------------

---

<b>UNIT TITLE</b>	Threat/Hazard Assessment
-------------------	--------------------------

---

<b>OBJECTIVES</b>	<ol style="list-style-type: none"><li>1. Identify the threats and hazards that may impact a building or site</li><li>2. Define each threat and hazard using the FEMA 426 methodology.</li><li>3. Provide a numerical rating for the threat or hazard and justify the basis for the rating</li><li>4. Define the Design Basis Threat, Levels of Protection, and Layers of Defense.</li></ol>
-------------------	---

---

<b>SCOPE</b>	The following topics will be covered in this unit:
--------------	--

1. From what offices is threat and hazard information available?
  2. The spectrum of event profiles for terrorism and technological hazards from FEMA 386-7.
  3. The FEMA 426 approach to determine threat rating.
  4. A rating scale and how to use it to determine a threat rating.
  5. Activity: Identify the threat rating of the four threats selected for this course (Cyber Attack, Armed Attack, Vehicle Bomb, CBR Attack) against each identified asset using the Case Study.
- 

<b>REFERENCES</b>	<ol style="list-style-type: none"><li>1. FEMA 426, <i>Reference Manual to Mitigate Potential Terrorist Attacks Against Buildings</i>, pages 1-14 to 1-24</li><li>2. FEMA 452, <i>Risk Assessment: A How-To Guide to Mitigate Potential Terrorist Attacks Against Buildings</i>, pages 1-1 to 1-30</li><li>3. Case Study – Appendix A: Suburban, Hazardville Information Company or Appendix B: Urban, HazardCorp Building as selected</li><li>4. Student Manual, Unit III-A or Unit III-B as selected (info only – not in SM)</li><li>5. Unit III visuals (info only – not in SM)</li></ol>
-------------------	---

---

<b>REQUIREMENTS</b>	<ol style="list-style-type: none"><li>1. FEMA 426, <i>Reference Manual to Mitigate Potential Terrorist Attacks Against Buildings</i> (one per student)</li><li>2. FEMA 452, <i>Risk Assessment: A How-To Guide to Mitigate Potential Terrorist Attacks Against Buildings</i> (one per student)</li><li>3. Instructor Guide, Unit III-A</li><li>4. Student Manual (one per student) for selected Case Study</li></ol>
---------------------	--

---

5. Overhead projector or computer display unit
6. Unit III visuals
7. Risk Matrix poster and box of dry-erase markers (one per team)
8. Chart paper, easel, and markers (one per team)

<b>UNIT III OUTLINE</b>	<u>Time</u>	<u>Page</u>
III. Threat / Hazard Assessment	75 minutes	IG III-1
1. Threats and Hazards	11 minutes	IG III-5
2. Steps to the Threat Selection and Rating Process	6 minutes	IG III-10
3. Threat Sources, Design Basis Threat, and Levels of Protection	11 minutes	IG III-15
4. Summary, Student Activity, and Transition	2 minutes	IG III-22
5. Activity: Threat / Hazard Rating (Version <b>(S) Suburban</b> ) [30 minutes for students, 15 minutes for review]	45 minutes	IG III-A-25
6. Activity: Threat / Hazard Rating (Version <b>B Urban</b> ) [30 minutes for students, 15 minutes for instructor review or as adjusted based upon how long Items 1 to 5 took above]	45 minutes	IG III-B-32

## PREPARING TO TEACH THIS UNIT

- **Tailoring Content to the Local Area:** This is a generic instruction unit that does not have any specific capability for linking to the Local Area. However, Local Area discussion may be generated as students have specific situations for which they would like to determine threat rating or their own experiences in trying to obtain threat and threat rating information in their Local Area.

The Instructor will begin this unit with a brief discussion of terrorism and technological hazards worldwide and within the United States. The probability of natural hazards and how they are considered during design will be compared to the probability of manmade hazards, both terrorism and technological accidents. This sets the stage for identifying where to get information about threats and hazards.

Next, the Instructor will use **FEMA 386-7** to describe the spectrum of tactics or events that can occur. This leads into the five components used to define a threat (or hazard).

A simplified threat rating approach will be presented that can be used during a design charette for new construction or major renovation. This **FEMA 426** approach forms the basis of the Unit III student activity.

- **Optional Activity:** There are no optional activities in this unit, except Student Activity questions that are applicable to the selected Case Study (Suburban or Urban).
- **Activity:** The Unit III student activity begins with a threat definition or threat score for a 500-pound vehicle bomb using **FEMA 452 Table 1-4** criteria as Step 1 of the process. Then Step 2 has the students applying the techniques (threat identification, threat description, and threat rating) to the Case Study to identify and rate the threat from cyber attack, armed attack, explosive blast, and agents (chemical, biological, and radiological) against the assets identified and rated in the previous student activity. Note that these event profiles can result from terrorism, criminal activity, or technological hazards.
- Refer students to their Student Manuals for worksheets and activities.
- Direct students to the appropriate page in the Student Manual.
- Instruct the students to read the activity instructions found in the Student Manual.
- Explain that the threat / hazard ratings determined by the team must be transferred to the Risk Matrix poster.
- Tell students how long they have to work on the requirements.
- While students are working, all instructors should closely observe the groups' process and progress. If any groups are struggling, immediately assist them by clarifying the assignment and providing as much help as is necessary for the groups to complete the requirement in the allotted time. Also, monitor each group for full participation of all members. For example, ask any student who is not fully engaged a question that requires his/her viewpoint to be presented to the group.
- At the end of the working period, reconvene the class.
- After the students have completed the assignment, "walk through" the activity with the students during the plenary session. Call on different teams to provide the answer(s) for each question. Then simply ask if anyone disagrees. If the answer is correct and no one disagrees, state that the answer is correct and move on to the next requirement. If there is disagreement, allow some discussion of rationale, provide the "school solution" and move on.

- If time is short, simply provide the “school solution” and ask for questions. Do not end the activity without ensuring that students know if their answers are correct or at least on the right track.
- Ask for and answer questions.

## VISUAL III-1

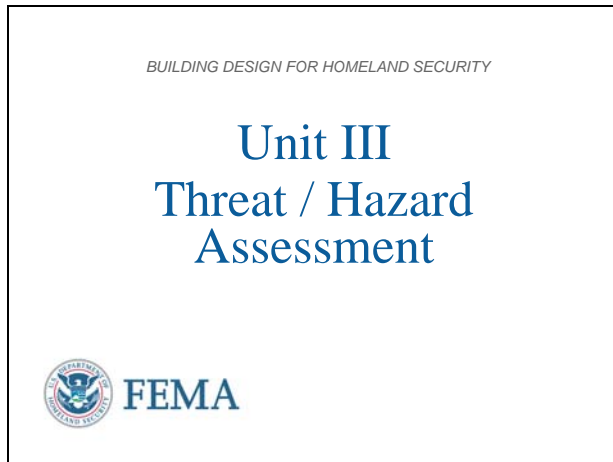

The students will apply these techniques (threat identification, threat description, and threat rating) to the Case Study to identify and rate the threat from explosive blast and agents (chemical, biological, and radiological). Note that these event profiles can result from terrorism or technological hazards. They will also rate the threat for Cyber Terrorism and Armed Attack.

## VISUAL III-2

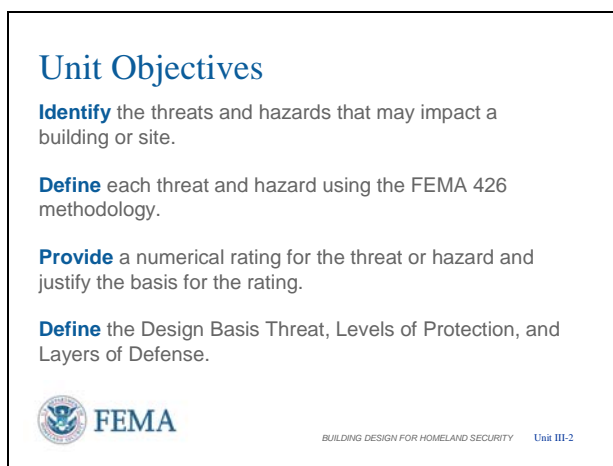

## Introduction and Unit Overview

This is Unit III Threat / Hazard Assessment. The unit starts with a brief discussion of terrorism and technological hazards worldwide and within the United States. The probability of natural hazards and how they are considered during design will be compared to the probability of manmade hazards, both terrorism and technological accidents.

The five components used to define a threat (or hazard) is taken from an approach developed by the US Marshals Service and is used to illustrate how assessment analysis can be coupled with increasing threat levels.

## Unit Objectives

At the end of this unit, the students should be able to:

1. Identify the threats and hazards that may impact a building or site.
2. Define each threat and hazard using the **FEMA 426** methodology.
3. Provide a numerical rating for the threat or hazard and justify the basis for the rating.
4. Define the Design Basis Threat, Levels of Protection, and Layers of Defense.

VISUAL III-3

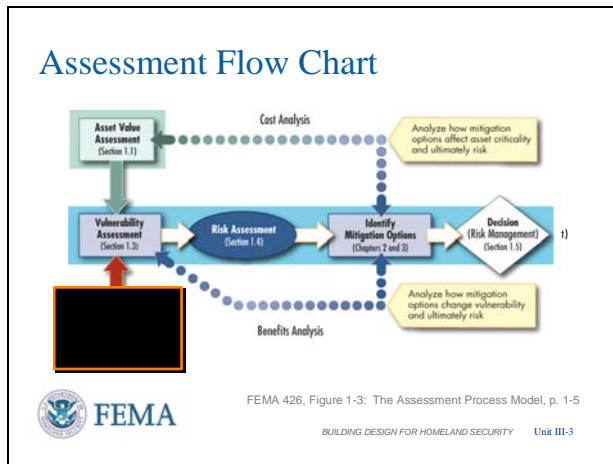

Assessment Flow Chart

Reviewing the Assessment Flow Chart, the Threat Assessment is the next step in the risk assessment process.

VISUAL III-4

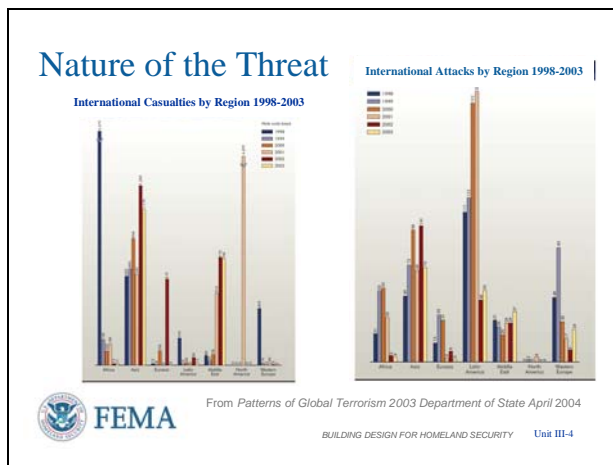

Nature of the Threat (1/3)

With enhanced migration of terrorist groups from conflict-ridden countries, the formation of extensive international terrorist infrastructures and the increased reach of terrorist groups, terrorism has become a global concern.

Terrorism and physical attacks on buildings have continued to increase in the past decade. The geographical isolation of the United States is not a sufficient barrier to prevent an attack on U.S. cities and citizens. These data in this and the next two slides from the Department of State and FBI shows these trends and demonstrate the far reaching incidents and diverse natures and targets of recent terrorist attacks.

For example, his slide shows the varying trends of attacks and casualties by continent around the world. Some trends are up, some are down, but the presence and capability is there.

VISUAL III-5

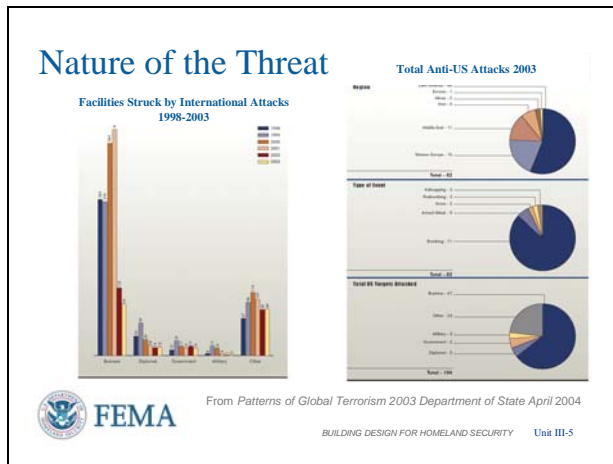

Nature of the Threat (2/3)

This slide illustrates Anti-US attacks are predominantly NOT against diplomatic, government, and military targets, but against business and others.

Also the predominant Anti-US tactic used was bombing over this reporting period.

VISUAL III-6

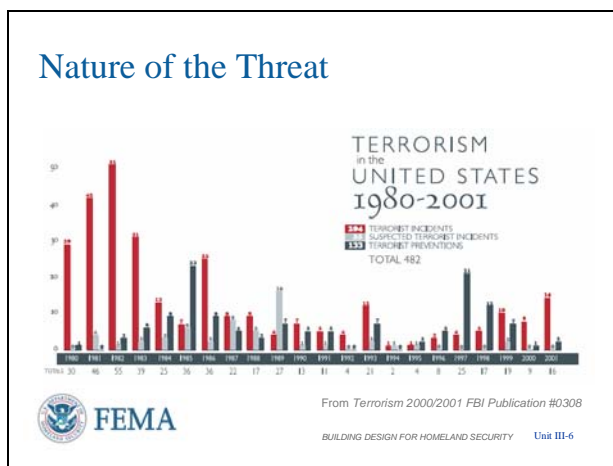

Nature of the Threat (3/3)

Finally, this slide illustrates that incidents of terrorism inside the US is generally going down, but the incidents that have occurred to the right of this chart over this 22 year period are especially horrific.

VISUAL III-7

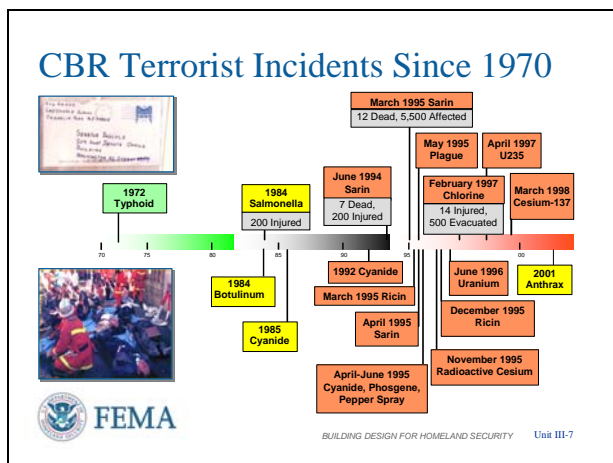

CBR Terrorist Incidents Since 1970

- CBR attacks have been used since ancient times and, in the past 20 years, over 50 attacks have occurred.
- CBR attacks require the right weather, population, and dispersion to be effective.
- Recent attacks have had limited effectiveness or have been conducted on a relatively small scale.
- Future attacks with Weapons of Mass Destruction could occur on a regional or global scale.



VISUAL III-8

**Hazard**

**Hazard** - A source of potential danger or adverse condition.

- Natural Hazards are naturally-occurring events such as floods, earthquakes, tornadoes, tsunamis, coastal storms, landslides, hurricanes, and wildfires.

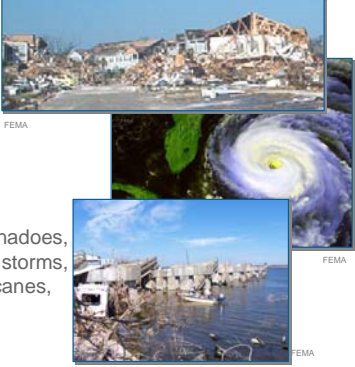

FEMA FEMA FEMA

BUILDING DESIGN FOR HOMELAND SECURITY Unit III-8

**Hazard**

- **Hazard** - A source of potential danger or adverse condition.
- **Natural Hazards** are naturally-occurring events such as floods, earthquakes, tornadoes, tsunamis, coastal storms, landslides, hurricanes, and wildfires.
- A natural event is a hazard when it has the potential to harm people or property (FEMA 386-2, *Understanding Your Risks*).
- The risks of natural hazards may be increased or decreased as a result of human activity. (Like building in a floodplain (bad) or hardening for hurricanes (good))

VISUAL III-9

**Manmade Threats**

**Threats** – Any indication, circumstance, or event with the potential to cause loss of, or damage to an asset. They can be technological accidents and terrorist attacks.



*Technological accident* *Terrorism act*

FEMA FEMA

BUILDING DESIGN FOR HOMELAND SECURITY Unit III-9

**Manmade Threats/Hazards**

- **Technological Accidents** are incidents that can arise from human activities such as manufacturing, transportation, storage, and use of hazardous materials. For the sake of simplicity, it is assumed that technological emergencies are accidental and that their consequences are unintended.
- **Terrorism** is the unlawful use of force and violence against persons or property to intimidate or coerce a government, the civilian population, or any segment thereof, in furtherance of political or social objectives. (28 CFR, Section 0.85)

### VISUAL III-10

**Threat Overview**

Any indication, circumstance, or event with the potential to cause loss of, or damage to an asset

Involves two steps:

- **Selection of primary threats:** tools and tactics as well as people with intent to cause harm
- **Determine the threat rating:** a parameter used to quantify your losses

Weapons, tools, and tactics can change faster than a building can be modified.



BUILDING DESIGN FOR HOMELAND SECURITY Unit III-10

### Two-Step Process

A two-step process is utilized to complete the threat assessment.

- The first step is the selection of the primary threats that may affect your building.
- The second is the determination of the threat rating.

### VISUAL III-11

**Threat Overview**

- Improvised Explosive Device (Bomb)
- Armed Attack
- Chemical Agent
- Biological Agent
- Radiological Agent
- Cyberterrorism



BUILDING DESIGN FOR HOMELAND SECURITY Unit III-11

### Identify Each Threat / Hazard

- **Table 1-3 in FEMA 426 (page 1-17)** outlines the broad spectrum of terrorist threats and technological hazards. Some of the items are listed here.
- While we can think of terrorist tactics and technological hazards (such as HazMat releases), a runaway truck crashing into a power line, a storage tank, or a telephone pedestal can be equally detrimental. Similarly, surveillance of a company's operations may divulge company trade secrets that are detrimental to the company's economic bottom line or an industry in a country.

VISUAL III-12

### Step 1: Selection of Primary Threats

Criteria

Selected Threats

- Cyber Attack
- Armed Attack
- Vehicle Bomb
- CBR Attack

Scenario	Access to Agent	Knowledge/ Expertise	Criteria				Level of Defense
			History of Threats (Building Functions/ Tenants)	Asset Visibility/ Symbolic	Asset Accessibility	Site Population/ Capacity	
9-10	Highly available	Basic knowledge/ open source	Local incident, occurred recently, caused great damage, building function and tenants were primary targets	Exists widely known/ iconic	Open access, unrestricted parking	> 5,000	Little to no defense against threat. No security design was taken into consideration and no mitigation measures adopted.
8-8	Easy to produce	Builder's design or technical school/open scientific or technical literature	Regional/State incident, occurred a few years ago, caused substantial damage, building function and tenants were one of the primary targets	Exists locally known/ landmark	Open access, restricted parking	1,001-5,000	Minimal defense against threat. Minimal security design was taken into consideration and minimal mitigation measures adopted.
3-5	Difficult to produce or acquire	Advanced training/area scientific or technical literature	National incident, occurred some time in the past, caused important damage, building function and tenants were one of the primary targets	Exists published/ well known	Controlled access, potential entry	251-1,000	Significant defense against threat. Significant security design was taken into consideration and substantial mitigation measures adopted.
1-2	Very difficult to produce or acquire	Advanced design or training/ classified information	International incident, occurred every years ago, caused localized damage, building function and tenants were not the primary targets	Exists not well known/ no symbolic importance	Remains isolated, secure perimeter, closed grounds, tightly controlled access	1-250	Extensive defense against threat. Extensive security design was taken into consideration and extensive mitigation measures adopted.

FEMA 452, Table 1-4: Criteria to Select Primary Threats, p. 1-20

BUILDING DESIGN FOR HOMELAND SECURITY Unit III-12

**Step 1: Selection of Primary Threats**

To select the primary threats, the selected criteria outlined on this slide are designed to help you to rank potential threats from 1-10 (10 being the greater threat).

- **Access to Agent:** The access to agent is the ease by which the source material can be acquired to carry out the attack. Consideration includes the local HazMat inventory, farm and mining supplies, major chemical or manufacturing plants, university and commercial laboratories, and transportation centers.
- **Knowledge/Expertise:** The general level of skill and training that combines the ability to create the weapon (or weaponize an agent) and the technical knowledge of the systems to be attacked (HVAC, nuclear, etc.). Knowledge and expertise can be gained by surveillance, open source research, specialized training, or years of practice in industry.
- **History of Threats Against Buildings:** What has the potential threat element done in the past and how many times? When was the most recent incident and where, and against what target? What tactics did they use?
- **Asset Visibility/Symbolic:** The economic, cultural, and symbolic importance of the building to society that may be exploited by the terrorist seeking to cause monetary or political gain through their actions.
- **Asset Accessibility:** The ability of the terrorist to become well-positioned to carry out an attack at the critical location against the intended target. The critical location is a function of the site, the building layout, and the security

measures in place.

- **Site Population/Capacity:** The population demographics of the building and surrounding area.
- **Level of Defense:** What security measures are in place and how effective are they against the available tactics currently in use?

VISUAL III-13

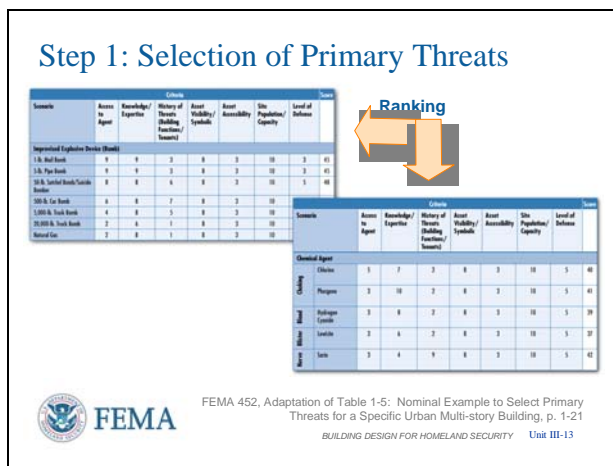

**Selection of Primary Threats**

This figure illustrates a nominal example of applying the threat scoring to blast and CBR. Note that the scores are first estimated for each criterion, and are then added on the far right column.

More sophisticated methods to score threats include Army-Air Force Technical Manual 5-853; State of Florida HLS-CAM (Homeland Security Comprehensive Assessment Model); and the DoD CARVER (criticality, accessibility, recuperability, vulnerability, effect, and recognizability) process. CARVER is a special operations forces acronym used throughout the targeting and mission planning cycle to assess mission validity and requirements. Essentially a military methodology that has similar parallels with a terrorist approach to targeting an asset.

VISUAL III-14

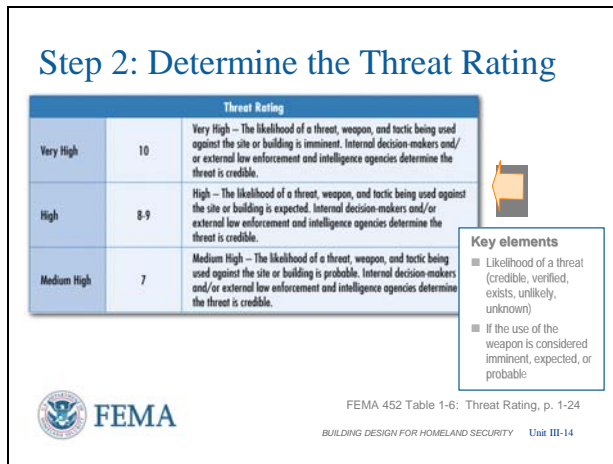

**Step 2: Determine the Threat Rating**

Having selected the primary threats for the building, the next step is to determine how the threat will affect the functions and critical infrastructure. The threat rating is an integral part of the risk assessment and is used to determine, characterize, and quantify a loss caused by an aggressor using a weapon or agent and tactic against the target (asset). The threat rating deals with the likelihood or probability of the threat occurring and the consequences of its occurrence.

This figure provides a scale for selecting your threat rating. Similar to the asset value scale (Unit II), the scale is a combination of a seven-level linguistic scale and a ten-point numerical scale. The key elements of this scale are likelihood / credibility of a threat, potential weapons to be used during a terrorist attack, and information available to decision-makers. This is a subjective analysis based on consensus opinion of the building stakeholders, threat specialists, and engineers. The primary objective is to look at the threat; the geographic distribution of functions and critical infrastructure; redundancy; and response and recovery to evaluate the impact on the organization should an attack occur.

VISUAL III-15

**Step 2: Determine the Threat Rating**  
(continued)

Threat Rating		
Medium	5-6	Medium – The likelihood of a threat, weapon, and tactic being used against the site or building is possible. Internal decision-makers and/or external law enforcement and intelligence agencies determine the threat is known, but is not verified.
Medium Low	4	Medium Low – The likelihood of a threat, weapon, and tactic being used in the region is probable. Internal decision-makers and/or external law enforcement and intelligence agencies determine the threat is known, but is not likely.
Low	2-3	Low – The likelihood of a threat, weapon, and tactic being used in the region is possible. Internal decision-makers and/or external law enforcement and intelligence agencies determine the threat exists, but is not likely.
Very Low	1	Very Low – The likelihood of a threat, weapon, and tactic being used in the region or against the site or building is very negligible. Internal decision-makers and/or external law enforcement and intelligence agencies determine the threat is non-existent or extremely unlikely.

**Key elements**

- Likelihood of a threat (credible, verified, exists, unlikely, unknown)
- If the use of the weapon is considered imminent, expected, or probable

FEMA 452 Table 1-6: Threat Rating, p. 1-24  
BUILDING DESIGN FOR HOMELAND SECURITY Unit III-15

**Step 2: Determine the Threat Rating (continued)**

As explained on the previous slide, the threat rating includes the consequences of the threat occurrence.

- The consequences may be a feature attractive to the terrorist in their targeting philosophy.
- Conversely, threat and overall risk may be low, but if consequences are extremely high, then actions have been taken even against low threats and low risk because the organization did not want to contend with the consequences.

Thus, consequences may overtake perceived threat, especially if the threat is low. Think of the Murrah Federal Building threat rating before and after the McVeigh bombing and flying large aircraft into buildings before and after 9/11/2001.

VISUAL III-16

**Critical Functions**

Function	Cyber attack	Armed attack (single gunman)	Vehicle bomb	CBR attack
<b>Administration</b>				
Asset Value	5	5	5	5
<b>Threat Rating</b>	8	4	3	2
Vulnerability Rating				
<b>Engineering</b>				
Asset Value	8	8	8	8
<b>Threat Rating</b>	8	5	6	2
Vulnerability Rating				

FEMA 426, Adaptation of Table 1-20: Site Functional Pre-Assessment Screening Matrix, p. 1-38  
BUILDING DESIGN FOR HOMELAND SECURITY Unit III-16

**Critical Functions**

After each threat / hazard has been identified, the threat rating for each threat / hazard must be determined. The threat rating is a subjective judgment of a terrorist threat based on existence, capability, history, intentions, and targeting.

It is a snapshot in time, and can be influenced by many factors, but the given threat value will typically be the same for each function (going down the columns). Organizations that are dispersed in a campus environment may have variations.

While the Asset Value of a Function or Infrastructure row is constant across all Threats / Hazards, the Threat / Hazard column may or may not be the same across all assets. The main reasons include whether or not the asset is being specifically targeted, the relative location

On a scale of 1 to 10, 1 is a very low probability and 10 is a very high probability of a terrorist attack.



of the assets for that threat (vehicle bomb would have the same threat rating for all assets of a small footprint building, but not for a large footprint building) and the capability of use of the threat (Armed Attack, for example, would have a greater capability for assets on the exterior wall of a building or near an entrance vice assets in the core of a building behind multiple security/access control layers or non-observable layers. This is a fine line between threat and vulnerability – is a stand-off weapon armed attack a high threat because the terrorists have used this tactic or have the terrorists used the tactic because assets targeted were very susceptible to the attack method and thus were very vulnerable.

VISUAL III-17

**Critical Infrastructure**

Infrastructure	Cyber attack	Armed attack (single gunman)	Vehicle bomb	CBR attack
<b>Site</b>				
Asset Value	4	4	4	4
<b>Threat Rating</b>	4	4	3	2
Vulnerability Rating				
<b>Structural Systems</b>				
Asset Value	8	8	8	8
<b>Threat Rating</b>	3	4	3	2
Vulnerability Rating				

 FEMA  
FEMA 426, Adaptation of Table 1-21: Site Infrastructure Systems Pre-Assessment Screening Matrix, p. 1-39  
 BUILDING DESIGN FOR HOMELAND SECURITY Unit III-17

Following the same logic for determining threat ratings as explained on the previous slide, the threat rating to the site from Cyber Attack would be higher than structural systems because the access control or CCTV surveillance equipment across the site may be accessible from the internet. Structural systems are generally not connected to the internet or any electronic communication, except in the case of seismic dampers. The seismic dampers could be part of a “smart building” system where the responsive dampers are adjusted for the accelerations

**Critical Infrastructure**

The Critical Infrastructure matrix has a similar threat rating approach as previously seen in the Critical Function matrix.

Note that the threat ratings for the Site and Structural Systems are almost identical, only varying for Cyber Attack as explained in the left-hand column.

The other threat ratings for Site and Structural Systems are on the low side of the scale because the targeting value to the terrorist and the consequences of using that attack mode on that asset are relatively low.

imposed upon the structure, especially high-rises.

### VISUAL III-18

**Threat Sources**

- Identify** Threat Statements
- Identify** Area Threats
- Identify** Facility-Specific Threats
- Identify** Potential Threat Element Attributes

Seek information from local law enforcement, FBI, U.S. Department of Homeland Security, and Homeland Security Offices at the state level.

FEMA  
BUILDING DESIGN FOR HOMELAND SECURITY Unit III-18

### Exam Questions #A3 and B4

Note: For technological hazards, it is also important to gather information from the local fire department and hazardous materials (HazMat) unit, Local Emergency Planning Committee (LEPC), and State Emergency Response Commission (SERC). LEPC and SERC are local and state organizations established under a U.S. Environmental Protection Agency (EPA) program. They identify critical facilities in vulnerable zones and generate emergency management plans. Additionally, most fire departments understand which industries in the local area handle the most combustible materials and the HazMat unit understands who handles materials that could have a negative impact upon people and the environment. In many jurisdictions, the HazMat unit is part of the fire department.

### Threat Sources

A manmade threat / hazard analysis requires coordination with security and intelligence organizations that understand the locality, the region, and the Nation. These organizations include the police department (whose jurisdiction includes the building or site), the local state police office, and the local office of the FBI. In many areas of the country, there are threat-coordinating committees, including FBI Joint Terrorism Task Forces, which facilitate the sharing of information. Computer systems are also in place to disseminate intelligence information down to the lowest levels and up to the highest levels.

Other sources of potential threat information are available on the internet, such as the Southern Poverty Law Center, which tracks hate groups in the United States, at their web site: [www.splcenter.org](http://www.splcenter.org).



## VISUAL III-19



Note: Facility designers need to have the size and type of bomb, vehicle, gun, CBR, or other threat tactic, weapon, or tool identified in order to provide an appropriate level of protection.

There are several methodologies and assessment techniques that can be used. Historically, the U.S. military methodology (with a focus on explosive effects, CBR, and personnel protection) has been used extensively for military installations and other national infrastructure assets.

- The Department of State (DOS) adopted or co-developed many of the same blast and CBR design criteria as DoD and GSA.
- The GSA further developed criteria for Federal buildings as a result of the attack on the Murrah Federal Building.
- The Department of Commerce (DOC) Critical Infrastructure Assurance Office (CIAO) established an assessment framework, which focused on information technology infrastructure.

## Design Basis Threat

We first applied a systems engineering evaluation process to determine a building's critical functions and critical infrastructure. Then we achieve an understanding of the aggressors' likely weapons and attack delivery mode. The next step in the process of quantifying a building's risk assessment is determining the "Design Basis Threat" – the minimum threat tactic that the designers and engineers use in designing a new structure or renovation. The final step in this threat process is the senior management selection of the "Level of Protection" which is also required by the designers and engineers as part of the building design or renovation.

After review of the preliminary information about the building functions, infrastructure, and threats, senior management should establish the "Design Basis Threat" and select the desired "Level of Protection."

## VISUAL III-20

### Levels of Protection

Layers of Defense Elements

- Deter
- Detect
- Deny
- Devalue

The strategy of Layers of Defense uses the elements and Levels of Protection to develop mitigation options to counter or defeat the tactics, weapons, and effects of an attack defined by the Design Basis Threat.



FEMA 426, p. 1-9  
BUILDING DESIGN FOR HOMELAND SECURITY Unit III-20

## Levels of Protection (1/3)

Layers of Defense elements, that along with Levels of Protection, provide the strategy for developing mitigation options.

- Deter
- Detect
- Deny
- Devalue

Let's look at these in more detail on the next slides.

## Exam Questions #A18 and B17

## VISUAL III-21

### Levels of Protection

**Deter:** The process of making the target inaccessible or difficult to defeat with the weapon or tactic selected. It is usually accomplished at the site perimeter using highly visible electronic security systems, fencing, barriers, lighting and security personnel; and in the building by security access with locks and electronic monitoring devices.

**Detect:** The process of using intelligence sharing and security services response to monitor and identify the threat before it penetrates the site perimeter or building access points.



FEMA 426, p. 1-9  
BUILDING DESIGN FOR HOMELAND SECURITY Unit III-21

## Levels of Protection (2/3)

Layers of Defense elements

- Deter
  - Harden the perimeter or building in a fashion that the terrorist will not think the available tactics will work against the asset
  - This can be perceived hardening by the terrorist doing target planning vice actual hardening, such as a dog at an access control point
  - Preferably done at a significant distance from the asset
- Detect
  - Identify the attempted access or preparation of a tactic prior to reaching the asset or where the tactic can be employed
  - Usually done in conjunction with Deny as explained on the next slide

VISUAL III-22

### Levels of Protection

**Deny:** The process of minimizing or delaying the degree of site or building infrastructure damage or loss of life or protecting assets by designing or using infrastructure and equipment designed to withstand blast and chemical, biological, or radiological effects.

**Devalue:** The process of making the site or building of little to no value or consequence, from the terrorists' perspective, such that an attack on the facility would not yield their desired result.



FEMA 426, p. 1-9  
BUILDING DESIGN FOR HOMELAND SECURITY Unit III-22

Levels of Protection (3/3)

Layers of Defense elements

- Deny
  - In conjunction with Detect, a security evaluation is made and a response is initiated to delay or capture aggressors or deny their access to their target.
  - Hardening the asset so as to withstand the employment of the tactic without detriment to people, critical functions, or critical infrastructure
- Devalue
  - Make the asset a less desirable actual or perceived target by dispersing, camouflage, concealment, or deception

VISUAL III-23

### Levels of Protection

Level**	Typical Location	Examples of Tenant Agencies***	Security Measures (based on evaluation)
I	10 Employees (Federal) 2,500 Square Feet Low Volume Public Contact Small "Store Front" type Operation	Local Office District Office Visitor Center USDA Office Ranger Station Commercial Facilities Industrial/Manufacturing Health Care	High Security Locks Intercom Pump Hole (Wide View) Lighting w/ Emergency Backup Power Controlled Utility Access Annual Employee Security Training
II	11 - 150 Employees (Federal) 2,500 - 80,000 Square Feet Moderate Volume Public Contact Routine Operations Similar to Private Sector and/or Facility Shared with Private Sector	Public Offices Park Headquarters Regional/State Offices Commercial Facilities Industrial Manufacturing Health Care	Entry Control Package w/ Closed Circuit Television (CCV) Visitor Control/Screening Shipping/Receiving Procedures Guard/Patrol Assessment Intrusion Detection w/ Central Monitoring CCV Surveillance (Pan-Tilt, Zoom System) Duness Alarm w/ Central Monitoring



FEMA 426, Table 1-6: Classification Table Extracts, p. 1-26  
BUILDING DESIGN FOR HOMELAND SECURITY Unit III-23

Levels of Protection (1/2)

This table – extracted from the U.S. Department of Justice’s *Vulnerability Assessment of Federal Facilities* (1995) – presents a series of security measures for typical sizes and types of sites, in addition to a transferable example of appropriate security measures for typical locations and occupancies.

Here is the lower end of the Levels of Protection which is a quick assessment of asset value, critical functions and critical infrastructure and the physical security measures that a security professional would select from to apply.

VISUAL III-24

Levels of Protection (continued)

Level**	Typical Location	Examples of Target Agencies***	Security Measures (based on evaluation)
III	151 - 450 Employees (Federal) Multi-Story Facility 80,000 - 150,000 Square Feet Medium/High Volume Public Contact Agency Mix: Law Enforcement Operations Court Functions Government Records	Inspectors General Criminal Investigations Regional/State Offices GSA Field Offices Local Schools Commercial Facilities Industrial Manufacturing Health Care	Guard Patrol on Site Visitor Control/Screening Shipping/Receiving Procedures Intrusion Detection w/ Central Monitoring CCV Surveillance (Pan-Tilt/Zoom Systems) Diverse Alarm w/ Central Monitoring
IV	>450 Employees (Federal) Multi-Story Facility >150,000 Square Feet High Volume Public Contact High Risk Law Enforcement/Intelligence Agencies District Court	Significant Buildings and Some Headquarters Federal Law Enforcement Agencies Local Schools, Universities Commercial Facilities Health Care	External Perimeter (Concrete/Steel Barriers) 24 Hour Guard Patrol Adjacent Parking Control Backup Power System Hardened Parking Barriers
V	Level IV Profile and Agency/Mission Critical to National Security	Principal Department Headquarters	Agency-Specific

FEMA 426, Table 1-6: Classification Table Extracts, p. 1-26



Levels of Protection (1/2)

This is the upper end of the table, with associated higher asset value, greater targeting potential, greater consequences, and significantly greater physical security measures.

VISUAL III-25

Levels of Protection

DoD Minimum Antiterrorism (AT) Standards for New Buildings

Level of Protection	Potential Structural Damage	Potential Door and Glazing Hazards	Potential Injury
Below AT standards	Severely damaged. Frame collapse/massive destruction. Little left standing.	Doors and windows fail and result in lethal hazards	Majority of personnel suffer fatalities.
Very Low	Heavily damaged - onset of structural collapse. Major deformation of primary and secondary structural members, but progressive collapse is unlikely. Collapse of non-structural elements.	Glazing will break and is likely to be propelled into the building, resulting in serious glazing fragment injuries, but fragments will be reduced. Doors may be propelled into rooms, presenting serious hazards.	Majority of personnel suffer serious injuries. There are likely to be a limited number (10 percent to 25 percent) of fatalities.

FEMA 426, Table 4-1, p. 4-9



Levels of Protection  
DoD Minimum Antiterrorism (AT)  
Standards for New Buildings (1/2)

In contrast to the GSA security levels and criteria, the DoD correlates levels of protection with potential damage and expected injuries.

At the levels shown here, there is significant damage, injury, and an estimated number of dead.

VISUAL III-26

Levels of Protection (continued)

Level of Protection	Potential Structural Damage	Potential Door and Glazing Hazards	Potential Injury
Low	Damaged - repairable. Major deformation of non-structural elements and secondary structural members, and minor deformation of primary structural members, but progressive collapse is unlikely.	Glazing will break, but fall within 1 meter of the wall or otherwise not present a significant fragment hazard. Doors may fail, but they will rebound out of their frames, presenting minimal hazards.	Majority of personnel suffer significant injuries. There may be a few (<10 percent) fatalities.
Medium	Damaged - repairable. Minor deformations of non-structural elements and secondary structural members and no permanent deformation in primary structural members.	Glazing will break, but will remain in the window frame. Doors will stay in frames, but will not be reusable.	Some minor injuries, but fatalities are unlikely.
High	Superficially damaged. No permanent deformation of primary and secondary structural members or non-structural elements.	Glazing will not break. Doors will be reusable.	Only superficial injuries are likely.

DoD Minimum Standards

FEMA 426, Table 4-1, p. 4-9



Levels of Protection  
DoD Minimum Antiterrorism (AT)  
Standards for New Buildings (2/2)

A low level of protection should be the minimum sought in a design using the “Design Basis Threat” for hardening. Few fatalities are expected.

Medium and high levels of protection will cost more to achieve.

## VISUAL III-27

Levels of Protection	
UFC 4-010-01 APPENDIX B DoD MINIMUM ANTITERRORISM STANDARDS FOR NEW AND EXISTING BUILDINGS	
Standard 1	Minimum Stand-off Distances
Standard 2	Unobstructed Space
Standard 3	Drive-Up/Drop-Off Areas
Standard 4	Access Roads
Standard 5	Parking Beneath Buildings or on Rooftops
Standard 6	Progressive Collapse Avoidance
Standard 7	Structural Isolation
Standard 8	Building Overhangs
Standard 9	Exterior Masonry Walls
Standard 10	Windows, Skylights, and Glazed Doors
Standard 11	Building Entrance Layout
Standard 12	Exterior Doors

 FEMA

BUILDING DESIGN FOR HOMELAND SECURITY Unit III-27

## Levels of Protection

DoD Antiterrorism Standards 1 to 12.

Highlight Standards 1, 2, and 4, and refer to **the Building Vulnerability Assessment Checklist** questions for blast evaluation.

- DOD Std 1 – Minimum Stand-off Distance
  - Separation distance – vehicle bomb to building
  - Analysis to show level of protection achieved if minimum stand-off cannot be met
- DoD Std 2 – Unobstructed Space
  - Clear Zone around building preventing a package bomb from being hidden
  - No equipment or enclosures within unobstructed space
- DoD Std 4 – Access Roads
  - Access control measures that ensure unauthorized vehicles do not get inside the minimum stand-off distance

Each standard correlates to a Level of Protection and Design Basis Threat.

VISUAL III-28

UFC 4-010-01 APPENDIX B DoD MINIMUM ANTITERRORISM STANDARDS FOR NEW AND EXISTING BUILDINGS	
Standard 13	Mailrooms
Standard 14	Roof Access
Standard 15	Overhead Mounted Architectural Features
Standard 16	Air Intakes
Standard 17	Mailroom Ventilation
Standard 18	Emergency Air Distribution Shutoff
Standard 19	Utility Distribution and Installation
Standard 20	Equipment Bracing
Standard 21	Under Building Access
Standard 22	Mass Notification

 FEMA

BUILDING DESIGN FOR HOMELAND SECURITY Unit III-28

### Levels of Protection

DoD Antiterrorism Standards 13 to 22.

Highlight Standards 16, 17, and 18, and the impacts on HVAC.

- DOD Std 16 – Air Intakes
  - Prevent easy introduction of CBR agents into the HVAC system
  
- DoD Std 17 – Mailroom Ventilation
  - Separate HVAC system serving only the mailroom
  - Configure room pressures so that mailroom is at a lower pressure than other adjacent parts of building and air leakage only comes into the mailroom, preventing spread of contaminants until HVAC system is shut down
  
- DoD Std 18 – Emergency Air Distribution Shutdown
  - Immediately shut down air distribution throughout building except where interior pressure and airflow control would more efficiently prevent spread of airborne contaminants and/or ensure the safety of egress pathways.

## VISUAL III-29

### Summary

Process

- Identify each threat/hazard
- Define each threat/hazard
- Determine threat level for each threat/hazard

Threat Assessment Specialist Tasks

Critical Infrastructure and Critical Function Matrix

Determine the “Design Basis Threat”

Select the “Level of Protection”



BUILDING DESIGN FOR HOMELAND SECURITY Unit III-29

## Summary

The process for developing threat assessments:

- Identify each threat / hazard
- Define each threat / hazard
- Determine threat level for each threat / hazard

Use Federal, state, or local law enforcement to help determine threat ratings.

Complete the Critical Functions and Critical Infrastructure Matrices.

Establish the Design Basis Threat.

Select the Level of Protection.

Use Layers of Defense strategy to mitigate attack and develop mitigation options.

## VISUAL III-30

### Unit III Case Study Activity

#### Threat Ratings

#### Background

Hazards categories: natural and manmade

Case Study Threats: Cyber Attack, Armed Attack, Vehicle Bomb, and CBR Attack (latter two are main focus of course)

Result of assessment: “Threat Rating,” a subjective judgment of threat

#### Requirements

Refer to Case Study data

Complete worksheet tables:

- Critical Function Threat Rating
- Critical Infrastructure Threat Rating



BUILDING DESIGN FOR HOMELAND SECURITY Unit III-30

## Student Activity

After assets that need to be protected are determined, an assessment is performed to identify the threats and hazards that could cause harm to the building and the inhabitants of the building.

Hazards are categorized into two groups:

- Natural
- Manmade

To focus the class and improve the learning experience by eliminating excessive variation among threats, the Case Study is limited to four threats as shown on the Risk Matrix:

- Cyber attack
- Armed attack
- Explosive blast
- Chemical, biological, and/or radiological “agents”

Refer participants to **FEMA 426** and the Unit III Case Study activity in the Student Manual.

Members of the instructor staff should be available to answer questions and assist groups as needed.

At the end of 30 minutes, reconvene the class.

The plenary session to facilitate group reporting has 15 minutes to go through and discuss the answers.

The result of this assessment is a “Threat Rating.” The threat rating is a subjective judgment of a threat based on:

- Existence
- Capability
- History
- Intentions
- Targeting

The rating scale is a scale of 1 to 10:

- 1 is a very low probability of a terrorist attack
- 10 is a very high probability.

### **Activity Requirements**

Working in small groups, refer to the Case Study and complete the worksheet tables for:

- HZC Critical Functions
- HZC Critical Infrastructure

Take 30 minutes to complete this activity. Solutions will be reviewed in plenary group.

### **Transition**

Unit IV will cover Vulnerability Assessment and Unit V will cover Risk Assessment / Risk Management.



*This page intentionally left blank.*

**UNIT III-A CASE STUDY ACTIVITY:  
THREAT/HAZARD RATING  
(Suburban Version)**

After assets that need to be protected are determined, an assessment is performed to identify the threats and hazards that could cause harm to the building and the inhabitants of the building. Hazards are categorized into two groups: natural and manmade. Although natural hazards could logically be expected to affect the HIC, the Case Study only describes the threat from explosive blast and from chemical, biological, and/or radiological “agents.”

To complete the threat assessment, the two-step process has been selected. Step 1 is to identify the primary threats according to criteria shown on the following page.

For the sake of this course, the four primary threats have been determined to be Cyber Attack, Armed Attack, Vehicle Bomb, and CBR Attack. However, to familiarize yourself with the process of determining the primary threats, determine the threat score for a 500-lb. vehicle bomb.

The second step of the threat assessment process is the determination of the “Threat Rating.” The rating scale is a scale of 1 to 10, with 1 a very low probability of a terrorist attack and 10 a very high probability.

**Requirements**

Refer to the HIC Case Study data and GIS portfolio and complete the following worksheets. Each student will interpret the HIC threat information and should have a number close to the value shown. Any function with key IT systems connected to the Internet should get high cyber values. Functions that are susceptible to blast should get high numbers. A CBR attack would impact the entire facility.

**Step 1: Determine the score for a 500-lb. vehicle bomb**

<b>Criteria</b>								
Scenario	Access to Agent	Knowledge / Expertise	History of Threats Against Buildings	Asset Visibility / Symbolic	Asset Accessibility	Site Population/ Capacity	Level of Defense	Score
<b>Improvised Explosive Device (Bomb)</b>								
500 lb. Vehicle Bomb	9	8	7	4	9	2	9	48

**Rationale for Above Numbers using FEMA 452 Criteria on next page**

“Farm” explosives

- Access to Agent -- Readily available
- Knowledge/Expertise --Instructions on internet
- History gets a higher rating closer to home -- Regional/State good choice for urban environment

- Asset Visibility / Existence published / well known
- Asset Accessibility – currently open access, unrestricted parking
- Site Population – HIC Building about 75, all buildings in office park about 250
- Level of Defense – Little or no defense against threats. No specific security design taken into consideration or adopted for this threat.

<b>FEMA 452 Criteria</b>							
<b>Scenario</b>	<b>Access to Agent</b>	<b>Knowledge/ Expertise</b>	<b>History of Threats Against Buildings</b>	<b>Asset Visibility/ Symbolic</b>	<b>Asset Accessibility</b>	<b>Site Population/ Capacity</b>	<b>Level of Defense</b>
9-10	Readily available	Basic knowledge/ open source	Local incident	Existence widely known/ iconic	Open access, unrestricted parking	> 5,000	Little or no defense against threats. No security design was taken into consideration and no mitigation measures adopted.
6-8	Easily producible	Bachelor or technical school/open scientific or technical literature	Regional/ State	Existence locally known/ landmark	Open access, restricted parking	1,001-5,000	Minimal defense against threats. Minimal security design was taken into consideration and minimal mitigation measures adopted.
3-5	Difficult to produce or acquire	Advanced training/rare scientific or declassified literature	National	Existence published / well-known	Controlled access, protected entry	251-1,000	Significant defense against threats. Significant security design was taken into consideration and substantial mitigation measures adopted.
1-2	Very difficult to produce or acquire	Advanced degree or training/ classified information	International	Existence not well known/ no symbolic importance	Remote location, secure perimeter, armed guards, tightly controlled access	1-250	Extensive defense against threats. Extensive security design was taken into consideration and extensive mitigation measures adopted.

**Step 2: Determine the threat rating for HIC**

**HIC Critical Functions Threat Rating**

<b>Function</b>	<b>Cyber Attack</b>	<b>Armed Attack</b>	<b>Vehicle Bomb</b>	<b>CBR Attack</b>	<b>Rationale</b>
1. Administration	8	3	6	4	Local and international groups with the capability, intentions, and targeting expertise are known to be in the area.
2. Engineering / IT Technicians	8	3	6	4	Local and international groups with the capability, intentions, and targeting expertise are known to be in the area.
3. Loading Dock / Warehousing	8	3	6	4	Local and international groups with the capability, intentions, and targeting expertise are known to be in the area.
4. Data Center	8	3	6	4	Local and international groups with the capability, intentions, and targeting expertise are known to be in the area.

Function	Cyber Attack	Armed Attack	Vehicle Bomb	CBR Attack	Rationale
5. Communications	8	3	6	4	Digital communications tend to have a higher threat rating than analog communication systems because analog communications are generally hardwired and not connected to internet. Access by wireless or telephone call up would increase the threat rating by increasing accessibility with wireless having a higher threat rating than telephone call up.
6. Security	8	3	6	4	Local and international groups with the capability, intentions, and targeting expertise are known to be in the area.
7. Housekeeping	8	3	6	4	Local and international groups with the capability, intentions, and targeting expertise are known to be in the area.

**HIC Infrastructure Threat Rating**

Infrastructure	Cyber Attack	Armed Attack	Vehicle Bomb	CBR Attack	Rationale
1. Site	1	3	6	4	Local and international groups with the capability, intentions, and targeting expertise are known to be in the area.
2. Architectural	1	3	6	4	Local and international groups with the capability, intentions, and targeting expertise are known to be in the area.
3. Structural	1	3	6	4	Local and international groups with the capability, intentions, and targeting expertise are known to be in the area.
4. Envelope Systems	1	3	6	4	Local and international groups with the capability, intentions, and targeting expertise are known to be in the area.

<b>Infrastructure</b>	<b>Cyber Attack</b>	<b>Armed Attack</b>	<b>Vehicle Bomb</b>	<b>CBR Attack</b>	<b>Rationale</b>
5. Utility Systems	5	5	6	4	Local and international groups with the capability, intentions, and targeting expertise are known to be in the area.
6. Mechanical Systems	5	5	6	4	Local and international groups with the capability, intentions, and targeting expertise are known to be in the area.
7. Plumbing and Gas Systems	1	3	6	4	Local and international groups with the capability, intentions, and targeting expertise are known to be in the area.
8. Electrical Systems	5	3	6	4	Local and international groups with the capability, intentions, and targeting expertise are known to be in the area.

<b>Infrastructure</b>	<b>Cyber Attack</b>	<b>Armed Attack</b>	<b>Vehicle Bomb</b>	<b>CBR Attack</b>	<b>Rationale</b>
9. Fire Alarm Systems	2	3	6	4	Local and international groups with the capability, intentions, and targeting expertise are known to be in the area.
10. IT / Communications Systems	10	3	6	4	Local and international groups with the capability, intentions, and targeting expertise are known to be in the area.



**UNIT III-B CASE STUDY ACTIVITY:  
THREAT / HAZARD RATING  
(Urban Version)**

After assets that need to be protected are determined, the next step is to identify the threats and hazards that could harm the building and its inhabitants. Hazards are categorized into two groups: natural and manmade. For the sake of this course, the four primary threats selected are Cyber Attack, Armed Attack, Vehicle Bomb, and CBR Attack.

**Requirements**

Refer to the Appendix B Case Study data and complete the following worksheets. Each student as part of their assessment team will interpret the HZC threat information and should select and justify a threat/hazard rating number with rationale.

- Any function with key IT systems connected to the Internet should get high cyber threat values.
- The threat of explosive blast should be looked upon as either as directly targeted or as collateral damage. Before giving a consistently low rating, consider your answer to Step 1 below as it would have been applied to the Murrah Building in Oklahoma City in 1995.
- A CBR attack or nearby HazMat spill could impact the entire facility, but to varying degrees by floors in a 50-story building if the agent is heavier or lighter than air.

Thus, to illustrate threat assessment, two separate steps were selected for their different methodology.

- Step 1 uses the FEMA 452 Criteria that has its basis in the rating process developed by the US Marshals Service after the Murrah Building bombing in Oklahoma City. The US Marshals Service process was then used by GSA to begin assessing Federal buildings. This method tends to look at the building as a whole.
- Step 2 uses the FEMA 426 methodology of applying a threat rating using specific or generic tactics in a given threat scenario against a specific asset, such as critical functions or critical infrastructure. Thus, this method tends to look at the various components of the building so as to focus limited resources to achieve maximum risk reduction by taking care of the most critical assets.

Final Action: Transfer answers from the Threat Rating tables below to the Risk Matrix poster after team agreement on team answer.

**Step 1: Determine the threat score for a 500-lb. vehicle bomb as applied to HZC**

Familiarize yourself with the process of determining the primary threats according to the FEMA 452 criteria (**Table 1-4, page 1-21, FEMA 452**) by determining the threat score for a 500-lb. (TNT equivalent) vehicle bomb using the information on the next page and in the Appendix B Case Study.

As shown in Table 1-5, page 1-22, FEMA 453, you can use this scoring methodology to determine your primary threats based upon the threats that achieve the highest scores. However note that the criteria actually intersperses Asset Value Rating, Threat Rating, and Vulnerability Rating as indicated below:

- Access to Agent (Threat – capability of potential threat elements)
- Knowledge/Expertise (Threat – capability of potential threat elements)
- History of Threats/Actual Usage (Threat – rhetoric and actual use by potential threat elements)
- Asset Visibility / Symbolic (Asset Value – but in eyes of potential threat elements as target)
- Asset Accessibility (Vulnerability)
- Site Population / Capacity (Asset Value or Threat (Targeting))
- Level of Defense (Vulnerability)

<b>FEMA 452 Table 1-4 Criteria</b>								
Scenario	Access to Agent	Knowledge/Expertise	History of Threats Against Buildings	Asset Visibility/Symbolic	Asset Accessibility	Site Population/Capacity	Level of Defense	Score
<b>Improvised Explosive Device (Bomb)</b>								
500 lb. Vehicle Bomb	9	9	7	5	10	10	9	59

**Rationale for Above Numbers using FEMA 452 Criteria on next page**

“Farm” explosives

- Access to Agent -- Readily available
- Knowledge/Expertise --Instructions on internet
- History gets a higher rating closer to home -- Regional/State good choice for urban environment
- Asset Visibility / Symbolic– well known, but not a landmark
- Asset Accessibility – currently open access, unrestricted underground parking
- Site Population – 9,000 average
- Level of Defense – Little or no defense against threats. No specific security design taken into consideration or adopted for this threat.

<b>FEMA 452 Criteria</b>							
<b>Scenario</b>	<b>Access to Agent</b>	<b>Knowledge/ Expertise</b>	<b>History of Threats Against Buildings</b>	<b>Asset Visibility/ Symbolic</b>	<b>Asset Accessibility</b>	<b>Site Population/ Capacity</b>	<b>Level of Defense</b>
9-10	Readily available	Basic knowledge/ open source	Local incident	Existence widely known/ iconic	Open access, unrestricted parking	> 5,000	Little or no defense against threats. No security design was taken into consideration and no mitigation measures adopted.
6-8	Easily producible	Bachelor or technical school/open scientific or technical literature	Regional/ State	Existence locally known/ landmark	Open access, restricted parking	1,001-5,000	Minimal defense against threats. Minimal security design was taken into consideration and minimal mitigation measures adopted.
3-5	Difficult to produce or acquire	Advanced training/rare scientific or declassified literature	National	Existence published / well-known	Controlled access, protected entry	251-1,000	Significant defense against threats. Significant security design was taken into consideration and substantial mitigation measures adopted.
1-2	Very difficult to produce or acquire	Advanced degree or training/ classified information	International	Existence not well known/ no symbolic importance	Remote location, secure perimeter, armed guards, tightly controlled access	1-250	Extensive defense against threats. Extensive security design was taken into consideration and extensive mitigation measures adopted.

**Step 2: Determine Threat Ratings for HazardCorp Building**

The second step is the FEMA 426 method for determining the “Threat Rating.” The rating scale is a scale of 1 to 10, with 1 being a very low probability of a terrorist attack and 10 a very high probability.

**NOTE 1:** In the previous student activity to determine Asset Value Rating, there was only one value of an asset – it did not change based upon threat or situation. The impact if the asset was damaged or lost is a view of its value.

**NOTE 2:** In like manner, the Threat Rating will tend to be the same across all assets. Variances can occur across large buildings where all functions may not exist in all portions of the building or the targeting of the asset may be negligible – no history, no capability – such as Cyber Attack against an asset that has no computer and no connection to the internet. This can be called a very low threat, but it also indicates that since cyber attack cannot occur, the asset has no vulnerabilities to that threat.

**HZC Critical Functions Threat Rating**

Function	Cyber Attack	Armed Attack	Vehicle Bomb	CBR Attack	Rationale
1. Administration	6	6	9	6	Local and international groups with the capability, intentions, and targeting expertise are known to be in the area.
2. Engineering / IT Technicians	6	4	9	6	Local and international groups with the capability, intentions, and targeting expertise are known to be in the area.

Function	Cyber Attack	Armed Attack	Vehicle Bomb	CBR Attack	Rationale
3. Loading Dock / Warehousing	6	7	9	6	Local and international groups with the capability, intentions, and targeting expertise are known to be in the area.
4. Data Center	6	3	9	6	Local and international groups with the capability, intentions, and targeting expertise are known to be in the area.
5. Communications	6	4	9	6	Digital communications tend to have a higher threat rating than analog communication systems because analog communications are generally hardwired and not connected to internet. Access by wireless or telephone call up would increase the threat rating by increasing accessibility with wireless having a higher threat rating than telephone call up.

Function	Cyber Attack	Armed Attack	Vehicle Bomb	CBR Attack	Rationale
6. Security	6	7	9	6	Local and international groups with the capability, intentions, and targeting expertise are known to be in the area
7. Housekeeping	2	2	9	6	Local and international groups with the capability, intentions, and targeting expertise are known to be in the area

**HZC Infrastructure Threat Rating**

Infrastructure	Cyber Attack	Armed Attack	Vehicle Bomb	CBR Attack	Rationale
1. Site	1	3	9	6	Local and international groups with the capability, intentions, and targeting expertise are known to be in the area.
2. Architectural	1	3	9	6	Local and international groups with the capability, intentions, and targeting expertise are known to be in the area.

Infrastructure	Cyber Attack	Armed Attack	Vehicle Bomb	CBR Attack	Rationale
3. Structural	1	3	9	4	Local and international groups with the capability, intentions, and targeting expertise are known to be in the area.
4. Envelope Systems	1	3	9	6	Local and international groups with the capability, intentions, and targeting expertise are known to be in the area.
5. Utility Systems	1	3	9	6	Local and international groups with the capability, intentions, and targeting expertise are known to be in the area.
6. Mechanical Systems	5	3	9	6	Local and international groups with the capability, intentions, and targeting expertise are known to be in the area.

<b>Infrastructure</b>	<b>Cyber Attack</b>	<b>Armed Attack</b>	<b>Vehicle Bomb</b>	<b>CBR Attack</b>	<b>Rationale</b>
7. Plumbing and Gas Systems	1	3	9	6	Local and international groups with the capability, intentions, and targeting expertise are known to be in the area.
8. Electrical Systems	5	5	9	6	Local and international groups with the capability, intentions, and targeting expertise are known to be in the area.
9. Fire Alarm Systems	2	2	9	6	Local and international groups with the capability, intentions, and targeting expertise are known to be in the area.
10. IT / Communications Systems	8	4	9	6	Local and international groups with the capability, intentions, and targeting expertise are known to be in the area.



*This page intentionally left blank*

## Unit IV

---

<b>COURSE TITLE</b>	Building Design for Homeland Security	<b>TIME</b>	105 minutes
---------------------	---------------------------------------	-------------	-------------

---

<b>UNIT TITLE</b>	Vulnerability Assessment
-------------------	--------------------------

---

<b>OBJECTIVES</b>	<ol style="list-style-type: none"><li>1. Explain what constitutes a vulnerability</li><li>2. Identify vulnerabilities using the Building Vulnerability Assessment Checklist</li><li>3. Understand that an identified vulnerability may indicate that an asset is vulnerable to more than one threat or hazard and that mitigation measures may reduce vulnerability to one or more threats or hazards</li><li>4. Provide a numerical rating for the vulnerability and justify the basis for the rating</li></ol>
-------------------	--

---

<b>SCOPE</b>	The following topics will be covered in this unit:
--------------	--

1. Review types of vulnerabilities, especially single-point vulnerabilities and tactics possible under threats/hazards for which there are no mitigation measures.
2. Various approaches and considerations to determine vulnerabilities – FEMA, Department of Defense, Department of Justice, and Veterans Affairs.
3. A rating scale and how to use it to determine a vulnerability rating. One or more specific examples will be used to focus students on the following activity.
4. Activity: Make an initial identification of vulnerabilities present in the selected Case Study answering the selected Vulnerability Assessment Checklist questions. Then, determine the vulnerability rating for each asset-threat/hazard pair of interest, using the four threats selected for this course (Cyber Attack, Armed Attack, Vehicle Bomb, CBR Attack) as applied against the identified assets. Achieve team concurrence on answers.

---

<b>REFERENCES</b>	<ol style="list-style-type: none"><li>1. FEMA 426, <i>Reference Manual to Mitigate Potential Terrorist Attacks Against Buildings</i>, pages 1-24 to 1-35 and pages 1-45 to 1-93</li><li>2. FEMA 452, <i>Risk Assessment: A How-To Guide to Mitigate Potential Terrorist Attacks Against Buildings</i>, pages 3-1 to 3-20</li><li>3. Case Study – Appendix A: Suburban, Hazardville Information</li></ol>
-------------------	--

---

- 
- Company or Appendix B: Urban, HazardCorp Building as selected
  - 4. Student Manual, Unit IV-A or Unit IV-B as selected (info only – not listed in SM)
  - 5. Unit IV visuals (info only – not listed in SM)
- 

**REQUIREMENTS**

- 1. FEMA 426, *Reference Manual to Mitigate Potential Terrorist Attacks Against Buildings* (one per student)
- 2. FEMA 452, *Risk Assessment: A How-To Guide to Mitigate Potential Terrorist Attacks Against Buildings* (one per student)
- 3. Instructor Guide, Unit IV
- 4. Student Manual (one per student) for selected Case Study
- 5. Overhead projector or computer display unit
- 6. Unit IV visuals
- 7. Risk Matrix poster and box of dry-erase markers (one per team)
- 8. Chart paper, easel, and markers

**UNIT IV OUTLINE**

	<u>Time</u>	<u>Page</u>
IV. Vulnerability Assessment	105 minutes	IG IV-1
1. Introduction and Unit Overview	5 minutes	IG IV-5
2. Identification of Vulnerabilities	30 minutes	IG IV-7
3. Rating of Vulnerabilities	10 minutes	IG IV-22
4. Summary/Activity/Transition	5 minutes	IG IV-26
5. Activity: Vulnerability Rating (Versio <b>n A Suburban</b> ) [30 minutes for students, 15 minutes for review]	45 minutes	IG IV-A -28
6. Activity: Vulnerability Rating (Versio <b>n B Urban</b> ) [30 minutes for students, 15 minutes for review]	45 minutes	IG IV-B -33

**PREPARING TO TEACH THIS UNIT**

- **Tailoring Content to the Local Area:** This is a generic instruction unit, but it has great capability for linking to the Local Area. Local Area discussion may be generated as students have specific situations for which they would like to determine vulnerabilities or vulnerability rating prompted by points brought up in the presentation.

The Instructor will discuss generic vulnerabilities found in a building and how tactics possible under threats/hazards can be used against a building. In essence, the students will see the terrorist's thought process for selecting a tactic against a target. Conversely, the students will also be presented vulnerabilities that exist for many tactics. Similar to the ratings presented in Units II and III, various approaches to identify vulnerabilities will be presented.

The students will be introduced to the **Building Vulnerability Assessment Checklist (Table 1-22, pages 1-46 to 1-93, of FEMA 426)** during this unit. Use of the checklist will be reemphasized in Units IX and X covering Chapters 2 and 3 of **FEMA 426**. Note that the vulnerability rating at this point in the assessment process is a rapid screening approach. It provides an initial vulnerability rating based upon mitigation measures already in place against the threat/hazard tactic. It is derived from the interview process with the building management and staff to focus the more in-depth vulnerability assessment using the complete checklist.

- **Optional Activity:** There are no optional activities in this unit, except Student Activity questions that are applicable to the selected Case Study (Suburban or Urban).
- **Activity:** The students will apply the vulnerability identification (or lack of mitigation measures) and vulnerability rating to the Case Study to identify and rate the vulnerabilities found in the Case Study for each asset-threat/hazard pair of interest. The students will quickly review/scan the building data, physical security, building structure, electrical systems, mechanical systems information systems, communications, emergency response, and geographic information system (GIS) portfolio to have a sense of the vulnerabilities at the building being assessed. The **Building Vulnerability Assessment Checklist (Table 1-22, pages 1-46 to 1-93, of FEMA 426)** can be used to capture the sense of potential vulnerabilities and mitigation measures.
- Refer students to their Student Manuals for worksheets and activities.
- Direct students to the appropriate page in the Student Manual.
- Instruct the students to read the activity instructions found in the Student Manual.
- Explain that the vulnerability ratings determined by the team must be transferred to the Risk Matrix poster.
- Tell students how long they have to work on the requirements.
- While students are working, all instructors should closely observe the groups' process and progress. If any groups are struggling, immediately assist them by clarifying the assignment and providing as much help as is necessary for the groups to complete the requirement in the allotted time. Also, monitor each group for full participation of all members. For example,

ask any student who is not fully engaged a question that requires his/her viewpoint to be presented to the group.

- At the end of the working period, reconvene the class.
- After the students have completed the assignment, “walk through” the activity with the students during the plenary session. Call on different teams to provide the answer(s) for each question. Then simply ask if anyone disagrees. If the answer is correct and no one disagrees, state that the answer is correct and move on to the next requirement. If there is disagreement, allow some discussion of rationale, provide the “school solution” and move on.
- If time is short, simply provide the “school solution” and ask for questions. Do not end the activity without ensuring that students know if their answers are correct or at least on the right track.
- Ask for and answer questions.

INSTRUCTOR NOTES

CONTENT/ACTIVITY

VISUAL IV-1

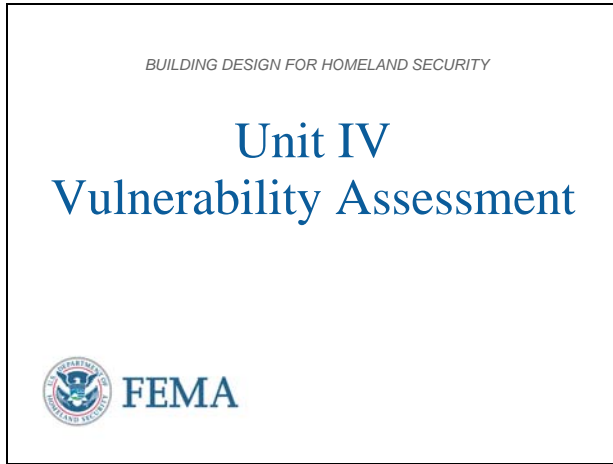

**Introduction and Unit Overview**

This is Unit IV Vulnerability Assessment. In this unit, we will review types of vulnerabilities, considerations to identifying vulnerabilities, and review a vulnerability rating scale.

This unit also introduces the **FEMA 426 Building Vulnerability Assessment Checklist (Table 1-22, pages 1-46 to 1-93)** to assist in identifying vulnerabilities. This checklist will see extensive use in Units IX, X, and XI (9, 10, and 11).

VISUAL IV-2

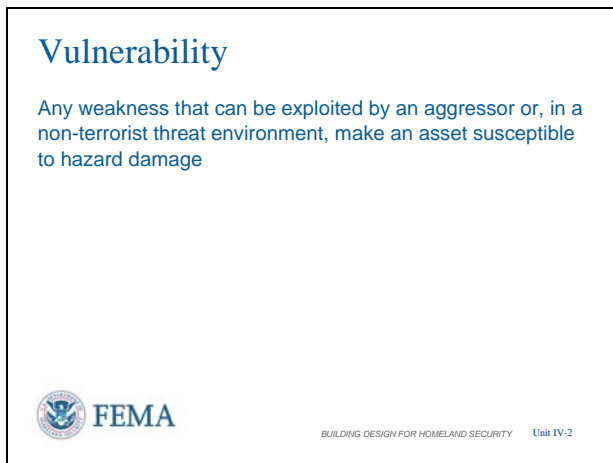

**Vulnerability**

The definition of vulnerability is any weakness that can be exploited by an aggressor or, in a non-terrorist threat environment, make an asset susceptible to hazard damage.

Essentially it is looking at a tactic against an asset and how successful that tactic can be.

VISUAL IV-3

**Unit Objectives**

**Explain** what constitutes a vulnerability.

**Identify** vulnerabilities using the Building Vulnerability Assessment Checklist.

**Understand** that an identified vulnerability may indicate that an asset:

- is vulnerable to more than one threat or hazard;
- and that mitigation measures may reduce vulnerability to one or more threats or hazards.

**Provide** a numerical rating for the vulnerability and justify the basis for the rating.



BUILDING DESIGN FOR HOMELAND SECURITY Unit IV-3

**Unit Objectives**

At the end of this unit, the students should be able to:

1. Explain what constitutes a vulnerability.
2. Identify vulnerabilities using the **Building Vulnerability Assessment Checklist (Table 1-22, pages 1-46 to 1-93, of FEMA 426)**.
3. Understand that an identified vulnerability may indicate that an asset is vulnerable to more than one threat or hazard, and that mitigation measures may reduce vulnerability to one or more threats or hazards.
4. Provide a numerical rating for the vulnerability and justify the basis for the rating.

VISUAL IV-4

**Vulnerability Assessment**

**Identify** site and building systems design issues

**Evaluate** design issues against type and level of threat

**Determine** level of protection sought for each mitigation measure against each threat



BUILDING DESIGN FOR HOMELAND SECURITY Unit IV-4

**Vulnerability Assessment** in this context has three components:

- Identify site and building systems design issues
- Evaluate design issues against type and level of threat
- Determine level of protection sought for each mitigation measure against each threat

[The goal is to see if existing conditions provide the level of protection desired. Then mitigation measures are sought to achieve the level of protection where it has not been achieved.]

Vulnerability assessments occur at different levels or magnitude of scale, including:

- State / Regional / Business Sector
- Site / Building / Tenant or Occupant

VISUAL IV-5

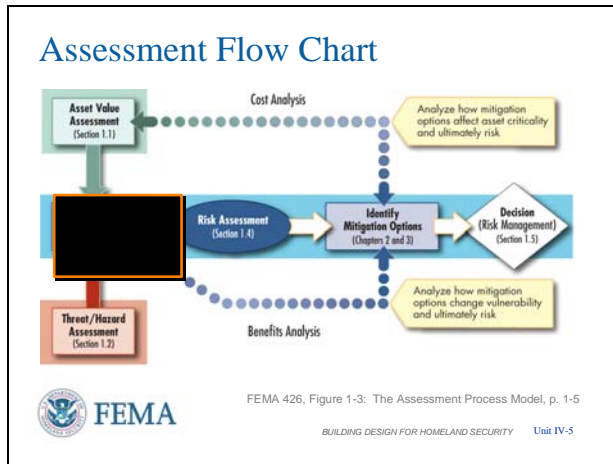

Assessment Flow Chart

Reviewing the Assessment Flow Chart, the vulnerability assessment is the next step in the risk assessment process.

In the prior steps, assets and their respective values were assigned, the threat was analyzed, a Design Basis Threat was established, and a Level of Protection was selected.

The next step is to conduct the vulnerability assessment, which is an in-depth analysis of the building functions, systems, and site characteristics to identify building weaknesses and lack of redundancy, and determine mitigations or corrective actions that can be designed or implemented to reduce the vulnerabilities.

VISUAL IV-6

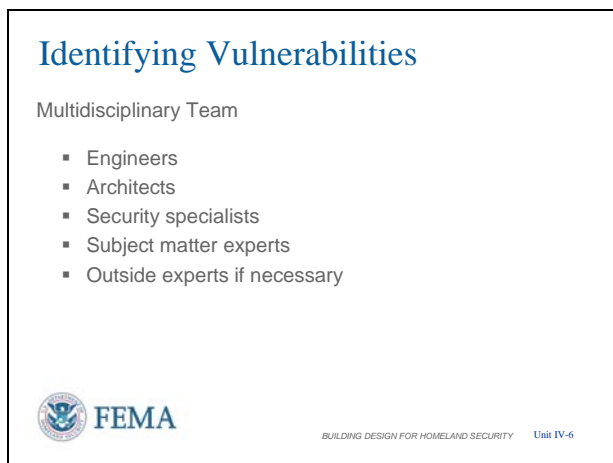

Identifying Vulnerabilities

Assessing a building's vulnerabilities requires a multidisciplinary team. It should not be conducted solely by an engineer or by a security specialist. Only a balanced team can have an understanding of the identified aggressors or threat/hazards and how they can affect the building's critical functions and infrastructure.

Team members include:

- Engineers
- Architects
- Security specialists
- Subject matter experts
- Outside experts if necessary

Tailor the team to the individual project. A building owner could use his handyman, the local sheriff, his workers, the local volunteer fire department, the service representatives from the local utilities, etc., for an initial



VISUAL IV-7

**Vulnerability Assessment Preparation**

Coordinate with the building stakeholders:

- Site and Building Plans
- Utilities
- Emergency Plans (shelter, evacuation)
- Interview schedules
- Escorts for building access



BUILDING DESIGN FOR HOMELAND SECURITY Unit IV-7

assessment. What cannot be answered by this initial team can then be taken to personnel at the next higher level(s) with more expertise and experience in the respective areas.

**Vulnerability Assessment Preparation**

After assembling a team, the assessment process starts with a detailed planning and information collection of the site. If possible, the information should be gathered in a GIS format.

Types of coordination with the building stakeholders include:

- Site and Building Plans
- Utilities
- Emergency Plans (shelter, evacuation)
- Interview schedules [ensure the people who can answer the team assessment questions are available]
- Escorts for building access

Note that no matter how much preparation is done prior to an assessment, the process on site will reveal new information.

Conversely, if preparation is not done, much can be missed because the “right” questions may not have been asked on site.

VISUAL IV-8

Assessment GIS Portfolio



BUILDING DESIGN FOR HOMELAND SECURITY Unit IV-8

Note: For additional information on HAZUS-MH, refer the student to [www.HAZUS.org](http://www.HAZUS.org).

Another important resource is Geospatial One-Stop ([www.geo-one-stop.gov](http://www.geo-one-stop.gov)), a one-stop source of geospatial information from across the nation. Geospatial information allows decisions to be viewed in a community context (e.g., showing the geographic components of buildings, lifelines, hazards, etc.).

Google Earth is also a powerful tool for the novice to gather like information.

**Assessment GIS Portfolio**

A technique to organize required information is to develop an Assessment GIS Portfolio. The portfolio is designed to support vulnerability and risk assessments through identification of:

- Critical infrastructure
- Critical nodes within the surrounding area.
- Nearby functions, including emergency response

The data sets are a combination of commercial and government (FEMA – HAZUS-MH, USGS, state, and local data) imagery interpretation, as well as open source transportation, utility, flood plains, and political boundaries.

Portfolios are tailored to each individual site.

This slide displays a satellite image of the region with state boundaries delineated. This map provides a general overview for user's initial orientation to a site.

The next series of slides shows how GIS can be used in an outside-to-inside approach to support threat analysis and vulnerability assessments.

VISUAL IV-9

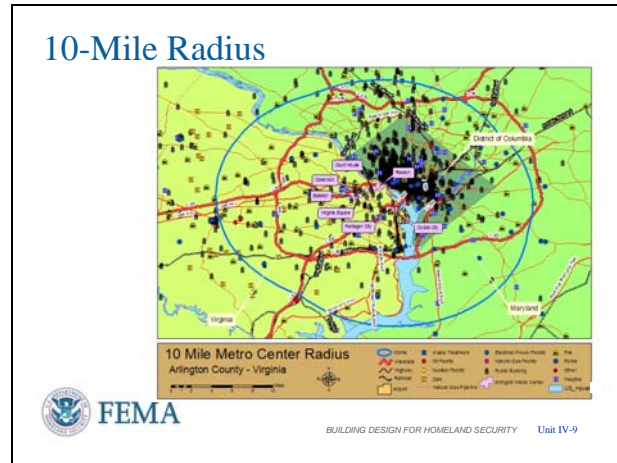

**10-Mile Radius**

This map displays infrastructure and features within a 10-mile radius that could have an impact on the site. Features mapped include utilities, major transportation networks, first responders, and government facilities.

VISUAL IV-10

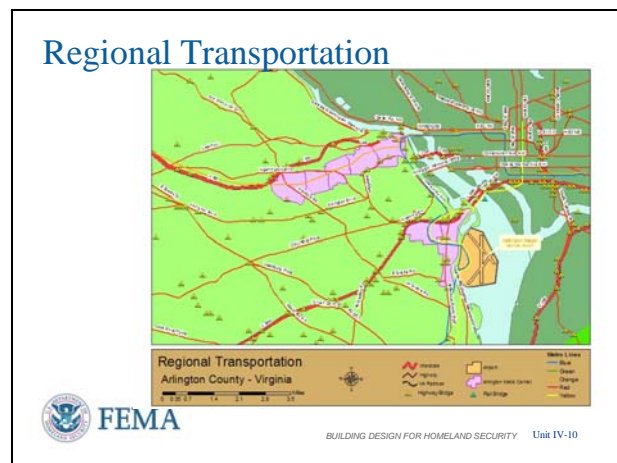

**Regional Transportation**

The regional transportation map can be used for planning evacuation routes and identifying single-point nodes such as bridges and tunnels.

VISUAL IV-11

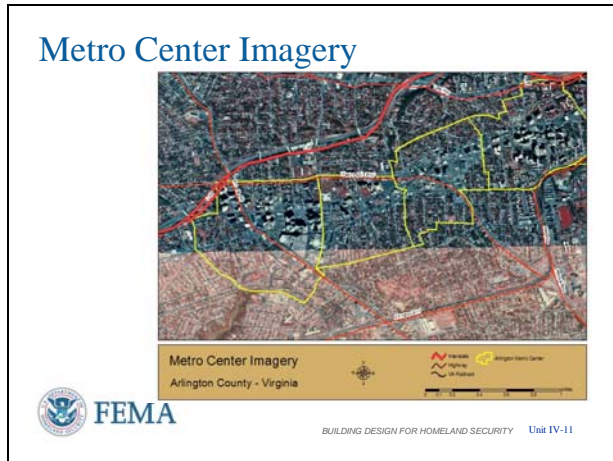

**Metro Center Imagery**

Satellite imagery of the region surrounding a site provides users an additional perspective to go with the data sets information. Commercial, industrial, and residential areas can easily be differentiated, as well as rural and urban areas. This map can be used for an overview of the surrounding area and for determining if collateral damage is a significant risk.

VISUAL IV-12

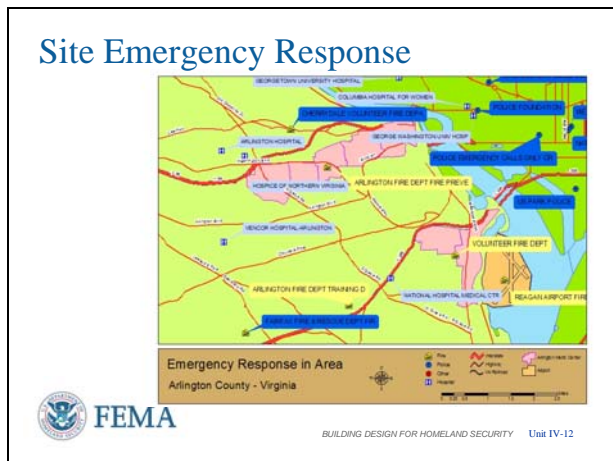

**Site Emergency Response**

This map displays first responders and hospitals near a site and can be used to estimate response times during an emergency.

VISUAL IV-13

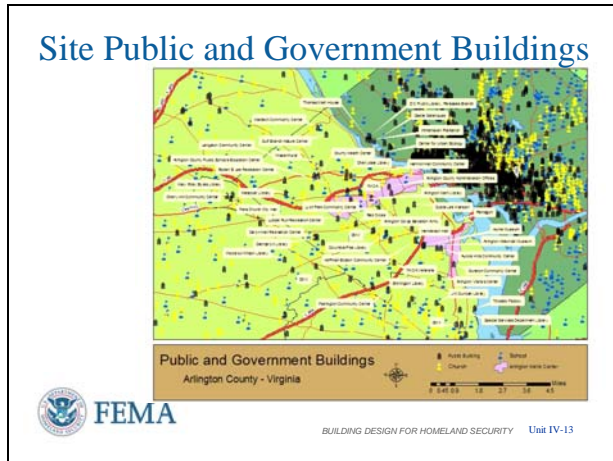

### Site Public/Government Buildings

This map shows the location of government and public buildings in the region, including government facilities, schools, and churches. Government buildings potentially could be the target of terrorist operations. Therefore, the possibility of collateral damage should be considered for sites in close proximity. Additionally, some churches and schools may be designated community shelters and resources during emergencies.

VISUAL IV-14

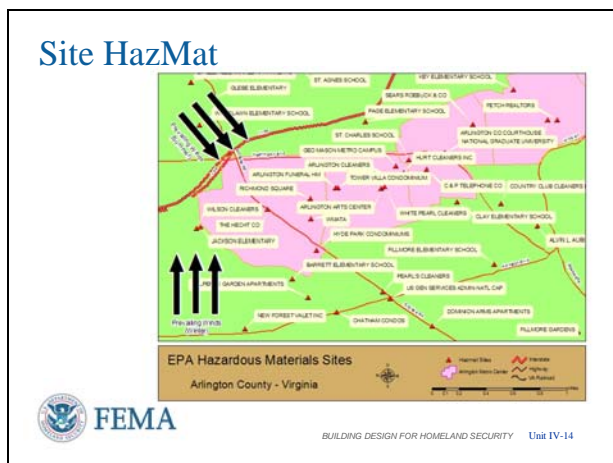

### Site HazMat

This map displays hazardous materials (HazMat) sites tracked by various EPA databases. They include large HazMat sites such as refineries and chemical plants, but also include smaller sites with small quantities of chemicals such as schools and dry cleaners. Some sites that contain very small amounts of HazMat are filtered out.

Prevailing wind direction from the National Oceanic and Atmospheric Administration (NOAA) Climatic Data Center is shown to help evaluate the vulnerabilities from surrounding hazards that can be used by a terrorist as a supplemental weapon.



VISUAL IV-15

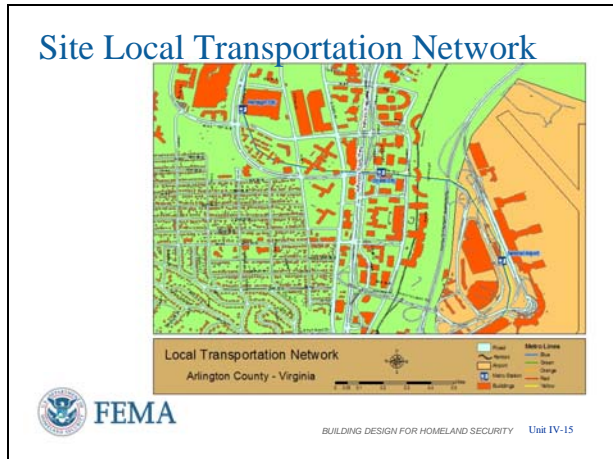

### Site Local Transportation Network

The local transportation map provides greater resolution of transportation routes in the local area surrounding a site.

It can be used for planning evacuation routes and alternate routes during for an emergency.

It also shows proximity to routes that do or could carry hazardous materials.

VISUAL IV-16

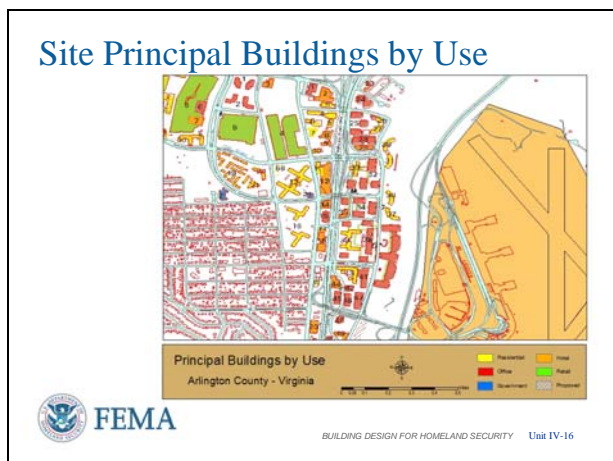

### Site Principal Buildings by Use

This map provides a quick overview of the primary use of principal buildings surrounding a site.

It is useful when conducting threat assessments to help identify potential surrounding terrorist targets and the likelihood of collateral damage.

VISUAL IV-17

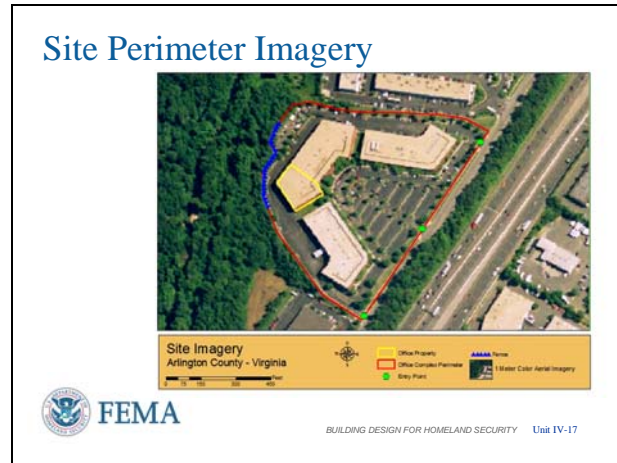

**Site Perimeter Imagery**

Site imagery gives a view of the site and allows assessors to analyze the layout of the site, including site entry points and building separation.

The imagery can also be integrated with building plans to provide important information for implementing mitigation measures and making other security decisions.

VISUAL IV-18

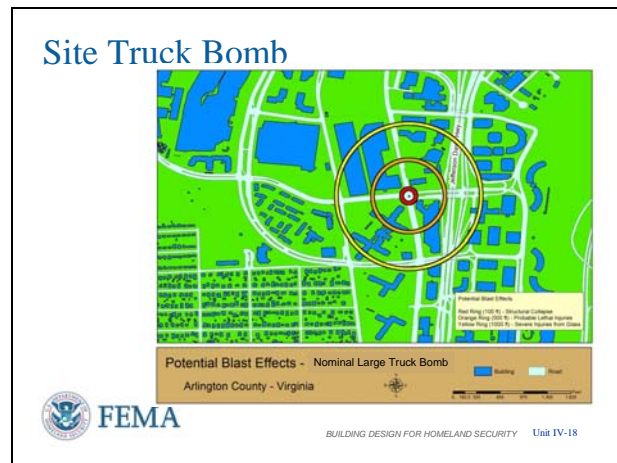

**Site Truck Bomb**

Displays the potential effects of a nominal truck bomb assuming a nominal building structure.

It is an estimation based on range-to-effects charts and is useful for analyzing vehicular flow and stand-off issues. The results of more accurate site-specific blast analysis can be used to replace the nominal estimations, especially for more accurate cost estimating of mitigation measures.

VISUAL IV-19

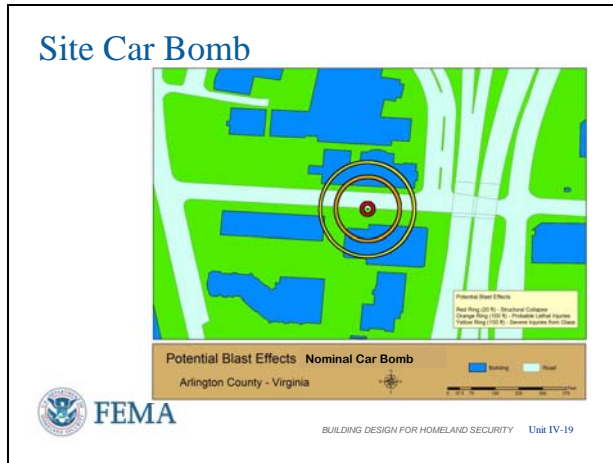

Site Car Bomb

This is an example of the potential blast effects associated with a nominal car bomb against a building with nominal construction.

Obviously, the effects of the car bomb are much less than those from a truck bomb.

VISUAL IV-20

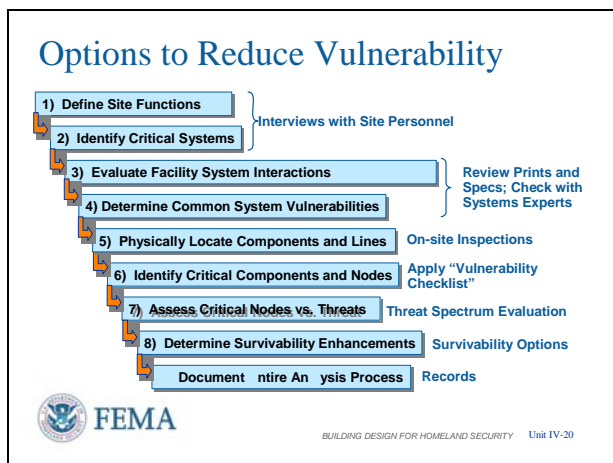

Options to Reduce Vulnerability

After identifying and collecting information on the site, the multidisciplinary team follows the nine steps listed here:

1. Define Site Functions
2. Identify Critical Systems
3. Evaluate Facility System Interactions
4. Determine Common System Vulnerabilities
5. Physically Locate Components and Lines
6. Identify Critical Components and Nodes
7. Assess Critical Nodes Versus Threats
8. Determine Survivability Enhancements (and Options) [Mitigation measures]
9. Document Entire Analysis Process [To avoid having to recreate it, but moreso to allow adjustments as threats change and as mitigation measures are implemented so as to track the current state if an attack should occur.]

This process is explained in more detail in FEMA 452. For this course, this is an overview of what a more detailed on-site assessment should accomplish.



VISUAL IV-21

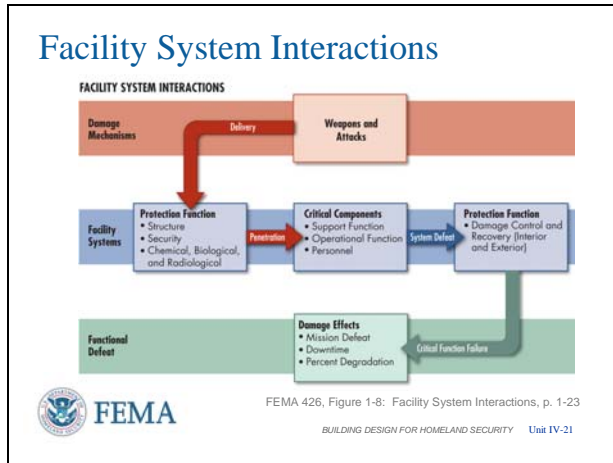

**Facility System Interactions**

Every building or facility can be attacked and damaged or destroyed as illustrated in the flow chart.

A terrorist selects the weapon and tactic that will destroy the building or infrastructure target.

At a site with multiple buildings, **Tables 1-5 through 1-17 in FEMA 426** can be used to rank order these buildings and thus to determine which buildings require more in-depth analysis.

VISUAL IV-22

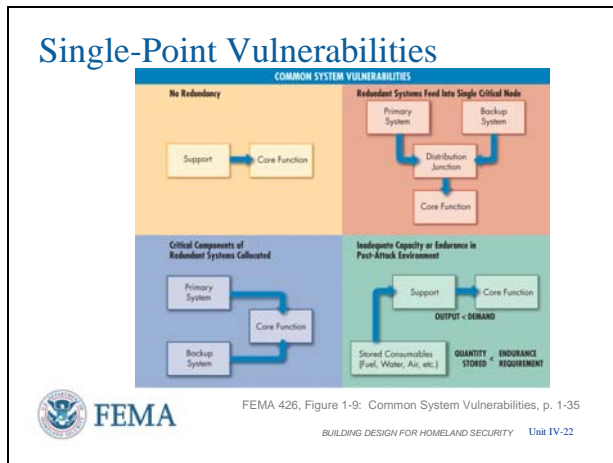

**Single-Point Vulnerabilities (SPVs)**

The function and infrastructure analysis will identify the geographic distribution within the building and interdependencies between critical assets. Ideally, the functions should have geographic dispersion as well as a recovery site or alternate work location. However, some critical building functions and infrastructure do not have a backup, or will be found collocated. This design creates what is called a Single-Point Vulnerability.

Identification and protection of these Single-Point Vulnerabilities is a key aspect of the assessment process.

**Exam Questions #A4 and B3**

Single-Point Vulnerabilities are critical functions or systems that lack redundancy and, if damaged by an attack, would result in immediate organization disruption or loss of capability.

This chart provides examples of this concept:

1. No Redundancy
2. Redundant Systems Feed Into Single Critical Node
3. Critical Components of Redundant Systems Collocated
4. Inadequate Capacity or Endurance in Post-Attack Environment

VISUAL IV-23

Functional Analysis SPVs



Standard 11	The loading dock and warehouse provide single point of entry to the interior
Standard 13 and 17	The mailroom is located within the interior and not on exterior wall or separate HVAC system
Standard 1	The telecom switch and computer data center are adjacent to the warehouse
Standard 1	The trash dumpster and emergency generator are located adjacent to the loading dock



FEMA 426, Figure 1-10: Non-Redundant Critical Functions Collocated Near Loading Dock, p. 1-41  
BUILDING DESIGN FOR HOMELAND SECURITY Unit IV-23

VISUAL IV-24

Infrastructure SPVs



Air Intakes



Drive Through



Electrical Service



Telecom Service



FEMA 426, Figure 1-11: Vulnerability Examples, p. 1-42  
BUILDING DESIGN FOR HOMELAND SECURITY Unit IV-24

Functional Analysis SPVs

There are both Functional Analysis SPVs and Infrastructure SPVs.

Functional Analysis SPVs are depicted in this chart. This figure shows an example of a building that has numerous critical functions and infrastructure collocated, which creates a single-point vulnerability.

Infrastructure Analysis SPVs

Typical infrastructure SPVs are depicted here:

- Air intakes at ground level
- Ground level drive through drop-off atrium with no anti-vehicle barrier
- Single primary electrical service
- Single telecom switch room in parking garage

Many commercial buildings have collocated electrical, mechanical, and telecom rooms that share a common central distribution core or chase.

VISUAL IV-25

**Building Vulnerability Assessment Checklist**

- Compiles best practices from many sources
- Includes questions that determine if critical systems will continue to function during an emergency or threat event
- Organized into 13 sections
  - Each section should be assigned to a knowledgeable individual
  - Results of all sections should be integrated into a master vulnerability assessment
  - Compatible with CSI Master Format standard to facilitate cost estimates



BUILDING DESIGN FOR HOMELAND SECURITY Unit IV-25

The **Building Vulnerability Assessment Checklist** is based on a checklist developed by the Department of Veterans Affairs (VA). The checklist can be used as a screening tool for preliminary design vulnerability assessment. In addition to examining design issues that affect vulnerability, the checklist includes questions that determine if critical systems continue to function in order to enhance deterrence, detection, denial, and damage limitation, and to ensure that emergency systems function during and after a threat or hazard situation.

**Building Vulnerability Assessment Checklist**

**FEMA 426** provides the **Building Vulnerability Assessment Checklist (Table 1-22, pages 1-46 to 1-93)**, which compiles many best practices based on technologies and scientific research to consider during the design of a new building or renovation of an existing building.

This helps guide the multidisciplinary team through the vulnerability analysis. It allows a consistent security evaluation of designs at various levels, whether accomplished as owner/user or in-depth with technical experts.

The assessment checklist has been used by experienced engineers who were not experienced vulnerability assessors. These engineers commented that although the checklist seemed laborious at first, when they finished assessing multiple sites across the country they felt very confident that they had identified the vulnerabilities and had provided solid recommendations for mitigation measures.

The CSI (Construction Specification Institute) format has other advantages that designers and engineers can develop detailed specifications that communicate requirements to building contractors..

VISUAL IV-26

Building Vulnerability Assessment Checklist

- |                                   |                                      |
|-----------------------------------|--------------------------------------|
| Site                              | Electrical Systems                   |
| Architectural                     | Fire Alarm Systems                   |
| Structural Systems                | Communications and IT Systems        |
| Building Envelope                 | Equipment Operations and Maintenance |
| Utility Systems                   | Security Systems                     |
| Mechanical Systems (HVAC and CBR) | Security Master Plan                 |
| Plumbing and Gas Systems          |                                      |



BUILDING DESIGN FOR HOMELAND SECURITY Unit IV-26

**Building Vulnerability Assessment Checklist (Table 1-22, pages 1-46 to 1-93, of FEMA 426)**

Each section of the checklist can be assigned to an engineer, architect, or subject matter expert who is knowledgeable and qualified to perform an assessment of the assigned area in order to perform a detailed assessment.

As stated before, an initial assessment can be performed by craftsmen and other knowledgeable people that may provide the decision maker all that is necessary or indicate more expertise is needed in specific areas.

**Building Vulnerability Assessment Checklist (Table 1-22, pages 1-46 to 1-93, of FEMA 426)**

Each assessor should consider the questions and guidance provided to help identify vulnerabilities and document results in the observations column. Not all possible questions are in the checklist, but it provides a good basis to guide the assessment.

VISUAL IV-27

Building Vulnerability Assessment Checklist

Vulnerability Question	Guidance	Observations
<b>6 Mechanical Systems (HVAC and CBR)</b>		
<b>6.1</b> Where are the air intakes and exhaust louvers for the building? (low, high, or midpoint of the building structure)  Are the intakes and exhausts accessible to the public?	Air intakes should be located on the roof or as high as possible. Otherwise secure with CPIED-compliant fencing or enclosure. The fencing or enclosure should have a sloped roof to prevent throwing anything into the enclosure near the intakes.  Ref: CDC/NIOSH Pub 2002-139	
<b>6.2</b> Is roof access limited to authorized personnel by means of locking mechanisms?  Is access to mechanical areas similarly controlled?	Roofs are like entrances to the building and are like mechanical rooms when HVAC is installed. Adjacent structures or landscaping should not allow access to the roof.  Ref: GSA PBS -P100, CDC/NIOSH Pub 2002-139, and LBNL Pub 51959	



FEMA 426, Adapted from Table 1-22: Building Vulnerability Assessment Checklist, p. 1-46 to 1-92  
 BUILDING DESIGN FOR HOMELAND SECURITY Unit IV-27

VISUAL IV-28

### Building Vulnerability Assessment Checklist



1.15	Is there minimum setback distance between the building and parked cars?
4.1	What is the designed or estimated protection level of the exterior walls against the postulated explosive threat?
4.2	Is the window system design on the exterior façade balanced to mitigate the hazardous effects of flying glazing following an explosive event? (glazing, frames, anchorage to supporting walls, etc.)?



FEMA 426, Adapted from Table 1-22: Building Vulnerability Assessment Checklist, p. 1-46 to 1-92  
BUILDING DESIGN FOR HOMELAND SECURITY Unit IV-28

**Building Vulnerability Assessment Checklist (Table 1-22, pages 1-46 to 1-93, of FEMA 426)**

Notice that the checklist leads assessment team members to see the same critical functions or infrastructure from different perspectives.

For example, here a parking lot is analyzed by questions from both the site and building envelope sections. (Sections 1 and 4)

This cross analysis is one of the strengths of the methodology.

VISUAL IV-29

### Building Vulnerability Assessment Checklist



2.19	Are loading docks and receiving and shipping areas separated in any direction from utility rooms, utility mains, and service entrances, including electrical, telephone/data, fire detection/alarm systems, fire suppression water mains, cooling and heating mains, etc.?
1.16	Does adjacent surface parking on site maintain a minimum stand-off distance? For initial screening consider using 25 meters (82 feet) as a minimum with more distance needed for unreinforced masonry or wooden walls. Reference: GSA PBS-P100



FEMA 426, Adapted from Table 1-22: Building Vulnerability Assessment Checklist, p. 1-46 to 1-92  
BUILDING DESIGN FOR HOMELAND SECURITY Unit IV-29

**Building Vulnerability Assessment Checklist (Table 1-22, pages 1-46 to 1-93, of FEMA 426)**

In this example, the same function, a loading dock, is addressed by different sections (Sections 1 and 2 – Site and Architectural).

The location of the trash dumpster, building overhang, and exposed loading dock columns make this area susceptible to significant blast damage.

VISUAL IV-30

**Building Vulnerability Assessment Checklist**



6.1	Where are the air intakes and exhaust louvers for the building? (low, high, or midpoint of the building structure) Are the intakes and exhausts accessible to the public?
1.9	Is there any potential access to the site or building through utility paths or water runoff? (Eliminate potential site access through utility tunnels, corridors, manholes, storm water runoff culverts, etc. Ensure covers to these access points are secured.)
3.1	What type of construction? What type of concrete and reinforcing steel? What type of steel? What type of foundation?

 FEMA 426, Adapted from Table 1-22: Building Vulnerability Assessment Checklist, p. 1-46 to 1-92  
 BUILDING DESIGN FOR HOMELAND SECURITY Unit IV-30

**Building Vulnerability Assessment Checklist (Table 1-22, pages 1-46 to 1-93, of FEMA 426)**

In this example, the same feature, an air intake, is addressed by questions from three sections:

- #1 – Site
- #3 – Structural Systems
- #6 – Mechanical Systems

VISUAL IV-31

**Building Vulnerability Assessment Checklist**



5.19	By what means does the main telephone and data communications interface the site or building?
5.20	Are there multiple or redundant locations for the telephone and communication service? Does the fire alarm system require communication with external sources?
5.21	By what method is the alarm signal sent to the responding agency: telephone, radio, etc.? Is there an intermediary alarm monitoring center?

 FEMA 426, Adapted from Table 1-22: Building Vulnerability Assessment Checklist, p. 1-46 to 1-92  
 BUILDING DESIGN FOR HOMELAND SECURITY Unit IV-31

**Building Vulnerability Assessment Checklist (Table 1-22, pages 1-46 to 1-93, of FEMA 426)**

Section 5 of the **Building Vulnerability Assessment Checklist** addresses Utility Systems.

Utility systems are normally that portion of utilities that is outside the building. However, the demark (demarcation line) can be just inside the building. Up to this point is the responsibility of the utility company. After the demark is part of the building and is handled by other sections in the Building Vulnerability Assessment Checklist.

VISUAL IV-32

**Vulnerability Rating**

Criteria		
Very High	10	Very High – One or more major weaknesses have been identified that make the asset extremely susceptible to an aggressor or hazard. The building lacks redundancies/physical protection and the entire building would be only functional again after a very long period of time after the attack.
High	8-9	High – One or more major weaknesses have been identified that make the asset highly susceptible to an aggressor or hazard. The building has poor redundancies/physical protection and most parts of the building would be only functional again after a long period of time after the attack.
Medium High	7	Medium High – An important weakness has been identified that makes the asset very susceptible to an aggressor or hazard. The building has inadequate redundancies/physical protection and most critical functions would be only operational again after a long period of time after the attack.

**Key elements**

- Number of weaknesses
- Aggressor potential accessibility
- Level of redundancies /physical protection
- Time frame for building to become operational again

FEMA 452, Table 3-4: Vulnerability Rating, p. 3-16  
BUILDING DESIGN FOR HOMELAND SECURITY Unit IV-32

**Vulnerability Rating (1/2)**

The results of the 13 assessment sections should be integrated into a master vulnerability assessment in order to provide the basis for determining vulnerability rating numeric values.

In the rating scale of 1 to 10, a rating of 10 means one or more major weaknesses exist to make an asset extremely susceptible to an aggressor’s tactics.

- **Very High** – One or more major weaknesses have been identified that make the asset extremely susceptible to an aggressor or hazard. The building lacks redundancies/physical protection and will not be functional again after an attack.
- **High** – One or more significant weaknesses have been identified that make the asset highly susceptible to an aggressor or hazard. The building has poor redundancies/physical protection and most parts of the building will not be operational until 1 year after an attack.
- **Medium High** – An important weakness has been identified that makes the asset very susceptible to an aggressor or hazard. The building has inadequate redundancies/physical protection and some critical functions will not be operational until 9 months after an attack.



VISUAL IV-33

**Vulnerability Rating** (continued)

Criteria		
Medium	5-6	Medium – A weakness has been identified that makes the asset fairly susceptible to an aggressor or hazard. The building has insufficient redundancies/physical protection and most part of the building would be only functional again after a considerable period of time after the attack.
Medium Low	4	Medium Low – A weakness has been identified that makes the asset somewhat susceptible to an aggressor or hazard. The building has incorporated a fair level of redundancies/physical protection and most critical functions would be only operational again after a considerable period of time after the attack.
Low	2-3	Low – A minor weakness has been identified that slightly increases the susceptibility of the asset to an aggressor or hazard. The building has incorporated a good level of redundancies/physical protection and the building would be operational within a short period of time after an attack.
Very Low	1	Very Low – No weaknesses exist. The building has incorporated excellent redundancies/physical protection and the building would be operational immediately after an attack.

**Key elements**

- Number of weaknesses
- Aggressor potential accessibility
- Level of redundancies /physical protection
- Time frame for building to become operational again

FEMA 452, Table 3-4: Vulnerability Rating, p. 3-16  
BUILDING DESIGN FOR HOMELAND SECURITY Unit IV-33



**Vulnerability Rating (2/2)**

On the other end of the vulnerability rating scale is the rating of 1 which means very low and no weaknesses exist.

- **Medium** – A weakness has been identified that makes the asset fairly susceptible to an aggressor or hazard. The building has insufficient redundancies/physical protection and some critical functions will not be operational until 6 months after an attack.
- **Medium Low** – A weakness has been identified that makes the asset somewhat susceptible to an aggressor or hazard. The building has incorporated a fair level of redundancies/physical protection and the building will be operational 3 months after an attack.
- **Low** – A minor weakness has been identified that slightly increases the susceptibility of the asset to an aggressor or hazard. The building has incorporated good redundancies/physical protection and will be operational a few weeks after an attack.
- **Very Low** – No weaknesses exist. The building has incorporated excellent redundancies/physical protection and will be operational immediately after an attack.



VISUAL IV-34

**Critical Functions**

Function	Cyber attack	Armed attack (single gunman)	Vehicle bomb	CBR attack
<b>Administration</b>				
Asset Value	5	5	5	5
Threat Rating	8	4	3	2
Vulnerability Rating	7	7	9	9
<b>Engineering</b>				
Asset Value	8	8	8	8
Threat Rating	8	5	6	2
Vulnerability Rating	2	4	8	9

 FEMA 426, Adaptation of Table 1-20: Site Functional Pre-Assessment Screening Matrix, p. 1-38  
BUILDING DESIGN FOR HOMELAND SECURITY Unit IV-34

The Vulnerability Rating is subjective and the assessor has to take into account how well the asset is protected against that threat, if redundancy is in place, and the effect of the tactics and weapons against the asset as it currently exists.

VISUAL IV-35

**Critical Infrastructure**

Infrastructure	Cyber attack	Armed attack (single gunman)	Vehicle bomb	CBR attack
<b>Site</b>				
Asset Value	4	4	4	4
Threat Rating	4	4	3	2
Vulnerability Rating	1	7	9	9
<b>Structural Systems</b>				
Asset Value	8	8	8	8
Threat Rating	3	4	3	2
Vulnerability Rating	1	1	8	1

 FEMA 426, Adaptation of Table 1-21: Site Infrastructure Systems Pre-Assessment Screening Matrix, p. 1-39  
BUILDING DESIGN FOR HOMELAND SECURITY Unit IV-35

**Critical Functions Matrix**

The Vulnerability Rating is entered into the same Critical Functions that we saw in Units II and III.

The Vulnerability Ratings under the Administration Function and under the Engineering Function are highlighted.

Since vulnerability is a measure of the success and effects of employing a threat against asset, the vulnerability varies based upon location, hardening, ability to use the tactic, redundancy, etc.

A medium-high (7) and high (9) Vulnerability Rating was assigned to the Administration Function threat pairs to illustrate an exposed function near exterior walls and entrances.

A range of ratings was assigned for the Engineering Function threat pairs to illustrate a function that is typically in the interior core, but shares common HVAC systems and is likely within a blast damage zone based upon the potential weapon size.

**Critical Infrastructure Matrix**

The Vulnerability Rating is entered into the same Critical Infrastructure Matrix that we saw in Units II and III.

The Vulnerability Ratings under the Site and Structural Systems are highlighted.

NOTE: It is easier to keep the threat in mind and move between assets to assess vulnerability than it is to keep the asset in mind and move between threats.

Cyber Attack: Rating of 1 for both.

**INSTRUCTOR NOTES**

**CONTENT/ACTIVITY**

- Site: Rating of 1 as no internet connected system in place, like a perimeter access control system, or connection to other accessible media (phone lines).
- Structural: Rating of 1 as no electronic systems at all, but could have an active damping system for earthquake or high winds that is accessible over the internet which would give it a rating higher than 1

Armed Attack:

- Site: Rating of 7 as it is fairly open but with some obscuration, many manned windows overlooking the parking lots, CCTV coverage, and roving patrols at variable times
- Structural: Rating of 1 as this tactic would have no impact upon the structural members

Vehicle Bomb

- Site: Rating of 9 as a vehicle bomb would cause extensive destruction to site and hinder operations for extended time due to limited access and blowing debris damage to buildings
- Structural: Rating of 8 as building is a high-rise and not designed for progressive collapse, but stand-off provides some level of protection.

CBR Attack

- Site: Rating of 8, because depending upon agent used the access to site could be restricted from hours to years or until decontamination is complete, which would not be a speedy process
- Structural: Rating of 1 as agent would not restrict structural system in any fashion in performance of its engineered design

VISUAL IV-36

**Summary**

Step-by-Step Analysis Process:

- Expertly performed by experienced personnel
- Determines critical systems
- Identifies vulnerabilities
- Focuses survivability mitigation measures on critical areas
- Essential component of Critical Infrastructure and Critical Function Matrices



BUILDING DESIGN FOR HOMELAND SECURITY Unit IV-36

**Summary**

- Expertise and experience as required for the level of assessment and the criticality of the building
- Dig deeper in identifying Critical Functions and Critical Infrastructure as the systems interfaces are better understood
- Apply understanding of threats as they interact with assets to identify vulnerabilities and understand benefit of selected mitigation measures
- Apply vulnerability ratings to the Critical Functions and the Critical Infrastructure Matrices based upon how that threat can interact and impact that asset.

VISUAL IV-36

**Unit IV Case Study Activity**

**Vulnerability Rating**

**Background**

**Vulnerability:** any weakness that can be exploited by an aggressor or, in a non-terrorist threat environment, make an asset susceptible to hazard damage

**Requirements: Vulnerability Rating Approach**

Use rating scale of 1 (very low or no weakness) to 10 (one or major weaknesses)

Answer selected initial Vulnerability Assessment Checklist questions

Refer to Case Study and rate the vulnerability of asset-threat/hazard pairs:

- Critical Functions
- Critical Infrastructure



BUILDING DESIGN FOR HOMELAND SECURITY Unit IV-37

**Student Activity**

Vulnerability is any weakness that can be exploited by an aggressor or, in a non-terrorist threat environment, make an asset susceptible to hazard damage.

**Discussion Question**

What indicators do you look for to determine if any vulnerability exists in the building design?

**Suggested Responses:**

- *Critical functions or systems that lack redundancy and if damaged would result in immediate organization disruption or loss of capability (“Single-Point Vulnerability”).*
- *Redundant systems feeding into a single critical node.*
- *Critical components of redundant systems collocated.*
- *Inadequate capacity or endurance in post-attack environment.*

Refer students to the Unit IV Case Study activity in the Student Manual.

At the end of the working session (35 minutes), reconvene the class and facilitate group reporting (plenary group 10 minutes).

**Activity Requirements:**

- Working in small groups, answer the worksheet questions from the Building Vulnerability Assessment Checklist and record relevant observations regarding the building and site.
- Determine what, if any, vulnerability exists and provide an initial vulnerability rating for all asset-threat / hazard pairs in the Critical Functions and Critical Infrastructure Matrices.
- Transfer your team answers to the Risk Matrix poster.

Take 35 minutes to complete this part of the activity.

**Transition**

Unit V will cover Risk Assessment/Risk Management and complete instruction on the risk assessment process. Unit VI will present the FEMA 452 Risk Assessment database as an improvement over the manual process.

**UNIT IV-A CASE STUDY ACTIVITY:  
VULNERABILITY RATING  
(Suburban Version)**

Vulnerability is any weakness that can be exploited by an aggressor or, in a non-terrorist threat environment, make an asset susceptible to hazard damage. Vulnerabilities may include:

- Critical functions or systems that lack redundancy and if damaged would result in immediate organization disruption or loss of capability (“Single-Point Vulnerability”)
- Redundant systems feeding into a single critical node
- Critical components of redundant systems collocated
- Inadequate capacity or endurance in post-attack environment

Vulnerability rating requires identifying and rating the vulnerability of each asset-threat/hazard pair of interest. In-depth vulnerability assessment of a building evaluates specific design and architectural features and identifies all vulnerabilities of the building functions and building systems.

**Requirements**

For an example of how a specific asset is assessed, answer the following questions and record relevant observations on the following table regarding the HIC site and building. Determine what, if any, vulnerability exists:

Section	Vulnerability Question	Guidance	Observations
1.16	Does adjacent surface parking on site maintain a minimum stand-off distance?	<p>The specific stand-off distance needed is based upon the design basis threat bomb size and the building construction. For initial screening, consider using 25 meters (82 feet) as a minimum, with more distance needed for unreinforced masonry or wooden walls.</p> <p>Reference: GSA PBS-100</p>	<p><i>There is no adjacent parking per se, but there is one parking lot or area that any tenant or visitor to the office park can use. Stand-off distance to the front parking lot is less than the 82 feet screening value. Cars or trucks can drive up to the loading dock in the rear.</i></p>

Section	Vulnerability Question	Guidance	Observations
1.19	Do site landscaping and street furniture provide hiding places?	<p>Minimize concealment opportunities by keeping landscape plantings (hedges, shrubbery, and large plants with heavy ground cover) and street furniture (bus shelters, benches, trash receptacles, mailboxes, newspaper vending machines) away from the building to permit observation of intruders and prevent hiding of packages.</p> <p>If mail or express boxes are used, the size of the openings should be restricted to prohibit the insertion of packages.</p> <p>Reference: <i>GSA PBS-100</i></p>	<p>There is no street furniture shown for this building. The landscaping shown is grass and trees are mature/tall enough so that a package cannot be hidden at the base. The hedge along the building drip line may conceal a package, if allowed to get taller or denser. There is no mail or express box and there is no slot in the glass main entrance door. Due to the size of the building columns, a package could be overlooked.</p>
2.15	<p>Are critical assets (people, activities, building systems and components) located close to any main entrance, vehicle circulation, parking, maintenance area, loading dock, or interior parking?</p> <p>Are the critical building systems and components hardened?</p>	<p>Critical building components include: Emergency generator, including fuel systems, day tank, fire sprinkler, and water supply; Normal fuel storage; Main switchgear; Telephone distribution and main switchgear; Fire pumps; Building control centers; Uninterruptible power supply (UPS) systems controlling critical functions; Main refrigeration and ventilation systems if critical to building operation; Elevator machinery and controls; Shafts for stairs, elevators, and utilities; Critical distribution feeders for emergency power. Evacuation and rescue require emergency systems to remain operational during a disaster and they should be located away from attack locations. Primary and backup systems should be separated to reduce the risk of both being impacted by a single incident if collocated. Utility systems should be located at least 50 feet from loading docks, front entrances, and parking areas.</p> <p>One way to harden critical building systems and</p>	<p>This building is not large enough to maintain separation distances. Attack from the front of the building could primarily impact office space. Attack from the rear would affect critical utilities and, through the loading dock area, the heart of the company – the computer center. No critical components are hardened as seen by the natural gas and electric service to the building. The UPS, mechanical and electrical room, and the diesel generator could be affected by a single bomb less than 50 feet from all these areas or taken out by a single wayward truck.</p>

Section	Vulnerability Question	Guidance	Observations
		<p>components is to enclose them within hardened walls, floors, and ceilings. Do not place them near high-risk areas where they can receive collateral damage.</p> <p>Reference: <i>GSA PBS-100</i></p>	
2.16	<p>Are high value or critical assets located as far into the interior of the building as possible and separated from the public areas of the building?</p>	<p>Critical assets, such as people and activities, are more vulnerable to hazards when on an exterior building wall or adjacent to uncontrolled public areas inside the building.</p> <p>Reference: <i>GSA PBS-100</i></p>	<p>People are located along the exterior wall at the front of the building. The secure space has the best interior space location – not on an exterior wall, as does the conference room. The office space acts as the buffer between the critical functions in the back and the public area of the building at the main entrance.</p>
4.2	<p>Is there less than 40 percent fenestration openings per structural bay?</p> <p>Is the window system design on the exterior façade balanced to mitigate the hazardous effects of flying glazing following an explosive event? (glazing, frames, anchorage to supporting walls, etc.)</p>	<p>The performance of the glass will similarly depend on the materials. Glazing may be single pane or double pane, monolithic or laminated, annealed, heat strengthened, or fully tempered.</p> <p>The percent fenestration is a balance between protection level, cost, the architectural look of the building within its surroundings, and building codes. One goal is to keep fenestration to below 40 percent of the building envelope vertical surface area, but the process must balance differing requirements. A blast engineer may prefer no windows; an architect may favor window curtain walls; building codes require so much fenestration per square footage of floor area; fire codes require a prescribed window opening area if the window is a designated escape route; and the building owner has cost concerns.</p> <p>Ideally, an owner would want 100 percent of the glazed area to provide the design protection level against the postulated explosive threat (design basis threat – weapon size at the</p>	<p>Windows are only used in the office space area of the building. Although dimensions are not given, it looks like the glass is at least 75 percent of the wall area between building structural columns. The window system is a standard commercial installation and thus, the glass, framing, and anchorage are expected to be insufficient for the design basis threat at the available stand-off. One benefit is that there are windows only on two sides of the building.</p>

**Course Title: Building Design for Homeland Security**

Unit IV-A: Vulnerability Assessment

---

<b>Section</b>	<b>Vulnerability Question</b>	<b>Guidance</b>	<b>Observations</b>
		<p>expected stand-off distance). However, economics and geometry may allow 80 percent to 90 percent due to the statistical differences in the manufacturing process for glass or the angle of incidence of the blast wave upon upper story windows (4th floor and higher).</p> <p>Reference: <i>GSA PBS-100</i></p>	



### HIC Critical Functions Vulnerability Rating

#### Requirements

Refer to the HIC Case Study and rate the vulnerability of the following asset-threat/hazard pairs of interest.

Function	Cyber Attack	Armed Attack	Vehicle Bomb	CBR Attack
1. Administration	4	8	8	6
2. Engineering/IT Technicians	4	6	8	6
3. Loading Dock/Warehouse	2	8	8	6
4. Data Center	3	4	8	6
5. Communications	3	4	8	6
6. Security	4	8	8	6
7. Housekeeping	2	2	8	6

### HIC Critical Infrastructure Vulnerability Rating

#### Requirements

Refer to the HIC Case Study and rate the vulnerability of the following asset-threat/hazard pairs of interest.

Infrastructure	Cyber Attack	Armed Attack	Vehicle Bomb	CBR Attack
1. Site	1	8	8	6
2. Architectural	1	8	8	1
3. Structural Systems	1	8	8	1
4. Envelope Systems	1	8	8	1
5. Utility Systems	5	7	6	1

**Course Title: Building Design for Homeland Security**

Unit IV-A: Vulnerability Assessment

---

6. Mechanical Systems	5	7	8	7
7. Plumbing and Gas Systems	1	3	8	1
8. Electrical Systems	5	7	8	5
9. Fire Alarm Systems	2	3	8	3
10. IT/Communications Systems	7	4	8	6

**UNIT IV-B CASE STUDY ACTIVITY:  
VULNERABILITY RATING  
(Urban Version)**

Vulnerability is any weakness that can be exploited by an aggressor or, in a non-terrorist threat environment, make an asset susceptible to hazard damage. Vulnerabilities may include:

- Critical functions or systems that lack redundancy and if damaged would result in immediate organization disruption or loss of capability (“Single-Point Vulnerability”)
- Redundant systems feeding into a single critical node
- Critical components of redundant systems collocated
- Inadequate capacity or endurance in post-attack environment

Vulnerability rating requires identifying and rating the vulnerability of each asset-threat/hazard pair of interest. An in-depth vulnerability assessment of a building evaluates specific design and architectural features and identifies all vulnerabilities of the building functions and infrastructure systems.

**Requirements**

1. Answer the following Building Vulnerability Checklist Questions and record relevant observations in the table regarding the HZC site and building information from the Appendix B Case Study. Determine if the observation indicates that any vulnerabilities exist:
2. Complete the tables for HZC Critical Functions Vulnerability Rating and HZC Critical Infrastructure Vulnerability Rating by filling in the initial vulnerability rating for the asset-threat/hazard pairs.
3. Transfer the vulnerability ratings to the Risk Matrix poster after reaching team consensus on the team answer.

Section	Vulnerability Question	Guidance	Observations
1.16	Does adjacent surface parking on site maintain a minimum stand-off distance?	The specific stand-off distance needed is based upon the design basis threat bomb size and the building construction. For initial screening, consider using 25 meters (82 feet) as a minimum, with more distance needed for unreinforced masonry or wooden walls.  Reference: GSA PBS-100	<i>On the east side of the plaza is a drop off zone where no parking is allowed and building stand-off is 80 feet. On the north and west sides of the building for the whole building block, parking is restricted to government vehicles only with designated parking spaces. Double parking next to the government vehicles provides 15 feet of stand-off on the north side and 10 feet of stand-off on the west.</i>

Section	Vulnerability Question	Guidance	Observations
			<p><i>Commercial parking is allowed on the south side in support of the Loading Dock and stand-off is 10 feet.</i></p>
1.19	<p>Do site landscaping and street furniture provide hiding places?</p>	<p>Minimize concealment opportunities by keeping landscape plantings (hedges, shrubbery, and large plants with heavy ground cover) and street furniture (bus shelters, benches, trash receptacles, mailboxes, newspaper vending machines) away from the building to permit observation of intruders and prevent hiding of packages.</p> <p>If mail or express boxes are used, the size of the openings should be restricted to prohibit the insertion of packages.</p> <p>Reference: <i>GSA PBS-100</i></p>	<p>There is no site landscaping or street furniture shown for this building, although the plaza on the east side would be suitable for planters and benches to establish and maintain stand-off.</p>
2.15	<p>Are critical assets (people, activities, building systems and components) located close to any main entrance, vehicle circulation, parking, maintenance area, loading dock, or interior parking?</p> <p>Are the critical building systems and components hardened?</p>	<p>Critical building components include: Emergency generator, including fuel systems, day tank, fire sprinkler, and water supply; Normal fuel storage; Main switchgear; Telephone distribution and main switchgear; Fire pumps; Building control centers; Uninterruptible power supply (UPS) systems controlling critical functions; Main refrigeration and ventilation systems if critical to building operation; Elevator machinery and controls; Shafts for stairs, elevators, and utilities; Critical distribution feeders for emergency power. Evacuation and rescue require emergency systems to remain operational during a disaster and they should be located away from attack locations. Primary and backup systems should be separated to reduce the risk of both being impacted by a single incident if collocated. Utility systems should be located at least 50 feet from loading docks, front</p>	<p>The building administration and electrical utilities are located on the first floor near the street and the entrance to underground parking. Utilities enter the site underground and transit the underground parking levels before reaching the vertical risers and proceeding to the mechanical floors, which start on the 4<sup>th</sup> floor. This provides much protection for utilities and backup generators by keeping them well above street level. There is one fuel tank underneath the loading dock. The building core places most critical assets toward the interior of the building with the exception of that above, with elevators and stairs having slightly less than 50 foot separation distance from the loading dock.</p> <p>No critical building systems or components are specifically hardened.</p>

Section	Vulnerability Question	Guidance	Observations
		<p>entrances, and parking areas.</p> <p>One way to harden critical building systems and components is to enclose them within hardened walls, floors, and ceilings. Do not place them near high-risk areas where they can receive collateral damage.</p> <p>Reference: <i>GSA PBS-100</i></p>	
2.16	<p>Are high value or critical assets located as far into the interior of the building as possible and separated from the public areas of the building?</p>	<p>Critical assets, such as people and activities, are more vulnerable to hazards when on an exterior building wall or adjacent to uncontrolled public areas inside the building.</p> <p>Reference: <i>GSA PBS-100</i></p>	<p>Tenants occupy floors six and higher which removes them from the primary uncontrolled public areas on the first through third floors. However, many tenants require uncontrolled public access to transact business. Except for building administration and electrical utilities, no critical assets are near an outside wall on the first three floors. However, the underground parking is open to the public and all utilities transit the underground parking levels.</p>
4.2	<p>Are there less than 40 percent fenestration openings per structural bay?</p> <p>Is the window system design on the exterior façade balanced to mitigate the hazardous effects of flying glazing following an explosive event? (glazing, frames, anchorage to supporting walls, etc.)</p>	<p>The performance of the glass will similarly depend on the materials. Glazing may be single pane or double pane, monolithic or laminated, annealed, heat strengthened, or fully tempered.</p> <p>The percent fenestration is a balance between protection level, cost, the architectural look of the building within its surroundings, and building codes. One goal is to keep fenestration to below 40 percent of the building envelope vertical surface area, but the process must balance differing requirements. A blast engineer may prefer no windows; an architect may favor window curtain walls; building codes require so much fenestration per square footage of floor area; fire codes require a prescribed</p>	<p>The building uses window curtain walls for its exterior envelope which places the fenestration (windows) at close to 100 percent. Some of the windows are spandrel elements (not used for vision, but cover structural members or mechanical floors where vision is not desired).</p> <p>The glass has varying thickness and strength with safety levels provided at street level to avoid injury to pedestrian traffic and strength increasing with elevation due to wind loading requirements.</p>

Section	Vulnerability Question	Guidance	Observations
		<p>window opening area if the window is a designated escape route; and the building owner has cost concerns.</p> <p>Ideally, an owner would want 100 percent of the glazed area to provide the design protection level against the postulated explosive threat (design basis threat – weapon size at the expected stand-off distance). However, economics and geometry may allow 80 percent to 90 percent due to the statistical differences in the manufacturing process for glass or the angle of incidence of the blast wave upon upper story windows (4th floor and higher).</p> <p>Reference: <i>GSA PBS-100</i></p>	

## HZC Critical Functions Vulnerability Rating

### Requirements

Refer to the Appendix B Case Study and rate the vulnerability of the following asset-threat/hazard pairs of interest. Transfer vulnerability ratings to the Threat Matrix and achieve team consensus on the answers.

Function	Cyber Attack	Armed Attack	Vehicle Bomb	CBR Attack
1. Administration	5	6	10	6
2. Engineering / IT Technicians	3	3	9	5
3. Loading Dock / Warehouse	2	6	10	7
4. Data Center	7	3	10	5
5. Communications	7	3	10	5
6. Security	7	7	10	7
7. Housekeeping	1	2	8	5

Cyber Attack is based upon the level of interaction the function has with the internet. Thus, the Loading Dock and Housekeeping have very little, whereas the Data Center, Communications, and Security are all co-located and have various internet connections. Engineering/IT Technicians is more the building operations and maintenance personnel whose systems are normally stand-alone or that allow access from home through passwords and firewalls to monitor and adjust parameters of concern.

Armed Attack is based upon target value, location, and accessibility. Thus, Administration and Loading Dock are relatively high, along with Security which is readily identified. Engineering is normally throughout the building in a random manner and behind locked doors on mechanical floors. Communications and Data Center are behind another layer of protection within the Administration area on the first floor, thus, are less vulnerable than Administration as a whole. Building Management offices are also located in the public access area of the third floor, which increases their vulnerability.

Vehicle Bomb demonstrates the indiscriminate nature of this tactic which has a global effect on the building. Engineering and housekeeping are less vulnerable as they are further from the vehicle bomb, either by location or time of day (housekeeping normally would do their work

before or after business hours on the first three floors for example, as well as in offices on upper floors).

CBR Attack is also a global effect upon the building, with variation based upon location within the building, time of day, and layers of protection available for an external release.

### HZC Critical Infrastructure Vulnerability Rating

#### Requirements

Refer to the Appendix B Case Study and rate the vulnerability of the following asset-threat/hazard pairs of interest. Transfer vulnerability ratings to the Threat Matrix and achieve team consensus on the answers.

Infrastructure	Cyber Attack	Armed Attack	Vehicle Bomb	CBR Attack
1. Site	2	5	9	7
2. Architectural	1	5	10	5
3. Structural Systems	1	1	10	1
4. Envelope Systems	1	6	10	1
5. Utility Systems	5	1	8	1
6. Mechanical Systems	4	2	7	7
7. Plumbing and Gas Systems	4	1	7	3
8. Electrical Systems	4	3	9	3
9. Fire Alarm Systems	4	1	7	2
10. IT / Communications Systems	9	2	10	3

Cyber Attack is based upon connectivity to the internet. The Site has some access control and security systems that increase its vulnerability. Architectural, Structural Systems, and Envelope Systems have no internet connectivity. Utility Systems coming to the site are controlled by their respective companies and have more points of attack than the HZC building. Internal building



utility systems have various levels of computer controls and access to internet. Finally, IT/Communications Systems have the greatest connectivity, and, thus, the greatest vulnerability.

Armed Attack follows the same logic as critical functions, except that damage to the infrastructure by an armed attack has a greater consideration. Accessibility to the Site as a whole, layout of functions with public access under Architectural, and the fragility of the Envelope Systems to a projectile all receive higher vulnerability ratings. Utility Systems and building systems that are well hidden are given the lowest rating, but Electrical Systems, Mechanical Systems, and IT/Communications Systems which are readily identifiable have slightly higher ratings with respectively greater damage caused by a single projectile.

Vehicle Bomb exhibits its global effects nature with proximity to bomb raising the vulnerability rating. The IT/Communications and Electrical Utilities on the first floor increase their vulnerability. Site to Envelope Systems consider that same proximity to an explosion just outside the exterior wall of the building. The remaining systems also receive high ratings due to the size of the design basis threat, the lack of hardening, and the public access to the underground parking.

CBR Attack is also global, but takes into account the effect of the CBR agents on the equipment, its operation, and the accessibility of operations and maintenance personnel to ensure system operations. Thus, the Site for general accessibility, Architectural due to the layout of functions and accessibility and Mechanical Systems get higher ratings. Structural Systems, Envelope Systems, and Utility Systems get the lowest rating as there will be no effect and access for operations is negligible. The remaining assets receive slightly higher ratings as these may require access to ensure operation shortly after the CBR attack.

## Unit V

---

<b>COURSE TITLE</b>	Building Design for Homeland Security	<b>TIME</b>	45 minutes
---------------------	---------------------------------------	-------------	------------

---

<b>UNIT TITLE</b>	Risk Assessment / Risk Management
-------------------	-----------------------------------

---

<b>OBJECTIVES</b>	<ol style="list-style-type: none"><li>1. Explain what constitutes risk</li><li>2. Evaluate risk using the Threat-Vulnerability (Risk) Matrix to capture assessment information</li><li>3. Provide a numerical rating for risk and justify the basis for the rating</li><li>4. Identify top risks for asset-threat/hazard pairs of interest that should receive measures to mitigate vulnerabilities and reduce risk</li></ol>
-------------------	---

---

<b>SCOPE</b>	<p>The following topics will be covered in this unit:</p> <ol style="list-style-type: none"><li>1. Definition of risk and the various components to determine a risk rating.</li><li>2. The FEMA 426 approach to determining risk.</li><li>3. A rating scale and how to use it to determine a risk rating. One or more specific examples will be used to focus students on the following activity.</li><li>4. The relationships between high risk, the need for mitigation measures, and the need to identify a Design Basis Threat and Level of Protection.</li><li>5. Activity: Determine the risk rating for the asset-threat/hazard pairs of interest. Identify the top three risk ratings for the Case Study.</li></ol>
--------------	--

---

<b>REFERENCES</b>	<ol style="list-style-type: none"><li>1. FEMA 426, <i>Reference Manual to Mitigate Potential Terrorist Attacks Against Buildings</i>, pages 1-35 to 1-44</li><li>2. FEMA 452, <i>Risk Assessment: A How-To Guide to Mitigate Potential Terrorist Attacks Against Buildings</i>, pages 4-1 to 4-9</li><li>3. Case Study – Appendix A: Suburban, Hazardville Information Company or Appendix B: Urban, HazardCorp Building as selected</li><li>4. Student Manual, Unit V-A or Unit V-B as selected</li><li>5. Unit V visuals</li></ol>
-------------------	--

---

<b>REQUIREMENTS</b>	<ol style="list-style-type: none"><li>1. FEMA 426, <i>Reference Manual to Mitigate Potential Terrorist Attacks Against Buildings</i> (one per student)</li><li>2. FEMA 452, <i>Risk Assessment: A How-To Guide to Mitigate</i></li></ol>
---------------------	--

---

*Potential Terrorist Attacks Against Buildings* (one per student)

3. Instructor Guide, Unit V
4. Student Manual (one per student) for selected Case Study
5. Overhead projector or computer display unit
6. Unit V visuals
7. Risk Matrix poster and box of dry-erase markers (one per team)
8. Chart paper, easel, and markers

**UNIT V OUTLINE**

	<u>Time</u>	<u>Page</u>
V. Risk Assessment / Risk Management	45 minutes	IG V-1
1. Introduction and Unit Overview	5 minutes	IG V-5
2. Risk and Rating Approaches	7 minutes	IG V-7
3. Selecting Mitigation Measures	5 minutes	IG V-10
4. Process Review/Summary/Transition	3 minutes	IG V-12
5. Activity: Risk Rating (Version <b>A Suburban</b> ) [15 minutes for students, 10 minutes for review]	25 minutes	IG V-A-15
6. Activity: Risk Rating (Version <b>B Urban</b> ) [15 minutes for students, 10 minutes for review]	25 minutes	IG V-B-18

**PREPARING TO TEACH THIS UNIT**

- **Tailoring Content to the Local Area:** This is a generic instruction unit that does not have any specific capability for linking to the Local Area.

The Instructor will define risk by its components and the approach used in this unit to determine risk. An example will be used to show the students how to determine and evaluate the risk rating for each asset-threat/hazard pair of interest in the threat-vulnerability (risk) matrix. The Instructor will also discuss the relationship between an identified high risk asset-threat/hazard pair of interest and the need for mitigation measures to reduce that risk by reducing the vulnerability rating.

- **Optional Activity:** There are no optional activities in this unit, except Student Activity questions that are applicable to the selected Case Study (Suburban or Urban).
- **Activity:** The student activity is primarily a math exercise in multiplying threat, asset value, and vulnerability ratings to determine the risk rating and then compare it against the risk

rating scale. The top three risks should receive additional emphasis during an actual vulnerability assessment to validate the risk by identifying vulnerabilities and as an input to select mitigation measures.

- Refer students to their Student Manuals for worksheets and activities.
- Direct students to the appropriate page in the Student Manual.
- Instruct the students to read the activity instructions found in the Student Manual.
- Explain that the risk ratings determined by the team must be transferred to the Risk Matrix poster.
- Tell students how long they have to work on the requirements.
- While students are working, all instructors should closely observe the groups' process and progress. If any groups are struggling, immediately assist them by clarifying the assignment and providing as much help as is necessary for the groups to complete the requirement in the allotted time. Also, monitor each group for full participation of all members. For example, ask any student who is not fully engaged a question that requires his/her viewpoint to be presented to the group.
- At the end of the working period, reconvene the class.
- After the students have completed the assignment, “walk through” the activity with the students during the plenary session. Call on different teams to provide the answer(s) for each question. Then simply ask if anyone disagrees. If the answer is correct and no one disagrees, state that the answer is correct and move on to the next requirement. If there is disagreement, allow some discussion of rationale, provide the “school solution” and move on.
- If time is short, simply provide the “school solution” and ask for questions. Do not end the activity without ensuring that students know if their answers are correct or at least on the right track.
- Ask for and answer questions.

*This page intentionally left blank*

**INSTRUCTOR NOTES**

**CONTENT/ACTIVITY**

**VISUAL V-1**

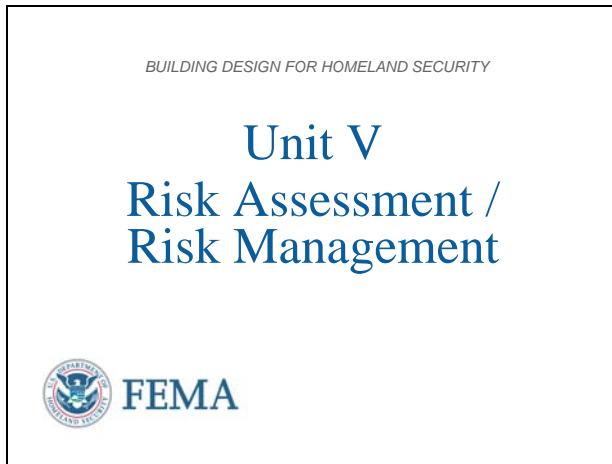

**Introduction and Unit Overview**

This is Unit V Risk Assessment / Risk Management. The unit will provide a definition of risk and the various components to determine a risk rating, review various approaches to determine risk, review a rating scale, and demonstrate how to use the scale to determine a risk rating.

**VISUAL V-2**



**Unit Objectives**

At the end of this unit, the students should be able to:

1. Explain what constitutes risk.
2. Evaluate risk using the Threat-Vulnerability Matrix (Risk Matrix poster) to capture assessment information.
3. Provide a numerical rating for risk and justify the basis for the rating.
4. Identify top risks for asset-threat/hazard pairs of interest that should receive measures to mitigate vulnerabilities and reduce risk.

VISUAL V-3

**Risk Management**

**Risk management is the deliberate process of understanding “risk”** – the likelihood that a threat will harm an asset with some severity of consequences – and deciding on and implementing actions to reduce it.

**GAO/NSIAD-98-74: Combating Terrorism – Threat and Risk Assessments Can Help Prioritize and Target Program Investments**, April 1998



BUILDING DESIGN FOR HOMELAND SECURITY Unit V-3

**Risk Management**

Risk management incorporates an understanding of the vulnerability of assets to the consequences of threats and hazards.

The objective is to reduce the vulnerability of assets through mitigation actions. Reducing vulnerabilities is the most straightforward approach to reducing risk.

However, realize that risk reduction has two other components, albeit not applicable to building design:

- Reduce asset value (Devalue the asset)
- Reduce threat (intelligence and law enforcement team to arrest terrorists before an attack can be carried out)

VISUAL V-4

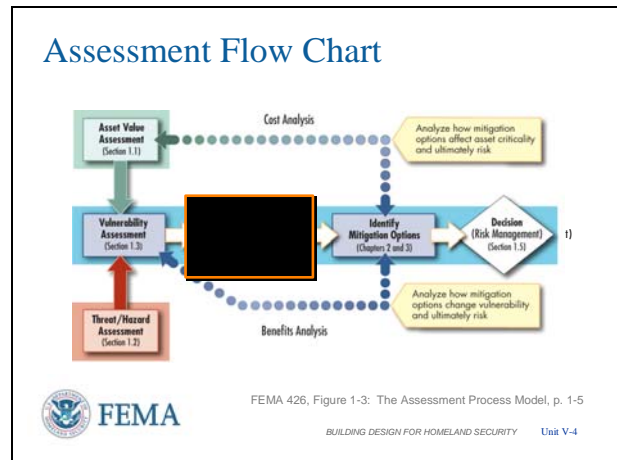

**Assessment Flow Chart**

Reviewing the Assessment Flow Chart, the determination of quantitative risk values is the next step in the risk assessment process.

VISUAL V-5

**Definition of Risk**

Risk is a combination of:

- The probability that an event will occur, and
- The consequences of its occurrence

	Low Risk	Medium Risk	High Risk
Risk Factors Total	1-60	61-175	> 176

$Risk = Asset\ Value \times Threat\ Rating \times Vulnerability\ Rating$



FEMA

FEMA 426, Table 1-19: Total Risk Color Code, p. 1-38  
BUILDING DESIGN FOR HOMELAND SECURITY Unit V-5

**Risk**

Risk can be defined as the potential for a loss or damage to an asset to occur. It takes into account the **value of an asset**, the **threats or hazards** that potentially impact the asset, and the **vulnerability** of the asset to the threat or hazard.

Values can be assigned to these three components of risk to provide a risk rating.

VISUAL V-6

**Quantifying Risk**

**Risk Assessment**

- Determine Asset Value
- Determine Threat Rating Value
- Determine Vulnerability Rating Value
- Determine relative risk for each threat against each asset

*Select mitigation measures that have the greatest benefit/cost for reducing risk*



FEMA

FEMA 426, Table 1-19: Total Risk Color Code, p. 1-38  
BUILDING DESIGN FOR HOMELAND SECURITY Unit V-6

**Quantifying Risk**

There are at least four steps or **required tasks** in the risk assessment process. A determination of the *Asset Value*, *Threat Rating Value*, *Vulnerability Rating Value*, and identifying or recommending appropriate *mitigation measures to reduce the risk*.

Determining the relative risk of threat against asset justifies the use of limited resources to reduce the greatest risk and focuses the mitigation measures needed.

**Exam Questions #A5 and B5**



VISUAL V-7

**An Approach to Quantifying Risk**

Risk = Asset Value x Threat Rating x Vulnerability Rating

Table 1-18: Risk Factors Definitions

Very High	10
High	8-9
Medium High	7
Medium	5-6
Medium Low	4
Low	2-3
Very Low	1

Table 1-19: Total Risk Color Code

	Low Risk	Medium Risk	High Risk
Risk Factors Total	1-40	61-175	> 176

FEMA 426, p. 1-38  
BUILDING DESIGN FOR HOMELAND SECURITY Unit V-7



Exam Questions #A6 and B7

VISUAL V-8

**Critical Functions**

Function	Cyber attack	Armed attack (single gunman)	Vehicle bomb	CBR attack
<b>Administration</b>	<b>280</b>	<b>140</b>	<b>135</b>	<b>90</b>
Asset Value	5	5	5	5
Threat Rating	8	4	3	2
Vulnerability Rating	7	7	9	9
<b>Engineering</b>	<b>128</b>	<b>160</b>	<b>384</b>	<b>144</b>
Asset Value	8	8	8	8
Threat Rating	8	5	6	2
Vulnerability Rating	2	4	8	9

FEMA 426, Adaptation of Table 1-20: Site Functional Pre-Assessment Screening Matrix, p. 1-38  
BUILDING DESIGN FOR HOMELAND SECURITY Unit V-8



**An Approach to Quantifying Risk**

The risk assessment analyzes the threat, asset value, and vulnerability to ascertain the **level of risk** for each critical asset against each applicable threat.

An understanding of risk levels enables the owner of assets to prioritize and implement appropriate mitigation measures, paying particular attention to high consequence threats, to achieve the desired level of protection.

A simplified approach to quantifying risk is shown here. Values can be assigned to asset value/criticality, the threat or hazard, and vulnerability of the asset to the threats, and numerical scores can be determined that depict relative risk of these assets to manmade hazards. (FEMA 426 Chapter 1, FEMA 452 Steps 1, 2, 3, and 4.)

**Critical Functions Matrix**

This analysis completes the Critical Functions and the Critical Infrastructure Matrices that we saw in Units II, III, and IV.

The risk formula is applied and the numeric values color coded as discussed on the previous slide. The color code helps visualize the functions and infrastructure that are vulnerable and the scale helps to identify those areas for in-depth mitigation measures analysis.

The risk ratings under the Administration and Engineering Functions are highlighted. The numeric values result in Medium and High risk ratings for the Functions asset-threat/hazard pairs.

VISUAL V-9

### Critical Infrastructure

Infrastructure	Cyber attack	Armed attack (single gunman)	Vehicle bomb	CBR attack
<b>Site</b>	<b>48</b>	<b>80</b>	<b>108</b>	<b>72</b>
Asset Value	4	4	4	4
Threat Rating	4	4	3	2
Vulnerability Rating	3	5	9	9
<b>Structural Systems</b>	<b>48</b>	<b>128</b>	<b>192</b>	<b>144</b>
Asset Value	8	8	8	8
Threat Rating	3	4	3	2
Vulnerability Rating	2	4	8	9

 FEMA 426, Adaptation of Table 1-21: Site Infrastructure Systems Pre-Assessment Screening Matrix, p. 1-39  
 BUILDING DESIGN FOR HOMELAND SECURITY Unit V-9

**Critical Infrastructure Matrix**

The risk ratings under the Site and Structural Systems are highlighted. The numeric values result in Low to Medium risk ratings for the Infrastructure asset-threat/hazard pairs, except for Structural Systems – Vehicle Bomb which has a High risk rating.

VISUAL V-10

### Risk Assessment Results

Function	Cyber Attack	Armed Attack (single gunman)	Vehicle bomb	CBR Attack
<b>Administration</b>	<b>200</b>	<b>140</b>	<b>135</b>	<b>90</b>
Asset Value	3	3	3	3
Threat Rating	8	4	3	3
Vulnerability Rating	7	7	9	9
<b>Engineering</b>	<b>138</b>	<b>138</b>	<b>100</b>	<b>144</b>
Asset Value	6	6	6	6
Threat Rating	3	4	3	2
Vulnerability Rating	3	4	8	9
<b>Manufacturing</b>	<b>36</b>	<b>36</b>	<b>31</b>	<b>54</b>
Asset Value	2	2	2	2
Threat Rating	6	4	3	2
Vulnerability Rating	4	3	9	9
<b>Power Control</b>	<b>60</b>	<b>120</b>	<b>110</b>	<b>144</b>
Asset Value	6	6	6	6
Threat Rating	6	4	3	2
Vulnerability Rating	3	8	9	9
<b>Food Service</b>	<b>3</b>	<b>32</b>	<b>40</b>	<b>36</b>
Asset Value	2	2	2	2
Threat Rating	1	4	3	2
Vulnerability Rating	1	8	8	9
<b>Security</b>	<b>200</b>	<b>140</b>	<b>140</b>	<b>108</b>
Asset Value	3	3	3	3
Threat Rating	8	4	3	2
Vulnerability Rating	5	3	8	9
<b>Housekeeping</b>	<b>16</b>	<b>16</b>	<b>40</b>	<b>36</b>
Asset Value	2	2	2	2
Threat Rating	6	4	3	2
Vulnerability Rating	1	8	8	9
<b>Day Care</b>	<b>36</b>	<b>108</b>	<b>140</b>	<b>144</b>
Asset Value	6	6	6	6
Threat Rating	3	4	3	2
Vulnerability Rating	2	9	9	9

 FEMA 426, Table 1-20: Site Functional Pre-Assessment Screening Matrix, p. 1-38  
 BUILDING DESIGN FOR HOMELAND SECURITY Unit V-10

**Risk Assessment Results**

The process is continued for all the asset-threat/hazard pairs of interest. This is a nominal example of a completed risk table.

The risk assessment results in a prioritized list of risks (i.e., asset – threat / hazard / vulnerability combinations) that can be used to select safeguards to reduce vulnerabilities (and risk) and to achieve a certain level of protection.

As stated previously, this subjective process is best applied to small organizations with few decision makers / decision levels.

This subjective risk assessment process will probably not result in hard numbers that can be compared across different assessment teams, but the relative ranking of the asset-threat/hazard pairs on each team will have great correlation if both teams have consistent perspectives. Thus, the highest and lowest identified risks may not have the same rating numbers, but the same asset-threat/hazard pairs by the two teams will be close to identical. Divergence will occur if one team is concentrating on terrorism and

the other team is concentrating on continuity of business operations.

Large organizations require a more objective approach where the results of different assessment teams working independently can be compared by decision makers at many levels. These risk ratings will then be comparable across teams as to their numeric value, which is needed in a large organization.

In either case, the goal is to find where the application of limited resources will have the greatest benefit to reducing risk at the least cost.

### Selecting Mitigation Measures

In every design and renovation project, the owner ultimately has three choices when addressing the risk posed by terrorism. They can:

1. Do nothing and accept the risk (no cost).
2. Perform a risk assessment and manage the risk by installing reasonable mitigation measures (some cost).
3. Harden the building against all threats to achieve the least amount of risk (but at greatest cost).

### VISUAL V-11

### Selecting Mitigation Measures

**Three Options:**

- Do nothing and accept the risk.
- Perform a risk assessment and manage the risk by installing reasonable mitigation measures.
- Harden the building against all threats to achieve the least amount of risk.



FEMA 426, Figure 1-13: Risk Management Choices, p. 1-44  
BUILDING DESIGN FOR HOMELAND SECURITY Unit V-11



### Exam Questions #A7 and B8

VISUAL V-12

**Mitigation Measures**

A mitigation measure is an action, device, or system used to reduce risk by affecting an asset, threat, or vulnerability.

- Regulatory measures
- Rehabilitation of existing structures
- Protective and control structures



BUILDING DESIGN FOR HOMELAND SECURITY Unit V-12

**Mitigation Measures**

After determining how specific threats potentially impact an asset (and occupants), the architect and building engineer can work with security and risk specialists to identify mitigation measures to reduce risk. Because it is not possible to completely eliminate risk, it is important to determine what level of protection is desirable, and the options for achieving this level through risk management.

VISUAL V-13

**Mitigation Measures**

Mitigation measures can be evaluated against the following parameters

- Political Support
- Community Acceptance
- Cost and Benefit
- Financial Resources
- Legal Authority
- Adversely Affected Population
- Adversely Effects on the Built Env.
- Environmental Impact
- Technical Capacity
- Maintenance and Operations
- Ease and Speed of Implementation
- Timeframe and Urgency
- Short-term and Long-Term Solutions
- Estimated Cost



BUILDING DESIGN FOR HOMELAND SECURITY Unit V-13

**Measures to Reduce Risk**

Higher risk hazards require mitigation measures to reduce risk. Mitigation measures are conceived by the design professional and are best incorporated into the building architecture, building systems, and operational parameters, with consideration for life-cycle costs.

There are many factors that impact what mitigation measures can be implemented at low, medium, and high levels of difficulty.

In some cases, mitigation measures to enhance security may be in conflict with other design intentions, building codes, planning board master plans, etc.

VISUAL V-14

**Achieving Building Security:  
Planning Factors**

Building security integrates multiple concepts and practices.

Objective is to achieve a balanced approach that combines aesthetics, enhanced security, and use of non-structural measures.



BUILDING DESIGN FOR HOMELAND SECURITY Unit V-14

**Achieving Building Security**

The assessment process provides concepts for integrating land use planning, landscape architecture, site planning, and other strategies to mitigate the Design Basis Threats as identified in the risk assessment.

Integrating security measures into design and/or maintenance of buildings presents the asset owner with multiple opportunities of achieving a balance among many objectives such as reducing risk; facilitating proper building function; aesthetics and matching architecture; hardening of physical structures beyond required building codes and standards; and maximizing use of non-structural systems.

[The last point tries to illustrate that the balanced approach to building security tries not to place everything into hardening the structure to deny the consequences to the terrorist's tactics. Thus, non-structural systems, especially in renovation projects, may provide a level of risk reduction comparable to structural hardening but at a must reduced cost or at a more timely implementation.]

VISUAL V-15

**Process Review**

**Calculate** the relative risk for each threat against each asset

**Identify** the high risk areas

**Identify** Mitigation Options to reduce the risk



BUILDING DESIGN FOR HOMELAND SECURITY Unit V-15

**Process Review**

- Calculate the relative risk for each threat against each asset
- Identify the high risk areas
- Identify Mitigation Options to reduce the risk

To get the maximum benefit from limited resources, realize that certain mitigation measures can reduce risk for multiple, high-risk asset – threat / hazard pairs.

INSTRUCTOR NOTES

CONTENT/ACTIVITY

VISUAL V-16

**Summary**

Risk Definition

Critical Function and Critical Infrastructure Matrices

Numerical and color-coded risk scale

Identify Mitigation Options



BUILDING DESIGN FOR HOMELAND SECURITY Unit V-16

**Summary**

- Risk Definition
- Critical Function and Critical Infrastructure Matrices
- Numerical and Color-coded Risk Scale
- Identify Mitigation Options

VISUAL V-17

**Unit V Case Study Activity**

**Risk Rating**

**Background**

Formula for determining a numeric value risk for each asset-threat/hazard pair:

**Risk = Asset Value x Threat Rating x Vulnerability Rating**

**Requirements: Vulnerability Rating Approach**

Use worksheet tables to summarize Case Study asset, threat, and vulnerability ratings conducted in the previous activities

Use the risk formula to determine the risk rating for each asset-threat/hazard pair for:

- Critical Functions
- Critical Infrastructure



BUILDING DESIGN FOR HOMELAND SECURITY Unit V-17

**Student Activity**

One approach to conducting a risk assessment is to assemble the results of the asset value assessment, the threat assessment, and the vulnerability assessment, and determine a numeric value of risk for each asset-threat/hazard pair using the following formula:

$$\text{Risk} = \text{Asset Value} \times \text{Threat Rating} \times \text{Vulnerability Rating}$$

**Activity Requirements**

Working in small groups, use the worksheet tables to summarize the asset, threat and vulnerability assessments conducted in the previous three unit student activities for the selected Case Study.

Then use the risk formula to determine the risk rating for each asset-threat/hazard pair identified under Critical Functions and under Critical Infrastructure.

Take 15 minutes to complete this activity.

Refer participants to the Unit V Case Study activity in the Student Manual.

Members of the instructor staff should be available to answer questions and assist groups as needed.

At the end of 15 minutes, reconvene the class and facilitate group reporting (plenary group will take about 10 minutes).

**INSTRUCTOR NOTES**

**CONTENT/ACTIVITY**

Solutions will be reviewed in plenary group.

**Transition**

Unit VI tomorrow morning will provide an alternate to performing this risk assessment process manually as you have done today in your student activities.

**UNIT V-A CASE STUDY ACTIVITY:  
RISK RATING  
(Suburban Version)**

One approach to conducting a risk assessment is to assemble the results of the asset value assessment, the threat/hazard assessment, and the vulnerability assessment, and determine a numeric value of risk for each asset-threat/hazard pair of interest using the following formula:

$$\text{Risk} = \text{Asset Value} \times \text{Threat Rating} \times \text{Vulnerability Rating}$$

**Requirements**

1. Use the following tables to summarize the HIC asset, threat, and vulnerability assessments conducted in the previous three unit activities. Then use the formula above to determine the risk rating for each asset-threat/hazard pair of interest identified under Critical Functions and under Critical Infrastructure. Transfer to the Risk Matrix and reach team consensus on answers.
2. Identify the highest risk ratings and use **Figure 1-13 of FEMA 426 (page 1-44)** to begin a determination of the risk management options available to reduce these risk ratings by reducing applicable individual ratings for asset value, threat/hazard, or vulnerability. Then identify the top three risk ratings and keep in mind as mitigation measures are discussed in future instruction units.

**HIC Critical Functions Risk Rating**

Function	Cyber Attack	Armed Attack	Vehicle Bomb	CBR Attack
<b>1. Administration Risk Rating</b>	<b>128</b>	<b>96</b>	<b>192</b>	<b>96</b>
Asset Value	4	4	4	4
Threat Rating	8	3	6	4
Vulnerability Rating	4	8	8	6
<b>2. Engineering/IT Technicians Risk Rating</b>	<b>160</b>	<b>90</b>	<b>240</b>	<b>120</b>
Asset Value	5	5	5	5
Threat Rating	8	3	6	4
Vulnerability Rating	4	6	8	6
<b>3. Loading Dock/ Warehouse Risk Rating</b>	<b>80</b>	<b>120</b>	<b>240</b>	<b>120</b>
Asset Value	5	5	5	5
Threat Rating	8	3	6	4
Vulnerability Rating	2	8	8	6



<b>4. Data Center Risk Rating</b>	<b>240</b>	<b>120</b>	<b>480</b>	<b>240</b>
Asset Value	10	10	10	10
Threat Rating	8	3	6	4
Vulnerability Rating	3	4	8	6
<b>5. Communications Risk Rating</b>	<b>192</b>	<b>96</b>	<b>384</b>	<b>192</b>
Asset Value	8	8	8	8
Threat Rating	8	3	6	4
Vulnerability Rating	3	4	8	6
<b>6. Security Risk Rating</b>	<b>224</b>	<b>168</b>	<b>336</b>	<b>168</b>
Asset Value	7	7	7	7
Threat Rating	8	3	6	4
Vulnerability Rating	4	8	8	6
<b>7. Housekeeping Risk Rating</b>	<b>16</b>	<b>6</b>	<b>48</b>	<b>24</b>
Asset Value	1	1	1	1
Threat Rating	8	3	6	4
Vulnerability Rating	2	2	8	6

**HIC Critical Infrastructure Risk Rating**

<b>Infrastructure</b>	<b>Cyber Attack</b>	<b>Armed Attack</b>	<b>Vehicle Bomb</b>	<b>CBR Attack</b>
<b>1. Site Risk Rating</b>	<b>5</b>	<b>120</b>	<b>240</b>	<b>160</b>
Asset Value	5	5	5	5
Threat Rating	1	3	6	4
Vulnerability Rating	1	8	8	6
<b>2. Architectural Risk Rating</b>	<b>5</b>	<b>120</b>	<b>240</b>	<b>20</b>
Asset Value	5	5	5	5
Threat Rating	1	3	6	4
Vulnerability Rating	1	8	8	1
<b>3. Structural Systems Risk Rating</b>	<b>5</b>	<b>120</b>	<b>240</b>	<b>20</b>
Asset Value	5	5	5	5
Threat Rating	1	3	6	4
Vulnerability Rating	1	8	8	1

<b>Infrastructure</b>	<b>Cyber Attack</b>	<b>Armed Attack</b>	<b>Vehicle Bomb</b>	<b>CBR Attack</b>
<b>4. Envelope Systems Risk Rating</b>	<b>5</b>	<b>120</b>	<b>240</b>	<b>20</b>
Asset Value	5	5	5	5
Threat Rating	1	3	6	4
Vulnerability Rating	1	8	8	1
<b>5. Utility Systems Risk Rating</b>	<b>125</b>	<b>175</b>	<b>180</b>	<b>20</b>
Asset Value	5	5	5	5
Threat Rating	5	5	6	4
Vulnerability Rating	5	7	6	1
<b>6. Mechanical Systems Risk Rating</b>	<b>175</b>	<b>245</b>	<b>336</b>	<b>196</b>
Asset Value	7	7	7	7
Threat Rating	5	5	6	4
Vulnerability Rating	5	7	8	7
<b>7. Plumbing and Gas Systems Risk Rating</b>	<b>5</b>	<b>45</b>	<b>240</b>	<b>20</b>
Asset Value	5	5	5	5
Threat Rating	1	3	6	4
Vulnerability Rating	1	3	8	1
<b>8. Electrical Systems Risk Rating</b>	<b>175</b>	<b>147</b>	<b>336</b>	<b>140</b>
Asset Value	7	7	7	7
Threat Rating	5	3	6	4
Vulnerability Rating	5	7	8	5
<b>9. Fire Alarm Systems Risk Rating</b>	<b>30</b>	<b>45</b>	<b>240</b>	<b>60</b>
Asset Value	5	5	5	5
Threat Rating	2	3	6	4
Vulnerability Rating	3	3	8	3
<b>10. IT/Communications Systems Risk Rating</b>	<b>400</b>	<b>120</b>	<b>480</b>	<b>240</b>
Asset Value	10	10	10	10
Threat Rating	10	3	6	4
Vulnerability Rating	4	4	8	6

**UNIT V-B CASE STUDY ACTIVITY:  
RISK RATING  
(Urban Version)**

One approach to conducting a risk assessment is to assemble the results of the asset value assessment, the threat/hazard assessment, and the vulnerability assessment, and determine a numeric value of risk for each asset-threat/hazard pair of interest using the following formula:

$$\text{Risk} = \text{Asset Value} \times \text{Threat Rating} \times \text{Vulnerability Rating}$$

**Requirements**

1. Use the following tables to summarize the HZC asset, threat, and vulnerability assessments conducted in the previous three unit activities. Then use the formula above to determine the risk rating for each asset-threat/hazard pair of interest identified under Critical Functions and under Critical Infrastructure. Transfer to the Risk Matrix and reach team consensus on answers.
2. Identify the highest risk ratings and use **Figure 1-13 of FEMA 426 (page 1-44)** to begin a determination of the risk management options available to reduce these risk ratings by reducing applicable individual ratings for asset value, threat/hazard, or vulnerability. Then identify the top three risk ratings and keep in mind as mitigation measures are discussed in future instruction units.

**HZC Critical Functions Risk Rating**

Function	Cyber Attack	Armed Attack	Vehicle Bomb	CBR Attack
<b>1. Administration Risk Rating</b>	<b>210</b>	<b>252</b>	<b>630</b>	<b>252</b>
Asset Value	7	7	7	7
Threat Rating	6	6	9	6
Vulnerability Rating	5	6	10	6
<b>2. Engineering/IT Technicians Risk Rating</b>	<b>144</b>	<b>96</b>	<b>648</b>	<b>240</b>
Asset Value	8	8	8	8
Threat Rating	6	4	9	6
Vulnerability Rating	3	3	9	5

Function	Cyber Attack	Armed Attack	Vehicle Bomb	CBR Attack
<b>3. Loading Dock/ Warehouse Risk Rating</b>	<b>60</b>	<b>210</b>	<b>450</b>	<b>210</b>
Asset Value	5	5	5	5
Threat Rating	6	7	9	6
Vulnerability Rating	2	6	10	7
<b>4. Data Center Risk Rating</b>	<b>420</b>	<b>90</b>	<b>900</b>	<b>300</b>
Asset Value	10	10	10	10
Threat Rating	6	3	9	6
Vulnerability Rating	7	3	10	5
<b>5. Communications Risk Rating</b>	<b>336</b>	<b>96</b>	<b>720</b>	<b>240</b>
Asset Value	8	8	8	8
Threat Rating	6	4	9	6
Vulnerability Rating	7	3	10	5
<b>6. Security Risk Rating</b>	<b>168</b>	<b>196</b>	<b>360</b>	<b>168</b>
Asset Value	4	4	4	4
Threat Rating	6	7	9	6
Vulnerability Rating	7	7	10	7
<b>7. Housekeeping Risk Rating</b>	<b>4</b>	<b>8</b>	<b>144</b>	<b>60</b>
Asset Value	2	2	2	2
Threat Rating	2	2	9	6
Vulnerability Rating	1	2	8	5

**HZC Critical Infrastructure Risk Rating**

<b>Infrastructure</b>	<b>Cyber Attack</b>	<b>Armed Attack</b>	<b>Vehicle Bomb</b>	<b>CBR Attack</b>
<b>1. Site Risk Rating</b>	<b>10</b>	<b>75</b>	<b>405</b>	<b>270</b>
Asset Value	5	5	5	5
Threat Rating	1	3	9	6
Vulnerability Rating	2	5	9	9
<b>2. Architectural Risk Rating</b>	<b>7</b>	<b>105</b>	<b>630</b>	<b>210</b>
Asset Value	7	7	7	7
Threat Rating	1	3	9	6
Vulnerability Rating	1	5	10	5
<b>3. Structural Systems Risk Rating</b>	<b>8</b>	<b>24</b>	<b>720</b>	<b>32</b>
Asset Value	8	8	8	8
Threat Rating	1	3	9	4
Vulnerability Rating	1	1	10	1
<b>4. Envelope Systems Risk Rating</b>	<b>7</b>	<b>126</b>	<b>630</b>	<b>42</b>
Asset Value	7	7	7	7
Threat Rating	1	3	9	6
Vulnerability Rating	1	6	10	1
<b>5. Utility Systems Risk Rating</b>	<b>40</b>	<b>24</b>	<b>576</b>	<b>46</b>
Asset Value	8	8	8	8
Threat Rating	1	3	9	6
Vulnerability Rating	5	1	8	1

<b>Infrastructure</b>	<b>Cyber Attack</b>	<b>Armed Attack</b>	<b>Vehicle Bomb</b>	<b>CBR Attack</b>
<b>6. Mechanical Systems Risk Rating</b>	<b>160</b>	<b>48</b>	<b>504</b>	<b>336</b>
Asset Value	8	8	8	8
Threat Rating	5	3	9	6
Vulnerability Rating	4	2	7	7
<b>7. Plumbing and Gas Systems Risk Rating</b>	<b>32</b>	<b>32</b>	<b>504</b>	<b>144</b>
Asset Value	8	8	8	8
Threat Rating	1	3	9	6
Vulnerability Rating	4	1	7	3
<b>8. Electrical Systems Risk Rating</b>	<b>160</b>	<b>120</b>	<b>648</b>	<b>144</b>
Asset Value	8	8	8	8
Threat Rating	5	5	9	6
Vulnerability Rating	4	3	9	3
<b>9. Fire Alarm Systems Risk Rating</b>	<b>64</b>	<b>16</b>	<b>504</b>	<b>96</b>
Asset Value	8	8	8	8
Threat Rating	2	2	9	6
Vulnerability Rating	4	1	7	2
<b>10. IT/Communications Systems Risk Rating</b>	<b>576</b>	<b>64</b>	<b>720</b>	<b>144</b>
Asset Value	8	8	8	8
Threat Rating	8	4	9	6
Vulnerability Rating	9	2	10	3

*This page intentionally left blank*

## Unit VI

---

<b>COURSE TITLE</b>	Building Design for Homeland Security	<b>TIME</b>	60 minutes
---------------------	---------------------------------------	-------------	------------

---

<b>UNIT TITLE</b>	FEMA 452 Risk Assessment Database
-------------------	-----------------------------------

---

<b>OBJECTIVES</b>	<ol style="list-style-type: none"><li>1. Explain the database install process</li><li>2. Identify where to save photos, maps, drawings, plans, etc. to interface with the database</li><li>3. Explain the information required for the database to function within each screen, how to move between screens, and switch between the assessor's tool and the master database</li><li>4. Explain the benefit and approaches to setting priorities on identified vulnerabilities</li><li>5. Explain how to use the master database to produce standard reports and search the database for specific information</li></ol>
-------------------	--

---

<b>SCOPE</b>	The following topics will be covered in this unit:
--------------	--

1. The installation of the assessor tool database and the master database as selected to do.
  2. Inputting data into the database and linking associated information, such as GIS images, Miscellaneous files, and Photos.
  3. Navigation in the database to operate all functions.
  4. Risk management capability using the database.
  5. Activity: Students will follow the instruction unit by installing the databases as selected to do and navigating the databases following the instructor's presentation.
- 

<b>REFERENCES</b>	<ol style="list-style-type: none"><li>1. FEMA 426, <i>Reference Manual to Mitigate Potential Terrorist Attacks Against Buildings</i>, Chapter 1</li><li>2. FEMA 452, <i>Risk Assessment - A How-To Guide to Mitigate Potential Terrorist Attacks Against Buildings</i>, pages 4-1 to 4-10</li><li>3. FEMA 452 Risk Assessment Database CD with Install Wizard (latest version)</li><li>4. Student Manual, Unit VI</li><li>5. Unit VI visuals</li></ol>
-------------------	--

---



- 
- REQUIREMENTS**
1. FEMA 426, *Reference Manual to Mitigate Potential Terrorist Attacks Against Buildings* (one per student)
  2. FEMA 452, *Risk Assessment - A How-To Guide to Mitigate Potential Terrorist Attacks Against Buildings* (one per student)
  3. Instructor Guide, Unit VI
  4. FEMA 452 Risk Assessment Database CD with Install Wizard (latest version)
  5. Overhead projection or computer display unit
  6. Unit VI visuals
- 

<b>UNIT VI OUTLINE</b>	<u>Time</u>	<u>Page</u>
VI. FEMA 452 Risk Assessment Database (84 Slides, estimated 0.75 minutes/slide)	75 minutes	IG VI-1
1. Introduction and Unit Overview	2.25 minutes	IG VI-5
2. Program Installation – Assessor Tool	5.25 minutes	IG VI-7
3. Program Installation – Master Database	5.25 minutes	IG VI-10
4. Database Overview	1.5 minutes	IG VI-13
5. Open Assessor Tool	2.25 minutes	IG VI-14
6. Assessor Tool – Site Information	1.5 minutes	IG VI-16
7. Assessor Tool – Load Added Files	2.25 minutes	IG VI-18
8. Assessor Tool – Team Members	3 minutes	IG VI-19
9. Assessor Tool – Points of Contact	1.5 minutes	IG VI-21
10. Assessor Tool – Link and Load Added Files	5.25 minutes	IG VI--22
11. Assessor Tool – Threat Matrices	3 minutes	IG VI-25
12. Assessor Tool – Checklists	3 minutes	IG VI-26
13. Assessor Tool – Executive Summary	1.5 minutes	IG VI-29
14. Assessor Tool – Vulnerabilities	2.25 minutes	IG VI-30
15. Assessor Tool – Import Assessment Information	3 minutes	IG VI-33

---

16. Close Assessor Tool	0.75 minutes	IG VI-36
17. Empty Assessor Database	0.75 minutes	IG VI-37
18. Switch to Master Database Mode	1.5 minutes	IG VI-37
19. Open Master Database	2.25 minutes	IG VI-38
20. Master Database -- Checklists	1.5 minutes	IG VI-39
21. Master Database -- Reports	1.5 minutes	IG VI-40
22. Master Database – Threat Matrix	2.25 minutes	IG VI-41
23. Master Database – Other Reports / Search	0.75 minutes	IG VI-43
24. Master Database – Vulnerability Assessment Checklist	2.25 minutes	IG VI-43
25. Master Database – Administrative Functions	1.5 minutes	IG VI-45
26. Master Database – Import Database	8.25 minutes	IG VI-45
27. Summary	1.5 minutes	IG VI-50

## **PREPARING TO TEACH THIS UNIT**

- **Tailoring Content to the Local Area:** This instruction unit has no requirement to include any tailoring of content to the Local Area.
- **Software Familiarity:** The instructor for this unit should first read the User Guide for the Version 2.0 database. Then the instructor should understand how to work with the FEMA 452 Risk Assessment Database Version 2.0 by following along with the slides and actually working with the software.
- **Optional Activity:** There are no optional activities in this unit. This instruction unit is Case Study independent – it does not matter what Case Study is being used, this instruction unit does not change.
- **Activity:** During this presentation the students with laptops will benefit from a demonstration / performance instruction methodology by actually following along with the instructor and performing the actions installing and navigating the software using the Database CD provided to each student at the start of this unit.
- Refer students to their Student Manuals, Unit VI, for an explanation of this activity.

- Ask for and answer questions at the end of this presentation.

VISUAL VI-1

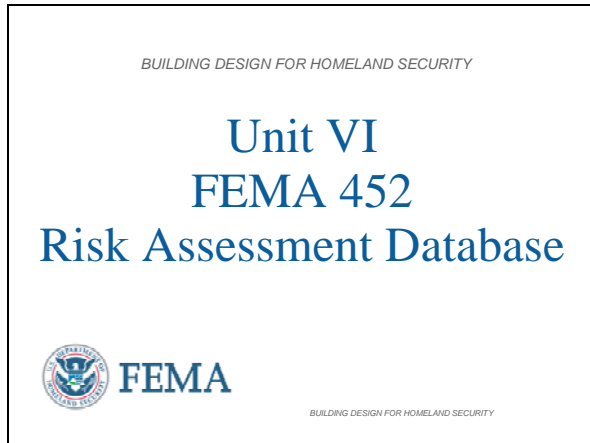

**NOTE:** This Instruction Unit is designed to use FEMA 452 Database Version 2.0 Install Wizard: April 5, 2006 with Record Delete

**Introduction and Unit Overview**

Yesterday you performed the risk assessment using manual techniques. This instruction unit shows the database available to collect and analyze the same information, but in a more efficient manner, especially if risk management applies to multiple buildings or sites.

- **NOTE 1:** When the US Army Corps of Engineers used the RAM-D assessment process to assess the 360+ dams the Corps is responsible across the US, the result was three 3-inch binders of information for each dam (over 1,000 binders. For risk management / program management, a database with the results in separate records that allow search and report capability is a better long-term solution.
- **NOTE 2:** There are currently two versions of the database. Version 1.0, which currently comes with the hardcopy FEMA 452 publication (inside back cover), needs an IT Professional and/or a Database Manager (DBM) / Database Administrator (DBA) to configure the database on a server for use by many persons simultaneously and to move data between Assessor Tool and the Master Database. Version 2.0, the one being presented here does not require an IT Professional / Database Administrator / or Database Manager to perform most functions. It can handle a limited number of users accessing the master database at one time. It is designed for the Assessor or Program Manager who does not have the IT or Database expertise on staff that is needed by Version 1.0.

## VISUAL VI-2

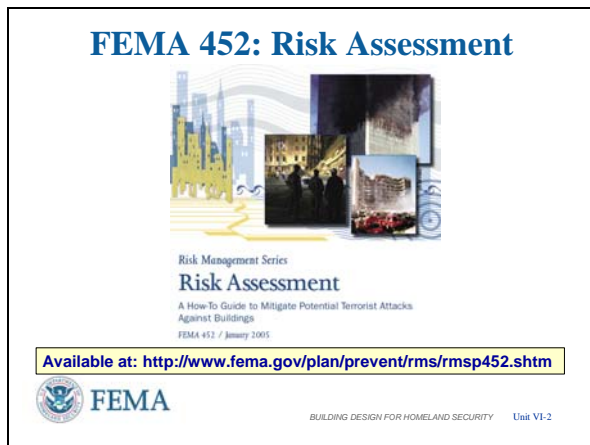

## Introduction and Unit Overview

To support the facility assessment process, an easy to use Risk Assessment Database application is provided in conjunction with FEMA 452, *Risk Assessment: A How-To Guide to Mitigate Potential Terrorist Attacks Against Buildings*.

The Risk Assessment Database is a standalone application that is both a data collection tool and a data management tool. Assessors can use the tool to assist in the systematic collection, storage and reporting of assessment data. It has functions, folders and displays to import and display threat matrices, digital photos, cost data, site plans, floor plans, emergency plans, and certain GIS products as part of the record of assessment. Managers can use the application to store, search and analyze data collected from multiple assessments, and then print a variety of reports.

The FEMA 452 publication is available at the URL shown.

## VISUAL VI-3

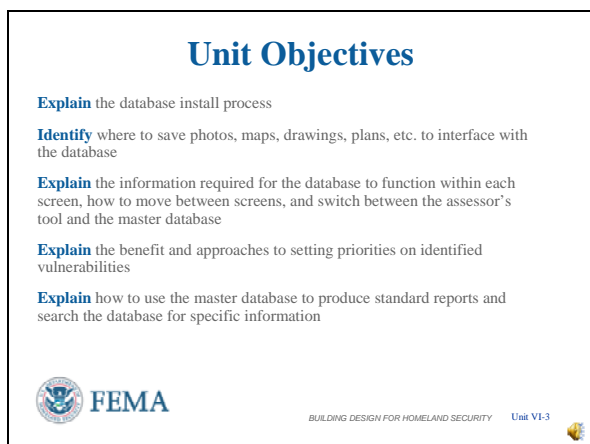

## Unit Objectives

At the end of this unit, the students should be able to:

- **Explain** the database install process
- **Identify** where to save photos, maps, drawings, plans, etc. to interface with the database
- **Explain** the information required for the database to function within each screen, how to move between screens, and switch between the Assessor's tool and the Master Database
- **Explain** the benefit and approaches to setting priorities on identified vulnerabilities
- **Explain** how to use the master database to

produce standard reports and search the database for specific information

## VISUAL VI-4

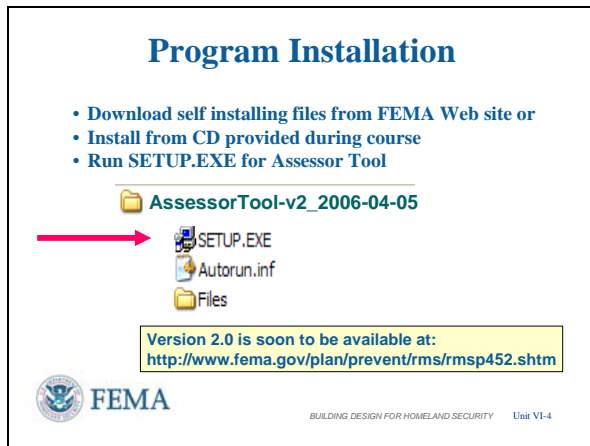

**NOTE: V3.0 is the only version available for download starting June 2007 from the FEMA Security Risk Management Series web site. This instruction unit is based upon Version 2.0.**

## Program Installation – Assessor Tool

The first task is to download and install the two database programs from the FEMA website or from the CD provided during this course. Follow the download and self installation instructions. We begin with the installations process with the Assessor Tool.

- Install the Assessment Tool on the computers that your Assessors will use to collect data, such as laptops. This is intended to be a temporary database that can be used to collect data, pass the collected data on to the Master Database, and than be deleted of data and used for other assessments.
- We begin the installation process by left clicking on the SETUP.EXE for the Assessor Tool. The normal way to install a program is to close all other programs, then left click <Start>, <Run>, identify the location where the SETUP.EXE program can be found (CD, C:/Temp, or some other storage location on hard drive or media) and Run.
- Currently Version 1 is available for download from the indicated web site, with Version 2 to be added some time in the near future (Fall 2006).

VISUAL VI-5



**Program Installation – Assessor Tool**

The Install Wizard first identifies the name of the software being installed. Left click <Next> to continue after confirming that this is the software you want to install.

VISUAL VI-6

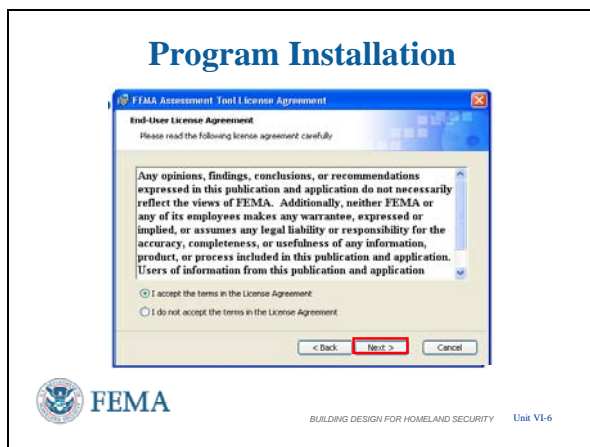

**Program Installation – Assessor Tool**

Again, a standard screen showing the End User License Agreement. Read as you feel appropriate, then left click on the <Accept> circle, then left click on <Next> to continue with the installation.

VISUAL VI-7

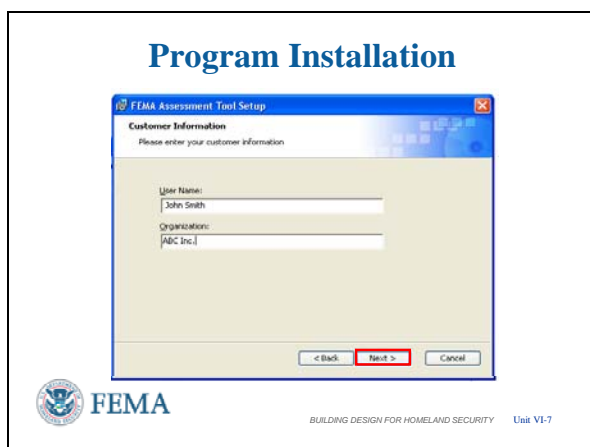

**Program Installation – Assessor Tool**

Then add the User Name and Organization in the appropriate windows. And continue with the installation by left clicking <Next>.

VISUAL VI-8



**Program Installation – Assessor Tool**

There is no advantage in using the Custom Installation. There are no component programs to select. The only feature that the Custom Installation allows is to change the file name and/or file location which can result in an excessive path length that aborts the installation. It is recommended to follow the Typical Installation. To proceed, left click on <Typical>.

VISUAL VI-9



**Program Installation – Assessor Tool**

Another standard screen to ensure you are ready to install. Proceed by left clicking <Install>.

VISUAL VI-10



**Program Installation – Assessor Tool**

If the Access program is not located in the standard location, the Install Wizard will take a long time looking for it with a searching flashlight. It should eventually find it and get to this screen.

The final standard screen indicates the Install Wizard has completed the installation. Left click <Finish> to end the installation.



VISUAL VI-11

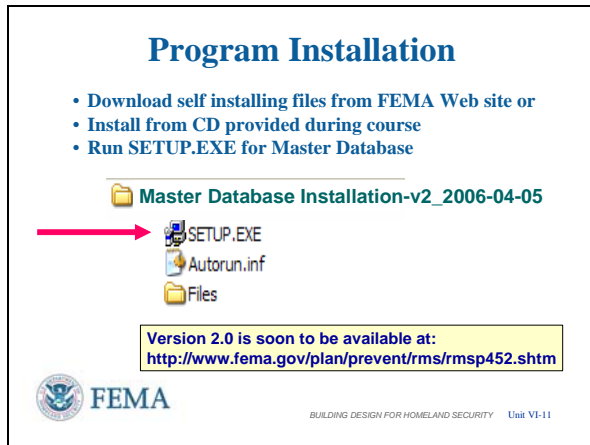

**Program Installation – Master Database**

- After installing the Assessment Tool, follow the same procedure to install the Master Database using the Install Wizard.
- Install the Master Database program on a computer at your organization's headquarters. This is the permanent database that stores assessments, produces reports, and is used to manage the assessment program. This is installed one time and is the permanent program. For small organizations, the Master Database can also perform the functions of the Assessment Tool and directly collect assessment data.
- The Master Database does not have to be installed in order to use the Assessor Tool. However, they both can be loaded on the same laptop or desktop as needed, particularly by a Program Manager that also performs assessments.
- Begin the installation process by left clicking on the SETUP.EXE for the Master Database. The normal way to install a program is to close all other programs, then left click <Start>, <Run>, identify the location where the SETUP.EXE program can be found (CD, C:/Temp, or some other storage location on hard drive or media).

VISUAL VI-12



**Program Installation – Master Database**

As before, the title confirms the installation of the Master Assessment Database. Left click <Next> to continue.

VISUAL VI-13

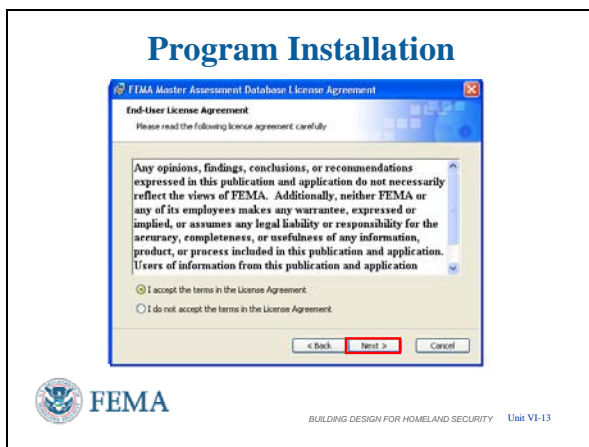

**Program Installation – Master Database**

Same process with the End-User License Agreement. Left click <Accept> circle and then left click <Next>.

VISUAL VI-14



**Program Installation – Master Database**

As before, input User Name and Organization, and then left click <Next> to continue.

VISUAL VI-15



**Program Installation – Master Database**

- Recommend using the TYPICAL installation. There is no advantage in using the Custom Installation. There are no component programs to select. The only feature that the Custom Installation allows is to change the file name and/or file location which can result in an excessive path length that aborts the installation.
- To proceed, left click on <Typical>.

VISUAL VI-16



**Program Installation – Master Database**

- This screen is a double check to ensure the installation of this software is what is desired.
- Left click <Next> to proceed.

VISUAL VI-17

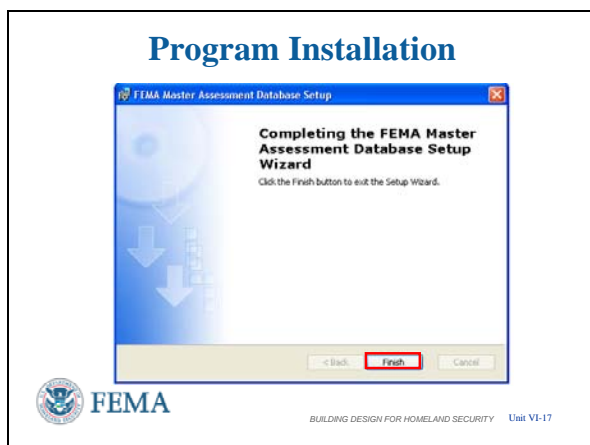

**Program Installation – Master Database**

And when the installation is complete, you are notified and left click <Finish> to end the installation. If the Assessor Tool installation searched for the Microsoft Access program, then this installation will do the same.

VISUAL VI-18

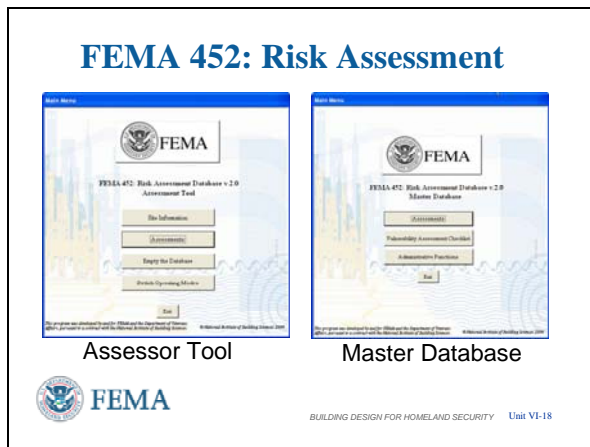

Database Overview

- The first thing to understand is that there are really two databases, the Assessment Tool for conducting assessments in the field, and the Master Database for collecting the results from the Assessors, printing reports, and archiving the results from any number of assessments. The Master Database also provides the using organization the ability to search for vulnerabilities common to many assessed sites, search for specific vulnerabilities, etc. Essentially it can be used as a Risk Management Tool to identify and track mitigation measures to reduce risk.
- The Assessment Tool was designed for engineers and security specialists to be able to easily collect data from the site being assessed. As you will see, the software is very user friendly. The Master Database was designed for the Program Manager.

VISUAL VI-19

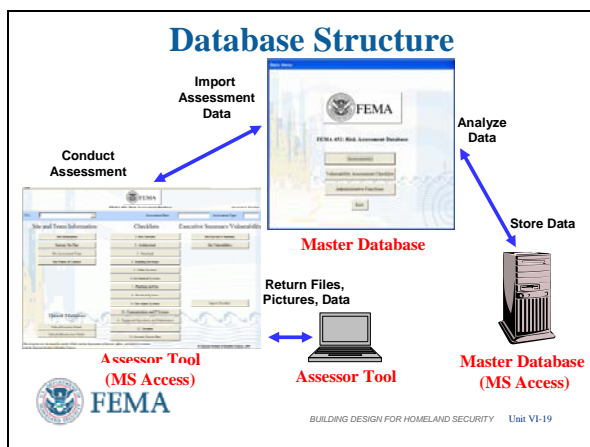

Database Overview

This diagram shows how the two databases interact. When an organization collects information and prepares to conduct an assessment of a site or a series of sites, the blank temporary Assessment Tool program is also prepared. Into this Assessment Tool is placed references, site plans, GIS portfolios, and other site specific data that is known about the assessment site or is developed during the pre-assessment phase. Loading this information can be done by a Program Manager before the assessment or by an Assessor during the assessment for Version 2.0. It has to be done by a Database Manager in Version 1.0.

This Assessment Tool is then given to the assessment team and is loaded on one or more assessment computers (usually laptop

computers). The assessment team then conducts the assessment and records information in the Assessor Database. At the end of the assessment, the assessment team combines their data, photos, and miscellaneous files into the Lead Assessor's database and folders and passes these files back to the Master Database Program Manager. The Program Manager then loads the data and files into the Master Database for printing and analysis.

VISUAL VI-20



### Open Assessor Tool

To open the Assessor Tool you first left click on <Start>, then <Programs>, and look for the <FEMA Assessor Tool> to left click. The FEMA Assessor Tool will be at the end of the Startup Program Menu after the installation.

You can move the buttons for the FEMA Assessment Tool and / or the FEMA Master Assessment Database to another location within the Startup Menu at any time, such as in alphabetical order. Simply drag and drop.

VISUAL VI-21

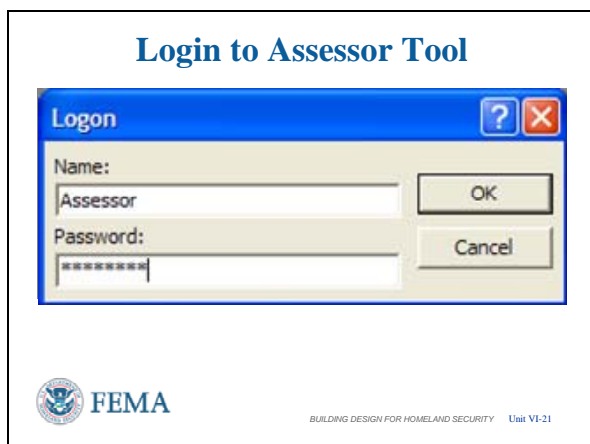

### Open Assessor Tool

The first action to enter the Assessment Tool is the Logon. You can enter the Assessment Tool as an Assessor. The initial Password is Assessor.

A Database Manager or Database Administrator is needed to change the Logon Names and Passwords.

## VISUAL VI-22

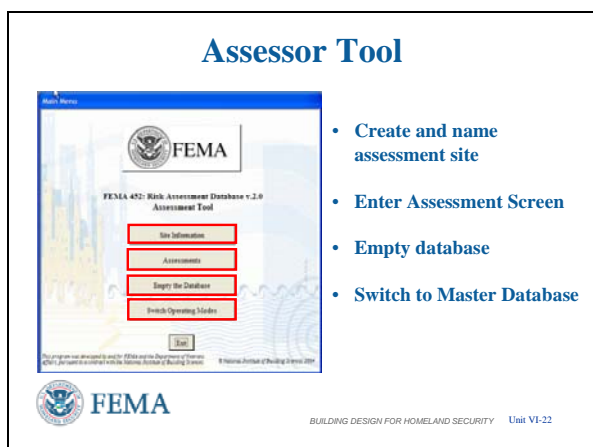

## Open Assessor Tool

This is the main page of the Assessor Tool in Version 2. It is not found in Version 1 which goes directly to the Assessment screen. [Left Click to advance the slide bullets as you brief.]

- The first action is to identify the site assessment in the Assessment Tool by left clicking on <Site Information> and creating a new site. Any Assessor can create a site in the Assessment Tool. [Left Click to advance slide bullets.]
- If the Site Information has already been loaded, you can go directly to the assessment screen by left clicking on <Assessments>. [Left Click to advance slide bullets.]
- Assessor laptops have limited storage capacity and can become bogged down by continuing to store many assessments. The <Empty Database> feature allows clearing of the database (with multiple requests for confirmation). Copy the database and all other collected information to a CD before emptying, as Assessors may find it beneficial to refer to similar entries from previous assessments, especially recommended mitigation measures for similar vulnerabilities. To save time recommend using a consistent filing / naming system to find past assessments.
  - **Note:** <Empty Database> **cleans** Site Information, Team Members, Points of Contact, Observations, Recommendations, Vulnerabilities, Status, Costs, and the Executive Summary for ALL sites in the Assessment Tool database.
  - However, it does **NOT** empty the GIS Portfolio, Miscellaneous Files, and Photos in their separate subfolders, as these are not part of the Microsoft Access database. Thus, these files

have to be deleted separately after using the same filing / naming system for recording.

[Left Click to advance slide bullets.]

- The <Switch Operating Modes> tab takes you to the Master Database features and allows the Assessor to use the reports feature to check the final look of the information entered, to identify / prevent duplicate entries, and to easily review the information rather than having to scroll through the Assessment Tool database. [Left Click to Advance Slide Action]

In the next slide we will create a new site in Site Information.

VISUAL VI-23

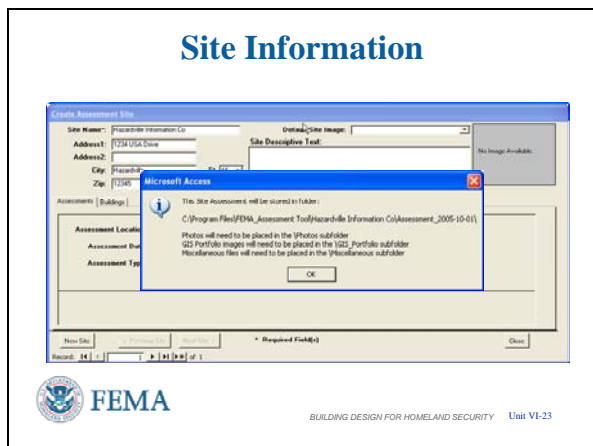

### Assessor Tool – Site Information

The first time you enter the database (with no prior assessments entered), click <Site Information> and the software will immediately go to the <Create Assessment Site> input screen. If assessments have already been entered, then a new assessment can be created by left clicking on the <New Site> button in the lower left corner.

Note the asterisked (\*) entries that are the minimum required to create a site: Site Name, Assessment Location, Assessment Date, and Assessment Type. Site Name, Assessment Location, and Assessment Date are self explanatory. However, Assessment Type needs some clarification. Refer to FEMA 452, Page 3-2, for information on Assessment Type / Level of Assessment. [This information is in the **Instructor Notes** in the left column under the slide for instructor ease of access.]

### Instructor Notes: Assessment Type / Level of Assessment

1. **Tier 1.** A Tier 1 assessment is a screening phase that identifies the primary vulnerabilities and mitigation options, and is a “70 percent” assessment (see Table 3-1). A Tier 1 assessment can typically be conducted by one or two experienced assessment professionals in approximately 2 days with the building owner and key staff; it involves a “quick look” at the site perimeter, building, core functions, infrastructure, drawings, and plans. A Tier 1 assessment will likely be

When data input is complete, left click <Close> to create the Assessment Site.

- **Note** that <Close> is the standard method to move between screens in the Assessment Tool, except for one instance

sufficient for the majority of commercial buildings and other noncritical facilities and infrastructure.

2. **Tier 2.** A Tier 2 assessment is a full on-site evaluation by assessment specialists that provides a robust evaluation of system interdependencies, vulnerabilities, and mitigation options; it is a “90 percent” assessment solution (see Table 3-2). A Tier 2 assessment typically requires three to five assessment specialists, can be completed in 3 to 5 days, and requires significant key building staff participation (e.g., providing access to all site and building areas, systems, and infrastructure) and an in-depth review of building design documents, drawings, and plans. A Tier 2 assessment is likely to be sufficient for most high-risk buildings such as iconic commercial buildings, government facilities, schools, hospitals, and other designated high value infrastructure assets.

**Tier 3.** A Tier 3 assessment is a detailed evaluation of the building using blast and weapons of mass destruction (WMD) models to determine building response, survivability, and recovery, and the development of mitigation options. A Tier 3 assessment (see Table 3-3) typically involves engineering and scientific experts and requires detailed design information, including drawings and other building information. Modeling and analysis can often take several days or weeks and is typically performed for high value and critical infrastructure assets. The Assessment Team is not defined for this tier; however, it could be composed of 8 to 12 people.

where there is no <Close> button.

- **Always** use the <Close> button if one is available.

When you create the site, the software automatically creates subfolders named GIS Portfolio, Miscellaneous Files, and Photos, all under a main folder that uses the assessment location and assessment date as the main folder name. If you changed the program location using Custom Installation, then you should make note of the file path that these subfolders are placed in, as you will need that information to properly load and link the contents of these subfolders to the Assessment Tool database.

Left click <OK> to finish creating the Assessment Site.

[Note to instructor – this may be a good place to use a laser pointer to show these entries as they are being mentioned.]



VISUAL VI-24

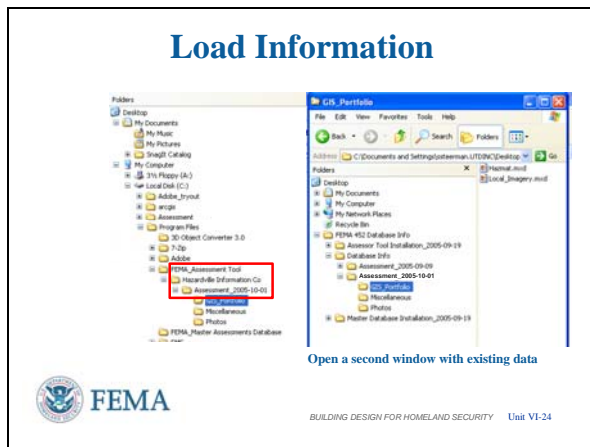

### Assessor Tool – Load Added Files

Let's look at the process to load the information into these newly created subfolders.

- First open My Computer or Windows Explorer to find the storage locations created by the Site Information creation process.
  - Folder names must match Assessment Location and Date to ensure future linkages for loading
- Next, open another window in My Computer or Windows Explorer to find the information collected either before or during the assessment.
  - **NOTE:** For student convenience, the Database CD contains subfolders that have the files shown in these slides to illustrate the transfer process.
- This example shows two GIS Images to transfer.

VISUAL VI-25

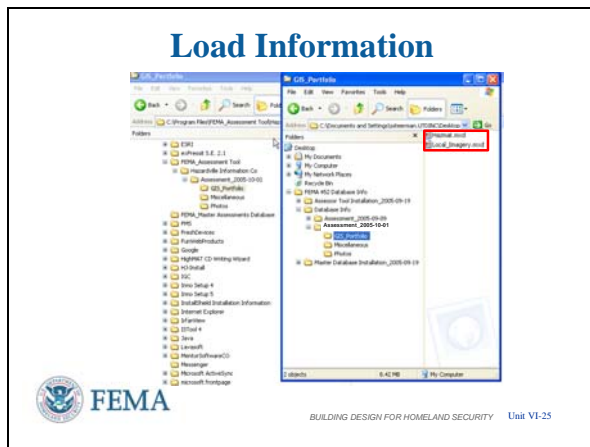

### Assessor Tool – Load Added Files

A Drag-and-Drop operation is shown to transfer the files to the necessary subfolders to later link with the database.

- To ensure copying depress <Shift> or <Ctrl> to get the small plus sign in a box, otherwise the files will be moved.
- You can also <Right Click> on the collected files, copy them by left clicking <Copy> in the pull down menu, and then move to the necessary subfolders, <Right Click> on the appropriate folder, then paste by left clicking <Paste> in the pull down menu.
- Just ensure that all files are transferred – either copied or moved into the necessary subfolder with the GIS Portfolio being shown here.

VISUAL VI-26

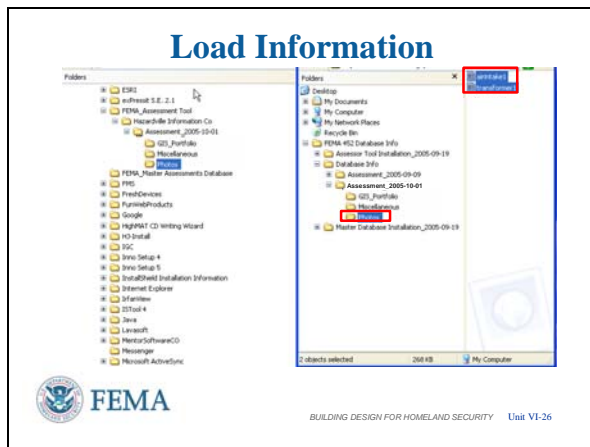

Assessor Tool – Load Added Files

The same Drag-and-Drop operation between the two windows allows transfer of the files contained in the folders marked Miscellaneous and Photos.

VISUAL VI -27

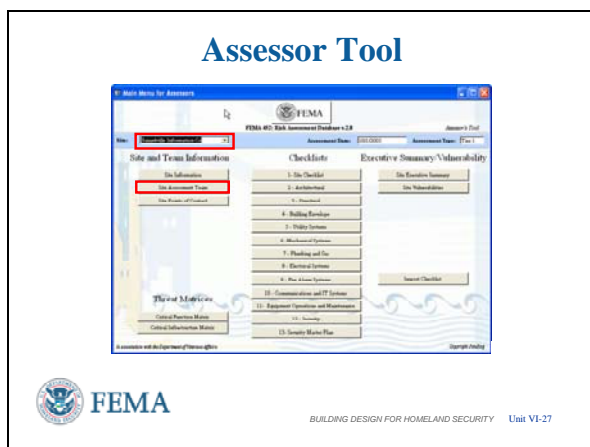

Assessor Tool – Team Members

From the **Assessment Tool Main Menu**, left click on <Assessments> to enter the Main Menu for Assessors.

[Slide VI-22 (Assessment Tool Main Menu) shows where <Site Information> was entered first and the second button is <Assessments>]

The first action on this screen is to choose an assessment site, since several may be loaded. This is done using the pull-down list in the “Site:” window in the top left corner.

The list will show the names of the sites that have been loaded. Once an assessment site has been chosen, the Assessor can go into any of the data entry areas: Site Information, Team Information, Site Points of Contact, Threat Matrices, Checklists, Executive Summary or Site Vulnerabilities.

Left click on <Site Assessment Team> to start entering data.

VISUAL VI-28



Assessor Tool – Team Members

The Site Assessment Team tab takes the Assessor to fill-in-the-blank lists for keeping track of Team Members.

Left Click on <Add New Team Member> to access the input screen.

VISUAL VI-29

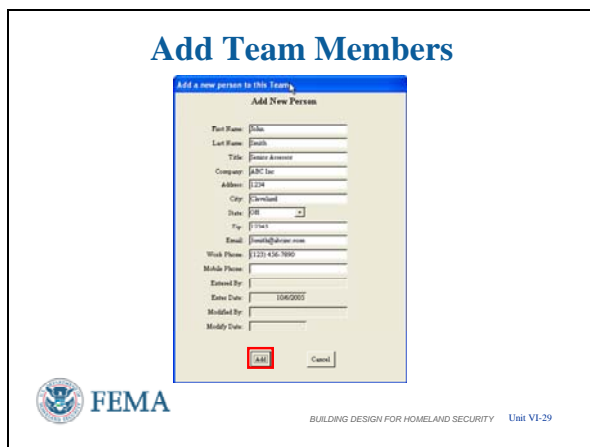

Assessor Tool – Team Members

Fill in this screen with as much information as is available or desired.

Then left click the <Add> button to place this team member in the database.

VISUAL VI-30

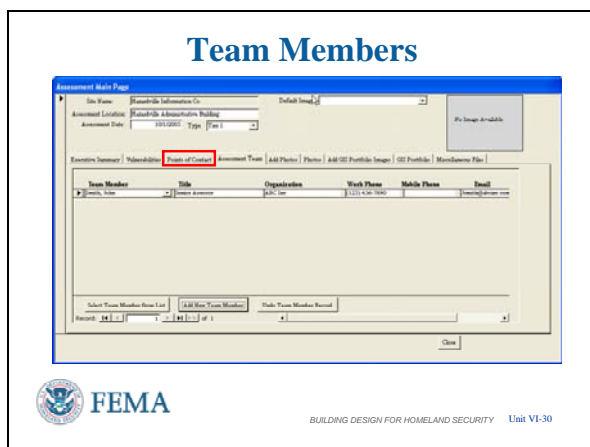

Assessor Tool – Team Members

After adding the Team Member, you are taken back to the Team Members List and you can see the information entered.

- Use the slide scale or direction arrows in the lower right to see the remaining information.
- The other buttons allow you to select the Team Member from a List or remove the Team Member from this assessment.
- At this point you can left click <Close> to go back to the Assessments screen or you can continue loading information using the

VISUAL VI-31

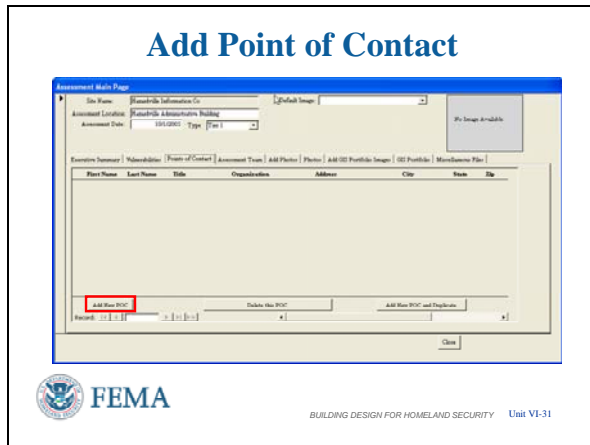

tabs in the middle of the screen.

- Let us now go to the <Points of Contact> by left clicking the tab.

**Assessor Tool – Points of Contact**

The Points of Contact tab takes the Assessor to the Points of Contact screen for keeping track of the people to be contacted during the assessment or that were identified and met during the assessment.

- The buttons across the bottom allow you to add or delete Points of Contact as needed. Let’s add a POC by left clicking on <Add New POC>.

VISUAL VI-32

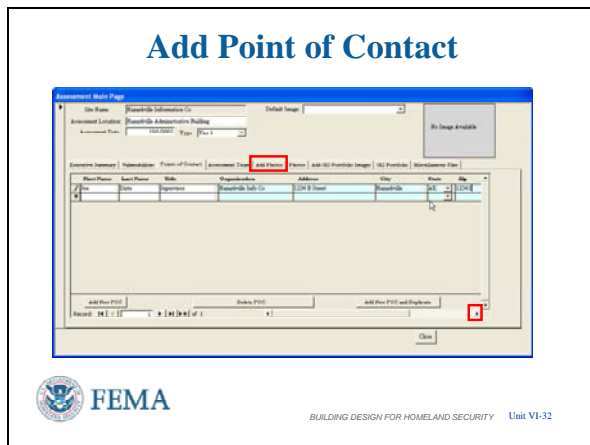

**Assessor Tool – Points of Contact**

This input screen is different than the Team Members input screen as you enter the information directly in each cell. You can enter the information and move to the next cell by using the <Tab> or by <Left Clicking on the Cell directly>.

- Use the bar or arrow in the lower right to move the screen to see the remaining information on the POC line.
- Then you must press <Enter> after the cells are complete to add the information to the database.
- There’s even a feature in the POC list to duplicate the address from previous entries. Just <Left Click> the left column to get the right arrow on the entry to indicate selection. Then by left clicking on the tab <Add New POC and Duplicate> the light blue blocks will be duplicated on the next entry line. This is useful because it is likely that many, if not all, of the POC’s will share the same business address.

- Continuing with the data entries, we next go directly to Adding Photos by left clicking on the <Add Photos> tab in the center of the screen.

VISUAL VI-33

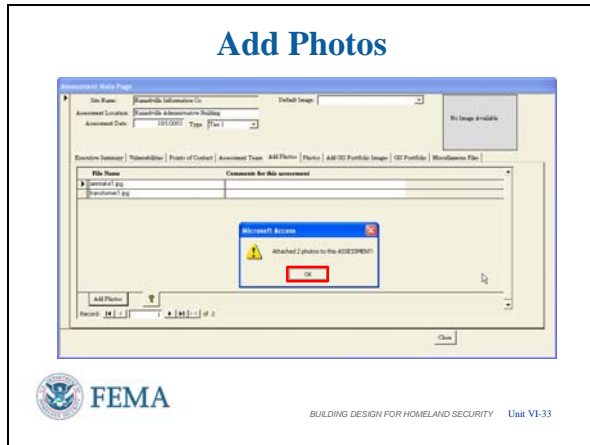

### Assessor Tool – Link and Load Added Files

Even though we have placed the GIS Portfolio, Miscellaneous Files, and Photos into the proper subfolders, we must still link them to the database in a two step process.

- In the Add Photos screen we first left click the <Add Photos> button in the lower left to perform the first step.
- The software confirms that the files were added and attached as indicated by their entry in the list. Left click <OK> to continue with each pop up that confirms the process to this point.

VISUAL VI-34

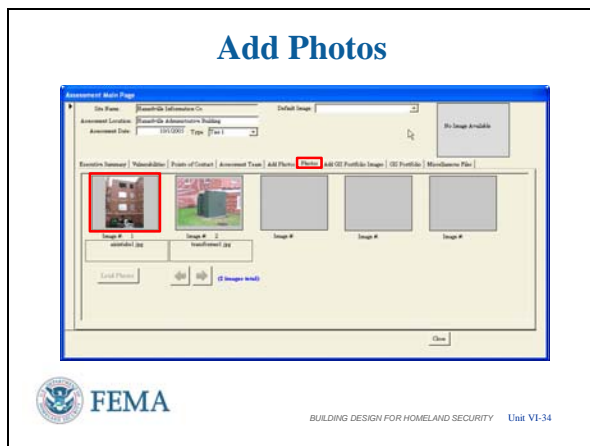

### Assessor Tool – Link and Load Added Files

- Next you have to left click on the <Photos> tab to continue the process.
- Then left click the <Load Photos> tab in the lower left corner.
- Once in the Photos screen, you need to left click on <Load Photos> in the lower left corner, which makes the linked photos visible within the Assessor Tool.
- Then thumbnails of the photos loaded are shown. Left click on the a thumbnail to see additional features

VISUAL VI-35



### Assessor Tool – Link and Load Added Files

- After left clicking on a photo, a Photo Zoom screen appears which gives a limited capability for viewing the photo in different sizes. Left click the tabs <Zoom>, <Clip>, or <Internet Explorer> across the bottom of the photo to see the differences.
- When done, left click <Close> to exit.

VISUAL VI-36

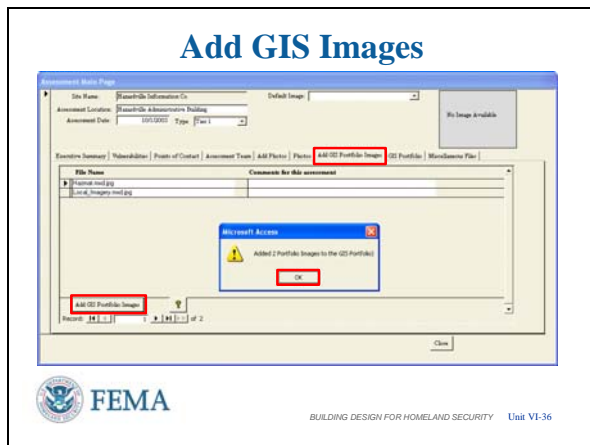

### Assessor Tool – Link and Load Added Files

- Continuing with the linking of collected data. You can next left click on the <Add GIS Portfolio Images> tab in the center of the screen.
- Then left click on the <Add GIS Portfolio Images> in the lower left corner. This then lists all the GIS Portfolio Images
- As with Photos, adding GIS Portfolio Images goes through the notifications of adding the images and attaching the images. Left click <OK> on the pop-up that confirms the images have been loaded.

VISUAL VI-37

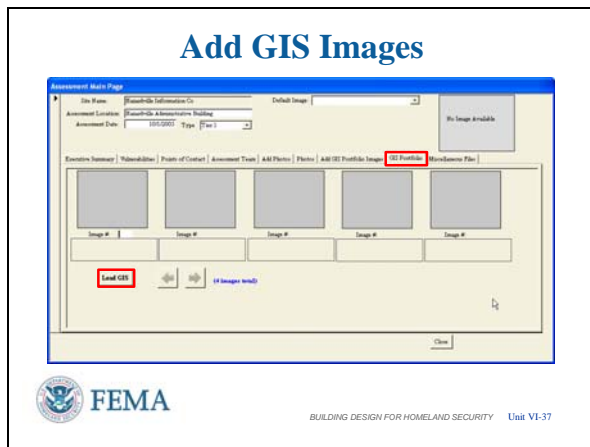

Assessor Tool – Link and Load Added Files

The process is the same when loading the GIS Portfolio Images.

- Left click on the <GIS Portfolio> button in the center of the screen.
- Then left click on the <Load GIS> tab in the lower left corner.

VISUAL VI-38

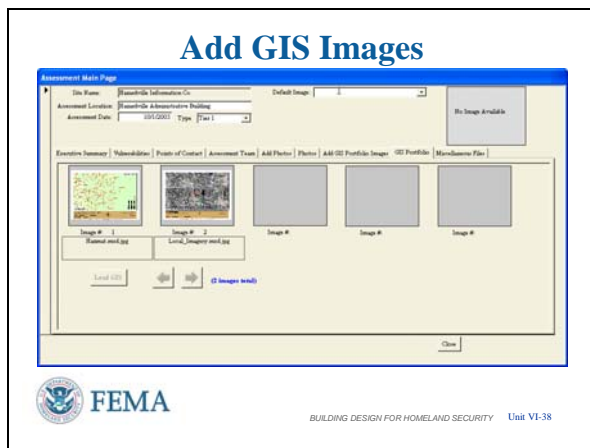

Assessor Tool – Link and Load Added Files

- The GIS Images have the same capability as Photos by left clicking on the images and seeing them in other sizes.
- Completing the GIS Images collected data entry process, left click next on the <Miscellaneous Files> tab.

VISUAL VI-39

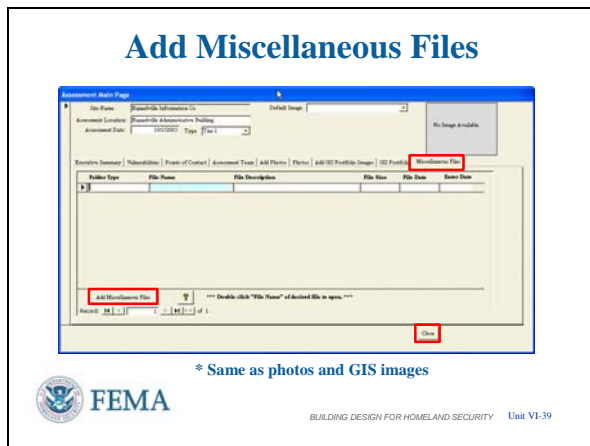

Assessor Tool – Link and Load Added Files

The process for Miscellaneous files is the same as for Photos and GIS Images.



VISUAL VI-40



Assessor Tool – Threat Matrices

After the available preliminary information is loaded, you can work the Threat Matrices for Critical Functions and Critical Infrastructure. This is an electronic way of collecting the information you recorded by hand yesterday.

To get to these screens choose an assessment site and left click the <Critical Functions Matrix> in the lower left corner of the Main Menu for Assessors to start the review.

VISUAL VI-41

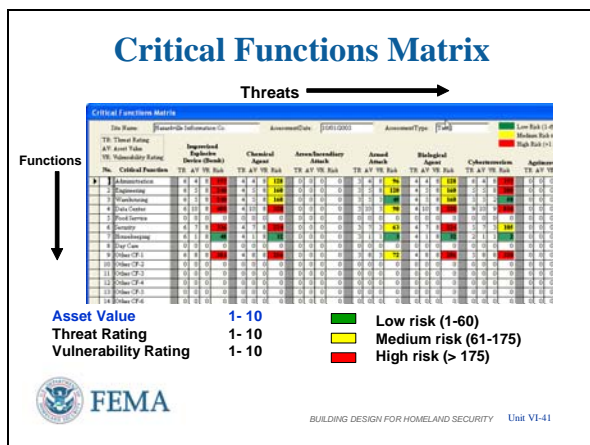

Assessor Tool – Threat Matrices

Selecting the <Critical Function Matrix> button will display this screen. Listed are a range of established threats and functions. The matrix allows entry of Threat Rating, Asset Value, and Vulnerability Rating following the 1 to 10 scale as listed in FEMA 452. The Risk Rating is then automatically computed and color coded according to the established scale.

To maintain the FEMA 452 process, the basic Threats and Functions can not be renamed. However, there are unassigned placeholders that can be used to record an organization’s unique Critical Functions and Threats. The placeholders for functions are listed under the Critical Function column as “Other CF-1” to “Other CF-10”. The threat placeholders are listed across the top of the matrix as “Other 1” and “Other 2”. Organizations can designate a meaning for a placeholder, use the placeholder to collect data, then after exporting the matrix to Microsoft Excel®, change the name of the placeholder to a specific threats or function.



VISUAL VI-42



**Assessor Tool – Threat Matrices**

The next step is to enter the Critical Infrastructure Threat Matrix to input this information as part of the assessment.

Left click the <Critical Infrastructure > button.

VISUAL VI-43

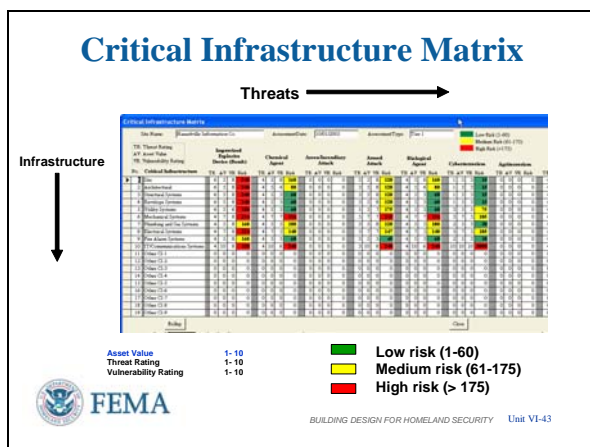

**Assessor Tool – Threat Matrices**

As with the Critical Functions Threat Matrix, you get a range of established threats and functions with some “Blank / Unnamed” entries to track specific threats and functions. The matrix uses the 1 to 10 scale for Asset Value, Threat Rating, and Vulnerability Rating. The Risk Rating is similarly computed and color coded.

VISUAL VI-44

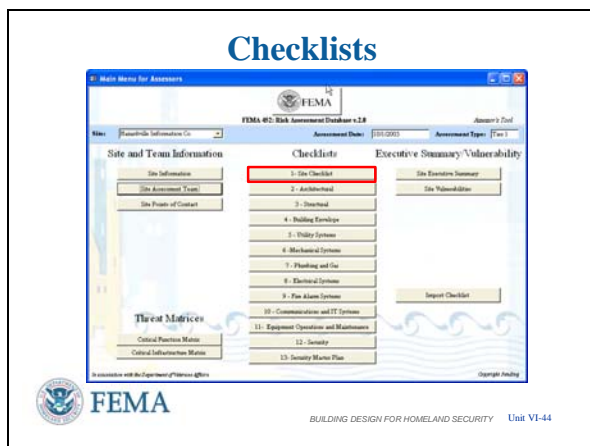

**Assessor Tool – Checklists**

The 13 checklist categories, as in FEMA 426, run down the middle of the Main Menu for Assessors screen. Select an assessment site, then left click on the <1 – Site Checklist> as an example.

We can then see the format of all checklists within the Assessment Tool.

VISUAL VI-45

Q#	Observation	Recommendation/Remediation	Value?	Vulnerability Assessment Question	Guidance
1.1	Three Critical Element Facilities within 1/4 mile and a Home Run II SADMAT Facility within 7 miles. Major interstates highway within 1/4 mile. Two railroads have tracks within 1/2 mile with no restrictions on automatic control. Fuel supply located near facility.	Excluded effects of attack or accident impact EC - similar to CBE attack. See recommendations for NIMC system.		What major structures surround the facility (city or building)? - What critical infrastructure, government, military, or sensitive facilities are in the local area that impact transportation, utilities, and related systems critical to the facility operation?	Examine infrastructure to consider include - Telecommunication infrastructure - Facilities for broadcast TV, radio, TV, cellular networks, emergency services, gas/diesel, and distribution, radio stations, cables, bus stations, libraries, hospitals and... Dependence on low water can bring heavy rains, which raised recommendations by providing tanks, and reduce the effectiveness of any fire fighting - Reference: USAF Facilities Fire Protection Guide.
1.2	The site is above the flood plain and the used parking area dips away from the building to a stream, which allows water to pour over the structure unobstructed.	None		Does the terrain place the building in a exposure or low area?	
1.3	With a building deck on the west side, it is possible for vehicles to park right next to the building. Normal parking for employees is in front, the closest one is 40 feet from the front fence.	Increased stand-off or increased access control is needed to reduce risk of vehicle-borne unexploded ordnance device. Any action will require coordination with Bureau Park Management and other tenants due to impacts on the overall business park.		Do buses, school buses, fire trucks have parking places uncontrolled parked vehicle incompatible close to a building in public right-of-way?	Where distance from the building to the nearest curb provide sufficient setback, restrict parking to the curb lane. For typical city streets this may require engineering to close the curb-lane. In-Road is common terminology for the distance between a building and...

Assessor Tool – Checklists

The Site Checklist is like all the other checklists.

- The first column contains an arrow to indicate which row is selected for data entry.
- The second column on the left is the checklist question number [Section Number – Question Number]
- The third column is the Observation made during the assessment. This could describe a vulnerability identified by the Assessor.
  - **Note:** Since reports do not include the original questions to save space, it is prudent to draft your answer so that it includes the question information to that the answer can be understood.
- The fourth column is the Recommendation / Remediation made by the Assessor to mitigate concerns with this question and observation.
  - **Note:** Similar to Observations, include some understanding of the question when drafting the Recommendation/ Remediation so that it too can stand alone in a report.
- The fifth column is reserved for identifying the questions which have an observation identified as a vulnerability.
- The sixth column is the question itself, taken right from the FEMA 426 Building Vulnerability Assessment Checklist.
- The seventh column is the guidance associated with that question, also found in the FEMA 426 Building Vulnerability Assessment Checklist.
- [Left Click] The Observation and Recommendation / Remediation boxes can accept inputs into the database. The Left Click will highlight each box.
- [Left Click] The boxes can have

information as shown. The Left Click shows all six boxes populated with some information.

- [Left Click] Question 1-3 was identified by the Assessor as a vulnerability to consider. He places a check mark in the box by putting the pointer on the box and left clicking.
  - **Note 1:** The software indicates that more information – building number and priority – will be sought when the Vulnerabilities Screen is opened.
  - **Note 2:** Each time a checkmark is placed in this box, another entry is placed in the Vulnerabilities Section.
- When all the information is input to the visible screen, you can scroll the screen using the right side vertical slide bar or use the question selector in the lower left corner to get to the question desired.

As before, when finished left click on the <Close> button in the lower right corner to go back to the Assessment Screen.

VISUAL VI-46

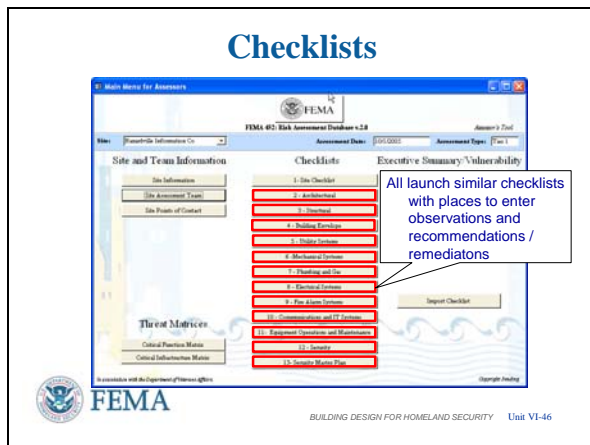

### Assessor Tool – Checklists

The remaining buttons in the Checklist column all function the same way to capture observations and recommendations or remediations.

VISUAL VI-47



### Assessor Tool – Executive Summary

The Site Executive Summary section of the Assessment Tool allows an Assessor, usually the Lead Assessor, to write a page to summarize general information about the facility and this assessment.

Left clicking on the <Site Executive Summary> tab will take you to that screen.

VISUAL VI-48

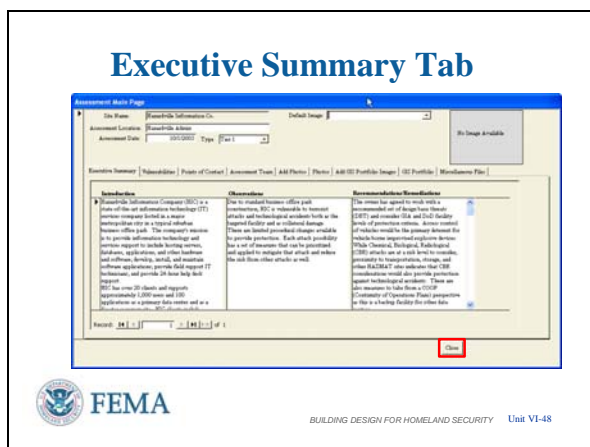

### Assessor Tool – Executive Summary

The Site Executive Summary section of the Assessment Tool provides three fields for the Lead Assessor (or Team Leader) to summarize general information about the facility and this assessment. When printed, these three fields appear as a single document with three main sections: Introduction, Observations, and Recommendations / Remediations.

- The Introduction field should contain some background information, site location, mission, dates, etc. The Observations field should contain general information about what was found, but particularly, vulnerabilities...are they security related, critical infrastructure related, etc. Finally, the Recommendations / Remediations field is for general recommendations about current conditions, mitigation measures that are applicable to the major vulnerabilities and other pertinent information to consider.
- Note that you can use the tabs above the three fields to go from this section to many others to review information as necessary while writing the Executive

Summary.

- One word of caution regarding the Executive Summary: The import/export utility will not transfer this section of the tool between Assessors, so if an assessment team member other than the Lead Assessor fills in these fields, there are two ways to transfer the information between laptops: one method is for the drafter of the Executive Summary to switch to Master Database mode, go to Site Reports / Executive Summary / Publish as a Word Document / Save the Word Document where it can then be transferred to the Lead Assessor as a Word Document file. An alternative is to cut and paste the three paragraphs into a document and transfer the temporary document between computers. Then the Lead Assessor can cut and paste the individual paragraphs back into the Executive Summary.

Use <Close> to return to the Main Menu for Assessors Screen.

VISUAL VI-49

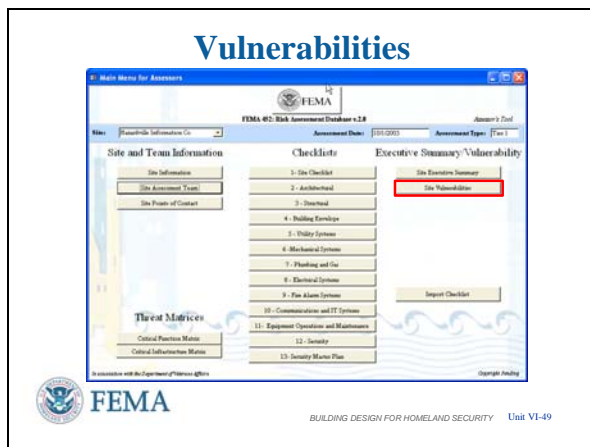

### Assessor Tool – Vulnerabilities

The Site Vulnerabilities section of the Assessment Tool provides a means to further analyze the vulnerabilities found during the assessment. By displaying on one list the site's vulnerabilities, their location and the initial recommended remediation, Assessors can determine common weaknesses and mediation strategies that will work for multiple vulnerabilities. This also aids in the analysis of prioritization for mediation.

Left clicking on the <Site Vulnerabilities> tab will take you to that screen.

VISUAL VI-50

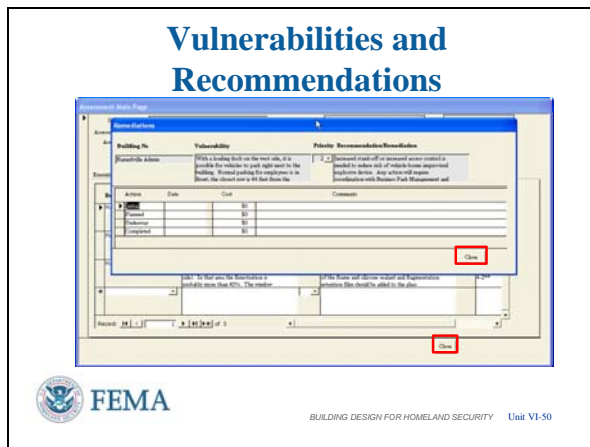

Assessor Tool – Vulnerabilities

This is the Vulnerability and Recommendation screen of the Assessment Tool. It is automatically populated with the previously entered Observations and Recommendation / Remediation when the “Vuln?” box is checked when completing a question on the checklists. Thus, the assessor believes that there is a sufficient Vulnerability rating to this Observation that remediation action should be identified and tracked. Note that the rightmost column of the page shows the checklist section from where vulnerabilities were transferred. Assessors can also populate the list by typing vulnerabilities onto the page (for example, a vulnerability identified that may not be associated with a checklist question).

This screen has two fields that must be completed as indicated when the checklist “Vuln? Box was checked:

- Record a building name or number in the first column to focus where this vulnerability is located.
- Prioritize the vulnerability so as to better identify which vulnerabilities require mitigation based upon the limited resources available – get the best benefit / cost ratio for reducing overall risk.
  - **CAUTION:** If a priority of 1-5 is not entered before the inputs are accepted by the database, the number will be set to zero and this entry will come out on the top of the vulnerability report.
  - Prioritization is based on the severity of the vulnerability and the availability of resources for mitigation as determined by the Program Manager or owning organization. For example: Priority 1 vulnerabilities are the most important

to mitigate...fix it now. Priority 5 vulnerabilities can wait until extra funds are available.

The Master Database can be searched based on this field...all Priority 1 vulnerabilities, all Priority 1 and 2 vulnerabilities, etc.

There are two other ways to get Vulnerabilities and Recommendations / Remediations into the fields:

- The Assessors can type them directly into the fields. They will not show linkage to specific checklist questions unless that information is also added.
- Vulnerabilities and Recommendations / Remediations can be imported from the Assessment Tools of other Assessors using the tool's import utility. In doing this, the Lead Assessor has the option of importing all of a Team Member's vulnerabilities and recommendations, or choosing specific ones to transfer.

Finally, the Assessment Tool allows an assessment team to provide a cost estimate (dollar values) to the individual recommendations: New fence \$100,000, Vehicle barriers \$25,000, etc.

- Left click on <Vulnerability Status / Cost> from the Site Vulnerabilities page to enter the Remediation module.
- The Program Manager can then track the cost information throughout the process to implement the recommendation.

Left click <Close> to exit the Remediations screen and left click <Close> to exit the Site Vulnerabilities screen.



VISUAL VI-51

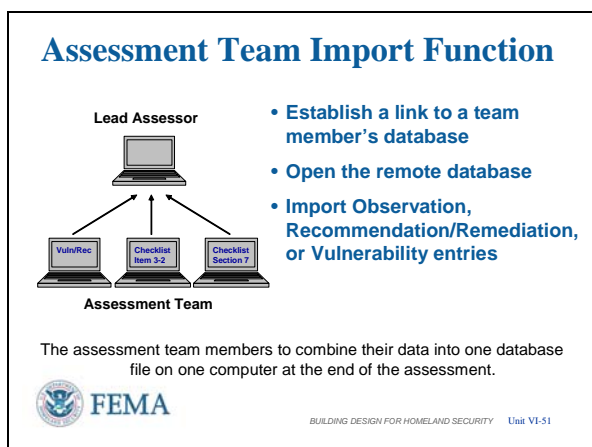

### Assessor Tool – Import Assessment Information

After the assessment team has completed its data collection effort, the checklist questions, vulnerabilities, and remediations have to be combined into one Assessment Tool database before the data can be transferred to the Master Database. This is accomplished by using the import function to transfer collected data from the Team Members Assessment Tool Databases to the Lead Assessor's Assessment Tool Database.

Let's say there are five members of the assessment team: A Lead Assessor, a Security Specialist, a Mechanical/Electrical Assessor, a Structural Engineer, and a Cost Estimator. Before the start of the assessment, the Lead Assessor (or Team Leader) should assign Checklist sections to each member of the team. For example, the Structural Engineer would do Checklist Sections 2, 3 and 4. Checklist sections can be split among team members; this makes importing only slightly more complex.

The import utility of the Assessment Tool allows the Lead Assessor to collect checklist observations and comments, along with vulnerabilities and the associated recommendations from the team members. This consolidated database is the responsibility of the Lead Assessor to ensure technical editing, consistency, and a flowing report to become part of the Master Database.

The process is simple but it takes some practice. The steps to remember are:

- Establish link to team member's database
- Open the remote database
- Import Observation, Recommendation / Remediation, or Vulnerability entries



VISUAL VI-52

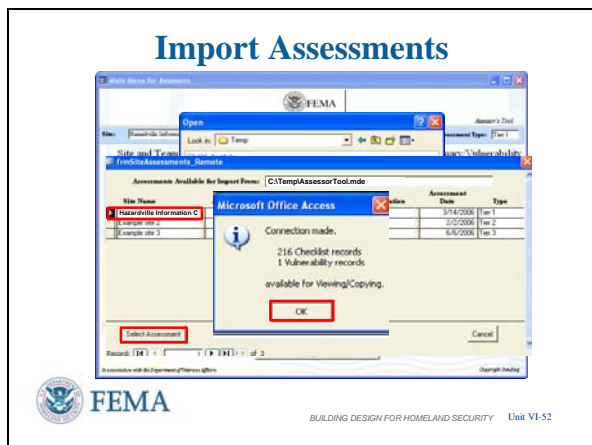

### Assessor Tool – Import Assessment Information

The first step is to establish a link between the Lead Assessors database and a copy of the team member's database.

- Each team member must copy his Assessment Tool database file to a transfer device -- a USB drive works well. The file will be a large (several dozen MB) Microsoft Access<sup>®</sup> MDE Database file.
- The Lead Assessor inserts the USB drive into his own laptop and copies the file into a working folder for the assessment site with a readily identifiable file name. Then, from the Main Menu for Assessors, the Lead Assessor should select the site being assessed from the pull down list, and click on the <Import Checklist> button.
- This brings up a request window to identify the file to select for import. Left click <Browse> to find the file.
- After finding the database file either double left click on the file or left click once on the file and then left click the <Open> button to have the file name and location appear in the field. Finish the process by left clicking on the <Import> button.
- This will bring up a window listing all the available assessment sites available to import. Click on the assessment site you want to link with, then click <Select Assessment> to establish a connection between databases.
- This will bring up a small window to indicate the connection between databases has been made, and # of Checklist records and # of Vulnerability records available for viewing and copying to the Lead Assessor's database.

**Warning:** It is important to realize that the wrong database can be imported as easily as

VISUAL VI-53

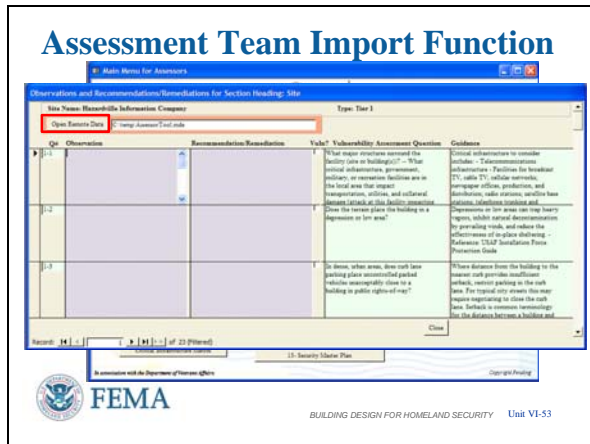

the correct one. It is imperative for the Lead Assessor to keep accurate track of files copied from other Assessors.

### Assessor Tool – Import Assessment Information

Once the link is complete, then the selection and importing the desired data into the Lead Assessor’s database is the next step.

- The Lead Assessor goes to the Checklist Section of the Main Menu for Assessors that he wants to import. Left click <1 – Site Checklist> to illustrate.
- The next screen is the standard checklist screen with one addition – there is a tab <Open Remote Database> and a window showing the linked database all framed in orange. Left click on the tab <Open Remote Database> to begin selecting data for importing.

VISUAL VI-54

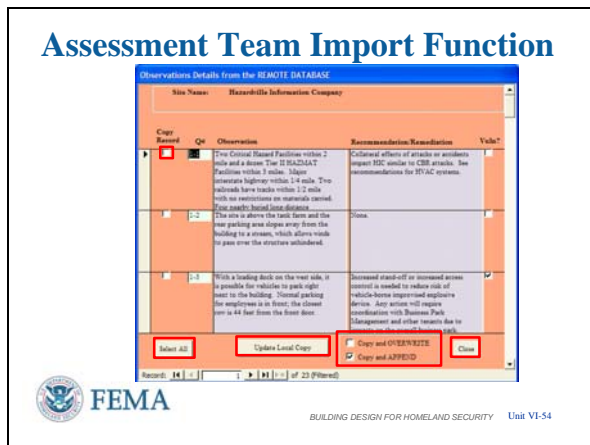

### Assessor Tool – Import Assessment Information

- The next screen shows the information in Section 1, Site Checklist, of the Remote Database.
- The Lead Assessor can then select the specific observations and comments he wants to import by putting a check mark in <Copy Record> [Left mouse click will highlight the <Copy Record> box in red.]
- Or choose <Select All> to input all questions and associated entries in this section. [Left mouse click will highlight the <Select All> tab in red.]
- The Lead Assessor has two options for how the new information is entered:
  - A checkmark in the <Copy and Append> box will add the information

- to what is already entered without changing the existing information.
- A checkmark in the <Copy and Overwrite> will overwrite anything previously entered.
- The default is <Copy and Append>.
- After making some or all selections to transfer to the Lead Assessor database, left click the <Update Local Copy> tab.
- Upon left clicking the <Close> tab to close the remote data selection window, you are taken back to the checklist screen. Notice that the data is now populated in the appropriate blocks.
- The process is the same for importing vulnerabilities and recommendations. This is a very handy tool, allowing the Lead Assessor to have all of the collected data in one computer in one database before leaving the site at the end of the assessment.

**Note:** Just as the GIS Portfolio Images, Miscellaneous Files, and Photos had to be placed into the appropriate subfolders, each Team Member must also provide these files on the USB thumb drive or other media for transfer to the Lead Assessor's computer and placement in the proper folders.

## VISUAL VI-55

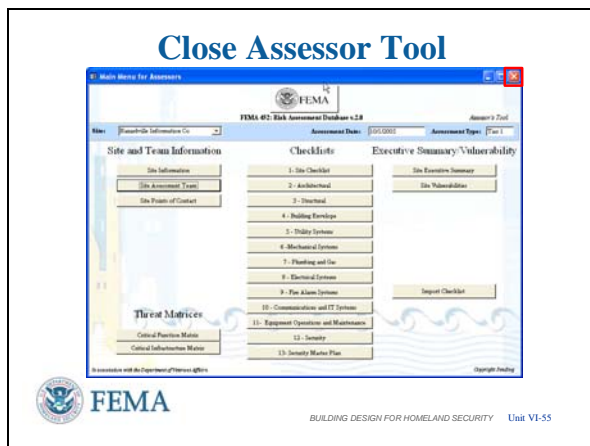

## Close Assessor Tool

Now it is time to show how to switch to the Master Database mode from the Assessor Tool. This is one of the few times in which the <X> box in the upper right corner is used, especially since there is no <Close> button Main Menu for Assessors to use.

- Left clicking on the <X> box returns the program to the Assessor Tool main page in Version 2.0.
- In Version 1.0 this would close the Assessor Tool completely.

VISUAL VI-56

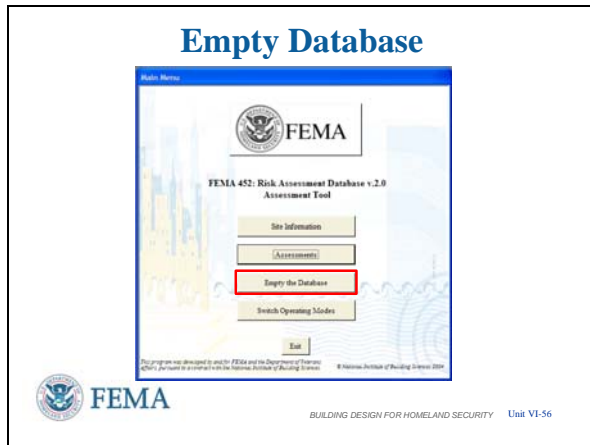

**Empty Assessor Database -- Erasing All Assessments in the Assessment Tool**

In Version 1.0, Database Administrators have the capability to erase all records in an Assessment Tool database, **permanently**. This is only done after transferring the data to a Master Database and when starting a new assessment. This enables an Assessor to start with an empty database for the new assessment. It also serves to control information. Note: this is permanent.

In Version 2.0, the Assessor or Program Manager can perform this complete operation.

**WARNING: Confirm you have transferred the information to the Master Database before you erase the data.**

Left click on <Empty the Database>. The next window confirms that you want to **permanently** erase all assessment data. Left click on <Yes> to continue or left <No or Cancel> to stop the process and retain all data in the database.

VISUAL VI-57

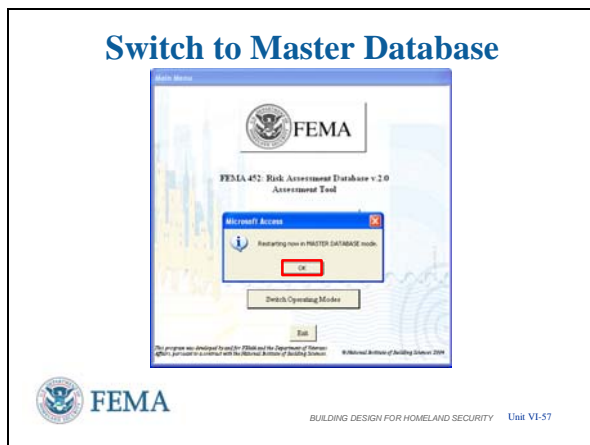

**Switch to Master Database Mode**

The last item on the main page of the Assessment Tool is the ability to switch to the Master Database mode. Switching is as simple as left clicking on the <Switch Operating Modes> button.

The next window confirms that you want to switch modes.

Left click on <Yes> to continue or the other buttons if you do not want to change modes.

Then another confirmation window pops up. Left click on <OK>.

VISUAL VI-58

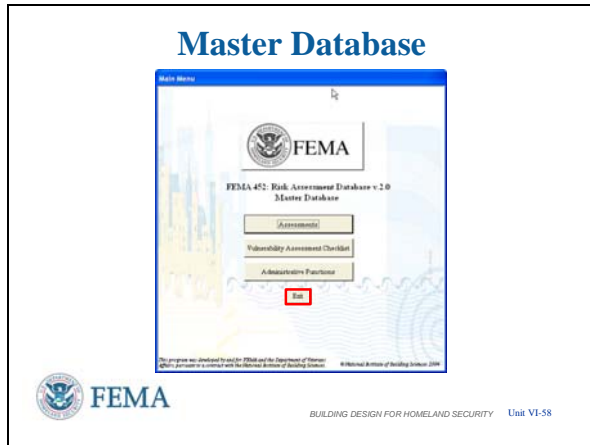

**Master Database Mode**

We are then in Master Database mode with the Master Database main page showing.

Because we logged in as Assessor we do not have all the features of the Master Database, such as importing assessments, but the available features are very useful to ensure the information provided will look correct in reports or use searches to see if information was entered. It also allows each Team Member to ensure duplication has not occurred due to inadvertent actions so as to provide a clean database to the Lead Assessor.

- For example, seeing what the Site Vulnerabilities Report looks like to ensure no ZERO priority entries were captured by mistake.

Left click on <Exit> and we will enter the Master Database directly, much in the same way that we entered the Assessor Tool.

VISUAL VI-59

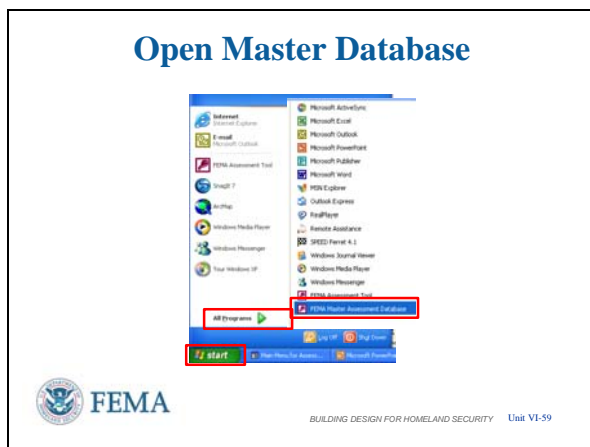

**Open Master Database**

The procedure to open the Master Database directly is very similar to opening the Assessor Tool.

- You first left click on <Start>, then <Programs>, and look for the <FEMA Master Assessment Database> to left click.
- The FEMA Master Assessment Database will be at the end of the Startup Program Menu after the installation, just like the Assessor Tool. You can move the entry for the FEMA Assessment Tool and / or the FEMA Master Assessment Database to another location within the Startup Menu at any time.

VISUAL VI-60



### Open Master Database

The first action to enter the Master Database is the Logon.

You can enter the Master Database as an Assessor or as an Administrator, with Administrator having more capabilities.

The Password is identical to the Name.

A Database Manager / Administrator is needed to change the Logon Names and Passwords.

VISUAL VI-61

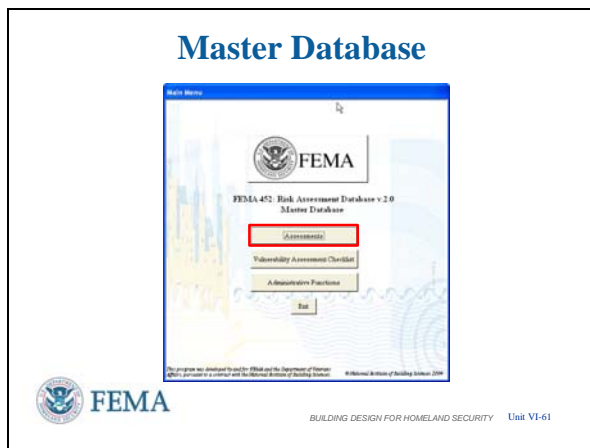

### Open Master Database

The Assessment Function gives the Program Manager or an Assessor the ability to review assessment data, photos and files, search for specific observations, vulnerabilities, etc.

Printing reports from individual sites or from the results of the searches is also a Master Database capability.

To begin this process left click on the <Assessments> button on the Main Menu.

VISUAL VI-62

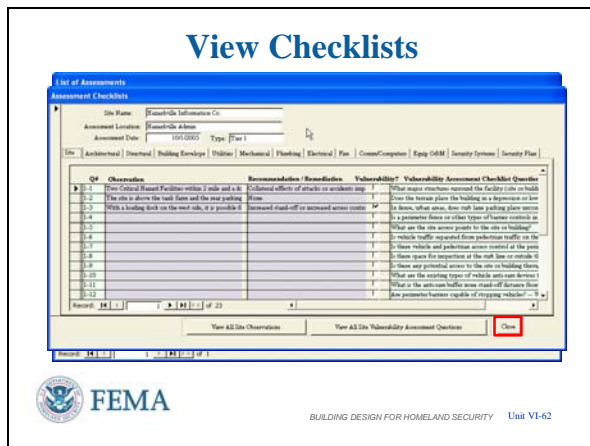

### Master Database - Checklists

- This form provides the Program Manager the ability to review assessment data, photos and files; search for specific observations, vulnerabilities, etc.; and print reports from individual sites or from the results of the searches.
- The first step is to select one of the assessments by left clicking on the far left column of the List of Assessments. This will mark the assessment desired with a right pointing arrow head if one is not already there. This selects the assessment and links the buttons across the bottom to



that assessment.

- All underlying screens mirror the screens for the same named items in the Assessor Tool, except for the Assessment Checklist. To investigate left click on the <Assessment Checklist> button.
- As can be seen the initial screen is a summary type slide showing the Site Checklist questions. Left clicking on any cell of a row retrieves underlying screens that look much the same as in the Assessor Tool.
- Alternately, left clicking on the <View Site Observations> button will expand all Site Checklist questions and show what has been entered in Observations and Recommendations. It also looks much like the Assessor Tool data entry screen.
- Similarly, left clicking on the <View All Site Vulnerability Assessment Questions> will make the Questions and Guidance more accessible and easier to read.
- Left click on <Close> to return to the List of Assessments

### VISUAL VI-63

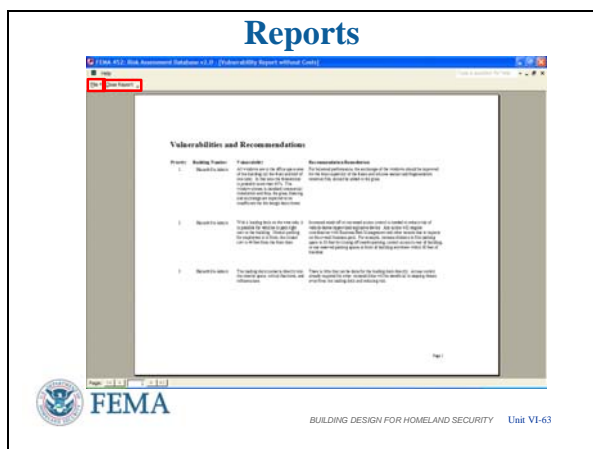

### Master Database - Reports

- Left click on the <Site Reports> button to bring up the standard reports and left click on <Vulnerabilities> button as the first Site Report to illustrate.
- The Vulnerability Site Report comes out as a Word document which can be sent to a printer or published and saved as a Word document using the <File> Pull Down Menu in the upper left corner.
- To close the report you will also find the <Close Report> button in the upper left corner vice the lower right corner as found on data entry screens.

VISUAL VI-64

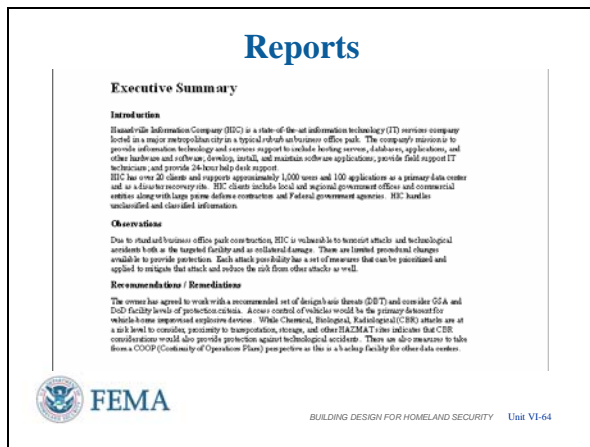

Master Database - Reports

Similarly, the Executive Summary can be printed directly or published and saved as a Word document. Thus, the intent is to make it very easy to collect information from the Master Database to be able to cut and paste into a Word Document report or Power Point presentation.

VISUAL VI-65

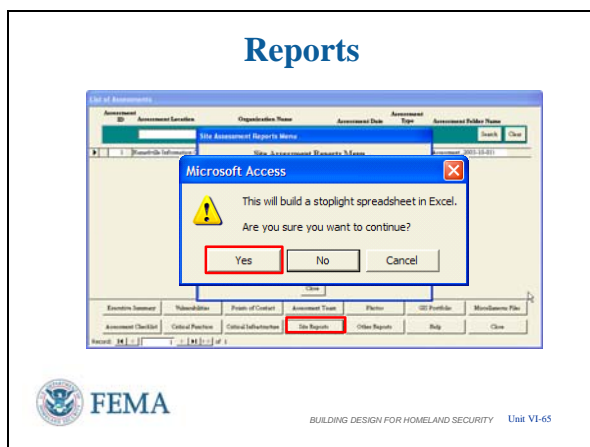

Master Database – Threat Matrix

Re-entering the Site Reports takes us to the Threat Matrix. This Report gets generated as an Excel spreadsheet as seen in the confirmation pop-up.

- Left click on <Yes> button to continue.

VISUAL VI-66

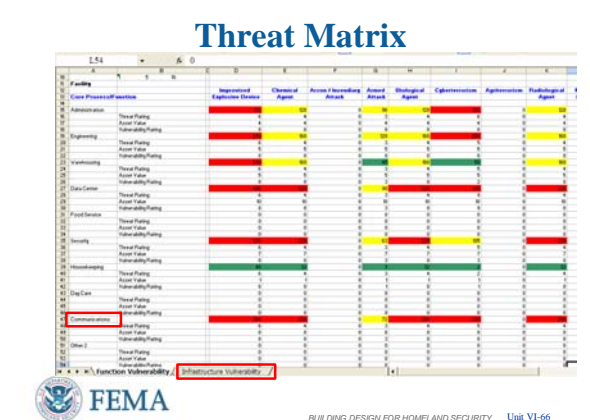

Master Database – Threat Matrix

The spreadsheets build in sequence starting with Function, then Infrastructure. Left click on the <Function Vulnerability> tab to bring it up.

- Since a Database Administrator is needed to change headings in the database, here is one way to ensure the threats, functions, and infrastructure headings are tracked by the general user.
  - For example, The Core Process / Function labeled in the database as Other 1 can be changed to Communications.



[Left click shows the change.]

- Also you need not enter information in all rows and columns if the Function or Threat is not applicable to that assessment.
  - See Food Service in the Function column and Arson / Incendiary Attack in the Threat row, respectively.
- The spreadsheet is Fully Interactive – any rating cell can be changed resulting in new totals and color adjustments in accordance with the risk assessment scale. Changes to any cell can be printed or saved with these changes.
- **Caution:** Changes made to either Spreadsheet do not work back into the Master Database. Those changes would have to be input separately into the database.

Left click on the <Infrastructure Vulnerability> tab to see that spreadsheet.

VISUAL VI-67

**Master Database – Threat Matrix**

The Infrastructure Threat Matrix spreadsheet has all the same features as the Function spreadsheet just illustrated.

The image shows a screenshot of a spreadsheet titled "Threat Matrix". The spreadsheet has a grid with rows representing different functions and columns representing different threats. The functions listed on the left include:
 

- Code of Infrastructure
- Site
- Accessibility
- Structure of Systems
- Structure Systems
- Utility Systems
- Information Systems
- Planning and Control Systems
- Chemical Systems
- Fire Safety Systems
- IT and Communications Systems

 The threats listed at the top are:
 

- Biological Agent
- Chemical Agent
- Explosive Device
- Arson / Incendiary Attack
- Biological Agent
- Cyberterrorism
- Agroterrorism
- Biological Agent

 Each cell in the grid contains a risk rating, represented by a color: red (High Risk), yellow (Medium Risk), and green (Low Risk). For example, the "Code of Infrastructure" row shows high risk for Biological Agent, Chemical Agent, and Arson / Incendiary Attack, and medium risk for Explosive Device. The "Site" row shows high risk for Arson / Incendiary Attack and medium risk for Biological Agent, Chemical Agent, and Explosive Device.

At the bottom left of the spreadsheet, there is a FEMA logo and the text "FEMA BUILDING DESIGN FOR HOMELAND SECURITY Unit VI-67".

VISUAL VI-68

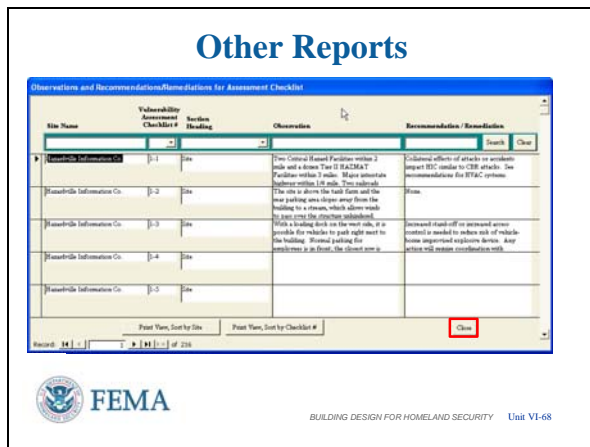

Master Database – Other Reports / Search

From the Master Database List of Assessments screen, left clicking on the <Other Reports> button takes us to the search function of the Master Database.

- The pop-up screen allows us to search Observations and Recommendations or be more focused in searching just the Vulnerabilities and Recommendations. Both work the same so we will enter the Observations / Recommendations to illustrate. Left click on the top button (<Search Observations>).
- The data entry boxes across the top allow selection of any of these inputs or searching on a word or phrase in those boxes throughout the Master Database using the <Search> button at the end of the row.
- Note that to start a new search you should left click on the <Clear> button next to the Search button, unless you desire to limit the search based upon the previous entries in the boxes.
- As before, left click <Close> to return to the previous screen.

VISUAL VI-69

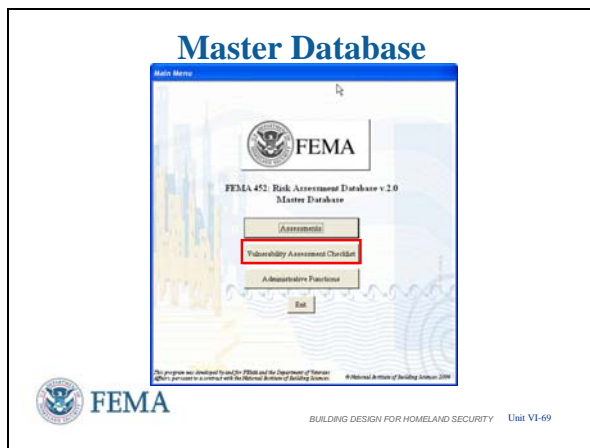

Master Database -- Vulnerability Assessment Checklist

The Vulnerability Assessment Checklist Function gives the Program Manager or Assessor the ability to view all answers for individual checklist questions. To begin this process left click on the <Vulnerability Assessment Checklist> button from the Main Menu.

VISUAL VI-70

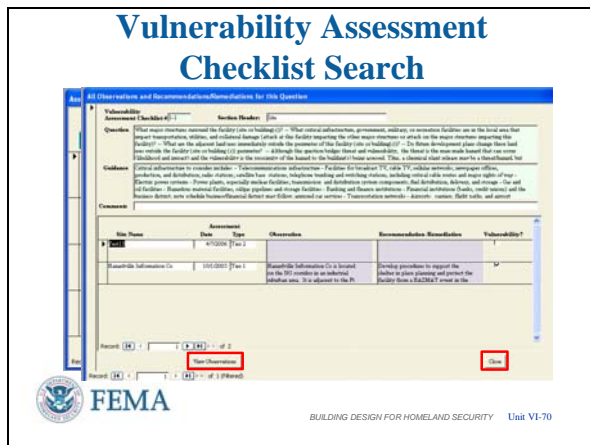

Master Database -- Vulnerability Assessment Checklist

This screen shows the all observations and recommendation / remediation answers for each assessment checklist question in the database.

- The right facing black arrowhead indicates the Checklist Question that is selected.
- The green search query bar allows the user quick access to the assessment questions by using a drop down menu to select the Checklist section. Keyword searching is also possible, similar to the search routine in the Master Database previously shown.
- The <Search> button performs search based on criteria entered into the fields described above. Subsequent searches will only be of the previous results unless the <Clear> button is first clicked.
- The <Clear> button will allow all questions to be seen again.
- Left clicking on the <View Questions / Observations> button opens the screen showing All Observations and Recommendations / Remediations in the database for this Question based on the question selected.
  - The question that is displayed is determined by the location of the arrow in the left column, not by the results of a search that was conducted.
  - It displays the question, guidance, and comments at the top of the screen. The bottom of the screen displays all information entered in the database for that specific question number.
- The <View Observations> button creates a report of all entries in the database for the designated question, including the question and guidance. The report can be printed or converted to Microsoft Word<sup>®</sup> for additional editing, formatting, etc. [Instructor Note: The report screen will not come up upon mouse click, the

VISUAL VI-71

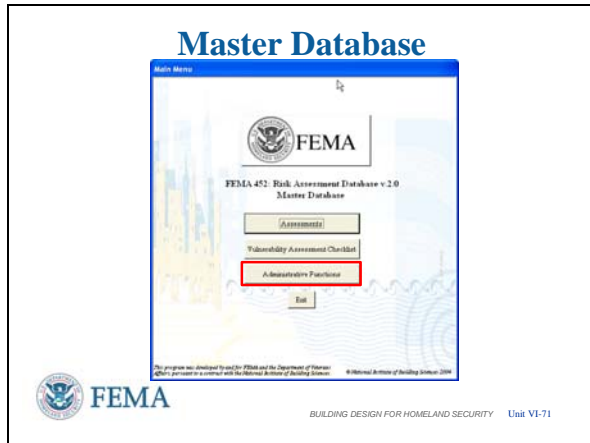

explanation above is sufficient.

- Left click <Close> in the lower right corner to go back to the Master Database Main Menu.

### Master Database – Administrative Functions

The final features needed to understand about the Master Database are the most important – the administrative functions. These include:

- Emptying the Master Database (if there is ever a reason to do this)
- Deleting an assessment from the Master Database (more likely if the wrong database is imported)
- Importing the Lead Assessor’s Assessment Tool database into the Master Database.

Begin by left clicking on the <Administrative Functions> button.

VISUAL VI-72

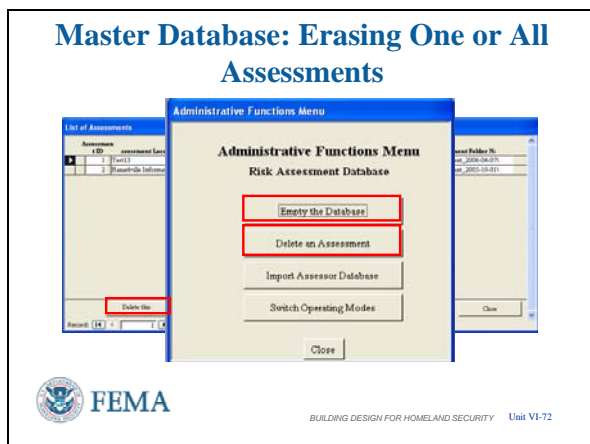

### Master Database – Administrative Functions

Erasing one or all assessments in the Master Database

Administrators have the ability to erase one or all records in the database, **permanently**.

Empty the Database is usually only done when starting a new program. Selecting the <Empty the Database> button opens a confirmation window, to ensure you want to permanently erase all assessment data. Left click on <Yes> to continue or <No or Cancel> if you do not.

Erasing a Single Assessment in the Master Database: This is usually only done when an assessment was loaded in error. Selecting the <Delete an Assessment> button opens a list of assessments. Select the assessment to erase, then left click <Delete This

Assessment>. This will open a confirmation window, to ensure you want to permanently erase the selected assessment. Left click on <Yes> to continue or <No or Cancel> if you do not.

VISUAL VI-73

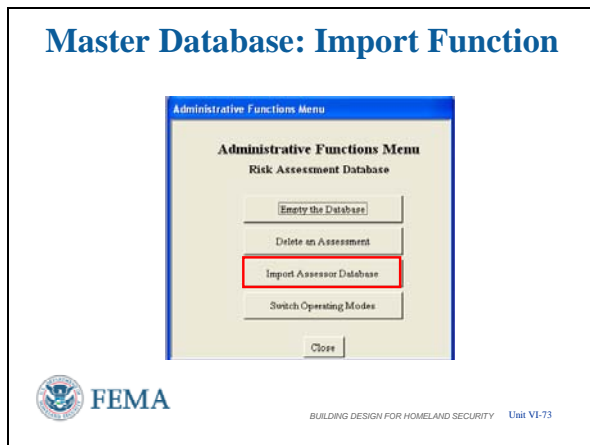

### Master Database -- Import Database

To import an Assessment Tool Database, left click on the <Import Assessor Database> button.

**NOTE 1:** if the <Import Assessor Database> button is grayed out, it means that you have entered the Master Database by switching modes from the Assessor Tool, or you logged into the Master Database as Assessor vice as Administrator. To Import always enter the Master Database as Administrator.

**NOTE 2:** The import function in Version 2.0 is a one-button operation with some additional linkages later. In Version 1.0, it is a manual operation taking 20 minutes by an Information Technology specialist, such as a Database Manager, knowledgeable in Microsoft Access.

VISUAL VI-74

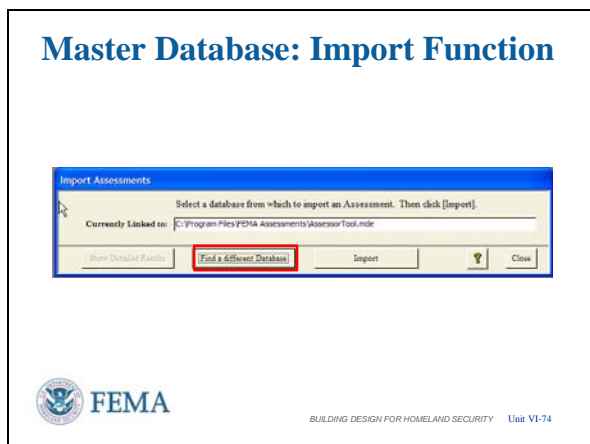

### Master Database -- Import Database

The first step is to find the Assessor Tool database to import.

- This screen opens with the file identified to which the Master Database is currently linked.
- Left click on the <Find a different Database> button to find the Assessor Tool database that you want to import.

VISUAL VI-75

### Master Database: Import Function

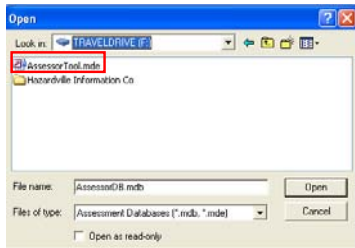

BUILDING DESIGN FOR HOMELAND SECURITY Unit VI-75

### Master Database -- Import Database

With this screen you identify the Assessor Tool database that you want to open in order to import it into the Master Database.

- Single left click on the file to import which will put that file into the File Name window; which then requires a left click on the <Open> button OR
- Double left click on the file as we do here to link to this file.

VISUAL VI-76

### Master Database: Import Function

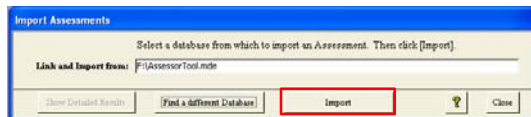

BUILDING DESIGN FOR HOMELAND SECURITY Unit VI-76

### Master Database -- Import Database

- Returning to the Imports Assessments screen the Link and Import window now correctly identifies the database to be imported.
- Now left click the <Import> button to initiate the import.

VISUAL VI-77

### Master Database: Import Function

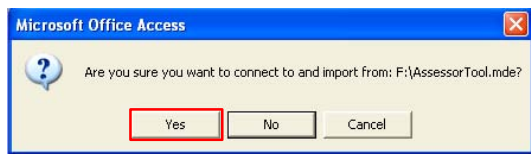

BUILDING DESIGN FOR HOMELAND SECURITY Unit VI-77

### Master Database -- Import Database

- A confirmation screen then pops up to ensure this is the desired action for the indicated file.
- Left click on <Yes> to continue.

VISUAL VI-78

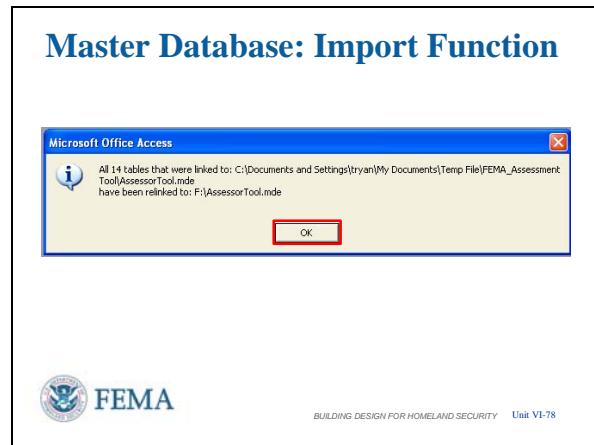

Master Database -- Import Database

- The import function confirms the linking to the desired database has been accomplished.
- Left click on <OK> to continue.

VISUAL VI-79

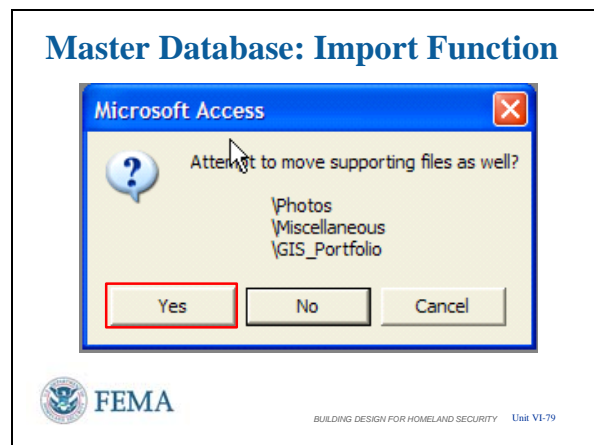

Master Database -- Import Database

- This is one feature not in the Assessor Tool. Instead of manually moving the files in these subfolders between locations as in the Assessor Tool, the import function of the Master Database allows a one-button operation to do the same thing.
  - As with the manual transfers in the Assessor Tool, it is equally important to ensure the folders in the Remote Database are properly named with the Assessment Location and Date to effect this transfer
- The supporting file folders must be using the same naming conventions and in the same name assessment folder as the imported database.
- Left click on <Yes> to make these transfers.



VISUAL VI-80

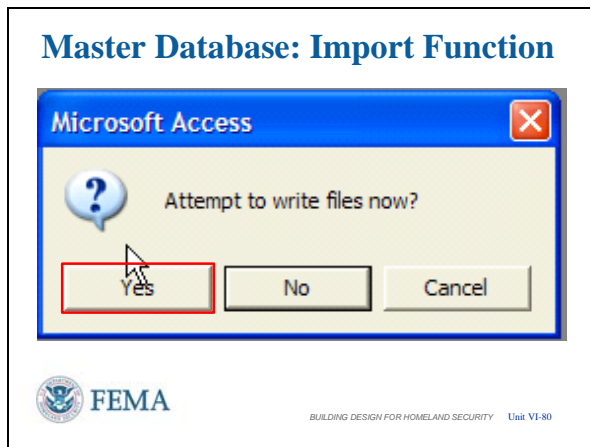

Master Database -- Import Database

- The final confirmation pop-up wants to know if you want to write the files now.
- Left click <Yes> to complete the import process.

VISUAL VI-81

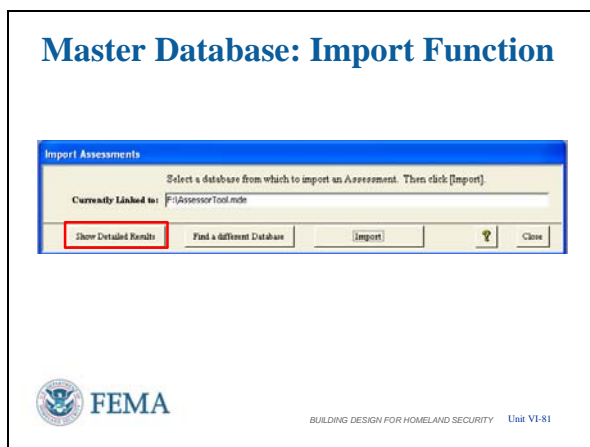

Master Database -- Import Database

- As in every process, it is always necessary to confirm that what you wanted to have done was actually done.
- Next left click on <Show Detailed Results> to check that all transfers were successful.

VISUAL VI-82

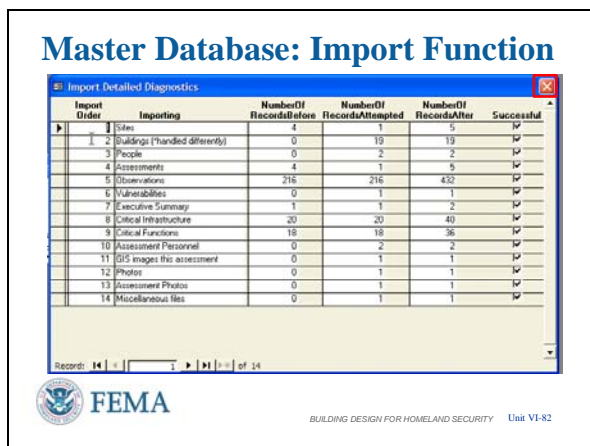

Master Database -- Import Database

- The Import Detailed Diagnostics screen shows what was in the Master Database before the import, the number of records attempted by the import, and the records after the import. The quick check is to scan the right hand Successful column to ensure all boxes are checked.
- Another check is to scan Row 4, Assessments. The number of assessments in being imported should match the number of assessments attempted.
- [Left Click] This is also one of the few times you left click on the <X> box in the



upper right corner to close the window and return to the previous screen.

### VISUAL VI-83

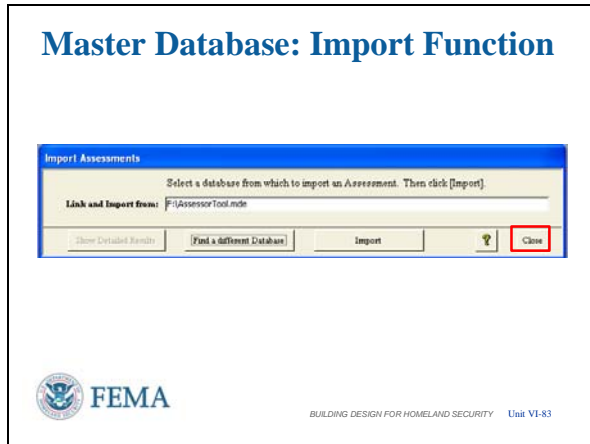

### Master Database -- Import Database

- That completes the import function.
- Left click on the <Close> button in the lower right corner to return to the Master Database main page

### VISUAL VI-84

#### Summary

- Installation and opening of databases
- Filing of GIS Portfolio, Miscellaneous, and Photos to link with the databases
- Moving about the database software and between the Assessor Tool and the Master Database
- Setting priorities on identified vulnerabilities and how the software handles it
- Production of standard reports and searching the database for specific information



BUILDING DESIGN FOR HOMELAND SECURITY Unit VI-84

#### Summary

You have been show how to:

- Install and open the Assessor Tool and the Master Database.
- Link collected data to the databases
- Move around the software and between the Assessor Tool and Master Database.
- Handle vulnerabilities, including setting of priorities
- Produce standard reports and searches for specific information showing the benefits of the FEMA 452 databases in performing a Risk Management Program.

### NO VISUAL

#### Student Activity

The student activity was having the students with laptops load the software and follow along in a Demonstration / Performance instruction methodology.

#### Transition

In the next unit, we will investigate the basics of Explosive Blast to better understand the value of mitigation measures presented.

**UNIT VI CASE STUDY ACTIVITY:  
FEMA 452 RISK ASSESSMENT DATABASE**

To this point the assessment procedures have been done manually to understand the thought process. Once the process is understood, the need to be able to manage assessment information, especially from multiple assessments, becomes evident. This unit shows the features of the FEMA 452 Risk Assessment Database v2.0, 5 April 2006, in a demonstration/performance instruction approach.

**Requirements**

Students ideally should have individual personal laptops that they have brought to the course. The instructor will provide a CD to each student at the beginning of this instruction block. The CD contains the install wizard programs to install the assessor tool database and master database on the laptop. It also contains other files to illustrate the user interface, input, and functions of the database.

As the instructor presents the instruction unit, the student will follow on their laptop so that at the end of the instruction block the student has an initial familiarization of the database features, how to use the database as a risk assessment/risk management tool, and has it loaded on the laptop for their personal use in the future.

If the student does not have a laptop, they may look over the shoulder of someone who does have a laptop or just follow along the slide presentation which uses screen captures of the software throughout the processes demonstrated.

*This page intentionally left blank*

## Unit VII

---

<b>COURSE TITLE</b>	Building Design for Homeland Security	<b>TIME</b>	75 minutes
---------------------	---------------------------------------	-------------	------------

---

<b>UNIT TITLE</b>	Explosive Blast
-------------------	-----------------

---

<b>OBJECTIVES</b>	<ol style="list-style-type: none"><li>1. Explain the basic physics involved during an explosive blast event, whether by terrorism or technological accident</li><li>2. Explain building damage and personnel injury resulting from the blast effects upon a building</li><li>3. Perform an initial prediction of blast loading and effects based upon incident pressure</li></ol>
-------------------	---

---

<b>SCOPE</b>	<p>The following topics will be covered in this unit:</p> <ol style="list-style-type: none"><li>1. Time-pressure regions of a blast event and how these change with distance from the blast</li><li>2. Difference between incident pressure and reflected pressure</li><li>3. Differences between peak pressure and peak impulse and how these differences affect building components</li><li>4. Building damage and personal injuries generated by blast wave effects</li><li>5. Levels of protection used by the Department of Defense and the General Services Administration</li><li>6. The nominal range-to-effect chart [minimum stand-off in feet versus weapon yield in pounds of TNT-equivalent] for an identified level of damage or injury</li><li>7. The benefits of stand-off distance</li><li>8. Approaches to predicting blast loads and effects, including one using incident pressure</li></ol>
--------------	--

---

**REFERENCES**

1. FEMA 426, *Reference Manual to Mitigate Potential Terrorist Attacks Against Buildings*, Chapter 4
2. Case Study – Appendix A: Suburban, Hazardville Information Company or Appendix B: Urban, HazardCorp Building as selected
3. Student Manual, Unit VII
4. Unit VII visuals

**REQUIREMENTS**

1. FEMA 426, *Reference Manual to Mitigate Potential Terrorist Attacks Against Buildings* (one per student)
2. Instructor Guide, Unit VII
3. Student Manual (one per student) as selected
4. Overhead projector or computer display unit
5. Unit VI visuals, including E155\_Unit07\_Manchester.mpg which must be in the same electronic folder as the Unit VI visuals -- E155\_Unit07.ppt
6. Chart paper, easel, and markers

**UNIT VII OUTLINE**

	<u>Time</u>	<u>Page</u>
VII. Explosive Blast (35 Slides at 1.5 minutes/slide – approx. 52.5 minutes)	75 minutes	IG VII-1
1. Introduction and Unit Overview	4.5 minutes	IG VII-5
2. Blast Characteristics and Their Interaction with Buildings	12 minutes	IG VII-6
3. Types of Building Damage and Personal Injuries Caused by Blast Effects	15 minutes	IG VII-12
4. Levels of Protection Used by Federal Agencies	3 minutes	IG VII-17
5. The Nominal Range-to-Effect Chart and Benefits of Stand-off	7.5 minutes	IG VII-18
6. Predicting Blast Loads and Effects	6 minutes	IG VII-22
7. Manchester Bombing Video	4.5 minutes	IG VII-24
8. Activity: Stand-off Distance and the Effects of Blast (10 minutes for the students, 10 minutes for instructor review)	20 minutes	IG VII-25

## Preparing To Teach This Unit

- **Tailoring Content to the Local Area:** This is a generic instruction unit that does not have any specific capability for linking to the Local Area. However, Units IX, Site and Layout Design Guidance, and X, Building Design Guidance are excellent opportunities to illustrate the concepts in this instruction unit as applied to the Local Area.
- **Optional Activity:** There are no optional activities in this unit, except Student Activity questions that are applicable to the selected Case Study.
- **Additional Information Suburban Case Study:** Figures 8, 9, and 10 in Appendix A: Suburban, Hazardville Information Company use the following information to obtain the radius (in feet) of the rings. Using FEMA 426, Figure 4-5, page 4-11, the structural damage is taken from the Threshold, Concrete Columns Fail curve, the probable lethal injuries are taken from the Potentially Lethal Injuries curve, and the severe injuries from glass are taken from the Glass with Fragment Retention Film – Severe Wounds curve. Approximate Weapon Yield used are Figure 8 – 135 pounds TNT equivalent, Figure 9 – 20,000 pounds TNT-equivalent, and Figure 10 – 1,000 pounds TNT equivalent.
- **Additional Information Urban Case Study:** Figures 10, 11, and 12 in Appendix B: Urban, HazardCorp Building use the following information to obtain the radius (in feet) of the rings. Using FEMA 426, Figure 4-5, page 4-11, the structural damage is taken from the Threshold, Concrete Columns Fail curve, the probable lethal injuries are taken from the Potentially Lethal Injuries curve, and the severe injuries from glass are taken from the Glass with Fragment Retention Film – Severe Wounds curve. Approximate Weapon Yield used are Figure 10 – 500 pounds TNT equivalent, however Figures 11 and 12 are composites – 40,000 pounds TNT equivalent for Threshold Concrete Column Fail, 10,000 pounds TNT equivalent for Potentially Lethal Injuries, and 500 pound for Glass – Severe Wounds (no .Fragment Retention Film)
- **Activity:** The students will answer questions in the Student Activity exercises the Case Study to identify the Design Basis Threat and using the range-to-effects chart and estimated pressures chart in FEMA 426 to evaluate stand-off distances and expected damage for selected questions.
- Refer students to their Student Manuals for worksheets and activities.
- Direct students to the appropriate page in the Student Manual.
- Instruct the students to read the activity instructions found in the Student Manual.
- Tell students how long they have to work on the requirements.
- While students are working, all instructors should closely observe the groups' process and progress. If any groups are struggling, immediately assist them by clarifying the assignment

and providing as much help as is necessary for the groups to complete the requirement in the allotted time.

- At the end of the working period, reconvene the class.
- After the students have completed the assignment, “walk through” the activity with the students during the plenary session. Call a different student forward to the screen to answer the questions associated with each chart, including the Case Study values if time permits.
- If time is short, simply provide the “school solution” and ask for questions. Do not end the activity without ensuring that students know if their answers are correct or at least on the right track.
- Ask for and answer questions.

**INSTRUCTOR NOTES**

**CONTENT/ACTIVITY**

**VISUAL VII-1**

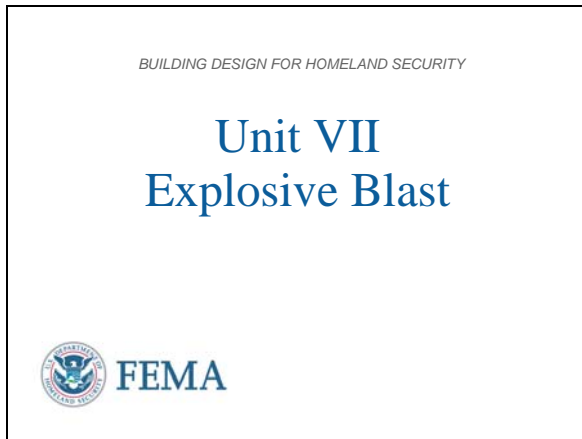

**VISUAL VII-2**

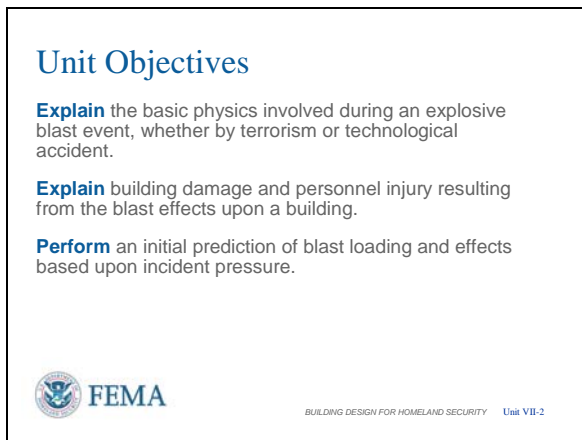

**VISUAL VII-3**

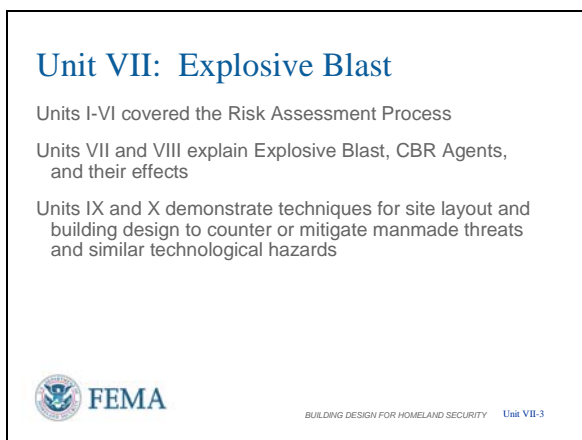

**Introduction and Unit Overview**

This is Unit VII Explosive Blast. Note that we are covering **pages 4-1 to 4-20 in FEMA 426** during this unit.

In the previous units, we determined the various initial ratings during the assessment process.

In this unit, we will examine how explosive blast impacts buildings and people to better understand the design recommendations and mitigation options presented in later units.

**Unit Objectives**

At the end of this unit, the students should be able to:

1. Explain the basic physics involved during an explosive blast event, whether by terrorism or technological accident.
2. Explain building damage and personnel injury resulting from the blast effects upon a building.
3. Perform an initial prediction of blast loading and effects based upon incident pressure.

**Explosive Blast**

So far we have looked at the risk assessment process with the level of understanding achieved from the instruction yesterday.

Today we go into the technical basics of Explosive Blast and CBR agents to understand their effects and the benefit of their associated mitigation measures.

Then we will look at Site and Layout Design and Building Design mitigation measures for these terrorist tactics and similar technological hazards.



VISUAL VII-4

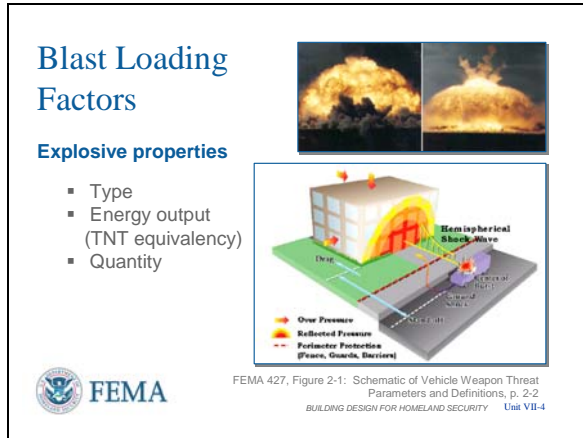

Pressure TNT equivalency can generally range from 0.14 to 1.7. If the pressure TNT equivalency is above 1.0, this means the explosive achieves a higher pressure (pressure equivalency) than TNT.

VISUAL VII-5

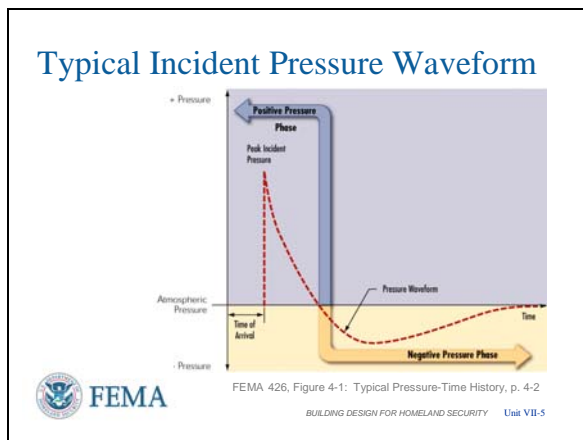

Exam Questions #A8 and B6

**Blast Loading Factors**

Explosive properties types – Is it a high explosive or low-order explosive?

Is it specifically designed for the purpose – military grade explosive (C4, landmine, etc.) or a combination of generally available materials (ANFO, black powder)?

The energy output of explosives can be related by TNT (trinitrotoluene) equivalency. TNT equivalency is usually considered to be the relative pressure achieved by the explosive compared to what TNT can achieve.

Aside from TNT equivalency, the larger the quantity of an explosive, the higher the pressures and the larger the impulse.

**Typical Incident Pressure Waveform**

The explosive detonation generates a bubble of air moving at supersonic speed from the bomb location. About one-third of the explosive material contributes to the detonation.

As it reaches a point in space, such as a person or building, the pressure goes rapidly from atmospheric to peak pressure in very little time. The pressure at this point decays rapidly as the supersonic bubble moves on, its pressure reducing exponentially as the surface area of the bubble increases, expending energy over an ever increasing area. The pressure also drops off due to the completion of the chemical reaction of the explosive mixture (burning of the remaining two-thirds of the material). If the explosion occurs within a confined space, the gases generated by the burning of the explosive are contained and keep the pressure elevated over a longer

VISUAL VII-6

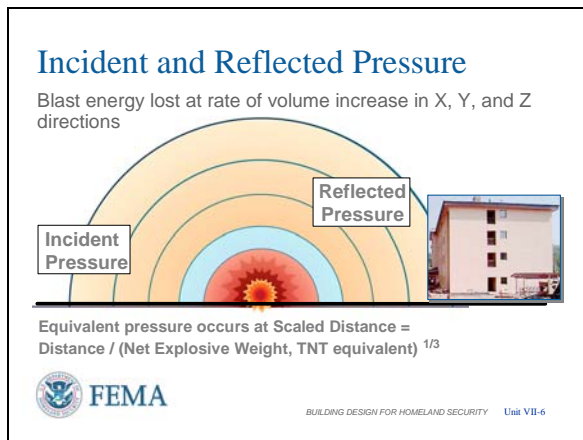

VISUAL VII-7

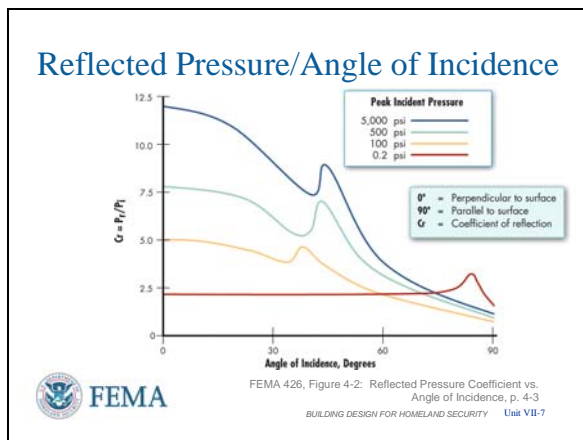

period of time. [Indicate a longer tail off of the positive phase to illustrate the confined space variation.] Design is typically based on positive pressures.

The negative phase of the blast wave is the ambient air rushing in behind the blast wave to return to a stable pressure. Although the negative phase has much less energy than the positive phase, it can hit the structure at the most inopportune moment in its vibration, resulting in unexpected consequences – increased damage or having windows blow OUT of the building rather than into it.

**Incident and Reflected Pressure**

When the incident pressure wave impinges on a structure that is not parallel to the direction of the wave’s travel, it is reflected and reinforced. The reflected pressure is always greater than the incident pressure at the same distance from the explosion, and varies with the incident angle.

**Reflected Pressure versus Angle of Incident**

When the blast wave strikes an immovable surface, the wave reflects off the surface, resulting in an increase in pressure. This reflected pressure actually causes the damage to the building. A very high reflected pressure may punch a hole in a wall or cause a column to fail, while a low reflected pressure will try to push over the whole building.

The worst case is when the direction of travel for the blast wave is perpendicular to the surface of the structure and the incident pressure is very high. The Coefficient of

VISUAL VII-8

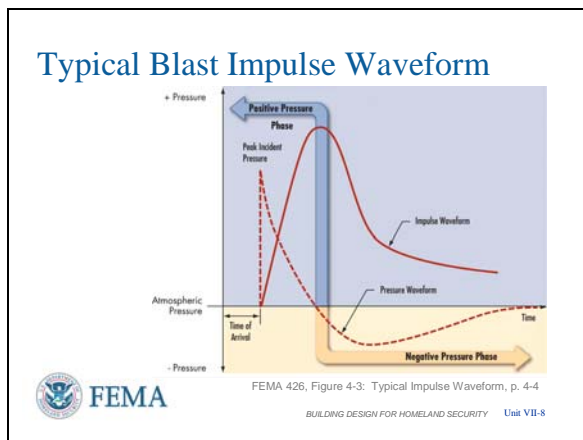

There is also a TNT equivalency based upon impulse and that ranges from 0.5 to 1.8. If the impulse TNT equivalency is above 1.0, then the explosive has a longer push (impulse equivalency) than TNT.

Reflection can be greater than 12 for high incident pressures.

By keeping the incident pressure low (by limiting the size of the explosive, maintaining a large distance between the explosive and the building, or both), the reflected pressure can be kept low. Keeping the Coefficient of Reflection below 2.5 by keeping the peak incident pressure below 5 psi (pounds per square inch) is a desirable goal.

### Typical Blast Impulse Waveform

Another consideration is the impulse of the blast wave, which is the integration of the peak incident pressure (both positive phase and negative phase) at the point in question over time.

A general rule of thumb:

- Brittle materials (like glass) respond to peak incident pressure and are less affected by impulse. Thus a high order explosive with high incident pressure will easily damage glass.
- Ductile materials (like most building structures), on the other hand, respond more to impulse (the total push) rather than peak incident pressure (the maximum hit). Thus, a low order explosive with a large impulse that pushes for a longer time will cause more damage to buildings.

VISUAL VII-9

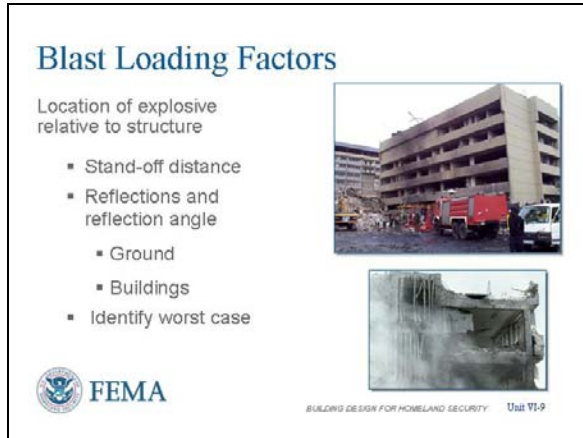

**Blast Loading Factors**

**Location Relative to Structure:** Stand-off distance is your best friend. The larger the distance between the explosive and the structure:

- The lower the incident pressure and
- The lower the resultant reflected pressure.

We will investigate this in more detail later.

As we have already seen, the reflection angle at which the blast wave strikes the structure also affects the value of reflected pressure.

The ground is also a reflection surface to consider.

- If the bomb is placed close to the ground, the ground reflection adds a small amount of incident pressure to the situation.
- If the bomb is elevated (a more difficult task), the ground reflection can become significant, but the reflection off the building surface diminishes.

Identifying the worst case situation begins by finding the:

- Closest approach (stand-off distance) between the explosive and the building
- Then consider the angle of reflection.

Or put another way – place the explosive directly perpendicular to the largest face of the building, with the explosive centered upon the building’s face as close as you can get.

VISUAL VII-10

**Blast Compared to Natural Hazards**  
**Higher incident pressures and relatively low impulse**

- High explosive (C-4)
- Low-order explosive (ANFO)
- Aircraft or vehicle crash combines kinetic energy (velocity, mass), explosive loads, and fuel/fire
- 200 mph hurricane generates only 0.8 psi, but with very large impulse



 FEMA

BUILDING DESIGN FOR HOMELAND SECURITY Unit VII-10

**Blast Compared to Natural Hazards**

There are a number of similarities between blast loading and building response in comparison to building response from earthquake, flood, or wind loading, but there are also significant differences.

- Low-order explosives generate less pressure than high-order explosives, but the low-order impulse lasts longer than high-order (in the range of hundreds of milliseconds versus tens of milliseconds).
- Blast loads are high amplitude, low duration (milliseconds) events that create an air pressure wave that acts over the entire building envelope. They have relatively low impulse whether high or low order compared to natural hazards.
- Earthquake loads are usually low amplitude, high-energy, long-duration (seconds) events that are transferred through the foundation.
- Flood loading has high-energy, relatively high amplitude, and very long duration loading (minutes) that impact everything in its path with increased reflected pressures and extensive damage. The higher the velocity of the flood waters coupled with the increased mass of water results in extensive damage.
- High winds are dynamic and typically affect the envelope, but are of low amplitude compared to blast. However, they push for a very long time (in the range of seconds or longer) and, thus, have very large impulse. (Note: wind gusts are rated for 3 seconds duration minimum, but sustained winds can push for minutes.).
- A nuclear blast or millions of pounds of high explosives would generate high pressures AND long duration impulse (in the range of seconds).

VISUAL VII-11

**Blast Compared to Natural Hazards**

**Direct airblast causes more localized damage**

- Component breakage
- Penetration and shear
- Building's other side farther away
- Reflections can increase damage on any side

**Greater mass historically used for blast protection**

- Greater mass usually detrimental during earthquake due to resonance



 FEMA

BUILDING DESIGN FOR HOMELAND SECURITY Unit VII-11

Many of the mitigation options for seismic and hurricane retrofit such as moment connections, elimination of progressive collapse, laminated glass, and strengthened architectural elements mitigate many explosive blast vulnerabilities.

**Blast Compared to Natural Hazards**

Explosive blast tends to cause localized damage compared to other hazards that may destroy the whole building.

- The first building surface struck will get the greatest pressures, and expect it to receive the greatest damage. The blast may break a building component by punching through it (window or wall) or shearing it (column).
- The other side of the building, due to its greater distance from the explosion, will see lower pressures, unless there are nearby buildings that will reflect the blast wave back to the building in question.
- Reflections can increase damage to the building, but are hard to quantify.
- Greater mass has usually been the design of choice to protect against explosive blast. The inertia of the mass slows the structural reactions to the point that the impulse is over before the building tends to move.
- Conversely, additional mass is usually undesirable during an earthquake due to the long duration, low frequency forces that can get the mass moving. Earthquake design usually concentrates on lighter structures with great ductility and additional reinforcement at weak points.

VISUAL VII-12

**Factors Contributing to Building Damage**

First approximations based upon:

- Quantity of explosive
- Stand-off distance between building and explosive
- Assumptions about building characteristics



BUILDING DESIGN FOR HOMELAND SECURITY Unit VII-12

**Factors Contributing to Building Damage**

Certain prediction of damage to buildings and people during an explosive event is beyond the scope of the reference manual. There are too many variables that would have to be considered and modeling would take many months for analysis by supercomputer. Thus, as in standard building design, we use approaches with safety factors that provide adequate first approximations to estimate response based upon the:

- The amount of explosive usually expressed as TNT equivalent weight.
- The stand-off distance between the explosive and the building or person.
- Assumptions about building characteristics – the exterior envelope construction (walls and windows) and the framing or load-bearing system used.
- The building characteristics provide insight into weaknesses and allow general predictions about how the building will respond.

VISUAL VII-13

**Types of Building Damage**

**Direct Air Blast**

- Component failure
- Additional damage after breaching

**Collapse**

- Localized
- Progressive



BUILDING DESIGN FOR HOMELAND SECURITY Unit VII-13

**Types of Building Damage**

- Direct air blast, especially from close-in explosions, results in component failure of walls, windows, columns, and beams / girders.
- The pressures experienced by the building can far exceed the building's original design and can occur in directions that were not part of the original design.
- Once the exterior envelope is breached, the blast wave causes additional structural and non-structural damage inside the building.
- Collapse, which is covered in more detail in **Chapter 3 of FEMA 426**, is a primary cause of death and injury in an explosive blast if it occurs.

**Exam Questions #A9 and B10**



VISUAL VII-14

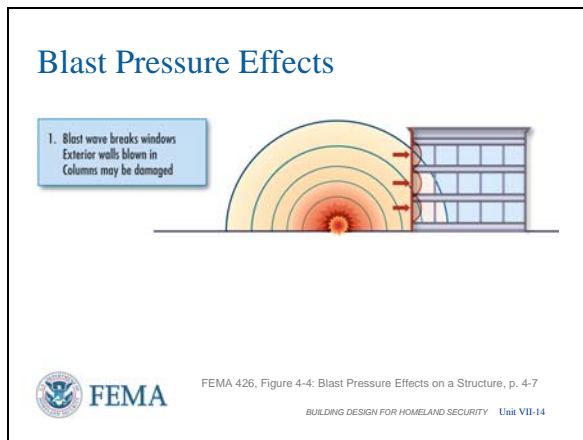

- Localized collapse may have a load-bearing wall, or portion thereof, on one side of the building fall to the ground or a single column fails and the surrounding floors fall with it.
- Progressive collapse is more disastrous as a single component failure, like a wall or column, results in the failure of more walls and columns so that more of the building falls to the ground than what the explosive initially affected.

**Blast Pressure Effects**

- The air blast strikes the exterior wall and the weakest component will fail first – usually the windows, which saves the walls and columns, but causes much non-structural damage inside the building.
- Note that unreinforced masonry walls can be weaker than windows, especially if they are non-load bearing.
- If the explosive is close enough, the walls can breach and one or more columns can fail in addition to the windows.
- Based upon the reflection angle, one can expect the lowest or lower floors (1 to 3) to receive the greatest damage.
- If the blast wave strikes the whole surface of the exposed side simultaneously, this is called a laminar situation, and breaching (puncture) of walls and failure of columns is less likely. This is what is sought by achieving a large stand-off distance.



VISUAL VII-15

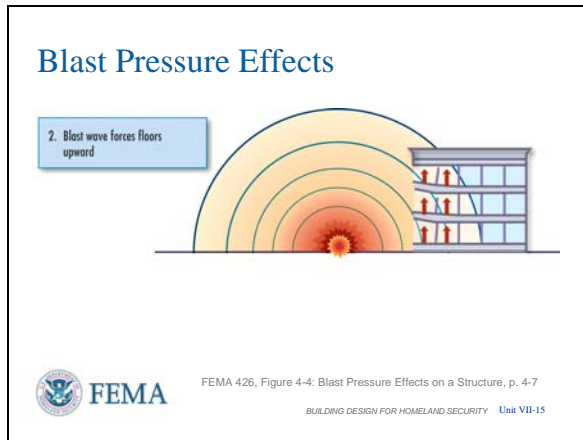

VISUAL VII-16

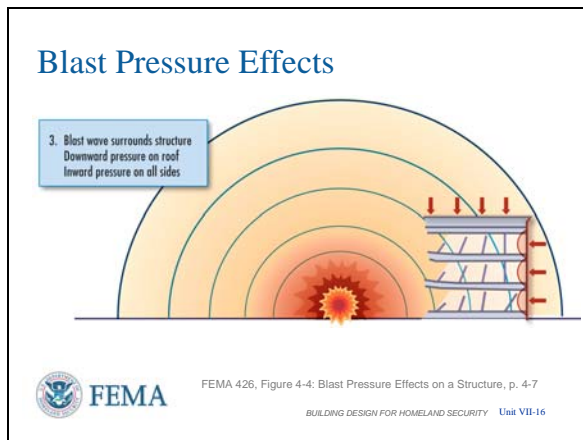

**Blast Pressure Effects**

- Once the blast wave enters the building, it is trapped and more air enters the building, further increasing the pressure. Structural components like flooring and shear walls now are moving in directions for which they were not designed.
- Floor failure can result in three effects:
  - Concrete chunks raining down, causing injury and possibly death
  - Whole floor gives way and pancakes downward with obviously more serious consequences
  - If flat slab construction is present (thickened floors act as beams in the framing system), the floors can disconnect from the columns, resulting in floor AND column failure.

**Blast Pressure Effects**

- The blast wave continues to engulf the building. Any building component that traps the blast wave, like an overhanging roof, can expect increased damage, based upon how it is constructed and attached.
- The roof and sides parallel to the blast wave movement will see incident pressure only, which should result in little or no damage.
- Once the blast wave has passed the building, the far side (opposite the side first experiencing the blast wave) will see increased pressure as a slight vacuum forms and the ambient air rushes back in to achieve equilibrium. Reflections of the blast wave off other buildings behind this one can also increase the pressure impinging the far side.

VISUAL VII-17

**Causes of Blast Injuries**

**Overpressure**

- Eardrum rupture
- Lung collapse/failure

**Blast Wave**

- Blunt trauma, lacerations, and impalement



BUILDING DESIGN FOR HOMELAND SECURITY Unit VII-17

**Causes of Blast Injuries**

- Injuries and casualties occur in three ways during explosive blast by:
  - Overpressure
  - Motion of person by blast wave
  - Fragmentation generated by blast wave
- Overpressure causes eardrum rupture first, which is normally not lethal.
- Overpressure can also overdrive the lungs, causing injury or death. The relationship between pressure and impulse is very evident in lung response. An incident pressure of 102 psi for 3 milliseconds is the threshold of lethality as is an incident pressure of 23 psi for 18.5 milliseconds.
- Blunt trauma, lacerations, and impalement injuries occur when the blast wave picks up the person and throws them against a surface or object (translation), or glass and wall fragments cause lacerations or blunt trauma on impact. In relative distance terms, death by translation occurs at a greater distance for the same bomb size than death by lung overpressure.

VISUAL VII-18

**Causes of Blast Injuries**



**Fragmentation**

Bomb or vehicle

Street furniture or jersey barriers

Building component failure

- Glass – predominant
- Walls
- Floors



BUILDING DESIGN FOR HOMELAND SECURITY Unit VII-18

**Causes of Blast Injuries**

- Fragmentation from any source can result in blunt trauma, impact, and penetration, or laceration injuries.
- The fragments can come from around the bomb or from parts of the vehicle.
- They can be picked up either intact or damaged by the blast wave as it travels along – street furniture or jersey barriers.
- Building component failure also causes material fragments with sufficient velocity to injure or kill. Note that upward of 80 percent of all injuries from explosive blast can be attributed to lacerations caused by broken glass. The most effective way to reduce injuries during explosive blast is harden the glass and window frame system and/or reduce the amount of glass.

**Exam Questions #A10 and B9**

VISUAL VII-19



**Murrah Federal Building**

The Murrah Federal Building is typical of many commercial properties in the current inventory. The bomb was designed as a shape charge and detonated in the drop-off area, destroying two primary columns and causing the spandrel beam to rotate. The floors above failed in progressive collapse and the blast wave penetrated deeply into the interior.

VISUAL VII-20

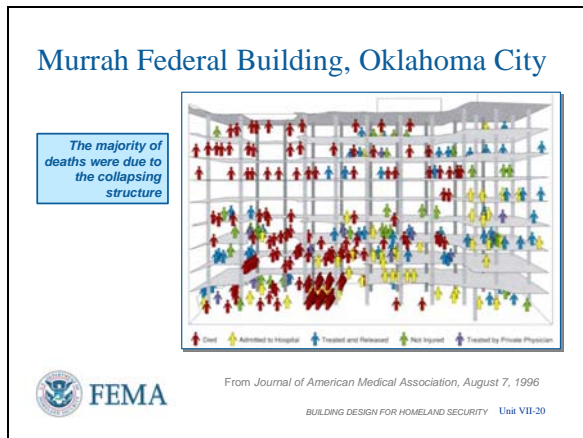

**Murrah Federal Building**

The majority of deaths were caused by the collapsing structure.

VISUAL VII-21

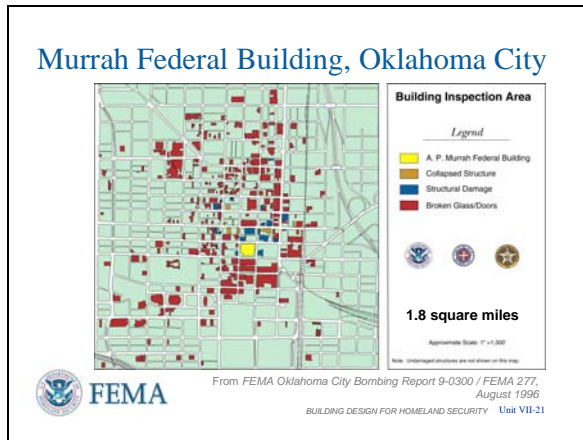

The map is approximately 1.35 miles on a side.

VISUAL VII-22

**Levels of Protection**

CONVENTIONAL CONSTRUCTION		INCIDENT OVERPRESSURE	
Level of Protection	Potential Structural Damage	Potential Door and Glazing Hazards	Potential Injury
<b>Below AT standards</b>	Severely damaged. Frame collapse/massive destruction. Little left standing.	Doors and windows fail and result in lethal hazards. GSA 5	Majority of personnel suffer fatalities.
<b>Very Low</b> psi = 3.5	Heavily damaged - onset of structural collapse. Major deformation of primary and secondary structural members, but progressive collapse is unlikely. Collapse of non-structural elements.	Glazing will break and is likely to be propelled into the building, resulting in serious glazing fragment injuries, but fragments will be reduced. Doors may be propelled into rooms, presenting serious hazards. GSA 4	Majority of personnel suffer serious injuries. There are likely to be a limited number (10 percent to 25 percent) of fatalities.
<b>Low</b> psi = 2.3	Damage - unreparable. Major deformation of non-structural elements and secondary structural members and minor deformation of primary structural members, but progressive collapse is unlikely.	Glazing will break, but fall within 1 meter of the wall or otherwise not present a significant fragment hazard. Doors may fail, but they will rebound out of their frames, presenting minimal hazards. GSA 3a	Majority of personnel suffer significant injuries. There may be a few (<10 percent) fatalities.

FEMA 426, Adapted from Table 4-1. DoD Minimum Antiterrorism Standards for New Buildings, p. 4-9

BUILDING DESIGN FOR HOMELAND SECURITY Unit VII-22

**Murrah Federal Building**

The collateral damage zone extended out several thousand feet, with extensive glass and debris injuries.

Glass was broken as far as 0.9 miles away.

**Levels of Protection**

- The Department of Defense (DoD) and the General Services Administration (GSA) call out similar levels of protection that relate building damage and potential injury. This slide and the next summarize these perspectives.
- **NOTE:** The GSA glass ratings and estimated incident pressure levels are added to the DoD UFC criteria as best meet the description for comparison.
- This slide represents the conventional construction found in most buildings.
- Note the relatively low values for incident pressure for each level of protection.
- The Low Level of Protection can be interpreted as the threshold of lethality and is a desirable minimum design goal to achieve. If the risk, such as the likelihood, of experiencing an explosive blast is high, consideration for use of a higher level of protection would be in order.

VISUAL VII-23

**Levels of Protection**

CONVENTIONAL CONSTRUCTION		INCIDENT OVERPRESSURE	
Level of Protection	Potential Structural Damage	Potential Door and Glazing Hazards	Potential Injury
Medium psi = 1.8	Damaged – repairable. Minor deformations of non-structural elements and secondary structural members and no permanent deformation in primary structural members.	Glazing will break, but will remain in the window frame. Doors will stay in frames, but will not be reusable. GSA 2	Some minor injuries, but fatalities are unlikely.
High psi = 1.1	Superficially damaged. No permanent deformation of primary and secondary structural members or non-structural elements.	Glazing will not break. Doors will be reusable. GSA 1	Only superficial injuries are likely.

FEMA 426, Adapted from Table 4-1: DoD Minimum Antiterrorism Standards for New Buildings, p. 4-9  
BUILDING DESIGN FOR HOMELAND SECURITY Unit VII-23

Exam Questions #A11 and B11

VISUAL VII-24

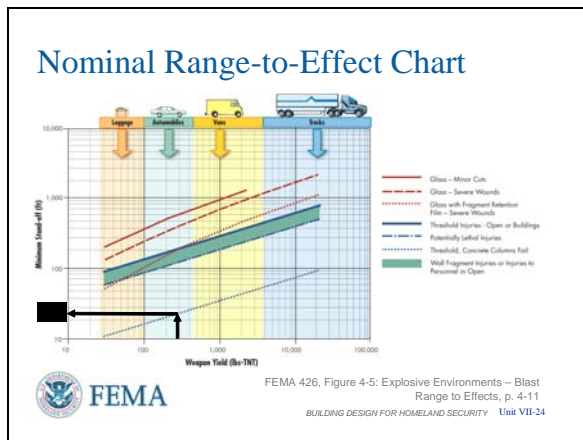

Direct students’ attention to **Figure 4-5 on page 4-11 of FEMA 426.**

**Levels of Protection**

- When greater protection resulting in less damage and injury is desired, this slide indicates that the pressures must be kept low for conventional construction.
- Alternately, the building must be hardened to achieve these lower levels of damage and resultant injury. This is especially necessary when the incident pressure is higher due to the design basis threat explosive quantity being at a closer stand-off distance than conventional construction can handle.

The building owner selects the Level of Protection and the Design Basis Threat, which in turn determines the stand-off distance required.

**Nominal Range-to-Effect Chart**



- The Nominal Range-to-Effect Chart is a handy way to represent the stand-off distance at which a given bomb size produces a given effect.
- If you are below the curve for the given effect, that effect has the potential to occur. The further below the curve, the more likely it will happen and the greater the expected damage.
- Conversely, an intersection point between range or stand-off distance and weapon yield or bomb size in TNT equivalent weight that is above the curve for the given effect indicates that there is a good chance that that effect will not occur. However, many variables can alter these curves, such as reflections, resulting in damage at a point above the curve.
- The chart also concentrates upon the two prominent concerns during explosive blast – glass injury and progressive building collapse. In most, but not all cases, the glass is the weakest component of the

building envelope. Conversely, the columns, whether concrete or steel, are usually the strongest components of the building envelope. [A workable rule of thumb is that steel columns require about twice the stand-off distance compared to concrete columns for the same weapon yield.]

- **Question:** Ask what stand-off distance for a 300-pound (TNT-equivalent) bomb is needed to just exceed the threshold of concrete column failure?
  - **Answer:** Approximately 25 feet.

VISUAL VII-25

**Comparison of Stand-off**

	
<b>Murrah Federal Building</b>	<b>Khobar Towers</b>
YIELD (≠TNT Equiv.) 4,000 lb.	YIELD (≠TNT Equiv.) 20,000 lb.
Reflected PRESSURE 9,000 psi.	Reflected PRESSURE 800 psi.
Stand-off 15 feet	Stand-off 80 feet
166 killed	19 killed

 BUILDING DESIGN FOR HOMELAND SECURITY Unit VII-25

**Comparison of Stand-off**

The Murrah Federal Building and Khobar Towers vividly illustrate the response of a building to a blast event.

The Murrah Federal Building had less than 20 feet of stand-off and was not designed to prevent progressive collapse.

Khobar Towers was designed using British code to prevent progressive collapse and had approximately 80 feet of stand-off distance.

Notice the size of the weapons.

The Murrah Federal Building was unsalvageable and demolished, while Khobar Towers only lost the front façade and was restored and placed back into service.



VISUAL VII-26

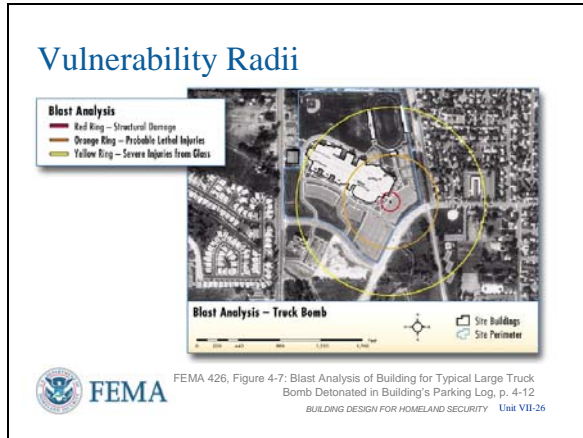

**Vulnerability Radii**

- Graphically portraying the information from the Nominal Range-to-Effect Chart can be done in two ways. As shown in **Figures 4-6 and 4-7 in FEMA 426 (page 4-12)**, vulnerability radii show how far a given type of damage will extend from a bomb location for a given weapon yield upon the building of interest for which the blast analysis was performed.
  - The rings indicate where that level of damage starts and whatever is inside the ring will experience that damage.
  - The expected damage increases as you move from the ring to the explosion.
  - Hardening and other mitigation measures can be compared using this representation (for example, existing glass, glass with fragment-retention film installed, or upgraded glass).
- This representation works well when showing the effects of different bomb locations and the extent of the building affected by that bomb.

VISUAL VII-27

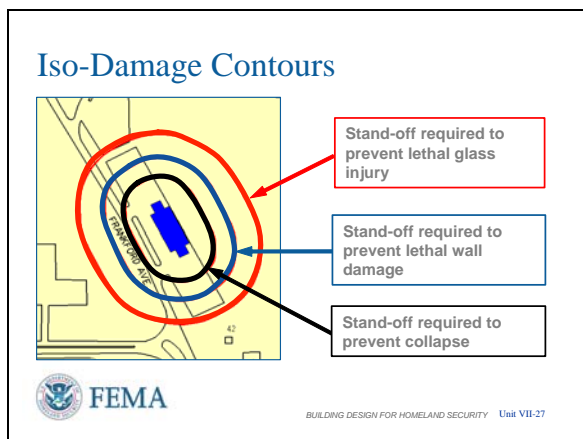

**Iso-Damage Contours**

- Alternately, the nominal range-to-effect information can be graphically represented as iso-damage contours. For a given weapon yield against a building of known construction, the contour indicates how far the bomb or vehicle must be kept away to prevent the damage indicated in this slide.
  - The intent here is to focus on the required stand-off distance to prevent or reduce the weapon effect portrayed by the contour.
  - Thus, to prevent structural collapse, vehicle parking should be eliminated or tightly restricted inside the black contour.
  - Likewise, to prevent lethal glass

VISUAL VII-28

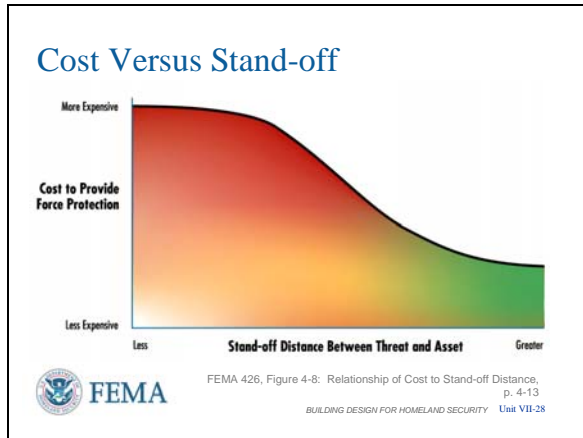

injury, the vehicle parking should be outside the red contour.

**Cost versus Stand-off**

- As in any design for new construction or renovation, there are trade-offs that must be considered. Although increasing the distance between the closest approaches of a vehicle bomb to the building is highly desirable, it is not without a cost.
- The increased distance means more land is needed, which may require considerable time and expense to acquire. The increased land also means a larger perimeter boundary that then requires more perimeter fencing, landscaping, vehicle barriers, lighting, closed-circuit television, etc. Thus, while the increased stand-off allows a less expensive building to be constructed, there are other costs that must be considered in the overall project.
- Where stand-off distance cannot be increased, building hardening is usually necessary to achieve the same level of protection against the Design Basis Threat weapon yield. As the stand-off distance decreases, the cost of hardening significantly increases because the building must now withstand damage that it would not experience at higher stand-off.
- Consider progressive collapse. At large stand-off distance, the design of the building framing and columns should meet basic design to prevent progressive collapse. This would be for the loss of one column, for example. At smaller stand-off distances, the columns may require additional hardening to prevent the failure of more than one column during an explosive blast event.



VISUAL VII-29

### Blast Load Predictions

Incident and reflected pressure and impulse

- Software
  - Computational Fluid Dynamics
  - ATBLAST (GSA)
  - CONWEP (US Army)
- Tables and charts of predetermined values



BUILDING DESIGN FOR HOMELAND SECURITY Unit VII-29

**Blast Load Predictions**

- The first step in designing a building for explosive blast is to understand the pressures and impulses the building may experience during the potential blast event.
  - If reflections are a concern, then high-level software, such as Computational Fluid Dynamics (CFD), may be in order.
  - Defense Threat Reduction Agency software (not CFD) – Vulnerability Assessment and Protection Option (VAPO) can handle reflections, but modeling takes much longer than simpler models and reflection analysis takes hours of computation time on a laptop.
  - As a first effort, simpler software, such as ATBLAST and CONWEP, can give a prediction of incident blast loading values and a prediction for reflected pressure and impulse using simplifying assumptions.
- Pressure versus distance (**Figure 4-10 in FEMA 426, page 4-17**) is another method for predicting the incident pressure as shown in the next slide.

VISUAL VII-30

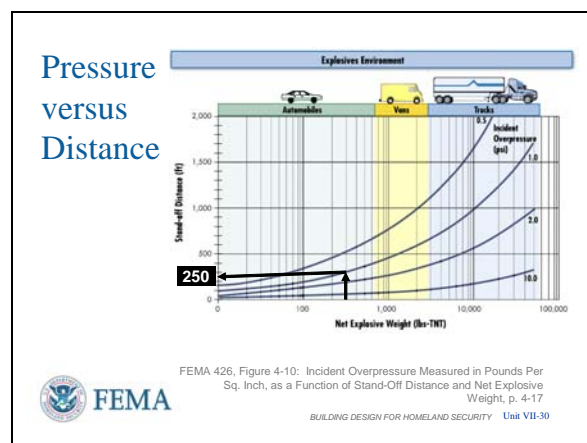

**Pressure versus Distance**

- Figure 4-10 breaks the blast load estimate into the essential elements of weapon yield or explosive weight in TNT equivalent on the x-axis and stand-off distance on the y-axis to give an incident pressure value that a building can experience.
- Note that the x-axis is logarithmic and the y-axis is linear. If both axes were logarithmic as used on the range-to-effect chart presented earlier, the curves of this chart would be straight lines. In other words, on a log-log scale of explosive weight and stand-off distance, a straight line indicates a pressure relationship (not

**INSTRUCTOR NOTES**

Direct students' attention to **Figure 4-10, page 4-17 of FEMA 426.**

**VISUAL VII-31**

### Blast Damage Estimates

**Assumptions - pressure and material**

- Software - SDOF
  - AT Planner (U.S. Army)
  - BEEM (TSWG)
  - BlastFX (FAA)
- Software - FEM
- Tables and charts of predetermined values



BUILDING DESIGN FOR HOMELAND SECURITY Unit VII-31

**VISUAL VII-32**

### Blast Damage Estimates

Damage	Inc dent Pressure (psi)
Typical window glass breakage (1)	0.15 - 0.22
Minor damage to some buildings (1)	0.5 - 1.1
Panels of sheet metal buckled (1)	1.1 - 1.8
Failure of unreinforced concrete blocks walls (1)	1.8 - 2.9
Collapse of wood frame buildings (2)	Over 5.0
Serious damage to steel framed buildings (1)	4 - 7
Severe damage to reinforced concrete structures (1)	6 - 9
Probable total destruction of most buildings (1)	10 - 12

FEMA 426, Table 4-3: Damage Approximations, p. 4-19

Level of Protection	Inc dent Pressure (psi)
High	1.2
Medium	1.9
Low	2.3
Very Low	3.5
Below AT Standards	> 3.5



BUILDING DESIGN FOR HOMELAND SECURITY Unit VII-32

**CONTENT/ACTIVITY**

impulse).

- **Question:** Ask what stand-off distance is required for a 300-pound bomb to keep the incident pressure at 1.0 psi or lower.
  - **Answer:** Approximately 250 feet.

**Blast Damage Estimates**

- Whereas normal design usually uses constant loading and linear response, blast loading is very dynamic, as you have seen, and damage of building components enters its nonlinear material range prior to failure.
- Conversely, higher level modeling may result in reduced construction costs due to a better understanding of how the building components will respond during a blast for the given site, layout, and building design parameters selected. This is balanced by the additional cost of the higher level modeling.

**Blast Damage Estimates**

- In this slide, you see Damage Approximations for different types of damage and a range of incident pressures at which this damage is expected to occur.
- Note that, logically, higher pressure results in greater damage and the range of incident pressure indicates the construction variation that may be found.

**Instructor Note:** Table 4-3 on page 4-19 of FEMA 426 is based upon information from the following publications:

- "*Explosive Shocks in Air*" Kinney and Graham, 1985
- "*Facility Damage and Personnel Injury from Explosive Blast*" Montgomery and Ward, 1993
- "*The Effects of Nuclear Weapons, 3rd Edition*", Glasstone and Dolan, 1977

VISUAL VII-33

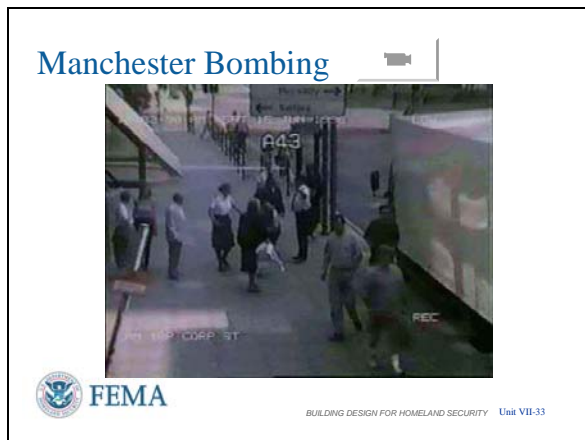

**Instructor Note:** Ensure the video file (**E155\_Unit07\_Manchester.mpg**) is in the same folder as the PowerPoint presentation to have the camera link after the slide title to work.

**QUESTION:** Ask students -- How big do you think this bomb was?

**Answer:** Reported to be 3,300 pounds but not stated as either actual weight or TNT equivalent. The bomb smashed almost every window in a half-mile radius.

Even with the advance notification Manchester's ambulance services counted 206 injured people (NO DEATHS). Most injuries were sustained from falling glass and building debris. In the immediately ensuing chaos, ambulances and private cars were used to shuttle victims to local and regional hospitals.

The majority (129, 62%) of casualties sustained minor injuries from flying glass. A significant number of casualties (36, 18%) presented with emotional distress or medical problems. A wide age range of casualties was involved. Few patients (19, 9%) required admission to hospital. There were

**Manchester Bombing**

General Points to make as the video runs

- The truck was parked at about 9:20am, and the bomb exploded just under 2 hours later. The blast was audible over 8 miles away.
- Irish Republican Army gave advance notification at about 1 hour prior to detonation to newspapers, radio stations, and at least one hospital
- The police began clearing the street 40 minutes before the blast, but people still walk past the suspected truck at 17 minutes prior to the explosion.
- British Telecom has a special terrorist pager that identifies location and time in order to notify building occupants of the situation and direct evacuation routes
- This is the High Street of Manchester – the center of the city’s business district at 10 AM on a Saturday morning just before Father’s Day
- Note that the High Street of many British cities are well covered by CCTV
- The double line on the street by the curb means no parking, thus making the truck suspicious -- as nothing was being off-loaded or on-loaded.
- Robot sent in to identify the bomb and possibly disarm it, but without success
- Bomb goes off with a great noise, then the explosion is shown in slow motion – note the 1/3 of the explosive providing the supersonic shock wave followed by the 2/3 of the explosive adding to the blast wave but also supporting the fireball through the conflagration (burning)
- Note the amount of debris, that NO buildings collapsed, that SOME walls remained intact, that ALMOST ALL glass was shattered, with damage being reduced the further the building was from the bomb
- The Post Office box, looks like a single heavy bollard survived the blast and has a

**INSTRUCTOR NOTES**

no deaths and no casualties sustained major trauma.

**VISUAL VII-34**

**Summary**

Explosive blast physics  
Blast damage to buildings  
Injury to personnel  
Prediction of loading, damage, and injury

- Range-to-effect chart
- Incident pressure chart



BUILDING DESIGN FOR HOMELAND SECURITY Unit VII-34

**VISUAL VII-35**

**Unit VII Case Study Activity**

**Explosives Environment, Stand-off Distance, and the Effects of Blast**

**Background**  
Purpose of activity: check on learning about explosive blast

**Requirements**  
Refer to FEMA 426 and answer worksheet questions on explosive blast

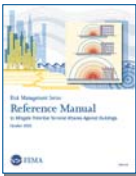

BUILDING DESIGN FOR HOMELAND SECURITY Unit VII-35

**CONTENT/ACTIVITY**

commemorative plaque installed

- Prior to the bombing the Manchester High Street was quickly going down hill, but after the bombing there was a big influx of investment, and after 4 years of reconstruction the High Street is now among the best in Great Britain.

**Summary**

- You now have an understanding of the basic physics involved during an explosive blast event.
- You can now explain building damage and injury to people resulting from the blast effects upon a building and injury to people in the open.
- You can perform an initial prediction of blast loading and effects based upon incident pressure using a nominal range-to-effect chart or the incident pressure charts.

**Student Activity**

This activity provides a check on learning about explosive blast.

**Activity Requirements**

Working in small groups, refer to **FEMA 426** and complete the worksheet questions in the Unit VII Case Study activity in the Student Manual.

After 10 minutes, solutions will be reviewed in plenary group. This is a good opportunity to select two members of the class to go to the screen and answer the questions using the charts.

**Transition**

Unit VIII will cover CBR measures and introduce the basic science needed to

**Course Title: Building Design for Homeland Security**

Unit VII: Explosive Blast

**INSTRUCTOR NOTES**

**CONTENT/ACTIVITY**

understand building protection against chemical, biological, and radiological agents. Unit IX will begin the process of reviewing the site, layout, and building design guidance, further vulnerability assessment, and recommended mitigation options.

**UNIT VII CASE STUDY ACTIVITY:  
STAND-OFF DISTANCE AND THE EFFECTS OF EXPLOSIVE BLAST**

The requirements in this unit's activity are intended to provide a check on learning about explosive blast.

**Requirements**

1. In the empty cells in the table below, identify whether the adjacent description defines incident pressure or reflected pressure.

Definition	Type of Pressure
Characterized by an almost instantaneous rise from atmospheric pressure to peak overpressure.	<i>Incident pressure</i>
When it impinges on a structure that is not parallel to the direction of the wave's travel, the pressure wave is reflected and reinforced.	<i>Reflective Pressure</i>

2. Refer to **Figure 4-5 in FEMA 426 (page 4-11)** to answer the following questions regarding the explosives environment:

- What is the minimum stand-off distance from explosion of a 100-pound (TNT equiv.) bomb to have a level of confidence that severe wounds from glass (without fragment retention film) will not occur? *270 feet*
- What damage will be sustained at 400 feet from a 5,000-pound (TNT equiv.) explosion? *Wall fragment injuries or injuries to personnel in the open and all curves above that point -- glass injuries ranging from minor cuts to severe wounds, with or without fragment retention film.*

3. Refer to **Figure 4-10 and Table 4-3 (pages 4-17 and 4-19, respectively) in FEMA 426** to answer the following questions regarding the explosives environment.

- What is the minimum stand-off required to limit the incident pressure to under 0.5 psi for a 100-pound (TNT equiv.) bomb? *Approximately 325 feet*
- What incident pressure would be expected at 500 feet from a 500-pound (TNT equiv.) bomb and what is the approximate damage? *Approximately 0.75 psi, minor damage to some buildings or severe wounds from broken glass*

4. Refer to **Figure 4-5 (page 4-11) in FEMA 426** to answer the following questions.

- For the Design Basis Threats of the selected Case Study being used in this course offering, determine the standoff distance for the damage or injury indicated:
  - \_\_\_\_\_ pounds TNT-equivalent
    - Glass – Severe Wounds – \_\_\_\_\_ feet
    - Potentially Lethal Injuries – \_\_\_\_\_ feet
    - Threshold, Concrete Columns Fail – \_\_\_\_\_ feet
  - \_\_\_\_\_ pounds TNT-equivalent
    - Glass – Severe Wounds – \_\_\_\_\_ feet
    - Potentially Lethal Injuries – \_\_\_\_\_ feet
    - Threshold, Concrete Columns Fail – \_\_\_\_\_ feet
  - ***250 pounds TNT-equivalent (suburban)***
    - Glass – Severe Wounds – ***400 feet***
    - Potentially Lethal Injuries – ***125 feet***
    - Threshold, Concrete Columns Fail – ***23 feet***
  - ***500 pounds TNT-equivalent (urban)***
    - Glass – Severe Wounds – ***530 feet***
    - Potentially Lethal Injuries – ***142 feet***
    - Threshold, Concrete Columns Fail – ***30 feet***
  - ***5,000 pounds TNT-equivalent (suburban and urban)***
    - Glass – Severe Wounds – ***1,310 feet***
    - Potentially Lethal Injuries – ***320 feet***
    - Threshold, Concrete Columns Fail – ***60 feet***

## Unit VIII

---

<b>COURSE TITLE</b>	Building Design for Homeland Security	<b>TIME</b>	75 minutes
---------------------	---------------------------------------	-------------	------------

---

<b>UNIT TITLE</b>	Chemical, Biological, and Radiological (CBR) Measures
-------------------	---

---

<b>OBJECTIVES</b>	<ol style="list-style-type: none"><li>1. Explain the five possible protective actions for a building and its occupants</li><li>2. Compare filtration system efficacy relative to the particles present in CBR agents.</li><li>3. Explain the key issues with CBR detection</li><li>4. Identify the indications of CBR contamination</li></ol>
-------------------	---

---

<b>SCOPE</b>	<p>The following topics will be covered in this unit:</p> <ol style="list-style-type: none"><li>1. Five protective actions for a building and its occupants: evacuation; sheltering in place; personal protective equipment; air filtration and pressurization; and exhausting and purging</li><li>2. Air filtration and cleaning principles and its application</li><li>3. CBR detection technology currently available</li><li>4. Indications of CBR contamination that do not use technology</li></ol>
--------------	---

---

<b>REFERENCES</b>	<ol style="list-style-type: none"><li>1. FEMA 426, <i>Reference Manual to Mitigate Potential Terrorist Attacks Against Buildings</i>, Chapter 5</li><li>2. FEMA 426, Appendix C, Chemical, Biological, and Radiological Glossary</li><li>3. Case Study – Appendix A: Suburban, Hazardville Information Company or Appendix B: Urban, HazardCorp Building as selected</li><li>4. Student Manual, Unit VIII</li><li>5. Unit VIII visuals</li></ol>
-------------------	--

---

<b>REQUIREMENTS</b>	<ol style="list-style-type: none"><li>1. FEMA 426, <i>Reference Manual to Mitigate Potential Terrorist Attacks Against Buildings</i> (one per student)</li><li>2. Instructor Guide, Unit VIII</li><li>3. Student Manual (one per student) for selected Case Study</li><li>4. Overhead projector or computer display unit</li><li>5. Unit VIII visuals</li><li>6. Chart paper, easel, and markers</li></ol>
---------------------	--

---



<b>UNIT VIII OUTLINE</b>	<u>Time</u>	<u>Page</u>
VIII. CBR Measures (61 slides at 55 minutes = approx. 0.9 minutes/slide)	75 minutes	IG VIII-1
1. Introduction and Unit Overview	8 minutes	IG VIII-5
2. Chemical Agents	5.5 minutes	IG VIII-10
3. Biological Agents	6 minutes	IG VIII-13
4. Radiological Materials	4.5 minutes	IG VIII-18
5. CBR Detection and Technology	5.5 minutes	IG VIII-21
6. CBR Protection Strategies	15 minutes	IG VIII-25
7. Other Issues for Consideration	10 minutes	IG VIII-38
8. Activity: CBR Measures (15 minutes for the students, 5 minutes for instructor review)	20 minutes	IG VIII-46
<b>WRITTEN EXAM</b>	1 hour	
Exam	30 minutes	
Feedback	30 minutes	

### **PREPARING TO TEACH THIS UNIT**

- **Tailoring Content to the Local Area:** This is a generic instruction unit that does not have any specific capability for linking to the Local Area. However, Units IX, Site and Layout Design Guidance, and X, Building Design Guidance are excellent opportunities to illustrate the concepts in this instruction unit as applied to the Local Area.
- **Optional Activity:** There are no optional activities in this unit, except Student Activity questions that are applicable to the selected Case Study.
- **Activity:** The students will answer questions in the Student Activity exercises using the Case Study to identify prevalent CBR threats (Design Basis Threat and others) and using FEMA 426 to answer selected filtration and mitigation measure questions.
- Refer students to their Student Manuals for worksheets and activities.
- Direct students to the appropriate page in the Student Manual.

- Instruct the students to read the activity instructions found in the Student Manual.
- Tell students how long they have to work on the requirements.
- While students are working, all instructors should closely observe the groups' process and progress. If any groups are struggling, immediately assist them by clarifying the assignment and providing as much help as is necessary for the groups to complete the requirement in the allotted time.
- At the end of the working period, reconvene the class.
- After the students have completed the assignment, “walk through” the activity with the students during the plenary session. Call on different teams to provide the answer(s) for each question. Display the charts applicable to the respective question to illustrate the answer.
- If time is short, simply provide the “school solution” and ask for questions. Do not end the activity without ensuring that students know if their answers are correct or at least on the right track.
- Ask for and answer questions.

*This page intentionally left blank.*

**INSTRUCTOR NOTES**

**CONTENT/ACTIVITY**

VISUAL VIII-1

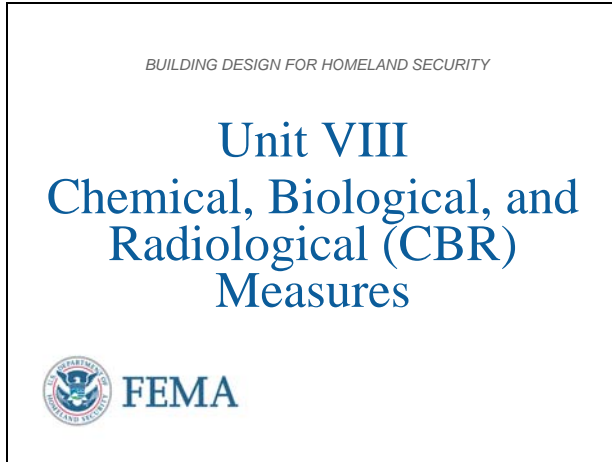

**Introduction and Unit Overview**

This is Unit VIII CBR Measures. In this unit, CBR protective measures and actions to safeguard the occupants of a building from CBR threats are presented. The unit is based largely on CDC/NIOSH and DoD guidance.

VISUAL VIII-2

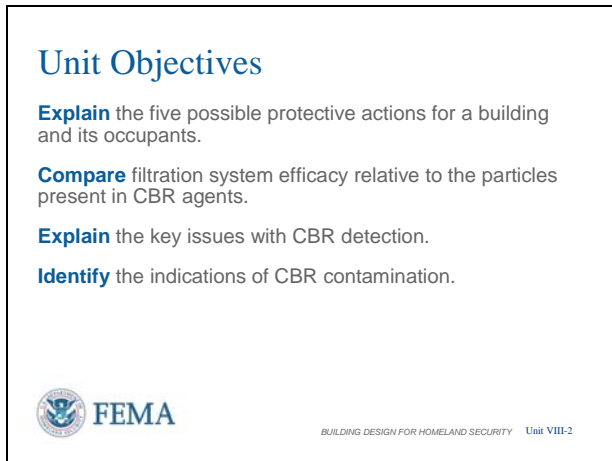

**Unit Objectives**

At the end of this unit, the students should be able to:

1. Explain the five possible protective actions for a building and its occupants.
2. Compare filtration system efficacy relative to the particles present in CBR agents.
3. Explain the key issues with CBR detection.
4. Identify the indications of CBR contamination.

**INSTRUCTOR NOTES**

**CONTENT/ACTIVITY**

**VISUAL VIII-3**

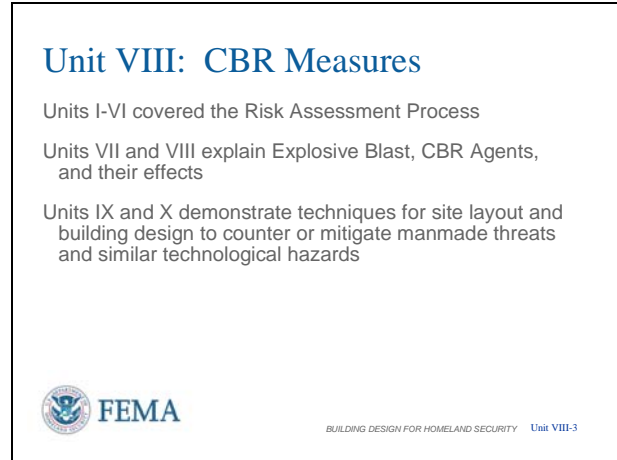

**CBR Measures**

This unit is based on guidance from the CDC/NIOSH and the DoD and presents protective measures and actions to safeguard the occupants of a building from CBR threats. The following will be discussed:

- Evacuation
- Sheltering in place
- Personal protective equipment
- Air filtration and pressurization
- Exhausting and purging
- CBR detection

Additionally, CBR design and mitigation measures are discussed in:

- **Chapter 3 of FEMA 426**
- **Appendix C of FEMA 426** contains a glossary of CBR terms and a summary of CBR agent characteristics

Recent terrorist events have increased interest in the vulnerability of buildings to CBR threats. Of particular concern are building HVAC systems, because they can become an entry point and distribution system for airborne hazardous contaminants. Even without special protective systems, buildings can provide protection in varying degrees against airborne hazards that originate outdoors.

VISUAL VIII-4

**CBR Measures: An Overview**

FEMA 426, Chapter 5 is based on best practices for safeguarding building occupants from CBR threats. This module is organized into four sections :

- Protective Actions for Buildings and Occupants
- Air Filtration and Cleaning Principles and Technology
- CBR Detection and Current Technology
- Non-Technology CBR Contamination Indications



SOURCE: SENSIR TECHNOLOGIES  
BUILDING DESIGN FOR HOMELAND SECURITY Unit VIII-4



**CBR Measures: FEMA 426 Chapter 5 Overview**

This Unit draws on the latest research from CDC/NIOSH to present the best practices for detecting CBR agents, and safeguarding building occupants from the effects of CBR contamination.

**Chapter 5 of FEMA 426** provides an overview on CBR Detection and Current Technology; and Indications of CBR Contamination, Evacuation, Sheltering in Place, Air Filtration and Pressurization, and Exhausting and Purging.

VISUAL VIII-5

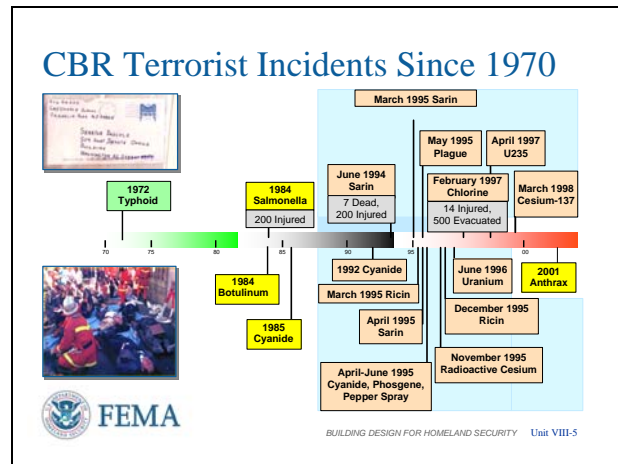

**CBR Terrorist Incidents Since 1970**

CBR attacks have been used since ancient times and, in the past 20 years, over 50 attacks have occurred.

CBR attacks require the right weather, population, and dispersion to be effective.

Recent attacks have had limited effectiveness or have been conducted on a relatively small scale.

Future attacks with Weapons of Mass Destruction could occur on a regional or global scale.

VISUAL VIII-6

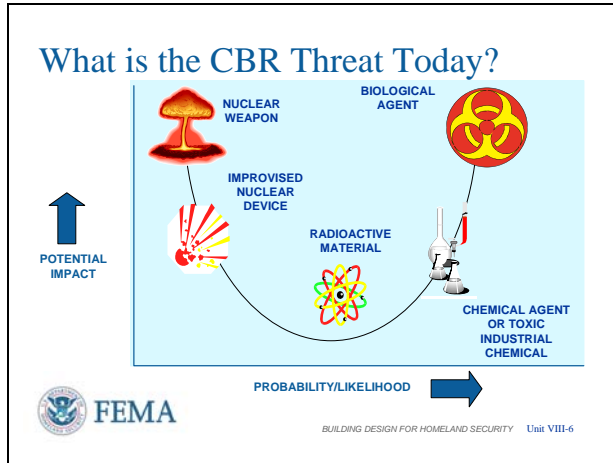

**What is the CBR Threat?**

A fundamental question, *What is the CBR threat today?* This slide shows the relationship between the probability or likelihood of threats, and their potential impacts.

VISUAL VIII-7

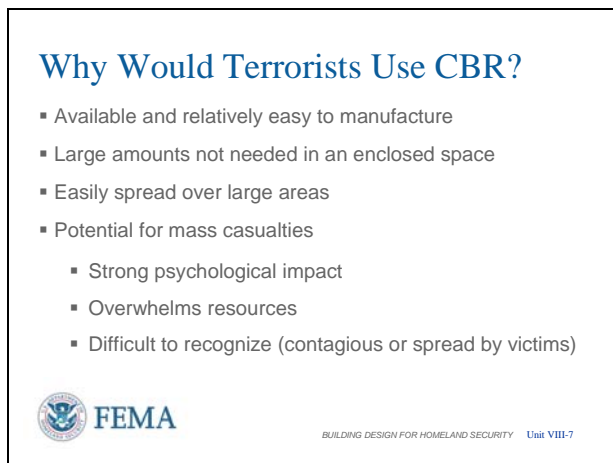

**Why Would Terrorists Use CBR?**

- Available and relatively easy to manufacture
- Large amounts not needed in an enclosed space
- Easily spread over large areas
- Potential for mass casualties
  - Strong psychological impact
  - Overwhelms resources
  - Difficult to recognize (contagious or spread by victims)

Recent events have shown that people not directly affected by the attack, but nearby, will seek medical confirmation of health / non-contamination and quickly overwhelm medical resources.



INSTRUCTOR NOTES

CONTENT/ACTIVITY

VISUAL VIII-8

**CBR Sources**

- Laboratory/commercial
- Industrial facilities
- Foreign military sources
  - At least 26 countries possess chemical agents or weapons
  - 10 countries are suspected to possess biological agents or weapons
- Medical/university research facilities
- Nuclear facilities
- Home production



BUILDING DESIGN FOR HOMELAND SECURITY Unit VIII-8

**CBR Sources**

There are many potential sources of chemical and biological agents, including laboratory and commercial production; and home production in those cases involving low concentrations of impure and inexpensive materials. Other sources include:



- Industrial facilities
- Foreign military sources
- Medical/university research facilities
- Nuclear facilities

The next series of slides will examine in more detail the properties of chemical and biological agents, **with implications for building design.**

VISUAL VIII-9

**Limitations of CBR Materials**

- Targeted dissemination is difficult
- Delayed effects can detract from impact
- Counterproductive to terrorists' support
- Potentially hazardous to the terrorist
- Development and use require time and expertise



BUILDING DESIGN FOR HOMELAND SECURITY Unit VIII-9

**Limitations of CBR Materials**

- Targeted dissemination is difficult. While agents can be spread over a wide area with relative ease, targeting with sufficient concentration is much more difficult.
- Delayed effects can detract from impact. Terrorist seek immediate media impact, but many agents take time to result in impact
- Counterproductive to terrorists' support. Indiscriminate use of any WMD (Weapon of Mass Destruction), especially ones difficult to target with success, can attack innocents and those in the support base, thus reducing support of the populace for the terrorists' objectives.
- Potentially hazardous to the terrorist. Lack of expertise among terrorists can result in deadly contact with the CBR agents being produced, or premature explosion of bombs during the bomb

The slide shows the cover of Ben Laden's Terrorism Bible and The Mujahideen Poisons Handbook by Abdel Aziz. "Majahideen" - Arabic word meaning "holy warriors." This book is part of the Encyclopedia Jihad. The aim of this book is to further the military/political preparations, skills and knowledge of Mujahideen the world over.



VISUAL VIII-10

**Chemical Agents:  
Characteristics and Behavior**

- Generally liquid (when containerized)
- Normally disseminated as aerosol or gas
- Present both a respiratory and skin contact hazard
- May be detectable by the senses (especially smell)
- Influenced by weather conditions



 FEMA

BUILDING DESIGN FOR HOMELAND SECURITY Unit VIII-10

Subway riders injured in Aum Shinrikyo Sarin gas attack, in Tokyo, March 20, 1995.

VISUAL VIII-11

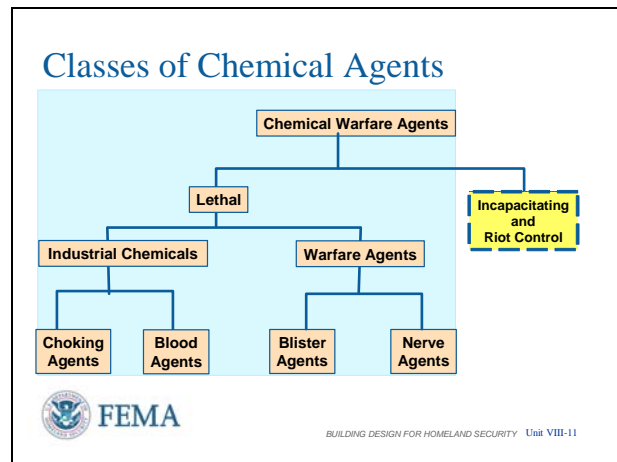

making process with deadly consequences

- Development and use require skill. More than one terrorist has produced bombs that will not explode and CBR agents that will not impact upon human beings to the level desired.

**Chemical Agents: Characteristics and Behavior**

These are the general characteristics of chemical agents

- Liquids that are spread as aerosols or gases
- Impact breathing and attack exposed skin
- May have a distinct odor that allow detection
- Greatly influenced by the weather – rain, wind, sunlight, including its own physical characteristics – heavier or lighter than air

**Classes of Chemical Agents**

Chemical agents are classified as either lethal or incapacitating and “riot control,” according to their intended use. For the purposes of this presentation, the emphasis has been placed on lethal agents as a consequence of their greater capacity for terrorist mischief.

- **Lethal:** These have been subdivided into two categories: industrial materials used or considered as chemical warfare agents, and chemical warfare agents, which have little or no other purpose beyond their intended use as weapons of mass destruction on the battlefield.

VISUAL VIII-12

Industrial Chemicals		
<i>Industrial chemicals previously used as chemical warfare agents</i>	Choking Agents Chlorine/Phosgene	Blood Agents Hydrogen Cyanide/ Cyanogen Chloride
<b>Physical Appearance</b>	Greenish-yellow vapor/ colorless vapor	Colorless vapor
<b>Odor</b>	Bleach/mown hay	Bitter almonds
<b>Signs and Symptoms</b>	Coughing, choking, tightness in chest	Gasping for air Red eyes, lips, skin
<b>Protection</b>	Respiratory	Respiratory
<b>Treatment</b>	Aeration	Aeration, cyanide kit

*as chemical warfare agents*



BUILDING DESIGN FOR HOMELAND SECURITY Unit VIII-12

- **Incapacitating and Riot Control:** Not considered as primary terrorist threats, due primarily to their relatively short duration of effects and minimal toxicity. Therefore, they are not discussed in detail in this unit.

**Industrial Chemicals**

This chart lists four industrial chemicals that were previously used as chemical warfare agents. These chemicals are used in the:

- Sanitation industry
- Plastics industry
- Pesticide industry.

All of these agents are generally respiratory agents and can be protected against by effective respiratory protection (i.e., self-contained breathing apparatus (SCBA)).

Skin contact with concentrated material may cause chemical burns and contact with eyes has similar effects as indicated by the MSDS (Material Safety Data Sheets) for these chemicals. However the main tactic for use of these chemicals does not seek this effect.

They are all exceedingly volatile and dissipate rapidly outdoors.

VISUAL VIII-13

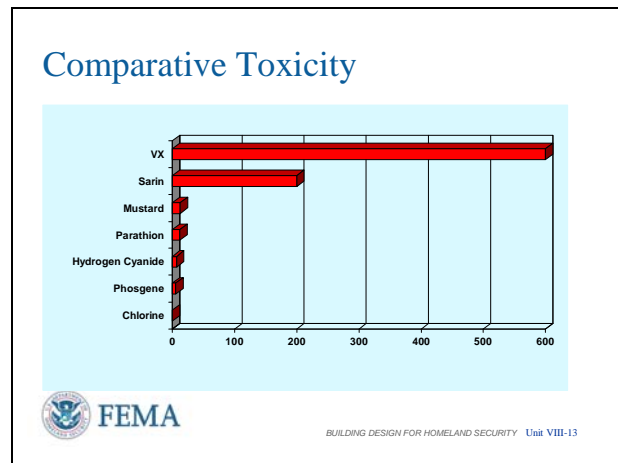

Note: At this point, reinforce the following:  
*...as we collectively examine and identify opportunities to improve building safety from CBR, it is important to understand the characteristics of CBR, and their potential consequences for the public, and first responders.... detailed information on the properties of these agents can be found in Appendix C of FEMA 426.*

VISUAL VIII-14

Structure	Lethal Amount
Domed Stadium	107 kg (26 gals)
Movie Theater	1.2 kg (5 cups)
Auditorium	52 g (1/4 cup)
Conference Room (50-100 seating)	33 g (1 shot glass)

*LD<sub>50</sub> amounts for 1 minute exposure to Sarin aerosol*

Exam Questions #A15 and B15

Comparative Toxicity

This is a graphical comparison of the approximate lethalties of some chemical agents. They are based relative to Chlorine (CL or Cl) in terms of respiratory toxicity. If we use Chlorine as a baseline (1.0 on the graph):

- Phosgene (CG) is about 6 times more toxic.
- Hydrogen Cyanide (AC) is about 7 times more toxic.
- Parathion, an insecticide ingredient, is about 12 times more toxic.
- Mustard (H) is about 13 times more toxic.
- Sarin (GB) is about 200 times more toxic.
- VX (nerve agent) is about 600 times more toxic.

For skin toxicity, less than a pinhead of mustard agent is required to achieve a small blister. Less than a pinhead of VX can be lethal.

How Much Sarin Does it Take?

We have all heard of Sarin, which is among the most lethal of chemical agents. It is both odorless and colorless in pure form.

These numbers are the Lethal Doses 50 (LD<sub>50</sub>) amounts for 1 minute of exposure to Sarin aerosolized liquid. This means that, in a 1-minute period, it would take approximately 26 gallons of Sarin to kill 50 percent of the people in a domed stadium, 5 cups of Sarin to kill 50 percent of the people in a movie theater, only about 1/4 cup of Sarin to kill 50 percent of the people in an auditorium, and the equivalent of a shot glass to kill 50 percent of the people in a 50-100 person conference room.

**INSTRUCTOR NOTES**

**CONTENT/ACTIVITY**

**VISUAL VIII-15**

**Chemical Agents Key Points**

- Chemical agents are super toxic
- Relative toxicity: industrial chemicals < mustard < nerve
- Normal states are as a liquid or a vapor
- Inhalation hazard is of greatest concern



BUILDING DESIGN FOR HOMELAND SECURITY Unit VIII-15

It is the aerosol that is most often fatal. For example, the Tokyo subway attack used Sarin liquid and the liquid caused very few deaths. Most casualties were from the closed subway environment where the Sarin aerosolized (evaporated) on its own in the confined space of the subway reaching toxic levels.

**Chemical Agents Key Points**

- Chemical agents are supertoxic. These agents were deliberately developed to cause injury or death to individuals.
- Relative toxicity: industrial chemicals < mustard < nerve. In terms of relative toxicity, the same amount of an industrial chemical is less toxic than a blister agent, and both are less toxic than a nerve agent.
- Normal states are as a liquid or a vapor. These agents are either a liquid or a vapor in their normal state. But the vapor is a more effective WMD.
- Inhalation hazard is of greatest concern. Nerve and blister agents pose both a skin and inhalation hazard. The inhalation hazard is of greater concern.

**VISUAL VIII-16**

**Biological Warfare Agents**



BUILDING DESIGN FOR HOMELAND SECURITY Unit VIII-16

**Biological Warfare Agents**

Emphasize differences between chemical and biological agents:

- **Delayed effects:** The biggest difference is time. Unlike chemical agents, most of which have an immediate effect, most biological agents have a delayed effect ranging from several hours to days, and in some cases, weeks. In the event of a biological incident, there may be no casualties and nothing significant initially.
- **Toxicity:** By weight, biological agents

VISUAL VIII-17

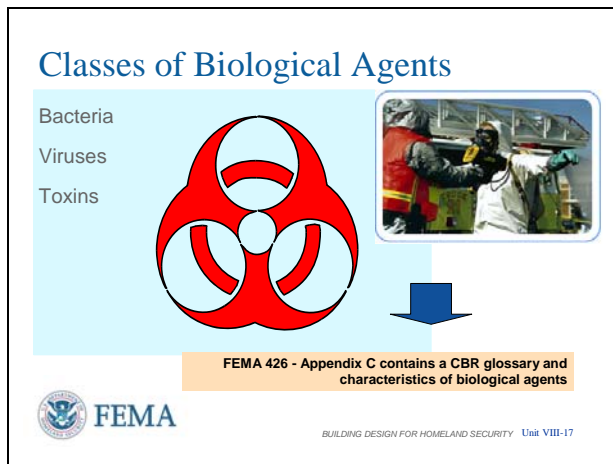

Note: As we look at biological agents, you will see some similarities with what we discussed earlier with chemical agents, but you will also note some significant differences. Selected bacterial, viral, and toxin agents, their characteristics, and treatment are of particular concern when preparing for biological terrorism.

are generally more toxic than chemical agents. For example, Ricin is 6 to 9 times more toxic than Sarin, and Botulinum, another toxin, is 15,000 to 30,000 times more toxic than Sarin.

- **Human detection:** Biological agents are undetectable by the human senses.

**Classes of Biological Agents**

- Both **bacteria** and **viruses** are living organisms and, as such, require an environment in which to live and reproduce.
- They can enter the body through inhalation or ingestion, through a break in the skin, or through other body openings or orifices.
- Once the organisms invade the body, they begin to grow and reproduce. They can also produce toxins that may poison the body.
- **Toxins** are poisonous substances produced as a byproduct of pathogens or plants and even some animals.

VISUAL VIII-18

Bacteria		
	Anthrax	Plague
Incubation Period	1 to 6 days	2 to 3 days for pneumonic 2 to 10 days for bubonic
Contagious	NO	YES (pneumonic) NO (bubonic)
Signs and Symptoms	Chills, fever, nausea, swollen lymph nodes	Chills, high fever, headache, spitting up blood, shortness of breath
Protection	Standard Precautions	Standard Precautions and Droplet Precautions
Treatment	Antibiotics and vaccines	Antibiotics and vaccines

 BUILDING DESIGN FOR HOMELAND SECURITY Unit VIII-18

**Bacteria**

Anthrax and plague are two examples of diseases caused by bacteria. This chart highlights the important characteristics of each, including:

- Incubation period
- Whether they are contagious or not
- Signs and symptoms
- Protection
- Treatment

Again, a basic understanding of these characteristics will be valuable in developing an **appropriate and effective protective action strategy for your facility.**

VISUAL VIII-19

Viruses		
	Smallpox	Viral Hemorrhagic Fevers
Contagious	YES	YES
Signs and Symptoms	Fever, rigors, vomiting, headache, pustules	Fever, vomiting, diarrhea, mottled/lotchy skin
Protection	Standard Precautions + Droplet + Airborne + Contact Precautions	Standard Precautions + Droplet + Airborne + Contact Precautions
Treatment	Vaccine, supportive therapy	Vaccines available for some

 BUILDING DESIGN FOR HOMELAND SECURITY Unit VIII-19

**Viruses**

Two viruses are highlighted: **Smallpox** and **Viral Hemorrhagic Fevers**. Both are contagious, and protective actions include the use of standard, airborne, and contact precautions.

For example, most contagion in smallpox is from people inhaling small droplets from the coughing of infected/contagious persons.

**INSTRUCTOR NOTES**

**CONTENT/ACTIVITY**

**VISUAL VIII-20**

Toxins		
	Neurotoxin (Botulinum)	Cytotoxin (Ricin)
Onset of Symptoms	1 to 3 days	4-8 hours after ingestion 12-24 hours after inhalation
Contagious	NO	NO
Signs and Symptoms	Weakness, dizziness, dry mouth and throat, blurred vision, paralysis	Chills, high fever, headache, spitting up blood, shortness of breath
Protection	Standard Precautions	Standard Precautions
Treatment	Supportive care, antitoxins, and vaccines	Supportive oxygenation and hydration

Note: There are numerous naturally-occurring toxins. For our purposes, we will group them into two categories.

BUILDING DESIGN FOR HOMELAND SECURITY Unit VIII-20



**Toxins**

Finally, there are numerous naturally-occurring **toxins**. For our purposes, we will group them into two categories:



- **Neurotoxins:** Neurotoxins attack the nervous system. They are fairly fast-acting and can act in a manner opposite to that of the nerve agents because they prevent nerve-to-muscle stimulation.
- **Cytotoxins:** Cytotoxins are cell poisons. They are slower acting and can have a variety of symptoms, including vomiting, diarrhea, rashes, blisters, jaundice, bleeding, or general tissue deterioration.

There are numerous other modes of action of toxins, which are beyond our need to discuss here.

**VISUAL VIII-21**

**Biological Agents Key Points**

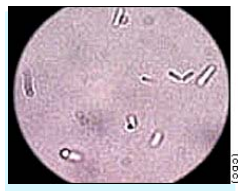
- Onset of symptoms
- Potentially contagious
- Signs and symptoms
- Protection
- Treatment

BUILDING DESIGN FOR HOMELAND SECURITY Unit VIII-21



**Biological Agents Key Points**

NOTE: A very low dose of a biological agent can cause infection and spread disease, thus detection requires high sensitivity, but because there are many biologicals in the environment, detection requires selectivity, and since biological agents are very complex molecules making them difficult to identify/detect.

- **Onset of symptoms:** Most biological agents have an incubation period. Delayed effects will make identifying a biological attack more difficult.
- **Potentially Contagious:** Only a few biological agents are contagious: plague, smallpox, and viral hemorrhagic fevers (VHF), such as Ebola.
- **Signs and symptoms:** Signs and symptoms of many biological attacks initially manifest themselves as flu-like; therefore, it may be difficult to identify

**Exam Questions #A14 and B13**

Biological weapons are considered the emerging mass weapon of destruction of choice for terrorists because many agents can be made with standard commercial laboratory or brewing equipment.



VISUAL VIII-22

**Biological Agent Categories**

**Some Biological agent(s)**

- Variola major
- Bacillus anthracis
- Yersinia pestis
- Clostridium botulinum
- Ebola, Marburg
- Coxiella burnetii
- Brucella spp.
- Burkholderia mallei
- Burkholderia pseudomallei
- Toxins
- Food/Water safety threats
- Emerging threat agents

**Disease**

**Category A**

- Smallpox
- Anthrax
- Plague
- Botulism
- Tularemia
- Viral hemorrhagic fevers

**Category B**

- Q Fever
- Brucellosis
- Glanders
- Melioidosis
- Psittacosis
- Ricin toxin
- Typhus
- Cholera
- Shigellosis

FEMA

BUILDING DESIGN FOR HOMELAND SECURITY Unit VIII-22

that an attack has occurred.

- **Protection:** Standard precautions will be adequate protection against most biological agents.
- **Treatment:** Some biological agents can be treated with antibiotics, vaccines, and antitoxins; for agents for which there are none of the aforementioned treatments, supportive care should be administered, such as treating the symptoms.

The recent SARS and Avian Flu outbreaks demonstrate the relative ease by which naturally-occurring biological agents can quickly transmutate and spread across the globe. The flu strain that caused the Flu Pandemic of 1918 is still an active strain.

**Biological Agent Categories**

Agents are placed in one of three priority categories for initial public health Preparedness efforts based on the overall criteria and weighting of each agent.

**Category A:** Carry the highest priority because they:

- Can be easily disseminated or spread person-to-person
- Can be highly lethal
- Have the potential for serious public health impact
- Can potentially cause public panic and lead to social disruption

**Category B:** Carry the second-highest priority because they:

- Are moderately easy to disseminate
- Usually result in moderate morbidity
- Are generally less lethal

**Category C:** They include emerging pathogens that could potentially be engineered for future mass dissemination.



**Course Title: Building Design for Homeland Security**

Unit VIII: Chemical, Biological, and Radiological (CBR) Measures

**INSTRUCTOR NOTES**

**CONTENT/ACTIVITY**

- Nipah virus
- Hantavirus

Not believed to present a high bio terrorism risk to the public health today, but could emerge as future threats.

VISUAL VIII-23

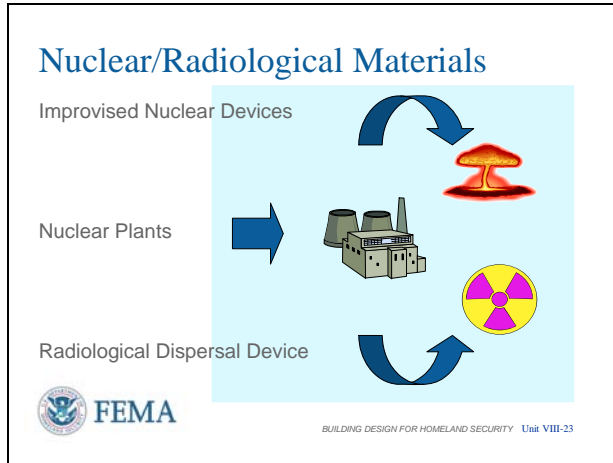

**Nuclear/Radiological Materials**

Of the three types of threats (chemical, biological, or nuclear/radiological), a **nuclear weapon explosion** is considered the least likely for terrorist use; however, the potential exists for it to happen and even more potential exists for the use of radiological materials.

Possible scenarios:

- Detonation of an **improvised nuclear device** (IND)
- Terrorist attack on a **nuclear plant**
- Use of a **radiological dispersal device** (RDD), or “dirty” bomb – the simple act of spreading the materials

VISUAL VIII-24

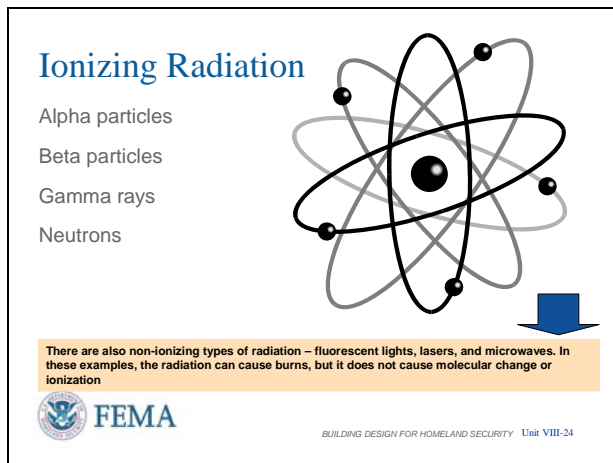

**Ionizing Radiation**

Ionizing radiation is either particle radiation or electromagnetic radiation in which an individual particle/photon carries enough energy to ionize an atom or molecule by completely removing an electron from its orbit. If the individual particles do not carry this amount of energy, it is essentially impossible for even a large flood of particles to cause ionization. These ionizations, if enough occur, can be very destructive to living tissue, and can cause DNA damage and mutations.

**Exam Questions #A13 and B12**

Note: In its simplest definition, radiation can be defined as either electromagnetic or particulate emissions of energy from the disintegration of the nucleus of an atom. This energy, when impacting on or passing through material, including humans, can cause some form of reaction.

For our purposes, ionizing radiation includes:

- **Alpha particles**
- **Beta particles**
- **Gamma rays**
- **Neutrons**

Again, for the purposes of this course, we are primarily concerned with the *hazard*, the *detection* of the hazard, and *protective*

**INSTRUCTOR NOTES**

**CONTENT/ACTIVITY**

**Radioactive material:** Any material that is giving off some form of ionizing radiation.

**VISUAL VIII-25**

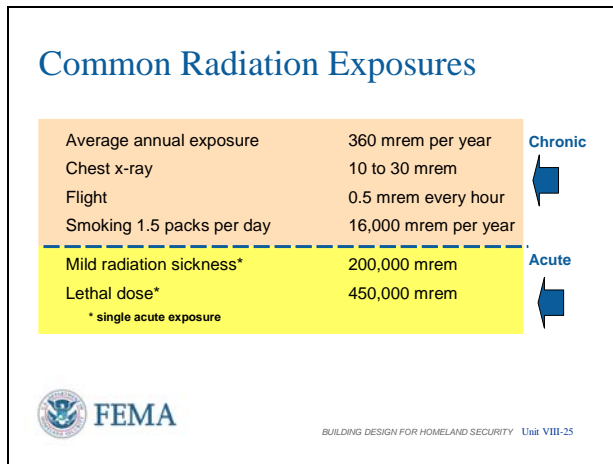

Note: Mild radiation sickness (i.e., nausea, vomiting, and diarrhea) may onset after receiving a whole body dose of approximately 200,000 mrem in a short amount of time (generally less than 24 hours). The Lethal Dose (LD), known as the LD50/60, is a single, acute, whole body exposure of around 450,000 mrem. The LD50/60 is defined when 50 percent of all people present at an incident receive 450,000 mrem and die after 60 days after receiving no medical treatment.

actions that we can take.

Ionizing radiation is what causes injury or death, and is also a characteristic by which nuclear materials can be measured and identified.

**Common Radiation Exposures**

This chart reflects naturally-occurring radiation doses (and doses received during normal activities) to provide a point of reference and for comparison. The threshold for any real consequences begins around 200,000 mrem.

The average annual radiation exposure has been calculated as:

Naturally occurring	295 mrem
Medical	52 mrem
Consumer products	10 mrem
Other	<u>3 mrem</u>
<i>Total</i>	<i>360 mrem</i>

VISUAL VIII-26

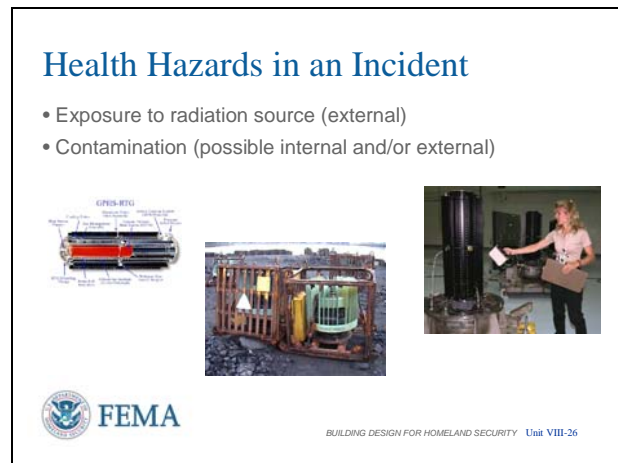

**Exam Questions #A24 and B25**

Note: Internal exposure through wounds or broken skin is also possible. Responders should take extra precautions when sharp objects, such as broken glass or jagged metal, are at the scene.

Left Photo - This image shows the cut-away of an actual Radioisotope Thermoelectric Generators (RTG) Unit which produces electricity via the thermoelectric effect.  
Center Photo - RTG from the Cassini program.  
Right Photo - RTG abandoned on the Kola Peninsula, Russia

**Exam Questions #A24 and B25**

**Health Hazards**

The two radiation concerns at an incident are exposure and contamination by radioactive material. External irradiation occurs when all or part of the body is exposed to penetrating radiation from an external source. Contamination means that radioactive materials in the form of gases, liquids, or solids are released into the environment and get on people externally, get in them internally, or both.

Incidents involving either an explosion or fire will elevate the potential for internal or external contamination due to the spreading of the radioactive material in the form of small fragments (dust) or smoke. These materials can often be carried long distances downwind.

Radiological materials are both colorless and odorless.

VISUAL VIII-27

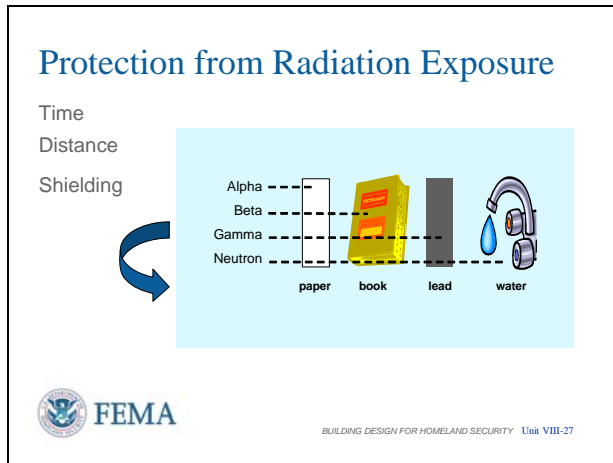

Note: Do not shield neutron-producing sources with lead or dense materials as the neutrons react with the material to produce gamma rays. Use wax, water, or plastic instead.

VISUAL VIII-28

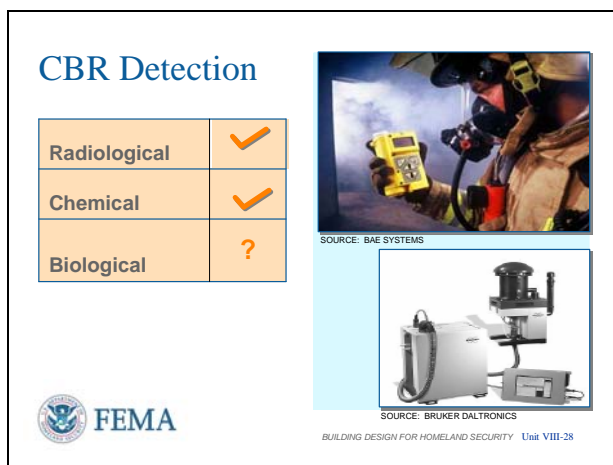

Exam Questions #A14 and B13

Exam Questions #A19 and B20

**Protection from Radiation Exposure**

The radiation exposure received will depend on the type and strength of radiation source. This exposure can be reduced by effective use of:

- **Time:** The radiation dose is reduced in proportion to reduction in exposure time.
- **Distance:** Distance is also critical for reducing radiation exposure dose. Although alpha particles only travel a little over an inch in air, and beta particles will travel only a few yards in air, gamma rays can travel extensive distances.
- **Shielding:** Radiation can also be blocked or reduced by various materials. Alpha radiation is stopped by a sheet of paper, beta radiation is stopped by aluminum foil or clothing, gamma rays are only reduced by dense materials such as lead or earth, and neutrons are slowed or stopped by hydrogenous materials, such as wax or water.

**CBR Detection**

The underlying theme of this chapter is that effective protection against potential releases of CBR is a function of:

- 1) Effective and timely detection of the agent(s); and
- 2) A public that is knowledgeable of the most appropriate protective actions to take in the event of a CBR release.

The discussion on **CBR detection** includes:

- CBR detection technology currently available.
- Indications of CBR contamination.
- Mass spectrometry. (can positively identify a chemical agent at very low concentrations)

**INSTRUCTOR NOTES**

**CONTENT/ACTIVITY**

Sources of useful technical information:

- *NBC Products and Services Handbook* contains a catalogue of CBR detection equipment.
- *Guide for the Selection of Chemical Agent and Toxic Industrial Material Detection Equipment for Emergency First Responders*, published by the National Institute of Justice (NIJ) (Guide 100-00, Vols 1 & 2), June 2000.
- *An Introduction to Biological Agent Detection Equipment for Emergency First Responders*, published by the NIJ (Guide 101-00): December 2001.

**Exam Questions #A14 and B13**

**Exam Questions #A19 and B20**

VISUAL VIII-29

**CBR Incident Indicators**

Indicator	Chemical	Biological	Radiological
Dead Animals	✓		✓
Lack of Insect life	✓		
Physical Symptoms	✓	✓	✓
Mass Casualties	✓		✓
Unusual Liquids	✓		
Unexplained Odors	✓		
Unusual Metal Debris/Canisters	✓	✓	✓
Heat Emitting or Glowing			✓
Spray Mechanisms	✓	✓	

 **FEMA**

BUILDING DESIGN FOR HOMELAND SECURITY Unit VIII-29

**Exam Questions #A16 and B16**

- Most strategies for protecting people from airborne hazards require a means of detection (determining that a hazard exists).
- **Chemical detection** technology has improved vastly since Operation Desert Storm (when many military detection systems experienced high false-alarm rates). Current chemical detectors work in about 10 seconds.
- **Biological detection** technology has not matured as fast; generally require trained specialists to administer; biological signatures can take 30 minutes to detect. Biological detection requires sensitivity (very low effective dose must be detected), selectivity (there are many biologicals in the environment, thus must discern the contagious/deadly ones), and identification of very complex molecules (the complexity makes them difficult to identify).

A variety of **radiological detectors** have been developed for the nuclear industry and are commercially available.

**CBR Incident Indicators**

This is a summary table indicating warning properties of CBR agents in terms of dead animals, lack of insect life, physical symptoms, mass casualties, unusual liquids, unexplained odors, unusual metal debris, heat emitting or glowing, and spray mechanisms.

Details provided in visuals VIII-30, -31, -32, and -33.

**INSTRUCTOR NOTES**

**CONTENT/ACTIVITY**

In general, chemical agents will typically have a rapid onset of symptoms, while the response to biological or radiological agents can be delayed. Potential indicators of threats include suspicious packages or containers or unusual powders or liquids, droplets, mists, or clouds found near air-intake, in air-ventilation ductwork, and HVAC systems.

**VISUAL VIII-30**

**Chemical Incident Indicators (1)**

<b>Dead animals, birds, fish</b>	Not just an occasional roadkill, but numerous animals (wild and domestic, small and large), birds, and fish in the same area.
<b>Loss of insect life</b>	If normal insect activity (ground, air, and/or water) is missing, check the ground/water surface/shore line for dead insects. If near water, check for dead fish/aquatic birds.
<b>Physical symptoms</b>	Numerous individuals experiencing unexplained water-like blisters, wheals (like bee stings), pinpointed pupils, choking, respiratory ailments, and/or rashes.
<b>Mass casualties</b>	Numerous individuals exhibiting unexplained serious health problems ranging from nausea to disorientation to difficulty in breathing to convulsions to death.
<b>Definite pattern of casualties</b>	Casualties distributed in a pattern that may be associated with possible agent dissemination methods.

**Chemical agents have a rapid onset of symptoms**



FEMA 426, Table 5-2: Indicators of a Possible Chemical Incident, p. 5-34  
BUILDING DESIGN FOR HOMELAND SECURITY Unit VIII-30

**Chemical Incident Indicators**

Most hazardous chemicals have warning properties that provide a practical means for detecting a hazard and initiating protective actions. Such warning properties make chemicals perceptible; for example, vapors or gases can be perceived by the human senses (i.e., smell, sight, taste, or irritation of the eyes, skin, or respiratory tract) before serious effects occur.

In the absence of a warning property, people can be alerted to some airborne hazards by observing symptoms or effects in others. This provides a practical means for initiating protective actions, because the susceptibility to hazardous materials varies from person to person.

**VISUAL VIII-31**

**Chemical Incident Indicators (2)**

<b>Illness associated with confined geographic area</b>	Lower attack rates for people working indoors than those working outdoors, and vice versa.
<b>Unusual liquid droplets</b>	Numerous surfaces exhibit oily droplets film; numerous water surfaces have an oily film (No recent rain.)
<b>Areas that look different in appearance</b>	Not just a patch of dead weeds, but trees, shrubs, bushes, food crops, and/or lawns that are dead, discolored, or withered. (Not current drought.)
<b>Unexplained odors</b>	Smells may range from fruity to flowery to sharp/pungent to garlic/horse-radish like to bitter almond/peach kernels to new mown hay. It is important to note that the particular odor is completely out of character with its surroundings.
<b>Low-lying clouds</b>	Low-lying clouds/fog-like condition that is not explained by its surroundings.
<b>Unusual metal debris</b>	Unexplained bomb/munitions-like material, especially if it contains a liquid. (No recent rain.)



FEMA 426, Table 5-2: Indicators of a Possible Chemical Incident, p. 5-34  
BUILDING DESIGN FOR HOMELAND SECURITY Unit VIII-31

Chart 2 depicts the following chemical indicators: definite pattern of casualties; illness associated with a confined geographic area; unused liquid droplets; areas that look different in appearance; unexplained odors; low-flying clouds; and unusual metal debris.



VISUAL VIII-32

**Biological Incident Indicators**

Unusual numbers of sick or dying people or animals	Any number of symptoms may occur. As a first responder, strong consideration should be given to calling local hospitals to see if additional casualties with similar symptoms have been observed. Casualties may occur hours to days or weeks after an incident has occurred. The time required before symptoms are observed is dependent on the biological agent used and the dose received. Additional symptoms likely to occur include unexplained gastrointestinal illnesses and upper respiratory problems similar to flu/colds.
Unscheduled and unusual spray being disseminated	Especially if outdoors during periods of darkness.
Abandoned spray devices	Devices will have no distinct odors.

**Biological agents will typically have a more delayed effect**

 FEMA FEMA 426, Table 5-3: Indicators of Possible Biological Incident, p. 5-35  
BUILDING DESIGN FOR HOMELAND SECURITY Unit VIII-32

**Exam Questions #A16 and B16**

**Biological Incident Indicators**

In the case of a biological incident, the onset of symptoms takes days to weeks and, typically, there will be no characteristic indicators. Because of the delayed onset of symptoms in a biological incident, the area affected may be greater due to the migration of infected individuals.

The indicators of biological attack easiest to identify are unscheduled and unusual spraying and abandoned spray devices.

Let's make a distinction between bioterrorism against people and against animals:

**People:** Farmers might see cows/livestock get anthrax after an anthrax biological attack (but not cats and dogs). No other commonly discussed biological agents used for people will affect animals. Alternately, rats carry fleas that spread plague, but the rats don't get plague.

**Animals:** Unlikely to happen and if it does few people are going to see it for what it is. It makes another distinction between biological and chemical indicators. However, if the attack is against animals, then animal effects are indications. For example foot and mouth disease or pseudo rabies or swine flu or bird flu would cause huge animal losses but no human deaths (unless you count the recent bird flu deaths by people handling infected poultry and this in contact). But these latter instances are not bioterrorism yet.



VISUAL VIII-33

### Radiological Incident Indicators

Unusual numbers of sick or dying people or animals	As a first responder, strong consideration should be given to calling local hospitals to see if additional casualties with similar symptoms have been observed. Casualties may occur hours to days or weeks after an incident has occurred. The time required before symptoms are observed is dependent on the radioactive material used and the dose received. Additional symptoms likely to occur include skin reddening and, in severe cases, vomiting.
Unusual metal debris	Unexplained bomb/munitions-like material.
Radiation symbols	Containers may display a radiation symbol.
Heat emitting material	Material that seems to emit heat without any sign of an external heating source.
Glowing material/particles	If the material is strongly radioactive, it may emit a radioluminescence.

**Radiological agents will typically have a more delayed effect**

 FEMA FEMA 426, Table 5-4: Indicators of a Possible Radiological Incident, p. 5-36  
BUILDING DESIGN FOR HOMELAND SECURITY Unit VIII-33

### Radiological Incident Indicators

In the case of a radiological incident, the onset of symptoms also takes days to weeks to occur and typically there will be no characteristic indicators. Radiological materials are not recognizable by the senses because they are colorless and odorless.

It is fortunate the radiological detectors are so mature to detect radiation sources and residual radiation.

VISUAL VIII-34

### CBR Protection Strategies

**Protective Actions:**

- Evacuation
- Sheltering in Place
- Personal Protective Equipment
- Air Filtration, Pressurization, and Ultraviolet Light
- Exhausting and Purging

 FEMA FEMA 426, Table 5-4: Indicators of a Possible Radiological Incident, p. 5-36  
BUILDING DESIGN FOR HOMELAND SECURITY Unit VIII-34

### CBR Protection Strategies

Once the presence of an airborne hazard is detected, there are five possible **protective actions** for a building and its occupants. In increasing order of complexity and cost, these actions are:

- Evacuation
- Sheltering in Place
- Personal Protective Equipment
- Air Filtration and Pressurization
- Exhausting and Purging

To ensure the protective actions are effective you must have:

- A protective action plan specific to each building
- Training and familiarization for occupants

Protective actions are discussed in more detail in the following sections.

VISUAL VIII-35

**Evacuation**

- Determine airborne hazard source -- internal or external
- Determine if evacuation will make things better or worse
- Assembly should be upwind, at least 1,000 feet away, and three different locations (A, B, C plan)
- In most cases, existing plans for fire evacuation apply – follow through - exercise



FEMA

BUILDING DESIGN FOR HOMELAND SECURITY Unit VIII-35

This map displays 1,000 foot radius to determine minimum evacuation distance, 2,000 feet would be better.

VISUAL VIII-36

**Sheltering in Place**

A building can provide substantial protection against agents released outside if uptake of contaminated air can be halted or reduced and/or if uptake of fresh/filtered air can be increased.

The amount of protection varies with:

- How tight the building is
- Level of exposure (dose x time)
- Purging or period of occupancy
- Natural filtering

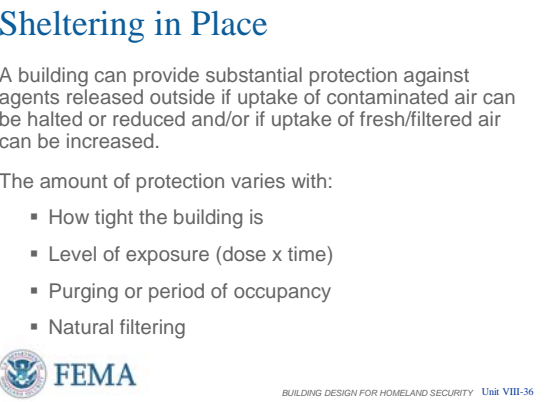

FEMA

BUILDING DESIGN FOR HOMELAND SECURITY Unit VIII-36

Exam Questions #A12 and B14

**Evacuation**

- Evacuation is the most common protective action taken when an airborne hazard, such as smoke or an unusual odor, is perceived in a building.
- There must be some detection method or knowledgeable personnel in place to make the determination of what to do – evacuate or some other action. This may be trained first responders, but even their response time can be too long depending upon the situation.
- Orderly evacuation is the simplest and most reliable action for an internal airborne hazard, but may not be the best action in all situations, especially in the case of an external CBR release, particularly one that is widespread.
- If some agent has infiltrated the building and evacuation is deemed not to be safe, the use of protective hoods may be appropriate.
- The evacuation plan should list each contingency and the decision process.

**Sheltering in Place**

Interrupting the flow of fresh air is the principal applied in the protective action known as sheltering in place.

**Advantage:** It can be implemented rapidly.

**Disadvantage:** Protection is variable and diminishes with the duration of the hazard.

The level of protection that can be attained by sheltering in place is substantial, but it is less than can be provided by high-efficiency filtration of the fresh air introduced into the building.

**INSTRUCTOR NOTES**

**CONTENT/ACTIVITY**

In most cases, air conditioners and combustion heaters cannot be operated while sheltering in place because operating them increases the outdoor-indoor exchange of air.

Sheltering in place is, therefore, suitable *only for exposures of short duration*, roughly 2 hours or less, depending on conditions.

Because the building slowly releases contaminants that have entered, at some point during cloud passage the concentration inside exceeds the concentration outside. Maximum protection is attained by increasing the air exchange rate after cloud passage or by exiting the building into clean air. The tighter the building, the greater the effect of this natural filtering.

**Exam Questions #A12 and B14**

The amount of protection varies with:

**The building's air exchange rate.** The tighter the building (i.e., the lower the air exchange rate), the greater the protection it provides.

- Sealing dampers on air intakes
- Previously sealed all identifiable air leakage in building envelope (smoke test or infrared survey on very hot or very cold day)
- This presupposes that all HVAC and other mechanical means that move air, including bathroom exhausts and elevators, are shutdown to not draw outside air into the building

**The level of exposure.** Protection varies with agent concentration and time, diminishing as the time of exposure increases or as concentration of agent increases. Thus a high-concentration plume passing quickly over a building would indicate sheltering in place to be the best option.

**Purging or period of occupancy.** How long occupants remain in the building after the hazardous cloud has passed also affects the level of protection. However, after the high-concentration plume passes, there will be some inleakage of agent that does occur and the longer one stays in the building the higher the exposure, unless the building is purged or aired out.

**Natural filtering.** Some filtering occurs when the agent is deposited in the building shell or upon interior surfaces as air passes into and out of the building.

VISUAL VIII-37

**Sheltering in Place**

Sheltering Plan should:

- Identify all air handling equipment to deactivate
- Identify cracks, seams, joints, and doors to seal (with method)
- Preposition needed supplies
- Identify safe rooms/safe havens
- Identify procedures for purging or airing out building
- Identify procedures for voluntary occupant participation
- Maintain comms - TV or radio



FEMA 453, Multihazard Shelter (Safe Havens) Design  
BUILDING DESIGN FOR HOMELAND SECURITY Unit VIII-37

**Exam Questions #A20 and B19**

Floor plans of gym area.

Note: Although sheltering is for protection against an external release, it is possible, but more complex, to shelter in place in one or more floors of a multi-story building after an internal release has occurred. In these circumstances, it is critical to turn off all air handling equipment, isolate stairwells, and not use elevators.

**Sheltering in Place**

If the office environment is complex, planning and exercises are important. The sheltering plan should include:

- Identifying all air handling units, fans, bathroom exhausts, and the switches needed to deactivate them
- Identifying cracks, seams, and joints in the building shell to be permanently sealed or temporarily sealed, along with sealing doors with duct tape
- Prepositioning supplies that are needed to initiate and sustain sheltering in place
- Identifying safe rooms or safe havens
- Identifying procedures for purging or airing out after an internal release
  - This must be done on a case-by-case basis for the agent involved and the agent concentration to be spread during the purging.
  - Competent first responder authority may best make this determination.
  - Sealing the release area and evacuating the building may be a better option and do not touch those purge fans!
- Identifying procedures for voluntary occupant participation
- Maintaining communications to understand what is occurring by monitoring TV or radio

During an event, the decision to shelter in place is voluntary, but people should enter the designated shelter area within 3-5 minutes. Depending upon plume speed and distance to travel, even this may be too long.

VISUAL VIII-38



Note: This slide depicts individuals wearing universal-fit escape hoods (upper left-hand corner picture and middle picture on the slide) that have been developed for short-duration "escape-only" wear to protect against chemical agents, aerosols (including biological agents), and some toxic industrial chemicals. The hoods are compact enough to be stored in desks (see picture in upper left-hand corner of the slide) or to be carried on the belt.

**Exam Questions #A21 and B23**

**Personal Protective Equipment**

- A wide range of **individual protection equipment** is available, including respirators, protective hoods, protective suits, CBR detectors, decontamination equipment, etc.
- If masks have been issued, ensure that training is conducted on how to put on and wear the masks.
- No selection of personal protective equipment is effective against every possible threat. Selection must be tied to specific threat/hazard characteristics.
- Universal hoods designed for short duration escape wear only protect against chemical agents by using both HEPA and carbon filters.
  - Carbon filters are designed to filter a broad range of toxic chemicals, but not all chemicals.
  - The EVAC-U8 hood was recalled in April 2006 due to a problem with removing carbon monoxide, which was a stated claim, applicable to its use as a fire escape hood, but it is NOT a CBR hood.

VISUAL VIII-39



Shows pictures of aftermath of the tragic 9-11 events.

VISUAL VIII-40

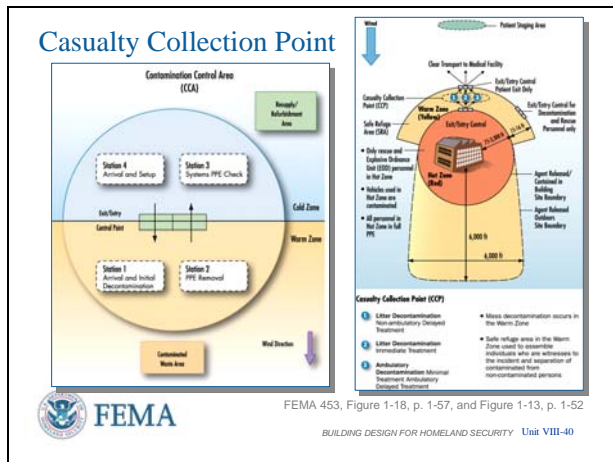

9-11 Dramatic Events

Assembly should be to the upwind side of the building and at least 1,000 feet away, since any airborne hazard escaping the building will be carried downwind.

Starting from top left:

Photo 1 - Remains Recovery

Photo 2 - Evacuation by Helicopter

Photo 3 - Arlington County EMS unit

Photo 4 - NMRT decontamination corridor

Bottom left:

Photo 5 - Evidence Collector

Photo 6 - Man covered in debris from the Twin Towers collapse

Photo 7 - FEMA Urban Search and Rescue Team from Montgomery County, MD is briefed before beginning work at Pentagon following 9-11 attacks.

Photo 8 - FBI and US&R

Casualty Collection Point

Emergency operations need to be designed to allow law, fire, and medical vehicles and personnel access for mass decontamination operations.

The Contamination Control Area is located on the boundary of the Cold Zone and Warm Zone and used by the rescue and decontamination personnel to enter and exit the Warm Zone. There are several processing stations, a resupply and refurbishment area, and a contaminated waste storage area. Runoff from decontamination operations must be controlled or contained to prevent further site contamination.

Casualty Collection Point is a critical element to save lives. The following operations may take place during an

**INSTRUCTOR NOTES**

**CONTENT/ACTIVITY**

emergency operation.

- The Patient Staging Area (PSA) is located in the Cold Zone and is the transfer point for victims that have been stabilized for transport to higher care medical facilities or for fatalities to be transported to morgue facilities. The PSA area must be large enough to accommodate helicopter operations and a large number of ambulances.
- The Casualty Collection Point is located in the Warm Zone and will have typically have three processing stations:
  - Station 1 – Litter decontamination and non-ambulatory delayed treatment patients
  - Station 2 – Litter decontamination and immediate treatment patients
  - Station 3 – Ambulatory decontamination, minimal treatment patients, and ambulatory delayed treatment patients
- Mass casualty decontamination occurs in the Warm Zone. The Safe Refuge Area is located in the Warm Zone and is used to assemble individuals who were witness to the incident and separation of contaminated from non-contaminated persons.



VISUAL VIII-41

**Air Filtration and Pressurization**

- Requires modifications to HVAC and electrical systems – significant initial and life-cycle costs
- Introduces filtered air at a rate sufficient to produce an overpressure and create an outward flow through leaks and cracks

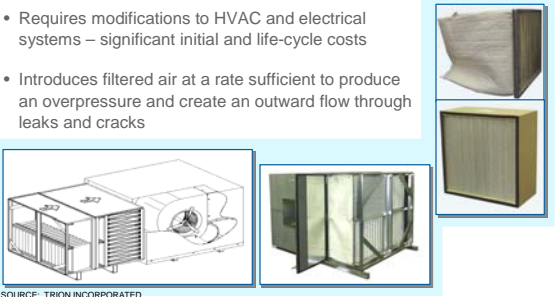

The diagram shows a cross-section of a building with an air filtration unit (AFU) installed. The AFU is connected to the HVAC system and is shown filtering air before it enters the building. The building is pressurized, and air is shown flowing out through cracks and leaks. The AFU is labeled with '302' and '303'. The diagram is credited to TRION INCORPORATED.

SOURCE: TRION INCORPORATED

FEMA 426, Figures 5-5 and 5-12: Bag Filter and HEPA Filter; Commercial Air Filtration Unit, p. 5-12 and 5-22  
BUILDING DESIGN FOR HOMELAND SECURITY Unit VIII-41

**Exam Questions #A22 and B22**

Note: Applying external filtration to a building requires modification to the building's heating, ventilation, and air conditioning (HVAC) system and electrical system. These changes are necessary to ensure that, when the protective system is in operation, all outside air enters the building through filters. The air exchange that normally occurs due to wind pressure, chimney effect, and operation of fans must be reduced to zero.

**Exam Questions #A22 and B22**

**Air Filtration and Pressurization**

- Two basic methods of applying air filtration to a building are external filtration and internal filtration. External filtration involves filtering and/or cleaning of the air drawn from the **outside**, while internal filtration involves filtering and/or cleaning of the air drawn from **inside** the building. Both methods require HVAC modifications that can be costly.
- Among the various protective measures for buildings, high efficiency air filtration/cleaning provides the highest level of protection against an outdoor release of hazardous materials.



VISUAL VIII-42

**Air Filtration and Cleaning**

**Two Types of Collection Systems:**

- Particulate air filtration
  - Principles of collection
  - Types of particulate filters
  - Filter testing and efficiency ratings
- Gas-phase air filtration
  - Principles of collection
  - Types of gas-phase filters



BUILDING DESIGN FOR HOMELAND SECURITY Unit VIII-42

**Exam Questions #A23 and B21**

See CDC/NIOSH *Guidance for Filtration and Air-Cleaning Systems to Protect Building Environments from Airborne Chemical, Biological, or Radiological Attacks*.

Publication No. 2003-136, April 2003 for good explanations of these two types of filtration.

**Air Filtration and Cleaning**

Air filtration is the removal of particulate contaminants from the air. Air cleaning is the removal of gases or vapors from the air. The collection mechanisms for these two types of systems are very different.

**Particulate air filtration** consists of fibrous materials, which capture aerosols. Their efficiency will depend on the size of the aerosol, the type of filter, the velocity of the air, and the type of microbe. The basic principle of particulate air filtration is not to restrict the passage of particles by the gap between fibers, but by altering the airflow streamlines. The airflow will slip around the fiber, but higher density aerosols and particulates will not change direction as rapidly. Particulate filters are not intended to remove gases and vapors.

**Gas-phase air filtration** sorbent filters use one of two mechanisms for capturing and controlling gas-phase air contaminants: physical adsorption and chemisorption. Both mechanisms remove specific types of gas-phase contaminants in indoor air. Unlike particulate filters, sorbents cover a wide range of highly porous materials, ranging from simple clays and carbons to complex engineered polymers. Activated carbon is the most common sorbent, but does not capture all chemicals.

Sorbent filtration needs adequate residence time to ensure adsorption of the gas or vapors; that is adequate contact time for the flow rate of the air passing through the filters. In some cases, two sorbent filters may be needed in series to achieve needed residence time.

VISUAL VIII-43

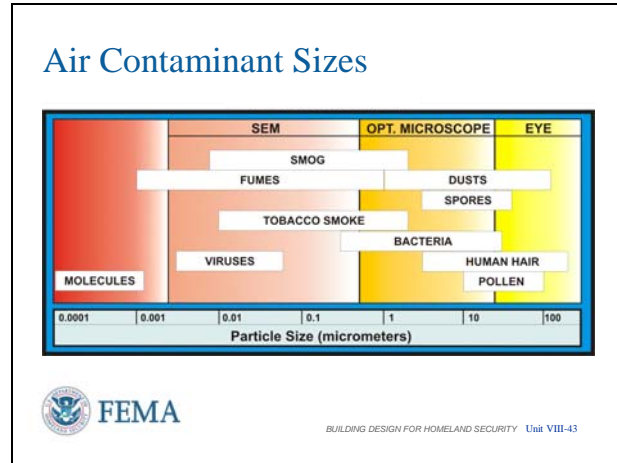

Exam Questions #A22 and B22

VISUAL VIII-44

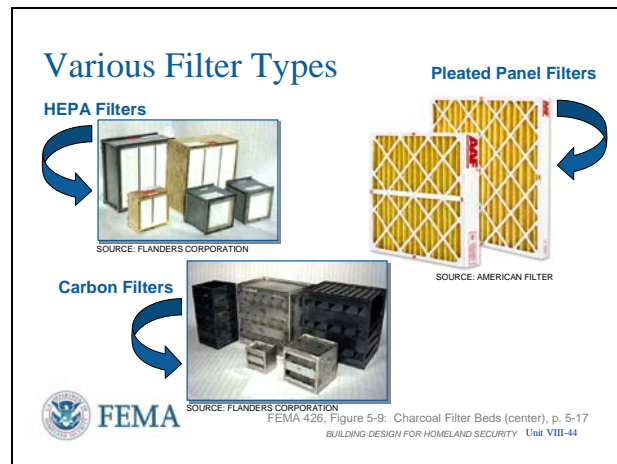

**Air Contaminant Sizes**

This chart illustrates the particle size for a number of the chemical, biological, and radiological agents of concern. Viruses are the smallest and most difficult to protect against.

In FEMA 426, Table 5-1, page 5-12, lists the new ASHRAE 52.2 Standards for particulate filter ratings to remove a given particle size. In most cases, new generation Minimum Efficiency Reporting Value (MERV) 11 to MERV 13 filters can be used in commercial buildings and effectively remove most particulates of CBR concern.

**Various Filter Types**

A wide variety of filters are available to meet many specialized needs:

**HEPA** (high efficiency particulate air) **Filters** - high performance filters that are typically rated as 99.97 percent effective in removing dust and particulate matter greater than 0.3 micron in size.

**Carbon Filters** - sorbent filters (gas-phase) that remove gas and vapors using the thousands of bonding sites on the huge surface area of activated carbon.

**Pleated Panel Filters** - particulate air filters consisting of fibrous materials that capture aerosols.

VISUAL VIII-45

ASHRAE Standards

MERV	ASHRAE 52.2			ASHRAE 52.1		Particle Size Range, $\mu\text{m}$	Applications
	Particle Size Range			Test			
	3 to 10 $\mu\text{m}$	1 to 3 $\mu\text{m}$	3 to 1 $\mu\text{m}$	Arrestance	Dust Spot		
1	< 20%	-	-	< 65%	< 20%	> 10	Residential, light, pollen, dust mites
2	< 20%	-	-	65 - 70%	< 20%		
3	< 20%	-	-	70 - 75%	< 20%		
4	< 20%	-	-	> 75%	< 20%		
5	20 - 35%	-	-	80 - 85%	< 20%	3.0 - 10	Industrial, Dust, Molds, Spores
6	35 - 50%	-	-	> 90%	< 20%		
7	50 - 70%	-	-	> 90%	20 - 25%		
8	> 70%	-	-	> 95%	25 - 30%		



FEMA

FEMA 426, Table 5-1: Comparison of ASHRAE Standards 52.1 and 52.2, p. 5-12  
BUILDING DESIGN FOR HOMELAND SECURITY Unit VIII-45

ASHRAE Standards

The new ASHRAE Standard 52.2 is a more descriptive test than ASHRAE Standard 52.1. Standard 52.2 quantifies filtration efficiency in different particle size ranges and is more applicable in determining a filter's effectiveness to capture a specific agent. Standard 52.2 reports the particle size efficiency results as a MERV rating between 1 and 20. A higher MERV rating indicates a more efficient filter.

VISUAL VIII-46

ASHRAE Standards

9	> 85%	< 50%	-	> 95%	40 - 45%	1.0 - 3.0	Industrial, Legionella, dust
10	> 85%	50 - 65%	-	> 95%	50 - 55%		
11	> 85%	65 - 80%	-	> 98%	60 - 65%		
12	> 90%	> 80%	-	> 98%	70 - 75%		
13	> 90%	> 90%	< 75%	> 98%	80 - 90%	0.3 - 1.0	Hospitals, Smoke removal, Bacteria
14	> 90%	> 90%	75 - 85%	> 98%	90 - 95%		
15	> 90%	> 90%	85 - 95%	> 98%	> 95%		
16	> 95%	> 95%	> 95%	> 98%	> 95%		
17	-	-	= 99.97%	-	-	< 0.3	Clean rooms, Surgery, Chembio, Viruses
18	-	-	= 99.99%	-	-		
19	-	-	= 99.999%	-	-		
20	-	-	= 99.9999%	-	-		



FEMA

FEMA 426, Table 5-1: Comparison of ASHRAE Standards 52.1 and 52.2, p. 5-12  
BUILDING DESIGN FOR HOMELAND SECURITY Unit VIII-46

ASHRAE Standards

The standard provides a table (depicted on the slide) that shows minimum Particle Size Efficiency (PSE) for three size ranges for each of the MERV numbers 1 through 16. Thus, if the size of a contaminant is known, an appropriate filter with the desired PSE for that particular particle size can be identified.

VISUAL VIII-47

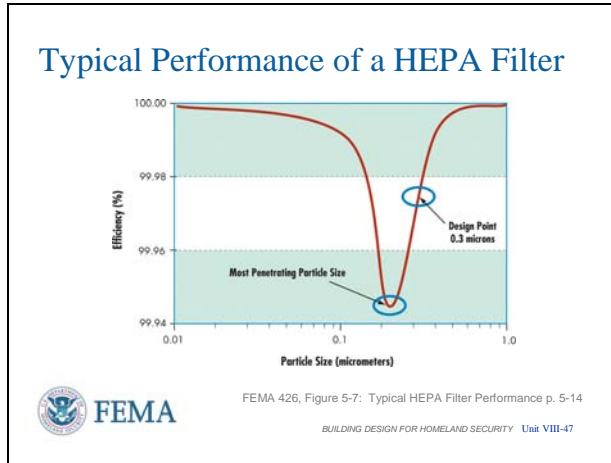

### Typical Performance of a HEPA Filter

HEPA filters are typically rated as 99.97 percent effective in removing dust and particulate matter greater than 0.3 micron in size.

A typical HEPA performance curve is depicted on this slide. The dip between 0.1 and 0.3 micron represents the most penetrating particle size. Many bacteria and viruses fall into this size range. Fortunately, microbes in this range are also vulnerable to ultraviolet radiation. For this reason, many facilities couple particulate air filters with ultraviolet germicidal irradiation (UVGI). UVGI will be discussed on slide VIII-55.

VISUAL VIII-48

### Inside Versus Outside Releases

#### Outside Release

- Keep people inside building
- Reduce indoor/outdoor air exchange – close dampers
- Shut off air handling systems and equipment that moves air – HVAC, exhausts, combustion, computers, elevators
- Close all windows and doors
- Once the outdoor hazard has dissipated
  - Open all doors and windows
  - Turn on all fans, including purging systems

FEMA BUILDING DESIGN FOR HOMELAND SECURITY Unit VIII-48

### Outside Versus Inside Releases

#### Outside Release

The intent is to limit exposure (dose x time) of individuals by keeping the agent and people separated to greatest extent possible. Use natural wind, sunlight, and agent material properties to allow the high-concentration plume to pass the building and minimize the agent that gets into the building.

- Keep individuals inside the building – use the building envelope as a protective enclosure
- Reduce the indoor/outdoor air exchange (seal dampers – low leakage, fast acting (much less than 30 seconds to close) dampers) to prevent contaminated air from passing through the HVAC system by normal chimney and wind effects
- Immediately shut off the air handling systems and any other system that has a fan that moves air – bathroom exhausts,

**INSTRUCTOR NOTES**

**CONTENT/ACTIVITY**

**VISUAL VIII-49**

**Inside Versus Outside Releases**  
**Inside Release**

- Turn off all air handling equipment if no special stand-alone systems installed
- If special systems installed, i.e. mailroom
  - Place air handling system on full (or 100% outside air) to pressurize the space around release room
  - Turn off all air handling supplying release room
- Consider activating fire sprinklers in release room if toxic chemicals involved
- Evaluate evacuation routes for contamination
- Evacuate building in accordance with emergency plan



BUILDING DESIGN FOR HOMELAND SECURITY Unit VIII-49

combustion burners, computer cabinet cooling fans, etc. Note that elevator operation acts as a big air pump that changes air pressure throughout the building. Do not want to set up a pressure differential that pulls outside air into the building when this outside air is contaminated.

- Close all windows and doors – Should have sealed all other leakage points throughout the building envelope as part of mitigation plan
- Once the outdoor hazard has dissipated, open all doors and windows and turn on all fans to ventilate the building. While the amount of agent entering the building should be low (low dose) if you do not ventilate the building the exposure time becomes great and the overall level of exposure can become dangerous.

**Outside Versus Inside Releases**

**Inside Release**

The intent here is to keep the release contained to the greatest extent possible and prevent it from getting to the other parts of the building or outside the building.

- This process must be well thought out, coordinated, and tested to ensure the building will function as desired.
- If the building cannot be operated this way, then follow outside release procedures, but with evacuation.

- If no special stand-alone systems, then shut down all air movement equipment
- If release is in a room with a special stand-alone system, then shut down that system and place the rest of the building's air handling system on "full (or 100%) outside air to keep the agent inside the release room.

**INSTRUCTOR NOTES**

**CONTENT/ACTIVITY**

- If advised of an in-building release of hydrogen cyanide gas, chlorine gases, or other toxic industrial chemicals, consider activating the fire sprinklers (water) to help wash the contaminant from the air stream. This would probably help for particulate aerosols like anthrax but will probably not work for vapors such as hydrogen cyanide gas or chlorine gas.
  - The negative to this process is that the water is now contaminated and can spread throughout the building.
  - The runoff water will also contaminate building components to a greater extent than if the sprinklers were not used, necessitating a greater clean-up effort.
  - Note that this type of operation is not standard on fire sprinkler systems and would be very difficult to implement.
  
- Evacuate the building in accordance with the building's emergency evacuation plan. Evacuation routes may be hazardous because they may take people through contaminated areas. It is necessary to evaluate the scenario prior to evacuating the building to prevent additional injuries from occurring.

VISUAL VIII-50

### Exhausting and Purging

#### Basic Principles:

- Use ventilation and smoke/purge fans to remove airborne hazards
  - Use primarily after an external release plume has passed
  - Selectively use for internal release – may spread contamination further
- Purging should be carefully applied
  - Primarily when agent has spread throughout building



BUILDING DESIGN FOR HOMELAND SECURITY Unit VIII-50

#### Exam Questions #A25 and B24

Note: Mention that a ventilation system and smoke purge fans can be used to purge the building after an external release after the hazard outdoors has dissipated, and it has been confirmed that the agent is no longer present near the building.

#### Exam Questions #A25 and B24

### Exhausting and Purging

The fifth protective measure for CBR covered in **FEMA 426** is **Exhausting and Purging**. Turning on a building's ventilation fans and smoke-purge fans is a protective action for purging airborne hazards from the building and reducing the hazard to which building occupants are exposed.

- Purging must be carefully applied with regard to the location of the source and the time of the release. The main action is final clean-out of the building to allow a return to occupancy.
- If the hazardous material has been identified before release or immediately upon release, purging should not be employed, because it may spread the hazardous material throughout the building, the adjacent area, and to nearby buildings. In this case, all air handling units should be turned off to isolate the hazard while evacuating or temporarily sheltering in place.
- When purging, the indoor-outdoor air exchange rate can be increased by opening all windows and energizing all other fans.

VISUAL VIII-51

### HVAC System Upgrade Issues

- What is the threat? Toxic Industrial Chemicals, particulate, gaseous, chemical, biological?
- How clean does the air need to be and what is the associated cost?
- What is the current system capacity?
- Is there filter bypass and how significant is air infiltration into the building envelope?
- Will improved indoor air quality offset upgrade costs?
- Is system maintenance addressed?



BUILDING DESIGN FOR HOMELAND SECURITY Unit VIII-51

### HVAC System Upgrade Issues

- What is the threat?
- How clean does the air need to be and what is the associated cost?
- What is the current system capacity?
- Is there filter bypass and how significant is air filtration into the building envelope?
- Will improved indoor air quality offset upgrade costs?
- Is system maintenance addressed?



VISUAL VIII-52

**Economic Issues to Consider**

Initial Costs

- Filters, housing, blowers
- Factors including flow rate, contaminant concentration

Operating Costs

- Maintenance, replacement filters, utilities, waste disposal

Replacement Costs

- Filter life (factors include continued concentration and particle size distribution, flow rates, etc.)



BUILDING DESIGN FOR HOMELAND SECURITY Unit VIII-52

**Economic Issues to Consider**

In developing, implementing, and sustaining a program to reduce vulnerability to terrorist threats, there are economic issues to consider, including three categories of costs:

- Initial costs
- Operating costs
- Replacement costs

These need to be factored into protection strategies.

VISUAL VIII-53

**Access to Outdoor Intakes**

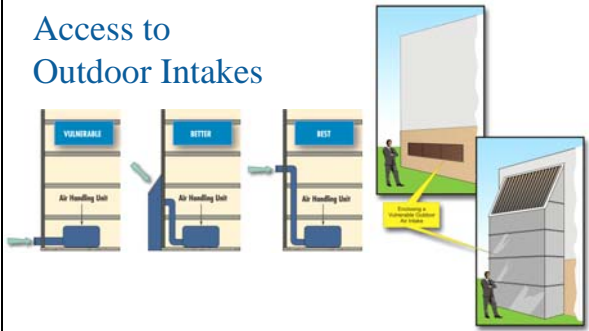

FEMA 426, Figure 3-8, Example of Protecting Outdoor Air Intakes, p. 3-36 and Figure 3-11, Example of Enclosing Existing Vulnerable Air Intake, p.3-38



BUILDING DESIGN FOR HOMELAND SECURITY Unit VIII-53

**Access to Outdoor Intakes**

- Several physical security measures can be applied to reduce the potential for hazardous materials entering a building through the HVAC system.
- One of the most important steps in protecting a building's indoor environment is the security of the outdoor air intakes. Outdoor air enters the building through these intakes and is distributed throughout the building by the HVAC system.
- If relocation of outdoor air intakes is not feasible, intake extensions can be constructed without creating adverse effects on HVAC performance.

This is a good idea for other reasons, such as keeping grass clippings, lawnmower fumes, and/or traffic fumes from being pulled into the building because of a low intake.

Note: The goal of this protective measure is to minimize public accessibility. In general, this means ***the higher the extensions, the better***—as long as other design constraints (excessive pressure loss, dynamic and static loads on structure) are appropriately considered.

VISUAL VIII-54

### Extension Design Recommendations

- Lowest edge as high as possible (> 12ft)
- Sloped intake (min. 45° recommended)
- Metal mesh protecting intake

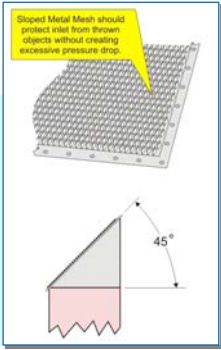

Sloped Metal Mesh should protect inlet from thrown objects without creating excessive pressure drop.

From CDC/NIOSH 2002-139, Guidance for Protecting Building Environments from Airborne Chemical, Biological, or Radiological Attacks, p. 21  
BUILDING DESIGN FOR HOMELAND SECURITY Unit VIII-54

### Extension Design Recommendations

An extension height of 12 feet will place the intake out of reach of individuals without some assistance. Also, the entrance to the intake should be covered with a sloped metal mesh to reduce the threat of objects being tossed into the intake. A minimum slope of 45° is generally adequate. Extension height should be increased where existing platforms or building features (i.e., loading docks, retaining walls) might provide access to the outdoor air intakes.

VISUAL VIII-55

### Ultraviolet Germicidal Irradiation

All viruses and almost all bacteria (excluding spores) are vulnerable to moderate levels of UVGI exposure

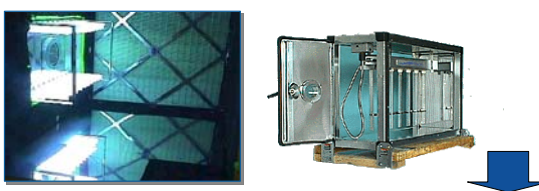

UV lamps resemble ordinary fluorescent lamps, but are designed to emit germicidal UV

FEMA 426, Figure 5-10: UVGI Array with Reflective Surfaces, p. 5-19  
BUILDING DESIGN FOR HOMELAND SECURITY Unit VIII-55

### Ultraviolet Germicidal Irradiation (UVGI)

A design utilizing a combination of filtration and UVGI can be very effective against biological agents.

- Smaller microbes are difficult to filter out, but tend to be more susceptible to UVGI
- Larger microbes, such as spores, which are more resistant to UVGI, tend to be easier to filter out.

Note: UVGI has long been used in laboratories and health care facilities. Ultraviolet radiation in the range of 2,250-3,020 Angstroms is lethal to microorganisms. All viruses and almost all bacteria (excluding spores) are vulnerable to moderate levels of UVGI exposure. Spores, which are larger and more resistant to UVGI than most bacteria, can be effectively removed through high efficiency air filtration.

Consequently, most UVGI systems are installed in conjunction with high efficiency

filtration systems.

A UVGI system is being tested under the sponsorship of the Defense Advanced Research Projects Agency (DARPA). For additional information consult:

<http://www.novatronic.com/technology/>.

VISUAL VIII-56

### URV AND UVGI INFORMATION

URV Average Intensities and Doses			
URV (UVGI Rating Value)	Average Intensity $\mu\text{W}/\text{cm}^2$	Dose at 1 (line) = 0.5 sec $\mu\text{W}\cdot\text{s}/\text{cm}^2$	TB (Tuberculosis) Kill Rate %
9	250	125	23.4
10	500	250	41.3
11	1,000	500	65.5
12	1,500	750	79.8
13	2,000	1,000	88.1
14	3,000	1,500	95.9

URV = UVGI Rating Value

UVGI = Ultraviolet Germicidal Irradiation

Simulation Results for Air Intake Release			
Predicted Performance	Anthrax	Smallpox	TB Bacilli
URV 11 - UVGI Removal Rate%	8.0	53.4	65.6
MERV 11 Filter Removal %	56.7	32.3	14.1
Combined Removal Rate %	60.2	68.5	70.4
Baseline Casualties (release over 8 hour period) %	99.0	99.0	99.0
Casualties with Filters and UVGI %	1.0	1.5	1.5

From "Immune Building Systems Technology", Kowalski 2003

BUILDING DESIGN FOR HOMELAND SECURITY Unit VIII-56

**URV and UVGI Information**

This table displays UVGI Rating Value (URV) for air disinfections systems that parallel the ASHRAE 52.2-1999 method for testing and rating filters known as MERV (minimum efficiency reporting value). The proposed URV rating system consists of 20 separate levels of average UVGI intensity.

**Simulation Results for Air Intake Release**  
 Various simulations were run in the reference shown indicating the removal rates for three design basis pathogens for MERV 11 filters, URV 11 UVGI systems, and both working together. Note the almost 100 % casualties if the agent is released into the air intake over an 8-hour period without any protective systems installed, and that about 1 % casualties occur with MERV 11 and URV 11 systems working together for the same release.

VISUAL VIII-57

**Infiltration and Bypass**

**Infiltration**

- Building envelope tightness and ventilation control are critical

**Bypass**

- Filters should be airtight
- Check gaskets and seals
- Periodically check



 FEMA

BUILDING DESIGN FOR HOMELAND SECURITY Unit VIII-57

Note: Building envelopes in residential and commercial buildings are, in general, quite leaky, and significant quantities of air can infiltrate the building envelope with minimal filtration. Field studies have shown that, unless specific measures are taken to reduce infiltration, as much air may enter a building through infiltration as through the mechanical ventilation system.

**Infiltration and Bypass**

**Infiltration.** Building managers *should not expect filtration alone to protect a building from outdoor releases*, particularly for systems in which no make-up air or inadequate overpressure is present. Filtration, in combination with other steps, such as building pressurization and tightening the building envelope, should be considered to increase the likelihood that the air entering the building actually passes through the filtration and air-cleaning systems.

**Bypass.** Filter bypass is a common problem found in many HVAC filtration systems. It occurs when air, rather than moving through the filter, goes around it, decreasing collection efficiency and defeating the intended purpose of the filtration system. Filter bypass is often caused by poorly fitting filters, poor sealing of filters in their framing systems, missing filter panels, or leaks and openings in the air handling unit downstream of the filter bank and upstream of the blower. Simply improving filter efficiency without addressing filter bypass provides little, if any, improvement to system efficiency. As a mechanical system loads with particulates over time, its collection efficiency increases, but so does the pressure drop.

INSTRUCTOR NOTES

CONTENT/ACTIVITY

VISUAL VIII-58

**Things Not to Do**

- Outdoor air intakes should not be permanently sealed.
- HVAC systems (includes filter upgrades) should not be modified without understanding the effects on building systems or occupants.
- Fire protection and life safety systems should only be modified after careful analysis and review.



BUILDING DESIGN FOR HOMELAND SECURITY Unit VIII-58

**Things Not to Do**

More than anything else, building owners and managers should ensure that any actions they take do not have a detrimental effect on the building systems (HVAC, fire protection, life safety, etc.) or the building occupants under normal building operation.

Some efforts to protect the building from a CBR attack could have adverse effects on the building's indoor environmental quality. This can result in higher levels of illness among building occupants, much like “sick” building situations or long distance air travel.

Building owners and managers should understand how the building systems operate and assess the impact of security measures on those systems.

VISUAL VIII-59

**Things to Do**

- Have a current emergency plan that addresses CBR concerns
  - Exercise plan
  - Revise plan based upon lessons learned
- Understand your HVAC building vulnerabilities
- Conduct periodic walk-through of the system for evidence of irregularities or tampering
- Recognize that there are fundamental differences among various CBR events



BUILDING DESIGN FOR HOMELAND SECURITY Unit VIII-59

**Things to Do**

Facilities managers should have a current emergency plan that addresses chemical, biological, and radiological (CBR) attacks, know their building HVAC system vulnerabilities, and conduct periodic walk-through inspections of the systems for evidence of irregularities or tampering.

Individuals developing emergency plans and procedures should recognize that there are fundamental differences among various CBR agents.

**INSTRUCTOR NOTES**

**CONTENT/ACTIVITY**

**VISUAL VIII-60**

**Summary**

- CBR threats are real and growing.
- Industrial chemicals are readily available.
- Military chemicals require specialty expertise.
- Most buildings provide a reasonable level of protection.
- Inside versus outside building release determines evacuation and other reaction decisions.
- Develop an emergency plan and ensure it works.



BUILDING DESIGN FOR HOMELAND SECURITY Unit VIII-60

**Summary**

- CBR threats are real and growing.
- Industrial chemicals are readily available.
- Military chemicals require specialty expertise.
- Most buildings provide a reasonable level of protection.
- Inside versus outside building release determines evacuation decision.

Bottomline: Develop an emergency plan for CBR attacks, knowing what actions will be taken, exercise the capability and ensure it works.

**VISUAL VIII-61**

**Unit VIII Case Study Activity**  
**Chemical, Biological, and Radiological (CBR) Measures**  
**Background**  
Purpose of activity: check on learning about the nature of chemical, biological, and radiological agents

**Requirements**  
Refer to Case Study and FEMA 426  
Answer worksheet questions



BUILDING DESIGN FOR HOMELAND SECURITY Unit VIII-61

**Student Activity**

This activity provides a check on learning about the nature of chemical, biological, and radiological agents.

**Activity Requirements**

Working in small groups, refer to the HIC Case Study and **FEMA 426** to answer the worksheet questions.

Take 10 minutes to complete this activity. Solutions will be reviewed in the plenary group.

Refer participants to **FEMA 426** and the Unit VIII Case Study activity in the Student Manual.

Members of the instructor staff should be available to answer questions and assist groups as needed.

At the end of 10 minutes, reconvene the class and facilitate group reporting.

**Transition**

This completes the information Units I through VII. A written exam will cover these units.

Unit IX will cover Building Design Guidance. Units IX through XII will not have a written exam.

**INSTRUCTOR NOTES**

**CONTENT/ACTIVITY**

1. Distribute the exam (Version A or B) and answer sheet. Ask the students to record their name and the date on both the answer sheet and exam. Remind them that the test is an open book exam.
2. Allow 30 minutes for test completion and then collect the exams and answer sheets.
3. Review the test with the students by asking them to provide the correct answers any confirming if they are right. Encourage them to ask questions, and explain (as needed) why each answer is correct.
4. Score the tests prior to the end of the day and identify any questions where more than half of the class got the answers wrong. Include this information in the test database.
5. Identify any student who has not achieved a 70 % score. These individuals will require remedial instruction that night. Then take the other version of the exam the next day. This second exam will require a passing score of 70 % in order to pass the course.
6. Update the exams and instructor guides for all questions that were not answered correctly by 50 % or more of the students.

When the test is finished, **collect the exams and answer sheets.**

**WRITTEN EXAM**

There are two versions of the written exam:

- Version A
- Version B

Use the provided Scoring Sheet.

Correct answers and their sources are listed on the Answer Keys, which follow.

## UNIT VIII CASE STUDY ACTIVITY: CHEMICAL, BIOLOGICAL, AND RADIOLOGICAL (CBR) MEASURES

The requirements in this unit's activity are intended to provide a check on learning about the nature of chemical, biological, and radiological agents and associated mitigation measures.

### Requirements

1. Identify the prevalent CBR threat(s) that exist and/or are identified as the Design Basis Threat in the selected Case Study.

#### Appendix A: Suburban, Hazardville Information Company

##### **Design Basis Threat**

**Chemical:** *Large quantity gasoline spill and toxic plume from the adjacent tank farm, small quantity (tanker truck and rail car size) spills of HazMat materials (chlorine).*

**Biological:** *Anthrax delivered by mail or in packages, smallpox distributed by spray mechanism mounted on truck or aircraft around metropolitan area.*

**Radiological:** *Small "dirty" bomb detonation within the 10-mile radius of the HIC building.*

##### **Other:**

- Chemical:**
- 1) *There are a significant number of hazardous waste sites in near proximity to the HIC building. The vast majority are small generators such as gas stations, dry cleaning, and other commercial businesses.*
  - 2) *HIC is surrounded by a number of commercial activities and key national critical infrastructure to include Hazardous Material (HazMat) facilities, HazMat being transported on the roads and rails, a nearby fuel tank farm, and an airport.*
  - 3) *There are two large manufacturing plants with large quantities of hazardous materials stored on site within 2 miles of the HIC Headquarters, one to the north and the other to the southwest. In addition, there are more than a dozen Tier II HazMat facilities within 3 miles of the building (in all directions)*
  - 4) *Approximately 5,000 trucks per day pass the HIC office on the nearby interstate highway. About 30 percent of these trucks (1,500 trucks/day) carry placards indicating that HazMat is aboard, but only about 5 percent (250 trucks/day) carry sufficient HazMat to warrant placarding.*
  - 5) *Approximately 50 percent of the HazMat passing the HIC office is Class 3 (flammable and combustible liquids). Class 2 (gases) and Class 8 (corrosives) each constitute about 15 percent.*



*Approximately 10 percent of the trucks carry more than one class of HazMat.*

- 6) It is estimated that approximately 10,000 railcars of HazMat move through this area each year. Hazardous materials range from liquid petroleum products to chlorine to anhydrous ammonia.*
- 7) A leg of the Piedmont Petroleum Pipeline (PPP) runs underneath the office park in the vicinity of HIC Headquarters. Part of Piedmont's regional network, this portion of the pipeline normally carries a variety of refined products, including commercial and military jet fuels, diesel and three grades of gasoline, home heating fuels, etc. Four buried pipes carry approximately 20 million gallons per day.*
- 8) Connected to the pipeline, less than 1 mile from HIC, is a 20-million gallon capacity fuel farm. Operated by the Shellexico Company, this tank farm stores a variety of petroleum products, primarily gasoline. Thirteen tank trucks were observed leaving the tank farm in a 1- hour period, indicating a calculated movement rate of approximately 300 trucks per day (about 3 million gallons of fuel).*

#### Appendix B: Urban, HazardCorp Building

##### **Design Basis Threat**

*Chemical: Large quantity gasoline spill and toxic plume from the upwind petroleum tank farm or large quantity chlorine release from the upwind chemical storage tank farm. Small quantity (tanker truck and rail car size) spills of HazMat materials (chlorine).*

*Biological: Anthrax delivered by mail or in packages, smallpox distributed by spray mechanism mounted on truck or aircraft around metropolitan area*

*Radiological: Small "dirty" bomb detonation within the 10-mile radius of the HazardCorp Building.*

##### **Other:**

- Chemical:*
- 1) More than 2,000 trucks loads of hazardous materials are transported each day within city limits.*
  - 2) Two large Hazardous Material (HazMat) Storage facilities are to the west of the building. One a large petroleum tank farm and the other a chemical storage tank farm with chlorine, liquid natural gas, and hydrofluoric acid. These tank farms receive and distribute product by truck, rail, and ship.*
  - 3) Shipping along the river to the west of the building carries petroleum products, fertilizer, and liquid natural gas among other items.*
  - 4) There are on average 100 hazardous materials spills and releases each year in the city.*

- 5) *There are a significant number of hazardous materials use and waste sites in near proximity to the HazardCorp Building. The vast majority are small generators such as gas stations, dry cleaning, and other commercial businesses.*
- 6) *Large generators are also in the area: HC Telecon has 3 facilities within 0.5 to 2.5 miles, two Shellexico Tank Farms within 3 miles, two HC Chemical Storage sites at 1.5 and 4 miles, HC Fuel Tank Cleaning at 1.5 miles, HC Hazardous Waste Storage at 3 miles, HC Chromium Plating at 1.3 miles, two HC Brass sites at 3 miles, and HC Electroplating at 3 miles.*
- 7) *In addition, rail and maritime transportation move significant hazardous materials through the area.*

*Radiological: HC Radiological at 2.5 miles*

Refer to **Table 5-1 on page 5-12 of FEMA 426** and answer the following questions:

2. What size filtration unit (MERV) is required to filter out 80 percent of Legionella and dust particulates (1 to 3 microns)? *12*
3. What range of MERV is required to remove 85 percent of smoke particles greater than 0.3 micron in size? *15 or higher*
4. What mitigation measure can be used in HVAC system to destroy bacteria and viruses?  
*UVGI lamps*

*This page intentionally left blank.*

## Unit IX-A

---

<b>COURSE TITLE</b>	Building Design for Homeland Security	<b>TIME</b>	150 minutes
---------------------	---------------------------------------	-------------	-------------

---

<b>UNIT TITLE</b>	Site and Layout Design Guidance
-------------------	---------------------------------

---

- |                   |  |
|-------------------|--|
| <b>OBJECTIVES</b> | <ol style="list-style-type: none"><li>1. Identify site planning concerns that can create, reduce, or eliminate vulnerabilities and understand the concept of “Layers of Defense”.</li><li>2. Recognize protective issues for suburban site planning.</li><li>3. Compare the pros and cons of barrier mitigation measures that increase stand-off or promote the need for hardening of buildings at risks.</li><li>4. Understand the need for keeping up with the growing demand for security design.</li><li>5. Understand the benefits that can be derived from appropriate security design.</li><li>6. Understand the benefits of adopting a creative process to face current design challenges.</li><li>7. Understand the benefits of including aesthetic elements compatible with security and architecture characteristics of building and surrounding environment.</li><li>8. Apply these concepts to an existing site or building and identify mitigation measures needed to reduce vulnerabilities</li></ol> |
|-------------------|--|
- 

<b>SCOPE</b>	The following topics will be covered in this unit:
--------------	--

1. Land use considerations both outside and inside the property line
  2. Site planning issues to include site design, layout and form, vehicular and pedestrian circulation, and landscape and urban design
  3. Creating stand-off distance using perimeter controls, non-exclusive zones, and exclusive zones along with the design concepts and technology to consider
  4. Design considerations and mitigation measures for site security
-

**REFERENCES**

1. FEMA 426, *Reference Manual to Mitigate Potential Terrorist Attacks Against Buildings*, Chapter 2; Checklist at end of Chapter 1
2. FEMA 430, *Primer for Incorporating Building Security Components in Architectural Design*
3. FEMA 452, *Risk Assessment: A How-To Guide to Mitigate Potential Terrorist Attacks Against Buildings*, pages 5-1 to 5-16
4. Case Study – Appendix A: Suburban, Hazardville Information
5. Student Manual, Unit IX-A
6. Unit IX-A visuals

**REQUIREMENTS**

1. FEMA 426, *Reference Manual to Mitigate Potential Terrorist Attacks Against Buildings*
2. FEMA 452, *Risk Assessment: A How-To Guide to Mitigate Potential Terrorist Attacks Against Buildings*
3. Instructor Guide, Unit IX-A
4. Student Manual, Unit IX-A
5. Overhead projector or computer display unit
6. Unit IX-A visuals
7. Threat Matrices poster and dry-erase markers (one per team)
8. Chart paper, easel, and markers

**UNIT IX-A OUTLINE**

	<u>Time</u>	<u>Page</u>
IX-A. Site and Layout Design Guidance and Student Activity [56 slides about 1.5 minutes per slide for 90 minutes]	150 minutes	IG IX-A-5
1. Introduction and Unit Objectives Layers of Defense	10.5 minutes	IG IX-A-5
2. First Layer, Survey Surroundings	1.5 minutes	IG-IX-A-11
3. First Layer, Access Points	3 minutes	IG-IX-A-11
4. Second Layer, Layout/Site Considerations	6 minutes	IG IX-A-13
5. First/Second Layer, Barriers/Bollards/Fencing	21 minutes	IG IX-A-16
6. First/Second Layer, Gatehouses/Screening	1.5 minutes	IG IX-A-23
7. First Second Layer, Sidewalks/Curbs	3 minutes	IG-IX-A-24
8. First/Second Layer, Street Furniture	4.5 minutes	IG-IX-A-25

---

9. Second Layer, Yards and Plazas	7.5 minutes	IG-IX-A-26
10. Second Layer, Roadways	1.5 minutes	IG-IX-A-29
11. Second Layer, Parking	9 minutes	IG-IX-A-29
12. Second Layer, Signage	1.5 minutes	IG-IX-A-33
13. First/Second Layer, Security Lighting	1.5 minutes	IG-IX-A-34
14. First Layer, Sensors/CCTV	1.5 minutes	IG-IX-A-34
15. Second Layer, Site Utilities	4.5 minutes	IG-IX-A-35
16. Best Practices	4.5 minutes	IG-IX-A-38
17. Activity: Site and Layout Design Guidance [45 minutes for students, 15 minutes for instructor review]	60 minutes	IG IX-A-40

## PREPARING TO TEACH THIS UNIT

- Tailoring Content to the Local Area:** Review the Instructor Guides to identify topics that should focus on the local area. Plan how you will use the generic content, and prepare for a locally oriented discussion. The locally oriented discussion should be in conjunction with the version of the case study selected as the student activity used during the course offering.
- Optional Activity:** There are three versions of the student activity available for use during this course -- Suburban, Urban, or Continuity of Operations Planning (COOP).  
Group Roundtable / Plenary / Discussion session can occur after Unit IX with regular student activity for Unit IX being combined with Unit X at end of Unit X. In certain course offerings the experience of well-qualified students can enhance learning through cross pollination of lessons learned, impediments, successes, etc. Students may consider doing some parts of Unit IX student activity for homework. [Hidden slide at end of Visuals IX-A cover this and replaces existing last slide.]
- Activity:** The students will continue the familiarization with the Case Study materials. The Case Study is a complete risk assessment and analysis of mitigation options and strategies for a typical commercial office building located in a mixed urban-suburban environment business park (suburban), a 50-story high-rise office building located in a downtown urban environment (urban), or an alternate facility to be assessed for potential COOP use (based upon the suburban building). The assessment will use the DoD Antiterrorism Standards and the GSA Interagency Security Criteria to determine Levels of Protection and identify specific

vulnerabilities. Mitigation options and strategies will use the concepts provided in **FEMA 426** and other FEMA publications related to emergency planning and disaster recovery.

- Refer students to their Student Manuals for worksheets and activities.
- Direct students to the appropriate page in the Student Manual.
- Read the activity instructions found in the Student Manual.
- Describe how the selected case study appendix in the Student Manual is used to obtain the data needed for the building assessment.
- “Walk through” the pages of the activity with the students, describing the steps followed to obtain the answers in the completed examples, and what is expected of the groups for this activity.
- If applicable to this activity, explain what information is to be transferred to the Risk Matrix poster. For this activity, the assessment of the building in greater depth may result in the groups adjusting the Risk Matrix scores for vulnerability rating, with resultant changes to risk rating.
- Tell students how long they have to work on the requirements.
- While students are working, all instructors should closely observe the groups’ process and progress. If any groups are struggling, immediately assist them by clarifying the assignment and providing as much help as is necessary for the groups to complete the requirement in the allotted time. Also, monitor each group for full participation of all members. For example, ask any student who is not fully engaged a question that requires his/her viewpoint to be presented to the group.
- At the end of the working period, reconvene the class.
- Ask a representative from one group to provide the answer to the first requirement. Then simply ask if anyone disagrees. If the answer is correct and no one disagrees, state that the answer is correct and move on to the next requirement. If there is disagreement, provide the “school solution” and move on.
- If time is short, simply provide the “school solution” and ask for questions. Do not end the activity without ensuring that students know if their answers are correct or at least on the right track. Note, there are no right or wrong answers, but all answers must be justified with rationale.
- Ask for and answer questions.

**INSTRUCTOR NOTES**

**CONTENT/ACTIVITY**

Unit IX-A-1

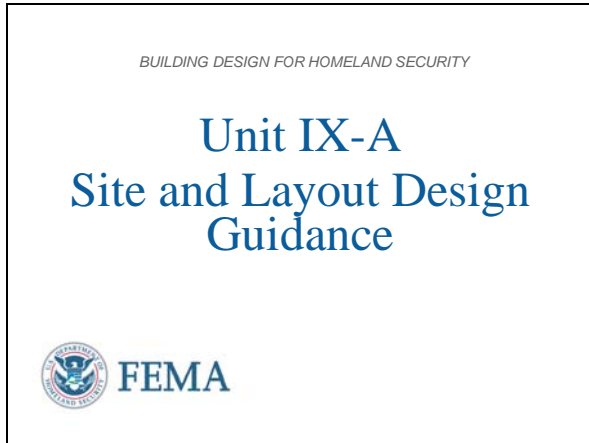

**Introduction and Unit Overview**

This is Unit IX, Site and Layout Design Guidance. This lecture will examine site level considerations and concepts for integrating land use planning, landscape, architecture, site planning, and other strategies to mitigate the design basis threats. The students will gain an understanding of the myriad options available to enhance site design taking into account many environmental challenges.

Unit IX-A-2

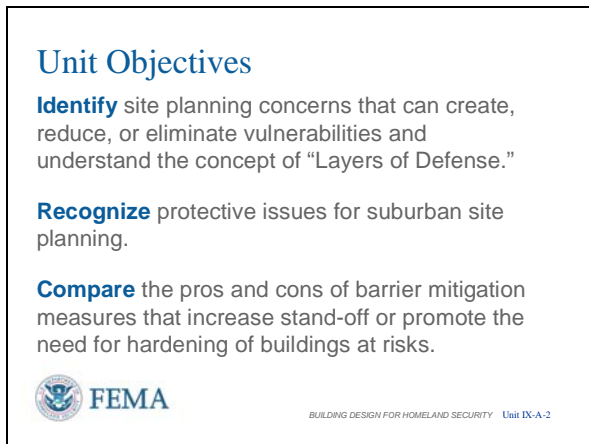

**Unit Objectives**

At the end of this unit, the students should be able to:

1. Explain the concerns of basic land use planning that affect vulnerabilities to threats and hazards due to terrorism and technological accidents.
2. Understand the concept of “Layers of Defense” which will be applied throughout this instruction unit and the next.
3. Recognize protective issues for suburban site planning so as to aid in selecting appropriate mitigation measures.
4. Compare the pros and cons of barrier mitigation measures that increase stand-off and the need for hardening buildings at risk.



**INSTRUCTOR NOTES**

**CONTENT/ACTIVITY**

Unit IX-A-3

**Unit Objectives**

**Understand** the following critical issues:

- Keeping up with growing demand for security design
- Understanding benefits that can be derived from appropriate security design

**References**

FEMA Building Vulnerability Assessment Checklist, Chapter 1, page 1-46, FEMA 426

Site and Layout Design Guidance, Chapter 2, FEMA 426

FEMA 430, Primer for Incorporating Building Security Components in Architectural Design



BUILDING DESIGN FOR HOMELAND SECURITY Unit IX-A-3

Unit IX-A-4

**Unit Objectives**

**Understand** the following critical issues (continued):

- Adopting a creative process to face current design challenges
- Including aesthetic elements compatible with security and architecture characteristics of building and surrounding environment

**References**

FEMA Building Vulnerability Assessment Checklist, Chapter 1, page 1-46, FEMA 426

Site and Layout Design Guidance, Chapter 2, FEMA 426

FEMA 430, Primer for Incorporating Building Security Components in Architectural Design



BUILDING DESIGN FOR HOMELAND SECURITY Unit IX-A-4

**Unit Objectives (cont.)**

5. Understand the benefits in keeping up with the growing demand for security design issues. The technology and manufacturing continues to improve.
6. Understand the benefits that can be derived from appropriate security design. Meeting security design can satisfy other requirements at the same time.

FEMA 426 and FEMA 430 contain architectural and site planning considerations for new design or renovation of existing.

**Unit Objectives (cont.)**

7. Understand that there are benefits to adopting a creative process to face current design challenges. While many criteria are prescriptive, there are many techniques to meet the spirit, intent, purpose, and performance sought.
8. Understand that design can include aesthetic elements that are compatible with security and architectural characteristics of the building and surrounding environment. Blending security so that it does not look like security so that buildings feel open and friendly should be a goal.

Unit IX-A-5

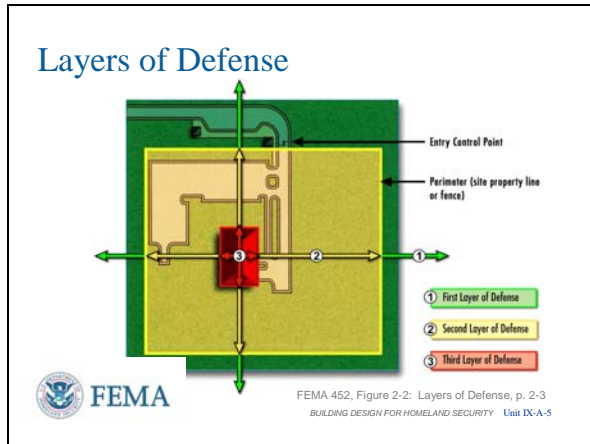

From FEMA 452

The layers of defense is a traditional approach in security engineering and use concentric circles extending out from an area or site to the building or asset that requires protection. They can be seen as demarcation points for different security strategies. Identifying the layers of defense early in the assessment process will help you to understand better the assets that require protection and determine your mitigation options. Figure 2-2 shows the layers of defense described below.

**First Layer of Defense.** This involves understanding the characteristics of the surrounding area, including construction type, occupancies, and the nature and intensity of adjacent activities. It is specifically concerned with buildings, installations, and infrastructure outside the site perimeter. For urban areas, it also includes the curb lane and surrounding streets. **The building owner has little or no control outside of working with the city or municipality. The first layer of defense should be designed to prevent large bombs or weapons into the site and control access**

Layers of Defense

There should always be multiple layers of defense in order to deter and detect potential threat elements that attempt to access critical assets to their benefit and everyone else's detriment. There may be an additional layer applied around a building when a site is large or one or more additional layers inside a building when a building has functions at various levels of security. The intent is to deter first, then detect sufficiently quickly to have a response force engage the potential threat elements prior to reaching the next layer.

The first layer is the demarcation between control and no control. Outside the first layer the local, regional, and national police and intelligence forces work to track, detain, and arrest the potential threat elements before they can initiate an incident. This should be a controlled perimeter whose intent is to keep large threats outside by deterrence or detect them at this point and prevent entry. If the weapon activates at this layer the effectiveness is reduced if sufficient stand-off exists.

The second layer keeps any smaller weapons that may slip past the first layer from getting close enough to the critical asset to cause damage. This layer should mitigate the effectiveness of tactics, reduce the impact due to insider action, and controls the stand-off from the building for the smaller weapons that may get through.

The first and second layers are primarily the venue for site and layout design, the basis for this unit.

The third layer (usually 3 layers are the minimum found) is the building envelope which also deters and detects, but if an incident occurs this layer is the only one that provides

**of personnel.**

**Second Layer of Defense.** This refers to the space that exists between the site perimeter and the assets requiring protection. It involves the placement of buildings and forms in a particular site and understanding which natural or physical resources can provide protection. It entails the design of access points, parking, roadways, pedestrian walkways, natural barriers, security lighting, and signage. For urban areas, it refers specifically to the building yard. **The building owner has control of this layer. The second layer controls stand-off from the building which provides protection from weapons that may slip through the first layer of defense.**

**Third Layer of Defense.** This deals with the protection of the asset itself. It proposes to harden the structures and systems, incorporate effective HVAC systems and surveillance equipment, and wisely design and locate utilities and mechanical systems. Note that, of all blast mitigation measures, distance is the most effective measure because other measures vary in effectiveness and can be more costly. However, often it is not possible to provide adequate stand-off distance. For example, sidewalks in many urban areas may be less than 10 meters (33 feet), while appropriate stand-off may require a minimum of 25 meters (82 feet). **The building owner has control of this layer and its main mitigation measures are hardening against blast and security sensors/CCTV as final access control.**

any level of protection during the tactic and weapon release. The third layer is the venue for building design which will be found in the next instruction unit.

It is important to remember that the nature of any threat is always changing. Consideration should be given to accommodating enhanced protection measures in response to future threats that may emerge. Asset protection must be balanced with other design objectives, such as the efficient use of land and resources, and must also take into account existing physical, programmatic, and fiscal constraints.

Unit IX-A-6

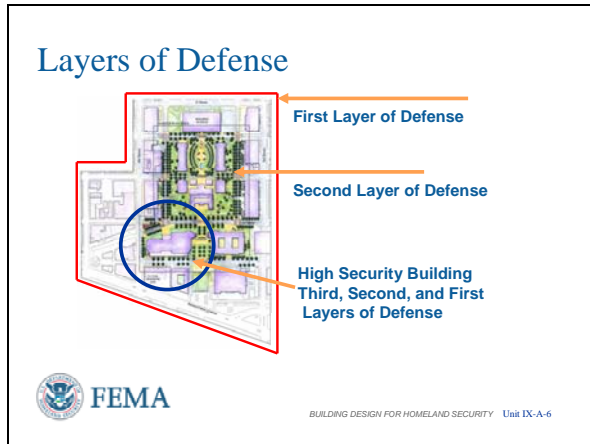

The layers of defense are not predetermined and they may vary from site to site and from building to building. If a particular building requiring protection is part of a campus or located in a rural, semi-rural, or urban area, a similar analysis may be applicable for all cases when determining the importance of the asset. However, the security elements necessary to protect the building can be entirely different, depending on its location. The approach suggests establishing different demarcation points in order to identify sound security strategies. The layers of defense concept proposes that each designer study a particular site and determine critical assets that need to be protected and how protection should take place.

Note: Layers of Defense will be during this and the next two instruction units to illustrate the elements:

- Deter
- Detect
- Deny
- Devalue

**Layers of Defense**

The layers of defense convey the idea of using concentric circles extending out from an area or site to the building that requires protection. They are used as demarcation points for different security strategies. The objective of layers of defense is to create succeeding more difficult layers to security to penetrate, provide additional warning and response time, and allow building occupants to move into defensive positions or designated Safe Haven protection.

The layers of defense defines sites and projects as follows (*While the previous slide is a generic explanation, this slide shows the campus or suburban situation where there are more options to the layers of defense*):

- The first layer addresses the characteristics of the surrounding area and the public realm. It starts at the site perimeter and outward. The building owner has very limited or no control to implement mitigation measures.
- Although a controlled access zone is one of the best methods of ensuring stand-off, issues as the size of site, site limitations, building siting within the parcel, and property line restrictions do not always allow this zone to be created.
- The second layer is concerned with the space and physical barriers at the perimeter of the site to keep explosives at a distance to protect buildings. It comprises the space between the site perimeter and building. The building owner has the authority and control to implement mitigation measures.
- The third deals with the protection integral to the building itself. The building owner has certain level of control to implement mitigation measures. Incorporating the protection in initial design, whether blast hardening or security, is the least expensive approach. Retrofitting after the building

**INSTRUCTOR NOTES**

**CONTENT/ACTIVITY**



Instructors may want to relate to a castle – First layer of defense is clearing all trees and vegetation out to the effective range of arrows and crossbows. Second layer of defense is moat and initial castle wall. Third layer of defense is the castle keep where the last defensive position exists with its additional walls.

Unit IX-A-7

**Layers of Defense**

Layers of Defense	Survey Surroundings	Access Points	Layout / Site Considerations	Barriers / Bollards / Fencing	Gatehouses / Screening	Sidewalks and Curbs	Street Furniture	Yards and Plazas	Roadways	Parking	Signage	Security Lighting	Sensors / CCTV	Site Utilities
First Layer	Yellow	Yellow	Yellow	Yellow	Yellow	Yellow	Yellow	Yellow	Yellow	Yellow	Yellow	Yellow	Yellow	Yellow
Second Layer	White	White	White	White	White	White	White	White	White	White	White	White	White	White
Third Layer	White	White	White	White	White	White	White	White	White	White	White	White	White	White

FEMA  
BUILDING DESIGN FOR HOMELAND SECURITY Unit IX-A-7

has been constructed can cost up to 30% of the original construction, if the retrofitting can be done.

**Layers of Defense**

There are many mitigation techniques available that can be used at one or more layers of defense. This instruction unit concentrates on site and layout design, thus it looks primarily at the first and second layers of defense and emphasizes the predominant layer of defense considered.

Here are general mitigation considerations for the suburban environment and this presentation will follow the flow of these measures from left to right – starting with Survey Surroundings on the left and ending with Site Utilities on the right.

The flow also follows the general assessment approach of looking from outside to inside and going from general information to specific information.

Unit IX-A-8

**First Layer of Defense**

**Survey Surroundings / Data Collection**

- 360 degrees - all directions
- Use GIS and local authorities to understand your surroundings
  - Buildings
  - Infrastructure
  - Geographic/topographic elements
- Overhead and underground utilities



Local Imagery - HIC  
Responsibility Information Company

FEMA 426, Figure 2-1: Example of Using GIS to Identify Adjacent Hazards, p. 2-5  
BUILDING DESIGN FOR HOMELAND SECURITY Unit IX-A-8



**Survey Surroundings – Data Collection**

In a suburban environment, this action normally follows the points on a compass -- in the horizontal plane.

However, understanding the surroundings includes any structures above and under the building and site of interest as to their impact on design or assessment. GIS applications are excellent resources that enable designers and building owners to analyze various demographic, hazardous areas, transportation networks, access control points, etc., in order to identify potential threats, hazards, and vulnerabilities. These applications may depict a truer picture of the surrounding situation, allowing decision-makers to take proactive measures to mitigate potential vulnerabilities.

Geographic and topographic concerns include terrain that limits access of vehicles – natural barriers, like water, slope, vegetation, etc.

Unit IX-A-9

**First Layer of Defense**

**Access Points**

- Have commercial vehicle gates if possible
- Provide traffic calming
- Avoid high speed approaches
- Control angles of approach
- Prevent unauthorized access
- Avoid traffic queuing
- Have equal security capacity for exit



FEMA 426, Figure 2-2: Example of Using GIS to Identify Adjacent Hazards, p. 2-5  
BUILDING DESIGN FOR HOMELAND SECURITY Unit IX-A-9



**Access Points**

Entry control and vehicular access should:

- Prevent unauthorized access
  - Avoid traffic queuing (queues become potential targets)
  - Have commercial vehicle gates if possible – keep larger vehicles further away and barriers increased in capability to handle. Have an Alternate Plan B if a suspected vehicle closes down one or the other vehicle gates
  - Provide traffic calming
  - Avoid high speed approaches
  - Have equal security capacity for exit
- Traffic calming strategies seek to use design measures to cue drivers as to the acceptable speed for an area. These include raised



crosswalks, speed humps and speed tables, pavement treatments, build outs, and traffic circles. Additionally, by controlling the angle of approach, requiring turns or providing curves, vehicles must slow down.

The arrival sequence design to and through a site contribute to the project's identity, including the visitor's orientation to the site and route to reach their destination. The circulation routes, signage, checkpoints, control of site lines (screening or emphasizing views of certain areas), and topography all contribute to the arrival process and legibility of the site. The establishment of circulation and access points may differentiate between entries and routes for pedestrians, staff, visitors, deliveries and service, each with differing security requirements to be satisfied.

### Access Points

Gatehouses, lobbies, and guard posts should be provided with clear views of approaching traffic -- pedestrian and vehicular. Screening areas and entries may be located to offer more privacy and protection.

It is advisable to design circulation to separate different types of traffic and provide separate routes for staff, for visitors, and for deliveries. With the separation of vehicle types, security can more easily address differing needs for screening, observation, and potential threat mitigation.

Roadway network design that uses straight-line approaches to buildings may give approaching vehicles the opportunity to gather the necessary speed to ram protective barriers and crash into buildings. Possible solution: design approaches to be parallel to the façade, with berms, high curbs, trees, and other measures used to prevent vehicles from departing the

### Unit IX-A-10

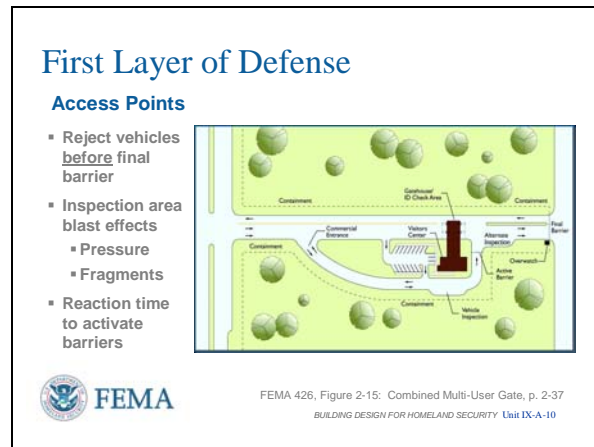

Location selection for vehicular access and entry control for a building starts with an evaluation of the anticipated demand for access to the controlled site. An analysis of traffic origin and destination, and an analysis of the capability of the surrounding connecting road network, including its capacity to handle additional traffic, should then be performed. Expansion capacity

**INSTRUCTOR NOTES**

should also be considered. The analysis should be coordinated with the state and local departments of transportation.

Two security measures that are overlooked are: First, allowing the vehicle to enter the site so that it can turn around and leave. A proper entry control point would never allow the vehicle to enter the site if it were not authorized. Second, there are multiple reaction times that must be added – guard recognition that vehicle is avoiding security, guard reaction to activate final barriers, and activation time from closed to open for the final barriers. The time delay from recognition to deployment must be less than the speed of the vehicle between the recognition point and the final barrier.

Unit IX-A-11

### Second Layer of Defense

The following considerations can have an impact in the layout site design:

- Clustered versus dispersed facilities/functions
- Orientation
- Siting and view relationships

BUILDING DESIGN FOR HOMELAND SECURITY Unit IX-A-11

**CONTENT/ACTIVITY**

roadway.

The existing terrain can have a significant impact on the suitability of a potential entry control point site. Flat terrain with no thick vegetation is generally preferred. A gentle rise in elevation up to the entry control guard building allows for a clear view of arriving vehicles. Consider how existing natural features such as bodies of water or dense tree stands may enhance perimeter security and vehicle containment, without restricting observation capability or allowing easier surveillance of the building by potential threat elements. Entry control spatial requirements vary, depending on the type, the traffic demand, and the necessary security measures.

**Second Layer of Defense**

The following aspects of the building program and layout impact the site design and assessment:

- Overall size and number of structures placed on site with high-risk buildings clustered together for increased security or stand-off or dispersed to devalue as a target.
- Orientation of buildings to reduce damage from bomb blast and prevent direct approaches by high speed vehicles.
- Increase views of approaches to the building, but screen views from outside surveillance.



Unit IX-A-12

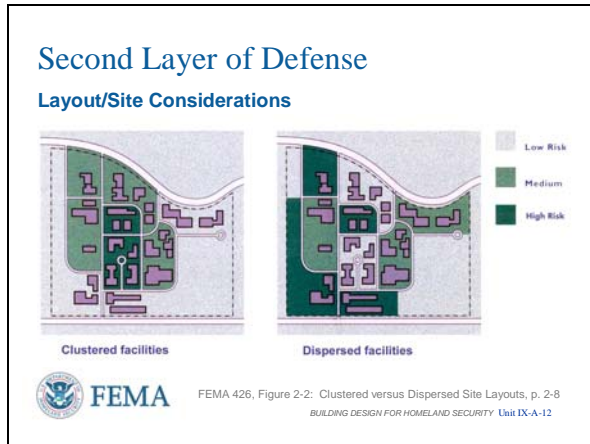

**Layout / Site Considerations – Clustered versus Dispersed Facilities**

Depending on the site characteristics, the occupancy requirements, and other factors, buildings may be clustered tightly in one area, or dispersed across the site. Both patterns have compelling strengths and weaknesses.

Concentrating people, property, and operations in one place creates a target-rich environment, and the mere proximity of any one building to any other may increase the risk of collateral impacts. Additionally, the potential exists for the establishment of more single-point vulnerabilities in a clustered design than would exist in a more dispersed pattern. However, grouping high risk activities, concentrations of personnel, and critical functions into a cluster can help maximize stand-off from the perimeter and create a “defensible space.”

Unit IX-A-13

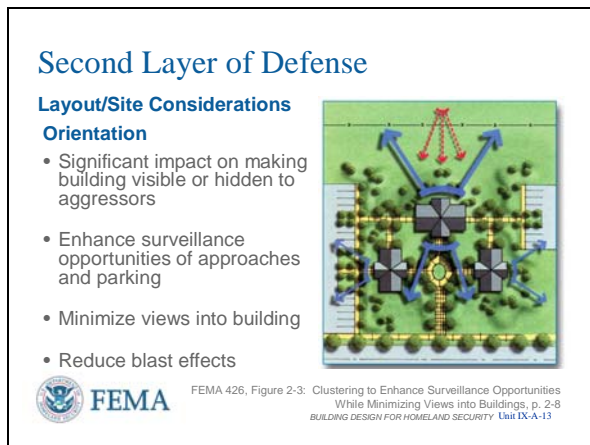

**Layout / Site Considerations -- Orientation**

Orientation is the building’s spatial relationship to the site, its orientation relative to the sun, and its vertical or horizontal aspect relative to the ground.

- How many times have you seen aluminum foil on windows because the afternoon summer sun overcomes the air-conditioning capacity along that side of a building?

The physical positioning of a building relative to its surroundings may seem subtle, but can be a greater determinant of security.

Good site design, orientation, and building placement should allow building occupants to look out of the facility while minimizing views into the building.

The proximity of a vulnerable façade to a parking area, street, adjacent site, or other area

INSTRUCTOR NOTES

CONTENT/ACTIVITY

Unit IX-A-14

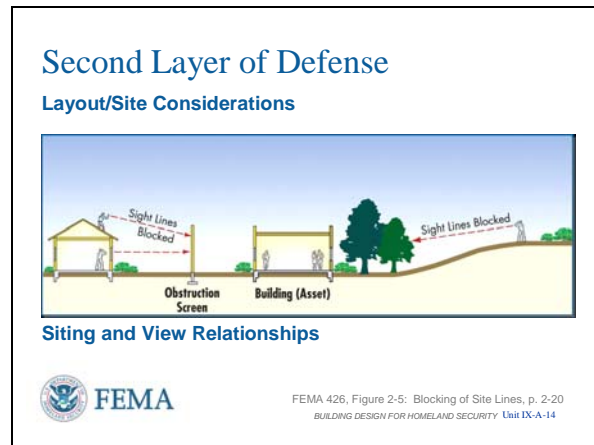

that is accessible to vehicles and/or difficult to observe can greatly contribute to its vulnerability.

**Layout / Site Considerations – Siting and View Relationships**

Landscape and urban design inherently define the “line of sight” in a space. Operational security is not a traditional element of master planning, but managing the threat of hostile surveillance is a significant consideration in protecting people, property, and operations. With careful selection, placement, and maintenance, landscape elements can provide visual screening that protects sensitive operations, gathering areas, and other activities from surveillance without creating concealment for covert activity.

These techniques seek to deny aggressors a “line of sight” to a potential target, either from on or off site. This increases the protection of sensitive information and inhibits operation of stand-off weapons. In addition to the use of various screening options, anti-surveillance measures (e.g., building orientation, landscaping, screening, and landforms) can also be used to block sight lines.

The design should maximize opportunities for internal surveillance of site perimeters and screening of internal areas from external observation. Topography, relative elevation, walls, and fences are design elements that can open and close views. Vegetation can open, close, or block views, not only for security purposes but also to provide beauty and to support wayfinding. As a rule of thumb, vegetation should be very high or very low, to keep views open. Vegetation at the base of buildings and structures should be designed and maintained to prevent explosives from being hidden from view – easily see a briefcase

**INSTRUCTOR NOTES**

**CONTENT/ACTIVITY**

Unit IX-A-15

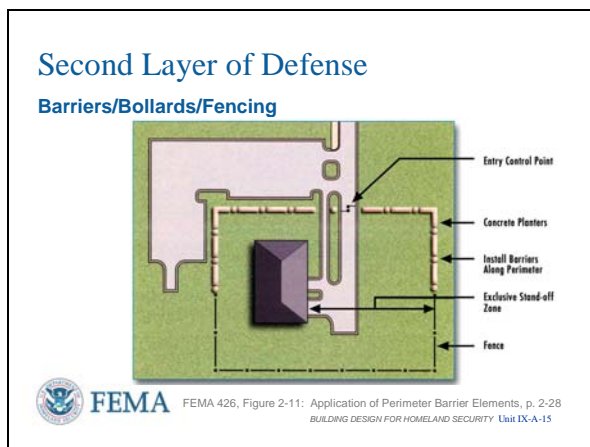

or a backpack.

Landforms can have a direct bearing on the security of a facility. They can be either beneficial (e.g., an elevated site that may enhance the surveillance of the surrounding area), or detrimental to anti-surveillance.

Generally speaking:

- For security purposes, buildings should not be sited immediately adjacent to higher surrounding terrain or buildings if at all possible.

**Barriers / Bollards /Fencing**

A number of elements may be used to create a physical barrier, some natural and some manmade. Natural barrier elements include rivers, lakes, waterways, steep terrain, mountains, barren areas, plants, soft sand, and other terrain features that are difficult to traverse. Manmade elements include fencing, walls, buildings, bollards, planters, concrete barriers, and fountains. Selection of elements must consider the level of security desired and the type of threat most likely to occur.

When placing bollards, make sure you adhere to ADA (Americans with Disabilities Act) compliance.

Unit IX-A-16

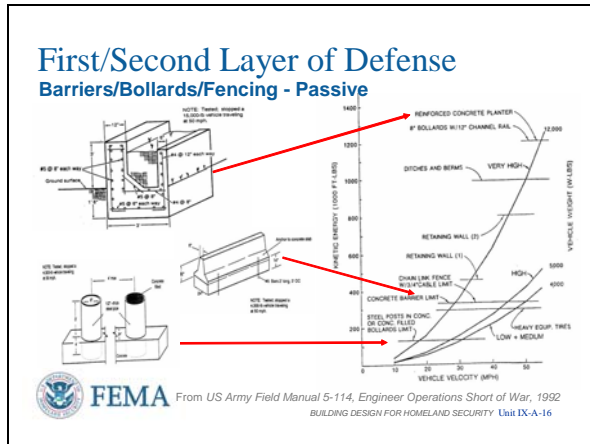

Discuss the mass (vehicle size) and vehicle speed in the chart. Note that since speed is squared ( $K.E. = \frac{1}{2} * \text{mass} * \text{speed} * \text{speed}$ ), controlling speed is a primary concern.

Unit IX-A-17



**Barriers / Bollards /Fencing – Passive Barriers**

It is one thing to provide a passive barrier, it is another to ensure the barrier will provide the protection level sought. We have talked about controlling vehicle speed approaching access points and buildings. Essentially, any barrier will stop a given level of kinetic energy which is  $\frac{1}{2} \text{ mass} * \text{velocity squared}$ . Thus, the bigger the vehicle and the higher its speed the stronger the barrier must be as shown by this chart.

The greater the barrier mass and reinforcement and the deeper it is connected to the earth, the higher its rating.

Notice the jersey barrier has the rating listed only if there are four rebar pinning the barrier at least 18 inches into pavement. Alternately, a 1-inch steel cable linking the jersey barriers would be an alternate technique, but with some penetration.

**Barriers / Bollards /Fencing – Water Barriers**

Water-filled barriers are another approach as they are lightweight and easy to deploy. The left photo shows the stopping power and the right photo shows water barriers that support a fence. Filling the barriers with sand make them less portable.

As with jersey barriers, linking the barriers with 1-inch steel cable improves their performance, but with additional penetration (less mass). Also, these barriers must be checked periodically for leaks, especially if allowed to freeze when filled with water. Without water or sand these would lack critical needed mass.

Unit IX-A-18

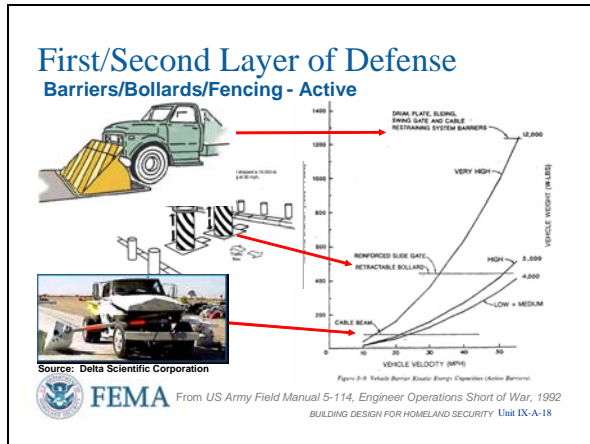

**Barriers / Bollards /Fencing – Active Barriers**

As with passive barriers, active barriers also have different levels of kinetic energy stopping power, based upon mass and connection to the earth.

The advantage of active barriers is that access points and building access to loading docks or for maintenance can allow vehicles to pass or not based upon authorization.

One company is marketing a turntable that allows the fixed bollards to be turned 90 degrees to the vehicle path, then rotated back to block vehicle traffic.

Unit IX-A-19



**Barriers / Bollards /Fencing – Active Barriers**

These photos show retractable bollards stopping a substantial truck with very little penetration.

An active barrier can be activated in seconds (1 to 3) and should be either always up (sally port concept) or deployed upon identification that the gate is being crashed (taking into consideration response time, maximum vehicle speed and activation speed).

Pop-up barriers can create serious damage to vehicles, especially if deployed when a vehicle is above the barrier. Consider manual activation to avoid unnecessary damage (avoid magnetic vehicle loops to redeploy a barrier that will catch a tailgating vehicle).

Unit IX-A-20



**Barriers and Street Closure**

In alleys and typical urban streets adequate stand-off distance is an impossibility without street closure. This is generally undesirable because of the disruption caused to traffic patterns.

The top and left photos show permanently installed barriers, while the bottom right photo shows temporary barriers that can be rapidly deployed and moved into position to control site and parking access, control traffic flow, and provide stand-off distance for buildings.

Improvised closures tend to destroy the attractiveness of the street with a combination of security personnel and ugly temporary barriers. Configuration for access, queuing, and inspection should be planned in any case to reduce potential problems by reducing circulation and aggregated space in a city.

Full closure is often impossible because of the need for service entry. Temporary closure can be achieved by active or manual barriers, combined with public works and security personnel.

Consider the “Ring of Steel” being installed in a core area of London, England. It acts as a first layer of defense, inspecting, restricting, and documenting all vehicles that enter the core area to keep larger weapons out.



Unit IX-A-21

**First/Second Layer of Defense**  
**Barriers, Bollards, and Fencing**

Department of State periodically issues list of manufacturers and model numbers certified in meeting prescribed testing criteria (March 2003)

Rating	Vehicle Weight (lbs.)	Vehicle Speed (mph)	Distance Past Barrier (ft)
K4	15,000	30	<= 3.3
K8	15,000	40	<= 3.3
K12	15,000	50	<= 3.3

Check site utilities, water runoff, and other subterranean Conditions when installing bollards and barriers



BUILDING DESIGN FOR HOMELAND SECURITY Unit IX-A-21

**Department of State Barrier Ratings**

Department of State barrier ratings are probably more suitable to an urban environment where stand-off is limited -- the 3.3 feet distance allowed past the barrier is for the leading edge of the cargo area of the truck (where the bomb is most likely being carried).

Also, Department of State has found that diesel trucks have greater penetration capability, so their tests now require the use of diesel trucks vice gasoline powered trucks.

Unit IX-A-22

**First/Second Layer of Defense**  
**Barriers, Bollards, and Fencing**

Department of Defense periodically issues list of manufacturers and model numbers certified in meeting prescribed testing criteria (August 2003)

Vehicle Weight (lbs.)	Vehicle Speed (mph)	Distance Past Barrier (ft)
15,000	30	<=3(L3)/20(L2)/50(L1)
15,000	40	<=3(L3)/20(L2)/50(L1)
15,000	50	<=3(L3)/20(L2)/50(L1)
10,000	50	0 to 50
10,000	15	50 to 100



BUILDING DESIGN FOR HOMELAND SECURITY Unit IX-A-22

**Department of Defense Barrier Ratings**

Department of Defense barrier ratings use the old Department of State criterion that allows the front of the vehicle to penetrate a given distance past the barrier. This would be more suitable in a suburban environment where there is greater distance between the barrier and the nearest building than in the urban environment.

Unit IX-A-23

**First/Second Layer of Defense**  
**Barriers, Bollards, and Fencing**

- Fixed bollards
- Retractable bollards
- Planters



Fixed bollards



BUILDING DESIGN FOR HOMELAND SECURITY Unit IX-A-23

**Barriers / Bollards /Fencing – Bollards and Planters**

Sidewalks serve as the common space for pedestrian interaction, movements, and activity.

Extending barriers into sidewalks, streets or parking lanes may provide additional stand off distance. While this is technically possible, this approach often creates negative impacts within the public realm, which may make this an unfeasible solution. Be sure that introduced security measures are effective.

Unit IX-A-24



**CONFIRM REFERENCES??**

Unit IX-A-25



Bollards and other barriers are ideally the first layer of defense in the urban environment so as to obtain the most stand-off possible.

**Barriers / Bollards /Fencing -- Retractable Bollards**

Retractable bollards are an excellent (though expensive) solution when the use of security elements is critical and the width of the street does not allow their permanent placement.

Effective bollards must be carefully engineered with deep foundations and the additional depth required for retractability may cause problems with underground utilities and services, building basements extending under sidewalks in urban areas, and other structures that may exist under sidewalks that affect retractable bollard performance.

**Barriers / Bollards /Fencing -- Planters**

Bollards and planters can help create an appealing streetscape depending upon their design and the current environment in which they are installed.

When placed, make sure that they accomplish their function and distance between them is appropriate. The distance must allow free flow of pedestrians, but restrict flow of vehicles.

Fragmentation is always a concern with any barrier system, whether caused by bomb blast or vehicle impact.



Unit IX-A-26

**First/Second Layer of Defense**  
**Barriers, Bollards, and Fencing**

Avoid designing barriers that impair access by first responders:

- Intersection with driveways and gates
- Crossing of pedestrian paths and handicapped ramps
- Fire hydrants



BUILDING DESIGN FOR HOMELAND SECURITY Unit IX-A-26

**Barriers / Bollards /Fencing -- Jersey Barriers**

Least desirable of barrier types

- Difficult to place and move
- No vehicle stopping capability unless tied to pavement with at least 4 pieces of #4 (1/2-inch diameter) rebar into pavement about 18 inches deep and/or tied together with steel cable (3/4 to 1-inch)
- Can cause sidewalk failure due to concentrated load and fact that sidewalk may be hollow underneath for storage or utilities
- Adds to fragmentation (barrier shatters) if vehicle bomb explodes next to barrier
- They impede access – pedestrians and first responders
  - Utilities (if placed on top of manholes)
  - Emergency access (fire trucks, ambulance, police)
  - ADA (Americans with Disabilities Act) access – crosswalks and ramps

Unit IX-A-27

**First/Second Layer of Defense**  
**Barriers, Bollards, and Fencing**

Long expanses of bollards should be carefully designed and sited to avoid monotony



Bollard spacing should ensure no vehicles can get through

Pay attention to how bollards or fences turn the corner, intersect with driveways and gates, and cross pedestrian paths and handicapped ramps



BUILDING DESIGN FOR HOMELAND SECURITY Unit IX-A-27

**Barriers / Bollards /Fencing -- Bollards**

When placed, make sure that they accomplish their barrier function with an appropriate distance of not less than 4 feet-between them.

Bollards placed in long unbroken rows present a monotonous appearance and may appear as a wall from some angles.

Pay attention to how bollards or fences:

- Turn the corner
- Intersect with driveways and gates
- Cross pedestrian paths and handicapped ramps

In an urban environment, bollards and barriers are ideally the first layer of defense to obtain the most stand-off possible.

INSTRUCTOR NOTES

CONTENT/ACTIVITY

Unit IX-A-28

**First/Second Layer of Defense**  
**Barriers, Bollards, and Fencing**

Fencing

- Delineates layer of defense
- Demarcates stand-off required
- Provides access control
- Augments existing security
- Channels vehicle/pedestrian traffic
- Enhances electronic security



 FEMA

BUILDING DESIGN FOR HOMELAND SECURITY Unit IX-A-28

**Barriers / Bollards /Fencing -- Fencing**

Fencing can be limited to channeling law-abiding people (pedestrians and vehicles) to massive with the intent of controlling malicious people and vehicles.

As a basic it provides access control for pedestrians and vehicles (with the help of other barriers). Fencing in each layer of defense is enhanced with electronic security – sensors and CCTV, be it the first layer or a restricted area around a building.

Unit IX-A-29

**First/Second Layer of Defense**  
**Gatehouses/Screening**

Access control with human intervention

- Hardened as determined by threat
- Protection from elements
- Located to minimize queuing



 FEMA

BUILDING DESIGN FOR HOMELAND SECURITY Unit IX-A-29

**Gatehouses / Screening**

Gatehouses are to assist the screening of vehicles and pedestrians to ensure they have proper authorization for access. This can be at the first layer of defense (normally) or at any restricted perimeter

- Depending on the threat the gatehouse should be hardened, but at the very least PPE (personal protective equipment, like bullet-resistant vests) should be worn
- The elements – wind, rain, heat, cold make this job difficult enough that the gatehouse should provide a refuge with water, heat, and air conditioning, including a rest room
- Proper placement so that the guard can interact with drivers without having to cross the traffic lane and adequate throughput so that queues will not form waiting for access.

Unit IX-A-30

**First/Second Layer of Defense**

**Sidewalks and Curbs**

- Creating stand-off in lieu of hardening is usually less expensive
- High curbs can keep vehicles from departing roadway
- Do not remove curbside parking unless additional stand-off absolutely required

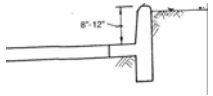

 FEMA

BUILDING DESIGN FOR HOMELAND SECURITY Unit IX-A-30

**Sidewalks and Curbs**

Sidewalks serve as the common space for pedestrian interaction, movements, and activity. Sidewalks should be open and accessible to pedestrians to the greatest extent possible and security elements should not interfere with circulation particularly in crowded locations

Curbside parking should not be removed unless additional stand-off distance is absolutely necessary for high-risk buildings. Prohibiting on street parking or closing lanes should only be used as a temporary measure during times of increased alert.

High curbs and other measures may be installed to keep vehicles from departing the roadway (especially if curb height is at the axle height) in an effort to avoid other security counter measures. In one instance, an armored car firm was asked to park their vehicles around a building that had received credible threats to act as barriers and increase stand-off.

Unit IX-A-31

**First/Second Layer of Defense**

**Sidewalks and Curbs**

An alternate to visible barriers/bollards/fencing is collapsible sidewalks using low-strength concrete

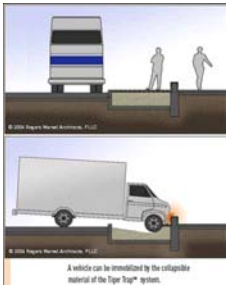

 FEMA

BUILDING DESIGN FOR HOMELAND SECURITY Unit IX-A-31

**Sidewalks and Curbs**

Another unobtrusive approach for providing a vehicle barrier is combining collapsible sidewalk with a small wall that will catch a vehicle bumper. The sidewalk is made of low-strength concrete that takes pedestrian weight but not vehicle weight.

These graphics are of the Rock Twelve Security Architecture Tiger Trap™ and their product literature information:

- Designed to reduce the impact of security on public space, this innovative vehicle arrest system utilizes a subgrade compressible material that lowers the elevation of an attacking vehicle and a

Unit IX-A-32

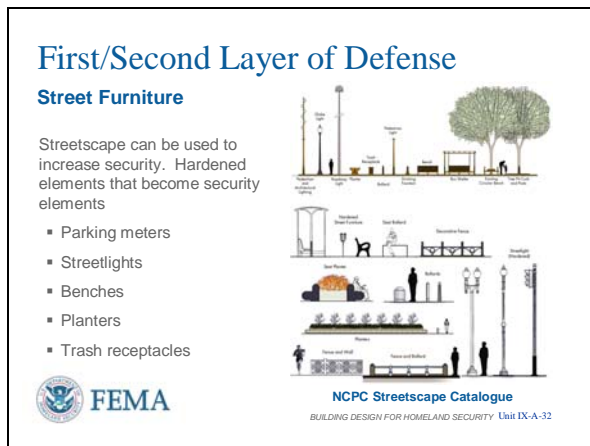

low wall that then halts the lowered vehicle.

- The subgrade compressible material allows the rear wall to be as low as a bench or even completely below grade.
- The compressible material combined with a decorative covering surface supports pedestrian loads, but fails under the weight of a vehicle.

**Street Furniture**

At the site perimeter, walls and fences may be hardened (strengthened) to resist the impact of a weapon-laden vehicle. However, planters, bollards or decorative boulders can accomplish the same objective in a much more aesthetically pleasing manner.

The streetscape can included hardened versions of parking meters, street lights, benches, planters and trash receptacles that act as barriers to moving vehicles.

The National Capital Planning Commission (NCPCC) provides a catalog that shows several examples of hardened streetscape furniture.

Unit IX-A-33



**Street Furniture**

The scale of the streetscape should be appropriate to its primary users and it can be manipulated to increase the comfort level of desired users while creating a less inviting atmosphere for users with malicious intent.

It is critical to maintain important functions such as adequate space for pedestrian circulation and appropriate distances between vehicles and security barriers. The recommended distance to place streetscape security components is at least 24 inches from

INSTRUCTOR NOTES

CONTENT/ACTIVITY

Unit IX-A-34

**First/Second Layer of Defense**

**Street furniture**

- Treatment of security elements should be compatible with existing elements
- Perimeter barriers can go hand-in-hand with streetscape improvements and plantings
- Appropriate design can blend security into existing streetscape; serving as amenities for tenants and neighbors



 FEMA

BUILDING DESIGN FOR HOMELAND SECURITY Unit IX-A-34

Unit IX-A-35

**Second Layer of Defense**

- Buildings with front yards
- Buildings with plazas



 FEMA

BUILDING DESIGN FOR HOMELAND SECURITY Unit IX-A-35

the edge of the curb to allow for the opening of car doors and pedestrian movement from car to sidewalk.

Well planned barriers can also assist in clearly defining areas of public and private space and in protecting pedestrians from traffic.

**Street Furniture**

Numerous urban design elements present opportunities to provide security. Even at the pedestrian scale, certain operational requirements must be accommodated. For example, although efficient pedestrian and vehicle circulation systems are important for day-to-day living, they are also critical for emergency response, evacuation, and egress. Furthermore, despite an emphasis on downsizing the scale of the streetscape, it is critical to maintain the maximum stand-off distance possible between vehicles and structures.

**Yards and Plazas**

Three generic site types will be found in the central business district of any large city.

- Buildings with zero setback and alleys. The building face is on the property line. An alley is a narrow street that divides a city block and provides service access to the side or rear of the building.
- Buildings with front yards. The building is set back from its property line and the space is usually landscaped. The building yard includes pedestrian entries and loading docks.
- Building with plazas. The building is placed within an open space that is publicly accessible.



Unit IX-A-36

**Second Layer of Defense**

**Building Yard**

- Generally small
- Usually provided for governmental & institutional buildings



Narrow yard incorporating low stone wall and metal fence



Small yard with wide pavement that provide some useful stand-off



BUILDING DESIGN FOR HOMELAND SECURITY Unit IX-A-36

**Building Yard**

Some buildings have a “yard” between the building face and the sidewalk. The yard is within the property line and typically consists of a grassy or planted area adjacent to the building.

Yards are typical, narrow, of the order of 10 to 20 feet, providing some stand-off distance.

The yard may be flush or raised above the level of the sidewalk. A raised yard can provide a barrier to vehicles.

Major public buildings may have wide yards that are more of a landscaped forecourt that can offer reasonable stand-off distance. Yards are usually provided for governmental or institutional buildings in which coverage of the entire property may not be economically critical as is the case for private development.

Sometimes small yards (within the property line) are matched with a wide sidewalk provided by the city.

Unit IX-A-37

**Second Layer of Defense**

**Building Yard**



Low planting makes a moderate barrier



High stepped yard on sloping site make a strong barrier



BUILDING DESIGN FOR HOMELAND SECURITY Unit IX-A-37

**Building Yard**

A typical raised, low planter that can act as a bench (or plinth wall that holds back soil or rock), as shown in the left photo, presents a significant barrier to small and medium-sized vehicles. The high stepped yard in the right photo, which is along the side of the building, is a significant barrier and could also act as a deflector of blast from a curbside vehicle.

Unit IX-A-38

**Second Layer of Defense**

**Building Yard**



Monumental yards make excellent barriers and elements of beautification



BUILDING DESIGN FOR HOMELAND SECURITY Unit IX-A-38

**Building Yard**

Security elements within the building yard should complement the building architecture and landscaping and should be designed so as to appear as well designed landscape objects rather than expressing security. The security elements should be located near the outer edge of the yard to maximize stand-off.

Good examples of this are shown in these photos.

Unit IX-A-39

**Second Layer of Defense**

**Plaza**

- An expanded building yard
- Moved out from the controlled building access
- A developer provided public space
- A well designed plaza can provide visual interest at same time providing good stand-off



BUILDING DESIGN FOR HOMELAND SECURITY Unit IX-A-39

**Plaza**

Extensive business district development with very large buildings began after World War II. The straight tower with no setbacks became fashionable, but new ordinances permitted building developers to construct taller buildings, with greater floor area, if a public plaza was incorporated. In fact, in Tokyo, new high-rises must ensure they do not completely block the sun from surrounding buildings.

In effect, the plaza became an expanded building yard. It was moved outside the controlled access space of the building and became public space provided by the developer.

The additional space provided by plazas enables a more effective second layer of defense to be achieved. Often an acceptable stand-off distance can be created on one or more faces of the building depending on the plaza /building layout.

Unit IX-A-40

**Second Layer of Defense**

**Roadways**

- Minimize interruption or closure of street
- Ensure minimal conflict between pedestrian and traffic flow



 FEMA

BUILDING DESIGN FOR HOMELAND SECURITY Unit IX-A-40

**Roadways**

Given that the energy transferred when one object strikes another is a function of its mass and its velocity, a bollard that can stop a 15,000-pound truck moving at 35 miles per hour may not be able to stop the same truck moving at 55 miles per hour. In developing a system of street alignments with protection in mind, the designer cannot determine the size or weight of a vehicle that will travel along the road, because that is a management decision. However, the designer can propose a roadway system to minimize vehicle velocity, thus using the roadway itself as a protective measure.

Minimizing street closure and disrupting vehicle and pedestrian patterns should always be a goal. But at higher threats, it may be one of the few available mitigation options.

Unit IX-A-41

**Second Layer of Defense**

**Parking**

- Restrict parking from the interior of a group of buildings and away from restricted area
- Locate parking within view of occupied buildings
- If possible, design the parking lot with one-way circulation



 FEMA

Adapted from FEMA 452, Figure 2-4: Layers of Defense, p. 2-5  
BUILDING DESIGN FOR HOMELAND SECURITY Unit IX-A-41

**Parking**

Building placement on the site must balance stand-off distances; relationship to adjacent streets and buildings; siting of utilities, parking areas, and driveways; as well as access to parking and loading areas.

There are three primary types of parking facilities, all of which present security trade-offs.

- Surface lots can be designed to keep vehicles away from buildings, but they consume large amounts of land and, if constructed of impervious materials, can contribute greatly to stormwater runoff volume. They can also be hazardous for pedestrians if dedicated pedestrian pathways are not provided.
- In contrast, non-street parking is often convenient for users and a source of revenue for local governments, but this type of parking may provide little or no setback.



- Finally, garage structures provide revenue and can be convenient for users, but they may require structural measures to ensure blast resistance as well as crime prevention measures to prevent street crime.

Although the cost of land suggests that the construction of a garage below a building (either underground or aboveground) may be the most economically viable approach for many developments, they can be highly vulnerable to vehicle-borne weapons, endangering the building above. If garages must be used, human security procedures (e.g., vehicle searches) and electronic systems (e.g., closed circuit television) may be necessary.

Parking structures open to the public should be sited and evaluated with concern for stand-off from other buildings, screening from critical operations and sensitive areas that might be observed from within the parking structure, and as a point of access or staging for use of weapons or explosives. Progressive collapse can become a concern in parking structures.

If stand-off distance is needed between a building and a First Layer controlled perimeter, placing parking in this area is an excellent use of the available space, as shown in this graphic.

### Parking

Parking layout and circulation is often one of the largest program elements in site design. Public street parking, parking lots, free standing structured parking buildings, and underground parking have different characteristics to be considered.

Note the limited physical barriers that are in place to prevent unauthorized vehicles from parking underneath this building as shown in the slide. Also note the limited stand-off and the parking proximity to columns supporting

### Unit IX-A-42

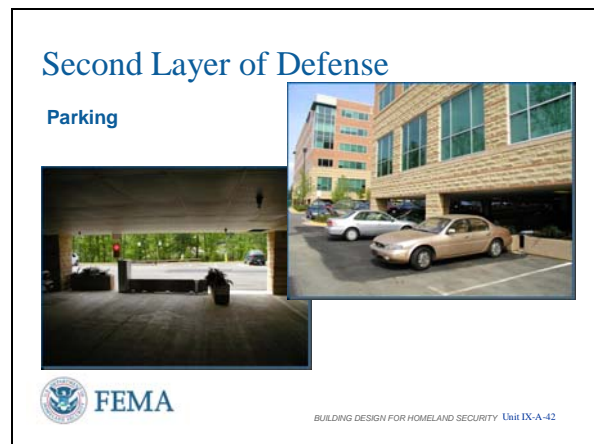

**INSTRUCTOR NOTES**

**CONTENT/ACTIVITY**

Unit IX-A-43

**Second Layer of Defense**

**Parking**

- Avoid parking too close to the building
- Design of good parking away from the building can avoid the need to harden the building
- Screening of vehicles and pedestrians at building may be necessary



 FEMA

BUILDING DESIGN FOR HOMELAND SECURITY Unit IX-A-43

Unit IX-A-44

**Second Layer of Defense**

**Parking**

- Restrict parking and access between buildings
- Consider one-way circulation in parking lots
- Locate parking within view of occupied buildings
- Restrict parking underneath buildings
- Well-lit, with security presence, emergency communications, and/or CCTV
- Apply progressive collapse hardening to columns when parking garage is in the building



BUILDING DESIGN FOR HOMELAND SECURITY Unit IX-A-44

the exterior wall of the building.

**Parking**

Avoid parking too close to the building, especially large vehicles.

Good parking design can prevent the need to harden the building.

**Parking**

When designing parking, the following should be taken into consideration:

- Maintain stand-off distance from building
- Restrict parking from the interior of a group of buildings and away from any restricted area
- Avoid having parking near, within or underneath buildings – Consider hardening against progressive collapse if parking garage is in the building.
- Locate parking within view of occupied buildings
- If possible, design the parking lot with one-way circulation that restricts straight-on high-speed approaches to buildings
- Provide signage to clearly mark separate entrances for different parking lots
- Keep parking areas well lit; use emergency communications, and/or CCTV

Unit IX-A-45

**Second Layer of Defense**

**Parking - Loading Docks**

- Avoid trucks parking into or underneath of the buildings
- Keep dumpsters away from buildings
- Separate loading docks from building critical functions
- Design to prevent progressive collapse



 FEMA

BUILDING DESIGN FOR HOMELAND SECURITY Unit IX-A-45

Significant structural damage to the walls and ceiling of the loading dock may be acceptable; however, the areas adjacent to the loading dock should not experience severe structural damage or collapse.

This photo is a good example of a loading dock that is not underneath the building. This will be covered in more detail in the next instruction unit.

Unit IX-A-46

**Second Layer of Defense**

**Parking - Loading Docks**

- Ensure separation from critical systems, functions, and utility service entrances
- Provide sufficient area for screening vehicles and packages



 FEMA

BUILDING DESIGN FOR HOMELAND SECURITY Unit IX-A-46

**Parking – Loading Docks**

Loading docks and service access areas are commonly required for a building and are typically desired to be kept as invisible as possible.

- Locate loading docks so that vehicles will not be allowed underneath the building or too close to the building at the curb lane. If this is not possible, the dock area should be hardened for blast.
- Design to prevent progressive collapse, especially if loading dock is under the building.
- Separate (by at least 50 feet) loading docks and shipping and receiving areas in any direction from utility rooms, utility mains, and service entrances, including electrical, telephone/data, fire detection/alarm systems, fire suppression water mains, cooling and heating mains, etc.
- Siting and layout of loading areas should be secured and accommodate sufficient area for screening vehicle and packages.
- Trash dumpsters should be relocated away from the building. (Explosive devices can be tossed in the dumpster creating a blast effect.)

**Parking – Loading Docks**

Loading dock on-site accommodation is essential. Security issues relating to loading docks must be examined on a site by site basis, possibly involving the cooperation of civic authorities, especially in an urban environment.

For increased threat levels, you may coordinate local policy to screen vehicles before approaching the loading dock. In any case, the vehicles need an inspection area established for normal operations at lower threat levels in

Unit IX-A-47

**All Layers of Defense**  
**Signage**

- Unless required, do not identify sensitive areas
- Minimize signs identifying critical utilities
- Warning signs limiting access to control areas should be posted at all entrances
- Signpost may be hardened and included as part of the perimeter barrier
- The lighting of signage should enhance nighttime safety
- Warning signs should be posted in languages commonly spoken



BUILDING DESIGN FOR HOMELAND SECURITY Unit IX-A-47

Whatever the strategy for signage, it is important that signage be developed in concert with other site design elements, be included in the site design palette, and designed and placed in coordination with all other materials. To reduce the potential of clutter, signage should be integrated with other streetscape elements and architectural elements. Access, maintenance, and adaptability should be considered in selection of signage systems. Periodically changes are required to signage content. A comprehensive signage plan should be tailored to the mission of the facility accompanying the FEMA 426 guidelines.

order to protect the building.

**Signage**

Building owners should determine how visible the project should be and corresponding implications for site signage. For some projects, a degree of anonymity may be part of the security strategy.

- Unless required, signs should not identify sensitive areas.
- Minimize signs identifying critical utility complexes, such as power plants and water treatment plants.
- Warning signs should be posted at all entrances to limited, controlled, and exclusion areas.
- The wording on the signs should denote warning of a restricted area.
- Signs should be posted at intervals of no more than 100 feet and should not be mounted on fences equipped with intrusion-detection equipment.
- Signage may be mounted on other elements, such as fences and walls to reduce the number of posts along the street or perimeter.
- Signposts may be hardened and included as part of the perimeter barrier.
- The lighting of signage may also enhance nighttime safety to those who come to the site during evening or early morning hours.
- Locate variable message signs, which give information on site/organization special events and visitors, so that they are not observable from site perimeters (first layer)
- Warning signs must use languages commonly spoken.

Unit IX-A-48

**First/Second Layer of Defense**  
**Security Lighting**  
High-mast lighting at entry control points

Continuous lighting

- Glare projection
- Controlled lighting (avoid glare)
- Closed circuit television (CCTV)

Standby lighting  
Movable lighting  
Emergency lighting



BUILDING DESIGN FOR HOMELAND SECURITY Unit IX-A-48

**Security Lighting**

Security lighting should be provided for overall site and building illumination and along the perimeter to allow security personnel to maintain visual assessment during darkness. Lighting is desirable around areas such as piers, fence lines, loading docks, storage areas, and parking lots. At entry points, a recommended minimum surface lighting average of 4 horizontal foot candles will help ensure adequate lighting.

Security lighting has different purposes – to blind, to allow vehicle inspection, to identify credentials, to support CCTV capabilities, etc. Thus, security lighting must be coordinated for all purposes.

Unit IX-A-49

**First Layer of Defense**  
**Sensors / CCTV**

- When stand-off and hardening are not possible, security must rely upon sensors and CCTV
- Look for suspicious vehicles and people, especially those that seem to be profiling your building
- Monitor access to utilities serving the building
- Currently high tech monitoring systems need to be selected and placed by experts



BUILDING DESIGN FOR HOMELAND SECURITY Unit IX-A-49

**Sensors / CCTV**

Manned and electronic security increases deterrence and detection with attendant reduction in risk. It is the fastest technology to add and upgrade when selected, installed, and used properly.

It should cover vehicle, pedestrian, and utility entrances as all of these are potential approaches for terrorist tactics.

This will be covered in more detail under Electronic Security Systems later.

Unit IX-A-50



A thorough walk-through of the site property should be conducted and proper protection devices should be applied to exposed utilities. The electrical substation shown can be easily damaged from outside the fenceline by projectiles or short circuiting actions. The structure on the right only has fencing on three sides.

Unit IX-A-51



Site Utilities

Utility systems can suffer significant damage when subjected to the shock of an explosion. Some of these utilities may be critical for safely evacuating people from the building. Their destruction could cause damage that is disproportionate to other building damage resulting from an explosion.

Loss of a utility because access was readily available to a potential threat element is one reason for assessing site utilities to ensure physical security measures are in place to limit access to authorized personnel only.

Site Utilities

- Top Right – Open Gate allowing access to Critical Cooling Unit for Computer Center
- Lower Right – Exposed air conditioning systems
- Middle – antenna system for Emergency Operations Center accessible from the ground
- Lower Left – Exposed generator and natural gas regulators

Concealed or underground utilities are easier to protect than exposed or aboveground constructions.

Access to utilities should be protected or secure, allowing only authorized personnel access to perform maintenance and repair.



If physical security measures cannot limit access, then add sensors/CCTV to provide added protection.

The location and accessibility of site utilities directly impacts the vulnerability of systems to disruption and failure.

Incoming utility systems should have two entry points to the site for redundancy as required by criticality.

Looped versus radial distribution of utilities on site allows for higher system reliability and faster repair by avoiding utility loss by a single incident.

When selecting locations for utilities, be aware of possible conflicts and spacing requirements both horizontally and vertically. In addition there can be demand for underground zones for planting beds and foundations for hardened street furniture.

### Site Utilities

The U.S. utility infrastructure is highly concentrated, utilizing the same rights-of-way, tunnels, underground conduits, and other service points. Examine where the utilities intersect (manholes, poles, city blocks, etc.) to find critical nodes.

Even if the utility is underground, manholes that provide access to the system should be physically secured.

Install fencing and if possible, remote monitoring capability at key electrical substations, pumping plants, and communications vaults.

### Unit IX-A-52

#### Second Layer of Defense

##### Site Utilities

Control access to tanks of critical supplies on site



Place public address system/call boxes in parking lots and gathering areas to improve communications with security personnel



BUILDING DESIGN FOR HOMELAND SECURITY Unit IX-A-52

Unit IX-A-53



**Best Practices**

Best practices include but are not restricted to the following:

- Appropriate design can blend security into the existing streetscape and serve as amenities for tenants and neighbors --
- Treatment of the security elements should be compatible existing elements – so that they do not look like security elements
- Perimeter barriers can be hand-in-hand with streetscape improvements and street planting
- Careful design should be paid to how bollards or fences turn the corner, intersect with driveways and gates, cross pedestrian paths and handicapped ramps
- Avoid street closure and removal of parking as the only solution of establishing stand-off distance
- Landscaping can provide visual interest and at the same time provide good stand-off

Unit IX-A-54



**Best Practices**

Good examples to follow and bad examples to avoid:

- Avoid introducing inappropriate security elements that will make tenants and neighbors feel more vulnerable and can detract from surrounding architecture and streetscape – jersey barrier at entrance steps – also ineffective as placed directly on pavement
- Signage and way-finding should be carefully designed to increase security
- Long expanses of bollards should be carefully designed and sited to avoid monotony – as can be seen in the lower photo
- Use perimeter barriers to define pedestrian



Unit IX-A-55

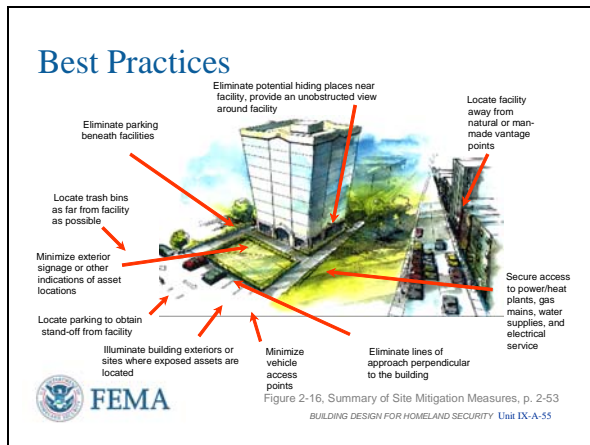

Page 2-52 of FEMA 426 provides a comprehensive list of security/protection measures that can be taken – increasing in *protection, cost, and level of effort* – that complements this graphic on Site Mitigation Measures.

Unit IX-A-56

**Unit IX Case Study Activity**  
**Site and Layout Design Guidance**  
**Background**  
FEMA 426, Building Vulnerability Assessment Checklist: screening tool for preliminary design vulnerability assessment  
**Requirements: Vulnerability Rating Approach**  
Assign sections of the checklist to qualified group members  
Refer to Case Study and GIS portfolio, and answer worksheet questions  
Review results to identify site and layout vulnerabilities and possible mitigation measures



BUILDING DESIGN FOR HOMELAND SECURITY Unit IX-A-56

Refer participants to **FEMA 426**, the Unit IX Case Study activity in the Student Manual.

zones and increase the safety of pedestrian by separating them from vehicular traffic

- Avoid designing perimeter barriers that impair access by first responders

**Best Practices**

To summarize:

- A broad spectrum of mitigation actions can be taken – with a wide range of cost, protection provided, and level of effort required by the asset owner.
- The nominal ranking of mitigation measures on Page 2-52 provides a framework for the identification of short-term and long-term measures that can be taken.
- This is a great summary slide and can be found in FEMA 426 and the Air Force Installation Force Protection Guide on your Student Reference CD.

**Student Activity**

The **Building Vulnerability Assessment Checklist in FEMA 426** can be used as a screening tool for preliminary design vulnerability assessment or for assessing an existing site. The checklist includes questions that determine if critical systems will continue to function to enhance deterrence, detection, denial, and damage limitation, and if emergency systems will function during a threat or hazard situation.

**Activity Requirements**

- Continue working in small groups.
- Assign sections of the checklist to the

**INSTRUCTOR NOTES**

**CONTENT/ACTIVITY**

Members of the instructor staff should be available to answer questions and assist groups as needed.

There are 38 questions to answer by the team and then confer. With an average of 7 team members this means each member answers about 6 questions or about 5 minutes per question during their 30 minutes of research.

group member who is most knowledgeable and qualified to perform an assessment of the assigned area.

- Refer to the Case Study to determine answers to the worksheet questions.
- Then review results to identify vulnerabilities and possible mitigation measures.

Take 45 minutes to complete this activity broken down as 30 minutes of research and 15 minutes of group interaction to compare information and discuss mitigation measures. Solutions will be reviewed in plenary group, taking about 15 minutes to ensure no group is drastically off track.

**Transition**

Unit X will cover Building Design Guidance.

**UNIT IX-A -- CASE STUDY ACTIVITY:  
SITE AND LAYOUT DESIGN GUIDANCE  
(Suburban Version)**

The **Building Vulnerability Assessment Checklist in FEMA 426 (Table 1-22, pages 1-46 to 1-93)** can be used as a screening tool for preliminary design vulnerability assessment of the site where the building is located and the layout of the building on that site. The checklist includes questions that determine if critical systems will continue to function to enhance deterrence, detection, denial, and damage limitation, and emergency systems function during a threat or hazard situation.

**Requirements**

Assign sections of the checklist to the group members who are most knowledgeable and qualified to perform an assessment of the assigned area. Refer to the Case Study to determine answers to the questions. Then review results as a team to identify vulnerabilities and possible mitigation measures.

1. Complete the following components of the **Building Vulnerability Assessment Checklist (FEMA 426, Table 1-22, pages 1-46 to 1-93)**, which address site and layout. Note: Vulnerability Questions that cannot be answered with the case study information provided have not been included in this student exercise.
2. Upon completion of these portions of the checklist, refer back to the vulnerability ratings determined in the Unit IV Case Study Activity and, based on this more detailed analysis, decide if any vulnerability rating needs adjustment. Adjust the Threat Matrix chart accordingly.
3. Select mitigation measures to reduce vulnerability and associated risk from the site and layout perspective.
4. Estimate the new risk ratings for high-risk asset-threat pairs (as adjusted in step 2 above) based on the recommended mitigation measures.

Section	Vulnerability Question	Guidance	Observations
<b>1</b>	<b>Site</b>		
1.1	What major structures surround the facility (site or building(s))?  What critical infrastructure, government, military, or recreation facilities are	<b>Critical infrastructure to consider includes:</b> <b>Telecommunications infrastructure</b> Facilities for broadcast TV, cable TV; cellular networks; newspaper offices, production, and distribution; radio stations; satellite base stations; telephone	<i>There are two Critical Hazard Facilities within 2 miles of the HIC Headquarters, one to the north and the other to the southwest. In addition, there are more than a dozen Tier II HAZMAT Facilities within 3 miles of the building (in all</i>

Section	Vulnerability Question	Guidance	Observations
	<p>in the local area that impact transportation, utilities, and collateral damage (attack at this facility impacting the other major structures or attack on the major structures impacting this facility)?</p>	<p>trunking and switching stations, including critical cable routes and major rights-of-way</p> <p><b>Electric power systems</b> Power plants, especially nuclear facilities; transmission and distribution system components; fuel distribution, delivery, and storage</p> <p><b>Gas and oil facilities</b> Hazardous material facilities, oil/gas pipelines, and storage facilities</p> <p><b>Banking and finance institutions</b> Financial institutions (banks, credit unions) and the business district; note schedule business/financial district may follow; armored car services</p> <p><b>Transportation networks</b> Airports: carriers, flight paths, and airport layout; location of air traffic control towers, runways, passenger terminals, and parking areas Bus Stations Pipelines: oil; gas Trains/Subways: rails and lines, railheads/rail yards, interchanges, tunnels, and cargo/passenger terminals; note hazardous material transported Traffic: interstate highways/roads/tunnels/ bridges carrying large volumes; points of congestion; note time of day and day of week Trucking: hazardous materials cargo loading/unloading facilities; truck terminals, weigh stations, and rest areas Waterways: dams; levees; berths and ports for cruise ships, ferries, roll-on/roll-off cargo vessels, and container ships; international (foreign) flagged vessels (and cargo)</p> <p><b>Water supply systems</b> Pipelines and process/treatment facilities, dams for water collection; wastewater treatment</p> <p><b>Government services</b> Federal/state/local government</p>	<p><i>directions).</i></p> <p><i>A major interstate highway is located within ¼ mile of the HIC Headquarters.</i></p> <p><i>CSX Transportation and Norfolk-Southern Railway maintain a transportation corridor about ½ mile from HIC. There appear to be no restrictions on the material carried along these rail lines.</i></p> <p><i>A leg of the Piedmont Petroleum Pipeline (PPP) runs underneath the office park in the vicinity of HIC Headquarters. Part of Piedmont’s regional network, this portion of the pipeline normally carries a variety of refined products, including commercial and military jet fuels, diesel and three grades of gasoline, home heating fuels, etc. Four buried pipes carry approximately 20 million gallons per day.</i></p> <p><i>Connected to the pipeline, less than 1 mile from HIC, is a 20-million gallon capacity fuel farm. Operated by the Shellexico Company, this tank farm stores a variety of petroleum products, primarily gasoline.</i></p> <p><i>Two airports are in the vicinity of HIC. One is a major international airport approximately 8 miles away. The other is a small, but busy general aviation airport approximately 2 miles away.</i></p>

Section	Vulnerability Question	Guidance	Observations
		<p>offices – post offices, law enforcement stations, fire/rescue, town/city hall, local mayor’s/governor’s residences, judicial offices and courts, military installations (include type-active, Reserves, National Guard)</p> <p><b>Emergency services</b> Backup facilities, communications centers, Emergency Operations Centers (EOCs), fire/Emergency Medical Service (EMS) facilities, Emergency Medical Centers (EMCs), law enforcement facilities</p> <p><b>The following are not critical infrastructure, but have collateral damage potential to consider:</b>  <b>Agricultural facilities:</b> chemical distribution, storage, and application sites; crop spraying services; farms and ranches; food processing, storage, and distribution facilities  <b>Commercial/manufacturing/industrial facilities:</b> apartment buildings; business/corporate centers; chemical plants (especially those with Section 302 Extremely Hazardous Substances); factories; fuel production, distribution, and storage facilities; hotels and convention centers; industrial plants; raw material production, distribution, and storage facilities; research facilities and laboratories; shipping, warehousing, transfer, and logistical centers  <b>Events and attractions:</b> festivals and celebrations; open-air markets; parades; rallies, demonstrations, and marches; religious services; scenic tours; theme parks  <b>Health care system components:</b> family planning clinics; health department offices; hospitals; radiological material and medical</p>	

Section	Vulnerability Question	Guidance	Observations
		<p>waste transportation, storage, and disposal; research facilities and laboratories, walk-in clinics</p> <p><b>Political or symbolically significant sites:</b> embassies, consulates, landmarks, monuments, political party and special interest groups offices, religious sites</p> <p><b>Public/private institutions:</b> academic institutions, cultural centers, libraries, museums, research facilities and laboratories, schools</p> <p><b>Recreation facilities:</b> auditoriums, casinos, concert halls and pavilions, parks, restaurants and clubs (frequented by potential target populations), sports arenas, stadiums, theaters, malls, and special interest group facilities; note congestion dates and times for shopping centers</p> <p>References: <i>FEMA 386-7, FEMA SLG 101, DOJ NCJ181200</i></p>	
1.2	Does the terrain place the building in a depression or low area?	<p>Depressions or low areas can trap heavy vapors, inhibit natural decontamination by prevailing winds, and reduce the effectiveness of in-place sheltering.</p> <p>Reference: <i>USAF Installation Force Protection Guide</i></p>	<p>Based on terrain elevation data, the ground level of the tank farm is 49 feet higher than the ground level at HIC. Only some of the fuel tanks are bermed, but leaking fuel is not likely to reach HIC's office park. The interstate highway between the two is 16 feet lower than the tank farm and slightly lower than the office park.</p> <p>The rear parking area behind HIC slopes steeply away from the building to a stream which allows winds to pass over the structure unhindered.</p> <p>Thus, HIC is not in a depression or low area.</p>

Section	Vulnerability Question	Guidance	Observations
1.3	In dense, urban areas, does curb lane parking place uncontrolled parked vehicles unacceptably close to a building in public rights-of-way?	<p>Where distance from the building to the nearest curb provides insufficient setback, restrict parking in the curb lane. For typical city streets, this may require negotiating to close the curb lane. Setback is common terminology for the distance between a building and its associated roadway or parking. It is analogous to stand-off between a vehicle bomb and the building. The benefit per foot of increased stand-off between a potential vehicle bomb and a building is very high when close to a building and decreases rapidly as the distance increases. Note that the July 1, 1994, Americans with Disabilities Act Standards for Accessible Design states that required handicapped parking shall be located on the shortest accessible route of travel from adjacent parking to an accessible entrance.</p> <p>Reference: <i>GSA PBS-P100</i></p>	<p>With a loading dock on the west side, it is possible for vehicles to park right next to the building. Normal parking for employees is in front; the closest parking slot is 44 feet from the front door.</p>
1.4	Is a perimeter fence or other types of barrier controls in place?	<p>The intent is to channel pedestrian traffic onto a site with multiple buildings through known access control points. For a single building, the intent is to have a single visitor entrance.</p> <p>Reference: <i>GSA PBS-P100</i></p>	<p>There is no fence or other type of barrier on the site's perimeter. The only fence is a short 4-foot high fence for life safety to keep anyone from falling down the steep embankment in the rear of the building.</p>
1.5	What are the site access points to the site or building?	<p>The goal is to have at least two access points – one for passenger vehicles and one for delivery trucks due to the different procedures needed for each. Having two access points also helps if one of the access points becomes unusable, then traffic can be routed through the other access point.</p> <p>Reference: <i>USAF Installation Force Protection Guide</i></p>	<p>There are three vehicle access points into the parking lot spread along the main road.</p> <p>Access to the HIC building includes the loading dock on the west side (rear) of the building and front entrance with an 8-foot overhang.</p> <p>There are three exits from the mezzanine and four additional exits from the building.</p>

Section	Vulnerability Question	Guidance	Observations
1.6	Is vehicle traffic separated from pedestrian traffic on the site?	<p>Pedestrian access should not be endangered by car traffic. Pedestrian access, especially from public transportation, should not cross vehicle traffic if possible.</p> <p>References: <i>GSA PBS-P100 and FEMA 386-7</i></p>	<p>Sidewalks at the front of the building allow access to the site without pedestrian/vehicle interface. However, pedestrians must negotiate the parking lot to access the sidewalk.</p>
1.7	Is there vehicle and pedestrian access control at the perimeter of the site?	<p>Vehicle and pedestrian access control and inspection should occur as far from facilities as possible (preferably at the site perimeter) with the ability to regulate the flow of people and vehicles one at a time.</p> <p>Control on-site parking with identification checks, security personnel, and access control systems.</p> <p>Reference: <i>FEMA 386-7</i></p>	<p>There is no access control to the site; however, security personnel monitor parking areas, and rear parking areas are well lit and monitored by CCTV cameras. Front parking areas are lit only.</p> <p>Area proximity card prevent access to HIC building by unauthorized personnel.</p>
1.8	<p>Is there space for inspection at the curb line or outside the protected perimeter?</p> <p>What is the minimum distance from the inspection location to the building?</p>	<p>Design features for the vehicular inspection point include: vehicle arrest devices that prevent vehicles from leaving the vehicular inspection area and prevent tailgating.</p> <p>If screening space cannot be provided, consider other design features such as: hardening and alternative location for vehicle search/ inspection.</p> <p>Reference: <i>GSA PBS-P100</i></p>	<p>The building has no protected perimeter; however, there is adequate space for an inspection area at the southern-most parking lot access. This area is 125 feet away from the nearest building and 500 feet away from HIC. The added advantage of this location is that the vehicle inspections are adjacent to an embankment and the building is on top of the embankment. The embankment catches fragmentation and blast is directed upward.</p> <p>If this area is used to search visitor vehicles, then once access is given, the visitor must drive all the way around the office park to get access to the front parking lot.</p>



Section	Vulnerability Question	Guidance	Observations
1.13	Does site circulation prevent high-speed approaches by vehicles?	<p>The intent is to use site circulation to minimize vehicle speeds and eliminate direct approaches to structures.</p> <p>Reference: <i>GSA PBS-P100</i></p>	<p>No, entering at the center access point from the main road, turning left, and then turning right to proceed in front of the southern-most building, a car could easily reach 75 mph when striking the HIC building.</p>
1.14	Are there offsetting vehicle entrances from the direction of a vehicle's approach to force a reduction of speed?	<p>Single or double 90-degree turns effectively reduce vehicle approach speed.</p> <p>Reference: <i>GSA PBS-P100</i></p>	<p>There are three long straightaways approaching the building, with only one straight enough to achieve a high speed approach to the HIC building.</p> <p>Using speed bumps, especially angled speed bumps would be one way to reduce speed. Using barriers to direct traffic so there is no long straightaway is another approach, but an "S" route entrance may be frustrating for visitors, but would significantly reduce the maximum speed capability of any vehicle approach to the buildings. As a minimum, closing off the last openings near each building should be considered as a minimum.</p>
1.15	Is there a minimum setback distance between the building and parked vehicles?	<p>Adjacent public parking should be directed to more distant or better-protected areas, segregated from employee parking and away from the building. Some publications use the term setback in lieu of the term stand-off.</p> <p>Reference: <i>GSA PBS-P100</i></p>	<p>It is possible for vehicles to park right next to the building near the loading dock. Normal parking for employees is in front; the closest parking slot is 44 feet from the building.</p>
1.16	Does adjacent surface parking on site maintain a minimum stand-off distance?	<p>The specific stand-off distance needed is based upon the design basis threat bomb size and the building construction. For initial screening, consider using 25 meters (82 feet) as a minimum with more distance needed for unreinforced masonry or wooden walls.</p>	<p>Adjacent parking is that parking associated with the next building or site that is not under the control of the owners of the building being assessed.</p> <p>There is no adjacent parking per se as it is one office park,</p>

Section	Vulnerability Question	Guidance	Observations
		Reference: <i>GSA PBS-P100</i>	but there is one parking lot or area that any tenant or visitor to the office park can use. Stand-off distance to the front parking lot is less than 82 feet. Cars or trucks can drive up to the loading dock in the rear.
1.17	Do standalone, aboveground parking garages provide adequate visibility across as well as into and out of the parking garage?	<p>Pedestrian paths should be planned to concentrate activity to the extent possible.</p> <p>Limiting vehicular entry/exits to a minimum number of locations is beneficial.</p> <p>Stair tower and elevator lobby design shall be as open as code permits. Stair and/or elevator waiting areas should be as open to the exterior and/or the parking areas as possible and well lighted. Impact-resistant, laminated glass for stair towers and elevators is a way to provide visual openness.</p> <p>Potential hiding places below stairs should be closed off; nooks and crannies should be avoided, and dead-end parking areas should be eliminated.</p> <p>Reference: <i>GSA PBS-P100</i></p>	No aboveground parking garages exist on site. However the open, ground-level parking provides adequate visibility across the lot.
1.19	Do site landscaping and street furniture provide hiding places?	<p>Minimize concealment opportunities by keeping landscape plantings (hedges, shrubbery, and large plants with heavy ground cover) and street furniture (bus shelters, benches, trash receptacles, mailboxes, newspaper vending machines) away from the building to permit observation of intruders and prevent hiding of packages.</p> <p>If mail or express boxes are used, the size of the openings should be restricted to prohibit the insertion of packages.</p> <p>Reference: <i>GSA PBS-P100</i></p>	<p>There is no street furniture shown for this building.</p> <p>The landscaping shown is grass and trees are mature/tall enough so that a package cannot be hidden at the base. The hedge along the building drip line may conceal a package, if allowed to get taller or denser.</p> <p>There is no mail or express box and there is no slot in the glass main entrance door.</p> <p>Due to the size of the building columns, a package</p>

Section	Vulnerability Question	Guidance	Observations
			could be overlooked.
1.20	Is the site lighting adequate from a security perspective in roadway access and parking areas?	<p>Security protection can be successfully addressed through adequate lighting. The type and design of lighting, including illumination levels, is critical. Illuminating Engineering Society of North America (IESNA) guidelines can be used. The site lighting should be coordinated with the CCTV system.</p> <p>Reference: <i>GSA PBS-P100</i></p>	Both rear and front parking areas are well lit. Rear areas are also monitored by CCTV cameras.
1.21	Are line-of-sight perspectives from outside the secured boundary to the building and on the property along pedestrian and vehicle routes integrated with landscaping and green space?	<p>The goal is to prevent the observation of critical assets by persons outside the secure boundary of the site. For individual buildings in an urban environment, this could mean appropriate window treatments or no windows for portions of the building.</p> <p>Once on the site, the concern is to ensure observation by a general workforce aware of any pedestrians and vehicles outside normal circulation routes or attempting to approach the building unobserved.</p> <p>Reference: <i>USAF Installation Force Protection Guide</i></p>	No, lines of sight are not integrated with landscaping and green space. There are clear, approximately 300-foot, lines of sight in all directions from off the office park to buildings in this office park.
1.22	Do signs provide control of vehicles and people?	<p>The signage should be simple and have the necessary level of clarity. However, signs that identify sensitive areas should generally not be provided.</p> <p>Reference: <i>GSA PBS-P100</i></p>	There are no parking lot signs.
1.23	Are all existing fire hydrants on the site accessible?	<p>Just as vehicle access points to the site must be able to transit emergency vehicles, so too must the emergency vehicles have access to the buildings and, in the case of fire trucks, the fire hydrants. Thus, security considerations must accommodate emergency</p>	Yes, fire hydrants in the office park are accessible and the hydrant nearest to HIC is 200 feet away.

Section	Vulnerability Question	Guidance	Observations
		response requirements.  Reference: <i>GSA PBS-P100</i>	
<b>2</b>	<b>Architectural</b>		
2.1	Does the site and architectural design incorporate strategies from a Crime Prevention Through Environmental Design (CPTED) perspective?	<p><b>The focus of CPTED is on creating defensible space by employing:</b></p> <p><b>1. Natural access controls:</b></p> <ul style="list-style-type: none"> <li>- Design streets, sidewalks, and building entrances to clearly indicate public routes and direct people away from private/restricted areas</li> <li>- Discourage access to private areas with structural elements and limit access (no cut-through streets)</li> <li>- Loading zones should be separate from public parking</li> </ul> <p><b>2. Natural surveillance:</b></p> <ul style="list-style-type: none"> <li>- Design that maximizes visibility of people, parking areas, and building entrances: doors and windows that look out on to streets and parking areas</li> <li>- Shrubbery under 2 feet in height for visibility</li> <li>- Lower branches of existing trees kept at least 10 feet off the ground</li> <li>- Pedestrian-friendly sidewalks and streets to control pedestrian and vehicle circulation</li> <li>- Adequate nighttime lighting, especially at exterior doorways</li> </ul> <p><b>3. Territorial reinforcement:</b></p> <ul style="list-style-type: none"> <li>- Design that defines property lines</li> <li>- Design that distinguishes private/restricted spaces from public spaces using separation, landscape plantings; pavement designs (pathway and roadway placement); gateway treatments at lobbies, corridors, and door placement; walls, barriers, signage, lighting, and "CPTED" fences</li> <li>- "Traffic-calming" devices for vehicle speed control</li> </ul> <p><b>4. Target hardening:</b></p>	<p>Site design has some features of Crime Prevention Through Environmental Design strategies.</p> <p>The site clearly directs visitors to the front of the building and to clearly marked entrances.</p> <p>Loading areas are separate from public parking.</p> <p>Natural surveillance is maximized towards the building front with many occupied windows having a clear view of the central parking lot.</p> <p>There is adequate lighting at night in front and back parking areas.</p> <p>There is electronic access control to gain entrance to buildings in the office park.</p> <p>Where people cannot observe from windows, CCTV cameras provide coverage.</p>

Section	Vulnerability Question	Guidance	Observations
		<ul style="list-style-type: none"> <li>- Prohibit entry or access: window locks, dead bolts for doors, interior door hinges</li> <li>- Access control (building and employee/visitor parking) and intrusion detection systems</li> </ul> <p><b>5. Closed circuit television cameras:</b></p> <ul style="list-style-type: none"> <li>- Prevent crime and influence positive behavior, while enhancing the intended uses of space. In other words, design that eliminates or reduces criminal behavior and at the same time encourages people to "keep an eye out" for each other.</li> </ul> <p>References: <i>GSA PBS-P100 and FEMA 386-7</i></p>	
2.2	Is it a mixed-tenant building?	<p>Separate high-risk tenants from low-risk tenants and from publicly accessible areas. Mixed uses may be accommodated through such means as separating entryways, controlling access, and hardening shared partitions, as well as through special security operational countermeasures.</p> <p>Reference: <i>GSA PBS-P100</i></p>	<p>The building is a multiple-tenant facility and there are multiple buildings in the office park with multiple tenants.</p> <p>HIC has neighbors on one side in its building and a different neighbor in the adjacent building.</p>
2.3	Are pedestrian paths planned to concentrate activity to aid in detection?	<p>Site planning and landscape design can provide natural surveillance by concentrating pedestrian activity, limiting entrances/exits, and eliminating concealment opportunities. Also, prevent pedestrian access to parking areas other than via established entrances.</p> <p>Reference: <i>GSA PBS-P100</i></p>	<p>Each tenant facility has its own entrance, spreading pedestrian activity across the front of the buildings within easy observation of each entrance to aid in detection.</p> <p>Loading docks are likewise spread out across the rear of the buildings. HIC uses a CCTV camera on the building rear to aid in detection of personnel approaching the rear entrance.</p>
2.4	Are there trash receptacles and mailboxes in close proximity to the building	<p>The size of the trash receptacles and mailbox openings should be restricted to prohibit insertion of packages. Street furniture, such as newspaper vending machines,</p>	<p>There is no indication that there are trash receptacles and mailboxes in close proximity to the building.</p>

Section	Vulnerability Question	Guidance	Observations
	that can be used to hide explosive devices?	<p>should be kept sufficient distance (10 meters or 33 feet) from the building, or brought inside to a secure area.</p> <p>References: <i>USAF Installation Force Protection Guide and DoD UCF 4-010-01</i></p>	The dumpster is approximately 50 feet from the rear of the building.
<b>5</b>	<b>Utility Systems</b>		
5.1	<p>What is the source of domestic water? (utility, municipal, wells, lake, river, storage tank)</p> <p>Is there a secure alternate drinking water supply?</p>	<p>Domestic water is critical for continued building operation. Although bottled water can satisfy requirements for drinking water and minimal sanitation, domestic water meets many other needs – flushing toilets, building heating and cooling system operation, cooling of emergency generators, humidification, etc.</p> <p>Reference: <i>FEMA 386-7</i></p>	<p>The water to the fire protection system within the building and the fire hydrants in the office park comes from the local municipal distribution mains which is also the source for all water uses in the building – rest rooms, kitchen/break room, HVAC equipment, etc. There is only one water supply line to the HIC building.</p> <p>Per request from employees, four bottled water dispensers are throughout the building, with an average of 2 water bottles (5 gallons each) in reserve at any given time for each dispenser.</p>
5.4	<p>Does the building or site have storage capacity for domestic water?</p> <p>How many gallons of storage capacity are available and how long will it allow operations to continue?</p>	<p>Operational facilities will require reliance on adequate domestic water supply. Storage capacity can meet short-term needs and use water trucks to replenish for extended outages.</p> <p>Reference: <i>Physical Security Assessment for Department of Veterans Affairs Facilities.</i></p>	<p>The building currently stores drinking water as delivered in 5-gallon bottles. The site has the capacity to have 80 gallons on hand at the time of delivery. The bottled water supply would last for a few days to one week for drinking purposes only.</p> <p>There are no storage tanks for servicing other water uses in the HIC building.</p>
5.5	What is the source of water for the fire suppression system? (local utility company lines, storage tanks with	The fire suppression system water may be supplied from the domestic water or it may have a separate source, separate storage, or nonpotable alternate sources.	The only water source for fire suppression is the municipal water mains serving the office park.

Section	Vulnerability Question	Guidance	Observations
	utility company backup, lake, or river)  Are there alternate water supplies for fire suppression?	For a site with multiple buildings, the concern is that the supply should be adequate to fight the worst case situation according to the fire codes. Recent major construction may change that requirement.  Reference: <i>FEMA 386-7</i>	
5.6	Is the fire suppression system adequate, code-compliant, and protected (secure location)?	Standpipes, water supply control valves, and other system components should be secure or supervised.  Reference: <i>FEMA 386-7</i>	Yes, the fire suppression system is adequate and meets all fire codes.
5.10	What fuel supplies do the building rely upon for critical operation?	Typically, natural gas, propane, or fuel oil is required for continued operation.  Reference: <i>Physical Security Assessment for the Department of Veterans Affairs Facilities</i>	Heating for the HIC building is provided by a combination of natural gas and electricity.  Backup electric generators use diesel fuel.
5.11	How much fuel is stored on the site or at the building and how long can this quantity support critical operations?  How is it stored?  How is it secured?	Fuel storage protection is essential for continued operation.  Main fuel storage should be located away from loading docks, entrances, and parking. Access should be restricted and protected (e.g., locks on caps and seals).  References: <i>GSA PBS-P100 and Physical Security Assessment for the Department of Veterans Affairs Facilities</i>	Emergency power is provided by a single diesel generator, located in a shed in the rear parking lot. The generator has a 50-gallon day tank, maintained at 80 percent capacity. A 2,000-gallon main tank is buried under the parking lot, near the generator.  There are no security measures for the fuel.
5.12	Where is the fuel supply obtained?  How is it delivered?	The supply of fuel is dependent on the reliability of the supplier.  Reference: <i>Physical Security Assessment for the Department of Veterans Affairs Facilities</i>	Natural gas enters the building through two meters under the loading dock staircase and is supplied from the local gas distribution company.  Electric power for the HIC office is provided by Hazardville Electric Power Company through two transformers outside the building. Two sets of buried transmission lines deliver

Section	Vulnerability Question	Guidance	Observations
			<p>12,470 volt (12.47KV) power to two separate transformers outside the building from a nearby substation.</p> <p>Diesel fuel is delivered by truck from a local supplier, who normally responds the day after being called.</p>
5.13	<p>Are there alternate sources of fuel?</p> <p>Can alternate fuels be used?</p>	<p>Critical functions may be served by alternate methods if normal fuel supply is interrupted.</p> <p>Reference: <i>Physical Security Assessment for the Department of Veterans Affairs Facilities</i></p>	<p>The single electric generator powered by diesel fuel is the only alternate long-term fuel supply to electricity.</p> <p>However, batteries to support the UPS (Uninterruptible Power Supply) are in a small room next to the UPS room. The UPS provides enough electric power for an orderly shutdown of the computer.</p>
5.14	<p>What is the normal source of electrical service for the site or building?</p>	<p>Utilities are the general source unless co-generation or a private energy provider is available.</p> <p>Reference: <i>Physical Security Assessment for the Department of Veterans Affairs Facilities</i></p>	<p>Main power for the HIC office is provided by Hazardville Electric Power Company through two transformers outside the building. Two sets of buried transmission lines deliver 12,470 volt (12.47KV) power to the transformers (one set to each) from a nearby substation.</p>
5.15	<p>Is there a redundant electrical service source?</p> <p>Can the site or buildings be fed from more than one utility substation?</p>	<p>The utility may have only one source of power from a single substation. There may be only single feeders from the main substation.</p> <p>Reference: <i>Physical Security Assessment for the Department of Veterans Affairs Facilities</i></p>	<p>Each transformer with its respective feeder can handle the complete electrical load of HIC.</p> <p>However, both feeders come from the same substation.</p>
5.16	<p>How many service entry points does the site or building have for electricity?</p>	<p>Electrical supply at one location creates a vulnerable situation unless an alternate source is available.</p> <p>Ensure disconnecting requirements according to NFPA 70 (National Fire Protection</p>	<p>There are two service entrance points for electricity, one feeding the Computer Center Bus and the other feeding the Support Bus as shown in Figure 19 of Appendix A.</p>



Section	Vulnerability Question	Guidance	Observations
		<p>Association, National Electric Code) are met for multiple service entrances.</p> <p>Reference: <i>Physical Security Assessment for the Department of Veterans Affairs Facilities</i></p>	
5.17	Is the incoming electric service to the building secure?	<p>Typically, the service entrance is a locked room, inaccessible to the public.</p> <p>Reference: <i>Physical Security Assessment for the Department of Veterans Affairs Facilities</i></p>	The electric service entrance comes into the Mechanical and Electrical Room from underground. The room is inside a secured facility and the room has a keyed lock to limit access to authorized personnel.
5.18	<p>What provisions for emergency power exist?</p> <p>What systems receive emergency power and have capacity requirements been tested?</p> <p>Is the emergency power collocated with the commercial electric service?</p> <p>Is there an exterior connection for emergency power?</p>	<p>Besides installed generators to supply emergency power, portable generators or rental generators available under emergency contract can be quickly connected to a building with an exterior quick disconnect already installed.</p> <p>Testing under actual loading and operational conditions ensures the critical systems requiring emergency power receive it with a high assurance of reliability.</p> <p>Reference: <i>GSA PBS-PI00</i></p>	<p>Emergency power is provided by a single diesel generator with a maximum capacity of 1250 KW/1563 KVA. This generator is large enough to take the complete load of the building.</p> <p>The backup diesel generator has never had to support HIC's power demands for longer than about 2 hours, and never with more than one chiller operating. It has never been tested for an extended period under a heavy load. The diesel generator is configured to automatically start upon loss of commercial power to the Computer Center Bus (CCB). This happens about twice a year due to electrical storms or utility maintenance in the neighborhood.</p> <p>Batteries to support the UPS were tested 2 years ago and calculated to provide 60 minutes of power for orderly shutdown of the Computer Center.</p> <p>At 319 GPH at 1250 KW loading, the backup generator consumes 0.255 gallons per</p>

Section	Vulnerability Question	Guidance	Observations
			<p>hour per KW. This is NOT a very efficient generator as 0.07 gallons per hour per KW is a DoD design minimum. This generator with a 2,000 gallon tank will carry the maximum load for a little over 6 hours, which would require frequent refilling for an extended outage.</p> <p>The generator is outside the HIC building, but the Automatic Transfer Switch and commercial power service entrances are collocated in the Mechanical and Electrical Room.</p> <p>There is no exterior connection for electric power (like a fire pumper Siamese connection). A backup generator to the backup would either have to be wired to the Automatic Transfer Switch or spliced into the cables leaving the installed generator.</p>
5.19	By what means do the main telephone and data communications interface the site or building?	<p>Typically communication ducts or other conduits are available. Overhead service is more identifiable and vulnerable.</p> <p>Reference: <i>Physical Security Assessment for the Department of Veterans Affairs Facilities</i></p>	<p>HIC has two T1 lines and one T3 line connected at the demark to ATT's high performance backbone network. The ATT fiber connectivity provides more than enough bandwidth for HIC's current needs and planned future expansion.</p> <p>The demark is in the Comm Center on the opposite side of the building from the Mechanical and Electrical Room.</p> <p>As with all other utilities, the telephone and data service is underground.</p>

Section	Vulnerability Question	Guidance	Observations
5.21	<p>Does the fire alarm system require communication with external sources?</p> <p>By what method is the alarm signal sent to the responding agency: telephone, radio, etc.?</p> <p>Is there an intermediary alarm monitoring center?</p>	<p>Typically, the local fire department responds to an alarm that sounds at the station or is transmitted over phone lines by an auto dialer.</p> <p>An intermediary control center for fire, security, and/or building system alarms may receive the initial notification at an on-site or off-site location. This center may then determine the necessary response and inform the responding agency.</p> <p>Reference: <i>Physical Security Assessment for the Department of Veterans Affairs Facilities</i></p>	<p>The Security Officer has a key to the building that has the main fire panel. The main fire panel is located in the lobby area, which is open to unrestricted access during normal business hours. In the event of a fire, the panel alerts the local fire department and the security company using dedicated telephone lines.</p> <p>There is no intermediary alarm monitoring center, but the security company acts as a backup to ensure the fire department is alerted.</p>
5.22	<p>Are utility lifelines aboveground, underground, or direct buried?</p>	<p>Utility lifelines (water, power, communications, etc.) can be protected by concealing, burying, or encasing.</p> <p>Reference: <i>GSA PBS-P100 and FEMA 386-7</i></p>	<p>Utility lines are buried at this location.</p>

*This page intentionally left blank*

## Unit X

---

<b>COURSE TITLE</b>	Building Design for Homeland Security	<b>TIME</b>	150 minutes
---------------------	---------------------------------------	-------------	-------------

---

<b>UNIT TITLE</b>	Building Design Guidance
-------------------	--------------------------

---

<b>OBJECTIVES</b>	<ol style="list-style-type: none"><li>1. Explain architectural considerations to mitigate impacts from blast effects and transmission of chemical, biological, and radiological agents from exterior and interior incidents</li><li>2. Identify key elements of building structural and nonstructural systems for mitigation of blast effects</li><li>3. Compare and contrast the benefit of building envelope, mechanical system, electrical system, fire protection system, and communications system mitigation measures, including synergies and conflicts</li><li>4. Apply these concepts to an existing building or building conceptual design and identify mitigation measures needed to reduce vulnerabilities</li></ol>
-------------------	--

---

<b>SCOPE</b>	The following topics will be covered in this unit:
--------------	--

1. Architectural considerations, including building configuration, space design, and special situations
2. Building structural and nonstructural considerations with emphasis on progressive collapse, loads and stresses, and good engineering practices
3. Design issues for the building envelope, including wall design, window design, door design, and roof system design with approaches to define levels of protection
4. Mechanical system design issues, including interfacing with operational procedures, emergency plans, and training
5. Other building systems design consideration for electrical, fire protection, communications, electronic security, entry control, and physical security that mitigate the effects of a threat or hazard
6. Activity: Select mitigation measures that reduce vulnerability and associated risk from the building perspective for the highest risk pairs (asset - threat/hazard) identified in Unit V-B.

**REFERENCES**

1. FEMA 426, *Reference Manual to Mitigate Potential Terrorist Attacks Against Buildings*, pages 3-1 to 3-46 and 3-48 to 3-52; Checklist at end of Chapter 1
2. FEMA 427, *Primer for Design of Commercial Buildings to Mitigate Terrorist Attacks*
3. FEMA 430, *Primer for Incorporating Building Security Components in Architectural Design* (when available)
4. FEMA 452, *Risk Assessment: A How-To Guide to Mitigate Potential Terrorist Attacks Against Buildings*, pages 5-1 to 5-16
5. Student Manual, Unit X-A or Unit X-B as selected
6. Case Study – Appendix A: Suburban, Hazardville Information Company or Appendix B: Suburban, HazardCorp Building as selected
7. Unit X visuals

**REQUIREMENTS**

1. FEMA 426, *Reference Manual to Mitigate Potential Terrorist Attacks Against Buildings* (one per student)
2. FEMA 452, *Risk Assessment: A How-To Guide to Mitigate Potential Terrorist Attacks Against Buildings* (one per student)
3. Instructor Guides, Unit X
4. Student Manual(one per student) for selected case study
5. Overhead projector or computer display unit
6. Unit X visuals
7. Threat Matrices and dry-erase markers
8. Chart paper, easel, and markers

**UNIT X OUTLINE**

	<u>Time</u>	<u>Page</u>
X. Building Design Guidance [65 slides at about 1.5 minutes per slide over 90 minutes]	150 minutes	
1. Introduction and Unit Overview Third Layer of Defense	13.5 minutes	IG X-5
2. Architecture	15 minutes	IG X-11
3. Structural Systems	9 minutes	IG X-18
4. Building Envelope	24 minutes	IG X-24
5. Utility Systems	4.5 minutes	IG X-39

6. Mechanical and Electrical Systems	10.5 minutes	IG X-41
7. Plumbing and Gas Systems	1.5 minutes	IG-X-48
8. Fire Alarm Systems	1.5 minutes	IG-X-49
9. Communications – Information Technology Systems	3 minutes	IG-X-50
10. Equipment Operations and Maintenance	3 minutes	IG-X-52
11. Security Systems	4.5 minutes	IG-X-54
12. Practical Applications	1.5 minutes	IG-X-58
13. Building Materials: General Guidance	1.5 minutes	IG-X-58
14. Desired Building Protection Level	1.5 minutes	IG-X-59
15. Summary	1.5 minutes	IG-X-60
16. Student Activity Instructions	1.5 minutes	IG-X-61
17. <u>Student Activity</u> : Building Design Guidance (Version <b>A Suburban</b> ) [45 minutes for students, 15 minutes for instructor review]	60 minutes	IG X-A-62
18. <u>Student Activity</u> : Building Design Guidance (Version <b>B Urban</b> ) [45 minutes for students, 15 minutes for instructor review]	60 minutes	IG X-B-83

## PREPARING TO TEACH THIS UNIT

**Tailoring Content to the Local Area:** Review the Instructor Guides to identify topics that should focus on the local area. Plan how you will use the generic content, and prepare for a locally oriented discussion. The locally oriented discussion should be in conjunction with the version of the case study selected as the student activity used during the course offering.

**Optional Activity:** There are three versions of the student activity available for use during this course -- Suburban, Urban, or Continuity of Operations Planning (COOP).

**Activity:** The students will continue the familiarization with the Case Study materials. The Case Study is a complete risk assessment and analysis of mitigation options and strategies for a typical commercial office building located in a mixed urban-suburban environment business park (suburban), a 50-story high-rise office building located in a downtown urban environment (urban), or an alternate facility to be assessed for potential COOP use (based

upon the suburban building). The assessment will use the DoD Antiterrorism Standards and the GSA Interagency Security Criteria to determine Levels of Protection and identify specific vulnerabilities. Mitigation options and strategies will use the concepts provided in **FEMA 426** and other FEMA publications related to emergency planning and disaster recovery.

Refer students to their Student Manuals for worksheets and activities.

- Direct students to the appropriate page in the Student Manual.
- Read the activity instructions found in the Student Manual.
- Describe how the selected case study appendix in the Student Manual is used to obtain the data needed for the building assessment.
- “Walk through” the pages of the activity with the students, describing the steps followed to obtain the answers in the completed examples, and what is expected of the groups for this activity.
- If applicable to this activity, explain what information is to be transferred to the Risk Matrix poster. For this activity, the assessment of the building in greater depth may result in the groups adjusting the Risk Matrix scores for vulnerability rating, with resultant changes to risk rating.
- Tell students how long they have to work on the requirements.
- While students are working, all instructors should closely observe the groups’ process and progress. If any groups are struggling, immediately assist them by clarifying the assignment and providing as much help as is necessary for the groups to complete the requirement in the allotted time. Also, monitor each group for full participation of all members. For example, ask any student who is not fully engaged a question that requires his/her viewpoint to be presented to the group.
- At the end of the working period, reconvene the class.
- Ask a representative from one group to provide the answer to the first requirement. Then simply ask if anyone disagrees. If the answer is correct and no one disagrees, state that the answer is correct and move on to the next requirement. If there is disagreement, provide the “school solution” and move on.
- If time is short, simply provide the “school solution” and ask for questions. Do not end the activity without ensuring that students know if their answers are correct or at least on the right track. Note, there are no right or wrong answers, but all answers must be justified with rationale.
- Ask for and answer questions.



**INSTRUCTOR NOTES**

**CONTENT/ACTIVITY**

VISUAL X-1

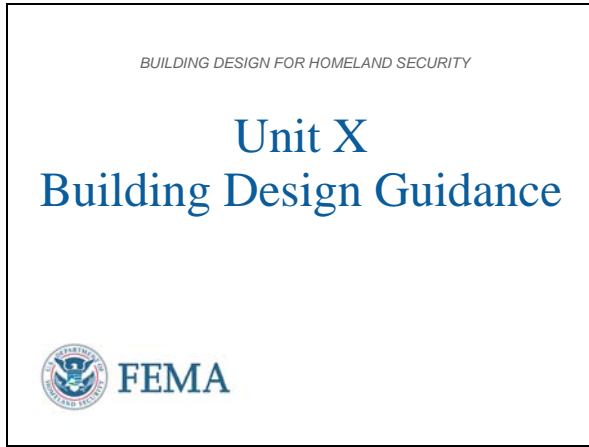

**Introduction and Unit Overview**

This is Unit X Building Design Guidance. Continuing with our understanding of vulnerability and mitigation measures, we have looked at site and layout concerns and now turn our attention to what considerations are needed in building design to mitigate tactics involving explosive blast or CBR agents.

We will examine design considerations that achieve a balanced building envelope that provides a defensive layer against the given terrorist tactic and avoids creating ripple effects where one incident may affect more than one building system.

Catastrophic collapse of any building is a primary concern. Historically, the majority of fatalities that occur in terrorist attacks directed against buildings are due to building collapse. This was true for the Oklahoma City bombing in 1995 when 87 percent of the building occupants who were killed were in the collapsed portion of the Murrah Federal Building. But glass causes over 80 percent of injuries during bomb blast and there are some low cost techniques to keep CBR agents outside of buildings or to limit their spread inside.

VISUAL X-2

**Unit Objectives**

**Explain** architectural considerations to mitigate impacts from blast effects and transmission of chemical, biological, and radiological agents from exterior and interior incidents.

**Identify** key elements of building structural and non-structural systems for mitigation of blast effects.



BUILDING DESIGN FOR HOMELAND SECURITY Unit X-2

**References**

FEMA Building Vulnerability Assessment Checklist, Chapter 1, page 1-46, FEMA 426

Building Design Guidance, Chapter 3, FEMA 426

FEMA 430, Primer for Incorporating Building Security Components in Architectural Design

VISUAL X-3

**Unit Objectives (cont.)**

**Compare** and contrast the benefit of building envelope, mechanical system, electrical system, fire protection system, and communication system mitigation measures, including synergies and conflicts.

**Apply** these concepts to an existing building or building conceptual design and identify mitigation measures needed to reduce vulnerabilities.



BUILDING DESIGN FOR HOMELAND SECURITY Unit X-3

**Unit Objectives**

At the end of this unit, the students should be able to:

Explain architectural considerations due to impact from blast effects and transmission of chemical, biological, and radiological agents from exterior and interior incidents.

Identify key elements of a building's structural and non-structural systems for mitigation of blast effects.

In addition to FEMA 426, also consult [FEMA 430](#) (future) for additional design concepts.

**Unit Objectives (continued)**

Compare and contrast the benefit of building envelope, mechanical system, electrical system, fire protection system, and communication system mitigation measures, including synergies and conflicts.

Apply these concepts to an existing building or building conceptual design and identify mitigation measures needed to reduce vulnerabilities.

VISUAL X-4

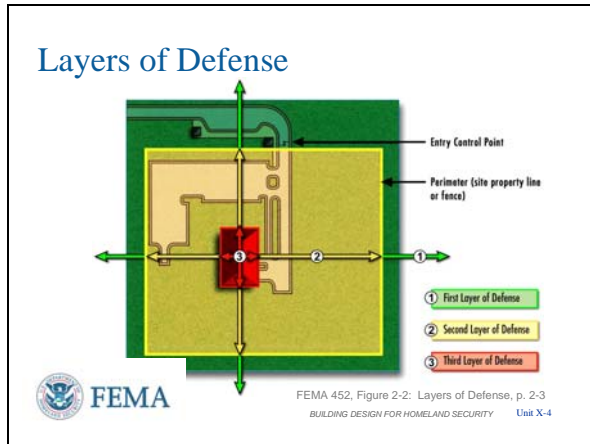

From FEMA 452

The layers of defense is a traditional approach in security engineering and use concentric circles extending out from an area or site to the building or asset that requires protection. They can be seen as demarcation points for different security strategies. Identifying the layers of defense early in the assessment process will help you to understand better the assets that require protection and determine your mitigation options. Figure 2-2 shows the layers of defense described above.

**Layers of Defense**

The first and second layers were discussed in the previous instruction unit. The Third Layer of Defense is applicable to Building Design – starting at the building drip line, taking into account the complete building envelope, and including any additional considerations found anywhere in the building.

**FEMA 452 -- Third Layer of Defense.** This deals with the protection of the asset itself. It proposes to harden the structures and systems, incorporate effective HVAC systems and surveillance equipment, and wisely design and locate utilities and mechanical systems. Note that, of all blast mitigation measures, distance is the most effective measure because other measures vary in effectiveness and can be more costly. However, often it is not possible to provide adequate stand-off distance. For example, sidewalks in many urban areas may be less than 10 meters (33 feet), while appropriate stand-off may require a minimum of 25 meters (82 feet). **The building owner has control of this layer and its main mitigation measures are hardening against blast and security sensors/CCTV as final access control.**

VISUAL X-5

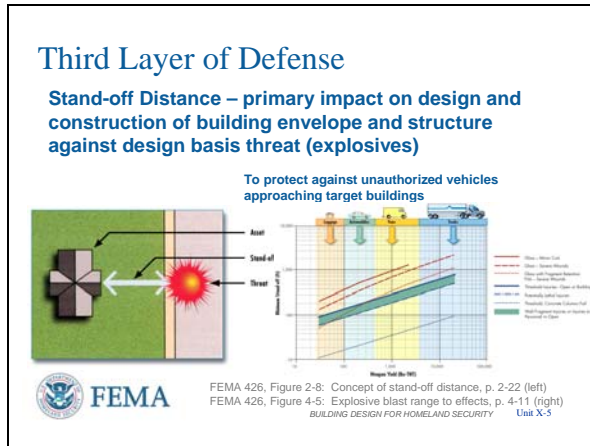

**Third Layer of Defense**

**Stand-off Distance versus Hardening of Structures**

Of all blast mitigation measures, distance is the most effective measure because other measures vary in effectiveness and can be more costly. However, many times it is not possible to provide adequate stand-off distance.

Desired minimum stand-off in the DoD Unified Facility Criteria (UFC) and used as the initial screening distance in FEMA 426 is 82 feet. However, this may only protect against column collapse for a 250 pound car bomb at 82 feet.

The design basis threat weapon yield and the level of protection desired drive the hardening required for the stand-off distance available.

VISUAL X-6

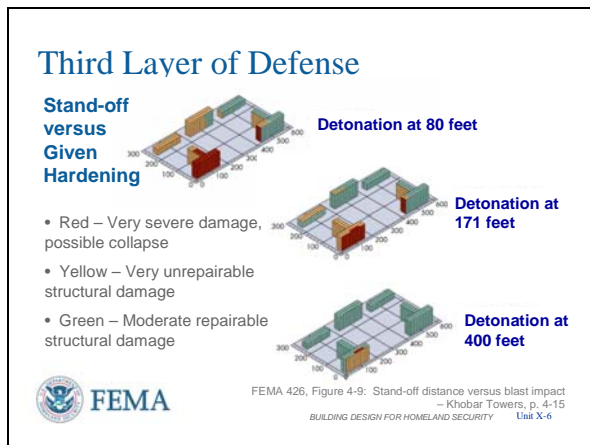

**Third Layer of Defense**

**Stand-off versus Given Hardening**

This representation of the estimated damage at Khobar Towers uses the blast modeling software available circa 1997. It shows the front façade of the target building receiving very severe damage when the estimated bomb is at 80 feet. Increasing the stand-off using the same building construction and bomb size shows that the stand-off required to limit damage is 400 feet.

**INSTRUCTOR NOTES**

**CONTENT/ACTIVITY**

**VISUAL X-7**

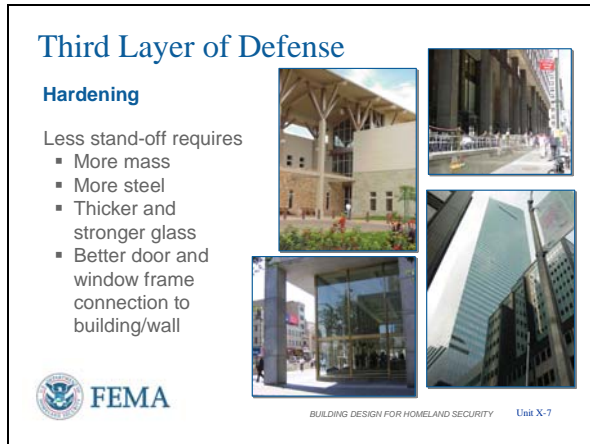

U.S. Embassy: Kampala, Uganda designed to resist explosive blast [upper left – DOS and Hinman]. Other three photos are from New York City indicating glass and overhang (poor) [lower left], similar glass and overhang (poor) but with wall (better) [upper right], and window curtain wall (usually poor) [lower right].

**VISUAL X-8**

Layers of Defense	Architecture	Structural Systems	Building Envelope	Utility Systems	Mechanical & Electrical Sys	Plumbing & Gas Systems	Fire Alarm Systems	Comm - Info Technology Sys	Equipment Ops & Maint	Security Systems
First Layer										
Second Layer										
Third Layer										

Note that one mitigation measure may reduce the risk of more than one asset-threat/hazard pair of interest as illustrated by **Table 2-1, page 2-54, of FEMA 426**, where a mitigation measure may apply to multiple tactics. On

**Third Layer of Defense Hardening**

Less stand-off requires more mass and more steel for hardening, thicker and stronger glass, and better window frame connection to the building/wall. However, this should be done in concert with good architecture design and aesthetics principles. As you can see, the other photos show architectural treatments that increase blast damage – overhangs and much glass.

Note that 82 feet of stand-off allows use of conventional construction with minimal upgrades when used in conjunction with a controlled perimeter that detects larger bombs prior to getting anywhere near the building.

**Third Layer of Defense**

The third layer of defense deals with the protection of the asset itself. The column headings include key elements of protection and the row headings includes the three layers of defense. The matrix allows designers to consider different methods of protection and when they could be used. For the third layer of defense, designers should go through each system to take appropriate mitigation measures for an existing building or provide increased hardening when designing a building.

The rest of this instruction unit will follow along the column headings in the order shown. This is the same order as found in the Building Vulnerability Checklist at the end of Chapter 1 of FEMA 426.

**INSTRUCTOR NOTES**

**CONTENT/ACTIVITY**

the other hand, a mitigation measure against one tactic may increase the vulnerability to other tactics.

**VISUAL X-9**

**Third Layer of Defense**

When hardening a building, the following should be considered:

- Progressive collapse
- Appropriate security systems
- Hardening the building envelope
- Appropriate HVAC systems to mitigate CBR
- Hardening the remaining structure
- Hardening and location of utilities



BUILDING DESIGN FOR HOMELAND SECURITY Unit X-9

**Third Layer of Defense**

**Hardening Considerations:**

- **Progressive collapse**  
This should be the first consideration as most deaths result from building collapse and life safety seeks to ensure safe evacuation of a building during or after any incident. Structural framing and load-bearing components are the concern here.
- **Appropriate security systems**  
For an existing building the addition of security systems to deter, detect, and deny the building needs to be done whether or not building hardening can be done.
- **Hardening the building envelope**  
After progressive collapse, hardening the building envelope provides the most protection against injury during blast events and aligns with building tightness considerations for exterior CBR releases.
- **Appropriate HVAC systems to mitigate against CBR**  
Next the control of HVAC operation for exterior and interior CBR releases should be considered based upon the complexity of the existing or designed system.
- **Hardening the structure**  
After progressive collapse and hardening the building envelope, hardening the rest of the structural/nonstructural components to reduce injury should be considered.
- **Hardening and location of utilities**  
This might be the most expensive to do with an existing building, but should be fully implemented in a new building design. Accessible, aboveground utilities should receive first consideration for hardening.

VISUAL X-10

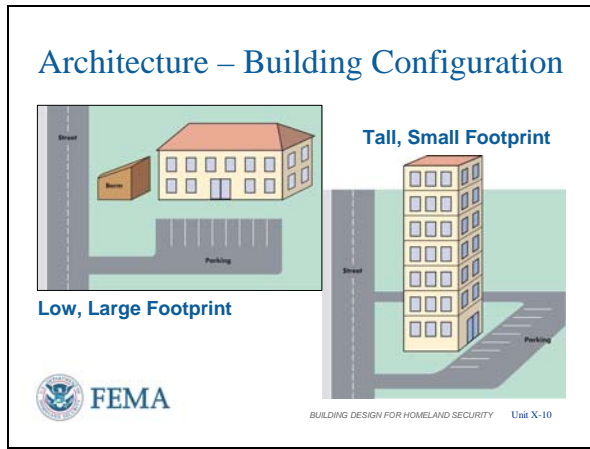

**Architecture – Building Configuration**

Designers should balance a number of relevant considerations to the extent that site, economic, and other factors allow.

Some of the relevant considerations include the following:

- The shape of the building
- Low, large footprint buildings
- Tall, small footprint buildings

General benefits of the two basic approaches:

Low, Large Footprint:

- Reduced effect of explosive blast (catches less of the blast wave) – Dispersed and blast wave rolls over the top.
- Reduced effect of progressive collapse (less of the building can fall) – Due to less structural members impacted.
- Reduced surveillance or easier mitigation (lower height allows terrain and landscaping options)
- Better energy conservation (green roof potential and earth-sheltered design – earth berm reduces energy loss and directs blast wave over the building if the berm is as high as the building)

Tall, Small Footprint:

- Reduced blast effects on upper floors
- Air intakes better protected against CBR events
- Site runoff reduced, reducing culvert size as a covert entry point
- More parking space that meets local planning commission/building code



VISUAL X-11

**Architecture – Building Configuration**

Rectangular versus “U”, “L” or “E”

Avoid re-entrant corners

Flush face versus eaves and overhangs

**Shapes That Accentuate Blast**

FEMA 426, Figure 3-2: Re-entrant corners in a floor plan, p. 3-6  
 FEMA 427, Figure 6-3: Effects of building shape vs. air blast, p. 6-9  
 BUILDING DESIGN FOR HOMELAND SECURITY Unit X-11

FEMA

**Architecture – Building Configuration**

A lot can be done architecturally to mitigate the effects of a terrorist bombing on a facility. These measures often cost nothing or very little if implemented early in the design process. FEMA 430 (future) will contain an expanded discussion of incorporating security components in architectural design.

- Further looking at building shapes, certain configurations trap the blast wave, increasing overall damage to the structure. For example, “U” or “L” shaped buildings, overhangs, and re-entrant corners in general should be avoided. Either the reflected pressure increases as it cannot vent around the building or the building gets hit with reflected blast waves at points already hit by the initial blast wave.

VISUAL X-12

**Architecture – Building Configuration**

**Hardening – Story height vs Stand-off**

- Hardening of first three floors is critical as these take brunt of blast
- At third through sixth floor, hardening can be reduced due to reflection angle
- Above the sixth floor, conventional construction may be sufficient depending upon design threat and reflections off adjacent buildings

FEMA

BUILDING DESIGN FOR HOMELAND SECURITY Unit X-12

**Architecture – Building Configuration**

GSA has stated the hardening for the urban situation will be fully evaluated for the first three floors of the building because these floors are most vulnerable. At the third through sixth floor, the hardening can be reduced, but some hardening is still necessary. Above the sixth floor may need only conventional construction with minimal hardening -- because the reflection angle is going to result in a lower coefficient of reflection and the increased stand-off distance to these floors also results in less reflected pressure.

However, as the bomb gets bigger, the upper floors will see severe damage even with the increased reflection angles just due to the higher incident pressure generated by larger bombs.

The GSA approach would hold very well for a



**INSTRUCTOR NOTES**

**CONTENT/ACTIVITY**

high-rise building surrounded by low-rise buildings (3 floors and less), but is probably less applicable for the high-rise building surrounded by other high-rise buildings. Blast wave reflections off adjacent buildings, will affect all floors of the building of interest to varying degrees. The reflections will follow much longer paths resulting in larger effective stand-off distances and the various reflection angles will result in lower incident and reflected pressures compared to the initial blast wave. Unfortunately, the reflections may hit a very weak point in the response motion of the building or building component at any floor level resulting in more damage than would have been originally expected.

**Architecture – Building Configuration**

- Elevating the ground floor makes moving vehicle attack more difficult
- If the glazing looks perpendicular to the direction of travel for the blast wave, the glass sees less reflected pressure.
- Do not have structural elements, like columns, easily exposed on the outside of the building. This goes for any architectural feature that can become damaged or disconnected by a blast wave.
- If armed attack includes Molotov cocktails or home-made grenades, pitched roofs and pitched window sills tend to cause the thrown item to roll off and away from the building. Air intakes have similar considerations.

**VISUAL X-13**

**Architecture – Building Configuration**

Ground floor elevation 4 feet above grade

Orient glazing perpendicular to principal threat direction

Avoid exposed structural elements

Pitched roofs and pitched window sills

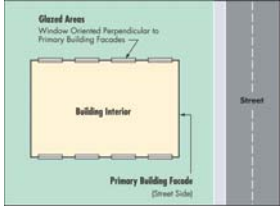

FEMA 426, Figure 3-1: Glazed areas perpendicularly oriented away from streets, p. 3-5  
BUILDING DESIGN FOR HOMELAND SECURITY Unit X-13



VISUAL X-14

**Architecture – Building Configuration**

**Loading Docks**

- Avoid trucks parking in or underneath buildings
- Design to prevent progressive collapse
- Ensure separation from critical systems, functions, and utility service entrances
- Separate loading docks from building critical functions



- Provide sufficient area for screening vehicles and packages
- Keep dumpsters away from buildings



BUILDING DESIGN FOR HOMELAND SECURITY Unit X-14

**Architecture – Building Configuration**

**Loading Docks**

- Loading docks are higher risk locations as larger vehicles with potentially larger bombs are allowed minimal stand-off from the building.
- Building design calls for the basics of preventing progressive collapse, and separating critical equipment, systems, components and functions away from the loading dock.
- Do not provide a hiding location by placing dumpsters adjacent to the building
- Screen packages and vehicles coming to the loading dock at other locations or in an area of sufficient size to allow searches and sufficient distance from the building to reduce the impact of any incident.

VISUAL X-15

**Architecture – Building Configuration**

**Parking Considerations**



- Restrict parking underneath buildings
- Well-lit, security presence, emergency communications, and/or CCTV
- Apply progressive collapse hardening to columns when parking garage is in building

- Garage elevators service garage only to unsecured zone of lobby



BUILDING DESIGN FOR HOMELAND SECURITY Unit X-15

**Architecture – Building Configuration**

**Parking Considerations**

- As with loading docks, parking underneath a building is a higher risk situation as larger bombs than can be hand-carried approach the building with minimal stand-off.
- As with loading docks, progressive collapse is a primary concern
- Restrict parking to vetted vehicles, but also provide access control and security systems
- Access from underground parking (stairwells and elevators) to the building should be only to unsecured spaces where access control then occurs, such as outside the footprint of the building

VISUAL X-16

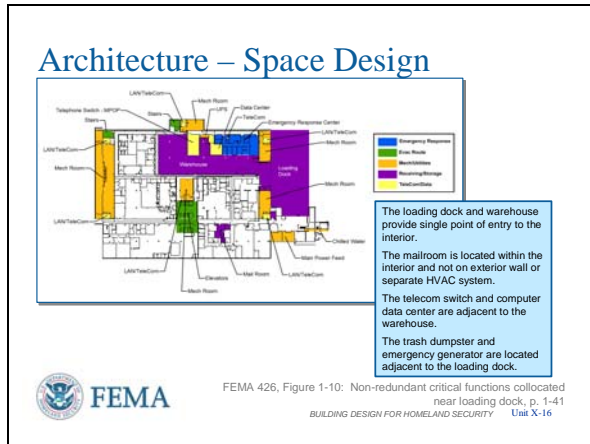

**Architecture – Space Design**

**Functional Layout**

Public areas such as the lobby, loading dock, mail room, garage, and retail areas need to be separated from the more secured areas of the facility. This can be done by creating internal “hard lines” or buffer zones, using secondary stairwells, elevator shafts, corridors, and storage areas between public and secured areas.

In lobby areas, the architect would be wise to consider the queuing requirements in front of the inspection stations so that visitors are not forced to stand outside during bad weather conditions or in a congested line inside a small lobby while waiting to enter the secured areas. Consider allowing enough lobby space for future inspection equipment.

VISUAL X-17

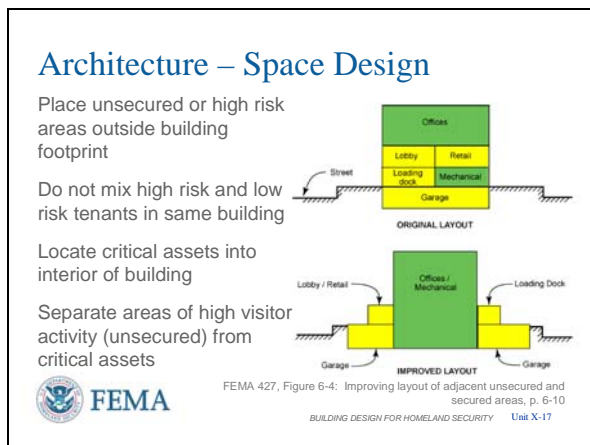

**Architecture – Space Design**

**Structural Layout**

Unsecured areas should be physically separated from the main building to the extent possible.

For example, a separate lobby pavilion or loading dock outside the main footprint provides enhanced protection against damage and potential building collapse in the event of an explosion. Similarly, placing parking areas outside the main footprint of the building can be highly effective in reducing the vulnerability to catastrophic collapse.

**Mixed occupancies.** High-risk tenants should not be housed with low-risk tenants. Terrorists may identify some targets based on their symbology, visibility, ideology, political views, potential for publicity, or simply the

VISUAL X-18

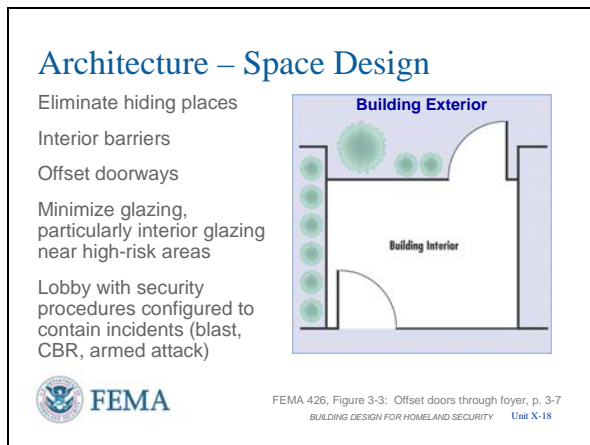

consequences of their loss. Low-risk tenants are then placed at higher risk due to proximity.

- However, if there are very few high-risk tenants among many low-risk tenants, then dispersal and devalue can be mitigation techniques.
- After Oklahoma City, day care centers (low-risk) are separated from the main building functions (high-risk) to reduce the risk to the day care centers. This has been done at the Pentagon, with a relatively minor decrease in convenience.

**Architecture – Space Design**

**Design Measures**

- Eliminate hiding places  
Generally a good security idea, especially in any areas where few people may frequent, like stairwells or underground parking
- Interior barriers  
Channel building staff and visitors to their respective areas and use interior barriers to provide separation between unsecure and secure areas
- Offset doorways  
If an explosive blast breaches the first door in a foyer, the offset will provide additional protection to the next door -- less incident pressure striking the interior door due to swirling of the blast wave.
- Minimize glazing  
Glass, unless hardened, adds to injuries during incidents. Reducing glazing is one approach, hardening is another, and proper placement is a third.
- Lobby design  
While it is a given that security and access control should be in the lobby, but design should accommodate the occurrence of an incident within lobby – reversal of standard design pressures, containment of the event

INSTRUCTOR NOTES

CONTENT/ACTIVITY

VISUAL X-19

**Architecture – Other Location Concerns**

- Safe havens / shelters
- Office locations
- Public toilets and service areas
- Retail spaces
- Stairwells
- Mailroom



BUILDING DESIGN FOR HOMELAND SECURITY Unit X-19

For additional information on safe havens, see **FEMA 453** (future) - *Multihazard Shelter (Safe Havens) Design*

inside the lobby without affecting the rest of the building, control of agents and toxic gases, and hardening against armed attack.

**Architecture – Other Location Concerns**

When designing high-risk buildings, engineers and architects should consider the following:

The innermost layer of protection within a physical security system is the **safe haven**. Safe havens are not intended to withstand a disciplined, paramilitary attack featuring explosives and heavy weapons. They are locations where sheltering-in-place for CBR, protection from natural hazards or bomb blast can occur.

**Offices** considered to be high risk (more likely to be targeted by terrorists) should be placed or glazed so that the occupants cannot be seen from an uncontrolled public area such as a street. Whenever possible, these spaces should face courtyards, internal sites, or controlled areas.

**Public toilets and service areas**, or access to vertical circulation systems (stairwells and elevators) should not be located in any non-secure areas, including the queuing area before visitor screening at the public entrance.

**Retail and other mixed uses**, which have been encouraged in public buildings by the Public Buildings Cooperative Use Act of 1976, create spaces that are open and inviting. Although important to the public nature of the buildings, the presence of retail and other mixed uses may present a risk to buildings and their occupants and should be carefully considered on a project-specific basis during project design. Consider allowing access to retail space only from the outside of the building and not between any interior spaces

or consider access configuration so that movement from retail spaces must go past security to get to the rest of the building.

**Stairwells** required for emergency egress should be located as remotely as possible from areas where blast events might occur and, wherever possible, should not discharge into lobbies, parking, or loading areas. When possible, emergency egress stairwells should be separate from the main building ingress stairwells, and secured to prevent individuals from accessing the secured floors of the building. Also do “What-If” as what would be done if a stairwell is lost as an egress during an incident.

**Mailrooms** should be located away from facility main entrances, areas containing critical services, utilities, distribution systems, and important assets. Avoid locating a mailroom in the same building as a child care center. In fact, the processing and inspection of mail and packages is best done in a separate building if possible. If an incident requires evacuation of the building, a separate building would limit the impact, vice a high-occupancy office building. Ditto, do “What-If” and plan alternatives.

### Structural Systems

#### Progressive Collapse Design

Progressive collapse is a situation where local failure of a primary structural component leads to the collapse of adjoining members, which, in turn, leads to additional collapse. Hence, the total damage is disproportionate to the original cause. Progressive collapse is a chain reaction of structural failures that follows from damage to a relatively small portion of a structure. More information on progressive collapse can also be found in

### VISUAL X-20

## Structural Systems

### Progressive Collapse Design

GSA Progressive Collapse Analysis and Design Guidance for New Federal Office Buildings and Major Modernization Projects

DoD Unified Facilities Criteria - Minimum Antiterrorism Standards for Buildings

BUILDING DESIGN FOR HOMELAND SECURITY Unit X-20

**INSTRUCTOR NOTES**

**CONTENT/ACTIVITY**

To minimize the potential for **progressive collapse**, designers should understand the following:

- The use of **redundant** lateral and vertical load paths is highly encouraged.
- Ductile materials are needed for both primary and secondary structural elements to be capable of deforming well beyond the elastic limit.
- Both the primary and secondary structural elements should be designed to resist load reversals.
- Primary structural elements should be able to resist shear failures by having flexural capacity greater than shear capacity.
- Fire protection should be applied to structural members to survive a worst-case fire duration allows fire fighters to control damage prior to initiation of structural collapse. Suggest reviewing the National Institute of Standards and Technology (NIST) report dealing with World Trade Center 7 (WTC 7) which collapsed due to fire.

**FEMA 427**, *Primer for Design of Commercial Buildings to Mitigate Terrorist Attacks*.

Buildings should be designed with the intent of reducing the potential for progressive collapse as a result of an abnormal loading event, regardless of the required level of protection.

- Primary structural elements are columns girders and roof beams that are the first items for design to prevent progressive collapse.
- Secondary structural elements, such as floor beams and slabs, also may contribute to progressive collapse. Of particular weakness to progressive collapse is flat slab construction where the floor is thickened in areas to substitute for beams in the interest of cost savings. Floor connections to columns are the concern in this type of construction. This has been a standard office building design for many years, but should not be used if progressive collapse is a concern.
- Primary nonstructural elements, such as ceilings and heavy suspended mechanical equipment, contribute to casualties but not progressive collapse.
- Secondary nonstructural elements, such as partitions, furniture, and light fixtures, like primary nonstructural elements, also contribute to casualties, but not progressive collapse.



VISUAL X-21

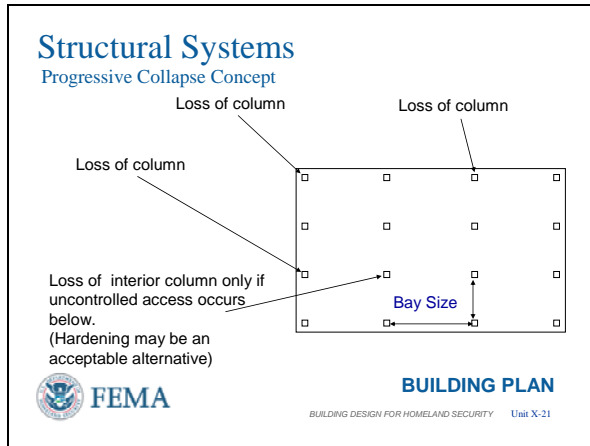

NOTE: The BAY SIZE is the distance between columns in the vertical and horizontal directions. The Bay Size can be identical or different in any part of the building and change between different parts of the building.

## Structural Systems

### Progressive Collapse Concept

The GSA and DoD require that the structural response of a building be analyzed in a methodology that removes a key structural element (e.g., vertical load carrying column, section of bearing wall, beam, etc.) to simulate local damage from any incident. If effective alternative load paths are available for redistributing the loads that was originally supported by the removed structural element, the building has a low potential for progressive collapse.

- If a column is lost, will the rest of the building still stand?
- If an exterior beam is lost, will the rest of the building still stand?
- If connections between column and floors are lost will the slenderized column still be able to carry the load or if the column fails, will the rest of the building still stand?  
DoD criteria states that columns of high-occupancy buildings will remain standing if all the floor connections on a given floor connecting to that column are lost.

If the threat can get to an interior column or beam, the same questions apply, such as underground parking or a mailroom.

Note that the more complex the structure layout (differing from square or rectangle) the more components (columns and beams) that must be analyzed.



INSTRUCTOR NOTES

CONTENT/ACTIVITY

VISUAL X-22

**Structural Systems -- Collapse**

GSA and DoD criteria do not provide specific guidance for an engineering structural response model

These organizations are working toward Interagency Security Committee consolidated guidance

Owner and design team should decide how much progressive collapse analysis and mitigation to incorporate into design.



BUILDING DESIGN FOR HOMELAND SECURITY Unit X-22

**Structural Systems -- Collapse**

- Although these criteria provide specific guidance on which structural elements must be analyzed for removal from the structural design configuration, they do not provide specific guidance for choosing an engineering structural response model for verifying the effectiveness of alternate load paths.
- Unless a building is being designed to meet the GSA or DOD criteria, it is up to the owner and the design team to decide how much progressive collapse analysis and mitigation to incorporate into their design.
- Priority should be given to the critical elements that are essential to mitigating the extent of collapse. Designs for secondary structural elements should minimize injury and damage.
- Consideration should be given to reducing damage and injury from primary as well as secondary nonstructural elements.

Both GSA and DoD take a threat-independent approach to progressive collapse – it does not matter how the column or beam is damaged or removed, the intent is that the building will remain standing. However, the concept is a single structural member being removed – if the Design Basis Threat is large enough to damage two components simultaneously, then additional analysis would be needed.

VISUAL X-23

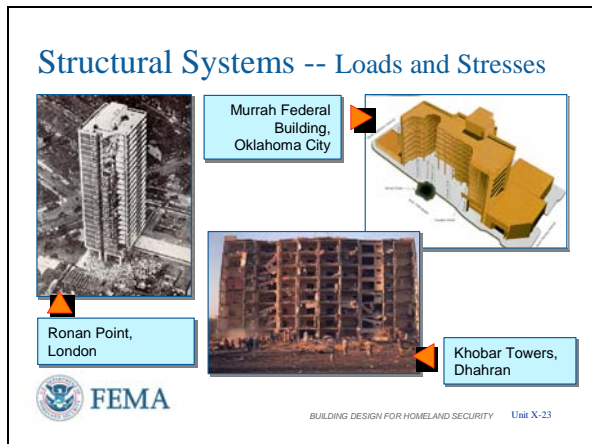

**Structural Systems -- Loads and Stresses**

The DoD designates the level of blast protection a building must meet based on how many occupants it contains and its function. The demands on the structure will be equal to the combined effects of dead, live, and blast loads. Blast loads or dynamic rebound may occur in directions opposed to typical gravity loads.

Ronan Point had a whole section of the building collapse due to load-bearing precast concrete panels in one apartment being lost. That incident changed the British Code to prevent similar occurrences.

Khobar Towers was designed to the British Code, and only the façade was lost.

The Murrah Federal Building was not designed to the British Code and the loss of one column then affected a transfer girder. There were discontinuities in columns across the lobby causing multiple columns to fail when the transfer girder became unsupported, resulting in load transfers that the building could not handle.

The minimum goal is to have continuous columns from foundation to roof. When assessing a building any discontinuity of columns is a flag indicated the need for further analysis.

Ronan Point: On the morning of 16 May 1968, Mrs. Ivy Hodge, a tenant on the 18th floor of the 22 (24 in other reports) -story Ronan Point apartment tower in Newham, east London, struck a match in her kitchen. The match set off a gas explosion that knocked out load-bearing precast concrete panels near the corner of the building. The loss of support at the 18th floor caused the floors above to collapse all the way to the roof.

The impact of these collapsing floors set off a chain reaction of collapses almost all the way to the ground. The ultimate result can be seen in Figure 1: the corner bay of the building has collapsed from top to bottom. Mrs. Hodge survived but four others died.

Construction of Ronan Point primarily consisted of precast concrete panels. While this type of construction can be designed to avoid progressive collapse from abnormal loading conditions, Ronan Point lacked the connection details necessary to effectively redistribute load. The essential missing detail was reinforcement continuity between panels. Because of this, there was no mechanism in place for achieving effective alternate load

**INSTRUCTOR NOTES**

**CONTENT/ACTIVITY**

paths once failure began to propagate.

Khobar Towers was built to the British Standard that was a result of Ronan Point.

The Murrah Building owner wanted no columns in the lobby, thus designer used transfer beams to carry the load of the upper columns.

**VISUAL X-24**

**Structural Systems – Best Practices**

Consider incorporating active or passive internal damping into structural system (sway reduction in high-rise)

Use symmetric reinforcement, recognizing components might act in directions opposite to original or standard design – flooring especially

Column spacing should be minimized (<=30 feet)



BUILDING DESIGN FOR HOMELAND SECURITY Unit X-24

**Structural Systems – Best Practices**

The following guidelines are commonly used to mitigate the effects of blast on structures and to mitigate the potential for progressive collapse. These guidelines are not meant to be complete, but are provided to assist the designer in the initial evaluation and selection of design approaches. For example:

- Consider incorporating internal damping into the structural system to absorb the blast impact. Although mass has been the blast design approach in the past, using more ductile materials with damping is being investigated. Damping systems will most likely be found in high-rise buildings.
- The use of symmetric reinforcement can increase the ultimate load capacity of the structure. This is especially true for load reversals on floor slabs.
- A practical upper level for column spacing is 30 feet, but 20 feet is better. If the column is lost, the remaining beam must span 40 to 60 feet. Above 60 feet, the beam becomes unreasonably large and expensive. Note that the Murrah Building had 40-foot column spacing in the lobby.

VISUAL X-25

**Structural Systems – Best Practices (cont.)**

Stagger lap splices and other discontinuities and ensure full development of reinforcement capacity or replace with more flexible connections – floors to columns especially

Protect primary load carrying members with architectural features that provide 6 inches minimum of stand-off

Use ductile detailing requirements for seismic design when possible



BUILDING DESIGN FOR HOMELAND SECURITY Unit X-25

**Structural Systems – Best Practices (cont.)**

- Lap splices must be upgraded from those found in conventional construction to handle the forces during a blast event. Consider interlocking “J” splices.
- By keeping a 6-inch stand-off from vertical load carrying members, a small weapons charge is less likely to shear the member.
- In many cases, the ductile detailing requirements for seismic design and the alternate load paths provided by progressive collapse design assist in the protection from blast.
- Ductility can be imbedded in the material, like steel reinforcing of concrete, or added to an existing component, like fragment-retention film on windows or spray-on truck bed liner on walls to strengthen weaker structures and catch fragmentation.

VISUAL X-26

**Building Envelope**

During actual blast or CBR event, building envelope provides some level of protection for people inside:

- Walls
- Windows
- Doors
- Roofs

Soil can be highly effective in reducing damage during an explosive event

Minimize “ornamentation” that may become flying debris in an explosion.



BUILDING DESIGN FOR HOMELAND SECURITY Unit X-26

**Building Envelope**

General principles:

- The exterior envelope of the building is the most vulnerable to an exterior explosive threat because it is closest to the blast.
- The exterior envelope also impacts the infiltration of CBR agents into the structure, but tight building construction must be done in conjunction with other actions to ensure some level of protection
- Soil can be highly effective in reducing the impact of a major explosion by reducing fragmentation off walls and street furniture or directing a blast wave over a building.
- Minimize “ornamentation” that may become flying debris in an explosion.

VISUAL X-27

**Building Envelope – Walls**

Design should ensure a flexible failure mode

Resist actual pressures and impulses acting on exterior wall surfaces from design basis threats

Withstand dynamic reactions from windows and windows stay connected to walls

Use multiple barrier materials and construction techniques – composites can add ductility and strength at savings

As desired Level of Protection increases, additional mass and reinforcement may be required



BUILDING DESIGN FOR HOMELAND SECURITY Unit X-27

This includes street furniture, overhangs, sculptures, etc.

**Building Envelope – Walls**

Ideally, the exterior walls need to be able to resist the loads transmitted by the windows and doors. It is not uncommon for bullet-resistant windows to have a higher ultimate capacity than the walls to which they are attached.

Beyond ensuring a flexible failure mode, design the exterior wall to resist the pressure levels of the design basis threat. Special reinforcing and anchors should be provided around blast-resistant window and door frames.

Deflections around certain members, such as windows, should be controlled to prevent premature failure. Additional reinforcement is generally required. Window frame deflection must not cause premature window glazing failure and window frame deflection must not differ greatly from the wall deflections. Seismic pinning of window frames may be required.

Poured-in-place reinforced concrete will provide the highest level of protection, but solutions like pre-cast concrete, reinforced CMU block, metal studs, and a combination of these may also be used to achieve lower levels of protection. Connections are the key, especially for pre-cast concrete curtain walls.

Retrofitting existing unreinforced masonry walls may consider steel plates, metal studs, reinforced concrete backing wall, high-strength fibers glued to the wall, or spray-on truck bed liner. If the wall is double-wythe (two wall system) – usually a brick exterior, air gap, and interior CMU block, consider

VISUAL X-28

**Building Envelope – Best Wall Practices**

Use symmetric reinforcement, recognizing that components might act in directions opposite to original or standard design

- Lobbies and mailrooms

Use wire mesh in plaster – reduces spalling / fragmentation

Floor to floor heights should be minimized (<=16 feet)



BUILDING DESIGN FOR HOMELAND SECURITY Unit X-28

spraying vermiculite into the air gap to add mass and ductility.

When the design basis threat increases or the level of protection desired increases, the solution is more mass and more reinforcement to add ductility. Increasing the ductility of exterior walls along with mass are suitable ways to ensure blast pressure and fragmentation do not readily enter the building.

**Building Envelope – Best Wall Practices**

The following best practices are commonly used to mitigate the effects of blast on structures and to mitigate the potential for progressive collapse. These guidelines are not meant to be complete, but are provided to assist the designer in the initial evaluation and selection of design approaches. For example:

Just as mentioned with structural framing, symmetrical reinforcement adds strength to masonry and concrete walls, especially on the side away from the bomb where the reinforcement increases the tensile strength of the concrete. Thus, for lobbies and mailrooms the bombs can be exterior (where standard design places wind loading, rain, snow, and flying debris) or interior, so the symmetric reinforcement adds strength to the wall in either direction.

Wire mesh keeps plaster together, adds tensile strength, reduces spalling of the plaster, and assists in keeping fragmentation from entering the room (plaster or otherwise).

In general, floor to floor heights should be minimized. Unless there is an overriding architectural requirement, a practical limit is generally less than or equal to 16 feet. Consider bond beams (which connect

**INSTRUCTOR NOTES**

**CONTENT/ACTIVITY**

VISUAL X-29

**Building Envelope – Best Wall Practices (cont.)**

Connect façade from floor slab to floor slab to avoid attachments to columns (one-way wall elements)

- Limits forces transferred to vertical structural elements

No unreinforced CMU – use fully grouted and reinforced construction



BUILDING DESIGN FOR HOMELAND SECURITY Unit X-29

columns at about the mid-point between floor or run across the top of doors and windows), as used in seismic zones, to reduce the effective height of the wall. Since the walls are connected to the floor above and below, the shorter the wall height the stronger the wall all other things being equal.

**Building Envelope – Best Wall Practices (cont.)**

Additional best practices include:

The reason why the walls are connected to the floor above and the floor below is to ensure there is no direct loading on the columns. Since the walls are only pinned at the top and the bottom this is called one-way. If they were also pinned to the columns on each side they would be two-way wall elements. Good blast design seeks to keep the structural framing as the absolute last component of the building to fail, thus the use of one-way wall elements.

Avoid the use of unreinforced masonry when blast is a threat. Masonry walls break up readily and become secondary fragments during blasts. Grout (mass) and reinforcement (ductility) are definitely required for blast resistance. The Ufundi building next to the Kenya embassy was all unreinforced brick and the bomb blast toppled the whole building.



VISUAL X-30

**Building Envelope – Windows**  
Balanced Window Design

- Glass strength
- Glass connection to window frame (bite)
- Frame strength
- Frame anchoring to building
- Frame and building interaction



BUILDING DESIGN FOR HOMELAND SECURITY Unit X-30

**Building Envelope – Windows**

Window systems on the exterior façade of a building should be designed to mitigate the hazardous effects of flying glass during an explosion event. Designs should integrate the features of the glass, connection of the glass to the frame (bite), and anchoring of the frame to the building structure to achieve a “balanced design.” This means all the components should have compatible capacities and theoretically would all fail at the same pressure-pulse levels. In this way, the damage sequence and extent of damage are controlled.

Ultimately, in a “balanced” design, the order of failure should be:

- Glass
- Window frame and frame anchoring
- Wall
- Building structural framing

The pressure differences should not be large and the Level of Protection for the Design Basis Threat should be met.

VISUAL X-31

**Building Envelope – Windows**

**Glass (weakest to strongest)**

- Annealed (shards)
- Heat Strengthened (shards)
- Fully Thermally Tempered (pellets)
- Laminated (large pieces)
- Polycarbonate (bullet-resistant)



**“Balanced Design”**



BUILDING DESIGN FOR HOMELAND SECURITY Unit X-31

**Building Envelope – Windows**

Five types of glass are commonly used in window glazing systems: annealed glass, heat strengthened glass, fully thermally tempered, laminated glass, and polycarbonate. Other types of glass materials exist, but are not commonly used in typical commercial window systems. Of the five common types, **annealed glass** and **fully thermally tempered glass** are the type of windows for most office buildings.

**Annealed glass**, also known as float, plate, or sheet glass, is the most common glass type used in commercial construction. Annealed



**INSTRUCTOR NOTES**

**CONTENT/ACTIVITY**

glass is of relatively low strength and, upon failure, fractures into razor sharp, dagger-shaped fragments (see slide -- the right photo is annealed glass failing during an actual explosive test and the left photo is a close-up of the shards). Annealed glass breaks at about 0.2 psi (incident pressure).

**Heat strengthened glass (HS)**, also known as double strength glass, is used where wind loading starts becoming a problem. It breaks like annealed glass, but at about 0.4 psi (incident pressure).

**Fully thermally tempered glass (TTG)** is typically four to five times stronger than annealed glass. Instead of shards, TTG breaks into pellets that can be stopped by a regular suit coat. It breaks at about 0.8 psi (incident pressure).

**Laminated glass** is a pane with multiple glass layers and a pliable interlayer material (usually made from polyvinyl butyral (PVB)) between the glass layers. This interlayer should have a thickness of 30 mils [30 thousandths of an inch] (minimum) or 60 mils (recommended). Do not use an interlayer of 15 mils.

**Thermoplastic polycarbonates** are very strong and suitable for blast- and forced entry-resistant window design. They are usually laminated in 3 or more layers with glass on the outside to prevent environmental degradation of the plastic (yellowing) and to aid in cleaning (avoid scratches).

**Wire-reinforced glass** is a common glazing material. It consists of annealed glass with an embedded layer of wire mesh. It is usually used for fire resistance and as a forced entry barrier. It is not recommended for blast design.

VISUAL X-32

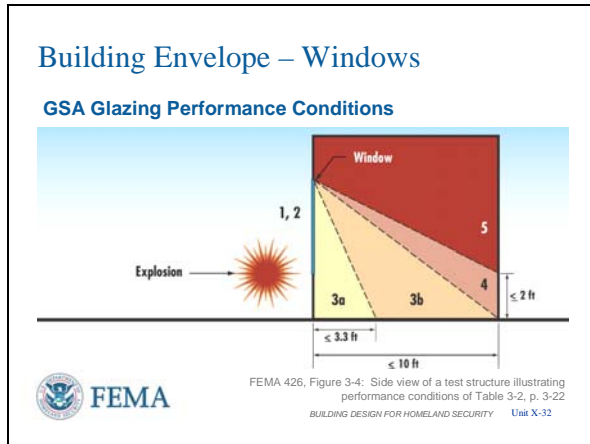

**Building Envelope – Windows**

**GSA Glazing Performance Conditions**

**Table 3-1, page 3-21, in FEMA 426** presents six GSA glazing protection levels based on how far glass fragments would enter a space and potentially injure its occupants (known as a flight model). This slide depicts how far glass fragments could enter a structure for each GSA performance condition. The divide between performance conditions 3a and 3b can be equated to the “threshold of injury.” The divide between performance conditions 4 and 5 can be equated to the “threshold of lethality.” A person standing in the room has a potential of being hit in the upper body/head area by glass fragments that are traveling fast enough to penetrate the body.

The GSA glazing performance conditions shown will correlate with the DoD levels of protection presented in **Table 3-2, page 3-22, in FEMA 426** as shown previously in Unit VII, Explosive Blast.

VISUAL X-33

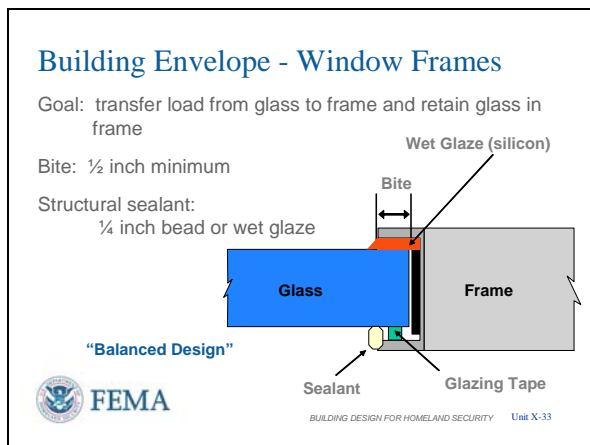

**Building Envelope -- Window Frames**

Window frames need to retain the glass so that the entire pane does not pull out (glass flexes and can pull out of frame during the blast) and also should be designed to resist the breaking stress of the window glass.

The window bite (i.e., the depth of window captured by the frame) needs to be at least 1/2 inch. DoD criteria call for a minimum 3/8-inch bite if silicon sealant is applied, but call for a 1-inch bite if no silicone sealant is used. Butt-glazed strip windows can require even more bite with or without sealant, since there is bite only on the top and bottom of the window.

VISUAL X-34

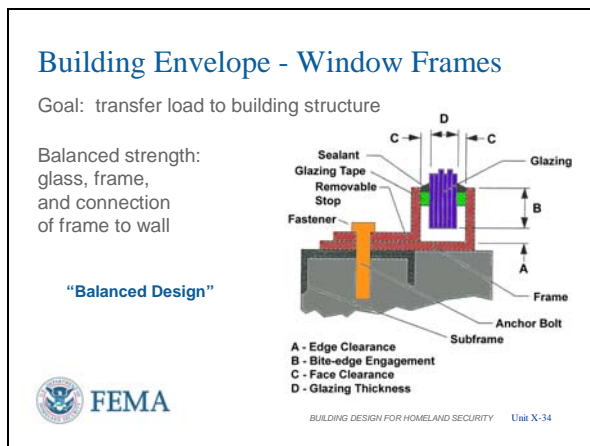

To retain the glass in the frame, a minimum of a ¼-inch bead of structural sealant (i.e., silicone or polyvinyl butyral) should be used around the inner perimeter of the window. This should be done on all four sides of the window. Since strip windows with butt glazing can only apply sealant on the top and bottom, they are not good options for blast as the bite must be large, even with sealant.

**Window Frames**

The frame must not flex during the blast loading and cause the glass to pop out.

The blast loading across the glass and frame now transfers to the frame connections to the building. These connections must handle the shear and tensile stresses and the bending moments of the connection design.

The frame members connecting adjoining windows are referred to as mullions. These members may be designed using a static approach when the breaking strength of the window glass is applied to the mullion, or a dynamic load may be applied using the peak pressure and impulse values. Because mullions only connect at their top and bottom ends to the building structure, the mullion must handle the transferred blast loading from both adjacent windows.

Other considerations for windows must balance the amount of light, energy conservation, noise transmission, venting of fumes, and emergency egress in addition to blast response and CBR protection.

VISUAL X-35

**Building Envelope - Fragment Retention Film**



Clear tough polyester film attached to inside of glass surface with strong pressure-sensitive adhesive

Also known as shatter-resistant film, safety film, or protective film

Relatively low installation costs

Level of protection varies with thickness of film and method of installation

Limited life for FRF



 FEMA

BUILDING DESIGN FOR HOMELAND SECURITY Unit X-35

When obscuration of rooms cannot be handled by site and layout design, one alternative is to install glazing with mirrored finishes or add fragment retention film that is mirrored. This works fairly well with single pane windows, but double pane windows may overheat with the mirrored fragment retention film – consult window manufacturer if there is a question. Realize, however that the mirrored finishes work best during daytime ambient light (room light less bright compared to ambient light). At night time or on overcast days, observation into the room is possible if interior lights are on. Shades or Venetian blinds can provide obscuration during low ambient light.

**Building Envelope – Fragment Retention Film (FRF)**

Another treatment used for mitigating the effects of an explosive attack is **security window film**. The polyester film used in commercial products is commonly referred to as fragment retention film (FRF), safety film, security film, protective film, or shatter-resistant film. These films adhere to the interior surface of the window to provide fragment retention and reduce the overall velocity of the glass fragments at failure. The film greatly increases the tensile strength of thin annealed glass and limits the deflection of the glass under blast loading.

Fragment retention film combines a strong pressure sensitive adhesive with a tough polyester layer. It should be limited to use in retrofit applications due to degradation of the film and adhesive by ultraviolet light. Do not use for new construction and it is of little to negative benefit on thicker, higher strength glass. For example, applying FRF to 3/8-inch thermally tempered glass will INCREASE the stand-off required for a given bomb size as the film will hold the glass together, acting like a sail and increasing the distance that the glass will fly into the test room.

Note that fragment retention film can be justified for multiple reasons – blast protection, physical security (smash and grab), and energy conservation (mirrored or tinted). Thus, justification can be based upon the multiple benefits derived for little difference in cost.

VISUAL X-36

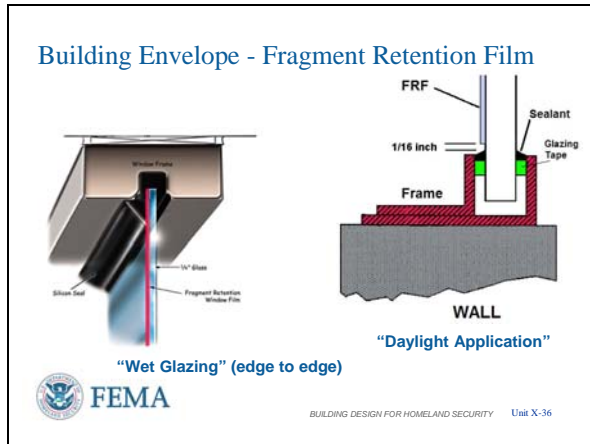

**Building Envelope – Fragment Retention Film**

Fragment retention film behaves similarly to relatively thin laminated and polycarbonate glazing in terms of fragmentation. It is available in common thicknesses of 2, 4, 7, and 10 mils. Also found up to 15 mils. The Navy recommends 10 mils.

Fragment retention film improves the performance of the glass under blast loading to varying degrees, depending on the thickness, quality, and type of film installation. Note a daylight application will leave a 1/16 inch space around the edge of the FRF where water used to apply the FRF is squeegeed out. Daylight application of FRF to very thin glass can reduce the stand-off distance in half for a given level of protection. The best performance is achieved when the film is installed into the bite of the glazing or is connected to the frame (mechanically or with chemical sealants).

Fragment retention film can also be purchased with tinted, mirrored, or solar versions that provide energy conservation benefits when using air conditioning.

VISUAL X-37

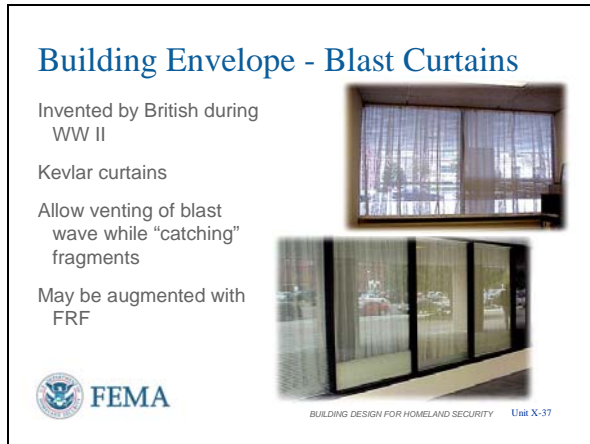

**Building Envelope – Blast Curtains**

- Can now see out of these curtains as opposed to the “blackout” curtains from WWII -- uses Kevlar or other high strength fibers. In fact it is easier to see out of sheer black curtains than sheer white curtains.
- They allow venting of the blast wave while “catching” glass fragments
- May be augmented with FRF (British only specify them with FRF)
- Connections of curtains or blast shields to building frame are critical.

VISUAL X- 38

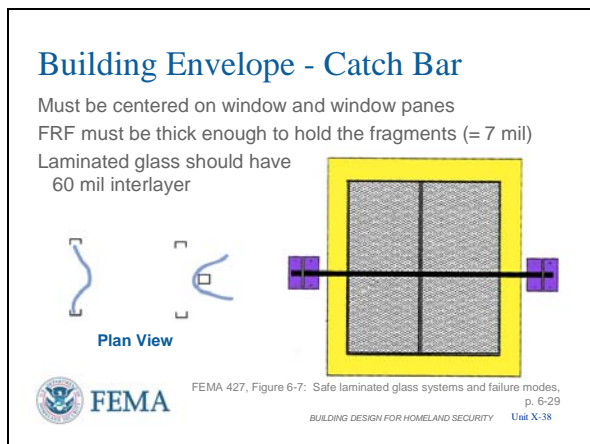

**Building Envelope – Catch Bar**

Increased safety for fragment retention can be obtained in the event of catastrophic failure from an explosive blast by placing a decorative catch bar or grillwork on the interior of the glazing. Note, catch bars must be mounted across the center of mass of each window pane (vision area of glass) to be effective. A catch bar is ineffective with 4 mil FRF as the FRF will just tear (shear) on the catch bar. This is also another reason why the Navy recommends 10 mil.

Catch bars are usually considered with a retrofit of fragment retention film to not only catch the glass, but also catch the existing window frame that may not be adequately connected to the wall. They can also be considered for laminated glass.

**INSTRUCTOR NOTES**

**CONTENT/ACTIVITY**

**VISUAL X-39**

**Building Envelope – Best Window Practices**

- No windows adjacent to doors
- Minimize number and size of windows - watch building code requirements
- Laminated glass for high-occupancy buildings
- Stationary, non-operating windows, but operable window may be needed by building code
- Steel versus aluminum window framing



BUILDING DESIGN FOR HOMELAND SECURITY Unit X-39

**Building Envelope – Best Window Practice**

Windows adjacent to doors allow easy access to the locking mechanism on the door by just breaking the window and reaching in.

Smaller windows are stronger against blast for a given window material and less expensive as well. Using fewer windows also reduces cost. However, building codes may specify the square footage of windows required based upon the total square footage of the floor level the windows are on.

Laminated glass is required for high-occupancy buildings by DoD. For life cycle costing and blast resistance, especially at the lower end of weapon yield, laminated glass is the best choice.

Life safety/fire codes may require operable windows as an escape route in certain occupancies (dormitories, for example). Recommend sliding or swing-out windows for better blast performance.

Heavy duty aluminum frames have performed well, although steel should be specified if design basis threat is large.

VISUAL X-40

**Building Envelope – Doors**

Balanced strength

- Door
- Frame
- Anchorage to building

Hollow steel doors or steel-clad doors

Steel door frames

Blast-resistant doors available

- Generally heavy
- Generally expensive



 FEMA

BUILDING DESIGN FOR HOMELAND SECURITY Unit X-40

**Building Envelope – Doors**

A door system includes the door, frame, and anchorage to the building. As part of a balanced design approach, exterior doors in high risk buildings should be designed to withstand the maximum dynamic pressure and duration of the load from the design threat explosive blast. Other general door considerations are as follows:

Provide hollow steel doors or steel-clad doors with steel frames.

Provide blast-resistant doors for high threats and high levels of protection.

Limit normal entry/egress through one door, if possible.

Keep exterior doors to a minimum while accommodating emergency egress.

Ensure that exterior doors open outward from inhabited areas. If inward opening the locking mechanism must handle the blast loading [A 3 foot by 7 foot door has  $3 \times 7 \times 144 = 3,024$  square inches of surface area. A reflected blast pressure of 2 psi puts 3 tons of force on that locking mechanism.] If outward opening the whole door frame takes the blast loading.

Replace externally mounted locks and hasps with internally locking devices because the weakest part of a door system is the latching component.

Install doors, where practical, so that they present a blank, flush surface to the outside to reduce their vulnerability to attack.

Locate hinges on the interior or provide concealed hinges to reduce their vulnerability to tampering. [Ask students if they see anything wrong with the door in the photo – exterior hinges. However, there is a balanced magnetic switch on the inside of the door connected to the security alarm which mitigates the



VISUAL X-41

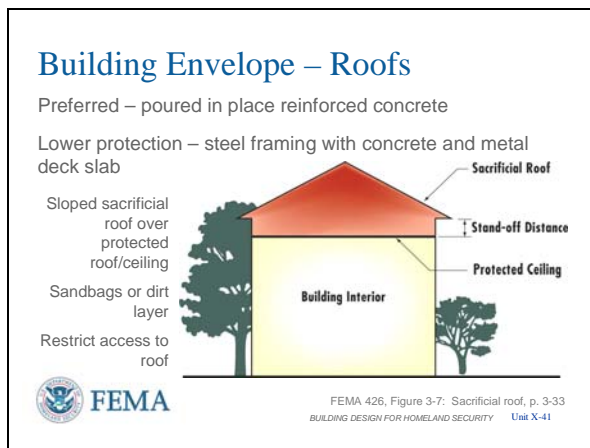

exterior hinges.  
Install emergency exit doors so that they facilitate only exiting movement.  
Equip any outward-opening double door with protective hinges and key-operated mortise-type locks.  
Provide solid doors or walls as a backup for glass doors in foyers.

**Building Envelope – Roofs**

For an explosive threat, especially for thrown explosives (e.g., satchels, hand grenades, and even mortars), the primary loading on the roof is downward over-pressure. The stand-off to the protected ceiling provides the protection. The sloped roof tends to cause the explosive to roll off and away from the building. For explosions at ground level, secondary loads include upward pressure on the protected ceiling and roof due to the blast penetrating through openings and upward suction during the negative loading phase. The upward pressures may have an increased duration due to multiple reflections of the air blast internally. It is conservative to consider the downward and upward loads separately.

The preferred system is to use poured-in-place reinforced concrete with beams in two directions. If this system is used, beams should have stirrups along the entire span spaced not greater than one half the beam depths. Steel pan formwork provides additional protection as the formwork mitigates falling debris, but since load reversals may occur, the concrete in the steel pan formwork should have steel in both faces (symmetrical reinforcement).

Less desirable systems include metal plate systems without concrete, and precast and pre/post tensioned systems.

**INSTRUCTOR NOTES**

**CONTENT/ACTIVITY**

Precast roof panels are problematic because of the tendency to fail at the connections, like pre-cast curtain walls.

Pre/post tensioned systems tend to fail in a brittle manner if stressed beyond their elastic limit and they also are not able to accept upward loads without additional reinforcement.

Standard construction found in the Middle East, for example, uses soil/dirt as insulation in the roof at a thickness of 18 inches or so. The soil is placed on a waterproofed concrete poured-in-place deck and covered with 1-meter square concrete panels that are waterproofed and sloped to roof drains. With two layers of standard sand bags (about 8 inches in total deep) on top, this roof, has a high level of protection.

Many conventional roof designs will provide a suitable blast response for most buildings, considering minimum Design Basis Threats. The intent here is to point out what roofs may be a problem and why. For higher Design Basis Threats and tactics involving the roof, the protected ceiling and sacrificial roof concept applies.

**INSTRUCTOR NOTES**

**CONTENT/ACTIVITY**

VISUAL X-42

**Utility Systems**

Building Service

- Electric – commercial and backup
- Domestic water
- Fire protection water
- Fuel – coal, oil, natural gas, or other
- Steam heat with or without condensate return
- Hot water heat



BUILDING DESIGN FOR HOMELAND SECURITY Unit X-42

**Utility Systems**

**Building Service**

While Utility Systems are first and foremost considered under Site and Layout Design, they have a direct impact on the building envelope based upon where and how they enter the building to provide service to that structure. While most will think of what is brought into a building, it is equally important to note what needs to be taken out of the building to maintain function and operation.

For example, steam heat may be provided by a central boiler plant on the site/campus that requires condensate to be returned for energy efficiency. But steam heat purchased from a commercial steam heat company in an urban environment is usually dumped to drain to prevent contaminants beyond the steam heat company's control from fouling their boilers.

VISUAL X-43

**Utility Systems**

Building Service (cont)

- Sewer – piping and sewage lift stations
- Storm drainage
- Information
- Communications
- Fire alarm
- Security systems and alarms



BUILDING DESIGN FOR HOMELAND SECURITY Unit X-43

**Utility Systems**

**Building Service (cont.)**

Thus, anything feeding into and out of the building should be considered due to its impact on the building envelope and building operations if damaged.

For example, water service into a building balances against sewer service to get it out of the building. A sewage lift pump or station that is not on backup power results in raw sewage backing up into the building.

VISUAL X-44

**Utility Systems**

Entrances

- Proximity to each other
- Aboveground or underground
- Accessible or secure

Delivery capacity

- Separate
- Aggregate

Storage capacity

- Outage duration
- Planned or historical



BUILDING DESIGN FOR HOMELAND SECURITY Unit X-44

**Utility Systems**

Service entrances of utilities into buildings take on the following concerns:

- Reduce the number of utility openings, manholes, tunnels, air conditioning ducts, filters, and access panels into the structure. Balance this with having two well separated service entrances for each utility.
- Proximity: How close are the service entrances to each other and can a single event affect more than one utility – for example all utilities entering along the loading dock ramp because the utility room is adjacent or underneath the loading dock.
  - Locate utility systems away from likely areas of potential attack, such as loading docks, lobbies, and parking areas. The alternative is hardening.
- Above or below ground: Below ground is preferred, but gas meters and pressure regulators, electric meters and transformers, and tankage may be aboveground. By building code gas lines must come above ground before entering a building to prevent gas leaks from following the piping into the building and reaching explosive concentrations in a basement.
- Can someone outside the building access the utility where it enters the building or use it as a way of getting into the building?
  - Use lockable systems for utility openings and manholes where appropriate. Infrequently used utility covers/manholes can be tack-welded as an inexpensive alternative to locking tamper-resistant covers.

Delivery capacity is an operational consideration before and after an incident:

**INSTRUCTOR NOTES**

**CONTENT/ACTIVITY**

**VISUAL X-45**

**Mechanical & Electrical Systems**

Functional layout – physical separation or hardening

Structural layout – systems installation

Do not mount utility equipment or fixtures on exterior walls or mailrooms

Avoid hanging utility equipment and fixtures from roof slab or ceiling



 FEMA

BUILDING DESIGN FOR HOMELAND SECURITY Unit X-45

- Will each service entrance handle 50% of the total building needs or 100% (like hospitals require for electric service). Emergency operations plans should consider all contingencies for losing either or both service entrances for each given utility.

Storage capacity is a concern during:

- Evacuation (i.e., How long will the emergency lighting system continue to operate?)
- Orderly shutdown of a computer system (battery backup for uninterruptible power supply)
- Continued operations (fuel stored for emergency generator use to last as long as historically longest commercial outage or until contingency contracts in place can refuel the generator on an acceptable schedule).

**Mechanical and Electrical Systems**

The major security functions of an electrical are to maintain power to essential building services, provide lighting and surveillance to deter criminal activity, and provide emergency communications.

The primary goal of a mechanical and electrical system after a terrorist attack should be to continue to operate key life safety and evacuations systems.

The following suggestions attempt to protect the mechanical and electric systems during an explosive blast event:

- Do not mount plumbing, electrical fixtures, or utility lines on the inside of exterior walls, but, when this is unavoidable, mount fixtures on a separate wall at least 6 inches from the exterior wall face.

**INSTRUCTOR NOTES**

**CONTENT/ACTIVITY**

**VISUAL X-46**

**Mechanical & Electrical Systems**

Overhead components, architectural features, and other fixtures > 14 kilograms (31 pounds), especially in occupied spaces

- Mount to resist forces 0.5 x W in any direction and 1.5 x W in downward direction (DoD Unified Facilities Criteria)
- Plus any seismic requirements



 FEMA

BUILDING DESIGN FOR HOMELAND SECURITY Unit X-46

- Avoid suspending plumbing fixtures and piping from the ceiling or roof slab. Remember the upheaval if the blast wave gets inside the building.
  - The roof slab is part of the building envelope.
  - The ceiling is less sturdy than the floor above.
- When the above cannot be done, add ductility, additional supports, and hardening to achieve some level of protection.

**Mechanical and Electrical Systems**

**Nonstructural Elements**

False ceilings, light fixtures, Venetian blinds, ductwork, air conditioning components, and other equipment may become flying debris in the event of an explosion once the building envelope is breached. Marques and other exterior nonstructural elements must also be considered since upward blast pressure will be much greater.

Wherever possible, it is recommended that the design be simplified to limit these hazards. Placing heavy equipment such as air conditioners near the floor rather than the ceiling is one idea; using curtains rather than Venetian blinds, and using exposed duct work as an architectural device are others.

When using seismic requirements added to the above will require about a Seismic Zone 4 (old system) [highest level] design. For example, 30 years ago 2-foot 4-foot light fixtures in drop ceilings required additional support (other than the drop ceiling support) on two opposing corners using 9-gauge wire. Seismic Zone 4 would consider threaded rod on all four corners to satisfy the requirement.

INSTRUCTOR NOTES

CONTENT/ACTIVITY

VISUAL X-47



**Mechanical and Electrical Systems**

Distribution – similar to comments about utility systems previously

- Multiple risers and looping on each floor with isolation valving or switches adds redundancy
- As high voltage and low voltage electricity is separated from communications circuits due to capacitive coupling and fault tolerance situations, other systems should not share the same pipe chases or provide vertical separation to overcome secondary effects of leakage.

Locations of emergency equipment also figure into redundancy:

- Locate components in less vulnerable areas such as away from loading docks, entrances and parking. Seek 50-foot separation as a minimum.
- Placing emergency switchgear and commercial switchgear in the same room allows one event in either system to affect the other.
- Fuel tanks should be mounted near the emergency generator(s) and be given the same protection as the generator. Separating them puts the fuel distribution at greater risk due to the distance of the separation.
- If an emergency generator cannot be justified, consider running conduits with conductors through a manual transfer switch to a quick disconnect on the outside of the building. A rental generator / company can be prearranged to provide rapid backup power as required without major rewiring. This would be equivalent to a Siamese water connection for fire fighting.
- Similarly, placing electric fire pumps and diesel fire pumps side-by-side allows one event to affect both primary and backup

VISUAL X-48

**Mechanical & Electrical Systems**

Restrict access - locks / alarms / surveillance

- Utility floors / levels
- Rooms
- Closets
- Roofs
- Security locks/interlocks comply with building code
- Building information
- Also consider for other systems



BUILDING DESIGN FOR HOMELAND SECURITY Unit X-48

VISUAL X-49

**Mechanical & Electrical Systems**

Building lighting and CCTV compatibility

- Intensity
- Resolution
- Angle
- Color

Exit lighting – consider floor level, like airplanes  
Emergency lighting – battery packs have their place



BUILDING DESIGN FOR HOMELAND SECURITY Unit X-49

systems. The event is not just loss of commercial power.

**Mechanical and Electrical Systems**

**Restrict Access**

- Physical security for utility rooms, closets, etc., should be implemented to prevent tampering with the systems and to prevent the direct introduction of hazardous materials into heating, ventilating, and air conditioning (HVAC) ducts that distribute air to portion(s) of the building.
- Public access to building roofs should be prevented. Access to the roof may allow entry to the building and access to air intakes and HVAC equipment (e.g., self-contained HVAC units, laboratory or bathroom exhausts) located on the roof.
- Access to information on building operations (including mechanical, electrical, vertical transport, fire and life safety, security system plans and schematics, and emergency operations procedures) should be strictly controlled.

**Mechanical and Electrical Systems**

Closed circuit television/security cameras and building lighting must be worked as a system to ensure compatible operation:

- The intensity, angle, and color of the lighting affect camera resolution, including low-light and infra-red
  - Detection for response versus identification for police/legal action
- Exit lighting has traditionally been at top of door level shining downward to floor or along halls. After incidents smoke, heat, and toxic fumes are normally lighter than air so traditional exit lighting is obscured. Putting exit lighting at floor level works whether walking upright or crawling.



**INSTRUCTOR NOTES**

**CONTENT/ACTIVITY**

VISUAL X-50

**Mechanical & Electrical Systems**  
Ventilation and Filtration – HVAC Control Options

- Building specific
- System shutdown – configuration and access
  - HVAC fans and dampers
  - Include 24/7 exhausts, i.e. restrooms
- Zone pressurization
  - Doors and elevator use
  - Shelter-in-place

 **FEMA**

BUILDING DESIGN FOR HOMELAND SECURITY Unit X-50

- Emergency lighting from a distribution system with central batteries and backup generator is one design approach, but distributed emergency lighting with self-contained battery packs along the egress route ensures operation during a wider range of potential incidents. Do not forget restrooms in the emergency lighting scheme.

**Mechanical and Electrical Systems**

**Ventilation and Filtration – HVAC Control Options**

Available options are specific to the building as HVAC equipment and configuration, building functions, continuing operations, and other factors affect what can be done.

- HVAC control may not be appropriate in all emergency situations. Protection from CBR attacks depends upon the design and operation of the HVAC system and the nature of the CBR agent release.
  - Ducted returns (vice using hallways as returns) offer limited access points to introduce a CBR agent. The return vents can be placed in conspicuous locations, reducing the risk of an agent being secretly introduced into the return system.
  - Large buildings usually have multiple HVAC zones, with each zone served by its own air handling unit and duct system.
- Complete system shutdown of all HVAC systems is the simplest initial approach to handle either external or internal releases
  - Since speed is critical, a single shutdown point is desirable, but the larger the system(s) the difficult this becomes.
  - A rapid response may involve closing various dampers, especially those

**INSTRUCTOR NOTES**

**CONTENT/ACTIVITY**

controlling the flow of outdoor air (in the event of an exterior CBR release).

- Consideration should be given to installing low leakage dampers to minimize this flow pathway.
- Must include all air handling systems, such as restroom exhausts that run continuously.
- If zone pressurization is designed into the system (for fire fighting as an example, where the fire floor is ventilated to remove heat and adjacent areas are overpressurized to keep smoke and gases contained), then realize that opening and closing doors or operating elevators will change the zone pressurization being attempted.
  - Even without zone pressurization, opening and closing doors and operating elevators will affect the flow of air and spread smoke, toxic fumes, and CBR agents within the building.
  - Consider “shelter-in-place” rooms or areas where people can congregate in the event of an outdoor release and, in some cases, indoor releases.
    - Without pressurization the goal is to create areas where outdoor air infiltration is very low.
    - With pressurization requires a filtered air supply from an installed or portable unit with filters suitable for the agent released.

VISUAL X-51

**Mechanical & Electrical Systems**  
**Ventilation and Filtration – HVAC Control Options**

- Specialized exhaust for some areas – i.e., lobbies and mailrooms
  - Air purge (e.g., 100 percent outside air if internal release)
  - CBR filters to trap and prevent spread elsewhere
- Pressurized egress routes (may already exist)
  - Filtered air supply or shutdown if release external

 FEMA

BUILDING DESIGN FOR HOMELAND SECURITY Unit X-51

**Mechanical and Electrical Systems**

**Ventilation and Filtration – HVAC Control Options**

- To prevent widespread dispersion of a contaminant released within lobbies, mailrooms, and loading docks, their HVAC systems should be isolated and the areas maintained at a negative pressure relative to the rest of the building, but at positive pressure relative to the outdoors.
  - Air purge is suitable for removal of smoke and toxic fumes from fire or explosive blast
  - If a CBR release, an air purge would not be suitable as it would just spread the agent vice controlling it unless CBR filters installed on exhaust to trap the agents and prevent spreading them.
  - Another consideration is glazing in these areas.
    - If not hardened, then windows will be blown out during an internal blast which lessens the need for air purge. This is a good design example for a frangible panel that vents pressure and reduces pressure on the walls shared by the rest of the building.
    - If hardened, then smoke and gases are trapped and air purge is beneficial. However, all walls will require additional hardening because of the increased internal blast pressures.
- Egress routes (stairwells) are normally pressurized to prevent smoke from internal fire from entering the stairwells. An external CBR release would be pulled into the stairwells by this system. Thus, either the pressurization system must be turned off during an external release or a filtering

VISUAL X-52

### Plumbing and Gas Systems

Same considerations as electrical and mechanical systems

Added concern is fuel distribution

- Heating sources / open flames / fuel load

Interaction with other systems during an incident

- Fuel versus alarms / electric / fire protection water / structure
- Water versus electronic / electric



BUILDING DESIGN FOR HOMELAND SECURITY Unit X-52

system must engage to provide clean air to the stairwells.

### Plumbing and Gas Systems

All systems distributed throughout the building have similar consideration. There are other concerns based upon “What-If” scenarios, such as leaks occurring in plumbing or gas systems.

- Look at the physical relationship between the systems (which also includes utilities as they enter the building)
  - Will a leak in a fuel system reach a heat source and will the fuel distribution system aid in spreading the fire throughout the building?
  - Will leaks from water or fuel systems fall upon electrical systems and equipment?
    - For example, standard underground construction always puts water systems above sewer systems so that a sewer leak will have less chance of contaminating the water system.
    - Additionally, are flammable systems like fuel/natural gas separated from mass notification/communication systems so that an initial fire incident does not disable the mass notification system?

VISUAL X-53

**Fire Alarm Systems**

Considerations similar to information and communications systems, but tighter building codes

- Centralized or localized
- Fire alarm panel access for responding fire fighters or fire control center
- Interaction with other building systems
  - Telephone / IT
  - Energy management
  - HVAC controls
- Off-premises reporting and when

 **FEMA**

BUILDING DESIGN FOR HOMELAND SECURITY Unit X-53

**Fire Alarm Systems**

Similar concerns as with communications systems to be covered next, but building codes based upon National Fire Protection Association standards are more prescriptive

- First alarm to evacuate, then call the fire department
  - If localized, alarm bells sound to evacuate the building, then automatically calls fire department
  - If centralized (hotels for example), a response would verify fire before sounding evacuation and calling fire department from manned location
- Fire alarm panels are normally near main entrances of buildings so first responder fire fighters can determine which zone of the building alarmed if fire location is not obvious
  - Fire control centers are normally manned and fire department should know where they are located
- Interaction with other systems should confirm wiring of the fire alarm system, whether it is combined with any other system for information flow, and whether or not an alarm activation also initiates actions through other systems, like energy management, SCADA (Supervisory Control and Data Acquisition), or HVAC controls.
- Finally, as explained above, how is off-premises reporting done – direct telephone line to fire department, reporting to a commercial central security/fire company who contacts the fire department, centralized system manned in building which then triggers a call to the fire department or calls 911, autodial to someone else, etc.

VISUAL X-54

**Communications - Information Technology Systems**  
Looped versus radial distribution

**Redundancy**

- Landline, security, fire watch
  - Copper
  - Fiber optics
- Cell phones (voice, walkie-talkie, text)
- Handheld radios / repeaters
- Radio telemetry / microwave links
- Satellite



**Mass notification**

- Loud speakers
- Telephone hands-off speaker
- Computer pop-up
- Pager

 **FEMA**

BUILDING DESIGN FOR HOMELAND SECURITY Unit X-54

**Communications – Information Technology Systems**

Distribution considerations are the same as for other systems, especially to ensure some communications capability if an incident affects communication lines

- **Redundancy** is always a consideration and technology selected has pros and cons
  - Copper easier to tap through electromagnetic signals
  - **Cell phones** get tied up during major incidents, especially analog voice (which locks bandwidth), but walkie-talkie and text features on phones or Blackberrys use packet transmission when bandwidth is available so there is more capability as found during Hurricane Katrina
  - **Handheld radios** have blind spots both in dispersed campuses and high-rise buildings, necessitating use of repeaters or distributed antennas to maintain coverage. Consider a base radio communication system with antenna(s) installed in stairwells, and portable sets distributed on floors.
  - **Alarm and information systems.** Should not be collected and mounted in a single conduit, or even collocated. Circuits to various parts of the building should be installed in at least two directions and/or risers
  - **NOTE:** The red phone shown is a telephone connected to the local telephone company and powered by the telephone company. It is the backup to VOIP phones throughout the campus.
- Mass notification to building occupants can take many approaches, but must ensure system capability or redundancy for the range of potential incidents. Keeping occupants informed as response requirements change is vital to save lives.

VISUAL X-55

**Communications - Information Technology Systems (cont.)**

Empty conduits

- Future growth
- Speed repair

Battery and backup power for IT

- Hubs, switches, servers, switchboards, MW links, etc.
- VOIP, building ops, alarms, etc.

Fire stopping in conduits between floors



Secure dedicated lines between critical security functions

Backup control center with same capability as primary



BUILDING DESIGN FOR HOMELAND SECURITY Unit X-55

**Communications – Information Technology Systems (cont.)**

The one thing about information is that it is ever expanding, thus future load growth should always be considered, especially extra conduits that assist repairs and allow additional capability as needed.

- These conduits are for future dedicated electrical circuits, updated information systems, and additional security systems. The last being the quickest way to provide reduction in risk.

Note that battery backup and emergency power must be at or link to all distributed equipment in the IT system to keep system functional

- If other capabilities like VOIP (Voice Over Internet Protocol) telephones, building operations, or alarms on IT Systems increases need for the electric backup

Historically, communications systems have been installed without consideration for other building codes – for example, conduits between floors must have fire stopping installed to prevent spread of fires, fuel leaks, gas leaks, defeat of zone pressurization, or spread of CBR agents and other toxic materials.

Security information and flow of information to building occupants is critical before, during, and after an incident. Dedicated communication lines between security functions – such as central security control and entry control stations keeps information current, especially during deter and detect situations. Control centers for security, fire, and emergency operations may have backup locations depending upon the size of the organization or site. Communications

VISUAL X-56

**Equipment Operations and Maintenance**

Preventive Maintenance and Procedures

- Drawings indicating locations and capacities are current?
- Maintenance critical to keep systems operational
  - Critical systems air balanced and pressurization monitored regularly?
  - Periodic recommissioning of major systems?
- Regularly test strategic equipment
  - Sensors, backup equipment and lighting, alarms, and procedures tested regularly to ensure operation when needed?
  - Backup systems periodically tested under worst case loadings?



BUILDING DESIGN FOR HOMELAND SECURITY Unit X-56

capability should be replicated at the backup site, or if alternative methods are used, staff must be trained for both primary and backup procedures and equipment.

**Equipment Operations and Maintenance**

- Keeping drawings up to date and ensuring capacities meet current needs as functions and infrastructure changes occur are necessary for proper maintenance and operation
- An emergency system that will not function properly when called upon will result in increased damage and casualties
  - In the past, US military installations in a foreign country tested their Class B generator plant (sized to support the complete installation when commercial power lost) at 5:00 am on Sunday morning to avoid inconveniencing people. Class A plants are prime power and used where there is no reliable commercial power. Class C units are also backups but of smaller size and distributed at the critical loads and buildings. One engineer knew that this did not ensure operation when needed and convinced decision makers to run the test during the peak electrical load of the month (units were tested once a month for two hours). It took almost six months of incremental repair before the plant could run for the full 2 hours. Six months later a country-wide power outage occurred. This installation was the only US installation that stayed fully operational for the whole commercial power outage.
- Bottom line: Preventive maintenance and testing that ensures the systems will work in all required modes, including emergency situations, must be done to ensure proper functioning when they are called upon.



VISUAL X-57

**Equipment Operations and Maintenance**

Maintenance Staff Training

- System upgrades will require new training
- Specific instructions for CBR event (internal vs external release)
- Systems accessible for adjustment, maintenance, and testing



BUILDING DESIGN FOR HOMELAND SECURITY Unit X-57

**Equipment Operations and Maintenance**

**Maintenance Staff Training**

Since emergency systems, especially HVAC, are not standard building components, the staff must receive training in how the upgraded mechanical systems are designed to work, how they should be operated, and how they should be maintained and tested.

- A high-rise in Chicago was designed to have all lights burning 24 hours a day in the winter as part of the heating system design. A new manager demanded the lights be turned off and the staff could not explain why so they were turned off. A cold snap hit and the small supplemental boiler in the basement and the lights turned back on took 4 days to bring the building back to desired office temperatures.
- Maintenance and operational staff must have the training in the operational procedures for all potential situations in how the building will be reconfigured, especially for CBR events outside and inside the building.
- Another point based upon experience, is that maintenance staff will be more likely to perform maintenance, repairs, and testing if the equipment is accessible. The more difficult it is to perform these actions the less likely they will be done.
  - Example – steam boiler in penthouse of 3-story building required weekly replenishment of water treatment chemicals. An elevator got the heavy chemicals to the third floor, but to get to the penthouse required winding through offices and then carrying them up a vertical ladder to a roof hatch. The building was originally designed for a location with water that did not need water treatment.

VISUAL X-58

**Security Systems**

**Electronic Security Systems**

Purpose is to improve the reliability and effectiveness of life safety systems, security systems, and building functions.

- Detection
- Access control
- Duress alarms
- Primary and backup control centers – same procedures



 FEMA

BUILDING DESIGN FOR HOMELAND SECURITY Unit X-58

**Chapter 3 of FEMA 426** is not a design guide for Electronic Security Systems (ESS). The following criteria are only intended to stress those concepts and practices that warrant special attention to enhance public safety. Consult design guides pertinent to the specific project for detailed information about electronic security. A description of Electronic Security Systems is provided in **Appendix D of FEMA 426**.

**Security Systems**

**Electronic Security Systems**

The purpose of electronic security is to improve the reliability and effectiveness of life safety systems, security systems, and building functions. When possible, accommodations should be made for future developments in security systems.

- Basic intrusion detection devices should be provided: magnetic reed switches for interior doors and openings, glass break sensors for windows up to scalable heights, and balanced magnetic contact switch sets for all exterior doors, including overhead/roll-up doors. Roof intrusion detection should be reviewed.
- A color CCTV surveillance system with recording capability should be provided to view and record activity at the perimeter of the building, particularly at primary entrances and exits.
- Consider duress alarms at Entry Control Stations, where the general public has contact, and other locations as deemed necessary from threat or past history. Also call boxes in parking areas for similar function.
- The Operational Control Center (OCC), Fire Command Center (FCC), and Security Control Center (SCC) may be collocated. If collocated, the chain of command should be carefully pre-planned to ensure the most qualified leadership is in control for specific types of events. Secure information links should be provided between the OCC, FCC, and SCC.
- A Backup Control Center (BCC) should be provided in a different location, such as a manager's or engineer's office. If

**INSTRUCTOR NOTES**

**CONTENT/ACTIVITY**

**VISUAL X-59**

**Security Systems**

**Entry Control Stations**

Channel visitors entering building to access control in lobby  
Signs should assist in controlling authorized entry  
Have sufficient lobby space for security measures (current or future)  
Avoid extensive queuing, especially outside building  
Proper lighting, especially if manned 24 hours/ day  
Hardened against attack based upon security needs



BUILDING DESIGN FOR HOMELAND SECURITY Unit X-59

- feasible, an off-site location should be considered.
- A fully redundant BCC should be installed (this is an alternative to the above).
  - An on-site monitoring center should be used during normal business hours and be operational 24 hours. When not manned the monitoring center responsibility can be transferred to an off-site location

These criteria primarily address access control design, including stair and lobby design, because access control must be considered when design concepts for a building are first conceived. Although fewer options are available for modernization projects, some designs can be altered to consider future access control objectives.

**Security Systems**

**Entry Control Stations**

Entry control stations should be provided at main perimeter entrances of the building where security personnel are present (see **Figure 3-12, page 3-48, of FEMA 426**). In addition, entry control stations should be located close to the perimeter entrance to permit people inside the entry control station to maintain constant surveillance over the entrance and its approaches. Note that many of the considerations for entry control stations listed here are appropriate for Site and Layout Design as discussed in **Chapter 2 of FEMA 426**. Additional considerations at entry control stations include:

- Channel visitors to access control with appropriate signage to differentiate between visitors and building occupants / tenants
- Additional space is needed for metal

detectors and x-ray machines. If not installed initially, allow future space in case they may be installed later.

- Queuing should be limited, i.e. access control should have sufficient throughput to avoid having a high concentration of personnel at the entrance at any time. Queuing that takes the line outside the building should be avoided at all costs.
- Lighting, with CCTV should assist in identification and access control.
- Entry control stations should be hardened against attacks according to the type of threat. The methods of hardening may include:
  - Reinforced concrete or masonry
  - Steel plating
  - Bullet-resistant glass
  - Commercially fabricated, bullet-resistant building components or assemblies
- Entry control stations adjacent to the building but not inside should have appropriate environmental support (heat / air conditioning), lighting, and sufficient glassed area to afford adequate observation for people inside.

VISUAL X-60

### Security Systems

#### Emergency Plans

All buildings should have current plans

- Building evacuation with signage & emergency lighting
- Accountability – rally points, call-in
- Incorporate CBR scenarios into plans
  - General occupant actions
  - Response staff actions – HVAC and control centers

Exercise the plans to ensure they work

- Coordinate with local emergency response personnel
- Test all aspects



BUILDING DESIGN FOR HOMELAND SECURITY Unit X-60

### Security Systems

#### Emergency Plans

All buildings should have current **emergency plans** to address fire, weather, and other types of emergencies.

In light of past U.S. experiences with anthrax and similar threats, these plans should be updated to consider CBR attack scenarios and the associated procedures. Emergency plans should have procedures for communicating instructions to building occupants, identifying suitable shelter-in-place areas (if they exist), identifying appropriate use and selection of

**INSTRUCTOR NOTES**

**CONTENT/ACTIVITY**

personal protective equipment (i.e., clothing, gloves, respirators), and directing emergency evacuations.

Building design should be able to ensure the optimal operation of the emergency plans. The emergency plans should not default to only what can be done after the building is constructed. In other words, like security and homeland defense, emergency planning should be an up-front design consideration that gets incorporated into the planning, budgeting, and design of the building.

Note that bomb threats have been used in the past by terrorists to evaluate evacuation procedures and determine where the evacuees congregate after leaving the building. Consider multiple rally points (A, B, and C) and vary their use so that a pattern cannot be determined by terrorist surveillance.

Then the plans must be tested to ensure they work in all situations, that what is written can actually be done, especially at the speed required, and that the plans and equipment operation work in agreement.

Note that walking egress routes are not always down a single stairwell, especially in high-rise building as in the World Trade Center Complex. Recommend exercising an annual evacuation exercise to ensure most people know the egress routes (primary and alternate) and can negotiate them in a speedy manner. Signage and lighting along the whole route should also be evaluated at the same time.

Additionally, all security locking arrangements on doors used for egress must comply with requirements of the National Fire Protection Association (NFPA) 101, Life Safety Code.

VISUAL X-61

**Practical Applications**

What can be done with a reasonable level of effort?

End of Chapter 3, FEMA 426 listing of mitigation measures

- Less protection, less cost, with less effort
- Greater protection, greater cost, at greater effort



BUILDING DESIGN FOR HOMELAND SECURITY Unit X-61

Direct students to **Table 2-1 in FEMA 426** and arrow listing on **pages 3-51 and 3-52 of FEMA 426.**

VISUAL X-62

**Building Materials: General Guidance**

All building materials and types acceptable under building codes are allowed.

Special consideration should be given to materials having inherent flexibility and ability to respond to load reversals.

Careful detailing is required for materials (such as pre-stressed concrete, pre-cast concrete, and masonry) to adequately respond to design loads.

Construction type selected must meet all performance criteria of specified protection level.



BUILDING DESIGN FOR HOMELAND SECURITY Unit X-62

**Practical Applications**

*What can be done with a reasonable level of effort?*

Consult **Table 2-1, page 2-54, of FEMA 426** to understand the benefit of various mitigation efforts against a range of terrorist tactics.

There is a range of FEMA 426 mitigation efforts at a range of cost. Consult **pages 3-51 and 3-52 of FEMA 426** to see the range of relative costs for most situations.

**Building Materials: General Guidance**

- All building materials and types acceptable under model building codes are allowed (except unreinforced masonry – brick and/or CMU (concrete masonry unit) – concrete block).
- Special consideration should be given to materials that have inherent flexibility and that are better able to respond to load reversals (i.e., cast in place reinforced concrete and steel construction).
- Careful detailing is required for material such as pre-stressed concrete, pre-cast concrete, and masonry (brick and concrete masonry unit) to adequately respond to the design loads. Even calling out seismic connections may not be adequate as the workforce may not be familiar with the changes from their norm; thus detailing is very important.
  - For example, aluminum wiring is not used in homes in the US because copper trained electricians over-

**INSTRUCTOR NOTES**

**CONTENT/ACTIVITY**

**VISUAL X-63**

**Desired Building Protection Level**  
**Component design based on:**  
Design Basis Threat  
Threat Independent approach  
Level of Protection sought  
Leverage natural hazards design/retrofit  
Incorporate security design as part of normal capital or O&M program  
Use existing tools/techniques, but augment with new standards/guidelines/codes



BUILDING DESIGN FOR HOMELAND SECURITY Unit X-63

Establishing the design basis threat early in the design cycle reduces cost, has synergies with other requirements – seismic and wind, and should never be an afterthought of the design. Even for a low threat, there is value

torqued the connections, causing cold flow, loose connections, and fires. Great Britain took path to put copper on the outside of aluminum, taking advantage of the less expensive aluminum without getting the cold flow problem.

- Another example, plastic water pipe initially installed by copper-trained plumbers were not twisted 90 degrees to spread the glue as this was not needed when soldering copper. Imperfections in the plastic would scrape the glue away resulting in leaks. Plumbers now know this procedure and we still use plastic water piping.
- The construction type selected must meet all performance criteria of the specified level of protection.
- The designer must bear in mind that the design approaches are, at times, in conflict. These conflicts must be worked out on a case by case basis.

**Desired Building Protection Level**

The assessment process to this point should determine the level of protection sought for the building structure based upon the threat / hazard specific to the facility. Explosive blast threats usually govern building structural design for high risk buildings.

Some design approaches are threat independent, such as progressive collapse. Other approaches depend upon an identified Design Basis Threat. The design basis threat is the terrorism hazard equivalent to the natural hazards design basis which is based upon recorded history, measurement methods to determine the magnitude of the hazard and have been established as building codes based on the weather and geological conditions of the locality.

**INSTRUCTOR NOTES**

in providing certain minimum features to the site and building design. This allows adjustment to the level of protection if the level of threat changes. This is the current philosophy of the Department of Defense.

Even if no design changes result, the understanding in going through the assessment process, especially in the data collection and identifying Points of Contact, is beneficial if future man-made hazards threaten or occur.

**VISUAL X-64**

**Summary**

**Building Design Guidance and Mitigation Options**

Using the FEMA 426 Checklist will help identify vulnerabilities and provide recommended mitigation options.

There are many methods to mitigate each vulnerability.

Relatively low cost mitigations significantly reduce risk.



BUILDING DESIGN FOR HOMELAND SECURITY Unit X-64

**CONTENT/ACTIVITY**

Whenever there are projects to accomplish in a building, seek to leverage natural hazard upgrades, energy conservation upgrades, and other capital improvement or O&M (Operations and Maintenance) work to achieve synergies at less cost to achieve HVAC upgrades and building hardening.

In every design situation, the intent is to seek a balance between all the different requirements to include in the design (e.g., antiterrorism, energy conservation, building code, seismic, wind, snow loading, handicap access, adjacent architecture, etc.).

**Summary**

To summarize:

This unit provides a foundation for a systematic approach to assessing the vulnerabilities of a building to manmade hazards.

**The Building Vulnerability Assessment Checklist in FEMA 426** can provide an excellent framework for the identification of mitigation options that will, over time, significantly reduce the vulnerability of a building to manmade hazards.

Note that there are many different techniques to mitigate each vulnerability. They have different costs and may increase, reduce, or have no effect on risk for other tactics. Thus, each mitigation measure needs to be compared to every threat / hazard tactic for the building particulars.

Antiterrorism assessment teams that have been operating over 5 years indicate that historically about 80 percent of mitigation recommendations are low cost /no cost



**INSTRUCTOR NOTES**

**CONTENT/ACTIVITY**

VISUAL X-65

**Unit X Case Study Activity**  
**Building Design Guidance and Mitigation Measures Background**  
Emphasis:

- Providing a balanced building envelope that is a defensive layer against the terrorist tactic of interest
- Avoiding situations where one incident affects more than one building system

FEMA 426, Building Vulnerability Assessment Checklist

**Requirements**  
Assign sections of the checklist to qualified group members  
Refer to Case Study, and answer worksheet questions  
Review results to identify vulnerabilities and possible mitigation measures



BUILDING DESIGN FOR HOMELAND SECURITY Unit X-65

Refer participants to **FEMA 426**, the Unit X Case Study activity in the Student Manual.

Members of the instructor staff should be available to answer questions and assist groups as needed.

At the end of 45 minutes, reconvene the class and facilitate group reporting. Take 15 minutes to review group results.

There are 48 questions to answer by the team and then confer. With an average of 7 team members this means each member answers about 7 questions or about 4 minutes per question during their 30 minutes of research.

planning and procedural changes.

**Student Activity**

The **Building Vulnerability Assessment Checklist in FEMA 426** can be used as a screening tool for vulnerability assessment of an existing building or a preliminary design.

The checklist includes questions that determine if critical systems will continue to function to enhance deterrence, detection, denial, and damage limitation, and emergency systems function during a threat or hazard situation.

**Activity Requirements**

- Continue working in small groups.
- Assign sections of the checklist to the group members who are most knowledgeable and qualified to perform an assessment of the assigned area. There are 49 questions so that with 7 students (working group size sought), each student would need to answer 7 questions in about 30 minutes (4-5 minutes per question) leaving 15 minutes to discuss results as a group.
- Refer to the Case Study to determine answers to the worksheet questions.
- Then review results as a team to identify vulnerabilities and possible mitigation measures.

Take 45 minutes to complete this activity. Solutions will be reviewed in plenary group.

**Transition**

Unit XI will cover Electronic Security Systems.

**UNIT X-A CASE STUDY ACTIVITY:  
BUILDING DESIGN GUIDANCE  
(Suburban Version)**

In this unit, the emphasis will be upon providing a balanced building envelope that is a defensive layer against the terrorist tactic of interest and avoiding situations where one incident affects more than one building system. The **Building Vulnerability Assessment Checklist in FEMA 426** can be used as a screening tool for preliminary building design vulnerability assessment.

**Requirements**

Assign sections of the checklist to the group members who are most knowledgeable and qualified to perform an assessment of the assigned area. Refer to the Case Study to determine answers to the questions. Then review results as a team to identify vulnerabilities and possible mitigation measures.

1. Complete the following questions of the **Building Vulnerability Assessment Checklist (FEMA 426, Table 1-22, pages 1-46 to 1-93)** that address building design. Note: Vulnerability Questions that cannot be answered with the case study information provided have not been included in this student exercise.
2. Upon completion of these portions of the checklist, refer back to the vulnerability ratings determined in the Unit IV Case Study Activity and, based on this more detailed analysis, decide if any vulnerability rating needs adjustment. Adjust the Threat Matrix chart accordingly.
3. Select mitigation measures to reduce vulnerability and associated risk based upon the building design.
4. Estimate the new risk ratings for high-risk asset-threat pairs (as adjusted in step 2 above) based on the recommended mitigation measures.

Section	Vulnerability Question	Guidance	Observations
<b>2</b>	<b>Architectural</b>		
2.5	Do entrances avoid significant queuing?	If queuing will occur within the building footprint, the area should be enclosed in blast-resistant construction. If queuing is expected outside the building, a rain cover should be provided. For manpower and equipment requirements, collocate or combine staff and visitor entrances.  Reference: GSA PBS-P100	<i>Because of the mixed time of employees coming to work, queuing at the entrance is minimal to non-existent. Visitors are also few in number so that they do not exceed the reception area capacity.</i>

Section	Vulnerability Question	Guidance	Observations
2.7	Is access control provided through main entrance points for employees and visitors? (lobby receptionist, sign-in, staff escorts, issue of visitor badges, checking forms of personal identification, electronic access control systems)	Reference: Physical Security Assessment for the Department of Veterans Affairs Facilities	<p>Visitor access control is handled in the lobby by the receptionist, who signs the visitors in and contacts staff to provide escort. Employees use electronic access control to enter the building.</p> <p>Access control at other companies within the complex is unknown.</p>
2.8	Is access to private and public space or restricted area space clearly defined through the design of the space, signage, use of electronic security devices, etc.?	<p>Finishes and signage should be designed for visual simplicity.</p> <p>Reference: Physical Security Assessment for the Department of Veterans Affairs Facilities</p>	<p>The building is monitored by door and window alarms, which connect to ADT, the nationwide alarm company. Unauthorized opening of any door or window will immediately notify ADT via telephone. ADT will normally call the HIC Security Office prior to contacting the police and DPS. Employees have proximity cards to allow them to enter the front and loading dock doors without activating the alarm.</p> <p>The innermost layer of physical security involves the Computer Data Center and the Communications Center. Equipped with locked doors, these two rooms meet the government's requirements for handling classified</p>

Section	Vulnerability Question	Guidance	Observations
			material. Only authorized employees possess the necessary proximity cards and PINs to gain access.
2.9	Is access to elevators distinguished as to those that are designated only for employees and visitors?	Reference: Physical Security Assessment for the Department of Veterans Affairs Facilities	No elevators in building.
2.10	Do public and employee entrances include space for possible future installation of access control and screening equipment?	These include walk-through metal detectors and x-ray devices, identification check, electronic access card, search stations, and turnstiles.  Reference: GSA PBS-P100	Yes, lobby / reception area within building could accommodate space-saving screening equipment. Interior office space also has adequate room for such equipment.
2.11	Do foyers have reinforced concrete walls and offset interior and exterior doors from each other?	Consider for exterior entrances to the building or to access critical areas within the building if explosive blast hazard must be mitigated.  Reference: U.S. Army TM 5-853	The exterior walls are made of CMU with a brick veneer on the outside. Steel framework supports the structure, and exposed columns are enclosed in gypsum wallboard. The exterior wall of the foyer has extensive glass.  The exterior and interior doors of the foyer are in a straight line  The construction of interior walls is gypsum wallboard on metal studs.

Section	Vulnerability Question	Guidance	Observations
2.13	Do circulation routes have unobstructed views of people approaching controlled access points?	<p>This applies to building entrances and to critical areas within the building.</p> <p>References: USAF Installation Force Protection Guide and DoD UFC 4-010-01</p>	<p>Yes, circulation routes have unobstructed views of people approaching controlled access points. The front door is monitored both by the receptionist and CCTV. The rear entrance is monitored by CCTV.</p>
2.15	<p>Are critical assets (people, activities, building systems and components) located close to any main entrance, vehicle circulation, parking, maintenance area, loading dock, or interior parking?</p> <p>Are the critical building systems and components hardened?</p>	<p>Critical building components include: Emergency generator including fuel systems, day tank, fire sprinkler, and water supply; Normal fuel storage; Main switchgear; Telephone distribution and main switchgear; Fire pumps; Building control centers; Uninterruptible Power Supply (UPS) systems controlling critical functions; Main refrigeration and ventilation systems if critical to building operation; Elevator machinery and controls; Shafts for stairs, elevators, and utilities; Critical distribution feeders for emergency power. Evacuation and rescue require emergency systems to remain operational during a disaster and they should be located away from potential attack locations. Primary and backup systems should be separated to reduce the risk of both being impacted by a single incident if</p>	<p>Electrical service is provided through two buried transmission lines from two separate pad-mounted transformers outside the building near the rear loading dock. Emergency power is provided by a single diesel generator, located in a shed in the rear parking lot, also near the loading dock. The generator has a 50-gallon day tank, maintained at 80 percent capacity. The 2,000-gallon main tank is buried under the parking lot, near the generator.</p> <p>The batteries to support the UPS are in a small room next to the UPS room.</p> <p>Natural gas enters the building through two meters under the loading dock staircase and goes overhead to the mechanical and electrical (M&amp;E) room</p>

Section	Vulnerability Question	Guidance	Observations
		<p>collocated. Utility systems should be located at least 50 feet from loading docks, front entrances, and parking areas.</p> <p>One way to harden critical building systems and components is to enclose them within hardened walls, floors, and ceilings. Do not place them near high-risk areas where they can receive collateral damage.</p> <p>Reference: GSA PBS-P100</p>	<p>at the building's southwest corner.</p> <p>Thus, most of the critical utilities are either in the rear parking area or near the loading dock or both.</p>
2.16	<p>Are high-value or critical assets located as far into the interior of the building as possible and separated from the public areas of the building?</p>	<p>Critical assets, such as people and activities, are more vulnerable to hazards when on an exterior building wall or adjacent to uncontrolled public areas inside the building.</p> <p>Reference: GSA PBS-P100</p>	<p>People are located along the exterior wall at the front of the building. The secure space has the best interior space location – not on an exterior wall, as does the conference room. The office space acts as the buffer between the critical functions in the back and the public area of the building at the main entrance.</p> <p>M&amp;E room is located on an exterior wall.</p> <p>There are no public use areas within the building.</p>
2.17	<p>Is high visitor activity away from critical assets?</p>	<p>High-risk activities should also be separated from low-risk activities. Also, visitor activities should be separated from daily</p>	<p>All visitors enter through a common front entrance. Once admitted to the site, visitor activity is escorted and</p>

Section	Vulnerability Question	Guidance	Observations
		<p>activities.</p> <p>Reference: USAF Installation Force Protection Guide</p>	<p>part of daily activities.</p>
2.19	<p>Are loading docks and receiving and shipping areas separated in any direction from utility rooms, utility mains, and service entrances, including electrical, telephone/data, fire detection/alarm systems, fire suppression water mains, cooling and heating mains, etc.?</p>	<p>Loading docks should be designed to keep vehicles from driving into or parking under the building. If loading docks are in close proximity to critical equipment, consider hardening the equipment and service against explosive blast. Consider a 50-foot separation distance in all directions.</p> <p>Reference: GSA PBS-P100</p>	<p>No, the loading dock connects directly into interior space, critical functions, and infrastructure. A commercial power transformer, the natural gas meters, and the M&amp;E rooms are within 50 feet of the loading dock.</p>
2.20	<p>Are mailrooms located away from building main entrances, areas containing critical services, utilities, distribution systems, and important assets?</p> <p>Is the mailroom located near the loading dock?</p>	<p>The mailroom should be located at the perimeter of the building with an outside wall or window designed for pressure relief.</p> <p>By separating the mailroom and the loading dock, the collateral damage of an incident at one has less impact upon the other. However, this may be the preferred mailroom location.</p> <p>Off-site screening stations or a separate delivery processing building on site may be cost-effective, particularly if several buildings may share one mailroom. A separate delivery processing</p>	<p>HIC has no mail room. Incoming mail is normally processed by the receptionist inside the front door. Large packages are delivered to the loading dock.</p> <p>The foyer, where mail is delivered, is of standard office construction. Blast would affect exterior walls (glazing) and interior walls (gypsum board on metal studs) about equally.</p>

Section	Vulnerability Question	Guidance	Observations
		<p>building reduces risk and simplifies protection measures.</p> <p>Reference: GSA PBS-P100</p>	
2.21	<p>Does the mailroom have adequate space available for equipment to examine incoming packages and for an explosive disposal container?</p>	<p>Screening of all deliveries to the building, including U.S. mail, commercial package delivery services, delivery of office supplies, etc.</p> <p>Reference: GSA PBS-P100</p>	<p>HIC has no mail room. Mail is delivered to the receptionist in the foyer. Space is limited for mail screening equipment, especially if personnel screening equipment is installed.</p> <p>However, package screening could be done at or near the loading doc, where there would be sufficient room for the equipment. However, someone from Security would have to process the mail as the reception desk cannot be left unmanned.</p>
2.22	<p>Are areas of refuge identified, with special consideration given to egress?</p>	<p>Areas of refuge can be safe havens, shelters, or protected spaces for use during specified hazards.</p> <p>Reference: FEMA 386-7</p>	<p>Yes, the Computer Data Center and the large conference room are identified as areas of refuge.</p>
2.23	<p>Are stairwells required for emergency egress located as remotely as possible from high-risk areas where blast events might occur?</p> <p>Are stairways maintained with positive pressure or are there other smoke</p>	<p>Consider designing stairs so that they discharge into other than lobbies, parking, or loading areas.</p> <p>Maintaining positive pressure from a clean source of air (may require special filtering) aids in egress by keeping smoke,</p>	<p>Stairways are located in the interior of the building, away from the perimeter walls. They are part of the steel mezzanine design and are towards the front of the building. Multiple exits are located around the building and from</p>



Section	Vulnerability Question	Guidance	Observations
	control systems?	heat, toxic fumes, etc. out of the stairway. Pressurize exit stairways in accordance with the National Model Building Code.  Reference: GSA PBS-P100 and CDC/NIOSH, Pub 2002-139	both the front and rear.  Stairways are open and not designed with any fire protection features, such as a positive pressure system.
2.25	Do interior barriers differentiate level of security within a building?	Reference: USAF Installation Force Protection Guide	Electronic controls exist in the form of alarms, door locks, proximity cards, and use of PIN numbers for room/area access.
2.26	Are emergency systems located away from high-risk areas?	The intent is to keep the emergency systems out of harm's way, such that one incident takes out all capability – both the regular systems and their backups.  Reference: FEMA 386-7	The high risk areas are the front entrance and the rear loading dock. Emergency/backup generator is located over 50 feet away from main power supply lines, loading dock, and M&E room. UPS is located inside the building's high bay area, but probably within 50 feet of the loading dock.
<b>3</b>	<b>Structural Systems</b>		
3.1	What type of construction?  What type of concrete and reinforcing steel?  What type of steel?  What type of foundation?	The type of construction provides an indication of the robustness to abnormal loading and load reversals. A reinforced concrete moment-resisting frame provides greater ductility and redundancy than a flat-slab or flat-plate construction. The ductility of steel frame with metal deck depends on the connection details and pre-tensioned or post-tensioned construction provides little capacity for abnormal loading patterns and load reversals. The resistance of load-bearing wall structures varies to a great extent, depending on whether the	Located in a suburban office complex, the HIC office building comprises a 19,000- square foot main floor for offices and computers, and a 3,300-square foot executive mezzanine (a second floor over part of the office).  The building that houses the Hazardville Information Company (HIC) is an office building of standard construction.  The walls are made of concrete blocks (CMU-

Section	Vulnerability Question	Guidance	Observations
		<p>walls are reinforced or unreinforced. A rapid screening process developed by FEMA for assessing structural hazards identifies the following types of construction with a structural score ranging from 1.0 to 8.5. A higher score indicates a greater capacity to sustain load reversals.</p> <p>Wood buildings of all types - 4.5 to 8.5                      Steel moment-resisting frames - 3.5 to 4.5                      Braced steel frames - 2.5 to 3.0                      Light metal buildings - 5.5 to 6.5                      Steel frames with cast-in-place concrete shear walls - 3.5 to 4.5                      Steel frames with unreinforced masonry infill walls - 1.5 to 3.0                      Concrete moment-resisting frames - 2.0 to 4.0                      Concrete shear wall buildings - 3.0 to 4.0                      Concrete frames with unreinforced masonry infill walls - 1.5 to 3.0                      Tilt-up buildings - 2.0 to 3.5                      Precast concrete frame buildings - 1.5 to 2.5                      Reinforced masonry - 3.0 to 4.0                      Unreinforced masonry - 1.0 to 2.5</p> <p>References: <i>FEMA 154 and Physical Security Assessment for the Department of Veterans Affairs Facilities</i></p>	<p>concrete masonry units) with a brick veneer on the outside. Steel framework supports the structure, and exposed columns are enclosed in gypsum wallboard. The roof is a metal deck with gravel on top and insulation underneath. It is slightly angled to allow water to drain. The roof overhangs the front entrance by 8 feet. This provides a covered area for employees to stay dry on rainy days. Cylindrical columns support the overhang.</p>
3.5	<p>Will the structure suffer an unacceptable level of damage resulting from the postulated threat (blast loading or weapon impact)?</p>	<p>The extent of damage to the structure and exterior wall systems from the bomb threat may be related to a protection level. The following is for new buildings:</p> <p><b>Level of Protection Below Antiterrorism Standards</b> - Severe damage. Frame collapse/massive destruction. Little left standing. Doors and windows fail and result in lethal hazards. Majority</p>	<p>The standard construction techniques used to build the site HIC occupies do not create buildings that withstand explosive blasts. Terrorist threat was not a part of design consideration.</p>

Section	Vulnerability Question	Guidance	Observations
		<p>of personnel suffer fatalities.</p> <p><b>Very Low Level Protection -</b>                      Heavy damage. Onset of structural collapse. Major deformation of primary and secondary structural members, but progressive collapse is unlikely. Collapse of non-structural elements. Glazing will break and is likely to be propelled into the building, resulting in serious glazing fragment injuries, but fragments will be reduced. Doors may be propelled into rooms, presenting serious hazards. Majority of personnel suffer serious injuries. There are likely to be a limited number (10 percent to 25 percent) of fatalities.</p> <p><b>Low Level of Protection -</b>                      Moderate damage, unrepairable. Major deformation of non-structural elements and secondary structural members and minor deformation of primary structural members, but progressive collapse is unlikely. Glazing will break, but fall within 1 meter of the wall or otherwise not present a significant fragment hazard. Doors may fail, but they will rebound out of their frames, presenting minimal hazards. Majority of personnel suffer significant injuries. There may be a few (&lt;10 percent) fatalities.</p> <p><b>Medium Level Protection -</b>                      Minor damage, repairable. Minor deformations of non-structural elements and secondary structural members and no permanent deformation in primary structural members. Glazing will break, but will remain in the window frame. Doors will stay in frames, but will not be reusable. Some minor injuries, but fatalities are unlikely.</p> <p><b>High Level Protection -</b></p>	

Section	Vulnerability Question	Guidance	Observations
		<p>Minimal damage, repairable. No permanent deformation of primary and secondary structural members or non-structural elements. Glazing will not break. Doors will be reusable. Only superficial injuries are likely. Reference: <i>DoD UFC 4-010-01</i></p>	
3.10	<p>Will the loading dock design limit damage to adjacent areas and vent explosive force to the exterior of the building?</p>	<p>Design the floor of the loading dock for blast resistance if the area below is occupied or contains critical utilities.  Reference: <i>GSA PBS-P100</i></p>	<p>The loading dock is the weakest part of the exterior rear wall. There are no hardened walls between the loading dock and the rest of the building as the plan shows only standard gypboard and metal stud walls.</p> <p>Thus the loading dock will not limit any damage into the building and anything occurring on the loading dock will directly affect the building interior.</p>
<b>4</b>	<b>Building Envelope</b>		
4.1	<p>What is the designed or estimated protection level of the exterior walls against the postulated explosive threat?</p>	<p>The performance of the façade varies to a great extent on the materials. Different construction includes brick or stone with block backup, steel stud walls, precast panels, curtain wall with glass, stone, or metal panel elements.</p> <p>Shear walls that are essential to the lateral and vertical load bearing system and that also function as exterior walls should be considered primary structures and should resist the actual blast loads predicted from the threats specified. Where exterior walls are not designed for the full design loads, special consideration should be given to construction types that reduce the potential for injury.</p> <p>Reference: <i>GSA PBS-P100</i></p>	<p>There was no postulated explosive threat in the original design of the building or site. Thus, it is estimated that the protection level will be very poor for the assessment design basis threat.</p> <p>The exterior walls are made of CMU with a brick veneer on the outside. Steel framework supports the structure</p> <p>Windows are double glazed, 1/4-inch thick annealed glass.</p>

Section	Vulnerability Question	Guidance	Observations
4.2	<p>Is there less than 40 percent fenestration per structural bay?</p> <p>Is the window system design on the exterior façade balanced to mitigate the hazardous effects of flying glazing following an explosive event? (glazing, frames, anchorage to supporting walls, etc.)</p> <p>Do the glazing systems with a ½-inch (¾-inch is better) bite contain an application of structural silicone?</p> <p>Is the glazing laminated or is it protected with an anti-shatter (fragment retention) film?</p> <p>If an anti-shatter film is used, is it a minimum of a 7-mil thick film, or specially manufactured 4-mil thick film?</p>	<p>The performance of the glass will similarly depend on the materials. Glazing may be single pane or double pane, monolithic or laminated, annealed, heat strengthened or fully tempered.</p> <p>The percent fenestration is a balance between protection level, cost, the architectural look of the building within its surroundings, and building codes. One goal is to keep fenestration to below 40 percent of the building envelope vertical surface area, but the process must balance differing requirements. A blast engineer may prefer no windows; an architect may favor window curtain walls; building codes require so much fenestration per square footage of floor area; fire codes require a prescribed window opening area if the window is a designated escape route; and the building owner has cost concerns.</p> <p>Ideally, an owner would want 100 percent of the glazed area to provide the design protection level against the postulated explosive threat (design basis threat– weapon size at the expected stand-off distance). However, economics and geometry may allow 80 percent to 90 percent due to the statistical differences in the manufacturing process for glass or the angle of incidence of the blast wave upon upper story windows (4th floor and higher).</p> <p>Reference: <i>GSA PBS-P100</i></p>	<p>All windows are in the office space area of the building (complete in the front and half of one side). In that area the fenestration is probably more than 40%.</p> <p>Fenster is German for window.</p> <p>The window system is standard commercial construction and thus, the glass, framing, and anchorage are expected to be insufficient for the design basis threat at the available stand-off. One benefit is that there are windows only on two sides of the building.</p>
<b>6</b>	<b>Mechanical Systems (HVAC and CBR)</b>		
6.1	<p>Where are the air intakes and exhaust louvers for the building? (low, high, or midpoint</p>	<p>Air intakes should be located on the roof or as high as possible. Otherwise secure within CPTED-compliant fencing or enclosure. The fencing or</p>	<p>Outside air is brought in through a vent in the wall. The vent is alarmed to prevent intruder access.</p>

Section	Vulnerability Question	Guidance	Observations
	<p>of the building structure)</p> <p>Are the intakes and exhausts accessible to the public?</p>	<p>enclosure should have a sloped roof to prevent the throwing of anything into the enclosure near the intakes.</p> <p>Reference: <i>GSA PBS-P100</i> states that air intakes should be on the fourth floor or higher and, on buildings with three floors or less, they should be on the roof or as high as practical. Locating intakes high on a wall is preferred over a roof location.</p> <p>Reference: <i>DoD UFC 4-010-01</i> states that, for all new inhabited buildings covered by <i>FEMA 426</i>, all air intakes should be located at least 3 meters (10 feet) above the ground.</p> <p>Reference: <i>CDC/NIOSH, Pub 2002-139</i> states: “An extension height of 12 feet (3.7 m) will place the intake out of reach of individuals without some assistance. Also, the entrance to the intake should be covered with a sloped metal mesh to reduce the threat of objects being tossed into the intake. A minimum slope of 45° is generally adequate. Extension height should be increased where existing platforms or building features (i.e., loading docks, retaining walls) might provide access to the outdoor air intakes.”</p> <p>Reference: <i>LBNL Pub 51959</i>: Exhausts are also a concern during an outdoor release, especially if exhaust fans are not in continuous operation, due to wind effects and chimney effects (air movement due to differential temperature).</p>	<p>A screened exhaust duct is on the roof.</p>
6.3	<p>Are there multiple air intake locations?</p>	<p>Single air intakes may feed several air handling units. Indicate if the air intakes are localized or separated. Installing low-leakage dampers is one way</p>	<p>No, there is only one air intake.</p>

Section	Vulnerability Question	Guidance	Observations
		<p>to provide the system separation when necessary.</p> <p>Reference: <i>Physical Security Assessment for the Department of Veterans Affairs Facilities</i></p>	
6.4	<p>What are the types of air filtration? Include the efficiency and number of filter modules for each of the main air handling systems.</p> <p>Is there any collective protection for chemical, biological, and radiological contamination designed into the building?</p>	<p>MERV – Minimum Efficiency Reporting Value</p> <p>HEPA – High Efficiency Particulate Air</p> <p>Activated charcoal for gases</p> <p>Ultraviolet C for biologicals</p> <p>Consider mix of approaches for optimum protection and cost-effectiveness.</p> <p>Reference: <i>CDC/NIOSH Pub 2002-139</i></p>	<p>The air used to heat or cool the building is filtered in the HVAC room using standard industrial grade MERV 8 filters.</p> <p>There is no CBR protection designed into the building.</p>
6.8	<p>How are the air handling systems zoned?</p> <p>What areas and functions do each of the primary air handling systems serve?</p>	<p>Understanding the critical areas of the building that must continue functioning focuses security and hazard mitigation measures.</p> <p>Applying HVAC zones that isolate lobbies, mailrooms, loading docks, and other entry and storage areas from the rest of the building HVAC zones and maintaining negative pressure within these areas will contain CBR releases. Identify common return systems that service more than one zone, effectively making a large single zone.</p> <p>Conversely, emergency egress routes should receive positive pressurization to ensure contamination does not hinder egress. Consider filtering of the pressurization air.</p> <p>Reference: <i>CDC/NIOSH, Pub 2002-139 and LBNL PUB 51959</i></p>	<p>HVAC Supply is split into two zones, one for the Computer Data Center and one for the rest of the building.</p> <p>The Data Center maintains a slight net positive pressure compared to the main office areas.</p> <p>The ducts are divided in half to allow them to serve as supply and return headers. The divider is insulated to minimize heat transfer from one side to the other.</p> <p>Stairwells are not separately pressurized.</p>

Section	Vulnerability Question	Guidance	Observations
6.9	<p>Are there large central air handling units or are there multiple units serving separate zones?</p>	<p>Independent units can continue to operate if damage occurs to limited areas of the building.</p> <p>Reference: <i>Physical Security Assessment for the Department of Veterans Affairs Facilities</i></p>	<p>The Computer Center and the Communications Center use Digital Environmental Managers (DEMs).</p> <p>Cooling (or heat removal) is done by two chillers in the M&amp;E room. Three Trane 100-ton chillers are available; normally only two are needed to cover all heat loads. The chillers remove heat from the chilled water system, and use the condenser water system to send the waste heat to two rooftop cooling towers. The chilled water is then routed from the chillers to air handlers for the majority of the building; cooling for the Computer Center and the Communications Center is done by directing chilled water to the DEMs.</p>
6.13	<p>What is the method of temperature and humidity control?</p> <p>Is it localized or centralized?</p>	<p>Central systems can range from monitoring only to full control. Local control may be available to override central operation.</p> <p>Of greatest concern are systems needed before, during, and after an incident that may be unavailable due to temperature and humidity exceeding operational limits (e.g., main telephone switch room).</p> <p>Reference: <i>DOC CIAO Vulnerability Assessment Framework 1.1</i></p>	<p>The main system for the building has limited humidity control through heating and cooling coils contained air handlers.</p> <p>The Computer Center and the Communications Center use Digital Environmental Managers (DEM) to direct the warm air where it is needed, add or remove humidity from the air, or even cool some areas while warming others.</p>
6.16	<p>Are there any smoke evacuation systems installed?</p> <p>Does it have purge capability?</p>	<p>For an internal blast, a smoke removal system may be essential, particularly in large, open spaces. The equipment should be located away from high-risk areas, the system controls and wiring should be protected, and it should be connected to emergency power. This exhaust capability can be built into areas with significant</p>	<p>No, the building has no specific smoke evacuation or purge capability.</p>



Course Title: **Building Design for Homeland Security: Resident Course**

Unit X-A: Building Design Guidance

Section	Vulnerability Question	Guidance	Observations
		<p>risk on internal events, such as lobbies, loading docks, and mailrooms. Consider filtering of the exhaust to capture CBR contaminants.</p> <p>References: <i>GSA PBS-P100, CDC/NIOSH Pub 2002-139, and LBNL Pub 51959</i></p>	
6.18	<p>Are fire dampers installed at all fire barriers?</p> <p>Are all dampers functional and seal well when closed?</p>	<p>All dampers (fire, smoke, outdoor air, return air, bypass) must be functional for proper protection within the building during an incident.</p> <p>Reference: <i>CDC/NIOSH Pub 2002-139</i></p>	<p>HVAC fire and smoke dampers in the M&amp;E room air handling unit (AHU).</p>
6.20	<p>Do elevators have recall capability and elevator emergency message capability?</p>	<p>Although a life-safety code and fire response requirement, the control of elevators also has benefit during a CBR incident. The elevators generate a piston effect, causing pressure differentials in the elevator shaft and associated floors that can force contamination to flow up or down.</p> <p>Reference: <i>LBNL Pub 51959</i></p>	<p>No elevators in HIC.</p>
6.21	<p>Is access to building information restricted?</p>	<p>Information on building operations, schematics, procedures, plans, and specifications should be strictly controlled and available only to authorized personnel.</p> <p>References: <i>CDC/NIOSH Pub 2002-139 and LBNL Pub 51959</i></p>	<p>No, there is no specific information that the office park management company restricts access to building information.</p>
<b>8</b>	<b>Electrical Systems</b>		
8.1	<p>Are there any transformers or switchgears located outside the building or accessible from the building exterior?</p> <p>Are they vulnerable to</p>	<p>Reference: <i>Physical Security Assessment for the Department of Veterans Affairs Facilities</i></p>	<p>The two 12.47KV feeders lead to two separate transformers outside the building, one near the north side by the loading dock, and the other near the south side by the M&amp;E room.</p> <p>These transformers are in the rear parking lot, accessible to</p>

Section	Vulnerability Question	Guidance	Observations
	<p>public access?</p> <p>Are they secured?</p>		<p>the public and secured only by a heavy duty lock.</p>
8.4	<p>Are critical electrical systems collocated with other building systems?</p> <p>Are critical electrical systems located in areas outside of secured electrical areas?</p> <p>Is security system wiring located separately from electrical and other service systems?</p>	<p>Collocation concerns include rooms, ceilings, raceways, conduits, panels, and risers.</p> <p>Reference: <i>Physical Security Assessment for the Department of Veterans Affairs Facilities</i></p>	<p>Yes, the electrical system is located adjacent to the main telecommunication and server closet. The HVAC room is also located adjacent to the electrical distribution room.</p> <p>Commercial and backup switchgear are both in the M&amp;E room. Wiring is run as inexpensively as possible to minimize rental costs, which means in same pipe chases or adjacent conduit.</p>
8.6	<p>Does emergency backup power exist for all areas within the building or for critical areas only?</p> <p>How is the emergency power distributed?</p> <p>Is the emergency power system independent from the normal electrical service, particularly in critical areas?</p>	<p>There should be no single critical node that allows both the normal electrical service and the emergency backup power to be affected by a single incident. Automatic transfer switches and interconnecting switchgear are the initial concerns.</p> <p>Emergency and normal electrical equipment should be installed separately, at different locations, and as far apart as possible.</p> <p>Reference: <i>GSA PBS-P100</i></p>	<p>Yes, emergency backup power exists and can be routed to all areas of the building. The automatic transfer switch in the M&amp;E room is a single point vulnerability in the system.</p> <p>Critical computer systems are backed up by an UPS (uninterruptible power supply) that is maintained separately from the site's generator back-up power.</p> <p>All individual computers / monitors have small (~750va) UPSs.</p>
<b>9</b>	<b>Fire Alarm Systems</b>		
9.1	<p>Is the building fire alarm system centralized or localized?</p> <p>How are alarms made known, both locally and centrally?</p> <p>Are critical documents and control systems located in a secure yet</p>	<p>Fire alarm systems must first warn building occupants to evacuate for life safety. Then they must inform the responding agency to dispatch fire equipment and personnel.</p> <p>Reference: <i>Physical Security Assessment for the Department of Veterans Affairs Facilities</i></p>	<p>The building fire alarm system is centralized. The fire alarm is routed over the telephone lines directly to the fire department. No intermediate monitoring agency is required for notification. An intermediate monitoring system is only used for the security alarm.</p>

Section	Vulnerability Question	Guidance	Observations
	accessible location?		
9.2	Where are the fire alarm panels located?  Do they allow access to unauthorized personnel?	Reference: <i>Physical Security Assessment for the Department of Veterans Affairs Facilities</i>	The fire alarm panels are located in the building portion adjacent to HIC. The HIC security manager has a key to that part of the building for access to the fire alarm panels. However, the panels are accessible to the occupants / tenants of that building portion.
9.3	Is the fire alarm system standalone or integrated with other functions such as security and environmental or building management systems?  What is the interface?	Reference: <i>Physical Security Assessment for the Department of Veterans Affairs Facilities</i>	The fire alarm system is standalone and separate from the security system. The system uses the telephone circuits to place a call to the local fire department.
9.5	Is there redundant off-premises fire alarm reporting?	Fire alarms can ring at a fire station, at an intermediary alarm monitoring center, or autodial someone else. See Items 5.21 and 10.5 of the checklist.	Yes, there is redundant off-premises fire alarm reporting through the security alarm service. This will notify an intermediate alarm monitoring center.
<b>10</b>	<b>Communications and IT Systems</b>		
10.1	Where is the main telephone distribution room and where is it in relation to higher-risk areas?  Is the main telephone distribution room secure?	One can expect to find voice, data, signal, and alarm systems to be routed through the main telephone distribution room.  Reference: <i>FEMA 386-7</i>	The main telephone distribution center is located next to the electrical and HVAC (mechanical). The alarm systems are routed through the telephone room (and circuits). The room is within the interior of the secured building and access is restricted to authorized personnel only. Outside repair contractors are escorted at all times.
10.5	Are there redundant communications systems available?	Critical areas should be supplied with multiple or redundant means of communications. Power outage phones can provide redundancy as they connect directly to the local	No, there are no redundant communication systems available as part of any building system. The only redundant communications are cell phones which

Section	Vulnerability Question	Guidance	Observations
		<p>commercial telephone switch off site and not through the building telephone switch in the main telephone distribution room.</p> <p>A base radio communication system with antenna can be installed in stairwells, and portable sets distributed to floors.</p> <p>References: <i>GSA PBS-P100 and FEMA 386-7</i></p>	<p>operate throughout the building.</p>
10.6	<p>Where are the main distribution facility, data centers, routers, firewalls, and servers located and are they secure?</p> <p>Where are the secondary and/or intermediate distribution facilities and are they secure?</p>	<p>Concern is collateral damage from manmade hazards and redundancy of critical functions.</p> <p>Reference: <i>DOC CIAO Vulnerability Assessment Framework 1.1</i></p>	<p>The Computer Data Center is interior to the building and is behind layers of security. The Communications Center is on an outside wall, but also behind security.</p>
10.8	<p>What type, power rating, and location of the uninterruptible power supply (UPS)? (battery, on-line, filtered)</p> <p>Are the UPS also connected to emergency power?</p>	<p>Consider that UPS should be found at all computerized points from the main distribution facility to individual data closets and at critical personal computers/terminals.</p> <p>Critical LAN sections should also be on backup power.</p> <p>Reference: <i>DOC CIAO Vulnerability Assessment Framework 1.1</i></p>	<p>The UPS system is based on a lead acid battery bank. Currently, there is no exhaust system for the battery bank. The UPS system can be fed from the emergency backup power (generator).</p>
10.12	<p>Where is the disaster recovery/mirroring site?</p>	<p>A site with suitable equipment that allows continuation of operations or that mirrors (operates in parallel to) the existing operation is beneficial if equipment is lost during a natural or manmade disaster. The need is based upon the criticality of the operation and how quickly replacement equipment can be put in place</p>	<p>HIC is the recovery site for many clients.</p> <p>HIC maintains an off-site storage location for clients that require backup data to be stored at a separate site.</p> <p>Classified backup data for certain government clients are stored in a special</p>

Section	Vulnerability Question	Guidance	Observations
		and operated.  Reference: <i>DOC CIAO Vulnerability Assessment Framework 1.1</i>	fireproof safe in the Secure Space.
10.15	Is there a mass notification system that reaches all building occupants? (public address, pager, cell phone, computer override, etc.)  Will one or more of these systems be operational under hazard conditions? (UPS, emergency power)	Depending upon building size, a mass notification system will provide warning and alert information, along with actions to take before and after an incident if there is redundancy and power.  Reference: <i>DoD UFC 4-010-01</i>	The telephone system has a building-wide announcing feature that can be activated by pressing one button at any phone. It reaches all users within audible distance of a phone.  This system will continue to operate on the UPS and/or backup generator power.
10.16	Do control centers and their designated alternate locations have equivalent or reduced capability for voice, data, mass notification, etc.? (emergency operations, security, fire alarms, building automation)  Do the alternate locations also have access to backup systems, including emergency power?	Reference: <i>GSA PBS-P100</i>	The emergency operations center is the large conference room. There is no designated alternate.  The room is equipped with network and telephone connections and cell phones are able to receive a signal.
<b>11</b>	<b>Equipment Operations and Maintenance</b>		
11.8	Is stairway and exit sign lighting operational?	The maintenance program for stairway and exit sign lighting (all egress lighting) should ensure functioning under normal and emergency power conditions.  Expect building codes to be updated as emergency egress lighting is moved from upper walls and over doorways to floor level as heat and smoke drive occupants to crawl along the	Yes, standard door or ceiling mounted exit signs and emergency lighting (battery packs) are in place for all six exits from the building.

Section	Vulnerability Question	Guidance	Observations
		<p>floor to get out of the building. Signs and lights mounted high have limited or no benefit when obscured.</p> <p>Reference: <i>FEMA 386-7</i></p>	
<b>13</b>	<b>Security Master Plan</b>		
13.1	<p>Does a written security plan exist for this site or building?</p> <p>When was the initial security plan written and last revised?</p> <p>Who is responsible for preparing and reviewing the security plan?</p>	<p>The development and implementation of a security master plan provides a roadmap that outlines the strategic direction and vision, operational, managerial, and technological mission, goals, and objectives of the organization's security program.</p> <p>Reference: <i>DOC CIAO Vulnerability Assessment Framework 1.1</i></p>	<p>The Security Officer maintains the fire evacuation and response plan and has posted fire evacuation routes in key office hallways and break areas.</p> <p>HIC does not have a mass evacuation plan and rally point.</p>

**Building Design Mitigation Measures  
(Suburban Version)**

Asset-Threat/Hazard Pair	Current Risk Rating	Suggested Mitigation Measure	Revised Risk Rating
1. Explosive Blast/Structural	High	FRF film on window	Medium
2. Explosive Blast/Structural	High	Enclose open entrance area	Medium
3. Chemical/Mechanical	High	Extend Air Intake	Medium
4. Biological/Mechanical	High	Extend Air Intake	Medium
5. Radiological/Site	Medium	Mass Evacuation Plan and Rally Point	Low

**UNIT X-B CASE STUDY ACTIVITY:  
BUILDING DESIGN GUIDANCE  
(Urban Version)**

In this unit, the emphasis will be upon providing a balanced building envelope that is a defensive layer against the terrorist tactic of interest and avoiding situations where one incident affects more than one building system. The **Building Vulnerability Assessment Checklist in FEMA 426 (Table 1-22, pages 1-46 to 1-93)** can be used as a screening tool for preliminary building design vulnerability assessment or for assessment of an existing building. The checklist includes questions that determine if critical and emergency systems will continue to function to enhance deterrence, detection, denial, and damage limitation during and after a threat or hazard situation.

**Requirements**

Assign sections of the checklist to the group member who is most knowledgeable and qualified to perform an assessment of the assigned area. Refer to the Appendix B Case Study to determine answers to the questions. Then review results as a team to identify vulnerabilities and possible mitigation measures.

1. Complete the following questions of the **Building Vulnerability Assessment Checklist (FEMA 426, Table 1-22, pages 1-46 to 1-93)** which address building design.

**Note:** There are 49 questions below (**157** in Section 2, **7** in Section 3, **2** in Section 4, **7** in Section 6, **3** in Section 7, **3** in Section 8, **4** in Section 9, **5** in Section 10, **2** in Section 11, and **1** in Section 13), so it is recommended that the team split up the questions among themselves taking 7-9 questions each and review the Appendix B Case Study for answers. Apportion the available time for gathering the answers and then provide each other the answers while performing the two actions below.

2. Upon completion of these portions of the checklist, refer back to the vulnerability ratings determined in the Unit IV Case Study Activity and, based on this more detailed analysis, decide if any vulnerability rating needs adjustment. Adjust the Threat Matrix chart accordingly for vulnerability rating and risk rating.
3. Select mitigation measures to reduce vulnerability and associated risk based upon the building design.
4. Estimate the new risk ratings for high risk asset-threat pairs (as adjusted in step 2 above) based on the recommended mitigation measures.

Section	Vulnerability Question	Guidance	Observations
<b>2</b>	<b>Architectural</b>		
2.5	Do entrances avoid significant queuing?	<p>If queuing will occur within the building footprint, the area should be enclosed in blast-resistant construction. If queuing is expected outside the building, a rain cover should be provided. For manpower and equipment requirements, collocate or combine staff and visitor entrances.</p> <p>Reference: <i>GSA PBS-P100</i></p>	<p>The HazardCorp Building has a spacious lobby that avoids queuing.</p>
2.6	<p>Does security screening cover all public and private areas?</p> <p>Are public and private activities separated?</p> <p>Are public toilets, service spaces, or access to stairs or elevators located in any non-secure areas, including the queuing area before screening at the public entrance?</p>	<p>Retail activities should be prohibited in non-secured areas. However the Public Building Cooperative Use Act of 1976 encourages retail and mixed uses to create open and inviting buildings. Consider separating entryways, controlling access, hardening shared partitions, and special security operational countermeasures.</p> <p>Reference: <i>GSA PBS-P100 and FEMA 386-7</i></p>	<p>The Lobby has open access to retail, atrium, mailroom, and meeting room spaces. Thus, public and private activities are not completely separated.</p> <p>Visitors to controlled floors are instructed to go to the Lobby Reception Desks and call the office to be visited to get an escort. That escort will come to the desk and take the visitor to the office. However, not all floors are controlled, so visitors can get off at those floors to transact business.</p> <p>Security desk as required by tenants are at one or more elevator lobbies at the floors rented by those tenants. Some tenants have a security desk at only one floor, with access to other floors controlled.</p> <p>Designated elevators, including one service elevator, have card readers and PIN (Personal Identification Number) keypads for movement to and from access controlled floors.</p> <p>The building stairways extending into the underground parking have card readers and PIN keypads at each level of underground parking to gain entrance to the</p>



Section	Vulnerability Question	Guidance	Observations
			stairways.
2.7	Is access control provided through main entrance points for employees and visitors? (lobby receptionist, sign-in, staff escorts, issue of visitor badges, checking forms of personal identification, electronic access control systems)	Reference: <i>Physical Security Assessment for the Department of Veterans Affairs Facilities</i>	Electronic access control is set up for building occupants / tenants. Visitor access control is handled at the Lobby Reception Desk for those requiring escort to controlled floors. There is no other control for visitors for retail, lobby, meeting rooms, or floors who do not have specific security needs.
2.8	Is access to private and public space or restricted area space clearly defined through the design of the space, signage, use of electronic security devices, etc.?	Finishes and signage should be designed for visual simplicity.  Reference: <i>Physical Security Assessment for the Department of Veterans Affairs Facilities</i>	Currently electronic security is the only indication differentiating private and public space. The only signage is the standard menu board that indicates what tenant is on what floor.
2.9	Is access to elevators distinguished as to those that are designated only for employees and visitors?	Reference: <i>Physical Security Assessment for the Department of Veterans Affairs Facilities</i>	Twenty-eight passenger elevators and three service elevators serve the various levels of the building. Two building elevators provide service to the underground parking levels. The plaza underground parking has two elevators that are located just east of the plaza parking entrance and exit.  Designated elevators, including one service elevator, have card readers and PIN (Personal Identification Number) keypads for movement to and from access controlled floors. To get the elevator to move to a specific floor you have to press the floor key, read your card, and enter your PIN. In addition, there is a Duress PIN that alerts building and floor security that an authorized person is moving to a controlled floor with a security problem. Two of the

Section	Vulnerability Question	Guidance	Observations
			<p>designated building elevators with access controls serve the underground parking levels.</p> <p>Visitors are not capable of using the controlled access elevators.</p> <p>The elevators and stairwells serving the underground parking that is not under the building have no access control equipment installed.</p>
2.10	Do public and employee entrances include space for possible future installation of access control and screening equipment?	<p>These include walk-through metal detectors and x-ray devices, identification check, electronic access card, search stations, and turnstiles.</p> <p>Reference: <i>GSA PBS-P100</i></p>	Yes, the Lobby has more than adequate space for reconfiguring to any security format desired for any security equipment needed.
2.11	Do foyers have reinforced concrete walls and offset interior and exterior doors from each other?	<p>Consider for exterior entrances to the building or to access critical areas within the building if explosive blast hazard must be mitigated.</p> <p>Reference: <i>U.S. Army TM 5-853</i></p>	<p>The building has a window curtain wall on the exterior. The Lobby, albeit having stronger glass has fewer structural members to which to transfer blast loading, and will be affected the most by this blast location.</p> <p>There are no exterior doors in the Lobby that are aligned with interior doors.</p> <p>None of the Lobby is hardened and the Lobby atrium is open for the first 3 floors.</p>
2.13	Do circulation routes have unobstructed views of people approaching controlled access points?	<p>This applies to building entrances and to critical areas within the building.</p> <p>References: <i>USAF Installation Force Protection Guide and DoD UFC 4-010-01</i></p>	<p>CCTV is set up at most exterior entrances to the building. CCTV is also at elevator lobbies, especially if secure access is the policy on that floor.</p> <p>Security personnel at the Lobby Reception Desk have full view of the entrances and elevator circulation routes.</p>

Section	Vulnerability Question	Guidance	Observations
2.15	<p>Are critical assets (people, activities, building systems and components) located close to any main entrance, vehicle circulation, parking, maintenance area, loading dock, or interior parking?</p> <p>Are the critical building systems and components hardened?</p>	<p>Critical building components include: Emergency generator including fuel systems, day tank, fire sprinkler, and water supply; Normal fuel storage; Main switchgear; Telephone distribution and main switchgear; Fire pumps; Building control centers; Uninterruptible Power Supply (UPS) systems controlling critical functions; Main refrigeration and ventilation systems if critical to building operation; Elevator machinery and controls; Shafts for stairs, elevators, and utilities; Critical distribution feeders for emergency power. Evacuation and rescue require emergency systems to remain operational during a disaster and they should be located away from potential attack locations. Primary and backup systems should be separated to reduce the risk of both being impacted by a single incident if collocated. Utility systems should be located at least 50 feet from loading docks, front entrances, and parking areas.</p> <p>One way to harden critical building systems and components is to enclose them within hardened walls, floors, and ceilings. Do not place them near high-risk areas where they can receive collateral damage.</p> <p>Reference: <i>GSA PBS-P100</i></p>	<p>Utility entrances into the building are expected to be exposed in the underground parking levels. The loading dock has utility services under it as well as a fuel storage tank. Electrical utilities room is on an outside wall of the first floor with little stand-off and next to an underground vehicle parking ramp.</p> <p>Vertical utility distribution is in separated pipe chases or in elevator shafts.</p> <p>Egress stairwells do not discharge to the outside, but to the loading dock and to the area near the electrical utilities room.</p> <p>None of the critical building systems are hardened.</p>
2.16	<p>Are high-value or critical assets located as far into the interior of the building as possible and separated from the public areas of the building?</p>	<p>Critical assets, such as people and activities, are more vulnerable to hazards when on an exterior building wall or adjacent to uncontrolled public areas inside the building.</p> <p>Reference: <i>GSA PBS-P100</i></p>	<p>This high-rise building uses vertical separation to provide protection to high-value and critical assets.</p> <p>The assets are not well separated from public areas of the building in every case, especially in the underground parking levels under the building. Critical assets are</p>

Section	Vulnerability Question	Guidance	Observations
			also contained on exterior walls: administration and electric utilities room, for example.
2.17	Is high visitor activity away from critical assets?	High-risk activities should also be separated from low-risk activities. Also, visitor activities should be separated from daily activities.  Reference: <i>USAF Installation Force Protection Guide</i>	Low-risk activities are limited to floors 1 to 3. All visitors enter through the first floor. At times, visitors may be one floor above or below critical assets.  Otherwise the security protocols in place keep visitors away from the critical assets as much as can be expected.
2.19	Are loading docks and receiving and shipping areas separated in any direction from utility rooms, utility mains, and service entrances, including electrical, telephone/data, fire detection/alarm systems, fire suppression water mains, cooling and heating mains, etc.?	Loading docks should be designed to keep vehicles from driving into or parking under the building. If loading docks are in close proximity to critical equipment, consider hardening the equipment and service against explosive blast. Consider a 50-foot separation distance in all directions.  Reference: <i>GSA PBS-P100</i>	No, the loading dock connects directly into interior space, critical functions, and infrastructure, including an egress stairwell and the service elevators.  50-foot separation is not present in most cases.
2.20	Are mailrooms located away from building main entrances, areas containing critical services, utilities, distribution systems, and important assets?  Is the mailroom located near the loading dock?	The mailroom should be located at the perimeter of the building with an outside wall or window designed for pressure relief.  By separating the mailroom and the loading dock, the collateral damage of an incident at one has less impact upon the other. However, this may be the preferred mailroom location.  Off-site screening stations or a separate delivery processing building on site may be cost-effective, particularly if several buildings may share one mailroom. A separate delivery processing building reduces risk and simplifies protection measures.	HazardCorp receives mail, packages, and equipment at the loading dock where a recently renovated (per DoD criteria) mailroom/shipping office inspects the items using x-ray and other equipment before distributing to tenants within the building. By agreement, HazardCorp Building accepts deliveries for specific tenants in other buildings in the immediate vicinity (within 2 city blocks) due to this mailroom capability.  Mailroom is adjacent to the loading dock and far from other entrances.

Section	Vulnerability Question	Guidance	Observations
		Reference: <i>GSA PBS-P100</i>	
2.22	Are areas of refuge identified, with special consideration given to egress?	Areas of refuge can be safe havens, shelters, or protected spaces for use during specified hazards.  Reference: <i>FEMA 386-7</i>	There are no specific safe havens provided by HazardCorp in this building and no information that any of the tenants have a shelter. The Office of Emergency Management (25 <sup>th</sup> floor) may have shelter capability built-in due to the Emergency Operations Center on this floor supported by extensive backup electric generation.
2.23	Are stairwells required for emergency egress located as remotely as possible from high-risk areas where blast events might occur?  Are stairways maintained with positive pressure or are there other smoke control systems?	Consider designing stairs so that they discharge into other than lobbies, parking, or loading areas.  Maintaining positive pressure from a clean source of air (may require special filtering) aids in egress by keeping smoke, heat, toxic fumes, etc. out of the stairway. Pressurize exit stairways in accordance with the National Model Building Code.  Reference: <i>GSA PBS-P100 and CDC/NIOSH, Pub 2002-139</i>	Stairwell #1 is located on the southwest side (exits near loading dock) and Stairwell #2 is located on the northwest side within the central core (exits near the electrical utilities room and vehicle ramp to underground parking). Both exit stairwells discharge to the building interior at ground level or to the parking levels underneath the building.  Per local building code the stairwells are pressurized to keep smoke out during fires.
2.25	Do interior barriers differentiate level of security within a building?	Reference: <i>USAF Installation Force Protection Guide</i>	Electronic controls exist in the form of alarms, door locks, proximity cards, and use of PIN numbers for stairwell and elevator access.
2.26	Are emergency systems located away from high-risk areas?	The intent is to keep the emergency systems out of harm's way, such that one incident takes out all capability – both the regular systems and their backups.  Reference: <i>FEMA 386-7</i>	Emergency power generators are on the 4 <sup>th</sup> floor or higher. However, four fuel tanks are under the loading dock area.  Communications have redundancy located away from high-risk areas.
<b>3</b>	<b>Structural Systems</b>		
3.1	What type of construction?	The type of construction provides an indication of the robustness to abnormal loading and load reversals. A reinforced	Steel moment-resisting-frame construction uses steel columns and beams.

Section	Vulnerability Question	Guidance	Observations
	<p>What type of concrete and reinforcing steel?</p> <p>What type of steel?</p> <p>What type of foundation?</p>	<p>concrete moment-resisting frame provides greater ductility and redundancy than a flat-slab or flat-plate construction. The ductility of steel frame with metal deck depends on the connection details and pre-tensioned or post-tensioned construction provides little capacity for abnormal loading patterns and load reversals. The resistance of load-bearing wall structures varies to a great extent, depending on whether the walls are reinforced or unreinforced. A rapid screening process developed by FEMA for assessing structural hazards identifies the following types of construction with a structural score ranging from 1.0 to 8.5. A higher score indicates a greater capacity to sustain load reversals.</p> <p>Wood buildings of all types - 4.5 to 8.5                      Steel moment-resisting frames - 3.5 to 4.5                      Braced steel frames - 2.5 to 3.0                      Light metal buildings - 5.5 to 6.5                      Steel frames with cast-in-place concrete shear walls - 3.5 to 4.5                      Steel frames with unreinforced masonry infill walls - 1.5 to 3.0                      Concrete moment-resisting frames - 2.0 to 4.0                      Concrete shear wall buildings - 3.0 to 4.0                      Concrete frames with unreinforced masonry infill walls - 1.5 to 3.0                      Tilt-up buildings - 2.0 to 3.5                      Precast concrete frame buildings - 1.5 to 2.5                      Reinforced masonry - 3.0 to 4.0                      Unreinforced masonry - 1.0 to 2.5</p> <p>References: <i>FEMA 154 and Physical Security Assessment for the Department of Veterans Affairs Facilities</i></p>	<p>The office floor slab is an electrified composite 3-inch metal deck with 2-1/2- inch normal-weight concrete fill spanning between the steel beams.</p> <p>The underground parking floor slabs are substantial cast-in-place reinforced concrete with reinforced concrete columns that align with steel columns on the first floor and have additional columns to handle the vehicle loading.</p> <p>The lateral load resisting system (for wind loads only) consists of four perimeter moment frames, with a column spacing of approximately 15 feet , one at each exterior wall, augmented by two-story belt trusses between the 4th and 6th floors and the 22nd and 24th floors. There are additional trusses at the north and south elevations below the 4th floor. An interior cross braced core extends from the foundations to the 6th floor. The horizontal shear is transferred into the core at the 4th and 6th floors. The 4th floor diaphragm consists of a 14-inch thick reinforced concrete slab with embedded T-sections. The 6th floor is an 8-inch thick reinforced concrete slab.</p> <p>The building foundations are reinforced concrete caissons. The caissons are needed due to the proximity to the water.</p>

Section	Vulnerability Question	Guidance	Observations
3.3	<p>Are the steel frame connections moment connections?</p> <p>Is the column spacing minimized so that reasonably sized members will resist the design loads and increase the redundancy of the system?</p> <p>What are the floor-to-floor heights?</p>	<p>A practical upper level for column spacing is generally 30 feet. Unless there is an overriding architectural requirement, a practical limit for floor-to-floor heights is generally less than or equal to 16 feet.</p> <p>Reference: <i>GSA PBS-P100</i></p>	<p>The connections for this steel structure are moment connections.</p> <p>The first to third floors is an open atrium and 60 foot transfer trusses at the fourth floor span between the core and girders towards the front of the atrium to provide clear space</p> <p>The lateral load resisting system (for wind loads only) consists of four perimeter moment frames, with a column spacing of approximately 15 feet , one at each exterior wall, augmented by two-story belt trusses between the 4th and 6th floors and the 22nd and 24th floors.</p> <p>Along the four exterior elevations, center-to-center column spacing is approximately 15 feet. Column trees are used at these locations. A column tree is a shop-fabricated column assembly with beam stubs shop-welded to the column flanges.</p> <p>Along the exterior elevations, and within the core up to the 6th floor, the spans are approximately 30 feet. Interior column spacing is approximately 30 feet. At these locations, traditional moment frame construction is used.</p> <p>Some columns below the 6th floor are special large sections or built-up box shapes with plates up to 10 inches thick welded from flange to flange, parallel to the web, to provide the necessary section properties.</p> <p>The floor-to-floor story height</p>

Section	Vulnerability Question	Guidance	Observations
			<p>for office and parking garage floors is 12 feet. The first three floors are 14 feet and the mechanical floors are 16 feet in height.</p>
3.4	<p>Are critical elements vulnerable to failure?</p>	<p>The priority for upgrades should be based on the relative importance of structural or non-structural elements that are essential to mitigating the extent of collapse and minimizing injury and damage.</p> <p>Primary Structural Elements provide the essential parts of the building's resistance to catastrophic blast loads and progressive collapse. These include columns, girders, roof beams, and the main lateral resistance system.</p> <p>Secondary Structural Elements consist of all other load bearing members, such as floor beams, slabs, that are essential for life safety systems or elements which can cause substantial injury if failure occurs, including ceilings or heavy suspended mechanical units.</p> <p>Secondary Non-Structural Elements consist of all elements not covered in primary non-structural elements, such as partitions, furniture, and light fixtures.</p> <p>Reference: <i>GSA PBS-P100</i></p>	<p>The four most prominent elements vulnerable to failure are the canopy at the plaza main entrance, the atrium vertical columns that support transfer girders, the loading dock area, and the columns of the underground parking levels.</p> <p>The canopy must be able to take load reversals, thus hardening is in order.</p> <p>Even though the atrium columns are substantially strengthened, a progressive collapse analysis is needed or these columns must receive additional hardening so that they do not fail under Design Basis Threat blast loads or smaller hand carried weapons.</p> <p>Hardening of the loading dock walls to direct the blast away from the building is also a consideration due to the proximity of the loading dock to egress and critical equipment.</p> <p>The columns and column to floor connections of the underground parking levels are also of concern, especially for that parking below the building.</p> <p>Other Secondary Non-Structural Elements of particular concern due to no consideration in original design are the components of the atrium that would be affected by blast entering at the level of the first three floors.</p>



Section	Vulnerability Question	Guidance	Observations
3.5	Will the structure suffer an unacceptable level of damage resulting from the postulated threat (blast loading or weapon impact)?	<p>The extent of damage to the structure and exterior wall systems from the bomb threat may be related to a protection level. The following is for new buildings:</p> <p><b>Level of Protection Below Antiterrorism Standards -</b> Severe damage. Frame collapse/massive destruction. Little left standing. Doors and windows fail and result in lethal hazards. Majority of personnel suffer fatalities.</p> <p><b>Very Low Level Protection -</b> Heavy damage. Onset of structural collapse. Major deformation of primary and secondary structural members, but progressive collapse is unlikely. Collapse of non-structural elements. Glazing will break and is likely to be propelled into the building, resulting in serious glazing fragment injuries, but fragments will be reduced. Doors may be propelled into rooms, presenting serious hazards. Majority of personnel suffer serious injuries. There are likely to be a limited number (10 percent to 25 percent) of fatalities.</p> <p><b>Low Level of Protection -</b> Moderate damage, unrepairable. Major deformation of non-structural elements and secondary structural members and minor deformation of primary structural members, but progressive collapse is unlikely. Glazing will break, but fall within 1 meter of the wall or otherwise not present a significant fragment hazard. Doors may fail, but they will rebound out of their frames, presenting minimal hazards. Majority of personnel suffer significant injuries. There may be a few (&lt;10 percent) fatalities.</p> <p><b>Medium Level Protection -</b></p>	<p>Progressive collapse is a concern because the first to third floors is an open atrium and 60 foot transfer trusses at the fourth floor span between the core and girders towards the front of the atrium to provide clear space.</p> <p>The building exterior is clad with an aluminum/glass curtain wall attached to the face of the building structure. Typical glazing is 1/4 inch or 3/8 inch annealed single pane double strength glass. The first three floors are 3/8 inch thermally tempered single-pane glass.</p> <p>In the urban environment without significant stand-off and the design used for this building, the estimated damage level will be very high.</p>

Section	Vulnerability Question	Guidance	Observations
		<p>Minor damage, repairable. Minor deformations of non-structural elements and secondary structural members and no permanent deformation in primary structural members. Glazing will break, but will remain in the window frame. Doors will stay in frames, but will not be reusable. Some minor injuries, but fatalities are unlikely.</p> <p><b>High Level Protection -</b> Minimal damage, repairable. No permanent deformation of primary and secondary structural members or non-structural elements. Glazing will not break. Doors will be reusable. Only superficial injuries are likely.</p> <p>Reference: <i>DoD UFC 4-010-01</i></p>	
3.8	<p>Are there transfer girders supported by columns within unscreened public spaces or at the exterior of the building?</p>	<p>Transfer girders allow discontinuities in columns between roof and foundation. This design has inherent difficulty in transferring load to redundant paths upon loss of a column or the girder. Transfer beams and girders that, if lost, may cause progressive collapse are therefore highly discouraged.</p> <p>Reference: <i>GSA PBS-P100</i></p>	<p>The open 3-story atrium has transfer girders on the fourth floor to handle the columns in the 47 stories above. These columns are in the unscreened public area of the building and are on the first layer of columns inside the building on the plaza main entrance side.</p>
3.10	<p>Will the loading dock design limit damage to adjacent areas and vent explosive force to the exterior of the building?</p>	<p>Design the floor of the loading dock for blast resistance if the area below is occupied or contains critical utilities.</p> <p>Reference: <i>GSA PBS-P100</i></p>	<p>The loading dock area has hardening only in those areas affected by the renovation of the mailroom for upgraded security.</p> <p>There is significant critical infrastructure underneath the loading dock area that requires hardening and the remaining standard construction walls need hardening to direct blast away from the building without any other impact. This includes adjacent column hardening.</p>

Section	Vulnerability Question	Guidance	Observations
3.11	Are mailrooms, where packages are received and opened for inspection, and unscreened retail spaces designed to mitigate the effects of a blast on primary vertical or lateral bracing members?	<p>Where mailrooms and unscreened retail spaces are located in occupied areas or adjacent to critical utilities, walls, ceilings, and floors, they should be blast- and fragment-resistant.</p> <p>Methods to facilitate the venting of explosive forces and gases from the interior spaces to the outside of the structure may include blow-out panels and window system designs that provide protection from blast pressure applied to the outside, but that readily fail and vent if exposed to blast pressure on the inside.</p> <p>Reference: <i>GSA PBS-P100</i></p>	<p>HazardCorp receives mail, packages, and equipment at the loading dock where a recently renovated (per DoD criteria) mailroom/shipping office inspects the items using x-ray and other equipment before distributing to tenants within the building. By agreement, HazardCorp Building accepts deliveries for specific tenants in other buildings in the immediate vicinity (within 2 city blocks) due to this mailroom capability.</p> <p>Retail space is another matter as it is unscreened and has access to the Lobby. The retail space has no hardening of shared walls. As a minimum the doors entering the Lobby should be used as emergency exits only with crash bars and alarms.</p>
<b>4</b>	<b>Building Envelope</b>		
4.1	What is the designed or estimated protection level of the exterior walls against the postulated explosive threat?	<p>The performance of the façade varies to a great extent on the materials. Different construction includes brick or stone with block backup, steel stud walls, precast panels, curtain wall with glass, stone, or metal panel elements.</p> <p>Shear walls that are essential to the lateral and vertical load bearing system and that also function as exterior walls should be considered primary structures and should resist the actual blast loads predicted from the threats specified. Where exterior walls are not designed for the full design loads, special consideration should be given to construction types that reduce the potential for injury.</p> <p>Reference: <i>GSA PBS-P100</i></p>	<p>A window curtain wall of aluminum and glass, even slightly thicker thermally tempered glass will not provide the desired level of protection without additional hardening. Hardening the glass is one concern, but hardening the framing of the curtain wall is of greater concern as blast resistant curtain wall design was not available when this building was originally built.</p> <p>A blast analysis would be in order to specify the type and level of hardening required.</p>

Section	Vulnerability Question	Guidance	Observations
4.2	<p>Is there less than 40 percent fenestration per structural bay?</p> <p>Is the window system design on the exterior façade balanced to mitigate the hazardous effects of flying glazing following an explosive event? (glazing, frames, anchorage to supporting walls, etc.)</p> <p>Do the glazing systems with a 1/2-inch (3/4-inch is better) bite contain an application of structural silicone?</p> <p>Is the glazing laminated or is it protected with an anti-shatter (fragment retention) film?</p> <p>If an anti-shatter film is used, is it a minimum of a 7-mil thick film, or specially manufactured 4-mil thick film?</p>	<p>The performance of the glass will similarly depend on the materials. Glazing may be single pane or double pane, monolithic or laminated, annealed, heat strengthened or fully tempered.</p> <p>The percent fenestration is a balance between protection level, cost, the architectural look of the building within its surroundings, and building codes. One goal is to keep fenestration to below 40 percent of the building envelope vertical surface area, but the process must balance differing requirements. A blast engineer may prefer no windows; an architect may favor window curtain walls; building codes require so much fenestration per square footage of floor area; fire codes require a prescribed window opening area if the window is a designated escape route; and the building owner has cost concerns.</p> <p>Ideally, an owner would want 100 percent of the glazed area to provide the design protection level against the postulated explosive threat (design basis threat– weapon size at the expected stand-off distance). However, economics and geometry may allow 80 percent to 90 percent due to the statistical differences in the manufacturing process for glass or the angle of incidence of the blast wave upon upper story windows (4th floor and higher).</p> <p>Reference: <i>GSA PBS-P100</i></p>	<p>Window curtain walls have almost 100 percent glazing or windows per structural bay (the distance between two exterior columns). Most of the glazing is optical, but the glazing that covers the structural components above the lower drop ceiling to the floor above is called spandrel glass.</p> <p>Fenster is German for window.</p> <p>The framing of window curtain walls is weaker that can be designed for windows connected to more substantial wall material. Recent testing shows that window curtain walls can be hardened and, with their inherent flexibility, can survive higher blast loadings.</p> <p>The strongest glass in the building is 3/8-inch thermally tempered on the first three floors. The remaining glass is 1/4-inch or 3/8-inch annealed double strength. All glass is single pane without any other hardening.</p>
<b>6</b>	<b>Mechanical Systems (HVAC and CBR)</b>		
6.1	<p>Where are the air intakes and exhaust louvers for the building? (low, high, or midpoint</p>	<p>Air intakes should be located on the roof or as high as possible. Otherwise secure within CPTED-compliant fencing or enclosure. The fencing or</p>	<p>The air used to heat and cool the HazardCorp Building is filtered in the various mechanical rooms using standard industrial grade</p>

Section	Vulnerability Question	Guidance	Observations
	<p>of the building structure)</p> <p>Are the intakes and exhausts accessible to the public?</p>	<p>enclosure should have a sloped roof to prevent the throwing of anything into the enclosure near the intakes.</p> <p>Reference: <i>GSA PBS-P100</i> states that air intakes should be on the fourth floor or higher and, on buildings with three floors or less, they should be on the roof or as high as practical. Locating intakes high on a wall is preferred over a roof location.</p> <p>Reference: <i>DoD UFC 4-010-01</i> states that, for all new inhabited buildings covered by <i>FEMA 426</i>, all air intakes should be located at least 3 meters (10 feet) above the ground.</p> <p>Reference: <i>CDC/NIOSH, Pub 2002-139</i> states: “An extension height of 12 feet (3.7 m) will place the intake out of reach of individuals without some assistance. Also, the entrance to the intake should be covered with a sloped metal mesh to reduce the threat of objects being tossed into the intake. A minimum slope of 45° is generally adequate. Extension height should be increased where existing platforms or building features (i.e., loading docks, retaining walls) might provide access to the outdoor air intakes.”</p> <p>Reference: <i>LBNL Pub 51959</i>: Exhausts are also a concern during an outdoor release, especially if exhaust fans are not in continuous operation, due to wind effects and chimney effects (air movement due to differential temperature).</p>	<p>MERV 8 filters. Outside make-up air is brought in through vents in the wall located at the associated mechanical room floor, with the lowest vent being on the 4<sup>th</sup> floor. The main mechanical rooms are located on the 26<sup>th</sup>, 49<sup>th</sup>, and 50<sup>th</sup> floors.</p> <p>Screened exhaust ducts are located at the mechanical floor level or are extended to the roof.</p> <p>Thus, the intakes and exhausts are not accessible to the public.</p>
6.3	<p>Are there multiple air intake locations?</p>	<p>Single air intakes may feed several air handling units. Indicate if the air intakes are localized or separated. Installing low-leakage dampers is one way</p>	<p>There are multiple air intake locations – one or more on every mechanical floor and other additional smaller units on other floors.</p>

Section	Vulnerability Question	Guidance	Observations
		<p>to provide the system separation when necessary.</p> <p>Reference: <i>Physical Security Assessment for the Department of Veterans Affairs Facilities</i></p>	
6.4	<p>What are the types of air filtration? Include the efficiency and number of filter modules for each of the main air handling systems.</p> <p>Is there any collective protection for chemical, biological, and radiological contamination designed into the building?</p>	<p>MERV – Minimum Efficiency Reporting Value</p> <p>HEPA – High Efficiency Particulate Air</p> <p>Activated charcoal for gases</p> <p>Ultraviolet C for biologicals</p> <p>Consider mix of approaches for optimum protection and cost-effectiveness.</p> <p>Reference: <i>CDC/NIOSH Pub 2002-139</i></p>	<p>The air used to heat and cool the HazardCorp Building is filtered in the various mechanical rooms using standard industrial grade MERV 8 filters.</p> <p>There is no CBR protection designed into the building.</p>
6.5	<p>Is there space for larger filter assemblies on critical air handling systems?</p>	<p>Air handling units serving critical functions during continued operation may be retrofitted to provide enhanced protection during emergencies. However, upgraded filtration may have negative effects upon the overall air handling system operation, such as increased pressure drop.</p> <p>Reference: <i>CDC/NIOSH, Pub 2002-139</i></p>	<p>The ductwork for return air from conditioned spaces has sufficient room inside the ductwork and mechanical room area for equipment under control of Building Management to incorporate additional filters and equipment. HVAC systems within tenant spaces usually have much less space for making changes</p>
6.8	<p>How are the air handling systems zoned?</p> <p>What areas and functions do each of the primary air handling systems serve?</p>	<p>Understanding the critical areas of the building that must continue functioning focuses security and hazard mitigation measures.</p> <p>Applying HVAC zones that isolate lobbies, mailrooms, loading docks, and other entry and storage areas from the rest of the building HVAC zones and maintaining negative pressure within these areas will contain CBR releases. Identify common return systems that service more than one zone, effectively making a large single zone.</p>	<p>A zoned, smoke control system is provided in the building. This system is designed to pressurize the floors above and below the floor of alarm and exhaust the floor of alarm to limit smoke and heat spread. Thus, the building is separated into many zones that can be controlled independently.</p> <p>The mailroom is the only part of the building designed as a separate zone during its renovation.</p> <p>The egress stairwells were built</p>

Section	Vulnerability Question	Guidance	Observations
		<p>Conversely, emergency egress routes should receive positive pressurization to ensure contamination does not hinder egress. Consider filtering of the pressurization air.</p> <p>Reference: <i>CDC/NIOSH, Pub 2002-139 and LBNL PUB 51959</i></p>	<p>of fire-rated construction using gypsum wall board and are pressurized to keep smoke out of the stairwells during a fire per local building code.</p>
6.14	<p>Where are the building automation control centers and cabinets located?</p> <p>Are they in secure areas?</p> <p>How is the control wiring routed?</p>	<p>Access to any component of the building automation and control system could compromise the functioning of the system, increasing vulnerability to a hazard or precluding their proper operation during a hazard incident.</p> <p>The HVAC and exhaust system controls should be in a secure area that allows rapid shutdown or other activation based upon location and type of attack.</p> <p>Reference: <i>FEMA 386-7, DOC CIAO Vulnerability Assessment Framework 1.1, and LBNL PUB 51959</i></p>	<p>Building Management has SCADA (Supervisory Control and Data Acquisition), EMCS (Energy Management and Control System), and Building Security systems coordinated with the tenants needs and the building overall. Note that the Building Management Systems are connected to the internet for alarms / monitoring / adjustment by engineering/security personnel from home. Building Management is collocated with the Building Security Center / Fire Control Center.</p> <p>Administration, electrical, and utilities, along with the utility risers have controlled access, either key lock, electronic lock using proximity card, and/or balanced magnetic switch with fixed Black and White CCTV (Closed Circuit Television) coverage.</p> <p>More than one vertical riser/pipe chase is used to run any system.</p>
<b>7</b>	<b>Plumbing and Gas Systems</b>		
7.1	<p>What is the method of water distribution?</p>	<p>Central shaft locations for piping are more vulnerable than multiple riser locations.</p> <p>Reference: <i>Physical Security Assessment for Department of Veterans Affairs Facilities</i></p>	<p>The primary water supply is provided by a dedicated fire yard main looped around the complex. This main is supplied directly from the municipal water supply.</p> <p>There are water tanks on each mechanical floor (4<sup>th</sup>, 26<sup>th</sup>, and</p>

Section	Vulnerability Question	Guidance	Observations
			<p>50<sup>th</sup>). The tanks are 2,000 gallons for potable water and 3,000 gallons for sprinkler systems. There are two water service lines, one coming into the building from the west side and one coming from the south (under the loading dock). Electric pumps at various levels pump water from the street level to the tanks for distribution throughout the building.</p> <p>The white blocks in the core of Figure 9 contain the toilets, air conditioning ducts, and risers for electrical, telecom, computer, fire protection, and plumbing unless indicated elsewhere.</p>
7.3	Is there redundancy to the main piping distribution?	<p>Looping of piping and use of section valves provide redundancies in the event sections of the system are damaged.</p> <p>Reference: <i>Physical Security Assessment for Department of Veterans Affairs Facilities</i></p>	
7.4	<p>What is the method of heating domestic water?</p> <p>What fuel(s) is used?</p>	<p>Single source of hot water with one fuel source is more vulnerable than multiple sources and multiple fuel types. Domestic hot water availability is an operational concern for many building occupancies.</p> <p>Reference: <i>Physical Security Assessment for Department of Veterans Affairs Facilities</i></p>	
<b>8</b>	<b>Electrical Systems</b>		
8.1	Are there any transformers or switchgears located outside the building or accessible from the building exterior?	Reference: <i>Physical Security Assessment for the Department of Veterans Affairs Facilities</i>	<p>Only electrical service entrances are accessible in the underground parking levels, vulnerable to public access, and not secured.</p> <p>Once inside the building, all transformers and equipment</p>



Section	Vulnerability Question	Guidance	Observations
	<p>Are they vulnerable to public access?</p> <p>Are they secured?</p>		are not accessible, have limited vulnerability, and are secure.
8.3	How are the electrical rooms secured and where are they located relative to other higher risk areas, starting with the main electrical distribution room at the service entrance?	Reference: <i>Physical Security Assessment for Department of Veterans Affairs Facilities</i>	<p>Administration, electrical, and utilities, along with the utility risers have controlled access, either key lock, electronic lock using proximity card, and/or balanced magnetic switch with fixed Black and White CCTV (Closed Circuit Television) coverage.</p> <p>There are two service entrances to transformers on the 4<sup>th</sup> floor. The electrical utility room on the first floor is the most vulnerable component as it is on an exterior wall with little stand-off.</p>
8.4	<p>Are critical electrical systems collocated with other building systems?</p> <p>Are critical electrical systems located in areas outside of secured electrical areas?</p> <p>Is security system wiring located separately from electrical and other service systems?</p>	<p>Collocation concerns include rooms, ceilings, raceways, conduits, panels, and risers.</p> <p>Reference: <i>Physical Security Assessment for the Department of Veterans Affairs Facilities</i></p>	<p>While there is some collocation of critical electrical systems, such as backup generators and automatic transfer switches, there has been an effort to provide multiple paths in separate risers to provide some level of redundancy.</p> <p>The same can be said for security system wiring which may also run in risers with other utility systems.</p>
8.6	<p>Does emergency backup power exist for all areas within the building or for critical areas only?</p> <p>How is the emergency power distributed?</p> <p>Is the emergency power system independent from</p>	<p>There should be no single critical node that allows both the normal electrical service and the emergency backup power to be affected by a single incident. Automatic transfer switches and interconnecting switchgear are the initial concerns.</p> <p>Emergency and normal electrical equipment should be installed separately, at different locations,</p>	<p>Building Management provides backup generator and systems for life-safety code requirements. Tenants provide their own backup generator for their critical needs. Thus, critical loads are only supplied, not the whole building.</p> <p>Emergency power has generators distributed</p>

Section	Vulnerability Question	Guidance	Observations
	<p>the normal electrical service, particularly in critical areas?</p>	<p>and as far apart as possible.</p> <p>Reference: <i>GSA PBS-P100</i></p>	<p>throughout the building on various floors to support those tenants that need backup power. A fairly good job has been done to make the emergency power system independent of the normal electrical service wherever possible.</p> <p>The weakest link in the emergency power system is the fuel distribution system based upon the location of tanks relative to generation and how the fuel is supplied or replenished.</p>
<b>9</b>	<b>Fire Alarm Systems</b>		
9.1	<p>Is the building fire alarm system centralized or localized?</p> <p>How are alarms made known, both locally and centrally?</p> <p>Are critical documents and control systems located in a secure yet accessible location?</p>	<p>Fire alarm systems must first warn building occupants to evacuate for life safety. Then they must inform the responding agency to dispatch fire equipment and personnel.</p> <p>Reference: <i>Physical Security Assessment for the Department of Veterans Affairs Facilities</i></p>	<p>The building fire alarm system is centralized with a Fire Control Center collocated with Building Security.</p> <p>Monitoring of the fire-alarm control panel for the building is provided independently at a central station.</p> <p>There is also a Fire Watch phone in each stairwell on each floor that provides communications with the Building Security Office/Fire Control Center. It is a copper wire system powered from the Fire Control Center that provides a backup to other communications for the trained Fire Watch personnel on each floor.</p> <p>As with other systems, the fire alarm systems are accessible where needed or secure where necessary.</p> <p>Critical documents are the responsibility of respective tenants or Building Management as appropriate.</p>

Section	Vulnerability Question	Guidance	Observations
9.2	Where are the fire alarm panels located?  Do they allow access to unauthorized personnel?	Reference: <i>Physical Security Assessment for the Department of Veterans Affairs Facilities</i>	The Fire Control Center in the Administration area of the first floor is where the fire alarm panels are located.  The Administration area is under access control.
9.3	Is the fire alarm system standalone or integrated with other functions such as security and environmental or building management systems?  What is the interface?	Reference: <i>Physical Security Assessment for the Department of Veterans Affairs Facilities</i>	The fire alarm system is standalone and separate from other systems. Note that most other building management systems have internet connections for convenience.
9.5	Is there redundant off-premises fire alarm reporting?	Fire alarms can ring at a fire station, at an intermediary alarm monitoring center, or autodial someone else. See Items 5.21 and 10.5 of the checklist.	Yes, monitoring of the fire-alarm control panel for the building is provided independently at a central station.
<b>10</b>	<b>Communications and IT Systems</b>		
10.1	Where is the main telephone distribution room and where is it in relation to higher-risk areas?  Is the main telephone distribution room secure?	One can expect to find voice, data, signal, and alarm systems to be routed through the main telephone distribution room.  Reference: <i>FEMA 386-7</i>	Each tenant and Building Management have different voice telecommunication providers. Some tenants use VOIP (Voice Over Internet Protocol) voice providers and others use separate copper or fiber service to analog or digital telephone service providers. One tenant has a satellite communications dish that has two voice circuits built in for trouble shooting satellite connectivity.  There are multiple telephone service entrances (3 total) and each tenant has a separate telephone distribution room.  Telecommunications has same security and access control throughout building as other utilities.

Section	Vulnerability Question	Guidance	Observations
10.2	Does the telephone system have an UPS (uninterruptible power supply)? -- What is its type, power rating, operational duration under load, and location? (battery, on-line, filtered)	<p>Many telephone systems are now computerized and need an UPS to ensure reliability during power fluctuations. The UPS is also needed to await any emergency power coming on line or allow orderly shutdown.</p> <p>Reference: <i>DOC CIAO Vulnerability Assessment Framework 1.1</i></p>	<p>Building Management uses VOIP as their main voice telecom service and ensures there are Uninterruptible Power Supplies (UPS) on all powered connection points and that these points are also on backup generator power.</p> <p>The tenants have their own systems that may or may not have UPS installed.</p>
10.5	Are there redundant communications systems available?	<p>Critical areas should be supplied with multiple or redundant means of communications. Power outage phones can provide redundancy as they connect directly to the local commercial telephone switch off site and not through the building telephone switch in the main telephone distribution room.</p> <p>A base radio communication system with antenna can be installed in stairwells, and portable sets distributed to floors.</p> <p>References: <i>GSA PBS-P100 and FEMA 386-7</i></p>	<p>Each tenant and Building Management has different voice telecommunication providers. Some tenants use VOIP (Voice Over Internet Protocol) voice providers and others use separate copper or fiber service to analog or digital telephone service providers. One tenant has a satellite communications dish that has two voice circuits built in for trouble shooting satellite connectivity.</p> <p>Building Management uses VOIP as their main voice telecom service and ensures there are Uninterruptible Power Supplies (UPS) on all powered connection points and that these points are also on backup generator power. The Building Security Office/Fire Control Center on the first floor has a “red” phone copper landline connection to a telephone central office as backup communications to the VOIP. Certain tenants also use this system as backup.</p> <p>Cell phones work in various portions of the building.</p> <p>There are repeaters for Building Security’s handheld radios positioned throughout the building to ensure coverage in any location for use by</p>

Section	Vulnerability Question	Guidance	Observations
			<p>security and maintenance personnel. The Building Security Office has spare radios to issue as necessary. The repeaters are on UPS and connected to backup generator power. The repeaters also support the fire department and police department hand held frequencies for both transmission and reception. These frequencies are tested by respective department personnel once a quarter.</p>
10.15	<p>Is there a mass notification system that reaches all building occupants? (public address, pager, cell phone, computer override, etc.)</p> <p>Will one or more of these systems be operational under hazard conditions? (UPS, emergency power)</p>	<p>Depending upon building size, a mass notification system will provide warning and alert information, along with actions to take before and after an incident if there is redundancy and power.</p> <p>Reference: <i>DoD UFC 4-010-01</i></p>	<p>Speakers for voice evacuation announcements are located throughout the building and are activated manually at the Fire Control Center (FCC).</p>
10.16	<p>Do control centers and their designated alternate locations have equivalent or reduced capability for voice, data, mass notification, etc.? (emergency operations, security, fire alarms, building automation)</p> <p>Do the alternate locations also have access to backup systems, including emergency power?</p>	<p>Reference: <i>GSA PBS-P100</i></p>	<p>The Building Security Center, Fire Control Center, and Building Management Control Center are all collocated in the Administration area on the first floor. There is no backup location.</p>

Section	Vulnerability Question	Guidance	Observations
<b>11</b>	<b>Equipment Operations and Maintenance</b>		
11.7	Are backup power systems periodically tested under load?	<p>Loading should be at or above maximum connected load to ensure available capacity and automatic sensors should be tested at least once per year. -- Periodically (once a year as a minimum) check the duration of capacity of backup systems by running them for the expected emergency duration or estimating operational duration through fuel consumption, water consumption, or voltage loss.</p> <p>Reference: <i>FEMA 386-7</i></p>	<p>Testing of generators is done by each respective tenant for their systems. The Building Management generators are run once every three months for 2 hours, exercising all components of the system under near maximum load conditions. If the 2 hour test fails, then repairs are made and another test is coordinated within 2 weeks and so on until the system runs successfully for 2 hours.</p> <p>Uninterruptible Power Supplies for tenant data computer systems are varied based upon the needs of the tenants and the available space in their rented area. Capacity varies from 10 minutes to 2 hours. Actual testing to confirm these capacities is unknown.</p> <p>In addition to the emergency generators, the existing uninterruptible power supply (UPS) provides 4 hours of full operation for the fire alarm system and 212 hours of standby operation.</p> <p>Again, testing to confirm these durations is unknown.</p>
11.8	Is stairway and exit sign lighting operational?	<p>The maintenance program for stairway and exit sign lighting (all egress lighting) should ensure functioning under normal and emergency power conditions.</p> <p>Expect building codes to be updated as emergency egress lighting is moved from upper walls and over doorways to floor level as heat and smoke drive occupants to crawl along the floor to get out of the building.</p>	<p>Emergency power generators are located on various levels and provide back-up power for emergency lighting in corridors and stairwells. Emergency lighting units in the exit stairwells, elevator lobbies and elevator cabs are equipped with individual backup batteries.</p> <p>Battery operated emergency lighting is provided in the stairwells and photo-</p>

Section	Vulnerability Question	Guidance	Observations
		<p>Signs and lights mounted high have limited or no benefit when obscured.</p> <p>Reference: <i>FEMA 386-7</i></p>	<p>luminescent paint is placed on the edge of the stair treads to facilitate emergency exits. In addition to the battery-powered lighting, the stairs also have emergency system lighting powered by the generators.</p> <p>While installed, there is no indication that these systems are on a maintenance program or that they are tested periodically.</p>
<b>13</b>	<b>Security Master Plan</b>		
13.1	<p>Does a written security plan exist for this site or building?</p> <p>When was the initial security plan written and last revised?</p> <p>Who is responsible for preparing and reviewing the security plan?</p>	<p>The development and implementation of a security master plan provides a roadmap that outlines the strategic direction and vision, operational, managerial, and technological mission, goals, and objectives of the organization's security program.</p> <p>Reference: <i>DOC CIAO Vulnerability Assessment Framework 1.1</i></p>	<p>The HazardCorp Building has a Building Security Committee made up of security representatives from each tenant. Building Management heads this committee with the Building Security Chief as the chairman. The committee coordinates the specific and general security needs of the tenants with each other and for the building as a whole.</p> <p>The Building Security Committee maintains the fire evacuation and response plan for the building, coordinated with the fire evacuation and response plan for each tenant.</p>

**Building Design Mitigation Measures  
(Urban Version)**

<b>Asset-Threat/Hazard Pair</b>	<b>Current Risk Rating</b>	<b>Suggested Mitigation Measure</b>	<b>Revised Risk Rating</b>
1. Envelope Systems / Vehicle Bomb	High	Harden windows and window curtain wall framing after blast analysis	Medium
2. Structural Systems / Vehicle Bomb	High	Harden atrium columns and use architectural stand-off to add protection. Harden underground parking columns and control access to underground parking under the building to tenants only.	Medium
3. Mechanical Systems / CBR Attack (Chemical)	High	Upgrade filters to MERV 11 or 2 stage filters with HEPA as second filter. Add sensors to switch in activated charcoal filters. Consider on critical floors.	Medium
4. Mechanical Systems / CBR Attack (Mechanical)	High	Add UVGI to HVAC system on critical floors	Medium
5. Mechanical Systems / CBR Attack (Radiological)	Medium	Upgrade filters to MERV 11 or 2 stage filters with HEPA as second filter	Low



## Unit XI

---

<b>COURSE TITLE</b>	Building Design for Homeland Security	<b>TIME</b>	45 minutes
---------------------	---------------------------------------	-------------	------------

---

<b>UNIT TITLE</b>	Electronic Security Systems
-------------------	-----------------------------

---

<b>OBJECTIVES</b>	<ol style="list-style-type: none"><li>1. Explain the basic concepts of electronic security system components, their capabilities, and their interaction with other systems</li><li>2. Describe the electronic security system concepts and practices that warrant special attention to enhance public safety</li><li>3. Use the assessment process to identify electronic security system requirements that can mitigate vulnerabilities</li><li>4. Justify selection of electronic security systems to mitigate vulnerabilities</li></ol>
-------------------	--

---

<b>SCOPE</b>	The following topics will be covered in this unit:
--------------	--

1. Perimeter layout and zoning of sensors
  2. Intrusion detection systems and sensor technologies
  3. Entry-control systems and electronic entry control technologies
  4. Closed circuit television and data-transmission media
  5. Control centers and building management systems
  6. Definitions of the degree of security and control
- 

<b>REFERENCES</b>	<ol style="list-style-type: none"><li>1. FEMA 426, <i>Reference Manual to Mitigate Potential Terrorist Attacks Against Buildings</i>,<ol style="list-style-type: none"><li>a. Pages 3-47 to 3-50</li><li>b. Appendix D</li><li>c. Security Systems and Security Master Plan sections of Checklist at the end of Chapter 1, pages 1-81 and 1-92</li></ol></li><li>2. Case Study – Appendix A: Suburban, Hazardville Information Company or Appendix B: Urban, HazardCorp Building as selected</li><li>3. Student Manual, Unit XI-A or Unit XI-B as selected (info only – do not list in SM)</li><li>4. Unit XI visuals (info only – do not list in SM)</li></ol>
-------------------	---

<b>REQUIREMENTS</b>	<ol style="list-style-type: none"><li>1. FEMA 426, <i>Reference Manual to Mitigate Potential Terrorist</i></li></ol>
---------------------	--

*Attacks Against Buildings*, pages 3-47 to 3-50; Appendix D; and Security Systems and Security Master Plan sections of the Checklist at the end of Chapter 1 (pages 1-81 to 1-92)

2. Instructor Guide, Unit XI
3. Student Manual (one per student) for selected Case Study
4. Overhead projector or computer display unit
5. Unit XI visuals
6. Risk Matrix poster and box of dry-erase markers (one per team)
7. Chart paper, easel, and markers

<b>UNIT XI OUTLINE</b>	<u>Time</u>	<u>Page</u>
XI. Electronic Security Systems	45 minutes	IG XI-1
1. Introduction and Unit Overview	3 minutes	IG XI-5
2. Perimeter Layout and Zoning Sensors	1 minute	IG XI-7
3. Intrusion Detection Systems and Technology	12 minutes	IG XI-8
4. Entry Control Systems and Technology	5 minutes	IG XI-16
5. CCTV Systems and Data Transmission Media	1 minute	IG XI-23
6. Security Operations Center	1 minute	IG XI-23
7. Summary/Student Activity/Transition	2 minutes	IG XI-24
8. <u>Activity</u> : Electronic Security Systems (Version <b>A - Suburban</b> ) [15 minutes for students, 5 minutes for instructor review]	20 minutes	IG XI-A-27
9. <u>Activity</u> : Electronic Security Systems (Version <b>B - Urban</b> ) [15 minutes for students, 5 minutes for instructor review]	20minutes	IG XI-B-31

## **PREPARING TO TEACH THIS UNIT**

- **Tailoring Content to the Local Area:** This instruction unit is generic and need not be applied to the Local Area. However, this unit comes after Units IX and X where Local Area content is most easily inserted and this instruction unit supplements Units IX and X. Then,

as appropriate, locally oriented discussion can be inserted, especially if done in conjunction with the Case Study version selected for the course offering.

- **Optional Activity:** There are no optional activities in this unit, except Student Activity questions that are applicable to the selected Case Study (Suburban or Urban).
- **Activity:** The students will complete their familiarization with the Case Study materials. The Case Study is a complete risk assessment and analysis of mitigation options and strategies for a typical commercial office building located in a mixed urban-suburban environment business park (suburban) or a 50-story high-rise office building located in a downtown urban environment (urban). The assessment will use the DoD Antiterrorism Standards and the GSA Interagency Security Criteria to determine Levels of Protection and identify specific vulnerabilities. Mitigation options and strategies will use the concepts provided in **FEMA 426** and other FEMA publications related to risk management, emergency planning, and disaster recovery.
- Refer students to their Student Manuals for worksheets and activities.
- Direct students to the appropriate page in the Student Manual.
- Instruct the students to read the activity instructions found in the Student Manual.
- Tell students how long they have to work on the requirements.
- While students are working, all instructors should closely observe the groups' process and progress. If any groups are struggling, immediately assist them by clarifying the assignment and providing as much help as is necessary for the groups to complete the requirement in the allotted time. Also, monitor each group for full participation of all members. For example, ask any student who is not fully engaged a question that requires his/her viewpoint to be presented to the group.
- At the end of the working period, reconvene the class.
- After the students have completed the assignment, "walk through" the activity with the students during the plenary session. Call on different teams to provide the answer(s) for each question. After each response simply ask if anyone disagrees. If the answer is correct and no one disagrees, state that the answer is correct and move on to the next requirement. If there is disagreement, provide the "school solution" and move on.
- If applicable to this activity, explain what information is to be transferred to the Risk Matrix poster. For this activity, the assessment of the building's security systems in greater depth may prompt the groups to adjust the vulnerability ratings in their Threat Matrix, with resultant changes to risk ratings.
- If time is short, simply provide the "school solution" and ask for questions. Do not end the activity without ensuring that students know if their answers are correct or at least on the

right track. Note, there is no right or wrong answer, but all answers must be justified with rationale.

- Ask for and answer questions.

INSTRUCTOR NOTES

CONTENT/ACTIVITY

VISUAL XI-1

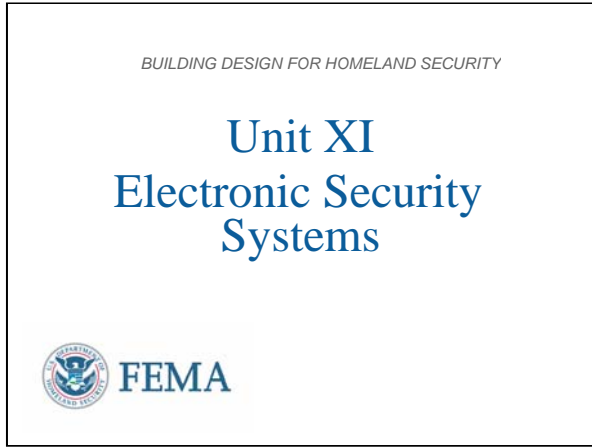

VISUAL XI-2



**Introduction and Unit Overview**

This is Unit XI Electronic Security Systems (ESS). This unit will describe the types of sensors, concepts of operation of electronic security systems, and terminology used in the industry.

**Unit Objectives**

At the end of this unit, the students should be able to:

1. Explain the basis concepts of electronic security system components, their capabilities, and their interaction with other systems.
2. Describe the electronic security system concepts and practices that warrant special attention to enhance public safety.
3. Use the **Building Vulnerability Assessment Checklist (Table 1-22, pages 1-81 to 1-89 of FEMA 426)** to identify electronic security system requirements that are needed to mitigate vulnerabilities.
4. Justify selection of electronic security systems to mitigate vulnerabilities.

VISUAL XI-3

**Electronic Security System (ESS) Concepts**

- Basic concepts of site security systems
- Use of ESS
- General ESS Description
- ESS Design Considerations



BUILDING DESIGN FOR HOMELAND SECURITY Unit XI-3

**Electronic Security Systems Concepts**

The **Building Vulnerability Assessment Checklist, Section 12 (Table 1-22, pages 1-81 to 1-89 of FEMA 426)** can be used for the assessment of security systems. Security systems historically have been designed, installed, serviced, and monitored by physical security companies, typically after the completion of the building. New Internet and wireless technologies have significantly changed the way in which security systems are designed and now incorporation of security system design and processes should begin at the earliest stages of design or renovation. An electronic security system is the physical implementation of the elements of the Layers of Defense:

- Deter
- Detect
- Deny
- Devalue

In this unit, the student should have an appreciation for:

- Basic concepts of ESS
- Use of ESS
- General ESS Description
- ESS Design Considerations

Fundamental objective:

Provide appropriate, effective, and economical protective design for assets.

Approach:

Coordinated effort between security, law enforcement, and engineering communities.

VISUAL XI-4

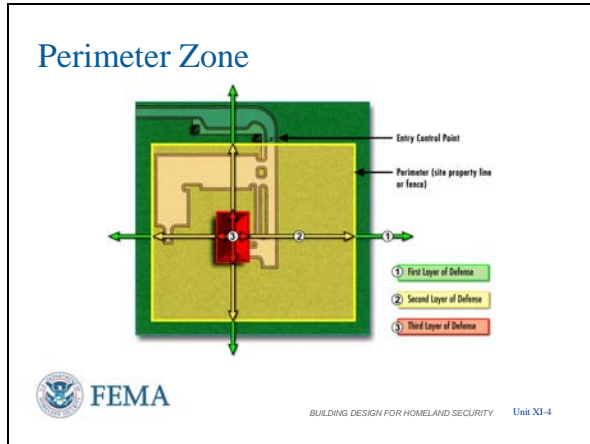

**Perimeter Zone**

The protection of a facility is designed with layers of defense, detection, and response. Before we discuss security systems, we need to review several basic concepts:

- A protected area's perimeter is usually defined by an enclosing wall or fence, or a natural barrier, such as water. For exterior sensors to be effective, the perimeter around which they are to be deployed must be precisely defined.

**Perimeter Zone and Layers of Defense**

- First layer of defense is from the perimeter outward (either fenceline or owned property).
- Second layer of defense is between the perimeter and the building.
- Third layer of defense is the building envelope.
- A fourth layer of defense may be a room inside the building.

VISUAL XI-5

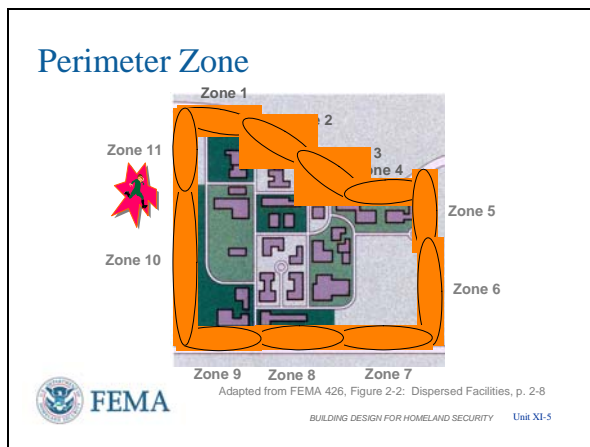

**Perimeter Layout and Zoning Sensors**

- After the perimeter has been defined, the next step is to divide it into specific detection zones. The length of each detection zone is determined by evaluating the contour, the existing terrain, and the operational activities along the perimeter.
- The exterior and interior Intrusion and Detection Systems should be configured as layers of unbroken rings concentrically surrounding the asset. These rings should correspond to defensive layers that constitute the delay system. The first detection layer is located at the outermost defensive layer necessary to provide the required delay. Detection layers can be on

VISUAL XI-6

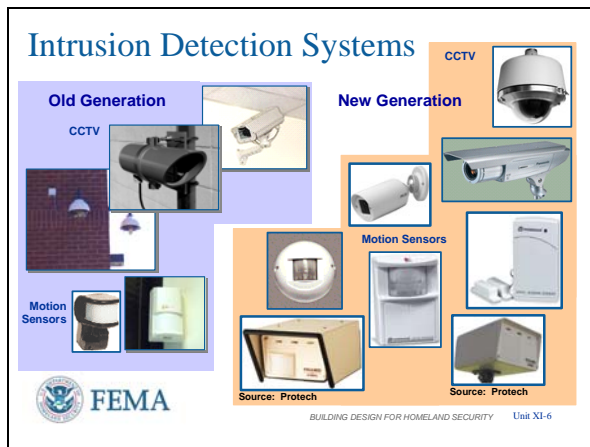

This slide shows old generation and new generation CCTV cameras and motion detectors.

VISUAL XI-7

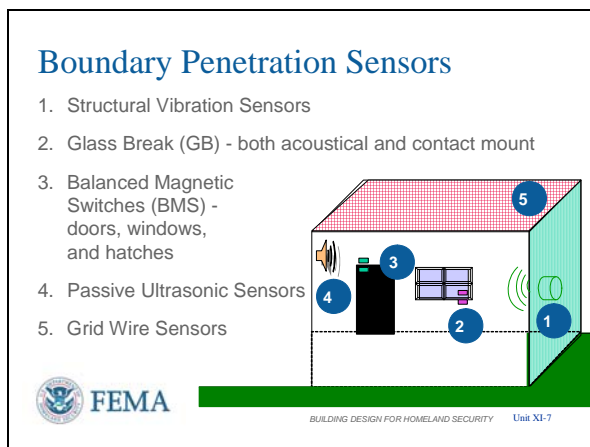

a defensive layer, in the area between two defensive layers, or on the asset itself, depending on the delay required.

- If an alarm occurs in a specific zone, the operator can readily determine its approximate location by referring to a map of the perimeter.

**Intrusion Detection Systems**

There are a number of different sensor technologies:

- Boundary Penetration Sensors
- Volumetric Motion Sensors
- Exterior Intrusion Detection Sensors
- Fence Sensors
- Buried Line Sensors
- Microwave Sensors
- Infrared Sensors
- Video Motion Sensors

**Boundary Penetration Sensors**

- Structural Vibration Sensors
- Glass Breaking Sensors
- Balanced Magnetic Switches
- Passive Ultrasonic Sensors
- Grid Wire Sensors

**Structural vibration sensors** detect low-frequency energy generated in an attempted penetration of a physical barrier (such as a wall or a ceiling) by hammering, drilling, cutting, detonating explosives, (subterranean digging) or employing other forcible methods of entry.

**Glass breaking sensors** detect the breaking



**INSTRUCTOR NOTES**

**CONTENT/ACTIVITY**

of glass. The noise from breaking glass consists of frequencies in both the audible and ultrasonic range. (This type of sensor should not be used without another sensor type).

**Balanced magnetic switches** (BMSs) are typically used to detect the opening of a door. These sensors can also be used on windows, hatches, gates, or other structural devices that can be opened to gain entry.

**Passive ultrasonic sensors** detect acoustical energy in the ultrasonic frequency range, typically between 20 and 30 kilohertz (kHz). They are used to detect an attempted penetration through rigid barriers (such as metal or masonry walls, ceilings, and floors), and windows and vents covered by metal grilles, shutters, or bars if these openings are properly sealed against outside sounds.

**Grid wire sensors** consist of a continuous electrical wire arranged in a grid pattern. The wire maintains an electrical current. An alarm is generated when the wire is broken. The sensor detects forced entry through walls, floors, ceilings, doors, windows, and other barriers. (This type sensor can be used well with structural vibration sensors).

VISUAL XI-8

**Volumetric Motion Sensors**

Designed to detect intruder motion within the interior of the protected volume

- Microwave Motion Sensors
- Passive Infrared (PIR) Motion Sensors
- Dual Technology Sensors
- Video Motion Sensors
- Point Sensors
- Capacitance Sensors
- Pressure Mats
- Pressure Switches



BUILDING DESIGN FOR HOMELAND SECURITY Unit XI-8

**Volumetric Motion Sensors**

Designed to detect intruder motion within the interior of the protected volume:

- Microwave Motion Sensors
- Passive Infrared (PIR) Motion Sensors
- Dual Technology Sensors
- Video Motion Sensors
- Point Sensors
- Capacitance Sensors
- Pressure Mats
- Pressure Switches

**Microwave motion sensors** use high-frequency electromagnetic energy to detect an intruder’s motion within the protected area. Interior or sophisticated microwave motion sensors are normally used.

**Interior microwave motion sensors** are typically monostatic; the transmitter and the receiver are housed in the same enclosure (transceiver).

**Sophisticated microwave motion sensors** may be equipped with electronic range gating. This feature allows the sensor to ignore the signals reflected beyond the settable detection range. Range gating may be used to effectively minimize unwanted alarms from activity outside the protected area.

**Passive infrared (PIR) motion sensors** detect a change in the thermal energy pattern caused by a moving intruder and initiate an alarm when the change in energy satisfies the detector’s alarm criteria. These sensors are passive devices because they do not transmit energy; they monitor the energy radiated by the surrounding environment.

**Dual technology sensors** combine two different technologies in one unit to minimize the generation of alarms caused by sources

**INSTRUCTOR NOTES**

**CONTENT/ACTIVITY**

other than intruders.

- Stereo Doppler is a dual channel microwave design. The combination of a Microwave (MW) Sensor and a Passive Infrared Sensor (PIR) must activate simultaneously to create an alarm.

**Video motion sensors** generate an alarm when an intruder enters a selected portion of a CCTV camera's field of view. The sensor processes and compares successive images between the images against predefined alarm criteria. There are two categories of video motion detectors, analog and digital. Analog detectors generate an alarm in response to changes in a picture's contrast. Digital devices convert selected portions of the analog video signal into digital data that are compared with data converted previously; if differences exceed preset limits, an alarm is generated. The signal processor usually provides an adjustable window that can be positioned anywhere on the video image.

**Point sensors** are used to protect specific objects within a facility. These sensors (sometimes referred to as proximity sensors) detect an intruder coming in close proximity to, touching, or lifting an object. Several different types are available, including capacitance sensors, pressure mats, and pressure switches.

**Capacitance sensors** detect an intruder approaching or touching a metal object by sensing a change in capacitance between the object and the ground. Think of some types of car alarms.

**Pressure mats** generate an alarm when pressure is applied to any part of the mat's surface, such as when someone steps on the mat.

VISUAL XI-9

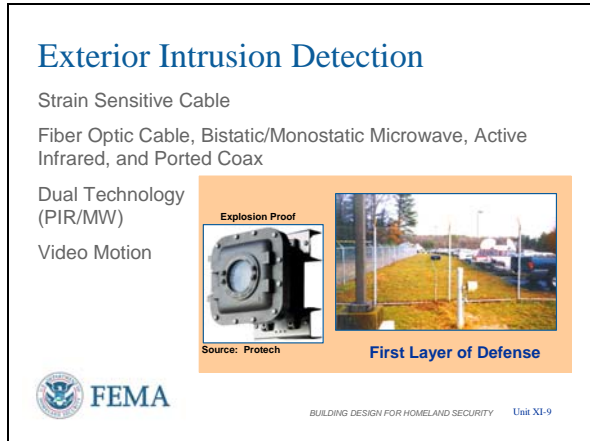

**Pressure switches** are mechanically activated contact switches or single ribbon switches.

**Exterior Intrusion Detection Sensors**

- Strain Sensitive Cable - fences and gates
- Fiber Optic Cable - fences, gates, and gravel pathways
- Bistatic/Monostatic Microwave - line of sight, clear zones
- Active Infrared - portals, short perimeter gap fillers
- Ported Coax - exterior clear zones
- Dual Technology (PIR/MW) - portals and gap fillers
- Video Motion - volumetric traffic, open areas

Exterior intrusion detection sensors are customarily used to detect an intruder crossing the boundary of a protected area. They can also be used in clear zones between fences or around buildings, for protecting materials and equipment stored outdoors within a protected boundary, or in estimating the POD (Probability of Detection) for buildings and other facilities.

Because of the nature of the outdoor environment, exterior sensors are also more susceptible to nuisance and environmental alarms than interior sensors. Inclement weather conditions (e.g., heavy rain, hail, and high wind), vegetation, the natural variation of the temperature of objects in the detection zone, blowing debris, and animals are major sources of unwanted alarms.

The combination of MW (Microwave) and PIR (Passive Infrared) works well to eliminate weather, birds/animals, vegetation, blowing debris, hail etc from causing false

VISUAL XI-10

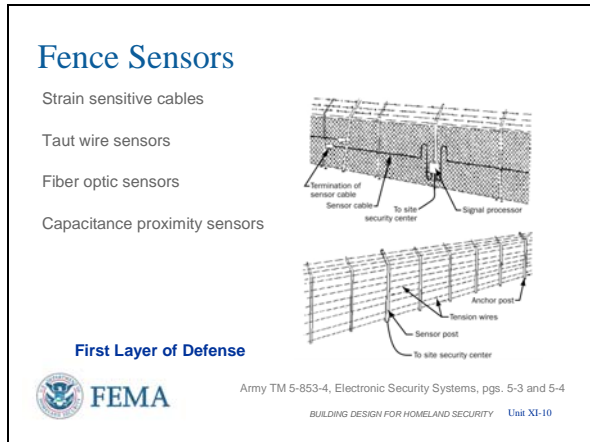

alarms.

**Fence Sensors**

- Strain sensitive cables
- Taut wire sensors
- Fiber optic sensors
- Capacitance proximity sensors

Fence sensors detect attempts to penetrate a fence around a protected area. Penetration attempts (e.g., climbing, cutting, or lifting) generate mechanical vibrations and stresses in fence fabric and posts that are usually different than those caused by natural phenomena like wind and rain.

**Strain sensitive cables** are transducers that are uniformly sensitive along their entire length. They generate an analog voltage when subject to mechanical distortions or stress resulting from fence motion.

**Taut wire sensors** combine a physically taut-wire barrier with an intrusion detection sensor network. The taut wire sensor consists of a column of uniformly spaced horizontal wires up to several hundred feet in length and securely anchored at each end.

**Fiber optic sensors** are functionally equivalent to the strain-sensitive cable sensors previously discussed. However, rather than electrical signals, modulated light is transmitted down the cable and the resulting received signals are processed to determine whether an alarm should be initiated.

**Capacitance proximity sensors** measure the electrical capacitance between the ground and an array of sense wires. Any variations in capacitance, such as that caused by an intruder approaching or touching one of the sense wires, initiates an alarm.

VISUAL XI-11

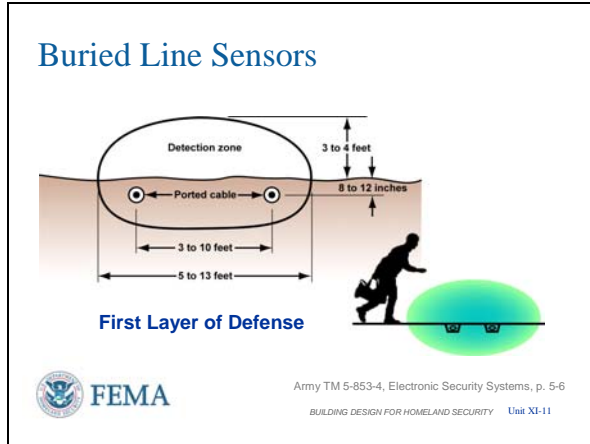

**Buried Line Sensors**

A buried line sensor system consists of detection probes or cable buried in the ground, typically between two fences that form an isolation zone. These devices are wired to an electronic processing unit. The processing unit generates an alarm if an intruder passes through the detection field.

Buried line sensors have several significant features:

- They are hidden, making them difficult to detect and circumvent.
- They follow the terrain's natural contour.
- They do not physically interfere with human activity, such as grass mowing or snow removal.
- They are affected by certain environmental conditions, such as running water and ground freeze/thaw cycles.

VISUAL XI-12

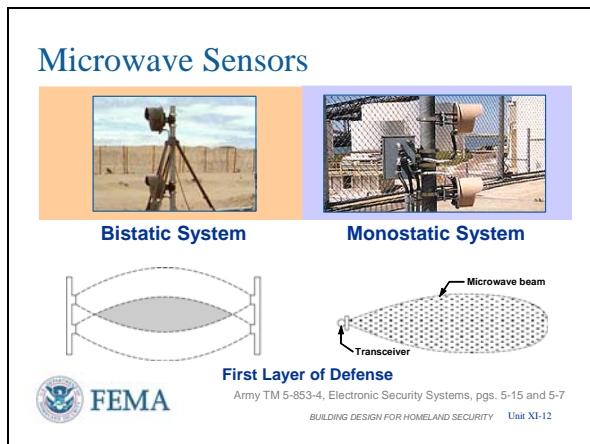

**Microwave (MW) Sensors**

- Bistatic system
- Monostatic

Microwave intrusion detection sensors are categorized as bistatic or monostatic. Bistatic sensors use transmitting and receiving antennas located at opposite ends of the microwave link, whereas monostatic sensors use the same antenna.

A bistatic system uses a transmitter and a receiver that are typically separated by 100 to 1,200 feet and that are within direct line of sight of each other.

Monostatic microwave sensors use the same antenna or virtually coincident antenna arrays

VISUAL XI-13



for the transmitter and receiver, which are usually combined into a single package.

**Infrared (IR) Sensors**

The IR sensors are available in both active and passive models. An active sensor generates one or more near-IR beams that generate an alarm when interrupted. A passive sensor detects changes in thermal IR radiation from objects located within its field of view.

Active sensors consist of transmitter/receiver pairs. The transmitter contains an IR light source (such as a gallium arsenide light-emitting diode [LED]) that generates an IR beam. The receiver detects changes in the signal power of the received beam. To minimize nuisance alarms from birds or blowing debris, the alarm criteria usually require that a high percentage of the beam be blocked for a specific interval of time.

VISUAL XI-14

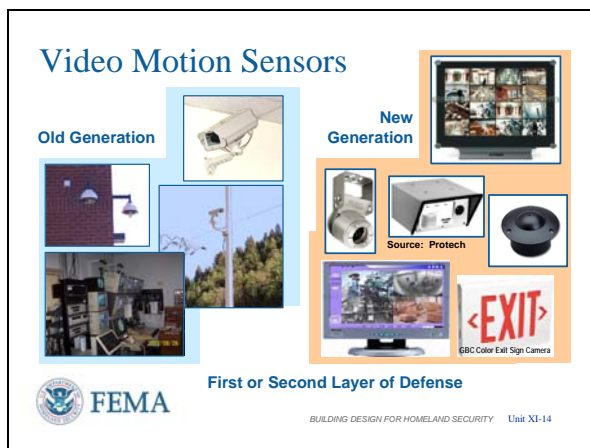

**Video Motion Sensors**

Video motion sensors are available on most digital video recorders used in security applications.

- They can be programmed to activate alarms, initiate recording, or any other designated action when motion is detected by a security camera.
- Some digital video recorders can be programmed to monitor very specific fields of view for specific rates of motion in order to increase effectiveness and minimize extraneous detections.
- Video motion sensors can also greatly improve the efficiency of security personnel monitoring security cameras by alerting them when motion is detected.

This slide shows old generation and new generation video motion sensors.



VISUAL XI-15



**Entry Control Systems and Technology**

- Coded Devices
- Credential Devices
- Biometric Devices

The function of an entry control system is to ensure that only authorized personnel are permitted into or out of a controlled area. Entry can be controlled by locked fence gates, locked doors to a building or rooms within a building, or specially designed portals. These means of entry control can be applied manually by guards or automatically by using entry control devices.

- In a manual system, guards verify that a person is authorized to enter an area, usually by comparing the photograph and personal characteristics of the individual requesting entry.
- In an automated system, the entry control device verifies that a person is authorized to enter or exit. The automated system usually interfaces with locking mechanisms on doors or gates that open momentarily to permit passage.

All entry control systems control passage by using one or more of three basic techniques (e.g., something a person knows, something a person has, or something a person is or does). Automated entry control devices based on these techniques are grouped into three categories: coded, credential, and biometric devices.



VISUAL XI-16



**Coded Devices**

- Electronic Keypad Devices
- Computer Controlled Keypad Devices

**Coded devices** operate on the principle that a person has been issued a code to enter into an entry control device. This code will match the code stored in the device and permit entry. Depending on the application, a single code can be used by all persons authorized to enter the controlled area or each authorized person can be assigned a unique code. Group codes are useful when the group is small and controls are primarily for keeping out the general public. Individual codes are usually required for control of entry to more critical areas. Electronically coded devices include electronic and computer controlled keypads.

**Electronic keypad devices** are similar to telephone keypads (12 keys). This type of keypad consists of simple push-button switches that, when depressed, are decoded by digital logic circuits. When the correct sequence of buttons is pushed, an electric signal unlocks the door for a few seconds.

**Computer controlled keypad devices** are devices similar to electronic keypad devices, except they are equipped with a microprocessor in the keypad or in a separate enclosure at a different location. The microprocessor monitors the sequence in which the keys are depressed and may provide additional functions, such as personal ID and digit scrambling. When the correct code is entered and all conditions are satisfied, an electric signal unlocks the door.

**PRECAUTIONS:**

- Care should be taken so other persons cannot observe individuals entering

VISUAL XI-17

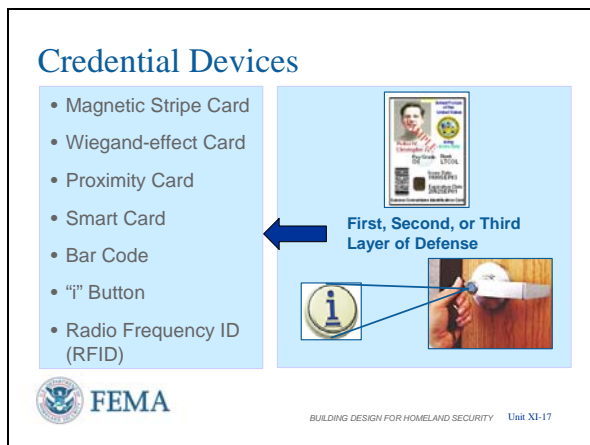

their assigned code. Installation of an opaque shield around the device aids in control of unauthorized observations. This helps to eliminate the use of another's code to gain entry into an unauthorized area.

- Also, care should be taken to replace coded pads that show wear from repeated code entries. Code compromise may be accomplished by attempting use of the worn keys (which results in less permutations of the combination to gain access).
- Individual codes are best for access control and accountability.

### Credential Devices

- Magnetic Stripe Card
- Wiegand-effect Card
- Proximity Card
- Smart Card
- Bar Code
- Button
- Radio Frequency Identification Device

A credential device identifies a person having legitimate authority to enter a controlled area. A coded credential (e.g., plastic card or key) contains a prerecorded, machine-readable code. An electric signal unlocks the door if the prerecorded code matches the code stored in the system when the card is read.

A **magnetic stripe card** is a strip of magnetic material located along one edge of the card that is encoded with data (sometimes encrypted). The data are read by moving the card past a magnetic read head.

A **Wiegand-effect card** contains a series of small-diameter, parallel wires approximately

**INSTRUCTOR NOTES**

**CONTENT/ACTIVITY**

½-inch long, embedded in the bottom half of the card. The wires are manufactured from ferromagnetic materials that produce a sharp change in magnetic flux when exposed to a slowly changing magnetic field. This type of card is impervious to accidental erasure. The card reader contains a small read head and a tiny magnet to supply the applied magnetic field. It usually does not require external power.

A **proximity card** is not physically inserted into a reader; the coded pattern on the card is sensed when it is brought within several inches of the reader. Several techniques are used to code cards. One technique uses a number of electrically tuned circuits embedded in the card. Data are encoded by varying resonant frequencies of the tuned circuits. The reader contains a transmitter that continually sweeps through a specified range of frequencies and a receiver that senses the pattern of resonant frequencies contained in the card. Another technique uses an integrated circuit embedded in the card to generate a code that can be magnetically or electrostatically coupled to the reader.

A **smart card** is embedded with a microprocessor, memory, communication circuitry, and a battery. The card contains edge contacts that enable a reader to communicate with the microprocessor. Entry control information and other data may be stored in the microprocessor's memory.

A **bar code** consists of black bars printed on white paper or tape that can be easily read with an optical scanner. This type of coding is not widely used for entry control applications because it can be easily duplicated.

The “**i**” **button** is a computer chip enclosed inside a 16mm stainless steel can. The “**i**” button can grant its owner access to a building, a PC, a piece of equipment, or a vehicle. Some “**i**” buttons can be used to store cash for small transactions, such as transit systems, parking meters, and vending machines. Also used as an electronic asset tag to store information needed to keep track of valuable capital equipment.

The Radio Frequency Identification Device (RFID) Systems rely on a radio frequency identification chip implanted in an access card, i.e., Proximity, Smart, or similar which transmits card owner information wirelessly.

Although this is leading edge technology, significant security and privacy issues exist to a level that government agencies eager to use this technology have abandoned their acceptance and use until the security and privacy issues are resolved. The ability for the remote operation of this technology gives it great interest for now and the future.

Without a biometric device necessary to be used with a credential device the only thing to be verified from an after incident entry point log review is “the device” was used to enter the area. Without some other means of identification (biometrics or Personal Identification Number), a person other than the owner can use a lost or stolen card, and cannot be tied to the card.

In the absence of biometric devices, anti-pass back devices, and procedures should be in place to eliminate unauthorized usage. Assign responsibility of the person issued the device for ensuring two people cannot use the same credential device. This is commonly occurs when one tells another they “forgot” their device.

VISUAL XI-18

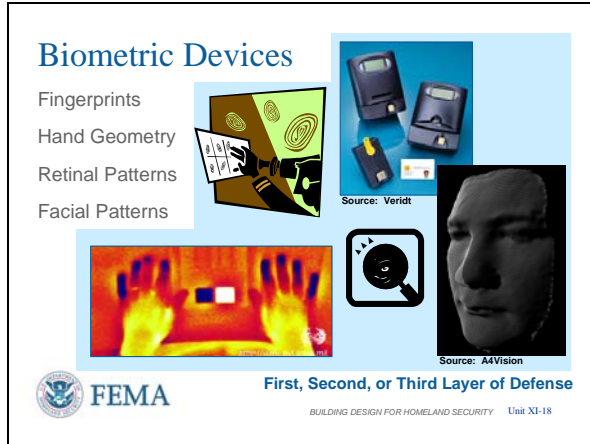

**Biometric Devices**

- Fingerprints
- Hand Geometry
- Retinal Patterns
- Facial Recognition

The third basic technique used to control entry is based on the measurement of one or more physical or personal characteristics of an individual. Because most entry control devices based on this technique rely on measurements of biological characteristics, they have become commonly known as biometric devices. Characteristics such as fingerprints, hand geometry, voiceprints, handwriting, and retinal blood-vessel patterns have been used for controlling entry. Typically, in enrolling individuals, several reference measurements are made of the selected characteristic and then stored in the device's memory or on a card. From then on, when that person attempts entry, a scan of the characteristic is compared with the reference data template. If a match is found, entry is granted.

**Fingerprint** verification devices use one of two approaches. One is pattern recognition of the whorls, loops, and tilts of the referenced fingerprint, which is stored in a digitized representation of the image and compared with the fingerprint of the prospective entrant. The second approach is minutiae comparison, which means that the endings and branching points of ridges and valleys of the referenced fingerprint are compared with the fingerprint of the prospective entrant.

**Hand geometry** devices use a variety of physical measurements of the hand, such as finger length, finger curvature, hand width,

**INSTRUCTOR NOTES**

**CONTENT/ACTIVITY**

webbing between fingers, and light transmissivity through the skin to verify identity. Both two- and three-dimensional units are available.

**Retinal pattern** is based on the premise that the pattern of blood vessels on the human eye's retina is unique to an individual. While the eye is focused on a visual target, a low-intensity IR light beam scans a circular area of the retina. The amount of light reflected from the eye is recorded as the beam progresses around the circular path. Reflected light is modulated by the difference in reflectivity between blood-vessel pattern and adjacent tissue. This information is processed and converted to a digital template that is stored as the eye's signature.

**Facial Recognition** is a facial identification/verification reader system with touch screen PIN (Personal Identification Number) and 3D facial biometric access. An audio request for a PIN entry references the 3D face template stored in the database with the corresponding PIN. Verification is made from the correct PIN entry matching the reader image. Night, changing light conditions, and motion will not change the high rate of accuracy according to the manufacturer.

VISUAL XI-19

**Closed Circuit Television**

**Interior CCTV**  
Alarm assessment, card reader door assessment, emergency exit door assessment, and surveillance of lobbies, corridors, and open areas

**Exterior CCTV**  
Alarm assessment, individual zones and portal assessment, specific paths and areas, exclusion areas, and surveillance of waterside activities

First, Second, or Third Layer of Defense



Source: Protech Protection Technologies, Inc.



 FEMA

BUILDING DESIGN FOR HOMELAND SECURITY Unit XI-19

**Closed Circuit Television Systems**

- Interior CCTV - alarm assessment, card reader door assessment, emergency exit door assessment, and surveillance of lobbies, corridors, and open areas
- Exterior CCTV - alarm assessment, individual zones and portal assessment, specific paths and areas, exclusion areas, and surveillance of waterside activities
- Transmission media includes twisted pair telephone cable, coaxial TV cable, LAN (Local Area Network) cable, fiber optics, and wireless. Each has cost, line length, resolution, reliability, and quality considerations. Security, encryption, and redundancy are also concerns throughout the length of run from sensor to monitor/alarm.
- Only color should be installed. There is very little use of black and white television when attempting to assemble a description of an individual who is wearing clothing in the shades of gray to white. Were they wearing blue jeans, or black or green trousers?

VISUAL XI-20

**Security Operations Center**  
**Enhancements to Overcome Operator/System Limitations**

- Workspace / Hardening
- Alarm Recognition / Alerts
- CCTV Image Alarm - Motion Detection
- Smart CCTV Auto Pan/Tilt/Zoom on Tripped Sensor Location
- Forwarding Alarms to Pagers, PDAs, Radios
- Data Recording - DVR
- Line Supervision / Backup Feeds
- Emergency Power to System



 FEMA

BUILDING DESIGN FOR HOMELAND SECURITY Unit XI-20

**Security Operations Center**

The operator monitoring the alarms and displays of a Security Operations Center is probably the most ineffective sensor in the system.

- The workspace should be conducive to maintaining attention, not like the two smaller photos where the monitors are outside the normal line of sight and in glare.
- The workspace should have some hardening as it is a single point of vulnerability in the system where response is initiated.
- Visual and/or audio alerts need to draw the

**INSTRUCTOR NOTES**

**CONTENT/ACTIVITY**

operators attention to alarms and focus the operator on the specific monitor with the detection information requiring real-time assessment for action.

- CCTV can assist in these alerts using image-based motion detection or SMART CCTV where attention is drawn to the camera that pan/tilts/zooms to the location from which the alarm is coming, such as the door where a balanced magnetic switch loses continuity or a motion detector senses motion where none is expected.
- Forwarding of alarms to cell phones, pagers, personal digital assistants, or radios keeps the staff on notice that a problem exists. It also allows the operator to take a bathroom break without having to have another person stand-in at the monitors.
- Digital Video Recorders (DVR) store more information with better quality resolution for not only detection, but also assessment and future potential criminal proceedings.
- Like fire alarm systems, all physical lines carrying alarm information should be supervised to identify any tampering with a line and to ensure functionality. Backup feeds or alternate feeds following different routes also increase reliability, especially in computer-based IP (Internet Protocol) systems.
- Since electric power is needed for system operation throughout the system, backup power with redundant lines should also be considered.



VISUAL XI-21

**Summary**

Use the Building Vulnerability Assessment Checklist to identify electronic security system requirements.

Public safety is enhanced by electronic security systems (deter, detect, deny, devalue).

Electronic security systems components and capabilities interact with other systems (LAN, doors, windows, lighting, etc.).

Electronic security systems can be used to mitigate vulnerabilities.



BUILDING DESIGN FOR HOMELAND SECURITY Unit XI-21

**Summary**

Remember all the different components of the system must support each others' function. For example, the best barriers are those tied to a detection system, like a strain sensitive cable alarm sensor on a chain link fence, with a steel cable woven into the fence, delay function, and overseen by an assessment method, such as a CCTV system.

The best practice is to evaluate products against operational and desired results criteria. This has proven to be a problem during attempted evaluations conducted by agencies trying to compare two different systems. System operating protocols were different from each other and, as a result, could not produce compatible/comparable results.

**NOTE:** All system control boxes should be equipped with an intrusion detection alarm which annunciates at the box and at the system control console, and is tied electronically to the events report log to be acknowledged, investigated (response) and cleared on the log. A link to CCTV recorded events is also advisable for immediate visual response/review.

- Use the **Building Vulnerability Assessment Checklist (Table 1-22, pages 1-81 to 1-89 of FEMA 426)** to identify electronic security system requirements.
- Public safety is enhanced by electronic security systems (deter, detect, deny, devalue).
- Electronic security systems components and capabilities interact with other systems (LAN, doors, windows, lighting, etc.).
- Electronic security systems can be used to mitigate vulnerabilities.

VISUAL XI-22

**Unit XI Case Study Activity**  
**Electronic Security Systems**

**Background**

**Emphasis:** Various components and technology available for use in electronic security systems

FEMA 426, Building Vulnerability Assessment Checklist

Assess Electronic Security Systems in Case Study for vulnerabilities and recommended mitigation measures



**FEMA**

BUILDING DESIGN FOR HOMELAND SECURITY Unit XI-22

Refer participants to **FEMA 426**, Vulnerability Checklist Section 12 and Tab XI-A or XI-B in the Student Manual for the selected Case Study activity.

At the end of 10 minutes, reconvene the class and facilitate group reporting. The plenary session should take 5 minutes.

**Student Activity**

In this unit, the emphasis was upon the various components and technology available for use in electronic security systems.

The **Building Vulnerability Assessment Checklist in FEMA 426 (Table 1-22, pages 1-81 to 1-89)** can be used as a screening tool for preliminary building design vulnerability assessment and assessment of existing buildings.

**Activity Requirements**

- Working in small groups, refer to the selected Case Study to determine answers to the worksheet questions.
- Then review results to identify vulnerabilities and possible mitigation measures.

Take 10 minutes to complete this activity. Solutions will be reviewed in plenary group.

**Transition**

In the next unit, you will finalize and present the Case Study Results determined by your team. This will include preparation and presentation of the top three risks identified by the group, the vulnerabilities identified for these risks, and top three recommended mitigation measures to reduce vulnerability and risk, although other vulnerabilities and recommended mitigation measures may also be presented. Prioritize the top three risks and the top three recommended mitigation measures with rationale and justification. Include any consideration for changes to security systems per this instruction unit.

**UNIT XI-A CASE STUDY ACTIVITY:  
ELECTRONIC SECURITY SYSTEMS  
(Suburban Version)**

In this unit, the emphasis will be upon the various components and technology available for use in electronic security systems. The **Building Vulnerability Assessment Checklist in FEMA 426** can be used as a screening tool for preliminary building design vulnerability assessment or for assessment of an existing building and site.

**Requirements**

Refer to the Appendix A Case Study to determine answers to the following questions. Then review results to identify vulnerabilities and possible mitigation measures.

1. Complete the following components of the **Building Vulnerability Assessment Checklist (Table 1-22, pages 1-81 to 1-89 of FEMA 426)** that address security systems.
2. Upon completion of these portions of the checklist, refer back to the risk ratings determined in Unit V-A Student Activity and, based on this detailed analysis, decide if any rating needs adjustment.
3. Select mitigation measures among security system design and operation features to reduce vulnerability and associated risk.
4. Estimate the new risk ratings for high risk asset-threat pairs of interest based on the recommended mitigation measures and complete the table.

Section	Vulnerability Question	Guidance	Observations
<b>12</b>	<b>Security Systems</b>		
	<b>Perimeter Systems</b>		
12.1	Are black/white or color CCTV (closed circuit television) cameras used?  Are they monitored and recorded 24 hours/7 days a week? By whom?  Are they analog or digital by design?  What is the number of fixed, wireless and pan-tilt-zoom cameras used?	Security technology is frequently considered to complement or supplement security personnel forces and to provide a wider area of coverage. Typically, these physical security elements provide the first line of defense in deterring, detecting, and responding to threats and reducing vulnerabilities. They must be viewed as an integral component of the overall security program. Their design, engineering, installation, operation, and management must be able to meet daily security challenges from a cost-effective	<i>The parking lot behind the HIC building is well lit and monitored by older generation analog CCTV cameras using telephone wires that are connected to video displays in the HIC Security Officer's office and recorded on standard VHS tape.</i>  <i>The CCTV cameras are commercial</i>

Section	Vulnerability Question	Guidance	Observations
	<p>Who are the manufacturers of the CCTV cameras?</p> <p>What is the age of the CCTV cameras in use?</p>	<p>and efficiency perspective. During and after an incident, the system, or its backups, should be functional per the planned design.</p> <p>Consider color CCTV cameras to view and record activity at the perimeter of the building, particularly at primary entrances and exits. A mix of monochrome cameras should be considered for areas that lack adequate illumination for color cameras.</p> <p>Reference: <i>GSA PBS P-100</i></p>	<p><i>grade black and white with a 180-degree field of view that the security officer can control via the display panel.</i></p> <p><i>The front parking lot is lit, but not monitored.</i></p>
12.2	<p>Are the cameras programmed to respond automatically to perimeter building alarm events?</p> <p>Do they have built-in video motion capabilities?</p>	<p>The efficiency of monitoring multiple screens decreases as the number of screens increases. Tying the alarm system or motion sensors to a CCTV camera and a monitoring screen improves the man-machine interface by drawing attention to a specific screen and its associated camera. Adjustment may be required after installation due to initial false alarms, usually caused by wind or small animals.</p> <p>Reference: <i>Physical Security Assessment for the Department of Veterans Affairs Facilities</i></p>	<p>Unknown without a more detailed assessment.</p>
12.5	<p>Are intercom call boxes used in parking areas or along the building perimeter?</p>	<p>See Item 12.4.</p>	<p>No.</p>
12.6	<p>What is the transmission media used to transmit camera video signals: fiber, wire line, telephone wire, coaxial, wireless?</p>	<p>Reference: <i>Physical Security Assessment for the Department of Veterans Affairs Facilities</i></p>	<p>Telephone wire.</p>
12.7	<p>Who monitors the CCTV system?</p>	<p>Reference: <i>DOC CIAO Vulnerability Assessment Framework 1.1</i></p>	<p>The HIC security officer.</p>

**Security System Mitigation Measures  
(Suburban Version)**

<b>Asset-Threat/Hazard Pair</b>	<b>Current Risk Rating</b>	<b>Suggested Mitigation Measure</b>	<b>Revised Risk Rating</b>
1. Site / Vehicle Bomb	High	Upgrade CCTVs to digital and use DVRs. Install CCTVs to monitor front parking and expand back parking coverage.	Medium
2. Architectural / Vehicle Bomb	High	Upgrade CCTVs to digital and use DVRs. Install CCTVs to monitor interior lobby and loading dock.	Medium
3. Mechanical Systems / Chemical (CBR Attack)	High	Evaluate installation of basic chemical sensors on outside air intake of HVAC system or acquisition of portable sensors for use by Building Security. (Intrusion Detection equivalent)	Medium
4. Mechanical Systems / Biological (CBR Attack)	High	Evaluate acquisition of portable or basic level biological sensors for use by Building Security. (Intrusion Detection equivalent)	High to Medium
5. Mechanical Systems / Radiological (CBR Attack)	High	Evaluate acquisition of portable or basic level radiological sensors for use by Building Security. (Intrusion Detection equivalent)	High to Medium

**UNIT XI-B CASE STUDY ACTIVITY:  
ELECTRONIC SECURITY SYSTEMS  
(Urban Version)**

In this unit, the emphasis will be upon the various components and technology available for use in electronic security systems. The **Building Vulnerability Assessment Checklist in FEMA 426** can be used as a screening tool for preliminary building design vulnerability assessment or for assessment of an existing building and site.

**Requirements**

Refer to the Appendix B Case Study to determine answers to the following questions. Then review results to identify vulnerabilities and possible mitigation measures.

1. Complete the following components of the **Building Vulnerability Assessment Checklist (Table 1-22, pages 1-81 to 1-89 of FEMA 426)** which address security systems.
2. Upon completion of these portions of the checklist, refer back to the risk ratings determined in Unit V-B Student Activity and, based on this detailed analysis, decide if any ratings need adjustment.
3. Select mitigation measures among security system design and operation features to reduce vulnerability and associated risk.
4. Estimate the new risk ratings for high risk asset-threat pairs of interest based on the recommended mitigation measures and complete the table.

Section	Vulnerability Question	Guidance	Observations
<b>12</b>	<b>Security Systems</b>		
	<b>Perimeter Systems</b>		
12.1	<p>Are black/white or color CCTV (closed circuit television) cameras used?</p> <p>Are they monitored and recorded 24 hours/7 days a week? By whom?</p> <p>Are they analog or digital by design?</p> <p>What is the number of fixed, wireless and pan-tilt-zoom cameras used?</p>	<p>Security technology is frequently considered to complement or supplement security personnel forces and to provide a wider area of coverage. Typically, these physical security elements provide the first line of defense in deterring, detecting, and responding to threats and reducing vulnerabilities. They must be viewed as an integral component of the overall security program. Their design, engineering, installation, operation, and management must be able to meet daily security challenges from a cost-effective</p>	<p><i>There is a mixture of black/white and color CCTV used. All entries to the building, especially the Loading Dock, are covered by color CCTV systems. The cameras are color, pan, tilt, and zoom. Elevator lobbies on underground parking levels both under the building and under the plaza are also on color cameras with pan, tilt, and zoom.</i></p>

Section	Vulnerability Question	Guidance	Observations
	<p>Who are the manufacturers of the CCTV cameras?</p> <p>What is the age of the CCTV cameras in use?</p>	<p>and efficiency perspective. During and after an incident, the system, or its backups, should be functional per the planned design.</p> <p>Consider color CCTV cameras to view and record activity at the perimeter of the building, particularly at primary entrances and exits. A mix of monochrome cameras should be considered for areas that lack adequate illumination for color cameras.</p> <p>Reference: GSA PBS P-100</p>	<p><i>Underground parking has fixed black and white CCTV cameras except at the vehicle entrances and exits where the cameras are color, pan, tilt, and zoom to aid in identifying people who do not pay or cause damage to the drop arms or automated equipment. There are black and white cameras covering stairwell doors on underground parking levels.</i></p> <p><i>One person in Building Security Office monitors cameras and alarms on a 24/7 basis. DVR (Digital Video Recording) is used to record all perimeter color cameras.</i></p> <p><i>Requires further investigation to determine analog or digital design of cameras, only know that DVR for recording is digital.</i></p> <p><i>There are 14 fixed B/W cameras, no wireless cameras were identified during assessment, and 24 color cameras with pan-tilt-zoom.</i></p> <p><i>The manufacturers and age of the CCTV cameras require further investigation.</i></p>

Section	Vulnerability Question	Guidance	Observations
12.2	<p>Are the cameras programmed to respond automatically to perimeter building alarm events?</p> <p>Do they have built-in video motion capabilities?</p>	<p>The efficiency of monitoring multiple screens decreases as the number of screens increases. Tying the alarm system or motion sensors to a CCTV camera and a monitoring screen improves the man-machine interface by drawing attention to a specific screen and its associated camera. Adjustment may be required after installation due to initial false alarms, usually caused by wind or small animals.</p> <p>Reference: <i>Physical Security Assessment for the Department of Veterans Affairs Facilities</i></p>	<p>No perimeter cameras are programmed to respond to perimeter building alarms. However, the access keypads on the two building elevators and the two building stairwells serving the UG parking levels have Duress PINs. These alarms can be easily set to draw attention to the specific camera covering the area. See Question 12.13 for capability configured on Interior Systems.</p> <p>There is no video motion capability installed.</p>
12.4	<p>Are panic/duress alarm buttons or sensors used, where are they located, and are they hardwired or portable?</p>	<p>Call buttons should be provided at key public contact areas and as needed in offices of managers and directors, in garages and parking lots, and other high risk locations by assessment.</p> <p>Reference: <i>GSA PBS P-100</i></p>	<p>There are no panic/duress alarms or call buttons available to the general public in the parking areas.</p> <p>However, there are Duress PINs that work on perimeter access keypads in the building UG parking – elevators and stairwells. These are only available to tenants and staff.</p>
12.5	<p>Are intercom call boxes used in parking areas or along the building perimeter?</p>	<p>See Item 12.4.</p>	<p>No intercom call boxes were identified during the assessment, either in parking areas or along the building perimeter.</p> <p>See Question 12.4</p>



Section	Vulnerability Question	Guidance	Observations
12.7	Who monitors the CCTV system?	Reference: <i>DOC CIAO Vulnerability Assessment Framework 1.1</i>	One Building Security person per shift monitors cameras and alarms in Building Security Office (Security Operations Center / Fire Control Center) located in the Administration area on the first floor and providing 24/7 coverage.
12.8	<p>What is the quality of video images both during the day and hours of darkness?</p> <p>Are infrared camera illuminators used?</p>	Reference: <i>Physical Security Assessment for the Department of Veterans Affairs Facilities</i>	<p>Lighting is coordinated with CCTV requirements to ensure good quality pictures, both on the monitors and on recordings, especially where color cameras are installed.</p> <p>There are no infrared camera illuminators installed.</p>
12.9	Are the perimeter cameras supported by an uninterruptible power supply, battery, or building emergency power?	Reference: <i>Physical Security Assessment for the Department of Veterans Affairs Facilities</i>	The access control systems, CCTV systems, and physical security alarms are on building emergency power.
<b>Interior Systems</b>			
12.12	<p>Are black/white or color CCTV (closed circuit television) cameras used?</p> <p>Are they monitored and recorded 24 hours/7 days a week? By whom?</p> <p>Are they analog or digital by design?</p> <p>What is the number of fixed, wireless and pan-tilt-zoom</p>	Security technology is frequently considered to compliment or supplement security personnel forces and to provide a wider area of coverage. Typically, these physical security elements provide the first line of defense in deterring, detecting, and responding to threats and reducing vulnerabilities. They must be viewed as an integral component of the overall security program. Their design, engineering, installation, operation, and management must	There is a mixture of black/white and color CCTV used. The Lobby on the first floor and the elevator lobbies on all floors are on color CCTV systems and cameras are color, pan, tilt, and zoom. Administration, electrical, and utilities, along with the utility risers have fixed Black and

Section	Vulnerability Question	Guidance	Observations
	<p>cameras used?</p> <p>Who are the manufacturers of the CCTV cameras?</p> <p>What is the age of the CCTV cameras in use?</p>	<p>be able to meet daily security challenges from a cost effective and efficiency perspective. During and after an incident, the system, or its backups, should be functional per the planned design.</p> <p>Consider color CCTV cameras to view and record activity at the perimeter of the building, particularly at primary entrances and exits. A mix of monochrome cameras should be considered for areas that lack adequate illumination for color cameras.</p> <p>Reference: <i>GSA PBS P-100</i></p> <p>See Item 12.1. --Reference: <i>Physical Security Assessment for Department of Veterans Affairs Facilities</i></p>	<p>White CCTV (Closed Circuit Television) coverage.</p> <p>One person in Building Security Office monitors cameras and alarms on a 24/7 basis. The Lobby on the first floor and the elevator lobbies on all floors are on color CCTV systems and these are also on recorded using DVR (Digital Video Recording).</p> <p>Requires further investigation to determine analog or digital design of cameras, only know that DVR for recording is digital.</p> <p>There are about 250 fixed B/W cameras, no wireless cameras were identified during assessment, and about 200 color cameras with pan-tilt-zoom.</p> <p>The manufacturers and age of the CCTV cameras would have to be further investigated.</p>
12.13	<p>Are the cameras programmed to respond automatically to perimeter building alarm events?</p> <p>Do they have built-in video motion capabilities?</p>	<p>The efficiency of monitoring multiple screens decreases as the number of screens increases. Tying the alarm system or motion sensors to a CCTV camera and a monitoring screen improves the man-machine interface by drawing attention to a specific screen and its associated camera.</p> <p>Reference: <i>Physical Security Assessment for Department of</i></p>	<p>When an Administration, electrical, and utilities, or utility riser door is opened, the CCTV monitor that includes coverage of that door alerts Building Security in conjunction with the door alarms to assist</p>

Section	Vulnerability Question	Guidance	Observations
		<p><i>Veterans Affairs Facilities</i></p>	<p>in identifying the activity. This is also used proactively in that anyone opening a controlled space contacts the Building Security Office prior to opening the controlled space and the person monitoring the CCTVs verifies the person before the space is opened.</p> <p>No video motion capability in installed.</p>
<p>12.24</p>	<p>Are panic/duress alarm buttons or sensors used?</p> <p>Where are they located?</p> <p>Are they hardwired or portable?</p>	<p>Call buttons should be provided at key public contact areas and as needed in offices of managers and directors, in garages and parking lots, and other areas high risk locations by assessment.</p> <p>Reference: <i>GSA PBS P-100</i></p>	<p>Designated elevators, including one service elevator, have card readers and PIN (Personal Identification Number) keypads for movement to and from access controlled floors. To get the elevator to move to a specific floor you have to press the floor key, read your card, and enter your PIN. In addition, there is a Duress PIN that alerts building and floor security that an authorized person is moving to a controlled floor with a security problem.</p> <p>The building stairwells extending into the underground parking have card readers and PIN keypads at each level of underground parking to gain entrance to the</p>

Section	Vulnerability Question	Guidance	Observations
			stairwells. A Duress PIN also works at these stairwells.

**Security System Mitigation Measures  
(Urban Version)**

Asset-Threat/Hazard Pair	Current Risk Rating	Suggested Mitigation Measures	Revised Risk Rating
1. Site / Vehicle Bomb		Improve CCTV throughout UG parking – convert B/W to color, expand coverage beyond elevators and stair access. Add coverage of complete perimeter.	
2. Architectural / Vehicle Bomb		Add CCTV (color digital, pan-tilt-zoom) to both building stairwells and both plaza UG parking stairwells.	
3. Architectural / Armed Attack		Access Control – Redesign Lobby to channel pedestrians for screening, add manned armed guards (GSA requirement) to man screening equipment.  Convert retail space on first floor to outside access only, but alarm secondary emergency exits (3 existing) into Lobby. May be overcome by Lobby Redesign.	

---

<b>Asset-Threat/Hazard Pair</b>	<b>Current Risk Rating</b>	<b>Suggested Mitigation Measures</b>	<b>Revised Risk Rating</b>
4. Mechanical Systems / Chemical (CBR Attack)		Evaluate installation of basic chemical sensors on outside air intake of HVAC system or acquisition of portable sensors for use by Building Security. (Intrusion Detection equivalent)	
5. Mechanical Systems / Biological (CBR Attack)		Evaluate acquisition of portable or basic level biological sensors for use by Building Security. (Intrusion Detection equivalent)	
6. Mechanical Systems / Radiological (CBR Attack)		Evaluate acquisition of portable or basic level radiological sensors for use by Building Security. (Intrusion Detection equivalent)	

## Unit XII

---

<b>COURSE TITLE</b>	Building Design for Homeland Security	<b>TIME</b> 135 minutes
---------------------	---------------------------------------	-------------------------

---

<b>UNIT TITLE</b>	Case Study
-------------------	------------

---

<b>OBJECTIVES</b>	<ol style="list-style-type: none"><li>1. Explain building security design issues to a building owner for consideration prior to a renovation or new construction</li><li>2. Explain the identification process to arrive at the high risk asset-threat/hazard pairs of interest</li><li>3. Justify the recommended mitigation measures, explaining the benefits in reducing the risk for the high risk situations of interest</li></ol>
-------------------	---

---

<b>SCOPE</b>	<p>The following topics will be covered in this unit:</p> <ol style="list-style-type: none"><li>1. Activity: Preparation and presentation of the top three risks identified by the groups, the vulnerabilities identified for these risks, and top three recommended mitigation measures to reduce vulnerability and risk. The top three risks will be prioritized as well as the top three recommended mitigation measures with rationale and justification. This includes any consideration for changes to electronic security systems per Unit XI.</li></ol>
--------------	---

---

<b>REFERENCES</b>	<ol style="list-style-type: none"><li>1. FEMA 426, <i>Reference Manual to Mitigate Potential Terrorist Attacks Against Buildings</i></li><li>2. FEMA 452, <i>Risk Assessment: A How-To Guide to Mitigate Potential Terrorist Attacks Against Buildings</i>, pages 5-1 to 5-18</li><li>3. Case Study – Appendix A: Suburban, Hazardville Information Company</li><li>4. Student Manual, Unit XII-A</li><li>5. Unit XII-A visuals</li></ol>
-------------------	---

---

<b>REQUIREMENTS</b>	<ol style="list-style-type: none"><li>1. FEMA 426, <i>Reference Manual to Mitigate Potential Terrorist Attacks Against Buildings</i></li><li>2. Instructor Guide, Unit XII-A</li><li>3. Student Manual, Unit XII-A (one per student)</li><li>4. Overhead projector or computer display unit</li></ol>
---------------------	---

---

5. Unit XII-A visuals
6. Threat Matrices poster and dry-erase markers (one per team)
7. Chart, paper, easel, and markers

<b>UNIT XI OUTLINE</b>	<u>Time</u>	<u>Page</u>
XII-A. Case Study	135 minutes	
1. Case Study Review as needed		IG-XII-A-5
2. Activity: Preparation of Presentation by Groups	45 minutes	IG XII-A-17
3. Presentation by Groups	90 minutes	IG XII-A-17
4. Case Study Solutions as needed		IG XII-A-18
5. Student Activity		IG XII-A-37

### PREPARING TO TEACH THIS UNIT

- **Tailoring Content to the Local Area:** Review the Instructor Notes to identify topics that should focus on the local area. Plan how you will use the generic content, and prepare for a locally oriented discussion.

The Instructor will review the Hazardville Information Company site and building portfolio, DoD Antiterrorism Standards, and GSA Interagency Security Criteria, and provide the parameters for the Design Basis Threat and Levels of Protection.

- **Optional Activity:** There are no optional activities in this unit.
- **Activity:** The students will prepare and present the top three risks identified by the group, the vulnerabilities identified for these risks, and the top three recommended mitigation measures to reduce vulnerability and risk. The top three risks will be prioritized as well as the top three recommended mitigation measures with rationale and justification. Includes any consideration for changes to electronic security systems per Unit X.
- Refer students to their Student Manuals for worksheets and activities.
- Direct students to the appropriate page in the Student Manual.
- Read the activity instructions found in the Student Manual.
- Describe how the Student Manual requirements are used to obtain the data needed for that aspect of the HIC building assessment and walk through the information provided.

- “Walk through” the pages of the activity with the students, describing the steps followed to obtain the answers in the completed examples, and what is expected of the groups for this activity.
- If applicable to this activity, explain what information is to be transferred to the Risk Matrix poster.
- Tell students how long they have to work on the requirements.
- While students are working, all instructors should closely observe the groups’ process and progress. If any groups are struggling, immediately assist them by clarifying the assignment and providing as much help as is necessary for the groups to complete the requirement in the allotted time.
- At the end of the working period, reconvene the class.
- Ask a representative from one group to provide the answer to the first requirement. Then simply ask if anyone disagrees. If the answer is correct and no one disagrees, state that the answer is correct and move on to the next requirement. If there is disagreement, provide the “school solution” and move on.
- If time is short, simply provide the “school solution” and ask for questions. Do not end the activity without ensuring that students know if their answers are correct or at least on the right track.
- Ask for and answer questions.



*This page intentionally left blank*

VISUAL XII-A-1 (XI-1)

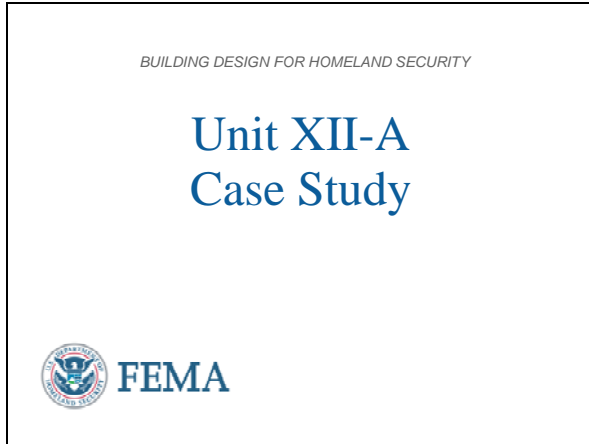

**Introduction and Unit Overview**

This is Unit XII Case Study activity. This unit will review the Hazardville Information Company site and building portfolio, DoD Antiterrorism Standards, and GSA Interagency Security Criteria, and provide the parameters for the Design Basis Threat and Levels of Protection.

Students will prepare and present the top three risks identified by the group, the vulnerabilities identified for these risks, and the top three recommended mitigation measures to reduce vulnerability and risk. The top three risks will be prioritized as well as the top three recommended mitigation measures with rationale and justification. Includes any consideration for changes to electronic security systems per Unit X.

VISUAL XII-A-2 (XI-2)



**Unit Objectives**

At the end of this unit, the students should be able to:

1. Explain building security design issues to a building owner for consideration prior to a renovation or new construction.
2. Explain the identification process to arrive at the high risk asset-threat/hazard pairs of interest.
3. Justify the recommended mitigation measures, explaining the benefits in reducing the risk for the high risk situations of interest.

VISUAL XII-A-3 (XI-3)

### Hazardville Information Company

- Company
    - Functions
    - Infrastructure
  - Threats/Hazards
    - Design Basis Threat
    - Levels of Protection
  - Vulnerabilities
    - Impact
    - Mitigation
- Report



Hazardville Information Company (HIC)



### Hazardville Information Company

The Case Study will be a comprehensive review and practical application of **FEMA 426**.

In this unit, the following topics will be presented:

- Company Functions
- Company Infrastructure
- Threats/Hazards (including Design Basis Threat and Levels of Protection)
- Vulnerabilities (including Impact and Mitigation)

VISUAL XII-A-4 (XI-4)

### Hazardville Information Company

- IT services and support
  - 130 employees
- Two-story building in small corporate office park
- Located in suburban area of major metropolitan city
- "Neighbors" include:
  - Offices
  - Industry
  - Road, Rail, Air traffic



### Hazardville Information Company

The Hazardville Information Company supports approximately 1,000 users and 100 applications as a primary data center and as a disaster recovery backup site.

HIC has over 130 employees and approximately 80 to 100 employees are in the building at any given time.

- Regional computer center
- Suburban business park
- Customers and neighbors

VISUAL XII-A-5 (XI-5)

HIC 5-Mile Building Radius

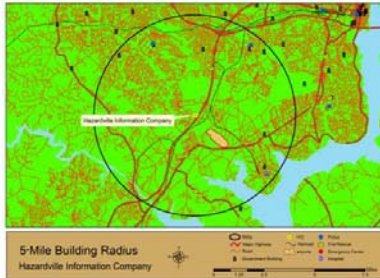

BUILDING DESIGN FOR HOMELAND SECURITY Unit XI-5

**HIC 5-Mile Building Radius**

The Hazardville Information Company is located approximately 15 miles outside of a major urban city in the suburbs, and adjacent to a major interstate highway. There are several commercial iconic properties, one military installation, and several government offices within a 5-mile radius of the HIC building.

VISUAL XII-A-6 (XI-6)

HIC Local Imagery



BUILDING DESIGN FOR HOMELAND SECURITY Unit XI-6

**HIC Local Imagery**

The office building is part of a corporate business park. HIC does not control the front parking area, signage, or other general site conditions such as stormwater drainage, lighting, or vehicle and pedestrian traffic flow and movement. The business park is responsible for grounds maintenance to include cutting the grass, planting flowers, trimming trees, sweeping the parking lot, and towing unauthorized vehicles. Trash service is the responsibility of tenants. HIC has a large dumpster located at the rear of the loading dock area approximately 50 feet from the building.

HIC receives the mail and packages at the front office lobby desk. Large packages and equipment are delivered to the rear loading dock. HIC does not have a separate mail room, but does have an internal administrative space with copiers, printers, supplies, and staff mailboxes. The front desk receptionist is responsible for sorting and screening all mail.

The business park is adjacent to a major





VISUAL XII-A-9 (XI-9)

### HIC Emergency Response



BUILDING DESIGN FOR HOMELAND SECURITY Unit XI-9

### HIC Emergency Response

The local emergency response capabilities include primary police, fire, and medical facilities approximately 8 to 10 miles away. There are multiple means of ingress and egress to the HIC building complex and the site is served by fire mains with a hydrant located approximately 200 feet from the HIC office.

VISUAL XII-A-10 (XI-10)

### HIC Functional Layout



BUILDING DESIGN FOR HOMELAND SECURITY Unit XI-10

### HIC Functional Layout

- Downstairs: Computer Center, Communications, Staff
- Upstairs: Executive offices
- Highbay loading dock, mechanical and electrical (M&E) room

VISUAL XII-A-11 (XI-11)

### HIC Car Bomb Blast Effects



BUILDING DESIGN FOR HOMELAND SECURITY Unit XI-11

### HIC Car Bomb Blast Effects

The nominal range-to-effects chart radius of influence of a small car bomb detonation at the front entrance indicates that the building would experience significant damage, but would likely not suffer progressive collapse. The front façade of the building is approximately 75 percent annealed glass and has an 8-foot overhang. The terrain slopes upward from the parking lot to the main entrance, and is landscaped with flower beds and trees. Key staff would

VISUAL XII-A-12 (XI-12)

HIC Truck Bomb Blast Effects



BUILDING DESIGN FOR HOMELAND SECURITY Unit XI-12

probably be killed and administrative functions destroyed, but the Computer Center and Communications functions would likely survive relatively intact.

**HIC Truck Bomb Blast Effects**

A truck bomb detonation occurring on the interstate would also significantly damage the HIC building, primarily glass breakage and potentially some structural damage. If the truck bomb were to detonate near the tank farm, the ensuing explosion, fire, and plume would have significant impact on the HIC building.

VISUAL XII-A-13 (XI-13)

HIC Truck Bomb Blast Effects

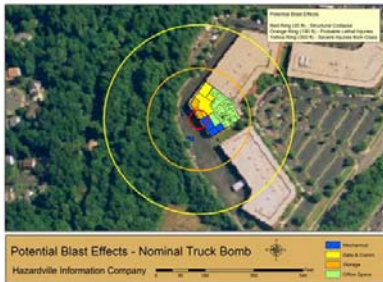

BUILDING DESIGN FOR HOMELAND SECURITY Unit XI-13

**HIC Truck Bomb Blast Effects**

A truck bomb detonation at the rear of the HIC building at the loading dock would result in significant structural damage and potentially progressive collapse. The Computer Center, Communications, and other critical functions would be destroyed. Critical infrastructure that would be destroyed includes the mechanical/electrical room.

VISUAL XII-A-14 (XI-14)

### HIC Building Data

**Infrastructure**

- Structural
  - 2 Story steel frame with brick façade
  - Annealed glass
- Mechanical
  - HVAC
  - Gas
  - Fire Systems
- Electrical
  - Primary
  - Back-up
- IT
  - Data Center
  - Telecom
- Physical Security

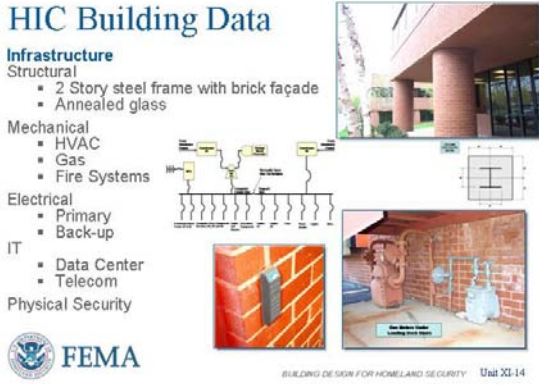

FEMA

BUILDING DESIGN FOR HOMELAND SECURITY Unit XI-14

### HIC Building Data (Infrastructure)

- Structural
- Mechanical
- Electrical
- IT
- Physical Security

### HIC Structural System

The HIC building is a two-story steel frame structure with a brick facade and annealed glass.

VISUAL XII-A-15 (XI-15)

### HIC Mechanical Systems

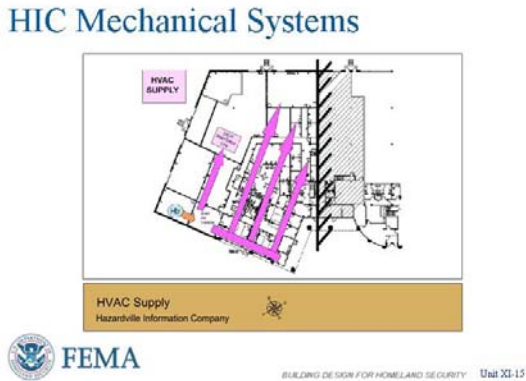

HVAC Supply  
Hazardville Information Company

FEMA

BUILDING DESIGN FOR HOMELAND SECURITY Unit XI-15

### HIC Mechanical Systems

The air used to heat or cool the HIC Headquarters building is filtered in the HVAC room using standard industrial grade MERV 8 filters. Outside make-up air is brought in through a vent in the wall located approximately 3 feet above ground level.

The Computer Data Center has two additional air cooling units located in the data center and uses the main chill water supply. The data center maintains a slight net positive pressure compared to the main office areas.

VISUAL XII-A-16 (XI-16)

### HIC Mechanical Systems

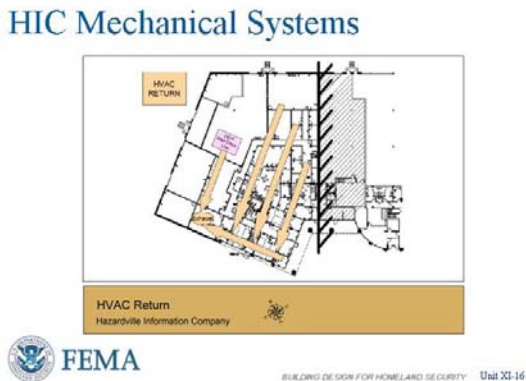

HVAC Return  
Hazardville Information Company

FEMA

BUILDING DESIGN FOR HOMELAND SECURITY Unit XI-16

### HIC Mechanical Systems

The return air for the main office space has sufficient room inside the ductwork and mechanical room area to incorporate additional filters and equipment.



VISUAL XII-A-17 (XI-17)

### HIC Mechanical Systems

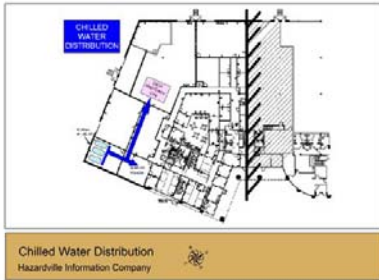

BUILDING DESIGN FOR HOMELAND SECURITY Unit XII-17

### HIC Mechanical Systems

Chiller operation along with chilled water and condenser water flow are managed from a single control unit in the M&E room. A single chilled water pump provides adequate flow for all cooling situations; a backup pump is available at the push of a button. The same is true for the condenser water pumps.

VISUAL XII-A-18 (XI-18)

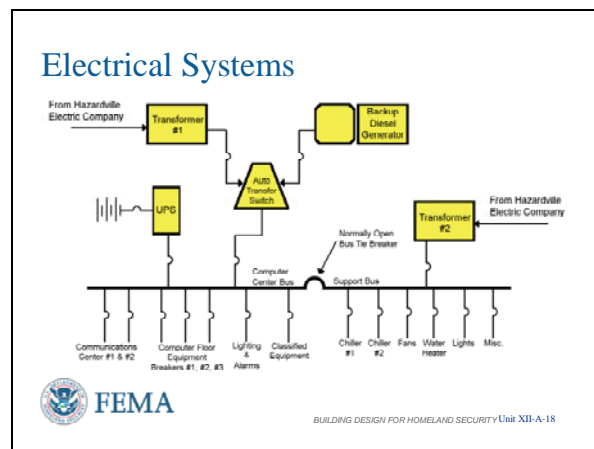

BUILDING DESIGN FOR HOMELAND SECURITY Unit XII-A-18

### HIC Electrical System

HIC's electrical loads are divided between two main electrical buses, the Computer Center Bus (CCB) and the Support Bus (SB). They are located in separate "closets" of the building. A tie breaker allows the buses to be connected, so they can be powered by a single main transformer, or to allow SB loads to be carried by the backup diesel generator. The system is monitored by a digital energy management system, which provides indications, alarms, and instructions.

VISUAL XII-A-19 (XI-19)

HIC Mechanical and Electrical Room

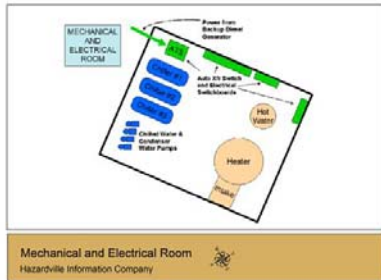

BUILDING DESIGN FOR HOMELAND SECURITY Unit XI-19

**HIC Mechanical and Electrical Room**

Typical of many commercial office buildings, the mechanical and electrical systems share common utility penetrations and floor space. There are no redundant utility feeds to the building from different directions.

VISUAL XII-A-20 (XI-20)

HIC IT



BUILDING DESIGN FOR HOMELAND SECURITY Unit XI-20

**IT**

The Computer Center is the heart of the Hazardville Information Company's (HIC) operation.

The Computer Center is composed of several interconnected systems and one independent system for classified data processing. The systems run either VMS, Unix, or Windows.

Data:

HIC has two T1 lines and one T3 line connected at the demark to ATT's high performance backbone network. The ATT fiber connectivity provides more than enough bandwidth for HIC's current needs and planned future expansion.

Telecom and Network Connections:

- Two T1 lines (1.544 Mbps)
- One T3 (45 Mbps)
- Frame Relay
- Narrowband ISDN (64/128 Kbps)

Voice

VISUAL XII-A-21 (XI-21)



NEC DS2000 telephone systems that come with an 8-slot cabinet that can handle 32 lines from 48 stations.

**Physical Security**

HIC uses a layered approach to physical security:

The outermost physical security layer is provided by a contract security firm and the Defense Protective Service (DPS).

- The parking lot behind the HIC office is well lit and monitored by older generation analog CCTV cameras.
- The front parking lot is lit, but not monitored.

HIC's middle layer of security is the building envelope.

- The building is monitored by door and window alarms, which connect to ADT, the nationwide alarm company.

The innermost layer of physical security involves the Computer Center and the Communications Center.

- Equipped with locked doors, rooms meet the government's requirements for handling classified material.
- Only authorized employees possess the necessary proximity cards and PINs to gain access.

VISUAL XII-A-22 (XI-22)

### HIC Emergency Response



### Emergency Response

In the event of an emergency, HIC senior management use the large conference room as an emergency operations center. The room is equipped with network and telephone connections and cell phones are able to receive a signal.

The nearest fire station is approximately 2½ miles north of the HIC Headquarters. Seven others are within 5 miles of the site. Firefighters are trained as Emergency Medical Technicians (EMTs) and Hazardous Material Technicians. Many are also skilled in technical rescue (high places, confined spaces, etc.). Ambulances are also dispatched from these stations. Emergency response time for emergencies is estimated to be 8-10 minutes. Fire hydrants are available in the office park.

The nearest hospital with an emergency room is 5 miles away.

VISUAL XII-A-23

### Threats/Hazards

**Threats include:**

- Terrorism
  - No direct threat to HIC
  - Government, military, industry in the area
- Intelligence Collection
- Crime
  - High threat in metro area, lower in suburbs



FEMA logo and 'BUILDING DESIGN FOR HOMELAND SECURITY Unit XII-A-23' text are at the bottom.

### Threats/Hazards – Terrorism, Intelligence, and Crime

- Terrorism – no direct threat, but collateral damage possible
- Intelligence – due to work done by CI/BC this is always a concern
- Crime – relatively low for the type of work being done

VISUAL XII-A-24 (XI-23)

Threats/Hazards

Threats include:

Terrorism

- No direct threat to HIC
- Government, military, industry in the area

Intelligence Collection

Crime

- High threat in metro area, lower in suburbs

HazMat

- Many facilities nearby
  - Fuel farm and pipeline
  - Interstate highway
  - Rail line

Natural Hazards

- Hurricanes – Infrequent
- Tornadoes – Almost every Spring
- Earthquakes – Infrequent
- Lightning - Frequent



BUILDING DESIGN FOR HOMELAND SECURITY Unit XI-23

Threats/Hazards – HazMat, Technological, and Natural

Many forms of HazMat in the local area, but especially the Tank Farm and the Interstate Highway are potential locations for Technological Hazards (accidents).

Natural Hazards consist of various windstorms and lightning, with other hazards occurring less frequently.

VISUAL XII-A-25

Computerized Elevation Looking Northwest



BUILDING DESIGN FOR HOMELAND SECURITY Unit XII-A-25

Elevation Looking Northwest

The lay of the land indicates that a fuel spill from the Tank Farm will not get to the HIC building, as well as any liquid spill on the Interstate Highway.

VISUAL XII-A-26

Computerized Elevation Looking Northeast

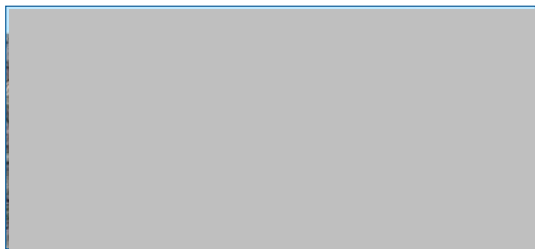

BUILDING DESIGN FOR HOMELAND SECURITY Unit XII-A-26

Elevation Looking Northeast

Similarly, along the back of the office park the terrain makes vehicle approach very difficult and liquid HazMat spills from the railroad line will not flow to the HIC building. The slope will also tend to direct any gases blown toward HIC from the southwest to be propelled up and over the HIC portion of the building.

VISUAL XII-A-27 (XI-24)

### Design Basis Threat

**Explosive Blast:** Car Bomb 250 lb TNT equivalent. Truck Bomb 5,000 lb TNT equivalent (Murrah Federal Building class weapon)

**Chemical:** Large quantity gasoline spill and toxic plume from the adjacent tank farm, small quantity (tanker truck and rail car size) spills of HazMat materials (chlorine)

**Biological:** Anthrax delivered by mail or in packages, smallpox distributed by spray mechanism mounted on truck or aircraft in metropolitan area

**Radiological:** Small "dirty" bomb detonation within the 10-mile radius of the HIC building



BUILDING DESIGN FOR HOMELAND SECURITY Unit XI-24

### Design Basis Threat

**Explosive Blast:** Car Bomb – approximately 250 lb TNT equivalent. Truck Bomb – approximately 5,000 lb TNT equivalent (Murrah Federal Building class weapon)

**Chemical:** Large quantity gasoline spill and toxic plume from the adjacent tank farm, small quantity (tanker truck and rail car size) spills of HazMat materials (chlorine)

**Biological:** Anthrax delivered by mail or in packages, smallpox distributed by spray mechanism mounted on truck or aircraft around metropolitan area.

**Radiological:** Small "dirty" bomb detonation within the 10-mile radius of the HIC building.

VISUAL XII-A-28 (XI-25)

### Levels of Protection

#### GSA Interagency Security Criteria

Level II Building – between 11-150 employees; 2,500 to 80,000 sq ft

- Perimeter Security
- Entry Security
- Interior Security
- Administrative Procedures
- Blast/Setback Standards



BUILDING DESIGN FOR HOMELAND SECURITY Unit XI-25

### Levels of Protection

#### GSA Level II Interagency Security Criteria

- Perimeter Security
- Entry Security
- Interior Security
- Administrative Procedures
- Blast/Setback Standards



VISUAL XII-A-29 (XI-26)

Levels of Protection

DoD Antiterrorism Standards

Level of Protection	Potential Structural Damage	Potential Door and Glazing Hazards	Potential Injury
Low	Damage – unreparable. Major deformation of non-structural elements and secondary structural members and minor deformation of primary structural members, but progressive collapse is unlikely.	Glazing will break, but fall within 1 meter of the wall or otherwise not present a significant fragment hazard. Doors may fail, but they will rebound out of their frames, presenting minimal hazards.	Majority of personnel suffer significant injuries. There may be a few (<10 percent) fatalities.

Adapted from Table 4-1, DoD Minimum Antiterrorism Standards for New Buildings, page 4-9, FEMA 426



BUILDING DESIGN FOR HOMELAND SECURITY Unit XI-26

Levels of Protection

DoD Low, Inhabited Building

- Potential Structural Damage
- Potential Door and Glazing Hazards
- Potential Injury

VISUAL XII-A-30 (XI-27)

Levels of Protection

DoD Antiterrorism Standards

Location	Building Category	Stand-off Distance or Separation Requirements			
		Applicable Level of Protection	Conventional Construction Stand-off Distance	Effective Stand-off Distance	Applicable Explosives Weight
Controlled Perimeter or Parking and Roadways without a Controlled Perimeter	Inhabited Building	Very Low	25 M	10 M	Approx. 250 lbs
			82 ft	33 ft	

Adapted from Table 4-1, DoD Minimum Antiterrorism Standards for New Buildings, page 4-9, FEMA 426



BUILDING DESIGN FOR HOMELAND SECURITY Unit XI-27

Levels of Protection

DoD Low, Inhabited Building Stand-off Distance or Separation Requirements

VISUAL XII-A-31 (XI-28)

Levels of Protection

UFC 4-010-01 APPENDIX B DoD MINIMUM ANTITERRORISM STANDARDS FOR NEW AND EXISTING BUILDINGS	
Standard 1	Minimum Stand-off Distances
Standard 2	Unobstructed Space
Standard 3	Drive-Up/Drop-Off Areas
Standard 4	Access Roads
Standard 5	Parking Beneath Buildings or on Rooftops
Standard 6	Progressive Collapse Avoidance
Standard 7	Structural Isolation
Standard 8	Building Overhangs
Standard 9	Exterior Masonry Walls
Standard 10	Windows, Sights, and Glazed Doors
Standard 11	Building Entrance Layout
Standard 12	Exterior Doors



BUILDING DESIGN FOR HOMELAND SECURITY Unit XI-28

Levels of Protection

UFC 4-010-01 Appendix B  
DoD Minimum Antiterrorism Standards for New and Existing Buildings Standards 1-12

What standards are applicable to the Case Study?

VISUAL XII-A-32 (XI-29)

Levels of Protection (continued)

UFC 4-010-01 APPENDIX B DoD MINIMUM ANTITERRORISM STANDARDS FOR NEW AND EXISTING BUILDINGS	
Standard 13	Mallrooms
Standard 14	Roof Access
Standard 15	Overhead Mounted Architectural Features
Standard 16	Air Intakes
Standard 17	Mallroom Ventilation
Standard 18	Emergency Air Distribution Shutoff
Standard 19	Utility Distribution and Installation
Standard 20	Equipment Bracing
Standard 21	Under Building Access
Standard 22	Mass Notification



BUILDING DESIGN FOR HOMELAND SECURITY Unit XI-29

VISUAL XII-A-33 (XI-30)

Unit XI Case Study Activity

Finalization and Presentation of Group Results

Purpose

- Groups finalize their assessments
- Decide on high priority risk concerns
- Determine appropriate mitigation measures
- Present findings to class

Requirements

Based on findings from previous 10 activities, complete the worksheet table

Prepare to present conclusions and justify decisions to class in a 5- to 7-minute presentation



BUILDING DESIGN FOR HOMELAND SECURITY Unit XI-30

Members of the instructor staff should be available to answer questions and assist groups as needed.

At the end of 45 minutes, reconvene the class and facilitate group reporting.

Levels of Protection

UFC 4-010-01 Appendix B  
DoD Minimum Antiterrorism Standards for New and Existing Buildings Standards 13-22

What standards are applicable to the Case Study?

In addition to the standards, review the DoD Recommendations for New and Existing Buildings, Appendix C.

Case Study Activity

In this unit, the students will finalize the assessment, determine high priority risk concerns, recommend appropriate mitigation options, and present findings to the class.

Activity Requirements

- Working in small groups, refer to the HIC Case Study and the GIS portfolio to determine answers to the worksheet questions.
- Then review results to identify vulnerabilities and possible mitigation measures, and rank and prioritize the findings.



VISUAL XII-A-34 (C-34)

**Vulnerability/Mitigation**  
**Basis of Mitigation Measures**

Recommendations ultimately require an understanding of benefit (capability) versus cost to implement

Blast Modeling

- Various scenarios run at Tier III level for comparison using Design Basis Threats
  - Truck bomb is worst case
  - Car bomb also analyzed for comparison
  - Some interesting and unexpected results
- More analysis required for final design



BUILDING DESIGN FOR HOMELAND SECURITY COOP T-t-T Unit XII-C-34

**Vulnerability Mitigation – Basis of Measures - Blast**

Need to understand benefit versus cost.

Blast modeling concentrates upon worst case, but must work all scenarios. Since both positive and negative blast wave phases are used in retrofitting existing buildings, results were interesting and, in some cases unexpected.

The higher tier assessment indicates the first cut of possible approaches, but more analysis is needed to work with the architects and engineers in achieving a final design.

VISUAL XII-A-35 (C-35)

**Vulnerability/Mitigation**  
**Basis of Mitigation Measures**

Plume Modeling (CBR or HazMat)

- Tier II / Tier III performed for selected Design Basis Threats external to building
- Additional Tier III analysis required inside building
  - Understand internal pressure changes during building operation
  - Understand how HVAC and other changes implemented in response plans affect building
  - Supports design of CBR measures



BUILDING DESIGN FOR HOMELAND SECURITY COOP T-t-T Unit XII-C-35

**Vulnerability Mitigation – Basis of Measures - Plume**

Plume modeling for CBR or HazMat follows similar approaches to indicate actions to consider, then followed by more detailed analysis to achieve the final design.

VISUAL XII-A-36 (C-36)

**Vulnerability/Mitigation**  
**Basis of Mitigation Measures**  
Cost Estimates are ROM (Rough Order of Magnitude)

- Assumes 10% Overhead and 10% Profit
- Assumes Area Cost Factor of 1.0 (DoD) or 100 (RS Means)
  - DoD Range: **0.84** (Huntsville AL) to **1.67** (Anchorage AK)
  - RS Means Range: **82.5** (Baton Rouge LA) to **131.9** (New York NY)
  - Adjusted for July 2006
- Anti-Terrorism / Force Protection equipment and construction costing information is still immature



BUILDING DESIGN FOR HOMELAND SECURITY COOP T-t-T Unit XII-C-36

**Vulnerability Mitigation – Basis of Measures – Cost**

When comparing benefit versus cost, the cost is equally difficult to determine due to the still immature nature of anti-terrorism / force protection costing information.

The costing used in this presentation assumes 10% overhead, 10% profit, an Area Cost Factor of 1.0, and adjusted for July 2006.

For your actual situation you can then adjust the dollar values given for your conditions.

VISUAL XII-A-37 (C-37)

**Vulnerability/Mitigation**  
**Site / Vehicle Bomb**  
Maximize available stand-off

- Front side along sidewalk to prevent direct approach into building and ensure stand-off – 100 LF
- Due to straightaways on front and back of building, need K12 stopping power
  - Planters - \$22.3K
  - Plinth wall - \$50.7K
  - Landscaping (boulders) - \$19.5K



BUILDING DESIGN FOR HOMELAND SECURITY COOP T-t-T Unit XII-C-37

**Vulnerability/Mitigation – Site / Vehicle Bomb**

The front side and rear of the building have access roads that allow straightaway approaches to the building, especially the front. The achievable speed requires K12 stopping power.

For the front of the building, there are three options to hinder this approach and provide some stand-off to the situation. Landscaping using large boulders is the cheapest and has aesthetic qualities.

VISUAL XII-A-38 (C-38)

**Vulnerability/Mitigation**  
**Building Envelope / Vehicle Bomb**  
Harden windows (balanced envelope)

- Fragment Retention Film
  - Not costed -- could not meet performance required for upgraded stand-off
- Laminated glass -- 56 windows
  - ½" laminated interior pane with 0.060 PVB interlayer, air gap to 0.25 inches, and retention of exterior pane - \$170.8K



BUILDING DESIGN FOR HOMELAND SECURITY (COOP) T-T-T Unit XII-A-38

**Building Envelope / Vehicle Bomb**

The windows are those found in standard commercial construction. They are relatively weak and require significant increase in tensile strength.

The goal is to achieve a balanced envelope between windows and walls.

While fragment retention film (FRF) comes to mind as the first glazing mitigation measure, it is not always successful in achieving protection for the existing stand-off available or the upgraded stand-off achieved through other measures. In this case 15 mil FRF requires 92 feet of stand-off for the Small DBT and is greater than 500 feet for the Large DBT. Thus putting a controlled perimeter on the main road outside the office park would not achieve protection from the Large DBT. And achieving 92 feet of stand-off from HIC will greatly impact parking at the office park, especially if the mitigation measure is extended to the other buildings in the office park.

Laminated glass with a 60 mil interlayer was selected for the interior pane so that the existing 1-inch IGU (insulated glass unit) frame could be reused to save money. This resulted in reducing the 1/2" air gap to 1/4" and retaining the exterior pane. This turned out to be the minimum upgrade for the projected controlled perimeter stand-off distance.

VISUAL XII-A-39 (C-39)

**Window Hardening**

Original Glazing

- Large DBT – 1,136 ft
- Small DBT – 338 ft

Hardened Glazing

- Large DBT – 422 / 579 ft
- Small DBT – 29 / 150 ft

Between the two hardened glazing distances glass blows OUT of building



FEMA

BUILDING DESIGN FOR HOMELAND SECURITY COOP T-t-T Unit XII-C-39

**Window Hardening**

As can be seen the Large DBT for the original glazing (thicker red contour) encompasses much of the interstate highway. The Small DBT (thinner red contours) covers a good portion of the parking lot.

The upgraded window with the 1/2" laminated glass inserted as the interior pane (and confirmation that the window frame connections to the building can survive the blast loading) reduces the stand-off to a controlled perimeter at the entrances to the office park for the Large DBT.

For the Small DBT, building occupants are protected down to a 29-foot stand-off. Although from 29 feet to 150 feet the glazing blows OUT of the building during the negative phase of the blast.

VISUAL XII-A-40 (C-40)

**Vulnerability/Mitigation**

**Building Envelope / Vehicle Bomb**

Harden exterior -- Close in overhang

- Brick bonded to 4" Reinforced Concrete Wall, #3 rebar @12 inches each way - \$64.2K
- Brick backed with truck bed liner - \$34.6K
- Deduct window hardening if overhang enclosed – (\$85.4K)



BUILDING DESIGN FOR HOMELAND SECURITY COOP T-t-T Unit XII-C-40

**Building Envelope / Vehicle Bomb**

Next, the goal is to enclose the overhang as this architectural feature greatly increases blast damage. Two mitigation options were analyzed. A benefit of enclosing the overhang results the savings indicated as half the windows in the HIC building would then not require hardening.

Note that brick is retained for architectural compatibility and the Spray-On Polymer (truck bed liner) is significantly cheaper than the reinforced concrete backing wall.

VISUAL XII-A-41 (C-41)

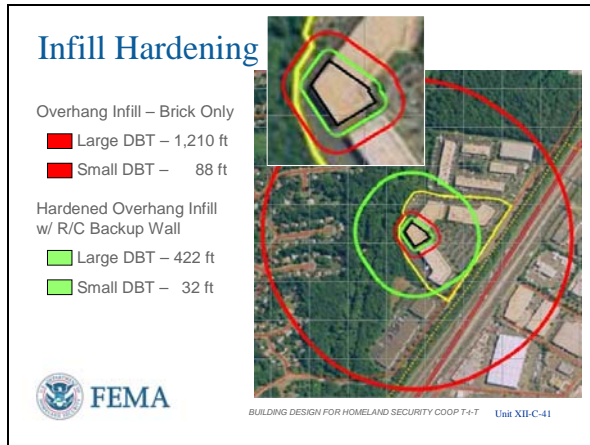

**Infill Hardening – R/C Backing Wall**

Comparing to a Brick Only wall (which is also an indication of the blast resistance of the outer wythe of the double wythe wall) shows that Brick is even weaker than the windows.

The reinforced concrete backing wall helps by keeping the Large DBT contour inside the main road serving the office park. The standoff for the Small DBT also has limited impact on changing parking in front of the HIC building.

VISUAL XII-A-42 (C-42)

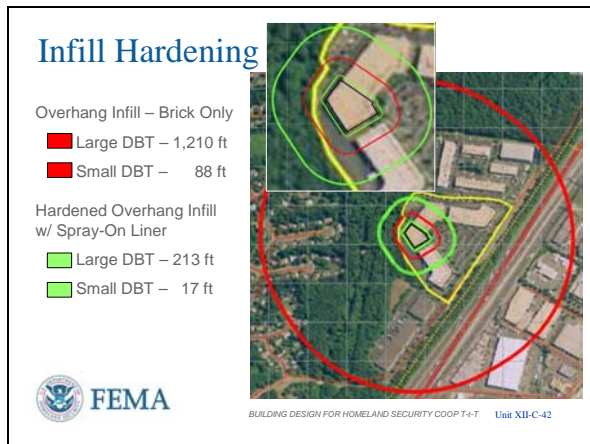

**Infill Hardening – Spray-On Polymer Liner**

The performance of the truck bed liner is remarkable considering it is only 1/4” thick with a 1 foot overlap onto the concrete overhang ceiling and the concrete overhang floor.

The Spray-On Polymer Liner shows about half the stand-off distance compared to the R/C Backing Wall, and, since it is cheaper, then it is the preferred mitigation measure. Be aware that the Spray-On Liner has some environmental concerns during installation and fire concerns due to its fuel capacity.

VISUAL XII-A-43 (C-43)

**Vulnerability/Mitigation**  
**Building Envelope / Vehicle Bomb**  
Harden walls (balanced envelope)

- Vermiculite in wall cavity - \$23.5K
- Spray on truck bed liner - \$43.4K



BUILDING DESIGN FOR HOMELAND SECURITY COOP T-t-T Unit XII-C-43

**Wall Hardening**

The cavity wall (Brick / Cavity / CMU) gains strength if both walls act together to resist the blast pressure vice working independently like tearing individual pages of a phone book to tear a phone book in half.

The Vermiculite in the wall cavity has mechanical properties that supports the need to tie the two walls together so that they act as one.

The Spray-On Polymer Liner (truck bed liner) is expected to have good performance per the Infill Hardening just presented, but at almost twice the cost of the Vermiculite. The exterior walls must be stripped to the CMU surface for applying the Liner, and then wallboard has to be replaced.

VISUAL XII-A-44 (C-44)



**Wall Hardening**

Cavity Wall – CMU Only

- Large DBT – 1,022 ft
- Small DBT – 230 ft

Hardened Cavity Walls w/ Vermiculite in gap

- Large DBT – 371 ft
- Small DBT – 31 ft



BUILDING DESIGN FOR HOMELAND SECURITY COOP T-t-T Unit XII-C-44

**Wall Hardening – Vermiculite**

The Vermiculite provides comparable stand-off to that needed for retention of parking and using the entrances to the office park as the controlled perimeter access control points.



VISUAL XII-A-45 (C-45)

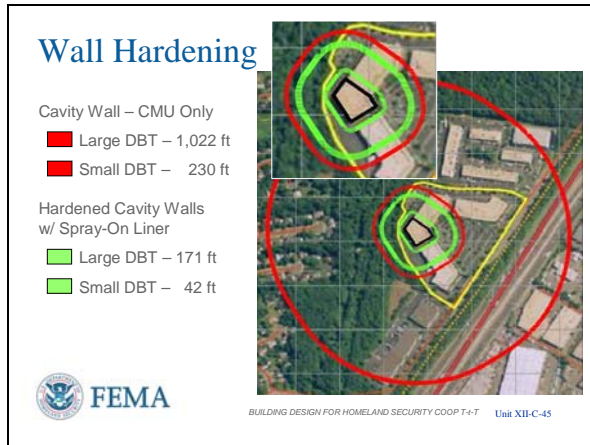

VISUAL XII-A-46 (C-46)



**Wall Hardening – Spray-On Liner**

As expected, the Spray-On Polymer Liner has very good performance, especially for the Large DBT. However, the controlled perimeter location and the additional cost of the Liner, justifies going with the Vermiculite to achieve a balanced envelope.

**Site / Vehicle Bomb**

Establishing a controlled perimeter is the next step (but should be started first as it affects all the other office park tenants).

K8 ratings along the main road will provide the level of protection needed with three entrances as follows:

- Truck entrance
- Car entrance
- Truck exit (one-way traffic flow with trucks only allowed on the back side of the office park buildings).

If screening is not done at the vehicle entrance, then pre-screening off-site will be very expensive comparatively with a facility and annual labor. Access control can be by tenant with scheduled deliveries and remote control barrier operation linked with CCTV.

VISUAL XII-A-47 (C-47)

**Vulnerability/Mitigation**  
**Architectural / Vehicle Bomb**  
Strengthen overhead anchorage elements

- Heaters - \$2.1K



BUILDING DESIGN FOR HOMELAND SECURITY COOP T-T-T Unit XII-C-47

**Architectural / Vehicle Bomb**

A low cost mitigation measure is to upgrade the supports for the overhead heaters the areas near the loading dock per DoD guidelines.

VISUAL XII-A-48 (C-48)

**Vulnerability/Mitigation**  
**Site / Armed Attack (Physical Security)**  
Controlled Perimeter

- Fencing on three sides of site not on main road - \$66.0K
- Upgrade Security Ops Center (security managers office) – digital CCTV, digital video recording (DVR), and cameras for complete building coverage - \$55.0K



BUILDING DESIGN FOR HOMELAND SECURITY COOP T-T-T Unit XII-C-48

**Site / Armed Attack (Physical Security)**

In addition to the controlled perimeter along the main road, upgrading the fencing around the back of the office park is also in order to control foot access

Upgrading the Security Operations Center with updated digital CCTV, digital recording, and cameras for complete building coverage would also be in order, in addition to vehicle access points.



VISUAL XII-A-49 (C-49)

**Vulnerability/Mitigation**  
**Architectural / Mailroom**  
Separate front lobby from interior office space

- Harden wall between lobby and office space - \$22.9K
- Harden door between lobby and office space - \$4.4K
- Separate HVAC system - \$4.4K
- Total \$31.7K

Separate Mailroom, hardened with separate HVAC - \$40.0K



BUILDING DESIGN FOR HOMELAND SECURITY COOP T-T-T Unit XII-C-49

**Architectural / Mailroom**

Two approaches for the mailroom were considered:

- The first is to convert the receptionist lobby into a mailroom operation area (to continue using the receptionist as the mail clerk).
- The second is to build a separate mailroom, which will probably require someone else to perform mail duties.
- In either case, sealing, hardening, and separate HVAC are in order.

VISUAL XII-A-50 (C-50)

**Vulnerability/Mitigation**  
**Utilities / Mechanical Systems / Vehicle Bomb**  
Natural gas meters / pressure regulators

- Bollards, K12, 3 total - \$2.3K
- Fencing (access control) - \$0.20K

**Utilities / Electrical Systems / Vehicle Bomb**  
Electrical transformers

- Bollards, K12, 6 total - \$4.6K



BUILDING DESIGN FOR HOMELAND SECURITY COOP T-T-T Unit XII-C-50

**Utilities / Vehicle Bomb**

Protection of utilities on the backside of the building also comes under the low cost umbrella. As stated previously the straightaway allows high-speed approach to the back of the HIC building. K12 fixed bollards and fencing to prevent approach to these systems needs consideration.

VISUAL XII-A-51 (C-51)

**Vulnerability/Mitigation**  
**Mechanical Systems / Fire Alarm Systems / General Vulnerability – Redundancy**  
Fire Alarm / Suppression

- Install annunciator panel - \$3.5K
- Fire detection zones for C/IBC corporate space with dual detection in Data Center - \$81.0K
- Convert Data Center to clean agent to supplement water (check local code) - \$137.5K

Chilled Water

- Install backup piping to primary air handling units - \$26.0K



BUILDING DESIGN FOR HOMELAND SECURITY COOP T-T-T Unit XII-C-51

**Mechanical / Fire / General Vulnerability - Redundancy**

For better control of the Fire Alarm and Fire Suppression Systems, install a fire annunciator panel in HIC area of the building.

Rezone the fire alarms throughout the building and install dual zones in the Data Center to support adding the Clean Agent system in the Data Center (and probably the Communications Center). Note that depending upon local codes the Clean Agent system will NOT REPLACE the water sprinkler system.

The Chilled Water supply and return lines are vital to the proper operation of the Data Center. Adding redundant lines should be considered to maintain 24/7 operations.

VISUAL XII-A-52 (C-52)

**Vulnerability/Mitigation**  
**Electrical Systems / General Vulnerability – Redundancy**  
Increase size of generator fuel tank

- 2,000 to 3,000 gallons (30 hours at full output) - \$17.0K
- 3,000 gallons of diesel fuel - \$8.7K
- Total \$25.7K
- Arrange multiple suppliers for daily deliveries under worst case conditions

Conduct full and extended load test of emergency generator and UPS system to confirm performance



BUILDING DESIGN FOR HOMELAND SECURITY COOP T-T-T Unit XII-C-52

**Electrical / General Vulnerability – Redundancy**

Since electricity is vital to 24/7 operations the existing 2,000 gallon fuel tank (and 250 gallon day tank) will not last long enough to maintain a once-per-day delivery schedule at full load (which may occur only during the heat of the summer). The generator consumes 100 gallons per hour. Replacing the fuel tank is one approach, or renting a fuel truck during the peak summer season when the 2,000 gallon fuel tank re has insufficient fuel capacity is another.

Multiple fuel suppliers should be arranged to prevent a single occurrence (like a utility power outage) from preventing deliveries or fuel supplies should be canvassed to determine if they have backup generators to overcome utility power outages.

VISUAL XII-A-53 (C-53)

**Vulnerability/Mitigation**

**Mechanical Systems-HVAC / CBR Attack**

- Protect outside air intake - \$21.0K (architecturally compatible)
- Emergency shut down switch - \$10.0K
- Upgrade filters to MERV 11/13 (gasoline plume and radioactive particulates)
  - \$25.0K (filter assembly only) to
  - \$500.0K (upgraded air handling)

 **FEMA**

BUILDING DESIGN FOR HOMELAND SECURITY (COOP) T-t-T Unit XII-A-53

Finally, upgrading the generator and UPS testing program is in order.

- Test the generator and outage sensor system once per month for 2 hours at the peak electrical consumption of the week.
- Test the battery capacity of the UPS once per year to ensure it can carry the load for the time required for orderly shutdown.

**HVAC / CBR Attack**

Raising the outside air intake is probable the first action to take to make it less vulnerable to attack and reduce the risk of heavier-than-air agents. This measure is more expensive because it will have to be architecturally compatibility (brick).

The second action is the emergency shutdown switch to shut down all air handling equipment in the building. If funds are tight, this should be the first action as it is less expensive than raising the air intake.

Upgrading the filters of the HVAC systems from MERV 8 to MERV 11/13 has a potential range of cost that requires further investigation. It is beneficial whenever there are particulates involved. It can be as simple as adding the filters or as expensive as upgrading the complete air handling system to accommodate the pressure drop of the higher MERV filters.

VISUAL XII-A-54 (C-54)

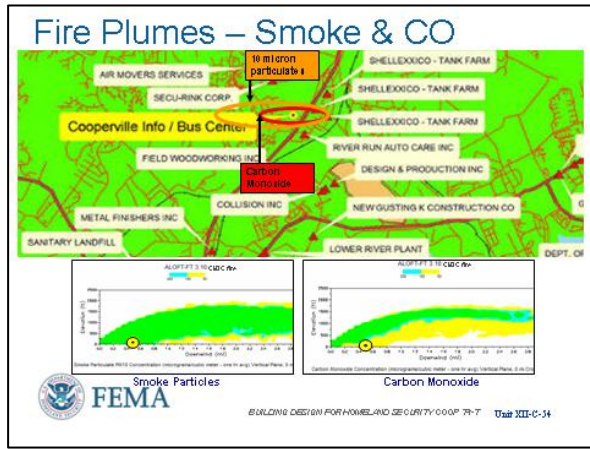

**Fire Plumes – Smoke and Carbon Monoxide**

Two points to consider are smoke particles that MERV 11.13 filters will capture and carbon monoxide, a lighter-than-air gas that kills by overcoming the oxygen in a room. The wind direction for this scenario does not follow the predominant wind patterns shown in earlier HazMat slides.

Circles on the lower graphs indicate the approximate location of the HIC building.

The smoke particles will be in high concentration as they reach the HIC building as shown in the lower left graphic. Filtering of these smoke particles is not only a concern from a human health standpoint, but also for sensitive electronic equipment, such as computer and communications.

Alternately, the carbon monoxide will be at a lesser concentration, but still high, although not high enough to be instantly fatal. This allows for evacuation from the site if a plume heads for the building. Sheltering-in-place is not recommended in this case.

VISUAL XII-A-55 (C-55)

**Vulnerability/Mitigation**

**Mechanical Systems-HVAC / CBR Attack**

- Evaluate carbon filters for chlorine type spills - \$130.0K
- Evaluate UVGI - \$8.0K

FEMA

**HVAC / CBR Attack**

Carbon filters for removal of chlorine gas and similar gaseous spills is expensive and the filters should be on a sensor to switch them into the system when needed, rather than always being in operation – pressure drop and eventual consumption of capacity.

Ultraviolet Germicidal Irradiation (UVGI) in contrast is very reasonable and has the added benefit of killing biological agents in addition to standard infections. Thus, building air recirculation through the UVGI will not only protect from (CBR) attack, but has the

VISUAL XII-A-56 (C-56)

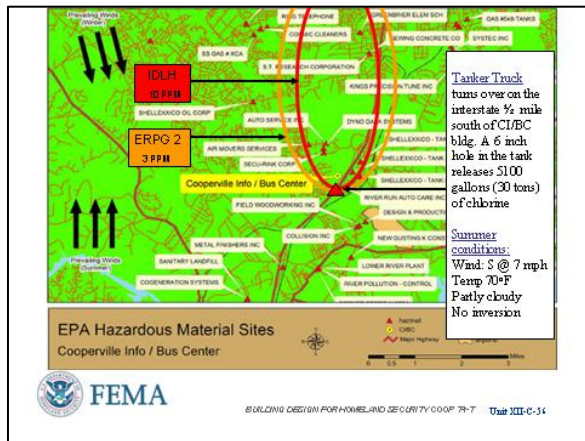

capability of reducing employee downtime due to spreading normal diseases (flu, colds, etc.) through the air handling system.

### Chlorine Spill – Tanker Truck on Interstate Highway

In this case the prevailing winds are from the south, sending the chlorine plume over the HIC building.

- Immediately Dangerous to Life or Health (**IDLH**) refers to a concentration, formally defined as the maximum exposure concentration of a given chemical from which one could escape within 30 minutes without any escape-impairing symptoms or any irreversible health effects. The IDLH for chlorine is 10 ppm.
- The **ERPG-2** is the maximum airborne concentration below which it is believed that nearly all individuals could be exposed for up to 1 hr without experiencing or developing irreversible or other serious health effects or symptoms which could impair an individual's ability to take protective action.

VISUAL XII-A-57

**HIC Chlorine Release Parameters**

**SITE DATA INFORMATION:**  
 Location: FAIRFAX, VIRGINIA  
 Building Air Exchanges Per Hour: 0.24 (sheltered double stored)  
 Time: November 29, 2005 11:11 hours EST (using computer's clock)

**CHEMICAL INFORMATION:**  
 Chemical Name: CHLORINE Molecular Weight: 70.91 g/mol  
 ERPG-3: 20 ppm ERPG-2: 3 ppm ERPG-1: 1 ppm  
 IDLH: 10 ppm  
 Carcinogenic risk - see CAMEO  
 Normal Boiling Point: -29.3° F Ambient Boiling Point: -29.7° F  
 Vapor Pressure at Ambient Temperature: greater than 1 atm  
 Ambient Saturation Concentration: 1,000,000 ppm or 100.0%

**ATMOSPHERIC INFORMATION: (MANUAL INPUT OF DATA)**  
 Wind: 7 mph from 180° true at 3 meters  
 No Inversion Height  
 Stability Class: 0 Air Temperature: 70° F  
 Relative Humidity: 50% Ground Roughness: urban or forest  
 Cloud Cover: 5 tenths

**SOURCE STRENGTH INFORMATION:**  
 Leak from hole in horizontal cylindrical tank  
 Tank opening diameter: 6 inches tank height: 24.1 feet  
 Tank Volume: 5100 gallons Tank contains liquid  
 Internal Temperature: 20° F  
 Chemical Mass in Tank: 30 tons Tank is 100% full  
 Circular Opening Diameter: 6 inches  
 Opening is 6 inches from tank bottom  
 Release Duration: 2 minutes  
 Max Average Sustained Release Rate: 57,700 pounds/min  
 (averaged over a minute or more)  
 released: 59,200 pounds  
 total escaped as a mixture of gas and aerosol (two phase flow).

FEMA  
 BUILDING DESIGN FOR HOMELAND SECURITY Unit XII-A-57

**HIC Chlorine Release Parameters**

This slide shows the information available from the CAMEO toxic industrial chemical (TIC) modeling program of EPA and NOAA and can be downloaded at <http://archive.orr.noaa.gov/cameo/aloha.html>.

- It is important to note that chlorine is approximately 2.5 times heavier than air so it will not readily disperse into the atmosphere. Instead it will hug the ground as it disperses and will settle in the lowest elevations.
- Notice this release is a rapid release of 5100 gallons (30 tons) of chlorine through a 6-inch hole in the tanker truck. The entire release occurs in approximately two minutes.
- A much smaller leak was also modeled (such as might occur in a ruptured hose) in order to demonstrate how changing just one variable makes a tremendous difference in the release and potentially in the response.



VISUAL XII-A-58

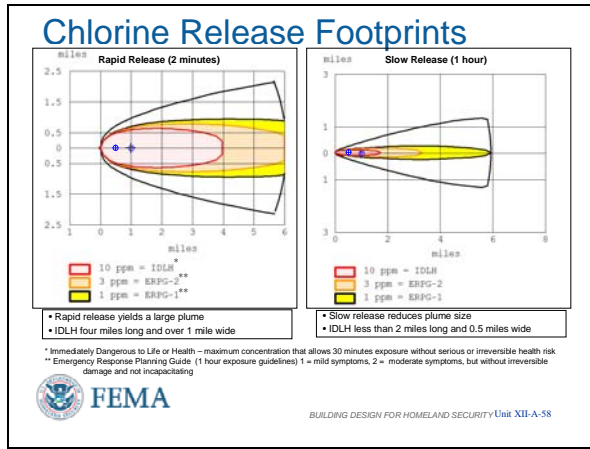

The **ERPG-3 (not shown)** is the maximum airborne concentration below which it is believed that nearly all individuals could be exposed for up to 1 hour without experiencing or developing life-threatening health effects.

**Chlorine Release Footprints**

On the left is a basic plume footprint for the rapid release of chlorine [5100 gallons (30 tons) at 225 psi over 2 minutes].

On the right is the footprint for a slower release, occurring over the course of one hour.

The blue circle with plus sign indicates the range of building location versus spill site (from 0.5 miles to one mile).

Note how a rapid release covers a much wider area, but reduces the DOSE (concentration x time) that can be received. Whereas the slow release is a bigger problem as a high concentration is present for a much longer time.

Immediately Dangerous to Life or Health (IDLH) [30 minutes] was defined earlier.

Emergency Response Planning Guides (ERPG) are defined in thin three categories

- The **ERPG-1** is the maximum airborne concentration below which it is believed that nearly all individuals could be exposed for up to 1 hr without experiencing other than mild transient adverse health effects or perceiving a clearly defined, objectionable odor.
- The **ERPG-2** is the maximum airborne concentration below which it is believed that nearly all individuals could be exposed for up to 1 hr without experiencing or developing irreversible or other serious health effects or symptoms which could impair an individual's ability to take protective action.

VISUAL XII-A-59

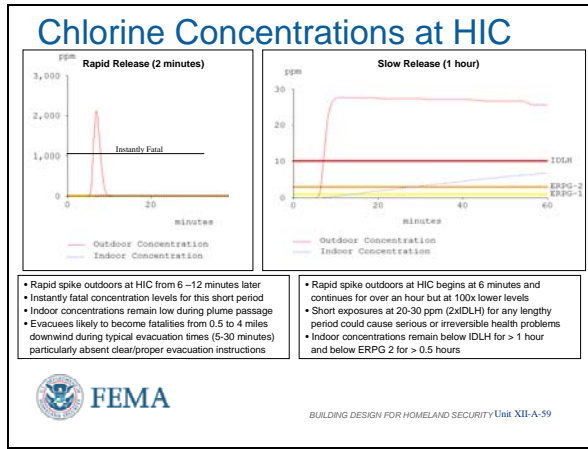

VISUAL XII-A-60

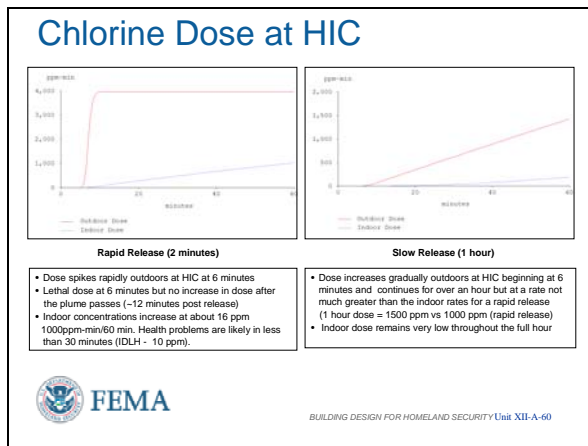

**Chlorine Concentrations at HIC**

**Bottomline:** In all circumstances it is best to remain indoors unless or until the facts related to the release are clear and it can be determined safe evacuation is possible. For even more protection move to upper floors and if intakes are roof-mounted - turn the HVAC on high (pressurize) until the odor of chlorine is noticed.

If configured, HVAC carbon filters can be put into operation or go to shelter-in-place configuration and turn on roof-mounted pressurization units.

**Chlorine Dose at HIC**

**Bottomline:** Once again it is clear that remaining indoors is the best option until or unless it is clear evacuation can be accomplished safely. It should be noted that while the total indoor dose for the slow release is approximately **100 ppm-min** this only equals about 1.6 ppm (concentration) – well below IDLH and ERPG 2.

Any efforts to maintain a positive pressure in the building and seal exterior openings (particularly at the lowest levels) could further reduce the infiltration and therefore dosage for occupants.

After the plume passes, this would be the time to purge the building to reduce the indoor concentration and, thus reduce the dose to people inside the building. While high concentrations are a concern for immediate effects, high dosage is a concern for long-term effects.



VISUAL XII-A-61 (C-61)

Vulnerability/Mitigation  
**IT Communications Systems / Utility Systems / Cyber Attack - Redundancy**  
Identify alternate telecom carrier circuits and availability



BUILDING DESIGN FOR HOMELAND SECURITY COOP T-T-T Unit XII-C-11

**IT Communication Systems – Redundancy**

Currently there is only one telecom carrier provider. Identifying an alternate telecom carrier and the availability of circuits that can be run to the HIC building provides similar backup as the generator and UPS provide to the electrical utility.

Since communications (data and voice) is so important to the HIC 24/7 operations, backup in this area should receive equivalent consideration.

**NOTE:** Since the HIC building needs a satellite communications link to satisfy DAI COOP requirements, this satellite link can provide the redundancy sought here.

VISUAL XII-A-62 (C-62)

Vulnerability/Mitigation  
**Emergency Operations & Response**  
Post shelter and evacuation procedures - \$900  
Identify rally points (A, B, C) at sites away from building - \$900  
Conference Room for shelter-in-place (130 people) [Sealing and Overpressurization] –\$177.4K  
Personal protective evacuation hoods - \$180 / person - \$23.4K



BUILDING DESIGN FOR HOMELAND SECURITY COOP T-T-T Unit XII-C-12

**Emergency Operations and Response**

Low cost, no cost actions, especially shelter, evacuation, and rally point procedures should be the first step. And these should be updated as the building is reconfigured for updated operations.

For sheltering-in-place the conference room will require 3 filter/pressurization units on the roof to overpressurize the Conference Room. This will allow a longer shelter-in-place strategy, but NOT at a low cost.

Protective evacuation hoods are cheaper than overpressurization systems, but may not work with all agents with which personnel may contend. Recommend labeling the evacuation hoods for their design contaminants (or label them for the NON-DESIGN contaminants, whichever list is smaller).

---

**Transition**

This completes the Building Design for Homeland Security instruction. In this course, you have learned how to perform a multihazard risk assessment of a building and have become familiar with the key concepts of how to protect buildings from manmade threats and hazards:

- Asset Value
- Design Basis Threat
- Levels of Protection
- Layers of Defense
- Vulnerability Assessment
- Risk Assessment
- Mitigation Options

Using the approach and guidance provided in **FEMA 426 / FEMA 452**, the majority of building owners should be able to complete a risk assessment of their building in a few days and identify the primary vulnerabilities, mitigation options, and make informed decisions on the ability of their building to survive, recover, and operate should an attack or event occur.

The next instruction unit will cover how to teach this course by covering basic Train-the-Trainer concepts and the support requirements for this course.

---

*This page intentionally left blank*

**UNIT XII-A CASE STUDY ACTIVITY:  
PREPARATION AND PRESENTATION OF GROUP RESULTS**

In this activity, students work with their groups to finalize their assessments, decide on high priority risk concerns, determine appropriate mitigation measures and present findings to the class.

**Requirements**

1. Based on findings from the previous activities completed in the previous instruction units, complete the following table.
  
2. Be prepared to present conclusions and to justify decisions to the class in a 5-7 minute presentation.

<b>Prioritized Asset-Threat/Hazard Pair of Interest</b>	<b>Requirements to Mitigate</b>	<b>Rationale</b>
Car Bomb Blast/Site and Building	Protect front entrance from car bomb blast – 82-foot stand-off  Use planters, plinth walls, landscaping  FRF film on windows or replace with laminated glass  Consider closing in overhang area	<i>DoD Standard 1, 8, and 10 apply in that there are stand-off concerns, window strength concerns, and architectural feature / building envelope concerns.</i>
Truck Bomb/Site	Protect rear parking area from truck bomb  Use chain link gate, vehicle pop barriers, pre-screening away from building  Consider closing in overhang area	DoD Standard 1  DoD Standard 6  DoD Standard 8

**Course Title: Building Design for Homeland Security**

Unit XII-A: Case Study

<p>Chemical/Mechanical-HVAC</p>	<p>Install emergency shut down switch, protect outside air intake</p> <p>Evaluate carbon filters for chlorine type spills</p> <p>Upgrade filters to MERV 11 to remove gasoline plume and other particulates</p>	<p>DoD Standard 17</p> <p>DoD Standard 18</p> <p>DoD Recommendation 6</p>
<p>Biological/Mechanical-HVAC</p>	<p>Evaluate UVGI</p> <p>Evaluate a standalone mailroom on separate HVAC zone</p>	<p>DoD Standard 13</p> <p>DoD Standard 17</p> <p>DoD Standard 18</p>
<p>Radiological/Site</p>	<p>Install emergency shut down switch on HVAC</p> <p>Upgrade filters to MERV 11 to remove radioactive particulates</p>	<p>DoD Standard 17</p> <p>DoD Standard 18</p>
<p>Blast Site</p>	<p>Separate front lobby from interior office space with security door if primary mail entry point is the lobby area</p> <p>Distribute internal functions for redundancy</p> <p>Evaluate other utility connections/distribution capability for redundant feed to the building</p>	<p>DoD Standard 11</p> <p>DoD Standard 19</p> <p>DoD Recommendation 2</p> <p>DoD Recommendation 3</p> <p>DoD Recommendation 12</p> <p>DoD Recommendation 13</p> <p>DoD Recommendation 15</p>
<p>Blast/Structural and Building</p>	<p>Strengthen overhead anchorage elements - Heaters</p>	<p>DoD Standard 15</p> <p>DoD Standard 20</p>

Course Title: Building Design for Homeland Security

Unit XII-A: Case Study

<p>Blast or Armed Attack/Mechanical</p>	<p>Fire sprinklers - Install annunciator panel and go to zones, dual stage in data center, clean agents versus water</p> <p>Chill water - Install backup piping to primary air handling units</p> <p>Install exhaust fan in UPS room (lead acid batteries)</p> <p>Place bollards around or relocate natural gas meters</p>	<p>DoD Standard 16</p> <p>DoD Standard 17</p> <p>DoD Standard 18</p> <p>DoD Standard 19</p>
<p>Blast or Armed Attack/Electrical</p>	<p>Primary Bus - Separate Computer Center Bus from Support Bus</p> <p>Place bollards or fencing around transformers</p> <p>Increase size of generator fuel tank</p>	<p>DoD Standard 18</p> <p>DoD Standard 19</p>
<p>Cyber Attack and Blast/IT Systems</p>	<p>Store backup tapes/data at least 10 miles away</p> <p>Identify alternate telecom carrier circuits and availability</p> <p>Conduct full extended load test of emergency power/UPS system</p>	<p>DoD Standard 18</p> <p>DoD Standard 19</p> <p>DoD Standard 20</p>
<p>Blast or Armed Attack/Physical Security</p>	<p>Raise height of rear perimeter fencing</p> <p>Evaluate installing a small Security Operations Center and increase monitoring/awareness of exterior</p> <p>Upgrade CCTV system to digital and DVR and install</p>	<p>DoD Standard 1</p> <p>DoD Standard 2</p>

**Course Title: Building Design for Homeland Security**

Unit XII-A: Case Study

	additional cameras to view front parking, lobby, and loading dock	
Blast and CBR/Emergency Operations/Disaster Recovery	Post shelter and evacuation procedures  Identify rally point at site away from building  Use Computer Center for shelter-in-place  Acquire personal protective evacuation hoods	DoD Standard 22  DoD Recommendation 14

## Unit XIII

---

<b>COURSE TITLE</b>	Building Design For Homeland Security	<b>TIME</b>	60 minutes
---------------------	---------------------------------------	-------------	------------

---

<b>UNIT TITLE</b>	Course Wrap-Up
-------------------	----------------

---

<b>OBJECTIVES</b>	<ol style="list-style-type: none"><li>1. Reflect upon the reasons for attending the course provided during Unit 1 Introductions (any Case Study version) and the conduct of the course.<ol style="list-style-type: none"><li>a. Expectations met?</li><li>b. Likes and dislikes?</li><li>c. Value?</li></ol></li><li>2. Provide written feedback to the Course Director and Instructors through course evaluation forms and verbal comments related to the course specifically or building design for Homeland Security in general. This feedback is critical to improving the course.</li></ol>
-------------------	--

---

<b>SCOPE</b>	<ol style="list-style-type: none"><li>1. Discussion of general issues and concerns</li><li>2. Course evaluations – forms and verbal comments</li><li>3. Distribution of course certificates</li></ol>
--------------	---

---

<b>REFERENCES</b>	No references are required for this unit.
-------------------	---

---

<b>REQUIREMENTS</b>	<ul style="list-style-type: none"><li>• Course evaluation form (one per student)</li><li>• Record any verbal comments from students to distribute to course director and instructors.</li><li>• Course certificates</li></ul>
---------------------	---

---

<b>PREPARATION</b>	Before training this unit, review the students' lists of expectations recorded in Unit I.
--------------------	---

---



**Unit XIII Outline**

	<u>Time</u>	<u>Page</u>
XIII. Course Wrap-Up	60 minutes	IG XIII-1
1. General Discussion	15 minutes	IG XIII-3
2. Course Evaluations	15 minutes	IG XIII-3
3. Distribution of Course Certificates	30 minutes	IG XIII-3

INSTRUCTOR NOTES	CONTENT/ACTIVITY
<p>Review the students' course expectations, as listed in Unit I during the Introductions.</p> <p>Relate those expectations to key concepts covered in each unit of the course.</p> <p>Determine whether the students feel that each expectation was met, and discuss as needed.</p> <p>Invite questions and comments from the students related to the training or to building design for Homeland Security in general. (e.g., state or local issues, funding sources, use of <b>FEMA 426</b>, use of <b>FEMA 452</b> databases, etc.).</p> <p>Address the students' concerns, as needed.</p>	<p><b>General Discussion</b></p> <p>Sample questions to ask include:</p> <ul style="list-style-type: none"><li>• How does this expectation relate to material covered in the course?</li><li>• Has this expectation been met?</li><li>• Have any issues have been left unaddressed?</li><li>• How does this issue relate to your role in building design for Homeland Security, and how do you expect to apply this material on the job?</li><li>• Are there any questions or comments about the course content, exercises, written exam or other aspects of the training?</li><li>• Are there any questions or comments about building design for Homeland Security in general?</li></ul>
<p>Distribute the course evaluation forms.</p> <p>Ask the students to take their time in completing the evaluation.</p>	<p><b>Course Evaluations</b></p> <p>FEMA uses the evaluations to improve future course deliveries. The students' feedback is very important for ensuring a quality program.</p>
<p>Distribute the course certificates to the students.</p>	<p><b>Distribution of Course Certificates</b></p>

---

<b>INSTRUCTOR NOTES</b>	<b>CONTENT/ACTIVITY</b>
-------------------------	-------------------------

---

*This page intentionally left blank*